

DOT/FAA/ND410-96/1
DOT-VNTSC-FAA-96-9.1

Office of
Communications,
Navigation and
Surveillance Systems
Terminal Surveillance
Product Team
Washington, DC 20591

Low-Cost ASDE Evaluation Report: Raytheon Marine (Phase I) Radar at MKE (ARPA M3450 / 18CPX-19) Volume I

Research and
Special Programs
Administration
Volpe National
Transportation Systems Center
Cambridge, MA 02142-1093

Final Report
July 1996

This document is available to the public
through the National Technical Information
Service, Springfield, VA 22161

19961004 182

DTIC QUALITY INSPECTION



U.S. Department of Transportation
Federal Aviation Administration

DISCLAIMER NOTICE



**THIS DOCUMENT IS BEST
QUALITY AVAILABLE. THE
COPY FURNISHED TO DTIC
CONTAINED A SIGNIFICANT
NUMBER OF PAGES WHICH DO
NOT REPRODUCE LEGIBLY.**

**Low-Cost ASDE Evaluation Report:
Raytheon Marine (Phase I) Radar at MKE
(ARPA M3450 / 18CPX-19)
Volume I**

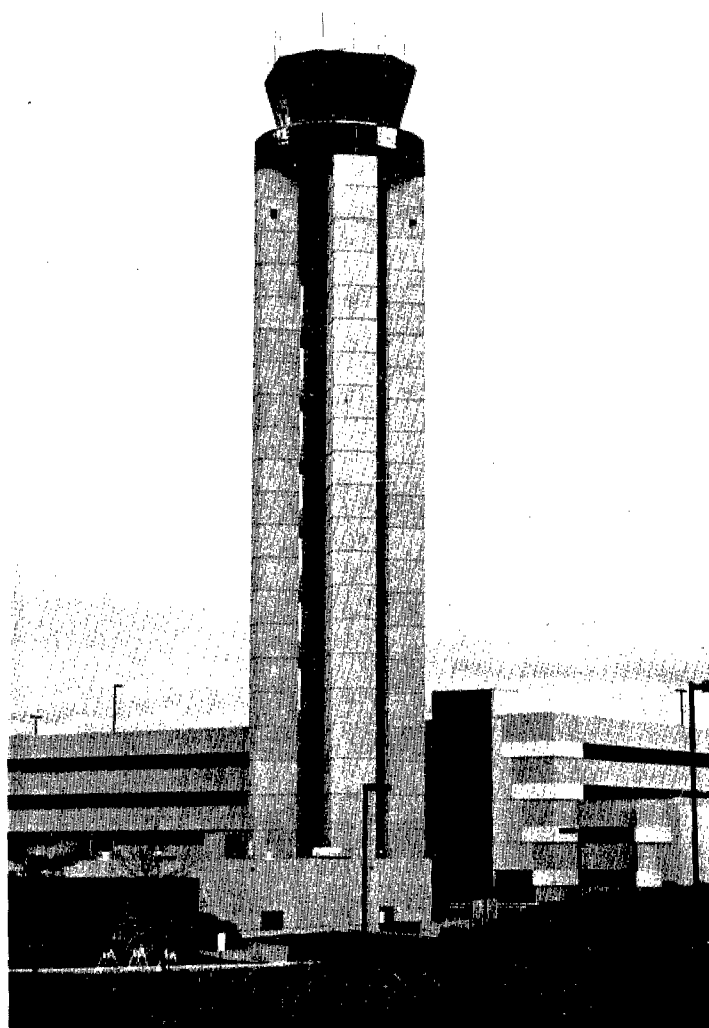

NOTICE

This document is disseminated under the sponsorship of the Department of Transportation in the interest of information exchange. The United States Government assumes no liability for its contents or use thereof.

REPORT DOCUMENTATION PAGE

Form Approved
OMB No. 0704-0188

Public reporting burden for this collection of information is estimated to average 1 hour per response, including the time for reviewing instructions, searching existing data sources, gathering and maintaining the data needed, and completing and reviewing the collection of information. Send comments regarding this burden estimate or any other aspect of this collection of information, including suggestions for reducing this burden, to Washington Headquarters Services, Directorate for Information Operations and Reports, 1215 Jefferson Davis Highway, Suite 1204, Arlington, VA 22202-4302, and to the Office of Management and Budget, Paperwork Reduction Project (0704-0188), Washington, DC 20503.

1. AGENCY USE ONLY (Leave blank)		2. REPORT DATE July 1996		3. REPORT TYPE AND DATES COVERED Final Report August 1995 - March 1996	
4. TITLE AND SUBTITLE Low-Cost ASDE Evaluation Report: Raytheon Marine (Phase I) Radar at MKE (ARPA M3450/18CPX-19)				5. FUNDING NUMBERS FA6P8/A6029	
6. AUTHOR(S) C. Bandon, J. Blasier ¹ , F. Bouchard ² , V. Capezzuto ³ , F. Coyne, C. Franck ⁴					
7. PERFORMING ORGANIZATION NAME(S) AND ADDRESS(ES) U.S. Department of Transportation Research & Special Programs Administration John A. Volpe National Transportation Systems Center 55 Broadway Cambridge, MA 02142-1093				8. PERFORMING ORGANIZATION REPORT NUMBER DOT-VNTSC-FAA-96-9.1	
9. SPONSORING/MONITORING AGENCY NAME(S) AND ADDRESS(ES) U.S. Department of Transportation Federal Aviation Administration Office of Communications, Navigation and Surveillance Systems Terminal Surveillance Product Team/AND-410 800 Independence Avenue, S.W. Washington, DC 20591				10. SPONSORING/MONITORING AGENCY REPORT NUMBER DOT/FAA/ND410-96/1	
11. SUPPLEMENTARY NOTES ¹ NATCA, ² SRC, ³ JIL, ⁴ Rannoch					
12a. DISTRIBUTION/AVAILABILITY STATEMENT This document is available to the public through the National Technical Information Service, Springfield, VA 22161				12b. DISTRIBUTION CODE	
13. ABSTRACT (Maximum 200 words) The FAA has identified the Airport Surface Detection Equipment as a radar system that aids air traffic controllers in low visibility conditions to detect surface radar targets and sequence aircraft movement on active runways. Though 35 major U.S. airports will have an ASDE-3 by the year 2000, its high cost precludes its use at hundreds of smaller airports; for them, low-cost COTS radar ("ASDE-X") shows promise as a controllers' aid in monitoring surface traffic and as a second sensor input to counteract shadowing, blanking and multipath problems. The FAA tasked the Volpe Center to evaluate Raytheon Marine's ASDE-X. The Phase I evaluation was made with Raytheon's Model ARPA M3450/18CPX-19, a COTS radar with options added to adapt performance to the airport environment. This report details the characteristics, installation, and evaluation of this system at Milwaukee's General Mitchell International Airport (MKE). (Phase II will more closely approximate ASDE-3 functionality.) Test results show that, in low-visibility conditions, the system enhanced controllers' situational awareness, detected and displayed targets, aided movement area clearance, and enabled confirmation of pilots' reported positions and compliance with instructions. The ASDE-X's positive initial acceptance and low cost (\$100k versus ASDE-3's \$6m) make it potentially a good choice for small airports seeking effective ground surveillance radar.					
14. SUBJECT TERMS Airport Surface Detection Equipment (ASDE), ASDE-3, ASDE-X, radar, Phase I system, Phase II system				15. NUMBER OF PAGES 200	
				16. PRICE CODE	
17. SECURITY CLASSIFICATION OF REPORT Unclassified	18. SECURITY CLASSIFICATION OF THIS PAGE Unclassified	19. SECURITY CLASSIFICATION OF ABSTRACT Unclassified	20. LIMITATION OF ABSTRACT		

PREFACE

The Federal Aviation Administration's Terminal Surveillance Project Team (AND-410) tasked the Volpe Center to evaluate low-cost alternatives to the ASDE-3, a surface surveillance radar system to be installed at major U.S. airports by the year 2000 for a suitable solution for hundreds of smaller airports nationwide. This report, the first of a series prepared by the Volpe Center's evaluation team, describes and gives test results of an off-the-shelf Raytheon Marine radar installed at General Mitchell International Airport (MKE) in Milwaukee, WI.

A team is only as good as its members, and the Volpe Center extends thanks to the many people and organizations involved in the effort: the staff at General Mitchell Airport (MKE) for their cooperation and enthusiasm, especially the Air Traffic Controllers, MKE SSC Radar and Environmental Specialties; NATCA for excellent test coordination; Phillip-Morris for its test pilots and planes; TAMSCO (with an assist from Ideal Helicopter) for a swift and efficient installation; JIL, Rannoch, SRC, and Camber for exhaustive test and documentation support.

A special acknowledgment goes out to Steve Davis, FAA/NATCA, whose vision and dedication spearheaded the entire MKE radar project.

Thanks also to Raytheon Marine for permission to use the equipment drawings in Section 1 and the original text and figures for Section 3, to Ken Baker for his photos, and to Jeppesen / Sanderson Corp. for their recently updated MKE map.

METRIC/ENGLISH CONVERSION FACTORS

ENGLISH TO METRIC	METRIC TO ENGLISH
<p style="text-align: center;">LENGTH (APPROXIMATE)</p> <p>1 inch (in) = 2.5 centimeters (cm) 1 foot (ft) = 30 centimeters (cm) 1 yard (yd) = 0.9 meter (m) 1 mile (mi) = 1.6 kilometers (km)</p>	<p style="text-align: center;">LENGTH (APPROXIMATE)</p> <p>1 millimeter (mm) = 0.04 inch (in) 1 centimeter (cm) = 0.4 inch (in) 1 meter (m) = 3.3 feet (ft) 1 meter (m) = 1.1 yards (yd) 1 kilometer (km) = 0.6 mile (mi)</p>
<p style="text-align: center;">AREA (APPROXIMATE)</p> <p>1 square inch (sq in, in²) = 6.5 square centimeters (cm²) 1 square foot (sq ft, ft²) = 0.09 square meter (m²) 1 square yard (sq yd, yd²) = 0.8 square meter (m²) 1 square mile (sq mi, mi²) = 2.6 square kilometers (km²) 1 acre = 0.4 hectare (ha) = 4,000 square meters (m²)</p>	<p style="text-align: center;">AREA (APPROXIMATE)</p> <p>1 square centimeter (cm²) = 0.16 square inch (sq in, in²) 1 square meter (m²) = 1.2 square yards (sq yd, yd²) 1 square kilometer (km²) = 0.4 square mile (sq mi, mi²) 10,000 square meters (m²) = 1 hectare (ha) = 2.5 acres</p>
<p style="text-align: center;">MASS - WEIGHT (APPROXIMATE)</p> <p>1 ounce (oz) = 28 grams (gm) 1 pound (lb) = .45 kilogram (kg) 1 short ton = 2,000 pounds (lb) = 0.9 tonne (t)</p>	<p style="text-align: center;">MASS - WEIGHT (APPROXIMATE)</p> <p>1 gram (gm) = 0.036 ounce (oz) 1 kilogram (kg) = 2.2 pounds (lb) 1 tonne (t) = 1,000 kilograms (kg) = 1.1 short tons</p>
<p style="text-align: center;">VOLUME (APPROXIMATE)</p> <p>1 teaspoon (tsp) = 5 milliliters (ml) 1 tablespoon (tbsp) = 15 milliliters (ml) 1 fluid ounce (fl oz) = 30 milliliters (ml) 1 cup (c) = 0.24 liter (l) 1 pint (pt) = 0.47 liter (l) 1 quart (qt) = 0.96 liter (l) 1 gallon (gal) = 3.8 liters (l) 1 cubic foot (cu ft, ft³) = 0.03 cubic meter (m³) 1 cubic yard (cu yd, yd³) = 0.76 cubic meter (m³)</p>	<p style="text-align: center;">VOLUME (APPROXIMATE)</p> <p>1 milliliter (ml) = 0.03 fluid ounce (fl oz) 1 liter (l) = 2.1 pints (pt) 1 liter (l) = 1.06 quarts (qt) 1 liter (l) = 0.26 gallon (gal) 1 cubic meter (m³) = 36 cubic feet (cu ft, ft³) 1 cubic meter (m³) = 1.3 cubic yards (cu yd, yd³)</p>
<p style="text-align: center;">TEMPERATURE (EXACT)</p> <p style="text-align: center;">$^{\circ}\text{C} = 5/9(^{\circ}\text{F} - 32)$</p>	<p style="text-align: center;">TEMPERATURE (EXACT)</p> <p style="text-align: center;">$^{\circ}\text{F} = 9/5(^{\circ}\text{C}) + 32$</p>

QUICK INCH-CENTIMETER LENGTH CONVERSION

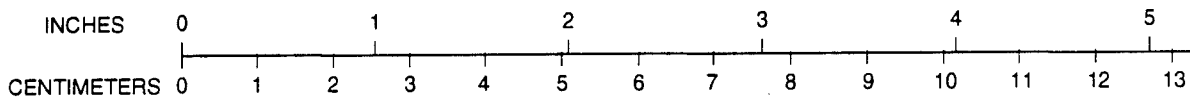

QUICK FAHRENHEIT-CELSIUS TEMPERATURE CONVERSION

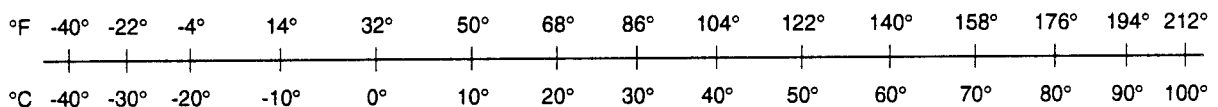

For more exact and or other conversion factors, see NIST Miscellaneous Publication 286, Units of Weights and Measures. Price \$2.50. SD Catalog No. C13 10286.

Updated 8/1/96

TABLE OF CONTENTS

<u>Section</u>	<u>Page</u>
1. RADAR SYSTEM.....	1-1
1.1 Phase I: Marine Radar.....	1-1
1.1.1 Transceiver.....	1-1
1.1.2 Antenna.....	1-2
1.1.3 Antenna Pedestal.....	1-3
1.1.4 Display.....	1-4
1.1.5 Dehydrator.....	1-5
1.2 Phase II Radar.....	1-6
1.3 Comparisons of ASDE-X (Phase II) to Raytheon India ASDE.....	1-7
1.4 Comparative System Costs.....	1-7
2. INSTALLATION.....	2-1
2.1 Airport Profile.....	2-1
2.1.1 MKE Weather-Related Incursions.....	2-2
2.1.2 MKE Reduced Visibility Data.....	2-4
2.2 Site Engineering Survey and Report.....	2-5
2.3 Statement of Work.....	2-5
2.4 Site Installation Survey and Plan.....	2-6
2.5 Radar Installation and Report.....	2-7
3. ALIGNMENT AND ADJUSTMENTS.....	3-1
3.1 Transceiver.....	3-1
3.1.1 Low Voltage Power Supply Adjustments.....	3-2
3.1.2 HVPS Adjustments.....	3-5
3.1.3 Transmitter Adjustments.....	3-6
3.1.4 Receiver.....	3-8
3.2 Monitor Linking.....	3-13
3.2.1 Isolation Rectifier (A2) (115 / 230 VAC Operation).....	3-13
3.2.2 Low-Line Isolation Rectifier 100/200 VAC Operation.....	3-14
3.2.3 EIU Linking.....	3-14
3.2.4 Control Panel Interface (CPI).....	3-15
3.2.5 Backplane Connections.....	3-16
3.2.6 Video Processor A (VPA).....	3-17
3.2.7 Adaptive Interface Linking.....	3-17
3.3 System Setup Adjustments.....	3-19
3.3.1 Display Adjustments.....	3-19

TABLE OF CONTENTS (cont.)

<u>Section</u>	<u>Page</u>
3.3.2 System Configuration.....	3-22
3.3.3 Operational Preferences	3-25
3.3.4 ARPA Configuration - Clock Set.....	3-25
3.3.5 Adaptive Interface Video Adjustment	3-25
3.3.6 Tuning Preset.....	3-27
3.3.7 Final Video Adjustment	3-28
3.3.8 Noise Threshold	3-28
3.3.9 VPA Alignment.....	3-30
3.3.10 Record Parameters and Reset Switches.....	3-33
3.4 Certification	3-33
4. TEST AND EVALUATION.....	4-1
4.1 Equipment Checklist and Tests.....	4-1
4.1.1 RF Low-Loss Cable (LLC) Attenuation Calibration	4-3
4.2 Fixed Target Reflector (FTR) Setup.....	4-4
4.3 DGPS Measurement of Fixed Target Locations	4-6
4.4 Functional Tests	4-8
4.4.1 Transmitter and Receiver Measurements	4-8
4.4.2 System Measurements.....	4-14
4.4.3 Radar Alignment to FTR	4-16
4.4.4 Display Map Generation.....	4-19
4.4.5 Range and Azimuth Resolution Demonstration.....	4-22
4.5 Data Sheets.....	4-23
4.5.1 Calibration Data Sheet	4-23
4.5.2 DGPS Measurements Data Sheet	4-23
4.5.3 Functional Test Data Sheet.....	4-24
5. OPERATOR EVALUATION	5-1
5.0.1 Operational Tests.....	5-1
5.0.2 Test Personnel and Equipment	5-3
5.0.3 Test Support and Setup.....	5-4
5.0.4 Safety Precautions.....	5-4
5.0.5 Display Control Definitions	5-5
5.1 Display Satisfaction Testing.....	5-8
5.2 Demonstration of Maximum Height Coverage	5-12
5.3 Demonstration of Dissimilar Sized Targets and Shadowing Effects.....	5-18
5.4 Radar Registration of Targets in Hold Position at Runway Ends.....	5-22
5.5 Registration of Non-Aircraft Targets in Tandem	5-25
5.6 High-Speed Turn-off Demonstration	5-30
5.7 Radar Presentation and Detection	5-33
5.8 Target Display Presentation.....	5-35

TABLE OF CONTENTS (cont.)

<u>Section</u>	<u>Page</u>
5.9 False Target Display Presentation	5-37
5.10 Positioning Accuracy Testing	5-43
5.11 Surveillance Update Rate	5-49
5.12 Probability of Detection.....	5-50
5.13 Low Visibility Presentation Test	5-51
6. ANALYSIS AND RECOMMENDATIONS.....	6-1
6.1 Analysis.....	6-1
6.2 Recommendations.....	6-16
APPENDIX A - CALCULATIONS FOR REFERENCE SIGNAL TO NOISE RATIO.....	A-1
APPENDIX B - RSEC CALCULATION.....	B-1
APPENDIX C - DISPLAY TEST/RESET MENU.....	C-1
APPENDIX D - DISPLAY ALIGNMENTS	D-1
APPENDIX E - OPERATIONAL TEST WEATHER AND VISIBILITY OBSERVATIONS (ASOS AND RVR DESCRIPTIONS).....	E-1
APPENDIX F - RECOMMENDED MONTHLY MAINTENANCE PROCEDURES.....	F-1

LIST OF FIGURES

<u>Figure</u>	<u>Page</u>
1-1 Transceiver	1-2
1-2 Antenna with Pedestal.....	1-3
1-3 Display	1-4
1-4 Dehydrator	1-5
2-1 MKE Airport Map (Jeppesen)	2-3
2-2 MKE ATCT Radar Equipment Layout	2-6
2-3 Installation Schedule	2-8
2-4 Installation of Antenna and Pedestal	2-9
2-5 Display on Moveable Platform.....	2-10
2-6 Display in Tower, Showing Cable Drop.....	2-11
2-7 Transceiver, Radar Power Distribution Panel, and Dehydrator, Installed	2-12
2-8 ASDE-X Radar Transmission Permit	2-13
2-9 Construction Permit for MKE FTRs	2-14
3-1 Transceiver in Service Position	3-1
3-2 LVPS Pulled Out to Service Position.....	3-2
3-3 LVPS in Service Position	3-2
3-4 Frequency at Service Loop	3-3
3-5 Low Voltage Power Supply.....	3-4
3-6 Magnetron Heater Scheduling PCB.....	3-4
3-7 High Voltage Power Supply in Service Position.....	3-5
3-8 High Voltage Power Supply in Installed Position.....	3-5
3-9 MTR PRF Adjustment	3-7
3-10 Magnetron Heater Switch	3-8
3-11 Magnetron Heater Scheduling Adjust	3-8
3-12 Low Noise Front End Adjustment	3-8

LIST OF FIGURES (cont.)

<u>Figure</u>		<u>Page</u>
3-13	Oscilloscope Reference for IF Waveform.....	3-9
3-14	STC Waveform.....	3-10
3-15	Logic and Fault PCB.....	3-10
3-16	Desired Amplitude of IF Waveform.....	3-11
3-17	Resolver Drive (A10) PCB Alignment.....	3-12
3-18	Isolation Rectifier Module.....	3-13
3-19	I/R Module - Left Side.....	3-14
3-20	EIU PCB.....	3-14
3-21	Control Panel Interface.....	3-15
3-22	Backplane Connections on Card Rack Assembly.....	3-16
3-23	Backplane Connections.....	3-16
3-24	Video Processor A PCB.....	3-17
3-25	Adaptive Interface Module.....	3-17
3-26	Adaptive Interface Linking.....	3-18
3-27	Control Panel LED View.....	3-20
3-28	Write Protect Switches.....	3-20
3-29	5-Volt Power Supply.....	3-21
3-30	12-Volt Power Supply.....	3-21
3-31	System Setup and Configuration.....	3-22
3-32	Gyro Compass Parameters.....	3-23
3-33	Transceiver Configuration.....	3-24
3-34	Transceiver XCVR Parameters.....	3-24
3-35	Operational Preferences.....	3-25
3-36	ARPA Options.....	3-25

LIST OF FIGURES (cont.)

<u>Figure</u>	<u>Page</u>
3-37 Display Circuit Boards	3-26
3-38 Adaptive Interface Video Adjustment	3-26
3-39 System Setup and Test Menu	3-27
3-40 Visual Adjustment Calibration.....	3-27
3-41 System Calibration.....	3-27
3-42 Final Video Adjustment	3-28
3-43 Adjusting Noise Threshold.....	3-29
3-44 Bright Display Nautical Mile and Pulse Combinations.....	3-30
3-45 VPA PCB	3-31
3-46 VPA Alignment Test.....	3-31
3-47 STC Offset Adjustment	3-32
3-48 STC Offset Incorrect	3-32
3-49 STC Offset Correct	3-32
3-50 STC Amplifier Incorrect.....	3-32
3-51 STC Amplifier Correct.....	3-33
4-1 Interconnection Diagram	4-2
4-2 FTR Configuration at MKE	4-5
4-3 Power Requirements and System Wiring	4-15
4-4 Target at Correct Bearing.....	4-17
4-5 Zero Range Adjustment Completed.....	4-18
4-6 Maps Function Page	4-19
4-7 Frequency Spectrum, Below Peak.....	4-25
4-8 Frequency Spectrum, Above Peak.....	4-25
4-9 Map Generation (Standard Mode)	4-26
4-10 Map Generation (Fast Target Mode)	4-27

LIST OF FIGURES (cont.)

<u>Figure</u>	<u>Page</u>
4-11 Final FTR Configuration at MKE	4-28
5-0a MKE Airport Map.....	5-2
5-0b ASDE-X Operational Pretest Form	5-6
5-2a MKE ATCT, Showing Radar Vertical Coverage	5-12
5-2b Video Showing Target at 500 Feet	5-14
5-2c Video Showing Target at 700 Feet	5-15
5-2d Video Showing Target at 950 Feet	5-16
5-2e Video Showing No Target at 1200 Feet.....	5-17
5-5a Three Vehicles Traveling in Tandem, Images Separate but Fading.....	5-28
5-5b Two Trucks Traveling in Tandem, Images Fused	5-29
5-9a False Target between Approach Ends of 25R and 19R.....	5-39
5-9b False Target Intersection 1R-M.....	5-40
5-9c False Target at Approach End of 1L.....	5-41
5-13 Low Visibility Presentation Test Form.....	5-52
6-1 Display Showing Target in Three Levels of Brilliance, at .75 nm Range with MKE Overlay	6-8
6-2 Three Vehicles Traveling West on Taxiway K, Merged as One Image.....	6-9
6-3 Three Vehicles Traveling East on Taxiway A, Separated as Three Targets	6-9
6-4 Typical Vertical Antenna Pattern for Horn Used in Phase I.....	6-11
6-5 Target Split, Traveling North of Taxiway B	6-12
6-6 False Target, Stationary Near Approach End of Runway 1L	6-13
6-7 HS-28 in High-Speed Transition from Runway 7R to Taxiway E.....	6-14

LIST OF TABLES

<u>Table</u>	<u>Page</u>
1-1 COTS Radar Phase I Options	1-1
1-2 Transceiver Specifications	1-2
1-3 Antenna Specifications.....	1-3
1-4 Antenna Pedestal Specifications	1-4
1-5 Display Specifications	1-5
1-6 Dehydrator Specifications	1-6
1-7 Phase I to Phase II Enhancements.....	1-7
1-8 ASDE-X Radar Price Schedule	1-8
2-1 MKE Airport Data	2-2
2-2 MKE Reduced Visibility Data Summary.....	2-4
2-3 MKE Foggy Day Percentages	2-4
3-1 Alignment Data Sheet	3-34
6-1 Phase 1 Functional Test Measurements.....	6-3
6-2 Comparison of ASDE-3 and ASDE-X	6-4
6-3 Average Radar Settings	6-6

ACRONYM LIST

NOTE: Acronyms mentioned only once in the text are omitted from this list.

AF	Airways Facilities
AFC	Automatic Frequency Control
ALG	FAA Great Lakes Region
AMASS	Airport Movement Area Safety System
ARPA	Automatic Radar Plotting Aid
ASDE	Airport Surface Detection Equipment, surveillance radar
ASDE-3	ASDE, Version 3
ASDE-X	ASDE, low-cost version
ASOS	Automated Surface Observation System
ASSD	Airport Surface Surveillance System Deployment
AT	Air Traffic
ATC	Air Traffic Control(ler) ("controller")
ATCT	Air Traffic Control Tower ("tower")
CDU	Control Display Unit ("display")
COTR	Contract Officer Technical Representative
COTS	Commercial Off-The-Shelf
CP	Circular Polarization
CPI	Control Panel Interface
CRT	Cathode Ray Tube
dB	Decibel
dB(A)	Decibel, Frequency Weighting A
dBm	Decibel, referenced to one milliwatt
DC	Direct Current
DGPS	Differential Global Positioning System
EIU	External Interface Unit
ESD	Electrostatic Discharge
ESU	Environmental Systems Unit
FAA	Federal Aviation Administration
ft	Foot
FTR	Fixed Target Reflector
g	Gravity
GPS	Global Positioning System
HVPS	High Voltage Power Supply
Hz	Hertz, cycles per second, also GHz (Gigahertz) and MHz (Megahertz)
IR	Isolation Rectifier
ITR	TAMSCO's <i>Installation Technical Report</i> (Volume II)
LC	Local [Air Traffic] Controller
LLC	Low-Loss Cable
LNFE	Low Noise Front End
LRU	Line Replaceable Unit
LVPS	Low Voltage Power Supply
MDS	Minimum Discernible Signal
MKE	General Mitchell International Airport (Cudahy, Milwaukee Co., WI)
MTI	Moving Target Indicator
MTR	Modulator Transmitter/Receiver ("transceiver")
NATCA	National Air Traffic Controllers Association
nm	Nautical Mile(s)
OPU	Optional Processor Unit
PASS	Professional Airways Systems Specialists

PCB	Printed Circuit Board
PRF	Pulse Repetition Frequency
RF	Radio Frequency
RPDP	Radio Power Distribution Panel
RR	Range Rings
RSEC	Radio Spectrum Engineering Criteria
RVR	Runway Visual Range
SER	VOLPE's <i>Site Engineering Report for MKE</i> (Volume II, Appendix A)
SOW	Statement of Work
TAMSCO	Technical and Management Services Corporation (Calverton, MD)
TIM	Technical Interchange Meeting
TOP	Target Of Opportunity
VAC	Voltage, Alternating Current
VOLPE	John A. Volpe Transportation Systems Center (Cambridge, MA)
VPA	Video Processor A
VSWR	Voltage Standing Wave Ratio

EXECUTIVE SUMMARY

In its mandate for improving airport surface safety, the Federal Aviation Administration (FAA) has identified the Airport Surface Detection Equipment (ASDE) as a radar system that augments the air traffic controller situational awareness in low visibility conditions, aids in their detection and separation of surface radar targets and facilitates effective sequencing of arrivals and departures on active runways. Though 35 major (Level 1) US airports will have a full-scaled ASDE-3 by the year 2000, its high cost (\$7m installed) precludes it as a solution for hundreds of Level 2 - 4 airports. Among the viable surface surveillance systems the FAA has under evaluation for smaller airports, "ASDE-X" is a low-cost commercial off-the-shelf radar that shows great promise as a controllers' aid in monitoring surface traffic of non-cooperative targets. It also may be useful as a second sensor input to improve tracking at airports experiencing shadowing, blanking and multipath problems.

The FAA tasked the Volpe Center to assemble a team to install, test and evaluate an ASDE-X manufactured by Raytheon Marine of Manchester, NH. Though Raytheon had recently delivered two low-cost ASDE-type systems to Bombay, India, the long lead time they needed to produce a scaled-down version of this system led the team to procure a Raytheon commercial off-the-shelf (COTS) marine radar (Model: ARPA M3450 / 18CPX-19) for its initial (Phase I) evaluation. The radar cost of \$75k increased to \$90k when Air Traffic/Air Facilities training and hardware enhancements were added to adapt system performance to the airport environment. This report details the characteristics, installation, and evaluation of the Phase I system. Phase II, scheduled for installation in August 1996 for an added \$250k as a scaled-down version of the India ASDE-X, will more closely approximate ASDE-3 functionality.

Milwaukee's General Mitchell International Airport (MKE) in the Great Lakes Region (ALG) was designated as the test site for three salient reasons: its fast growth, severe fog conditions, and--most importantly--a recent incursion which caused MKE's AT to request an ASDE-3 ground surveillance system. After installation, calibration, and verification, the evaluation team set up targets, made system measurements, and conducted both functional and operational tests.

Test results show that the ASDE-3 provides more functionality and a higher definition radar presentation than the ASDE-X. Controllers, however, found that the test system enhanced situation awareness during low-visibility operations. AT verified the radar's capability to detect and display targets in conditions of fog (<1/4 nm visibility), moderate rain, driving freezing rain, and snow. AT found that the ASDE-X enabled them to confirm pilots' reported positions and aircraft/vehicle compliance with instructions and aided their clearances of aircraft/vehicles on the movement area during low visibility conditions. The ASDE-X's positive initial acceptance and its relatively low cost (\$100k plus \$57k installation versus the ASDE-3's \$6m plus \$1m) make it potentially a good choice for the many small airports seeking an effective ground surveillance radar.

OVERVIEW

This brief overview serves as the reader's roadmap to this report's sections and appendices.

Section 1 describes each major component of Raytheon's marine radar system used for Phase I and lists its specifications. It then describes upgrades to the MKE installed system for Phase II, and similarities to Raytheon's ASDE-X radar system in use at Bombay (India) International Airport. Enhancements to the COTS for Phase I, and from Phase I to Phase II, and their respective price schedules, are given.

Section 2 explains the MKE environment: airport layout, recent incursion history, reduced visibility data and fog quotient. A brief summary of the site engineering survey's *Site Evaluation Report* (SER, Volume II, Appendix A) follows, and a facsimile of the FAA construction permit for location of fixed target reflectors. The Phase I installation is also outlined, including the Statement of Work, schedule and costs. The installation plan and installation are recapped in a summary of the *Initial Installation Technical Report* (ITR, Volume II available by special request to the Volpe Center.)

Section 3 details the system alignments, and references Raytheon's certification of the system.

Sections 4 and 5 describe the entire sequence of testing performed by the evaluation team. Section 4 begins with equipment checklist and calibration, set-up and DGPS survey. Functional tests include measurements of the radar components (transceiver, display, waveguide, antenna), radar alignment with fixed target reflectors (FTRs), and map generation. Data sheets provide a checklist summary of all recorded calculations and checked verifications.

Evaluation of the radar (Section 5) by its users--the Air Traffic Controllers--begins with explanation of the test format, background data, radar screen definitions, and the test coordinators' pretest form. Thirteen operators' tests of the ASDE-X effectiveness follow, each isolating a specific area of system operation, such as aircraft presentation, target registration, and false target display.

Section 6 analyzes ASDE-X performance and makes recommendations for post-Phase II modifications. MKE ASDE-X performance history is reviewed in a summary of events, and direct comparisons are made between ASDE-X and ASDE-3 system profiles. Task performance is analyzed for range and azimuth resolution, height coverage, isolation and identification of false targets. Recommendations are made regarding the following: modifications to the manufacturer's approved operating procedures and its schedule for maintaining the radar, the supply of spare parts, and suggested improvements and tweaks for Phase II.

Appendices follow. Those in Volume I (this volume) address Calculations for Reference Signal to Noise Ratio (Appendix A), RSEC Calculation (B), Display Test / Reset Menu (C), Display Alignments (D), Operational Test Weather and Visibility Observations (ASOS and RVR Descriptions) (E), and Recommended Monthly Maintenance Procedures (F). TAMSCO's ITR, attached as Volume II, was assembled in a grey binder with its own appendices, VOLPE's SER (Appendix A), ASDE-X Radar Installation Fabrication Drawings (B), Raytheon's Sector Blanking Kit (C), and Raytheon's Certification Report (D). All references to appendices are to Volume I, unless otherwise specified.

CONTACT LIST

FAA Headquarters

Rick Castaldo	(202) 267-3078	AND-410
Doug Perkins	(202) 267-8428	IPT Lead for Terminal Products, (Air Traffic)

FAA MKE

Tom Johnson	(414) 747-5525	Airway Facilities Chief
Jayne Blasier	(414) 747-5523	National ASDE-X NATCA Representative

JIL

Vincent Capezzuto	(202) 267-8263	Systems Engineer
-------------------	----------------	------------------

Rannoch Corp.

Charmaine C. Franck	(703) 838-9780x203	Senior Electrical Engineer
---------------------	--------------------	----------------------------

DOT/Volpe Center/DTS-502

Christina Bandon	(617) 494-2054	Electrical Engineer
Fred Bouchard (SRC)	(617) 494-3325	Technical Editor
Frank Coyne	(617) 494-2228	Electrical Engineer
Ian McWilliams	(617) 494-2244	Project Engineer

Raytheon Marine

John Higgins	(603) 634-4739	Project Engineer
Peter Redes	(603) 647-7530	Engineering Manager

TAMSCO

Faye Francy	(301) 595-0710	Program Manager
Ken Baker	(301) 595-0710	Lead Project Engineer

1. RADAR SYSTEM

The following description of the Raytheon Marine Radar system under evaluation is based on the manufacturer's product information. Raytheon has recently delivered two ASDE radars to India to support ATC needs at Bombay International Airport. Due to the long lead time Raytheon required to manufacture an ASDE radar, the evaluation team decided to evaluate the radar in a two-phase effort. For Phase I, the team procured from Raytheon a commercial off-the-shelf (COTS) marine radar, model ARPA M3450 / 18CPX-19. For Phase II, the team requested Raytheon to upgrade the Phase I radar to a scaled-down equivalent of the system they had sent to India. Individual Phase I components are described below and their specifications listed.

Brief descriptions of Phase II equipment follow; characteristics of the Phase II and the India ASDE systems are compared. Two tables show system improvements: the first lists options added to the Phase I system, the second lists enhancements from Phase I to Phase II. Finally, the costs of the Phase I and Phase II systems are compared.

1.1 PHASE I: MARINE RADAR

The Phase I radar system first installed at MKE was the Raytheon ARPA M3450/18CPX-19. Modifications (see Table 1-1) were made to an off-the-shelf system to enhance its ASDE capability. This radar, one of Raytheon's AN/SPS-64 family of Marine Radars, has options that enable it to serve as a sensor for the detection, surveillance, and control of surface vehicles at airports when the visual line-of-sight is limited due to weather. This high-resolution, ground-surveillance radar presents the controller/operator with a screen display of stationary and/or moving aircraft and vehicles. The system has a 50kW X-band transmitter, a low-noise receiver, a 34 cm raster display, and an 18-foot circularly polarized antenna. Advanced digital signal processing provides the controller with a reliable means of monitoring vehicles in poor visibility. The primary radar operating parameters include: X-band, 9375 MHz, an operating frequency that offers optimum tradeoff between resolution and weather performance; 60 nanosecond (nsec) pulse width for improved range resolution; beamwidths of 0.45° (horizontal) and 19° (vertical); and a 6.5 dB noise figure receiver.

Included in this section are the manufacturers' specifications for the system's major components: transceiver, antenna and pedestal, radar display, and dehydrator.

Table 1-1. COTS Radar Phase I Options.

<i>Option</i>	<i>Improvement</i>
18' circular polarized (CP) antenna	Provides cancellation of rain reflections
.4° horizontal, 19° vertical antenna beamwidth	Improves system azimuth resolution
Low noise receiver front end	Improves signal to noise ratio (SNR)
Waveguide dehydrator	Dries moisture, a cause of high power arcing
Sector blanking	Averts potential interference w/ on-site navigation/communication equipment

1.1.1 Transceiver

The Phase I Modulator Transmitter/Receiver (MTR) is Raytheon's 50 kW unit, shown in Figure 1-1. Specifications for the MTR ("transceiver") are given in Table 1-2.

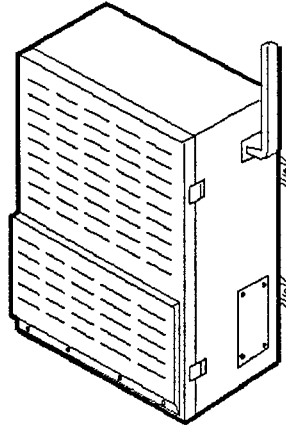

Figure 1-1. Transceiver.

Table 1-2. Transceiver Specifications.

Output Power:	50 kW Peak, nominal at transmitter output
Frequency:	9375 ± 30 MHz
Output Device Type:	Magnetron
Pulse Repetition Frequency:	3600, 1800, and 900 pulses per sec.
Pulse Width:	0.06, 0.5, and 1.0 μsec
Receiver Type:	Logarithmic
Receiver Noise Figure:	6.5 dB (Low Noise Amplifier)
Minimum Discernible Signal:	-92 dBm wide band, -98 dBm narrow band
Receiver Bandwidth:	24 MHz (@ -3 dB Point) 4.0 MHz (@ -3 dB Point)
Dynamic Range:	80 dB Minimum
IF Frequency:	45 ± 5 MHz
Video Bandwidth:	20 MHz Minimum
<i>Environmental Requirements</i>	
Operating Temperature:	0° C to +55° C
Humidity:	0 to 95% Relative
Vibration:	1g Peak at 5 to 50Hz in 3 perpendicular planes
Shock:	5g Operating
Size:	33" high, 24" wide, 13" deep
Weight:	105 Pounds

1.1.2 Antenna

The antenna (see Figure 1-2) is an 18-foot, X-band, slotted waveguide array with fixed circular polarization, is designed to withstand 100 knot winds with a 1" ice buildup. The integral radome covering the antenna's radiating aperture requires no external radome. Specifications are shown in Table 1-3.

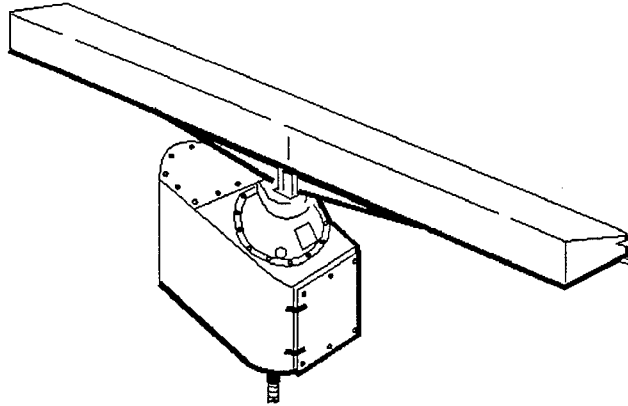

Figure 1-2. Antenna with Pedestal.

Table 1-3. Antenna Specifications.

Type:	Slotted waveguide array integral flared-horn reflector
Horizontal Beamwidth, @ 3 dB Pt:	0.4° ± 0.05°
Vertical Beamwidth, @ 3 dB Pt:	19.0° Nominal, 20.5° Maximum
Frequency:	9375 MHz ± 30 MHz
Gain:	34 dB Minimum
Polarization:	Circular
Sidelobe Level:	Horizontal sidelobes within ±7.5° >26 dB down
VSWR:	1.2:1 Maximum
RF Power Input:	65 kW Maximum
Radome:	Built-in.
Size:	1' x 1.3' x 18.5'
Weight:	100 Pounds
Operating Temperature:	-25° C to +65° C

1.1.3 Antenna Pedestal

The antenna pedestal (Figure 1-2) provides a mounting surface for the 18-foot array. It houses the drive components that produce the antenna scan and all components necessary to monitor antenna position and transmit position information to the radar display. A rotary waveguide joint in the pedestal permits RF energy transmission between the transceiver and the rotating antenna. A resolver in the pedestal develops signals used by the display to correlate the antenna position with radar returns. The pedestal is powered by a 1 horsepower motor operating on 208 VAC, 3 phase power. It requires an operating current of approximately 2 amps per phase, and has a start up surge of 15 to 20 amps. Raytheon reports that this motor will reliably rotate the antenna at 30 RPM in winds up to 70 knots, gusting to 80 knots; it will withstand winds up to 110 knots. The specifications for the X-band pedestal are shown in Table 1-4.

Table 1-4. Antenna Pedestal Specifications.

Height (without array):	49"
Weight (without array):	210 pounds
<i>Input Power Requirements</i>	
Input Voltage	208 VAC, 3 Phase, 60 Hz
Input Voltage Variation:	± 10%
Frequency Variation:	± 6%
Drive Motor Size:	1 hp
Scan Rate:	30 RPM (standard, with options of 12, 24 and 60 RPM)
<i>Environmental Requirements</i>	
Operating Temperature:	-25° C to +65° C
Humidity:	100% Relative
Vibration:	2g Peak @ 5 to 30 Hz, 1g Peak @ 30 to 50 Hz in 3 mutually perpendicular planes
Shock:	15g Operating
Wind:	100 Knots Relative Operating, 140 Knots Survival
Ice:	1" Build-Up, Operating
Swing Circle (radius):	222"
Size	39" x 32" x 61"

1.1.4 Display

The Control Display Unit, (CDU, called "display", see Figure 1-3), was designed for a fixed installation, but made portable to facilitate movement out of the MKE tower cab's main work area when not in use or being evaluated. Display specifications are given in Table 1-5.

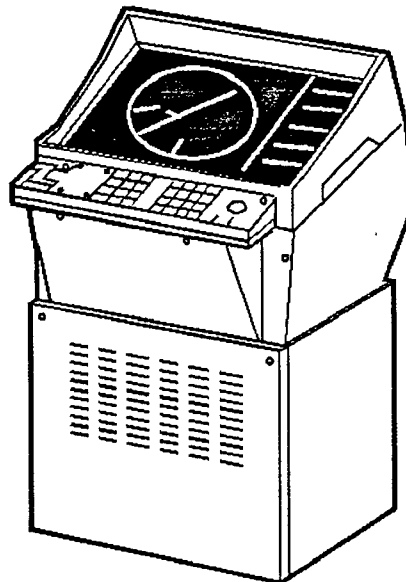

Figure 1-3. Display.

Table 1-5. Display Specifications.

CRT Screen Size (Diagonal):	58.4 cm (23 inches)
PPI Diameter:	34 cm (13.4 inches)
CRT Phosphor:	GREEN (P-39)
Resolution:	768 x 1024 LINES (786,432 pixels)
Range Scales:	.25, .5, .75, 1.5, 3, 6, 12, 24 nm
Minimum Range:	25 meters (27 yards)
Range Resolution:	0.3% or 3.6 meters, whichever is greater.
Bearing Accuracy:	1°
Bearing Resolution:	0.3°
Maximum Tracked Targets:	20
Maximum Number Of True Marks:	10
Acquisition and Tracking Range:	0.1 to 34 nm
Operating Modes:	Stabilized N-up/course-up; centered or offset
Cursor Readout Res. Range/Bearing:	0.01 nm to 10 nm, 0.1 nm to 48 nm/1°
Processor:	Motorola 68000
Program Memory:	EPROM
Size:	47" high, 27" wide, 30" deep
Weight:	216 Pounds
Power Consumption:	115 VAC, 2.6 A or 220 VAC

1.1.5 Dehydrator

The free-standing dehydrator (see Figure 1-4) is an unmodified MR-050 Series commercial unit manufactured by Andrew. It provides low-pressure (approximately 4 psi) dry air to the EW-85 waveguide assembly. The positive pressure in the waveguide prevents moisture accumulation with temperature changes that could lead to arcing. Dehydrator specifications are shown in Table 1-6.

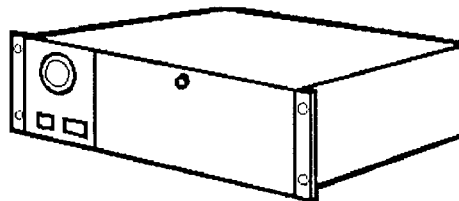

Figure 1-4. Dehydrator.

Table 1-6. Dehydrator Specifications.

Pressure Range:	3.0 to 5 ± 0.3 pounds per square inch
Output Flow Rate:	3 cubic feet per hour
Output Dew Point:	-40°F
Operating Temperature:	32° to 100°F
Input Power Requirements:	115 VAC, 60 Hz
Low Pressure Alarm Set Point:	0.5 pounds per square inch
Desiccant Material:	Color indicating material, w/drying capacity approx. 200 cu ft at 80% relative humidity.
Power Input:	120 VAC, 60 Hz, 170 Watts
Size:	6 in H x 8.6 in D x 19 in W
Output Connector:	Single 3/8" compression fitting, w/shutoff valve

1.2 PHASE II RADAR

The Phase II modifications to the MKE installation, scheduled to be made in July and August, 1996, will enhance the radar to the second-level ASDE-X configuration. Component modifications will be:

- **Array:** Replace the 18CPX-19 (19° vertical beamwidth) with the 18CPX-12 (12° vertical beamwidth.) This replacement of the penthouse antenna array will improve resolution, increase the gain, and reduce ground clutter.
- **Pedestal:** Increase in the antenna rotation rate to 60 RPM will nearly triple the update rate for better resolution of moving targets. This will require the addition of slow-start circuitry and a new drive motor in the pedestal. It may also require a modified gearbox to withstand the greater loads associated with the higher rotation rate.
- **Transceiver:** Replace the 50kW Pathfinder Transceiver with the 25kW STX ASDE Transceiver, designed for airport surface vehicle detection with features like Automatic Frequency Control (AFC) to ensure receiver/transmitter frequency tracking for optimum performance; BITE for local monitoring; and a 40 nsec pulse width for improved range resolution.
- **Display/Processor:** Replace the M34 ARPA display and processor with a high-brightness 19" monitor and a radar processor with operating features, software, and hardware designed specifically for ASDE. This includes modified software for map features, an LCD Control Touch Panel, and a trackball. The upgraded radar will not contain the tracking features of a full Raytheon low-cost ASDE system.

MKE radar enhancements planned between Phase I and Phase II are shown in Table 1-7.

Table 1-7. Phase I to Phase II Enhancements.

<i>Enhancement</i>	<i>Improvement</i>
CP antenna w/ 12° vertical beamwidth	Reduces clutter volume
Pedestal motor increasing antenna rotation rate from 22 rpm [measured] to 60 rpm	Improves update rate of tracked targets
Azimuth position generator	Improved from resolver to encoder
Integral transceiver/display processor decreases transmit pulsewidth, 60ns to 40ns	Improves range resolution
Automatic Frequency Control (AFC)	Minimizes manual adjustments to tune radar
Improved display processor software	Improves map definition of rwys / twys
Masking capability	Removes unwanted clutter on display
Variable range scale adjustments	Permit adjustments at 1/4nm increments
Improved receiver	Increases dynamic range
Mountable, high-brightness displays	Improve screen visibility

1.3 COMPARISONS OF ASDE-X (PHASE II) TO RAYTHEON INDIA ASDE

In November 1995, Raytheon installed a low-cost ASDE radar system at the Bombay International Airport in India. The major differences between the Phase II MKE and Bombay systems are that the latter has target tracking and redundant transceivers and display processors.

- **Plot Extraction and Target Tracking** reject high-resolution clutter, permit alerts of conflicts and runway incursions, and include image-processing algorithms to reduce target break-up and provide size and shape information.
- **Dual Redundant Electronics and Performance Monitoring** provide high system availability and automatic switchover.

1.4 COMPARATIVE SYSTEM COSTS

Raytheon's cost of the basic COTS marine radar was approximately \$75k; AT / AF training costs and certain hardware enhancements (outlined above in Table 1-1) increased the Phase I cost to approximately \$90k. In parallel to the Phase I radar procurement, the FAA requested from Raytheon a cost estimate for modifying Phase I radar to Phase II. Comparative price quotes are shown in Table 1-8.

Table 1-8. ASDE-X Radar Price Schedule.

PHASE I

Part: Description (Product Numbers)	Cost
Transceiver: 50kW X-Band, SS, LNFE (M28111)	\$15,441
Display: ARPA 34 with ENP (M28031)	24,666
Antenna: MCPX19 18' X-Band Array (M27999)	27,025
Pedestal and Motor (MKII-X) (M27812A)	14,809
Dehydrator: Andrew MR-050	2,500
Adaptive Interface Kit (M28043)	2,912
Waveguide: elliptical, plus parts	1,811
Cables	1,279
Total	\$89,443

PHASE II

Part: Description	Cost
Transceiver: upgrade to ASDE-X/Processor Cabinet	\$75,571
Display: ASDE HiBrite, LCD Panel, Trackball, J-Box	37,332
Antenna: CPX-12 mod plus external controller	54,764
Pedestal and Motor (MKII-X), 60 rpm mod	1,144
External Antenna Controller	893
Engineering Costs	71,249
Total	\$240,953

2. INSTALLATION

The installation of Raytheon's marine radar at MKE occurred in seven steps. Steps 1-5 are treated in Sections 2.1 through 2.5; Section 3 treats Alignment and Certification.

Step 1: Site Identification. FAA identifies MKE as the ASDE-X evaluation site (see Section 2.1) and interviews local FAA and AT personnel for their receptivity.

Step 2: Site Engineering Survey. FAA identifies MKE and local personnel responsible for various aspects of the system and calls a technical information exchange meeting (TIM) to introduce the radar, rally support, and identify and isolate potential problems and pitfalls during the project lifecycle. FAA appoints an evaluation team who surveys the MKE site, interviews MKE personnel, and produces a *Site Engineering Report* (SER, see Section 2.2 and Vol. II, Ap. B).

Step 3: Statement of Work. A delivery order is issued to procure installation support for the radar at MKE. TAMSCO is awarded the contract.

Step 4: Site Installation Survey. A detailed site survey is conducted and installation requirements developed in a *Final Installation Plan* (FIP, see Section 2.4).

Step 5: Installation. FAA reviews and approves plan, and installation proceeds. An *Installation Technical Report* (ITR, see Section 2.5 and Vol. II) details the construction.

Step 6: Alignment. Evaluation team performs Raytheon-supplied alignment procedures to MKE radar and display equipment; Raytheon checks the system alignments. (Sections 3.1 through 3.3).

Step 7: Certification. Raytheon certifies system accuracy and utility and hands off system to MKE AT for evaluation (Section 3.4 and Vol. II, Ap. C).

NOTE: Minor milestones included the FAA's frequency transmitting authorization (see Figure 2-8) allowing MKE's radar transmissions at 9.375 MHz from the National Telecommunication and Information Administration. The FAA also issued a permit (see Figure 2-9) for the temporary siting of Fixed Target Reflectors (FTRs) used in the radar tests, south of MKE's Runway 1L.

2.1 AIRPORT PROFILE

Milwaukee's General Mitchell International Airport (MKE), Cudahy WI, in the Great Lakes Region (AGL), was designated as the ASDE-X test site for three salient reasons: a recent incursion (see Section 2.1.1) which caused local AT to request an ASDE surveillance system, MKE's often severe fog conditions (see Section 2.1.2) and its fast growth. According to FAA projections, MKE, a Level 4 facility, will be the eighth fastest growing airport in the country over the next decade.

The evaluation team surveyed the MKE site in July 1995 and prepared the *Site Evaluation Report* (SER, see Vol. II, Ap. B). The MKE airport map (Figure 2-1) shows five working runways: 1L - 19R, 1R - 19L, 7L - 25R, 7R - 25L, 13 - 31. Existing runway configurations for ILS approach are: 1L (Cat III), 19R (Cat I), 7R (Cat I). Instrument runway minima are: 1L (RVR 07), 19R (200 1/2), 1R (200 1/2), 19L (200 1/2). The ATCT height is 204.5 ft. Maximum range to runway ends is 1 1/2 nm. Other MKE data is shown in Table 2-1.

Table 2-1. MKE Airport Data.

Airport Elevation	723.5 MSL
Mean Max. Temp. of Hottest month	83° F
Airport Nav aids	ASR, NDB, LLWAS, ILS, RVR
Airport Reference point	Lat. N 42°56'48.432" Lon. W 87°53'49.224"
Airport Category	Transport
Airport Reference Code	MKE

2.1.1 MKE Weather-Related Incursions

The MKE airport experienced seven runway incursions during 1993-95: one in 1993 (out of 201,000 airport operations), three in 1994 (216,000 operations) and three in 1995 (192,000 operations). MKE's incursion rate shows a steady increase over the last four years: in 1992, 1993, 1994, and 1995, the rate was 0.493, 0.497, 1.390, and 1.566 respectively. (The national average incursion rate in those years was 0.35, 0.30, 0.33, and 0.40, respectively.)

Three of the seven incursions were pilot deviations and four were operator errors, with no vehicle/pedestrian deviations. Two of the incursions were weather related, one pilot deviation and one operator error. Since the ASDE-X radar seeks to reduce weather-related incursions, those two events are summarized below.

Pilot Error

The MKE weather-related pilot deviation took place on April 26, 1995 at night (Universal Time Code (UTC) 2223)). It involved a wrong turn made by a DC9 in fog where the MKE local controller (LC) could not see the aircraft, whereas the pilot of a holding aircraft (AC2) could. See MKE Airport Map, Figure 2-1. The following summary of the incident is adapted from the FAA's Investigation of Pilot Deviation, Report PGLTMKE95003.

The DC9 landed on Rwy 7R. A second aircraft (AC2) was in position and hold on Rwy 19R. LC asked DC9 its position, and pilot responded by intersection of 19R. LC instructed DC9 to turn left on Rwy 19L and stay with him. DC9 responded roger. When LC asked DC9 if he was clear of the intersection, he responded yes. LC cleared AC2 for takeoff Rwy 19R. AC2 declined clearance, saying that he could see lights ahead on 19R. LC asked DC9 if he was on Rwy 19R, and he responded yes. Note that LC could see neither aircraft nor the runways in the fog, but since the aircraft could see each other, a more serious occurrence was prevented.

Operator Error

The MKE weather-related operational error occurred on January 25, 1994 at UTC 1525. In this case, according to the FAA's Operational Error/Deviation Report MKE-T-94-E-001, a terminal employee "did not fully brief the relieving specialist of the specific presence and location of [a county vehicle] on Rwy 19R."

JEPPESEN

3 MAY 96

(10-9)

KMKE

AIRPORT

ATIS 126.4	MILWAUKEE Departure (R)	
MILWAUKEE	Rwy 1L-19R in use:	125.35 West of LOC crs
Clearance (Cpt) 120.8		119.65 East of LOC crs
Ramp hold 127.85	Rwy 7R-25L in use:	125.35 North of LOC crs
Tower 119.1		119.65 South of LOC crs
Ground 121.8		VOT 109.0

MILWAUKEE, WISC
 GEN MITCHELL INTL
 N42 56.8 W087 53.8
 118.8°/19.9 From BAE 116.4
 Var 02°W Elev 723'

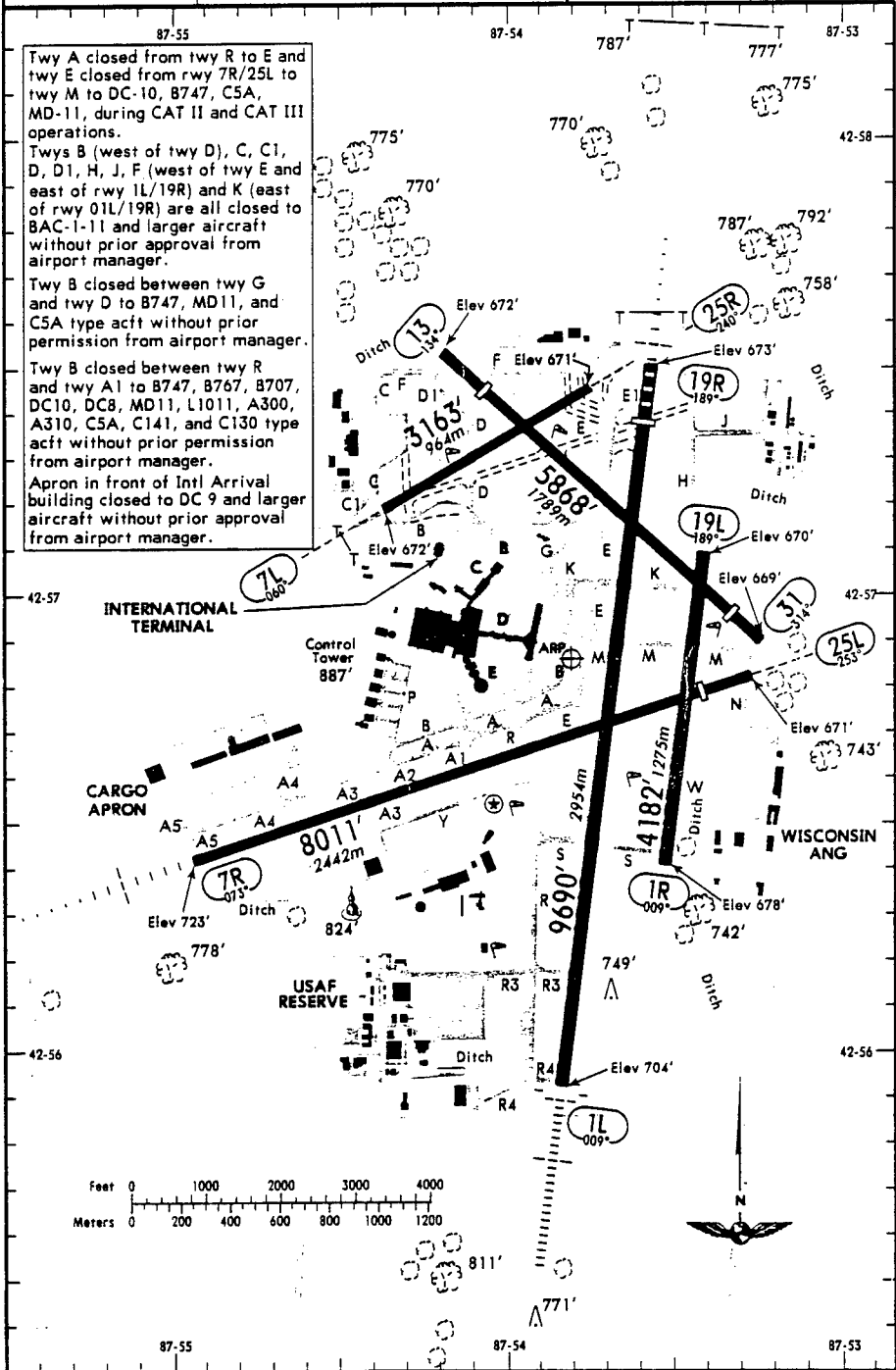

Twy A closed from twy R to E and twy E closed from rwy 7R/25L to twy M to DC-10, B747, C5A, MD-11, during CAT II and CAT III operations.
 Twys B (west of twy D), C, C1, D, D1, H, J, F (west of twy E and east of rwy 1L/19R) and K (east of rwy 01L/19R) are all closed to BAC-1-11 and larger aircraft without prior approval from airport manager.
 Twy B closed between twy G and twy D to B747, MD11, and C5A type acft without prior permission from airport manager.
 Twy B closed between twy R and twy A1 to B747, B767, B707, DC10, DC8, MD11, L1011, A300, A310, C5A, C141, and C130 type acft without prior permission from airport manager.
 Apron in front of Intl Arrival building closed to DC 9 and larger aircraft without prior approval from airport manager.

CHANGES: Construction areas added, notes.

© JEPPESEN SANDERSON, INC., 1987, 1996. ALL RIGHTS RESERVED.

Reproduced with permission from Jeppesen Sanders, Inc.

Figure 2-1. MKE Airport Map (Jeppesen).

2.1.2 MKE Reduced Visibility Data

MKE's proximity to Lake Michigan makes it subject to fog in the autumn months, and its severe low-visibility conditions frequently hamper ATC operations. The following MKE climatological summary, taken from data archived at the National Climatic Data Center, is based on surface observations taken at three-hour intervals during a thirteen month period from September 1994 through September 1995. MKE reduced visibility data indicates an annual average of 10.1% for visibility < 3 miles, 3.8% for visibility < 1 mile and 1.5% for visibility < 0.5 miles. (See Tables 2-2 and 2-3.)

Table 2-2. MKE Reduced Visibility Data Summary.

Month/Year	Number of Days with a Fog Occurrence	Number of Observations		
		Visibility ≤3 miles	Visibility ≤1 miles	Visibility ≤.5 miles
September '95	11	4	0	1
August '95	25	23	5	4
July '95	15	10	1	6
June '95	19	13	1	1
May '95	13	8	1	4
April '95	16	15	11	3
March '95	14	12	15	4
February '95	12	9	1	0
January '95	17	25	11	9
December '94	25	33	7	6
November '94	13	10	8	2
October '94	13	7	1	2
September '94	24	16	5	2
Total	217	185	67	44

NOTE: Each visibility observation is counted as a separate occurrence. For example: a visibility count of .8 miles is counted as "≤1 mile" and not recorded again as "≤3 miles."

Table 2-3. MKE Foggy Day Percentages.

NOTE: Data based on 2920 total observations per year.

Days with fog occurrence	56.4%	Occurs 1.13 times every 2 days
Visibility ≤ 3 mi.:	10.1%	Occurs once in every 10 observations or equates to 3 hr. visibility ≤ 3 mi. every 30 hr. (1 hr. of equivalent visibility every 10 hr.)
Visibility ≤ 1 mi.:	3.8%	Occurs once in every 26 observations or equates to 3 hr. visibility ≤ 1 mi. every 3.25 days (1 hr. of equivalent visibility every 26 hr.)
Visibility ≤ .5 mi.:	1.5%	Occurs once in every 67.9 observations or equates to 3 hr. visibility ≤ .5 mi. every 8.4 days (1 hr. of equivalent visibility every 2.8 days)

2.2 SITE ENGINEERING SURVEY AND REPORT

The ASDE-X evaluation team visited MKE in August 1995 to participate in a technical interchange meeting (TIM) and to perform a site survey. The *Site Engineering Report* (SER), based on that survey, is summarized here and included in its entirety (Vol II, Ap. A).

Attending the TIM were local Air Traffic (AT) personnel, the evaluation team, National Air Traffic Controllers Association (NATCA), Airway Facilities (AF), Environmental Systems Unit (ESU), and representatives of the Professional Airways Systems Specialists (PASS). The TIM introduced local personnel to the radar equipment and gave them the opportunity to recommend preferred equipment locations and system configurations. Local personnel were invited as participants in the evaluation effort and would be trained accordingly. Concerns were aired regarding the possible disruption of local operations. It was decided that the optimum time for system evaluation would be October and November, to coincide with the likeliest season for low-visibility weather conditions. It was agreed that the phasing of the installation would be planned so as to cause minimal disruption to controller operations.

Locations for system components were recommended. Antenna and pedestal were to be centered on the ATCT roof. The transceiver and dehydrator were to be located in the cable chase room at the ATCT junction level. The waveguide was to link the antenna and transceiver via an internal run and be attached to a center mullion at the north end of the cab. The display (processor and monitor) was to be located in the tower cab, and made mobile to shuttle between local and ground controllers when being evaluated, and otherwise moveable off to the side.

Concerns about the physical installation centered on issues such as the roof hatch location, the transport of the antenna to the roof, and the possible relocation of roof equipment (communications antennas, lightning rods, and obstruction lights). Questions voiced about the radar operation included environmental conditions of the unheated cable chase room on the junction level, and the radar's potential for interfering with other airport systems.

2.3 STATEMENT OF WORK

The objective of the FAA's delivery order was to procure support in the installation of the Raytheon marine radar at MKE. The task was broken down into the following efforts:

1. **Planning Support** in the purchase and installation of the radar at MKE. This task includes developing the installation plan.
2. **System Definition Support** to the FAA in defining functional requirements.
3. **System Procurement** in acquiring the radar and all its components, and all associated activities.
4. **Site Characterization and Installation** includes acquiring or developing airport diagrams, maps, pertinent existing system specifications, operational considerations, procedural requirements, data requirements, installation details, and coordinating activities with appropriate airport authorities.

The installation contract, Contract No. DTRS-57-93-D-00145, Delivery Order 002, was designated by the Department of Transportation, Volpe National Transportation Systems Center, as a Time and Materials contract. The contract was awarded in August 1995 to the Technical and Management Services Corporation (TAMSCO) of Calverton, MD.

The estimated level of effort includes a total estimate of labor hours of 620. Estimated travel includes 33 days of per diem for three personnel, plus car rental. This level of effort was estimated at \$57k, with approximately \$10k for supplies. Supplies include platforms, aluminum planking, welding fees, tool rentals and wiring.

2.4 SITE INSTALLATION SURVEY AND PLAN

To finalize system configuration and facilitate the detailed installation design, a detailed survey of the MKE site was performed using the SER as a guideline. The result of the survey was a *Final Installation Plan* (Volume III) that needed FAA approve before installation began.

Major installation issues involved the antenna, transceiver, and display. The 18' antenna had no adequate access through the ATCT interior to the roof. Options considered were to use a crane, hoist it up the outer wall with ropes, or airlift it by helicopter to the roof. The cost of the crane and the degree of risk involving the hoist made the helicopter the preferred method.

The transceiver was required to be installed on the SW wall of the cable chase room of the ATCT's junction level, below the cab. Prime power was obtained from the Critical Power Breaker Panel mounted on the NE wall. The cable chase room met with environmental requirements and the proposed waveguide run fell within the manufacturer's 20m limit.

The SER expressed an ATC request for the display to be mounted on a movable platform for storage and the display processor's wire harness unit to be dropped down from the ceiling to facilitate freedom of movement, allow wider visibility, and minimize tripping hazards. The cab area features also include a special "conductive" carpet to minimize Electrostatic Discharge (ESD) effects.

TAMSCO was required to make every effort not to alter the existing structure or adversely impact airport operations. Where it was necessary to alter existing structures, consideration would be given to the post-evaluation restoration of the facility. Tower personnel were required to relocate during any potentially hazardous activity required directly over the ATC cab area.

Safety concerns demanded that the penthouse work surface, located above the ATCT cab's acoustical-tile ceiling be non-flammable because there was no sprinkler system in the tower penthouse. The penthouse roof deck needed a non-skid surface. Ground wires through the power cable harness were required to ground each chassis. Low direct current (dc) bonds were required to connect the radar units to the facility power ground and the ATCT lightning rod ground cable. The final configuration of the system features is shown in the equipment layout, Figure 2-2.

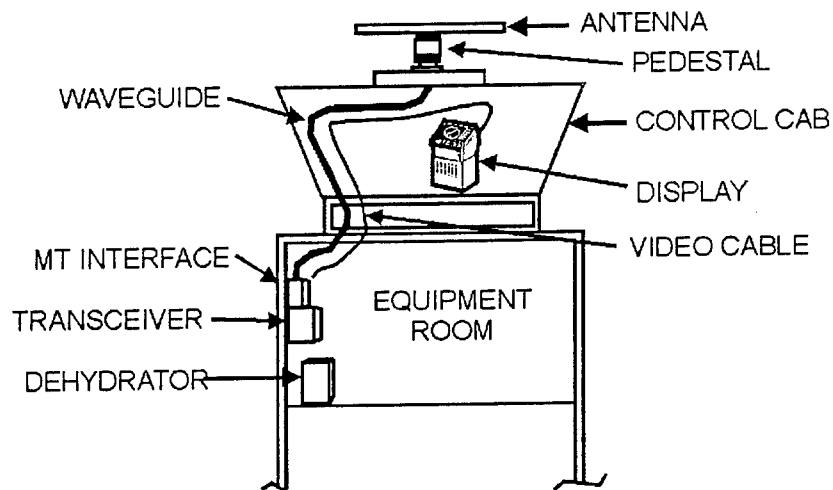

Figure 2-2. MKE ATCT Radar Equipment Layout.

2.5 RADAR INSTALLATION AND REPORT

The MKE installation was conducted on a quick reaction basis with the time from contract award to presentation of the installation to Raytheon field engineers for final alignment check and certification taking 65 calendar days; the actual installation schedule is shown in Figure 2-3. These goals for the installation were met; to:

1. Minimize disruptions to normal AT operations.
2. Accommodate AT/AF suggestions for equipment location, availability, convenience.
3. Have system ready in time for the engineering evaluation to occur during MKE's normally adverse weather conditions (heavy autumn ground fog).
4. Avoid structural modifications to the control tower, as the installation is subject to Phase II upgrades.

Tower personnel were temporarily relocated in a secondary control center (Midwest Express) on the three occasions when potentially hazardous activity was required directly over the cab area: while the work surface was being installed in the penthouse; during the helicopter lift of the antenna and pedestal to the roof, and when the ceiling was opened to route the cables and install the drop.

NOTE: TAMSCO's *ASDE-X Initial Installation Technical Report* (ITR) is attached as Volume II to this document. The following brief synopsis of that report summarizes sections which deal directly with test and evaluation of the ASDE-X radar.

The ITR explains the configuration and installation of the final radar system components. The antenna and pedestal were installed on the tower penthouse roof (see Figure 2-4). The antennas, lightning rods, and hazard warning lights already on the penthouse tower required no relocation, as they did not interfere with antenna clearance or radar operation.

The display (radar video console) in the tower cab (see Figure 2-5) was mounted on a heavy-based platform to lower its center of gravity and stabilize it. Added casters gave the bulky unit mobility to be stored away from the cab's work area when not in use. Signal and power cables were harnessed and dropped through the ceiling, a solution that avoided creating floor hazards and obstructing sightlines (see Figure 2-6).

The transceiver, radar power distribution panel, and dehydrator were installed in the cable chase room below the tower cab (see Figure 2-7) because it offered access to transceiver and antenna waveguide for maintenance and test, met the minimal range requirements, and provided easier access to facility power. The radar power distribution panel and dehydrator were installed there for proximity to the transceiver.

The installation (ITR Section 4) commences with descriptions, specifications, and photographs of all system components--transceiver, antenna and pedestal, display, dehydrator, waveguide, wire harness and cable drop (including power and grounding.) It delineates step-by-step installation procedures, including execution of the construction plan for the penthouse work surface, with construction drawings illustrating the suspended aluminum planking.

Section 5 details the ASDE-X interconnection diagram (see Figure 4-1.) The system's electrical interfaces are listed in Tables VIII through XII respectively for: MKE Facility Power / ASDE-X Radar, Radar Power Distribution Panel / LRU, MTR Antenna / Ground, MTR / CDU, Dehydrator MTR / Power. Section 6 discusses Raytheon's operational alignment; Volume II, Appendix D documents the certification. Brief instructions by Raytheon included here can be followed to activate the sector scan blanking option, disabled during alignment. Section 7 summarizes the installation, and makes brief recommendations.



Figure 2-4. Installation of Antenna and Pedestal.



Figure 2-5. Display on Moveable Platform.

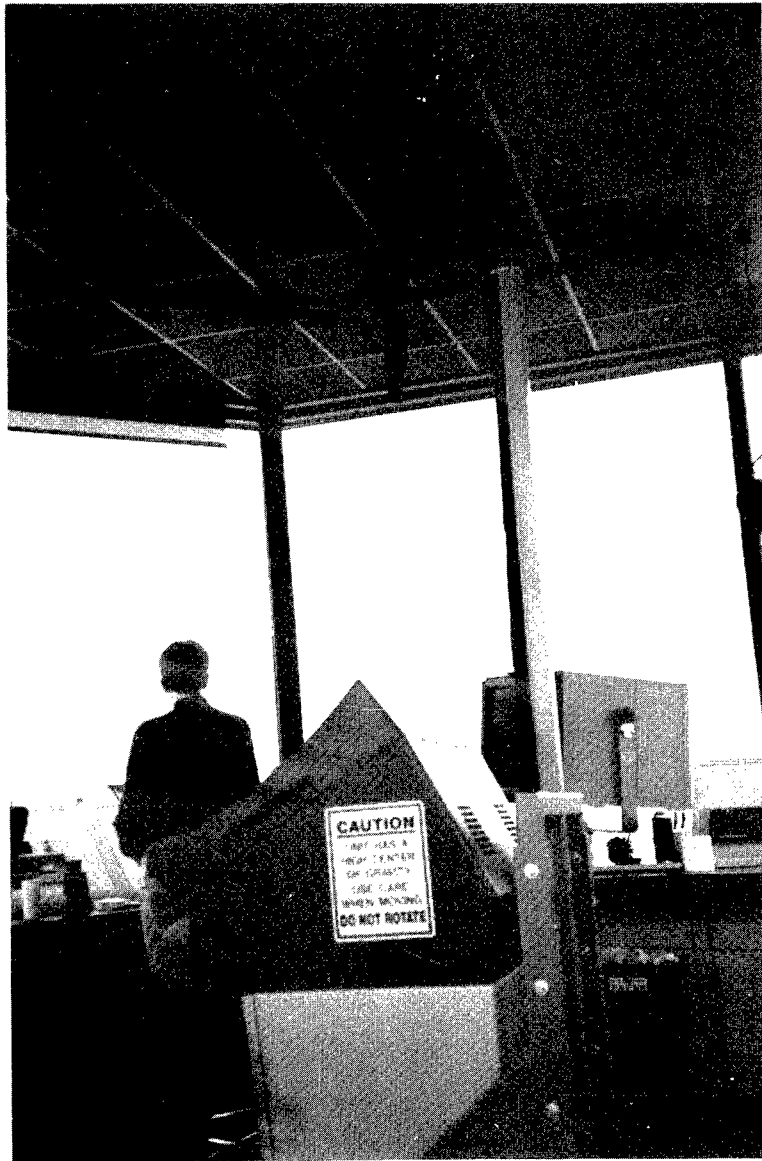

Figure 2-6. Display in Tower, Showing Cable Drop.

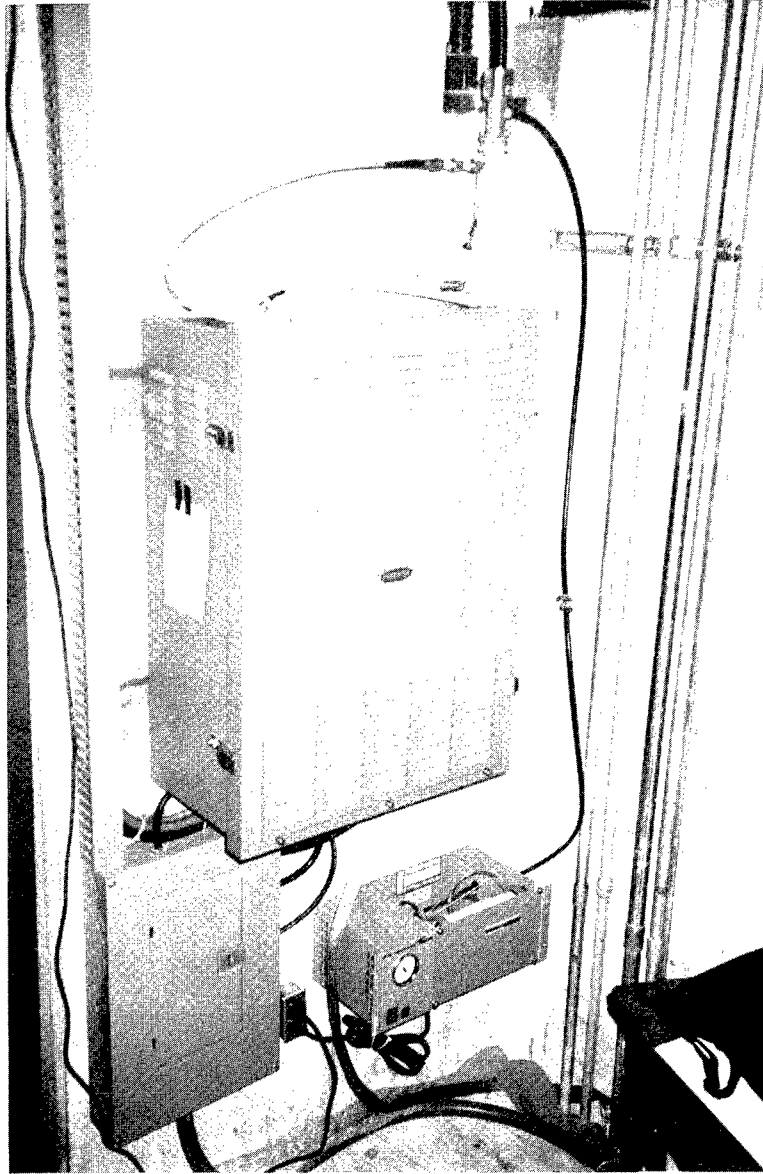

Figure 2-7. Transceiver, Radar Power Distribution Panel, and Dehydrator, Installed.



AUTHORIZATION NUMBER
AGL-96-3720

UNITED STATES OF AMERICA
DEPARTMENT OF TRANSPORTATION
FEDERAL AVIATION ADMINISTRATION

FACILITY TRANSMITTING AUTHORIZATION

In accordance with authority granted the Federal Aviation Administration by the National Telecommunications & Information Administration through the Interdepartmental Radio Advisory Committee, this Authorization is issued for the operation of this facility.

FACILITY: MILWAUKEE, WI COORDINATES: 42° 56' 52" N 087° 54' 23" W

FREQUENCY	FAC. TYPE	MAX. POWER	CLASS	TYPE OF SERVICE	COST CENTER	IDENT	FAA SERIAL	MISCELLANEOUS REMARKS
9375.00 MHz	ASDE	22.0 kW	XR			MKE	960046	PRR=3.63 kHz

Note: This Frequency Transmitting Authorization is to support the development of a X-band ASDE radar. This assignment is on a non-interference basis to operational systems and must immediately cease operations when instructed to do so by the Great Lakes Region Frequency Management Office or the FAA Spectrum Policy and Management Program. Use of this frequency for development purposes does not imply that operational X-band ASDE radars can use this frequency or frequencies in this area of the X-band. This Frequency Transmitting Authorization expires at midnight December 31 1997.

23 February 1996 George E. Ambler 1 of 1
EFFECTIVE DATE GREAT LAKES FREQUENCY MANAGEMENT OFFICER PAGE
FAA REGION

Figure 2-8. ASDE-X Radar Transmission Permit.

DO NOT REMOVE CARBONS

Form Approved OMB No 2120-

NOTICE OF PROPOSED CONSTRUCTION OR ALTERATION			Regional Office Number
<p>1. Nature of Proposal</p> <p>A Type <input checked="" type="checkbox"/> New Construction <input type="checkbox"/> Alteration</p> <p>B Class <input type="checkbox"/> Permanent <input checked="" type="checkbox"/> Temporary (Duration <u>2</u> months)</p> <p>C Work Schedule Dates Beginning <u>11/15/95</u> End <u>12/31/95</u></p>			<p>2. Complete Description of Structure</p> <p>A Include effective radiated power and assigned frequency of all existing proposed or modified AM, FM or TV or radio stations utilizing this structure.</p> <p>B Include size and configuration of power transmission line and their supporting towers in the vicinity of FAA facility and public airports.</p> <p>C Include information showing site orientation, dimensions and construction materials of the proposed structure.</p> <p>Location of points A, B, C, D based on the GPS coordinates of the Runway 1L Inner Marker and derived using mathematical calculations. Coordinates based on Mag. Var.</p> <p>A 42-55-46.120 87-53-56.988 B 42-55-46.121 87-53-58.332 C 42-55-47.108 87-53-58.331 D 42-55-47.108 87-53-56.987 <i>(if more space is required, continue on a separate sheet.)</i></p>
<p>3 A Name and address of individual, company, corporation, etc. proposing the construction or alteration. (Number, Street, City, State and Zip Code)</p> <p>() area code Telephone Number</p> <p>TO AND-410 Rick Castaldo 800 Independence Avenue SW Washington, D. C. 20591</p> <p>B Name, address and telephone number of proponent's representative if different than 3 above</p> <p>Vincent Capezzuto 414-747-5500</p>			
<p>4. Location of Structure</p> <p>A Coordinates (to nearest second) of see below Latitude</p> <p>B Nearest City, Town and State Milwaukee, Wis. Miles</p> <p>C Name of nearest airport, heliport, flight park or seaplane base on airport property (1) Distance from structure to nearest point of nearest runway (2) Direction from structure to airport on airport property</p>			<p>5. Height and Elevation (Complete to the nearest 5)</p> <p>A Elevation of site above mean sea level 706 USGS</p> <p>B Height of Structure including all appurtenances and lighting (if any) above ground, or water if so situated 6</p> <p>C Overall height above mean sea level (A + B) 712</p>
<p>D Description of location of site with respect to highways, streets, airports, parks, etc. Attach a US Geological Survey quadrangle map or equivalent showing the relationship of construction site to nearest airport(s) (if more space is required, continue on a separate sheet of paper and attach to this notice.)</p> <p>An L shaped arrangement of reflectors (temporary) on 6 foot poles that will be established within the box designated by points A, B, C, D. See attached portion of "Airport Obstruction Chart" (OC 262), 11th edition, for coordinates.</p>			
<p>Notice is required by Part 77 of the Federal Aviation Regulations (14 C.F.R. Part 77) pursuant to Section 1101 of the Federal Aviation Act of 1958 as amended (49 U.S.C. 1101). Persons who knowingly and willingly violate the Notice requirements of Part 77 are subject to a fine (criminal penalty) of not more than \$500 for the first offense and not more than \$2,000 for subsequent offenses, pursuant to Section 902(a) of the Federal Aviation Act of 1958, as amended (49 U.S.C. 1472(a)).</p>			
<p>I HEREBY CERTIFY that all of the above statements made by me are true, complete, and correct to the best of my knowledge. In addition, I agree to obstruction mark and/or light the structure in accordance with established marking & lighting standards if necessary.</p>			
Date	Typed Name/Title of Person Filing Notice		Signature
10/17/95	Vincent Capezzuto		<i>Vincent Capezzuto</i>
FOR FAA USE ONLY			
<p>The Proposal:</p> <p><input type="checkbox"/> Does not require a notice to FAA.</p> <p><input type="checkbox"/> Is not identified as an obstruction under any standard of FAR, Part 77, Subpart C, and would not be a hazard to air navigation.</p> <p><input type="checkbox"/> Is identified as an obstruction under the standards of FAR, Part 77, Subpart C; but would not be a hazard to air navigation.</p> <p><input type="checkbox"/> Should be obstruction MARKED.</p> <p><input checked="" type="checkbox"/> Lighted per FAA Advisory Circular 70/7460-1; Chapter(s) _____</p> <p><input type="checkbox"/> Obstruction marking and lighting are not necessary.</p>			
<p>Supplemental Notice of Construction FAA Form 7460-2 is required any time the project is abandoned, or</p> <p><input type="checkbox"/> At least 48 hours before the start of construction.</p> <p><input type="checkbox"/> Within five days after the construction reaches its greatest height.</p> <p>This determination expires on _____ unless</p> <p>(a) extended, revised or terminated by the issuing office;</p> <p>(b) the construction is subject to the licensing authority of the Federal Communications Commission and an application for a construction permit is made to the FCC on or before the above expiration date; in such case the determination expires on the date prescribed by the FCC for completion of construction, or on the date the FCC denies the application.</p> <p>NOTE: Request for extension of the effective period of this determination must be postmarked or delivered to the issuing office at least 15 days prior to the expiration date.</p> <p>If the structure is subject to the licensing authority of the FCC, a copy of this determination will be sent to that Agency.</p>			
Remarks:			
Issued in	Signature		Date

Figure 2-9. Construction Permit for MKE FTRs.

3. ALIGNMENT AND ADJUSTMENTS

After the MKE radar installation was complete, Raytheon personnel inspected the installation, performed the operational alignment, and signed the certification papers to activate the system's warranty. Procedures detailing the technical radar alignment follows. A reference to system certification ends this section, and copies of the certification papers may be found in Volume II, Appendix D.

Each procedure ends by asking the user to **CHECK** the appropriate box in the alignment data sheets. (See Table 3-1, p. 3-34.)

NOTE: During alignment it was determined that the sector scan option was not required. At that point the sector scan option was tested then disabled. Instructions were left with local AF for reactivating this option if it is desired in the future.

3.1 TRANSCEIVER

Equipment: Oscilloscope, volt meter, miscellaneous screwdrivers, tweaker.

Adjustment of the MTR (see Figure 3-1) power supplies must be accomplished in the sequence given. The Low Voltage Power Supply (LVPS) is adjusted first, and then the High Voltage Power Supply (HVPS) is adjusted next.

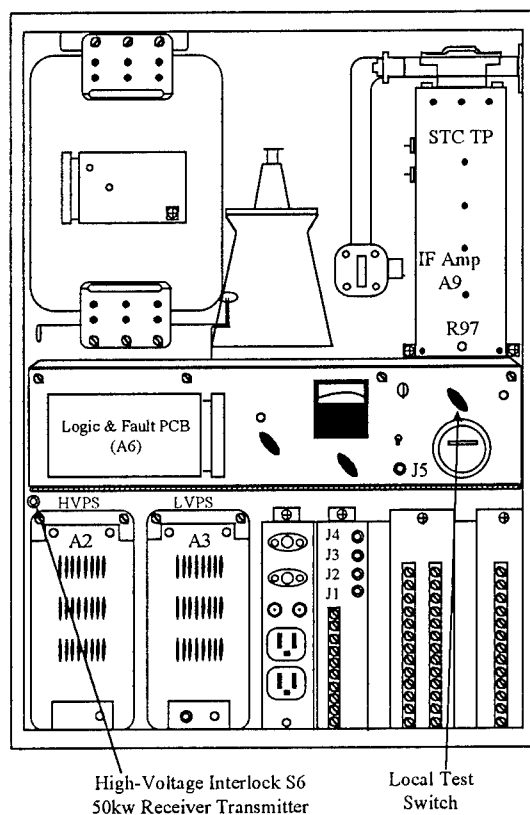

Figure 3-1. Transceiver in Service Position.

3.1.1 Low Voltage Power Supply Adjustments

1. At the MTR, set the LOCAL TEST switch to STBY and the LOCAL PRF switch to LONG.
2. Tilt LVPS out to service position (see Figure 3-2).
3. Hook an oscilloscope probe onto the insulated service loop wire on the Pre-Regulator PCB (A1) in order to observe the 40 kHz switching waveform. (DO NOT penetrate insulation on this loop.) (See Figure 3-3.)

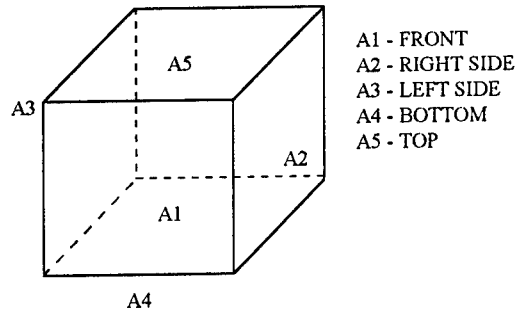

Figure 3-2. LVPS Pulled Out to Service Position.

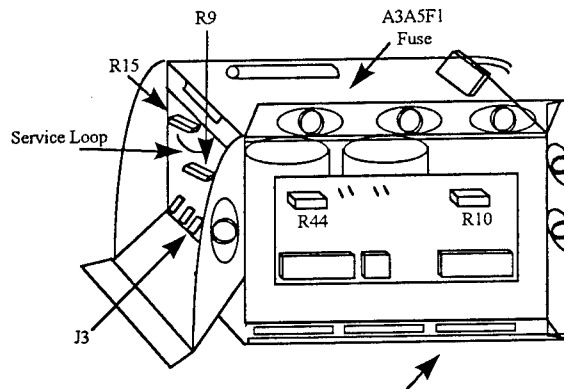

Figure 3-3. LVPS in Service Position.

3.1.1.1 Frequency

1. Adjust oscilloscope to observe a square wave of $25\mu\text{s}$ period (see Figure 3-4). Slight reorientation of the probe may assist in obtaining a clean waveform.
2. If necessary, adjust A1 R9 to achieve $25\mu\text{s}$ period, **CHECK**.

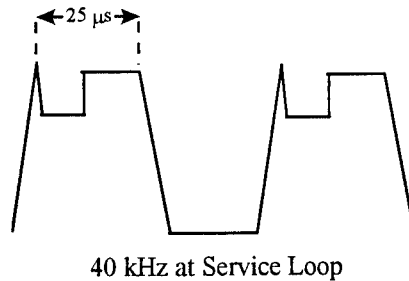

Figure 3-4. Frequency at Service Loop.

CAUTION!

Many power supply voltage checks are referenced to Floating Common. This Floating Common **MUST NOT** be grounded through test equipment leads.

3.1.1.2 5 Volt

Connect a multimeter between J3-2 (positive) and J3-3 (negative) of A1 (pre-regulator) and measure +5.1 Vdc. (see Figure 3-3). If necessary, adjust A1 R15 to obtain this reading, **CHECK**.

3.1.1.3 Voltage Sense

NOTE: This adjustment is normal factory set.

1. Verify line voltage at the MTR to be 105 to 125 Vac.
2. Voltage Sense is not normally field-adjustable. To check, connect a multimeter between E1 (positive) and E2 (negative) of the Chopper Control PCB (A2). This reading should be 6.4 to 7 Vdc.
3. If necessary, adjust A2 R44 to obtain this reading. Carefully remove the leads after adjustment completion, **CHECK**.

NOTE: This is a preliminary adjustment of R1.

3.1.1.4 Output LVPS

1. Shut off the power to the MTR.
2. Remove the Chopper Control PCB from the Low Voltage Power Supply (see Figure 3-5).
3. Remove the Chopper Control PCB from the High Voltage Power Supply.
4. Install the Chopper Control PCB from the Low Voltage Power Supply, which has already been adjusted into the High Voltage Power Supply.
5. Install the PCB from the High Voltage Power Supply into the Low Voltage Power Supply.
6. Local test switch to STDBY. Repeat Voltage Sense adjustment instructions above as described in 3.1.1.3 at the Low Voltage Power Supply.

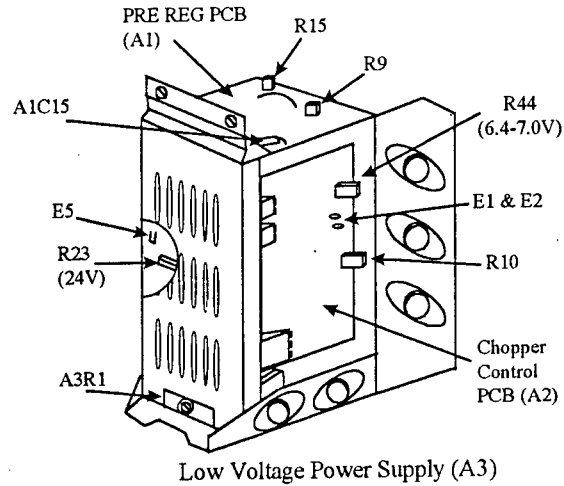
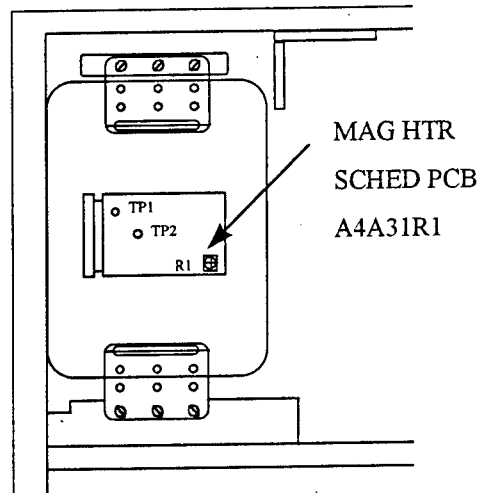

Figure 3-5. Low Voltage Power Supply.

7. Connect multimeter between A3A5 F1 (+) and ground (-). This reading should be $24 \pm 0.1\text{Vdc}$.
8. If necessary, adjust A3A4 R23, **CHECK**.

3.1.1.5 6.3 VDC Filament

1. Connect multimeter between Mag Heater Scheduling PCB (A4A3) TP1(+) and TP2(-) (see Figure 3-6). This reading should be $7.55 \pm 0.1\text{Vdc}$. [MTR IN STBY]
2. If necessary, adjust A3R1 on the Low Voltage Power Supply, **CHECK**.



MAG HTR SCHED PCB LOCATION

Figure 3-6. Magnetron Heater Scheduling PCB.

3.1.2. HVPS Adjustments

1. Pull MTR HV interlock switch to energize HVPS.
2. Tilt HVPS out to service position (see Figure 3-7).
3. Hook oscilloscope probe onto the insulated service loop wire on the Pre-Regulator PCB (A1) in order to observe the 40 kHz switching waveform, **CHECK**. (DO NOT penetrate insulation on this loop.) See Figure 3-8.

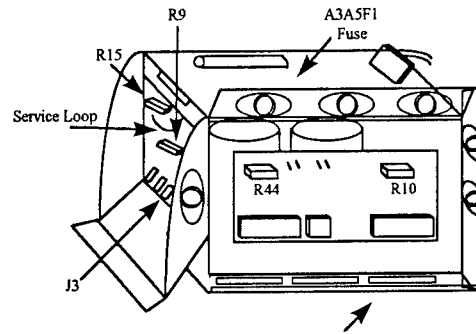

Figure 3-7. High Voltage Power Supply in Service Position.

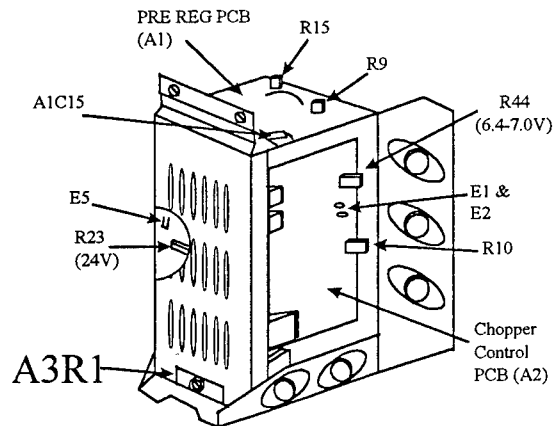

Figure 3-8. High Voltage Power Supply in Installed Position.

3.1.2.1 Frequency

1. Adjust oscilloscope to observe a square wave of 25 μ s period. Slight reorientation of the probe may assist in obtaining a clean waveform.
2. If necessary, adjust A1 R9 to achieve 25 μ s period, **CHECK**

CAUTION!

Many power supply voltage checks are referenced to Floating Common. This Floating Common **MUST NOT** be grounded through test equipment leads.

3.1.2.2 5 Volt

1. Connect a multimeter between J3-2 (positive) and J3-3 (negative) and measure +5.1 Vdc. If necessary, adjust A1 R15 to obtain this reading.
2. Set LOCAL TEST switch to ON, **CHECK**.

NOTE: At this point it may be necessary to wait approximately 30 seconds before the HVPS times out again.

3.1.2.3 Voltage Sense

NOTE: This adjustment is normal factory set.

1. Verify line voltage at the MTR to be 105 to 125 Vac.
2. Voltage Sense is not normally field-adjustable. To check, connect a multimeter between E1 (positive) and E2 (negative) of the Chopper Control PCB (A2). This reading should be 6.4 to 7 Vdc.
3. If necessary, adjust A2 R44 to obtain this reading. Carefully remove the leads after adjustment completion, **CHECK**.

NOTE: This is a preliminary adjustment of R1.

3.1.3 Transmitter Adjustments

Equipment: Oscilloscope, tweaker, volt meter.

3.1.3.1 MTR PRF Adjustment

1. Set LOCAL Test Switch to ON.
2. Set LOCAL PRF switch to SHORT.
3. Connect oscilloscope to front panel TRIGGER jack J5 on the front panel of the MTR to view local PRF Triggers (see Figure 3-9).
4. Set for 2V/division sensitivity and 100 μ s/division time base (short, medium), and 200 μ s (long).

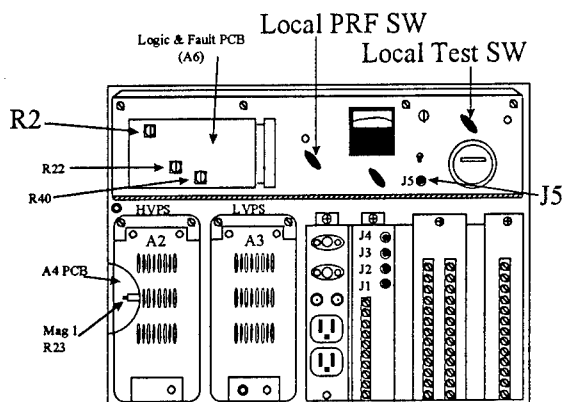

Figure 3-9. MTR PRF Adjustment.

5. When the MTR has timed out, trigger the oscilloscope internally to view two consecutive positive going triggers.
6. On the Logic & Fault PCB (A6) adjust R2 to obtain a period of $278\mu\text{s}$ between trigger pulses on the oscilloscope.
7. Confirm $555\mu\text{s}$ in the MEDIUM and $1111\mu\text{s}$ in the LONG pulse lengths settings, **CHECK**.

NOTE: On solid state Fault & Logic PCB (A6) R6 is set fully CCW.

3.1.3.2 Magnetron Current Adjustment

1. Set LOCAL PRF switch to LONG.
2. Deenergize interlock and put HVPS module into service position. Reenergize interlock for high voltage.

NOTE: Mag Heater Scheduling adjustments should be performed only after the installation of a new magnetron. As the magnetron ages (1000 - 2000 hrs.) the voltage at TP1 and TP2 will increase by .3 to .5 volts in Solid State MTRs. If Mag Heater Scheduling voltage between TP1 and TP2 is correct, insure Mag I is adjusted per instructions below.

3. Set MONITOR SELECT switch to MAG I (see Figures 3-10).
4. Adjust HVPS A2A4 R23 to obtain an indication in the upper portion of the green zone on Meter M1, **CHECK**.

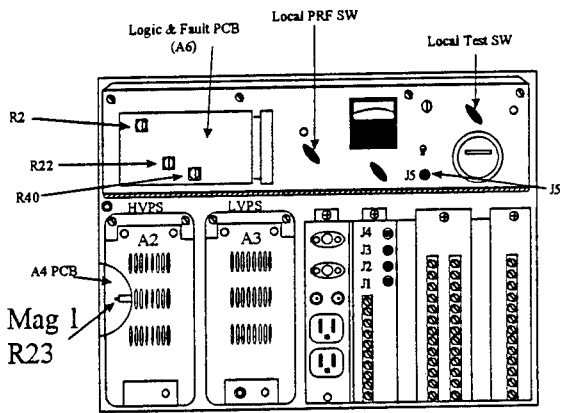
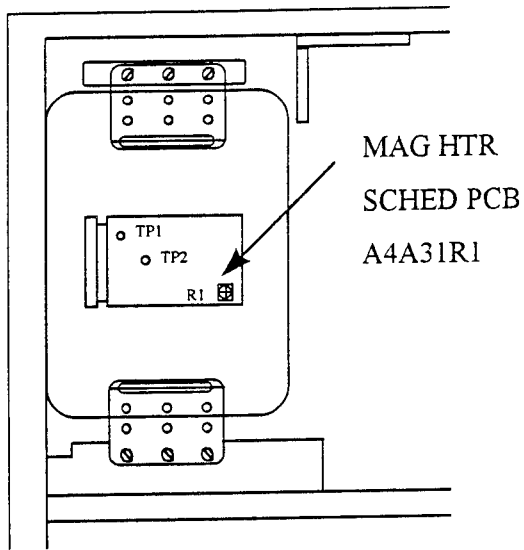

Figure 3-10. Magnetron Heater Switch.



MAG HTR SCHED PCB LOCATION
Figure 3-11. Magnetron Heater Scheduling Adjust.

3.1.3.3 Mag Heater Scheduling Adjustments

1. Connect multimeter between TP1 (+) and TP2 (-) on Mag Heater Sched. PCB. Reading should be 2.4VDC (see Figure 3-11).
2. If necessary adjust A4A3 R1.
3. Set MONITOR SELECT SW to MAG I.
4. Upon completion of the Mag Heater Sched PCB Adjustments, reset HVPS A2A4 R23 to obtain a MAG I indication in the mid-level green zone on meter M1, CHECK.

3.1.4 Receiver

3.1.4.1 Low Noise Front End (LNFE) Adjustments

See Figure 3-12.

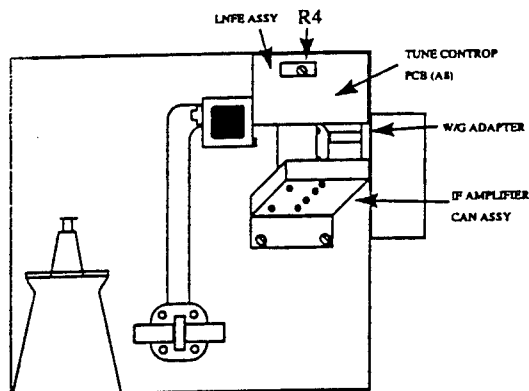

Figure 3-12. Low Noise Front End Adjustment.

Ensure the following settings:

<u>MTR Control</u>	<u>Setting</u>
LOCAL TEST SW	REMOTE
LOCAL PW SELECTOR	REMOTE
ANTENNA ROTATION	OFF
HV INTERLOCK	PULLED OUT

<u>INDICATOR Control</u>	<u>Setting</u>
OFF/STBY/TX ON	TX ON
RANGE SELECT	12NM
STC CONTROL	CCW
FTC	CCW
RAIN RATE	CCW
TUNE CONTROL	12 o'clock position
	-4 VDC measured at A1 A3 TB4-8

1. Using a BNC "T" connector, connect an oscilloscope to IF video output jack (J3) at IF Amplifiers output on the front of the MTR.
2. Set oscilloscope for 1V/division sensitivity and 5us/division time base (see Figure 3-13).
3. Defeat HV Interlock so that radar is transmitting.
4. Set antenna rotation switch in MTR to OFF. Stop antenna at a location where strong target returns are clearly visible on the oscilloscope.
5. On the local oscillator TUNE Control PCB (A8), adjust R4 fully CW.

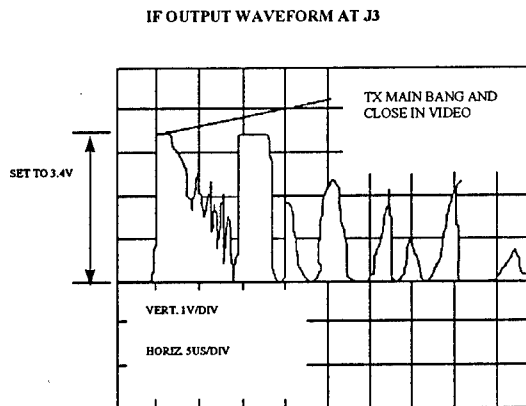

Figure 3-13. Oscilloscope Reference for IF Waveform.

6. While observing oscilloscope, turn R4 CCW to the first video peak. Adjust R4 for maximum target signal amplitude.
7. Set the MTR controls as follows:

<u>MTR Control</u>	<u>Setting</u>
LOCAL TEST	REMOTE
LOCAL PW SELECTOR	REMOTE
ANTENNA ROTATION	ON

- Replace MTR cover and verify maximum target returns by observing the radar display and verify that the display tune control operates properly. Remove test equipment, **CHECK**.

3.1.4.2 MTR STC Adjustment (LOG SYSTEM)

- Set the MTR LOCAL TEST switches to ON.
- Monitor STC Waveform on STC feed through on side of IF AMP Assembly (see Figure 3-14).
- Set oscilloscope controls for internal negative trigger, 2V/division (vert) and 1 μ s/division (horizontal)

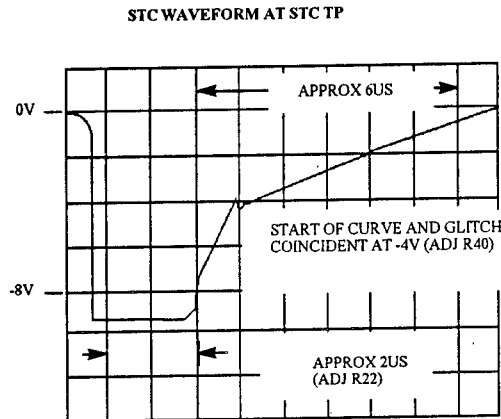

Figure 3-14. STC Waveform.

- Adjust A6 R40 on the Logic & Fault PCB (see Figure 3-15), such that the STC curve starts at -4 volts.

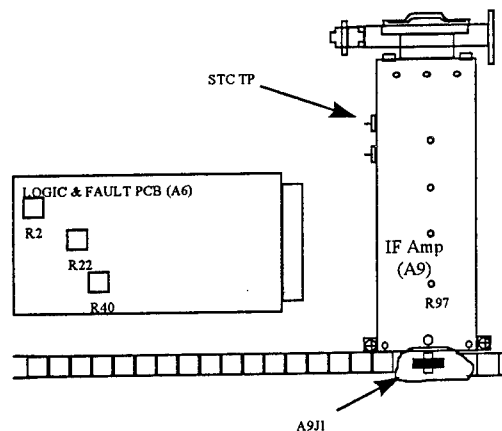

Figure 3-15. Logic and Fault PCB.

- Adjust STC delay A6 R22 such that the -4 volt starting point of the STC waveform is coincident with the start of the XMIT pulse. There is a small glitch on the STC waveform which can be used as a XMIT indication of the start of the XMIT pulse, **CHECK**.

3.1.4.3 IF Video Gain Adjust (A9)

- Connect oscilloscope vertical input to A9 J1 on the IF Amp (A9) utilizing a BNC to BNC coaxial cable and a "T" connector. Connect external trigger of oscilloscope to J5 of MTR.

2. Adjust A9 R7 (bottom access hole of IF AMP) for 3.4V peak at IF AMP video output (see Figure 3-16), **CHECK**.

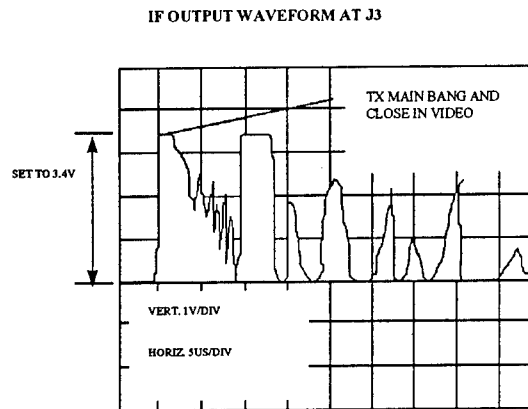

3.1.4.4 Resolver Drive (A10) PCB Adjustment

1. Set LOCAL TEST switch to OFF and Master Indicator to TX.

NOTE: Lower the control panel for access to Resolver Drive PCB A10 (see Figure 3-17).

2. Disconnect plug connected at jack J1 of the Resolver Drive PCB.
3. Connect oscilloscope, set for DC input coupling and minimum volts/division (50mV/division), at TB2-5.
4. Set oscilloscope input switch to ground and adjust for zero VDC reference on center of display, then return input switch to DC coupling.
5. Set LOCAL TEST switch to ON.
6. Adjust R37 on Resolver Drive PCB to obtain 0.0 VDC on oscilloscope. (There will be a certain amount of noise present as you view the oscilloscope. While on the most sensitive scale, center this noise around ZERO VDC.)
7. Connect oscilloscope at TB2-7

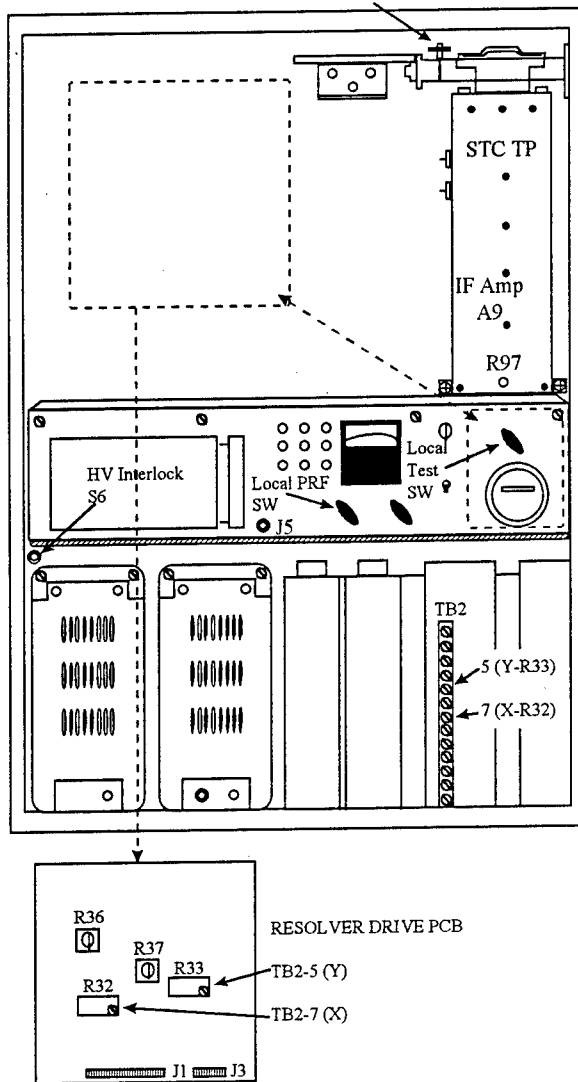

Figure 3-17. Resolver Drive (A10) PCB Alignment.

8. Adjust R36 on Resolver Drive PCB to obtain 0.0 Vdc on oscilloscope as above.
 9. Turn local SW OFF.
 10. Connect plug removed from J1 of Resolver Drive PCB. Turn ON, **CHECK**.
 11. Connect oscilloscope at TB2-7, and turn MTR antenna SW on.
- NOTE: The amplitude of the 900 Hz signal varies with antenna rotation (approximately 2 Hz rate).
12. Adjust R32 on the Resolver Drive PCB to obtain an exact 12 volt peak-to-peak signal.
 13. Connect oscilloscope at TB2-5.

14. Adjust R33 on the Resolver Drive PCB to obtain an exact 12 volt peak-to-peak signal, **CHECK**.

NOTE: Upon completion of MTR alignment check that all local controls are in their proper position for indicator operation.

SET:	
LOCAL TEST	Remote Enable
LOCAL PRF	Remote
ANT SW	ON

3.2 MONITOR LINKING

Equipment: Volt meter, miscellaneous screwdrivers.

The following describe the procedures for system linking.

NOTE: This procedure applies to an Adaptive Interface system.

CAUTION!
Power selection for input voltages should always be made with power removed from the unit.

3.2.1 Isolation Rectifier (A2) (115 / 230 VAC Operation)

The toggle switch cover on the front of the Isolation Rectifier (IR) Module (see Figure 3-18) exposes the voltage rating of the AC connection (115VAC or 230VAC) made to the unit.

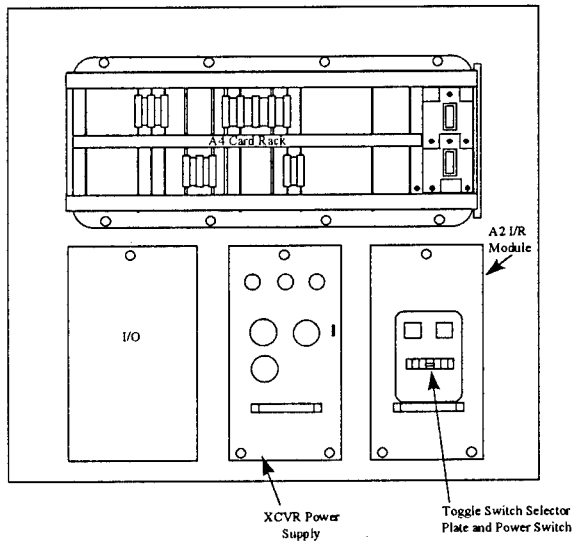

Figure 3-18. Isolation Rectifier Module.

1. To change the IR configuration, remove the two screws that secure the toggle switch selector plate.
2. Rotate the plate to expose the voltage rating of the AC connection made to the unit. Check that this is 115VAC, **CHECK**.

3.2.2 Low-Line Isolation Rectifier 100/200 VAC Operation

1. To change the IR configuration for low line operation (100VAC or 200VAC), remove the IR module and remove the left-side cover of the module (see Figure 3-19).
2. Remove the connection on T1 pin 1 (high) and reconnect it to T1 pin 2 (low).
3. Remove the connection on T1 pin 3 (high) and reconnect it to T1 pin 4 (low).
4. The toggle switch input selector will now select 100 or 200 VAC operation.
5. Reinstall the IR module, **CHECK**.

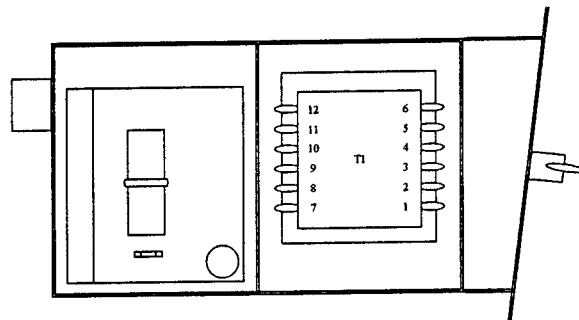

Figure 3-19. I/R Module - Left Side.

3.2.3 EIU Linking

Indicator toggle switch off. Remove retaining bar. The External Interface Unit (EIU) PCB (see Figure 3-20) allows selection of various types of input sensors, such as gyro compass and speed log.

NOTE: To select gyro compass, B-C link J3-J8, J9-J12, and J18-J19. To produce a simulated gyro input for a stable tower as ship, A-B link J5.

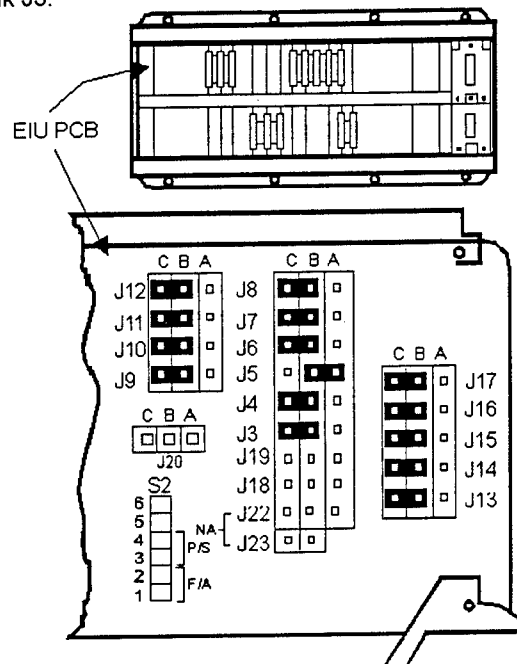

Figure 3-20. EIU PCB.

3.2.4 Control Panel Interface (CPI)

The ST display has various alarms which indicate system or processor faults and also a switch panel 'beep' which may be disabled completely or have its volume changed (see Figure 3-21).

These alarm functions are controlled by changing links on the CPI PCB located beneath the front Control Panel Assembly (A6). To gain access to this PCB, remove the five recessed screws securing the upper portion of the control panel assembly. DO NOT REMOVE THE SCREWS (NON-RECESSED) WHICH SECURE THE LOWER PORTION OF THE FRONT PANEL CONTROL ASSEMBLY TO THE DISPLAY BRACKET.

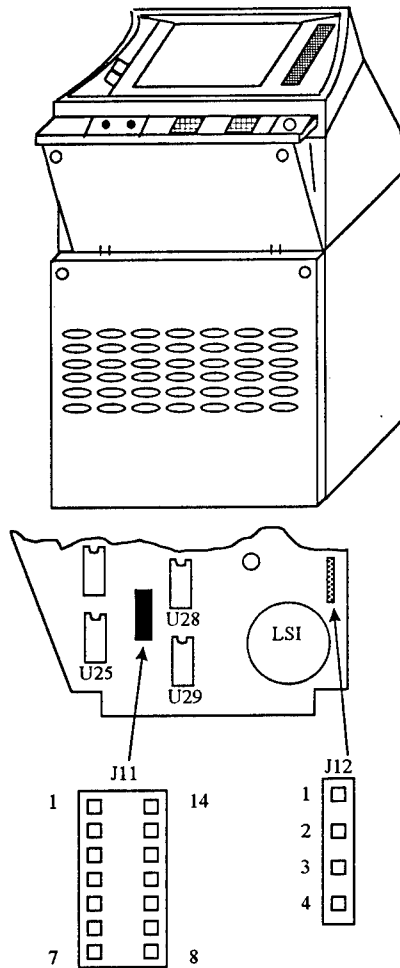

Figure 3-21. Control Panel Interface.

When any switch function on the front control panel is pressed, a short 'beep' is sounded. If desired, this switch 'beep' may be disabled by calling up test 6.1 of the SETUP AND TEST MENU.

Check that the audio alarms are set as follows. Please note that these are personal preferences, and may be changed, **CHECK**.

1. Warnings Alarm (J11)	ENABLED - LK 3-12	*DISABLED - LK 1-14
2. CPU Failure Alarm (J11)	ENABLED - LK 5-10	DISABLED - LK 7-8
3. Volume (J12)	HIGH - LK 3-4	MED - LK 2-3 LOW - LK 1-2

*Disables switch "beep" regardless of selection of 6.1 of previous step, **CHECK**.

3.2.5 Backplane Connections

These connections are found on the rear side of the lower backplane of the card rack assembly (A4) (see Figure 3-22). These are normally connected at the factory. The exception occurs when installing the ISU and remote monitor options. Access is obtained by removing the eight screws securing the card rack assembly to the chassis and swinging it out to its service position (see Figure 3-23).

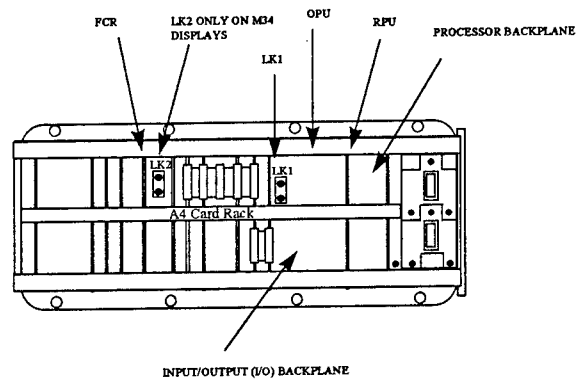

Figure 3-22. Backplane Connections on Card Rack Assembly.

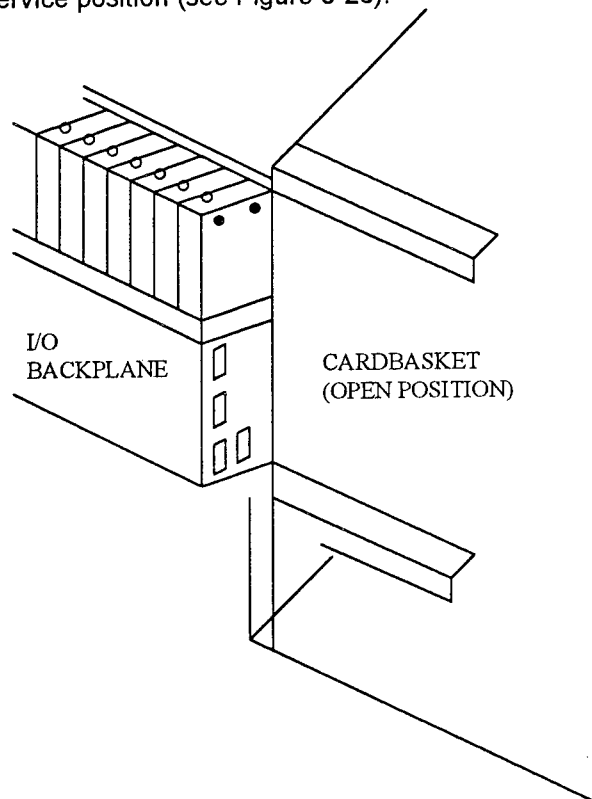

Figure 3-23. Backplane Connections.

Links LK1 and LK2 are installed on the card slot side of the processor backplane. LK1 is removed when the Option Processor Unit (OPU) is installed. LK2 is reserved for future use.

Check that there are connections on the backplane, and that LK1 and LK2 are installed as shown, **CHECK**.

3.2.6 Video Processor A (VPA)

Check that link LK1 on the VPA PCB, (found in card rack assembly A4) is linked A-B (see Figure 3-24),
CHECK.

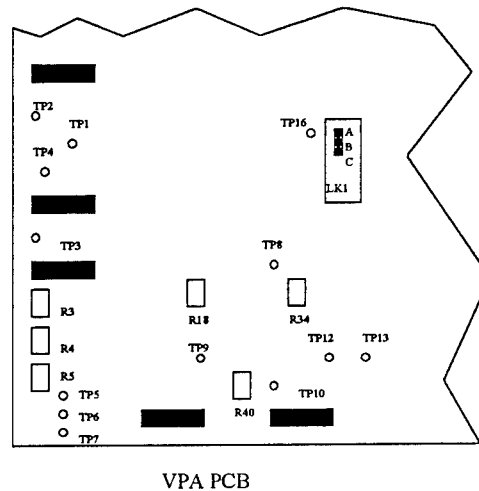

Figure 3-24. Video Processor A PCB.

3.2.7 Adaptive Interface Linking

The Adaptive Interface Module converts radar data from a non-ST radar into a format compatible with the ST Display (see Figure 3-25). This radar data may be from another manufacturer's system or from the previously installed Raytheon Bright Display series of radar.

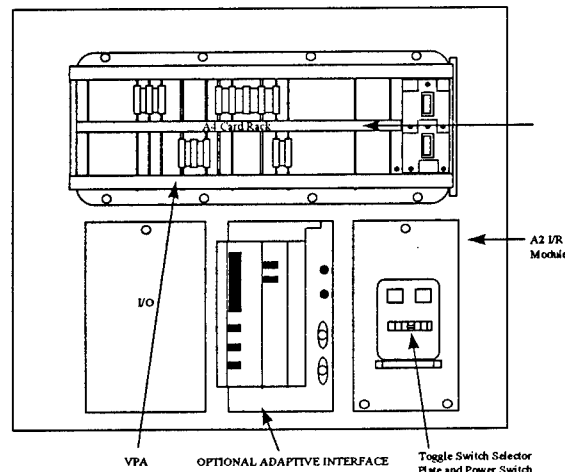

Figure 3-25. Adaptive Interface Module.

The module mounts in the display cabinet in the position that would normally be occupied by the ST XCVR power supply in a ST XCVR-UP configuration.

When interfacing to other manufacturer's radar, the module contains two PCB's, the Radar Interface and Downlink Generator, in addition to a power supply.

When the ST Display is to be utilized with the Raytheon Bright display radar, a third PCB (the Uplink Separator) is added to provide MASTER control capabilities within that system.

CHECK that the left most board (Radar Interface PCB - see Figure 3-26) of the three has the following links set:

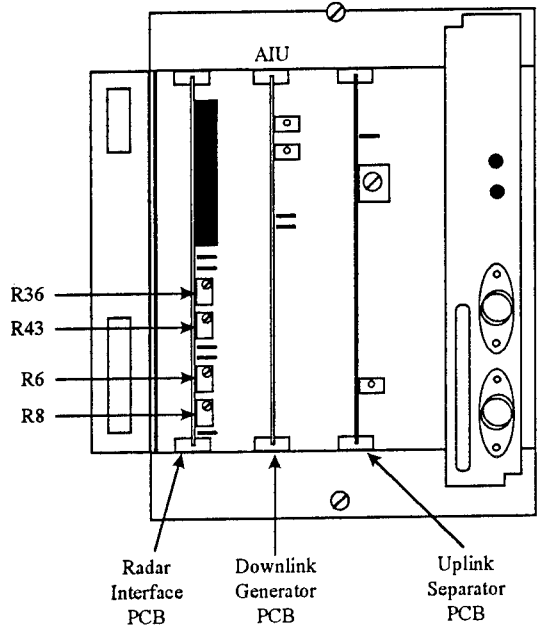

Figure 3-26. Adaptive Interface Linking.

CONDITION	JUMPER CONDITION
Video A & B = Positive Voltage	J1 to J7 = B-C
Video A & B Termination 75 ohm	J11, J12 = Installed
ACK A & B Termination 75 ohm	J9, J10 = Installed
Resolver for Input A & B	J13 through J21, J26 through J43 = A-B J22 through J25 = Removed
XMIT Delay Message	J44 Standard System B-C

3.3 SYSTEM SETUP ADJUSTMENTS

This section provides information and instructions concerning the set-up, alignment and maintenance for a Raytheon Pathfinder/ST Display.

The maintenance philosophy for this system is based on module and mainframe replacement. Component level replacement shall normally be performed by the manufacturer.

WARNING!

When operating, the Pathfinder/ST display contains voltages hazardous to life. Hazardous AC voltage is present in the units even though they are de-energized, unless the primary power circuit breakers have been turned off. Maintenance personnel are cautioned to exercise extreme care and use common sense when servicing these units.

CAUTION!

Always de-energize equipment by turning the I/R off before removing plug-in printed circuit boards and assemblies.

3.3.1 Display Adjustments

3.3.1.1 Preliminary Settings

1. Ensure that all system linking has been accomplished (see Section 3.2).
2. Close the breaker(s) supplying power to the radar system.
3. At the display, turn the Isolation Rectifier power switch to the ON position (see Figure 3-18).
4. At the MTR chassis, turn main power switches and the MTR power supply ON.
5. Ensure the radar power is turned on and that the radar is properly tuned.
6. Verify that power is available at the display by observing the red LED at the Raster Display Unit control panel ON switch (see Figure 3-27).
7. On the RPU PCB set the WRITE PROTECT switch S3 to OFF (to the left) (see Figure 3-28).

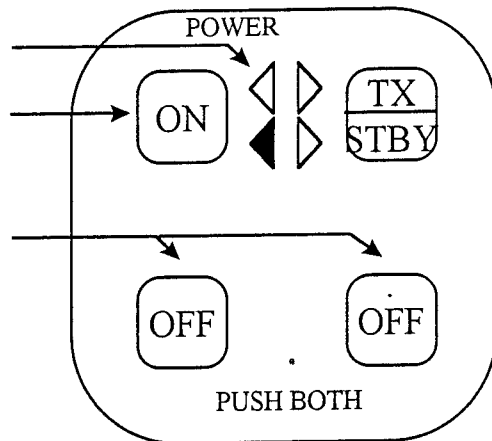

Figure 3-27. Control Panel LED View.

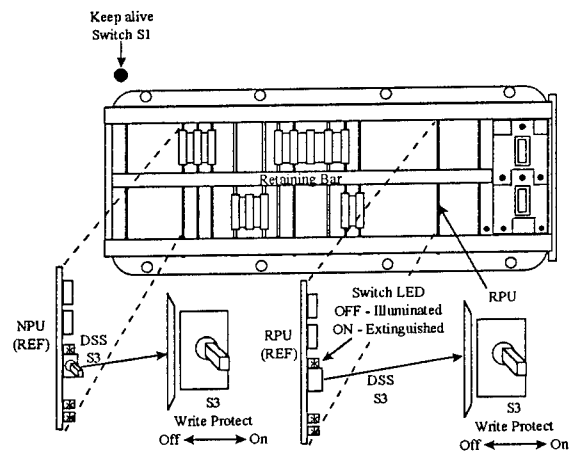

Figure 3-28. Write Protect Switches.

8. On the NPU PCB set the switch to OFF (to the left).

At the Display control panel:

9. Press **ON**; the green LED is illuminated indicating that power is now applied to all circuits, **CHECK**.

NOTE: To turn the Display off, press both OFF switches and hold until green LED is extinguished. The page showing the software revision and built in test results will be displayed.

NOTE: Use Steps 7 and 8 only for changing values.

3.3.1.2 Power Supply Output Adjustments

All display power supply outputs are set at the factory and normally should not require adjustments. The output voltages should be the following:

5 Volt supply (TM & ARPA) (see Figure 3-29):

Test points: TP2(orange)=+5VDC
TP3(black)=GND
Adjustment: R25
Output voltage: 5VDC \pm 2V

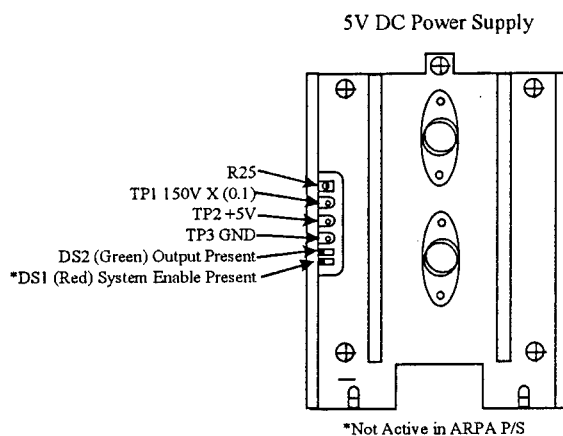

Figure 3-29. 5-Volt Power Supply.

+/-12 Volt supply (see Figure 3-30):

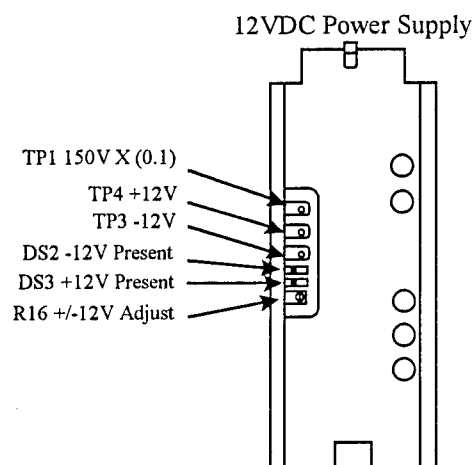

Figure 3-30. 12-Volt Power Supply.

Test points: TP4(red)=+12VDC
 TP3(violet)=-12VDC
 (use chassis for reference)

Adjustment: R16

Output voltage: Adjust for a balance between+12VDC and -12 VDC

CAUTION!

When checking or setting the output voltages on the power supply, the display should be turned off, voltmeter connected to test points, then display power applied to avoid shorting power supply to ground.

CHECK.

3.3.2 System Configuration

3.3.2.1 Default Settings

1. Press the TEST RESET button. The System Setup and Test Menu will be displayed (see Figure 3-31).

SYSTEM SETUP AND TEST

1. VIDEO DISPLAY TESTS
2. EQUIPMENT TESTS
3. SYSTEM CONFIGURATION
4. CALIBRATION: DIRECT DATA ENTRY
5. CALIBRATION: VISUAL ADJUSTMENT
6. OPERATIONAL PREFERENCES
7. ARPA CONFIGURATION

TO SELECT
 TO EXIT

SYSTEM CONFIGURATION

- 3.1. GYRO CONFIGURATION
- 3.2. SPEED LOG
- 3.3. TRANSCEIVER CONFIGURATION
- 3.4. TRANSCEIVER SETUP
- 3.5. SYLEDIS PORT CONFIGURATION
- 3.6. DELAY BOARD INSTALLATION
- 3.7. AUTO PILOT
- 3.8. LOAD DEFAULT CONFIGURATION

TO SELECT
 TO EXIT

Figure 3-31. System Setup and Configuration.

2. Use the Trackball and move the cursor to select Test 3 and press **ENTER**. The SYSTEM CONFIGURATION Menu will be displayed.
3. Use the Trackball and move the cursor to select Test 3.8 and press **ENTER**. LOAD DEFAULT CONFIGURATION will be highlighted in inverse video.
4. At the DATA ENTRY keypad, press 5 5 5 E. LOADING RPU DEFAULT Parameters will flash once on the screen, **CHECK**.

All previously stored fixed parameters are now set to their DEFAULT state.

NOTE

All previously stored fixed parameters are now set to their DEFAULT state. All correct parameters MUST now be ENTERED.

3.3.2.2 Entered Settings

1. Use the Trackball and move the cursor to select Test 3.1 and press **ENTER**. The GYRO COMPASS PARAMETERS Menu will be displayed (see Figure 3-32).
2. Use the Trackball and move the cursor to select Test 3.1.1 and press ENTER. Test 3.1.1 will be highlighted.
3. Using DATA ENTRY keypad, enter 2 for gyro type then press E.
4. Press CNCL to return to SYSTEM CONFIGURATION menu, **CHECK**.

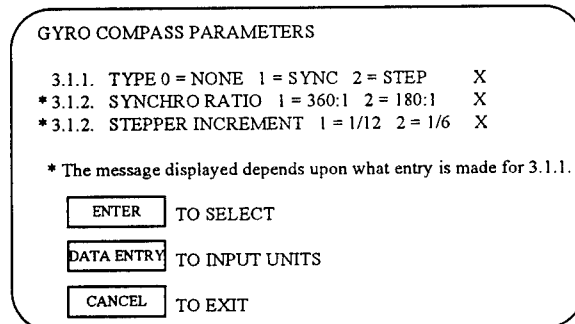

Figure 3-32. Gyro Compass Parameters.

3.3.2.3 Transceiver Configuration

1. Select Test 3.3, TRANSCEIVER CONFIGURATION, press ENTER. The TRANSCEIVER CONFIGURATION menu will be displayed (see Figure 3-33).

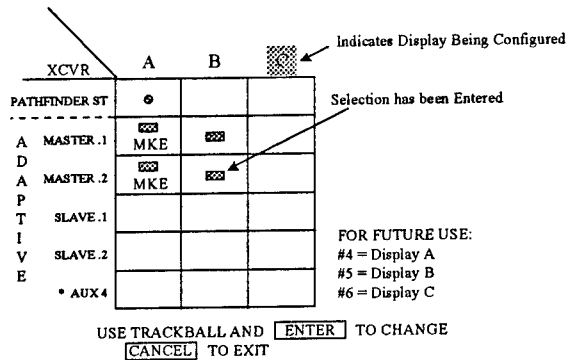

Figure 3-33. Transceiver Configuration.

2. For a single system, use the trackball and ENTER to identify what type of radar is connected to the display.
3. Use Trackball to move cursor to Pathfinder ST block under current display (display A) then press ENTER.
4. Use Trackball to move cursor to MASTER.1 block under current display (display A) then press ENTER.
5. Use Trackball to move cursor to MASTER.2.
6. Press CANCEL to go back to menu, **CHECK**.

3.3.2.4 Transceiver SETUP

1. Select Test 3.4, TRANSCEIVER SETUP, press ENTER. The TRANSCEIVER (XCVR) PARAMETERS menu will be displayed (see Figure 3-34).

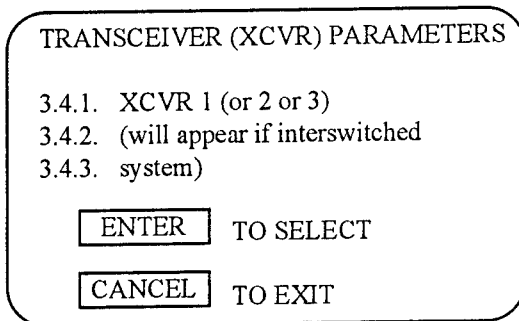

Figure 3-34. Transceiver XCVR Parameters.

2. Select the first XCVR and enter parameters defined at the end of the data sheets.
3. See Appendix A for calculation of Reference Signal to Noise.
4. Check that the values follow according to the Display Test/Reset Menu (Appendix C).
5. Select CANCEL to go back to System Setup Test Menu, **CHECK**.

3.3.3 Operational Preferences

1. On the SYSTEM SETUP AND TEST menu, use the Trackball to select Test 6 OPERATIONAL PREFERENCES (see Figure 3-35).

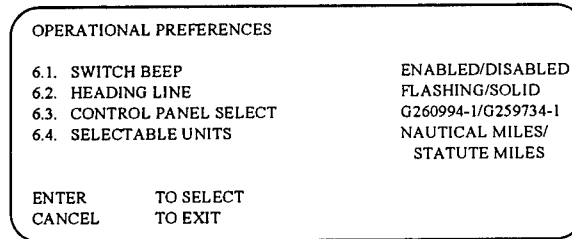

Figure 3-35. Operational Preferences.

NOTE: Selections of the above Tests will 'toggle' by using the ENTER key. In Test 6.3, setting is determined by the control name on the button at PUSH and HOLD area on the left side of the control panel.

2. TEST RESET = G260994-1
3. PUSH HOLD = G259734-1
4. Press CNCL to return to the SYSTEM SETUP and TEST menu, **CHECK**.

3.3.4 ARPA Configuration - Clock Set

1. On the SYSTEM SETUP AND TEST menu, select Test 7, ARPA CONFIGURATION, and press ENTER (see Figure 3-36).

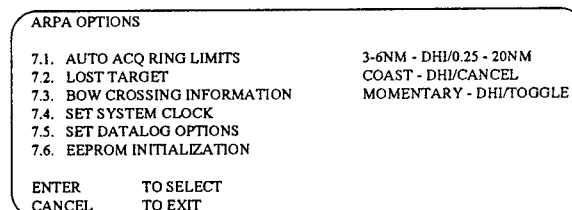

Figure 3-36. ARPA Options.

2. Select Test 7.4 (SET SYSTEM CLOCK) and press ENTER.
3. Enter date at DATE ENTRY keypad and press E.
4. Enter time at DATA ENTRY keypad and press E. The system clock will then be set, **CHECK**.

NOTE: Test 7.6 is designed as an aid for the service engineer. Entry of this will CLEAR all stored maps and also perform a diagnostic test of the EEPROM. This test should be only performed at original installation or upon replacement of the NPU PCB.

3.3.5 Adaptive Interface Video Adjustment

NOTE: Ensure coarse tuning is correct and that the Video outputs of each MTR are balanced before proceeding.

1. Connect an oscilloscope to TP1 on the Downlink Generator PCB. See Figure 3-37. Adjust R6 on Radar Interface PCB to obtain 7.0V (non-saturating) video for system A.
2. Place oscilloscope at TP3 of VPA PCB and adjust R3 so that the video signal level of close-in targets (1/2 to 1 mi.) is 2.5V. See Figure 3-38. **CHECK.**

NOTE: Data level is 2.7V, Video is 2.5V

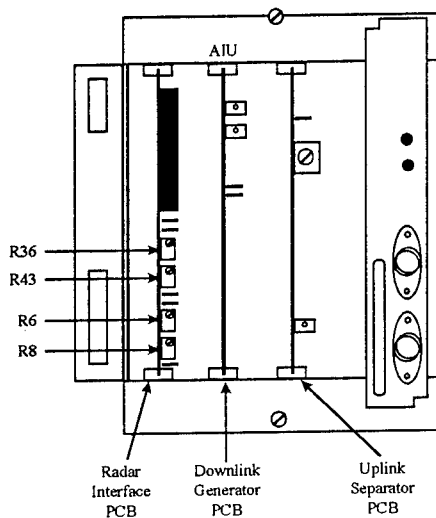

Figure 3-37. Display Circuit Boards.

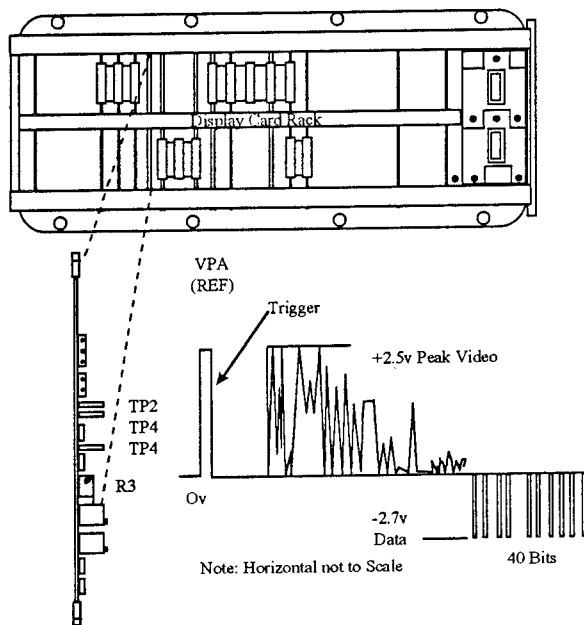

Figure 3-38. Adaptive Interface Video Adjustment.

3.3.6 Tuning Preset

3.3.6.1 ST XCVR

1. Press the TEST RESET button until the screen blanks. When self test/revision level page is displayed, press the TEST RESET once more; the SYSTEM SETUP AND TEST menu will be displayed (see Figure 3-39).
2. Using the trackball, select Test 5. CALIBRATION: VISUAL ADJUSTMENT and press ENTER. The screen will display the menu (see Figure 3-40).
3. Select 5.2 TUNING PRESET and press ENTER. The screen will display the system calibration (see Figure 3-41).

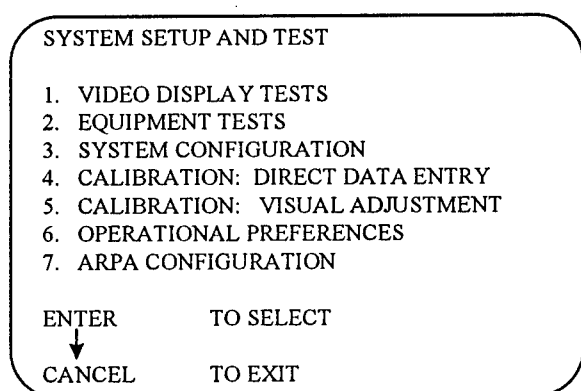

Figure 3-39. System Setup and Test Menu.

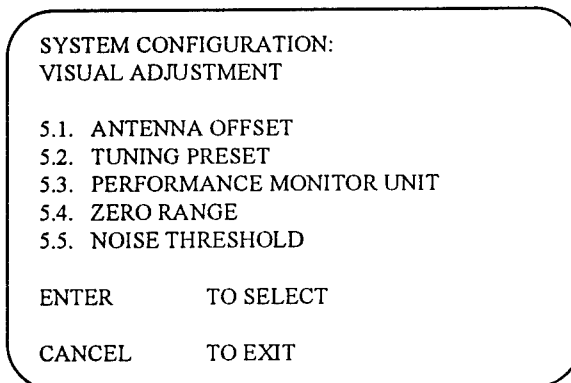

Figure 3-40. Visual Adjustment Calibration.

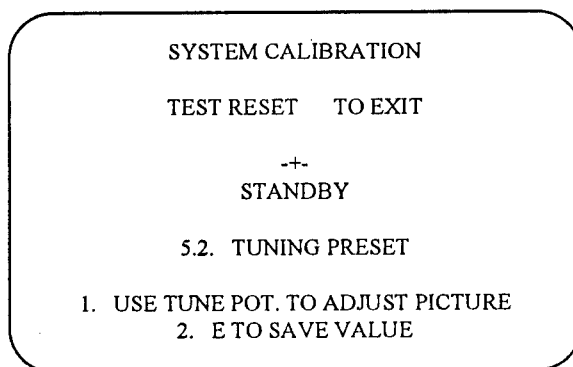

Figure 3-41. System Calibration.

4. Press TX to place the radar in transmit mode.
5. Select the 24nm range scale. Set the SEA, RAIN RATE, and FTC to OFF. Set the GAIN to mid range on the bar graph.
6. Release the Tune Locking knob and adjust the TUNE control for maximum deflection on the tuning bar graph as well as maximum target returns. When observing target video on the display, turn the control slowly and allow for three complete scans of the antenna to observe results.

- When the control has been set for maximum bar deflection and maximum target return, press E on the DATA ENTRY keypad. Lock TUNE control knob, **CHECK**.

3.3.6.2 Adaptive Master

- Set Range Scale to 12NMI.
- Use a DVM to measure the tune output (DC voltage) at the I/O PCB, A1A3TB4-8.
- Adjust front panel tune control for a reading of -4VDC at A1A3TB4-8.

NOTE: This reading should be obtained when the front panel tune knob is near mechanical center.

- At the MTR (LNFE) - adjust LNFE PCB potentiometer for best video presentation.
- For Standard Front End - adjust LO frequency screw fully CCW and then CW for first video peak.
- For IF Amplifiers having R97 (video out adj) set output for 3.4V peak video.
- Recheck AIU adjustment in Adaptive Interface Video Adjustment section above. Adjust R6 if necessary for 7.0V, **CHECK**.

3.3.7 Final Video Adjustment

- At the VPA PCB, place an oscilloscope probe on TP3.
- Adjust R3 until the nearest targets (1/2nm - 1nm) reach a 2.5V level (see Figure 3-42).

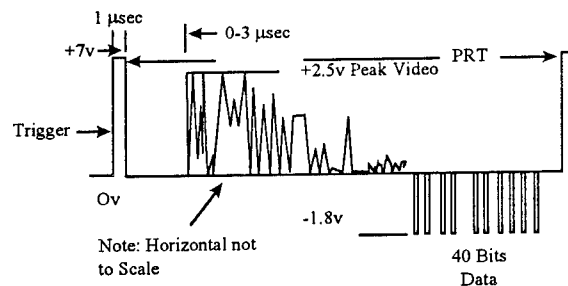

Figure 3-42. Final Video Adjustment.

NOTE: You should be able to get to -1.8V. Record final video adjustment, **CHECK**.

3.3.8 Noise Threshold

NOTE: Ensure the radar is properly tuned, and VPA alignments are correct before proceeding with the following adjustment.

For Master Adaptive systems, to ensure there are no actual target returns to interfere with the detection of the receivers noise level, one of the following two MTR set up methods must be performed.

- Place Dummy Load at waveguide port output of MTR. Disconnect antenna stop at MTR TK 1-7; place local on/off switch to TX ON.
- Disconnect trigger and acknowledge Pulse BNC plugs from MTR.

3. Connect plugs together using BNC T on barrel connector.
 4. Place Local On/Off switch to TX ON. Disconnect antenna stop at MTR TB 1-7,
- NOTE:** If Rep rate doesn't change, open J9 on Radar Interface PCB Method 2 was performed on MKE unit.
5. Select Test 5.5 NOISE THRESHOLD, and press ENTER (see Figure 3-43).
 6. Press the TX button to place radar in transmit. NOT TRANSMITTING will be displayed on the screen. This is normal for this test (set-up).
 7. Select the 24nm range.
 8. Turn the RAIN/FTC and SEA controls OFF. (Observe bar graphs).
 9. Set the GAIN control so that the bar graph deflects to mid-range.

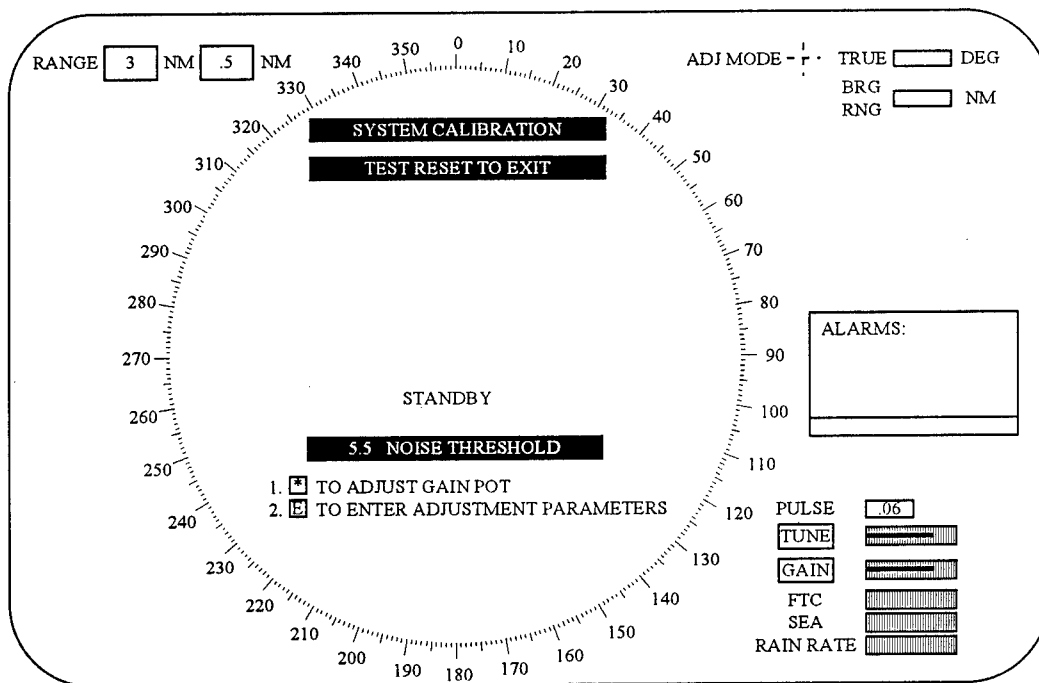

Figure 3-43. Adjusting Noise Threshold.

10. Press * on the DATA ENTRY keypad.

NOTE: The following procedure adjusts the noise speckle using the GAIN control. With the exception of the immediate area surrounding the tower, the adjustment criteria is an even speckle density of noise across the entire display at the dim level (reduced ambient lighting may aid in this determination). Noise density should be equal on all ranges.

11. Set RR (Range Rings) to maximum intensity.
12. While observing the area between the fourth and fifth RR, adjust GAIN control for equal noise speckle at the dim level with only a random number of hits breaking into the high level. (The gain

should be changed in increments, allowing for a three scans between each setting before observing the results).

13. When the presentation is correct, press E.
14. Repeat the noise threshold settings selecting each different range group (see Figure 3-44).

Range Scale	Pulse Width
24NM	1.0 μ s
12NM	.5 μ s
3NM	0.06 μ s

Figure 3-44. Bright Display Nautical Mile and Pulse Combinations.

15. Return the MTR (or XCVR) to its normal operating condition.
16. Return to the normal operating screen by pressing TEST RESET and then CNCL. Set the GAIN to fill six divisions on the bar graph and press TX.
17. Check all ranges and pulse width combinations to ensure that noise speckle does appear but does not change greatly as you change range scales, with the fixed setting of the GAIN Control. Also observe that the screen will not saturate when GAIN is set to maximum, nor will the strongest targets be eliminated when GAIN is set to minimum. If necessary, return to the beginning of this paragraph and correct those ranges on which the noise threshold proved incorrect, **CHECK**.

3.3.9 VPA Alignment

NOTE: The VPA board (see Figure 3-44) contains factory adjustments that determine the proper gain and offset of the computer generated SEA, GAIN, and RAIN Clutter curves. It is normally not required to perform these adjustments in the field. However, if there are complaints of poor target detection or adjustment of the FTC either increases the background noise or causes targets to disappear, then the VPA alignment should be checked and, if necessary, performed. The VPA extender card will be required to perform these adjustments.

CAUTION!

When removing or replacing circuit cards in the display card rack assembly, turn display unit off and remove power from the display with the S1 power switch on the isolation rectifier module.

NOTE: The steps for Zero Trim Adjustment must be performed in the sequence given.

3.3.9.1 Zero Trim Adjustment

1. Turn display OFF.
2. Place VPA PCB on an extender card.
3. Turn display ON. (Observe bearing scale.)
4. Use a jumper to ground TP3 (Signal) to TP4 (Analog Ground) (see Figure 3-45). Observe vertical bars.

7. Press ENTER and select Test 1.1.6.1, STC OFFSET ADJUSTMENT and start test (see Figure 3-47). (Trackball and ENTER.)
8. Place oscilloscope probe on VPA TP9, sync on VPA TP12 and ground on VPA TP4 (Analog Ground).
9. Set oscilloscope to measure 50mV per division.
10. Adjust VPA R34 to match offset (at the 240 μ sec point from trigger) (see Figure 3-48).

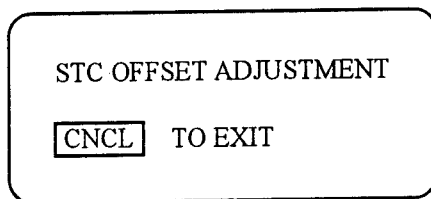

Figure 3-47. STC Offset Adjustment.

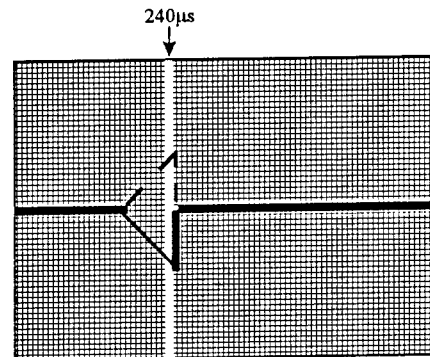

Figure 3-48. STC Offset Incorrect.

11. Place oscilloscope probe on VPA TP7.
12. Adjust VPA R18 to match offset (see Figure 3-49).
13. Press CNCL and select Test 1.1.6.2, STC AMPLIFIER ADJUSTMENT (Trackball and ENTER).
14. Place oscilloscope probe on VPA TP9 and observe waveform. Adjust VPA R4 until foot of slope matches baseline (see Figure 3-50).
15. Place oscilloscope on VPA TP7 and adjust VPA R5 until foot of slope matches baseline (see Figure 3-51).

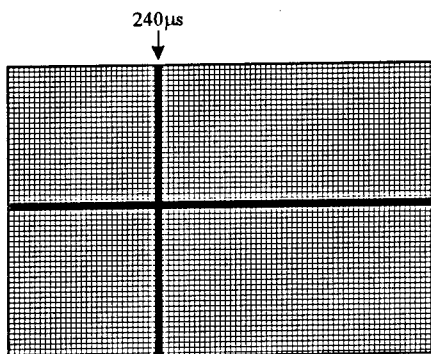

Figure 3-49. STC Offset Correct.

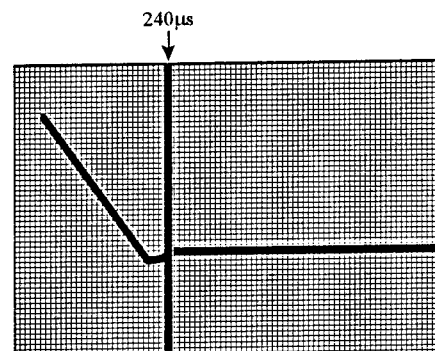

Figure 3-50. STC Amplifier Incorrect

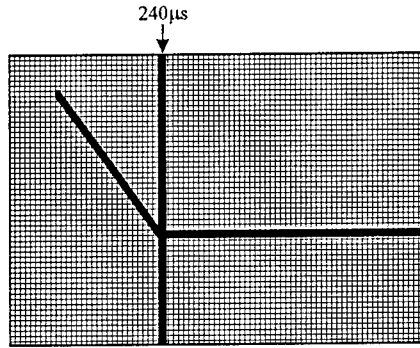

Figure 3-51. STC Amplifier Correct.

16. This completes the VPA adjustment. Press CNCL four times to return to SETUP AND TEST menu, CHECK.

3.3.10 Record Parameters and Reset Switches

1. Press TEST RESET until screen blanks. Test screen will now be shown.
2. Press TEST RESET to enter tests.
3. Select Test 4 (DIRECT DATA ENTRY).
4. Select the appropriate XCVR. ENTER will toggle selection.
5. Record data for all available XCVRs on Initial Checks Sheet.
6. Press CANCEL to return to system SETUP AND TEST PAGE.
7. Select Test 3 and press ENTER.
8. Select Test 3.4 and press ENTER.
9. Select each XCVR in turn and record parameters on Initial Checks Sheet.
10. If VDU alignment appears correct:
 - a) Ensure entire is operational.
 - b) **Set RPU switches to right hand positions.**
 - c) Replace card retaining bar and front cover.
 - d) Return unit to normal operating condition.
11. If VDU requires alignment see Volume I, Appendix D. CHECK.

3.4 CERTIFICATION

Raytheon's technicians verbally stated that the installation was approved and that they were pleased with the radar's operation. A complete alignment and operational check was performed. Copies of the installation certification report and checklists for the radar components are included in Volume II, Appendix D. Raytheon also provided two days of operational training for local controllers responsible for the operational evaluation of the system.

Table 3-1. Alignment Data Sheet.

NOTE: MKE technicians have kept a monthly record of the Phase I alignment, entering values or checkmarks, as appropriate.

Para.	Section Title	Jan	Feb	Mar	Apr	May
3.1.1.1	Frequency (μ s)	25	25	25	25	25
3.1.1.2	5 Volt (v)	5.10	5.10	5.10	5.11	5.11
3.1.1.3	Voltage Sense (vdc)	6.61	6.53	6.63	6.53	6.73
3.1.1.4	Output LVPS (vdc)	23.96	24.03	23.43	24.05	24.02
3.1.1.5	6.3 VDC Filament (vdc)	7.56	7.58	7.58	7.59	7.59
3.1.2.1	Frequency (μ s)	25	24.9	25	25	25
3.1.2.2	5 Volt (v)	5.10	5.10	5.10	5.10	5.10
3.1.2.3	Voltage Sense (vdc)	6.61	6.5	6.63	6.58	6.70
3.1.3.1	MTR PRF Adjustment	√	√	√	√	√
3.1.3.2	Magnetron Current Adjustment	√	√	√	√	√
3.1.3.3	Mag Heater Scheduling Adjustments (vdc)	2.61	2.60	3.90	2.59	2.477
3.1.4.1	Low Noise Front End (LNFE) Adjustments	√	√	√	√	√
3.1.4.2	MTR STC Adjustments (v)	3.5	√	-4	-4	-4
3.1.4.3	IF Video Gain Adjustments (v)	√	√	3.4	3.45	3.4
3.1.4.4	Resolver Drive Adjustments	√	√	√	√	√
3.2.1	Isolation Rectifier	√	√	√	√	√
3.2.2	Low Line Isolation Rectifier	√	√	√	√	√
3.2.3	Control Panel Interface	√	√	√	√	√
3.2.4	Back plane Connections	√	√	√	√	√
3.2.5	Video Processor A (VPA)	√	√	√	√	√
3.2.6	Adaptive Interface Linking	√	√	√	√	√
3.3.1.1	Preliminary Settings	√	√	√	√	√
3.3.1.2	Power Supply Output Adjustments	√	√	√	√	√
3.3.2.1	Default Settings	√	√	√	√	√
3.3.2.2	Entered Settings	√	√	√	√	√
3.3.2.3	Transceiver Configuration	√	√	√	√	√
3.3.2.4	Transceiver SETUP	√	√	√	√	√
3.3.3	Operational Preferences	√	√	√	√	√
3.3.4	ARPA Configuration - Clock Set	√	√	√	√	√
3.3.5	Adaptive Interface Video Adjustments	√	√	√	√	√
3.3.6.1	ST XCVR	√	√	√	√	√
3.3.6.2	Adaptive Master	√	√	√	√	√
3.3.7	Final Video Adjustment	√	√	√	√	√
3.3.8	Noise Threshold	√	√	√	√	√
3.3.9.1	Zero Trim Adjustment	√	√	√	√	√
3.3.9.2	STC Adjustments	√	√	√	√	√
3.3.10	Record Parameters and Reset Switches	√	√	√	√	√

4. TEST AND EVALUATION

The following tests and procedures aided in the evaluation of the MKE Raytheon Marine Radar system in three ways:

- described the tests necessary to demonstrate ASDE-X performance compared to an ASDE-3.
- evaluated the manufacturer's claims to the ASDE-X radar performance.
- provided information to compare the theoretical performance of the radar system to the actual measured system parameters.

The tests include: the fixed target reflector (FTR) setup, measurements of Differential Global Positioning System (DGPS), functional tests which measure parameters of the transceiver and of system performance, alignment of radar to FTR, procedures for generating display maps and demonstrating range and azimuth resolution. Tests were performed at MKE control tower from December 1995 to April 1996.

Data sheets for each series of tests appear in Section 4.5. Technicians have recorded entries on them at critical steps in each procedure; they are indicated by **RECORD** (where values have been entered) or **CHECK** (where checkmarks suffice.)

4.1 EQUIPMENT CHECKLIST AND TESTS

Before performing the tests and procedures, verify that equipment requiring calibration has been calibrated and **CHECK** compliance for each piece of equipment on the calibration data sheet (see Sections 4.1.1 and 4.5.1). Also **CHECK** in Section 4.5.1 that the wiring of the system is identical to the Interconnection Diagram, Figure 4-1.

<u>ITEM</u>	<u>PART NUMBER</u>
Microwave Frequency Counter	EIP 585
Signal Generator Synthesizer	HP 83731A/2A
Power Meter w/ Peak Power Sensor	HP 84815A
Spectrum Analyzer	HP 8563A
Oscilloscope	Tektronix 2246
Plotter	HP 7440A
Detector Diode	HP 8474
Waveguide Bi-directional Coupler	Raytheon M27197
Waveguide Termination, 50 ohm	Raytheon 1035435-1
Acoustic Noise Meter w/ Sound Level Calibrator	B & K 2236 D
Flow Meter	Omega FMA 1806
Digital Voltmeter with ammeter attachment	Fluke 23 (80i-600A)
Low Loss RF Cable(LLC)	Macom 1999-0072 (2)
Attenuators	Macom 3082-6191-03
Waveguide Transition	Maury Microwave 213D2
GPS Receiver	Garmin GPS 45
Radio Beacon Receiver	Starlink MRB-2A MSK
Antenna	Starlink BCLA6
Power supply	12-volt (DC)
Cellular phones	Motorola
Video camera	
Fixed Target Reflectors (FTRs)	Raytheon Trihedrals, 2 x 3m ² , 2 x 1m ²

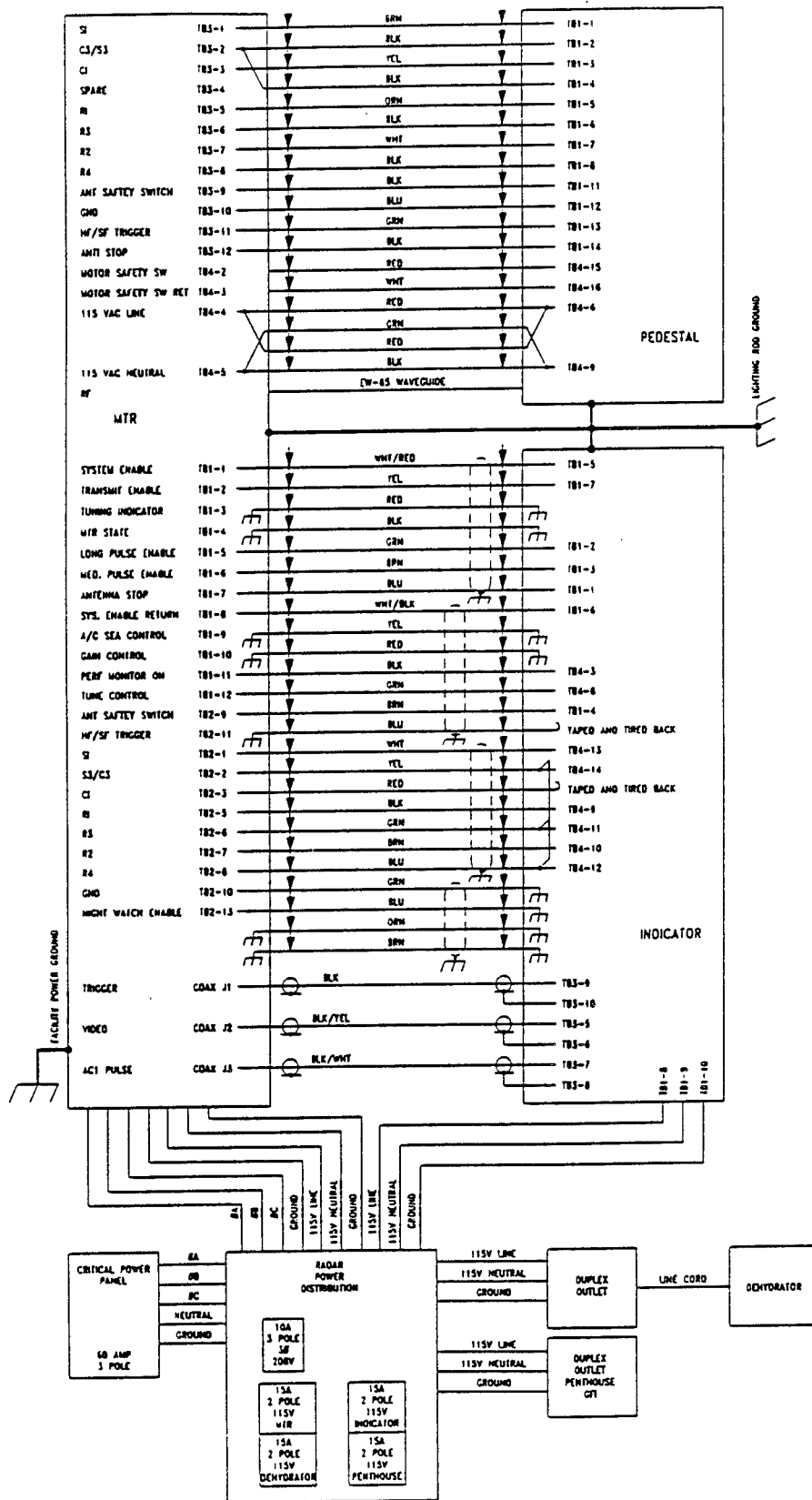

Figure 4-1. Interconnection Diagram.

4.1.1 RF Low-Loss Cable (LLC) Attenuation Calibration

Setup:

Signal Generator:	Frequency:	9.375 GHz
	Trigger:	Internal
	Power:	10 dB
Peak Power Meter:	Channel	1

Procedure (4.1.1.n):

1. Connect power meter to signal generator.
2. Adjust signal generator until power meter reads 10 dB.
3. Connect LLC between signal generator and power meter.
4. Subtract power meter reading from 10 dB; **RECORD** in Section 4.5.3.

4.2 FIXED TARGET REFLECTOR (FTR) SETUP

Equipment:

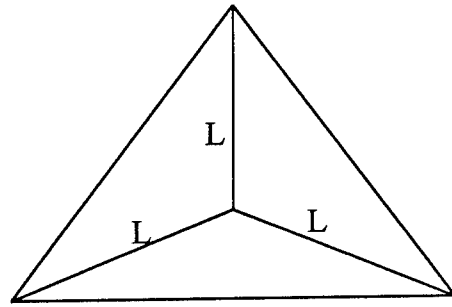

Trihedral Reflector: Isosceles Triangles

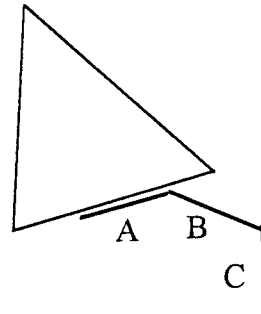

Mounting Bracket

A = 4.4", B = 3", C = 4.3"

The maximum radar cross-section obtained on the symmetry axis is given by:

$$\sigma = \frac{4\pi (0.2898 L^2)^2}{\lambda^2}$$

$$L = \left(\frac{\sigma \lambda^2}{4\pi (0.2898)^2} \right)^{1/4}$$

where L = the length of each side of the reflector.

$\lambda = .032$ meters.

0.289 is obtained by considering the fraction of the trihedral projected area that participates fully in the triple reflection process.

$\sigma = 1\text{m}^2$

L = 7.02"

$\sigma = 3\text{m}^2$

L = 9.24"

Setup:

The FTRs were mounted with radiator clamps to aluminum pipes of 4" diameter and 6' long. The pipes, mounted to 4' x 4' plywood, were staked to the ground, and bent at a 12° angle to minimize radar return. The FTR area is located south of Runway 1L in a field west of the approach lights (see Figure 4-2). The grade has a slight upward northward slope, with a direct sight line to ATCT. Grass was cut to 1" in the 100' x 100' FTR area. Two 3 m² FTRs (T1, T2) were staked 80' apart on a tape-measured azimuth. One 1 m² FTR (T3) was staked 40' in front of the 3 m² FTR further west, radially aligned with ATCT. The other 1 m² FTR (T4) was mobile to aid resolving ambiguities. See Sections 4.4.3 and 4.4.5.

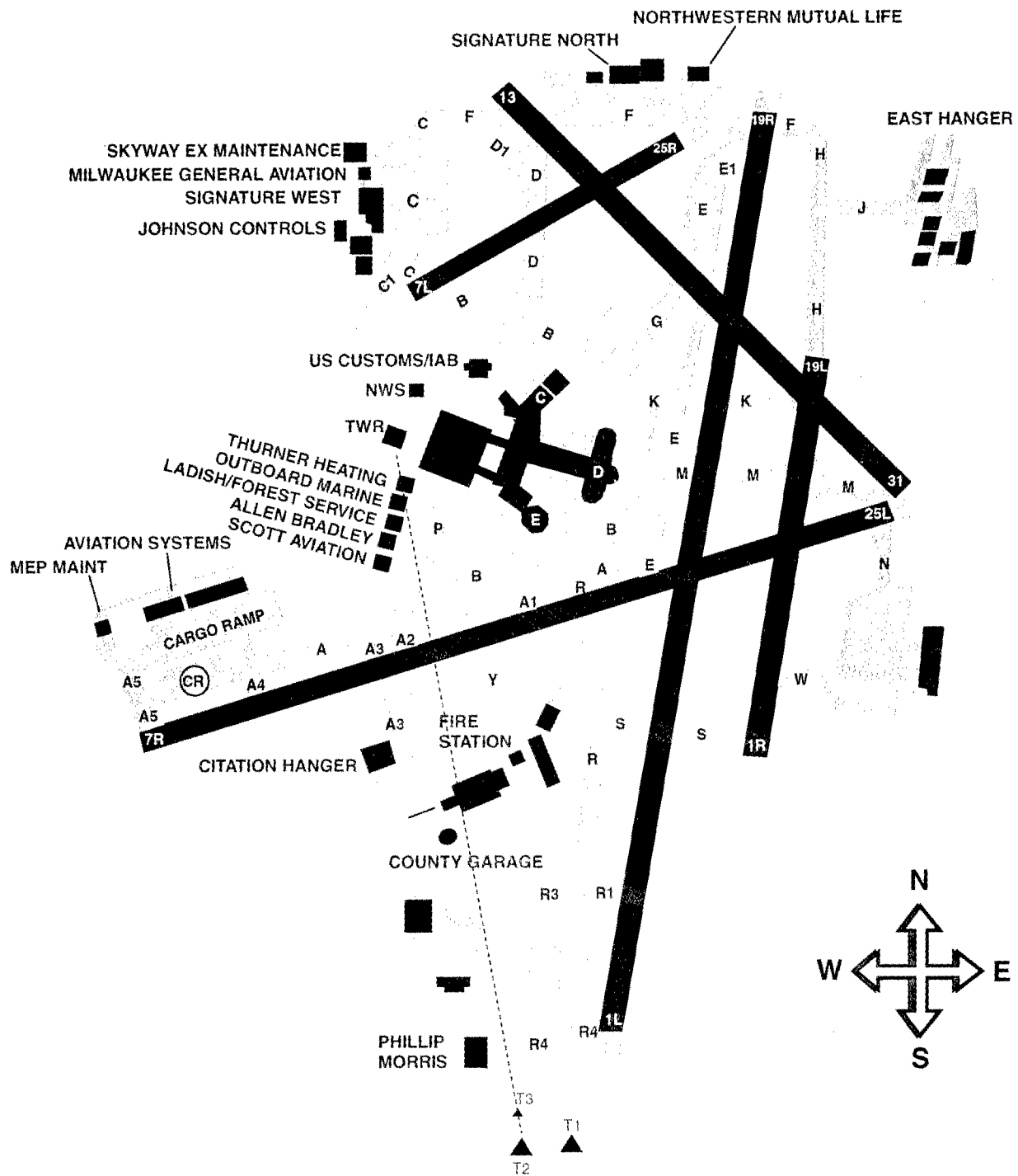
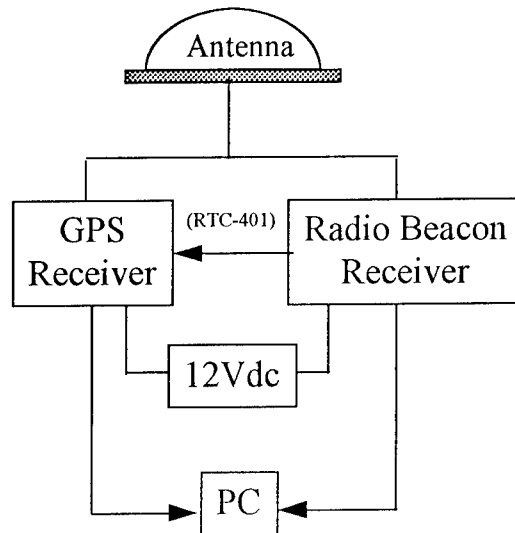

Figure 4-2. FTR Configuration at MKE.

4.3 DGPS MEASUREMENT OF FIXED TARGET LOCATIONS

Equipment:



NOTE: Shadowing antenna will affect signal quality. Set up tripod away from obstructions and stand away.

Setup:

1. DGPS Radio Beacon Receiver:

Milwaukee, WI DGPS Beacon Specifications

Status:	On-line operational testing
RBn Antenna Location (A):	43 00.1N, 087 53.3W
REFSTA Ant Location (A):	43 00.15170N, 087 53.30641W
REFSTA Ant Location (B):	43 00.14137N, 087 53.29261W
REFSTA RTCM SC-104 ID (A):	106
REFSTA RTCM SC-104 ID (B):	107
Broadcast Site ID:	833
Transmission Frequency:	297 kHz
Transmission Rate:	100 BPS
RTCM Correction Message:	TYPE-9
Morse Code Identifier:	None (Single carrier operation)
Signal Strength:	75 uV at 140 SM
Planned/Observed Outages:	Off-air 0055Z 28 Sep to 0143Z 28 Sep 95 Off-air 211140Z 27 Sep to 2200Z 27 Sep 95

2. GPS Receiver

"AutoLocate Mode" to force a search for a new set of satellites

Enter your initial position.

Position Format (hddd mm.mmm)

Map Datum (WGS-84)

CDI Scale

Units of Measure (Nautical)

Heading Reference (Auto Mag)

Range and bearing between tower and targets is calculated using the "Method of Sodano." Record data in Section 4.5.2.

Procedure: Survey Tower Location

1. Set up the antenna (place in the middle of the radar antenna array).
2. Power up system.
3. Check beacon status.
4. Set system for differential data collection.

5. When system reaches "3D Navigation" status clear track log buffer.
6. Set collection criteria to every 10 seconds.
7. Check I/O criteria (RTCM/NMEA).
8. Collect data for 20 minutes.
9. Note ATCT position data.
10. Set Location as a waypoint ("MKE").
11. Set up system for "Track Log Transfer to PC."
12. Transfer data to PC (filename: tower.dat).
13. Average Lat/Lon data in tower.dat.
14. Check data against noted position data and **RECORD**.

Procedure: Locate Target

15. Set up antenna.
16. Power up system.
17. Check beacon status with PC connection.
18. Set system for differential data collection.
19. When system reaches "3D Navigation" status clear track log buffer.
20. Set collection criteria to every 10 seconds.
21. Set I/O criteria (RTCM/NMEA).
22. Note FTR position data (3 entries).
23. Collect data for 20 minutes.
24. Set Location as a waypoint ("TRn"...n = 0-9).
25. Determine range and bearing from "MKE" waypoint (ATCT location).
26. Set up system for track log transfer to PC.
27. Transfer data to the PC (filename: target_n.dat).
28. Average Lat/Lon data in target_n.dat.
29. Check data with the recorded position data, **RECORD**.
Repeat steps 15-29 for T2 and T3.

4.4 FUNCTIONAL TESTS

NOTE: Record all test data in Section 4.5.3.

4.4.1 Transmitter and Receiver Measurements

4.4.1.1 Minimum Discernible Signal (MDS) Test

Equipment:

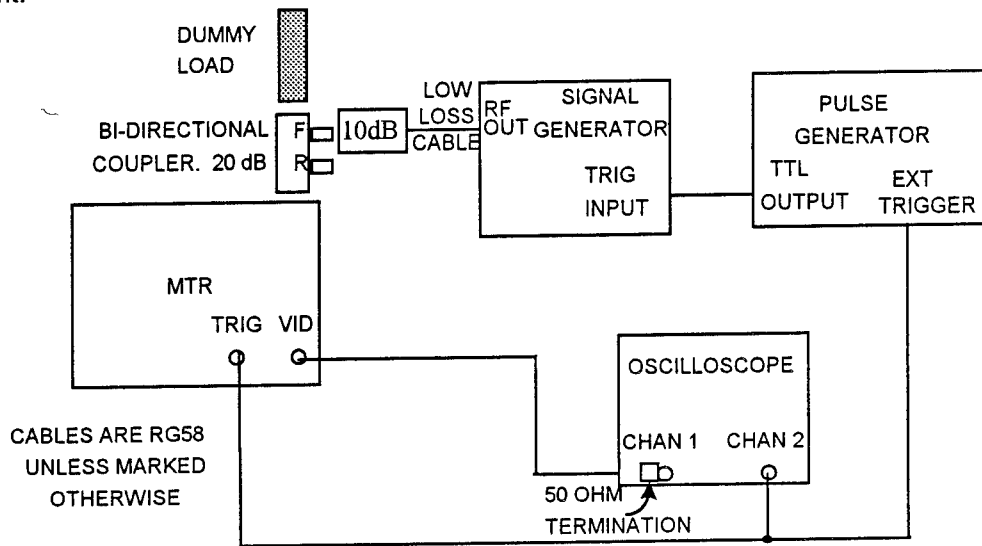

Setup:

MTR:	Local PRF Selector switch:	Short
	Local Test switch:	STBY
Display:	Power switch:	STBY
Oscilloscope	Trigger:	Channel 2
Pulse Generator:	PRF:	3600 Hz
	Pulse width:	60 ns
	Delay:	60 μ s
	Trigger:	External
Signal Generator:	Frequency:	9.375 GHz
	Trigger:	External
	Power:	-10 dB

Procedure (4.4.1.1.n):

1. Remove transceiver front cover.
2. Bypass transceiver interlock by pulling interlock to service position.
3. Set R/T LOCAL MTR TEST switch to ON.
4. Set signal generator RF output attenuation control to display a nonsaturated video pulse on oscilloscope and adjust frequency control to maximize video pulse amplitude.
5. Decrease signal generator power until video pulse is barely discernible above noise.
6. Adjust scope volts/division settings for maximum sensitivity.
7. **RECORD** signal generator power.
8. Add values of LLC (1 dB), bi-directional coupler (20 dB), and attenuator pad (10 dB) to signal generator power; **RECORD**.

4.4.1.2 Dynamic Range Test

Equipment: See 4.4.1.1.

Setup: See 4.4.1.1.

Procedure (4.4.1.2.n):

1. Find MDS [follow Procedure 4.4.1.1]
2. Increase signal generator power output to 57 dB above MDS level [4.4.1.1.7].
3. Note the amplitude of the video signal on channel 1 of the oscilloscope.
4. Increase the signal generator power output by 3 dB.
5. Verify that the amplitude of the video signal on channel 1 of the oscilloscope increases by at least 25%.
6. Continue increasing the signal generator output level by 3 dB increments until the video signal amplitude saturates and increases less than 25% (1 dB compression point).
7. Determine the maximum signal generator output that will yield a 25% increase in video amplitude. Subtract the signal generator output level, adding in test setup losses, from the recorded MDS value; **RECORD** system's dynamic range.
8. Set R/T LOCAL MTR TEST switch to OFF.
9. Disconnect test equipment.
10. Close transceiver service panel and tighten fasteners.

4.4.1.3 Radio Spectrum Engineering Criteria (RSEC) Test

Equipment:

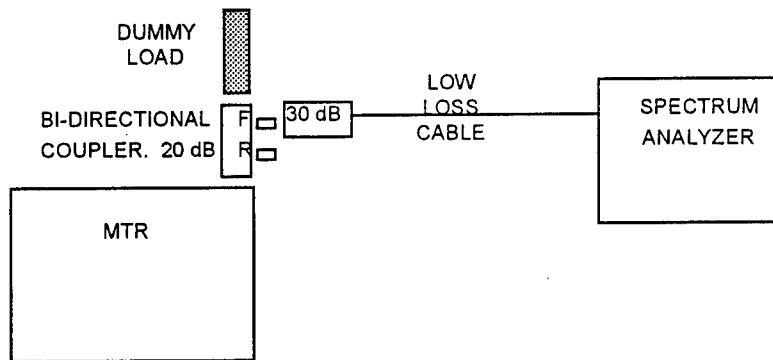

Setup:

MTR:	Local PRF Selector switch:	Short
	Local Test switch:	On
Display:	Power switch:	STBY

Procedure (4.4.1.3.n):

1. Use "peak find" function to get to the peak of the signal.
2. Find the frequency below peak that is -40 dB from the peak; **RECORD**.
3. Find the frequency above peak that is -40 dB from the peak; **RECORD**.
4. Calculate RSEC using equations given in Appendix C; **RECORD**.

NOTE: Frequency spectrum results are shown in Figures 4-7 and 4-8.

4.4.1.4 Peak Power Test

Equipment:

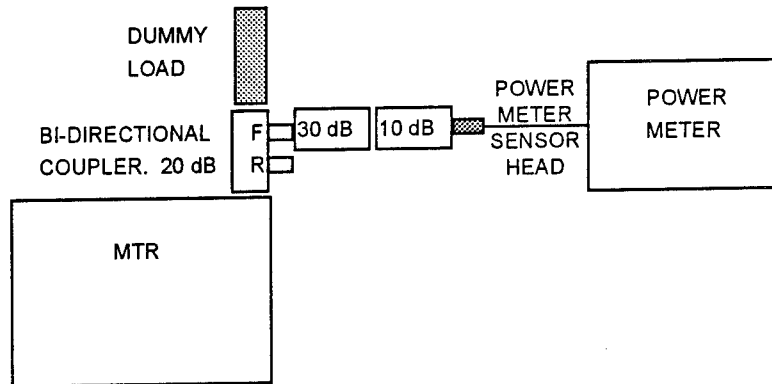

Setup:

MTR:	Local PRF Selector switch:	Short
	Local Test switch:	On
Display:	Power Switch:	STBY
Peak Power Meter:	Channel:	1

Procedure (4.4.1.4.n):

1. Set power meter to obtain full amplitude of peak power pulse.
2. **RECORD** peak power meter reading.
3. Compute transmitter peak power output by summing power meter reading, adding in values for attenuator pads (30 dB, 10 dB) and bi-directional coupler (20 dB); **RECORD**.
4. Disconnect test equipment.

4.4.1.5 Pulse Width, Rise Time, and Fall Time Measurements

Equipment:

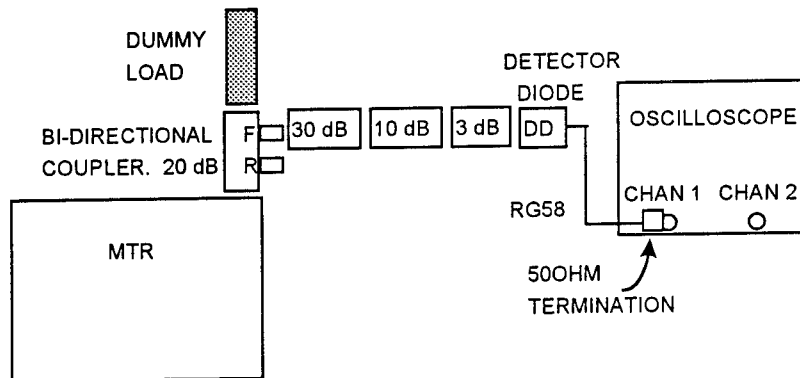

Setup:

MTR:	Local PRF Selector switch:	Short
	Local Test switch:	On
Display:	Power:	STBY
Oscilloscope:	Trigger:	Internal
	Channel:	1

Procedure (4.4.1.5.n):

1. Adjust the oscilloscope seconds/division and volts/division and trigger settings to view pulse on scope.
2. Set pulse peak to the center horizontal graticule of the scope display.

3. Remove the 3 dB pad.
4. Measure the pulse width from where pulse rising edge crosses the center graticule to where the pulse falling edge crosses it. **RECORD.**
5. Adjust the variable amplitude on channel 1 such that the pulse fills the 0 - 100 marks on the scope display.
6. Measure the time the pulse takes rising from 10% line to 90% line; **RECORD.**
7. Measure the time the pulse takes falling from 90% line to 10% line; **RECORD.**

4.4.1.6 Frequency Stability Test

Equipment:

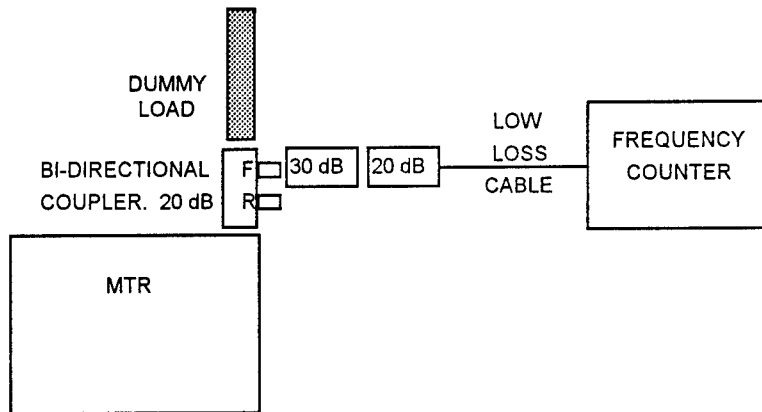

Setup:

MTR:	Local PRF Selector switch:	Short
	Local Test switch:	On
Display:	Power switch:	STBY

Procedure (4.4.1.6.n):

1. **RECORD** frequency value displayed on frequency counter.
2. Subtract measured frequency from the manufacturer's listed frequency; **RECORD** the absolute value.

4.4.1.7 Pulse Repetition Frequency (PRF) Test

Equipment:

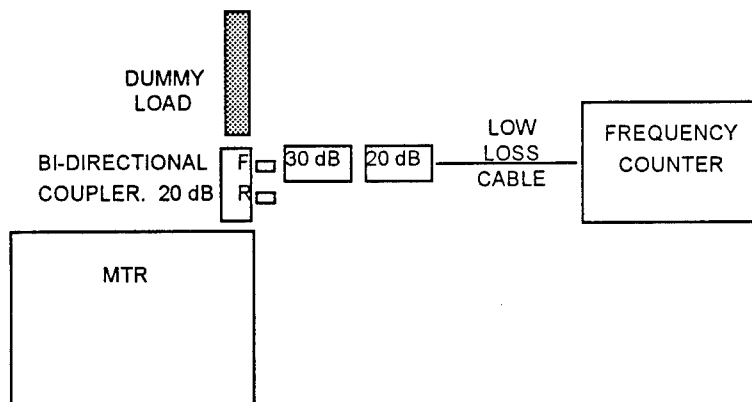

Setup:

MTR:	Local PRF Selector switch:	Short
	Local Test switch:	On
Display:	Power switch:	STBY

Procedure (4.4.1.7.n):

1. Select PRF function on the frequency counter. (Press: *Special*, 6, 7, *Period*.)
2. **RECORD** PRF value.

4.4.1.8 Voltage Standing Wave Ratio (VSWR)

Equipment:

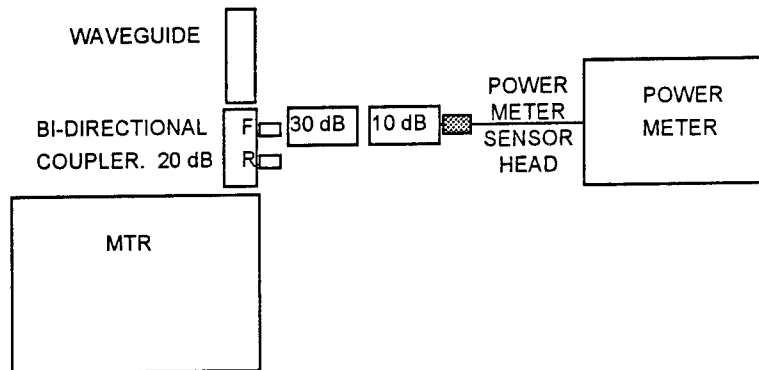

Setup:

MTR:	Local PRF Selector switch:	Short
	Local Test switch:	On
Display:	Power switch:	STBY

Procedure (4.4.1.8.n):

1. Measure the forward power; **RECORD**.
2. Add value of the bi-directional coupler (20 dB) and attenuator pads (10 dB, 30 dB) to the measured forward power (PF); **RECORD**.
3. Remove the 30 dB attenuator pad from the test equipment setup.
4. Reconnect the power meter and 10 dB attenuator pad to the reverse port of the bi-directional coupler.
5. Measure the reflected power (PR); **RECORD**.
6. Add in value of bi-directional coupler (20 dB) and attenuator (10 dB); **RECORD**.
7. Convert step 2 and step 6 recorded values to watts, using:

$$\log^{-1}[(\text{dB}) / 10] \times 1 \text{ mwatt.}$$

8. Calculate the VSWR using:

$$\frac{1 + \sqrt{\frac{P_R}{P_F}}}{1 - \sqrt{\frac{P_R}{P_F}}}$$

RECORD calculated VSWR.

4.4.1.9 Waveguide Insertion Loss Test

Equipment:

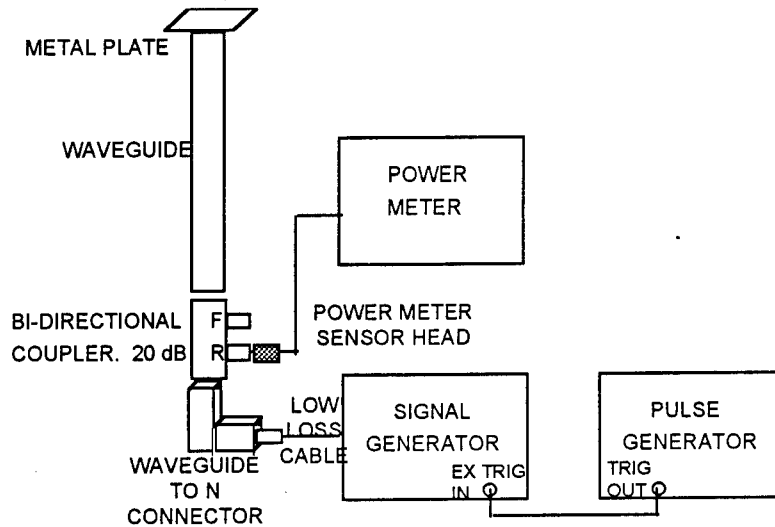

Setup:

MTR:	Local PRF Selector switch:	Short
	Local Test switch:	STBY
Display:	Power switch:	STBY
Pulse Generator:	PRF:	3600 Hz
	Pulse width:	60 ns
	Delay:	60 μ s
	Trigger:	Internal
Signal Generator:	Frequency:	9.375 GHz
	Trigger:	External
	Power:	+10 dB

Procedure (4.4.1.9.n):

1. Connect power meter to signal generator via the LLC.
2. Adjust signal generator until power meter reads +10 dBm.
3. Disconnect power meter from LLC and connect it to the reflected port of the bi-directional coupler.
4. Connect signal generator via LLC to the N port of the waveguide-to-N connector.
5. Measure reflected power displayed on the power meter; **RECORD**.
6. Correct for bi-directional coupler loss and note value.
7. Subtract noted value from 10 and divide the result by two; **RECORD**.
8. Disconnect all test equipment and reconnect antenna and MTR.

4.4.2 System Measurements

4.4.2.1 Safety Interlocks Test

Setup:

MTR:	Local PRF Selector switch:	Remote
	Local Test switch:	Remote Enable
Display:	Power switch:	STBY

Procedure (4.4.2.1.n):

1. Loosen transceiver front cover latches and remove front cover.
2. Set display POWER switch to TXON. Verify that RT TRANSMIT ON lamp is flashing on and off.
3. Set display POWER switch to STBY.
4. Bypass transceiver interlock by pulling interlock switch out to locked position.
5. Set display POWER switch to TXON; verify that RT TRANSMIT ON lamp is lit (steady on).
6. Set display POWER switch to STBY.
7. **CHECK** appropriate box.

4.4.2.2 Antenna Safety Switch Test

Setup:

MTR:	Local PRF Selector switch:	Remote
	Local Test switch:	Remote Enable
Display:	Power switch:	STBY

Procedure (4.4.2.2.n):

1. Set display POWER switch to TXON.
2. Adjust display controls for desired display.
3. Set antenna safety switch to DISABLE.
4. Verify that rotating sweep and area video are not displayed.
5. Verify antenna is not rotating; **CHECK**.
6. Set antenna safety switch to ENABLE.

4.4.2.3 Current and Voltage Measurement

Equipment:

See Figure 4-3, Power Requirements and System Wiring.

Setup:

MTR:	Local PRF Selector switch:	Remote
	Local Test switch:	Remote Enable
Display:	Power switch:	TXON

Procedure (4.4.2.3.n):

1. Remove covers from Critical Power Facility and Radio Power Distribution Panel (RPDP).
2. Verify wiring is properly marked between panels.
3. Measure voltages at RPDP Main Circuit Breaker (CB) (A to B, B to C, C to A); **RECORD**.
4. Measure current at RPDP, Phases A, B, C; **RECORD**.
5. Measure current at RPDP CB1 (A, B, C), CB2 (B), and CB3 (B); **RECORD**.

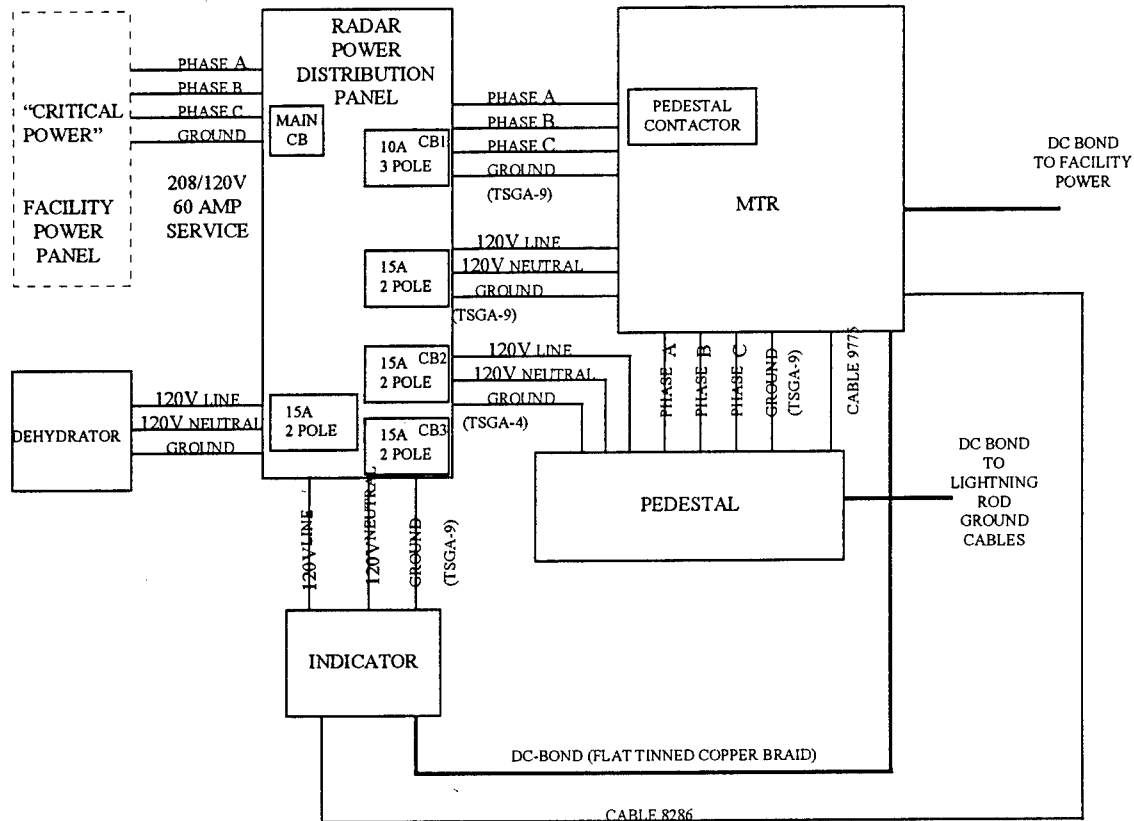

Figure 4-3. Power Requirements and System Wiring.

4.4.2.4 Acoustical Noise Test

Setup:

SLM Calibration: 1 kHz signal of 94 dB
 Measuring range: 10 - 90 dB
 Frequency weightings: A.

Procedure (4.4.2.4.n):

1. Turn the radar display off.
2. Measure environment from center of the room at least 5' from the radar display; **RECORD**.
3. Turn on system and remeasure; **RECORD**.

NOTE: Take measurements at a time when minimal noise is being produced in the environment. Since the airport is never closed, it is not possible to take measurements with all systems off.

NOTE: A noise peak (thump) occurs when the antenna first starts spinning. This should not be considered a factor in measurements, since the system will be operating continuously.

4.4.3 Radar Alignment to FTR

The following series of radar alignment tests is performed on the ARPA ST XCVR display in the tower cab. To access calibration test menu, press Test Reset, select SYSTEM CALIBRATION: VISUAL ADJUSTMENT. The radar system tests 5.1 and 5.4 below refer to menu figures in Section 4.4.3.3, Tuning Preset. For FTR bearings, see Section 4.5.2, DGPS data sheet.

4.4.3.1 Range Scale Demonstration

Setup:

MTR:	Local PRF Selector switch:	Remote
	Local Test switch:	Remote Enable
Display:	Power switch:	TXON

Procedure (4.4.3.1.n):

1. While viewing radar screen, adjust range scale with buttons on left side of control panel.
2. Observe whether radar correctly displays range changes; **CHECK**.

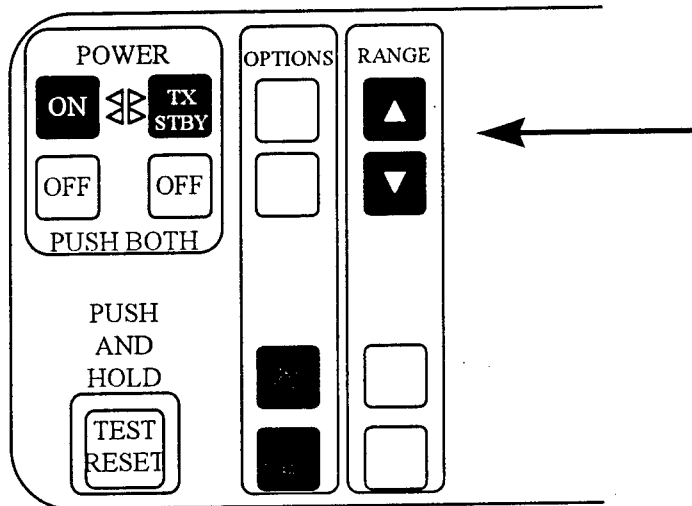

4.4.3.2 FTR Alignment

Procedure (4.4.3.2.n):

NOTE: This procedure requires two technicians, communicating via cellular phones; one in the field adjusts the targets, one in the tower cab observes the targets' return on the display unit.

1. Turn all target reflectors to determine that no energy is being reflected from the pipes (target stands).
2. Focus each target independently, starting with Target 1 (T1).
 - Loosen the radiator clamp holding the trihedral to the pipe.
 - Adjust the height or angle of the reflector, in increments of 1/4" and 1/8".
 - Tighten the clamp and move away from the target.
 - When the field technician is a sufficient distance (100') from the target, wait for three sweeps of the radar before making an observation.
 - Observe target strength and request readjustment as needed via phone.
3. **CHECK** data sheets.
4. Repeat steps 2 and 3 for both T2 and T3.

4.4.3.3 Radar Registration Demonstration

4.4.3.3.1 Antenna Offset

Setup:

MTR:	Local PRF Selector switch:	Remote
	Local Test switch:	Remote Enable
Display:	Power switch:	TXON
	Write protect:	OFF
Reflector:	Position:	About a mile from tower

Procedure (4.4.3.3.1.n)

1. Push and hold TEST/RESET button on display until Test Menu appears.
2. With trackball cursor, select Test 5, SYSTEM CALIBRATION; press [ENTER].
3. With trackball cursor, select Test 5.1 ANTENNA OFFSET; press [ENTER].
4. Select the 0.75 range scale (see 4.4.3.1).
5. Offset the display to FTR T1 (for range and bearing, see Data Sheet 4.5.2.)
6. Press the TX button to place the radar in transmit.
7. Select HD UP.
8. Maximize T1 return by adjusting SEA and RAIN RATE.
9. Note T1 range and bearing with trackball cursor.
10. If T1 does not match DGPS value (see Data Sheet 4.5.2), adjust to correct position as follows:
 - Find T1 on the radar display.
 - Place cursor on the target and press ENTER.
 - Observe the cursor bearing readout and move the cursor to correct bearing. The target reference line will remain at the target's location.
 - Press ENTER. The radar picture rotates so that T1 is at the correct bearing.
 - Repeat last three steps if minor corrections are required.
11. Press TEST RESET to return to Visual Adjustment menu.
12. CHECK.

NOTE: An example of a target at correct bearing is shown in Figure 4-4.

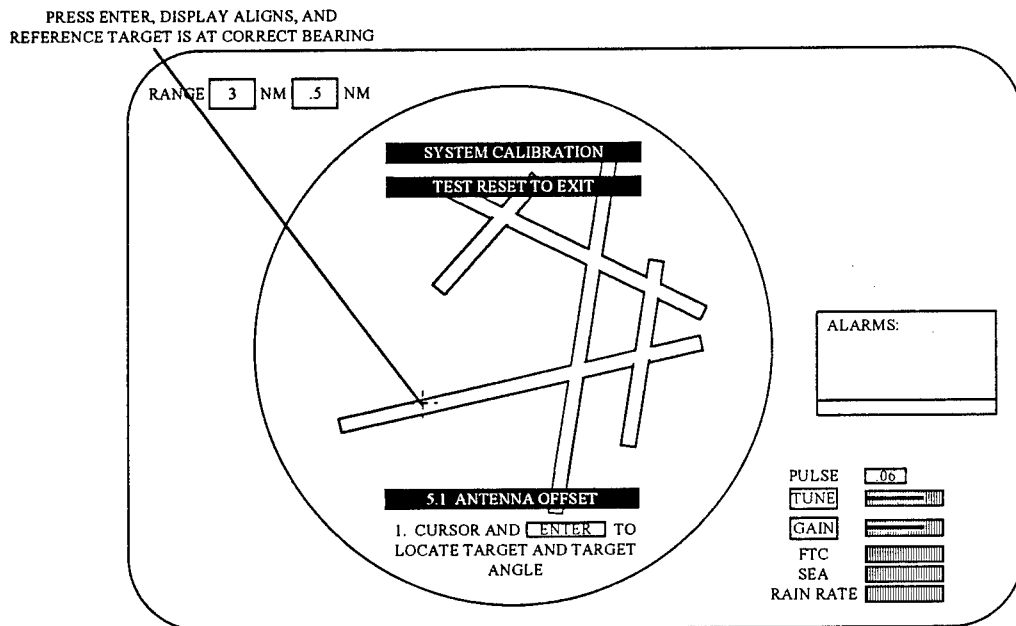

Figure 4-4. Target at Correct Bearing.

4.4.3.3.2 Zero Range Test

Setup:

As 4.4.3.3.1.

Procedure (4.4.3.3.2.n)

1. Push and hold TEST/RESET button on display until Test Menu appears.
2. With trackball cursor, select Test 5, SYSTEM CALIBRATION; press [ENTER].
3. With trackball cursor, select 5.4 ZERO RANGE.
4. Select the 0.75 nm range scale (see 4.4.3.1)
5. Offset the display to FTR T1 (for range and bearing, see Data Sheet 4.5.2).
6. Press TX button to place the radar in transmit mode.
7. Maximize T1 return by adjusting SEA and RAIN RATE.
8. Observing the cursor readout, move cursor to correct T1 bearing.
9. Press ENTER. A ring will appear at the selected range.
10. Position the target leading edge of the ring and press ENTER.
11. Press TEST RESET to return to SYSTEM CALIBRATION menu.
12. CHECK.

An example of a completed zero range adjustment is shown in Figure 4-5.

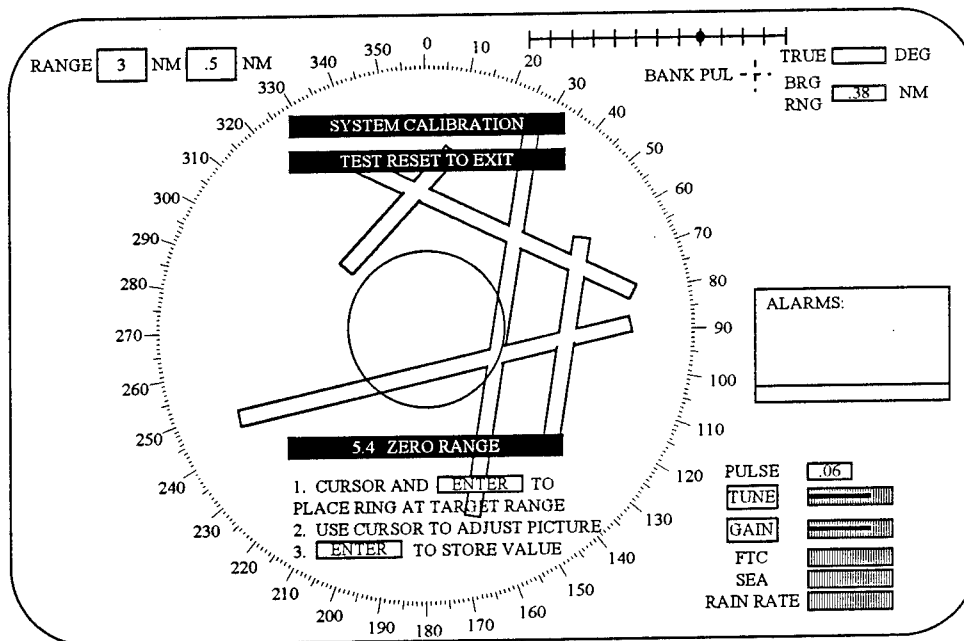

Figure 4-5. Zero Range Adjustment Completed.

4.4.4 Display Map Generation

4.4.4.1 Map Generation Demonstration

Setup:

MTR:	Local PRF Selector switch:	Remote
	Local Test switch:	Remote Enable
Display:	Power switch:	TXON
	Range:	0.75 nm

General Procedure (4.4.4.1.n):

1. Press the switch located directly below the MAPS legend in the lower right hand corner of the operating screen, to summon Maps Function Page (Figure 4-6) to the screen.

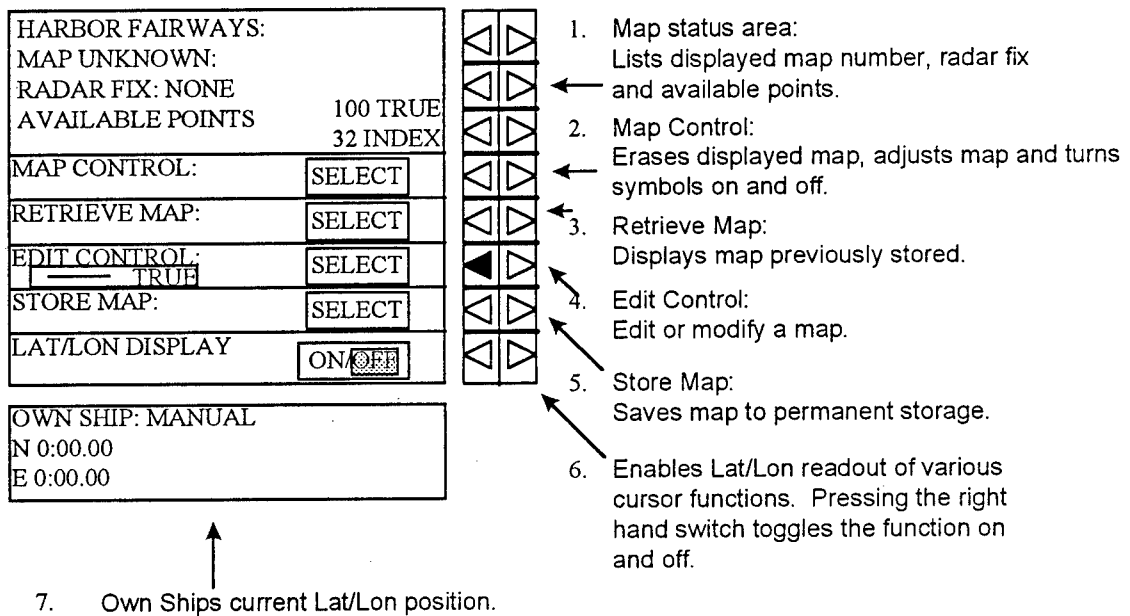
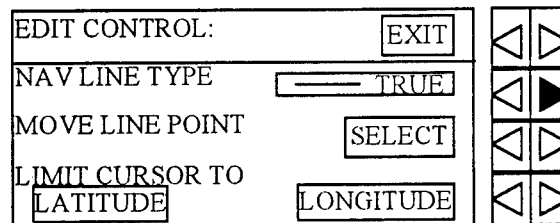

Figure 4-6. Maps Function Page.

2. Select Nav Line type to be drawn by pressing the left pointing triangle switch by the Edit Control box. This switch toggles the Nav line function to allow choice of line type. A better selection is NAV LINE TYPE on the Edit Control Pop Up Menu, which provides more control of the map drawing functions.



3. Press the NAV LINE button on the bottom right of the keypad to select the Nav Line function. This allows you to draw a map.
4. Press right pointing triangle button by Edit Control box to bring up Edit Control PopUp menu.

5. Select line type to be drawn by using the right pointing triangle Nav Line Type button. (This works like left pointing triangle button in the Edit Control box on Maps Function page above.)
6. Place cursor at line starting point; press ENTER. Use trackball to draw line to desired point, press ENTER to end the leg, and draw a new leg from the same point. Continue this process until the required legs have been drawn. Press ENTER, then CANCEL to end the Nav Line set. Change the line type at the end of any leg by using the NAV LINE TYPE switch.

Procedure (Specific to airport):

1. Use up to 115 True type lines (99 solid and 16 dashed) to make maps.
2. Create a pre-layout sequence for drawing the runways and taxiways.
3. Consult with AT personnel for critical taxiways.
4. Increase gain (clutter) to better distinguish runways and taxiways on display.
5. Use solid lines to draw runways; let no lines cross runway intersections.
6. Store the runway configuration in two places, as working backup.
7. Draw the taxiways with the remaining lines available.
8. Make frequent backups.
9. Save working map and reference backup.
10. Have AT personnel review finished map.
11. Work with AT personnel, using airport vehicle, to align airport map.
 - Start with the runway ends first.
 - Match up the vehicle with each corner of the runway.
 - Line up runway and taxiway intersections using the same method.
 - Make final decision on critical taxiways.
 - Store the final map in two files, as an operational map and backup.
12. CHECK data sheets when completed.

4.4.4.2 Map Storage and Recovery Demonstration

Setup:

MTR:	Local PRF Selector switch:	Remote
	Local Test switch:	Remote Enable
Display:	Power switch:	TXON
	Range:	0.75 nm

Procedure (4.4.4.2.n):

1. Press the right pointing triangle key adjacent to SELECT in the Store Map box.
2. The Store Map Pop Up menu appears. If there is room in storage for more maps, the menu lists empty locations. If the menu shows that all twenty (20) available map locations are filled, you must overwrite an existing map.

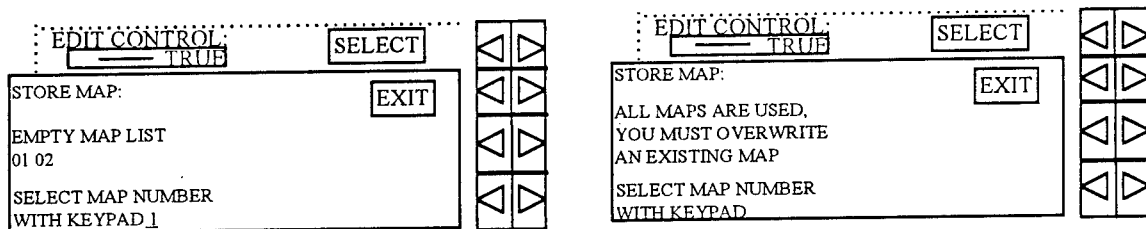

3. Empty map numbers are shown in the menu. If you wish to use first available location, press E in the DATA ENTRY keypad; if not, overwrite desired location number and press E.
4. To overwrite an existing map with the one presently displayed, select the map you wish to overwrite in memory and overwrite it by pressing E.
5. In either case when E is pressed, the displayed map is automatically placed in storage in the location chosen. While the map is being stored, a message appears in the WARNINGS area, SAVING MAP 01; when the map has been saved the message changes to MAP 01 SAVED and then disappears.
6. If it is desired to create an empty location (e.g., #1) in permanent storage, first erase the displayed map, then store the screen to the location you wish to empty by repeating the first three steps above. When E is pressed, a message MAP 01 DELETED appears momentarily in the WARNING area.
7. To cancel the Store Map Pop Up menu, press the right pointing triangle switch adjacent to EXIT. As with all pop up menus, if no entry is made by the operator for one minute, the screen will revert to the normal Maps Function Page.
8. A local map in permanent storage may be recalled to the screen by the procedure outlined below.
NOTE: Before attempting to retrieve a map, ensure that Own Ship Display has had tower coordinates entered.
9. Press right pointing triangle key adjacent to SELECT in the Retrieve Map box.
10. The Retrieve Map Pop Up Menu appears. LOCAL is highlighted in inverse video, meaning that you may retrieve maps which have True points which are within 24 nm of tower position. The numbers of these maps are highlighted in inverse video in the List of Maps.

MAP CONTROL:		SELECT	◀▶
RETRIEVE MAP:		EXIT	◀▶
MAP RETRIEVAL TYPE?		LOCAL	◀▶
DISTANT			◀▶
LIST OF MAPS:			◀▶
◻ = WITHIN 24 NM			◀▶
◻ 01	◻ 02	03	04
SELECT MAP TO DISPLAY			◀▶
WITH KEYPAD			◀▶

11. Select a map to be retrieved using the DATA Entry keypad. Its number will appear in the menu; press ENTER to display map.
12. If a local map does not appear on the screen when retrieved, increase the range scale to 24 nm. At least a portion of the map should then appear.
13. CHECK data sheets when completed.

4.4.5 Range and Azimuth Resolution Demonstration

Equipment:

See FTR setup, Figure 4-2.

Setup:

FTR:	T1 to T2 is 80'; T2 to T3 is 40' (see 4.2)	
MTR:	Local PRF Selector switch:	Remote
	Local Test switch:	Remote Enable
Display:	Power switch:	TXON
Range setting:		0.75 nm
Offset:		To see reflectors

NOTE: These procedures require at least two technicians: one in the field and one in the tower.

Azimuth Procedure (4.4.5.1.n):

1. Turn T3 away from ATCT to avoid target returns on display.
2. Check whether T1 and T2 images on display are both visible and separate.
3. If yes, go to step 8.
4. If not visible and separate, try to achieve separation by refocusing targets. If targets become visible and separate, go to step 8.
5. If not visible and separate, turn T2 away from the tower, locate T4 (portable FTR) 5' west of T2 (along the T1 - T2 azimuth) and focus T4.
6. Check whether T1 and T4 images on the display are both visible and separate. If yes, go to step 7. If no, move T4 west of T2 (i.e., away from T1 along their azimuth) in 5' increments, refocusing T4 at each move, until the images separate.
7. Move T4 east toward T2 in 1' increments, refocusing T4 at each move, until images merge. Go to step 8, adding 1' to the measured and recorded value.
8. Measure with a 100' tape-measure the distance between the targets in question.
RECORD.

Range Procedure (4.4.5.2.n):

1. Turn T1 away from ATCT to avoid target returns on display.
2. Check whether T2 and T3 images on display are both visible and separated.
3. If yes, go to step 8.
4. If not visible and separate, try to achieve separation by refocusing targets. If targets become visible and separate, go to step 8.
5. If not visible and separate, turn T3 away from the tower, locate T4 (portable FTR) 5' north of T2 (along the ATCT - T2 radial) and focus T4.
6. Check whether T2 and T4 images on the display are both visible and separate. If yes, go to step 7. If no, move T4 north of T2 (i.e., toward the ATCT along their radial) in 5' increments, refocusing T4 at each move, until the images separate.
7. Move T4 south toward T2 in 1' increments, refocusing T4 at each move, until images merge. Go to step 8, adding 1' to the measured and recorded value.
8. Measure with a 100' tape-measure the distance between the targets in question.
RECORD.

4.5 DATA SHEETS

4.5.1 Calibration Data Sheet

ITEM	PART NUMBER	CHECK
Microwave Frequency Counter	EIP 585	√
Signal Generator Synthesizer	HP 83731A/2A	√
Power Meter	HP 84815A	√
Peak Power Sensor	HP 84815A	√
Spectrum Analyzer	HP 8563A	√
Oscilloscope	Tektronix 2246	√
Detector Diode	HP 8474	√
Waveguide Bi-directional Coupler	Raytheon M27197	√
Waveguide Termination, 50 ohm	Raytheon 1035435-1	√
Acoustic Noise Meter	B & K 2236 D	√
Flow Meter	Omega FMA 1806	√
DVM with ammeter attachment	Fluke 23 (80i -- 600A)	√
Low Loss RF Cable	Macom 1999-0072 (2)	√
Attenuators	Macom 3082-6191-03	√
Waveguide Transition	Maury Microwave 213D2	√
Interconnection Diagram (Fig. 4-1)		√

4.5.2 DGPS Measurements Data Sheet

Step #	FTR Target	GPS Measured (WGS 84)			RECORD
		Latitude	Longitude	Range/Bearing > ATCT	
4.3.14	ATCT	N 42 56.8684	W 87 54.3804	----	
4.3.29	T1, 3 m ²	N 42 55.7465	W 87 53.9195	1.171 / 163.23	
4.3.29	T2, 3 m ²	N 42 55.7461	W 87 53.9372	1.167 / 163.84	
4.3.29	T3, 1 m ²	N 42 55.752	W 87 53.9402	1.160 / 163.85	
----	T4, 1 m ²	Portable	---	---	----

4.5.3 Functional Test Data Sheet

NOTE: Each record on this data sheet is identified by the test section and step number requiring test technicians to make an entry, either RECORD or CHECK.

Paragraph and Record Entry	Units	Meas	Check	Figure
4.1.1.4 Measured LLC1 RF Cable	dB	1 dB		
4.4.1.1.7 Signal generator power	dB	-59.1		
4.4.1.1.8 Minimum Discernible Signal	dB	-90.1		
4.4.1.2.7 Dynamic Range	dB	-60.0		
4.4.1.3.2 Freq. -40 dB below peak	MHz	-198		4-7
4.4.1.3.3 Freq. -40 dB above peak	MHz	82		4-8
4.4.1.3.4 RSEC	MHz	±155		
4.4.1.4.2 Peak power reading	dB	13.4		
4.4.1.4.3 Peak power output	dB	73.4		
4.4.1.5.4 Pulse width	nsec	53.9		
4.4.1.5.6 Pulse rise time	nsec	8.7		
4.4.1.5.7 Pulse fall time	nsec	24.8		
4.4.1.6.1 Frequency	GHz	9.404		
4.4.1.6.2 Frequency variance	MHz	29		
4.4.1.7.2 Pulse Repetition Freq	Hz	3630		
4.4.1.8.1 Measured Forward Power	dB	12.5		
4.4.1.8.2 Actual Forward Power	dB	72.5		
4.4.1.8.5 Measured Reflec Power	dB	19.25		
4.4.1.8.6 Actual Reflected Power	dB	49.25		
4.4.1.8.8 VSWR		1.145:1		
4.4.1.9.5 Measured Reflect Power	dB	-14.4		
4.4.1.9.7 Waveguide Insert Loss	dB	2.2		
4.4.2.1.7 Safety Interlock Check			√	
4.4.2.2.5 Antenna Safety Check			√	
4.4.2.3.3 RPDP Voltage (main)				
Phase A/B	Vac	208		
Phase B/C	Vac	208		
Phase C/A	Vac	209		
4.4.2.3.4 RPDP Overall Current-main				
Phase A	Amp	2.1		
Phase B	Amp	8		
Phase C	Amp	2.1		
4.4.2.3.5 Individual Currents				
Pedestal (CB1) - Phase A	Amp	2.12		
Phase B	Amp	1.85		
Phase C	Amp	2.07		
MTR (CB2)- Phase B	Amp	2.54		
Display (CB3)- Phase B	Amp	2		
4.4.2.4.2 Acoustic Noise Off	dB(A)	41		
4.4.2.4.3 Acoustic Noise On	dB(A)	47		
4.4.3.1.2 Radar Range Check			√	
4.4.3.2.3 FTR Alignment, T1			√	
4.4.3.2.3 FTR Alignment, T2			√	
4.4.3.2.3 FTR Alignment, T3			√	
4.4.3.3.1.12 Antenna Offset			√	
4.4.3.3.2.12 Zero Range Test			√	
4.4.4.1.12 Map Generation Demo			√	4-9,10
4.4.4.2.13 Map Storage/Recovery			√	
4.4.5.1.3 Azimuth Resolution	feet	80	√	4-11
4.4.5.2.3 Range Resolution	feet	60	√	4-11

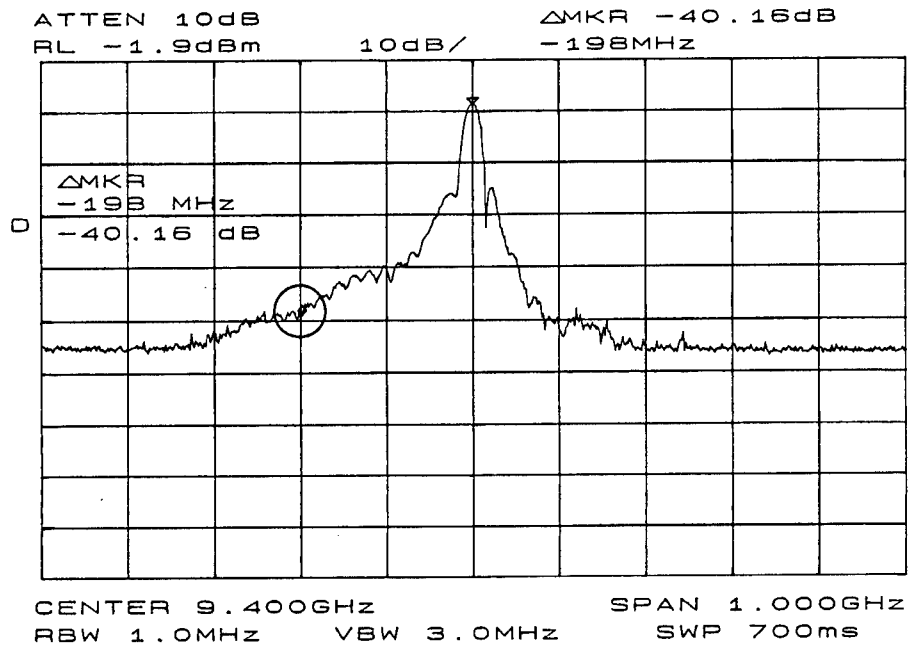

Figure 4-7. Frequency Spectrum, Below Peak.

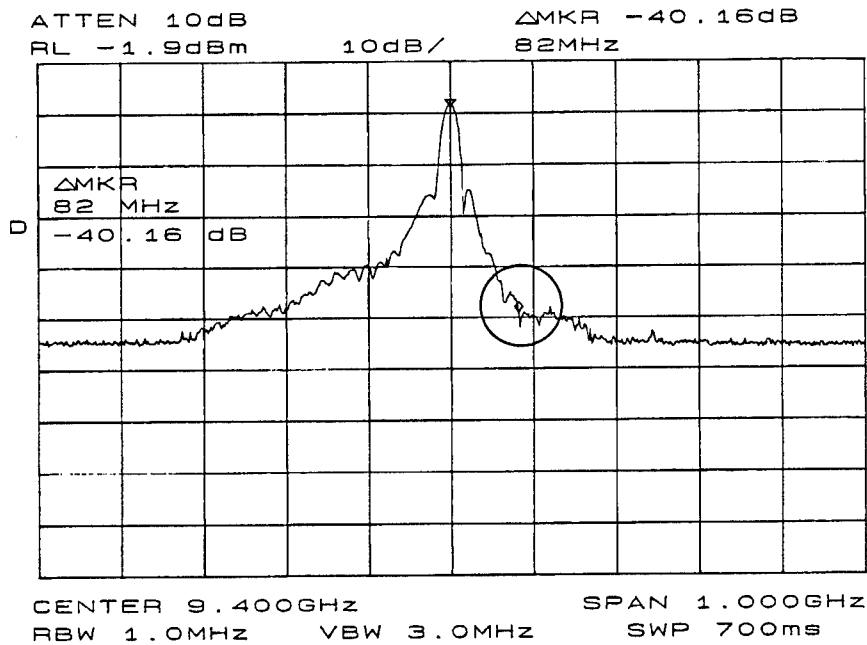

Figure 4-8. Frequency Spectrum, Above Peak.

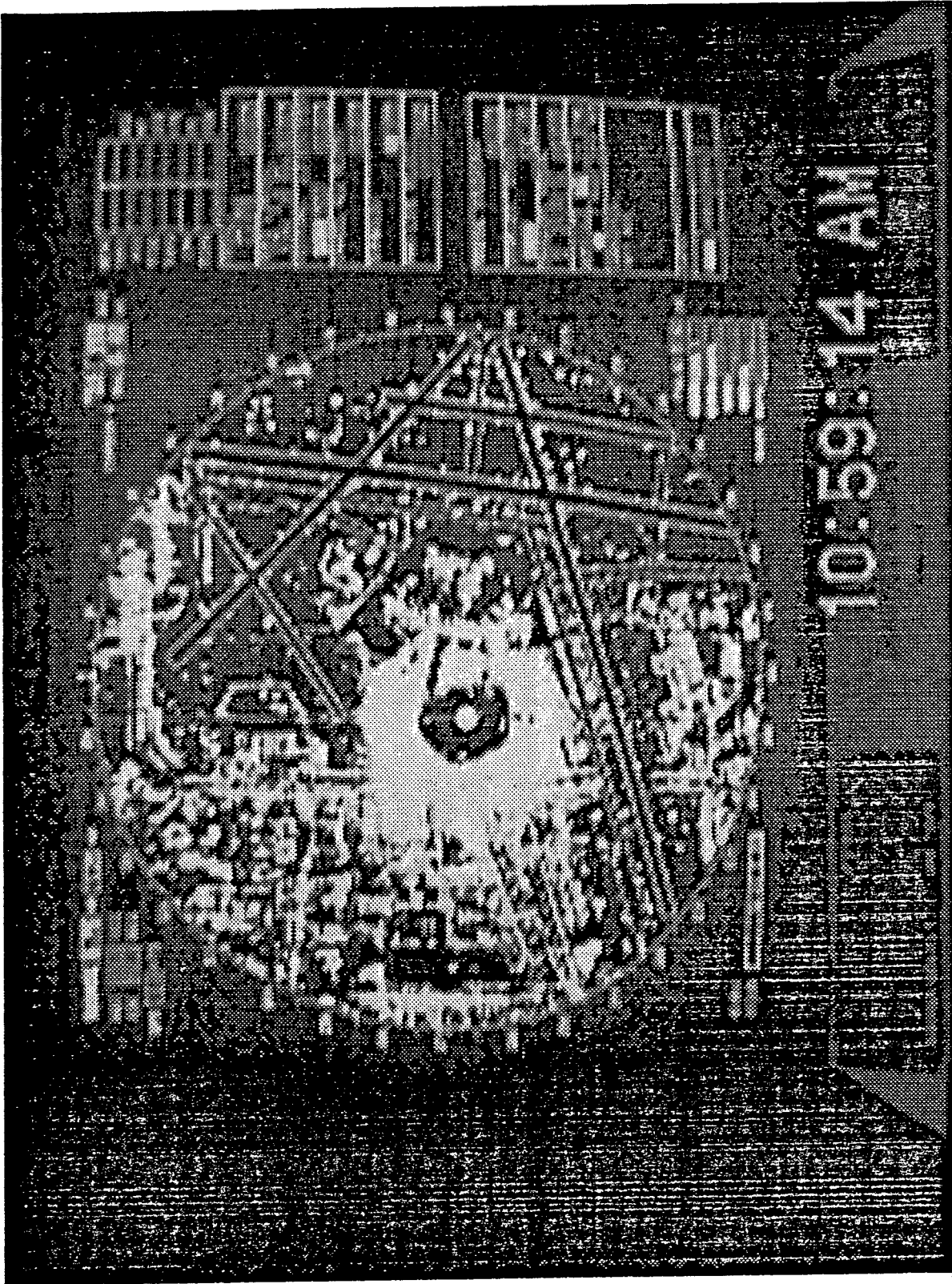

Figure 4-9. Map Generation (Standard Mode).

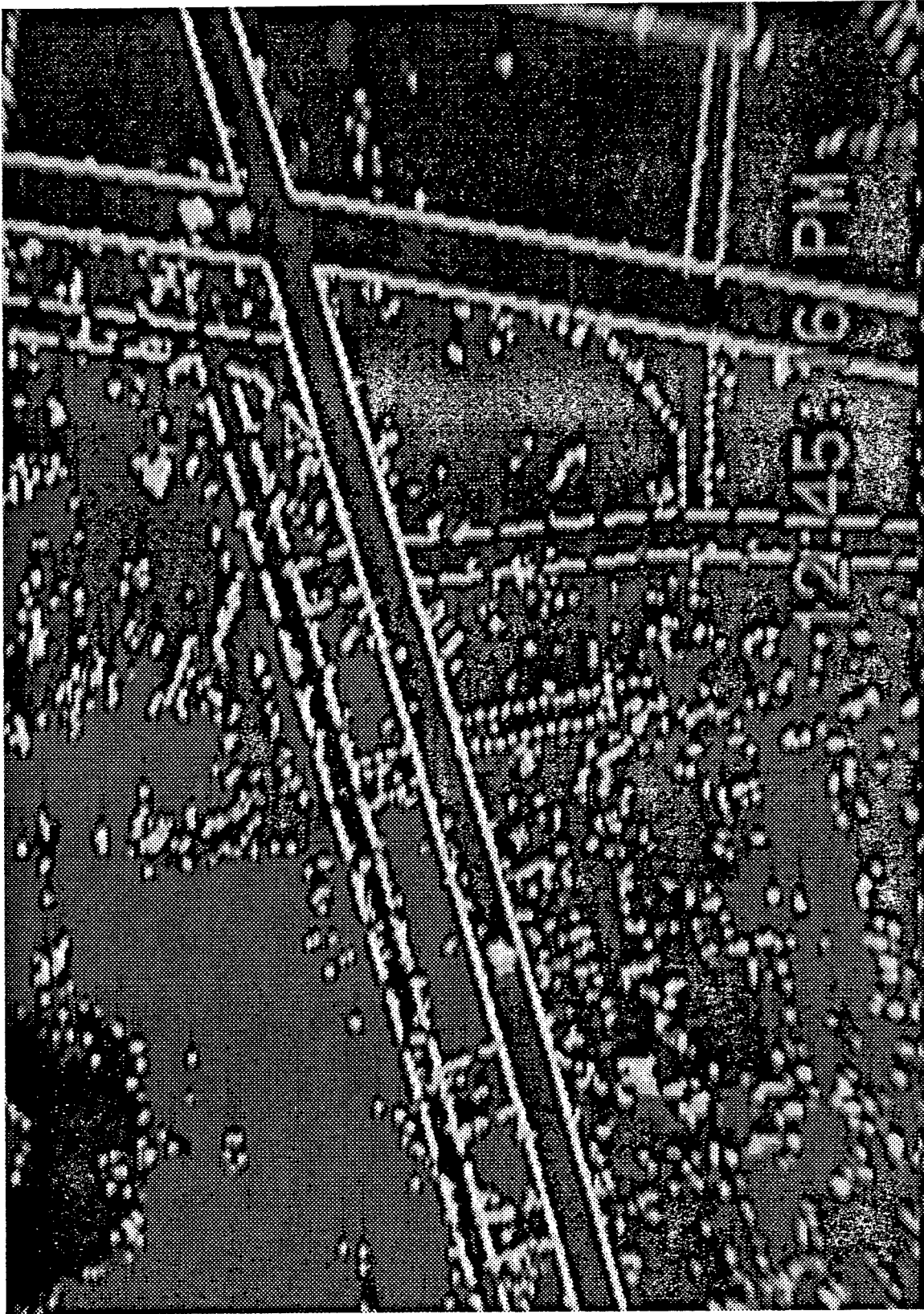

Figure 4-10. Map Generation (Fast Target Mode).

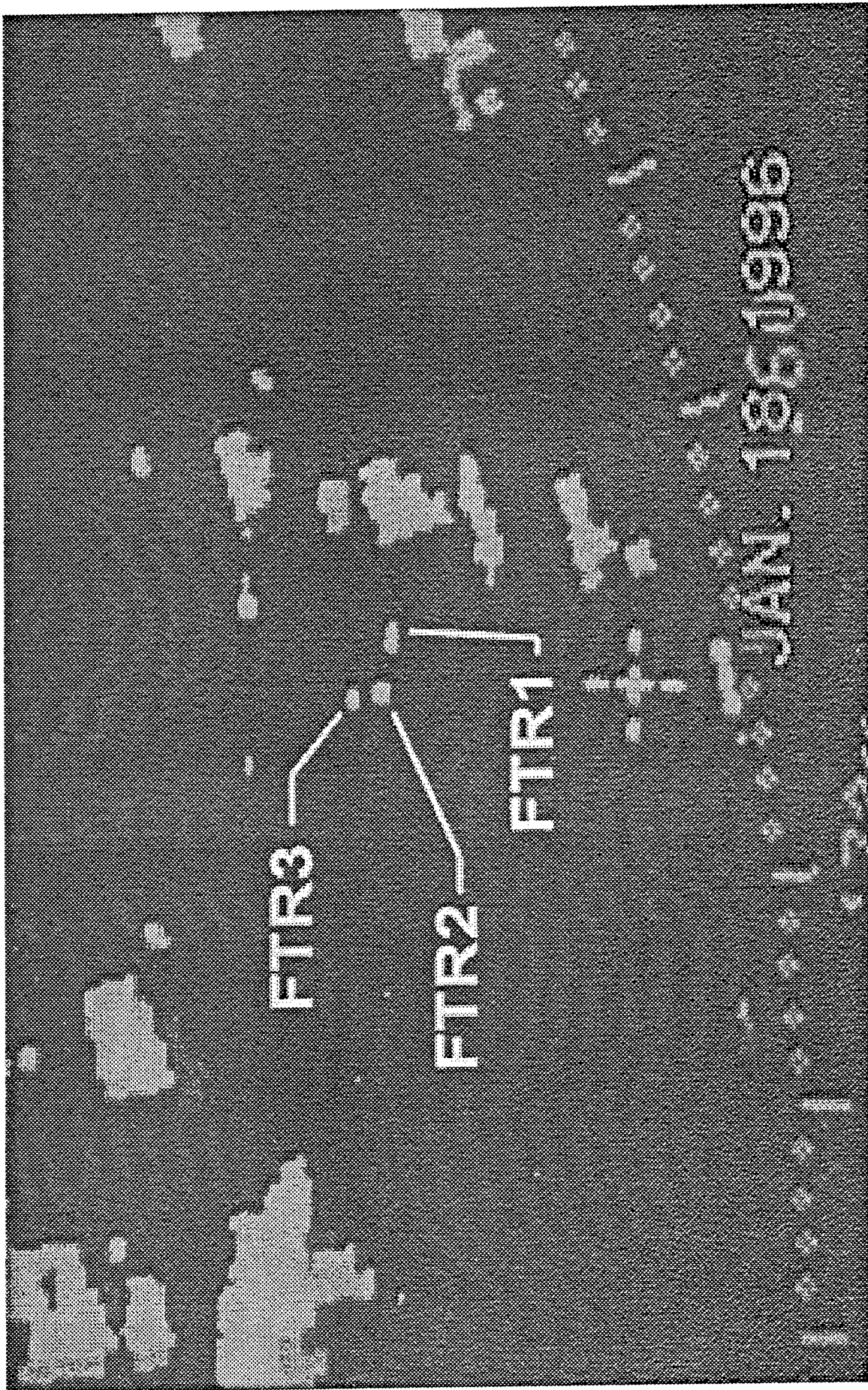

Figure 4-11. Final FTR Configuration at MKE.

5. OPERATOR EVALUATION

The ASDE-X operator evaluation section details both the tests performed and the evaluations written by controllers at the General Mitchell International Airport (MKE) in Milwaukee, WI. The tests were run to familiarize local AT with ASDE-X system operation and to test its utility during airport-specific operations in the ATC environment. Two MKE controllers were trained in ASDE-X operation by Raytheon Marine at their Manchester, NH training center. As the controllers came to know the radar's advantages and limitations, this experience coupled with their knowledge of the MKE airport, proved to be an invaluable asset while developing the test procedures.

Tests were conducted dynamically, modified and customized as they proceeded. As the controllers performed the tests, they developed preferences for setting up and using the system. They learned and noted system limits for future operations. They recorded their opinions and a wish list to be used in developing the Phase II upgrade of ASDE-X and to inform the designing of future low cost ASDE type radar. A video camera trained on the display recorded all radar returns during testing.

Test procedures 5.1 through 5.12 were performed at MKE during the week of December 11, 1995. Most test forms included modified MKE Airport Maps (shown in detail in Figure 5-0a) for the controllers to mark with target observation points and rating key numbers (see p. 5-18 for example). To enhance the testing of the system during low visibility conditions, the test team developed Test 5.13 and left the two-sided test form in the tower cab. Controllers ran this test periodically during periods of low visibility between January and March, 1996.

While writing the procedures, the evaluation team kept in mind the ASDE-3 operators test procedures, and attempted to capture the FAA's past experiences with these tests.

5.0.1 Operational Tests

The operators' tests consist of thirteen separate procedures. Each procedure details the test objective, equipment and personnel required, and gives the steps for the procedure. Blank test forms are attached as Appendix F. These customized forms captured AT observations such as target type, location of target, target quality, and specifics about radar performance. The data summaries include comments by observing controllers. Included with these observations are video snapshots of pertinent events, especially in tests that involved tracking targets (e.g., Tests 5.5, 5.6).

Test 5.1: Display Satisfaction Testing. This initial procedure gave AT an opportunity to critique system controls and features and to suggest enhancements to facilitate ATC operations. This was the first operator test and took place in early December 1995.

Test 5.2: Demonstration of Maximum Height Coverage Using Live Targets. This test evaluated the maximum height coverage of the system. Video bitmaps are included to show effective target tracking.

Test 5.3: Demonstration of Dissimilar Sized Targets and Shadowing Effects. This procedure tested for potential shadowing effects at various locations across the airport movement area. Shadowing can occur when a larger aircraft obscures the radar view of a smaller aircraft. Radial lines were extended from the tower on an airport surface map to identify potential problem areas.

Test 5.4: Radar Registration of Targets on Runway Ends. AT used this procedure to test system performance and usability for viewing aircraft in hold position at runway ends.

Test 5.5: Registration of Non-Aircraft Targets Traveling in Tandem. This procedure tested the radar's effectiveness in registering non-aircraft targets (land vehicles) traveling in tandem on the airport surface.

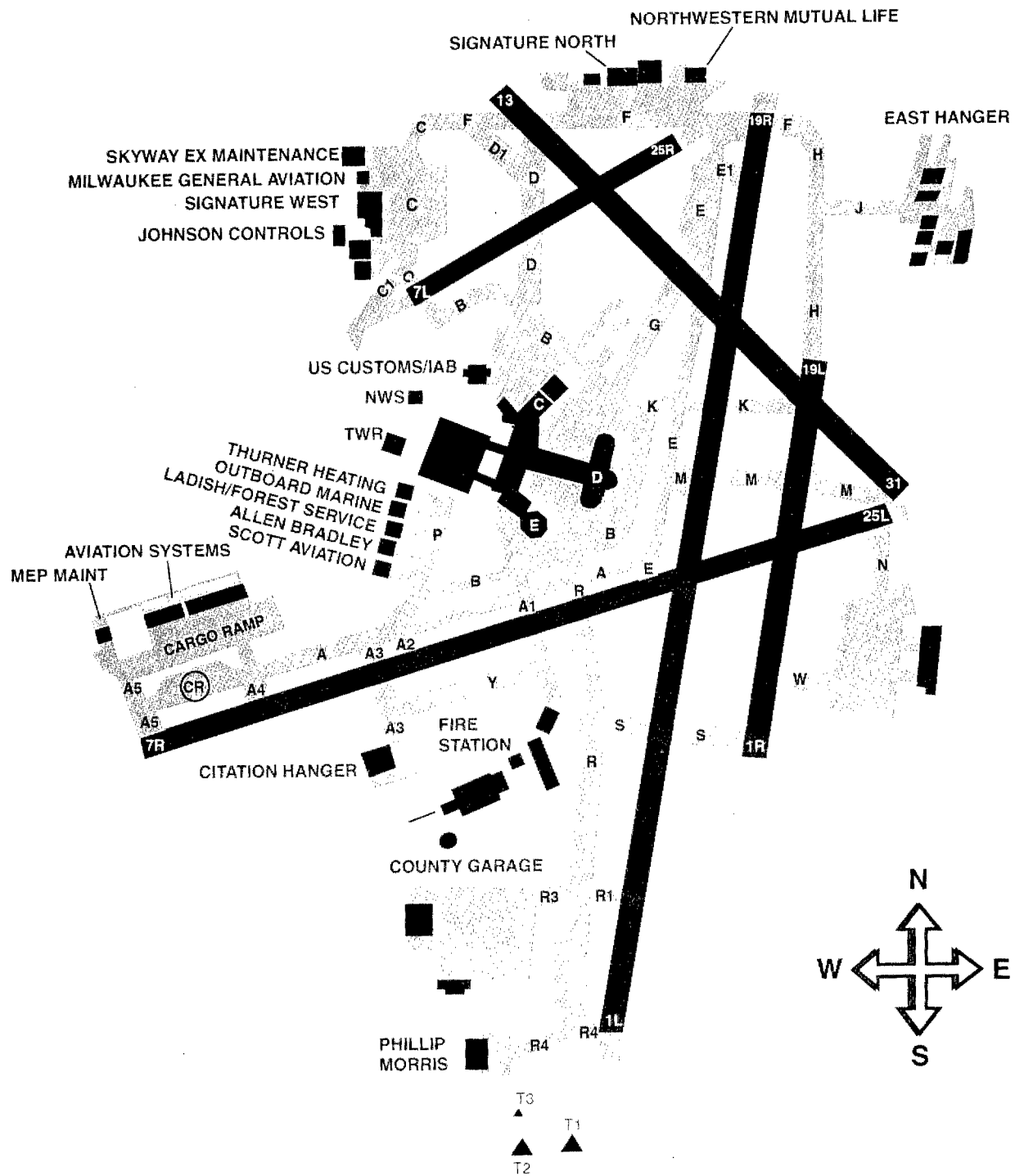

Figure 5-0a. MKE Airport Map.

Test 5.6: High-Speed Turn-off Demonstration. AT tested system performance during high-speed turn-off procedures normally performed at MKE. The test demonstrates system reaction as a target's aspect angle changes during the turn off.

Test 5.7: Radar Detection and Presentation. This procedure tests the potential delay in presentation as an aircraft crosses the runway threshold during approach. The procedure demonstrates the limits of the system due to the rotation rate of the antenna, and inherent system processing delay.

Test 5.8: Target Display Presentation. This procedure requested controller feedback on radar presentation of targets of opportunity during typical operations.

Test 5.9: False Target Display Presentation. This procedure identified false targets displayed by the system. Video bitmaps show false target presentation.

Test 5.10: Position Accuracy Testing. This test recorded the radar's relative map-to-target accuracy, covering all MKE movement areas. Controllers identified and recorded the location and the quality of targets on a map of the movement area. The procedure also identified potential problem areas associated with target registration.

Test 5.11: Surface Update Rate. This procedure tested operators' visual identification of the system's update capabilities.

Test 5.12: Probability of Detection. This procedure allowed visual testing of the system's probability of detection rate and compared it to the 90% ASDE-3 requirement.

Test 5.13: Aircraft Presentation During Foul Weather. AT used this procedure to test the system during periods of low visibility and precipitation. This was the last test developed, and ran the longest--over a three-month period. The pre-test and test specific forms were combined into one, and copies were left in the tower cab for controllers to fill out during appropriate weather conditions.

5.0.2 Test Personnel and Equipment

Test Personnel

- Test coordinator
- Test observers /controllers (2)
- Pilot of test plane
- Drivers of county vehicles

Aircraft and Vehicles

- Phillip Morris - HS28
- County - Three Trucks
- Airways Facilities - Van
- Targets of Opportunity (TOPs, e.g., DC-9, L-1011)

Equipment

- Two Fixed Target Reflectors (FTRs), 3²m
- Two FTRs, 1²m
- Scanner
- Ground to Tower Communications (ground control frequency)
- Stop Watch
- Video Recording Equipment
- Automated Surface Observing System (ASOS) [see Appendix E]
- Runway Visual Range (RVR) equipment [see Appendix E]

5.0.3 Test Support and Setup

In order to ensure proper system setup and to maintain standards of data collection, a test coordinator (FAA's National ASDE-X Representative) and a team of several observers (controllers) supported and ran each test. The test coordinator and an MKE AT training specialist were trained by Raytheon Marine in the radar operation. They in turn trained local controllers to perform as observers during the evaluation. The coordinator also acted as an observer during most tests. The following pretest setup steps were performed before each test:

1. Coordinator establishes that Phase I system has been operating and was tuned a minimum of 30 minutes before the procedure.
2. Coordinator fills in pre-test forms, recording the Phase I system's current operating status and current weather and visibility conditions (see below).
3. Coordinator establishes that the Phase I system is aligned to properly record the test, i.e., map, range setting, map alignment.
4. Coordinator establishes that the video recorder is operating, focused, recording display information, and will not be interfered with during the duration of the test.
5. Coordinator has the proper fill-in sheets available for the test team.
6. AT established communications with test aircraft and/or vehicles and determines whether it is safe to proceed with the test. (see Safety Precautions, 5.0.4).

A two-page general pretest form was filled out prior to every test (see Figure 5-0b) and updated during the test duration, as weather and other conditions warranted. The pretest form includes the following information:

Personnel and Equipment: Date, time, test team member names, test vehicle used (aircraft, car or truck), current operating settings of the radar (such as GAIN, FTC, TUNE settings, and whether Fast Targets or Standard Scan was selected), as well as radar performance at various settings and system reaction to adjustments.

Weather Conditions: Coordinators recorded data from Automated Surface Observing System (ASOS) before each test. When low-visibility conditions warranted (at MKE, fog can make for variable visibility between the ground and ATCT cab), coordinators also recorded Runway Visual Range (RVR) data and AT's tower cab observations. Space was included for notations on video camera usage.

NOTE: Explanations of the ASOS and RVR systems and terminology are included in Appendix E.

5.0.4 Safety Precautions

AT was responsible for safety during each test. They assessed ongoing AT operations and determined whether potential conflicts between testing and traffic warranted postponement of a test (see Section 5.0.3, Step 6). AT actually called for a postponement of Test 5.2 during congested traffic conditions.

Test team members were cautioned to use extreme care on all aircraft movement areas during testing. Personnel within testing areas (e.g., the technician relocating the FTRs) and all test vehicles were radio equipped (ground control frequency).

5.0.5 Display Control Definitions

This brief glossary may aid interpretation of the radar information section of the tests. Terms in capital letters refer to adjustment controls on the radar display in the tower cab. Other definitions explain concepts involved in radar display.

Fast Targets operating mode where all moving target returns are updated each scan. Stationary targets are reduced to low video in three scans.

FTC control performs the differentiating or filtering of rain clutter by restoring weak targets lost due to rain adjustment. Also reduces land echoes and thins out large targets.

GAIN adjusts the sensitivity of the radar display. Controls strength of target video and noise. Once set, the gain will be maintained at all ranges.

Inverse Video indicates an on/off status of the RAIN, FTC, and SEA adjustments. Grey is "off" and white is "on."

Offset allows the operator to offset the display of the tower by up to 70% in any direction. This function increases the field of view of runway ends without the use of longer range settings. When offset is selected, the radar screen blanks and rebuilds in three antenna revolutions.

RAIN control enables the operator to suppress undesirable "rain clutter" (radar returns resulting from signals reflected from rain drops) into a very light speckle at the dim level.

Range allows the operator to change the scale of the radar's presentation. Settings include 3/4, 1.5, 3, 6, 12, 24 and 48nm. If the range scale is increased to greater than 3 nm the systems pulse width will automatically increase. Most procedures were run at the 3/4 nm range setting.

SEA (STC) control gives even clutter suppression. The ideal setting reduces moving grass returns to a light speckle. Adjustments should be made in small increments, with pauses to observe three scans for results. In heavy grass clutter, peaks may come through at brighter levels, so an average setting is usually more effective.

Scan to Scan Integration (or Standard) is a digital video processing technique, requiring three complete scans of the antenna in order to "build up" or "decay" detected targets. When the target is first detected it is painted dim. On the second scan it is painted mid and on the third it is painted bright. If the target is lost it will fade in three scans. Thus it is important when operating the sensitivity controls to keep in mind that it requires three complete scans to properly observe the results of a single adjustment.

Standard see Scan to Scan Integration.

TUNE control tunes the receiver frequency to match that of the transmitter. The tuning should be made on the high range scales (3 nm) that show radar returns. Unlock the tune knob and adjust TUNE for maximum Tune Bar indication as showed by the Tune bar graph on the CRT screen. Tune the system on the fixed targets.

Target quality (display registration) definitions:

Target Split: splits into two or more targets, traveling in parallel.

Target Breakup: breaks into several parts traveling on the same vector.

Target Fade: loses intensity.

Operations Assessment of Raytheon Marine Radar Located at
General Mitchell International Airport

Test: _____

Date: _____ Time: _____

Test Team: Coordinator: _____

Observer: _____

Observer: _____

Pilot: _____

Test Plane: Model: _____ Make: _____

Model: _____ Make: _____

Test Vehicle: Model: _____ Make: _____

Model: _____ Make: _____

Model: _____ Make: _____

Radar Information:

1. The radar has been operating for longer than thirty minutes.
2. The fixed targets have been identified.
3. The map has been aligned for full view of the test area.

Radar Settings:

TUNE INVERSE VIDEO

GAIN INVERSE VIDEO

RAIN INVERSE VIDEO

FTC INVERSE VIDEO

SEA INVERSE VIDEO

FAST TARGETS STANDARD

PULSE WIDTH _____ RANGE SETTING _____

Comments on radar presentation: _____

Figure 5-0b. ASDE-X Operational Pretest Form.

Weather:

Automated Surface Observing System (ASOS):

Location Identifier: _____ Type of Report: _____

Time of Report: _____ Station Type: _____

Sky Condition Below 12,000' AGL: _____

Visibility: _____ Present Weather: _____

Obstructions to Vision: _____

Sea-Level Pressure _____ Temperature _____

Dew Point _____ Wind Direction, Speed and Character _____

Altimeter Setting _____

Remarks _____ Precipitation _____

Status Remarks _____

Runway Visual Range (RVR):

Runway One Left RVR _____, MID _____, ROLLOUT _____

Runway One Nine Right RVR _____

Runway One Nine Right RVR _____

Air Traffic Control Observed Visibility:

Visibility _____ Markers Observed _____

Weather & Obstruction to Vision _____

Video Equipment:

Tape # _____

Set Up

Record

Figure 5-0b. ASDE-X Operational Pretest Form (cont.).

5.1 DISPLAY SATISFACTION TESTING

AT used this procedure to test the system display, controls, functions, and capabilities. It also gave controllers an opportunity to comment whether display features are easy-to-use or burdensome, useful or unnecessary, and to suggest enhancements that would facilitate ATC operations. Between the steps notes are added to remind the operators of the radar control terminology (see 5.0.5 above) and their adjustments. This was the first procedure executed in December 1995.

Equipment and Personnel:

Test Coordinator
2 Observers / Controllers in MKE tower
Targets of opportunity
Test log

Procedure:

NOTE: This test covers the general operation of the display unit. The test starts with a power-up of the system and tuning the display unit. Controllers should operate the unit and independently record their views on system operation. Statements describing features that should be added may be included here. This test should be run at least twice, once in daylight and once at night, preferably under adverse weather conditions.

1. Power the system up.

NOTE: The transmitter frequency will drift for the first thirty minutes of operation from a cold start due to inherent magnetron characteristics. The system should be tuned after thirty minutes of operation. The tuning should also be checked every four hours thereafter.

2. Adjust sensitivity controls according to notes provided below. Tune the system to the FTRs located past the end of 1L across College Road. Comment on both the individual sensitivity controls and on the controls as a whole.

3. Comment on the Scan to Scan Integration as it relates to detecting moving and stationary targets.

NOTE: Adjust GAIN for light background speckle (dim level). A gain bar graph in the lower right corner of the screen indicates the setting of gain control. Once set, GAIN will be maintained at all ranges. GAIN should be readjusted as conditions change (rain).

4. Record GAIN setting, sensitivity of adjustment and general comments.

NOTE: TUNE control tunes the receiver frequency to match that of the transmitter. The tuning should be made on the high range scales (3 miles) that show radar returns. Unlock the tune knob and adjust TUNE for maximum Tune Bar indication. Tune the system on the FTRs. When tuning to a weak target, disable the scan to scan integration by pressing FAST TRGTS button.

5. Record Tune setting, sensitivity of adjustment and general comments. Readjust GAIN if necessary.

6. Record GAIN setting, and general comments.

NOTE: Adjust SEA (STC) control for even clutter suppression. The ideal setting reduces moving grass returns to a light speckle. Adjust SEA in small increments, with pauses to observe three scans for results. In heavy grass clutter peaks may come through at brighter levels, so average settings work best.

7. Record SEA setting, sensitivity of adjustment and general comments.

NOTE: Adjust RAIN and FTC controls as required. These enable the operator to suppress radar returns resulting from radar signals reflected from rain drops (rain clutter) and grass (ground clutter). Advance RAIN slightly and observe the results (three scans). The idea is to push nearby rain clutter down to a very light speckle at the dim

level. FTC filters or differentiates rain clutter; restoring weaker targets lost due to RAIN adjustment, reducing land echoes, and thinning out larger targets. The RAIN and FTC indicators appear in the lower right of the screen.

8. Record RAIN and FTC setting, sensitivity of adjustment and general comments.
9. Comment on the tuning and overall adjustment of the sensitivity controls.
10. Readjust the sensitivity controls after 30 minutes of operation. Record and comment on the settings.

NOTE: If either of the RANGE increase/decrease buttons are held down, the range scale selection is stepped at the rate of two ranges per second. Pressing and releasing these buttons scale the range one step. The system will be tested at the .75, 1.5, and 3 mile ranges.

11. Operate the system at the various range levels. Comment on the presentation of targets, situation awareness, map presentation and general usefulness of each range level. Include preferred operating range versus airport configuration and/or operating conditions.

NOTE: The DATA BRILLIANCE switch varies the intensity of all data *outside* the radar display area. Perform testing at all three settings (dim, mid, or bright.)

12. Set the system on each level of Data Brilliance. Comment on the usefulness of this feature. Include preferred operating mode for day and night operation.

NOTE: Pressing the Fast Targets switch causes fast moving, significant targets to appear brighter. The three scan integration is removed, and all returns are updated each scan. When this function is active, clutter may also appear brighter on the display.

13. Most operational tests will be performed in both Standard and Fast Target Mode. This section is an opportunity to comment generally on both modes of operation. Indicate preferred mode in general and as specific to the various ATC operations.

NOTE: The Offset button enables the tower to be offset up to 70% in any direction. This function increases the field of view of runway ends without the use of longer range settings. When offset is selected, the radar display area will blank and rebuild in three revolutions of the antenna.

14. Comment on the usefulness of the Offset mode in the all three modes of range operation. List the different operations offset could be used for and any safety issues that may occur.

NOTE: The Map Feature (NAV LINES) push button in the cursor group allows the operator to make display maps with up to 100 true points or up to 99 contiguous lines (Rwy - Twy map). These marks may be placed on selected points when in North-Up or Course-Up operation. Once entered into the system, the lines are treated as stationary objects by being true motion stabilized and fixed to the radar map. Its length and position are changed to reflect any changes in range scale, and display offsets.

15. Use the NAV LINES feature to create a runway/taxiway map. Comment on the map building process. Comment on how multiple maps can be used to enhance operations at the airport. Comment on how this feature can be enhanced.

Data Summary:

Operator Observations on Phase I Display Capabilities

Scan to Scan Integration:

1. I think the integration works well.
2. Target return is better as vehicle/aircraft move slower (target is bigger, stronger).

Gain Setting:

1. The more gain, the more clutter. I find the gain which eliminates bleed over the runway edge is best. [Maximize] gain to the edge of the runway.
2. Knob is very sensitive. 4 1/2 on bar graph is optimal. [Control] needs to be increased to pick up vehicles closer to clutter areas, and decreased to reduce clutter over some taxiways.

Tune Setting:

1. Seems pretty steady when locked.

SEA Setting:

1. Works best in inverse video with a touch of bar.
2. Just need to highlight or 1/2. More reduces the target quality. Less makes clutter/background too bright.

RAIN Setting:

1. With no precipitation, it's best turned off.

FTC Setting:

1. Works best with inverse video and a touch of bar.

Overall Adjustment:

1. Overall, we can make very minor adjustments to see what we need to see in different areas.

Radar Degradation After Thirty Minutes' Operation:

1. I observed no degradation after 30 minutes.

Range Operation:

1. We only use .75 miles
2. Need 1 mile range. Can't get entire N/S runway in 3/4 mile range. 1.5 mile is too small.

Data Brilliance Operation:

Good.

Fast Target Mode Operation:

1. Coming off fast target is best to see stationary aircraft on runway. Otherwise fast target selection works great.
2. Targets easier to track in this mode. When they stop, however, the target disappears rather than just going down to low video [dim].

Offset Operation:

1. Works great. 70% is all we need for our purpose. 100% would be nice in case we go to a smaller range.

Map Building and Rotation:

1. Seems O.K. to me.
2. Rotation does not coincide with video rotation. Would like to be able to do both [at once.]

5.2 DEMONSTRATION OF MAXIMUM HEIGHT COVERAGE

AT used this procedure to test the ASDE-X range of vertical coverage utilizing live targets flying above the airport surface area. The test was performed with flyovers on Rwy 19R - 1L, MKE's longest and most distant from the ATCT. The test was scheduled to be performed with a FAA Flight Check Aircraft, using Rwy 25L, 19R, and 13. Due to weather related delays, the test was performed using a Phillip Morris owned and piloted Hawker/Siddeley HS25. Time constraints and local traffic limited the test to RW 19R - 1L. The pilot was asked to fly at various altitudes associated with maximum height coverage: 1/4 mi. to 1 1/4 mi. Figure 5-2a shows the estimated heights based on the array's 19° (3 dB) vertical beamwidth. The radar was set to a range of .75 nm to maximize target detection. At this range Rwy 19R-1L was not completely displayed. The display was offset before each run to display the approach end of each pass.

Equipment and Personnel:

- 1 Test Coordinator
- 2 Observer / controllers in MKE tower
- 2 Phillip Morris pilots in test aircraft
- 1 Hawker/Siddeley HS25 aircraft
- Equipment to monitor flight check frequency
- Video recording equipment

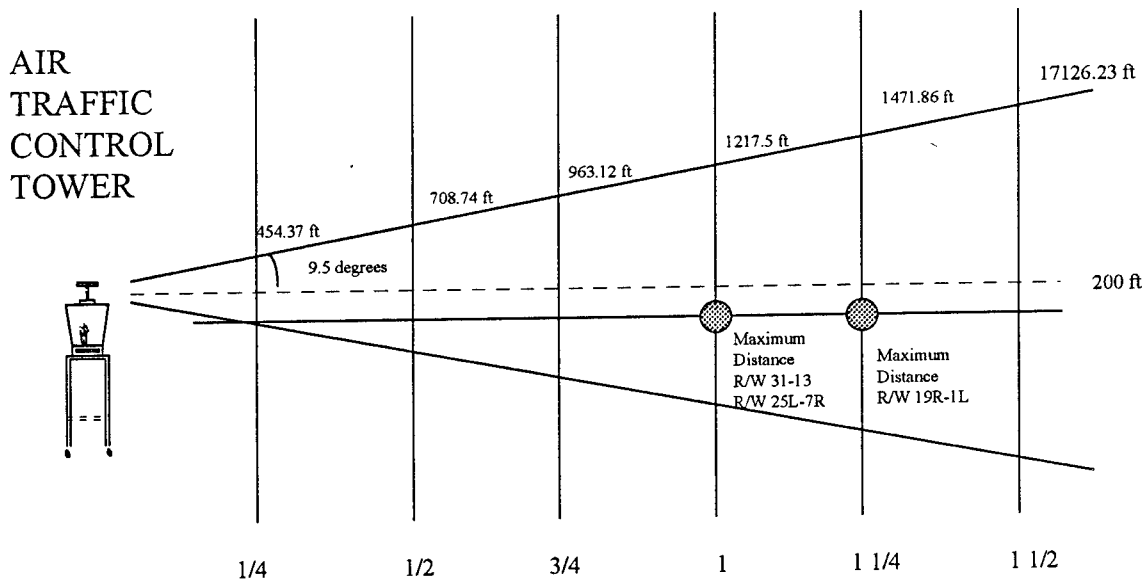

Figure 5-2a. MKE ATCT, Showing Radar Vertical Coverage.

Procedure:

1. With AT support, the test aircraft aligns itself with Rwy 19R - 1L and flies over it at 500 feet.
2. The flight test pilot notifies the test team when he is over each runway threshold.
3. The test team records:
 - speed of the aircraft
 - altitude of the aircraft
 - visual detection of the target
 - detection of the target on the display

- approximate location of the detected target on form's runway map.
 - the quality of the detected target.
4. The pilot increases the test aircraft's altitude to 700 feet, realigns the aircraft with the runway, and proceeds to fly over it.
 5. Steps 1 through 4 are repeated until the test team is no longer able to detect the aircraft on the radar display (950 and 1200 feet).
 6. The pilot decreases aircraft altitude establishing a maximum altitude coverage contour for the system.

Data Summary:

Two observers recorded display data and one observer gave audio verification as the aircraft passed over each runway end and each taxiway and runway intersection. Video snapshots of the display supporting the controllers observations are included (Figures 5b to 5e.)

Date: 12-15-95

Test Plane:



Model: HS25

Make: Hawker/Siddely

Radar Information:

1. The radar was operating for longer than thirty minutes.
2. The FTRs were identified.
3. The map was aligned to full 19R - 1L.

Radar Settings:

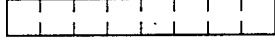
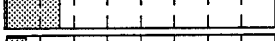
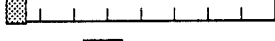
TUNE		
GAIN		
RAIN		INVERSE VIDEO <input type="checkbox"/>
FTC		INVERSE VIDEO <input checked="" type="checkbox"/>
SEA		INVERSE VIDEO <input checked="" type="checkbox"/>
FAST TARGETS	<input checked="" type="checkbox"/>	STANDARD <input type="checkbox"/>
PULSE WIDTH .06 μ sec		RANGE SETTING .75 nm

Weather: ASOS: MKE SA 1656 A02A CLR BLO 120

Maximum Height Coverage Data Sheet

500 Feet Above Ground Level

Approach from: 19R (north to south) Time: 10:50 Local Speed 200 Knots
Observer 1: Targets detected entire runway length. Targets faded between K and S
Observer 2: Targets were registered toward runway ends.
Video (Figure 5-2b) shows HS25 over left side 19R; H1 shows mid hit of previous scan; H2 shows bright hit of actual target.

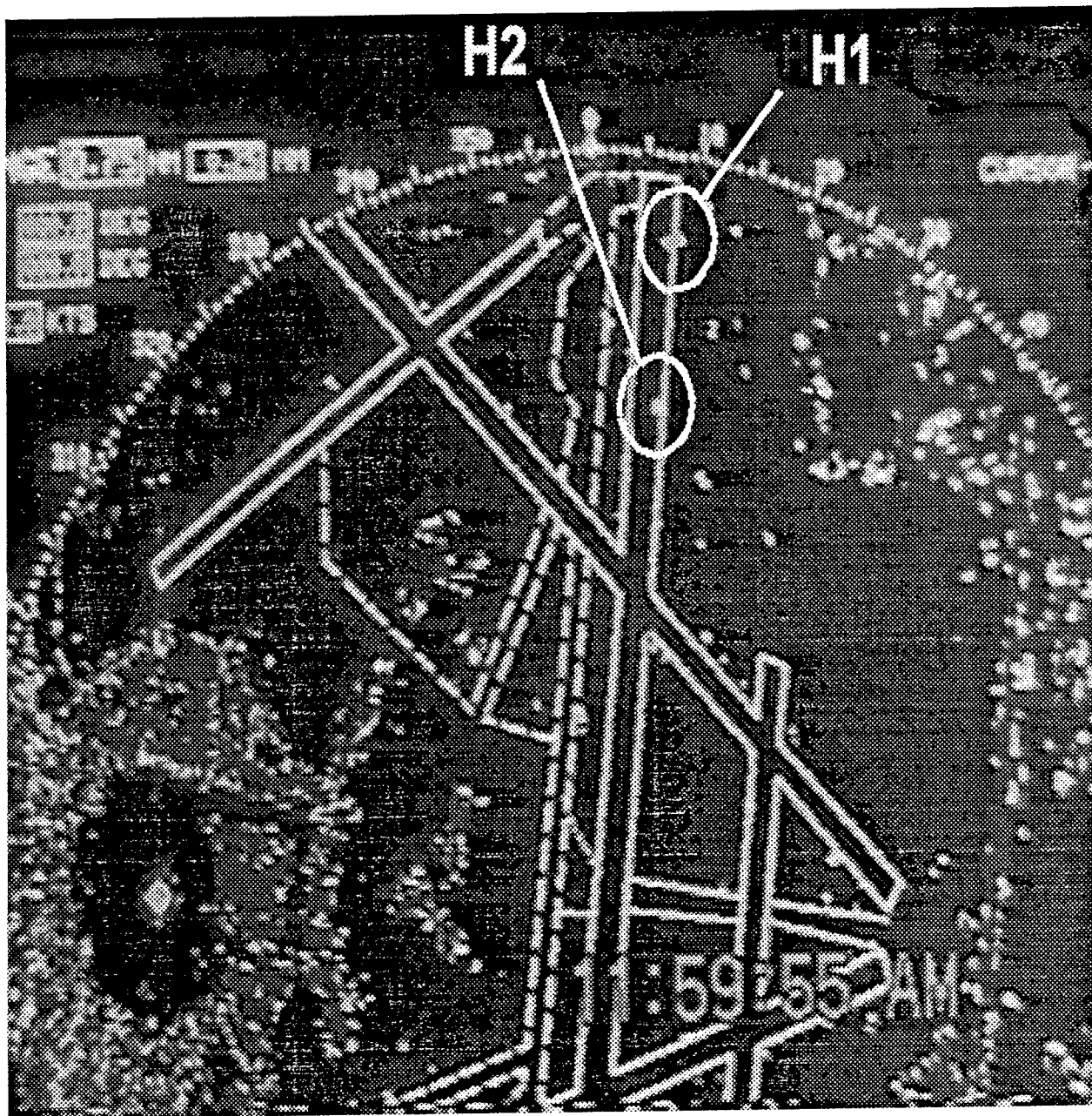

Figure 5-2b. Video Showing Target at 500 Feet.

700 Feet Above Ground Level

Approach from: 1L (south to north) Time: 11:03 Local Speed 200 Knots

Observer 1: Lost target between Twy S and Twy M

Observer 2: Lost target between Twy S and Twy M.

 Target registered at Runway M. Lost target after Runway M

Video (Figure 5-2c) shows HS25 along 1L; H1 shows mid hit of previous scan;

H2 shows bright hit of actual target.



Figure 5-2c. Video Showing Target at 700 Feet.

800 Feet Above Ground Level

Approach from: 19R. Time: 11:20 Local Speed 140 Knots
Observer 1: Good target from M to the departure end.
Observer 2: Target did not show until Twy Mike. Good target until the end of Rwy 1L.

900 Feet Above Ground Level

Approach from: 1L. Time: 11:15 Local Speed 140 Knots
Observer 1: Target visible from runway 1L end to S. Target not visible after that.
Observer 2: Target visible from runway 1L end to S

950 Feet Above Ground Level

Approach from: 19R. Time: 11:05 Local Speed 200 Knots
Observer 1: One hit near the approach end. No other observed targets.
Observer 2: One hit near the end of the runway. Target centered.
Video (Figure 5-2d) shows HS 25 at 950 feet.

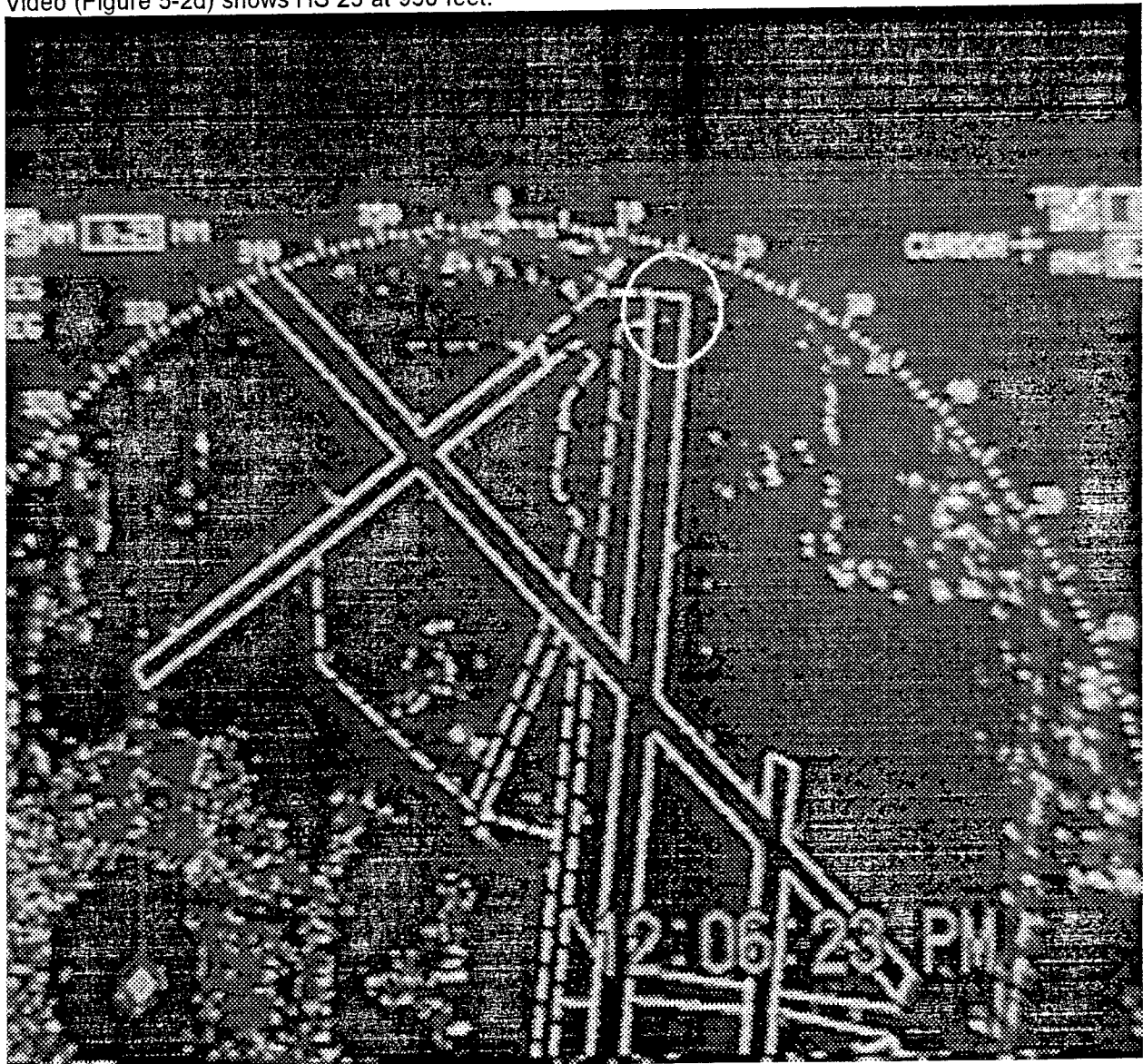

Figure 5-2d. Video Showing Target at 950 Feet.

1200 Feet Above Ground Level

Approach from: 1L. Time: 11:08 Local.

Speed 200 Knots

Observer 1: No targets observed.

Observer 2: No hits.

Video (Figure 5-2e) shows no hits.

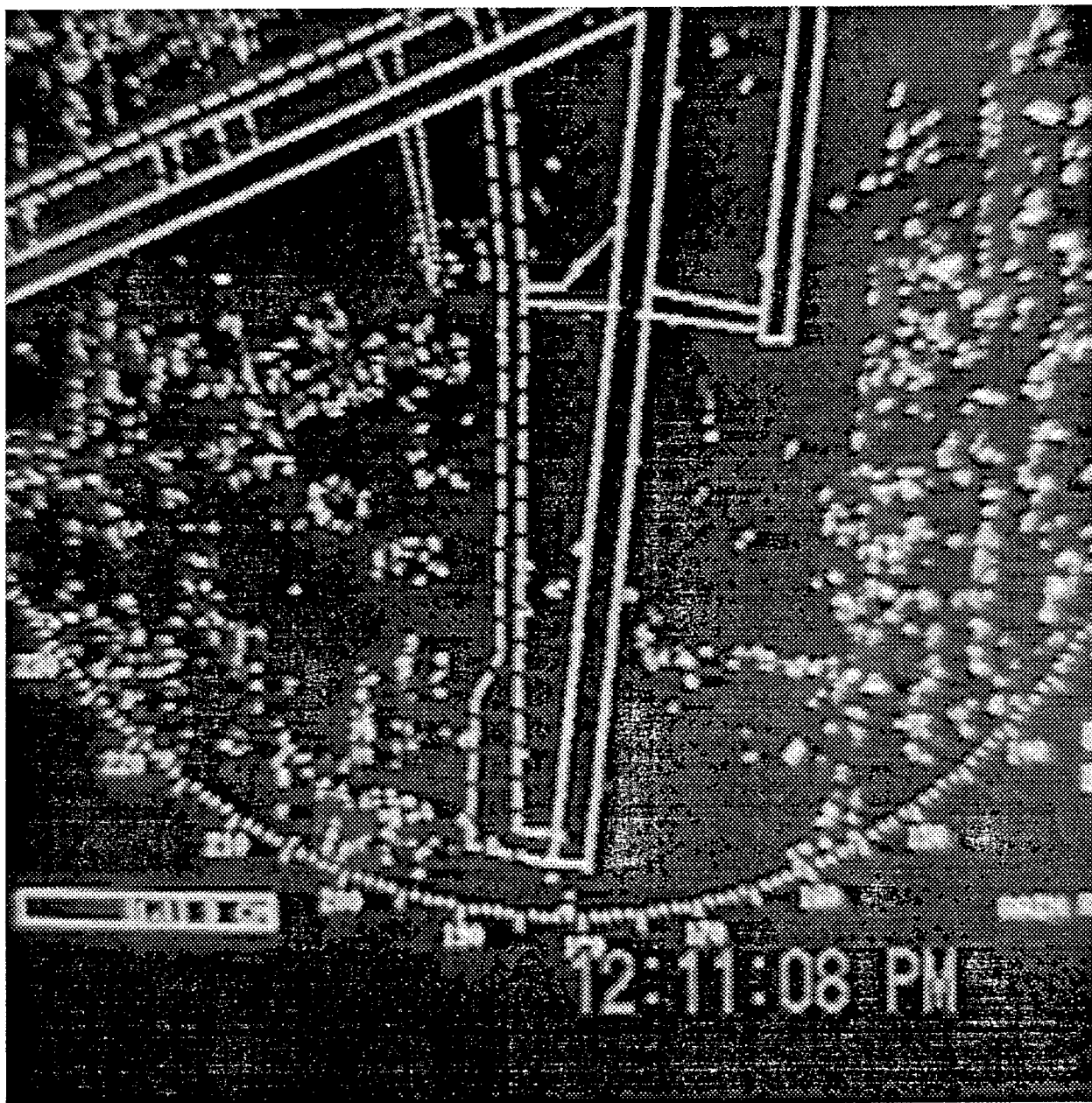

Figure 5-2e. Video Showing No Target at 1200 Feet.

5.3 DEMONSTRATION OF DISSIMILAR SIZED TARGETS AND SHADOWING EFFECTS

AT used this procedure to identify potential shadowing scenarios at various line-up points on the airport surface. Shadowing obscures the registration of the smaller target on the display. Radial lines were extended from the tower on an airport surface map to identify potential problem areas. Using a Phillip Morris HS28 as the smaller target and larger targets of opportunity, potential problem areas on the airport surface were tested. Critical areas included the cargo ramp, queue-ups on taxiway M, runway 7R run-up pad, runway 1L run-up pad, and runway 19R run up pad.

Equipment and Personnel:

- 1 Test Coordinator
- 2 Observers, ATCs in MKE tower
- Pilots in Phillip Morris aircraft
- Phillip Morris HS28 aircraft
- Equipment to monitor flight check frequency
- Video recording equipment
- Targets of Opportunity (TOPs)

Procedure:

Small aircraft (Test Aircraft, TA) Phillip Morris HS28

Large aircraft (Target of Opportunity, TOP)

The accompanying map keys potential shadowing problem areas tested.

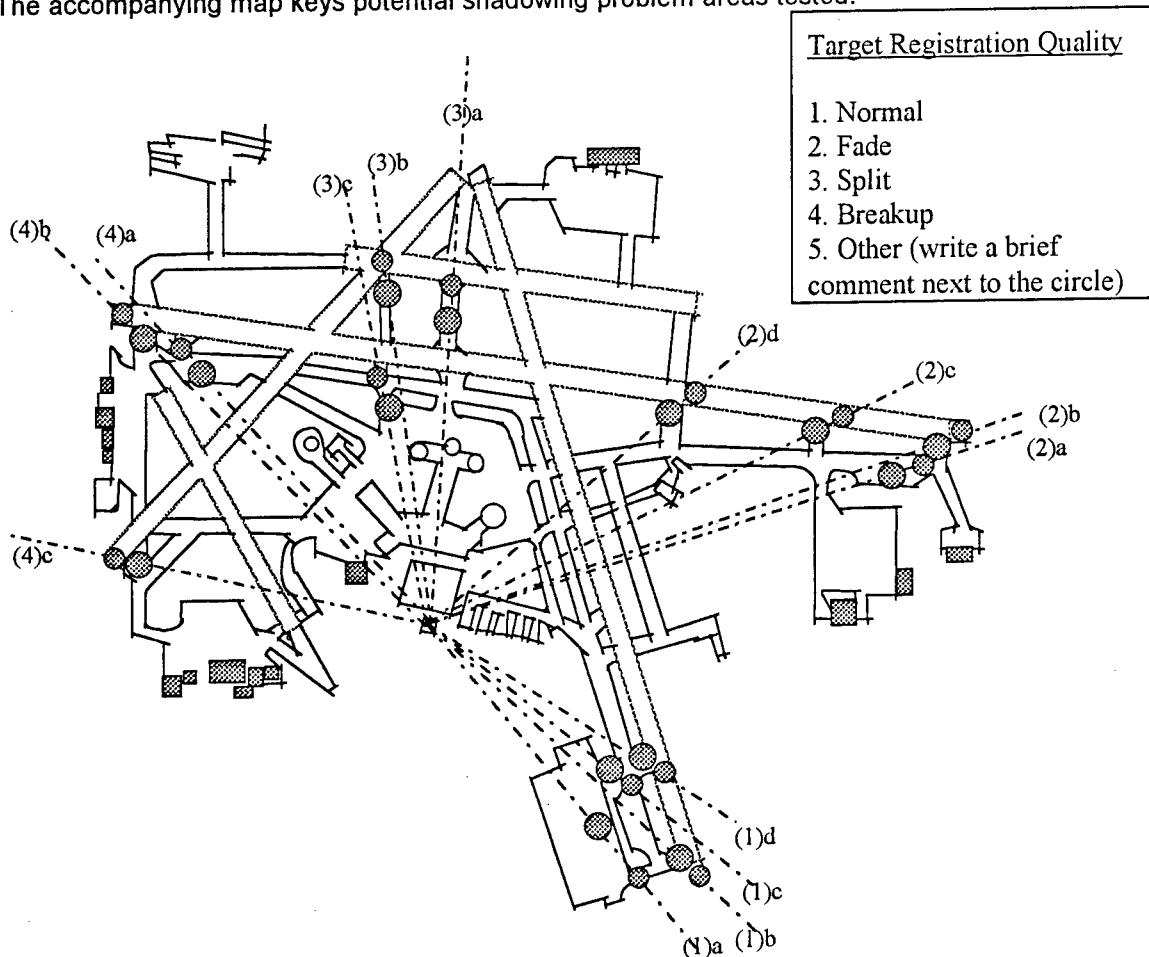

1. Cargo Ramp Area:

- a. *Small aircraft:* directed to the A5 taxiway/Cargo Ramp point.
Large aircraft: in Cargo Ramp is directed to line up radially with small target and tower.
- b. *Large aircraft:* directed to the A4 taxiway/Cargo Ramp point.
Small aircraft: directed to CR and to line up radially with the large aircraft.
- c. *TOP:* directed to the A5 taxiway/7R hold point.
TA: directed to 7R runway end and to line up radially with TOP and tower.
- d. *TOP:* directed to the A4 taxiway/7R hold point.
TA: directed to 7R runway and to line up radially with TOP and tower.

2. 1L Run Up Pad:

- a. *TA:* positioned so it leads TOP up 1L run-up pad toward end of Rwy 1L. TA is directed to traverse the pad so it is in radial line with TOP and the tower.
- b. *TOP:* directed to the R4 taxiway/1L hold line.
TA: directed to 1L runway end and to line up radially with TOP and the tower.
- c. *TOP:* directed to the R3 taxiway/1L hold line.
TA: directed to 1L runway and lined up radially with TOP and the tower.
- d. *TOP:* directed to the S taxiway/1L hold line.
TA: directed to 1L runway and to line up radially with TOP and the tower.

3. Taxiway Mike:

- a. *TA:* positioned so it leads TOP up taxiway M toward 25L and 31. TA is directed to traverse the pad so it is in radial line with TOP and the tower.
- b. *TOP:* directed to the K taxiway/31 hold line.
TA: directed to 31 runway end and to line up radially with TOP and the tower.
- c. *TOP:* directed to the K taxiway/E taxiway hold line.
TA: directed to E taxiway and lined up radially with TOP and the tower.

4. 19R Run Up Pad:

- a. *TA:* positioned so it leads TOP up 19R run-up pad toward end of Rwy 19R. TA is directed to traverse the pad so it is in radial line with TOP and the tower.
- b. *TOP:* directed to the F taxiway/19R hold line.
TA: directed to 19R runway end and to line up radially with TOP and the tower.
- c. *TOP:* directed to the D1 taxiway.
TA: directed to runway 13 and to line up radially with TOP and the tower.

Test Data

Date: 12-14-95

Time: 12:15:00pm Local Time

Test Plane:

Model: HS25

Make: Hawker/Siddeley

Radar Information:

- 1. The radar was operating for longer than thirty minutes.
- 2. The FTRs were identified.

Radar Settings:

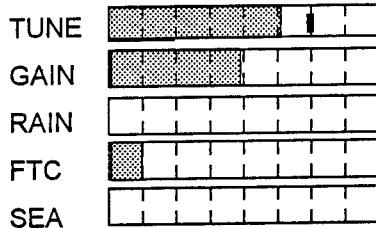

- INVERSE VIDEO
- INVERSE VIDEO
- INVERSE VIDEO

FAST TARGETS
PULSE WIDTH .06 μ sec

STANDARD
RANGE SETTING .75 nm

Weather: ASOS: MKE SA 1156 A02A M8OVC 5F

Data Summary:

- 1(a) Small Aircraft: HS25 Large Aircraft: DC8
Observer 1: The small aircraft faded and briefly disappeared behind the tail of the DC8.
Observer 2: Targets good up to position. When stopped, no target - could not see the smaller aircraft.
- 1(b) (1956Z A02A E7 BKN 12 OVC 3 1/2 ZR) weather and time update
Small Aircraft: BE02 Large Aircraft: DC9
Observer 1: Both targets were readily visible. Targets were separate
- 1(c) (2049Z A02A E7 BKN 12 OVC 2 1/2 ZR) weather and time update
Small Aircraft: C421 Large Aircraft: B727
Observer 1: Both targets showed good return. As C421 went past the B727, target faded just a bit but was still visible and targets were discernible
- 1(d) Small Aircraft: HS25 Large Aircraft: DC9
Observer 1: Targets remain intact and distinguishable. Observer 2: Good strong targets. No problem differentiating.

2(c) Small Aircraft: HS25 Large Aircraft: DC9

Observer 1: No problems noted

3(a) Small Aircraft: HS25 Large Aircraft: DC9

Observer 1: Targets are steady and strong. Targets readily discernible

3(c) Small Aircraft: HS25 Large Aircraft: ATR-42

Observer 1: Both targets registered normal.

Observer 2: The HS25 was very small and the ATR very large, strong. The two targets were very distinguishable.

4(a) 12/13/95, 10am

Small Aircraft: C402 Large Aircraft: WW4

Observer 1: Both targets were very strong. WW4 following C402 very closely. Two targets were readily discernible at all times.

4(b) Small Aircraft: C402 Large Aircraft: DC9

Observer 1: Both targets were very strong. C402 following DC9 very closely. Two targets were readily discernible

5.4 RADAR REGISTRATION OF TARGETS IN HOLD POSITION AT RUNWAY ENDS

AT used this procedure to demonstrate targets in position and hold at the runway end. The controllers tested the system tracking targets to a hold position and while searching for targets already in a hold position. Procedures were performed while the radar was in both fast target and standard modes. Runway ends to be recorded were 7R, 1R, 25L, 19R, 7L.

Equipment and Personnel:

- 1 Test Coordinator
- 2 Observers, controllers in MKE tower
- Targets of Opportunity (aircraft)
- Video recording equipment

Procedure:

The procedures were performed in the two modes of operation; normal and fast track. The test team recorded multiple events for each runway end in each mode of operation. Various aircraft types were monitored.

Tracked Target:

1. The controller views the display and monitors AT communications.
2. Using only the display, the controller tracks the aircraft to its runway hold position.
3. The team records the controller's observations.
4. The controller looks away from the display for a minimum of three scans and then relocates the target and records what he observes.

Non-Tracked Target (Search):

1. The controller monitors AT communications without tracking the target.
2. Once the target is in a runway hold position and the system has made a minimum of three scans, the controller locates the target.
3. The team records the controller's observations.

Target Registration Data Sheets

Date: Week of 12-11-95

Radar Information:

1. The radar was operating for longer than thirty minutes.
2. The FTRs were identified.

Radar Settings:

TUNE		INVERSE VIDEO	<input type="checkbox"/>
GAIN		INVERSE VIDEO	<input type="checkbox"/>
RAIN		INVERSE VIDEO	<input type="checkbox"/>
FTC		INVERSE VIDEO	<input checked="" type="checkbox"/>
SEA		INVERSE VIDEO	<input checked="" type="checkbox"/>

FAST TARGETS

STANDARD

PULSE WIDTH .06 μ sec

RANGE SETTING .75 nm

Weather: ASOS: M 90 0VC 10+

Data Summary:

Runway end: 25L

Observation: **Tracked**

Date: 12-11-95 1840Z Aircraft: BE02 S4X1135 Mode: Fast Target
Comments: Target was weak.

Date: 12-11-95 2005Z Aircraft: C9 E666 Mode: Fast Target
Comments: Target disappeared in hold position. When moving the target was solid.

Date: 12-11-95 1822Z Aircraft: BE02 SYX1834 Mode: Fast Target
Comments: Target initially weak in P & H short on 25L. Once on runway target was easy to see and aligned .

Observation: **Non-Tracked**

Date: 12-11-95 2032Z Aircraft: B737 COA 1248 Mode: Fast Target
Comments: Very weak or no return for 10 sweeps.

Runway end: 7L

Observation: **Tracked**

Date: 12-12-95 1519L Aircraft: PA28 X67V Mode: Standard
Comments: Good target but GAIN was turned up; clutter partially washed out the Rwy.

Runway end: 7R

Observation: **Tracked**

Date: 12-12-95 1650L Aircraft: BE02 GLA917 Mode: Fast Target
Comments: Aircraft faded once in hold after three to four sweeps.

Date: 12-12-95 0131Z Aircraft: DC9 MEP268 Mode: Standard
Comments: Good Return.

Date: 12-13-95 1405 Aircraft: DC9 Midwest Mode: Fast Target
Comments: Target faded once stopped.

Observation: **Non-Tracked**

Date: 12-12-95 0125Z Aircraft: BE02 SYX1166 Mode: Standard
Comments: Solid return.

Date: 12-12-95 0130Z Aircraft: BE02 SYX1027 Mode: Fast Target
Comments: Target faded when stopped then solid return on roll.

Date: 12-13-95 1405Z Aircraft: BE02 Skyway Mode: Fast Target
Comments: When moving it was a strong target, but faded when stopped.

Date: 12-13-95 15:00L Aircraft: BE02 S4X1135 Mode: Standard
Comments: Very strong steady target.

Comments: Very strong steady target.

Date: 12-13-95 15:00 Aircraft: DC9 Midwest Mode: Standard
Comments: Strong, steady target.

Runway end: **19R**

Observation: **Tracked**
Date: 12-13-95 8:41L Aircraft: AT72 ECF 233 Mode: Fast Target
Comments: Target faded into the background intensity.

Date: 12-13-95 1607Z Aircraft: BE02 S4X1904 Mode: Fast Tgt/Std.
Comments: Target faded, mode switched to standard and became a solid return.

Date: 12-13-95 1400 Aircraft: DC9 Midwest Mode: Fast Target
Comments: Visible but faint.

Date: 12-14-95 0750L Aircraft: DC9 Midwest Mode: Fast Target
Comments: Faded In Position

Date: 12-14-95 0750 L Aircraft: BE02 Skyway Mode: Fast Target
Comments: Very, very faint - Good target once he started.

Observation: **Non-Tracked**

Date: 12-13-95 15:05L Aircraft: DC9 TWA Mode: Standard
Comments: Strong, steady target.

Date: 12-14-95 9:40L Aircraft: BE09 Skyway Mode: Standard
Comments: Good Target

Date: 12-14-95 9:40L Aircraft: DC9 TWA Mode: Standard
Comments: Good Target.

5.5 REGISTRATION OF NON-AIRCRAFT TARGETS IN TANDEM

AT used this procedure to test the radar's effectiveness in registering non-aircraft targets traveling in tandem on the airport surface. AT tested the radar registration of one car and two truck types normally used at MKE. Driving on frequently used routes, the vehicles traveled alone or in pairs, as in normal operations. This test was performed both in standard and fast target mode. Critical routes include the fire station to A1, the fire station to R to S, and the Taxiway E / Runway 13 intersection. Two bitmaps (Figures 5-5a, 5-5b) illustrate the separation and fusion of targets.

Equipment and Personnel:

- 1 Test Coordinator
- 2 Observers, controllers in MKE tower
- Targets of opportunity
- 3 County Trucks
- Communications equipment (County to Tower)
- Video recording equipment

Procedure:

Single Vehicle, 1L and S

1. Vehicle is instructed to travel from the fire house to Rwy 1L via Twy S.
2. Vehicle is instructed to wait for clearance to cross 1L.
3. Vehicle is instructed to cross Rwy 1L and continue along Twy S.

Two Vehicles in Tandem, 1L and S

1. Vehicles are instructed to travel in tandem from the fire house to Rwy 1L via Twy S.
2. Vehicles are instructed to wait for clearance to cross 1L.
3. Vehicles are instructed to cross Rwy in tandem 1L and continue along Twy S.

Single Vehicle, 7R and A1

1. Vehicle is instructed to travel from the fire house to Rwy 7R via Twy A1.
2. Vehicle is instructed to wait for clearance to cross A1.
3. Vehicle is instructed to cross Rwy 7R and continue along Twy A.

Two Vehicles in Tandem, 7R and A1

1. Vehicles are instructed to travel in tandem from the fire house to Rwy 7R via Twy A1.
2. Vehicles are instructed to wait for clearance to cross 7R.
3. Vehicles are instructed to cross Rwy in tandem 7R and continue along Twy A.

Non-Aircraft Targets In Tandem Data Sheets

Date: 12-12-95

Time: 8:40 -9:30am Local Time

Test Vehicle:

Model: car

Make: T-19

Blower

54







Flyer

61

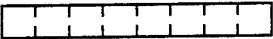
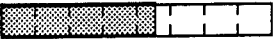
Radar Information:

1. The radar was operating for longer than thirty minutes.
2. The FTRs were identified.

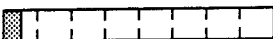
Radar Settings:

TUNE		INVERSE VIDEO	
GAIN		INVERSE VIDEO	
RAIN		INVERSE VIDEO	<input type="checkbox"/>
FTC		INVERSE VIDEO	
SEA		INVERSE VIDEO	
FAST TARGETS	<input type="checkbox"/>	STANDARD	<input type="checkbox"/>
PULSE WIDTH .06 μ sec		RANGE SETTING .75 nm	

Weather: ASOS: MKE SA 1656 A02A CLR BLO 120

Data Summary:

7R and A1 (car traveling alone, trucks in tandem)

1. **Firehouse to 7R to A3 via A1, A**
Car is intermittently visible. Two trucks (20' apart) intermittently visible singly and apart.
2. **Crossing 7R, west on A to A3**
Car is intermittent.
The two trucks are sometimes one target.
When the trucks are 50 feet apart they are separate strong targets.

1L and S (car traveling alone, trucks in tandem)

1. **Holding short of 1L on S**
3 Vehicles appear as one (fast target mode).
2. **Car crosses 1L and stops on S before 1R**
Initially the target was displayed as it started to move on S. It was lost as it crossed 1L. The car was again picked up on the other side of 1L, but when it stopped it could no longer be seen.
3. **Trucks cross 1L in tandem and stop on S before 1R (Figure 5-5a)**
The trucks were merged as one target which was seen all the way.
4. **Car crosses back across 1L via S by itself**
The target was not detected.
5. **Trucks cross back on 1L via S, in tandem but 50' apart**
Two targets were detected on the display.

7R and A1 (car traveling alone, trucks in tandem)

1. Car and Trucks on A1

Separate targets were displayed.

2. Stopped short of 7R

Car by itself. Trucks merged as one target.

With fast target off, the car could be seen in hold position (target very small).

3. Car crossed 7R then west to A3

Target registration was small but visible all the way.

4. Trucks in tandem crossed 7R then west to A3

They registered as one large target when < 50' apart.

Two targets when >50' apart.

13 and E (all vehicles traveled in tandem)

1. Traveling in tandem to G via E (the car is trailing the trucks) (Figure 5-5b)

First could not see the car

Then picked up all three

Vehicles lost around A1

Picked up past E

Faded around M.

2. Vehicles on K

Targets Faded. As vehicles stopped they became one target.

3. Vehicles traveling in tandem (50' apart) to 31 via G

Target were three separate targets.

4. North on G in tandem

Target visible (good).

Target Separation and Fusion

In the circle in Figure 5-5a is the display image of the three vehicle targets, traveling North on Rwy E, passing Rwy M. The two trucks are leading the car, and they are all greater than 50' apart. The image, taken in Standard Mode, shows the targets fading.

In the circle in Figure 5-5b, the image of the two trucks is merged as they are in hold position less than 50' apart. Also Standard Mode.

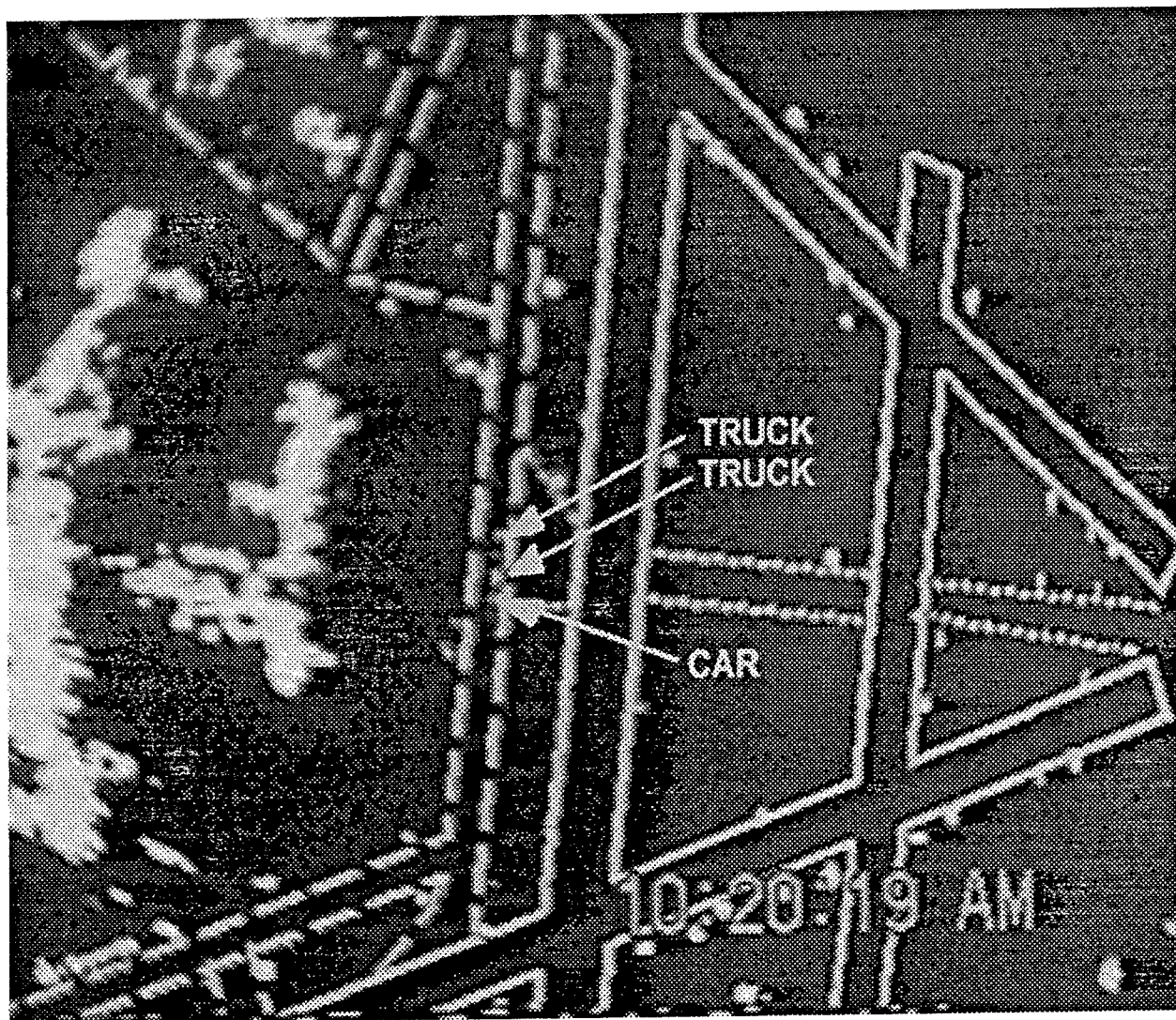

Figure 5-5a. Three Vehicles Traveling In Tandem, Images Separate but Fading.

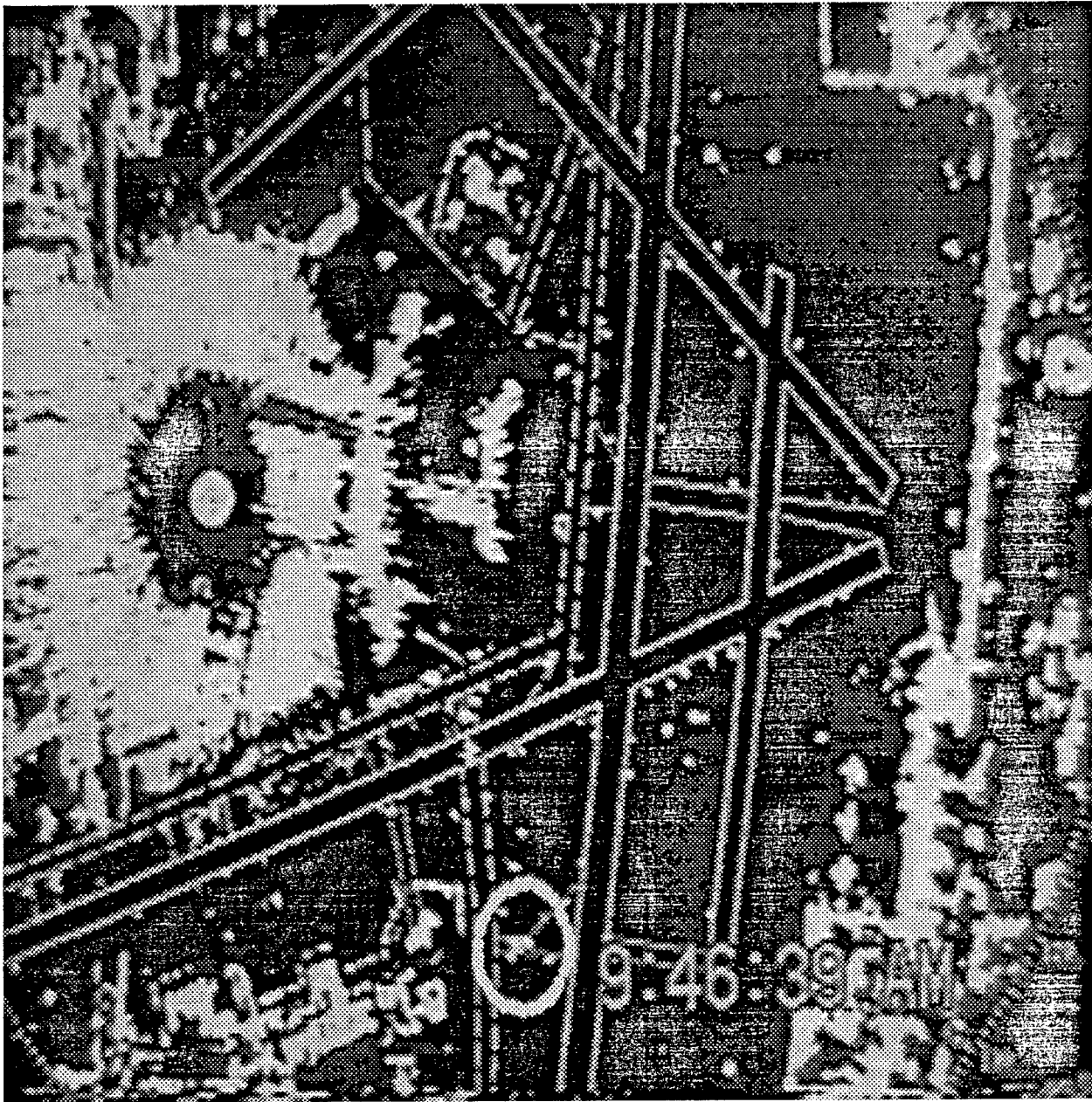

Figure 5-5b. Two Trucks Traveling In Tandem, Images Fused.

5.6 HIGH-SPEED TURN-OFF DEMONSTRATION

AT used this procedure to demonstrate moving targets transitioning from Runway to Taxiway.
Critical areas for testing included intersections: 19R / S, 1L / M, 25L / A2, 7R / E.

Equipment and Personnel:

- 1 Test Coordinator
- 2 Observers / controllers in tower
- 2 Pilots in Phillip Morris HS 28 aircraft
- Phillip Morris HS28 aircraft
- Targets of opportunity
- Equipment to monitor flight check frequency
- Video recording equipment

Procedure:

1. AT directed the aircraft to make an approach to Runway 19R and perform a high speed exit onto Taxiway S.
2. The observer marked the data sheet where the display registers the target after each update.
3. Steps 1 and 2 were repeated for a high speed exit off Runway 1L onto Taxiway M, off Runway 25L onto A2, off Runway 7R onto Taxiway E.

High-Speed Turn-Off Data

Date: 12-14-95

Time: 1200 to 1305Z

Test Plane:

Model: HS25

Make: Hawker/Siddely

Radar Information:

1. The radar was operating for longer than thirty minutes.
2. The FTRs were identified.

Radar Settings:

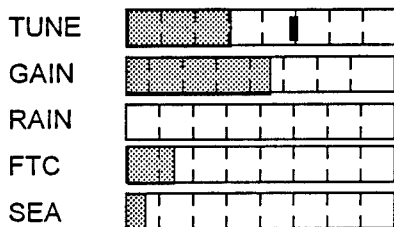

INVERSE VIDEO

INVERSE VIDEO

INVERSE VIDEO

INVERSE VIDEO

INVERSE VIDEO



FAST TARGETS



STANDARD



PULSE WIDTH .06 μ sec

RANGE SETTING .75 nm

Weather: ASOS: MKE SA 1656 A02A CLR BLO 120

Data Summary:

Intersection: 25L - A2

Date:12-14-95 Time: 12:50L Speed 35 Knots

Observer 1: Normal

Observer 2: Target good. No change during transition from Runway to Taxiway

Intersection: 7R - E

Date:12-14-95 Time: 12:25L Speed 20 Knots

Observer 1: Target normal throughout

Observer 2: Target steady. No difference transition from Runway to Taxiway

Intersection: 25L - A2

Date:12-14-95 Time: 9:40L Speed 20 Knots

Observer 1: Good target quality. No noticeable difference transitioning from Rwy to Twy.

Date: 12-15-95

Test Plane:



Model: HS25

Make: Hawker/Siddely

Radar Information:

1. The radar was operating for longer than thirty minutes.
2. The FTRs were identified.

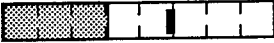
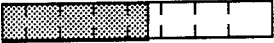
Radar Settings:

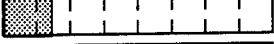
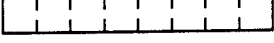
TUNE		INVERSE VIDEO	<input type="checkbox"/>
GAIN		INVERSE VIDEO	<input type="checkbox"/>
RAIN		INVERSE VIDEO	<input type="checkbox"/>
FTC		INVERSE VIDEO	<input checked="" type="checkbox"/>
SEA		INVERSE VIDEO	<input checked="" type="checkbox"/>
FAST TARGETS	<input checked="" type="checkbox"/>	STANDARD	<input type="checkbox"/>
PULSE WIDTH .06 μ sec		RANGE SETTING .75 nm	

Weather: ASOS: MKE SA 12567 A02A M10 BKN 170VC 10+

Data Summary:

Intersection: 19R - S

Date:12-14-95 Time: 12:44L Speed 90 Knots

Observer 1: Target was good but the aircraft could not make the turn due to ice.

Intersection: 1L - M

Date:12-14-95 Time: 13:02L Speed 90 Knots

Observer 1: Target normal

Observer 2: Slight target fade exiting Runway.

5.7 RADAR PRESENTATION AND DETECTION

AT used this procedure to test the potential delay in presentation as an aircraft crosses the runway threshold during an approach. The procedure demonstrates the limits of the system due to the rotation rate of the antenna. The test measures time delta from when a target physically crosses runway threshold and it appears at runway threshold on the radar display. Approaches to Rwy 25L were used during this test.

Equipment and Personnel:

- 1 Test Coordinator
- 2 Observers / Controllers in MKE tower
- 1 Field Observer
- Targets of opportunity
- Equipment to communicate between ATCT and airfield
- Video recording equipment
- Test log
- Stopwatch

Procedure:

1. Field observer sets up at a vantage point to observe aircraft crossing runway end.
2. Coordinator establishes communication between the field observer and tower observers.
3. Tower observer informs the team that a TOP approaches the tested runway.
4. Field observer calls tower when an aircraft passes over the runway end ("MARK").
5. Tower observer starts the stopwatch.
6. Second tower observer informs team at point when the target appears on the runway ("MARK") and the stopwatch will be stopped.
7. Coordinator logs the test and repeats steps 3 - 7 a minimum of ten times.

Radar Presentation and Detection Data Sheet

Date: 12-14-95 Time: 2:00:00pm Local

Radar Information:

1. The radar was operating for longer than thirty minutes.
2. The FTRs were identified.
3. The map was aligned to observe 25L.

Radar Settings:

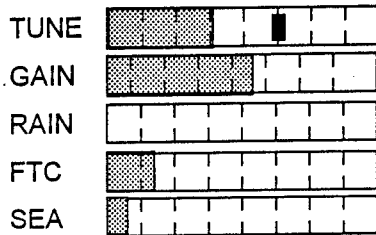

INVERSE VIDEO
 INVERSE VIDEO
 INVERSE VIDEO
 INVERSE VIDEO
 INVERSE VIDEO

FAST TARGETS

STANDARD

PULSE WIDTH: .06 μ sec

RANGE SETTING: .75 nm

Weather: ASOS: MKE SA 1756 A02A M8 OVC 5

Data Summary:

TEST	Δ TIME (seconds)
1	1.5
2	1.38
3	1.81
4	2.88
5	6.15
6	1.37
7	3.08
8	3.23
9	2.79

5.8 TARGET DISPLAY PRESENTATION

This general procedure requested controller feedback on target presentation using targets of opportunity in typical operations. The procedure had controllers observe TOPs and verify target characteristics (i.e., target split, break-up, fading, scattering, false target, etc.) This test offered an opportunity for controllers not otherwise involved in testing to comment on the radar's operation.

Equipment and Personnel:

Test Coordinator
 2 Observers - Controller in MKE tower
 Targets of opportunity
 Airport Vehicle
 Video recording equipment

Procedure:

1. Observe TOPs taxiing on the airport surface.
2. Record target type and comment on target characteristics throughout its route.

Date: 12-13-95

Time: 9:00--10:10:am Local

Radar Information:

1. The radar was operating for longer than thirty minutes.
2. The FTRs were identified.

Radar Settings:

TUNE 

GAIN 

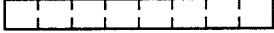
RAIN 

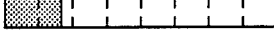
FTC 

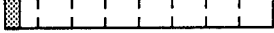
SEA 

INVERSE VIDEO

INVERSE VIDEO

INVERSE VIDEO

INVERSE VIDEO

INVERSE VIDEO

FAST TARGETS

STANDARD

PULSE WIDTH: .06 μ sec

RANGE SETTING: .75 nm

Weather: ASOS: MKE SA 1556 A02A E 12 OVC 10+

Display Presentation Data Sheet

Time: 10:07am **Route: Gate 23-G-E-19R** Aircraft: DC9 TWA 627 Mode: Fast Target
Comments: Good target the whole way.

Time: 8:50am **Route: 7R-A-E-K-B-C** Aircraft: C172 Skylink Mode: Fast Target
Comments: Split at M and E. Breakup on 7R after R3. Able to track the aircraft the entire route.

Time: 9:05am **Route: 7R-1R-M** Aircraft: DC9 MEP 521 Mode: Fast Target
Comments: Split at 1R and M. Major split when aircraft turned on M.

Time: 9:15am **Route: B-M-E** Aircraft: 727 AMT 250 Mode: Fast Target
Comments: Split at B and M. Signature split up as the aircraft turned right on to M.

Time: 9:30am **Route: NR-19R** Aircraft: LR25 LN415LJ Mode: Fast Target
Comments: Split E and 19R. Fade after 7R

Time: 9:37am **Route: 7R-A1-A-E-K-Ramp** Aircraft: BE02 SYX1909 Mode: Standard
Comments: Very strong target the entire route.

Time: 9:42am **Route: 7R-E-K-B-Gate 24** Aircraft: E120 BTA3357 Mode: Standard
Comments: Very strong target the entire route.

Time: 9:47am **Route: 7R-E-F-North Ramp** Aircraft: WW4 N4WG Mode: Standard
Comments: Very strong target the entire route.

5.9 FALSE TARGET DISPLAY PRESENTATION

AT used this procedure to observe occurrences of false targets and identify their causes. The display was divided into three regions viewed independently for false targets. The controllers were educated on the potential cause and most likely locations for false targets to occur, and were asked to note conditions during occurrence.

Equipment and Personnel:

- 1 Test Coordinator
- 1 Observer / controller in tower
- Data logs
- Video recording equipment

Procedure:

NOTE: The movement area was divided into three regions, each observed individually for four 1-hour periods. During observations, the two regions not being observed were blocked from view.

1. Set up the display for observation of Region 1.
2. Start the video camera.
3. Observe display and log targets in the movement area.
4. Verify targets existence by sighting target in the movement area.
5. Mark and log any false targets on the data sheet.
6. Use a new video tape for each observation period.
7. Repeat test for Regions 2 and 3.

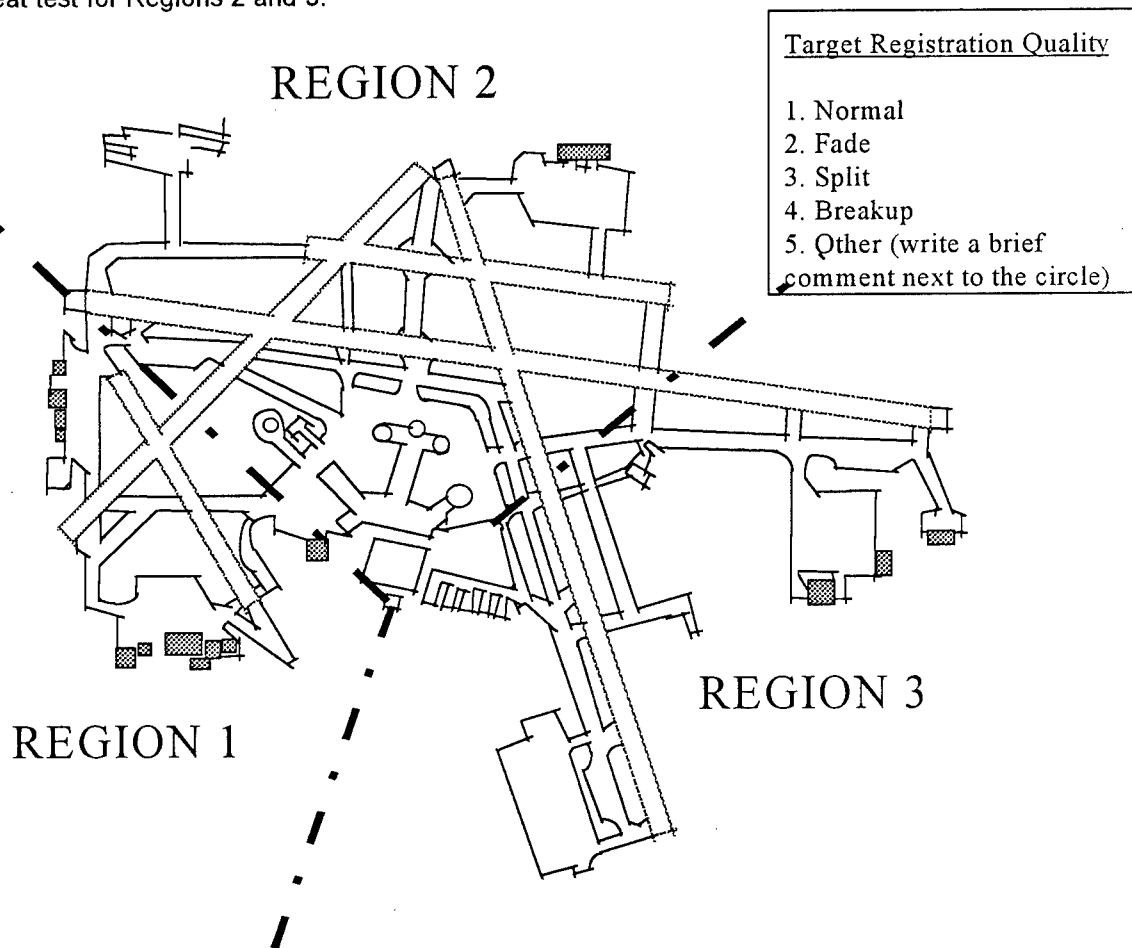

False Target Display Data Sheets

Date: 12-13-95

Time: 8:50 am - 1:30 pm Local

Radar Information:

1. The radar was operating for longer than thirty minutes.
2. The FTRs were identified.

Radar Settings:

TUNE		INVERSE VIDEO	<input type="checkbox"/>
GAIN		INVERSE VIDEO	<input type="checkbox"/>
RAIN		INVERSE VIDEO	<input type="checkbox"/>
FTC		INVERSE VIDEO	<input checked="" type="checkbox"/>
SEA		INVERSE VIDEO	<input checked="" type="checkbox"/>
FAST TARGETS	<input checked="" type="checkbox"/>	STANDARD	<input type="checkbox"/>
PULSE WIDTH .06 μ sec		RANGE SETTING .75 nm	

Weather: ASOS: MKE SP 1409Z A02 M14 OVC 10+

Data Summary:

- Time: 8:50 - 9:20am **Region: 1** Mode: Fast Target
 Comments: False target between approach end of 25R and 19R (about every other sweep). Eliminated all but one when the gain is turned down to (4 1/4 to 4 1/2). One false target remains between 25R and 19R (see Figure 5-9a).
- Time: 9:30 - 10:00am **Region: 2** Mode: Fast Target
 Comments: False target 1R and M for one sweep (see Figure 5-9b).
- Time: 10:15 - 10:45am **Region: 3** Mode: Fast Target
 Comments: Approach end 1L (see Figure 5-9c). Steady for the first five minutes, then present only intermittently. In fast target mode, virtually nonexistent. As the target crosses R on 7R, target split to the right (south of actual target.) At 10:32, even in fast target, false target reappears. Target appears more split and or broken in this mode.

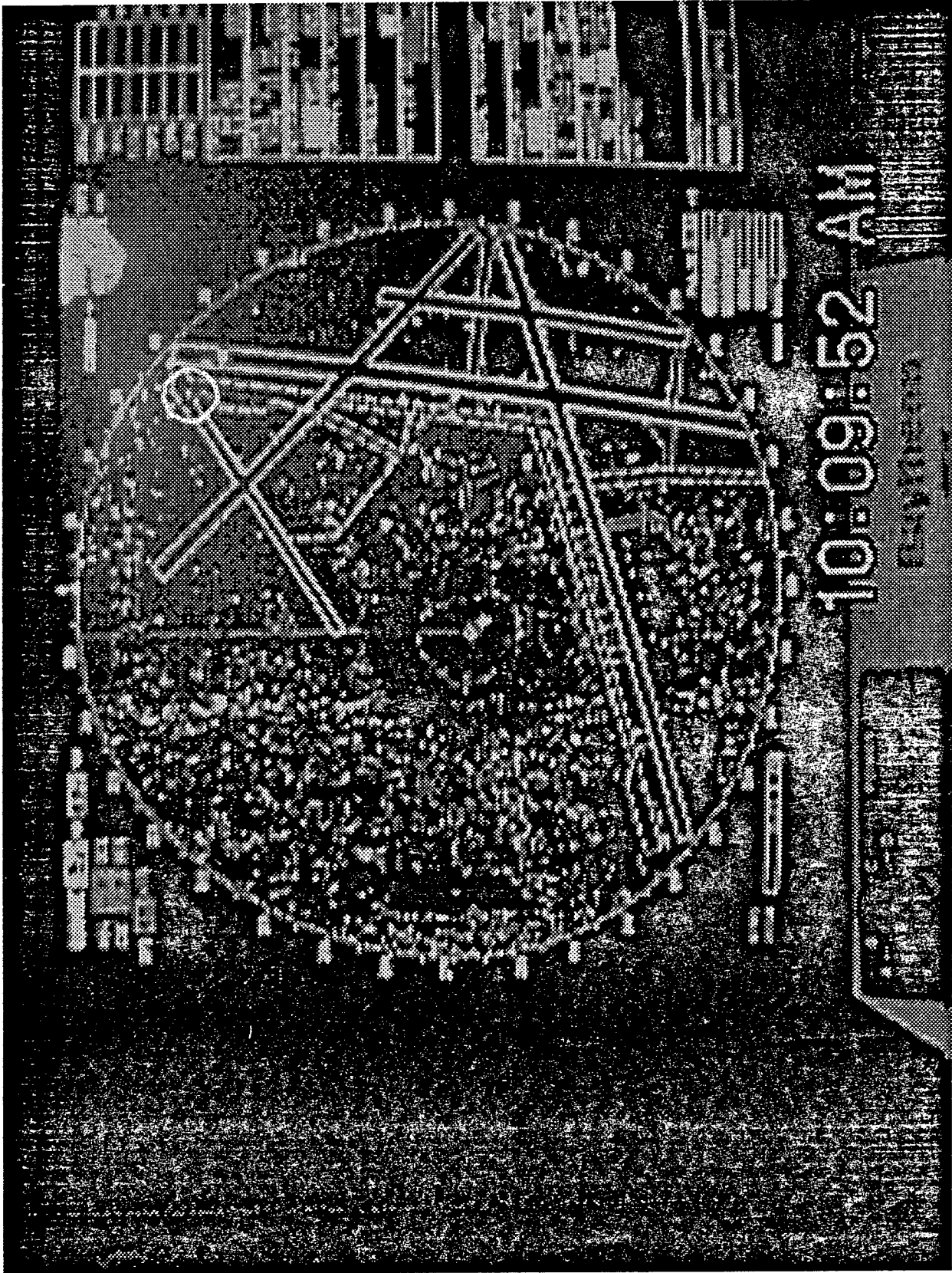

Figure 5-9a. False Target between Approach Ends of 25R and 19R.

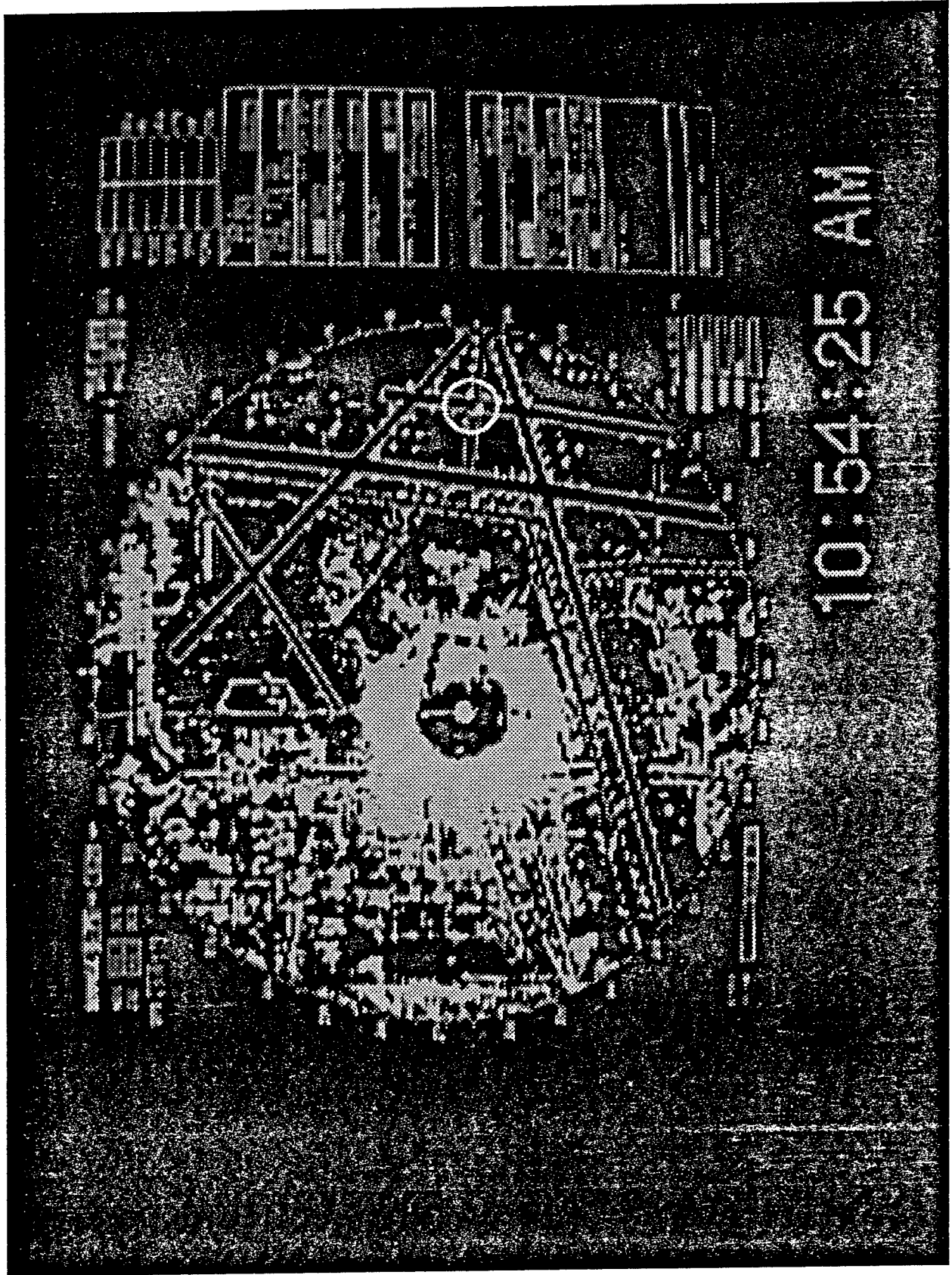

Figure 5-9b. False Target Intersection 1R-M.

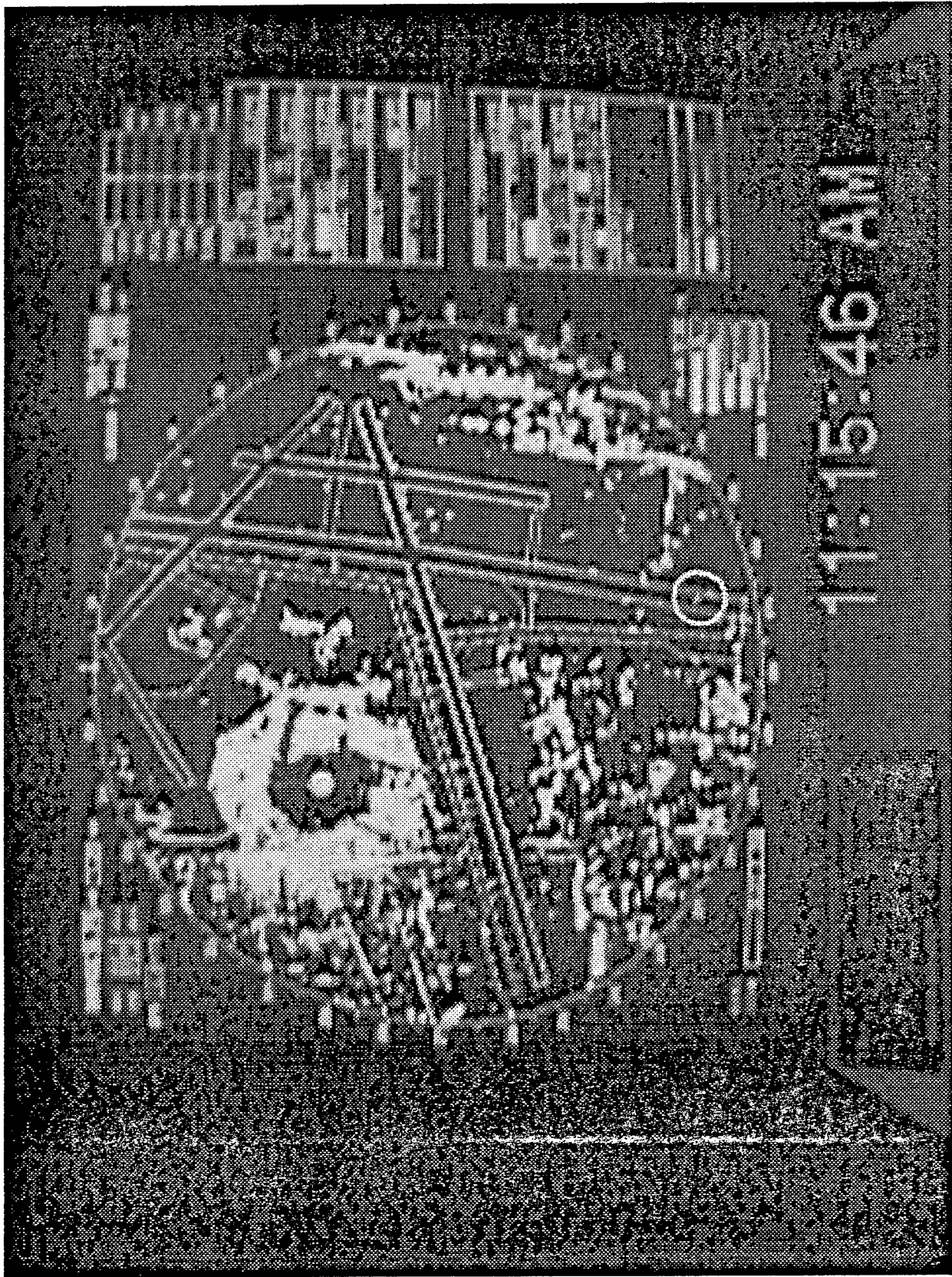

Figure 5-9c. False Target at Approach End of 1L.

5.10 POSITIONING ACCURACY TESTING

It is important that controllers have confidence in the system's ability to accurately represent target location. This procedure verifies that targets (in this case, a county truck) are displayed accurately in reference to the overlay map. System limitations were verified in reference to the airport layout (runways, taxiways, ramps, terminals, etc.) The test covers all control movement areas at MKE. Controllers were to identify, record the location and the quality of the target vehicle on a map of the movement area. This procedure also identified potential problem areas associated with target registration.

Personnel and Equipment:

- 1 Test Coordinator
- 2 Observers / controllers in tower
- Driver of County Truck
- County Truck
- Truck to tower communications
- Video recording equipment

Procedure:

The test team observed and recorded the truck in all movement areas. The truck covered the center of each runway and taxiway, as well as all gate areas considered movement areas. The truck traversed the movement area at 10 mph. The test team recorded the truck's movements and corresponding target quality, making special note of any abnormalities.

Truck's Driving Sequence:

1. US customs/IAB building and terminal B: Starting at terminal C the van will travel parallel paths separated by 50 feet, back and forth from terminal C to the US customs side of the terminal area.
2. Terminal D and terminal C: Starting at terminal D the van will travel parallel paths separated by 50 feet, back and forth from terminal D to terminal C.
3. Terminal E and terminal D: Starting at terminal E the van will travel parallel paths separated by 50 feet, back and forth from terminal E to terminal D.
4. South/west side of terminal E.
5. The van will travel from terminal E to taxiway P via taxiway B.
6. The van will travel taxiway A to taxiway A4 to the Cargo Ramp.
7. The cargo ramp will be covered with parallel paths at 50 feet separation.
8. The van will then enter Runway 7R via taxiway A5.
9. The van will travel the length of Runway 7R down the center.
10. The van will travel taxiway M to taxiway E to taxiway A.
11. The van will travel taxiway A toward runway end 7R stopping at runway hold points E, R, A1, A2, A3, A4 and A5.
12. The van will travel up the right side of runway 7R to taxiway N. The van will travel from Taxiway N to Taxiway W via Runways 25L and 1R.
13. The van will travel from Taxiway W to the Fire Station via taxiway S.
14. The van will travel from the Fire Station to the Citation Hanger.
15. The van will travel from the Citation Hanger to taxiway A3 to taxiway B.
16. From taxiway B the van will travel to Y via A1.
17. From taxiway Y the van will travel B via taxiway R.
18. From taxiway B to the USAF Reserve via taxiway R and taxiway R3.
19. The van will cover the USAF Reserve with parallel paths 50 feet apart.
20. The van will travel from USAF Reserve to Phillip Morris via taxiway R3 and taxiway R4.
21. The van will travel the center of Runway 1L.

22. The van will travel to the east hangers via taxiways F, H and J.
23. The van will cover the East hangers by traveling parallel paths 50 feet apart.
24. The van will travel to runway 19L via Taxiway H.
25. The van will travel to runway end 31 via runway 1R and taxiway M.
26. The van will travel Runway 31 down the center.
27. The van will travel to the Skyway Maintenance area via taxiways F and C.
28. The van will cover the Maintenance area with parallel paths 50 feet apart.
29. The van will travel taxiway C1 to runway 7L.
30. The van will travel Runway 7L down the center.
31. The van will travel to taxiway D via taxiway F.
32. The van will travel taxiway D to runway end 7L via taxiway B.
33. The van will travel to D1 via runway 7L and taxiway D.
34. The van will travel to taxiway E via taxiway F.
35. The van will travel from taxiway E to runway 25L stopping at taxiway hold point E1.
36. The van will travel to taxiway K via runways 25L and 31.
37. The van will travel to taxiway G via taxiway K.
38. The van will travel to taxiway B via taxiways G, E, F and D.
39. The van will travel taxiway B.

Data

Date: 12-14-95

Test Plane:



Model: HS25

Make: Hawker/Siddely

Radar Information:

1. The radar was operating for greater than thirty minutes.
2. The fixed targets were identified.

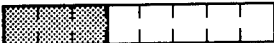
Radar Settings:

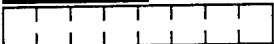
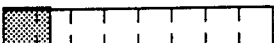
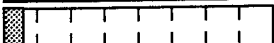
TUNE		INVERSE VIDEO	<input type="checkbox"/>
GAIN		INVERSE VIDEO	<input type="checkbox"/>
RAIN		INVERSE VIDEO	<input type="checkbox"/>
FTC		INVERSE VIDEO	<input checked="" type="checkbox"/>
SEA		INVERSE VIDEO	<input checked="" type="checkbox"/>
FAST TARGETS	<input type="checkbox"/>	STANDARD	<input type="checkbox"/>
PULSE WIDTH: .06 μ sec		RANGE SETTING: .75 nm	

Weather: ASOS: MKE SA 1756 A02A M65 OVC 10+

Data Summary:

DRIVING SEQUENCE 1 - 10

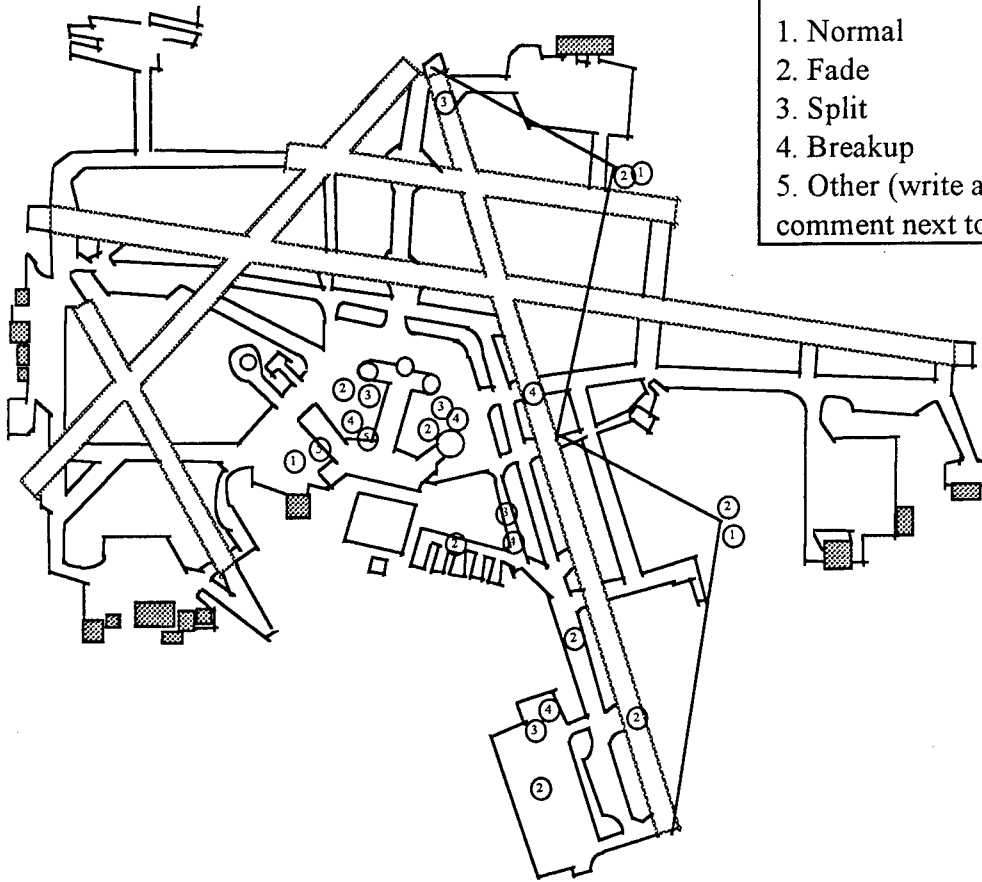

Target Registration Quality

1. Normal
2. Fade
3. Split
4. Breakup
5. Other (write a brief comment next to the circle)

Comments:

Observer 1.

- Concourse "C" - US Customs The target was shadowed on "C" Concourse side.
- Concourse "D" - Concourse "C" Shadowed on East side of "D" concourse (traveling south).
- Shadowed and breakup on east side of "D" concourse.
- Lost target in "U" shape of "C" and "D" concourses.
- Very small and hard to notice target in and out of "P."
- Whole length of 7R OK. Some fade.

Observer 2.

- Concourse "C" - US Customs 5 - Target blends in with background. Not visible.
- B - just east of Concourse "C", vehicle shadowed. Couldn't see at all.
- Concourse ramps generally normal except as indicated.
- Targets passing (about 50 feet) were distinguishable.
- Coverage non-existent Southwest of NW concourse.
- West edge of ramp good.
- B to P (corporate) coverage on P normal but very weak.
- On Cargo Ramp - directly behind aircraft non detectable.
- Overall coverage on Cargo Ramp was poor.
- A5 - 7R - Generally target size and intensity uniform and normal the entire length of Rwy.
- M - E - A all "A" turn-offs - Generally the target looked uniform.

DRIVING SEQUENCE 11 - 18

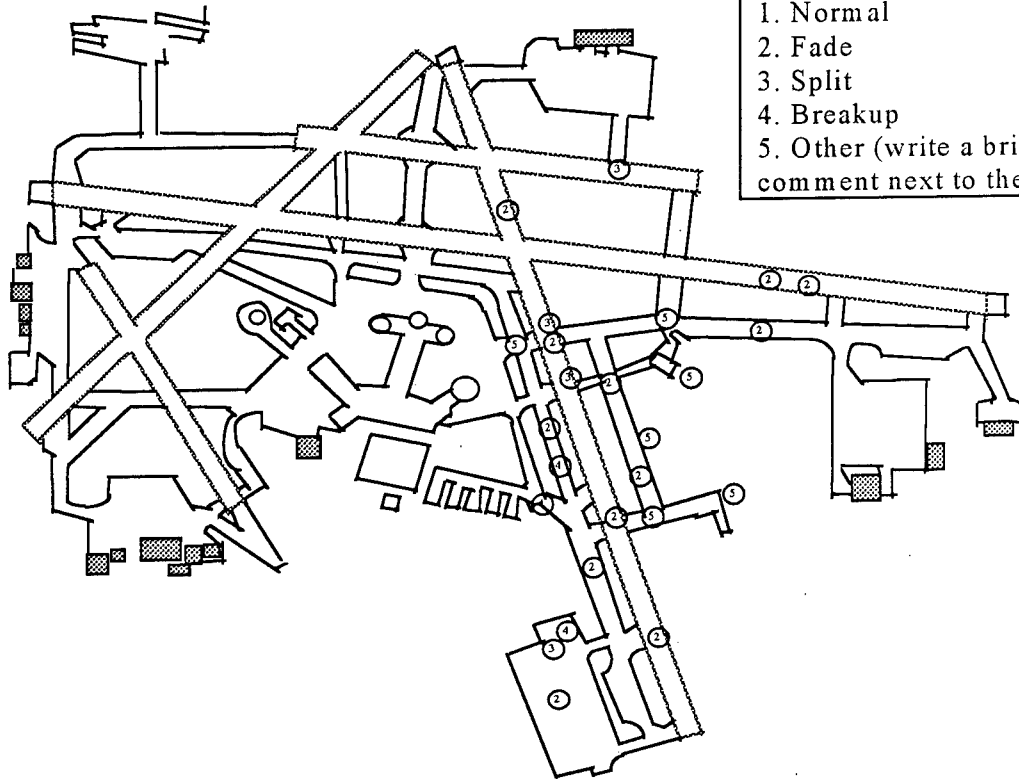

Target Registration Quality

1. Normal
2. Fade
3. Split
4. Breakup
5. Other (write a brief comment next to the circle)

Comments:

Observer 1.

- 7R South Side - Split at W, system was in fast target.
- In standard, the target looked good.
- 1R, S to fire House - Target was very strong.
- Y to Citation Hanger - Good target.
- When in Fast Target the vehicle was lost.
- Could see target all the way on to the Citation ramp.
- A3-B-Y: Target good.
- Y to R, North then reverse course - Lost the target crossing 7R.

Observer 2.

- 7R - Right (south side).
- Fade - Between A2 and A3.
- Fade - Path to the firehouse.
- Split - At Twy R.
- Fade - After 1L.
- 5 - Shadowing - Lost the target in fast mode when the target stopped. Changed to normal mode to regain the target.
- Lost the target in the clutter/ Citation aircraft parallel to the target in the area.
- Broken up and faded. May have stopped.
- Twy B - Took out of fast target and reduced gain to eliminate clutter / this reduced the target size - Re-attained target.
- R/B - Readjusted Gain / Lost the target behind a parked aircraft's tail.
- R/S - Stopped - Took out of fast target to re-attain the target.

DRIVING SEQUENCE 19 - 29

Target Registration Quality

1. Normal
2. Fade
3. Split
4. Breakup
5. Other (write a brief comment next to the circle)

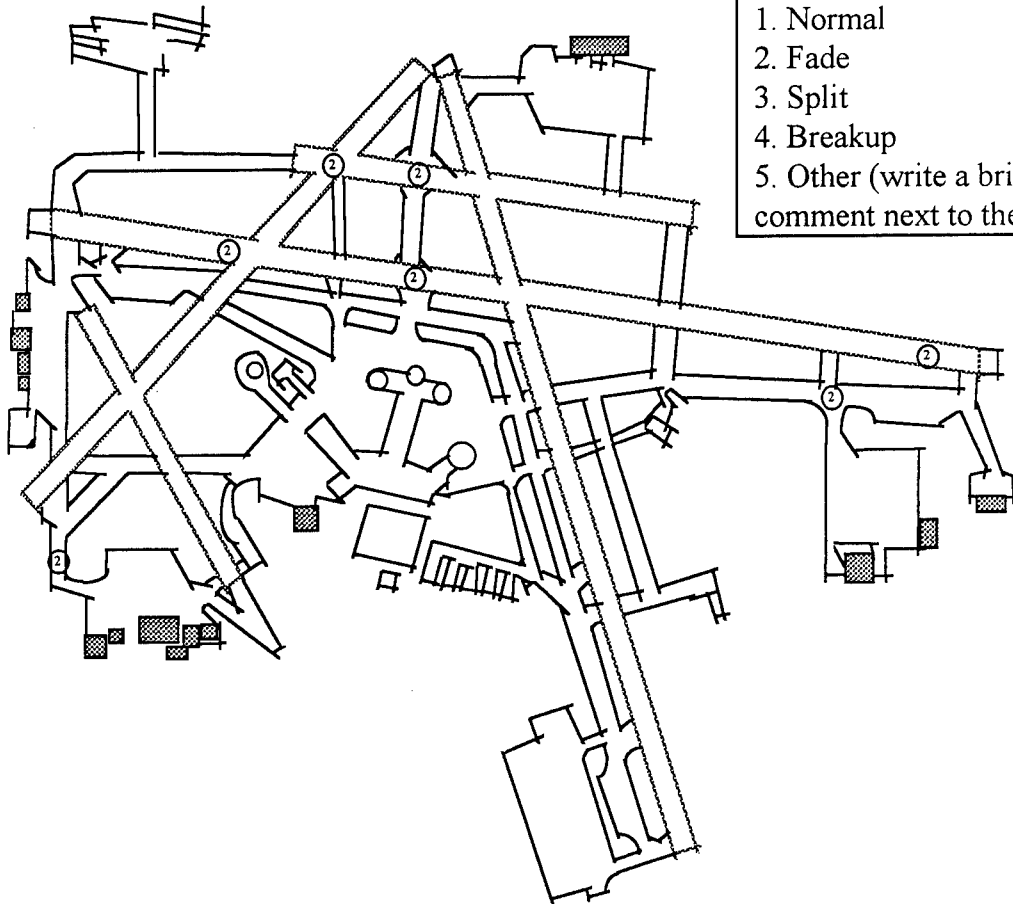

Comments:

Observer 1

- Reserve ramp - Couldn't track T-16 very well.
- Ramp to R3 - Good, Strong target.
- F to H to J - Target good steady.
- Disappeared as soon as the target got to the hangers.
- H, south - 19R South Strong steady target on 19L.
- Rwy 31 - Strong, steady target except where noted.
- Good return on F.
- Excellent coverage on Skyway ramp.
- C to 7L - Target Steady but weak (small).

Observer 2

- USAF reserve / Lost (in and out among the aircraft).
- Could not track truck in USAF reserve area.
- Skipped Phillip Morris ramp.
- Fade - Turned up the gain.
- Fade at Mike traveling 7R.
- Traveled H in fast target mode to distinguish from clutter.
- Coverage looks good in the East Hangers.
- Fade as passing Mike on 19L.
- Traveling back on 31 the target was not centered.

DRIVING SEQUENCE 29 - 39

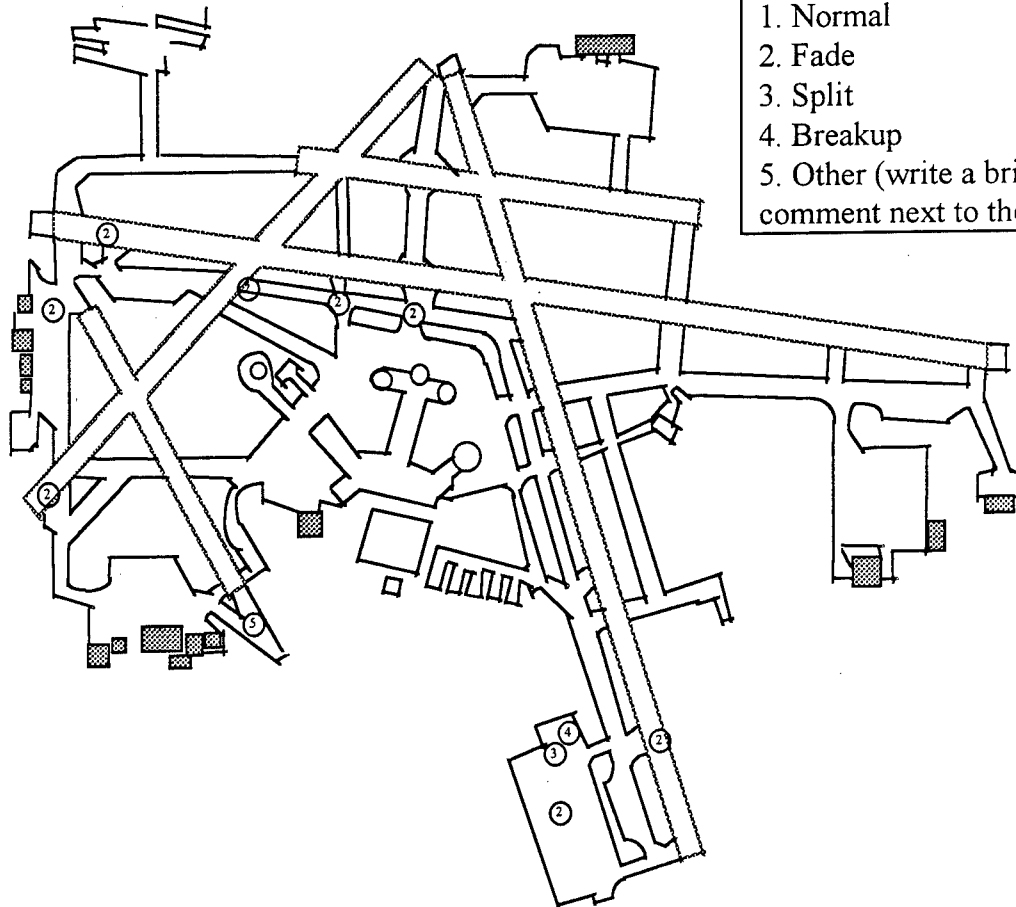

Target Registration Quality

1. Normal
2. Fade
3. Split
4. Breakup
5. Other (write a brief comment next to the circle)

Comments:

Observer 1:

- 7L - Target Steady, but small - F West to D.
- D South to B - Strong target.
- Target lost crossing approach end of 31.
- D1 - Target steady - strong.
- E, K, G good targets - steady.

Observer 2:

- Lost at Rwy end 7L.
- Increased Gain to strengthen return from the target.
- Faded at F and 13.
- D1 - Fade Run-up area.
- Crossing 31 - Lost the target temporarily.
- Lost at E - 7R.
- K - Target speeded up / Lost the target temporarily.

5.11 SURVEILLANCE UPDATE RATE

This test observed and recorded the display update rate by counting radar sweeps.

Personnel and Equipment:

2 Observers / Controllers in MKE tower
 Targets of opportunity
 Test Log
 Stop Watch
 Video recording equipment

Procedure:

1. Focus on the fixed target. Start stopwatch.
2. Count 100 sweeps.
3. Stop stopwatch when 100 sweeps have been counted. Record time.
4. Repeat steps 1 - 3 ten times.

Date: 12-12-95 Time: 7:45pm Local Time

Radar Information:

1. The radar was operating for longer than thirty minutes.
2. The FTRs were identified.

Radar Settings:

TUNE		INVERSE VIDEO	<input type="checkbox"/>
GAIN		INVERSE VIDEO	<input type="checkbox"/>
RAIN		INVERSE VIDEO	<input type="checkbox"/>
FTC		INVERSE VIDEO	<input checked="" type="checkbox"/>
SEA		INVERSE VIDEO	<input checked="" type="checkbox"/>
FAST TARGETS	<input type="checkbox"/>	STANDARD	<input checked="" type="checkbox"/>
PULSE WIDTH .06 μsec		RANGE SETTING .75 nm	

Weather: ASOS: MKE SA 1256 A02A M80 OVC 10+

Data Summary:

Test	1	2	3
Time	4:38.59	4:35.74	4:38.41

5.12 PROBABILITY OF DETECTION

An important test for the ASDE-X radar is that it provide surface detection coverage with a probability factor of at least 90% (the ASDE-3 requirement) during a single scan for a target within the coverage space having a radar cross-section of three square meters. Testing was done both in Standard Mode and Fast Target Mode.

Personnel and Equipment:

2 Observers /controllers in tower
 One 3 square meter FTR
 Video recording equipment

Procedure:

1. Establish the location of the three meter FTR on the display.
2. Observe the target for 100 scans of the radar.
3. Record the number of scans where the FTR was detected.
4. Repeat steps 1 through 3 ten times.

Data

Date: 12-13-95 Time: 1:50pm Local Time

Radar Information:

1. The radar was operating for longer than thirty minutes.
2. The FTRs were identified.
3. The map was aligned to the FTRs.

Radar Settings:

TUNE			
GAIN			
RAIN		INVERSE VIDEO	<input type="checkbox"/>
FTC		INVERSE VIDEO	
SEA		INVERSE VIDEO	
FAST TARGETS	<input type="checkbox"/>	STANDARD	<input type="checkbox"/>
PULSE WIDTH .06 μsec		RANGE SETTING .75 nm	

Weather: ASOS:

Reading A: 12-13-95 MKE SA 1946 A02A M10V OVC 10+

Reading B: 12-14-95 MKE 1506Z SP M 8 OVC 10+

Data Summary:

The probability of detection average was 93.8%, well within the ASDE-3 requirement.

KEY: Test Mode is S = standard or FT = Fast targets. Hits = FTR detections in 100 sweeps.

Test	1	2	3	4	5	6	7	8	9	10
ASOS	A	A	A	A	B	B	B	B	B	B
Mode	S	S	S	S	FT	FT	FT	S	S	S
Hits	85	87	100	98	94	89	92	100	96	97

5.13 LOW VISIBILITY PRESENTATION TEST

AT used this procedure to test the system during periods of low visibility and precipitation. The pretest and test specific forms were combined into one two-sided form. Trained controllers filled out the form during low-visibility periods. This test were performed as opportunity presented from January through March, 1996, in both modes of operation, normal and fast target.

Equipment and Personnel:

- 1 Test Coordinator
- 1 Observer / Controller in MKE tower
- Targets of opportunity.

Procedure:

1. For each target, mark the map for the duration the target appears on the display.
2. Note areas of recurring abnormalities and record them on the fill-in maps and the comment sections of the procedure-specific forms.

Test Forms:

Since this test was meant to be performed informally, instructions on test procedures were included on the form (Figure 5-13). Copies of this form were left in the tower cab to be filled out by the controllers as opportunities presented themselves.

Data:

A summary of the data sheets filled out by the MKE controllers during January and February, 1996 is included below.

Operations Assessment of Raytheon Marine Radar
 Located at General Mitchell International Airport

Test: Air Traffic Observations of the ASDE-X Radar During Low Visibility Periods

Procedure:

The information obtained from this test will be used to develop operational procedures for the use of the ASDE-X system during low-visibility operations. It is important to identify the strengths and weaknesses of the system. The test team is also looking to capture the controllers' general impressions of the system. The controllers' suggestions for enhancements to the system will affect the configuration of future Low Cost ASDE systems and potentially affect the second phase of the Milwaukee installation.

It is important that data be captured during rainfall. Rain has the most adverse effect on the radar. The controller should take special note to document any adjustments made to the system's controls to reduce clutter due to the precipitation.

Date: _____ Time: _____

Test Team: _____ Observer: _____

Aircraft/Vehicle: _____ Model: _____ Make: _____

Radar Information:

Radar Settings:

TUNE	<input type="checkbox"/>	<input type="checkbox"/>	<input type="checkbox"/>	<input type="checkbox"/>	<input type="checkbox"/>	<input type="checkbox"/>	<input type="checkbox"/>	<input type="checkbox"/>	<input type="checkbox"/>
GAIN	<input type="checkbox"/>	<input type="checkbox"/>	<input type="checkbox"/>	<input type="checkbox"/>	<input type="checkbox"/>	<input type="checkbox"/>	<input type="checkbox"/>	<input type="checkbox"/>	<input type="checkbox"/>
RAIN	<input type="checkbox"/>	<input type="checkbox"/>	<input type="checkbox"/>	<input type="checkbox"/>	<input type="checkbox"/>	<input type="checkbox"/>	<input type="checkbox"/>	<input type="checkbox"/>	<input type="checkbox"/>
FTC	<input type="checkbox"/>	<input type="checkbox"/>	<input type="checkbox"/>	<input type="checkbox"/>	<input type="checkbox"/>	<input type="checkbox"/>	<input type="checkbox"/>	<input type="checkbox"/>	<input type="checkbox"/>
SEA	<input type="checkbox"/>	<input type="checkbox"/>	<input type="checkbox"/>	<input type="checkbox"/>	<input type="checkbox"/>	<input type="checkbox"/>	<input type="checkbox"/>	<input type="checkbox"/>	<input type="checkbox"/>

INVERSE VIDEO	<input type="checkbox"/>
INVERSE VIDEO	<input type="checkbox"/>
INVERSE VIDEO	<input type="checkbox"/>

FAST TARGETS

PULSE WIDTH _____

STANDARD

RANGE SETTING _____

Weather: Automated Surface Observing System (ASOS):

Comment: _____ Precipitation _____

Figure 5-13. Low Visibility Presentation Test Form.

A target should be tracked for the duration of its operation on the airport surface. Numerically mark events on the map and describe the event on the comment sheet. Potential events include:

Target Split - target splits into two or more targets, traveling in parallel.

Target Breakup - Target breaks into several parts traveling on the same vector.

Target Fade - Target loses intensity

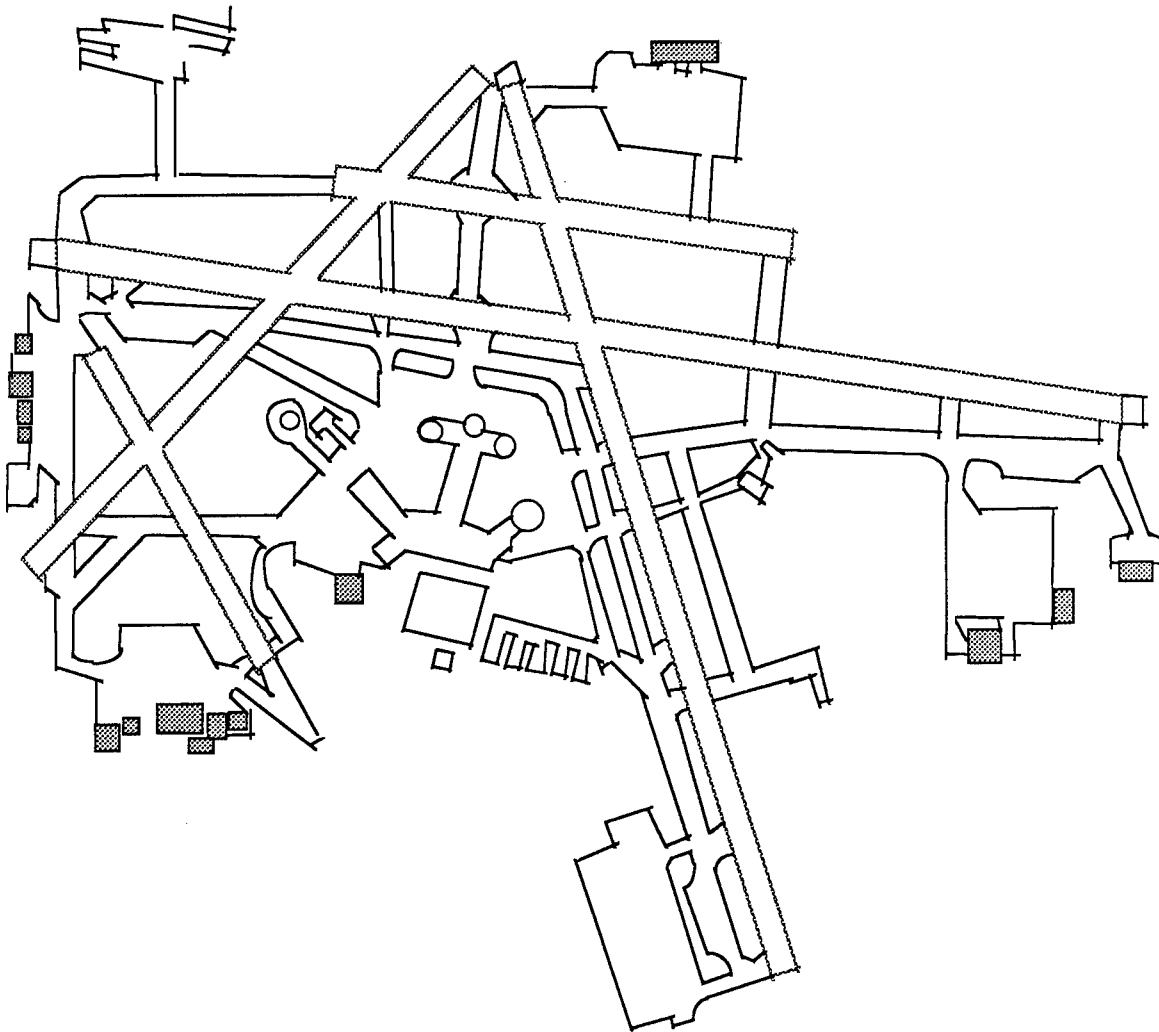

Comments: _____

Figure 5-13. Low Visibility Presentation Test Form (cont.).

Low Visibility Presentation Test Data Sheets

1. Date: 1-3-96

Time: 12:00:00Z

Test Vehicle:

Model: Ford

Make: Explorer

Radar Information:

Radar Settings:

TUNE		INVERSE VIDEO	<input type="checkbox"/>
GAIN		INVERSE VIDEO	<input checked="" type="checkbox"/>
RAIN		INVERSE VIDEO	<input checked="" type="checkbox"/>
FTC			
SEA			

FAST TARGETS	<input checked="" type="checkbox"/>	STANDARD	<input type="checkbox"/>
PULSE WIDTH .06 μ sec		RANGE SETTING .75 nm	

Weather: ASOS: M11 BKN 40 OVC 1 1/2S-F

Precipitation: 0000

Data Summary:

- 1 - Targets fading, very small and difficult to track - attempted to enhance w/more gain, less FTC, SEA to no avail.
- 2 - Very strong, good target in these areas.

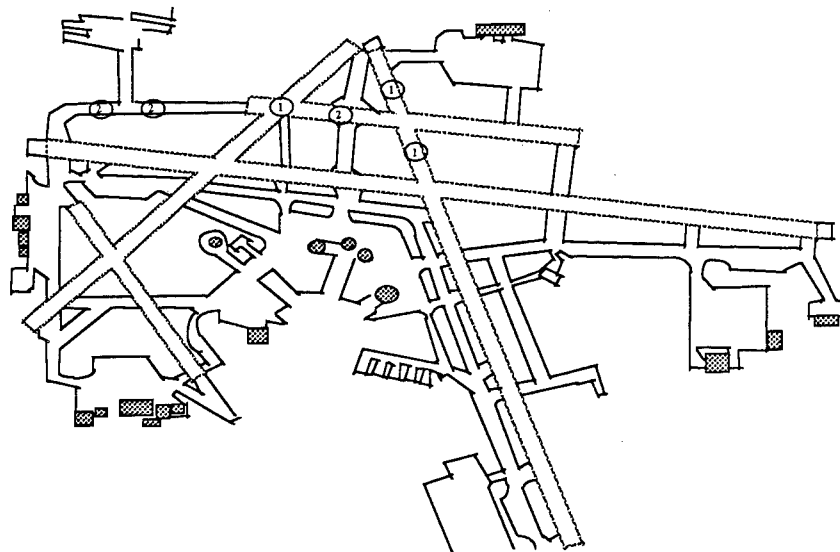

2. Date: 1-11-96

Time: 1305Z

Test Vehicle:

Model: UNK

Make: Snowplow

Radar Information:

Radar Settings:

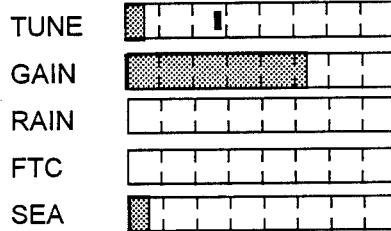

INVERSE VIDEO

INVERSE VIDEO

INVERSE VIDEO

FAST TARGETS

PULSE WIDTH .06 μ sec

STANDARD

RANGE SETTING .75 nm

Weather: ASOS: W5X 3/4 S-F

Precipitation: None

Data Summary:

Vehicles followed on Rwy 1L looked good. Aircraft were also defined well off 7R. Full length. Trucks often stopped on 1L. You could see very well.

3. Date: 1-16-96

Time: 2047Z

Test Vehicle:

Model: SW4

Make:

Radar Information:

Radar Settings:

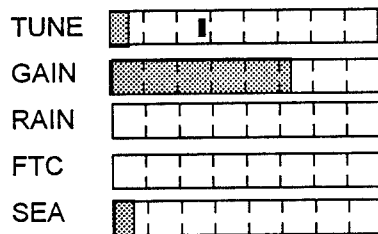

INVERSE VIDEO

INVERSE VIDEO

INVERSE VIDEO

FAST TARGETS

PULSE WIDTH .06 μ sec

STANDARD

RANGE SETTING .75 nm

Weather: ASOS: M5 OVC 3/4 F

Precipitation: 0000

Data Summary:

Solid target all the way from Rwy to gate (1L & R3 to Terminal D via R)

4. Date: 1-16-96

Time: 2053Z

Test Vehicle:

Model: Citation

Make: C650

Radar Information:

Radar Settings:

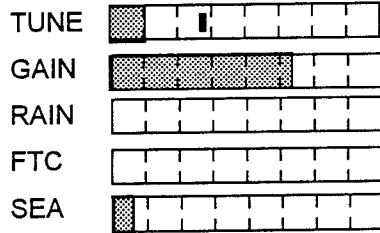

INVERSE VIDEO

INVERSE VIDEO

INVERSE VIDEO

FAST TARGETS

PULSE WIDTH .06 μ sec

STANDARD

RANGE SETTING .75 nm

Weather: ASOS: M3 OVC 1/2 F

Precipitation: 0000

Data Summary:

Good target all the way to Sig North

5. Date: 1-16-96

Time: 2105Z

Test Vehicle:

Model: BE10

Make: Beechcraft

Radar Information:

Radar Settings:

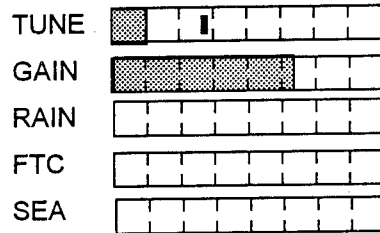

INVERSE VIDEO

INVERSE VIDEO

INVERSE VIDEO

FAST TARGETS

PULSE WIDTH .06 μ sec

STANDARD

RANGE SETTING .75 nm

Weather: ASOS: E1 OVC < 1/4 F

Precipitation: 0000

Data Summary:

Solid target all the way from 25L at E to Sig North via Rwy 31 unway to gate (1L & R3 to Terminal D via R)

6. Date: 1-16-96

Time: 2255Z

Test Vehicle:

Model: Citation

Make: 650

Radar Information :

Radar Settings:

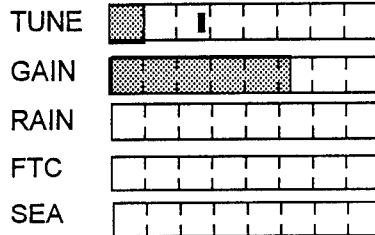

INVERSE VIDEO

INVERSE VIDEO

INVERSE VIDEO

FAST TARGETS STANDARD

PULSE WIDTH .06 μ sec RANGE SETTING .75 nm

Weather: ASOS: WIX <1/4 F

Precipitation: 0000

Data Summary: Good target from Citation service Center via A and E to Rwy 19R

7. Date: 1-25-96

Time: 9:45 pm

Test Vehicle:

Model: Everything

Make:

Radar Information :

Radar Settings:

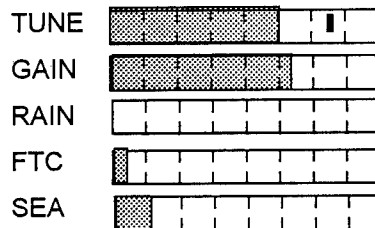

INVERSE VIDEO

INVERSE VIDEO

INVERSE VIDEO

FAST TARGETS STANDARD

PULSE WIDTH .06 μ sec RANGE SETTING .75 nm

Weather: ASOS: 28 + 1S - F

Precipitation: S-

Data Summary: Everything looked beautiful. We could see trucks, cars and all airplanes.

8. Date: 1-17-96

Time: 1147Z

Test Vehicle:

Model: BE10

Make:

Radar Information:

Radar Settings:

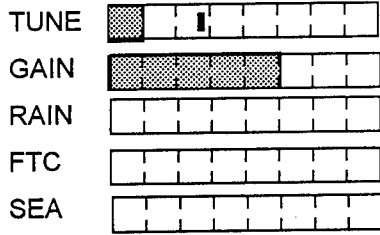

INVERSE VIDEO

INVERSE VIDEO

INVERSE VIDEO

FAST TARGETS
PULSE WIDTH .06 μ sec

STANDARD

RANGE SETTING .75 nm

Weather: ASOS: WIX <1/4 F

Precipitation: 0000

Data Summary: King Air taxied from North ramp to Scott Av. Target fading (north Ramp) in this area, rest of route, very strong, good target.

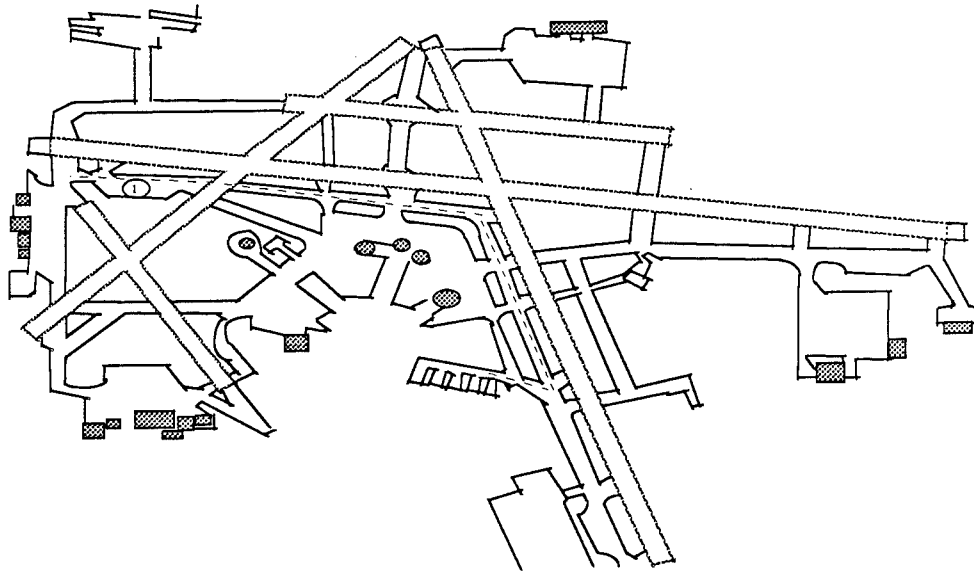

9. Date: 1-17-96

Time: 1220Z

Test Vehicle:

Model: 2 SHD3s & DC9

Make:

Radar Information:

Radar Settings:

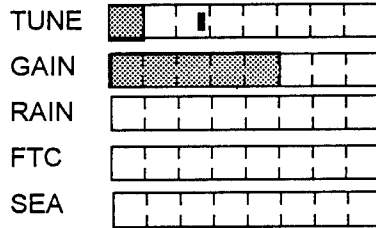

INVERSE VIDEO

INVERSE VIDEO

INVERSE VIDEO

FAST TARGETS

STANDARD

PULSE WIDTH .06 μ sec

RANGE SETTING .75 nm

Weather: ASOS: WIX <1/4 F

Precipitation: 0000

RVR 1L Touchdown 14, Midfield 16, Rollout 14

Data Summary: 2 SHD3's off cargo ramp to 1L, following DC9. 2 SHD3 stopped short of R, targets disappear in fast target, but were readily discernible when not in fast target. Targets were 2 distinct targets while stopped about 50 ft apart.

MAP KEY: 1 - DC9 route, 2 - SHD3 route, 3 - stopped position for SHD3s.

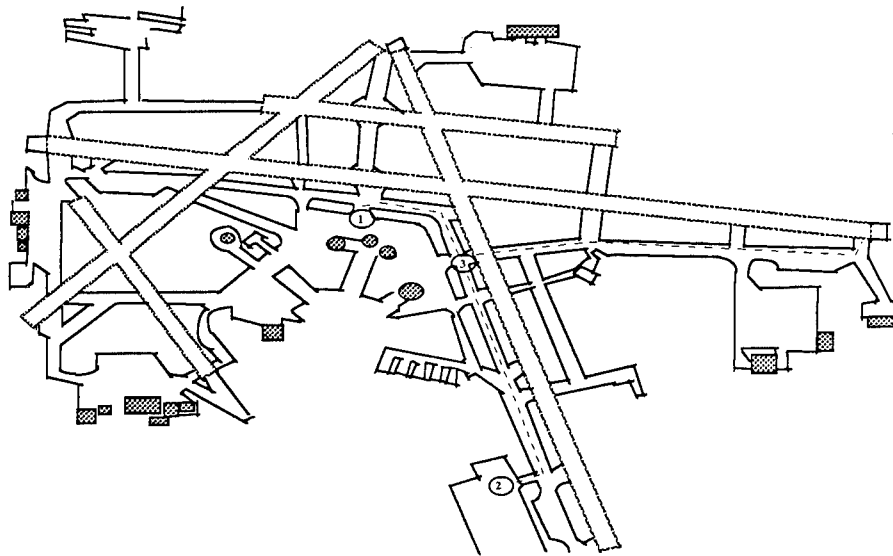

10. Date: 2-22-96

Time: 6:00 am local

Test Vehicle:

Model: DC8

Make:

Radar Information:

Radar Settings :

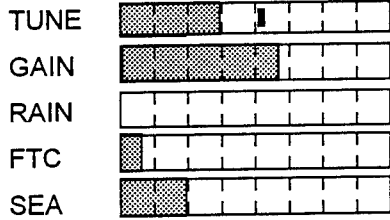

- INVERSE VIDEO
- INVERSE VIDEO
- INVERSE VIDEO

FAST TARGETS

PULSE WIDTH .06 μ sec

STANDARD

RANGE SETTING .75 nm

Weather: ASOS: M1 OVC 1/2 F

Precipitation: 0000

Data Summary: Heavy DC8 taxiing the indicated route on taxiway "A" had a trailing target to the left and rear, indicated on map by lines off the circles, in grass between taxiway "A" and Rwy 7R.

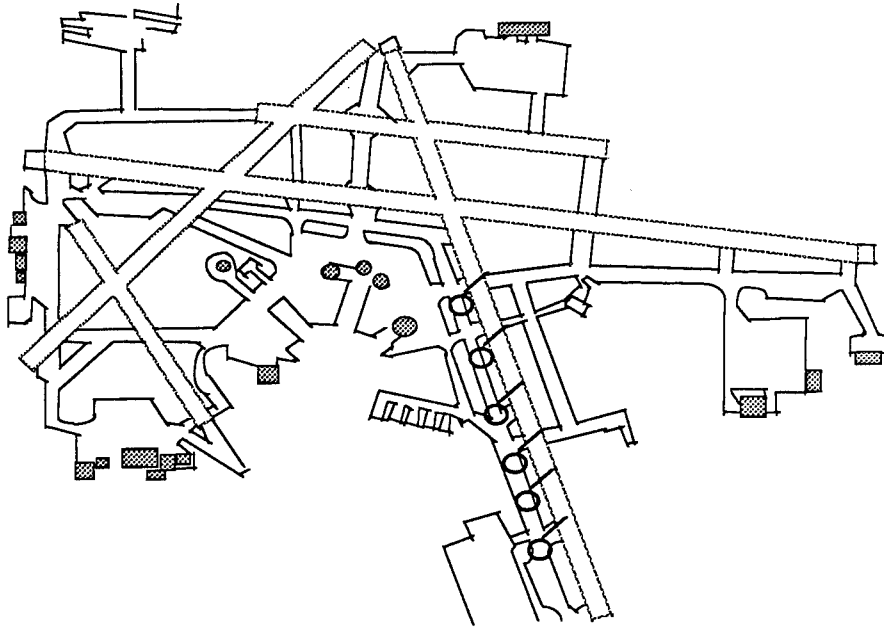

13. Date: 2-27-96

Time: 1510Z

Test Vehicle:

Model: KE35/ and DC10

Make:

Radar Information:

Radar Settings:

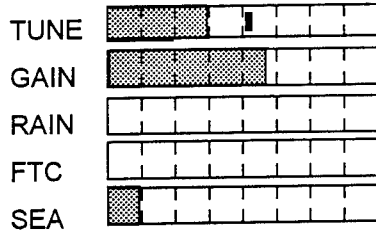

INVERSE VIDEO

INVERSE VIDEO

INVERSE VIDEO

* FAST TARGETS

PULSE WIDTH .06 μsec

STANDARD

RANGE SETTING .75 nm

Weather: ASOS: M1 OVC <1/4 F

Precipitation: 0000

Data Summary:

Good strong target on both aircraft taxiing for departure. (WIANG to 7R via M and A)

14. Date: 2-27-96

Time: 9:15 am lcl

Test Vehicle:

Model: DC9

Make:

Radar Information:

Radar Settings:

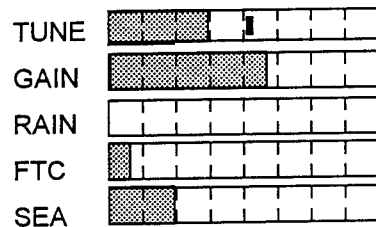

INVERSE VIDEO

INVERSE VIDEO

INVERSE VIDEO

FAST TARGETS

PULSE WIDTH .06 μsec

STANDARD

RANGE SETTING .75 nm

Weather: ASOS: M1 OVC 1/4 F

Precipitation: 0000

Data Summary: DC9 landing Rwy 7R (direction indicated w/arrows) - as aircraft exited Northbound on 1R, target broke up (about 3 distinct targets) and almost appeared as though aircraft was reversing course. As aircraft continued north and then west on taxiway M, target returned to normal, strong, distinguishable target.

15 Date: 2-27-96

Time: 6:00 am lcl

Test Vehicle: Model: Everything

Make:

Radar Information:

Radar Settings:

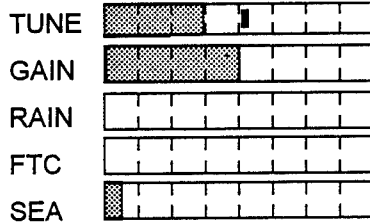

INVERSE VIDEO

INVERSE VIDEO

INVERSE VIDEO

FAST TARGETS

STANDARD

PULSE WIDTH .06 μ sec

RANGE SETTING .75 nm

Weather: ASOS: M1 OVC 1/4 F

Precipitation: 0000

Data Summary: Tower could not see the ground and used ASDE for confirmation. System was outstanding with proper adjustments (Gain level, SEA, and FTC) This equipment works great! All moving targets were displayed.

The following additional controller comments were entered in the site logbook.

2/23 1517: DC9 arrival off 19R, instructed to taxi via "R" and "B". (ACKNOWLEDGED) North of 7R DC9 turned east on Twy "A" according to ASDE. Asked DC9 if he was on "B", he said he was on "A". Rwy's and Twys not visible from cab.

2/23: Visibility 1/4 R-F 19R targets exhibiting on "S" fading until established northbound on R (also R3 to R). Targets indistinguishable from ground clutter on A from A4 to A1 and most of Yankee.

2/23: ASDE was not useful for Twys (targets not clearly defined.) But ASDE was very useful for determining when and where the aircraft cleared the Rwy. (Rwys and Twys not visible).

6. ANALYSIS AND RECOMMENDATIONS

6.1 ANALYSIS

Raytheon's marine radar (ARPA M3450 / 18-CPX-19) is a viable surface surveillance system option for smaller airports. The low-cost COTS radar has shown promise as a controllers' aid in monitoring surface traffic of non-cooperative targets. This analysis summarizes and critiques the radar's performance record, compares the functional test data and specifications to ASDE-3, and analyzes the operators' assessment of the system's utility and serviceability in the ATC environment.

EQUIPMENT

Raytheon's marine radar ARPA M3450 / 18CPX-19 (Phase I) radar is a high-resolution, ground-surveillance radar which presents the controller with a screen display of stationary and/or moving aircraft and vehicles. It is a low cost, solid state, production model marine radar available from the General Services Administration (GSA) Federal Supply Service. It is designed with standardized, modular components which provide interchangeability, shorter mean time to repair, and reduced spares requirements for a given service area. The system came with a one-year service and parts warranty.

This radar has options that enable it to serve as a sensor for the detection, surveillance, and control of surface vehicles at airports when the visual line-of-sight is limited. The radar provided good range and azimuth resolution and produced well defined images at a range of 1 1/4 nm. The system has a 50kW X-band transmitter, a low-noise receiver, and a 34 cm raster display. It is a pulse-type system with a capability of operating at three distinct pulse widths. The short pulsewidth of 60ns, with a Pulse Repetition Interval of 3600 Hz, was used exclusively during the evaluation. The system had 10 range scale settings available. The 3/4 nm setting was the preferred controller setting. The X-band radar operates at 9375 MHz, an operating frequency affording optimum tradeoff between resolution and weather performance.

This COTs radar's cost of \$75k increased to \$100k when AT / AF training and hardware enhancements were added to adapt its performance to the airport environment. These enhancements included a circularly polarized antenna with a 19° vertical beamwidth and horizontal beamwidth of 0.4°, an LNFE azimuth blanking option, and a dehydrator to avert arc-inducing humidity in the system's waveguide.

The antenna secured to the top of the pedestal has an X-band waveguide flange interconnection. The slotted array is enclosed — top, bottom and rear — by an aluminum housing. The front of the array is covered with a flat section of radome material making it a compact, self contained rotating structure. During the evaluation the antenna experienced no icing problems during an unusually harsh winter. The antenna was driven at a uniform rate of 22 rpm by the motor drive system in the pedestal.

The blanking option permits the transmitter to be disabled over a sector of the 360° scan. This feature was purchased because of the possibility of interference with and/or from various airport systems. The option was tested at turn-on and then disabled when found unnecessary. Although the airport has experienced no interference problems, local AF radar technicians have been left with instructions to reimplement this option if necessary.

SYSTEM OPERATION

The MKE operations team has been recording since December 1995 a daily events log of the Phase I performance. From the outset, the system experienced, both at startup and in switching from long to short pulse, turn-on delays in short pulse transmission. These delays increased from a few minutes to

half an hour, until on January 5, 1996, the radar failed completely to transmit in short pulse. Raytheon was contacted, and on January 10 sent a service technician, who replaced the magnetron and tailbiter board located in the transceiver assembly. At this point, the controllers reported that the radar tune setting indicators were misaligned but that the system was usable; they continued their data collection.

On January 20, the system experienced a second failure to transmit in short pulse. Local AF radar personnel identified a faulty tailbiter board and had Raytheon ship a replacement. AF replaced the tailbiter and a faulty temperature switch on January 23. The two faulty tailbiter boards and the magnetron were sent to Raytheon Marine for analysis.

On January 26, the system experienced its third tailbiter failure. Raytheon determined that the failures were due to faulty saturable reactors located on the tailbiter. The saturable reactors were not being manufactured to Raytheon's specifications. The problem, fully investigated by Raytheon and reported to the evaluation team, was traced to a third-party manufacturing quality defect, which they have since remedied. Raytheon found that the saturable reactors failed because high voltage corona caused short circuiting. The corona was caused by air pockets in the potting epoxy used in the reactor's insulation. Use of an approved epoxy and tested potting procedure has eliminated air pocketing and subsequent short circuiting.

On January 30, AF installed a saturable reactor determined by Raytheon to meet specification. The system has experienced no failure or degradation in operation since.

TESTING

After calibration and certification, the evaluation team made system measurements and conducted both functional and operational tests. In order to operate this X-band system on the surface of MKE, a frequency allocation permit was obtained through the FAA Frequency Management personnel (reference Section 2). If a decision were made to deploy this system throughout the NAS at airports non-eligible for ASDE-3, the FAA would have to make the appropriate provisions to operate this portion of X-band normally used for marine radar.

Equipment checks and adjustments were made to the radar, specially constructed Fixed Target Reflectors (FTRs) were erected near the tower, and a DGPS survey conducted. Functional tests included measuring parameters of the radar components (transceiver, display, waveguide, antenna), aligning the radar with the FTRs, range and azimuth resolution test (see Figure 4-11), acoustic noise measurements and making airport maps on the display. Data sheets provide a checklist summary of all recorded calculations and checked verifications (Section 4.5).

FUNCTIONAL TESTS

After the radar was installed and certified, a functional evaluation of the radar was conducted to verify system performance prior to performing the operational tests. Functional tests performed for system characteristics and the measured values recorded are shown in Table 6-1.

Table 6-1. Phase I Functional Test Measurements.

Phase I Component	System Parameter	Measured Value
Receiver	Minimum Discernible Signal	-90.1 dB
	Dynamic Range	60.0 dB
Transmitter	Frequency -40 dB below peak	-198 MHz
	Frequency -40 dB above peak	82 MHz
	Peak power output	73.4 dBm
	Pulse width	53.9 nsec
	Pulse rise time	8.7 nsec
	Pulse fall time	24.8 nsec
	Frequency	9.404 GHz
	Frequency variance	29 MHz
	Pulse Repetition Frequency	3630 Hz
Antenna and Waveguide	Voltage Standing Wave Ratio	1:1.145
	Waveguide Insertion Loss	2.2 dB
Tower Cab Environment	Acoustic Noise, System Off	41 dBA
	Acoustic Noise, System On	47 dBA
General	Azimuth Resolution	80 ft.
	Range Resolution	60 ft.

There is no doubt that the ASDE-3 radar provides a higher definition radar presentation than the ASDE-X radar. Yet controllers found that, once familiar with the radar controls and airport layout, the Phase I ASDE-X was capable of providing a similar service. In fact, certain distinct radar signatures evident with the ASDE-3 were also evident with the ASDE-X, such as the video "tail" on the L1011 or DC-10. This evaluation is not meant to be a one-on-one comparison of the two systems, but it makes sense to use ASDE-3 as a benchmark for testing any low-cost ASDE solution for lower level airports and a baseline for developing a low-cost ASDE functional or system specification. Table 6-2 compares common parameters of the ASDE-3 and Phase I ASDE-X radars.

Table 6-2. Comparison of ASDE-3 and ASDE-X.

Key: OP = operational; NOP = non-operational; VL = Vernier-Labeled.

PARAMETER	ASDE-3	ASDE-X (PHASE 1)
ANTENNA / PEDESTAL		
Operating Voltage	208 VAC, 3 Phase	208 VAC, 3 Phase
Running Current	7 amps	2 amps
Antenna Type	Reflector (CSC pattern)	Slotted Array
Horizontal 3 dB Beamwidth	0.25 °	0.40 °
Vertical 3 dB Beamwidth	1.60 °	19.0 °
Polarization	Circular	Circular
Integrated Cancellation Ratio	17 dB min	17 dB min
Gain	44 dB	36 dB
Horizontal Sidelobes	< 5°=-24dB, > 5° = -30dB	< 7.5°=-26dB, >7.5°=-30dB
Field of View	360 °	360 °
Scan Rate	60 RPM	22 RPM
Azimuth Position Generator	Encoder	Resolver
Motor	5 hp	1 hp
Humidity	100 %	100 %
Operating Temp.	-50 to +70 C	-25 to +65 C
Rotodome/Radome	Yes - Rotodome	Yes - Rotodome
Max. Wind Load	130 mph (NOP)	125 mph (NOP)
Max. Wind Load	85 mph (OP)	80-90 mph (OP)
Ice Loading	1/2" (NOP)	1" (OP)
Dimensions	10.6'(h) x 18'(diameter)	Antenna = 1'x1.3'x18.5 Pedestal = 39"x32"x61"
Weight	4800 lbs.	320 lbs.
TRANSCEIVER		
Operating Voltage	208 VAC	120 VAC, 1 phase
Current Load	2.1 A	2.54 A
Type	Pulse	Pulse
Band Designator	Ku	X
RF Amplifier	TWT	Magnetron
Peak RF Power	3.5 kW	18 kW (actual)
Average Power	2.2 W	3.8 W
PRF	16384	3600
Frequency	15.7 - 16.2 GHz	9.375 GHz
Frequency Agility	16 channels @ 25 MHz	none
Pulse Width	40 ns	60 ns
Wavelength	1.8 cm	3 cm
Spectrum	-40 dB @ +/- 212 MHz	-40 dB @ +82 MHz, -198 MHz
Receiver IF	1.25 GHz	45 MHz
Receiver Bandwidth	50 MHz	25 MHz
Noise Figure	4.2 dB	6.5 dB
Frequency Tune	AFC	Manual - VL: "TUNE"
MDS	-90 dB	-92 dB
Dynamic Range	30 dB	60 dB
RFSTC	Auto	Manual - VL: "SEA"
Adaptive Gain	Auto	Manual - VL: "GAIN & RAIN"
Sector Blanking	Yes	Yes
Area Detection Threshold	2 Adaptive, 1 Fixed	1 Fixed, Manual - VL: "FTC"
Dimensions	72" x 24" x 24"	33" x 24" x 13"
Weight	750 lbs.	105 lbs.

Table 6-2. Comparison of ASDE-3 and ASDE-X. (cont.)

DISPLAY PROCESSOR		
Operating Voltage	208 VAC, 3 Phase	120 VAC, 1 Phase
Current Load	2.1 A	2.0 A
Update Rate	1 second	2.7 seconds
Cursor Report	Yes	Yes
Airport Map Overlay	Yes	Yes
Range Scale Adjust	Yes	Yes
Display Info Offset	Yes	Yes
Multiple Map Storage	Yes	Yes
Coordinate Conversion	Polar to Cartesian	Polar to Cartesian
Dimensions (HxWxD)	72" x 24" x 24"	47" x 27" x 30"
Weight	625 lbs.	216 lbs.
DISPLAY		
Operating Voltage	115 VAC, 1 Phase	NA (w/display CPU)
Current Load	2.1 A	NA
High Brightness	Yes	Yes
Resolution	1024 x 1024 pixels	768 x 1024 pixels
Dimensions (HxWxD)	16 " x 16.5" x 26.5"	NA
Weight	270 lbs.	NA
SYSTEM		
Number of Point Target Hits Rec'd Between 1/2 Power BW Points	13	11
Safety Interlocks	Yes	Yes
Waveguide Insert Loss	1.24 dB	2 dB ¹
VSWR	1.5 : 1	1.14 : 1 ²
CAB Acoustic Noise	No greater than: 31 Hz = 66 dB 63 Hz = 71 dB 125 Hz = 73 dB 250 Hz = 71 dB 500 Hz = 72 dB 1000 Hz = 69 dB 2000 Hz = 57 dB 4000 Hz = 46 dB 8000 Hz = 46 dB	47 dB (A) ³
Azimuth Resolution	0.25 °	0.40 °
Range Resolution	20'	60'
Azimuth Accuracy	0.04 °	0.087 °
Range Accuracy	12'	24'

OPERATORS' EVALUATION

Radar evaluation was conducted by system users--the Air Traffic Controllers--at MKE between December 1995 and March 1996. Each of the thirteen tests (Sections 5.1 through 5.13) evaluated the radar's effectiveness, isolating specific areas of system operation, such as aircraft presentation, target registration, and false target display. The tests used test aircraft, test vehicles, FTRs, and targets of opportunity to verify these and other performance parameters:

¹ ASDE-3 value approximate loss for 60' WR - 187 waveguide
² Measured from transmitter up to antenna
³ ASDE-3 referenced to FAA-G-2100C;
ASDE-X referenced to FAA -G-2100F: requires no greater than 55 dBA.

- Maximum height coverage
- Minimum range
- Demonstration of fast moving targets transitioning from runway to taxiway
- Demonstration of shadowing between dissimilar sized targets
- Demonstration of ground targets in reference to map overlay
- Demonstration of targets during low visibility conditions
- Observation of targets for fade / breakup
- Observation of display for non-aircraft or false targets

The controllers recorded the operational test data on test procedure forms and the test team backed up the results on videotape. The Phase I evaluation has continued after the end of the formal operational test; controllers are filling in response forms on radar operation during low-visibility conditions (Test 5.13).

Raytheon provided operator training both at their Manchester, NH training facility and on-site at MKE when Raytheon certified the system. The on-site operator training was considered more effective, as it was "hands-on" in an airport environment with "real time" situations and familiar targets. It was suggested that Raytheon explore upgrading their operators' training to be more appropriate to the airport environment, using ASDE-3 training courses as a model.

AT verified the radar's capability to detect and display targets in conditions of fog (<1/4 nm visibility), moderate rain driving rain and snow. AT found that the Phase I radar enabled controllers to confirm pilots' reported positions and aircraft/vehicle compliance with instructions, and aided their clearance of aircraft vehicles on the movement area during low visibility conditions. The controllers' comments regarding the system's capability were consistently favorable throughout the evaluation. Though the system was not without limitations, the controllers generally adapted to these limitations and continued to operate the system effectively.

Display Settings (Sensitivity Controls)

Before each evaluation, the controllers recorded on data sheets their settings of the radar's display control, located on the top surface of the display unit. These settings, occasionally adjusted as the test proceeded, determine the quality of the presentation. Controls for brightness and contrast, once set, were rarely readjusted. Average radar settings are shown in Table 6-3.

Table 6-3. Average Radar Settings.

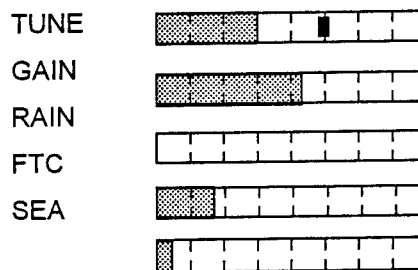

Adjustments were either made to enhance weak targets or to reduce clutter. Controllers found a tradeoff between these two factors and adjusted the system to their individual preferences. Adjustments also became area specific. For example, GAIN settings were lowered on taxiways where clutter causes problems for the controllers' visual tracking of targets, and raised, enhancing targets, where clutter was less of a problem. These differences were usually associated with the distance from the radar. Areas in the terminal area generally had greater clutter than areas at the runway ends. The major radar settings and their evaluations follow.

TUNE: The tune setting rarely required adjustment. The test coordinator set the tuning with initial system turn-on and locked its position. The manufacturer suggested retuning the system after a thirty-minute warm-up period. The system's transceiver was located in a room where the environmental conditions were not controlled. Under severe cold conditions it is possible that the warm-up period can vary. It is suggested the system have an additional tuning four hours after initial turn on. The system was operated continuously during the evaluation so tuning adjustments were minimal. Exceptions were after system failure and repair.

The manufacturer also indicated that as the system's magnetron degrades the system will need retuning. Because of the saturable reactor failures during January and the magnetron swap out, the effects of a degrading magnetron were not observed. Magnetron degrading and its effect on the operation of the system will need further analysis before the system is used in an airport environment.

GAIN: The Gain setting on the system was by far the most adjusted. As mentioned above, there was a trade-off between target strength and clutter when adjusting Gain. Target image definition and strength deteriorated with range, as shown in test data and videos. Controllers often increased Gain to better observe smaller targets (car, small aircraft) toward the end of Runway 1L, the most distant coverage area. They often reduced the gain to minimize clutter problems, prevalent near terminal areas.

RAIN: The Rain setting was the least used adjustment during testing. The controllers reported that this adjustment was effective in eliminating any rain clutter due to heavy rain. There were in fact few substantial rain storms during the test period. Test data showed that the Rain adjustment was unnecessary during low visibility periods of fog or snow.

FTC and SEA: These settings were often adjusted in conjunction with each other. SEA adjustments attempted to reduce clutter due to moving grasses or snow cover. FTC was then adjusted in an effort to restore weak targets lost with SEA or RAIN adjustments. The controllers' preferred settings were to simply turn them on (inverse video) and sometimes add a "touch of bar."

The Phase I radar required realignment each time the system failed in January 1996. From January 10-30, the radar setting indicators were not properly aligned (see Test 5.13). With a magnetron life estimate of 2000 hours, operation realignments will occur periodically and should include a controller check to validate the system performance.

Modes of Operation

The two modes of operation offered to the controllers were "Standard" (Scan to Scan Integration) and "Fast Target". Standard is a digital video processing technique which requires three complete scans of the antenna in order to "build-up" or "decay" detected targets. When the target is first detected it is painted "dim." On the second scan it is painted "mid" and on the third it is painted "bright." If the target is lost it will fade in three scans. This is important when the controllers operated the sensitivity controls, because it requires three complete scans to properly observe the results of a single adjustment.

Fast Targets causes moving targets to appear brighter. The three scan integration is removed, and all returns are updated at each scan. When this function is active, stationary targets are stepped down through the three levels of video until they are in the dim video level.

In both modes of operation, a moving target registers as three hits in three different levels of video (see Figure 6-1). This has the effect of giving the controller a sense of the target's speed and direction. However, targets traveling slowly may appear stretched or longer. This can affect the controllers' ability to separate targets traveling in tandem at close proximity (less than 50'). The targets potentially will appear as a blob.

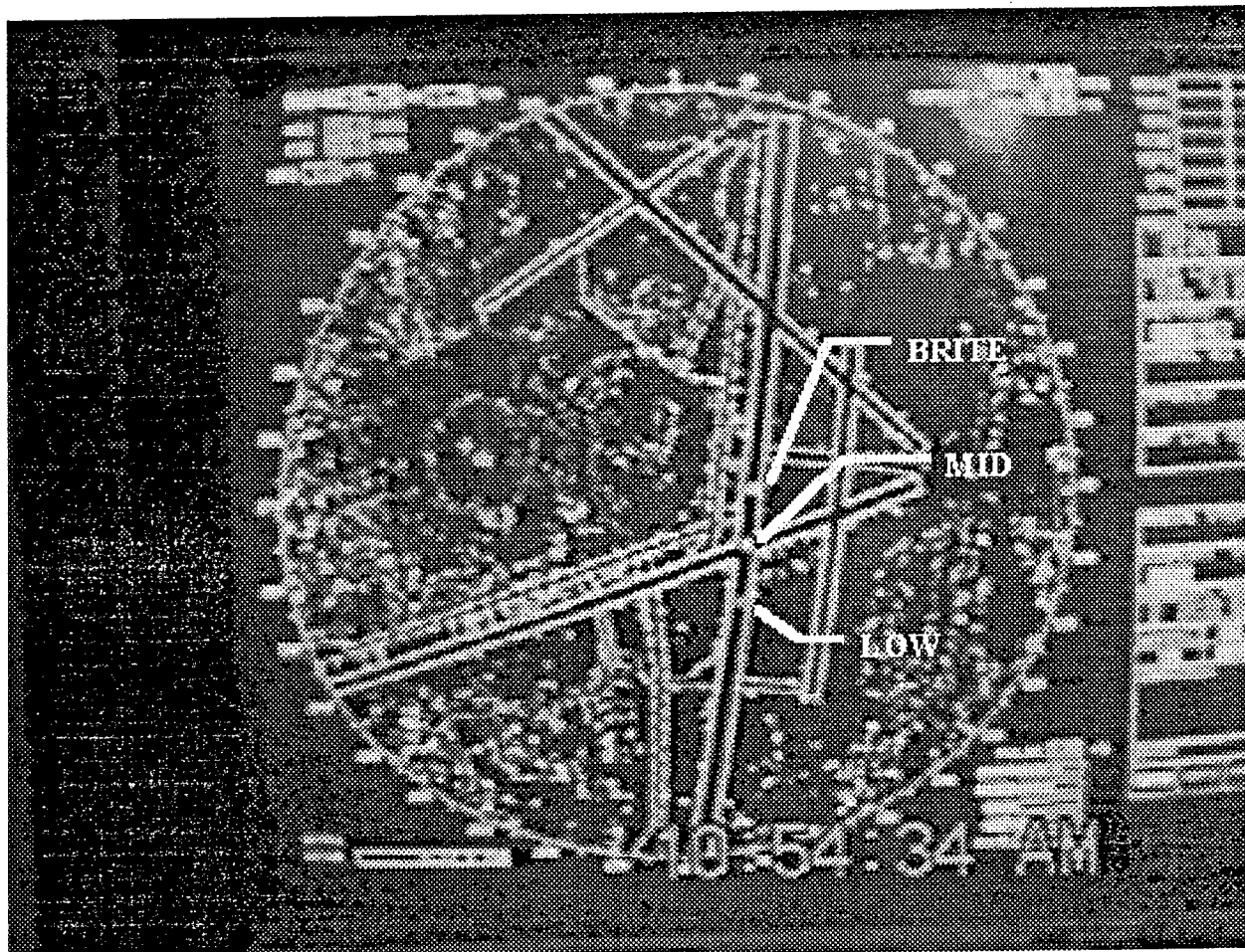

Figure 6-1. Display Showing Target in Three Levels of Brilliance, at .75 nm Range with MKE Overlay.

The controllers preferred mode of operation during testing was Fast Targets. This mode set a moving target registration to high at detection. This enabled the controllers to distinguish a moving target from the clutter. During Test 5.4, Radar Registration of Targets, the controllers observed that when operating in Fast Target mode, the target "faded" or "disappeared" once in hold position. The target would become indistinguishable from the clutter and/or be lost from view. The tower cab's bright ambient light contributed to poor target detection at low video. This observation was recorded at all runway ends tested. This was not a factor when the system operated in Standard mode. The controllers soon learned to compensate for "fading" by switching from Fast Target to Standard once a tracked target stopped or to detect stationary targets.

Non-Aircraft Targets Traveling In Tandem

The two modes of operation were again demonstrated during Test 5.5, Registration of Non-aircraft Targets. This test gave the controllers a look at how the system displayed vehicles traveling in typical configurations, such as County trucks and cars traveling in tandem on the airport surface. Observations showed that when targets traveled in close proximity (less than 50 feet), they merged as one target (Figure 6-2). When the test observer asked that the vehicles separate more than 50 feet, the targets appeared as separate (Figure 6-3.) Fifty feet was an estimated distance given to the test team by the vehicle operators. The system was operated in Fast Target mode when the targets were in motion and often switched to Standard to assist in detecting the targets when they became stationary. As mentioned above the three step integration is a factor in distinguishing targets traveling in tandem. The three scan fade of one target interfered with the registration of a second target traveling closely behind.

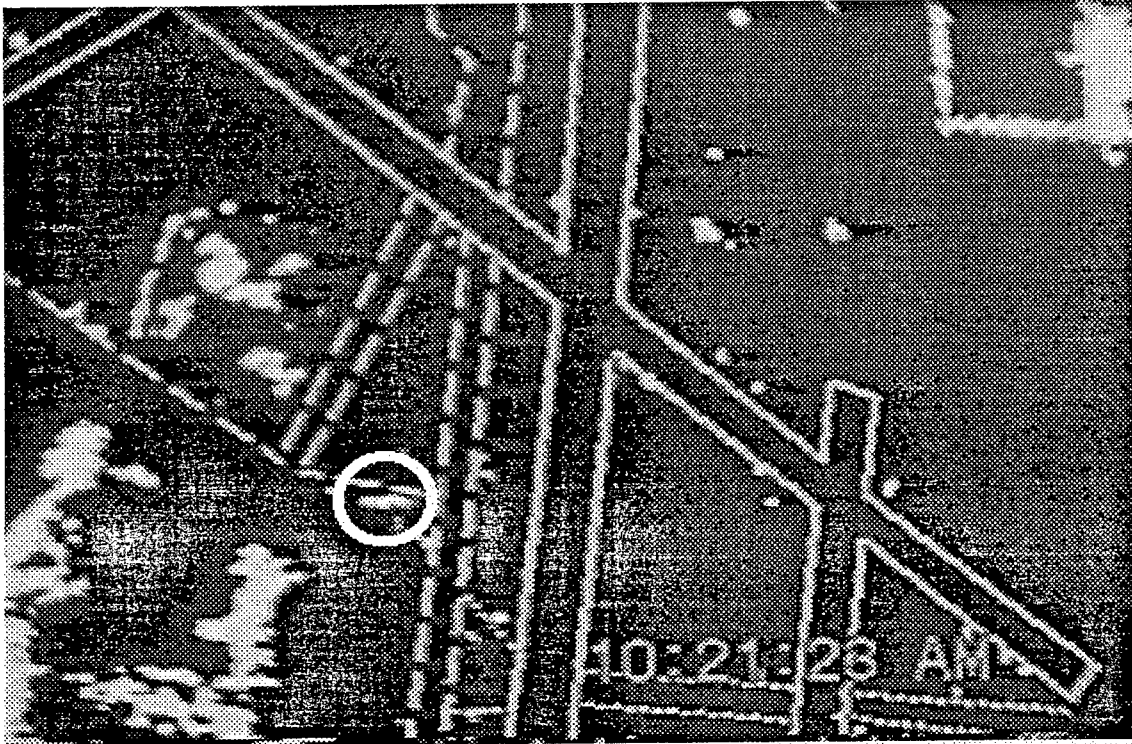

Figure 6-2. Three Vehicles Traveling West on Taxiway K, Merged as One Image.

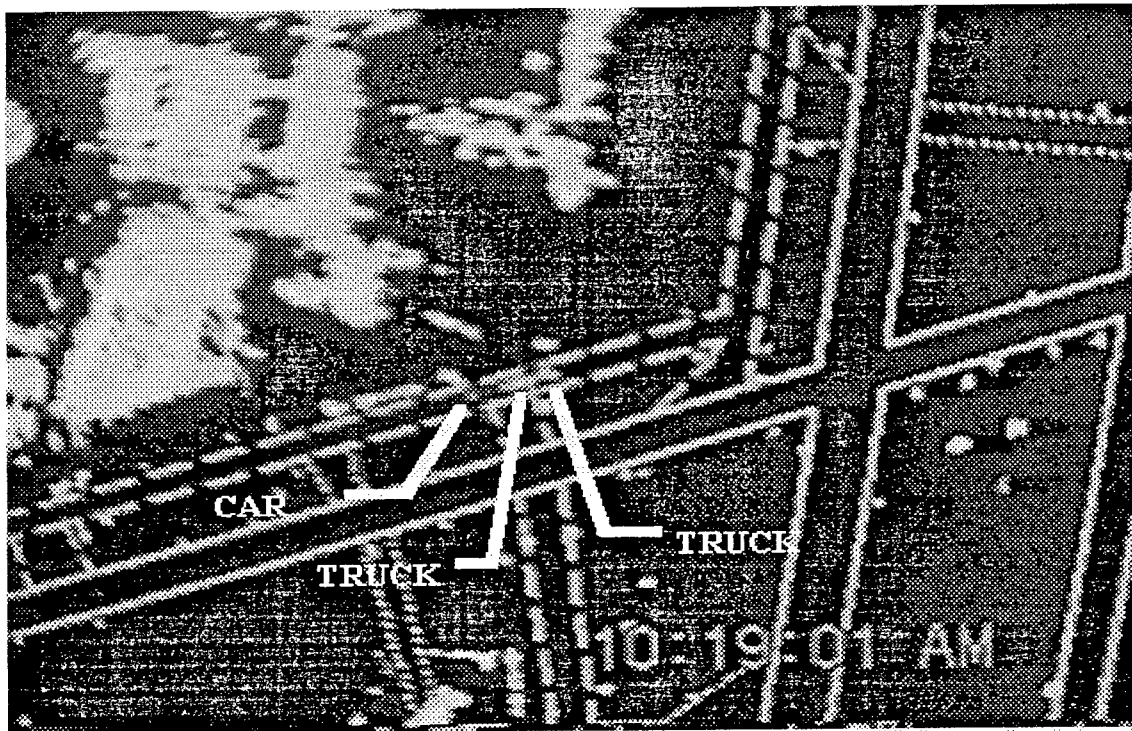

Figure 6-3. Three Vehicles Traveling East on Taxiway A, Separated as Three Targets.

Airport Map Overlay

The controllers expressed concern with how the runway/taxiway overlay related to the actual airport surface. During Test 5.10 ("Position Accuracy Testing") the controllers developed confidence in the accuracy of the overlay. The overlay was produced using the Navigation Lines feature of the radar display unit. The 99 TRUE and 16 RELATIVE lines allowed complete overlay of all runways but only limited overlay of the taxiways (Figure 6-1). The system is capable of storing ten overlays in protected memory.

The controllers' involvement in designing the test overlay assured that MKE's most active taxiways were covered. Controllers found the system usable despite the limited overlay. They were able to track targets through all non-overlaid taxiways by using their knowledge of the actual taxiway configuration and referencing the overlay. Standard mode operation further facilitated locating unplotted taxiways by increasing grass clutter displayed along their edges.

Once a target was detected in these areas, controllers switched the system to fast target to better observe the movement of the target. Although the system is usable, its operability could be greatly enhanced with additional Navigation lines to overlay the remaining taxiways, the terminals and other buildings on the airport's surface. Another solution would be to store several maps covering specific taxiways for the various airport landing /takeoff configurations. Specific overlays would be called upon when the airport is operating in a related configuration. (The Phase II upgrade will enhance the map overlay capability from 115 to 999 lines.)

Range and Offset Operation

During testing, the controllers preferred the .75nm range setting (Figure 6-1). Because the entire airport surface was not covered at .75nm and the 1.5 nm setting was considered too small, the controllers quickly became proficient using the Offset function. This function enabled the controllers to offset the display up to 75% from the center (tower) of the display. The controllers often offset the display to cover a current Landing/Takeoff configuration and adjusted it if a target being tracked traveled off the display. The controllers expressed a desire for more control of the range increments in future systems, thus enabling them to cover all movement areas at a desirable viewing range. (The Phase II upgrade will allow controllers to customize the display to retain up to six range settings, in multiples of 1/4 mi. increments.)

Maximum Height

One evaluation test measured the maximum height a target could be detected over the airport. The ASDE-3 requirement of coverage 200 feet above ground level was not a concern because the antenna was mounted on top of MKE's 200 foot tower. However, the test team wanted the maximum height coverage to project performance of the system when mounted at various heights in possible future installations. A manufactured supplied vertical antenna pattern (~19-degree beam width, Figure 6-4) and the controllers visibility map were used to estimate the system's coverage (see Figure 5-2a). A HS-28 Hawker/Siddeley was flown over Runway 19R - 1L to test the system's maximum height coverage. The system registered the target across the entire runway at 500 feet above ground level traveling at 200 knots. Maximum distance from the antenna (Runway end 1L) was approximately 1 1/4 nm. Minimum distance was just over 1/2 nm. At 700 feet the target did not register between taxiways "S" (3/4 nm) and "M" (5/8nm). Further flyovers increased the increments until the target no longer registered along the runway. Flyovers between 500 and 700 feet were not done due to increased traffic. The test shows that there will be coverage from 300 feet above the installed antenna height at a range of 1/2 mile to 1 1/4 from the antenna.

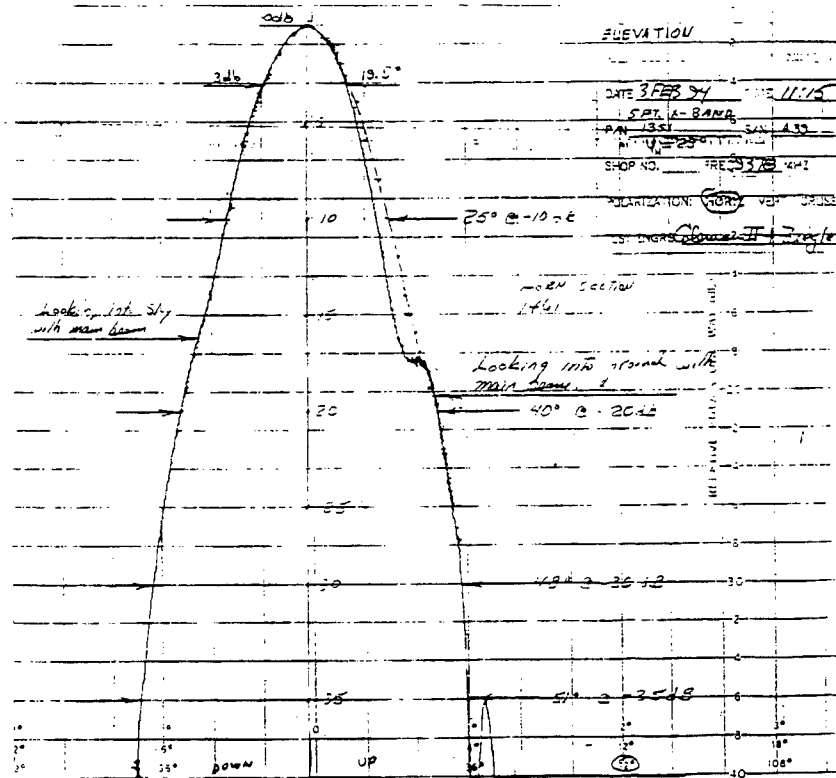

Figure 6-4. Typical Vertical Antenna Pattern for Horn Used in Phase I.

Shadowing Due To Dissimilar Targets and Buildings

Controllers examined various lineup areas where aircraft often travel in tandem. During Test 5.3, Dissimilar Size Targets, small aircraft (HS-28) were lined up radially with a larger aircraft (DC8, DC9) in potential problem areas and their display was noted. No problems were noted with shadowing of targets in either the formal test or through observation of targets of opportunity. The height of the antenna (200 ft) and the MKE layout preclude any major shadowing problems when aircraft are in lineup situations.

Shadowing from terminal buildings was a problem area demonstrated during Test 5.10, Position Accuracy Testing. The controllers often reported targets "lost" or "fading" when they traveled close to terminals. Hangar areas also accounted for shadowing occurrences, such as the Cargo Ramp, USAF Reserve, East hangers and Signature North. Targets traveling in these areas were often "lost" behind buildings or among parked aircraft.

False Targets

False targets are often problems associated with radar systems operating in an airport environment. The Phase I system was evaluated for occurrence of false targets. Ground conditions during Tests 5.8 and 5.9, were a snow-covered airfield with plowed runways and taxiways. The false targets were all temporary occurrences. When ground conditions changed, the false targets were no longer found in places previously recorded. False targets included target splits at M and E, B and M and at E and 19R. The video showed the target splitting as an aircraft traveled on B around Terminal E (Figure 6-5). Stationary false targets were located between Runways 25R and 19R and at the approach end of 1L (Figure 6-6.)

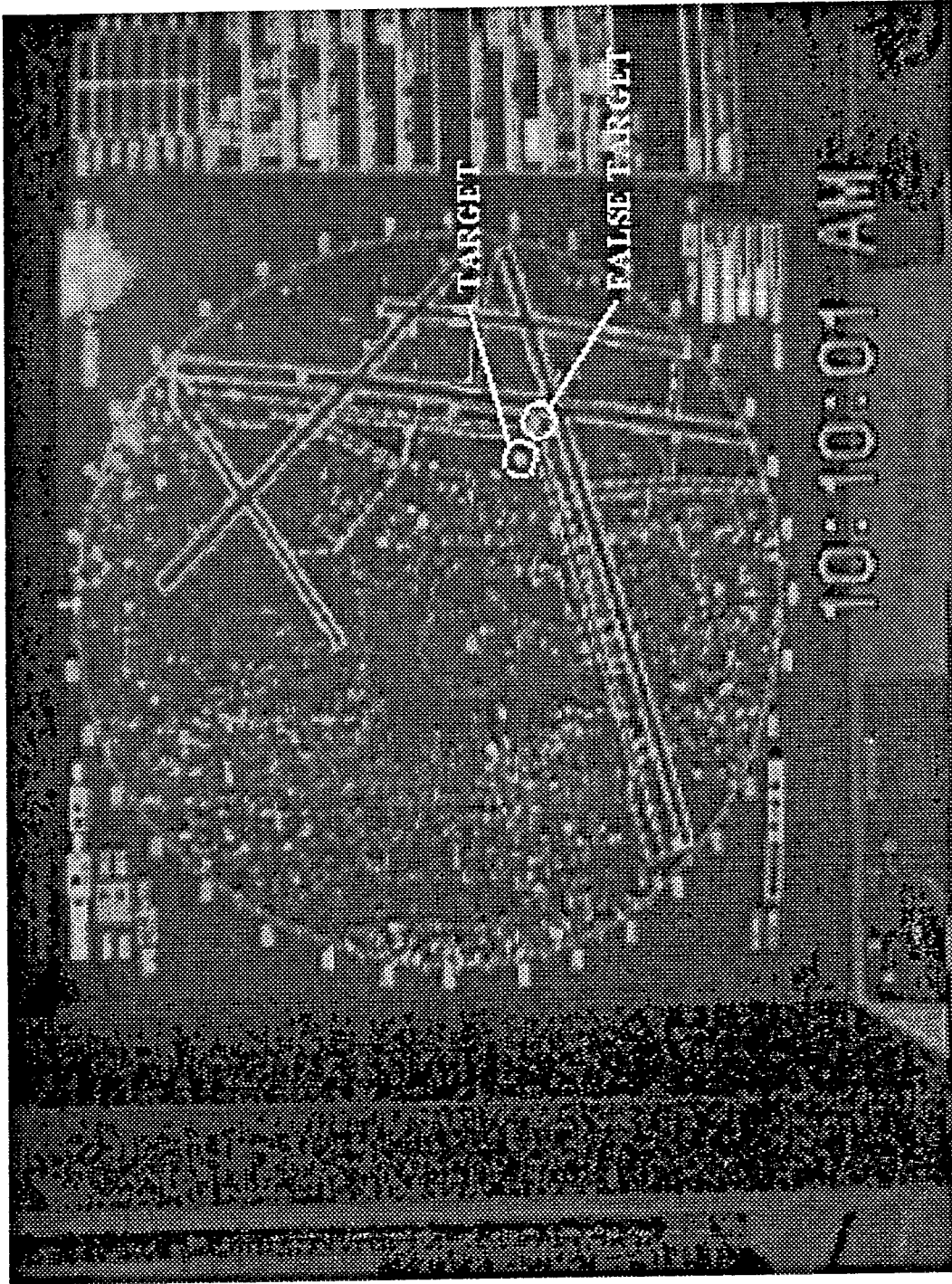

Figure 6-5. Target Split, Traveling North of Taxiway B.

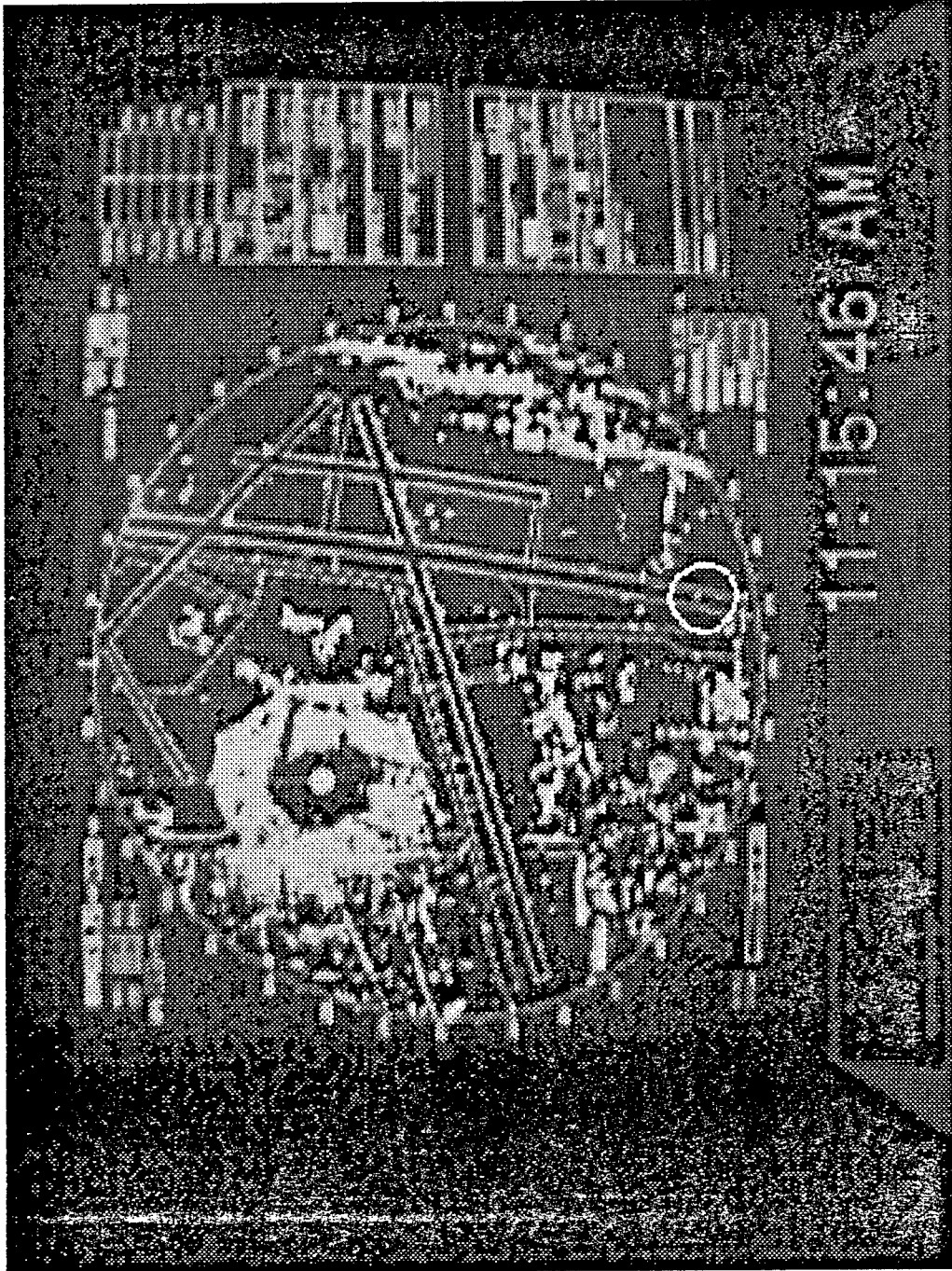

Figure 6-6. False Target, Stationary Near Approach End of Runway 1L.

High Speed Transition between Runway and Taxiway

As aircraft transition from runways to taxiways their radar cross section will vary as the aircraft's aspect angle to the radar changes, potentially causing target loss or fade. High speed transitions were demonstrated (Test 5.6, High Speed Turn-off Demonstration) at runway/taxiway intersections where most of MKE's high speed transitions occur, namely 19R/S, 1L/M, 25L/A2 and 7R/E. No major problems were reported during this test. Most of the transitions made at normal speed (20 -35 knots) looked good (Figure 6-7).

Targets of opportunity transitioning from runways to taxiways or from taxiways to runways were often recorded by controllers as "fading" or "splitting." Reviews of the video showed that signs located at these intersections were highlighted as the target passed them caused the target to appear to split or fade. The changing of the target's aspect angle to the radar antenna also reduced the target's return.

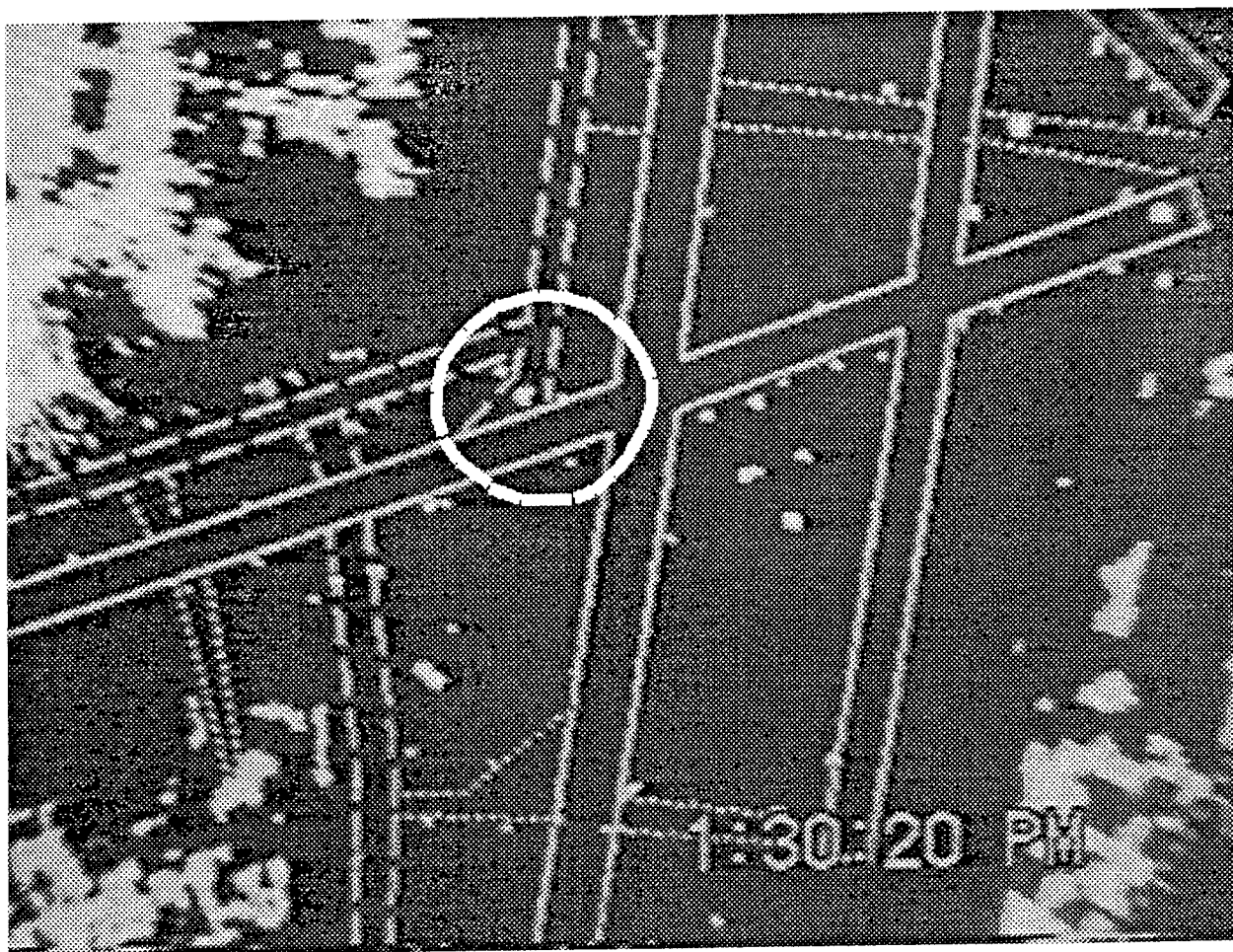

Figure 6-7. HS-28 in High Speed Transition from Runway 7R to Taxiway E.

Radar Detection and Presentation

The controllers measured the sweep time of the antenna in Test 5.11, Surface Update Rate. The measured sweep of approximately 2.78 seconds is calculated to 21.58 revolutions per minute. This should be the maximum time between updates of a target.

The average time delta between an approaching aircraft crossing the runway end to presentation (Test 5.7, Radar Detection) was measured at 2.69 seconds, with a minimum of 1.38 seconds and a maximum of 6.15 seconds.

Target detection sensitivity (Test 5.12, Probability of Detection) was shown to be 92.5 (Standard) and 94.67 (Fast Target). The scan to scan Integration should be considered as a factor affecting this measurement. When operated in standard mode, a lost target will be displayed for an additional two sweeps before being lost from view. This is not a factor in Fast Target mode, where a stationary target is displayed in dim video and will not be displayed when not detected.

6.2 RECOMMENDATIONS

Though the Phase I radar does not meet all ASDE-3 requirements, its performance, both functional and operational, showed its usefulness as a low-cost ATC aid and surface surveillance solution for Level 1 through 3 airports.

The ARPA M3450 / 18CPX-19 can be bought from the GSA Federal Supply Service with a one-year warranty and supported by readily available spares and an established training course. Installation was relatively straightforward: two months is a reasonable timeframe.

The system is not without its limitations, but the controllers easily adapted to them: they were soon using the system efficiently to detect and track targets on all parts of the airport surface during low visibility (<1/4 mile) operations.

The importance of the early participation of MKE personnel in the evaluation process cannot be overestimated. MKE personnel, including local NATCA and PASS representatives, were involved from project initiation through system evaluation. The effort to include MKE personnel paid off with a quick turnaround installation and an evaluation team which enthusiastically developed and ran a comprehensive test and evaluation plan. The plan covered both general and site-specific AT operations and took into account past ASDE-3 evaluations. Future evaluation efforts should make a top priority the enlisting of local airport personnel as integral team members.

In deciding on additional requirements and enhancements for the Phase I system, the team had to consider whether a production radar of this type should be bought or whether relatively costly modifications should be permitted. The operators were asked to come up with a "wish list" of improvements for Phase I. Their summarized list (in italics) reflects their experience with the radar, the testing, and their knowledge of Phase II and ASDE-3 functionality.

1. ***Incorporate one-mile range setting.*** The Phase I configuration includes a .75 nm and 1.5 nm range setting. At .75 nm, the entire airport movement cannot be displayed, and 1.5 was not considered an optimum viewing range. Controllers normally operated in the .75 range, offsetting the display toward the more active movement areas. Incorporating variable range settings (1/4 mile increments) would enhance system utility.
2. ***Time delay, in fast target mode, to keep previously moving targets bright for a given period of time.*** "Fast target" was the controllers' operating mode of choice. The fading of targets in hold position was one of their major concerns; they would switch to "Standard" mode only after a tracked target reached a hold position. Delaying the transition of stationary targets to low video in "Fast Target" mode will eliminate their need to switch modes of operation while tracking targets. Permanently fixed targets (buildings, fences, signs, etc.) will continue to be at low video. A variable time delay would enable each controller to enter his preferred settings. If masking is incorporated (as it will be in Phase II), Fast Target mode should become less important, as it is used mostly to attenuate fixed clutter.
3. ***Eliminate ownship and speed entries.*** These entries, inherent to a marine radar system, are expendable in a stationary (i.e., airport tower) installation.
4. ***Utilize two independent display stations.*** This wish reflects the need for independent displays for both the Local and Ground control locations in the tower cab. Independent controls with the ability to display different views of the airport surface simultaneously would also be a desirable feature. This redundancy would also comply with FAA safety considerations.
5. ***Improve update rate to 1 second (+ 10%).*** Filling this request will put the ASDE-X on an update rate par with ASDE-3's requirement of 1 second, but may force a trade-off with target definition. Further study of update rates and their effect on system efficiency is recommended.

6. **Allow unblinking with minimum keystrokes if targets enter blanked areas.** This request is also based on the controllers' understanding of the functionality of the ASDE-3 and the Phase II radar, both of which feature area masking (blinking). The controllers have expressed concern over the number of keystrokes it will take to unmask an area in which a target has been lost.
7. **Allow a viewing offset and range setting at an area of interest, regardless of the antenna location on the display.** This feature will allow operators to focus on and magnify areas of interest with minimal keystrokes (i.e., enable function, use trackball to create a box defining the area, press Enter.) The display should show the area of interest at center screen at the best possible range resolution. Currently the offset is limited to 70% of the screen and is dependent on antenna location.
8. **Allow independent control of radar intensity versus map intensity.** Currently the map overlay is displayed at high intensity. Targets crossing overlay lines from runways to taxiways can be obscured. The ability to reduce overlay intensity while retaining target intensity will enhance system effectiveness.
9. **Save up to twenty different combinations of operator settings (e.g., radar intensity, map intensity, range setting, offset setting.)** Airports operate in various Landing /Takeoff configurations depending on current weather conditions. These configurations create higher traffic concentrations over certain runways and taxiways. The capability of storing sets of pre-defined radar settings specific to each configuration would enhance system usability.

The Phase II ASDE-X will afford the FAA the unique opportunity to implement operators' requests and evaluate enhancements in a short time span at the identical test site with the same personnel. Phase II will significantly improve Phase I's already adequate performance. Phase II is scheduled to be installed during July and August, 1996 at an additional cost of about \$250k.

Phase II will facilitate incorporating most of the above requests, as shown on this list of scheduled enhancements:

Enhancement	Reason
CP antenna w/ 12° vertical beamwidth	Reduces clutter volume
Pedestal motor increasing antenna rotation rate from 22 rpm to 60 rpm	Improves visual target tracking
Azimuth position generator	Improves from resolver to encoder
Integral transceiver / display processor decreases transmit pulsewidth from 60ns to 40ns	Improves range resolution
Automatic Frequency Control (AFC)	Minimizes manual operations required to tune radar
Improved display processor software	Improves map definition of rwys / twys
Masking capability	Removes unwanted clutter on display
Variable range scale adjustments	Permit 1/4nm display increments
Improved receiver	Increases radar dynamic range
Mountable, high-brightness displays	Improve screen visibility

Equipment used in both Phases was kept to a minimum to reduce costs. Neither Phase incorporates redundant transceivers or multiple display stations. Redundancy is recommended for any fully operational low-cost ASDE.

Appendix B

RSEC Calculation

NOTE: The RSEC calculation is required to perform the RSEC functional test (Section 4.4.1.3 above). References in this appendix are to the MRFM, described below.

A radio frequency spectrum standard is one of the Radio Spectrum Engineering Criteria (RSEC) that bounds the spectrum-related parameters and characteristics of a radio system in order to manage the Radio Frequency Spectrum. The wide application of radar for various functions makes large demands on the electromagnetic spectrum, and requires the application of effective frequency management measures for the equipment and systems involved. RSEC are specified for certain equipment characteristics to establish and ensure that an acceptable degree of electromagnetic compatibility is maintained among radar systems, and between such systems and those of other radio services sharing the frequency spectrum.

According to the *Manual of Regulations and Procedures for Radio Frequency Management (MRFM)*, the theoretical RSEC value is for Phase I Radar at MKE is: -408 MHz, 310 MHz. This value falls within this type of system's acceptable specifications, as given in the manual.

The RSEC value for the Phase I radar was found by making the following calculations [MRFM, Section 5].

- Determine characteristics of the radar system.

The Phase I radar parameters (used to cross-reference tables in the manual) are:

Frequency:	9.375 GHz
Peak power output:	50 kW
Rise time (t_r):	$10\eta\text{sec} = 0.01 \mu\text{sec}$
Pulse width (t):	$60\eta\text{sec} = 0.06 \mu\text{sec}$

NOTE: Figure B-1 shows rise time and pulsewidth measurements. Nominal flat top level delineates the pulse peak level with "bumps" smoothed out. Arrows indicate pulsewidth and rise time.

- Look up levels of unwanted emissions and frequency tolerances in the Table of Frequency Tolerances and Unwanted Emissions [5-2 - 5-4] using the correct frequency band.

For MKE, the range is 4000 MHz to 10.5 GHz.

The sub category is radar, in the Radionavigation Stations section.

The level of unwanted emissions is category F; determine tolerances using [5.3].

- Look up Applicable Criteria based on the Radar Description [Table, p. 5-7.]

The Phase I radar group is group B, radars having a rated peak power of more than 1 kW but not more than 100 kW and operating between 2900 MHz and 40 GHz. This group was used because of the frequency, and the peak power being within the specifications. This put the radar system in Criteria B of applicable criteria.

- Look up calculations for Criteria B [Section 5.3.1]. Since the Phase I radar is a non-FM pulse radar system built after October 1, 1980, the equation used is:

$$B(-40 \text{ dB}) = (7.6 / \sqrt{t_r t}) \text{ or } (64 / t)$$

(whichever is less)

t_r is rise time, and t is pulse width, both given in μsec .

$$B(-40) = 7.6 / \sqrt{.0006} = 310 \text{ or } 1067 \text{ MHz}$$

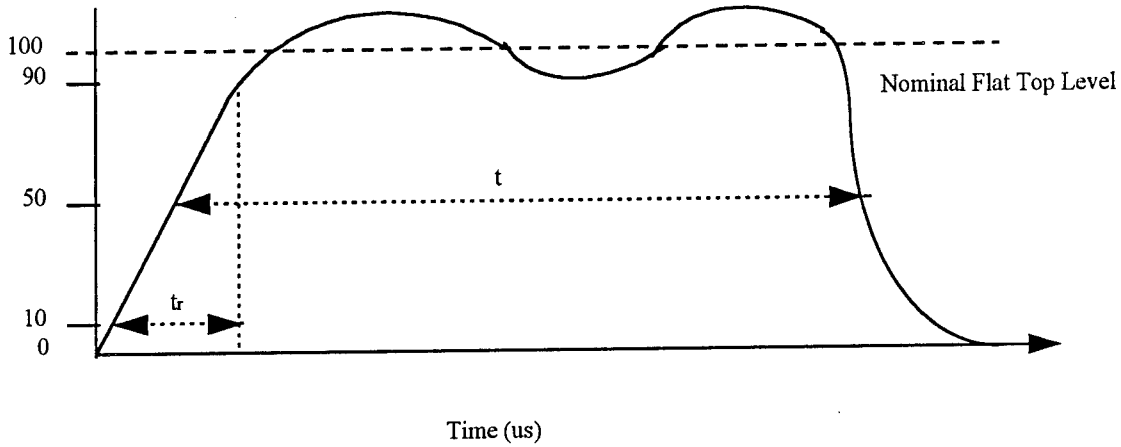

Figure B-1. Pulse Measurement.

The emission bandwidth for radars at the antenna input shall not exceed the following limits:
 $B(-40 \text{ dB}) = 310 \text{ MHz}$.

Appendix C

Display Test / Reset Menu

NOTE: This list gives the settings that appear in the test menus on the display of the Phase I system after all alignments have been made. If any changes are made to the system via display menu entries, record the new values below. These menus are referenced in Transceiver Setup, Section 3.3.2.4.

1. Video Display Tests
 - 1.1 Video Processor
 - 1.1.1 VPA TEST
 - 1.1.2 VPB TEST
 - 1.1.3 VRM CELL TEST
 - 1.1.4 ARPA CELL TEST
 - 1.1.5 RING CELL TEST
 - 1.1.6 VPA ALIGNMENT [Service Personnel Only]
 - 1.2 Scan Converter
 - 1.3 Monitor Interface
 - 1.4 CRT Test Pattern
 - 1.5 Video Memory
2. Equipment Tests
 - 2.1 Speed Log
 - 2.2 Gyro Compass
 - 2.3 Transceiver Link
3. System Configuration
 - 3.1 Gyro Compass
 - 3.1.1 Type 0=none, 1=sync, 2=step 2
 - 3.1.2 Stepper Increment 1=1/12, 2=1/6 2
 - 3.2 Speed Log
 - 3.2.1 Type 0=none, 1=single, 2=dual 0
 - 3.3 Transceiver Configuration
 - 3.4 Transceiver Setup
 - 3.4.1 Transceiver 1.1
 - 3.4.1.1 Antenna Height (meter) 62
 - 3.4.1.2 Antenna to Log Distance (meter) 0
 - 3.4.1.3 Antenna to Turning Point Distance (meter) 0
 - 3.4.1.4 PMU 0=not installed, 1=x band, 2=s band 0
 - 3.4.1.5 Frequency 1=x band, 2=s band 1
 - 3.4.1.6 Transmission Line Length (0 for up) (meter) 20
 - 3.4.1.7 Horizontal Beam Width (degrees) .45
 - 3.4.1.8 Antenna Rate (RPM) 30
 - 3.4.1.9 Short Pulse Width (us) .06
 - 3.4.1.10 Short PRF (Hz) 3600
 - 3.4.1.11 Short Reference Signal/Noise (dB) 35
 - 3.4.1.12 Short Bandwidth (MHz) 24
 - 3.4.1.13 Med Pulse Width (us) .5
 - 3.4.1.14 Med PRF (Hz) 1800
 - 3.4.1.15 Med Reference Signal/Noise (dB) 50
 - 3.4.1.16 Med Bandwidth (MHz) 4
 - 3.4.1.17 Long Pulse Width (μs) 1
 - 3.4.1.18 Long PRF (Hz) 900
 - 3.4.1.19 Long Reference Signal/Noise (dB) 50
 - 3.4.1.20 Long Bandwidth (MHz) 4
 - 3.4.2 Transceiver 1.2
<same settings as for 1.1>

3.5	Syledis Port Configuration		
	3.5.1 Baud Rate		300/600/1200/2400/4800/9600
	3.5.2 Parity		NONE/ODD/EVEN
	3.5.3 Data Bits		7/8
	3.5.4 Stop Bits		1/2
	3.5.5 Handshake		NONE/XON XOFF/CTS
3.6	Relay Board Installation		
	3.6.1 Relay Board 1		installed/not installed
	3.6.2 Relay Board 2		installed/not installed
3.7	Autopilot		
	3.7.1 Type		none/steermaster 2000
3.8	Load Default Configurations		
4.	Calibration: Direct Data Entry		
	4.1 XCVR 1.1 1.2	(1.1) (1.2)	
	4.2 Antenna Offset	105.7 97.7	
	4.3 Tuning Preset	128	
	4.4 Performance Monitor Unit	15	
	4.5 Zero Range	23	
5.	Calibration: Visual Adjustment		
6.	Operational Preferences		
	6.1 Switch Beep		enable/disabled
	6.2 Heading Line		flashing/solid
	6.3 Control Panel Select		G260994-1/G259734-1
	6.4 Selectable Units		nautical miles/statute miles
7.	ARPA Configuration		
	7.1 Auto Acquisition Rings Limits		3-6nm-DHI/.25-20nm
	7.2 Lost Target		coast-DHI/cancel
	7.3 Bow Crossing Information		momentary-DHI/toggle
	7.4 Set System Clock		
	7.5 Set Datalog Options		
	7.6 EEPROM Initialization		Caution! See note, p. 3-25.

Appendix D

Display Alignments

NOTE: If the Phase I radar display requires realignments following test reset (see Section 3.3.10) or for other reasons, use the following guidelines.

Adjustments are provided on the radar display PCBs for the alignment of screen presentation. A test pattern in the self-test mode will assist the technician in this alignment. Currently the radar display contains both low and high voltage power supplies and a screen-drive PCB.

It is very unusual that a total alignment will ever be needed. Observe the screen to determine which (if any) adjustment(s) should be made. The results of any alignments should be:

- Proper brilliance, contrast and focus.
- The picture outline fits within the bezel.
- The radar display area is circular not oval.
- The soft switch boxes line up with their respective buttons.

Preliminary Alignments

1. Loosen the control panel thumbscrews and swing the panel down.
2. Ensure that display BRILL control on bezel is set full CW (Max).
3. Loosen the two Phillips-head screws at the front of the bezel and lift the bezel up.
4. Remove the 4 hex head (10mm) bolts at corners of the display where it mounts to the plastic case and swing the entire assembly out.
5. Turn the display ON.
6. Press TEST RESET until the display resets.
7. Press TEST RESET to enter tests.
8. Select Test 1 VIDEO DISPLAY TESTS.
9. Select screen TEST PATTERN. The test pattern should appear.

Display Alignment

The alignment may be performed in its entirety or for selected problems as listed. (Ensure that display power supply outputs are correct before proceeding).

WARNING!

AS HIGH VOLTAGES ARE PRESENT ON THE VIDEO DRIVE PCB, MAKE ALL ADJUSTMENTS WITH A NON-METALLIC TUNING TOOL.

Brilliance and Video Gain Adjustments

NOTE: If overall screen brilliance is low, make the following adjustments *in normal ambient viewing light, not in direct sunlight or overhead artificial light.*

1. Adjust BRILLIANCE PRESET R117 for maximum brilliance with a slight amount of Raster visible (any part of the viewing area where video is not present). Then adjust display BRILL (on Bezel) until the raster just disappears.
2. On the test pattern are 3 blocks that represent the 3 video levels (low, high, & combination of the two). The adjustments on the Video Drive PCB allow for adjustment of the most significant bit

(brightest level video) and least significant bit (lowest level video) independent of each other. The MSB is adjusted with R226 and the LSB is adjusted with R228. Adjust R228 so that the right hand video block is visible at a brightness level above that of the Raster. Then adjust R226 for the brightest video in the left hand video block without defocusing. When R228 and R226 are properly set, the middle video block will have a brightness level which is approximately midway between the right and left blocks. Repeated adjustments may be needed to achieve these results.

3. After setting R228 and R226, use an oscilloscope (if available) to verify the adjustments that follow.
4. Connect the oscilloscope's vertical input to R234 (screen cathode) on the Video Drive PCB; trigger the oscilloscope internally and adjust vertical gain, triggering and horizontal time base controls so that the video levels for the three blocks of video are dark, medium, then light.
5. While observing the test pattern and the oscilloscope, adjust R226 and R228 so that the three video blocks are equal in vertical amplitude on the oscilloscope and that the video is not saturated on the screen. Video saturation is evidenced when the left hand block of video (brightest) begins to expand. This can best be seen by observing the vertical junction of the left and middle blocks of video.

Focus Adjustments

NOTE: Screen focus and brilliance are interactive adjustments i.e., if brilliance is set too high, defocusing will occur. Prior to attempting to adjust overall focus, turn down the DISPLAY BRILL (on Bezel) slightly and observe overall screen focus. If the screen is now focused, turn DISPLAY BRILL up until defocusing occurs, then adjust STATIC FOCUS R83. If the brightness level at which focus can be achieved is unacceptable for the operational requirements of the Display, proceed to the Troubleshooting Section.

If the entire (or part of) screen appears out of focus, perform the following adjustments:

1. Adjust STATIC FOCUS R83 for best focus at center and outer corners of the screen using the lettering in these areas as an indication of focus, i.e. the lettering should be well defined and not blurred, lines forming the letters should be as thin as possible.
NOTE: Dynamic focus adjustments are not normally required unless a screen or Video Drive PCB has been changed.
2. Adjust R85 VERTICAL DYN FOCUS for best focus in the vertical line in the middle area of screen.
3. Adjust R80 HORIZ DYN FOCUS for best focus in horizontal line in the middle area of screen.

Screen Size Adjustments

The properly adjusted display presentation should just fill the viewing area of the bezel, and the soft switch boxes should line up with their respective buttons. This should be checked when the display and Bezel Assembly are in their normal viewing position. It is helpful to mark the bezel outline on the screen face at key reference points using a Plotting Marker (P/N 168780-1). This removes the need to raise and lower the assemblies to check alignment. After determining which area(s) need adjustment, raise the bezel and swing out the display. Proceed as follows:

Vertical Alignment

1. Adjust VERT POS R143 to center the picture vertically between the vertical reference marks.
2. Use a flexible ruler to determine if the vertical dimensions (170mm) of the vertical reference line are correct. This dimension should be checked from the center out to the 170mm marks at the top and bottom of the screen.

3. If both dimensions are off but equal, adjust VERT SIZE R7 so that the total length is correct.
4. If only one dimension is off, adjust VERT LIN R22 so that the dimensions are equal, then adjust VERT SIZE R7 for the correct total length.
5. The Vertical adjustments interact and may have to be repeated several times to achieve correct results. The respective soft switch boxes should closely line up with the vertical soft switch reference marks.
6. When no further improvement can be made in Vertical Alignment, proceed with Horizontal Alignment.

Horizontal Alignment

1. Adjust HORIZ PHASE R55 to center the video information (not the Raster) between the horizontal reference marks.
2. Use a flexible ruler to determine if the horizontal dimensions (170mm) of the horizontal reference line are correct. This dimension should be checked from the center out to the 170mm marks at the right and left of the sides of the screen.
3. If both dimensions are off but equal, adjust HORIZ SIZE R34 so that the total length is correct.
4. If only one dimension is off, adjust the knurled finger adjustment (NOT the core) on the HORIZ LIN coil so that the dimensions are equal, then adjust HORIZ SIZE R34 for the correct total length.
5. The Horizontal adjustments interact and may have to be repeated several times to achieve correct results.
6. When no further improvement can be made in horizontal alignment, remove reference marks with a soft cloth and return display and bezel to normal operating position.

Final Checks

NOTE: Picture should now be centered and fill the viewing area. The soft switch boxes should line up closely with their respective buttons.

1. Call up the SCAN CONVERTER TEST (1.2). The circles presented in this test should be round.

Call up the VIDEO MEMORY TEST (1.5). The checkerboard pattern presented should have equally sized squares across the screen in the horizontal and vertical directions.

Appendix E

Operational Test Weather and Visibility Observations

The operational tests for the Phase I radar required the test team's careful observation and recording of weather conditions. The observations took three forms: ASOS, RVR, and visibility. Automated Surface Observation System (ASOS) provides continuous minute by minute observations. Runway Visual Range (RVR) visibility values are measured by transmissometers mounted on towers along the runway. Prevailing visibility refers to observations made by controllers from the ATCT cab. At least one of these three weather observation media (usually ASOS) is entered on the Weather line in the test data sheets (Section 5). The controllers interpreted the data using the following brief explanations of these systems.

ASOS

1. System Description

(a) The ASOS at each airport location consists of four main components:

1. Individual weather sensors
2. Data collection packages
3. Acquisition control unit
4. Peripherals and displays

The ASOS sensors perform the basic function of data acquisition. They continuously sample and measure the ambient environment, derive raw sensor data and make them available to the collocated DCP.

Every ASOS contains the following basic sensors:

- Cloud height indicator
- Visibility sensor
- Precipitation identification sensor
- Freezing rain sensor
- Pressure sensors
- Ambient temperature/dew point temperature sensor
- Anemometer (wind direction and speed sensor)
- Rainfall accumulation sensor

2. ASOS Message

1. Station Identifier: Three alphanumeric characters identifying observation site.

2. Observation Type:

- Record observations (SA) are scheduled on a routine basis;
- Special observations (SP) are taken whenever certain events occur;
- Record Special Observations (RS) are record observations coincidental with the occurrence of certain events;
- Urgent Special Observations (USP) are taken to report tornadoes.

3. Time: Observation time, in coordinated universal time (UTC) using 24-hour clock.

4. Station Type: Unaugmented or unedited ASOS observations are identified as AO2; ASOS observations identified as AO2a are augmented and or edited.

5. Sky Condition: CLR BLO 120 means no clouds detected below 12,000 feet over the ASOS cloud height indicator. SCT (scattered) means .1 to .5 of sky is covered; BKN (broken) means .6 to .9 is covered; OVC (overcast) means all the sky is covered. The number preceding the

SCT, BKN, or OVC is the height in hundreds of feet. The height of the BKN or OVC is preceded by a ceiling designator: M (measured) or E (estimated). If V appears after the height, the ceiling is variable and a remark is included. W indicates an indefinite ceiling, The number after the W is the vertical visibility in hundreds of feet, and X indicates the sky is totally obscured.

6. Visibility: reported instrumentally derived visibility values, from: $< \frac{1}{4}$, $\frac{1}{4}$, $\frac{1}{2}$, $\frac{3}{4}$, 1, $1\frac{1}{4}$, $1\frac{1}{2}$, $1\frac{3}{4}$, 2, $2\frac{1}{2}$, 3, $3\frac{1}{2}$, 4, 5, 7, to 10+ statute miles. If the visibility is variable, a V is added to the average reportable value and a remark is included in the observation. When tower visibility is less than 4 miles and less than surface visibility, tower visibility will be reported in the body of the report as prevailing visibility, and surface visibility will be reported in remarks.

7. Weather and Obstructions to Vision: Weather refers to precipitation, tornadoes and thunder; obstructions to vision refer to phenomena that reduce visibility but are not precipitation.

(S)	Snow
(R)	Rain
(ZR)	Freezing Rain
(P-)	Light precipitation that ASOS cannot identify

S, R, and ZR can be identified as (+) heavy or (-) light. Tornadoes (TORNADO), thunder (T), and hail (A) are augmented by an observer. Obstructions to vision are either fog (F), visible minute water droplets, of haze (H), fine suspended particles of dust, salt, combustion or pollution products. Volcanic ash (VOLCANIC ASH) is augmented by an observer as an obstruction to vision if visibility is less than 7 miles.

8. Sea-Level pressure: theoretical pressure at sea-level reported in millibars.

9. Temperature: Air temperature in degrees Fahrenheit.

10. Dew-Point Temperature: Temperature to which air must be cooled at constant pressure and water vapor content for saturation to occur reported in degrees Fahrenheit.

11. Wind: The direction reported in tens of degrees from true North from which the wind is blowing; may be estimated

12. Wind Speed: Reported in whole knots; may be estimated (E). If wind is calm, direction and speed are reported as 0000.

13. Wind Character: Gusts (G) and squalls (Q) are reported in whole knots.

14. Altimeter Setting: Used for setting aircraft altimeters; reported in hundreds of inches of mercury using only the units, tenths, and hundreds digits without a decimal point.

15. Remarks Note:

RVR - Runway Visible Range is in hundreds of feet
Volcanic ASH -
VIRGA - precipitation falling from clouds but not reaching the ground
CIG minVmax - Variable ceiling
TWR VSBY - Visibility reported by the air traffic control tower
VSBY - Visibility reported by ASOS sensor
VSBY minVmax - Variable visibility
Btt-Ett-Time of beginning and ending weather
PCPN rrr - Hourly precipitation accumulation remark where rrr is liquid equivalent in hundreds of an inch of all precipitation since last hourly update
WSHFT hhmm - wind shift remark with time wind shift occurred.
WND ddVdd - Variable wind direction remark

PK WND -peak wind remark
PRESRR - pressure rising rapidly
PRESFR -pressure falling rapidly
PRJMP - pressure jump remark
PWINO - precipitation Identifier sensor not operational
ZRNO - Freezing rain sensor not operational
TNO - Thunderstorm information not available
\$ - Maintenance check indicator.

(1) Sky Condition: The ASOS cloud sensor is a vertically pointing laser ceilometer, and is referred to as the cloud height indicator (CHI). This CHI issued to detect the presence of clouds directly overhead up to 12000 feet.

(2) Visibility: ASOS sensor visibility is based on the measurement of a small volume sample with extrapolation to overall aerial visibility. ASOS visibility is based on the scattering of light by air molecules, precipitation, fog droplets, haze specks, or other particles suspended in the air. The visibility sensor projects a beam of light and the light that is scattered is detected by a receiver. The amount of light scattered is detected by a receiver. The amount of light scattered and received by the sensor is converted into a visibility value.

(3) Present weather / Obstructions to Vision: There are currently two ASOS present weather sensors. They are the precipitation identification (PI) sensor which discriminates between rain and snow, and the freezing rain sensor. ASOS algorithms have also been developed to evaluate multiple sensor data and infer the presence of obstructions to vision (fog or haze). The PI sensor has a rainfall and snow detection threshold of 0.01 inch per hour. The freezing rain sensor is sensitive enough to measure accumulation rates as low as 0.01 of an inch per hour. Only one present weather phenomenon other than thunder, tornado, or hail will be reported at one time, i.e., ASOS does not report mixed precipitation.

(4) Temperature and Dew Point:

(5) Wind:

(6) Pressure:

(7) Precipitation Accumulation: ASOS uses a heated tipping bucket (HTB) precipitation gauge. The HTB at high rain rates underestimates rainfall, and a correction factor is applied to 1-minute rainfall amounts to correct for this error. The gauge data are used by ASOS to compile a variety of cumulative precipitation remarks/messages. These remarks/messages include:

- (a) SAO hourly precipitation (PCPN rrr) remark
- (b) SAO 3- and 6- hourly precipitation report (6RRR/) remark.
- (c) SAO 24-Hour precipitation accumulation remark (7R24R24R24R24)
- (d) Daily and monthly cumulative precipitation totals
- (e) SHEF messages.

Runway Visual Range (RVR) visibility values are measured by transmissometers mounted on towers along the runway. A full RVR system consists of :

1. Transmissometer projector and related items.
2. Transmissometer receiver (detector) and related items.
3. Analog recorder
4. Signal data converter and related items.
5. Remote digital or remote display programmer.

An RVR transmissometer established on a 500 ft. baseline provides digital readouts to a minimum of 1,000 ft. A system established on a 250 ft. baseline provides digital readouts to a minimum of 600 ft., displayed in 200 ft. increments to 3,000 ft. and in 500 ft. increments from 3,000 ft. to a maximum value of 6,000 ft.

RVR values for Category IIIa operation extend down to 700 ft. RVR; however, only 600 and 800 ft are reportable RVR increments. The 800 RVR reportable value covers a range of 701 feet to 900 feet and is therefore a valid minimum indication of Category IIIa operations.

Approach categories with corresponding minimum RVR values:

Nonprecision	2400 feet
CAT I	1,800 feet
CAT II	1,200 feet
CAT IIIa	700 feet
CAT IIIb	150 feet
CAT IIIc	0 feet

Ten minute maximum and minimum RVR values for designated RVR runway are reported in the remarks section of the aviation weather report when prevailing visibility is less than one mile and/or the RVR is 6000 feet or less. ATCT's report RVR when prevailing visibility is 1 mile or less and/or the RVR is 6000 feet or less.

Reporting Prevailing Visibility

(a) Surface (horizontal) visibility is reported in weather observations in terms of statute miles and increments of 1/16, 1/8, 1/4, 1/2, 3/4, 1, 1 1/4, etc. Visibility is determined through the ability to see and identify persecuted and prominent objects at a known distance from the usual point of observation. Visibility determined to be less than 7 miles, identify obscuring atmospheric conditions; e.g., fog, haze, smoke, etc., or combinations thereof.

(b) Prevailing visibility is the greatest visibility equaled or exceeded throughout at least half of the horizontal circle, which need not be continuous. Segments of the horizontal circle which may have a significantly lower visibility may be reported in the remarks section of the weather report.

(c) When prevailing visibility at the usual point of observation, or at the tower level, is less than four miles, certified tower personnel will take visibility observations in addition to those taken at the usual point of observation. The lower of these two values will be used as the prevailing visibility for aircraft operations.

Appendix F

Recommended Monthly Maintenance Procedures

NOTE: The following maintenance procedures for the MKE Raytheon Marine (Phase I) radar have been adapted from Raytheon's maintenance procedures in *Instruction Manual: Mariners Pathfinder, MKII-X Pedestal, G262084 Rev A (2/94)*. References are called out in brackets.

Precautions [Chapter 4]:

Whether operating or de-energized, the radar equipment contains AC input voltage that is hazardous to life. Maintenance personnel are cautioned to exercise extreme care and use common sense when servicing the equipment, and must always observe these safety precautions:

- De-energize equipment, tag and turn off associated circuit breakers before servicing.
- Never service equipment unless another person is nearby.
- When it is necessary to make adjustments inside equipment that is operating, do so using one hand, keeping the other hand clear of equipment chassis.
- Become familiar with artificial respiration techniques.
- Adhere to the safety notices that appear at the front of the manual.
- Never work without proper safety equipment and supervision.

Physical Inspection:

Check Mark

1. Ensure that all cabling and connections to the transmitter/receiver, Pathfinder/ST Display, and antenna pedestal are secure, free from chafing, damage or corrosion, including the elliptical waveguide. (Check O-rings if waveguide is opened. Add silicon grease only.) _____
2. Wash the antenna and pedestal exterior with fresh water to prevent exterior corrosion. Inspect the exterior of all units for dust and finish deterioration. Clean or repair as necessary. _____
3. Check the mounting hardware to ensure the mechanical integrity of the installation. _____
4. Tighten mounting hardware. _____
5. Check for corrosion free contact of the copper bonding strap. Clean connection if necessary. _____
6. Inspect internal cable connections for loose or corroded terminal screws and lugs. Repair or replace as necessary. _____

Antenna:

1. Check all rubber isolators for cracking and dry-rot. _____
2. Wash exterior with fresh water to prevent corrosion. _____
3. Inspect the exterior for dust and finish deterioration. _____

Pedestal [Ch. 4.5.2]:

WARNING

REMOVE POWER FROM THE RADAR SYSTEM AND SET ANTENNA SAFETY SWITCH TO OFF WHEN PERFORMING MAINTENANCE AT THE ANTENNA PEDESTAL.

1. Listen for any unusual noises indicating unbalance, loose belts, low lubrication etc. _____
2. Check gasket between pedestal and stub mass for any degradation. _____
3. Verify that all belts are tight. If needed, follow Belt Tension, Check and Adjustment procedures [Chapter 4.5.3, p. 4-6 for changing V-belts part number 167591-4]. _____

CAUTION!

OVER-TIGHTENING BELTS MAY CAUSE PREMATURE WEAR TO BELTS AND BEARING.

NOTE: If correct tension cannot be achieved by adjustment, replace belts [Ch. 4.8.2, p. 4-15.] _____

4. Check for corrosion due to weather . _____
5. Lubricate access cover gasket to ensure proper seal. Replace cover. _____
6. Verify that the compartment is free of belt dust. _____
7. Perform Pulley Alignment Check [Ch. 4.5.4, p. 4-6.] _____
8. Perform Drive System Inspection [Ch. 4.5.5, p. 4-8.] _____
9. Check oil level; it should be approximately ½ inch below the parting line of the gear assembly casting. If necessary, follow procedures [Ch. 4.5.2.1, p. 4-5] for changing the Synolec 9920 SAE75W-140 part N. 817-854-6321oil or Mobil Gear box synthetic oil. _____

NOTE: The MKE ASDE-X radar system's oil should be changed on the first day of good weather (50°F).

10. Perform Access Hatch Gasket Inspection [Ch 4.5.6, p. 4-8.] _____
11. Seal gasket with grease for environmental protection. _____

Dehydrator:

1. Ensure pressure stability is stable. _____
2. Check whether desiccant is still good; if it has turned pink, perform one of these steps. _____
 - Place the pink crystals under a heat lamp until blue and then reuse or _____
 - Replace with the manufactures recommended cartridge. _____

Maintenance performed by: Name(s) _____ Date _____