

FAA-81-23

DOT/FAA/RD-81-64  
DOT-TSC-FAA-81-23

# Test Plan for SSR Antenna Rotation Rate Stabilization

Janis Vilcans

U.S. Department of Transportation  
Transportation Systems Center  
Cambridge MA 02142

October 1981  
Final Report

This document is available to the public  
through the National Technical Information  
Service, Springfield, Virginia 22161.



U.S. Department of Transportation  
**Federal Aviation Administration**

Systems Research and Development Service  
Washington DC 20590

**NOTICE**

This document is disseminated under the sponsorship of the Department of Transportation in the interest of information exchange. The United States Government assumes no liability for its contents or use thereof.

**NOTICE**

The United States Government does not endorse products or manufacturers. Trade or manufacturers' names appear herein solely because they are considered essential to the object of this report.

1. Report No. DOT-FAA-RD-81-64		2. Government Accession No.		3. Recipient's Catalog No.	
4. Title and Subtitle TEST PLAN FOR SSR ANTENNA ROTATION RATE STABILIZATION				5. Report Date October 1981	
				6. Performing Organization Code	
7. Author(s) Janis Vilcans				8. Performing Organization Report No. FA-180-PM-81-40	
9. Performing Organization Name and Address U.S. Department of Transportation Research and Special Programs Administration Transportation Systems Center Cambridge MA 02142				10. Work Unit No. (TRAVIS) FA280/R2104	
				11. Contract or Grant No.	
12. Sponsoring Agency Name and Address U.S. Department of Transportation Federal Aviation Administration Systems Research and Development Service Washington DC 20590				13. Type of Report and Period Covered Final Report	
				14. Sponsoring Agency Code	
15. Supplementary Notes					
16. Abstract A comprehensive test plan is presented to evaluate the impact of wind and ice loading on the rotation rate stability of a Secondary Surveillance Radar (SSR) antenna used for air traffic control surveillance. Antenna rotation rate variations may introduce errors in the estimate of a position of an intruding aircraft in a passive collision avoidance system used in conjunction with the SSR antenna. The test plan provides a method for determining the statistics of the antenna rotation rate variations. Analytical methods are then presented to assess the affects on CAS performance. The measurement system design, mathematical model development of the antenna system, test data reduction, and analysis programs are presented in detail. Sample calculations of preliminary field data are given and compared with the results obtained from computer simulations. The computer simulations are also intended to predict antenna rotation rate variations at the upper limits of the FAA specified range, which were not generally encountered during normal operations.					
17. Key Words -Radar Antennas, Antenna Model, ATC Surveillance Accuracy, Scan Rate Accuracy, Rotation Rate Instrumentation			18. Distribution Statement DOCUMENT IS AVAILABLE TO THE PUBLIC THROUGH THE NATIONAL TECHNICAL INFORMATION SERVICE, SPRINGFIELD, VIRGINIA 22161		
19. Security Classif. (of this report) UNCLASSIFIED		20. Security Classif. (of this page) UNCLASSIFIED		21. No. of Pages 126	22. Price

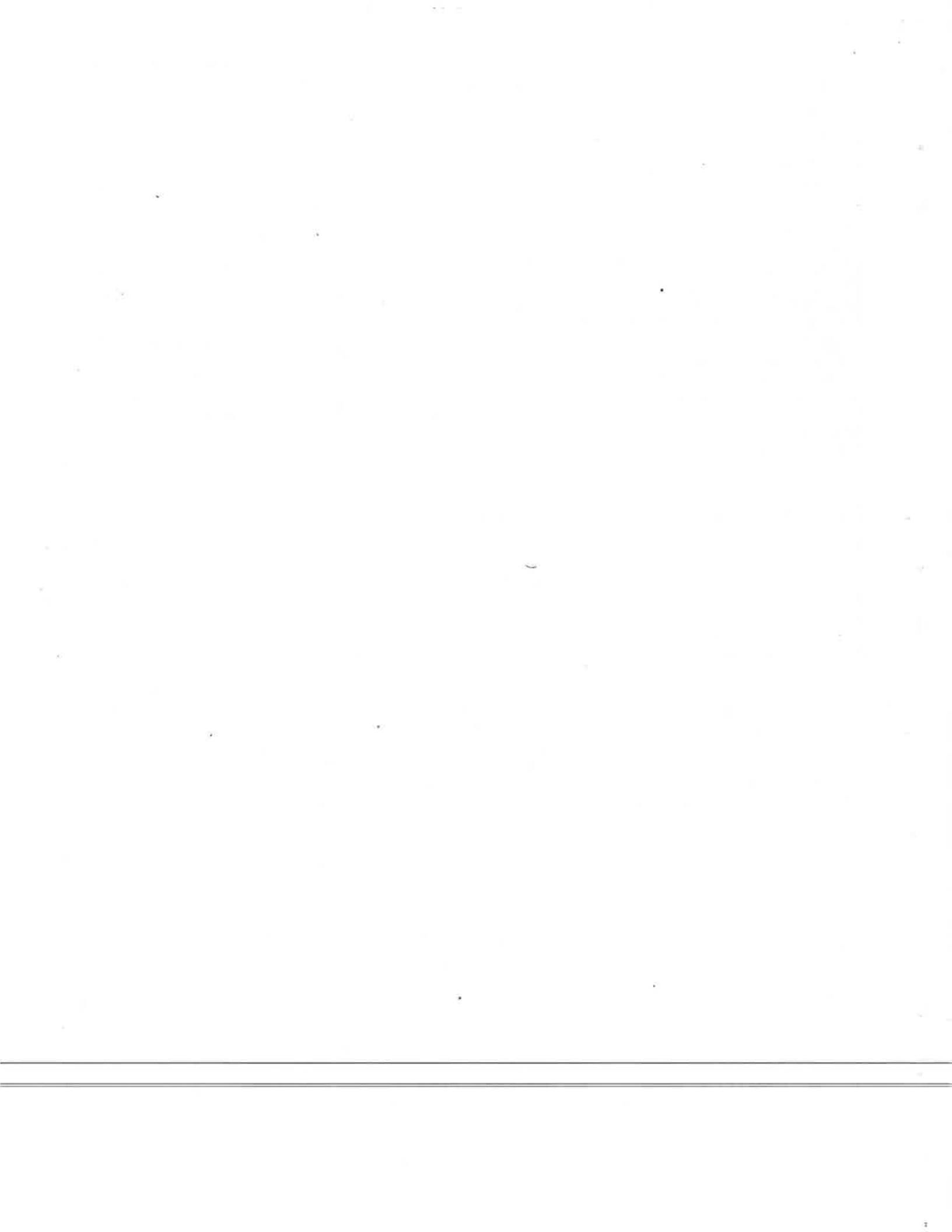

## PREFACE

Airborne collision avoidance systems can be characterized as being active or passive depending upon how the protected aircraft obtains surveillance information. The active CAS utilizes an on-board interrogator capable of independent surveillance of surrounding traffic. The passive CAS obtains similar surveillance information primarily by listening-in to the ground interrogations and surrounding aircraft replies. One of the design options of a passive CAS is to use the Secondary Surveillance Radar (SSR) antenna rotation position as azimuth reference. Such information is obtained by decoding the regularly broadcasted Discrete Address Beacon System (DABS) (Mode S) squitter messages from the ground-based Radar Beacon Transmitter (RBS) located at the same SSR site. The antenna rotation rate constancy between the uplink squitter messages becomes a critical parameter in deriving the position of an intruder. This test plan is intended to determine, by measurements and analysis, the impact of such antenna rotation rate variations.

A high precision measurement system was developed to evaluate the SSR antennas rotation rate stability under environmental conditions encountered at a test site. For the extreme environmental conditions, a mathematical model was also developed to extrapolate its performance. Measurement system design, software, a mathematical model, and data analysis programs were developed at TSC, by the staff of the Telecommunication Branch (DTS-531). Support was provided for test system software design, by Martindale Associates, Inc., Reading, MA, especially by Maurice C. Devine.

Preparation of the test plan required efforts of many individuals and organizations. Particular recognition goes to John L. Brennan, ARD-243 for coordination of tasks and specifying requirements and George Mahnken, ATC-154 for arranging the test site, installation of test equipment, and conducting the tests. The contribution of following TSC personnel are hereby gratefully acknowledged: Dr. Kanti Prasad for mathematical model development and the initial design of the test equipment; and William Wade and Robert Jones for design, development and checking-out of the system; Juris Raudseps for specifying output data formats; and Marsha D. O'Connell for developing mathematical algorithms for the data analysis programs.

# METRIC CONVERSION FACTORS

Approximate Conversions to Metric Measures			Approximate Conversions from Metric Measures		
When You Know	Multiply by	To Find	When You Know	Multiply by	To Find
<b>LENGTH</b>					
in	2.5	centimeters	mm	0.04	inches
ft	30	centimeters	cm	0.4	inches
yd	0.9	meters	m	3.3	feet
mi	1.6	kilometers	km	1.1	yards
				0.6	miles
<b>AREA</b>					
sq in	6.5	square centimeters	sq cm	0.16	square inches
sq ft	0.09	square meters	sq m	1.2	square feet
sq yd	0.8	square meters	sq km	0.4	square kilometers
sq mi	2.6	square kilometers	ha	2.5	hectares (10,000 m <sup>2</sup> )
					acres
<b>MASS (weight)</b>					
oz	28	grams	g	0.035	ounces
lb	0.45	kilograms	kg	2.2	pounds
		tonnes	t	1.1	short tons
<b>VOLUME</b>					
teaspoons	5	milliliters	ml	0.03	fluid ounces
tablespoons	16	milliliters	l	2.1	pints
fluid ounces	30	milliliters	qt	1.06	quarts
cups	0.24	liters	gal	0.26	gallons
pints	0.47	liters	cu ft	35	cubic feet
quarts	0.95	liters	cu yd	1.3	cubic yards
gallons	3.8	liters			
cubic feet	0.03	cubic meters			
cubic yards	0.76	cubic meters			
<b>TEMPERATURE (exact)</b>					
Fahrenheit temperature	5/9 (after subtracting 32)	Celsius temperature	Celsius temperature	9/5 (then add 32)	Fahrenheit temperature
°F		°C	°C		°F

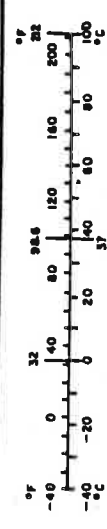
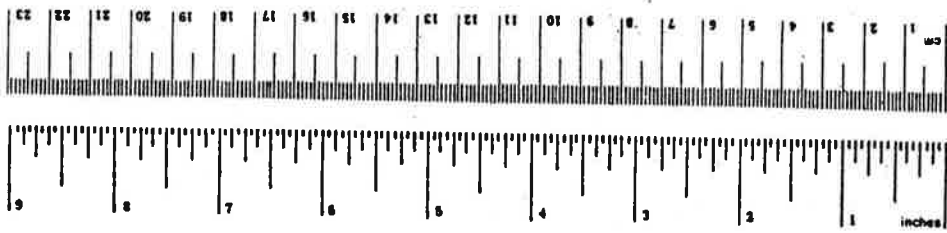

## TABLE OF CONTENTS

<u>Section</u>	<u>Page</u>
1. INTRODUCTION AND BACKGROUND.....	1-1
1.1 Introduction.....	1-1
1.2 Background.....	1-4
2. TEST OBJECTIVES.....	2-1
2.1 Determine Capability of SSR Antenna Rotation Rate Stability with the Full BCAS Design Requirement.....	2-1
2.2 Identify Antenna Rotation Stabilization Alternatives, if Required.....	2-1
3. SCOPE.....	3-1
3.1 Scope of the Tasks.....	3-1
3.1.1 Requirements for Field Measurements..	3-1
3.2 Data Collection.....	3-3
3.2.1 Selection of Test Sites.....	3-3
3.2.2 Test Planning.....	3-3
3.3 Analysis.....	3-4
3.3.1 Mathematical Analysis.....	3-4
3.3.2 Simulation.....	3-9
3.3.3 Preliminary Data Analysis.....	3-9
3.4 Identification of Alternative Designs.....	3-16
4. TECHNICAL APPROACH	
4.1 Definition of Tasks.....	4-1
4.2 Measurement Technique.....	4-2
4.3 Input Signals.....	4-2
4.4 Output Data.....	4-7
4.5 Recorded Data Formats.....	4-7
5. DESCRIPTION OF THE TEST.....	5-1
5.1 Unit Under Test.....	5-1
5.2 Test Equipment.....	5-1
5.3 SSR Test Computer Assembly.....	5-1

## TABLE OF CONTENTS (CONTINUED)

<u>Section</u>	<u>Page</u>
5.3.1 Intel SBC-905, Input Data Counter.....	5-4
5.4 Computer Flow Charts.....	5-30
6. DATA COLLECTION PLAN.....	6-1
6.1 Approach.....	6-1
7. DATA ANALYSIS PLAN.....	7-1
7.1 Precision of Recorded Data.....	7-1
7.2 Sampled Data Statistics: Mean, Variance, and Standard Deviation.....	7-1
7.2.1 Mean, Variance, and Standard Deviation.	7-1
7.2.2 Sliding Window Sum Total Variations (Histogram).....	7-2
7.3 A Cumulative Sum Comparison with the Nominal..	7-6
7.4 Sample Statistics: Inference.....	7-6
7.5 Correlation of Data Derived from a Mathema- tical Model with Data Measured in the Field...	7-6
8. SCHEDULES.....	8-1
APPENDIX A - ORGANIZATIONAL RESPONSIBILITIES.....	A-1
APPENDIX B - SIMULATION SOFTWARE FOR SOLVING SSR ANTENNA SYSTEM MODEL.....	B-1
APPENDIX C - SOURCE LISTINGS FOR BCAS DATA REDUCTION AND ANALYSIS.....	C-1



## LIST OF ILLUSTRATIONS

<u>Figure</u>	<u>Page</u>
1. Single Site Static Solution with RBX.....	1-3
2. Reflector Speed Vs. Wind Angle of Incidence.....	1-5
3. Calculated Dynamic Yaw Moment Vs. Wind Angle of Incidence.....	1-6
4. 5-HP Motor Torque Characteristics.....	1-7
5. 30 HP Motor Torque Characteristics.....	1-8
6. FAATC SSR Measured Data.....	1-10
7. Yawing Moment Forces for the S 264 Antenna.....	1-11
8. Installation of ATCRBS Antenna on ASR-7 Structure...	3-2
9. ASR-8/SSR Antenna System Simulation Model.....	3-4
10. Equivalent Circuit of the Induction Motor.....	3-5
11. SSR Antenna System Simulation Model (FAA Tech Center ASR-8 Model).....	3-7
12. Computed Component Yaw Moment Vs Wind Angle of Incidence.....	3-10
13A. Calculated Yaw Moment Vs Wind Angle.....	3-11
13B. Measurement Yaw Moment Vs Wind Angle.....	3-11
14. Computed SSR Antenna Rotation Rate (Wind- 0 mi/hr),...	3-12
15. Computed SSR Antenna Rotation Rate (Wind- 15 mi/hr)..	3-13
16. Computed SSR Antenna Rotation Rate (Wind- 30 mi/hr)..	3-14
17. Computed SSR Antenna Rotation Rate (Wind- 97.8 mi/hr)	3-15
18. Computed SSR Antenna Yaw Moment (Wind 15 mi/hr).....	3-17
19. Computed SSR Antenna Yaw Moment (Wind-97.8 mi/hr)....	3-18
20. Measurement Technique.....	4-3
21. ATCRBS Processor Functional Block Diagram.....	4-4
22. Azimuth Pulse Generator (APG) Block Diagram.....	4-5

LIST OF ILLUSTRATIONS (CONTINUED)

<u>Figure</u>	<u>Page</u>
23. Simplified Block Diagram.....	4-6
24. Logical Record Structure on Data Tape.....	4-8
25. FAA Technical Center Terminal Radar Beacon Test Facility (TRBTF).....	5-2
26. SSR Antenna Rotation Rate Test Equipment Assembly..	5-3
27. Input Data Counter Schematic.....	5-5
28. Power Wiring Diagram.....	5-8
29. SBC 80/20 Schematic Diagram, Sheet 1.....	5-11
30. SBC 80/20 Schematic Diagram, Sheet 2.....	5-12
31. SBC 80/20 Schematic Diagram, Sheet 3.....	5-13
32. SBC 80/20 Schematic Diagram, Sheet 4.....	5-14
33. SBC 80/20 Schematic Diagram, Sheet 5.....	5-15
34. SBC 80/20 Schematic Diagram, Sheet 6.....	5-16
35. SBC 116 Schematic Diagram, Sheet 1.....	5-24
36. SBC 116 Schematic Diagram, Sheet 2.....	5-25
37. SBC 116 Schematic Diagram, Sheet 3.....	5-26
38. SBC 116 Schematic Diagram, Sheet 4.....	5-27
39. SBC 116 Schematic Diagram, Sheet 5.....	5-28
40. SBC 116 Schematic Diagram, Sheet 6.....	5-29
41. Initialization Routine.....	5-31
42. ACP Count and Routing Interrupt Routine.....	5-32
43. ACP Count Loading and Record Count Routines.....	5-33
44. Wind Speed and Wind Direction Routines.....	5-34
45. Data Record Interrupt Routine.....	5-35
46. Measurement Data Collection Routine.....	6-2

LIST OF ILLUSTRATIONS (CONTINUED)

<u>Figure</u>		<u>Page</u>
47.	Measured Data Statistics- Mean.....	7-3
48.	Measured Data Statistics- Standard Deviation.....	7-4
49.	Histogram.....	7-5
50.	Cumulative Measured Vs. Nominal Clock Pulse Summation.....	7-7
51.	SSR Antenna Rotation Rate Study Schedule.....	8-2

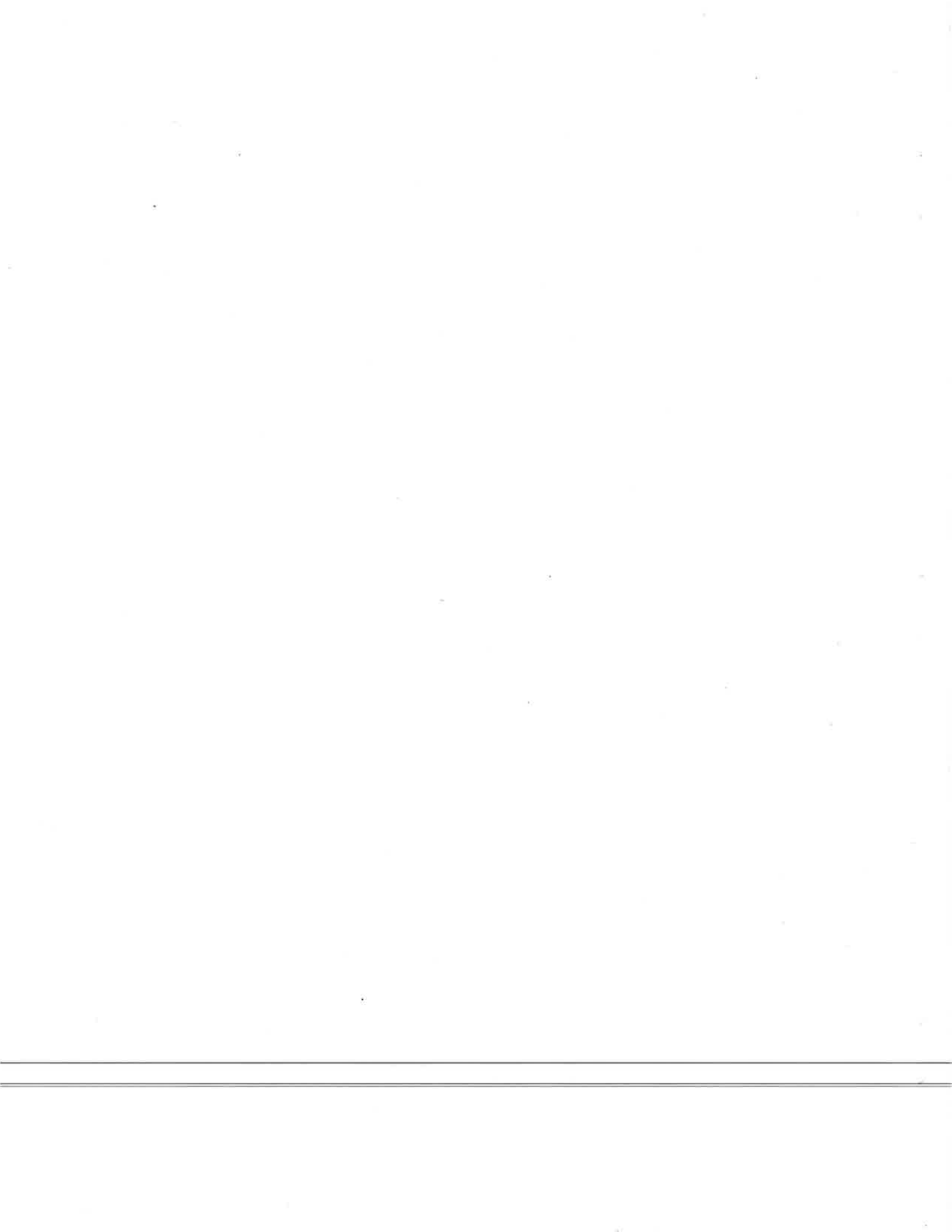

## 1. INTRODUCTION AND BACKGROUND

### 1.1 INTRODUCTION

The FAA, under the Air Traffic Control Radar Beacon System (ATCPBS) improvement program, has requested the TSC (1) to present a plan to investigate the impact of wind loading on the rotational stability of the Secondary Surveillance Radar (SSR) antenna mounted on the ASR-7 or 8 pedestal, and (2) to assess the impact on the passive BCAS operation. This plan gives the sequence of tests to be performed at the test sites, the analysis and computer simulation to be carried out using field data and mathematical models, and to make appropriate conclusions.

This test plan specifies the measurements to be performed and the analysis to be conducted in order to determine the variations that may occur in the Secondary Surveillance Radar (SSR) antenna rotation rate under different environmental conditions and to evaluate the effect of those variations on Full Beacon Collision Avoidance System (BCAS) operation. Alternatives will be proposed if the current design is found to be inadequate. The FAA specifications for the antenna rotation rate of the Airport Surveillance Radar (ASR) (to which the SSR antenna is rigidly attached) is 12.5 rpm  $\pm 10$  percent over the range of service conditions, which include wind velocities up to 85 knots and a 1/2 inch radial icing conditions. Analyses conducted by the Institute for Defense Analyses (IDA)<sup>1</sup> have indicated that such variations may lead to unacceptably large errors in calculated relative target position for the Full BCAS.

The passive and semiactive modes of Full BCAS calculations of position for ground radar sites and aircraft requires a knowledge of aircraft azimuth relative to the SSR sites. The determination of azimuth is based on measurements of time of receipt

<sup>1</sup>Report No. FAA-RD-79-18, A Review and Analysis of the FAA BCAS Concept, Irvin W. Kay, June 1979, Page 35.

of the ground squitter messages and of the time when the rotating interrogation beam passes the aircraft.

Approximately once per second the Radar Based Transponder (RBX) at an SSR site emits a squitter message giving the current direction of the SSR antenna main beam. The BCAS determines the time of passage of the SSR main beam past the own aircraft by estimating the centroid of the sequence of approximately 16 ATCRBS interrogation pulse pairs which it receives while in the beam.

The bearing of the BCAS from the SSR (own azimuth) can be calculated by adding the antenna angle (at the time of the squitter message) to the change in antenna angle between the time of the squitter and the time the main beam passes the BCAS. If the antenna is assumed to rotate at a constant rate, the change in antenna angle is assumed to rotate at a constant rate, the change in antenna angle is the observed time interval multiplied by the rotation rate.

Similar calculations can be performed to determine the bearing of a target from the SSR (target azimuth) and the differential azimuth. The time of passage of the antenna main beam past the target is estimated from the centroid of the sequence of elicited target transponder replies. The angle calculations again depend upon an assumption of a constant rotation rate.

Even when the period of a complete antenna revolution remains constant, wind loads on the antenna may cause significant accelerations and decelerations within each revolution giving instantaneous rotation rates substantially different from the average rate. Figure 1 illustrates the error that may result in the computed position of a target relative to BCAS if the rotation rate deviates 10 percent from its average value while the antenna rotates through a differential azimuth angle of approximately  $40^\circ$ . The maximum possible separation in angle between BCAS and a target is  $\leq 90^\circ$  for a 1-second squitter rate and at a 15-rpm antenna rotation rate.



The tests and analyses specified herein will determine what deviations of antenna rotation rate from the nominal will occur under different environmental conditions, and will calculate the extent to which these deviations will degrade BCAS target tracking accuracy.

## 1.2 BACKGROUND

During ATRCBS improvement studies in 1973,<sup>2,3</sup> some analyses were performed to predict antenna performance for dynamic operation and for antenna survival.

Some analytical data are available which may be applicable to this current problem. Illustrative samples of these data are given in Figures 2 and 3. A sample plot of antenna speed vs. wind angle-of-incidence for an 85-knot wind and icing conditions is shown in Figure 2, and yawing moment as a function of wind angle-of-incidence alone is shown in Figure 3.

From the analysis, it is concluded that the dynamic yaw moment can change the antenna rotation speed, and since the antenna drive motor is vital in maintaining a constant antenna rotation rate, the motor should be studied. Induction motors are used. From the manufacturer's test data of the torque-speed characteristics, it is possible to predict acceptable performance limits and to specify modifications for improvements, provided that the other system and environmental factors are also known. Typical torque-speed plots for the 5-hp motor presently used for ATRCBS antenna drives are shown in Figure 4 and for comparison a curve for a 30-hp motor is shown in Figure 5.

Under a Texas instruments in-house effort,<sup>4</sup> a one fourth scale SSR antenna model was constructed and tested in a wind

---

<sup>2</sup>Preliminary Draft of Report 10991, Phase I, ATRCBS Antenna Modification Kit, Section IV, Hazeltine Company.

<sup>3</sup>Draft Report, ATRCBS Phase I Engineering Report, July 25, 1973, by Texas Instruments.

<sup>4</sup>Armand J. Maillet, AF230, Private Communications.



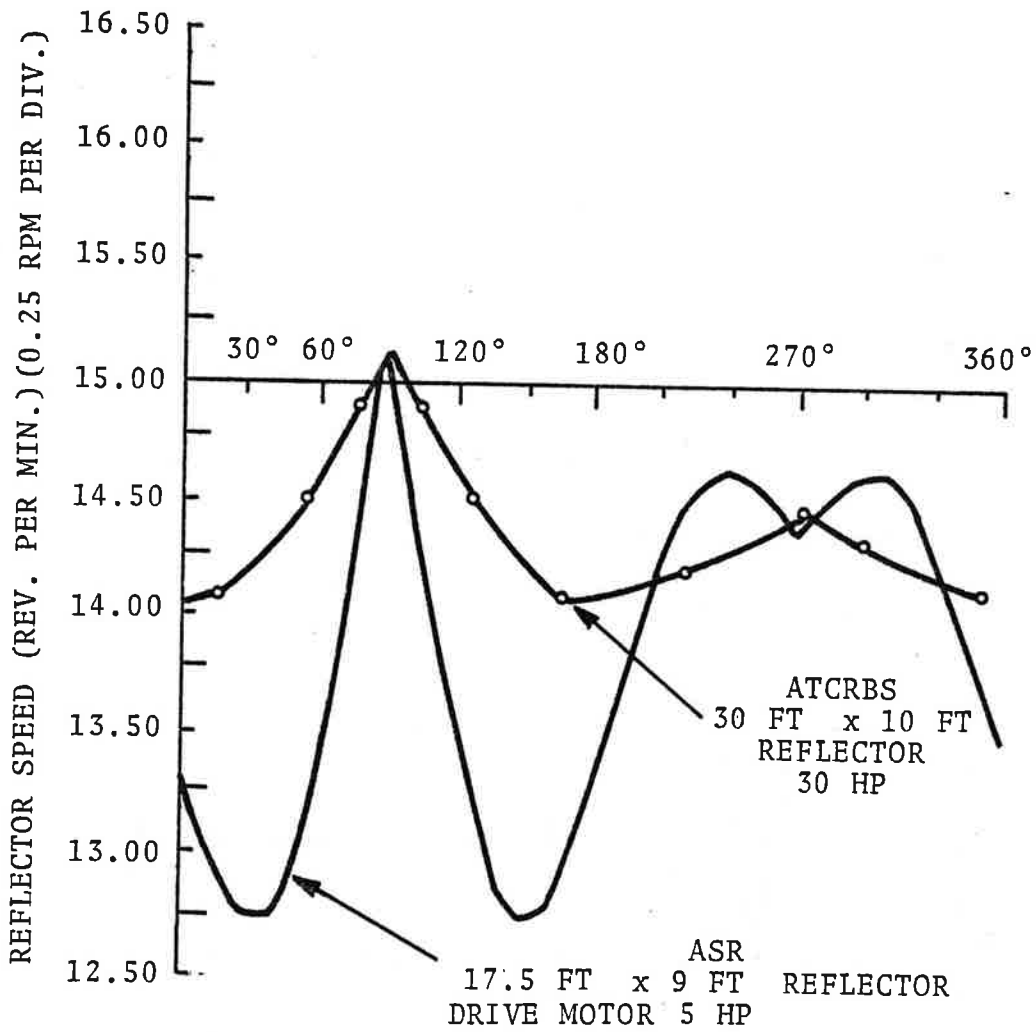

FIGURE 2. REFLECTOR SPEED VS WIND ANGLE OF INCIDENCE

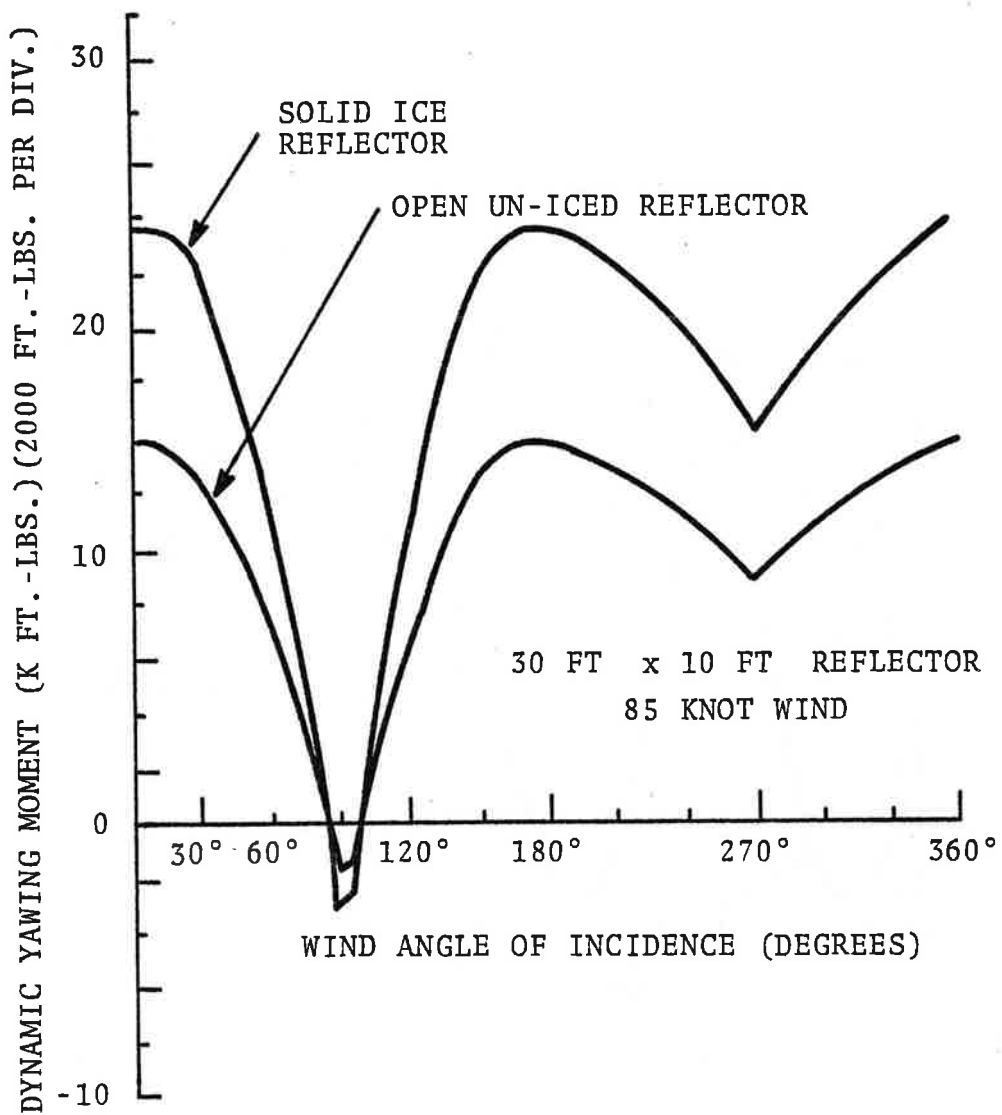

FIGURE 3. CALCULATED DYNAMIC YAW MOMENT VS WIND ANGLE OF INCIDENCE

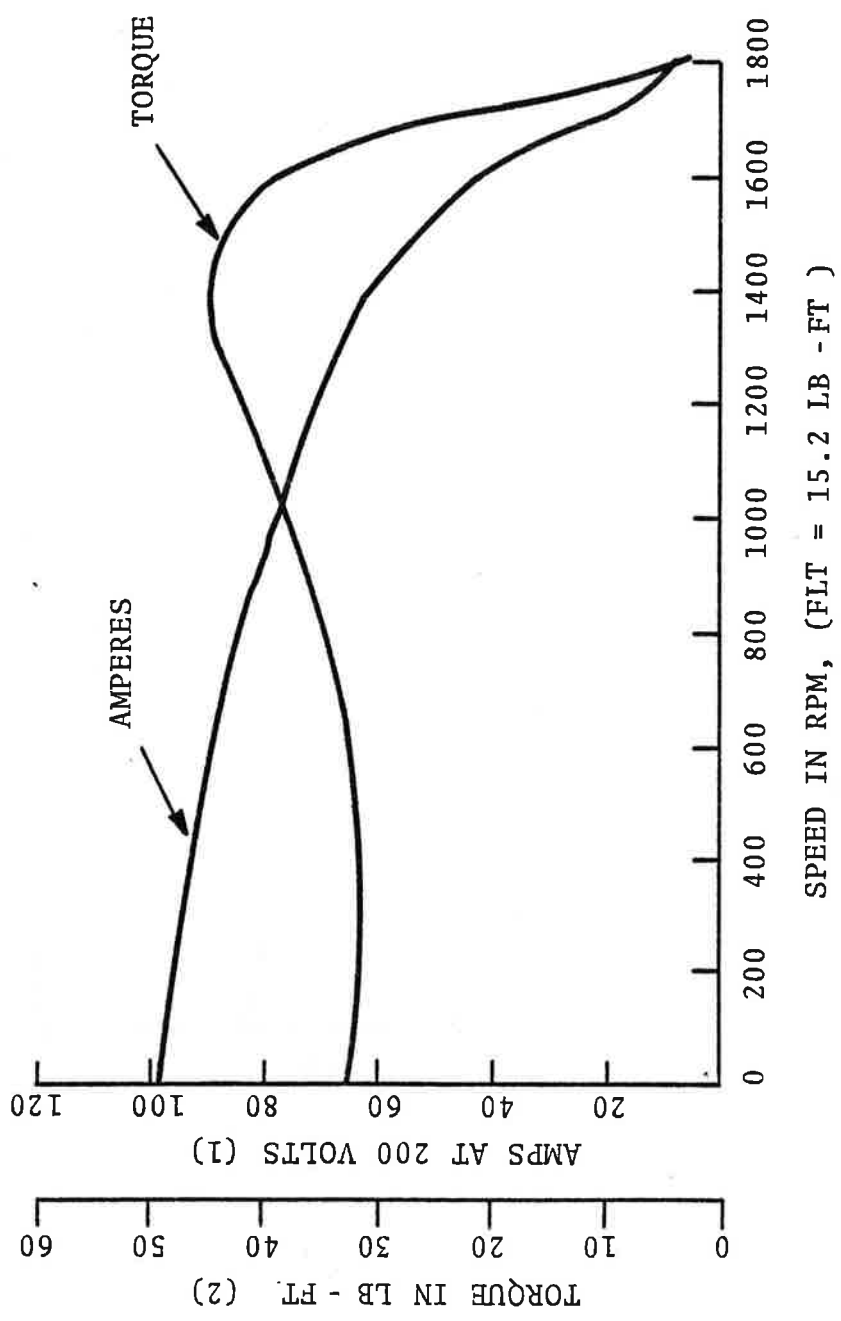

FIGURE 4. 5-HP MOTOR TORQUE CHARACTERISTICS

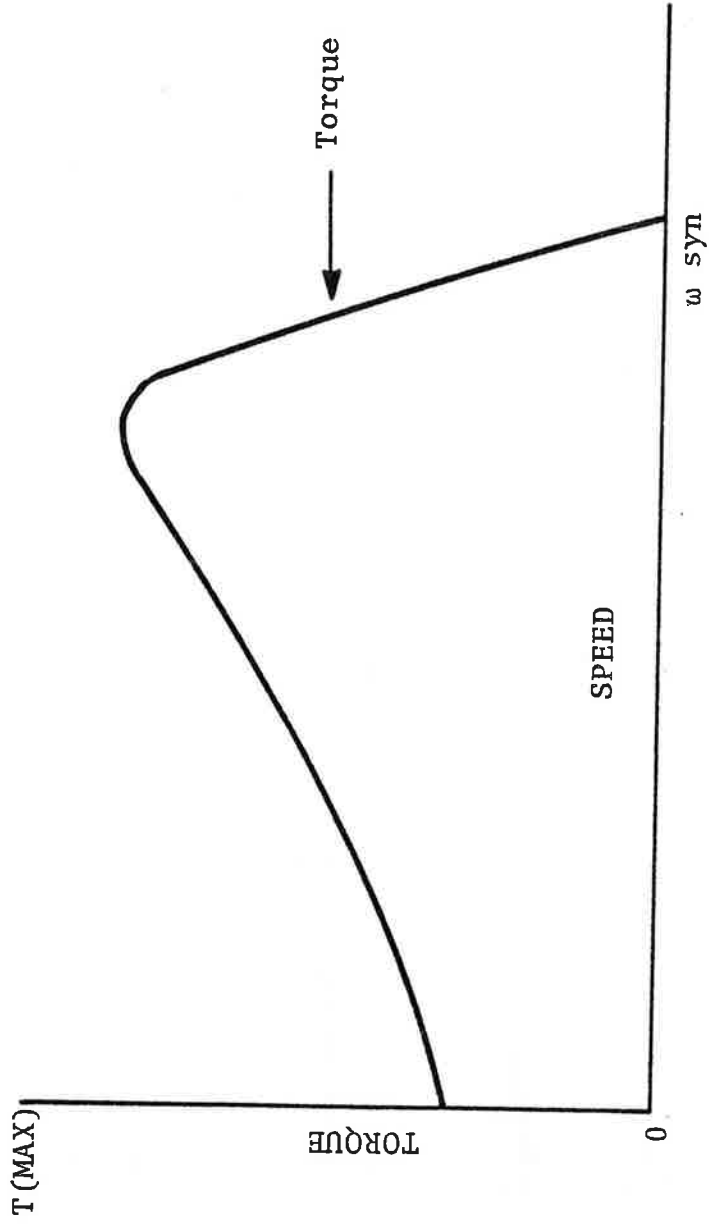

FIGURE 5. 30 HP MOTOR TORQUE CHARACTERISTICS

tunnel. Two field tests were also conducted. The results of a field test conducted by the FAA Technical Center<sup>5</sup> over a limited range of environmental conditions, are shown in Figure 6. The results of the second, a large military antenna, do indicate the effects of wind and have some bearing on the current problem. See Figure 7 . Nevertheless, there are no known data from dynamic field tests which would be useful for (Full BCAS program) answering the SSR rotation constancy question satisfactorily.

---

<sup>5</sup>George J. Hartranft, ANA-120, Memo-Wind Speed Affects on ACP Count at NAFEC ASR-7 Site, January 14, 15, 16, 1976.

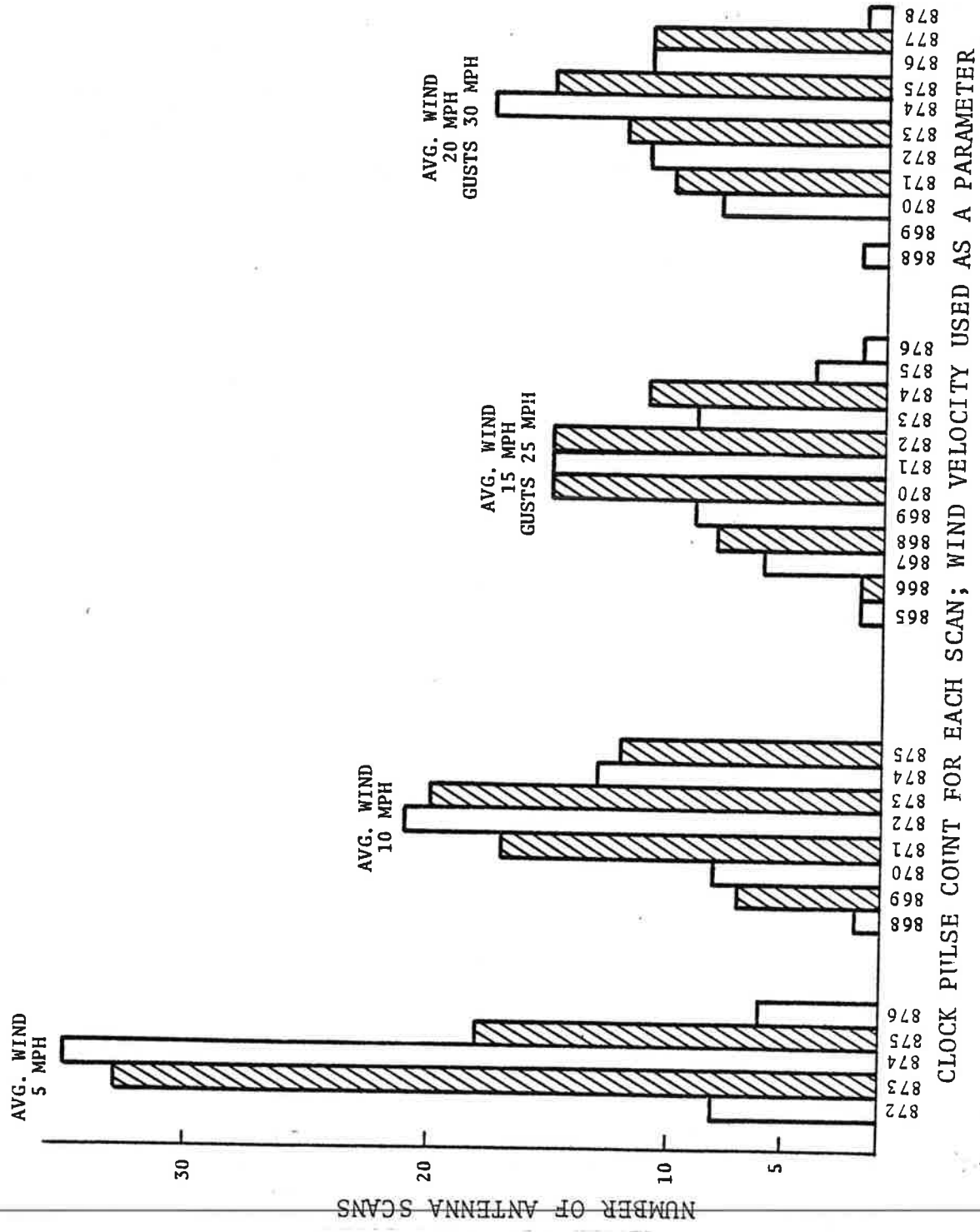

FIGURE 6. FAATC SSR MEASURED DATA

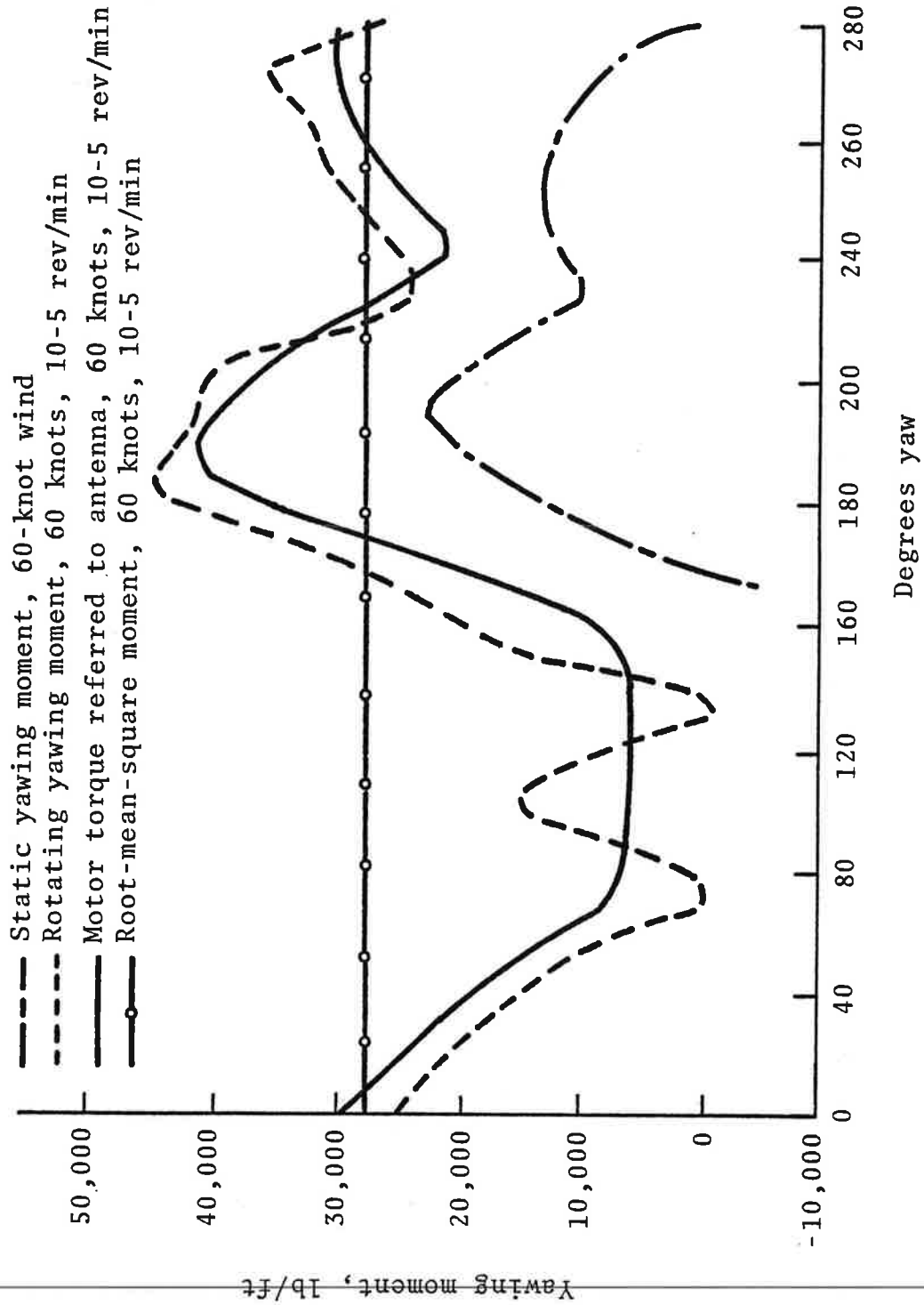
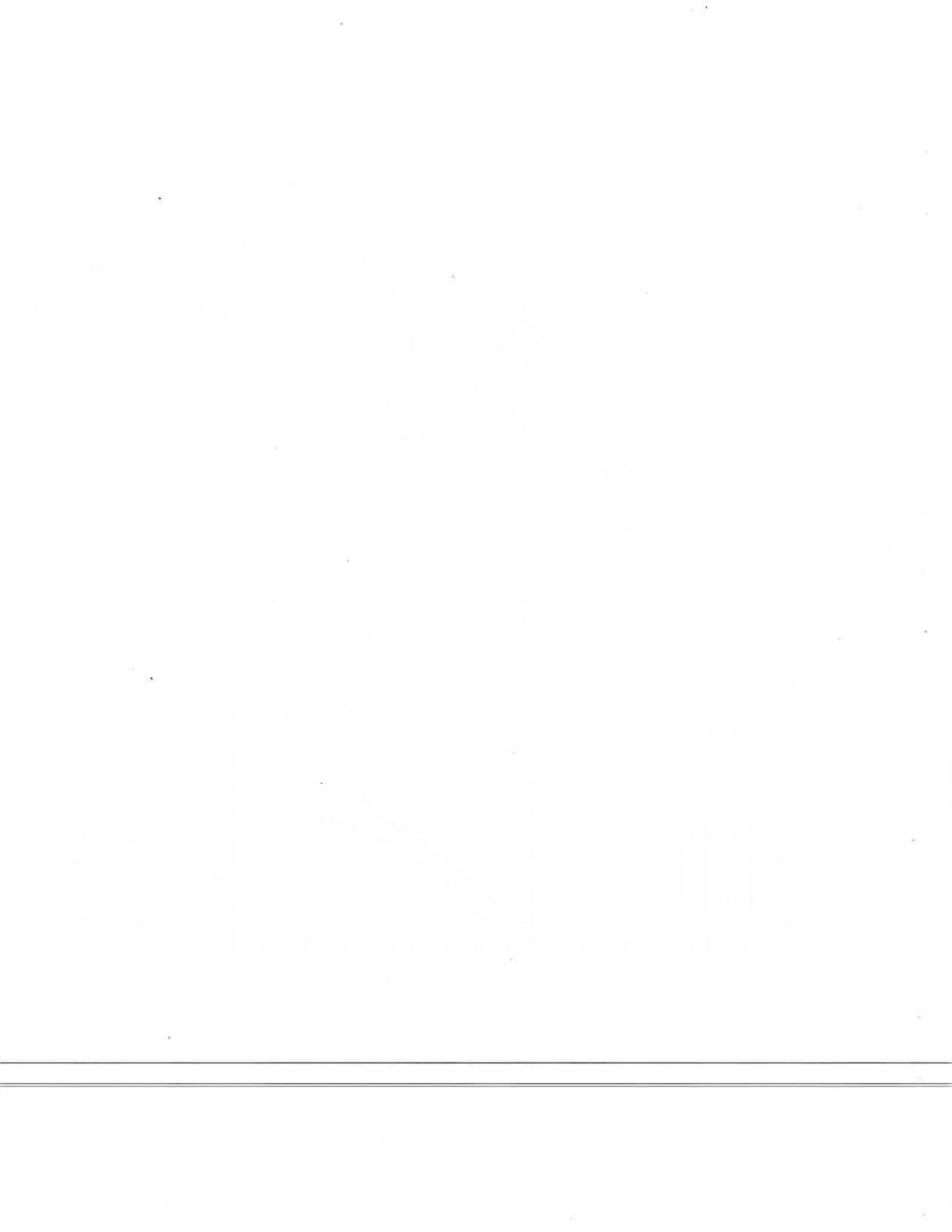

FIGURE 7. YAWING MOMENT FORCES FOR THE S 264 ANTENNA





## 2. TEST OBJECTIVES

### 2.1 DETERMINE CAPABILITY OF SSR ANTENNA ROTATION RATE STABILITY WITH THE FULL BCAS DESIGN REQUIREMENT.

1. To perform SSR antenna rotation rate measurements in the field for a wide range of environmental conditions in order to determine the range of conditions over which rotational stability under the Full BCAS concept is acceptable.
2. To assess performance degradation of Full BCAS outside this range of conditions.

### 2.2 IDENTIFY ANTENNA ROTATION STABILIZATION ALTERNATIVES, IF REQUIRED

Conduct data reduction and analysis of the field data and compare these data with analytical data, and with parametric simulation results. Assess whether or not current performance is adequate for Full BCAS utilization. If not, then evaluate improvements by analysis and simulation using various alternative approaches and identify more promising ones for field evaluation.

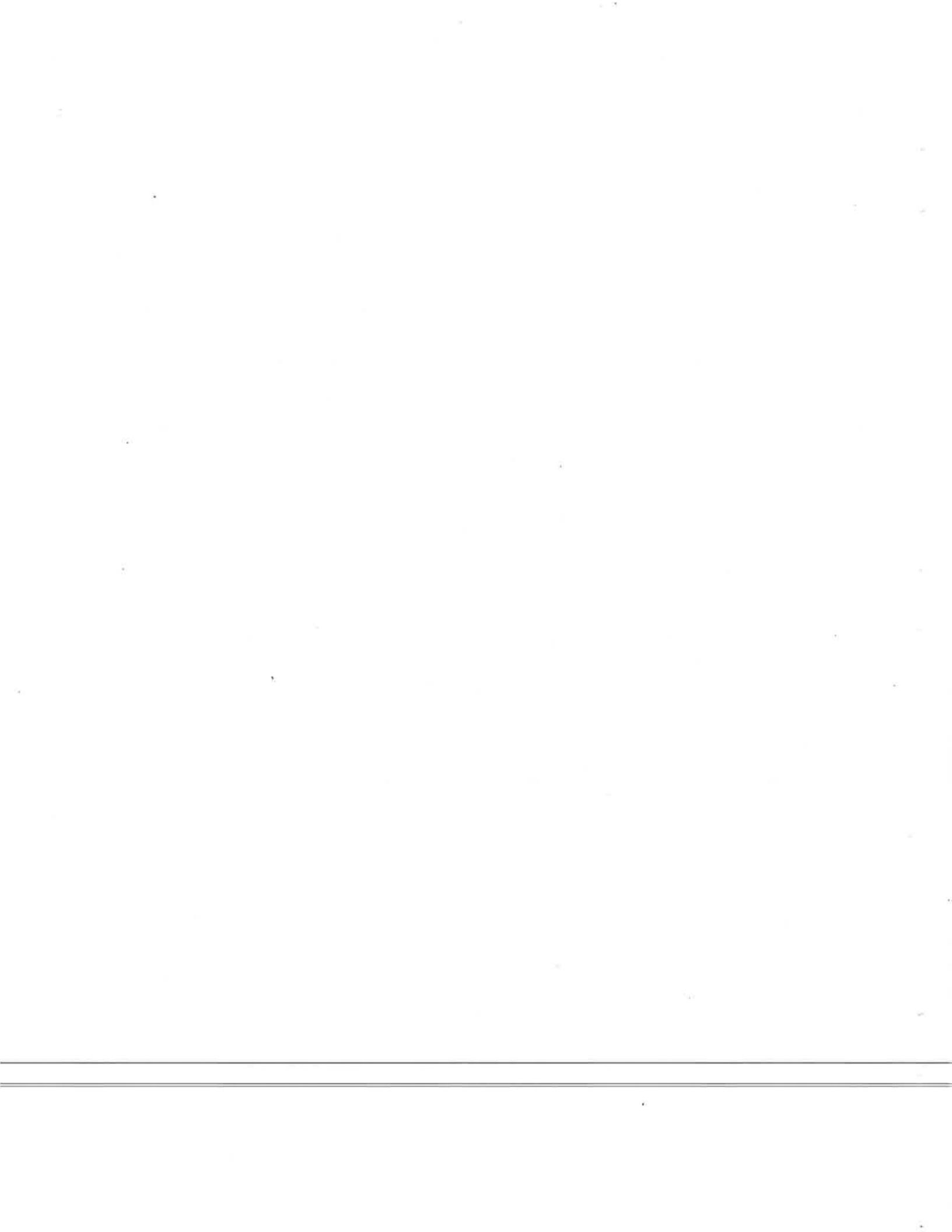

### 3. SCOPE

#### 3.1 SCOPE OF THE TASKS

The thrust of this effort lies in obtaining useful field measurements of antenna rotation speed, supplemented by analyses and simulation, for the range of environmental conditions specified by the FAA. The final recommendations will be based on these results. With the foregoing in mind, the program will consist of the following elements, which are of equal importance.

1. Field measurements at operational sites,
2. Analysis,
3. Simulation,
4. Evaluation of alternatives by analysis and simulation and identification of alternatives for field evaluation.

##### 3.1.1 Requirements for Field Measurements

3.1.1.1 Types of SSR and ASR Antennas - The present antenna for ATCRBS sites is the ATCRBS five-foot open array antenna, Type FA-9764, colocated with the ASR or ARSR antenna. "Colocated" means that the beacon antenna is mounted on the same pedestal as the primary antenna. This setup, although very convenient for ATCRBS antenna installation, is of some concern in the implementation of the Full BCAS concept because of the much larger projected area of the antenna which is exposed to the wind loads and icing conditions. The Open Array antenna has replaced the Hog Trough antennas which was specified by FAA for the Terminal and En Route sites. Under the ATCRBS improvement program, the DABS systems is being developed. It is currently proposed that DABS sites will have two types of antenna installations, either the Open Array, FAA-E-2660, or the Back-to-Back, FAA-ER-240-35a, antenna. The Open Array Antenna mounted on top of an ASR-7 antenna is shown in Figure 8.

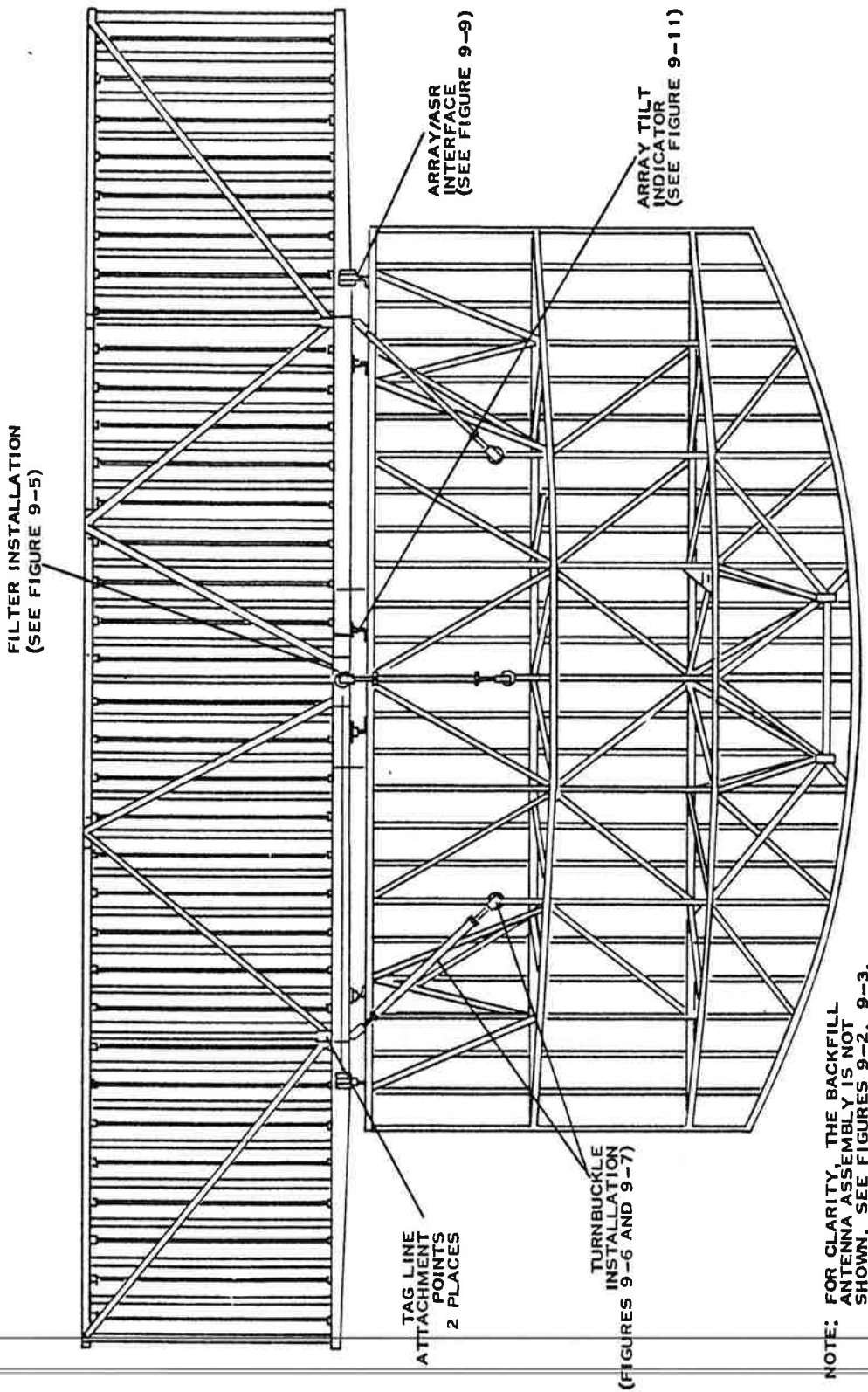

FIGURE 8. INSTALLATION OF ATCRBS ANTENNA ON ASR-7 STRUCTURE

With the Open Array antenna installation, the antenna rotation speed may be affected even more by wind than before, because the projected area for the Open Array is 5 ft x 28 ft, and the antenna has to maintain the same rotational speed of up to 15 rpm.

Only the SSR Open Array antenna will be tested beginning with the Open Array, FAA-E-2660, installed at the FAA Technical Center Terminal Radar Beacon Test Facility (TRBTF) site, Atlantic City, N.J.

## 3.2 DATA COLLECTION

### 3.2.1 Selection of Test Sites

To obtain as many field measurements as possible during extreme environmental changes, a variety of climates at the selected sites is required. Test areas other than Federal Aviation Administration Technical Center, Atlantic City, NJ are being considered, including remote sites, such as, sites in Alaska or Greenland or windy, desert areas in California. The Full BCAS concept is based on the reception of both ATCRBS and DABS signals. Although ATCRBS and DABS sites have some distinct differences, test results are to be compatible.

It is worthwhile to notice that all en route ARSR antennas are protected by radomes, and it is assumed for our purposes that the drag torque, inertia-induced torque, and the off-center torque will have a minimal effect on the dynamic yaw moment and therefore will not require any testing.

### 3.2.2 Test Planning

Major items facing the planning of the study of the SSR antenna rotation rate constancy are the progress of the Full BCAS design definition and the engineering model development tasks. Timely inputs at various phases during these developments are anticipated at the early stages in the program. More comprehensive results are expected by May 1, 1982 when the First

Phase Report is to be released which will summarize the test results, the impact assessments on Full BCAS performance, and identify the problem areas. A detailed schedule of the tests to be performed and test options are given in Section 8.0 of this test plan.

### 3.3 ANALYSIS

Analyses will include the derivation of results from the field measurements, analysis of mathematical models, design of algorithms, and computer simulation.

#### 3.3.1 Mathematical Analysis

Total dynamic yaw moment may produce non-uniform SSR rotation of the antenna when it is subjected to environmental changes. All components of the total yaw moment under dynamic conditions contribute in varying degrees. A colocated ASR-8 antenna and SSR antenna simulation model is shown in Figure 9 . It consists of three major subassemblies:

Induction Motor,  
Gear Train, and  
ASR-8/SSR Antennas.

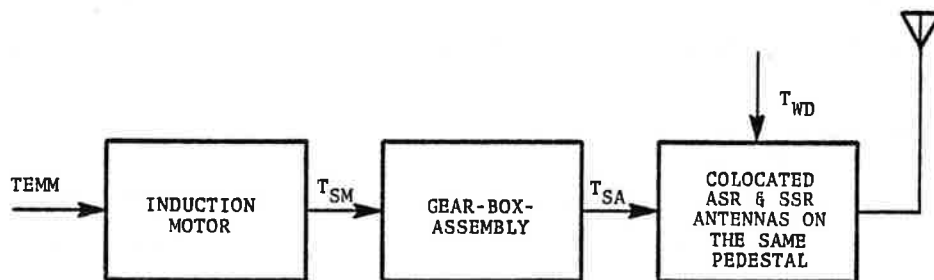

FIGURE 9. ASR-8/SSR ANTENNA SYSTEM SIMULATION MODEL

The 5-hp induction motor rotates the ASR-8 and SSR antennas at 15 rpm under all weather conditions. A typical ASR-8 site installation will have two induction motors, however the test site selected at TRBTF site has only one 5-hp induction motor and, therefore this site represents a typical ASR-7 site.

### 3.3.1.1 Induction Motor Equivalent Circuit

As equivalent circuit of the induction motor is shown in Figure 10 .

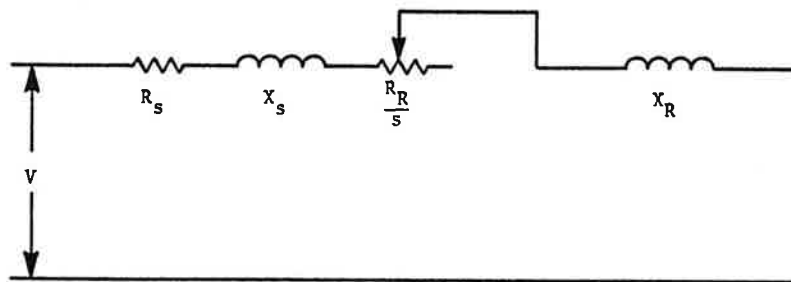

FIGURE 10. EQUIVALENT CIRCUIT OF THE INDUCTION MOTOR

Using mathematical expressions and substituting the given motor parameters, the following equation of motion can be derived for the electromagnetic torque to be generated for the system.

$$T_{EMM} = J_M \frac{d^2 \theta_M}{dt^2} + B_M \frac{d\theta_M}{dt} + T_{SA}$$

$T_{EMM}$  = Electromagnetic motor torque

$J_M$  = Viscous damping

$T_{SA}$  = shaft torque applied to antenna =  $J\ddot{\theta} + T_{WD}$

$J\ddot{\theta}$  = Antenna Torque

---

$T_{WD}$  + Yaw torque due to wind variation

### 3.3.1.2 Gear Train

The gear train reduces the speed of the drive shaft of the antenna by an 1800:15 ratio, where

$$\theta = \theta_M/n$$

$$\dot{\theta} = \dot{\theta}_M/n$$

$$\ddot{\theta} = \ddot{\theta}_M/n$$

$$T_{SA} = n/T_{SM}$$

and  $\theta$ ,  $\dot{\theta}$ , and  $\ddot{\theta}$  represent the displacement angle, angular velocity, and angular acceleration for the antenna and  $\theta_M$ ,  $\dot{\theta}_M$ , and  $\ddot{\theta}_M$  represent same parameters for the motor,  $T_{SA}$  and  $T_{SM}$  are the torque for antenna and the motor respectively, and  $n$  is the gear ratio.

The other components of the yaw torque are,

1. Wind velocity induced torque,

$$M_\omega = F_D \frac{\omega W}{v} - \frac{W}{6} |\cos\beta|$$

$F_D$  is the dynamic drag force,  $F_D = 1/2\rho v^2 C_D HW$

$\rho$  is the density of air

$v$  is stream velocity

$C_D$  is the drag coefficient, which varies with icing conditions

$H$  and  $W$  are height and width of the antenna

$\omega$  is the reflector rotation rate

2. Offset induced torque,  $M_o = F_D b \sin(\cos B)$

$b = 1.5$  feet

3. Inertia induced torque,  $M_I = I_M (\Delta\omega)$ , (ft-lbs).

$I_M$  is the mass moment of inertia



SSR ANTENNA  
SYSTEM SIMULATION MODEL  
(FAA TECH CENTER ASR-8 MODEL)

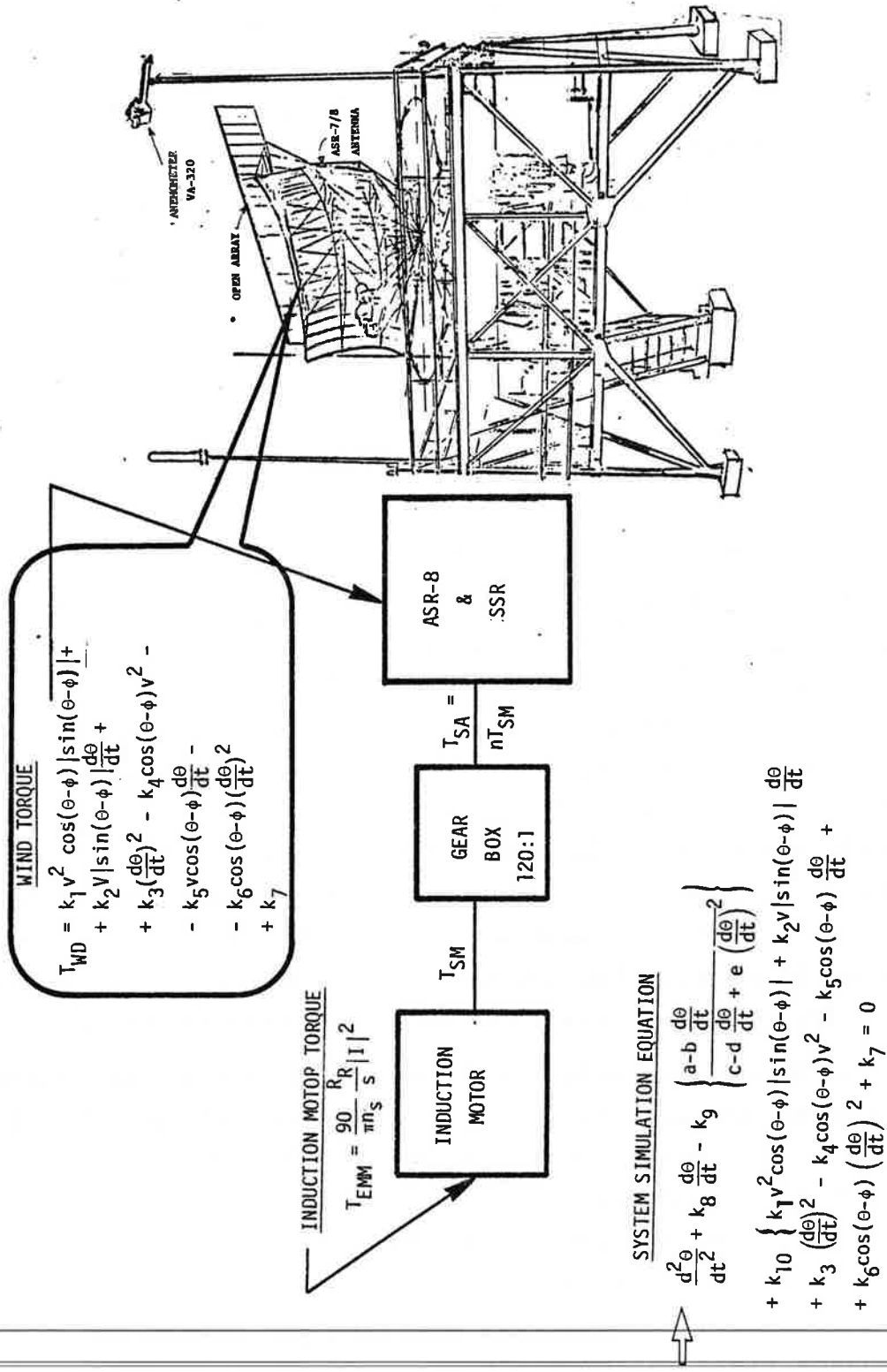

FIGURE 11. SSR ANTENNA SYSTEM SIMULATION MODEL (FAA TECH CENTER ASR-8 MODEL)

4. Friction torque,  $T_f = 100$  ft-lbs for ASR
5. "Fanning" torque,  $M_F = 2\rho C_D \omega^2 \frac{W^4}{64} H$
6. Feedhorn induced torque,  $M_H = \sum q (A \times d) \sin\beta$ (ft-lbs)  
 $q = 1/2 \rho v^2 C_D$   
 $v_s$  net wind velocity on the effective area of the feedhorn  
 $d$  is distance to feedhorn  
 $A$  is effective area at distance  $d$

Then the total dynamic yaw is:

$$M_{YAW} = M_W + M_O + M_I + M_f + M_F + M_H$$

$$= T_{EMM}$$

Figure 11 is a mathematical model developed for the ASR-8/SSR antenna system to be used in analysis. All parameters for this study are the actual values at the test site. The wind-induced torque with ice or heavy rain conditions is the most significant one for this study. A typical graph showing the relative contribution of each torque is given in Figure 12. It is desirable to test antenna rotation speed at 15 rpm and at wind speeds of 85 knots. Estimates predict that the peak torque in winds of 30 knots is about 50 percent of the peak wind torque in winds of 85 knots. Parametric studies may be performed for estimating drag coefficients to match field test results.

Performance obtained from the field operational measurements will not be adequate to define the cause of the problem for two reasons: (1) probably not all limiting environmental cases can be obtained from a few selected sites, and (2) speed variation is due to the composite effect of numerous factors which may not be identifiable from the data collected in the field. To overcome this limitation, mathematical analysis and simulation will be used to enhance field measurements.

### 3.3.2 Simulation

Parametric evaluation and trade-off studies will be made using computer simulations to synthesize the total dynamic yaw moment and its effects on the antenna rotation rate. To achieve this, the equation of motion must be developed so as to include dynamics of the drive motor, gear train, and antenna, which are subject to the wind and other torque effects. From the parametric study, the significance of the wind component, backlash, and inertia will be determined. Proposed design modifications will be introduced and simulate operation of the modified system.

A typical simulation result is shown in Figure 13A. It may be compared with the actual data measured in the field, Figure 13B. Nonlinearities were omitted in this simulation, which shows poor agreement with the measurements except for the amplitudes of the yaw moment, which agree satisfactorily.

### 3.3.3 Preliminary Data Analysis

A rate of change of SSR antenna rotation as computed from the mathematical model is shown in Figure 14, 15, 16, and 17. Preliminary analysis is used to compare derived data with measured data at a wind velocity of 15 mph.

The results are as follows.

Wind velocity 15 mph -- 15 rpm is reduced by 2.9%, computed for 70° change in antenna pointing direction.

15 rpm is reduced by 0.7%, measured for 45° change in antenna pointing direction.

SSR antenna rotation rate changes predicted at higher wind velocities using the same mathematical model are as follows,

30 mph - will produce 3.3% reduction in rotation rate

97.8 mph (85 knots) - will produce 22.2% reduction in rotation rate.

---

There are no data to verify these predictions.

---

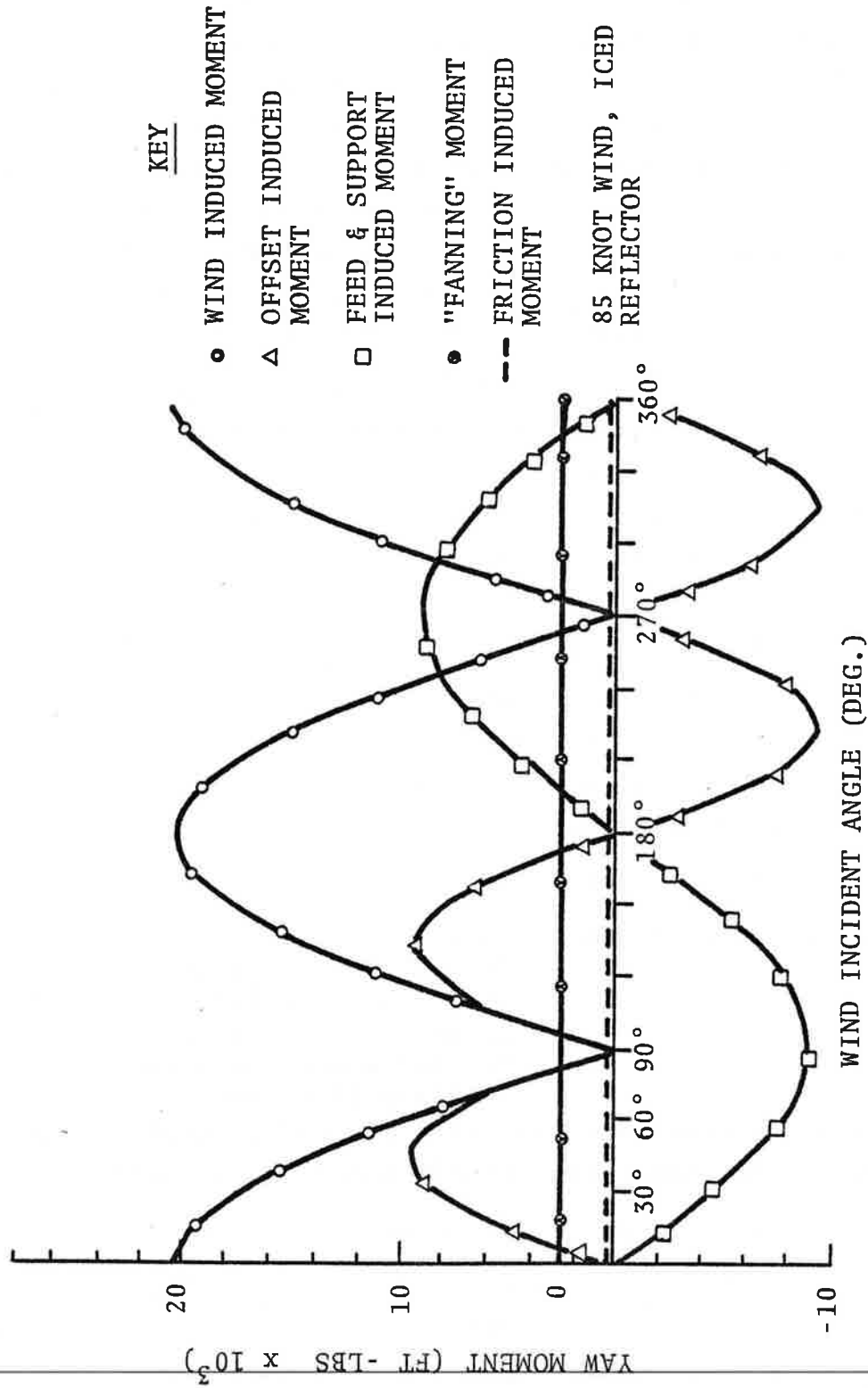

FIGURE 12 COMPUTED COMPONENT YAW MOMENT VS WIND ANGLE OF INCIDENCE

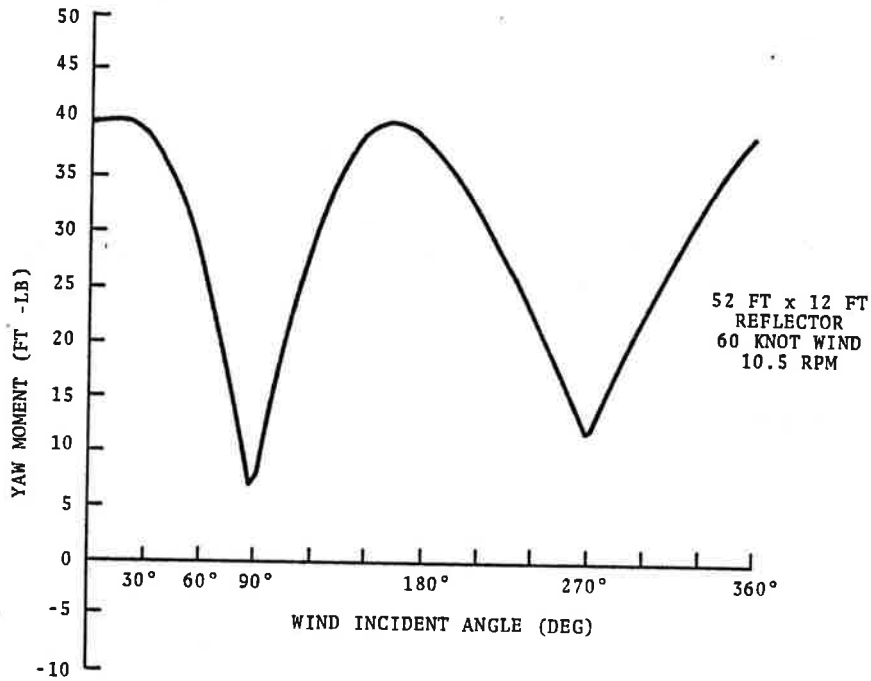

FIGURE 13A CALCULATED YAW MOMENT VS WIND ANGLE

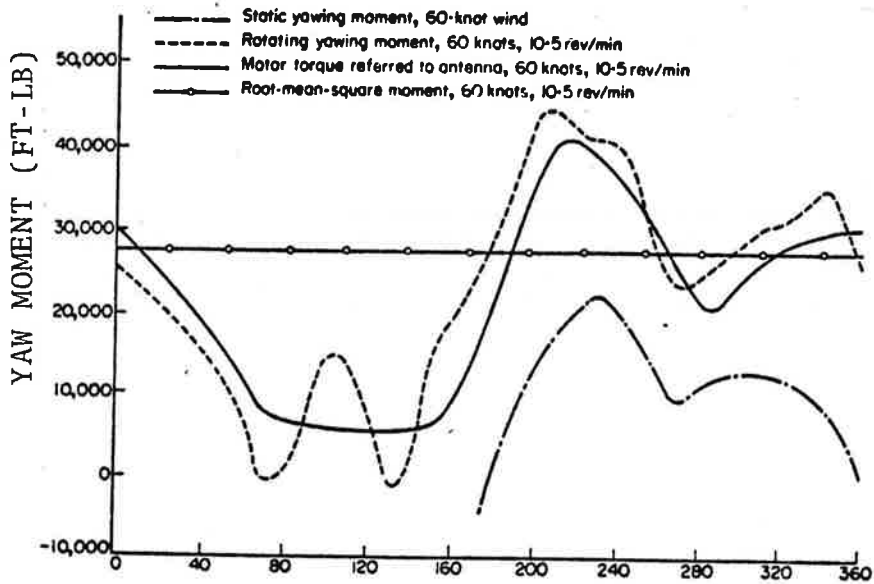

FIGURE 13B. MEASURED YAW MOMENT VS WIND ANGLE

INITIAL CONDITION TETA=0 DTETA/DT=0 FOR T=0

V (M/HOUR) = 0.0 PSI (DEG) = 0.0

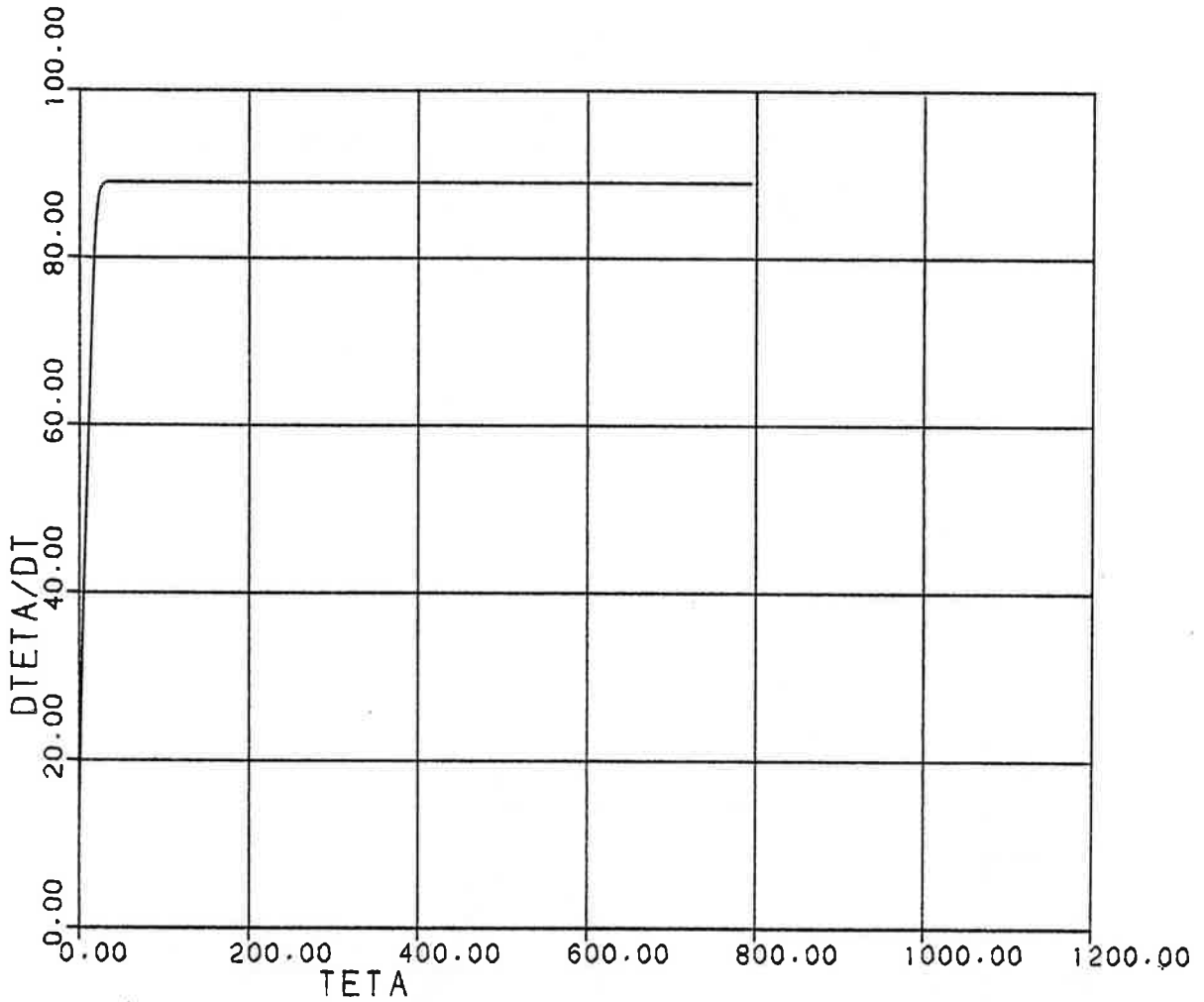

FIGURE 14. COMPUTED SSR ANTENNA ROTATION RATE

INITIAL CONDITION TETA=0 DTETA/DI=L      7=0

V(M/HOUR)= 15.0 PSI(DEG)= 0.0

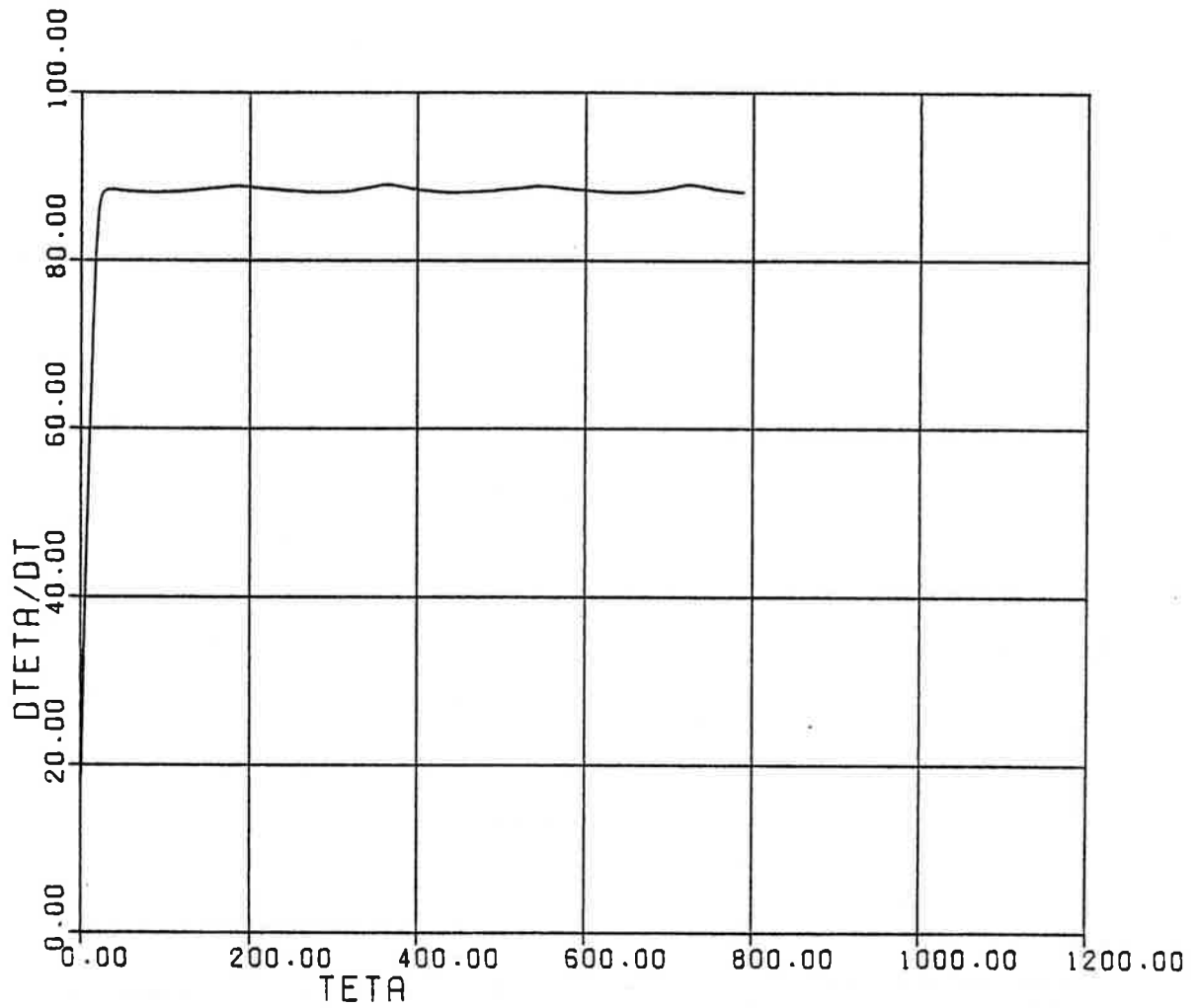

FIGURE 15. COMPUTED SSR ANTENNA ROTATION RATE

INITIAL CONDITION TETA=0 DTETA/DT=0 FOR T=0

V (M/HOUR) = 30.0 PSI (DEG) = 0.0

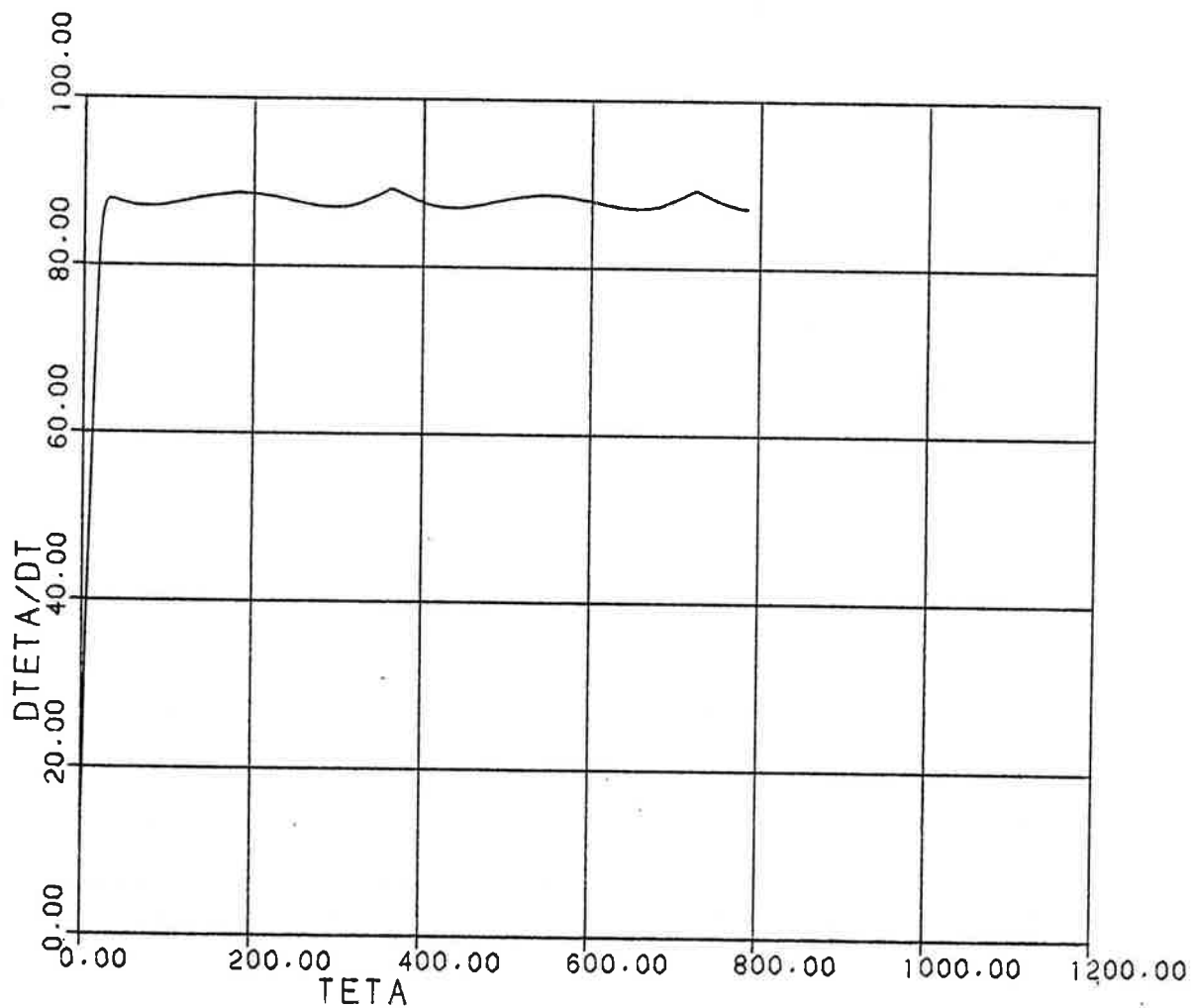

FIGURE 16. COMPUTED SSR ANTENNA ROTATION RATE



INITIAL CONDITION TETA=0 DTETA/DT=0 FOR T=0

V(M/HOUR)= 97.8 PSI(DEG)= 0.0

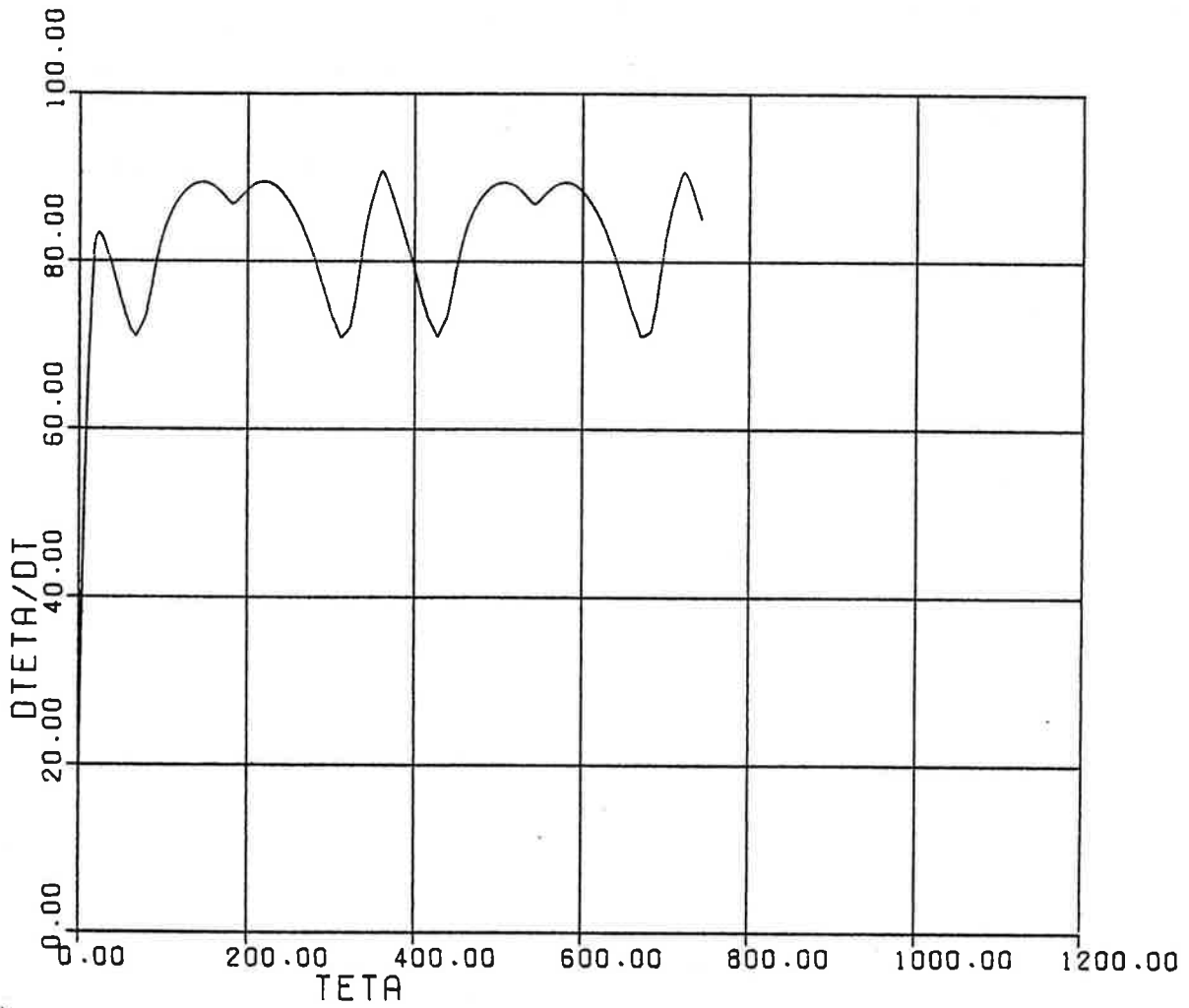

FIGURE 17. COMPUTED SSR ANTENNA ROTATION RATE

A corresponding variation also occurs in the Yaw Moment and is shown in Figures 18 and 19.

#### 3.4 IDENTIFICATION OF ALTERNATIVE DESIGNS

From the analysis, collected field data, and simulation results, the most promising alternative designs will be evaluated by parametric studies and identified for additional evaluation in the field

INITIAL CONDITION TETA=0 DTETA/DT=0 FOR T=0

V(M/HOUR)= 15.0 PSI(DEG)= 0.0

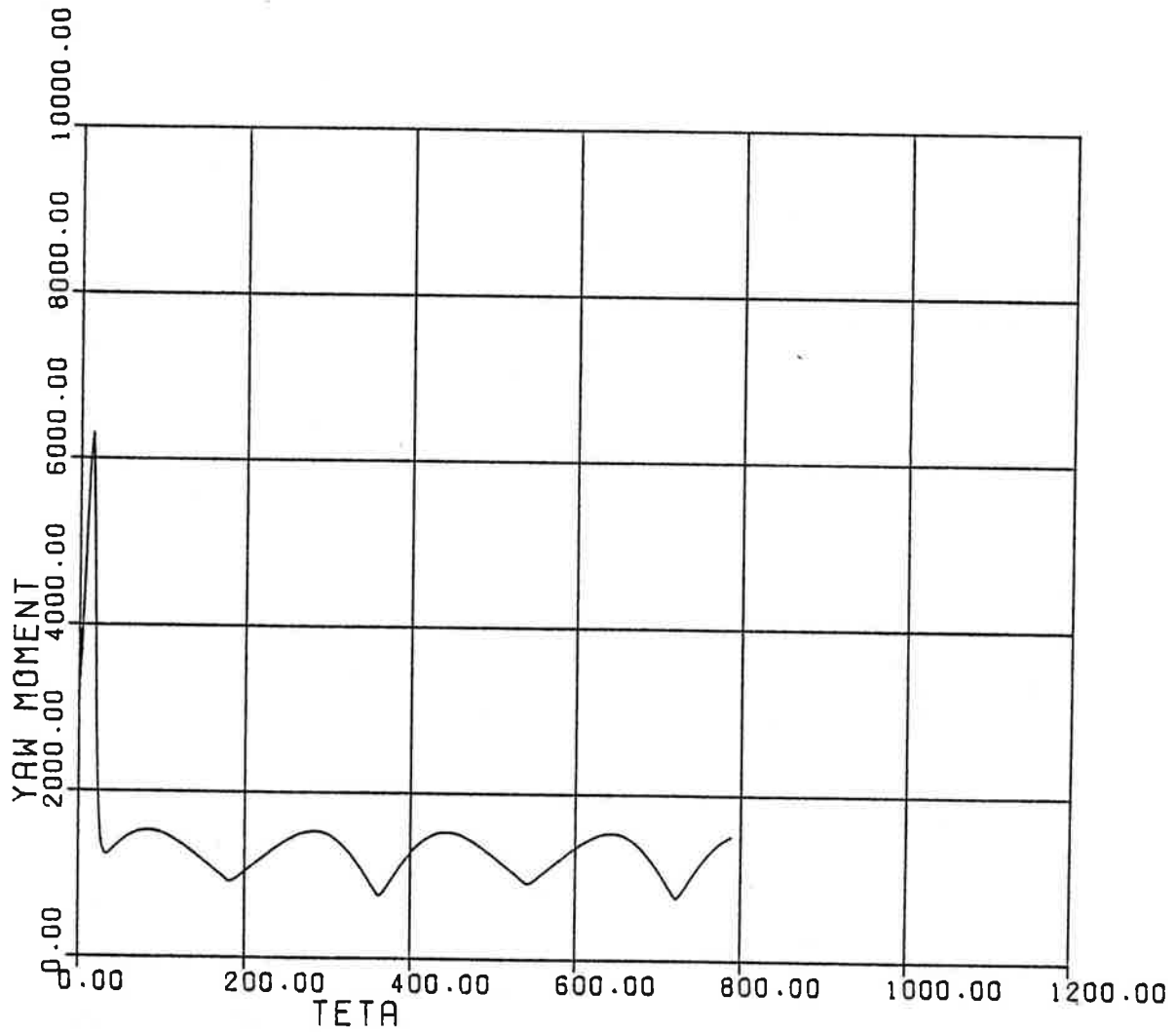

FIGURE 18. COMPUTED SSR ANTENNA YAW MOMENT

INITIAL CONDITION TETA=0 DTETA/DT=0 FOR T=0

V(M/HOUR)= 97.8 PSI(DEG)= 0.0

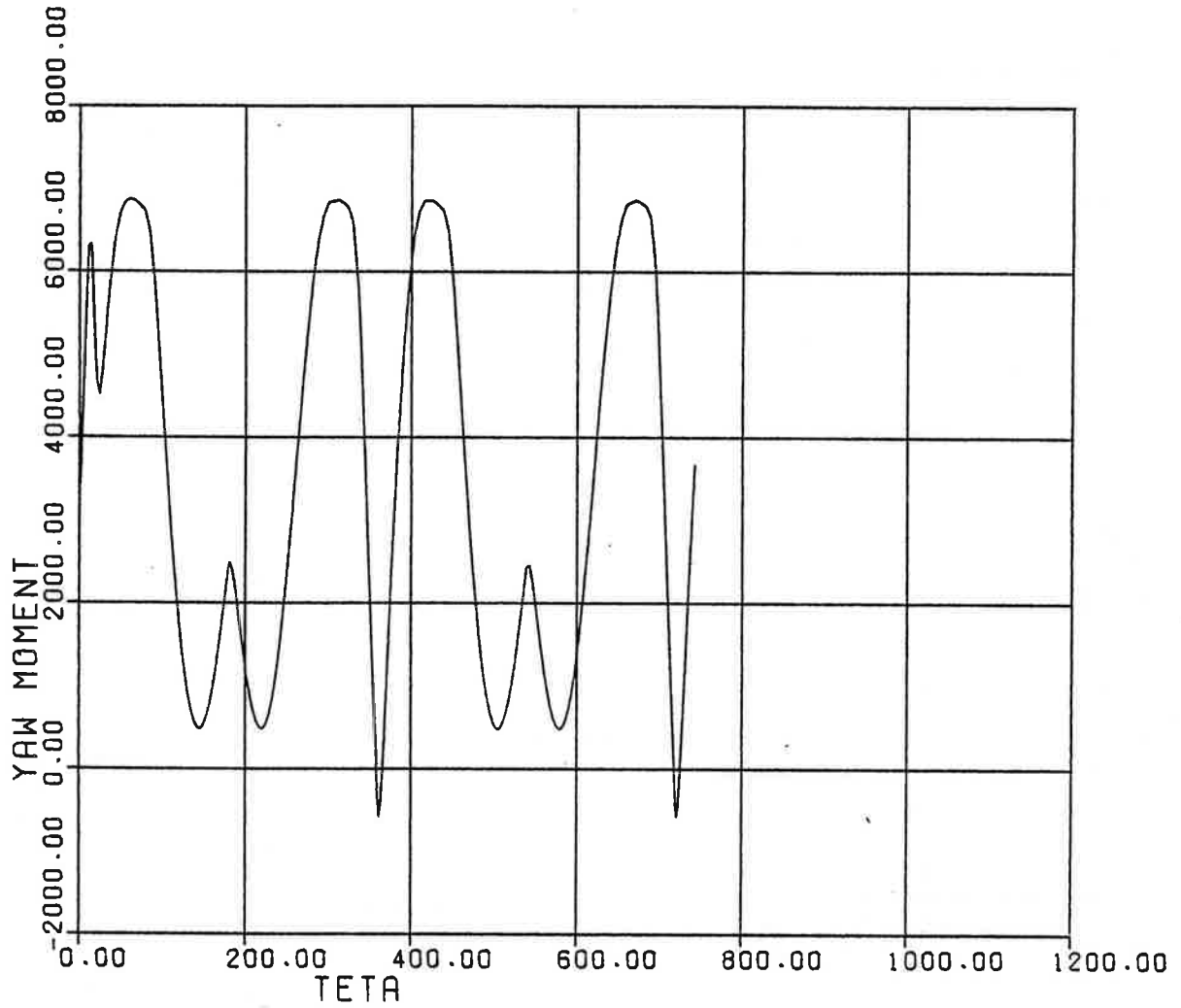

FIGURE 19. COMPUTED SSR ANTENNA YAW MOMENT

## 4. TECHNICAL APPROACH

### 4.1 DEFINITION OF TASKS

The basic approach used to determine if the SSR antenna rotation rate is stable enough to support FULL BCAS operation, will be the analysis of the measurements collected in the field and of the mathematical model of the antenna system. If it is not stable enough then approaches for improving the rotation rate stability will be identified. The total effort will consist of two parts.

1. Perform field measurements at selected sites by collecting SSR antenna rotation measurements under different service conditions.
2. Analyze the collected data, identify service conditions for which Full BCAS performance would be acceptable, and predict performance degradation outside those limits. Perform analysis and simulation studies for the whole range of service conditions as specified by FAA. Then on the basis of these analyses, the measured data, and the simulation, identify alternatives which will meet requirements over the full range of operational conditions. Using mathematical models and computer simulation, perform parametric studies of the alternative designs.

Under the proposed measurement method, antenna rotation rate variations will be measured between the two pulses of each Azimuth Change Pulse (ACP) pair (4096 ACP pulses per revolution) and will be compared with wind characteristics measured at the same time and sampled at 54 ACP pulse intervals.

All analysis is being performed at TSC, using a DEC-10 computer. Data reduction software and mathematical models and algorithms to conduct simulation analysis are also being developed at TSC. (For R&D computer programs see Appendix B.)

## 4.2 MEASUREMENT TECHNIQUE (Figure 20)

The azimuth change pulses (ACP's) and azimuth reference pulses (ARP's) are received from the SSR's antenna system [Antenna-Azimuth-Range-Timing Unit (AARTU)] as shown in the Test System Block Diagram, Figure 21. Intervals between successive ACP's will be measured by counting clock pulses from the 1 MHz system clock. These counts, together with antenna position data, will be recorded on magnetic tape. Concurrently, wind speed and direction will be measured. The data will be written on magnetic tape in logical records of 64 bytes each; 32 logical records of 2048 bytes written by the Kennedy recorder on 9-track standard magnetic tape at a density of 1600 bpi.

## 4.3 INPUT SIGNALS

Azimuth Change Pulses (ACP's) originating in the Antenna-Range-Timing-Unit (AARTU) (Figure 21) already processed by the Azimuth Pulse Generator (APG) Shaper Assembly (Figure 22) and accessed through a BNC connector at the antenna sight are fed into the SSR Antenna Computer Assembly at a rate of 4096 ACP pulses per revolution. A counter counts the number of clock pulses from an internal 1 MHz clock between successive ACP's and the total count, modulo 256, is entered into the computer on an interrupt basis as an 8-bit number (see Figure 23).

Azimuth Reference Pulses (ARP's) are generated like the ACP's, except at a much lower rate - one pulse for every 4096 ACP counts. The ARP pulses are made to coincide with one of the ACP pulses and provide information on antenna zero crossings thus indicating the completion of a full revolution.

Weather Data Wind speed and direction data are received serially on two independent channels and are entered into the computer under interrupt control.

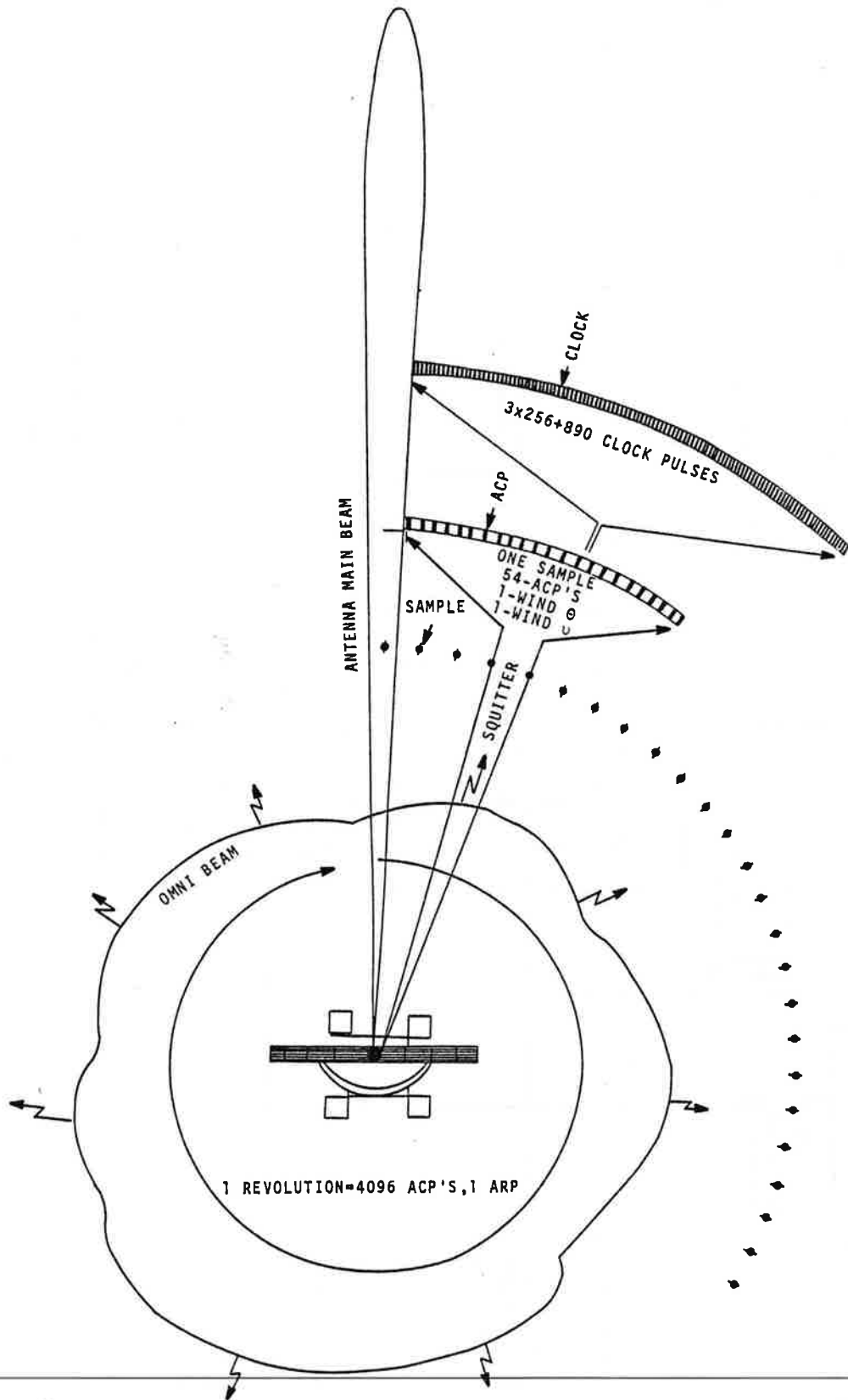

FIGURE 20. MEASUREMENT TECHNIQUE

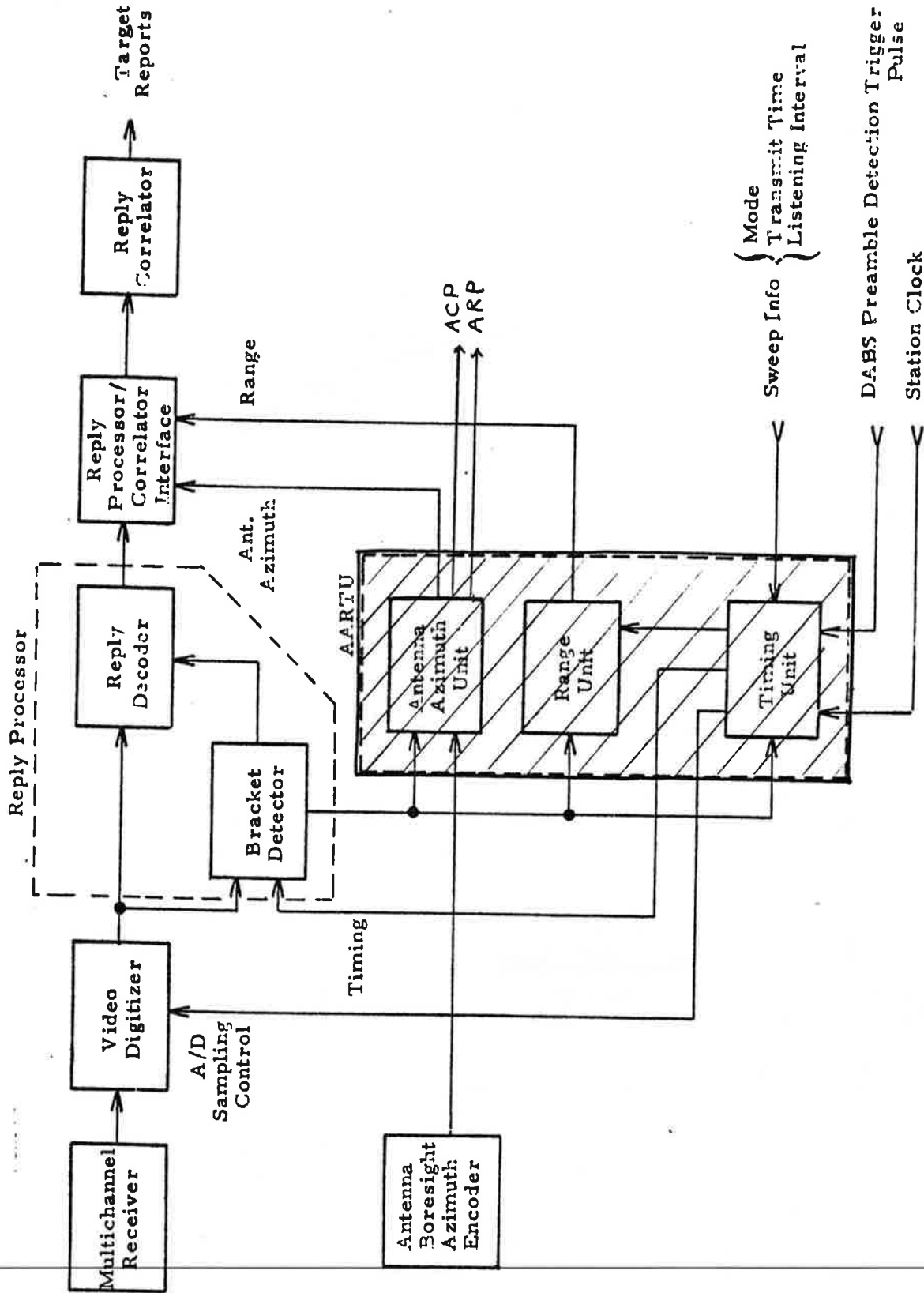

FIGURE 21. ATCRBS PROCESSOR FUNCTIONAL BLOCK DIAGRAM



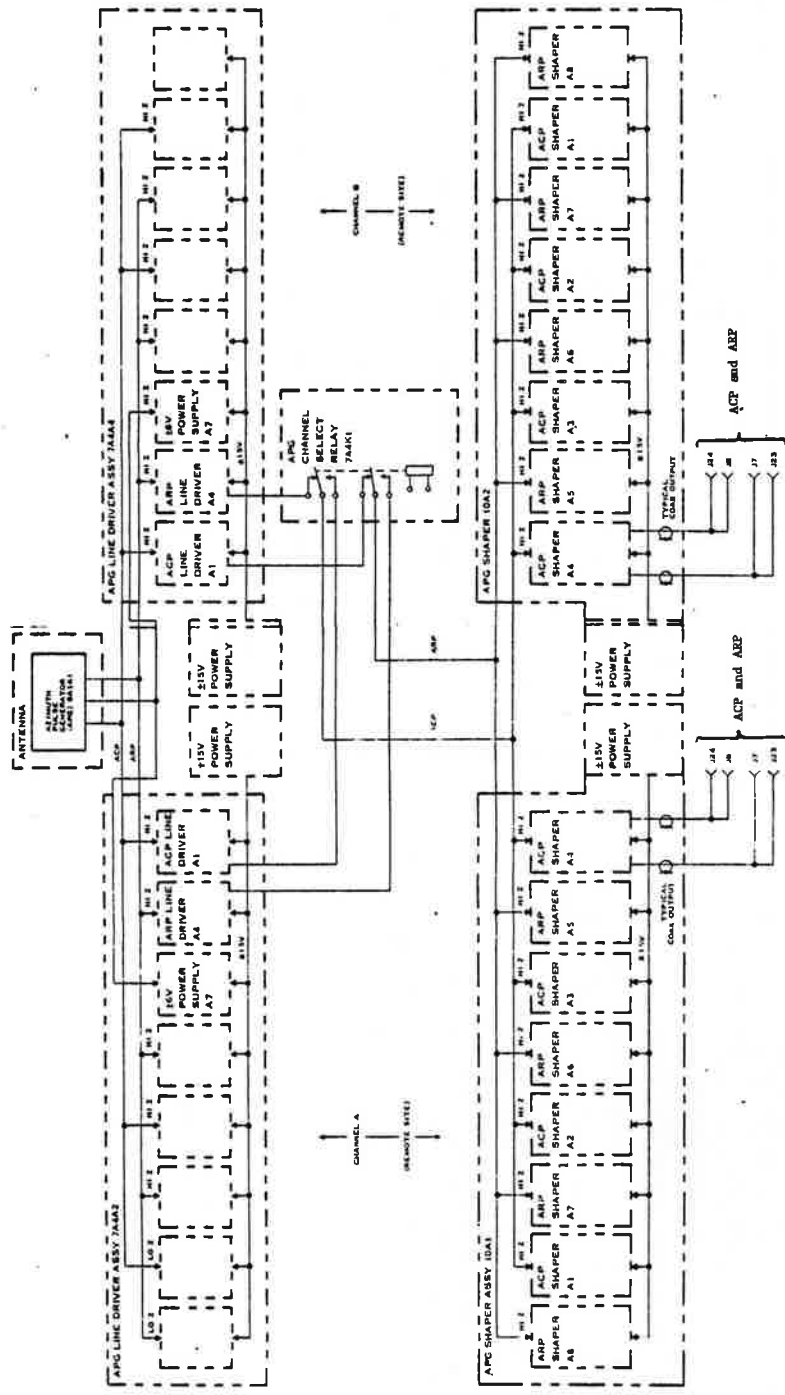

Figure 15 Azimuth Pulse Generator (APG) Block Diagram

FIGURE 22. AZIMUTH PULSE GENERATOR (APG) BLOCK DIAGRAM

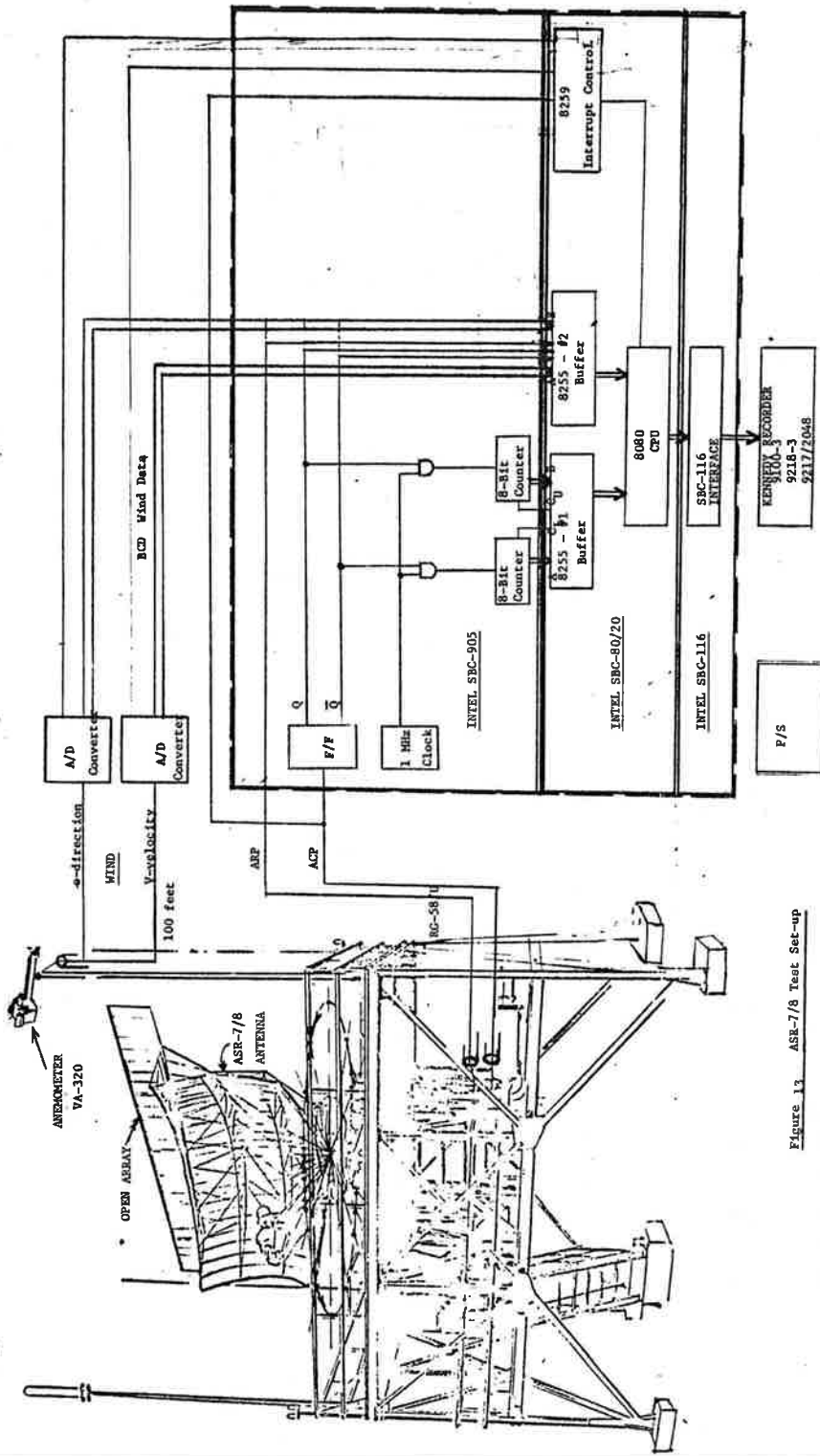

Figure 13 ASR-7/8 Test Set-up

FIGURE 23. SIMPLIFIED BLOCK DIAGRAM

#### 4.4 OUTPUT DATA

The output will consist of clock pulse counts (approximately 1000, given modulo 256) between each pulse of an ACP pair and of formatted wind data written on a magnetic tape. The magnetic tape recorder will be able to collect 7 hours of test data on a 10.5 inch (2400 feet) reel of tape in standard 9-channel format at 1600 bpi.

#### 4.5 RECORDED DATA FORMATS

The logical record (see Figure 24) will contain, in order:

The record sequence number (binary, 2 bytes).

Wind direction in degrees from magnetic north, given as three decimal digits, expressed in binary, one per byte.

Wind speed in statute miles per hour given as three decimal digits expressed in binary, one per byte.

Antenna direction, given as a count of ACP pulses since the last ARP pulse (binary number in two bytes).

Fifty-four (54) consecutive bytes, each giving the clock count between a pair of successive ACP pulses. The clock count is given modulo 256 as an 8-bit binary number. If  $n$  is the count of ACP pulses since the last ARP pulse, then the first clock count will be the interval between the  $n$ -th and  $n+1$ st ACP pulse, the next for the interval between  $n+1$ st and  $n+2$ nd, etc. The ACP pulse coincidence with the ARP pulse is considered to be numbered zero.

Byte #	Content
1	consecutive logical record #, byte 1
2	consecutive logical record #, byte 2
3	wind direction, 100's of degrees
4	wind direction, 10's of degrees
5	wind direction, degrees
6	wind speed, 100's of mph
7	wind speed, 10's of mph
8	wind speed, mph
9	ACP count since last ARP, byte 1
10	ACP count since last ARP, byte 2
11	clock period count
12	clock period count
'	
'	
'	
'	
'	
'	
'	
'	
'	
'	
64	clock period count

FIGURE 24. LOGICAL RECORD STRUCTURE ON DATA TAPE

## 5. DESCRIPTION OF THE TEST

### 5.1 UNIT UNDER TEST

Figure 25 shows the SSR site under test with an Open Array colocated with the primary radar (ASR-8) antennas. The test site selected is the FAA Technical Center's Terminal Radar Beacon Test Facility (TRBTF) site. Of the two 5-hp induction motors used in the system, (a typical ASR-8 site installation), only one motor is being used at the TRBTF site for driving the antennas. Therefore, this site represents a typical ASR-7 site installation, which is of primary interest for this study.

### 5.2 TEST EQUIPMENT

The SSR antenna rotation rate measurement test equipment assembly is shown in Figure 26. The assembly consists of the following units:

1. Anemometer, VA-320 with digitized output and 140-foot RF cable; mounted on the pole close to the Open Array under test.
2. Kennedy digital tape recorder, Model 9100-3, with accessories - rack mounted
3. SSR Antenna Test Computer Assembly - rack mounted
  - INTEL SBC-905 Board - rack mounted
  - INTEL SBC-80/20 Board - rack mounted
  - INTEL SBC-116 Board - rack mounted

A simplified block diagram of the test set-up was shown in Figure 23 which also shows the hardware and software interfaces and data extraction.

### 5.3 SSR TEST COMPUTER ASSEMBLY

The Computer Assembly for the SSR test consists of three INTEL Single Board Computer Assemblies modified to process input signals

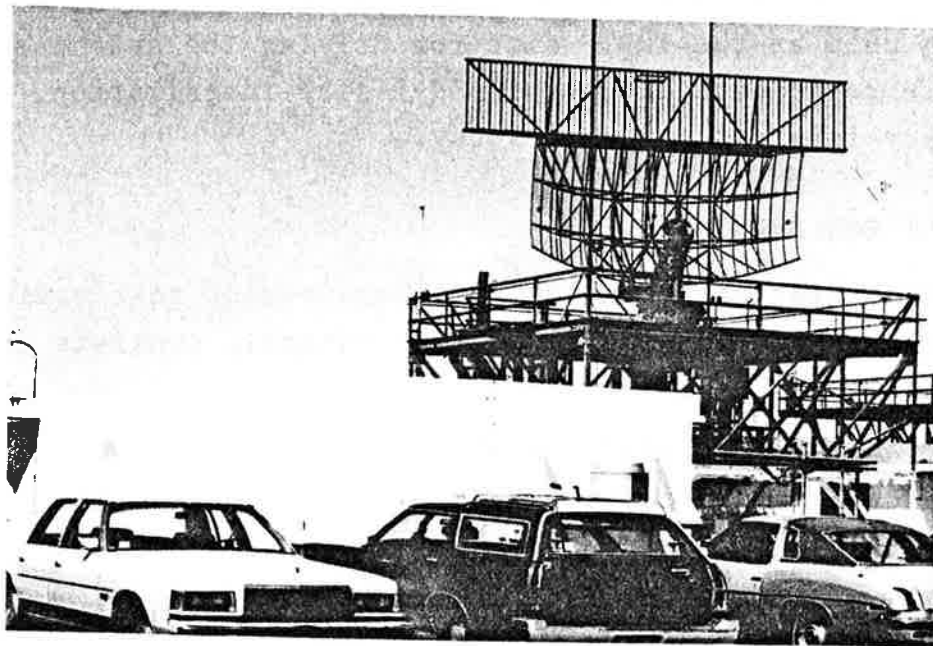

(OPEN ARRAY AT UPPER RIGHT)

FIGURE 25. FAA TECHNICAL CENTER TERMINAL  
RADAR BEACON TEST FACILITY (TRBTF)

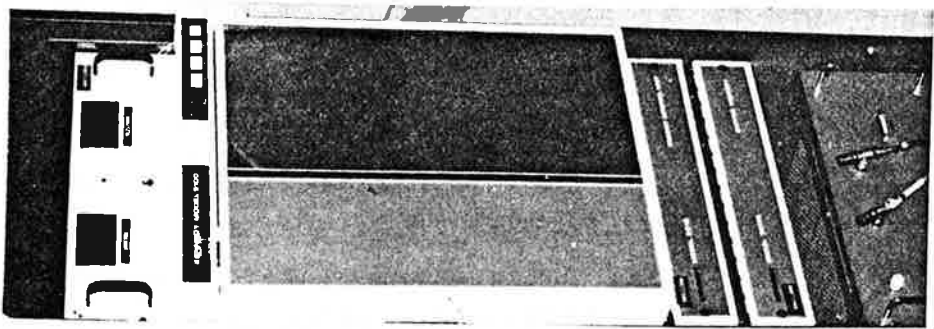
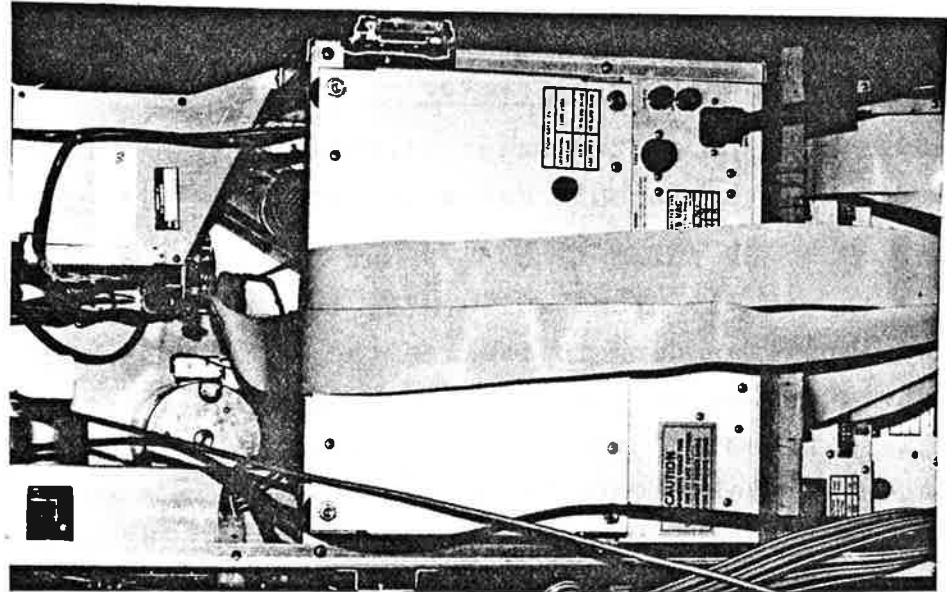

FRONT BACK  
FIGURE 26. SSR ANTENNA ROTATION RATE TEST EQUIPMENT ASSEMBLY

and the sampled output data. An Input Data Counter Schematic in Figure 27 shows interconnections of INTEL SBC-905 and INTEL SBC-80/20, as well as all input and output signals of ACP, ARP and wind velocity and wind direction signals.

### 5.3.1 INTEL SBC-905, Input Data Counter

The SBC-905 consists of two major circuits, the Azimuth Change Pulse (ACP) logic and the Azimuth Reference Pulse (ARP) logic.

ACP Logic. The ACP pulse (BNC on Front Panel) is connected to a 74C14 (U1) on pin #1. The 74C14 (U-1) is a high-impedance, input-inverting amplifier used to isolate the input from the radar system during power shut-down. Since the 74C14 is an inverting amplifier its output pin, #2, is connected to a 74LS04 (U2A) inverting amplifier on pin #1 which makes the ACP pulse positive logic and TTL compatible. The output is pin #2 which is connected to a 74S74 (U3A) pin #3, which is an Edge-Triggered Flip-Flop. This Flip-Flop is so configured that the Preset and Clear are tied through 10k-ohm resistors to the 5-volt power. The  $\bar{Q}$  output is tied to the D input so as to have complementary Q and  $\bar{Q}$  outputs.

The Q output, pin #5, is connected to pin #1 of a 7408A, which is a 2-input positive AND gate. The other input to this AND gate, pin #2, is connected to a 1 MHz signal source.

1 MHz Signal Source. The 1 MHz signal is derived from a 4 MHz crystal oscillator. The 4 MHz crystal oscillator is a standard configuration for an oscillator using a 7404 (U9). The output pin #6 is connected to pin #1 of a 7493 (U10), which is a 4-bit binary counter, configured to be a "divide-by-4" counter. The output pin #8 is connected to pins #2 and 5 of U4.

The output pin #3 of the U4A is the ACP pulse with the 1 MHz signal superimposed on the peak. This signal is connected to pin #14 of "Counter A," consisting of two-74793's (4-bit binary counters) so configured as to create an 8-bit counter, U5 and U6. This is done by connecting pin #11 of U5 to pin #14 of U6.



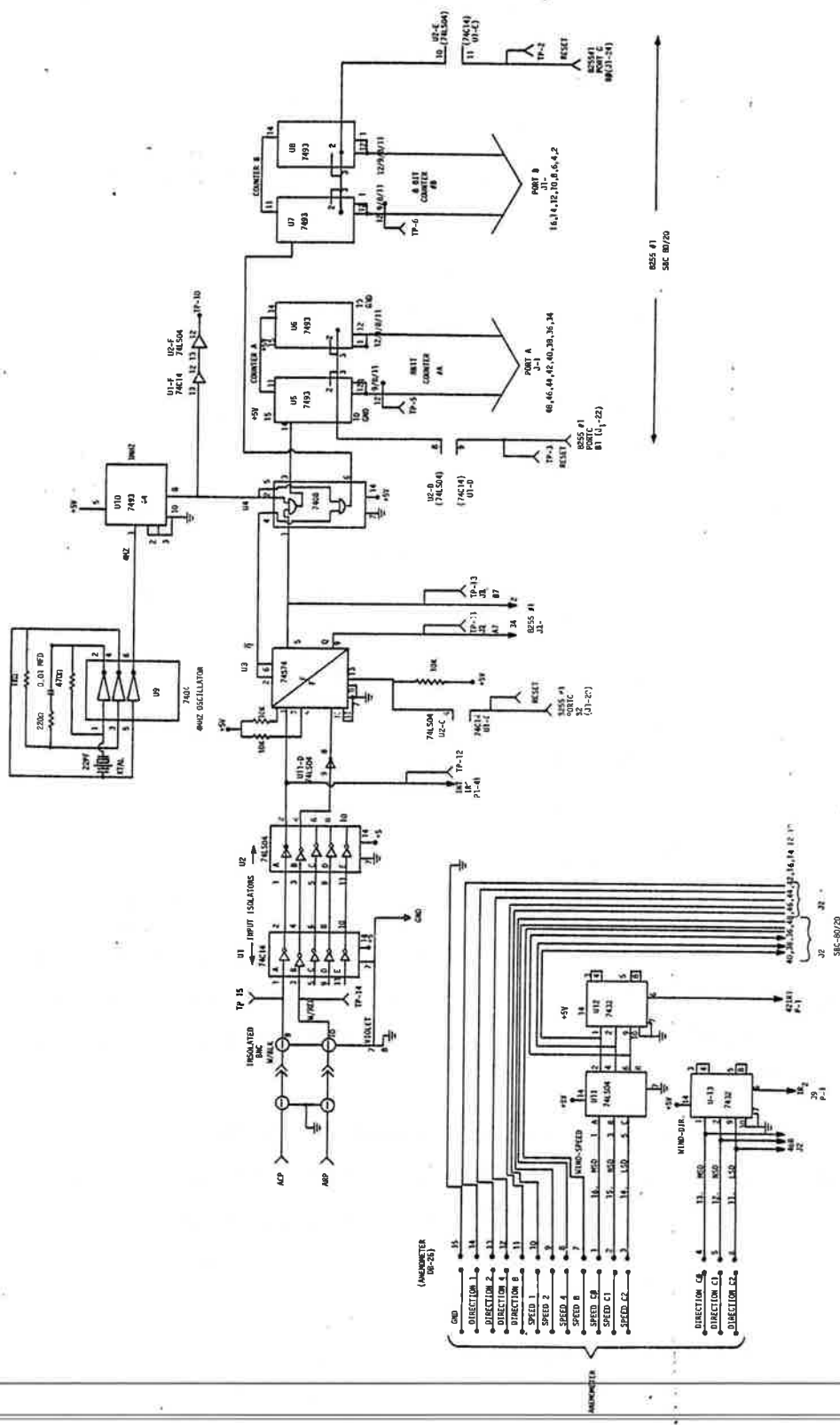

FIGURE 27. INPUT DATA COUNTER SCHEMATIC

Pin #12, the output, is connected to pin #1 to create a 4-bit ripple-through counter. The same configuration applies to U6, which completes the 8-bit counter.

The resetting of Counter A is done by connecting, F-1, pin #22 (bit #1, Port C, 8255 #1) of the SBC-80/20 CP4 board to 1-D(74C14) pin #9. Its output pin, #8, is connected to U2-D (74LS04) pin #9 and its output pin, #8, is connected to pins #2 and 3 of U5 and pins #2 and 3 of U6.

The use of U1-D, U2-D, which are inverting amplifiers, are for buffering the 8255 #1 (C-MOS) to the U-5, U-6 (TTL) counters.

The  $\bar{Q}$  output pin, #6, of U-3 is connected to pin #4 of U-4, which is a 2-input positive AND gate, the other input to this AND gate, pin #5, is connected to a 1 MHz signal source at pin #2.

The output pin, #6, is connected to pin #14, of U-7, Counter B. Counter B is configured the same as Counter A. The reset for Counter B is derived from the SBC-80/20, J1 pin #24, (Part C, Bit- $\phi$  of the 8255 #1). This in turn is connected to U-1E; pin #11, (C74C14). Its output pin, #10, is connected to U-2E pin #11, (C74LS04) and its output pin, #10, is connected to pins #2 and 3 of U-7 and pins #2 and 3 of U-8.

The use of U-1E, U-2E, which are inverting amplifiers, are for buffering the 8255 #1 (C-MOS) to the U-7, U-8 (TTL Counters).

ARP Logic. The ARP pulse (BNC connector on Front Panel) is connected to U-1B, pin #3 (74C14) which is a high impedance, input inverting amplifier used to isolate the input from the radar systems during power shut-down.

The output, pin #4, of U-1B is connected to U-2B, pin #3, (74LS04) an inverting amplifier which makes the ARP pulse positive logic and TTL compatible. The output, pin, #4, is connected to U-11D, pin #9, an inverting amplifier, to create a negative logic pulse output.

U-11D, output pin #8, is connected to U-3B, pin #10. U-3B is a D-type, Edge-Triggered Flip-Flop, and its' pins #11 (C input) and #12 (D input) are tied Low (Ground). Pin #10 is the preset input

and pin #13 is connected through a 10k-ohm resistor to High (+5V) Pin #13 is also connected to the output, pin #6, of U-2C which is a reset pulse from the SBC-80/20 board, C8255 #1, Part C, J-1 pin #20. It is then connected to U-1C a 74C14 pin #5. The output of U-1C, pin #6 is connected to U-2C pin #5, 74LS04. U-1C and U-2C, are used as buffers for the SBC-80/20, 8255 #1 (C-MOS).

The output of U-3B, pin #9, is connected to the SBC-80/20 board, J-1, pin #34, which is in the Port A, (bit 7) of the 8255 #2, (Test pin #11).

The output of U-3A, pin #5 is connected to the SBC-80/20 board, J-1 pin #2, which is the Port B (bit 7) at the 8255 #2, (Test point #13).

U-11, a 74LS04, is used as an inverting amplifier-buffer for the digital output of the anemometer wind speed which is C-MOS. The significant digit of wind speed ( $C\phi$ ) is connected to U-11A at pin #1. The output of U-11A is pin #2 which is connected to a U-12, 432 (2-input positive-OR gate) at pin #1 (1A). The next significant digit,  $C1$ , is connected to a U-11B at pin #3. The output of U-11B, pin #4, is connected to pin #2 of the U-12 (1B) which creates an output at pin #3 (1Y). (Positive Logic:  $Y = A + B$ ). Pin #3 of U-12(1Y) is connected to pin #4 (2A) of U-12. The least significant digit,  $C2$ , is connected to U-11C at pin #5. The output of U-11C, pin #6, is connected to #9 of the U-12(3A). Pin #10(3B) is connected to ground, this creates an output at U-12(3Y) pin #8. Pin #8 of U-12(3Y) is connected to U-12 (2B) pin #5 to create an output at U-12(2Y) pin #6. Pin #6 is connected to connector, P-1, pin #42 (interrupt Routine #1), which is connected to, P-1, pin #42, of the SBC-80/20 board.

The most significant digit of wind direction ( $C0$ ) is connected to U-13 (2-input positive-OR gate) at pin #1, digit of wind direction ( $C1$ ) is connected to U-13 #2(1B) which creates an output at pin #3(1Y). Pin #3 of U-13 is connected to pin #4(2A) of U-13. The least significant digit of wind direction is ( $C2$ ) connected to U-13 pin #9(3A). Pin #10 of -13 is connected to ground. This creates an output at U-13 pin #8(3Y). Pin #8 is connected to U-13 pin #5(2B), this creates an output at U-13 pin #6(2Y).

U-13 pin #6 (interrupt Routine #2) is connected to J-1 at pin #39. J-1 pin #39 is connected to J-1 pin #39 of SBC-80/20 board.

Power Supply

The power supply and the wiring diagram are shown in Figure 28.

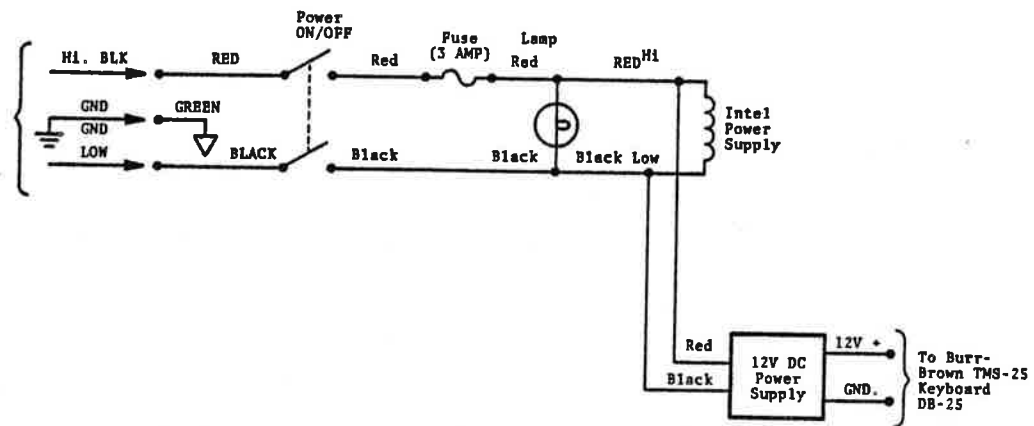

FIGURE 28. POWER WIRING DIAGRAM

## Test Points

The following test points are located at socket U-14, at pin #:

TP1 + TP16 = +5.0 V, (Vcc)

TP8 + TP9 = Ground

TP2 = Reset Counter B (U7, U8) see waveform #

TP3 = Reset Counter A (U5, U6) see waveform #

TP4 = Reset ARP (U3B) see waveform #

TP5 = Output of Counter A (U5B) see waveform #

TP6 = Output of Counter B (U7B) see waveform #

TP7 = \_\_\_\_\_

TP10 = 1 MHz Clock (U2F) see waveform #

TP11 = SARP see waveform #

TP12 = BACP see waveform #

TP13 = Gate see waveform #

TP-14 = ARP see waveform #

TP-15 = ACP see waveform #

SBC 80/20, MICROPROCESSOR, I/O ASSIGNMENTS

SBC 80/20 board: I/O Assignments See Figures 29 to 34

8255 #1 (port adr OE4H) PORT A:  
INPUTS  
DO-D7 is counter A DO-D7  
(port adr OE5H) PORT B: (INPUTS)  
DO-D7 is counter B DO-D7  
(port adr OE6H) Port C:  
b0=Counter A reset pulse; 1 = reset  
b1=Counter B reset pulse, 1 = reset  
b2=x-floop-  
b3=x  
  
b4= main loop test flag  
b5= ACPINT test flag  
b6= SPINT test flag  
b7= DRINT test flag

8255 #2 (port adr OE8H) Port A: (Wind speed inputs)  
b0-b3 is 4 bit BCD, b0=LSB  
b4= C0 pulse, speed, 1=TRUE  
b5= C1 pulse, speed, 1=True  
b6= C2 pulse, speed, 1=true  
b7= ARP input, 1=ARP  
(Port OE9H) Port B: (Wind direction, inputs)  
b0-b3 is 4 bit BCD, b0=LSB  
b4= C0 pulse, direction, 1=True  
b5= C1 pulse, direction, 1=True  
b6= C2 pulse, direction, 1=True  
b7= Counter B RSAD=1  
(Port OEAH) Port C: (Status inputs)

8259 INPUTS:

IR0-Positive-going ACP pulse, not divided  
IR1-Speed C0,C1,C2, OR'ed, positive pulse  
IR2-Direction C0,C1,C2 OR'ed, positive pulse  
IR#-IR7 should be disabled (grounded)

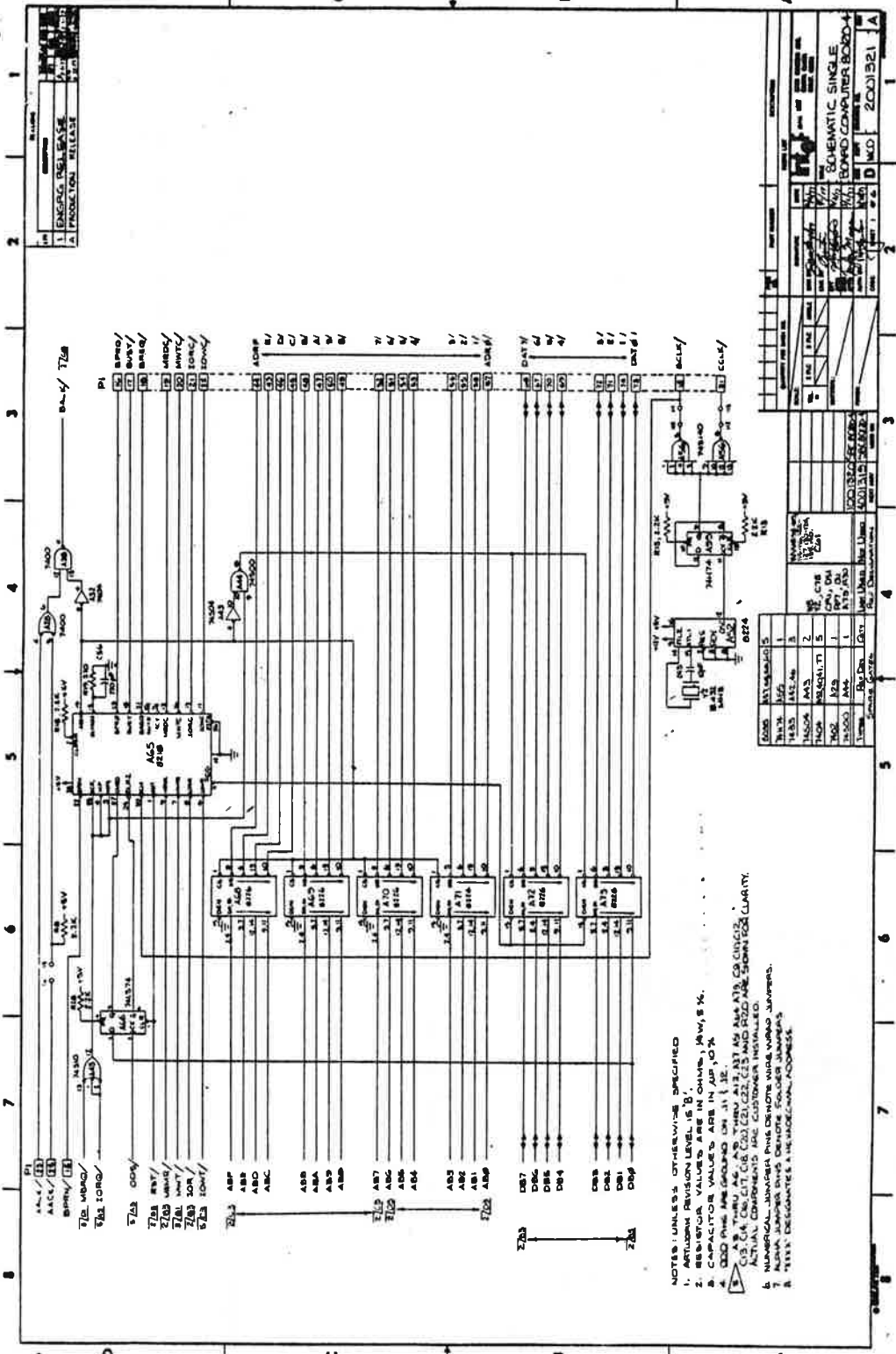

Figure A-2. SBC 80/20-4 Schematic Diagram (Sheet 1 of 6)

FIGURE 29. SBC 80/20 SCHEMATIC DIAGRAM, SHEET 1

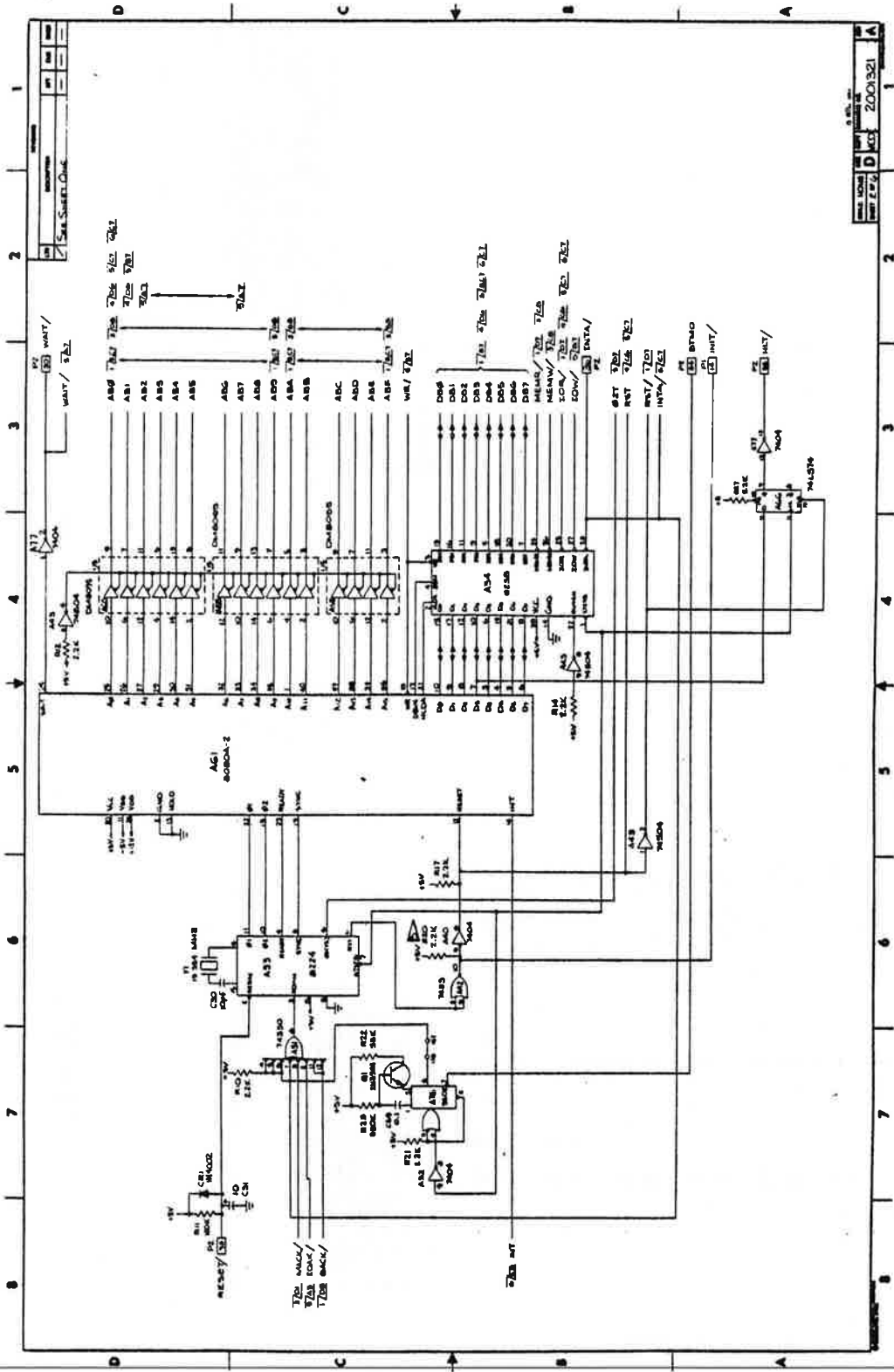

Figure A-2. iSBC 80/20-4 Schematic Diagram (Sheet 2 of 6)

FIGURE 30. SBC 80/20 SCHEMATIC DIAGRAM, SHEET 2



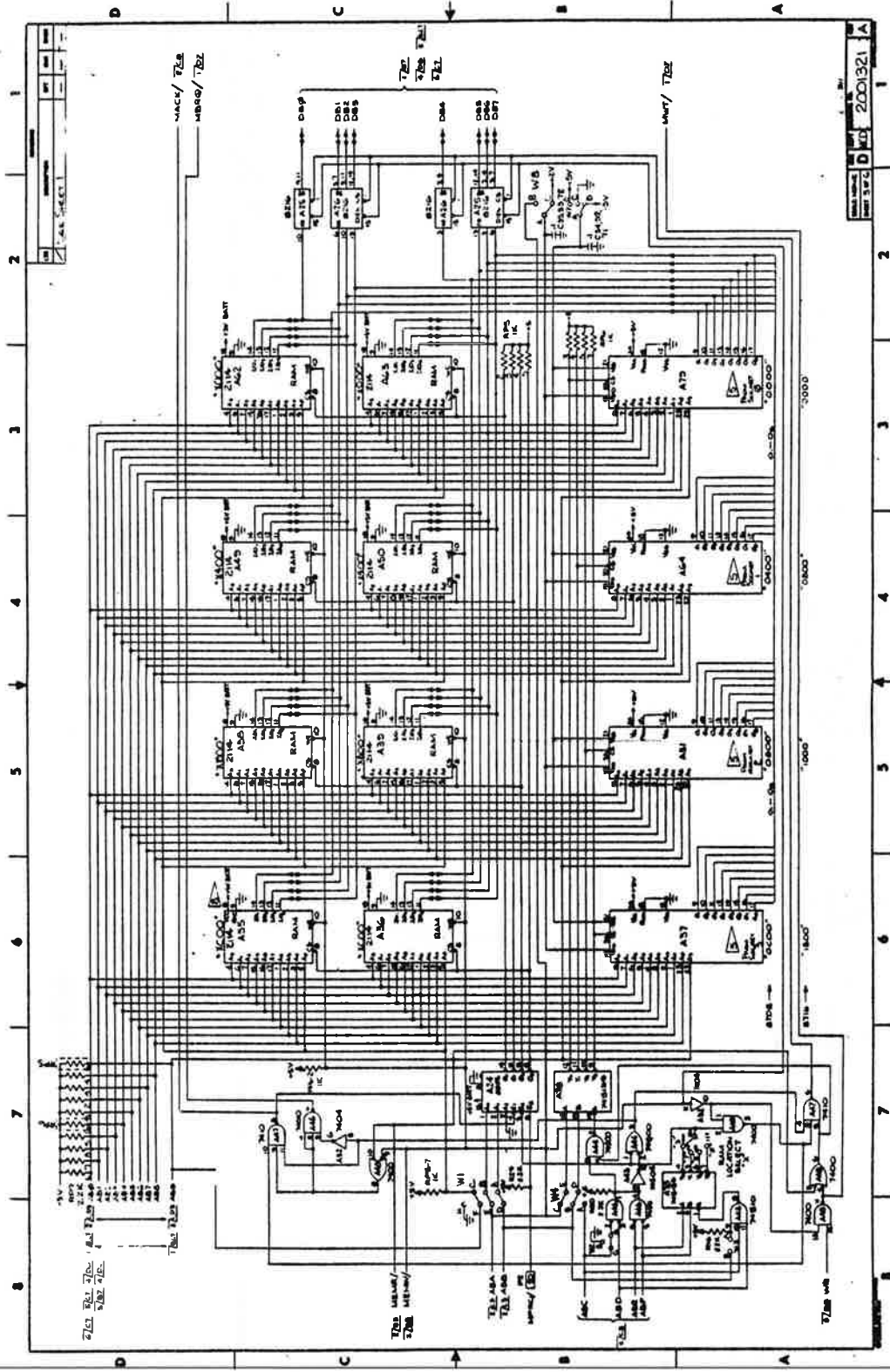

Figure A-2. SBC 80/20-4 Schematic Diagram (Sheet 3 of 6)

FIGURE 31. SBC 80/20 SCHEMATIC DIAGRAM, SHEET 3

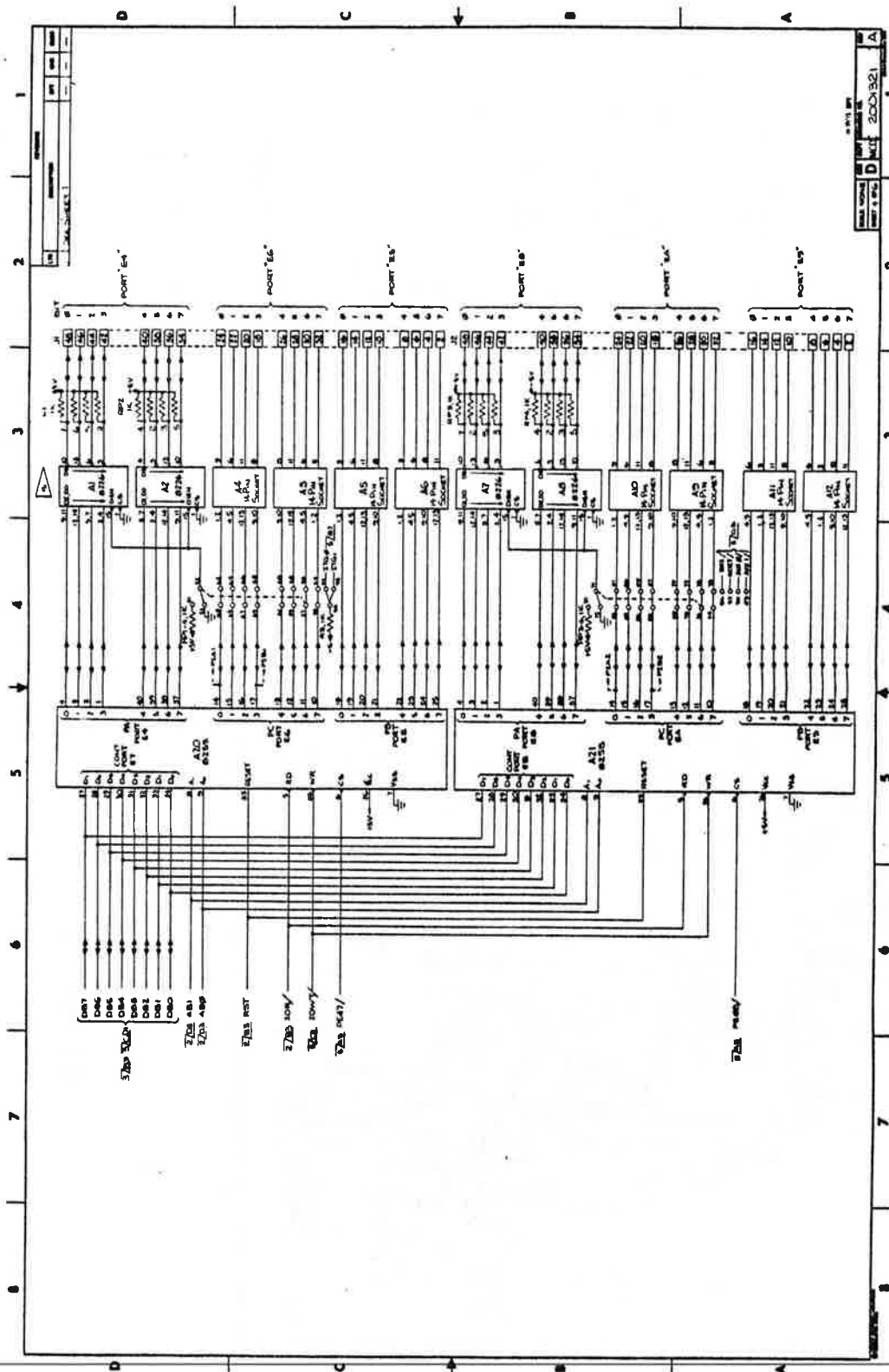

Figure A-2. ISBC 80/20-4 Schematic Diagram (Sheet 4 of 6)

FIGURE 32 SBC 80/20 SCHEMATIC DIAGRAM, SHEET 4

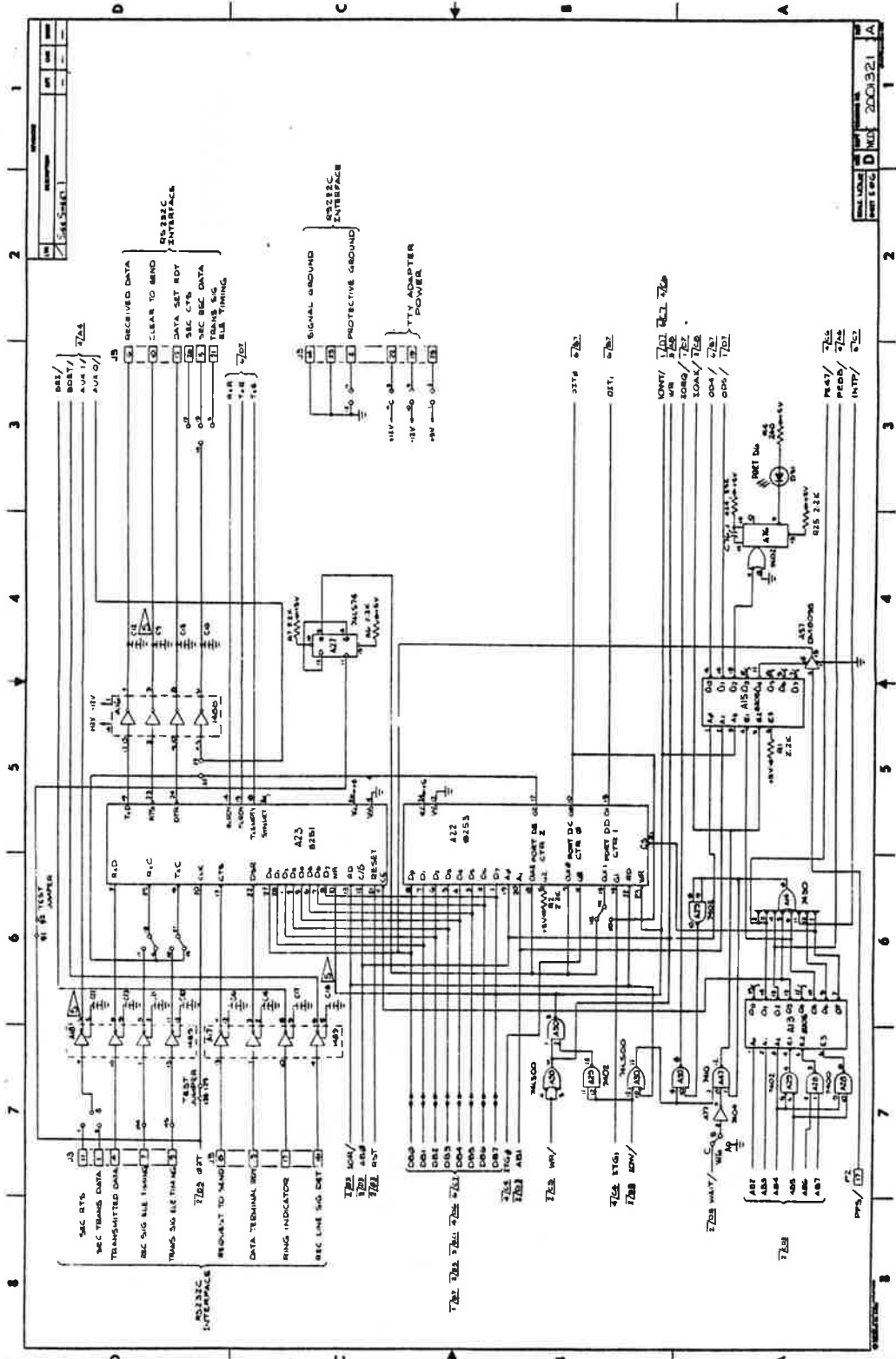

FIGURE 33. SBC 80/20 SCHEMATIC DIAGRAM, SHEET 5

Figure A-2. SBC 80/20-4 Schematic Diagram (Sheet 5 of 6)

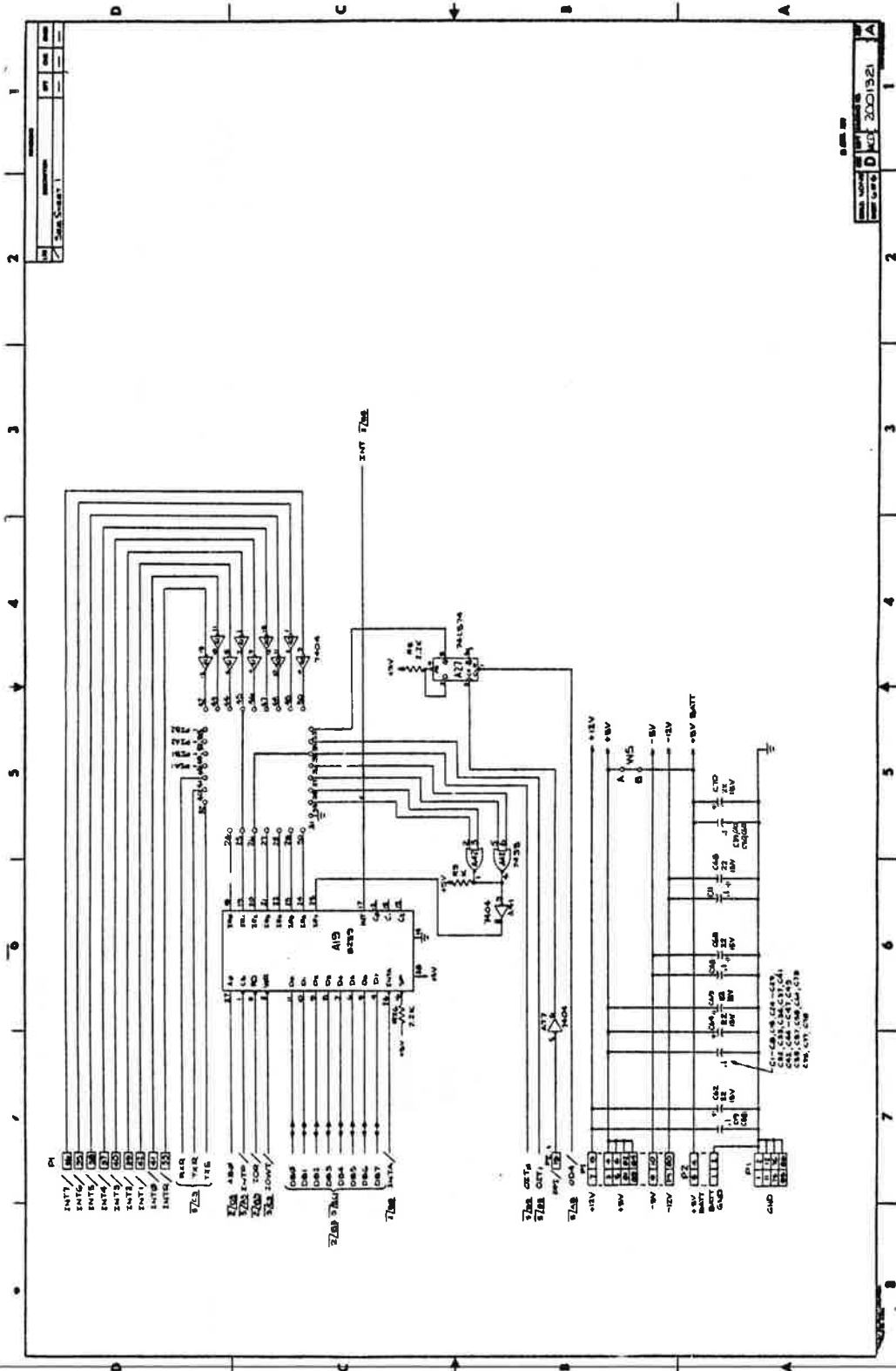

Figure A-2. SBC 80/20-4 Schematic Diagram (Sheet 6 of 6)

FIGURE 34. SBC 80/20 SCHEMATIC DIAGRAM, SHEET 6

Jumper Wire List for SBC-80/20 Board

Location	Pin #	to	Pin #
A20	51		52
A21	70		71
A5	1,2		3
A5	4,5		6
A5	12,13		11
A5	9,10		8
A6	1,2		3
A6	4,5		6
A6	12,13		11
A6	9,10		8
A11	1,2		3
A11	4,5		6
A11	12,13		11
A11	9,10		8
A12	1,2		3
A12	4,5		6
A12	12,13		11
A12	9,10		8
A19	27,28,29,30		31 (GND.)
A19	43		24
A19	44		25
A19	45		26

Interconnection Wiring  
SBC-905 to SBC-80/20

SBC-905		SBC-80/20	
Connector	Pin #	Connector	Pin #
PCC-1	2	J-1	2
PCC-1	4	J-1	4
PCC-1	6	J-1	6
PCC-1	8	J-1	8
PCC-1	10	J-1	10
PCC-1	12	J-1	12
PCC-1	14	J-1	14
PCC-1	16	J-1	16
PCC-1	20	J-1	20
PCC-1	22	J-1	22
PCC-1	24	J-1	24
PCC-1	34	J-1	34
PCC-1	36	J-1	36
PCC-1	38	J-1	38
PCC-1	40	J-1	40
PCC-1	42	J-1	42
PCC-1	44	J-1	44
PCC-1	46	J-1	46
PCC-1	48	J-1	48

Interconnection Wiring

Anemometer to SBC-905 and SBC-80/20

Rear Panel		SBC-905		
Anemometer DB-25	Pin #	UX-1	Pin #	
P1	1	UX-1	1	
P1	2	UX-1	2	
P1	3	UX-1	3	
P1	4	UX-1	4	
P1	5	UX-1	5	
P1	6	UX-1	6	
P1	7			
P1	8	SBC-80/20	J-2 Pin #	
P1	9	J-2	48	
P1	10	J-2	46	
P1	11	J-2	44	
P1	12	J-2	42	
P1	13	J-2	16	
P1	14	J-2	14	
P1	15 (GND)	J-2	12	
		J-2	10	
		GND		
SBC-905	UX-1	Pin #		
UX-1		16		
UX-1		15	SBC-80/20	J-2 Pin #
UX-1		14	J-2	40
UX-1		13	J-2	38
UX-1		12	J-2	36
UX-1		11	J-2	8
			J-2	6
			J-2	4

Interconnection Wiring

SBC-905 to SBC-80/20

SBC-905	Pin #		SBC-80/20	Pin #
P-2	1	10	J-2	34
P-2	2	9	J-2	2

SBC-905	Pin #		SBC-80/20	Pin #
P-1	41		P-1	41
P-1	42		P-1	42
P-1	39		P-1	39



Interconnection Wiring

Front Panel	SBC-905	Pin #
ACP - J-1 (Center Pin)	UX-1	9
ARP - J-1 (Center Pin)	UX-1	10
ACP + ARP - J-1's (shell, GND.)	UX-1	7,8 (GND.)
Terminal Connector	SBC-80/20	Pin #
DB-25            Pin #	J3	

### Interconnection Wiring

Anemometer Terminal Board	to	DB-25	Pin #
Speed C0 (MSD)	to	DB-25	1
Speed C1 (NSD)	to	DB-25	2
Speed C2 (LSD)	to	DB-25	3
Direction C0 (MSD)	to	DB-25	4
Direction C1 (NSD)	to	DB-25	5
Direction C2 (LSD)	to	DB-25	6
Speed 8	to	DB-25	7
Speed 4	to	DB-25	8
Speed 2	to	DB-25	9
Speed 1	to	DB-25	10
Direction 8	to	DB-25	11
Direction 4	to	DB-25	12
Direction 2	to	DB-25	13
Direction 1	to	DB-25	14
Ground	to	DB-25	15

## SBC 116, OUTPUT DATA INTERFACE

### Interface Wiring SBC-116 to Kennedy, Model 9217B Buffer Formatter

SBC-116 (See Figures 35 to 40)

From Connector #, Pin #	To DB-25F	To DB-25M	Kennedy, Connector & Pin #
J1-16 Bit 0 (Form ENA)	1	1	P1-18
J1-14 Bit 1 (Write SEL)	2	2	P1-5
J1-24 Bit 0 (Write Data Strobe)	3	3	P1-6
J1-22 Bit 1 (Off Line)	4	4	P3-8
J1-20 Bit 2 (Init)	5	5	P2-4
J1-18 Bit 3 (Rew)	6	6	P1-9
J1-26 Bit 4 (EOF)	7	7	P1-8
J1-28 Bit 5 (EOR)	8	8	P1-7
J2-34 Bit 7 (On Line)	9	9	P3-4
J2-36 Bit 6 (EOT)	10	10	P1-3
J2-42 Bit 3 (WR RDY)	11	11	P1-11
J2-44 Bit 2 (Load Pt.)	12	12	P1-2
J2-46 Bit 1 (MEM Busy)	13	13	P1-4
J2-48 Bit 0 (FMTR Busy)	14	14	P3-18
J2-16 Bit 0 (Data Bit 0)	15	15	P1-10
J2-14 Bit 1 (Data Bit 1)	16	16	P1-11
J2-12 Bit 2 (Data Bit 2)	17	17	P1-12
J2-10 Bit 3 (Data Bit 3)	18	18	P1-13
J2-8 Bit 4 (Data Bit 4)	19	19	P1-14
J2-6 Bit 5 (Data Bit 5)	20	20	P1-15
J2-4 Bit 6 (Data Bit 6)	21	21	P1-16
J2-2 Bit 7 (Data Bit 7)	22	22	P1-17

Pin # 23, 24, 25 are ground connections

A jumper wire is connected from Pin #53 to Pin #54

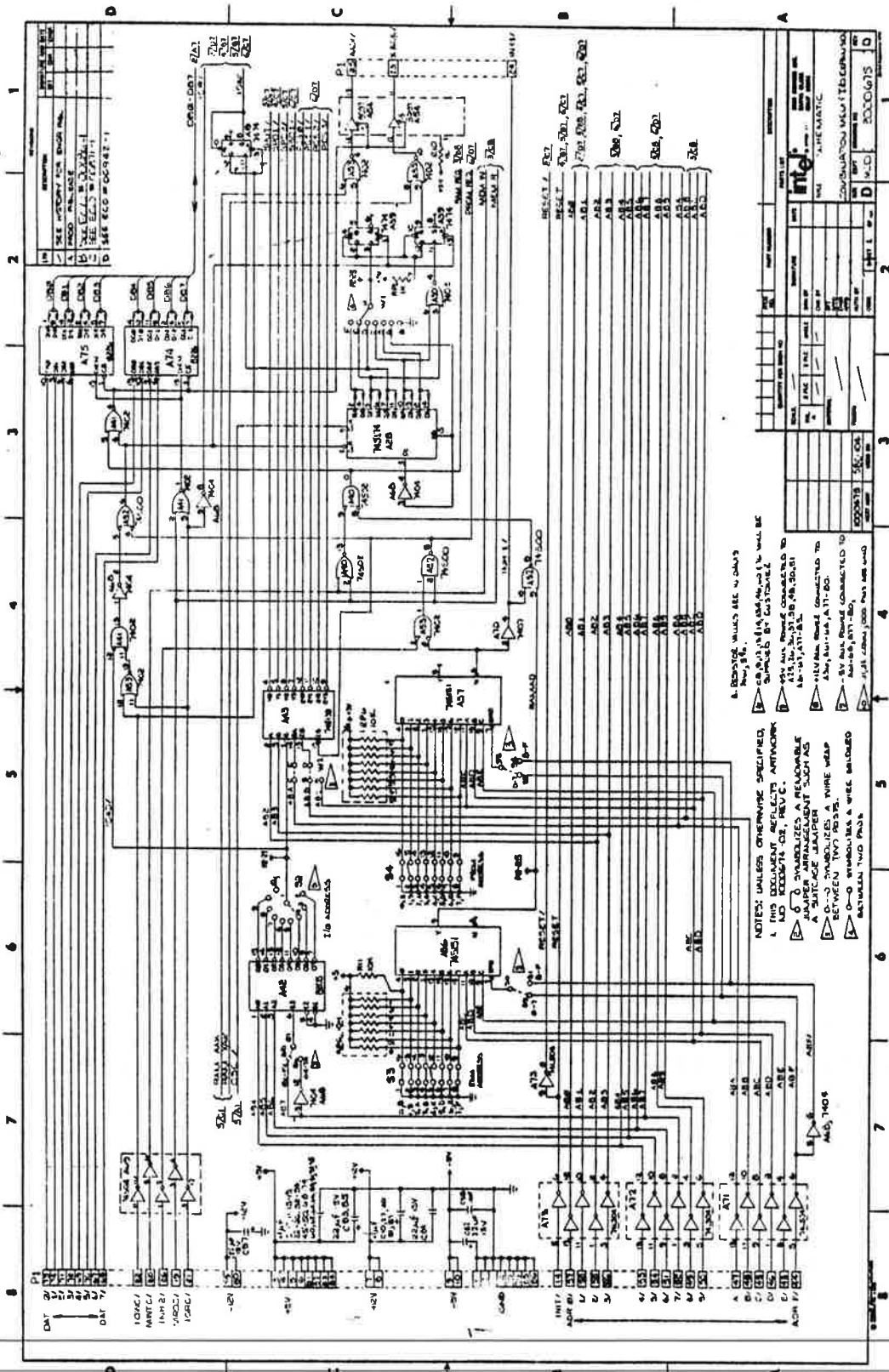

Figure 3-2. ISBC 104/100/116 Schematic Diagram (Sheet 1 of 6)

FIGURE 35. SBC 116 SCHEMATIC DIAGRAM, SHEET 1

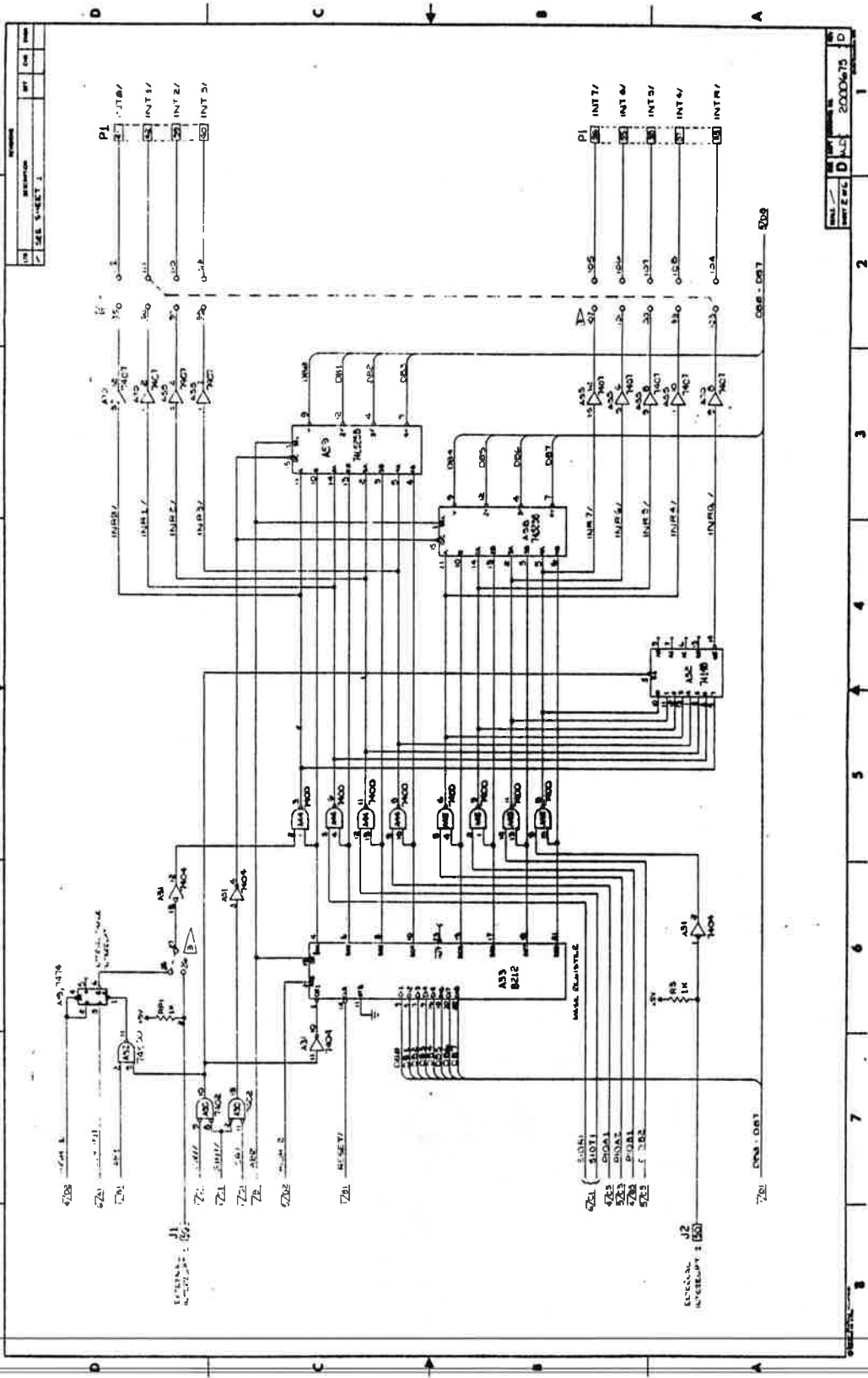

Figure 5-2. SBC 104/106/116 Schematic Diagram (Sheet 2 of 6)

FIGURE 36. SBC 116 SCHEMATIC DIAGRAM, SHEET 2

SBC 104106/116

Service Information

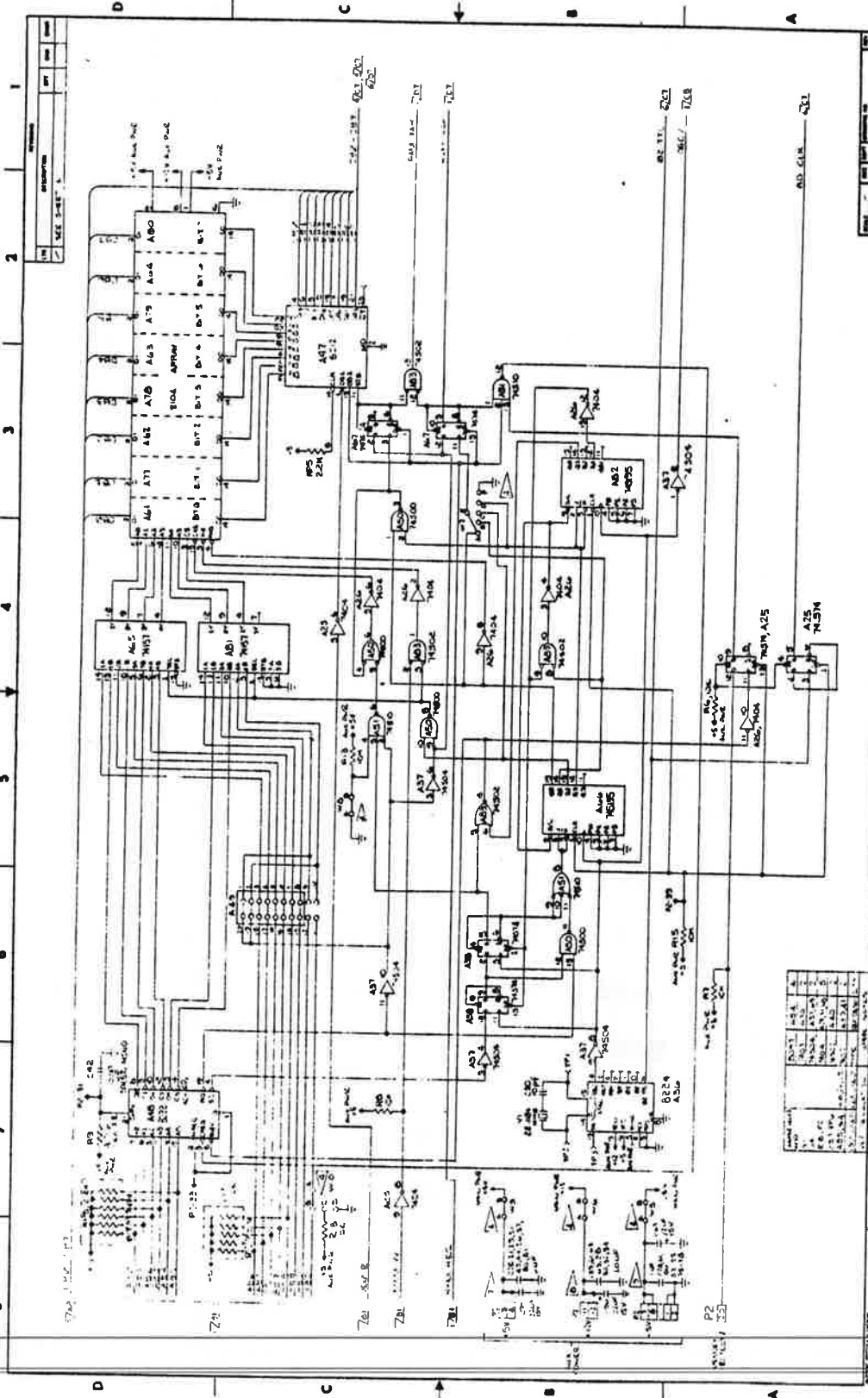

Figure 5-2. SBC 104106/116 Schematic Diagram (Sheet 3 of 6)

FIGURE 37. SBC 116 SCHEMATIC DIAGRAM, SHEET 3

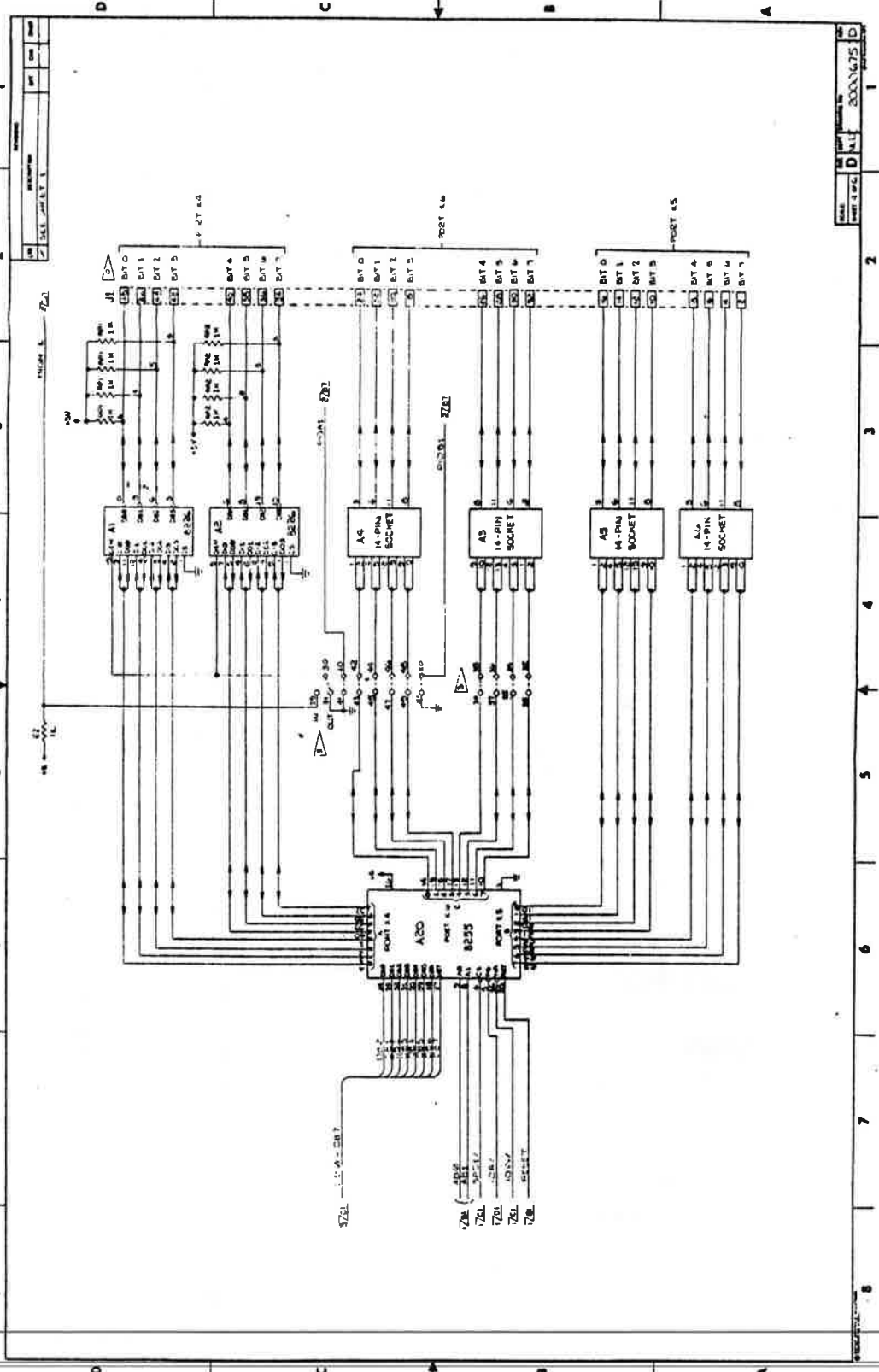

Figure 5-2. SBC 104/100/116 Schematic Diagram (Sheet 4 of 6)

5-195-14

FIGURE 38. SBC 116 SCHEMATIC DIAGRAM, SHEET 4

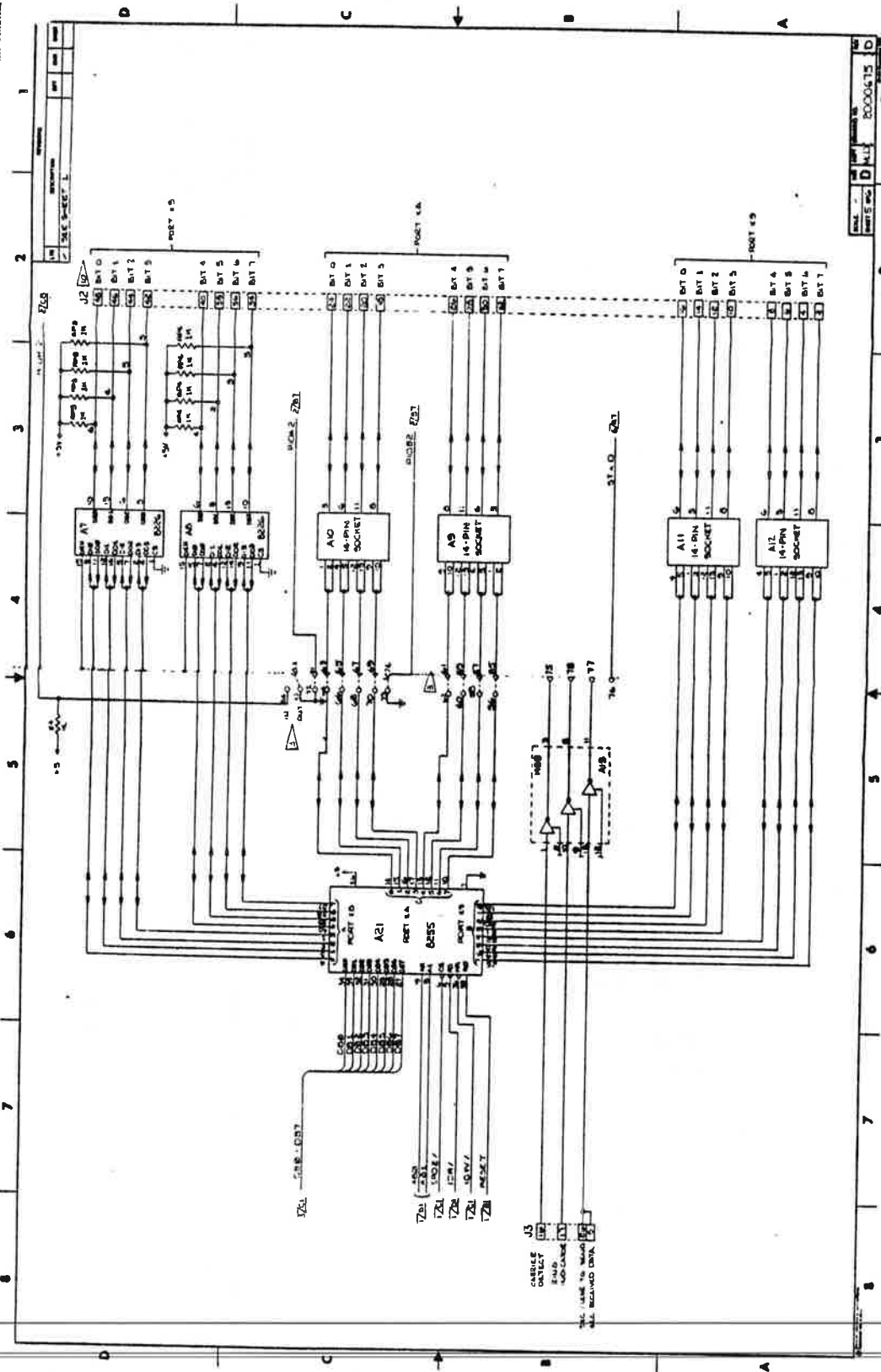

Figure 5-2. ISBC 104/100/116 Schematic Diagram (Sheet 5 of 6)

FIGURE 39. SBC 116 SCHEMATIC DIAGRAM, SHEET 5



Service Information

ISBC 104/100-116

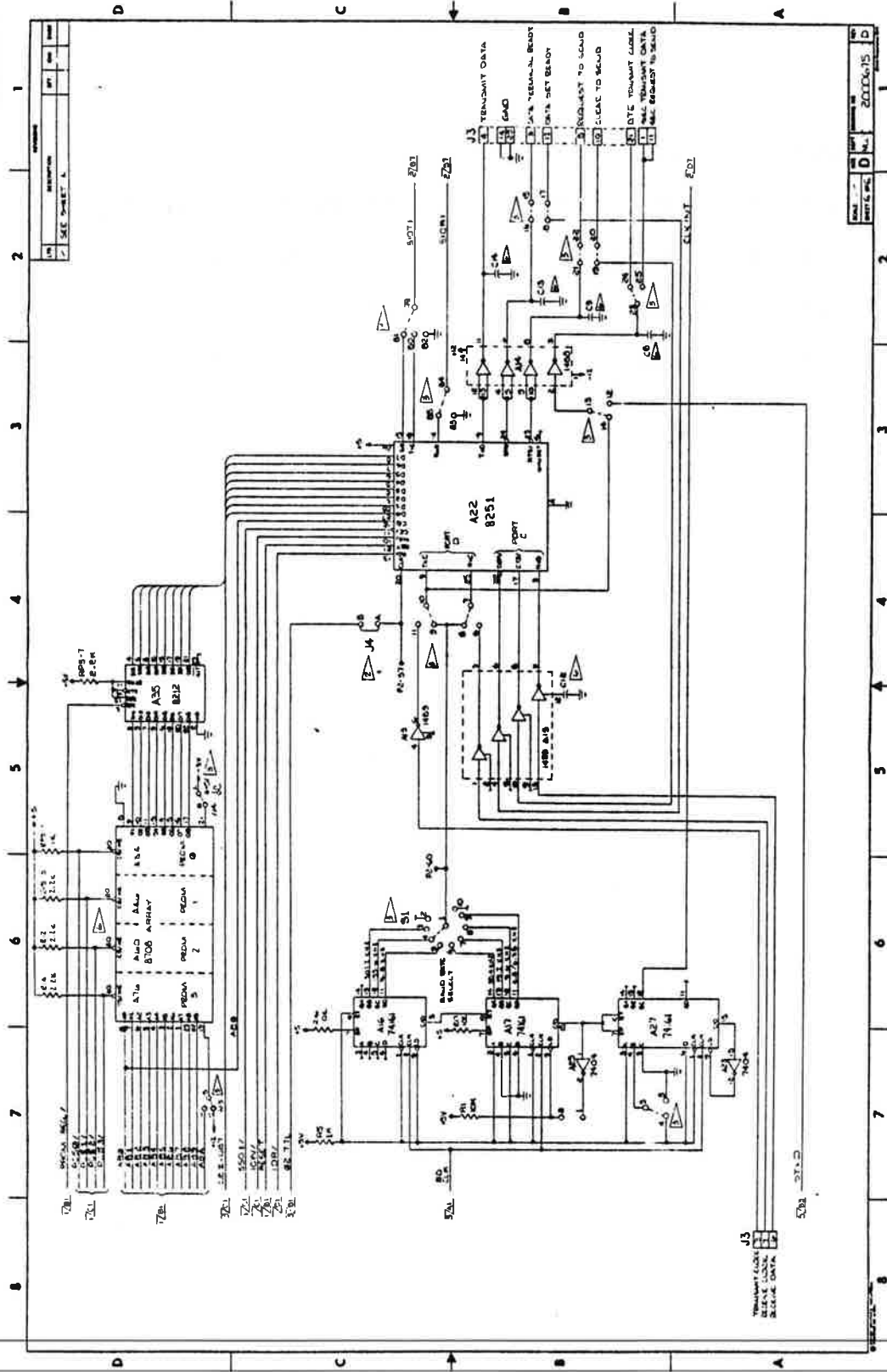

Figure 5-2. ISBC 104/100-116 Schematic Diagram (Sheet 6 of 6)

5-1775-10

FIGURE 40. SBC 116 SCHEMATIC DIAGRAM, SHEET 6

## 5.4 COMPUTER FLOW CHARTS

FIGURE 41. INITIALIZATION ROUTINE

FIGURE 42. ACP COUNT AND ROUTING INTERRUPT ROUTINE

FIGURE 43. ACP COUNT LOADING AND RECORD COUNT ROUTINE

FIGURE 44. WIND SPEED AND WIND DIRECTION ROUTINES

FIGURE 45. DATA RECORD INTERRUPT ROUTINE

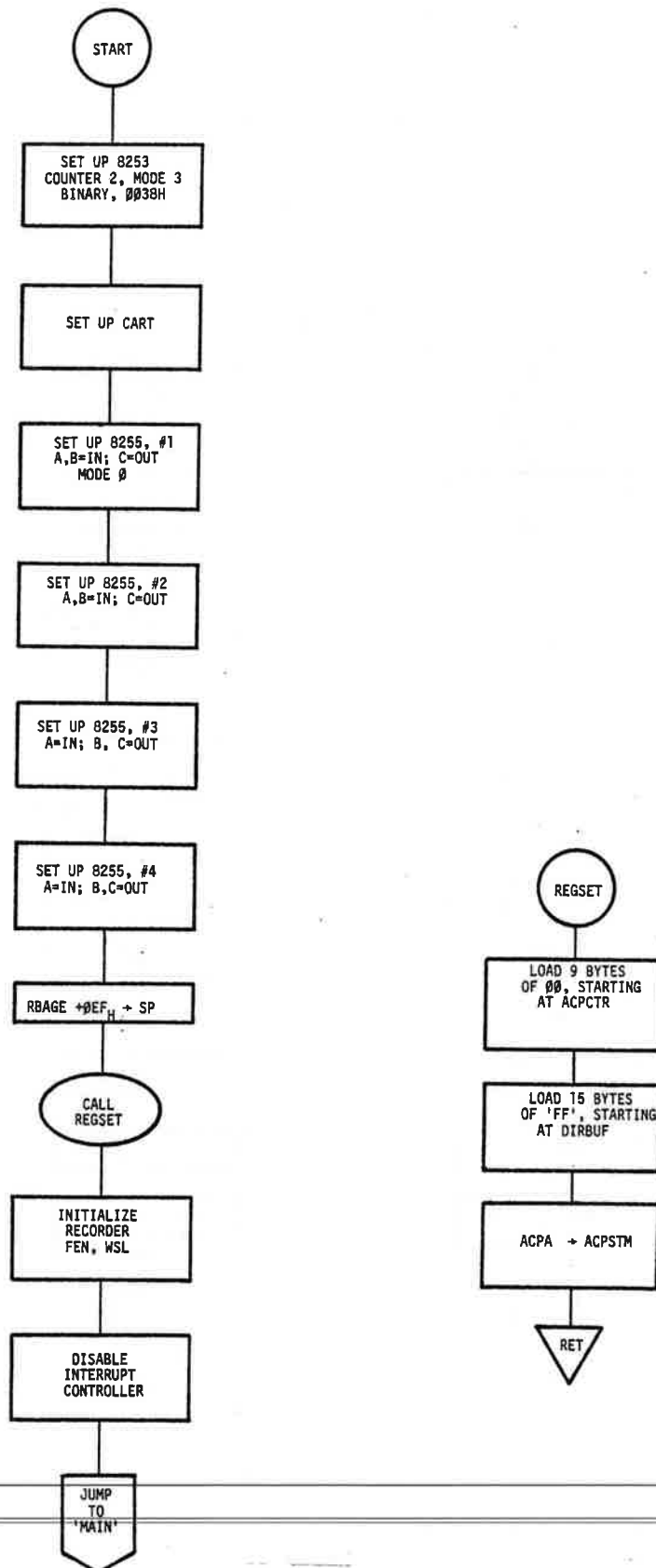

FIGURE 41. INITIALIZATION ROUTINE

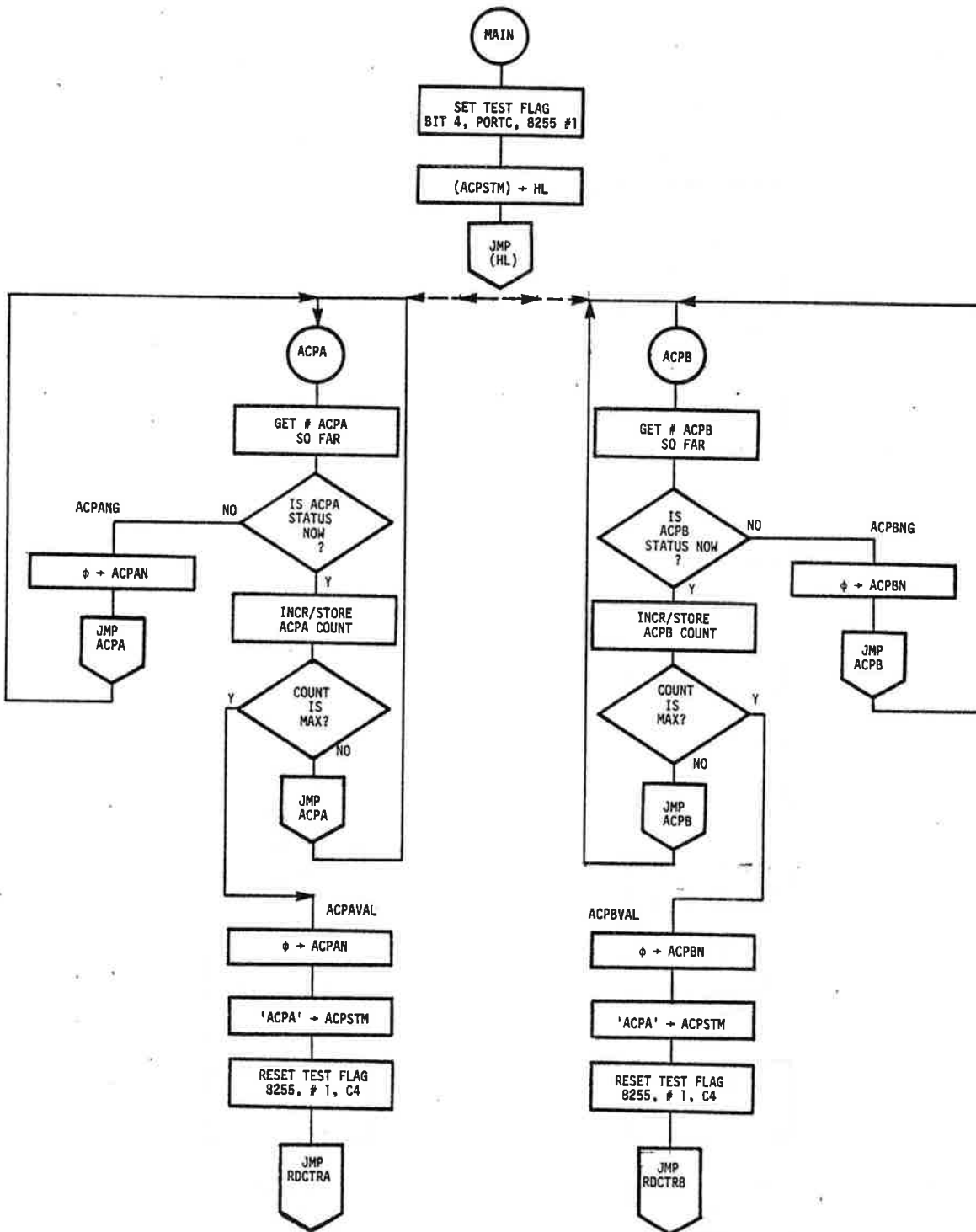

FIGURE 42. ACP COUNT AND ROUTING INTERRUPT ROUTINE

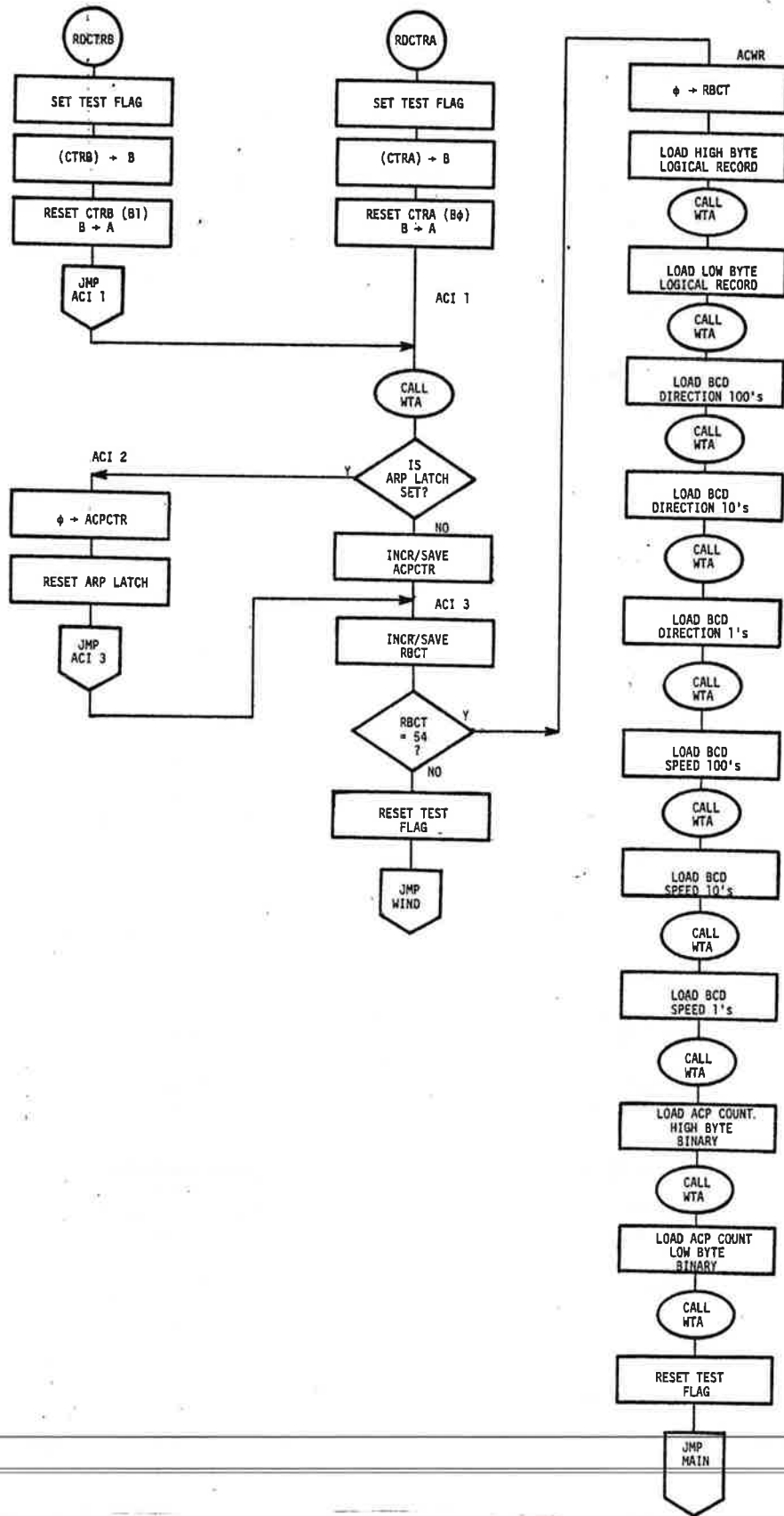

FIGURE 43. ACP COUNT LOADING AND RECORD COUNT ROUTINES

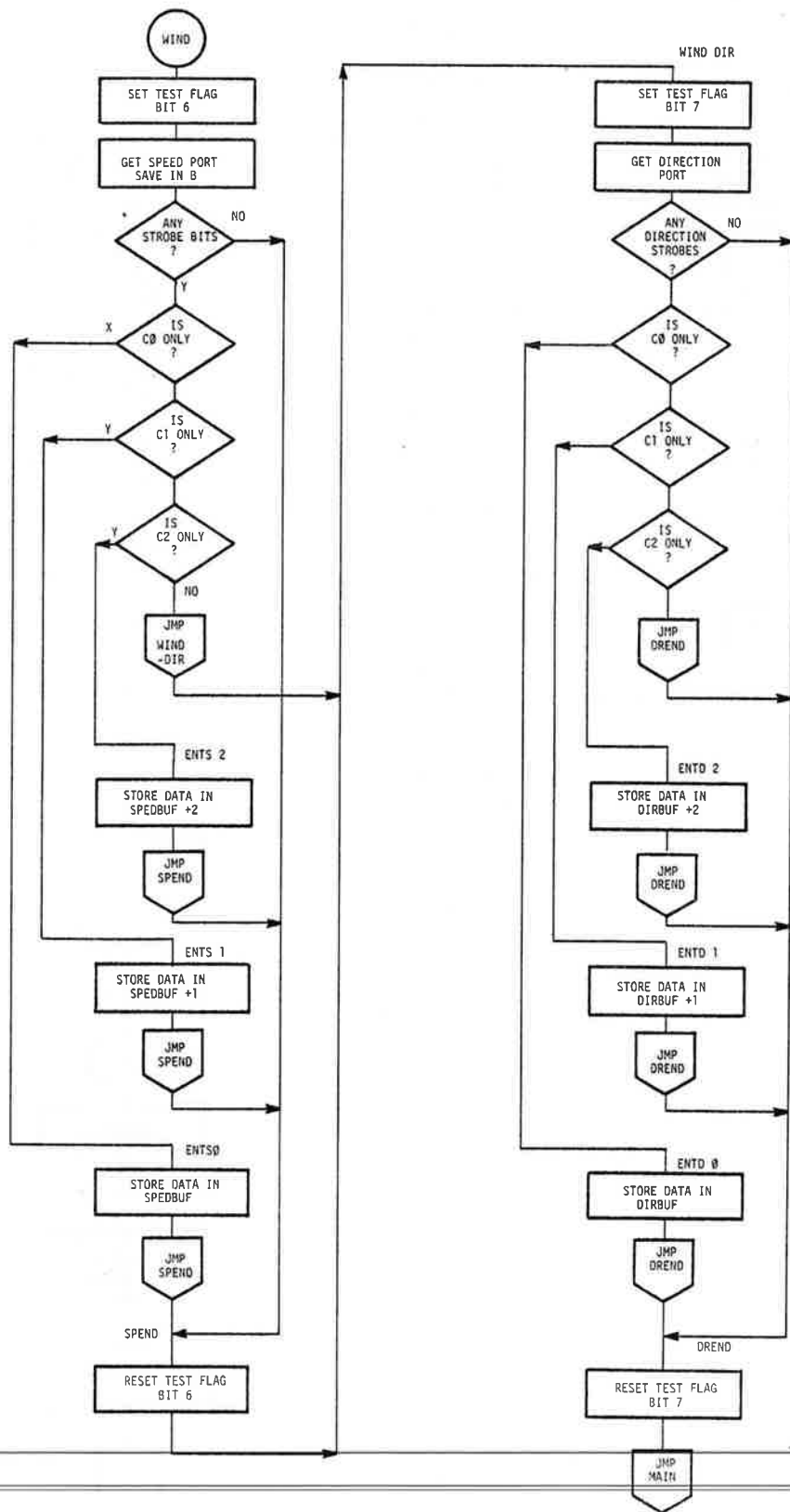
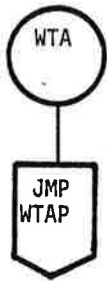

FIGURE 44. WIND SPEED AND WIND DIRECTION ROUTINES



OVERLAYS GO HERE  
TO LINK TESTING ROUTINES

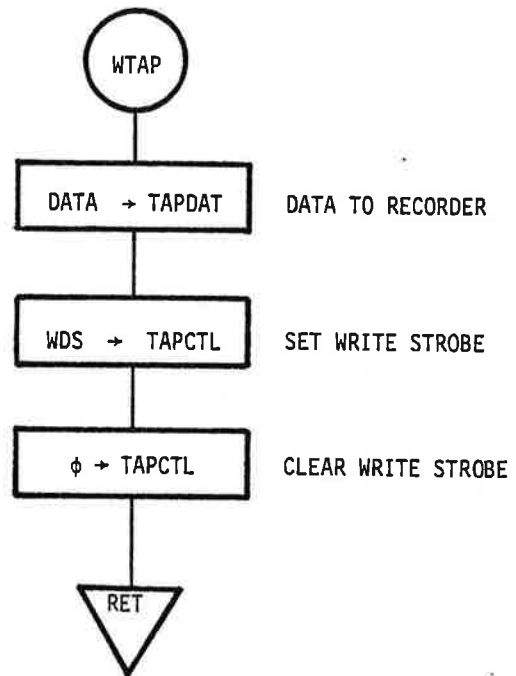
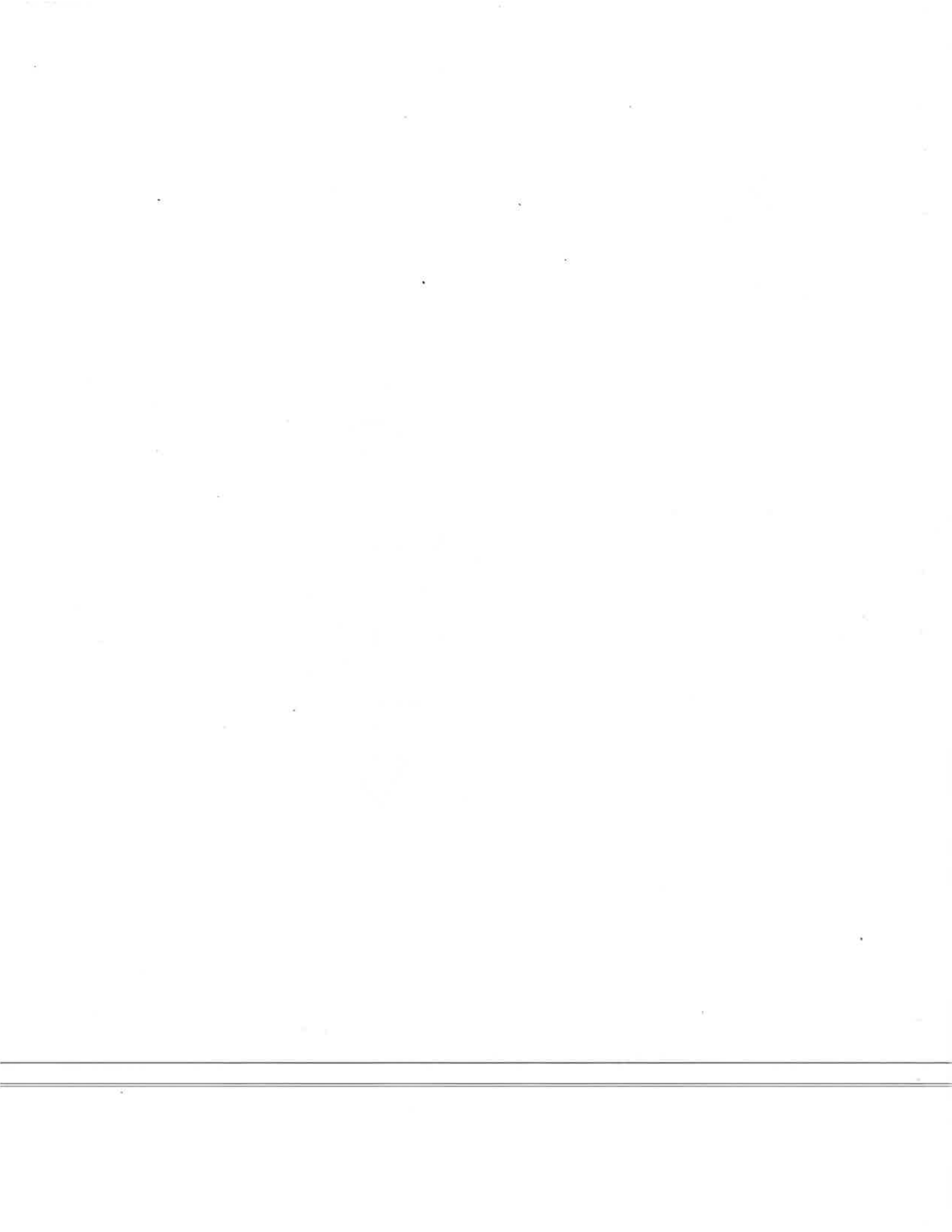

FIGURE 45. DATA RECORD INTERRUPT ROUTINE





## 6. DATA COLLECTION PLAN

### 6.1 APPROACH

The data collection flow diagram is shown in Figure 46. The data format consists of 64 byte logical record containing the clock counts for each two-pulse spacing of 54 ACP pulses (given modulo 256) and 3-digit direct recording of wind velocity and direction samples stored in two, 1028-bit buffers each and recorded on a 10.5 inch (2400 feet) reel of magnetic tape in standard 9-channel format at 1600 bpi with a capability of collecting 7 hours of test data.

Mathematical methods have been developed to derive statistics from the collected data at the sites and then applied to make inferences about these sites.

Collection of data is intended at different sites and over a wide range of environmental conditions as found at the sites enumerated earlier. The details of data collection plan presented in Section 8 of this test plan.

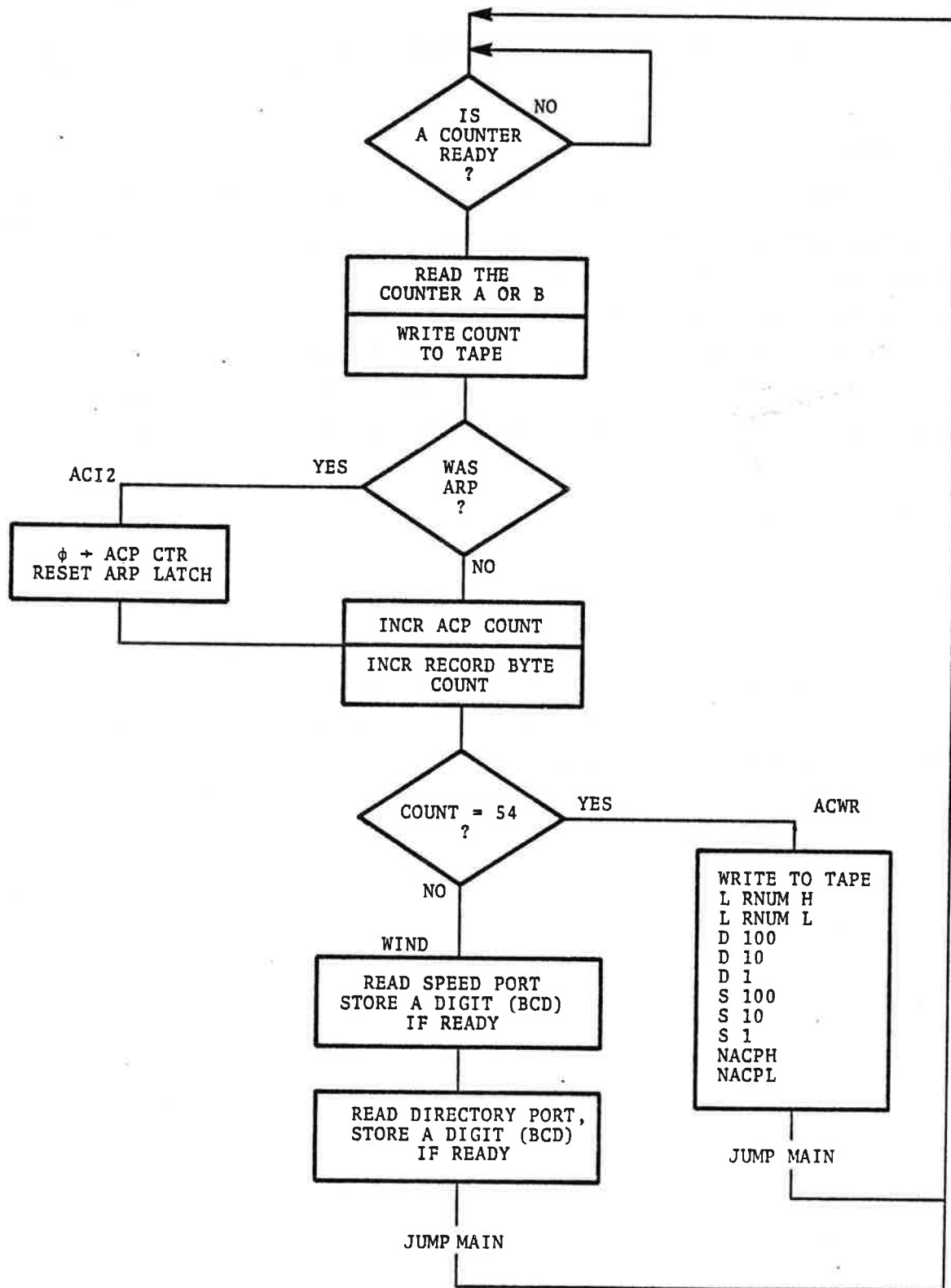

FIGURE 46. MEASUREMENT DATA COLLECTION ROUTINE

## 7. DATA ANALYSIS PLAN

### 7.1 PRECISION OF RECORDED DATA

Antenna Azimuth Angle. By using a 0.99985 MHz counter, precision in measuring the time between the two pulses of an ACP pair may be assured as follows;

$$\Delta\theta^{\circ}\text{precision} = \frac{360^{\circ}}{4096(\text{ACP}'\text{s}) \times 890(\text{CP})} = 9.87 \times 10^{-5} \text{ degrees}$$

Wind Velocity. Speed constant for the VA-320 Anemometer is:

Speed Constant = 6 mm.

Using sampling rate of 52 milliseconds it is possible to sense wind changes of

$$v = \frac{D}{t} = \frac{0.6}{2.54 \times 12 \times .052} \sim 4 \text{ ft/sec. or } 2.3 \text{ mi/hr.}$$

Accuracy of wind speed measurement is  $\pm 2\%$  full scale

Accuracy of wind direction measurement  $\pm 4^{\circ}$  at 4.5 mph

$\pm 2^{\circ}$  above 9 mph

### 7.2 SAMPLED DATA STATISTICS: MEAN, VARIANCE, AND STANDARD DEVIATION

#### 7.2.1 Mean, Variance, and Standard Deviation

A direct measurement of the clock counts (n) is recorded in each pulse-pair interval and a variation in the  $n_i$  among consecutive ACP's is interpreted as variation in the antenna rotation speed within the revolution. It is assumed that there are no angular variations between the ACP pulse intervals. A single complete revolution is indicated by an ARP pulse always following 4096 equally positioned ACP pulses. Wind loading affects the actual time to reach next ACP pulse position but not the angular increment ( $0.088^{\circ}$ ) which is fixed within  $360^{\circ}$  of azimuth.

For the sample calculations of the sample mean and variance used in the data analysis shown in Figure 47 and 48. It is the data sampled in one logical record consisting of 54 consecutive ACP's and in addition wind velocity and direction information. The sample mean is defined as

$$m_s = \frac{1}{54} \sum_{i=1}^{54} n_i$$

where

$n_i$  = the remainder in the counter after 3 x 256 overflow (modulo 256).

A mean of one revolution is computed by averaging the sample means of 75 logical records.

$$m_r = \frac{1}{75} \sum_{i=1}^{75} m_{s_i}$$

Variations of the samples are derived by squaring the difference between two means, i.e., a mean of a single logical record minus the mean for that revolution as computed from the sample taken from the same revolution.

$$s^2 = \frac{1}{75} \sum_{i=1}^{75} \left( m_{s_i}^2 \right) - m_r^2$$

Standard deviation as defined here is,

$$s_{SD} = \sqrt{s^2}$$

### 7.2.2 Sliding Window Sum Total Variations (Histogram)

A plot of additive sums ( a sliding window) sliding forward to complete one revolution is shown in Figure 49, where 75 logical records approximate one full antenna revolution. From these data a possible error in azimuth estimate based on an earlier squitter reading may be derived. The error estimate is

TAPE ID: FT-1

REVOLUTION NUMBER: 2

APRIL 13, 81 LOW OVERCAST GUST TO 40

LEGEND  
□ = MEANS CP  
○ = MAX. CP  
△ = MIN. CP  
+ = WIND SPD  
x = WIND DIR

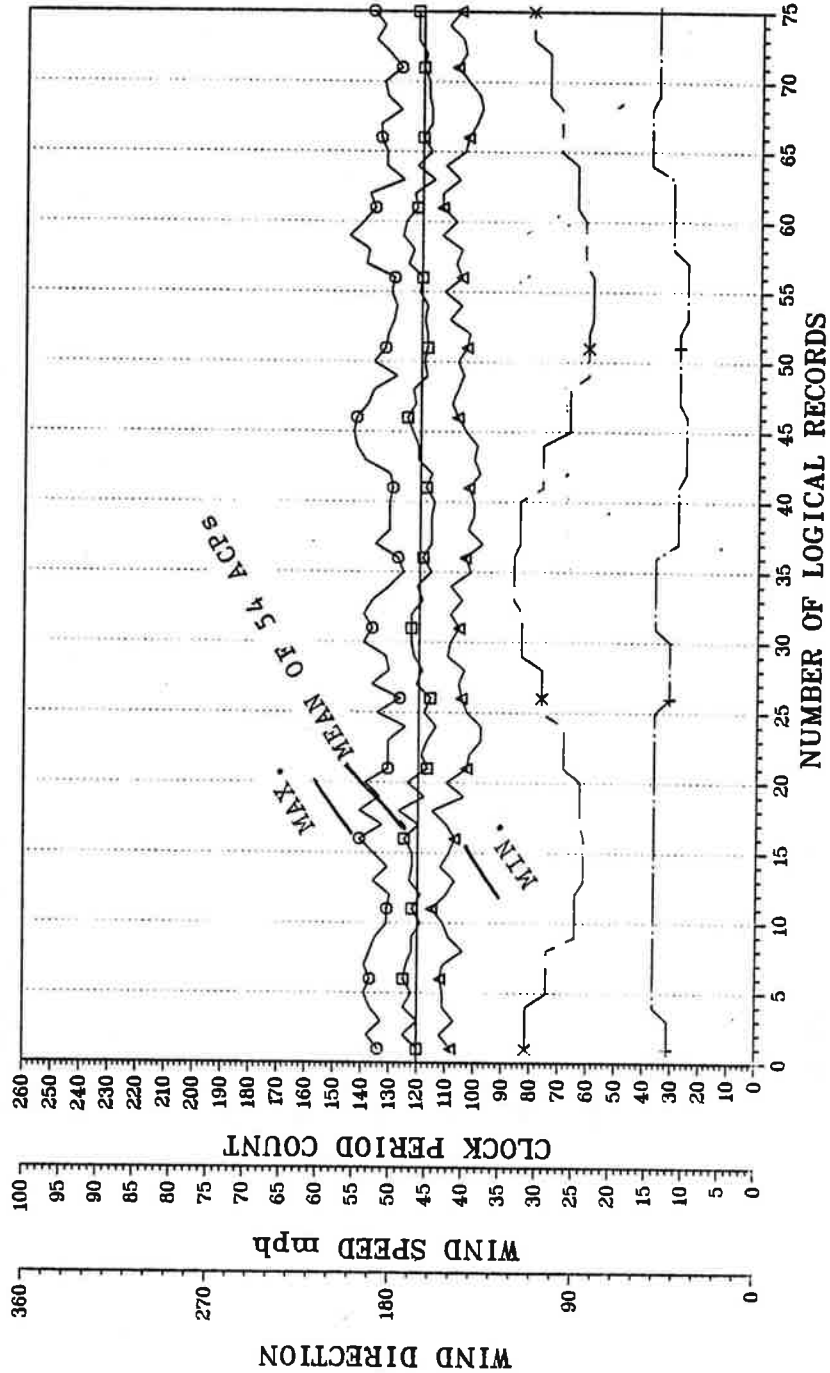

FIGURE 47. MEASURED DATA STATISTICS - MEAN

TAPE ID: FT-1

REVOLUTION NUMBER: 2

APRIL 13, 81 LOW OVERCAST GUST TO 40

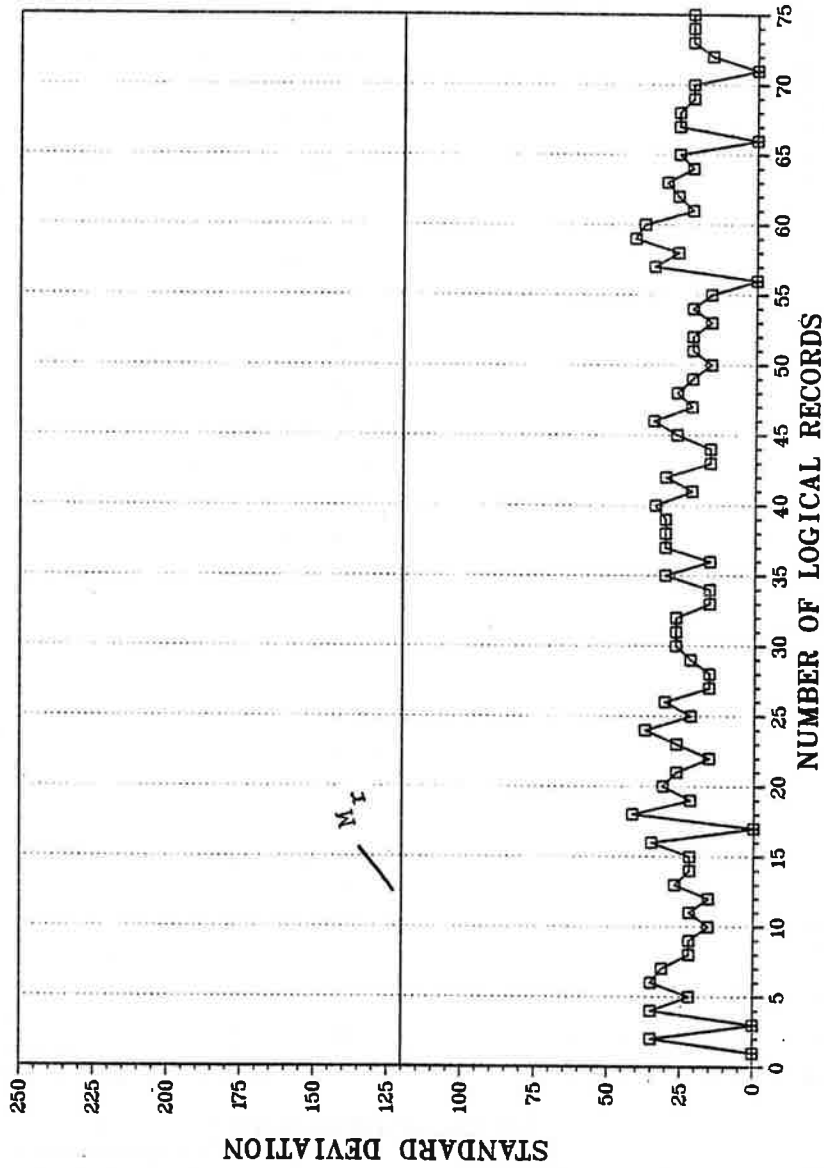

FIGURE 48. MEASURED DATA STATISTICS - STANDARD DEVIATION

TAPE ID: FT-1

REVOLUTION NUMBER: 3

APRIL 13, 81 LOW OVERCAST GUST TO 40

LEGEND  
□ = 10 ACP CLOCK COUNTS  
○ = 54 ACP CLOCK COUNTS  
△ = 100 ACP CLOCK COUNTS  
+ = 200 ACP CLOCK COUNTS  
x = 500 ACP CLOCK COUNTS  
◇ = MAXIMUM VALUE  
■ = MINIMUM VALUE

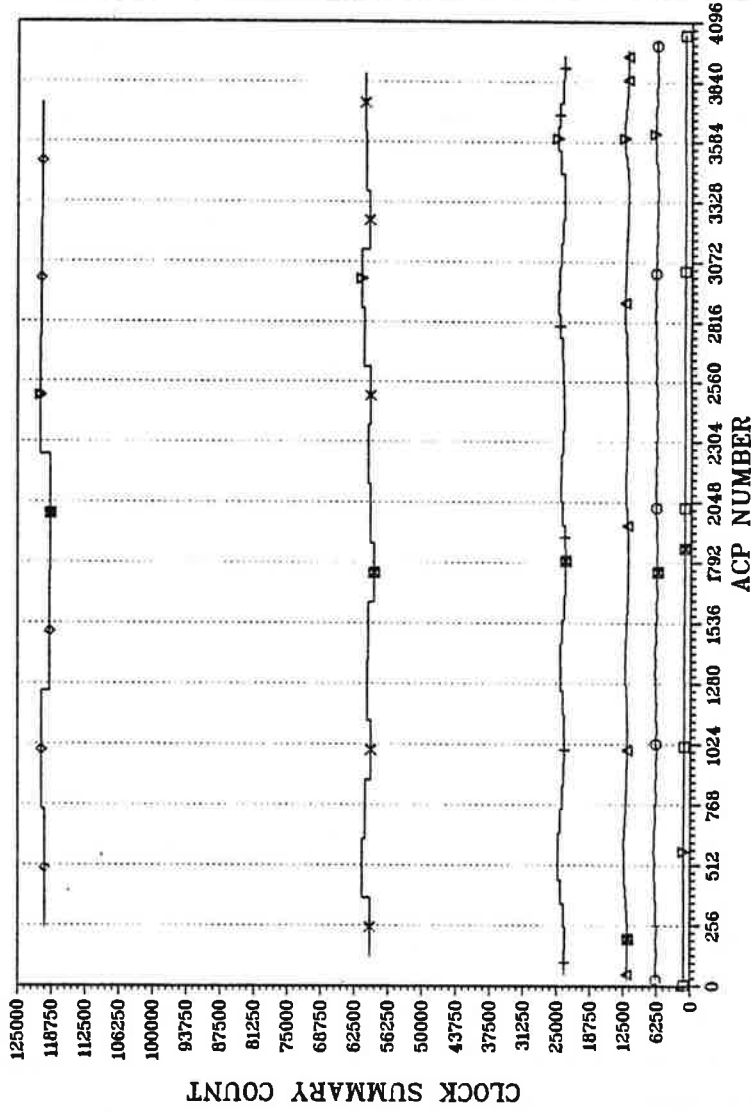

FIGURE 49. HISTOGRAM

based on the difference between the two clock count sums converted into degrees, thus representing a difference in azimuth between two readings

$$\Delta\theta_{AZ} = \frac{0.088^\circ \times \Delta N}{890}$$

where,

$\Delta N$  = difference between two sums in comparison.

### 7.3 A CUMULATIVE SUM COMPARISON WITH THE NOMINAL

A computer plot of a cumulative sum for one completed revolution is plotted in Figure 50. Adding of these pulses begins with an ARP pulse time. A straight line, constant slope projection is used for comparing actual measured data with ideal conditions.

For deriving the total sum, the clock counts between each of 4096 ACP pulses are added increasingly as follows,

$$N_K = \sum_{i=1}^K n_i$$

where,

$n_i$  = clock count between two adjacent ACPs in a partially filled register based on modulo 3.

### 7.4 SAMPLE STATISTICS: INFERENCES

Field test data will be analyzed to make inferences about the SSR antenna rotation rate stability. Significance levels will be determined between various test sites based on wind and icing characteristics over the seasons.

### 7.5 CORRELATION OF DATA DERIVED FROM A MATHEMATICAL MODEL WITH DATA MEASURED IN THE FIELD

Analytical data will be compared with the data collected at the radar site, and extrapolated for the service ranges where such data may not be obtainable in the field. Critical parameters



TAPE ID: FT-1

REVOLUTION NUMBER: 2

APRIL 13, 81 LOW OVERCAST GUST TO 40

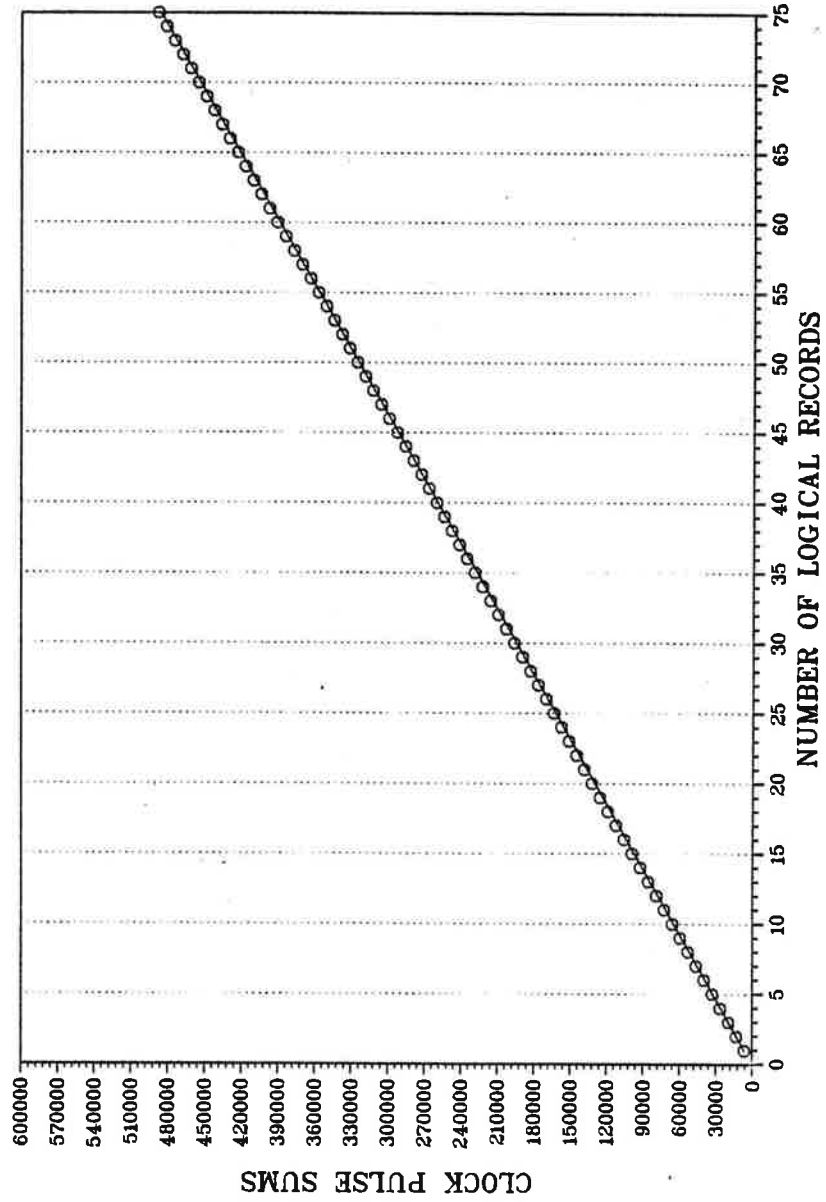

FIGURE 50. CUMULATIVE MEASURED VS NOMINAL CLOCK PULSE SUMMATION

of the system will be set and used in the parametric studies to arrive at satisfactory fixes for the service ranges outside of which the Full BCAS performance is not acceptable.

## 8. SCHEDULES

A detailed test schedule is presented in Figure 51. Two major factors will determine the route to be taken as testing progresses. These factors are the preliminary analysis of the data collected at the FAA Technical Center and the TSC in-house computer simulation results. A decision will be made to either continue with the testing at the Technical Center or to move the equipment to one or more other sites.

The principal activities are as follows:

1. Test Plan  
Draft - November 1980  
Final - September 1981
2. Equipment: Hardware and  
Software Development and  
Debugging  
March 1981
3. Equipment Installed, Debugged  
and Operating at the FAA  
Technical Center  
April 1981
4. Tests Continue at FAA  
Technical Center  
December 1981  
Optional February 1983
5. Decision on Testing at  
Multiple Sites  
November 1981
6. Defining the Problem  
January 1982
7. Reports  
Interim: February 1982  
First June 1982  
Final April 1983

The major purpose in going to alternative sites is to be able to collect wind data for the whole operational range specified by the FAA. By extending tests at a single site, possibly for each season, significant variations in the environmental conditions may be encountered. This would allow reliable

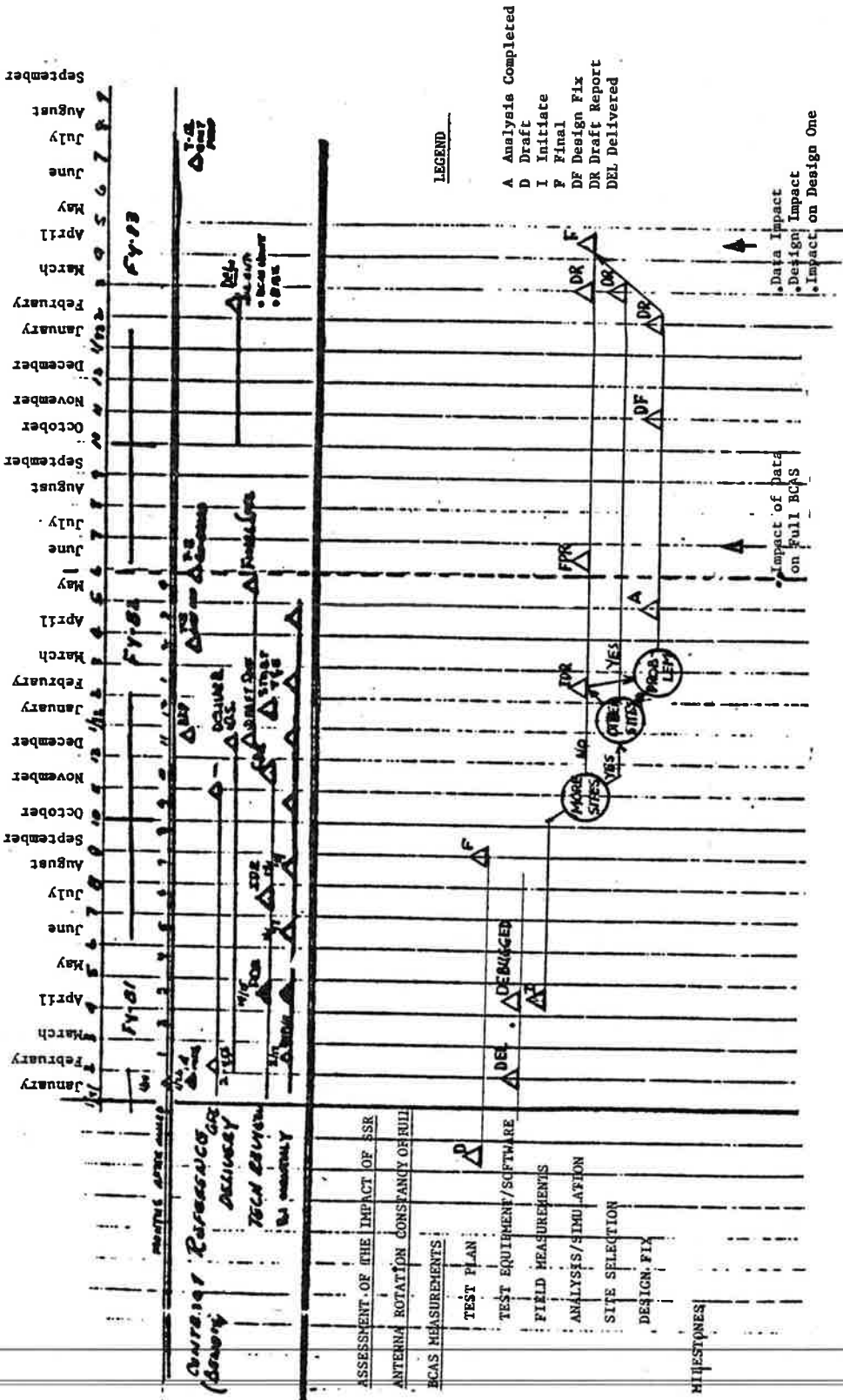
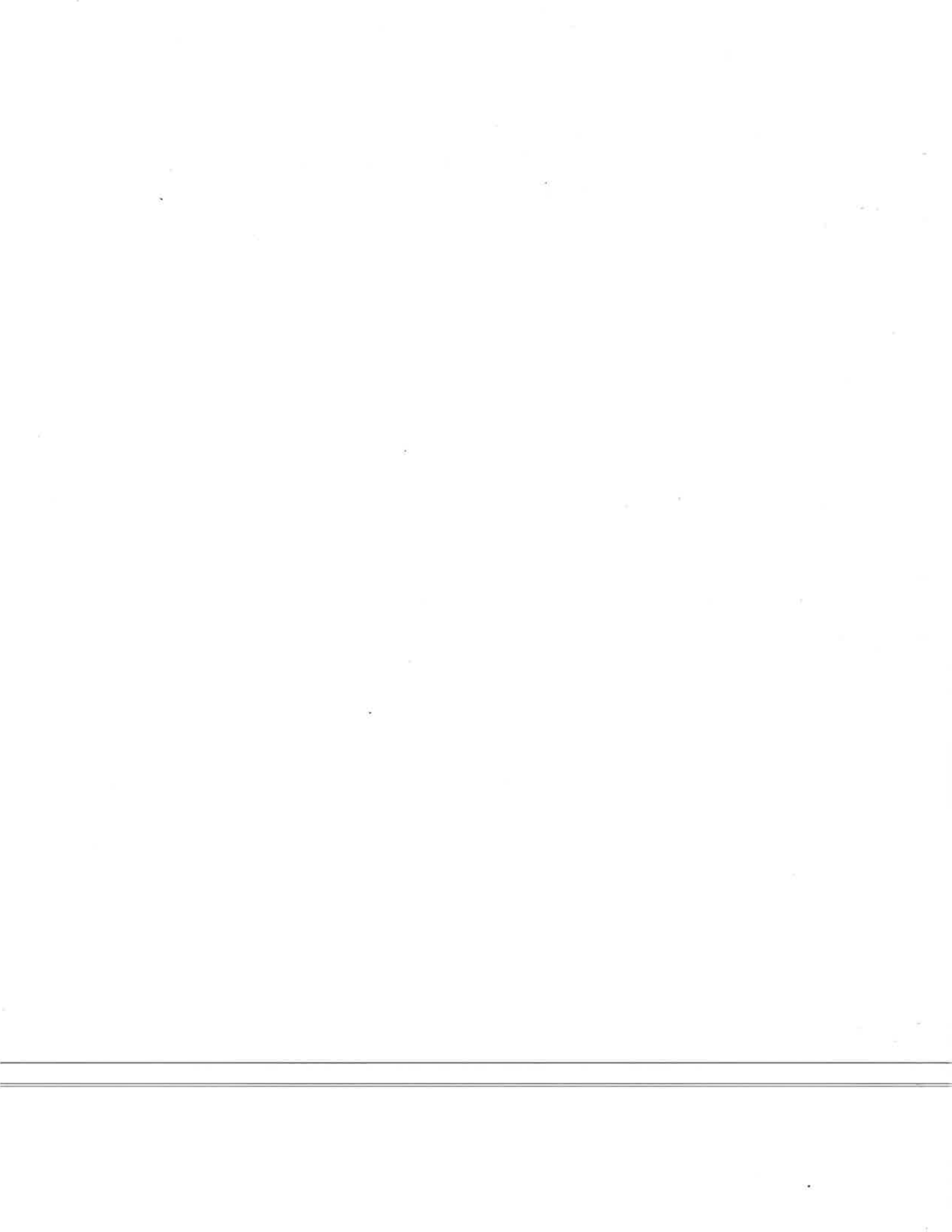

FIGURE 51. SSR ANTENNA ROTATION RATE STUDY SCHEDULE

conclusions as to the acceptable operational range for that site. Also, environmental characteristics for individual sites may have some unique differences.



APPENDIX A  
ORGANIZATIONAL RESPONSIBILITIES

Organizational responsibilities for the SSR Antenna Rotation Stability Studies program are divided among ARD-240, TSC, and the FAA Technical Center, as shown in the following chart.

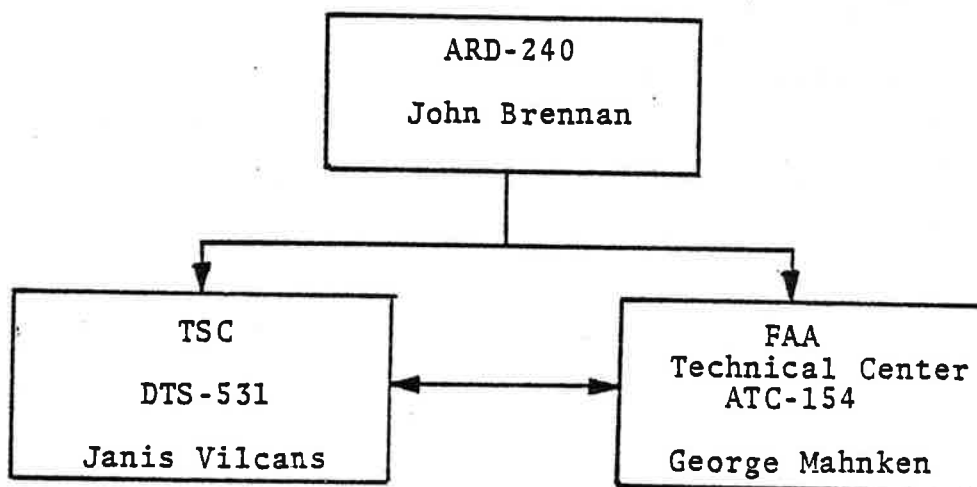

ARD-240, as the sponsoring organization, has overall management responsibility and direct responsibility for the following specific details:

1. Obtaining access to the district sites
2. Selecting and approving the test sites

TSC, DTS-531, has primary responsibility for the technical success of the programs with the following specific details:

1. Designing, building, and debugging one set of test hardware and software.
2. Designing algorithms and software for data reduction and analyses.
3. Designing mathematical models and performing parameter trade-offs using analysis and computer simulation.

4. Selecting alternatives for improvement.
5. Preparing draft interim data report and final report.

FAA Technical Center, has coordination responsibility with District sites, ARD, and TSC. Detailed tasks are:

1. Supporting installation at the TRBTF site and running the tests.
2. Coordination and scheduling of tests at other sites, if required.
3. Responsibility for supplying test equipment to the sites and interfacing with the site operational technical personnel.
4. Collecting and delivering field data to TSC for analysis.



APPENDIX B

SIMULATION SOFTWARE FOR SOLVING SSR ANTENNA  
SYSTEM MODEL

B-1 SOLUTION OF THE SSB ANTENNA SYSTEM SIMULATION ALGORITHM

```

C TYPE DIFFERENTIAL FOR
C PSI -- IS THE WIND DIRECTION IN RADIAN
C U - IS THE WIND SPEED IN MILES PER HOUR
C EPS,ETA - ARE SMALL NUMBERS
C H - CURRENT STEP
C Y(1)=X*ETA
C Y(2) - B TETA/D T
C
C LET CS=COS(ETA-PSI)
C SN=ABS(SIN(ETA-PSI))
C PD TETA/D T
C Q=E1*U*CS*SN+E2*U*P*SN+E3*P*E4*U*CS+E5*U*CS+E6*CS*P+E7
C THEN OUR EQUATION IS
C
C B2 TETA/D T2 = -(A1*P+A2*(C1+C2*P))/(D1+D2*P+D3*P*P)+A3*Q)
C
C
C
C COMMON /API /V,PSI
C COMMON /DAT/ A1,A2,A3,C1,C2,D1,D2,D3,E1,E2,E3,E4,E5,E6,E7
C DIMENSION Y(2),Y2(2),Y3(2),Y(400),TETA(400)
C 1 DIETA(400),YNDM(400)
C
C
C ALL COEFFICIENTS AND PARAMETERS ARE INPUTED IN NEXT DATA STATEMENTS
C
C DATA A1,A2,A3/0.001377, -0.078125, 0.000651 /
C DATA C1,C2/ 450.47, -286.78 /
C DATA D1,D2,D3 /18.27,-21.7, 6.7 /
C DATA E1,E2,E3,E4,E5,E6,E7 /1.035867, 31.324,
C 243.74, -0.17083, -1.778, -4.644, 225. /
C DATA Y /0. 10./
C DATA EPS,ETA,EP/0.0001,0.0001,0.0001,0.0000001/

```

C VALUES OF V\*PSI ARE TO BE ASSIGNED ON TERMINAL.

```
WRITE (5,81)
FORMAT ('GIVE V*PSI VALUES')
READ (5,11) V, PSI
FORMAT (2F)
S=180./3.1415927
IS=0
NUH=1
X=0.
Y(1)=X
TETA(1)=Y(1)*8
DIETA(1)=Y(2)*8
CS=COS(Y(1)-PSI)
SN=ABS(SIN(Y(1)-PSI))
P=Y(2)
ONUM=SN*V*(E1*V*CS+E2*P)+E3*P*P+(E4*V+E5*P)*CS*V+E6*CS*P*P+E7
RNUM=(C1+C2*P)/(D1+D2*P+D3*P*P)
D2TETA=- (A1*P+A2*RNUM+A3*ONUM)
YMOH(NUH)= ONUM+1410.0*D2TETA
XFIN=9.2
HMIN=0.001
H=HMIN*10
PSI=PSI/8
C
C BEGIN OF RUNGE-KUTTA
C
13 CALL RK1ST(X,Y,Z,H,XI,YI)
20 CALL RK1ST(X,Y,H,X2,Y2)
25 DO 30 K=1,2
O1=ABS(YI(K))
O2=ABS(Y3(K))
IF(O1.GT.O2)GO TO 17
O1=O2
IF(O1.GT.ETA)GO TO 27
O1=ETA
27 D=ABS(YI(K)-Y3(K))/O1
IF(D.GT.EPS)GO TO 50
CONTINUE
30 IF(18.NE.5)GO TO 45
IS=0
H=H*2.
43 IS=IS+1
46 X=X3
NUH=NUH+1
47 DO 47 K=1,2
Y(K)=Y3(K)
T(NUH)=X
TETA(NUH)=Y(1)*8
DIETA(NUH)=Y(2)*8
CS=COS(Y(1)-PSI)
SN=ABS(SIN(Y(1)-PSI))
P=Y(2)
ONUM=SN*V*(E1*V*CS+E2*P)+E3*P*P+(E4*V+E5*P)*CS*V+E6*CS*P*P+E7
RNUM=(C1+C2*P)/(D1+D2*P+D3*P*P)
D2TETA=- (A1*P+A2*RNUM+A3*ONUM)
YMOH(NUH)= ONUM+1410.0*D2TETA
IF(X-XFIN) 13,100,100
50 IF(H-HMIN) 46,46,55
55 H=H*0.5
X1=X2
DO 40 K=1,2
YI(K)=Y2(K)
60 TO 20
```

```

C PRINT RESULTS ON DATA FILE='KANT.DAT'
C
C
100 WRITE(5,155) NUM
155 FORMAT(1X,'NUM OF POINT FOR PLOT IS',I)
OPEN (UNIT=21,FILE='KANT.DAT')
PSI=PSIG
WRITE(21,105)
FORMAT(10X,'I')
105 WRITE(21,103)V,PSI
103 FORMAT(2X,'INITIAL CONDITION TETA=0 DIETA/DI=0 FOR T=0'
/2X,'UM/MOUR'= ,FS,I,' PSI(DEG)= ,PS,I/)
102 WRITE(21,102)NUM,NUM
107 FORMAT(2X,2F) TETA/1X,I,10X,'1'/1X,I)
WRITE(21,107)(I(I),TETA(I),I=1,NUM)
FORMAT(10X,'I')
108 WRITE(21,103)V,PSI
WRITE(21,109)NUM,NUM
109 FORMAT(2X,'TETA',/DTETA/DI'/1X,I,10X,'I'/1X,I)
WRITE(21,108)
WRITE(21,103)V,PSI
WRITE(21,111) NUM, NUM
111 FORMAT(' TETA',/ YAW MOMENT/1X,I,10X,'1'/1X,I)
WRITE(21,107)(TETA(I),MH(I),I=1,NUM)
WRITE(21,108)
STOP
END
C
C
C
C
C THIS SUBROUTINE COMPUTES
C YH(1) - VALUE OF FUNCTION
C YH(2) - VALUE OF DERIVATIVE
C AT POINT XH=X+8
C IF WE KNOW
C Y(1) - VALUE OF FUNCTION
C Y(2) - VALUE OF DERIVATIVE
C AT POINT X.
C
C
SUBROUTINE RK18T(X,Y,6 ,XH,YH)
COMMON /API' V,PSI
COMMON /DAT/ A1,A2,A3,C1,C2,D1,D2,D3,E1,E2,E3,E4,E5,E6,E7
DIMENSION Y(2),YH(2),Z(2),I(2),I(5)
A(1)=0.5*8
A(2)=0.5*8
A(5)=0.5*8
A(3)=S
A(4)=6
XH=X
DO 5 K=1,2
YH(K)=Y(K)
M(K)=Y(K)
DO 200 J=1,4
Z(1)=M(2)
CS=COS(W(1)-PSI)
SN=ABS(SIN(W(1)-PSI))

```

```

P=M(2)
R1=D1+D2*P+D3*P*P
IF(ABS(R1).LT.EP) GO TO 99
R2=A2*(C1+C2*P)/K1+A1*P
R3=V*G*(E2*P+E1*V*CS)+E3*P*P+(E4*V+E5*P)*CS*V
Z(2)=-R2-A3*(R3+E4*CS*P*P+E7)
XH=Y(A(J))
DO 200 N=1,2
  YH(K)=YH(K)+A(J+1)*Z(K)/73
  WK(K)=Y(K)+A(J)*Z(K)
CONTINUE
RETURN
STOP

```

```

99 WRITE(5,101)R1
101 FORMAT(1X,'DENOMINATOR='*F)
GO TO 98
END

```

```

*TYPE DIFFUC.FOR
PSI - IS THE WIND DIRECTION IN RADIANS
V - IS THE WIND SPEED IN MILES PER HOUR
EPS,ETA - ARE SMALL NUMBERS
H - CURRENT STEP
Y(1)=X-TETA
Y(2) = D TETA/D T

```

```

LET CS=COS(TETA-PSI)
SN=ABS(SIN(TETA-PSI))
P=D TETA/D T
Q=E1*V*V*CS*SN+E2*V*PSN+E3*P*P+E4*V*V*CS*E5*V*P*P+E6*P*P+E7

```

```

THEN OUR EQUATION I

```

```

D2 TETA/D T2 = -(A1*P+A2*(C1+C2*P)/(D1+D2*P+D3*P*P)+A3*Q)

```

```

COMMON /API /V,PSI
COMMON /DAT /A1,A2,A3,C1,C2,D1,D2,D3,E1,E2,E3,E4,E5,E6,E7
DIMENSION Y(2),Y2(2),Y3(2),Y(2),T(400),TETA(400),
1 TDIETA(400),YDHT(400)

```

```

ALL COEFFICIENTS AND PARAMETERS ARE INPUTED IN NEXT DATA STATEMENTS

```

```

DATA A1,A2,A3/0.001377, -0.078125, 0.000651 /
DATA C1,C2/ 450.47, -284.78 /
DATA D1,D2,D3 /18.27,-21.7, 6.7 /
DATA E1,E2,E3,E4,E5,E6,E7 /1.03586, 31.324,
243.74, -0.17083, -1.778, -4.644, 225.7
DATA EPS,ETA,EP,0.0001,0.0001,0.0000001/
VALUE OF PSI ARE TO BE ASSIGNED ON TERMINAL.
WRITE (5,81)

```

```

81 FORMAT ('OBTIVE PSI VALUE')

```

```

READ (5,11) PSI

```

```

FORMAT (2F)

```

```

S=180./3.1415927

```

```

OPEN (UNIT=21,FILE='KANT.DAT')

```

```

WRITE(21,105)

```

```

FORMAT(10X,'33')

```

```

DO 1000 IV=1,11

```

```

V=(IV-1)*10.0

```





```

KJ=V*SN*(E2*F+I1*V*CS)+E3*P*P*(E4*V+E5*P)*CS*V
Z(2)=K2-A3*(K3*E4*CS*P*P+E7)
XH=X+A(J)
DO 200 N=1,I2
  YH(K)=YH(K)+A(JH1)*Z(K)/3
  W(K)=Y(K)+A(J)*Z(K)
CONTINUE
98 RETURN
99 STOP
101 WRITE(5,101)R1
      FORMAT(1X,'DENOMINATOR='F)
      GO TO 98
      END

```

```

.EX DIFHUL.FOR
LINK: Loading
LINKKCT DIFHUL execution

```

```

GIVE FBI VALUE
0.0

```

```

NUM OF POINT FOR PLOT IS      B2
NUM OF POINT FOR PLOT IS      135
NUM OF POINT FOR PLOT IS      140
NUM OF POINT FOR PLOT IS      139
NUM OF POINT FOR PLOT IS      138
NUM OF POINT FOR PLOT IS      140
NUM OF POINT FOR PLOT IS      197
NUM OF POINT FOR PLOT IS      196
NUM OF POINT FOR PLOT IS      200
NUM OF POINT FOR PLOT IS      203
NUM OF POINT FOR PLOT IS      194
STOP

```

```

END OF EXECUTION
CPU TIME: 54.93 ELAPSED TIME: 1110.90
EXIT

```

```

.HG HTA16/REEL1182/VID1/PRASAD 9-TRK.800BPI PLOT TAPE'/ME

```

```

Request queued
Waiting...2 'C's to Exit

```

```

^C
^C

```

```

.HD/C

```

```

1. M Job13 11Y25 3137/575 1 MOUNT HTA 16 /REELID1 1182 /V1 PRASAD 9-TRK,800BPI PLOT TAPE'

```

```

/UE
1 Command in Queue

```

```

.HD/C

```

```

1. M Job13 11Y25 3137/575 1 MOUNT HTA 16 /REELID1 1182 /V1 PRASAD 9-TRK,800BPI PLOT TAPE'

```

```

/UE
1 Command in Queue

```

```

.HD/C

```

```

1. M Job13 11Y25 3137/575 1 MOUNT HTA 16 /REELID1 1182 /V1 PRASAD 9-TRK,800BPI PLOT TAPE'

```

```

/UE
1 Command in Queue

```

```

.R SYSB

```

```

UNIT JOB

```

```

HTA0 FREE

```

```

HTA1 FREE

```

```

HTA2 FREE

```

```

HTA3 FREE

```



0100 FREE  
0105 FREE  
MTAG FREE

.R GRIPE

Yes? (Depress ESCape key when through)  
PLEASE MOUNT TAPE-ALL PORTS FREE!  
Thank you

.NO/C  
1. H Job13 11Y25 3137:575 1 MOUNT MTA 16 /REELID1 1182 /VT PRASAD 9-TRK;800BPI PLOT TAPE  
/ME  
1 Command in Queue

.NO/C  
1. H Job13 11Y25 3137:575 1 MOUNT MTA 16 /REELID1 1182 /VT PRASAD 9-TRK;800BPI PLOT TAPE  
/ME  
1 Command in Queue

.NO/C  
1. H Job13 11Y25 3137:575 1 MOUNT MTA 16 /REELID1 1182 /VT PRASAD 9-TRK;800BPI PLOT TAPE  
/ME  
1 Command in Queue

.NO/C  
1. H Job13 11Y25 3137:575 1 MOUNT MTA 16 /REELID1 1182 /VT PRASAD 9-TRK;800BPI PLOT TAPE  
/ME  
1 Command in Queue

.NO/C  
1. H Job13 11Y25 3137:575 1 MOUNT MTA 16 /REELID1 1182 /VT PRASAD 9-TRK;800BPI PLOT TAPE  
/ME  
1 Command in Queue

.NO/C  
No Commands in Queue  
.REM 161

.R PUB1PLOT23

INPUT THE DATA FILE NAME. FORMAT(R10)  
KANT.DAT

STOP

END OF EXECUTION  
CPU TIME: 39.53 ELAPSED TIME: 119.88

EXIT

.REM 161

.DIS 161

MTA005 Dismounted

.PRINT KANT.DAT  
Total of 302 blocks in 1 file in LPT request

.PRI

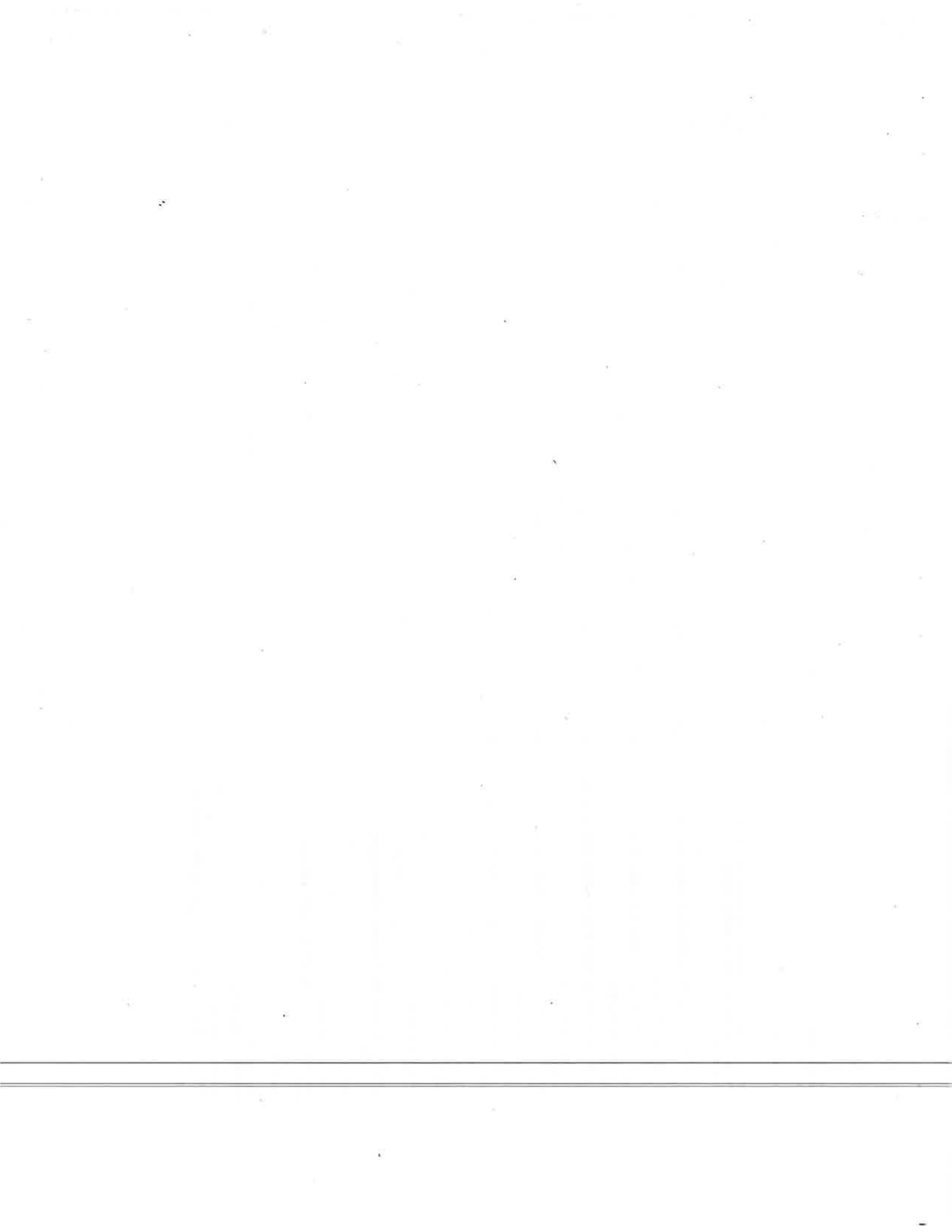

## APPENDIX C

### SOURCE LISTINGS FOR BCAS DATA REDUCTION AND ANALYSIS

- C-1 OPERATIONAL PROCEDURES
  - C-1.1 Procedure to Reduce Data Tapes
  - C-1.2 Procedure to Transfer Data Files from Prime to Scratch Tape (PDATA)
  - C-1.3 Procedure to Input Plot Data onto KL-10.
  - C-1.4 Procedure to Run Plot Program on KL=10
- C-2 BCAS Program Source Listings
- C-3 Program BCASPL
  - C-3.1 Initialization
  - C-3.2 Subroutine One
  - C-3.3 Subroutine Two
  - C-3.4 Subroutine Three
  - C-3.5 Subroutine Four

C-1.1 Procedure to Reduce BCAS Data Tapes and Generate Plot Files on Prime 550

- 1 Mount Magnetic Tapes on Tape Unit 0
- 2 At User Terminal Type Underlined Sections:
- 3 Login Yutkins  
Name: Yutkins Password: BCAS Account #: A1700B  
(Messages.....)
- 4 OK, Assign MTO  
Device MTO Assigned
- 5 OK, SEG # BCAS  
BCAS Program  
(Source Program Listing, C-2.)  
Tape on unit (0/1)? 0  
Enter Tape Label - FT-4  
Do you Wish a Dump of the Tape? Yes  
Do you Want Data for Plots? Yes  
Enter Max. Number of Revolutions to Be Examined. 2  
Enter Any Comments (A40). Test Run  
100 Logical Records  
4 Physical Records  
Spool FT-4 - FTN : For Tape Dump Listing  
File DP-FT-4 : Contains Means Plot Data  
File SS-FT-4 : Contains Sliding Sum
- 6 OK, Spool FT-4 - FTN  
[Spool Rev 18.1]  
PRT001 Spooled, Records: 19, Name FT-4
- 7 Rewind and Remove Data Tape.

C-1.2 Procedure to Transfer Data Files From Prime to Scratch Tape (PDATA)

- 1 Mount Scratch Tape  
(System Utility Program)
- 2 OK, Magnet  
[Magnet Rev. 18,1]  
Option: Write  
MTU # = 0  
MT File # = 1  
Logical Record Size = 80  
Blocking Factor = 1  
ASCII, BCD, Binary, or EBCDIC? ASCII  
Input File: PD-FT-4  
Done... 102 Physical Records Output to Tape
- 3 OK, Magnet  
[Magnet Rev. 18,1]  
Option: Write  
MTU # = 0  
Mt. File # - 2  
Logical Record Size = 256  
Blocking Factor = 1  
ASCII, BCD, Binary, or EBCDIC? ASCII  
Input File: SS-FT-4  
Done... 1434 Physical Records Output to Tape
- 4 OK, Unassign MT0  
Device Released.  
OK,
- 5 Rewind and Remove Scratch Tape

6 OK, Logout

Yutkins Logged out at 15:27 082081

Time Used 0:11 0:34 0:10

OK,

C-1.3 Procedure to Input Plot Data Onto KL-10

1 Login

2 Mount MTA: PDATA/REEL10: PDATA/VIO: PDATA 9-TRK  
800-BPI/WL

Request Queued

Waiting... Two C's to Exit

PDATA Mounted. MTA012 Used

(Load Means and Variances Data File to Disk)

3 R TAPIN (System Utility Program)

Input Device: PDATA

Code: ASCII

CRLF in Input? No

[Block Length 80 Bytes]

Logical Record Length: 80

Delete Sequence Numbers? No

Suppress Trailing Spaces? Yes

Output Device: DSK

Output Filename.Ext: FT4.DMN

[Copying.]

[End of File]

[Odd Parity is Set.]

[Block Number 103]

[102 Logical Records, 102 Blocks Read.]

[ 0 Soft Read Errors]

[0 Hard Read Errors]

More? N

Exit

(Loads Sliding Sum Data File to Disk).

4 R TAPIN

Input Device: PDATA

[Input Mag Tape Density: 800, Reel ID: PDATA]

Code: ASCII

CRLF in Input? No  
[Block Length 256 Bytes]

Logical Record Length: 256  
Delete Sequence Numbers: No  
Suppress Trailing Spaces? Yes

Output Device: DSK  
Output Filename.Ext: FT1.SUM

[Copying.]

[End of File]

[Odd Parity is Set]

[Block Number 1436]

[1434 Logical Records 1435 Block Read.]

[0 Soft Read Errors.]

[0 Hard Read Errors.]

More? No

Exit

o Dismount PDATA: /R

PDATA Dismounted.



C-1.4 Procedure to Run Plot Program on KL-10

(At User Terminal Type in Underlined Sections.)

- 1 Log 3072, 541  
Name: YUTKINS Password: BCAS
- 2 Mount MTA: 16 /Reelid: 2267/Vid: '2267 9-TRK  
800-BPI '/WL  
Request Queued  
Waiting... 2 C's to Exit  
16 Mounted, MTA012 Used
- 3 Run BCAS PL  
Enter Field Tape Number: FT4  
(See Program BCASPL Source Listings C-3.2-3.5)  
Plotting Commencing  
  
End of DISSPLA 8.2 - 118997 Vectors Generated in 8  
Plot Frames.  
  
End of Execution  
CPU Time: 1:21:98  
Exit
- 4 Rewind 16:
- 5 Dismount 16:/R  
MTA012 Dismounted
- 6 K/N (Logout)
- 7 Submit, Plot to DEC-10 I/O Window for Actual Plotting  
on Calcomp.

\*\*\*\*\*  
\*\*\*\*\*  
C-2 PROGRAM BCAS  
\*\*\*\*\*

\* WRITTEN BY: RICHARD YUTKINS  
\* SYSTEM DEVELOPMENT CORP.      MAY 15, 1981

\*\*\*\*\*  
\$INSERT COMBLK  
    WRITE(1,1000)  
1000 FORMAT(/,3X,'BCAS PROGRAM WORKING...',//)  
    CALL INITAL  
    CALL CONTAB  
10  CALL ROREC  
    IF(EOF) CALL DONE  
    CALL CONFGR  
    CALL PPOREC  
    GO TO 10  
    END

\*\*\*\*\*

\*\*\*\*\*

\*  
\* Labeled COMMON BLOCKS  
\*

\*\*\*\*\*

\*  
\* COMMON/RDDATA/IA(64,32),LREC,PREC,NAUX,AUX(25),MAXREV,NUMREV  
\*

\*  
\* IA - ARRAY CONTAINING CONVERTED AND FORMATTED DATA  
\*

\*  
\* PREC - PHYSICAL RECORD COUNTER  
\*

\*  
\* LREC - LOGICAL RECOD COUNTER  
\*

\*\*\*  
\* MAXREC - MAXIMIUM NUMBER OF REVOLUTIONS TO BE PROCESSED  
\*

\*\*\*  
\* NUMREC - NUMBER OF REVOLUTIONS COUNTED  
\*

\*  
\* AUX - OPTIOAAL OUTPUT ARRAY  
\*

\*  
\* NAUX - NUMBER OF AUX ELEMENT USED  
\*

\*\*\*  
\*  
\* COMMON/TABLE/TAB(0:255)  
\*

\*  
\* TAB- CONTAINS REVERSEDBIT LOOKUP TABLE  
\*

\*\*\*  
\*  
\* COMMON/RDATA/ONEREC(64),RNUM,WSPC,WDIR,ACP,CPMAX,CPMIN,CPH  
\*

\*  
\* ONEREC - SINGLE LOGICAL RECORD ARRAY - CONTAINING THE FOLLOWING VARIABLES  
\*

\*  
\* CP - CLOCK PERIOD COUNT ARRAY  
\*

\*  
\* RNUM - CONSECUTIVE LOGICAL RECORD NUMBER  
\*

\*  
\* WDIR - WIND DIRECTION  
\*

\*  
\* WSPD - WIND SPPEED (MPH)  
\*

\*  
\* ACP - ACP COUNT SINCE LAST ARP  
\*

\*  
\* CPMAX - MAXIMIUM CLOCK Period PER LOGICAL RECORD  
\*

\*  
\* CPMIN MINIUM CLOCK PERIOD per logical record  
\*

\*  
\* CPH - CLOCK PERIOD MEANS  
\*

\*\*\*\*\*

```

*****
*
* COMMON/PRINTD/FIRSTR,DFLAG,LOPT,EOF,RECYCLE,PFLAG,HFLAG
*
* DFLAG - LOGICAL OPTIONAL DUMP .TRUE.
* FIRSTR - FIRST RECORD FLAG
*
*
* HFLAG - LOGICAL TOP OF PAGE HEADING FLAG
*
* RECYCLE - LOGICAL FLAG TRUE= ACP COUNT RECYCLED
*           FALSE= SAME REVOLUTION
* LCPT - LOGICAL FLAG TRUE= CALL TO SUB OPTION
*
* PFLAG = LOGICAL FLAG TRUE= CALLS SUB PLTCMP
*
* EOF - END-OF-FILE FLAG
*
*
* COMMON/TAPE/TAPID,COMMENT
*
* TAPID - TAPE ID SUPPLY BY USER
*
* *** COMMENT - 40 CHAREATER ARRAY CONTAINING USERS TAPE COMMENTS
*
* COMMON/VARIBU/OACP,PRINTL(7)
* COMMON BUFF(1024),IUNIT
*
*
* BUFF ONE PHYSICAL UNFORMATTED RECORD
* INTEGER*2 BUFFER(32,32)
* INTEGER*4 PREC,MAXREV,NUMREV,LREC
* INTEGER*2 ONEREC,CP(54)
* INTEGER*4 NAUX
* INTEGER*4 RAUM,LSPO,WDIR,ACP,CPMAX,CPMIN,CFP,AUX
* INTEGER*4 PRINTL
* INTEGER*4 OACP
* INTEGER*2 BUFF,TAB,IUNIT
* REAL XCPH
*
* CHARACTER*40 COMMENT
* CHARACTER*15 TAPID
*
*
* EQUIVALENCE (ONEREC(1),CP(1))
* EQUIVALENCE (BUFF(1),BUFFER(1,1))
*
*
* LOGICAL EOF,FIRSTR,LOPT,DFLAG,RECYCLE,PFLAG,HFLAG
*
*****

```

\*\*\*\*\*

\*\*\*\*\*

```
*  
*      SUBROUTINE CGNTAB  
*  
*      NO LIST  
*INSERT COMBLK  
*      LIST
```

\*\*\*\*\*

```
*  
*      FUNCTION: CREATE LOOKUP TABLE FOR REVERSED BYTE CONVERSION  
*  
*      INPUTS: COMMON BLOCK  
*  
*      CUTPUTS: COMMON BLOCK  
*  
*      CALLED FROM: MAIN  
*  
*      CALLS TO : ACNE  
*
```

\*\*\*\*\*

```
C      ROUTINE TO CREATE LOOKUP TABLE FOR REVERSE BIT CONVERSICNS  
      INTEGER*2 PL(8),I1,NUM  
C  
      DATA PW/7,6,5,4,3,2,1,0/  
      DO 20 I=0,255  
      NUM=I  
      DO 10 J=1,8  
      I1=AND(NUM,(2**(J-1)))  
      IF(I1.EQ.0) GO TO 10  
      TAB(I)=TAB(I)+2**PL(J)  
      10 CONTINUE  
      20 CONTINUE  
C      WRITE(1,2000)  
C2000 FORMAT(/,3X,'LOOK-UP TABLE COMPLETED',/)  
      RETURN  
      END
```

\*\*\*\*\*

\*\*\*\*\*

\*  
SUBROUTINE RDREC

\*  
NO LIST  
\$INSERT COMBLK  
LIST

\*\*\*\*\*

\*  
INTEGER\*2 ALT

\*  
N=1024  
ASSIGN 75 TO ALT

\*  
C CALL ISBM05(0,BUFF,N,0)  
CALL READA

\*  
PREC=PREC+1  
EOF=.FALSE.

\*  
C WRITE(1,33) BUFF  
C 33 FORMAT(128(/,8(I6,3X)))  
RETURN

\*  
\*\*\* END-OF-FILE

\*  
75 CONTINUE

\*  
EOF=.TRUE.  
WRITE(1,2001)  
2001 FORMAT(/,3X,'END-OF-FILE',/)

\*  
RETURN  
END

\*\*\*\*\*

\*  
SUBROUTINE CONFOR

\*  
NO LIST  
\$INSERT COMBLK  
LIST

\*\*\*\*\*

\*  
FUNCTION: ROUTINE TO CONVERT REVERSED BIT TO FORMATTED ARRAY

\*  
INPUTS: COMMON BLOCK

\*  
OUTPUTS: COMMON BLOCK

\*  
CALLED FROM: MAIN

\*

```

*****
*      CALLS TO: NONE
*
*****
*****
      INTEGER*2 MSK,I1,I2
*
***   MASK LOWER 8-BITS
*
      MSK=255
*
***   K - RECORDS # INDEX
*
      DO 50 K=1,32
*
      L=1
*
***   J - WORD INDEX
*
      DO 40 J=1,32
*
***   FIRST HALF
*
      I1=RS(BUFFER(J,K),8)
      IA(L,K)=TAB(I1)
      L=L+1
*
***   SECOND HALF
*
      I2=AND(BUFFER(J,K),MSK)
      IA(L,K)=TAB(I2)
      L=L+1
*
      40 CONTINUE
*
*
*
      50 CONTINUE
*
***   RETURN
*
      RETURN
*
      END
*****
*
      SUBROUTINE PROREC
*
      NO LIST
$INSERT COMBLK
      LIST
*****
*
      FUNCTION: SETS UP SINGLE RECORD ARRAY OPTION DUMP

```

```

*****
*
*           CALCULATE MEANS AND FIND MAX. AND MIN.
*           CP VALUES PER LOGICAL RECORD
*
*   INPUTS: COMMON BLOCKS
*
*   OUTPUTS: COMMON BLOCKS
*
*   CALLED FROM: MAIN
*
*   CALLS TO: OPTIONAL DUMP
*             CALG ROUTINE OPTIONAL CALCULATION ROUTINE
*****
*
*   INTEGER=2 MLLT(3),IACP,IRNM
*
*   LOGICAL LASTR,EOR
*
*   DATA MULT/100,10,1/
*
*   *** I- LOGICAL RECORD COUNTER INDEX
*
*   DO 50 I=1,32
*
*       CPMAX=0
*       CPMIN=9999
*
*       CPM=0
*       LRFC=LREC+1
*       XCPM=0.0
*
*   *** J= BYTE COUNTER
*
*   DO 10 J=1,64
*       ONEREC(J)=IA(J,I)
*
*   *** CALCULATE MEANS, FIND MIN, MAX. CP VALUES
*
*       IF(J.GT.54) GO TO 10
*
*       CPMAX=MAX0(ONEREC(J),CPMAX)
*       CPMIN=MIN0(ONEREC(J),CPMIN)
*
*       XCPM=XCPM+ONEREC(J)
*   10 CONTINUE
*
*       CPM=(XCPM/54.0)+0.5
*
*       WSPD=0
*       WDIR=0
*
*

```



\*\*\*\*\*

```
*
*** CALCULATE WIND SPEED AND DIRECTION
*
DO 20 K=1,3
WDIR=WDIR+(ONEREC(56+K)*MULT(K))
*
WSPD=WSPD+(ONEREC(59+K)*MULT(K))
20 CONTINUE
*
*** FIND CONSECUTIVE RUN #
*
IRNM=LS(ONEREC(55),8)
RNUM=OR(IRNM,ONEREC(56))
*
*** ACP COUNT SINCE LAST ARP
*
IACP=LS(ONEREC(63),8)
ACP=OR(IACP,ONEREC(64))
*
*** INITIALIZE CACP ON FIRST RECORD
*** CACP = PREVIOUS ACP VALUE
*
IF(.NOT.FIRSTR) GO TO 25
FIRSTR=.FALSE.
CACP=9999
25 CONTINUE
*
*** CHECK FOR ACP RECYCLE
*** SET HFLAG
*
HFLAG=.FALSE.
IF(OACP.GE.ACP) HFLAG=.TRUE.
RECYLE=.FALSE.
IF(OACP.GE.ACP) RECYLE=.TRUE.
*
*** INCREMENT NUMREV FOR EACH ACP RESTART
**** SET LASTR TO TRUE WHEN NUMREV EQUALS MAX REV
*
EOR=.FALSE.
LASTR=.FALSE.
IF(.NOT.RECYLE) GO TO 30
EOR=.TRUE.
NUMREV=NUMREV+1
IF(NUMREV.GT.MAXREV) LASTR=.TRUE.
30 CONTINUE
*
CALL OPTION
40 CONTINUE
IF(LASTR) GO TO 42
*
*** SET UP PRINTL LINE
```

```

*****
*
*   PRINTL(1)=RNUM
*   PRINTL(2)=WDIR
*   PRINTL(3)=LSPD
*   PRINTL(4)=ACP
*   PRINTL(5)=CPM
*   PRINTL(6)=CPMAX
*   PRINTL(7)=CFMIN
*
*** CHECK DUMP FLAG
*
  IF(.NOT.DFLAG) GO TO 42
  CALL DUMP
  42 CONTINUE
*
*** CHECK PLOT DUMP FLAG
*
  IF(.NOT.PFLAG) GO TO 46
  IF(.NOT.EOR.OR.NUMREV.EQ.1) GO TO 45
  HFLAG=.FALSE.
  CALL PLTDMP
  hflag=.true.
  45 CONTINUE
  IF(LASTR) HFLAG=.FALSE.
  CALL PLTDMP
  46 CONTINUE
*
*** SET OACP EQUAL TO ACP
*
  CACP=ACP
*
*** IF LASTR TRUE THEN ALL DONE
*
  IF(LASTR) CALL DONE
*
  50 CONTINUE
*
*** RETURN
*
  RETURN
  END
*****
*
  SUBROUTINE DUMP
*
  NO LIST
  SINSERT COMBLK
  LIST
*****
*
  FUNCTION: PRINT A SINGLE FORMATTED RECORD
*

```

```

*****
* INPUTS: COMMON BLOCK
*
* OUTPUTS: LPT
*
* CALLED FROM: PROCRC
*
* CALLS TO : NONE
*
*****

```

```

*** CHECK HEADING FLAG

```

```

IF(.NOT.HFLAG) GO TO 20
WRITE(10,2000) TAPID,NUMREV,COMMENT
20 CONTINUE

```

```

WRITE(10,2001) (FRINTL(II),II=1,7)

```

```

*** FORMATS *****

```

```

2000 FORMAT(/,1H1,/,20X,'TAPE ID: ',A15,
A//,20X,'REVOLUTION NUMBER ',I7,/,20X,A40,
B//,10X,'RECCRD',4X,'WIND',6X,'WIND',
16X,'ACP',7X,'CLOCK PERIOD COUNT',/,
A10X,'NUMBER',4X,'DIRECTION',1X,'SPEED',
25X,'COUNT',/,20X,'(DEGREES)',1X,'(MPH)',
315X,'(MEANS)',3X,'(MAX.)',4X,'(MIN.)'/)

```

```

2001 FORMAT(10X,I6,5X,I3,8X,I3,4(5X,I5))

```

```

***RETURN

```

```

RETURN
END

```

```

*****
* SUBROUTINE INITAL

```

```

NO LIST
$INSERT COMBLK
LIST

```

```

*****
* FUNCTION: INITIALIZE COUNTERS OPEN TAPE UNIT
* INPUTS: COMMON BLOCKS
*
* OUTPUTS: COMMON BLOCKS
*
* CALLED FROM: MAIN
*

```

\*\*\*\*\*

\* CALLS TO: NGNE

\*\*\*\*\*

INTEGER\*2 ALT  
CHARACTER\*15 FNAME,PFILE,SFILE  
CHARACTER\*4 FILE,  
LOGICAL\*4 FILEF

\*\*\* SET RECORD COUNTERS TO ZERO

LREC=0  
PREC=0  
NAUX=0  
MAXREV=0  
NUMREV=0

DO 2 II=1,13  
AUX(II)=0  
2 CONTINUE

\*\*\* SET FLAG DEFAULTS

CFLAG=.TRUE.  
LOPT=.TRUE.  
FIRSTR=.TRUE.  
PFLAG=.TRUE.

\*\*\* OPEN MTO

C CALL CSMOS(1,DUM,0,0)  
CALL INIT

\*\*\* REWIND TAPE DRIVE

IDRIVE=IUNIT+21

REWIND IDRIVE

\*\*\* ENTER TAPE LABEL

5 CONTINUE  
WRITE(1,2003)  
2003 FORMAT(//,3X,'ENTER TAPE LABEL',/,10X)  
READ(1,1000) TAPID

FNAME=TAPID  
PFILE='PD\_ '//FNAME(1:12)  
SFILE='SS\_ '//FNAME(1:12)

\*\*\* REQUEST TAPE DUMP REPLY

WRITE(1,200)

\*\*\*\*\*

```
      READ(1,100) IRELY
      *
      IF(IRELY.EQ.1HY) GO TO 10
      DFLAG=.FALSE.
      GO TO 15
10    CONTINUE
      *
      *** CHECK IF DATA DUMP FILE NAME ALREADY EXIST
      *
      INQUIRE(FILE=FNAME,EXIST=FILEF)
      *
      IF(FILEF) GO TO 70
      *
      *** OPEN DISK OUTPUT FILE
      *
      CPEN(10,FILE=FNAME,STATUS='NEW',ACCESS='SEQUENTIAL',
      ARECL=132,ERR=75)
      *
      *** REQUEST PLOT DATA DUMP
      *
15    CONTINUE
      *
      WRITE(1,201)
      READ(1,100) JREPLY
      *
      IF(JREPLY.EQ.1HY) GO TO 20
      PFLAG=.FALSE.
      GO TO 25
20    CONTINUE
      *
      **** CHECK IF PLOT DATA FILENAME ALREADY EXIST
      *
      INQUIRE(FILE=PFILE,EXIST=FILEF)
      *
      IF(FILEF) GO TO 70
      *
      *** OPEN DISK FILE FOR PLOT DATA OUTPUT
      *
      OPEN(11,FILE=PFILE,STATUS='NEW',ACCESS='SEQUENTIAL',
      ARECL=256,ERR=75)
      *
      *
      **** CHECK IF SLIDE_SUM DATA FILENAME ALREADY EXIST
      *
      INQUIRE(FILE=SFILE,EXIST=FILEF)
      *
      IF(FILEF) GO TO 70
      *
      *** OPEN DISK FILE FOR SLIDING SUM DATA
      *
      CPEN(13,FILE=SFILE,STATUS='NEW',ACCESS='SEQUENTIAL',
      ARECL=80,ERR=75)
      *
```

\*\*\*\*\*

25 CONTINUE

\*  
\*\*\* ENTER MAX. NUMBER OF RECORDS TO BE PROCESSED

\*  
WRITE(1,2004)  
READ(1,102) MAXREV

\*  
\*\*\*\* ENTER ANY COMMENTS

\*  
WRITE(1,2005)  
READ(1,103) COMMENT

\*  
\*\*\* RETURN

\*  
RETURN

\*  
\*\*\* ERROR IN OPEN

\*  
70 CONTINUE

\*  
WRITE(1,2006) FNAME  
GO TO 5

\*  
75 CONTINUE

\*  
PRINT 1001

\*  
RETURN

100 FORMAT(A1)  
102 FORMAT(I4)  
103 FORMAT(A40)  
200 FORMAT(/,3X,'DO YOU WISH A DUMP OF THE TAPE ?')  
201 FORMAT(/,3X,'DO YOU WANT DATA FOR PLOTS ?')  
1000 FORMAT(A15)  
1001 FORMAT(/,3X,'ERROR IN OPENING FILE',/)  
2004 FORMAT(/,3X,'ENTER MAX NUMBER OF REVOLUTIONS TO BE EXAMINED ?')  
2005 FORMAT(/,3X,'ENTER ANY COMMENTS (A40) ?')  
2006 FORMAT(/,3X,'FILE ',A15,' ALREADY EXIST')  
END

\*\*\*\*\*

\*  
SUBROUTINE DCNE

\*  
NO LIST

\*  
\$INSERT COMBLK

\*\*\*\*\*  
LIST

\*  
FUNCTION: TERMINATE MAIN

\*\*\*\*\*

\*  
\* INPUTS: COMMON BLOCKS  
\*  
\* OUTPUTS: TTY  
\*  
\* CALLED FROM: MAIN  
\*  
\* CALLS TO: NONE  
\*

\*\*\*\*\*

\*  
\* WRITE(1,1000) LREC,PREC  
\* NUNIT=IUNIT+21  
\* REWIND NUNIT  
\*  
\* IF(.NOT.DFLAG) GO TO 25  
\* WRITE(1,2000) TAPIO  
\* CLOSE(UNIT=10)  
25 CONTINUE  
\* IF(.NOT.PFLAG) GO TO 50  
\* WRITE(1,2001) TAPIO,TAPIO  
\* CLOSE(UNIT=11)  
\* CLOSE(UNIT=13)  
50 CONTINUE  
\* CALL EXIT  
1000 FORMAT(//,3X,I6,' LOGICAL RECORDS',//,  
13X,I6,' PHYSICAL RECORDS',//)  
2000 FORMAT(/,3X,'SPOOL ',A15,' -FTN IFOR TAPE DUMP LISTING')  
2001 FORMAT(/,3X,'FILE PD\_',A15,' CONTAINS MEAN PLOT DATA',//,  
A3X,'FILE SS\_',A15,' CONTAINS SLIDING SUM PLOT DATA',//)  
\* END

\*\*\*\*\*

\*  
\* SUBROUTINE PLTDMP  
\*  
\* NO LIST  
\* INSERT COMBLK  
\* LIST

\*\*\*\*\*

\*  
\* FUNCTION: OPTIONAL CALL DUMPS DATA INTO DISK FILE LOGICAL # 11  
\*  
\* INPUTS: COMMON BLOCKS  
\*  
\* OUTPUTS: DISK FILE LOGICAL # 11  
\*  
\* CALLED FROM: PROREC  
\*  
\* CALLS TO : NONE  
\*

\*\*\*\*\*

\*\*\*\*\*

```
*
*
*      ICYCLE=-1111
***   IF HFLAG TRUE WRITE HEADER INFO
*
*      IF(.NOT.HFLAG) GO TO 10
*      WRITE(11,2000) NUMREV,TAPID,COMMENT
*      RETURN
***   IF RECYCLE TRUE WRITE END-OF -CYCLE DATA
*
*      10 CONTINUE
*
*      IF(.NOT.RECYLF) GO TO 20
*      WRITE(11,2001) ICYCLE,(AUX(KK),KK=1,NAUX)
*      RETURN
***   WRITE DATA RECORD
*
*      20 CONTINUE
*      WRITE(11,2001)(PRINTL(JI),JI=1,7),(AUX(LJ),LJ=1,NAUX)
*      RETURN
*
****  FORMATS      *****
*
*      2000 FORMAT(1X,I7,A15,A40)
*      2001 FORMAT(20(1X,I7))
*
*      END
```



\*\*\*\*\*

C-3 . PROGRAM BCASPL

\*\*\*\*\*

\* WRITTEN BY: RICHARD YUTKINS  
\* SYSTEM DEVELOPMENT CORP. MAY 15, 1981

\*\*\*\*\*

C-3.1 INITIALIZE PLOTTER

CALL UDEV('16','CALCOMP')

\*  
\*\*\* OPEN DATA FILES  
CALL FILOFN

\*  
\*\*\* READ IN COMMON BLOCK VARIABLE  
CALL RDCOM

\*  
\*\*\* READ DATA FILL PLOTTING ARRAY AND CALL PLOT ROUTINE  
CALL REAPLT

\*  
CALL REASIL

\*\*\*  
\* CLOSE DEVICES

CALL DONEPL

CLOSE(UNIT=20)  
CLOSE(UNIT=21)  
REWIND 16  
CALL EXIT  
END

\*\*\*\*\*

SUBROUTINE FILOFN

\*\*\*\*\*

\* FUNCTION: USER INPUT FIELD TAPE NUMBER ROUTINE  
\* OPEN CORRESPONDING DATA FILES.

\* INPUTS: TTY

\* OUTPUTS: TTY

\* CALLED FROM: MAIN

\* CALLES TO: NONE

\*\*\*\*\*

DOUBLE PRECISION MFILE, SFILE

```

INTEGER FILE1(2),FILE2(2)

EQUIVALENCE (FILE1(1),INN)
EQUIVALENCE (FILE2(1),INN)
EQUIVALENCE (FILE1(1),MFILE)
EQUIVALENCE (FILE2(1),SFILE)

DATA FILE1/5H      .5H .CMM/
DATA FILE2/5H      .5H .SUM/

5  CONTINUE

***  ACCT FIELD TAPE NUMBER

TYPE 200
ACCEPT 100, INN
INN=INN

***  OPEN MEAN DATA FILE UNIT # 20

OPEN(UNIT=20,DEVICE='DSK',ACCESS='SEQIN',FILE=MFILE,
1RECORDSIZE=256,ERR=90)

***  OPEN SILING SUM DATA FILE UNIT # 21

OPEN(UNIT=21,DEVICE='DSK',ACCESS='SEQIN',FILE=SFILE,
1RECORDSIZE=80,ERR=90)

RETURN

90  CONTINUE

****  ERROR IN OPEN

TYPE 201, INN
GO TO 5

***  FORMATS  ****

100  FORMAT(A5)
200  FORMAT(/,3X,'ENTER FIELD TAPE NUMBER ',S)
201  FORMAT(/,3X,'TAPE NUMBER ',A5, 'NOT FOUND')

END

```

\*\*\*\*\*

C-3.2 SUBROUTINE PLOTONE

INCLUDE 'COMBLK/WCLIST'

\*\*\*\*\*

\*  
\* FUNCTION: PLOT THE MEAN, MAX, AND MIN CLOCK PERIOD COUNTS  
\* ALONG WITH WIND SPEED AND WIND DIRECTION  
\*  
\* INPUTS: COMMON ELCKC  
\*  
\* OUTPUTS: PLOTTER  
\*  
\* CALLED FROM: REAPLT  
\*  
\* CALLS TO: NONE  
\*

\*\*\*\*\*

INTEGER IPKRAY(40)

\*  
\*\*\* INITIALIZE LEVEL ONE  
\*  
CALL BGNPL(NPLOT)  
\*  
\*\*\* SET LETTERING STYLE  
\*  
CALL TRIPX  
CALL BASALP('STAND')  
CALL MIXALP('L/CST')  
\*  
\*\*\* SET PAGE SIZE TO 11. BY 8.5 AND PLOT AREA TO 8.0 BY 5.5  
\*  
CALL PHYSOR(2.75,1.0)  
CALL PAGE(11.,8.5)  
CALL TITLE(0.,0.,LRALAB,100,0,0,8.,5.5)  
\*  
\*\*\* SET EXTRA TICKS PER STEP ON X-AXIS INTEGERIZE ALL Y -AXIS  
\*\*\* NUMBERING HORIZONTAL  
\*  
CALL XTICKS(5)  
CALL YTICKS(5)  
CALL YAXANG(0.0)  
CALL INTAXS  
\*  
\*\*\* SET GRACE MARGIN TO 0.0 AND SET SCALING PARAMETERS  
\*  
CALL GRACE(0.0)

```

CALL GRAP (LRSV, LBSTP, LREV, CPSV, CPSTP, CPEV)

*
***
DRAW A GRID LINE EVERY OTHER STEP IN THE X DIRECTION
*
C
CALL GRID (-2,0)
*
***
CHANGE TO DOTTED LINE MODE. DRAW GRID LINE EVERY STEP IN X DIR.
*
CALL DOT
CALL GRID (1,0)
CALL RESET ('DOT')
*
****
****
****
*
***
SET Y-AXIS SCALE FOR ACP COUNT PLOTS
*
CALL YGRAIS (CPSV, CPSTP, CPEV, 5.5, CPALAB, 100, 0.0, 0.0)
***
DRAW MEAN OF REVOLUTION LINE
*
CALL BLVEC (0., MEANR, 75.0, MEANR, 0)
*
***
SET HEIGHT OF CURVE MARKERS
*
CALL HEIGHT (0.07)
*
*
***
PLOT CPMEAN CPMAX, CPMIN
*
CALL CURVE (LR, CPMEAN, NPT, 5)
CALL CURVE (LR, CPMAX, NPT, 5)
CALL CURVE (LR, CPMIN, NPT, 5)
*
***
PLOT POINTS WIND SPEED
***
CHANGE LINE MODE

CALL CHNDOT
*
*
CALL CURVE (LR, WSPD, NPT, 25)
*
***
PLOT WIND DIRECTION CURVE
*
***
CHANGE LINE MODE

CALL CHWDSH
CALL CURVE (LR, WEIR, NPT, 25)
*
*
***
RESET HEIGHT
*
CALL RESET ('HEIGHT')
*
***
SHIFT X-ORIGIN BACK 1.5 INCHES TO DRAW SECNDARY
***
Y-AXIS FOR WIND SPEED
*

```

```

CALL BSHIFT(-0.8,0.0)
*
*** MAKE TICK MARKS EVERY 5 STEP
*
CALL YTICKS(5)
*
*** SET NEW Y-AXIS SCALING FOR WIND SPEED
*
CALL YGRAXS(WSSV,WSSTP,WSEV,5.5,WSALAB,100,0.0,0.0)
*
*** SHIPT X-AXIS BACK TO -2.0 INCHES FOR WIND DIRECTION AXIS
*
CALL BSHIPT(-1.6,0.0)
*
*** SET TICKS MARK EVERY 9 STEPS
*
CALL YTICKS(9)
*
*** SET NEW Y-AXIS SCALING FOR WIND DIRECTION
*
CALL YGRAXS(WDSV,W DSTP,WDSV,5.5,WDALAB,100,0.0,0.0)
*
*** PACK LINES FOR LEGEND
*
J=LINEST(IPKRAY,40,10)
IF(J.LT.5) TYPE 22, J
22 FORMAT(' LEGEND ERROR J= ',I4)
*
*** PACK LINES
*
CALL LINES('MEANS CPS',IPKRAY,1)
CALL LINES('MAX. CPS',IPKRAY,2)
CALL LINES('MIN. CPS',IPKRAY,3)
CALL LINES('WIND SPDS',IPKRAY,4)
CALL LINES('WIND DIRS',IPKRAY,5)
*
*
*** FIND HIRGHT AND WIDTH OF LEGEND AREA
*
XWID=XLEGND(IPKRAY,5)
YHGT=YLEGND(IPKRAY,5)
*
*** FIND COORDINATES OF LEGEND
*
XLC=8.0+1.6-XWID
YLC=8.5-YHGT-.5
*
*** DRAW LEGEND
***
CALL LEGEND(IPKRAY,5,XLC,6.0)
*
*** DRAW LEGENDS
*
CALL MESSAG(MESS1,100,0.0,7.0)
CALL MESSAG(MESS2,100,0.0,6.5)
CALL MESSAG(MESS3,100,0.0,6.0)
*
*
*

```

```

***      END-OF-PLOT
*
***      RETURN
*
      CALL ENDPL(0)

      RETURN
      END

```

C-3.3 SUBROUTINE PLTTWC

```

      INCLUDE 'CONBLK/WOLIST'
*****
*
*      FUNCTION: PLOT VARIANCE AND MEAN OF REVOLUTIONS
*
*      INPUTS: COMMON BLCKC
*
*      OUTPUTS: PLOTTER
*
*      CALLED FROM: REAPLT
*
*      CALLS TO: NONE
*
*****

      INTEGER IPKBY(40)

*
***      INITIALIZE LEVEL ONE
*
      CALL BGNPL(NPLOT)
*
***      SET LETTERING STYLE
*
      CALL TRIPLEX
      CALL BASALP('STAND')
      CALL NIALP('L/CST')
*
***      SET PAGE SIZE TO 11. BY 8.5 AND PLOT AREA TO 8.0 BY 5.5
*
      CALL PHYSOR(2.75,1.0)
      CALL PAGE(11.,8.5)
      CALL TITLE(0.,0.,LRALAB,100,0,0,0.,5.5)
*
***      SET EXTRA TICKS PER STEP ON X-AXIS INTEGERIZE ALL Y -AXIS
***      NUMBERING HORIZONTAL
*
      CALL XTICKS(5)
      CALL YTICKS(5)
      CALL YAXANG(0.0)
      CALL INTAYS
*
***      SET GRACE MARGIN TO 0.0 AND SET SCALING PARAMETERS
*
      CALL GRACE(0.0)
      CALL GRAF(LRSV,LRSTP,LREY,VARSV,VARSTP,VAREV)
*
***      DRAW A GRID LINE EVERY OTHER STEP IN THE X DIRECTION
*

```

```

C      CALL GRID(-2,0)
*
***   CHANGE TO DOTTED LINE MODE. DRAW GRID LINE EVERY STEP IN X DIR..
*
      CALL DOT
      CALL GRID(1,0)
      CALL RESET('DOT')
*
****
****
****
*
***   SET Y-AXIS SCALE FOR ACF COUNT PLOTS
*
      CALL YGHAIS(VARSV,VARSTP,VAREV,5.5,VARLAB,100,0.0,0.0)
***   DRAW MEAN OF REVOLUTION LINE
*
      CALL BLVEC(0.,MEANE,75.0,MEANE,0)
***   SET HEIGHT OF CURVE MARKERS
*
      CALL HEIGHT(0.07)
*
*
*
***   PLOT VARIANCE
*
      CALL CURVE(LR,VAR,NPT,1)
*
***   RESET HEIGHT
*
      CALL RESET('HEIGHT')
*
*
*
***   DRAW MESSAGES
*
      CALL MESSAG(MESS1,100,0.0,7.0)
      CALL MESSAG(MESS2,100,0.0,6.5)
      CALL MESSAG(MESS3,100,0.0,6.0)
*
*
*
***   END-OF-PLOT
*
***   RETURN
*
      CALL ENDBL(0)
*
      RETURN
      END

```

C-3.4 SUBROUTINE PLYIII

```

      INCLUDE 'COMBLK/NOLIST'
*****
*
*   FUNCTION: DERIVE DEVIATION FROM THE NOMINAL
*             SUM CLOCK PULSE NUMBER FROM 1 TO 4096
*

```

```

*
* INPUTS: COMMON BLCCK
*
* OUTPUTS: PLOTTER
*
* CALLED FROM: BEAPIT
*
* CALLS TO: NONE
*
*****
INTEGER IPKRAY(40)
*
*** INITIALIZE LEVEL ONE
*
CALL HGBPL(NPLOT)
*
*** SET LETTERING STYLE
*
CALL TRIPLX
CALL BASALF('STAND')
CALL HIXALF('L/CST')
*
*** SET PAGE SIZE TO 11. BY 8.5 AND PLOT AREA TO 8.0 BY 5.5
*
CALL PHYSOR(2.75,1.0)
CALL PAGE(11.,8.5)
CALL TITLE(0.,0.,IRALAB,100,0,0,8.,5.5)
*
*** SET EXTRA TICKS PER STEP ON X-AXIS INTEGERIZE ALL Y -AXIS
*** NUMBERING HORIZONTAL
*
CALL ITICKS(5)
CALL YTICKS(5)
CALL YAXANG(0.0)
CALL INTAIX
*
*** SET GRACE MARGIN TO 0.0 AND SET SCALING PARAMETERS
*
CALL GRACE(0.0)
CALL GRAF(LRSV,LRSTP,LREV,SCPSV,SCPSTP,SCPEV)
*
*** DRAW A GRID LINE EVERY OTHER STEP IN THE X DIRECTION
*
C CALL GRID(-2,0)
*
*** CHANGE TO DOTTED LINE MCDM. DRAW GRID LINE EVERY STEP IN X DIR.
*
CALL DOT
CALL GRID(1,0)
CALL RESET('DOT')
*
****
****
****
*
*** SET Y-AXIS SCALE FOR ACP COUNT PLOTS

```



```

*
CALL YGRAVS (SCPSV,SCPSTP,SCPEV,5.5,SCPLAB,100,0.0,0.0)
***
DRAW NOMINAL MEAN OF REVOLUTION CURVE
*
CALL CURVE(LB,SCFNN,NPT,0)
*
***
SET HEIGHT OF CURVE MARKERS
*
CALL HEIGHT(0.07)
*
*
*
***
PLOT SUM OF THE CLOCK PULSES
*
CALL CURVE(LB,SCP,NPT,-1)
*
***
RESET HEIGHT
*
CALL RESET('HEIGHT')
*
*
*
***
DRAW MESSAGES
*
CALL MESSAG(MESS1,100,0.0,7.0)
CALL MESSAG(MESS2,100,0.0,6.5)
CALL MESSAG(MESS3,100,0.0,6.0)
*
*
*
***
END-OF-PLOT
*
***
RETURN
*
CALL ENDPL(0)
*
RETURN
END
C-3.5 SUBROUTINE PLTIV

```

```

*****
*
*
FUNCTION: PLOTS SLIDING SUN DATA GROUPS VS ACP NUMBER*
INPUTS: COMMON BLOCK
*
*
OUTPUTS: PLOTTER
*
*
CALLED FROM: REASIL
*
*
CALLS TO: NONE
*
*****
*
INTEGER IPRHAY(200)
*
***
INITIALIZE LEVEL ONE
*
CALL BGMPL(NPLOT)
*

```

```
*** DRAW TAPE ID,IRVV # COMMENTSEX  
CALL MESSAG (MESS1,100,0.0,7.0)  
CALL MESSAG (MESS2,100,0.0,6.5)  
CALL MESSAG (MESS3,100,0.0,6.0)
```

```
*  
*  
*  
***  
*  
***  
*
```

```
END-OF-PLCT  
RETURN  
CALL ENDPL(0)  
RETURN  
END
```

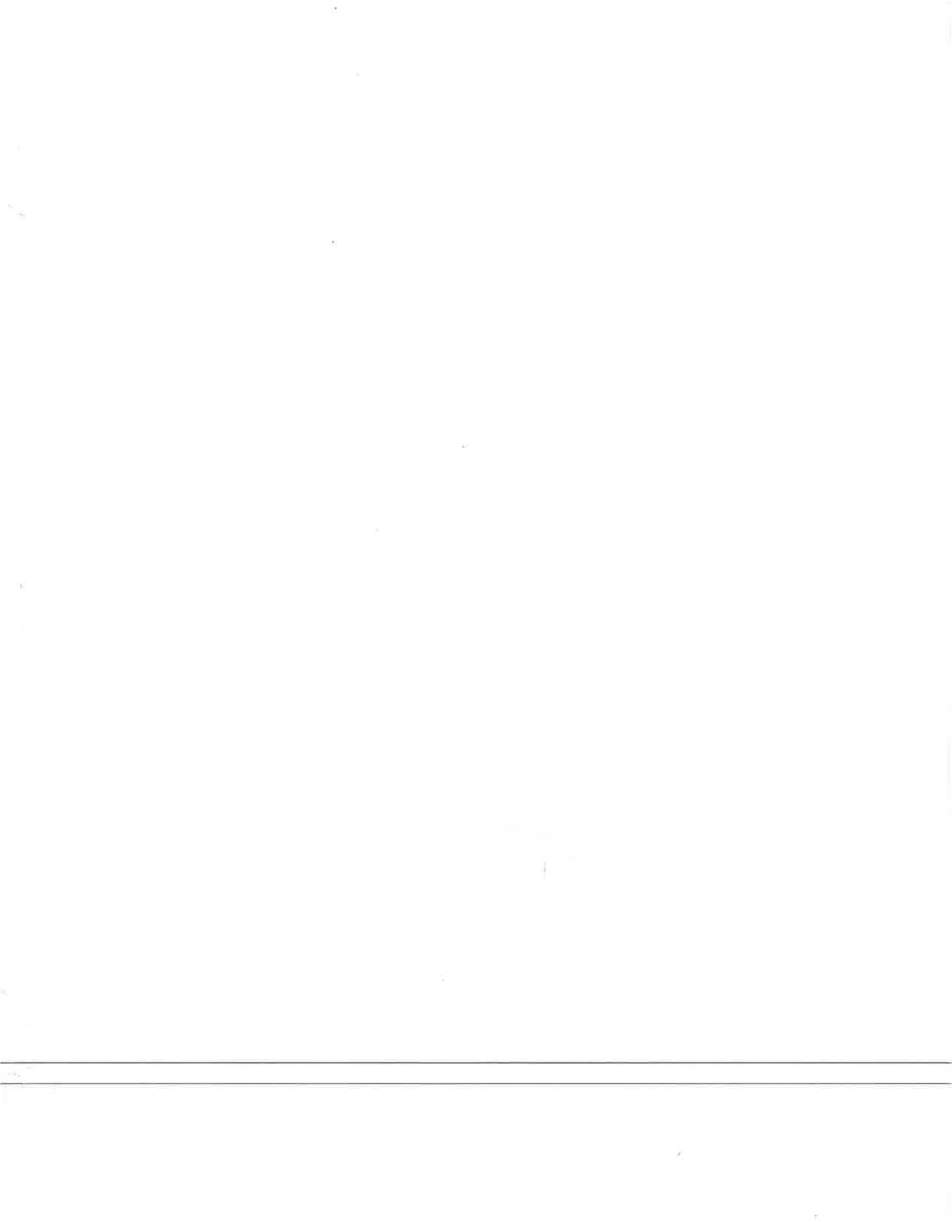

**U.S. Department  
of Transportation  
Research and  
Special Programs  
Administration**

Kendall Square  
Cambridge, Massachusetts 02142

Official Business  
Penalty for Private Use \$300

Susan Happy/930  
Building 1 Room 8-45

10

Postage and Fees Paid  
Research and Special  
Programs Administration  
DOT 513

