

REPORT NO. *FAA-79-25*
FAA-RD-79-96

TEST PLAN FOR EXPERIMENTAL MEASUREMENTS
OF RADIO NOISE AND ELECTROMAGNETIC INTERFERENCE
AT LOGAN AND BURLINGTON AIRPORTS

Peter G. Mauro
John D. Gakis



OCTOBER 1979

INTERIM REPORT

DOCUMENT IS AVAILABLE TO THE PUBLIC
THROUGH THE NATIONAL TECHNICAL
INFORMATION SERVICE, SPRINGFIELD,
VIRGINIA 22161

Prepared for

U.S. DEPARTMENT OF TRANSPORTATION
FEDERAL AVIATION ADMINISTRATION
Systems Research and Development Service
Washington DC 20591

NOTICE

This document is disseminated under the sponsorship of the Department of Transportation in the interest of information exchange. The United States Government assumes no liability for its contents or use thereof.

NOTICE

The United States Government does not endorse products or manufacturers. Trade or manufacturers' names appear herein solely because they are considered essential to the object of this report.

1. Report No. FAA-RD-79-96		2. Government Accession No.		3. Recipient's Catalog No.	
4. Title and Subtitle TEST PLAN FOR EXPERIMENTAL MEASUREMENTS OF RADIO NOISE AND ELECTROMAGNETIC INTERFERENCE AT LOGAN AND BURLINGTON AIRPORTS				5. Report Date October 1979	
				6. Performing Organization Code	
7. Author(s) Peter G. Mauro, John D. Gakis				8. Performing Organization Report No. DOT-TSC-FAA-79-25	
9. Performing Organization Name and Address U.S. Department of Transportation Research and Special Programs Administration Transportation Systems Center Cambridge MA 02142				10. Work Unit No. (TRAIS) FA078/R0523	
				11. Contract or Grant No.	
12. Sponsoring Agency Name and Address U.S. Department of Transportation Federal Aviation Administration Systems Research and Development Service Washington DC 20591				13. Type of Report and Period Covered INTERIM REPORT MAY 1979 - JULY 1979	
				14. Sponsoring Agency Code	
15. Supplementary Notes					
16. Abstract A test plan is designed to: a) evaluate the performance of several types of LORAN-C receivers in the vicinity of both a large metropolitan and a small rural airport, b) measure the electromagnetic interference in the LORAN-C band (100 ± 50 KHZ) at various locations likely to produce radio noise, and c) determine the amplitude, frequency and modulation of all significant interfering signals in the LORAN-C band using as primary measurement equipment, a calibrated antenna system and a spectrum analyzer.					
17. Key Words ELECTROMAGNETIC INTERFERENCE, LORAN-C NAVIGATION			18. Distribution Statement DOCUMENT IS AVAILABLE TO THE PUBLIC THROUGH THE NATIONAL TECHNICAL INFORMATION SERVICE, SPRINGFIELD, VIRGINIA 22161		
19. Security Classif. (of this report) UNCLASSIFIED		20. Security Classif. (of this page) UNCLASSIFIED		21. No. of Pages 28	22. Price

PREFACE

The measurement techniques described in this report are designed to contribute significant data for assessing the operational performance of the LORAN-C system in aviation related environments. The data to be collected from the described experiments will complement results appearing in a prior report entitled "The Effects of Primary Power Transmission Lines on the Performance of LORAN-C Receivers in Experimental Terrestrial Applications," Report No. DOT-TSC-RSPA-79-8.

METRIC CONVERSION FACTORS

Approximate Conversions to Metric Measures

Symbol	When You Know	Multiply by	To Find	Symbol
LENGTH				
in	inches	2.5	centimeters	cm
ft	feet	30	centimeters	cm
yd	yards	0.9	meters	m
mi	miles	1.6	kilometers	km
AREA				
in ²	square inches	6.5	square centimeters	cm ²
ft ²	square feet	0.09	square meters	m ²
yd ²	square yards	0.8	square meters	m ²
mi ²	square miles	2.6	square kilometers	km ²
	acres	0.4	hectares	ha
MASS (weight)				
oz	ounces	28	grams	g
lb	pounds	0.45	kilograms	kg
	short tons (2000 lb)	0.9	tonnes	t
VOLUME				
tsp	teaspoons	5	milliliters	ml
Tbsp	tablespoons	15	milliliters	ml
fl oz	fluid ounces	30	milliliters	ml
c	cups	0.24	liters	l
pt	pints	0.47	liters	l
qt	quarts	0.95	liters	l
gal	gallons	3.8	liters	l
ft ³	cubic feet	0.03	cubic meters	m ³
yd ³	cubic yards	0.76	cubic meters	m ³
TEMPERATURE (exact)				
°F	Fahrenheit temperature	5/9 (after subtracting 32)	Celsius temperature	°C

Approximate Conversions from Metric Measures

Symbol	When You Know	Multiply by	To Find	Symbol
LENGTH				
mm	millimeters	0.04	inches	in
cm	centimeters	0.4	inches	in
m	meters	3.3	feet	ft
km	kilometers	1.1	yards	yd
		0.6	miles	mi
AREA				
cm ²	square centimeters	0.16	square inches	in ²
m ²	square meters	1.2	square yards	yd ²
km ²	square kilometers	0.4	square miles	mi ²
ha	hectares (10,000 m ²)	2.5	acres	
MASS (weight)				
g	grams	0.035	ounces	oz
kg	kilograms	2.2	pounds	lb
t	tonnes (1000 kg)	1.1	short tons	
VOLUME				
ml	milliliters	0.03	fluid ounces	fl oz
l	liters	2.1	pints	pt
l	liters	1.06	quarts	qt
l	liters	0.26	gallons	gal
m ³	cubic meters	35	cubic feet	ft ³
m ³	cubic meters	1.3	cubic yards	yd ³
TEMPERATURE (exact)				
°C	Celsius temperature	9/5 (then add 32)	Fahrenheit temperature	°F

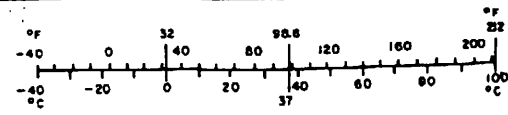

A.T.

TABLE OF CONTENTS

<u>Section</u>	<u>Page</u>
1. INTRODUCTION.....	1
2. TEST OBJECTIVES.....	2
2.1 General.....	2
2.2 Detailed Test Objectives.....	2
3. TEST PLAN.....	3
3.1 Electromagnetic Interference (EMI) at Airports.....	3
3.2 Site Selection.....	3
3.3 LORAN-C Mobile Laboratory.....	7
Data Acquisition.....	10
3.4 Test Procedures.....	14
4. DATA ANALYSIS AND TEST RESULTS.....	22
4.1 General	19
4.2 Analysis of Specific Measured Items.....	19
5. SCHEDULE.....	23

LIST OF ILLUSTRATIONS

<u>Figure</u>	<u>Page</u>
1. LOCATION OF SELECTED SITES AT LOGAN AIRPORT.....	5
2. LOCATION OF SELECTED SITES AT BURLINGTON AIRPORT.	6
3. DOT/TSC MOBILE LORAN-C LABORATORY.....	8
4. FUNCTIONAL BLOCK DIAGRAM OF DOT/TSC MOBILE LORAN-C TEST FACILITY.....	9
5. LORAN EXPERIMENT DATA.....	11
6. FUNCTIONAL BLOCK DIAGRAM OF DATA ACQUISITION SYSTEM.....	12

1. INTRODUCTION

The LORAN-C system of navigation is currently receiving greater attention for civil aviation applications because of a) the requirement of offshore operators to have navigation systems available as they perform their low-level operations from 150 to 200 nautical miles offshore; and b) the increase in coverage area of LORAN-C since it was selected as the navigation system for U.S. Coastal Confluence Zone. With the new LORAN-C chains being installed, LORAN-C will become available in a high percentage of the U.S. airspace. For these reasons, the Federal Aviation Administration (FAA) has initiated a program to evaluate the signal characteristics of LORAN-C in various aviation-related situations. The agency will evaluate new navigation systems to meet future requirements for air navigation.

Although the LORAN-C system has been in operation for more than 20 years, it has very little history insofar as civil aviation is concerned. Therefore, it must be treated as any new system and the signal characteristics in many operational situations must be considered. This requires additional information about the LORAN-C signal in an interference environment such as that surrounding a well-instrumented airport. The test plan for this evaluation is comprised of three parts.

1. The general and specific test objectives of the test program are defined.

2. The test conditions and the sites as well as the procedures and equipment that will be used to perform the measurements will be described; then the amount and frequency of the interference will be recorded.

3. Finally, the type of graphical data, and the technique which will analyze and compare the data gathered at the two airports will be defined.

2. TEST OBJECTIVES

2.1 GENERAL

Major airports have a large variety of navigation and communication facilities which radiate electromagnetic energy. Airport-related facilities also produce substantial, but often erratic, man-made radio noise. These signals and the noise can adversely affect the performance of sensitive radio receivers. Previous data collected by TSC at Burlington and Barre-Montpelier Airports in Vermont suggests that an investigation at a major airport be conducted to assure that LORAN-C receivers would not be adversely affected. Major airports are usually located outside city environments and they contain more navigation aids and communication systems which are capable of generating Electromagnetic Interference (EMI).

2.2 DETAILED TEST OBJECTIVES

One of the primary areas of investigation is the assessment of the LORAN-C signal quality in the noise and interference environment of typical urban and suburban airport surfaces. The major portion of these tests will consist of measuring and recording LORAN-C signal and LORAN-C receiver performance a) in the proximity of ground communication/navigation facilities and b) in areas surrounding the airports in which high voltage transmission lines are present.

The following objectives will be accomplished by making the measurements described in the test plan.

1. Evaluate the performance of the LORAN-C receivers in the ground environment of an urban and rural airport.
2. Document short and long term variations in reception of LORAN-C signals during the period of the tests.
3. Measure the EMI at both airports to identify, if possible, major interference sources that dominate these environments.

3. TEST PLAN

The procedures of the test plan are designed to assess the performance of LORAN-C receivers in conditions of radio interference and to make measurements of that noise. The U.S. Northeast Coast LORAN-C chain will be used. Its transmitters are located at:

Seneca, New York	Master	
Caribou, Maine	Secondary	X
Nantucket, Massachusetts	Secondary	Y
Carolina Beach, North Carolina	Secondary	Z

3.1 ELECTROMAGNETIC INTERFERENCE (EMI) AT AIRPORTS

The susceptibility of LORAN-C receivers to airport related emissions and noise will be explored at Logan Airport and Burlington Airport. A mobile laboratory containing LORAN-C receivers and other associated instrumentation will be located in the proximity of selected navigation and communication facilities; then the performance of these LORAN-C receivers in the presence of other radio emissions and noise will be measured. Noise measurements will also be made with the TSC mobile LORAN-C Laboratory located at or near several types of airport-related facilities which include:

1. Non-Directional region
2. Compass locator
3. Marker beacons
4. Glideslope (ILS)
5. Localizer (ILS)
6. VOR
7. UHF/VHF Communications
8. Metal hangers and other structures
9. Airport ground traffic

3.2 SITE SELECTION

Several sites at both airports were selected in advance to avoid interfering with normal traffic patterns at the airports.

These sites were both close and far from buildings, terminals, hangars and electronic equipment such as ground surveillance radar, weather sensors, etc.

The layout of Logan International Airport's runways and taxiways is shown in Figure 1. This map is representative of a large metropolitan airport. These seven selected sites were chosen for the following reasons:

Logan Airport

- Site 1 - Outer perimeter road - Bird Island Flats
Selected as the southernmost remote location away from all possible sources of interference.
- Site 2 - In front of the International Terminal
Selected as a close-in site on the north side.
- Site 3 - In front of the North Terminal
Selected as a close-in site on the east side.
- Site 4 - In front of the South Terminal
Selected as the site closest to the busiest terminal.
- Site 5 - At the location of most of the airport electronics, FAA Transmitters.
- Site 6 - Outer perimeter road - easternmost point at the airport start of Runway 33L.
- Site 7 - Outer perimeter road - northernmost point at the airport start of Runway 22L.

Burlington International Airport in Burlington, Vermont was selected as representative of small rural airports. This rather busy airport is one of the largest in its category of rural airports. It was chosen because of its full complement of radio navigation beacons, surveillance radar and communication electronics. The selected sites at this airport (Figure 2) were chosen for the following reasons:

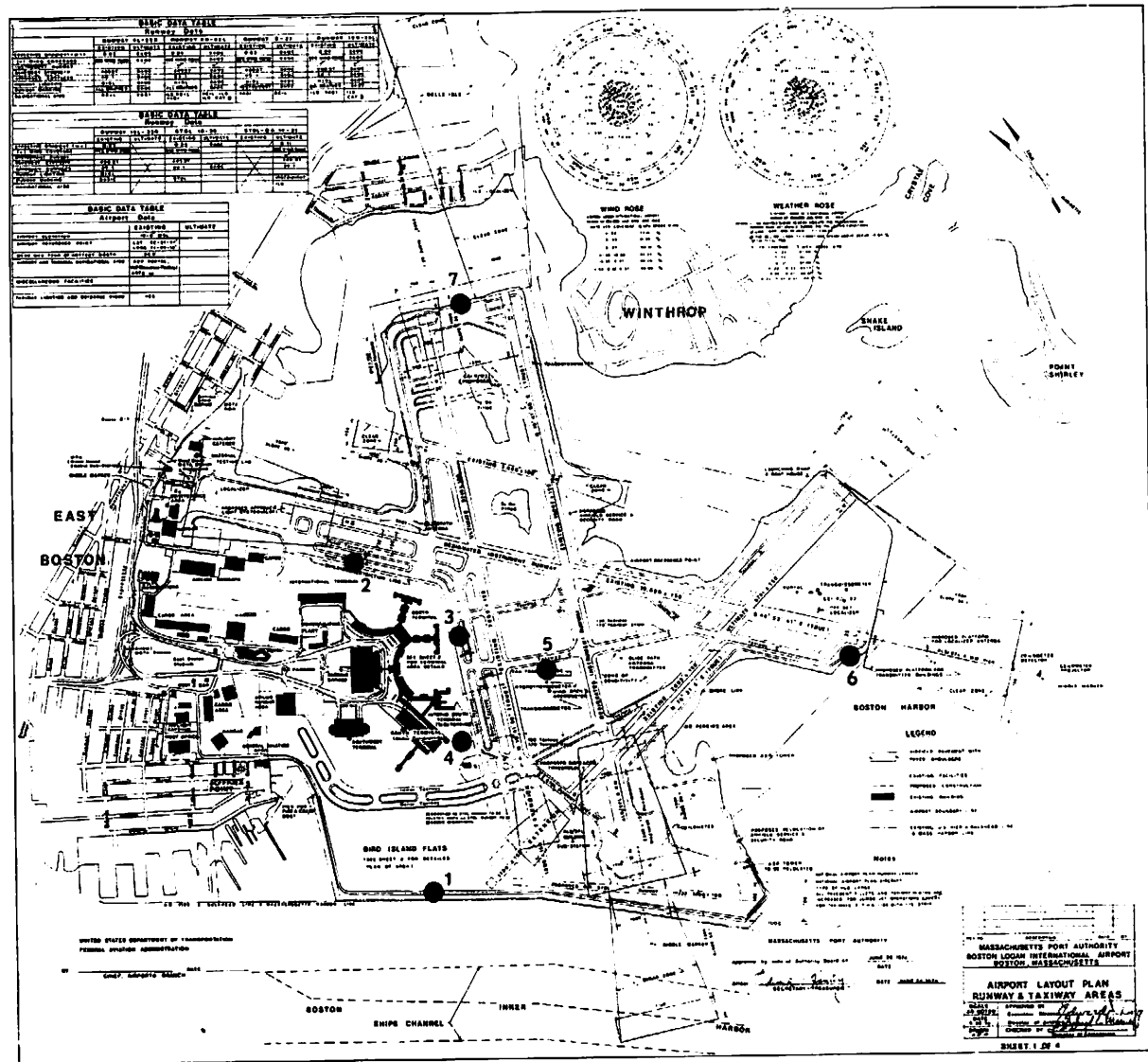
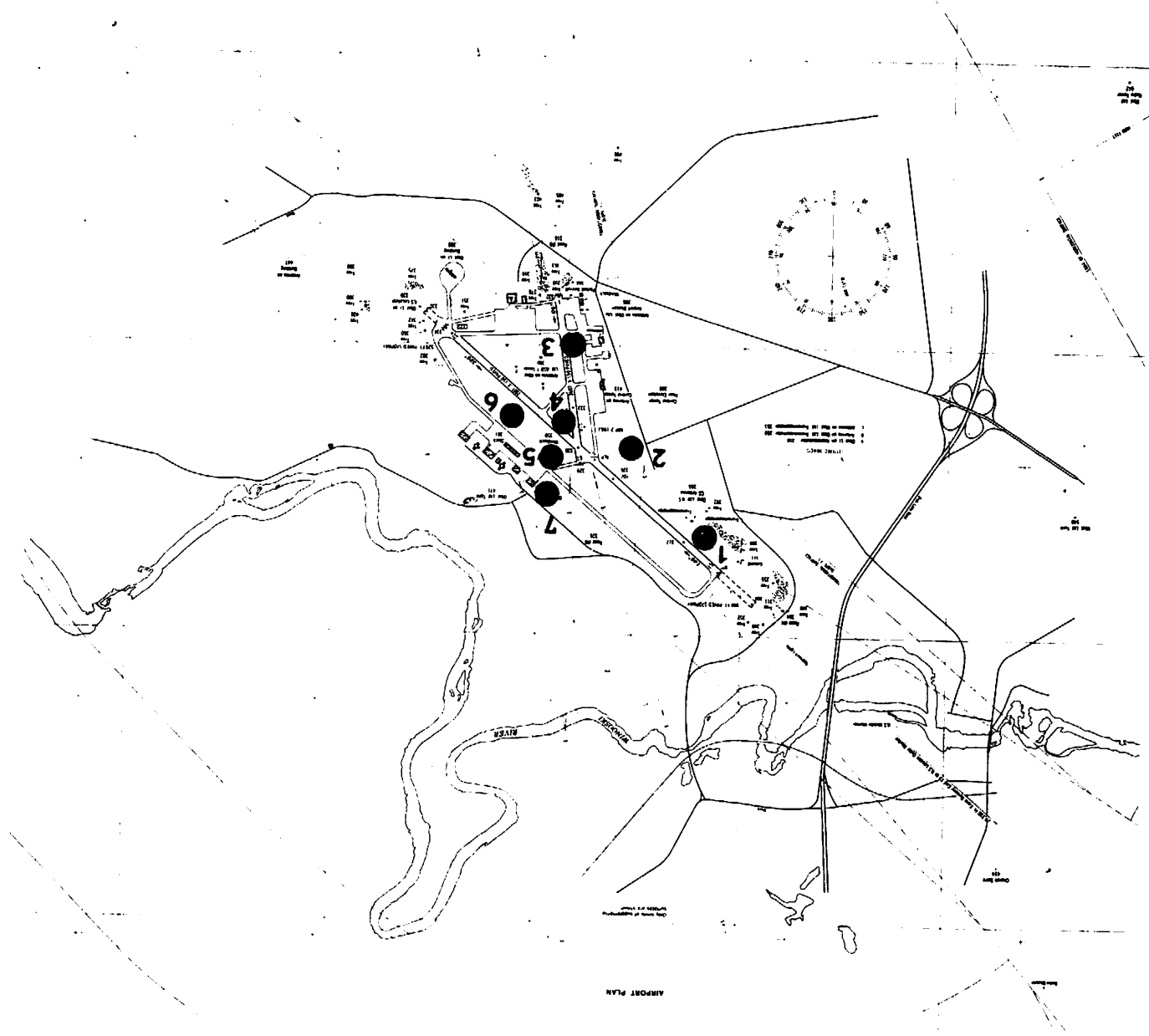

FIGURE 1. LOCATION OF SELECTED SITES AT LOGAN AIRPORT

FIGURE 2. LOCATION OF SELECTED SITES AT BURLINGTON AIRPORT



Burlington Airport

- Site 1 - 1000 meters north of terminal far from any local interference.
- Site 2 - Parking lot adjacent to north side of terminal - close to internal interference sources, such as solenoids and other electrical equipment which generate noise.
- Site 3 - 1000 meters south of terminal in front of Air North terminal.
- Site 4 - Directly in front of terminal on runway.
- Site 5 - 1000 meters from front of terminal on runway.
- Site 6 - Adjacent to the airport surveillance radar.
- Site 7 - Surveyed site southeast corner of airport.

3.3 LORAN-C MOBILE LABORATORY

The mobile LORAN-C Laboratory (Figure 3) was developed to measure LORAN-C parameters recording LORAN-C coordinates, and odometer measured distance while it is driven along a roadway. It contains spectrum analyzers, precise time clocks and other laboratory equipment for measuring noise and radio frequency interference. Figure 4 is a block diagram of the equipment configuration. The experiment is controlled by a Tektronix 4051 Graphic Computing System operating from a real-time BASIC program stored in 30K of RAM. Data are sampled at a four second rate on command from the Micrologic LORAN-C receiver. All data are loaded in parallel (broad side) to a shift register whose length is sufficient to accommodate all sources simultaneously to insure accurate tracking of distance, time and LORAN-C coordinates.

During the 4-second interval between sample commands, the data are formatted into 8-bit bytes and transmitted over the General Purpose Interface Bus to the Tektronix controller where processing and recording are accomplished before the next sample command. The data are also recorded on magnetic tape for further analysis back in the lab. The software allows the operator to control navigation

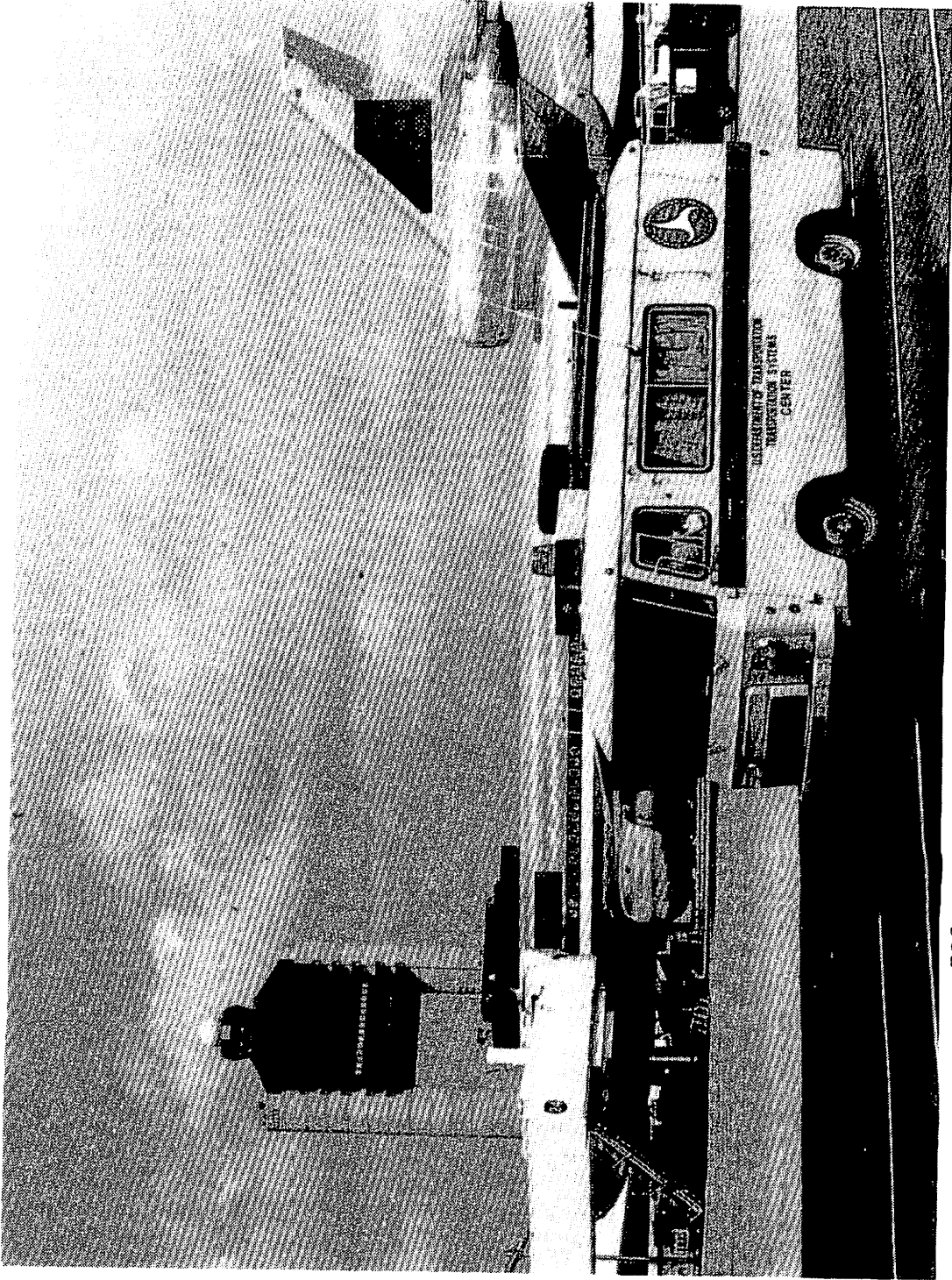

FIGURE 3. DOT/TSC MOBILE LORAN - C LABORATORY

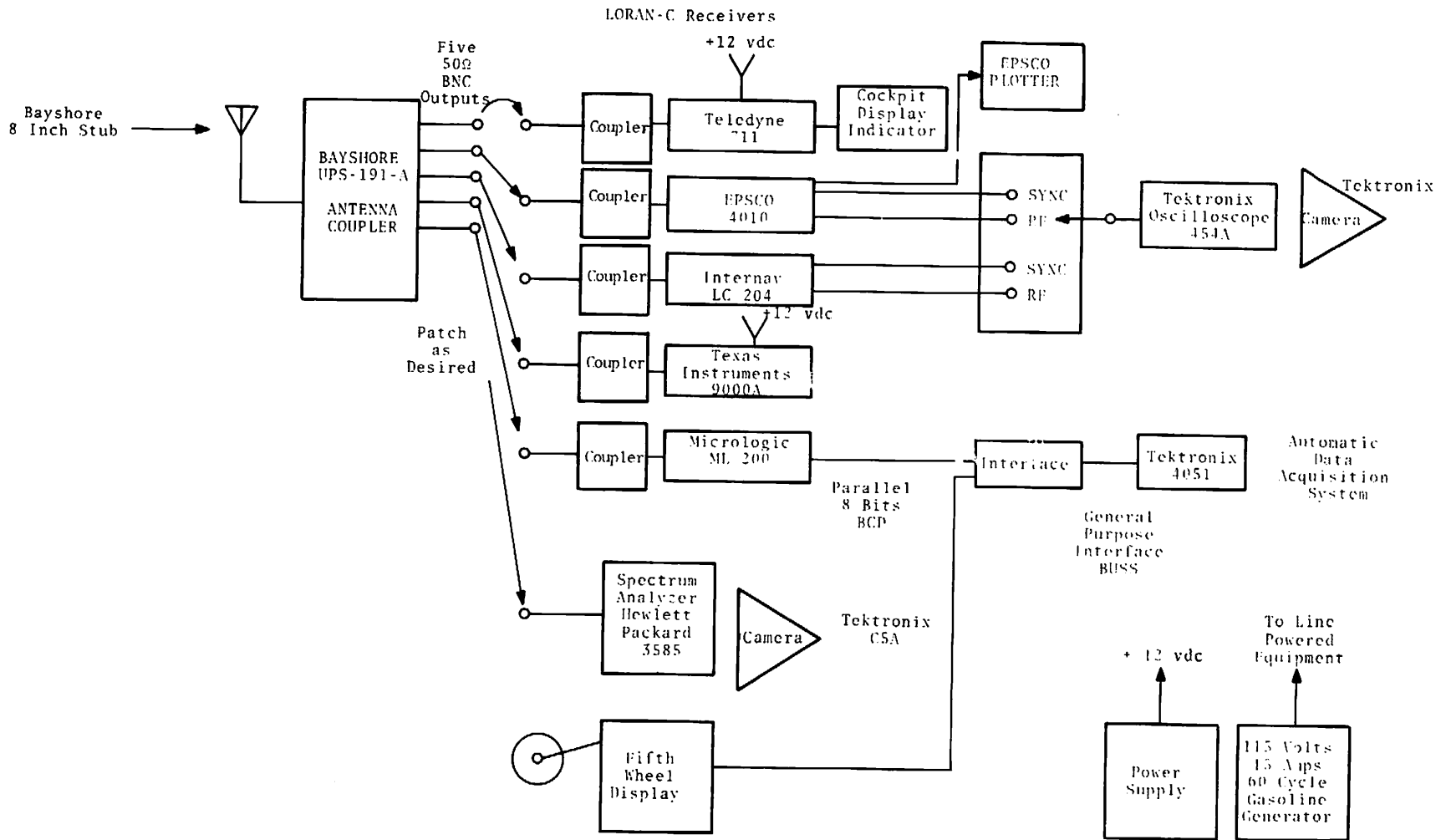

FIGURE 4. FUNCTIONAL BLOCK DIAGRAM OF DOT/TSC MOBILE LORAN-C TEST FACILITY

system mode, data gathering, memory, inspection, and other system functions, all through the User Definable Keys.

Data Acquisition

The New Northeast Coast chain has three operational secondary stations, at Caribou, Maine, Carolina Beach, North Carolina and Nantucket, Massachusetts. The master is located at Seneca, New York. The two secondaries providing the optimum crossing angles, (making Lines of Position (LOP) of each station cross at nearly right angles) in the Boston area are Caribou and Carolina Beach. The secondary transmitter located in Nantucket provides an exceptionally strong signal; however, it is not preferred over those stations which have good crossing angles.

The data can be displayed in tabular form on the screen of the Tektronix controller as shown in Figure 5. This allows monitoring of the results as the experiment progresses. The first two columns are the time difference measurements, in microseconds, between the master station and secondary A (TDA) and secondary B (TDB). Column three will be the odometer measured distance to one-hundredth of a mile. Note that when the vehicle is stationary, this reading is zero. Column four is the odometer readout, in feet. It appears simultaneously on the data printout and on the electronic display of the odometer. Columns labeled Alarm 1 and 2 are status indicators for the LORAN-C receivers being used. A number displayed for every possible operating mode of the receiver, Alarm 1, is associated with TDA, and Alarm 2 with TDB. The number may range from 1 to 128 to indicate the status of the transmitter or receiver equipment. The number 4, for example, indicates that both the transmitters and receivers are operating correctly.

The Tektronix 4051 is supplied with software support programs which enable a complete statistical analysis of the data collected at a fixed location, including mean, variance, standard deviation, skewness, kurtosis, etc.

Figure 6 is a functional block diagram of the Data Acquisition system. Digital, manually recorded, and photographic data will be obtained at both airports. The photographic records of the spectrum

RUN NUMBER 4 <u>TDA</u>	DATE 7/12/78 <u>TDB</u>	<u>MILES</u>	<u>DIST.</u>	<u>ALARM 1</u>	<u>ALARM 2</u>
14041.0	44355.0	0.00	8775	4	4
14040.9	44354.9	0.00	8776	4	4
14040.9	44354.8	0.00	8776	4	4
14040.9	44354.9	0.00	8776	4	4
14040.9	44355.0	0.00	0000	4	4
14040.8	44354.9	0.23	0000	4	4
14040.7	44354.9	0.23	0000	4	4
14040.9	44354.9	0.23	0000	4	4
14040.9	44355.0	0.00	0000	4	4
14041.0	44354.9	0.00	0000	4	4
14041.0	44354.9	0.00	0000	4	4
14040.9	44355.0	0.00	0000	4	4
14040.9	44355.0	0.00	0000	4	4
14040.9	44354.9	0.01	0004	4	4
14040.9	44354.9	0.02	0047	4	4
14041.0	44354.8	0.04	0119	4	4
14041.0	44354.8	0.07	0227	4	4
14041.2	44354.7	0.10	0362	4	4
14041.4	44354.6	0.13	0519	4	4
14041.5	44354.4	0.16	0682	4	4
14041.6	44354.1	0.20	0857	4	4
14041.8	44353.6	0.28	1045	4	4
14042.0	44353.3	0.32	1454	4	4
14042.2	44353.3	0.36	1675	4	4
14042.3	44353.1	0.40	1899	4	4
14042.6	44352.9	0.44	2123	4	4
			2349	4	4

11

FIGURE 5. LORAN EXPERIMENT DATA

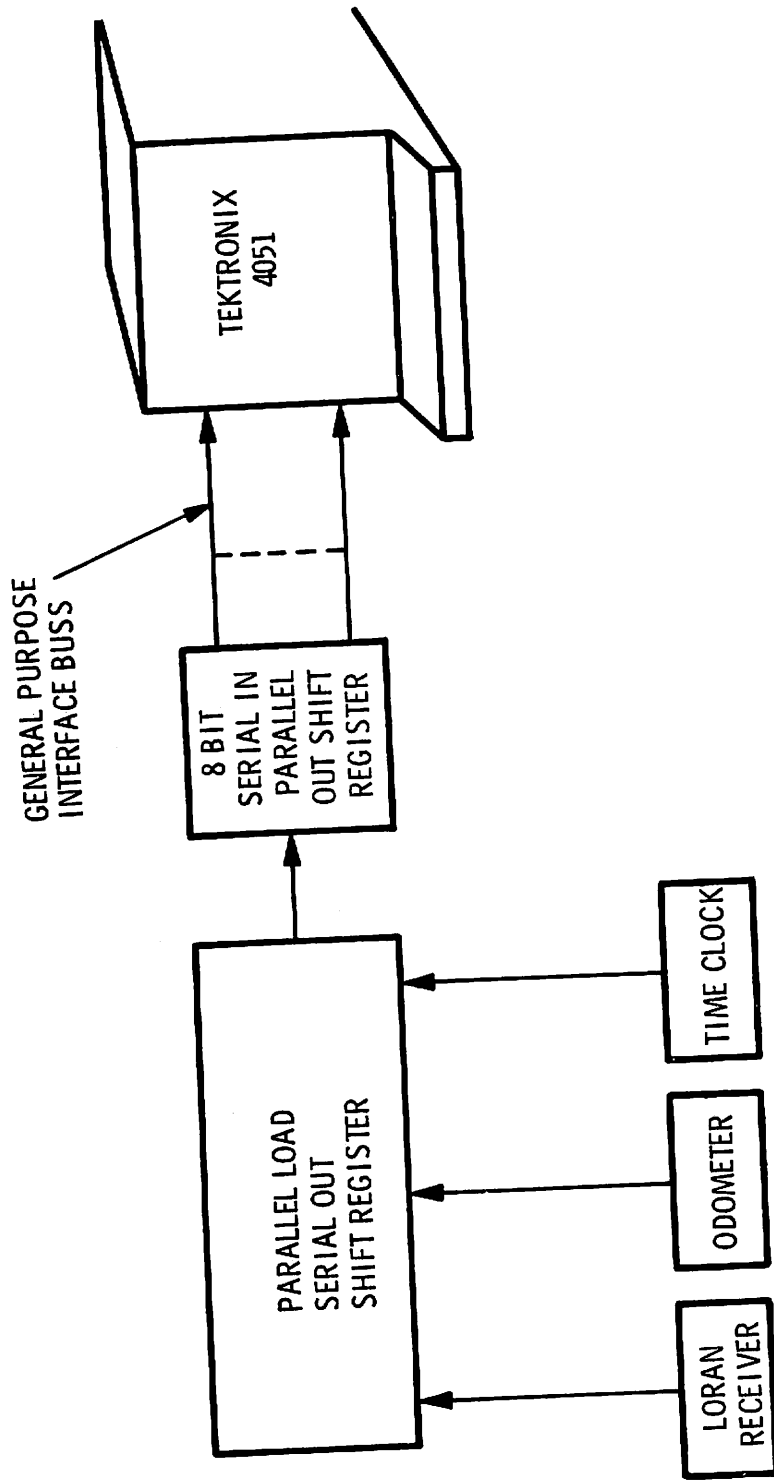

FIGURE 6. FUNCTIONAL BLOCK DIAGRAM OF DATA ACQUISITION SYSTEM

of 100 ± 50 kHz will provide information on the types and magnitudes of the kinds of EMI found at each location. The data will be analyzed for signal-to-noise ratios, signal anomalies, etc. The other data will provide receiver performance position repeatability information so that the accuracy of LORAN-C navigation can be analyzed. Each type is described in the following:

Photographic Data: A Polaroid oscilloscope camera will be used to obtain a photographic record of the spectrum of LORAN-C, EMI and any other radio noise found at each site. Each photograph will contain the following information:

- Date/Time
- Location
- Center Frequency
- Frequency Span
- Sweep Time
- Amplitude Scale Factor
- Resolution Bandwidth
- Video Bandwidth
- Marker Frequency or Display Line Level.

Magnetic Tape: LORAN-C Time-Delay data will be recorded on magnetic tape for subsequent computer processing. The following information will be entered manually into Tektronix 4051 computer system:

1. Date and Time
2. LORAN-C Chain Identification
3. Site Identification

The following data will be recorded from the Micrologic LORAN-C receiver for 20 minutes at each site:

1. Time-Delay Readings
2. Signal-to-Noise Ratio
3. Envelope-to-Cycle Differences.

Manually Recorded Data: Field test personnel will maintain a comprehensive and accurate log of routine and special events observed during all tests. This log will be used to aid both in the analysis of LORAN-C data and in the interpretation of unusual

events. The log will contain the following items of information:

1. Test site location by map reference number
2. Time-delay readings from all five LORAN-C receivers and consecutive readings from the micrologic (see procedures)
3. Notch filter settings (if they require a non-zero setting to assure proper operation, all notch filters will ordinarily be switched out to eliminate an additional operational variable)
4. Receiver mode of operation - Each receiver has an indicator of improper cycle selection and low signal-to noise ratio; these indications will be worded.
5. Ten measurements of acquisition time of two secondaries for each of the time LORAN-C receivers at each test site location, will be made.
6. All incidents of lock loss will be recorded and explained.
7. Explanation for loss of digital data
8. Weather summary reports on daily basis
9. Comments including equipment failures, explanation for van downtimes, observed LORAN-C signal outages, unusual EMI or noise, etc.

3.4 TEST PROCEDURES

Initially, the test sites will be located by choosing a distance close to buildings and hangers. (See map.) These various sites near different sources of noise have been selected in order to identify a significant noise increase when the test vehicle is close to an emitter. Optimum noise-recording sites cannot be determined experimentally because at a busy airport vehicle cruising isn't feasible.

Once the van has stopped within ± 1000 feet of the location indicated on the airport map, that location will be noted by LORAN-C coordinates. This enables repositioning the test facility on subsequent trips with precision equal to the 2drms error of

LORAN-C (i.e., ± 300 feet).

Measurements will consist of monitoring and recording LORAN-C receiver performance when operating in the proximity of major navigation and communications facilities associated with airports. Also, the magnitude and extent of EMI and other radio noise in the LORAN-C spectrum will be documented. Measurements will be made with the van located in the vicinity of hangars, airport structures, power lines and airport activity.

The measurements will be conducted in a manner which will minimize the impact on operations at Logan Airport and Burlington Airport. This will require coordination between the test personnel and the Port Authority of Boston and the control tower at Burlington. A test procedure for EMI measurements and LORAN-C receiver performance measurements is as follows:

1. Turn all van measurement equipment power on and warm up equipment. Set the spectrum analyzer controls as follows:
 - a. Center Frequency - 100 kHz
 - b. Frequency scan width at 100 kHz
 - c. Video bandwidth at 300 Hz
 - d. Sweep time 200 seconds.
2. Connect the spectrum analyzer RF input to the Bayshore antenna coupler and photograph the display.
3. If unusual and unexpected EMI or spurious signals are noted in Step 2, adjust the spectrum analyzer and display controls to maximize the definition of each and re-photograph the display.
4. If EMI or spurious signals are found which might originate from a nearby emitter, coordinate with Logan or FAA personnel to briefly turn off the suspected source and re-photograph the spectrum display.

A caution in this procedure is to minimize emitter downtimes. This will keep disruption of airport operation to an absolute minimum. A few seconds of off-time should be sufficient to identify the impact of an emitter on EMI observations.

Using a communication link (UHF 2-way radio) between an operator of a suspected source of EMI and the LORAN-C mobile test facility, coordinate the timing of on-off operations to conclusively identify the source of interference.

5. Monitor LORAN-C signals and accumulate 20 minutes of receiver data.

The EPSCO 4010, the Internav LC204 and the Texas Instrument 9000 LORAN-C receiver's readings must be recorded manually then monitored for the remaining time. The Micrologic ML-200 has the capability of recording automatically its time-delay, signal-to-noise, envelope-to-cycle delay and tracking mode reading enabling constant consecutive monitoring of these parameters to detect synchronous or near-synchronous interference.

Test set-up arrangements may be somewhat different for each site, and site-related factors are as follows:

Non-Directional Beacon (NDB): Every airport regardless of size, has at least one NDB transmitter. This is a continuous wave transmission at a low frequency, in the band 200 to 400 kHz.

Compass Locator: The compass locator, because of its low-to-medium frequency band (200 kHz to 400 kHz), is considered to be a potential source of EMI which could degrade performance of the LORAN-C receiver (which operated in the 90 kHz to 110 kHz band.) At the present time, only one compass locator operates at Logan Airport. It uses a frequency of 220 kHz, and is located at the outer marker, 4.28 nautical miles (nmi) from the threshold of Runway 33. The compass locator is on private property, suggesting that coordination of access will be required. Since the compass locator and the outer marker beacon are collocated, tests with the marker beacon should be conducted at the same time as the compass locator tests.

It is recommended that the measurement van be located 300 to 500 feet from the compass locator transmitting antenna at any convenient azimuth. The precise location need not be prespecified the precise location must be recorded in the test log.

Marker Beacons: Marker beacons (inner, middle and outer) are located along the final approach to the runways at Logan Airport. The marker beacons operate on a frequency of 75 MHz.

Glideslope: Instrument Landing Systems (ILS) Glidescope transmitters are located approximately east and north of the runway.

The test van should be located along the runway approach course as close as is practical to the glidescope antenna. A distance between the van and the antenna of about 500 feet is recommended.

Localizer (ILS): The localizer (ILS) at Logan Airport is located east of the threshold of runway 27R. The test van should be located as close as is practical to the localizer (approximately 50 feet). (Site 6)

VORTAC: The Logan VORTAC is located at the intersection of the major runways. The test van should be located as close as practical to the VORTAC (approximately 50 feet). (Site 5)

VHF/UHF Communications: The major location with VHF and UHF communications equipment is in the center of the airport. EMI and LORAN-C receiver operation will be checked at Site 5.

Metal Hangers and Other Structures: Metallic structures can reflect electromagnetic signals and shield areas causing signal degradation. Also, operations within buildings may cause unusual forms of EMI. To investigate such effects on LORAN-C reception, a series of measurements near buildings and structures is planned. Structures suitable for the measurements are the Logan hangars located at the tower and the fire stations.

The test van should be located at the following distances from the airport hangar for measurements:

1. 20 feet
2. 250 feet
3. 500 feet.

The test van should be located between 50 to 100 feet from the control tower.

Aircraft Ground Traffic: Aircraft and associated equipment can cause LORAN-C signals to be reflected and disturbed, and can generate EMI. LORAN-C reception and EMI at typical aircraft operating sites will be measured including the following cases:

1. Van located 50 feet from a stationary aircraft with and without engines running.
2. Van located 50 feet from a stationary aircraft operating from an external motor generator.
3. Van located near a taxiway used by aircraft.

4. DATA ANALYSIS AND TEST RESULTS

4.1 GENERAL

Data will be accumulated in two general categories: First, information about the LORAN-C receivers performance at each location will be recorded; second, noise and interference in the LORAN-C bandwidth will be measured.

4.2 ANALYSIS OF SPECIFIC MEASURED ITEMS

The operation of each LORAN-C receiver at each test site and a comparison of the operation of all receivers will be discussed in the final report. In particular, the measured acquisition time for both secondaries for all receivers will allow an evaluation in a quantitative way of:

1. Erratic operation
2. Long acquisition time
3. Failure to acquire

Further, the time delay readings will be compared against the calculated values for surveyed points at each airport. This may reveal the presence of a synchronous interference source by displaying a constant bias error in the time delay value. In addition, the consecutive readings taken at 4 second intervals for a 15-minute period (to be recorded automatically) will make obvious any oscillation in the time delay reading. A slow drifting oscillation of greater than 0.2 microsecond peak amplitude would indicate a near-synchronous interference continuous wave transmission in or near the LORAN-C bandwidth.

Conclusions will be drawn from the recorded receiver performance about the significance and severity of the airport-generated interference in the LORAN-C bandwidth.

Further information about the signal quality may be obtained from the signal-to-noise measurements at test site.

In the second category of measured data, analysis of the

interference and noise measurements will be discussed and examined.

Each of the spectrum photographs will be examined for the presence of unaccounted-for spectral lines in the 100 ± 50 kHz region.

Each spectral line above an experimentally determined threshold will be measured with the internal frequency counter, and a photo will be taken with an expanded sweep having the spike at the center of the screen will be taken. In this fashion, we will attempt to determine the nature, modulation, source, etc., of each of the significant spikes in the vicinity of the LORAN-C frequency allocation.

5. SCHEDULE

The test period is planned for a 2-month period. A single trip to the Burlington, Vermont airport for several days should allow sufficient time to gather an adequate amount of data to describe this environment. Several day trips to Logan International will be made as required. The proximity of Logan enables us to make as many trips as necessary with interspaced days of data analysis to confirm our approach to the experimental technique. The draft of the final report will be available during the first quarter of Fiscal Year 1980.

220 Copies