

COPY 9/2/83

27
134
134
DOT/FAA/CT-82/134

Fire Management/Suppression Systems/Concepts Relating to Aircraft Cabin Fire Safety

K. R. Miniszewski
T. E. Waterman

IIT Research Institute
10 West 35th Street
Chicago, Illinois 60616

J. A. Campbell
F. Salzberg

Gage-Babcock and Associates, Inc.
135 Addison Avenue
Elmhurst, Illinois 60126

October 1983

Final Report

This document is available to the U.S. public
through the National Technical Information
Service, Springfield, Virginia 22161.



U.S. Department of Transportation
Federal Aviation Administration
Technical Center
Atlantic City Airport, N.J. 08405

NOTICE

This document is disseminated under the sponsorship of the Department of Transportation in the interest of information exchange. The United States Government assumes no liability for the contents or use thereof.

The United States Government does not endorse products or manufacturers. Trade or manufacturer's names appear herein solely because they are considered essential to the object of this report.

TECHNICAL REPORT STANDARD TITLE PAGE

1. Report No. DOT/FAA/CT-82/134		2. Government Accession No.		3. Recipient's Catalog No.	
4. Title and Subtitle Fire Management/Suppression Systems/Concepts Relating to Aircraft Cabin Fire Safety				5. Report Date July, 1982	
				6. Performing Organization Code	
7. Author(s) Campbell, J., Salzberg, F., Mniszewski K., and Waterman, T.				8. Performing Organization Report No. J06532/C06554	
9. Performing Organization Name and Address IIT Research Institute Gage Babcock & Assoc. 10 W. 35th Street 135 Addison Chicago, IL 60616 Elmhurst, IL 60126				10. Work Unit No.	
				11. Contract or Grant No. DTFA30-80-C-00092	
12. Sponsoring Agency Name and Address Department of Transportation Federal Aviation Administration Tech. Center Atlantic City, New Jersey 08405				13. Type of Report and Period Covered Final Report 9/26/80 - 2/28/82	
				14. Sponsoring Agency Code	
15. Supplementary Notes					
16. Abstract <p>The purpose of this study was to provide FAA with a comprehensive review of the applicability of fire protection (management/suppression) system (or concepts) to aircraft cabin fire safety. Both "inflight fires" and "post crash" fires were considered by the study. Included in the study were establishment and documentation of the feasibility of each system/concept, determination of costs and benefits for systems judged feasible, and development of test programs to evaluate systems for unknown (undocumented) feasibility.</p> <p>The study included a literature search to document the course and consequences of past accidents, and the degree to which various fire protection concepts had been developed. Fire scenarios were developed from accident histories and engineering analysis, and used to assist in judging the potential of the various systems/concepts examined. The study encompassed fire prevention, detection, confinement, and suppression; handling of combustion products; and escape aids.</p>					
17. Key Words Aircraft, in-flight fires, post-crash fires, fire detection, fire suppression, fire compart- mentation, smoke control, fire barriers, evacuation.			18. Distribution Statement		
19. Security Classif. (of this report) U		20. Security Classif. (of this page) U		21. No. of Pages	22. Price

METRIC CONVERSION FACTORS

Approximate Conversions to Metric Measures

Symbol	When You Know	Multiply by	To Find	Symbol
LENGTH				
	inches	2.5	centimeters	cm
	feet	30	centimeters	cm
	yards	0.9	meters	m
	miles	1.6	kilometers	km
AREA				
	square inches	6.5	square centimeters	cm ²
	square feet	0.09	square meters	m ²
	square yards	0.8	square meters	m ²
	square miles	2.6	square kilometers	km ²
	acres	0.4	hectares	ha
MASS (weight)				
	ounces	28	grams	g
	pounds	0.45	kilograms	kg
	short tons (2000 lb)	0.9	tonnes	t
VOLUME				
	teaspoons	5	milliliters	ml
	tablespoons	16	milliliters	ml
	fluid ounces	30	milliliters	ml
	cups	0.24	liters	l
	pints	0.47	liters	l
	quarts	0.95	liters	l
	gallons	3.8	liters	l
	cubic feet	0.03	cubic meters	m ³
	cubic yards	0.76	cubic meters	m ³
TEMPERATURE (exact)				
	Fahrenheit temperature	5/9 (after subtracting 32)	Celsius temperature	°C

1 in = 2.54 exactly. For other exact conversions and more detailed tables, see NBS Misc. Publ. 286, Units of Weights and Measures, Price \$2.25, SD Catalog No. C13.10:286.

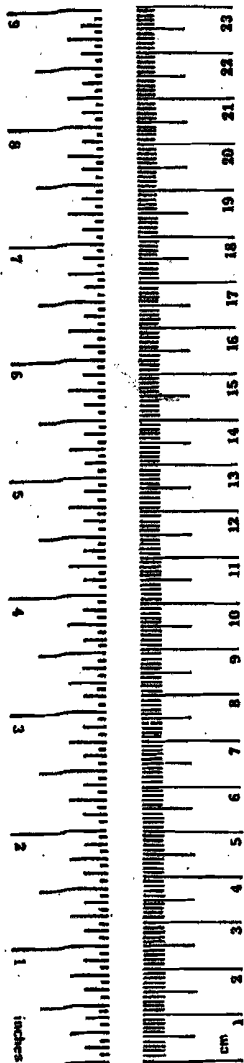

Approximate Conversions from Metric Measures

Symbol	When You Know	Multiply by	To Find	Symbol
LENGTH				
mm	millimeters	0.04	inches	in
cm	centimeters	0.4	inches	in
m	meters	3.3	feet	ft
m	meters	1.1	yards	yd
km	kilometers	0.6	miles	mi
AREA				
cm ²	square centimeters	0.16	square inches	in ²
m ²	square meters	1.2	square yards	yd ²
km ²	square kilometers	0.4	square miles	mi ²
ha	hectares (10,000 m ²)	2.5	acres	
MASS (weight)				
g	grams	0.035	ounces	oz
kg	kilograms	2.2	pounds	lb
t	tonnes (1000 kg)	1.1	short tons	
VOLUME				
ml	milliliters	0.03	fluid ounces	fl oz
l	liters	2.1	pints	pt
l	liters	1.06	quarts	qt
l	liters	0.26	gallons	gal
m ³	cubic meters	35	cubic feet	ft ³
m ³	cubic meters	1.3	cubic yards	yd ³
TEMPERATURE (exact)				
°C	Celsius temperature	9/5 (then add 32)	Fahrenheit temperature	°F

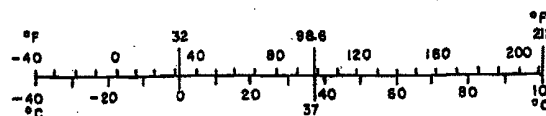

FOREWORD

This document was prepared by IIT Research Institute (IITRI) and Gage-Babcock and Associates, Inc. (GBA) as the final report on the program entitled, "Fire Management/Suppression Systems/Concepts Relating to Aircraft Cabin Fire Safety." The work was performed for the Federal Aviation Administration Technical Center under Contract DTFA03-80-C-00092 (IITRI Project J06532). The authors are indebted to Mr. R. G. Hill and Mr. G. B. Geyer, the FAA Contract Officer's Technical Representatives, for their guidance during the course of the program.

Contractor personnel and consultants who contributed to the program include C. Bandemer, A. Hauser, E. Kaminski, and B. Silvis of IITRI; and G.T. Dahl (consultant), W. Backes, J. Behn, and J. Gruettner of GBA.

Respectfully submitted,

IIT RESEARCH INSTITUTE



T. E. Waterman
Engineering Adviser
Fire and Explosion Research

Approved by



M. J. Klein
Vice President
Research Operations

EXECUTIVE SUMMARY

The purpose of this study is to provide the FAA with a comprehensive review of the applicability of fire protection (management/suppression) systems (or concepts) to aircraft cabin fire safety. Both in-flight and post-crash fires are considered by the study. The feasibility of each system or concept, is established and documented, the costs and benefits of systems judged feasible are determined, and test programs to evaluate systems of unknown (undocumented) feasibility are developed.

The study includes a literature search to document the course and consequences of past accidents and the degree to which various fire protection concepts have been developed. Fire scenarios are developed from accident histories and engineering analysis and are used to assist in judging the potential of the various systems examined. The study encompasses fire prevention, detection, confinement, and suppression; handling of combustion products; and escape aids.

The literature gathered during the course of the program was organized by author and by keywords drawn from each document title, and was delivered to the Contract Monitor under separate cover. The reviewed literature and engineering calculations provide the basis for developing a series of aircraft fire scenarios. These are organized first by location of fire origin and then by materials first ignited. The rate and direction of fire growth is estimated for each scenario.

Suppression of aircraft cabin fires is considered using water, water and AFFF, Halon 1301, and Halon 1211. System designs are developed for use in the open cabin, and spot protection systems are described for lavatories and carry-on storage areas. Heat detectors are recommended for activating suppression.

Early warning fire detection is described and a system developed by other investigators is suggested with modifications. Recommended system characteristics include dual generic (ion-photoelectric), pumped sensors with variable gating and sensitivity to provide reliability under the wide range of operating environments encountered.

Smoke control for in-flight fires is directed toward smoke containment accompanied by rapid fire suppression, followed by smoke removal. Smoke control in the post-crash fire scenario is defined as ineffective unless coupled to adequate fire compartmentation.

The primary concerns of thermal hardening in the post-crash fire involve the integrity of the fuselage envelope (skin, windows, exitways, etc.). However, since fuselage fractures or inadvertently opened doors as well as post-crash fires of internal origin can directly affect the cabin, means of enhancing cabin compartmentation and adding protection for overhead spaces are described. Emergency barriers are considered as a means of back-up

protection. The status of developments in interior finish and furnishings are reviewed and their possible limitations noted.

Rapid exiting is considered to be of equal value to delayed fire development, and various means are described to enhance ease of evacuation. Promising devices and techniques include improved (radiation-resistant) escape slides, passenger face masks/hoods, improved evacuation markers, improved crew protection, and improved passenger preparedness.

All systems and concepts reviewed during the program are summarized. The feasibility of each system is identified for fires of in-flight, ramp, or post-crash origin. Brief explanatory remarks are presented and primary references listed.

All systems require some design and testing before being incorporated into new or existing aircraft. Research and testing directed toward establishing system or concept feasibility falls into three general areas for which work scopes are developed and costs estimated:

- On-board suppression
- Compartmentation
- Cabin materials.

Costs are developed using detailed estimating procedures for suppression systems applied to both narrow and wide-body aircraft. These costs are contrasted to costs of comparably sized industrial systems and components to provide cost multipliers with which to translate costs of other industrial systems to aircraft use.

The benefits of systems use are described in terms of potential reduction in lives lost, injuries sustained, and airframe damage from records of past accidents. Loss of revenue was not included since the size of the affected airline strongly influenced the magnitude of this loss. Historically, major losses have occurred in post-crash or emergency landing fires; these were therefore selected as a basis for benefits analysis. Each past accident was reviewed and subjective judgments were made on the effectiveness of the various systems.

Cost/benefit ratios derived in the above-described manner are not absolute, but offer a relative ranking of concepts. Their value is severely restricted by the limited number of incidents upon which to base benefits, and by the subjective nature of the benefits analysis.

On the basis of cost/benefit ratio, the more promising concepts are those related to escape aids. These items also appear to be developed to the point of near-term implementation. Recent improvements in windows and frames are expected to enhance the fire resistance of the fuselage envelope. Attention is drawn to emergency barriers and preassessment of external fire conditions before opening exitways. Cabin compartmentation coupled with on-board suppression appear necessary if the effects of the post-crash fire with fractured fuselage are to be ameliorated.

On-board suppression is found effective for fires of cabin origin, but unattractive at this time because of poor post-crash fire performance in the laboratory. Proper compartmentation could modify this conclusion. Early warning detection appears more cost effective.

In summary, no one concept is found to provide ideal protection; a proper blend of systems will be required to extract the maximum fire protection at reasonable cost.

TABLE OF CONTENTS

	Page
Foreword.....	ii
Executive Summary.....	iii
1. INTRODUCTION.....	1
2. SCENARIO DEFINITION.....	3
2.1 Post-Crash Fires.....	3
2.1.1 Origins of Post-Crash Fires.....	3
2.1.2 External Fire Characterization in Post-Crash Scenarios.....	5
2.1.3 Penetration of Fuselage by Exterior Fires.....	6
2.1.3.1 Skin Melt-Through Times.....	6
2.1.3.2 Fuselage Insulation.....	13
2.1.3.3 Cabin Wall Panels.....	18
2.1.4 Window Penetration.....	19
2.1.5 Open Doors and Fractured Fuselages.....	19
2.1.6 Emergency Evacuation.....	20
2.1.6.1 Environment Related Factors.....	21
2.1.6.2 Machine Related Factors.....	21
2.1.6.3 Man Related Factors.....	22
2.1.6.4 Post-Crash Impact Characterization.....	22
2.2 In-Flight Fires Inside Aircraft.....	23
2.2.1 Origins of Fires Within Aircraft.....	24
2.2.1.1 Flight Station.....	24
2.2.1.2 Cabin.....	25
2.2.1.3 Food Service/Galley.....	27
2.2.1.4 Lavatory.....	28
2.2.1.5 Cargo Compartment.....	28
2.2.1.6 Attic.....	29
2.2.1.7 Landing Gear Wells.....	29
2.2.1.8 Electrical and Avionic Service Centers.....	29
2.2.2 In-Cabin Fire Characterization.....	29
2.2.2.1 Smoke Density and Visibility.....	30
2.2.2.2 Smoke Production.....	31
2.2.2.3 Smoke Movement.....	34
2.2.2.4 Toxic Gases.....	35
2.2.2.5 Temperatures.....	37
2.3 Summary of Fire Scenarios.....	41

TABLE OF CONTENTS (continued)

	Page
3. SYSTEM FEASIBILITY.....	45
3.1 Priorities of Need.....	45
3.1.1 In-Flight Fires.....	45
3.1.2 Post-Crash Fires.....	46
3.1.3 Synopsis.....	46
3.2 Suppression-Oriented Cabin Fire Management.....	47
3.2.1 Suppression Agents.....	49
3.2.2 Suppression System Actuation.....	50
3.2.3 Automatic Sprinkler Cabin Protection.....	51
3.2.3.1 Background.....	51
3.2.3.2 Sprinkler Operation.....	52
3.2.3.3 Aircraft Cabin Sprinklers.....	52
3.2.4 Zoned Waterspray System.....	60
3.2.5 Halon 1301 Total Flooding Protection.....	64
3.2.5.1 General Criteria.....	64
3.2.5.2 Typical Design Concepts.....	67
3.2.5.3 Safety Considerations.....	70
3.2.5.4 System Effectiveness.....	70
3.2.6 Halon 1211 Surface Application.....	73
3.2.7 Spot Protection.....	80
3.2.8 Cabin Depressurization.....	82
3.2.9 Early Warning Fire Detection.....	84
3.2.9.1 Background.....	85
3.2.9.2 Previous System Design.....	88
3.2.9.3 Suggested Modifications.....	88
3.3 Smoke Control.....	88
3.3.1 In-Flight Fires.....	88
3.3.1.1 Decrease of Smoke Production.....	89
3.3.1.2 Containment of Smoke.....	89
3.3.1.3 Venting of Smoke.....	91
3.3.2 Post-Crash Fires.....	92
3.4 Thermal Hardening.....	93
3.4.1 External Envelope.....	93
3.4.1.1 Thermal Insulation.....	93
3.4.1.2 Interior Panels.....	94
3.4.1.3 Windows.....	94
3.4.1.4 Doors.....	95
3.4.1.5 Emergency Barriers.....	95

TABLE OF CONTENTS (continued)

	Page
3.4.2 Interior.....	96
3.4.2.1 Fire Compartmentation.....	96
3.4.2.2 Interior Finish and Furnishings.....	97
3.4.2.3 Upper Cabin.....	98
3.5 Emergency Evacuation Assistance.....	98
3.5.1 Mechanical Escape Devices.....	99
3.5.2 Personal Protective Devices.....	100
3.5.3 Evacuation Markers.....	101
3.6 Summary of Systems and Feasibility Determinations.....	101
4. RESEARCH/TEST PROGRAMS.....	107
4.1 Program Number 1--Performance of On-Board Suppression Systems in Post-Crash Fires.....	107
4.2 Program Number 2--Compartmentation.....	108
4.3 Program Number 3--Cabin Materials.....	110
5. COST/BENEFIT ANALYSES.....	111
5.1 Cost Analyses.....	112
5.2 Historical Benefit Analysis.....	113
5.3 Cost/Benefit Results.....	114
6. CONCLUSIONS AND RECOMMENDATIONS.....	125
 References.....	 127
Appendix A. Aircraft Fire Incidents (U.S. Air Carriers)	
Appendix B. Cost Estimates for Suppression Systems	

LIST OF ILLUSTRATIONS

Figure		Page
1	Skin Heat Transfer Model.....	7
2	Aluminum Skin Temperature with the Inside Surface Losing Heat to a Constant 80°F Environment.....	9
3	Aluminum Skin Temperature with the Inside Surface Perfectly Insulated.....	10
4	Effect of Flame Temperature on Skin Melt-Through Time.....	11
5	Temperature of 0.100 in. Thick Aluminum Skin Heated by Radiation Only (No Contact with Flames).....	12
6	Effect of Heat Fluxes on the Melt-Through Time of the Aluminum Skin.....	13
7a	Temperature Distribution of the Skin Insulation Assembly: Insulation 1-in. Thick, Aluminum Skin 0.016-in. Thick.....	14
7b	Temperature Distribution of the Skin Insulation Assembly: Insulation 1-in. Thick, Aluminum Skin 0.060-in. Thick.....	15
7c	Temperature Distribution of the Skin Insulation Assembly: Insulation 1-in. Thick, Aluminum Skin 0.100-in. Thick.....	16
8	Temperature Distribution of the Skin Insulation Assembly: Insulation 2-in. Thick, Aluminum Skin 0.060 in. Thick.....	17
9	Typical Interior Cabin Panel.....	18
10	Concentration of Carbon Monoxide in a Wide-Body Aircraft Due to an Interior Liquid Fuel Fire.....	36
11	Air Temperature Rise in a Wide-Body Cabin Due to an Interior Liquid Fuel Fire.....	38
12	Air Temperature Rise in a 1000 ft ³ Compartment Due to a 3 x 3 ft Interior Liquid Fuel Fire.....	40
13	Layout of Automatic Sprinkler on Typical Narrow-Body Jet Transport.....	54
14	Schematic of Automatic Sprinklers on Typical Narrow-Body Jet Transport.....	55
15	Water Supply and Installation Details for Automatic Sprinkler Systems for Jet Transports.....	56
16	Layout of an Automatic Sprinkler on a Typical Wide-Body Jet Transport.....	57
17	Schematic of an Automatic Sprinkler on a Typical Wide-Body Jet Transport.....	58

LIST OF ILLUSTRATIONS (continued)

Figure		Page
18	Layout of Zoned Water Spray System on a Typical Narrow-Body Jet Transport.....	61
19	Schematic of Zoned Water Spray System on a Typical Narrow-Body Jet Transport.....	62
20	Electrical Schematic of Water Spray System.....	63
21	Layout of Zoned Water Spray System on a Typical Wide-Body Jet Transport.....	65
22	Schematic of a Zoned Water Spray System on a Typical Wide-Body Jet Transport.....	66
23	Layout of a Halon 1301 System on Narrow-Body Transport.....	68
24	Halon 1301 Total Flooding in a Narrow-Body Jet.....	69
25	Layout of Halon 1301 Suppression System Nozzle and Tubing on a Wide-Body Transport.....	71
26	Schematic of the Nozzle and Tubing of a Halon 1301 Suppression System in a Wide-Body Transport.....	72
27	Nozzle Layout for a Halon 1211 Spray System on a Typical Narrow-Body Jet Transport.....	74
28	Schematic of a Halon 1211 Spray System on a Typical Narrow-Body Jet Transport.....	75
29	Typical Halon 1211 Supply and Installation Details.....	76
30	Nozzle Layout for Halon 1211 Spray System on a Typical Wide-Body Jet Transport.....	78
31	Schematic of a Halon 1211 Spray System on a Typical Wide-Body Jet Transport.....	79
32	Spot Fire Protection Systems for Lavatories and "Hang-up" Storage Compartments.....	81
33	Panel Display--Fire Management System for Wide-Body Jet Transport.....	87

LIST OF TABLES

Table	Page
1 Composition of State-of-the-Art Cabin Panels.....	19
2 Air Entrainment Rates for Different Size Fires.....	33
3 Typical Volumes and Ventilation in a Wide-Body Aircraft.....	34
4 Estimated Minimum Time for Human Collapse Due to Exposure to Calm Heated Air in Enclosed Space.....	41
5 Aircraft Fire Scenarios Originating in the Cabin Proper.....	42
6 Materials First Ignited in Fire Scenarios in the Cabin Proper.....	43
7 Aircraft Fire Scenarios Originating Outside the Cabin Proper.....	44
8 Summary of Suppression System Characteristics.....	48
9 Spot Protection System Specifications.....	82
10 Hypoxia Effects Versus Altitude.....	83
11 Summary of Cabin Related Fire Suppression Systems/Concepts.....	102
12 Subjective Assignment (0-5) of Suppression.....	103
13 Summary of Early Warning Fire Detection Concepts.....	103
14 Detector Deployment in Wide-Body Aircraft.....	104
15 Summary of Cabin Smoke Protection Concepts.....	105
16 Summary of Fire Hardening of Fuselage Envelope Against Post-Crash External Fire.....	105
17 Summary of Fire Hardening of Cabin and Adjacent Compartments.....	106
18 Summary of Evacuation Assistance Concepts.....	106
19 Forty Accidents Representative of U.S. Carrier Crashes/Fires.....	116
20 Estimated Impact of Various Fire Management/Suppression Concepts on Recent U.S. Air Carrier Accidents--Suppression Systems.....	118
21 Estimated Impact of Various Fire Management/Suppression Concepts on U.S. Air Carrier Accidents--Fire Hardening.....	119
22 Estimated Impact of Various Fire Management/Suppression Concepts on U.S. Air Carrier Accidents--Smoke Protection.....	121
23 Estimated Impact of Various Fire Management/Suppression Concepts on U.S. Air Carrier Accidents--Evacuation Assistance.....	122
24 Summary of Cost Benefit Analysis.....	123

1
2
3
4
5
6
7
8
9
10
11
12
13
14
15
16
17
18
19
20
21
22
23
24
25
26
27
28
29
30
31
32
33
34
35
36
37
38
39
40
41
42
43
44
45
46
47
48
49
50
51
52
53
54
55
56
57
58
59
60
61
62
63
64
65
66
67
68
69
70
71
72
73
74
75
76
77
78
79
80
81
82
83
84
85
86
87
88
89
90
91
92
93
94
95
96
97
98
99
100

1. INTRODUCTION.

Despite aviation's enviable safety record, aircraft accidents do occur, and the Federal Aviation Administration (FAA) is ever seeking to improve aviation safety. Among the areas requiring scrutiny is the loss of life of passengers and crew due to fire.

Historically, the impact-survivable post-crash fire, which can occur during approach, take-off, or landing, produces fire deaths.¹ In-flight fires have occasionally produced fatalities (France, 1973; Saudi Arabia, 1980). In U.S. air space, however, the last fatalities caused by in-flight aircraft cabin fire occurred during the 1964 crash of a Viscount near Parrottsville, Tennessee. Ramp fires generally involve empty aircraft with little incidence of injury or death.

In the light of this experience, past efforts to reduce human loss have rightly addressed the post-crash fire. Activities have centered on the development of airport crash-fire rescue services, control of fuel ignition (flash point, misting), and control of aircraft cabin materials. A variety of studies have investigated on-board active fire control and passive measures, but these have not received the attention or the coordination of use and application given ground fire control, fuel, and cabin materials. Yet these on-board measures might favorably affect the expected injury and loss of life in post-crash fires as well as provide added protection from in-flight or ramp fires.

Since the depth of previous studies of on-board fire control, as well as the implementation of their results, have been very fragmented, it is appropriate to review and critique past efforts before any extensive research efforts or aircraft modification are begun. The objective of this program was to provide the FAA with a comprehensive review of the state of the art of all fire protection (management, suppression) systems (or system concepts) and their applicability to aircraft cabin safety under in-flight or post-crash fire conditions.

This review was supported by a literature search that identified, collected, and catalogued previous studies, experiments, analyses, designs, and experience applicable to the promotion of aircraft cabin fire safety. Included were items developed for other applications, but interpretable for aircraft purposes. To provide for ready reference to all documents gathered for the study, each was entered into an IITRI PRILIB (private library) system. Hard copy output was generated to permit accession by author, accession number, assigned keywords, and KWIC (keyword in context).^{*} One set of this output was provided to the FAA's Contracting Officer's Technical Representative under separate cover.

* An alphabetical listing of all titles, by every keyword (all but prepositions and conjunctions) appearing in each title.

The various fire protection systems or concepts had to be judged in context, that is, in scenarios representing realistic in-flight or post-crash fires in order to assess their benefits (effectiveness) properly. In Chapter 2, these scenarios are characterized on the basis of experience and analysis and by analytical description of the development of various fire products.

The systems and concepts identified during the literature review are described in Chapter 3, where the feasibility of applying them to in-flight, ramp, and post-crash fires is discussed. Chapter 4 provides program descriptions and estimates of the effort required to establish the feasibility of those systems having unknown feasibility but significant potential benefit. (All systems are assumed to require large-scale design validation experiments before being adapted to existing or future aircraft.)

To the degree possible, the cost of implementing each feasible system is established in Chapter 5. The application of feasible systems to new aircraft and system retrofit into the existing fleet are both considered. System benefits (reduced losses) against post-crash fires* as well as benefit/cost ratios were developed on the basis of accident records. Cost levels were also provided for conceptual systems of unknown feasibility but significant potential benefit, in terms of both research costs and implementation costs.

In Chapter 6, we recommend the order in which feasible systems should be implemented, based on apparent benefit/cost ratio and on cost.

* Insufficient data preclude a similar treatment of in-flight fires. Indeed, the infrequency and variety of post-crash fires limits the credibility of statistically based conclusions.

2. SCENARIO DEFINITION.

Any effort directed toward providing effective fire protection, whether active or passive, is predicated on an understanding of the expected fire scenarios. In the case of aircraft, the variety of configurations, both exterior and interior, the amount and distribution of combustible content, and the wide range of location and intensity of ignition sources can create a myriad of fire situations.

By itself, this is nothing new to the fire protection engineer, who faces similar problems with ordinary structural fires. Two elements, however, are unique to aircraft cabin fire protection. First, a very rapid and intense fire can develop around a crash-landed aircraft. The fire protection must maintain a living environment within the cabin sufficiently long to permit passengers to leave the plane on their own or for ground-based crash-fire rescue teams to arrive and suppress the fire or assist in evacuating passengers. Corresponding fire scenarios must therefore describe the characteristics of the external fire and its effect on the fuselage.

Secondly, in-flight confinement of passengers requires very rapid suppression and/or containment of incipient fires. This makes the initial stages of fire development very critical. Scenarios describing in-flight fires must therefore provide information on the time-related behavior of the materials involved as a function of the ignition source.

For completeness, consideration should be given the scenarios of ramp fires. Assuming that aircraft are unoccupied, these can be treated as an extension of certain in-flight cases to longer periods of fire development.

2.1 POST-CRASH FIRES.

2.1.1 Origins of Post-Crash Fires.

Post-crash fires generally originate in one of six ways (several of these can occur concurrently):

- (1) From release of fuel caused by wing separation during impact-survivable accidents
- (2) From release of fuel from damaged fuel tanks or fuel lines during impact-survivable accidents
- (3) From fuel tank explosions caused by external heating and other ignition sources during crash conditions
- (4) From ignition of materials in the cabin under crash conditions
- (5) Propulsion system fires
- (6) Landing gear system fires.

Wing separation incidents occur when an aircraft either undershoots an approach or fails to remain airborne during takeoff. The aircraft then collides with structures, separating a wing and releasing large quantities of fuel.

The fire characteristics of this scenario depend on the manner in which fuel is released. Fuel can be released either during impact or during ground deceleration at the point where a wing or wings have been severed. The air shear forces imparted to the fuel cause the small fuel droplets to form a mist that is readily ignited by sparks, contact with hot engine, etc. A fuel mist fire can ignite fuel spilled from tanks to form a pool fire, and eventually envelope an entire aircraft in flames.

Fuel tank or fuel line damage occurs in accidents during takeoff and landing as a result of impact with obstacles or of landing gear rupturing the tank during an impact. This damage is usually associated with less severe crash forces than those required to sever a wing, but both may occur in the same accident. This localized damage to fuel tanks or lines can result in effects ranging from release of no fuel from empty tanks to a disastrous liquid pool fire very similar to that caused by wing separation incidents.

Fuel tank explosions that occur during impact-survivable accidents are usually caused by external fires fed by fuel released from severed tanks and lines. There have also been cases of in-flight tank explosions resulting from lightning strikes and hot engine disintegrations.

An external fire can heat the fuel in a tank thereby increasing the fuel vapor pressure. Usually this pressure is relieved by a local tank or connection failure. However, occasionally the pressure increases until an overpressure rupture of the entire tank occurs. This type of rupture is more likely with bladder type fuel tanks than with the common integral tanks. If such a rupture occurs, a significant portion of the released superheated fuel vaporizes; the vapor and entrained mist can burn rapidly producing a large fireball.

Under certain combinations of fuel and temperature a flammable vapor-air mixture will be present in a tank and may be ignited by the external fire at the tank vent. This produces flames that can propagate through the vent system into the fuel tanks. Such explosions can greatly expand the pool fire and impede rescue operations.

Scenarios involving the **ignition of the materials of the cabin interior** and the contribution of the internal fire to the overall post-crash scenario offer a particularly severe compounding of effects. In this case, the influence of burning interior materials on survivability and evacuation is synergistically related to the extent of structural damage, impact injuries, crew/passenger evacuation efficiency, day/night conditions, etc. Little accident data are available to assist the development of this scenario; however, full-scale tests have shown that a relatively small fire of interior materials can quickly fill an entire cabin with a dense black smoke.

Propulsion system fires usually involve leakage of a combustible fluid in the engine compartment and result in ignition of the fluid by contact with hot engine surfaces. Bleed air duct failure can also ignite flammable materials, as can internal engine failure due to rapid fire propagation involving materials of

construction such as magnesium. These engine fire scenarios can lead to secondary fires involving fuel spills if not brought under control quickly.

Landing gear hydraulic fluid fires have been caused by dragging brakes, wheel failures, blown tires, leaks, and collapsed landing gear after a hard landing. Burning hydraulic fluids can lead to burning tires, burning wires, melting of aluminum lines, and can ignite spilled pools of fuel.

2.1.2 External Fire Characterization in Post-Crash Scenarios.

Any abnormal landing of an aircraft may produce a large fuel spill. Post-crash fires frequently take place since ignition sources are usually present. These fires present the most serious threat to occupants in a survivable aircraft accident. For this and other reasons, aircraft fuel fires have been the subject of numerous studies. Of particular interest here is the radiation field produced by the fire and its effect on the exposed fuselage.

Many parameters determine the development and subsequent intensity of the radiation field. During the transient phase, ignition occurs and flames spread over the fuel surface. The development and duration of this initial phase is determined by the type of fuel and to some extent the environmental conditions. Fuel with high flash point, such as Jet-A, may need as much as several minutes for the flame to cover the entire fuel surface. This time can be reduced by fuel misting or by wind spreading the ignited vapors. On the other hand, aircraft fuels with relatively low flash points, such as JP-4, may require only a few seconds for the flame to spread over their surface, and this time is little influenced by common prevailing winds. The ultimate radiation field produced by the fire can also be affected by the type of fuel, the amount and size of the spill, the substrate of the spill, the prevailing wind, and even by the presence of the aircraft within the boundary of burning fuel. Fortunately, only a few of the variables play a significant role and some may cancel the effects of others. For example, deep spills sometimes encountered with crashed aircraft can lessen and even entirely negate the effect of the substrate.

Alger and Capener studied the importance of various variables on fire characteristics.² Their most significant conclusion was that the radiation field produced by controlled and apparently similar fires was variable. This and other available evidence clearly suggest a simple but realistic model for describing the radiation field produced by post-crash fires. Other researchers reached similar conclusions in their treatment of post-crash aircraft fires.^{3,4}

Basically, the radiation field from a liquid fuel fire can be specified by four parameters: (1) the flame temperature, (2) the flame emissivity, (3) the size of the convective column, and (4) its configuration. The most severe case, posing the greatest threat to life, occurs when the fuselage is either partially or fully located within the boundary of the fire. When the fuselage is outside the fire area, this threat decreases rapidly with distance since the level of radiation intensity is, approximately, inversely proportional to the square of the distance from the fire.

Conditions producing the most severe heating of the crashed aircraft are of major interest to this study. Under those conditions, because of the closeness of the flames to the heated surfaces, the radiant fluxes impinging on the fuselage depend

only on the temperature and emissivity of the flames. For the purpose of calculations, we assumed that an average fire has flame temperatures⁵ of 1500° to 1700°F and an emissivity² of 1. Under these conditions, the heat fluxes impinging on the fuselage are 7.1 to 10.5 Btu/sec-ft². Although local conditions such as firewhirls can substantially increase the heat output⁴ and values as high as 19 Btu/sec-ft² have been reported,^{4,6} 8 to 9 Btu/sec-ft² is most frequently used to describe the radiant heat output from liquid fuel fires.³

2.1.3 Penetration of Fuselage by Exterior Fires.

Any fire protection system for crashed aircraft must be predicated on the assumption that the evacuation of passengers may take place before, during, or after fire suppression activities. The circumstances of abnormal landings, however, often delay ground-based fire suppression and evacuation efforts, thus any means of extending the time by which passengers can still safely leave the plane considerably increases their chances of survival. The presence of excessive combustion products and/or air temperature can destroy a habitable environment within any part of the cabin. It is therefore critical to know why and when events occur in order to evaluate the fire vulnerability of crashed aircraft.

The post-crash external spill fire attacks all possible avenues to the cabin interior through: (1) direct penetration of the fuselage, insulation, and cabin liner, (2) flame radiation or fire penetration of windows, (3) flame passage and/or flame radiation through inadvertently opened doors, and (4) flame passage and/or flame radiation through fractures resulting from the crash. As mentioned earlier, a wide variety of interior ignition and fuel sources may cause fire as a result of a crash. These ignition/fuel combinations are potential in-flight fire sources as well and will be addressed from the in-flight standpoint.

The effect of an external fire on the cabin environment, in addition to its severity, depends on: (1) the material and thickness of the fuselage skin, (2) the thickness and type of fuselage insulation, and (3) the material and configuration of the cabin wall panels. Although all act together, much can be learned by studying these three fire barriers individually. We therefore conducted a theoretical analysis in conjunction with available experimental data. Following the actual chronology of events, melt-through times of the skin were determined first.

2.1.3.1 Skin Melt-Through Times.

In our theoretical analysis, we assumed a constant fire output, even though the fire may require a short time to reach its full intensity. We also assumed that the skin was aluminum 0.016 in. to 0.100 in. thick and the inside surface was either partially or fully insulated. Calculations were performed assuming one-dimensional heat transfer and no temperature gradient through the skin. Both assumptions are quite appropriate considering the large dimensions of the surfaces involved and the high thermal conductivity of the aluminum. A check of the uniformity of the temperature of a 0.100-in. thick skin showed no discernible gradient within the material.

The heat transfer model of the skin and the nomenclature were as follows:

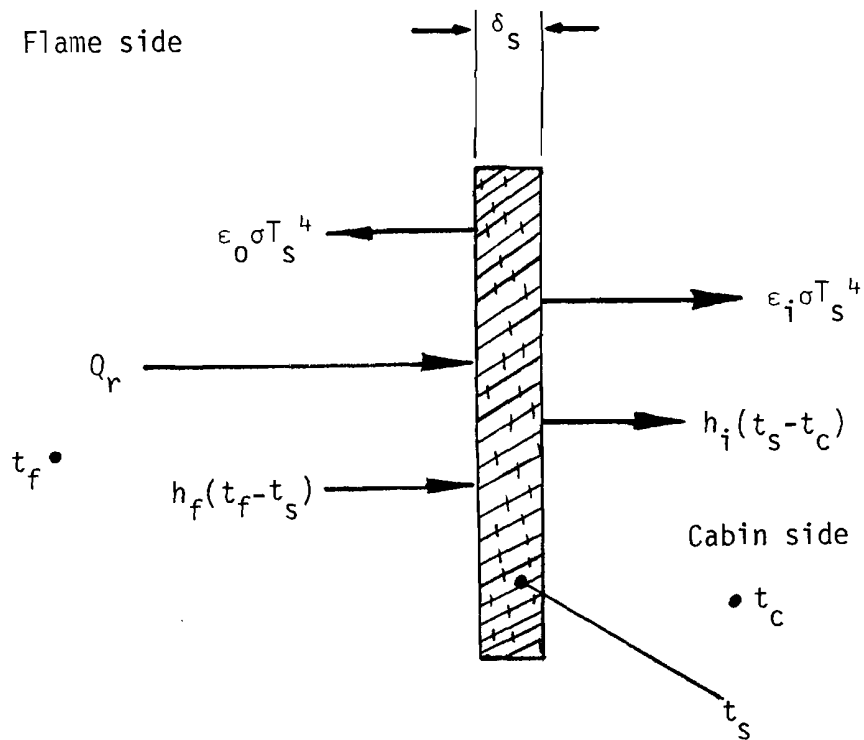

FIGURE 1. SKIN HEAT TRANSFER MODEL.

- where
- ρ_s = density of the skin, lb/ft³
 - c_s = specific heat of the skin, Btu/lb°F
 - h_f = the heat transfer coefficient between the skin and flames, Btu/hr-ft² °F
 - h_i = the heat transfer coefficient on the cabin side, Btu/hr-ft² °F
 - Q_r = radiative heat input from the fire, Btu/hr-ft²
 - t_c = the cabin temperature, °F
 - t_f = the flame temperature, °F
 - t_s = the skin temperature, °F
 - T_s = the absolute skin temperature, °R
 - δ_s = the thickness of the skin, ft
 - ϵ_f = the emissivity of flames
 - ϵ_i = the emissivity of skin radiative heat loss--cabin side
 - ϵ_o = the emissivity of skin radiative heat loss--flame side
 - σ = Stephan-Boltzman constant, 0.174×10^{-8} Btu/hr-ft² °R⁴
 - τ = time, hr

From Figure 1, the heat balance on the aluminum skin is:

$$\rho_s c_s \delta_s \frac{dt_s}{d\tau} = Q_r + h_f (t_f - t_s) - \epsilon_o \sigma T_s^4 - \epsilon_i \delta T_s^4 - h_i (t_s - t_c) \quad (1)$$

In the above equation the left term represents the net heat gained by the aluminum skin. It represents the difference between the amount of heat entering and leaving the skin material, assuming that no melting of the aluminum is taking place. Because the melting process absorbs some part of the heat input, it must be accounted for by modifying Equation 1. For this purpose, we used a relationship proposed by Geyer.³ It assumes that the heat, q_m , required to melt a layer of the skin is inversely proportional to the range of melting temperatures of the aluminum alloy comprising the skin material. Thus,

$$q_m = \frac{\rho_s \delta_s \Delta H_f}{(t_E - t_B)} \frac{dt_s}{d\tau} \quad (2)$$

where ΔH_f = the heat of fusion (Btu/lb)

t_B = temperature of the skin at the start of melting, 900°F

t_E = temperature of the skin at the end of melting, 1200°F

Introducing Equation 2 into Equation 1 gives:

$$\left[\rho_s c_s \delta_s + \frac{\rho_s \delta_s \Delta H_f}{(t_E - t_B)} \right] \frac{dt_s}{d\tau} = Q_r + h_f (t_f - t_s) - \epsilon_o \sigma T_s^4 - \epsilon_i \sigma T_s^4 - h_i (t_s - t_c) \quad (3)$$

When the aluminum skin of the fuselage begins to melt, some of it may flow down or even be removed in solid pieces by the turbulence of the convective column.³ The latter will depend on the homogeneity of the alloy, the uniformity of heating, the geometrical configuration, and possibly several other factors. Although there is insufficient information to predict the mode of skin removal accurately, this process has been accounted for in our calculations. We assumed that the onset of melting produced a continuous reduction of skin thickness directly proportional to its temperature, i.e.:

$$\delta_s = \delta_{s,0} \frac{t_s - t_B}{t_E - t_B} \quad (t_s > t_B) \quad (4)$$

where $\delta_{s,0}$ is the initial thickness of the skin.

Temperatures within the aluminum skin were determined from Equation 3 using the standard method of relaxation for solving heat transfer problems. To evaluate the effect of pertinent parameters, we performed calculations over a range of input values. Melt-through times for an inside skin surface exposed to a constant 80°F environment are shown in Figure 2 and for a perfectly

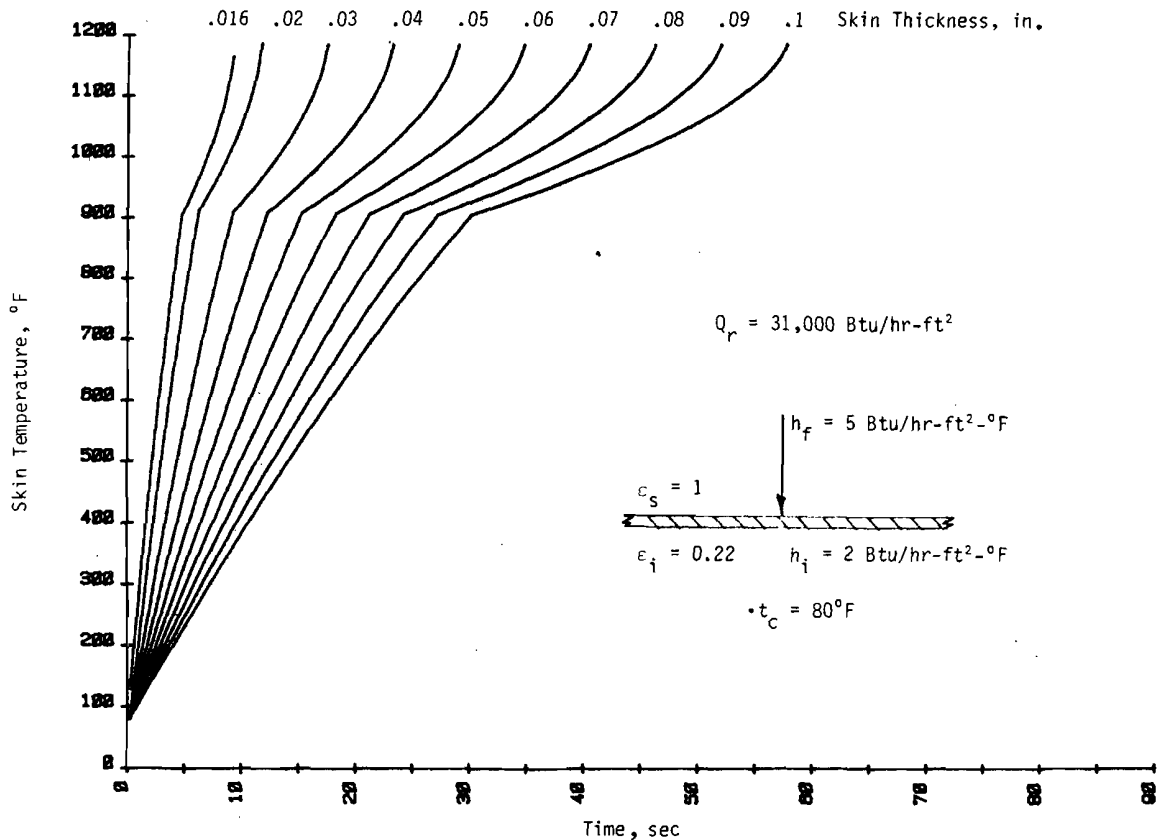

FIGURE 2. ALUMINUM SKIN TEMPERATURE WITH THE INSIDE SURFACE LOSING HEAT TO A CONSTANT 80°F ENVIRONMENT

insulated skin in Figure 3. Because the two cases differ only by a few seconds, the effects of various other parameters on skin temperature were evaluated, assuming that the inside skin surface is perfectly insulated. Although this may produce somewhat shorter melt-through times, these results are well within the overall accuracy of the problem at hand.

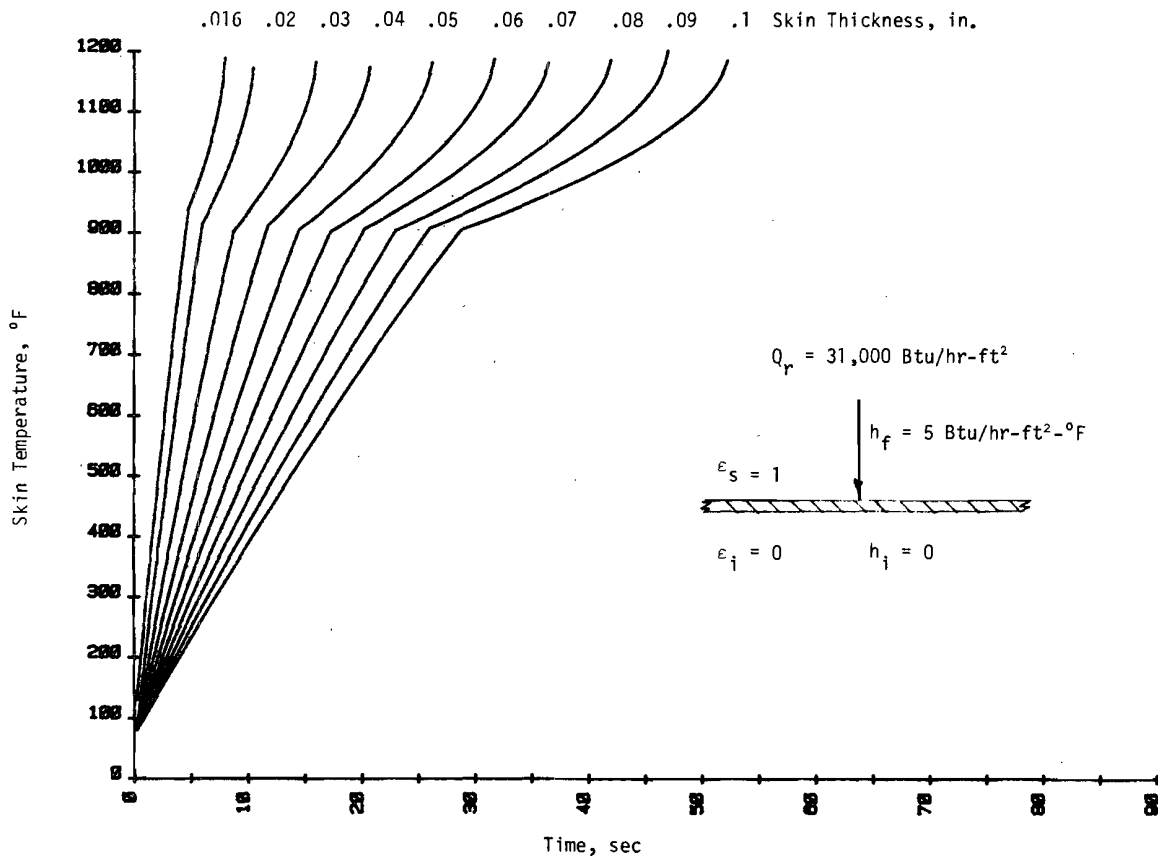

FIGURE 3. ALUMINUM SKIN TEMPERATURE WITH THE INSIDE SURFACE PERFECTLY INSULATED.

The effect of the flame temperatures on the melt-through times is shown in Figure 4. In these cases we assumed flame temperatures to determine the radiant fluxes to the skin ($Q_r = \epsilon_f \sigma T_f^4$). As can be readily noted, the drop of the flame temperature from 2100° to 1500°F extends the melt-through time only about 10 sec for the 0.016-in. thick skin. Even for the 0.100-in. thickness this difference is less than 50 sec. Thus for an aircraft engulfed in a fire, the variation in normally encountered flame temperatures will not materially affect the melt-through times.

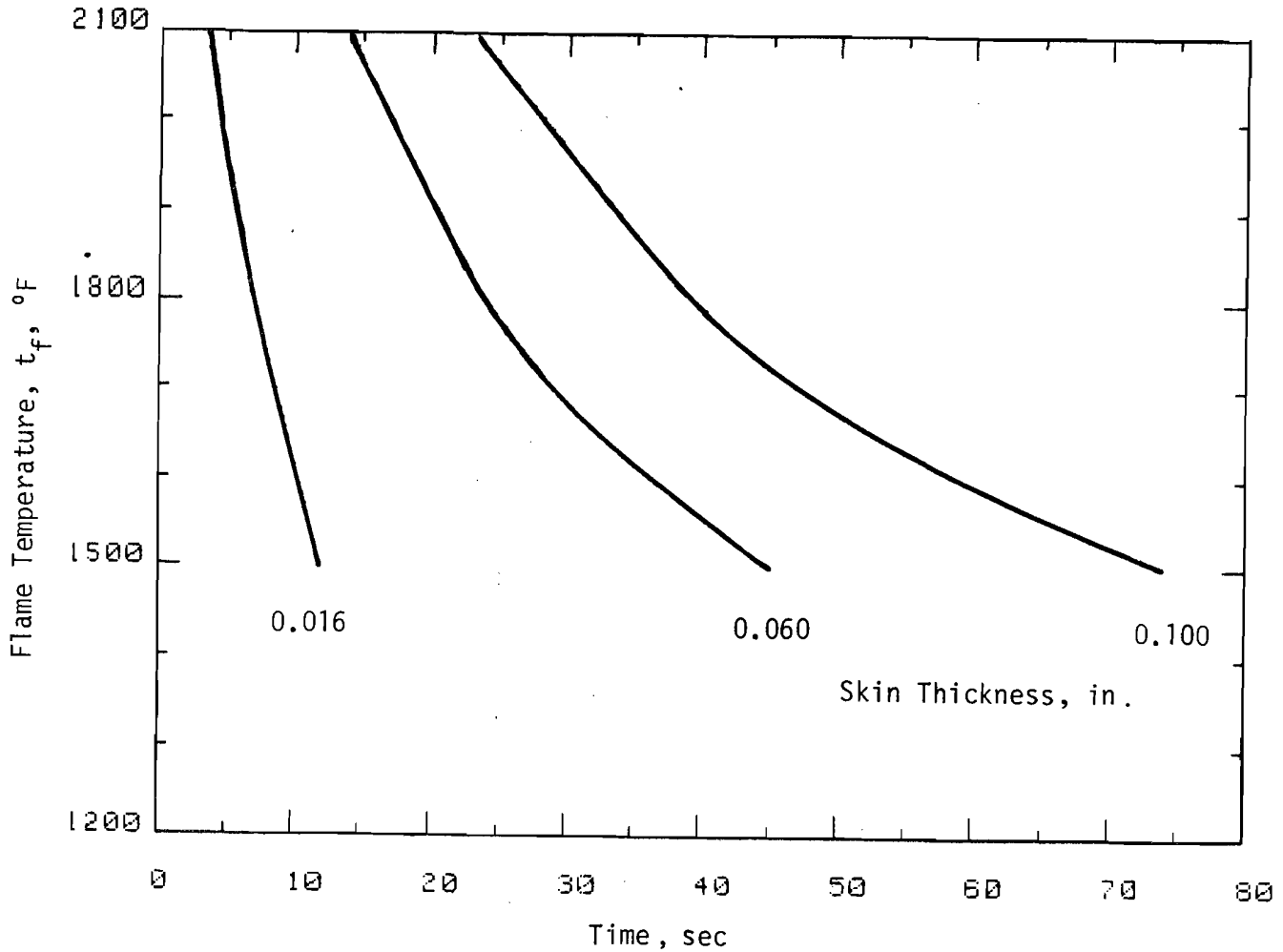
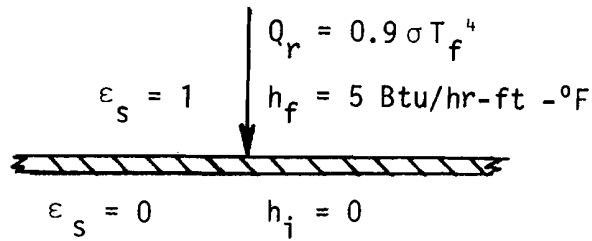

FIGURE 4. EFFECT OF FLAME TEMPERATURE ON SKIN MELT-THROUGH TIME.

Depending on the position of the fuselage relative to the convective column, radiant fluxes impinging on the fuselage can vary. Figure 5 shows the skin temperatures of 0.10-in. thick fuselage located outside the fire and receiving fractions of 31,000 Btu/hr-ft² radiant flux. We assumed that no convective heating of the fuselage was taking place. The results show the heat flux must drop 40 percent in order to add an additional minute to the melt-through time.

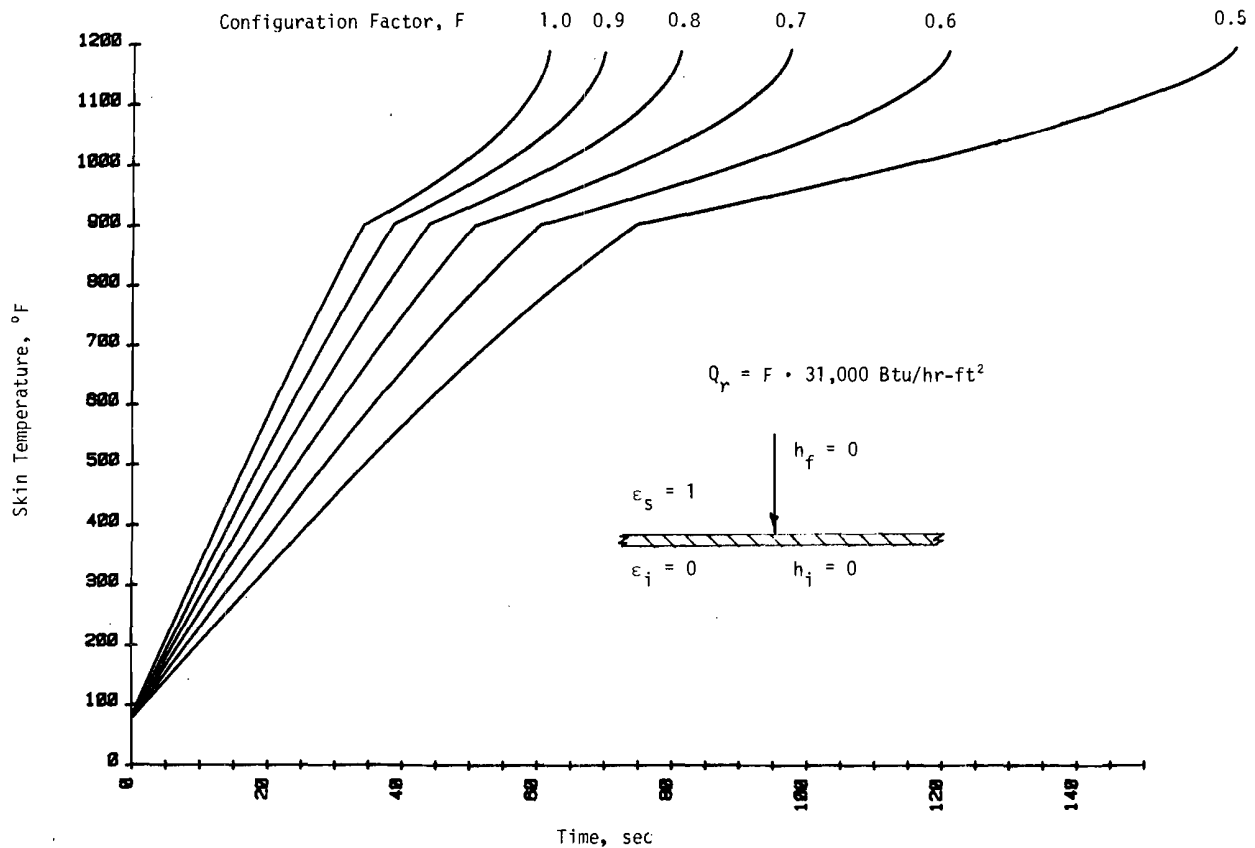

FIGURE 5. TEMPERATURE OF 0.100 IN. THICK ALUMINUM SKIN HEATED BY RADIATION ONLY (NO CONTACT WITH FLAMES).

Melt-through times for a fuselage inside the fire as a function of the heat fluxes are shown in Figure 6. As expected, the effects of changing radiant flux become more pronounced as the skin thickness increases.

A review of generated skin temperatures shows that for thicknesses up to 0.060 in., the melt-through times range from 10 to 80 sec depending on the variation of the fire parameters. Thus, when an aircraft lies fully or partially within the fire perimeter, the aluminum skin only protects the fuselage against the thermal effect of the fire for a very short time. Similar results were obtained by Geyer³ from exposures of full-scale aircraft sections to JP-4 fires. Therefore, the survival time of passengers within a crashed aircraft in a flaming environment will depend to a considerable degree on the fire resistance offered by the skin insulation and cabin walls.

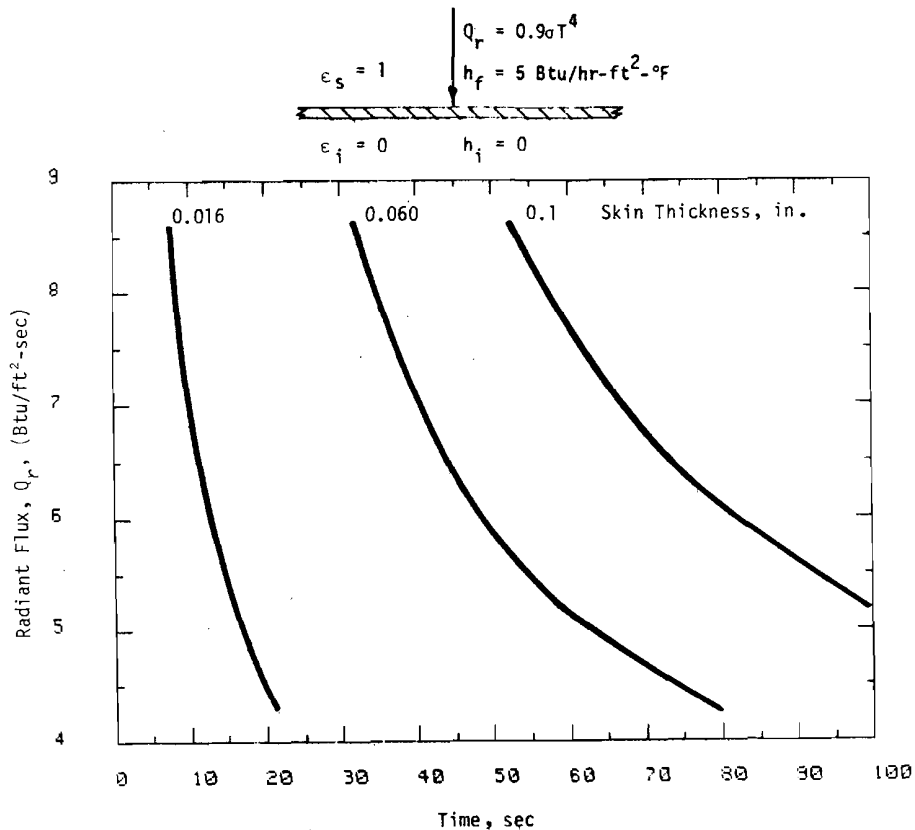

FIGURE 6. EFFECT OF HEAT FLUXES ON THE MELT-THROUGH TIME OF THE ALUMINUM SKIN.

2.1.3.2 Fuselage Insulation.

The normal function of current glass fiber fuselage insulation is to maintain acceptable noise and temperature levels within the aircraft cabin. Although not specifically designed for this purpose, skin insulation can provide valuable protection against post-crash fires, as will be seen from our analysis of temperature distribution within high temperature insulating material exposed to liquid fuel fires.

Calculations were made using several simplifying assumptions in order to avoid undue complexities and to overcome uncertainties of critical parameters. These were: (1) physical and chemical integrity of the insulating material is preserved, (2) one-dimensional heat transfer, (3) negligible thermal resistance between the insulation and the aluminum skin, and (4) exposure of the insulation surface facing the cabin to a constant 80°F environment. Of these, preserving the physical and chemical properties of the insulating material is the most restrictive since changes in these parameters can have a profound effect on the fire resistance properties of the insulating material. Other constraints will not materially affect the final results. For example, neglecting the thermal resistance between the aluminum and the insulation will be of little consequence since the aluminum skin only briefly delays the

direct exposure of the insulation to fire.

The results of our calculations are shown for insulations of 1 in. (Figure 7) and 2 in. (Figure 8) thicknesses. The methodology used in the calculations was basically an extension of the one previously used for determining the aluminum skin temperature. The insulation material selected was mineral fiber with a density of 0.6 lb/ft³, specific heat of 0.16 Btu/lb°F, and thermal conductivity of 0.0583 Btu/ft °F. The exposing fire produces a radiant heat input of 31,000 Btu/hr-ft². For the purpose of calculation, the insulation was subdivided into layers of equal thickness (0.25 in.) and each layer was assigned an identifying number. Number 1 shown in the graphs corresponds to the layer initially in contact with the aluminum skin and subsequently exposed directly to the fire. Layer number 4 (or 8) is assumed to be exposed to the 80°F environment. The graphs shown in Figures 7 and 8 were obtained for constant thermal properties of the insulation.

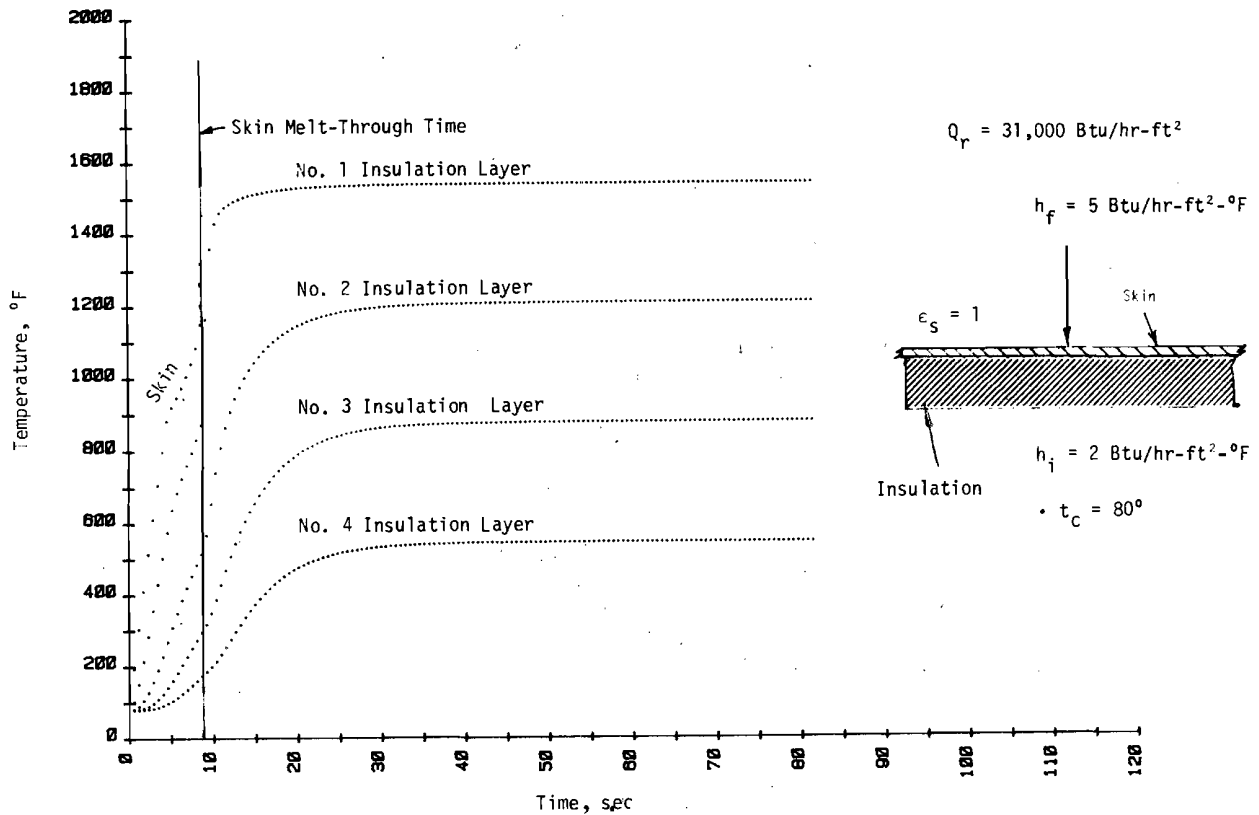

FIGURE 7A. TEMPERATURE DISTRIBUTION OF THE SKIN INSULATION ASSEMBLY:
INSULATION 1-in. THICK, ALUMINUM SKIN 0.016-in. THICK

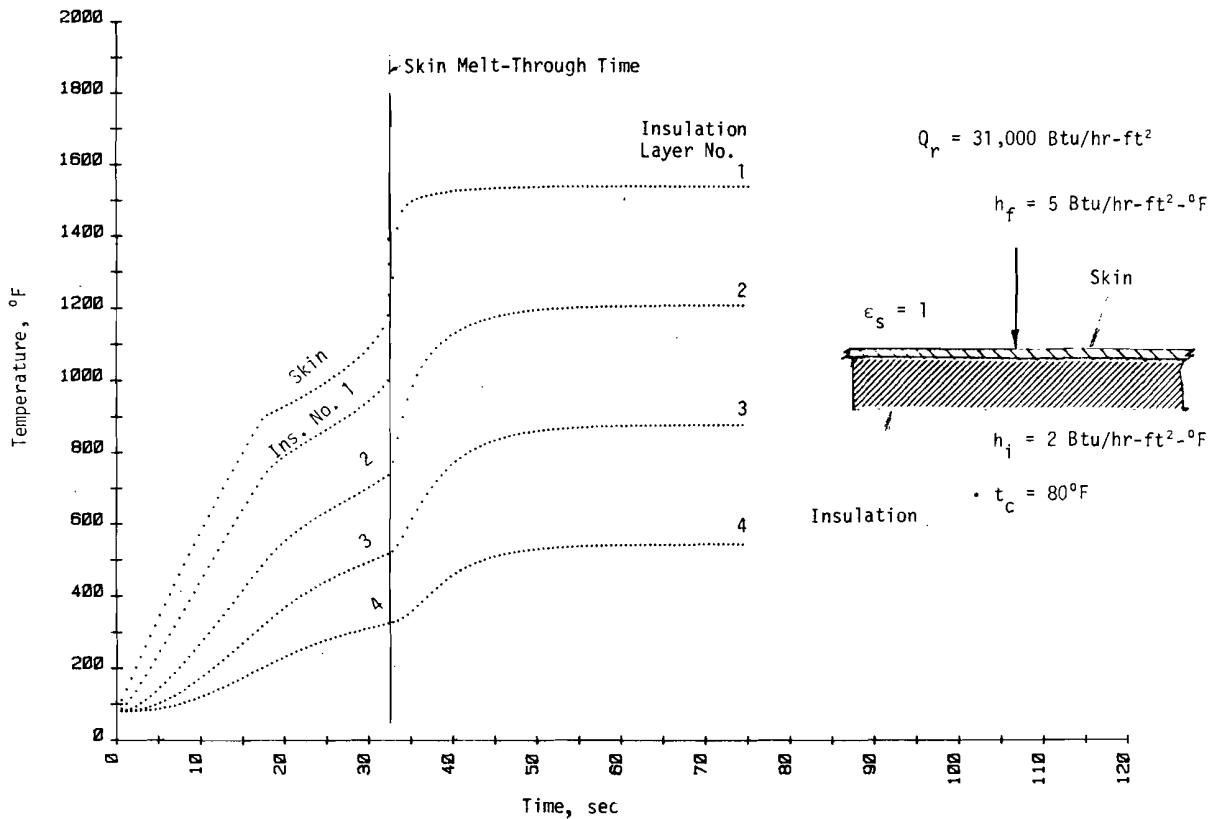

FIGURE 7B. TEMPERATURE DISTRIBUTION OF THE SKIN INSULATION ASSEMBLY: INSULATION 1-in. THICK, ALUMINUM SKIN 0.060-in. THICK.

Comparing Figures 7B and 8 shows that, all other conditions remaining the same, increasing the insulation thickness from 1 to 2 in. decreases the temperature of the insulation surface on the cabin side almost proportionally. As shown in Figure 8, shortly after the melt-through the inside surface (layer number 8) attains an equilibrium temperature of about 300°F, whereas 1 in. thick insulation results in 600°F. This and other temperatures shown in Figure 7 were obtained assuming that the inside insulation surface is exposed to an 80°F constant environment. In the actual application, the insulation rests against the cabin wall panels, which retard heat loss from the insulation material. As a result, the insulation can reach temperatures higher than those shown in Figures 7B and 8. This may be of secondary importance since the surface temperatures of wall panels are of primary interest. A comparison of

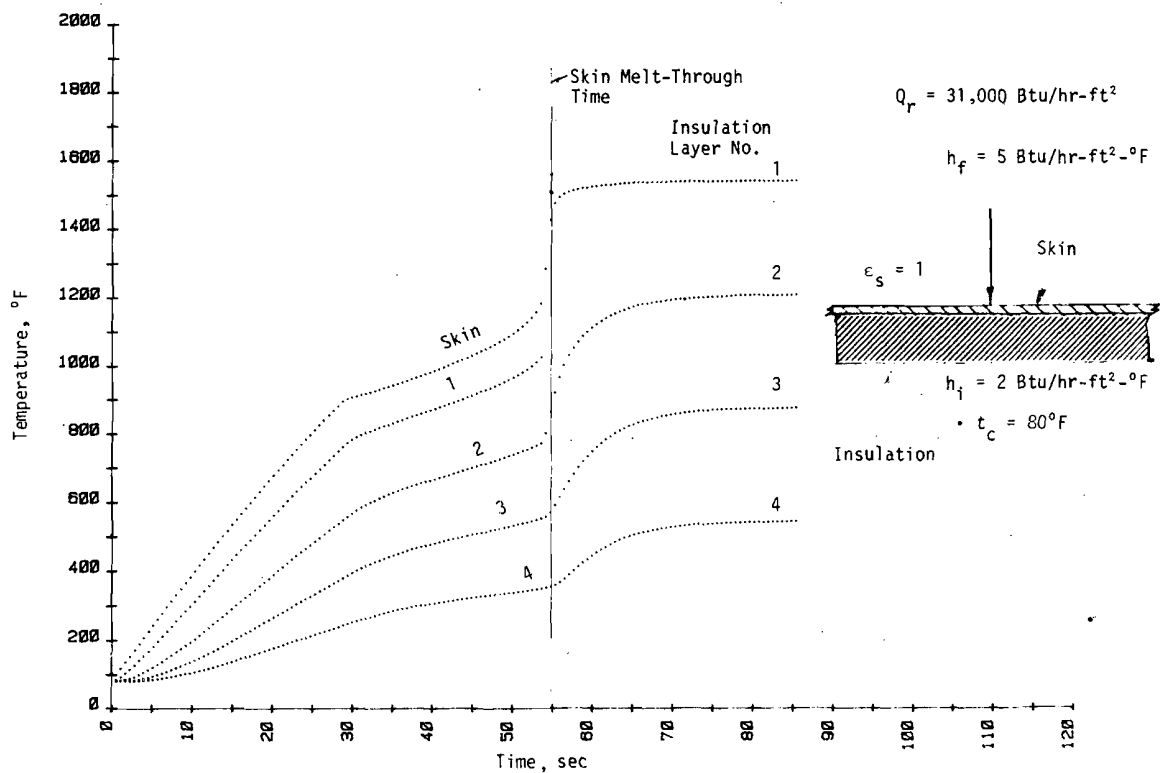

FIGURE 7C. TEMPERATURE DISTRIBUTION OF THE SKIN INSULATION ASSEMBLY:
INSULATION 1-in. THICK, ALUMINUM SKIN 0.100-in. THICK.

properties affecting heat transfer shows that the panels have higher densities than the insulation, but similar thermal conductivities.⁷ Thus a wall panel offers thermal protection similar to that provided by insulating material of an equivalent thickness. Hence, as the first approximation, the temperature distributions shown in Figure 8 could be construed as corresponding to an assembly of insulation and wall panel totaling 2 in. in thickness.

Of particular note is that following melt-through of the skin, the temperature profiles within the insulation quickly reached steady state conditions and are almost unaffected by the thickness of the aluminum skin. This again confirms previous observations that the skin is only a time delay factor. This could be independently determined and used to shift the time scale for describing the response of the insulation to the fire.

Examination of the temperature profiles that were developed clearly shows that conceptually the insulation provides effective protection of the cabin

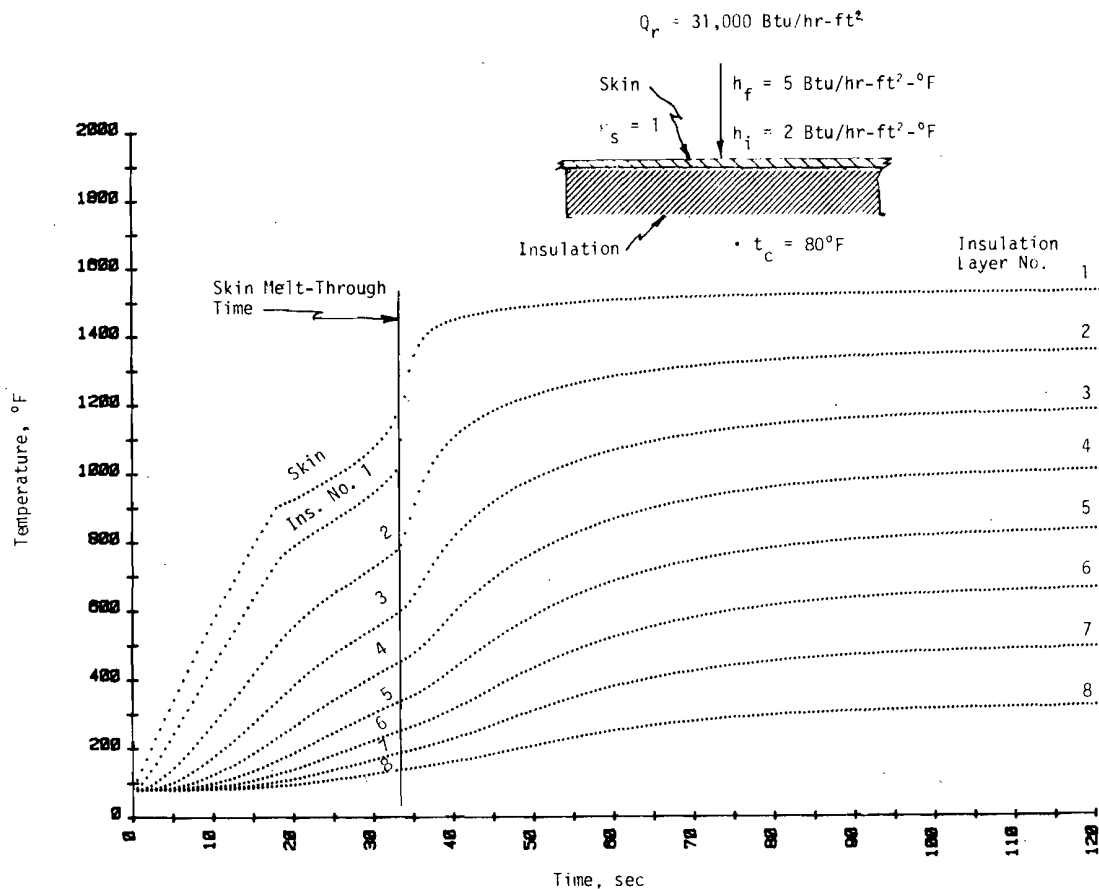

FIGURE 8. TEMPERATURE DISTRIBUTION OF THE SKIN INSULATION ASSEMBLY, INSULATION 2-in. THICK, ALUMINUM SKIN 0.060-in. THICK.

environment. It must be recognized, however, that this conclusion is based on fully preserving the chemical and physical integrity of the insulating material. Available evidence suggests that this assumption is very optimistic. For example, when an insulated 28-ft titanium fuselage section was exposed to a JP-4 fire,⁴ the temperature rose significantly, smoke and toxic combustible gases were produced within the cabin about 1 min after fuel ignition, and a flash fire resulted 2 min after fuel ignition. Since no melting of the skin took place, these conditions were attributed to gases produced by the decomposing insulation binder and cabin pressure sealant.⁸ Rapid melting of the aluminum skin can permit venting of these combustion products, and at the same time cause accelerated degradation of the physical integrity of the insulating material. Although in the titanium fuselage the insulating material was not in direct contact with flames,⁴ the postfire photographs show considerable sagging, distortion, and even total displacement of the insulation. In the case of the aluminum fuselage, the removal of skin due to melting exposes the insulation to additional distorting effects produced by high turbulence within the liquid fuel fires.³ Thus, shortly after the skin melt-through, segments of the cabin walls may become exposed directly to the external fuel fire. In the absence of experimental data, however, this sequence of events cannot be quantitatively described.

2.1.3.3 Cabin Wall Panels.

In the chronology of events, cabin walls provide the last defense against burnthrough. Although relatively thin, properly selected wall materials can add valuable minutes to the time available for evacuating the passengers. For this reason, cabin walls were the subject of numerous studies in recent years which investigated the selection of materials and the experimental determination of fire resistance. The latter seems to offer the most direct and reliable source of information on the behavior of cabin walls during fires.

Cabin walls--sidewalls, partitions, ceiling panels, and overhead storage bins--are basically composite sandwich panels comprised of several materials. As currently used, these panels vary slightly in configuration and composition depending on the particular application. A typical composite panel, illustrated in Figure 9 and described in Table 1, consists of thin decorative polyvinyl flouride films printed with an acrylic ink and bonded to laminate faces which are in turn bonded to the core structure.

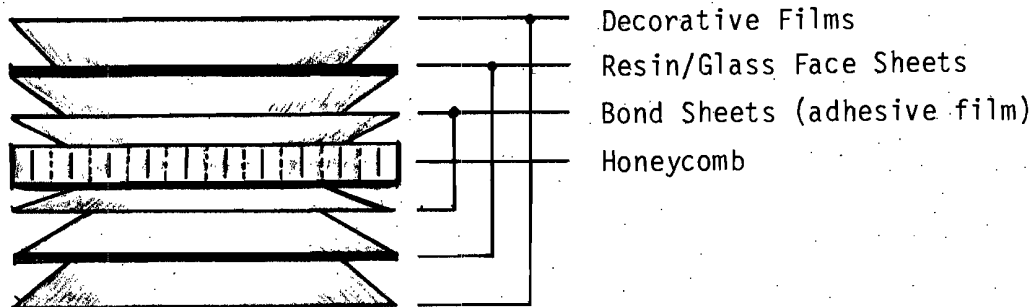

FIGURE 9. TYPICAL INTERIOR CABIN PANEL.

The panels described in Table 1 were used to determine the fire behavior of cabin walls exposed to heat fluxes typical to those encountered in aircraft fuel fires.⁷ Also studied were the toxic gases and smoke emitted by the heated materials.

Based on the results of the experimental studies,^{7,9} the major loss in the panel weight occurs when the temperature of its back face reaches 482°F, corresponding to an exposure time of approximately 2.5 min. Complete pyrolysis occurs at 1000°F after about 3 to 4 min of exposure.⁹ Because the rapid loss of weight is associated with high production of toxic gases and smoke, the optimum protection offered by the cabin walls may be limited to 2.5 min. This criterion is based on experiments using single panels with no consideration given to physical distortions. Lack of a good seal or thermally induced separation between panels can provide the fire direct access into the cabin, as demonstrated during a recent DC-10 crash fire.¹⁰ After protecting the

TABLE 1. COMPOSITION OF STATE-OF-THE-ART CABIN PANELS⁷

<u>Item</u>	<u>Composite 1</u>	<u>Composite 2</u>
A Decorative surface, (cm thick)	(0.002) PVF clear acrylic ink (0.005) PVF	(0.002) PVF acrylic ink (0.005) PVF
B Face sheet, resin/ fabric, (% wt)	Phenolic type, A/7581 glass	Epoxy type, H/181 E glass, (B + C = 35.9%)
C Bond sheet, resin/fabric	Phenolic type, B/120 glass	Epoxy type, H/120 glass
D Core type; thickness, cm; cell size, cm; density, kg/cm ³ ; filler	Aromatic polyamide- paper honeycomb; 2.413;0.31; 48.06; no core filler	Aromatic polyamide- paper honeycomb; 2.413;0.31; 48.06; no core filler
E Bond sheet, resin/fabric	Same as 1C	Same as 2C
F Face sheet, resin/fabric	Same as 1B	Same as 2B
G Surface finish	None	None

cabin from a nearby fire for about 5 min, the wall panels showed the first signs of fire penetration along their edges and joints.

2.1.4 Window Penetration.

None of the transparent polymers currently used as aircraft windows are noted for their fire resistance. Aircraft windows may thus be the weakest link in the protection of the cabin against the adjacent fuel spill fires. This is clear both from a recent wide-body accident¹¹ and from experimental investigations subjecting windows to heat fluxes of 9.96 Btu/sec-ft², typical of JP-4 fuel fires.¹² Exposed to the experimental fire environment, acrylic windows melted, reticulated, combusted, and burned through within about 1 min. This is much less time than is needed for the fire to penetrate the fuselage wall. Also, the burning of acrylic inner windows was found to produce more carbon monoxide than any other cabin material.¹³

An immediate consequence of fire penetration through windows is the ignition of nearby cabin materials. This threat can be considerably increased when the removal of window coverings permits formation of air currents. Such currents can cause flames to spread rapidly through the cabin area and allow hot gases to flow in from the external fire. Unfortunately, conditions conducive to such extreme fire situations also exist during the evacuation process, when doors are usually opened on the side opposite the fire.

2.1.5 Open Doors and Fractured Fuselages.

Of all the impact-survivable post-crash fire scenarios, the greatest threat to passengers and crew occurs when opened doors or a fractured fuselage permit direct exposure of the cabin interior to adjacent spill fires. Driven by fire or wind-induced air currents, the flames from ignited materials, and possibly

from the external fire, can quickly traverse the cabin area. As demonstrated by an experimental study, even a 2 mph wind can cause the adjacent fire to enter the cabin within 15 sec.¹⁴ In similar investigations,¹⁵ opened doors allowed a severe accumulation of smoke in the cabin within 10 sec and total obscuration of visibility within 25 sec, which would considerably hinder the evacuation process. Recent FAA tests in a fully furnished wide-body cabin produced interior flashover within 2 min of exposure to an adjacent fire through an open doorway.

Even without direct contact with flames, the fractured fuselage can expose the interior of the cabin to radiative heating. Impinging fluxes can ignite cabin materials and produce extreme discomfort to the passengers. Entering air can also cause flashover of a smoldering fire present within the aircraft prior to the crash.¹⁶

2.1.6 Emergency Evacuation.

In impact-survivable air carrier accidents, ultimate survival is largely determined by the ability of the passengers to find their way to the exits in environments that may be smoke-filled, toxic, and heated. Lucha et al.¹⁷ studied incidents and found that between 1963 and 1973, 12 accidents involved severe evacuation problems. Though many aspects of air travel have changed in recent years, little progress appears to have been made in this area. Since the ultimate purpose of aircraft fire management or suppression is to minimize the intensity and the time of exposure of passengers to the effects of fire, any means that shortens the time that passengers are exposed to a fire environment can be considered an indirect means of "managing" the fire. Thus, we will examine briefly those aspects of post-crash aircraft evacuation that detract from its rapid accomplishment.

Studies by the National Transportation Safety Board¹⁸ have identified several factors that have an important influence on the characteristics of evacuation:

- | | |
|----------------------------------|--|
| (1) Environment-Related Factors: | Weather
External illumination
Terrain
Aircraft attitude
Fire and smoke |
| (2) Machine-Related Factors: | Evacuation slides
Emergency lighting systems
Emergency communication equipment
Obstructions to egress |
| (3) Man-Related Factors: | Passenger preparedness
Crew training
Crew procedures |

2.1.6.1 Environment-Related Factors.

Weather can affect the response speed of crash rescue vehicles in many ways. Wind has the greatest impact on fire effects and on rapid evacuation. In terms of ease of evacuation, wind becomes a particular hindrance to successful deployment of escape slides. This problem is compounded when there is no external illumination to allow crew members to determine the adequacy of escape slide deployment and inflation or to assess conditions of the terrain. Studies have shown a marked increase in escape slide injuries when passengers are discharged onto hard surfaces as opposed to soft grassy surfaces.¹⁸

Aircraft attitude is a combination of environment- and machine-related factors. It affects the ease with which passengers can negotiate the aircraft aisles and, in extreme cases, can prohibit successful deployment of escape slides.

The most crucial environment-related factors, however, are produced by the fire, mitigation of which is the primary concern of this study.

In addition to the constraints posed by the post-crash in-cabin fire environment, for evacuation to take place, the thermal environment of the external escape path must also be within acceptable limits. As stated by Buettner,¹⁹ radiant heat flux of 1 Btu/sec-ft² (0.271 cal/sec-cm²) can produce unbearable pain in about 5 sec and severe burns in about 20 sec. It may be necessary to endure these fluxes if no other alternative for survival is available. It is questionable, however, whether passengers will be willing to take this course of action or seek the temporary safety provided by the cabin interior.

2.1.6.2 Machine-Related Factors.

Evacuation slides and slide/rafts are the primary means of deplaning passengers in an emergency. Several slide problems may, however, occur:¹⁸

- Improper installation and maintenance, leading to inflation failures
- Slower than desired slide deployment times
- Wind interference with slide deployment
- Poor heat and puncture resistance of slides. (Heat resistance is of particular concern under post-crash fire conditions.)

Both interior and exterior emergency lighting are big factors in evacuation, especially at night. However, studies have shown¹⁸ that present emergency lighting systems lack sufficient intensity under smoke-filled conditions to allow passengers to locate emergency exits, and suggest that some emergency lighting should be located near floor level, under the potential smoke layer.

Ineffective (or ineffective use of) emergency communication equipment including public address, evacuation alarm, and megaphones can result in longer than necessary evacuation times.

Many interior compartments of an aircraft can fail and shift after a crash. Several fixtures in the cabin often cited as obstructions include ceiling panels, overhead racks, life rafts, galley components and supplies, movie projectors and screens, oxygen masks, and carry-on baggage. This aspect of the crash is given further treatment in Section 2.1.6.4.

2.1.6.3 Man-Related Factors.

Passenger preparedness currently depends on the effectiveness of the pre-takeoff briefing, passenger information cards, and preevacuation briefings (if any). Studies have shown¹⁸ that techniques for presenting safety information may be inadequate. The action of the aircraft's crew members have a far-reaching effect on emergency evacuations. The NTSB study¹⁸ indicates that the evacuation procedures of some air carriers are deficient, more crew training in a realistic manner is necessary, and procedures must be standardized to ensure timely evacuations.

2.1.6.4 Characterization of Post-Crash Impact.

The impact of an aircraft crash can be categorized according to the resultant aircraft damage which in turn affects, either directly or indirectly, the condition of the occupants, the movement rates, and travel distances from any point to an available exit. One possible categorization would be:

- No apparent impact forces. Occupants are capable of evacuation, although there may be minor difficulties in movement because of carry-on materials and passenger comfort items in the aisles and by the doors.
- Light impact forces such as in a belly landing. Forces will have acted in all major aircraft axes. Although the principal forces will be vertical and longitudinal, lateral loads will still be a significant factor. Some overhead and other storage compartments will have opened and caused random injuries from falling carry-on items or other materials that can impede escape movement. Some overhead and side panels may also be dislodged slightly, injuring passengers. The resultant damage may increase the time occupants need to get to the aisles, create additional need for helping people partly debilitated, and slow down travel through the aisles because of debris. Very localized structural damage may prevent exits from opening and possibly facilitate the penetration of an exterior fuel fire; both of these are unlikely in such an accident.
- Impact forces sufficient to cause general incipient seat failure. Some seats will be broken loose and overhead racks and panels partially dislodged; most compartments will have opened and there will be considerable spillage of carry-on materials and passenger comfort items. Injury, debilitation, and general shock will affect the occupants' reaction time and the travel rate will be considerably slower. Such an accident may have high longitudinal and vertical impact forces and lower the still significant lateral loads. Structural damage and distortion may prevent an exit from opening and some damage may preclude access to exits. Openings or damage to the fuselage may also provide vent openings for

fire to enter and in a few rare cases for people to exit.

- High impact forces sufficient to cause a large number of seat failures. This represents an upper limit to survivable aircraft accidents; the interior of the aircraft will sustain significantly damaged overhead panels, stowage compartment collapses, and considerable debris in the aisles. The structural integrity of the cabin is likely to be compromised, allow fire to penetrate, and prevent some exits from being opened. Many of the occupants will be debilitated; those that can evacuate will react and move relatively slowly. Major active fire suppression is required. Outside help will have to reach the scene and remove the general and/or internal fire threats in order for debilitated occupants to survive.

A survey during the early period of jet transport use indicated that 73 percent of all accidents and 68 percent of all fatalities occurred during the approach and landing or takeoff phase of the flight. During these phases, aircraft speed is comparatively low and the flight path angles are generally small. As a result, most aircraft crash forces are such that the fuselage is most likely to remain virtually intact and the accelerations are not in excess of the human tolerance. In this type of accident the fire can represent the primary and critical hazard that determines whether the occupants survive or not. However, even in these stages of flight there are impact speeds and angles that are beyond human survival, such as the DC-10 takeoff at O'Hare Field in which the fuselage was totally destroyed.

2.2 IN-FLIGHT FIRES AND FIRES INSIDE AIRCRAFT.

Although of considerable interest, there is very little quantitative information on the progress of past accidental aircraft fires. Considering the destructive potential of accidental fires, it is not surprising that they often preclude eyewitness reports. Available sequential descriptions of fire development are mostly limited to localized fires, with a very terse treatment of more involved cases. The nature of the data²⁰⁻²² is shown in Tables A-1 through A-6 of Appendix A. Of main value are the indicated ignition sources and their effect on the ultimate damage. The latter requires some additional qualifications. In most ground (ramp) fires, the aircraft were unoccupied and in the process of being serviced. Incipient fires were fought by service and/or crew personnel with subsequent, often massive, suppression efforts by the fire department. As shown in Appendix A, even these activities could not always prevent severe damage, clearly demonstrating that any on-board fire protection system must focus on the initial stages of incipient fires.

With this in mind, the scenarios of on-board fires will be described in terms of the following four phases: (1) response of the exposed material to the ignition source, (2) development of incipient fires, (3) fire spread within the compartment of origin, and (4) fire spread between compartments. Each of these phases has been the subject of various theoretical and experimental studies. Some were concerned directly with aircraft fires, others with related situations or with the basic behavior of fires. Despite these efforts, there is no methodology readily available for quantitatively

describing the various phases of fire development. This is understandable, considering the complexity of a problem involving numerous interacting processes. Most theoretical modeling requires extensive programming and computer times. In addition, these efforts are frequently handicapped by many uncertainties of the fire problem under study.

Based on these considerations, we selected a pragmatic approach to describe the scenarios of on-board aircraft fires. We applied available data to the various phases of fire development taking into account, when appropriate, the role of passengers in creating and responding to the fire situation. For example, a lighted match dropped on a garment would certainly be extinguished by the wearer. Thus, it would be unrealistic to pursue the nature of this hazard. Similarly, a study of the flashover in an occupied cabin is of little interest since no life can be sustained under such conditions.

Any analysis of accidental fires must include the physical and chemical characteristics of the materials involved. Although parameters such as humidity, temperature, and even normal use may influence the behavior of fires, these are secondary effects and can be disregarded in view of the overall accuracy of the problem. Also, it seems more appropriate to describe pertinent parameters by a range rather than specific values. Consequently, in the formulated scenarios, the rate of fire development will be characterized as:

- Rapid if less than 1 min
- Moderate if between 1 and 5 min
- Slow if more than 5 min.

These classifications were made using available data or, if necessary information was lacking, a consensus among fire researchers.

2.2.1 Origins of Fires Within Aircraft.

Typical materials and ignition sources at various locations within an aircraft are described in References 20 and 22. This information provides the basis of the discussion that follows.

2.2.1.1 Flight Station.

Electrical short circuits can cause ignitions in the flight station. Although very critical from the navigation point of view, the fire within the control panel would be of moderate intensity, with the output limited primarily to smoke and toxic gases. Because the panel is continuously monitored, the crew would be expected to respond immediately. Smoke and gases would spread to the cabin at a moderate to slow rate.

A mishap in the crew's oxygen system would present a formidable danger. Oxygen enriched atmospheres permit ignition by less energetic sources and promote rapid fire growth near the release point. Greater local fire intensity can penetrate quickly to adjacent compartments or even melt the fuselage skin. In addition, an oxygen-fed fire is almost impossible to suppress by means of hand extinguishers. For these reasons, a valve is placed

to limit the length of O₂ charged line in the cockpit. This can be expected to greatly reduce the likelihood of accidental oxygen release.

2.2.1.2 Cabin

Ignitions within the cabin can result from:

- Oxygen system failures
- Liquid fuel spills
- Electrical short circuits
- Matches
- Lighters
- Cigarettes/cigars
- Carry-on luggage.

As in any situation, a quick release of oxygen can enhance ignitions and support an intense, rapidly developing fire. Its source can be located near the point of release or other locations, involving materials normally not subject to flaming ignition.²³ Immediate response of the crew would be of little use unless the flow of oxygen were stopped.

Liquid fuel fires in cabins can result either from an intentional or an accidental action of a passenger or from damage sustained by a crashed aircraft. The development of the incipient fire would be a function of the amount and distribution of ignited liquid fuel and involved cabin materials.

Even a small quantity of burning liquid fuel spilled in the cabin can produce a large incipient fire, particularly when ignited materials are not fire-resistant. Laboratory tests of 100 cabin materials conducted by Marcy et al.²⁴ have shown that 22 percent were not self-extinguishing and some produced a prohibitive quantity of smoke. Also, as demonstrated by full-scale tests, when these materials ignited, the cabin fire spread rapidly. More recently developed cabin materials exposed to a moderate ignition source show higher fire resistance than those used by Marcy. However, this difference can be expected to be much less evident when the ignition source is very intense, as from a liquid fuel spill fire.

It is crucial to control the fire rapidly and follow this closely with venting of the cabin since the burning fuel alone can produce sufficient quantities of combustion products to render the cabin uninhabitable in a short time. As demonstrated experimentally using a Boeing 737 fuselage,²⁵ 1 gal of fuel burning just below the floor in a 2 ft² pan rendered the fuselage uninhabitable within 5 min. This time could drop much further as other materials within the cabin become involved. In particular, the spread of fire within the cabin can be very rapid if seats are ignited from underneath by the fuel burning along the floor surface.²⁶

Depending on the sustained damage and the construction of the aircraft, liquid fuel can enter the cabin during a crash landing. If the fuel is released slowly and over a localized area, the ensuing fire can produce conditions similar to those resulting from spills in the cabin. Possible increased

intensity of the incipient fire could be offset by venting the cabin through openings produced by the crash and/or open doors. However, doors must be opened carefully to avoid formation of air currents that will direct the fire into occupied cabin areas and/or expose the cabin to the effects of an adjacent external fire. For example, full-scale experiments¹⁵ have shown that with one door opened directly to the adjacent fire, another door opened downwind, and wind perpendicular to the fuselage, smoke can totally obscure visibility in the cabin within 25 sec. In addition, the temperature near the cabin ceiling can reach 1300°F within 50 sec. In contrast, opening the second door on the upwind side serves as a buffer against expanding fire gases which can produce cabin ceiling temperatures of about 220°F in 50 sec.

Any aircraft has numerous sources for electrical short circuits. Manifested first by sparks, smoke, and odor, electrical short circuits that occur in occupied areas are readily recognized and their effects minimized or negated by an appropriate action. Undetected, as the case would be in unoccupied concealed spaces, an electrical short circuit can produce a serious fire problem.

As often experienced, an overloaded electrical wire can reach temperatures capable of melting and igniting the insulation coating. The resulting fire can propagate along the wire surface and/or ignite adjacent combustible materials. In this context this is a slow process and could be readily halted if detected in its initial stages. Experience shows the opposite when electrical short circuits occur in concealed spaces. By the time smoke and toxic gases become noticeable in the cabin area, a serious fire can exist. Effective suppression can be very difficult to conduct because the discharging combustion products are often far removed from the hidden seat of the fire.

Once fully developed, fire in a concealed space can quickly produce untenable conditions within the cabin area. This can be particularly true if the aircraft lacks fire stops, permitting convective currents to carry the smoke and toxic gases to various points within the cabin. Decomposing and burning electrical insulation is capable of contributing to a toxic cabin environment.²⁷

With some exceptions, matches, lighters, cigarettes, and cigars are not usually the cause of serious fires in occupied cabins. Normally, cabin occupants act immediately to prevent the development of sustained incipient fires. Exceptions could occur when a passenger accidentally or purposely drops a cigarette or cigar into a concealed space within the panel walls or folds of a seat. In this case, a slowly developing incipient fire could form and, as with all fires in concealed spaces, locating and suppressing the fire could be difficult. Initial fire output is primarily in the form of smoke and gaseous combustion products. The fire would probably be confined to a localized area for an extended period.

Carry-on luggage, unless so intended, is not expected to be the cause of a fire. Of particular concern is the increase in the cabin fire load and the nature of the introduced materials. The latter is, in most cases, much more flammable than the cabin furnishings, and so can enhance the potential of cabin fires due to causes previously considered.

In general, modern cabin liner materials can effectively resist the growth of incipient fires.²⁸ However, passengers may experience breathing and eye

irritation caused by released products of combustion. These effects may be of somewhat lesser severity in wide-body aircraft. Their cabins contain large amounts of air to dilute the gases and also permit moving passengers some distance away from the fire. Both of these effects can be thwarted by the air circulating devices, which are capable of spreading the fire and smoke quickly to other parts of the aircraft.

An in-flight cabin fire can also present the additional danger of sudden decompression caused by failure of the windows when subjected to localized excessive heating. Some window materials have melted and burned during laboratory tests.

The preceding paragraphs present a rather bleak picture of a multitude of potential fires originating in the cabin space. We should emphasize that the cabin has not been the source of significant in-flight fires. Early human detection and manual suppression appear to have quickly and effectively controlled fires of this nature.

2.2.1.3 Food Service Galley.

The food service galley has been most frequently the site of reported fire incidents,^{1,20} all of which have been promptly extinguished with handheld extinguishers. In broad categories, the sources included:

- Ovens and oven exhaust system
- Electrical equipment
- Food waste storage
- Oxygen.

Ovens and exhaust systems are of particular concern in wide-body aircraft where food is not merely warmed but actually prepared. Any accumulation of grease can result in an intense fire capable of igniting adjacent materials.

Electrical equipment, such as coffee makers, water heaters, refrigerators, lift controls from the lower galley, and lighting, presents common electrical problems such as short circuits. Unless involving concealed spaces, incipient fires from these sources grow slowly, producing primarily smoke and toxic gases. There are exceptions. When combustible materials such as napkins are ignited during accidental contact with the heated surfaces they can be quickly suppressed and generally do not involve other materials.

Large amounts of combustible waste resulting from in-flight meal service creates a potential site for an incipient fire. A fire can start in discarded smoking material placed into a waste container from usually hurriedly collected food trays. An ensuing smoldering fire can seriously contaminate the cabin atmosphere. The problem could be further exacerbated if ignited waste is stored in plastic bags, as is sometimes the case. Lack of confinement permits not only a quick release of the combustion products, but also offers the potential of spreading the fire within the cabin area.

As in any other location in the aircraft, an uncontrolled discharge of oxygen in the galley can cause an intense fire. Particularly when hot surfaces are

present during food preparation, an oxygen-saturated atmosphere can encourage a rapidly spreading destructive fire. Suppression would be extremely difficult without stopping the flow of oxygen.

2.2.1.4 Lavatory.

The lavatory in an aircraft is one of the few locations where, because of its enclosure and ventilation, a fire can develop undetected until it reaches a dangerous level. In addition, when flying through turbulent weather, lavatories cannot be used for a period of time so that manual detection is unreliable. Full-scale tests have shown that a lavatory fire can develop into flashover within 2 min.²⁹ Even before flashover, it can easily grow beyond the control of on-board aircraft fire extinguishers. Since the VARIG airline accident near Orly Airport, some improvements have been made in fire hardening of lavatory and lavatory waste paper storage areas. Experiments have shown that a standard Boeing 747 lavatory enclosed by contemporary wall panels contained a fire involving maximum cabin waste load for a period of 30 min.²⁹ Controls have been placed on ignition sources within the lavatory by prohibiting smoking therein. This measure, however, is probably both ineffective and of no benefit. The lavatories are the only locations where passengers can smoke marijuana cigarettes and where those who sit in no-smoking areas can smoke. It must be anticipated that some passengers will smoke within the lavatories regardless of any prohibition.

Most reported fires occur in the waste container under the sink and are attributed to discarded cigarettes. However, the cigarette is not the likely source of more serious flaming fires, even in the lavatory waste paper storage containers or in galley waste often placed in the lavatory near the end of the flight. Extensive informal tests conducted by the authors indicate that only under very extreme sequences of ventilation and waste configuration (towelling and tissues) can the cigarette-initiated smoldering fire sustain and develop to a flaming state. Incendiary causes or the discarded match are more likely the sources of serious fires of human origin. Because of its history as a point of ignition, FAA regulations now require that the lavatory waste compartment be able to contain fires within. Some airlines use small, self-contained Halon 1301 suppression systems to protect the waste compartment interior.

Other potential sources of fire are light wiring, speaker transformers, fluorescent light ballasts, the water heater, and the flushing motor. Some can produce a concealed fire of serious consequence. Most will result in a slow burning fire, with the amount of smoke that penetrates the cabin again limited by the high ventilation rates usually employed in the lavatories, thus delaying manual detection. Those flaming fires that do develop, unless controlled or contained by fire-resistive lavatory walls, will spread into the cabin area at a stage of fire development not easily suppressed.

2.2.1.5 Cargo Compartment.

Electrical short circuits and cargo are the most probable sources of incipient fires. Depending on the nature of the cargo and the compartment size, the fire can be surface or ventilation controlled. Either can present a serious problem. Even in a confined space, a surface-controlled fire could be sufficiently intense to penetrate the cabin floor area, as apparently experienced

in one aircraft fire. On the other hand, a ventilation-controlled fire, by producing large quantities of combustible gases, may be conducive to a catastrophic explosion following a sudden influx of air into the cargo compartment. Since the space beneath the cabin floor contains control cables and wiring, fire penetration of the cargo compartment liner may have serious consequences even if the cabin floor is not penetrated.

2.2.1.6 Attic.

Movie projectors, electric motors, and controls may be possible causes of attic fires. Because concealed spaces along the length of the aircraft are involved, attic fires can present a serious problem. Smoldering at first, these fires can subsequently spread rapidly along the attic space, in particular if supported by discharging oxygen. Historically, the attic has not been the seat of the fire; however, the attic can quickly become heated by fires in the cabin or adjacent compartments below. In-flight, this can endanger control and communication systems. Post-crash exiting problems caused by loss of lighting and communication can further be compounded by debris from rapidly deteriorating ceiling panels.

2.2.1.7 Landing Gear Wells.

These unpressurized compartments, in addition to the landing gears, may contain hydraulic fuel lines, electrical controls and devices, and water line heaters. Each presents a fire potential, with overheated brakes and tires being one possible source of ignition. Although possibly of low intensity, the damage produced by the ensuing fire can jeopardize the safety of the aircraft.

2.2.1.8 Electrical and Avionic Service Centers.

The potential ignition sources in electrical and avionic service centers are primarily electrical controls and actuating devices. In general, incipient fires are of low intensity, although burning aircraft batteries have been found to be capable of melting compartment walls. Because the electrical and avionic centers contain navigational and control equipment, any fire in these locations can have serious consequences.

2.2.2 In-Cabin Fire Characterization.

Effects other than burns contribute substantially to fire deaths. Reports in the literature³⁰ claim that over 50 percent of casualties in structural fires are caused by smoke, heat, noxious gases, and hypoxia (oxygen deficiency). No such statistics are available for aircraft fires; however, smoke and toxic gases were found to be responsible for many casualties in past accidents.²⁰

Although all fire effects are important, the discussion which follows will deal first with smoke. It is the most noticeable manifestation of a fire, and its ability to reduce or even totally obscure visibility and debilitate passengers can seriously endanger their safety. Furthermore, measures against smoke are also effective against heat and toxic or noxious gases, and hence offer an additional protection for the occupants.

Once the hazards created by combustion products were recognized, it became evident that an effective fire management system must provide protection against smoke. This need became even more acute when attempts to reduce the flammability of materials were found to sometimes increase their potential for smoke and toxic gas production. For these reasons, numerous studies were conducted during the last two decades to gain a quantitative knowledge of smoke production, its movement, and, above all, methods of controlling smoke. Almost all these efforts were concerned with structural fires, in particular those expected in single or multilevel shopping malls and high rise buildings. Nevertheless, the theoretical and experimental data developed seem to be sufficiently general to permit us to analyze the development of combustion products within an aircraft cabin and the probable effectiveness of certain protective measures. Verification of the conclusions we reached is not only highly desirable, but will ensure that the data, analyses, and concepts used are applicable to the scale and conditions encountered in aircraft fires.

2.2.2.1 Smoke Density and Visibility.

Smoke results from incomplete combustion of materials. Although smoke contains toxic gases, for the purpose of this discussion it is defined as particulate matter, primarily unburned carbon and dispersed liquid suspended in air. The visible particles (carbon and tars) are generally not toxic. Smoke can, however, contain strong irritants and lachrymators affecting eyes and nasal passages.³⁰ These irritants are capable of reducing vision, producing coughing, and causing passengers extreme discomfort and pain, all of which can lead to panic, seriously endangering the safety of the occupants.

There is a wide variation in the appearance of smoke. It can range from light colors to black. Most of the data on smoke emissions relate to visibility. As determined experimentally, visibility can be drastically reduced by a very small quantity of burning material. For example, burning 1 lb of wood in a 1250 ft³ compartment reduces visibility to 3 ft, or about the length of an outstretched arm.³¹ Equivalent quantities of other materials produce similar results, e.g., 4 oz of expanded polystyrene, 1 lb of polyurethane foam, and 1/2 lb of kerosene. This clearly demonstrates how little material is required to produce an extreme smoke hazard, particularly when considering that even in wide-body aircraft several compartments have volumes less than 1250 ft³. The volume of the flight station, for example, is approximately 400 ft³.

Smoke characteristics are usually described in terms of the light obscuration index, S_x , the optical density, D_x , and the specific optical density, D_s . The light obscuration index measures the attenuation of light received by an optical instrument after passing through smoke of path length x . In percentages, it is given by:

$$S_x = 100 \left(1 - \frac{I_x}{I_0}\right) \quad (5)$$

where I_x is intensity of the attenuated light beam and I_0 is intensity of the unattenuated light beam.

Because the intensity of light as it passes through successive smoke layers decreases logarithmically, attenuation is often described in terms of the optical density:

$$D_x = \log_{10} \frac{I_o}{I_x} \quad (6)$$

where the meaning of I_o and I_x is the same as in Equation 5.

To compare the smoke-producing potential of materials and also to provide means for extrapolating the experimental data to different room volumes, Robertson et al.^{32,33} introduced the concept of specific optical density:

$$D_s = \frac{V}{AX} (D_x) \quad (7)$$

where A is the area of the heated specimen and V is the volume of the experimental chamber.

All equations relate to smoke densities and become much more meaningful when correlated with visibilities. Butcher³¹ plotted the data reported by Jin³⁴ and others to show that visibility is approximately a linear function of optical density. By this relationship, the generally accepted value for the optical density of an undiluted dense smoke is 3 ft. This corresponds to a visibility of about 4 in., which for all practical purposes can be considered as nil. For structural fires, the recommended limiting optical density for the escape routes is about 0.06/ft. This corresponds to a visibility of 16 ft, which seems to be a reasonable limit to escape from aircraft cabin fires.

According to Rasbash,³⁵ for a given smoke and path length, optical density is proportional to the concentration of smoke. Thus, if all other conditions remain the same, optical density decreases by a factor of n if the smoke is uniformly mixed with fresh air n-times its own volume. This suggests that, to change the optical density of a dense smoke to 0.06/ft, the volume of fresh air required must be 50 times that occupied by the smoke (3.0/ft optical density of the dense smoke divided by 50 = 0.06/ft). Since in most cases this would be very difficult if not impossible to achieve, the idea of decreasing smoke effects by diluting the smoke with fresh air seems to be impractical.

2.2.2.2 Smoke Production.

In an aircraft cabin, the severity of smoke effects depends on the rate of smoke production and available ventilation. As previously defined, smoke is basically a particulate matter dispersed in air. Thus, in a cabin fire, the production of smoke depends on the rate that combustion products are being generated by burning materials and how rapidly they mix with the cabin air. Although not entirely independent, both processes can be considered separately.

The rate, composition, and color of the smoke produced in a fire strongly depend on the nature of the materials involved and the availability of oxygen for the combustion process. Experimental data show that with some exceptions (e.g., acrylic sheets), polymeric materials generate more smoke in flaming combustion.^{36,37} The reverse is true with cellulosic materials, which reduce

the amount of smoke emitted when combustion changes from smoldering to flaming.

In general, the amount of smoke from polymeric materials is much larger, sometimes by a factor of 100, than that produced by cellulosic materials.³⁰ Higher heating levels of polymeric materials also increase their production of smoke. This is particularly critical with composite materials when increased heating causes additional materials to be decomposed. For example, a sandwich panel exposed to 3.81 W/cm² produces 10 times more smoke than when irradiated with 2.54 W/cm² because higher irradiation intensity can decompose the adhesive material.³⁷

As previously implied, although the actual amount of the particulate matter emitted by the burning material is relatively small, it can produce a dramatic effect. The reason is that the production of smoke is approximately equal to the rate at which air is entrained and contaminated by the rising column of hot gases and flames.³⁸ Thus, the amount of smoke produced in a fire can be determined by calculating the amount of the entrained air.

The amount of the entrained air and hence the smoke produced is a function of the fire size. For the purpose of theoretical analysis, fires have been classified as small, large but not fully developed, and fully developed.³¹

A fire is defined as small when its diameter is much smaller than the compartment height. All fires can be considered small during their initial stages. Since aircraft cabins have ceiling heights of 8 ft or less, however, small fires by definition are about 1 to 2 ft in diameter. Because fires of this size can be readily suppressed, smoke should not present a major problem. On the other extreme, a fully developed fire involving an extensive cabin area would be fatal to the aircraft. Hence, from practical considerations, the large but not fully developed fire is of main interest for in-flight conditions.

The large but not fully developed fire can be defined as a fire with flames extending to the smoke layer. Under these conditions, as derived by Thomas et al.,³⁹ the rate of entrained air (i.e., smoke produced) can be expressed by the following relationship:

$$M = 0.096 P \rho_0 y^{3/2} \left(g \frac{T_0}{T} \right)^{1/2} \quad (8)$$

where M = rate of entrained air, kg/sec

P = perimeter of the fire, m

ρ_0 = density of ambient air, 1.01 kg/m³ at 17°C
and 5,000 ft altitude

y = height of clear air below the smoke layer, m

g = gravitational constant, 9.81 m/sec²

T_0 = absolute temperature of ambient air, °K

T = absolute temperature of flames in smoke plume, °K

The rate of the smoke produced is directly proportional to the fire perimeter and decreases with increasing thickness of the smoke layer.

Volumetric rates of entrained air by various size fires were calculated using Equation 8 and are shown in Table 2. The air densities used were at 68° and 350°F, corresponding to the temperatures of the supplied fresh air and exhausted smoke, respectively. Selection of the latter was based on the data obtained from "not fully developed" experimental fires.⁴⁰

TABLE 2. AIR ENTRAINMENT RATES FOR DIFFERENT SIZE FIRES

Height Free of Smoke, ft	Volumetric Rate of Entrained Air at the Temperature Indicated, cfm*							
	3 ft x 3 ft		4 ft x 4 ft		5 ft x 5 ft		6 ft x 6 ft	
	68°F	350°F	68°F	350°F	68°F	350°F	68°F	350°F
7	4,522	6,941	6,030	9,254	7,537	11,568	9,045	13,881
6	3,589	5,508	4,786	7,344	5,982	9,180	7,178	11,017
5	2,730	4,189	3,641	5,587	4,465	6,983	5,460	8,379
4	1,954	2,997	2,605	3,998	3,257	4,997	3,908	5,997

*Cabin pressure corresponds to 5,000 ft altitude

As seen from Table 2, for a 3 x 3 ft fire, a 6 ft smoke-free air layer can be maintained above the cabin floor if 3589 cfm of fresh air is supplied and 5508 cfm of smoke exhausted. Compared to 4000 cfm ventilation rate used in a wide-body aircraft (Table 3), these values indicate that the cabin exhaust must be increased by 38 percent to maintain a "smoke-free" environment. The increase may be 85 percent if clearing the smoke from a 4 x 4 ft fire is desired. Larger size fires would necessitate higher rates of both supply and exhaust. Furthermore, as discussed later, an inefficiency of the exhaust can require even higher rates than given in Table 2.

TABLE 3. TYPICAL VOLUMES AND VENTILATION IN A WIDE-BODY AIRCRAFT²²

<u>Location</u>	<u>Volume, ft³</u>	<u>Ventilation Rates, cfm</u>	
		<u>Normal</u>	<u>Minimum</u>
Flight station	400	400	250
Forward lavatories	70 each	30 each	30 each
First class cabin	7,000	1,500	520
Coach class cabin	10,000	4,000	1,390
Attic	4,000	0	0
Aft lavatories	70 each	30 each	30 each
Afterbody except APU	2,100	2,100	2,100
Aft cargo (2)	2,300	10 each	10 each
MLG hydraulic service	700	700	700
Lower galley	1,400	400	0*
Forward cargo	1,600	10	10
Avionic service center	600	1,200	0*
Electrical service center	400	600	0*

*Minimum rate would require closing the exhaust vents.

2.2.2.3 Smoke Movement.

At the start of a flaming cabin fire, a convective column of smoke forms above the burning fuel. It contains heated products of combustion and the entrained air, both driven upward by the forces of buoyancy. Upon encountering the ceiling surface, the rising gases spread laterally and form a layer of smoke. Because of the differences in densities produced by a flaming fire, little mixing takes place between the smoke and underlying cold cabin air. As the smoke spreads, it reaches the end closures of the cabin, which forces its direction of flow to reverse back toward the fire. This process keeps repeating, increasing the thickness of the smoke layer which gradually fills more and more of the cabin volume. If the smoke is sufficiently cooled while traversing the cabin, it may drop and mix with the underlying air at the wall.

The lateral spread of the smoke layer is quite rapid, estimated to be about 3 ft/sec.³⁸ Thus, unless some preventive measures are available, smoke can be expected to traverse the length of the cabin ceiling quickly. The theoretical analysis by Hinkley³⁸ also shows that the time for the cabin to fill with smoke is very short and can be determined using the following expressions:

$$t = \frac{3.5258A}{P} \left(\frac{1}{y^{1/2}} - \frac{1}{h^{1/2}} \right) \quad (9)$$

where t = time for the smoke layer to reach y feet
above the floor, sec

A = floor area of the cabin, ft^2

y = distance from the floor to the lower surface
of the smoke layer, ft

h = height of cabin, ft

P = perimeter of the fire, ft

Accordingly, as given by Equation 9, a relatively small fire, 3 x 3 ft, in a cabin of 1,000 ft^2 floor area and 8 ft ceiling height could produce a smoke layer extending down to 4 ft above the floor in less than 45 sec. This certainly illustrates the ability of smoke to generate an untenable condition within the cabin area rapidly. It also indicates a need for a very quick response of protective measures to prevent the generation and accumulation of smoke. In this manner not only will the occupants be spared ill effects, but, as experience shows, smoke accumulation is more easily prevented than removed.³¹

2.2.2.4 Toxic Gases.

In the context of visibility, we defined smoke primarily as a mixture of air and particulate matter. However, it is well known that smoke also contains toxic gases responsible for many deaths in accidental fires. Depending on the materials involved and the availability of oxygen, different toxic gases can be produced by a fire. Of these, the most predominant and always present are carbon monoxide and carbon dioxide. Both have been the subject of numerous studies.

The effects of carbon monoxide can range from a slight headache to "instant death." The debilitation experienced depends on the amount of carbon monoxide absorbed by the blood of exposed individuals, i.e., the percent of carboxyhemoglobin. As found by Forbes et al.,⁴¹ the percentage of carboxyhemoglobin, COHb, in blood can be expressed by:

$$\text{COHb} = K \times \text{CO} \times \tau \quad (10)$$

where K = activity factor

CO = percent of CO in the air

τ = exposure time in min

For escape from aircraft fires, Pesman⁴² recommended a value of 8 for the constant K and 35 percent as the limiting concentration of carboxyhemoglobin. The value $K = 8$ corresponds to a light work activity used in Forbes studies and COHb of 35 percent would produce pronounced headache, fatigue, irritability, and impairment of judgment.

As derived by Campbell,⁴³ the concentration of carbon monoxide produced in a compartment fire can be expressed by:

$$c = \frac{0.02A}{E} \left(1 - e^{-\frac{E}{W}\tau}\right) \quad (11)$$

where c = carbon monoxide, %

A = fire area, ft^2

E = quantity of smoke exhausted, lb/min

W = quantity of air in the compartment, lb

τ = time, min

Figure 10 shows the concentration of carbon monoxide produced by 3 x 3 ft and 5 x 5 ft fuel surface-controlled fires in the coach cabin of a typical wide-body aircraft. Graphs were calculated using Equation 11, 10,000 ft^3 cabin

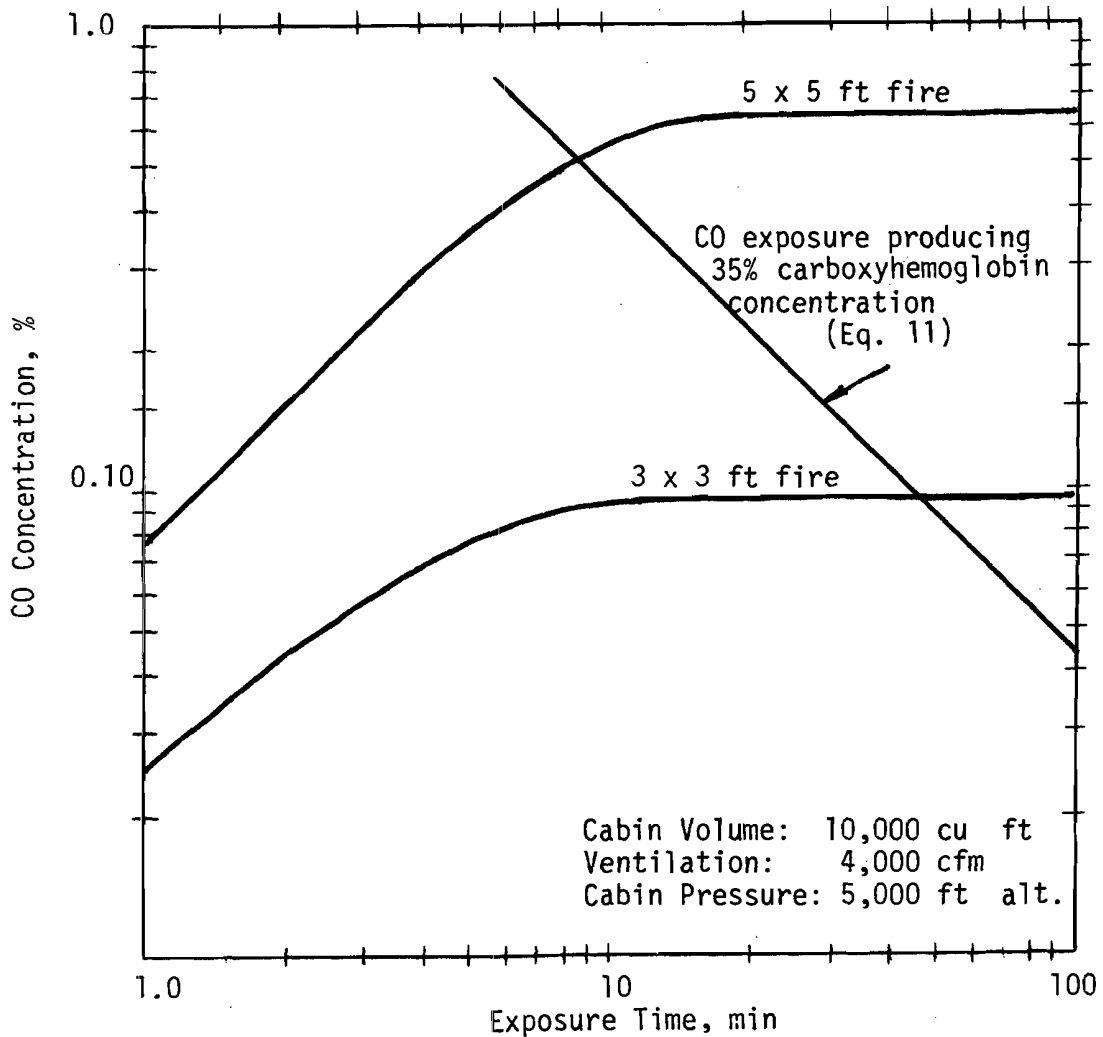

FIGURE 10. CONCENTRATION OF CARBON MONOXIDE IN A WIDE-BODY AIRCRAFT DUE TO AN INTERIOR LIQUID FUEL FIRE.

volume, 4,000 cfm smoke exhaust, and fresh air supplied at 70°F. Smoke temperatures needed to determine the quantity E in Equation 11 were obtained from the relationship derived in the next section. As indicated in Figure 10, for the cases considered, the carbon monoxide concentration reached steady state conditions at about 10 min after the start of the fire. Also, a 35 percent level of carboxyhemoglobin was reached after a relatively long burning period. For example, a 5 x 5 ft fire would require about 8 min to produce a critical concentration of carbon monoxide. As will be shown later, under the conditions given above, a rapidly developing, flaming 5 x 5 ft fire would result in untenable cabin air temperatures within a much shorter time. A slowly developing fire, however, can produce large quantities of smoke and toxic gases with a relatively low rise in the air temperature of the involved spaces. Indeed, experience with actual accidents shows that smoke can be the primary factor endangering the safety of the passengers exposed to a smoldering in-flight fire.

2.2.2.5 Temperatures.

In addition to smoke and toxic effects, the survival of occupants in an aircraft fire can depend on the level of air temperature within the cabin. As found from experimental studies, the cabin temperature produced by a fire, is a function of: (1) the intensity and extent of ignition, (2) the flammability of the materials involved, and (3) the confinement of the fire. These parameters determine both the level and rate of the temperature rise. The latter is of particular interest since it usually determines the time available for suppression activities and evacuation efforts.

In general, electrical short circuits and smoking material are the primary causes of in-flight fires. This does not preclude the possibility of fires being initiated accidentally or purposely by liquid fuel, the intensity of which is of particular concern during in-flight conditions. Studies by Stuckey⁴⁴ using 1 quart of JP-4 in a 1 x 1 ft pan placed underneath a seat in a Boeing 737 have shown profound differences in fire growth between pre-1968 and more modern types of cabin materials. Fires with pre-1968 materials produced a ceiling temperature of 1250°F within about 250 sec after the start of the fire, radiant fluxes at standing head level of 5 to 6 Btu/ft²-sec, and loss of visibility within 1 min. In addition, the quickly developing fire caused severe damage to much of the directly involved areas as well as to adjacent surfaces. The rapid rise of the temperature suggests a flash fire, which for all practical purposes coincides with the survival limit. For the same experimental conditions but more recent cabin materials, the fire produced a maximum ceiling temperature of 450°F, radiant fluxes at standing head level of approximately 1 Btu/ft²-sec, and loss of visibility in 2 min. In addition, fires with newer cabin materials caused substantially less damage than burning pre-1968 materials. These results clearly demonstrate the benefit derived from using cabin materials of low flammability.

All suppression activities require some time to get started, allowing the fire in the meantime to heat the cabin air. Temperatures produced by 3 x 3 ft and 5 x 5 ft fires in a typical cabin of a wide-body aircraft are shown in Figure 11. The graphs were constructed using the following equation:

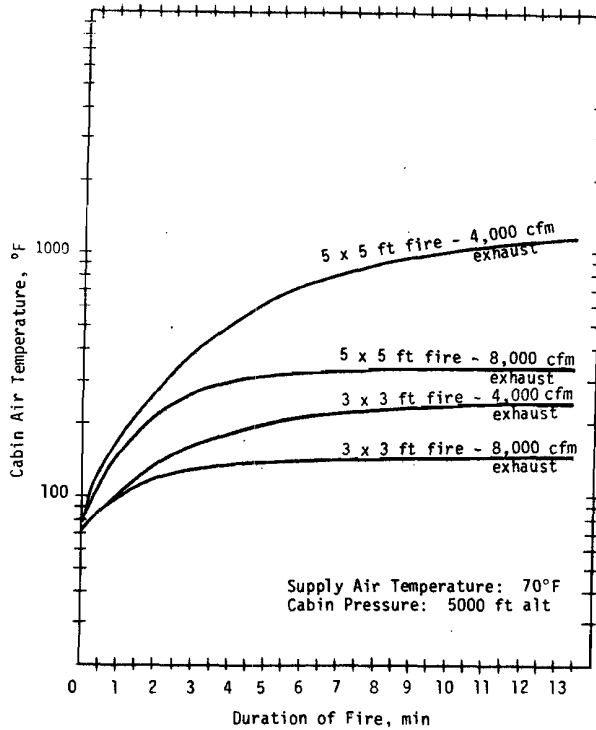

FIGURE 11. AIR TEMPERATURE RISE IN A WIDE-BODY CABIN DUE TO AN INTERIOR LIQUID FUEL FIRE.

$$t = \left(\frac{0.09}{c_p E_2} + t_s \frac{E_1}{E_2} \right) \left(1 - e^{-\frac{E_2}{w} \tau} \right) + t_i e^{-\frac{E_2}{w} \tau} \quad (12)$$

where A_f = fire area, ft^2

c_p = specific heat of air, 0.24 Btu/lb °F

E_1 = supplied air, lb/min

E_2 = exhausted air, lb/min

q = thermal energy released by burning material, $\text{Btu}/\text{ft}^2\text{-min}$
 ($8,400 \text{ Btu}/\text{ft}^2\text{-min} = 0.70 \times 12,000 \text{ Btu}/\text{ft}^2\text{-min}$)

t_i = initial cabin air temperature, °F (70°F)

t_s = temperature of supplied air, °F (70°F)

w = weight of the cabin air, lb

τ = time, min

For Equation 12, we assumed uniform cabin air temperature and a fuel surface-controlled fire with constant heat output of 12,000 Btu/ft² per min per fire area. Of this amount, 30 percent was considered to be emitted by radiation and the rest expended in heating the air. The temperature of the supply air was 70°F and cabin air pressure corresponded to 5,000 ft altitude.

Since some time is required for a fire to develop fully, we assumed that constant heat output would give higher temperatures than those produced by the actual fire. On the other hand, with a uniform cabin temperature, i.e., complete mixing of the air, the temperature is averaged over the entire cabin and lower values are predicted than would exist near the fire. Thus, mutual cancelling of these two effects can be expected to produce temperatures approximating those actually existing in the cabin.

As shown in Figure 11, even a 5 x 5 ft fire requires 3 min for the air within the coach cabin to reach 400°F. This time is certainly sufficient to begin suppression operations, which must take place before the fire reaches such a large size.

Ventilation also has an effect on cabin temperature. As indicated in Figure 11, doubling the ventilation rates to 8,000 cfm would maintain temperatures produced by a 3 x 3 ft fire at tolerable levels and give much lower temperatures with a 5 x 5 ft fire than obtained with 4,000 cfm.

Temperatures produced in a 1,000 ft³ compartmentized cabin at different rates of ventilation are shown in Figure 12, under the assumptions previously described. As readily seen, even a 3 x 3 ft fire can produce a drastic rise in the temperature, possibly to a level of flashover.

Similar temperature distributions were obtained in various experimental studies.⁴⁵ To maintain moderate temperature levels, as described in Figure 12, requires a ventilation rate of 3,000 cfm for a 1,000 ft³ volume, a much larger amount than presently used in aircraft. Of course, any exhaust of hot gases must be predicated on sufficient duct sizing and an incombustible ventilation system. Neither condition is met in current aircraft.

In post-crash fires, cabin air temperature can rise both from the ignition of the cabin interior and from fire gases entering the fuselage through open doors or other openings caused by the crash. Driven by the wind or the chimney effect developed through open doors, hot fire gases can rapidly replace the cabin air. For example, as previously mentioned, in experiments with a section of DC-7 fuselage exposed to a 400 ft² JP-4 fire near one open door, the cabin temperature at the ceiling reached 1,300°F within 50 sec.¹⁵ Closing the doors, except for one near the fire, retarded the flow of hot gases into the fuselage and produced temperatures of about 400°F. Although much lower, these temperatures are still above permissible levels for survival.

Such severe thermal environments can be precluded by safety measures, assuring that no doors are opened on the fire side. Under those conditions, the time necessary for the cabin air temperature to rise will depend on how quickly the cabin walls are penetrated by the fire. As indicated earlier, proper materials and design can considerably delay the penetration time.

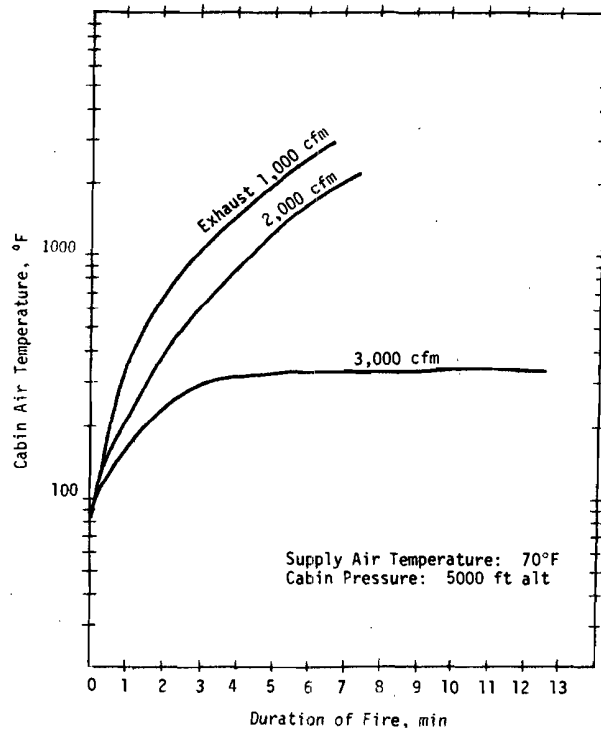

FIGURE 12. AIR TEMPERATURE RISE IN A 1000 ft³ COMPARTMENT DUE TO A 3 X 3 ft INTERIOR LIQUID FUEL FIRE.

Break-up of the fuselage during a crash landing presents a much more difficult problem in protecting the cabin against external fire. Protective measures will be discussed in Chapter 3. Lack or failure of these devices could produce conditions similar to those experienced when the aircraft doors are opened on the side adjacent to the external fuel fire.

A study of the literature¹⁶ reveals that the tolerance limits of humans subjected to circumambient air at a high temperature are not well known. The data reported have been extrapolated from short time exposures or are based on a single incident. Table 4 shows estimates made by Buettner¹⁹ of the minimum time required for humans to collapse when exposed to surrounding air at various temperature levels. The data of Table 4 are approximations only and can be drastically affected by air motion increasing the coefficient of heat transfer. All these uncertainties and possible long in-flight exposure times suggest that 158°F should be used as the permissible limit of cabin air temperature. As noted by Johnson et al.,¹⁶ this temperature can produce some discomfort but no physiological difficulty in breathing.

TABLE 4. ESTIMATED MINIMUM TIME FOR HUMAN COLLAPSE DUE TO EXPOSURE TO CALM HEATED AIR IN ENCLOSED SPACE¹⁹

<u>Temperature, °F</u>	<u>Minimum Collapse Time</u>
122	Several hours
158	1 hr
265	15 min
390	3 to 4 min (Ref. 16)*

*Estimated from approximate data with wet skin.

2.3 SUMMARY OF FIRE SCENARIOS.

The expected scenarios of fires originating inside and outside the cabin are presented in Tables 5, 6, and 7. In most cases the information given is based on data directly concerned with aircraft fires. When such data were lacking, the conclusions reached were derived from experience with related fires.

TABLE 5. AIRCRAFT FIRE SCENARIOS ORIGINATING IN THE CABIN PROPER

Scenario Number	Fire Location	Material First Ignited*	Incipient Fire		Characteristics of Initial Fire Growth
			Development	Flames	
1A	Floor	Aircraft fuel	Moderate to rapid	Large	Carpet: slow beyond wetted area Seating: rapid, if fire extends underneath or nearby Sidewalls: moderate, when reinforced by adjacent seating fire Clothing: moderate to rapid
1B	Floor	Volatile fuel	Rapid	Very Large	See Scenario 1A
1C	Floor	Beverage	Moderate to rapid	Small to medium	Carpet: nil beyond wetted area Seating: small but finite change of involvement Sidewalls: nil, unless seating fire develops Clothing: moderate spread if in immediate vicinity
1D	Floor	Trash	Slow to moderate	Small to medium	May involve seating, if underneath; clothing, if in close proximity: slow to moderate growth
2A	Seating	Volatile fuel	Rapid	Very large	Seating: rapid spread and contribution to fire intensity Sidewalls: moderate when reinforced by seating fire Clothing: rapid involvement Headliner: soon contributes to rapidly growing fire
2B	Seating	Beverage	Rapid	Small	Seating: slow initial growth, accelerates if unchecked Clothing: moderate
2C	Seating	Newspaper or trash	Slow	Small to none	Seating: highly dependent on configuration of materials first ignited; may be smoldering fire Clothing: moderate contribution, if in contact
2D	Seating	Seating	Slow	Small	Can be expected to self-extinguish upon removal of ignition source, unless prolonged (intentional)
3A	Open galley	Trash	Slow to moderate	Small to medium	Sidewalls: low to moderate involvement Floor: local, slight involvement (other galley combustibles may become involved)
3B	Open galley	Volatile liquids	Rapid	Large	Rapid involvement of entire galley, if sufficient liquid initially ignited
3C	Open galley	Grease (cold) Grease (hot)	Slow Rapid	Medium Large	Very slow involvement of sidewall, floor, if unchecked Potential for rapid involvement of adjacent combustibles from cooking accident

*See Table 6.

**TABLE 6. MATERIAL FIRST IGNITED IN FIRE SCENARIOS IN THE CABIN PROPER
(Asterisk in any Column Directs Specific Attention to Comments Column)**

<u>Material</u>	<u>Susceptibility to Direct, Sustained Ignition by</u>			<u>Comments</u>
	<u>Cigarette</u>	<u>Match/ Lighter</u>	<u>Electrical Arc or Spark</u>	
Volatile liquid (e.g., intentional)	Nil	100%	High	--
Aircraft fuel	Nil	100%	High	Postcrash break in tank, line, or fitting
Beverage	Nil	High*	Moderate*	Highly depend- ent on alcohol content
Trash* (including nonluggage carry- ons)	Low	High	Nil	Lavatory or galley produces high quantities. Electrical heaters in galley may serve as igni- tion source
Newspaper	Nil	High	Nil	--
Grease	None	Nil	Nil	Electric heat- ers have small probability to ignite in galley
Carpet	Nil	Nil	Nil	Requires supporting radiation to sustain
Seating	Nil	Low	Nil	--
Clothing*	Low	Moderate	Low	Not necessarily being worn at time
Sidewalls	Nil	Nil	Nil	--

TABLE 7. AIRCRAFT FIRE SCENARIOS ORIGINATING OUTSIDE THE CABIN PROPER
 [Asterisk in Any Column Directs Specific Attention to Comments Column]

Scenario Number	Location of Fire Origin	Incipient Fire		Spread into Cabin		Rate of Spread Within Cabin		Comments (*)
		Material Burning	Development Rate	Path	Penetration Rate	Flame	Combustion Products	
1A	Overhead compartment	Clothing, pillows, blankets	Slow to moderate(*)	Enclosing panels	Slow	Slow to moderate	Moderate to rapid	Primarily a smoldering fire if in a closed compartment
1B	Overhead compartment	Flammable fluid	Moderate to rapid	Enclosing panels	Moderate	Moderate to rapid	Rapid	Burning liquid fuel and other contents can produce voluminous gases
2A	Coat room	Garment bags, hanging clothes	Slow to moderate(*)	Enclosing walls	Slow	Slow to moderate	Moderate to rapid	Rate dependent on type and compactness of clothes
2B	Coat room	Flammable fluid	Rapid	Enclosing walls	Moderate to rapid	Moderate to rapid	Rapid	Rate dependent on type and compactness of clothes
3	Attic	Electric equipment	Slow	Ceiling	Slow to moderate	Slow to moderate	Moderate to rapid	Fire can propagate through concealed spaces along the length of aircraft
4A	Lavatory	Trash	Slow to moderate	Enclosing walls and door	Slow to moderate	Slow	Slow to moderate	Fire can propagate through concealed spaces to different locations of aircraft
4B	Lavatory	Electrical devices	Slow	Enclosing walls and door	Slow	Slow	Moderate	Fire can propagate through concealed spaces to different locations of aircraft
4C	Lavatory	Flammable fluid	Rapid	Enclosing walls and door	Moderate to rapid	Rapid	Rapid	Fire can propagate through concealed spaces to different locations of aircraft
5	Flight station	Electrical equipment	Slow	Door/ concealed spaces	Slow	Slow	Moderate	Primarily a smoldering fire
6A	Cargo hold	Ordinary cargo	Slow to moderate(*)	Floor	Slow to moderate	Moderate to rapid	Moderate to rapid	Unpressurized areas may retard development of fire
6B	Cargo hold	Flammable fluid and other haz. materials	Moderate to rapid	Floor	Moderate to rapid	Rapid	Rapid	
7	Electrical service center	Electrical devices, batteries	Slow	Floor	Slow to moderate	Slow to moderate	Moderate to rapid	
8	Landing gear well	Electrical components/ landing gear	Slow to moderate	Floor	Slow	Slow	Slow to moderate	
9A	External, adjacent to aircraft	Aviation fuel	Rapid	Skin, insulation liner	6 to 8 min(*) (wide-body)	Rapid	Rapid	Affected by wind
9B	External, adjacent to aircraft	Aviation fuel	Rapid	Window failure	<5 min(*)	Moderate to rapid	Moderate to rapid	Affected by wind
9C	External, adjacent to aircraft	Aviation fuel	Rapid	Open door	<1 min(*)	Moderate to rapid	Moderate to rapid	Affected by wind
9D	External, adjacent to aircraft	Aviation fuel	Rapid	Openings in fractured fuselage	<1 min(*)	Rapid	Rapid	Affected by wind
10	On-board(*)	Various	Rapid	Various	Rapid	Rapid	Rapid	Affected by discharging oxygen

3. SYSTEM FEASIBILITY.

3.1 PRIORITIES OF NEED.

The main hazards affecting the occupants in an aircraft fire are smoke, toxic gases, and heat. All are time dependent. In the case of aircraft fires, the involved time periods can be very short. For this reason, it is of major importance to the design of aircraft fire management/suppression systems to assign priorities for limiting the effects produced by the fire.

3.1.1 In-Flight Fires.

Any in-flight fire must be immediately controlled and rapidly extinguished, and the products of combustion must be diluted and removed from the cabin. Lack of a proper exhaust and failure to suppress the fire quickly could result in prohibitive concentrations of smoke, carbon monoxide, and high cabin air temperatures. A rapidly developed (to 25 ft² area), flaming liquid fuel fire in the cabin of a wide-body aircraft could be expected to produce:

- Temperatures exceeding 158°F¹⁶ in less than 1 min (Figure 11)
- Excessive blood carboxyhemoglobin (35 percent)⁴² in about 8 min (Figure 10)

However, most in-flight fires do not involve such extensive liquid fuel spills and develop at a relatively slower rate, producing smoke and toxic gases as the primary outputs of concern.

Both experiments and accident data indicate that, during in-flight fires, untenable levels of smoke are reached before those of toxic gases and heat. Marcy,²⁴ studying the flammability of cabin materials, states: "Up to the time of sudden occurrence of the flash fire, ambient temperature and carbon monoxide remain low compared to human survival limits. Smoke as compared to heat and carbon monoxide would be the most severe factor affecting the safety and comfort of passengers during early stages of the fire." Similar conditions can be expected from the on-board, post-crash fire, as in the case of the Boeing 727 accident in Salt Lake City,⁴⁶ where fire occurred inside the aircraft immediately after impact. Survivors reported that dense smoke obscured their vision and made breathing difficult from the very beginning of the fire.

Many of the accident data reported deal with pre-1968 cabin materials. Similar results can be expected with newer materials, which although less flammable can produce quantities of smoke under intense fire conditions. Hence, efficient limiting and removal of smoke are critical criteria for designing aircraft fire protection, and will also decrease the concentration of toxic gases and the temperature of the cabin air.

3.1.2 Post-Crash Fires.

Depending on the conditions of the crash, various untenable cabin environments can be quickly reached. Penetration of the fuselage by an external fire, exposure through open doors or fractures, or a fire resulting from fuel spills within the aircraft can cause a rapid rise in the cabin temperature, in addition to high concentrations of smoke and toxic gases. Hence, in any post-crash fire, the survival of the passengers depends on the rapid evacuation of the aircraft before critical cabin conditions are reached. Unlike in-flight fires, post-crash fires generally produce shorter exposure times, which permit us to assume that passengers will be able to endure higher cabin air temperature limits. Although a value of 390°F has been mentioned (Table 4), cabin air temperatures about 265°F seem a more realistic limit.

Smoke may again be an even more critical concern. Certainly it inhibited evacuation in the Salt Lake City crash mentioned above. Similarly, in simulating post-crash conditions, Brown concluded that the smoke hazard preceded that produced by the cabin air temperature.¹⁵ Although smoke and its associated irritants may not be directly life threatening during the short times predicated for post-crash escape, their presence delays evacuation processes both psychologically and physiologically. This may be a fatal delay because of the potential rapid increase in environmental heat and toxic gases.

The post-crash fire thus represents a multifaceted problem, each aspect demanding solution. The fire originating on-board or from limited penetration must be controlled. Likewise, and perhaps simultaneously, on-board effects of fires from large, external, adjacent fuel spills must be resisted. While the fire and its effects are being controlled, passengers must be removed from the plane since time is so critical.

3.1.3 Synopsis.

There is a wide variety of fire management or suppression systems. Some of them have been studied in the context of aircraft fire safety, others have yet to be seriously considered for aircraft applications but have been extensively developed for other applications. Concepts abound that await full development and application to fire problems, perhaps aircraft fire problems.

To facilitate a review and evaluation of the feasibility of this multitude of systems and concepts, we have grouped and treated them by the following categories:

- Cabin Fire Suppression (and Detection)
- Cabin Smoke Protection
- Fire Hardening of Fuselage Envelope
- Fire Hardening of Adjacent Compartments
- Evacuation Assistance.

3.2 SUPPRESSION-ORIENTED CABIN FIRE MANAGEMENT.

Suppression-oriented fire management systems for aircraft can be designed to protect both life and property from an in-flight or ground operations cabin fire and also protect the aircraft interior when it is not occupied. The latter benefit alone can be very important considering the concentration of values inside a modern jet transport. Any structure would almost certainly contain some built-in protection against fire if it could be provided at a cost as low as the systems described herein. The modern transport aircraft contains electrical power sources, a very heavy concentration of interior combustibles, and is unoccupied for a considerable portion of every day. Built-in protection could significantly reduce the risk of a major fire loss.

Existing fire protection technology has been used to develop conceptual designs for active fire suppression systems intended to:

- Suppress a fire that originates within a protected area either during flight or on the ground
- Impede the spread of an external crash fire into the aircraft, if the spread occurs only at a limited number of points within the protected zone.

These conceptual designs include both total cabin protection systems and spot protection systems covering specific spaces such as lavatories and coat rooms. All systems are able to suppress specific internal cabin fire scenarios; however, the ability to delay external crash fire spread into the cabin varies significantly among the various systems. None of the systems are effective in impeding the spread of fire which occurs over a wide area or at multiple entry points. A summary of the features and characteristics of each of these systems is presented in Table 8. Details of the conceptual designs are presented in Sections 3.2.1 through 3.2.7.

These active fire suppression systems are based on proven fire protection technology for structural, marine, or vehicular applications. Most systems are intended to suppress fires starting in the protected area or to impede the spread into the protected area at a few local points. The fire suppression agent is applied directly to the fire except in one total and some spot protection systems in which the agent fills the entire protected volume. The design of most of these systems is based on extensive testing and many years of actual fire experience; most, however, will require some components to be developed or modified for use in aircraft.

The weight and cost estimates of the conceptual designs are based on installation in a typical narrow body jet transport (Boeing 727-200) and a typical wide body jet transport (McDonnell-Douglas DC-10). The assumptions used in making the cost estimate are presented in Appendix B. Some installation features, such as suppression agent storage location, are largely arbitrary and could be readily modified. In addition, these concepts are based on a particular interior cabin configuration which is illustrated in the description of each system. Variations in the configuration among airlines are prevalent.

TABLE 8. SUMMARY OF SUPPRESSION SYSTEM CHARACTERISTICS

System	Agent	Actuation	Discharge Time	Weight, lb		Cost, \$		Seat Area	Concealed Space	Flam. Spill	Scenario Effectiveness***			Supplemental Operations
				727	DC-10	727	DC-10				Lavatory	Hang-up Storage	Crash Exposure	
Automatic Sprinklers	Water	Fusible Link/Sprinkler Head	5 min	760	1100	28.0	55.4	5	1	2	4	4	3	---
	AFFF					29.0	55.6	5	1	5	5	5	3	---
Zoned Water Spray	Water	Rate Anticipation Detectors in Cabin, Heat Detectors in Lavatories and	5 min	860	1190	57.6	86.3	5	1	2	4	4	2	---
	AFFF					57.7	86.5	5	1	5	5	5	2	---
Surface Application	Halon 1211	Hang-up Storage	30 sec	290	565	68.2	106.9	5	2	5	5	5	1	Shut lavatory vents
Total Flooding	Halon 1301	↓	10 sec	350	720	29.2	63.6	4	3	5	5	5	0	Shut all vents
Spot Application-Lavatories*	1211 or 1301	Fusible Link/Nozzle	5 sec	15	45	1.5	4.6	0	0	0	5	0	0	Shut lavatory vents
	Water or AFFF		20 sec	50	149	0.22	0.68							
Spot Application-Hang-up Storage**	1211 or 1301	↓	5 sec	16	28	1.4	2.5	0	0	0	0	4	0	---
	Water or AFFF		20 sec	66	116	0.30	0.53							

*Three in 727, nine in DC-10

**Four in 727, seven in DC-10

***Subjective ranking from 0 to 5

3.2.1 Suppression Agents.

The primary fire suppression agents currently being used in structural, marine, and vehicular fixed fire extinguishing systems are:

- Water
- Foam
- Halogenated hydrocarbons--Halon 1211 or Halon 1301
- High expansion foam
- Dry chemicals
- Carbon dioxide.

Conceptual designs were not developed for high expansion foam, dry chemical, or carbon dioxide agents; a preliminary evaluation judged these agents inappropriate for the specific application herein. High expansion foam was excluded because it is applied at a relatively slow rate compared to other agents, does not effectively expand when contaminated by some combustion products, and provides the psycho-physiological risk of a crowded cabin completely filled with foam. Dry chemical systems were also excluded because of the potential effects of powder particles on electrical contacts in the aircraft and visual acuity; and, the limited effect of dry chemical on certain types of fires.

High expansion foam is applied somewhat more slowly than other agents because of the time necessary to start generating the expanded foam and then to move the foam from the discharge outlet to the fire. The generation of high expansion foam also requires a supply of clean air. This would be readily available for in-flight fires, but in crash fires any intake air could be contaminated with products of combustion. Such contamination prevents proper expansion of the generated foam. An even more important consideration is the effect that filling a cabin with high expansion foam would have on passengers. Their vision would be completely obscured and local air circulation would be limited by the mass of bubbles. Experience has shown that healthy individuals can breathe and move through a high expansion foam-filled volume. There is no experience, however, to determine the physiological effect of high expansion foam in a compartment crowded with people of various ages and physical condition. The psycho-physiological risks of vision obscuration plus possible respiratory impairment are considered too high to warrant implementation.

A fixed dry chemical fire extinguishing system was not considered for the same reason that dry chemical fire extinguishers are not normally used on aircraft. The finely divided and dispersed powder may get onto electrical contacts and prevent their proper operation. Problems have been noted with dry chemical residue on some electrical equipment after small rapid transit fires. This risk would be considered an acceptable alternative to fire damage if possible electrical disruptions did not effect the ability to land the aircraft safely. However, because the dry chemical is very penetrating and would be dispersed throughout the aircraft fuselage, the zones of possible adverse influence cannot be predicted. In addition, although the monoammonium phosphate dry chemical has been approved by nationally recognized testing laboratories for use on fires involving ordinary combustibles, it is of doubtful effectiveness

on stored luggage, hanging garments, and seat cushions. Dry chemical fire suppressants act in the combustion zone and the monoammonium phosphate based agents also leave a sealing residue on the hot surfaces of burning combustibles. There is no significant cooling, penetration into surface, or residual atmospheric effects such as an inert atmosphere or wetting down of uninvolved combustibles.

Carbon dioxide was excluded because the concentrations necessary to suppress a fire by total compartment flooding would also suffocate the occupants. Carbon dioxide could be used to protect local areas, just as portable carbon dioxide fire extinguishers are now used in aircraft. However, fire protection experience has shown that such fixed systems are heavy and require about three times more agent by weight than halogenated hydrocarbon systems.

3.2.2 Suppression System Actuation.

Automatic fixed fire suppression systems can be activated by sensing combustion gases or smoke, temperature levels, temperature changes, or flame. The class of combustion gas sensors categorized as smoke detectors can provide early warning of many anticipated cabin fire scenarios, but also have a very high ratio of false or unwanted responses. From structural experience, even in well maintained installations of high quality equipment the ratio of false alarms to actual fires ranges from 15:1 to 25:1. There are many environmental signatures other than fire which also actuate smoke detectors, for example, moisture, aerosols, smoking, dust, electrical transients, etc. Installation of smoke detectors in compartments such as lavatories would likely produce an even higher ratio of false alarms from sources such as moisture, dust, and normal toilet products including hair spray, deodorant, perfumes, etc. In addition, smoke detectors are intended to alarm under conditions that may lead to fire but do not pose an immediate fire threat, such as smoldering materials. This is an essential feature in protecting buildings that are unoccupied or contain sleeping occupants. However, in areas containing awake occupants, smoldering fires will be manually detected long before a smoke detector operates. Even in relatively "clean" and uncluttered spaces, such as computer rooms, significant precautions are necessary to prevent inadvertent operation of fixed fire suppression systems actuated by smoke detectors.

Detectors which operate at a fixed temperature level and are suitable for actuating cabin fire suppression systems include eutectic and fusible devices and bimetallic switches. The eutectic and fusible devices activated by heat are the most reliable detection method for actuating fixed fire suppression systems. These devices are also relatively free of false or unwanted alarms in most operating environments. The automatic sprinkler, which is both a detector and extinguishing agent application nozzle, represents the most widely used device of this type. Although the eutectic or fusible device is also the slowest of all fire detectors to operate, its reaction is generally good under serious flaming fire threats. For example, in flaming fires, ordinary automatic sprinklers generally respond in sufficient time to suppress lethal fire gas accumulation within a room.

The bimetallic switch detectors operate more quickly than fusible or eutectic devices because of their low thermal inertia. However, the bimetallic switch cannot be directly integrated into suppression applications as readily as the fusible or eutectic devices.

Rate of rise and rate anticipation detectors provide a faster response than any of the fixed temperature devices. Rate anticipation detectors have been used on aircraft and in aerospace simulation chambers and are also relatively free from false or unwanted alarms. The rate anticipation detector is judged to be very appropriate for use in actuating aircraft cabin fire suppression systems. Although normal rate of rise fire detectors operate more quickly than the rate anticipation detectors, they could be actuated by cabin altitude changes. Current designs are not considered suitable for aircraft application.

Flame detectors can provide the most rapid response to a flaming fire, although the fire must be within line-of-site view of the detector. Flame detectors can, however, be actuated by matches and cigarette lighters and in some case by sunlight in certain artificial light. Because of line-of-site limitations and the potential for false alarms, flame detectors are not judged appropriate for this specific application.

3.2.3 Automatic Sprinkler Cabin Protection.

3.2.3.1 Background.

Automatic sprinkler protection is the oldest and most reliable protection system and has been shown to be, of all types of fixed fire suppression systems, the most free from inadvertent actuation. Sprinklers are widely and successfully used to protect both life and property in structural and marine applications. The sprinkler head is a detector, valve, and nozzle; heat from the fire actuates the sprinkler by opening the nozzle, which discharges water on the fire. Water is supplied under pressure to sprinkler heads from a suitable source through a pipe or tubing distribution system. In the normal sprinkler system, also called a wet pipe sprinkler system, the distribution piping is filled with water under pressure at all times. The sprinkler head contains an orifice nozzle and a deflector which disperse the water into an umbrella-shape pattern to cover a wide area uniformly. The orifice is sealed by a disk held in place by a two-piece mechanical linkage or glass bulb. The mechanical links are under stress and held together using a solder or eutectic material having a precise melting point. Heat from a fire melts the solder or eutectic, releasing the link and opening the orifice. In the glass bulb version, the orifice disk is held in place by a bulb containing a liquid. Heat expands the liquid, breaks the bulb, and opens the orifice. Some sprinklers also have a heat collector connected to the linkage, which improves convective and radiant heat transfer in order to reduce the time lag before sprinkler operation.⁴⁷

Recent experimental and development programs have produced⁴⁸⁻⁵¹ and validated new sprinkler heads intended specifically for use in occupied dwellings where very rapid response is necessary to protect life in confined spaces. These new sprinkler heads operate five times more quickly than ordinary sprinklers now on the market. Under most flaming fire scenarios, these new sprinklers suppress a fire before lethal combustion gases accumulate in typical dwellings, including such small volumes as found in mobile homes. However, their resistance to false actuation in the rigors of aircraft use is undocumented.

3.2.3.2 Sprinkler Operation.

Sprinklers are devices for automatically applying water to a fire in sufficient quantity to either extinguish the fire completely or control it so that it does not spread and can be quickly suppressed manually. When a fire is burning out of reach of the direct waterspray from the sprinklers, such as underneath a seat, the sprinkler can only control the fire and keep it small (although frequently such fires are suppressed by the indirect action of the spray mist or generated steam).^{52,53} In typical fire scenarios, this may require a few minutes of water discharge before the indirect application is effective; in some situations it may take considerably longer.

Automatic sprinkler systems are not designed to provide sufficient water to operate all sprinklers within a fire zone simultaneously. Just as water supplies for automatic sprinklers in building structures are not designed to supply water to every sprinkler head, the water system for the aircraft is only designed to supply water to the sprinklers that are operating to control a fire.⁵¹ This arrangement permits varying the operating flux by either increasing the operating pressure of the water supply or changing the sprinkler head orifices. The duration of discharge can be varied by varying the capacity of the water supply or adding additional water supply modules. Either of these can also be used to supply water to more sprinklers in order to handle a larger design basis fire.

The only sprinklers that open are those that are directly exposed to the heat of the fire. The systems are not designed for every sprinkler in an area to be open; normally, neither the piping nor the water supply is adequate for such extensive use. Sprinkler systems for single family dwellings are only designed for a maximum of two sprinkler heads operating simultaneously;⁵¹ sprinkler systems for commercial, industrial, and storage occupancies are typically designed for 8 to 50 sprinkler heads to operate simultaneously, depending on the fire hazard of the contents.⁵⁴

Sprinkler heads are spaced and the water supply and distribution systems sized so that water is supplied to the fire at a minimum application density, typically expressed in gallons per minute (gpm) per square foot (ft²). Single family dwelling sprinklers must supply 0.08 gpm/ft² with one sprinkler operating and 0.06 gpm/ft² with two sprinklers operating.⁵¹ Commercial, office, and multiple family residential densities normally provide 0.1 gpm/ft²; systems in industrial and storage buildings have considerably higher water application rates.⁵⁴

The water supply for sprinklers is designed to provide a minimum flow lasting from 10 min for dwellings to up to 2 hr for most commercial and industrial systems. In many cases, the water is supplied from the public water mains and the flow is available for an indefinite period of time. These flow durations include a considerable safety factor with time allowances for indirect suppression. In most actual fires, a few minutes of waterflow is adequate to suppress the flame.

3.2.3.3 Aircraft Cabin Sprinklers.

The design criteria for the aircraft cabin automatic sprinkler system were based on experimental and actual fire experience with structural and marine

sprinkler systems. Those criteria were modified and in some areas compromised because of the aircraft configuration, including furnishings, and the importance of weight. Certain elements of the design, such as the probable number of sprinkler heads likely to operate, the total amount of water needed, and the sprinkler head distribution pattern, must be experimentally verified.

The design concept for an automatic sprinkler system for transport aircraft is intended to apply water at a minimum density of approximately 0.09 gpm/ft² with four sprinkler heads open for 5 min. The head layout for a typical narrow body jet transport is illustrated in Figure 13; a piping schematic is presented in Figure 14. The sprinkler heads are located on a 7 ft spacing in the longitudinal direction with two heads spaced across the cabin. The system features are:

- Area covered per head--38.5 ft²
- Design flow, four heads operating--3.5 gpm per head
- Water supply for 5 min--70 gal
- Gross system weight--756 lb
- Installed cost--\$29,000.

Water is supplied to these sprinklers from a storage tank pressurized with a nitrogen cylinder as illustrated in Figure 15. Tank valve and pressure are supervised by sensors to indicate that the valve is open and that adequate pressure is available. These supervisory signals are displayed at a panel in a flight or cabin crew station.

An automatic sprinkler layout and a piping schematic for a typical wide body jet transport are presented in Figures 16 and 17. The system consists of three heads across on an 8-1/2 ft longitudinal spacing. The heads along the cabin center line cover an 8-1/2 x 8-1/2 ft area and the row of sprinkler heads near the cabin walls covers a 5 x 8-1/2 ft area.

The principal design features for the automatic sprinkler system installed in a typical wide body jet transport are:

- Area covered per sprinkler head--center, 73 ft²; outboard, 43 ft²
- Design discharge, four heads operating--6.5 gpm per head center; 4.0 gpm per head outboard
- Water supplied for 5 min operation--105 gal
- Gross system weight--1100 lb
- Installed cost--\$55,000.

The water is distributed to the sprinkler heads through aluminum tubing concealed above the head liner and/or in overhead luggage compartment assemblies. The tubing is filled with water under pressure at all times so that the heat capacity of the water helps protect the aluminum from thermal damage in a rapidly developing fire with localized high temperatures. Once the sprinklers open, the discharge of water should quickly reduce any high local temperatures that could damage the aluminum. These sprinkler heads should be designed to

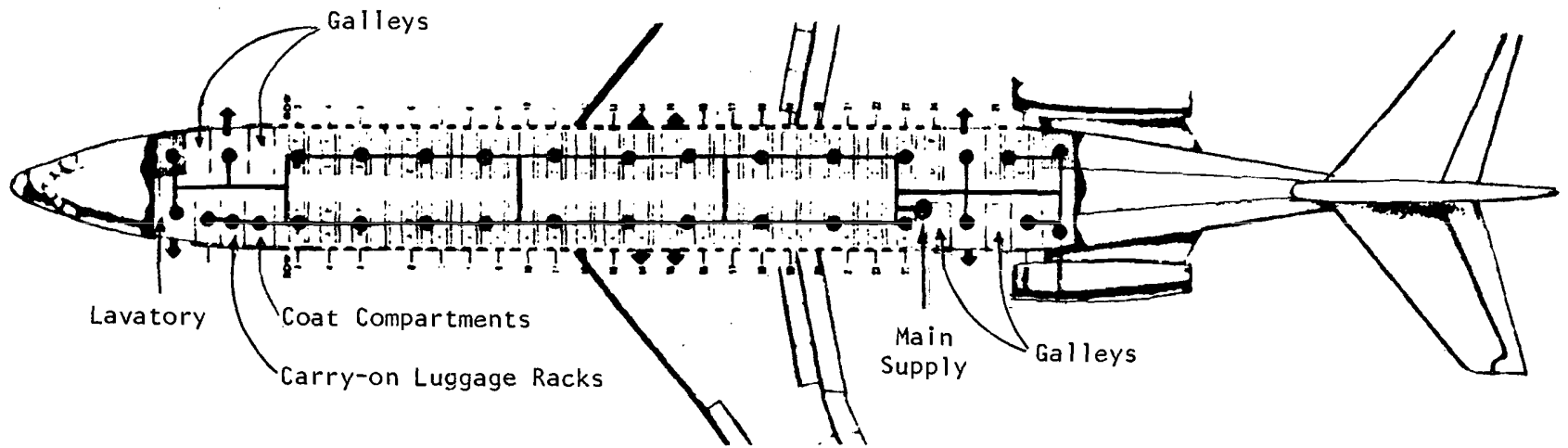
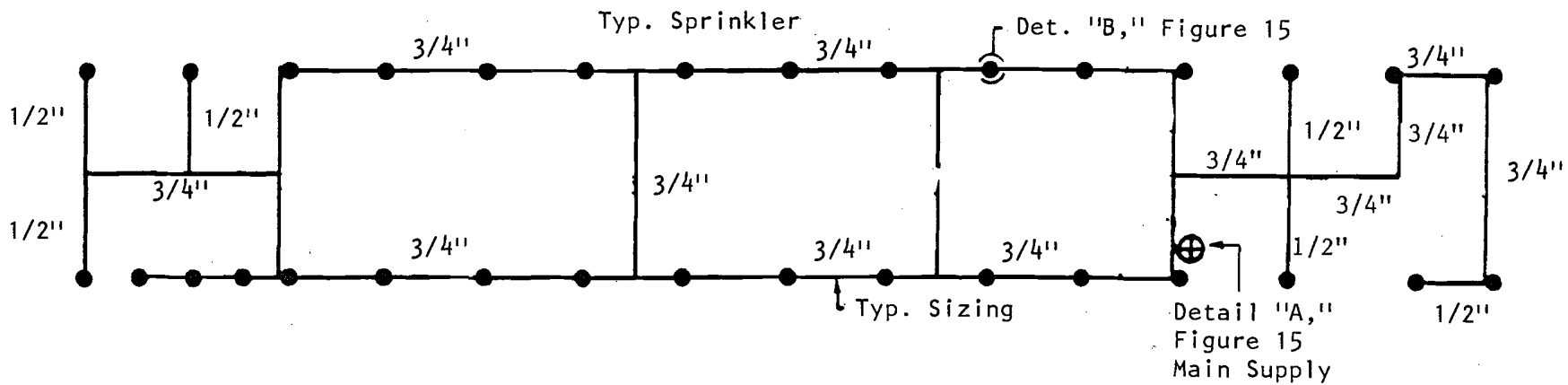
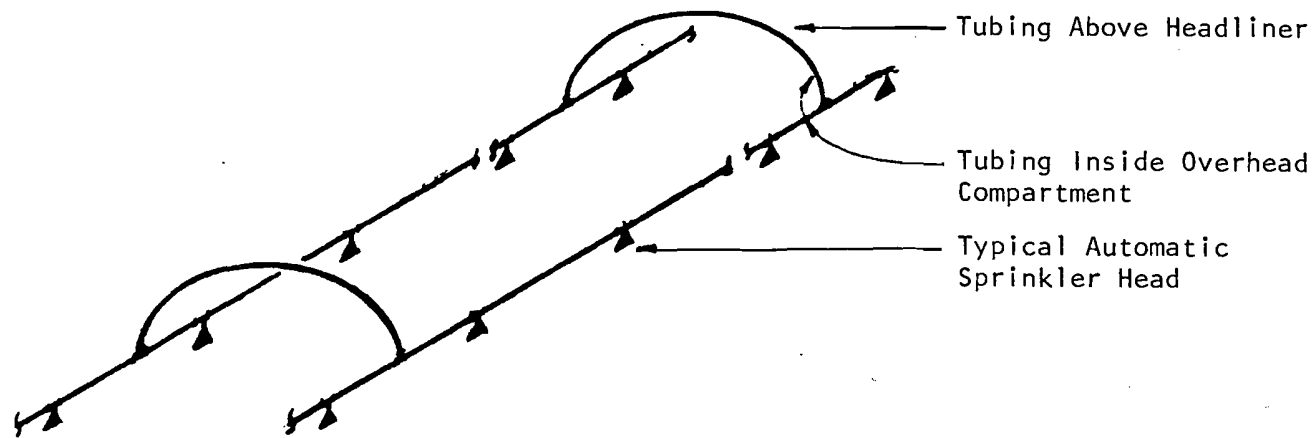

FIGURE 13. LAYOUT OF AUTOMATIC SPRINKLERS ON TYPICAL NARROW-BODY JET TRANSPORT



AUTOMATIC SPRINKLER AND TUBING PLAN

55



SPRINKLER AND TUBING SCHEMATIC

FIGURE 14. SCHEMATIC OF AUTOMATIC SPRINKLERS ON TYPICAL NARROW-BODY JET TRANSPORT

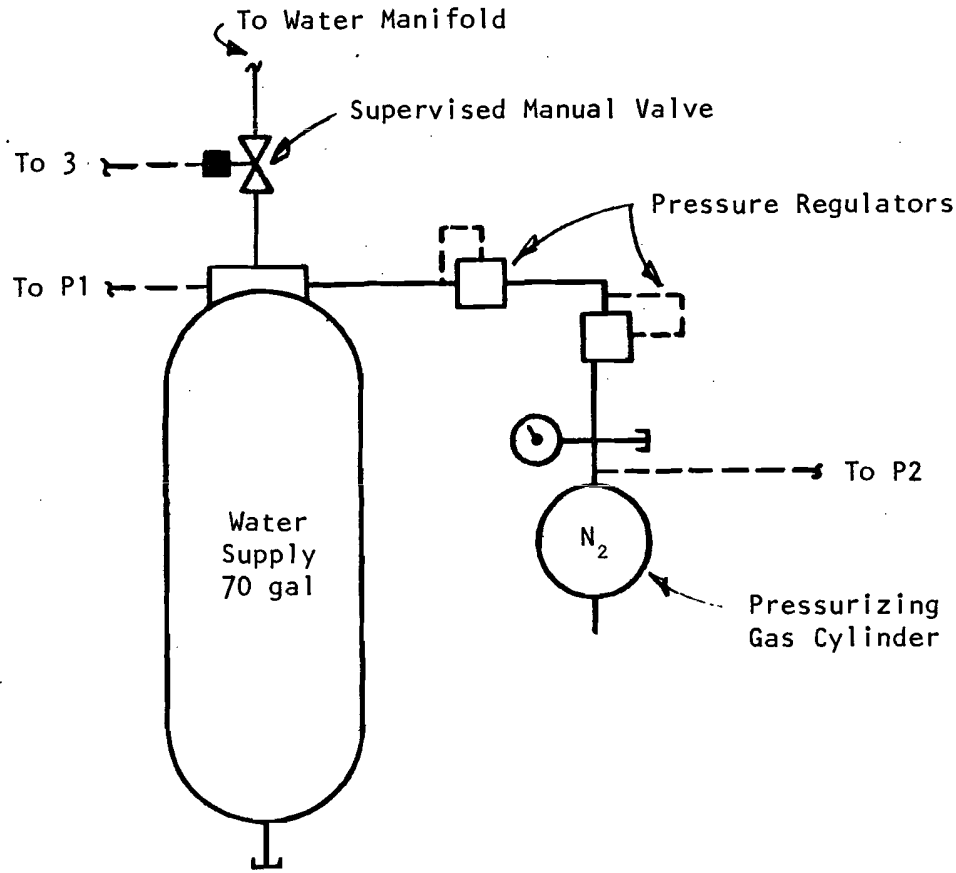

Detail "A" - Typical 70 gal Water Supply

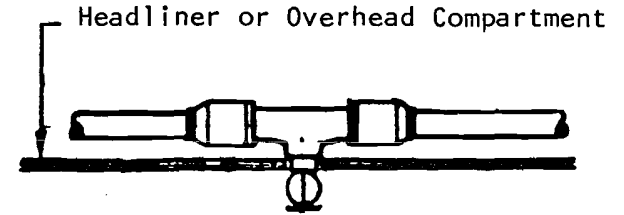

Detail "B" - Typical Sprinkler Head Installation

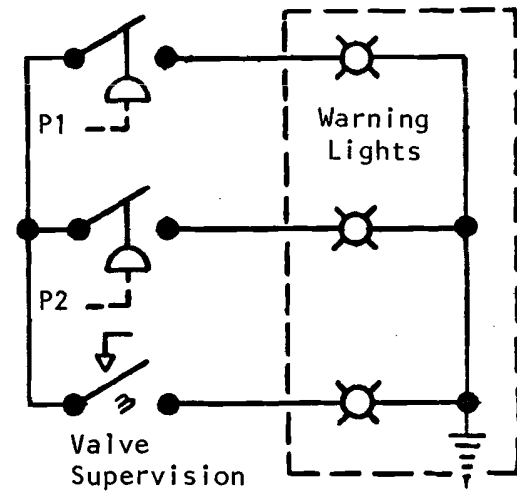

Detail "C" - Electrical Supervision

FIGURE 15. WATER SUPPLY AND INSTALLATION DETAILS FOR AUTOMATIC SPRINKLER SYSTEMS FOR JET TRANSPORTS

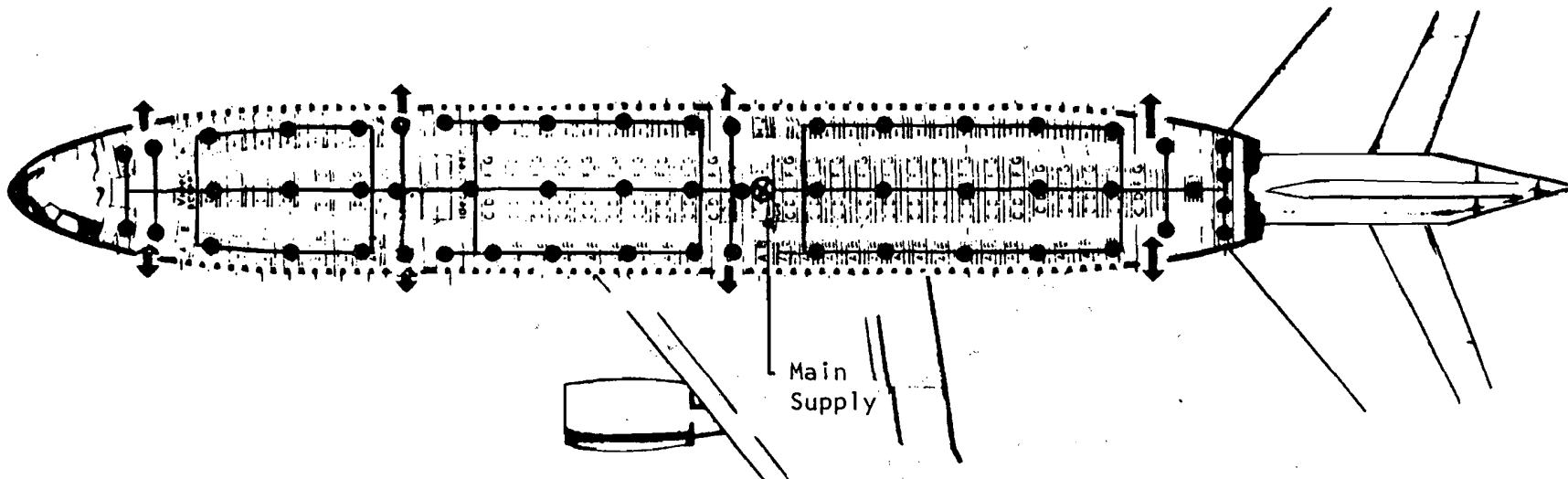
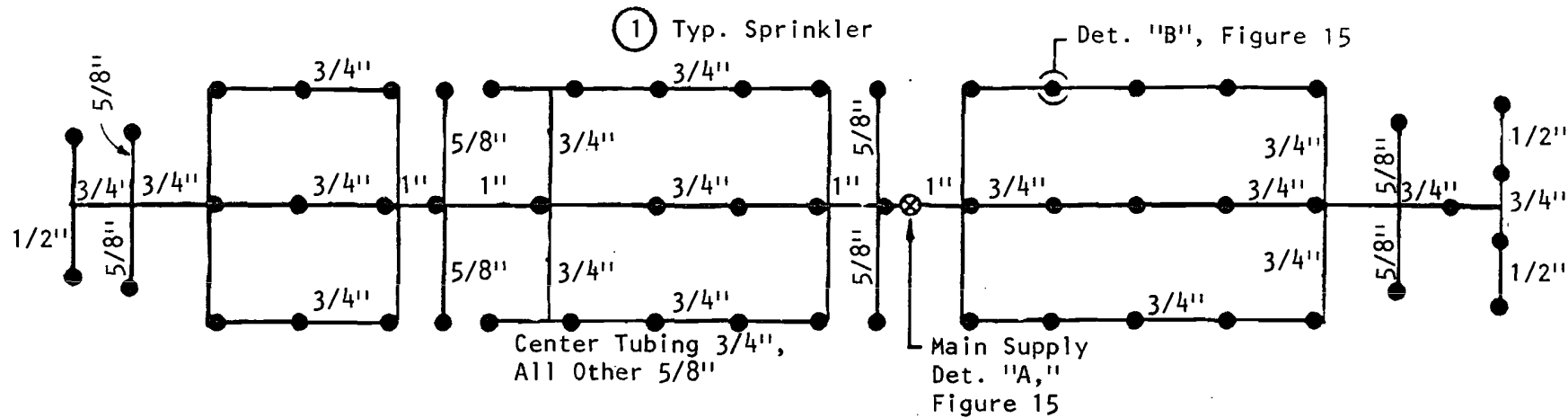
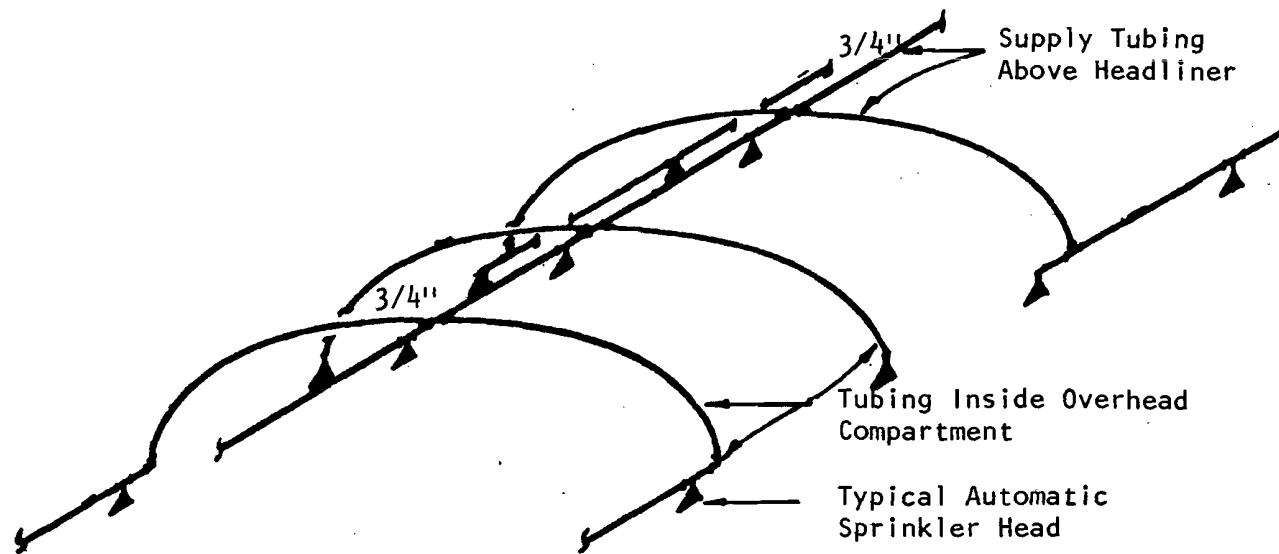

FIGURE 16. LAYOUT OF AUTOMATIC SPRINKLERS
ON A TYPICAL WIDE-BODY JET TRANSPORT



AUTOMATIC SPRINKLER AND TUBING PLAN



AUTOMATIC SPRINKLER AND PIPING SCHEMATIC

FIGURE 17. SCHEMATIC OF AUTOMATIC SPRINKLERS ON A TYPICAL WIDE-BODY JET TRANSPORT

respond very rapidly, as do those recently developed for use in single family dwellings and mobile homes. The orifice and deflectors will have to be custom designed for the aircraft in order to provide the necessary flow and distribution inside the aircraft cabin. The automatic sprinkler system will be very effective on all ordinary cabin fires both in-flight and on the ground as shown in Table 8. Water applied by sprinklers will be reasonably effective on nonpolar flammable liquid spills within the cabin such as might occur during a highjacking attempt. However, water alone is not as reliable in such fires as a foam (AFFF) water solution.

An AFFF/water solution instead of plain water in the automatic sprinklers has been shown to be very effective in controlling flammable liquid spill fires in industrial plants and aircraft hangars.⁵⁵⁻⁵⁷ Unlike most other types of foam, AFFF is effective without the use of special air-aspirating sprinkler heads. AFFF improves the wetting action of water, which then improves its effectiveness in fires involving ordinary solid combustibles. In addition, AFFF also seals a flammable liquid/solid spill fire and prevents reignition after all the suppression agent has been discharged.

The automatic sprinkler suppression system does not provide protection against overhead fires or those in unprotected concealed spaces (i.e., the overhead luggage rack). However, additional nozzles could easily be added to cover many of these concealed spaces should it be determined to be desirable. The sprinklers can provide limited protection against the spread of fire from an unprotected low level concealed space into the cabin, although they will not be actuated until the fire has penetrated the open area.

Crash fire penetration into the cabin can be impeded by sprinkler discharge as long as the exposure heat or locations do not open an excessive number of sprinkler heads. Although sprinklers are designed to extinguish a fire that starts in a protected area, there are many documented cases of sprinklers acting very effectively in reducing the risk of fire spread from an unprotected space into a protected area.

Radiant heating from an external fire through an open door is reduced by a sprinkler head discharging inside the door. The water absorbs and reflects some of the radiant heat and cools much of the interior that is exposed to that heat.⁵⁸ How much of a benefit reflection and absorption will prove to be cannot be predicted. Although it is not an efficient barrier to radiant heat, waterspray is known to provide some benefits as seen from firefighting experience. The effectiveness of sprinkler head discharge in reducing radiant heat penetration will have to be evaluated experimentally. Likewise, the effects on passengers of steam from sprinkler operation in the presence of a large exposing fire needs to be assessed.

Sprinkler performance during fires on the ground can be improved considerably by providing a connection so that crash fire rescue equipment can supplement on-board water. External fuselage connection(s) allow crash fire rescue equipment to pump water from their tanks directly into the aircraft sprinkler systems, just as structural fire fighting apparatus can supplement the water supply to automatic sprinklers in buildings. Routine connection of stationary water supplies to unattended aircraft can provide major "built-in protection" from many ramp fires.

3.2.4 Zoned Waterspray System.

The zoned waterspray system⁵⁹ applies the water to a cabin fire through an array of open spray nozzles arranged to operate simultaneously over a zone or area of a cabin. Two to seven nozzles are installed to cover each zone. The water is supplied to a distribution manifold which feeds the nozzles in each zone through a solenoid or electro-explosive valve. Opening a particular valve supplies water to all nozzles in that zone simultaneously. The valves are opened by the action of a rate anticipation fire detector located within each zone. The spray nozzles are installed below the headliners or overhead luggage compartments, similar to the automatic sprinkler installation described in Section 3.2.3. These nozzles are sized and directed to provide optimum coverage of the interior of the cabin. Water spray actuated by rate anticipation detectors responds faster than fusible automatic sprinkler nozzles, although the system is significantly more expensive, heavier, and more complex than sprinklers.

The water supply for this system is similar to that for automatic sprinklers (see Figure 15). The distribution manifold is normally filled with water under pressure up to the zone selector valves. As an option, the system can also be operated manually to suppress a smoldering or slowly developing fire threat or to wash down or blanket, if AFFF is used instead of water, a flammable liquid spill. The distribution manifold is made of aluminum tubing with flared joints. The integrity of the aluminum distribution network when exposed to fire depends on rapid actuation of the rate anticipation detector to suppress the fire before local elevated temperatures can damage the tube.

The layout and distribution schematic of a zoned waterspray system for a typical narrow body jet transport are illustrated in Figures 18 and 19. The nozzles are arranged in an approximately uniform manner dividing the cabin into 10 zones. The maximum area covered per zone is 168 ft². For simplicity, individual lavatory or coat and luggage compartments are considered zones. Water is supplied from a central storage tank of similar arrangement to that shown in Figure 15. The water supply zone valves are actuated by any one of three rate anticipation heat detectors located in each open area zone or by individual heat detectors located in small protected compartments such as lavatories (Figure 20). The tubing and water supply are designed to provide an application density of 0.09 gpm/ft² with up to two zones discharging simultaneously. The principal features of the narrow body jet transport waterspray system are:

- Maximum coverage per nozzle--42 ft²
- Design flow--3.8 gpm/per nozzle
- Maximum nozzles per zone--4
- Water discharge duration--1 zone, 5 min; 2 zones, 2-1/2 min
- Number of zones--10
- Water supply--76 gal
- Gross system weight--856 lb
- Installed cost--\$58,000.

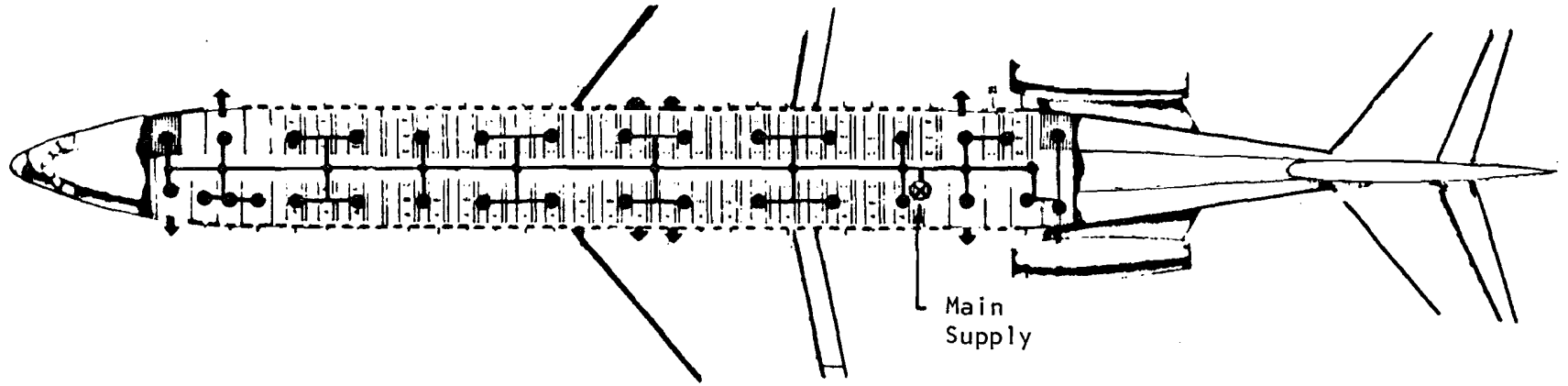
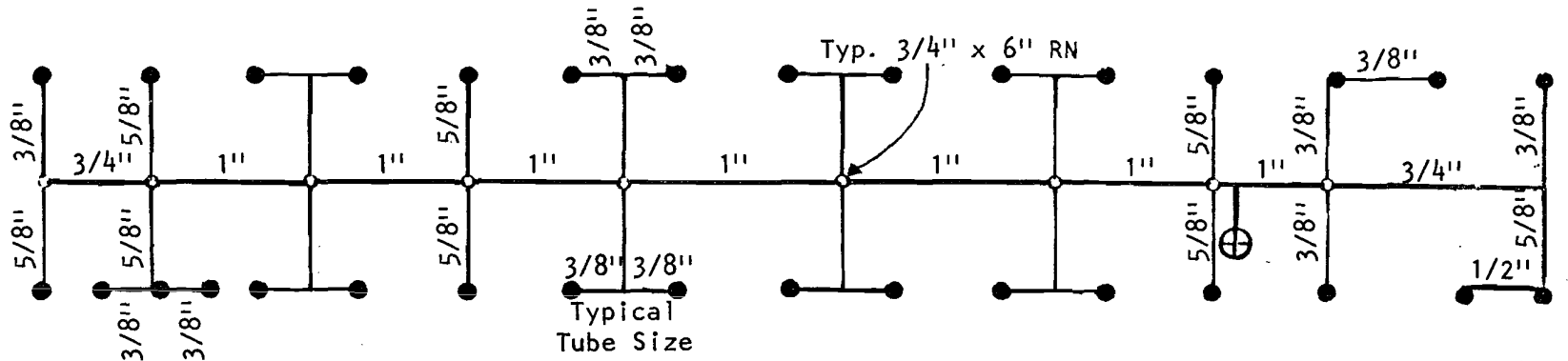
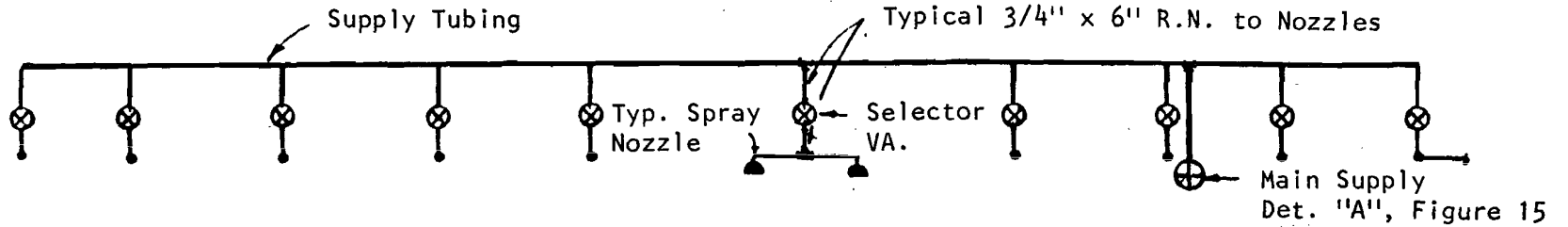

FIGURE 18. LAYOUT OF ZONED WATER SPRAY SYSTEM
ON A TYPICAL NARROW-BODY JET TRANSPORT



NOZZLE AND TUBING PLAN



SECTION - CONTROL VA. AND SUPPLY ARRANGEMENT

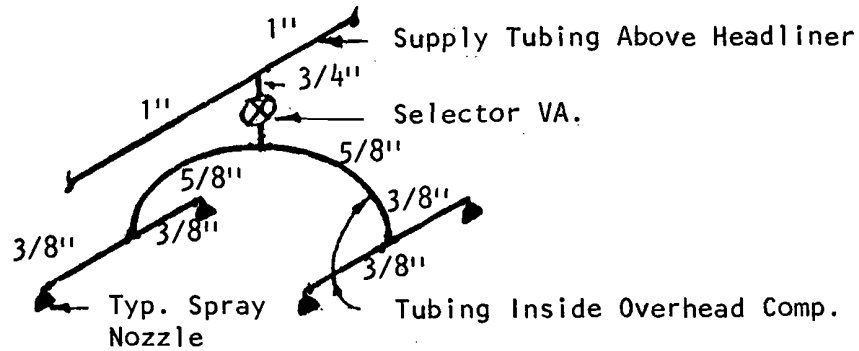

NOZZLE AND TUBING SCHEMATIC

FIGURE 19. SCHEMATIC OF ZONED WATER SPRAY SYSTEM OF A TYPICAL NARROW-BODY JET TRANSPORT

Note: Water Supply Supervision (Figure 15) Also Included in This Panel

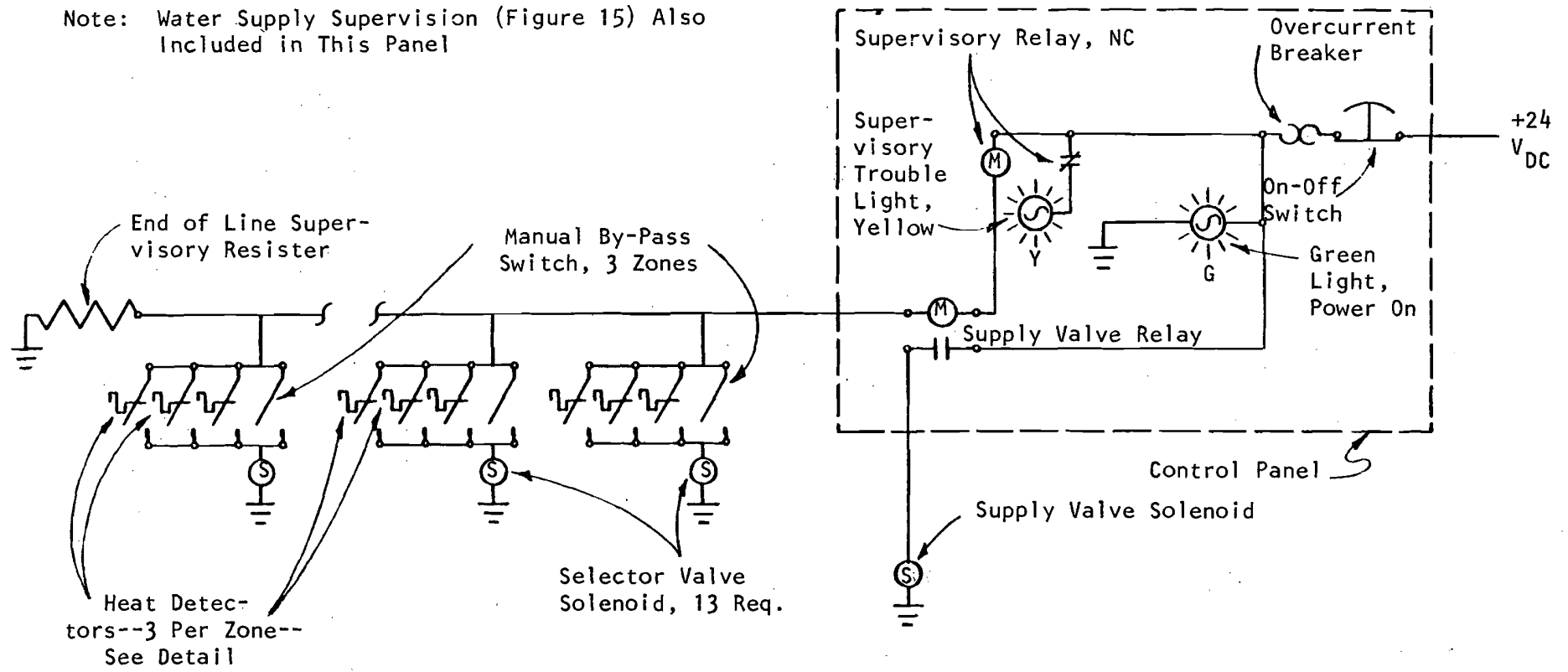

63

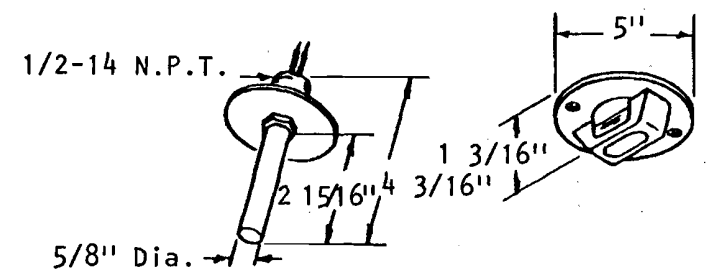

Detail A: Heat Detector

FIGURE 20. ELECTRICAL SCHEMATIC OF WATER SPRAY SYSTEM

The design concepts for a typical installation of the waterspray system in a wide body jet transport are illustrated in Figures 21 and 22. The basic nozzle arrangement for each zone includes a center spray nozzle covering the middle section seats and two rows of three nozzles each covering the outboard seats and sidewalls. The maximum open zone area coverage is 222 ft². Valves for each zone are operated by actuating any one of three rate anticipation fire detectors in the open areas or individual detectors in small compartments. Tubing and water supplies are sized so that any two adjacent zones can operate simultaneously. Specific features of the waterspray system on a typical wide body jet transport include:

- Maximum coverage per nozzle--center, 126 ft²; outboard, 16 ft²
- Design flow--center, 11.3 gpm; outboard, 1.5 gpm
- Water discharge duration--1 zone, 5 min; 2 zones, 2-1/2 min
- Number of zones--13
- Water supply--102 gal
- Gross system weight--1190 lb
- System cost--\$86,000.

The zoned waterspray system has the same general performance capability and limitations as the automatic sprinkler system (Table 8). The system can also be used with AFFF instead of plain water to improve performance with flammable liquid fires and provide added wetting of some ordinary combustibles. For improved exposure protection from external crash fires, separate zones are provided at each aircraft doorway so that a single nozzle covers each door. This provides both improved water distribution and longer duration flow compared to doorway coverage by one nozzle in a zone of seven. This system also can be supplemented through external connection by crash fire rescue vehicles or by stationary water when unattended.

3.2.5 Halon 1301 Total Flooding Protection.

3.2.5.1 General Criteria.

The aircraft cabin Halon 1301 total flooding system is based on the design of fire suppression systems currently used in structural, aircraft, marine, and vehicular fire protection.^{21,22,60-62} Halon 1301 systems are most commonly used to protect high value or critical equipment (computers or control rooms) and spaces that have a serious fire problem (engine compartments and vessel engine rooms). Halon 1301 is considered a relatively safe total flooding agent and national standards permit discharge into occupied rooms provided the concentration does not exceed 7 percent. (Concentrations as high as 10 percent are permitted in occupied rooms that can be evacuated in 1 min, which is not practical for an aircraft cabin in flight.) Halon 1301 is classified as a clean agent since it leaves no harmful residue to clean up. Possible corrosive effects of Halon 1301 decomposition products cannot be entirely ruled out, although actual experience including suppression of fires in telephone exchanges has not identified this as a problem.

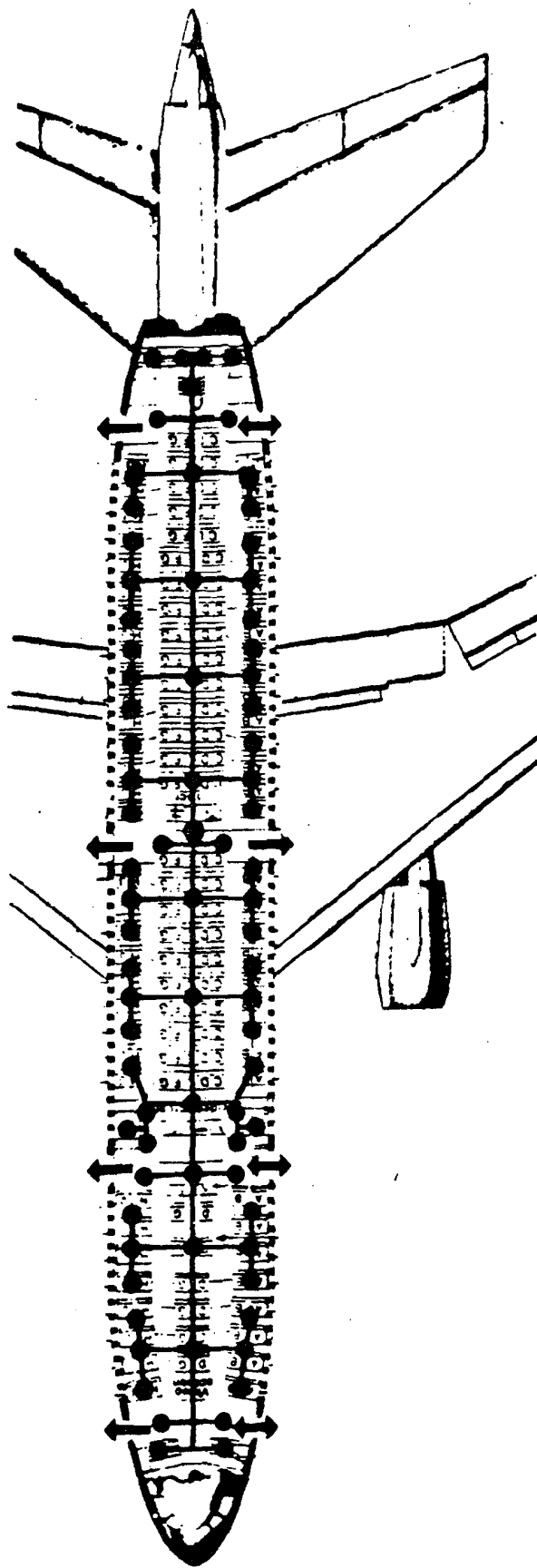
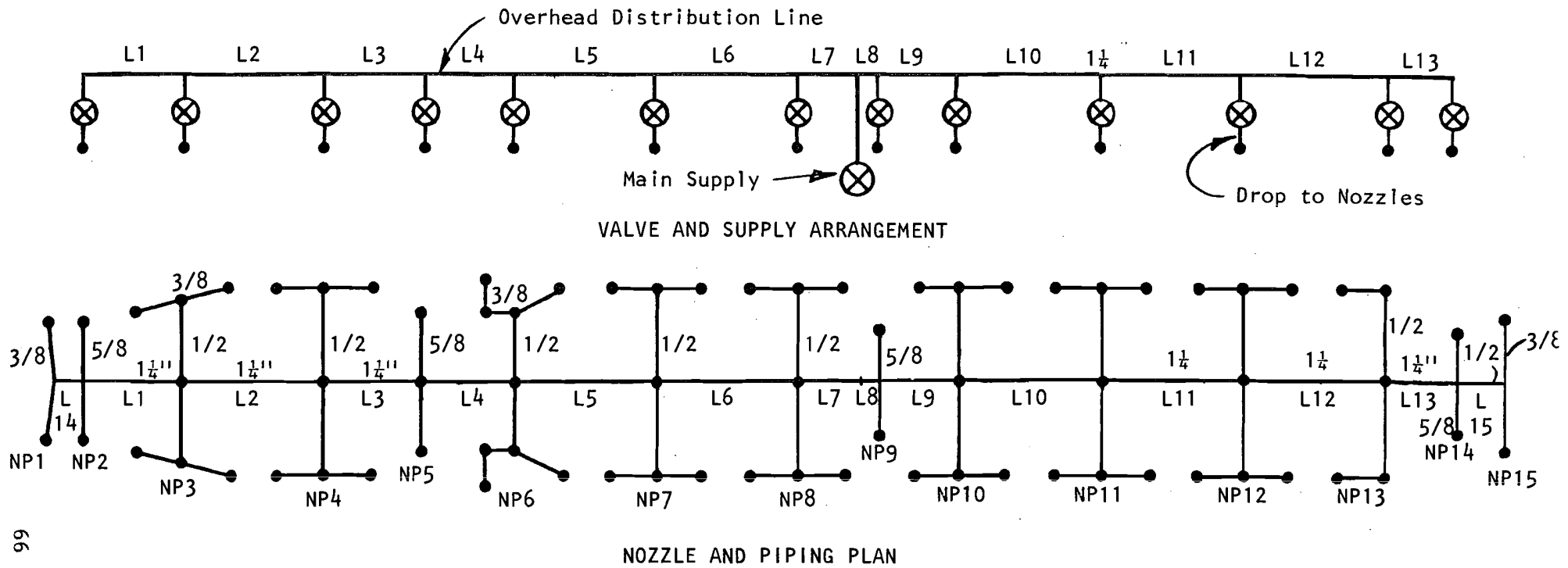
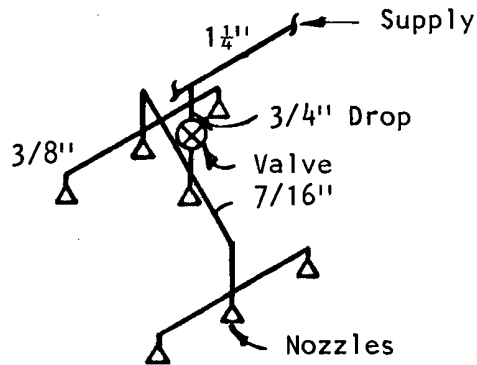

FIGURE 21. LAYOUT OF A ZONED WATER SPRAY SYSTEM
ON A TYPICAL WIDE-BODY JET TRANSPORT



96



Detail "A," Typical Nozzle and Piping Schematic

FIGURE 22. SCHEMATIC OF A ZONED WATER SPRAY SYSTEM ON A TYPICAL WIDE-BODY JET TRANSPORT

The Halon 1301 cabin fire suppression system is designed to discharge sufficient agent to produce a 5 percent concentration by volume at sea level with approximately 6 percent concentration at a pressure altitude of 5000 ft. This concentration is expected to suppress normally anticipated fires in the cabin, although in certain deep-seated fire configurations some manual action may be necessary to inhibit residual smoldering. Although the reaction of halon with hot combustion gases does produce some dangerous decomposition products, we expect this risk to be considerably less than that from gases produced by the fire itself. For in-flight fires, any toxic or noxious gases can be quickly ventilated after the fire is suppressed. In case of inadvertent operation, the halon concentrations will be within acceptable limits of exposure in occupied spaces; there may be a slight risk to some passengers in poor health.

The Halon 1301 cabin fire suppression system requires that, before the agent is discharged, the cabin ventilation be shut down except for air recirculation. Depending on the leakage characteristics of individual aircraft at flight altitudes, makeup air with an extended discharge of Halon 1301 may be necessary to maintain a safe cabin pressure and the proper concentration of Halon 1301 until the fire is suppressed. We do not anticipate that extended soaking of the cabin interior with the halogenated agent will be required, as is sometimes the case in certain structural fire situations, with the type of fire scenarios that can be expected in the cabin.

3.2.5.2 Typical Design Concepts.

The nozzle and distribution tubing layout schematics for a typical narrow body jet transport are illustrated in Figures 23 and 24. The Halon 1301 is stored in two containers manifolded together which supply agent to discharge nozzles through tubing running above the headliner down the center line of the aircraft. Six nozzles supply halon to the open cabin area, two intermediate size nozzles discharge in the fore and aft galleys, and four small nozzles protect coat closets and storage bins. Lavatory compartments are protected by separate self-contained systems. The Halon 1301 containers are sealed by pyrotechnically actuated valves which, when open, supply superpressurized halon to the tubing and nozzle distribution system. These valves can be actuated by 14 rate anticipation detectors located in the cabin area and four in the coat and storage spaces, or manually from fore and aft flight attendant stations. Self-contained systems with fusible nozzles protect the lavatory compartments; these are of the same configuration as described in Section 3.2.7. These lavatory units have a self-contained, exhaust shut-off damper that is automatically closed when the system is operated.

Specific design details for the main cabin protection system are:

- Primary agent supply--166 lb
- Discharge rate--33 lb/sec
- Discharge time--5 sec
- Lavatory agent supply--4.5 lb
- Complete system weight--335 lb
- Installed cost--\$33,000

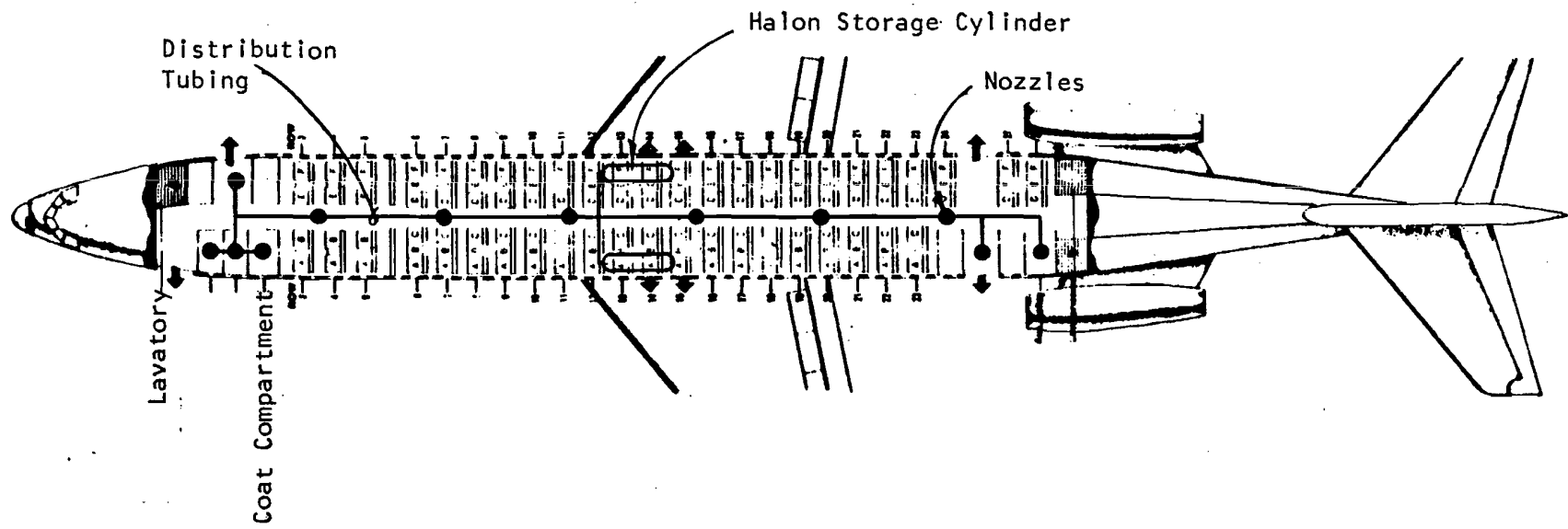

FIGURE 23. LAYOUT OF HALON 1301 SYSTEM ON NARROW-BODY TRANSPORT

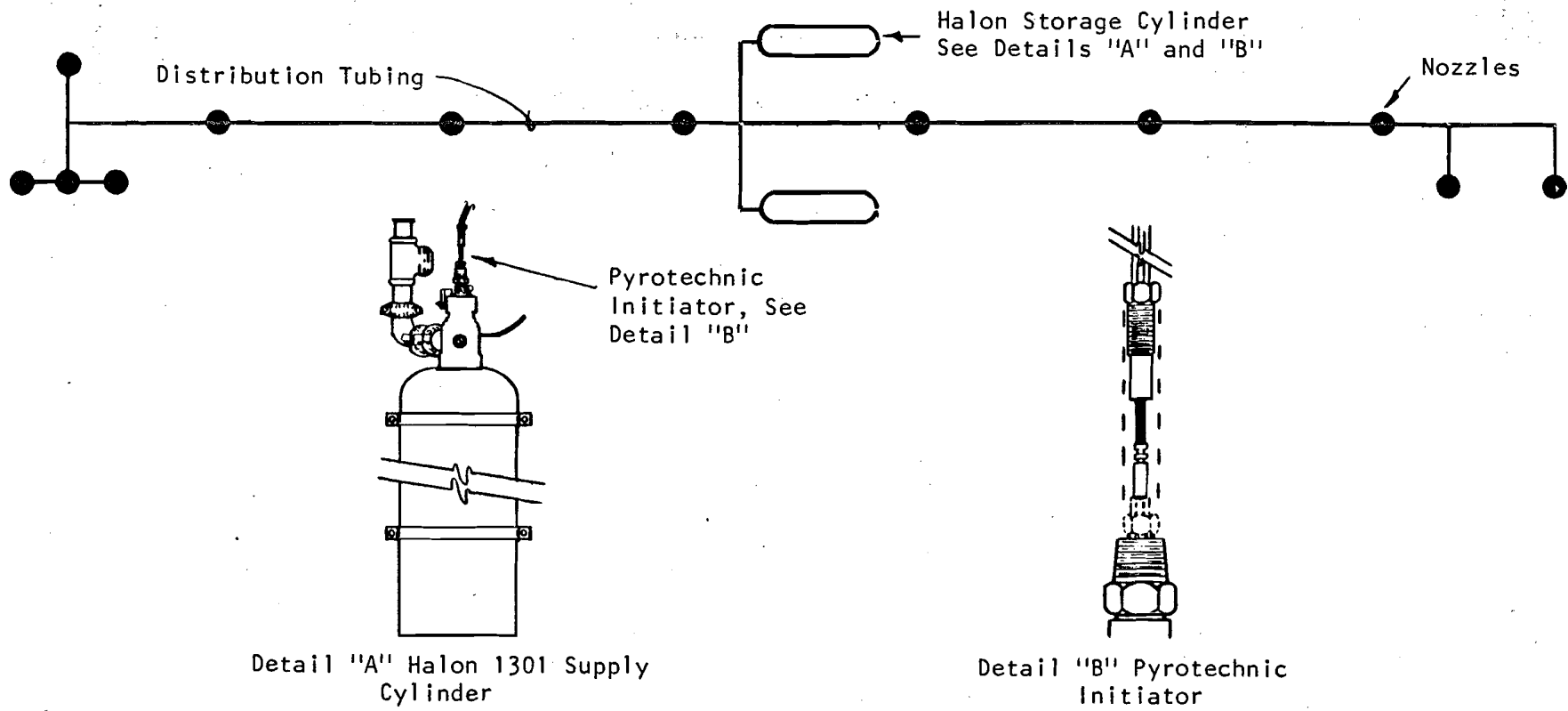

FIGURE 24. HALON 1301 TOTAL FLOODING IN A NARROW-BODY JET

Figures 25 and 26 illustrate the layout schematic of a Halon 1301 total flooding system in a typical wide-body jet transport. This concept features two halon systems that are simultaneously activated; one covers approximately the aft third of the cabin and the other the forward two thirds. Agent is discharged through 12 large overhead open nozzles and four smaller nozzles, which are supplied by tubing running above the headliner along each side of the aircraft. Storage cylinders or spheres are located below the floor and hold the Halon 1301 superpressurized with nitrogen to 360 psig. Twenty-eight open area rate anticipation fire detectors, eight compartment detectors, and a manual switch located at the cabin crew station operate the system. The lavatory compartments are protected by the self-contained systems operated by fusible nozzles. Specific criteria for the complete total flooding system for a typical wide body jet transport are:

- Primary agent supply--352 lb
- Discharge rate--70 lb/sec
- Discharge time--5 sec
- Lavatory agent supply--14.5 lb
- Total system weight--685 lb
- Installed cost--\$51,000.

3.2.5.3 Safety Considerations.

The quantity of toxic gases produced in extinguishing a fire with Halon 1301 depends upon the size of the fire when the agent is discharged and how rapidly it is suppressed. Early warning smoke detectors would be preferred; however, the state of the art of such devices is such that an excessively high false or unwanted alarm rate would result. Rate anticipation detectors proposed for this design would respond quickly in a rapidly developing fire threat; for more slowly developing fire threats, manual system actuation can provide an early discharge time. In addition, while a rapid rate of discharge reduces the amount of toxic decomposition products, it also produces extremely high cabin noise levels and requires very large diameter supply tubing and container valves. When the cabin fire suppression system is actuated, all cabin air ventilation will be shut off except for air recirculation and, depending on the aircraft and altitude, possible makeup air. Once the fire has been suppressed, combustion gases, agent decomposition products, and residual agents can be quickly cleared by turning on normal cabin ventilation. However, the shut-off dampers on the self-contained lavatory compartment suppression systems have to be opened manually in order to ventilate these spaces.

3.2.5.4 System Effectiveness.

The total flooding Halon 1301 system is primarily intended to protect the interior of the aircraft against fire threats that originate in the cabin and adjacent protected spaces, as noted in Table 8. Total flooding with Halon 1301 produces an interior atmospheric environment in which combustion will not continue; overhead, underseat, and fires in open compartments in the cabin can be as effectively suppressed as those in locations directly exposed to the agent discharge. Even fires in adjacent concealed spaces can be suppressed or at least inhibited by agent concentration migrating into those spaces.

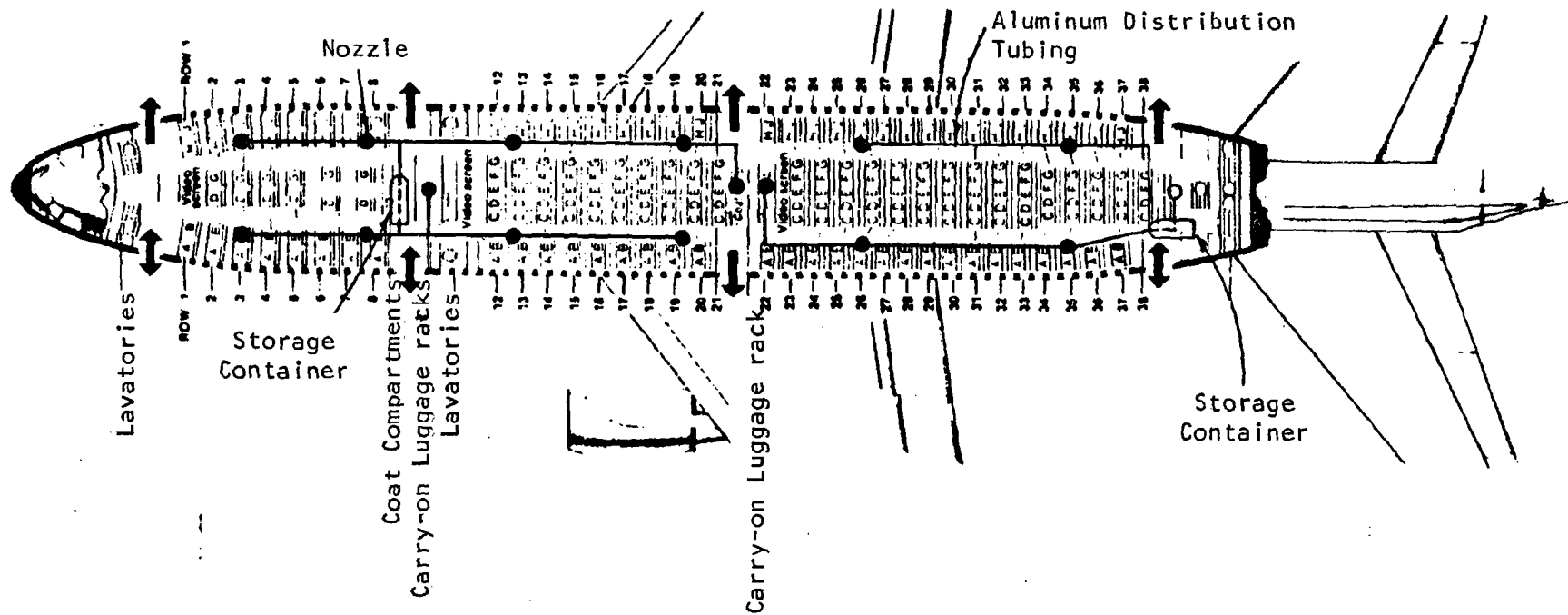

FIGURE 25. LAYOUT OF HALON 1301 SUPPRESSION SYSTEM NOZZLE AND TUBING ON A WIDE-BODY TRANSPORT

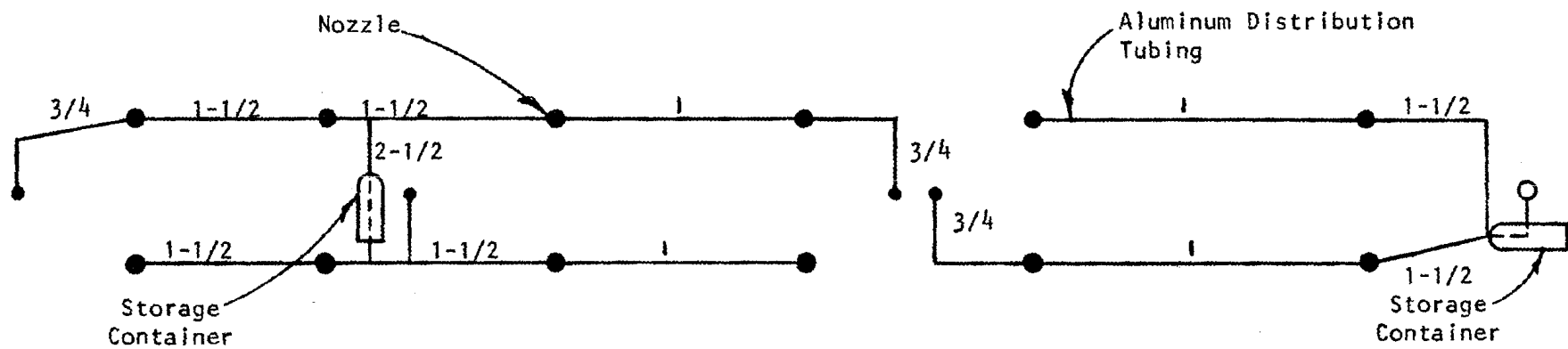

FIGURE 26. SCHEMATIC OF THE NOZZLE AND TUBING OF A HALON 1301 SUPPRESSION SYSTEM IN A WIDE-BODY TRANSPORT

This is not, however, considered a reliable mode of agent distribution. Total flooding with halon might provide some small benefits in case of a crash fire because it can impede small or local penetrations of fire into the fuselage. However, fire exposures through open doors, hatchways, or large damaged openings will dilute agent concentrations and can create large quantities of toxic halon decomposition products.⁶¹ System supplementation for unattended aircraft offers particular benefit.

3.2.6 Halon 1211 Surface Application.

The Halon 1211 surface application system⁶³ is conceptually very similar to the zoned waterspray system and incorporates many of its advantages with those of the Halon 1301 total flooding system. Suppressing agent is applied through overhead open spray nozzles interconnected in an array to cover a particular zone of the cabin. Agent is supplied to each zone by a distribution manifold through solenoid or electro-explosive actuated valves that control the flow to each zone. Halon 1211 is supplied from a storage container superpressurized with nitrogen to 360 psig and connected directly to the distribution manifold. The distribution manifold is filled with Halon 1211 and fully pressurized at all times. The zone selector valves are opened by actuating rate anticipation detectors located within the protected zone. The agent is discharged into separate compartments (lavatories, coatrooms, and storage areas) by means of fusible nozzles supplied from receivers filled from the distribution manifold through manual valves. The manual valve is closed after the filling. This limits the amount of agent that will be automatically discharged into small compartments but still allows additional agent to be discharged by opening the manual valve.

Design criteria for the surface application were developed from FAA tests⁶⁴ in which a 2-1/2 lb portable Halon 1211 extinguisher suppressed a well developed fire involving a triple aircraft seat. The surface application system is designed to discharge 2-1/2 lb per seat assembly in 20 sec. Aisle areas are covered with a fan-type spray nozzle which discharges 4 lb in 20 sec. A 50 percent safety factor has been added to the supply, plus capacity for simultaneous discharge of multiple zones as was provided by the waterspray system.

The design criteria for lavatory and storage spaces are based on a minimum 6 percent concentration with total flooding. However, since several compartments are supplied from the same receiver, the actual concentration will generally be higher. The fusible nozzle incorporates a pressure switch that closes a damper on the exhaust vents of the lavatories and actuates an alarm. This design concept is a direct adaptation of self-contained halon suppression systems that are commercially available for the protection of engine compartments of small pleasure boats.

The overhead nozzles are supplied through a network of aluminum tubing located above the headliner and in overhead luggage compartment assemblies. The integrity of the aluminum tubing under local fire exposure depends on rapid actuation of the suppressant agent to prevent damage from elevated temperatures.

The surface application system for a typical narrow-body jet transport consists of 15 open area zones containing one flat spray nozzle per seat assembly and a flat spray nozzle to cover the aisle areas, Figures 27, 28 and 29. A

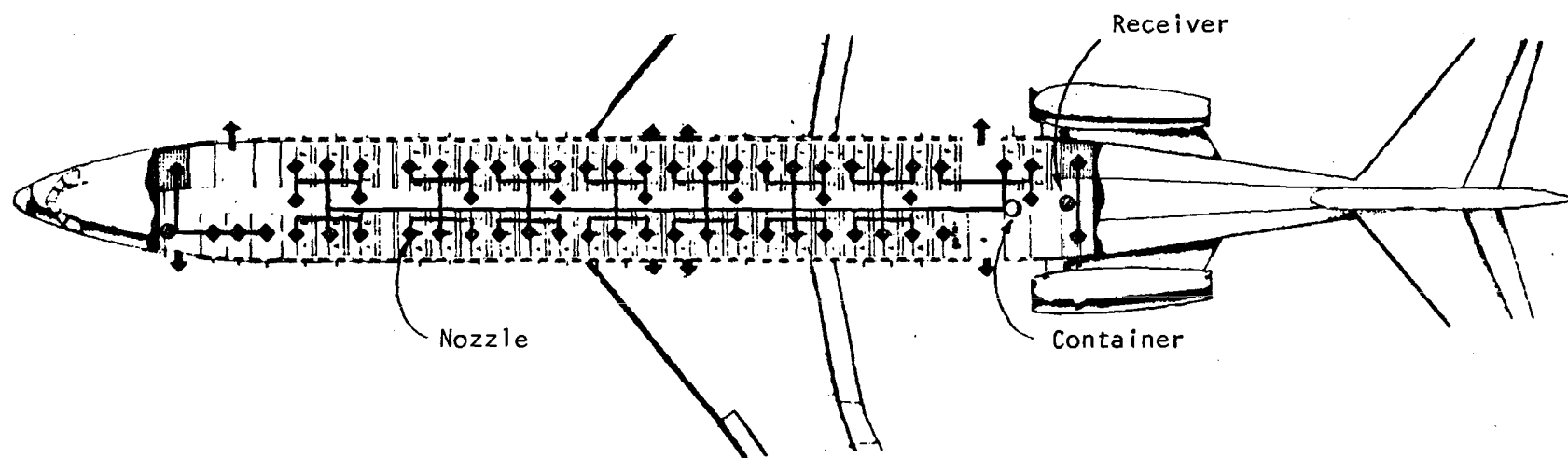
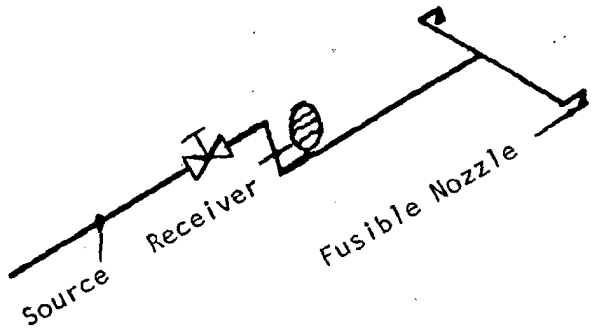
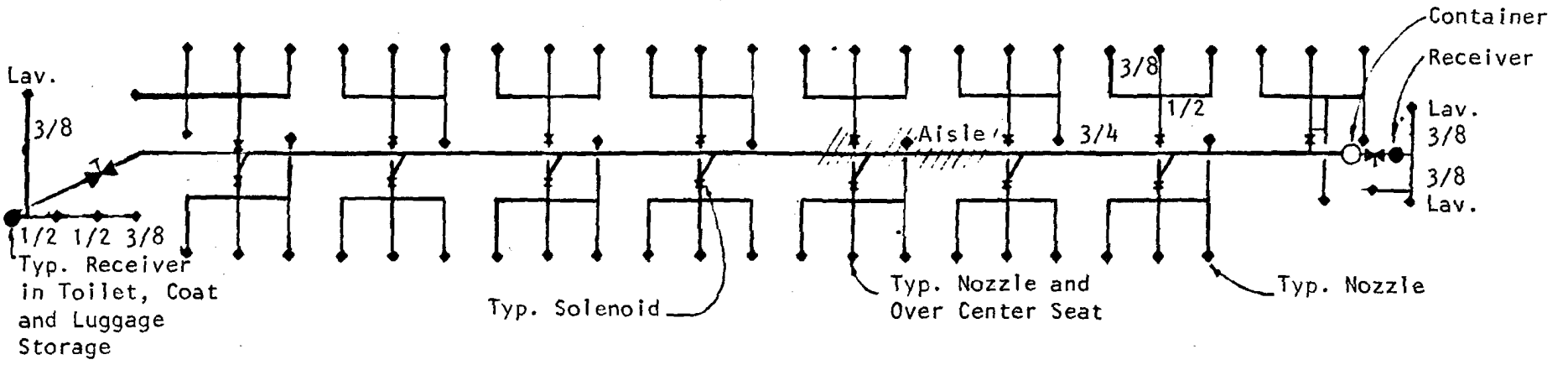
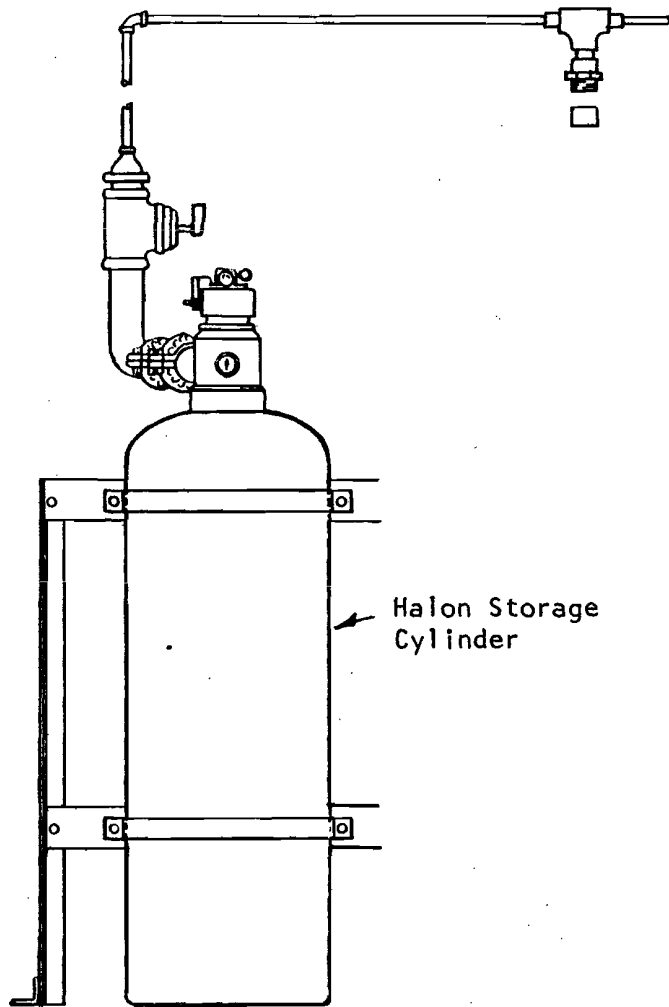

FIGURE 27. NOZZLE LAYOUT FOR A HALON 1211 SPRAY SYSTEM
ON A TYPICAL NARROW-BODY JET TRANSPORT



Detail Receiver-Typical for Toilets, Coat and Luggage Storage

FIGURE 28. SCHEMATIC OF A HALON 1211 SPRAY SYSTEM ON A TYPICAL NARROW-BODY JET TRANSPORT



Halon Storage Cylinder

Detail "A" Schematic Typical Halon Supply

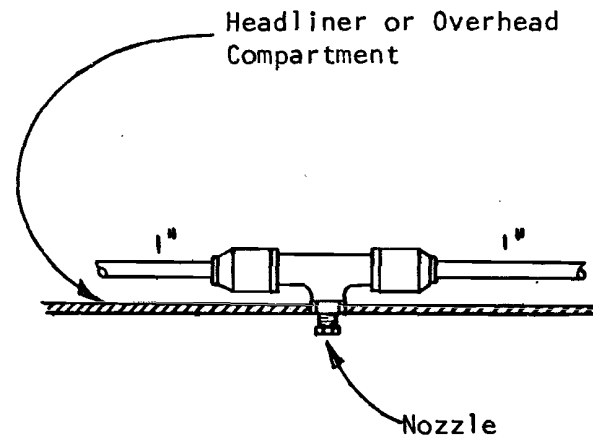

Headliner or Overhead Compartment

Nozzle

Detail "B" Schematic Typical Nozzle Head Installation

FIGURE 29. TYPICAL HALON 1211 SUPPLY AND INSTALLATION DETAILS

typical zone covers three seats on one side of the aisle, with aisle coverage from one of two adjacent zones. A receiver is located in the front and rear of the plane to supply halon to lavatory and storage compartments. The significant system criteria are:

- Number of open area zones--15
- Nozzles per zone--3 to 4
- Coverage per basic zone--3 seat assemblies or 3 seat assemblies plus aisle
- Discharge rate per basic zone--22.5 to 34.5 lb/min
- Discharge time, four zones operating: 30 sec
- Halon required--open area, 55.5 lb; lavatory and storage, 10.5 lb; ullage, 6 lb; total, 72 lb
- Total system weight--290 lb
- Installed cost--\$68,000.

The open area protection tubing and supply are sized to permit simultaneous operation of four basic zones, including two with aisle nozzles and two with only three-seat nozzles. Twenty-two rate anticipation detectors actuate the system through a logic circuit control. Actuation of any individual detector normally operates two to three zones in the aircraft simultaneously.

Complete discharge of the weight of the full amount of Halon 1211 into the cabin provides, when dispersed, an average concentration of 2 percent Halon 1211 at sea level and a slightly higher concentration at altitude. This is well within the tolerance levels for occupants from undecomposed agent alone, but a period of higher concentration will be experienced by passengers in the immediate discharge area. In general, toxicity problems are considered to be more severe when using Halon 1211 rather than Halon 1301 in enclosed spaces.⁶² Concentrations in lavatories and coat rooms would exceed human tolerances. Discharge would occur, however, only when the fusible elements on the nozzles open; at this time we expect that human tolerance will already have been exceeded by the fire environment. The risk of inadvertent operation of these nozzles is extremely low. If a failure inadvertently discharged the agent into an occupied lavatory with no fire present, there would be potential for injury; however, the risk of this inadvertent operation is extremely low.

The Halon 1211 surface application system arranged for a typical wide-body jet transport uses one nozzle per seat assembly, with separate zones covering the center seating area and two outboard seating areas, as shown in Figure 30. The aisles are covered by a fan spray nozzle supplied from the zones for the outboard seats. Four receivers are provided to serve lavatory and storage compartments, one in the front and rear and two in central locations. The valving arrangement and tubing schematic are shown in Figure 31. The detailed system design criteria for the typical wide body jet transport are:

- Number of open area zones--34
- Nozzles per open area zone--4-6

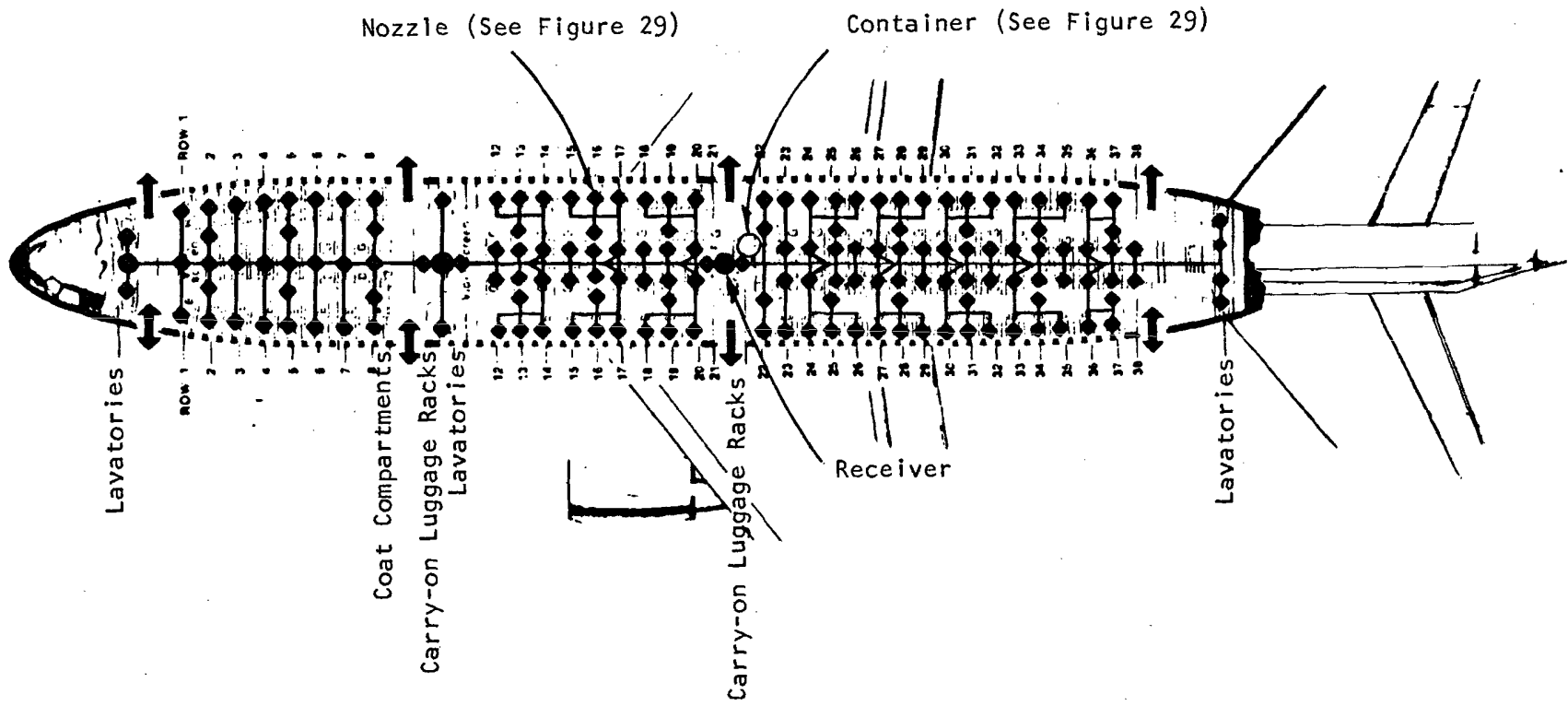
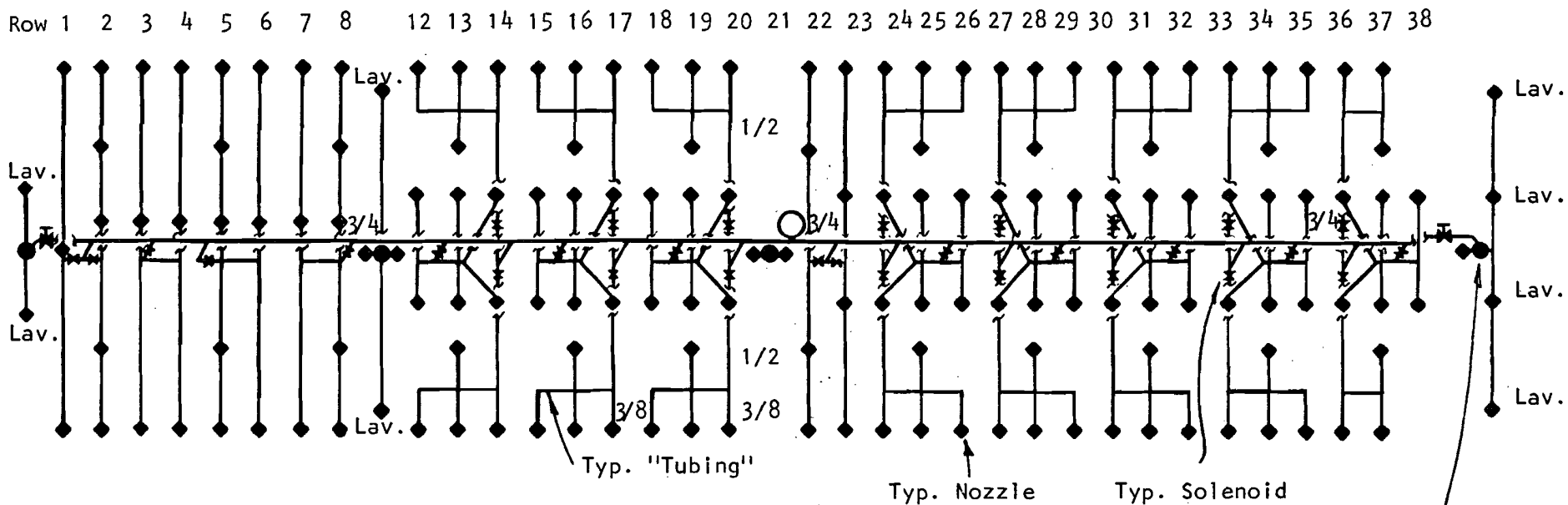
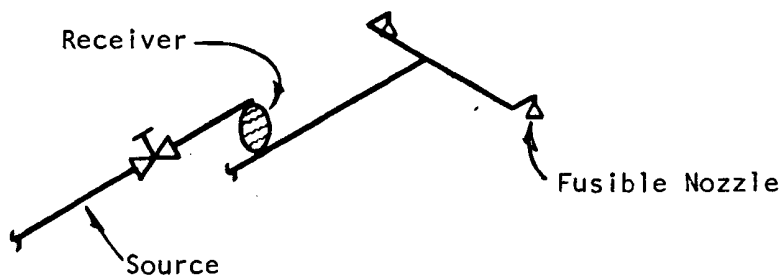

FIGURE 30. NOZZLE LAYOUT FOR HALON 1211 SPRAY SYSTEM ON A TYPICAL WIDE-BODY JET TRANSPORT



79

Typ. Receiver
Toilets, Coat
and Luggage
Storage, See
Detail "A"



Detail "A" Typical Nozzle and Piping Schematic

FIGURE 31. SCHEMATIC OF A HALON 1211 SPRAY SYSTEM ON A TYPICAL WIDE-BODY JET TRANSPORT

- Coverage per basic zone--outboard, 3 seat assemblies plus aisle; inboard, 6 seat assemblies
- Discharge rate per basic zone--34.5 to 45 lb/min
- Discharge time, two center and two outboard zones operating--30 sec
- Halon requirements--open area coverage, 79.5 lb; lavatory and storage, 24 lb; ullage, 10.5 lb; total, 114 lb
- Total system weight--564 lb
- System cost--\$107,000.

Discharge of the halon into the open cabin area will result in a concentration of approximately 1.2 percent at 70°F and sea level after the agent has been uniformly dispersed. This concentration is even lower than in the narrow body jet transport and well within human tolerances. Again, agent concentration in the lavatory compartment will exceed normal human tolerances. A total of 50 rate anticipation heat detectors will be used to operate the valves to discharge fire suppression agent.

3.2.7 Spot Protection.

Spot protection systems are completely self-contained fire extinguishing agent, storage, and application systems that are designed to cover small spaces or compartments. These systems are intended for use in either:

- Compartments capable of having a very rapidly developing fire such as coat closets, lavatories, and some galley areas
- Locations where a fire might develop slowly but undetected until it becomes a serious threat.

These spot protection systems are similar in capacity and size to a portable fire extinguisher; however, the discharge of the contents is automatic instead of manual. Similar automatic fire protection systems are commonly used in engine compartments on small boats, restaurant range hoods and ducts, small electrical closets, and other small rooms or areas. The spot protection design concepts presented herein use water, AFFF, Halon 1211, and Halon 1301 as the primary fire suppression agent. All systems contain the agent stored under pressure and released by a fusible nozzle.

The water and the AFFF/water solution systems are similar in concept to a small (1-1/2 gal capacity) pressurized portable fire extinguisher. The manual discharge valve, hose, and nozzle are, however, replaced with a small closed head automatic sprinkler used to control the discharge. The water or AFFF/water solution is discharged into the fire and generates steam to provide indirect protection and cooling, as well as direct cooling of burned and unburned combustibles. The AFFF has improved wetting action compared to water and can also blanket and suppress any flammable or combustible liquid spills. The specifications for these two design concepts are summarized in Table 9, and detailed in Figure 32.

The Halon 1211 and Halon 1301 systems are directly adapted from commercial products used to protect engine compartments on pleasure boats, racing cars,

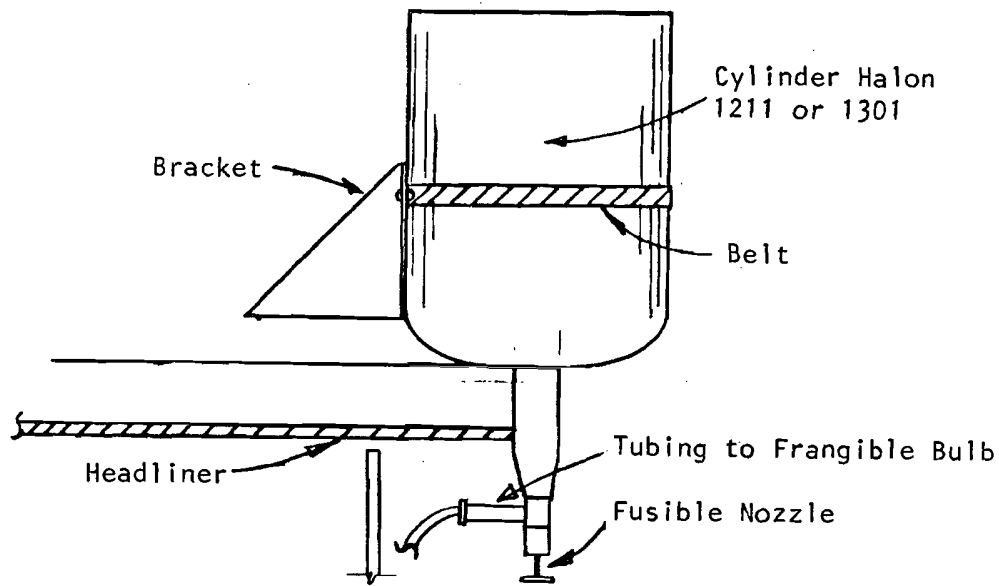

Detail "A" Halon Spot Protection

Note: Containers Can Be Stored on Side or Inverted If Standpipe is Used Inside.

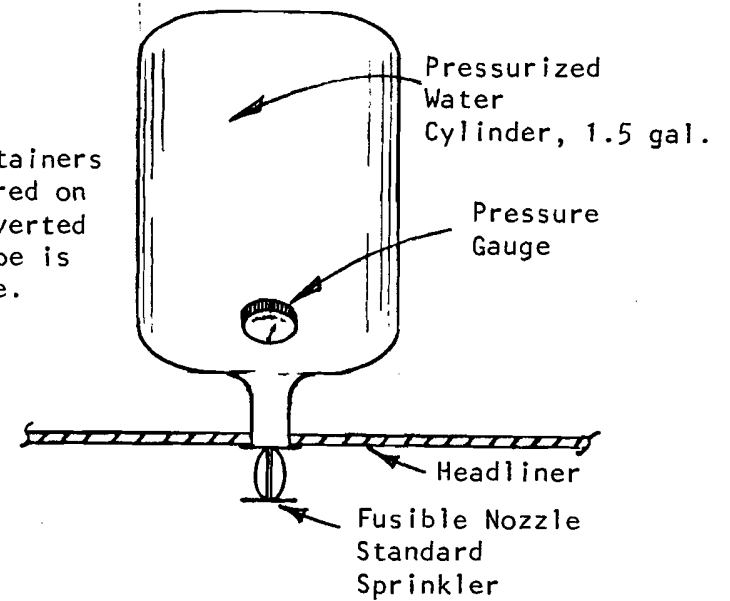

Detail "B" Water or Water/AFFF Spot Protection

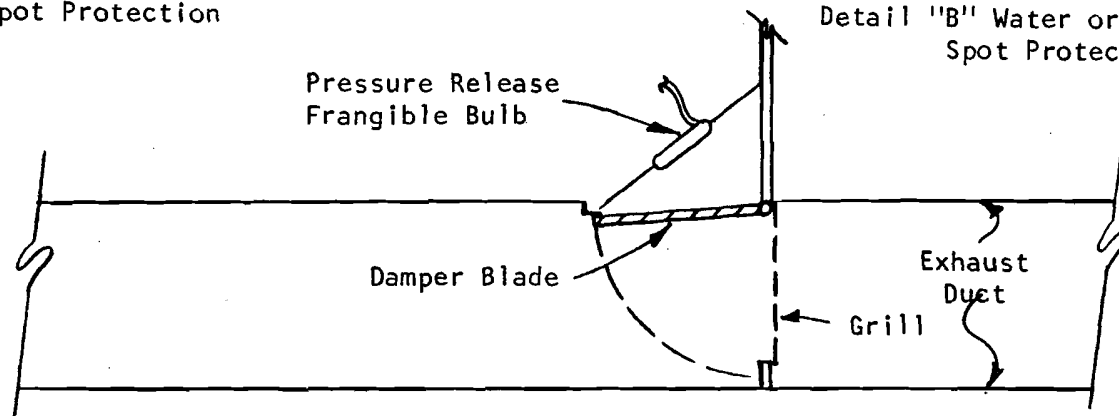

Detail "C" Typical Damper Installation In Lavatory Exhaust (Schematic Only)

FIGURE 32. SPOT FIRE PROTECTION SYSTEMS FOR LAVATORIES AND "HANG-UP" STORAGE COMPARTMENTS

TABLE 9. SPOT PROTECTION SYSTEM SPECIFICATIONS

<u>Suppressing Agent</u>	<u>Halon 1211 or 1301</u>	<u>Water or Water/AFFF</u>
Quantity of Agent	1.5 lb	1.5 gal (12.5 lb)
System Weight	3.3 lb	16.5 lb
Discharge Time	5 sec	20 sec
Lavatory Vent Damper Weight	1.7 lb	not required
Unit Cost	\$525.00	\$75

and small spaces such as vaults. The Halon 1211 system is superpressurized with nitrogen gas, while the Halon 1301 system can be self-pressurized or superpressurized with nitrogen gas. Both systems are designed to flood the local area with a concentration of agent sufficient to suppress a fire. The Halon 1211 spray also penetrates and provides some cooling to ordinary burning combustible materials. The basic agent capacity for both systems is 1-1/2 lb, although larger sizes can be used to cover compartments larger than lavatories or coat closets. Those halon systems installed in the lavatory compartments also require installation of a damper to shut off the exhaust ventilation in the system. The damper is held open by a frangible link that is ruptured by gas pressure when the nozzle fuses and opens. A constant spring force closes the damper, shutting off ventilation and allowing the agent to accumulate in the space. Specifications for each of these subsystem design concepts are also itemized in Table 9.

As indicated in Table 8, spot protection systems provide coverage to fires originating within the space or compartment in which the system is installed. While the response is slower than with systems operated by rate anticipation detectors, such as those installed in the main cabin area, the fusible nozzles are expected to operate sufficiently fast to prevent a serious fire threat from developing in this small compartment and spreading into the main cabin.

3.2.8 Cabin Depressurization.

Cabin depressurization is being considered by the FAA Technical Center as a potential means for rapidly removing smoke and possibly for suppressing in-flight fires.⁶⁵ In terms of fire suppression, the aircraft probably must be at or near cruising altitude for cabin depressurization to be effective. Assuming that this is the case, some indication of expected performance can be drawn from studies of the mechanisms of flame spread. McAlevy and Magee⁶⁶ developed an expression for horizontal flame spread over two plastics which indicated that flame spread decreases with approximately 0.8 power of pressure or that, at 30,000 ft altitude, flame spread is about 40 percent that at sea level. Starrett,⁶⁷ experimenting with various card stocks inclined 45°, states that it was not possible to sustain combustion with most of the specimens above 30,000 ft altitude.

Starrett⁶⁷ provides more definitive information from a full-scale test using a trash-covered, 1955 vintage, double aircraft seat placed in an altitude chamber. A fire was initiated using isopropyl alcohol at 8,000 ft altitude and allowed to develop for 38 sec before decompressing the chamber at 15,000 ft/min. Some reduction in fire intensity was observed when holding at 37,400 ft altitude for 6 min, but flames about 1 ft high persisted. Continuing to 50,000 ft altitude, no flames were observed but some smoking persisted. Upon returning to lower altitudes, the fire rekindled. Starrett concludes that decompression to normal cruise altitudes reduces fire severity which may aid in its control by other means; decompression alone, however, is not sufficient. He further points out "descent would soon be necessary in such an emergency."

Decompression at high altitudes is expected to produce severe physiological and psychological effects on the passengers and crew. As pointed out by Snyder and Stapp,⁶⁸ the available information was gathered from healthy young males, but little is known about the tolerances of the aged, infirm, or infant population. Data that are available (for healthy young males) are illustrated by Table 10 for hypoxia, a prominent effect:⁶⁹

TABLE 10. HYPOXIA EFFECTS VERSUS ALTITUDE⁶⁹

Ambient air	Breathing	
	100 % oxygen	Effects
0	34,000	None (Sea Level)
5,000	37,000	Night vision deficiency
10,000	40,000	Undetectable hypoxia
14,000	41,000	Appreciable handicap
16,000	43,000	Considerable handicap
18,000	44,000	Serious handicap
20,000	45,000	Imminent collapse*

* Other effects include decompression, cold exposure, and the inhalation of smoke; loss of consciousness results in minutes or less.

Table 10 has particular significance in the light of a decompression incident reported by Antley.⁷⁰ The incident involved 96 passengers, of whom only 20 ever got their masks on. Only quick descent prevented disaster.

3.2.9 Early Warning Fire Detection.

3.2.9.1 Background.

Fire detectors can be used as early warning devices or as a means of actuating suppression systems. Various designs sense one or more characteristic of an incipient or developing fire (e.g., smoke, gases, heat, "light," etc.) and usually are adjusted to indicate the presence of fire at a preset level or rate of change of intensity of the characteristic(s) being monitored. Fire detectors as suppression system actuators were discussed in Section 3.2.2. Detectors that respond to fire-related excursions in temperature were suggested as suppression system actuators because they are less susceptible to false alarms than are most other detection concepts. Thermal detectors could be used as early warning devices by lowering their operating threshold, though this would result in an unacceptably high incidence of false alarm. Fire detectors based on other fire signatures have proven more advantageous in this respect, and usually are considered in the early warning context.

All early warning fire detection systems are a compromise between sensitivity to real fires and discrimination against false alarms. The challenge to the designer is to select and apply the optimum system in the optimum manner in terms of the space to be protected. Still, the user is left with less than perfect protection.

In 1974, the U.S. National Bureau of Standards published a comprehensive review of the state of the art of fire detection.⁷¹ Since that time, hardware changes have improved the sensitivity to fire and the false alarm rejection of various detectors, but no new detection generics have been developed and successfully moved into the marketplace. In 1978, Mniszewski, Waterman, and Harpe provided the U.S. Fire Administration with a listing of fire detection devices and concepts, and a bibliography of fire detector-related literature available at that time.⁷² Despite an abundance of information on detector performance in laboratory experiments, field experience is poorly documented, primarily because of inadequate descriptions of detectors or detection systems present in past fires.⁷³ In addition, while the propensity to false alarm is a recognized problem of all fire detectors and the major environmental contributors to this problem are generally known, there is little quantitative information on the specific nature and frequency of false alarm signatures.^{73,74}

Despite a lack of information on the exact magnitude and nature of the false alarm problem, techniques have evolved for reducing its magnitude. The need to protect critical industrial installations has led to detector-operated suppression systems where the detectors are configured and/or monitored such that more than one signal is required to activate suppression.⁷⁵ The "cross zoned" system achieves this by monitoring two sets of detectors placed in a criss-cross pattern so that any one detector is surrounded by detectors of the other "zone." Ideally, the two zones are of differing generics. Alarm or suppression activation requires that the monitor receive a signal from at least one detector in each set. In its simplest form, the cross-zone system is reduced to a single enclosure containing two differing sensors, both of which must be activated before alarm or suppression is initiated ("AND" gate). The priority matrix system generally uses an array of detectors with the same generics, but requires signals from adjacent detectors before actuation.

The improvements in design mentioned earlier have greatly enhanced detector performance. Smoke entry problems of early ionization or photoelectric detectors have been recognized and corrected. Ionization detectors have been developed in which ambient atmosphere is pumped through the chamber and in some cases screened of large particles to improve sensitivity and reduce false alarms.^{76,77} The introduction of the pulsed LED light source into photoelectric detector design provides a long life source and permits ambient light discrimination.⁷⁸ These advances in detector technology combined with the advent of highly sophisticated, lightweight microprocessors offer the potential for using fire detection advantageously throughout the interior of a transport aircraft. Frequent examples of microprocessor aided fire detection systems are found throughout the recent literature.^{76,79-83}

3.2.9.2 Previous System Design.

The present U.S. transport aircraft fleet generally carries only those items of fire protection required by the Federal Aviation Regulations (FAR), Part 25.⁸⁴ FAR 25 requires that fire detection be provided in cargo compartments classed as B, C, or E (FAR 25.857), and that fire or overheat detection be provided in designated areas of the powerplant (FAR 25.1203). No fire detection requirements are placed on the passenger cabin or adjacent spaces not previously described as protected. FAA concern for these areas is reflected in a contract with Lockheed-California Company, who in 1975-76 conducted a feasibility study and trade-off analysis of the relative merits of active fire detection/suppression and improvements in interior materials.²² During that study, Starrett et al. reviewed fire detection techniques and recommended a system using ionization and photoelectric (light scattering) detectors. The system proposed by Starrett for wide-body jets is synopsized in the paragraphs to follow.

The design goals of the Starrett system include:

- Built-in test equipment (BITE) and line-replaceable unit (LRU) features to maximize reliability and maintainability
- Easily interpretable display of fire location and condition to facilitate rapid execution of fire management procedures
- Alarm on the basis of both rate of change of incipient particle concentration level and absolute particle concentration level
- Insensitivity to normal environmental influences of altitude, humidity, lint and dust, sunshine, temperature, fuel and hydraulic oil vapors, cleaning solvents, smoking materials, aerosol sprays, etc.
- Ability to automatically disperse suppressant for the parked, unattended condition with appropriate alarm to local fire-fighting personnel
- Providing, through modern microprocessor technology, maximum flexibility in setting (and altering, if desired) different alarm levels between zones of widely varying volumes and environments, including ventilation shutdown procedures, as necessary

- Low enough power consumption so that the system can operate for prolonged flight periods on emergency power and battery or ground power when parked on ramp
- Sufficient ruggedness to sustain aircraft vibration, shock, and maintenance handling.

The conceptual system is designed to use a series of dual sensor smoke detectors consisting of "flow-through" ionization and pulsed LED photoelectric units in a common housing. The individual units are "OR" gated for preliminary alerting and "AND" gated for alarm (or suppression, while in the ramp scenario).

Starrett et al²² recommend a system using dual detectors in all aircraft spaces. Their suggested detector placement in a wide-body jet transport, illustrated by Figure 33 which presents a suggested panel display at the flight engineer's station, is summarized below:

- Flight Station (Zone 1)
One dual detector assembly (DDA), primarily for ramp fire protection. (May be deactivated during the in-flight condition).
- Lavatories (Zones 2 and 6)
Protection for in-flight and ramp conditions with a DDA in each of seven lavatories.
- Cabin (Zones 3 and 4)
Protection against a ramp fire, two DDAs in each zone.
- Attic (Zone 5)
Protection against both in-flight and ramp fire situations, three DDAs.
- Cargo (Zones 9 and 12)
A DDA in each cargo zone.
- Lower Galley (Zone 11)
The high incident rate in galleys substantiates the need for a DDA to protect the in-flight and ramp operational modes.
- Equipment Compartments
Zones 7 and 8 (Afterbody and APU): Protection for in-flight, ramp, and crash-fire conditions with one DDA in each zone. Conventional continuous element heat detectors, already installed on some aircraft, may prove to be a more appropriate selection for the APU compartment.
- Zones 10 and 13 (Landing gear, Hydraulic Service Center):
For purposes of the study, one detector was provided for Zone 13 and two for Zone 10 (right and left main gear wheel wells).²² Other detector types are suggested as more appropriate for these locations.
- Zones 14 and 15 (Avionic and Electrical Service Center):
One active DDA for each of these zones for in-flight and ramp fires.

FIRE MANAGEMENT SYSTEM

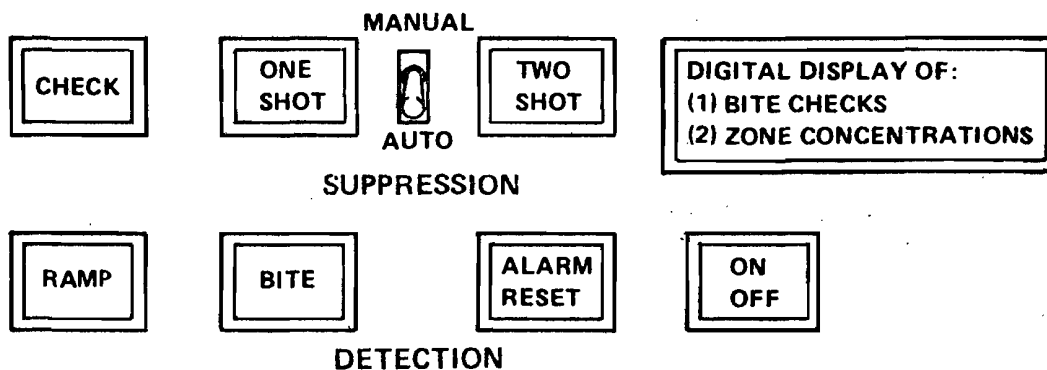
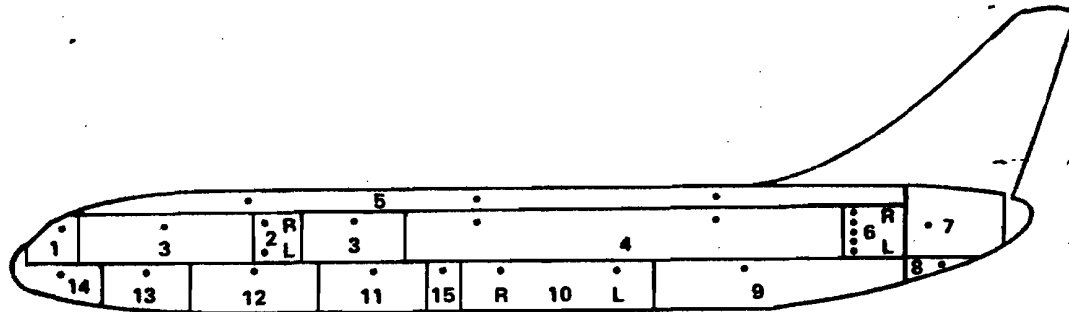

- NOTES: (1) DOTS IN ZONES REPRESENT LED LIGHTS INDICATING DDA STATUS, WARNING: YELLOW, ALARM: RED
 (2) R REPRESENTS RIGHT SIDE, L REPRESENTS LEFT SIDE, LOOKING FORWARD
 (3) CABIN ZONES (3 AND 4) DDA'S OPERATIONAL IN RAMP CONDITION ONLY

SIMPLIFIED CONTROLS CONCEPT

SWITCH	FUNCTION
ON/OFF	FMS ACTIVE STATUS
ALARM/RESET	ALARM INDICATION AND RESET CYCLING FOR VERIFICATION
BITE	SEQUENTIAL SELF-TEST OF ALL DDA'S FOR ACTIVE, PROPER OPERATION
RAMP	ACTIVATE CIRCUITS FOR EXTERNAL LOCAL AND RADIO-COMMUNICATION ALARMS
CHECK	GREEN: EXTINGUISHANT PRESSURE NORMAL RED: EXTINGUISHANT PRESSURE FAULTY
ONE SHOT	ACTIVATE EXTINGUISHANT DISPERSAL INTO LOCKED-IN, FIRE ZONE WHEN IN MANUAL MODE
MANUAL AUTO	EXTINGUISHANT SYSTEM OPERATION SELECTION
TWO SHOT	DOUBLE EXTINGUISHANT DISPERSAL INTO LOCKED-IN, FIRE ZONE WHEN IN MANUAL MODE
ALPHA-NUMERIC WINDOW DISPLAY	INDICATES FAULTY DDA(S) IN BITE CHECK BY ZONE LOCATION. INDICATES EXTINGUISHANT CONCENTRATION IN FIRE ZONE. INDICATES NON-CRITICAL EQUIPMENT AUTOMATIC SHUTDOWN AS PRESELECTED IN FIRE ZONE

FIGURE 33. PANEL DISPLAY--FIRE MANAGEMENT SYSTEM FOR WIDE-BODY JET TRANSPORT

The microprocessor system recommended by Starret et al.²² would evaluate both fixed levels and rates of change in the concentration of combustion particles as indicated by the various sensors. Rate-compensation circuitry is also suggested. Potential alarm signals would be verified by comparison over several scan cycles. The flight engineer would manually actuate any inter-connected suppression system during flight.

The total fire detection system for wide-body application is estimated to require 156 W of power, weigh 180 lb, and cost \$42,000 (1976 dollars).²²

3.2.9.3 Suggested Modifications.

The fire detection system design proposed by Starrett et al.²² incorporates the major features of the state of the art of 1982. Data from residential occupancies suggest that false alarm problems might persist in the lavatory and lower galley locations^{85,86} even though the dual detector ("AND" gated) concept would appear to greatly alleviate this problem. A cost-effective solution for lavatories would be to use single-station devices ("AND" gated dual generics). The lower galley could use heat detectors to reduce false alarms.

A concept recently proposed for residential systems⁷⁴ suggests another alternative. For the purposes of automatic remote residential alarm systems (ARRAS), residential false alarm frequencies must be reduced by many orders of magnitude. Since the occurrence of false alarms is closely tied to living habits, particularly meal times, the proposed concept adjusts detector sensitivity and gating ("OR" or "AND") with the time of day to match the appropriate levels of sensitivity and false alarm rejection for each time period.⁷⁴ For use in transport aircraft, the detector sensitivity levels or gating could be modified in the cabin, attic, lavatories, and lower galley to match conditions during flight, loading/unloading, or other ramp periods. Lavatory sensitivity could be further reduced when occupied, and lower galley sensitivity reduced during active food preparation.

3.3 SMOKE CONTROL.

As shown in Appendix A, fires can occur at numerous locations within an aircraft. All emit smoke which can seriously endanger the safety of both the crew and the passengers. Because of the wide differences between scenarios of in-flight and post-crash fires, they will be considered separately.

3.3.1 In-Flight Fires.

Any in-flight fire presents an imminent danger to the aircraft. No fire can be permitted to reach intensities affecting the structural integrity of the aircraft and/or its control mechanisms. Fire must be detected rapidly, with a response directed immediately to limit and suppress the fire. For these reasons, design criteria for protection against smoke during flight conditions can be based on the assumption of controllable, limited growth, moderate-size fires.

Protection against smoke refers here to one or a combination of several methodologies for maintaining habitable environments within the cabin and the flight station. Both can be subjected to internal or adjacent fires. Protective methods may include:

- Decrease of smoke production (fire control, suppression)
- Containment of smoke
- Removal of smoke.

3.3.1.1 Decrease of Smoke Production.

In any fire the amount of smoke produced depends on the nature of the materials involved, the local fire environment, and the size of the fire. The use of low smoke emitting combustibles would certainly be very beneficial for decreasing the smoke problem. Unfortunately, as previously stated, when the flammability of some materials is decreased, their potential for producing smoke tends to increase. Flammability is still of main concern. The state of the art offers few materials for aircraft use which not only meet flammability and other criteria, such as low weight, durability, appearance, etc., but that are also low smoke emitters.

It is readily apparent from Equation 8 (Section 2.2.2.2) that the amount of smoke generated is directly proportional to the fire perimeter. Thus, methods considered in Section 3.2 for rapid fire suppression provide the additional benefit of reducing smoke production. Although any decrease in smoke levels is very helpful, as previously shown, even a small amount of burning combustible can create a serious smoke hazard. Thus, to ensure the safety of the occupants, other control methods such as containment and smoke removal must be used after fire suppression.

3.3.1.2 Containment of Smoke.

To contain smoke, a physical barrier must be formed that will prevent the flow of smoke and other combustion products from a fire area into a protected area. For use in aircraft, such a barrier should ideally have the following characteristics:

- High thermal resistance
- Low weight
- Occupy little space when not in use
- Be readily deployed
- Provide a good seal
- Allow passage of occupants and crew.

Conditions for high thermal resistance and low weight require the use of either incombustible materials such as aluminum or asbestos, or flame-resistant materials such as certain plastics (e.g., Kapton®). For efficiency of space, the barrier must be very compact. A folding door placed against the sides of the fuselage, a curtain, or an inflatable membrane stored in the hat rack compartment are examples of possible designs.⁸⁷ In all cases,

ready-to-use conditions must exist. This would require either mounting the barriers at fixed locations or providing movable barriers with rapid positioning capabilities. Prepositioned barriers offer significant advantages when the total scenario of the fire is considered, particularly the presence and possible panic of passengers.

Requirements 5 and 6 above compete for priority in the design of a suitable system. The need for relatively tight barriers is borne out by Hill's experiments,⁴⁵ which considered various lesser barriers with less than encouraging results. Structural fire experience also strongly supports the necessity for barrier integrity but offers a trade-off for less than perfect seals.

Experiments with structural fires⁸⁸ show that 0.05 in. of water pressure differential is sufficient to prevent the flow of smoke into protected areas through minor openings. Providing such an overpressure in the occupied segment of the cabin seems to be the most effective means of sealing the barrier. This would require zone controls of the air supply into the cabin. In addition, pressurizing assists in limiting the amount of smoke entering the protected area when occupants or crew must cross the barrier. Referring again to structural fires, 0.05 in. of water overpressure maintained a smoke fire environment within a staircase in spite of the doors being briefly opened by entering occupants.⁸⁸

Air curtains, similar to those used at the entrance to shopping malls, have also been mentioned as possible means for blocking the lateral spread of smoke.⁸⁷ No experimental data exist dealing with this approach. Its usefulness has been questioned because of the turbulence generated by high velocity flows mixing the smoke with the underlying cabin air.³¹ This would not only negate the intended purpose of the air curtain but even further aggravate the smoke problem within the cabin. A potential solution, presently applied in industry and in some commercial occupancies, is the use of vertical overlapping flexible plastic strips that readily separate for exiting and then return to a relatively contiguous barrier.⁸⁹

A wide variety of other barrier configurations can be envisioned once the concept is defined as relative tightness coupled with differential pressurization. Many configurations are feasible on the basis of structural fire experiments and experience; all require design evaluation experiments for aircraft application.

In addition to the cabin proper, smoke can be also generated by fires in the lavatories, cargo compartment, concealed spaces, etc. Pressurizing the cabin can also be used to prevent the infiltration of smoke in these situations. The level required depends on the pressure produced by the fire. In unoccupied areas, fires are often controlled by confinement, which blocks the flow of oxygen necessary for the combustion process. This in turn can produce a pressure buildup, imposing unrealistic pressurization requirements on the cabin. Hence it is necessary that some means of venting the combustion gases is provided in these areas. The level of venting must be carefully chosen to allow only minimal air flow in the fire area.

3.3.1.3 Venting of Smoke.

Another method of in-flight fire protection is obtained when, by effective venting, smoke from a cabin fire is confined to the immediate vicinity of the fire. Because the specific location of a fire cannot be predicted a priori, provision must be made for channeling the smoke from the fire area into exhaust ports. This can be accomplished by means of reservoirs or curtains. In aircraft, the attic appears the length of the aircraft, encompasses a large volume (4,000 ft³ in a wide body aircraft), and is relatively close to all possible locations of cabin fires. Required modifications would include perforation of the cabin overhead to provide about 40 percent open area,³¹ compartmenting the attic into a series of smaller volumes, and protection of service equipment presently contained in the attic from hot combustion products.

If these or other considerations limit or even negate the use of the attic, smoke can be channeled to exhaust ports by means of vertical partitions extending downward from the ceiling. These would subdivide the ceiling space into reservoirs much like those of the attic, but provide a more limited height of "smoke-free" layer. They are often referred to as "screens" or "draft" curtains. The partitions can consist of thin noncombustible sheets, 3 to 4 ft high, held against the ceiling by hinges on one side and magnetic or mechanical latches on the other, manually actuated locally or from a centralized location.

It must be stressed again that the purpose of the reservoirs is to facilitate venting of smoke by limiting its horizontal spread. How well this is accomplished will determine the level of protection provided. For this reason, the smoke rising above a fire should be removed at the rate it is being generated. As previously defined, however, "smoke" is basically smoke-laden cabin air entrained by the fire. To maintain the exhaust flow of smoke, an equal amount of fresh air must be introduced into the cabin area. Because it must be supplied through ports near the floor, the air nozzles currently located above the passengers seats must be turned off during smoke exhaust operations.

To avoid undue mixing with the smoke, replacement air must be supplied at a moderate velocity. In general, the exhaust velocities also must not be excessive to prevent drawing the air underlying the smoke layer up into the vent. This condition may be difficult to achieve in aircraft where space limitations preclude the use of large ducts. Hence, an allowance may have to be made for larger exhaust volumes which, as found in structural fires, can contain up to 50 percent fresh air.⁹⁰

For efficiency of operation, zone control of the air supply and smoke exhaust is also desirable. This would permit a high capacity usage in the location directly affected, adjusting the flows according to the needs of adjacent areas. In any case, automatic or manual control of air handling will be required in order to provide a proper air flow for effective smoke removal.

Ideally, fully automatic operation of control devices with rapid response characteristics would be the most effective in preventing lateral spread of smoke. However, the possibility of false operation and added design problems suggests that all methods of activation be considered. When a fire in an occupied cabin is quickly detected, rapid countermeasures are usually taken by

well trained aircraft crew. Hence manual operation of control devices can play an important role in protecting the passengers against smoke. These may include: (1) opening the exhaust ports, (2) regulating the amount and the location of the supply air, (3) releasing stowed smoke curtains, and (4) closing fire/smoke barriers.

It should be noted that systems labeled as "smoke venting with draft curtains" and "smoke barriers and zonal overpressure" both attempt to confine smoke and then direct its flow overboard. The differences between these systems are the relative degree to which confinement and air handling are used.

3.3.2 Post-Crash Fires.

The protection methods considered here are based on the assumption that the aircraft is subjected to a survivable post-crash fire. This excludes cases of aircrafts being rapidly and totally engulfed by flames or suffering major structural damage allowing the fire to enter the cabin at several points.

A more realistic scenario, conducive to the survival of passengers, involves fires that initially are limited in extent. Whether external, internal, or both, these fires are assumed to allow at least the start of evacuation procedures. Unfortunately, as demonstrated in Section 2.1.3, a fuel spill fire can penetrate the fuselage in a relatively short time. Furthermore, any initial cabin fire can rapidly endanger the safety of the occupants. Thus, means of isolating the section of the cabin involved in the fire are needed to ensure survival and to facilitate rescue operations.

In this respect, the condition of the crash limits the number of techniques available. The expected lack of power prevents ready use of forced ventilation to redirect the flow of combustion products. Unpredictable wind behavior limits its utility for this purpose. Gravity venting would require that nearly all of the upper fuselage be capable of selective opening. Hence, compartmentation of the cabin appears to be the most feasible means of protection. The barrier materials used must be flame resistant and capable of preventing the flow of combustion products into the protected area.

The effectiveness of compartmentation in protecting cabin areas from the products of adjacent fires was studied by Hill et al.⁴⁵ Their results demonstrate that, depending on the fire dynamics, compartment subdivision with curtains can offer only limited protection against fires internal to the cabin. This is particularly true when the relative location of openings in the fuselage and the wind velocity tend to direct the combustion products toward the protected area. For example, the theoretical analysis by Stuart⁹¹ indicates that the ventilation rate caused by a 10 mph wind perpendicular to the fuselage can be about one order of magnitude greater than the in-flight air conditioning rate. Also, the change of local wind pattern can reverse the direction of the ventilation flow. Similarly, wind can be the dominant factor in igniting cabin materials exposed to an exterior pool fire through an open door.¹⁵

No wind direction or location of openings in a crashed aircraft can be predicted a priori. Hence, to achieve effective post-crash smoke compartmentation, separating barriers must provide a tight seal against the flow of combustion products and include a measure of fire resistance. Systems described

previously for use against in-flight fires with an added protective coating of intumescent paint might meet the prescribed criteria. It is more likely that for post-crash effectiveness, true fire compartmentation is necessary (see Section 3.4.2.1).

3.4 THERMAL HARDENING.

3.4.1 External Envelope.

As shown in the previous section, even when the structural integrity of the crashed aircraft is preserved, there is a high probability that the external fuel fire may quickly enter the cabin area. For this reason existing regulations mandate that passengers be evacuated within 90 sec. Such a rapid evacuation may be difficult to achieve, in particular when some exits are blocked by external fire or by structural damage. As a result, passengers may succumb to the deadly effects of the fire. In addition, the extreme haste of the evacuation procedure often results in serious injuries. Therefore, fire hardening the fuselage could considerably enhance the safety of passengers in survivable aircraft crashes by reducing the in-cabin insult and extending the period for evacuation.

As previously demonstrated, the aluminum skin melts in a very short time when exposed to an intense fuel fire, possibly in less than 1 min. Therefore, the main protection of the cabin against externally burning fires must be provided by the thermal insulation and the inside wall panels. Both barriers were therefore the subject of several investigations described below. Most of these studies were concerned with interior panels. Less attention was given to the thermal insulation, although for all practical purposes it provides the first line of defense against the post-crash fire.

3.4.1.1 Thermal Insulation.

Conceptually, it might be concluded from the heat transfer analysis (Figure 8) that glass fiber insulation can protect the cabin against external fuel fires reasonably well. Indeed, this may be the case in some crash situations. For example, photographs of a DC-10 crash fire¹⁰ clearly demonstrate the effectiveness of glass fiber as a thermal barrier. On the other hand, past crashes and experiments show that this is not always true. This discrepancy may be attributed to a failure in the physical integrity of the glass fiber insulation panels (introduced during fabrication or produced by the crash and/or the fire). It may also result from pyrolysis of the insulation binder. As previously stated, decomposing binder can produce toxic gases within the cabin before the aluminum skin melts.⁴ Thus the use of an inert binder is highly desirable.

No systematic investigations of glass fiber insulation in direct contact with aviation fuel fires seem to be reported in the literature. Available experiments show penetration times of about 1 min,²⁶ certainly much shorter than predicted by the heat transfer analysis based on idealized assumptions.

Neel et al.⁹² obtained protection much superior to glass fiber insulation using polyisocyanurate foam. Protected in this manner, the cabin temperature

showed little change during the first 6 min after exposure to a severe external fuel fire. After 12 min of exposure the cabin temperature reached only 300°F. In the same experiment, a part of the cabin protected solely by a 2-in. thick layer of glass fiber insulation attained 600°F within less than 2 min. Use of the polyisocyanurate foam would, however, add 1700 lb to a wide body aircraft. This weight penalty could be eliminated by integrating the design of the foam and the aircraft structure.

The application of intumescent paint may have contributed to the ability of the polyisocyanurate foam to offer such a high degree of protection. Expanding paint may have provided the seal necessary to block the flow of heat and toxic gases into the cabin area.

Another effort to increase the fire protection offered by insulating material can be found in the Lockheed L-1011 Tristar jet. In this aircraft, the fiberglass insulation is sealed in bags of Kapton,[®] a polyimide film. Lack of experimental data does not permit evaluation of the additional fire resistance provided by this method.

3.4.1.2 Interior Panels.

In addition to serving other purposes, wall panels offer the last defense against external fires breaching the aluminum skin and the thermal insulation. Because they are widely used throughout the aircraft, interior panels have been the subject of many studies, particularly for confining lavatory fires. These include the search for new materials⁹³ and proper evaluation procedures.⁶ All these activities resulted in prototypes of interior panels with much improved burn-through resistance. For example, at the same densities, the fire endurance rating of the prototype panel is about 10 min, compared to 2 min for the current state-of-the-art panel.⁹ Thus the application of newly developed interior wall panels would considerably enhance the thermal hardening of the fuselage. The extent of the added protection must, however, await experimental verification in full-scale tests. Most of the data reported were obtained from NASA AMES T-3 tests.⁶ These tests do not reflect the effects of aircraft structural configuration on the fire containment abilities provided by the interior panels. In particular, thermally induced expansions or deformations can cause separations between panels, allowing the flow of hot gases and flames into the cabin area. An application of intumescent paint could possibly resolve this problem, although the tendency of some paints to discolor the panels may be objectionable.

Thermal hardening must also include the cabin floor. This protection is needed because high radiant fluxes impinge on the lower surface of the fuselage exposed to adjacent fuel fires. It is also needed to protect the cabin from in-flight cargo fires since the floor may be the path of external fire penetration into the cabin area.⁹² Studies to improve the fire resistance of aircraft floor panels were conducted by Anderson et al.⁹⁴ Their results indicate a need for additional development and verification.

3.4.1.3 Windows.

The relatively large number of windows in an aircraft makes exposure of windows to a post-crash fire quite likely. For effective cabin protection, both the fuselage walls and windows should show approximately the same fire-

resistive properties.

Studies with window materials show that the stretched acrylic commonly used fails in less than 2 min when exposed to aircraft fuel fires.¹² That is certainly a very short time; by penetrating the windows, the fire can then circumvent thermal barriers offered by the fuselage walls. This has been well recognized in the past and a search for better window materials has been conducted for some time. The work by NASA shows that some candidate materials can resist burnthrough significantly longer than stretched acrylic. For example, epoxy-boroxide, E-112, 1.22 cm thick, withstood burnthrough in the NASA T-3 test⁹ for over 1080 sec. In comparison, 1.37 cm thick polymethylmethacrylate resisted burnthrough only for 100 sec.¹² Recent testing of other advanced aircraft windows shows that they were able to resist fire penetration several times more than current windows.⁹⁵ Before these advanced materials can be used for aircraft windows, however, such properties as strength and aging must be ascertained in addition to fire resistance.

Increasing the burn-through times can only be effective as long as the windows are held in place and do not allow passage of fire gases around their periphery. Meeting these criteria is essential in the overall hardening of aircraft windows and appears to have been accomplished in recent NASA testing.⁹⁶

The use of incombustible window shades could provide additional, or even total, protection of the window area against external fires. The concept involves thin shutters of high thermal resistance, such as titanium,⁴ tightly fitting into frames enclosing the window openings. Under normal operating periods the shades would serve their usual purpose.

3.4.1.4 Doors.

The literature shows no studies concerned with the fire resistance of aircraft doors. With the exception of hinges and the closure mechanism, thermal hardening of doors would be similar to that of the fuselage. This would include use of interior insulation and paneling of higher fire resistance.

Other segments for possible consideration involve peripheral sealing and reduction of thermal distortion. In the absence of experimental evidence, the nature and extent of needed improvement cannot be indicated at this time.

Of considerable importance is the fact that, once opened, emergency doors on widebody jets cannot be closed in a post-crash, powerless scenario.⁹⁷ The design would have to be modified appropriately to permit manual closure. In addition, improved visibility (door windows), heat detectors, or fiber optic viewing devices can be incorporated in emergency doors to permit assessment of fire/evacuation conditions before opening the door.⁹⁷

3.4.1.5 Emergency Barriers.

In the context of this section of the report, emergency barriers can serve two purposes. First, they can provide a method of closure of exitways inadvertently opened in a post-crash fire. Secondly, they can cover limited size, crash-related fractures of the fuselage. The primary difference in these two applications is the ability to reposition emergency closures for exitways.

The literature provides no direct information on these applications but certain items and materials are discussed that might serve these needs. The first of these is the use of large titanium shades such as was suggested for window protection in Section 3.4.1.3.⁴ These would be prepositioned over the exitways and fitted to slide and be captured by tracks on either side of the opening to provide a reasonable seal. Alternate materials may be found among those used to protect the proscenium opening of stages.⁹⁸ They could be operated manually or by releasing a fusible link.

A recently developed fire blanket appears to offer particular potential for this application. Designed as a personal protective device, the blanket is of woven wool saturated with a water-based gel.^{99,100} The blanket is stored in a polyethylene cannister before use, in its present configuration. The blanket has a three-year shelf life because of the antiseptic agents in the gel used for first-aid treatment of burns; without these, shelf life could be considerably extended.¹⁰⁰ Fire resistance appears to be increased by an order of magnitude over a blanket soaked only in plain water because of the increased amount of water trapped in the gel.^{99,100} The blanket offers potential for use in the prepositioned configuration, and supplementary blanket configurations might be devised for rapid deployment over some crash-induced fractures. The cost of a 5 x 8 ft blanket in the present cannister is about \$250 (1981 dollars).

3.4.2 Interior.

Any fire within an occupied aircraft quickly produces serious life-threatening conditions. Fire can originate in the cabin or in adjacent compartments where its effects are transported to the habited spaces. Historically, on-board fires of consequence have been of post-crash origin, initiated in fuel leaked to the interior by the crash or created by direct exposure of some portion of the interior to the external fuel pool fire. These are fires which grow to large dimensions in short periods of time. The intentional on-board liquid fuel fire, which has not yet been experienced, could exhibit similar characteristics. The fire hardening concepts directed toward limiting this category of insult lay primarily in the area of compartmentation. Further limiting the flammability of interior finish and furnishings can also contribute to lessening the threat of cabin fire.

Fires of slower growth potential or of accidental origin can occur in the contiguous cabin space or in adjacent compartments. Here, the full breadth of fire hardening techniques can be brought to bear, including all the concepts applied in professional fire protection of buildings. These passive measures include compartmentation, general limiting of fuel load and combustibility, and other localized protective measures.

3.4.2.1 Fire Compartmentation.

Materials are available for fire compartmentation of the aircraft interior.^{7,9,25,26,28,29,87,92,93} They are being applied to a degree, particularly in wide-body aircraft. At present, they have been applied primarily to the lavatory compartment and to the fuselage sidewalls (see Sections 3.4.1.1 and 3.4.1.2). In the case of the lavatory, improved fire hardening would include better sealing of the door to prevent movement of smoke, and securer

hinges and locking mechanisms to preclude the door being blown open by a sudden rise in fire-induced pressure).²⁸

Depending on the particular aircraft, the primary sites for compartmentation can be defined as those dividers already positioned for various aesthetic or functional purposes. What is generally required is the upgrading of these dividers to provide true fire compartmentation and the occasional introduction of additional barriers to ensure sufficient subdivisions. Thus galleys, lavatories, and other service compartments (e.g., attendant and cabin storage areas) can be incorporated into the compartmentation scheme.

The principal problem arises in the competing needs of the fire barrier and exiting requirements, as was the case with the smoke barriers described in Section 3.3.1.2. While materials of proven performance are available for the fixed portion of compartment fire barriers, the solution to the problems relating to providing exit doors through these barriers is less straightforward.⁴⁵ It consists of a compromise in which a doorway barrier of limited fire resistance (see Section 3.3.1.2) is used to permit exiting (perhaps no closure at all); once a compartment is evacuated, a barrier of measureable fire resistance is positioned. Such barriers were described in Section 3.4.1.5 to provide emergency closure of external openings. Barrier effectiveness can be enhanced if a water spray is directed on the fire side once the barrier is closed.⁵² Because of the small amount of water required, a self-contained "spot protection" water supply might be adapted from the designs presented in Section 3.2.7.

3.4.2.2 Interior Finish and Furnishings.

The present wide-body fleet and nearly all of the narrow-body fleet meet the 1972 standards of FAR Part 25.853.⁸⁴ Based on accident data, these have performed satisfactorily against in-flight fires in terms of ignitability and flame spread (with the possible exception of the recent Saudi incident, where a serious cargo fire apparently preceded the appearance of flames in the cabin).

Finish materials offering improved fire resistance and flammability have been developed by NASA and others.^{7,9,25,26,28,29,87,92,93} Their identities, application, and costs of implementation have been reported in great detail by Starrett et al.²² Also, improved materials for seat cushioning or seat cushion barriers have been identified²² and are under evaluation.⁶⁵ Both the FAA⁶⁵ and the SAFER Advisory Committee⁹⁷ have shown concern whether further material improvements and the associated costs will be reflected in improved benefits, particularly against the post-crash fire. Since present cabin finish and furnishings appear to resist accidental fires of on-board origin, improved safety can best be realized by reducing the hazard imposed by the post-crash scenarios or by potential incendiary on-board fires.

The FAA Technical Center is pursuing this question through large-scale tests in a C-133 fuselage equipped as a wide-body transport. Fire exposure is from

a burning pool immediately upwind of an open doorway. Early testing against this very severe scenario* indicated a significant reinforcing contribution between the action of the seating and that of the overhead finish. This is not to say the significant benefit would not have been achieved under a realistic but slightly less severe post-crash scenario. This effort is continuing. The authors recommend that results be gathered for a spectrum of exposures, including the presently used "worst case" scenario. Even so, it may be that other measures, such as compartmentation, provide a more positive and perhaps more cost-effective solution.

3.4.2.3 Upper Cabin.

A flaming fire in the cabin or in adjacent compartments can be expected to severely expose the upper cabin space and attic long before conditions near the cabin floor are fatal. This fact affects the design of fire compartmentation and suggests that specific attention be given to control, communication or lighting circuits, and oxygen lines placed in the attic or behind overhead storage. The need for such protection was mentioned earlier in the discussion on the use of the attic for venting smoke (Section 3.3.1.3), but it should not be limited to that consideration. Both the FAA⁶⁵ and SAFER⁹⁷ show concern for the attic spaces.

Improved protection of signalling and service equipment and wiring can be readily achieved by relocating the equipment or protecting it in place. Although there are no recognized standards for protecting cables and components from exposure fires, insulation procedures and materials for high temperature service can be applied. In addition, full-scale experiments on generic cable insulations by Sandia Laboratories and tests of site-specific protection concepts by Underwriters Laboratories and the Portland Cement Association offer potential means of protection. Specific needs and recommended modification for aircraft are detailed by Starrett et al.²²

Overhead storage compartments are of additional concern because of their location in the upper cabin. These have been designed to remain intact up to significant crash loading, but failure of the latching devices under thermal load appear not to have been addressed. Likewise, it is not clear that ceiling panels have been designed to be retained in-place during a fire.

3.5 EMERGENCY EVACUATION ASSISTANCE.

Accident data indicate¹⁰¹ that in most survivable air transport crashes to date, occupant survival has been largely determined by the ability of uninjured passengers to leave their seats and find an exit before being overcome by fire or smoke. Many concepts which seem to offer some improvement in the current state of the art of this subject are contained in References 101 and 102. Though all of these concepts are not included in this review, those which appear to show some promise or benefit are listed. Factors which were taken into consideration in the evaluation of these concepts include:

* Test witnessed by Messrs. Campbell and Waterman in the spring of 1981.

- Problems of aircraft attitude
- Smoke and gas effects on passengers
- Fire and heat effects on passengers
- Post-crash mental and physical capabilities of crew
- Crew efficiency and training
- Interior configuration of aircraft
- Structural damage in the crash impact
- Environmental factors during evacuation such as weather conditions
- Psychological feasibility
- Potential cost
- Weight penalties
- Problems of inadvertent system operations.

3.5.1 Mechanical Escape Devices.

Any device designed to assist post-crash emergency exit can be defined as a mechanical escape device. This may include improvements in the design of escape slides (which represent the best operational device in use today), alternatives to slides using tubes or mechanical stairways, larger exit doors, explosive-aided systems for creating evacuation openings in a fuselage, and various systems for automatically removing aircraft occupants during an emergency.

Experience and current practice indicate that inflatable devices offer the greatest versatility of use in the most cost-efficient manner. Of the problems associated with the use of these devices (Section 2.1.6.1), heat resistance is of major concern.⁶⁵ The 1978 incident in Los Angeles illustrates heat-related failure of a DC-10 escape slide.¹¹ As a direct result of this incident, the FAA Technical Center performed tests to make a preliminary assessment of the fire protection characteristics of various escape slide materials.¹⁰³ Among the findings was the fact that a thin coating of aluminum paint provides substantial heat reflection and thus extended life for the inflatable device in a fire environment.

Based on the conclusions and recommendations of the preliminary study,¹⁰³ a more comprehensive program was designed and conducted.¹⁰⁴ These tests support the findings that, when protected by an aluminized reflective coating, existing slides improve in performance. Further, to attain the full benefit of the coatings, new adhesives must be developed for seam fabrication. Neoprene Kevlar® fabrics were found to be far superior to other materials in current use, but they too require improved seam adhesives. Brown and Nicholas¹⁰⁴ recommend that all present slides be retrofit protected with aluminized paint and that additional full-scale tests be performed on newly fabricated slides of advanced materials.

3.5.2 Personal Protective Devices.

Items which can be donned by passengers and crew to isolate them from the smoke, heat, or toxic output of aircraft fires can be considered personal protective devices. Within the time and mobility constraints of the aircraft post-crash fire scenario, practical devices for passenger use probably are limited to head and face protection. That is, devices that protect the eyes from irritation, the breathing passages and lungs from highly toxic, irritating gases, or the whole face and head from excessive thermal radiation. The latter is considered for post-crash fire protection since passengers would not survive in-flight fires of that degree.

Eye protection is readily achieved. Indeed, Lopez³⁷ found that even contact lenses offer significant protection to individuals exposed to smoke. Goggles can be fitted to a wide variety of facial variations and by themselves offer evacuation assistance. Goggles combined with a modified oxygen mask system should offer reasonable protection from the products of in-flight fires. Modification is required since the present system merely enriches the oxygen content of inhaled cabin air to accommodate depressurization rather than providing an alternate respirable source. Indeed, the modified system should be designed to only supply fresh air rather than oxygen in an in-flight fire emergency, thus reducing the potential for released oxygen to support the fire.

Hoods or other devices providing self-contained oxygen or a cleansed air supply may enhance the success of post-crash evacuation. The concept of escape hoods is not new to the FAA. Research and development efforts were initiated in the mid-1960s.¹⁰⁵ In 1968, Roebuck¹⁰² reviewed the hood developed by the FAA, rated it as highy cost-effective, and suggested that a small compressed air source be added to extend its useful life. Subsequently, numerous investigators conducted exhaustive studies of various escape mask/hood devices. These are summarized by Snyder.¹⁰¹

In January 1969, the FAA proposed amending FAR 25⁸⁴ to require protective smoke hoods in all civil air carriers. Met with strong opposition, this proposed rule-making was withdrawn later that year. Among the considerations not supportive of escape hoods were:

- training requirements
- delayed evacuation due to donning time
- possible lack of passenger acceptance
- potential for suffocation in "trapped air" systems

In 1976, Snyder¹⁰¹ commented these this considerations should be reexamined in the light of the various improvements in the state of the art. He suggested that the latest versions of escape hoods with small, self-contained air supplies solve the question of suffocation brought forth in response to the FAA's 1969 attempt to require smoke hoods for air transport aircraft. Smoke hoods were among the "crashworthy" features promoted by Rep. J. C. Wright in hearings conducted by a Congressional subcommittee of the House Public Works and Transportation Committee.¹⁰⁶ To date, their use has not been implemented.

Critical to successful escape from a post-crash fire are the actions of crew members.¹⁸ Since they are, and can continue to be, highly trained and rehearsed, their protective equipment can and should be somewhat more effective, albeit complex. Nominally among the last to leave the aircraft, they require more substantial breathing aids and thermal protection. The design of crew protection is constrained by their need for mobility and communication. Protective breathing devices and gloves are considered the more important of potential crew protective devices,⁹⁷ although some attention has been directed to clothing.¹⁰⁷

3.5.3 Evacuation Markers.

As mentioned earlier, NTSB studies¹⁸ indicate that emergency lighting lacks intensity and should be supplemented with near-floor illumination. The SAFER committee suggests that auxiliary lighting be placed at or below the armrest level and recommends that tactile markings be made of access routes to emergency exits.⁹⁷ Current work at the FAA Technical Center is designed to expand on earlier CAMI experiments; preliminary results support lowering the position of present cabin lighting.^{65,108}

3.6 SUMMARY OF SYSTEMS AND FEASIBILITY DETERMINATIONS.

Tables 11 through 18 summarize the systems and concepts examined during the course of the program and elaborated upon in earlier parts of this section. The feasibility of each system or conceptual system is identified for application to fires occurring in scenarios generalized as:

- In-flight (i)
- Ramp (r)
- Post-crash (p).

No attempt was made to include systems deemed obviously impractical upon inspection (e.g., explosively ejected passenger seats, etc.). Included with each entry are brief explanatory remarks, followed by a listing of references pertinent to documenting the assigned feasibility ratings or system descriptions.

For this presentation, the various fire management/suppression systems/concepts have been grouped generically as:

- Cabin-Related Fire Suppression
- Early Warning Fire Detection
- Cabin Smoke Protection
- Fuselage Fire Hardening
- Fire Hardening of Cabin and Adjacent Spaces
- Evacuation Assistance.

No ranking is implied by the order of presentation within or between the tables.

TABLE 11. SUMMARY OF CABIN RELATED FIRE SUPPRESSION SYSTEMS/CONCEPTS

Item	Concept	Feasible*			Remarks (Also see Table 12)	References
		Yes	?	No		
1	Automatic Sprinklers	i,r	p		Adapted to entire cabin utilizing water or AFFF. Net effect of post-crash actuation on tenability is unknown.	47,48,49,50,51,52,53,54,55,56,57,58,109
2	Zone Water-Spray System	i,r	p		Adapted to entire cabin utilizing water or AFFF. Actuated by rate anticipation detectors.** Net effect of post-crash actuation on tenability unknown.	55,56,57,59,109
3	Halon 1301 Total Flooding	i,r		p	Adapted to each cabin compartment. Actuated by rate anticipation detectors in cabin; heat detectors in lavatory. Toxicity question under post-crash conditions. Loss of agent problem, if post-crash condition.	21,22,60,61,62
4	Halon 1211 Direct Application	i,r		p	Localized application system adapted to entire cabin. Actuated by rate anticipation detectors in cabin; heat detectors in lavatory. Toxicity problem in habited enclosure.	62,63,64
5	Supplemented Versions of 1,2,3, or 4		r	p	Systems, as above, adapted for external supply at ramp; CF/R vehicle if post-crash. Net effect on post-crash tenability unknown. Not generally applicable to in-flight fires; but, may permit support efforts if plane can quickly return to airfield.	
6	Lavatory and Carry-On Storage: Spot Water Spray	i,r			Fusible nozzle actuation. No particular post-crash benefit.	59,109
7	Lavatory and Carry-On Storage Spot Total Flooding	i,r			Halon 1301 or 1211; fusible nozzle actuation. No particular post-crash benefit.	60,62,63
8	Cabin Depressurization			i	All effects on passengers; may not sufficiently weaken fire. Not applicable to ramp or post-crash fires.	22,66,67,68,69,70
9	Suppression System Actuation	i		i	No particular post-crash benefit. Smoke detectors provide excessive reliability, maintain ability problems to prevent inadvertant suppression system activation during in-flight conditions (h-Heat, s-Smoke Detectors).	
		h		s		
		r				

* i = in-flight; r = ramp; p = post-crash; a = all
 ** manual override

**TABLE 12. SUBJECTIVE ASSIGNMENT (0-5) OF SUPPRESSION
(Effectiveness To In-flight and Post-crash Fires)**

Suppression System	Scenario/Fire Location				
	Cabin Seats	Cabin Concealed	In-Flight Flam. Spill Cabin	Lavatory Coat Room	Post crash
Auto-Sprinkler/Water	5	1	2	4	3
Auto-Sprinkler/AFFF	5	1	5	5	3
Zoned Water Spray	5	1	2	4	2
Zoned AFFF Spray	5	1	5	5	2
Direct Spray/Halon 1211	5	2	5	5	1
Total Flooding/Halon 1301	4	3	5	5	0
Spot-Water Spray or Spot Total Flooding (Lavatories)/Halon 1301 or Halon 1211	-	-	-	5	-
Spot-Water Spray or Spot-Total Flooding (Carry-on luggage, coats) Halon 1301 or Halon 1211	-	-	-	4	-

**TABLE 13. SUMMARY OF EARLY WARNING FIRE DETECTION CONCEPTS
No Particular Post-Crash Role**

Item	Concept	Feasible*			Remarks	References
		Yes	?	No		
1	Dual-Detectors (ION-Photo) (DDA)	i,r			"OR" gated for alert, "AND" gated for alarm	22,72,74, 75,76,77,78
2	Micro Processor Aided Detection System	i,r			Multi-Level sensing, variable threshold, analog detectors, etc.	22,76,79-83
3	Pumped Detectors	i,r			Eliminates smoke entry problems	22,74,76, 77,80

* i = in-flight; r = ramp

TABLE 14. DETECTOR DEPLOYMENT IN WIDE-BODY AIRCRAFT

<u>Location</u>	<u>Number of DDAs*</u>	<u>Alternatives</u>	<u>Remarks</u>
Flight station	One	None	Primarily for ramp use, deactivated in-flight
Lavatories	One each	Single station, dual generics, local alarm or sensitivity/gating modified for in-flight use	Area of potential high false alarms
Cabin	Two per zone	Sensitivity/gating modified for in-flight use	Primarily for ramp protection (unoccupied)
Attic	Three	Sensitivity/gating modified for in-flight use	
Cargo	One per zone	None	
Lower galley	One	Use heat detectors if sensitivity/gating modification is inadequate (False Alarms) for in-service time	Area of high incidence
Equipment compartments	One per zone	Ref. 22 suggests continuous element heat detectors for APU	
Landing gear hydraulic service	One per zone	Ref. 22 suggests other detector types more appropriate	
Avionic/electrical service center	One per zone	None	

*Recommendations from Ref. 22.

TABLE 15. SUMMARY OF CABIN SMOKE PROTECTION CONCEPTS

Item	Concept	Feasible*			Remarks	References
		Yes	?	No		
1	Smoke Barrier and Zonal Overpressure	i,r		p	Combination of concepts required for success of either. Apply to cabin compartmentation, lavatory, and carry-on storage areas. Question of ability to maintain zonal overpressure in post-crash scenario.	31,37,38,40,41,43,45,87,88,89
2	Air Curtains		i	p	Potential integration into smoke barrier (item 1). Effectiveness not established. Will require zonal overpressure adjunct. Limited by ability to supply air in post-crash scenario. No role in ramp scenario.	87
3	Smoke Venting/Air Handling	i,r		p	Post-suppression action. Ineffective without suppression. May be accomplished by other means (not on board) in ramp scenario.	30,31,33,36,37,43
4	Gravity Smoke Venting			p	Potentially effective; but, sufficient vent area may impair structural reliability.	31,36,37,38,39,42,90

* i = in-flight; r = ramp; p = post-crash; a = all

TABLE 16. SUMMARY OF FIRE HARDENING OF FUSELAGE ENVELOPE AGAINST POST-CRASH EXTERNAL FIRE (no benefit for in-flight or ramp fires)

Item	Concept	Feasible*			Remarks	References
		Yes	?	No		
1	Sidewalls and Headliners			p	New materials offer substantially higher resistance to external fire penetration based on single panel tests. Verification tests on behavior of panel assemblies are needed to assess "edge effects;" effects of crash and thermal distortions. Wide body experience indicates improved performance of recent materials.	3,6,7,9,20,22,93
2	Insulation Systems			p	Thermally resistant foams (e.g. polyisocyanurate) with intumescent paint on the external face of the foam can provide increased protection. Lockheed L-10 11 Tristar uses fiberglass in "Kapton" polyimide bags. In all cases, protection contingent on secure attachment and continuity of seal.	3,4,8,10,11,20,26,92
3	Intumescent Fuselage Paint			p	Doubtful protection due to erosion, probably drag increase.	
4	Window Materials			p	Modern materials exhibit improved resistance. Requires improved frames (recent FAA tests indicate this can be achieved).	6,10,11,12,13,20,95,96
5	Window Shades			p	Various metal or non-metal shades can provide protection. Must be tightly held by frames of comparable fire resistance.	4,96
6	Doors			p	Can apply fuselage materials to body of doors. Seals need development study.	22,96
7	Recloseable Doors			p	Design modification required for wide bodies. Means to check outside conditions prior to opening doors appears more promising (see item 9 below).	14,15,16,45,91,97
8	Emergency Barriers			p	A prepositioned "fire resistant" blanket installed above exits is feasible; its benefit will vary with intensity of external fire at opening. May trade-off with Item 9, below. Also, useful for closing minor openings; but, with logistics problem. "Window shade" (Item 5) can be adapted to exitways.	4,98,99,100
9	External Fire Assessment Prior to Opening Exit Door			p	Small "window" in door, temperature or heat sensing with warning light are among potential solutions. Crew indoctrination required.	97

* p = post-crash

TABLE 17. SUMMARY OF FIRE HARDENING OF CABIN AND ADJACENT COMPARTMENTS

Item	Concept	Feasible*			Remarks	References
		Yes	?	No		
1	Fire Compartmentation	i,r		p	Materials available. Can be incorporated with smoke barrier (see Table 15, Item 1). Exiting constraints may delay full protection.	7,9,20,25,26,28,29,45,52,87,92,93
2	Blankets and Curtains	i,p			Positioned to cover exitways in fire compartments, once passengers clear. Probably "one-shot" devices (wetted), not useful for ramp scenario. (Also see Table 16, Item 8)	4,98,99,100
3	Interior Finish Flame Spread	i,r		p	Modern materials appear adequate for in-flight and ramp scenarios. Ability to improve post-crash scenario currently under investigation at FAA.	7,9,20,22,25,26,28,29,87,92,93
4	Furnishings Combustibility	i,r		p	Benefits in post-crash scenario currently under investigation at FAA. Available materials improve in-flight scenario.	20,22,65
5	Overhead Storage	i,p			Materials available. Testing of latches under internal heating required. No requirement for ramp scenario.	22
6	Attic			a	Materials available. Control of electrical wiring location and enclosures advisable in future aircraft.	22,27
7	Lavatory	i,r			New panels capable of extended fire containment. Improved waste containers already in use. Doors secured against opening in case of fire; and, controlled venting of fire gases are highly desirable. No particular post-crash role.	7,9,20,22,26,29,44,93
8	Galley	i,r			Combustible discards generated during flight should be stored in fire resistive containers. No particular post-crash role.	20,22
9	Cargo			a	Much improved in recent years. Insulation, as in sidewalls of fuselage, could strengthen barrier to cabin. Controlled venting of fire gases is desirable in-flight.	20,22,29,92,94

* i = in-flight; r = ramp; p = post-crash; a = all

TABLE 18. SUMMARY OF EVACUATION ASSISTANCE CONCEPTS

Item	Concept	Feasible*			Remarks	References
		Yes	?	No		
1	Slides, Ramps			p	Improved fire resistance (radiation) primary concern. Inflatables require puncture resistance, reliability, deployability. Existing slides improved by aluminized reflective coating. Neoprene Kevlar fabrics far superior. Improved seam construction/adhesive required.	11,65,103,104
2	Protective Hoods, Masks for Passengers			p	Reduce eye irritation and inhalation of smoke, gases (delay incapacitation). Provide shielding of face from radiation upon leaving plane. Items available, quality undetermined, need testing.	37,101,102,105
3	Protective Clothing for Crew			p	Items available. May improve crews ability to enhance evacuation of passengers.	18,97,107
4	Evacuation Markers			p	Place emergency lighting near floor, reduce disorientation. Include tactile markers.	18,65,108

* p = post-crash

4. RESEARCH/TEST PROGRAMS.

This chapter presents estimates of the program scope and effort required to evaluate the feasibility of those systems listed as "feasibility unknown" in Chapter 3 (Tables 11-18). We recognize that all systems ultimately deemed feasible, as those identified as such herein, still require further design and testing before they can be incorporated into the air transport fleet. No attempt has been made to include these costs in the estimates presented here.

For uniformity of presentation, each research/test program is presented in the format shown below:

- System/concept
- Identifier (refers to the corresponding table (11-18) and item numbers)
- Research/test objectives
- Background
- Scope of work
- Manpower/duration
- Costs
- Remarks

4.1 PROGRAM NUMBER 1--PERFORMANCE OF ON-BOARD SUPPRESSION SYSTEMS IN POST-CRASH FIRES. (Table 11, Items 1-5)

Research/Test Operations

Determine applicability of on-board fire suppression systems to mitigate post-crash fire effects to extend escape and rescue time.

Background

Past experiments have demonstrated little benefit from on-board cabin fire suppression systems in post-crash fires; in fact, counterproductive effects have been noted. The use of on-board systems might be justified if they could be modified to benefit the post-crash scenario. This modification can take the form of operating the system in a compartmented aircraft.

Past experiments with compartmentation alone may not have considered all the potential for compartmentation, particularly in conjunction with suppression:

- Only two equally sized compartments were considered, one containing the fire
- Simple closures or partial closures were examined.

The scenario considered most advantageous for study is a multicompartamental cabin where the partitions and closures are constructed to provide a relatively tight barrier to penetration by fire gases. In this scenario, operating on-board water-based systems in the compartment directly exposed to fire can mitigate the involvement of compartment combustibles in the fire and assist in retaining the integrity of the fire barrier. Similar benefits can be expected from actuating a halon system in the fire zone; but the barrier is expected to resist gas penetration of these highly toxic products inadequately, making escape hoods or masks a necessity.

Scope of Work

Conduct a series of experiments in a simulated (or real) aircraft cabin to examine the possible synergistic use of on-board fire suppression systems and state-of-the-art compartmentation concepts. Multiple compartmentation should be considered, with each compartment sealed after a reasonable time for its evacuation. The effects on conditions within each compartment of partially closing barriers between refuge compartments are to be established. In certain experiments, a portion of the water supply is to be directed toward the overhead area. Benefits derived from suppression action are to be established for both a system limited to on-board water (estimated to be 75 gal) and one in which CF/R services are assumed to supplement the supply after appropriate time delays.

Testing will also establish the benefit or detriment to survival of opening other exitways within both the fire zone and refuge compartments.

Manpower/Duration: 5 man-years/one year

Probable Cost: \$500,000

Remarks

This effort appears most appropriate as an in-house effort of the FAA Technical Center unless a contractor with an existing, appropriate test bed (aircraft) is discovered. If the results are extremely positive, an added effort using halons might be considered.

4.2 PROGRAM NUMBER 2—COMPARTMENTATION. (Table 15, Items 1, 2; Table 17, Item 1)

Research/Test Objectives

Examine existing materials and technology to develop an optimum barrier for fire and smoke compartmentation of aircraft cabins and adjacent areas.

Background

Various means could be used to compartment the cabin area of transport aircraft. Ideal compartmentation must permit some movement of passengers and crew through the barrier while minimizing the transport of smoke, heat, and fire gases. For in-flight fires, the combined use of modest barriers and zonal overpressure offers a reasonable solution, with some attention to closure techniques for the exitway. The probable loss of air supply in the

post-crash fire requires that the barrier construction and exit closure be significantly upgraded.

Scope of Work

Develop a combined fire-smoke barrier for application to both in-flight and post-crash fire scenarios. The optimum barrier is expected to resemble a substantial partition with a simple exiting closure sufficient to provide protection from in-flight fires when combined with suppression and air handling techniques (zonal overpressure). A secondary closure is envisioned which seals the exit opening more tightly once evacuation is completed in any compartment. Alternate concepts will be considered. Preliminary design evaluations may be conducted in a suitable laboratory mock-up, but final systems must be validated in a full-scale aircraft cabin mock-up.

Two separate design and evaluation series are to be planned and executed. The first addresses optimizing means of effecting the simple exit closure and will consider, but not be limited to:

- Air curtains
- Flexible sheet or strip-curtains
- Folding doors.

The second series of designs and evaluations will consider the post-crash supplemental compartment exit closure to provide a tighter seal and increased fire resistance once a compartment has been evacuated. Designs to be considered include concepts incorporating:

- Thin titanium shades (fire doors) or similar devices
- Fire-resistive curtains of measureable fire and smoke resistance
- Gelled-water-impregnated blankets or other concepts for extending performance time.

Those designs showing promise in preliminary testing are to be validated for use without supplementary air handling. The use of a small (<75 gal) water supply to enhance fire resistance may be considered.

Manpower/Duration

Series 1: 2 man years/6 months; Series 2: 3 man years/6 months

Costs: Series 1: \$150,000; Series 2: \$250,000

Remarks

As in Program Number 1, this effort appears appropriate as an in-house effort of the FAA Technical Center unless a contractor with an existing fuselage test bed is identified. It would be appropriate to contract some preliminary design and laboratory work; some of this might be accomplished by potential suppliers of the compartmentation assemblies.

4.3 PROGRAM NUMBER 3—CABIN MATERIALS. (Table 17, Items 3, 4)

Research/Test Objectives

Evaluate alternate cabin furnishings and finishes to lessen the contribution of interior materials to the spread of post-crash, in-cabin fires from external exposure of the cabin through an open exitway or fuselage fracture.

Background

Recent large-scale testing at the FAA Technical Center has shown that modern cabin materials offer reasonable resistance to in-flight incidental cabin fires. The performance of these materials during exposure to post-crash external fuel fires has been less spectacular, even with the introduction of improved cabin seating. The effect of external fire penetration on burning of the cabin ceiling and overhead storage areas is suspected to be a major contributor to rapid fire involvement of the cabin space. Once involved in fire, these overhead areas rapidly spread flames and greatly accelerate seating involvement because of mutual reinforcement. Further improvements in reducing the flammability and fuel contribution of these materials may provide a satisfactory solution. Otherwise, the necessary development steps should be taken to incorporate emergency closures and/or multi-compartmentation into air frame design and to retrofit the existing fleet.

Scope of Work

Through full-scale experimentation, define the limiting flammability characterization of exposed upper cabin materials commensurate with current improved seating materials to limit rapid involvement of the cabin interior exposed to a post-crash external fuel fire. Candidate finish materials will be drawn from those showing promise on the basis of existing small-scale test procedures, or those evaluated by NASA or others for similar application. Testing should begin with materials most likely to succeed, regardless of cost, and be followed by materials showing greater potential cost reduction. If early testing shows unsatisfactory performance, the emphasis of the program will be to determine the effectiveness of partial barriers reducing the threat to the cabin interior to a level where cabin materials adequately resist the reduced fire effects. A maximum of eight to ten tests in an outfitted cabin are envisioned.

Manpower/Duration: 5 man years/12 months

Costs: \$500,000

Remarks

This program in particular is likely to be best conducted by the FAA Technical Center. The cooperation of materials suppliers should be sought for materials, suggestions, known fire properties, and preparation of specific materials and assemblies.

5. COST/BENEFIT ANALYSES.

Cost benefit analyses have been conducted on those systems or concepts deemed "feasible" or "feasibility unknown" in Tables 11-18. Estimated installation costs, system life, and operating costs were used to determine the present worth cost for each system for the life of an airplane which was assumed to be 20 years. The present worth of the benefits were calculated from annual benefit values for injuries prevented, lives saved, and hull damage avoided. The cost benefit ratio based on present worth is as follows:

$$(C/B)_\$ = \frac{\sum_{j=1}^m F_j (1+r)^{1-j} + \sum_{i=1}^n A_i (1+r)^{-i}}{\sum_{i=1}^n (C_L N_{L,i} + C_I N_{I,i} + D_i - D_{0,i})(1+r)^{-i}} \quad (13)$$

where

- F_j = capital investment for installation of system in years, dollars,
- m = number of times a system must be installed to provide service for the life of the aircraft (20 years)
- A_i = annual operating costs, dollars/year
- r = discount rate, decimal
- C_L = value of a life, dollars
- C_I = value of a major injury, dollars
- $N_{L,i}$ = number of lives saved by system in year i
- $N_{I,i}$ = number of injuries prevented by system in year i .
- D_i = aircraft property damage reduction by system in year i , dollars
- $D_{0,i}$ = aircraft property damage due to inadvertant system operation in year i , dollars
- n = life of aircraft, 20 years

and

$$D_i = \left(\sum_{k=1}^p C_{H,k} H_k \right)_i \quad (14)$$

where

- C_H = value of aircraft hull in historical accident k of year i.
 H = fraction of hull saved by system in historical accident k of year i.
 p = number of historical accidents in year i.

The cost of the system per life saved is as follows.

$$(C/B)_L = \frac{\sum_{j=1}^m F_j(1+r)^{1-j} + \sum_{i=1}^n A_i(1+r)^{-i}}{\sum_{i=1}^n N_{L,i}} \quad (15)$$

The number of lives saved, $N_{L,i}$, in the above equations is the net value, i.e., the number saved minus the number lost due to inadvertent system operation.

5.1 COST ANALYSES.

The cost data developed for this report are in 1981 dollars and are representative of current engineering and manufacturing practices. Detailed cost estimates item by item were developed for suppression systems; an overview of the cost procedure appears in Appendix B. Costs for other systems were estimated from costs experienced in industrial applications, adjusted to reflect cost increases for aircraft quality (cost multipliers developed from comparisons of aircrafts vs. industrial suppression systems and system components).

For purposes of the cost/benefit analyses, all costs and benefits were converted to equivalent present worth in 1981 dollars. Fabrication and installation costs, including costs of necessary aircraft modification to accommodate system volume and weight, were allocated at the beginning of the predicted useful life of each system. Operational costs were estimated in terms of weight penalties (higher fuel consumption or reduced payload), additional power requirements, maintenance, and inspection.

Nonrecurring costs (design, development, and test of prototype systems) and research costs to establish feasibility are not included as they have only a minor impact on the total costs evolved, well within the ability to estimate benefits. For example, the installation costs of an on-board zoned water spray suppression system are estimated to be \$57,600 on a narrow body jet.

Appendix B suggests that one-time costs for each type of narrow-body aircraft are as follows:

- Engineering: \$1,487,000
- Develop/test: 3.06 x \$57,600 = \$176,256

or a total of about \$1,663,000. For a high production aircraft (>1000 planes), the additional cost is \$1,663 per plane. A low production model (~200 planes) would incur costs of about \$8,000 per plane.

Costs to establish the feasibility of water-based, on-board suppression systems to moderate post-crash fire effects in the cabin are estimated at \$500,000. Spread over a fleet of more than 2500 aircraft, added cost becomes less than \$200 per plane.

No attempt has been made to distinguish between installed costs in new or existing aircraft. The costs of suppression systems were based on the assumption that they would be retrofit during other major refurbishing or modification requiring removal of the headliner. This philosophy can be applied to most retrofits to minimize costs.

5.2 HISTORICAL BENEFIT ANALYSIS.

Direct benefits attributable to each fire management/suppression system/concept can be defined in terms of:

- Reductions in fire-related life losses
- Reductions in numbers and severity of fire-related injuries
- Reductions in fire damage to aircraft
- Reductions in lost revenue due to loss of aircraft

The latter was not included in benefit analyses since revenue loss is highly dependent on the size of the airline. Thus, while loss of an aircraft may inconvenience a major airline and cause it to adjust schedules and assignments, a similar loss might bankrupt a small airline where one aircraft may represent a significant portion of its fleet.

System-related penalties or negative benefits accrue from:

- Occupant risks attributable to system use during flight
- Occupant risks attributable to inadvertent (non-fire) system activation
- Aircraft operational risks induced by fire-related system operation
- Aircraft operations risks induced by inadvertent system operation.

All benefits must be quantified in terms of dollars for complete development of the cost/benefit analyses.

The methodology for determining direct benefits was drawn from cost/benefit studies of crash/fire/rescue services.¹¹⁰ We reviewed records of past aircraft accidents and estimated the probable reductions in fatalities, injuries, and hull damage if each candidate fire management/suppression system/concept had been on-board. Since large fire-related losses historically have been associated with post-crash fires, only this scenario* was used in the analysis.

*Including fires in landing gear as a result of aborted take-offs, and engine fires resulting in emergency landings of various impacts.

The historical accidents chosen as a basis for the benefit analysis were U.S. air carrier accidents that involved fire and occurred between 1967 and 1979, since records for that period are relatively complete.

To initiate the accident listing, we reviewed computerized listing of air carrier accidents involving fire provided by the National Transportation Safety Board. These were screened to identify accidents where further fire management/suppression actions might provide benefit. Information supportive of the selection process was gathered from more detailed accident reports such as:

- NTSB individual accident reports (and Reference 1)
- NFPA Fire Journal (articles and incident summaries)
- Incident summaries adjunct to other studies of aircraft fires. 17,22,101,110,111

A final listing of 40 accidents was chosen to represent recent U.S. air carrier crash/fire experience (Table 19). For each accident, losses were identified in terms of fatalities, serious injuries, and percent of hull damaged. We then reviewed each fire management/suppression system/concept and estimated the modified losses that might be expected if each system/concept had been provided. The accident listing, actual losses, and modified losses are presented in Tables 20 through 23. The accident listing and actual losses appear in each table. Modified losses are grouped by system type as follows:

- Suppression Systems (Table 20)
- Fire Hardening (Table 21)
- Smoke Protection (Table 22)
- Evacuation Assistance (Table 23)

5.3 COST/BENEFIT RESULTS.

The results of our cost/benefit calculations are summarized in Table 24, which lists all systems or concepts of proven or unknown feasibility. Included in this table are the estimated installed costs of each system/concept in narrow-body (RB) and wide-body (WB) aircraft. Annual costs of operation (maintenance, weight penalties, etc.) are also provided in Table 24.

Annual benefits based on historical experience are presented as injuries and fatalities prevented and as hull damage reduced.

Fatalities are defined to include all injury-induced deaths that occur within seven days. Injuries must involve:

- Hospitalization within seven days, lasting a total of 48 hr or more

- Broken bones, except for fingers, toes, and nose
- Severe lacerations
- Internal organ damage
- Second or third degree burns
- Any burns affecting more than 5 percent of the body surface.

Reductions in hull damage were converted to dollars saved by use of hull values cited in Reference 110, updated to 1981 dollars. These are:

• Wide Body (747, DC10)	\$35,000,000
• Four engine jet (B707, CV880, DC8)	\$12,000,000
• Three engine jet (B727)	\$8,000,000
• Two engine jet (B737, DC9)	\$6,000,000
• Four engine turboprop (CL44, L382, Viscount)	\$4,000,000
• Two engine turboprop (BE99, CV580, CV640, N262)	\$2,000,000

Cost/benefit ratios are presented in Table 24 both as dollar ratios and as cost in dollars per life saved. To develop the dollar ratios, the fatality and injury values of Reference 110 were updated to 1981 dollars:

• Fatality:	\$480,000
• Injury (serious)	\$71,500

To convert costs (per aircraft-year) and benefits (per U.S. fleet-year) to a common basis, the U.S. air fleet was assumed to consist of 1970 narrow-body and 381 wide-body aircraft. We realize that this does not represent the average fleet over the years of interest. This error merely places a constant multiplier on all cost/benefit ratios obtained; earlier limiting of the accident sample had already reduced the cost/benefit data to a relative, not absolute, basis.

The conclusions drawn from the cost/benefit ratios of Table 24 should be carefully scrutinized in any case. The SAFER study⁹⁷ makes significant points regarding aircraft accident statistics. In Volume IIA of the SAFER Reports,⁹⁷ the Aircraft Accident Statistics Sub-Group concludes:

- "Statistics" cannot be used as a basis for making determinations for design changes in aircraft
- There are gaps in the data that have been collected.

The forty accidents listed in Table 19 hardly constitute a sound statistical sample. Their lack in number speaks highly of aviation's safety record; but, frustrates true statistical analysis. Also, in addition to those accidents not even listed, details of accidents on the list did not always permit confident judgement of the potential of the considered systems. As a result, cost/benefit ratios presented in Table 24 are quite sensitive to benefits assigned to a very few accidents.

TABLE 19. FORTY ACCIDENTS REPRESENTATIVE OF U.S. CARRIER CRASHES/FIRES

<u>Date</u>	<u>Location</u>	<u>Aircraft</u>	<u>Airline</u>	<u>Total on Board</u>	<u>Phase of Operation</u>	<u>Type of Accident</u>	<u>Losses Deaths/Injuries/ % Hull Damage</u>
4-25-67	San Juan, PR	Convair 640	Caribbean Atlantic AL	57	Landing, Traffic Pattern Circling	Inflight engine fire, Emergency landing--around loop, fire on ground	0/11/40
11-06-67	Erlanger, KY	Boeing 707	TWA	36	Takeoff, Aborted	Gear collapsed, ground slide, fire on ground	1/10/75
11-20-67	Constance, KY	Convair 880	TWA	82	Landing, final approach	Undershot, fire after impact	70/12/100
10-25-68	Hanover, HN	FH227C	Northwest	42	In-flight landing, descending	Collided with ground (hit mountaintop), fire after impact	32/08/100
12-27-68	Chicago, IL	Convair 580	North Central	45	Landing, final approach	Struck hangar, fire after impact	27/08/80
2-09-69	Berlin, W. Germany	Boeing 707	Pan Am	116	Takeoff Run	Engine failure, fire on ground	0/02/?
3-02-70	Chicago, IL	Boeing 720	United	95	Static, starting engine(s)	Engine caught fire on restart, fire on ground, evacuation slide problems	0/01/0
5-18-70	Chicago, IL	Boeing 727	United	72	Taxi from landing	APU hydraulic leak problem, fire on ground	0/01/20
6-09-70	Bangor, ME	Douglas DC 8F	Trans Caribbean Airways	228	Takeoff, aborted	Fire in the landing gear area, evacuation slide problems	0/31/10
6-26-70	Jamaica, NY	Boeing 747	TWA	Unknown	Landing-rollout	Engine fire, evacuation problems	0/14/80
11-27-70	Anchorage, AK	Douglas DC 8 63	Capital Intl. Airways	229	Takeoff, aborted	Collided with ditches, fire after impact	47/49/100
12-28-70	St. Thomas, VI	Boeing 727	Trans Caribbean Airways	55	Landing, level off/touch-down	Gear collapsed, fire after impact	2/11/80
6-07-71	New Haven, CN	Convair 580	Alleghany Airlines	31	Landing, final approach	Collided with residences, fire after impact	30/03/100
7-23-71	Chicago, IL	Boeing 747	United	199	Taxi from landing	Engine failure, fire on ground	0/01/~10
8-08-71	Honolulu, HI	Vickers 745D	Aloha Airlines	22	Taxi from landing	Fire on ground caused by electrical short; damage to cabin, cockpit, baggage compartment	0/00/15
5-30-72	Fort Worth, TX	Douglas DC 9 14	Delta	4	Landing, final approach	Collision with ground, to wake turbulence from DC-10, fire after impact	4/00/90
6-10-72	Flushing, NY	Boeing 727	American	77	Static parked-engines not starting	Explosion of portable oxygen bottle on ground when turned on for passenger's use, fire on ground	0/02/~10
9-01-72	Jamaica, NY	Boeing 747	TWA	353	Taxi to takeoff static-idle engine(s)	Fire on ground in landing gear	0/08/05
11-01-72	St. Louis, MO	Boeing 707	TWA	81	Landing, rollout	Engine fire on ground, evacuation problems	0/01/05
12-08-72	Chicago, IL	Boeing 737	United	61	Landing, final approach	Collision with houses, fire after impact	43/12/100
12-20-72	Chicago, IL	Douglas DC 9 31 and Convair 880	North Central	45	Takeoff, initial climb	Collision with taxiing aircraft, fire after impact	10/15/100

TABLE 19. FORTY ACCIDENTS REPRESENTATIVE OF U.S. CARRIER CRASHES/FIRES (Continued)

<u>Date</u>	<u>Location</u>	<u>Aircraft</u>	<u>Airline</u>	<u>Total on Board</u>	<u>Phase of Operation</u>	<u>Type of Accident</u>	<u>Losses Deaths/Injuries/ % Hull Damage</u>
6-20-73	Bangor, ME	Douglas DC 8	Overseas Natl. Airways	261	Takeoff, aborted	Landing gear failure, fire on ground	0/03/~10
12-17-73	Greensboro, NC	Douglas DC 9	Eastern	89	Takeoff, aborted	Skidded off snow covered runway, fire after impact	0/01/25
1-16-74	Los Angeles, CA	Boeing 707-131B	TWA	65	Landing, Level off/touchdown	Hard landing, fire after impact	0/08/100
1-30-74	Pago, Pago	Boeing 707	Pan Am	101	Landing, final approach	Undershot landing, hit trees, fire after impact	96/05/100
9-11-74	Charlotte, NC	Douglas DC 9	Eastern	82	Landing, final approach	Crashed during approach, hit trees, fire after impact	71/10/100
6-14-75	Los Angeles, CA	Lockheed L1011	TWA	243	Static, starting engine(s)	Engine failure, fire on ground, evacuation problems	0/01/0
6-24-75	Jamaica, NY	Boeing 727	Eastern	124	Landing, final approach	Collided with runway or approach lights, fire after impact	115/09/100
8-25-75	Jamaica, NY	Douglas DC 10	American	231	Takeoff run, aborted	Landing gear failure, fire after impact	0/03/100
8-30-75	Bambell, AK	Fairchild 278	Air Alaska	32	Landing	Missed approach, collision with ground, fire after impact	10/20/100
10-16-75	Seattle, WA	Douglas DC 10	United	132	Taxi to takeoff	Fuel control malfunctioned, fire on ground	0/01/0
11-12-75	Jamaica, NY	Douglas DC 10 30	Overseas Natl. Airways	139	Takeoff run, aborted	Struck birds, engine caught fire, landing gear collapsed during rollout	0/02/100
2-16-76	Denver, CO	Boeing 727	Continental	120	Takeoff run, aborted	Engine failure, fire on ground, evacuation slide problem	6/01/10
4-05-76	Ketchikan, AK	Boeing 727	Alaska Airlines	50	Landing level off/touchdown	Collided with ditches, fire after impact	1/11/100
4-27-76	St. Thomas, VI	Boeing 727	American	88	Landing level off/touchdown	Collided with object, fire after impact	37/38/95
11-16-76	Denver, CO	Douglas DC 9	Texas Intl.	86	Takeoff, aborted	Collided with ditches	0/02/75
3-27-77	Tefriff, Canary Is.	Boeing 747	Pan Am	396	Taxi to takeoff	Collision with aircraft both on ground, fire after impact	326/34/100
4-04-77	New Hope, GA	Douglas DC 9	Southern Airways	85	Landing level off/touchdown	Collision with ground, fire after impact	62/22/100
3-01-78	Los Angeles, CA	Douglas DC 10 10	Continental	200	Takeoff, aborted	Left landing gear collapsed, left tank ruptured, fire after impact	2/31/100
5-21-78	Erlanger, KY	Boeing 727	American	104	Takeoff, initial climb	Engine failure, precautionary landing, fire on ground	0/03/~10

TABLE 20. ESTIMATED IMPACT OF VARIOUS FIRE MANAGEMENT/SUPPRESSION CONCEPTS ON RECENT U.S. AIR CARRIER ACCIDENTS—
SUPPRESSION SYSTEMS

Date	Location	Aircraft	Airline	Losses Deaths/Injuries/ % Hull Damage	Automatic Sprinklers	Zoned Water Spray	Suppression System Modified Losses	
							Halon 1301 Total Flood	Halon 1211 Direct Application
4-25-67	San Juan, PR	Convair 640	Carribean Atlantic AL	0/00/40				
11-06-67	Erlanger, KY	Boeing 707	TWA	1/10/75				
11-20-67	Constance, KY	Convair 880	TWA	70/12/100				
10-25-68	Hanover, NH	FH227	Northeast	32/08/100				
12-27-68	Chicago, IL	Convair 580	North Central	27/08/80	16/10/--	16/10/--		
2-09-69	Berlin, W. Germany	Boeing 707	Pan Am	0/02/?				
3-02-70	Chicago, IL	Boeing 720	United	0/01/0				
5-18-70	Chicago, IL	Boeing 727	United	0/01/20				
6-26-70	Jamaica, NY	Boeing 747	TWA	0/31/10				
6-09-70	Bangor, ME	Douglas DC 8 8F	Trans Carribean Airways	0/14/80				
11-27-70	Anchorage, AK	Douglas DC 8 63	Capital Intl Airways	47/49/100	24/24/--	24/24/--	24/24/--	35/35/--
12-28-70	St. Thomas, VI	Boeing 727	Trans Carribean Airways	2/11/80				
6-07-71	New Haven, CN	Convair 580	Alleghany Airlines	30/03/100	15/10/--	15/10/--		
7-23-71	Chicago, IL	Boeing 747	United	0/01/~10				
8-08-71	Honolulu, HI	Vickers 745D	Aloha Airlines	0/00/15	0/00/05	0/00/05	0/00/05	0/00/05
5-30-72	Fort Worth, TX	Douglas DC 9 14	Delta	4/00/90				
6-10-72	Flushing, NY	Boeing 727	American	0/02/~10	0/01/05	0/01/05	0/01/05	0/01/05
9-01-72	Jamaica, NY	Boeing 747	TWA	0/08/05				
11-01-72	St. Louis, MO	Boeing 707	TWA	0/01/05				
12-08-72	Chicago, IL	Boeing 737	United	43/12/100	25/30/--	25/30/--	35/17/--	
12-20-72	Chicago, IL	Douglas DC 9 31 and Convair 880	North Central Delta	10/15/100 0/00/10	0/05/--	0/05/--	5/10/--	5/10/--
6-20-73	Bangor, ME	Douglas DC 8	Overseas Natl Airways	0/03/~10				
12-17-73	Greensboro, NC	Douglas DC 9	Eastern	0/01/25				
1-16-74	Los Angeles, CA	Boeing 707-131B	TWA	0/08/100	0/00/10	0/00/10	0/00/10	0/00/10
1-30-74	Pago, Pago	Boeing 707	Pan Am	96/05/100	48/29/--	48/29/--		
9-11-74	Charlotte, NC	Douglas DC 9	Eastern	71/10/100	55/20/--	55/20/--	60/21/--	60/21/--
6-14-75	Los Angeles, CA	Lockheed L1011	TWA	0/01/0				
6-24-75	Jamaica, NY	Boeing 727	Eastern	115/09/100				
8-25-75	Jamaica, NY	Douglas DC 10	American	0/03/100				
8-30-75	Bambell, AK	Fairchild 278	Air Alaska	10/20/100				
10-16-75	Seattle, WA	Douglas DC 10	United	0/01/0				
11-12-75	Jamaica, NY	Douglas DC 10 30	Overseas Natl Airways	0/02/100				
2-16-76	Denver, CO	Boeing 727	Continental	6/01/10				
4-05-76	Ketchikan, AK	Boeing 727	Alaska Airlines	1/11/100				
4-27-76	St. Thomas, VI	Boeing 727	American	37/38/95	18/40/--	18/40/--	25/40/--	30/40/--
11-16-76	Denver, CO	Douglas DC 9	Texas International	0/02/75	0/00/25	0/00/25	0/00/25	0/00/25
3-27-77	Tenriff Canary Is.	Boeing 747	Pan Am	326/34/100				
4-04-77	New Hope, GA	Douglas DC 9	Southern Airways	62/22/100	52/12/--	52/12/--		
3-01-78	Los Angeles, CA	Douglas DC 10 10	Continental	2/31/70				
5-21-78	Erlanger, KY	Boeing 727	American	0/03/~10				

--no effect on hull damage

TABLE 21. ESTIMATED IMPACT OF VARIOUS FIRE MANAGEMENT/SUPPRESSION CONCEPTS ON RECENT U.S. AIR CARRIER ACCIDENTS—
FIRE HARDENING

Date	Location	Aircraft	Airline	Losses Deaths/ Injuries/ % Hull Damage	Fire Hardening of Cabin, Adjacent Compartments and Fuselage				
					Active Barriers and Flamespread of Materials		Modified Losses		Passive Barriers
					Blankets and Curtains (Exterior Fire Penetration)	Window Shades	Flammability of Interior Finish and Combustibility of Seating	Cabin Compartment- mentation	F.R. Fuselage Envelope+
4-25-67	San Juan, PR	Convair 640	Carribean Atlantic AL	0/00/40					
11-06-67	Erlanger, KY	Boeing 707	TWA	1/10/75					
11-20-67	Constance, KY	Convair 880	TWA	70/12/100					
10-25-68	Hanover, NH	FH227C	Northeast	32/08/100					
12-27-68	Chicago, IL	Convair 580	North Central	27/08/80			16/10/--	20/10/--	
2-09-69	Berlin, W. Germany	Boeing 707	Pan Am	0/02/?					
3-02-70	Chicago, IL	Boeing 720	United	0/01/0					
5-18-70	Chicago, IL	Boeing 727	United	0/01/20					
6-26-70	Jamaica, NY	Boeing 747	TWA	0/31/10					
6-09-70	Bangor, ME	Douglas DC 8F	Trans Carribean Airways	0/14/80					
11-27-70	Anchorage, AK	Douglas DC 8 63	Capital Intl Airways	47/49/100			24/24/--	24/24/--	
12-28-70	St. Thomas, VI	Boeing 727	Trans Carribean Airways	2/11/80					
6-07-71	New Haven, CN	Convair 580	Alleghany Airlines	30/03/100	27/4/--	25/5/--	15/10/--	10/10/--	5/10/--
7-23-71	Chicago, IL	Boeing 747	United	0/01/~10					
8-08-71	Honolulu, HI	Vickers 745D	Aloha Airlines	0/00/15					0/00/05
5-30-72	Fort Worth, TX	Douglas DC 9 14	Delta	4/00/90					
6-10-72	Flushing, NY	Boeing 727	American	0/02/~10					0/01/05
9-01-72	Jamaica, NY	Boeing 747	TWA	0/08/05					
11-01-72	St. Louis, MO	Boeing 707	TWA	0/01/05					
12-08-72	Chicago, IL	Boeing 737	United	43/12/100	41/10/--	40/12/--	35/25/--	30/20/--	35/25/--
12-20-72	Chicago, IL	Douglas DC 9 31 and Convair 880	North Central Delta	10/15/100 0/00/10					
6-20-73	Bangor, ME	Douglas DC 8	Overseas Natl Airways	0/03/~10					
12-17-73	Greensboro, NC	Douglas DC 9	Eastern	0/01/25					
1-16-74	Los Angeles, CA	Boeing 707-131B	TWA	0/08/100					
1/30/74	Pago, Pago	Boeing 707	Pan Am	96/05/100	87/10/--	77/15/--		40/25/--	20/20/--
9-11-74	Charlotte, NC	Douglas DC 9	Eastern	71/10/100				55/20/--	
6-14-75	Los Angeles, CA	Lockheed L1011	TWA	0/01/0					
6-24-75	Jamaica, NY	Boeing 727	Eastern	115/09/100					
8-25-75	Jamaica, NY	Douglas DC 10	American	0/03/100					

TABLE 21. ESTIMATED IMPACT OF VARIOUS FIRE MANAGEMENT/SUPPRESSION CONCEPTS ON RECENT U.S. AIR CARRIER ACCIDENTS—
FIRE HARDENING (continued)

Date	Location	Aircraft	Airline	Losses Deaths/ Injuries/ % Hull Damage	Fire Hardening of Cabin, Adjacent Compartments and Fuselage				
					Active Barriers and Flamespread of Materials		Modified Losses		Passive Barriers
					Blankets and Curtains (Exterior Fire Penetration)	Window Shades	Flammability of Interior Finish and Combustibility of Seating	Cabin Compartmentation	F.R. Fuselage Envelope†
8-30-75	Bambell, AK	Fairchild 278	Air Alaska	10/20/100					
10-16-75	Seattle, WA	Douglas DC 10	United	0/01/0					
11-12-75	Jamaica, NY	Douglas DC 10 30	Overseas Natl Airways	0/02/100					
2-16-76	Denver, CO	Boeing 727	Continental	6/01/10					
4-05-76	Ketchikan, AK	Boeing 727	Alaska Airlines	1/11/100					
4-27-76	St. Thomas, VI	Boeing 727	American	37/38/95			27/25/--	17/58/--	
11-16-76	Denver, CO	Douglas DC 9	Texas International	0/02/75					
3-27-77	Tenfriff Canary Is.	Boeing 747	Pan Am	326/34/100					
4-04-77	New Hope, GA	Douglas DC 9	Southern Airways	62/22/100			52/10/--	52/10/--	
3-01-78	Los Angeles, CA	Douglas DC 10 10	Continental	2/31/70					
5-21-78	Erlanger, KY	Boeing 727	American	0/03/~10					

--no effect on hull damage

†includes improved windows and doors

TABLE 22. ESTIMATED IMPACT OF VARIOUS FIRE MANAGEMENT/SUPPRESSION CONCEPTS ON RECENT U.S. AIR CARRIER ACCIDENTS—
SMOKE PROTECTION

Date	Location	Aircraft	Airline	Losses	Modified Losses
				Deaths/Injuries/ % Hull Damage	Smoke Barrier/ Zonal Overpressures
4-25-67	San Juan, PR	Convair 640	Carribean Atlantic AL	0/00/40	
11-06-67	Erlanger, KY	Boeing 707	TWA	1/10/75	
11-20-67	Constance, KY	Convair 880	TWA	70/12/100	
10-25-68	Hanover, NH	FH227	Northeast	32/08/100	
12-27-68	Chicago, IL	Convair 580	North Central	27/08/80	
2-09-69	Berlin, W. Germany	Boeing 707	Pan Am	0/02/?	
3-02-70	Chicago, IL	Boeing 720	United	0/01/0	
5-18-70	Chicago, IL	Boeing 727	United	0/01/20	
6-26-70	Jamaica, NY	Boeing 747	TWA	0/31/10	
6-09-70	Bangor, ME	Douglas DC 8F	Trans Carribean Airways	0/14/80	
11-27-70	Anchorage, AK	Douglas DC 8 63	Capital Intl Airways	47/49/100	
12-28-70	St. Thomas, VI	Boeing 727	Trans Carribean Airways	2/11/80	
6/07/71	New Haven, CN	Convair 580	Alleghany Airlines	30/03/100	10/10/--
7-23-71	Chicago, IL	Boeing 747	United	0/01/~10	
8/08/71	Honolulu, HI	Vickers 745D	Aloha Airlines	0/00/15	
5-30-72	Fort Worth, TX	Douglas DC 9 14	Delta	4/00/90	
6-10-72	Flushing, NY	Boeing 727	American	0/02/~10	
9-01-72	Jamaica, NY	Boeing 747	TWA	0/08/05	
11-01-72	St. Louis, MO	Boeing 707	TWA	0/01/05	
12-08-72	Chicago, IL	Boeing 737	United	43/12/100	
12-20-72	Chicago, IL	Douglas DC 9 31 and Convair 880	North Central Delta	10/15/100 0/00/10	
6-20-73	Bangor, ME	Douglas DC 8	Overseas Natl Airways	0/03/~10	
12-17-73	Greensboro, NC	Douglas DC 9	Eastern	0/01/25	
1-16-74	Los Angeles, CA	Boeing 707-131B	TWA	0/08/100	
1-30-74	Pago, Pago	Boeing 707	Pan Am	96/05/100	
9-11-74	Charlotte, NC	Douglas DC 9	Eastern	71/10/100	50/20/--
6-14-75	Los Angeles, CA	Lockheed L1011	TWA	0/01/0	
6-24-75	Jamaica, NY	Boeing 727	Eastern	115/09/100	
8-25-75	Jamaica, NY	Douglas DC 10	American	0/03/100	
8-30-75	Bambell, AK	Fairchild 278	Air Alaska	10/20/100	
10-16-75	Seattle, WA	Douglas DC 10	United	0/01/0	
11-12-75	Jamaica, NY	Douglas DC 10 30	Overseas Natl Airways	0/02/100	
2-16-76	Denver, CO	Boeing 727	Continental	6/01/10	
4-05-76	Ketchikan, AK	Boeing 727	Alaska Airlines	1/11/100	
4-27-76	St. Thomas, VI	Boeing 727	American	37/38/95	
11-16-76	Denver, CO	Douglas DC 9	Texas International	0/02/75	
3-27-77	Tenriff, Canary Is.	Boeing 747	Pan Am	326/34/100	
4-04-77	New Hope, GA	Douglas DC 9	Southern Airways	62/22/100	
3-01-78	Los Angeles, CA	Douglas DC 10 10	Continental	2/31/70	
5-21-78	Erlanger, KY	Boeing 727	American	0/03/~10	

—no effect on hull damage

TABLE 23. ESTIMATED IMPACT OF VARIOUS FIRE MANAGEMENT/SUPPRESSION CONCEPTS ON RECENT U.S. AIR CARRIER ACCIDENTS—
EVACUATION ASSISTANCE

Date	Location	Aircraft	Airline	Losses Deaths/Injuries/ % Hull Damage	Evacuation Assistance Concepts Modified Losses		Evacuation Markers
					Improved Slides, Tubes, Ramps, etc.	Smoke Mask/ Hoods	
4-25-67	San Juan, PR	Convair 640	Caribbean Atlantic AL	0/00/40			
11-06-67	Erlanger, KY	Boeing 707	TWA	1/10/75	1/02/--		
11-20-67	Constance, KY	Convair 880	TWA	70/12/100			
10-25-68	Hanover, NH	FH227	Northeast	32/08/100			
12-27-68	Chicago, IL	Convair 580	North Central	27/08/80			
2-09-69	Berlin, W. Germany	Boeing 707	Pan Am	0/02/?			
3-02-70	Chicago, IL	Boeing 720	United	0/01/0			
5-18-70	Chicago, IL	Boeing 727	United	0/01/20			
6-26-70	Jamaica, NY	Boeing 747	TWA	0/31/10			
6-09-70	Bangor, ME	Douglas DC 8F	Trans Caribbean Airways	0/14/80			
11-27-70	Anchorage, AK	Douglas DC 8 63	Capital Intl Airways	47/49/100		30/30/--	44/46/--
12-28-70	St. Thomas, VI	Boeing 727	Trans Caribbean Airways	2/11/80	2/10/--	1/08/--	
6-07-71	New Haven, CN	Convair 580	Alleghany Airlines	30/03/100		10/10/--	
7-23-71	Chicago, IL	Boeing 747	United	0/01/~10	0/00/--		
8-08-71	Honolulu, HI	Vickers 745D	Aloha Airlines	0/00/15			
5-30-72	Fort Worth, TX	Douglas DC 9 14	Delta	4/00/90	3/00/--		
6-10-72	Flushing, NY	Boeing 727	American	0/02/~10			
9-01-72	Jamaica, NY	Boeing 747	TWA	0/08/05	0/00/--		0/07/--
11-01-72	St. Louis, MO	Boeing 707	TWA	0/01/05	0/00/--		
12-08-72	Chicago, IL	Boeing 737	United	43/12/100		16/20/--	
12-20-72	Chicago, IL	Douglas DC 9 31 and Convair 880	North Central Delta	10/15/100 0/00/10			
6-20-73	Bangor, ME	Douglas DC 8	Overseas Natl Airways	0/03/~10			
12-17-73	Greensboro, NC	Douglas DC 9	Eastern	0/01/25			
1-16-74	Los Angeles, CA	Boeing 707-131B	TWA	0/08/100	0/00/--		
1-30-74	Pago, Pago	Boeing 707	Pan Am	96/05/100	10/15/--	20/10/--	81/07/--
9-11-74	Charlotte, NC	Douglas DC 9	Eastern	71/10/100		50/20/--	
6-14-75	Los Angeles, CA	Lockheed L1011	TWA	0/01/0			
6-24-75	Jamaica, NY	Boeing 727	Eastern	115/09/100			
8-25-75	Jamaica, NY	Douglas DC 10	American	0/03/100			
8-30-75	Bambell, AK	Fairchild 278	Air Alaska	10/20/100			
10-16-75	Seattle, WA	Douglas DC 10	United	0/01/0			
11-12-75	Jamaica, NY	Douglas DC 10 30	Overseas Natl Airways	0/02/100			
2-16-76	Denver, CO	Boeing 727	Continental	6/01/10			
4-05-76	Ketchikan, AK	Boeing 727	Alaska Airlines	1/11/100			
4-27-76	St. Thomas, VI	Boeing 727	American	37/38/95		27/25/--	
11-16-76	Denver, CO	Douglas DC 9	Texas International	0/02/75			
3-27-77	Tenriff, Canary Is.	Boeing 747	Pan Am	326/34/100			
4-04-77	New Hope, GA	Douglas DC 9	Southern Airways	62/22/100		52/10/--	
3-01-78	Los Angeles, CA	Douglas DC 10 10	Continental	2/31/70	0/10/--		
5-21-78	Erlanger, KY	Boeing 727	American	0/03/~10			

--no effect on hull damage

TABLE 24 SUMMARY OF COST BENEFIT ANALYSIS

Concept Description	Estimated Installation Cost/Plane		Expected System Life++ (Years)	Annual Operational Cost/Plane		Benefits (annual basis per U.S. fleet)			\$Cost	
	RB	WB		RB	WB	Injuries Prevented	Deaths Prevented	\$Hull Damage Prevented	Per Benefit	Per Death Prevented
Automatic Sprinklers-water	28900	55400	20	9860	13600	-1.55	15.45	1,309,091	3.92	930,497
Automatic Sprinklers-AFFF	29000	55600	20	11660	15490					
Zoned Water Sprsy-water	57600	86300	20	9860	13900	-1.55	15.45	1,309,091	4.87	1,154,720
Zoned Water Spray-AFFF	57700	86500	20	11660	15490					
Direct Spray-Halon 1211	68200	106900	20	3490	6615	0.64	3.18	1,209,909	10.77	4,010,583
Total Flooding-Halon 1301	29200	63600	20	4150	8320	2.09	5.36	1,209,909	5.33	1,663,671
Spot Total Flooding-Halon 1301 (Lavatory)	1500	4600	20	315	670	--	--	--	--	--
Spot Total Flooding-Halon 1211 (Lavatory)	1500	4600	20	315	670	--	--	--	--	--
Spot Total Flooding Halon 1301 (Coats and Storage)	1400	2500	20	326	483	--	--	--	--	--
Spot Total Flooding Halon 1211 (Coats and Storage)	1400	2500	20	326	483	--	--	--	--	--
Spot Water Spray (Lavatory)	220	680	20	750	1939	--	--	--	--	--
Spot Water Spray (Coats and Storage)	300	530	20	926	1576	--	--	--	--	--
Heat Detection in Lavatory and Galleys	2000 (400)	4500 (900)	10	320 (182)	615 (372)	--	--	--	--	--
DDA (local alarm) in Lavatory/Lower Galley	400	900		182	372	--	--	--	--	--
Full Detection System ²²	19500	39000	20	2475	4730	--	--	--	--	--
Blankets and Curtains for Exterior Fire Protection	2000	4000	5	1100	495	-0.36	1.27	0	6.50	1,272,672
Window Shades for Exterior	1800	1800	20	495	6956	-1.09	2.45	0	3.85	716,260
Improved Interior Finish and Seating	131000	262000	20	3478	17760	2.55	7.0	0	15.71	3,384,511
Cabin Compartmentation	8000	20000	20	5920	4652	-2.73	15.0	0	2.31	459,194
Improved Attic Materials	5500	11000	20	3116	6113	--	--	--	--	--
Fire Retardant Fuselage Envelope	87333	174666	20	2324	4652	-3.18	9.91	0	7.59	1,476,593

TABLE 24 SUMMARY OF COST BENEFIT ANALYSIS (Continued)

Concept Description	Estimated Installation Cost/Plane		Expected System Life++ (Years)	Annual Operational Cost/Plane		Benefits (annual basis per U.S. fleet)				
	RB	WB		RB	WB	Injuries Prevented	Deaths Prevented	\$Hull Damage Prevented	Per Benefit	\$Cost Per Death Prevented
Fire Retardant Lavatory and Galley Hardening	3140	6260	20	814	1628	0.09	0	--	--	--
Smoke Barriers/Zonal Overpressure	4000	10000	20	1480	4440	-1.55	3.73	0	3.56	682,494
Post Suppression Air Dilution	3000	12000	20	1200	3600	--	--	--	---	---
Air Curtains	--	--	--	--	--	--	--	--	---	---
Improved Slides, Ramps, etc.	1600	3200	5	2640	5280	3.45	8.09	0	2.03	440,179
Smoke Masks/Hoods	2970	7965	3	614	1618	1.55	16.55	0	0.68	140,326
Evacuation Markers	1500	3000	2	200	400	0.18	1.64	0	3.63	754,704

*costs in () are for local alarm type

-not estimated

+annual fixed cost = installed cost/expected life

++20 yr = expected service life of aircraft

6. CONCLUSIONS AND RECOMMENDATIONS.

No one "magic" cure-all is available to eliminate all losses of life and property due to aircraft cabin fires. That such losses are small speaks highly of the design, engineering, and operation of the present U.S. air fleet. What remains to be accomplished is, by careful study of past and potential fire losses, to address those areas where experience or judgment suggest that improved benefits may result.

Indeed, such is the case in any carefully planned fire protection system. The various tools and techniques to prevent fire or to minimize its effects must be blended into a comprehensive system. It is not practical to include all protective means and devices. The challenge is to determine that combination of prevention and protection which will satisfactorily minimize losses without undue costs.

Fire in a large jet transport aircraft is like fire in a high-rise structure. While both are to be avoided, one such occurrence draws greater attention and cry for added protection than do the frequent "minor" fires that may cause greater annual fatalities and surely represent greater total property losses. One large loss incident is unfortunate but current protective measures should not be unduly criticized because of its occurrence.

Still, there are areas where improved protection is warranted. Fire insults following a survivable crash are not effectively ameliorated. In-flight fires affecting the cabin are generally minor in nature, but usually remain minor only because of the prompt action of the passengers and crew. Thus one might rank post-crash fire protection as the area most in need of improvements. The potential of in-flight fires, however, should not be overlooked, and low cost improvements are available.

Post-crash fire protection is that which permits those passengers and crew who survive the impact of the crash to escape before being exposed to debilitating fire effects. The means of achieving this protection include:

- Fire suppression or intensity reduction
- Delay of the spread of fire effects
- Increase in the ease and speed of escape.

On the basis of cost/benefit ratios, the more promising concepts appear to be in the general area of escape aids (improved slides/ramps, masks/hoods, evacuation markers). These items appear to be developed to a point where implementation is feasible in the near term.

The primary concern in the post-crash scenario is preventing external liquid fuel fires and fire effects from entering the aircraft cabin. The intact fuselage of modern wide-body aircraft offers reasonable fire resistance, but

improvements are possible. Of major concern here are means of protecting windows and exitways from fire penetration. Improved window materials appear to be an accomplished fact. Window shades offer a possible alternative for quick retrofit, but require action by passengers and crew to be effective. Emergency exitway closures or improved means of assessing fire effects before opening exitways should be addressed.

The most difficult of the post-crash fire scenarios to resolve are those where the integrity of the fuselage envelope is fractured and the external fire has direct access to the cabin interior. To protect against this situation, cabin compartmentation coupled with on-board suppression appears to be a solution, but is not yet proven. Combinations of improved materials/compartmentation/limited suppression may also be viable, but also are not proven.

Complete on-board suppression systems are a viable means of extinguishing in-flight fires in aircraft cabin and adjacent compartments. Their unproven and perhaps negative effects on the cabin in post-crash fires coupled with their relatively high costs make short-term implementation unattractive. Should performance be proven against post-crash fires coupled with compartmentation, the use of on-board suppression systems, probably water-based, would offer a broad protection base.

Despite past problems with early warning on-board smoke detectors, modern detectors combined in a dual generics, pumped sampling device offer promise for early detection of in-flight and ramp fires. The wide variations in environment to which these detectors would be exposed suggests that sensitivity and gating be programmed to accommodate specific in-flight and ramp periods. The use of detectors to protect the entire aircraft would be costly, however. A viable alternative is the addition of detectors only in lavatories and the lower galley (of wide-body jets). The most cost-effective configuration would be single-station, local-alarm devices, either dual generics with adjusted sensitivity and gating or admittedly less sensitive heat detectors.

Surviving any on-board, in-flight fire requires early discovery, containment, rapid extinguishment, and post-fire exhausting of the suppression-modified fire products. The lavatory, a frequent fire site, appears to provide containment and exhausting, but early warning and suppression rely on human actions. The cabin proper requires attention to containment and exhaustion, but in most cases probably can rely on passengers and crew for detection and crew for suppression.

REFERENCES

1. Special Study: U.S. Air Carrier Accidents Involving Fire, 1965 through 1974 and Factors Affecting the Statistics, National Transportation Safety Board, Report No. NTSB-AAS-77-1, 1977.
2. Alger, R. S., and Capener, E. L. Aircraft Ground Fire Suppression and Rescue Systems--Basic Relationships in Military Fires; Phases I and II, AGFSRS-72-1, April 1972 (AD745 122).
3. Geyer, G., Effects of Ground Crash Fire on Aircraft Fuselage Integrity, FAA Report No. NA69-37-(RO-69-46), December 1969.
4. Sarkos, C.P., Titanium Fuselage Environmental Conditions in Postcrash Fires, Federal Aviation Administration, Report No. FAA-RD-71-3, March 1971.
5. Gordon, W., and McMillan, R. O., Temperature Distribution Within Aircraft Fuel Fires, Fire Technology, 1965.
6. Fish, R. H., Ames T-3 Test Facility--Aircraft Crash Fire Simulation, National Aeronautics and Space Administration, Ames Research Center, J. Fire and Flammability, 7, 1976.
7. Kourtides, D. A., Parker, J. A., Gilwee, W. J., Jr., Lerner, R. N., Hilado, C. J., LaBossiere, L. A., and Hsu, M., Flammability Characteristics of Aircraft Interior Composites, J. Fire and Flammability, 7, 1976.
8. Sarkos, C. P., Small Scale Fire Tests of High-Temperature Cabin Pressure Sealant and Insulating Materials, Federal Aviation Administration, Report No. FAA-RD-71-67, November 1971.
9. Kourtides, D. A., Parker, J. A., and Gilwee, W. J., Jr., Thermochemical Characterization of Aircraft Interior Panel Materials, J. Fire and Flammability, 6, 1975.
10. Los Angeles Fire Department, Continental Airlines DC-10 Accident, Los Angeles International Airport, March 1978.
11. Aircraft Accident Report: Continental Airlines, Inc., McDonnell-Douglas DC-10-10, N68045, Los Angeles California, March 1, 1978, National Transportation Safety Board, Report No. NTSB-AAR-79-1, 1979.
12. Parker, J. A., Fohlen, G. M., and Sawko, P. M., Development of Transparent Composites and Their Thermal Responses, Conference on Transparent Aircraft Enclosures, Air Force Materials Laboratory and Air Force Flight Dynamics Laboratory at Las Vegas, Nevada, February 5-8, 1973.
13. Sarkos, C. P., Measurement of Toxic Gases and Smoke from Aircraft Cabin Interior Materials Using the NBS Smoke Chamber and Colorimetric Tubes, Federal Aviation Administration, Report No. FAA-RD-76-7, 1976.
14. Air Carrier Cabin Safety, A Survey, Federal Aviation Administration, Office of Aviation Safety, Washington, D.C., 1976.

15. Brown, L. J. Jr., Cabin Hazards from a Large External Fuel Fire Adjacent to Aircraft Fuselage, Federal Aviation Administration, Report No. FAA-RD-79-65, August 1979.
16. Johnson, N. B., Goebel, D. C., and Robertson, S. H., An Appraisal of the Postcrash Fire Environment, Dynamic Science, Report No. 70-22-CE, 1969 (AD 699-826).
17. Lucha, G. V., Robertson, M. A., and Schooley, F. A., An Analysis of Aircraft Accidents Involving Fires, NASA, CR 137690, May 1975.
18. Special Study--Safety Aspects of Emergency Evacuations From Carrier Aircraft, National Transportation Safety Board, NTSB-AAS-74-3, 1974.
19. Buettner, K., Effects of Extreme Heat on Man, Journal of the American Medical Association, 144(9), 1950.
20. Fire Safety Aspects of Polymeric Materials--Volume 6, Aircraft: Civil and Military, National Academy of Sciences, Publication NMAB 318-6, 1977.
21. Aircraft Interior Fire Protection, National Fire Codes, National Fire Protection Association, NFPA 421, 1980.
22. Starrett, P., Lopez, E., Silverman, B., Susersky, J., and Logan, J., Feasibility and Tradeoffs of a Transport Fuselage Fire Management System, Federal Aviation Administration, Lockheed-California Company, Report No. FAA-RD-76-54, 1976 (AD-A029 242).
23. Roth, E. M., Space-Cabin Atmospheres, Part II--Fire and Blast Hazards, National Aeronautics and Space Administration, NASA SP-4, 1964.
24. Marcy, J. F., Nicholas, E. B., and Demaree, J. E., Flammability and Smoke Characteristics of Aircraft Interior Materials, Federal Aviation Administration, Technical Report No. FAA AD5-3, January 1964.
25. Peterson, J. M., and Anderson, R. A., Commercial Airplane Cabin Interiors Fire Safety Materials and Full Scale Testing, Boeing Commercial Airplane Company for American Chemical Society, National Symposium on Fire Safety Aspects of Polymeric Materials, Washington, D.C., June 1977.
26. Kourtidis, D. A., and Johnson, G. A., Conference on Fire Resistant Materials: A Compilation of Presentations and Papers, NASA Conference, Publication 2094, March 1-2, 1979.
27. Punderson, J. O., Some Fundamental Problems in Toxic Hazard Evaluation for Wire and Cable Insulations, In: Flammability, Smoke, Toxicity, and Corrosive Gases of Electric Cable Materials, E.I. DuPont de Nemours and Company, The National Research Council, NMAB-342, 1978.
28. Duskin, F. E., Fire Testing of Aircraft Cabins, Interior Design Engineering, Douglas Aircraft Company, J. Fire and Flammability, 8, 1977.
29. Kourtidis, D. A., Parker, J. A., Hilado, C. J., Anderson, R. A., Tustin, E., Arnold, D. B., Gaume, G. G., Binding, A. T., and Mikeska, J. L., Fire Safety Evaluation of Aircraft Lavatory and Cargo Compartments, J. Fire and Flammability, 7, 1976.

30. Yuill, C. H., Bartosic, A. J., Castino, G. T., Eickner, H. W., Gaskill, J. R., Pearce, N. S., Robertson, A. F., and Zabowsky, Z., The Control of Smoke in Building Fires--A State of the Art Review, Subcommittee IV, Committee E-5, on Fire Test of Materials and Construction, Materials Research and Standards, MTRSA II(4), 16, 1977.
31. Butcher, E. G., and Parnell, A. C., Smoke Control in Fire Safety Design, E.S.F.N. Spoon, Ltd., London, 1979.
32. Gross, D., Loftus, J. J., and Robertson, A. F., Method for Measuring Smoke from Burning Materials, American Society for Testing and Materials, Philadelphia, S.T.P., No. 422, 1967, 166-204.
33. Robertson, A. F., Estimating Smoke Production from Rooms and Furnishings, C.I.B. Symposium on the Control of Smoke Movement in Building Fires, Building Research Establishment, Garston, England, 1975.
34. Jin, T., Visibility Through Fire Smoke, Building Research Institute, Tokyo, Report No. 30, 1970 and Report No. 33, 1971.
35. Rasbash, D. J., Efficiency of Hand Lamps in Smoke, International Fire Engineers Quarterly, 11, 46, 1951.
36. Robertson, A. F., Tests Indicate Venting Increases Smoke from Some Polymerics, Fire Engineering, 126(9), 97-98, September 1973.
37. Lopez, E. L., Smoke Emission from Burning Cabin Materials and the Effects on Visibility in Wide-Bodied Jet Transport, Department of Transportation, Federal Aviation Administration, Report No. FAA-RD-73-127, 1974.
38. Hinkley, P. L., Work by the Fire Research Station on the Control of Smoke in Covered Shopping Centers, Building Research Establishment, Current Paper, No. CP 83-75, September 1975.
39. Thomas, P. H., Hinkley, P. L., Theobald, C. R., and Simms, D. L., Investigation into the Flow of Hot Gases in Roof Venting, Fire Research Technical Paper No. 7, Her Majesty's Stationary Office, London, 1963.
40. Mniszewski, K. R., and Waterman, T. E., Effects of Open Doors on Sprinkler Effectiveness in a Patient Room, IIT Research Institute for Builders Hardware Manufacturers Association, June 1978.
41. Forbes, W. H., Sargent, F., and Roughton, F.J.W., The Rate of Carbon Monoxide Uptake by Man, American Journal of Physiology, 43, 1945.
42. Pesman, G. J., Appraisal of Hazard to Human Survival in Airplane Crash Fires, Lewis Flight Propulsion Laboratory, Technical Note No. 2996, National Advisory Committee for Aeronautics, Washington, D.C., 1953.
43. Campbell, J. A., Modern Application of the Smoke Lock Principle, NFPA Annual Meeting, Washington, D.C., May 1957.
44. Stucky, R. N., Supkins, D. E., and Price, L. J., Full Scale Aircraft Cabin Flammability Tests of Improved Fire-Resistant Materials, Lyndon B. Johnson Space Center, NASA TMX-58141, N74-28423, 1974.
45. Hill, R., Boris, P., and Johnson, G. R., Aircraft Cabin Compartmentation Concepts for Improving Postcrash Fire Safety, U.S. Department of Transportation, Report No. FAA-RD-76-131, 1976 (AD-A033 051).

46. LeRoy, C. H., Survival Study: Modern Commercial Jet Aircraft Landing Accident with Subsequent Interior Fire, 38th Annual Scientific Meeting of the Aerospace Medical Association, Washington, D.C., April 1967.
47. Allard, R., and Cote, R., Automatic Sprinklers, Section 17, Chapter 3 in Fire Protection Handbook, National Fire Protection Association, Boston, Mass., 1981.
48. Kung, H. C., Spaulding, R. D., and Hill, E. E., Jr., Sprinkler Performance in Residential Fire Tests, Factory Mutual Research Corporation 22574, U.S. Fire Administration FA-41, December 1980.
49. Castino, G. T., Development of the New Residential Sprinkler Product Acceptance Standard, Proc. of the Fourth Conference on Low-Cost Residential Sprinkler Systems, Federal Emergency Management Agency, U.S. Fire Administration, FA-22, Sept. 1979.
50. Manning, D. O., The Los Angeles Full Scale Residential Fire Test Program, Proc. of the Fourth Conference on Low-Cost Residential Sprinkler Systems, Federal Emergency Management Agency, U.S. Fire Administration, FA-22, Sept. 1979.
51. Standard for the Installation of Sprinkler Systems in Residential Occupancies, National Fire Codes, National Fire Protection Association, NFPA 13D 1981.
52. Waterman, T. E., Use of Simplified Sprinkler System to Protect Wood Doors, Fire Journal, 67(1), 1973.
53. Henderson, N. C., Riegel, P. S., Patton, R. M., and Larcomb, D. B., Investigation of Low-Cost Residential Sprinkler Systems, Battelle Columbus Laboratories for NSF/US Fire Administration, Contract No. NSF-C76-19323, June 1978.
54. Standard for the Installation of Sprinkler Systems, National Fire Codes, National Fire Protection Association, NFPA 13, 1980.
55. Aqueous Film Forming Foam in Deluge Sprinkler System Maximizes Fire Protection, Chemical Processing, 1978.
56. Breen, D. E., Hangar Fire Protection with Automatic AFFF Systems, Fire Technology, 9(2), 1973.
57. Burford, R. R., The Use of AFFF in Sprinkler Systems, Fire Technology, 12(1), 1976.
58. Heselden, A.J.M., and Hinkley, P. O., Measurement of Transmission of Radiation Through Water Sprays, Fire Technology, 1(2), 1965.
59. Standard for Water Spray Fixed Systems for Fire Protection, National Fire Codes, National Fire Protection Association, NFPA 15, 1979.
60. Standard on Halon 1301 Fire Extinguishing Systems, National Fire Codes, National Fire Protection Association, NFPA 12A, 1980.
61. Hill, R., Evaluation of a Halon 1301 System for Aircraft Internal Protection from a Postcrash External Fuel Fire, Federal Aviation Administration NAFEC, Report No. FAA-RD-76-218, 1977.
62. Christian, W. J., and Wands, R. C., Ed., An Appraisal of Halogenated Fire Extinguishing Agents, Proc. of a Symposium, National Academy of Sciences, April 1972.

63. Standard on Halon 1211 Fire Extinguishing Systems, National Fire Codes, National Fire Protection Association, NFPA 12B, 1980.
64. Personal communication with R. Hill, FAA Technical Center.
65. Engineering and Development Program Plan, Aircraft Cabin Fire Safety, Federal Aviation Administration, Technical Center, Report No. FAA-ED-18-7, 1980.
66. McAlevy, R. F., and Magee, R. S., The Mechanisms of Flame Spreading over the Surface of Igniting Condensed-Phase Materials, 12th Symposium (International) on Combustion, 1969, pp. 215-228.
67. Starrett, P. S., Factors Influencing Flame Spread Rates in Solid Materials, J. Fire and Flammability, 8, 5-25, 1977.
68. Snyder, R. G., and Stapp, J. P., Emergency In-Flight Evacuation from Future Commercial Air Transport Aircraft, Proc. of the Seventh Annual Symposium, Survival and Flight Equipment Associations, 1, 1969.
69. Duer, R. W., Safety, Altitude and Oxygen, Proc. of the Seventh Annual Symposium, Survival and Flight Equipment Association, 1, 1969.
70. Antley, W. H., Jr., Equipment and Physiological Training Needs in Modern Air Transports, Proc. of the Seventh Annual Symposium, Survival and Flight Equipment Association, 1, 1969.
71. Custer, R.L.P., and Bright, R. G., Fire Detection: The State-of-the-Art, National Bureau of Standards, NBS Technical Note 839, June 1974.
72. Mniszewski, K. R., Waterman, T. E., and Harpe, S. W., Detector Directory, IIT Research Institute and Underwriters Laboratories, Inc. for U.S. Fire Administration, December 1978.
73. Waterman, T. E., Mniszewski, K. R., and Spadon, D. J., Cost/Benefit Analysis of Fire Detectors, IIT Research Institute for U.S. Fire Administration, September 1978.
74. Welker, R., Waterman, T. E., Mniszewski, K. R., and Ledvina, S., Development of Improved Fire Detection Concepts, IIT Research Institute for U.S. Fire Administration, Grant No. 80129, March 1982.
75. Cholin, R. R., Reappraising Early Warning Detection, Fire Journal, 1975.
76. Street, T. T., Lawrence, K. D., Williams, F. W., and Alexander, J. I., NRL Processor-Aided Fire Detection System, NRL Report No. 8341, Naval Research Laboratory, 1979.
77. NASA's Space Shuttle Orbiter-Incipient Fire Detector--A New Concept, Celeasco Industries, Inc., Bulletin 01-378, October 1974.
78. Zimmerman, C. E., Development of Light Emitting Diodes for Photoelectric Smoke Detectors, Fire Technology, 11, 1975.
79. Larsen, T. E., Detector Innovations for High Hazard Applications, Fireline, 1978.
80. van der Walt, N. T., Bout, B. J., Anderson, O. S., and Newington, T. J., All-Analogue Fire Detection System for S. A. Gold Mines, Fire Protection, 1980.
81. Buck, R. J., Microprocessor Fire/Gas Systems for Offshore Platforms, Fire Protection, 1980.

82. Maclean, A. D., Fire Detection by Microprocessors, Fire, 1980.
83. McCallum, D., Microcomputers Will Monitor Shopping Center Alarm System, Fire, 1980.
84. Federal Aviation Regulations, Part 25, Airworthiness Standards: Transport Category Airplanes, Department of Transportation, Federal Aviation Administration, June 1974.
85. Gratz, D. B., and Hawkins, R. E., Evaluation of Smoke Detectors in Homes, Interim Report--Phase 1, International Association of Fire Chiefs Foundation for U.S. Fire Administration, FA-26, 1980.
86. Moore, D. A., Remote Detection and Alarm for Residences: The Woodlands Systems, FEMA/U.S. Fire Administration, FA-8, 1980.
87. Graham, E. F., Combustion-Product Retardent Barrier System for Aiding Passenger Escape from Aircraft Fuselage Structure, U.S. Patent 4,121,790, October 24, 1978.
88. Malhotra, H. L., and Millbank, N., Movement of Smoke in Escape Routes and Effect of Pressurization: Results of Some Tests Performed in a New Department Store, Fire Research Station, Borehamwood, England, Fire Research Note 566, 1964.
89. Thermoshild™ Flexible Strip Doors, Bulletin No. 2081, Environmental Products Company, 701 W. Illinois Avenue, Aurora, Ill. (example of product).
90. Spratt, D., and Heselden, A.J.M., Efficient Extraction of Smoke from a Thin Layer Under a Ceiling, Fire Research Station, Borehamwood, England, Fire Research Note No. 1001, 1974.
91. Stuart, J. W., Fuselage Ventilation Due to Wind Flow About A Postcrash Aircraft, Jet Propulsion Laboratory, JPL Publication No. 80-31, 1980.
92. Neel, C. B., Parker, J. A., Fish, R. H., Henshaw, J., Newland, H. J., and Tempesta, F. L., Heat Shields for Aircraft--A New Concept to Save Lives in Crash Fires, Astronautics and Aeronautics, 1971.
93. Anderson, R. A., Arnold, D. B., and Johnson, G. A., Development of Aircraft Lavatory Compartments with Improved Fire Resistance Characteristics - Phase II: Sandwich Panel Design Development, Boeing Commercial Airplane Company for Ames Research Center, NASA CR 151220, 1979.
94. Anderson, R. A., Ougland, R. M., and Karch, R. J., Development of Light-weight Fire-Retardant, Low-Smoke, Thermally Stable Aircraft Floor Paneling, Boeing Commercial Airplane Company, N79-21133, June 1978.
95. NAFEC Window Test, News and Meetings, Fire Technology, 1980.
96. Personal communication with G. Geyer, FAA Technical Center.
97. Enders, J. H., (Chairman), and Wood, E. D., (Executive Director), Final Report of the Special Aviation Fire and Explosion Reduction (SAFER) Advisory Committee, Volume 1, FAA-ASF-80-4, June 26, 1980.
98. Life Safety Code, National Fire Codes, National Fire Protection Association, NFP A101, 1981.
99. Fire Blanket: Protection for the Victims and the Firefighters--A Reality! Security Industry and Product News, 9(10), 1980.

100. Renner-Smith, S., Water-Gel Blanket Douses Flames, Aids Burn Victims, Popular Science, 1981.
101. Snyder, R. G., Advanced Techniques in Crash Impact Protection and Emergency Egress from Air Transport Aircraft, AGARD-ograph-221, 1976.
102. Roebuck, J. A., Jr., New Concepts for Emergency Evacuation of Transport Aircraft Following Survivable Accidents, Federal Aviation Administration, Report No. ADS-68-2, 1968.
103. Geyer, G. B., Brown, L. J., Jr., Neri, L. M., and O'Neill, J. H., Preliminary Assessment of the Integrity of Aircraft Evacuation Slide Material When Exposed to Thermal Radiation, Federal Aviation Administration, NAFEC, Letter Report NA-78-41-LR, 1978.
104. Brown, L. J., Jr., and Nicholas, E. B., Effect of Thermal Radiation on the Integrity of Pressurized Aircraft Evacuation Slides and Slide Materials, Federal Aviation Administration, Technical Center, Report No. FAA-CT-81-28, March 1981.
105. McFadden, E. B., Reynolds, H. I., and Funkhouser, G. E., A Protective Passenger Smoke Hood, Federal Aviation Administration, Office of Aviation Medicine, Report No. AM67-4, April 1967.
106. Walters, R. W., He Seeks New Ways of Surviving an Air Crash, Chicago Sunday Sun-Times, February 1, 1976.
107. Braun, E., Cobble, V. B., Krasny, J. F., and Peacock, R., Development of Proposed Flammability Standard for Commercial Transport Flight Attendant Uniforms, National Bureau of Standards for Federal Aviation Administration, Report No. FAA-RD-75-176, 1976.
108. Demaree, J. A., A Preliminary Examination of Interior Aircraft Emergency Lighting Under Simulated Portcrash Fire and Smoke Conditions, Federal Aviation Administration, NAFEC, Letter Report No. NA-79-46-LR, 1979.
109. Standard for the Installation of Foam-Water Sprinkler Systems and Foam-Water Spray Systems, National Fire Codes, National Fire Protection Association, NFPA 16, 1981.
110. Airport Crash/Fire/Rescue (CFR) Service Cost and Benefit Analysis, Volume I: Text, Volume II: Appendixes, Office of Airport Standards, Federal Aviation Administration, DOT/FAA/AS/80-2, 1980.
111. Horeff, T. G., A Crashworthiness Analysis with Emphasis on the Fire Hazard: U.S. and Selected Foreign Turbine Aircraft Accidents 1964-1974, Federal Aviation Administration, Report No. FAA-RD-75-156, 1976 (AD/A-029 162).

APPENDIX A. AIRCRAFT FIRE INCIDENTS
(U.S. AIR CARRIERS).

TABLE A-1. EXAMPLES OF CABIN FIRES

<u>Date</u>	<u>Location</u>	<u>Aircraft Type</u>	<u>Phase of Operation</u>	<u>Cause of Fire</u>	<u>Origin and Spread of Fire</u>	<u>Fire Damage</u>	<u>Remarks</u>
9/28/48	LaGuardia Airport, N.Y.	DC-4	Ground	Internal explosion of an oxygen line somewhere between the oxygen cart regulating valve and the first tank	From aft end at the right wing at the fuselage fillet to the entire cabin	Full involvement of upper portion of the cabin	
8/27/58	Bakersfield, Cal.	202	Ground	Electric system fault while connected to the ground power unit	Stewardess discovered smoke issuing from the rear of the cabin; the fire remained there	Limited to the rear of the cabin	All passengers were evacuated. The fire was put out with a carbon dioxide extinguisher.
7/14/59	Wold-Chamberlain Airport, Minneapolis-St. Paul, Minn.	Strato-cruiser	Ground	Fatigue failure of an oxygen valve	Ignited resin binding of glass wool insulation behind the coatroom to the cabin	Inside of the cabin	
1/04/61	-	-	Ground	Electrical short	Localized fire in reading light	Small burned area on an oxygen mask box	
3/01/61	Orly Field, Paris, France	707	Ground	Possible cigarette	Wicker basket containing a pressurized can of deodorizer near the rear cabin door; spread up and out from there	The area near the main cabin door, the upper half of the rear galley, including the ceiling area above (electrical wiring severely damaged)	Electrical power was not connected at the time of the fire, thus preventing a more serious fire.
10/18/61	Los Angeles Intl. Airport, Los Angeles, Cal.	707	Ground	Matches	Plastic grating ignited, producing smoldering fire on rug and plastic overhead near the aft water supply tank	Charred seat cover, aisle rug, and burned plastic grating	
12/01/62	Santa Cruz Airport, Bombay, India	707	Ground	Oxygen system pressure reducer	The crew's oxygen system pressure reducer; spread throughout the passenger and crew compartments	Cabin gutted	
5/50/63	Newark Airport, Newark, N.J.	990	Ground	Sparks from another aircraft taxiing into takeoff position	Either the cargo door or rear cabin passenger door; spread through cargo and passenger compartments	Entire interior badly gutted, including floor failure between the cargo and passenger compartments	Sparks may have entered one of the open doors and ignited the ordinary combustibles in that area.
8/08/63	-	707B	Ground	Cigarette	Market bag (ashtrays emptied into) on a seat in the first class section; no spread	Hole in seat cover	
12/31/63	-	-	Ground	Electrical wiring	Small flame at cabin heater	Heater and wiring damaged	
1/24/65	-	-	Ground	Flammable liquid	Flash fire	Cabin destroyed	

TABLE A-1. EXAMPLES OF CABIN FIRES (continued)

<u>Date</u>	<u>Location</u>	<u>Aircraft Type</u>	<u>Phase of Operation</u>	<u>Cause of Fire</u>	<u>Origin and Spread of Fire</u>	<u>Fire Damage</u>	<u>Remarks</u>
1/25/69	Boeing Field	-	Unknown	Possibly organic material in the oxygen hose lines or aircraft piping	Forward cargo compartment; burned a 2 sq ft hole through skin and started to spread down the fuselage	Sustained structural damage; some floor beams; electrical wiring and cables; one seat; melting of plastic materials in the area	"Nomex" was helpful in minimizing fire damage.
7/29/69	London Airport, London, England	Trident	Ground	Kerosene (arson suspected)	Floor level in the front compartment; spread upwards and outwards involving seats, bulkheads, curtains, and other cabin furnishings	Forward passenger compartment and a 5 ft diameter area of the floor buckled	
4/22/70	Weir-Cook Airport Indianapolis, Ind.	707	Ground	Faulty capacitor	Indirect lighting system; spread throughout the cabin	Entire cabin	
6/07/70	-	-	Ground	Oxygen	Oxygen hose burned at seat	Smoke in aft cabin	
12/31/70	Washington Natl. Airport	737	Ground	Possibly surge of oxygen pressure or contamination in the oxygen system	Oxygen compartment area; confined to the main cabin door	Cockpit area and smoke damage to most of the passenger cabin	Fire damage would have been greater if the fire was not confined as it was.
9/04/71	-	-	Ground	Electrical short	Smoke and flame from attendant central panel	Burned off the insulation of approximately 50 wires	
3/02/72	-	-	Ground	Electrical short	Stewardess' service panel producing smoke	Terminals and switch wiring	
3/15/72	-	-	Ground	Oxygen	Localized	Two passenger seats, hat rack, and side panel scorched	
5/01/72	-	-	Ground	Electrical short	Faulty electrical fixture behind cabin lining	Interior damage and burning into fuselage	
5/10/72	Atlanta Intl. Airport, Atlanta, Ga.	DC-9	Ground	Short in an "unused" electric receptacle	Adjacent honeycomb material from the aft passenger cabin; spread within the wall cavity	Entire cabin "guttled" and several holes burned through the fuselage	NTSB report recommended that all unused receptacles be capped or otherwise electrically deactivated to preclude inadvertent shorts of the type that occurred in this incident.
8/29/72	-	-	Ground	Oxygen shutoff valve	Shutoff valve fire; heavy smoke and flame through ventilation	Insulation blanket and panel	
3/22/73	-	-	Ground	Oxygen	Oily wool material in contact with leaking oxygen; fire just aft cockpit	Air conditioning duct; electrical plastic conduit	

TABLE A-2. EXAMPLES OF LAVATORY FIRES

<u>Date</u>	<u>Location</u>	<u>Aircraft Type</u>	<u>Phase of Operation</u>	<u>Cause of Fire</u>	<u>Origin and Spread of Fire</u>	<u>Fire Damage</u>
2/21/61	San Francisco Intl. Airport	707-131	Ground	Fault in electrical circuit	In or around lavatory "C"; along the interior cabin lining materials	Interior of cabin gutted
5/28/62	-	-	Ground	Fault in electrical wiring for razor outlet	Lint, paper, and lavatory walls near outlet	Extensive in the lavatory
8/07/69	Philadelphia Natl. Airport	-	Ground	Water penetration in razor outlet	Left aft lavatory through concealed spaces to structural framing, overhead ceiling, ceiling plenum to wings trailing edge, then below the ceiling to te cockpit door	Entire cabin gutted
1/29/70	-	-	In-flight	Cigarette/match and trash	Localized fire	Waste container
6/25/70	-	-	In-flight	Electrical short	Localized fire	Wires and towel container
2/28/73	-	-	In-flight	Cigarette	Localized fire	Waste container
9/05/73	-	-	In-flight	Cigarette	Localized fire	Refuse compartment and basin overflow lines
10/25/73	-	-	In-flight	Cigarette and paper toweling	Aft lavatory smoke	Waste container
9/13/75	-	-	In-flight	Possible cigarette	Localized fire	Lavatory waste chute

TABLE A-3. EXAMPLES OF COCKPIT FIRES

<u>Date</u>	<u>Location</u>	<u>Aircraft Type</u>	<u>Phase of Operation</u>	<u>Cause of Fire</u>	<u>Origin and Spread of Fire</u>	<u>Fire Damage</u>	<u>Remarks</u>
9/12/60	-	-	In-flight	Electrical short	Shorted internally, floor heater produced smoke and flames from floor plate	Smoke in cockpit	
11/16/63	Miami Intl. Airport	720	Ground	Oxygen valve	Localized burning in the cockpit	Fire burned through aircraft cabin insulation soundproofing and fuselage skin directly above the valve ("cutting torchlike action")	
9/07/68	Rio de Janeiro Intl. Airport	707	Ground	Some hydraulic oil injected into oxygen lines, oil heated by compression	Within oxygen lines; spread within the aircraft system	Aircraft destroyed	The fire could not be controlled.
10/16/71	-	-	In-flight	Auto soiler activator overheated	Flash fire at pedestal	Smoke in cockpit	

TABLE A-4. EXAMPLES OF CARGO FIRES

<u>Date</u>	<u>Location</u>	<u>Aircraft Type</u>	<u>Phase of Operation</u>	<u>Cause of Fire</u>	<u>Origin and Spread of Fire</u>	<u>Fire Damage</u>	<u>Remarks</u>
3/25/65	Albany, N.Y.	CV-440	Ground	Contact with 20 watt bulb	Mailbags in the rear baggage compartment ignited	Limited to the bulkhead inspection window; fuselage skin buckled	Bulb installed did not meet specifications (30 watts), did not have a lens covering, and was a type that generated greater heat.
6/13/67	Yokota Air Base, Japan	707	Ground	Unknown	Forward passenger compartment; fire progressed rapidly (3 oxygen cylinders ruptured in the forward cargo compartment)	Passenger compartment damaged and a 3-ft hole burned through the passenger deck above the ruptured oxygen cylinders	A muffled explosion sound was heard prior to the discovery of the fire.
5/25/70	Palmdale, Cal.	C5A	Ground	Electrical arc	Hydraulic fluid ignited in the cargo bay area	Total loss	No cargo aboard (training flight); major structural damage due to collision with fire truck.
1/25/72	Seattle-Tacoma Intl. Airport, Seattle, Wash.	720B	Ground	Defective circuitry that allowed the heating unit to be on with the blower down	Heating unit of recirculating air unit through the wiring system	Recirculating air unit area, wiring compartment overhead, and the cabin floor above the unit	The entire cabin area suffered extensive smoke damage.

TABLE A-5. EXAMPLES OF GALLEY FIRES

<u>Date</u>	<u>Location</u>	<u>Aircraft Type</u>	<u>Phase of Operation</u>	<u>Cause of Fire</u>	<u>Origin and Spread of Fire</u>	<u>Fire Damage</u>
2/17/61	-	DC-7	Ground	Acetone vapors	From galley to the interior of fuselage	Length of the cabin
1/19/64	-	-	In-flight	Cigarette	Food parcel	Minor damage to rug and side panel
3/12/66	Mid-Continent Intl. Airport, Kansas City, Mo.	707	Ground	Electrical fault created by water penetration	Electrical connector in the No. 3 galley; spread throughout the galley	Electric wiring and insulation above galley floor and window area; some cabin lining
7/12/68	-	-	In-flight	Electrical short	Overheated current limiter retention clip; right food service door	Fire damage to wiring; current limiter mounting blocks
11/18/68	-	-	In-flight	Electrical	Commissary storage area in galley	Electric power fuse holder damaged by arcing

TABLE A-6. EXAMPLES OF MISCELLANEOUS LOCATION FIRES

<u>Date</u>	<u>Phase of Operation</u>	<u>Cause of Fire</u>	<u>Origin and Spread of Fire</u>	<u>Fire Damage</u>
Electronic Compartment				
6/15/61	Ground	Collapsed nose gear	Fire spread to forward of cabin and to cockpit	The first two rows of seats
4/18/72	Ground	Lighting transformer	Flash and shower of sparks	Hole burned through lighting transformer
APU Fires				
5/27/72	Ground	Electrical short	Compartment set a flame	Wires in APU power generator burned

APPENDIX B. COST ESTIMATES FOR SUPPRESSION SYSTEMS.

Cost estimates for each system include a production and installation cost which is applicable to each airplane in which a system is installed and a one time engineering and development cost applicable only to each basic type of aircraft. Cost estimates were based partially on historical data and partially on estimates of each system installed on typical jet transports. For this study, a Boeing 727-200 was used as a typical narrow-body jet transport and a McDonnell Douglas DC-10 was used as a typical wide-body jet transport. Overall aviation fleet cost estimates were made by applying these costs to other aircraft of the same generic category. All costs are in 1981 dollars. Production phase costs include materials, components, assembly, installation, and check out. The rationale and assumptions used in the calculation include:

- The system will be installed when the aircraft is undergoing major modifications and the headliners have been removed for the modification.
- Aircraft composite salaries assumed were:

Engineer	\$35.00/hr	or	\$6070/mo
Mechanic	28.00/hr	or	4850/mo
Quality Assurance	27.00/hr	or	4680/mo
- Actual assembly and installation hours to perform a task were adjusted using a 0.85 factor for productivity and a 0.80 factor for performance. The productivity factor accounts for time lost for personal fatigue and delay and the performance factor for breaks, etc. These factors are applied to the assembly and installation hours.
- The total costs obtained are increased by a 1.10 factor to account for any random estimating error.
- The combined factor is $1.10/0.85 \times 0.80 = 1.6$
- A 10 percent contingency factor is applied to the labor hour and hardware costs to account for unknowns and changes that are likely to occur.
- A 5 percent miscellaneous factor is applied to the total labor and hardware cost for small items such as paper work, time keeping, etc.
- Historically, management has varied from approximately 8 to 15 percent of production costs; a 10 percent factor is used in this study.
- The costs assume a 12 percent fee or profit.

A one-time detailed design, development, and test program would be required for each type of aircraft in which a complete suppression system would be installed. A single effort is assumed to be capable of covering the various

models and interior configurations of the basic aircraft. This program would include:

- Setting up a complete mock-up and test system to validate design and demonstrate operation.
- Fabrication of tooling and jigs necessary for installation.
- Detailed review of information on the basic aircraft type and variations of the model and in interior configurations.
- Design of the system for the basic aircraft and model variations. This includes preparation of drawings and bills of material for each variation.
- Hydraulic, stress, weight, and other engineering analysis to support the design effort.

The cost estimate for this effort is based on the following assumptions, derived largely from historical cost experience:

- Material and labor costs for the test system will be 1.8 times the cost of a production system.
- Tooling and jigs will represent 20 percent of test item cost.
- Engineering and design will require 100 man months for a typical narrow-body jet transport and 120 man months for a typical wide-body jet transport.
- Testing phase will require 4 man months of technical time.
- Added factors are included to cover miscellaneous expenses such as drawing materials, time keeping, changes, manuals, etc., 15 percent; program management, 10 percent; and profit or fee, 12 percent.

The net cost for this phase based on the above assumptions becomes 3.06 times the cost of a production model, plus an engineering cost of \$1,487,000 for a typical narrow-body jet and \$1,776,000 for a typical wide-body jet. Design and development costs for the spot protection system were based on cost estimates for each system; these were assumed to be appropriate for each type of aircraft.

1
2
3

1

1
2
3
4
5
6
7
8
9
10
11
12
13
14
15
16
17
18
19
20
21
22
23
24
25
26
27
28
29
30
31
32
33
34
35
36
37
38
39
40
41
42
43
44
45
46
47
48
49
50
51
52
53
54
55
56
57
58
59
60
61
62
63
64
65
66
67
68
69
70
71
72
73
74
75
76
77
78
79
80
81
82
83
84
85
86
87
88
89
90
91
92
93
94
95
96
97
98
99
100

