

COPY 1

DOT/FAA/CT-82/116

Compatibility Study of Antimisting Kerosene and the DC-10/KC-10 Fuel System

FEDERAL AVIATION ADMINISTRATION

APR 29 1983

**TECHNICAL CENTER LIBRARY
ATLANTIC CITY, N.J. 08405**

F.Y. Ching
A.T. Peacock

March 1983

This document is available to the U.S. public
through the National Technical Information
Service, Springfield, Virginia 22161.

DOT/FAA
CT-82/116

AA
/116



U.S. Department of Transportation
Federal Aviation Administration
Technical Center
Atlantic City Airport, N.J. 08405

FAA TECHNICAL CENTER LIBRARY NJ

Douglas Airc/Compatibility study of anti



00008030

DOT/FAA Ching, F.Y.
CT-82/116 Compatibility study
c. 1 of antimisting kero-
sene and DC-10/KC-10..



This document is disseminated under the sponsorship of the Department of Transportation in the interest of information exchange. The United States Government assumes no liability for the contents or use thereof.

The United States Government does not endorse products or manufacturers. Trade or manufacturer's names appear herein solely because they are considered essential to the object of this report.

1. Report No. DOT/FAA/CT-82/116		2. Government Accession No.		3. Recipient's Catalog No.	
4. Title and Subtitle Compatibility Study of Antimisting Kerosene and the DC/KC-10 Fuel System				5. Report Date March 1983	
				6. Performing Organization Code	
7. Author(s) F. Y. Ching and A. T. Peacock				8. Performing Organization Report No.	
9. Performing Organization Name and Address Douglas Aircraft Company McDonnell Douglas Corporation 3855 Lakewood Blvd., Long Beach, CA 90846				10. Work Unit No. (TRAIS)	
				11. Contract or Grant No. F33700-81-C-0057	
12. Sponsoring Agency Name and Address U.S. Department of Transportation, Federal Aviation Administration Technical Center Atlantic City Airport, New Jersey 08405				13. Type of Report and Period Covered Final, March 1981-April 1982	
				14. Sponsoring Agency Code	
15. Supplementary Notes Project Manager, Bruce Fenton, Engine/Fuel Safety Branch, Aircraft Safety Development Division, FAA Technical Center, Atlantic City Airport, New Jersey 08405					
16. Abstract The compatibility of antimisting kerosene (AMK) with a contemporary fuel system was evaluated. AMK made with the FM-9 additive to the base fuel was used throughout the program. Tests were conducted to determine AMK effects on components and system performance, and component and system effects on the fuel. Some DC-10/KC-10 systems are incompatible with the AMK fuel. Systems and/or procedural revisions to accommodate the AMK do not appear to present technically insurmountable problems. AMK reduces the performance of some systems (e.g., jet pump transfer, gravity transfer, and suction feed) below normally accepted levels. Extensive study and testing will be required to certify the aircraft fuel system for use with the FM-9 AMK.					
17. Key Words Antimisting Kerosene AMK Aircraft fuel system Aviation fuels			18. Distribution Statement Document is available to the U.S. public through the National Technical Information Service, Springfield, VA 22161		
19. Security Classif. (of this report) Unclassified		20. Security Classif. (of this page) Unclassified		21. No. of Pages 131	22. Price

METRIC CONVERSION FACTORS

Approximate Conversions to Metric Measures

Symbol	When You Know	Multiply by	To Find	Symbol
LENGTH				
in	inches	*2.5	centimeters	cm
ft	feet	30	centimeters	cm
yd	yards	0.9	meters	m
mi	miles	1.6	kilometers	km
AREA				
in ²	square inches	6.5	square centimeters	cm ²
ft ²	square feet	0.09	square meters	m ²
yd ²	square yards	0.8	square meters	m ²
mi ²	square miles	2.6	square kilometers	km ²
	acres	0.4	hectares	ha
MASS (weight)				
oz	ounces	28	grams	g
lb	pounds	0.45	kilograms	kg
	short tons (2000 lb)	0.9	tonnes	t
VOLUME				
tsp	teaspoons	5	milliliters	ml
Tbsp	tablespoons	15	milliliters	ml
fl oz	fluid ounces	30	milliliters	ml
c	cups	0.24	liters	l
pt	pints	0.47	liters	l
qt	quarts	0.95	liters	l
gal	gallons	3.8	liters	l
ft ³	cubic feet	0.03	cubic meters	m ³
yd ³	cubic yards	0.76	cubic meters	m ³
TEMPERATURE (exact)				
°F	Fahrenheit temperature	5/9 (after subtracting 32)	Celsius temperature	°C

* 1 in = 2.54 (exactly). For other exact conversions and more detailed tables, see NBS Misc. Publ. 250, Units of Weights and Measures, Price \$2.25, SD Catalog No. C13,10286.

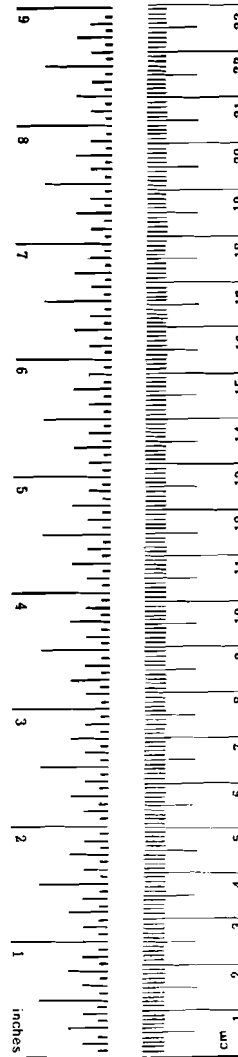

Approximate Conversions from Metric Measures

Symbol	When You Know	Multiply by	To Find	Symbol
LENGTH				
mm	millimeters	0.04	inches	in
cm	centimeters	0.4	inches	in
m	meters	3.3	feet	ft
m	meters	1.1	yards	yd
km	kilometers	0.6	miles	mi
AREA				
cm ²	square centimeters	0.16	square inches	in ²
m ²	square meters	1.2	square yards	yd ²
km ²	square kilometers	0.4	square miles	mi ²
ha	hectares (10,000 m ²)	2.5	acres	
MASS (weight)				
g	grams	0.035	ounces	oz
kg	kilograms	2.2	pounds	lb
t	tonnes (1000 kg)	1.1	short tons	
VOLUME				
ml	milliliters	0.03	fluid ounces	fl oz
l	liters	2.1	pints	pt
l	liters	1.06	quarts	qt
l	liters	0.26	gallons	gal
m ³	cubic meters	35	cubic feet	ft ³
m ³	cubic meters	1.3	cubic yards	yd ³
TEMPERATURE (exact)				
°C	Celsius temperature	9/5 (then add 32)	Fahrenheit temperature	°F

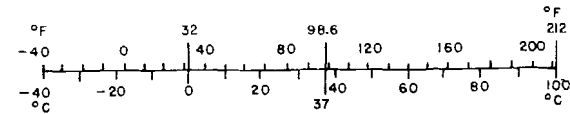

TABLE OF CONTENTS

	Page
INTRODUCTION	1
COMPONENTS AND SYSTEMS DESCRIPTIONS	1
Fuel System	1
Float Switches	4
Float Valves	5
Jet Pumps	5
Gravity Transfer Valve	7
Tank-Mounted Fuel Boost Pump	7
Fill System	8
Vent System	8
Engine Feed System	8
KC-10 Aerial Refueling Nozzle/Receptacle	8
TEST PROGRAM	13
Special Fuel Handling, Fuel Sample Acquisition	13
Component Testing	14
Float Switches	14
Float Valves	15
Jet Pumps	16
Gravity Transfer Valves	18
AMK Degradation versus Boost Pump Flow	21
Water Test	29
System Tests	34
Fill System Test	34
Vent System Test	39
Engine Feed System Test	43
Flight Cycle	51
KC-10 Aerial Refueling Nozzle/Receptacle	74
DISCUSSION	68

TABLE OF CONTENTS (Continued)

Component Testing	68
Water Test	71
System Tests	71
KC-10 Aerial Refueling Nozzle/Receptacle.....	73
Ultrasonic Flowmeter	73
CONCLUSIONS	78
BIBLIOGRAPHY	75
APPENDIX A. FUEL QUALITY TESTS PERFORMED BY JPL	A-1
APPENDIX B. ADDITIONAL DOUGLAS AMK OBSERVATIONS	B-1
APPENDIX C. AMK FUEL QUALITY LOG FOR DOUGLAS PROGRAM	C-1

LIST OF ILLUSTRATIONS

Figure		Page
1	Fuel Subsystems	2
2	Fuel Tankage — DC-10 Series 10	2
3	Outboard Main Fuel Tank, Fuel Usage Schedule	3
4	Float Switch	4
5	Float Valves	5
6	Scavenge Jet Pump and Jet Pump Transfer Systems	6
7	Outboard Compartment Gravity Transfer and Scavenge Systems	7
8	Fill System Flow Schematic	9
9	Vent System	10
10	Feed System	11
11	KC-10 Aerial Refueling	12
12	Sampling Vessel	13
13	Float Switch Test Setup	14
14	Float Valve Test Schematic	16
15	Scavenge Jet Pump Test Schematic	17
16	Scavenge Jet Pump Performance	19
17	Transfer Jet Pump Performance	19
18	Transfer Valve Test Schematic	21
19	Gravity Transfer Valve, Gravity Flow	22
20	AMK Degradation Versus Boost Pump Flow Schematic	23
21	Configuration 1, Boost Pump Test	23
22	Configuration 2, Boost Pump Test	24
23	Boost Pump Performance, Configuration 1	25
24	Filter Ratio, Configuration 1	27
25	ICI Cup Test, Configuration 1	27
26	FCTA Temperature, Configuration 1	28
27	Boost Pump Performance, Configuration 2	28
28	12K AMK Fuel Quality, Configuration 2	30
29	Water Test Schematic	31
30	Steam Box, Water Test	32
31	Test Tank and Steam Box, Water Test	32
32	Fill and Vent Simulation, Plan View	35
33	2300 Gallon Supply Tank	36
34	Fueling and Defueling Adapters	37
35	Adapters and Fuel Nozzle Assemblies	37
36	DC-10 Fill System Performance, Single Nozzle Filling No. 1 Tank	38
37	Disassembled Fill Valve Controller	41
38	Gel Formation on Controller Diaphragm	42
39	Gel Globules on Controller Housing	42
40	Vent System Performance Using Single Fueling Nozzle	43
41	Fuel Feed Test Rig, Elevation View	44
42	DC-10 Fuel Feed System Simulator	44

LIST OF ILLUSTRATIONS (Continued)

Figure		Page
43	Fuel Feed System Test Schematic — Plan View	46
44	Engine Fuel Schematic Test	47
45	Sampling at Engine Inlet and Interstage	48
46	Ultrasonic Flowmeter Calibration Setup	49
47	Fuel Filter Element	51
48	Fuel Feed System Performance — Tank Boost Pump Operating	52
49	Suction Feed Climb Test	53
50	Fuel Flow Characteristics During Simulated Flights	55
51	Tank AMK, Filter Ratio	56
52	Tank AMK, ICI Cup Test	57
53	Tank AMK, FCTA Temperature	58
54	Engine Inlet, Filter Ratio	59
55	Engine Inlet, ICI Cup Test	60
56	Engine Inlet, FCTA Temperature	61
57	Engine Interstage, Filter Ratio	62
58	Engine Interstage, ICI Cup Test	63
59	Engine Interstage, FCTA Temperature	64
60	KC-10 Aerial Refueling Nozzle/Receptacle Test Schematic	65
61	KC-10 Aerial Refueling System Simulator	65
62	KC-10 Aerial Refueling Nozzle/Receptacle Test	66
A1	Description of Filter Screen Assembly	A-2
A2	Flammability Comparison Test Apparatus (FCTA) Schematic	A-6
B1	AMK, Specific Gravity Versus Temperature	B-3

LIST OF TABLES

Table		Page
1	Float Switch Test	15
2	Float Valve Test	17
3	Jet Pump Test — AMK Quality	20
4	Gravity Transfer Valve Test	22
5	Boost Pump Performance, Configuration No. 1	26
6	Boost Pump Performance, Configuration No. 2	29
7	AMK Fuel Quality, Configuration No. 2	30
8	Water Test	33
9	Test Runs and Configurations	38
10	Fuel Quality for Single Nozzle Fill of No. 1 Tank	39
11	Fill System Test	40
12	Fill System Test, Fuel Quality	41
13	Feed System Test Instrumentation	45
14	Ultrasonic Flowmeter Calibration	50
15	Pressure Fuel Feed System Performance Test, Fuel Quality	52
16	Airplane Flight Regime and Fuel Usage for a Typical Flight	53
17	AMK Quality as Received for KC-10 Refueling System Test	67
18	RMH 1-144, AMK Fuel Quality	69
19	RMH 1-148, AMK Fuel Quality	69
A1	Component Guide	A-6
B1	Boost Pump Flow Point Selection Test	B-2

ACKNOWLEDGMENTS

The authors wish to thank Ted J. Baginski, Douglas Test Engineer, for his invaluable assistance in maintaining steady progress at the initial stage of the program and for his many helpful suggestions for expediting test setups and procedures. Mr. Baginski was the design engineer for the testing facility used in this program.

TESTING OF ANTIMISTING KEROSENE
IN THE DC-10/KC-10 FUEL SYSTEM SIMULATOR

- EXECUTIVE SUMMARY -

INTRODUCTION

The sequence of events in an aircraft accident may include the ejection of fuel into the airstream at a high velocity from ruptured tanks. The high-velocity interaction between fuel and air causes the liquid fuel to break up. A mist is generated which is easily ignited and burns rapidly. If ignited, flame fronts can easily propagate into pools of fuel in and around the aircraft.

AMK is a Jet-A fuel with a dissolved additive which precludes the possibility of a fine mist and the associated "fireball" which occurs in some impact survivable accidents. AMK fuel exhibits non-Newtonian fluid characteristics. Shearing of AMK can increase the viscosity by three orders of magnitude, affecting component and system performance (pressure drop, time response, etc.). In turn, high shear rates from the components can degrade the fuel, i.e., loss of antimisting and fire suppression qualities.

This program was designed to evaluate the compatibility of AMK (FM-9) in a contemporary wide-bodied aircraft fuel system.

TEST PROGRAM

Float Switch Test - Tests were conducted to determine the switch actuation levels at rates of fuel level change that represent normal rates. Two float switches were tested to compare the actuation levels using AMK to the levels of Jet-A. There was no difference in the actuation function of the float switches when using AMK compared to Jet-A.

Float Valve Test - These tests were conducted to determine the actuation levels of float valves at rates of fuel level change that approximate normal rates. Two float valves were tested with Jet-A to establish a baseline and then with AMK.

There was no difference in the actuation function of the float valves when using AMK and Jet-A.

Jet Pump Test - Two jet pumps were tested. Curves of secondary pressure rise versus secondary flow rate were determined. All testing was done with Jet-A fuel first and then repeated with AMK.

Both jet pumps exhibited lower performance when using AMK; a larger jet pump could be used to restore the desired performance.

Gravity Transfer Valve Test - This test was conducted to (1) determine the makeup flow rate using boost pump outlet pressure and the length of tubing involved, and (2) examine the capability of the AMK to initiate gravity flow through the valve and determine flow rate.

The makeup flow rate with AMK met the aircraft criterion. The AMK was able to initiate gravity flow through the valve without any problems. The gravity flow rate with AMK was about 25 percent lower than Jet-A. Gravity flow generated minimal AMK degradation.

Boost Pump Test - Tests were conducted to determine the amount of AMK degradation through the boost pump.

Boost pump performance was reduced when using AMK. The volume flow rate capability is diminished so some high flow rate requirements of the aircraft system may not be met. AMK degradation decreased when flow rate through the boost pump was increased. However, at the low flow rate, the fire protection qualities are still acceptable.

Fill System Test - During this test, fueling simulations were conducted using the DC-10/KC-10 production system. Fueling rates were measured. Operation of all functions, including precheck of high-level shutoff and intermediate-level fill termination at high and low nozzle pressures, were determined.

Slow system response and reduced flow rates with AMK, relative to Jet-A fuel were exhibited throughout the testing. Actuation and shutoff responses of the fill valve were sluggish. The lower flow rates imply an increased refueling time. Due to the increase in the overshoot volume, the current usable fuel tank volume would have to be reduced to maintain expansion space requirements. The AMK fuel quality data indicate only a slight amount of AMK degradation due to the fill system.

Vent System Test - The test was conducted to determine the AMK effects on airplane fuel tank overfill pressure by performing overfill tests in increasing nozzle pressure increments. The fuel tank over pressure during an overfill condition with AMK was equal to the Jet-A fuel.

Engine Feed System Test - The test was conducted to determine the flow characteristics of the system during sea level and altitude operations. Two feed system tests were run: (1) pressure fuel feed system performance, and (2) a suction feed climb test.

The pressure fuel feed performance test reinforces the data generated in the boost pump test. Boost pump performance decreased when using AMK. The highest degradation of AMK was found to be at the low flow rate condition.

In the suction feed climb test, the engine pump delivered the required flow/pressure up 31,000 feet when using the AMK. The system met flow and pressure requirements to the maximum certified altitude (42,000 ft.) on suction feed when using Jet-A fuel. The reason for fuel feed system altitude limitation deserves further investigation.

Flight Cycles - This work was done to determine the fuel quality in the fuel tank and at the engine fuel pump during a series of typical flights. The test procedure consisted of a takeoff, climb, cruise, and descent fuel flow profile and was repeated for a total of four simulated flights.

The flight cycle tests indicated lower boost pump performance for all the AMK runs compared to Jet-A. The AMK in the test tank was representative of unused fuel from the previous flight and new fuel for the next flight. AMK sampled from the tank exhibited good fire protection qualities. This would indicate that AMK in the aircraft fuel tank could be expected to retain most of its fire protection qualities throughout the flight.

Aerial Refueling Test - This test was conducted to determine fuel-flow effects of the KC-10 aerial refueling nozzle/receptacle coupling and the degradation of AMK fuel off-loaded from the tanker was determined. The data from the pressure drop versus flow rate indicated 12 percent higher system pressure loss with AMK as compared to Jet-A fuel. Minimal AMK degradation occurred in the KC-10 aerial refueling system. The quality of AMK fuel in a receiver airplane will be largely dependent upon the degradation experienced in the receiver airplane's system.

Water Test - This test was conducted to examine the effects of water concentration on the antimisting quality and physical appearance of AMK. The AMK was conditioned by adding water to get a total water content in the range of 250 to 300 ppm. Water was introduced using steam. Then the fuel was recirculated in a test tank to examine the effects of shear on water laden AMK.

No observable changes of the AMK occurred during the test. The AMK gave up water to the air. Free water in small quantities coming in contact with AMK causes water contamination locally; however, the effects quickly disappear.

DISCUSSION

Testing indicated that some system performance with AMK (FM-9) was below normally accepted levels with Jet-A. Water tolerance of the AMK was better than anticipated. Fuel system modifications and/or procedural revisions to maintain AMK quality do not appear to present technically insurmountable challenges. Any system changes would have to be made as part of a total aircraft fuel system review and design analysis conducted with the intent of certifying system performance on a particular AMK. An extensive fluid property data base, derived from testing, would be required to make the analysis.

CONCLUSIONS

- o Some aircraft systems reduce AMK quality
 - o System/Procedure revisions may be required
 - o Revisions are technically possible
- o AMK reduces some existing fuel subsystem performance below normally accepted levels.
- o Float switch, float valve and vent system performance on AMK was equal to Jet-A operation
- o Gravity transfer valve operation with AMK was comparable to Jet-A except the gravity flow rate was below normally accepted Jet-A levels.
- o AMK quality was maintained during four successive flight simulations
- o Additional programs will be required to certify an airplane with AMK
- o AMK (FM-9) is compatible with small amounts of water
- o Based on initial test results, the KC-10 aerial refueling system can deliver an AMK fuel of satisfactory quality.
- o AMK quality control measurements need development.

INTRODUCTION

BACKGROUND

Investigations of aircraft accidents reveal fire-related fatalities in impact-survivable accidents. The sequence of events in an accident may include the ejection of fuel into the airstream at a high velocity from ruptured tanks and fuel lines. The high-velocity interaction between fuel and air causes the liquid fuel to break up. A mist is generated which is easily ignited and burns rapidly. If ignited, flame fronts can propagate into pools of fuel in and around the aircraft.

Antimisting kerosene (AMK) is Jet A fuel with a dissolved additive which precludes the possibility of a fine mist and associated "fireball" which occurs in some impact-survivable accidents. AMK fuel exhibits non-Newtonian fluid characteristics. Shearing of AMK can increase the viscosity by three orders of magnitude, affecting component and system performance (pressure drop, time response, etc.). In turn, high shear rates from the components can degrade the fuel; i.e., loss of anti-misting and fire suppression qualities.

The AMK used was 0.30 percent by weight of FM-9 with a carrier fluid consisting of glycol and amine in Jet A (ASTM D-1655). The AMK was batch blended with the proprietary additive FM-9 by Imperial Chemical Industries (ICI), Americas in Wilmington, Delaware and was shipped to Douglas Aircraft Company in Long Beach, California. Shipments of AMK were in bulk (tank truck) or in drum lots by common carrier.

OBJECTIVE

This program was designed to evaluate the compatibility of AMK and a contemporary wide-bodied aircraft fuel system. Tests were conducted to determine AMK effects on components and system performances, and components and system effects on the fuel.

The objective was to conduct component flow and function tests on float switches/valves, the transfer valve, and jet pumps, and to examine water contamination. Fueling and overfill simulations were to be carried out on the full-scale fill-and-vent system simulator. On the full-scale engine fuel feed system test setup, suction feed and flight cycle simulations from sea level to cruise altitude operations as well as basic fuel feed performance were to be represented. Tests of the AMK were to be evaluated against baseline tests with Jet A fuel. The physical and flammability properties of the AMK were to be tracked and documented from start to finish of all tests. All tests were conducted at ambient temperatures.

COMPONENTS AND SYSTEMS DESCRIPTIONS

FUEL SYSTEM

The fuel system is made up of many systems which hold, manage, control, and measure the fuel aboard the aircraft (Figure 1). Figure 2 shows the basic tankage layout of the DC-10 airplane. Three main tanks are used, one for each of the three engines. Longer-range aircraft have auxiliary tankage in the center-wing area. The KC-10 has additional storage capability for off-load fuel, both forward and aft of the wing, in what are normally cargo holds below the main cabin floor. Fuel used for flight from the auxiliary tanks or from the off-load tanks is transferred to the main tanks before being fed to the engine.

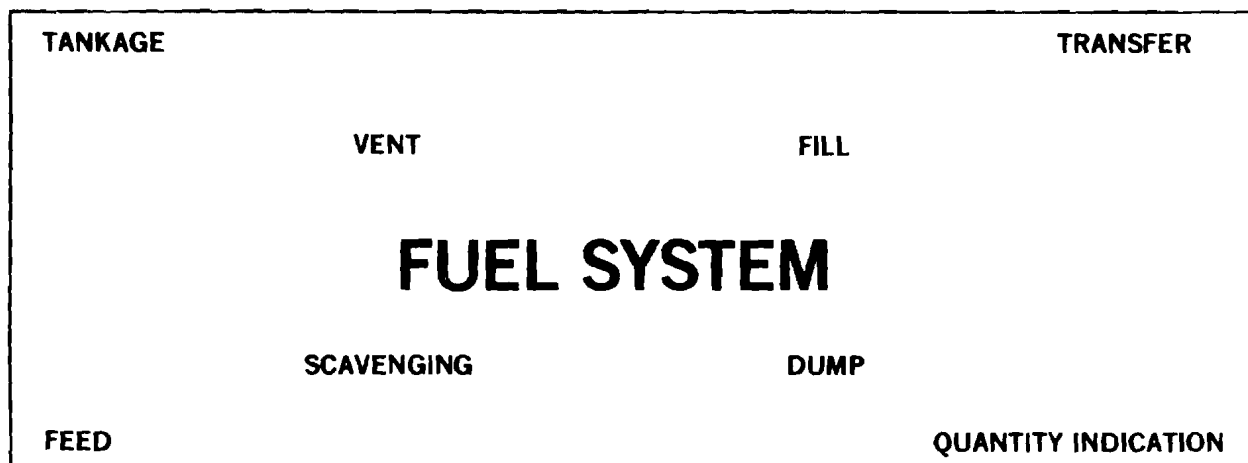

FIGURE 1. FUEL SUBSYSTEMS

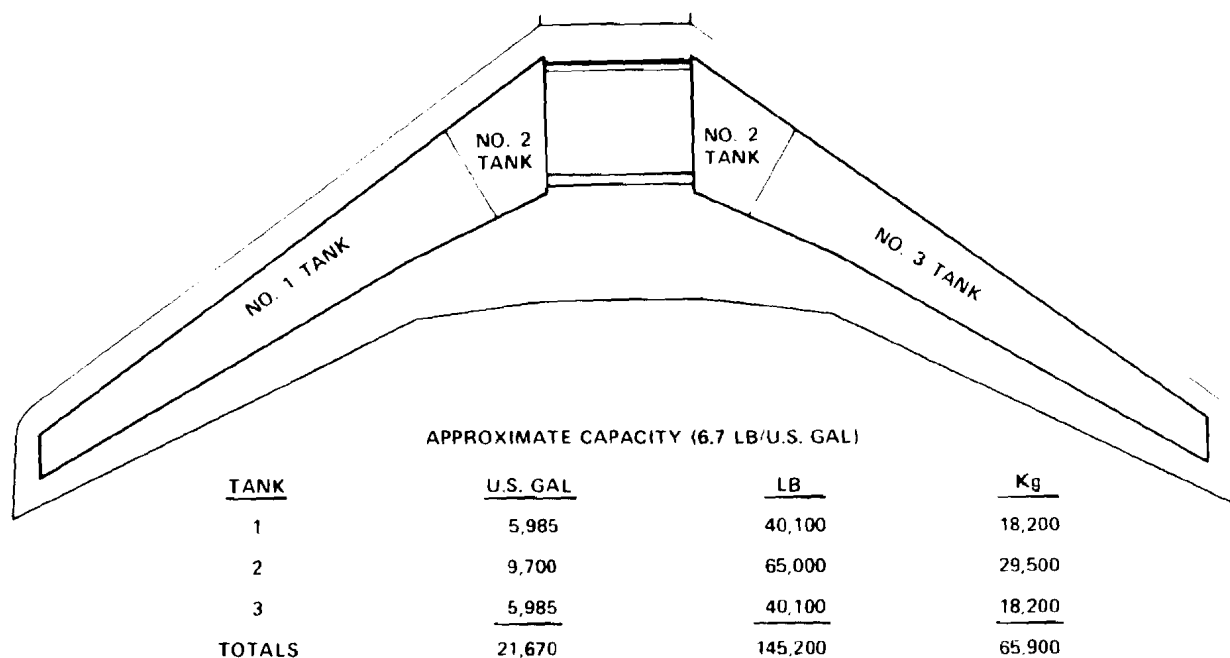

FIGURE 2. FUEL TANKAGE – DC-10 SERIES 10

The fill, vent, and feed systems are discussed in further detail in later sections. The other fuel subsystems involved in this program are transfer, scavenge, and fuel management monitoring and control systems. To meet the objectives of the test, test tanks were used which permitted realistic simulation of the aircraft configuration.

Component testing was an essential part of this program. The individual components used are described below. An overall picture of their functions and relationships with each other can be obtained by looking at the fuel handling process in the outboard main tanks (No. 1 or No. 3). The out-

board compartments of these tanks are also called tip tanks and these terms will be used interchangeably throughout the text.

Figure 3 is an elevation view of the No. 1 tank looking aft. The fuel is used in the order shown by the Roman numerals. Fuel is held in the outboard compartments of the outboard main tanks. This arrangement provides relief of wing bending moments due to air loads. The management of fuel is also important to the overall weight and balance and drag of the airplane.

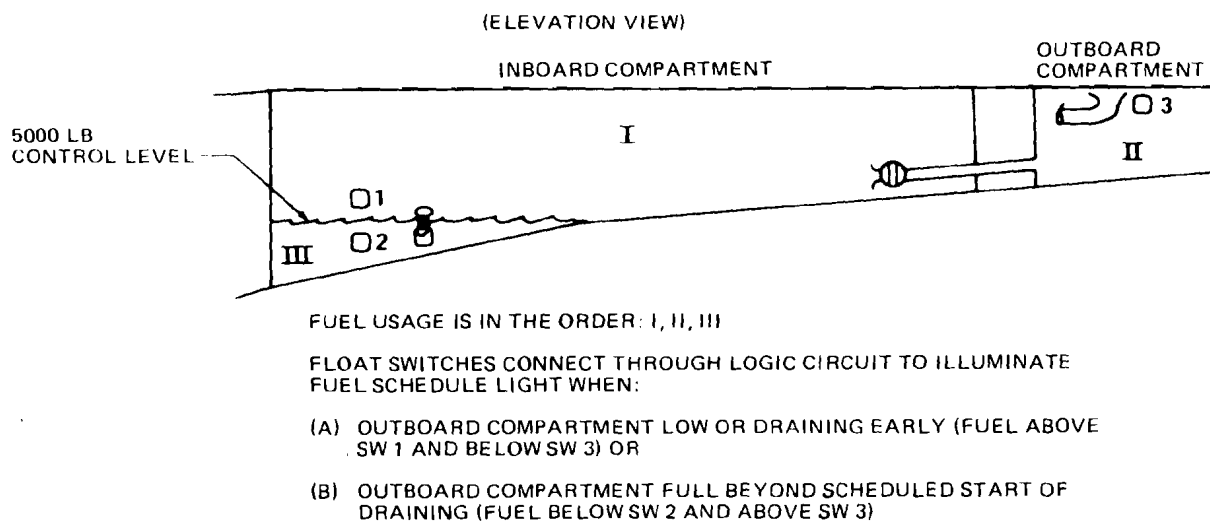

FIGURE 3. OUTBOARD MAIN FUEL TANK, FUEL USAGE SCHEDULE

It is known that water exists in aircraft fuel tanks because the tanks are open to the humidity in the atmosphere and because water becomes less soluble in the fuel as temperatures drop. A water removal system was developed for the DC-10/KC-10 aircraft as part of the original design. A system installed in the DC-10/KC-10 continually scavenges water and fuel from the tank low points and discharges it near the inlet of the boost pump. One scavenge rake is located in the inboard end of the tip tank. A continuous inboard flow from the tip occurs in this system. An outboard flow into the tip tank is necessary to make up for the scavenge flow to maintain the fuel weight outboard. The excess spills over the vent interconnect line and returns to the inboard compartment.

The makeup flow occurs during most of the flight mission for the reasons stated above. A float valve controls the makeup flow. The float valve at the inboard end of the tank maintains the fuel level there at a nominal 5000-pound level while the fuel from the outboard compartment is being used. When the inboard fuel level is above the float, pressurized fuel flows outboard to close the gravity transfer valve and to make up for the fuel being transferred inboard by the continuous scavenging system.

As fuel is used, the float is uncovered. Makeup flow stops and the gravity drain valve opens. Another float valve located near the makeup flow control float valve will be uncovered if gravity transfer cannot maintain the fuel level; e.g., at high nose-up attitudes. This float actuates the jet pump transfer system which also transfers fuel from the outboard compartment to the inboard part of the tank.

A system of float switches and indicator lights is used to alert the system engineer when the desired fuel schedule is not being maintained. If excessive swings in inboard fuel level were to result from sluggish valve operation or reduced system flows with AMK, these swings would give the crew a momentary indication of system failure and would result in blinking cockpit warning lights. This behavior in a warning system is unacceptable so system modification would be required.

FLOAT SWITCHES

The float switches in the aircraft fuel system are used for fuel level control and fuel management monitoring. A typical switch is shown in Figure 4.

Holes and a slot allow flow through the protective case to the float. A permanent magnet is encased in the float. The magnetic field opens and closes the internal circuit as the float is displaced up and down within the switch casing giving the fuel level indication signal.

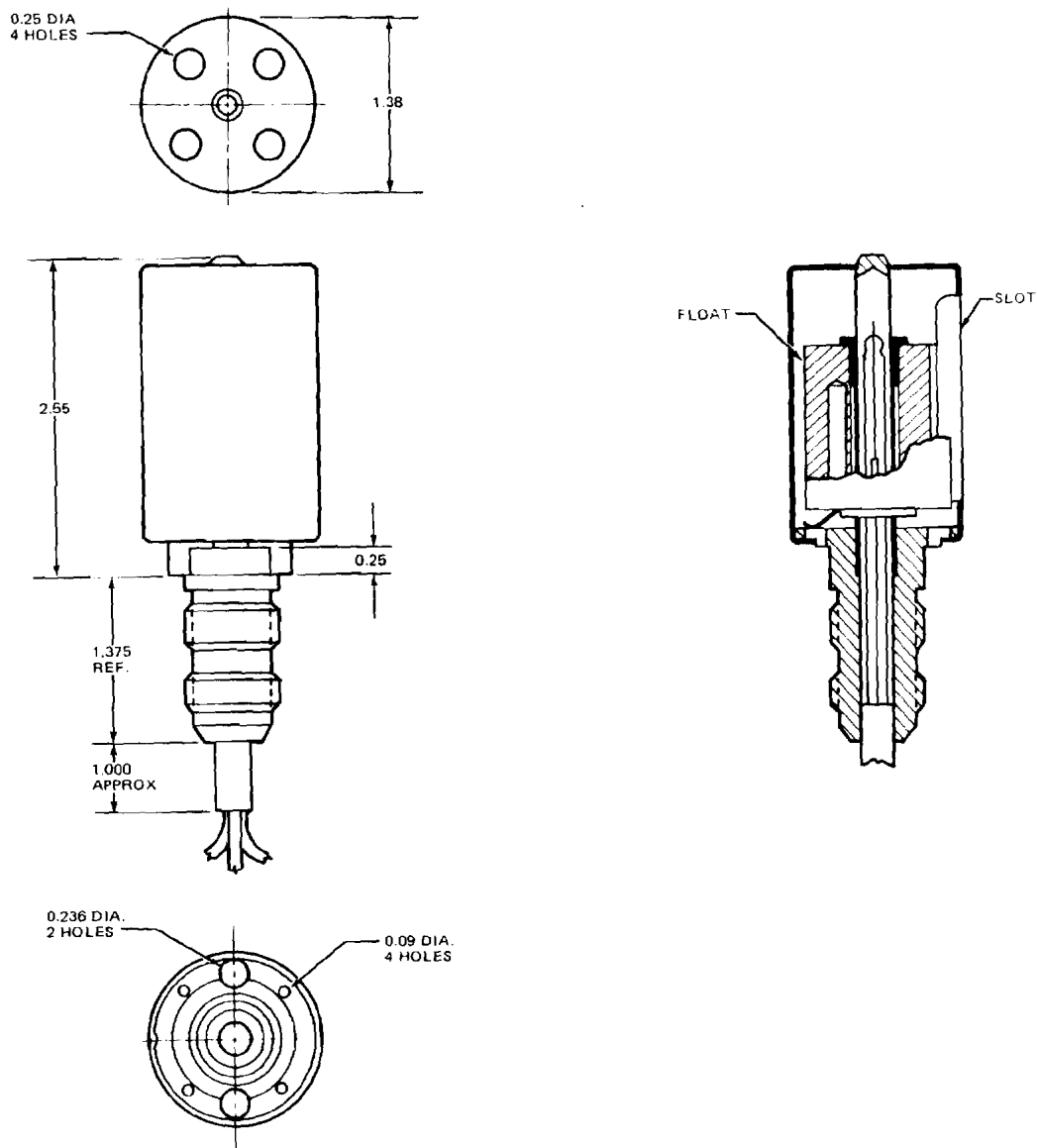

FIGURE 4. FLOAT SWITCH

FLOAT VALVES

Two types of float valves are used in the aircraft fuel system. These are shown in Figure 5.

Two transfer float valves are used to regulate flow from the tip tank inboard through two separate systems. The valves are situated nominally at the 5000-pound fuel level in the outboard main fuel tanks. Their operation was described above.

The fill shutoff pilot valve closes the fill valve when the fuel level in the main tank reaches the upper limit.

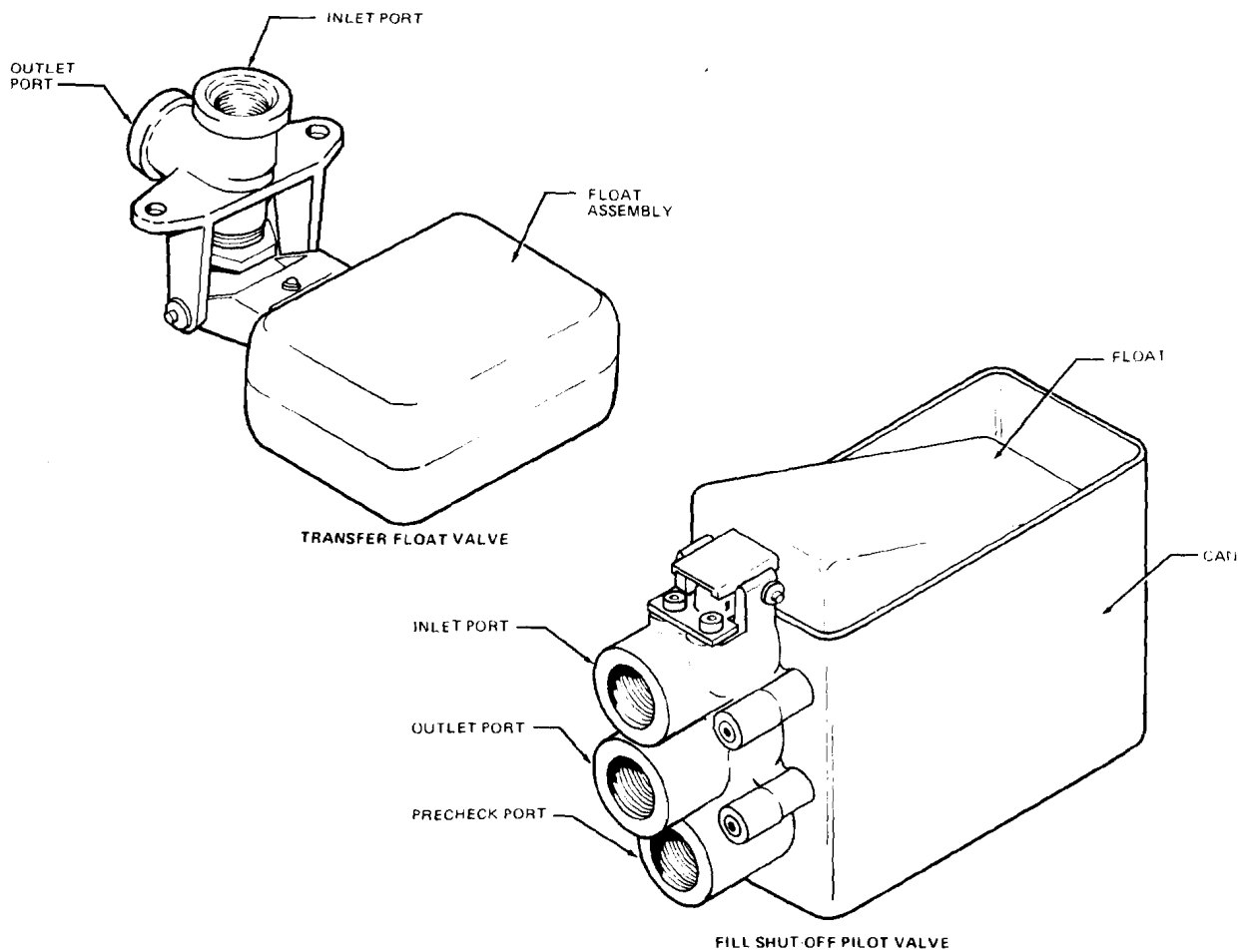
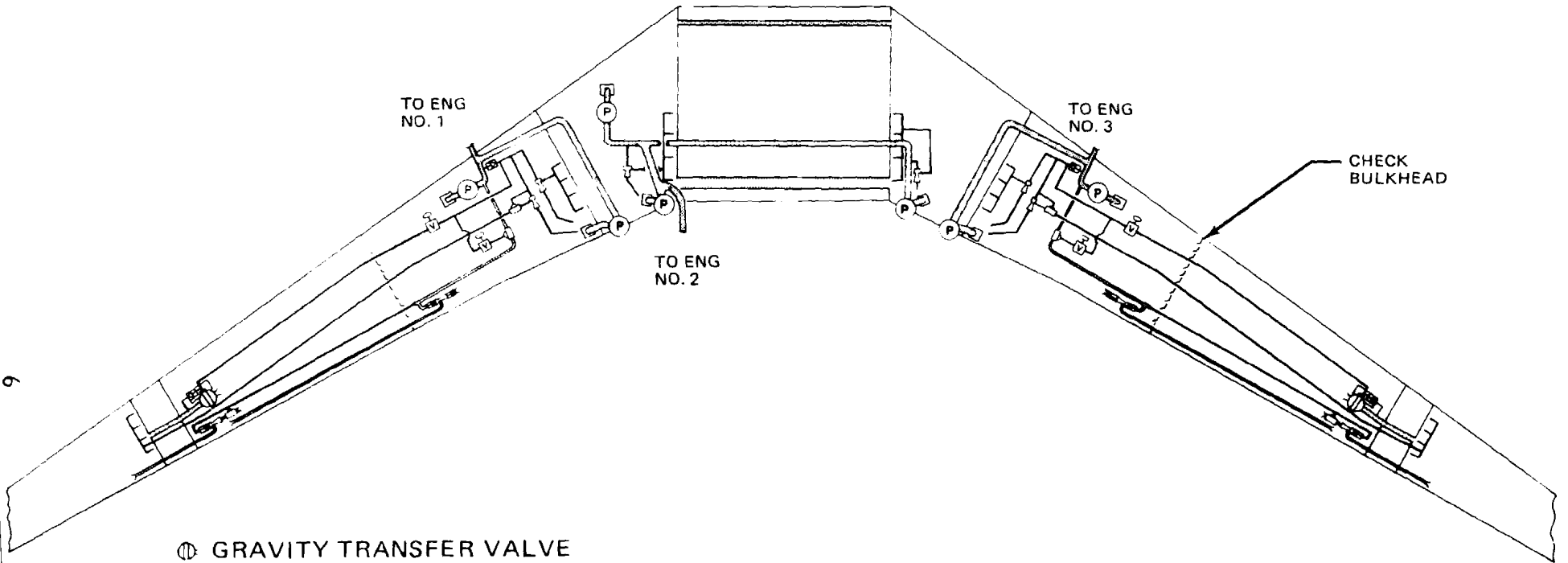

FIGURE 5. FLOAT VALVES

JET PUMPS

There are two jet pump systems in the fuel system. Both systems are driven off the boost pump discharge flow (i.e., tapped off the engine fuel feed line). Figure 6 shows the scavenge and jet pump transfer systems. Their operation was described above.

The jet pump transfer system uses two jet pumps. It comes into operation once the fuel level falls below the transfer float valve level in the inboard compartment. The outboard jet pump transports fuel from the outboard compartment to the inboard compartment, depositing fuel just inboard of



- ⊕ GRAVITY TRANSFER VALVE
- ⊞ JET PUMP
- ⊡ PRESSURE ACTUATED VALVE
- ⊞ CHECK VALVE
- ⊞ TRANSFER FLOAT VALVE
- ⊙ BOOST PUMP, AC

FIGURE 6. SCAVENGE JET PUMP AND TRANSFER JET PUMP SYSTEMS

the vent box. Another jet pump picks up this fuel and transfers it to the inboard side of the check bulkhead. The check bulkheads prevent outboard flow of fuel in the No. 1 or No. 3 tanks during high nose-up attitudes and in uncoordinated maneuvers. Outboard flow affects aircraft balance and fuel recovery.

GRAVITY TRANSFER VALVE

Transfer of outboard compartment fuel by gravity is controlled by the system shown in Figure 7. The transfer float at the inboard end of the tank maintains the fuel at a prescribed level. When the inboard fuel level is above the float, pressurized fuel from the feed line can flow outboard to make up for fuel being transferred inboard by the continuous scavenge system. When the float is uncovered, makeup flow stops and the gravity transfer valve opens as fuel pressure behind the valve diaphragm is relieved.

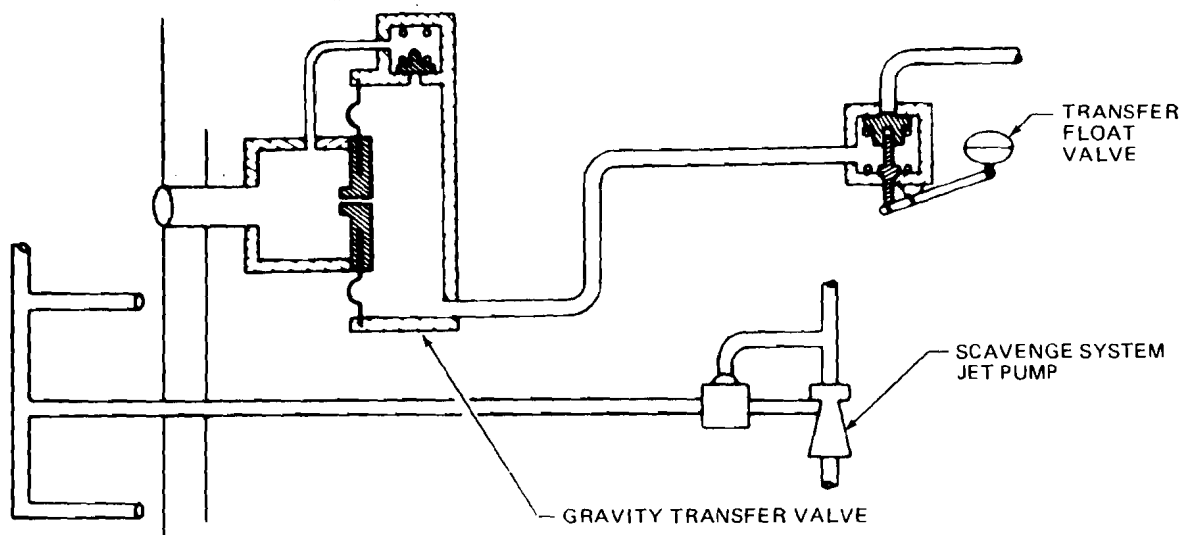

FIGURE 7. OUTBOARD COMPARTMENT GRAVITY TRANSFER AND SCAVENGE SYSTEMS

TANK-MOUNTED FUEL BOOST PUMP

The pumping unit consists of a fuel-cooled, a.c.-motor-driven pump impeller which, when installed in the housing assembly, comprises a fuel boost pump system. The boost pump is a constant-speed, mixed-flow type. The flow rate through the pump depends on operational conditions. The maximum flow rate capacity is 150 gpm.

In addition, all aft boost pumps and center wing auxiliary tank transfer pumps have inlet line-mounted jet pumps at each inlet basket. The inlet line-mounted jet pump was developed as a mechanism to increase the flow rate through the boost pump at low engine fuel flows and was used to increase the inlet pressure of the fuel boost pump. The increase in inlet pressure of the boost pump helps at altitude conditions where cavitation of pumps is likely to occur.

The KC-10 and the extended range DC-10 auxiliary tanks are divided into upper and lower compartments. Both compartments have two (transfer) pumps. The upper auxiliary tank compartment transfer pumps have the inlet jet pump.

FILL SYSTEM

The fill system flow schematic is shown in Figure 8.

To refuel the aircraft, one or more nozzles are attached to the adapters at the refueling panel. The nozzle is opened, and the refueling manifold is pressurized. The fill valves are signaled to open and fuel flow begins. Fill pressure is solely a function of ground equipment capability. A range of "normal" single-nozzle fill pressures is 35 to 50 psi, with corresponding flow rates of 400 to 480 gpm.

For the No. 1 and 3 tanks, the fuel passes through the fill valve into the outboard compartment. Once the outboard compartment is full, additional fuel spills over to the main compartment via a 4.50-inch line that connects the outboard compartment to the main. Fill shutoff pilot valves are connected to the fill valves and will stop refueling when the tank is full; i.e., when the tank has reached maximum allowable fuel volume.

For the No. 2 tank, the fuel passes through the No. 2 fill valve into the No. 2 right compartment. At the same time, the No. 2 left compartment is being filled via a 4.50-inch line connecting the two compartments. A fill shutoff pilot valve is located in the left compartment and is connected to the No. 2 fill valve.

VENT SYSTEM

The vent system schematic is shown in Figure 9. This system is provided to equalize internal tank pressures with ambient pressures. If the fill valve system fails, fuel will flow overboard through the vent system. The vent system is sized to maintain tank pressures below structural limits in case of overfill. The DC-10 has additional overpressure protection built into the fill valve controller.

ENGINE FEED SYSTEM

The feed system schematic is shown in Figure 10.

In the usual engine feed condition, the four aft main tank boost pumps are used. The No. 1 and 3 boost pumps feed the No. 1 and 3 engines, respectively, and the No. 2 boost pumps located in the No. 2 left and right compartments feed the No. 2 engine.

The other boost pumps and the transfer pumps are used for other modes of operation. Such conditions include "backup" pumps for aft boost pump failures, low fuel state fuel recovery, fuel transfer (one tank to another), and fuel jettison.

KC-10 AERIAL REFUELING NOZZLE/RECEPTACLE

The KC-10 fuel system is essentially the DC-10-30 long-range airplane system with the addition of tanks, hydraulically driven aerial refueling pumps (ARPs), and the capability to receive or deliver fuel in flight. A hose reel is provided for probe and drogue refueling. A flying boom conducts fuel through a nozzle to receptacle-equipped aircraft.

The aerial refueling system is shown in Figure 11.

The ARPs are centrifugal type pumps that vary speed with flow to maintain constant delivery pressure. One or more may be used. The KC-10 has a total of six ARPs.

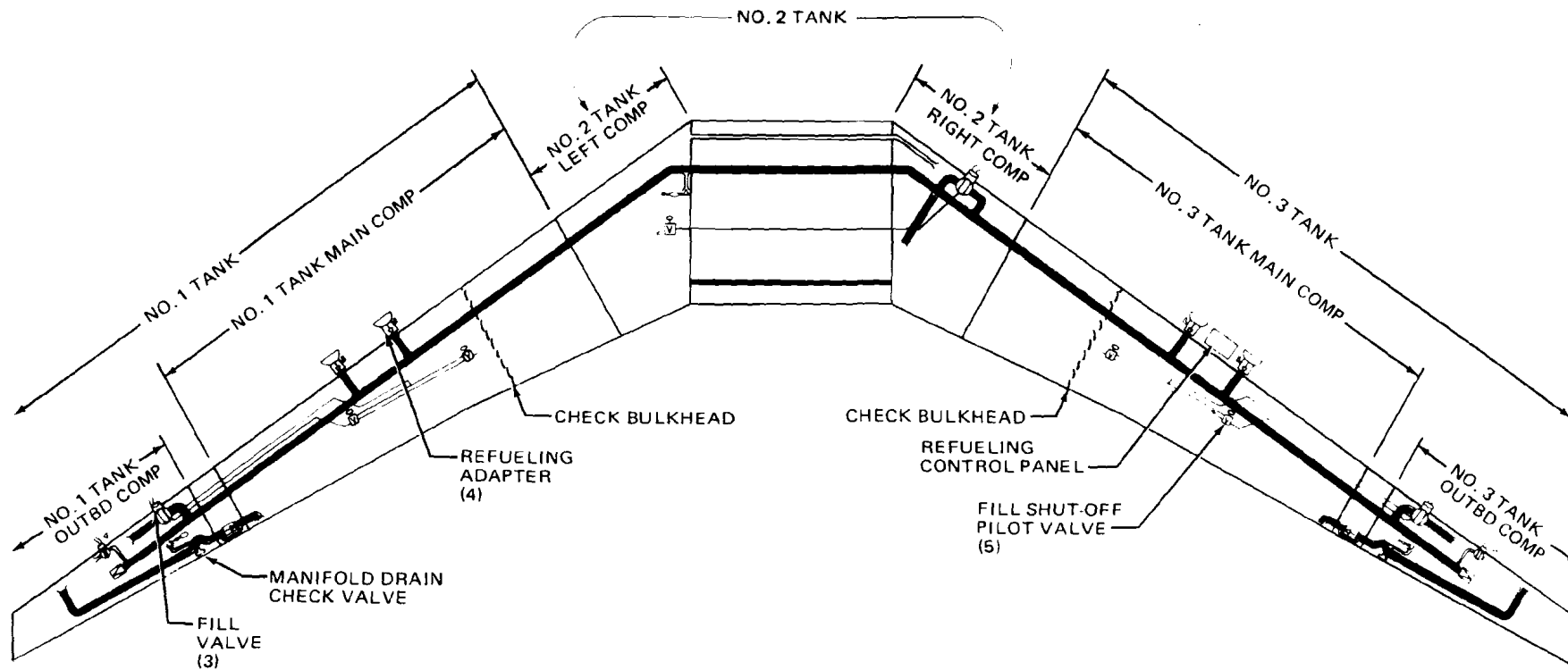

FIGURE 8. FILL SYSTEM FLOW SCHEMATIC

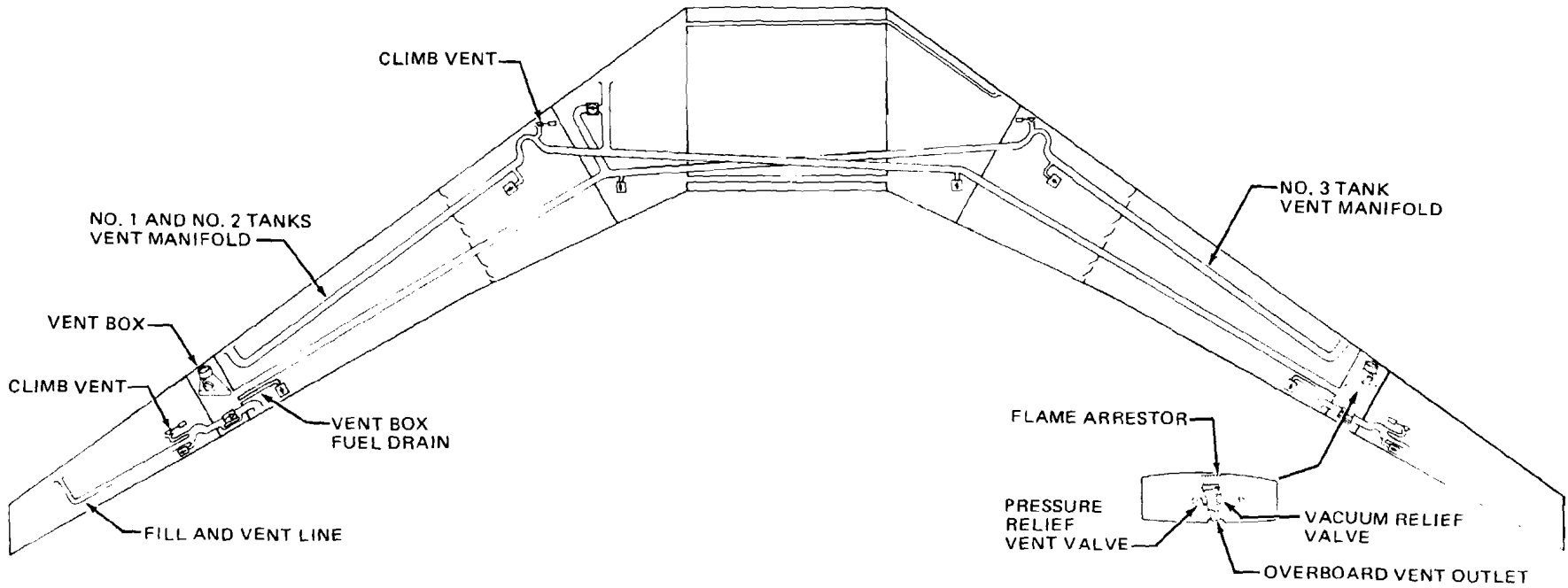

FIGURE 9. VENT SYSTEM

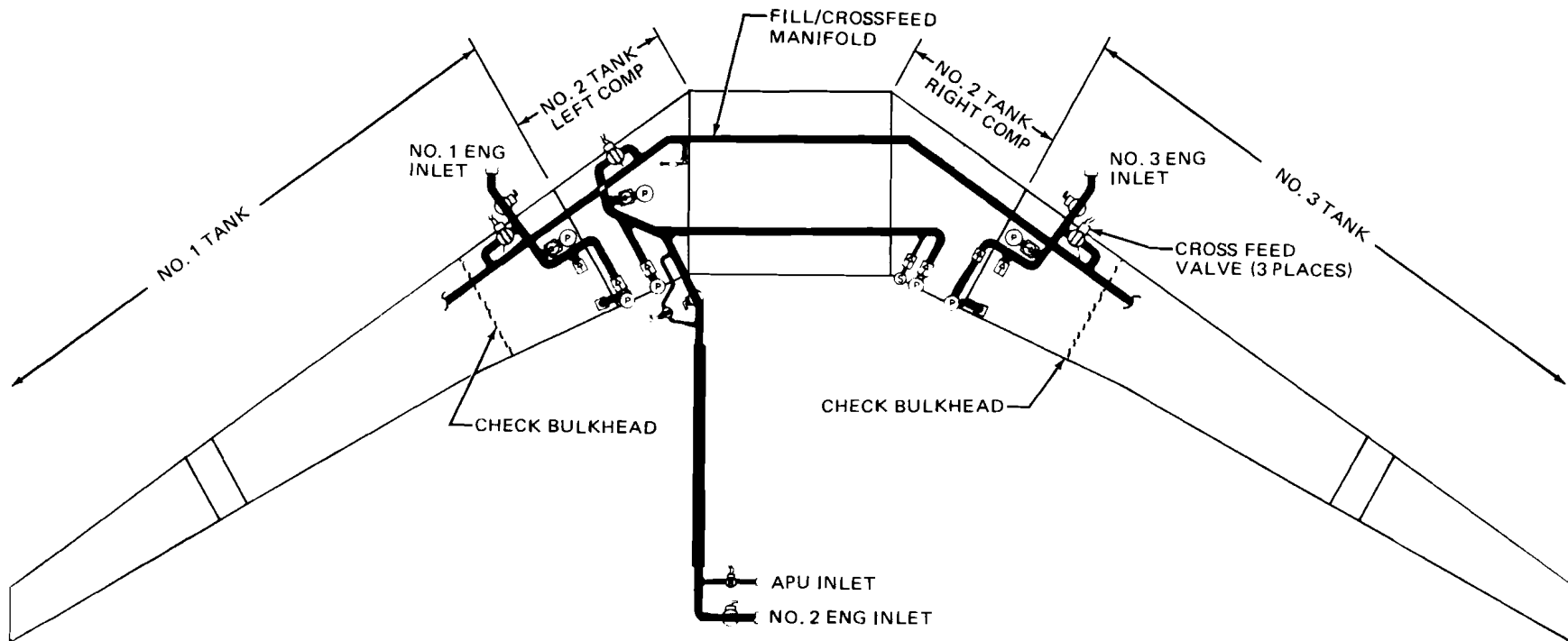

FIGURE 10. FEED SYSTEM

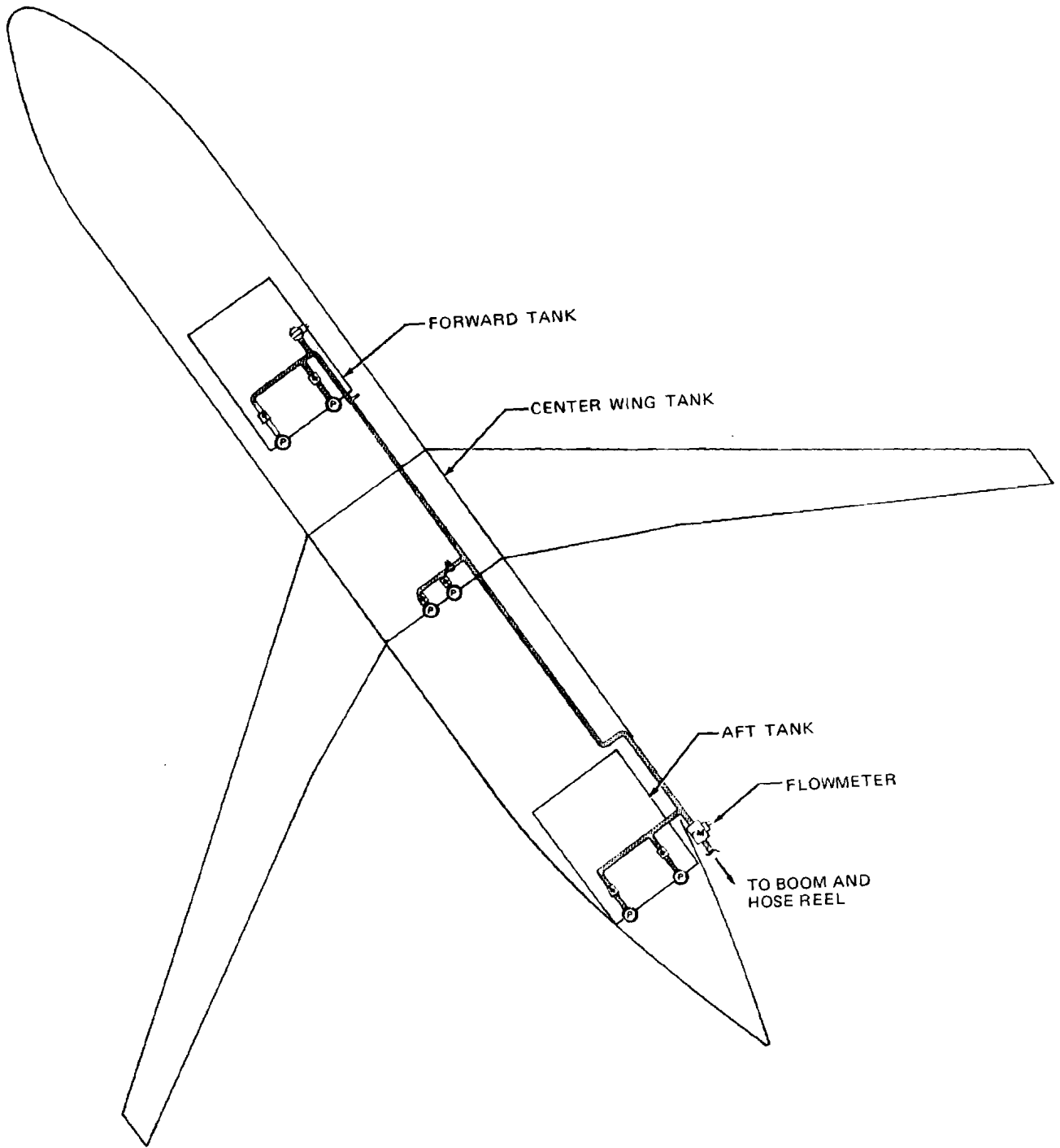

FIGURE 11. KC-10 AERIAL REFUELING

TEST PROGRAM

SPECIAL FUEL HANDLING, FUEL SAMPLE ACQUISITION

The FM-9 antimisting additive in the fuel may be degraded (loss of antimisting properties) by flowing through screens, any type of pump, and certain types of valves. Exposure of the fuel to extreme high or low temperatures and light or foreign substances will also cause AMK degradation. Therefore, special handling of the AMK fuel is required in order to minimize FM-9 degradation. Dry air pressure was used to transfer the AMK from the lab supply tanks. AMK fuel used in a test was not used again, except when called for in the test procedure.

Samples were taken throughout the program and care was exercised due to the above characteristics of the AMK. Whenever possible, a beaker was used to transfer the fuel sample from the point of interest to a 1-gallon plastic container. When in-line sampling was necessary, a sampling vessel of the type shown in Figure 12 was used.

The sampling vessel has three ports, and each port has a ball valve attached which provides no restriction in the open position. The following sampling procedure was used: (1) The vessel was positioned in the area of interest with Port A being the sample inlet; (2) initially, all ports were closed; (3) Port A was opened fully; (4) Port B was partially opened to drain the initial batch of incoming fuel; (5) Port B was closed and Port C was cracked open so that the incoming fuel sample would enter the vessel at a slow rate; (6) fuel was allowed to ooze out of Port C indicating that the sampling vessel was full; (7) Port C was closed and then Port A was closed; (8) the vessel was vented by slowly opening Port C all the way; (9) the sample was drained through Port B into a sample container. Fuel characterization was done by the Jet Propulsion Laboratory (JPL) in Pasadena, California. The JPL procedures are detailed in Appendix A.

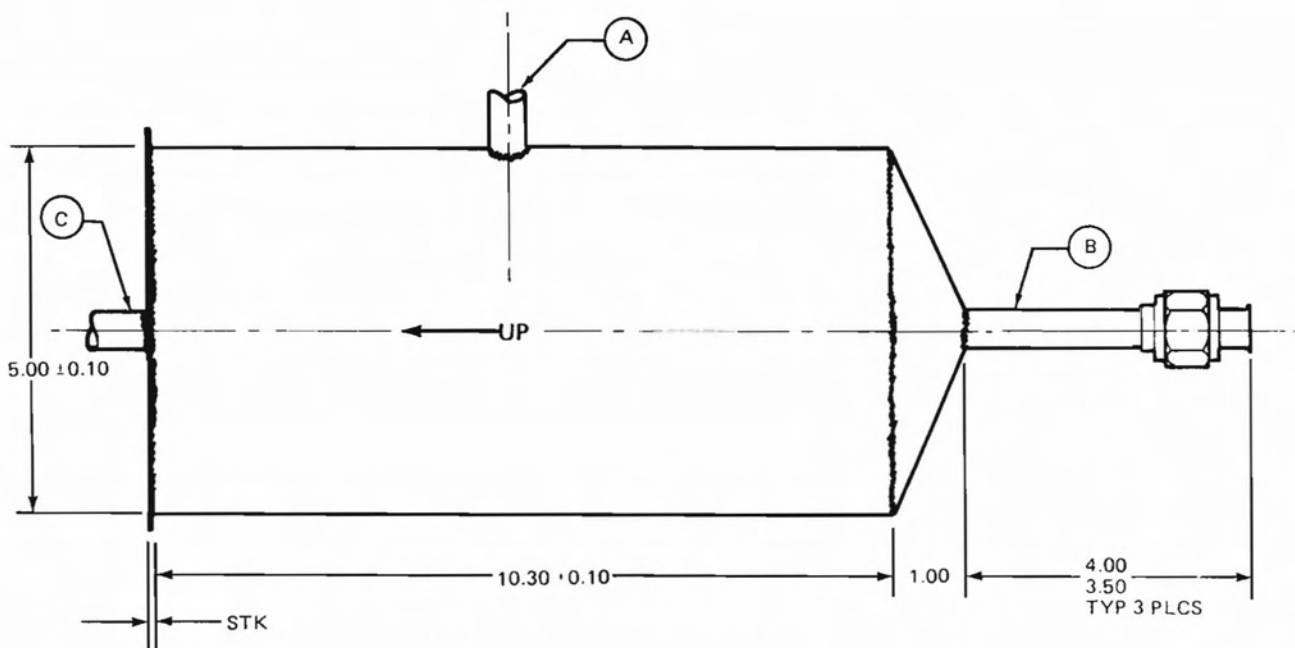

FIGURE 12. SAMPLING VESSEL

COMPONENT TESTING

Float Switch Test

Purpose: The float switch test was conducted to determine the switch actuation levels at rates of fuel level change that represent normal rates for the components in the DC-10/KC-10.

Method: The test setup is shown in Figure 13.

Two float switches were tested to compare the actuation levels using AMK to the levels of Jet A.

By pressurizing the supply, an ascending flow rate of 22 inches per minute was produced. For the high flow rate of 22 inches per minute, a 2300-gallon fuel supply tank was used with a maximum dry air pressure of 100 psi above the fuel. The 22 inches per minute represented the maximum upward fuel rate (80,000 pph) seen by the float switch in airline usage. This occurs in the vent box during fuel overfill.

By opening the drain valve, the descending flow rate of 2.0 inches per minute was generated. This flow rate (99,200 pph) simulated the maximum downward movement of fuel in the tank which is sensed by the float switch. This occurs in fuel dumping for the No. 1 or 3 main tanks.

The fuel rate was measured by height and time changes. Actuation levels of each switch were determined by noting circuit closure. Runs were made until actuation levels were reproducible within ± 0.5 inch.

Although the switches were not expected to affect fuel quality, samples were taken of the virgin AMK and of the AMK after the runs.

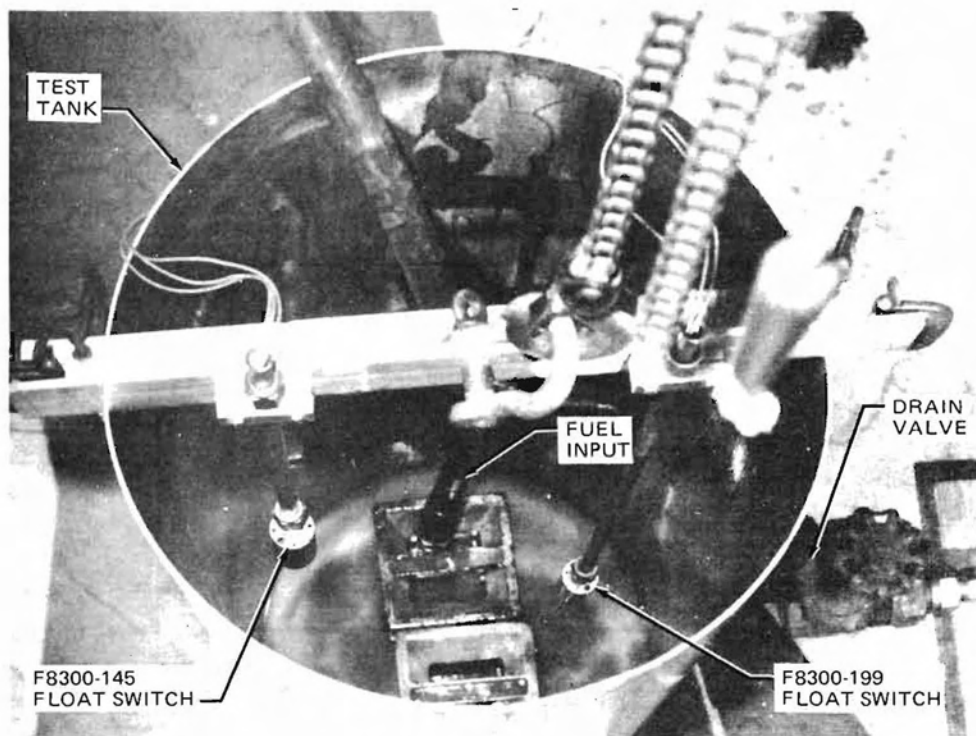

L109482

FIGURE 13. FLOAT SWITCH TEST SETUP

Data and Results: The test results are presented in Table 1 and discussed in the next section. Fuel quality test methods are presented in Appendix A.

A fuel quality check was not made upon arrival. It was not known at the time that degradation of the FM-9 may occur during shipment due to sloshing of the AMK.

Float Valve Test

Purpose: The float valve test was conducted to determine the actuation levels of float valves at rates of fuel level change that approximate normal rates for the components in the DC-10/KC-10.

Method: Figure 14 shows the test schematic. The test tank used in the float switch test was reused.

Two float valves were tested with Jet A fuel to establish a baseline and then with AMK fuel.

**TABLE 1
FLOAT SWITCH TEST**

<u>FLOAT SWITCH</u>	<u>P/N F8300-199</u>		<u>P/N F8300-145</u>	
Switch Location	Outboard Compartment Float Switch		Outboard Compartment Float Switch	
Fuel	Jet-A	AMK	Jet-A	AMK
Upward Fuel Rate (In/Min)	23	22	23	22
Upward Actuation Level (In)	13.6	13.5	26.0	25.9
Downward Fuel Rate (In/Min)	2.0	1.9	2.0	1.9
Downward Actuation Level (In)	13.3	13.5	25.3	25.4
<u>FUEL</u>	<u>FILTER RATIO (At 19.5°C)</u>	<u>ICI CUP TEST (At 20.0°C MI.)</u>	<u>FCTA RESULTS</u>	
Virgin AMK	18.3	3.7	96°C	
			97 psi	
			Speed Control (S.C.) 900	
AMK Following Test	18.2	3.6	96°C	
			97 psi	
			Speed Control (S.C.) 900	

The test tank had three individual compartments. Compartment 1 contained the secondary fuel supply, Compartment 2 the primary fuel supply, and Compartment 3 a mixture of the secondary and primary fuel; i.e., the jet pump discharge.

All pressures were measured using pressure gages. Flow rates were determined by measuring volume and time changes.

Compartments 1 and 2 were filled with fuel. The boost pump was turned on, and boost pump pressure and primary and secondary jet pump pressures were recorded. Secondary and total flow rates were measured.

The secondary line was bent with a large radius of curvature. Configurations A, B, and C of the secondary line were used to generate the performance curve of the jet pump. Configuration A was 5/8 inch in diameter by 47.75 feet long. Configuration B was 5/8 inch in diameter by 20.00 feet long. Configuration C was 1 inch in diameter by 15.00 feet long. Configuration A is the DC-10 configuration.

All testing was done with Jet A fuel first and repeated with AMK. Samples of virgin, secondary supply, and jet pump discharge fuel were taken for Configuration A.

The test setup for the transfer jet pump test was similar to the setup shown in Figure 15. The exceptions were: (1) the jet pump was larger, (2) the secondary pickup used had a bellmouth inlet instead of the scavenge rake, and (3) the secondary line geometries were different. Configuration A was 1-1/2 inches in diameter by 38.75 feet long line. Configuration B was 1-1/2 inches in diameter by 10.00 feet long line. Configuration C was 5/8 inch in diameter by 20.00 feet long line. Configuration A is the DC-10 configuration.

Data and Results: The jet pump performance data are plotted in Figures 16 and 17. The fuel quality data are listed in Table 3. The discussion of the data and results may be found in the next section.

Gravity Transfer Valve Test

Purpose: This test was conducted to (1) determine the makeup flow rate using boost pump outlet pressure and the length of tubing involved, and (2) examine the capability of the AMK to initiate gravity flow through the valve and then determine the resulting flow rate.

Method: The test schematic is shown in Figure 18.

Two sets of runs were made, the first to test the makeup flow operation and the second to test gravity flow operation. Compartments 1 and 2 of the test tank were used.

For the makeup flow run, Compartment 2 was filled with fuel. The pilot valve float was in the upward position. The boost pump was energized, and the makeup flow rate was measured by recording the fuel height change in the receiver tank and the time. The float of the pilot valve was lowered and the shutoff time noted.

For the AMK run, samples of the virgin and makeup flow fuel were taken.

For the gravity flow run, a 10-inch head of fuel was maintained in the receiver tank.

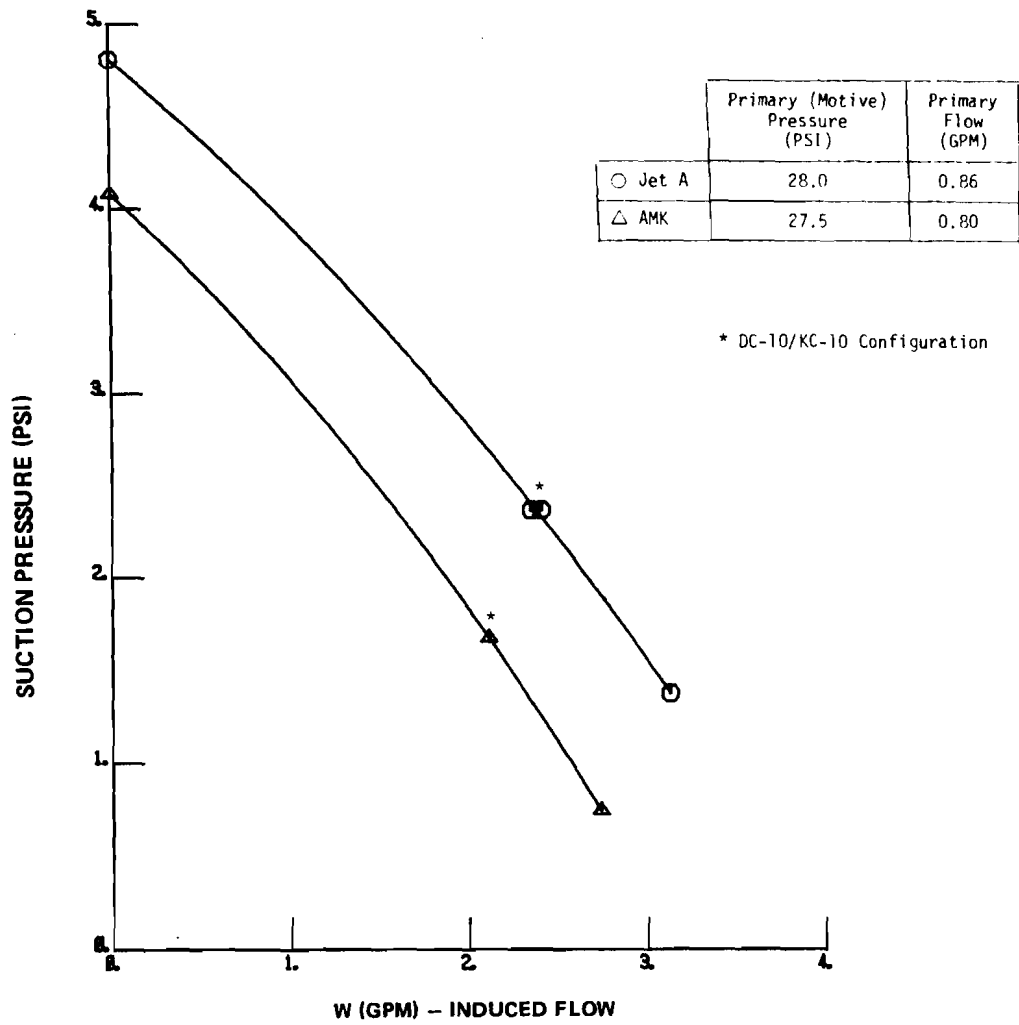

FIGURE 16. SCAVENGE JET PUMP PERFORMANCE

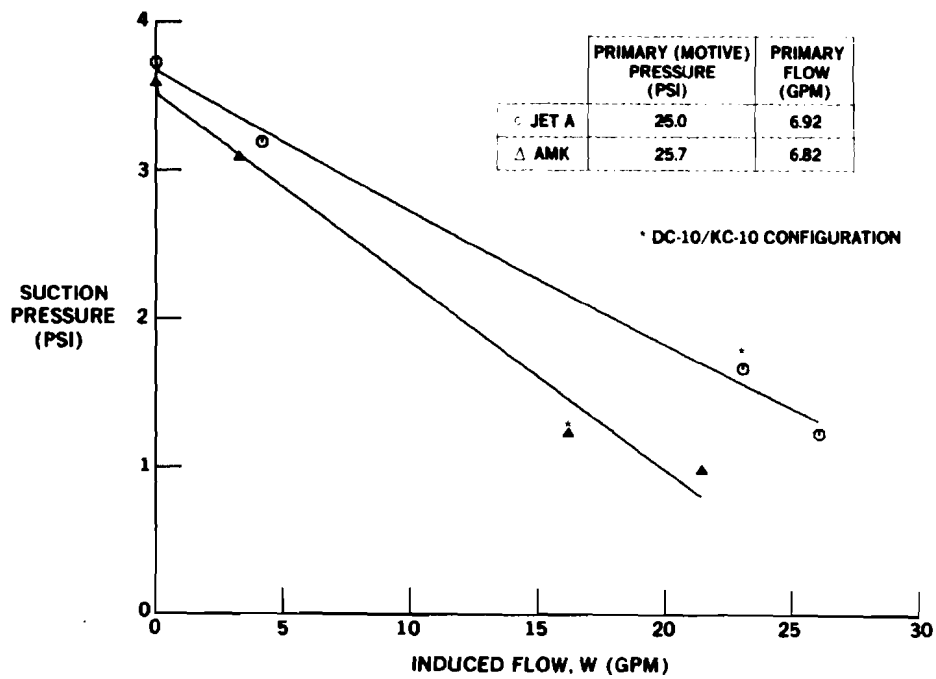

FIGURE 17. TRANSFER JET PUMP PERFORMANCE

TABLE 3
JET PUMP TEST – AMK QUALITY

SCAVENGE JET PUMP, P/N 60324

<u>Sample</u>	<u>Filter Ratio</u>	<u>ICI Cup Test (ml)</u>	<u>FCTA Results</u>
Virgin AMK	8.0 at 23 °C	6.1 at 23 °C	---
Jet Pump Discharge AMK	7.6 at 23 °C	7.0 at 23 °C	---
Secondary AMK Supply	12.0 at 21.9 °C	4.9 at 21.5 °C	95 psi S.C. 250 55 °C

Transfer Jet Pump, P/N 60102

<u>Sample</u>	<u>Filter Ratio</u>	<u>ICI Cup Test (ml)</u>	<u>FCTA Results</u>
Virgin AMK	20.0 at 22 °C	3.2 at 22 °C	95 psi S.C. 250 46 °C
Jet Pump Discharge AMK	4.5 at 21.8 °C	7.0 at 22 °C	95 psi S.C. 250 60 °C
Secondary AMK Supply	11.5 at 22.6 °C	5.0 at 22.3 °C	95 psi S.C. 250 72 °C

The float of the transfer float valve was lowered to initiate gravity flow. The gravity flow rate was measured by recording the volume and time in Compartment 1 of the test tank. Volume readings were taken every 10 seconds.

The float position was maintained and readings were taken until the same volume difference (V) was recorded in six consecutive readings to establish steady-state flow. The float was raised and the shutoff time noted.

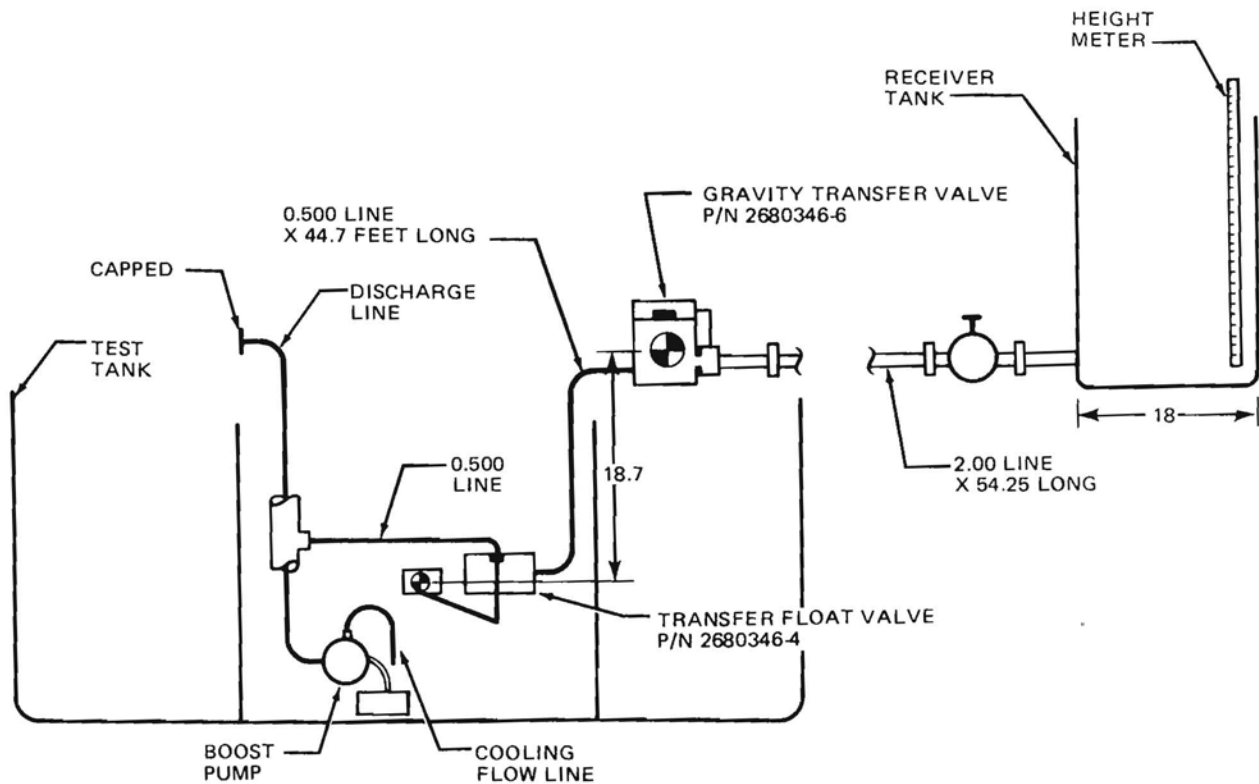

FIGURE 18. TRANSFER VALVE TEST SCHEMATIC

The float was then lowered and the readings repeated to complete the cycling of the system.

For the AMK runs, two AMK qualities were used in the receiver tank, virgin AMK and “degraded” AMK. The degraded AMK was virgin AMK that had passed through the boost pump and transfer valve system once and represented makeup flow fuel. A gravity flow sample was taken from the run that started with virgin AMK.

Data and Results: Test results are presented in Table 4 and discussed in the next section.

Figure 19 shows gravity flow occurring. A plastic bag over the valve prevented fuel from being lost outside the test tank.

AMK Degradation versus Boost Pump Flow

Purpose: These tests were conducted to determine the amount of AMK degradation through the boost pump.

Method: The test schematic is shown in Figure 20. The production configuration was called Configuration 1 and included a jet pump (ejector) in the pump inlet basket. Figure 21 shows the actual setup.

The Configuration 2 test setup (Figure 22) was the same as for Configuration 1 except the inlet line ejector and the check valve (P/N 2680355M1) located upstream of the sampling point were removed. The same test procedure was used for both configurations.

**TABLE 4
GRAVITY TRANSFER VALVE TEST**

<u>Fuel</u>	<u>Boost Pump Pressure (psi)</u>	<u>Flow Rate (GPM)</u>	<u>Head (In)</u>	<u>Filter Ratio (at 22 °C)</u>	<u>ICI Cup Test at 22 °C (ml)</u>	<u>FCTA Results (At S.C. 250, 95 psi)</u>
Virgin AMK				7.5	7.4	130 °C
<u>Makeup Flow</u>						
Jet-A	29.0	3.1				
AMK	29.0	3.1		5.7	7.2	125 °C
<u>Gravity Flow</u>						
Jet-A		19.8	10			
AMK		15.0	10	17.2	3.8	40 °C
*AMK-Degraded		18.0	10			

* Virgin AMK was passed through the boost pump and gravity transfer system once.
Shutoff times for the gravity flow were the same for all cases, less than 1 sec.

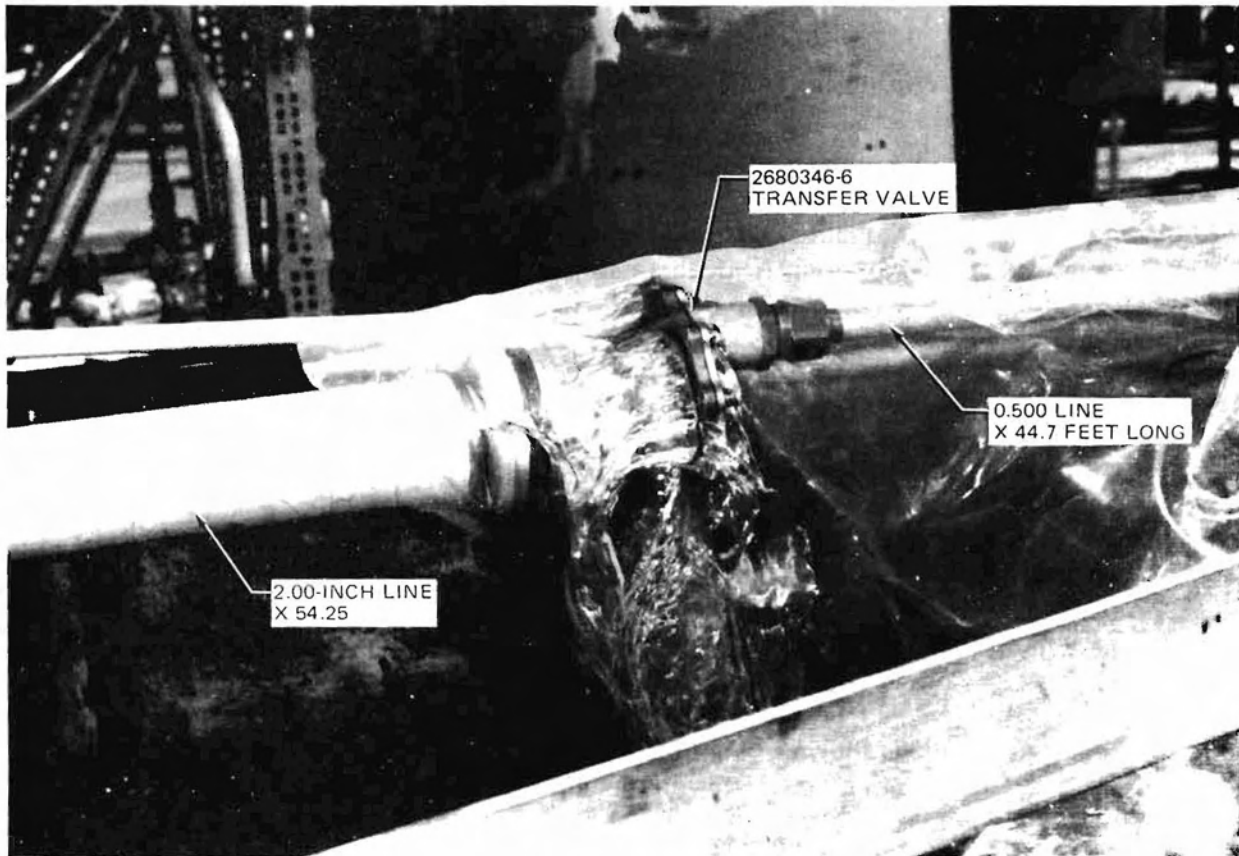
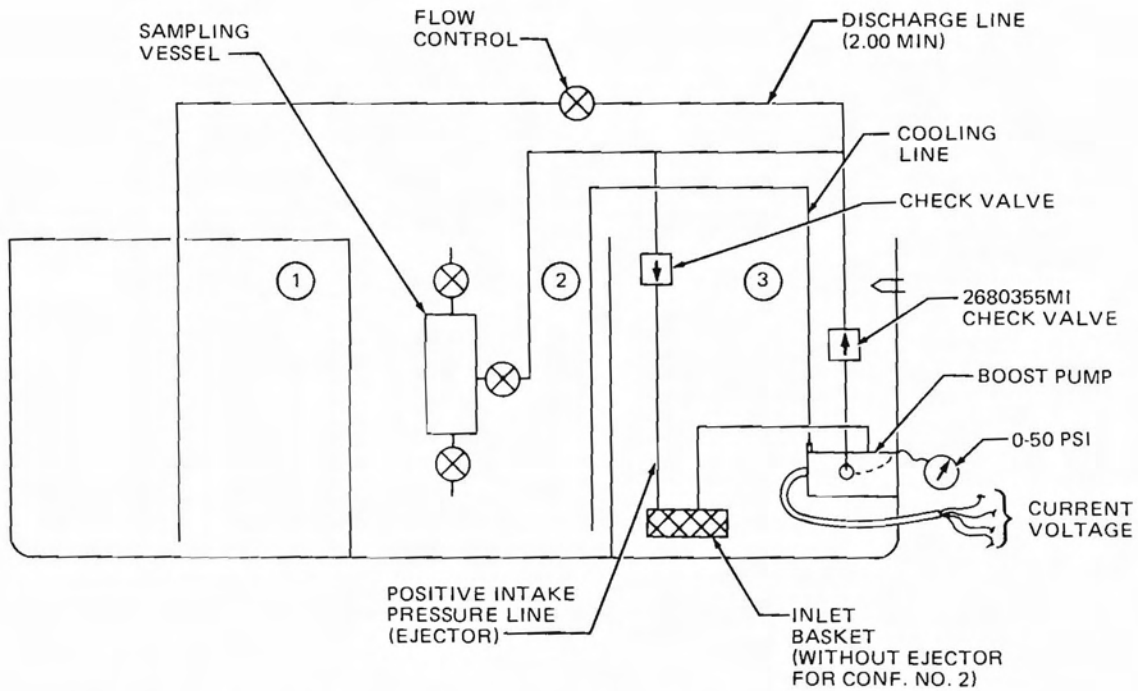

FIGURE 19. GRAVITY TRANSFER VALVE, GRAVITY FLOW



- NOTE 1. THE INLET JET PUMP LINE AND INLET BASKET ARE AN ASSEMBLED PART
2. ○ COMPARTMENT NUMBER

FIGURE 20. AMK DEGRADATION VERSUS BOOST PUMP FLOW SCHEMATIC

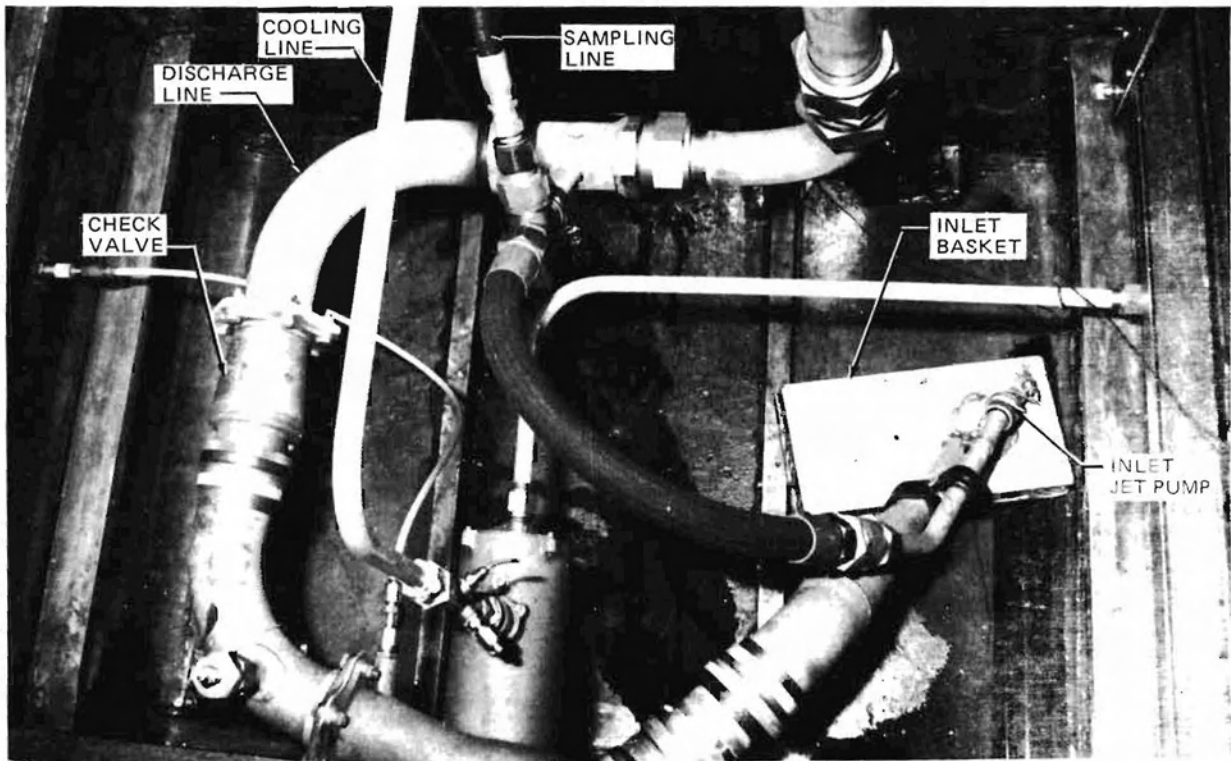

FIGURE 21. CONFIGURATION 1, BOOST PUMP TEST

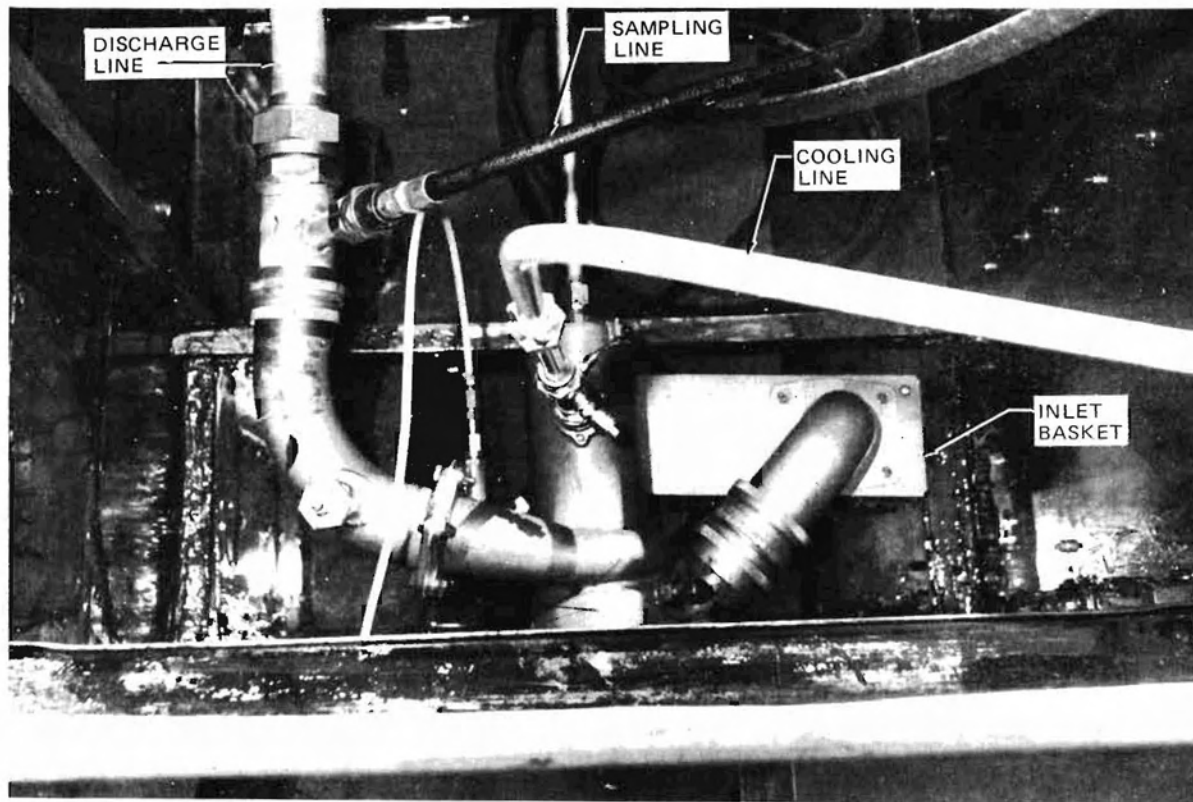

FIGURE 22. CONFIGURATION 2, BOOST PUMP TEST

The system was operated at six different flow rates by opening the flow control valve to each of six preselected positions. At each flow condition, the flow rate, boost pump discharge pressure, current, voltage, and fuel temperature were recorded.

Fuels used were Jet A (baseline), AMK from a 12,000-gallon storage tank (4 months old, virgin AMK), and newly blended AMK air freighted in drums especially for this test to reduce degradation in transit.

Samples were taken at each flow point. Virgin AMK samples were taken at the start of each test.

Data and Results: The AMK from the 12,000-gallon tank was delivered by tanker truck in two shipments*. The first shipment had a base fuel lot number of RMH11106. (The fuel lots were identified by base fuel number and not by batch number.) The second shipment of AMK had a base fuel lot number of RMH11118. Both shipments were stored in one tank, but were not force mixed.

The fuel quality check upon arrival for virgin AMK with base fuel lot number RMH11106 showed: filter ratio (FR) of 71-61 at 19°C; ICI Cup, 3.1 ml at 19°C; FTCA: 51.9°C, 99 psi, SC 250; and the fuel was clear. For the virgin AMK with base fuel lot No. RMH11118, the fuel qualities were: FR, 52 at 20°C; ICI Cup, 3.2 at 21°C; FCTA, 15.7°C, 97 psi, SC 250; and fuel clarity was clear.

*Properties of AMK fuel shipped from ICI, Americas fell within the following ranges: Filter Ratio — 40 minimum, 70 maximum; ICI Cup (ml) — 2.5 minimum, 3.0 maximum. FCTA temperatures on newly mixed AMK (IME 9) meeting the above qualities are reported by JPL to be in the range of 10°C to 50°C, with SC 200 and 90 to 95 psi pressure.

The same fuels were used for the engine feed system and flight cycle tests. In addition, the newly blended AMK, RMH1-230 and 231, was used in these tests. No quality check was made of the fuel upon arrival. This newly blended fuel was tested the next day so data from the virgin sample constituted a quality check.

The boost pump performance curves for Configuration 1 are plotted in Figure 23.

The test results are presented in Table 5. The boost pump has a three-phase motor. The current and voltage data are from one of those phases. Where more than one figure appears, the initial steady state, and the maximum and the minimum currents recorded, are shown with corresponding voltages.

The fuel quality data are shown in Figures 24, 25, and 26. Discussion of the data and results may be found in the next section. It should be noted that two virgin samples were taken for the AMK that was newly blended. The first three flow points were made with a mixture of RMH1-230 and RMH1-231. The last three flow rate (75.9, 99.2, and 109 gpm) runs were made with fuel from batch RMH1-230.

For Configuration 2 the boost pump performance curves are shown in Figure 27. Only two flow points were tested for the newly blended AMK due to the small amount of fuel left over from the Configuration 1 testing.

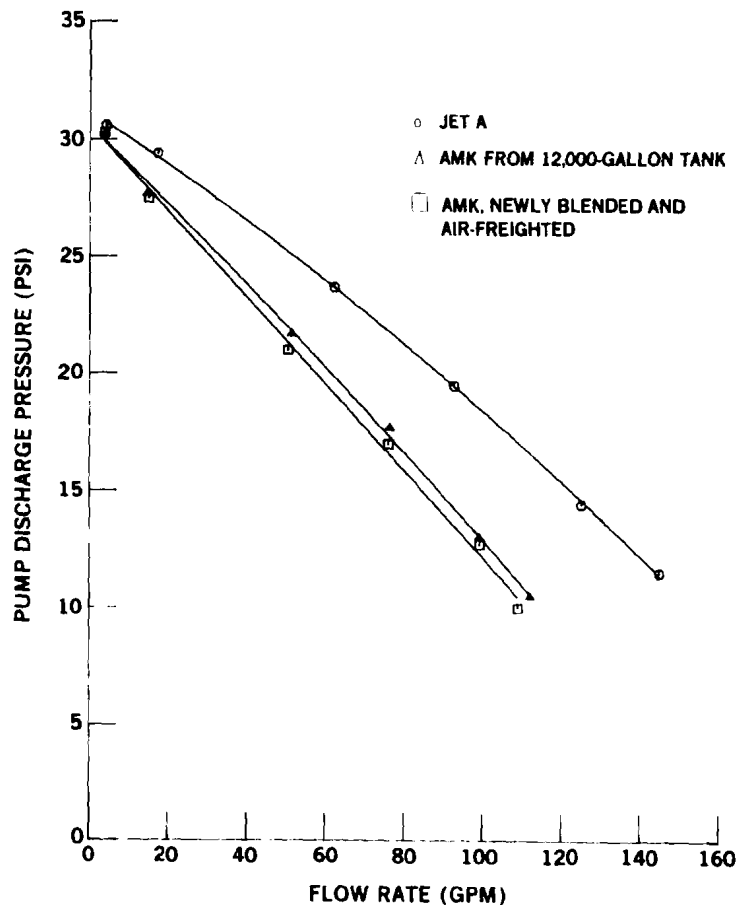

FIGURE 23. BOOST PUMP PERFORMANCE, CONFIGURATION 1.

TABLE 5
BOOST PUMP PERFORMANCE, CONFIGURATION NO. 1

FLOW CONTROL VALVE POSITION	TEST FUEL	FLOW RATE (GPM)	BOOST PUMP PARAMETER		
			DISCHARGE PRESSURE (PSI)	CURRENT (A)	VOLTAGE (V)
1	Jet-A	4.2	30.6	8.7	108.4
	12K-AMK	4.0	30.3	9.1-8.7	108.8-108.4
	AMK	3.7	30.3	9.7-8.7	108.8-109.2
2	Jet-A	17.3	29.4	9.2	108.5
	12K-AMK	14.7	27.7	9.6-9.3	108.8-108.8
	AMK	15.0	27.5	9.5-9.1	108.0-108.4
3	Jet-A	62.3	23.7	10.1	108.3
	12K-AMK	51.3	21.7	10.7-10.4	107.5-107.5
	AMK	50.4	21.0	10.9-10.5	108.0-108.0
4	Jet-A	92.7	19.5	10.9	108.0
	12K-AMK	76.2	17.7	11.3-10.9	108.0-108.0
	AMK	75.9	17.0	11.4-10.8	107.5-107.5
5	Jet-A	125	14.4	11.3	108.2
	12K-AMK	98.9	13.0	11.7-11.5	108.0-108.0
	AMK	99.2	12.7	12.6-11.5	107.5-107.5
6	Jet-A	145	11.5	11.1	107.6
	12K-AMK	112	10.5	12.9-11.7	107.5-108.4
	AMK	109	10.0	12.9-13.1-11.8	107.1-107.1-107.5

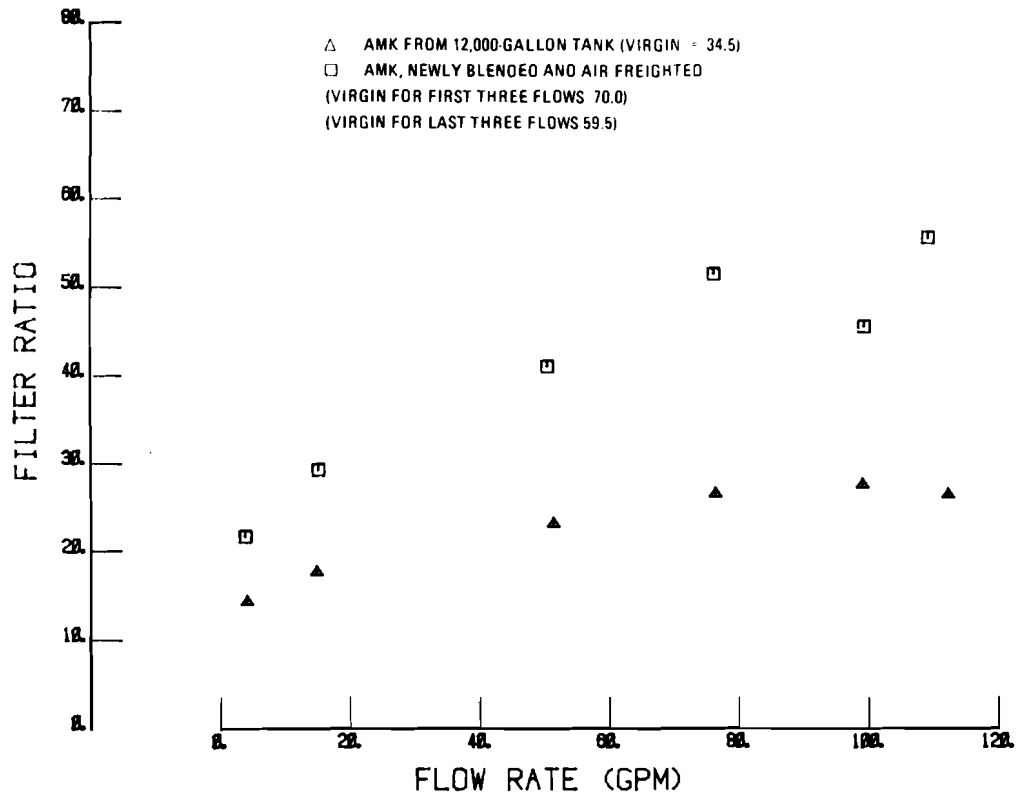

FIGURE 24. FILTER RATIO, CONFIGURATION 1

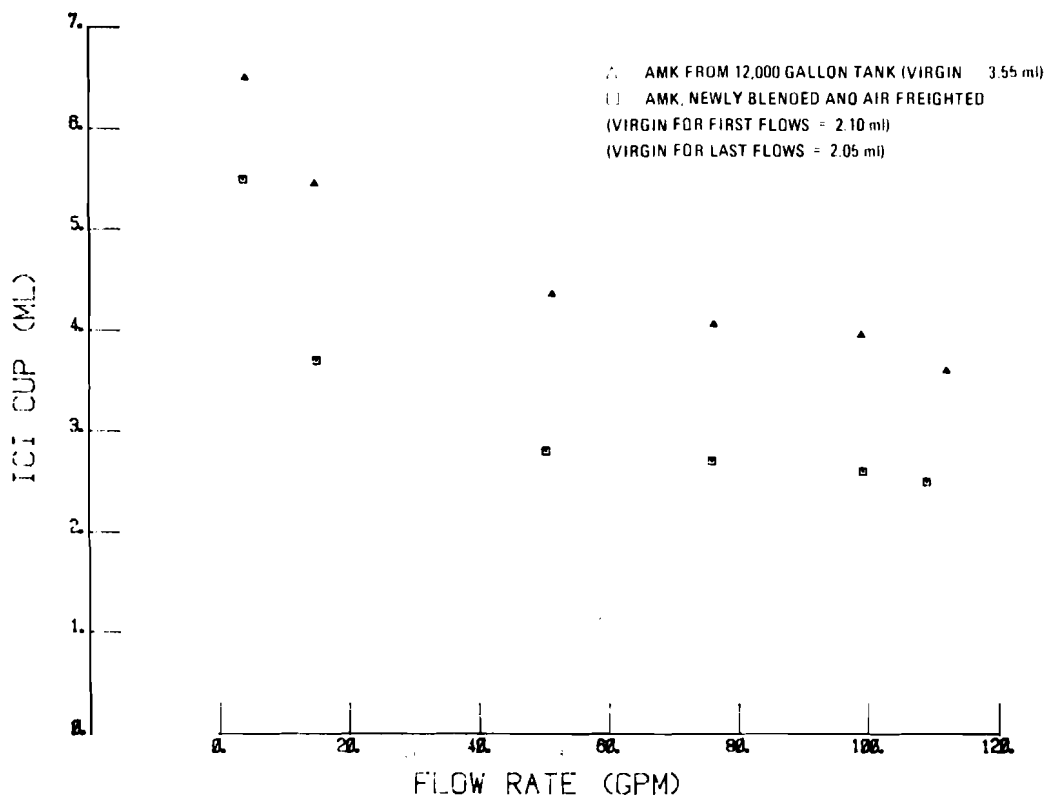

FIGURE 25. ICI CUP TEST, CONFIGURATION 1

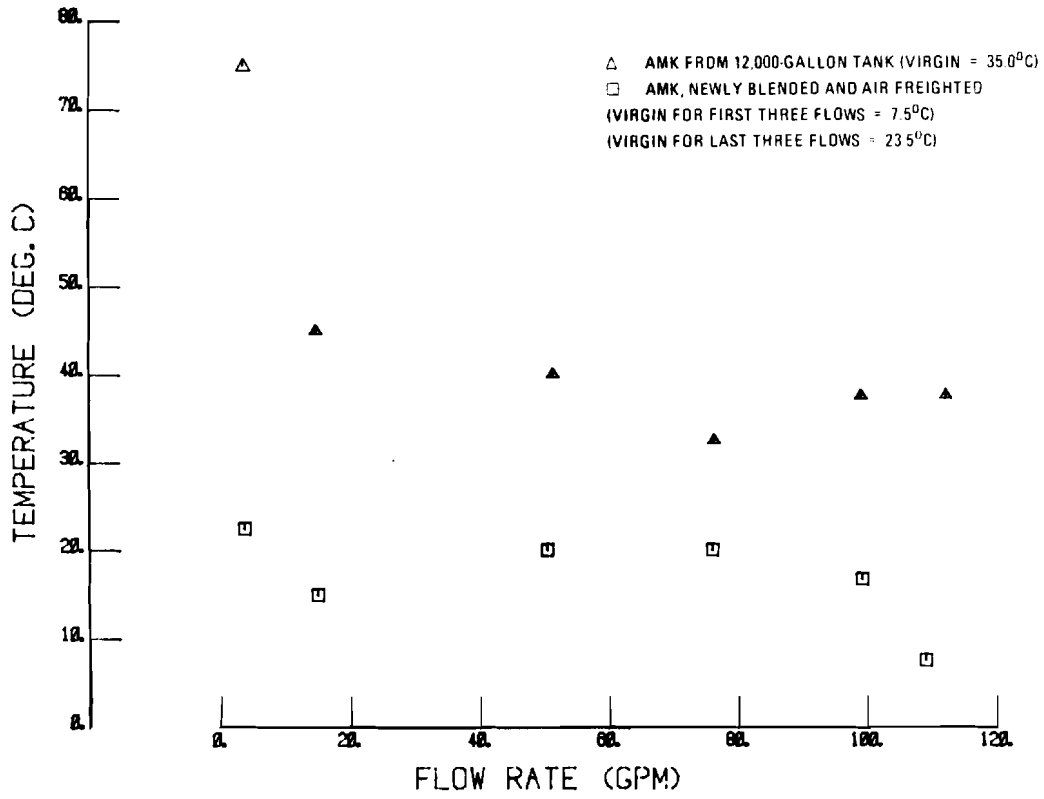

FIGURE 26. FCTA TEMPERATURE, CONFIGURATION 1

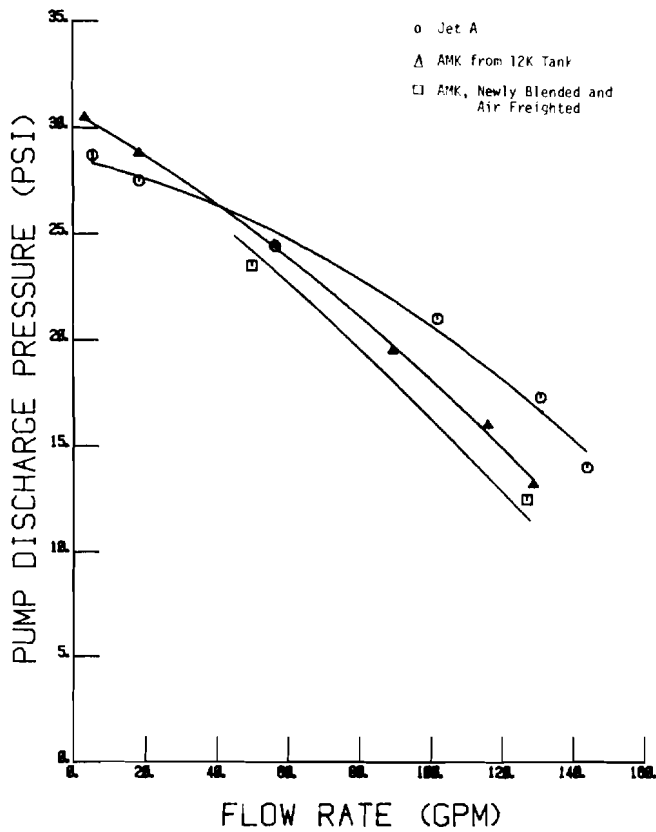

FIGURE 27. BOOST PUMP PERFORMANCE, CONFIGURATION 2

The test results are listed in Table 6. Fuel quality data for the AMK from the 12,000-gallon storage tank are plotted in Figure 28. The fuel quality data for the newly blended AMK are listed in Table 7.

WATER TEST

Purpose: This test was conducted to examine the effects of water concentration on the antimisting quality and physical appearance of the AMK. The AMK was conditioned by adding water to get a total dissolved water content in the range of 250 to 300 ppm.

**TABLE 6
BOOST PUMP PERFORMANCE, CONFIGURATION NO. 2**

FLOW CONTROL VALVE POSITION	TEST FUEL	FLOW RATE (GPM)	BOOST PUMP PARAMETERS		
			DISCHARGE PRESSURE (PSI)	CURRENT (A)	VOLTAGE (V)
1	Jet-A	5.5	28.7	8.9	109.0
	12K-AMK	3.3	30.5	9.3-9.6-9.1	110.0-109.6-109.2
2	Jet-A	18.5	27.5	8.9	109.0
	12K-AMK	18.5	28.8	9.1-8.8	108.8-108.8
3	Jet-A	56.6	24.4	9.7	108.7
	12K-AMK	56.3	24.5	10.7-10.1	108.0-107.6
	AMK	50.0	23.5	10.5-10.2	108.4-108.0
4	Jet-A	102	21.0	10.5	108.5
	12K-AMK	89.4	19.5	11.3-10.8	108.0-108.0
5	Jet-A	131	17.3	11.1	108.4
	12K-AMK	116	16.0	12.2-11.6	107.6-107.6
6	Jet-A	144	14.0	11.1	108.4
	12K-AMK	129	13.2	12.2-11.7	108.0-108.0
	AMK	127	12.5	12.7-11.7	108.4-108.0

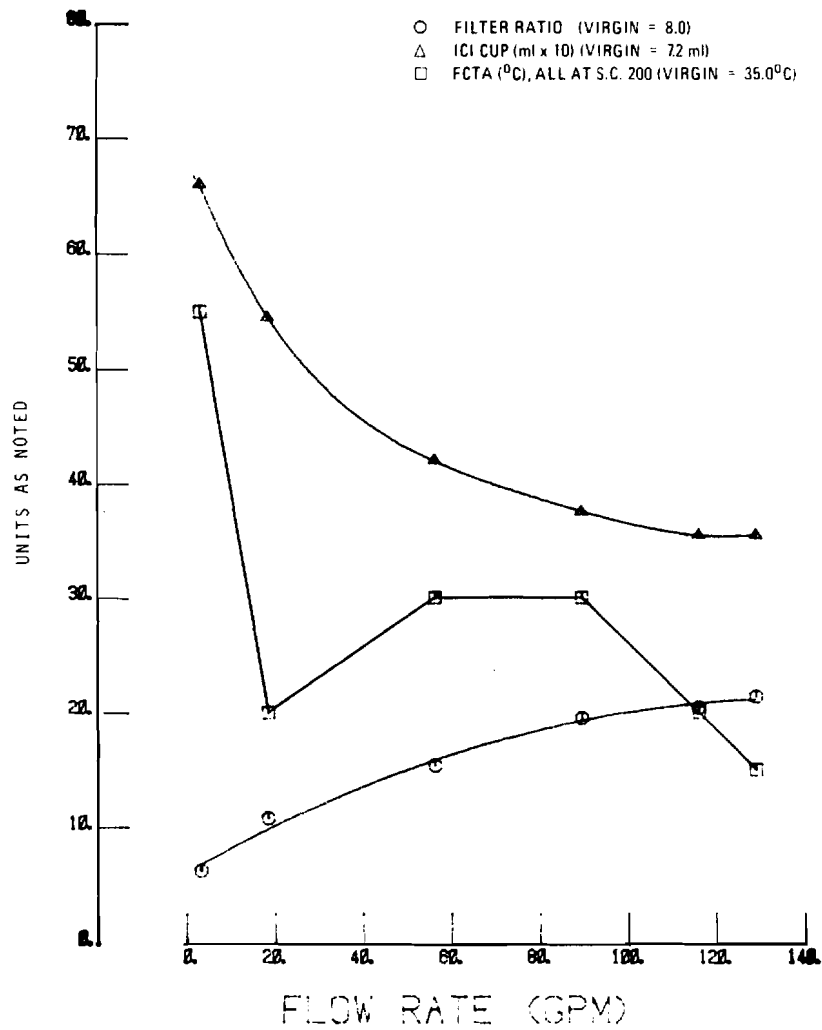

FIGURE 28. 12K AMK FUEL QUALITY, CONFIGURATION 2

TABLE 7
AMK FUEL QUALITY, CONFIGURATION NO. 2

<u>AMK SAMPLE</u>	<u>FILTER RATIO</u>	<u>ICI CUP TEST</u>	<u>FCTA RESULTS</u> <u>(S.C.200)</u>
VIRGIN	53.7 at 20.0 °C	2.15 at 20.0 °C	10 °C, 93 psi
AT 50 GPM	40.7 at 20.0 °C	2.75 at 20.0 °C	15 °C, 95 psi
AT 127 GPM	41.6 at 21.5 °C	2.50 at 19.0 °C	10 °C, 95 psi

Method: The test schematic is shown in Figure 29. The water had to be properly introduced before the test could be run. To add the water, a "steam box" method was developed by Jet Propulsion Laboratory (JPL) to make liquid-water-free steam available to the AMK surface (Figure 30).

The water was introduced to the AMK by steam condensation. Steam flowed through Port A. Port B was used to inject dry air into the steam box to move the steam over the AMK (Figure 31) and to speed up the contact of the water vapor with the fuel. Port C was the drain for any condensed water. A transparent cover was placed over the tank while the water was added. A wispy white surface film formed where the water condensed on the AMK surface. A low-speed stirrer was turned on to concentrate the surface film into a vortex, mixing the water into the the AMK. Samples were taken periodically to check the level of water in the AMK. The water content measurement was done by Karl Fischer titration.

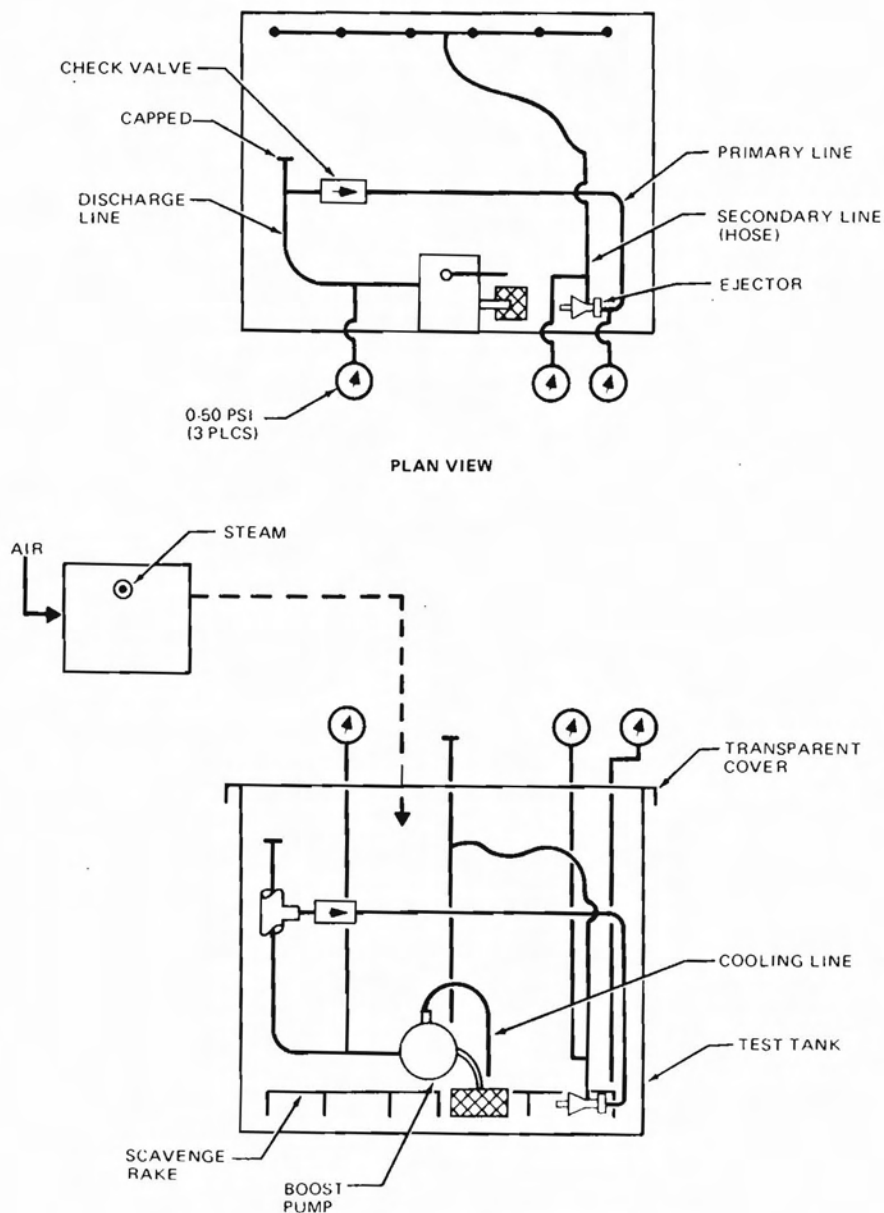

FIGURE 29. WATER TEST SCHEMATIC

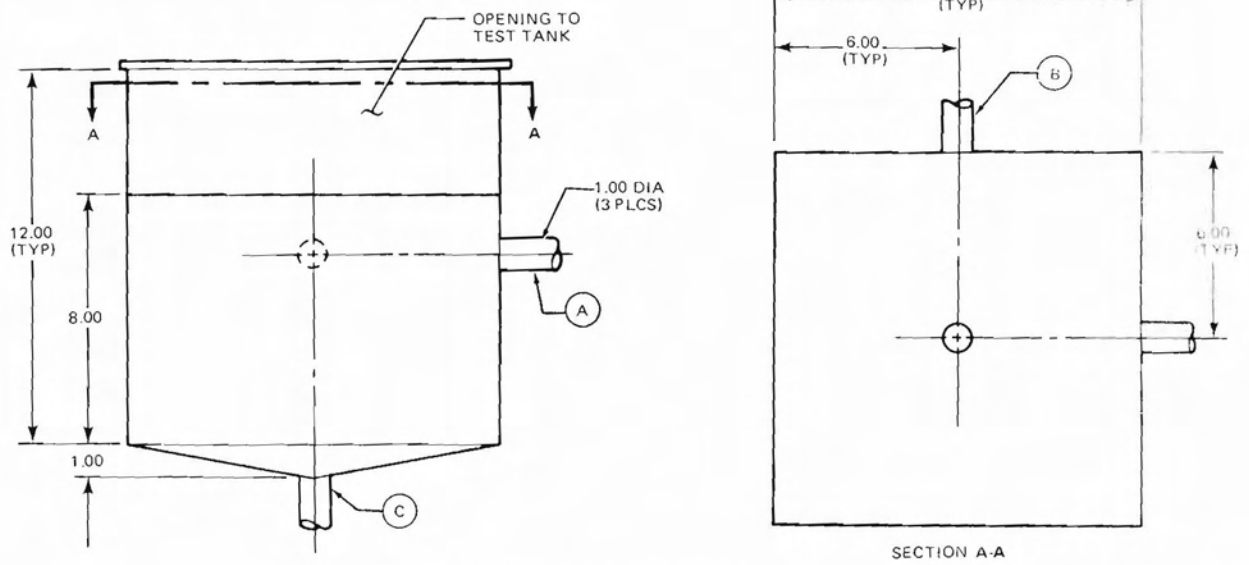

FIGURE 30. STEAM BOX, WATER TEST

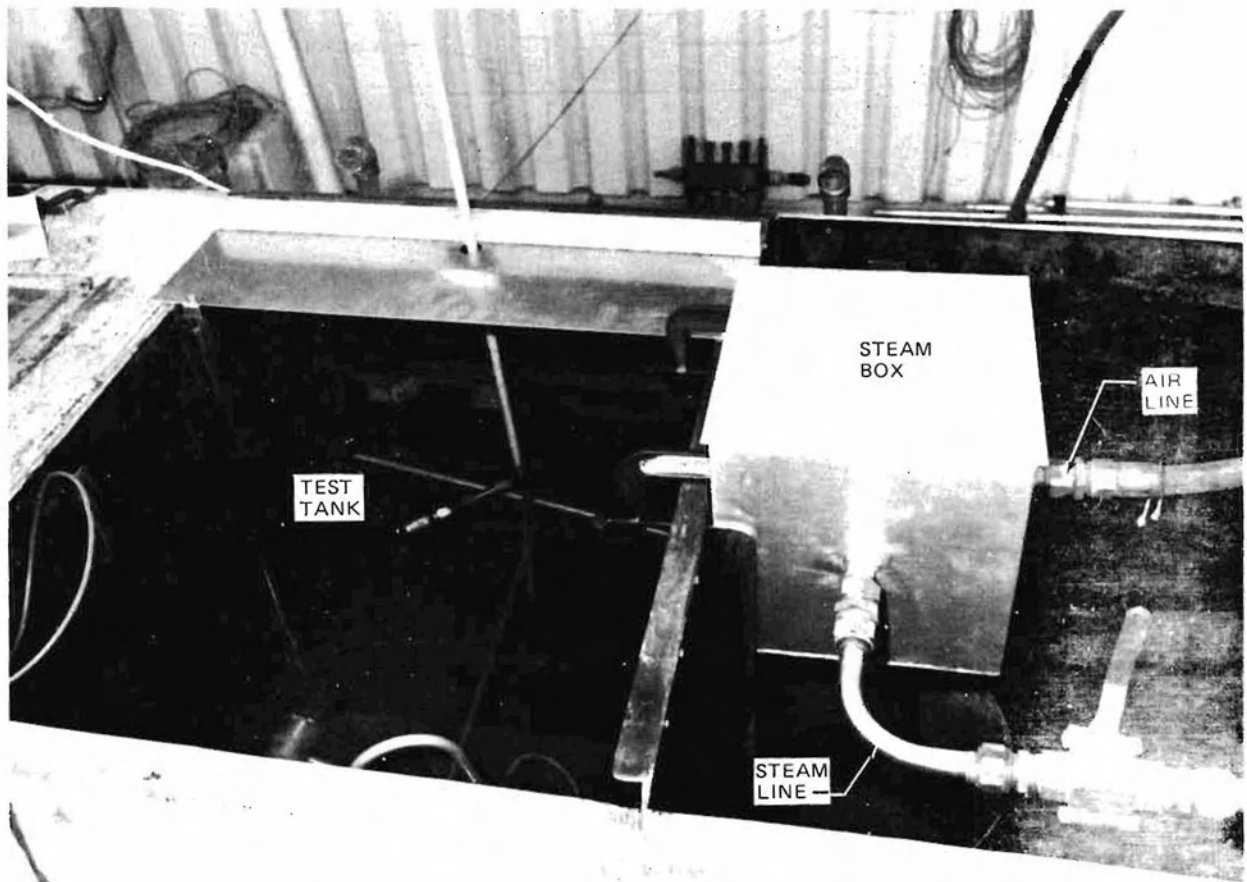

FIGURE 31. TEST TANK AND STEAM BOX, WATER TEST

Once the desired level of water content was obtained, the boost pump was turned on and the system run for a total of 5 hours, recirculating the fuel. The boost pump discharge pressure, jet pump primary and secondary pressures, and fuel temperature were recorded. Samples were taken throughout the run. The fuel appearance was noted periodically. After the fifth hour, the scavenge rake was positioned above the fuel level to take in the surrounding air. The system was turned back on to run for another 30 minutes. Fuel appearance was monitored.

The final run was made with the rake located in an adjoining tank which was flooded with steam, i.e., the secondary pickup was taking in steam and the jet pump was pumping the steam through the fuel.

The system ran for 50 minutes and a final fuel sample was taken.

Data and Results: The test results and fuel quality data are shown in Table 8.

The AMK used was RMH1-151. The fuel qualities before shipment were: ICI Cup, 2.60 ml; fuel, clear.

Though an initial fuel quality check was not made upon arrival (this was part of the first fuel delivery), a shelf-life check was made. Shelf-life data were taken due to the rescheduling of the water test to later in the program (requested by JPL and the FAA).

**TABLE 8
WATER TEST**

TIME	BOOST PUMP (PSI)	EJECTOR PRIMARY (PSI)	PARAMETERS SECONDARY (PSI)	FUEL TEMP (°F)	H ₂ O CONTENT (PPM)	F.P. (AT 20 °C)	ICI CUP (ML)	FCTA RESULTS AT 93 PSI
VIRGIN AMK BEFORE WATER ADDITION					149	32.4	3.0	69.2 °C S.C. 900
12:00 PM	30.0	29.5	-0.80	60.0	280	60.0	2.8	56.0 °C S.C. 900
12:30	29.5	28.5	-0.75					
1:00	29.0	28.3	-1.00					
1:30	28.8	27.8	-1.10					
2:00	28.5	27.4	-1.10			1.44	7.35	269.2 °C S.C. 250
2:30	28.2	27.4	-1.05	107.0				
3:00	28.0	27.3	-1.00					
3:30	28.0	27.3	-1.00	117.0				
4:00	28.0	27.0	-1.00	122.8	121	1.13	7.35	203.6 °C S.C. 250
4:30	28.0	26.9	-1.00					
8:25 AM	30.0	28.2	-1.25	53.2	71			
9:10				70.0				
STOP, POSITION RAKE ABOVE FUEL SURFACE								
10:30	29.0	27.5	-0.30	68.0				
11:00				83.5	72			
STOP, POSITION RAKE TO TAKE IN STEAM								
11:00	28.0	27.0	-.20	83.5				
11:30				103.0				
11:50				105.0	147	1.21	7.40	297.9 °C S.C. 250

A shelf-life sample was taken before the test. Fuel quality data were FR of 32 at 20.5°C and ICI Cup of 3.0 at 21.0°C; FCTA data were 32.3°C, 94 psi, SC 250, and fuel clarity, clear.

From visual inspection, no gross observable changes of the AMK were seen.

A milky haze was slightly thicker at 280 ppm total water content than when water addition was started. Originally, the water content was 149 ppm.

Water was added over a period of about 1 hour with several stops and inspections. The fuel was first stirred after a slight film of water became apparent on the surface. The stirrer was run continuously during subsequent water addition.

Drops of water collected on the plastic film covering the tank and dropped into the quiescent fuel. The fuel turned white locally and then dispersed as the water apparently spread out into the fuel. This happened within 1 minute. Drops of water were immediately dispersed when impinging on the moving fuel surface during stirring.

The boost pump was then started and allowed to drive the scavenge jet pump for a period of 4-1/2 hours. The boost pump electrical power and the jet pump performance held essentially constant for the total operating time. The fuel temperature increased from approximately 60°F to 123°F (this had a slight long-term effect on boost pump and jet pump pressures). The water content dropped to 121 ppm during the test.

The water content was found to be 71 ppm at 8:30 a.m. the next morning. The test was continued 1/2 hour more with no change in performance.

The system was then operated for an additional 30 minutes with the jet pump rake in the air above the surface of the fuel. This resulted in a great amount of air being mixed up in the fuel. From observation, the physical integrity of the AMK was not compromised; i.e., no gel or white precipitate formed. The effluent of the scavenge jet pump was a mixture of AMK and small air bubbles. The fuel cleaned up in approximately 1 minute after the rake was placed back in the fuel.

The system was then operated for 50 more minutes with the rake surrounded with steam. There was no indication of visible water in the fuel during this portion of the test. The fuel water content increased to 147 ppm during this additional 50 minutes.

Upon completion of the test, the boost pump was removed and examined. No water contamination or gel formation were found.

SYSTEM TESTS

Fill System Test

Purpose: Under this test, fueling simulations were conducted using the DC-10/KC-10 production system with test tanks attached. Fueling rates with one and two nozzles in use were measured. Operation of all functions, including precheck of high-level shutoff and intermediate-level fill termination at high and low nozzle pressures, were determined.

Method: The test rig is shown in Figure 32. The heavy lines represent the fuel tank boundaries.

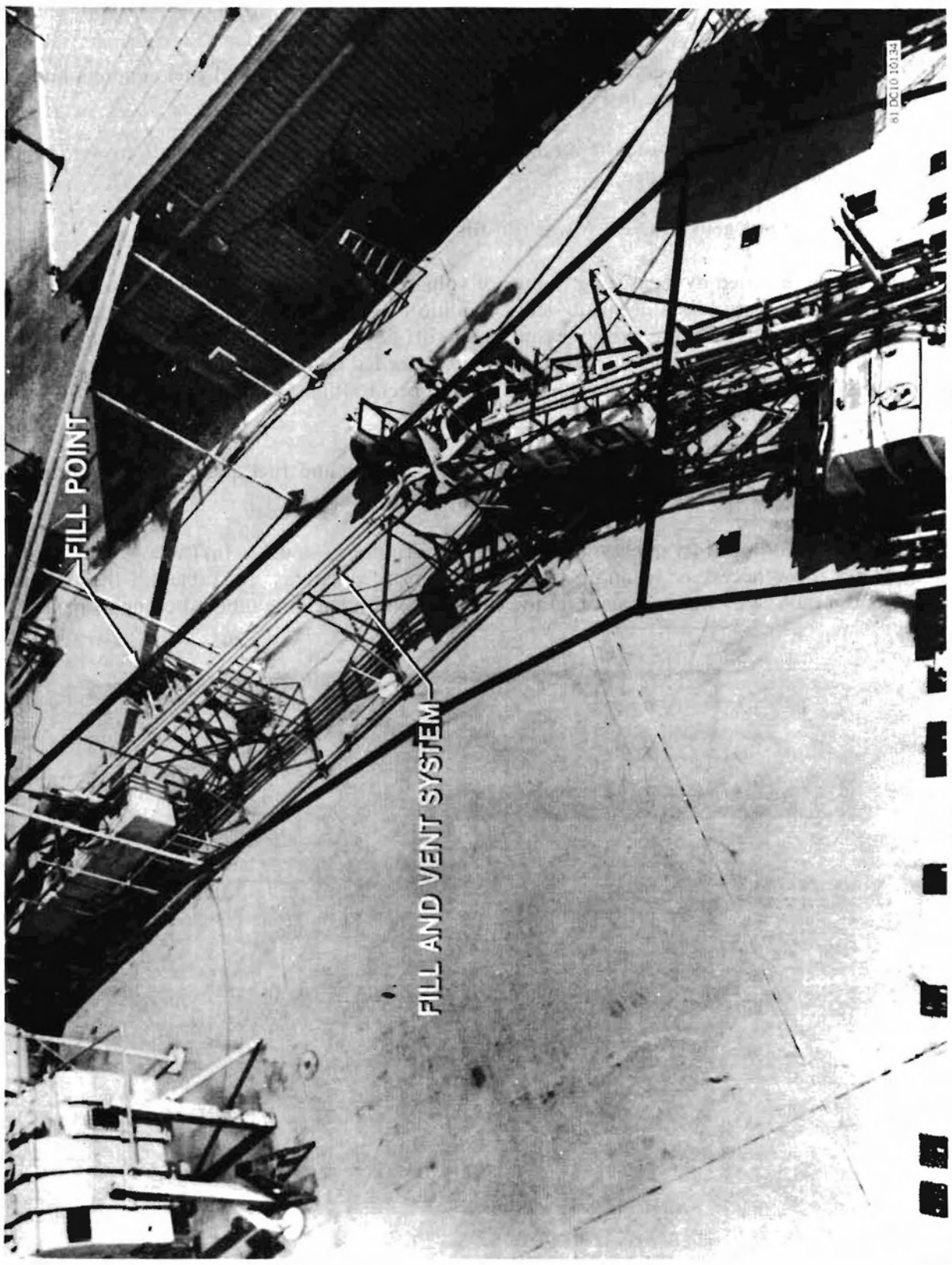

FIGURE 32. FILL AND VENT SIMULATION, PLAN VIEW

Because special handling of the AMK was required to prevent degradation, a supply tank (Figure 33) that could withstand high pressure was used to replace the normal pumped supply refueling procedure.

A 3-inch line connected the supply tank to the fuel nozzles. The left hand fuel adapters and the attached fuel nozzles are shown in Figures 34 and 35, respectively.

The fuel nozzle was opened before the supply tank was pressurized. Fueling simulations were begun by signaling the fill valves to open.

Table 9 shows the test activities. Jet A was run first as a baseline.

Flow rates were recorded by measuring change of volume (V) with respect to change of time (t). All flow rate data were taken at steady state conditions. Overshoot volumes, i.e. volume flow-through during fill valve closure, were measured. Shutoff times — the time it takes for the fill valve to close after the electrical or pressure signal — were recorded on oscillographs. Surge pressure — the peak pressure measured at the fill valve inlet with respect to fill pressure (fill valve closed) — was measured.

Data and Results: System performance is plotted in Figure 36 and fuel quality data are listed in Table 10. Note that Table 10 data are from Configurations 1 and 4.

Complete test result and fuel quality data are given in Tables 11 and 12. In Table 11, the supply pressures are those necessary to attain the required nozzle pressures. In Table 12, the tip tank represents the outboard compartment and the catch tank simulates the inboard compartment.

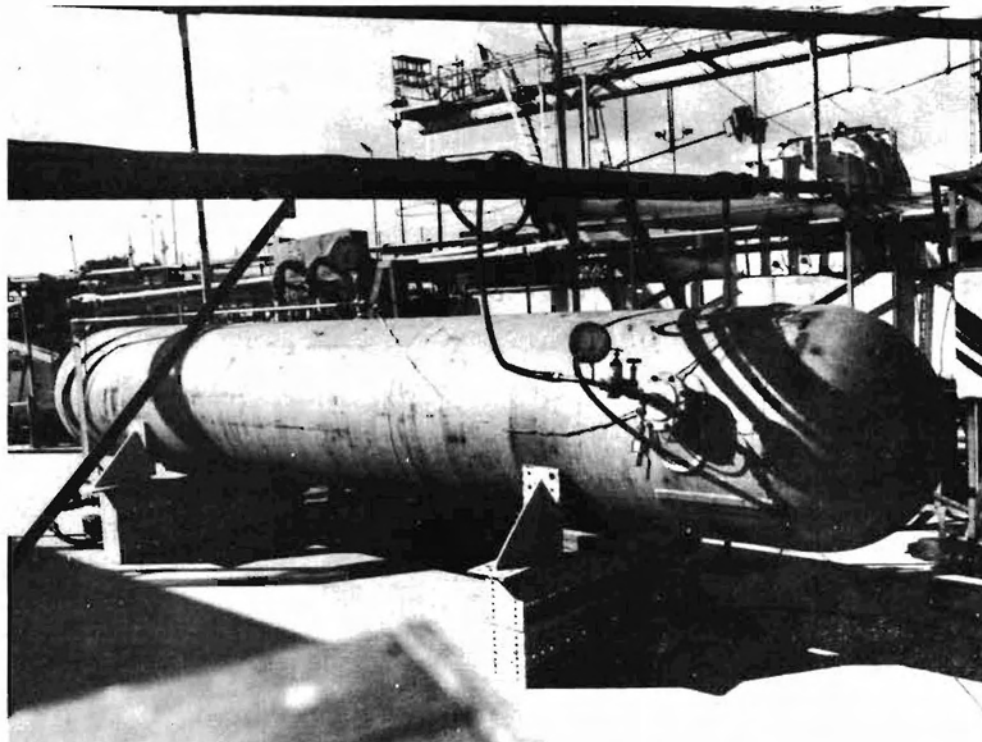

FIGURE 33. 2300 GALLON SUPPLY TANK

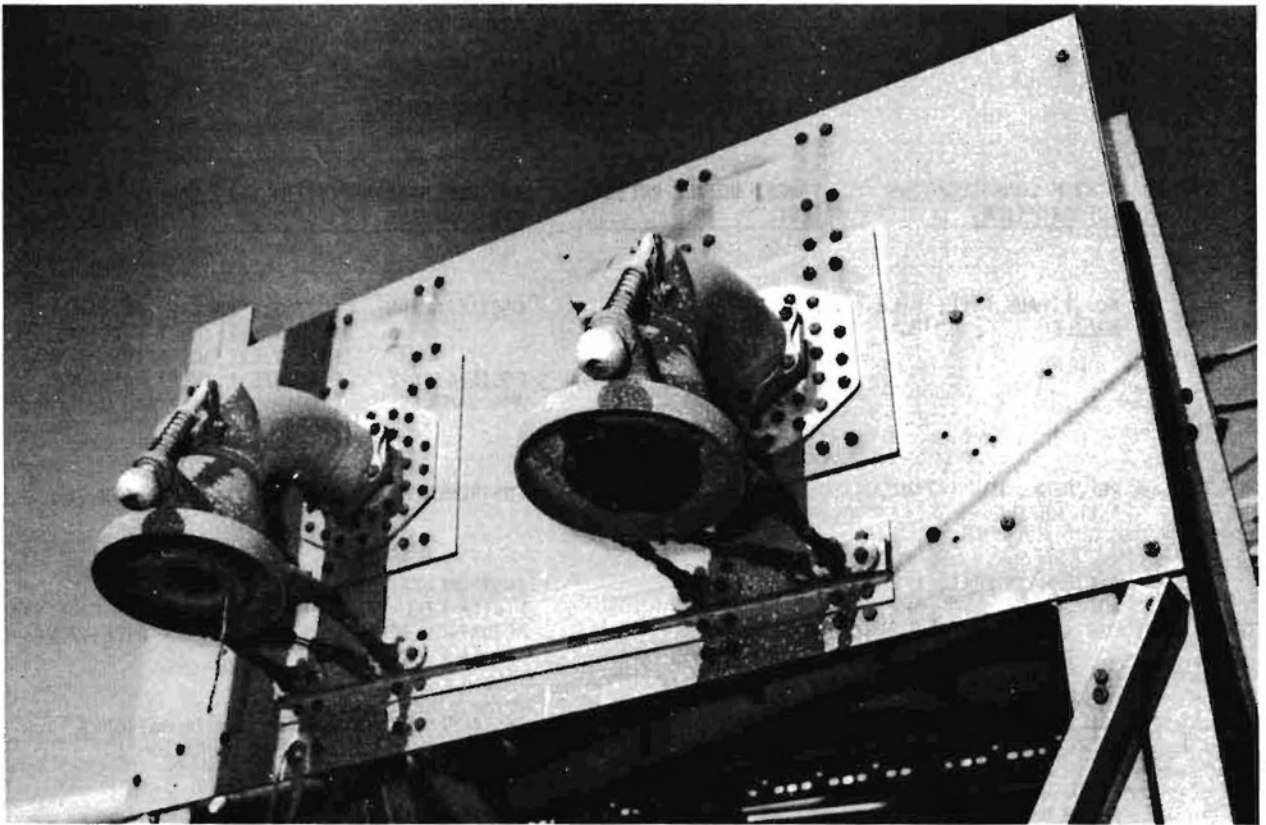

FIGURE 34. FUELING AND DEFUELING ADAPTERS

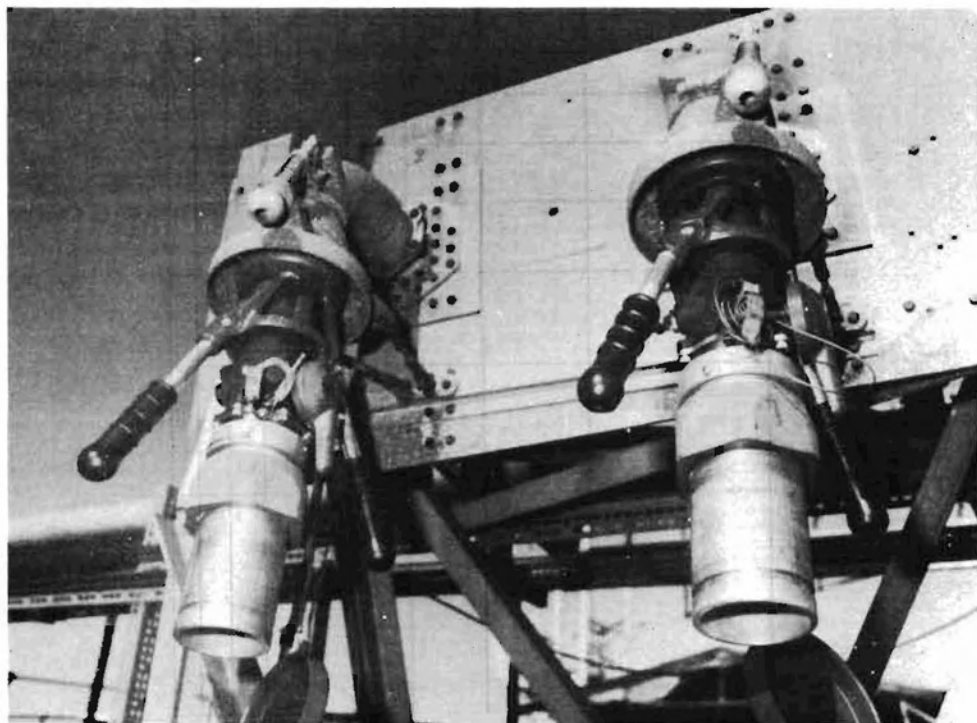

FIGURE 35. ADAPTERS AND FUEL NOZZLE ASSEMBLIES

**TABLE 9
TEST RUNS AND CONFIGURATIONS**

<u>CONF. NO.</u>	<u>SYSTEM CONFIGURATION (DESCRIPTION)</u>	<u>TARGET NOZZLE PRESS. (PSI)</u>	<u>INSTRUMENTATION (EVENT - E) AND SAMPLING</u>
1.	NO. 1 TANK FILL, 1 LH NOZZLE	35	OSCILLOGRAPH: NOZZLE PRESSURE FILL VALVE INLET PRESSURE FILL VALVE ACTUATION SIGNAL (E) OSCILLOSCOPE: FILL VALVE INLET PRESSURE AMK SAMPLES: VIRGIN, INBOARD AND OUTBOARD COMPARTMENTS.
2.	PRECHECK, NO. 1 TANK, 1 LH NOZZLE	35	INSTRUMENTATION SAME AS CONFIGURATION 1.
3.	ALL 3 MAIN FILL, 1 LH NOZZLE	35	INSTRUMENTATION SAME AS CONFIGURATION 1 WITH FILL VALVE INLET PRESSURE AND FILL VALVE ACTUATION RECORDED FOR EACH TANK FILL VALVE. AMK SAMPLES: VIRGIN
4.	ALL 3 MAIN FILL, 1 LH NOZZLE	20	INSTRUMENTATION SAME AS CONFIGURATION 3. AMK SAMPLES: SAME AS CONFIGURATION 1.
5.	ALL 3 MAIN FILL, 2 LH NOZZLES	35	INSTRUMENTATION SAME AS CONFIGURATION 3. AMK SAMPLES: SAME AS CONFIGURATION 4.

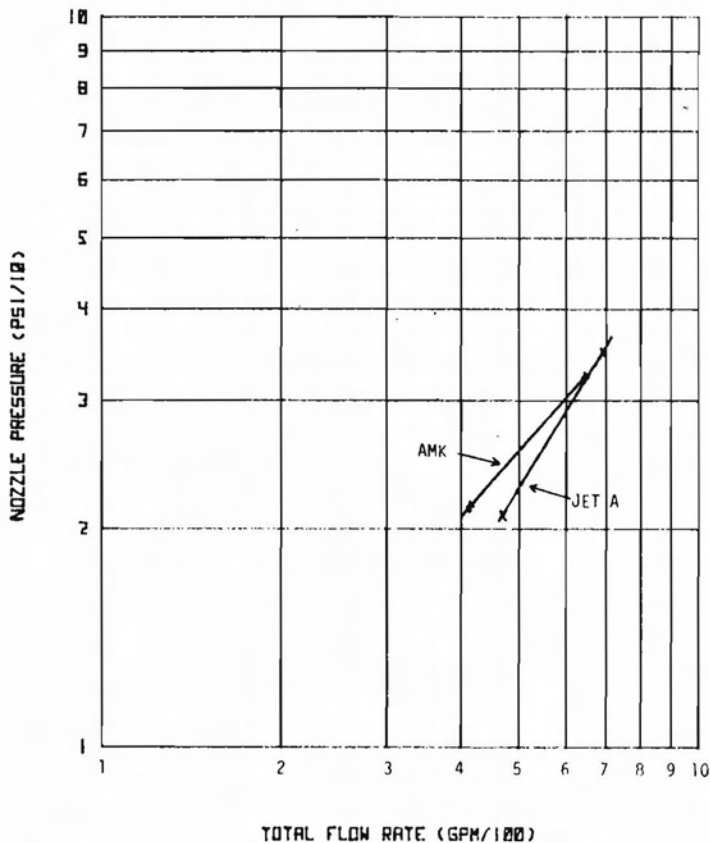
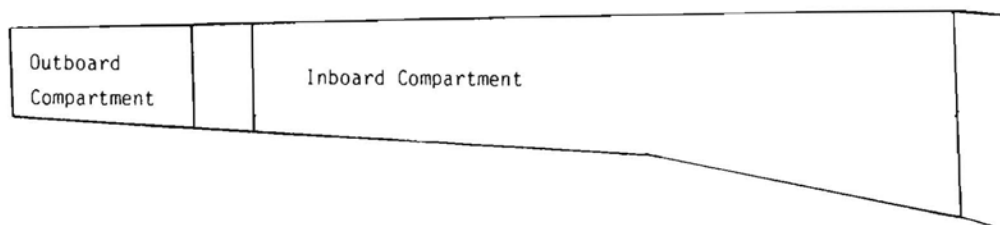

FIGURE 36. DC-10 FILL SYSTEM PERFORMANCE, SINGLE NOZZLE FILLING NO. 1 TANK

**TABLE 10
FUEL QUALITY FOR SINGLE NOZZLE FILL OF NO. 1 TANK**



	<u>Outboard Compartment</u>				<u>Inboard Compartment</u>		
	<u>Nozzle Press. (PSI)</u>	<u>F.R. (at 22°C)</u>	<u>ICI CUP at 22°C (ML)</u>	<u>FCTA (at 95 PSI, S.C. 250)</u>	<u>F.R. (at 22°C)</u>	<u>ICI CUP at 22°C (ML)</u>	<u>FCTA Results (at 95 PSI, S.C. 250)</u>
Virgin AMK	----	26.0	3.2	15	----	---	--
	37.0	18.1	4.0	10	17.0	4.2	10
Virgin AMK	----	20.0	3.6	10	----	---	--
	21.5	15.7	4.1	10	13.7	4.1	10

The AMK used, delivered in a three-compartment tanker truck, consisted of a mixture of 14 batches, RMH1-161 through 174.*

The fuel qualities upon arrival were:

- Compartment No. 1 — FR of 24.4 at 20°C and ICI Cup of 3.0 ml at 19.0°C; FCTA data were 79.2°C, 93 psi, SC 900, and fuel clarity, clear.
- Compartment No. 2 — FR of 27.8 at 20°C and ICI Cup of 2.7 ml at 19°C; FCTA data were 68°C, 92 psi, SC 900, and fuel clarity, clear.
- Compartment No. 3 — FR of 27.8 at 20°C and ICI Cup of 2.9 ml at 19°C; FCTA data were 71.2°C, 92 psi, SC 900, and fuel clarity, clear.

This bulk fuel delivery was used for both this test and the vent system tests.

During the AMK runs, the system acted sluggishly and system response deterioration was very noticeable. Gel was formed in the controller of the fill valve (Figures 37, 38, and 39). The gels were translucent globules that remained on the controller. The gels washed away with Jet A.

Vent System Test

Purpose: The test was conducted to determine the AMK effects on airplane fuel tank overfill pressure by performing overfill tests in increasing nozzle pressure increments.

*Properties of AMK fuel shipped from ICI, Americas fell within the following ranges: Filter Ratio — 40 minimum, 70 maximum, ICI Cup (ml) — 2.5 minimum, 3.0 maximum. FCTA temperatures on newly mixed AMK (FM-9) meeting the above qualities are reported by JPL to be in the range of 10°C to 50°C, with SC 200 and 90- to 95-psi pressure.

TABLE 11
FILL SYSTEM TEST

*Conf.	Fuel	Supply Press. (psi)	Nozzle Press.(N) (psi)		Fill Valve Press.(FV) (psi)			Surge Press.(PS) (psi)			Flow Rate(Q) (gpm)			Overshoot(ΔV) (gal)			Shutoff Time (sec)		
			N1	N2	FV1	FV2	FV3	PS1	PS2	PS3	Q1	Q2	Q3	$\Delta V1$	$\Delta V2$	$\Delta V3$	T1	T2	T3
1	Jet-A	48	35.0		22.9			4.0			379			22			5.3		
1	AMK	50	37.0		29.6			6.9			301			50			17.3		
2	Jet-A	48	35.5		23.1			6.0									9.4		
2	AMK	48	34.4		24.2			13.3									25.8		
3	Jet-A	80	34.9		15.9	14.1	10.4	3.6	9.5	14.3	237	230	225	17	12	15	5.7	4.1	4.7
3	AMK	80	32.3		14.3	13.0	10.0	8.8	2.1	4.0	190	248	207	40	10	30	15.1	10.1	11.4
4	Jet-A	40	20.9		11.0	11.1	10.5	.7	3.7	9.0	185	182	102	23	5	9	7.1	4.1	4.7
4	AMK	40	21.5		13.7	11.5	10.0	3.1	1.5	2.0	154	147	113	30	20	25	18.5	11.8	12.3
5	Jet-A	85	35.8	35.9	22.7	16.9	13.9	.5	6.8	12.7	270	373	263	16	5	24	5.7	3.7	4.9
5	AMK	85	31.6	32.7	21.0	16.5	13.7	6.3	.5	3.5	240	407	164	30	6	44	13.9	8.5	10.8

* See Table IX

** The number following the letters signifies the tank involved

**TABLE 12
FILL SYSTEM TEST, FUEL QUALITY**

<u>CONF.</u>	<u>TEST DATE</u>	<u>SAMPLE LOCATION (AMK)</u>	<u>JPL TEST DATE</u>	<u>FILTER RATIO AT 22 °C</u>	<u>ICI CUP TEST AT 22 °C (ml)</u>	<u>FCTA RESULTS* (°C)</u>
1	10-12-81	VIRGIN	10-29-81	26.0	3.2	15
1	10-12-81	TIP TANK	10-29-81	18.1	4.0	10
1	10-12-81	CATCH TANK	10-29-81	17.0	4.2	10
3	10-13-81	VIRGIN	10-29-81	18.5	3.5	15
4	10-13-81	VIRGIN	10-29-81	20.0	3.6	10
4	10-13-81	TIP TANK, LH	10-29-81	15.7	4.1	10
4	10-13-81	TIP TANK, RH	10-29-81	16.0	3.6	10
4	10-13-81	CATCH TANK, LH	10-29-81	13.7	4.1	10
4	10-13-81	CATCH TANK, RH	10-29-81	14.3	4.3	8
5	10-13-81	VIRGIN	10-29-81	19.3	3.5	20
5	10-13-81	TIP TANK, LH	10-29-81	13.4	4.5	10
5	10-13-81	TIP TANK, RH	10-29-81	13.6	4.0	15
5	10-13-81	CATCH TANK, LH	10-29-81	13.7	4.4	10
5	10-13-81	CATCH TANK, RH	10-29-81	16.2	4.1	10

*FCTA TESTS WERE DONE AT 95 PSI, S.C. 250

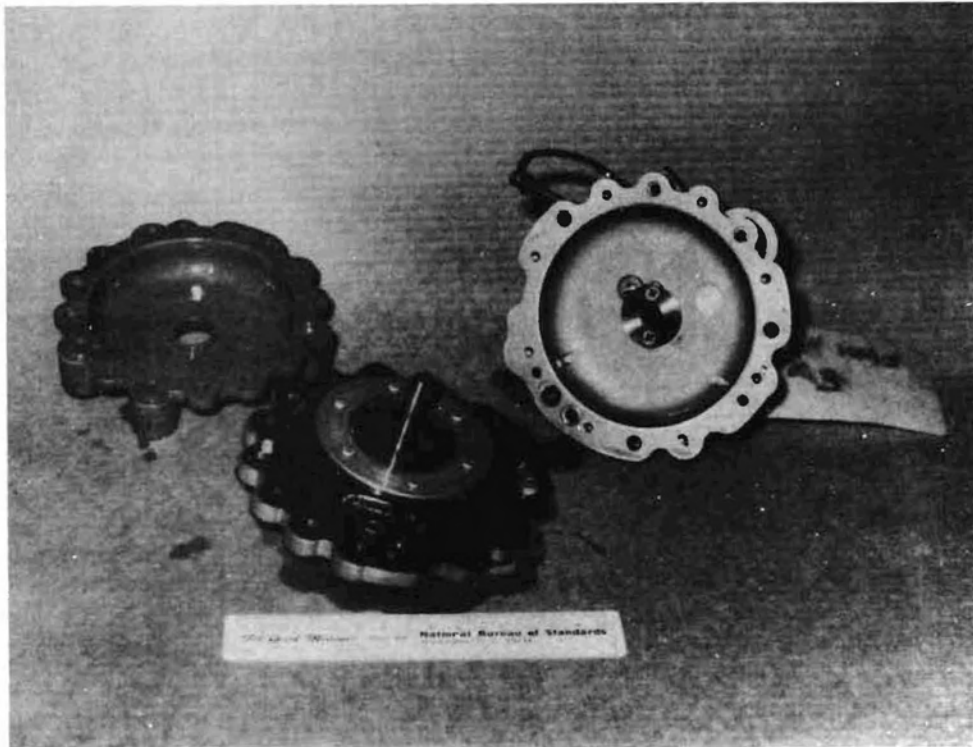

FIGURE 37. DISASSEMBLED FILL VALVE CONTROLLER

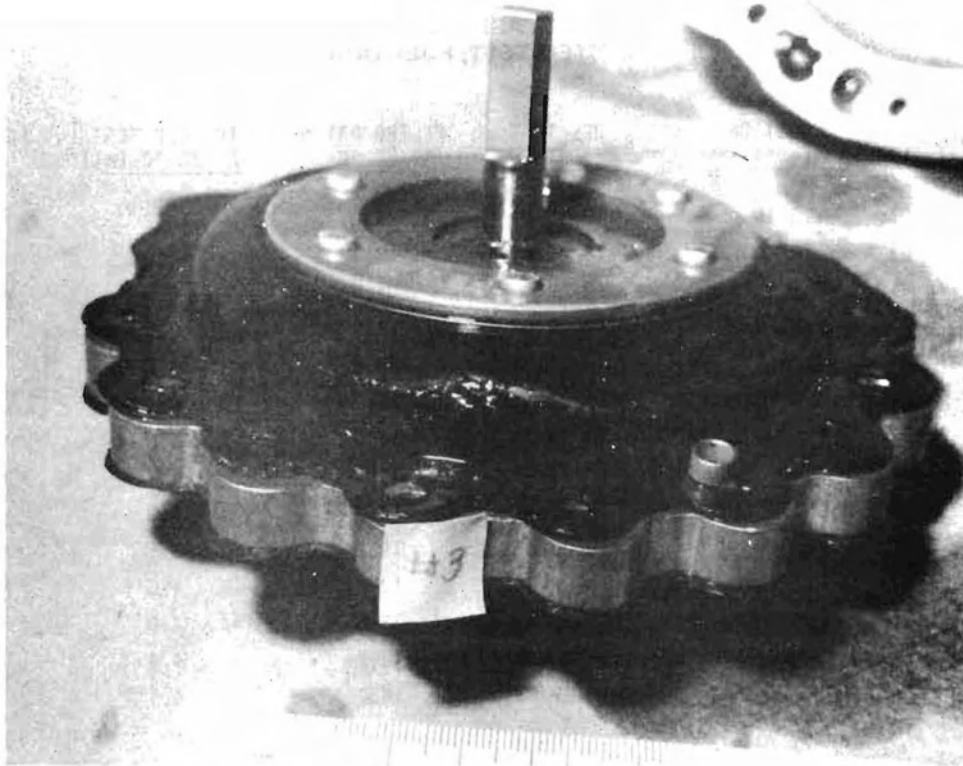

FIGURE 38. GEL FORMATION ON CONTROLLER DIAPHRAGM

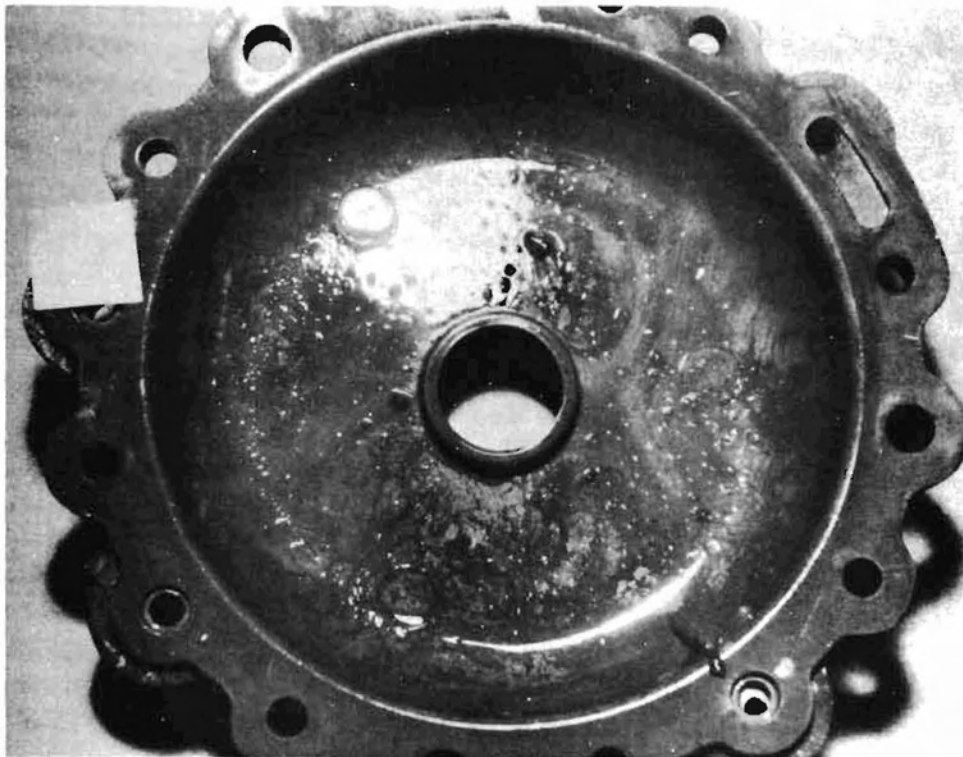

FIGURE 39. GEL GLOBULES ON CONTROLLER HOUSING

Method: The vent system test rig is shown in Figure 32.

The test procedure is similar to that of the fill system test. By allowing the fill system tankage to overfill, the vent system was used.

A single-tank, single-nozzle configuration was used. Thirty five- and 20-psi nozzle pressures were tested.

Supply, nozzle, tip tank (outboard compartment) and main tank (inboard compartment) pressures were measured with transducers. Flow rates were calculated by measuring change in volume (ΔV) with change in time (Δt).

This test was of system performance only. No fuel samples were taken.

Data and Results: The test results are plotted in Figure 40.

Engine Feed System Test

Purpose: The test was conducted to determine the flow characteristics of the system during sea level and altitude operations.

Method: The fuel feed system simulator is shown in Figures 41 and 42.

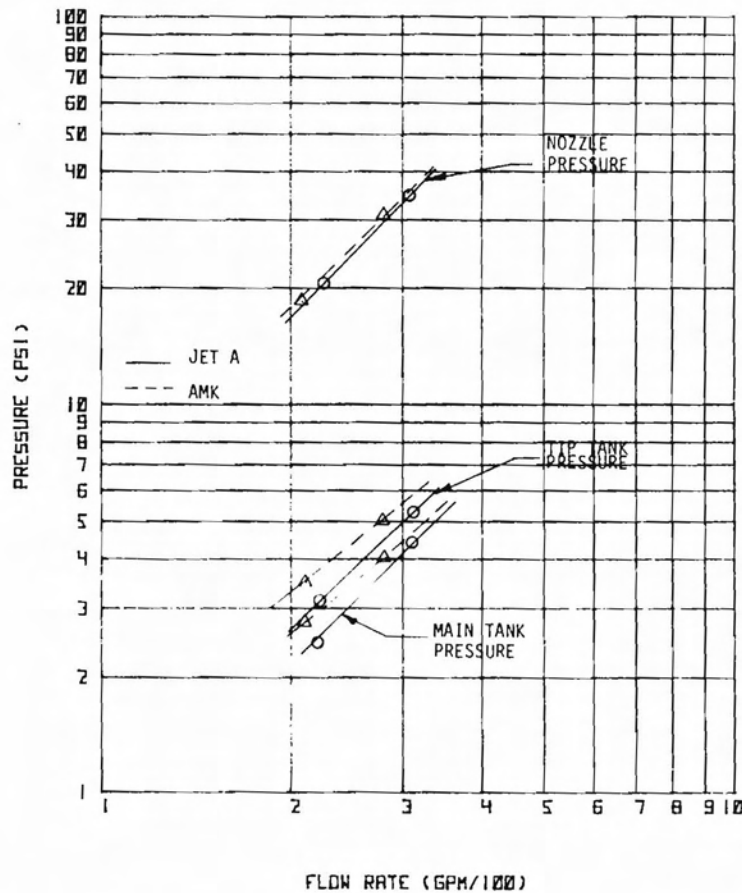

FIGURE 40. VENT SYSTEM PERFORMANCE USING SINGLE FUELING NOZZLE

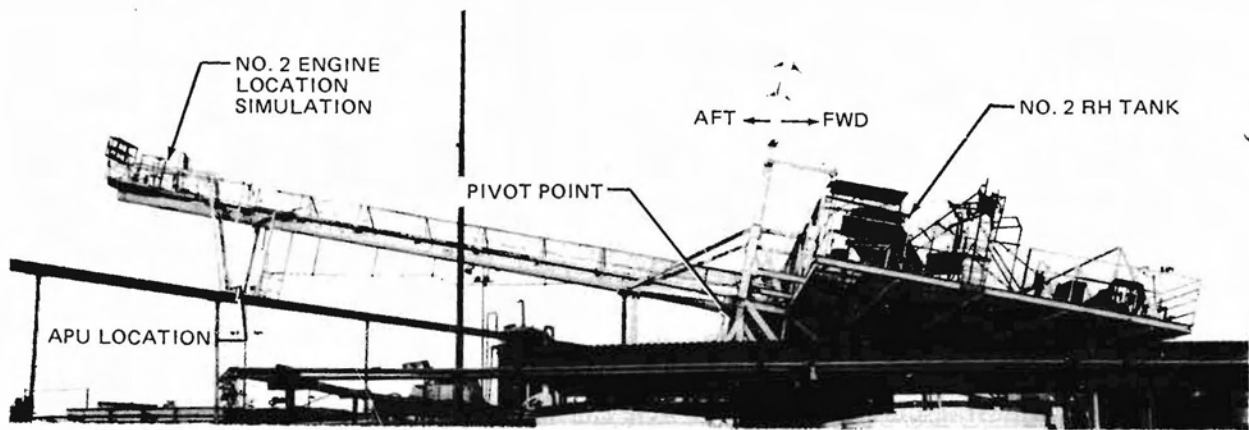

FIGURE 41. FUEL FEED TEST RIG, ELEVATION VIEW

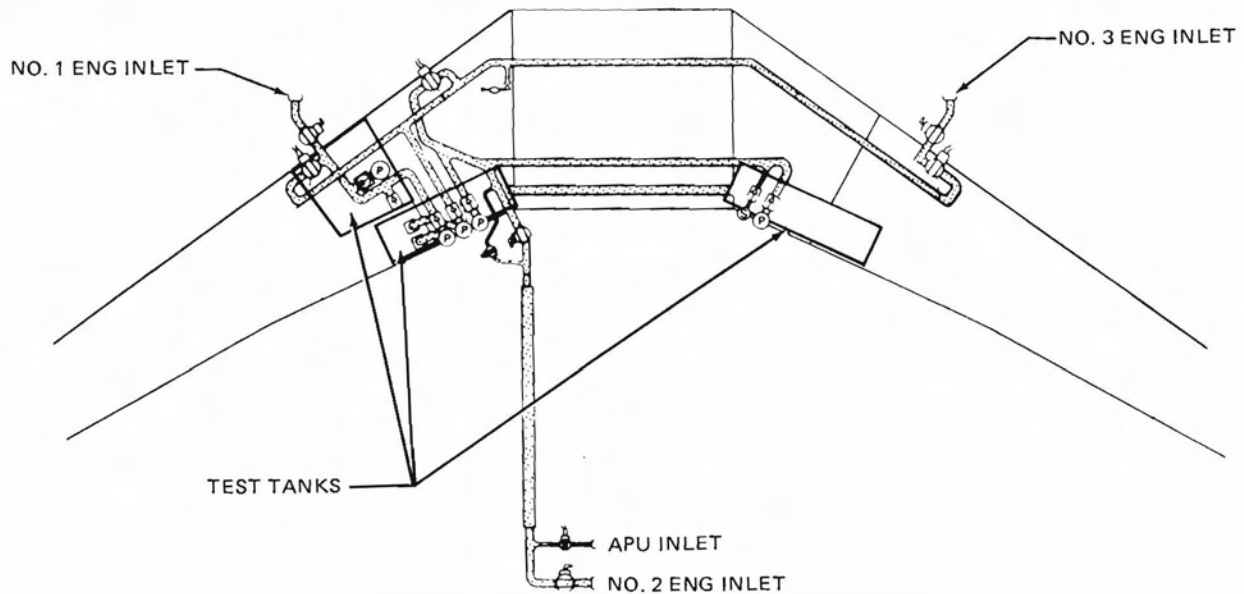

FIGURE 42. DC-10 FUEL FEED SYSTEM SIMULATOR

Two feed system tests were run. The left test tank, simulating the DC-10 No. 1 tank, was used to hold fuel for tests to determine a curve of pressure at the engine fuel pump inlet versus flow rate and the suction feed climb capability with AMK. A 2300-gallon tank located below the test rig was used to transfer fuel as necessary to maintain fuel head for these runs. Fuel was transferred by air pressure (9 to 10 psi) using large line (2-inch diameter).

A scavenge system jet pump was used for the pressure fuel feed system performance tests with tank boost pump operating. Bleed flow was simulated to the No. 1 tank jet pump transfer system. Main engine fuel flow was increased in increments to the maximum engine fuel flow. The test was performed with the fuel system in a horizontal airplane attitude.

The system configuration was basically the same for the suction feed climb test as for the pressure feed system performance tests. The test rig was at an aircraft angle of approximately 6 degrees nose up with the Number 1 main tank feeding the No. 1 engine by suction.

Instrumentation used for this test is listed in Table 13 and illustrated in Figures 43 and 44. All transducer signals were recorded.

**TABLE 13
FEED SYSTEM TEST INSTRUMENTATION**

<u>PRESSURE</u>	<u>GAGE</u>	<u>MANOMETER</u>	<u>TRANSDUCER</u>	<u>RANGE</u>
No. 1 Aft Pump	P_{p1}	—	—	0-50 psid
No. 2 Aft L.H. Pump	P_{p2}	—	—	0-50 psid + 50 psid(G)
Engine Inlet	P_{inlet}	—	P_{inlet}	0-50 psid(G) + 50 psid(T)
Engine Interstage	$P_{interstage}$	—	$P_{interstage}$	0-200 psid(G) 0-500 psid(T)
No. 1 Aft Tank	—	P_{T1}	P_{T1}	0-80000 ft(M) + 15 psid(T)
No. 2 L.H. Tank	—	P_{T2}	—	0-80,000 ft
No. 1 Fwd Tank	—	P_{T3}	—	0-80,000 ft
<u>Flow</u>	Controlotron System 480 Wide Beam Clamp-On Ultrasonic Turbine Flowmeter			
<u>Engine Pump RPM</u>	Frequency Counter			
<u>Time</u>	Stopwatches - 4 required			

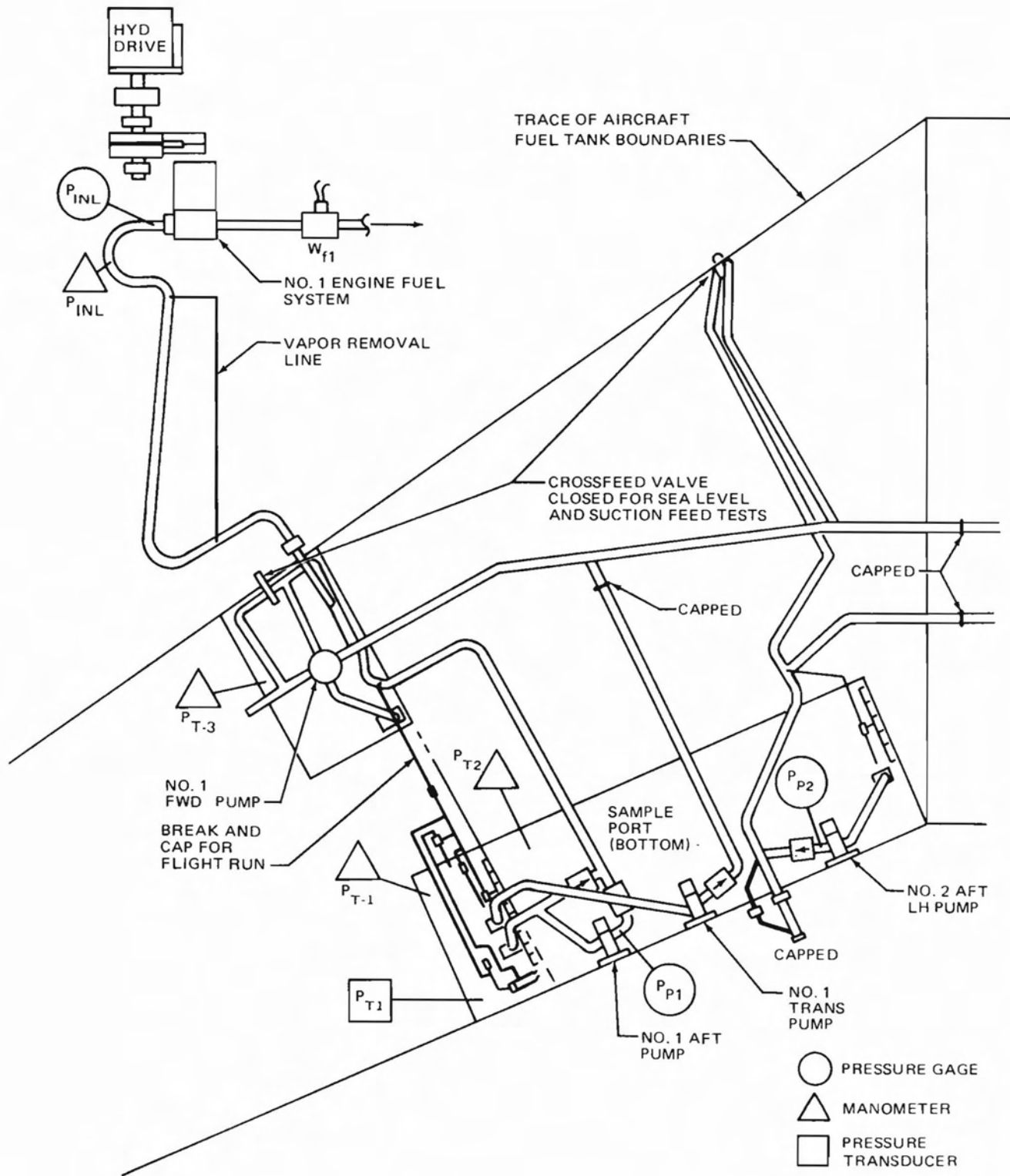

FIGURE 43. FUEL FEED SYSTEM TEST SCHEMATIC – PLAN VIEW

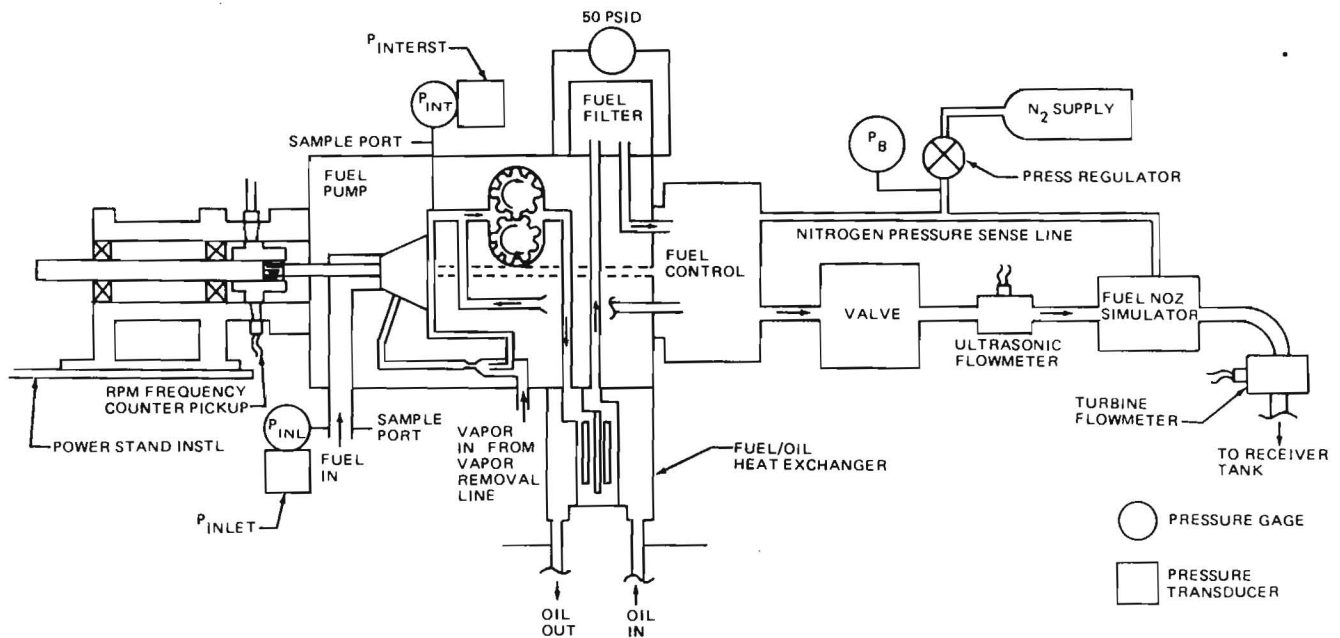

FIGURE 44. ENGINE FUEL SCHEMATIC TEST

Virgin, engine inlet, and interstage AMK samples were taken for the pressure fuel feed system performance runs. Engine inlet and interstage sampling vessels are shown in Figure 45. Engine inlet and interstage AMK were sampled at the maximum and minimum flow-rate conditions.

A virgin AMK sample was taken for the suction feed climb test.

In order to carry out specific system tests, an appropriate flow-measuring device was needed. The flowmeter had to have a real time response, be accurate, and impart no extraneous degradation to the AMK. The Controlotron 240 clamp-on ultrasonic flowmeter was selected.

The ultrasonic flowmeter was calibrated extensively, first by weight calibration of the AMK and then by comparison with output from a turbine flowmeter during the tests. The calibration setup is shown in Figure 46.

The test tank was filled with virgin AMK. The flow control valve was opened to a preset position. The shutoff valve was then closed.

The boost pump was turned on and the shutoff valve opened until the effluent flowed in a steady stream. This got rid of any air or vapor trapped in the system. The shutoff valve was then closed and the initial weight recorded.

The shutoff valve was opened a second time which simultaneously started the time. The system ran at a steady flow reading (gpm) on the ultrasonic flowmeter computer display.

The computer display was recorded. The shutoff valve was closed, which simultaneously stopped the time, and the final weight was measured.

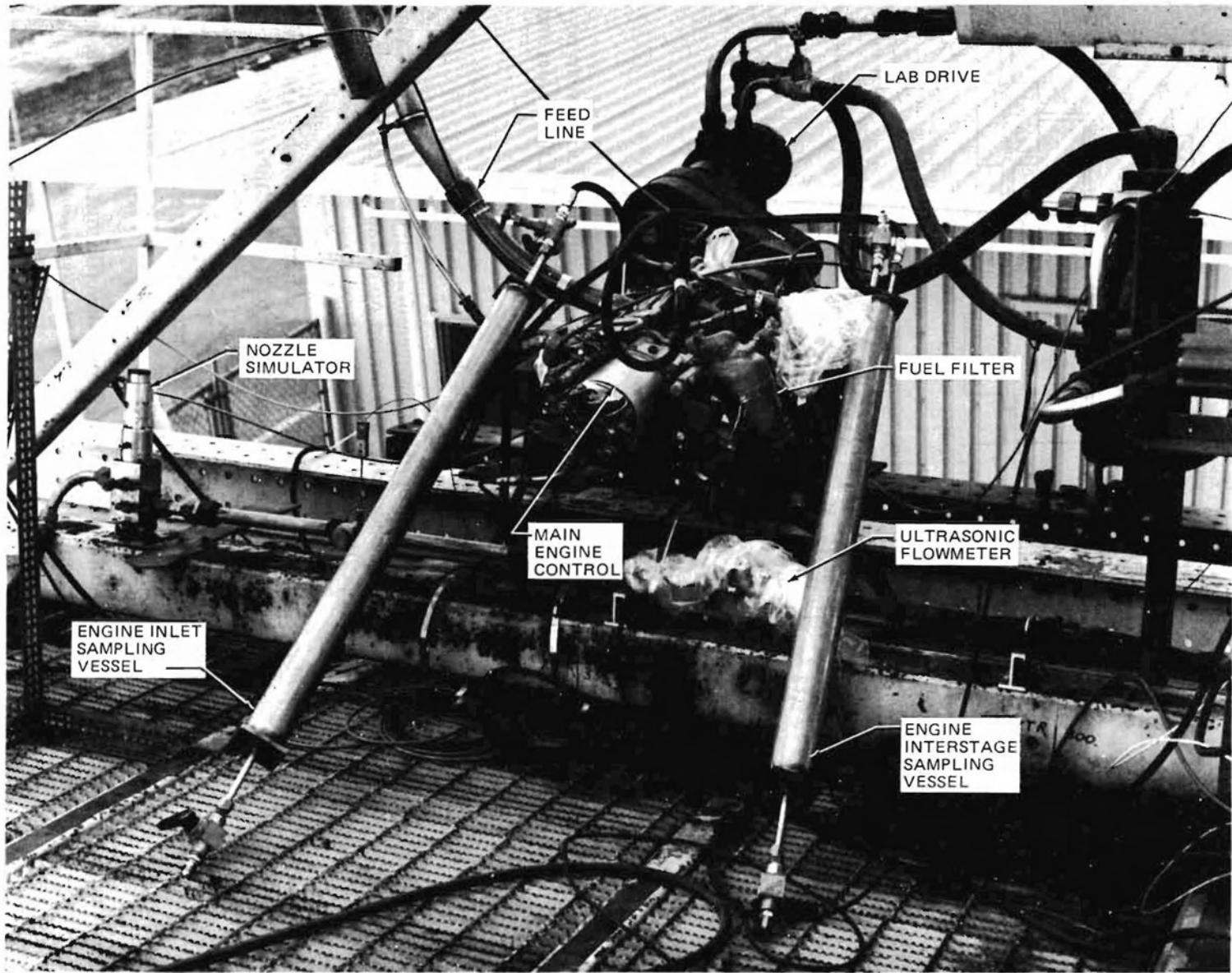

FIGURE 45. SAMPLING AT ENGINE INLET AND INTERSTAGE

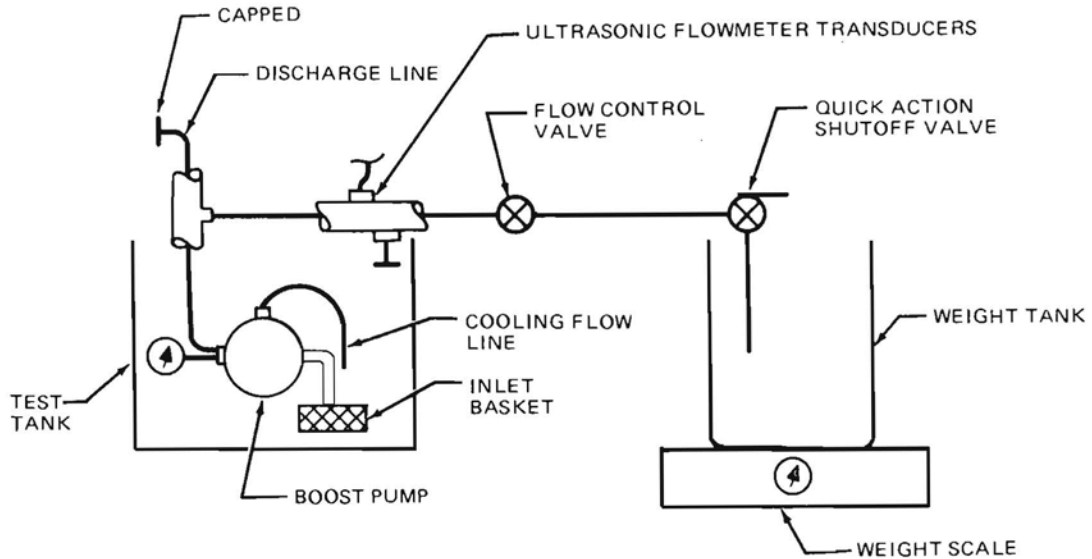

FIGURE 46. ULTRASONIC FLOWMETER CALIBRATION SETUP

The AMK fuel temperature and specific gravity were recorded from the weight tank. With these data, the $\Delta W/\Delta t$ was converted to gpm on the test site and compared.

Several flow points were run and repeated. The AMK was used once and was not reused.

Two test procedures were used: (1) pressure fuel feed system performance with tank boost pump operating, and (2) fuel system suction feed operating capability. The pressure fuel feed system performance test was conducted in several runs to investigate engine fuel pump inlet pressure under a range of fuel flow conditions. Jet A and AMK fuel were each used separately. Fuel temperature was as supplied from storage.

This test covered normal operation of the No. 1 main tank fuel feed system for the General Electric (GE) CF6-engine-powered airplane configuration. The No. 1 main aft pump fed the No. 1 engine. For the above test, the following data were recorded:

- Engine fuel pump inlet pressure
- Engine fuel flow
- Engine fuel pump speed up to 5800 rpm
- Head above pump inlet (10 inches above suction line)
- Boost pump outlet pressure.

The suction feed climb test investigated the fuel system suction feed operating capability. Tests were made using AMK and Jet A.

A climb was simulated until engine fuel feed system flow failure was observed. At that time, the aft boost pump was turned on and the climb continued to 42,000 feet.

The following parameters were controlled and/or recorded during the tests:

- Fuel flow to the engine

- System pressure altitude
- Engine fuel pump speed up to 5850 rpm
- Fuel head 28 inches above the pump inlet
- Fuel pressure at the engine fuel pump inlet.

Data and Results: The flowmeter calibration data are listed in Table 14. During the engine feed and flight cycle tests, the flow rate readings between the ultrasonic and turbine flowmeters were within 1 gpm of each other at the high flow rates. The difference in flowmeters was less at low flowrates. For example, the flow rate readings for the pressure fuel feed system performance test using AMK were:

Ultrasonic (gpm)	Turbine (gpm)
9.5	10.0
20.5	19.8
30.2	30.0
40.0	40.0
48.0	49.0

In the first AMK run, the fuel filter was “plugged” intermittently and fuel passed through the internal bypass valve. Upon removal of the filter element, no permanent gel formation, foreign materials, or water contaminants were found (Figure 47). The filter element was reinstalled (as requested by the engine manufacturer) and it continued to react in similar fashion as on the first run.

The pressure fuel feed system performance curves are plotted in Figure 48. Fuel samples were taken from the engine inlet and interstage at two flow points, the minimum and maximum flow rates. The fuel quality data for these samples are listed in Table 15.

Suction feed climb test results are shown in Figure 49. The engine fuel pump inlet pressure curve is of interest here. Using Jet A, the system provided the required flow for the entire climb test. The engine inlet pressure was always above that required for Jet A at 48.9°C (120°F), the DC-10 certification basis.

**TABLE 14
ULTRASONIC FLOWMETER CALIBRATION**

<u>FLOW RATE - ULTRASONIC (GPM)</u>	<u>ΔW (LB)</u>	<u>TIME (SEC)</u>	<u>SPECIFIC GRAVITY (60°F/60°F)</u>	<u>TEMP. (°F)</u>	<u>CONVERTED FLOW RATE (GPM)</u>
6.7	24	30.2	.813	60.6	7.0
6.8	24	30.0	.813	60.6	7.1
7.1	25	31.6	.813	60.6	7.0
7.2	22	27.0	.813	60.6	7.2
8.9	25	24.8	.810	68.2	9.0
8.9	27	26.5	.810	68.2	9.1
25.6	89	29.9	.810	68.2	26.5
25.6	85	28.9	.810	68.2	26.1
26.3	75	25.1	.810	68.2	26.6
26.4	79	26.3	.810	68.2	26.7



FIGURE 47. FUEL FILTER ELEMENT

Using AMK, the engine pump cavitated at 31,000 feet altitude and the aircraft tank boost pump was turned on for the rest of the test up to 42,000 feet. A virgin sample of AMK was taken only, FR was 35.4 at 21°C, ICI Cup was 3.60 ml at 21.5°C, and FCTA gave 20°C with SC at 200 and 93 psi air supply pressure.

Flight Cycle

Purpose: This work was done to determine the fuel qualities at the fuel tank, engine fuel pump inlet, and interstage for a typical flight.

Method: The flight cycle simulator is similar to the fuel feed system simulator. In the system configuration, the No. 2 LH test tank was used to hold fuel for the tests. A technique similar to that used in the engine feed tests — transfer fuel from an external tank by applying air pressure above the fuel — was used for these runs to maintain the proper fuel quantity.

The test simulated the fuel system operating capability during a typical flight. The altitude, the fuel used in each segment, and the fuel load per tank for the airplane flight to be simulated are shown in Table 16. Note the negligible fuel consumption during the descent and landing phase of the flight.

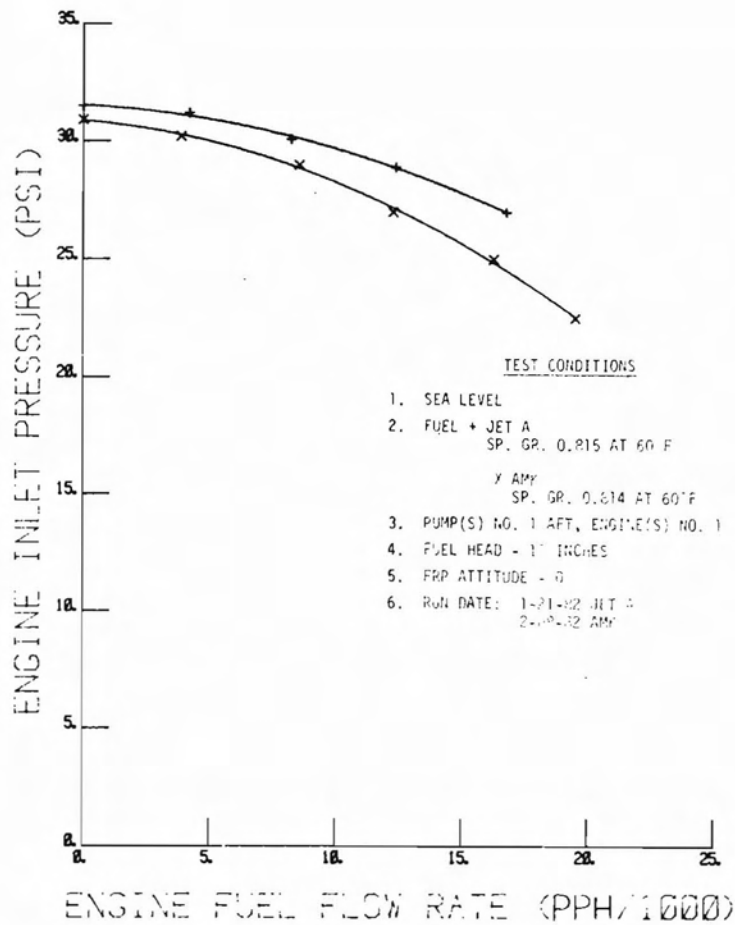

FIGURE 48. FUEL FEED SYSTEM PERFORMANCE – TANK BOOST PUMP OPERATING

TABLE 15
PRESSURE FUEL FEED SYSTEM PERFORMANCE TEST, FUEL QUALITY

<u>AMK Sample</u>	<u>Filter Ratio</u>	<u>ICI Cup Test (ml)</u>	<u>FCTA Results (at S.C. 200)</u>
Virgin	15.3 at 20.0 °C	7.00 at 21.0 °C	105.0 °C 93 psi
Engine Inlet @ 10 GPM	4.2 at 20.5 °C	7.20 at 21.0 °C	71.7 °C 93 psi
Engine Interstage @ 10 GPM	1.7 at 21.0 °C	7.30 at 21.0 °C	216.7 °C 94 psi
Engine Inlet @ 50 GPM	6.9 at 21.0 °C	7.20 at 21.0 °C	145.0 °C 94 psi
Engine Interstage @ 50 GPM	4.4 at 21.0 °C	7.20 at 21.0 °C	246.7 °C 95 psi

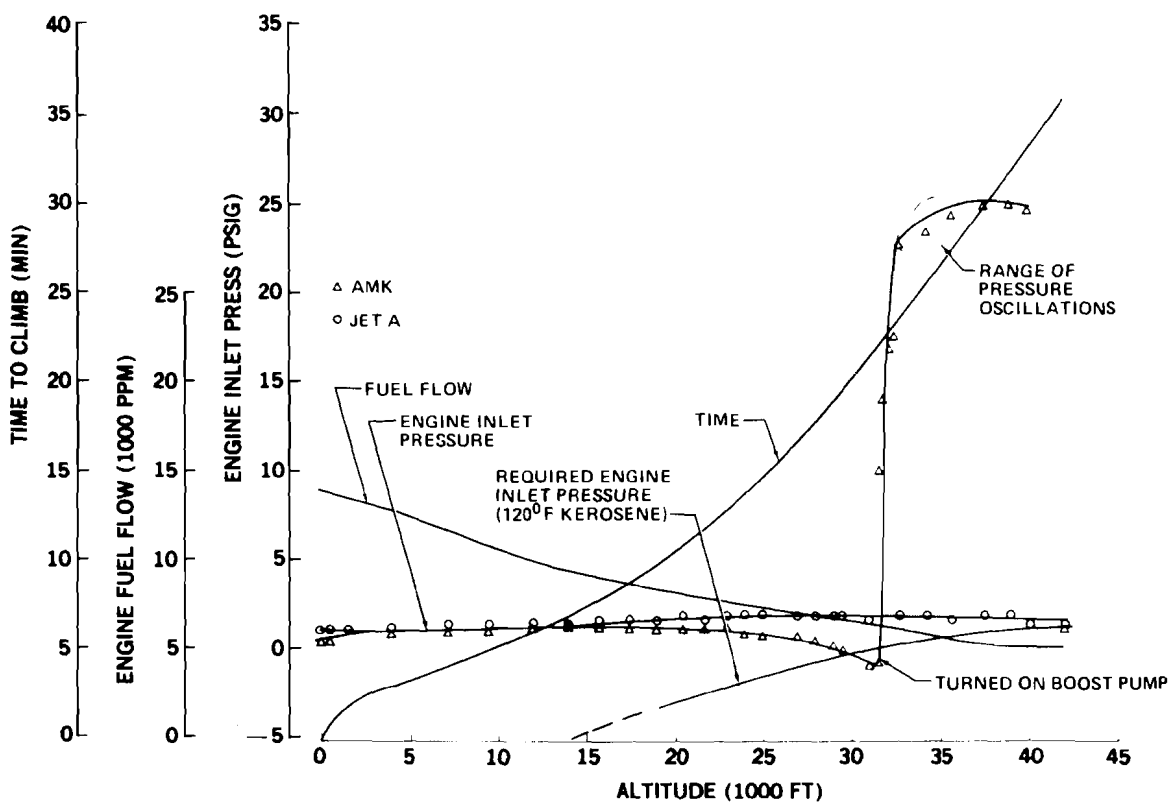

FIGURE 49. SUCTION FEED CLIMB TEST

TABLE 16
AIRPLANE FLIGHT REGIME AND FUEL USAGE FOR A TYPICAL FLIGHT

<u>Flight Segment</u>	<u>Altitude</u>	<u>Fuel Consumption (Lb.)</u>
Takeoff	Sea level to 2000 feet	1400 *
Climb	2000 feet to 39000 feet	9100 *
Cruise	39000 feet	13000*
Descent and Landing	39000 feet to sea level	Negligible
Total Fuel Consumption.....		23,500 lb.*
Total Reserve Fuel (200 n.mi. alternate)		17,200 lb.*
Fuel Loaded/Tank		13,600 lb.

* These figures represent fuel for the three engines

Though a finite but small amount of fuel is indeed consumed, the zero flow rate at the end of the flight will give a conservative tank fuel quality value due to the continual operation of the boost pump. The rate of fuel delivery to the engine was varied as necessary to match the flight conditions being simulated. The No. 2 LH tank, rather than the No. 1 tank was used to feed the No. 1 engine. The No. 2 LH tank has the necessary volume to maintain the required reserve fuel, 5733 pounds (17,200/3) in each main tank.

With the flight mission parameters, an analysis of the fuel use from the inboard end of the inboard compartment showed that the jet pump transfer system operation in the model mission was unlikely to occur for a significant length of time. Therefore, the fuel quality investigation on the test rig did not need to include a jet pump transfer system operation to simulate "reality".

The test rig was adjusted to a horizontal aircraft attitude with the No. 2 tank left compartment feeding the No. 1 engine.

Instrumentation was the same as for the engine feed tests.

AMK samples were taken as follows:

Location	Time Sampled During Flight Profile			
	Takeoff	Top of Climb	End of Cruise	End of Cycle
Test Tank	X	X	X	X
Engine Pump Inlet	X	X	X	
Engine Pump Interstage	X	X	X	

The tank was sampled from the bottom center of the No. 2 LH tank. This position was midway between the fuel input and the boost pump pickup point.

Engine pump inlet and interstage sampling was done in the same fashion as in the engine feed tests.

The test procedure consisted of a takeoff, climb, cruise and descent fuel flow profile. Zero fuel flow rate was used during descent. This was repeated for a total of four simulated flights.

The following data were controlled and/or recorded during the tests:

- Fuel flow to the engine
- System pressure altitude at sea level
- Engine fuel pump speed up to 5800 rpm during takeoff and climb, and 5300 rpm for cruise
- Fuel pressure at the engine inlet.

Data and Results: Fuel system performance curves for the simulated flights are plotted in Figure 50. The fuel quality data are plotted in Figures 51 through 59.

Flow rate readings between the ultrasonic and turbine flowmeters were in good agreement, within 1 gpm of each other.

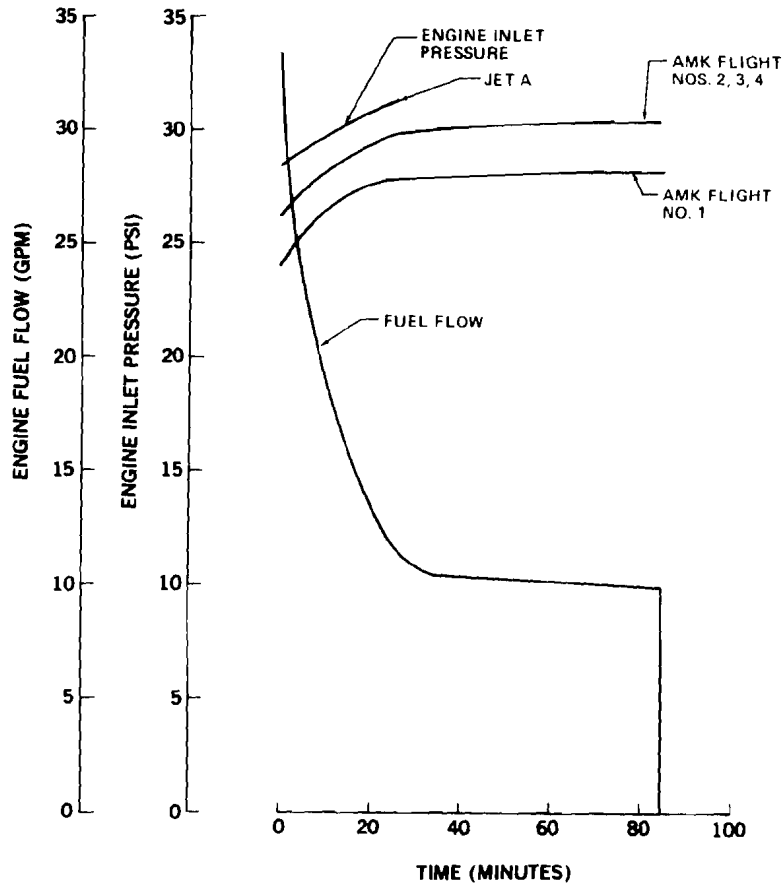

FIGURE 50. FUEL FLOW CHARACTERISTICS DURING SIMULATED FLIGHTS

The GE engine pump and fuel control unit (FCU) were returned to the manufacturer upon completion of the engine feed and flight cycle tests. The engine pump and FCU were left in their test facility for approximately 4 months before teardown and inspection of parts. When the engine pump and FCU were disassembled and inspected, no anomalies were found other than a gel in the fuel filter. This filter was the filter that was intermittently plugged while the fuel passed through the internal bypass valve. At the time of this report, the foreign material found in the fuel filter had not been analyzed.

KC-10 Aerial Refueling Nozzle/Receptacle

Purpose: This test was conducted to determine fuel-flow effects of the KC-10 aerial refueling nozzle/receptacle coupling. The pressure drop versus flow characteristics were found by measuring flow rates up to and including the maximum flow rate obtainable using two aerial refueling pumps. Finally, degradation of AMK fuel offloaded from the tanker was determined.

Method: A schematic of the KC-10 test rig is shown in Figure 60 and a photograph in Figure 61.

The ΔP_1 and ΔP_2 gages were used to measure the pressure drop through the nozzle/receptacle.

The KC-10 aft tank No. 4 cell was filled with fuel by pressurizing the shipping drums. Two aerial refueling pumps (ARPs) were turned on and the flow control valve was opened to a preset position. Pressure drops and flow rates were recorded.

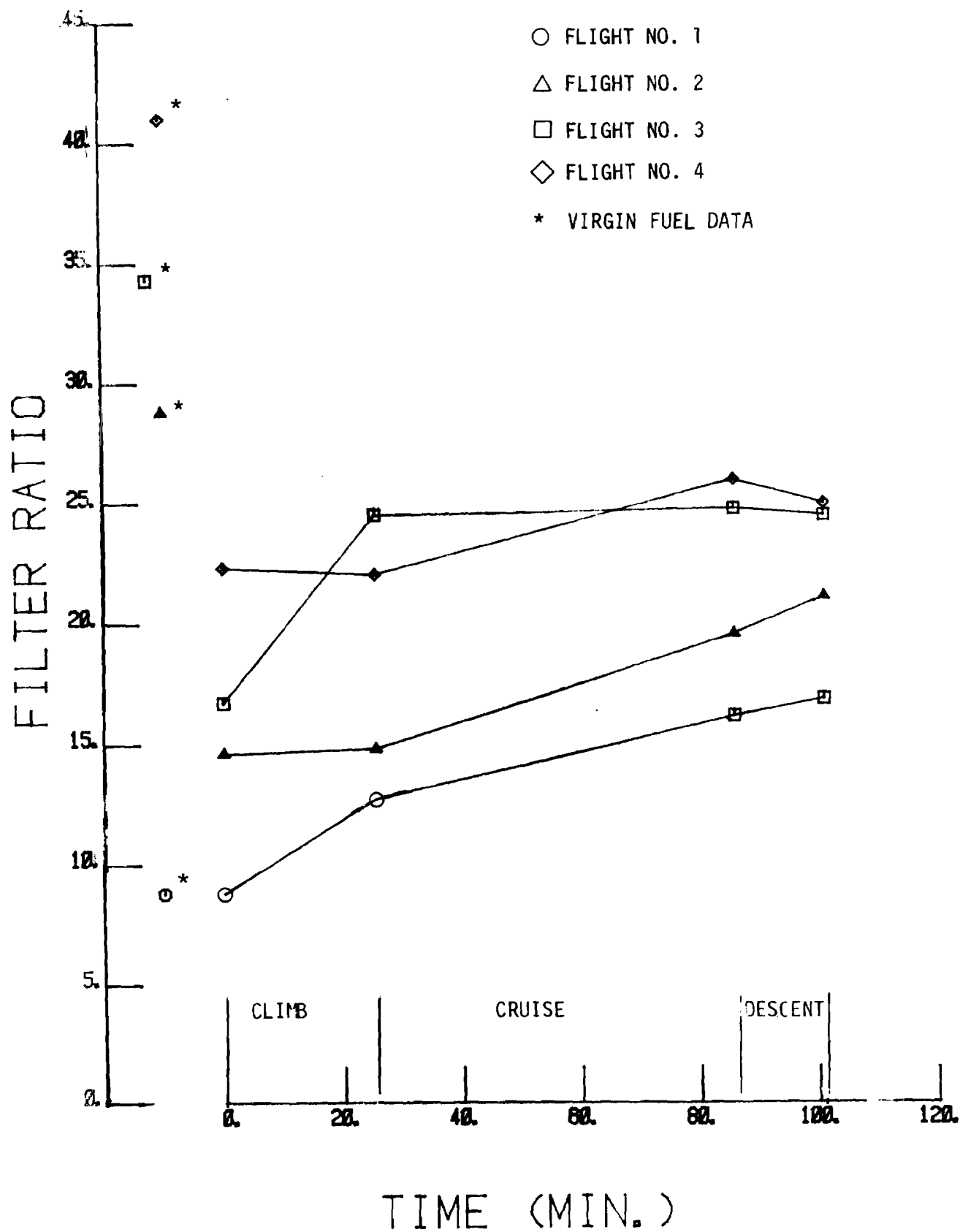

FIGURE 51. TANK AMK, FILTER RATIO

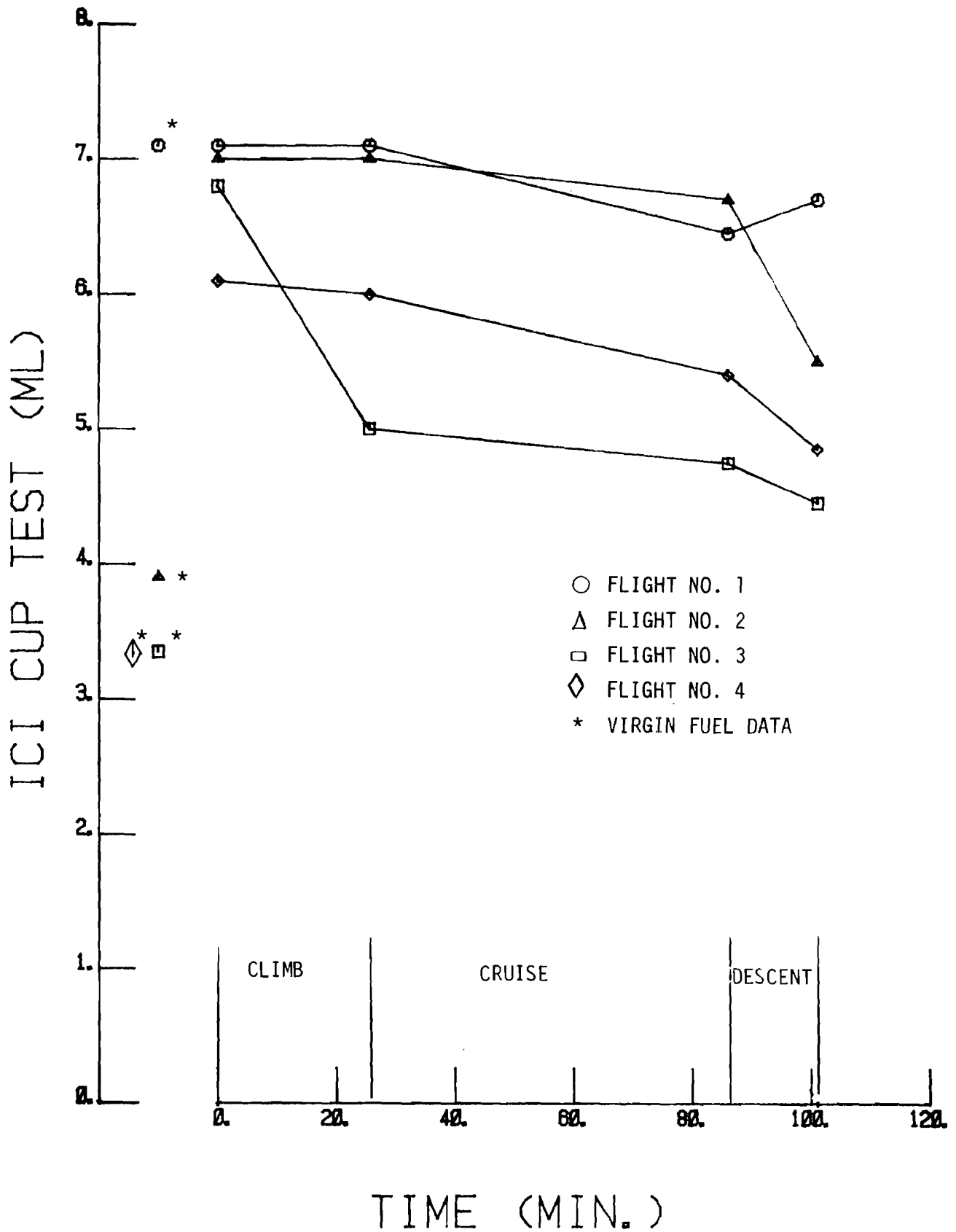

FIGURE 52. TANK AMK, ICI CUP TEST

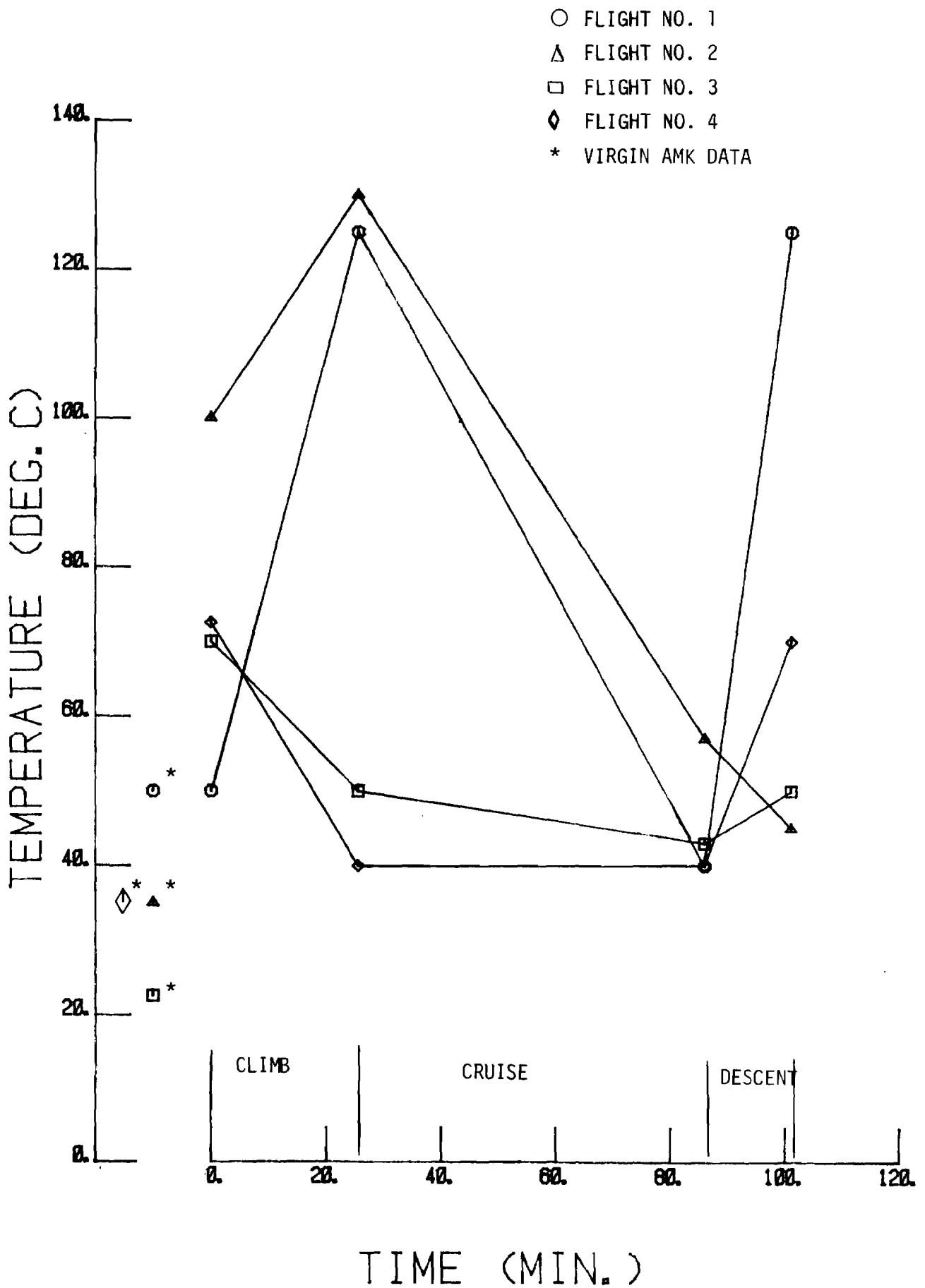

FIGURE 53. TANK AMK, FCTA TEMPERATURE

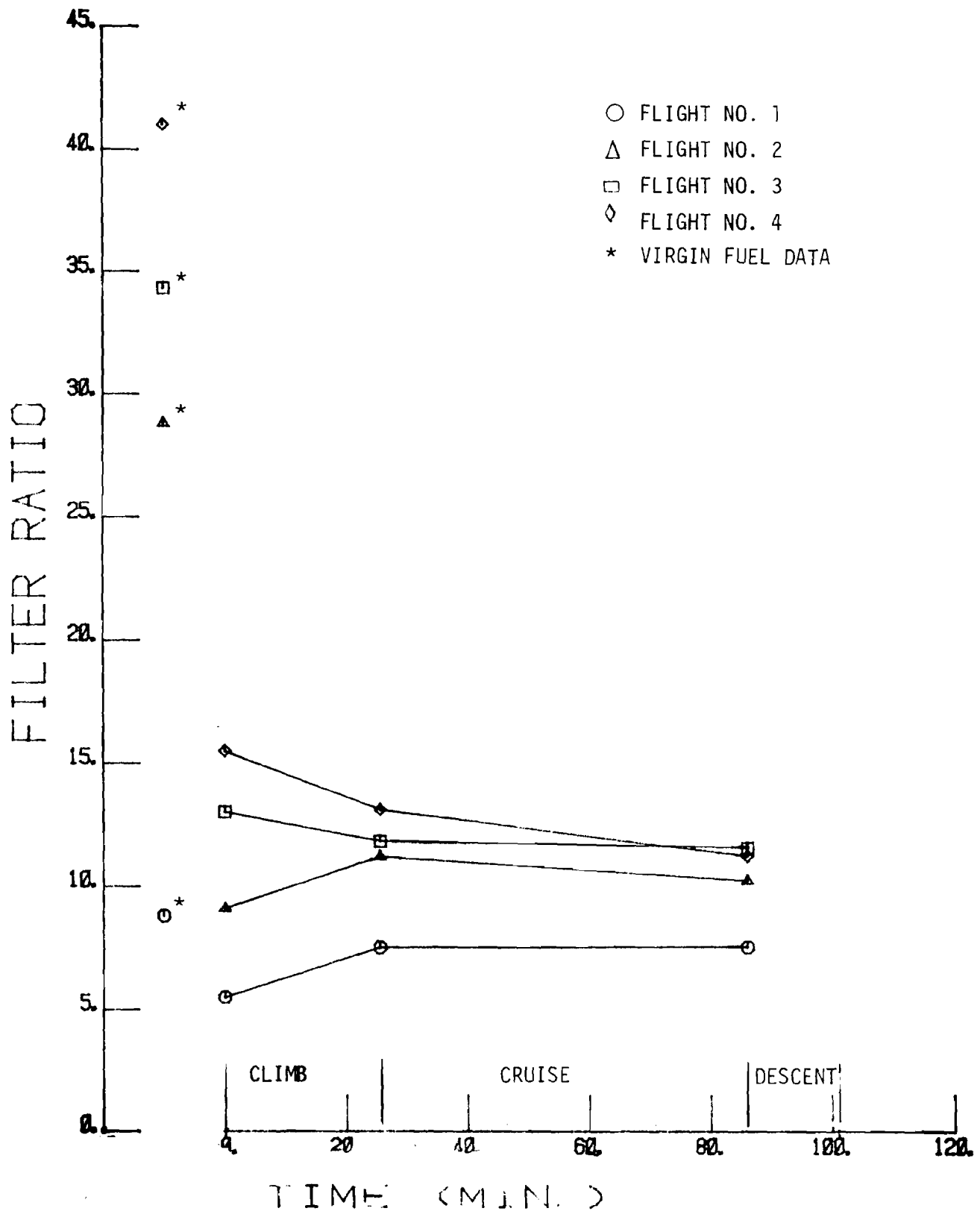

FIGURE 54. ENGINE INLET, FILTER RATIO

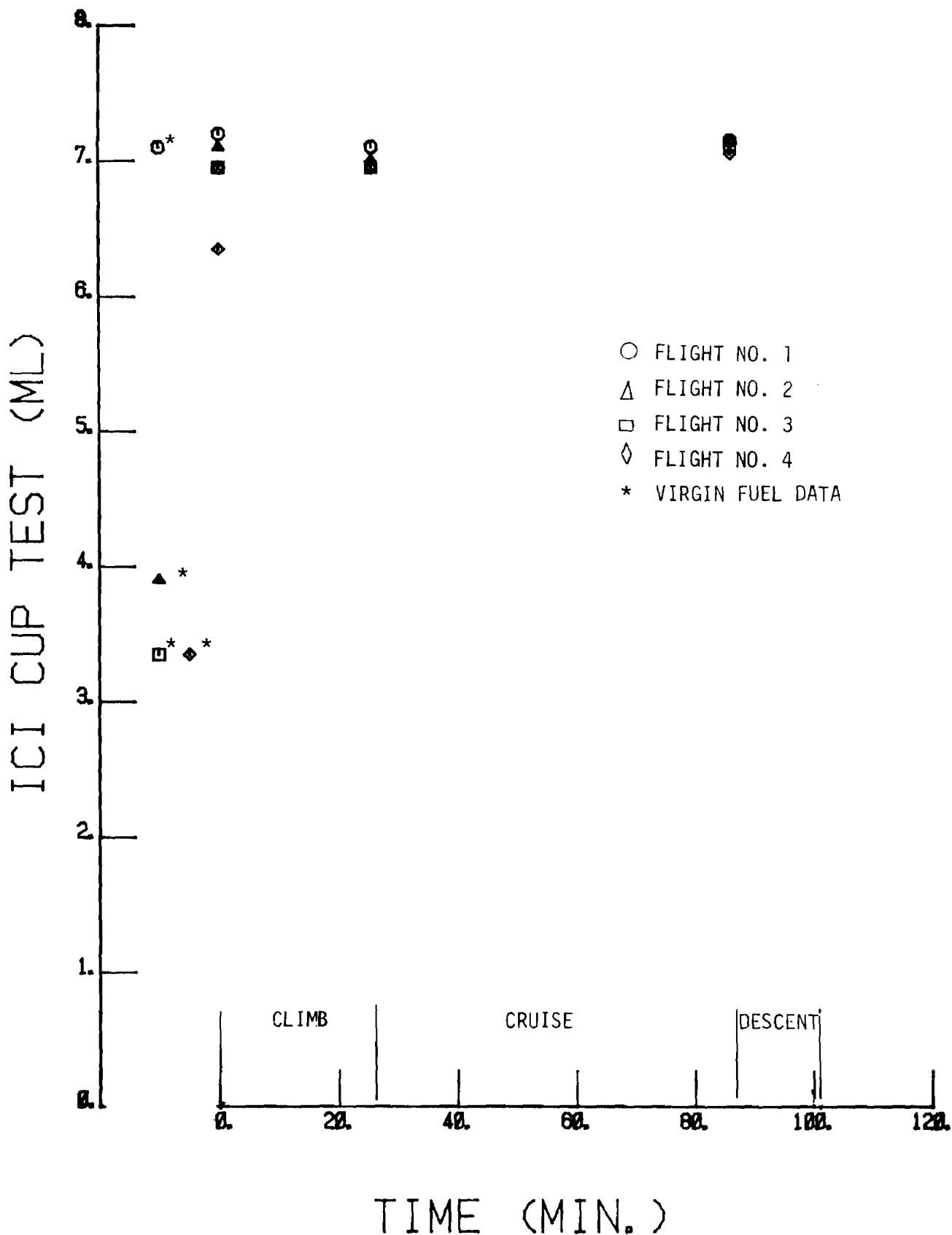

FIGURE 55. ENGINE INLET, ICI CUP TEST

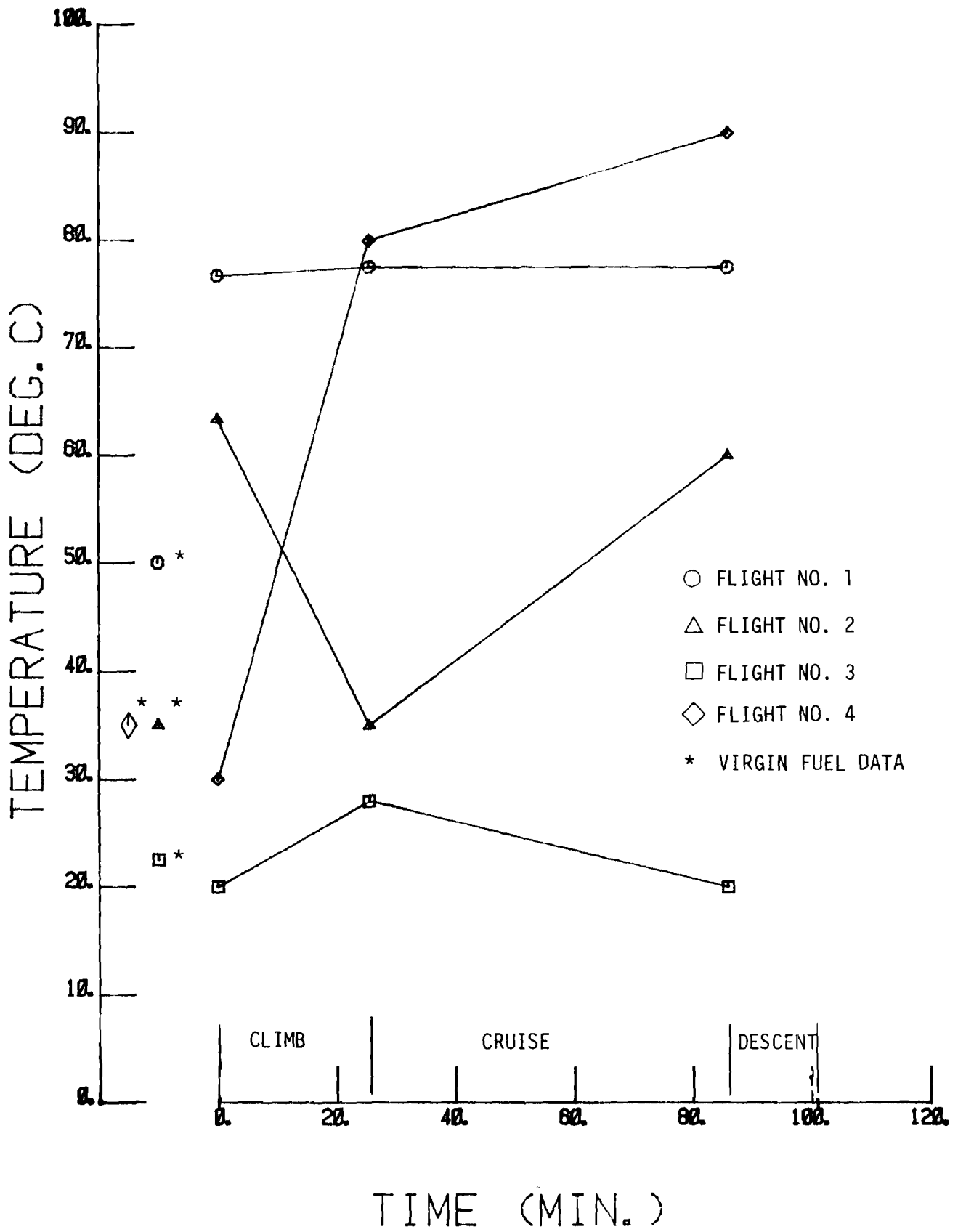

FIGURE 56. ENGINE INLET, FCTA TEMPERATURE

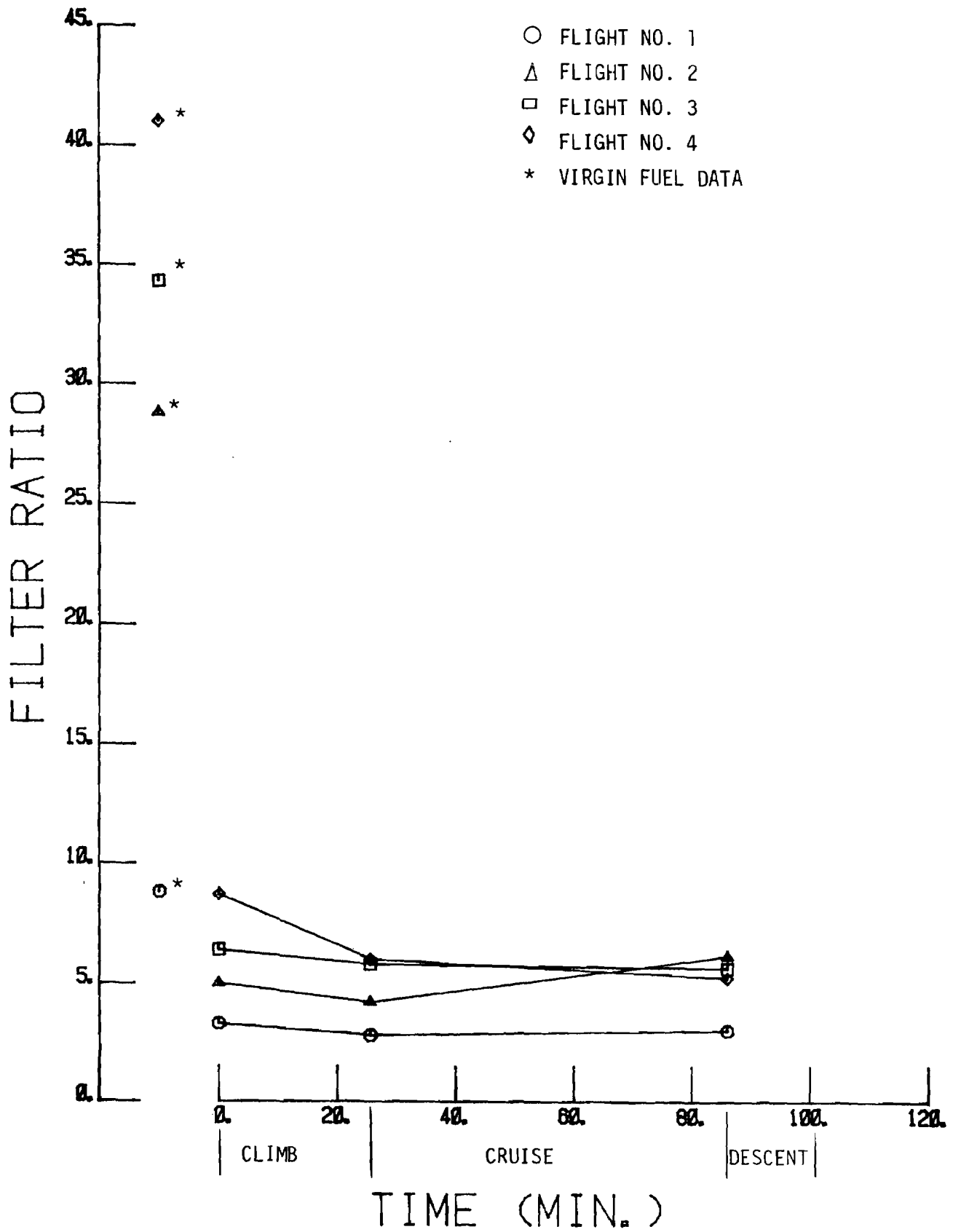

FIGURE 57. ENGINE INTERSTAGE, FILTER RATIO

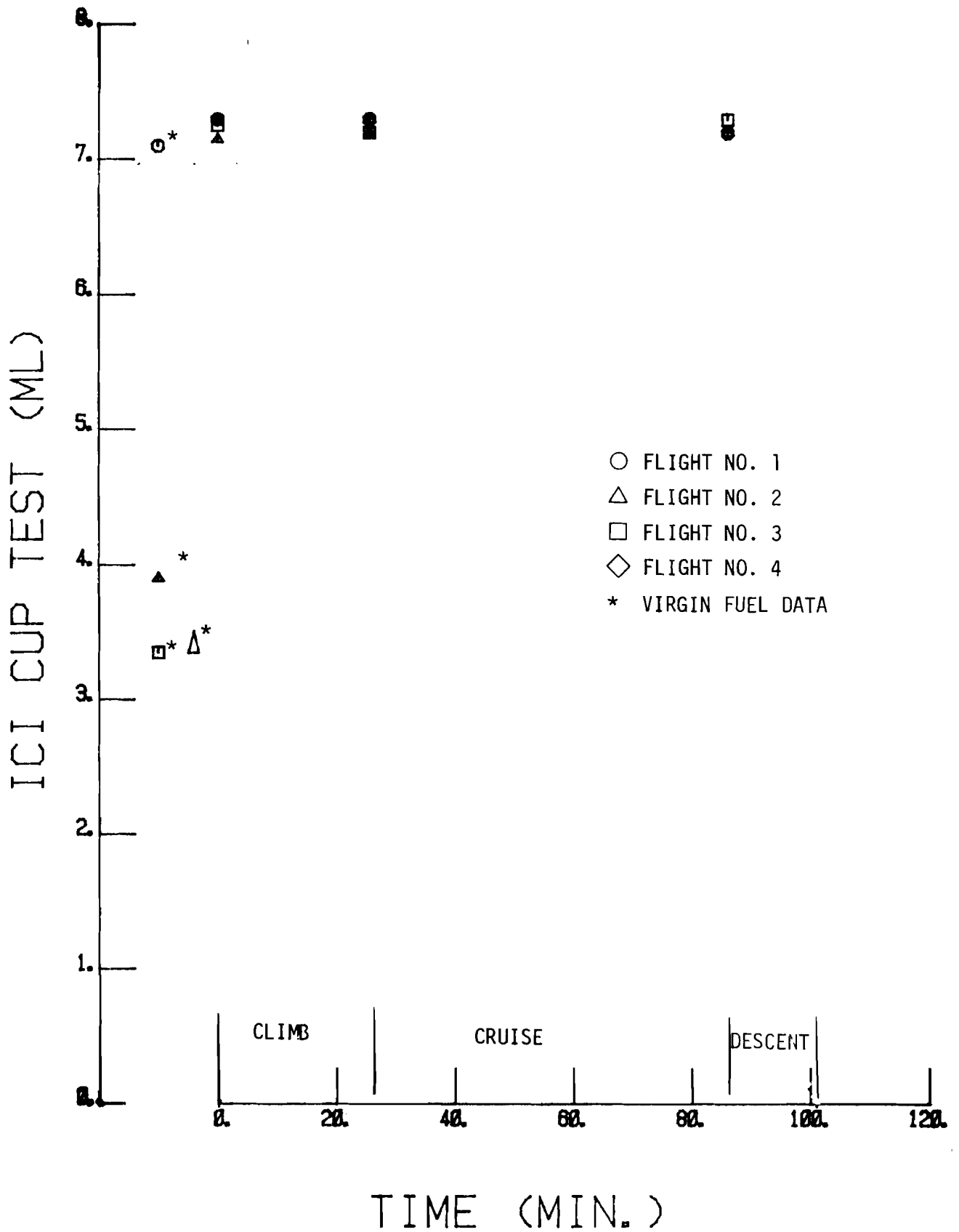

FIGURE 58. ENGINE INTERSTAGE, ICI CUP TEST

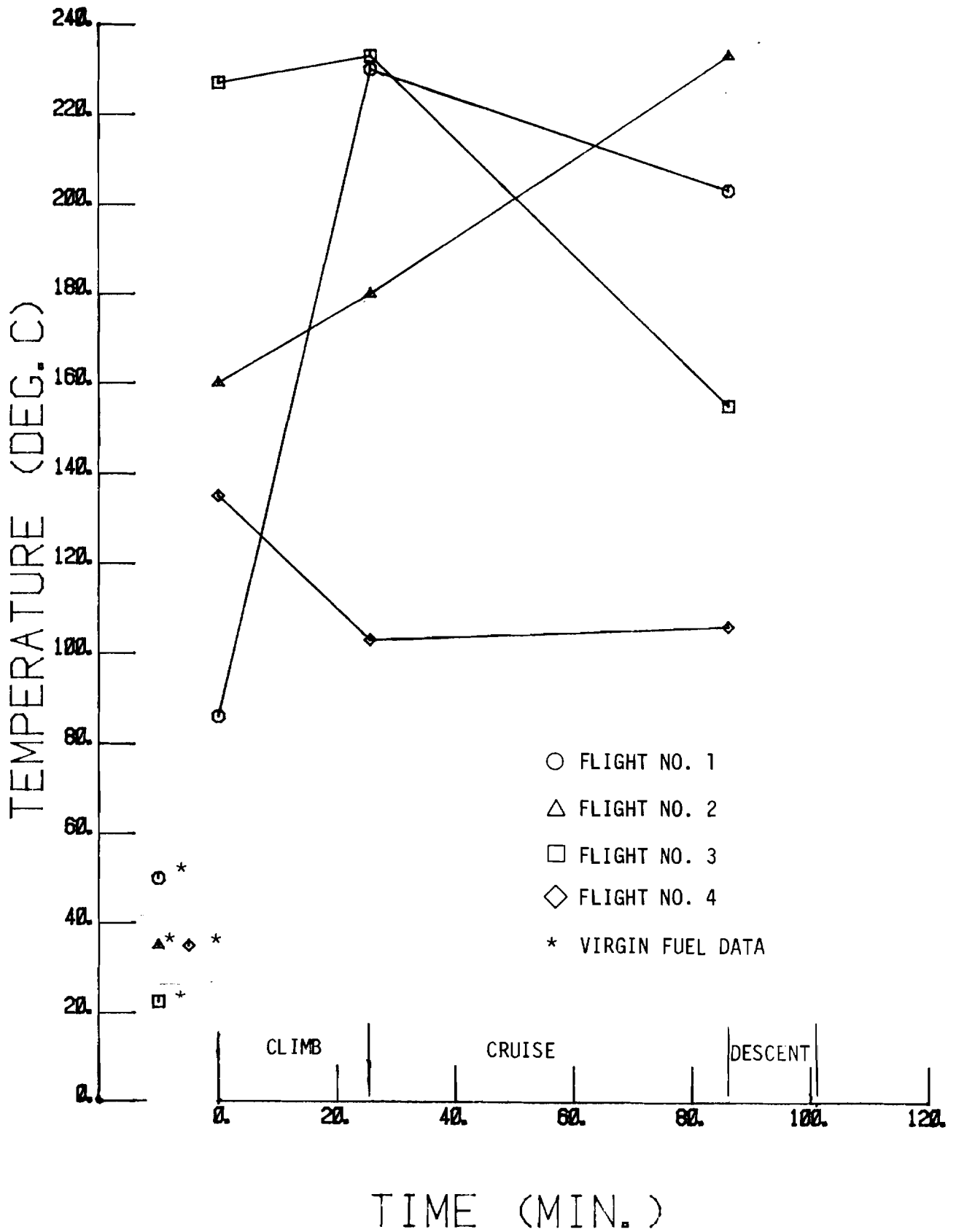

FIGURE 59. ENGINE INTERSTAGE, FCTA TEMPERATURE

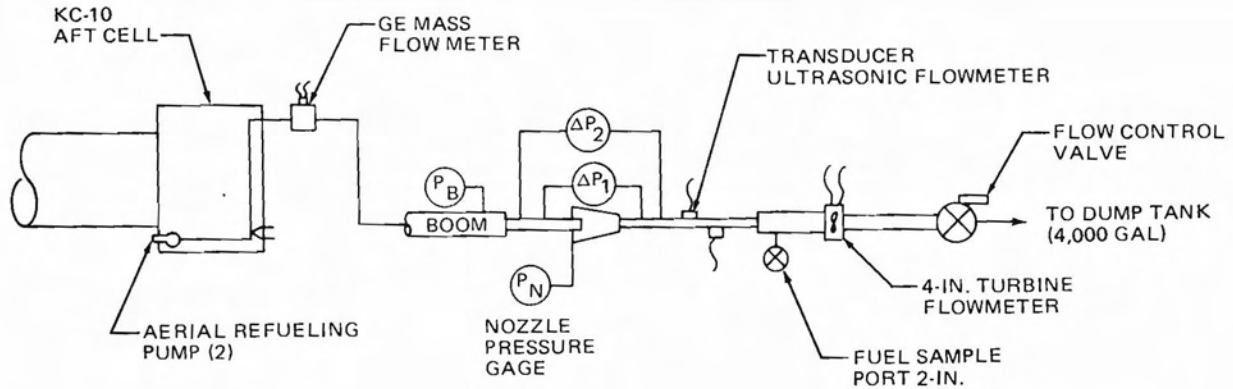

FIGURE 60. KC-10 AERIAL REFUELING NOZZLE/RECEPTACLE TEST SCHEMATIC



FIGURE 61. KC-10 AERIAL REFUELING SYSTEM SIMULATOR

The test was run at three flow rates, including maximum flow (flow control valve fully open). A sample was taken at each flow condition for the AMK runs.

Data and Results: The GE mass flowmeter (part of the KC-10 refueling system), the ultrasonic flowmeter, and the turbine flowmeter were in good agreement (1 gpm) when establishing baseline performance using Jet A. During the AMK runs, the flowmeter flow rate readings were not in good agreement.

The GE flowmeter rates shown were calculated using the meter totalizer and a stopwatch. GE recommended this procedure to improve accuracy over the chart run times. The measured flow rate was about 8 percent below the ultrasonic flowmeter.

The turbine flowmeter output was unsteady (fluctuating) for a specific flow condition though the system was steady (pressure readings were steady). The indicated flow rate was from 7 percent to 13 percent below the ultrasonic flowmeter.

The ultrasonic flowmeter registered steady output for each flow point tested. Because of the accuracy displayed during previous use, the ultrasonic flow rates were used for this test.

The system performance and fuel quality data are shown in Figure 62.

SAMPLE (AMK)	FILTER RATIO	ICI CUP (ml)	FCTA (92 PSI, S.C. 200)
VIRGIN FOR FLOW RATES OF 300 AND 900 GPM	40.2 at 22.0 °C	3.3 at 21.0 °C	40°C
VIRGIN FOR FLOW RATE OF 600 GPM	35.9 at 20.5 °C	4.2 at 21.0 °C	37°C

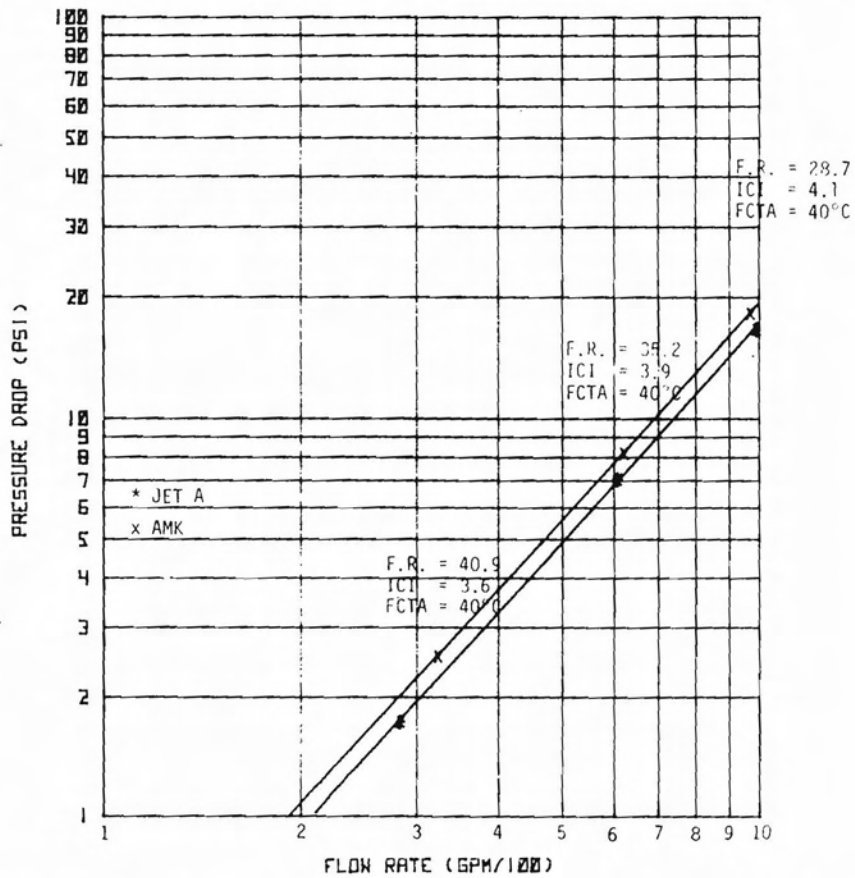

FIGURE 62. KC-10 AERIAL REFUELING NOZZLE/RECEPTACLE TEST

The AMK used in this test came in drums transported by a truck. The AMK batch numbers were RMH1-111 through RMH1-229. The fuel qualities for all the batches before the shipment were the same, ICI Cup was 2.4 ml and fuel clarity was clear.

The fuel qualities upon arrival are listed in Table 17.

TABLE 17
AMK QUALITY AS RECEIVED FOR KC-10 REFUELING SYSTEM TEST

<u>BATCH NO.</u>	<u>FILTER RATIO</u>	<u>ICI CUP TEST (ml)</u>	<u>FCTA RESULTS</u>
RMH 1-222	46 at 21 °C	3.2 at 21 °C	50 °C 95 psi S.C. 200
RMH 1-223	66 at 21 °C	2.3 at 22 °C	25 °C 95 psi S.C. 200
RMH 1-224	68 at 21 °C	2.2 at 22 °C	20 °C 95 psi S.C. 200
RMH 1-225	73 at 22 °C	2.3 at 22 °C	20 °C 95 psi S.C. 200
RMH 1-226	62 at 22 °C	2.2 at 22 °C	20 °C 95 psi S.C. 200
RMH 1-227	57 at 22 °C	2.4 at 22 °C	20 °C 91 psi S.C. 200
RMH 1-228	78 at 21 °C	2.3 at 22 °C	20 °C 93 psi S.C. 200
RMH 1-229	69 at 21 °C	2.3 at 21 °C	20 °C 93 psi S.C. 200

DISCUSSION

Effects on the airplane systems as indicated by test results are considered in the following discussion. These comments are necessarily of a qualitative nature. Quantitative studies or analyses were beyond the scope of this program. Eventually, fuel system operational requirements will be reassessed and redesign requirements will be determined as part of an overall design review and test certification process for the approval to use AMK.

COMPONENT TESTING

Float Switches

There was no difference in the actuation function of the float switches when using Jet A and AMK. It had been anticipated that there might be a slowing of switch operation due to the increased AMK viscosity relative to Jet A.

There was no significant change in the AMK during the switch testing. This test provided an opportunity for establishing a sample handling technique.

No potential problems are evident or expected in using this AMK fuel.

Float Valves

There was no difference in the actuation function of the float valves when using Jet A and AMK.

The float valves did not "degrade" the FM-9. The slight degradation of the fuel as indicated by the fuel quality measurements came about by the "reuse" of the fuel, i.e., the fuel used in this test was used before in the float switch test. It is likely that the measured degradation came about by the exposure of the fuel during the testing rather than from any significant shear experience associated with the valves themselves. At this time the effects of degradation by light were not known and the fuel handling in that regard was not as careful as that for samples taken during later testing.

No potential problems are evident or expected in using the float valve with AMK fuel.

Jet Pumps

Both jet pumps exhibited lower performance when using the AMK; the decrease in performance of the transfer jet pumps was more critical than that of the scavenge jet pump. A larger jet pump could be used to restore the desired performance. Any system changes would have to be made as part of a total aircraft fuel system review and design analysis conducted with the intent of certifying system performance on a particular AMK. An extensive fluid property data base derived from testing would be required to make the analysis.

Due to the current DC-10 fuel system configuration, the transfer of fuel by the jet pump systems will cause mixing of highly degraded fuel with fuel in the tanks. System revisions can be made to minimize this mixing. For example, a partial barrier box could be built around the outboard jet pump to localize the degraded fuel. The location of the inboard jet pump outflow could be continued to a point near the boost pump inlet to minimize mixing of bulk fuel and the degraded fuel from the jet pump.

Any system redesign may be expected to add weight to the airplane because the current systems are as near optimum as practically possible. It must be kept in mind that a system modified to improve

handling and performance with AMK will still have to meet the requirements of system operation with widecut fuels. Aircraft are frequently called upon to cross international boundaries as a requirement of operational flexibility. If AMK is not available, the aircraft must be able to perform with other acceptable fuels.

There are inconsistencies in the fuel quality data. For the scavenge jet pump test (P/N 60324), the virgin sample test results indicated high degradation. The secondary AMK supply gave slightly better antimisting quality readings even though the virgin and the secondary AMK were both "virgin" fuels. Tables 18 and 19 show a history of the fuel quality of the AMK used in the scavenge jet pump tests. Similar "scatter" is shown in the transfer jet pump fuel quality data (P/N 60102).

**TABLE 18
RMH 1-144, AMK FUEL QUALITY**

<u>DAC TEST</u>	<u>DATE</u>	<u>JPL TEST DATE</u>	<u>FILTER RATIO</u>	<u>ICI CUP TEST (ml)</u>	<u>FCTA RESULTS (S.C. 900)</u>
P/N 60324 Jet Pump Test	8-25-81	8-31-81	8.0 at 23.0 °C	6.1 at 23.0 °C	---
Boost Pump Flow Point Selection	7-1-81	7-10-81	23.0 at 24.0 °C	3.2 at 22.0 °C	91.2 °C 95 psi
Float Switch Test	7-23-81	7-28-81	18.3 at 19.5 °C	3.7 at 20.0 °C	96.0 °C 97 psi
Shelf-life Check	9-15-81	9-28-81	17.0 at 21.9 °C	3.0 at 22.0 °C	41.0 °C 95 psi
- Sample was cloudy - H ₂ O content of 280 PPM					

**TABLE 19
RMH 1-148, AMK FUEL QUALITY**

<u>DAC TEST</u>	<u>DATE</u>	<u>JPL TEST DATE</u>	<u>FILTER RATIO</u>	<u>ICI CUP TEST (ml)</u>	<u>FACT RESULTS</u>
Transfer Valve Test	9-21-81	10-1-81	7.5 at 22.0 °C	7.4 at 22.0 °C	130 °C 95 psi S.C. 250
Shelf-life Check	11-6-81	11-15-81	25.0 at 21.0 °C	3.7 at 20.5 °C	77.4 °C 93 psi S.C. 250
Shelf-life Check	1-5-82	1-12-82 1-13-82 1-22-82	20.0 at 25.5 °C	3.8 at 19.5 °C	86.7 °C 94 psi S.C. 900

There is no documented explanation of these anomalous data points. It may be that samples were mixed, although great care was exercised in sample labeling and handling. There were occasions when reruns of the "same" sample gave widely varying results. The fuel samples were tested off site with some time elapsed before sample test results were obtained. Testing on site and immediately after sampling could improve the identification of questionable data.

The jet pump discharge sample analysis indicated degraded AMK fuel because the primary flow comes from the boost pump. This implies that near the end of the flight mission, the transfer jet pump system may be transferring degraded AMK fuel.

Gravity Transfer Valve

The makeup flow rate of the AMK is acceptable. Aircraft capability requires the makeup flow rate to be greater than the scavenging flow rate. For the AMK fuel, this criterion is met.

The makeup flow was highly degraded. The makeup fuel comes directly from the boost pump. This implies that near the end of the flight, a portion of the fuel volume in the outboard compartment could be highly degraded. System revisions can be made to eliminate continued degradation due to the use of this system in normal operations. The affinity of the AMK (FM-9) for water indicates that the continuous scavenge system may be deleted so the makeup flow could be eliminated. System failures and leakage suggest that some means of maintaining outboard compartment fuel level will be required. It may be that under these conditions degradation of only part of the fuel load may be acceptable.

The AMK was able to initiate gravity flow through the valve without any problems. The gravity flow generated minimal degradation. The gravity system rather than the jet pump transfer system is the usual method of outboard fuel transfer. This would imply that good fuel quality would result.

The gravity flow rate was reduced by about 25 percent. This performance loss would have two effects: (1) there would be wider swings in the inboard fuel level, which could require fuel schedule system redesign, or (2) there would be increased fuel transfer by the jet pump transfer system, which would result in greater net degradation of wing tank fuel.

There is a discrepancy in the virgin AMK fuel quality data. Table 19 gives a history of the particular batch used in this test. As noted elsewhere, anomalies have occurred in the data for which there is no documented explanation.

AMK Degradation versus Boost Pump Flow

Boost pump performance was lowered when using AMK. Boost pump pressure requirements using low volatility fuels are generally low, but volume flow rate capability is not diminished. This means that some high flow rate requirements of the aircraft system may not be met. High flows are required when feeding two engines, when dumping fuel, and during high rate defuel requirements. Aerial refueling pumps may be at high rate when refueling large aircraft. The additional system backpressure resulting from using AMK will further reduce resulting system flow rates. Specific total system test and analysis will be required to determine whether all system requirements are met and where compromises must be evaluated for acceptability.

AMK degradation decreased with increased flow rate through the boost pump. Even at the low flow rate (highest amount of degradation), the antimisting qualities are still quite good provided that the virgin AMK started off with high qualities. The maintenance of good tank fuel quality would re-

quire more degradation by the engine system. It also means that if high-quality fuel was used at the start, then normal fuel transfer from tank to tank may be possible while maintaining a normal fuel management system. High fuel degradation with near-zero flows and low degradation at the high but temporary flows of transfer may result in an integrated-tank fuel quality of acceptable levels. The effects of cooling flow return were not evaluated. They may not be important because the cooling flow is localized near the pump inlet. Tests of pumped fuel transfer on an actual airplane will help answer these questions. These boost pump tests were directed to pump evaluation only.

From observation, the boost pump worked harder when pumping the AMK. This is evident in the current data of Tables V and VI. Areas of concern would be service life and maintenance costs, increased current draw, and fuel degradation during fuel transfer operation. The pump seemed to strain for a few seconds at the start of each run and then relaxed to a lower power draw condition. This transient was quite noticeable by changes in the pump noise level. Low temperature operation may heighten this effect. Testing should be done to obtain data with which to determine whether the rest of the electrical system would be put under unacceptable strain. It is likely that the airplane wiring is adequate but that a circuit breaker revision would be required.

WATER TEST

No observable changes of the AMK occurred during this test. The AMK "lost" its original water content. Theories had been put forward that the water would not be lost because it would be chemically bound to the glycol in the carrier fluid of the additive. This poses a question regarding the form of the water in the AMK (FM-9) and as to what changes may occur in the AMK when water is gained or lost.

Free water in small quantities coming in contact with AMK causes water contamination locally. However, the effects quickly disappear.

Upon completion of the water test, the boost pump was removed and examined. No water contamination or gel formation was found.

The AMK was highly degraded due to the boost pump working the fluid over and over again. The fuel quality tests showed high values just after water addition. The reasons for this increase are not known.

Due to AMK's affinity to water, system modifications can be made to the benefit of the aircraft as well as to the use of the AMK fuel. The continuous scavenge system may be eliminated and the existing makeup flow system modified. By changing the makeup flow system, transporting degraded fuel from the boost pump to the outboard compartment can be kept to a minimum.

SYSTEM TESTS

Fill System

Slow system response and reduced flow rates with AMK relative to Jet A were exhibited throughout the testing. Actuation and shutoff responses of the fill valve were sluggish. The shutoff delay resulted in larger volumes passing through the fill valve during valve closure which increased overshoot values. The delay probably was caused by an increased resistance to flow in the fill valve controller passages.

The lower flow rates imply increased refueling time causing longer turnaround time for the aircraft operators. Due to the increase in the overshoot volume, the current usable fuel tank volume would have to be reduced to maintain expansion space requirements.

Gel was formed in the fill valve controller. If gel accumulates in the fill valve, severe response deterioration can occur. This aspect of AMK (FM-9) use should be examined in long-term tests. The fill valve controller is a complicated piece of equipment that performs during several functions of the fuel system. The concept of a hydromechanical valve has many attractive features that would require extensive effort to replace. Therefore, its performance should be examined in detail to determine which functions can be retained in a system compatible with AMK.

This program used batch blended fuel. Fill system performance will probably be different with in-line blended AMK.

The AMK fuel quality data indicate that the amount of AMK degradation due to the fill system is slight.

Vent System

The fuel tank overpressure during an overfill condition with AMK was about equal to the neat fuel case. It was suspected that tank pressures during overfill might be reduced significantly because a large part of the vent system back pressure is line friction loss and the AMK has flow-improving properties in this regime.

The gellation and deposits found in the fill tests may affect the overpressure device due to plugging of small passages. There was no opportunity to check the overpressure shutoff feature of the fill valve because tank pressures were below actuation level.

The vent system design prevents fuel from flowing overboard during pitching, rolling, and uncoordinated maneuvers. Fuel (AMK) will enter the vent system and will reside in the lines until tank fuel levels are low enough for this fuel to drain out. If water condenses on the cold vent system during the descent into humid areas it is conceivable that water/AMK ratios may be high enough to prevent drainage of the fuel from the lines. This aspect of AMK (FM-9) use should be considered in aircraft rework to accommodate AMK (FM-9).

Engine Feed System

The basic fuel feed performance test reinforces the data generated in the AMK degradation versus boost pump flow test. Boost pump performance decreased when AMK was used. AMK samples were taken at two flow points, minimum and maximum flow. The highest degradation of the AMK was found to be at the low flow rate condition. The data will be of interest to the engine system designers examining AMK (FM-9) under separate contracts. The degree of degradation as a function of starting fuel quality was not examined.

In the suction feed climb test, the engine pump cavitated at 31,000 feet altitude when using the AMK. The system met flow and pressure requirements to the maximum certified altitude for the DC-10/KC-10 (42,000 feet) when using Jet A. Determining the reason for fuel feed system failures was not within the scope of this program. However, this is a result that deserves further investigation. Some aircraft systems are normally operated on suction feed. All fuel feed systems must have some suction feed capability to provide satisfactory engine operation in the event of electrical

failure. Dispatch with one or more boost pumps inoperative is a very desirable capability now enjoyed by operators. Aircraft which normally require boost pump operation will go on suction feed in the event of a pump failure if one was inoperative at dispatch.

Flight Cycle

The flight cycle tests indicated lower boost pump performance for all the AMK runs than that for the Jet A run. The engine inlet pressure curve was lower during the first AMK flight cycle than during the rest. This may be explained by the fact that flight cycle No. 1 had all virgin AMK in the test tank while subsequent runs (cycle Nos. 2, 3, 4) had a mixture of somewhat degraded AMK and virgin AMK. This mixture is representative of unused fuel from the previous flight and new fuel for the next flight mission.

In the flight cycle tests, AMK sampled from the tank exhibited good fire protection qualities. This would indicate that AMK in the fuel tank could be expected to retain most of its fire protection qualities throughout the flight mission. The DC-10 engine feed system degraded the AMK fuel to the point where the antimisting properties were somewhat lost. AMK degradation was higher through the feed system than the boost pump tests would indicate. However, in the feed system tests the scavenge system and pump cooling flow fuels were returned to the tank in the vicinity of the tank boost pump inlet. This degraded fuel was drawn into the feed system along with the fuel needed for the engine.

The engine fuel pump further degraded the fuel. Highly degraded AMK was found at the engine pump interstage.

KC-10 AERIAL REFUELING NOZZLE/RECEPTACLE

The pressure drop versus flow rate curve indicated higher system pressure loss with the AMK than with Jet A. Performance with JP-8 would be identical to Jet A performance.

The fuel quality measurements indicated that the AMK retains most of its fire protection qualities throughout the flow range of the test. Minimal AMK degradation occurred in the KC-10 aerial refueling system. This may have been because the aerial refueling pumps are slaved to the nozzle inlet pressure and their speed is reduced at low flows. The quality of AMK fuel in a receiver airplane will be highly a function of the degradation experienced in the receiver airplane system. Aerial refueling with AMK fuel using the KC-10 refueling boom is possible.

ULTRASONIC FLOWMETER

The ultrasonic flowmeter used in this program was the Controlotron Series 240 Clampitron Flowmeter. This flowmeter consists of two basic components, the transducers which transmit and receive a beam of ultrasonic energy, and the computer which analyzes the signal.

An ultrasonic beam is transmitted by a transducer through one side of the pipe, through the liquid, out the other side of the pipe, and is received by another transducer. The receiver transducer converts the sonic energy into an electronic signal. The beam velocity is effectively increased or decreased slightly by the liquid flow. The computer receives the signal, extracts the effect of the liquid flow on the apparent sonic beam velocity, and converts this to flow rate.

The ultrasonic flowmeter was used in the engine feed, flight cycle, and KC-10 system tests. In the engine feed and flight cycle tests, a turbine flowmeter was in series downstream of the ultrasonic meter. Throughout the tests, using both Jet A (baseline) and AMK, the flowmeters were within

1 gpm of each other. The flowmeters were downstream of the engine pump and fuel control unit. The AMK that was passing through the flowmeters was highly degraded.

In the KC-10 aerial refueling nozzle/receptacle tests, three flowmeters existed in the test setup. A GE mass flowmeter (part of the KC-10 refueling system) as well as ultrasonic and turbine flowmeters were in series (Figure 61). The flowmeters were in good agreement when using Jet A (1 gpm "scatter" in readings). For the AMK runs, the flow rate readings were highly scattered with the readings of three flowmeters being different for each flow condition. A preliminary run indicated changing response over the flow condition, but conditions were generally of a transient nature and no conclusions could be drawn.

The GE flowmeter required a stopwatch to obtain the flow rate. It recorded the fuel use in pounds. In order to get good flow rate data, long time intervals were required. This was not possible for the AMK runs due to fuel use.

The turbine flowmeter output was not steady during the AMK runs. At a preset opening on the flow control valve (Figure 61), the flow rate reading fluctuated during the run.

The ultrasonic flowmeter had proven to be a good measure of fuel flow during the component testing. Though the flow rate reading from the ultrasonic flowmeter differed from the rest, it remained steady during each run. The flow rate data used in the KC-10 system tests came from the ultrasonic flowmeter.

The AMK in the flowmeters was only slightly degraded compared with the engine feed and flight cycle test AMK. As reported by other investigators, inconsistent readings from the turbine flowmeter occur for the AMK unless it is degraded to an appreciable amount. The nonintrusive ultrasonic flowmeter seems to be a reliable flow measuring device for a wide range of AMK quality levels.

CONCLUSIONS

- Based on the limited amount of testing done in this program, two general conclusions evolve:
 1. Some DC-10/KC-10 systems are incompatible with AMK made with 0.30 percent FM-9 with carrier fluid. Fuel system modifications and/or procedural revisions to maintain the AMK quality do not appear to present technically insurmountable challenges.
 2. AMK (FM-9) reduces the performance of some fuel subsystems (e.g., jet pump transfer, gravity transfer, and suction feed) below normally accepted levels.
- AMK (FM-9) quality in tank bulk fuel appeared satisfactory throughout a simulation of four repeated flights.
- Extensive study and testing will be required to certify the aircraft fuel system for use with AMK.
- AMK (FM-9) was compatible with small amounts of water using a method of water addition simulating the situation for a wing fuel tank.
- Tests are required to examine components and systems to obtain data to specifically define requirements for fuel system modification.
- AMK quality measurement methods show wide variations in results.
- The KC-10 aerial refueling system can deliver AMK to a receiver airplane refueling manifold with only slight degradation.

BIBLIOGRAPHY

1. Peacock, A.T., "KC-10/DC-10 Fuel System Simulator," FAA-CT-81-181, February 1981.
2. Fiorentino, A., DeSaro, R. and Franz, T., "An Assessment of the Use of Antimisting Fuel in Turbofan Engines," NASA CR-165258, December 1980.
3. Peacock, A.T., "The DC-10 Fuel System," SAE 730386, April 1973.
4. Segall, J., "Application Consideration for Controlotron Ultrasonic Clampitron Flowmeter," ISA 75-822, October 1975.
5. Morris, H. M., "Ultrasonic Flowmeter Uses Wide Beam Technique to Measure Flow," Control Engineering, July 1980.

APPENDIX A FUEL QUALITY TESTS PERFORMED BY JPL

MODIFIED FILTRATION RATIO TEST PROCEDURE FOR AMK

The filter ratio test is a fixed-volume variable-time measurement. The time to pass a specific volume of AMK through a 16- to 18-micron filter is measured. This time is referenced to the time required to pass base fuel in the same test. This normalized parameter is the filter ratio. All testing must be done at $20^{\circ}\text{C} \pm 1^{\circ}\text{C}$.

This procedure was conceived by the Royal Aircraft Establishment (RAE) and modified by JPL. The filtration ratio test has been used in the past to assess the level of degradation of antimisting kerosene (AMK) after passage through various types of degraders. More recently its use has been extended to undegraded AMK fuels where it has been shown that the reproducibility of filtration ratio (FR) results for a particular additive batch dissolved in a particular kerosene is much better than previously thought. The test therefore appears useful as a quality control test for AMK fuel batches.

The following procedure contains improvements agreed to at the 9th U.S./U.K. Technical Group meeting on AMK and, if carefully followed, should give results which are reproducible and may be compared with those obtained by other workers.

Apparatus

- Modified filtration ratio apparatus as shown in Figure A1.
- A supply of pre-cut unused stainless steel filter discs stored in clean dust-free conditions. Disc specifications included twilled Dutch-weave GEBO metal filter cloth of absolute filter rating of 16 to 18 microns, 165 by 1400 mesh, warp diameter of 0.07 mm, and welt diameter of 0.04 mm, the filter cloth being pre-cut into circular discs of 36.3-mm diameter.
- Cleaning solvent, e.g., ethyl acetate, and compressed air or other means of drying the rinsed filter tube.
- Stopwatch.
- 200 ml each of the AMK sample and of the kerosene from which it was made.

Procedure

Check to see that the apparatus is firmly clamped in a vertical position.

Ensure that the apparatus is clean and dry. If necessary, rinse with the cleaning solvent and dry.

Holding a new filter disc by the edges only, carefully position it in the center of the lower filter holder after ensuring that both O-rings are correctly seated. Align the upper and lower filter holders and clamp together (see Note 3 in Note section that follows).

Insert a clean rubber bung in the bottom of the filter holder, choosing a size which does not contact the filter element.

Adjust the temperature of the unmodified and modified fuel samples to the agreed values ($20 \pm 1^{\circ}\text{C}$, $68 \pm 2^{\circ}\text{F}$). Record the ambient temperature, especially if very different from the test temperature.

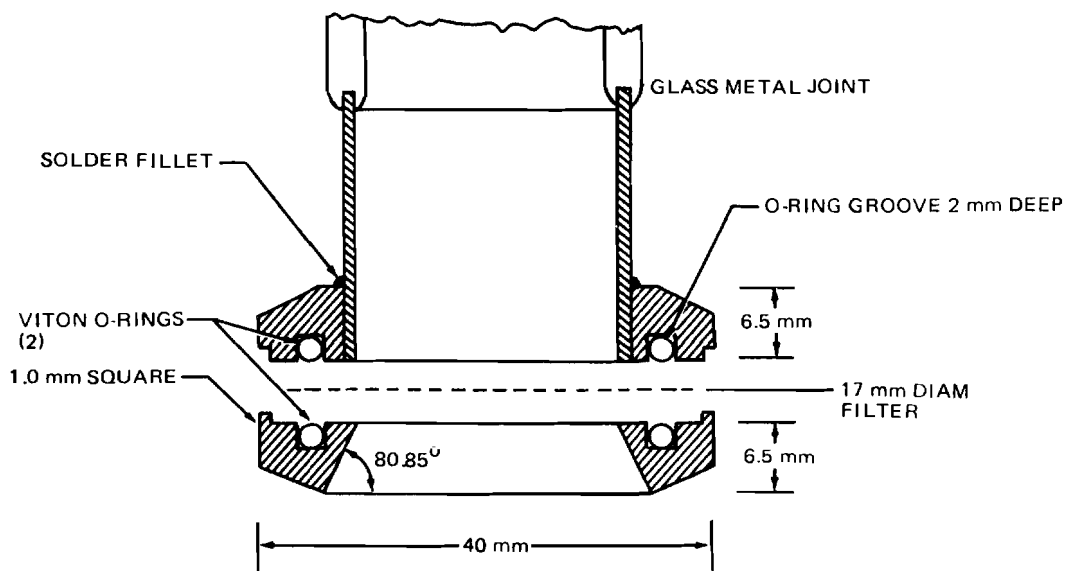
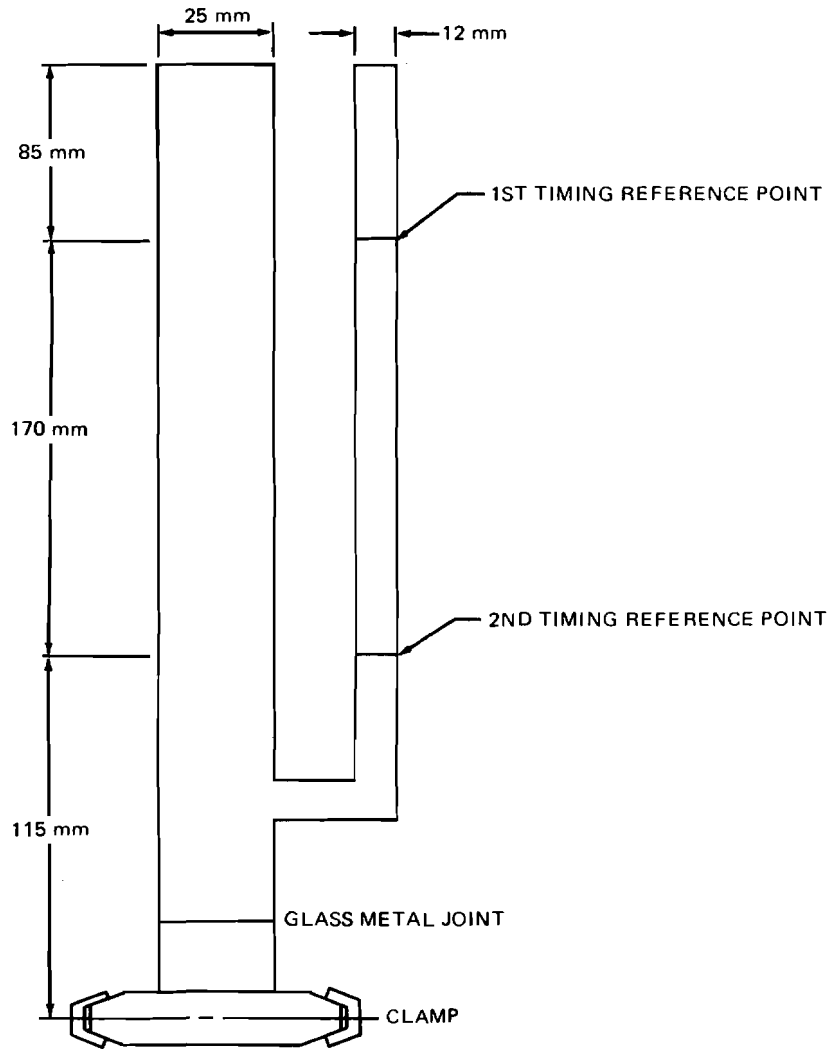

FIGURE A1. DESCRIPTION OF FILTER SCREEN ASSEMBLY

Fill the apparatus with the unmodified kerosene until the main tube just overflows.

Remove the bung. Record the time for passage of the fuel meniscus between the two marks.

Allow the apparatus to drain and then gently wipe the bottom of the lower filter holder dry with a tissue without touching the underside of the filter element. Clean and dry the bung and reposition it in the holder.

Slowly fill the apparatus with the modified AMK, taking 1-1/2 to 2 minutes, in such a way that its first contact with the filter element is brought about by a gentle covering rather than by sudden splashing. This stage is critical so that filling should be done as slowly as possible. Continue filling the tube slowly until the main tube overflows.

Leave the fuel standing for at least 1 minute, then re-zero the timer and remove the bung. Record the passage of time between marks as the tube empties.

When the test is complete, disassemble the filter assembly, discard the filter disc, and rinse the tubes, holder, and clamp with cleaning solvent in preparation for the next test. Allow the equipment to dry.

Present the following data:

- Test batch details
- Kerosene and AMK fuel temperatures
- Ambient temperature
- Kerosene filter time
- AMK filter time
- Filter ratio (FR).

Kerosene filter time = AMK filter time

Notes

1. The unmodified kerosene must be from the same batch used to make the AMK.
2. Different kerosenes vary in their viscosity, hydrocarbon composition, and boiling range. Fuel filter times may therefore vary even at a fixed test temperature. The resultant filter ratio may also change if the solvency of the kerosene changes for the additive.

It is most important that unmodified kerosene samples should be stored in clean containers in order to avoid any possible contamination with AMK; failure to do this could result in unrealistically high kerosene flow times and correspondingly low filter ratios. Flow times for simple Newtonian liquids such as kerosene should be proportional to their viscosities, and occasional measurement of the flow time of a pure hydrocarbon such as cyclohexane decane or dodecane may be beneficial in determining the purity of kerosene (coupled with viscosity measurements), or the area of filter exposed (see Note 3).

3. Some operators have been supplied with the appropriate filter apparatus by the RAE. Using this equipment, recent tests have indicated that due to different clamping pressures and O-ring projections, the area of filter element exposed to the test fuel may vary, giving corresponding

differences in kerosene and AMK filter times. The results of further investigations clearly indicate the filter ratio values are unaffected by such variations, but even so a standardization of the effective filter area is desirable.

For users of RAE-made equipment, the flow time differences are caused by the fact that when the O-rings project from their grooves by about 0.5 mm or less, the filter element is sealed against the metal surface of the upper filter holder. The effective filter disc diameter is therefore 23 mm, as intended, and typical flow times for unmodified U.K. Jet A-1 and U.S. Jet A are, respectively, about 4.5 and 5.4 seconds at 20°C. However, when the O-rings project by about 1 mm, the effective filter diameter may vary, according to clamp pressure, up to a maximum of the O-ring diameter (32 mm) and the typical U.K. Jet A-1 flow time may decrease to as little as 2.8 seconds. In order to standardize on a 23-mm filter diameter, which gives a 'straight-through' flow profile rather than a 'belling-out' flow, a metal annulus of inner and outer diameters of 23 mm and 37 mm, respectively, and of 0.5-mm thickness may be inserted on top of the filter disc when clamping the two halves together.

JPL OPERATING PROCEDURE FOR ICI CUP TEST

The ICI Cup test is a fixed-time, variable-volume measurement. The test fuel is allowed to pass through a standardized orifice (in the standard ICI Cup) for 30 seconds and the volume of the fluid is measured. This test is done at 20°C ± 1°C.

Cleaning Procedure

Place cup in Jet A. Fill cup about half way with Jet A.

Sonicate for 30 seconds in Jet A fuel; power rating at 7.

Blow until dry with 25-psi nitrogen (1/4-inch hose). It is important that the area around the hose, both inside and out, is completely dry and void of any particles.

Operating Procedure

Suspend cup inside ring on ring stand. Allow enough room below cup to permit introduction of graduated cylinder (preferably 10 cc).

Place finger over the hole and tilt cup slightly to one side. Pour in fuel sample allowing fuel to run down the sides of the cup rather than hitting the bottom directly.

Let fuel overflow into gallery.

Once cup is full, allow 30 seconds before releasing finger (fuel relaxation time).

Release finger at 30-second mark, recovering fuel in beaker beneath hole. Let the cup drain for another 30 seconds.

Again at the 30-second mark, simultaneously slide graduated cylinder in place of beaker. Collect for another 30 seconds and then remove graduated cylinder and replace beaker.

Record amount collected.

Discard collected material and repeat cleaning procedure.

After cleaning, the cup is stored in Jet A.

FLAMMABILITY COMPARISON TEST APPARATUS (FCTA)

The flammability comparison test measures the peak temperature of the flame produced by the test fuel in a standard apparatus. The FCTA has two controllable parameters, speed control and pressure. The speed control is related to the test fuel flow rate into the FCTA. The pressure is the supply pressure that moves the test fuel/air mixture through the FCTA to be ignited. The flame temperature is measured at a standardized distance downstream of the igniter.

The flammability comparison test apparatus was developed by the FAA so that each organization involved in antimisting fuel research efforts would have comparable equipment for studying the flammability of antimisting fuels. Units were built for:

- Jet Propulsion Lab
- Southwest Research Institute
- NASA Ames
- NASA Lewis
- Royal Aircraft Establishment
- FAA Technical Center.

The apparatus consists of three subsystems (Figure A2) controlled by a timer. The first system is a propane torch which serves as an ignition source for the fuel. The second subsystem provides air through a sonic orifice into a mixing tube and nozzle. Fuel is supplied by a piston pump into the mixing tube and is sheared by the high-velocity air. The fuel/air mixture is then exposed to the propane ignition source. A test consists of a number of runs with preset air and fuel flow rates. A thermocouple is used to determine the absolute flame temperature.

The operating procedure was somewhat abridged by JPL in this program. The finalized test procedure as developed by JPL was to set the speed control at 200 and the pressure at 90 to 95 psi. The flame temperature was measured.

Tests with FM-9 and Jet A indicate that the flammability comparison test apparatus provides useful information for screening antimisting fuels.

The specific operating requirements, procedure, and baseline testing are detailed in "Flammability Comparison Test Apparatus — Operator's Manual" by Augusto Ferrara and William Cavage (no date or publication number).

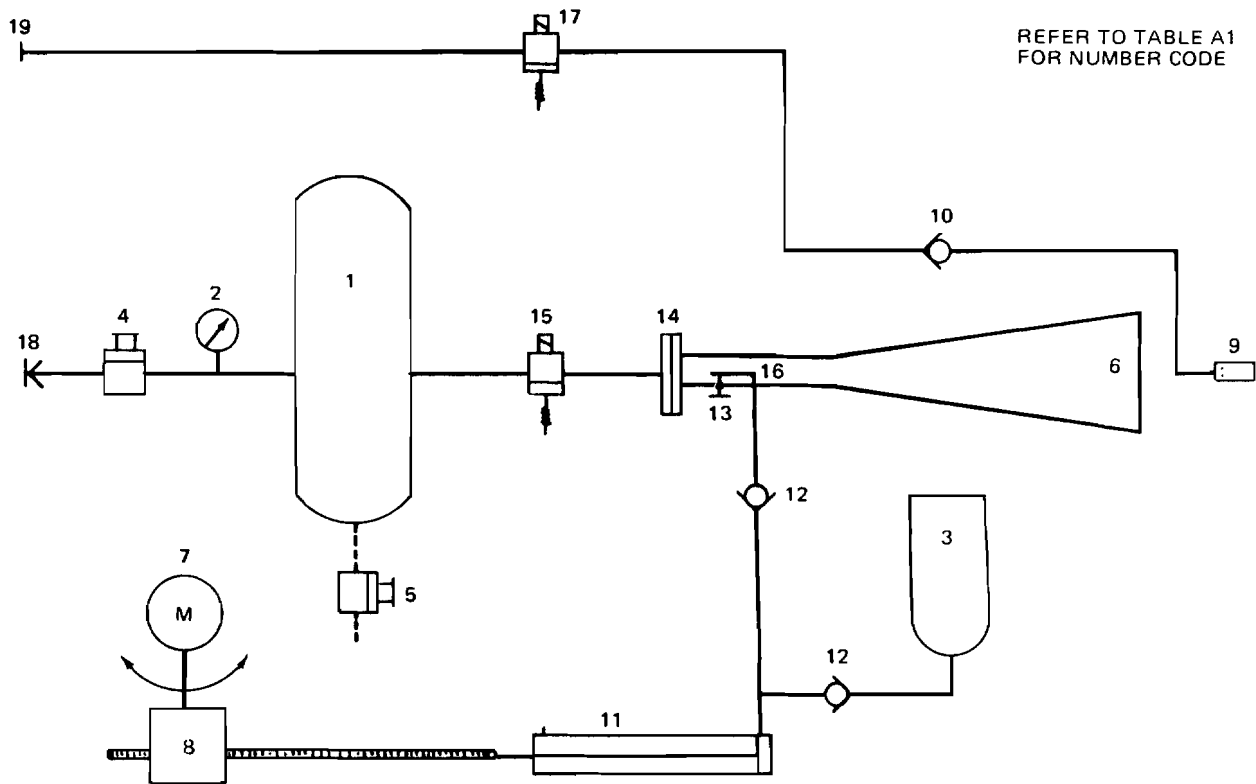

REFER TO TABLE A1
FOR NUMBER CODE

FIGURE A2. FLAMMABILITY COMPARISON TEST APPARATUS (FCTA) SCHEMATIC

TABLE A1
COMPONENT GUIDE

- | | |
|--|----------------------------------|
| 1. Air Tank | 11. Fuel Pump Cylinder/Piston |
| 2. Pressure Gage | 12. Check Valve Fuel |
| 3. Fuel Reservoir | 13. Fuel Discharge Tube Assembly |
| 4. Air Toggle Valve | 14. Sonic Orifice Assembly |
| 5. Air Tank Drain Valve | 15. Air Solenoid |
| 6. Deceleration Cone | 16. Mixing Tube |
| 7. Motor | 17. Propane Solenoid |
| 8. Jactuator [®] Unit (screw drive) | 18. Air Supply Quick Connect |
| 9. Propane Torch | 19. Propane Source Connection |
| 10. Check Valve (propane) | |

APPENDIX B ADDITIONAL DOUGLAS AMK OBSERVATIONS

BOOST PUMP FLOW POINT SELECTION

AMK conservation was of paramount interest during the program due to the high cost of the test fuel in the "research quantities" purchased. For the component testing, the DC-10/KC-10 tank-mounted boost pump was used extensively. The many systems (scavenge, transfer jet pump, makeup flow) operate from the pressurized fuel that is tapped off the boost pump discharge line.

To minimize "waste" fuel, two boost pump configurations were tested: "dead-head" where discharge flow was zero and "2 psi below deadhead" where a discharge flow existed.

The test setup was similar to that of the AMK degradation versus boost pump flow tests. (Because of this testing, the AMK degradation versus boost pump flow tests were added to the original program.)

The test results are presented in Table B1.

The amount of quality degradation is comparable. The subsequent component testings had zero boost pump discharge flow. Note that this test was a "screening" test to save fuel. The interested reader should refer to the AMK Degradation versus Boost Pump Flow section in the report proper for details.

SPECIFIC GRAVITY VERSUS TEMPERATURE

During the course of the program, it became of interest to determine the behavior of AMK in low temperatures. Of specific interest was the density of the AMK as a function of temperature. Due to wide use of mass flow rates in industry, it was necessary to be able to convert volumetric flow rates into mass flow rates and vice versa.

A simple test was devised. A 100-ml graduated cylinder was used to store the AMK with accompanying stoppers to prevent water from permeating into the fuel. A low-temperature compartment (6 by 3 by 3 feet high) was used and a hot water bath was used for high temperatures.

The test results are plotted in Figure B1. The minimum test temperature was -45.4°F (-43°C). This was the test readability limit of the hydrometer. Readability stands for the time the hydrometer can be read. When taking the hydrometer reading, an icy film formed on the outside wall of the graduated cylinder within a couple of minutes making it difficult to read the hydrometer.

No gellation or phase change was observed at this minimum temperature. The AMK was slightly cloudy. Great care was taken during the test. A stopper was used at all times except when hydrometer readings were taken. The stopper had an opening in which a thermometer could fit tightly. All readings (temperature and specific gravity) were taken in the compartment area.

At -16.6°F (-27°C), the AMK was clearing up, and the graduated cylinder was losing its icy film on the outside wall when the lid of the testing compartment was opened.

Water content was measured before and after the test —156 ppm and 163 ppm respectively. Karl Fischer titration was used.

**TABLE B1
BOOST PUMP FLOW POINT SELECTION TEST**

<u>CONFIGURATION</u>	<u>AMK SAMPLE</u>	<u>PRESSURE (PSI)</u>	<u>FILTER RATIO</u>	<u>ICI CUP TEST (ML)</u>	<u>FCTA RESULTS</u>
	Virgin		23 at 24.0°C	3.2 at 22.0°C	91.2°C 94-96 psi S.C. 900
Dead Head	Discharge	30	3.8 at 23.0°C	7.3 at 22.0°C	224 °C 97-100 psi S.C. 300
	Cooling Flow (1 gpm)		2.0 at 23.5°C	7.3 at 22.0°C	203 °C 92-98 psi S.C. 250
2 PSI Lower Than Dead Head	Discharge (10 gpm)	28	5.5 at 23.5°C	7.2 at 22.0°C	103 °C 95-99 psi S.C. 250
	Cooling Flow (1 gpm)		3.7 at 23.0°C	7.3 at 22.0°C	200 °C 94-90 psi S.C. 250

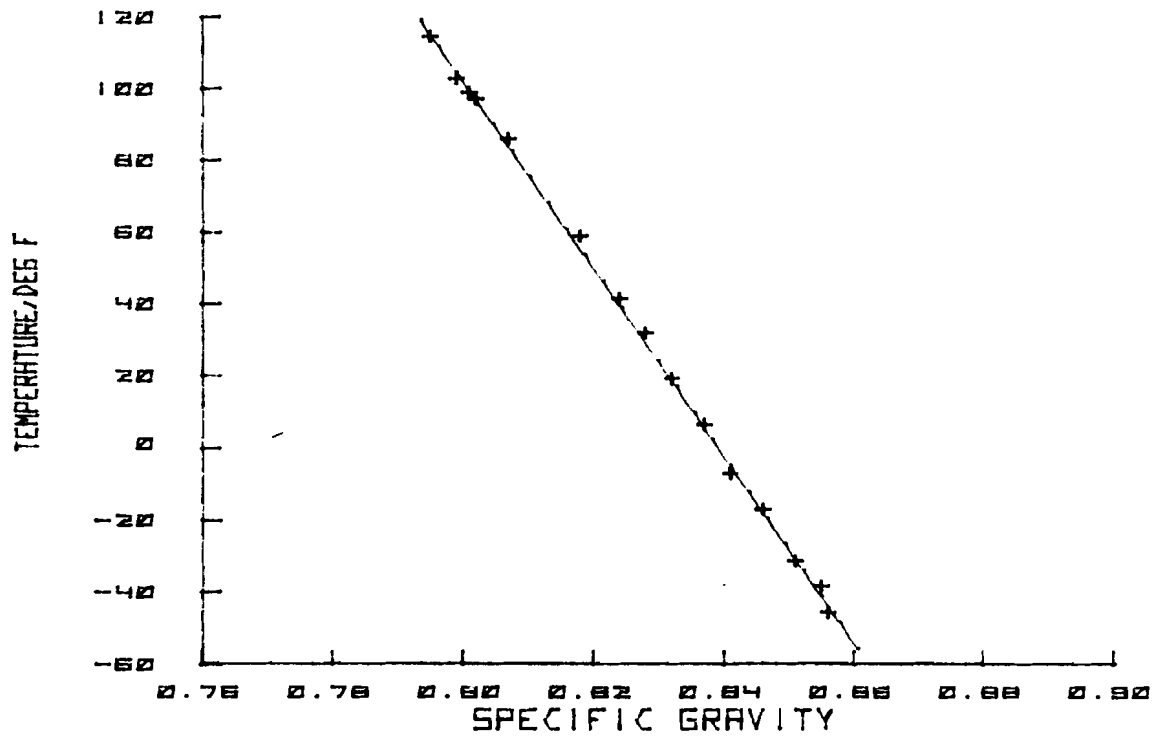
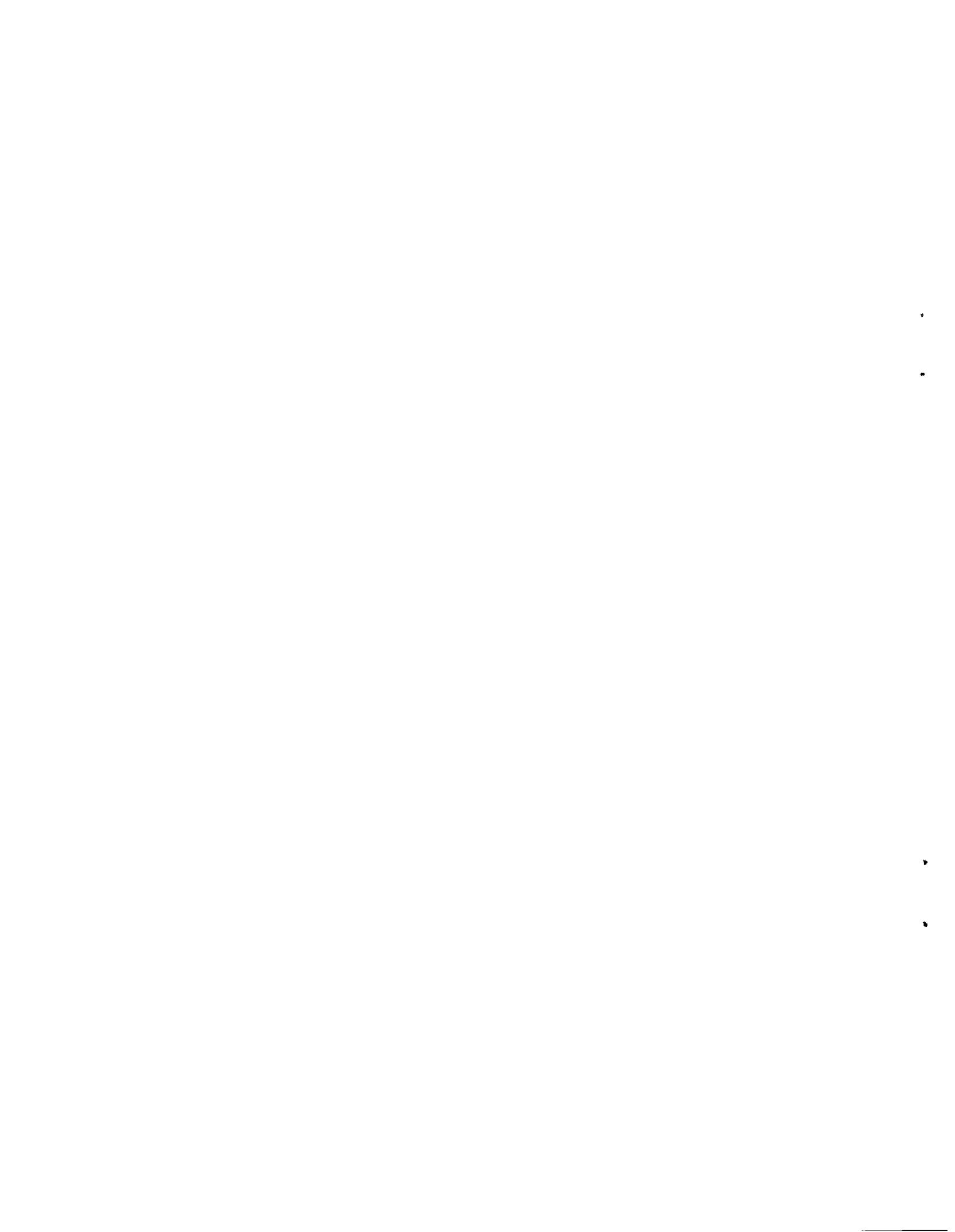

FIGURE B1. AMK, SPECIFIC GRAVITY VERSUS TEMPERATURE



**APPENDIX C
AMK FUEL QUALITY LOG FOR DOUGLAS PROGRAM**

A complete description in chronological order of the fuel quality data for this program is listed in the following pages. "AMK Identification" corresponds to the testing and additional sampling deemed necessary in the program.

<u>DAC TEST DATE</u>	<u>AMK IDENTIFICATION</u>	<u>JPL TEST DATE</u>	<u>FILTER RATIO</u>	<u>ICI CUP TEST (ML)</u>	<u>FCTA RESULTS</u>
Boost Pump Flow Point Selection 7/1/81	Virgin AMK RMH1-144 Base Fuel: 01105	7/10/81	23 at 24°C	3.2 at 22°C	91.2°C 94-96 psi S.C. 900
Boost Pump Flow Point Selection 7/1/81	Discharge at Dead Head	7/10/81	3.8 at 23°C	7.3 at 22°C	224°C 97-100 psi S.C. 300
Boost Pump Flow Point Selection 7/1/81	Cooling Flow at Dead Head	7/10/81	2.0 at 23.5°C	7.3 at 22°C	203°C 92-98 psi S.C. 250
Boost Pump Flow Point Selection 7/1/81	Discharge at 2 psi below Dead Head	7/10/81	5.5 at 23.5°C	7.2 at 22°C	103°C 95-99 psi S.C. 200
Boost Pump Flow Point Selection 7/1/81	Cooling Flow at 2 psi below Dead Head	7/10/81	3.7 at 23°C	7.3 at 22°C	200°C 94-99 psi S.C. 250
7/1/81	Base Fuel 01105	7/10/81	5.3 at 23°C	7.8 at 22°C	287°C 87-97 psi S.C. 200-300
7/1/81	Base Fuel 10608	8/19/81	6.0 at 22°C	7.9 at 22°C	_____
Float Switch Test 7/23/81	Virgin AMK RMH1-144 Base Fuel: 01105	7/28/81	18.3 at 19.5°C	3.7 at 20°C	96.0°C 97 psi S.C. 900
Float Switch Test 7/23/81	Sample After Testing	7/28/81	18.2 at 19.5°C	3.6 at 20°C	96.0°C 97 psi S.C. 900

<u>DAC TEST DATE</u>	<u>AMK IDENTIFICATION</u>	<u>JPL TEST DATE</u>	<u>FILTER RATIO</u>	<u>ICI CUP TEST (ML)</u>	<u>FCTA RESULTS</u>
Float Valve Test 7/23/81	Sample After Testing RMH1-144	7/28/81	16.8 at 20°C	3.9 at 20°C	110°C 97 psi S.C. 900
Fuel For Fill & Vent System Test 8/3/81	Virgin AMK RMH1-161 to 174 Compartment 1 Base Fuel: 10720 Sampled at Arrival	8/6/81	24.4 at 20°C	3.0 at 19.0°C	79.2°C 93 psi S.C. 900
Fuel For Fill & Vent System Test 8/3/81	Virgin AMK Compartment 2 Base Fuel: 10720 Sampled at Arrival	8/6/81	27.8 at 20°C	2.7 at 19.0°C	68°C 92 psi S.C. 900
Fuel For Fill & Vent System Test 8/3/81	Virgin AMK Compartment 3 Base Fuel: 10720 Sampled at Arrival	8/6/81	27.8 at 20°C	2.9 at 19.0°C	71.2°C 92 psi S.C. 900
8/12/81	Base Fuel 10720	8/13/81	6.3 at 22°C		_____
Scavenge Jet Pump Test 8/25/81	Virgin AMK RMH1-144 Base Fuel: 01105	8/31/81	8.0 at 23°C	6.1 at 23°C	_____
Scavenge Jet Pump Test 8/25/81	Scavenge J.P. Discharge	8/31/81	7.6 at 23°C	7.0 at 23°C	_____
Scavenge Jet Pump Test 8/25/81	Secondary AMK Supply-Scavenge J.P. Test	10/1/81	12.0 at 21.9°C	4.9 at 21.5°C	55°C 95 psi S.C. 250
Transfer Jet Pump Test 9/14/81	Virgin AMK RMH1-146 Base Fuel: 01105	10/1/81	20 at 22°C	3.2 at 22°C	46°C 95 psi S.C. 900
Transfer Jet Pump Test 9/14/81	Transfer J.P. Discharge	10/1/81	4.5 at 21.8°C	7.0 at 22°C	60°C 95 psi S.C. 250
Transfer Jet Pump Test 9/14/81	Secondary AMK Supply - Transfer J.P. Test	10/1/81	11.5 at 22.6°C	5.0 at 22.3°C	72°C 95 psi S.C. 250
Quality Check 9/15/81	Virgin AMK RMH1-144 Due to the "bad" data in Scavenge J.P. Test	10/1/81	17.9 at 21.9°C Fuel clarity was cloudy. was 280 ppm.	3.0 at 22°C Water content	_____

<u>DAC TEST DATE</u>	<u>AMK IDENTIFICATION</u>	<u>JPL TEST DATE</u>	<u>FILTER RATIO</u>	<u>ICI CUP TEST (ML)</u>	<u>FCTA RESULTS</u>
Gravity Transfer Valve Test 9/21/81	Virgin AMK RMH1-148 Base Fuel: 01105	10/1/81	7.5 at 22°C	7.4 at 22°C	130°C 95 psi S.C. 250
Gravity Transfer Valve Test 9/12/81	Gravity Flow	10/1/81	17.2 at 22°C	3.8 at 22°C	40°C 95 psi S.C. 250
Gravity Transfer Valve Test 9/12/81	Makeup Flow	10/1/81	5.7 at 21.9°C	7.2 at 22°C	125°C 95 psi S.C. 250
Fill System Test 10/12/81	Virgin AMK RMH1-161 to 174 Configuration 1	10/22 to 10/29	26 at 22°C	3.2 at 23°C	15°C 95 psi S.C. 250
Fill System Test 10/12/81	Tip Tank Configuration 1	10/22 to 10/29	18.1 at 22.5°C	4.0 at 22.5°C	10°C 95 psi S.C. 250
Fill System Test 10/12/81	Inboard Comp. Configuration 1	10/22 to 10/29	17 at 22°C	4.2 at 22°C	10°C 95 psi S.C. 250
Fill System Test 10/12/81	Virgin AMK RMH1-161 to 174 Configuration 3	10/22 to 10/29	18.5 at 21°C	3.5 at 21.3°C	15°C 95 psi S.C. 250
Fill System Test 10/12/81	Virgin AMK RMH1-161 to 174 Configuration 4	10/22 to 10/29	20 at 22°C	3.6 at 21.5°C	10°C 95 psi S.C. 250
Fill System Test 10/12/81	Tip Tank, LH Configuration 4	10/22 to 10/29	15.7 at 21°C	4.1 at 22°C	10°C 95 psi S.C. 250
Fill System Test 10/12/81	Inboard Comp, LH Configuration 4	10/22 to 10/29	13.7 at 21°C	4.1 at 21.8°C	10°C 95 psi S.C. 250
Fill System Test 10/12/81	Tip Tank, RH Configuration 4	10/22 to 10/29	16 at 21°C	3.6 at 22°C	10°C 95 psi S.C. 250
Fill System Test 10/12/81	Inboard Comp, RH Configuration 4	10/22 to 10/29	14.3 at 21°C	4.3 at 22°C	8°C 95 psi S.C. 250

<u>DAC TEST DATE</u>	<u>AMK IDENTIFICATION</u>	<u>JPL TEST DATE</u>	<u>FILTER RATIO</u>	<u>ICI CUP TEST (ML)</u>	<u>FCTA RESULTS</u>
Fill System Test 10/21/81	Virgin AMK RMH1-161 to 174 Configuration 5	10/22 to 10/29	19.3 at 21.5°C	3.5 at 22°C	20°C 95 psi S.C. 250
Fill System Test 10/21/81	Tip Tank, LH Configuration 5	10/22 to 10/29	13.4 at 21.5°C	4.5 at 21.5°C	10°C 95 psi S.C. 250
Fill System Test 10/21/81	Inboard Comp, LH Configuration 5	10/22 to 10/29	13.7 at 21°C	4.4 at 22°C	10°C 95 psi S.C. 250
Fill System Test 10/21/81	Tip Tank, RH Configuration 5	10/22 to 10/29	13.6 to 21°C	4.0 at 22°C	15°C 95 psi S.C. 250
Fill System Test 10/21/81	Inboard Comp, RH Configuration 5	10/22 to 10/29	16.2 at 21°C	4.1 at 22°C	10°C 95 psi S.C. 250
Shelf-Life Check 11/6/81	Virgin AMK RMH1-146 Base Fuel: 01105	11/15/81	24 at 20°C	3.4 at 21.0°C	62.5°C 95 psi S.C. 250
Shelf-Life Check 11/6/81	Virgin AMK RMH1-148 Base Fuel: 01105	11/15/81	25 at 21°C	3.7 at 20.5°C	77.4°C 93 psi S.C. 250
Shelf-Life Check 11/6/81	Virgin AMK RMH1-150 Base Fuel: 10608	11/15/81	34 at 20°C	3.2 at 21°C	41.7°C 97 psi S.C. 250
Shelf-Life Check 11/6/81	Virgin AMK RMH1-151 Base Fuel: 10608	11/15/81	32 at 20.5°C	3.0 at 21°C	32.3°C 94 psi S.C. 250
Fuel For Engine Feed and Flight Cycle Tests 11/23/81	Virgin AMK Identified By Base Fuel: RMH 11106 Sampled At Arrival	12/1/81 12/3/81 (FCTA)	71-61 at 19°C	3.1 at 19°C	 51.9°C 99 psi S.C. 250

<u>DAC TEST DATE</u>	<u>AMK IDENTIFICATION</u>	<u>JPL TEST DATE</u>	<u>FILTER RATIO</u>	<u>ICI CUP TEST (ML)</u>	<u>FCTA RESULTS</u>
Fuel For Engine Feed and Flight Cycle Tests 12/1/81	Virgin AMK Identified By Base Fuel: RMH 11118 Sampled at arrival	12/9/81 12/3/81 (FCTA)	52 at 20°C	3.2 at 21°C	15.7°C 97 psi S.C. 250
12/7/81	Base Fuel: RMH11106	_____	_____	_____	_____
12/14/81	Base Fuel: RMH11118	_____	_____	_____	_____
Water Test 12/22/81	Virgin AMK RMH1-151 Base Fuel: 10608 W/O Water Addition	1/13/82(F.R.) 1/12/82(ICI) 1/22/82(FCTA)	32.4 at 20.5°C	3.0 at 21°C	69.2°C 93 psi S.C. 900
Water Test 12/22/81	Virgin AMK RMH1-151 Base Fuel: 10608 W/Water, 280 ppm	1/13/82(F.R.) 1/12/82(ICI) 1/22/82(FCTA)	60 at 20.5°C	2.8 at 20°C	56.0°C 92 psi S.C. 900
Water Test 12/22/81	At 2:00 p.m. During the test	1/13/82(F.R.) 1/12/82(ICI) 1/22/82(FCTA)	1.44 at 20°C	7.35 at 20°C	269.2°C 94 psi S.C.250
water Test 12/22/81	At 4:00 p.m. During the test	1/13/82(F.R.) 1/12/82(ICI) 1/22/82(FCTA)	1.13 at 20°C	7.35 at 20°C	283.6°C 93 psi S.C.250
Water Test 12/22/81	At end of the test (12:00 p.m.)	1/13/82(F.R.) 1/12/82(ICI) 1/22/82(ICI)	1.21 at 20°C	7.4 at 20°C	297.9°C 93 psi S.C.250
Shelf-life Check 1/5/82	Virgin AMK RMH1-148 Base Fuel: 01105	1/13/82(F.R.) 1/12/82(ICI) 1/22/82(FCTA)	20 at 25.5°C	3.8 at 19.5°C	86.7°C 94 psi S.C. 900
Shelf-life Check 1/5/82	Virgin AMK RMH1-150 Base Fuel: 10608	1/13/82(F.R.) 1/12/82(ICI) 1/22/82(FCTA)	34 at 20°C	3.1 at 20°C	55°C 94 psi S.C. 900
Shelf-life Check 1/5/82	Virgin AMK RMH1-151 Base Fuel: 10608	1/13/82(F.R.) 1/12/82(ICI) 1/22/82(FCTA)	28 at 20°C	2.9 at 20°C	69.3°C 93 psi S.C. 900
Fuel For KC-10 Test 1/26/82	Virgin AMK RMH1-122 Base Fuel: 11005 Sampled at Arrival	2/15/82(F.R.) 2/18/82(ICI) 3/23/82(FCTA)	46 at 21°C	3.2 at 21°C	50°C 95 psi S.C. 200

<u>DAC TEST DATE</u>	<u>AMK IDENTIFICATION</u>	<u>JPL TEST DATE</u>	<u>FILTER RATIO</u>	<u>ICI CUP TEST (ML)</u>	<u>FCTA RESULTS</u>
Fuel For KC-10 Test 1/26/82	Virgin AMK RMH1-223 Base Fuel: 11005 Sampled at Arrival	2/15/82(F.R.) 2/18/82(ICI) 3/23/82(FCTA)	66 at 21°C	2.3 at 22°C	25°C 95 psi S.C. 200
Fuel For KC-10 Test 1/26/82	Virgin AMK RMH1-224 Base Fuel: 11005 Sampled at Arrival	2/15/82(F.R.) 2/18/82(ICI) 3/23/82(FCTA)	68 at 21°C	2.2 at 22°C	20°C 95 psi S.C. 200
Fuel For KC-10 Test 1/26/82	Virgin AMK RMH1-225 Base Fuel: 11214 Sampled at Arrival	2/15/82(F.R.) 2/18/82(ICI) 3/23/82(FCTA)	73 at 22°C	2.3 at 22°C	20°C 95 psi S.C. 200
Fuel For KC-10 Test 1/26/82	Virgin AMK RMH1-226 Base Fuel: 11214 Sampled at Arrival	2/15/82(F.R.) 2/18/82(ICI) 3/23/82(FCTA)	62 at 22°C	2.2 at 22°C	20°C 95 psi S.C. 200
Fuel For KC-10 Test 1/26/82	Virgin AMK RMH1-227 Base Fuel: 11214 Sampled at Arrival	2/15/82(F.R.) 2/18/82(ICI) 3/23/82(FCTA)	57 at 22°C	2.4 at 22°C	20°C 91 psi S.C. 200
Fuel For KC-10 Test 1/26/82	Virgin AMK RMH1-228 Base Fuel: 11214 Sampled at Arrival	2/15/82(F.R.) 2/18/82(ICI) 3/23/82(FCTA)	78 at 21°C	2.3 at 21°C	20°C 93 psi S.C. 200
Fuel For KC-10 Test 1/26/82	Virgin AMK RMH1-229 Base Fuel: 11214 Sampled at Arrival	2/15/82(F.R.) 2/18/82(ICI) 3/23/82(FCTA)	69 at 21°C	2.3 at 21°C	20°C 93 psi S.C. 200
Fuel For KC-10 Test 1/26/82	Base Fuel 11005	_____	_____	_____	_____
Fuel For KC-10 Test 1/26/82	Base Fuel 11214	_____	_____	_____	_____
Engine Feed Test-Press. Performance 2/8/82	Virgin AMK Identified By RMH11106 and 11118	2/24/82(F.R.) 3/10/82(ICI) 3/23/82(FCTA)	15.3 at 20°C	7.0 at 21°C	105°C 93 psi S.C. 200
Engine Feed Test-Press. Performance 2/8/82	Engine Inlet At 10 gpm	2/24/82(F.R.) 3/10/82(ICI) 3/23/82(FCTA)	4.2 at 20.5°C	7.2 at 21°C	71.7°C 93 psi S.C. 200

<u>DAC TEST DATE</u>	<u>AMK IDENTIFICATION</u>	<u>JPL TEST DATE</u>	<u>FILTER RATIO</u>	<u>ICI CUP TEST (ML)</u>	<u>FCTA RESULTS</u>
Engine Feed Test-Press. Performance 2/8/82	Engine Interstage At 10 gpm	2/24/82(F.R.) 3/10/82(ICI) 3/23/82(FCTA)	1.7 at 21°C	7.3 at 21°C	216.7°C 94 psi S.C. 200
Engine Feed Test-Press. Performance 2/8/82	Engine Inlet At 50 gpm	2/24/82(F.R.) 3/10/82(ICI) 3/23/82(FCTA)	6.9 at 21°C	7.2 at 21°C	145°C 94 psi S.C. 200
Engine Feed Test-Press. Performance 2/8/82	Engine Interstate At 50 gpm	2/24/82(F.R.) 3/10/82(ICI) 3/23/82(FCTA)	4.4 at 21°C	7.2 at 21°C	246.7°C 95 psi S.C. 200
Engine Feed Test-Suction Feed 2/15/82	Virgin AMK Identified By RMH1106 and 11118	3/2/82(F.R.) 3/8/82(ICI) 3/23/82(FCTA)	35.4 at 21°C	3.6 at 21.5°C	20°C 93 psi S.C. 200
Flight Cycle Test-Flight #1 2/9/82	Virgin AMK RMH1106 and 11118	2/26/82(F.R.) 3/9/82(ICI) 3/22/82(FCTA)	8.8 at 21°C	7.1 at 21°C	50°C 93 psi S.C. 200
"	Engine Inlet At Takeoff	2/26/82(F.R.) 3/9/82(ICI) 3/22/82(FCTA)	5.5 at 21.5°C	7.2 at 21°C	76.7°C 92 psi S.C. 200
"	Engine Interstage At Takeoff	2/26/82(F.R.) 3/9/82(ICI) 3/22/82(FCTA)	3.3 at 21.5°C	7.3 at 20.5°C	86°C 93 psi S.C. 200
"	Tank At Top of Climb	2/26/82(F.R.) 3/9/82(ICI) 3/22/82(FCTA)	12.7 at 22°C	7.1 at 21°C	125°C 91 psi S.C. 200
"	Engine Inlet Top of Climb	2/26/82(F.R.) 3/9/82(ICI) 3/22/82(FCTA)	7.5 at 21°C	7.1 at 21.5°C	77.5°C 93 psi S.C. 200
"	Engine Interstage At Top of Climb	2/26/82(F.R.) 3/9/82(ICI) 3/22/82(FCTA)	2.8 at 21°C	7.2 at 20°C	230°C 93 psi S.C. 200
"	Tank at End of Cruise	2/26/82(F.R.) 3/9/82(ICI) 3/22/82(FCTA)	16.1 at 21°C	6.5 at 21°C	40°C 91 psi S.C. 200

<u>DAC TEST DATE</u>	<u>AMK IDENTIFICATION</u>	<u>JPL TEST DATE</u>	<u>FILTER RATIO</u>	<u>ICI CUP TEST (ML)</u>	<u>FCTA RESULTS</u>
Flight Cycle Test-Flight #1 2/9/82	Engine Inlet At End of Cruise	2/26/82(F.R.) 3/9/82(ICI) 3/22/82(FCTA)	7.5 at 22°C	7.1 at 20.5°C	77.5°C 93 psi S.C. 200
"	Engine Interstage at End of Cruise	2/26/82(F.R.) 3/9/82(ICI) 3/22/82(FCTA)	3.0 at 21°C	7.2 at 20°C	203.3°C 94 psi S.C. 200
"	Tank at Descent and Landing	2/26/82(F.R.) 3/9/82(ICI) 3/22/82(FCTA)	16.8 at 22°C	6.7 at 21°C	125°C 91 psi S.C. 200
Flight #2 2/11/82	Virgin AMK RMH11106 and 11118	2/26/82(F.R.) 3/9/82(ICI) 3/23/82(FCTA)	28.8 at 21°C	3.9 at 21°C	35°C 93 psi S.C. 200
"	Tank at Takeoff	2/26/82(F.R.) 3/9/82(ICI) 3/23/82(FCTA)	14.6 at 21°C	7.0 at 21°C	100°C 92 psi S.C. 200
"	Engine Inlet at Takeoff	2/26/82(F.R.) 3/9/82(ICI) 3/23/82(FCTA)	9.1 at 21°C	7.1 at 20°C	63.3°C 93 psi S.C. 200
"	Engine Interstage at Takeoff	2/26/82(F.R.) 3/9/82(ICI) 3/23/82(FCTA)	5.0 at 21°C	7.3 at 21.5°C	160°C 93 psi S.C. 200
"	Tank at top of Climb	2/26/82(F.R.) 3/9/82(ICI) 3/23/82(FCTA)	14.8 at 22°C	7.0 at 21°C	130°C 93 psi S.C. 200
"	Engine Inlet At Top of Climb	2/26/82(F.R.) 3/9/82(ICI) 3/23/82(FCTA)	11.2 at 21°C	7.0 at 20.5°C	35°C 92 psi S.C. 200
"	Engine Interstage at Top of Climb	2/26/82(F.R.) 3/9/82(ICI) 3/23/82(FCTA)	4.2 at 21.5°C	7.3 at 21.5°C	180°C 93 psi S.C. 200
"	Tank at End of Cruise	2/26/82(FR) 3/9/82(ICI) 3/23/82(FCTA)	19.5 at 21°C	6.7 at 21.°C	56.7°C 93 psi S.C.200
"	Engine Inlet Inlet at End of Cruise	2/26/82(FR) 3/9/82(ICI) 3/23/82(FCTA)	10.2 at 21.5°C	7.1 at 20.5°C	60°C 92 psi S.C. 200

<u>DAC TEST DATE</u>	<u>AMK IDENTIFICATION</u>	<u>JPL TEST DATE</u>	<u>FILTER RATIO</u>	<u>ICI CUP TEST (ML)</u>	<u>FCTA RESULTS</u>
Flight #2 2/11/82	Engine Interstage at End of Cruise	2/26/82(F.R.) 3/9/82(ICI) 3/23/82(FCTA)	4.2 at 22°C	7.2 at 20°C	233.3°C 93 psi S.C. 200
"	Tank at Descent and Landing	2/26/82(F.R.) 3/9/82(ICI) 3/23/82(FCTA)	21 at 21°C	5.5 at 21°C	45°C 91 psi S.C. 200
Flight #3 2/11/82	Virgin AMK RMH11106 and 11118	2/26/82(F.R.) 3/9/82(ICI) 3/23/82(FCTA)	34.3 at 21°C	3.3 at 21°C	22.5°C 93 psi S.C. 200
"	Tank at Takeoff	2/26/82(F.R.) 3/9/82(ICI) 3/23/82(FCTA)	16.7 at 21°C	6.8 at 21°C	70°C 93 psi S.C. 200
"	Engine Inlet at Takeoff	2/26/82(F.R.) 3/9/82(ICI) 3/23/82(FCTA)	13.0 at 21°C	6.9 at 21.5°C	20°C 92 psi S.C. 200
"	Engine Interstage at Takeoff	2/26/82(F.R.) 3/9/82(ICI) 3/23/82(FCTA)	6.4 at 20°C	7.3 at 21.5°C	226.7°C 93 psi S.C. 200
"	Tank at Top of Climb	2/26/82(F.R.) 3/9/82(ICI) 3/23/82(FCTA)	24.5 at 21°C	5.0 at 20°C	50°C 94 psi S.C. 200
"	Engine Inlet at Top of Climb	2/26/82(F.R.) 3/9/82(ICI) 3/23/82(FCTA)	11.8 at 21°C	7.0 at 21.5°C	28 °C 93 psi S.C. 200
"	Engine Interstage at Top of Climb	2/26/82(F.R.) 3/9/82(ICI) 3/23/82(FCTA)	5.8 at 20.5°C	7.2 at 21.5°C	233.3°C 95 psi S.C. 200
"	Tank at End of Cruise	2/26/82(F.R.) 3/9/82(ICI) 3/23/82(FCTA)	24.7 at 21°C	4.7 at 21°C	42.5°C 93 psi S.C. 200
"	Engine Inlet at End of Cruise	2/26/82(F.R.) 3/9/82(ICI) 3/23/82(FCTA)	11.5 at 21°C	7.1 at 21.5°C	20°C 93 psi S.C. 200
"	Engine Interstage at End of Cruise	2/26/82(F.R.) 3/9/82(ICI) 3/23/82(FCTA)	5.6 at 20.5°C	7.3 at 21°C	155°C 94 psi S.C. 200
"	Tank at Descent and Landing	2/26/82(F.R.) 3/9/82(ICI) 3/23/82(FCTA)	24.4 at 20°C	4.5 at 21°C	50°C 93 psi S.C. 200

<u>DAC TEST DATE</u>	<u>AMK IDENTIFICATION</u>	<u>JPL TEST DATE</u>	<u>FILTER RATIO</u>	<u>ICI CUP TEST (ML)</u>	<u>FCTA RESULTS</u>
Flight #4 2/12/82	Virgin AMK By RMH11106 and 11118	2/26/82(F.R.) 3/9/82(ICI) 3/23/82(FCTA)	41.0 at 20.5°C	3.3 at 21°C	35°C 93 psi S.C. 200
"	Tank at Takeoff	2/26/82(F.R.) 3/9/82(ICI) 3/23/82(FCTA)	22.3 at 22°C	6.1 at 21°C	72.5°C 93 psi S.C. 200
"	Engine Inlet at Takeoff	2/26/82(F.R.) 3/9/82(ICI) 3/23/82(FCTA)	15.5 at 21°C	6.3 at 21°C	30°C 92 psi S.C. 200
"	Engine Interstage at Takeoff	2/26/82(F.R.) 3/9/82(ICI) 3/23/82(FCTA)	8.7 at 20.5°C	7.1 at 21°C	135°C 93 psi S.C. 200
"	Tank at Top of Climb	2/26/82(F.R.) 3/9/82(ICI) 3/23/82(FCTA)	22 at 22°C	6.0 at 21°C	40°C 92 psi S.C. 200
"	Engine Inlet at Top of Climb	2/26/82(F.R.) 3/9/82(ICI) 3/23/82(FCTA)	13.1 at 20.5°C	6.9 at 21.5°C	80°C 93 psi S.C. 200
"	Engine Interstage at Top of Climb	2/26/82(F.R.) 3/9/82(ICI) 3/23/82(FCTA)	6.0 at 21°C	7.2 at 21.5°C	103.3°C 94 psi S.C. 200
"	Tank at End of Cruise	2/26/82(F.R.) 3/9/82(ICI) 3/23/82(FCTA)	25.9 at 19.5°C	5.4 at 21°C	40°C 93 psi S.C. 200
"	Engine Inlet at End of Cruise	2/26/82(F.R.) 3/9/82(ICI) 3/23/82(FCTA)	11.2 at 20.5°C	7.1 at 21.5°C	90°C 92 psi S.C. 200
"	Engine Interstage at End of Climb	2/26/82(F.R.) 3/9/82(ICI) 3/23/82(FCTA)	5.2 at 21°C	7.2 at 21°C	106.7°C 93 psi S.C. 200
"	Tank at Descent and Landing	2/26/82(F.R.) 3/9/82(ICI) 3/23/82(FCTA)	24.9 at 20°C	4.7 at 21°C	70°C 93 psi S.C. 200
KC-10 Test 2/22/82	Virgin AMK RMH1-222 to 226	3/11/82(F.R.) 3/11/82(ICI) 3/23/82(FCTA)	40.2 at 21°C	3.3 at 21°C	40°C 92 psi S.C. 200
KC-10 Test 2/22/82	At 300 GPM	3/11/82(F.R.) 3/11/82(ICI) 3/23/82(FCTA)	40.9 at 21°C	3.6 at 21°C	35°C 91 psi S.C. 200

<u>DAC TEST DATE</u>	<u>AMK IDENTIFICATION</u>	<u>JPL TEST DATE</u>	<u>FILTER RATIO</u>	<u>ICI CUP TEST (ML)</u>	<u>FCTA RESULTS</u>
KC-10 Test 2/22/82	At Max Flow	3/11/82(F.R.) 3/11/82(ICI) 3/23/82(FCTA)	28.7 at 20°C	4.1 at 22°C	40°C 91 psi S.C. 200
KC-10 Test 2/22/82	Virgin AMK RMH1-226 to 229 For Last Flow Pt. (600 GPM)	3/11/82(F.R.) 3/11/82(ICI) 3/23/82(FCTA)	35.9 at 20.5°C	4.3 at 21°C	37.5°C 93 psi S.C. 200
KC-10 Test 2/22/82	At 600 GPM	3/11/82(F.R.) 3/11/82(ICI) 3/23/82(FCTA)	35.2 at 20.5°C	3.9 at 21°C	40°C 91 psi S.C. 200
Shelf-life 3/11/82	Virgin AMK Identified by RMH11106 and RMH11118	3/12/82(F.R.) 3/12/82(ICI) 3/23/82(FCTA)	23.4 at 24°C	3.3 at 23°C	37.5°C 91 psi S.C. 200
AMK Degrada- tion vs. Boost Pump Flow Test Configura- tion 1 13/12/82	Virgin AMK RMH11106 RMH11118	3/17/82(F.R.) 3/24/82(ICI) 3/23/82(FCTA)	34.2 at 21°C	3.5 at 21.5°C	35°C 91 psi S.C.200
"	At Flow Control Valve Position 1, RMH11106-11118	3/17/82(F.R.) 3/24/82(ICI) 3/23/82(FCTA)	14.3 at 19°C	6.5 at 21.5°C	75°C 93 psi S.C. 200
"	At Flow Control Valve Position 2, RMH11106-11118	3/17/82(F.R.) 3/24/82(ICI) 3/23/82(FCTA)	17.7 at 21°C	5.5 at 21.5°C	45°C 91 psi S.C. 200
"	At Flow Control Valve Position 3, RMH11106-11118	3/17/82(F.R.) 3/24/82(ICI) 3/23/82(FCTA)	23.1 at 20°C	4.3 at 21.5°C	40°C 91 psi S.C. 200
"	At Flow Control Valve Position 4, RMH11106-11118	3/17/82(F.R.) 3/24/82(ICI) 3/23/82(FCTA)	26.5 at 19°C	4.1 at 21.5°C	32.5°C 91 psi S.C.200
"	At Flow Control Valve Position 5, RMH11106-11118	3/17/82(F.R.) 3/24/82(ICI) 3/23/82(FCTA)	27.5 at 19.5°C	3.9 at 21.5°C	37.5°C 91 psi S.C. 200

<u>DAC TEST DATE</u>	<u>AMK IDENTIFICATION</u>	<u>JPL TEST DATE</u>	<u>FILTER RATIO</u>	<u>ICI CUP TEST (ML)</u>	<u>FCTA RESULTS</u>
AMK Degradation vs. Boost Pump Flow Test Configuration 1 13/12/82	At Flow Control Valve Position 6, RMH11106-11118	3/17/82(F.R.) 3/24/82(ICI) 3/23/82(FCTA)	26.4 at 19°C	3.6 at 19°C	37.5°C 91 psi S.C. 200
" 3/22/82	Virgin AMK RMH1-230 Base Fuel: 11214	4/12/82(F.R.) 4/8/82(ICI) 4/15/82(FCTA)	59.7 at 21°C	2.0 at 19°C	23.3°C 95 psi S.C. 200
"	At Flow Control Valve Position 6, RMH1-230	4/12/82 4/8/82 4/15/82	55.6 at 20°C	2.5 at 18.5°C	7.5°C 97 psi S.C.200
"	At Flow Control Valve Position 5, RMH1-230	4/12/82(F.R.) 4/8/82(ICI) 4/15/82(FCTA)	45.5 at 20°C (4/23/82 rechecked)	2.6 at 18.5°C	16.7°C 94 psi S.C.200
"	At Flow Control Valve Position 4, RMH1-230	4/12/82(F.R.) 4/8/82(ICI) 4/15/82(FCTA)	51.4 at 19°C	2.7 at 21.5°C	20°C 94 psi S.C. 200
"	Virgin AMK RMH1-230 and 231 Base Fuel: 11214	4/12/82(F.R.) 4/8/82(ICI) 4/15/82(FCTA)	70.1 at 20.5°C	2.1 at 20°C	7.5°C 95 psi S.C.200
"	At Flow Control Valve Position 3, RMH1-230-231	4/12/82(F.R.) 4/8/12(ICI) 4/15/82(FCTA)	41.0 at 20°C	2.8 at 20°C	20°C 94 psi S.C. 200
"	At Flow Control Valve Position 2, RMH1-230-231	4/12/82(F.R.) 4/8/82(ICI) 4/15/82(FCTA)	29.3 at 19°C	3.7 at 20°C	15°C 93 psi S.C.200
"	At Flow Control Valve Position 1, RMH1-230-231	4/12/82(F.R.) 4/8/82(ICI) 4/15/82(FCTA)	21.7 at 20°C	5.5 at 19°C	22.5°C 94 psi S.C.200
AMK Degradation vs. Boost Pump Flow Test Configuration 2 3/30/82	Virgin AMK Identified by RMH11106 and RMH11118	4/21/82(F.R.) 4/12/82(ICI) 4/15/82(FCTA)	8.0 at 21.5°C	7.2 at 19°C (4/23/82 rechecked)	35°C 93 psi S.C.200

<u>DAC TEST DATE</u>	<u>AMK IDENTIFICATION</u>	<u>JPL TEST DATE</u>	<u>FILTER RATIO</u>	<u>ICI CUP TEST (ML)</u>	<u>FCTA RESULTS</u>
AMK Degradation vs. Boost Pump Flow Test Configuration 2 3/30/82	At Flow Control Valve Position 1, RMH11106-11118	4/21/82(F.R.) 4/12/82(ICI) 4/15/82(FCTA)	6.3 at 21°C	6.6 at 19°C	55°C 93 psi S.C.200
"	At Flow Control Valve Position 2, RMH11106-11118	4/21/82(F.R.) 4/12/82(ICI) 4/15/82(FCTA)	10.8 at 21°C	5.5 at 19°C	20°C 93 psi S.C.200
"	At Flow Control Valve Position 3, RMH11106-11118	4/21/82(F.R.) 4/12/82(ICI) 4/15/82(FCTA)	15.4 at 21°C	4.2 at 19°C	30°C 92 psi S.C.200
"	At Flow Control Valve Position 4, RMH11106-11118	4/21/82(F.R.) 4/12/82(ICI) 4/15/82(FCTA)	19.5 at 21°C	3.7 at 19.5°C	30°C 93 psi S.C.200
"	At Flow Control Valve Position 5, RMH11106-11118	4/21/82(F.R.) 4/12/82(ICI) 4/15/82(FCTA)	20.9 at 21.5°C	3.5 at 20°C	20°C 92 psi S.C.200
"	At Flow Control Valve Position 6, RMH11106-11118	4/21/82(F.R.) 4/12/82(ICI) 4/15/82(FCTA)	21.4 at 21.5°C	3.5 at 20°C	15°C 93 psi S.C.200
"	Virgin ANK RMH-231 Base Fuel: 11214	4/21/82(F.R.) 4/12/82(ICI) 4/15/82(FCTA)	53.7 at 20°C	2.1 at 20°C	10°C 93 psi S.C.200
"	At Flow Control Valve Position 6, RMH1-231	4/21/82 4/12/82 4/15/82	41.6 at 21.5°C	2.5 at 19°C	10°C 95 psi S.C.200
"	At Flow Control Valve Position 3, RMH1-231	4/21/82 4/12/82 4/15/82	40.7 at 20°C	2.7 at 20°C	15°C 95 psi S.C.200
"	Base Fuel RMH11214	_____	_____	_____	_____

DOT/FAA **Compatibility study of**
CT-82/116 **antimisting kerosene and the**
 DC-10/KC-10 fuel system /
 00008030

4

5

6

7

