



Research Report

**EVALUATION OF NDOT'S CONSTRUCTION
STORMWATER DETENTION MEASURES USING
FULL-SCALE TESTING TECHNIQUES**

A Report on Research Sponsored by:
Nebraska Department of Transportation
and
Federal Highway Administration

Prepared by

Lillian Krueger Williams
Michael A. Perez, PhD, PE, CPESC
Wesley N. Donald, PhD

MAY 2026



AUBURN UNIVERSITY
Samuel Ginn College of Engineering

1. Report No. SPR-FY25(043)	2. Government Accession No.	3. Recipient Catalog No.	
4. Title and Subtitle Evaluation of NDOT's Construction Stormwater Detention Measures Using Full-Scale Testing Techniques		5. Report Date April 2026	
		6. Performing Organization Code	
7. Author(s) Lillian K. Williams, Michael A. Perez, and Wesley N. Donald		8. Performing Organization Report No.	
9. Performing Organization Name and Address Stormwater Research Facility Department of Civil Engineering 238 Harbert Engineering Center Auburn, AL 36849		10. Work Unit No. (TRAIS)	
		11. Contract or Grant No. 01071F SPR-FY25(043)	
12. Sponsoring Agency Name and Address Nebraska Department of Transportation 1400 Nebraska Parkway Lincoln, NE 68502		13. Type of Report and Period Covered Final Report July 2024 – May 2026	
		14. Sponsoring Agency Code	
15. Supplementary Notes			
16. Abstract Sediment is a leading pollutant in waterbodies, contributing to turbidity, pollutant transport, ecological degradation, and reduced flow capacity. Construction activities are major sources of sediment-laden runoff, necessitating regulatory compliance through Stormwater Pollution Prevention Plans. This study developed a full-scale testing methodology simulating Nebraska hydrologic conditions to evaluate the performance of Nebraska Department of Transportation silt traps and sediment traps at the Auburn University Stormwater Research Facility. Results showed that standard installations can be significantly improved through design modifications. For silt traps, pairing with a modified V-shaped, wire-backed silt fence with a central weir achieved the highest sediment retention (95.9%), substantial total suspended solids (TSS) reduction (89.1%), and turbidity reduction (67.7%). A slash mulch berm also performed well but may be limited by material availability. Structural testing of the low porosity silt fence indicated that reduced post spacing and fence height improved durability. For sediment traps, the use of coir baffles and a surface skimmer enhanced flow control, reduced turbulence, lowered downstream TSS and turbidity, and retained sediment (91.1%). Overall, optimized configurations significantly improved sediment capture and downstream water quality, supporting refined design recommendations for effective sediment control practices.			
17. Key Words Silt Trap, Sediment Trap, Detention Practice, Sediment Control, Construction Stormwater		18. Distribution Statement	
19. Security Classification (of this report) Unclassified	20. Security Classification (of this page) Unclassified	21. No. of Pages	22. Price None.

Disclaimer

The contents of this report reflect the views of the authors, who are responsible for the facts and the accuracy of the information presented herein. The contents do not necessarily reflect the official views or policies neither of the Nebraska Department of Transportations nor the Auburn University. This report does not constitute a standard, specification, or regulation. Trade or manufacturers' names, which may appear in this report, are cited only because they are considered essential to the objectives of the report.

The United States (U.S.) government and the State of Nebraska do not endorse products or manufacturers. This material is based upon work supported by the Federal Highway Administration under SPR-FY25(043). Any opinions, findings and conclusions or recommendations expressed in this publication are those of the author(s) and do not necessarily reflect the views of the Federal Highway Administration.

NOT INTENDED FOR CONSTRUCTION, BIDDING, OR PERMIT PURPOSES

Lillian Krueger Williams
Graduate Research Assistant

Michael A. Perez and Wesley N. Donald
Research Supervisors

Acknowledgements

This project was sponsored by the Nebraska Department of Transportation. The research presented in this report is based on the study project 01071F SPR-FY25(043). The authors greatly acknowledge the financial support.

Abstract

Sediment is a dominant pollutant in waterbodies due to the heightened turbidity, transport of other harmful pollutants, negative impacts on ecosystems, and reduction of flow capacity. Construction projects, especially during their earthwork phase, are one of the largest contributors of sediment-laden runoff. The United States Environmental Protection Agency and often many state regulatory agencies mandate that every project obtains a construction general permit which involves completing a Stormwater Pollution Prevention Plan. Detention practices are one of the common methods used for sediment control when employing a Stormwater Pollution Prevention Plan, but detention practices come in various forms and sizes. A methodology using simulated hydrologic and erosive conditions typical to Nebraska was developed to evaluate the performance of Nebraska Department of Transportation (DOT) silt trap and sediment trap practices. A full-scale testing apparatus was constructed at the Auburn University - Stormwater Research Facility. Through the analysis of sediment capture and water quality, the most feasible and effective installation of each practice was identified to provide design guidance for practice selection.

Silt traps can serve a contributory drainage area up to 1 ac (0.4 ha) while the sediment trap can serve an area from 1 ac (0.4 ha) to 5 ac (2.0 ha). Under a flow rate of 0.5 ft³/s with a sediment introduction rate of 36.6 lb/min and a flow rate of 1.0 ft³/s with a sediment introduction rate of 49.0 lb/min respectively, both Nebraska DOT standard installations presented opportunity for enhancement. The silt trap standard was evaluated in conjunction with an erosion check, various silt fence installations, rock checks, an earth check, and a slash mulch berm. The installation with the most overall improvement was the modified silt fence that created a V-shape of wire-backed, non-woven geotextile with an 18 in. (45.7 cm) weir cut out of the center. For the

modified silt fence, the resulting sediment retention was the highest achieved in testing at 95.9%, the highest impoundment at 35 ft (10.6 m) the TSS reduction from inflow to downstream was 89.1%, and the turbidity reduction from inflow to downstream was 67.7%. The reduced post spacing – from a standard 5 ft (1.5 m) to 3 ft (0.9 m) – used to create the fence shape and the wire backing with the geotextile increased structural abilities to withstand flow. The weir allowed for timely dewatering and protected from excessive impoundment. The installation had the highest sediment capture at 95.9% and the longest impoundment at 35 ft (10.7 m) for sedimentation to occur. The slash mulch berm had the second highest sediment capture at 94.6% and the most improved quality of water leaving the installation, 91.4% TSS reduction and 69.1% turbidity reduction. While slash mulch was a high performing installation, the issue of mulch availability must be considered for project implementation. In the silt trap testing, the low porosity silt fence failed, indicating a need for structural improvement. A series of clean water tests were conducted on various configurations of the low porosity silt fence to find the structural MFE-I. Factors tested were fence height, post material, post spacing, and fence shape. The best performing installation, based on least amount of post deflection, was adapted from the modified silt fence yet utilized the low porosity fence geotextile. The other high performing installation was a reduced fence height, from 30 in. (76.2 cm) to 24 in. (61.0 cm) and reduced post spacing, from 5.0 ft (1.5 m) to 2.5 ft (0.76 m). The sediment trap installation with most overall improvement was the installation with three wire-supported, coir baffles and a 1.5 in. (3.8 cm) surface skimmer. The combination of elements provided evident turbulence reduction and controlled dewatering to restore the available storage volume. The baffle and skimmer installation improved TSS from nearly 5,000 mg/L inflow average to under 500 mg/L downstream TSS and turbidity from around 1,600 NTU inflow average to around 700 NTU

despite having high background turbidity. The combination installation also had the second highest sediment capture at 91.1%, 0.8% below the highest sediment capture.

The results of full-scale testing indicate that the standard installation of the silt trap and sediment trap have opportunity for improvements through modifications. The silt trap increased sediment capture and improved water quality when it was paired with a modified silt fence while the sediment trap addressed various shortcomings, resulting in improved performance through the use of coir baffles and a skimmer. The most feasible and effective installation of the silt trap and sediment trap provided enhanced sediment capture and downstream water quality. Since the silt trap was found to perform better in conjunction with another practice, especially the modified silt fence, the recommendation is to always implement a silt trap with a ditch check. The structural, clean water testing indicated that fence with similar characteristics to the modified silt fence would improve the low porosity silt fence as would a reduced post spacing and reduced fence height installation. Since the sediment trap was shown to perform well in water quality and sediment capture on its own, the recommended baffles and skimmer advance the performance by dissipating incoming flow and enhancing downstream water quality while restoring storage volume for subsequent storm events.

Table of Contents

Abstract	4
1 Chapter One: Introduction	15
1.1 Background.....	15
1.2 Erosion and Sediment Control.....	17
1.3 Research Objectives.....	19
1.4 Expected Outcomes	20
1.5 Organization of Thesis	21
2 Chapter Two: Literature Review.....	22
2.1 Introduction.....	22
2.2 Testing Considerations.....	23
2.2.1 Regulations and Requirements	23
2.2.2 Scale of Testing.....	24
2.2.3 Performance Metrics.....	24
2.3 NDOT Silt Traps and Sediment Traps	25
2.4 Similar Practices According to State DOTs	29
2.5 Potential Modifications.....	35
2.5.1 Silt Fences, Ditch Checks, and Berms	35
2.5.2 Baffles and Skimmers	40
2.6 Literature Review Summary	42
3 Chapter Three: Methodology	44
3.1 Testing Methodology Overview	44
3.2 Statewide Analysis of Climate, Rainfall, and Soil.....	44
3.3 Flow Rate Determination.....	46

3.4	Sediment Introduction Rate Determination	51
3.5	Experimental Design and Construction	53
3.6	Data Collection	57
3.7	Testing Regime	61
3.8	Methodology Summary	62
4	Chapter Four: Results And Discussion	64
4.1	Introduction.....	64
4.2	Silt Trap Installations	64
4.2.1	Nebraska Standard Silt Trap	64
4.2.2	Temporary Erosion Check	65
4.2.3	High Porosity Silt Fence	67
4.2.4	Modified Silt Fence.....	68
4.2.5	Low Porosity Silt Fence.....	70
4.2.6	Temporary Rock Check	71
4.2.7	Modified Rock Check.....	73
4.2.8	Slash Mulch Berm.....	74
4.2.9	Temporary Earth Check	75
4.3	Comparison of Silt Trap Results.....	76
4.3.1	Sediment Capture, Impoundment, Dewatering, and Structural Performance.....	77
4.3.2	Water Quality	85
4.3.3	Silt Trap MFE-I.....	90
4.4	Structural Clean Water Tests.....	91
4.4.1	Installation 1.....	95

4.4.2	Installation 2.....	98
4.4.3	Installation 3.....	101
4.4.4	Installation 4.....	104
4.4.5	Installation 5.....	105
4.4.6	Low Porosity MFE-I Identification	108
4.5	Sediment Trap Installations	108
4.5.1	Nebraska Standard Sediment Trap.....	109
4.5.2	Standard Sediment Trap with Baffles	110
4.5.3	Standard Sediment Trap with a Skimmer	111
4.6	Comparison of Sediment Trap Results	112
4.6.1	Sediment Capture and Storage Volume	112
4.6.2	Water Quality	117
4.6.3	Sediment Trap MFE-I.....	122
4.7	Comparison of the Silt Trap and Sediment Trap.....	123
5	Chapter Five: Conclusion And Recommendations.....	125
5.1	Introduction.....	125
5.2	Conclusions and Impact.....	126
5.3	Recommendations for Implementation.....	131
5.4	Limitations and Future Research	132
6	References.....	135
	Appendix A.....	A-1
	Appendix B.....	B-1
	Appendix C.....	C-1

Appendix D.....	D-1
Appendix E	E-1
Appendix F.....	F-1
Appendix G.....	G-1
Appendix H.....	H-1
Appendix I	I-1

List of Tables

Table 2.1: Comparison of NDOT Detention Practices	26
Table 3.1: Flow Rates for Silt Trap and Sediment Trap.....	51
Table 3.2: Sediment Yield Calculation Summary	53
Table 4.1: Theoretical Impoundments Versus Actual Impoundments	85
Table 4.2: TSS Downstream Reduction from Inflow	86
Table 4.3: Turbidity Downstream Reduction from Inflow	86
Table 4.4: Summary of Results for Silt Trap Testing.....	91
Table 4.5: Structural Clean Water Installation Description	93
Table 4.6: Installation 1 Test Results	97
Table 4.7: Installation 2 Test Results	101
Table 4.8: Installation 3 Test Results	103
Table 4.9: Installation 5 Test Results	107
Table 4.10: Installation Comparison at 1 ac (0.4 ha) Rates	124

List of Figures

Figure 2.1: Pocket Guide Picture of Silt Traps (NDOT 2020a).....	27
Figure 2.2: Iowa DOT Detention Practices (Construction and Materials Bureau 2022).....	29
Figure 2.3: Iowa DOT Detention Practices (Construction and Materials Bureau 2022).....	30
Figure 2.4: MNDOT Sediment Trap.....	32
Figure 2.5: ALDOT Rock Ditch Check with Sump Excavation.....	33
Figure 2.6: NCDOT Type B Silt Basin.....	34
Figure 2.7: NCDOT Skimmer Basin.....	35
Figure 3.1: Analyzed Counties and Annual Rainfall Erosivity from Six Landscape Regions (Roche 2023).....	45
Figure 3.2: Nebraska Map of Rainfall Depth (in.) (Roche 2023).....	47
Figure 3.3: Nebraska Map of Weighted Average Curve Numbers (Roche 2023).....	47
Figure 3.4: SCS Hydrograph Inputs.....	50
Figure 3.5: Test Channel Configuration.....	54
Figure 3.6: Construction Process.....	55
Figure 3.7: Testing Inflow Apparatus.....	57
Figure 3.8: Silt Trap Water Quality Data Collection Locations.....	58
Figure 3.9: Sediment Trap Water Quality Data Collection Locations.....	59
Figure 3.10: Silt Trap Testing Regime.....	61
Figure 3.11: Sediment Trap Testing Regime.....	62
Figure 3.12: Tested Installations.....	62
Figure 4.1: NDOT Standard Silt Trap.....	65
Figure 4.2: Temporary Erosion Check.....	67

Figure 4.3: High Porosity Silt Fence.....	68
Figure 4.4: Modified Silt Fence	70
Figure 4.5: Low Porosity Silt Fence	71
Figure 4.6: Temporary Rock Check.....	72
Figure 4.7: Modified Rock Check	74
Figure 4.8: Slash Mulch Berm.....	75
Figure 4.9: Temporary Earth Check.....	76
Figure 4.10: Modified Silt Fence Sediment Settling Distribution	78
Figure 4.11: Sediment Capture per Installation	80
Figure 4.12: Impoundment Versus Sediment Capture	83
Figure 4.13: Downstream TSS per Installation.....	87
Figure 4.14: Downstream Turbidity per Installation.....	87
Figure 4.15: Standards vs. Modifications for TSS.....	89
Figure 4.16: Standards vs. Modifications for Turbidity.....	89
Figure 4.17: Low Porosity Silt Fence Failure.....	92
Figure 4.18: Structural Clean Water Testing Regime	93
Figure 4.19: Low Porosity Silt Fence Iterations	94
Figure 4.20: Plan View of Installation 1 Post Deflection	97
Figure 4.21: Installation 1 After Test C.....	98
Figure 4.22: Plan View of Installation 2 Post Deflection	100
Figure 4.23: Installation 2 After Test C.....	101
Figure 4.24: Plan View of Installation 3 Post Deflection	103
Figure 4.25: Installation 3 After Test C.....	104

Figure 4.26: Installation 4 Failure.....	105
Figure 4.27: Plan View of Installation 5 Post Deflection	107
Figure 4.28: Installation 5 After Test C.....	108
Figure 4.29: NDOT Standard Sediment Trap	110
Figure 4.30: Sediment Trap with Baffles	111
Figure 4.31: Sediment Trap with a Skimmer	112
Figure 4.32: Sediment Capture Per Installation.....	114
Figure 4.33: Sediment Particle Distribution of Highest Sediment Capture Install.....	116
Figure 4.34: Downstream TSS per Installation.....	118
Figure 4.35: Downstream Turbidity per Installation.....	119
Figure 4.36: Background TSS per Installation	120
Figure 4.37: Background Turbidity per Installation	121
Figure 4.38: Installation Inflow and Turbidity vs. MFE-I Inflow and Turbidity.....	122

Chapter One: Introduction

1.1 Background

The modern world hinges around the development and enrichment of everyday infrastructure, encompassing both manmade and natural systems. Mankind's infrastructure is comprised of buildings, roads, and bridges which play a role in the demand for connectedness and necessity of movement. In 2024, the total amount spent on put-in-place construction was around \$2.15 trillion, an increase of about 6.4% from the previous year. This number is expected to increase by 21% for 2028 (Guckes 2024). On linear projects, approximately \$150 billion was spent in 2024 (FMI Corporation 2024). Construction can become a source of pollution due to the substantial earthmoving activities that disturb an expanse of land, typically consisting of several acres of land at a time. The clearing and grubbing stage leaves behind uncovered, unprotected ground that will be reallocated as best suits the project. While sediment is the predominant construction-related pollutant, others such as fuel, paint, oil, and solvents are prevalent. Contaminants like these containing lead, zinc, cadmium, flame retardants, pesticide bifenthrin, and polycyclic aromatic hydrocarbons to name a few, are able to sorb to soil particles (Mahler 2018). When soil is exposed to the displacing energy of raindrops, the resultant erosion and subsequent flow cause runoff that suspends the sediment and carries it downstream. From data gathered by the Environmental Protection Agency (EPA), the percentage of impaired rivers, streams, and creeks is at 51% with lakes, ponds, and reservoirs at 55% impairment. Bays, estuaries, and harbors came in at 26% impaired. On average over 50% of the assessed waterways of the U.S. are reported as compromised (Kelderman et al. 2022).

An estimated 3.9 billion tons (3.5 billion metric tons) of sediment is annually discharged from construction sites into waterways across the U.S., due to the amount of construction taking place (Mitchell et al. 1991). Construction sites have runoff rates 10 to 20 times greater than agricultural lands and 1,000 to 2,000 times greater than forested land (USEPA Office of Water 2023). The lack of vegetative cover following soil disturbance on construction sites, results in the dislodgement of particles that are then transported in runoff that eventually enter natural waterbodies. Accelerated siltation reduces the useful volume of a reservoir, fills roadside ditches, irrigation canals, and navigational channels, and contributes to increased dredging and high maintenance costs. Sedimentation raises flooding probability and severity due to reduced stream capacity and buried wetland overflow areas (United States Department of Agriculture Economic Research Service 2019). Increased turbidity restricts sunlight for photosynthesis, harming vegetation and phytoplankton (Boyd and Lichtkoppler 1979). This causes disruptions at the base of the food chain that can propagate through higher trophic levels; for example, reduced phytoplankton populations affect zooplankton, insects, sunfish, and ultimately predatory fish such as freshwater bass (Boyd and Lichtkoppler 1979). Loss of vegetation diminishes sustenance resources, habitats for creatures, and the natural stabilization of waterbodies. Additionally, the transport of soil-bonded toxins corrupts aquatic habitats that support insect larvae, mollusks, crustaceans, amphibians, and fish, further degrading ecosystem health (Mahler 2018). The impacts reduce aquatic biodiversity, spoiling commercial and recreational fishing. Moreover, suspended sediment substantially escalates the cost of municipal and industrial water treatment (Kelderman et al. 2022).

Although estimates vary widely due to the copious areas of effect, sediment-related damages, from site remediation to waterway repairs, are generally estimated in billions of dollars

annually (USDA Economic Research Service 2019). Sedimentation is recognized as one of the leading causes of water pollution around the world producing extensive economic, societal, and environmental consequences. Mankind and nature have intertwining systems, both vital kinds of infrastructure. Since natural aquatic systems are inherently more fragile, they require proactive protection from pollution sources such as erosion and sedimentation.

1.2 Erosion and Sediment Control

Erosion is a process by which the behavior of wind, water, ice, or gravity wears away the surface of the land. Natural deterioration occurs at a slow rate and aids in maintaining environmental balances. Out of the elements listed, water generates the most damaging erosion. Major factors that affect erosion are soil erodibility, vegetative cover, topography, climate, and season. Closely examining erosion caused by rainfall, two physical processes are observed. The first is detachment where the force of the raindrop is applied vertically making it responsible for displacing particles of exposed soil. The second step is transport where the rain accumulates and flows horizontally across the particles. This suspends and transports the soil away. Erosion by water happens primarily in six different ways: splash, sheet-flow, rill, gully, streambank, and shoreline. Erosion control practices are used as mitigation measures and aim to inhibit, regulate, and reduce the different types of erosion in the context of agriculture, land development, and construction.

Because erosion cannot be completely prevented, sediment control must be implemented. Sediment control is designed to keep the eroded soil on site so that it does not become a source of pollution when transported in runoff. Sediment-laden stormwater pollution is considered a nonpoint source because it does not originate from a single identifiable source and often has a cumulative aspect. Sediment control is implemented in several ways, but the primary focus of

this research is on detention-based sediment control practices. Erosion control practices prevent erosion while sediment control practices reduce sediment discharge offsite. Erosion and sediment control (ESC) practices are combined to achieve maximum effectiveness in preventing the negatives of runoff and properly controlling stormwater flow.

The ESC movement was sparked after the Dust Bowl of the 1930s that swept sediment beyond the Great Plains. During this time, a drought storm covered Washington D.C. and sailed out into the Atlantic Ocean (Natural Resources Conservation Service 2025). As a result, the Soil Erosion Service, later renamed the Soil Conservation Service, was established. The conservation movement continued with the Clean Water Act in 1948 to regulate discharges of pollutants into U.S. waters (Environmental Protection Agency 2025). Under section 402, the National Pollution Discharge Elimination System (NPDES), limits were set on the effluents entering a body of water from a point source and eventually expanded to address stormwater runoff thus including nonpoint sources under phase two of NPDES (Kelsey 2023). The construction general permit (CGP) mandates projects disturbing one or more acres develop a Stormwater Pollution Prevention Plan (SWPPP) implementing practices to minimize the amount of sediment and other pollutants associated with construction sites from being discharged in stormwater runoff (USEPA 2017). Industry standards dictate that best management practices (BMPs) are employed when composing a SWPPP according to each state's environmental agency. To meet regulatory requirements, many Departments of Transportation (DOTs) have developed their own permitting agencies that exercise authority in their state over the EPA and their own stormwater management practices. For example, the state of Nebraska has the Department of Water, Environment, and Energy (DWEE) to issue their construction stormwater (CSW) general permits while the Nebraska Department of Transportation (NDOT) has developed BMP detention

practices such as silt traps, sediment traps, and sediment basins for their stormwater management manual. While not all BMPs are physical devices, for example managing work and communication are considered BMPs, the research in this project focuses on tangible detention-based BMPs. The examined BMPs are installations, practices, or products, that optimally control sediment-laden runoff. Many organizations and other entities have taken up the goal to increase performance-based BMPs ensuring high level protection of our soils and waters. From testing, research, specifications, and installation guidelines, the advancement of the industry has continued to flourish through the development of most feasible and effective installations (MFE-I).

1.3 Research Objectives

This research was divided into three principal components associated with the evaluation of stormwater detention practices, with specific emphasis on silt traps and sediment traps.

The specific objectives of this research are as follows:

- (1) Develop a methodology to evaluate and compare the performance of detention-based practices typical to Nebraska Department of Transportation (DOT) highway construction projects in the removal of sediment from construction generated runoff,
- (2) Conduct replicable full-scale testing on silt trap and sediment trap practices and modified installations that mimic Nebraska DOT conditions through corresponding soil losses and runoff volumes, and
- (3) Identify the most feasible and effective installations (MFE-I) discovered from data collection and field observations to provide implementable design guidance for use on Nebraska DOT projects.

To satisfy the research objectives, five tasks were identified:

- (1) Conduct a comprehensive literature review including the state-of-the-practice regarding silt traps and sediment traps and past testing results on efficiency and effectiveness of potential modifications,
- (2) Develop full-scale testing methodology based on local Nebraska values for quantities of sediment introduction and runoff flow rates,
- (3) Design and construct plans for experimental detention measures mimicking Nebraska highway conditions,
- (4) Perform full-scale testing of different practices and installation variations at the Auburn University – Stormwater Research Facility, and
- (5) Analyze the collected water quality and sediment data to determine performance results of various installations and distinguish the MFE-I of each practice.

1.4 Expected Outcomes

The outcomes of the research study are intended to enhance specific stormwater management techniques through informed design and implementation. The scientific results from full-scale testing are expected to provide Nebraska and the ESC industry with additional guidance for the application of silt traps and sediment traps. The performance of alternative designs found through standardized, repeatable tests serve to increase the water quality and sediment capture when employed. Improved detention measures will safeguard water quality downstream of developing areas, reduce regulatory compliance issues, aid in managing accompanying costs, and enhance public perception. Future research efforts are expected to continue advancing the knowledge and increasing the resources in stormwater management, the construction trade, and the field of ESC.

1.5 Organization of Thesis

This thesis is sectioned into five chapters that organize, illustrate, and describe the steps taken to meet the defined research objectives. Following this chapter, Chapter Two: *Literature Review*, provides an overview of current erosion and sediment control technology, research, and implementation. Chapter Three: *Methodology* describes the practice design, testing regime, collect and test procedures, and various apparatuses utilized for the evaluation of silt traps and sediment traps. The processes detailed in this section include the determination of soil losses, flow rates, and construction of full-scale measures. Chapter Four: *Results and Discussion* reviews the data collected from testing and establishes useable guidance based on the effectiveness of the tested practices. Chapter Five: *Conclusion and Recommendations* summarize the major findings and impact of this research effort. The MFE-I for each practice is formulated according to water quality and sediment retention data encompassed in the previous chapter. Additionally, this chapter highlights areas of potential future research for advancing stormwater management techniques and technologies.

Chapter Two: Literature Review

2.1 Introduction

Detention practices have been developed as a management technique to treat stormwater. Several types of underground and aboveground systems have been employed to remedy sediment-laden water primarily through sedimentation. Sedimentation describes the process by which soil particles and integrated pollutants gravitationally settle out of the water column. Sedimentation is based on the principles established in Stokes Law for settling solids. The settling velocity is dependent on the size and density of the clay, silt, fine sand, and some larger sand particles and the properties of the fluid such as density and viscosity (Erickson et al. 2013). For water, the density is almost constant with the viscosity varying due to temperature. The temperature of the water affects the solid settling velocity as colder temperatures considerably slow settling. Stokes Law among other settling formulas reveal that larger particles will settle faster than smaller particles of similar density, and that particles of larger density will settle faster than particles of smaller density when similar in particle size. If given longer residence time, a wider variety of particles will settle out of the water column and be retained by the detention practice (Erickson et al. 2013).

Other elements such as velocity reduction have a role in enabling higher settling. Turbulent flows are undesirable because of their delayed settling caused by prolonged suspension of solids (Goldman et al. 1986). Decreasing the turbulent flow velocity decreases the mixing happening between the water and the particles. One way to achieve velocity decrease is through impoundment. Impoundment, typically created by interrupting stormwater flow in a channel, is a pool of water where the average net velocity approaches zero. This velocity

reduction increases water depth above the critical flow depth, decreases channel erosion caused by shear stress, and decreases kinetic energy (Donald et al. 2016a). The outcomes generated by impoundment produce favorable conditions for sedimentation to occur. Impoundment is not the only way to accomplish velocity reduction and thereby sedimentation. Depending on the particular detention practice, other methods can be employed to reach the same energy dissipation of runoff and settling of particles as seen in the section on potential modifications.

Providing temporary storage for runoff is another component in facilitating sedimentation. Adequate capacity must be supplied in detention practices for the volume produced by a rainfall event and for the storage of accumulated sediment. Periodically, maintenance such as solids removal must be performed on the detention practice to preserve the effectiveness of the treatment (Erickson et al. 2013). The EPA considers sufficient volume to be either the volume of the 2-yr, 24-hr storm or 3,600 ft³/ac (251 m³/ha) (USEPA 1998). The designed storage volume allows residence time for sedimentation but must have a way to dewater for restoration of storage for subsequent events. Dewatering is the slow controlled removal of water. The dewatering of a detention practice balances adequate settling time with providing storage for runoff from ensuing runoff events (Perez et al. 2016).

2.2 Testing Considerations

2.2.1 Regulations and Requirements

All permitting agencies require that ESC practices minimize erosion and maximize sediment removal. The Nebraska DWEE issues CSW general permits before any land disturbances. These permits regulate discharges from stormwater, snowmelt, and drainage under NPDES and safeguard waters of the state from transported sediment and pollutants. This permit process involves submitting a SWPPP and agreeing to regular site inspections performed by the

DWEE throughout the duration of construction. The DWEE does not have regulations that specify total suspended solids (TSS) and turbidity effluent limits or specify minimum sediment capture rates for any ESC practices (Department of Water 2022).

2.2.2 Scale of Testing

The testing scale chosen for the silt trap and sediment trap testing was full-scale testing. Small-scale testing and field monitoring are inherently limited because they either fail to assess full system performance or are conducted under variable, uncontrolled conditions. To eliminate these limitations, large-scale testing must be conducted (Roche et al. 2024a). Full-scale testing is as close to field-scale as possible without relinquishing control of independent variables which would affect the outcome of the dependent variables being used as performance indicators. The need for reproducible, large-scale testing is recognized as imperative to improve current industry practices and achieve greater field operation (Perez et al. 2016). At this scale, any shortcomings are exposed when subjugated to realistic highway construction settings. Large-scale or full-scale research provides a method for testing predictable runoff and erosion contributions that mimic construction site conditions and highlights improvements when optimizing functionality. NDOT full-scale testing would be representative of the real-world application and allow thorough examination for developing implementation guidance.

2.2.3 Performance Metrics

Data collected throughout the respective silt trap and sediment trap testing provided comparative measures for performance evaluation of every configuration. The collected data included sediment capture weights and water quality grab samples. Sediment retention and downstream water quality improvement were two standard performance indicators across numerous states and research facilities (Bhattarai et al. 2016; Fang et al. 2015). Sedimentation

percentages, TSS, and turbidity were critical water quality metrics among detention practices. Sediment was collected on site post testing while the water quality was processed in lab according to standard testing specifications (Perez et al. 2016).

2.3 NDOT Silt Traps and Sediment Traps

NDOT has three detention practices – silt trap, sediment trap, and sediment basin – that are used to achieve the same benefits on different scales. The factors that differentiate the practices are their design, application, and capacity as the drainage area and corresponding runoff demand increases. Silt traps are the smallest option, consisting of a shallow excavated sump placed across the flow path to create a ponding area. The silt trap is typically used for drainage areas less than 1 ac (0.4 ha) and requires no dewatering device. Sediment traps are designed for moderate drainage areas up to 5 ac (2.0 ha). The sediment trap involves excavating a stabilized embankment including a riprap spillway to provide greater storage capacity. Sediment basins, used for drainage areas greater than 5 ac (2.0 ha), are the largest system employed. The basins are constructed either through excavation or by building an embankment across a drainage way and are sized to accommodate runoff from a 2-yr, 24-hr storm or a specified volume per acre. The sediment basin incorporates both an emergency spillway and a dewatering device that discharges from the top of the impoundment. The selection of these practices factors in the contributing drainage area, the right-of-way availability, the intended design lifespan, the downstream waterbody sensitivity, and the upstream disturbance duration. The differences between the detention practices are outlined in Table 2.1. This research project focused on the silt trap and sediment trap. The NDOT *Drainage Design and Erosion Control Manual* contains the current standards on their management practices. “Chapter Two Erosion and Sediment Control” outlined the specifications of silt traps and sediment traps (NDOT 2006). No literature has been

found on the scientific assessment of the silt trap or sediment trap as defined by Nebraska. Due to the lack of evaluation, opportunities existed to enhance both practices through research and testing.

Table 2.1: Comparison of NDOT Detention Practices

Practice	Description	Drainage Area	Size	Dewatering Device
Silt Trap	Excavated ditch across the path of water to form ponding area, often includes silt check	< 1 ac (0.4 ha)	1 ft (0.3 m) deep by 6 ft (1.8 m) wide	None
Sediment Trap	Excavation with stabilized embankment	≤ 5 ac (2.0 ha)	134 yd ³ /ac (253 m ³ /ha) typ. 67 yd ³ /ac (121 m ³ /ha) min. 2:1 min. L:W	Riprap spillway with weir height of 1 ft (0.3 m) & length depending on drainage area
Sediment Basin	Excavation or embankment across a drainage way	> 5 ac (2.0 ha)	Vol. equivalent to the local 2-yr, 24-hr storm or 3,600 ft ³ /ac (251 m ³ /ha)	Emergency spillway & dewatering device that pulls from top of impoundment

Note: language from NDOT Chapter 2 Draft

The temporary silt trap is intended to create a temporary ponding area to dissipate energy, generate sediment deposition, and offer temporary storage for runoff. The trap is constructed through the excavation of a small basin-like structure along the flow path of the water. Typically, the trap was 1 ft (0.3 m) deep with a minimum width of 6 ft (1.8 m). The width and length of the silt trap varies according to the site of placement with the overall rectangular shape having a longer dimension in the direction that was parallel to the water flow (NDOT 2017). In the Special Plans produced by the Roadway Design Division, the trap is to be excavated to the width of the existing ditch with a 2:1 slope on all sides. Any silt checks paired with the silt trap are placed 2 ft (0.6 m) downstream of the upper edge of the trap (Roadway Design Division 2024). The size, shape, location, and methods of construction are stipulated by project contract or by the

engineer (NDOT 2017). The silt trap does not require any additional practice, but it can be used in conjunction with various temporary sediment control measures. These measures included erosion checks, earth checks, rock checks, and silt fence (NDOT 2006). The excavated depression normally does not include outlet drains and does not have a specified dewatering time, meaning water within the practice evaporates or percolates into the ground. To maintain the trap functionality, the sediment is to be removed and properly disposed of at 50% capacity. Figure 2.1 contains an example of silt traps that is included in a pocket guide published by NDOT (NDOT 2020a).



Figure 2.1: Pocket Guide Picture of Silt Traps (NDOT 2020a)

The purpose of a sediment trap is to provide storage volume so that sediment could settle out of the detained runoff. The trap is built through excavation and the construction of an embankment for a contributory drainage area up to 5 ac (2 ha). The required storage volume, spillway dimensions, and elevations are factors for designing sediment traps. The embankment has a 5 ft (1.5 m) maximum height with a desirable top width of 4 ft (1.2 m) and side slopes of 3:1 (NDOT 2006). The water release is controlled by a rock spillway or pipe outlet. The most

common outlet for a sediment trap is a self-draining embankment, 1 ft (0.3 m) below the impermeable soil embankment made of Type A rock riprap with the weir length dependent on the drainage area. The storage volume requires 134 yd³/ac (253 m³/ha) which equates to the volume of the first inch of rain across the drainage area. The wet and dry storage are equal parts in volume at 67 yd³/ac (126 m³/ha). If the required volume cannot be met, the lost volume is from the wet storage volume, yet the storage volume cannot fall below the minimum volume of 67 yd³/ac (126 m³/ha). The sediment trap location is determined by the existing and proposed project topography. The natural topography should be maximized for easier construction and easier access for future clean outs. The traps are stated to remove the non-colloidal sediment up to an 80% efficiency which is comparable to sediment basins that have an acceptable and practicable removal of 70% to 90% of the particles larger than silt and clay which requires excessive retention and are stated to not be as feasible to remove. The NDOT manual also allows sediment traps to follow sediment basin design. There are two applications in the standard details plan set: typical roadside ditch and typical outlet swale. The typical roadside ditch sediment trap basin length and width are outlined in Table 2 of the plan set along with other pertinent feature dimensions (NDOT 2020b).

For the year 2024, across all DOT projects, the silt trap had 12 recorded units installed and the sediment trap had 109 recorded units installed. The cost for either trap was executed per unit. The silt trap was \$406 per unit on average, totaling \$4,876 for the year not including any practice that could accompany the silt trap. The sediment trap was \$2,715 per unit, totaling \$296,008 for the year. These values were published in the NDOT historical bid tabs (Nebraska Department of Transportation 2025).

2.4 Similar Practices According to State DOTs

Since Nebraska lies within the Midwest region of the U.S., detention practices in other Midwest states were investigated for comparison. This examination aided in the development of modifications that would optimize silt trap and sediment trap performance from practices that withstand similar hydraulic and soil conditions such as Iowa, adjacent to the eastern border of Nebraska, and Minnesota.

The Iowa DOT has sponsored various stormwater research projects and has programs established to improve stormwater management in the state. There are three detention systems listed in the state manual that relate to the silt trap and sediment trap. The silt dike or silt ditch is a depressed area used to capture sediment and keep it from migrating off a project site. At the base of the fore slope, earth is excavated to a uniform depth to create a ditch below the natural ground level. A ditch and dike may be used together or separately, typically using the material excavated for the ditch and placing it on the side to form a dike. Figure 2.2 illustrate the silt dike and silt ditch according to the Iowa manual (Construction and Materials Bureau 2022).

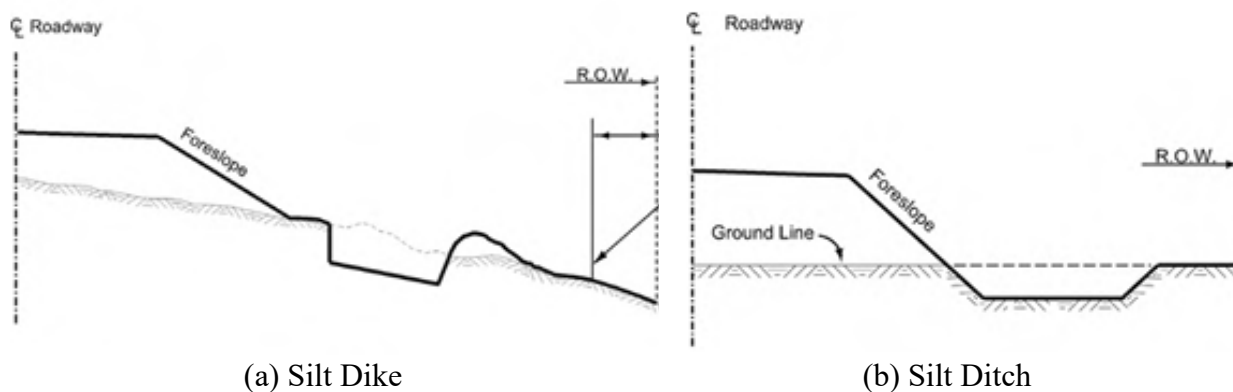

Figure 2.2: Iowa DOT Detention Practices (Construction and Materials Bureau 2022)

The Iowa silt basin functions to slow water, allow sediment to settle, and collect deposited silt. The amount of sediment that settles before the water exits the basin is dependent

on the quantity of drainage and the length to width ratio of the basin. The length is to be longer than the width to allow more time for sediment to settle out prior to flows being discharged from the basin. The silt basins are used in roadway ditches or placed in intervals in ditch grades of 1% or 2%. Clean out is required when silt basin capacity has been reduced by 50%. In the same way, a temporary sediment control basin uses ditch areas to create storage to enable sedimentation. An earthen berm is built across a ditch to form the sediment control basin. The basin also incorporates a riser pipe installed through the berm that utilized slots or holes to allow water to slowly discharge. The berm has a rock overflow to handle the volume generated by high intensity rain events (Construction and Materials Bureau 2022). Figure 2.3 contains the profile views of both types of related basins employed in Iowa.

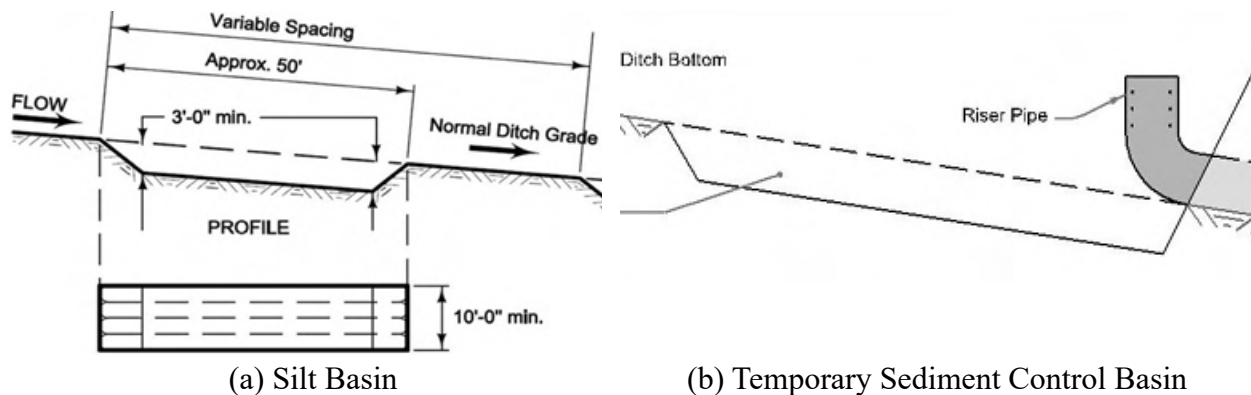

Figure 2.3: Iowa DOT Detention Practices (Construction and Materials Bureau 2022)

Minnesota (MN) has employed a comprehensive approach to stormwater management through its state regulations and BMPs. The MN Stormwater Manual circulated by the Pollution Control Agency has several practices that resemble the NDOT silt trap and sediment trap in function and usage. The difference between the MNDOT sediment trap and basin is their catchment area, retention time and means, and water release method. These stormwater treatment methods are intended to be established before upstream disturbance and remain until after final

stabilization of the contributory area. Sediment traps serve areas up to 5 ac (2 ha) with basins serving areas larger than 5 ac (2 ha). After construction of a trap or basin, the side slopes are stabilized by some means to prevent sediment from the trap or basin filling the available volume. For both practices, the length to width ratio is a 2:1 minimum with sufficient storage for the 2-yr, 24-hr storm runoff amount. If unable to calculate the runoff amount, 3,600 ft³/ac (251 m³/ha) of drainage area is required. The trap utilizes a stabilized weir of rock and a geotextile underlay. The trap uses embankments or other barriers with 2:1 slopes or flatter while discharging through an armor outlet or pipe. Figure 2.4 pictures the MNDOT sediment trap. Sediment traps are to avoid high-velocity flow areas where scour erosion and excessive turbulence may interfere with sedimentation. The sediment trap can be used in series along a drainage pathway in a way that resembles one of the uses of the NDOT silt trap. Basins are placed in low areas near the construction project edge where water is easily directed. To increase sediment removal efficiency, the distance between the inlet and outlet is maximized since a longer flow path generally means greater detention. The basin allows longer residence time for soil particles to settle and releases water via a riser or a floating skimmer that draws clarified surface water, minimizing the discharge of pollutants (Minnesota Pollution Control Agency 2006).

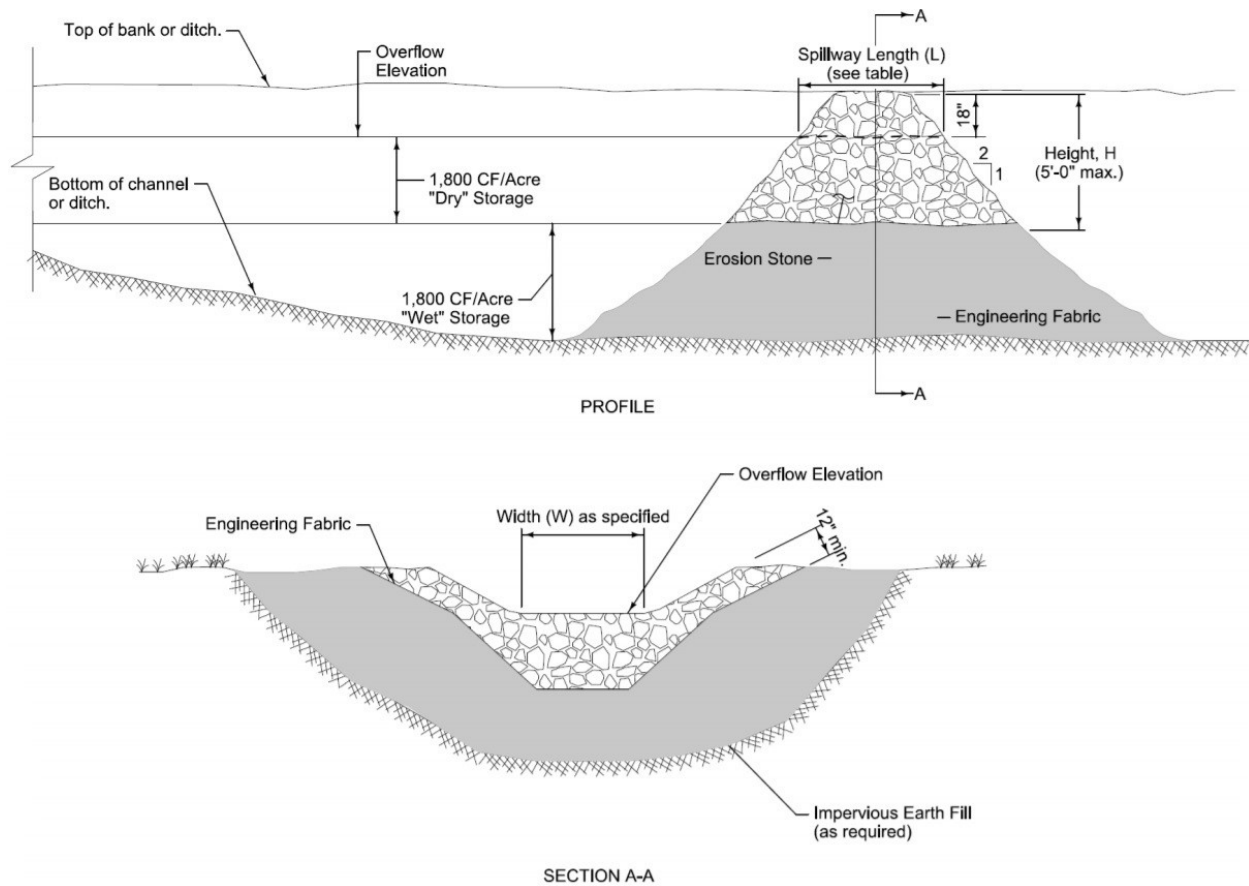

Figure 2.4: MNDOT Sediment Trap (Minnesota Pollution Control Agency 2006)

Various BMP elements are inspected for appropriate maintenance actions. The two biggest factors that pertain to the NDOT silt trap or sediment trap are the accumulation of sediment and standing water. For optimal performance, the sediment must be cleaned out, the standing water must be drained, and any material causing the residual pool must be removed. With correct installation and maintenance, the MNDOT sediment trap and sediment basin had efficiencies typically between 60% and 80%, especially for larger to medium-sized soil particles. In general, larger storage and longer detention time are needed to remove finer particles. The MNDOT sediment trap and sediment basin function to intercept and detain runoff and are stated to be one of the most effective and reliable measures for treating sediment-laden flow from MNDOT construction sites (Minnesota Pollution Control Agency 2006).

The other examined region of the United States was the south due to the high rainfall experienced and high erosivity conditions. Since ample research has been done at the AU-SRF for the Alabama Department of Transportation (ALDOT), their detention practices were considered in the literature review. The ALDOT rock ditch check with an excavated sump resembles the NDOT silt trap paired with one of the possible ditch checks. The sump is not applied as a stand-alone method rather as a combination with a ditch check. The length of the sump is at a minimum twice that of the width and has a minimum depth of 2 ft (0.6 m). The rock is placed at least 2 ft (0.6 m) downstream of the sump as seen in Figure 2.5. The sump is designed to dissipate water energy, allow large particles to settle out of suspension, and provide easy access for maintenance (Alabama Soil and Water Conservation Committee 2022).

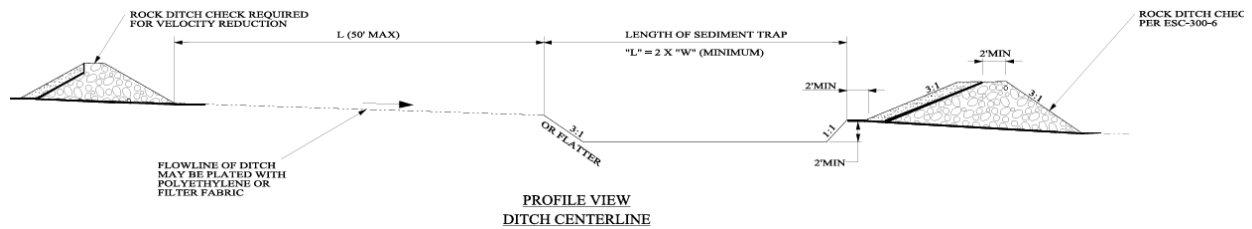

Figure 2.5: ALDOT Rock Ditch Check with Sump Excavation (Alabama Soil and Water Conservation Committee 2022)

The ALDOT sediment basin is a temporary impoundment constructed to capture sediment-laden runoff. This practice applies to sites where more storage is required and where turbidity needs to be reduced. The basin has a length to width ratio of at least 2:1. Water is diverted to the upper end of the pool to improve efficiency and enters the basin in a controlled manner that minimizes erosion. The basin inlet is on the opposite end of the basin from the surface dewatering device. The skimming device is prevented from settling into the mud and clogging by creating a landing pad. The basin uses at least three rows of porous coir baffles installed between the inlet and outlet discharge point. Baffles are placed perpendicular to the

flow, ensuring that water does not flow under or around the baffles. The three rows create four nearly equal volumes in the basin. When posts are utilized, support wire or rope is added to inhibit sagging. Other elements that have been used with the ALDOT basin are flocculants and an upstream forebay (Alabama Soil and Water Conservation Committee 2022).

The North Carolina Department of Transportation (NCDOT) has demonstrated successful stormwater measures and continues to pursue improvements through research within their own state universities. The detention measures NCDOT employs, similar to NDOT, are the Type B silt basin and the skimmer basin (North Carolina Department of Transportation 2015). The Type B silt basin collects sediment in a drainage way for an area up to 3 ac (1.2 ha). The design storage volume is 3,600 ft³/ac (251 m³/ha) with a minimum requirement of 1,800 ft³/ac (126 m³/ha) and is typically built with devices to control incoming flow such as a rock check. The maximum side slope is 1.5:1 with a minimum depth of 2 ft (0.6 m) and a minimum 2:1 length to width ratio. Figure 2.6 pictures the Type B silt basin according to NCDOT.

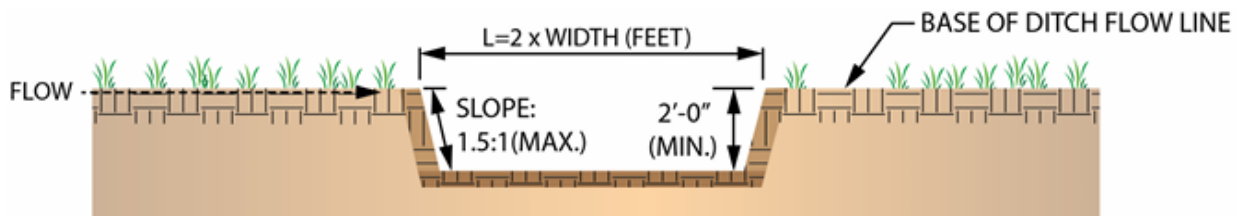

Figure 2.6: NCDOT Type B Silt Basin (North Carolina Department of Transportation 2015)

The skimmer basin is a temporary basin with a geotextile-lined, trapezoidal spillway. Designed for a contributory area up to 10 ac (4.0 ha), the same storage volume and length to width dimensions required of the Type B silt basin apply to this basin along with a 1 ft (0.3 m) spillway freeboard depth and a 4 ft (1.2 m) minimum weir length. The mandatory floating skimmer dewateres in two to three days from the top of the water column. NCDOT utilizes

skimmers as the preferred outlet device for basins. A minimum of three baffles is employed in the basin according to Figure 2.7.

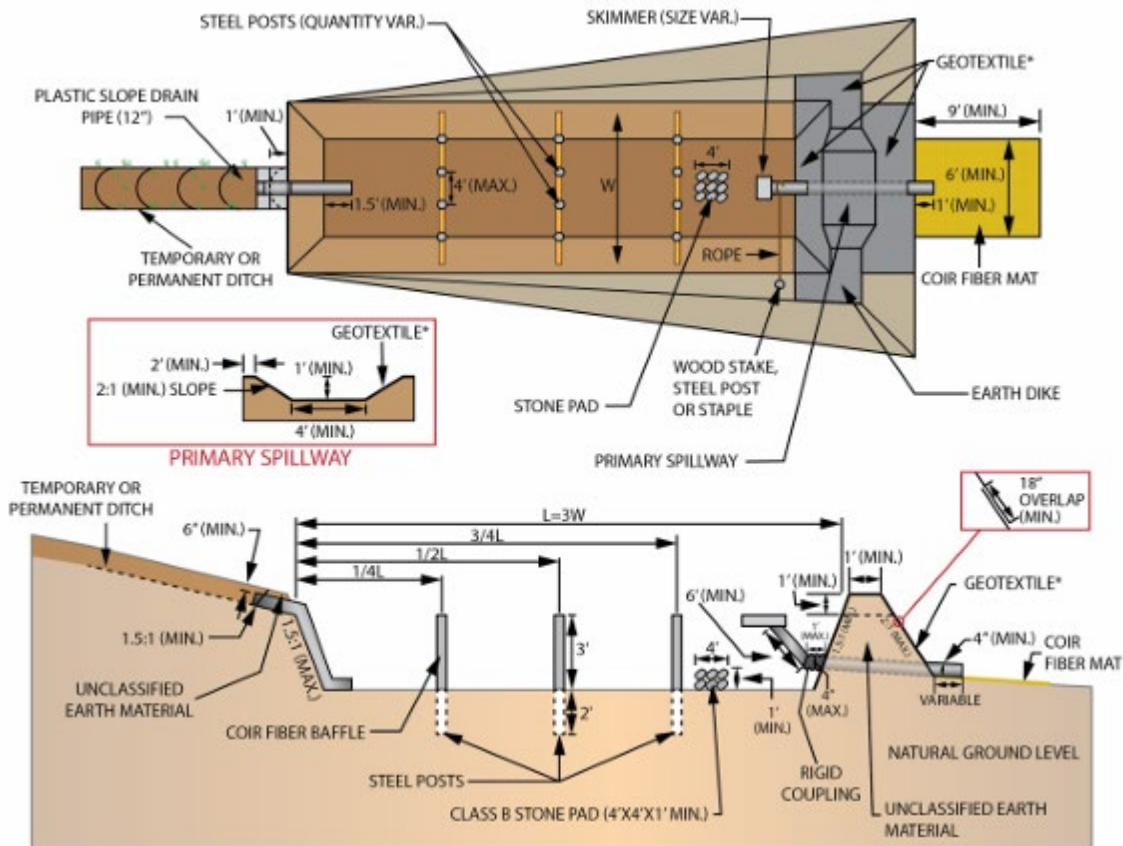

Figure 2.7: NCDOT Skimmer Basin(North Carolina Department of Transportation 2015)

2.5 Potential Modifications

Since there was a lack of literature on silt traps and sediment traps as outlined by Nebraska, the literature review from stormwater-reputable states guided the search for potential modifications for both of those detention practices. The silt trap focused on ditch checks while the sediment trap explored adding elements from typical sediment basins.

2.5.1 Silt Fences, Ditch Checks, and Berms

When examining the temporary sediment control devices that would be tested in conjunction with the silt trap, silt fence was listed as an option in the NDOT ESC manual

(NDOT 2006). The purpose of silt fence is to intercept sediment-laden runoff and form impoundment for sedimentation, keeping eroded soil on site and preventing pollution of water bodies. Silt fence installations were composed of varying geotextiles attached to varying types of posts and were typically finished by trenching the fence into the ground manually or using a slicing machine (USEPA 2012). Silt fences have been utilized at the toe of slopes, on site perimeters, and in long runs as j-hooks. Standards widely diverge due to conditions of different regions of the country; however, standards were often based on rule-of-thumb instead of site-specific conditions, especially on drainage areas for silt fence sections (Liu et al. 2021). NDOT had four types of silt fence: low profile, low porosity, high porosity, and coir (Roadside Stabilization Unit 2007). The low profile was 36 in. (91.4 cm) in height and made of a woven geotextile fabric, and the low porosity was a 42 in. (106.7 cm) minimum height and made of a woven geotextile with the same specifications as the low profile. The high porosity fence was a 42 in. (106.7 cm) minimum, woven geotextile often referred to as “Tennis Court Windscreen” or another approved geotextile meeting or exceeding the specifications (Roadside Stabilization Unit 2007). No studies were found evaluating the performance of high porosity silt fences. The coir was 100% coconut fiber material woven into a mat with a functional longevity of at least three years, a minimum of 36 in. (91.4 cm) height, and used in wetland or sensitive water areas. The high porosity fence was mostly used in high flow circumstances, and the low porosity fence in low flow circumstances. Since the start of this research project, the high porosity silt fence has been phased out of use in Nebraska and removed from the approved products list. The project technical advisory committee requested the low porosity silt fence to be tested despite flow conditions. Silt fence manufacturers claimed that filtration happens through the geotextile material, but research and testing have shown that only a small portion of sediment is trapped by

filtration (Barrett et al. 1996). Silt fence was shown to blind quickly and reduce flow-through (Liu et al. 2021). Rather than filtering for sediment-laden water, silt fence was intended to slow water velocity to allow soil to settle out of suspension. A study done on woven silt fences under Nebraska highway conditions reported performance results for the standard installation of the low porosity fence. At a flow rate of $0.0024 \text{ m}^3/\text{s}$ ($0.086 \text{ ft}^3/\text{s}$) and sediment introduction rate of $12.1 \text{ kg}/\text{min}$ ($26.6 \text{ lb}/\text{min}$), the fence experienced sagging, undermining, and slow dewatering. Under extreme case testing with much higher rates, the low porosity silt fence completely failed, ripping the fabric and allowing water to continue downstream unobstructed (Roche et al. 2024b). Another study was done on woven versus nonwoven silt fence materials. The mean turbidity reduction efficiency for nonwoven geotextile was 52% and for woven geotextile was 18%. The nonwoven also outperformed the woven in sediment concentration reduction efficiencies. The results were attributed to the apparent opening size of the fabrics along with the influence of the soil-water pressure on the fence which caused an increase in the geotextile openings (Gogo-Abite and Chopra 2013). A study conducted on nonwoven silt fence found that a dewatering board could be included in the installation to reduce dewatering time from over 24 hr to around 4 hr, thus minimizing stormwater retention time following rain events. The dewatering board was made of plywood and had a V-notch at the top of the board with dewatering holes down the front. The board had little to no adverse effects on sediment retention proficiencies when compared with an installation without dewatering capabilities. Additionally, structural analyses conducted on three steel and two hardwood silt fence support posts suggested that posts should be spaced properly to improve stability under hydrostatic loading (Whitman et al. 2021). Other silt fence literature revealed that a wire-backed, nonwoven geotextile silt fence could be the solution for increased silt trap function. Notable features of this fence installation were a steel

wire mesh backing of square spacing, sod staples to secure the fence to the channel using a spaced, staggered pinning, and an 18-in. (45.7 cm) weir cut out of the geotextile. The installation was placed at a 90-degree V-shape within the ditch or channel. The wire aided in structural reinforcement of the fence while the pinning facilitated stronger silt check to channel interface. The weir and fence shape created a more manageable impoundment behind the fence that resulted in a capture of over 90% of introduced sediment over the longevity tests conducted (Donald et al. 2016b). Utilizing a variation of a silt fence installation with a silt trap could prolong the lifespan of the fence and increase detention performance.

Ditch checks can be constructed using a variety of materials including wattles and aggregates. These practices were placed in the flow line of channels to interrupt and slow stormwater. The result created an impoundment directly upstream of the ditch check and caused energy dissipation. The energy dissipation reduced runoff velocities, shear stress, and turbulence within the channel. Due to the reduced kinetic energy produced by the ditch check upstream impoundment, sedimentation would occur (Donald et al. 2013). The NDOT ESC manual listed options for several wattles, also referred to as temporary erosion checks, of various sizes, materials, and manufacturers as listed in their approved products list (NDOT 2006). The wattle diameter and material could be chosen according to high and low flow scenarios. The proper installation of wattles was researched to find the best procedure that enabled high performance. According to one study, a statistical analysis conducted on normal installation procedures indicated that significant variables affecting the stormwater control aspect were trenching, staples, and underlays. Considering these essential variables and the installation that resulted in the largest increase in subcritical flow length, the authors recommended that a wattle installed as a ditch check via spaced out stapling, alternating front and back, with non-destructive teepee

staking. The wattle was further recommended to be placed on an underlay fabric without any trenching of the installation (Donald et al. 2013). Another study verified the teepee staking and special ditch protection underlay procedure through field observations. The special ditch protection was a natural fiber excelsior matting, but other possible underlays included geotextile or turf reinforcement mat for thorough ground contact. At installation, wattles were to extend past the channel side slopes to eliminate potential flow bypass (Schussler et al. 2021). On the opposite scale of ditch checks, the Nebraska rock check dam used Type A riprap which was the smallest of the riprap options. Since ditch checks primarily control erosion by causing supercritical flow to transform into subcritical flow by causing impoundment that decreases velocity and erosive shear stresses, riprap was needed to withstand runoff forces and maintain structural integrity. Riprap has been shown to dissipate channelized, high velocity flow, but passages between the aggregate allowed water to flow through the check resulting in shorter impoundment lengths. Adding smaller aggregate or adding 8 oz (227 g) nonwoven geotextile were two flow choking methods tested at high flow condition of 1.7 ft³/s (0.05 m³/s). The 8 oz. (227 g) nonwoven geotextile choker resulted in the longest impoundment length of 29.1 ft (8.9 m) and was the recommended solution (Zech and Fang 2014). This finding was confirmed by another study conducted for the Iowa DOT. The previous version of the rock check dam had an excavation beneath the rock, larger rock gradation, and larger dam width. After clean-water and sediment-laden testing, a rock check dam installation using the smaller erosion stone gradation and a geotextile overlay with dewatering holes was adopted. The geotextile generated higher impoundment lengths and depths while the weep holes reduced excessive dewatering periods, resulting in increased sediment capture and decreased discharge turbidity. The smaller rock, decreased installation width, and elimination of grade excavation beneath proved most cost

effective and easier to install. The installation improved performance and protected unstabilized channels from erosion (Roche et al. 2025). These ditch check installations – the wattle and the rock dam – were listed in the NDOT manual as an accompanying practice for the silt trap.

Nebraska has also employed the earthen berm, known as the temporary earth check, and the slash mulch berm as accepted practices. Literature on earthen berms was not found, however installation procedures included construction of the berm through compacted lifts at a specified width, height, and slope (Roadway Design Division 2024). Slash mulch was a biodegradable option often present after the clearing and grubbing stage of construction activities. This made the material a viable option when available. The construction of the mulch berm was an important factor in beneficial implementation. The berm was formed in three lifts, each firmly compacted. A study revealed that the most effective and efficient installation consisted of 75% less material than normal at 1.5 ft (0.5 m) in height and 3 ft (0.9 m) in width. Despite flow-through still occurring, the berm was able to impound and capture sediment while efficiently using resources from on site. The berm generated an impoundment depth of 4.9 in. (12.4 cm) and had an average discharge turbidity of 1,180 NTU. The sediment capture was at 98.9% of the introduced sediment, with 25.4% occurring within the practice and 73.5% occurring upstream (Roche et al. 2024c). The temporary earth check was listed for use with the silt trap, but the slash mulch berm was not listed since the practice was more recently developed.

2.5.2 Baffles and Skimmers

Two of the most common elements in a typical sediment basin were baffles and skimmer as indicated in numerous literature sources. Baffles can be made of several types of material, but coir was the most prominent with benefits of being biodegradable. One of the most important design considerations for the baffle was to be installed as perpendicular to the direction of flow

as permissible within the basin. The primary function of a baffle was to prevent short circuiting within the storage volume area by modifying the hydraulic flow conditions and distribute flow more evenly across the basin (A. Millen et al. 1997). Other design considerations included the height of the baffle and the baffle spacing throughout the basin. The standard implementation was three rows of wire-backed material that exceeded the full basin depth and the weir spillway height. If the elevation of the baffle fell below the runoff depth, the inflow would travel from the inlet to the outlet creating a zone of high velocity and turbulence that inhibits particle settling. The baffles not only dissipated flow but expanded the effective width of the basin (Perez et al. 2016). Baffles interrupted the path of the incoming runoff by forcing the flow spread along the face of the baffle promoting a more uniform, laminar conditions. The low turbulence allowed sedimentation to occur more quickly and effectively. The spacing of the baffles should roughly break the basin into four equal zones or bays. In one study, the introduced sediment from a simulated runoff event was collected and weighed from each bay. The distribution revealed that larger, heavier particles were deposited in the first bay and decreased in sediment particle size in each consecutive bay respectively. The sediment weight distribution was increasingly less overall moving toward the back of the basin (Fang et al. 2015). When properly designed, a baffle system increased sediment removal efficiency without requiring additional basin volume. A surface skimmer was designed to float on the surface of a basin and drain the least turbid water as sedimentation occurred. These devices consisted of a floating intake connected to a pipe that connected to a flexible hose that conveyed water to the skimmer outlet. The skimmer adjusted with the volume as the basin filled and drained to maintain consistent surface dewatering (Sharpe et al. 2023). This controlled dewatering process increased detention time, allowing suspended particles to settle before discharging. Ongoing research has shown that skimmers must be

appropriately sized to handle the stormwater received and regulate outflow rates but have the capacity to be adjusted as needed (Harrison et al. 2026). The skimmer allowed basins to maximize settling while restoring storage volume for subsequent rain events (Sharpe et al. 2023). Due to the discharged water being drawn from the least turbid zone, an appropriate skimmer significantly enhanced sediment removal efficiency and downstream water quality. To achieve sedimentation in the sediment trap, adding baffles, a skimmer, or a combination were probable in assisting in increased sediment capture and increased downstream water quality.

2.6 Literature Review Summary

The literature review conducted for this research project consisted of detention analysis, various testing considerations, NDOT standard practices, DOTs similar practices, and prospective modifications. For the detention analysis, the governing principle that drives detention is sedimentation. Sedimentation is based on Stokes Law for settling solids and considers factors like residence time via storage volume and dewatering as well as flow velocity reduction achieved through impoundment or other energy dissipation means. Since there were no water quality regulations to satisfy according to the CSW general permit, the only testing considerations were scale and performance indicators. The full-scale methods for testing were most suitable for determining performance using metrics of sediment capture, TSS, and turbidity. The function of the standard NDOT silt trap and sediment trap was outlined. The primary differences between the two practices are their design, application, and capacity. Examining detention-based applications from other DOTs revealed similar core philosophies including slowing water, increasing detention time, and managing discharge. Other consistent elements were basin geometry, designing to local conditions, and essential maintenance. Finally, the potential modifications include numerous forms of ditch checks for the silt trap and specific

added elements for the sediment trap. The modifications also investigated the installation procedures for enhanced practice performance according to past studies. The literature review was used as a foundation for the project, especially to inform the methodology along with the testing regime for the silt trap and sediment trap.

Chapter Three: Methodology

3.1 Testing Methodology Overview

The methodology of this thesis describes the systematic plan and approach used to achieve the goal of identifying the MFE-I of the silt trap and the sediment trap detention practices used by the DOT of the state of Nebraska. This section outlines the tools, techniques, and procedures employed to collect and analyze the data from each practice evaluation. A repeatable testing methodology was adapted from the testing method outlined in Schussler's dissertation (Schussler 2022). The testing methodology was developed in five stages: (1) determining flow and sediment introduction rates using regional means for hydrological factors and soil loss conditions, (2) developing a standardized highway construction roadside channel and testing introduction apparatus for simulation to occur, (3) selecting appropriate water quality sample locations for data collection, (4) defining the sediment retention determination method, and (5) selecting a testing regime and installations to test including standards of Nebraska and modifications found successful through a literature review.

3.2 Statewide Analysis of Climate, Rainfall, and Soil

Given the considerable variation in precipitation, climate, and soil types across Nebraska, the state was partitioned into similar zones to facilitate more effective analysis. Following the RUSLE2 results outlined in Roche et al., six distinct landscape regions were identified (Roche 2023). Figure 3.1 shows the counties considered in each region along with the rainfall erosivity factors (R-factors) throughout the state. In erosion equations and models, the rainfall-related components were considered most significant in impact. The R-factor linked the amount of erosion to the precipitation intensity based on historical rainfall data (Suhara et al. 2023). With

the R-factor quantifying the potential rain has to erode soil, the high values observed in the southeastern part of the state indicated higher risk of erosion when subjected to rainfall energy.

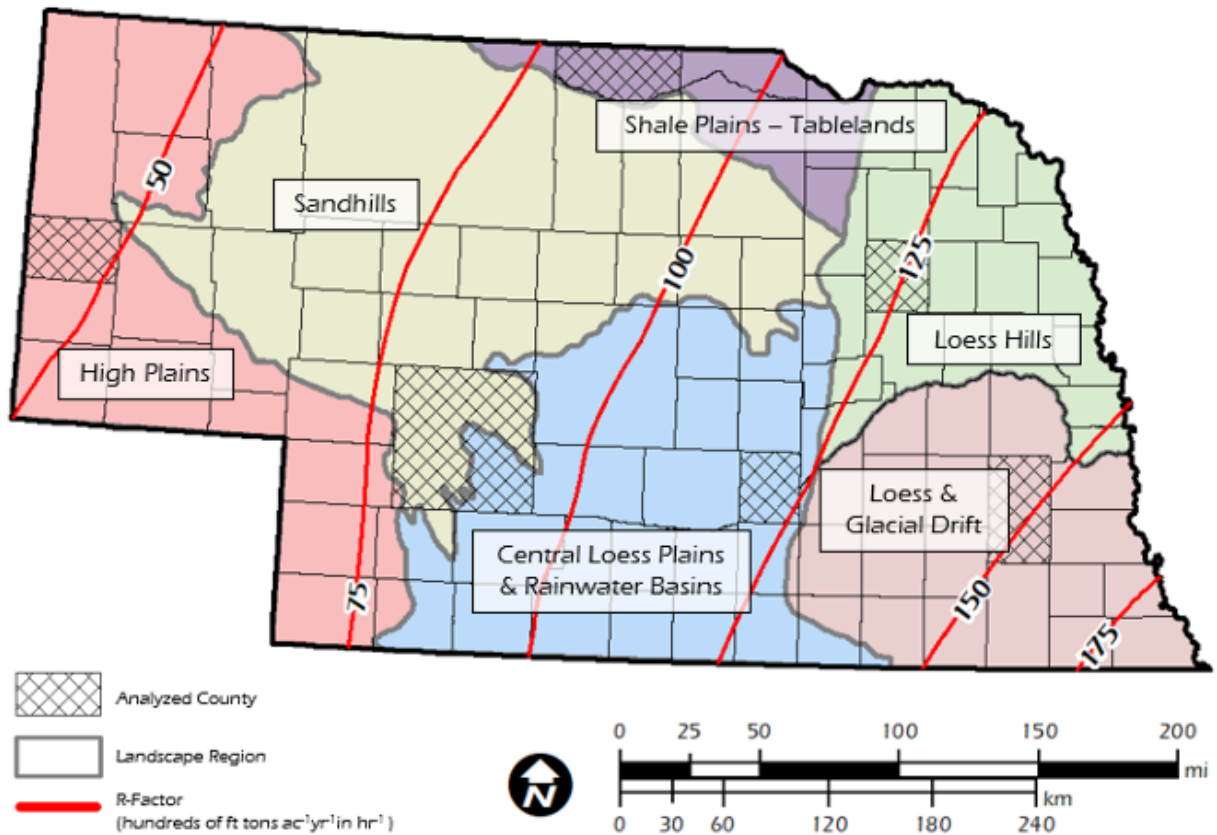

Figure 3.1: Analyzed Counties and Annual Rainfall Erosivity from Six Landscape Regions (Roche 2023)

Due to the variety of climate conditions, averages from select regions were deemed sufficient to determine flow rates and sediment introduction rates for testing. This ensured that the results for the NDOT silt trap and sediment trap practices would deliver outcomes that could adequately be applied to the entire state. The two regions experiencing the highest erosivity coincided with the regions facing the most rainfall and were selected to use in analysis calculations. Those regions were the Loess Hills and the Loess and Glacial Drift located on the eastern side of the state. The curve number and precipitation depth from those areas were

averaged when used as factors to determine the flow rate and sediment introduction rate for testing. If a practice meeting the demands of a region with a higher erosivity and annual precipitation was applied in a lower experiencing region, then the practice would continue to perform successfully while having a factor of safety. The testing rates were also calculated based on representative drainage areas. The silt trap was sized for 0.5 ac (0.2 ha), and the sediment trap was sized for 1.0 ac (0.4 ha) for testing purposes.

3.3 Flow Rate Determination

According to part 2.2.12 of the CGP, one of the design requirements was to provide storage for 1) the runoff volume of a 2-yr, 24-hr storm, or 2) 3,600 ft³/ac (251 m³/ha) of drainage area (USEPA 2022). This allowed permittees to design with their local storm event using the National Oceanic and Atmospheric Administration (NOAA) atlases or other verified methods to find the associated precipitation values. However, the USEPA can only exercise authority over states that do not have their own permitting authority. Nebraska has the DWEE as the permitting authority of the state. In the CSW general permit, the volume requirements are 3,600 ft³/ac (251 m³/ha). From a consensus of other studies and other DOT practices, the 2-yr, 24-hr storm was most likely to provide accurate flow rates for Nebraska and was utilized in analysis. In construction, the standard NDOT plan sets were followed for providing storage volume according to the CSW. In Figure 3.2, the rainfall depth is shown across Nebraska with the least amount of depth appearing in the northeast and progressively increasing toward the southeast. Within GIS, a process called raster clip was used to extract a portion of that data based on a defined boundary. This allowed for an accurate spatial analysis of the focus regions when determining the average rainfall depth for calculations.

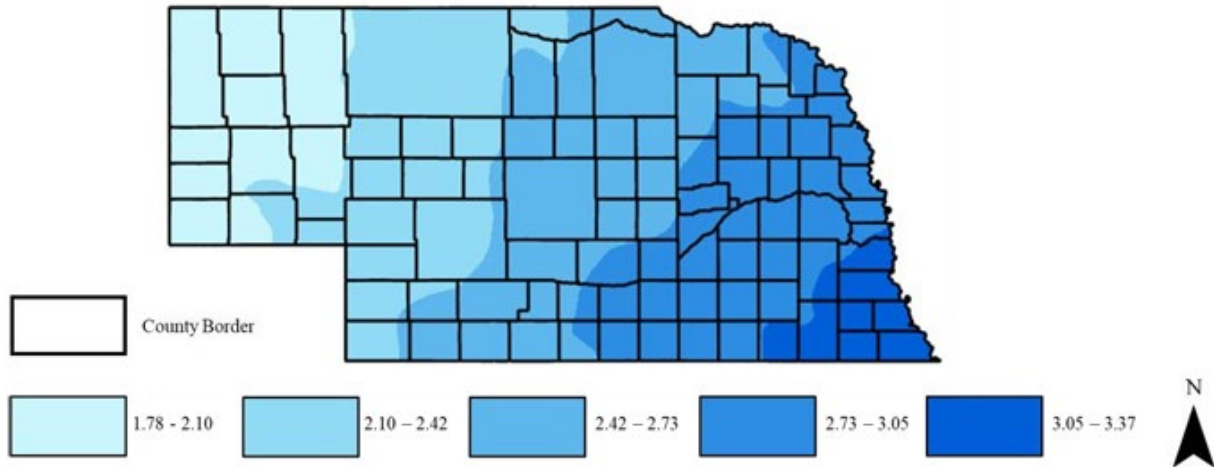

Figure 3.2: Nebraska Map of Rainfall Depth (in.) (Roche 2023)

The same GIS raster clip process was used to find the average curve number of the defined regions. In Figure 3.3, the average weighted curve numbers across the state show ample variability. This was because of the makeup of different hydrologic soil groups, land usages, and cover types. The analysis of the Loess Hills and the Loess and Glacial Drift regions for the curve number and rainfall depth resulted in an average value of 86.7 for the CN and an average value of 2.74 in. (6.96 cm) for the depth.

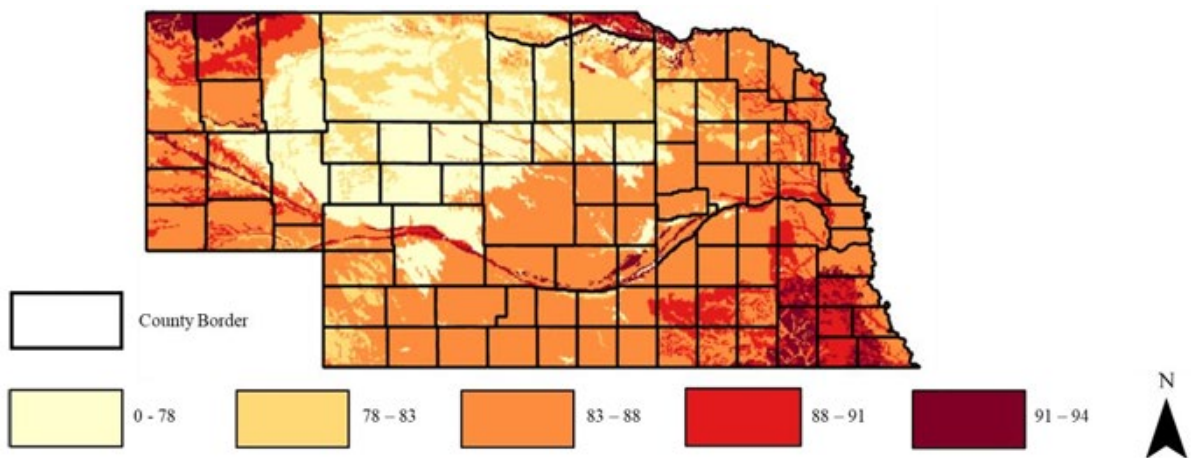

Figure 3.3: Nebraska Map of Weighted Average Curve Numbers (Roche 2023)

The amount of runoff produced by the design storm was computed with the TR-55 Urban Hydrology for Small Watershed design approach. Two equations were combined (eq. 2-3 and eq. 2-4 in the TR-55 Manual) for the resulting Equation 1 which can be utilized to calculate the runoff depth for an area (Natural Resources Conservation Service 1986).

$$Q = \frac{\left(P - \frac{200}{CN} + 2\right)^2}{P + \frac{800}{CN} - 8} \quad \text{Equation 1}$$

where,

Q = runoff depth (in.)

P = rainfall depth (in.)

CN = curve number

The runoff depth correlates to the average runoff amount produced by the design storm. The rainfall depth represents the amount of precipitation produced by the analyzed design storm. The curve number is the infiltration characteristic that functions by considering the impervious area and the soil classification of an identified area. Using the GIS values from earlier analysis, the runoff depth was found to be 1.49 in. (3.78 cm).

Further hydrological analysis was conducted using the hydraflow hydrograph extension in AutoCAD Civil3D. The method employed in creating the hydrographs was developed by the USDA Soil Conservation Service and was known as the SCS method for estimating excess produced by rainfall. The graphs and corresponding data were generated by inputting the CN, drainage area, storm distribution, time of concentration, and time interval. The curve number remained the average of the two assessed regions. The time of concentration (T_c) selected was input by user. A T_c of 5 minutes, which was commonly chosen for this variable, aided in evaluating the design rainfall intensity for the entire area of interest. The time interval was set to

the smallest possible value at 1 minute to provide greater precision. The storm distribution was a Type II meaning significant rainfall was experienced over a short duration for these storms and was based on the geographic location of Nebraska as depicted in Figure B-2 of the TR-55 manual. The CN, storm distribution, time of concentration, and time interval factors remained consistent for both the silt trap and sediment trap hydrographs. The differing factor for each practice was the drainage area. For the silt trap, an area of 0.5 ac (0.2 ha) was analyzed while an area of 1.0 ac (0.4 ha) was analyzed for the sediment trap. The hydrographs were input and run as seen in Figure 3.4 (a) and (b) for both traps.

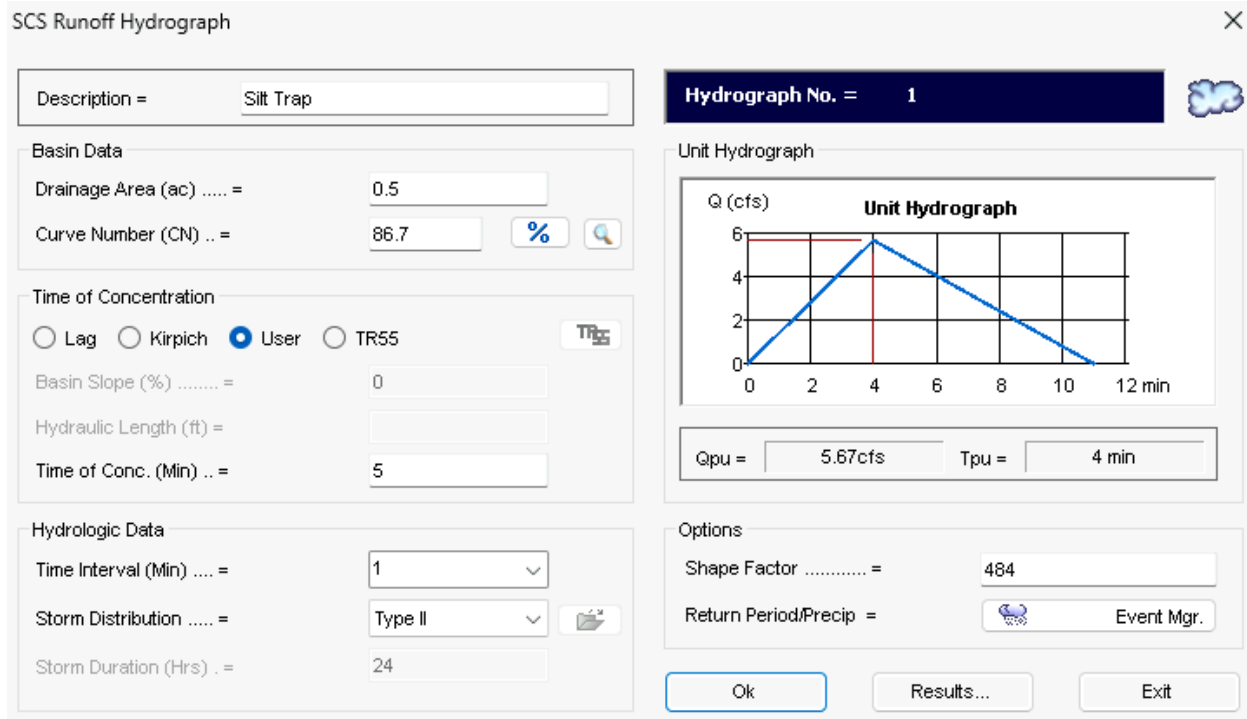

(a) Silt Trap Hydrograph

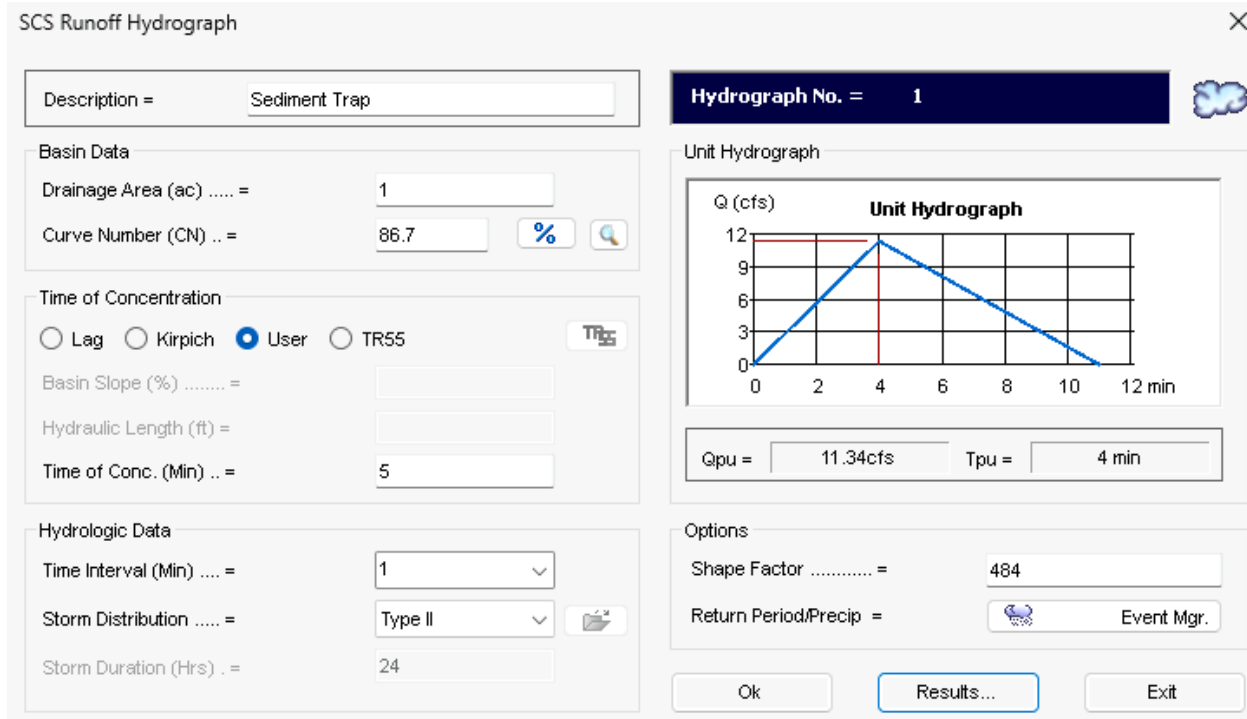

(b) Sediment Trap Hydrograph

Figure 3.4: SCS Hydrograph Inputs

After the hydrograph data was generated, the average flow rate of the peak 30 minutes of flow was obtained. The peak flow values were also noted. Table 3.1 records the resulting values for each drainage area. Based on the average flow for the peak 30 minutes of a local 2-yr, 24-hr storm, the flow rates determined for NDOT testing were 0.5 ft³/s (0.014 m³/s) for 0.5 ac (0.2 ha) and 1.0 ft³/s (0.028 m³/s) for 1.0 (0.4 ha) acre.

Table 3.1: Flow Rates for Silt Trap and Sediment Trap

Drainage Area	0.5 ac (0.2 ha)	1.0 ac (0.4 ha)
Peak 30-min Average Flow	0.47 ft ³ /s (0.013 m ³ /s)	0.93 ft ³ /s (0.026 m ³ /s)
Peak Flow	0.97 ft ³ /s (0.027 m ³ /s)	1.94 ft ³ /s (0.055 m ³ /s)

3.4 Sediment Introduction Rate Determination

The Modified Universal Soil Loss Equation (MUSLE) was used to determine the sediment runoff produced by the flow of the 2-yr, 24-hr storm from the Loess Hills and the Loess and Glacial Drift regions. The MUSLE applied a runoff factor that represented the energy associated with detachment and transport of sediment. This was pertinent to individual storms and increased sediment yield prediction accuracy (Williams and Berndt 1977). The factors in Equation 2 pertained to site-specific conditions to estimate the soil loss due to the rainfall impact and runoff energy from the design storm.

$$S = 95(Qq_p)^{0.56}KLSCP \quad \text{Equation 2}$$

where,

S = sediment yield (tons)

Q = runoff volume (acre-ft)

q_p = event peak discharge (ft³/s)

K = soil erodibility factor

LS = slope-length and steepness factor

C = cover and management factor

P = practice factor

Utilizing the hydrographs that established the testing flow rates, the runoff volume and event peak discharge factors were determined. A total volume was calculated from the average flow of the peak consecutive 30-min of the design storm. Likewise, the event peak discharge used was the average flow rate of that same 30-min since the actual occurring peak flow rate would not reasonably be sustained in a storm for the entire 30-min period of flow. This was done to help with accuracy of the calculation. The soil erodibility factor was dependent on the soil structure, texture, and permeability. With a GIS raster clip of the two analyzed eastern parts of the state, the resulting average was 0.357. The length-slope represented specific site topography including the slope length and the slope steepness. This variable was assumed to be 0.83 based on a 20 ft (6.1 m) typical highway cross section at a slope of 16% as seen on many highway construction projects (Perez 2016). One of the most influential factors was the cover and management factor. This ranged from exposed soil to established vegetation based on the phase of construction. Slopes on these roadside developments were not assumed to be bare; yet the detention installations would not solely rely on those practices. The C factor was assigned a value of 0.5 assuming there was some amount of exposed soil on site but also had erosion management practices in place. Additionally, other supporting practices were expected to be in place during the project lifespan leading to the determination of the P factor. Most iterations of this formula assumed a value of 1 because of the limited data when choosing an appropriate factor. Until this factor, the silt trap and sediment trap calculations utilized all the same values for the MUSLE variables. However, the P factor values were 0.5 for the silt trap and 0.3 for the sediment trap.

For the silt trap, the same assumptions used in the C factor were applied. For the sediment trap, the larger drainage area was expected to encompass more ESC methods upstream of the trap. The computation resulted in a total sediment yield of 0.564 tons (0.504 tonnes) for the silt trap and 0.736 tons (0.668 tonnes) for the sediment trap. Table 3.2 contained the sediment yield calculation summaries. The sediment introduction rate used in silt trap testing was 36.6 lb/min (16.6 kg/min) and was 49.0 lb/min (22.2 kg/min) in sediment trap testing.

Table 3.2: Sediment Yield Calculation Summary

	Runoff Volume	Event Peak Discharge	Soil Erodibility Factor	Slope- Length & Steepness Factor	Cover & Management Factor	Practice Factor	Sediment Yield
Silt Trap	0.019 ac-ft (23.4 m ³)	0.47 ft ³ /s (0.013 m ³ /s)	0.83	0.357	0.5	0.5	0.546 tons (0.504 tonnes)
Sediment Trap	0.039 ac-ft (48.1 m ³)	0.93 ft ³ /s (0.026 m ³ /s)	0.83	0.357	0.5	0.3	0.736 tons (0.668 tonnes)

3.5 Experimental Design and Construction

All testing was conducted at the AU-SRF in Opelika, Alabama. After surveying the available land at the research facility, the channel was arranged on the topography that most closely suited the proposed channel and assisted in convenient water recycling for testing. The test channel as seen in Figure 3.5 was designed following an NDOT roadside channel. The silt trap and the sediment trap tests were conducted using the same channel. The entire testing apparatus was constructed before commencing testing. The silt trap testing was completed first before sediment trap testing was launched. The silt trap was positioned in the channel ahead of the mouth of the sediment trap to prevent any error that would occur from water or sediment not

passing through the trap and the accompanying installed practice. The silt trap was removed, and the channel was refurbished prior to sediment trap testing.

Both side slopes of the channel were 3:1 (H: V) due to test location space constraints. After consulting Exhibit 2.9 “Erosion Check Usage Chart” in Chapter Two of the NDOT manual, the first 55 ft of the channel was chosen to be a 5% slope because it was in the middle range of steepness and allowed room for the theoretical impoundment within the testing location constraints (NDOT 2006). The silt trap would be situated near the end of this 55 ft section, meaning the tests could occur on the same channel slope. The entire channel length was 75 ft with the last 20 ft of the channel at a 3% slope for the mouth of the sediment trap. From the right slope toe to the left slope toe, the channel width was 10 ft. The channel depth was 30 in. (76.2 cm) from the channel bottom to the top of the slope bank. The limiting slope height occurred on the left side slope when oriented facing upstream. The channel configuration was shown in Figure 3.5. The excavation, construction, and grading processes were accomplished using a skid steer and a mini excavator. The evolution of that creation process is captured in Figure 3.6.

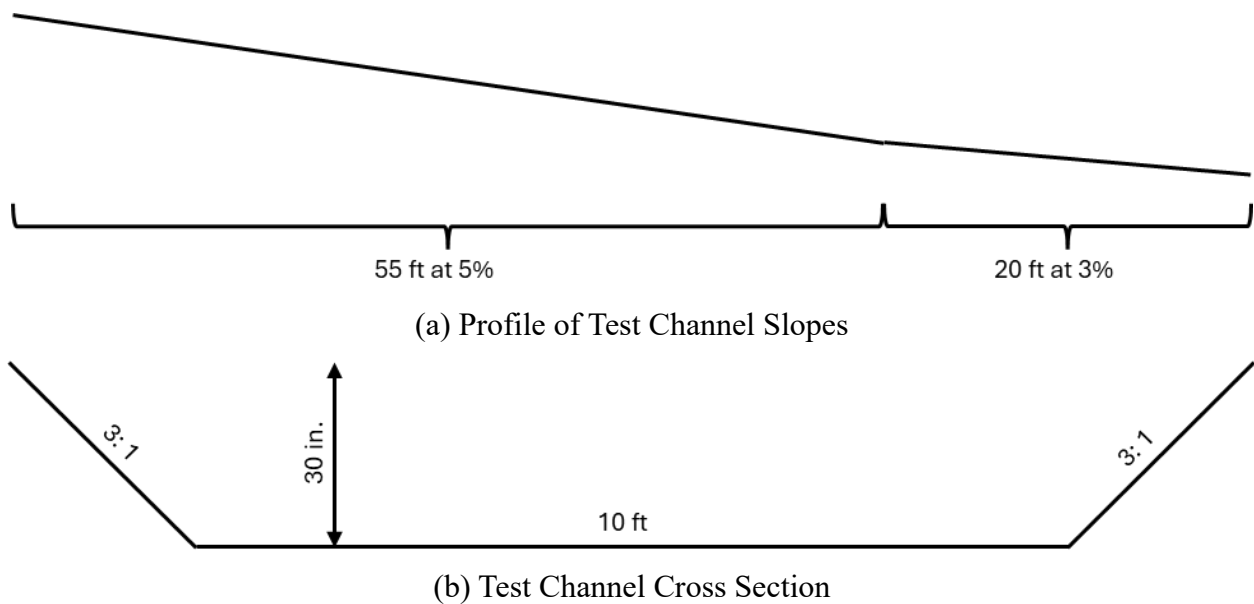

Figure 3.5: Test Channel Configuration



(a) Excavating Stage



(b) Rough Grading Stage



(c) Fine Grading Stage



(d) Final Stage

Figure 3.6: Construction Process

The silt trap was built following the NDOT special plan 5104 1 R0 “Silt Checks All Types” included as Appendix D. When conducting silt trap tests, the fully constructed sediment trap was barricaded with large interlocking sandbags to preserve the sediment trap basin integrity and cause water to flow out of the end of the channel. The sediment trap was built following the NDOT standard detail sheet 4505 5 R5 “Roadside Sediment Trap and Outlet” included as Appendix G. When the channel, silt trap, and sediment trap construction was completed, the entire testing area was covered in an 8 oz (227 g) geotextile that protected the grade and structural integrity of each area as well as function as a control for each installation tested.

Achieving and sustaining accurate flow rates were crucial for the performance evaluation of the silt trap and the sediment trap. On the upstream boundary of the channel, a flat compacted area was created to host the flow introduction apparatus on sturdy pavers positioned beneath the support legs. The apparatus was a 300-gal (1,136 L) tank with inlet fixtures, outflow valves, and a water pressure tube as pictured in Figure 3.7 (a). The water was pumped from the bottom supply pond through a 6 in. (15.2 cm) pump into a manifold to regulate the flow received in the trough using a gate valve on a pressure release hose. Two 4 in. (10.2 cm) hoses connected the manifold to the tank inlets for inflow purposes. The energy of the water entering the trough was dissipated on contact with a board situated across the center of the trough. The channel side of the tank had a calibrated weir that introduced flow upstream of the tested installation. The tube system was connected to the tank to monitor the inflow rates. Likewise, accurate and consistent sediment introduction rates were essential. The sediment introduction apparatus was placed directly underneath the weir to receive the water pouring from the trough as pictured in Figure 3.7 (b). The sediment introduction apparatus consisted of a wooden mixing trough sealed along the joints to ensure water and sediment would not escape before entering the channel. The soil used in testing was native to Opelika, Alabama where the testing site was located at the AU-SRF. The soil was classified in a study conducted at the same testing facility as a sandy loam with 59% sand, 26% silt, and 13% clay (Roche et al. 2024b). According to the Web Soil Survey, the soil was Cecil sandy loam from hydrologic soil group B and had a K value of 0.2. To create sediment consistency in each test, native soil from the AU-SRF on-site stockpile was sifted through a mechanical shaker to remove debris. The total amount of introduced sediment per test was divided into 60 buckets at 18.3 lb (8.3 kg) and 24.5 lb (11.1 kg) per bucket for the silt trap and sediment trap respectively. The measured buckets were dumped into the mixing trough at a

rate of 30 seconds per bucket. The turbulent flow induced by the trough structure aptly mixed with the introduced soil. The simulated sediment-laden flow would then travel down the channel to the silt trap or the sediment trap.



(a) Water Introduction Apparatus



(b) Sediment Introduction Apparatus

Figure 3.7: Testing Inflow Apparatus

3.6 Data Collection

The sediment capture was determined after finishing all the allocated tests per installation. This was accomplished by weighing the sediment that remained in and upstream of the silt trap or sediment trap. To account for the weight of the water in the recovered sediment, an average moisture content was found for the weighed sediment. The sediment was shoveled into self-dumping hopper and placed on an industrial scale. Each hopper filled had a moisture content associated with that load, leading to several moisture contents for one sediment capture capacity. The introduction sediment was also measured for moisture content. The moisture contents were taken to minimize errors in the calculation for quantifying sediment capture performance. The dry weight of the introduction sediment was compared to the dry weight of the post-test sediment. This comparison established a captured sediment percentage for that tested installation. The capture percentage was a significant factor in identifying the MFE-I.

During testing, water samples were taken at three locations at scheduled times to allow for water quality analysis. For the silt trap, the three locations were upstream of the installation at the inflow apparatus, in front of the installation within the silt trap, and downstream of the silt trap and paired installation as illustrated in Figure 3.8. The samples were taken every 3 minutes for the duration of the flow introduction which was a 30-min period (3, 6, 9, 12, 15, 18, 21, 24, 27, and 30 minutes after the start of water flow). For the time after flow introduction, samples were taken at 3-min intervals for 15 minutes (33, 36, 39, 42, and 45 minutes after the start of water flow), then 5-min intervals for the following 30 minutes (50, 55, 60, 65, 70, and 75 minutes after the start of water flow), and finally 15-min intervals for the remaining relevant dewatering period (90, 105, etc. minutes after the start of water flow). As outlined in Appendix I, water samples were tested for TSS using a 1.5 μm binder free glass microfiber filter and turbidity to aid in identifying the MFE-I.

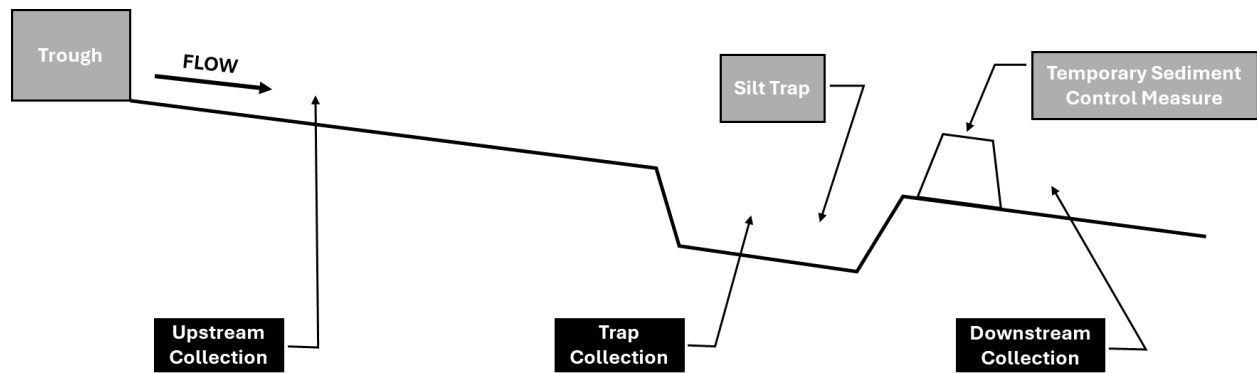

Figure 3.8: Silt Trap Water Quality Data Collection Locations

For the sediment trap, water samples were taken during testing at three locations at scheduled times to allow for water quality analysis. The three locations were upstream of the sediment trap at the inflow apparatus, within the sediment trap basin, and downstream of the sediment trap spillway or outlet pipe (for the skimmer test). These three locations were illustrated

in Figure 3.9. The samples were taken every 5 minutes for the duration of the flow introduction which was a 30-min period (5, 10, 15, 20, 25, and 30 minutes after the start of water flow). For the time after flow introduction, samples were taken at 10-min intervals for 1 hour (40, 50, 60, 70, 80, and 90 minutes after the start of water flow), then 30-min intervals for the following 3.5 hours (120, 150, 180, 210, 240, 270, and 300 minutes after the start of water flow), and finally three samples taken at 23, 23.5, and 24 hours after the start of water flow. Water samples were tested for TSS using a 1.5 μm binder free glass microfiber filter and turbidity each according to Appendix I to aid in identifying the MFE-I.

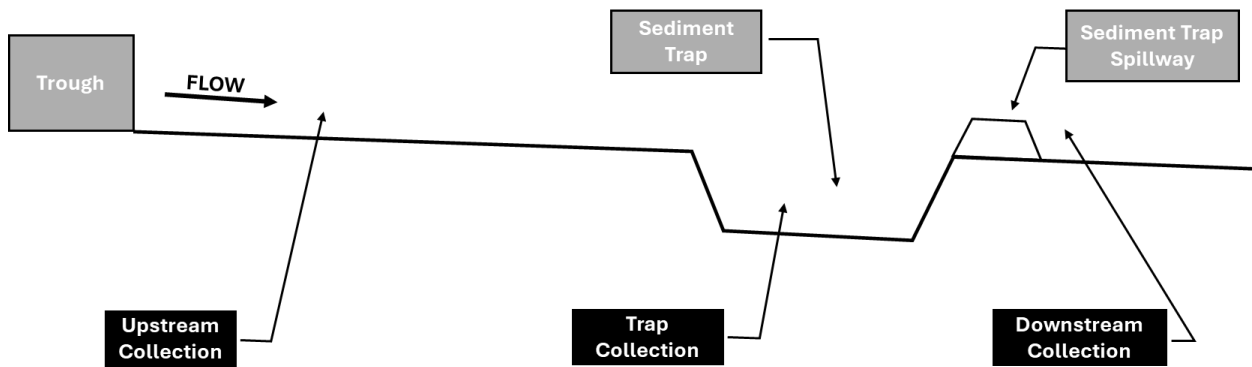

Figure 3.9: Sediment Trap Water Quality Data Collection Locations

A labeling system for easy identification of the water quality samples was created for the silt trap and sediment trap tests. Each test of the installation series was labeled with a consecutive letter of the alphabet: A, B, and C for the silt trap and A, B, C, and D for the sediment trap each corresponding with test 1, 2, 3, and 4 respectively. The next character of the labeling system was a number corresponding with the collection location of the samples. In Figure 3.8 and Figure 3.9, the upstream collection was identified as 1, the trap collection was identified as 2, and the downstream collection was identified as 3. Next was a dash with the final numbers of the labeling system that represented the sample collection order or sequential sampling. For

example, the third sample at the trap collection point of the second test of the series would be labeled B2-03 to be read as test, location, then order in which sample was taken.

Each tested installation for the silt trap was also assessed on its impoundment capabilities. The length and depth of the pool that formed before the installation were measured near the end of each 30-min inflow period, allowing the pool to become established. The impoundment length was measured using an open reel tape measure from the upstream side of the installed practice at the center point of the channel to the point where the water visibly changed from being turbulent to laminar. The impoundment depth was measured using a yard stick directly upstream of the installed practice at the center point of the channel. The measurements from the three tests were averaged for the final impoundment values. The impoundment length and depth were used to determine whether there was a correlation between impoundment and sediment capture. The impoundment values were also compared to theoretical impoundment values. Theoretical impoundment depth was based on the height of the installation. For example, a rock check with a height of 2 ft (0.6 m) would be expected to impound 2 ft (0.6 m) of water; however, the gaps in the rock structure allow water to pass through unhindered rather than impounding to the full depth of the installation. The actual depth was compared to the theoretical depth in a ratio given in Equation 3.

$$\text{Impoundment Ratio} = \frac{\text{Actual Impoundment}}{\text{Theoretical Impoundment}} \quad \text{Equation 3}$$

The same equation was used for theoretical impoundment length versus actual impoundment length achieved in testing. The theoretical impoundment length was based on the channel slope, 5%, and the height of the installation. A ratio less than one indicated the theoretical values were not achieved, a ratio of one meant the theoretical values were achieved, while a ratio more than one signified that the theoretical values were exceeded.

Each tested installation for the sediment trap was also assessed on its storage volume and dewatering capabilities. The water depth in the trap basin was tracked over time from the start of water flow. This measurement was amassed using a level logger. The resulting data and graphs from the logger would be able to indicate time to fill the trap, maximum reached depth in the trap, and water levels over a period of time after the inflow was stopped. The data was reported in discussions of dewatering time whether the installation tested was able to restore storage volume. For testing, the dewatering time started when the test flow was discontinued which was when the inflow pump was stopped. The dewatering lasted until no substantial flow continued downstream of the installation.

3.7 Testing Regime

For each silt trap installation, a series of three tests were run to simulate stormwater runoff events according to the predetermined conditions. These tests were allowed to dewater between flow introduction periods, but the installation remained in place to allow for longevity evaluations to be conducted. The testing started with the NDOT standard practice before other temporary checks were tested in union with the trap. The testing regime for the silt trap occurred in series as illustrated in Figure 3.10. In Figure 3.12, the tested installations for the silt trap were summarized in a flow chart.

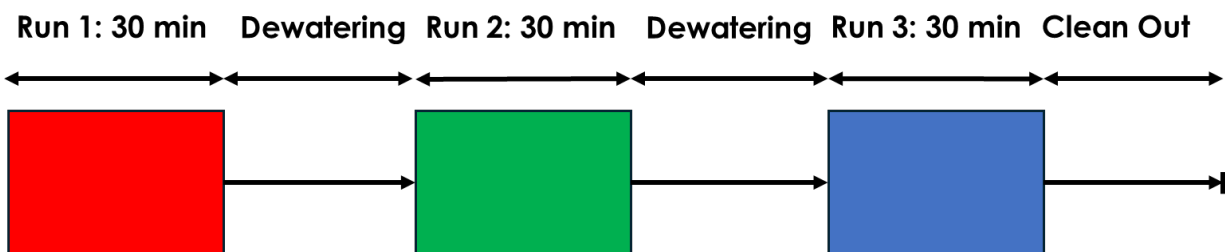

Figure 3.10: Silt Trap Testing Regime

For each sediment trap installation, a series of four tests were run to replicate stormwater runoff events according to the predetermined conditions. These tests were allowed 24 hours to dewater between flow introduction periods, but the installation remained in place to allow for longevity evaluations to be conducted. In between the last two tests of each installation, a 4.5-hour dewatering time was allotted. This back-to-back testing would simulate an overflow event that would test the ability of the sediment trap to handle multiple sizable storms in a short period of time. The testing regime for the sediment trap occurred in series as illustrated in Figure 3.11. The tested installations for the sediment trap were shown in Figure 3.12.

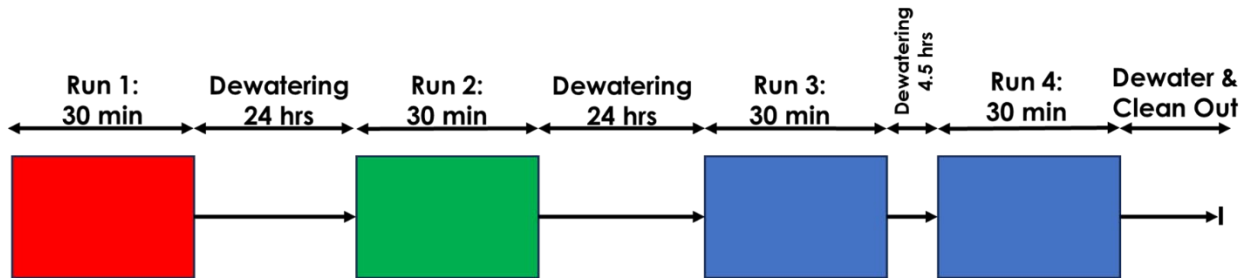

Figure 3.11: Sediment Trap Testing Regime

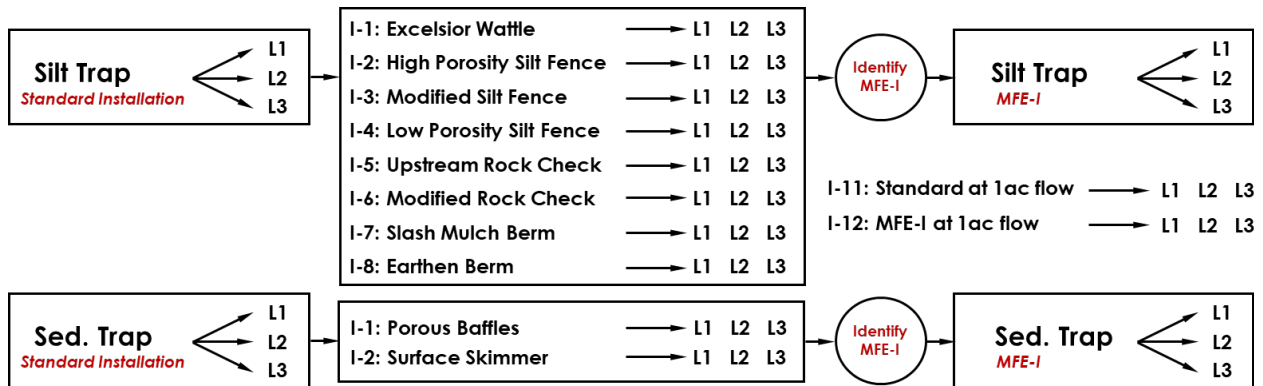

Figure 3.12: Tested Installations

3.8 Methodology Summary

The methodology establishes a repeatable approach for evaluating the performance of NDOT silt traps and sediment traps for the purpose of identifying an MFE-I. The state of

Nebraska was analyzed based on climate, rainfall, and soil characteristics. The Loess Hills and Loess and Glacial Drift regions that experienced higher erosivity and higher rainfall were used to ascertain the average factors of the 2-yr, 24-hr storm event. The factors were used in determining the flow rates and sediment introduction rates for testing. The silt trap – sized for 0.5 ac (0.2 ha) of drainage area – had a test flow rate of 0.5 ft³/s (0.014 m³/s) and sediment introduction rate of 36.6 lb/min (16.6 kg/min). The sediment trap – sized for sized for 1.0 ac (0.4 ha) of drainage area – had a test flow rate of 1.0 ft³/s (0.028 m³/s) and sediment introduction rate of 49.0 lb/min (22.2 kg/min). A full-scale roadside channel was constructed to replicate NDOT field conditions, and a testing apparatus controlled the simulated runoff and sediment loss delivery. Multiple test series implementing different modifications were conducted for each practice. Performance was measured primarily through sediment capture and water quality sampling for TSS and turbidity. Other indicators included physical observations such as impoundment and dewatering behavior.

Chapter Four: Results And Discussion

4.1 Introduction

The following section summarizes the findings from the silt trap testing and the sediment trap testing. Each trap configuration was evaluated on two major performance categories: sediment retention and water quality improvement. This section also includes low porosity silt fence structural, clean water testing due to the outcome during silt trap testing. To determine the MFE-I of the three types of testing, the various installations were subjected to Nebraska flows and, when applicable, sediment loss. The channel was lined with a geotextile to prevent channel erosion that would cloud the sediment capture results. This lining was maintained as a control throughout all tests.

4.2 Silt Trap Installations

There were nine iterations of the silt trap that were evaluated in the Nebraska channel at the AU-SRF. The installations tested in conjunction with the silt trap were Nebraska standard practices or practices modified based on prior research or test findings. The following subsections detail the installation procedures and materials used. All tested practices utilized typical materials that were readily available to the construction industry. For convention, the channel sides were distinguished as left and right when downstream of any installation facing upstream where the inflow apparatus was located.

4.2.1 Nebraska Standard Silt Trap

The silt trap was built according to NDOT specifications and was not required to have an accompanying practice when put on a construction site. The installation remained consistent for both the standard tests, at the 0.5 ac (0.2 ha) and 1.0 ac (0.4 ha) sediment and flow rates. The

standard silt trap was 0.3 m (1 ft) deep with 2:1 (H: V) side slopes. The length was twice the width of the excavated trap at 3.66 m (12 ft) and 1.83 m (6 ft) respectively. The top measurements of the trap were 4.88 m (16 ft) in length and 3.05 m (10 ft) in width. The silt trap took the entire width of the channel bottom. The trap was covered in an 8 oz (227 g) geotextile that was securely pinned down with 1 in. (2.5 cm) by 6 in. (15.2 cm) sod staples made of 11-gauge steel wire. The NDOT standard silt trap was considered the control for installation comparisons. Four angles of the silt trap were shown in Figure 4.1 before testing was started.



Figure 4.1: NDOT Standard Silt Trap

4.2.2 Temporary Erosion Check

A temporary erosion check was selected from the approved products list on the NDOT website. An excelsior wattle with a 12 in. (30.5 cm) diameter was chosen to meet the Type-1 and

Type-2 High temporary silt check requirements. The wattle was secured using a non-destructive staking pattern that inserted the 2 in. (5.0 cm) by 1 in. (2.5 cm) wood posts on the downstream side sloped across the wattle toward the upstream side. This kept the wattle in place against the flow. Since one excelsior wattle was not long enough to span the width of the channel and continue far enough up the side slopes, two were used and overlapped at the center of the channel. At the overlap, stakes were placed on both sides of the wattle in an A-frame or teepee manner to ensure the wattle maintained contact when subjected to flow. The bottom of the wattle was pinned on the downstream and upstream sides using 1 in. (2.5 cm) by 6 in. (15.2 cm) sod staples made of 11-gauge steel wire. The staples were laced through the netting that encased the wattle and driven into the ground to ensure the wattle was held down tightly. The excelsior wattle was positioned 2 ft (0.6 m) downstream of the silt trap edge as explicated in the silt trap plan set. Four angles of the silt trap and temporary erosion check were shown in Figure 4.2 before testing was started. Appendix E contains the installation details according to ALDOT.

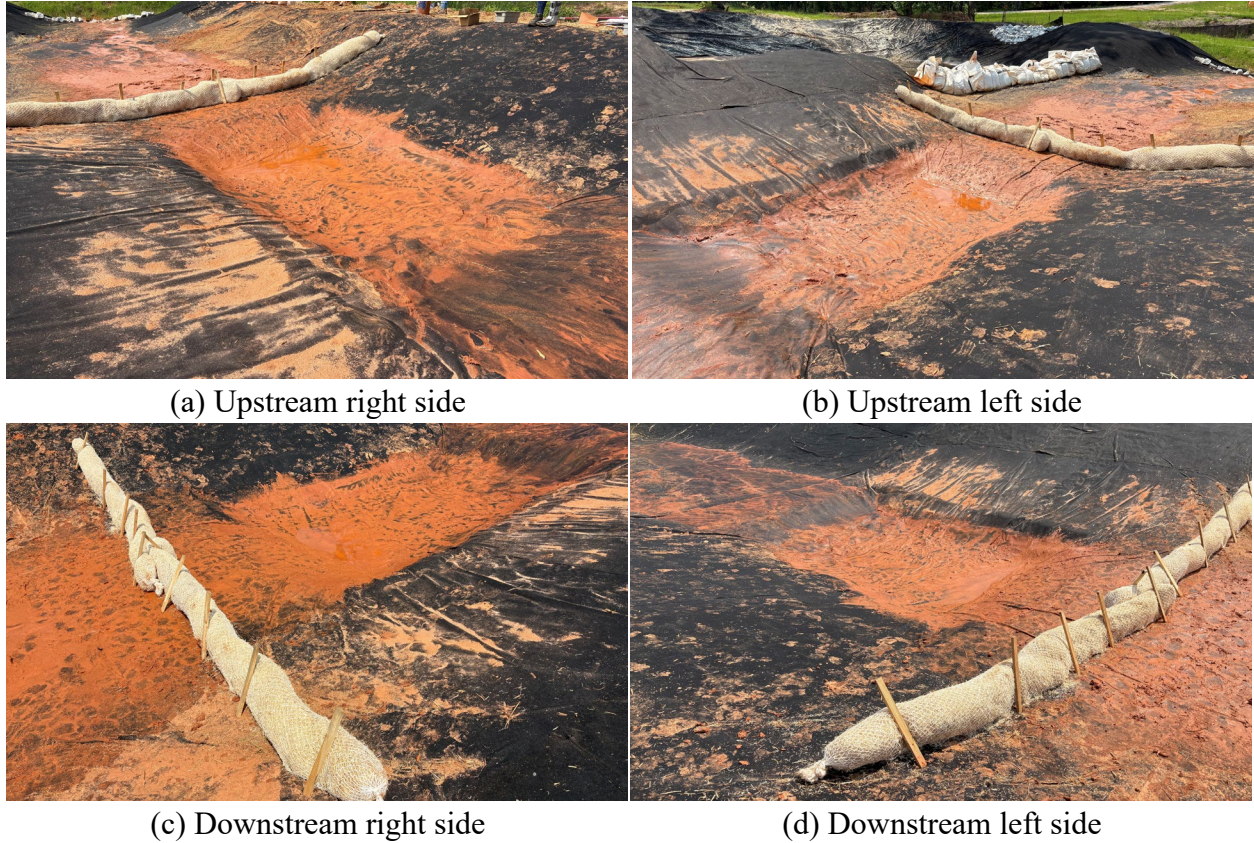

Figure 4.2: Temporary Erosion Check

4.2.3 High Porosity Silt Fence

The high porosity silt fence or high flow fence was a type of temporary silt fence NDOT employed in high flow areas as a sediment barrier. The fence was used alongside a silt trap positioned 2 ft (0.6 m) upstream of the fence. The fabric was woven synthetic material arranged in a horizontally striped manner as referred to as tennis court windscreen. The fence was supported by studded steel T-posts with a weight of 1.25 lb/ft (37 kg/m) at a maximum spacing of 6 ft (1.8 m). Due to the 10 ft (3.0 m) channel width, the posts were positioned with 5 ft (1.5 m) spacing based on a post centered in the channel to the toe of the bank and up the slope. The fence was attached to the top of every post with three UV stabilized, black zip ties with a 50 lb (22 kg) minimum tensile strength. The minimum roll width of the fence was 42 in. (106.7 cm), and the

fence height was required to be 30 in. (76.2 cm) above grade and entrenched at the base. Because the channel was lined with a geotextile, scour underneath the fence was not a concern as it would be on bare earth. For that reason, the trenching method was not used, rather the fence was fastened with 1 in. (2.5 cm) by 6 in. (15.2 cm) 11-gauge steel wire sod staples in two alternating rows along 6 in. (15.2 cm) of the bottom of the fence folded upstream. This stapling method resulted in a fence height of 36 in. (91.4 cm). Four angles of the silt trap and temporary high porosity silt fence were shown in Figure 4.3 before testing was started.

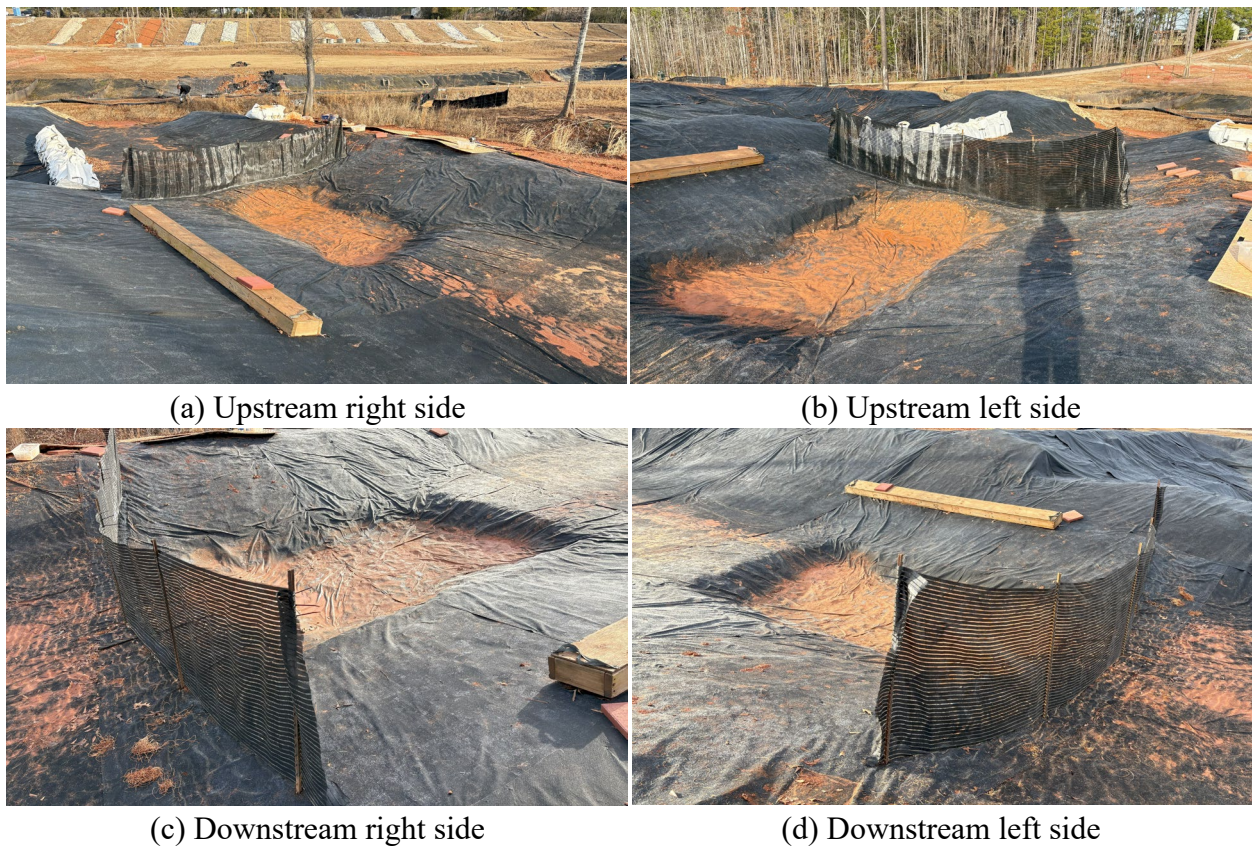

Figure 4.3: High Porosity Silt Fence

4.2.4 Modified Silt Fence

The modified silt fence was not a practice used in the state of Nebraska. The installation was adapted from the ALDOT silt fence ditch check as seen in Appendix F to use downstream of

a silt trap. The geotextile was a nonwoven polypropylene weighing 3.5 oz/yd² (118 g/m²). The support backing for the fence was 14.5-gauge steel wire with 12 in. (30.5 cm) spacing between the vertical wire and 3 in. (7.6 cm) horizontal spacing at the bottom up to 8 in. (20.3 cm) horizontal spacing at the top. The geotextile and wire were supported by studded steel T-posts with a weight of 0.95 lb/ft (1.4 kg/m) at a spacing of 3 ft (0.9 m). The center post was positioned 3 ft (0.9 m) from the edge of the center of the silt trap, unlike the typical 2 ft (0.6 m) offset. The next posts on either side of the center post were positioned 1 ft (0.3 m) from the edge of the silt trap with the next posts resting on the toe of the bank. In this manner, the fence posts continued up the side slopes. This created a V-shape fence behind the silt trap, opening toward the upstream side of the channel. The wire backing was attached at the top, middle, and bottom of the T-posts using 6.5 in. (16.5 cm) 11-gauge aluminum tie wire. The fence was then attached along the top of the wire backing using 11/16 in. (1.75 cm) 16-gauge galvanized steel C-ring staples. The height of the fence was 24 in. (61.0 cm). The bottom of the fence – a 6 in. (15 cm) fold upstream – was fastened to the ground using two alternating rows of 1 in. (2.5 cm) by 6 in. (15 cm) 11-gauge steel wire sod staples. The trenching method was not utilized due to the geotextile lining of the channel that prevented scour. In the modified silt fence, a 6 ft (1.8 m) long weir was cut at the center of the channel, spanning the three centermost T-posts. The height of the weir section was 18 in. (45.7 cm), and the edges along the weir were secured with C-ring staples. Four angles of the silt trap and modified silt fence were shown in Figure 4.4 before testing was started.



Figure 4.4: Modified Silt Fence

4.2.5 Low Porosity Silt Fence

The low porosity silt fence or low flow fence was a type of temporary silt fence NDOT employed in low flow situations as a sediment barrier. The geotextile was a single weave synthetic material with a low-profile fence width of 36 in. (91.4 cm). The fence was supported by studded steel T-posts with a weight of 1.25 lb/ft (37 kg/m) at a maximum spacing of 6 ft (1.8 m). The posts were based off the channel centerline and spaced 5 ft (1.5 m) apart to ensure contact with the toe of the bank. The posts were positioned perpendicularly to the channel and continued up the side slopes. The side slope on the left side facing upstream limited the extent that fence was able to stretch. To prevent bypassing, the fence was curved upstream in a U-shape to allow overtopping. The geotextile was attached to the top of every post with three UV stabilized, black

zip ties with a 50 lb (22 kg) minimum tensile strength. The fence height was 30 in. (76.2 cm) above grade and supposed to be entrenched at the base. Because the channel was lined with a geotextile, scouring was not a concern, so the fence was fastened with 1 in. (2.5 cm) by 6 in. (15.2 cm) 11-gauge steel wire sod staples in two alternating rows along the bottom 6 in. (15.2 cm) folded upstream. The fence was located 2 ft (0.6 m) downstream of the silt trap. Four angles of the silt trap and temporary low porosity silt fence are shown in Figure 4.5 before testing was started.

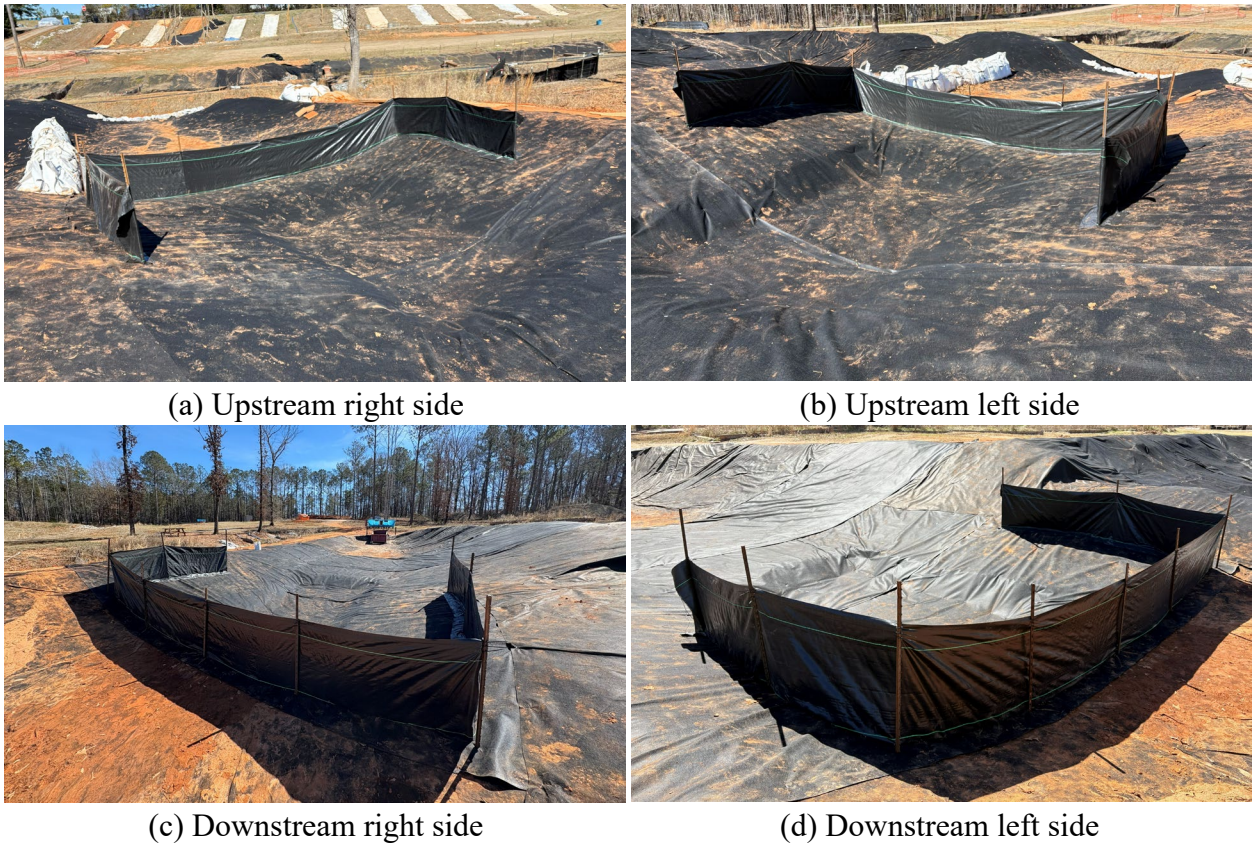

Figure 4.5: Low Porosity Silt Fence

4.2.6 Temporary Rock Check

The temporary rock check was a ditch check placed perpendicularly in the channel 2 ft (0.6 m) upstream of the silt trap. The rock was meant to be trenched below ditch grade, however,

the geotextile lining on the channel prevented this excavation method and past research indicated no difference in adding that element. The rock riprap used was an NDOT Type A where the mean stone size was 0.77 ft (0.23 m). As a conservative equivalent, the Alabama Class 1 riprap was sourced from a local rock carrier. The specifications of the Class 1 riprap were 10% at a diameter of 12 in. (30.5 cm) or greater, 50% at a diameter less than 10 in. (25.4 cm), and 10% less than 6 in. (15.2 cm). The rock check was 4 ft (1.2 m) wide at the bottom, 2 ft (0.6 m) tall, and 2 ft (0.6 m) wide at the top. The lowest point of the rock check occurred in the center of the channel. Four angles of the silt trap and temporary rock check were shown in Figure 4.6 before testing was started. Appendix D contains the installation plan details.

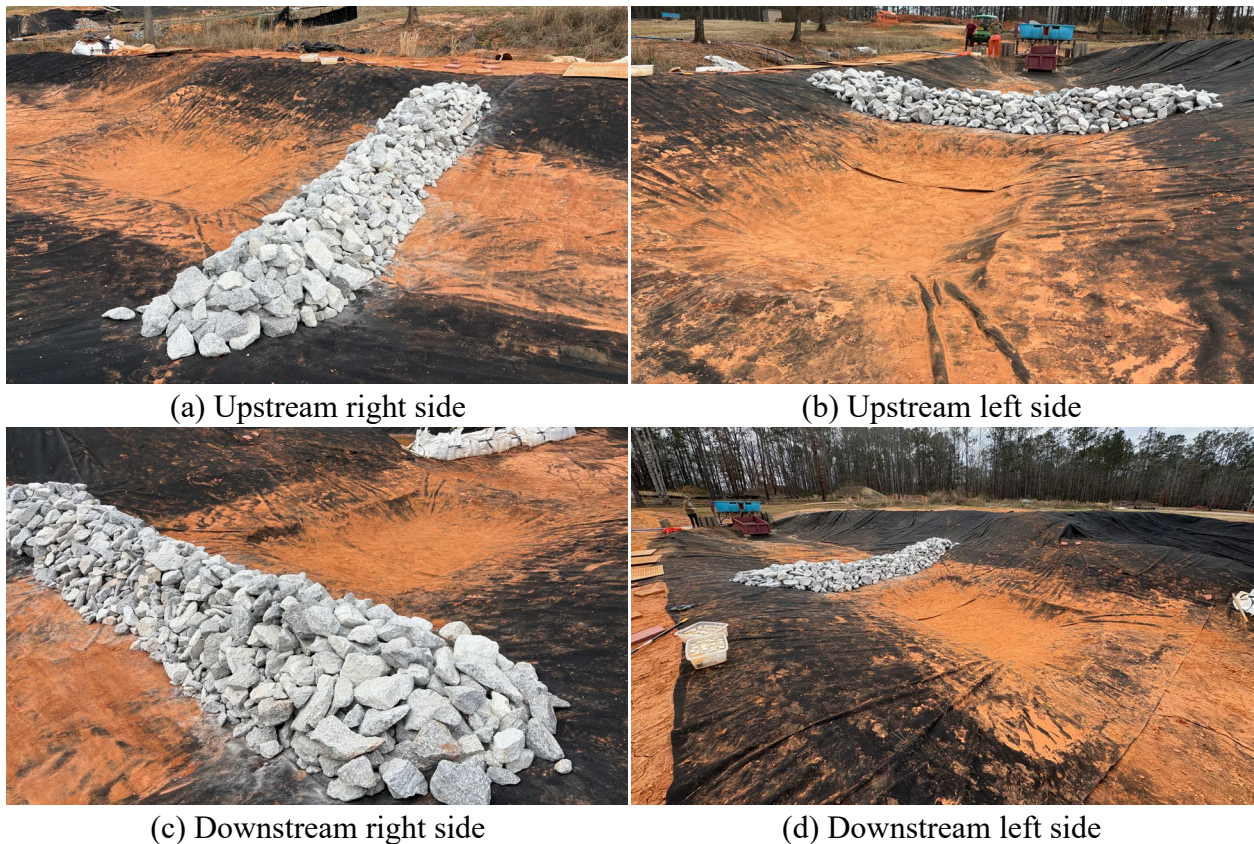

Figure 4.6: Temporary Rock Check

4.2.7 Modified Rock Check

The modified rock check retained the same dimensions as the temporary rock check: 4 ft (1.2 m) wide at the bottom, 2 ft (0.6 m) tall, and 2 ft (0.6 m) wide at the top. The rock was set 2 ft (0.6 m) downstream of the silt trap. The same conservative equivalent, Alabama Class 1 riprap, was used to represent the Type A riprap used by NDOT. The rock check was overlaid with an 8 oz (227 g) geotextile fabric. Loose rocks were used to secure geotextile along top backside of the check. In front of the check, the geotextile extended 6 ft (0.6 m) ending in the bottom of the silt trap. The front geotextile was secured using wire sod staples measuring 1 in. (2.5 cm) by 6 in. (15.2 cm) in 11-gauge steel. Nine dewatering holes, also known as weep holes, were added using a razor blade to the geotextile on the front face of the rock check. Three columns of holes were spaced 5 ft apart happening at the right toe, left toe, and center of the channel. The weep holes were spaced 9 in. (22.9 cm) apart starting at the ground. The lowest point of the modified rock check occurred in the middle of the channel. Four angles of the silt trap and modified rock check were shown in Figure 4.7 before testing was started.

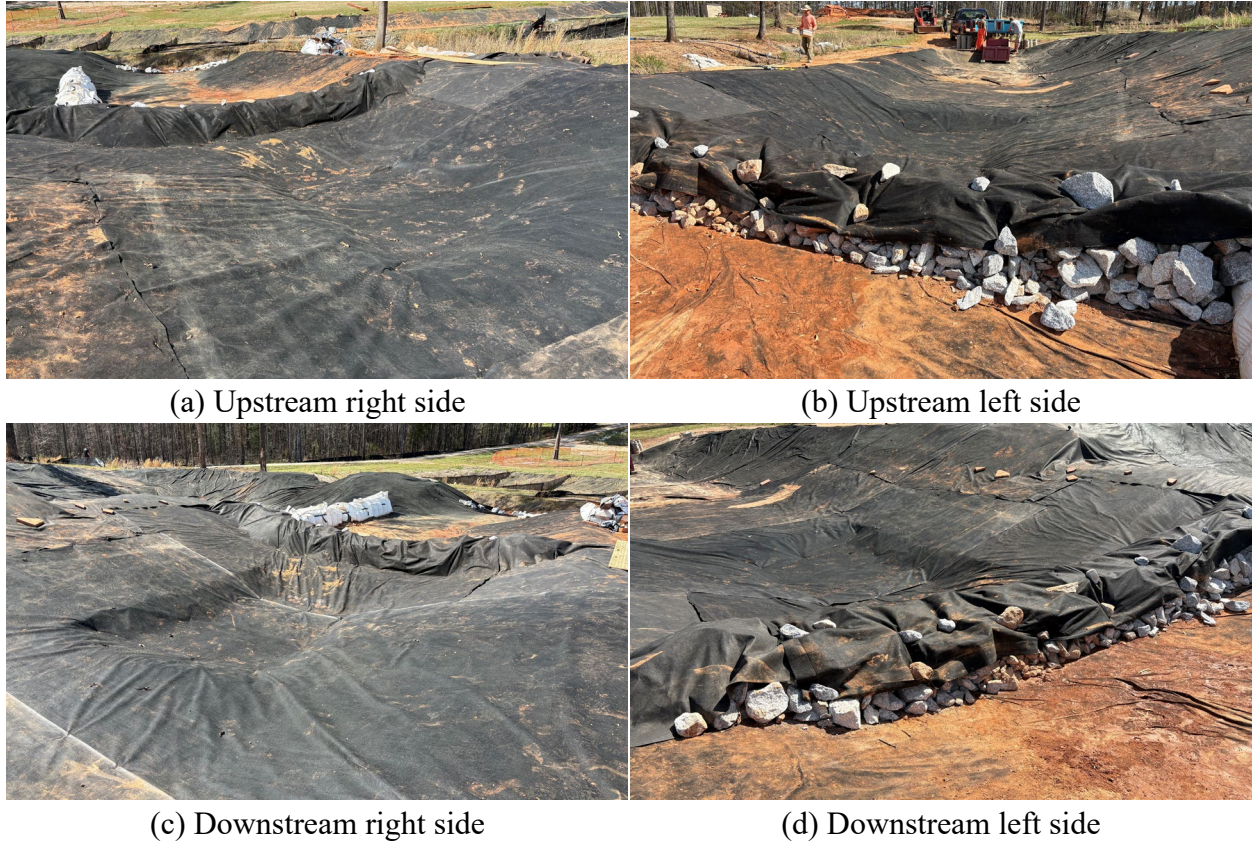

Figure 4.7: Modified Rock Check

4.2.8 Slash Mulch Berm

The slash mulch berm was constructed with freshly mulched tree material from a nearby Alabama construction site. The berm has a bottom width of 5 ft (1.5 m) wide, a top width of 2 ft (0.6 m), and a height of 2 ft (0.6 m). The perimeter slash mulch berm which had a taller but narrower build than the slash mulch ditch check was chosen over the ditch check due to the higher potential impoundment depth and length. The installation details are contained in Appendix D. This ditch check was placed perpendicular to the channel and offset 2 ft (0.6 m) downstream from the silt trap. The mulch was put in place using three even lifts, well compacted across the entire berm and on each berm face. The lowest point of the berm coincided with the

middle section of the berm. Four angles of the silt trap and slash mulch berm were shown in Figure 4.8 before testing was started.

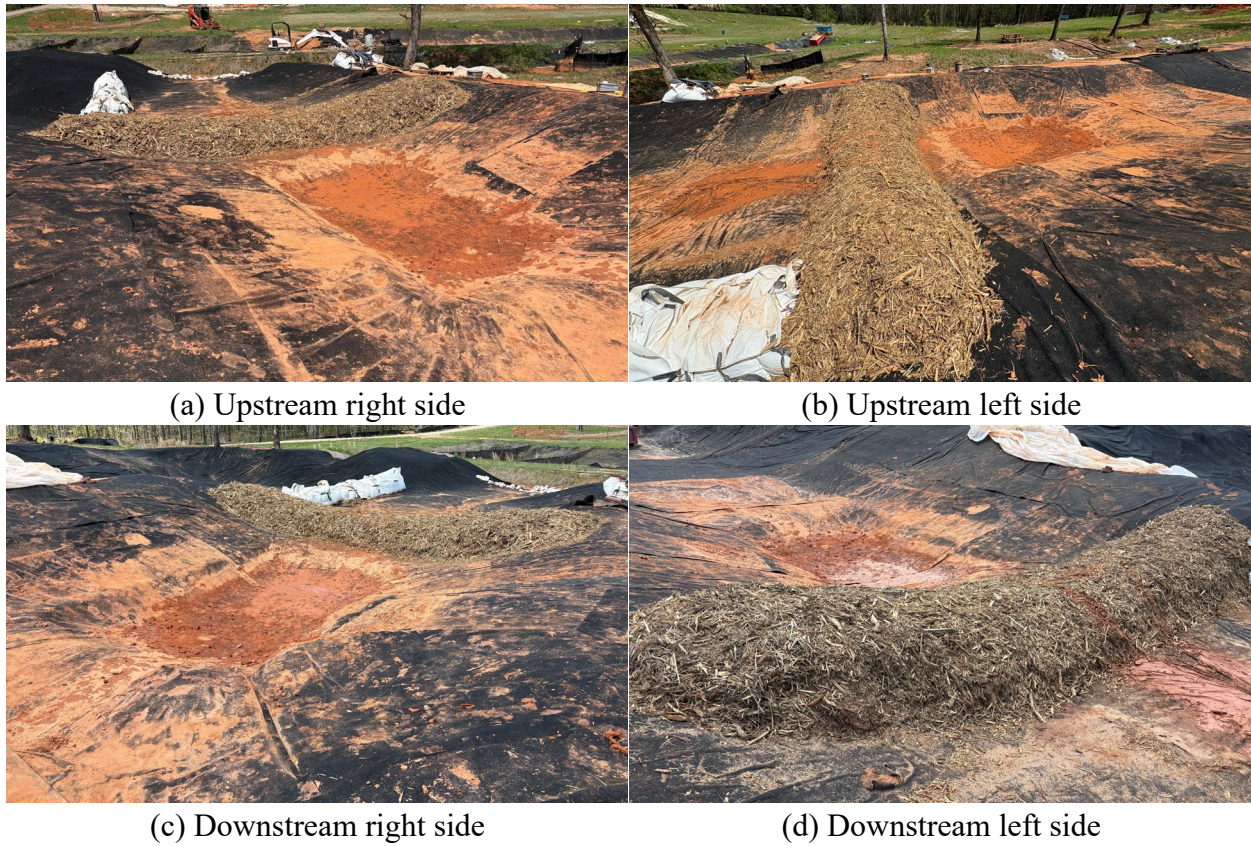

Figure 4.8: Slash Mulch Berm

4.2.9 Temporary Earth Check

The temporary earth check, also known as an earthen berm, was a type of ditch check used by NDOT included in Appendix D. The berm was erected perpendicularly to the channel and 2 ft (0.6 m) downstream of the silt trap. The base of the berm was 5 ft (1.5 m) wide, the height was 2 ft (0.6 m), and the top width was 2 ft (0.6 m). The structure was built in three even lifts using Alabama native soil. The front and back sides of the berm were compacted using a hand tamper. The lowest spot on the berm occurred across the middle section, centered in the

channel. Four angles of the silt trap and temporary earth check were shown in Figure 4.9 before testing was started.

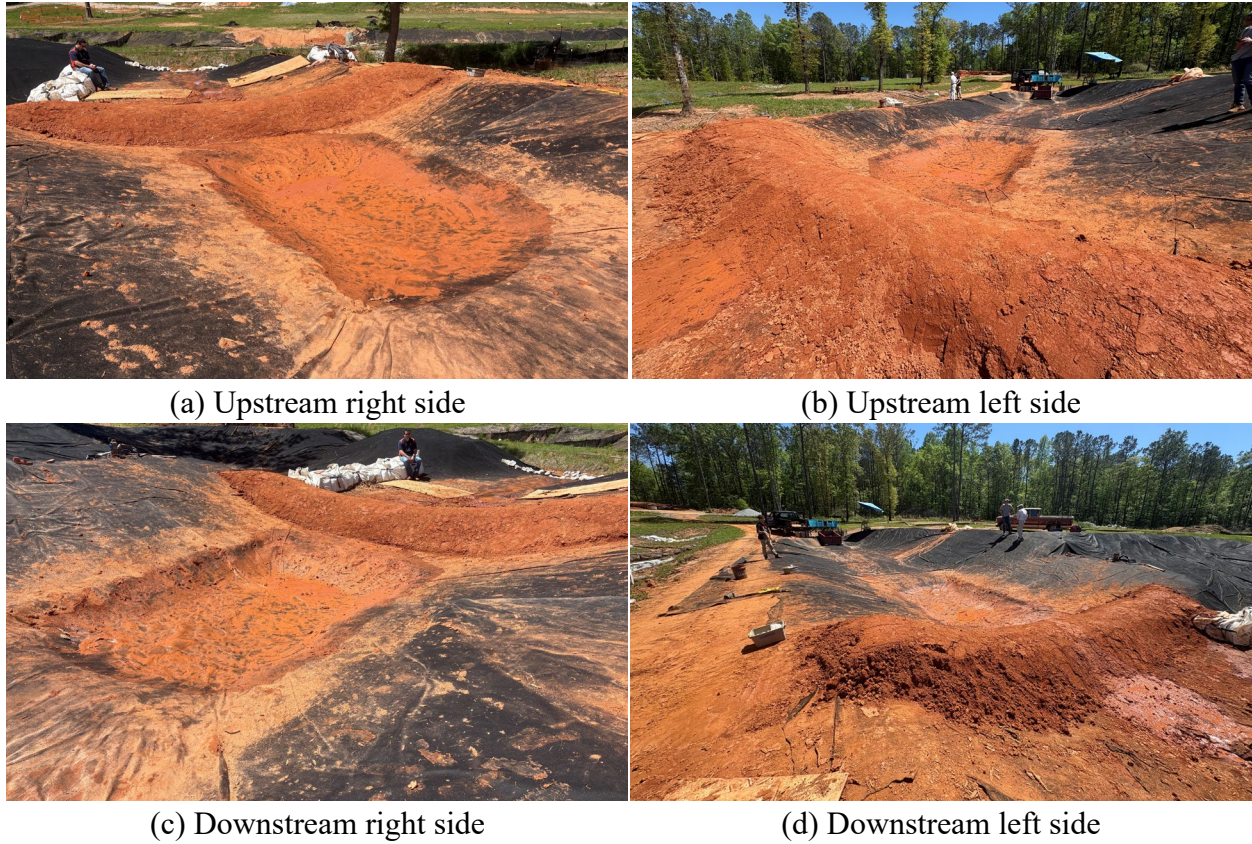

Figure 4.9: Temporary Earth Check

4.3 Comparison of Silt Trap Results

The data gathered during each silt trap test series comprised of sediment capture, impoundment measurements, TSS, and turbidity. Appendix A encompassed the data and included a test log with the metrics listed above plus photo documentation before and after every test. This section also discusses the trends seen in NDOT standard installations versus modified installations. Based on the analysis of the collected data, the MFE-I for the silt trap was identified.

4.3.1 Sediment Capture, Impoundment, Dewatering, and Structural Performance

The sediment capture for each temporary sediment control measure varied. The sediment from the silt trap and upstream of the evaluated installation was collected after the longevity series, consisting of three test runs on one installation, was conducted. The true mass of the remaining sediment was calculated by factoring in the individual moisture contents for each weight measured. The result was compared to the true amount of sediment introduced in that experiment series by factoring in the introduction moisture contents as well. At 95.9% retention, the highest sediment capture was produced by the modified silt fence. A majority of the larger sediment particles settled at the front edge of the impounded pool and the hydraulic jump. Finer sediment particles were mostly found within the silt trap or in front of the silt fence. The settling distribution of the remaining sediment was illustrated by the images in Figure 4.10 taken after the completion of Test C. The modified silt fence had the longest impoundment length of all the installations at a mean of 35 ft (10.7 m) with a depth of 19 in. (48.3 cm). The high impoundment facilitated a hydraulic jump further upstream of the silt trap and modified silt fence. At the hydraulic jump, inflow energy was dissipated before the water and sediment reached the silt trap allowing sedimentation to ensue. The dewatering period lasted 45 min after test flow stopped, giving more time for continued sedimentation. An installation was considered dewatered when no significant flow traveled downstream of the installation. In the case of the modified silt fence, the fence was dewatered when the impounded pool depth fell below the weir. The residual water was able to seep through the fence material until the water in front of the silt fence was gone. The seeping also increased the time in which sedimentation would transpire. The silt trap still held water that would either evaporate or percolate into the ground; however, the majority of the available storage volume was restored for the next storm event. After the conclusion of the

longevity evaluation, the modified silt fence remained intact with little deflection experienced by the T-posts. The geotextile noticeably had sediment on the face that would contribute to fence blinding, but longer evaluation was needed to determine when that would occur.



(a) Fine sediment particles

(b) Coarse sediment particles

Figure 4.10: Modified Silt Fence Sediment Settling Distribution

The slash mulch berm was the next highest performer in sediment capture at 94.6% leaving a difference of 1.3% from the modified silt fence. The particle setting distribution was similar to the modified silt fence with large particles deposited upstream at the hydraulic jump and fine particles deposited in the silt trap. The impoundment length created by the berm was 25 ft (7.6 m). The berm has an impoundment depth of 18 in. (45.7 cm) and was not overtopped in testing. The difference in impoundment lengths could be due to the porous nature of the mulch not being able to restrict the water flow-through like the fence material. The dewatering time at 43 min on average and the subsequent sedimentation periods were similar to the modified fence. The berm remained sturdy throughout testing because of its construction in lifts and repeated compaction. One instance of dislodged mulch occurred dropping the level of the storage volume till the area was blocked letting the pool return to the previous level. There was minimal mulch debris washed downstream. A limiting factor for the slash mulch installation would be the availability and amount of fresh mulch on or near the site of use.

The NDOT standard silt trap installation, which consisted of the trap alone, had a sediment capture of 74.2%. The sediment capture of the standard was used as the control to compare whether other installations add functional value to the silt trap when used together. For the standard silt trap, there was no impoundment outside of the length and depth of the silt trap, and no additional storage volume added to the existing trap volume causing there to be no dewatering time. The silt trap held water that would either evaporate or percolate into the ground. The silt trap was structurally sound in all tests.

Figure 4.11 shows the weight of the captured sediment as a percentage of the weight of the introduced sediment. The percentages were ordered from the highest performing installation at the top of the graph to the lowest performing at the bottom. The graph was categorized by similar performance as indicated by the green, orange, and blue bars. The installations with the highest sediment capture were in green and were within 1.3% of each other. The next grouping was 7.1% below the high-performance group and was colored orange. The three moderate-performance installations were within 3.7% of each other. The moderate-performance group was 6.0% above the low-performing group colored in blue. The spread across the low-performance installations was 4.0%. On the left side of the graph, the labels indicated which installation corresponds with each capture percentage. The low porosity silt fence failed 17 min into the first simulated storm event. Failure of the fence meant a complete collapse due to the force of the water collected on the face of the low porosity silt fence. The collapse of the fence indicated an inability to perform as intended and can be reasonably assumed to have capture similar to the silt trap alone. The low porosity silt fence was not included in the sediment capture analysis. The lowest performing installation was the temporary rock check yet was considered comparable in value to the control installation due to close capture values within 0.4%. The temporary rock

check provided no effectual difference in sediment capture than the silt trap alone. The graph visually displayed that the modified silt fence had an increase in sediment capture of 21.7% from the standard silt trap.

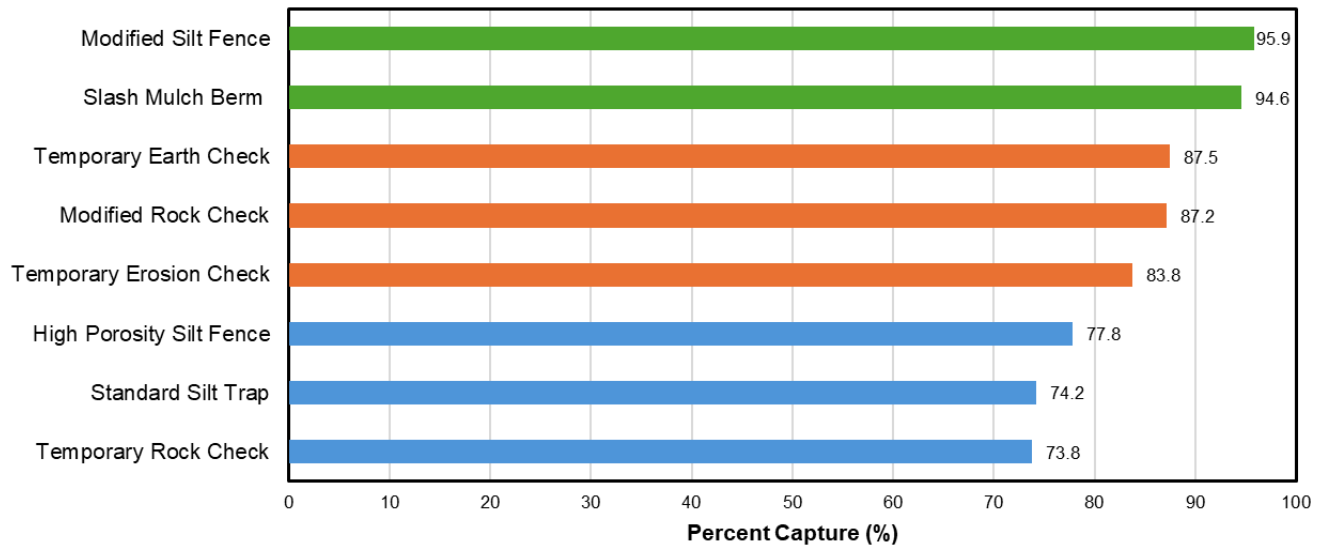

Figure 4.11: Sediment Capture per Installation

The temporary earth check and the modified rock check had almost identical sediment captures that resulted in a capture increase of about 13% from the standard silt trap. The temporary earth check had an impoundment length of 32 ft (9.8 m) with an impoundment depth of 2 ft (0.6 m). The earthen berm was overtopped in testing and had a dewatering time of 26 min after flow stopped. When dewatering ended or, in this case, when overtopping ended, the remaining pool of water was not able to continue downstream and would have to evaporate or percolate. The storage volume would be limited in the event of another storm passing before water had left from the previous storm thereby not allowing sedimentation to occur for the new onset of stormwater. From a structural performance standpoint, the temporary earth check was observed to be eroding on the downstream side of the berm. The erosion issue worsened with each test, removing more earth in succeeding runs, and could plausibly be assumed to produce a

crack through the berm. The loss of sediment due to the berm breaking was also problematic for the downstream water quality. For the modified rock check, the impoundment was 35 ft (10.7 m) long and 2 ft (0.6 m) deep. Water was able to flow through the rock and geotextile cover and still overtopped the installation in testing. The dewatering time was around 50 min with water continuing to seep through when dewatering was concluded. The seep-through resulted in a period of sedimentation that also restored storage volume. The rock and geotextile had no structural impairment save for the upstream side of the installation having sediment build up that could eventually blind the geotextile preventing flow-through dewatering.

The correlation between impoundment and sediment capture was explored in Figure 4.12 for both impoundment length and impoundment depth. The graph shows that the higher impoundment lengths are associated with higher sediment capture percentages. This relationship was also evident in the data for the temporary erosion check, high porosity silt fence, and the temporary rock check which all had low impoundment lengths and depths corresponding to the lower sediment capture. The temporary erosion check had an impoundment length that could not be determined since the impoundment pool did not extend past the upstream edge of the silt trap and a depth of 7 in. (17.8 cm) which did not overtop the wattle. The excelsior wattle had immediate flow-through and only 8 min on average for dewatering. The wattle experienced little to no structural degradation. The high porosity silt fence had roughly no determinable impoundment length for the same reason and only 9 in. (22.9 cm) of impoundment depth. The fence experienced immediate flow-through, but sediment eventually blinded the geotextile. This affected the impoundment depth as water rose till it could continue flowing downstream and the dewatering time varying from 20 min after test A to about an hour for test B and C. The high porosity silt fence felt no structural strain, rather it was limited operationally due to the geotextile

openings. The temporary rock check had impoundment approximately 5 ft (1.5 m) long with 2.5 in. (6.4 cm) depth. The rock had immediate flow-through and dewatered in 5 min. The rock nor the berm structure was affected. The graphs illustrate that generally higher impoundment lengths and depths are associated with higher sediment capture. The trend was likely due to higher impoundment providing more residence time and storage volume for sedimentation to occur. The higher sediment capture installations with higher impoundment values also coincided with the majority of installations that overtopped during testing. Overtopping of the installed practices indicates that the full impoundment depth capabilities were reached as seen in the modified silt fence, the modified rock check, and the temporary earth check. The slash mulch did not overtop but impounded to 18 in. (45.7 cm) rather than its height of 24 in. (61.0 cm). Both graphs contained a best-fit, linear trendline with the correlating equation and R^2 values. The R^2 indicated how well the line fit the data, encompassing just over 60% of the variability recorded throughout testing.

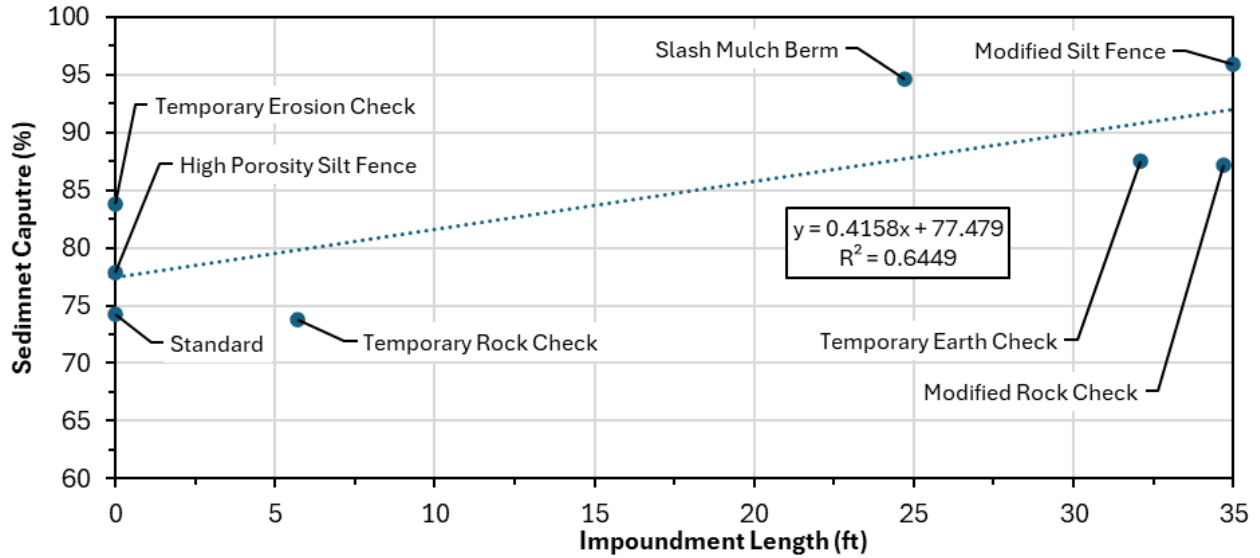

(a) Impoundment Length vs. Sediment Capture

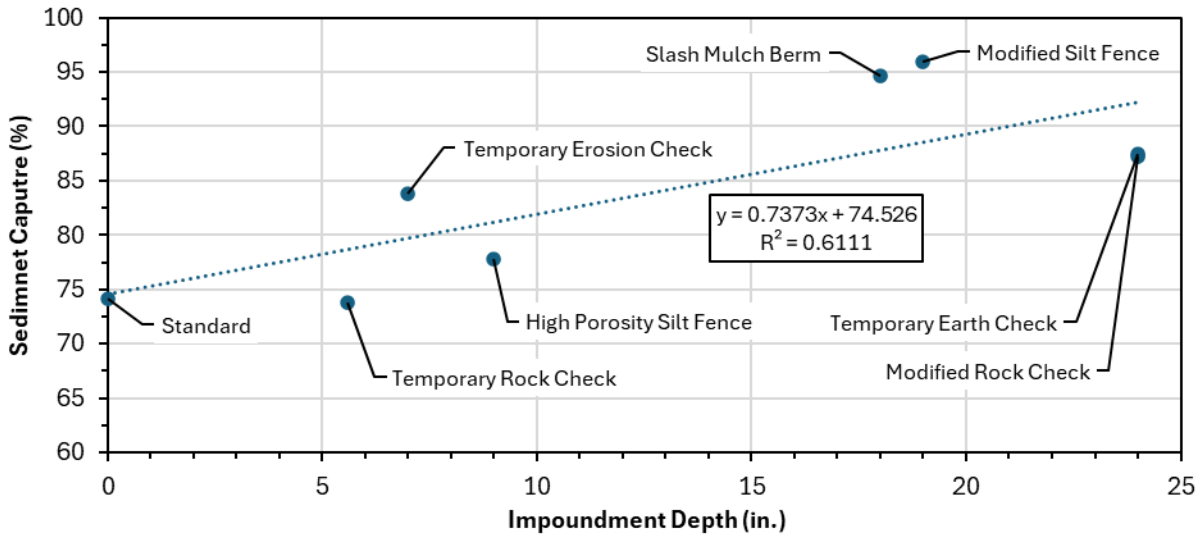

(b) Impoundment Depth vs. Sediment Capture

Figure 4.12: Impoundment Versus Sediment Capture

The actual impoundment measured during testing was compared to the theoretical impoundment for each installation. The theoretical impoundment depth was based on the installation height, since every installation was assumed to impound water till it overtopped the installation. The theoretical impoundment length was calculated based on the channel slope of 5% and the corresponding installation height. Table 4.1 lists the theoretical and actual impoundments along with the relationship between the two values described in ratio form. The

ratios under one communicate what percentage of the theoretical or expected was achieved. For the standard silt trap, the ratio did not apply due to no expectation of impoundment. The temporary erosion check and the high porosity silt fence had ratios of zero since their impoundment lengths could not be determined due to the silt trap in front of the practice. However, the corresponding impoundment depths indicated that the expected impoundment was fractionally achieved because of the high flow-through facilitated by the products. The only installation to achieve and exceed the theoretical values was the modified silt fence. The length recorded from testing was 5 ft (1.5 m) longer than the calculated length. The surpassing length could be caused by the V-shape of the fence in the channel. Rather than running perpendicular to flow, the V-shape funnels the pooling water to the weir potentially causing the pool to exceed expected values. The theoretical was calculated assuming the volume was flat at the installation height and then filled upstream. The surpassing depth could be attributed to the nappe which is the curtain of water flowing over the weir. The weir on the modified fence was 18 in. (45.7 cm); in order for water to flow over the weir, the depth had to exceed the height of the fence, resulting in the 19 in. (48.3 cm) actual depth.

Table 4.1: Theoretical Impoundments Versus Actual Impoundments

Installation	Theoretical Imp. Length, ft (m)	Actual Imp. Length, ft (m)	Imp. Length Ratio	Theoretical Imp. Depth, in. (cm)	Actual Imp. Depth, in. (cm)	Imp. Depth Ratio
Modified Silt Fence	30.0 (9.1)	35.0 (10.7)	1.17	18.0 (45.7)	19.0 (48.3)	1.06
Slash Mulch Berm	40.0 (12.2)	24.7 (7.5)	0.62	24.0 (61.0)	18.0 (45.7)	0.75
Temporary Earth Berm	40.0 (12.2)	32.1 (9.8)	0.80	24.0 (61.0)	24.0 (61.0)	1.00
Modified Rock Check	40.0 (12.2)	34.7 (10.6)	0.87	24.0 (61.0)	24.0 (61.0)	1.00
Temporary Erosion Check	20.0 (6.1)	0.0 (0.0)	0.00	12.0 (30.5)	7.0 (17.8)	0.58
High Porosity Silt Fence	60.0 (18.3)	0.0 (0.0)	0.00	36.0 (91.4)	9.0 (22.9)	0.25
Standard Silt Trap	0.0 (0.0)	0.0 (0.0)	N/A	0.0 (0.0)	0.0 (0.0)	N/A
Temporary Rock Check	40.0 (12.2)	5.7 (1.7)	0.14	24.0 (61.0)	5.6 (14.2)	0.23

The sediment capture, impoundment, and other metrics in this section were used to indicate installation effectiveness and feasibility. The two installations that had the greatest sediment captures were the modified silt fence and the slash mulch berm. The installations with the longest impoundments were the modified silt fence and the modified rock check.

4.3.2 Water Quality

The water quality analysis comprised of an assessment of TSS and turbidity for every single test run for each installation. The average value of the inflow was used to find the percent reduction of TSS and turbidity from the average of the water samples taken downstream of the

installation. In Table 4.3 and Table 4.2, the results were arranged with the highest reduction at the top to the lowest reduction at the bottom. The TSS and turbidity had differing reductions by installation. The low porosity silt fence was not included in the analysis due to failure.

Table 4.2: TSS Downstream Reduction from Inflow

Test	TSS
Slash Mulch Berm	91.4 %
Modified Rock Check	89.4 %
Modified Silt Fence	89.1 %
High Porosity Silt Fence	82.5 %
Temporary Erosion Check	79.5 %
Temporary Earth Check	70.8 %
Standard Silt Trap	70.6 %
Temporary Rock Check	63.8 %

Table 4.3: Turbidity Downstream Reduction from Inflow

Test	Turbidity
Slash Mulch Berm	69 .1 %
Modified Silt Fence	67.7 %
Standard Silt Trap	62.8 %
Modified Rock Check	60.7 %
Temporary Earth Check	53.0 %
High Porosity Silt Fence	51.9 %
Temporary Erosion Check	51.8 %
Temporary Rock Check	36.5 %

In both water quality considerations, the slash mulch berm and the modified silt fence were consistent top performers which aligned with the results from sediment capture. The modified rock check appeared as a top performer in TSS; however, it was in the middle performing category for turbidity. Since the average values only depict part of the interpretation of results and were affected by outliers, another type of graph was used to illustrate the water quality results. A box and whisker plot was created to display the range of data for the samples obtained downstream.

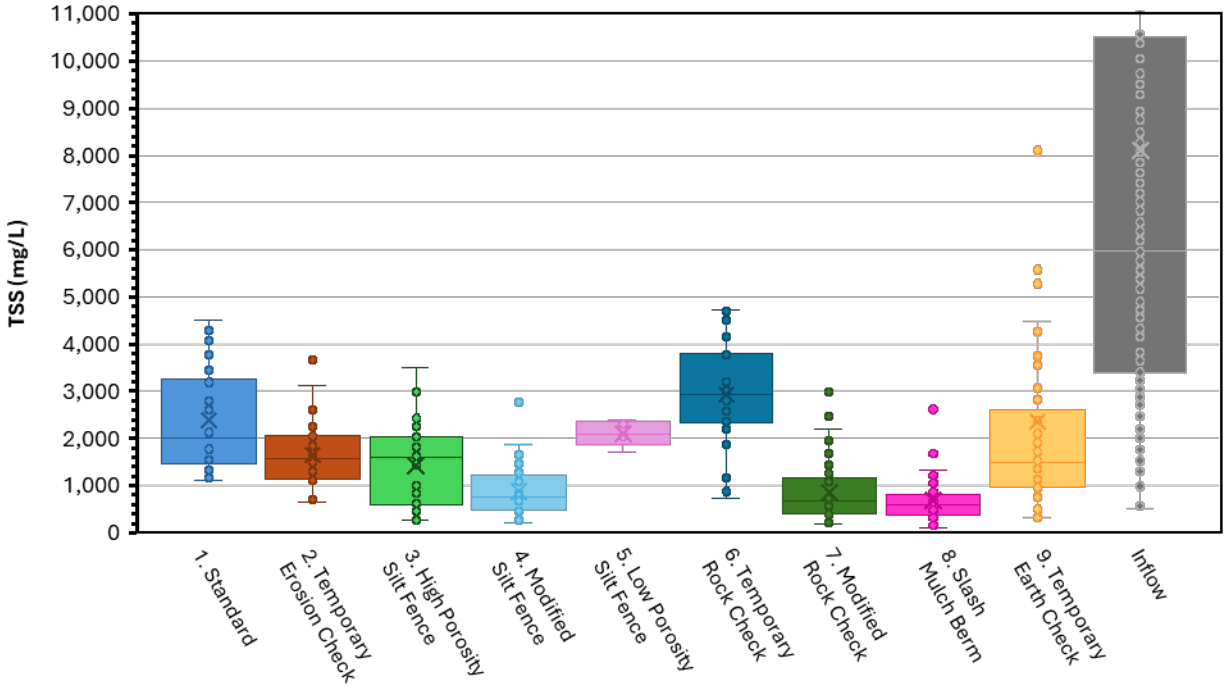

Figure 4.13: Downstream TSS per Installation

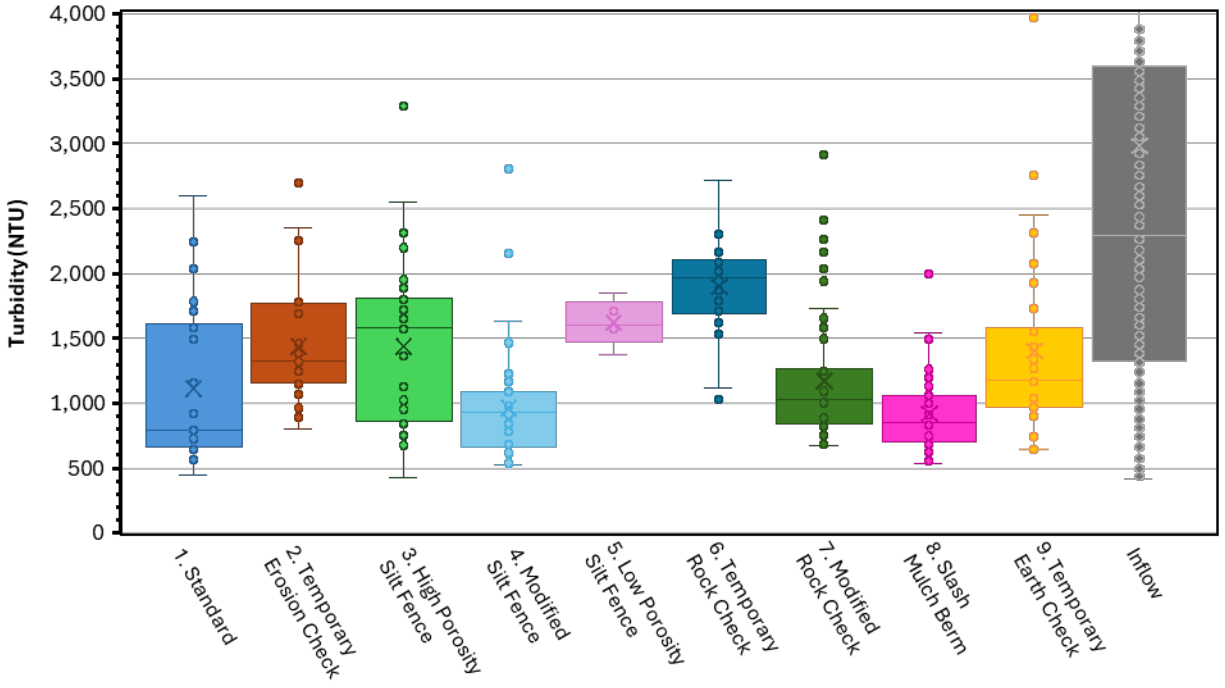

Figure 4.14: Downstream Turbidity per Installation

In the two graphs, the entirety of the inflow plot that represented the introduced water and sediment was not included due to its extensive range of values. The inflow upper quartile was contained in the graph, but the maximum score and outliers were not incorporated in order to enhance the view of the installation data ranges. Each box and whisker plot was labeled underneath with the installation name. Despite not being considered for the MFE-I, the low porosity silt fence was added to the graph with its limited data for comparison purposes.

Each installation resulted in lower downstream values when contrasted with those of the inflow, meaning each installation had a positive impact on downstream water quality. The positive impact was demonstrated by the inflow median occurring above the median for the other installations. When investigating the median in individual installations for TSS, the three best performing were the modified silt fence, the modified rock check, and the slash mulch berm. The TSS plots were consistent with the reduction analysis performed on the TSS averages. The interquartile range for the slash mulch berm was the least of those three practices. The modified silt fence and the modified rock check were nearly identical on their interquartile ranges. The turbidity medians detected that the three best performing installations were the standard silt trap, the modified silt fence, and the slash mulch berm. The standard silt trap had a longer box which indicated more dispersed data values or variability in the results. The modified silt fence and the slash mulch berm had almost duplicate ranges.

A trend was detected while analyzing TSS and turbidity. The performance of all temporary sediment control measures listed in the NDOT manual were compared to the modified practices that were tested. Although Nebraska has incorporated slash mulch berms in their current projects, it was considered a modification due to its relatively new development and acceptance. NDOT standard practices were colored blue, and modified practices were colored

orange. When comparing the modified practices to the standard practices, the overall trend is that there are benefits in making changes to the standard approaches.

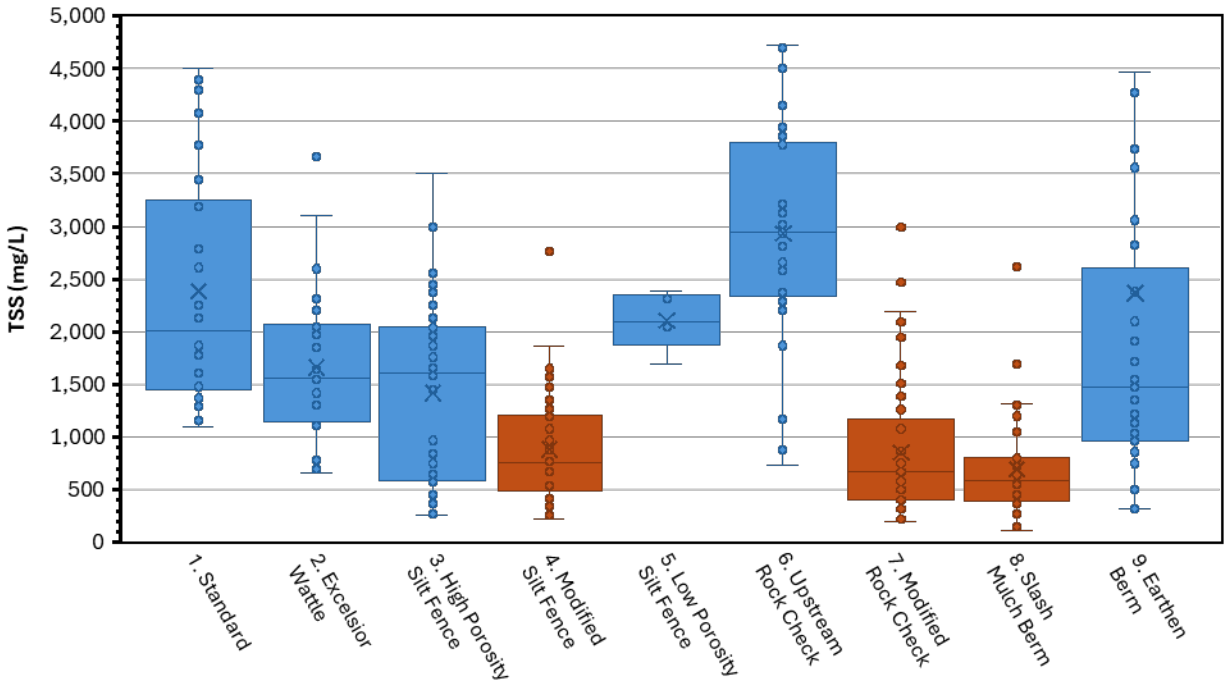

Figure 4.15: Standards vs. Modifications for TSS

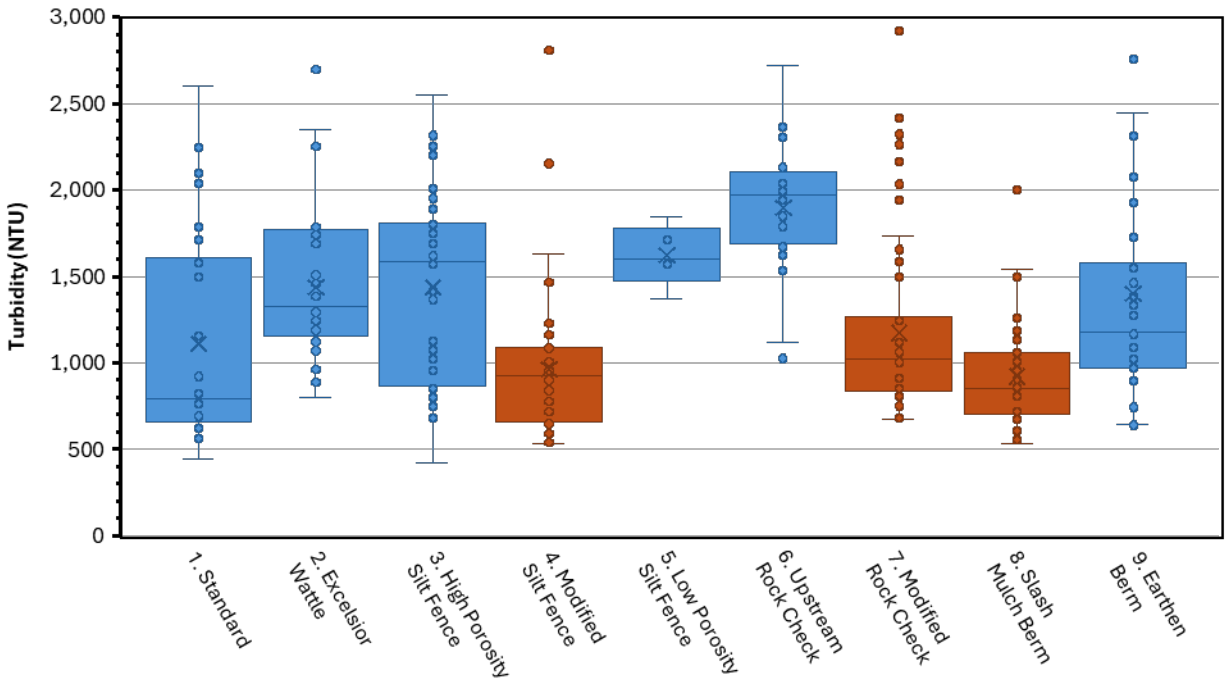

Figure 4.16: Standards vs. Modifications for Turbidity

The TSS, concentration of solid particles suspended in water, and turbidity, measured in nephelometric turbidity units, were parameters used to indicate installation effectiveness regarding the quality of the water that would leave the site. The two installations that had the greatest differences in water quality from inflow to downstream were the modified silt fence and the slash mulch berm.

4.3.3 Silt Trap MFE-I

A most feasible and effective installation is one that has been proven successful in accomplishing its specific purpose and is realistic to use in industry. For the silt trap, that purpose was to reduce sediment travelling downstream of the installation. Factors of high sediment capture and water quality improvement were deemed viable indicators in identifying an MFE-I. The installation that captured the most sediment was the modified silt fence at 95.9 %. The installation with the longest impoundment, which was shown to correlate with higher sediment capture, was the modified silt fence at an average of 35 ft (10.7 m). The fence also allowed ample dewatering time for sedimentation but was able to restore its original, usable storage volume. The modified silt fence did not undergo significant physical deformation and appeared structurally reliable. The installation also did not greatly increase installation endeavors or material costs compared to the other paired practices. In examining TSS and turbidity, the slash mulch berm was the installation with the highest reduction values at 91.4 % and 69.1 % respectively. Due to the aforementioned potential issues with the availability and amount of fresh mulch, this installation was not identified as the MFE-I but would be recommended as a suitable alternative. The next consistently high reductions were 89.1 % and 67.7 % respectively for the modified silt fence. Based on the data analyzed, the MFE-I was identified as the modified silt fence. A summary of each installation performance was given in Table 4.4.

Table 4.4: Summary of Results for Silt Trap Testing

Test	Sediment Capture, %	Avg. Impoundment Length, ft (m)	Avg. Impoundment Depth, in. (cm)	Avg. Discharge TSS, mg/L	Avg. Discharge Turbidity, NTU
Standard Silt Trap	74.2	0.0 (0.0)	0.0 (0.0)	2,384	1,110
Temporary Erosion Check	83.8	16.3 (5.0)	7.0 (17.8)	1,661	1,438
High Porosity Silt Fence	77.8	17.8 (5.4)	9.0 (22.9)	1,418	1,436
Modified Silt Fence	95.9	35 (10.7)	19.0 (48.3)	885	963
Low Porosity Silt Fence	88.0*	34.9* (10.6)	30.0* (76.2)	2,108*	1,621*
Temporary Rock Check	73.8	5.7 (1.7)	2.5 (6.4)	2,935	1,896
Modified Rock Check	87.2	34.7 (10.6)	24.0 (61.0)	856	1,174
Slash Mulch Berm	94.6	24.7 (7.5)	18.0 (45.7)	696	922
Temporary Earth Check	87.5	32.1 (9.8)	24.0 (61.0)	2,367	1,402

**Results based on limited data before fence failure*

4.4 Structural Clean Water Tests

When conducting silt trap testing with the low porosity silt fence, a need for running a structural improvement test series was recognized. The fence was intended for use in low flow areas, although “low flow” was not defined in the NDOT erosion and sediment control chapter, the 2-yr, 24-hr flow rate for 0.5 ac (0.2 ha) was assumed to constitute low flow. Due to the failure of the fence, an appropriate modification was necessary for the continued use of the low flow fence. Based on test observations, failure ensued once the built-up force of the water against the face of the fence was greater than the 1.25 lb/ft T-posts could support. Another noted observation

was the ripping of the silt fence as the zip ties holding the fence material to the T-posts broke through the fabric. Figure 4.17 highlighted the failure methods mentioned.



(a) Failure, facing downstream

(b) Failure, facing upstream

Figure 4.17: Low Porosity Silt Fence Failure

The methodology developed for this testing was similar to the silt trap testing methodology. Since the purpose of this test was structural improvement, not sediment capture, the sediment introduction and collection aspect was removed. The structural type of testing was referred to as clean water testing. The same channel was used for testing, but the silt trap was not included in the structural clean water evaluations. For water flow introduction, two additional flow rates were added to the 0.5 ft³/s (0.014 m³/s) regime: 1.0 ft³/s (0.028 m³/s) which was the 2-yr, 24-hr runoff rate for 1.0 ac (0.4 ha) and 1.4 ft³/s (0.040 m³/s) which was the highest attainable rate produced by the AU-SRF 6-in. (15.2 cm) pump. Each flow rate was run for 10 min and increased with each consecutive 10 min period. The total run-time was 30 min followed by a dewatering period to allow for a test reset. The three tests were run for longevity evaluations of the fence structure, so one iteration was installed for the three runs conducted. The testing regime was illustrated visually in Figure 4.18 with the different shades in each box representing a distinct 10 min period for each flow rate.

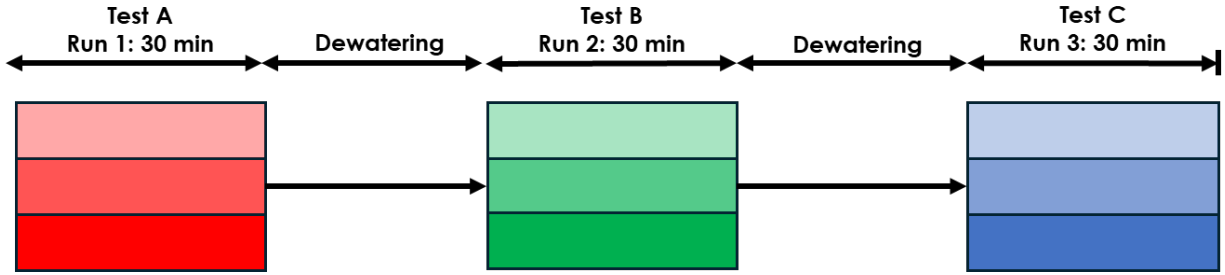

Figure 4.18: Structural Clean Water Testing Regime

The data collected was post deflection as well as impoundment length and depth. The impoundment depth and length for each test were measured from the T-post centered in the channel. Photos and videos were taken to record observations and included in Appendix B. For convention, the channel sides were distinguished as left and right when downstream of any installation facing upstream where the inflow apparatus was located, and for the examination of deflection, the posts were numbered from left to right. Five installations, described in Table 4.5, were selected for testing with the goal of identifying a structurally sound MFE-I of the low porosity silt fence.

Table 4.5: Structural Clean Water Installation Description

Installation	Fence Height, in. (cm)	Post Spacing, ft (m)	Fence Shape in Channel	Post Material
1	24 (61.0)	5.0 (1.5)	Perpendicular	Steel T-post
2	30 (91.4)	2.5 (0.8)	Perpendicular	Steel T-post
3	18 (45.7)	3.5 (1.1)	V-Shape	Steel T-post
4	30 (91.4)	5.0 (1.5)	Perpendicular	Wood
5	24 (61.0)	2.5 (0.8)	Perpendicular	Steel T-post

Figure 4.19 showed the low porosity silt fence iterations prior to commencing testing and included the standard low porosity installation as a reference. Structural stability would be indicated by minimal post deflection while maintaining adequate impoundment. The clean water testing did not address the upstream or downstream water quality performance of the low porosity silt fence installations tested. The same low porosity, single weave synthetic material

with a low-profile fence width of 36 in. (91.4 cm) was used in all tests. The installations employed material already accepted for application in Nebraska.



(a) Standard low porosity silt fence



(b) Installation 1



(c) Installation 2



(d) Installation 3



(e) Installation 4



(f) Installation 5

Figure 4.19: Low Porosity Silt Fence Iterations

4.4.1 Installation 1

The first installation was the low porosity silt fence folded along the top on the woven green line to achieve a fence height of 24 in. (61.0 cm). The T-posts used were 1.25 lb/ft (37 kg/m) steel with a post spacing of 5 ft (1.5 m) placed perpendicularly across the channel, ensuring contact with the centerline and toe of the left and right bank. The ends of the fence on the channel slopes were turned upstream to prevent bypassing of the installation due to channel dimension constraints. There were seven posts in this iteration. The fence was attached to every T-post using three UV stabilized, black zip ties with a 50 lb (22 kg) minimum tensile strength. The zip ties were positioned at the top of the post through both layers of the folded fence. Since the channel was lined with geotextile, the bottom 6 in. (15.2 cm) of the fence were secured to the ground rather than entrenched. Using 1 in. (2.5 cm) by 6 in. (15.2 cm) 11-gauge steel wire sod staples, a staggered pattern was applied on the upstream and downstream edges of the bottom fold of the fence to prevent undercutting of the silt fence.

The iteration of the low porosity silt fence, referred to as Installation 1, experienced some deflection on all seven of the posts with the most force felt on the middle post centered in the channel. As seen in the graph in Figure 4.20, the blue line indicated the fence when first installed before being subjected to water flow. The orange line indicated the fence position after experiencing all three tests. The Y axis of the graph represented the upstream side of the channel or the direction from which flow originated. The X axis of the graph showed the horizontal position of the fence along the channel length as it experienced deflection over the course of the tests. Figure 4.21 depicted the ending position of the fence following test C, the third and final test of the series. The installation started dewatering after the water flow was stopped and still retained some impounded water upstream of the installation. In Table 4.6, the averages for

impoundment and water depth for each flow rate were summarized. The impoundment did not greatly increase between the first and second flow rates, and it appeared to stabilize between the second and third flow rates. The impoundment ratio and depth ratio were based on theoretical impoundment length and depth. The theoretical length was 40 ft (12.2 m) based on the fence height and channel slope while the theoretical depth was 24 in. (61.0 cm) or the height of the fence. The ratios described what amount of those theoretical values were achieved in testing. Values closer to 1 or greater exceeded expectations for impoundment performance. A ratio of less than 1 indicated the fence height lowering likely due to the force of water on the fence and causing impoundment depth and length to decrease. The depth under the highest flow rate was close to the hypothetical value while the length did not meet the theoretical calculation. The maximum deflection represented the difference between the starting position before test A and the ending position after test C of the T-post that experienced the highest position displacement which was 6.7 in. (17.0 cm) in this test series.

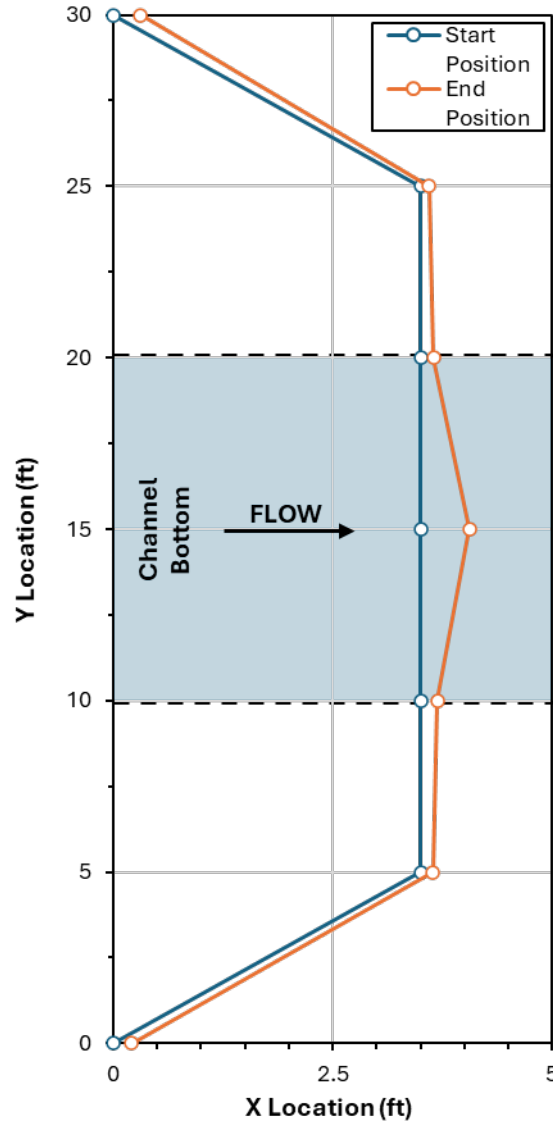

Figure 4.20: Plan View of Installation 1 Post Deflection

Table 4.6: Installation 1 Test Results

Flow Rates, ft ³ /s (m ³ /s)	0.5 (0.014)	1.0 (0.028)	1.4 (0.040)
Impoundment, ft (m)	24.0 (7.3)	27.7 (8.4)	28.0 (8.5)
Water Depth, in. (cm)	16.3 (41.4)	21.0 (53.3)	21.5 (54.6)
Impoundment Ratio	0.60	0.69	0.70
Depth Ratio	0.68	0.88	0.90
Max Deflection, in. (cm)	-	-	6.7 (17.0)



Figure 4.21: Installation 1 After Test C

4.4.2 Installation 2

The second installation of the low porosity silt fence had a fence height of 30 in. (76.2 cm). The 1.25 lb/ft (37 kg/m) steel T-posts were spaced 2.5 ft (0.8 m) perpendicularly across the channel on the centerline and toes of the left and right bank. The 2.5 ft (0.8 m) spacing continued one post further on each side slope of the channel then a 5 ft (1.5 m) spacing was carried on to efficiently utilize T-posts but were able to maintain fence integrity against the force of the water. The ends of the fence were turned upstream to prevent bypassing of the installation due to channel dimension constraints. There were eleven posts in this iteration. The fence was attached to every T-post using three UV stabilized, black zip ties with a 50 lb (22 kg) minimum tensile strength. The zip ties were positioned at the top of the post through the fabric. Since the channel was lined with geotextile, the bottom 6 in. (15.2 cm) of the fence were secured to the ground rather than entrenched. Using 1 in. (2.5 cm) by 6 in. (15.2 cm) 11-gauge steel wire sod staples, a

staggered pattern was applied on the upstream and downstream edges of the bottom fold of the fence to prevent undercutting of the silt fence.

The arrangement of the low porosity silt fence, referred to as Installation 2, experienced some deflection on all eleven of the posts with the end posts experiencing slight or negligible force while the force undergone on the middle posts in the channel was notable. As seen in the graph in Figure 4.22, the blue line indicated the fence when first installed before being subjected to water flow. The orange line indicated the fence position after experiencing all three tests. These positions were tracked in relation to the top of the post. The Y axis of the graph represented the upstream side of the channel or the direction from which flow originated. The X axis of the graph showed the horizontal position of the fence along the channel length as it experienced deflection over the course of the tests. Figure 4.23 (a) showed the ending position of the fence following test C. The installation started dewatering after the water flow was stopped and still retained some impounded water upstream of the installation. An issue in the operation of this installation was the fence ripping where the zip ties were attached to the post due to the force of the water against the fence. This ripping was heard during tests and observed in the aftermath of the tests as depicted Figure 4.23 (b). In Table 4.7, the averages for impoundment and water depth for each flow rate were summarized. The impoundment substantially increased between the first and second flow rates and continued to moderately increase between the second and third flow rates. The impoundment ratio and depth ratio were based on theoretical impoundment length and depth. The theoretical length was 50 ft (15.2 m) based on the fence height and channel slope while the theoretical depth was 30 in. (76.2 cm) which was the height of the fence. A ratio of less than 1 indicated the fence height lowering likely due to the force of water on the fence and causing impoundment depth and length to decrease. Examining the ratios for the highest

flow rate, the depth was close to the theoretical value while the length was slightly off expectation. The maximum deflection represented the difference between the starting position before test A and the ending position after test C of the T-post that experienced the highest position displacement. In these tests, the deflection was 21.2 in. (53.8 cm) which was the greatest deflection observed among the clean water test evaluations.

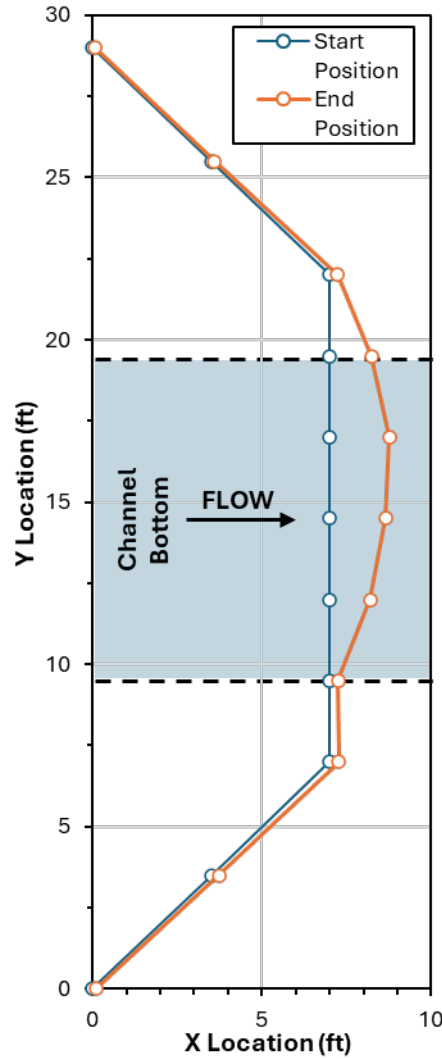

Figure 4.22: Plan View of Installation 2 Post Deflection

Table 4.7: Installation 2 Test Results

Flow Rates, ft³/s (m³/s)	0.5 (0.014)	1.0 (0.028)	1.4 (0.040)
Impoundment, ft (m)	21.7 (6.6)	35.0 (10.7)	40.3 (12.3)
Water Depth, in. (cm)	16.3 (41.4)	25.2 (64.0)	28.7 (72.9)
Impoundment Ratio	0.43	0.70	0.81
Depth Ratio	0.54	0.84	0.96
Max Deflection, in. (cm)	-	-	21.2 (53.8)



(a) Installation behavior

(b) Ripping around zip ties

Figure 4.23: Installation 2 After Test C

4.4.3 Installation 3

The third installation was the low porosity silt fence with a fence height of 30 in. (76.2 cm) and a 7 ft (2.1 m) long cut out weir with a height of 18 in. (45.7 cm) centered in the channel spanning three T-posts. The posts used were 1.25 lb/ft (37 kg/m) steel T-posts with a post spacing of 3.5 ft (1.1 m) placed in a 90-degree V-shape centered in the channel. This spacing allowed the T-posts on each side to be positioned at the toe of the bank with the point of the V at the channel center. There were eleven T-posts utilized. The fence was attached to the T-posts using three UV stabilized black zip ties with a 50 lb (22 kg) minimum tensile strength, positioned at the top of each post going through the fence material. On the posts where the 30-in. (76.2 cm) height met the 18-in. (45.7 cm) height, the three zip ties were attached at the top of the post per standard as well as two zip ties directly below the weir height to reinforce the corners that were categorized

as potential weak points. Since the channel was lined with geotextile, the bottom 6 in. (15.2 cm) of the fence were secured to the ground rather than entrenched. Using 1 in. (2.5 cm) by 6 in. (15.2 cm) 11-gauge steel wire sod staples, a staggered pattern was applied on the upstream and downstream edges of the bottom fold of the fence to prevent undercutting of the silt fence. This installation was adapted from the Alabama Department of Transportation silt fence check dam.

The iteration of the low porosity silt fence, referred to as Installation 3, experienced very little deflection on the eleven posts. As seen in the graph in Figure 4.24, the blue line indicated the fence when first installed before being subjected to water flow. The orange line indicated the fence position after experiencing all three tests. These positions were tracked in relation to the top of the post. The Y axis of the graph represented the upstream side of the channel or the direction from which flow originated. The X axis of the graph showed the horizontal position of the fence along the channel length as it experienced deflection over the course of the tests. The T-posts that experienced the most force were the two directly on either side of the center post which was the point of the V shape. Figure 4.25 depicted the ending position of the fence following test C, the final test of the series. The installation started dewatering after the water flow was stopped and still retained some impounded water upstream of the installation. In Table 4.8, the averages for impoundment and water depth for each flow rate were summarized. The impoundment increased moderately between the first and second flow rates and increased slightly between the second and third flow rates. The impoundment ratio and depth ratio were based on theoretical impoundment length and depth. The theoretical length was 30 ft (9.1 m) based on the fence height and channel slope while the theoretical depth was 18 in. (45.7 cm) or the height of the weir. The ratios described what amount of those theoretical values were achieved in testing. The later tests in this evaluation surpassed expectations for impoundment

performance, likely due to the constant flow of water over the weir adding extra depth. The maximum deflection represented the difference between the starting position before test A and the ending position after test C of the T-post that experienced the highest position displacement which was 5.6 in. (14.2 cm), achieving the lowest deflection of the clean water assessments.

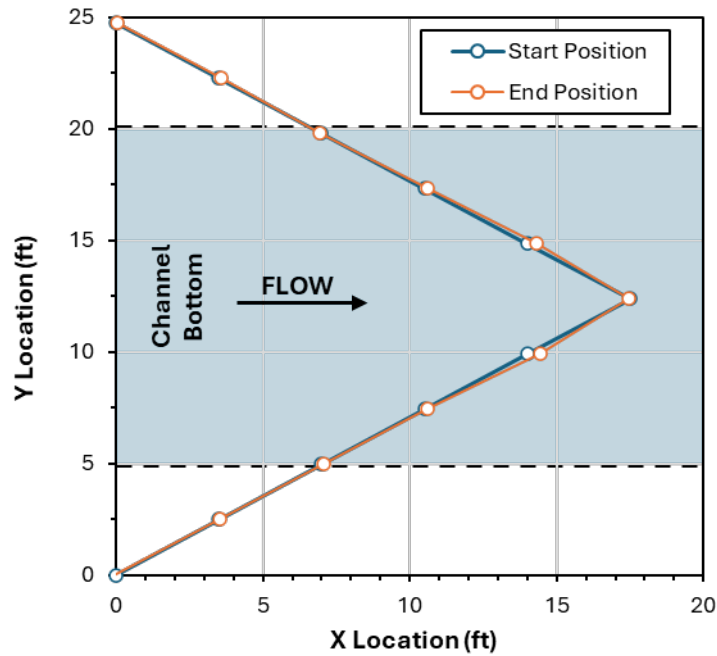

Figure 4.24: Plan View of Installation 3 Post Deflection

Table 4.8: Installation 3 Test Results

Flow Rates, ft ³ /s (m ³ /s)	0.5 (0.014)	1.0 (0.028)	1.4 (0.040)
Impoundment, ft (m)	23.3 (7.1)	28.7 (8.7)	30.7 (9.4)
Water Depth, in. (cm)	16.0 (40.6)	20.2 (51.3)	21.0 (53.3)
Impoundment Ratio	0.78	0.96	1.02
Depth Ratio	0.89	1.12	1.17
Max Deflection, in. (cm)	-	-	5.6 (14.2)



Figure 4.25: Installation 3 After Test C

4.4.4 Installation 4

The fourth installation was the low porosity silt fence with a fence height of 30 in. (76.2 cm). The posts used were 2 in. (5.1 cm) by 2 in. (5.1 cm) hardwood posts that were 48 in. (121.9 cm) tall with a post spacing of 5 ft (1.5 m) placed perpendicularly across the channel. The installation used seven wood posts. The fence was attached to the wood posts using a staple gun with two 1 in. (2.54 cm) by 1 in. (2.54 cm) 16-gauge galvanized wide crown staples at the top, one in the center of the post, and one at the bottom of the post. Since the channel was lined with geotextile, the bottom 6 in. (15.2 cm) of the fence were secured to the ground rather than entrenched. Using 1 in. (2.5 cm) by 6 in. (15.2 cm) 11-gauge steel wire sod staples, a staggered

pattern was applied on the upstream and downstream edges of the bottom fold of the fence to prevent undercutting of the silt fence.

The iteration of the low porosity silt fence, referred to as Installation 4, experienced severe deflection on the three posts in the center of the channel. Due to the force of the water, the installation failed due to the wood posts breaking off at the ground despite being driven nearly 1.5 ft (0.5 m) deep. The failure resulted in the impounded water rushing downstream with no installation left to dissipate flow energy or facilitate potential sedimentation. Figure 4.26 captured the failure of the fence after 19 minutes of flow in Test A. The failure comprised of the fence collapsing due to the force of the water collected on the face of the low porosity silt fence.



Figure 4.26: Installation 4 Failure

4.4.5 Installation 5

Installation 5 was developed based on the results of installation 1 and 2 to create a possible MFE-I by combining a low deflection install with a high impoundment install. This would pair the folded fence technique that achieved a fence height of 24 in. (61.0 cm) with the 2.5 ft (0.8 m) T-post spacing. The UV stabilized 50 lb (22 kg) minimum tensile strength, black zip ties would go through both layers of the folded fence to resist fence tearing due to the force of water. The 1.25 lb/ft (37 kg/m) steel T-posts would be spaced 2.5 ft (0.8 m) perpendicularly

across the channel center and revert to 5 ft (1.5 m) spacing on the side slopes when force would not be expected to impede performance enabling efficient use of T-post material and installation effort. Since the channel was lined with geotextile, the bottom 6 in. (15.2 cm) of the fence were secured to the ground rather than entrenched. Using 1 in. (2.5 cm) by 6 in. (15.2 cm) 11-gauge steel wire sod staples, a staggered pattern was applied on the upstream and downstream edges of the bottom fold of the fence to prevent undercutting of the silt fence.

The iteration of the low porosity silt fence, referred to as Installation 5, experienced deflection on the nine posts. As seen in the graph in Figure 4.27, the blue line indicated the fence when first installed before being subjected to water flow. The orange line indicated the fence position after experiencing all three tests. These positions were tracked in relation to the top of the post. The Y axis of the graph represented the upstream side of the channel or the direction from which flow originated. The X axis of the graph showed the horizontal position of the fence along the channel length as it experienced deflection over the course of the tests. The T-posts that experienced the most force were the ones within the channel with greater deflection observed on the right half. Figure 4.28 depicted the ending position of the fence following test C, the final test. The installation started dewatering after the water flow was stopped and still retained some impounded water upstream of the installation. In Table 4.9, the averages for impoundment and water depth for each flow rate were summarized. The impoundment jumped greatly between the first and second flow rates and leveled out between the second and third flow rates. The impoundment ratio and depth ratio were based on theoretical impoundment length and depth. The theoretical length was 40 ft (12.2 m) based on the fence height and channel slope while the theoretical depth was 24 in. (61.0 cm) or the height of the fence. The ratios were related to what percentage of those theoretical values were achieved in testing. Test B and C had favorable ratios

for impoundment performance. However, the maximum deflection which represented the T-post that experienced the highest position displacement from the starting position before Test A to the ending position after Test C was 16.2 in. (41.1 cm) which was higher than Installation 1 but less than Installation 2.

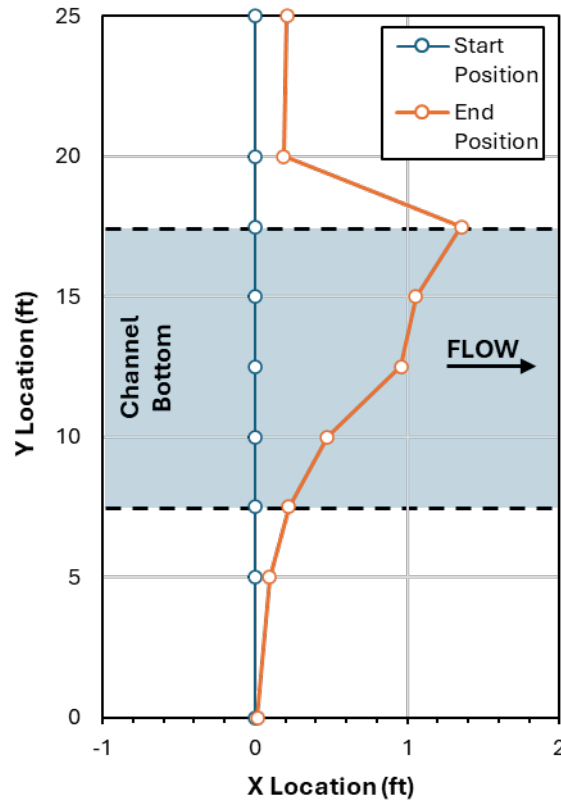

Figure 4.27: Plan View of Installation 5 Post Deflection

Table 4.9: Installation 5 Test Results

Flow Rates, ft³/s (m³/s)	0.5 (0.014)	1.0 (0.028)	1.4 (0.040)
Impoundment, ft (m)	16.7 (5.1)	29.3 (8.9)	32.0 (9.8)
Water Depth, in. (cm)	16.3 (41.4)	23.0 (58.4)	23.7 (60.2)
Impoundment Ratio	0.42	0.73	0.80
Depth Ratio	0.68	0.96	0.99
Max Deflection, in. (cm)	-	-	16.2 (41.1)



Figure 4.28: Installation 5 After Test C

4.4.6 Low Porosity MFE-I Identification

Based on the data, there were two installation options for the MFE-I of these clean water structural fence tests. The first proposed MFE-I would be Installation 5 because the impoundment length and depth were higher than in Installation 1 and because the maximum post deflection was less than in Installation 2. Installation 5 consisted of reduced post spacing – from 5 ft (1.5 m) to 2.5 ft (0.8 m) – and reduced fence height. To achieve the diminished height of 24 in. (61.0 cm), the fence was folded to create a double layer for the zip ties to be inserted and attached to the post. The double layer increased the fence strength which addressed the ripping issues observed in Installation 2. The other proposed MFE-I was Installation 3 with overall better structural performance due to its minimal deflection of 5.6 in. (14.2 cm) and from impoundment and depth ratios over 1.0 indicating its outperforming expectations.

4.5 Sediment Trap Installations

The sediment trap had three initial iterations to be evaluated in the Nebraska channel at the AU-SRF. The installations tested were the Nebraska standard sediment trap as well as

additional elements added to the sediment trap based on prior research or test findings. The following subsections detail the installation procedures and materials used. All tested practices utilized typical materials that were readily available to the construction industry. For convention, the channel sides were distinguished as left and right when downstream facing upstream where the inflow apparatus was located.

4.5.1 Nebraska Standard Sediment Trap

The Nebraska sediment trap was sized for 1 ac (0.2 ha) of contributing drainage area. According to the “Roadside Sediment Trap and Outlet” produced by the Roadway Design Division, the typical roadside ditch sediment trap basin had a bottom length of 22 ft. (6.7 m) and bottom width of 10 ft (3.0 m). The slopes into the trap were 3:1 on all sides with a depth of 3 ft (0.9 m) to the front edge of the spillway, a depth of 4 ft (1.2 m) to the lowest point of the rock weir, and a depth of 5 ft (1.5 m) to the top of the embankment. The sediment trap was excavated, and the embankments were stabilized then covered in an 8 oz (227 g) geotextile that was securely pinned down with 1 in. (2.5 cm) by 6 in. (15.2 cm) sod staples made of 11-gauge steel wire. The weir length was 4 ft (1.2 m) made of NDOT Type A riprap and a weir depth of 1 ft (0.3 m) and weir spillway side slopes of 2:1. As a conservative equivalent, the Alabama Class 1 riprap was used in place of the Type A riprap. A unique aspect of this trap was the 90-degree turn into the basin area from the 10 ft (3.0 m) roadside ditch. The NDOT standard silt trap was considered the control for installation comparisons. Figure 4.29 pictured two views of the standard sediment trap prior to testing.



(a) Sediment Trap from Weir

(b) Sediment Trap and Roadside Channel

Figure 4.29: NDOT Standard Sediment Trap

4.5.2 Standard Sediment Trap with Baffles

The same Nebraska sediment trap was used for the first modification iteration. The coir baffles were a porous material made of coconut fibers. Before adding the coir material, the 1.25 lb/ft (37 kg/m) steel T-posts were spaced 5 ft (1.5 m) apart and 14.5-gauge steel support wire was attached to the posts using 6.5 in. (16.5 cm) 11-gauge aluminum tie wire. The wire backing was attached at the top, middle, and bottom of the T-posts. The support wire had 12 in. (30.5 cm) spacing between the vertical wire and 3 in. (7.6 cm) horizontal spacing at the bottom up to 8 in. (20.3 cm) horizontal spacing at the top. The coir material was cut to the length of each of the three baffles and draped on each side of the wire and T-posts to create a double layer of coir. The three baffles were placed across the sediment trap. The placement of the baffles created four nearly equal bays within the basin. The first baffle perpendicularly intercepted flow entering the basin from the channel at the edge of the trap bottom elevation. The other two baffles fanned across the sediment trap so that the water would interact with each baffle before reaching the spillway to maximize the reduced turbulence effect. The height of the baffles was 4.5 ft (1.4 m) to ensure the incoming runoff would not overtop the baffles thereby undermining the intended energy dissipation, especially during the simulated consecutive storms, Test C and D. The excess coir material was stapled to the ground using 11-gauge steel wire 1 in. (2.5 cm) by 6 in. (15.2

cm) sod staples to prevent water from going underneath the baffle if the material were to float.

Figure 4.30 pictured two views of the sediment trap with the baffles added.



(a) Sediment Trap from Weir

(b) Sediment Trap and Roadside Channel

Figure 4.30: Sediment Trap with Baffles

4.5.3 Standard Sediment Trap with a Skimmer

The Nebraska sediment trap was used for the second modification iteration. A surface skimmer was added in the trap to dewater the runoff from the top of the pool that contained the most clarified water. The skimmer was a Faircloth skimmer made of PVC pipe as seen in Appendix H. The Faircloth Skimmer Sizing: Estimator's Calculator was utilized to determine the skimmer size and orifice opening needed for the sediment trap (Harrison et al. 2026). The goal for dewatering the sediment trap was 48 hours to allow sufficient sedimentation. The known, required trap volume of 3,618 ft³ (102 m³) was input resulting in a 1.5 in. (3.8 cm) skimmer at 100% orifice slider opening was needed for dewatering (NDOT 2006)(NDOT 2006). The skimmer's flex hose, which allowed the device to move up and down as depths varied, was attached to a PVC outlet pipe that sloped toward the back side of the weir underneath the ground. The pipe was installed during sediment trap construction and had a gate valve to stop flow from leaving the trap when the skimmer element was not in use. When the trap was empty, the skimmer rested on a concrete block to keep the device out of the retained sediment in the bottom

of the trap and prevent clogging due to contact with remaining sediment. A line was attached to the skimmer to be able to access the device with water present. The skimmer line was able to pull the device to the side of the basin if an adjustment or maintenance needed to be done. Figure 4.31 pictured two views of the sediment trap with the 1.5 in. (3.8 cm) skimmer added.



(a) Sediment Trap from Weir

(b) Sediment Trap and Roadside Channel

Figure 4.31: Sediment Trap with a Skimmer

4.6 Comparison of Sediment Trap Results

The data gathered during each sediment trap test series comprised of sediment capture, storage volume and temperature over time, and water quality comprising of TSS and turbidity. Appendix C contained test logs with the metric data results plus photo documentation before and after every individual test. Based on the analysis of the collected data, the MFE-I for the sediment trap was developed.

4.6.1 Sediment Capture and Storage Volume

The sediment capture for each variation of the sediment trap installation was above 85% for retention. The sediment that remained in the trap and upstream in the channel was collected after conducting the longevity testing, consisting of a series of four test runs on one installation. The sediment was shoveled into a hopper bin attached to a skid steer in order to transport the sediment to an industrial scale for measurement. The true mass of the remaining sediment was

calculated by factoring in the individual moisture content for each hopper that was weighed and factoring out the hopper weight of 600 lb (272 kg). The resulting weight of the summed remaining sediment was compared to true amount of introduced sediment which also factored in the moisture contents for each test of the installation series. At 91.9% retention, the highest sediment capture was produced by the baffle installation that contained three coir baffles dividing the basin into equal bays. The sediment capture of the baffle installation was 5.5% above the NDOT standard sediment trap installation which has a capture of 86.4% as seen in Figure 4.32. The NDOT standard sediment trap was used as the control to compare whether additional elements in the sediment trap enhanced detention practice functionality. The skimmer installation with the 1.5 in. (3.8 cm) surface skimmer achieved an 87.1% capture rate, 0.7% above the standard installation. The difference between the skimmer rate and the baffle rate was 4.8% capture. The MFE-I, which was a combination of the three coir baffles and the 1.5 in. (3.8 cm) skimmer, had the second highest sediment capture at 91.1% which was 0.8% below the highest performing and 4.7% above the standard installation. All sediment capture rates were close in value since the sediment trap basin and channel provided adequate volume for the incoming runoff from the 2-yr, 24-hr local storm. After test flow started, the runoff did not exit the basin until it reached the spillway weir height which occurred near the end of the testing period, except for the skimmer installation which allowed runoff to slowly exit through the dewatering device.

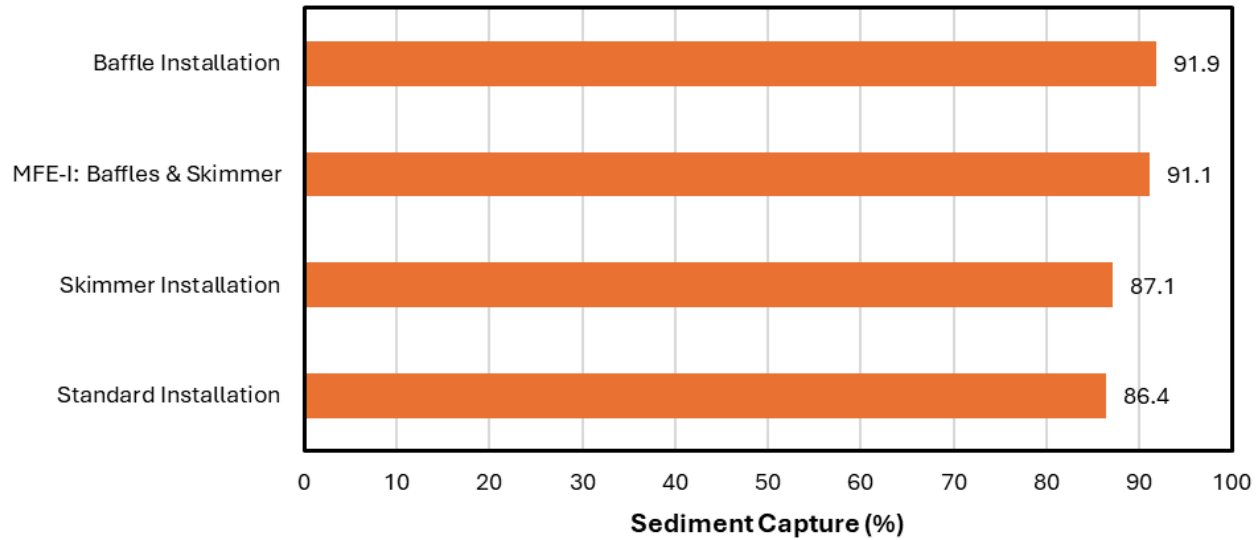

Figure 4.32: Sediment Capture Per Installation

After the conclusion of test D, the majority of the larger sediment particles were seen to have fallen in the channel, reaching upstream as far as the overflow volume from the sediment trap extended. During testing, water was seen to impound back up the channel, creating a hydraulic jump that dissipated flow velocity. The dissipation allowed for sedimentation to start. However, the runoff would not form that impoundment until the testing period neared the end when the sediment trap was completely filled and somewhat overflowed into the channel upstream of the trap. The large particles that settled in the channel were assumed to be washed further into the sediment trap with each successive test. The assumption of washing was supported by the hefty presence of larger sediment particles at the front edge of the first baffle which was situated across the toe of the sediment trap mouth. Testing observations also indicated that the first baffle caused the greatest decrease from turbulent flow to laminar flow than the second or third baffle. When water passed the second baffle, the slight flow turbulence that remained was expelled, and passing the third baffle, there was no noticeable change in flow. The finer sediment particles were mostly found within the sediment trap. The settling distribution of

the remaining sediment was illustrated by the images in Figure 4.33 taken after draining the basin upon the completion of Test D. The skimmer and standard installations had the larger sediment particles settling upstream in the channel similar to Figure 4.33 (a). For the skimmer and standard installs, the finer particles within the sediment trap itself. The distinction between particle size zones was not present as it was in the baffle installation. Because of the assumption that the sediment in the channel would eventually end up in the sediment trap, the trap would need maintenance when sediment has filled 50% of the trap. Maintenance ensured that the trap had capacity to handle runoff and would not result in resuspension and loss of sediment to downstream waterbodies.



(a) Channel Upstream of Sediment Trap



(b) First Bay of Sediment Trap



(c) Second Bay of Sediment Trap



(d) Third Bay of Sediment Trap



(e) Fourth Bay of Sediment Trap

Figure 4.33: Sediment Particle Distribution of Highest Sediment Capture Install

The dewatering period started when the 30 min test flow stopped and continued until the water stopped leaving the sediment trap. A longer dewatering period meant that the detention practice had a longer runoff residence time for sedimentation. For the standard and baffle installation, the sediment trap dewatered only through the rock weir of the spillway in under 5 hours for each test of the install series. The skimmer installation dewatered over 28 hours but did not achieve the 48-hour dewatering time. The orifice of the slider could be adjusted to a smaller opening, rather than 100% open, to achieve the longer residence time. The error occurred when entering the known, required basin volume, instead of accounting for the height of the bottom of the spillway. The spillway height retained less runoff because the flow passed through the weir. The lesser volume meant that the skimmer could have more residence time, meaning it could dewater more slowly. The residual water in each iteration would seep into the ground through the geotextile covering or evaporate into the atmosphere. The standard and the baffle installation held water under the spillway for a time over 24 hours with little to no change in depth. The majority of the storage volume was not restored and would not be available for use in close, subsequent storm events. The skimmer installation was the only iteration that restored the majority of the sediment trap volume, making it available for use in the next storm event. The

4.6.2 Water Quality

The water quality analysis comprised of an assessment of TSS and turbidity for every single test run for each installation. In all four installations, the sediment trap had improved water quality from the inflow values due to the amount of volume available to store the runoff and due to the controlled dewatering mechanisms through the spillway or the skimmer. Since average values only depict part of the interpretation of results and were affected by any outliers, another type of graph was used to illustrate the water quality results. A box and whisker plot was

created to display the range of data for the samples obtained downstream. Figure 4.34 showed the TSS results, and Figure 4.35 showed the turbidity results. In the two graphs, the inflow which represented the introduced water and sediment contained the inner quartiles but excluded the maximum score and outliers. Each box and whisker plot was labeled underneath with the installation name.

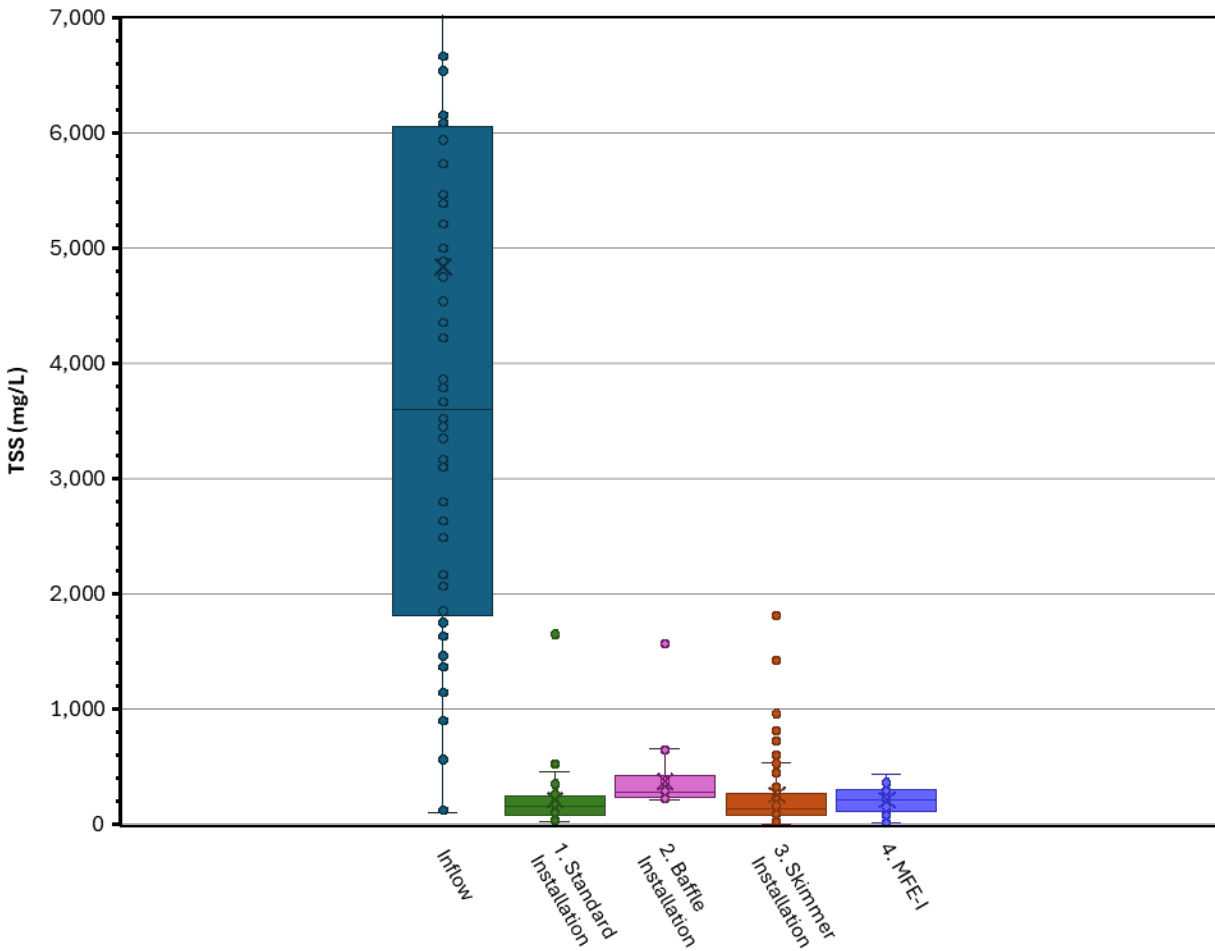

Figure 4.34: Downstream TSS per Installation

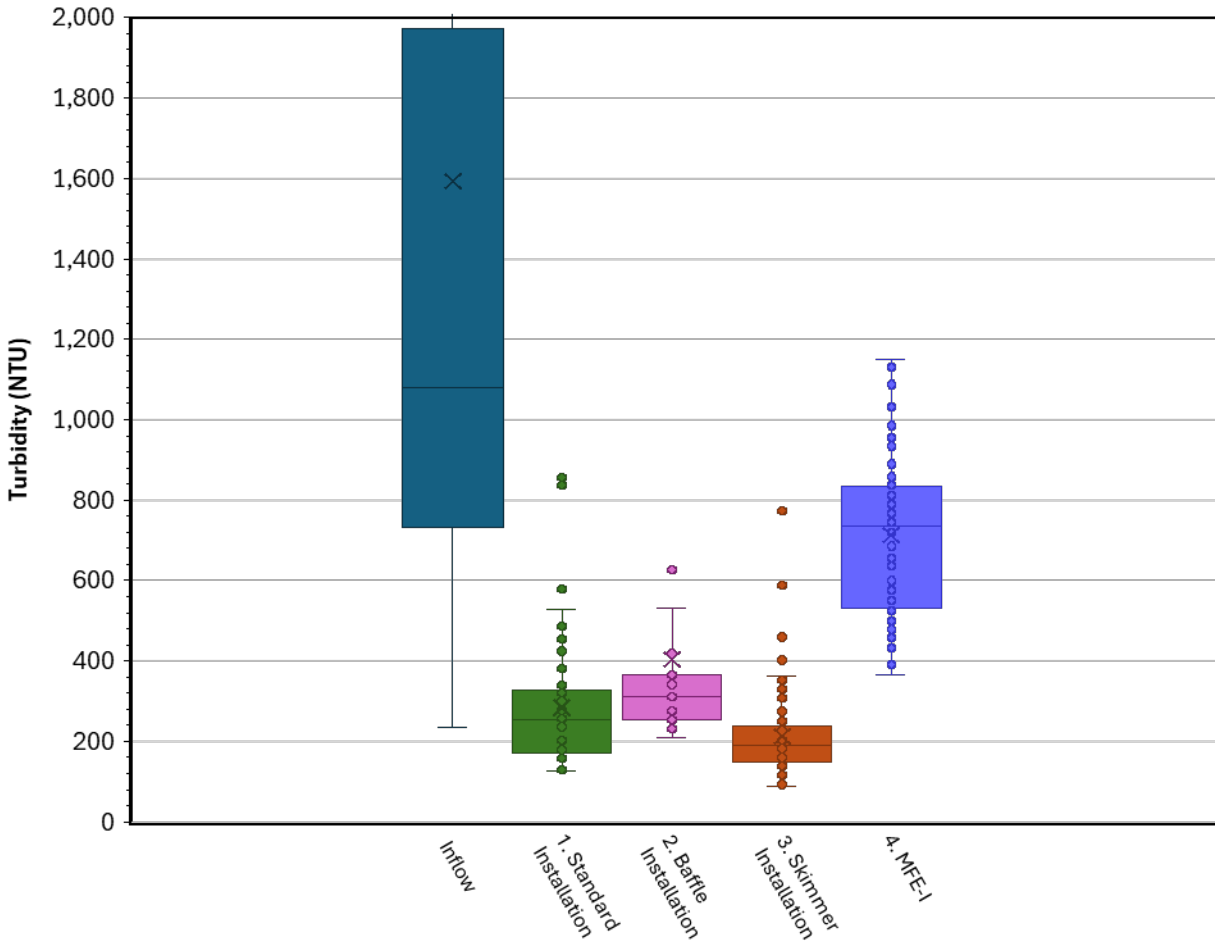

Figure 4.35: Downstream Turbidity per Installation

Each installation resulted in lower downstream TSS values when contrasted with those of the inflow, meaning each installation had a positive impact on downstream water quality. The enhancement was shown by the median TSS lines of each installation falling below 1,000 mg/L compared to the inflow median rising above 3,000 mg/L. The difference in each installation performance for TSS was too minor to make a claim of best practice since each installation performance was consistent with the others. Similarly, the installations resulted in lower downstream turbidity values when contrasted with those of the inflow, also positively impacting the downstream water quality. The installation enhancements were shown by the median turbidity lines which were below 400 NTU compared to the inflow median which was above

1,000 NTU. However, the MFE-I installation had a median turbidity of around 700 NTU. The resulting turbidity of the MFE-I did not adhere to the hypothesized performance. The hypothesized performance were values of TSS and turbidity that would reflect comparable results to the baffle installation results and the skimmer installation results. The reason for the high turbidity yet low TSS was the background turbidity from the pond water used for flow introduction. The test observations noted that the pond water had a strong cloudy appearance for the MFE-I tests compared to the other tests for the previous installations. A box and whisker plot was created for the background TSS and background turbidity of each installation as seen in Figure 4.36 and Figure 4.37.

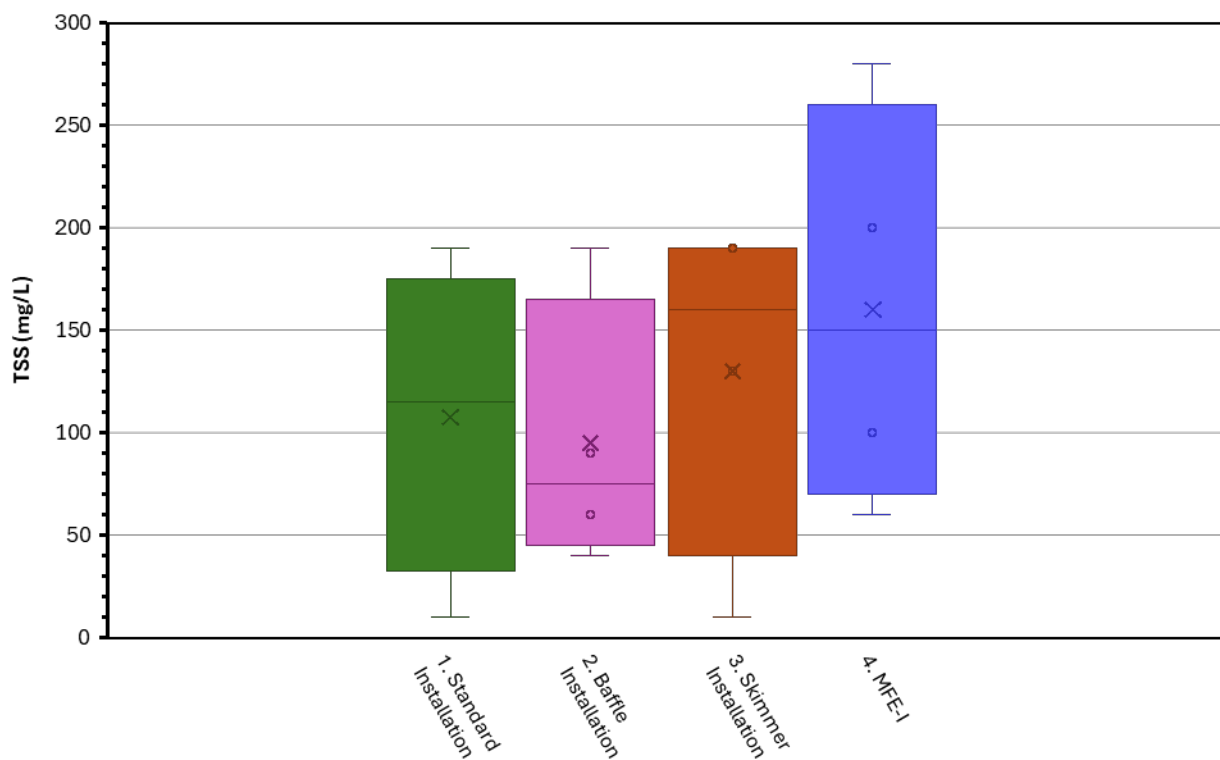

Figure 4.36: Background TSS per Installation

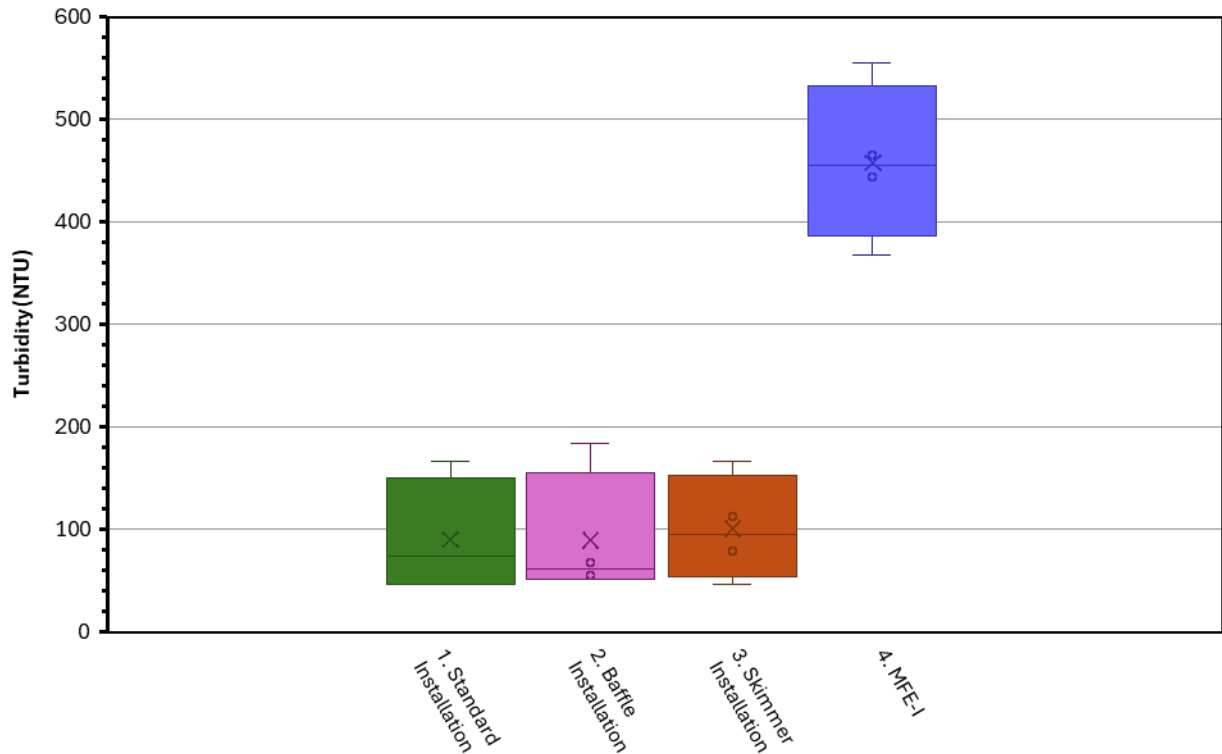

Figure 4.37: Background Turbidity per Installation

The background turbidity was noticeably higher than the other installations which led to the skewed downstream turbidity results. The inflow of the other installations was compared to the inflow of the MFE-I in Figure 4.38. The resulting graph did not indicate that the MFE-I inflow was greater than the inflow of the other installations as might be expected. The background turbidity did not affect the inflow values because the sediment dosage was reached or was well above the carrying capacity for the simulated runoff.

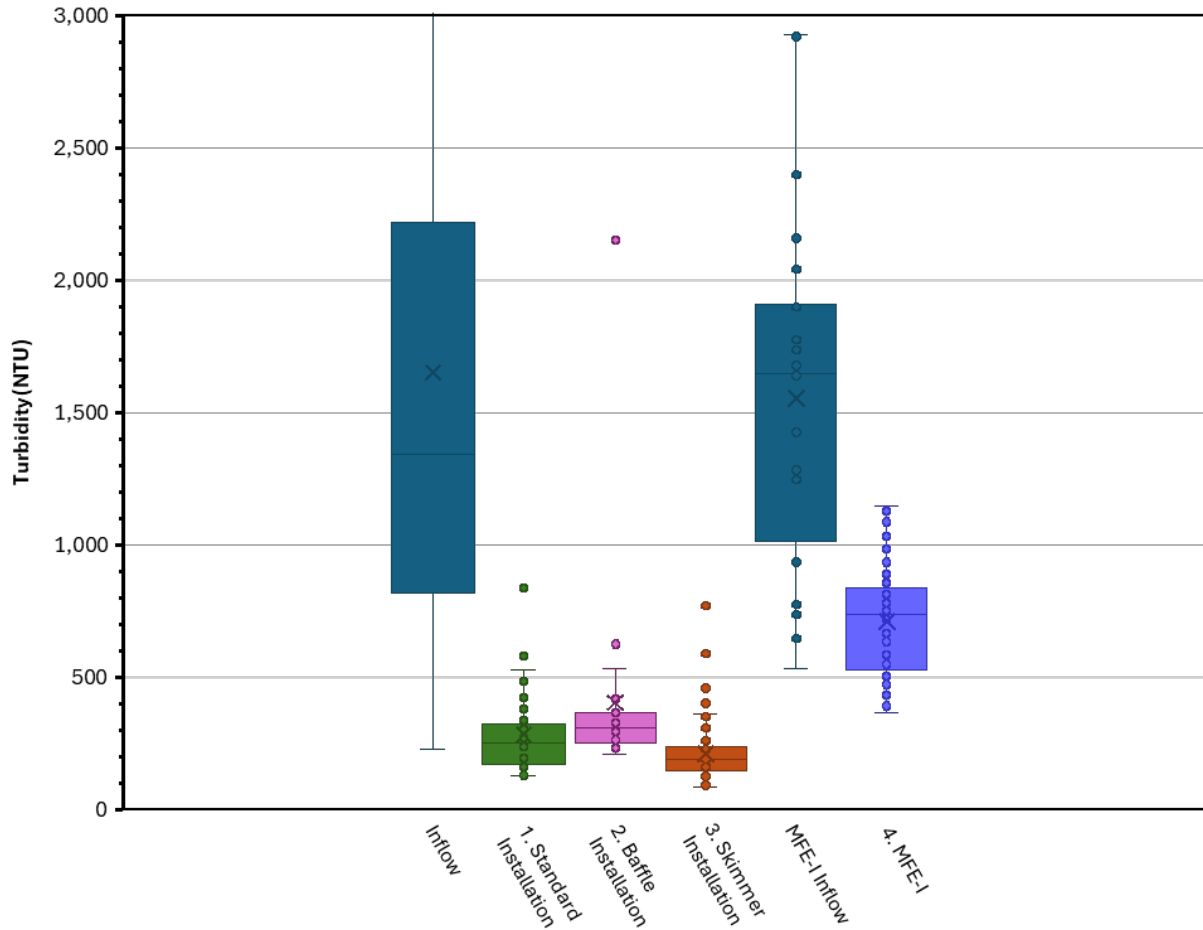

Figure 4.38: Installation Inflow and Turbidity vs. MFE-I Inflow and Turbidity

While the water quality results were not clear in all cases, the overall trend was that the sediment trap and the various installations of added elements created better downstream water in both TSS and turbidity as compared to the test inflow values.

4.6.3 Sediment Trap MFE-I

A most feasible and effective installation is one that has been proven successful in accomplishing its specific, realistic purpose for industry usefulness. For the sediment trap, that purpose was to retain sediment in the installation and generate cleaner water travelling downstream of the installation. Factors of high sediment capture and water quality improvement were deemed practical indicators in identifying an MFE-I. The sediment capture for the MFE-I

was the second highest retention rate at 91.1% which was 0.8% below the highest performing installation. The MFE-I increased the sediment capture by 4.7% from the standard installation. The TSS, concentration of solid particles suspended in water, and turbidity, measured in nephelometric turbidity units, were parameters used to indicate installation effectiveness regarding the quality of the water that would leave the site. Since all of the installations had downstream water quality improvements close in value, other benefits were considered for determining the MFE-I. The MFE-I was developed to incorporate the benefits produced by the baffle installation and skimmer installation. The baffle installation created a laminar flow situation by dissipating the incoming flow, increased the effective width of the sediment trap, and prevented the flow from traveling directly to the outlet. It also barred larger sediment particles from traveling further into the sediment trap as seen in the particle distribution. The skimmer installation allowed the sediment trap to slowly dewater and gradually restore the storage volume to be available for successive storms. The same trends of both installs were detected when the MFE-I was tested. The MFE-I included three coir baffles and a 1.5 in. (3.8 cm) surface skimmer.

4.7 Comparison of the Silt Trap and Sediment Trap

The standard silt trap and the silt trap MFE-I were tested at 1 ac (0.4 ha) rates for sediment introduction and flow introduction. The 1 ac (0.4 ha) tests were to compare silt trap performances to the standard sediment trap and the sediment trap MFE-I. The resulting sediment captures from each test were included in Table 4.10. The highest sediment capture of the tests was the sediment trap MFE-I at 91.1%. The silt trap MFE-I and the standard sediment trap were close in value with a difference of 0.9% capture. The silt trap standard installation had the lowest sediment capture. The standard silt trap at 1 ac (0.4 ha) rates had lower sediment capture than at 0.5 ac (0.2 ha) rates most likely due to the increased flow transporting sediment downstream

instead of pooling and settling within the trap. The silt trap MFE-I also had lower capture at 1 ac (0.4 ha) rates compared to the 0.5 ac (0.2 ha) rates also due to the increase in flow and sediment load. However, the MFE-I of the silt trap improved the sediment capture, approaching the function capacity of the sediment trap installations. The comparisons here led to a potential trend of increased flow and sediment loading resulting in less sediment capture. The comparisons additionally aid in practice selection guidance for NDOT project needs.

Table 4.10: Installation Comparison at 1 ac (0.4 ha) Rates

Detention Practice	Sediment Capture
Standard Silt Trap	53.3 %
Silt Trap MFE-I	85.3 %
Standard Sediment Trap	86.4 %
Sediment Trap MFE-I	91.1 %

Chapter Five: Conclusion And Recommendations

5.1 Introduction

Enhancing the silt trap and sediment trap stormwater management techniques through improved design and informed implementation will safeguard water quality downstream of developing areas, reduce regulatory compliance issues, manage accompanying costs, and enhance public perception. Detention measures are helpful tools in executing a SWPPP to obtain a CSW before a roadside construction project can commence in the state of Nebraska. The research completed for this study was divided into three principal components associated with evaluating the performance silt trap and sediment trap.

- (1) Developing a repeatable methodology to evaluate and compare the performance of detention practices typical utilized on NDOT highway construction projects to facilitate sedimentation in construction generated runoff,
- (2) Conducting full-scale testing that mimics Nebraska conditions through soil losses and runoff volumes on silt trap iterations and sediment trap installations, and
- (3) Identifying the MFE-I through data collection analysis and field observations to provide implementable results and design guidance for NDOT projects.

To satisfy these research objectives, five tasks were distinguished and completed.

- (1) A comprehensive literature review was conducted on the state-of-the-practice regarding silt traps and sediment traps and on research for efficient and effective potential modifications,

- (2) A full-scale testing methodology was developed based on the Loess Hills and Loess and Glacial Drift regional mean factors to determine sediment introduction and runoff flow rates,
- (3) The experimental roadside channel and detention practices were designed and constructed according to Nebraska standard plan sets mimicking highway conditions,
- (4) Full-scale testing was performed at the Auburn University – Stormwater Research Facility for the different practices and installation variations for each trap, and
- (5) The collected water quality and sediment capture data was analyzed to quantify performance results for extricating the MFE-I of each practice.

By accomplishing the five tasks and achieving the research objectives, this study provides insight into the performance of silt traps and sediment traps under simulated Nebraska highway construction conditions. The results provide implementable guidance on improving NDOT detention practices, as well as creating repeatable methodologies for assessment.

5.2 Conclusions and Impact

The first research objective was to develop a methodology to evaluate and compare the silt trap and sediment trap for their respective sediment removal and water quality improvement capabilities. A literature review was conducted on similar practices, related testing, and applicable modifications. Previous testing and comparable practices indicated that sedimentation was the primary way detention practices treated runoff. To achieve sedimentation, the generated sediment-laden flow needed to be slowed and given enough time to facilitate this remedial process. Velocity reduction eradicated the turbulence that mixed transported soil particles with water. The reduction was achieved for the silt trap through impoundment and achieved for the sediment trap through adequate use of storage volume. When the storage capacity for both

practices was designed for the local 2-yr, 24-hr storm event, the effective iterations provided enough temporary storage to handle the common occurrence storms while delivering longer, non-permanent residence time for settling. Other methods similar to the NDOT detention practices showed consistency across several aspects. One aspect was that sediment settling depended on the L:W ratio employed. A minimum 2:1 ratio or a ratio with even greater length than width supplied better sedimentation due to the long flow path. For any installation, stabilization was important in preventing erosion of the practice. Slow discharge was another important aspect for allowing prolonged sedimentation while eventually restoring available storage capacity. In both practices, routine maintenance was necessary to continue ideal operation. The modifications researched for the silt trap comprised of adding a ditch check or related system that attained the detention goals listed above. In paring a ditch check with a silt trap, the resultant method would encompass both erosion and sediment control applications. The optimum installation procedure was investigated for each proposed variation. The sediment trap derived its modifications from elements of a typical sediment basin to attain the detention goals listed above. Even though Nebraska did not have water quality regulations as far as TSS and turbidity compliance, water quality was still utilized as a performance metric alongside sediment capture rates when evaluating the full-scale tests.

The second research objective was to conduct replicable full-scale testing on silt trap and sediment trap iterations. Prior studies indicated this type of project would benefit from full-scale testing that simulated real-world circumstances while maintaining influence on the outcomes through the dependent and independent variables. The real-world circumstances involved determining the runoff volumes and soil losses that mimic NDOT conditions. A GIS analysis produced factors related to the amount of rainfall experienced and the soil erosivity of six

particular regions of the state. The Loess Hills and the Loess Hills and Glacial Drift regions were selected to represent the state due to their higher soil erosivity and high rainfall. Using Civil3D hydrograph, the peak runoff and peak 30-min. mean flow rate was obtained for the silt trap receiving flow from 0.5 ac (0.2 ha) and for the sediment trap receiving flow from 1.0 ac (0.4 ha). The resulting peak 30-min mean flow rates were used for testing flow rates. When determining the sediment introduction rates for testing, MUSLE utilized factors to characterize construction site conditions to better predict soil loss. A typical roadside channel was excavated with the silt trap and sediment trap components placed accordingly. With the sediment introduction rates and flow rates established, control tests were conducted on each standard NDOT detention system. Every test was run as a longevity test by testing one installation in triplicate.

The final objective identified the most feasible and effective installations (MFE-I) that withstood the simulated sediment loss and flow rates undergone in the 2-yr, 24-hr design storm. Nine installations were tested for the silt trap, and four installations were tested for the sediment trap. The standard testing for both traps presented opportunities for improvement in increasing sediment retention and enhancing water quality moving downstream. The test results were analyzed and compared leading to the following recommended installations:

- A silt trap alongside a non-woven silt fence with wire backing attached to T-posts in a V-shape and a weir of 18-in. (45.7 cm) cut out of the fence material
- A sediment trap incorporating properly spaced coir baffles and an appropriately sized surface skimmer.

The silt trap with the “modified” silt fence installation produced the most impoundment in length and depth and the highest sediment capture of 95.9%, which was 23.5% above the sediment capture produced by the standard silt trap. While not yielding the highest water quality

improvement, the TSS and turbidity were within 189 mg/L and 41 NTU respectively of the leading installation. These water quality values were 1,499 mg/L and 147 NTU below the standard silt trap water quality results. Adding a silt fence reduces amount of maintenance for the combined detention practice and acts as a factor of safety to keep particles from washing downstream when sediment is over the permissible silt trap capacity. Another high performing silt trap iteration was the slash mulch berm with the best improvement in TSS and turbidity and the second highest sediment capture and impoundment length. The limitation with slash mulch would be availability of fresh mulch on site, but the slash mulch berm was a viable option for silt trap.

As a result of the silt trap testing, the low porosity silt fence underwent structural performance testing. The sediment introduction aspect was removed which eliminated the water quality and sediment capture elements of assessment, so clean water was used in running the tests. Five installations with variations in post spacing, fence height, post material, and fence shape were subjected to three flow rates for longevity evaluation. The deflection and impoundment measurements were collected during each test run. The results indicate that the low porosity silt fence structurally performed best in a V-shape with an 18 in. (45.7 cm) weir cut from the fence material with closer post spacing than the standard 5 ft (1.5 m). Another structurally viable option was the 2.5 ft (0.8 m) post spacing with a 24 in. (61.0 cm) fence height created from folding the fence. Both of these low porosity silt fence installations were able to endure a flow rate from the 2-yr, 24-hr design storm for a contributory area above 1.0 ac (0.4 ha).

The sediment trap that incorporated the three baffles and a skimmer produced the highest sediment capture, most water quality improvement, and restored the storage volume for subsequent events. The three coir baffles prevented short circuiting, increased effective width,

and dissipated runoff energy while the skimmer gradually dewatered the more clarified water from the top of the pool. The sediment capture had a rate of 91.1% which was 4.7% above the sediment capture produced by the standard sediment trap. While the water quality across each iteration was improved, the skimmer and baffle installation resulted in low TSS values and distorted turbidity values due to the background turbidity of the tests. Adding a 1.5 in. (3.8 cm) skimmer that was sized for the particular sediment trap volume based on the contributory area allowed a residence time of over 30 hours for sedimentation to occur and was able to return the full volume capacity of the sediment trap. To achieve optimal performance for any detention practice, the proper installation techniques should be followed.

During testing, Alabama native soils were used to assess the performance of detention practices for the state of Nebraska. Owing to the fact that Alabama soils are sandier, the heavy sands benefitted sediment retention capabilities of the various installations as the particles were more apt to fall out of suspension. The higher coarse particles used in testing are not as prevalent in Nebraska. While sediment capture is expected to increase as informed by the conducted research, the exact retention percentages may not be achieved on NDOT projects because of the finer soil composition.

The research sought to contribute to the body of knowledge on the performance of detention practices, specifically the silt trap and sediment trap, in improving downstream water quality and capturing sediment on highway construction projects. The testing methodology outlined in Chapter 3 is repeatable for other regions or regulatory entities that aim to provide guidance on performance enhancements of detention practices. The testing completed on silt traps and sediment traps under Nebraska conditions endeavored to fill a research gap of performance evaluations on detention practices in the Midwest U.S. Additionally, contractors and

designers can use the dataset generated from testing to advance the state of practice in the erosion and sediment control industry for highway construction projects in Nebraska and elsewhere.

5.3 Recommendations for Implementation

The goal of this project was to evolve academic research into implementable, real-world solutions. Through data collection and field observations, design guidance was developed for use on Nebraska DOT projects. To adopt the findings of this research, the following action items and key findings have been listed:

- The silt trap alone provides substantial sediment capture (74.2%)
- The silt trap was enhanced with almost every ditch check and should therefore always be used in conjunction with a check
- The modified silt fence generated the highest sediment capture (95.9%), longest impoundment, high water quality, and manageable dewatering time
- The temporary rock check provided no effect on sediment capture or water quality
- Sediment capture increases as impoundment length and depth increases, consider implementing checks that provide high impoundment capacity
- The temporary erosion check, high porosity silt fence, and temporary rock check did not generate high impoundment values
- The low porosity silt fence Installation 3, V-shape with 18 in. (cm) weir, generated the least amount of post deflection
- Folding the low porosity silt fence strengthened the geotextile by creating a double layer for inserting the zip ties

- The sediment trap with the baffles and a skimmer had high sediment capture (91.1%) and manageable dewatering time
- The 1st baffle in the sediment trap dissipated incoming flow and captured the majority of the coarse particles, retaining the sediment upstream of the trap
- The skimmer in the sediment trap restored storage volume over an extended time for subsequent events

As a reasonable response to these findings, and in an effort to implement the discoveries made in this research, NDOT could consider revising and updating their ESC practices to reflect accordingly.

5.4 Limitations and Future Research

All modifications aimed to improve the sediment capture and water quality capabilities of the NDOT silt trap and sediment trap; other modifications that were not evaluated in this research likely exist that can further increase the performance. Typical project limitations such as timeline and budget applied to this research. An additional limitation was the climate dependency of the testing including time of year, temperature of water, moisture content of sediment. While measures were taken to minimize interference such as moisture content, these inconsistencies could have affected testing results. Other uncontrollable variations were in the materials tested, including wattles density fluctuating, silt fence materials having imperfections in the same roll, slash mulch varying within the same stockpile, baffles having disparities in opening sizes, and similar material inconsistencies.

The scientific results from the full-scale testing are expected to provide the state of Nebraska and the ESC industry with additional guidance for the application of silt traps and sediment traps. The MFE-I designs developed for the silt trap and sediment trap, found through

standardized, repeatable testing, served to increase the water quality and sediment capture when utilized. However, future research efforts are expected to continue the advancement of stormwater management in the construction trade or wherever ESC can be applied. The flow rates or sediment introduction rates can be adjusted to represent conditions in other areas of the United States to develop local base knowledge or an MFE-I. Moreover, additional forms of detention practices can be evaluated for performance utilizing the same testing apparatus or methodology. Another recommendation for improving testing comparison accuracy across states would be capturing the sediment gradation in testing. The gradation would enable different soil types to be juxtaposed for performance behavior.

The silt trap could be further investigated by testing additional ditch checks paired with the silt trap such as erosion checks made of different material. The dimensions of the silt trap, such as the depth, could be adjusted to evaluate whether additional volume depth provides more benefit.

As discussed in the result section, the sediment trap could be investigated for skimmer orifice restrictions for longer residence time. The goal was 48 hours and was not achieved due to the spillway height providing less resident volume in the trap. The estimator's calculator output a 70% orifice opening when the basin dimensions were input instead of the basin volume. Another recommendation for evaluation would be to use two baffles instead of three baffles. As observed in testing, the first baffles provided the most reduction of turbulence for incoming flow while the second baffle had minimal seen effect and rather reinforced the primary baffle. The third baffle added little to no observed assistance. The two baffles would especially apply to traps for smaller contributory areas. Another option would be to incorporate a forebay before the mouth of the sediment trap to make maintenance easier. The forebay would be expected to capture slightly

over 50% of the incoming sediment as demonstrated by the test of standard silt trap tested at 1 ac (0.4 ha) rates.

For the silt trap and sediment trap, more innovative methods could be tested such as a silt trap in series or the use of a floc generator in a sediment trap. The final suggestion for continued future research would be to test the silt trap in conjunction with the sediment trap to create a treatment train. The current scientific results from the full-scale testing of this project are expected to provide the state of Nebraska with additional guidance for the application of silt traps and sediment traps as well as contribute to the advancement of the ESC industry.

References

- A. Millen, J., A. R. Jarrett, and J. W. Faircloth. 1997. "Experimental Evaluation Of Sedimentation Basin Performance For Alternative Dewatering Systems." *Transactions of the ASAE*, 40 (4): 1087–1095. St. Joseph, MI: ASAE.
<https://doi.org/https://doi.org/10.13031/2013.21361>.
- Alabama Soil and Water Conservation Committee. 2022. "Erosion Control, Sediment Control and Stormwater Management on Construction Sites and Urban Areas (The Blue Book)." Montgomery, Alabama.
- Barrett, M. E., Jr. W. E. Kearney, T. McCoy, J. F. Malina, and R. J. Charbeneau. 1996. "An evaluation of the use and effectiveness of temporary sediment controls."
- Bhattarai, R., P. K. Kalita, C. B. Garcia, J. Monical, and P. Schumacher. 2016. "Evaluation of Ditch Checks for Sediment Retention." *Civil Engineering Studies, Illinois Center for Transportation Series*.
- Boyd, C. E., and F. Lichtkoppler. 1979. *Water Quality Management In Pond Fish Culture. Research and Development Series*. Auburn, AL.
- Construction and Materials Bureau. 2022. "Erosion & Sediment Control Field Guide." Ames, Iowa: IOWADOT.
- Department of Water, E. and E. 2022. "All About DWEE: Construction Storm Water Permit." Lincoln, Nebraska.
- Donald, W. N., W. C. Zech, X. Fang, and J. J. LaMondia. 2013. "Evaluation of Wheat Straw Wattles for Velocity Reduction in Ditch Check Installations." *Transportation Research Record*, 2358 (1): 69–78. <https://doi.org/10.3141/2358-08>.

- Donald, W. N., W. C. Zech, X. Fang, and M. A. Perez. 2016a. “Hydraulic Method to Evaluate the Performance of Ditch Check Practices and Products.” *Journal of Hydrologic Engineering*, 21: 4016042.
- Donald, W. N., W. C. Zech, M. A. Perez, and X. Fang. 2016b. “Evaluation and Modification of Wire-Backed Nonwoven Geotextile Silt Fence for Use As a Ditch Check.” *Journal of Irrigation and Drainage Engineering*, 142 (2): 04015050. American Society of Civil Engineers. [https://doi.org/10.1061/\(ASCE\)IR.1943-4774.0000959](https://doi.org/10.1061/(ASCE)IR.1943-4774.0000959).
- Environmental Protection Agency. 2025. “Summary of the Clean Water Act.” Accessed January 15, 2026. <https://www.epa.gov/laws-regulations/summary-clean-water-act>.
- Erickson, A. J., P. T. Weiss, and J. S. Gulliver. 2013. *Optimizing Stormwater Treatment Practices. Optimizing Stormwater Treatment Practices: A Handbook of Assessment and Maintenance*. New York, NY: Springer New York.
- Fang, X., W. C. Zech, and C. P. Logan. 2015. “Stormwater field evaluation and its challenges of a sediment basin with skimmer and baffles at a highway construction site.” *Water (Switzerland)*, 7 (7): 3407–3430. MDPI AG. <https://doi.org/10.3390/w7073407>.
- FMI Corporation. 2024. “New highway and street construction put in place in the United States from 2005 to 2023, with forecasts until 2028 (in billion current U.S. dollars).” *Statista*. Accessed January 7, 2025. <https://www.statista.com/statistics/226515/value-of-us-highway-and-street-construction/>.
- Gogo-Abite, I., and M. Chopra. 2013. “Performance evaluation of two silt fence geotextiles using a tilting test-bed with simulated rainfall.” *Geotextiles and Geomembranes*, 39: 30–38. <https://doi.org/https://doi.org/10.1016/j.geotexmem.2013.07.001>.

- Goldman, S. J., K. Jackson, and T. A. Bursztynsky. 1986. *Erosion and Sediment Control Handbook*. McGraw-Hill, New York: McGraw-Hill.
- Guckes, M. 2024. *U.S. Put-in-Place Construction Forecasts*.
- Harrison, C. G., A. R. Bosman, M. A. Perez, and W. N. Donald. 2026. “A Novel Approach to the Evaluation of Sediment Basin Floating Surface Skimmer Flow Rates.” *Water*, 18 (4).
<https://doi.org/10.3390/w18040500>.
- Kelderman, K., A. Phillips, T. Pelton, E. Schaeffer, P. MacGillis-Falcon, and C. Bernhardt. 2022. *The Clean Water Act at 50: Promises Half Kept at the Half-Century Mark*.
- Kelsey, K. 2023. “Erosion control history and evolution.” Accessed January 15, 2026.
<https://geosyntheticsmagazine.com/2023/02/01/erosion-control-history-and-evolution/>.
- Liu, L., M. A. Perez, J. B. Whitman, W. N. Donald, and W. C. Zech. 2021. “SILTspread: Performance-Based Approach for the Design and Installation of Silt Fence Sediment Barriers.” *Journal of Irrigation and Drainage Engineering*, 147 (10): 4021041.
[https://doi.org/10.1061/\(ASCE\)IR.1943-4774.0001608](https://doi.org/10.1061/(ASCE)IR.1943-4774.0001608).
- Mahler, B. J. 2018. “Sediment-Associated Contaminants.” *US Geological Survey: Water Resource Mission Area*.
- Minnesota Pollution Control Agency. 2006. “Sediment control practices - Sediment traps and basins.” *Minnesota Stormwater Manual*.
- Mitchell, G. F., M. S. Shad, and T. Masada. 1991. “Erosion and Sediment Control Practices in Highway Construction.” In: *Presented at Erosion Control: A Global Perspective, International Erosion Control Assn. Proceedings of Conference XXII*, 57–67. Orlando, FL USA.
- Natural Resources Conservation Service. 1986. *Urban Hydrology for Small Watersheds*.

Natural Resources Conservation Service. 2025. "NRCS History." Accessed January 15, 2026.

<https://www.nrcs.usda.gov/about/history/brief-history-nrcs>.

NDOT. 2006. "Drainage Design and Erosion Control Manual." Lincoln, Nebraska.

NDOT. 2017. "Standard Specifications for Highway Construction." Lincoln, Nebraska.

NDOT. 2020a. "Construction Stormwater Best Management Practices." Lincoln, Nebraska.

NDOT. 2020b. "Roadside Sediment Trap and Outlet." Lincoln, Nebraska.

Nebraska Department of Transportation. 2025. "English Average Unit Price for Lettings January 1, 2024 to December 31, 2024."

North Carolina Department of Transportation. 2015. "Erosion and Sediment Control Design and Construction Manual." Raleigh, North Carolina.

Perez, M. A. 2016. "Improvements in the Design and Application of Erosion and Sediment Control Technologies for the Construction Industry." Dissertation, Auburn University.

Pérez, M. A., W. C. Zech, X. Fang, and J. G. Vasconcelos. 2016. "Methodology and Development of a Large-Scale Sediment Basin for Performance Testing." *Journal of Irrigation and Drainage Engineering-asce*, 142: 4016042.

Perez, M. A., W. C. Zech, X. Fang, and J. G. Vasconcelos. 2016. "Methodology and Development of a Large-Scale Sediment Basin for Performance Testing." *Journal of Irrigation and Drainage Engineering*, 142 (10). American Society of Civil Engineers (ASCE). [https://doi.org/10.1061/\(asce\)ir.1943-4774.0001052](https://doi.org/10.1061/(asce)ir.1943-4774.0001052).

Roadside Stabilization Unit. 2007. "Erosion and Sediment Control Approved Products List." Lincoln, Nebraska: Nebraska Department of Roads.

Roadway Design Division. 2024. "Silt Checks All Types." Lincoln, Nebraska.

Roche, B. G. 2023. *Performance Evaluation of Sediment Control Practices*.

- Roche, B. G., W. N. Donald, X. Fang, and M. A. Perez. 2025. *Evaluation of Rock Check Dam Performance using Large-Scale Testing Techniques*.
- Roche, B. G., M. A. Perez, W. N. Donald, and J. B. Whitman. 2024a. "Large-Scale Performance Evaluation of Various Woven Silt Fence Installations under Nebraska Highway Conditions." *Water*, 16 (6). <https://doi.org/10.3390/w16060877>.
- Roche, B. G., M. A. Perez, W. N. Donald, and J. B. Whitman. 2024b. "Large-Scale Performance Evaluation of Various Woven Silt Fence Installations under Nebraska Highway Conditions." *Water*, 16 (6). <https://doi.org/10.3390/w16060877>.
- Roche, B. G., M. A. Perez, W. N. Donald, and J. B. Whitman. 2024c. *Evaluation of NDOT's Sediment Barrier Practices Using Performance Data Final Report* . Auburn, Alabama.
- Schussler, J. C. 2022. *Improvements in Stormwater Detention Technologies through Large-Scale Testing Techniques*.
- Schussler, J. C., B. Kazaz, M. A. Perez, J. B. Whitman, and B. Cetin. 2021. "Field Evaluation of Wattle and Silt Fence Ditch Checks." *Transportation Research Record*, 2675 (6): 281–293. <https://doi.org/10.1177/0361198121992073>.
- Sharpe, C., M. Perez, and W. Donald. 2023. "Evaluation of Surface Skimmer Flow Rates and Size Selection." *Transportation Research Record*.
- Suhara, K. K. S., A. Varughese, A. C. Sunny, and A. P. R. Krishna. 2023. "Erosivity Factor of the Revised Universal Soil Loss Equation (RUSLE) - A Systematized Review." *Current World Environment*, 18 (2): 433–445. Enviro Research Publishers. <https://doi.org/10.12944/cwe.18.2.02>.
- United States Environmental Protection Agency Office of Water. 2023. "Construction Site Runoff Control Minimum Control Measure." *Stormwater Phase II Rule*, Factsheet 2.6.

- USDA Economic Research Service. 2019. "Current Water Quality Conditions and Government Programs To Protect Water Quality." *Economics of Water Quality Protection*, 3–20.
- USEPA. 1998. "Federal register. Reissuance of NPDES general permits for storm water discharges from construction activities; notice." Washington, DC.
- USEPA. 2012. "Silt Fences." Washington, D.C.: Office of Water.
- USEPA. 2017. "Construction General Permit (CGP) Frequent Questions." *National Pollutant Discharge Elimination System*.
- USEPA. 2022. *2022 Construction General Permit (CGP)*.
- Whitman, J. B., M. A. Perez, W. C. Zech, and W. N. Donald. 2021. "Practical Silt Fence Design Enhancements for Effective Dewatering and Stability." *Journal of Irrigation and Drainage Engineering*, 147 (1): 04020039. American Society of Civil Engineers.
[https://doi.org/10.1061/\(ASCE\)IR.1943-4774.0001521](https://doi.org/10.1061/(ASCE)IR.1943-4774.0001521).
- Williams, J. R., and H. D. Berndt. 1977. *Sediment Yield Prediction Based on Watershed Hydrology*.
- Zech, W. C., and X. Fang. 2014. *Evaluation of ALDOT Ditch Check Practices using Large-Scale Testing Techniques*. Auburn, Alabama.

**Appendix A:
Silt Trap Testing Logs**

SILT TRAP TEST LOG

Test Summary

Installation:	Standard/Control
Test ID:	A
Date:	11/25/2024
Type:	Longevity
Flow Rate (cfs):	0.5
Sediment Load Rate (lb/min):	36.6

Picture of Installation



Note: pictured on upstream side facing downstream in channel

Installation Description & Test Notes: The standard Nebraska installation is the silt trap in conjunction with no other installation upstream or downstream. The trap is 1 foot deep with 2:1 horizontal to vertical side slopes. The bottom of the trap had a width of 6 feet and a length of 12 feet. The top of the trap had a width of 10 feet and a length of 16 feet. The NDOT – Drainage Design and Erosion Control Manual “Chapter Two: Erosion and Sediment Control” was followed for trap specifications. The standard installation was utilized as the control test.

Sediment Capture Efficiency

Capture of Introduced Sediment:	74.2 %
Improved Capture from Control:	N/A

Hydraulic Performance

Max Impoundment Depth (in.):	0	Impoundment Depth Ratio:	N/A
Impoundment Length (ft):	0	Impoundment Length Ratio:	N/A
Dewatering Time (min):	0	<i>Note: ratios based on theoretical impoundment</i>	







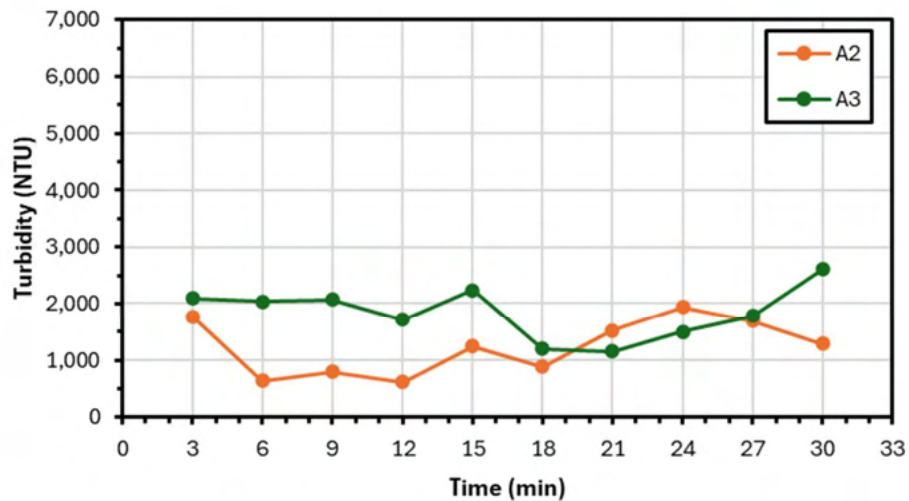
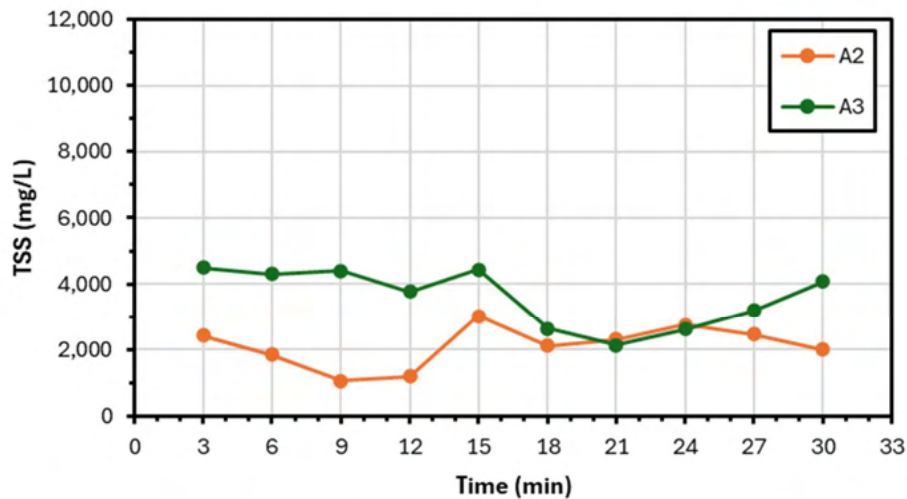
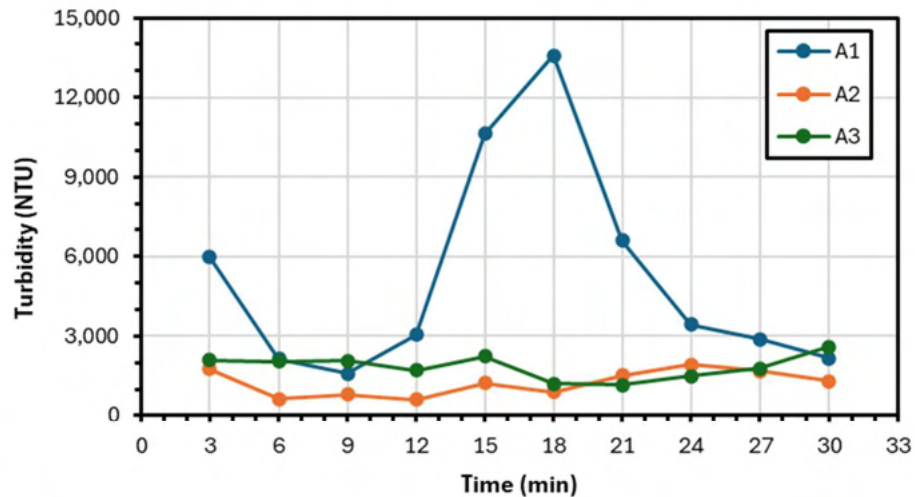
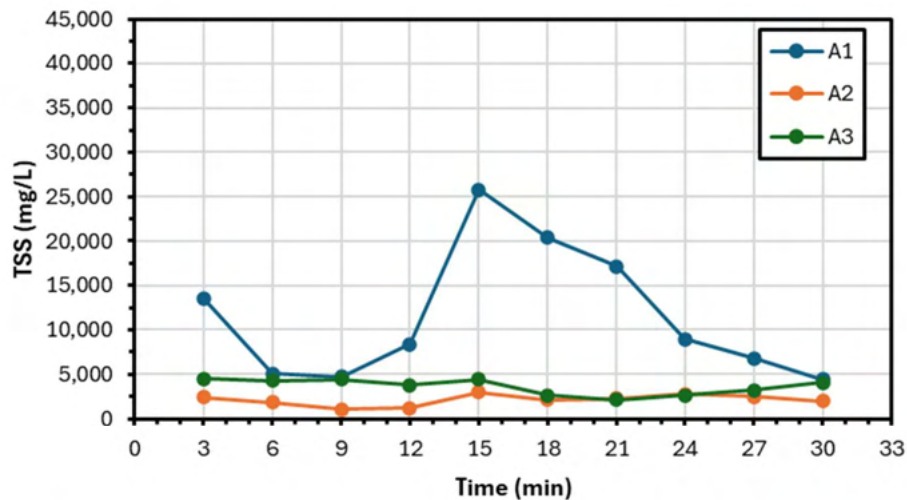

Water Quality Data Statistics





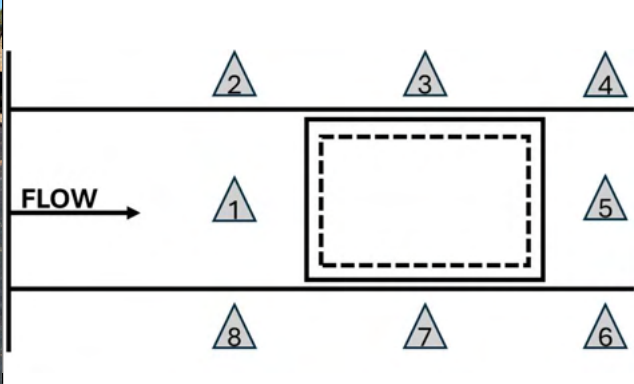

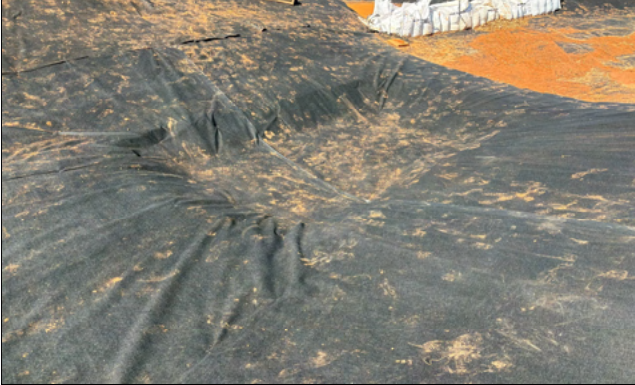

Measurement Location	Avg		Min		Max		Std. Dev.	
	NTU	TSS (mg/L)	NTU	TSS (mg/L)	NTU	TSS (mg/L)	NTU	TSS (mg/L)
Inflow	5,206	11,531	1,600	4,450	13,575	25,810	3,832	7,037
Trap	1,236	2,115	611	1,060	1,931	3,010	461	592
Downstream	1,839	3,603	1,157	2,130	2,602	4,500	438	844

TSS (mg/L) and Turbidity (NTU) Data Plots

Legend Interpretation: The letter (A, B, C, D) corresponds to the Test ID to indicate which test in the series. The number (1, 2, 3) corresponds to the data collection location with 1 indicating the inflow collection point, 2 indicating the “in-trap” collection point, and 3 indicating the downstream or discharge collection point.

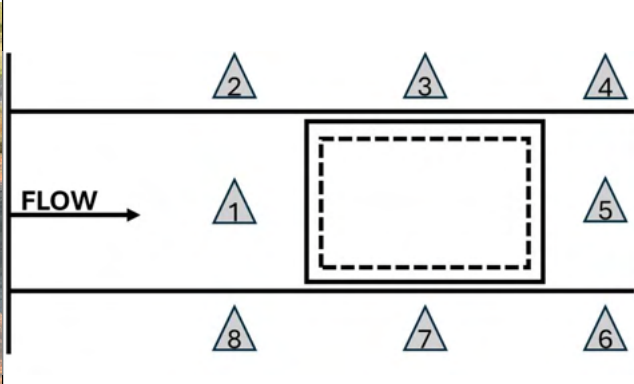

Test ID	Photo Documentation	Installation
A	Pre-Test	Standard Silt Trap
		
Location 2	Location 3	Location 4
		
Location 1		Location 5
		
Location 8	Location 7	Location 6

Test ID	Photo Documentation	Installation
A	Post-Test	Standard Silt Trap
		
Location 2	Location 3	Location 4
		
Location 1		Location 5
		
Location 8	Location 7	Location 6

SILT TRAP TEST LOG

Test Summary

Installation:	Standard/Control
Test ID:	B
Date:	11/25/2024
Type:	Longevity
Flow Rate (cfs):	0.5
Sediment Load Rate (lb/min):	36.6

Picture of Installation



Note: pictured on upstream side facing downstream in channel

Installation Description & Test Notes: The standard Nebraska installation is the silt trap in conjunction with no other installation upstream or downstream. The trap is 1 foot deep with 2:1 horizontal to vertical side slopes. The bottom of the trap had a width of 6 feet and a length of 12 feet. The top of the trap had a width of 10 feet and a length of 16 feet. The NDOT – Drainage Design and Erosion Control Manual “Chapter Two: Erosion and Sediment Control” was followed for trap specifications. The standard installation was utilized as the control test.

Sediment Capture Efficiency

Capture of Introduced Sediment:	74.2 %
Improved Capture from Control:	N/A

Hydraulic Performance

Max Impoundment Depth (in.):	0	Impoundment Depth Ratio:	N/A
Impoundment Length (ft):	0	Impoundment Length Ratio:	N/A
Dewatering Time (min):	0	<i>Note: ratios based on theoretical impoundment</i>	







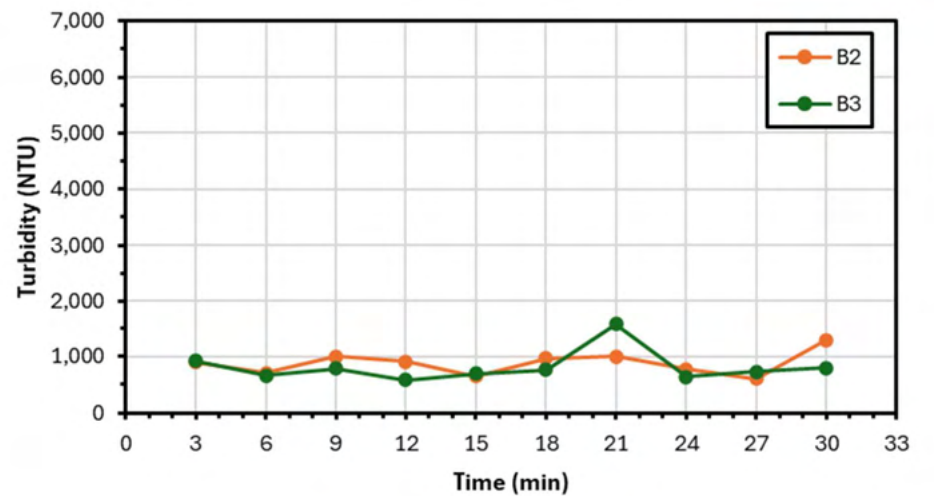
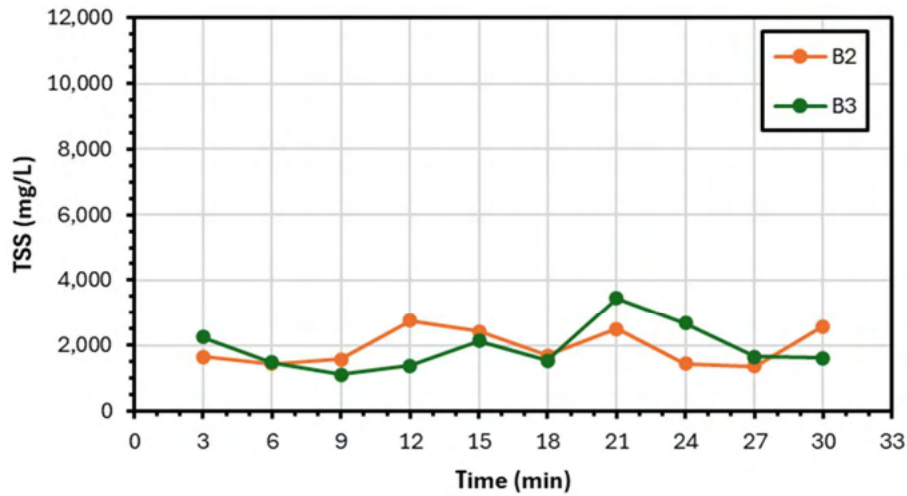
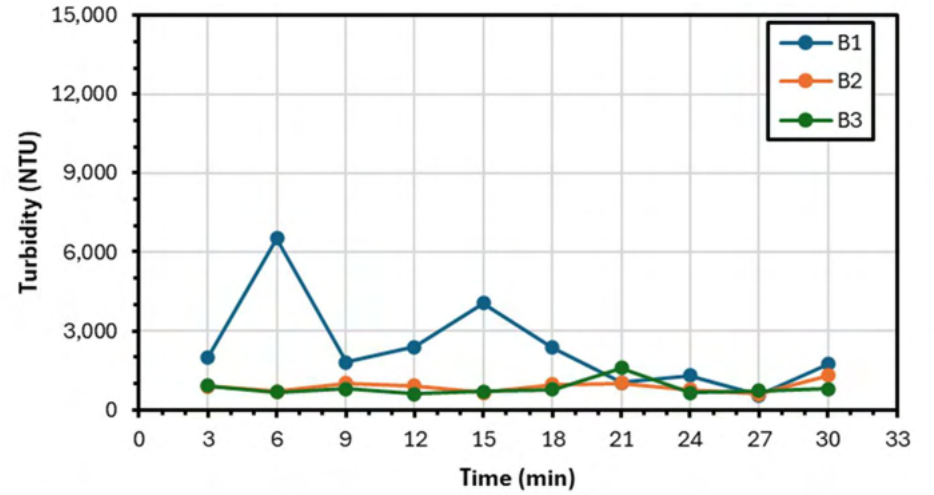
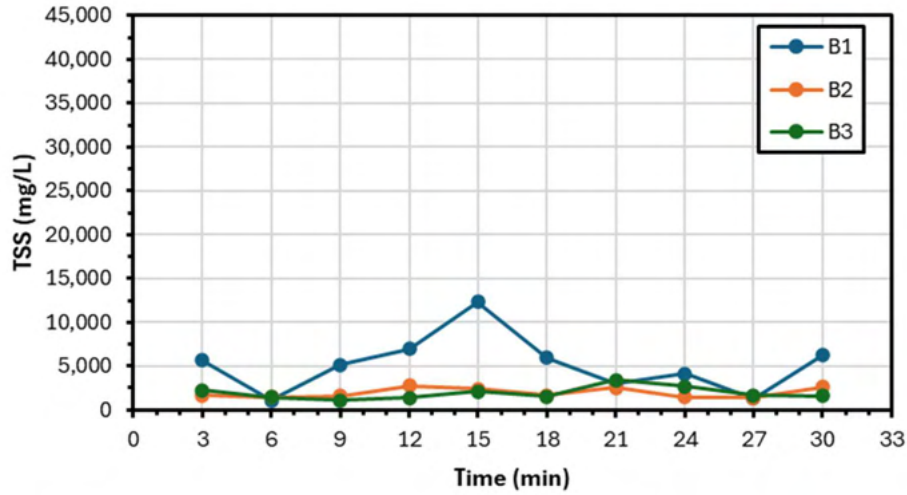

Water Quality Data Statistics





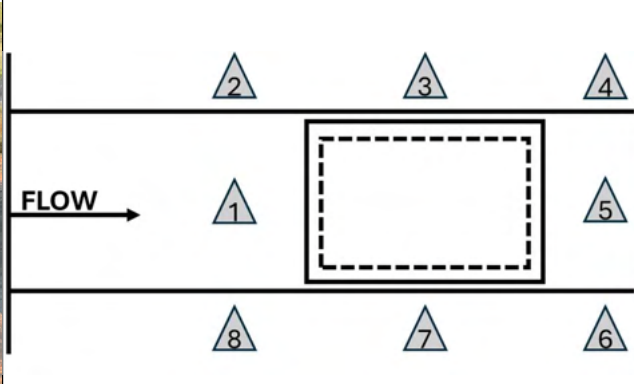



Measurement Location	Avg		Min		Max		Std. Dev.	
	NTU	TSS (mg/L)	NTU	TSS (mg/L)	NTU	TSS (mg/L)	NTU	TSS (mg/L)
Inflow	2,374	5,188	539	1,110	6,515	12,320	1,648	3,052
Trap	881	1,938	607	1,350	1,295	2,750	195	524
Downstream	815	1,923	588	1,100	1,578	3,440	269	672

TSS (mg/L) and Turbidity (NTU) Data Plots

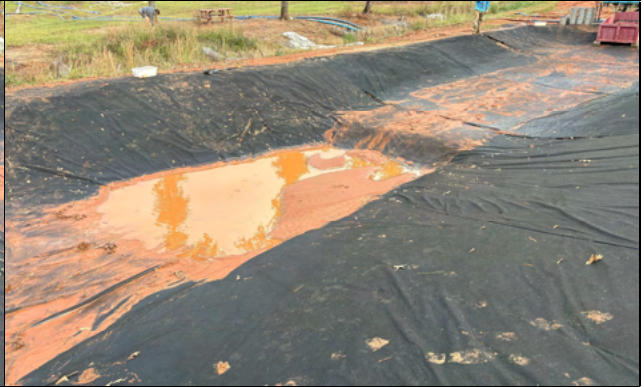
Legend Interpretation: The letter (A, B, C, D) corresponds to the Test ID to indicate which test in the series. The number (1, 2, 3) corresponds to the data collection location with 1 indicating the inflow collection point, 2 indicating the "in-trap" collection point, and 3 indicating the downstream or discharge collection point.

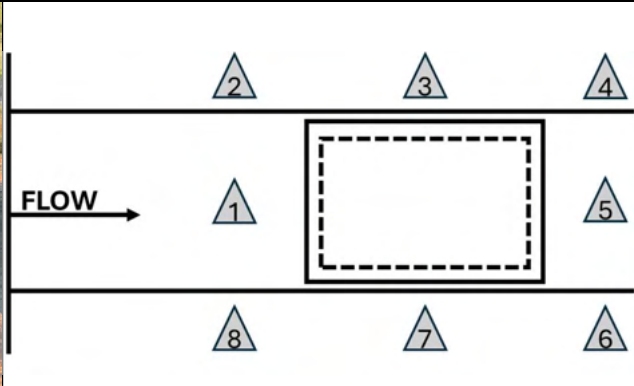

Test ID	Photo Documentation	Installation
B	Pre-Test	Standard Silt Trap
		
Location 2	Location 3	Location 4
		
Location 1		Location 5
		
Location 8	Location 7	Location 6

Test ID	Photo Documentation	Installation
B	Post-Test	Standard Silt Trap
		
Location 2	Location 3	Location 4
		
Location 1		Location 5
		
Location 8	Location 7	Location 6

SILT TRAP TEST LOG

Test Summary

Installation:	Standard/Control
Test ID:	C
Date:	11/26/2024
Type:	Longevity
Flow Rate (cfs):	0.5
Sediment Load Rate (lb/min):	36.6

Picture of Installation



Note: pictured on upstream side facing downstream in channel

Installation Description & Test Notes: The standard Nebraska installation is the silt trap in conjunction with no other installation upstream or downstream. The trap is 1 foot deep with 2:1 horizontal to vertical side slopes. The bottom of the trap had a width of 6 feet and a length of 12 feet. The top of the trap had a width of 10 feet and a length of 16 feet. The NDOT – Drainage Design and Erosion Control Manual “Chapter Two: Erosion and Sediment Control” was followed for trap specifications. The standard installation was utilized as the control test.

Sediment Capture Efficiency

Capture of Introduced Sediment:	74.2 %
Improved Capture from Control:	N/A

Hydraulic Performance

Max Impoundment Depth (in.):	0	Impoundment Depth Ratio:	N/A
Impoundment Length (ft):	0	Impoundment Length Ratio:	N/A
Dewatering Time (min):	0	<i>Note: ratios based on theoretical impoundment</i>	







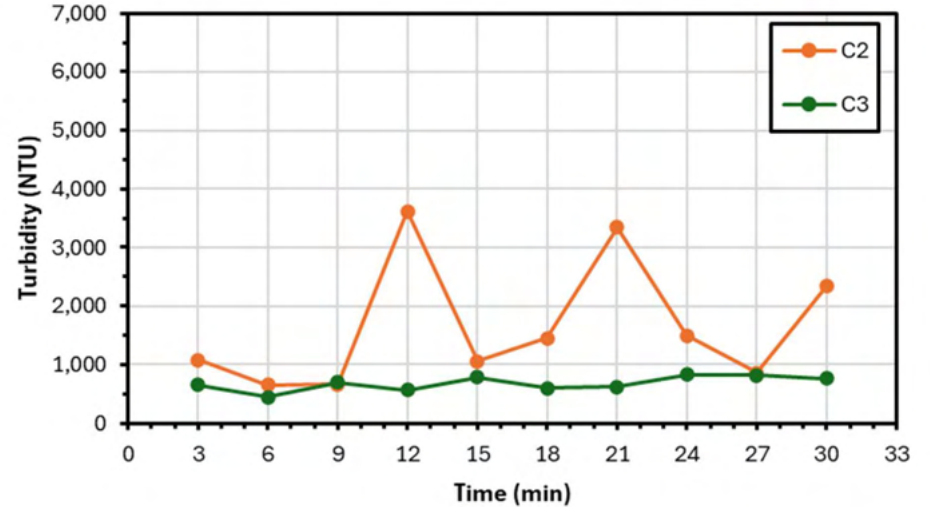
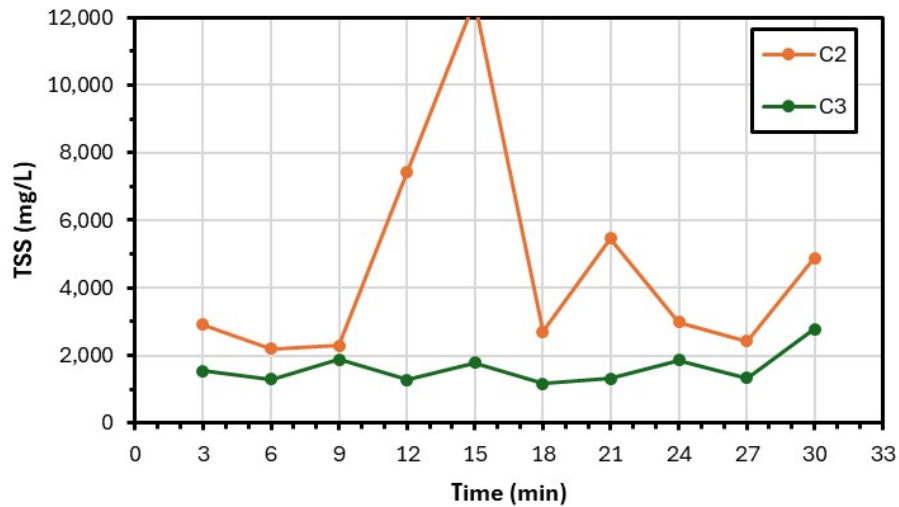
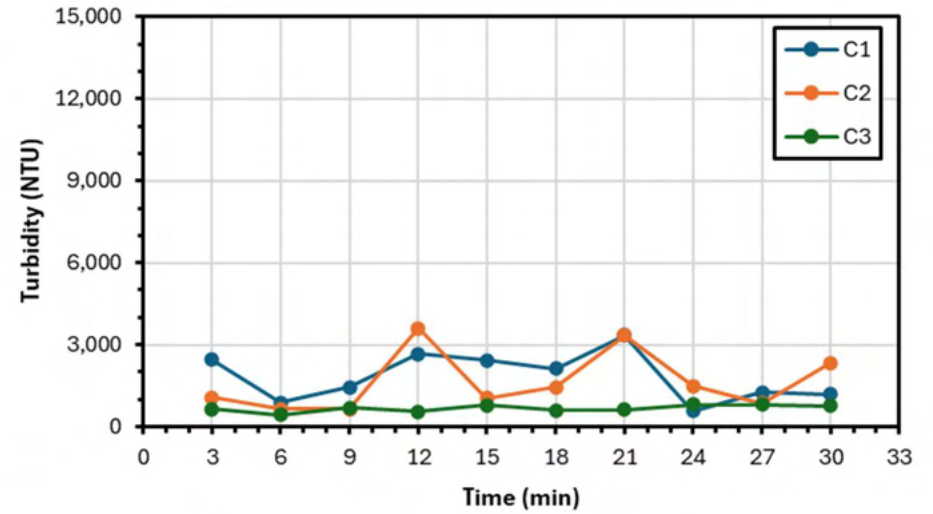
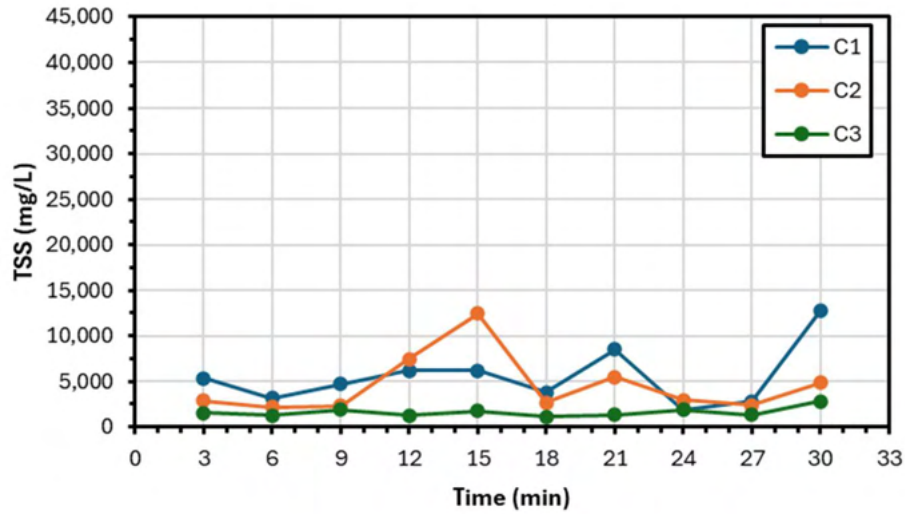

Water Quality Data Statistics





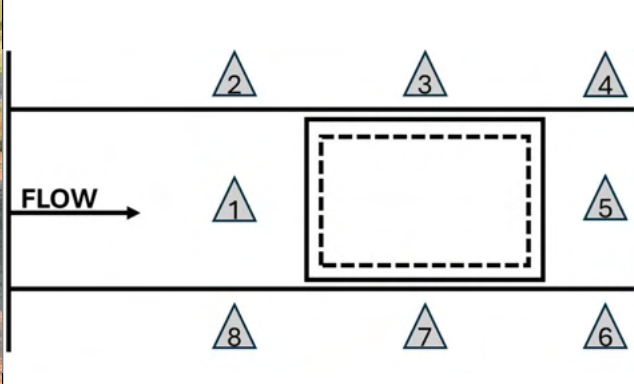



Measurement Location	Avg		Min		Max		Std. Dev.	
	NTU	TSS (mg/L)	NTU	TSS (mg/L)	NTU	TSS (mg/L)	NTU	TSS (mg/L)
Inflow	1,841	5,548	576	1,916	3,354	12,745	850	3,023
Trap	1,655	4,578	656	2,200	3,616	12,460	1,027	3,091
Downstream	677	1,627	443	1,160	824	2,790	118	461

TSS (mg/L) and Turbidity (NTU) Data Plots

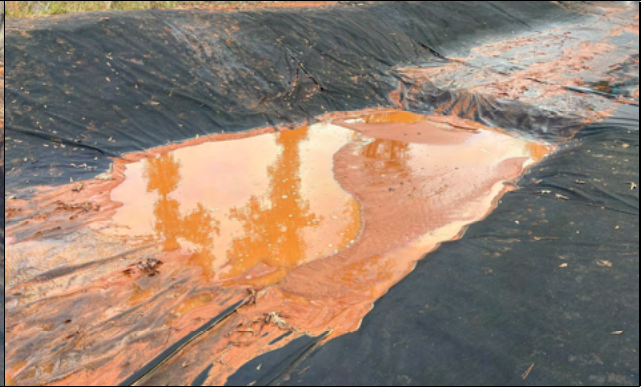
Legend Interpretation: The letter (A, B, C, D) corresponds to the Test ID to indicate which test in the series. The number (1, 2, 3) corresponds to the data collection location with 1 indicating the inflow collection point, 2 indicating the "in-trap" collection point, and 3 indicating the downstream or discharge collection point.

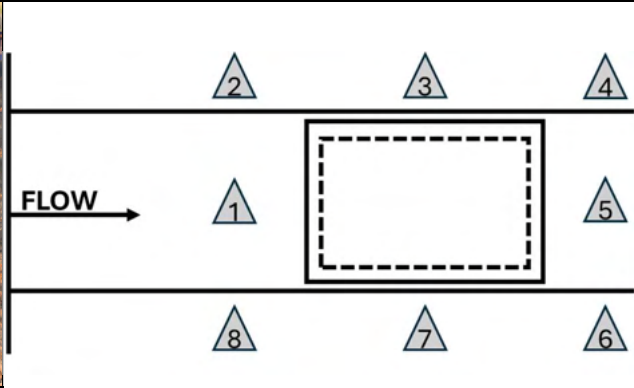

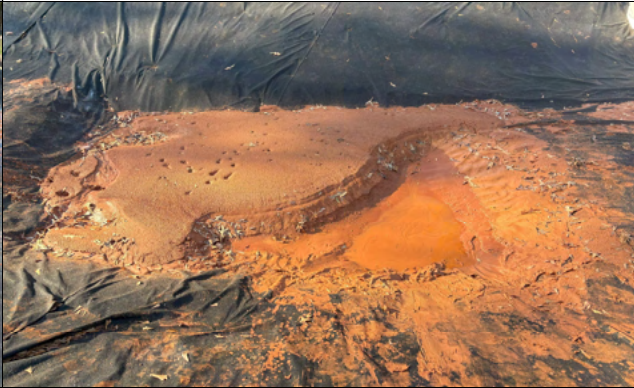
Test ID	Photo Documentation	Installation
C	Pre-Test	Standard Silt Trap
		
Location 2	Location 3	Location 4
		
Location 1		Location 5
		
Location 8	Location 7	Location 6

Test ID	Photo Documentation	Installation
C	Post-Test	Standard Silt Trap
		
Location 2	Location 3	Location 4
		
Location 1	Location 5	Location 5
		
Location 8	Location 7	Location 6

SILT TRAP TEST LOG

Test Summary

Installation:	Temporary Erosion Check
Test ID:	A
Date:	6/2/2025
Type:	Longevity
Flow Rate (cfs):	0.5
Sediment Load Rate (lb/min):	36.6

Picture of Installation



Note: pictured on upstream side facing downstream in channel

Installation Description & Test Notes: The silt trap was paired with a temporary erosion check. The check was placed two feet downstream of the trap. The 12 in. excelsior wattle was chosen because it was an approved product for high flow and low flow situations. The installation technique was followed according to literature indicating enhanced performance. The installation procedure used a non-destructive teepee wood stake pattern with sod staples to ensure ground contact, no trenching, and overlapping where the two wattles met in the center of the channel. No overtopping occurred. There was impoundment depth measured; however, the impoundment length was not distinguishable from the silt trap pool itself.

Sediment Capture Efficiency

Capture of Introduced Sediment:	83.8 %
Improved Capture from Control:	9.6 %

Hydraulic Performance

Max Impoundment Depth (in.):	5.0	Impoundment Depth Ratio:	0.42
Impoundment Length (ft):	N/A	Impoundment Length Ratio:	N/A
Dewatering Time (min):	7.0	<i>Note: ratios based on theoretical impoundment</i>	







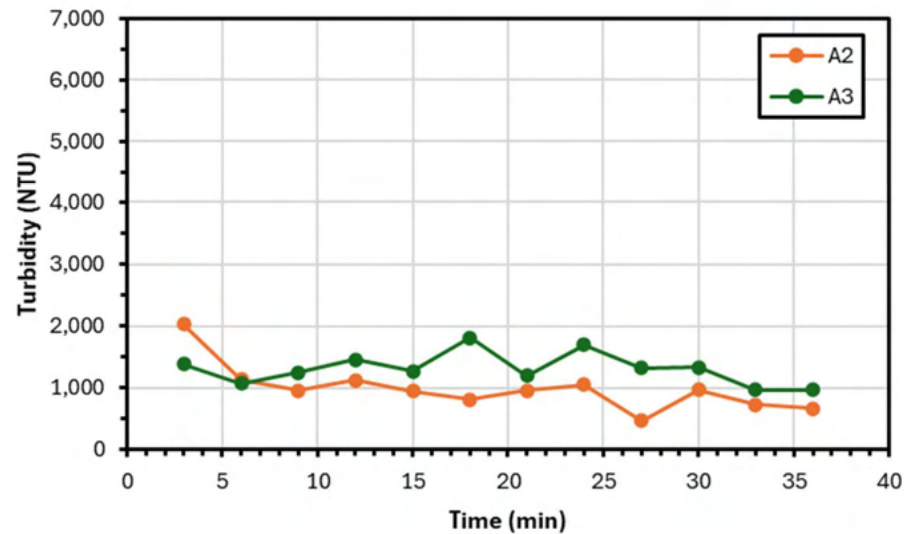
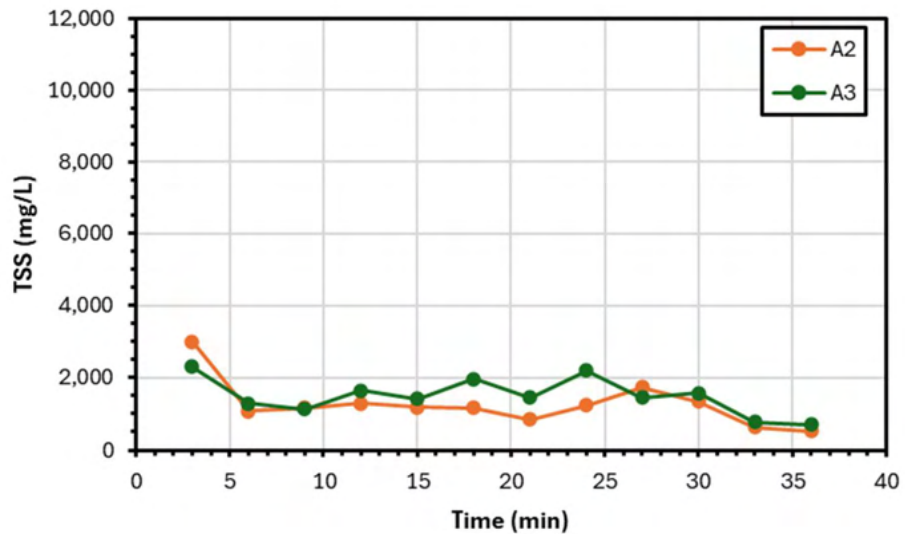
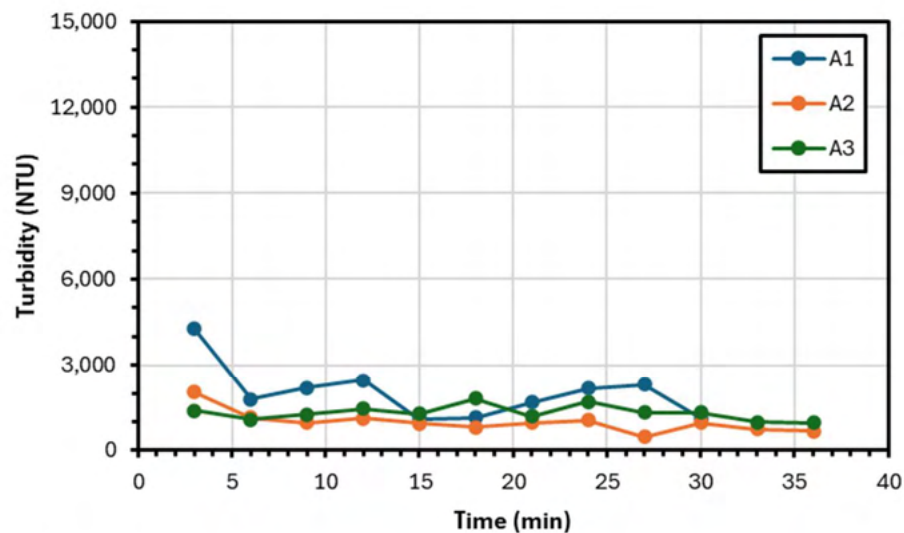
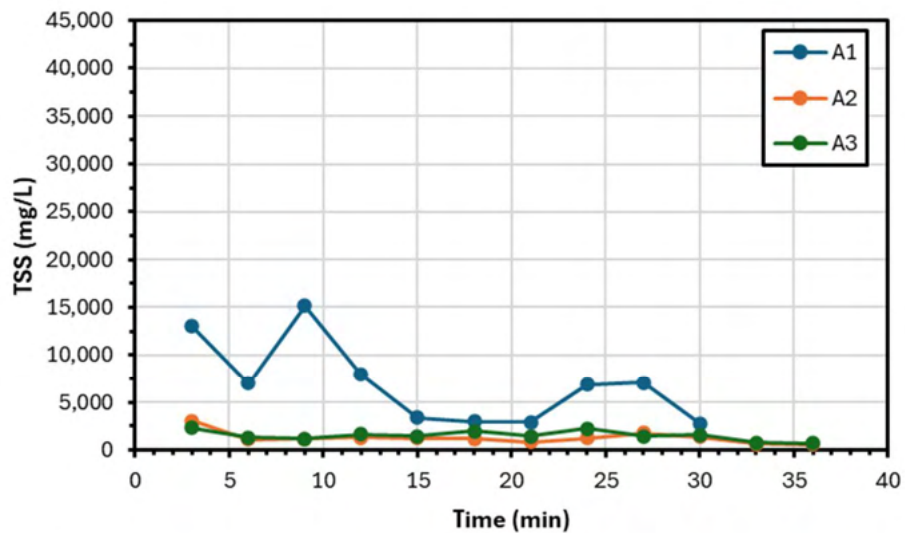

Water Quality Data Statistics





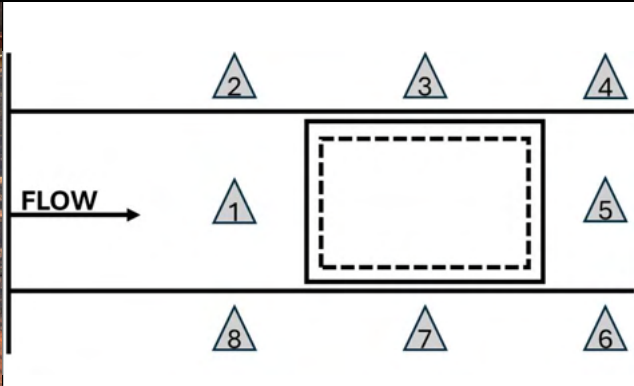



Measurement Location	Avg		Min		Max		Std. Dev.	
	NTU	TSS (mg/L)	NTU	TSS (mg/L)	NTU	TSS (mg/L)	NTU	TSS (mg/L)
Inflow	2,019	6,904	1,099	2,750	4,271	15,180	893	4096
Trap	986	1,267	465	530	2,026	3,000	365	606
Downstream	1,310	1,494	964	700	1,807	2,310	247	478

TSS (mg/L) and Turbidity (NTU) Data Plots

Legend Interpretation: The letter (A, B, C, D) corresponds to the Test ID to indicate which test in the series. The number (1, 2, 3) corresponds to the data collection location with 1 indicating the inflow collection point, 2 indicating the “in-trap” collection point, and 3 indicating the downstream or discharge collection point.

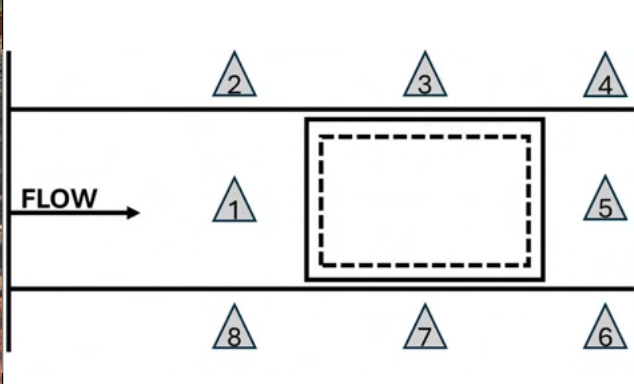

Test ID	Photo Documentation	Installation
<p style="text-align: center;">A</p> 	<p style="text-align: center;">Pre-Test</p> 	<p style="text-align: center;">Temporary Erosion Check</p> 
<p style="text-align: center;">Location 2</p>	<p style="text-align: center;">Location 3</p>	<p style="text-align: center;">Location 4</p>
		
<p style="text-align: center;">Location 1</p>		<p style="text-align: center;">Location 5</p>
		
<p style="text-align: center;">Location 8</p>	<p style="text-align: center;">Location 7</p>	<p style="text-align: center;">Location 6</p>

Test ID	Photo Documentation	Installation
A	Post-Test	Temporary Erosion Check
		
Location 2	Location 3	Location 4
		
Location 1		Location 5
		
Location 8	Location 7	Location 6

SILT TRAP TEST LOG

Test Summary

Installation:	Temporary Erosion Check
Test ID:	B
Date:	6/3/2025
Type:	Longevity
Flow Rate (cfs):	0.5
Sediment Load Rate (lb/min):	36.6

Picture of Installation



Note: pictured on upstream side facing downstream in channel

Installation Description & Test Notes: The silt trap was paired with a temporary erosion check. The check was placed two feet downstream of the trap. The 12 in. excelsior wattle was chosen because it was an approved product for high flow and low flow situations. The installation technique was followed according to literature indicating enhanced performance. The installation procedure used a non-destructive teepee wood stake pattern with sod staples to ensure ground contact, no trenching, and overlapping where the two wattles met in the center of the channel. No overtopping occurred. There was impoundment depth measured; however, the impoundment length was not distinguishable from the silt trap pool itself.

Sediment Capture Efficiency

Capture of Introduced Sediment:	83.8 %
Improved Capture from Control:	9.6 %

Hydraulic Performance

Max Impoundment Depth (in.):	7.0	Impoundment Depth Ratio:	0.58
Impoundment Length (ft):	N/A	Impoundment Length Ratio:	N/A
Dewatering Time (min):	8.0	<i>Note: ratios based on theoretical impoundment</i>	







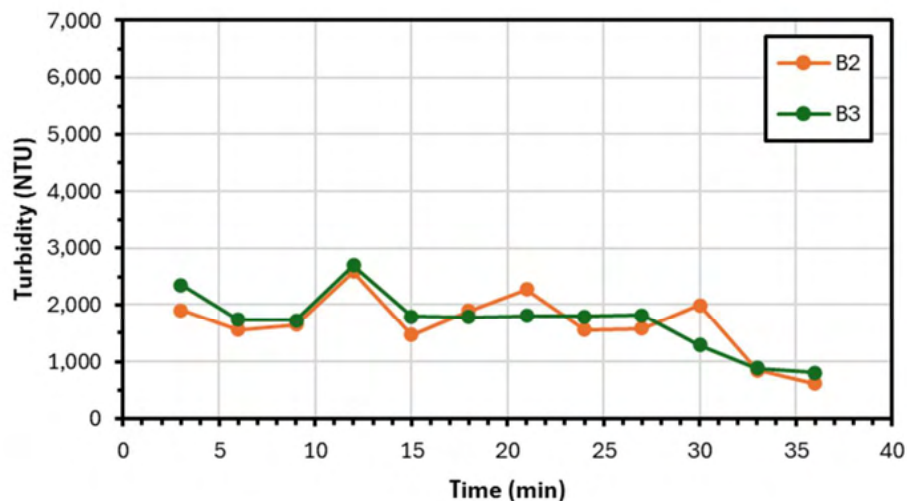
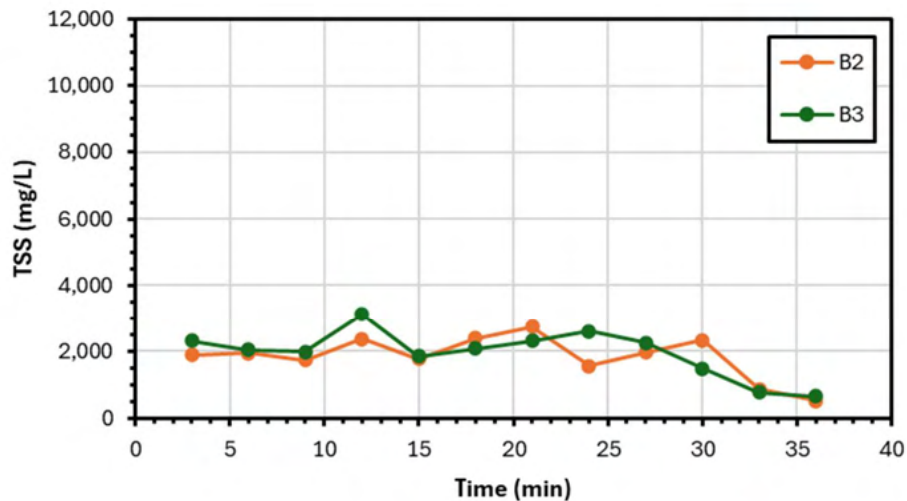
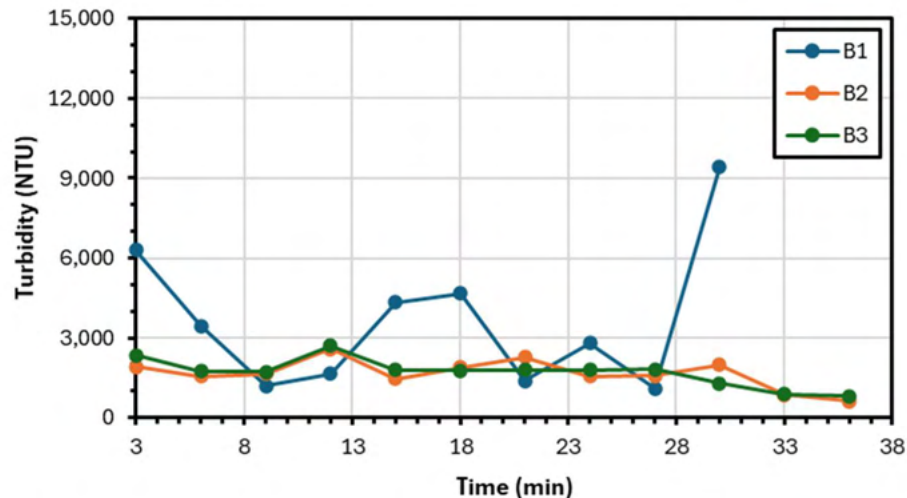
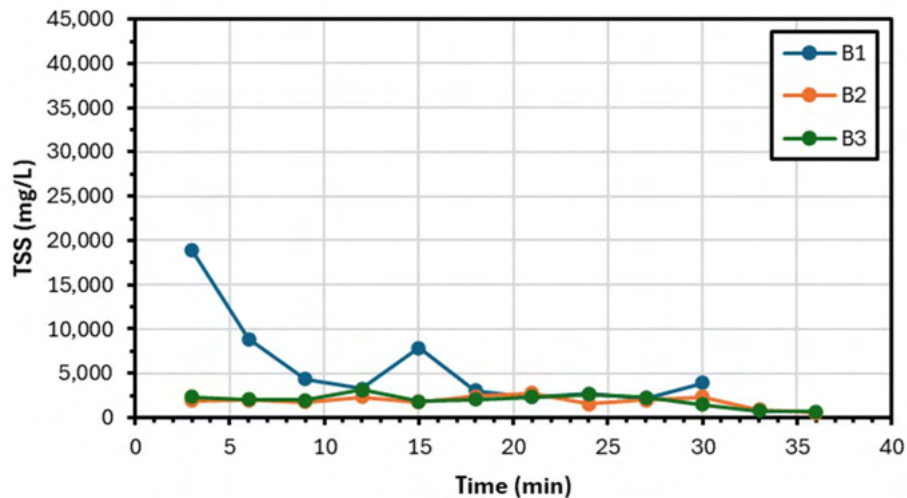

Water Quality Data Statistics





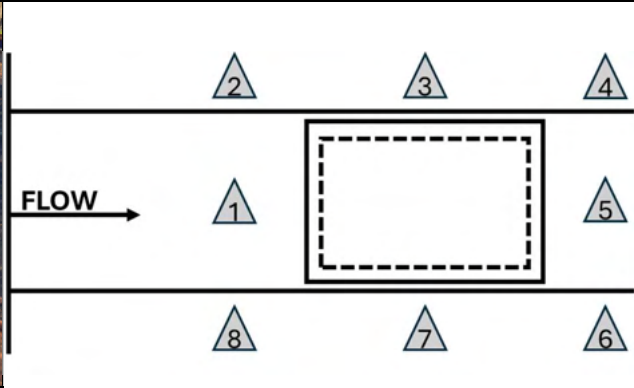



Measurement Location	Avg		Min		Max		Std. Dev.	
	NTU	TSS (mg/L)	NTU	TSS (mg/L)	NTU	TSS (mg/L)	NTU	TSS (mg/L)
Inflow	3,631	5,743	1,093	2,190	9,409	18,870	2,532	4,883
Trap	1,661	1,843	616	530	2,587	2,740	521	606
Downstream	1,706	1,956	803	660	2,696	3,110	507	673

TSS (mg/L) and Turbidity (NTU) Data Plots

Legend Interpretation: The letter (A, B, C, D) corresponds to the Test ID to indicate which test in the series. The number (1, 2, 3) corresponds to the data collection location with 1 indicating the inflow collection point, 2 indicating the “in-trap” collection point, and 3 indicating the downstream or discharge collection point.

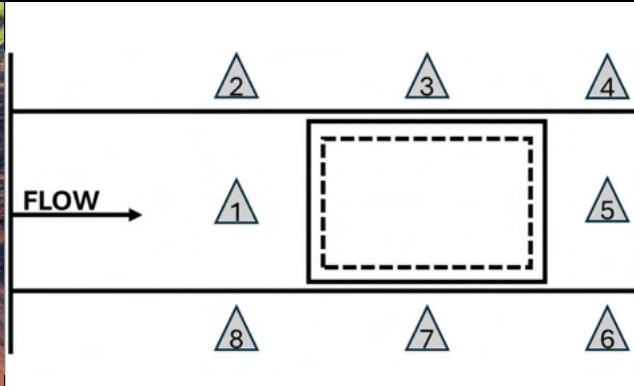

Test ID	Photo Documentation	Installation
B	Pre-Test	Temporary Erosion Check
		
Location 2	Location 3	Location 4
		
Location 1		Location 5
		
Location 8	Location 7	Location 6

Test ID	Photo Documentation	Installation
B	Post-Test	Temporary Erosion Check
		
Location 2	Location 3	Location 4
		
Location 1		Location 5
		
Location 8	Location 7	Location 6

SILT TRAP TEST LOG

Test Summary

Installation:	Temporary Erosion Check
Test ID:	C
Date:	6/3/2025
Type:	Longevity
Flow Rate (cfs):	0.5
Sediment Load Rate (lb/min):	36.6

Picture of Installation



Note: pictured on upstream side facing downstream in channel

Installation Description & Test Notes: The silt trap was paired with a temporary erosion check. The check was placed two feet downstream of the trap. The 12 in. excelsior wattle was chosen because it was an approved product for high flow and low flow situations. The installation technique was followed according to literature indicating enhanced performance. The installation procedure used a non-destructive teepee wood stake pattern with sod staples to ensure ground contact, no trenching, and overlapping where the two wattles met in the center of the channel. No overtopping occurred. There was impoundment depth measured; however, the impoundment length was not distinguishable from the silt trap pool itself.

Sediment Capture Efficiency

Capture of Introduced Sediment:	83.8 %
Improved Capture from Control:	9.6 %

Hydraulic Performance

Max Impoundment Depth (ft):	9.0	Impoundment Depth Ratio:	0.75
Impoundment Length (ft):	N/A	Impoundment Length Ratio:	N/A
Dewatering Time (min):	9.0	<i>Note: ratios based on theoretical impoundment</i>	







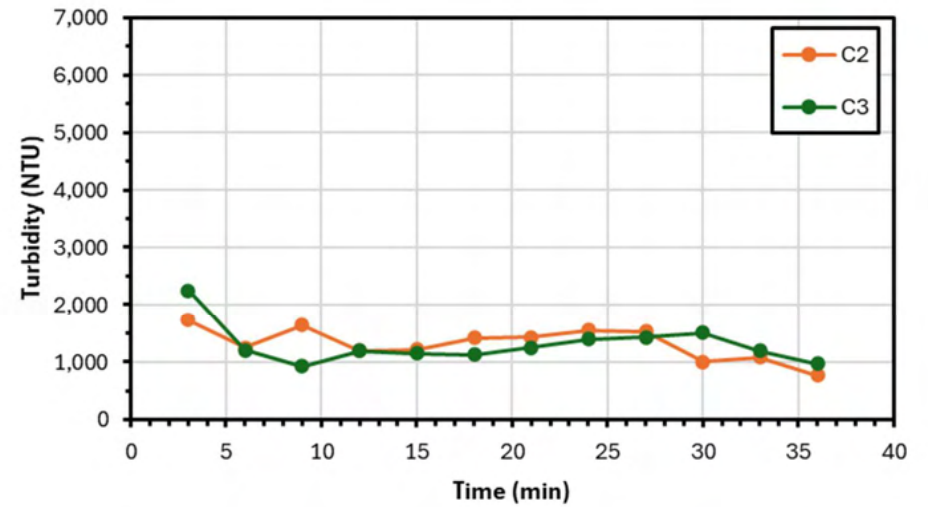
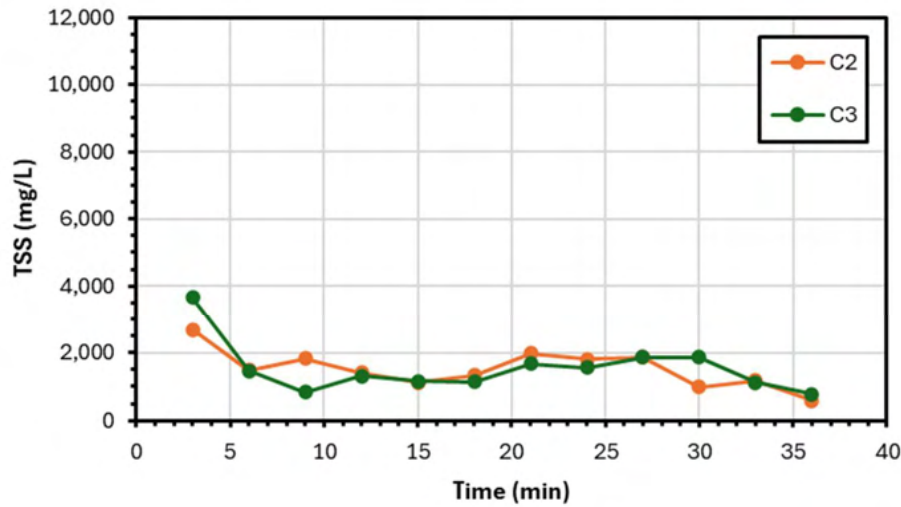
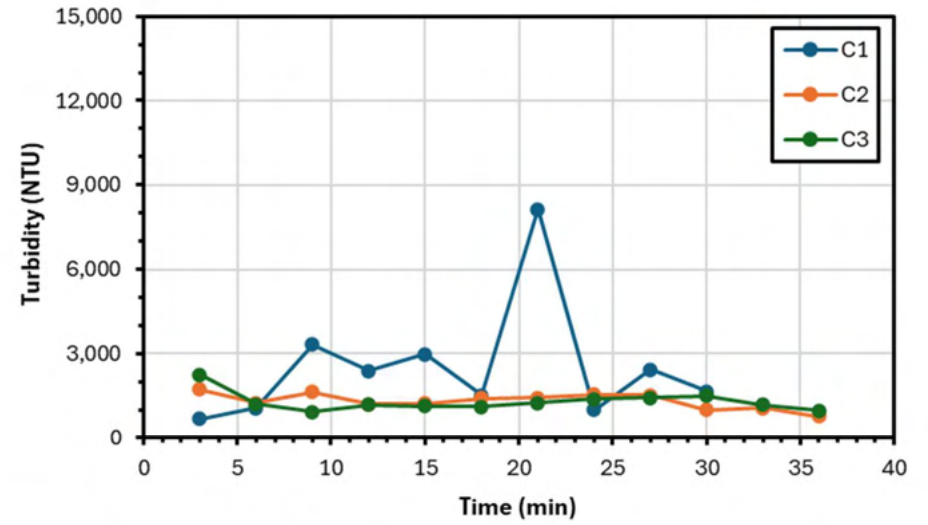
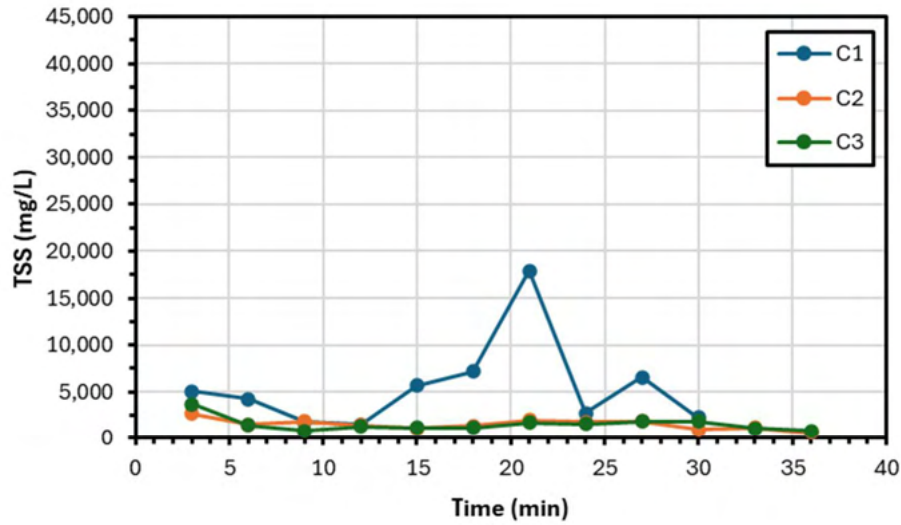

Water Quality Data Statistics





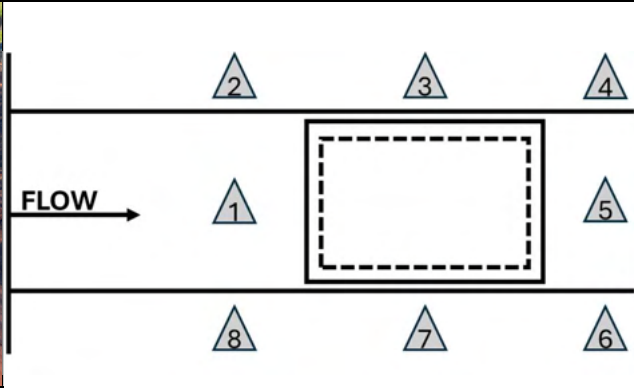



Measurement Location	Avg		Min		Max		Std. Dev.	
	NTU	TSS (mg/L)	NTU	TSS (mg/L)	NTU	TSS (mg/L)	NTU	TSS (mg/L)
Inflow	2,520	5,488	675	1,530	8,144	17,890	2,052	4,553
Trap	1,317	1,518	772	590	1,727	2,680	269	527
Downstream	1,299	1,534	927	780	2,254	3,660	331	728

TSS (mg/L) and Turbidity (NTU) Data Plots

Legend Interpretation: The letter (A, B, C, D) corresponds to the Test ID to indicate which test in the series. The number (1, 2, 3) corresponds to the data collection location with 1 indicating the inflow collection point, 2 indicating the "in-trap" collection point, and 3 indicating the downstream or discharge collection point.

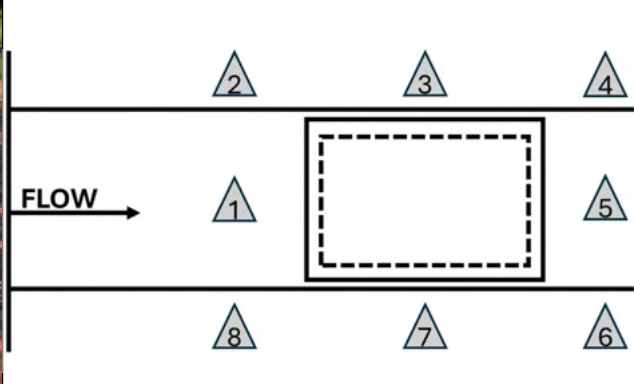

Test ID	Photo Documentation	Installation
C	Pre-Test	Temporary Erosion Check
		
Location 2	Location 3	Location 4
		
Location 1		Location 5
		
Location 8	Location 7	Location 6

Test ID	Photo Documentation	Installation
C	Post-Test	Temporary Erosion Check
		
Location 2	Location 3	Location 4
		
Location 1		Location 5
		
Location 8	Location 7	Location 6

SILT TRAP TEST LOG

Test Summary

Installation:	High Porosity Silt Fence
Test ID:	A
Date:	1/29/2025
Type:	Longevity
Flow Rate (cfs):	0.5
Sediment Load Rate (lb/min):	36.6

Picture of Installation



Note: pictured on upstream side facing downstream in channel

Installation Description & Test Notes: The silt trap was paired with a high porosity silt fence. The fence was placed two feet downstream of the trap. The high porosity silt fence was chosen because it was an approved product for high flow situations; however, it has since been phased out of practice and removed from the NDOT approved products list. The installation followed the NDOT standard installation procedure and materials. No overtopping occurred. There was impoundment depth measured; however, the impoundment length was not distinguishable from the silt trap pool itself.

Sediment Capture Efficiency

Capture of Introduced Sediment:	77.8 %
Improved Capture from Control:	3.6 %

Hydraulic Performance

Max Impoundment Depth (in.):	8.0	Impoundment Depth Ratio:	0.22.
Impoundment Length (ft):	N/A	Impoundment Length Ratio:	N/A
Dewatering Time (min):	20.0	<i>Note: ratios based on theoretical impoundment</i>	







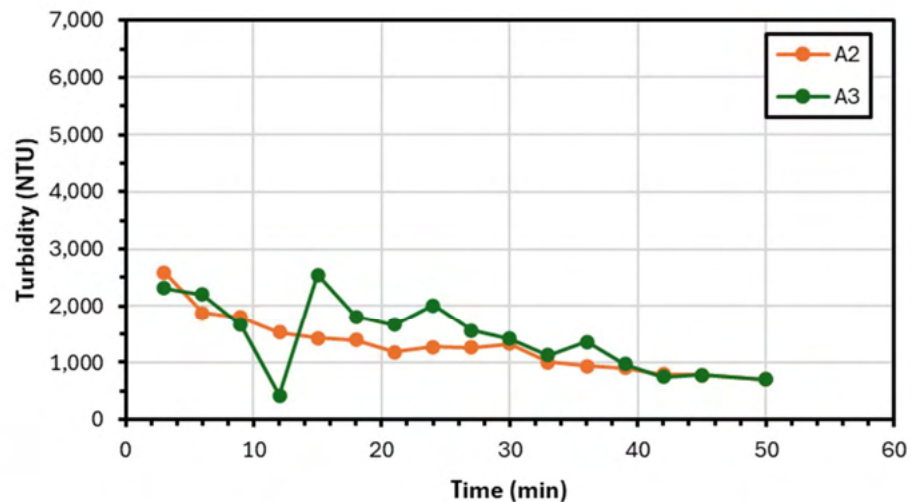
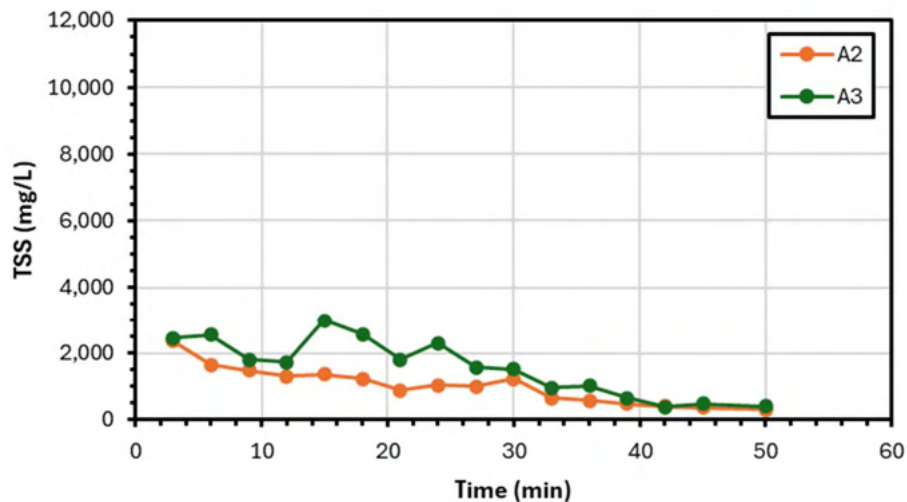
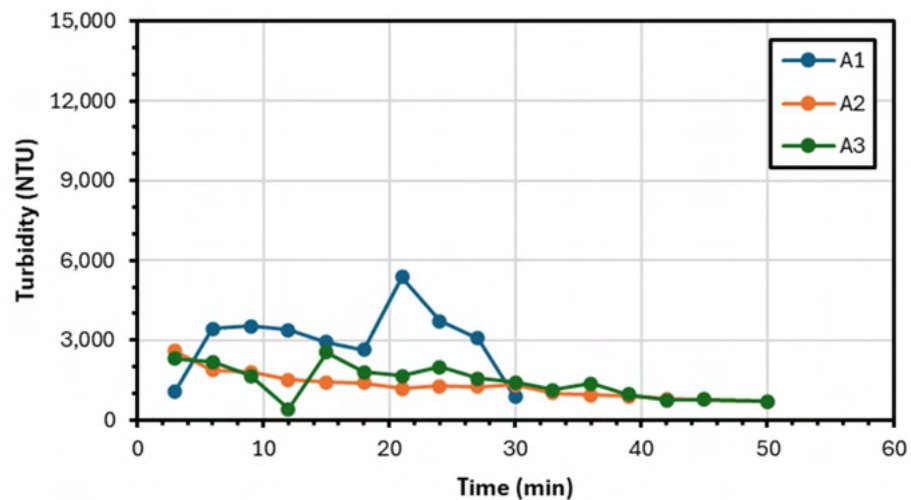
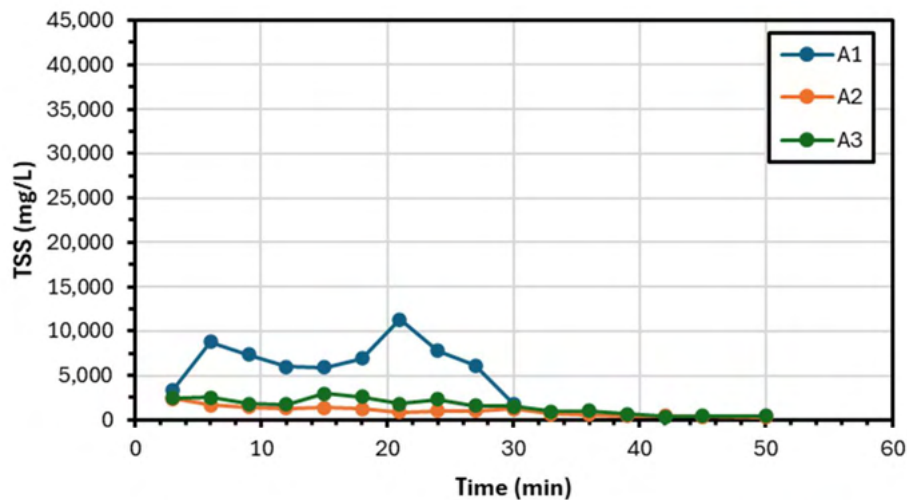

Water Quality Data Statistics



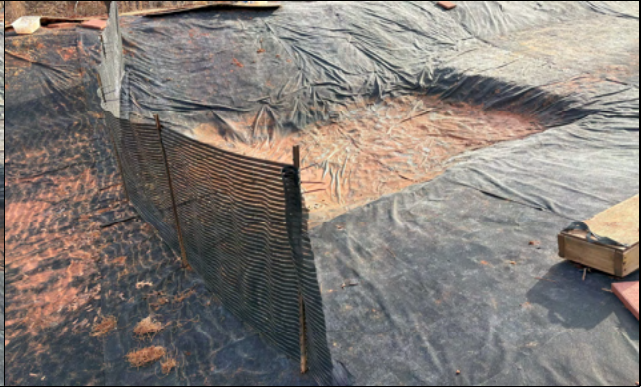

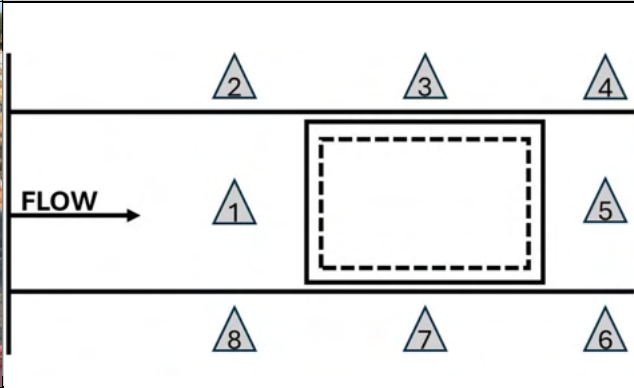



Measurement Location	Avg		Min		Max		Std. Dev.	
	NTU	TSS (mg/L)	NTU	TSS (mg/L)	NTU	TSS (mg/L)	NTU	TSS (mg/L)
Inflow	3,004	6,530	866	1,800	5,377	11,290	1,230	2,517
Trap	1,299	1,019	699	310	2,592	2,360	475	539
Downstream	1,457	1,578	422	390	2,551	2,990	610	825

TSS (mg/L) and Turbidity (NTU) Data Plots

Legend Interpretation: The letter (A, B, C, D) corresponds to the Test ID to indicate which test in the series. The number (1, 2, 3) corresponds to the data collection location with 1 indicating the inflow collection point, 2 indicating the "in-trap" collection point, and 3 indicating the downstream or discharge collection point.

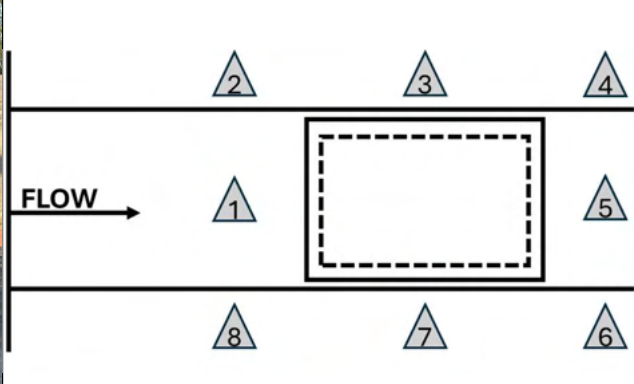

Test ID	Photo Documentation	Installation
A	Pre-Test	High Porosity Silt Fence
		
Location 2	Location 3	Location 4
		
Location 1		Location 5
		
Location 8	Location 7	Location 6

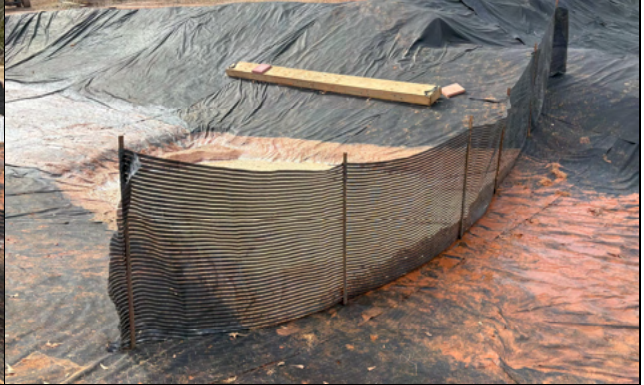
Test ID	Photo Documentation	Installation
A	Post-Test	High Porosity Silt Fence
		
Location 2	Location 3	Location 4
		
Location 1		Location 5
		
Location 8	Location 7	Location 6

SILT TRAP TEST LOG

Test Summary

Installation:	High Porosity Silt Fence
Test ID:	B
Date:	1/29/2025
Type:	Longevity
Flow Rate (cfs):	0.5
Sediment Load Rate (lb/min):	36.6

Picture of Installation



Note: pictured on upstream side facing downstream in channel

Installation Description & Test Notes: The silt trap was paired with a high porosity silt fence. The fence was placed two feet downstream of the trap. The high porosity silt fence was chosen because it was an approved product for high flow situations; however, it has since been phased out of practice and removed from the NDOT approved products list. The installation followed the NDOT standard installation procedure and materials. No overtopping occurred. There was impoundment depth measured; however, the impoundment length was not distinguishable from the silt trap pool itself. The fence blinded causing longer dewatering time.

Sediment Capture Efficiency

Capture of Introduced Sediment:	77.8 %
Improved Capture from Control:	3.6 %

Hydraulic Performance

Max Impoundment Depth (in.):	9.25	Impoundment Depth Ratio:	0.26
Impoundment Length (ft):	N/A	Impoundment Length Ratio:	N/A
Dewatering Time (min):	60.0	<i>Note: ratios based on theoretical impoundment</i>	







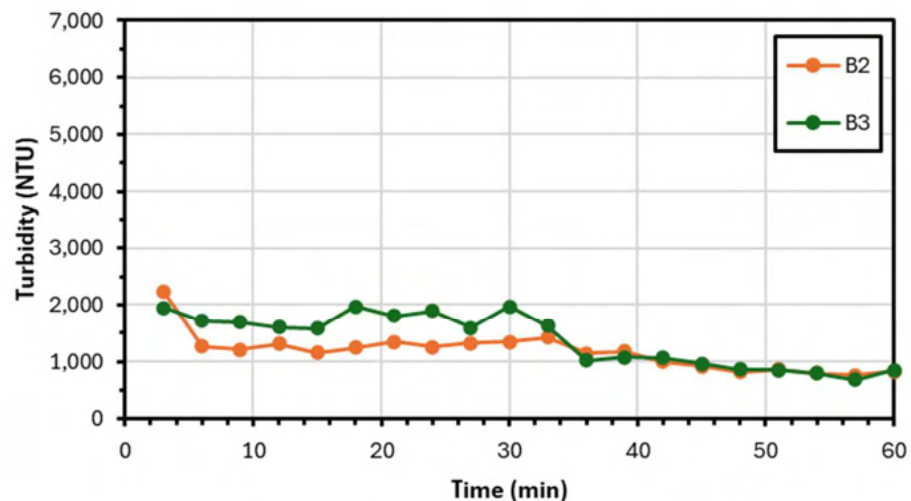
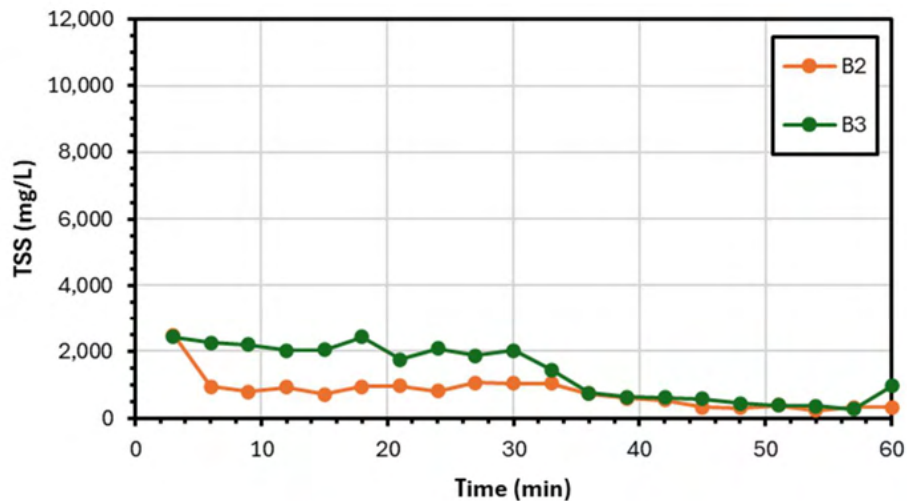
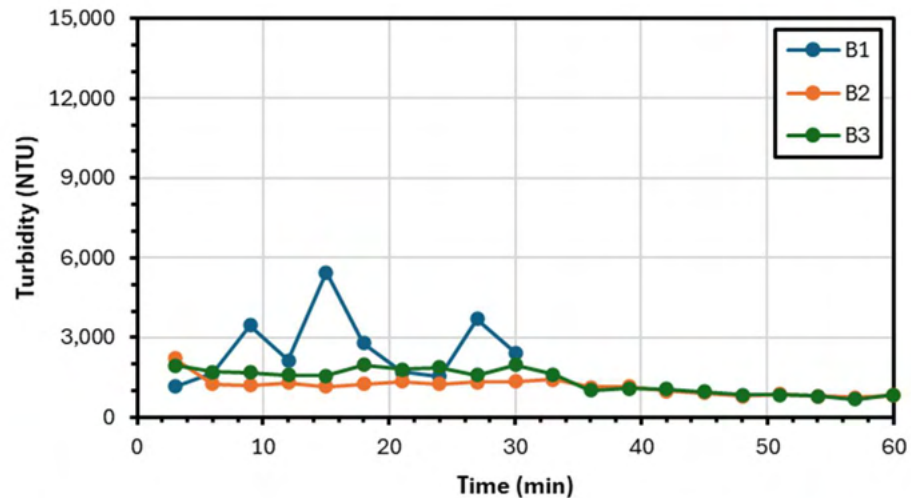
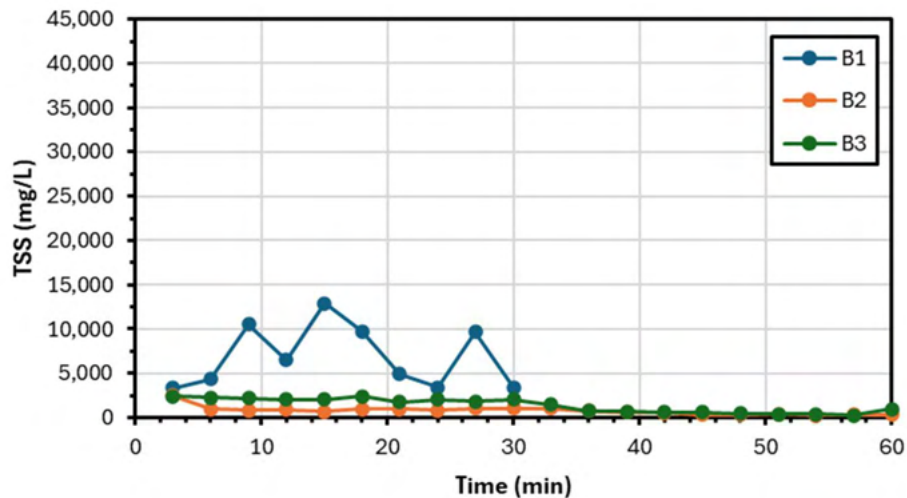

Water Quality Data Statistics



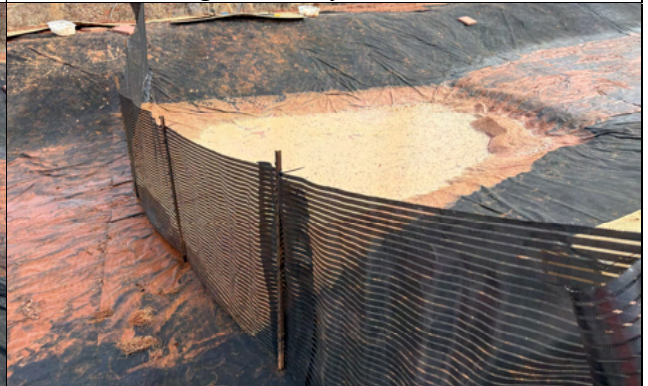

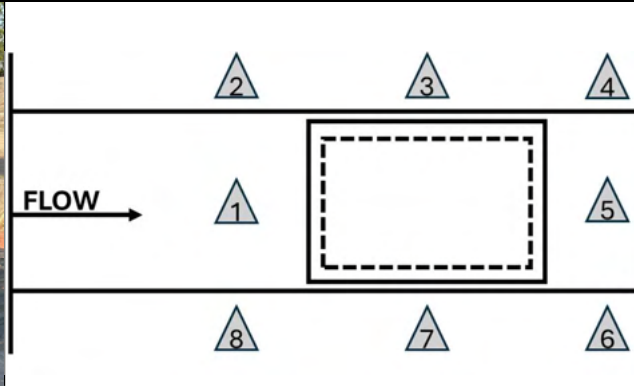



Measurement Location	Avg		Min		Max		Std. Dev.	
	NTU	TSS (mg/L)	NTU	TSS (mg/L)	NTU	TSS (mg/L)	NTU	TSS (mg/L)
Inflow	2,607	6,882	1,152	3,360	5,455	12,890	1,237	3,352
Trap	1,171	778	765	230	2,227	2,480	319	479
Downstream	1,378	1,381	679	270	1,976	2,430	448	781

TSS (mg/L) and Turbidity (NTU) Data Plots

Legend Interpretation: The letter (A, B, C, D) corresponds to the Test ID to indicate which test in the series. The number (1, 2, 3) corresponds to the data collection location with 1 indicating the inflow collection point, 2 indicating the "in-trap" collection point, and 3 indicating the downstream or discharge collection point.

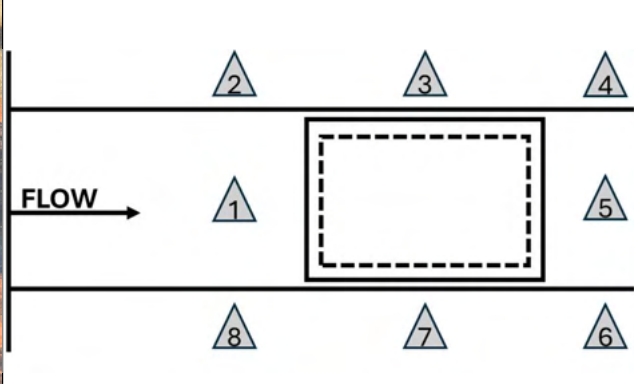

Test ID	Photo Documentation	Installation
B	Pre-Test	High Porosity Silt Fence
		
Location 2	Location 3	Location 4
		
Location 1		Location 5
		
Location 8	Location 7	Location 6

Test ID	Photo Documentation	Installation
B	Post Test	High Porosity Silt Fence
		
Location 2	Location 3	Location 4
		
Location 1		Location 5
		
Location 8	Location 7	Location 6

SILT TRAP TEST LOG

Test Summary

Installation:	High Porosity Silt Fence
Test ID:	C
Date:	1/29/2025
Type:	Longevity
Flow Rate (cfs):	0.5
Sediment Load Rate (lb/min):	36.6

Picture of Installation



Note: pictured on upstream side facing downstream in channel

Installation Description & Test Notes: The silt trap was paired with a high porosity silt fence. The fence was placed two feet downstream of the trap. The high porosity silt fence was chosen because it was an approved product for high flow situations; however, it has since been phased out of practice and removed from the NDOT approved products list. The installation followed the NDOT standard installation procedure and materials. No overtopping occurred. There was impoundment depth measured; however, the impoundment length was not distinguishable from the silt trap pool itself. The fence fully blinded in Test C with 4.5 in. of water standing in front of the fence.

Sediment Capture Efficiency

Capture of Introduced Sediment:	77.8 %
Improved Capture from Control:	3.6 %

Hydraulic Performance

Max Impoundment Depth (in.):	10.25	Impoundment Depth Ratio:	0.28
Impoundment Length (ft):	N/A	Impoundment Length Ratio:	N/A
Dewatering Time (min):	65.0	<i>Note: ratios based on theoretical impoundment</i>	







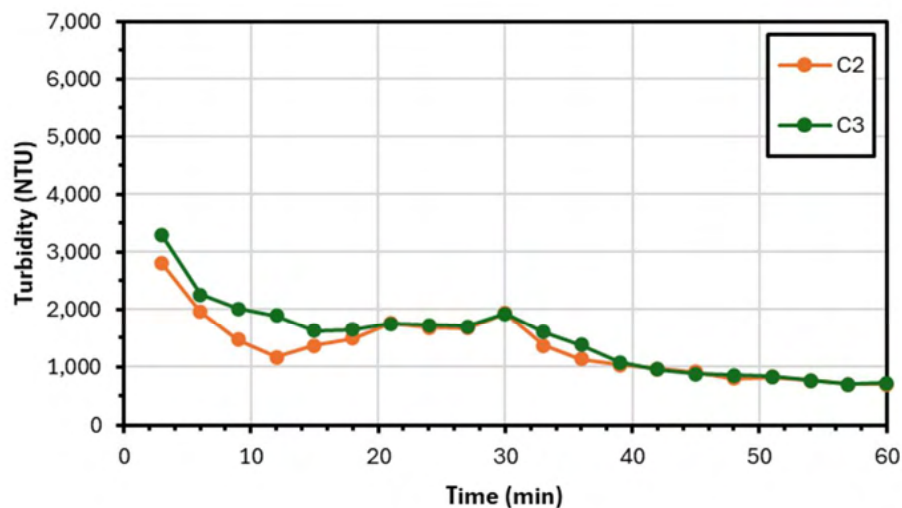
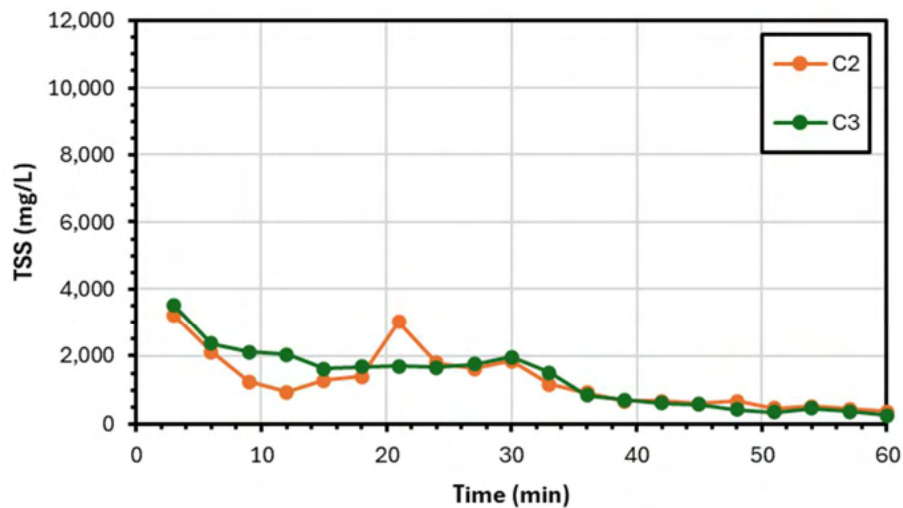
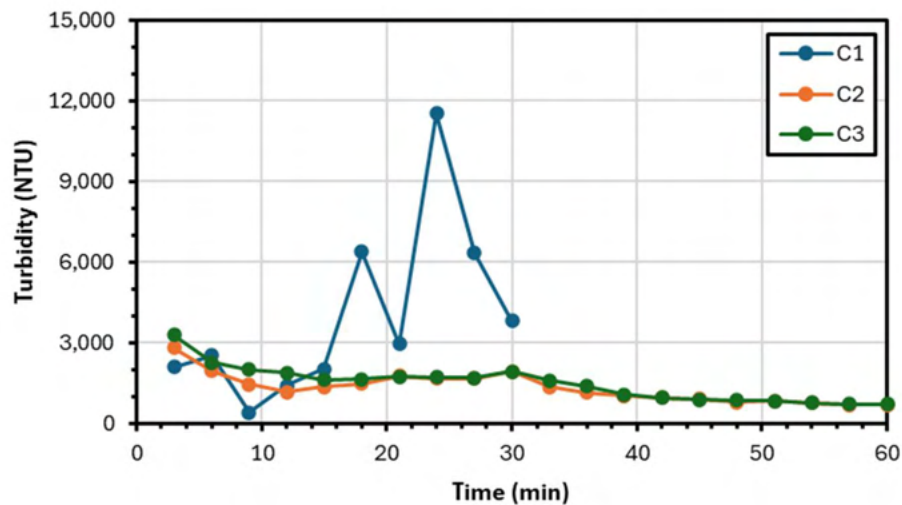
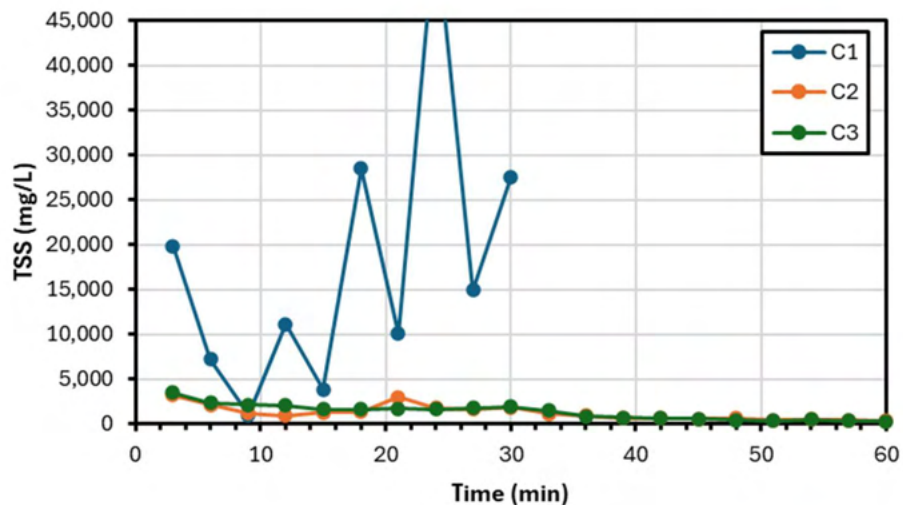

Water Quality Data Statistics





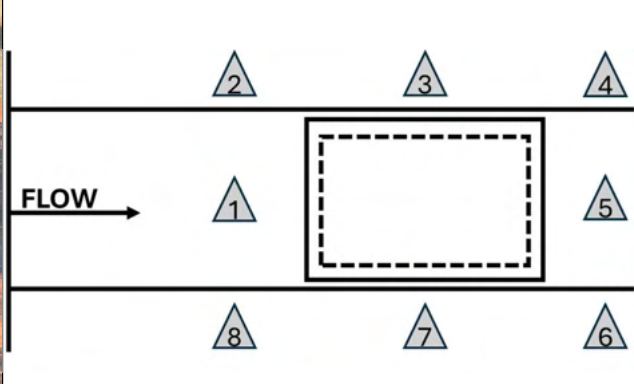



Measurement Location	Avg		Min		Max		Std. Dev.	
	NTU	TSS (mg/L)	NTU	TSS (mg/L)	NTU	TSS (mg/L)	NTU	TSS (mg/L)
Inflow	3,953	17,984	416	1,000	11,541	55,680	3,137	15,334
Trap	1,324	1,248	695	360	2,806	3,210	526	799
Downstream	1,479	1,328	705	260	3,287	3,510	634	849

TSS (mg/L) and Turbidity (NTU) Data Plots

Legend Interpretation: The letter (A, B, C, D) corresponds to the Test ID to indicate which test in the series. The number (1, 2, 3) corresponds to the data collection location with 1 indicating the inflow collection point, 2 indicating the "in-trap" collection point, and 3 indicating the downstream or discharge collection point.

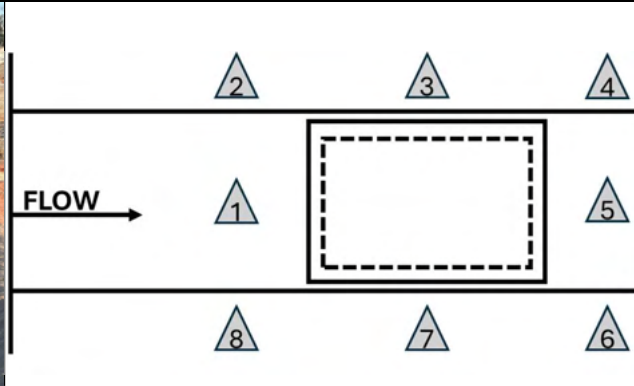

Test ID	Photo Documentation	Installation
C	Pre-Test	High Porosity Silt Fence
		
Location 2	Location 3	Location 4
		
Location 1		Location 5
		
Location 8	Location 7	Location 6

Test ID	Photo Documentation	Installation
C	Post-Test	High Porosity Silt Fence
		
Location 2	Location 3	Location 4
		
Location 1		Location 5
		
Location 8	Location 7	Location 6

SILT TRAP TEST LOG

Test Summary

Installation:	Modified Silt Fence
Test ID:	A
Date:	2/10/2025
Type:	Longevity
Flow Rate (cfs):	0.5
Sediment Load Rate (lb/min):	36.6

Picture of Installation



Note: pictured on upstream side facing downstream in channel

Installation Description & Test Notes: The silt trap was paired with a modified silt fence. The fence was a nonwoven geotextile with wire-backing in a V-shape with an 18 in. weir cut out of the center. The fence was placed two feet downstream of the trap. The flow overtopped the weir at 16 min.

Sediment Capture Efficiency

Capture of Introduced Sediment:	95.9 %
Improved Capture from Control:	21.7 %

Hydraulic Performance

Max Impoundment Depth (in.):	19.0	Impoundment Depth Ratio:	1.06
Impoundment Length (ft):	35.0	Impoundment Length Ratio:	1.17
Dewatering Time (min):	45.0	<i>Note: ratios based on theoretical impoundment</i>	







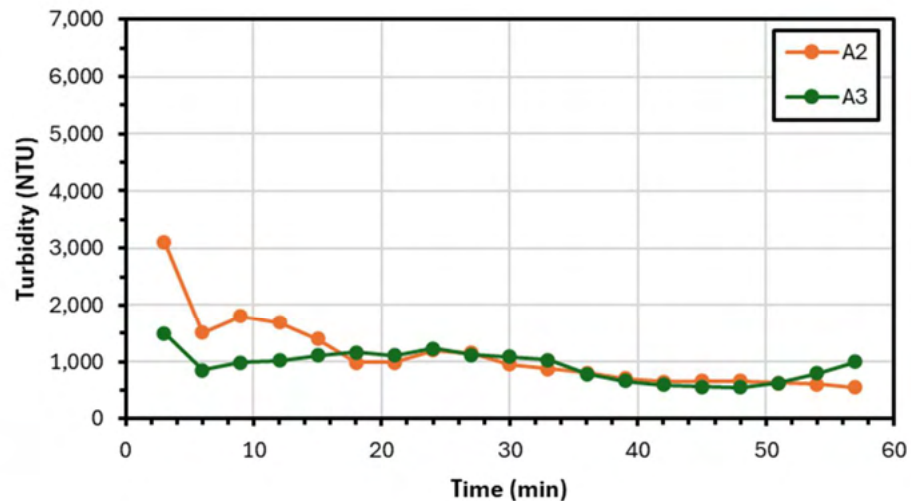
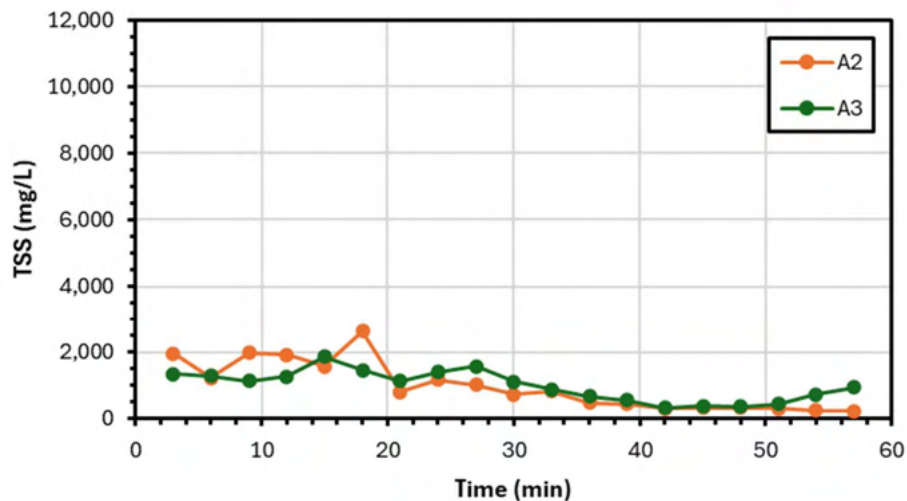
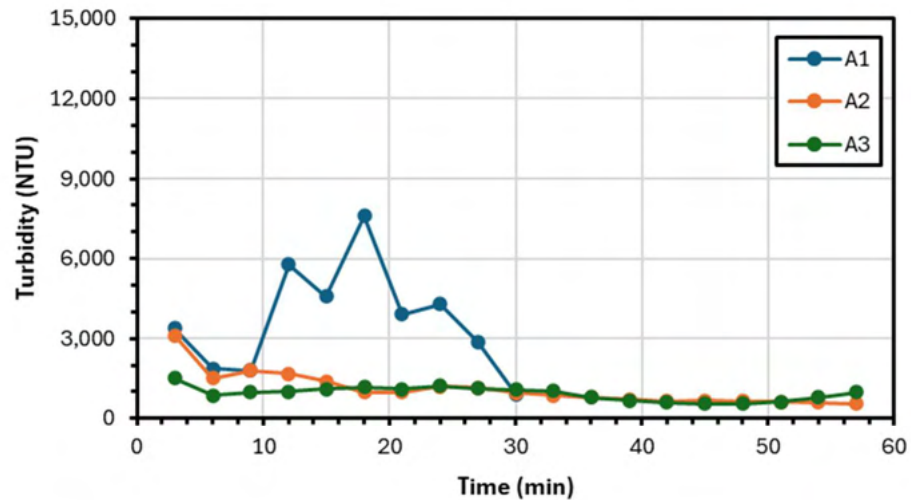
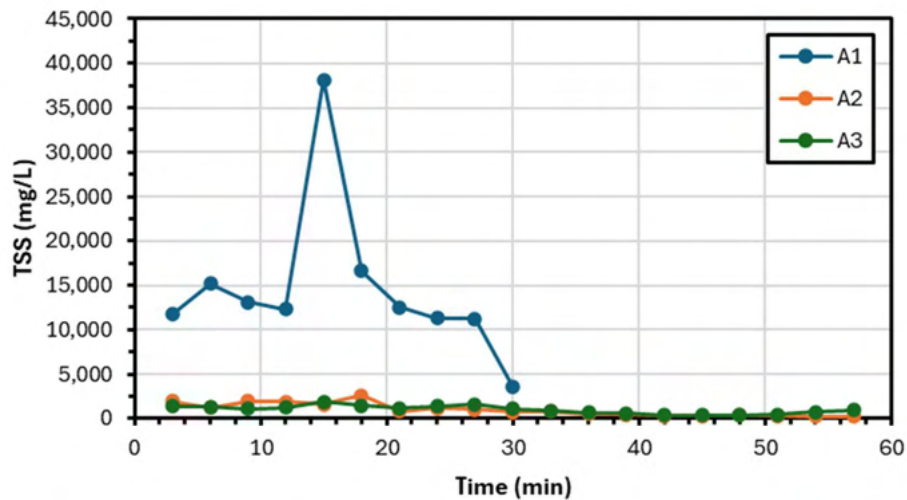

Water Quality Data Statistics





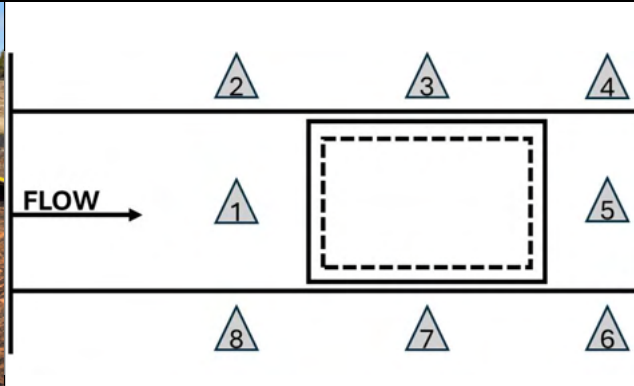

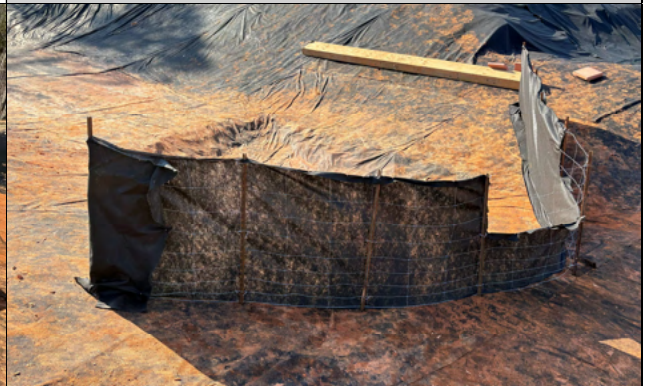

Measurement Location	Avg		Min		Max		Std. Dev.	
	NTU	TSS (mg/L)	NTU	TSS (mg/L)	NTU	TSS (mg/L)	NTU	TSS (mg/L)
Inflow	3,698	14,576	914	3,570	7,588	38,140	1,900	8,498
Trap	1,100	981	548	230	3,114	2,640	602	707
Downstream	934	998	551	340	1,497	1,860	253	440

TSS (mg/L) and Turbidity (NTU) Data Plots

Legend Interpretation: The letter (A, B, C, D) corresponds to the Test ID to indicate which test in the series. The number (1, 2, 3) corresponds to the data collection location with 1 indicating the inflow collection point, 2 indicating the "in-trap" collection point, and 3 indicating the downstream or discharge collection point.

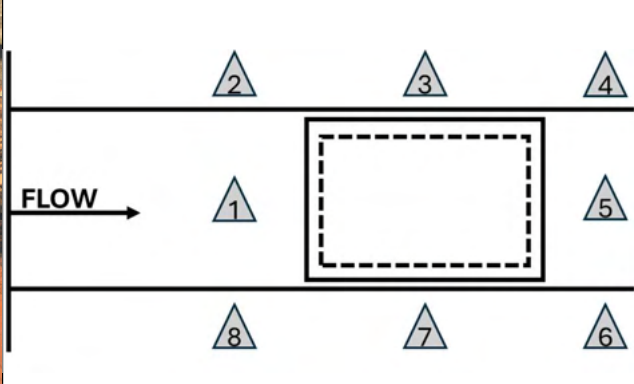

Test ID	Photo Documentation	Installation
A	Pre-Test	Modified Silt Fence
		
Location 2	Location 3	Location 4
		
Location 1		Location 5
		
Location 8	Location 7	Location 6

Test ID	Photo Documentation	Installation
A	Post-Test	Modified Silt Fence
		
Location 2	Location 3	Location 4
		
Location 1		Location 5
		
Location 8	Location 7	Location 6

SILT TRAP TEST LOG

Test Summary

Installation:	Modified Silt Fence
Test ID:	B
Date:	2/10/2025
Type:	Longevity
Flow Rate (cfs):	0.5
Sediment Load Rate (lb/min):	36.6

Picture of Installation



Note: pictured on upstream side facing downstream in channel

Installation Description & Test Notes: The silt trap was paired with a modified silt fence. The fence was a nonwoven geotextile with wire-backing in a V-shape with an 18 in. weir cut out of the center. The fence was placed two feet downstream of the trap. The flow overtopped the weir at 11 min.

Sediment Capture Efficiency

Capture of Introduced Sediment:	95.9 %
Improved Capture from Control:	21.7 %

Hydraulic Performance

Max Impoundment Depth (in.):	19.0	Impoundment Depth Ratio:	1.06
Impoundment Length (ft):	35.0	Impoundment Length Ratio:	1.17
Dewatering Time (min):	37.0	<i>Note: ratios based on theoretical impoundment</i>	







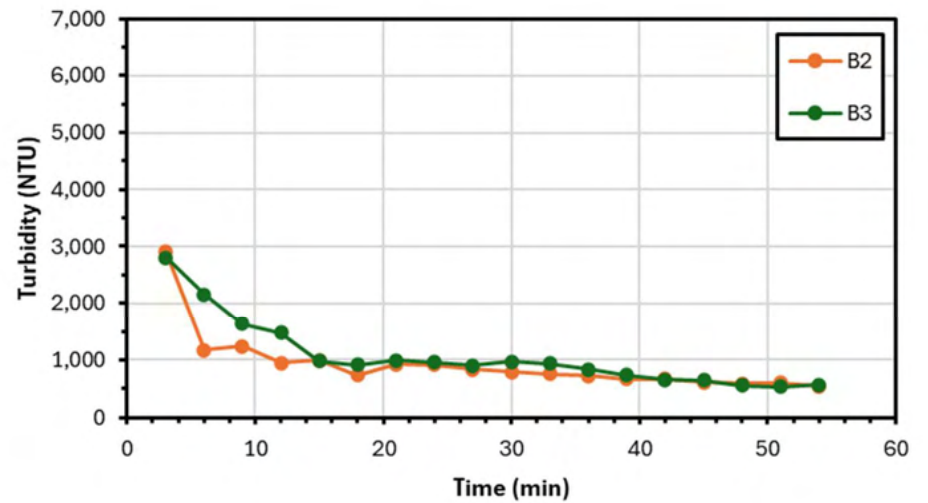
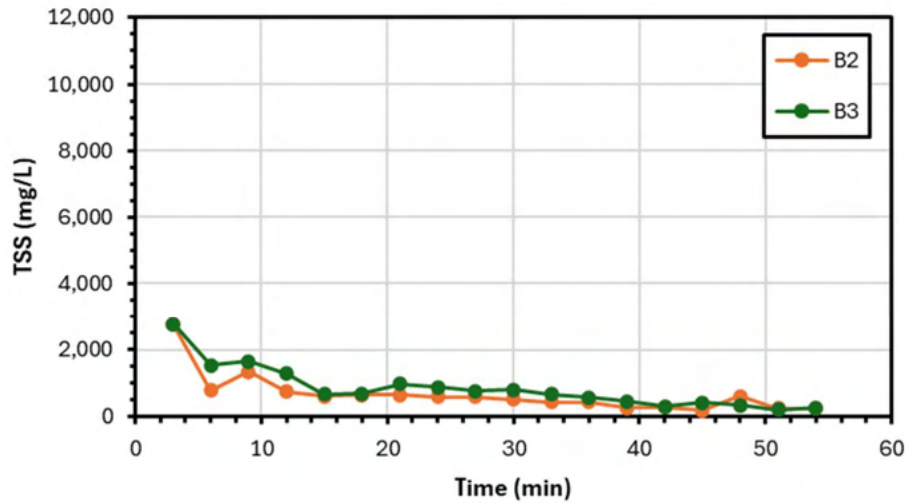
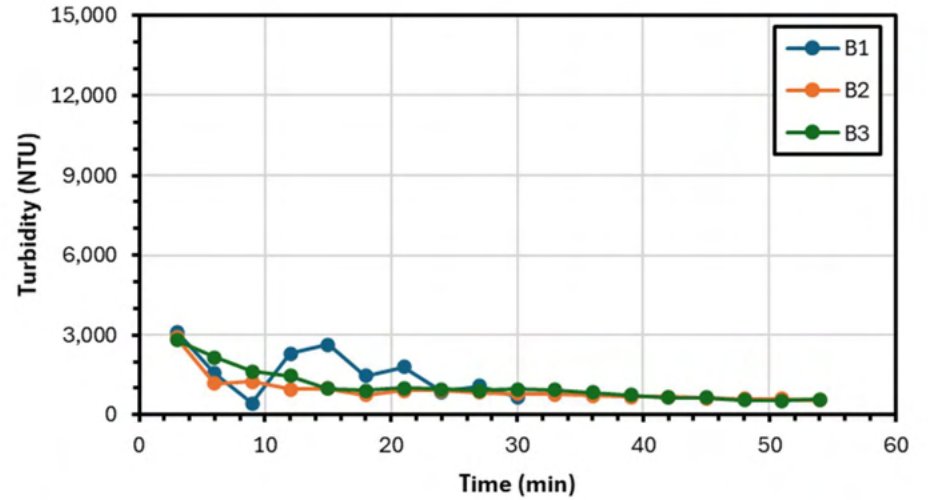
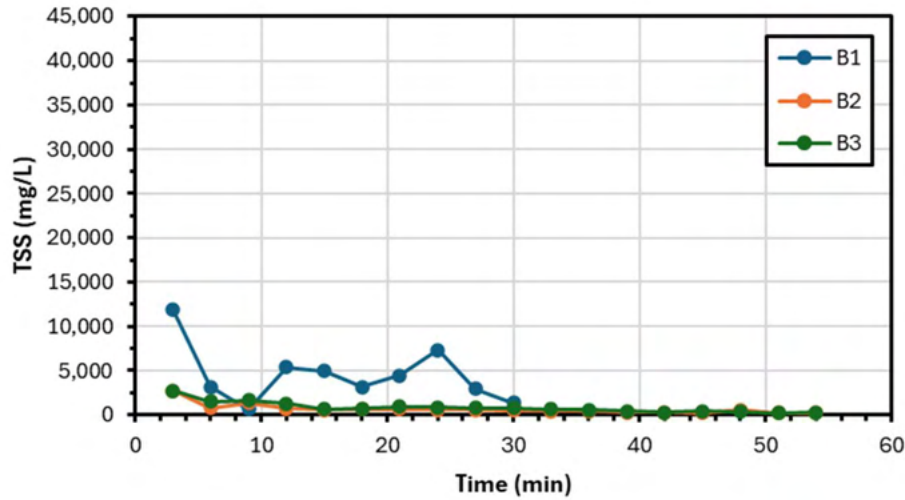

Water Quality Data Statistics





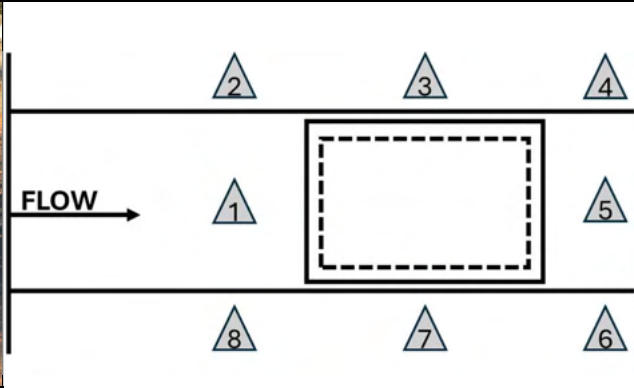



Measurement Location	Avg		Min		Max		Std. Dev.	
	NTU	TSS (mg/L)	NTU	TSS (mg/L)	NTU	TSS (mg/L)	NTU	TSS (mg/L)
Inflow	1,591	4,547	434	660	3,125	11,900	837	3,070
Trap	922	668	548	200	2,900	2,750	516	569
Downstream	1,069	848	529	220	2,807	2,760	582	614

TSS (mg/L) and Turbidity (NTU) Data Plots

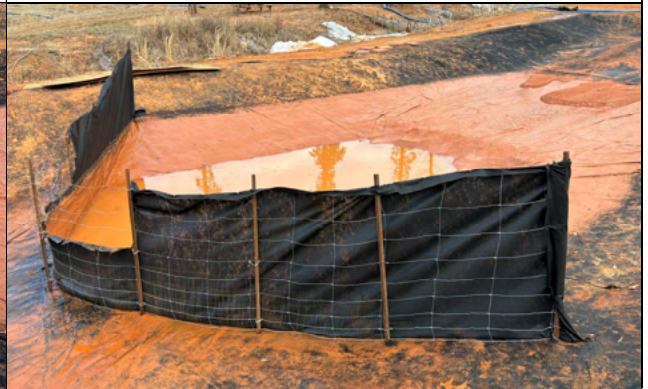
Legend Interpretation: The letter (A, B, C, D) corresponds to the Test ID to indicate which test in the series. The number (1, 2, 3) corresponds to the data collection location with 1 indicating the inflow collection point, 2 indicating the "in-trap" collection point, and 3 indicating the downstream or discharge collection point.

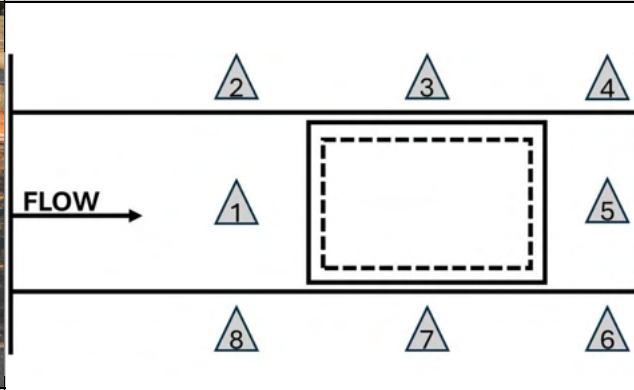

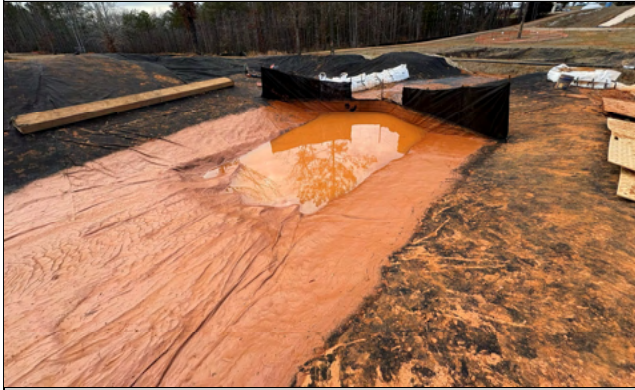
Test ID	Photo Documentation	Installation
B	Pre-Test	Modified Silt Fence
		
Location 2	Location 3	Location 4
		
Location 1		Location 5
		
Location 8	Location 7	Location 6

Test ID	Photo Documentation	Installation
B	Post-Test	Modified Silt Fence
		
Location 2	Location 3	Location 4
		
Location 1		Location 5
		
Location 8	Location 7	Location 6

SILT TRAP TEST LOG

Test Summary

Installation:	Modified Silt Fence
Test ID:	A
Date:	2/11/2025
Type:	Longevity
Flow Rate (cfs):	0.5
Sediment Load Rate (lb/min):	36.6

Picture of Installation



Note: pictured on upstream side facing downstream in channel

Installation Description & Test Notes: The silt trap was paired with a modified silt fence. The fence was a nonwoven geotextile with wire-backing in a V-shape with an 18 in. weir cut out of the center. The fence was placed two feet downstream of the trap. The flow overtopped the weir at 12 min.

Sediment Capture Efficiency

Capture of Introduced Sediment:	95.9 %
Improved Capture from Control:	21.7 %

Hydraulic Performance

Max Impoundment Depth (in.):	19.0	Impoundment Depth Ratio:	1.06
Impoundment Length (ft):	35.0	Impoundment Length Ratio:	1.17
Dewatering Time (min):	50.0	<i>Note: ratios based on theoretical impoundment</i>	







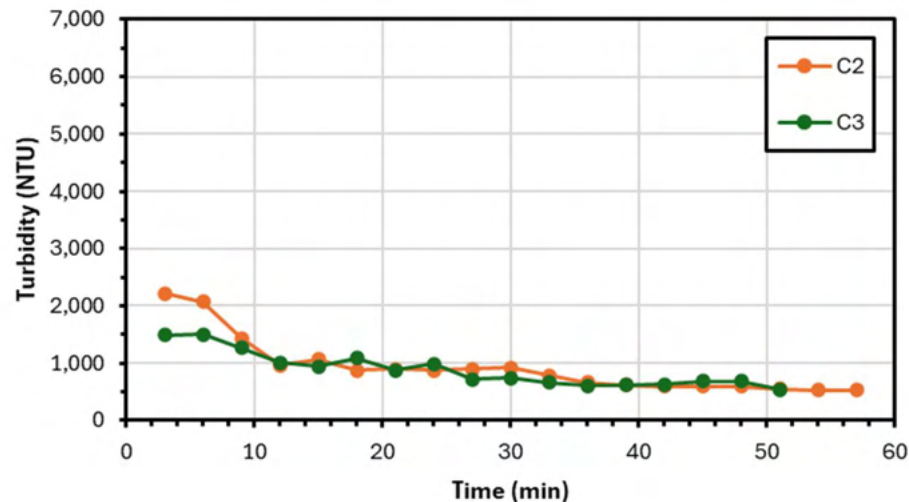
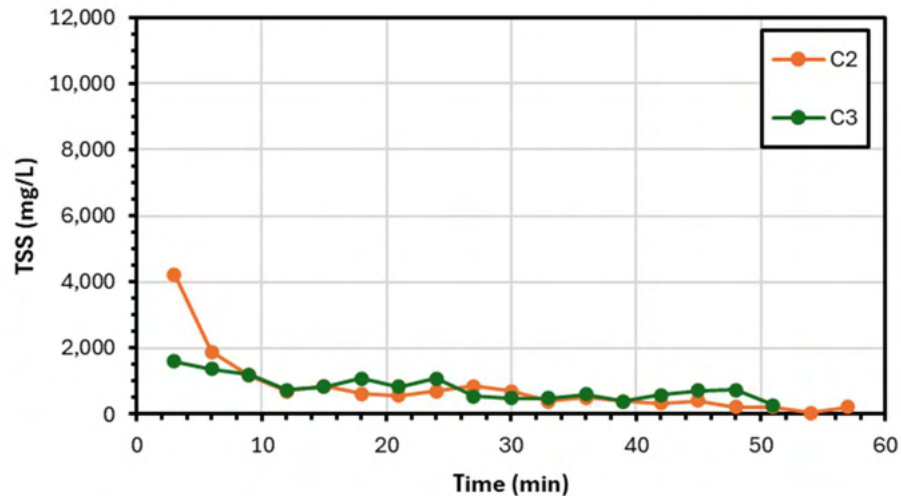
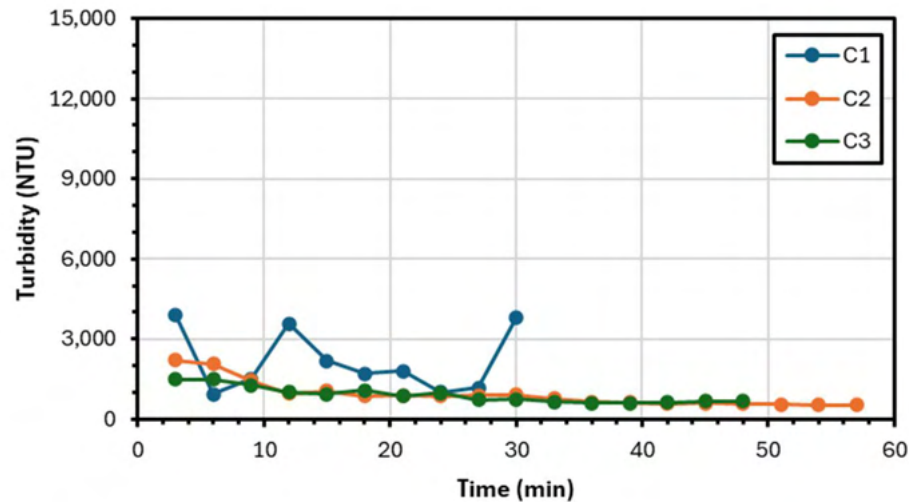
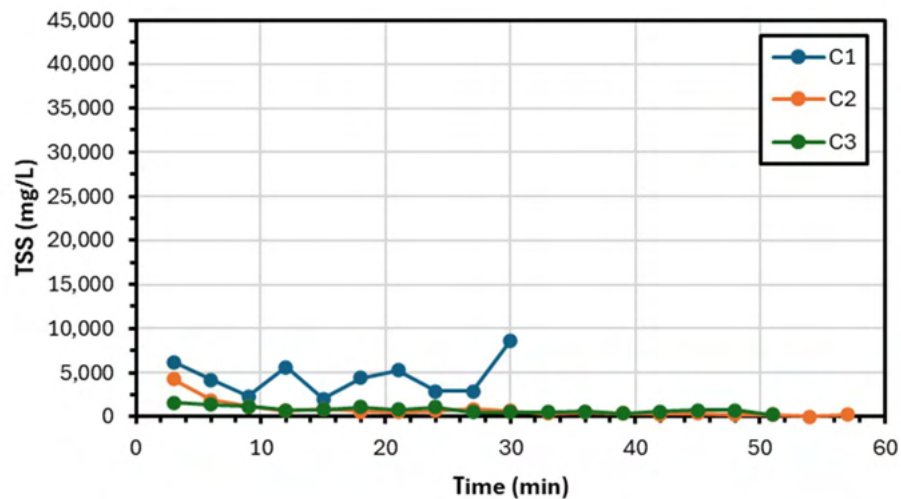

Water Quality Data Statistics

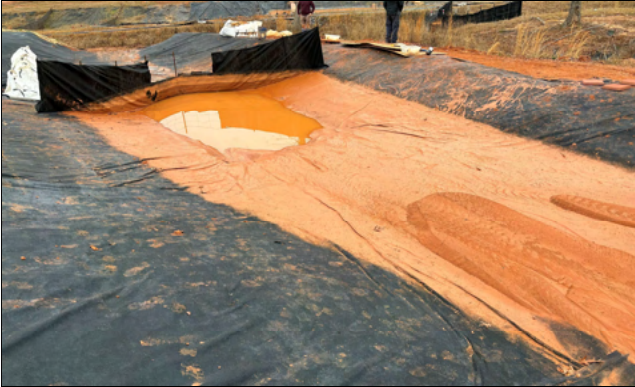



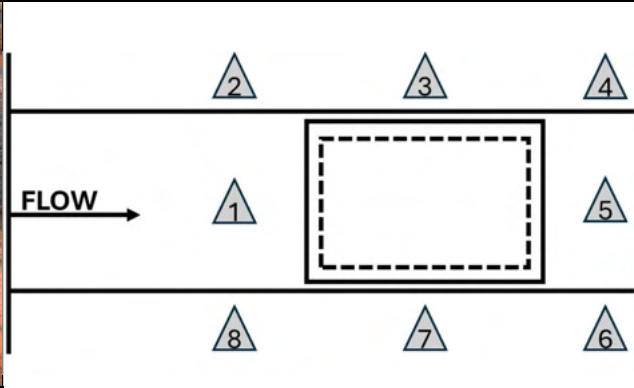



Measurement Location	Avg		Min		Max		Std. Dev.	
	NTU	TSS (mg/L)	NTU	TSS (mg/L)	NTU	TSS (mg/L)	NTU	TSS (mg/L)
Inflow	2,165	4,443	954	2,030	3,880	8,630	1,106	1,942
Trap	929	789	527	50	2,220	4,230	472	906
Downstream	884	797	541	270	1,498	1,600	294	351

TSS (mg/L) and Turbidity (NTU) Data Plots

Legend Interpretation: The letter (A, B, C, D) corresponds to the Test ID to indicate which test in the series. The number (1, 2, 3) corresponds to the data collection location with 1 indicating the inflow collection point, 2 indicating the "in-trap" collection point, and 3 indicating the downstream or discharge collection point.

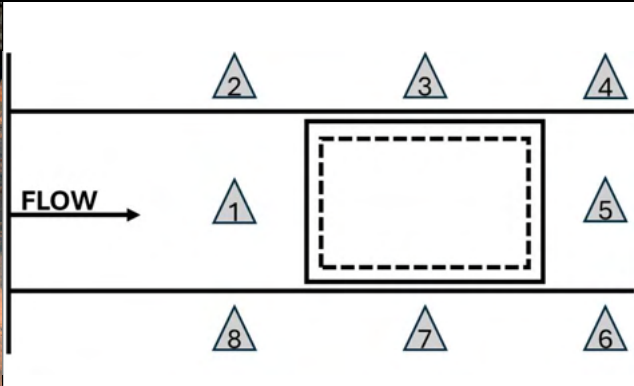

Test ID	Photo Documentation	Installation
C	Pre-Test	Modified Silt Fence
		
Location 2	Location 3	Location 4
		
Location 1	Location 5	Location 5
		
Location 8	Location 7	Location 6

Test ID	Photo Documentation	Installation
C	Post-Test	Modified Silt Fence
		
Location 2	Location 3	Location 4
		
Location 1		Location 5
		
Location 8	Location 7	Location 6

SILT TRAP TEST LOG

Test Summary

Installation:	Low Porosity Silt Fence
Test ID:	A
Date:	11/26/2024
Type:	Longevity
Flow Rate (cfs):	0.5
Sediment Load Rate (lb/min):	36.6

Picture of Installation

Note: pictured on upstream side facing downstream in channel

Installation Description & Test Notes: The silt trap was paired with a low porosity silt fence. The height was low profile of woven geotextile placed perpendicularly across the channel. The fence was placed two feet downstream of the trap and curved upstream to prevent bypass. Water overtopped fence. The fence failed 17 min into test A. Failure consisted of bending the T-posts and the fence ripping around the zip ties. The data included are based on samples taken before failure.

Sediment Capture Efficiency

Capture of Introduced Sediment:	88.0 %
Improved Capture from Control:	N/A

Note: Sediment capture percentage based on sediment introduced before failure.

Hydraulic Performance

Max Impoundment Depth (in.):	N/A	Impoundment Depth Ratio:	N/A
Impoundment Length (ft):	34.9	Impoundment Length Ratio:	0.70
Dewatering Time (min):	N/A	<i>Note: ratios based on theoretical impoundment</i>	







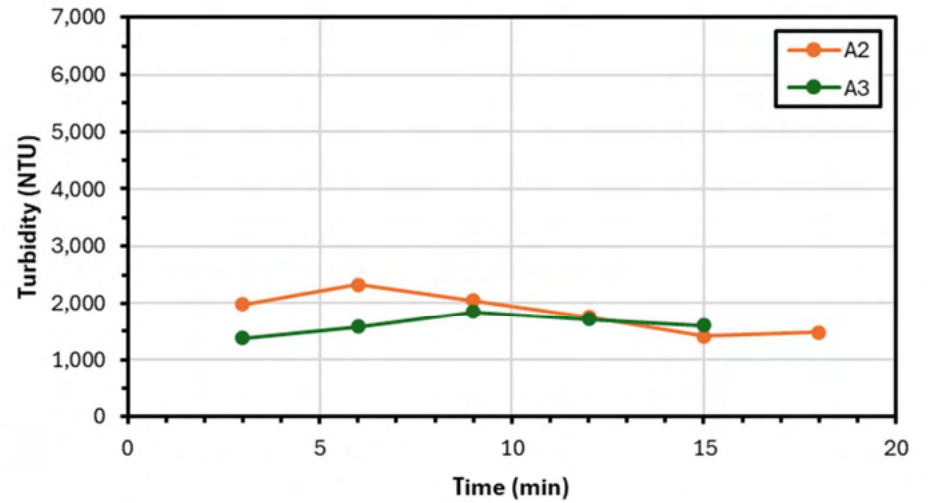
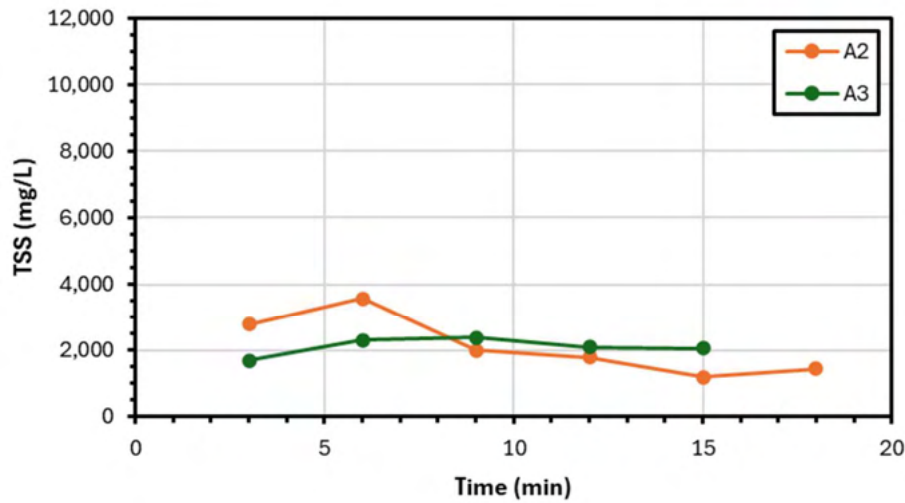
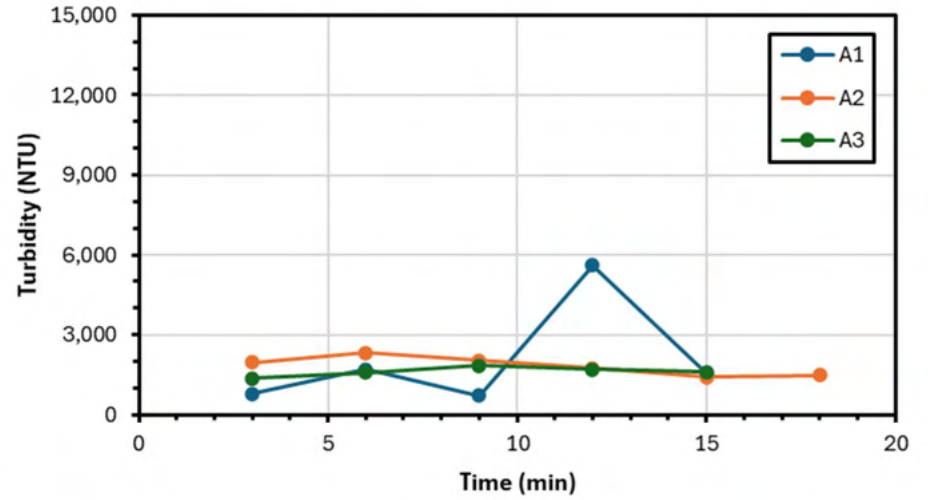
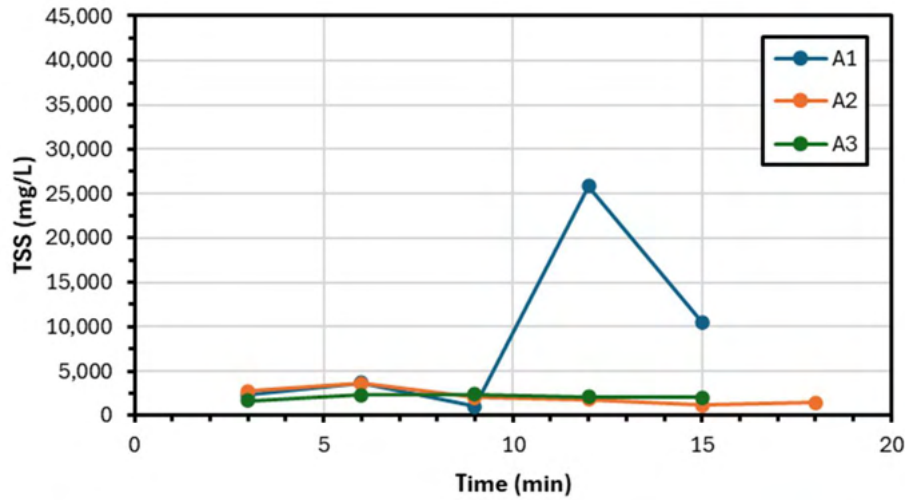

Water Quality Data Statistics





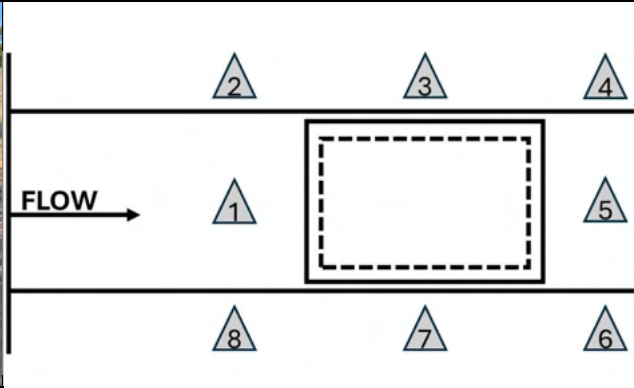



Measurement Location	Avg		Min		Max		Std. Dev.	
	NTU	TSS (mg/L)	NTU	TSS (mg/L)	NTU	TSS (mg/L)	NTU	TSS (mg/L)
Inflow	2,076	8,656	714	1,040	5,606	25,800	1,810	9,171
Trap	1,832	2,132	1,406	1,190	2,330	3,580	323	818
Downstream	1,621	2,108	1,373	1,698	1,845	2,390	157	242

TSS (mg/L) and Turbidity (NTU) Data Plots

Legend Interpretation: The letter (A, B, C, D) corresponds to the Test ID to indicate which test in the series. The number (1, 2, 3) corresponds to the data collection location with 1 indicating the inflow collection point, 2 indicating the "in-trap" collection point, and 3 indicating the downstream or discharge collection point.

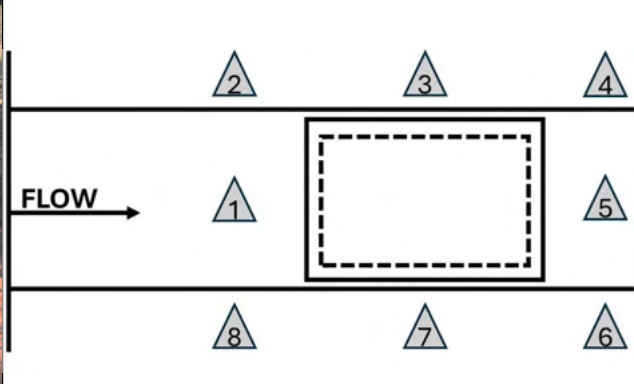

Test ID	Photo Documentation	Installation
A	Pre-Test	Low Porosity Silt Fence
		
Location 2	Location 3	Location 4
		
Location 1		Location 5
		
Location 8	Location 7	Location 6

Test ID	Photo Documentation	Installation
A	Post-Failure	Low Porosity Silt Fence
		
Location 2	Location 3	Location 4
		
Location 1		Location 5
		
Location 8	Location 7	Location 6

SILT TRAP TEST LOG

Test Summary

Installation:	Temporary Rock Check
Test ID:	A
Date:	3/3/2025
Type:	Longevity
Flow Rate (cfs):	0.5
Sediment Load Rate (lb/min):	36.6

Picture of Installation



Note: pictured on upstream side facing downstream in channel

Installation Description & Test Notes: The silt trap was paired with a temporary rock check. The AL Class 1 riprap was used as a conservative equivalent from the NE Type A riprap. The check was 2 ft tall and 4 ft wide with a top width of 2 ft. The low point of the check was in the center of the channel, and the check was perpendicular across the channel. The rock was placed two feet upstream of the trap. Water flowed through the rock immediately in testing. There were no recorded impoundment depths since the rock caused variability across the face of the check.

Sediment Capture Efficiency

Capture of Introduced Sediment:	73.8 %
Improved Capture from Control:	-0.4 %

Hydraulic Performance

Max Impoundment Depth (in.):	N/A	Impoundment Depth Ratio:	N/A
Impoundment Length (ft):	4.5	Impoundment Length Ratio:	0.11
Dewatering Time (min):	2.0	<i>Note: ratios based on theoretical impoundment</i>	







Water Quality Data Statistics

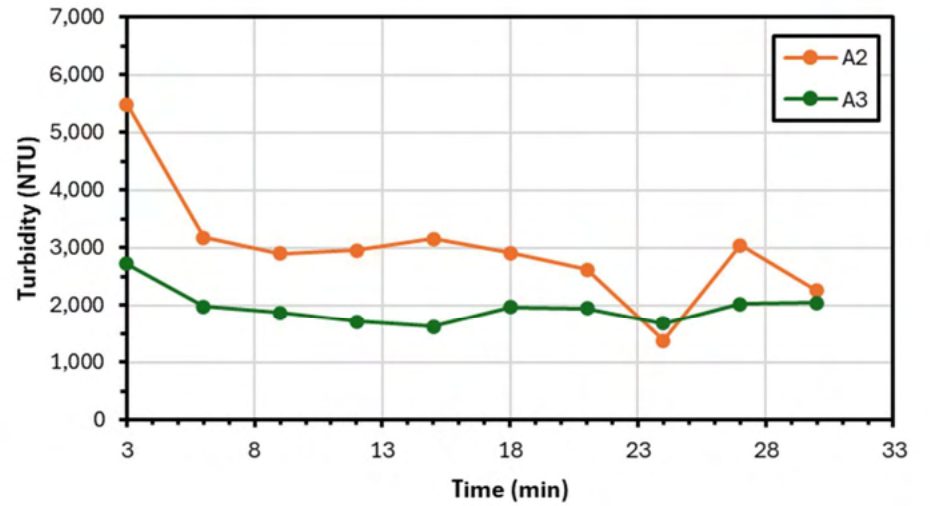
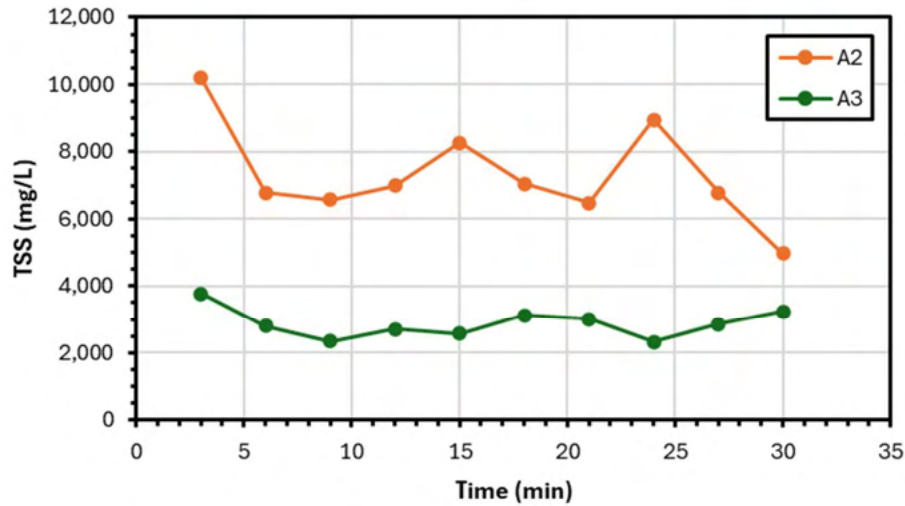
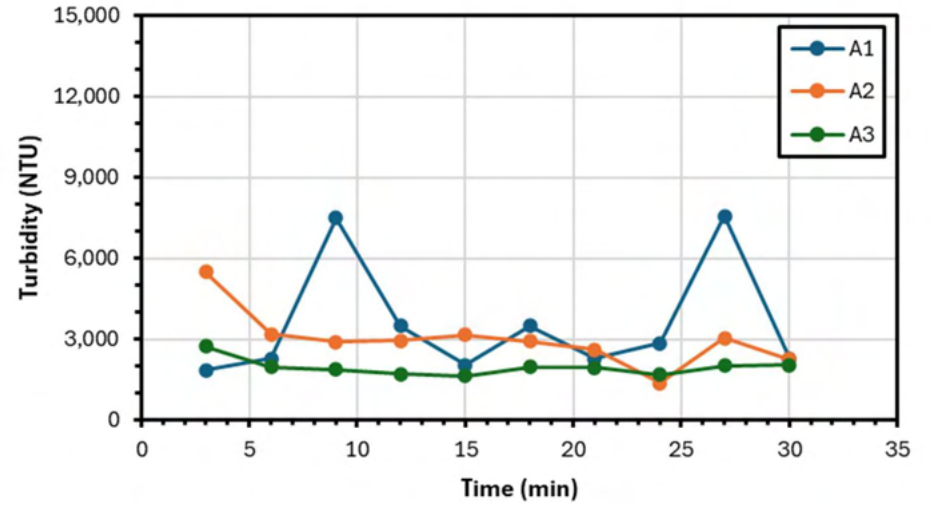
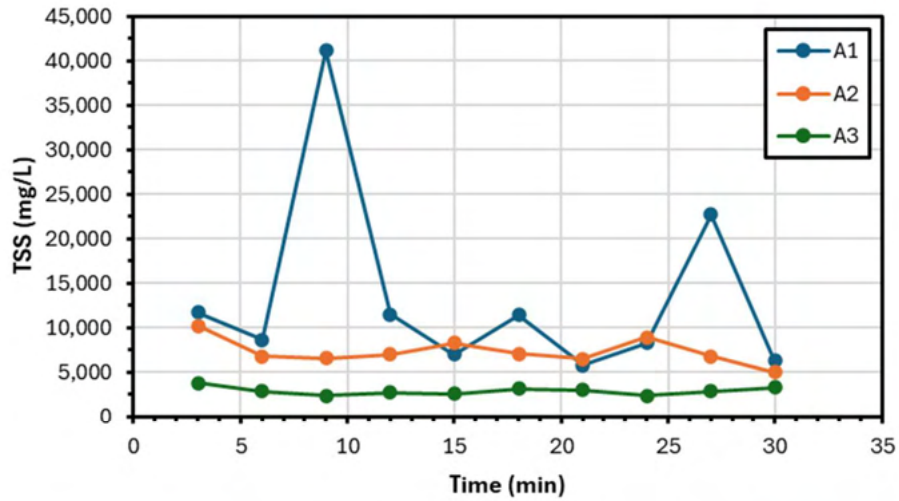



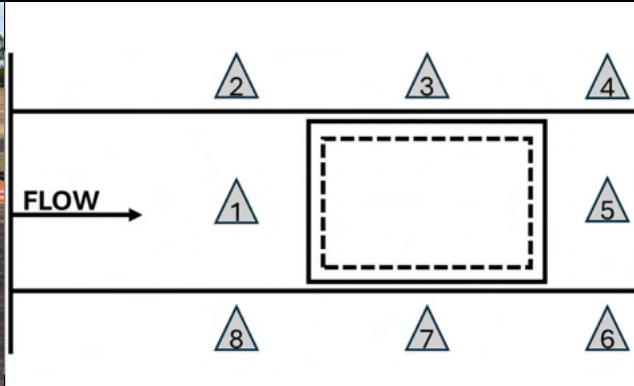



Measurement Location	Avg		Min		Max		Std. Dev.	
	NTU	TSS (mg/L)	NTU	TSS (mg/L)	NTU	TSS (mg/L)	NTU	TSS (mg/L)
Inflow	3,557	13,446	1,838	5,770	7,571	41,160	2,059	10,332
Trap	2,987	7,307	1,377	4,980	5,484	10,190	979	1,390
Downstream	1,953	2,878	1,625	2,330	2,721	3,780	293	418

TSS (mg/L) and Turbidity (NTU) Data Plots

Legend Interpretation: The letter (A, B, C, D) corresponds to the Test ID to indicate which test in the series. The number (1, 2, 3) corresponds to the data collection location with 1 indicating the inflow collection point, 2 indicating the "in-trap" collection point, and 3 indicating the downstream or discharge collection point.

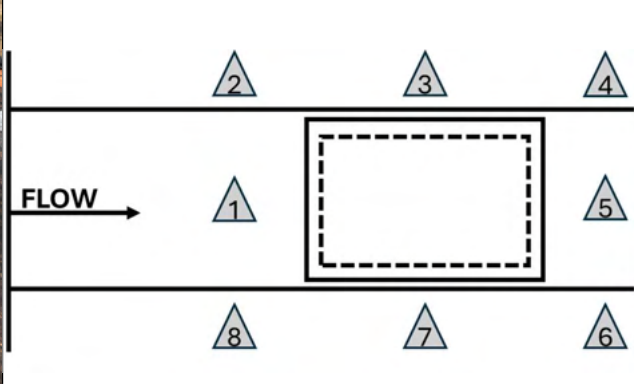

Test ID	Photo Documentation	Installation
A	Pre-Test	Temporary Rock Check
		
Location 2	Location 3	Location 4
		
Location 1		Location 5
		
Location 8	Location 7	Location 6

Test ID	Photo Documentation	Installation
A	Post-Test	Temporary Rock Check
		
Location 2	Location 3	Location 4
		
Location 1		Location 5
		
Location 8	Location 7	Location 6

SILT TRAP TEST LOG

Test Summary

Installation:	Temporary Rock Check
Test ID:	B
Date:	3/3/2025
Type:	Longevity
Flow Rate (cfs):	0.5
Sediment Load Rate (lb/min):	36.6

Picture of Installation



Note: pictured on upstream side facing downstream in channel

Installation Description & Test Notes: The silt trap was paired with a temporary rock check. The AL Class 1 riprap was used as a conservative equivalent from the NE Type A riprap. The check was 2 ft tall and 4 ft wide with a top width of 2 ft. The low point of the check was in the center of the channel, and the check was perpendicular across the channel. The rock was placed two feet upstream of the trap. Water flowed through the rock immediately in testing. There were no recorded impoundment depths since the rock caused variability across the face of the check.

Sediment Capture Efficiency

Capture of Introduced Sediment:	73.8 %
Improved Capture from Control:	-0.4 %

Hydraulic Performance

Max Impoundment Depth (ft):	N/A	Impoundment Depth Ratio:	N/A
Impoundment Length (ft):	5.5	Impoundment Length Ratio:	0.14
Dewatering Time (min):	7.0	<i>Note: ratios based on theoretical impoundment</i>	







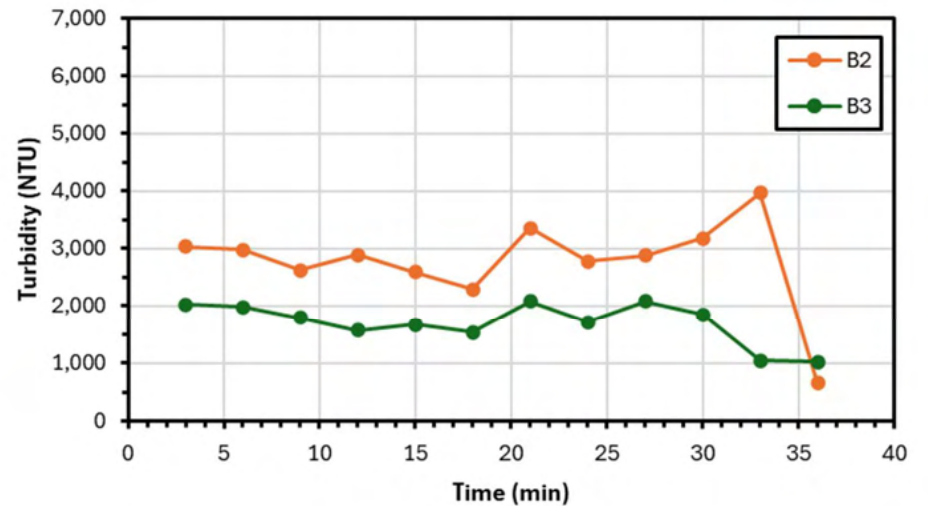
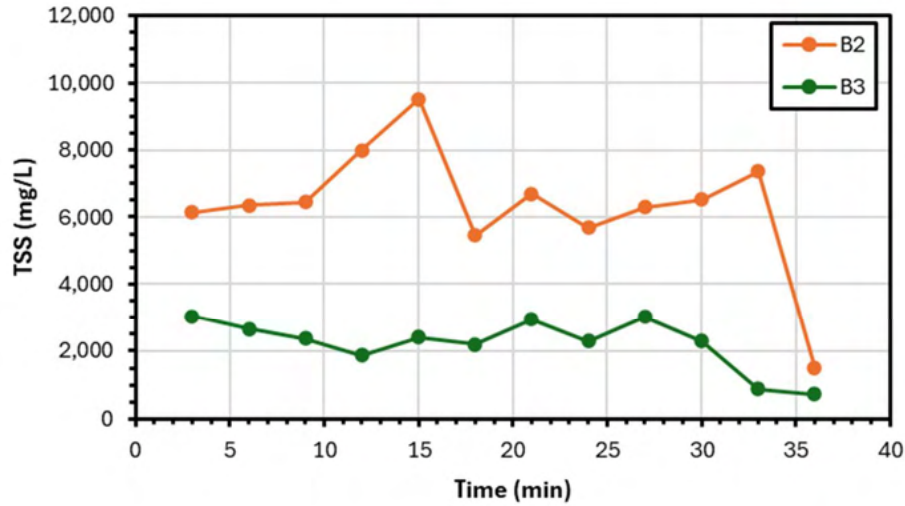
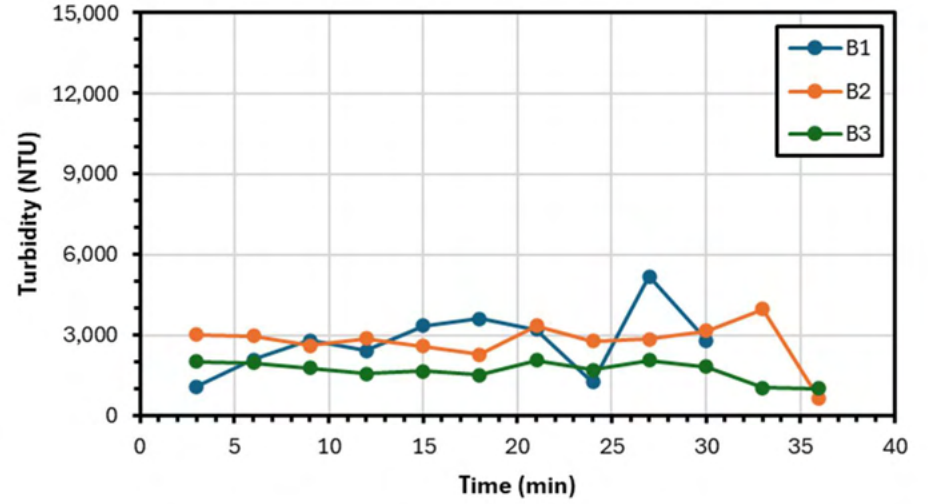
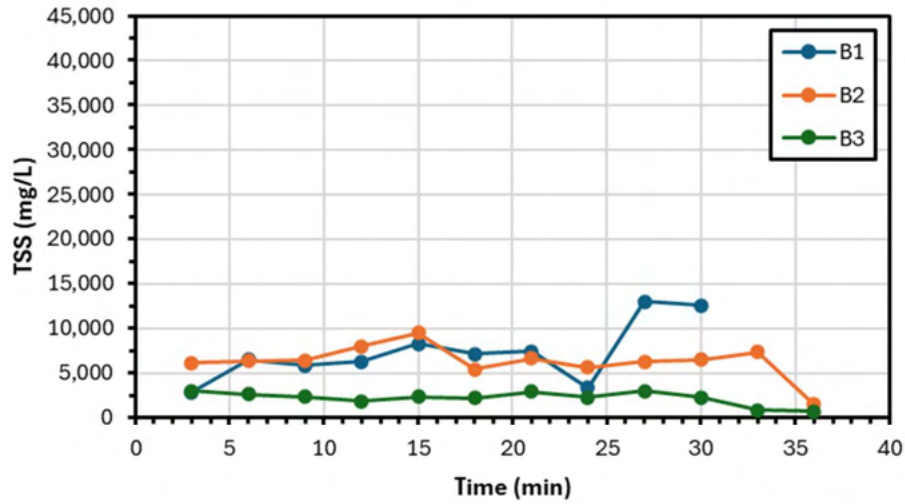

Water Quality Data Statistics





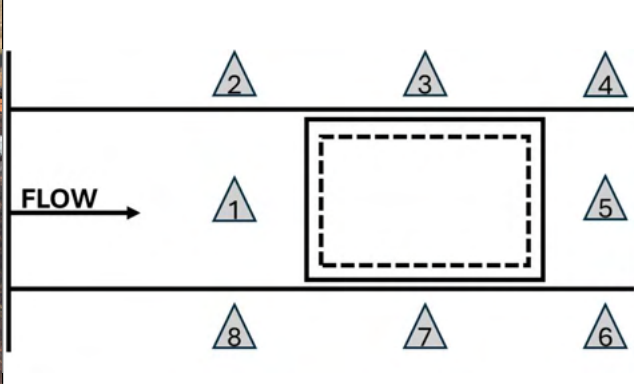



Measurement Location	Avg		Min		Max		Std. Dev.	
	NTU	TSS (mg/L)	NTU	TSS (mg/L)	NTU	TSS (mg/L)	NTU	TSS (mg/L)
Inflow	2,795	7,346	1,106	2,870	5,206	13,030	1,130	3,166
Trap	2,769	6,334	651	1,520	3,973	9,520	756	1,792
Downstream	1,697	2,223	1,025	730	2,083	3,030	345	719

TSS (mg/L) and Turbidity (NTU) Data Plots

Legend Interpretation: The letter (A, B, C, D) corresponds to the Test ID to indicate which test in the series. The number (1, 2, 3) corresponds to the data collection location with 1 indicating the inflow collection point, 2 indicating the "in-trap" collection point, and 3 indicating the downstream or discharge collection point.

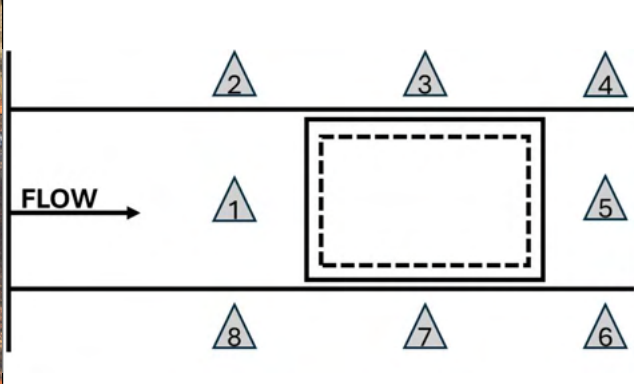

Test ID	Photo Documentation	Installation
B	Pre-Test	Temporary Rock Check
		
Location 2	Location 3	Location 4
		
Location 1		Location 5
		
Location 8	Location 7	Location 6

Test ID	Photo Documentation	Installation
B	Post-Test	Temporary Rock Check
		
Location 2	Location 3	Location 4
		
Location 1		Location 5
		
Location 8	Location 7	Location 6

SILT TRAP TEST LOG

Test Summary

Installation:	Temporary Rock Check
Test ID:	C
Date:	3/4/2025
Type:	Longevity
Flow Rate (cfs):	0.5
Sediment Load Rate (lb/min):	36.6

Picture of Installation



Note: pictured on upstream side facing downstream in channel

Installation Description & Test Notes: The silt trap was paired with a temporary rock check. The AL Class 1 riprap was used as a conservative equivalent from the NE Type A riprap. The check was 2 ft tall and 4 ft wide with a top width of 2 ft. The low point of the check was in the center of the channel, and the check was perpendicular across the channel. The rock was placed two feet upstream of the trap. Water flowed through the rock immediately in testing. There were no recorded impoundment depths since the rock caused variability across the face of the check.

Sediment Capture Efficiency

Capture of Introduced Sediment:	73.8 %
Improved Capture from Control:	-0.4%

Hydraulic Performance

Max Impoundment Depth (in.):	N/A	Impoundment Depth Ratio:	N/A
Impoundment Length (ft):	7.0	Impoundment Length Ratio:	0.18
Dewatering Time (min):	6.0	<i>Note: ratios based on theoretical impoundment</i>	







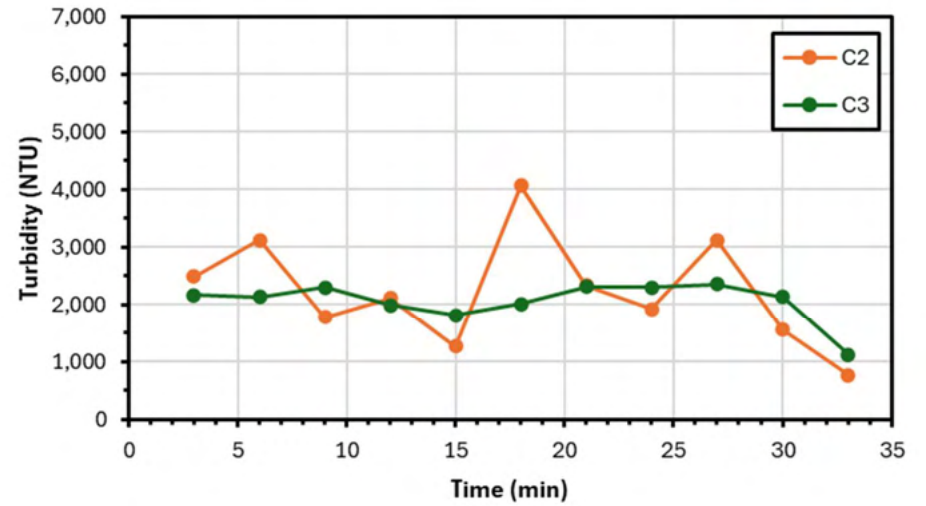
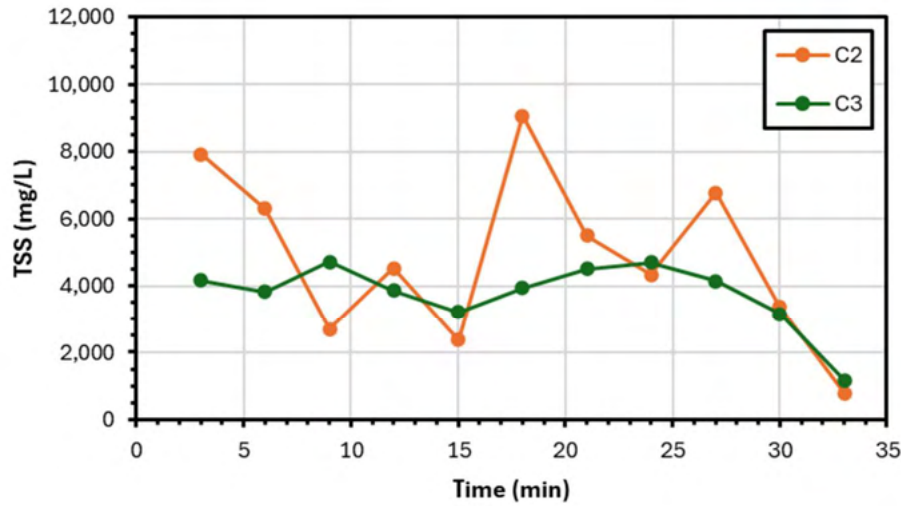
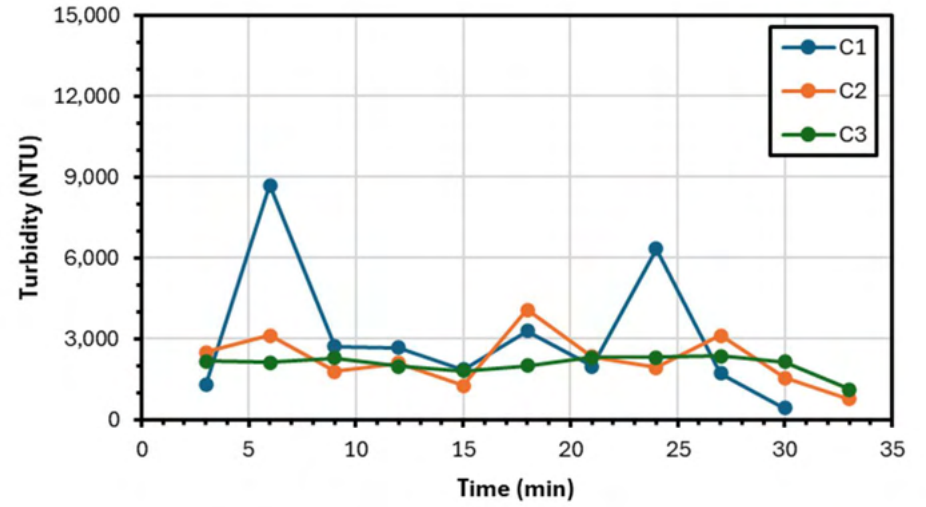
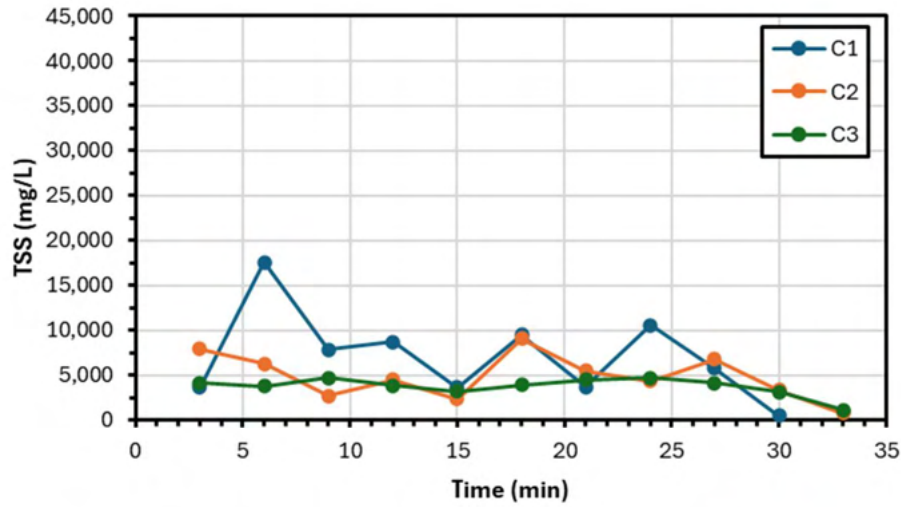

Water Quality Data Statistics





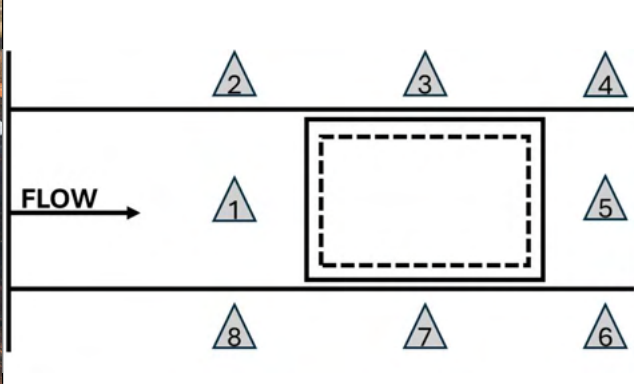



Measurement Location	Avg		Min		Max		Std. Dev.	
	NTU	TSS (mg/L)	NTU	TSS (mg/L)	NTU	TSS (mg/L)	NTU	TSS (mg/L)
Inflow	3,100	7,161	440	510	8,704	17,560	2,397	4,591
Trap	2,232	4,876	764	790	4,067	9,060	900	2,396
Downstream	2,041	3,712	1,122	1,170	2,361	4,720	369	1,049

TSS (mg/L) and Turbidity (NTU) Data Plots

Legend Interpretation: The letter (A, B, C, D) corresponds to the Test ID to indicate which test in the series. The number (1, 2, 3) corresponds to the data collection location with 1 indicating the inflow collection point, 2 indicating the “in-trap” collection point, and 3 indicating the downstream or discharge collection point.

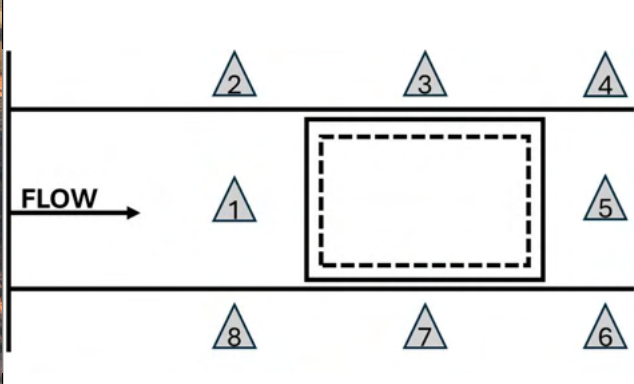

Test ID	Photo Documentation	Installation
C	Pre-Test	Temporary Rock Check
		
Location 2	Location 3	Location 4
		
Location 1		Location 5
		
Location 8	Location 7	Location 6

Test ID	Photo Documentation	Installation
C	Post-Test	Temporary Rock Check
		
Location 2	Location 3	Location 4
		
Location 1		Location 5
		
Location 8	Location 7	Location 6

SILT TRAP TEST LOG

Test Summary

Installation:	Modified Rock Check
Test ID:	A
Date:	3/19/2025
Type:	Longevity
Flow Rate (cfs):	0.5
Sediment Load Rate (lb/min):	36.6

Picture of Installation



Note: pictured on upstream side facing downstream in channel

Installation Description & Test Notes: The silt trap was paired with a modified rock check. The AL Class 1 riprap was used as a conservative equivalent from the NE Type A riprap. The check was 2 ft tall and 4 ft wide with a top width of 2 ft. The low point of the check was in the center of the channel, and the check was perpendicular across the channel. The rock was placed two feet downstream of the trap. The rock was covered in nonwoven geotextile and weep holes were cut in the face of the installation. No trenching of the rock. Water flowed through the covered rock check at 2 min into Test A, B, & C. The installation overtopped 15 min into the test and stopped overtopping at 43 min into the test.

Sediment Capture Efficiency

Capture of Introduced Sediment:	87.2 %
Improved Capture from Control:	13.0 %

Hydraulic Performance

Max Impoundment Depth (in.):	24.0	Impoundment Depth Ratio:	1.00
Impoundment Length (ft):	34.0	Impoundment Length Ratio:	0.85
Dewatering Time (min):	59.0	<i>Note: ratios based on theoretical impoundment</i>	







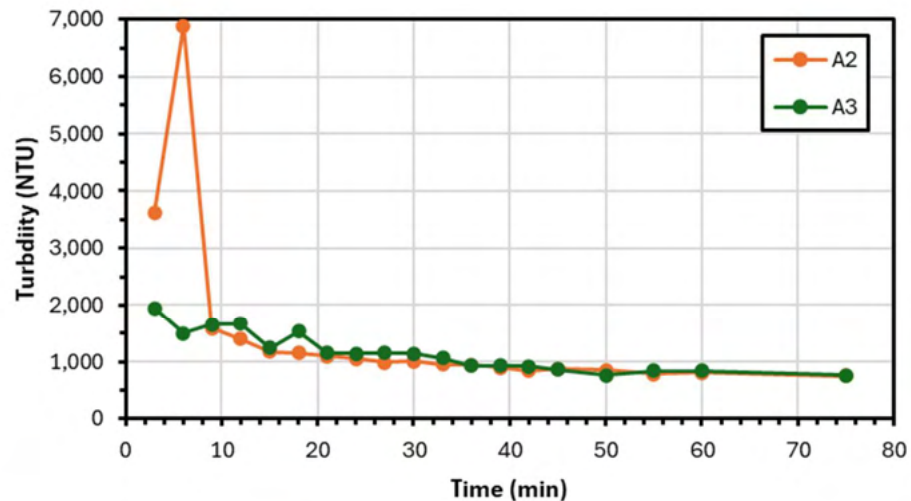
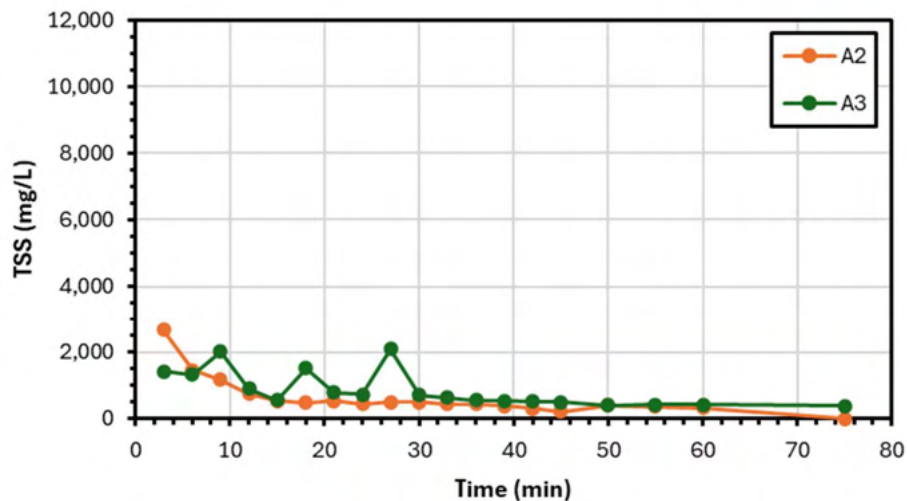
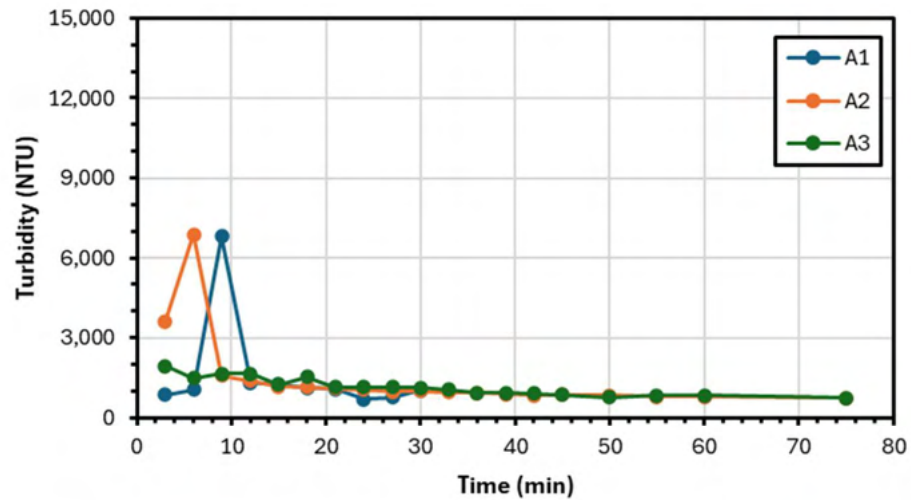
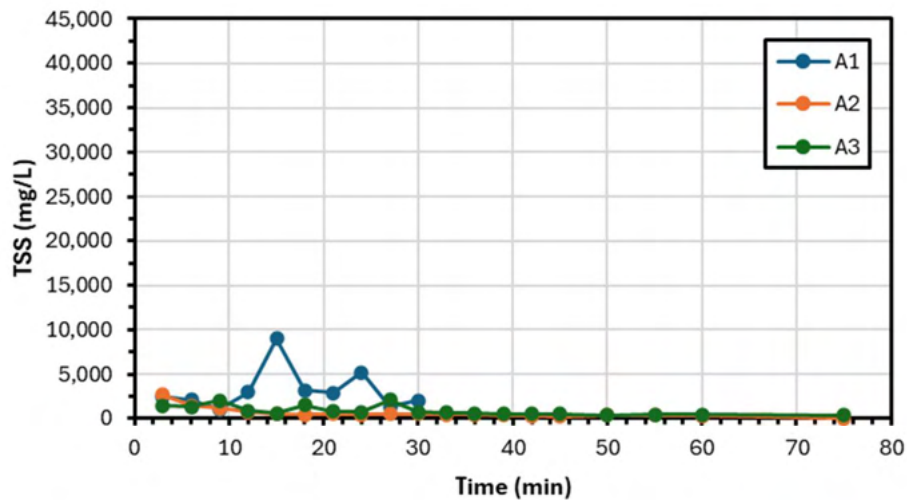

Water Quality Data Statistics

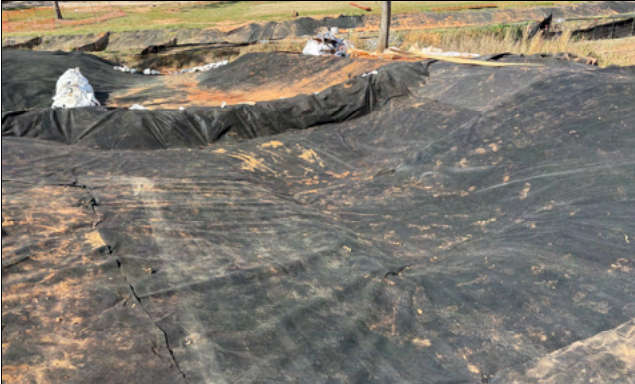



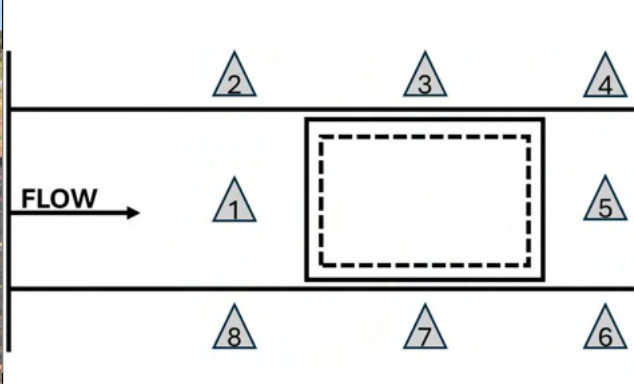



Measurement Location	Avg		Min		Max		Std. Dev.	
	NTU	TSS (mg/L)	NTU	TSS (mg/L)	NTU	TSS (mg/L)	NTU	TSS (mg/L)
Inflow	1,597	3,226	692	1,020	6,803	9,020	1,745	2,226
Trap	1,455	633	747	10	6,890	2,680	1,422	576
Downstream	1,158	868	756	390	1,943	2,090	338	525

TSS (mg/L) and Turbidity (NTU) Data Plots

Legend Interpretation: The letter (A, B, C, D) corresponds to the Test ID to indicate which test in the series. The number (1, 2, 3) corresponds to the data collection location with 1 indicating the inflow collection point, 2 indicating the "in-trap" collection point, and 3 indicating the downstream or discharge collection point.

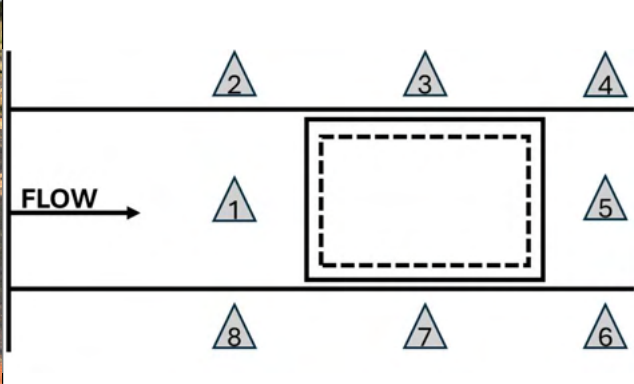

Test ID	Photo Documentation	Installation
A	Pre-Test	Modified Rock Check
		
Location 2	Location 3	Location 4
		
Location 1		Location 5
		
Location 8	Location 7	Location 6

Test ID	Photo Documentation	Installation
A	Post-Test	Modified Rock Check
		
Location 2	Location 3	Location 4
		
Location 1		Location 5
		
Location 8	Location 7	Location 6

SILT TRAP TEST LOG

Test Summary

Installation:	Modified Rock Check
Test ID:	B
Date:	3/20/2025
Type:	Longevity
Flow Rate (cfs):	0.5
Sediment Load Rate (lb/min):	36.6

Picture of Installation



Note: pictured on upstream side facing downstream in channel

Installation Description & Test Notes: The silt trap was paired with a modified rock check. The AL Class 1 riprap was used as a conservative equivalent from the NE Type A riprap. The check was 2 ft tall and 4 ft wide with a top width of 2 ft. The low point of the check was in the center of the channel, and the check was perpendicular across the channel. The rock was placed two feet downstream of the trap. The rock was covered in nonwoven geotextile and weep holes were cut in the face of the installation. No trenching of the rock. Water flowed through the covered rock check at 2min into Test A, B, & C. The rock overtopped at 16 min into the test and stopped overtopping at 43 min into the test.

Sediment Capture Efficiency

Capture of Introduced Sediment:	87.2 %
Improved Capture from Control:	13.0 %

Hydraulic Performance

Max Impoundment Depth (in.):	24.0	Impoundment Depth Ratio:	1.00
Impoundment Length (ft):	35.0	Impoundment Length Ratio:	0.88
Dewatering Time (min):	35.0	<i>Note: ratios based on theoretical impoundment</i>	







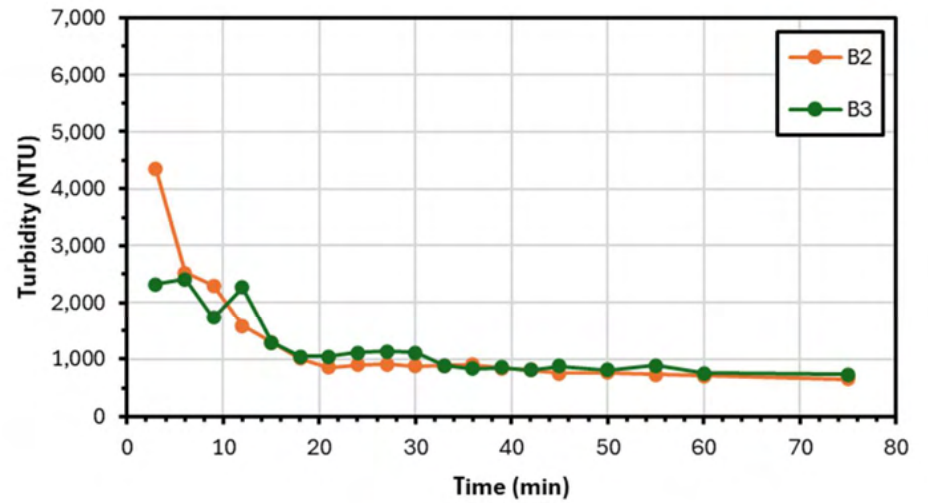
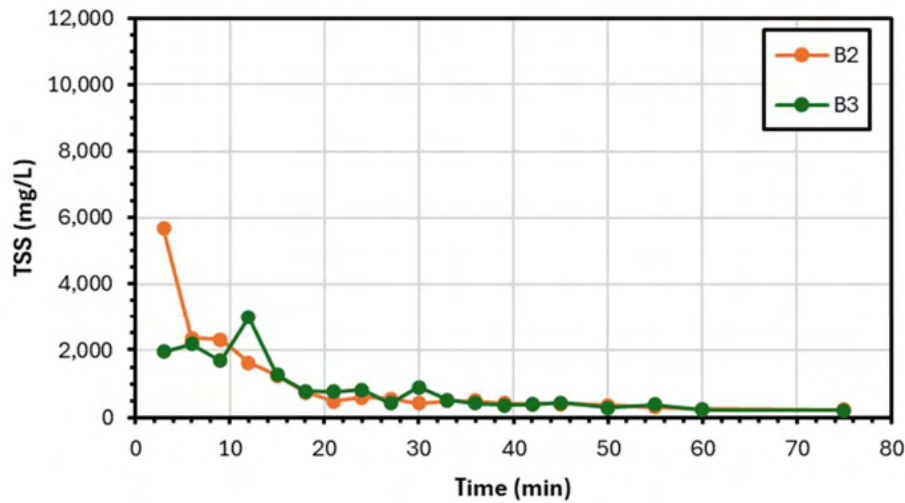
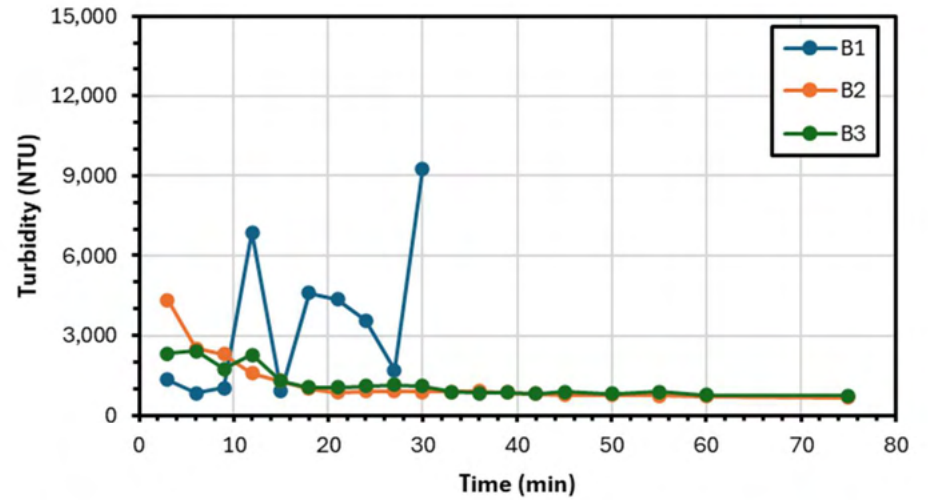
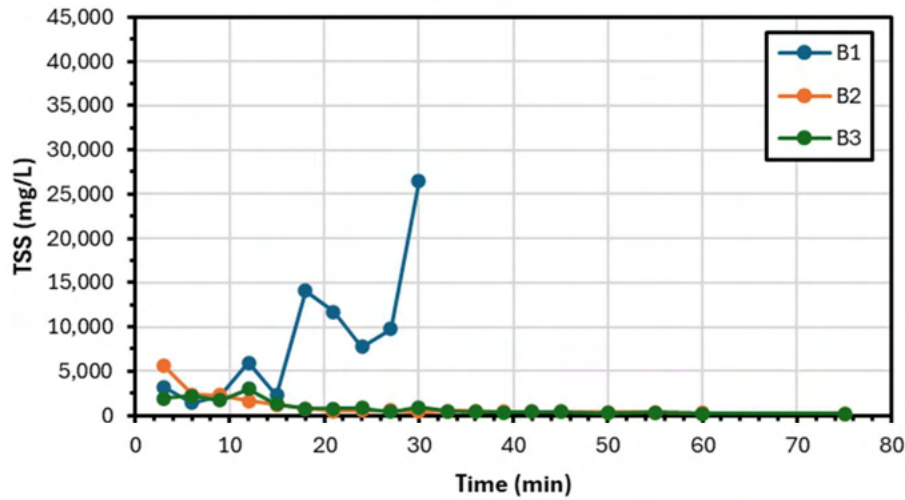

Water Quality Data Statistics





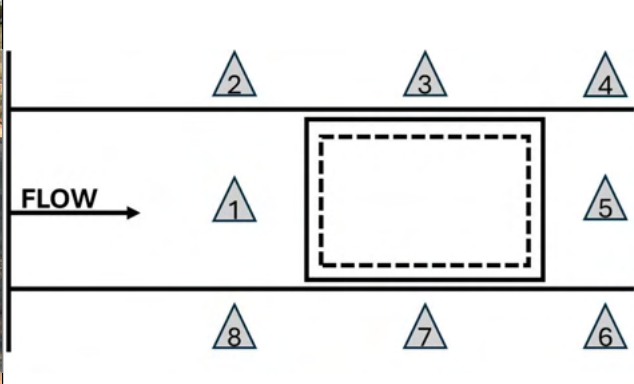

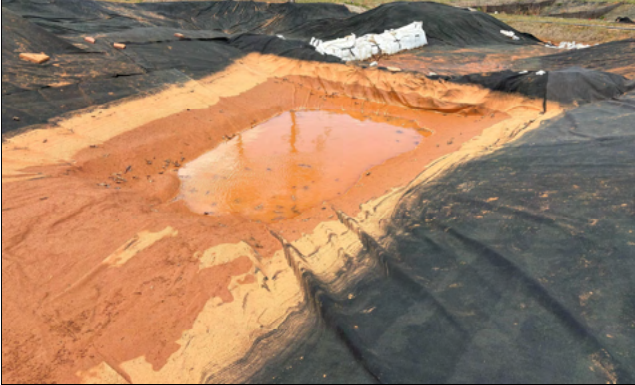

Measurement Location	Avg		Min		Max		Std. Dev.	
	NTU	TSS (mg/L)	NTU	TSS (mg/L)	NTU	TSS (mg/L)	NTU	TSS (mg/L)
Inflow	3,441	8,488	824	1,450	9,259	26,440	2,731	7,259
Trap	1,245	1,017	654	230	4,340	5,670	888	1,267
Downstream	1,205	891	726	200	2,414	2,990	539	758

TSS (mg/L) and Turbidity (NTU) Data Plots

Legend Interpretation: The letter (A, B, C, D) corresponds to the Test ID to indicate which test in the series. The number (1, 2, 3) corresponds to the data collection location with 1 indicating the inflow collection point, 2 indicating the "in-trap" collection point, and 3 indicating the downstream or discharge collection point.

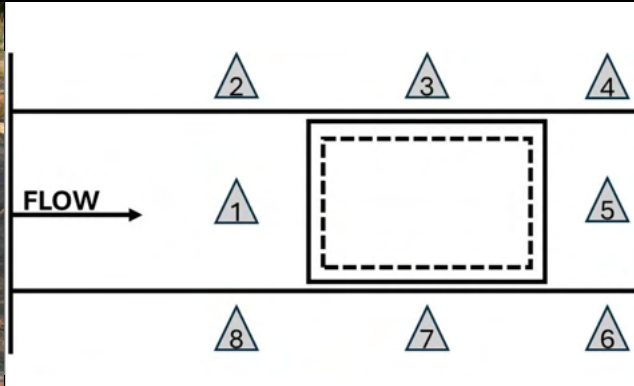

Test ID	Photo Documentation	Installation
B	Pre-Test	Modified Rock Check
		
Location 2	Location 3	Location 4
		
Location 1		Location 5
		
Location 8	Location 7	Location 6

Test ID	Photo Documentation	Installation
B	Post-Test	Modified Rock Check
		
Location 2	Location 3	Location 4
		
Location 1		Location 5
		
Location 8	Location 7	Location 6

SILT TRAP TEST LOG

Test Summary

Installation:	Standard/Control
Test ID:	A
Date:	11/26/2024
Type:	Longevity
Flow Rate (cfs):	0.5
Sediment Load Rate (lb/min):	36.6

Picture of Installation



Note: pictured on upstream side facing downstream in channel

Installation Description & Test Notes: The silt trap was paired with a modified rock check. The AL Class 1 riprap was used as a conservative equivalent from the NE Type A riprap. The check was 2 ft tall and 4 ft wide with a top width of 2 ft. The low point of the check was in the center of the channel, and the check was perpendicular across the channel. The rock was placed two feet downstream of the trap. The rock was covered in nonwoven geotextile and weep holes were cut in the face of the installation. No trenching of the rock. Water flowed through the covered rock check at 2min into Test A, B, & C. Overtopping occurred 15 min into the test and overtopping stopped 44 min into the test.

Sediment Capture Efficiency

Capture of Introduced Sediment:	87.2 %
Improved Capture from Control:	13.0 %

Hydraulic Performance

Max Impoundment Depth (in.):	24.0	Impoundment Depth Ratio:	1.00
Impoundment Length (ft):	35.0	Impoundment Length Ratio:	0.88
Dewatering Time (min):	47.0	<i>Note: ratios based on theoretical impoundment</i>	







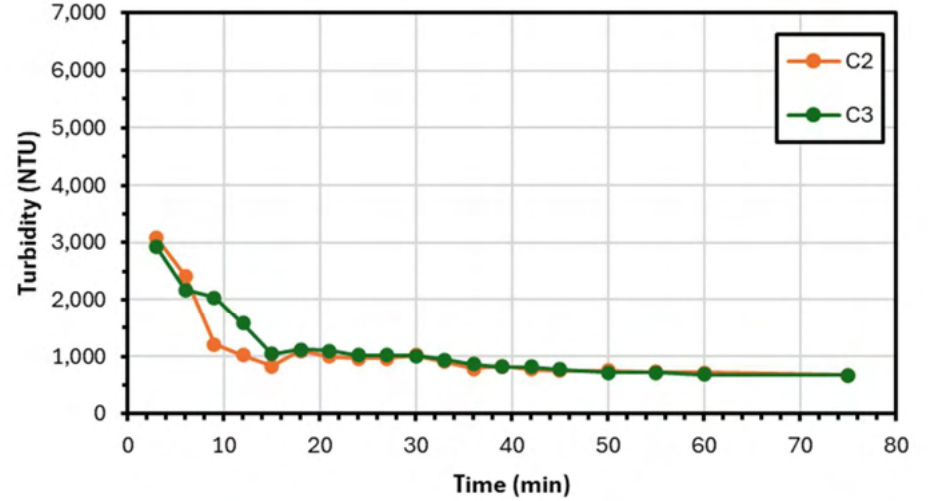
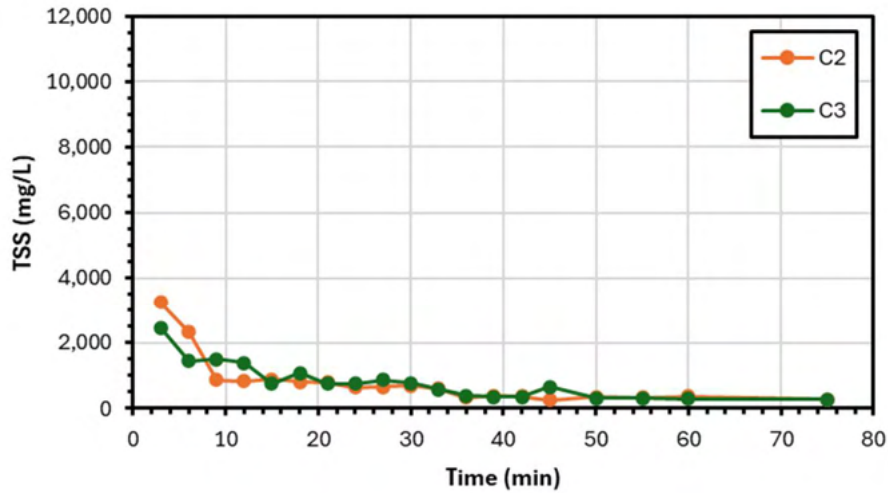
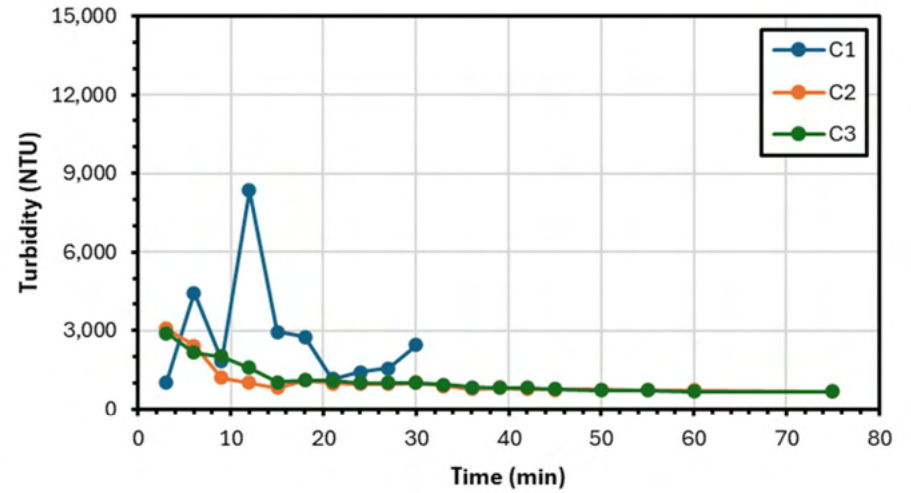
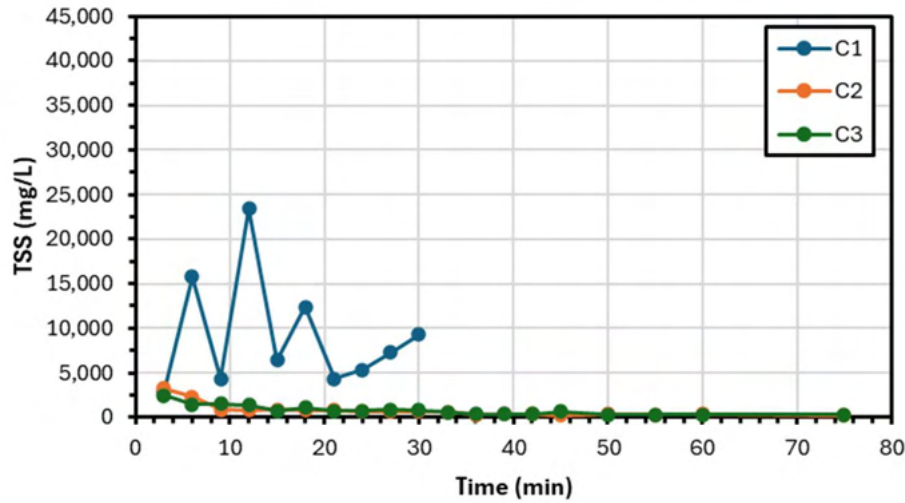

Water Quality Data Statistics





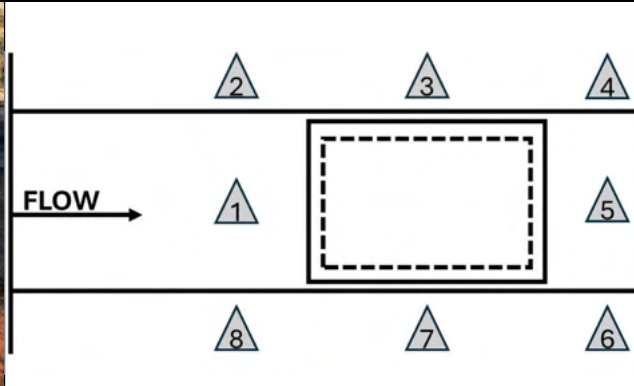

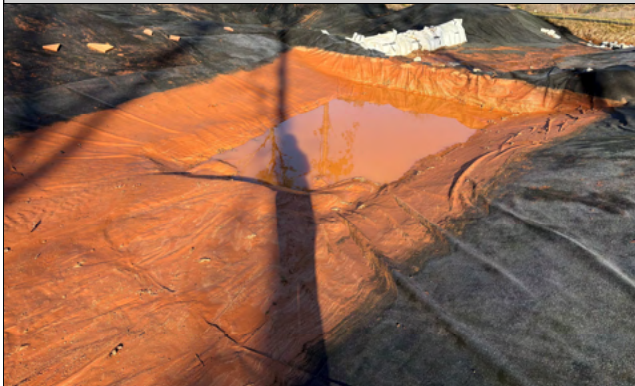

Measurement Location	Avg		Min		Max		Std. Dev.	
	NTU	TSS (mg/L)	NTU	TSS (mg/L)	NTU	TSS (mg/L)	NTU	TSS (mg/L)
Inflow	2,799	9,147	1,048	2,900	8,353	23,420	2,093	6,081
Trap	1,078	792	670	250	3,073	3,240	599	730
Downstream	995	675	675	280	2,033	1,510	337	366

TSS (mg/L) and Turbidity (NTU) Data Plots

Legend Interpretation: The letter (A, B, C, D) corresponds to the Test ID to indicate which test in the series. The number (1, 2, 3) corresponds to the data collection location with 1 indicating the inflow collection point, 2 indicating the "in-trap" collection point, and 3 indicating the downstream or discharge collection point.

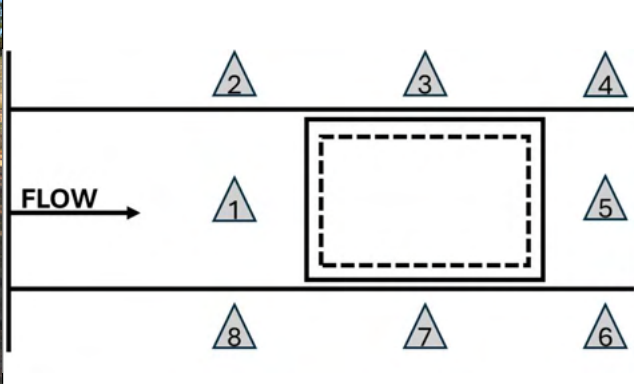

Test ID	Photo Documentation	Installation
C	Pre-Test	Modified Rock Check
		
Location 2	Location 3	Location 4
		
Location 1		Location 5
		
Location 8	Location 7	Location 6

Test ID	Photo Documentation	Installation
C	Post-Test	Modified Rock Check
		
Location 2	Location 3	Location 4
		
Location 1		Location 5
		
Location 8	Location 7	Location 6

SILT TRAP TEST LOG

Test Summary

Installation:	Slash Mulch Berm
Test ID:	A
Date:	4/2/2025
Type:	Longevity
Flow Rate (cfs):	0.5
Sediment Load Rate (lb/min):	36.6

Picture of Installation



Note: pictured on upstream side facing downstream in channel

Installation Description & Test Notes: The silt trap was paired with a slash mulch berm. The berm was 4 ft wide at the bottom and 2 ft wide at the top with a height of 2 ft. The berm was constructed with fresh mulch from a nearby site. The berm was built in three lifts with good compaction on each lift using a skid steer. The impoundment did not reach the full height of the berm and no overtopping occurred. Water flowed through the slash mulch berm at 5 min into the test. At 12 min into the test, the left side of dam (looking upstream) opened up increasing flow-through (probably compaction dislodging) lowering the pool volume till the berm spot filled/blocked again and the pool returned to previous levels.

Sediment Capture Efficiency

Capture of Introduced Sediment (%):	94.6 %
Improved Capture from Control:	20.4 %

Hydraulic Performance

Average Max Impoundment Depth (ft):	18.0	Impoundment Depth Ratio:	0.75
Average Impoundment Length (ft):	24.0	Impoundment Length Ratio:	0.60
Average Dewatering Time (min):	45.0	<i>Note: ratios based on theoretical impoundment</i>	







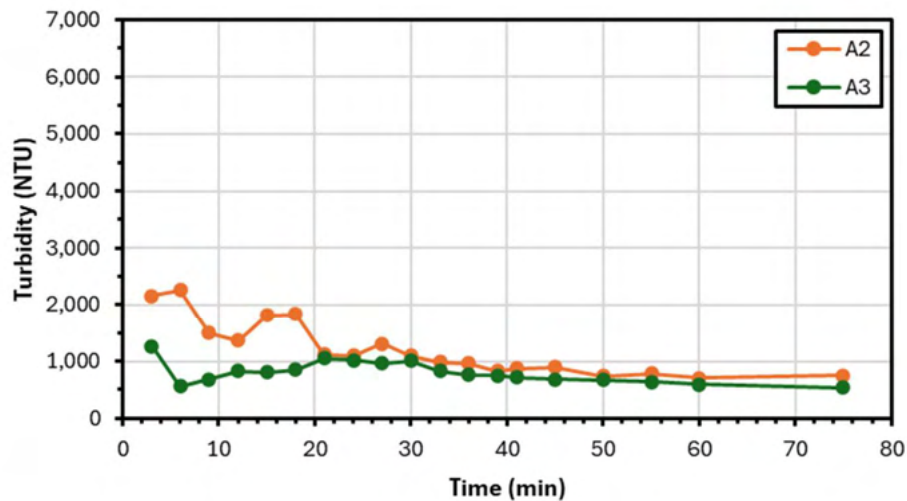
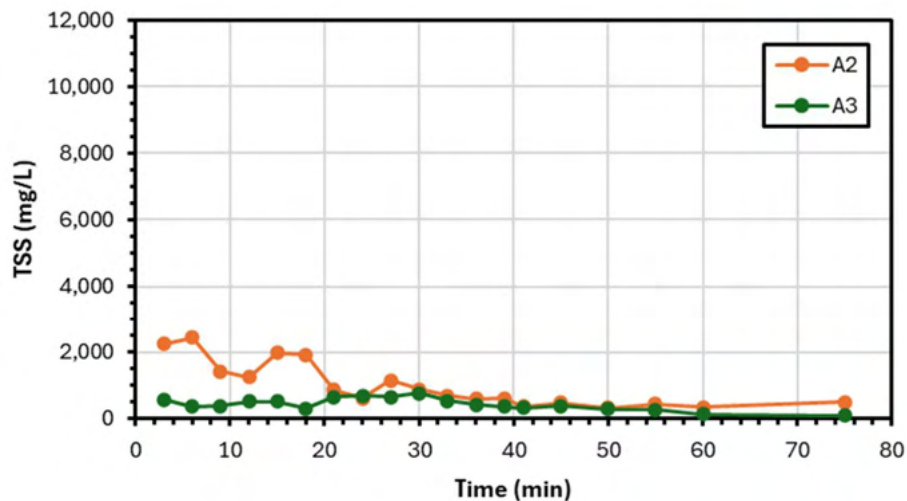
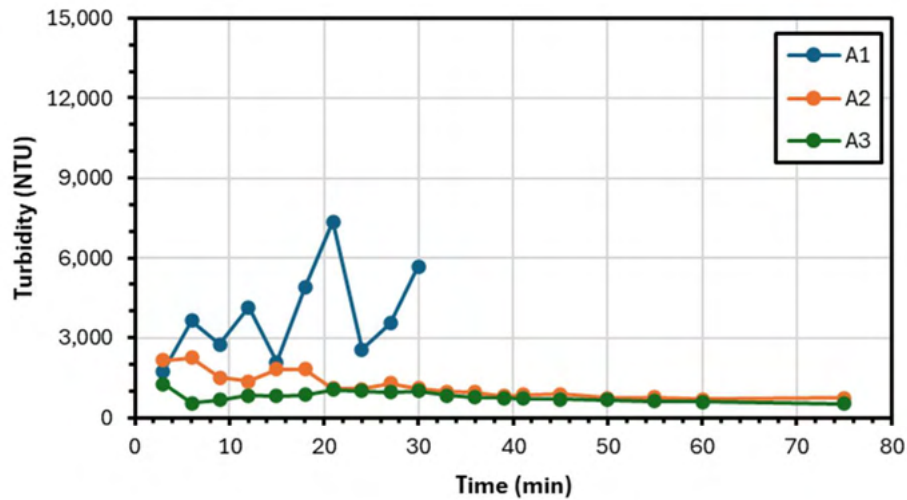
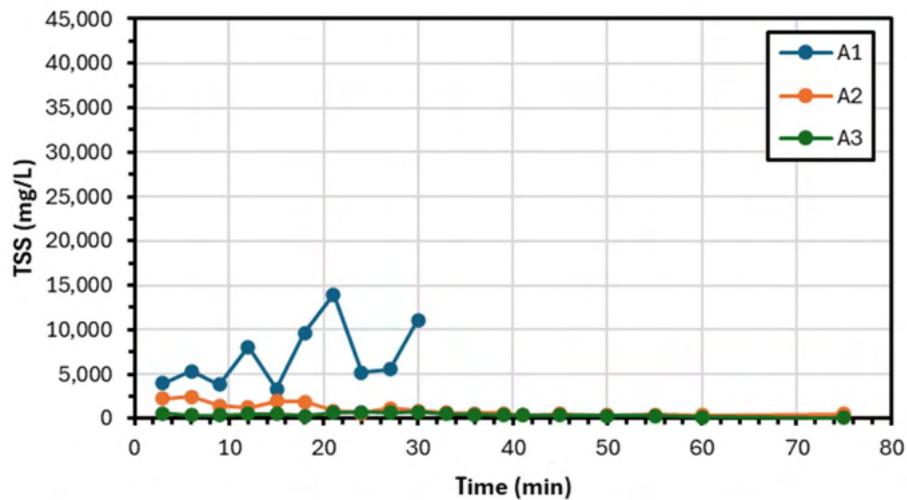

Water Quality Data Statistics





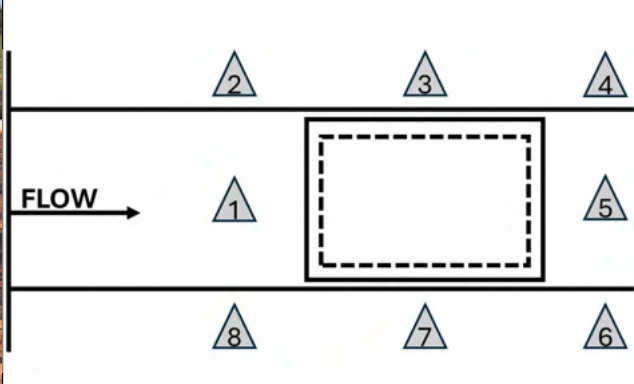



Measurement Location	Avg		Min		Max		Std. Dev.	
	NTU	TSS (mg/L)	NTU	TSS (mg/L)	NTU	TSS (mg/L)	NTU	TSS (mg/L)
Inflow	3,842	6,995	1,750	3,290	7,356	13,960	1,653	3,380
Trap	1,215	1,013	708	340	2,259	2,450	472	664
Downstream	801	443	534	110	1,265	770	186	176

TSS (mg/L) and Turbidity (NTU) Data Plots

Legend Interpretation: The letter (A, B, C, D) corresponds to the Test ID to indicate which test in the series. The number (1, 2, 3) corresponds to the data collection location with 1 indicating the inflow collection point, 2 indicating the “in-trap” collection point, and 3 indicating the downstream or discharge collection point.

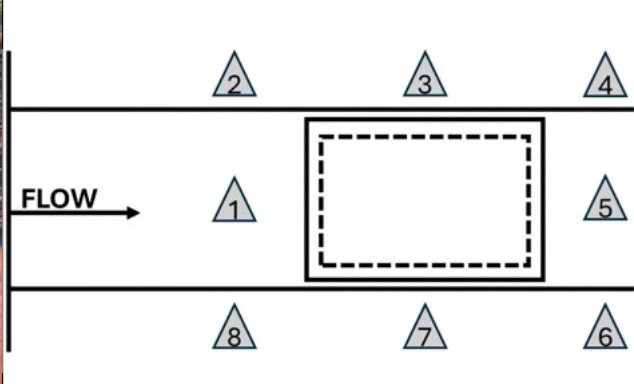

Test ID	Photo Documentation	Installation
A	Pre-Test	Slash Mulch Berm
		
Location 2	Location 3	Location 4
		
Location 1		Location 5
		
Location 8	Location 7	Location 6

Test ID	Photo Documentation	Installation
A	Post-Test	Slash Mulch Berm
		
Location 2	Location 3	Location 4
		
Location 1		Location 5
		
Location 8	Location 7	Location 6

SILT TRAP TEST LOG

Test Summary

Installation:	Standard/Control
Test ID:	B
Date:	4/3/2025
Type:	Longevity
Flow Rate (cfs):	0.5
Sediment Load Rate (lb/min):	36.6

Picture of Installation



Note: pictured on upstream side facing downstream in channel

Installation Description & Test Notes: The silt trap was paired with a slash mulch berm. The berm was 4 ft wide at the bottom and 2 ft wide at the top with a height of 2 ft. The berm was constructed with fresh mulch from a nearby site. The berm was built in three lifts with good compaction on each lift using a skid steer. The impoundment did not reach the full height of the berm and no overtopping occurred. Water flowed through the slash mulch berm at 2 min into the test.

Sediment Capture Efficiency

Capture of Introduced Sediment:	94.6 %
Improved Capture from Control:	20.4 %

Hydraulic Performance

Max Impoundment Depth (in.):	18.0	Impoundment Depth Ratio:	0.75
Impoundment Length (ft):	25.0	Impoundment Length Ratio:	0.63
Dewatering Time (min):	43.0	<i>Note: ratios based on theoretical impoundment</i>	







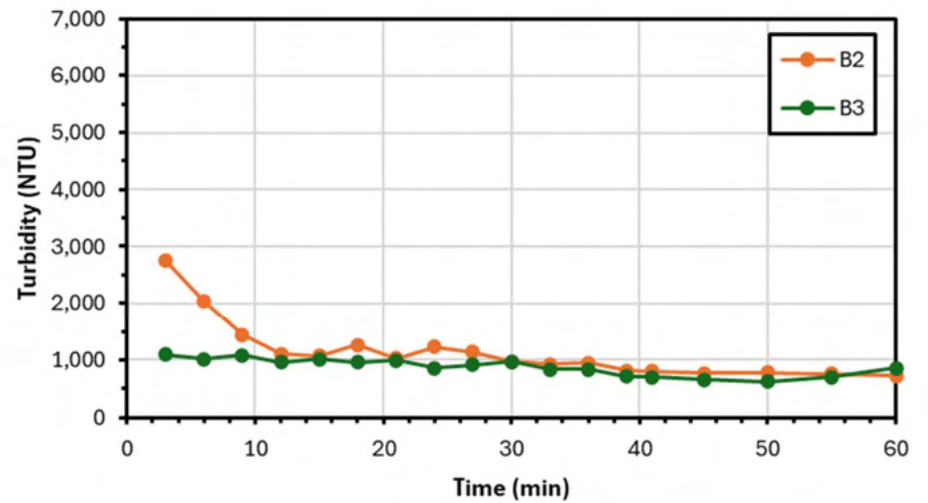
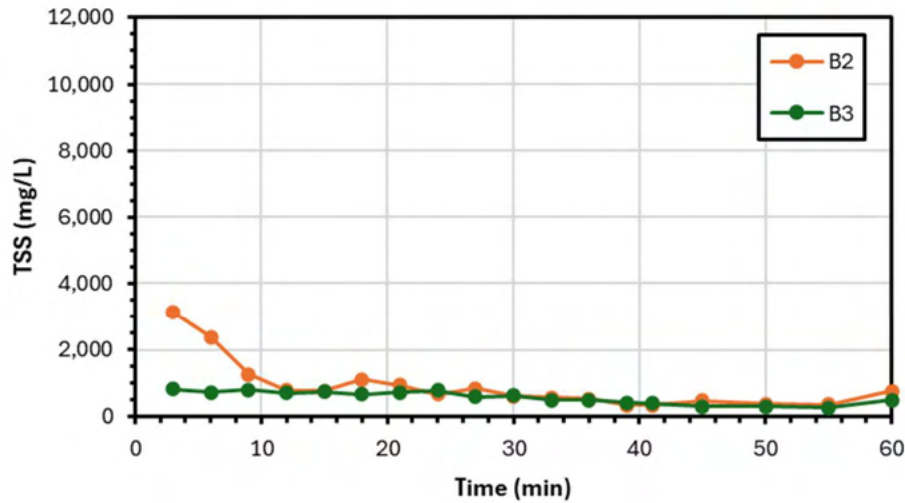
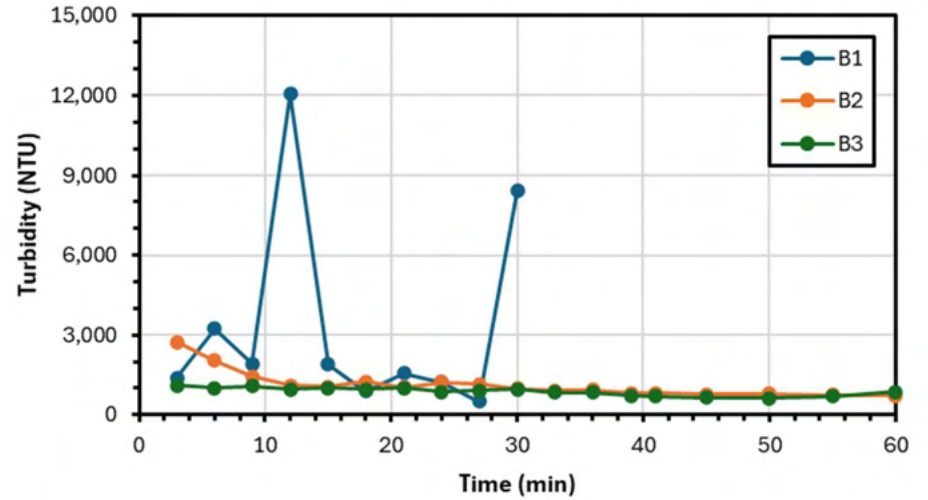
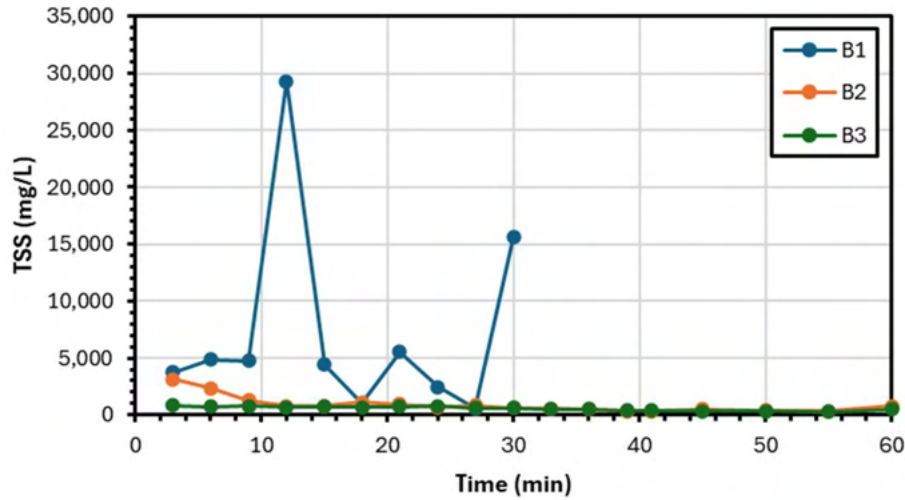

Water Quality Data Statistics





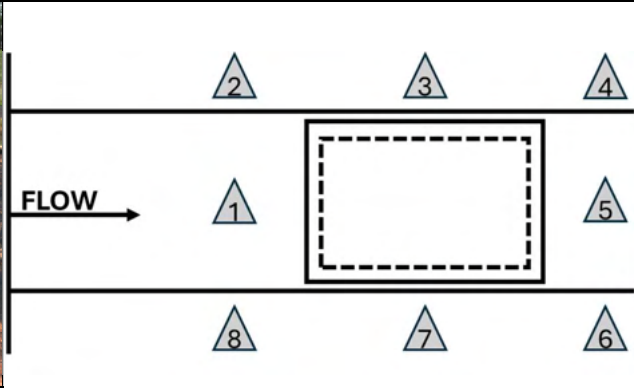



Measurement Location	Avg		Min		Max		Std. Dev.	
	NTU	TSS (mg/L)	NTU	TSS (mg/L)	NTU	TSS (mg/L)	NTU	TSS (mg/L)
Inflow	3,306	7,228	499	570	12,050	29,310	3,623	8,357
Trap	1,139	906	724	350	2,744	3,120	496	708
Downstream	876	578	621	270	1,092	820	143	177

TSS (mg/L) and Turbidity (NTU) Data Plots

Legend Interpretation: The letter (A, B, C, D) corresponds to the Test ID to indicate which test in the series. The number (1, 2, 3) corresponds to the data collection location with 1 indicating the inflow collection point, 2 indicating the "in-trap" collection point, and 3 indicating the downstream or discharge collection point.

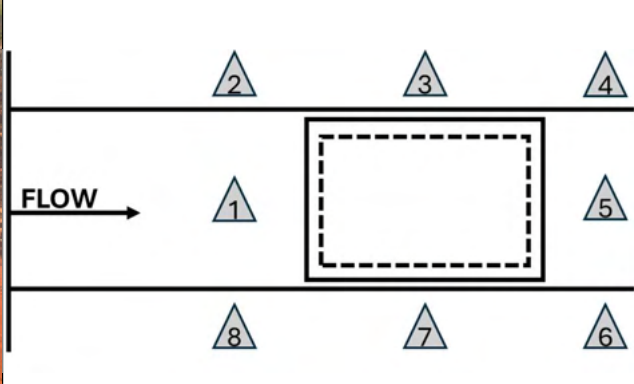

Test ID	Photo Documentation	Installation
B	Pre-Test	Slash Mulch Berm
		
Location 2	Location 3	Location 4
		
Location 1		Location 5
		
Location 8	Location 7	Location 6

Test ID	Photo Documentation	Installation
B	Post-Test	Slash Mulch Berm
		
Location 2	Location 3	Location 4
		
Location 1		Location 5
		
Location 8	Location 7	Location 6

SILT TRAP TEST LOG

Test Summary

Installation:	Slash Mulch Berm
Test ID:	C
Date:	4/3/2025
Type:	Longevity
Flow Rate (cfs):	0.5
Sediment Load Rate (lb/min):	36.6

Picture of Installation



Note: pictured on upstream side facing downstream in channel

Installation Description & Test Notes: The silt trap was paired with a slash mulch berm. The berm was 4 ft wide at the bottom and 2 ft wide at the top with a height of 2 ft. The berm was constructed with fresh mulch from a nearby site. The berm was built in three lifts with good compaction on each lift using a skid steer. The impoundment did not reach the full height of the berm and no overtopping occurred. Water flowed through the slash mulch berm at 2 min into the test.

Sediment Capture Efficiency

Capture of Introduced Sediment:	94.6 %
Improved Capture from Control:	20.4 %

Hydraulic Performance

Max Impoundment Depth (in.):	18.0	Impoundment Depth Ratio:	0.75
Impoundment Length (ft):	25.0	Impoundment Length Ratio:	0.63
Dewatering Time (min):	0	<i>Note: ratios based on theoretical impoundment</i>	







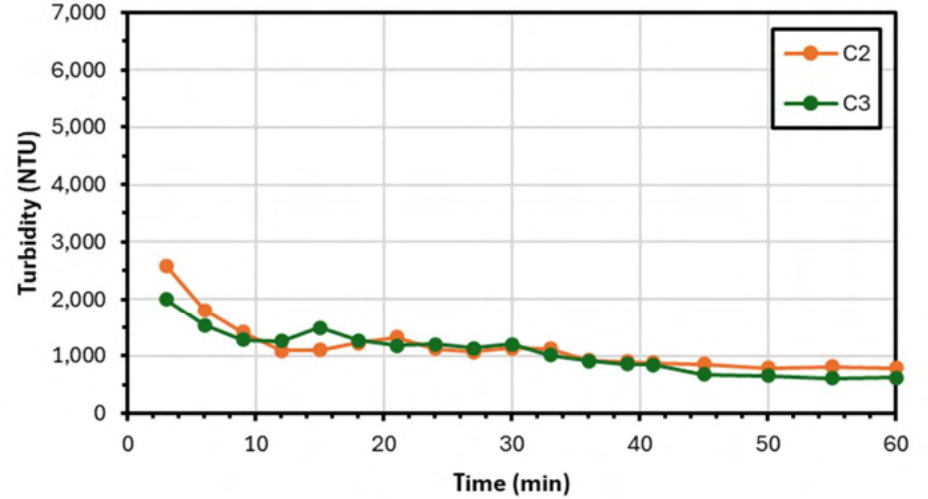
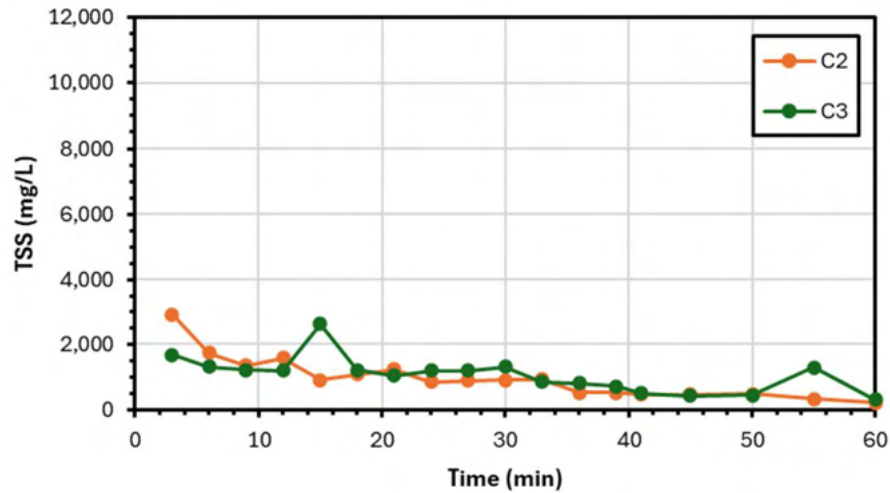
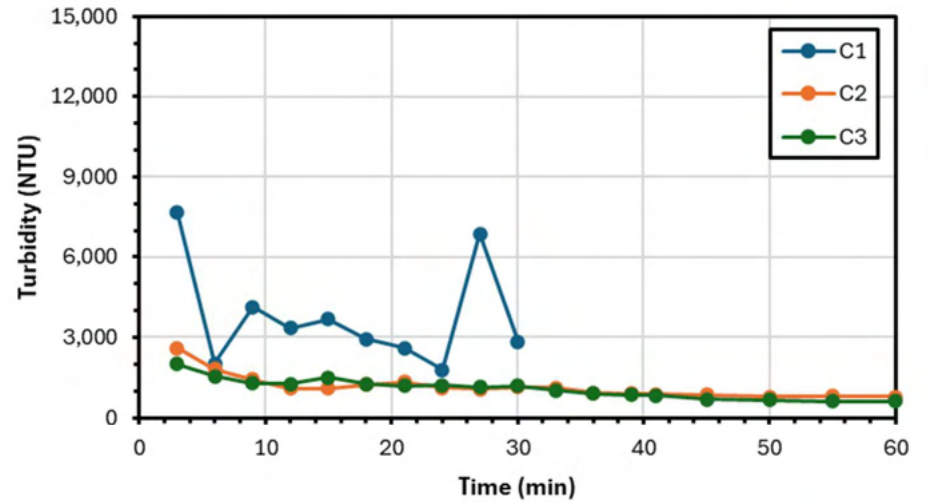
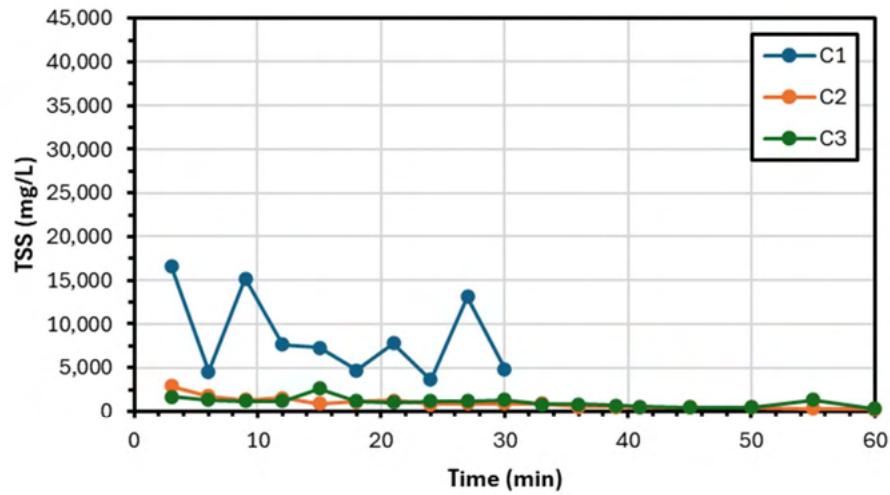

Water Quality Data Statistics





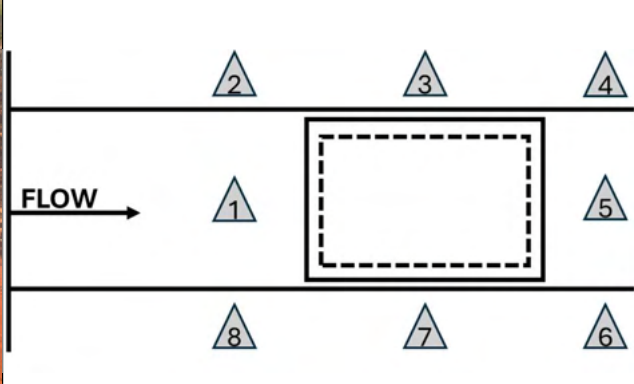

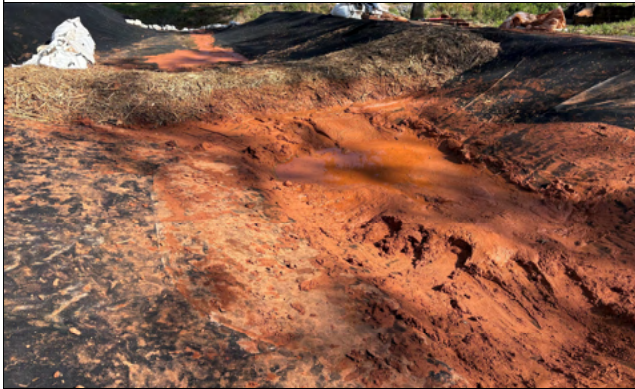

Measurement Location	Avg		Min		Max		Std. Dev.	
	NTU	TSS (mg/L)	NTU	TSS (mg/L)	NTU	TSS (mg/L)	NTU	TSS (mg/L)
Inflow	3,788	8,548	1,779	3,650	7,660	16,650	1,870	4,491
Trap	1,163	971	786	220	2,593	2,900	427	624
Downstream	1,011	1,029	607	320	1,495	2,620	271	529

TSS (mg/L) and Turbidity (NTU) Data Plots

Legend Interpretation: The letter (A, B, C, D) corresponds to the Test ID to indicate which test in the series. The number (1, 2, 3) corresponds to the data collection location with 1 indicating the inflow collection point, 2 indicating the "in-trap" collection point, and 3 indicating the downstream or discharge collection point.

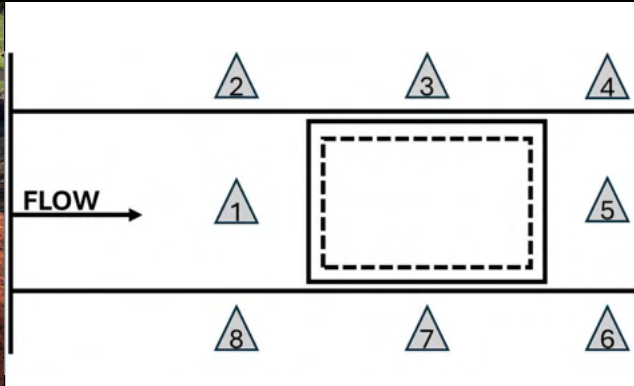

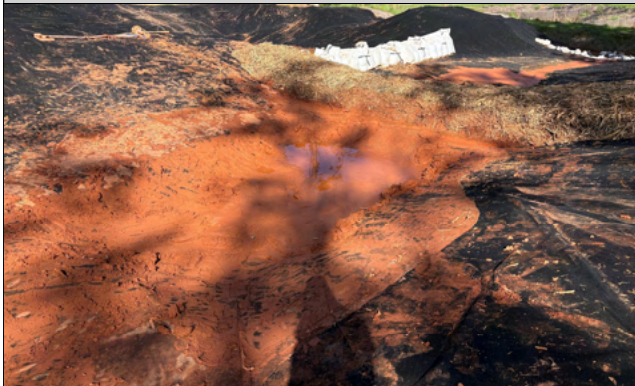
Test ID	Photo Documentation	Installation
C	Pre-Test	Slash Mulch Berm
		
Location 2	Location 3	Location 4
	 <p>Diagram illustrating the flow direction (indicated by the 'FLOW' arrow) and the locations of the slash mulch berms (numbered 1 through 8) relative to the test area. A dashed box highlights a central area.</p>	
Location 1		Location 5
		
Location 8	Location 7	Location 6

Test ID	Photo Documentation	Installation
C	Post-Test	Slash Mulch Berm
		
Location 2	Location 3	Location 4
		
Location 1		Location 5
		
Location 8	Location 7	Location 6

SILT TRAP TEST LOG

Test Summary

Installation:	Temporary Earth Check
Test ID:	A
Date:	4/14/2025
Type:	Longevity
Flow Rate (cfs):	0.5
Sediment Load Rate (lb/min):	36.6

Picture of Installation



Note: pictured on upstream side facing downstream in channel

Installation Description & Test Notes: The silt trap was paired with a temporary earth check. The check was 4 ft wide at the bottom and 2 ft wide at the top with a height of 2 ft. The check was constructed with AL native soil from an on-site stockpile. The earth berm was built in three lifts with good compaction on each lift using a skid steer. The impoundment reached the full height of the berm, incurring overtopping. The overtopping started 12 min into the test and stopped 21 min after the test flow stopped. The check started eroding on the downstream side as water overtopped the installation.

Sediment Capture Efficiency

Capture of Introduced Sediment:	87.5 %
Improved Capture from Control:	13.3 %

Hydraulic Performance

Max Impoundment Depth (in.):	24.0	Impoundment Depth Ratio:	1.00
Impoundment Length (ft):	33.0	Impoundment Length Ratio:	0.83
Dewatering Time (min):	21.0	<i>Note: ratios based on theoretical impoundment</i>	







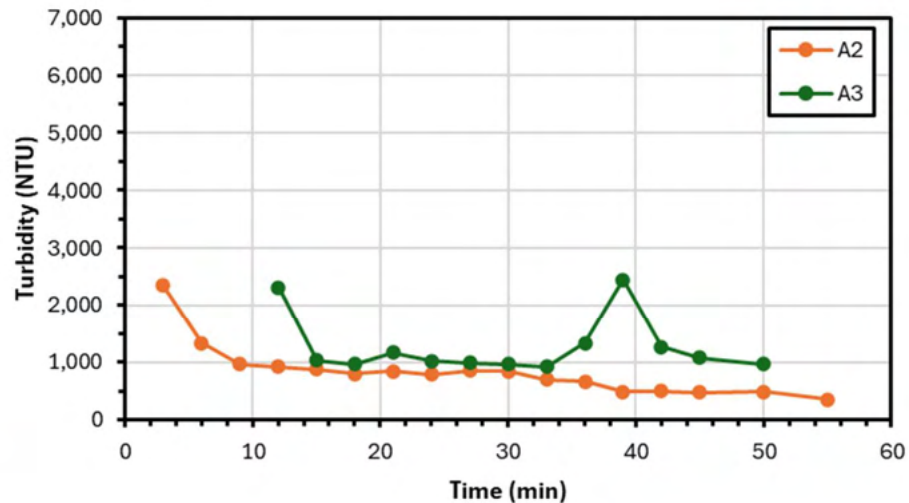
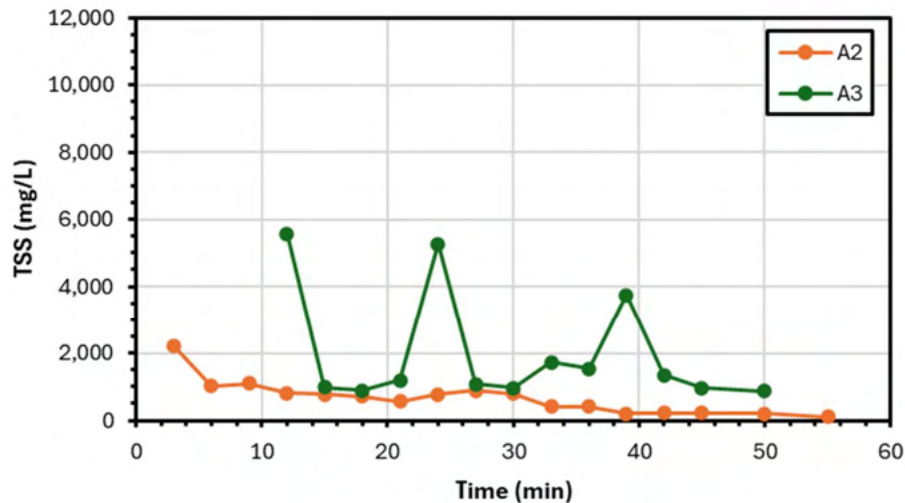
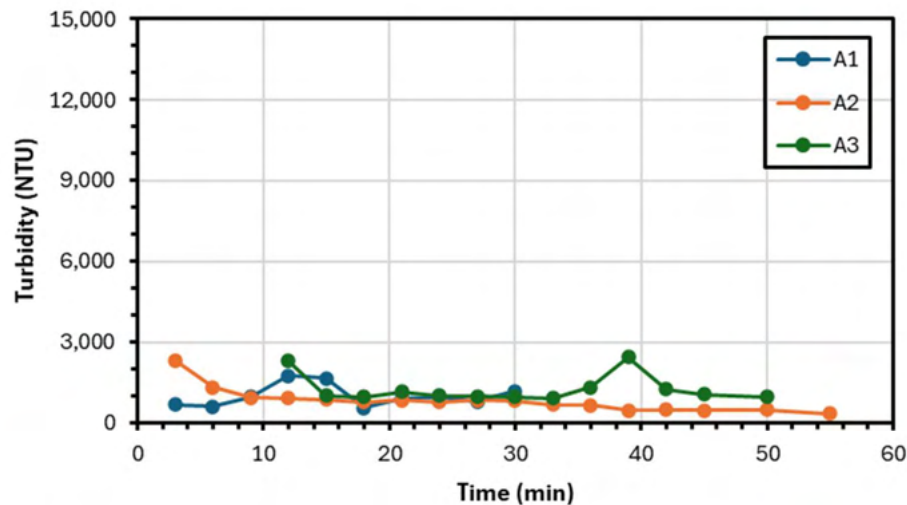
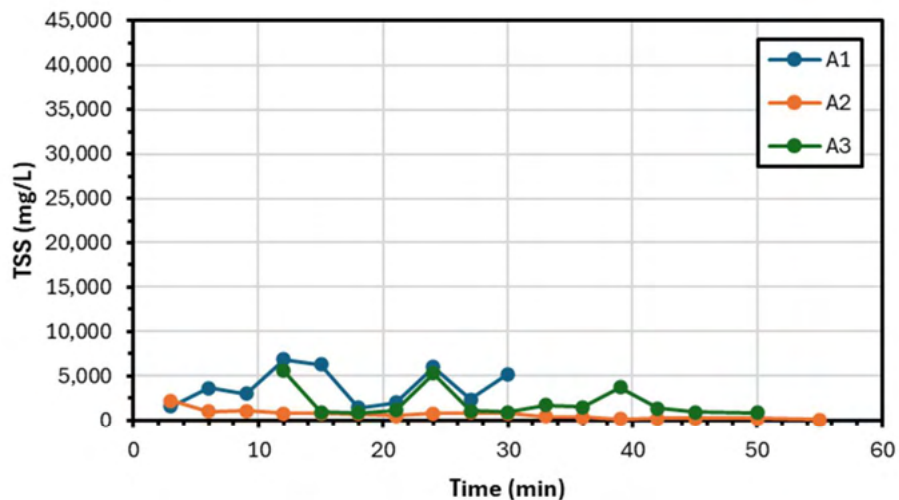

Water Quality Data Statistics





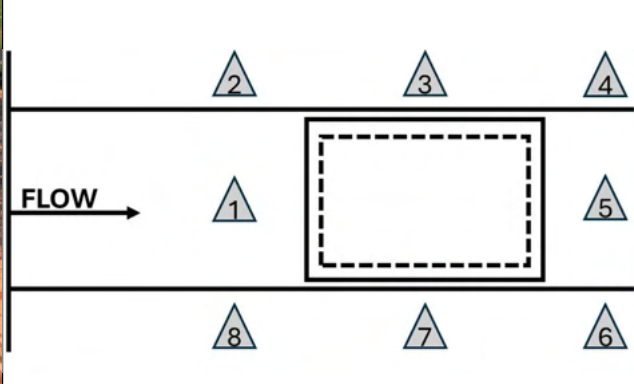

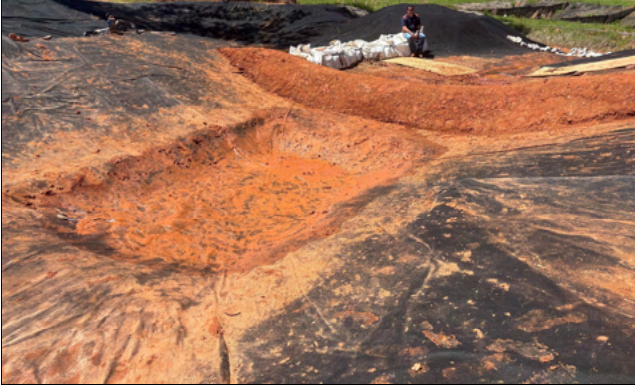

Measurement Location	Avg		Min		Max		Std. Dev.	
	NTU	TSS (mg/L)	NTU	TSS (mg/L)	NTU	TSS (mg/L)	NTU	TSS (mg/L)
Inflow	1,026	3,852	577	1,420	1,776	6,900	393	1,983
Trap	842	671	357	100	2,345	2,210	441	490
Downstream	1,271	2,011	929	860	2,448	5,580	488	1,630

TSS (mg/L) and Turbidity (NTU) Data Plots

Legend Interpretation: The letter (A, B, C, D) corresponds to the Test ID to indicate which test in the series. The number (1, 2, 3) corresponds to the data collection location with 1 indicating the inflow collection point, 2 indicating the “in-trap” collection point, and 3 indicating the downstream or discharge collection point.

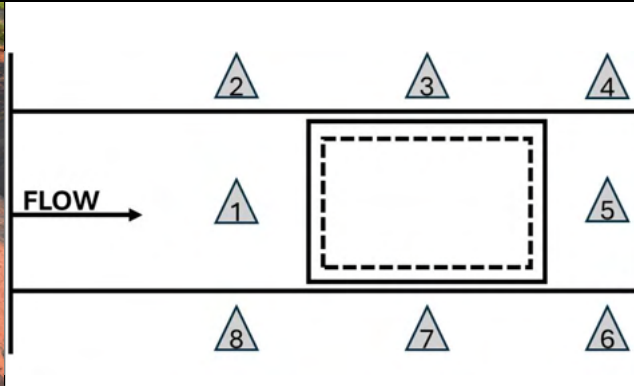

Test ID	Photo Documentation	Installation
A	Pre-Test	Temporary Earth Check
		
Location 2	Location 3	Location 4
		
Location 1		Location 5
		
Location 8	Location 7	Location 6

Test ID	Photo Documentation	Installation
A	Post-Test	Temporary Earth Check
		
Location 2	Location 3	Location 4
		
Location 1		Location 5
		
Location 8	Location 7	Location 6

SILT TRAP TEST LOG

Test Summary

Installation:	Temporary Earth Check
Test ID:	B
Date:	4/15/2025
Type:	Longevity
Flow Rate (cfs):	0.5
Sediment Load Rate (lb/min):	36.6

Picture of Installation



Note: pictured on upstream side facing downstream in channel

Installation Description & Test Notes: The silt trap was paired with a temporary earth check. The check was 4 ft wide at the bottom and 2 ft wide at the top with a height of 2 ft. The check was constructed with AL native soil from an on-site stockpile. The earth berm was built in three lifts with good compaction on each lift using a skid steer. The impoundment reached the full height of the berm, incurring overtopping. The overtopping started 12 min into the test and stopped 28 min after the test flow stopped. The check continued to erode on the downstream side as water overtopped the installation.

Sediment Capture Efficiency

Capture of Introduced Sediment (%):	87.5 %
Improved Capture from Control:	13.3 %

Hydraulic Performance

Max Impoundment Depth (in.):	24.0	Impoundment Depth Ratio:	1.00
Impoundment Length (ft):	31.0	Impoundment Length Ratio:	0.78
Dewatering Time (min):	28.0	<i>Note: ratios based on theoretical impoundment</i>	







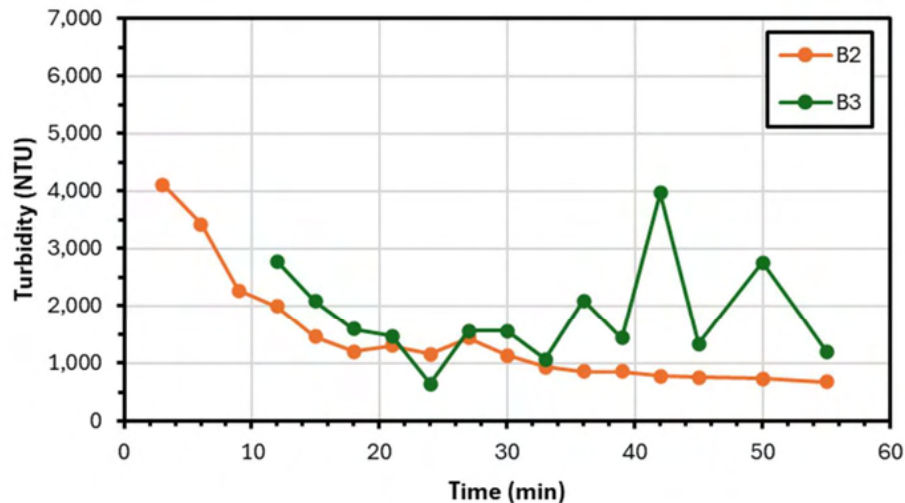
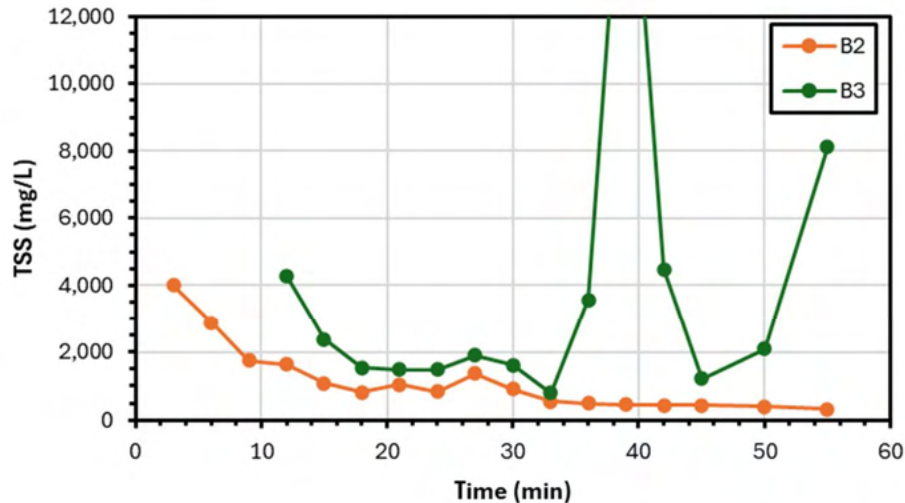
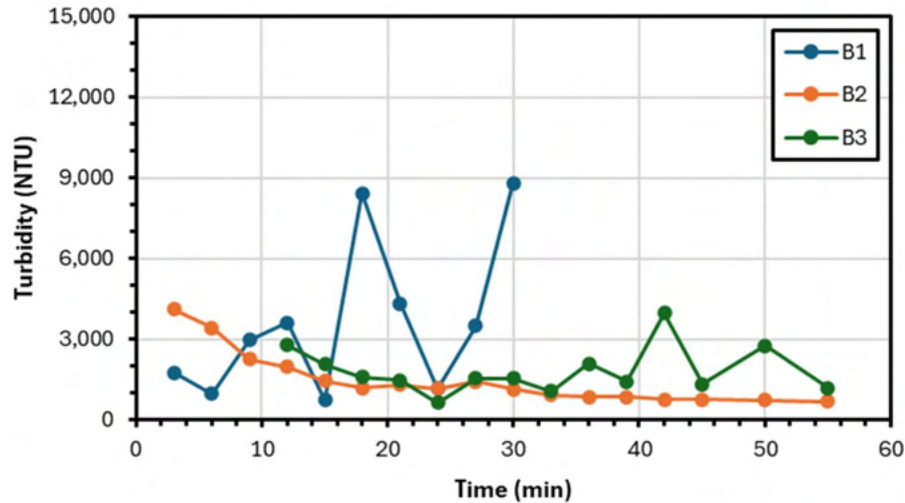
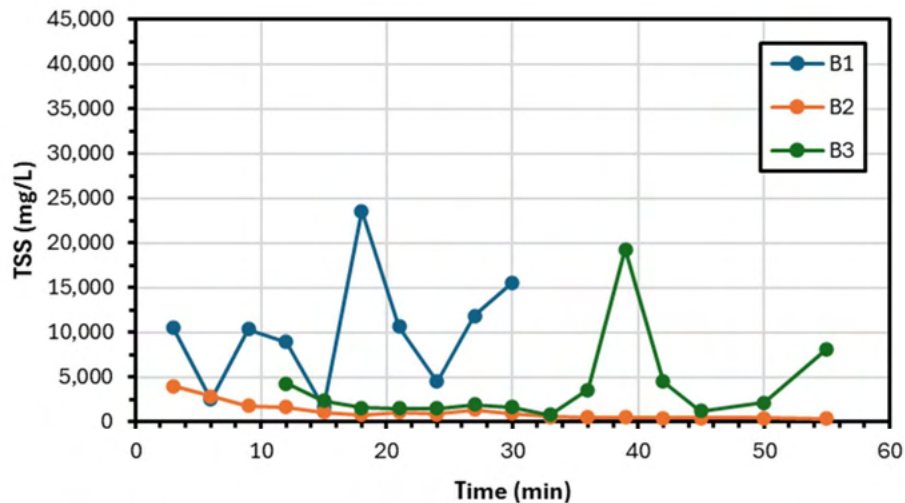

Water Quality Data Statistics





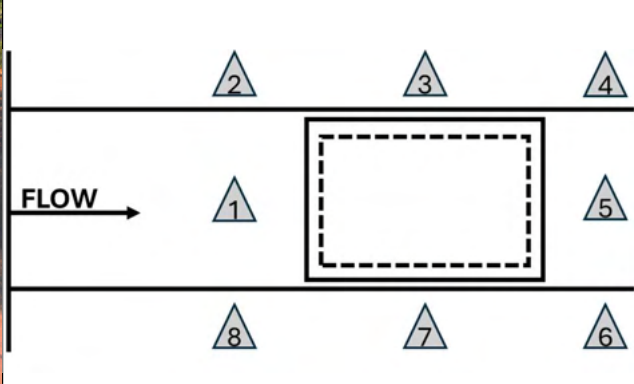



Measurement Location	Avg		Min		Max		Std. Dev.	
	NTU	TSS (mg/L)	NTU	TSS (mg/L)	NTU	TSS (mg/L)	NTU	TSS (mg/L)
Inflow	3,629	10,010	743	1,640	8,805	23,590	2,751	6,143
Trap	1,470	1,144	679	330	4,111	4,000	946	957
Downstream	1,818	3,871	643	790	3,969	19,250	828	4,650

TSS (mg/L) and Turbidity (NTU) Data Plots

Legend Interpretation: The letter (A, B, C, D) corresponds to the Test ID to indicate which test in the series. The number (1, 2, 3) corresponds to the data collection location with 1 indicating the inflow collection point, 2 indicating the “in-trap” collection point, and 3 indicating the downstream or discharge collection point.

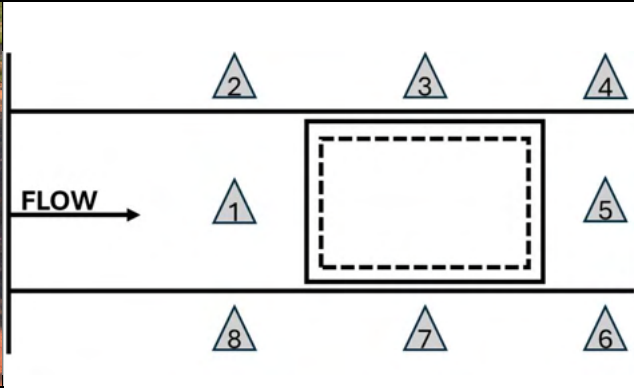

Test ID	Photo Documentation	Installation
B	Pre-Test	Temporary Earth Check
		
Location 2	Location 3	Location 4
		
Location 1		Location 5
		
Location 8	Location 7	Location 6

Test ID	Photo Documentation	Installation
B	Post-Test	Temporary Earth Check
		
Location 2	Location 3	Location 4
		
Location 1		Location 5
		
Location 8	Location 7	Location 6

SILT TRAP TEST LOG

Test Summary

Installation:	Temporary Earth Check
Test ID:	C
Date:	4/15/2025
Type:	Longevity
Flow Rate (cfs):	0.5
Sediment Load Rate (lb/min):	36.6

Picture of Installation



Note: pictured on upstream side facing downstream in channel

Installation Description & Test Notes: The silt trap was paired with a temporary earth check. The check was 4 ft wide at the bottom and 2 ft wide at the top with a height of 2 ft. The check was constructed with AL native soil from an on-site stockpile. The earth berm was built in three lifts with good compaction on each lift using a skid steer. The impoundment reached the full height of the berm, incurring overtopping. The overtopping started 12 min into the test and stopped 29 min after the test flow stopped. The check erosion on the downstream side was around halfway eroded through the check. The erosion affected downstream water quality.

Sediment Capture Efficiency

Capture of Introduced Sediment (%):	87.5 %
Improved Capture from Control:	13.3 %

Hydraulic Performance

Max Impoundment Depth (in.):	24.0	Impoundment Depth Ratio:	1.00
Impoundment Length (ft):	32.0	Impoundment Length Ratio:	0.80
Dewatering Time (min):	29.0	<i>Note: ratios based on theoretical impoundment</i>	







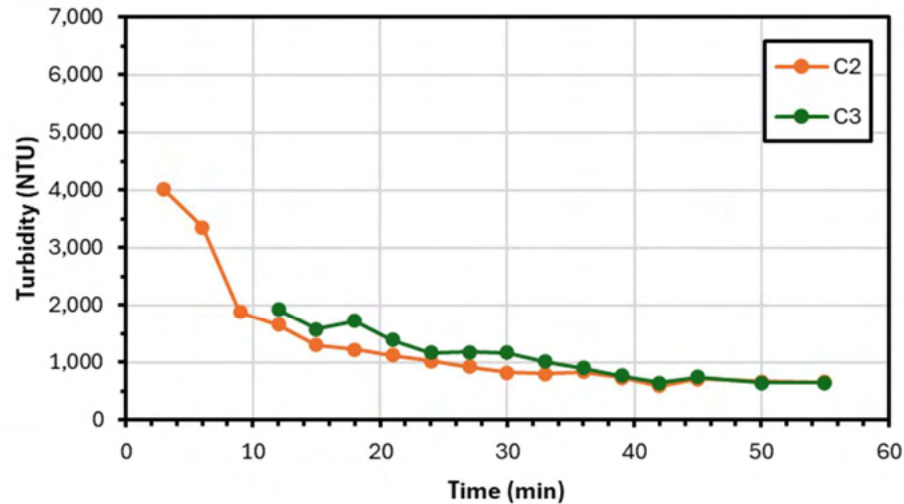
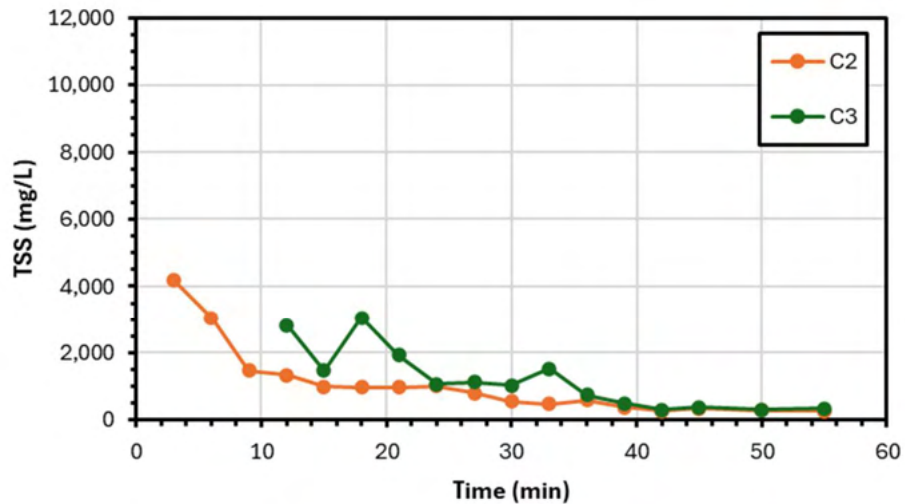
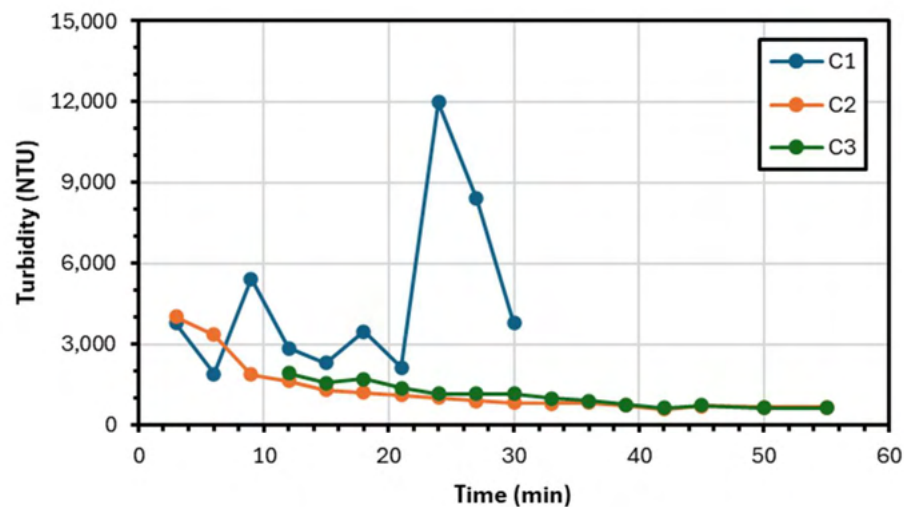
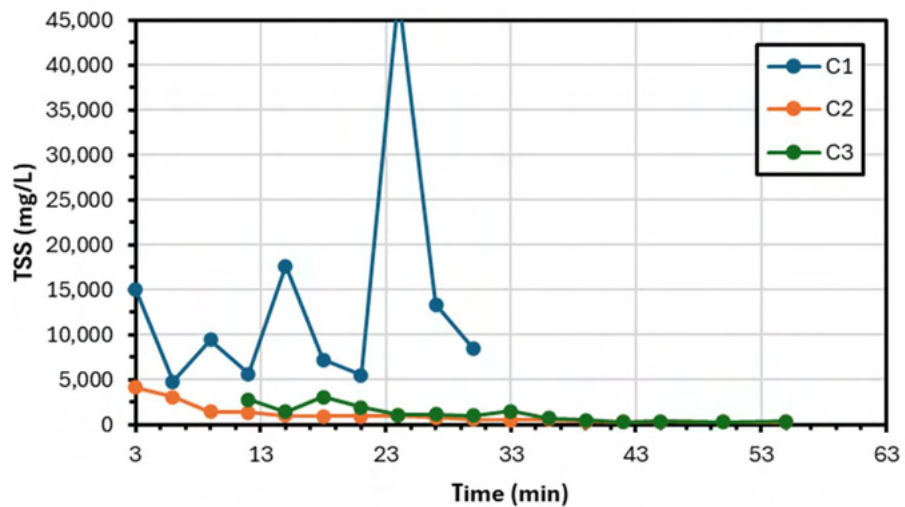

Water Quality Data Statistics





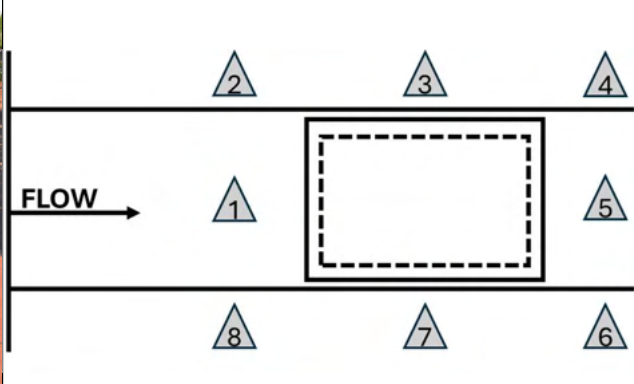

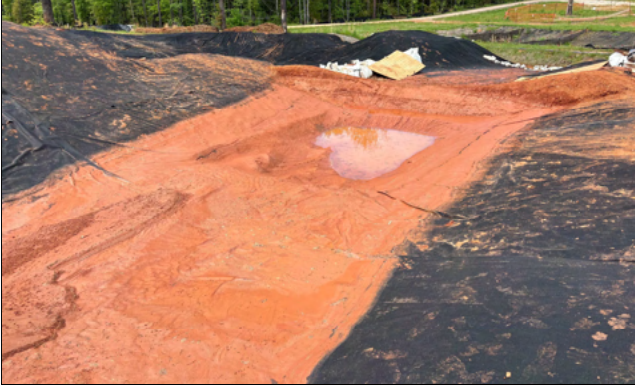

Measurement Location	Avg		Min		Max		Std. Dev.	
	NTU	TSS (mg/L)	NTU	TSS (mg/L)	NTU	TSS (mg/L)	NTU	TSS (mg/L)
Inflow	4,611	13,495	1,904	4,830	11,995	47,780	3,068	12,148
Trap	1,312	1,059	590	280	4,018	4,180	940	1,017
Downstream	1,106	1,193	641	320	1,927	3,060	407	865

TSS (mg/L) and Turbidity (NTU) Data Plots

Legend Interpretation: The letter (A, B, C, D) corresponds to the Test ID to indicate which test in the series. The number (1, 2, 3) corresponds to the data collection location with 1 indicating the inflow collection point, 2 indicating the "in-trap" collection point, and 3 indicating the downstream or discharge collection point.

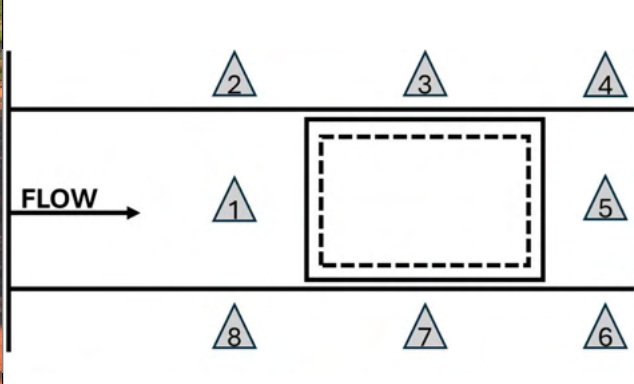

Test ID	Photo Documentation	Installation
C	Pre-Test	Temporary Earth Check
		
Location 2	Location 3	Location 4
		
Location 1		Location 5
		
Location 8	Location 7	Location 6

Test ID	Photo Documentation	Installation
C	Post-Test	Temporary Earth Check
		
Location 2	Location 3	Location 4
		
Location 1		Location 5
		
Location 8	Location 7	Location 6

SILT TRAP TEST LOG

Test Summary

Installation:	Standard at 1 ac Rates
Test ID:	A
Date:	4/30/2025
Type:	Longevity
Flow Rate (cfs):	1.0
Sediment Load Rate (lb/min):	49.0

Picture of Installation



Note: pictured on upstream side facing downstream in channel

Installation Description & Test Notes: The standard Nebraska installation is the silt trap in conjunction with no other installation upstream or downstream. The trap is 1 foot deep with 2:1 horizontal to vertical side slopes. The bottom of the trap had a width of 6 feet and a length of 12 feet. The top of the trap had a width of 10 feet and a length of 16 feet. The standard silt trap was tested at 1 ac rates which is the maximum contributory drainage area a silt trap can handle. The values can be compared to the sediment trap at 1 ac rates.

Sediment Capture Efficiency

Capture of Introduced Sediment:	53.3 %
Improved Capture from Control:	N/A

Hydraulic Performance

Max Impoundment Depth (in.):	0	Impoundment Depth Ratio:	N/A
Impoundment Length (ft):	0	Impoundment Length Ratio:	N/A
Dewatering Time (min):	0	<i>Note: ratios based on theoretical impoundment</i>	







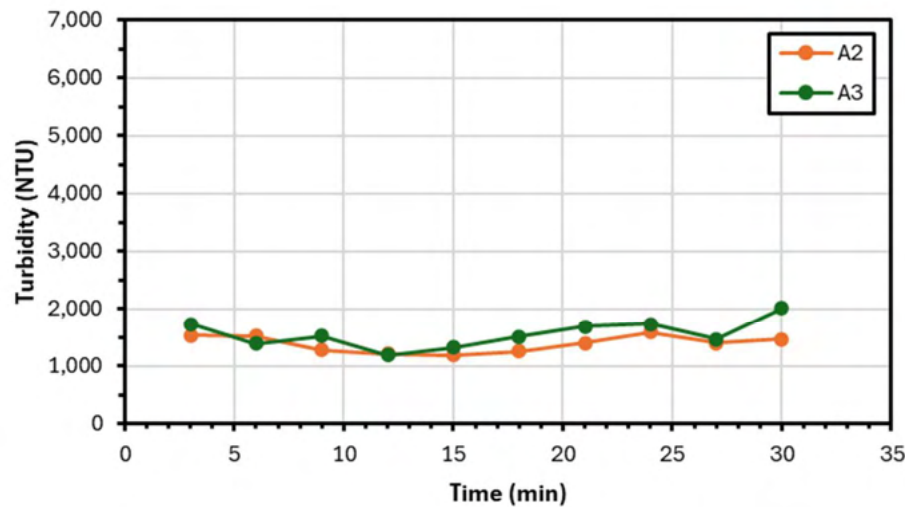
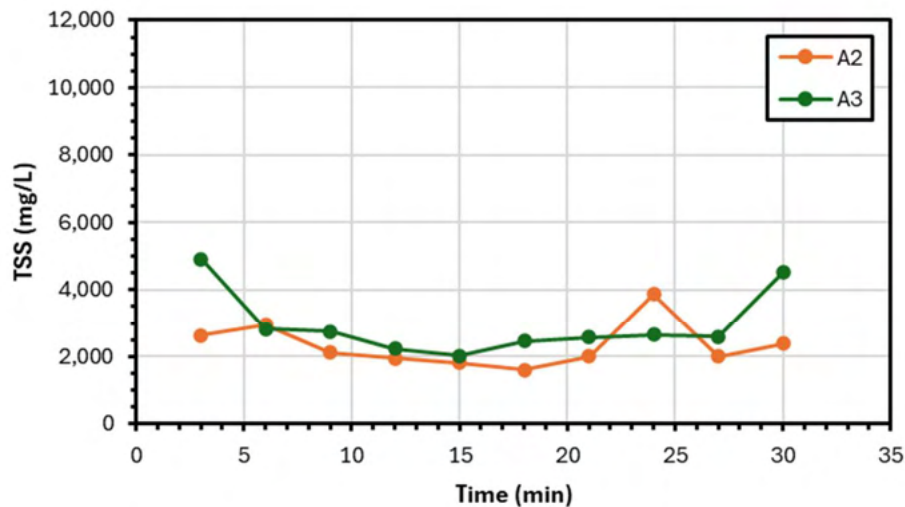
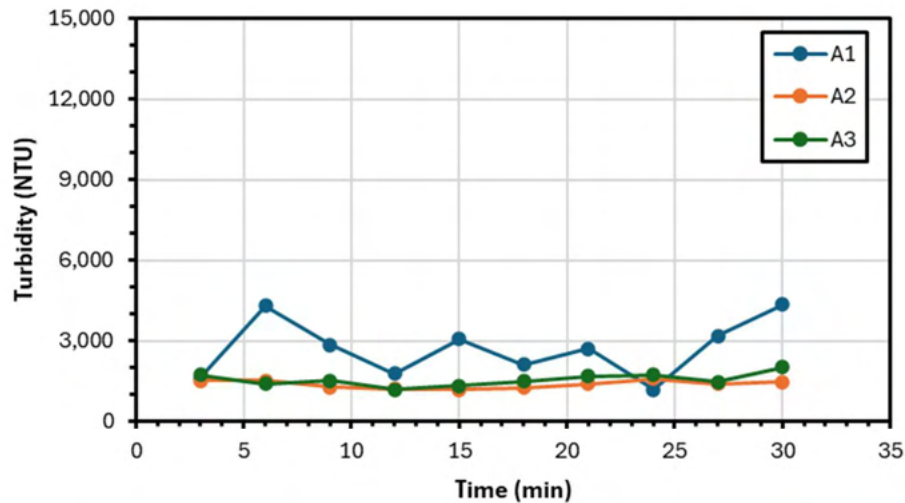
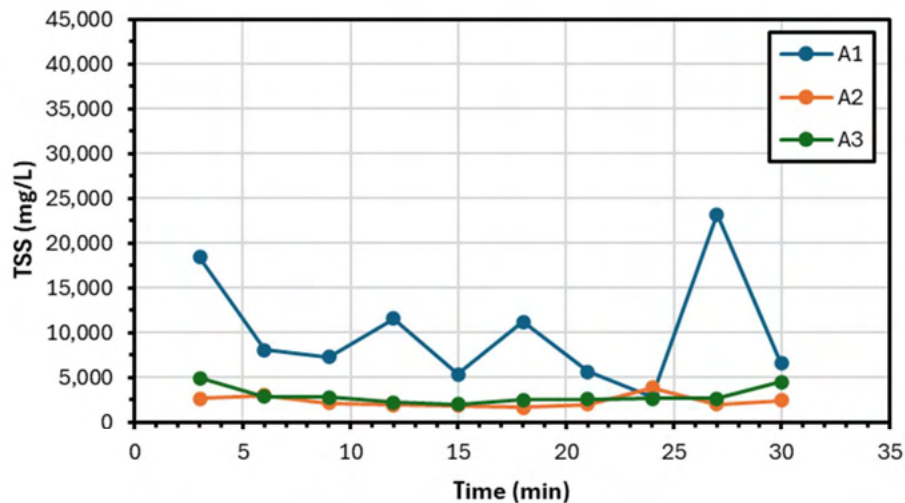

Water Quality Data Statistics



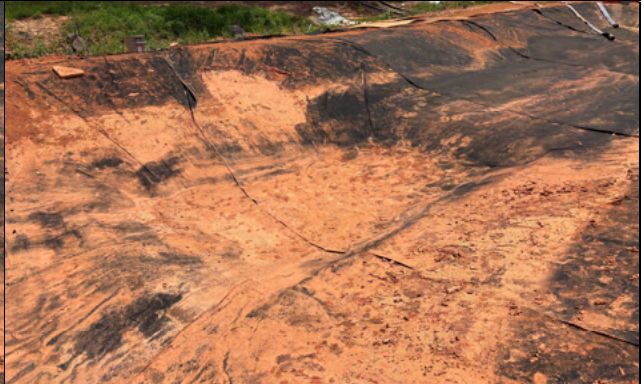

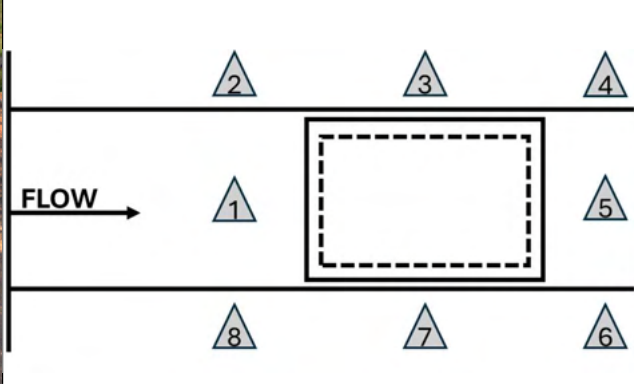

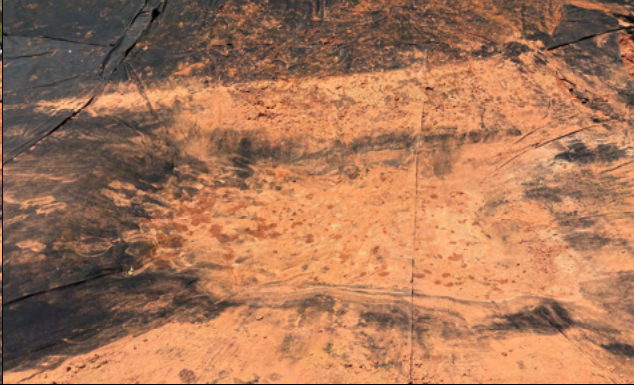

Measurement Location	Avg		Min		Max		Std. Dev.	
	NTU	TSS (mg/L)	NTU	TSS (mg/L)	NTU	TSS (mg/L)	NTU	TSS (mg/L)
Inflow	2,714	10,007	1,173	2,830	4,359	23,210	1,021	6,032
Trap	1,381	2,333	1,189	1,610	1,582	3,870	134	635
Downstream	1,555	2,952	1,187	2,020	2,012	4,920	228	914

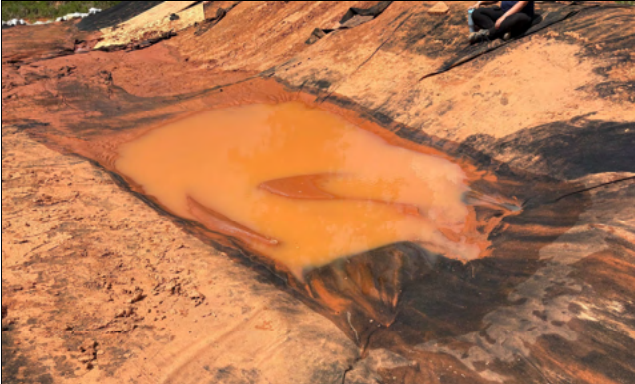
TSS (mg/L) and Turbidity (NTU) Data Plots

Legend Interpretation: The letter (A, B, C, D) corresponds to the Test ID to indicate which test in the series. The number (1, 2, 3) corresponds to the data collection location with 1 indicating the inflow collection point, 2 indicating the "in-trap" collection point, and 3 indicating the downstream or discharge collection point.

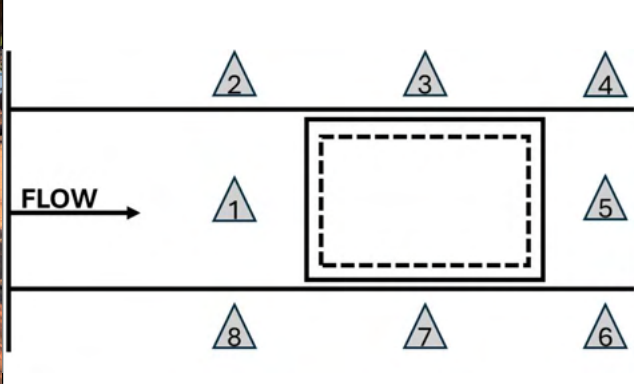

Test ID	Photo Documentation	Installation
A	Pre-Test	Standard Silt Trap at 1-acre rates
		
Location 2	Location 3	Location 4
		
Location 1		Location 5
		
Location 8	Location 7	Location 6

Test ID	Photo Documentation	Installation
A	Post-Test	Standard Silt Trap at 1-acre rates
		
Location 2	Location 3	Location 4
		
Location 1		Location 5
		
Location 8	Location 7	Location 6

SILT TRAP TEST LOG

Test Summary

Installation:	Standard at 1 ac Rates
Test ID:	B
Date:	4/30/2025
Type:	Longevity
Flow Rate (cfs):	1.0
Sediment Load Rate (lb/min):	49.0

Picture of Installation



Note: pictured on upstream side facing downstream in channel

Installation Description & Test Notes: The standard Nebraska installation is the silt trap in conjunction with no other installation upstream or downstream. The trap is 1 foot deep with 2:1 horizontal to vertical side slopes. The bottom of the trap had a width of 6 feet and a length of 12 feet. The top of the trap had a width of 10 feet and a length of 16 feet. The standard silt trap was tested at 1 ac rates which is the maximum contributory drainage area a silt trap can handle. The values can be compared to the sediment trap at 1 ac rates.

Sediment Capture Efficiency

Capture of Introduced Sediment:	53.3 %
Improved Capture from Control:	N/A

Hydraulic Performance

Max Impoundment Depth (in.):	0	Impoundment Depth Ratio:	N/A
Impoundment Length (ft):	0	Impoundment Length Ratio:	N/A
Dewatering Time (min):	0	<i>Note: ratios based on theoretical impoundment</i>	







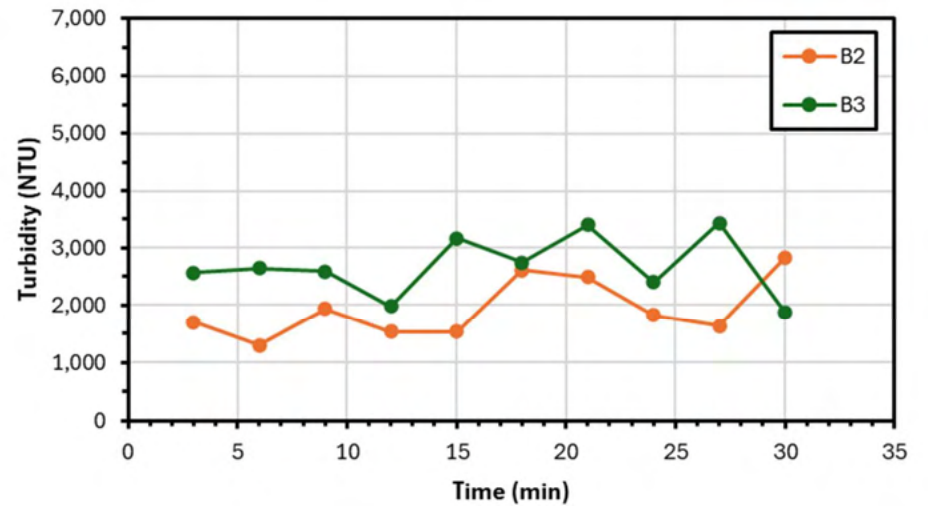
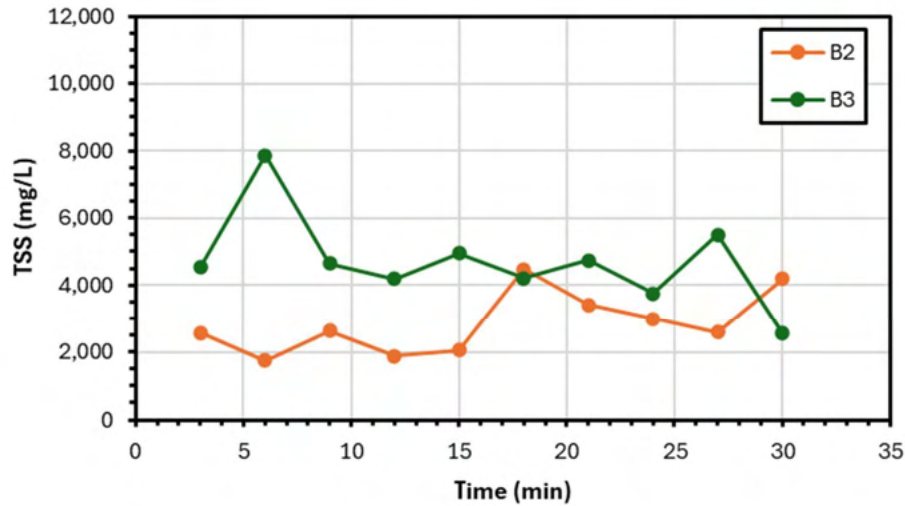
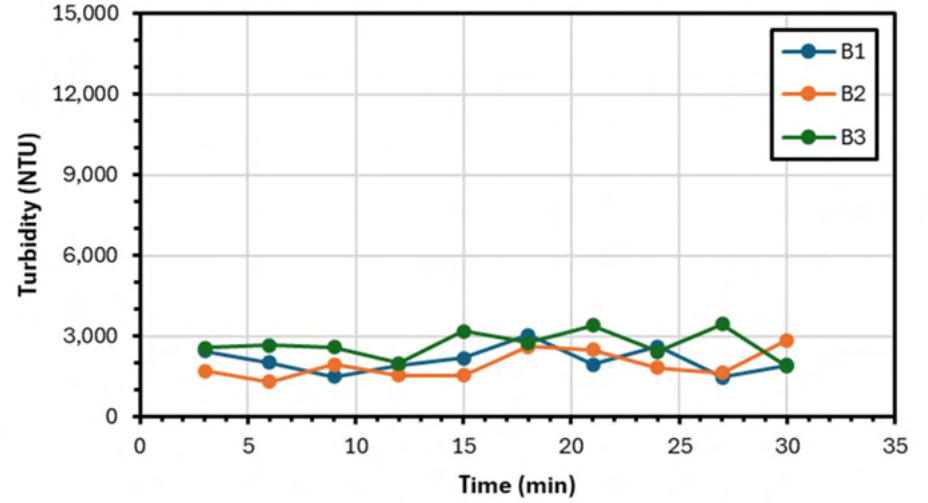
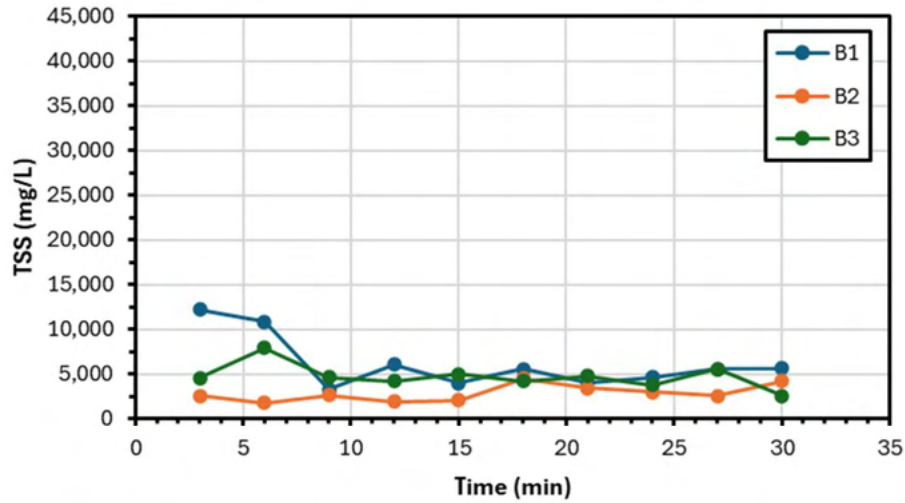

Water Quality Data Statistics

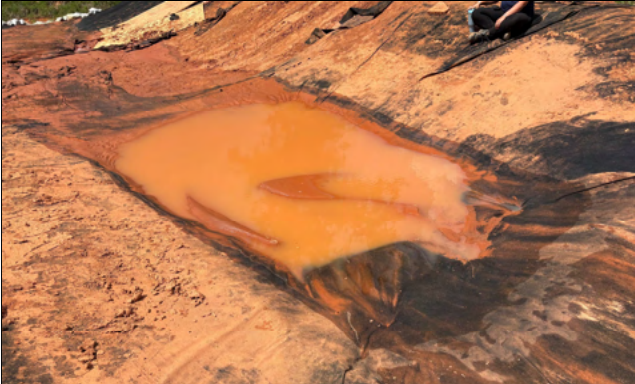



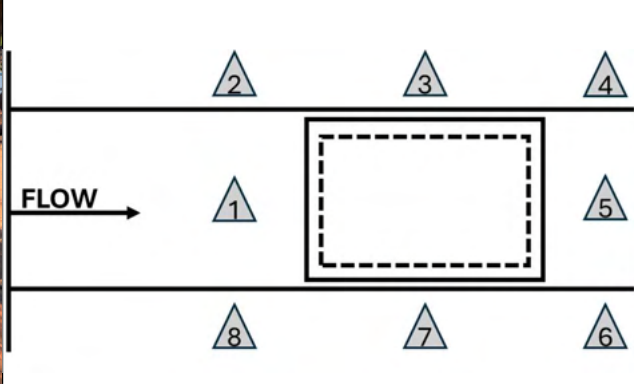



Measurement Location	Avg		Min		Max		Std. Dev.	
	NTU	TSS (mg/L)	NTU	TSS (mg/L)	NTU	TSS (mg/L)	NTU	TSS (mg/L)
Inflow	2,105	6,170	1,460	3,290	3,046	12,200	464	2,818
Trap	1,945	2,851	1,300	1,740	2,842	4,480	496	881
Downstream	2,684	4,693	1,874	2,540	3,443	7,870	509	1,299

TSS (mg/L) and Turbidity (NTU) Data Plots

Legend Interpretation: The letter (A, B, C, D) corresponds to the Test ID to indicate which test in the series. The number (1, 2, 3) corresponds to the data collection location with 1 indicating the inflow collection point, 2 indicating the "in-trap" collection point, and 3 indicating the downstream or discharge collection point.

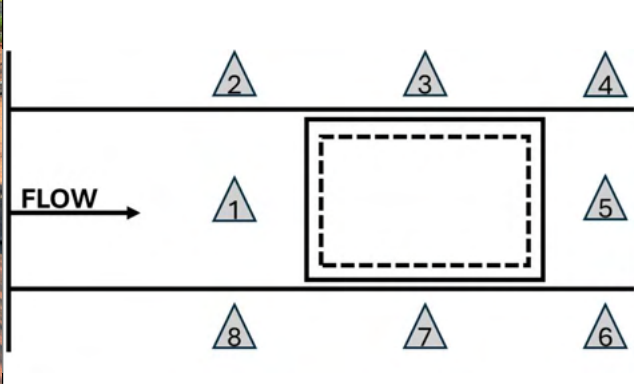
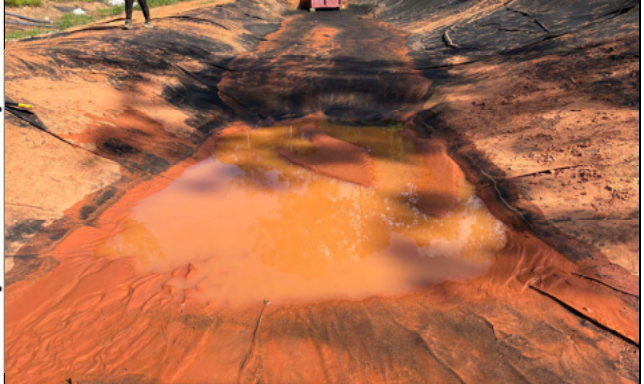

Test ID	Photo Documentation	Installation
B	Pre-Test	Standard Silt Trap at 1-acre rates
		
Location 2	Location 3	Location 4
		
Location 1		Location 5
		
Location 8	Location 7	Location 6

Test ID	Photo Documentation	Installation
B	Post-Test	Standard Silt Trap at 1-acre rates
		
Location 2	Location 3	Location 4
		
Location 1		Location 5
		
Location 8	Location 7	Location 6

SILT TRAP TEST LOG

Test Summary

Installation:	Standard at 1 ac Rates
Test ID:	C
Date:	4/30/2025
Type:	Longevity
Flow Rate (cfs):	1.0
Sediment Load Rate (lb/min):	49.0

Picture of Installation



Note: pictured on upstream side facing downstream in channel

Installation Description & Test Notes: The standard Nebraska installation is the silt trap in conjunction with no other installation upstream or downstream. The trap is 1 foot deep with 2:1 horizontal to vertical side slopes. The bottom of the trap had a width of 6 feet and a length of 12 feet. The top of the trap had a width of 10 feet and a length of 16 feet. The standard silt trap was tested at 1 ac rates which is the maximum contributory drainage area a silt trap can handle. The values can be compared to the sediment trap at 1 ac rates.

Sediment Capture Efficiency

Capture of Introduced Sediment:	53.3 %
Improved Capture from Control:	N/A

Hydraulic Performance

Max Impoundment Depth (in.):	0	Impoundment Depth Ratio:	N/A
Impoundment Length (ft):	0	Impoundment Length Ratio:	N/A
Dewatering Time (min):	0	<i>Note: ratios based on theoretical impoundment</i>	







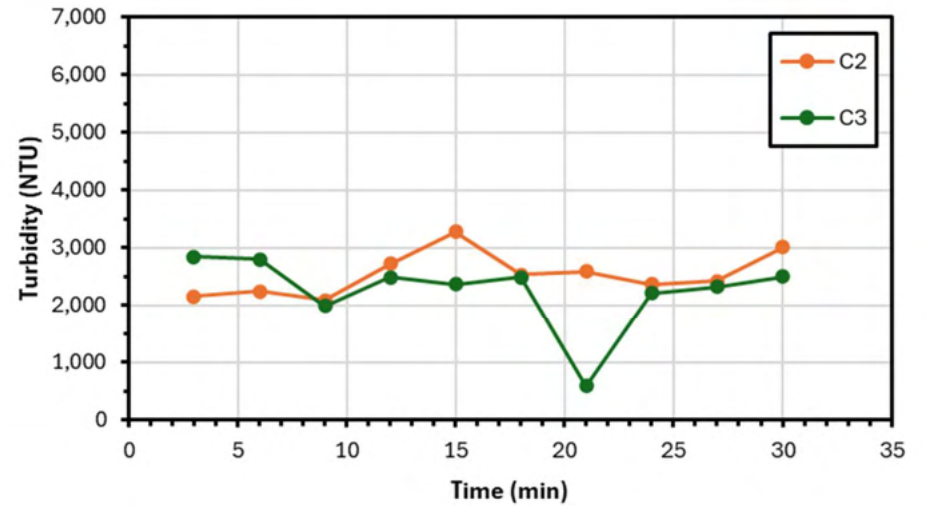
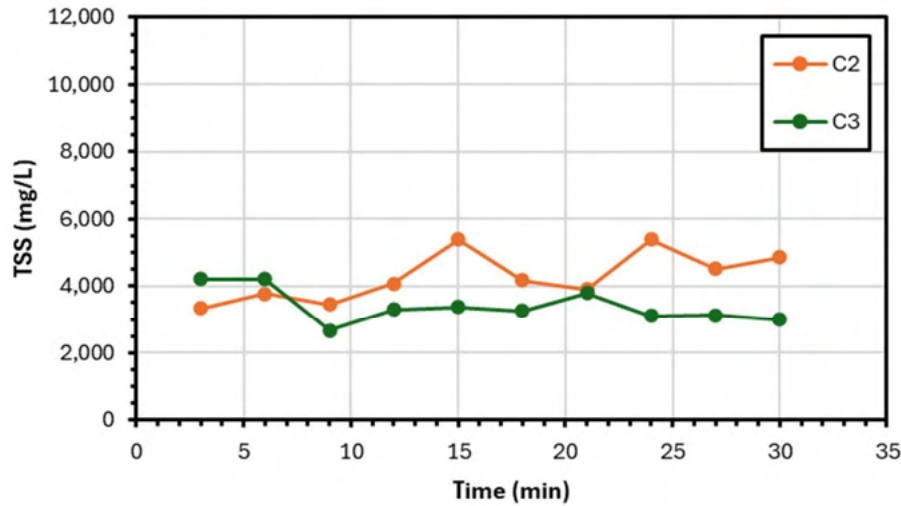
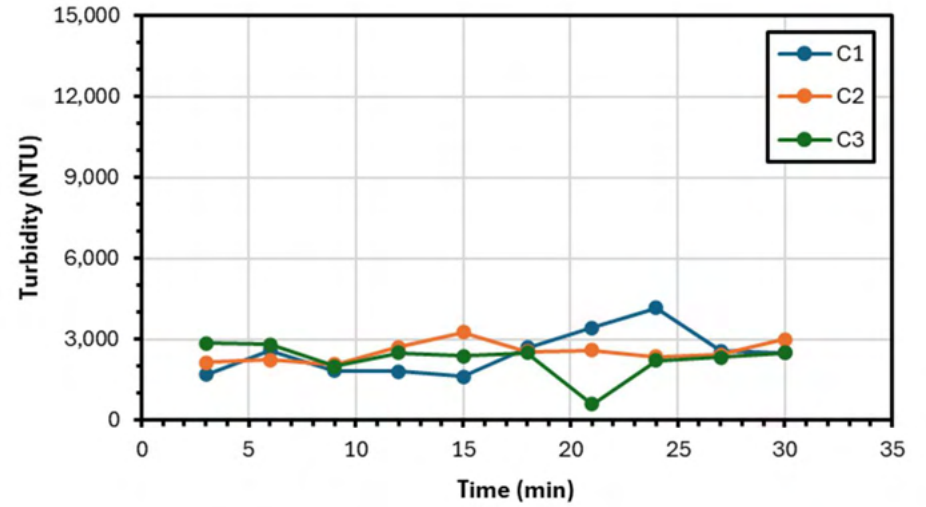
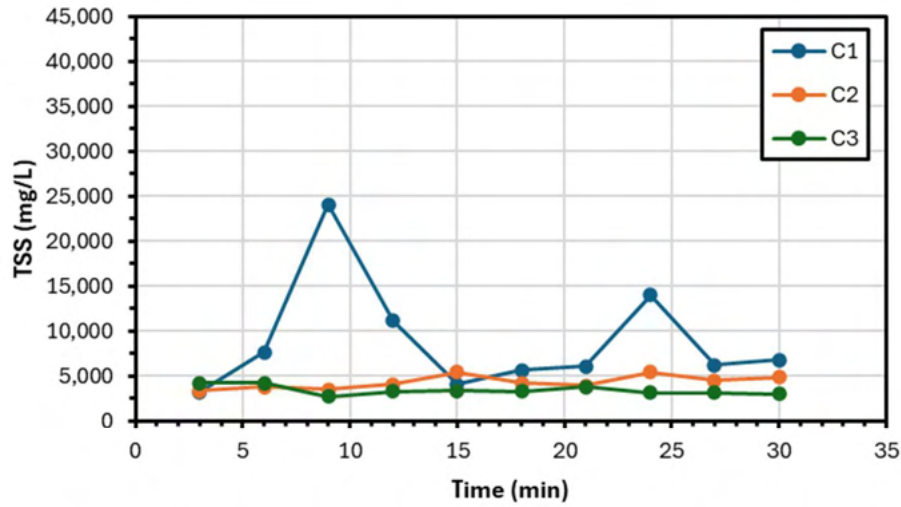

Water Quality Data Statistics





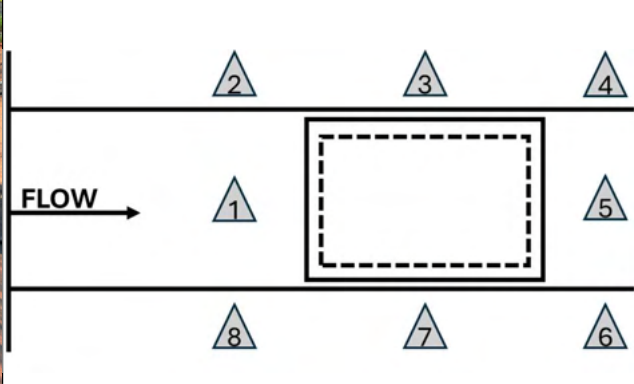
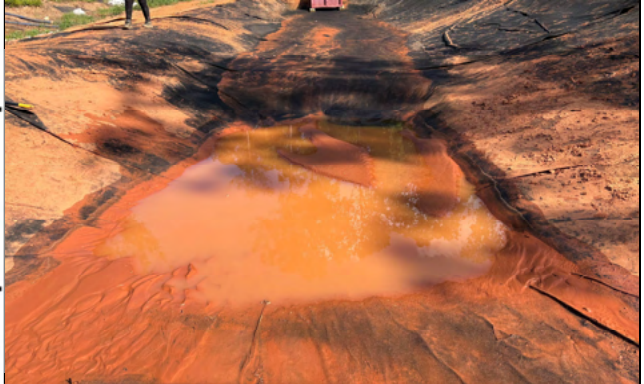

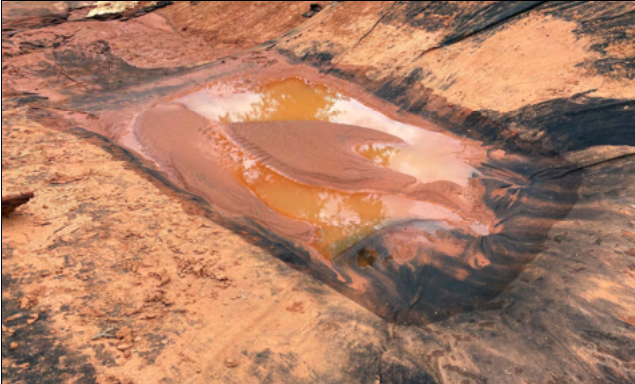

Measurement Location	Avg		Min		Max		Std. Dev.	
	NTU	TSS (mg/L)	NTU	TSS (mg/L)	NTU	TSS (mg/L)	NTU	TSS (mg/L)
Inflow	2,487	8,869	1,626	3,220	4,169	24,080	778	5,912
Trap	2,538	4,288	2,082	3,330	3,272	5,400	358	700
Downstream	2,260	3,404	584	2,670	2,848	4,210	609	486

TSS (mg/L) and Turbidity (NTU) Data Plots

Legend Interpretation: The letter (A, B, C, D) corresponds to the Test ID to indicate which test in the series. The number (1, 2, 3) corresponds to the data collection location with 1 indicating the inflow collection point, 2 indicating the "in-trap" collection point, and 3 indicating the downstream or discharge collection point.

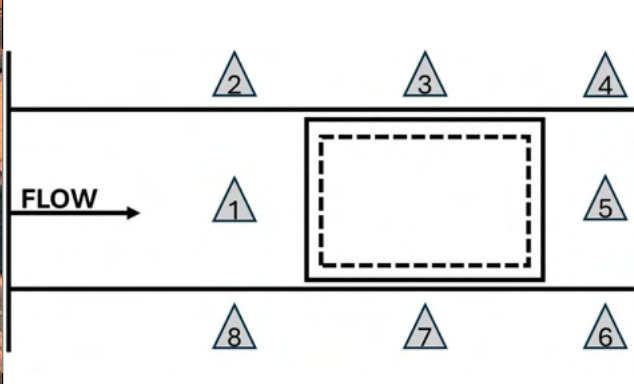

Test ID	Photo Documentation	Installation
C	Pre-Test	Standard Silt Trap at 1-acre rates
		
Location 2	Location 3	Location 4
	 <p>The diagram illustrates the experimental setup for a silt trap. A central rectangular area is outlined with a dashed line, representing the silt trap. An arrow labeled "FLOW" points from left to right, indicating the direction of water flow. Eight sampling locations are marked with triangles and numbered 1 through 8. Locations 1, 2, 3, and 4 are positioned along the top edge of the trap, while locations 5, 6, 7, and 8 are positioned along the bottom edge. Locations 1 and 5 are directly opposite each other, as are 2 and 6, 3 and 7, and 4 and 8.</p>	
Location 1		Location 5
		
Location 8	Location 7	Location 6

Test ID	Photo Documentation	Installation
C	Post-Test	Standard Silt Trap at 1-acre rates
		
Location 2	Location 3	Location 4
	 <p>The diagram illustrates the experimental setup for a silt trap. It shows a flow direction from left to right, indicated by an arrow labeled "FLOW". A dashed rectangular box represents the silt trap. Eight sampling points are marked with triangles: 1, 2, 3, 4, 5, 6, 7, and 8. Points 1, 2, 3, and 4 are along the top edge of the trap, while points 5, 6, 7, and 8 are along the bottom edge. Point 1 is at the inlet, and point 5 is at the outlet.</p>	
Location 1		Location 5
		
Location 8	Location 7	Location 6

SILT TRAP TEST LOG

Test Summary

Installation:	MFE-I at 1 ac Rates
Test ID:	A
Date:	7/28/2025
Type:	Longevity
Flow Rate (cfs):	1.0
Sediment Load Rate (lb/min):	49.0

Picture of Installation



Note: pictured on upstream side facing downstream in channel

Installation Description & Test Notes: The silt trap was tested with the MFE-I which was the V-shape, nonwoven geotextile, wire-backed fence with an 18 in. weir cut out of the center. The installation was tested at 1 ac rates to compare to the sediment trap and test at maximum contributory drainage area capacity. The fence overtopped at 6.5 min into the test.

Sediment Capture Efficiency

Capture of Introduced Sediment:	85.3 %
Improved Capture from Control:	32.0%

Note: Capture improvement based on 1 ac standard/control sediment capture

Hydraulic Performance

Max Impoundment Depth (in.):	19.0	Impoundment Depth Ratio:	1.06
Impoundment Length (ft):	36.0	Impoundment Length Ratio:	1.20
Dewatering Time (min):	45.0	<i>Note: ratios based on theoretical impoundment</i>	







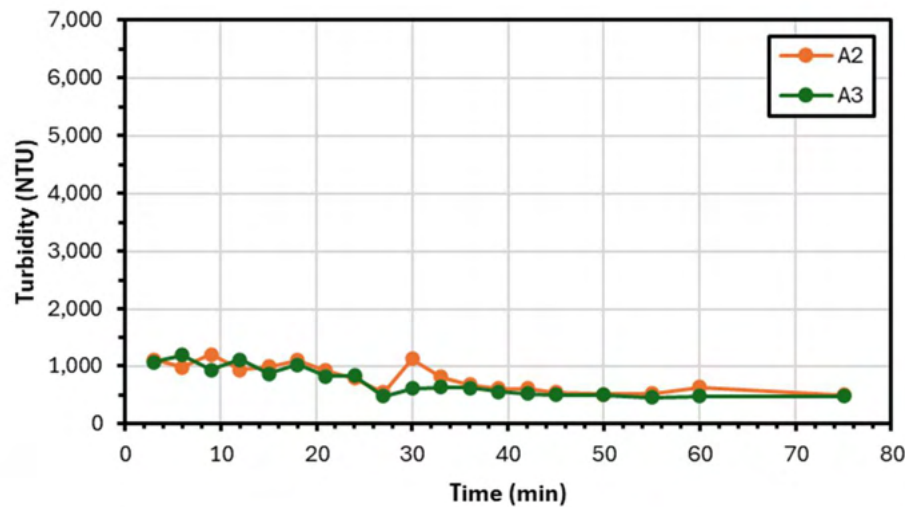
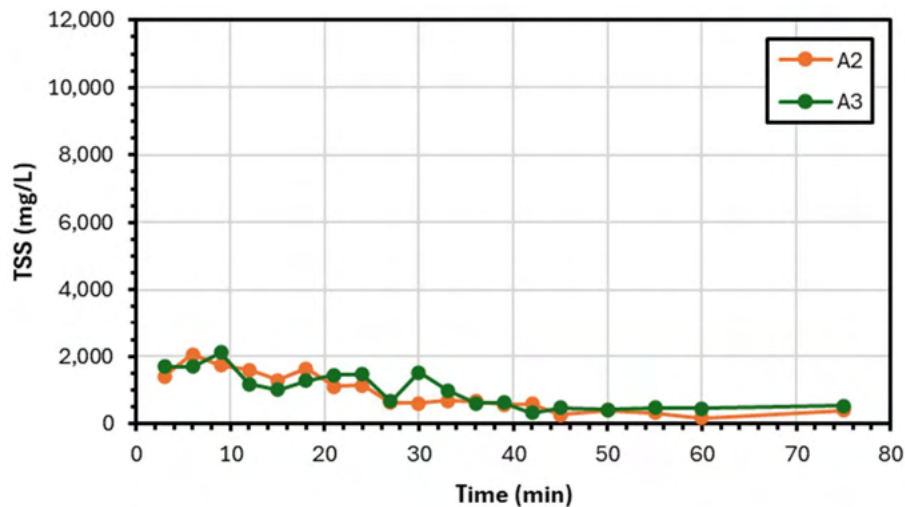
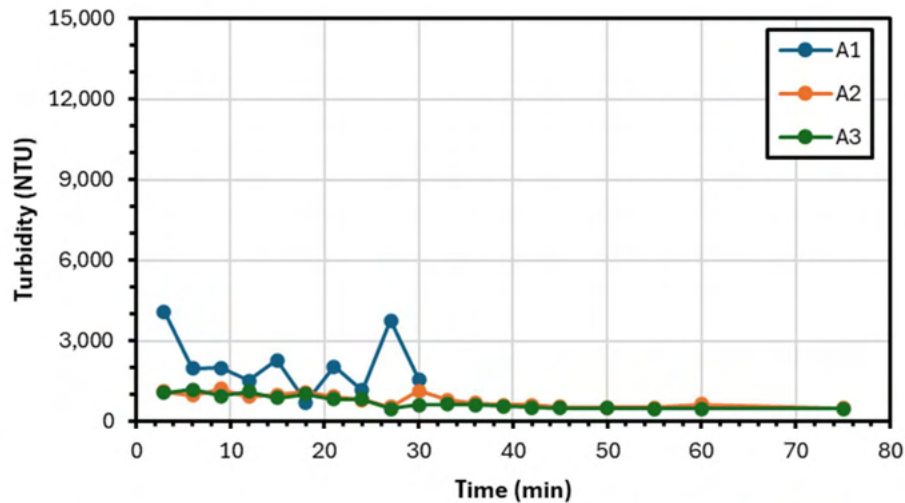
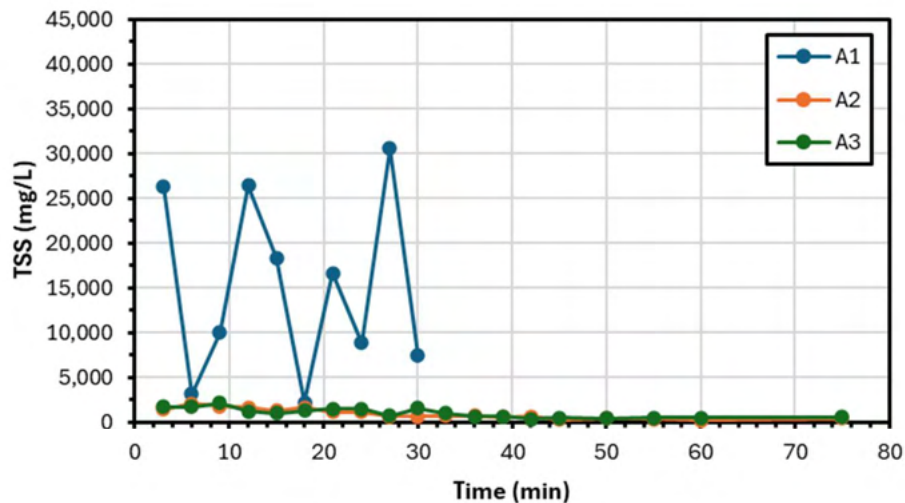

Water Quality Data Statistics





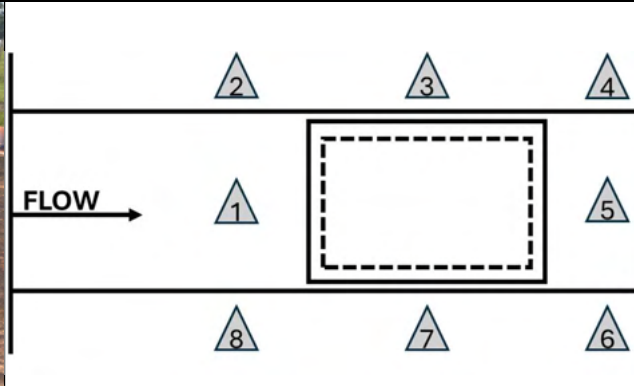



Measurement Location	Avg		Min		Max		Std. Dev.	
	NTU	TSS (mg/L)	NTU	TSS (mg/L)	NTU	TSS (mg/L)	NTU	TSS (mg/L)
Inflow	2,101	14,971	704	2,220	4,088	30,540	1,009	9,687
Trap	790	907	495	160	1,199	2,050	234	553
Downstream	715	998	455	330	1,185	2,120	243	528

TSS (mg/L) and Turbidity (NTU) Data Plots

Legend Interpretation: The letter (A, B, C, D) corresponds to the Test ID to indicate which test in the series. The number (1, 2, 3) corresponds to the data collection location with 1 indicating the inflow collection point, 2 indicating the “in-trap” collection point, and 3 indicating the downstream or discharge collection point.

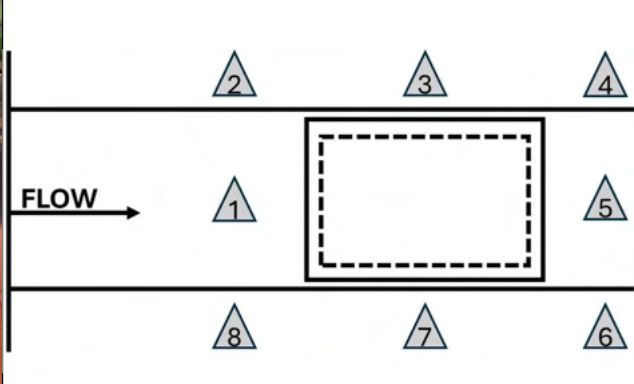

Test ID	Photo Documentation	Installation
A	Pre-Test	Silt Trap MFE-I at 1-acre rates
		
Location 2	Location 3	Location 4
		
Location 1		Location 5
		
Location 8	Location 7	Location 6

Test ID	Photo Documentation	Installation
A	Post-Test	Silt Trap MFE-I at 1-acre rates
		
Location 2	Location 3	Location 4
		
Location 1		Location 5
		
Location 8	Location 7	Location 6

SILT TRAP TEST LOG

Test Summary

Installation:	MFE-I at 1 ac Rates
Test ID:	B
Date:	7/29/2025
Type:	Longevity
Flow Rate (cfs):	1.0
Sediment Load Rate (lb/min):	49.0

Picture of Installation



Note: pictured on upstream side facing downstream in channel

Installation Description & Test Notes: The silt trap was tested with the MFE-I which was the V-shape, nonwoven geotextile, wire-backed fence with an 18 in. weir cut out of the center. The installation was tested at 1 ac rates to compare to the sediment trap and test at maximum contributory drainage area capacity. The fence overtopped at 3.5 min into the test.

Sediment Capture Efficiency

Capture of Introduced Sediment:	85.3 %
Improved Capture from Control:	32.0 %

Note: Capture improvement based on 1 ac standard/control sediment capture

Hydraulic Performance

Max Impoundment Depth (in.):	19.0	Impoundment Depth Ratio:	1.06
Impoundment Length (ft):	36.0	Impoundment Length Ratio:	1.20
Dewatering Time (min):	45.0	<i>Note: ratios based on theoretical impoundment</i>	







Water Quality Data Statistics

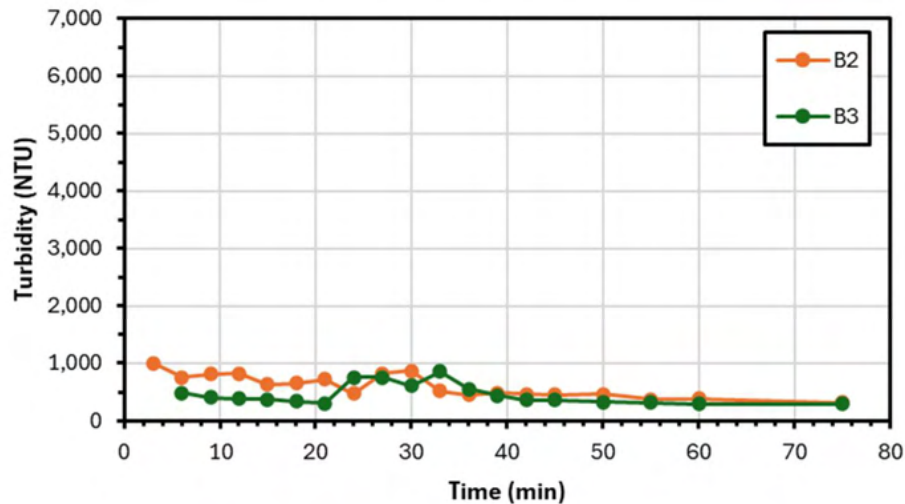
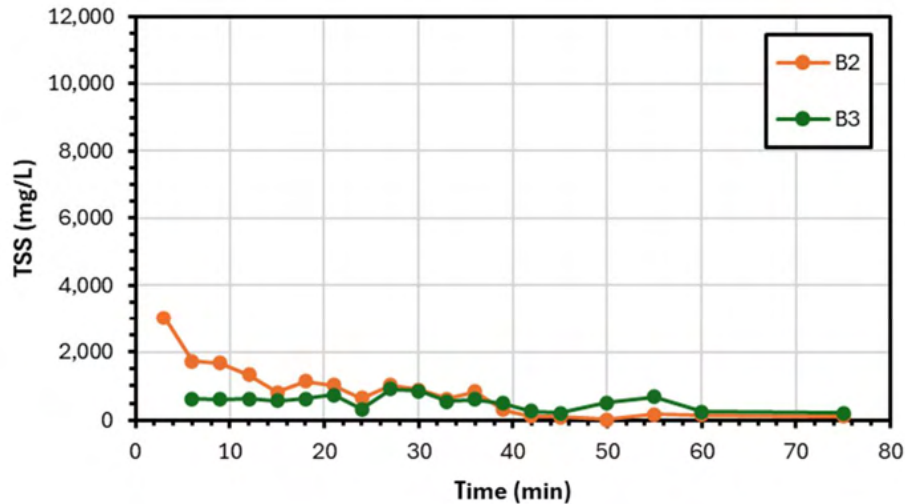
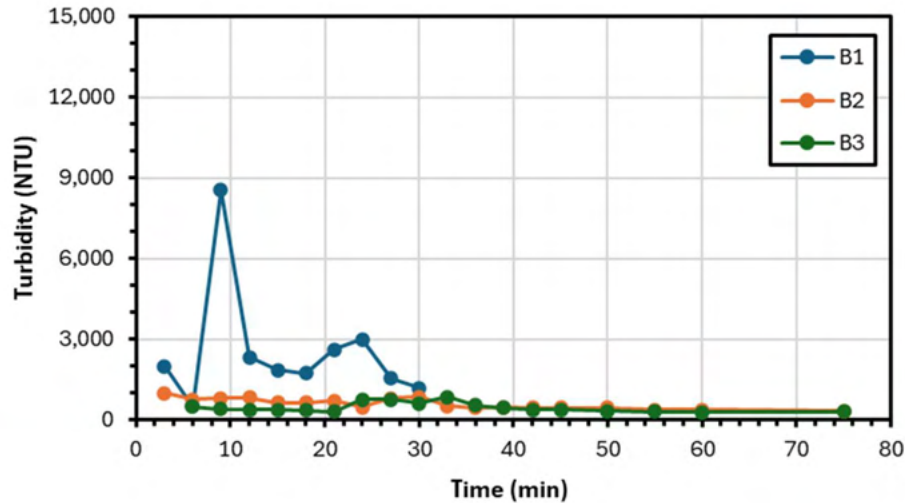
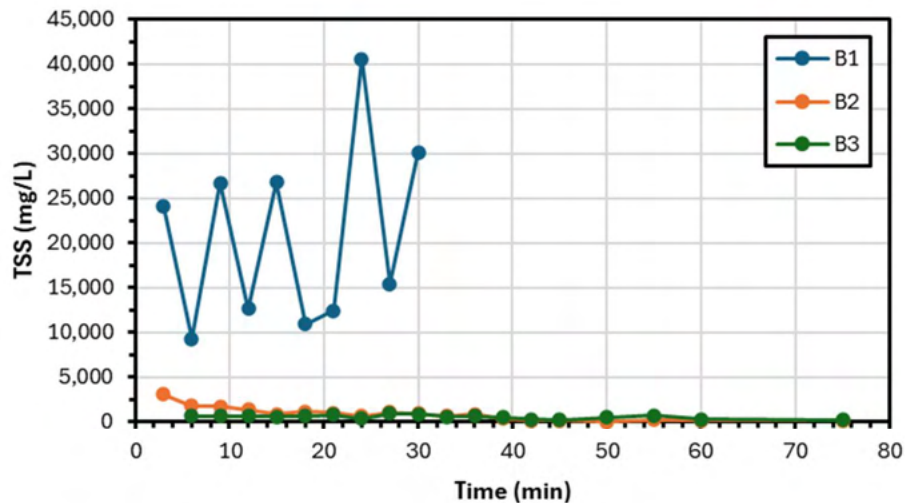



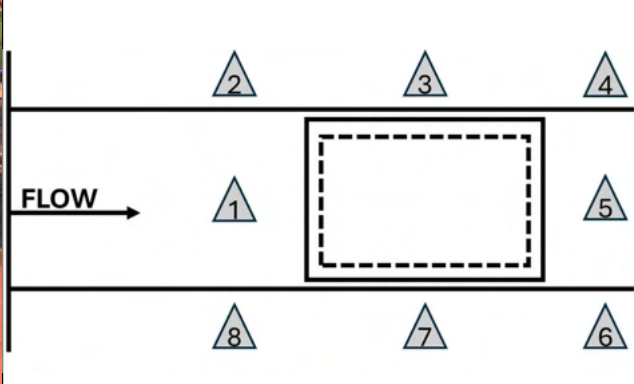

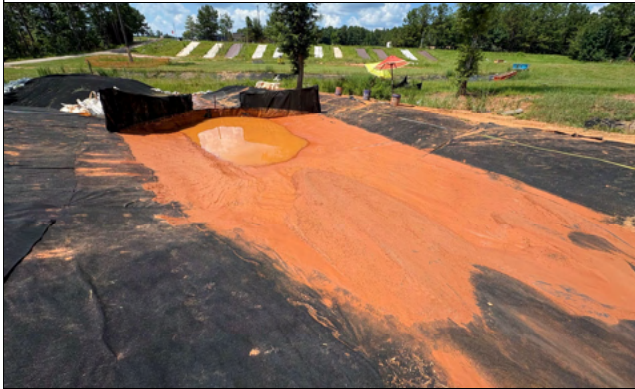

Measurement Location	Avg		Min		Max		Std. Dev.	
	NTU	TSS (mg/L)	NTU	TSS (mg/L)	NTU	TSS (mg/L)	NTU	TSS (mg/L)
Inflow	2,530	20,893	501	9,250	8,546	40,580	2,115	9,782
Trap	601	829	322	10	1,001	3,030	192	736
Downstream	456	537	290	200	851	910	169	206

TSS (mg/L) and Turbidity (NTU) Data Plots

Legend Interpretation: The letter (A, B, C, D) corresponds to the Test ID to indicate which test in the series. The number (1, 2, 3) corresponds to the data collection location with 1 indicating the inflow collection point, 2 indicating the “in-trap” collection point, and 3 indicating the downstream or discharge collection point.

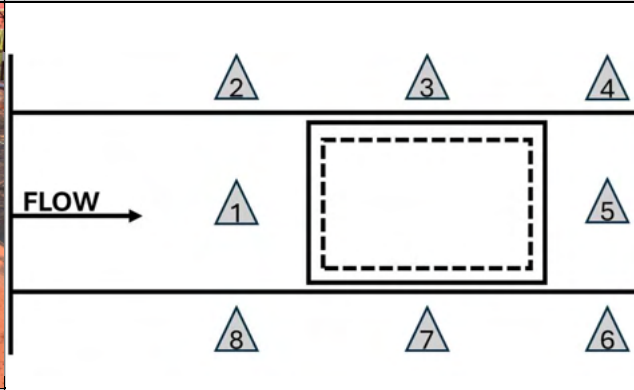

Test ID	Photo Documentation	Installation
B	Pre-Test	Silt Tap MFE-I at 1-acre rates
		
Location 2	Location 3	Location 4
		
Location 1		Location 5
		
Location 8	Location 7	Location 6

Test ID	Photo Documentation	Installation
B	Post-Test	Silt Trap MFE-I at 1-acre rates
		
Location 2	Location 3	Location 4
		
Location 1		Location 5
		
Location 8	Location 7	Location 6

SILT TRAP TEST LOG

Test Summary

Installation:	MFE-I at 1 ac Rates
Test ID:	C
Date:	7/29/2025
Type:	Longevity
Flow Rate (cfs):	1.0
Sediment Load Rate (lb/min):	49.0

Picture of Installation



Note: pictured on upstream side facing downstream in channel

Installation Description & Test Notes: The silt trap was tested with the MFE-I which was the V-shape, nonwoven geotextile, wire-backed fence with an 18 in. weir cut out of the center. The installation was tested at 1 ac rates to compare to the sediment trap and test at maximum contributory drainage area capacity. The fence overtopped at 3.5 min into the test.

Sediment Capture Efficiency

Capture of Introduced Sediment:	85.3 %
Improved Capture from Control:	32.0 %

Note: Capture improvement based on 1 ac standard/control sediment capture

Hydraulic Performance

Max Impoundment Depth (in.):	19.0	Impoundment Depth Ratio:	1.06
Impoundment Length (ft):	36.0	Impoundment Length Ratio:	1.20
Dewatering Time (min):	45.0	<i>Note: ratios based on theoretical impoundment</i>	







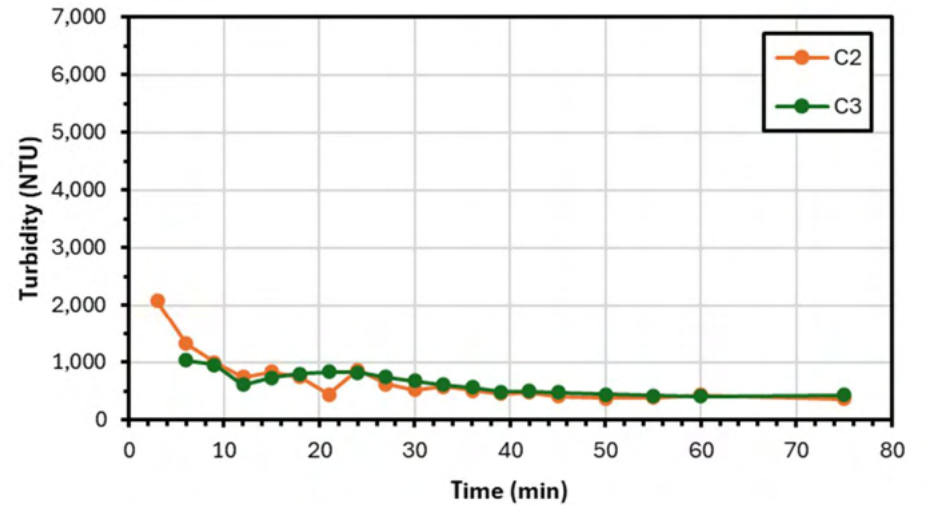
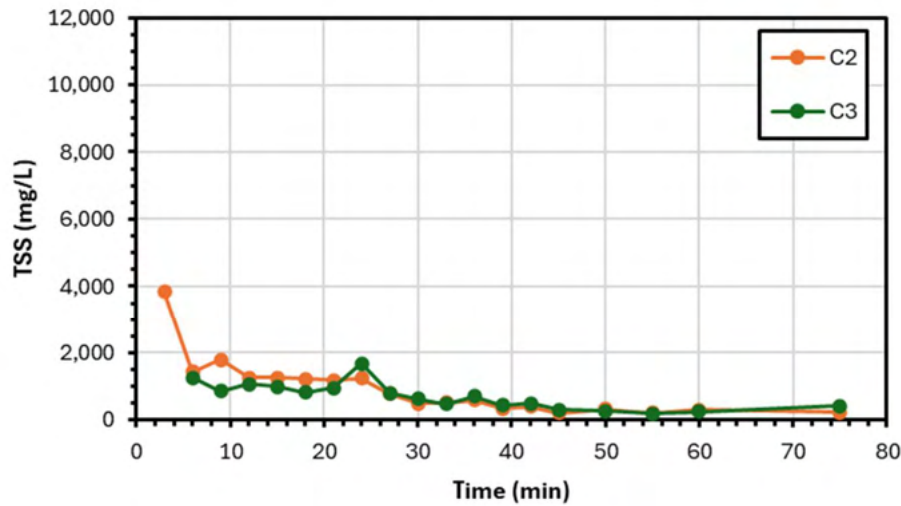
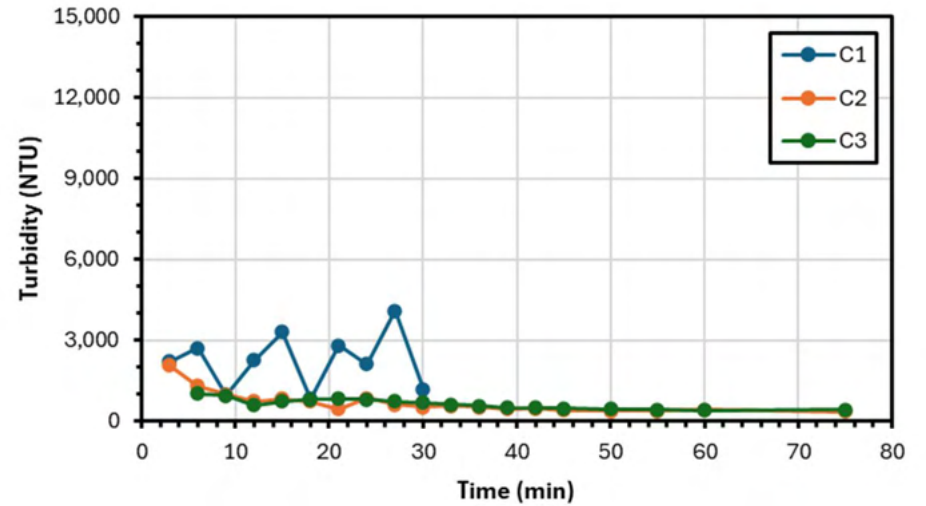
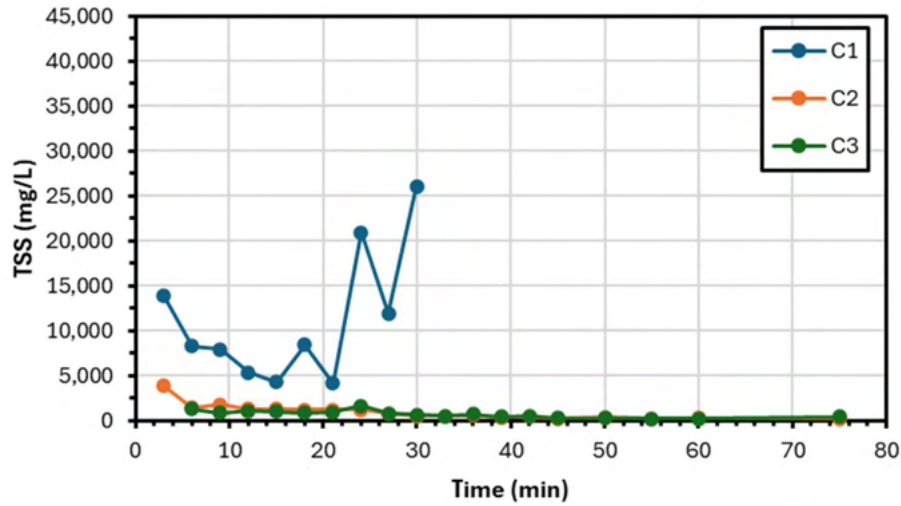

Water Quality Data Statistics

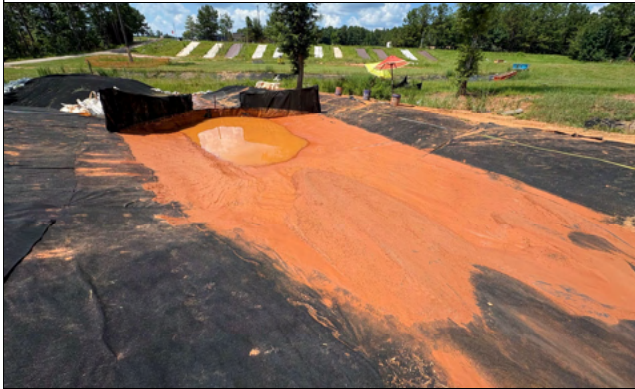



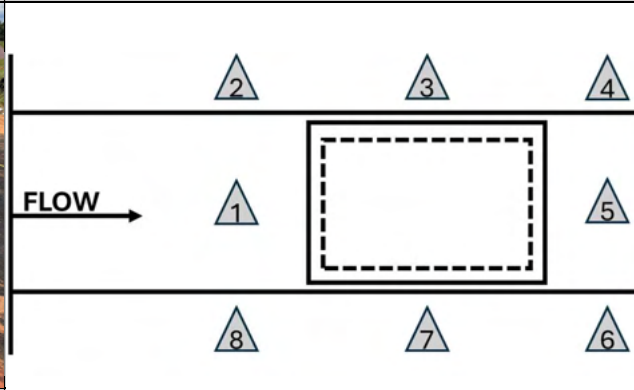



Measurement Location	Avg		Min		Max		Std. Dev.	
	NTU	TSS (mg/L)	NTU	TSS (mg/L)	NTU	TSS (mg/L)	NTU	TSS (mg/L)
Inflow	2,256	11,129	833	4,160	4,101	26,110	991	6,949
Trap	693	931	368	210	2,081	3,840	408	837
Downstream	620	672	416	190	954	1,680	165	370

TSS (mg/L) and Turbidity (NTU) Data Plots

Legend Interpretation: The letter (A, B, C, D) corresponds to the Test ID to indicate which test in the series. The number (1, 2, 3) corresponds to the data collection location with 1 indicating the inflow collection point, 2 indicating the "in-trap" collection point, and 3 indicating the downstream or discharge collection point.

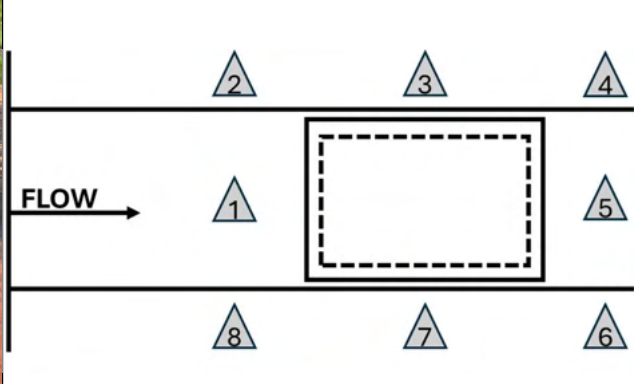

Test ID	Photo Documentation	Installation
C	Pre-Test	Silt Trap MFE-I at 1-acre rates
		
Location 2	Location 3	Location 4
		
Location 1		Location 5
		
Location 8	Location 7	Location 6

Test ID	Photo Documentation	Installation
C	Post-Test	Silt Trap MFE-I at 1-acre rates
		
Location 2	Location 3	Location 4
		
Location 1		Location 5
		
Location 8	Location 7	Location 6

**Appendix B:
Low Porosity Silt Fence
Structural, Clean Water Test Log**

LOW POROSITY SILT FENCE STRUCTURAL, CLEAN WATER TEST LOG

Test Summary

Installation:	24 in. fence height with 5 ft post spacing
Test ID:	A
Date:	11/11/2025
Type:	Longevity
Flow Rate (cfs):	0.5, 1.0, 1.4
Sediment Load Rate (lb/min):	N/A

Picture of Installation



Testing Regime: The testing period consisted of 30 min of flow at 3 flow rates. 10 min at 0.5 cfs, 10 min at 1.0 cfs, and 10 min at 1.4 cfs. The 1.4 cfs was the highest flow rate attainable by the pump.

Installation Description & Test Notes: The low porosity silt fence had a fence height of 24 in. by folding the fence along the green line. The fence was attached to 1.25lb/ft steel T-posts using 3 zip-ties at the top of each post threaded through the double-layer of folded material. The posts were spaced 5 ft apart perpendicularly to flow across the channel. The fence was stapled into the ground 6 in. apart on the front and back in a staggered pattern.

Impoundment Efficiency

Flow Rate (cfs)	0.5	1.0	1.4
Impoundment Length (ft)	22.0	27.0	28.0
Water Depth (in.)	14.5	21.0	22.0







Water Quality Data Statistics





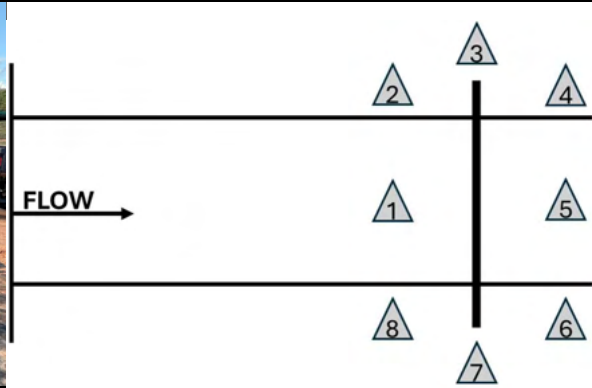

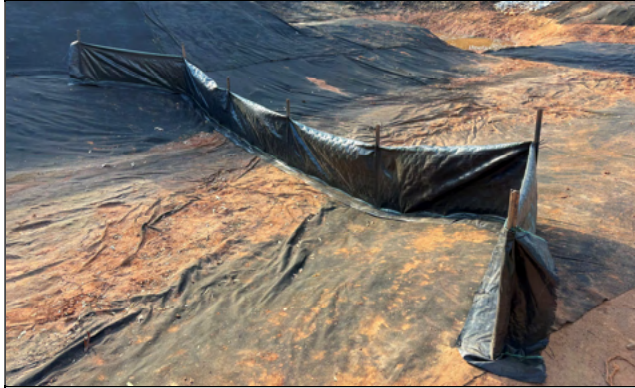

Post Number	Starting Post Deflection (°)	0.5 cfs Post Deflection (°)	1.0 cfs Post Deflection (°)	1.4 cfs Post Deflection (°)
1	0.0	0.0	3.9	4.9
2	0.0	0.0	1.8	3.6
3	1.8	1.8	6.4	9.2
4	5.5	5.5	15.3	16.2
5	2.9	2.9	8.5	9.5
6	0.0	0.0	1.8	1.8
7	0.0	0.0	6.0	8.0

*Note: When standing downstream facing flow/upstream, numbering started at post 1 on the left bank and moved across to the right bank.
Note: Deflection angle was measured from the top of each fence post.*

Overtopping Record

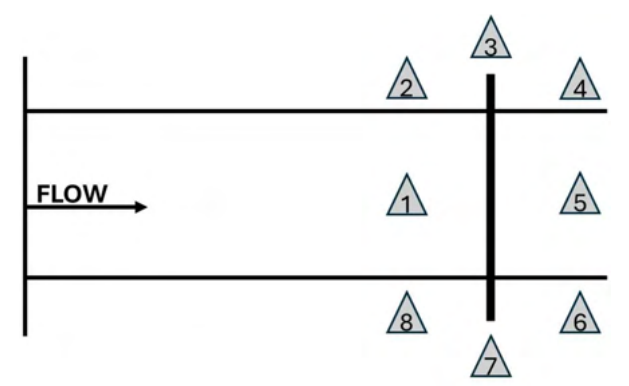
Fence Overtopped Start Time:	15 min into test
Fence Overtopped End Time:	5 min after test

Test ID	Photo Documentation	Installation
A	Pre-Test	24" fence height & 5' post spacing
	X	
Location 2	Location 3	Location 4
		
Location 1		Location 5
	X	
Location 8	Location 7	Location 6

Test ID	Photo Documentation	Installation
A	Post-Test	24" fence height & 5' post spacing
		
Location 2	Location 3	Location 4
		
Location 1		Location 5
		
Location 8	Location 7	Location 6

LOW POROSITY SILT FENCE STRUCTURAL, CLEAN WATER TEST LOG

Test Summary

Installation:	24 in. fence height with 5 ft post spacing
Test ID:	B
Date:	11/11/2025
Type:	Longevity
Flow Rate (cfs):	0.5, 1.0, 1.4
Sediment Load Rate (lb/min):	N/A

Picture of Installation



Testing Regime: The testing period consisted of 30 min of flow at 3 flow rates. 10 min at 0.5 cfs, 10 min at 1.0 cfs, and 10 min at 1.4 cfs. The 1.4 cfs was the highest flow rate attainable by the pump.

Installation Description & Test Notes: The low porosity silt fence had a fence height of 24 in. by folding the fence along the green line. The fence was attached to 1.25lb/ft steel T-posts using 3 zip-ties at the top of each post threaded through the double-layer of folded material. The posts were spaced 5 ft apart perpendicularly to flow across the channel. The fence was stapled into the ground 6 in. apart on the front and back in a staggered pattern.

Impoundment Efficiency

Flow Rate (cfs)	0.5	1.0	1.4
Impoundment Length (ft)	27.0	28.0	28.0
Water Depth (in.)	17.5	21.0	21.0









Water Quality Data Statistics





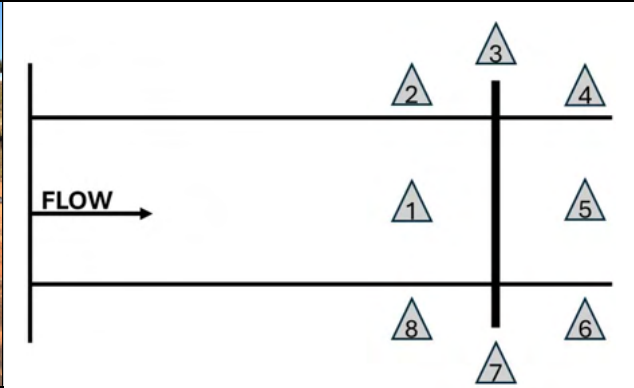



Post Number	Starting Post Deflection (°)	0.5 cfs Post Deflection (°)	1.0 cfs Post Deflection (°)	1.4 cfs Post Deflection (°)
1	2.5	4.9	4.9	4.9
2	2.0	3.6	3.6	3.6
3	3.5	6.4	6.4	7.4
4	9.0	16.2	16.2	17.9
5	3.5	6.7	6.7	6.7
6	1.0	1.8	1.8	1.8
7	4.0	8.0	8.0	8.0

*Note: When standing downstream facing flow/upstream, numbering started at post 1 on the left bank and moved across to the right bank.
Note: Deflection angle was measured from the top of each fence post.*

Overtopping Record

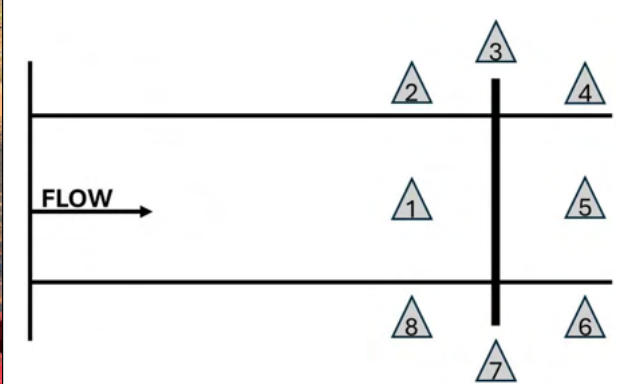
Fence Overtopped Start Time:	11 min into test
Fence Overtopped End Time:	9 min after test

Test ID	Photo Documentation	Installation
B	Pre-Test	24" fence height & 5' post spacing
		
Location 2	Location 3	Location 4
		
Location 1		Location 5
		
Location 8	Location 7	Location 6

Test ID	Photo Documentation	Installation
B	Post-Test	24" fence height & 5' post spacing
		
Location 2	Location 3	Location 4
	 <p>The diagram shows a horizontal flow direction indicated by an arrow labeled "FLOW" pointing to the right. A vertical barrier is positioned in the center of the flow path. Eight numbered locations are marked with triangles: 1, 2, 3, 4, 5, 6, 7, and 8. Locations 1, 2, 3, and 4 are on the upper side of the barrier, while 5, 6, 7, and 8 are on the lower side. Location 3 is at the top of the barrier, and location 7 is at the bottom.</p>	
Location 1		Location 5
		
Location 8	Location 7	Location 6

LOW POROSITY SILT FENCE STRUCTURAL, CLEAN WATER TEST LOG

Test Summary

Installation:	24 in. fence height with 5 ft post spacing
Test ID:	C
Date:	11/12/2025
Type:	Longevity
Flow Rate (cfs):	0.5, 1.0, 1.4
Sediment Load Rate (lb/min):	N/A

Picture of Installation

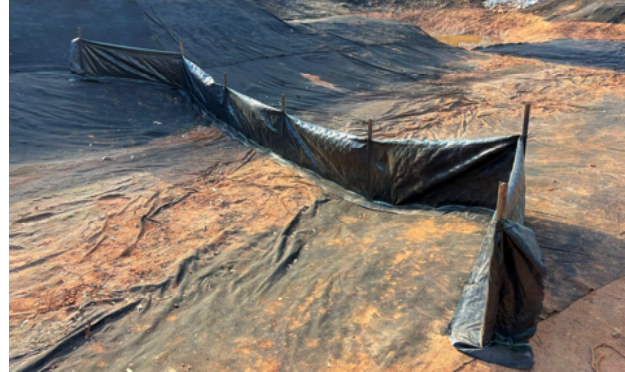

Testing Regime: The testing period consisted of 30 min of flow at 3 flow rates. 10 min at 0.5 cfs, 10 min at 1.0 cfs, and 10 min at 1.4 cfs. The 1.4 cfs was the highest flow rate attainable by the pump.

Installation Description & Test Notes: The low porosity silt fence had a fence height of 24 in. by folding the fence along the green line. The fence was attached to 1.25lb/ft steel T-posts using 3 zip-ties at the top of each post threaded through the double-layer of folded material. The posts were spaced 5 ft apart perpendicularly to flow across the channel. The fence was stapled into the ground 6 in. apart on the front and back in a staggered pattern.

Impoundment Efficiency

Flow Rate (cfs)	0.5	1.0	1.4
Impoundment Length (ft)	23.0	28.0	28.0
Water Depth (in.)	17.0	21.0	21.5

Water Quality Data Statistics









Post Number	Starting Post Deflection (°)	0.5 cfs Post Deflection (°)	1.0 cfs Post Deflection (°)	1.4 cfs Post Deflection (°)
1	3.9	3.9	3.9	3.9
2	2.7	2.7	2.7	2.7
3	4.6	4.6	5.5	5.5
4	13.6	13.6	16.2	16.2
5	3.8	3.8	5.7	5.7
6	1.8	1.8	1.8	1.8
7	6.0	6.0	6.0	6.0

*Note: When standing downstream facing flow/upstream, numbering started at post 1 on the left bank and moved across to the right bank.
Note: Deflection angle was measured from the top of each fence post.*

Overtopping Record

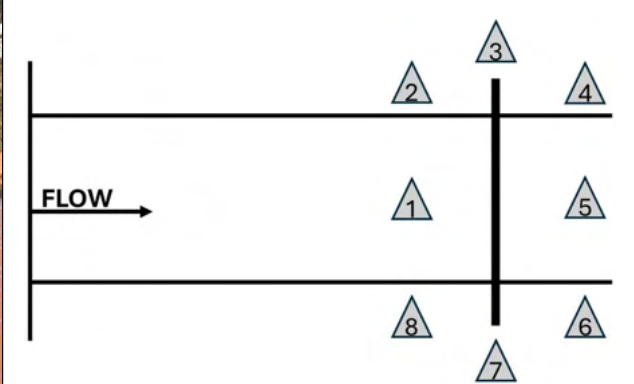
Fence Overtopped Start Time:	14 min into test
Fence Overtopped End Time:	10 min after test

Test ID	Photo Documentation	Installation
C	Pre-Test	24" fence height & 5' post spacing
		
Location 2	Location 3	Location 4
		
Location 1		Location 5
		
Location 8	Location 7	Location 6

Test ID	Photo Documentation	Installation
C	Post-Test	24" fence height & 5' post spacing
		
Location 2	Location 3	Location 4
		
Location 1		Location 5
		
Location 8	Location 7	Location 6

LOW POROSITY SILT FENCE STRUCTURAL, CLEAN WATER TEST LOG

Test Series Summary

Installation:	24 in. fence height with 5 ft post spacing
Test ID:	A, B, C

Test Series Data Summary

Test Flow Rates (cfs)	0.5	1.0	1.4
Average Impoundment (ft)	24.0	27.7	28.0
Average Water Depth (in.)	16.3	21.0	21.5
Theoretical Impoundment (ft)	40.0	40.0	40.0
Theoretical Water Depth (in.)	24.0	24.0	24.0
Impoundment Ratio	0.6	0.7	0.7
Depth Ratio	0.7	0.9	0.9
Max Deflection (in.)	-	-	6.7

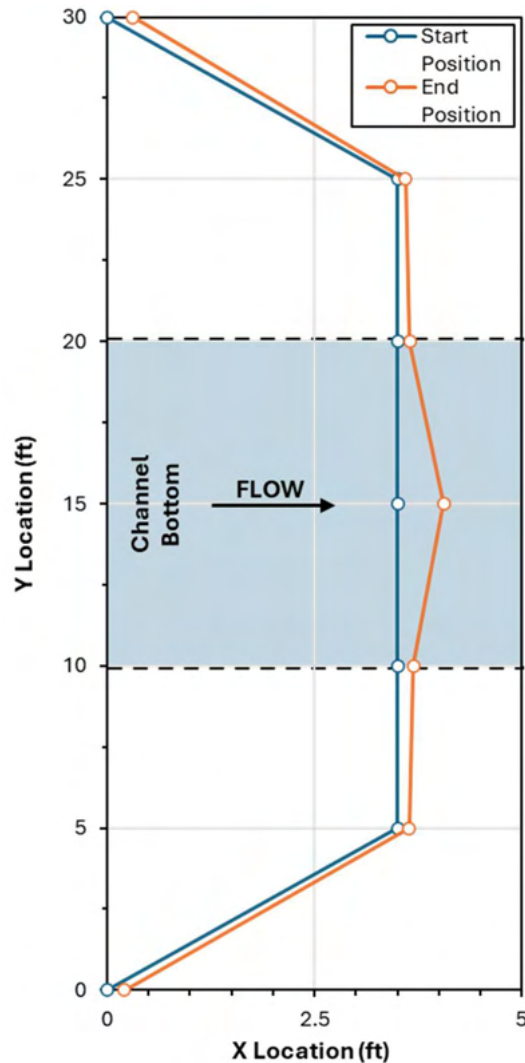

Note: Graph depicts a plan view of the channel and fence positions of the start and end of the test series.

LOW POROSITY SILT FENCE STRUCTURAL, CLEAN WATER TEST LOG

Test Summary

Installation:	30 in. fence height with 2.5 ft post spacing
Test ID:	A
Date:	11/13/2025
Type:	Longevity
Flow Rate (cfs):	0.5, 1.0, 1.4
Sediment Load Rate (lb/min):	N/A

Picture of Installation

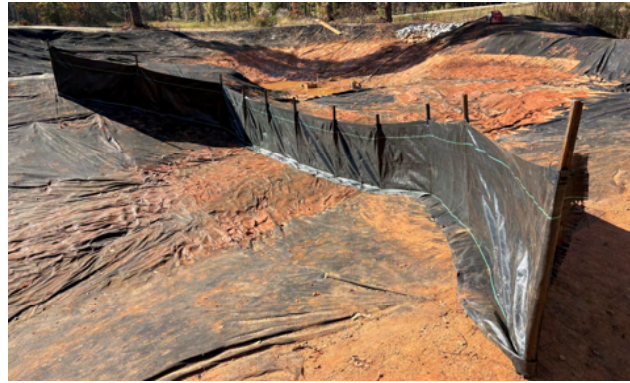

Testing Regime: The testing period consisted of 30 min of flow at 3 flow rates. 10 min at 0.5 cfs, 10 min at 1.0 cfs, and 10 min at 1.4 cfs. The 1.4 cfs was the highest flow rate attainable by the pump.

Installation Description & Test Notes: The low porosity silt fence had a fence height of 30 in. as standard low-profile installation. The fence was attached to 1.25lb/ft steel T-posts using 3 zip-ties at the top of each post threaded through the material. The posts were spaced 2.5 ft apart perpendicularly to flow across the channel. The fence turned upstream to prevent bypass. The fence was stapled into the ground 6 in. apart on the front and back in a staggered pattern. Fabric ripping was heard near the end of the test.

Impoundment Efficiency

Flow Rate (cfs)	0.5	1.0	1.4
Impoundment Length (ft)	21.0	30.0	41.0
Water Depth (in.)	15.0	21.0	29.0

Water Quality Data Statistics







Post Number	Starting Post Deflection (°)	0.5 cfs Post Deflection (°)	1.0 cfs Post Deflection (°)	1.4 cfs Post Deflection (°)
1	5.4	5.4	5.6	5.7
2	0.7	0.7	1.3	1.5
3	0.9	0.9	1.0	2.1
4	1.6	1.6	1.7	2.3
5	2.3	3.1	5.6	8.9
6	2.1	2.6	8.6	15.0
7	1.7	2.1	8.4	12.1
8	7.7	8.7	16.7	18.6
9	2.3	4.0	7.2	7.2
10	2.4	2.4	7.3	7.4
11	2.8	2.8	3.3	3.3



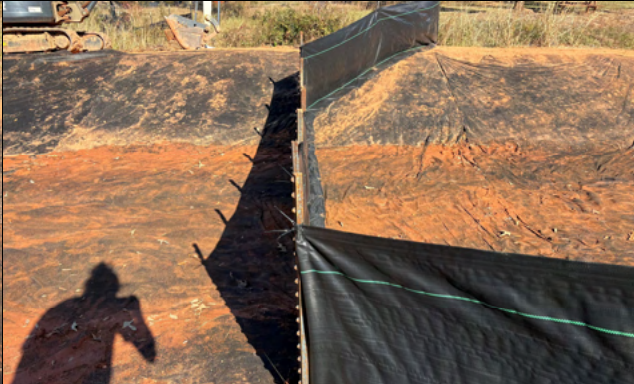

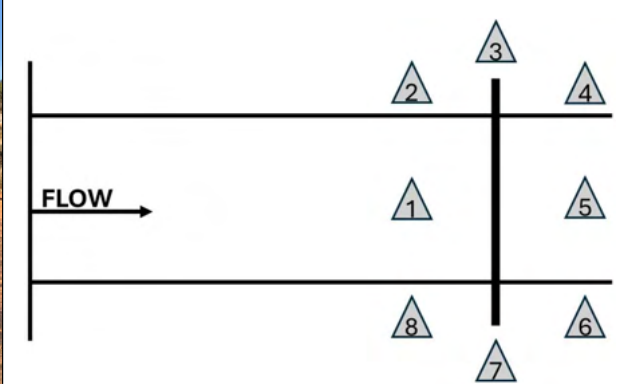



Note: When standing downstream facing flow/upstream, numbering started at post 1 on the left bank and moved across to the right bank.

Note: Deflection angle was measured from the top of each fence post.

Overtopping Record

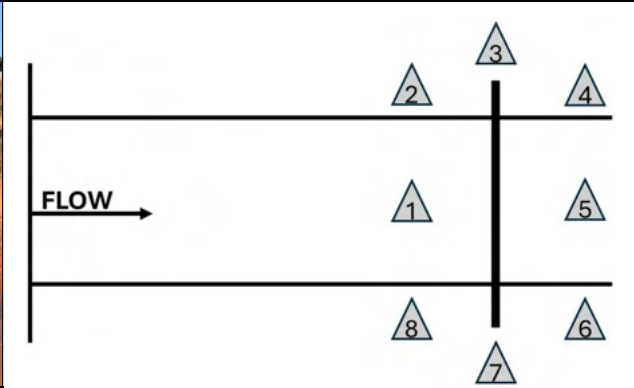
Fence Overtopped Start Time:	19 min into test
Fence Overtopped End Time:	6 min after test

Test ID	Photo Documentation	Installation
A	Pre-Test	30" fence height & 2.5' post spacing
		
Location 2	Location 3	Location 4
		
Location 1		Location 5
		
Location 8	Location 7	Location 6

Test ID	Photo Documentation	Installation
A	Post-Test	30" fence height & 2.5' post spacing
		
Location 2	Location 3	Location 4
		
Location 1	Location 5	Location 5
		
Location 8	Location 7	Location 6

LOW POROSITY SILT FENCE STRUCTURAL, CLEAN WATER TEST LOG

Test Summary

Installation:	30 in. fence height with 2.5 ft post spacing
Test ID:	B
Date:	11/14/2025
Type:	Longevity
Flow Rate (cfs):	0.5, 1.0, 1.4
Sediment Load Rate (lb/min):	N/A

Picture of Installation

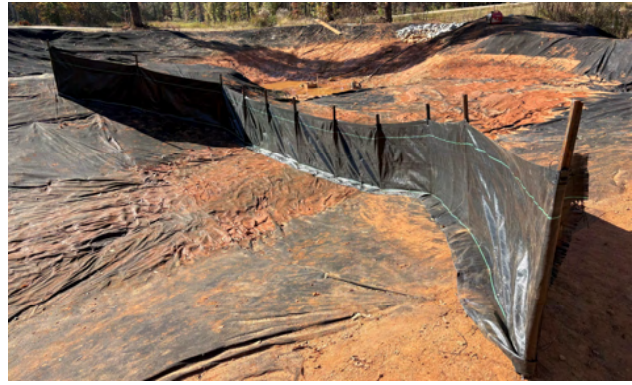

Testing Regime: The testing period consisted of 30 min of flow at 3 flow rates. 10 min at 0.5 cfs, 10 min at 1.0 cfs, and 10 min at 1.4 cfs. The 1.4 cfs was the highest flow rate attainable by the pump.

Installation Description & Test Notes: The low porosity silt fence had a fence height of 30 in. as standard low-profile installation. The fence was attached to 1.25lb/ft steel T-posts using 3 zip-ties at the top of each post threaded through the material. The posts were spaced 2.5 ft apart perpendicularly to flow across the channel. The fence turned upstream to prevent bypass. The fence was stapled into the ground 6 in. apart on the front and back in a staggered pattern.

Impoundment Efficiency

Flow Rate (cfs)	0.5	1.0	1.4
Impoundment Length (ft)	21.0	38.0	41.0
Water Depth (in.)	16.0	26.5	29.0

Water Quality Data Statistics









Post Number	Starting Post Deflection (°)	0.5 cfs Post Deflection (°)	1.0 cfs Post Deflection (°)	1.4 cfs Post Deflection (°)
1	5.4	2.6	5.1	6.8
2	5.1	1.0	2.8	4.2
3	3.8	1.7	1.2	5.6
4	1.0	0.9	3.8	5.8
5	8.6	10.2	19.3	21.3
6	14.8	15.8	22.0	29.8
7	11.4	13.5	20.0	28.9
8	13.5	16.4	24.0	27.9
9	2.8	4.2	8.0	8.6
10	4.2	1.9	5.9	6.0
11	2.8	4.5	2.1	2.6





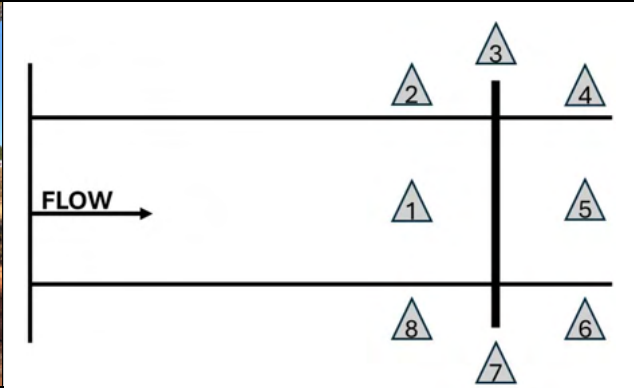

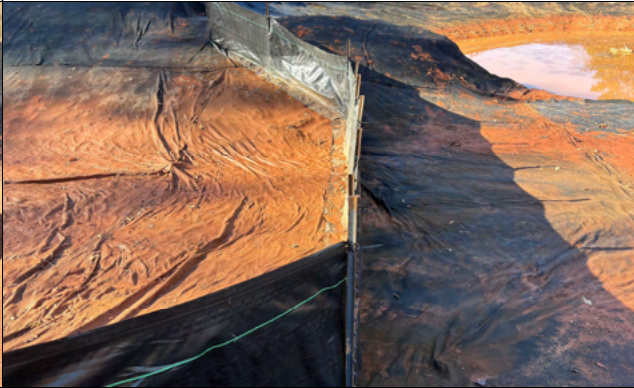

Note: When standing downstream facing flow/upstream, numbering started at post 1 on the left bank and moved across to the right bank.

Note: Deflection angle was measured from the top of each fence post.

Overtopping Record

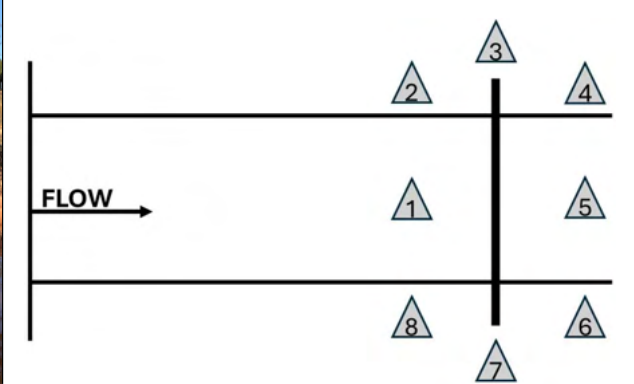
Fence Overtopped Start Time:	19 min into test
Fence Overtopped End Time:	9 min after test

Test ID	Photo Documentation	Installation
B	Pre-Test	30" fence height & 2.5' post spacing
		
Location 2	Location 3	Location 4
		
Location 1		Location 5
		
Location 8	Location 7	Location 6

Test ID	Photo Documentation	Installation
B	Post-Test	30" fence height & 2.5' post spacing
		
Location 2	Location 3	Location 4
	 <p>The diagram shows a rectangular pond with a central vertical channel. A horizontal line with an arrow labeled 'FLOW' points to the right. Eight sampling locations are marked with triangles: 1, 2, 3, 4, 5, 6, 7, and 8. Locations 1, 2, 3, and 4 are along the top edge; 5, 6, 7, and 8 are along the bottom edge. Location 3 is at the top of the central channel, and location 7 is at the bottom of the central channel.</p>	
Location 1		Location 5
		
Location 8	Location 7	Location 6

LOW POROSITY SILT FENCE STRUCTURAL, CLEAN WATER TEST LOG

Test Summary

Installation:	30 in. fence height with 2.5 ft post spacing
Test ID:	C
Date:	11/14/2025
Type:	Longevity
Flow Rate (cfs):	0.5, 1.0, 1.4
Sediment Load Rate (lb/min):	N/A

Picture of Installation

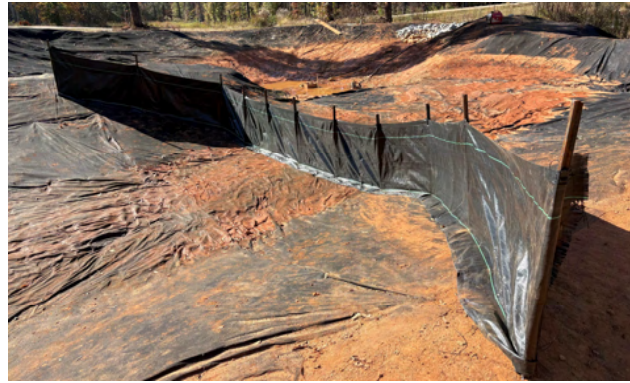

Testing Regime: The testing period consisted of 30 min of flow at 3 flow rates. 10 min at 0.5 cfs, 10 min at 1.0 cfs, and 10 min at 1.4 cfs. The 1.4 cfs was the highest flow rate attainable by the pump.

Installation Description & Test Notes: The low porosity silt fence had a fence height of 30 in. as standard low-profile installation. The fence was attached to 1.25lb/ft steel T-posts using 3 zip-ties at the top of each post threaded through the material. The posts were spaced 2.5 ft apart perpendicularly to flow across the channel. The fence turned upstream to prevent bypass. The fence was stapled into the ground 6 in. apart on the front and back in a staggered pattern. Fabric ripping found around the zip ties on every post, was heard near the end of the test.

Impoundment Efficiency

Flow Rate (cfs)	0.5	1.0	1.4
Impoundment Length (ft)	23.0	37.0	39.0
Water Depth (in.)	18.0	28.0	28.0









Water Quality Data Statistics





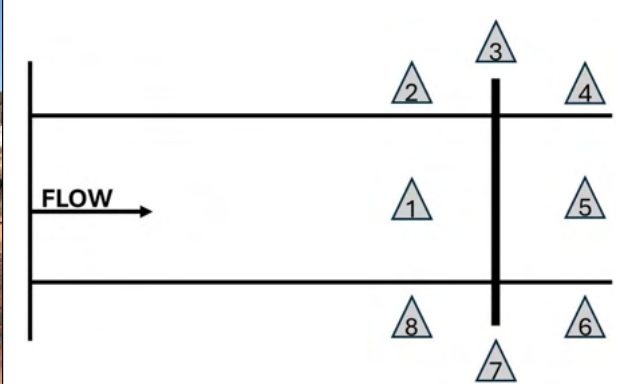



Post Number	Starting Post Deflection (°)	0.5 cfs Post Deflection (°)	1.0 cfs Post Deflection (°)	1.4 cfs Post Deflection (°)
1	5.8	5.8	5.8	7.2
2	1.6	1.6	4.7	5.1
3	2.8	2.8	4.9	6.1
4	3.1	3.8	5.8	6.3
5	15.5	17.1	23.6	25.9
6	18.2	24.0	33.5	35.6
7	19.1	24.4	33.3	37.8
8	17.2	24.5	30.8	32.1
9	4.3	5.4	7.7	6.8
10	2.4	2.4	4.5	4.4
11	3.1	3.1	4.0	4.4

*Note: When standing downstream facing flow/upstream, numbering started at post 1 on the left bank and moved across to the right bank.
Note: Deflection angle was measured from the top of each fence post.*

Overtopping Record

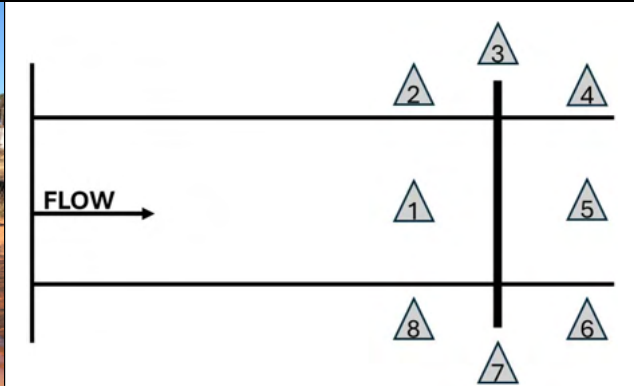
Fence Overtopped Start Time:	16 min into test
Fence Overtopped End Time:	10 min after test

Test ID	Photo Documentation	Installation
C	Post-Test	30" fence height & 2.5' post spacing
		
Location 2	Location 3	Location 4
		
Location 1		Location 5
		
Location 8	Location 7	Location 6

Test ID	Photo Documentation	Installation
C	Post-Test	30" fence height & 2.5' post spacing
		
Location 2	Location 3	Location 4
		
Location 1		Location 5
		
Location 8	Location 7	Location 6

LOW POROSITY SILT FENCE STRUCTURAL, CLEAN WATER TEST LOG

Test Series Summary

Installation:	30 in. fence height with 2.5 ft post spacing
Test ID:	A, B, C

Test Series Data Summary

Test Flow Rates (cfs)	0.5	1.0	1.4
Average Impoundment (ft)	21.7	35.0	40.3
Average Water Depth (in.)	16.3	25.2	28.7
Theoretical Impoundment (ft)	50.0	50.0	50.0
Theoretical Water Depth (in.)	30.0	30.0	30.0
Impoundment Ratio	0.4	0.7	0.8
Depth Ratio	0.5	0.8	1.0
Max Deflection (in.)	-	-	21.2

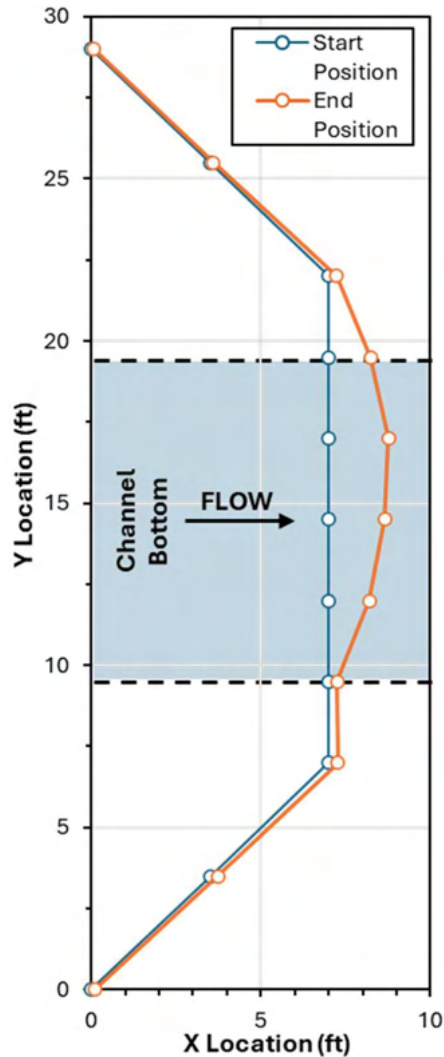

Note: Graph depicts a plan view of the channel and fence positions of the start and end of the test series.

LOW POROSITY SILT FENCE STRUCTURAL, CLEAN WATER TEST LOG

Test Summary

Installation:	18 in. weir height with 3.5 ft post spacing
Test ID:	A
Date:	12/3/2025
Type:	Longevity
Flow Rate (cfs):	0.5, 1.0, 1.4
Sediment Load Rate (lb/min):	N/A

Picture of Installation



Testing Regime: The testing period consisted of 30 min of flow at 3 flow rates. 10 min at 0.5 cfs, 10 min at 1.0 cfs, and 10 min at 1.4 cfs. The 1.4 cfs was the highest flow rate attainable by the pump.

Installation Description & Test Notes: The low porosity silt fence had a fence height of 30 in. and an 18 in. weir cut out of the center of the fence. The fence was attached to 1.25lb/ft steel T-posts using 3 zip-ties at the top of each post threaded through the material. The posts were spaced 3.5 ft apart in a 90-degree, V-shape across the channel based on ALDOT silt fence ditch check. The fence was stapled into the ground 6 in. apart on the front and back in a staggered pattern.

Impoundment Efficiency

Flow Rate (cfs)	0.5	1.0	1.4
Impoundment Length (ft)	20.0	30.0	30.0
Water Depth (in.)	14.0	20.5	21.0

Water Quality Data Statistics









Post Number	Starting Post Deflection (°)	0.5 cfs Post Deflection (°)	1.0 cfs Post Deflection (°)	1.4 cfs Post Deflection (°)
1	3.5	1.4	1.9	1.9
2	4.0	4.9	4.9	5.2
3	4.0	4.5	5.4	5.6
4	0.9	0.5	2.8	3.3
5	0.7	1.4	5.2	5.4
6	4.9	4.0	4.0	4.4
7	1.7	1.6	4.7	4.9
8	2.8	2.0	3.1	3.1
9	1.2	0.7	0.3	0.2
10	1.6	1.4	4.5	1.4
11	3.1	3.8	3.5	3.8





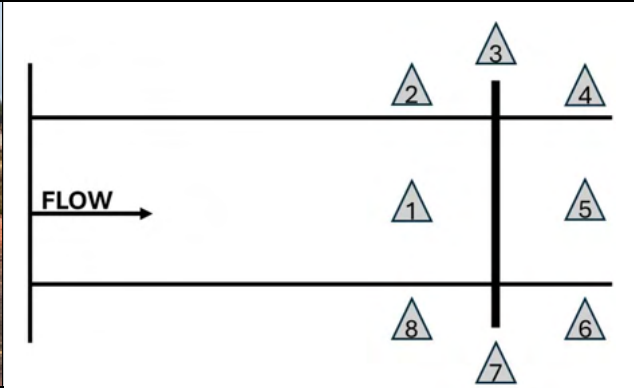



Note: When standing downstream facing flow/upstream, numbering started at post 1 on the left bank and moved across to the right bank.

Note: Deflection angle was measured from the top of each fence post.

Overtopping Record

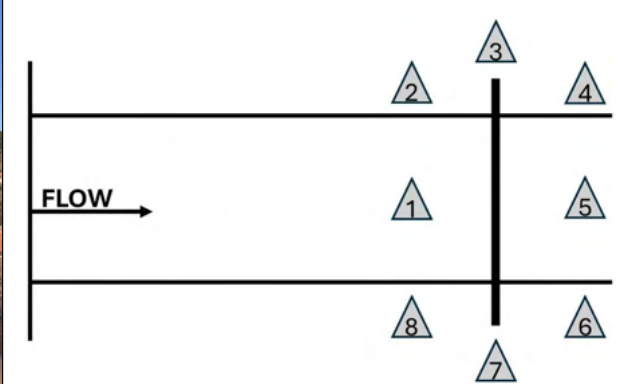
Fence Overtopped Start Time:	11 min into test
Fence Overtopped End Time:	8 min after test

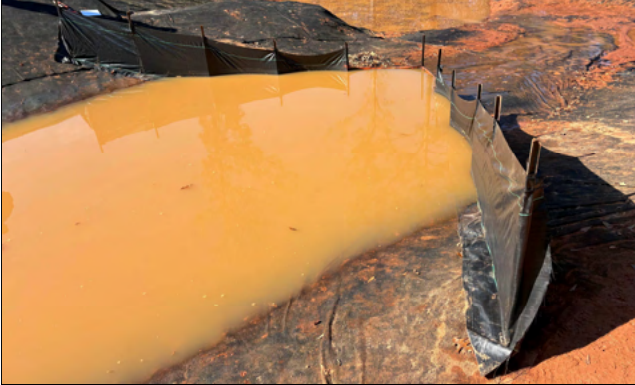
Test ID	Photo Documentation	Installation
A	Pre-Test	V-shape with 18" weir
		
Location 2	Location 3	Location 4
		
Location 1		Location 5
		
Location 8	Location 7	Location 6

Test ID	Photo Documentation	Installation
A	Post-Test	V-shape with 18" weir
		
Location 2	Location 3	Location 4
		
Location 1		Location 5
		
Location 8	Location 7	Location 6

LOW POROSITY SILT FENCE STRUCTURAL, CLEAN WATER TEST LOG

Test Summary

Installation:	18 in. weir height with 3.5 ft post spacing
Test ID:	B
Date:	12/3/2025
Type:	Longevity
Flow Rate (cfs):	0.5, 1.0, 1.4
Sediment Load Rate (lb/min):	N/A

Picture of Installation



Testing Regime: The testing period consisted of 30 min of flow at 3 flow rates. 10 min at 0.5 cfs, 10 min at 1.0 cfs, and 10 min at 1.4 cfs. The 1.4 cfs was the highest flow rate attainable by the pump.

Installation Description & Test Notes: The low porosity silt fence had a fence height of 30 in. and an 18 in. weir cut out of the center of the fence. The fence was attached to 1.25lb/ft steel T-posts using 3 zip-ties at the top of each post threaded through the material. The posts were spaced 3.5 ft apart in a 90-degree, V-shape across the channel based on ALDOT silt fence ditch check. The fence was stapled into the ground 6 in. apart on the front and back in a staggered pattern.

Impoundment Efficiency

Flow Rate (cfs)	0.5	1.0	1.4
Impoundment Length (ft)	25.0	28.0	31.0
Water Depth (in.)	17.0	20.0	21.0

Water Quality Data Statistics









Post Number	Starting Post Deflection (°)	0.5 cfs Post Deflection (°)	1.0 cfs Post Deflection (°)	1.4 cfs Post Deflection (°)
1	1.4	1.5	1.9	1.9
2	2.6	2.9	3.7	5.2
3	3.8	4.2	4.7	5.1
4	0.3	1.7	2.8	2.8
5	3.3	3.9	4.2	7.0
6	4.4	4.5	4.0	4.0
7	0.9	1.1	1.2	4.7
8	1.2	1.4	2.6	2.6
9	0.5	0.3	0.2	0.2
10	1.4	1.2	1.6	1.9
11	2.4	2.6	3.0	3.1





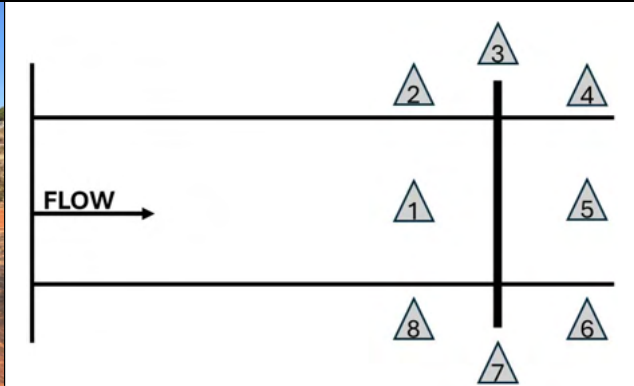



Note: When standing downstream facing flow/upstream, numbering started at post 1 on the left bank and moved across to the right bank.

Note: Deflection angle was measured from the top of each fence post.

Overtopping Record

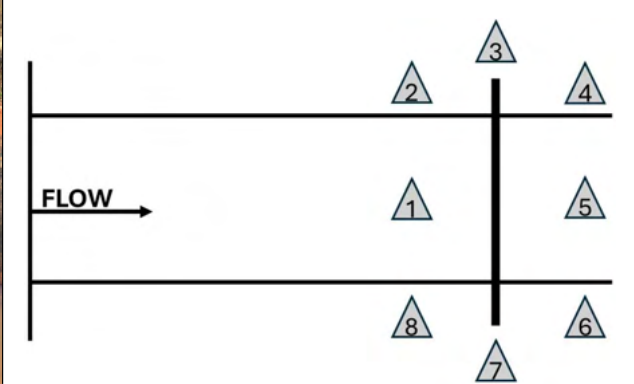
Fence Overtopped Start Time:	11 min into test
Fence Overtopped End Time:	10 min after test

Test ID	Photo Documentation	Installation
B	Pre-Test	V-shape with 18" weir
		
Location 2	Location 3	Location 4
		
Location 1		Location 5
		
Location 8	Location 7	Location 6

Test ID	Photo Documentation	Installation
B	Post-Test	V-shape with 18" weir
		
Location 2	Location 3	Location 4
	 <p>The diagram shows a V-shaped weir structure with flow entering from the left, indicated by an arrow labeled "FLOW". Eight sampling locations are marked with triangles and numbered 1 through 8. Locations 1, 2, 3, and 4 are along the top edge of the weir. Locations 5, 6, 7, and 8 are along the bottom edge. Location 3 is at the apex of the V, and location 7 is at the bottom vertex.</p>	
Location 1		Location 5
		
Location 8	Location 7	Location 6

LOW POROSITY SILT FENCE STRUCTURAL, CLEAN WATER TEST LOG

Test Summary

Installation:	18 in. weir height with 3.5 ft post spacing
Test ID:	C
Date:	12/3/2025
Type:	Longevity
Flow Rate (cfs):	0.5, 1.0, 1.4
Sediment Load Rate (lb/min):	N/A

Picture of Installation



Testing Regime: The testing period consisted of 30 min of flow at 3 flow rates. 10 min at 0.5 cfs, 10 min at 1.0 cfs, and 10 min at 1.4 cfs. The 1.4 cfs was the highest flow rate attainable by the pump.

Installation Description & Test Notes: The low porosity silt fence had a fence height of 30 in. and an 18 in. weir cut out of the center of the fence. The fence was attached to 1.25lb/ft steel T-posts using 3 zip-ties at the top of each post threaded through the material. The posts were spaced 3.5 ft apart in a 90-degree, V-shape across the channel based on ALDOT silt fence ditch check. The fence was stapled into the ground 6 in. apart on the front and back in a staggered pattern.

Impoundment Efficiency

Flow Rate (cfs)	0.5	1.0	1.4
Impoundment Length (ft)	25.0	28.0	31.0
Water Depth (in.)	17.0	20.0	21.0

Water Quality Data Statistics









Post Number	Starting Post Deflection (°)	0.5 cfs Post Deflection (°)	1.0 cfs Post Deflection (°)	1.4 cfs Post Deflection (°)
1	1.7	1.7	2.0	1.7
2	4.2	4.7	4.4	4.4
3	4.5	5.1	5.1	5.1
4	0.3	1.9	2.4	3.0
5	4.7	5.8	8.4	9.6
6	4.9	4.2	4.2	4.4
7	1.6	2.4	5.6	7.9
8	0.9	1.2	3.1	4.9
9	1.2	0.7	0.5	0.3
10	3.0	3.0	3.0	3.3
11	3.5	3.5	3.5	3.7





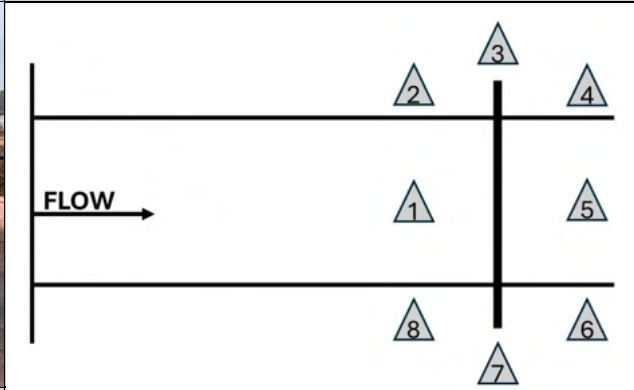



Note: When standing downstream facing flow/upstream, numbering started at post 1 on the left bank and moved across to the right bank.

Note: Deflection angle was measured from the top of each fence post.

Overtopping Record

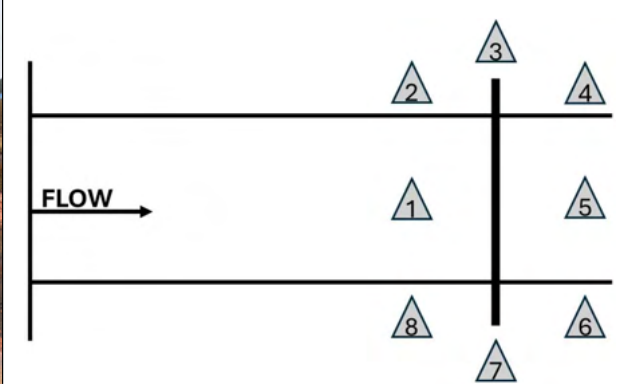
Fence Overtopped Start Time:	10 min into test
Fence Overtopped End Time:	10 min after test

Test ID	Photo Documentation	Installation
C	Pre-Test	V-shape with 18" weir
		
Location 2	Location 3	Location 4
		
Location 1		Location 5
		
Location 8	Location 7	Location 6

Test ID	Photo Documentation	Installation
C	Post-Test	V-shape with 18" weir
		
Location 2	Location 3	Location 4
		
Location 1		Location 5
		
Location 8	Location 7	Location 6

LOW POROSITY SILT FENCE STRUCTURAL, CLEAN WATER TEST LOG

Test Series Summary

Installation:	18 in. weir height with 3.5 ft V-shape post spacing
Test ID:	A, B, C

Test Series Data Summary

Test Flow Rates (cfs)	0.5	1.0	1.4
Average Impoundment (ft)	23.3	28.7	30.7
Average Water Depth (in.)	16.0	20.2	21.0
Theoretical Impoundment (ft)	30.0	30.0	30.0
Theoretical Water Depth (in.)	18.0	18.0	18.0
Impoundment Ratio	0.78	0.96	1.02
Depth Ratio	0.89	1.12	1.17
Max Deflection (in.)	-	-	5.6

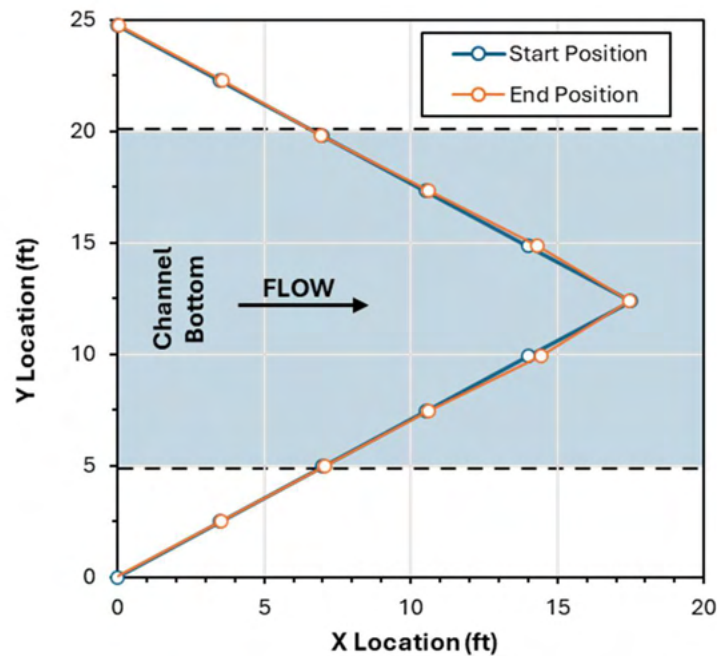

Note: Graph depicts a plan view of the channel and fence positions of the start and end of the test series.

LOW POROSITY SILT FENCE STRUCTURAL, CLEAN WATER TEST LOG

Test Summary

Installation:	30 in. fence height with wood post at 5 ft spacing
Test ID:	A
Date:	12/8/2025
Type:	Longevity
Flow Rate (cfs):	0.5, 1.0, 1.4
Sediment Load Rate (lb/min):	N/A

Picture of Installation



Testing Regime: The testing period consisted of 30 min of flow at 3 flow rates. 10 min at 0.5 cfs, 10 min at 1.0 cfs, and 10 min at 1.4 cfs. The 1.4 cfs was the highest flow rate attainable by the pump.

Installation Description & Test Notes: The low porosity silt fence had a fence height of 30 in. on 2 in. by 2in. hardwood posts. The fence was attached to the wood posts with staples along the face of the wood at the top, middle, and bottom of each post. The posts were spaced 5 ft apart perpendicularly to flow across the channel. The fence was stapled into the ground 6 in. apart on the front and back in a staggered pattern. The fence failed 19.5 minutes into the test after experiencing 0.5 cfs and 1.0 cfs flow rates. The fence failed by snapping the wood posts at the base, and the force of the water ripped the fence out of the staples after breaking.

Impoundment Efficiency

Flow Rate (cfs)	0.5	1.0	1.4
Impoundment Length (ft)	16.0	-	-
Water Depth (in.)	15.0	-	-

Water Quality Data Statistics







Post Number	Starting Post Deflection (°)	0.5 cfs Post Deflection (°)	1.0 cfs Post Deflection (°)	1.4 cfs Post Deflection (°)
1	0.2	0.2	0.3	-
2	3.0	3.0	4.2	-
3	3.0	5.1	15.5	-
4	4.5	6.3	17.9	-
5	1.0	0.3	6.3	-
6	-8.2	-8.2	-7.3	-
7	5.2	5.2	5.2	-





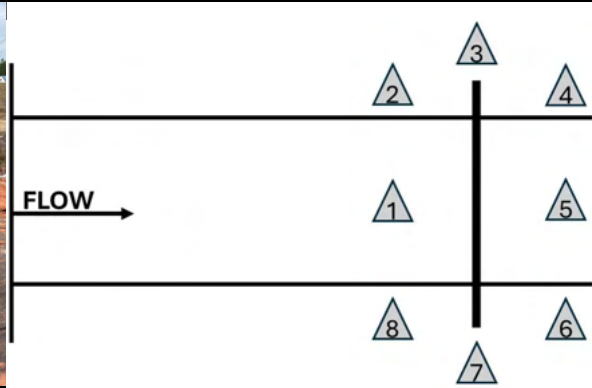

Note: When standing downstream facing flow/upstream, numbering started at post 1 on the left bank and moved across to the right bank.

Note: Deflection angle was measured from the top of each fence post.

Overtopping Record

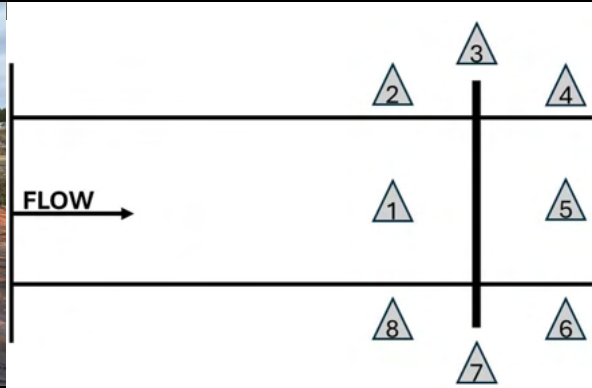
Fence Overtopped Start Time:	10 min into test
Fence Overtopped End Time:	N/A min after test

Test ID	Photo Documentation	Installation
A	Pre-Test	30" fence height & 5' wood post spacing
	<p style="text-align: center;">X</p>	
Location 2	Location 3	Location 4
		
Location 1		Location 5
	<p style="text-align: center;">X</p>	
Location 8	Location 7	Location 6

Test ID	Photo Documentation	Installation
A	Post-Failure	30" fence height & 5' wood post spacing
	X	
Location 2	Location 3	Location 4
		
Location 1		Location 5
	X	
Location 8	Location 7	Location 6

LOW POROSITY SILT FENCE STRUCTURAL, CLEAN WATER TEST LOG

Test Summary

Installation:	24 in. fence height with 2.5 ft post spacing
Test ID:	A
Date:	1/6/2026
Type:	Longevity
Flow Rate (cfs):	0.5, 1.0, 1.4
Sediment Load Rate (lb/min):	N/A

Picture of Installation



Testing Regime: The testing period consisted of 30 min of flow at 3 flow rates. 10 min at 0.5 cfs, 10 min at 1.0 cfs, and 10 min at 1.4 cfs. The 1.4 cfs was the highest flow rate attainable by the pump.

Installation Description & Test Notes: The low porosity silt fence had a fence height of 24 in. by folding the fence along the green line. The fence was attached to 1.25lb/ft steel T-posts using 3 zip-ties at the top of each post threaded through the double-layer of folded material. The posts were spaced 5 ft apart perpendicularly to flow across the channel. The fence was stapled into the ground 6 in. apart on the front and back in a staggered pattern.

Impoundment Efficiency

Flow Rate (cfs)	0.5	1.0	1.4
Impoundment Length (ft)	15.0	28.0	31.0
Water Depth (in.)	17.0	23.0	24.0







Water Quality Data Statistics



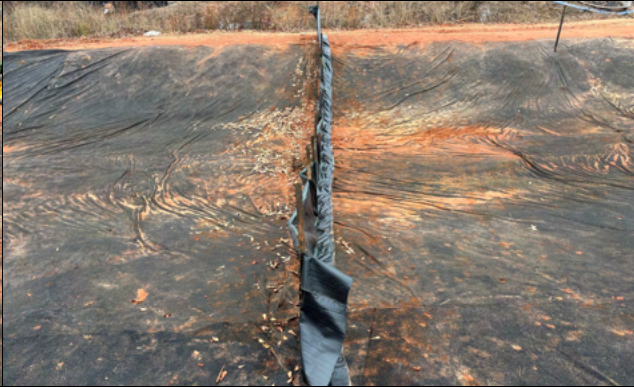

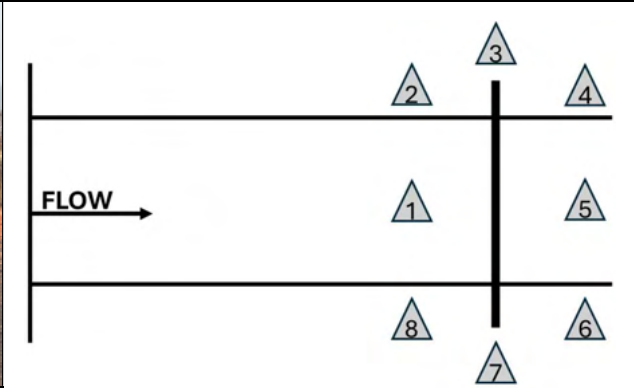



Post Number	Starting Post Deflection (°)	0.5 cfs Post Deflection (°)	1.0 cfs Post Deflection (°)	1.4 cfs Post Deflection (°)
1	4.2	4.2	4.5	5.0
2	1.2	1.2	2.3	2.6
3	0.3	0.5	3.3	5.1
4	0.2	1.7	7.2	7.7
5	1.2	3.1	9.6	12.1
6	1.0	3.1	9.1	11.6
7	5.5	5.8	12.0	14.3
8	3.7	3.7	6.5	7.5
9	2.6	2.6	3.8	6.3

*Note: When standing downstream facing flow/upstream, numbering started at post 1 on the left bank and moved across to the right bank.
Note: Deflection angle was measured from the top of each fence post.*

Overtopping Record

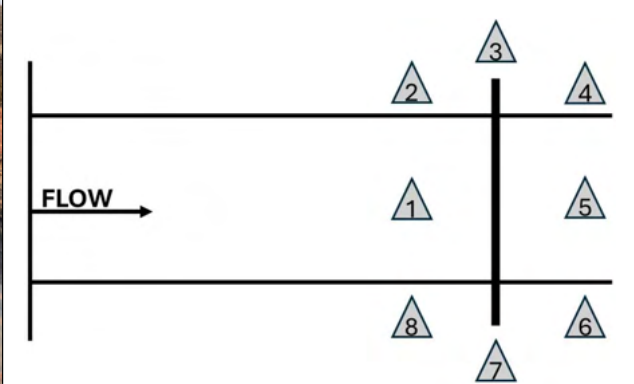
Fence Overtopped Start Time:	15 min into test
Fence Overtopped End Time:	10 min after test

Test ID	Photo Documentation	Installation
A	Pre-Test	24" fence height & 2.5' post spacing
		
Location 2	Location 3	Location 4
		
Location 1		Location 5
		
Location 8	Location 7	Location 6

Test ID	Photo Documentation	Installation
A	Post-Test	24" fence height & 2.5' post spacing
		
Location 2	Location 3	Location 4
	 <p>The diagram illustrates the flow direction and sampling locations. A horizontal line represents the flow path, with an arrow labeled 'FLOW' pointing to the right. A vertical line intersects this horizontal line. Eight sampling locations are marked with numbered triangles: 1, 2, 3, 4, 5, 6, 7, and 8. Locations 1, 2, 3, and 4 are along the top horizontal line; locations 5, 6, 7, and 8 are along the bottom horizontal line. Location 3 is at the top intersection, and location 7 is at the bottom intersection.</p>	
Location 1		Location 5
		
Location 8	Location 7	Location 6

LOW POROSITY SILT FENCE STRUCTURAL, CLEAN WATER TEST LOG

Test Summary

Installation:	24 in. fence height with 5 ft post spacing
Test ID:	B
Date:	1/6/2026
Type:	Longevity
Flow Rate (cfs):	0.5, 1.0, 1.4
Sediment Load Rate (lb/min):	N/A

Picture of Installation



Testing Regime: The testing period consisted of 30 min of flow at 3 flow rates. 10 min at 0.5 cfs, 10 min at 1.0 cfs, and 10 min at 1.4 cfs. The 1.4 cfs was the highest flow rate attainable by the pump.

Installation Description & Test Notes: The low porosity silt fence had a fence height of 24 in. by folding the fence along the green line. The fence was attached to 1.25lb/ft steel T-posts using 3 zip-ties at the top of each post threaded through the double-layer of folded material. The posts were spaced 5 ft apart perpendicularly to flow across the channel. The fence was stapled into the ground 6 in. apart on the front and back in a staggered pattern.

Impoundment Efficiency

Flow Rate (cfs)	0.5	1.0	1.4
Impoundment Length (ft)	16.0	31.0	33.0
Water Depth (in.)	17.0	24.0	24.0









Water Quality Data Statistics





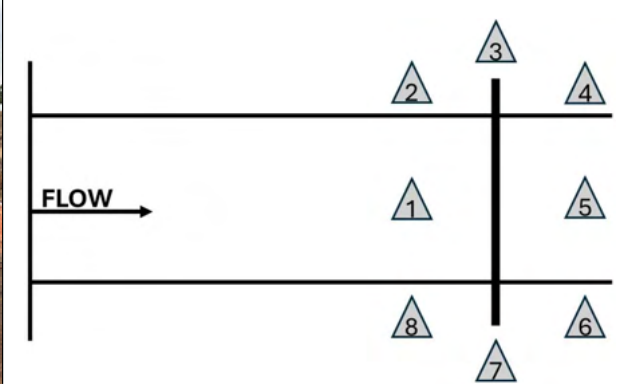



Post Number	Starting Post Deflection (°)	0.5 cfs Post Deflection (°)	1.0 cfs Post Deflection (°)	1.4 cfs Post Deflection (°)
1	4.0	4.4	4.5	4.7
2	1.2	1.7	1.9	3.3
3	0.9	1.9	4.1	4.9
4	3.1	4.9	7.0	8.7
5	5.9	7.9	11.8	16.7
6	6.1	7.3	12.0	17.1
7	9.8	10.3	17.3	19.8
8	5.1	6.1	7.9	8.4
9	5.2	5.4	5.6	6.8

*Note: When standing downstream facing flow/upstream, numbering started at post 1 on the left bank and moved across to the right bank.
Note: Deflection angle was measured from the top of each fence post.*

Overtopping Record

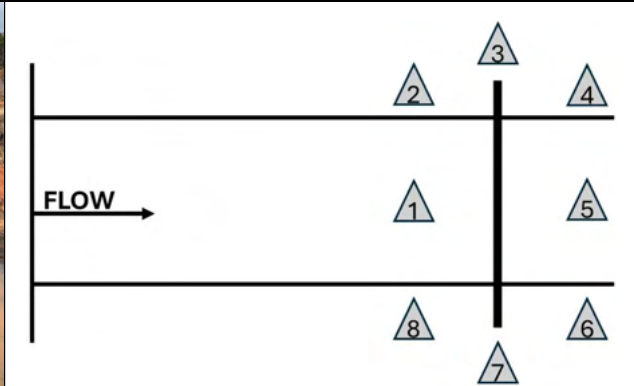
Fence Overtopped Start Time:	15 min into test
Fence Overtopped End Time:	10 min after test

Test ID	Photo Documentation	Installation
B	Pre-Test	24" fence height & 2.5' post spacing
		
Location 2	Location 3	Location 4
		
Location 1		Location 5
		
Location 8	Location 7	Location 6

Test ID	Photo Documentation	Installation
B	Post-Test	24" fence height & 2.5' post spacing
		
Location 2	Location 3	Location 4
		
Location 1		Location 5
		
Location 8	Location 7	Location 6

LOW POROSITY SILT FENCE STRUCTURAL, CLEAN WATER TEST LOG

Test Summary

Installation:	24 in. fence height with 5 ft post spacing
Test ID:	C
Date:	1/7/2026
Type:	Longevity
Flow Rate (cfs):	0.5, 1.0, 1.4
Sediment Load Rate (lb/min):	N/A

Picture of Installation



Testing Regime: The testing period consisted of 30 min of flow at 3 flow rates. 10 min at 0.5 cfs, 10 min at 1.0 cfs, and 10 min at 1.4 cfs. The 1.4 cfs was the highest flow rate attainable by the pump.

Installation Description & Test Notes: The low porosity silt fence had a fence height of 24 in. by folding the fence along the green line. The fence was attached to 1.25lb/ft steel T-posts using 3 zip-ties at the top of each post threaded through the double-layer of folded material. The posts were spaced 5 ft apart perpendicularly to flow across the channel. The fence was stapled into the ground 6 in. apart on the front and back in a staggered pattern.

Impoundment Efficiency

Flow Rate (cfs)	0.5	1.0	1.4
Impoundment Length (ft)	19.0	29.0	32.0
Water Depth (in.)	15.0	22.0	23.0









Water Quality Data Statistics





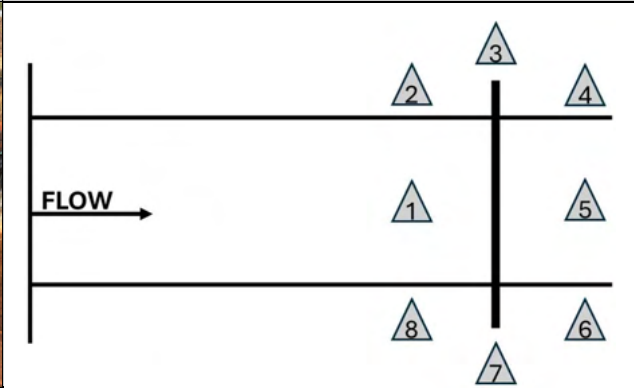



Post Number	Starting Post Deflection (°)	0.5 cfs Post Deflection (°)	1.0 cfs Post Deflection (°)	1.4 cfs Post Deflection (°)
1	4.0	4.0	4.5	4.5
2	0.7	0.9	2.4	3.0
3	1.2	1.7	4.5	4.5
4	4.0	5.4	9.1	9.3
5	10.7	11.4	18.5	19.8
6	10.7	11.7	18.7	21.6
7	20.0	21.4	30.0	32.3
8	4.9	6.5	7.3	7.3
9	5.4	5.6	6.6	6.6

*Note: When standing downstream facing flow/upstream, numbering started at post 1 on the left bank and moved across to the right bank.
Note: Deflection angle was measured from the top of each fence post.*

Overtopping Record

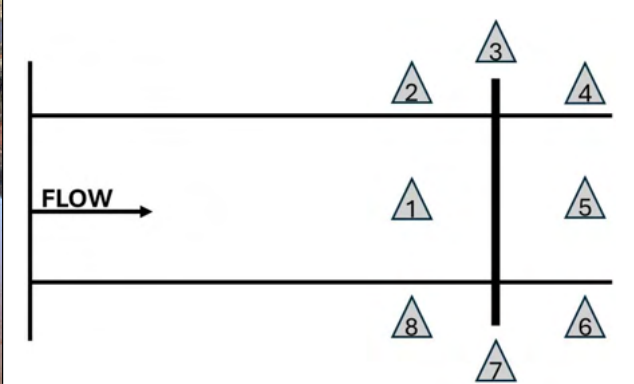
Fence Overtopped Start Time:	13 min into test
Fence Overtopped End Time:	11 min after test

Test ID	Photo Documentation	Installation
C	Pre-Test	24" fence height & 2.5' post spacing
		
Location 2	Location 3	Location 4
		
Location 1		Location 5
		
Location 8	Location 7	Location 6

Test ID	Photo Documentation	Installation
C	Post-Test	24" fence height & 2.5' post spacing
		
Location 2	Location 3	Location 4
		
Location 1		Location 5
		
Location 8	Location 7	Location 6

LOW POROSITY SILT FENCE STRUCTURAL, CLEAN WATER TEST LOG

Test Series Summary

Installation:	24 in. fence height with 2.5 ft post spacing
Test ID:	A, B, C

Test Series Data Summary

Test Flow Rates (cfs)	0.5	1.0	1.4
Average Impoundment (ft)	16.7	29.3	32.0
Average Water Depth (in.)	16.3	23.0	23.7
Theoretical Impoundment (ft)	40.0	40.0	40.0
Theoretical Water Depth (in.)	24.0	24.0	24.0
Impoundment Ratio	0.42	0.73	0.80
Depth Ratio	0.68	0.96	0.99
Max Deflection (in.)	-	-	16.2

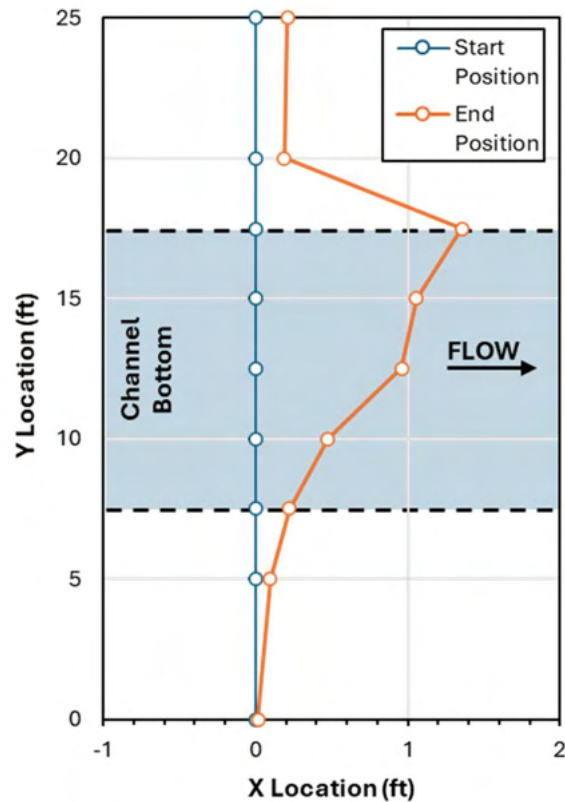

Note: Graph depicts a plan view of the channel and fence positions of the start and end of the test series.

**Appendix C:
Sediment Trap Test Logs**

SEDIMENT TRAP TEST LOG

Test Summary

Installation:	Standard/Control
Test ID:	A
Date:	8/25/2025
Type:	Longevity
Flow Rate (cfs):	1.0
Sediment Load Rate (lb/min):	49.0

Picture of Installation



Installation Description & Test Notes: The sediment trap, sized for 1 ac of contributory drainage, was installed according to the NDOT plan set. It had a 4 ft long rock weir that was 1 ft deep built with AL Class 1 riprap as a conservative equivalent for the NE Type A riprap. The trap bottom dimensions were 10 ft wide and 22 ft long. The test notes were that the water did not drain once the level dropped beneath the weir. The 2-yr, 24-hr design storm caused the trap basin to fill and the channel to fill near the mouth of the trap. The trap did not have outflow until 30 min into the test (when the flow was cut). The trap continued to dewater through the weir for three hours after the test flow period.

Sediment Capture Efficiency

Capture of Introduced Sediment (%):	86.4 %
Improved Capture from Control:	N/A %

Water Quality Data Statistics

Measurement Location	Avg		Min		Max		Std. Dev.	
	NTU	TSS (mg/L)	NTU	TSS (mg/L)	NTU	TSS (mg/L)	NTU	TSS (mg/L)
Inflow	2,130	9,098	816	4,240	4,008	29,020	957	8,937
Trap	442	558	141	100	1,478	2,770	377	723
Downstream	273	147	130	20	486	300	103	85

TSS (mg/L) and Turbidity (NTU) Data Plots



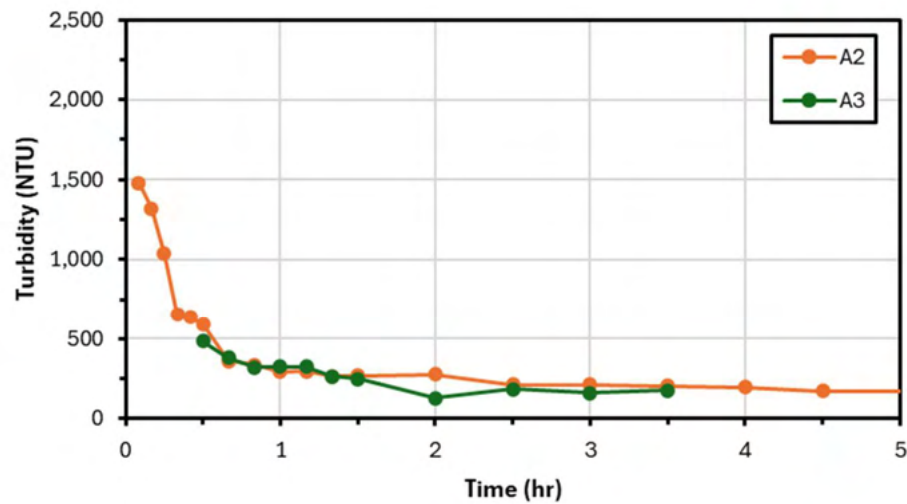
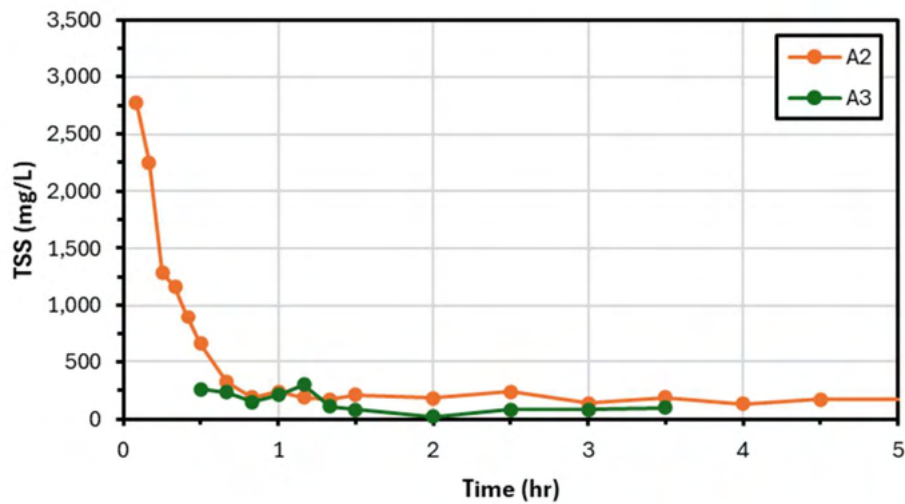
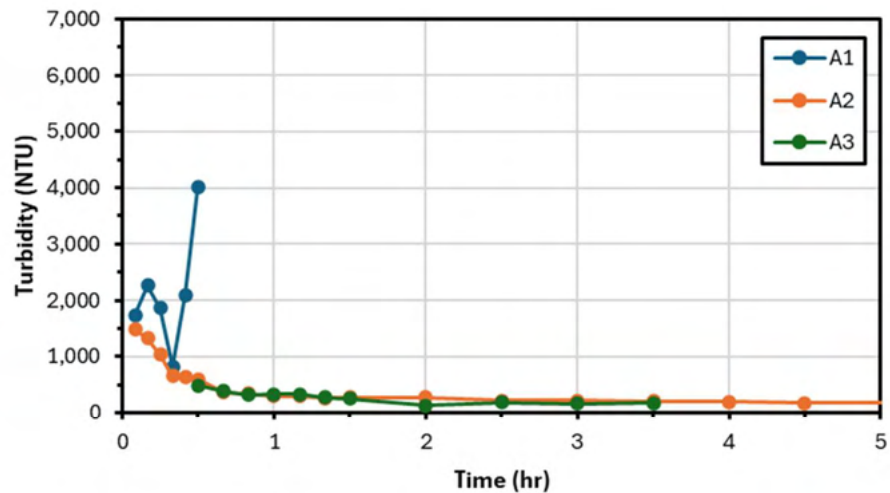
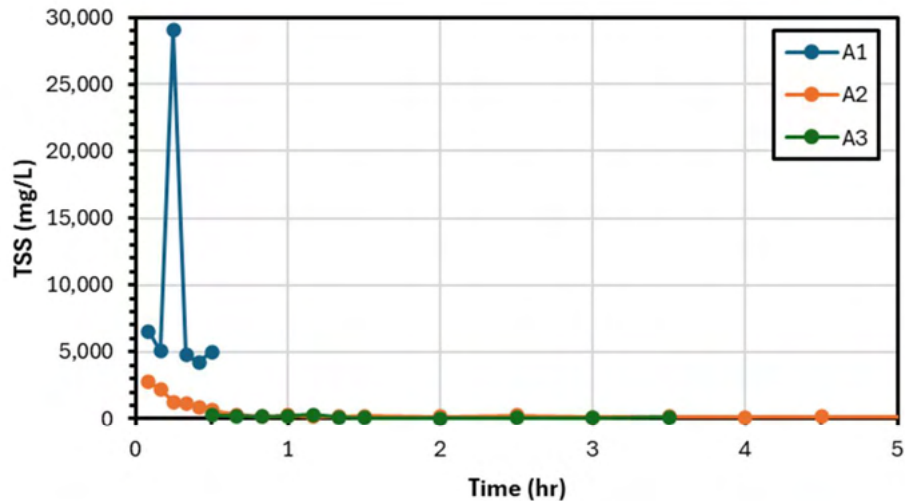



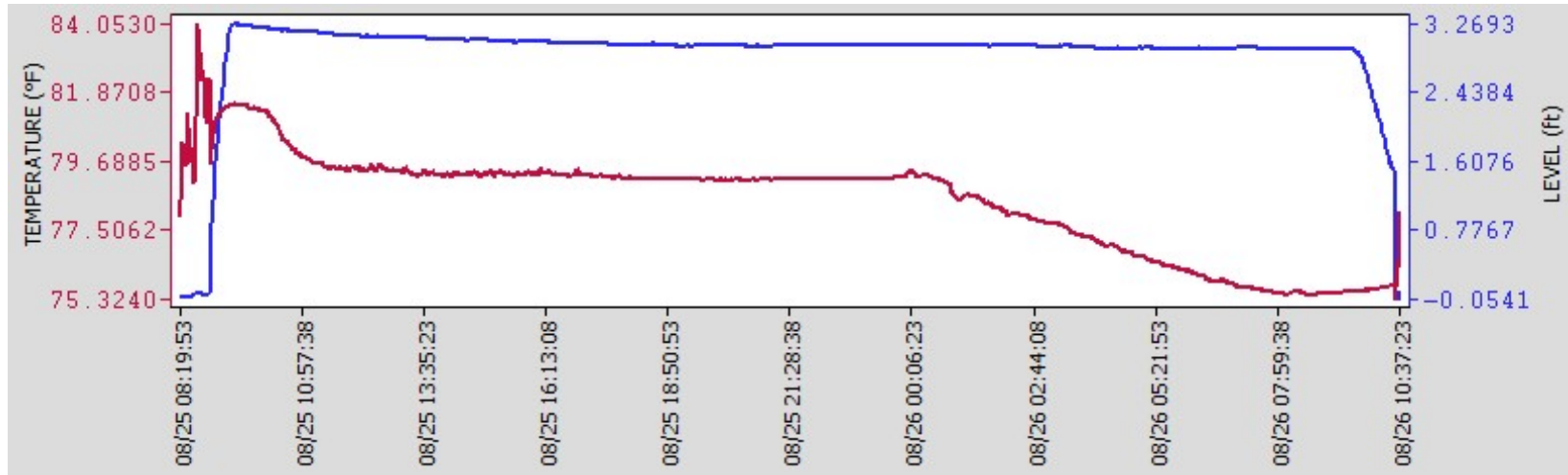

Legend Interpretation: The letter (A, B, C, D) corresponds to the Test ID to indicate which test in the series. The number (1, 2, 3) corresponds to the data collection location with 1 indicating the inflow collection point, 2 indicating the "in-trap" collection point, and 3 indicating the downstream or discharge collection point.





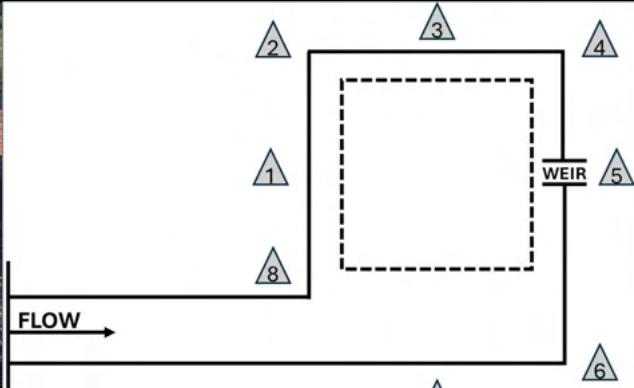





Temperature (°F) & Storage Volume Depth (Level, ft) Plot

Note: This data was produced by a level logger placed on the bottom of the sediment trap prior to test commencement until the trap dewatered (or the depth experienced no more change). The Temperature is represented by the red line, and the depth level is represented by the blue line. The corresponding dates and times are on the x-axis. The skimmer rested on a block at a depth of around 1 ft, meaning water would not be discharged below that level. For installations without a skimmer, the drop of the blue line on the right side of the graph indicates the water being drained to retrieve the level logger.

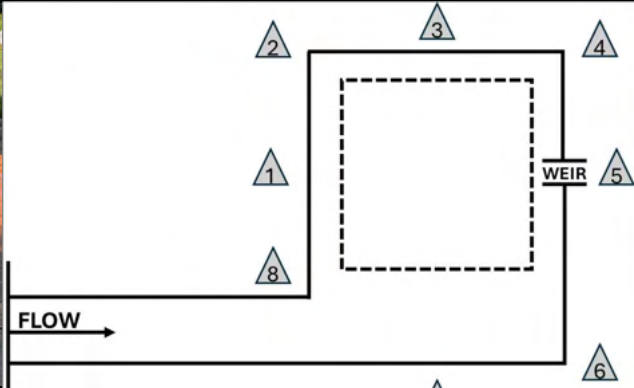

Test ID	Photo Documentation	Installation
A	Pre-Test	Standard Sediment Trap
		
Location 2	Location 3	Location 4
		
Location 1		Location 5
		
Location 8	Location 7	Location 6

Test ID	Photo Documentation	Installation
A	Post-Test	Standard Sediment Trap
		
Location 2	Location 3	Location 4
		
Location 1		Location 5
		
Location 8	Location 7	Location 6

SEDIMENT TRAP TEST LOG

Test Summary

Installation:	Standard/Control
Test ID:	B
Date:	8/26/2025
Type:	Longevity
Flow Rate (cfs):	1.0
Sediment Load Rate (lb/min):	49.0

Picture of Installation



Installation Description & Test Notes: The sediment trap, sized for 1 ac of contributory drainage, was installed according to the NDOT plan set. It had a 4 ft long rock weir that was 1 ft deep built with AL Class 1 riprap as a conservative equivalent for the NE Type A riprap. The trap bottom dimensions were 10 ft wide and 22 ft long. The test notes were that the water did not drain once the level dropped beneath the weir. The 2-yr, 24-hr design storm caused the trap basin to fill and the channel to fill near the mouth of the trap. The trap did not have outflow until 30 min into the test (when the flow was cut). The trap continued to dewater through the weir for three hours after the test flow period.

Sediment Capture Efficiency

Capture of Introduced Sediment (%):	86.4 %
Improved Capture from Control:	N/A %

Water Quality Data Statistics

Measurement Location	Avg		Min		Max		Std. Dev.	
	NTU	TSS (mg/L)	NTU	TSS (mg/L)	NTU	TSS (mg/L)	NTU	TSS (mg/L)
Inflow	723	1,847	234	560	1,406	3,790	399	998
Trap	236	278	107	20	702	1,300	163	349
Downstream	207	175	126	30	381	390	79	118

TSS (mg/L) and Turbidity (NTU) Data Plots



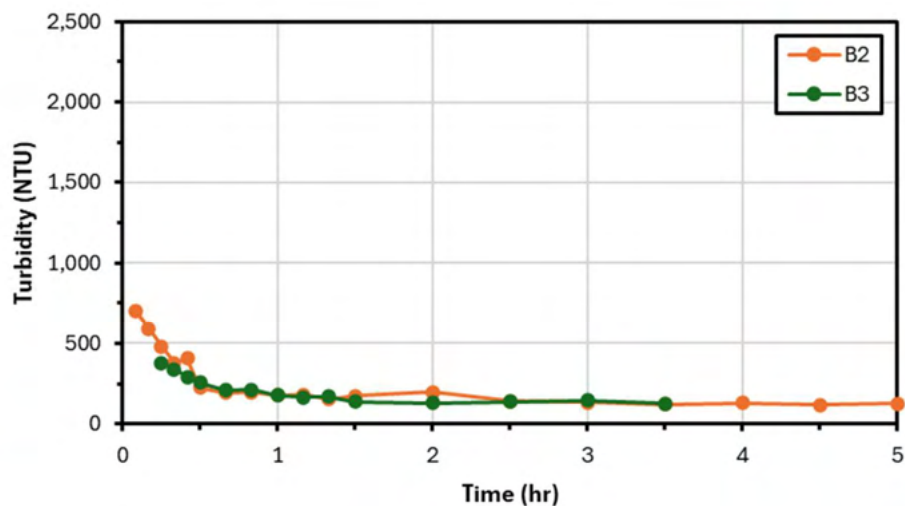
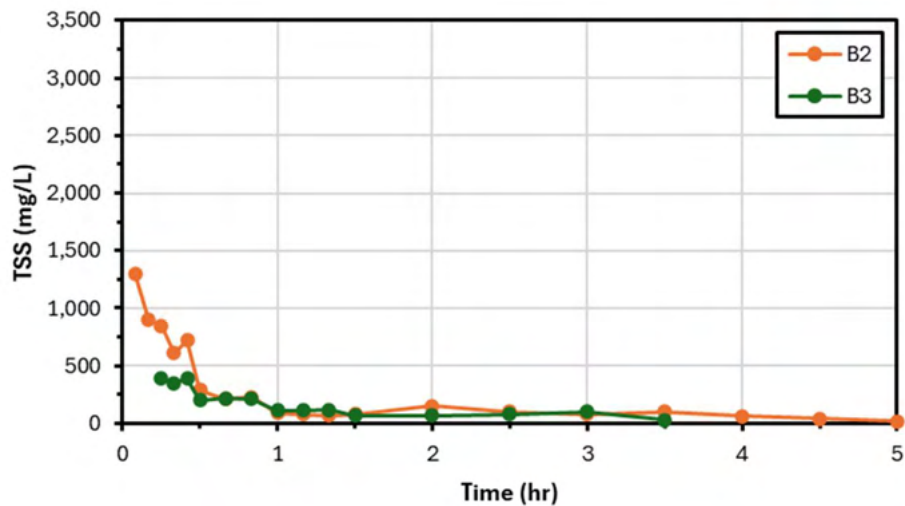
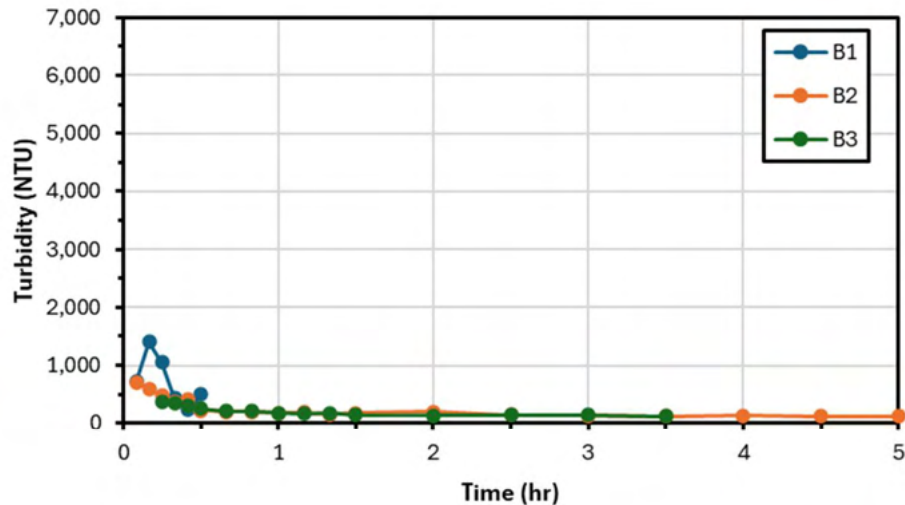
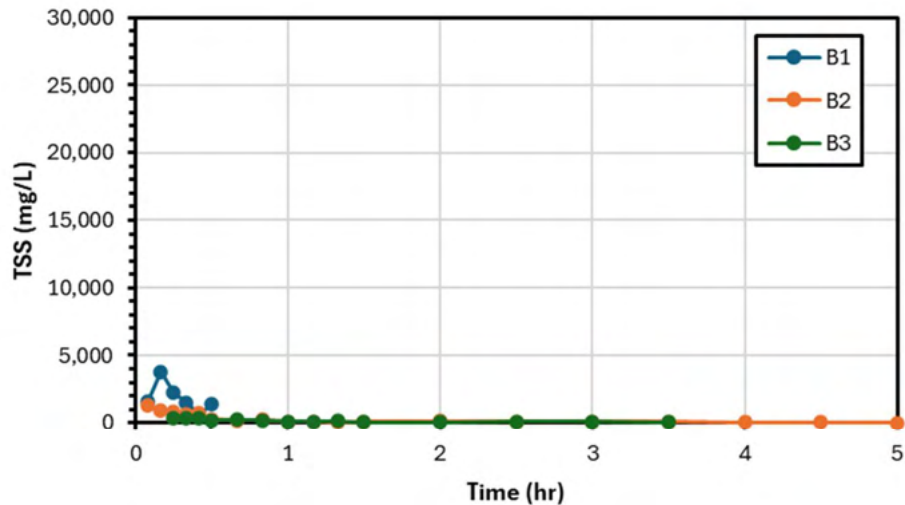



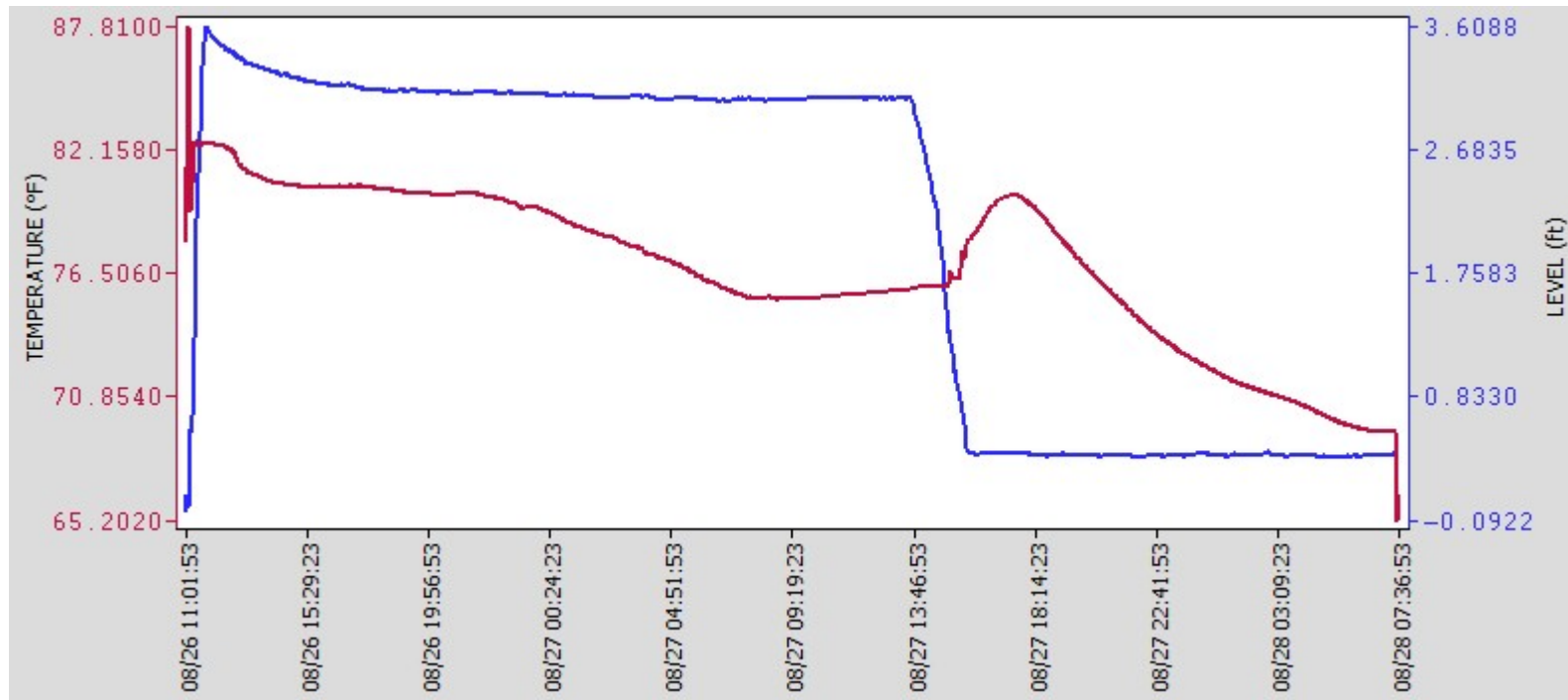

Legend Interpretation: The letter (A, B, C, D) corresponds to the Test ID to indicate which test in the series. The number (1, 2, 3) corresponds to the data collection location with 1 indicating the inflow collection point, 2 indicating the “in-trap” collection point, and 3 indicating the downstream or discharge collection point.





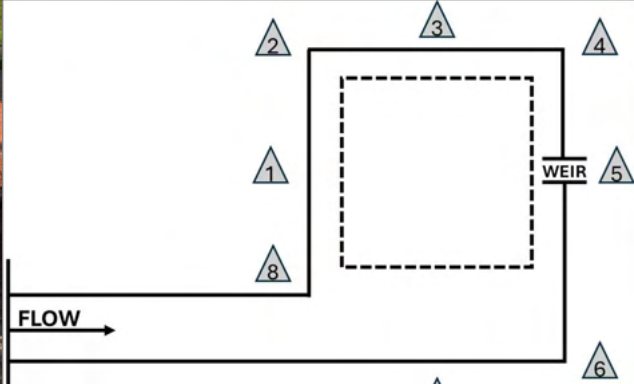





Temperature (°F) & Storage Volume Depth (Level, ft) Plot

Note: This data was produced by a level logger placed on the bottom of the sediment trap prior to test commencement until the trap dewatered (or the depth experienced no more change). The Temperature is represented by the red line, and the depth level is represented by the blue line. The corresponding dates and times are on the x-axis. The skimmer rested on a block at a depth of around 1 ft, meaning water would not be discharged below that level. For installations without a skimmer, the drop of the blue line on the right side of the graph indicates the water being drained to retrieve the level logger.

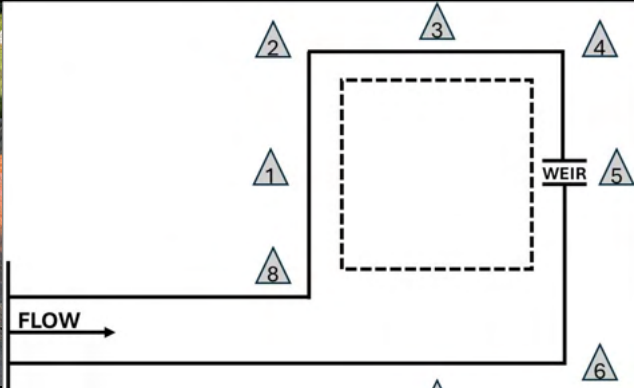

Test ID	Photo Documentation	Installation
B	Pre-Test	Standard Sediment Trap
		
Location 2	Location 3	Location 4
		
Location 1		Location 5
		
Location 8	Location 7	Location 6

Test ID	Photo Documentation	Installation
B	Post-Test	Standard Sediment Trap
		
Location 2	Location 3	Location 4
		
Location 1		Location 5
		
Location 8	Location 7	Location 6

SEDIMENT TRAP TEST LOG

Test Summary

Installation:	Standard/Control
Test ID:	C
Date:	8/28/2025
Type:	Longevity
Flow Rate (cfs):	1.0
Sediment Load Rate (lb/min):	49.0

Picture of Installation



Installation Description & Test Notes: The sediment trap, sized for 1 ac of contributory drainage, was installed according to the NDOT plan set. It had a 4 ft long rock weir that was 1 ft deep built with AL Class 1 riprap as a conservative equivalent for the NE Type A riprap. The trap bottom dimensions were 10 ft wide and 22 ft long. The test notes were that the water did not drain once the level dropped beneath the weir. The 2-yr, 24-hr design storm caused the trap basin to fill and the channel to fill near the mouth of the trap. The trap did not have outflow until 30 min into the test (when the flow was cut). The trap continued to dewater through the weir for three hours after the test flow period.

Sediment Capture Efficiency

Capture of Introduced Sediment (%):	86.4 %
Improved Capture from Control:	N/A %

Water Quality Data Statistics

Measurement Location	Avg		Min		Max		Std. Dev.	
	NTU	TSS (mg/L)	NTU	TSS (mg/L)	NTU	TSS (mg/L)	NTU	TSS (mg/L)
Inflow	2,062	8,062	770	2,490	6,478	20,550	2,014	6,510
Trap	437	458	148	40	1,806	2,270	391	499
Downstream	387	304	138	40	857	1,650	245	416

TSS (mg/L) and Turbidity (NTU) Data Plots



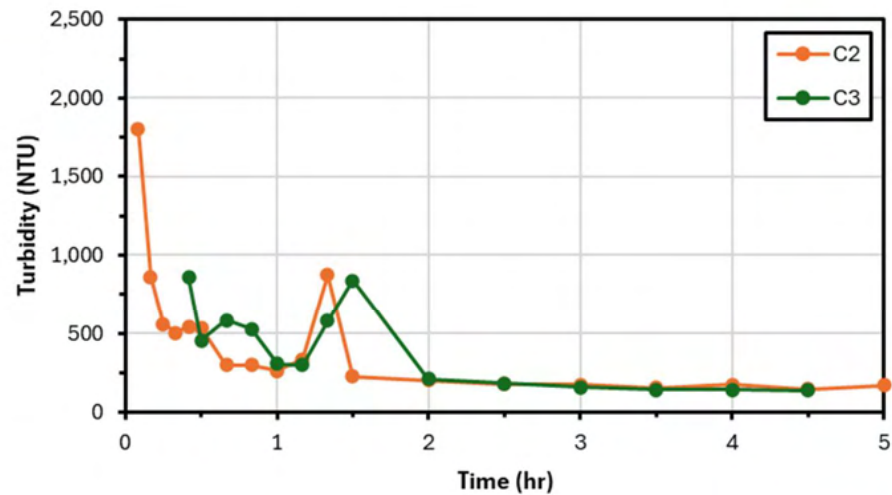
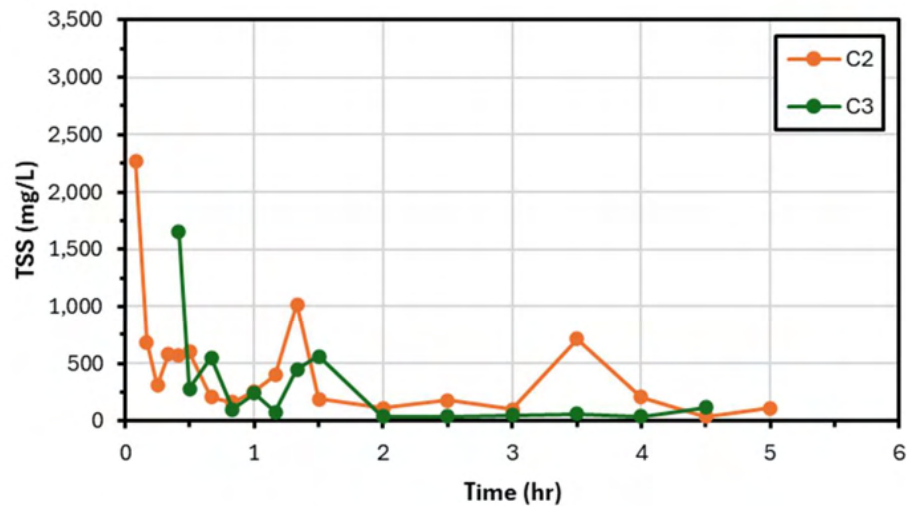
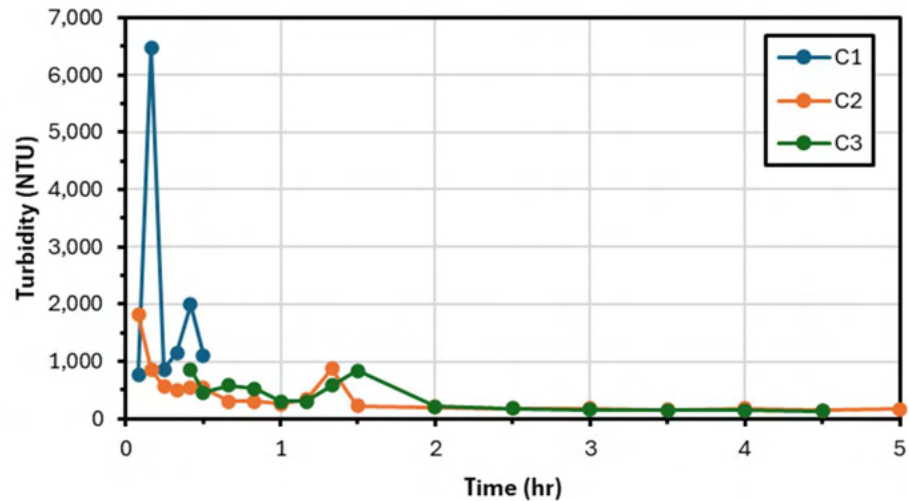
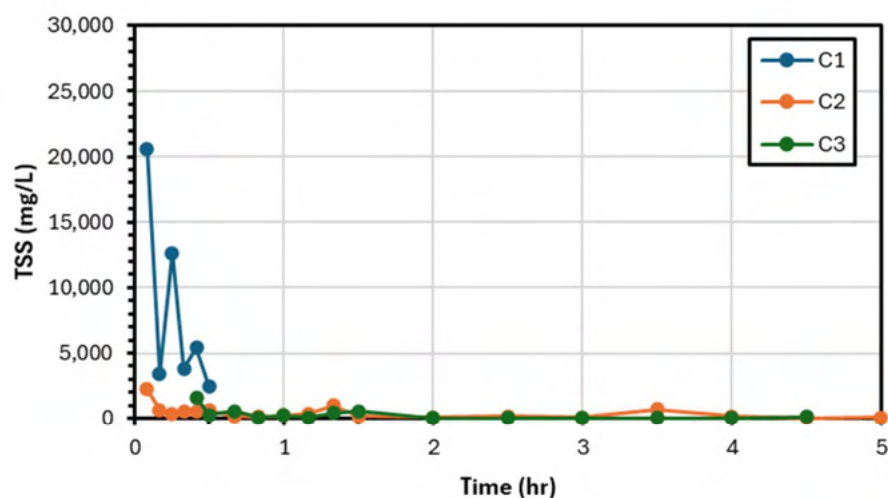



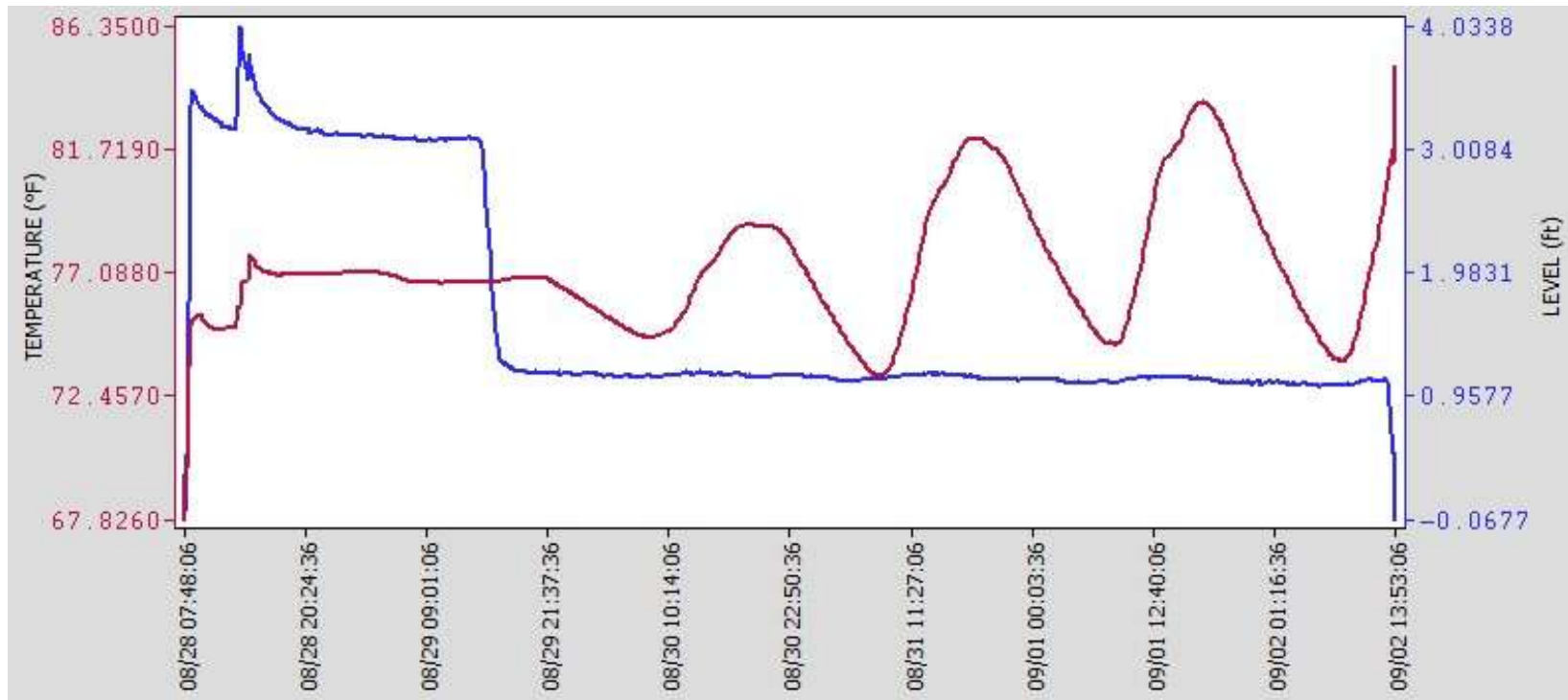

Legend Interpretation: The letter (A, B, C, D) corresponds to the Test ID to indicate which test in the series. The number (1, 2, 3) corresponds to the data collection location with 1 indicating the inflow collection point, 2 indicating the "in-trap" collection point, and 3 indicating the downstream or discharge collection point.





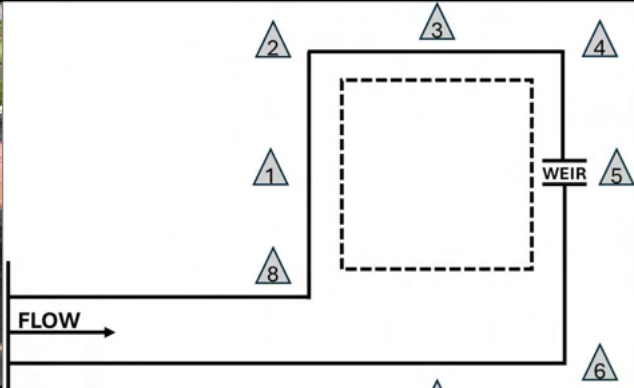





Temperature (°F) & Storage Volume Depth (Level, ft) Plot

Note: This data was produced by a level logger placed on the bottom of the sediment trap prior to test commencement until the trap dewatered (or the depth experienced no more change). The Temperature is represented by the red line, and the depth level is represented by the blue line. The corresponding dates and times are on the x-axis. The skimmer rested on a block at a depth of around 1 ft, meaning water would not be discharged below that level. For installations without a skimmer, the drop of the blue line on the right side of the graph indicates the water being drained to retrieve the level logger.

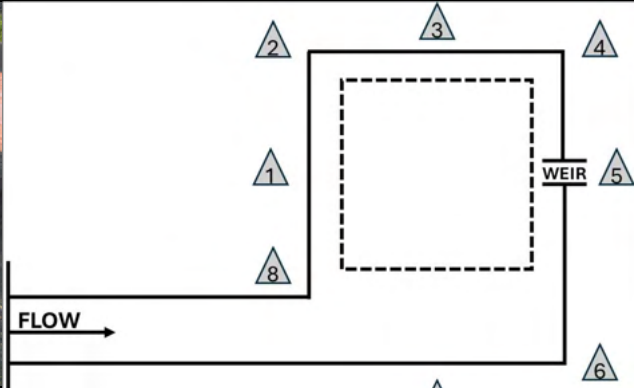

Test ID	Photo Documentation	Installation
C	Pre-Test	Standard Sediment Trap
		
Location 2	Location 3	Location 4
		
Location 1		Location 5
		
Location 8	Location 7	Location 6

Test ID	Photo Documentation	Installation
C	Post-Test	Standard Sediment Trap
		
Location 2	Location 3	Location 4
		
Location 1		Location 5
		
Location 8	Location 7	Location 6

SEDIMENT TRAP TEST LOG

Test Summary

Installation:	Standard/Control
Test ID:	D
Date:	8/28/2025
Type:	Longevity
Flow Rate (cfs):	1.0
Sediment Load Rate (lb/min):	49.0

Picture of Installation



Installation Description & Test Notes: The sediment trap, sized for 1 ac of contributory drainage, was installed according to the NDOT plan set. It had a 4 ft long rock weir that was 1 ft deep built with AL Class 1 riprap as a conservative equivalent for the NE Type A riprap. The trap bottom dimensions were 10 ft wide and 22 ft long. The test notes were that the water did not drain once the level dropped beneath the weir. The 2-yr, 24-hr design storm caused the trap basin to fill and the channel to fill near the mouth of the trap. The trap did not have outflow until 30 min into the test (when the flow was cut). The trap continued to dewater through the weir for three hours after the test flow period.

Sediment Capture Efficiency

Capture of Introduced Sediment (%):	86.4 %
Improved Capture from Control:	N/A %

Water Quality Data Statistics

Measurement Location	Avg		Min		Max		Std. Dev.	
	NTU	TSS (mg/L)	NTU	TSS (mg/L)	NTU	TSS (mg/L)	NTU	TSS (mg/L)
Inflow	1,459	3,380	445	1,140	4,171	8,750	1,304	2,695
Trap	335	410	157	110	778	1,150	144	304
Downstream	267	198	169	60	424	520	61	101

TSS (mg/L) and Turbidity (NTU) Data Plots



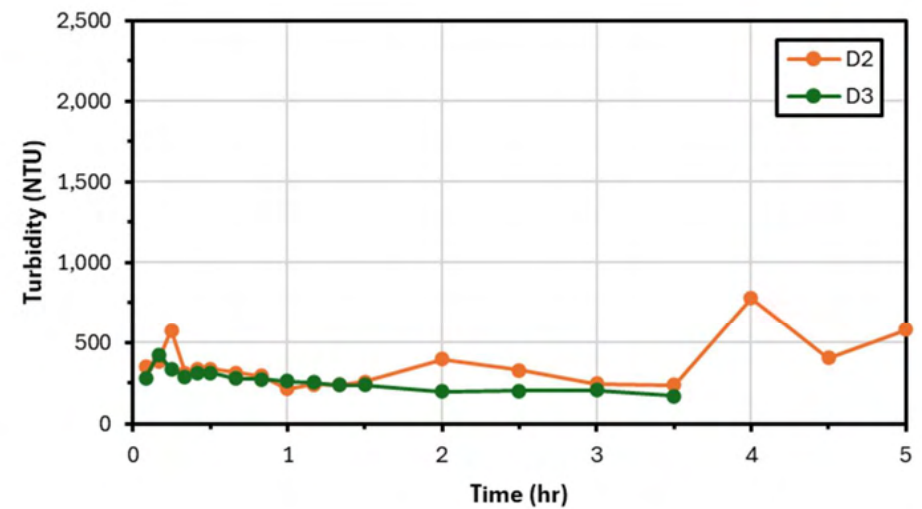
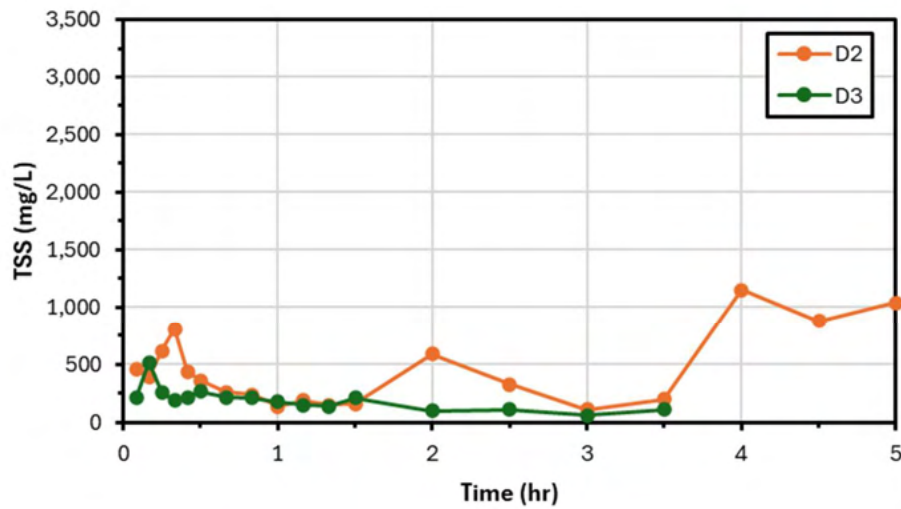
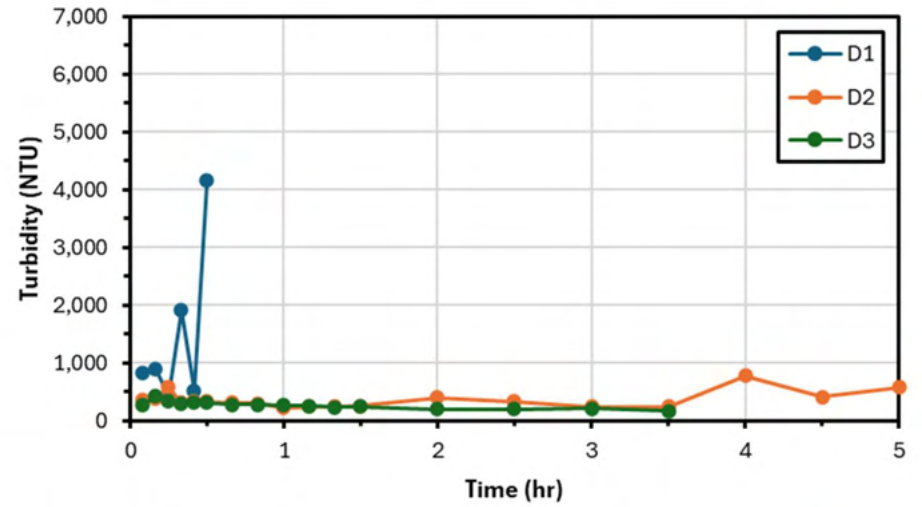
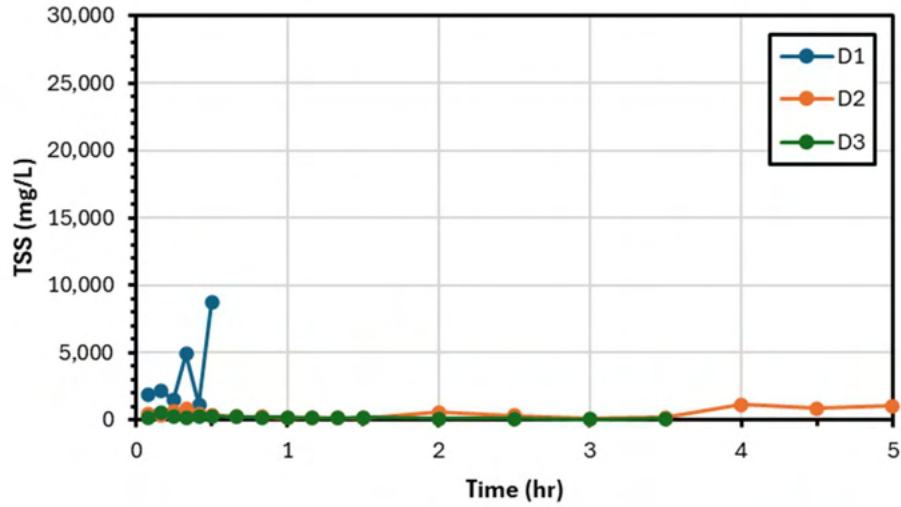



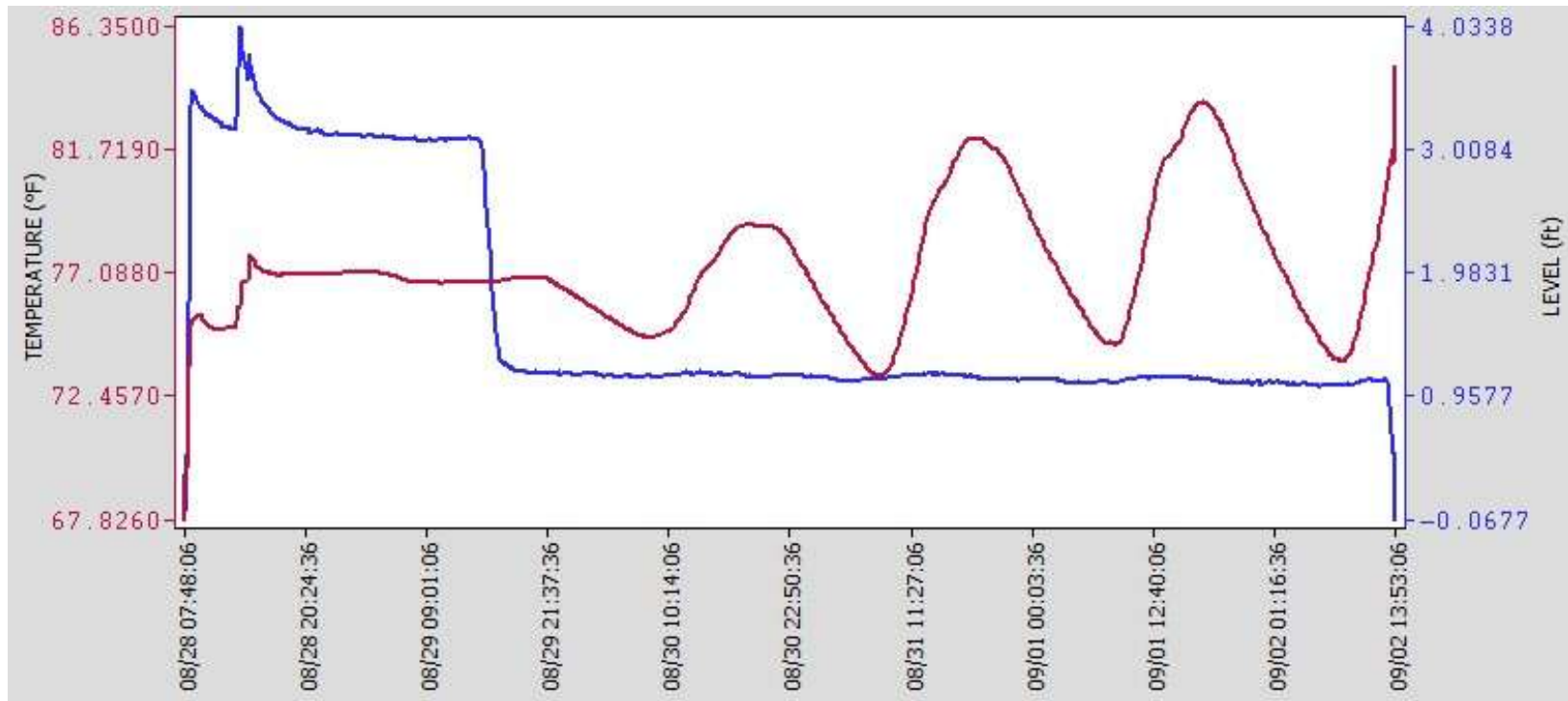

Legend Interpretation: The letter (A, B, C, D) corresponds to the Test ID to indicate which test in the series. The number (1, 2, 3) corresponds to the data collection location with 1 indicating the inflow collection point, 2 indicating the "in-trap" collection point, and 3 indicating the downstream or discharge collection point.





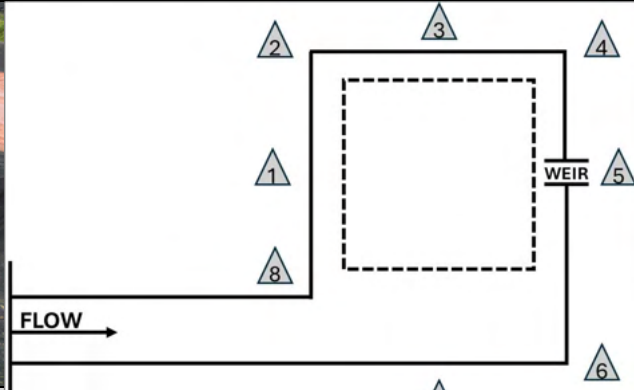





Temperature (°F) & Storage Volume Depth (Level, ft) Plot

Note: This data was produced by a level logger placed on the bottom of the sediment trap prior to test commencement until the trap dewatered (or the depth experienced no more change). The Temperature is represented by the red line, and the depth level is represented by the blue line. The corresponding dates and times are on the x-axis. The skimmer rested on a block at a depth of around 1 ft, meaning water would not be discharged below that level. For installations without a skimmer, the drop of the blue line on the right side of the graph indicates the water being drained to retrieve the level logger.

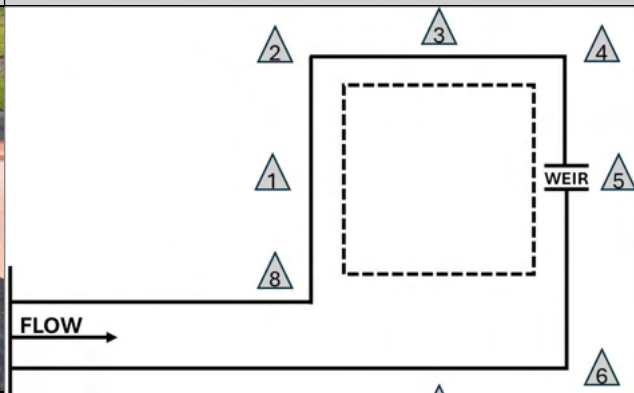

Test ID	Photo Documentation	Installation
D	Pre-Test	Standard Sediment Trap
		
Location 2	Location 3	Location 4
		
Location 1		Location 5
		
Location 8	Location 7	Location 6

Test ID	Photo Documentation	Installation
D	Post-Test	Standard Sediment Trap
		
Location 2	Location 3	Location 4
		
Location 1		Location 5
		
Location 8	Location 7	Location 6

SEDIMENT TRAP TEST LOG

Test Summary

Installation:	Baffles
Test ID:	A
Date:	9/15/2025
Type:	Longevity
Flow Rate (cfs):	1.0
Sediment Load Rate (lb/min):	49.0

Picture of Installation



Installation Description & Test Notes: The sediment trap, sized for 1 ac of contributory drainage, was paired with three coir baffles. The baffles were supported with wire attached to steel T-posts. The baffles divided the basin into four nearly equal bays including the channel near the mouth of the trap. The trap did not dewater through the weir until the test reached 25 to 30 min or around when the inflow was stopped. The weir dewatered for around 3 hours after the test inflow period ended then retained the remaining water in the trap. The first baffle was observed to visibly slow inflow from the first bay into the second bay. Any change produced by the third baffle was unnoticeable in testing.

Sediment Capture Efficiency

Capture of Introduced Sediment (%):	91.9 %
Improved Capture from Control:	5.5 %

Water Quality Data Statistics

Measurement Location	Avg		Min		Max		Std. Dev.	
	NTU	TSS (mg/L)	NTU	TSS (mg/L)	NTU	TSS (mg/L)	NTU	TSS (mg/L)
Inflow	2,445	6,320	1,084	3,150	3,524	9,720	838	2,419
Trap	364	321	171	80	1,132	1,360	238	324
Downstream	496	445	233	210	2,154	1,570	534	376

TSS (mg/L) and Turbidity (NTU) Data Plots



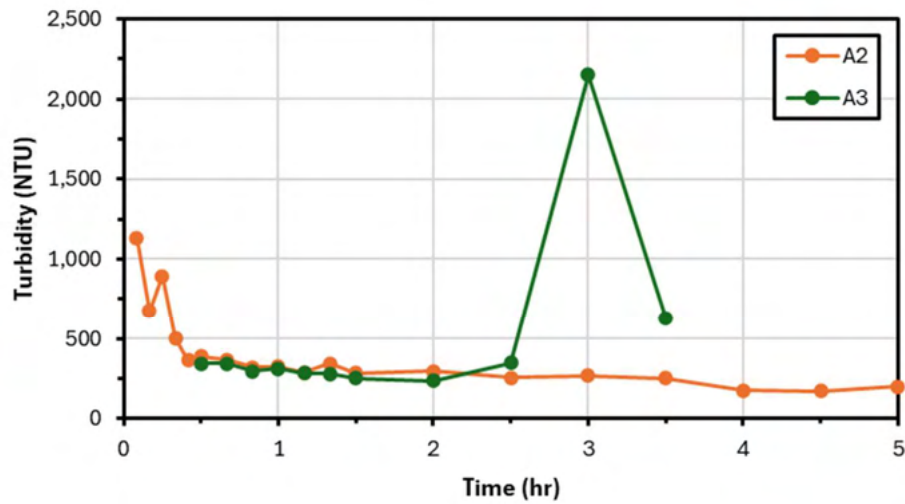
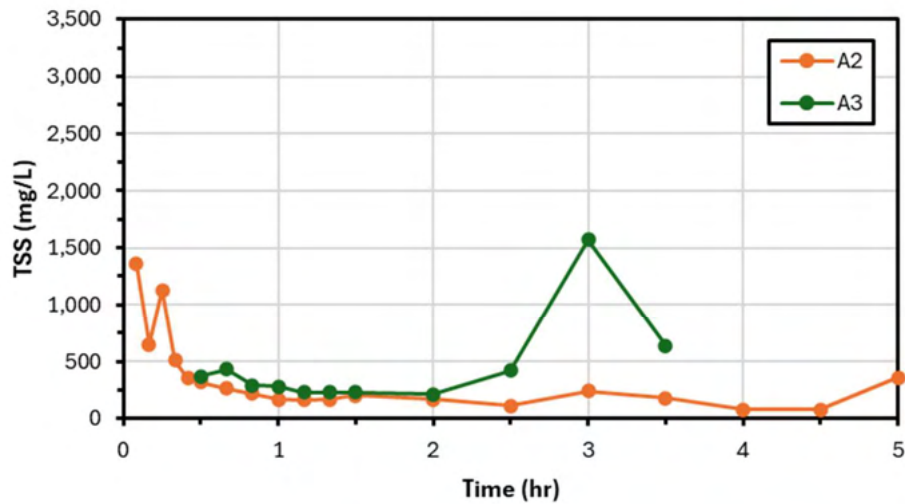
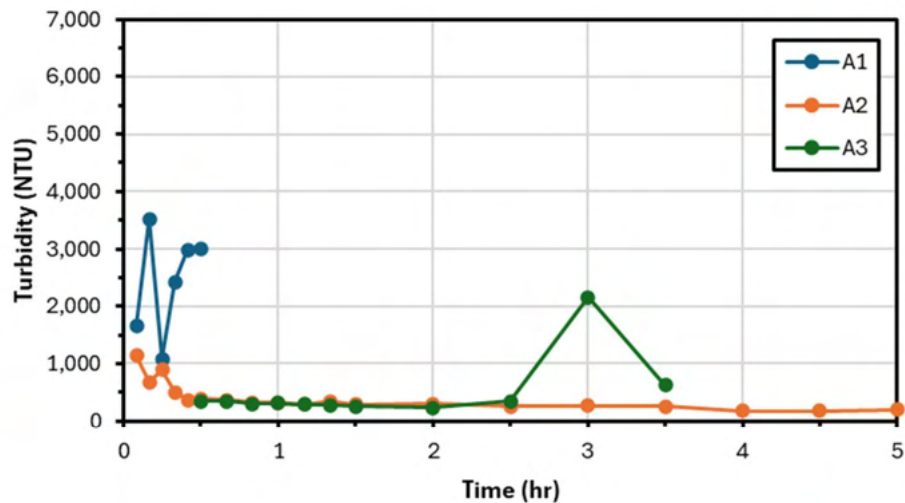
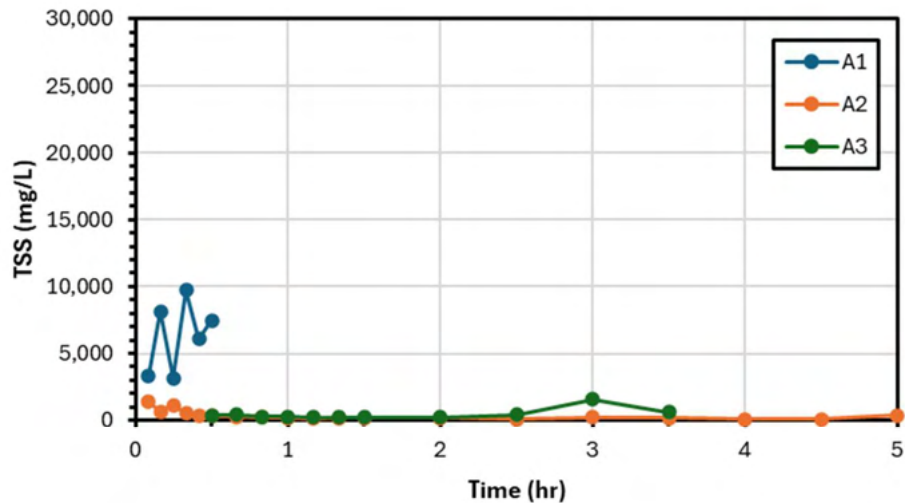



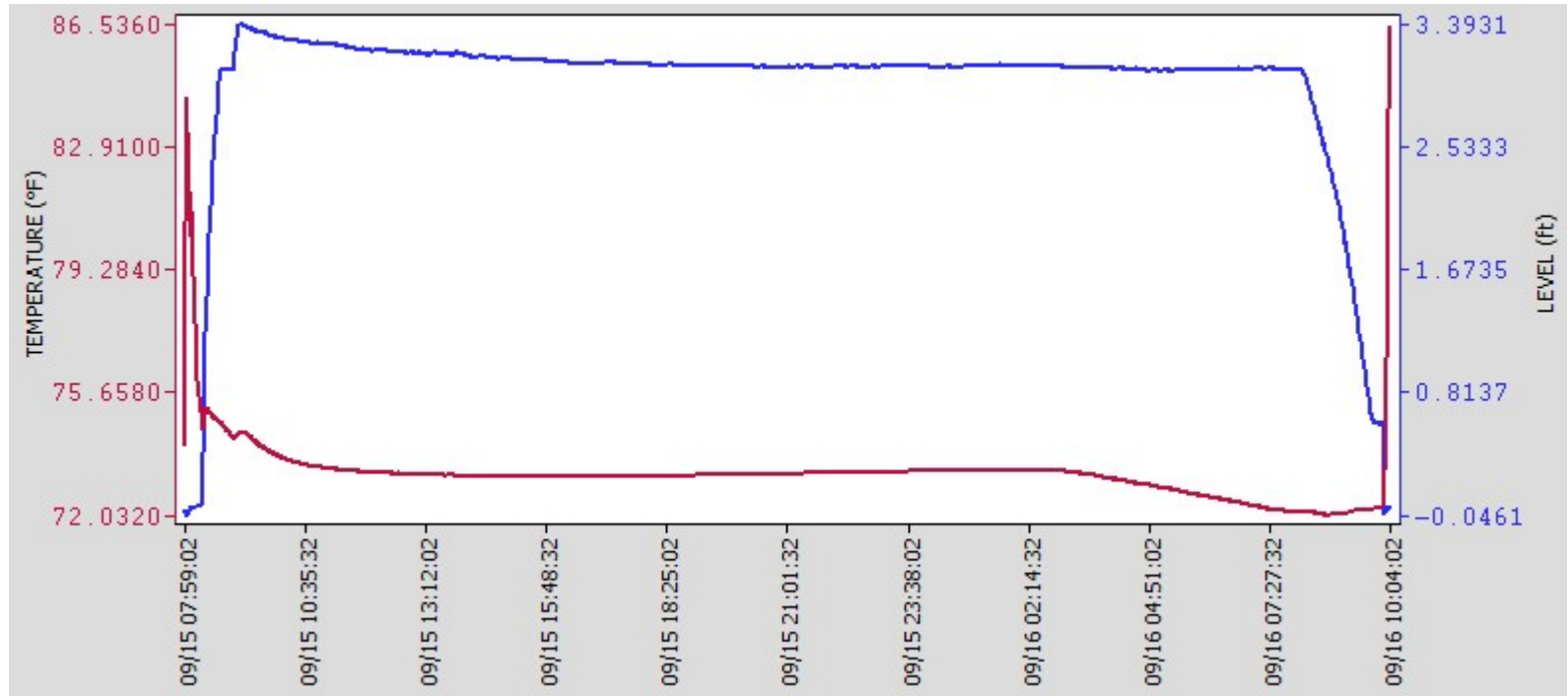

Legend Interpretation: The letter (A, B, C, D) corresponds to the Test ID to indicate which test in the series. The number (1, 2, 3) corresponds to the data collection location with 1 indicating the inflow collection point, 2 indicating the “in-trap” collection point, and 3 indicating the downstream or discharge collection point.





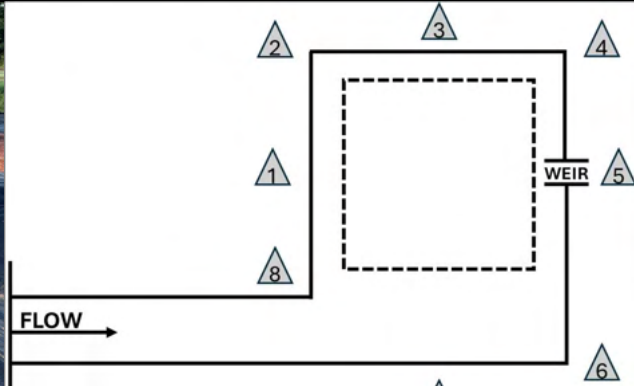





Temperature (°F) & Storage Volume Depth (Level, ft) Plot

Note: This data was produced by a level logger placed on the bottom of the sediment trap prior to test commencement until the trap dewatered (or the depth experienced no more change). The Temperature is represented by the red line, and the depth level is represented by the blue line. The corresponding dates and times are on the x-axis. The skimmer rested on a block at a depth of around 1 ft, meaning water would not be discharged below that level. For installations without a skimmer, the drop of the blue line on the right side of the graph indicates the water being drained to retrieve the level logger.

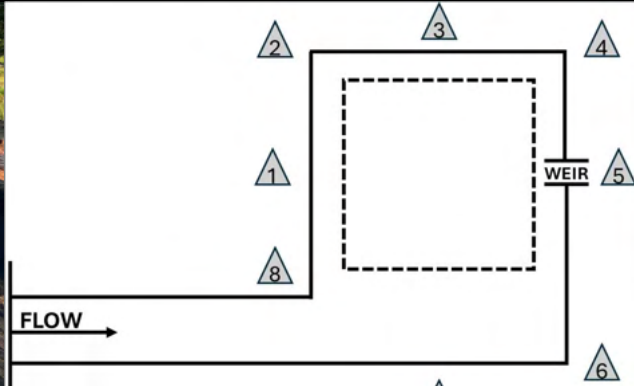

Test ID	Photo Documentation	Installation
A	Pre-Test	Sediment Trap with Baffles
		
Location 2	Location 3	Location 4
		
Location 1		Location 5
		
Location 8	Location 7	Location 6

Test ID	Photo Documentation	Installation
A	Post-Test	Sediment Trap with Baffles
		
Location 2	Location 3	Location 4
		
Location 1		Location 5
		
Location 8	Location 7	Location 6

SEDIMENT TRAP TEST LOG

Test Summary

Installation:	Baffles
Test ID:	B
Date:	9/16/2025
Type:	Longevity
Flow Rate (cfs):	1.0
Sediment Load Rate (lb/min):	49.0

Picture of Installation



Installation Description & Test Notes: The sediment trap, sized for 1 ac of contributory drainage, was paired with three coir baffles. The baffles were supported with wire attached to steel T-posts. The baffles divided the basin into four nearly equal bays including the channel near the mouth of the trap. The trap did not dewater through the weir until the test reached 25 to 30 min or around when the inflow was stopped. The weir dewatered for 3 hours after the test inflow period ended then retained the remaining water in the trap. The first baffle was observed to visibly slow inflow from the first bay into the second bay. Any change produced by the third baffle was unnoticeable in testing.

Sediment Capture Efficiency

Capture of Introduced Sediment (%):	91.9 %
Improved Capture from Control:	5.5 %

Water Quality Data Statistics

Measurement Location	Avg		Min		Max		Std. Dev.	
	NTU	TSS (mg/L)	NTU	TSS (mg/L)	NTU	TSS (mg/L)	NTU	TSS (mg/L)
Inflow	1,397	3,233	1,027	2,170	1,916	5,470	320	1,157
Trap	347	292	102	40	821	820	159	181
Downstream	321	305	208	220	531	650	88	119

TSS (mg/L) and Turbidity (NTU) Data Plots



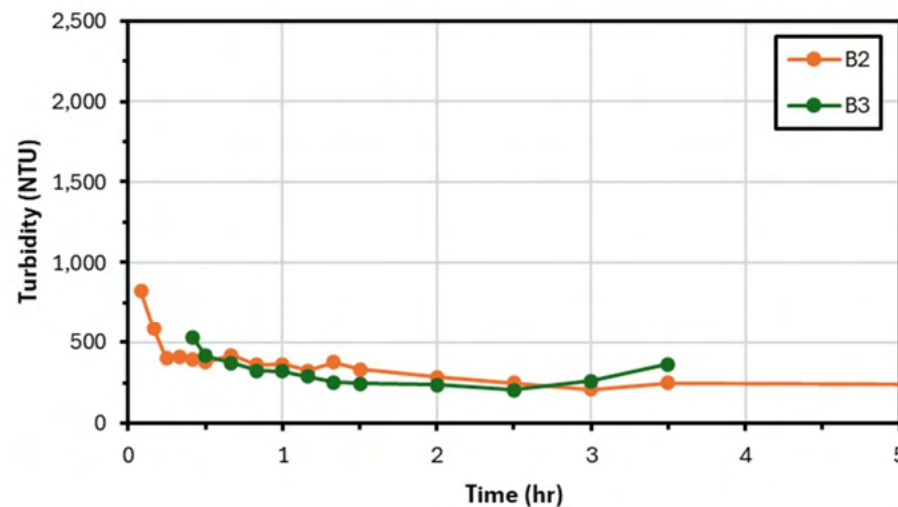
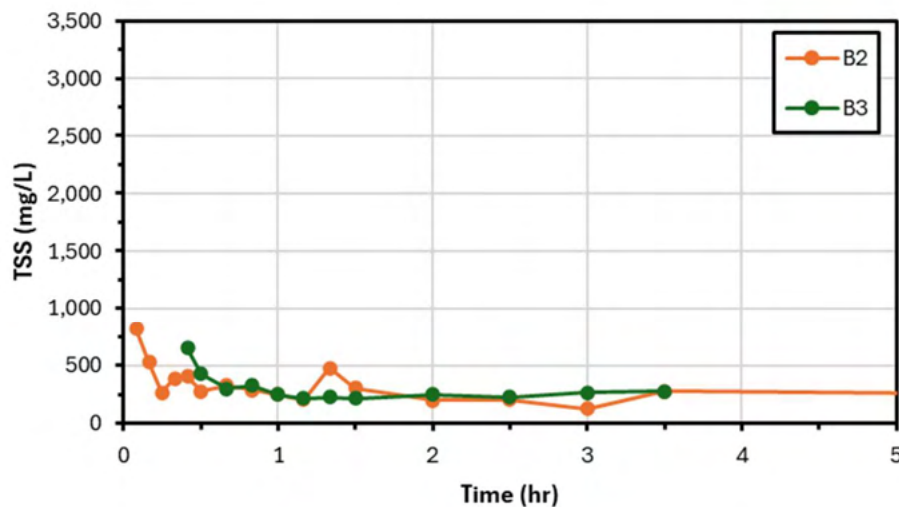
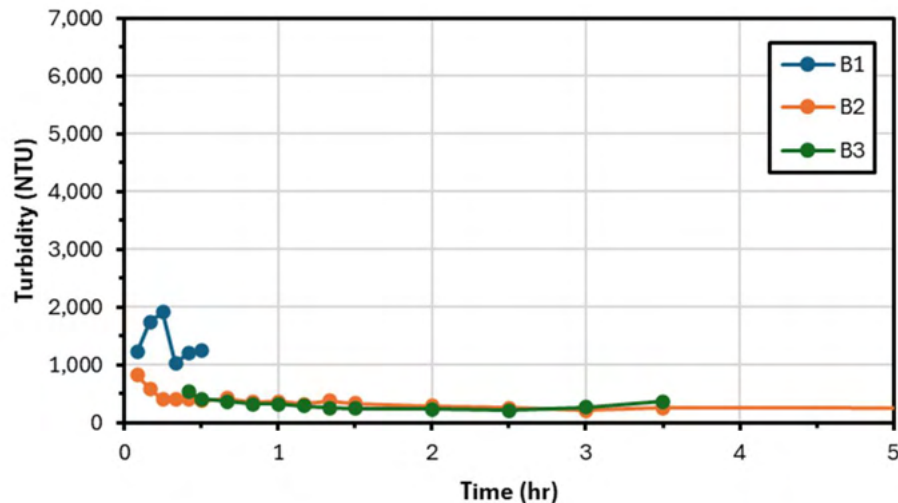
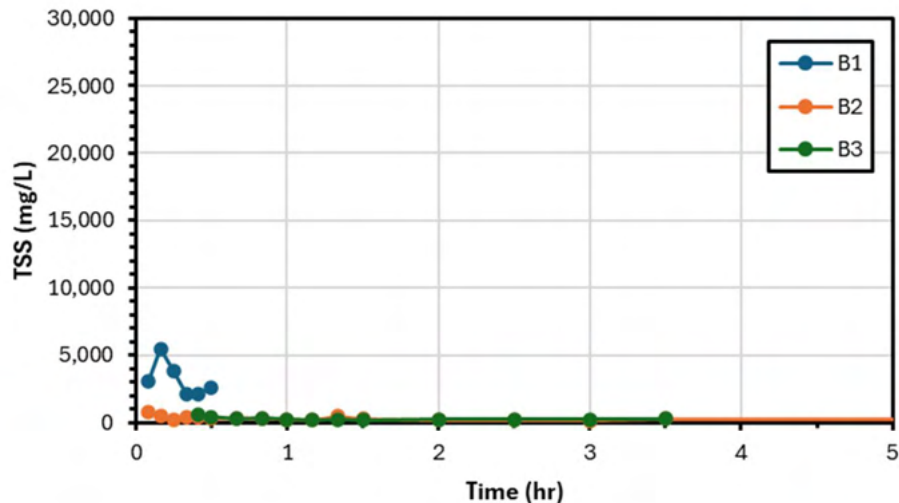



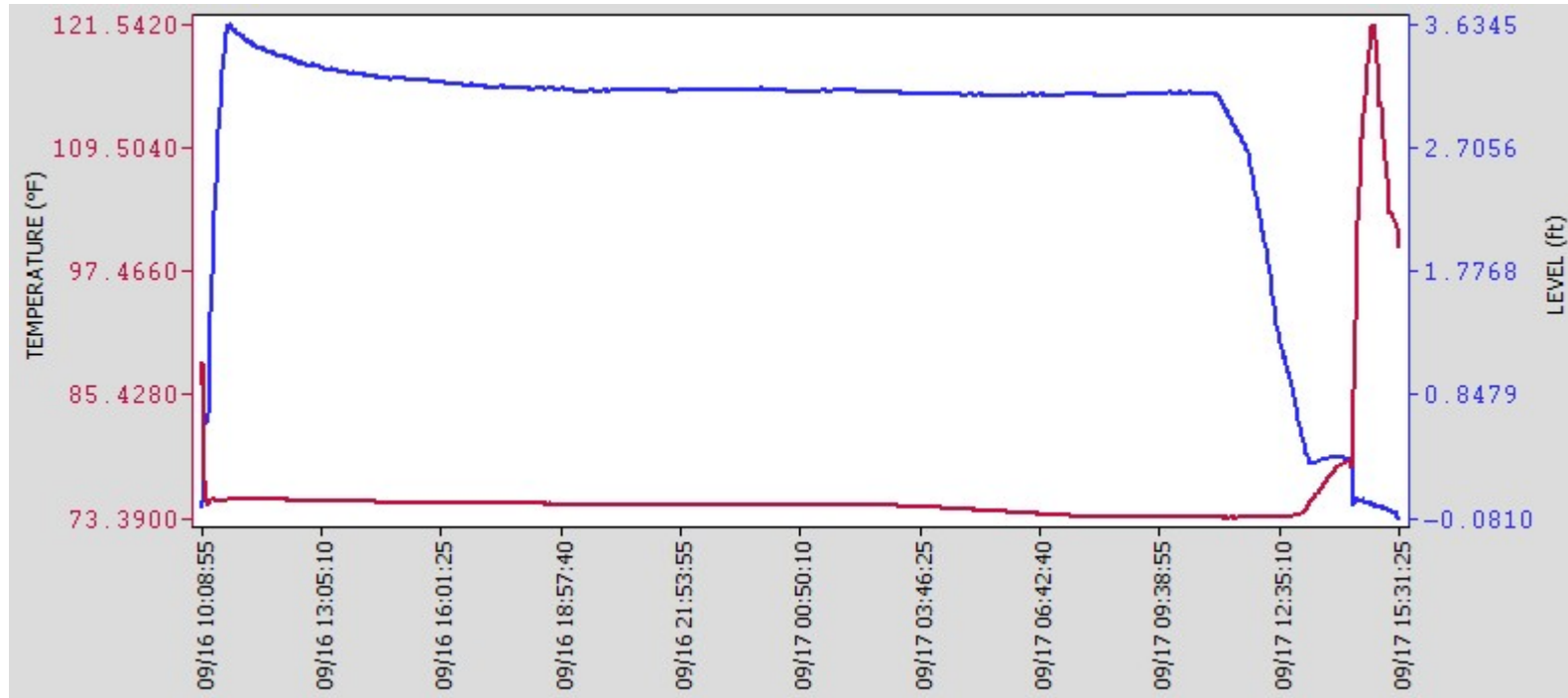

Legend Interpretation: The letter (A, B, C, D) corresponds to the Test ID to indicate which test in the series. The number (1, 2, 3) corresponds to the data collection location with 1 indicating the inflow collection point, 2 indicating the “in-trap” collection point, and 3 indicating the downstream or discharge collection point.





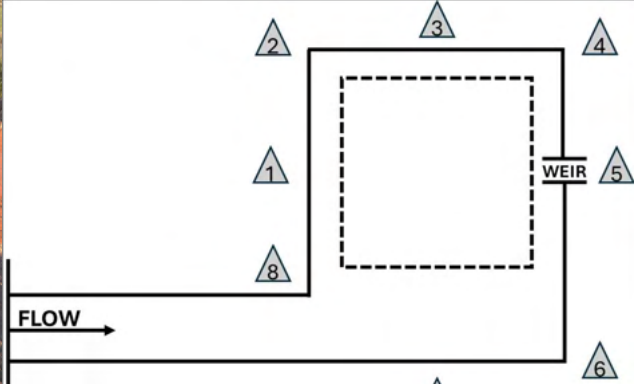





Temperature (°F) & Storage Volume Depth (Level, ft) Plot

Note: This data was produced by a level logger placed on the bottom of the sediment trap prior to test commencement until the trap dewatered (or the depth experienced no more change). The Temperature is represented by the red line, and the depth level is represented by the blue line. The corresponding dates and times are on the x-axis. The skimmer rested on a block at a depth of around 1 ft, meaning water would not be discharged below that level. For installations without a skimmer, the drop of the blue line on the right side of the graph indicates the water being drained to retrieve the level logger.

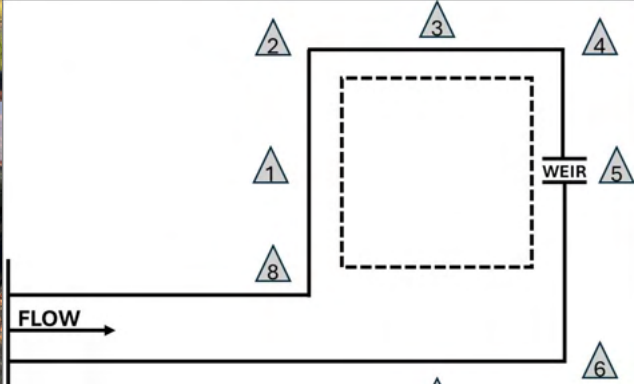

Test ID	Photo Documentation	Installation
B	Pre-Test	Sediment Trap with Baffles
		
Location 2	Location 3	Location 4
		
Location 1		Location 5
		
Location 8	Location 7	Location 6

Test ID	Photo Documentation	Installation
B	Post-Test	Sediment Trap with Baffles
		
Location 2	Location 3	Location 4
		
Location 1		Location 5
		
Location 8	Location 7	Location 6

SEDIMENT TRAP TEST LOG

Test Summary

Installation:	Baffles
Test ID:	C
Date:	9/18/2025
Type:	Longevity
Flow Rate (cfs):	1.0
Sediment Load Rate (lb/min):	49.0

Picture of Installation



Installation Description & Test Notes: The sediment trap, sized for 1 ac of contributory drainage, was paired with three coir baffles. The baffles were supported with wire attached to steel T-posts. The baffles divided the basin into four nearly equal bays including the channel near the mouth of the trap. The trap did not dewater through the weir until the test reached 25 min into the inflow period. The weir dewatered for 4 hours after the inflow test period then retained the remaining water in the trap. The first baffle was observed to visibly slow inflow from the first bay into the second bay. Any change produced by the third baffle was unnoticeable in testing.

Sediment Capture Efficiency

Capture of Introduced Sediment (%):	91.9 %
Improved Capture from Control:	5.5 %

Water Quality Data Statistics

Measurement Location	Avg		Min		Max		Std. Dev.	
	NTU	TSS (mg/L)	NTU	TSS (mg/L)	NTU	TSS (mg/L)	NTU	TSS (mg/L)
Inflow	1,565	7,003	521	3,170	2,730	10,750	829	2,634
Trap	431	341	252	170	1,031	960	178	176
Downstream	392	313	199	140	1,015	1,100	203	239

TSS (mg/L) and Turbidity (NTU) Data Plots



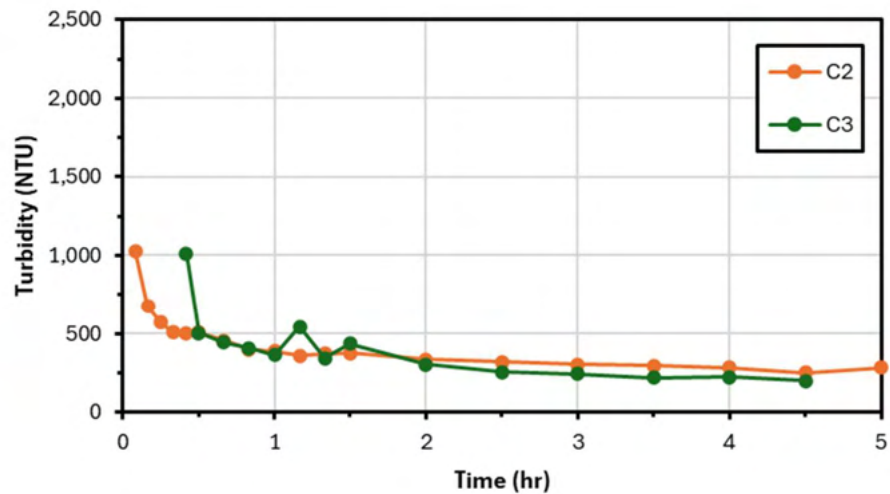
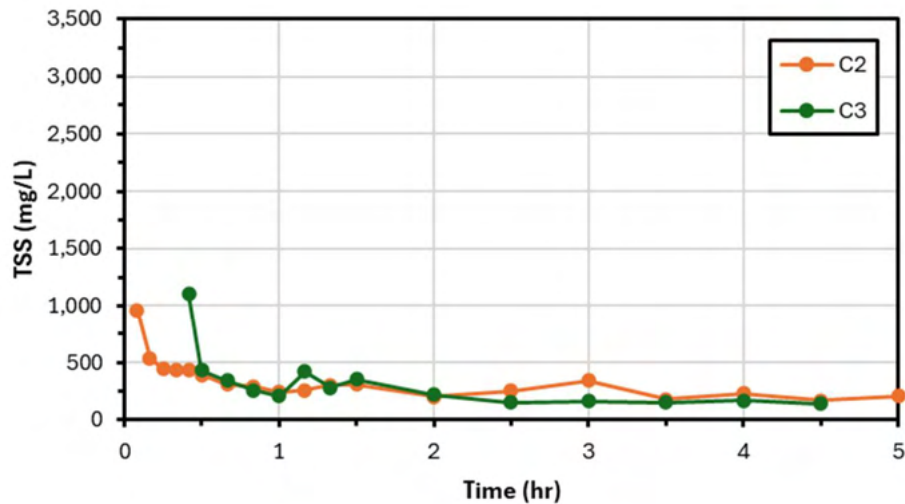
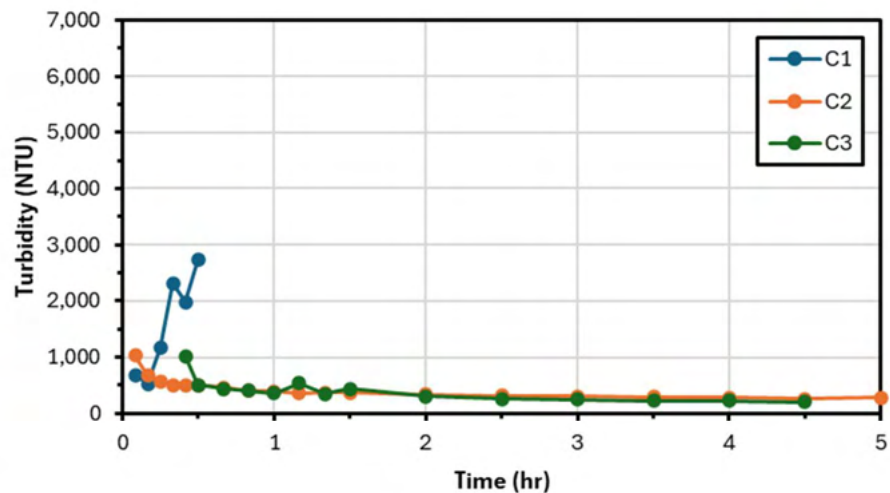
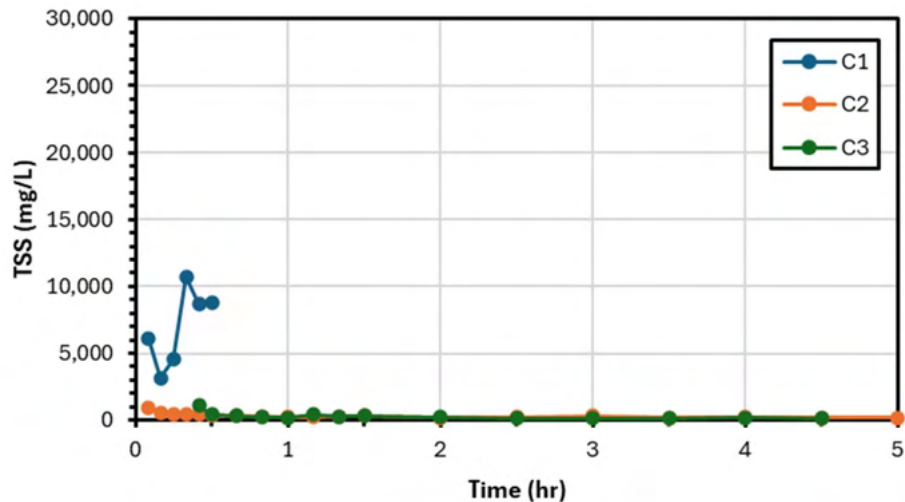



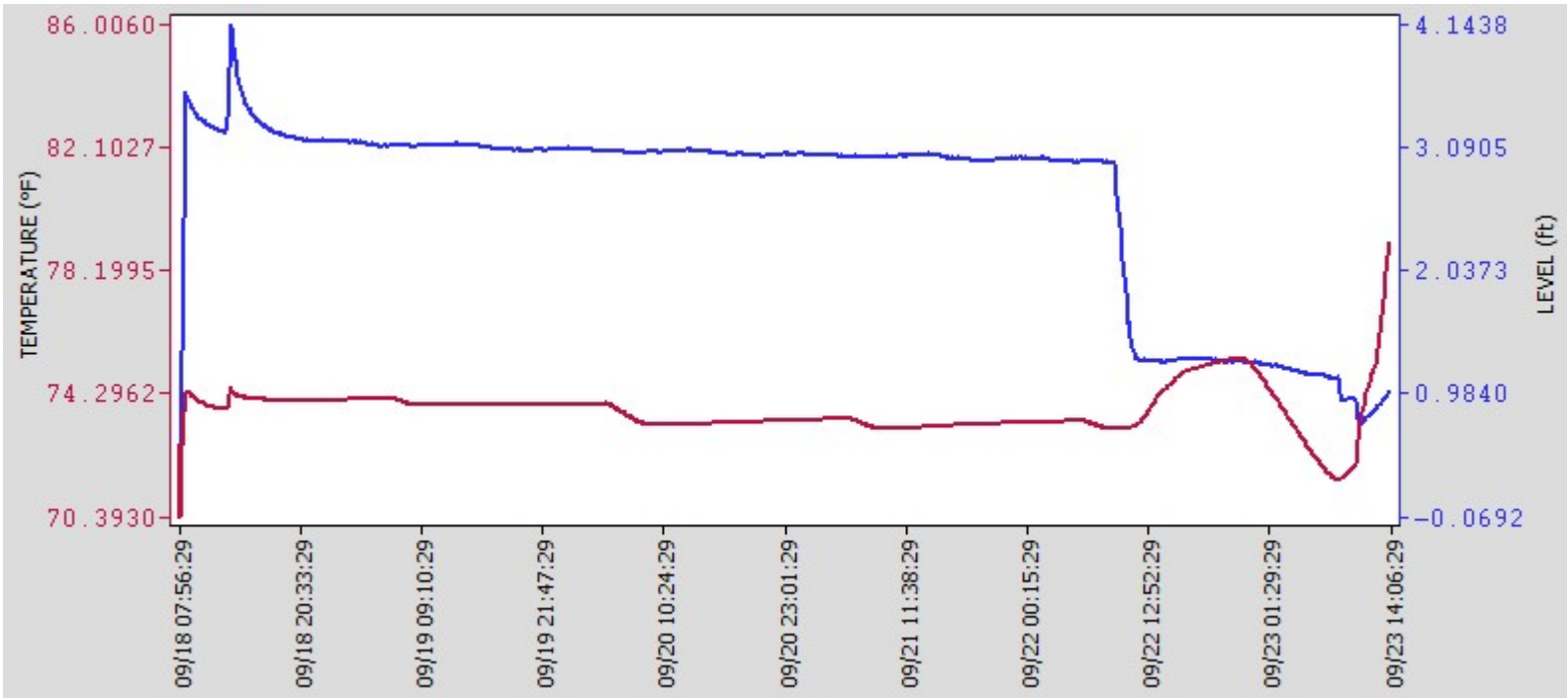

Legend Interpretation: The letter (A, B, C, D) corresponds to the Test ID to indicate which test in the series. The number (1, 2, 3) corresponds to the data collection location with 1 indicating the inflow collection point, 2 indicating the "in-trap" collection point, and 3 indicating the downstream or discharge collection point.





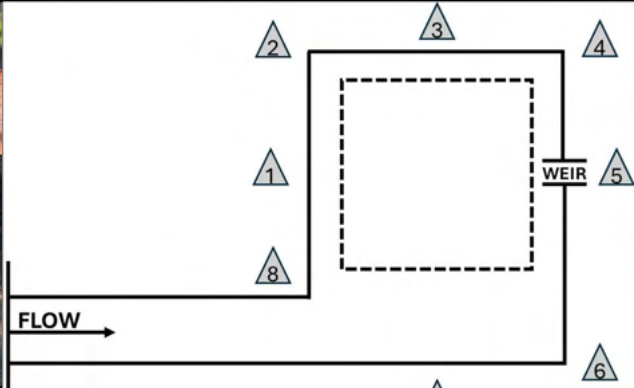





Temperature (°F) & Storage Volume Depth (Level, ft) Plot

Note: This data was produced by a level logger placed on the bottom of the sediment trap prior to test commencement until the trap dewatered (or the depth experienced no more change). The Temperature is represented by the red line, and the depth level is represented by the blue line. The corresponding dates and times are on the x-axis. The skimmer rested on a block at a depth of around 1 ft, meaning water would not be discharged below that level. For installations without a skimmer, the drop of the blue line on the right side of the graph indicates the water being drained to retrieve the level logger.

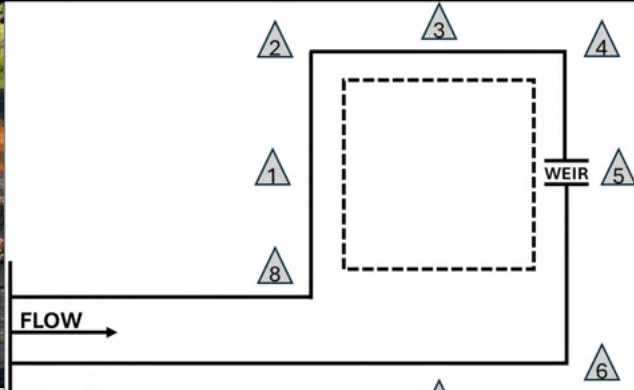

Test ID	Photo Documentation	Installation
C	Pre-Test	Sediment Trap with Baffles
		
Location 2	Location 3	Location 4
		
Location 1		Location 5
		
Location 8	Location 7	Location 6

Test ID	Photo Documentation	Installation
C	Post-Test	Sediment Trap with Baffles
		
Location 2	Location 3	Location 4
		
Location 1		Location 5
		
Location 8	Location 7	Location 6

SEDIMENT TRAP TEST LOG

Test Summary

Installation:	Baffles
Test ID:	D
Date:	9/18/2025
Type:	Longevity
Flow Rate (cfs):	1.0
Sediment Load Rate (lb/min):	49.0

Picture of Installation



Installation Description & Test Notes: The sediment trap, sized for 1 ac of contributory drainage, was paired with three coir baffles. The baffles were supported with wire attached to steel T-posts. The baffles divided the basin into four nearly equal bays including the channel near the mouth of the trap. The trap did not dewater through the weir until the test reached 25 to 30 min or around when the inflow was stopped. The weir dewatered for 4.5 hours after the test inflow period ended then retained the remaining water in the trap. The dewatering time was longer since test D was the second storm of the back-to-back, overflow simulation. The first baffle was observed to visibly slow inflow from the first bay into the second bay. Any change produced by the third baffle was unnoticeable in testing. Most of the water from test C remained in the trap when test D commenced. The baffles would need to be taller to maintain more clearance for larger storm events.

Sediment Capture Efficiency

Capture of Introduced Sediment (%):	91.9 %
Improved Capture from Control:	5.5 %

Water Quality Data Statistics

Measurement Location	Avg		Min		Max		Std. Dev.	
	NTU	TSS (mg/L)	NTU	TSS (mg/L)	NTU	TSS (mg/L)	NTU	TSS (mg/L)
Inflow	2,067	8,882	519	4,240	2,999	12,010	792	2,701
Trap	232	322	144	60	320	710	40	117
Downstream	337	414	229	190	818	1,220	129	229

TSS (mg/L) and Turbidity (NTU) Data Plots



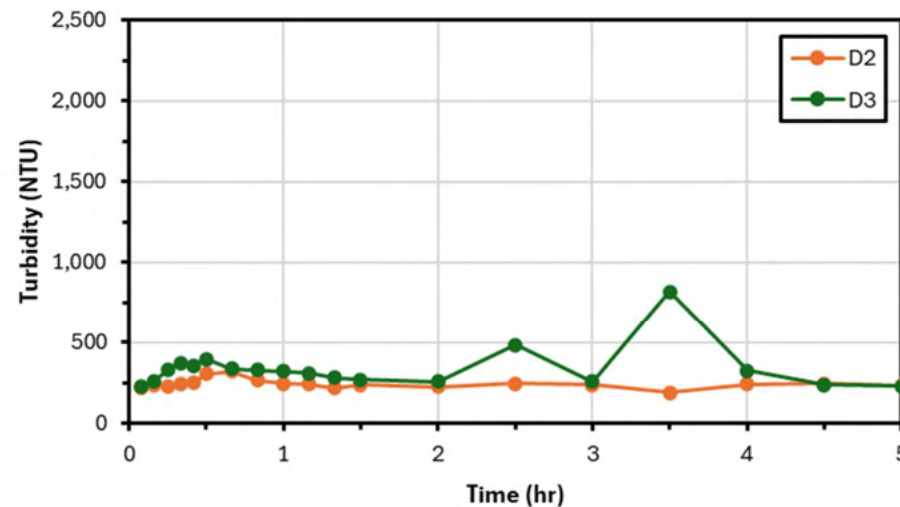
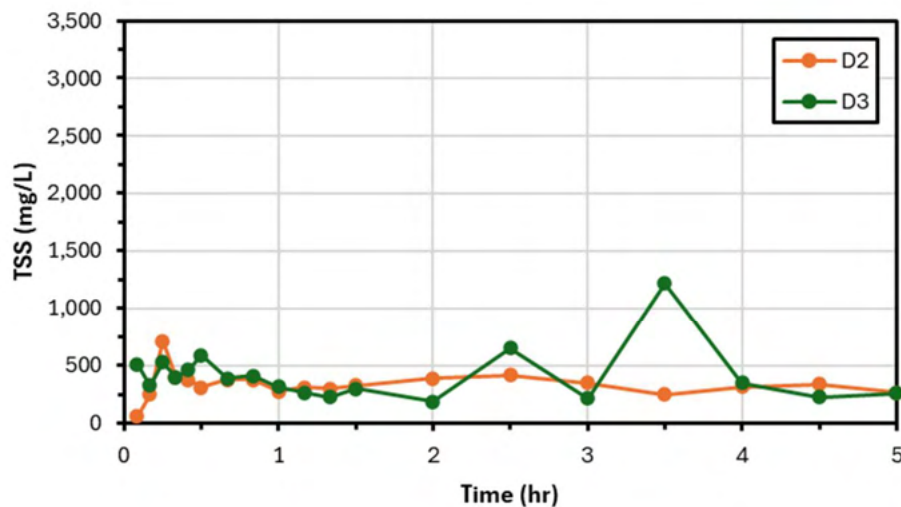
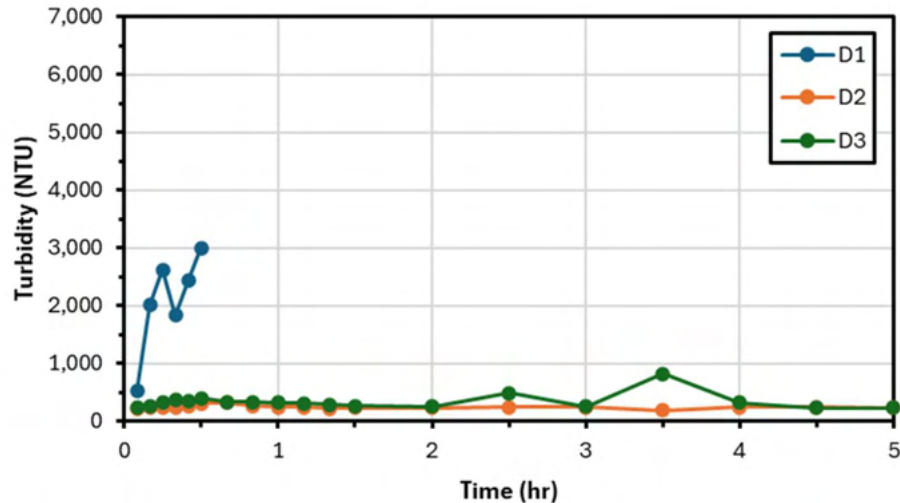
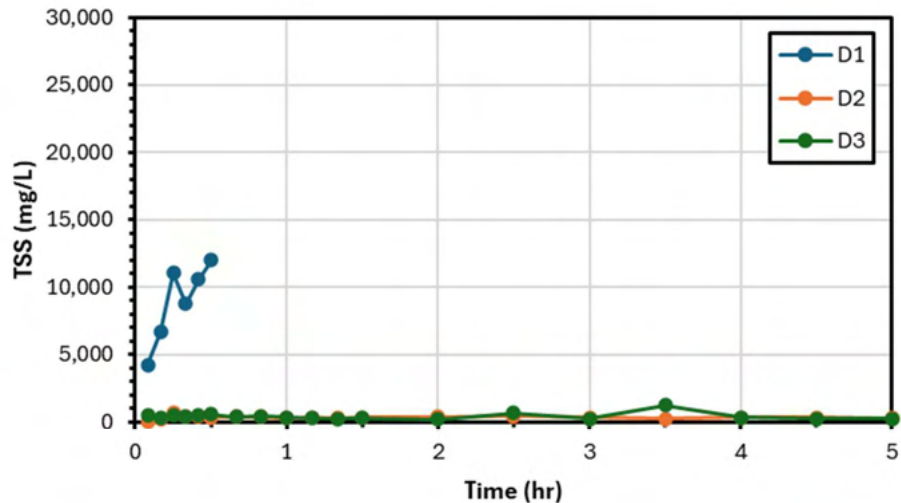



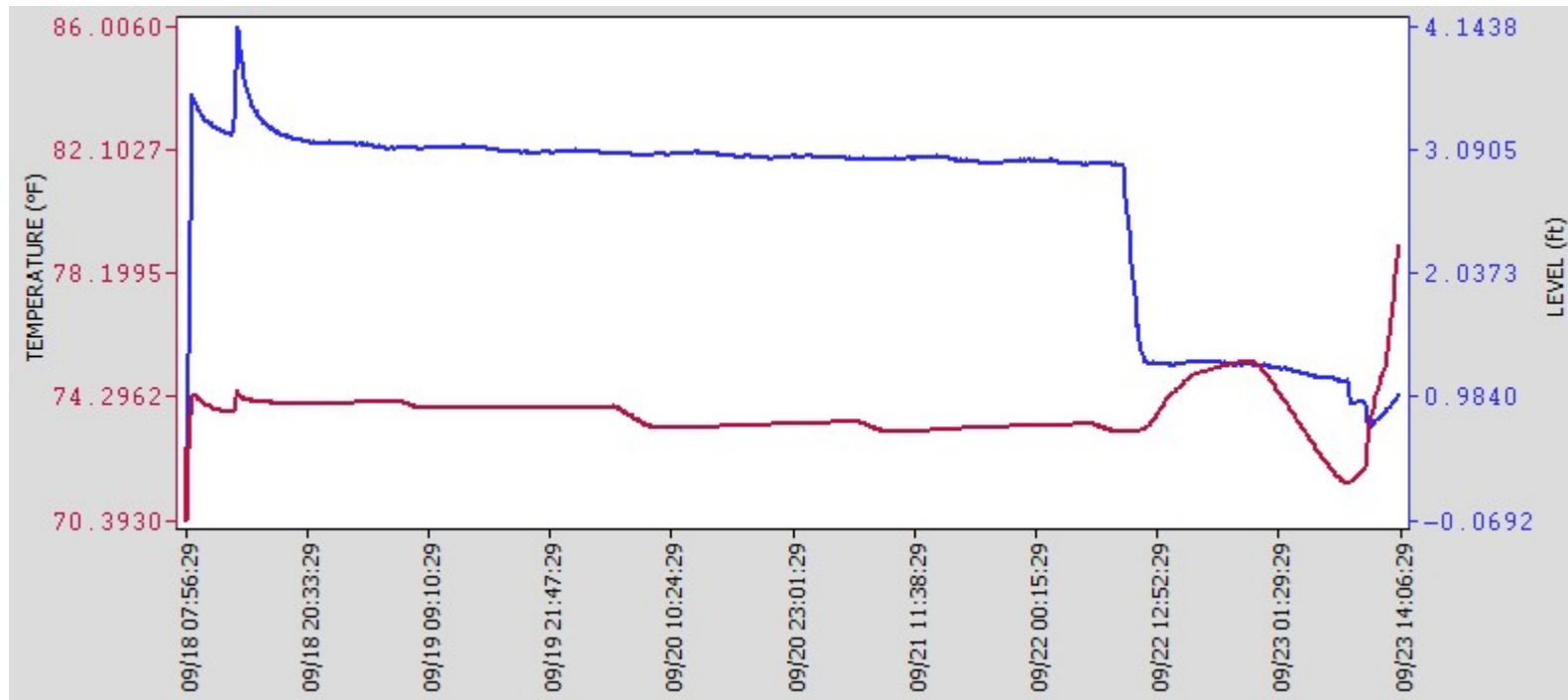

Legend Interpretation: The letter (A, B, C, D) corresponds to the Test ID to indicate which test in the series. The number (1, 2, 3) corresponds to the data collection location with 1 indicating the inflow collection point, 2 indicating the “in-trap” collection point, and 3 indicating the downstream or discharge collection point.





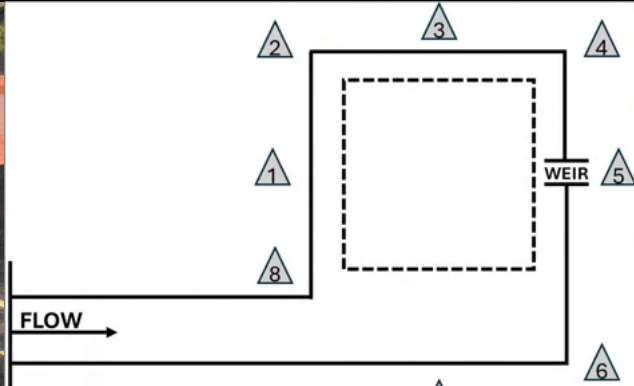





Temperature (°F) & Storage Volume Depth (Level, ft) Plot

Note: This data was produced by a level logger placed on the bottom of the sediment trap prior to test commencement until the trap dewatered (or the depth experienced no more change). The Temperature is represented by the red line, and the depth level is represented by the blue line. The corresponding dates and times are on the x-axis. The skimmer rested on a block at a depth of around 1 ft, meaning water would not be discharged below that level. For installations without a skimmer, the drop of the blue line on the right side of the graph indicates the water being drained to retrieve the level logger.

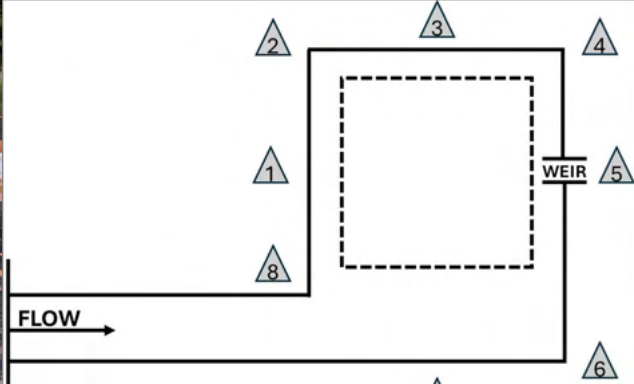

Test ID	Photo Documentation	Installation
D	Pre-Test	Sediment Trap with Baffles
		
Location 2	Location 3	Location 4
		
Location 1		Location 5
		
Location 8	Location 7	Location 6

Test ID	Photo Documentation	Installation
D	Post-Test	Sediment Trap with Baffles
		
Location 2	Location 3	Location 4
		
Location 1		Location 5
		
Location 8	Location 7	Location 6

SEDIMENT TRAP TEST LOG

Test Summary

Installation:	Skimmer
Test ID:	A
Date:	10/21/2025
Type:	Longevity
Flow Rate (cfs):	1.0
Sediment Load Rate (lb/min):	49.0

Picture of Installation



Installation Description & Test Notes: The sediment trap, sized for 1 ac of contributory drainage, was paired with a 1.5 in. skimmer with 100% orifice opening. The skimmer was sized with the Faircloth Estimator's Calculator based on the required volume with a goal of dewatering for a minimum of 48 hours. The skimmer dewatered in around 30 hours due to the spillway height (recommended that the basin dimensions be input into the calculator in the future). The first test was sampled hourly for two consecutive workdays following the test. The TSS and turbidity values decreased consistently over the extended sample period. During the test, inflow was observed pushing the skimmer to the far side of the basin until the trap filled and overflowed into the channel.

Sediment Capture Efficiency

Capture of Introduced Sediment (%):	87.1 %
Improved Capture from Control:	0.7 %

Water Quality Data Statistics

Measurement Location	Avg		Min		Max		Std. Dev.	
	NTU	TSS (mg/L)	NTU	TSS (mg/L)	NTU	TSS (mg/L)	NTU	TSS (mg/L)
Inflow	2,335	10,828	1,248	3,510	3,719	28,760	825	9,113
Trap	329	386	81	10	2,431	3,250	458	674
Downstream	205	141	87	20	588	730	116	145

TSS (mg/L) and Turbidity (NTU) Data Plots



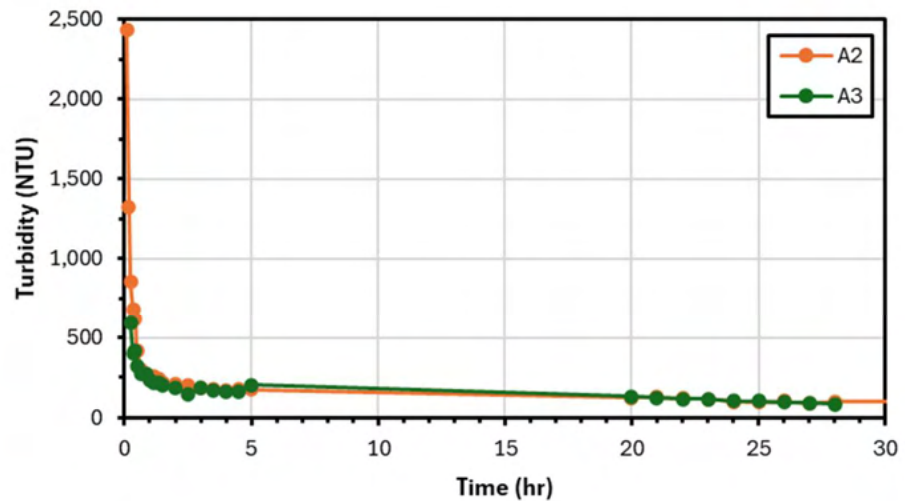
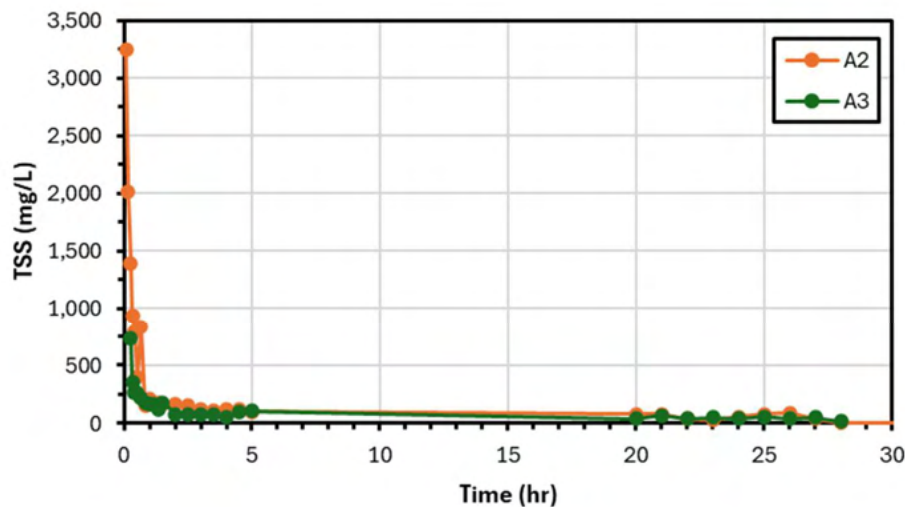
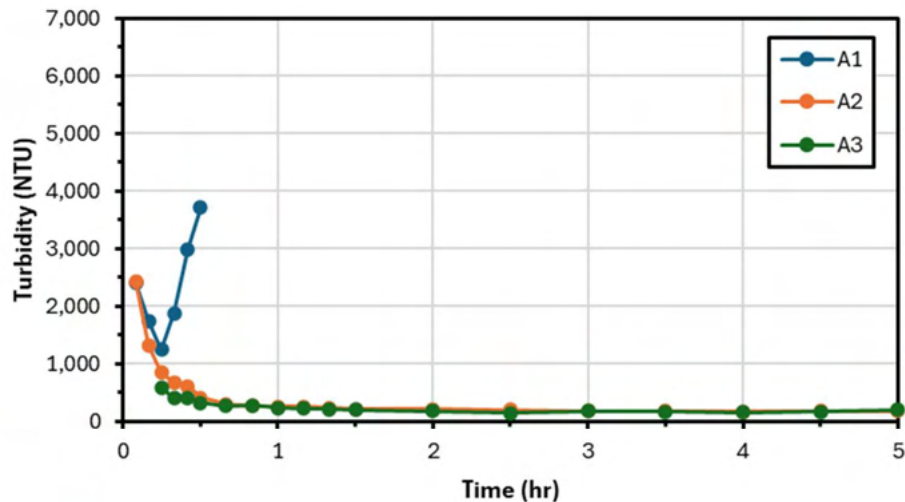
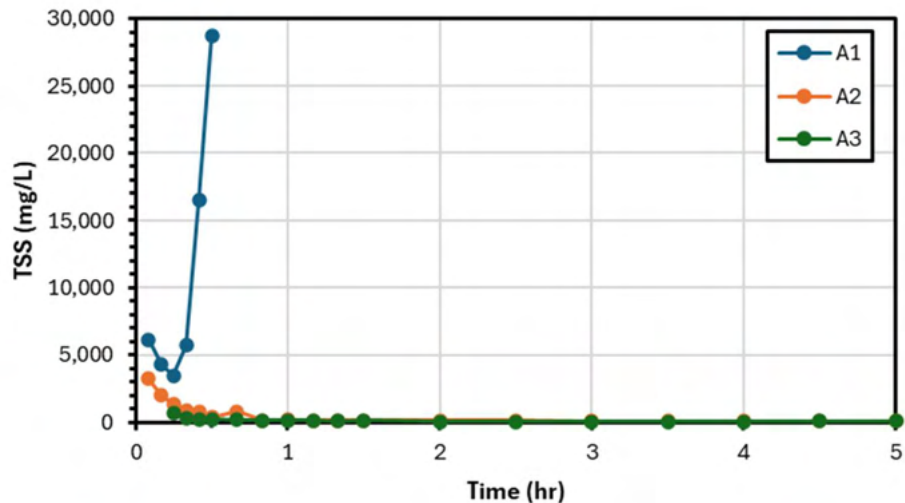



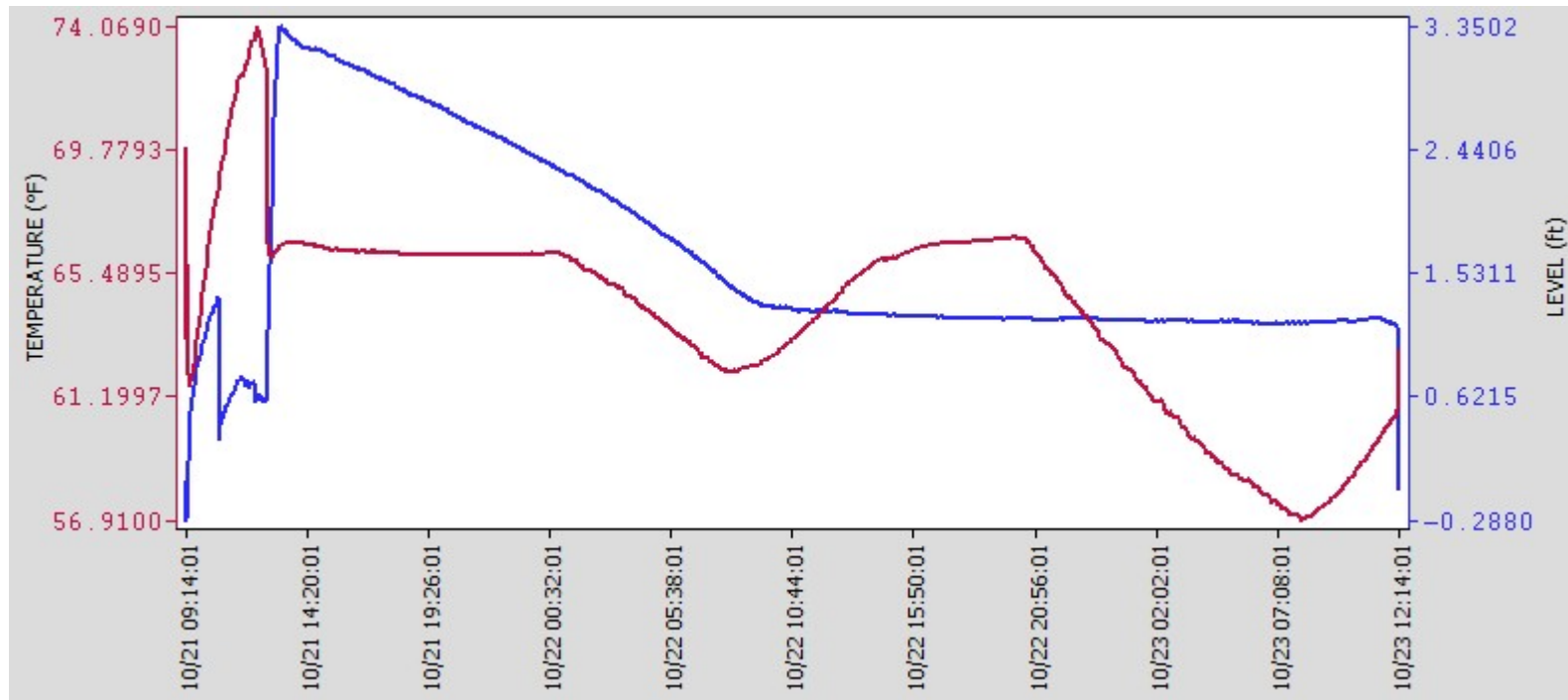

Legend Interpretation: The letter (A, B, C, D) corresponds to the Test ID to indicate which test in the series. The number (1, 2, 3) corresponds to the data collection location with 1 indicating the inflow collection point, 2 indicating the “in-trap” collection point, and 3 indicating the downstream or discharge collection point.





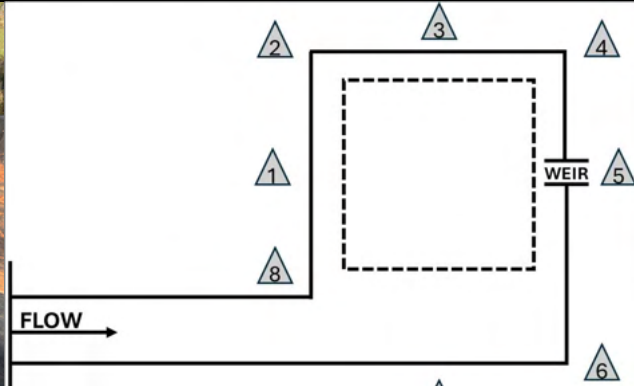





Temperature (°F) & Storage Volume Depth (Level, ft) Plot

Note: This data was produced by a level logger placed on the bottom of the sediment trap prior to test commencement until the trap dewatered (or the depth experienced no more change). The Temperature is represented by the red line, and the depth level is represented by the blue line. The corresponding dates and times are on the x-axis. The skimmer rested on a block at a depth of around 1 ft, meaning water would not be discharged below that level. For installations without a skimmer, the drop of the blue line on the right side of the graph indicates the water being drained to retrieve the level logger.

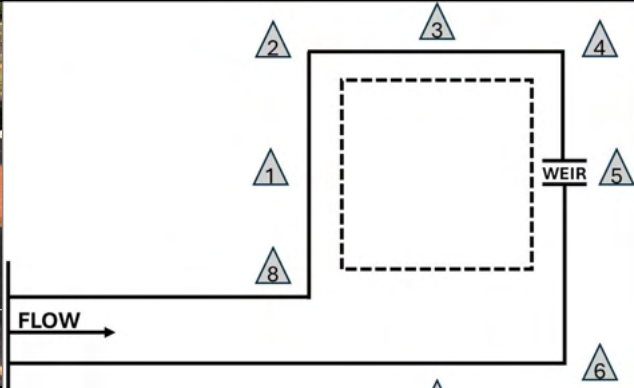

Test ID	Photo Documentation	Installation
A	Pre-Test	Sediment Trap with Surface Skimmer
		
Location 2	Location 3	Location 4
		
Location 1		Location 5
		
Location 8	Location 7	Location 6

Test ID	Photo Documentation	Installation
A	Post-Test	Sediment Trap with Surface Skimmer
		
Location 2	Location 3	Location 4
		
Location 1		Location 5
		
Location 8	Location 7	Location 6

SEDIMENT TRAP TEST LOG

Test Summary

Installation:	Skimmer
Test ID:	B
Date:	10/23/2025
Type:	Longevity
Flow Rate (cfs):	1.0
Sediment Load Rate (lb/min):	49.0

Picture of Installation



Installation Description & Test Notes: The sediment trap, sized for 1 ac of contributory drainage, was paired with a 1.5 in. skimmer with 100% orifice opening. The skimmer was sized with the Faircloth Estimator's Calculator based on the required volume with a goal of dewatering for a minimum of 48 hours. The skimmer dewatered in around 30 hours due to the spillway height (recommended that the basin dimensions be input into the calculator in the future). During the test, inflow was observed pushing the skimmer to the far side of the basin until the trap filled and overflowed into the channel.

Sediment Capture Efficiency

Capture of Introduced Sediment (%):	87.1 %
Improved Capture from Control:	0.7 %

Water Quality Data Statistics

Measurement Location	Avg		Min		Max		Std. Dev.	
	NTU	TSS (mg/L)	NTU	TSS (mg/L)	NTU	TSS (mg/L)	NTU	TSS (mg/L)
Inflow	708	1,847	229	560	1,378	3,790	390	998
Trap	249	315	114	20	688	1,300	165	362
Downstream	181	101	107	30	358	380	66	90

TSS (mg/L) and Turbidity (NTU) Data Plots



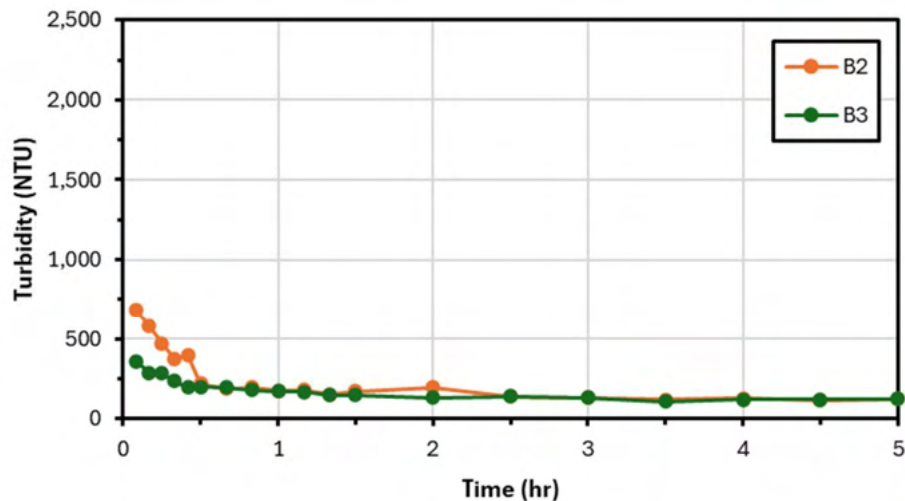
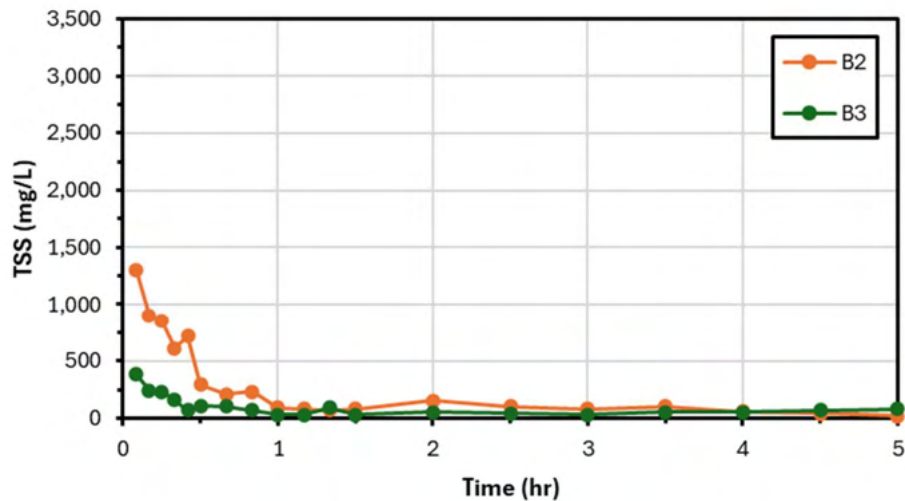
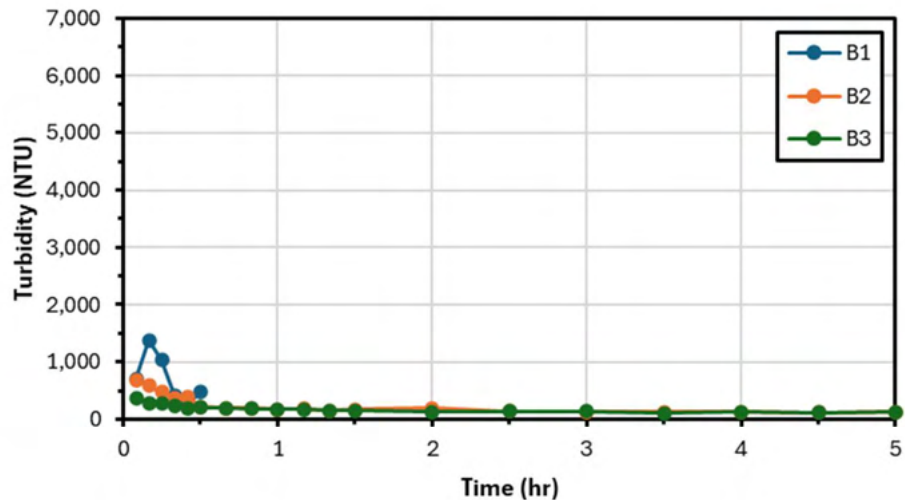
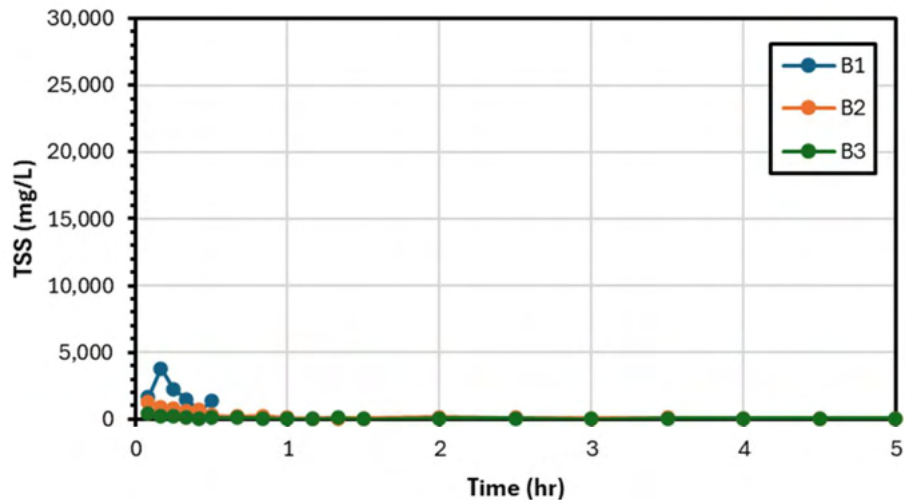



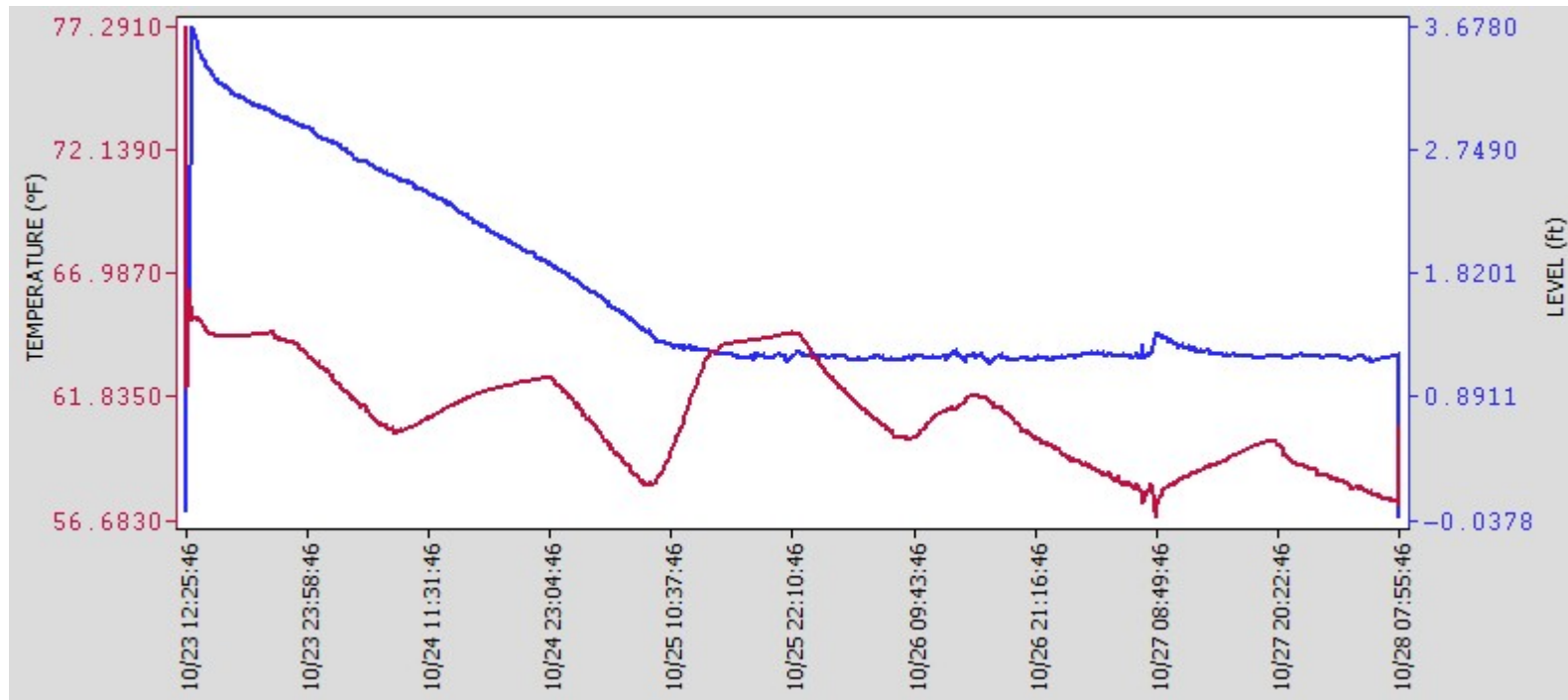

Legend Interpretation: The letter (A, B, C, D) corresponds to the Test ID to indicate which test in the series. The number (1, 2, 3) corresponds to the data collection location with 1 indicating the inflow collection point, 2 indicating the “in-trap” collection point, and 3 indicating the downstream or discharge collection point.





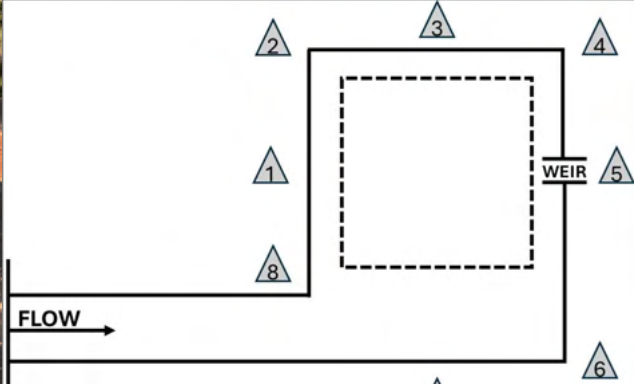





Temperature (°F) & Storage Volume Depth (Level, ft) Plot

Note: This data was produced by a level logger placed on the bottom of the sediment trap prior to test commencement until the trap dewatered (or the depth experienced no more change). The Temperature is represented by the red line, and the depth level is represented by the blue line. The corresponding dates and times are on the x-axis. The skimmer rested on a block at a depth of around 1 ft, meaning water would not be discharged below that level. For installations without a skimmer, the drop of the blue line on the right side of the graph indicates the water being drained to retrieve the level logger.

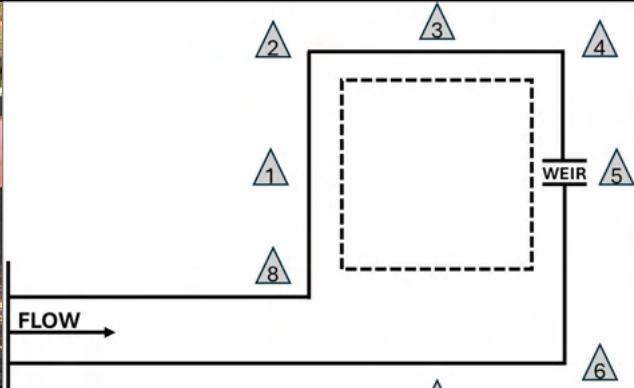

Test ID	Photo Documentation	Installation
B	Pre-Test	Sediment Trap with Surface Skimmer
		
Location 2	Location 3	Location 4
		
Location 1		Location 5
		
Location 8	Location 7	Location 6

Test ID	Photo Documentation	Installation
B	Post-Test	Sediment Trap with Surface Skimmer
		
Location 2	Location 3	Location 4
		
Location 1		Location 5
		
Location 8	Location 7	Location 6

SEDIMENT TRAP TEST LOG

Test Summary

Installation:	Skimmer
Test ID:	C
Date:	10/28/2025
Type:	Longevity
Flow Rate (cfs):	1.0
Sediment Load Rate (lb/min):	49.0

Picture of Installation



Installation Description & Test Notes: The sediment trap, sized for 1 ac of contributory drainage, was paired with a 1.5 in. skimmer with 100% orifice opening. The skimmer was sized with the Faircloth Estimator's Calculator based on the required volume with a goal of dewatering for a minimum of 48 hours. The skimmer dewatered in around 30 hours due to the spillway height (recommended that the basin dimensions be input into the calculator in the future). During the test, inflow was observed pushing the skimmer to the far side of the basin until the trap filled and overflowed into the channel.

Sediment Capture Efficiency

Capture of Introduced Sediment (%):	87.1 %
Improved Capture from Control:	0.7 %

Water Quality Data Statistics

Measurement Location	Avg		Min		Max		Std. Dev.	
	NTU	TSS (mg/L)	NTU	TSS (mg/L)	NTU	TSS (mg/L)	NTU	TSS (mg/L)
Inflow	1,478	3,665	574	900	2,815	6,090	668	1,679
Trap	356	391	80	20	984	1,280	259	347
Downstream	267	678	161	105	773	1,810	141	393

TSS (mg/L) and Turbidity (NTU) Data Plots



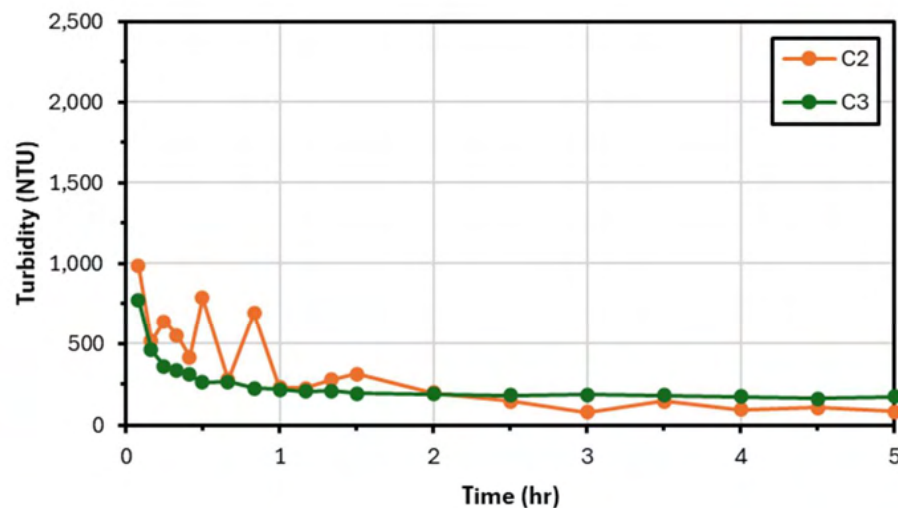
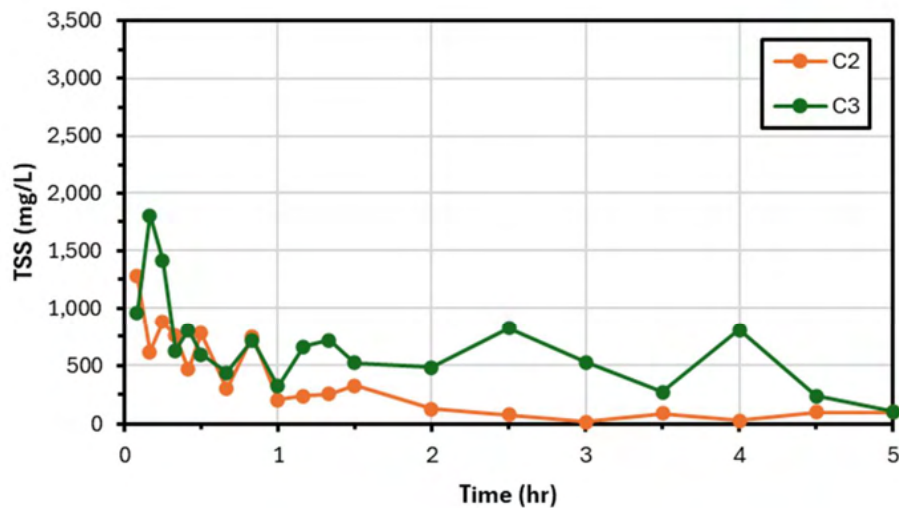
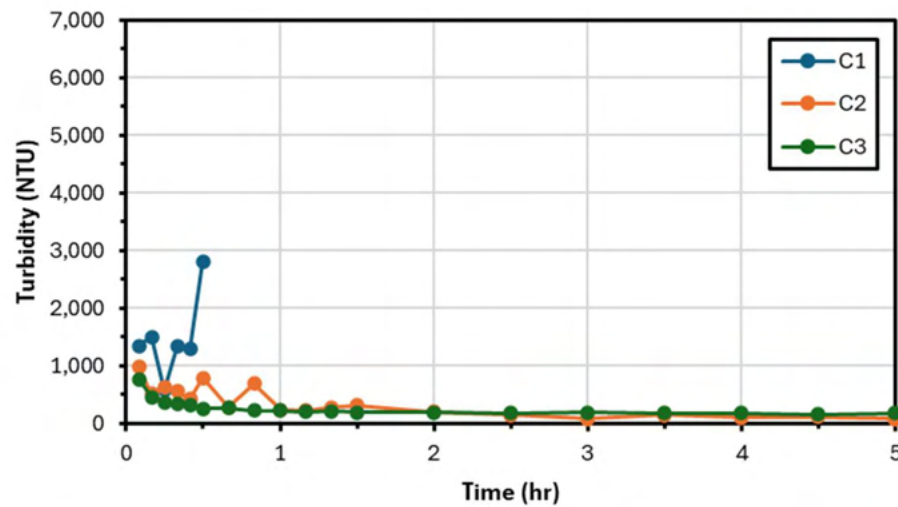
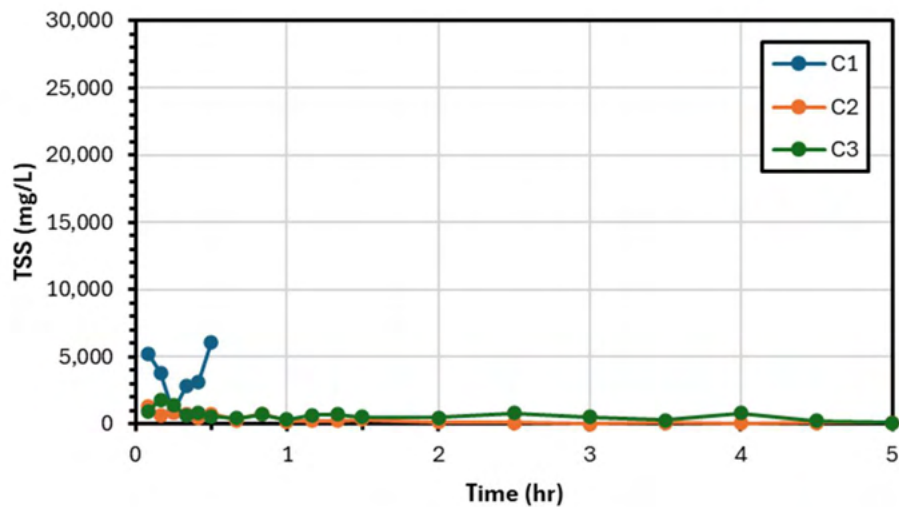



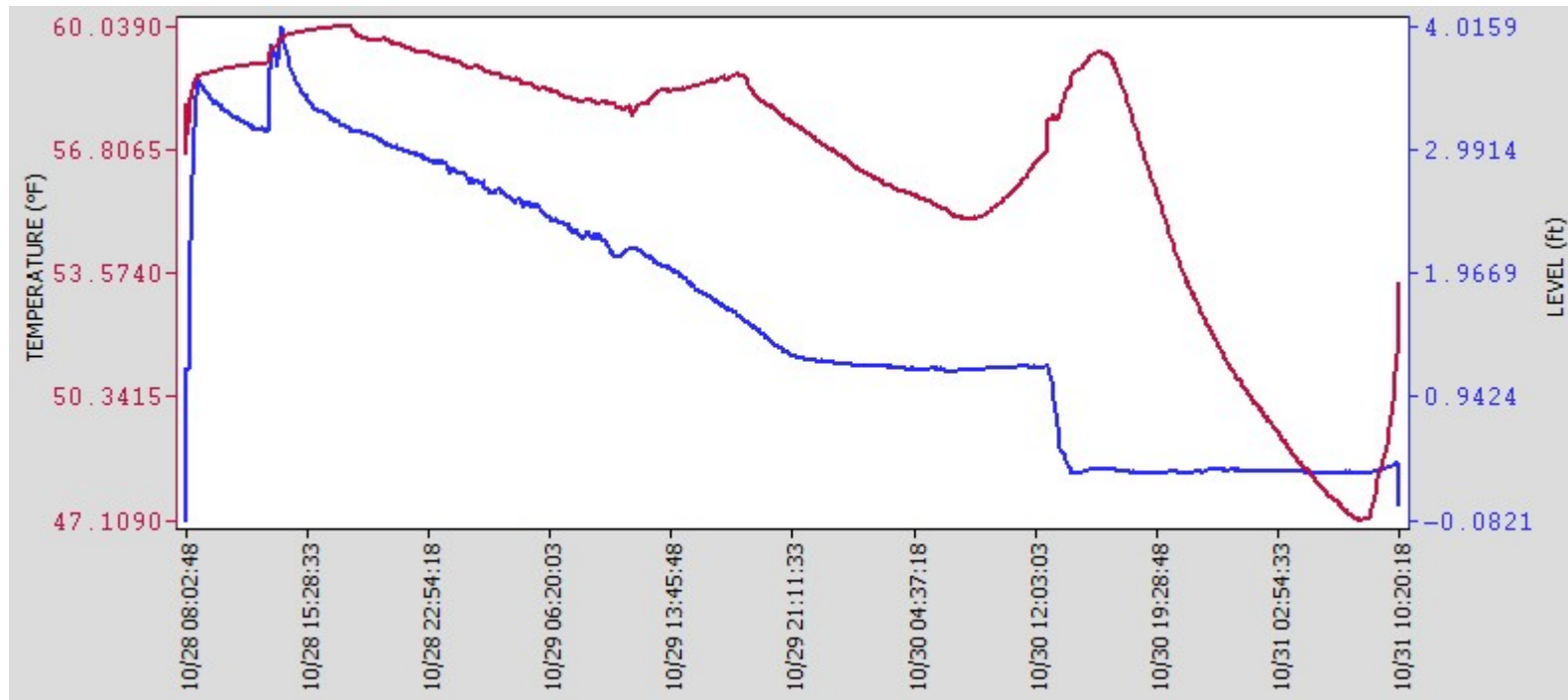

Legend Interpretation: The letter (A, B, C, D) corresponds to the Test ID to indicate which test in the series. The number (1, 2, 3) corresponds to the data collection location with 1 indicating the inflow collection point, 2 indicating the "in-trap" collection point, and 3 indicating the downstream or discharge collection point.





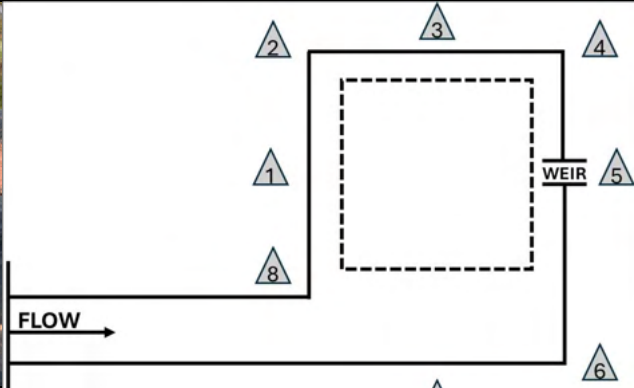





Temperature (°F) & Storage Volume Depth (Level, ft) Plot

Note: This data was produced by a level logger placed on the bottom of the sediment trap prior to test commencement until the trap dewatered (or the depth experienced no more change). The Temperature is represented by the red line, and the depth level is represented by the blue line. The corresponding dates and times are on the x-axis. The skimmer rested on a block at a depth of around 1 ft, meaning water would not be discharged below that level. For installations without a skimmer, the drop of the blue line on the right side of the graph indicates the water being drained to retrieve the level logger.

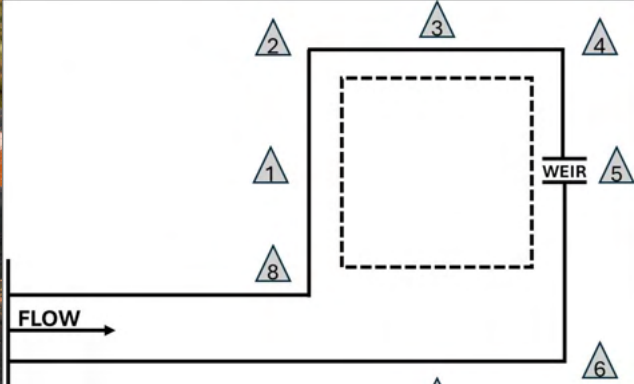

Test ID	Photo Documentation	Installation
C	Pre-Test	Sediment Trap with Surface Skimmer
		
Location 2	Location 3	Location 4
		
Location 1		Location 5
		
Location 8	Location 7	Location 6

Test ID	Photo Documentation	Installation
C	Post-Test	Sediment Trap with Surface Skimmer
		
Location 2	Location 3	Location 4
	 <p>The diagram shows a rectangular sediment trap with a dashed inner rectangle. Flow enters from the left, indicated by an arrow labeled 'FLOW'. A 'WEIR' is located on the right side. Eight numbered locations (1-8) are marked with triangles around the trap: 1, 2, 3, 4, 5, 6, 7, and 8.</p>	
Location 1		Location 5
		
Location 8	Location 7	Location 6

SEDIMENT TRAP TEST LOG

Test Summary

Installation:	Skimmer
Test ID:	D
Date:	10/28/2025
Type:	Longevity
Flow Rate (cfs):	1.0
Sediment Load Rate (lb/min):	49.0

Picture of Installation



Installation Description & Test Notes: The sediment trap, sized for 1 ac of contributory drainage, was paired with a 1.5 in. skimmer with 100% orifice opening. The skimmer was sized with the Faircloth Estimator's Calculator based on the required volume with a goal of dewatering for a minimum of 48 hours. The skimmer dewatered in around 30 hours due to the spillway height (recommended that the basin dimensions be input into the calculator in the future). During the test, inflow was observed pushing the skimmer to the far side of the basin until the trap filled and overflowed into the channel.

Sediment Capture Efficiency

Capture of Introduced Sediment (%):	87.1 %
Improved Capture from Control:	0.7 %

Water Quality Data Statistics

Measurement Location	Avg		Min		Max		Std. Dev.	
	NTU	TSS (mg/L)	NTU	TSS (mg/L)	NTU	TSS (mg/L)	NTU	TSS (mg/L)
Inflow	1,459	3,380	445	1,140	4,171	8,750	1,304	2,695
Trap	335	410	157	110	778	1,150	144	304
Downstream	200	149	139	80	352	350	49	55

TSS (mg/L) and Turbidity (NTU) Data Plots



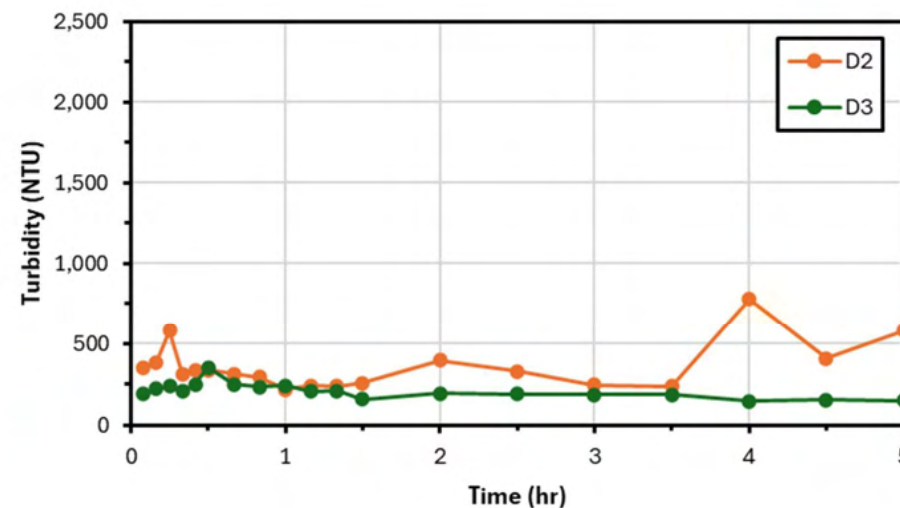
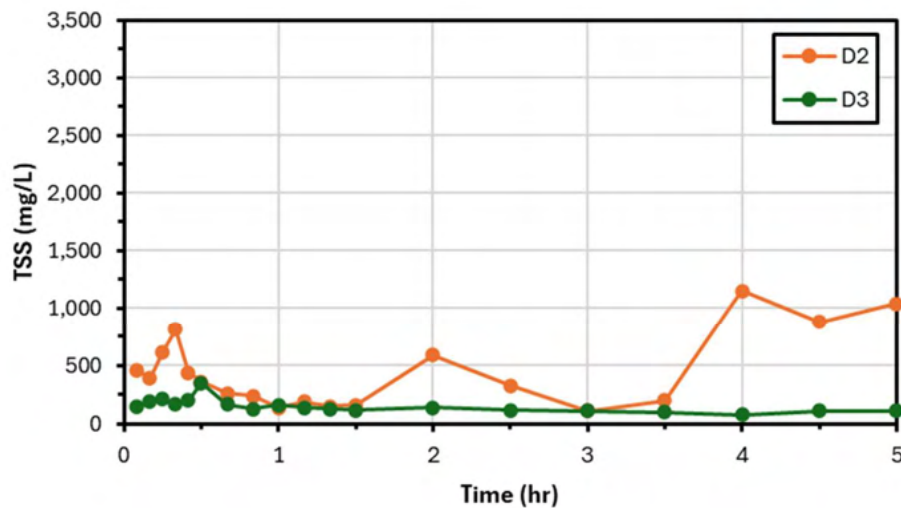
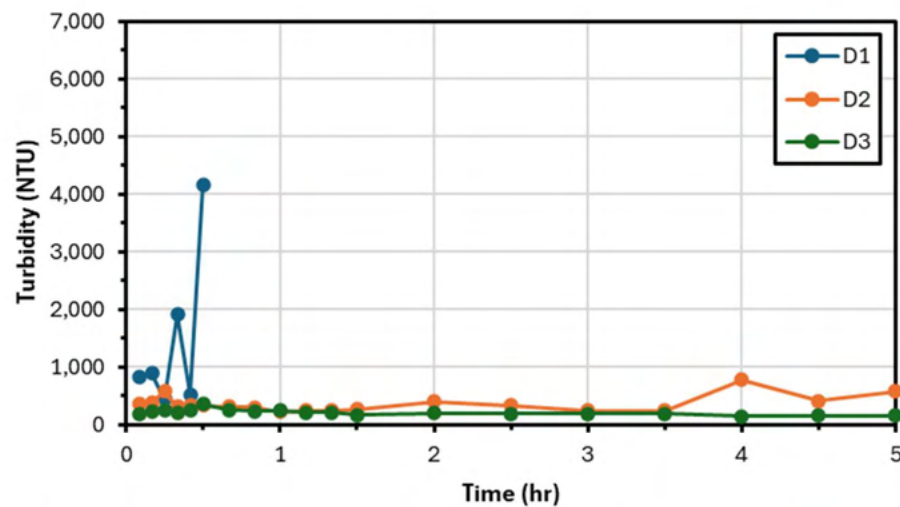
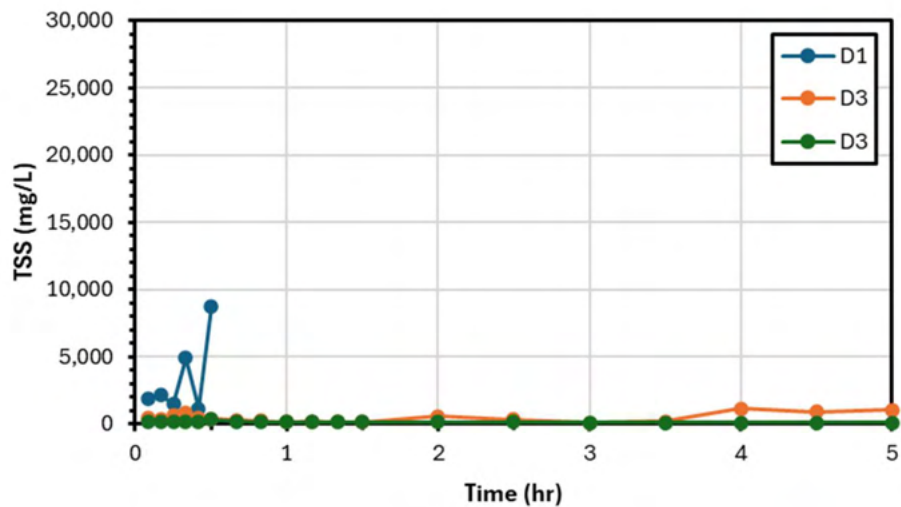



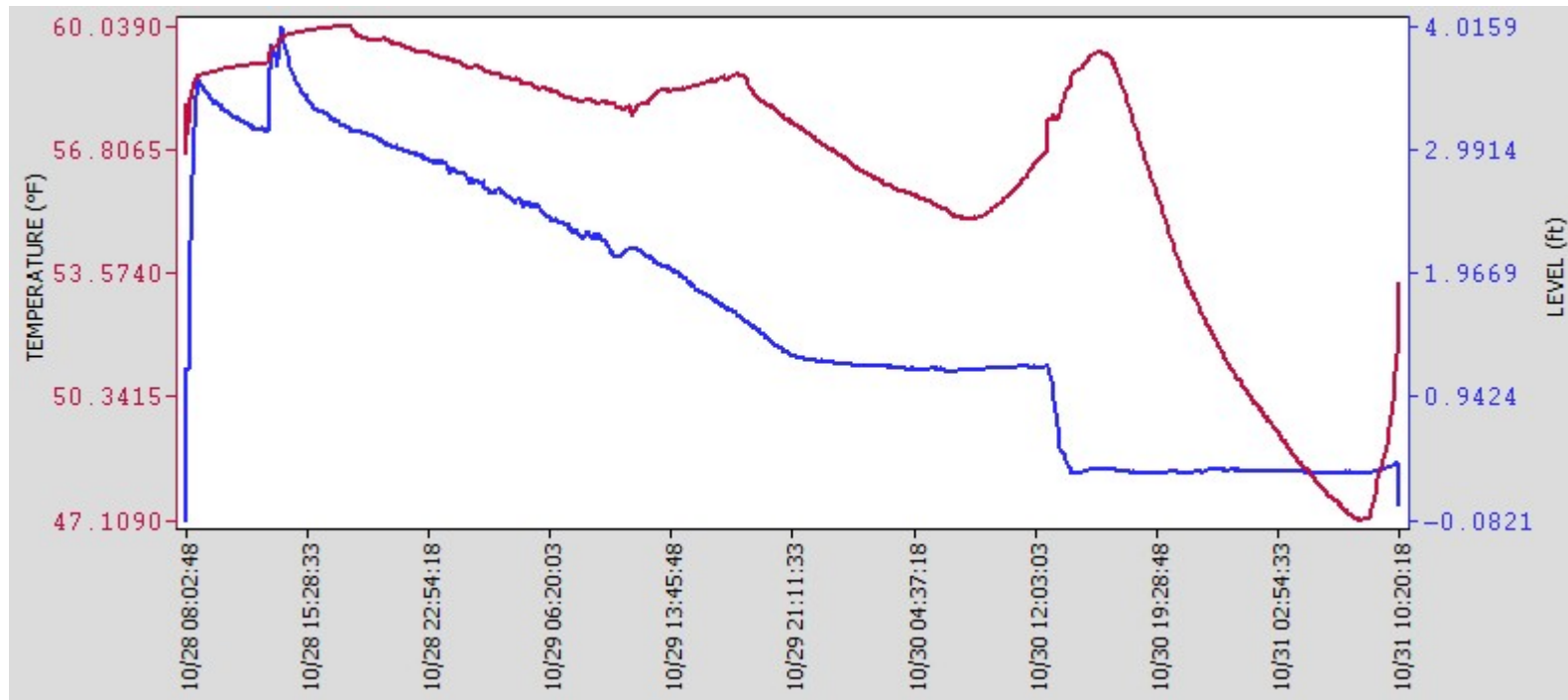

Legend Interpretation: The letter (A, B, C, D) corresponds to the Test ID to indicate which test in the series. The number (1, 2, 3) corresponds to the data collection location with 1 indicating the inflow collection point, 2 indicating the "in-trap" collection point, and 3 indicating the downstream or discharge collection point.





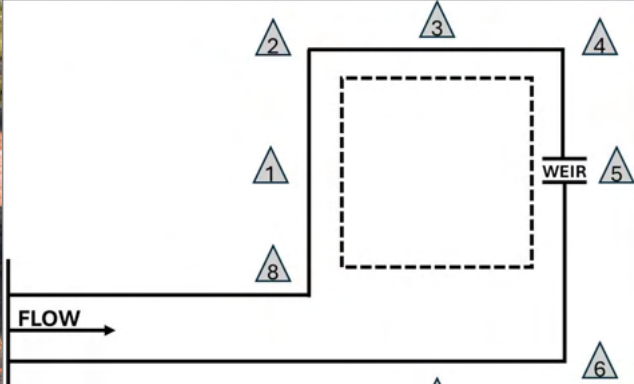





Temperature (°F) & Storage Volume Depth (Level, ft) Plot

Note: This data was produced by a level logger placed on the bottom of the sediment trap prior to test commencement until the trap dewatered (or the depth experienced no more change). The Temperature is represented by the red line, and the depth level is represented by the blue line. The corresponding dates and times are on the x-axis. The skimmer rested on a block at a depth of around 1 ft, meaning water would not be discharged below that level. For installations without a skimmer, the drop of the blue line on the right side of the graph indicates the water being drained to retrieve the level logger.

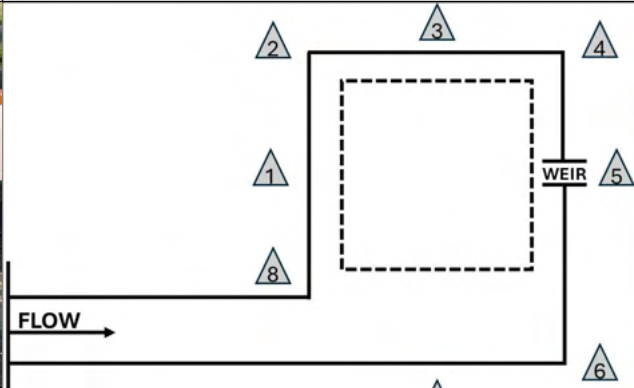

Test ID	Photo Documentation	Installation
D	Pre-Test	Sediment Trap with Surface Skimmer
		
Location 2	Location 3	Location 4
		
Location 1		Location 5
		
Location 8	Location 7	Location 6

Test ID	Photo Documentation	Installation
D	Post-Test	Sediment Trap with Surface Skimmer
		
Location 2	Location 3	Location 4
		
Location 1		Location 5
		
Location 8	Location 7	Location 6

SEDIMENT TRAP TEST LOG

Test Summary

Installation:	MFE-I
Test ID:	A
Date:	2/11/2026
Type:	Longevity
Flow Rate (cfs):	1.0
Sediment Load Rate (lb/min):	49.0

Picture of Installation



Installation Description & Test Notes: The sediment trap, sized for 1 ac of contributory drainage, was paired with three coir baffles and a 1.5 in. skimmer. The skimmer was placed behind the last baffle, furthest from the inflow. The lack of water and sediment resources at the AU-SRF affected the testing timeline, stretching over 2 months to complete all four tests. High background turbidity affected the turbidity results in the trap and downstream of the detention practice.

Sediment Capture Efficiency

Capture of Introduced Sediment (%):	91.1 %
Improved Capture from Control:	4.7 %

Water Quality Data Statistics

Measurement Location	Avg		Min		Max		Std. Dev.	
	NTU	TSS (mg/L)	NTU	TSS (mg/L)	NTU	TSS (mg/L)	NTU	TSS (mg/L)
Inflow	977	278	532	100	1,665	610	391	221
Trap	572	79	374	10	1,269	130	207	31
Downstream	579	51	392	10	1,093	130	190	31

TSS (mg/L) and Turbidity (NTU) Data Plots



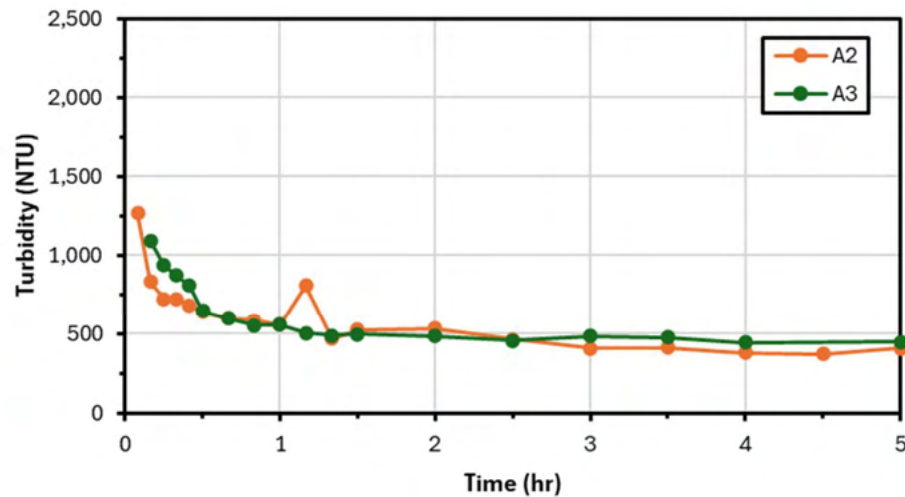
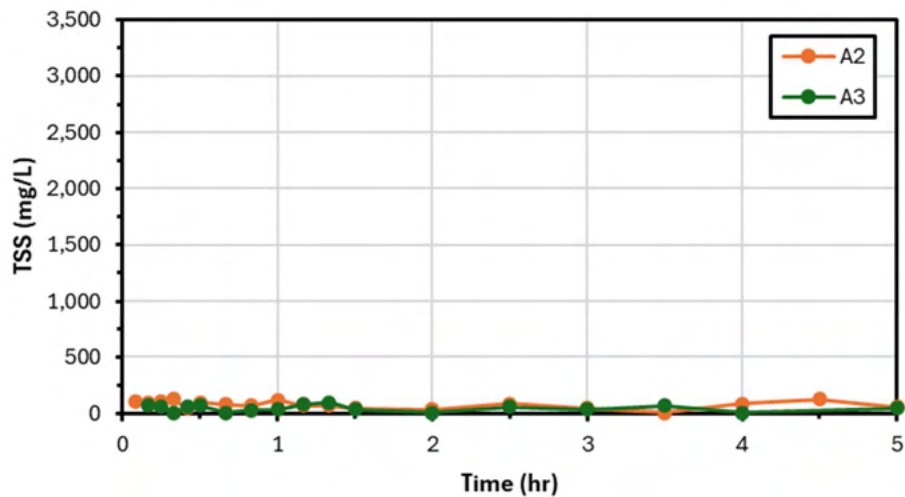
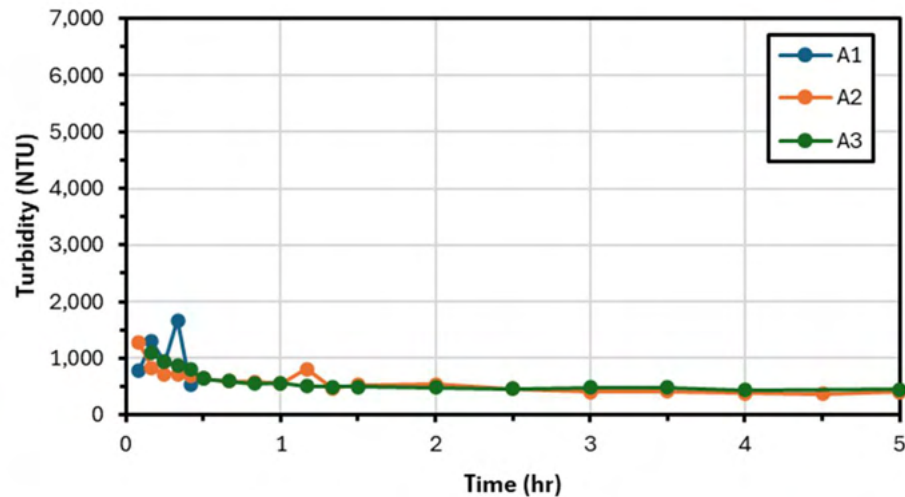
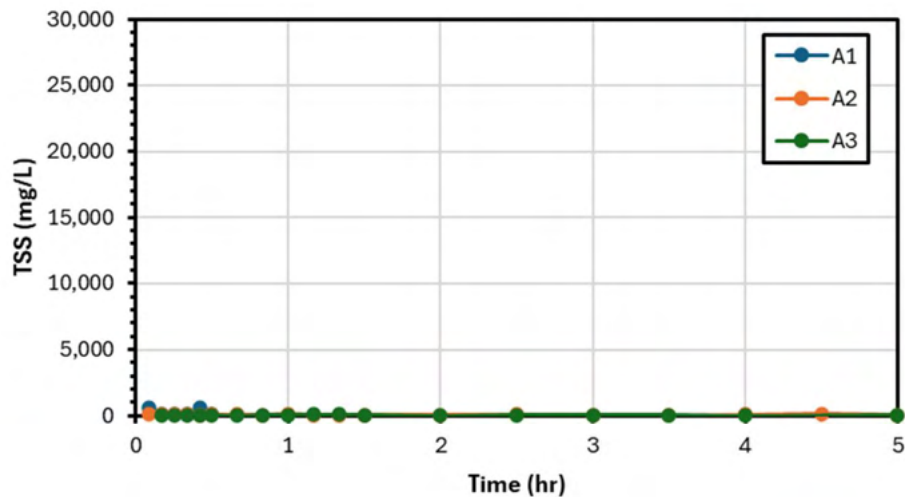



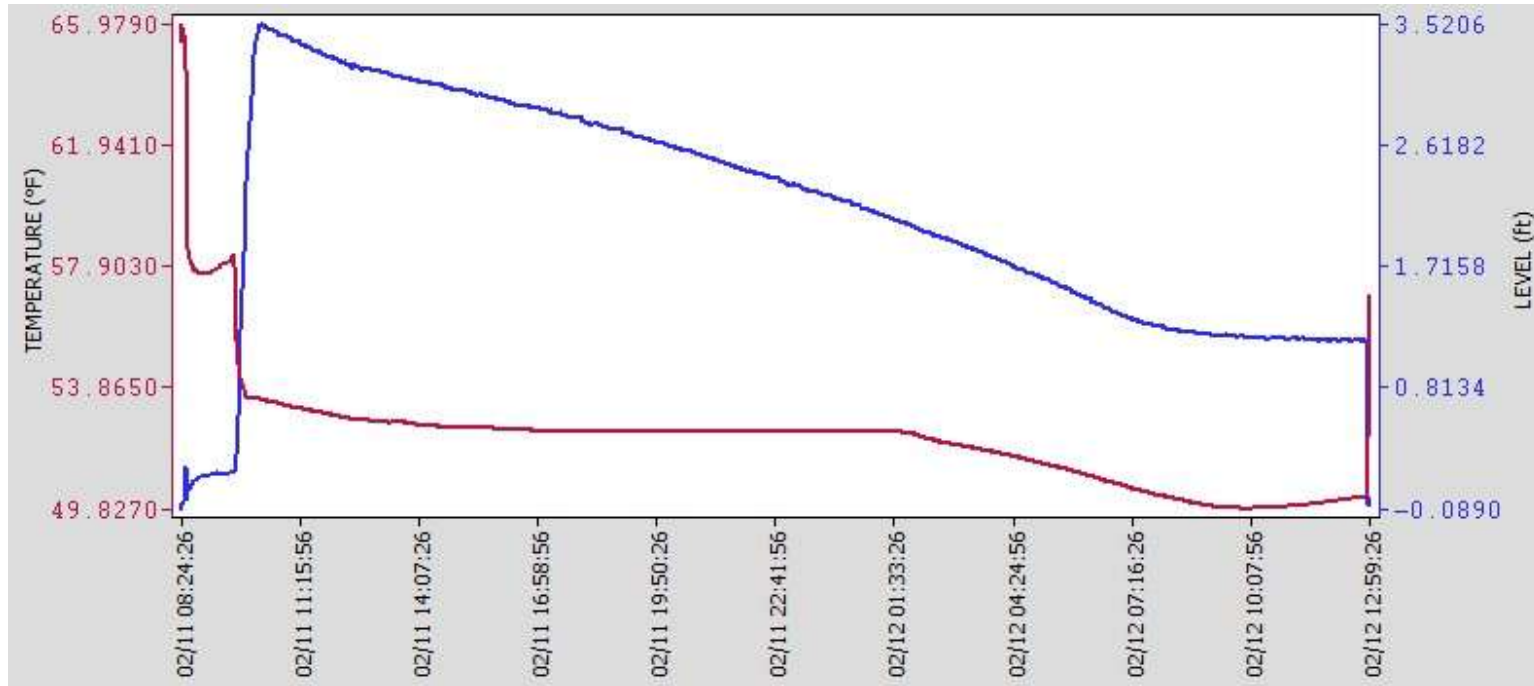

Legend Interpretation: The letter (A, B, C, D) corresponds to the Test ID to indicate which test in the series. The number (1, 2, 3) corresponds to the data collection location with 1 indicating the inflow collection point, 2 indicating the “in-trap” collection point, and 3 indicating the downstream or discharge collection point.





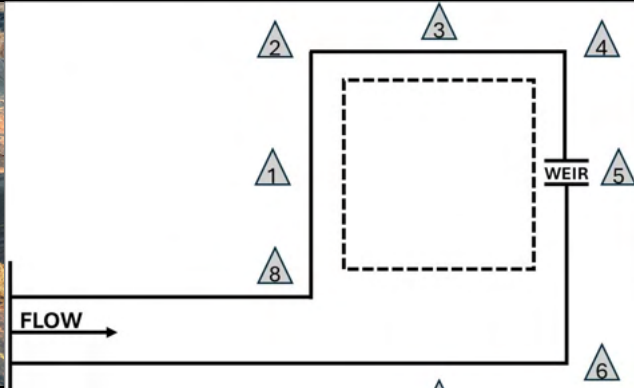





Temperature (°F) & Storage Volume Depth (Level, ft) Plot

Note: This data was produced by a level logger placed on the bottom of the sediment trap prior to test commencement until the trap dewatered (or the depth experienced no more change). The Temperature is represented by the red line, and the depth level is represented by the blue line. The corresponding dates and times are on the x-axis. The skimmer rested on a block at a depth of around 1 ft, meaning water would not be discharged below that level. For installations without a skimmer, the drop of the blue line on the right side of the graph indicates the water being drained to retrieve the level logger.

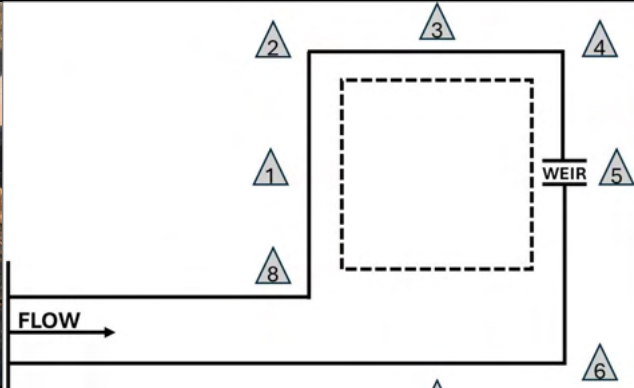

Test ID	Photo Documentation	Installation
A	Pre-Test	Sediment Trap MFE-I
		
Location 2	Location 3	Location 4
		
Location 1		Location 5
		
Location 8	Location 7	Location 6

Test ID	Photo Documentation	Installation
A	Post-Test	Sediment Trap MFE-I
		
Location 2	Location 3	Location 4
		
Location 1		Location 5
		
Location 8	Location 7	Location 6

SEDIMENT TRAP TEST LOG

Test Summary

Installation:	MFE-I
Test ID:	B
Date:	2/16/2026
Type:	Longevity
Flow Rate (cfs):	1.0
Sediment Load Rate (lb/min):	49.0

Picture of Installation



Installation Description & Test Notes: The sediment trap, sized for 1 ac of contributory drainage, was paired with three coir baffles and a 1.5 in. skimmer. The skimmer was placed behind the last baffle, furthest from the inflow. The lack of water and sediment resources at the AU-SRF affected the testing timeline, stretching over 2 months to complete all four tests. High background turbidity affected the turbidity results in the trap and downstream of the detention practice.

Sediment Capture Efficiency

Capture of Introduced Sediment (%):	91.1 %
Improved Capture from Control:	4.7 %

Water Quality Data Statistics

Measurement Location	Avg		Min		Max		Std. Dev.	
	NTU	TSS (mg/L)	NTU	TSS (mg/L)	NTU	TSS (mg/L)	NTU	TSS (mg/L)
Inflow	1,818	2,300	1,426	900	2,160	4,220	247	1,030
Trap	511	216	348	80	753	390	102	80
Downstream	632	205	435	80	791	330	100	70

TSS (mg/L) and Turbidity (NTU) Data Plots



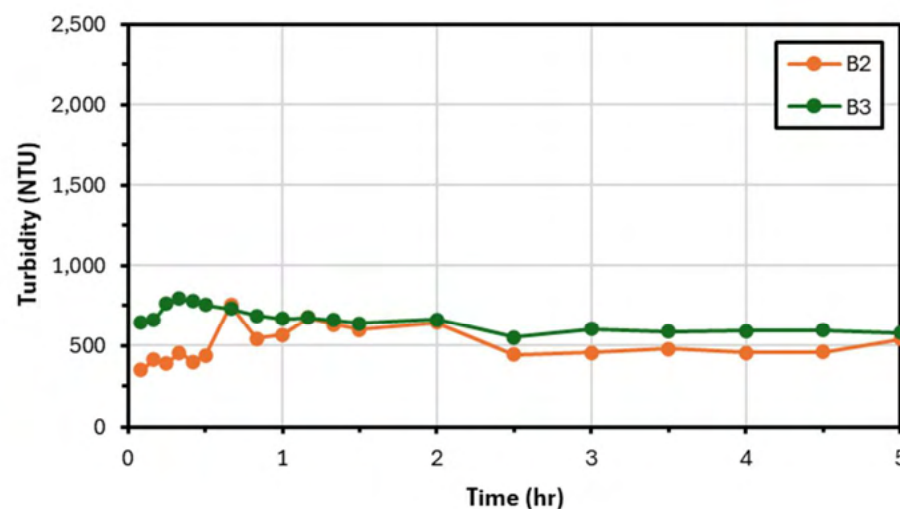
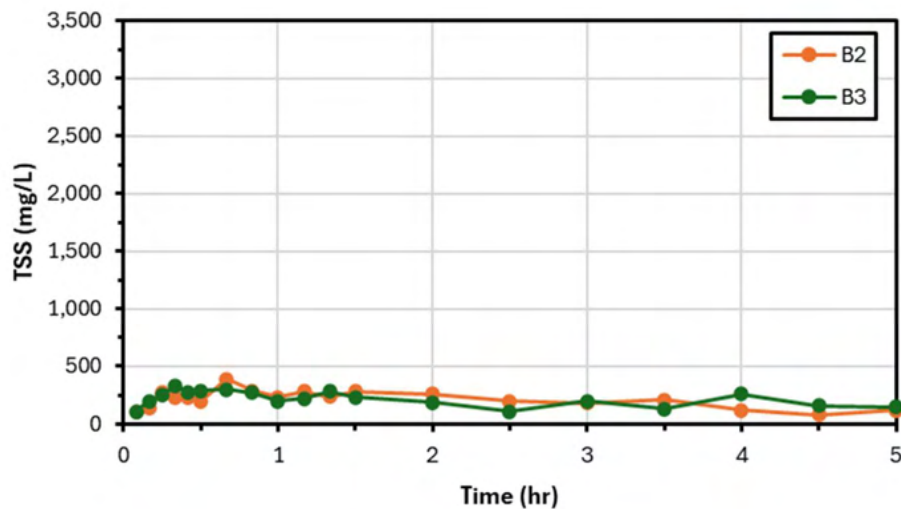
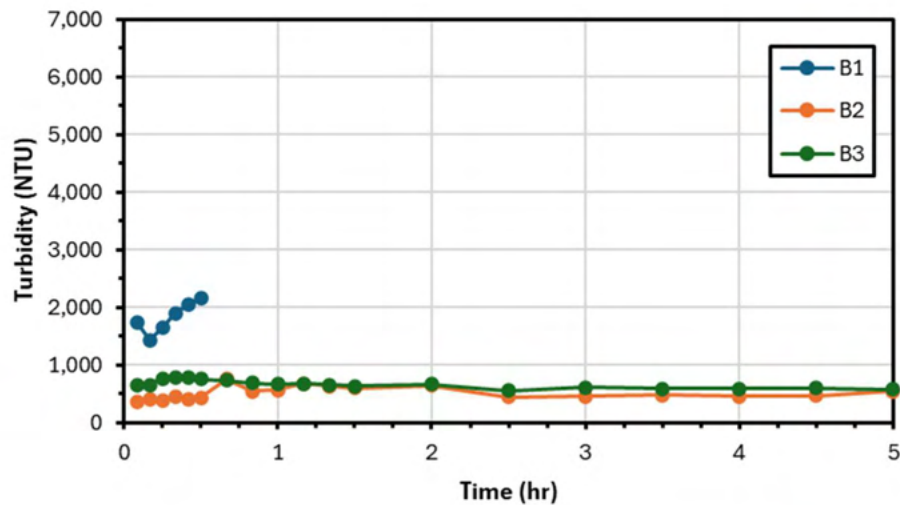
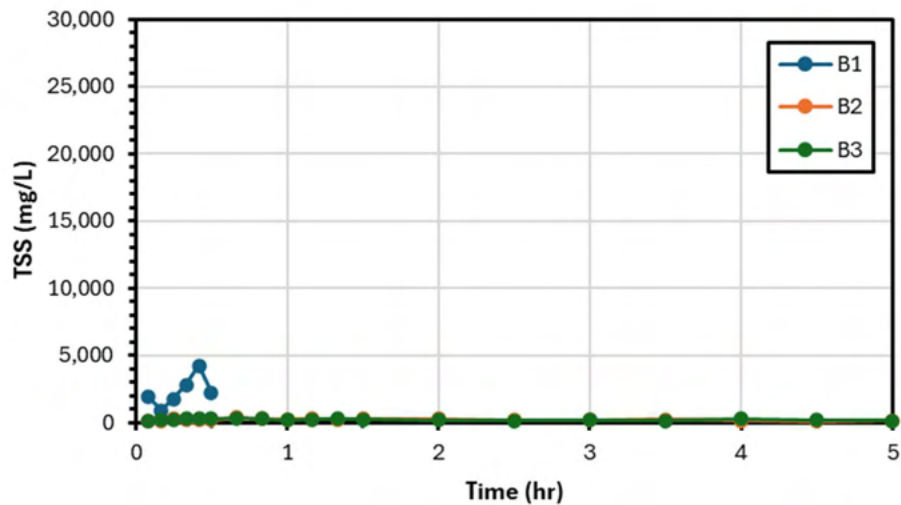



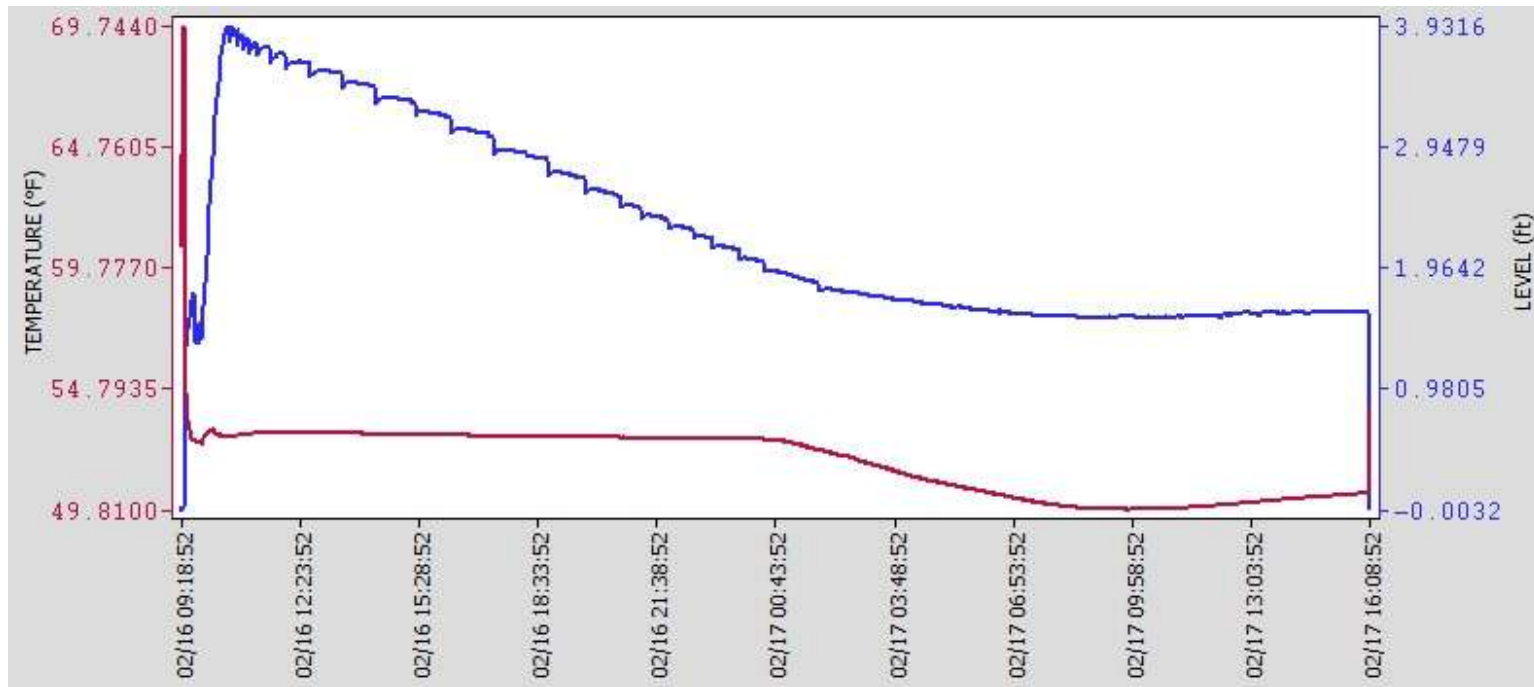

Legend Interpretation: The letter (A, B, C, D) corresponds to the Test ID to indicate which test in the series. The number (1, 2, 3) corresponds to the data collection location with 1 indicating the inflow collection point, 2 indicating the "in-trap" collection point, and 3 indicating the downstream or discharge collection point.





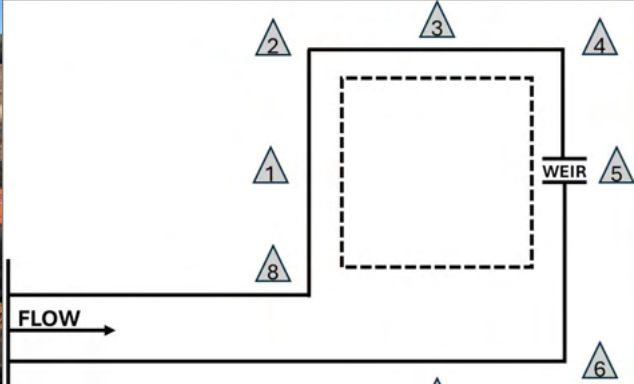





Temperature (°F) & Storage Volume Depth (Level, ft) Plot

Note: This data was produced by a level logger placed on the bottom of the sediment trap prior to test commencement until the trap dewatered (or the depth experienced no more change). The Temperature is represented by the red line, and the depth level is represented by the blue line. The corresponding dates and times are on the x-axis. The skimmer rested on a block at a depth of around 1 ft, meaning water would not be discharged below that level. For installations without a skimmer, the drop of the blue line on the right side of the graph indicates the water being drained to retrieve the level logger.

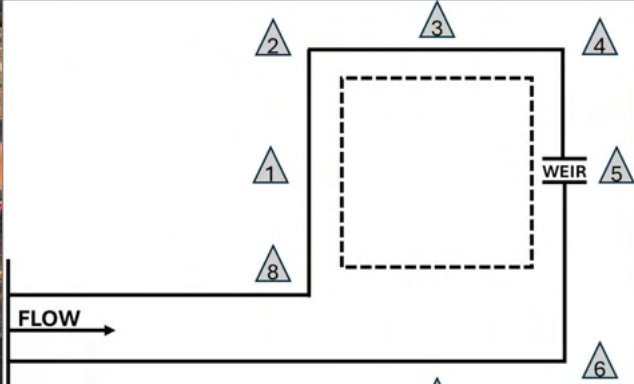

Test ID	Photo Documentation	Installation
B	Pre-Test	Sediment Trap MFE-I
		
Location 2	Location 3	Location 4
		
Location 1		Location 5
		
Location 8	Location 7	Location 6

Test ID	Photo Documentation	Installation
B	Post-Test	Sediment Trap MFE-I
		
Location 2	Location 3	Location 4
		
Location 1		Location 5
		
Location 8	Location 7	Location 6

SEDIMENT TRAP TEST LOG

Test Summary

Installation:	MFE-I
Test ID:	C
Date:	3/18/2026
Type:	Longevity
Flow Rate (cfs):	1.0
Sediment Load Rate (lb/min):	49.0

Picture of Installation



Installation Description & Test Notes: The sediment trap, sized for 1 ac of contributory drainage, was paired with three coir baffles and a 1.5 in. skimmer. The skimmer was placed behind the last baffle, furthest from the inflow. The lack of water and sediment resources at the AU-SRF affected the testing timeline, stretching over 2 months to complete all four tests. High background turbidity affected the turbidity results in the trap and downstream of the detention practice.

Sediment Capture Efficiency

Capture of Introduced Sediment (%):	91.1 %
Improved Capture from Control:	4.7 %

Water Quality Data Statistics

Measurement Location	Avg		Min		Max		Std. Dev.	
	NTU	TSS (mg/L)	NTU	TSS (mg/L)	NTU	TSS (mg/L)	NTU	TSS (mg/L)
Inflow	1,633	3,493	737	940	2,922	5,940	808	1,681
Trap	594	107	468	30	828	280	94	59
Downstream	919	301	524	120	1,149	430	155	97

TSS (mg/L) and Turbidity (NTU) Data Plots



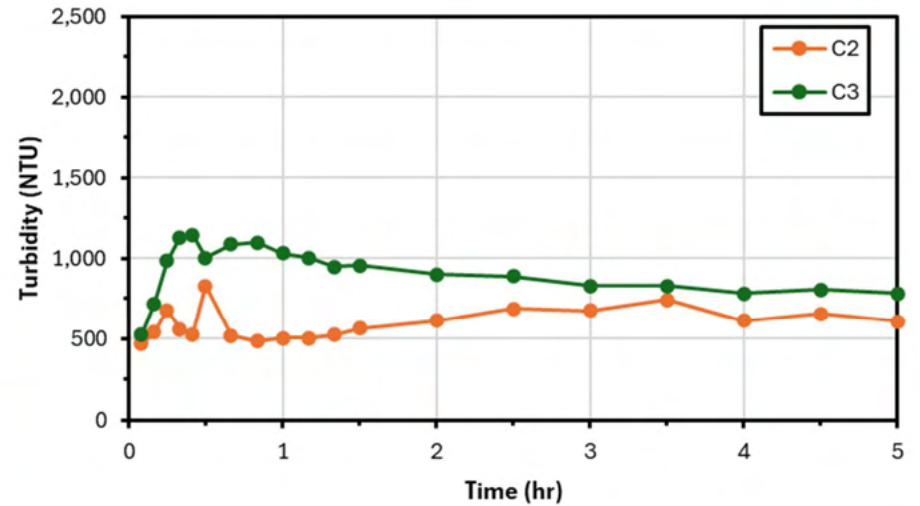
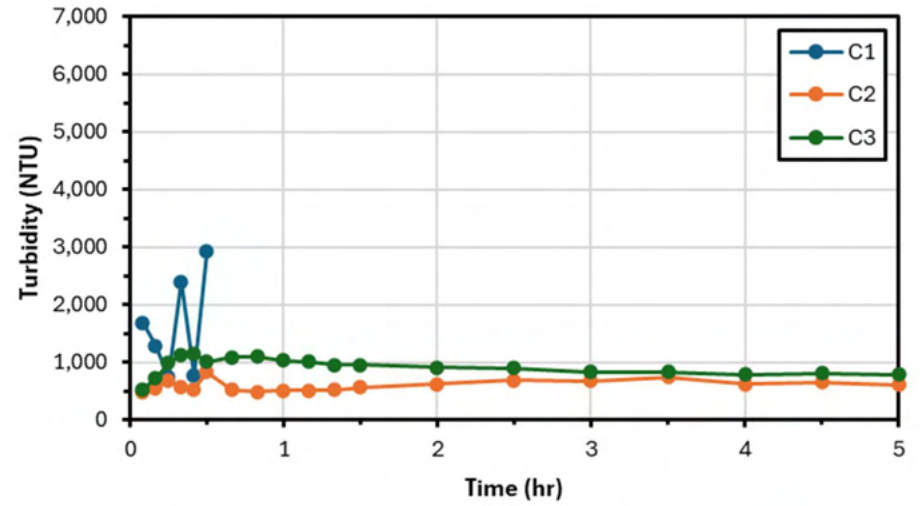
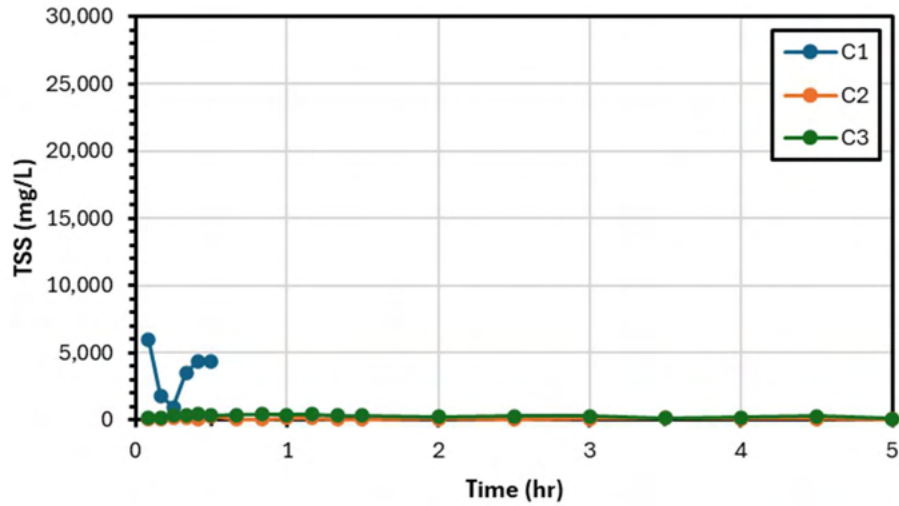



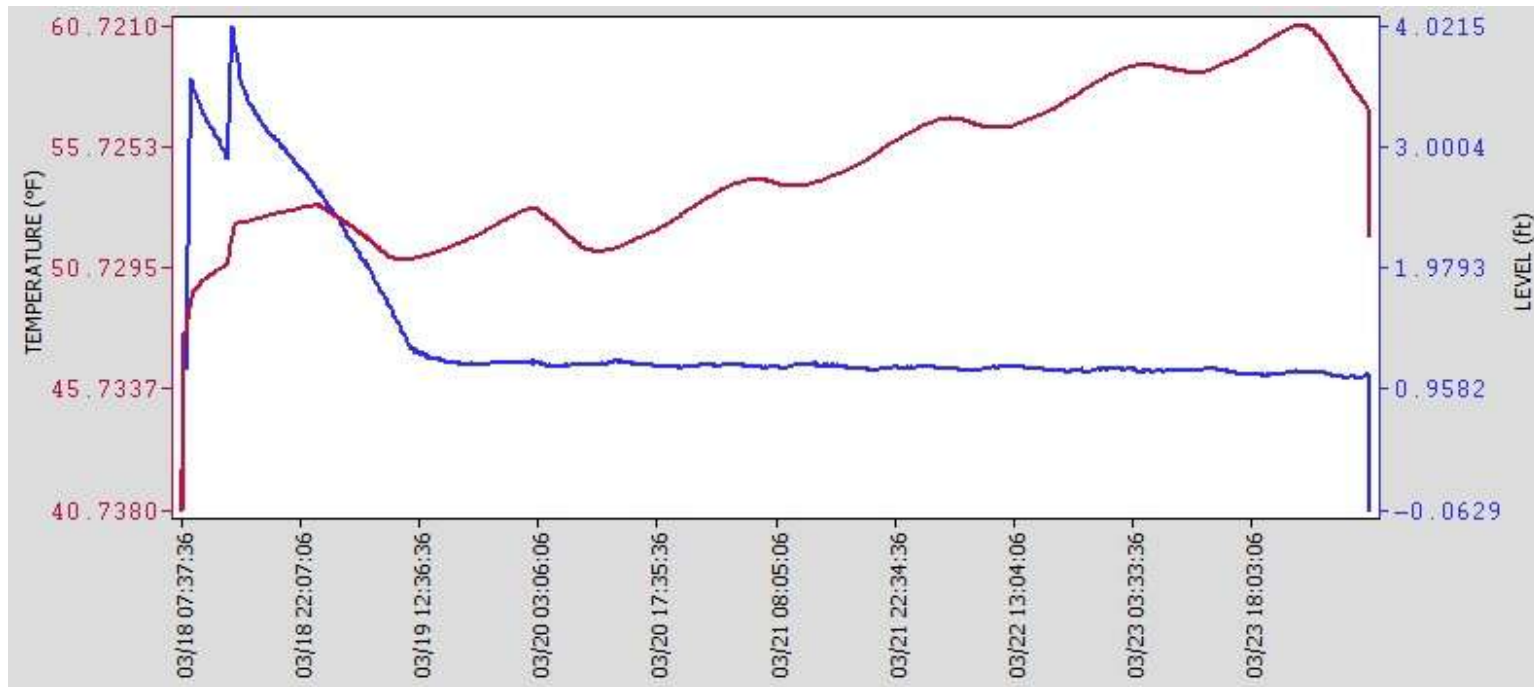

Legend Interpretation: The letter (A, B, C, D) corresponds to the Test ID to indicate which test in the series. The number (1, 2, 3) corresponds to the data collection location with 1 indicating the inflow collection point, 2 indicating the "in-trap" collection point, and 3 indicating the downstream or discharge collection point.





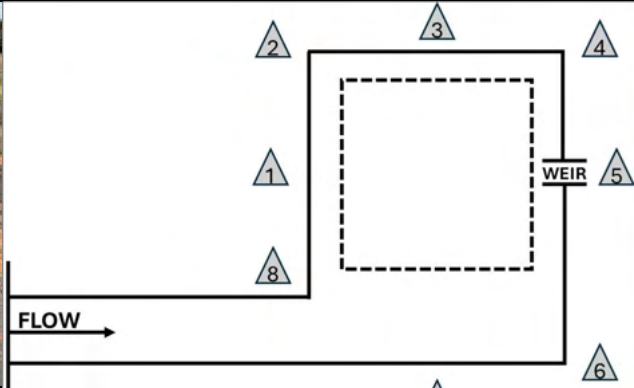





Temperature (°F) & Storage Volume Depth (Level, ft) Plot

Note: This data was produced by a level logger placed on the bottom of the sediment trap prior to test commencement until the trap dewatered (or the depth experienced no more change). The Temperature is represented by the red line, and the depth level is represented by the blue line. The corresponding dates and times are on the x-axis. The skimmer rested on a block at a depth of around 1 ft, meaning water would not be discharged below that level. For installations without a skimmer, the drop of the blue line on the right side of the graph indicates the water being drained to retrieve the level logger.

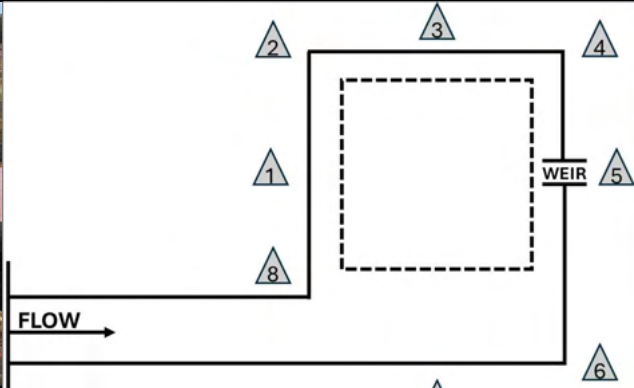

Test ID	Photo Documentation	Installation
C	Pre-Test	Sediment Trap MFE-I
		
Location 2	Location 3	Location 4
		
Location 1		Location 5
		
Location 8	Location 7	Location 6

Test ID	Photo Documentation	Installation
C	Post-Test	Sediment Trap MFE-I
		
Location 2	Location 3	Location 4
		
Location 1		Location 5
		
Location 8	Location 7	Location 6

SEDIMENT TRAP TEST LOG

Test Summary

Installation:	MFE-I
Test ID:	D
Date:	3/18/2026
Type:	Longevity
Flow Rate (cfs):	1.0
Sediment Load Rate (lb/min):	49.0

Picture of Installation



Installation Description & Test Notes: The sediment trap, sized for 1 ac of contributory drainage, was paired with three coir baffles and a 1.5 in. skimmer. The skimmer was placed behind the last baffle, furthest from the inflow. The lack of water and sediment resources at the AU-SRF affected the testing timeline, stretching over 2 months to complete all four tests. High background turbidity affected the turbidity results in the trap and downstream of the detention practice.

Sediment Capture Efficiency

Capture of Introduced Sediment (%):	91.1 %
Improved Capture from Control:	4.7 %

Water Quality Data Statistics

Measurement Location	Avg		Min		Max		Std. Dev.	
	NTU	TSS (mg/L)	NTU	TSS (mg/L)	NTU	TSS (mg/L)	NTU	TSS (mg/L)
Inflow	1,796	3,812	1,246	1,800	2,930	7,220	565	1,906
Trap	743	211	533	120	963	330	130	63
Downstream	735	275	366	140	952	420	153	85

TSS (mg/L) and Turbidity (NTU) Data Plots



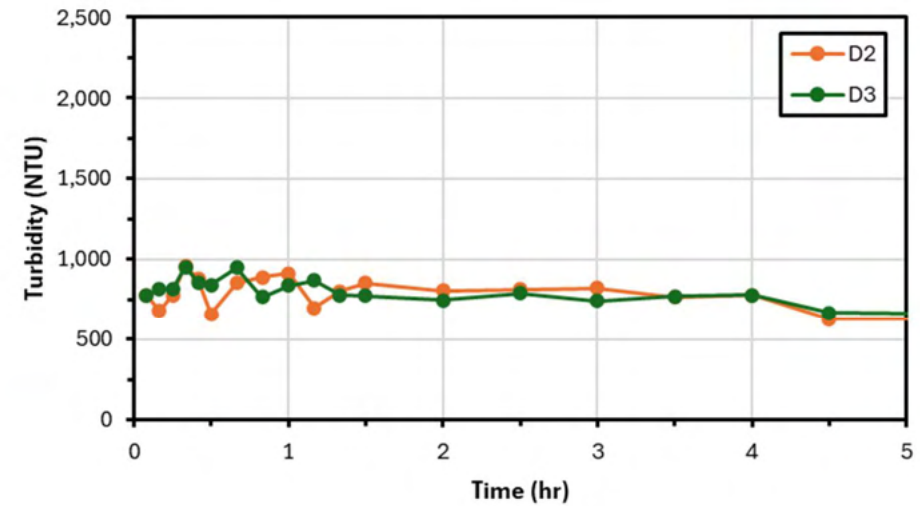
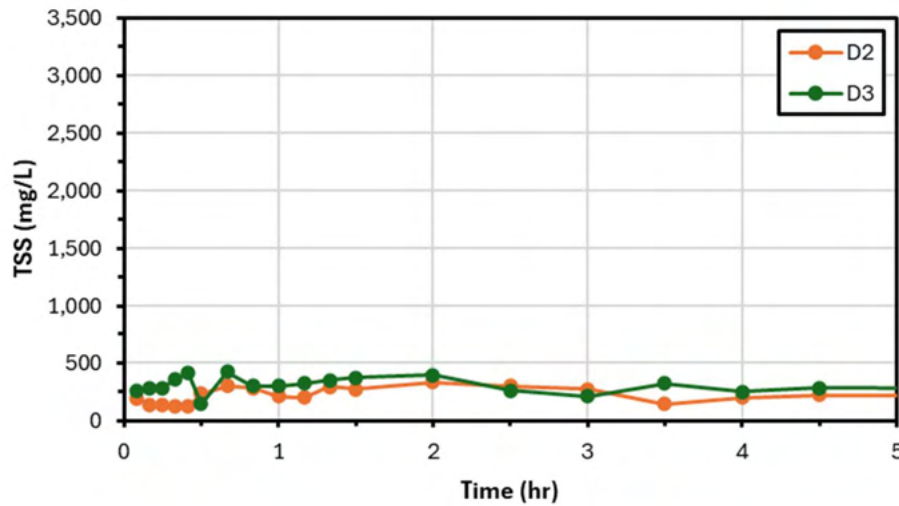
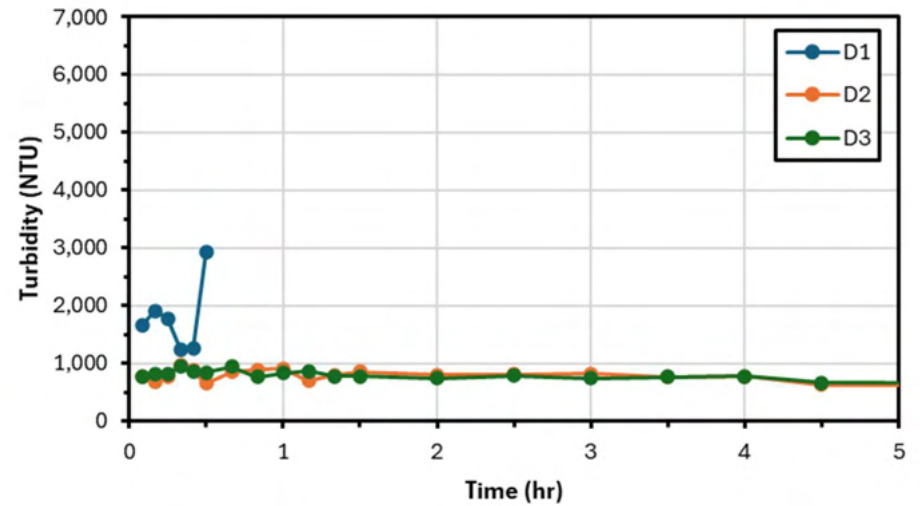
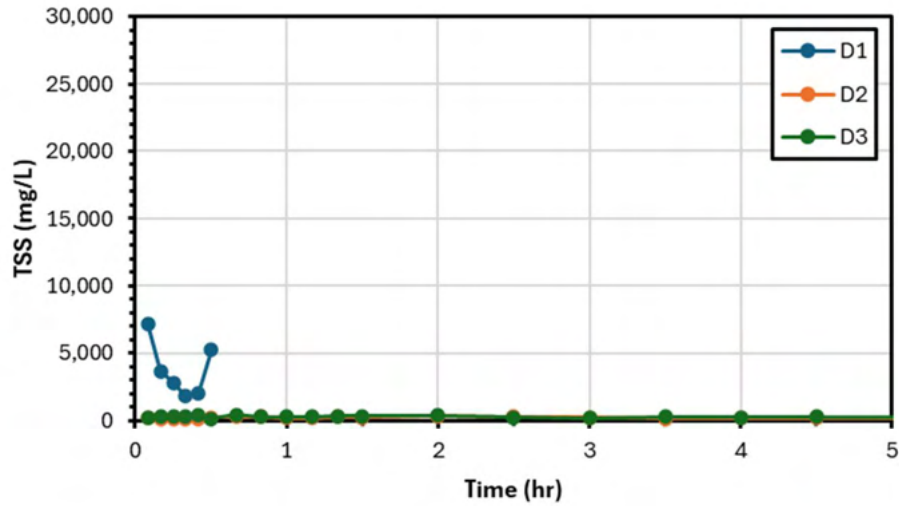



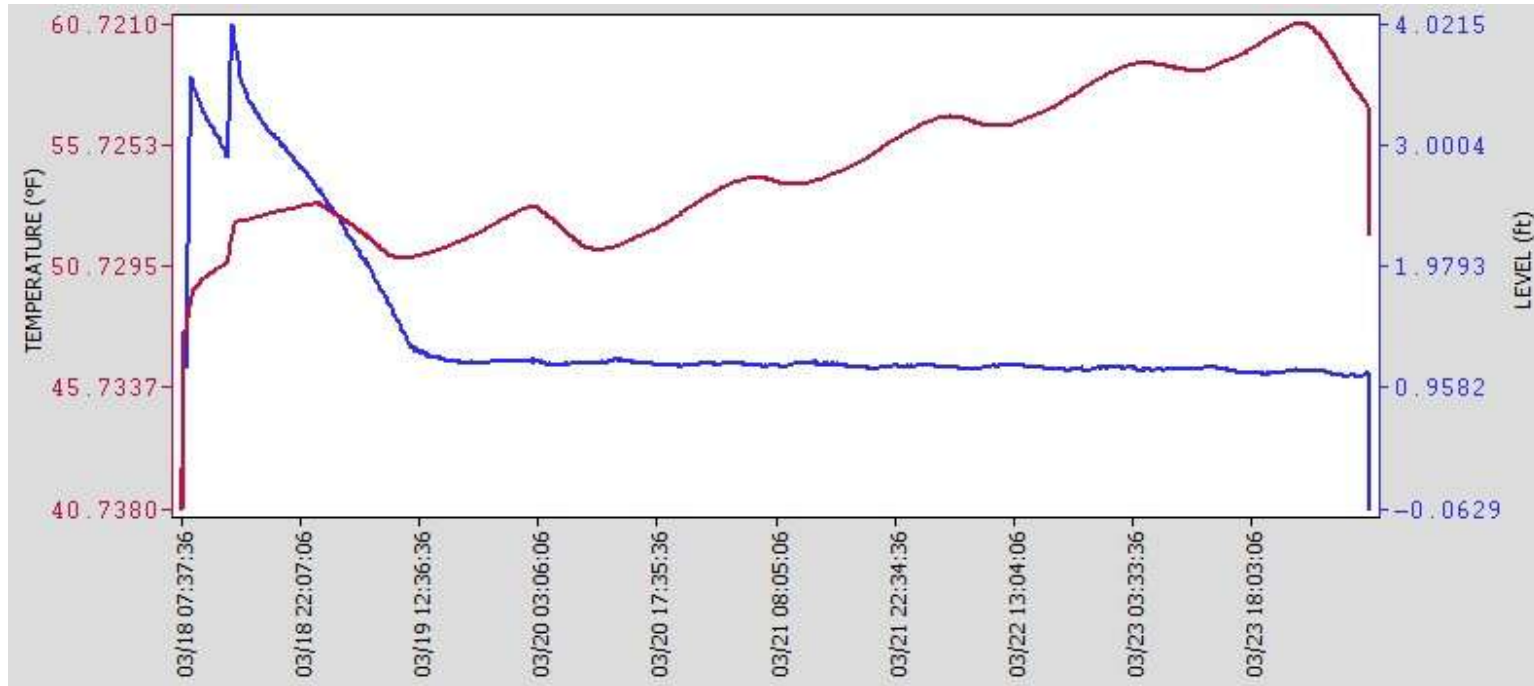

Legend Interpretation: The letter (A, B, C, D) corresponds to the Test ID to indicate which test in the series. The number (1, 2, 3) corresponds to the data collection location with 1 indicating the inflow collection point, 2 indicating the "in-trap" collection point, and 3 indicating the downstream or discharge collection point.





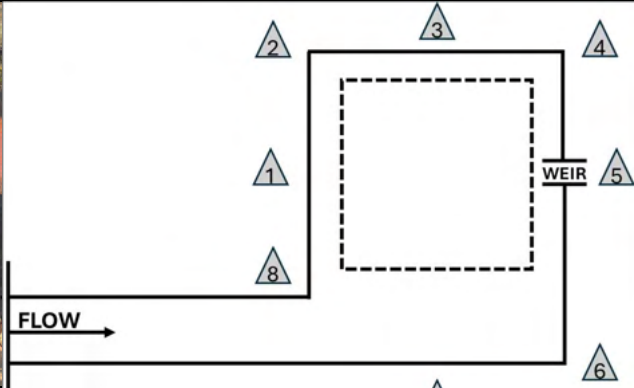





Temperature (°F) & Storage Volume Depth (Level, ft) Plot

Note: This data was produced by a level logger placed on the bottom of the sediment trap prior to test commencement until the trap dewatered (or the depth experienced no more change). The Temperature is represented by the red line, and the depth level is represented by the blue line. The corresponding dates and times are on the x-axis. The skimmer rested on a block at a depth of around 1 ft, meaning water would not be discharged below that level. For installations without a skimmer, the drop of the blue line on the right side of the graph indicates the water being drained to retrieve the level logger.

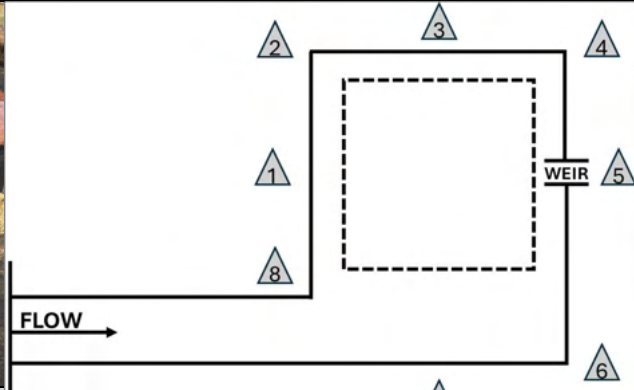

Test ID	Photo Documentation	Installation
D	Pre-Test	Sediment Trap MFE-I
		
Location 2	Location 3	Location 4
		
Location 1		Location 5
		
Location 8	Location 7	Location 6

Test ID	Photo Documentation	Installation
D	Post-Test	Sediment Trap MFE-I
		
Location 2	Location 3	Location 4
		
Location 1		Location 5
		
Location 8	Location 7	Location 6

Appendix D:
Silt Trap Plan and Various Silt Checks

Appendix E:
ALDOT Wattle Ditch Check Installation

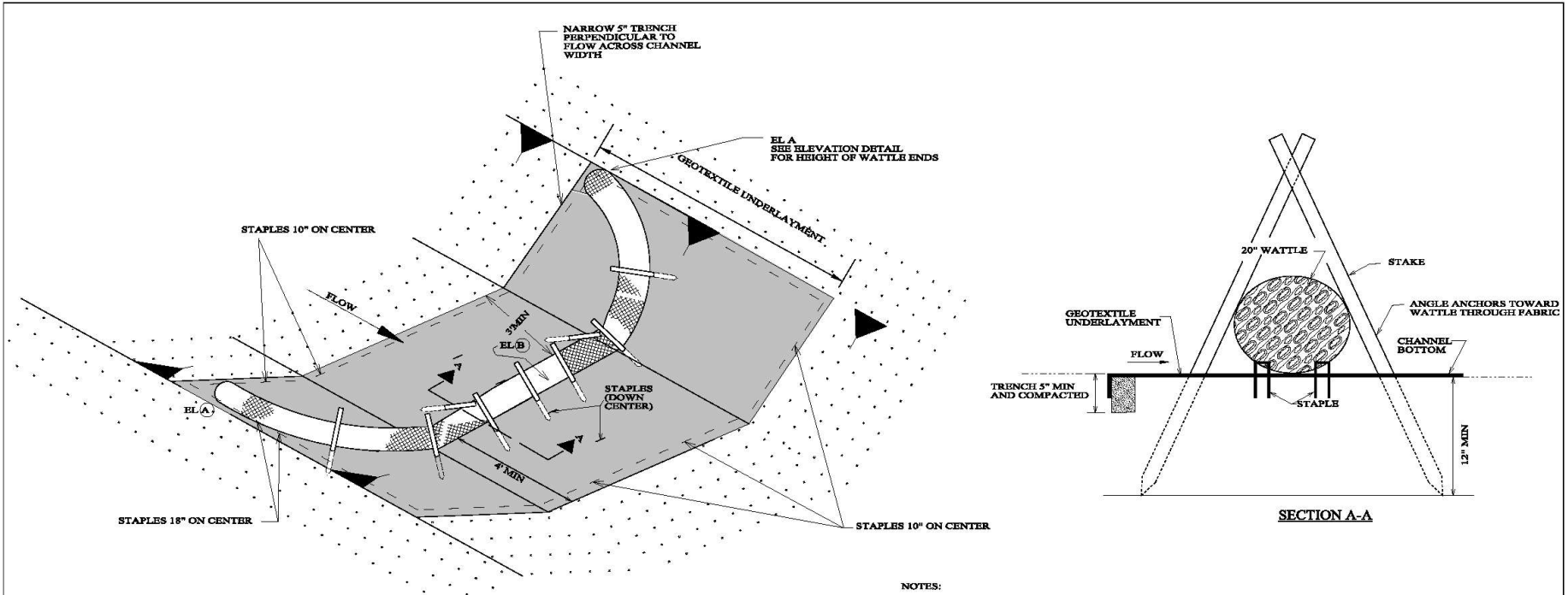

DETAIL (DITCH CHECK)

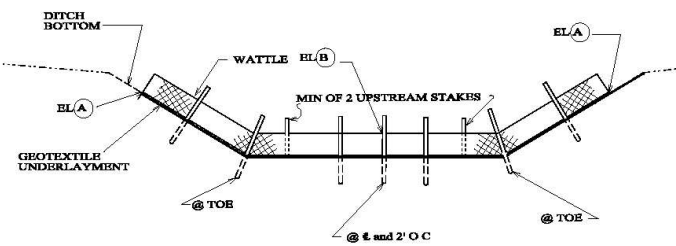

ELEVATION DETAIL

NOTE:
END POINTS A MUST BE HIGHER
THAN FLOWLINE POINT B

WATTLE DITCH CHECK SELECTION GUIDELINES

WATTLE DITCH CHECKS ARE APPROPRIATE FOR VELOCITY REDUCTION AND CONTROL OF SEDIMENT TRANSPORT UNDER LOW TO MEDIUM FLOW CONDITIONS NOT EXCEEDING 1.0 CU FT/SEC.

- NOTES:**
1. MINIMUM RECOMMENDED PLACEMENT INTERVAL BETWEEN WATTLE DITCH CHECK IS 100 FEET UNLESS SHOWN OTHERWISE ON THE PLANS OR APPROVED BY THE ENGINEER. SEE SPACING GUIDANCE ON ESC-300-1.
 2. ANCHORING STAKES SHALL BE SIZED, SPACED, DRIVEN, AND BE OF A MATERIAL THAT EFFECTIVELY SECURES THE CHECK. STAKE SPACING SHALL BE A MAXIMUM OF TWO FEET.
 3. WATTLES SHOULD NOT BE USED IN HARD BOTTOM CHANNELS.
 4. STAPLES SPACED 18 INCHES APART, ALONG THE CHANNEL EDGES AND DOWN THE CENTER OF THE CHANNEL. STAPLES SPACED 10 INCHES APART, ACROSS THE UPSTREAM AND DOWNSTREAM EDGES.
 5. STAPLES SHALL BE PLACED THROUGH THE BOTTOM NETTING OF THE WATTLE ON THE UPSTREAM AND DOWNSTREAM SIDES TO CREATE A SOLID INTERFACE BETWEEN THE WATTLE AND THE GEOTEXTILE UNDERLAYMENT. STAPLES SHALL BE PLACED 6" ON CENTER.

NOT TO SCALE

<p>ALABAMA DEPARTMENT OF TRANSPORTATION 1500 COLLEEN BOULEVARD MONTGOMERY, AL 36110-9000</p>	<p>THIS DRAWING REPRESENTS DESIGN PREPARED FOR THE BY THE ALABAMA DEPARTMENT OF TRANSPORTATION AND IS NOT TO BE COPIED, REPRODUCED, ALTERED, OR USED BY ANYONE OR ANY ORGANIZATION WITHOUT THE WRITTEN CONSENT OF THE ALABAMA DEPARTMENT OF TRANSPORTATION REPRESENTATIVE. AUTHORIZED TO APPROVE THIS DRAWING: [Signature] DATE: [Date]</p>	<p>REVISIONS</p> <ol style="list-style-type: none"> 1. Added to "SECTION A-A" REQUIRED REVISIONS and Added Note 5. 2. Added "GEOTEXTILE UNDERLAYMENT" and "RELATIONSHIP DETAIL" to "WATTLE DITCH CHECK SELECTION GUIDELINES" and adjusted and worked "SECTION A-A" as 9-24-2013 by J.F.T. 3. Revised Note 1 and 4 on 10-26-2013 by J.F.T. 4. Updated Special Drawing title from ESC-300 (REPEAT 4 OF 8) to ESC-300-4 on 10-26-2013 by J.F.T. & J.A.M. 5. Added "MIN" dimension from wattle to downstream edge of underlayment on 1-15-2013 by J.A.W. 6. Modified and Added Note 5 concerning "Staples shall be placed through the bottom netting..." on 6-20-2013 by J.F.T. 	<p>Project File No: <u>GLD</u></p> <p>DESIGNER: _____</p> <p>DATE DRAWN: <u>2006</u></p> <p>REVISED DATE: <u>8-29-2013</u></p>	<p>DESIGN BUREAU SPECIAL DRAWING</p> <p>DETAILS OF EROSION CONTROL WATTLE DITCH CHECKS</p>	<p style="text-align: center;">-SPECIFICATIONS- CURRENT ALABAMA DEPARTMENT OF TRANSPORTATION</p> <p>SPECIAL DRAWING NO ESC-300-4</p>	<p>BOOK NO 66515</p>
			<p>ALABAMA DEPARTMENT OF TRANSPORTATION</p>			<p>NOT TO SCALE</p>

Appendix F:
ALDOT Silt Fence Ditch Check Installation

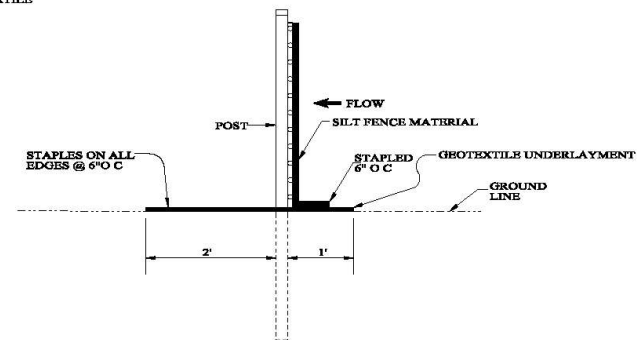
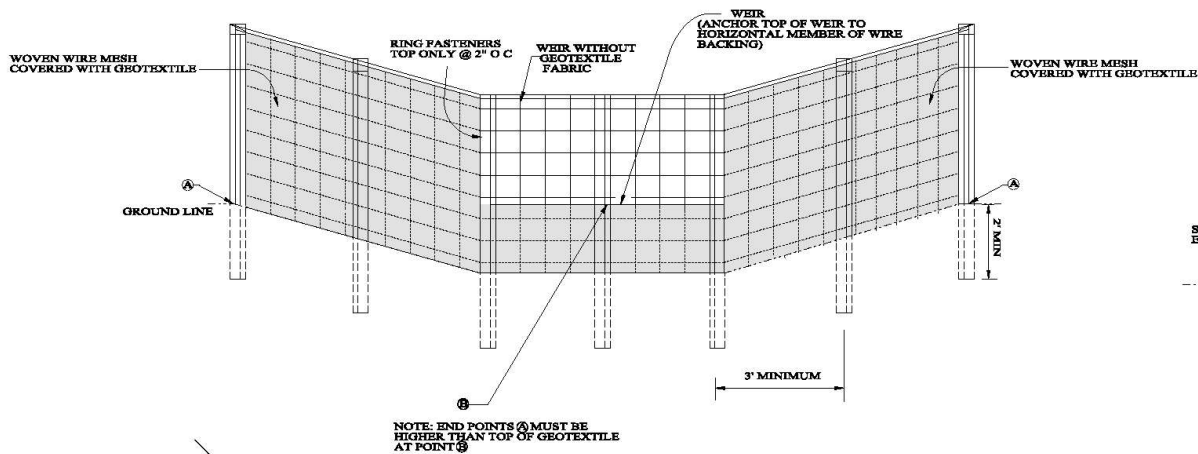

NOTE: END POINTS @ MUST BE HIGHER THAN TOP OF GEOTEXTILE AT POINT @

ELEVATION VIEW

SIDE VIEW

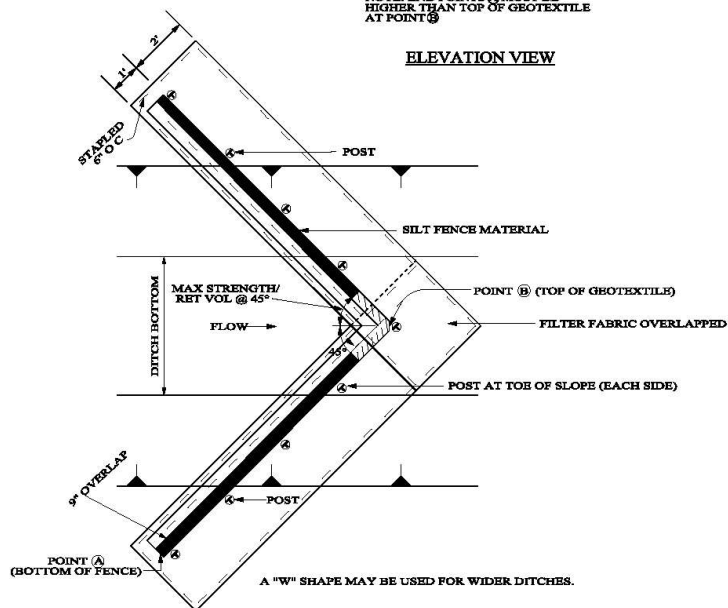

PLAN VIEW

NOTES:

1. SILT FENCE SHALL BE USED IN AREAS WHERE FLOW IS MODERATE TO HIGH OR AS DIRECTED BY THE ENGINEER.
2. SILT FENCES ARE TEMPORARY EROSION CONTROL ITEMS THAT SHALL BE ERECTED DOWN GRADE OF ERODIBLE AREAS SUCH AS NEWLY GRADED FILL SLOPES AND ADJACENT TO STREAMS AND CHANNELS.
3. IF THE TOP OF THE GEOTEXTILE AT POINT @ IS HIGHER THAN THE BOTTOM OF THE FENCE AT POINT @ THEN NO WEIR IS REQUIRED.
4. SEE ALDOT LIST II-3 FOR APPROVED SILT FENCE GEOTEXTILES.

NOT TO SCALE

—SPECIFICATIONS—
CURRENT ALABAMA DEPARTMENT OF TRANSPORTATION



ALABAMA DEPARTMENT OF TRANSPORTATION
1400 COLLESSION BOULEVARD
MONTGOMERY, AL 36103-0000

THIS DRAWING REPRESENTS DESIGNS PREPARED FOR USE BY THE ALABAMA DEPARTMENT OF TRANSPORTATION AND IS NOT TO BE COPIED, REPRODUCED, ALTERED, OR USED BY ANYONE, OR ANY ORGANIZATION WITHOUT THE EXPRESS WRITTEN CONSENT OF THE ALABAMA DEPARTMENT OF TRANSPORTATION REPRESENTATIVE AUTHORIZED TO APPROVE THIS USE. ANYONE MAKING UNAUTHORIZED USE OF THIS DRAWING MAY BE PROSECUTED TO THE FULLEST EXTENT OF THE LAW.

REVISES:
1. Revised "ELEVATION VIEW", "SIDE VIEW" and "PLAN VIEW". Revised Description Box, Revised and Renumbered Sheets 3 and 4. Deleted Notes 2 and 6 on 10-30-2014 by J.P.L.
2. Updated Special Drawing No. ESC-300 (00197 & 0) to ESC-300-8 on 10-31-2014 by J.P.L. & J.M.M.

DESIGNER: J.L.W.
DRAWN BY: J.M.M.
DATE DRAWN: 2008
REVISED DATE: 10-31-2014

DESIGN BUREAU SPECIAL DRAWING
DETAILS OF SILT FENCE
DITCH CHECKS

SPECIAL DRAWING NO
ESC-300-8

WORK NO
66519

Appendix G:
Sediment Trap Plan Set

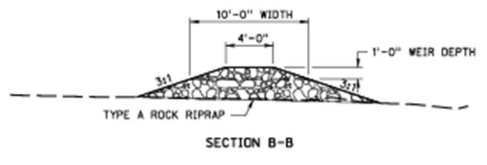
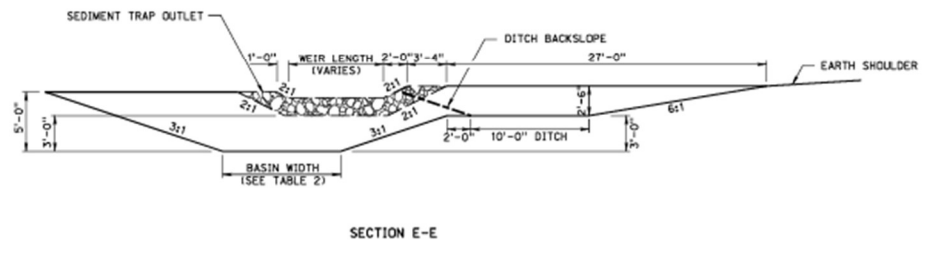
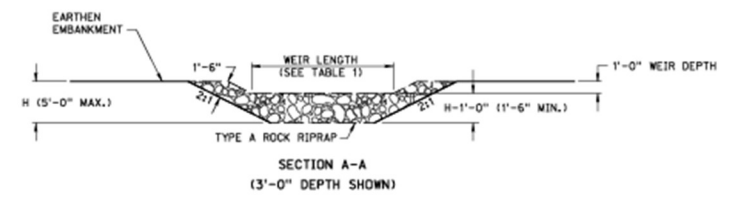
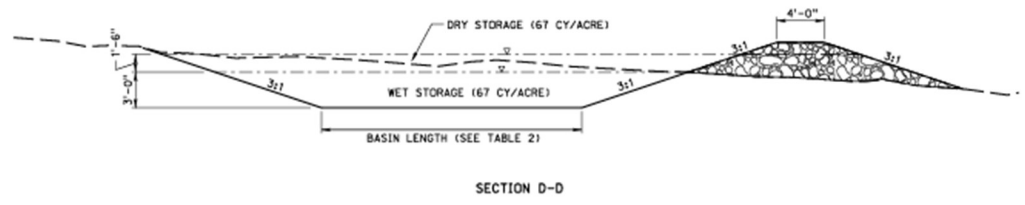
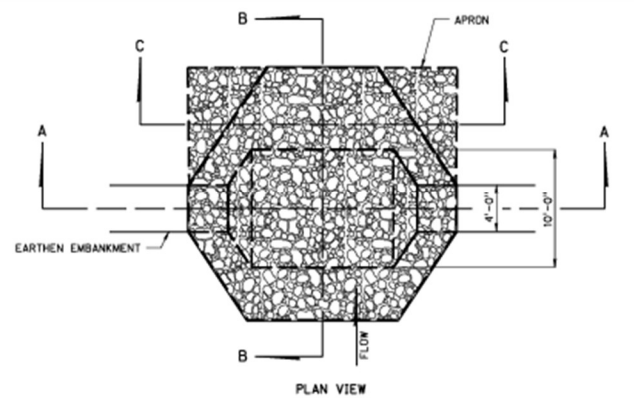

CONTRIBUTING DRAINAGE AREA	BASIN LENGTH (FT.)	BASIN WIDTH (FT.)
1 ACRE	22	10
2 ACRE	40	16
3 ACRE	58	23
4 ACRE	73	28
5 ACRE	85	34

TABLE 2

TYPICAL ROADSIDE DITCH SEDIMENT TRAP BASIN

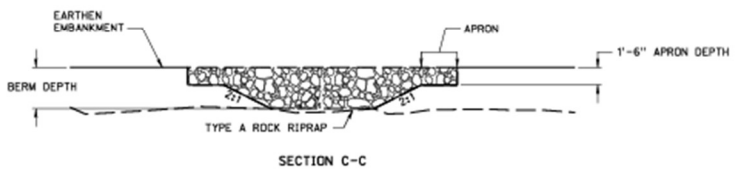

CONTRIBUTING DRAINAGE AREA	WEIR LENGTH (FT.)
1 ACRE	4
2 ACRE	5
3 ACRE	6
4 ACRE	10
5 ACRE	12

TABLE 1

SEDIMENT TRAP OUTLET

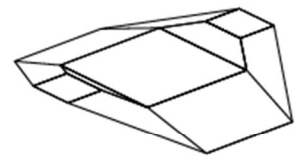
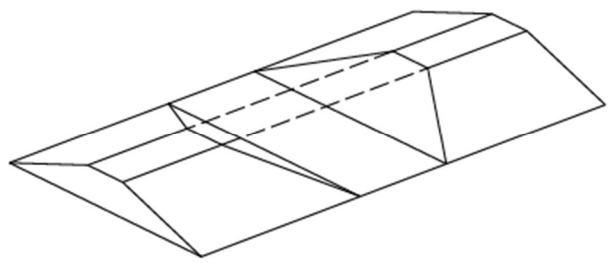

ROADSIDE SEDIMENT TRAP AND OUTLET

ROADWAY DESIGN DIVISION
Computer: NDOTDESIGN14
Date: 11-APR-2020 14:56
Sheet: 11ap-930am00.dgn

Appendix H:
Faircloth Skimmer Cut Sheet

1.5" SKIMMER CUT SHEET

Ships in cardboard box | Dimensions: 28" x 21" x 9"

Patent # 5,820,751

Faircloth Skimmer®

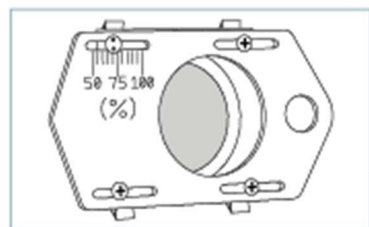

ADJUSTABLE ORIFICE GATE

Slide the orifice gate until the dots on the indicator screw match the opening percentage in the plans. Then tighten the three Phillips screws.

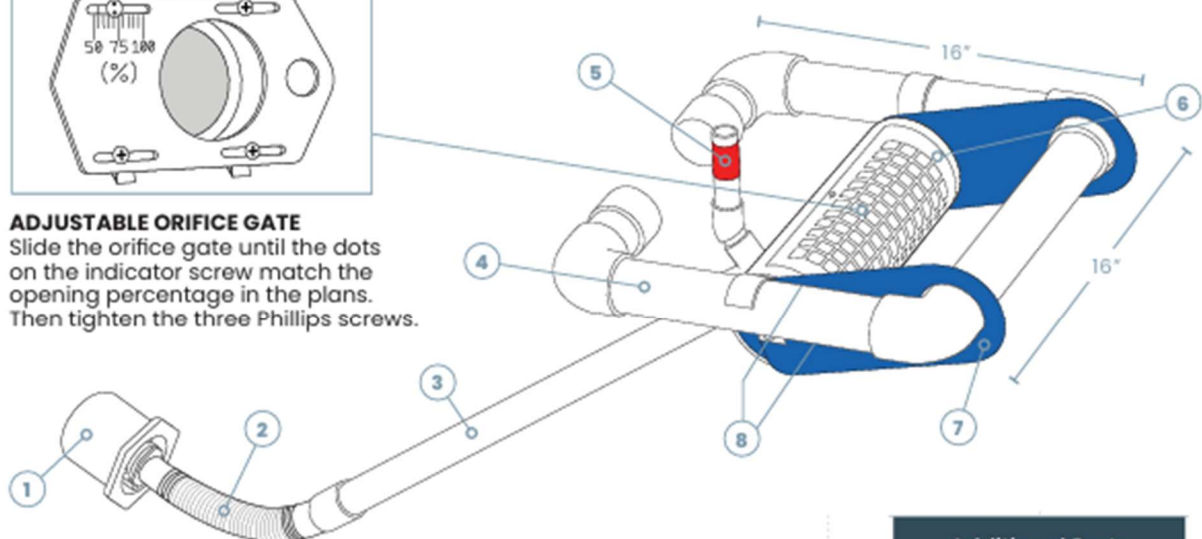

* Skimmer shown in floating position

- 1 4" Sch 40 coupling connection to be attached to a 4" outlet structure.
- 2 1½" Flex hose with 1½" female coupling to be connected to barrel pipe.
- 3 1½" Sch 40 solid PVC barrel (SUPPLIED BY USER). Barrel kit can be purchased separately.
- 4 2" PVC float.
- 5 1" Vent with RED tip.
- 6 Inlet assembly with aluminum screen that houses 1.5" adjustable orifice gate.
- 7 1/8" inch HDPE blue skirts.
- 8 1½" Head (distance from center of inlet to water surface).

PRE-ASSEMBLED
FLEX HOSE
ASSEMBLY

Additional Parts Included

12" of
4" Pipe



Can be added to 4" coupling to assist in attaching to outlet structure.

50'
Rope



Attach to skimmer so that it can be pulled to the side of the sediment basin for maintenance.

Non-Included Parts

1½" Sch 40 SOLID PVC barrel or "arm" (See #3)

SHIPS ASSEMBLED. USER INSTALLS COMPONENTS AND SETS ORIFICE GATE TO ENGINEER SPECIFIED OPENING PERCENTAGE.

For technical data, sizing, cut sheets, or design assistance please contact us at:
(919) 732-1244 or visit fairclothskimmer.com

Appendix I:
TSS and Turbidity Processing Procedures

TURBIDITY AND TSS PROCESSING PROCEDURES

Test Note: These water quality testing procedures conduct Turbidity and TSS sampling simultaneously to maintain work efficiency and reduce dilution errors.

Storage Note: Refrigerate water samples for a maximum of 72 hrs. until testing.



TSS Analysis Preparation

- Step 1:** Prepare glassware, deionized water, filtering apparatus, scales, turbidimeter, and vacuum pump.
- Step 2:** Prepare and label the required crinkle dishes and place filter membranes on each dish using clean tweezers. Do not use fingers.
- Step 3:** Prewash filter membranes by placing the filter disc on the filter holder of the filter apparatus with the wrinkled side upward, gridded side down. Attach the top funnel portion of the magnetic filter holder. Apply 10 mL of deionized water and provide suction to filter through membrane. Remove washed filter and place on corresponding crinkle dish. Repeat for all membranes.
- Step 4:** Place washed membranes in the oven at 103°C for one hour. Remove crinkle dishes and membranes from the drying oven and place in a desiccator and allow to cool to room temperature.
- Step 5:** Weigh the crinkle dish and filter using an analytical balance. Record weight to the nearest 0.0001 g.

Turbidity Analysis

- Step 6:** Confirm or recalibrate turbidimeter using standard samples.
- Step 7:** Vigorously shake the sample bottle to thoroughly mix all sediment in the solution.

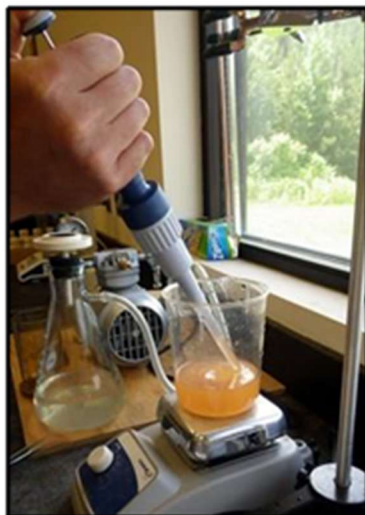

- Step 8:** Transfer sample to 1,000 mL beaker, insert stir bar and place on magnetic stirrer and mix until solution is uniform throughout. Mix continuously through steps 9 through 14.
- Step 9:** Set the pipette set at 7.5 mL volume and fill turbidity sample cell to the line with 15 mL of solution. Cap the cell.
- Step 10:** Place the cell into the turbidimeter with the white arrow on the cell facing the black arrow on the unit. Take a turbidity reading on the undiluted sample. If the turbidimeter over ranges, proceed to Step 5.
- Step 11:** If the sample over ranges: dilute the sample 1:2 by mixing 100 mL of original solution with 100 mL of deionized water in a beaker and mix.
- Step 12:** Pipette the 1:2 diluted sample into a sample cell. Read the turbidity. If the sample over ranges, repeat step 11-12 until a reading is taken. Record the measured turbidity value and the dilution factor. The dilution factor is calculated as $F = 2^x$, where x is the number of 1:2 dilutions performed (example for 3 dilutions, $F = 8$).



TSS Analysis

Step 13: Use tweezers to place the corresponding filter membrane on the filtering apparatus.

Step 14: Pipette 25 mL of diluted solution and place in apparatus.



Step 15: Filter sample through membrane using the vacuum pump. Rinse the filtrate on the filter with three 10 mL portions of deionized water.

Step 16: Slowly release the vacuum on the filtering apparatus. Gently remove the filter disc using the tweezers.

Step 17: Place the filter disc on its corresponding crinkle dish.

Step 18: Place membranes in the oven at 103°C for one hour. Remove crinkle dishes and membranes from the drying oven and place in a desiccator and allow to cool to room temperature.

Step 19: Weigh the crinkle dish and filter using an analytical balance. Record weight to the nearest 0.0001 g.