

**COPY 1**

af  
82  
90

NASA Contractor Report 165850  
FAA Report No. **DOT-FAA-CT-82-70**

# Transport Aircraft Accident Dynamics

OFFICE OF TECHNOLOGY

MAR 22 1982

TRANSPORT AIRCRAFT ACCIDENT DYNAMICS  
A. COMINSKY

**A. Cominsky**

McDonnell Douglas Corporation  
Douglas Aircraft Company  
Long Beach, California 90846

CONTRACT NAS1-16111  
MARCH 1982



National Aeronautics and  
Space Administration

Langley Research Center  
Hampton, Virginia 23665

DRYDEN FLIGHT RESEARCH FACILITY  
EDWARDS, CALIFORNIA



DEPARTMENT OF TRANSPORTATION  
Federal Aviation Administration

Federal Aviation Technical Center  
Atlantic City, New Jersey 08405

NASA Contractor Report 165850

FAA Report No. DOT-FAA-CT-82-70

TRANSPORT AIRCRAFT ACCIDENT DYNAMICS

A. COMINSKY, et al

Douglas Aircraft Company  
McDonnell Douglas Corporation  
Long Beach, California 90846

CONTRACT NAS1-16111  
March 1982

National Aeronautics and  
Space Administration

Langley Research Center  
Hampton, Virginia 23665  
AC804 827-3966

TABLE OF CONTENTS

<u>SECTION</u>	<u>PAGE</u>
List of References	xiii
1.0 Introduction . . . . .	1-1
2.0 Summary . . . . .	2-1
3.0 Conclusions and Recommendations . . . . .	3-1
4.0 Accident Data Base . . . . .	4-1
5.0 Characteristics of Accident Scenario Candidates . . . . .	5-1
6.0 Generalized Impact Scenarios . . . . .	6-1
6.1 Generalized Landing Mode Accident Scenario	
6.2 Generalized Rejected Takeoff Mode Accident Scenario	
7.0 Assessment of Advanced Materials . . . . .	7-1
7.1 Survey of Advanced Materials and Processes	
7.2 Aluminum Alloys	
7.3 Metal Matrix Materials	
7.4 Advanced Composites	
7.5 New Processes	
7.6 Test Recommendations for Advanced Composites	
8.0 Evaluation of the "Aircraft Crash Survival Design Guide" . . .	8-1
Conclusions	
9.0 Human Tolerance to Impact . . . . .	9-1
10.0 Merit Functions . . . . .	10-1
11.0 Analytical Methods . . . . .	11-1
11.1 Analytical Requirements	
11.2 Review of Existing Analysis Programs	
11-3 Analysis Recommendations	
12.0 Test Methods . . . . .	12-1
12.1 Review of Past Test Programs	
12.2 Recommendations for Future Tests	

TABLE OF CONTENTS (Cont)

<u>SECTION</u>		<u>PAGE</u>
APPENDIX A	Accident Data Base . . . . .	A-1
APPENDIX B	Scenario Candidates Accident Characteristics . . . . .	B-1
APPENDIX C	DC-7 Impact Test . . . . .	C-1
APPENDIX D	Test Program . . . . .	D-1
APPENDIX E	Review of the "Aircraft Crash Survival Design Guide" . .	E-1
APPENDIX F	Human Tolerance to Impact . . . . .	F-1

## PREFACE

This report was prepared by the Douglas Aircraft Company, McDonnell Douglas Corporation, Long Beach, California, under Contract NAS1-16111. It is the final technical report covering the review of survivable transport aircraft accidents, the association between structural systems and accident injuries and the identification of typical scenarios. This report also includes a review of the five volumes of the "Aircraft Crash Survival Design Guide", an overview of crash testing techniques and test recommendations, an overview and recommendations for analytical techniques and advanced material usage. This work was conducted between February 11, 1980 and May 26, 1981.

The following Douglas personnel were the principal contributors to the study:

E. Albano	Crash Analysis and Test
A. Cominsky	Principal Investigator
J. Gaume	Human Factors
H. Leve	Crash Analysis
M. Platte	Systems Analysis
H. Toellner	Advanced Materials
R. Reibold	Testing

The project was sponsored by the National Aeronautics and Space Administration (NASA), Langley Research Center. Dr. Robert G. Thompson was the project engineer for NASA.

## ILLUSTRATIONS

<u>NO.</u>	<u>TITLE</u>	<u>PAGE</u>
D-1	Landing Gear/Wing Drop Test	D-3
D-2	Fuselage, Static Crush Test	D-5
D-3	Fuselage Drop Test	D-5
D-4	Fuselage Break Test	D-5
D-5	Data Acquisition Set-Up for Impact Tests	D-10
D-6	Functional Diagram - Load and Motion Control	D-12
D-7	Functional Diagram - Data Acquisition	D-13
E-1	Typical Seat Pan, Dummy Chest and Pelvis Response	E-9
E-2	Method of Reinforcing Nose Structure	E-12
E-3	Overall Fuselage Concepts	E-14
E-4	Fuselage Sidewall Concepts	E-15
E-5	Energy Absorption Concepts	E-16
E-6	Examples of Energy Absorption Devices	E-17
E-7	Stress-Strain Relationship	E-18
E-8	Energy Absorption Concepts - Beams	E-20
E-9	Aircraft Troop/Passenger Restraint Systems	E-22
E-10	Aircraft Floor Longitudinal Pulses	E-25
E-11	Seat Forward Load and Deflection Requirements	E-27
E-12	Load-Displacement Requirements for Cargo	E-28
E-13	Requirements for Dynamic Tests	E-29
F-1	Experimental Verification of Dynamic Index	F-4
F-2	Wayne State Tolerance Curve for Forehead Impact	F-7
F-3	Acceleration Limit (+G <sub>xL</sub> )	F-11
F-4	Superposition of Shock Spectra and Human Tolerance	F-13
F-5	Impact G Tolerance as a Function of Age	F-15

TABLES

<u>NO.</u>	<u>TITLE</u>	<u>PAGE</u>
4-1	Accident Category Identification	4-3
4-2	Tenerife Accident Casualty Statistics	4-3
4-3	Injury Survey, 1960-1980 Commercial Transports	4-4
5-1	Accident Scenario Characteristics Groups	5-2
5-2	Approach Accidents Characteristics and Injuries	5-3
5-3	Landing Accidents Characteristics and Injuries	5-4
5-4	RTO Accidents Characteristics and Injuries	5-5
6-1	Generalized Crash Scenario Elements	6-2
6-2	Off Runway Obstructions, Landing Mode Accidents	6-4
6-3	On Runway Obstructions, Landing Mode Accidents	6-5
6-4	Aircraft Structural Damage, Landing Mode Accidents	6-6
A-1	Approach Accidents Data Base	A-2
A-2	Landing Accidents Data Base	A-4
A-3	Rejected Takeoff Accident Data Base	A-7
B-1	Approach Accidents - Characteristics and Injuries	B-2
B-2	Landing Accidents - Characteristics and Injuries	B-8
B-3	Takeoff Accidents - Characteristics and Injuries	B-20
E-1	Performance Requirements for Structural Impact Tolerance	E-4
E-2	Summary of Crash Impact Conditions for Helicopters and Light Fixed Wing Aircraft	E-5
E-3	Static Load Requirements for Ancillary Equipment Attachments	E-31

LIST OF ABBREVIATIONS

NTSB	National Transport Safety Board
SOLARAD	System of On-Line Analysis Retrieval of Accident Data
RT0	Rejected Takeoff
GIS	Generalized Impact Scenario
VRGA	Relative Ground Airspeed Velocity
IATA	International Air Transport Association
ICAO	International Civil Air Organization

## LIST OF REFERENCES

### NO.

- Aircraft Crash Survival Design Guide (VOLUMES I-V)
- 1 VOL. I USARTL-TR-79-22A  
Design Criteria and Checklists
  - 2 VOL. II USARTL-TR-79-22B  
Aircraft Crash Environment and Human Tolerance
  - 3 VOL. III USARTL-TR-79-22C  
Aircraft Structural Crashworthiness
  - 4 VOL. IV USARTL-TR-79-22D  
Aircraft Seats, Restraints, Litters, and Padding
  - 5 VOL. V USARTL-TR-79-22E  
Aircraft Post Crash Survival
  - 6 Application of Scale Modeling Techniques  
to Crashworthiness Research.  
Aircraft Crashworthiness - K. Saczalski  
University of Virginia Press 1975
  - 7 Crash Loads Environment Study  
Donald P. Fitzgibbon, Feb. 1967  
Mechanics Research, Inc., El Segundo, California
  - 8 NASA Report 165677
  - 9 R. F. Chandler, D. H. Laananen, "Seat/Occupant Crash  
Dynamic Analysis Verification Test Program",  
SAE Paper No. 790590, April 1979
  - 10 R. J. Hayduk, R. G. Thomson, G. Wittlin, M. P. Kamat,  
"Nonlinear Structural Crash Dynamics Analyses",  
SAE Paper No. 790588, April 1979
  - 11 D. H. Laananen, J. W. Coltman, "Modification and  
Experimental Validation of Program SOMLA",  
SIMULA Report No. TR8005, April 11, 1980
  - 12 D. H. Laananen, "Development of a Scientific Basis  
for Analysis of Aircraft Seating Systems",  
FAA-RD-74-130, 1975
  - 13 M. A. Gamon, "General Aviation Airplane Structural  
Crashworthiness User's Manual: Volume I - Program  
KRASH Theory", FAA-RD-77-189, I, February 1978

## LIST OF REFERENCES

### NO.

- 14 M. A. Gamon, G. Wittlin, W. L. LaBarge, "General Aviation Airplane Structural Crashworthiness User's Manual: Volume II - Input-Output, Techniques and Applications", FAA-RD-77-189, II, September 1979
- 15 W. H. Reed, S. H. Robertson, L. W. Weinberg, L. H. Tyndall, "Full-Scale Dynamic Crash Test of a Douglas DC-7 Aircraft", FAA-ADS-37, April 1965
- 16 W. H. Reed, S. H. Robertson, L. W. Weinberg, L. H. Tyndall, "Full-Scale Dynamic Crash Test of a Lockheed Constellation Model 1649 Aircraft", FAA-ADS-38, October 1965
- 17 Victor L. Vaughn, Emilio Alfaro-Bou, "Impact Dynamics Research Facility for Full-Scale Aircraft Crash Testing", NASA TN-8179, April 1976
- 18 Robert G. Thomson, Robert C. Goetz, "NASA/FAA General Aviation Crash Dynamics Program -- A Status Report", AIAA Paper 79-078
- 19 R. C. Tennyson, J. S. Hansen, H. Teichman, F. Cicci, M. Ioannou, "Crashworthiness of Aircraft Fuselage Structures", AIAA Paper 78-477, 1978
- 20 Richard F. Chandler, "Evaluation of Crashworthiness Test Data", SAE Paper 730290, April 1973
- 21 Bayard S. Holmes, James D. Colton, "Application of Scale Modeling Techniques to Crashworthiness Research", NASA 76A34161, October 1975
- 22 D. L. Greer, J. J. Greeden, T. L. Heid, "Crashworthy Design Principles", General Dynamics, Convair FAA Technical Report ADS-24, September 1964
- 23 W. H. Reed, J. P. Avery, "Principles for Improving Structural Crashworthiness for STOL and CTOL Aircraft", Aviation Safety Engineering and Research, USAAVLABS Technical Report 66-39, June 1966
- 24 D. L. Greer, T. L. Heide, J. D. Weber, "Design Study and Model Structures Test Program to Improve Fuselage Crashworthiness", General Dynamics, Convair FAA Technical Report DS-67-20, October 1967

## SECTION 1

### INTRODUCTION

The United States is a leader in the design and production of large commercial aircraft. The aircraft produced by the aircraft industry have been improved continuously because of the industry's concern for reliability and safety. Government regulatory and research activities share in the interest of improved services and increased safety for the public.

The purpose of this study was to investigate transport impact tolerance and to study the possibility of improving passenger and crew safety in transport aircraft. The structural integrity of the fuselage during a survivable impact was the primary concern.

The modern commercial aircraft requires maximum safety; however, new protective features must be justified by an increased level of safety with a minimum of added complexity, weight and operational constraints.

During the period 1959-1979, there were approximately 580 worldwide transport aircraft accidents which provided the source of the data base for this study. This study tended to confine itself to an examination of the modern jet of 27,200 kg (60,000 lb.) and up and non-turbulence, survivable accidents.

Thus, only approach, landing and rejected takeoff accidents were studied. These comprise 60% of all accidents which occurred in about 6% of the total operational time. The data base of this study is given in Appendix A in which 112 survivable accidents are listed in three categories.

The data base was examined and summarized in Section 6 and Appendix B. Typical accident scenarios were developed from this data for possible use as future design and test instruments.

Advanced materials and processes are playing increasing roles in future transport designs. Their potential impact properties are discussed, and steps needed to fill in the gaps in impact tolerance applications are suggested.

An evaluation of the "U. S. Army Aircraft Crash Survival Design Guide" was carried out to determine possible application to airline transport aircraft.

Various indices and criteria for relating impact acceleration with human tolerance with the intention of judging human survival were studied and evaluated.

A review of impact scenarios from the data base was carried out to identify major structural components which were involved in typical accidents.

Existing analytical techniques were evaluated and suggestions put forward for developing simple, economical and possibly more accurate procedures. Established test techniques were reviewed and a test program was outlined for providing data to assist in the development of simplified analysis techniques.

## SECTION 2

### SUMMARY

- Format -
- 2.1 Data Base and Scenario Candidates
  - 2.2 Characteristics of Scenario Candidates
  - 2.3 Generalized Impact Scenarios
  - 2.4 Advanced Materials Assessment
  - 2.5 Aircraft Crash Survival Design Guide
  - 2.6 Human Tolerance to Impact
  - 2.7 Merit Functions
  - 2.8 Analytical Methods
  - 2.9 Test Methods

#### 2.1 DATA BASE AND SCENARIO CANDIDATES

The accident data base for this study consists of 112 impact survivable transport aircraft accidents (world wide) that are listed in Appendix A. These were principally jet transport aircraft of 27,200 kg (60,000 lb.) and up. This study centered on the effect of impact on aircraft structure. Thus, the study was confined to approach, landing and takeoff flight segments. Accidents confined to flight turbulence, taxiing and parking were eliminated.

#### 2.2 CHARACTERISTICS OF SCENARIO CANDIDATES

The well documented accidents were studied to record significant characteristics, their frequency of occurrence, and effect on passenger injury. The details resulting from this review are listed in the three tables of Appendix B.

It was concluded that the condition of the fuselage shell and the cabin interior had a direct bearing on passenger impact injury. Other factors such as engine separation, landing gear separation and wing tank rupture were important because they led to fuel spill and a fuel fed fire which was a prime threat to passengers.

## 2.3 GENERALIZED IMPACT SCENARIOS

Generalized Impact Scenarios (GIS) are presented for landing and rejected takeoff accident categories. These scenarios were developed from data averages as well as from typical accidents and are confined to that data which affects the behavior of the structure during impact.

The Generalized Landing Mode Scenario consists of meteorological data and a description of the aircraft from just prior to impact through the slide to when the wreckage comes to a halt. This scenario contains two divisions:

- A) Touchdown short of the runway
- B) Touchdown on the runway

The Generalized Rejected Takeoff Mode Scenario consists of meteorological data and a description of the aircraft from the beginning of the takeoff roll through the runway overrun to when the wreckage comes to a halt. This scenario contains three divisions:

- A) Long runway overrun
- B) Short runway overrun
- C) Halted on the airport

## 2.4 ASSESSMENT OF ADVANCED MATERIALS

An assessment of advanced structural materials and advanced fabrication processes was made in Section 7. The materials were grouped into three categories:

1. Aluminum Alloys
2. Metal Matrix Materials
3. Advanced Composites

The processes were grouped into five categories:

1. Bonding
2. Diffusion Bonded/Superplastic Formed Titanium
3. Large Castings
4. Filament Winding
5. Trapped Rubber

Benefits and limitations of these materials and processes were discussed and attention was drawn to those materials and processes with substantial future promise.

## 2.5 AIRCRAFT CRASH SURVIVAL DESIGN GUIDE

This Design Guide comes in five volumes which are numbers 1 through 5 in the List of References. These reports present the state-of-the-art for impact survival design for use in design of army helicopters and lightweight general aviation aircraft. These reports were reviewed to determine possible application to transport aircraft design.

## 2.6 HUMAN TOLERANCE TO IMPACT

A survey was carried out of many indices and criteria that have been proposed for giving an indication of the degree of passenger injury during an impact sequence. These indices apply to spine, head, leg and arm injuries. This type of data is important to the evaluation of impact tolerance of future transport aircraft designs.

## 2.7 MERIT FUNCTIONS

The merit function evaluation is a useful method for comparing the degree of merit of competing safety concepts. The parameters that are useful for evaluating the merit function fall into three categories: cost, effectiveness and societal concerns. The elements of these parameters are described within.

## 2.8 ANALYTICAL METHODS

Considerable Research and Development is being carried on within NASA and the aircraft manufacturing companies toward developing computer analyses capable of describing the dynamic behavior of an aircraft (including structural deformation, acceleration, stresses and failure, as well as the forces and accelerations acting on the passengers and crew) subjected to an impact sequence of an accident scenario.

A review of three such computer analysis programs is presented in Section 11.0. These were the Krash, Dycast and Somla programs. Krash models the aircraft structure as a system of masses, springs and dashpots. This analysis method is well documented and is potentially well suited to describe large aircraft impact sequence simulation.

Dycast models the aircraft structure in great detail as a number of finite elements, but its size may render it too complex for complete aircraft usage. It may, however, be very useful for application to local portions of a structure.

Somla confines its analysis to the occupant and seat structure. The occupant is a mass/spring/dashpot system while the seat is modelled by a finite element system and works quite well.

Comments on analytical requirements and recommendations of impact analysis programs are also presented.

## 2.9 TEST METHODS

This section consists of a review of full scale aircraft structure impact type tests that have already been carried out. This section also deals with recommendations for future tests.

There are two full scale large transport aircraft impact tests that were carried out sixteen years ago. These consisted of a DC7 and a Lockheed Constellation, both propeller powered aircraft. The aircraft structure, equipment and dummies were well instrumented, and the resulting test data was very significant. The remainder of the tests and the results were only available for light general aviation aircraft and helicopters.

The objectives of future tests are considered to be:

- 1) Verify the accuracy of existing impact analysis programs
- 2) Provide impact data results for several sizes of aircraft
- 3) Provide data for use in developing simplified analysis methods of impact scenarios
- 4) Help to establish the impact capabilities of existing metal jet aircraft to establish levels of excellence for future advanced composite aircraft structures
- 5) Test out structural improvements by which impact tolerance could be improved.

A recommended test program to be carried out in the future is described in Section 12.0. Five categories of tests were described with the conclusion that:

Testing of structural subsystems could provide needed test results at economical costs. An extensive test program involving the use of structural subsystem specimens obtained from salvage sources is suggested to provide data for recommended follow on studies.

## SECTION 3

### CONCLUSIONS AND RECOMMENDATIONS

- Format -
- 3.1.0 Conclusions
  - 3.2.0 Recommendations
    - 3.2.1 Scenario Candidates
    - 3.2.2 Advanced Materials
    - 3.2.3 U.S. Army Aircraft Crash Survival Design Guide
    - 3.2.4 Human Tolerance To Impact
    - 3.2.5 Analytical Methods
    - 3.2.6 Test Methods

#### 3.1.0 CONCLUSIONS

The conclusions resulting from this study are:

- 1) The limited number of domestic and foreign transport aircraft survivable accidents and related passenger injuries over an eighteen year period (1961-1979) is an indication of the limited potential for impact tolerance improvement for metal aircraft.
- 2) Aircraft impact during the approach flight mode is equivalent to the aircraft flying into the ground and, as such, is too severe to constitute a practical design goal.
- 3) There are 50 percent more fire fatalities than impact trauma fatalities for survivable landing and takeoff mode accidents. Thus, post impact fire accidents are prime candidates for survivability improvement studies.

- 4) Nineteen out of forty-five survivable accidents involved light to heavy rain during survivable approach, landing and takeoff maneuvers. The avoidance of heavy rain situations especially during final approach and landing would reduce the probability that a pilot will encounter conditions which make aircraft control difficult. On-board radar makes this feasible.
  
- 5) Areas for research and development for aircraft impact tolerance improvement are:
  - o Landing gear attachments
  - o engine attachment
  - o wing tank structure
  - o fuselage structure and equipment
  
- 6) The "U. S. Army Crash Survival Design Guide" (References 1 through 5) provides a unique general aid to impact tolerant structural design with overwhelming emphasis to helicopters and light fixed wing aircraft. It is a good source of design methodology as in the definition of impact conditions in terms of acceleration versus time pulses (Reference Figure E-10). The treatment of design considerations for impact tolerant seats is comprehensive. A useful approach to impact tolerant structural design may be accomplished by expressing static strength requirements in terms of bounds on loads versus deformation curves (Reference Figures E-11 and E-12).
  
- 7) Available data concerning human tolerance to impact is primarily related to Air Force ejection seat design and thus should not be carried over to the transport passenger who exhibits a wide range in size, weight, age, physical condition and degree of restraint.

- 8) It is important that development continue on advanced impact dynamics analysis programs such as KRASH and DYCAST particularly in the area of large transport modelling. These will be needed as design assist and design verification tools.

### 3.2.0 RECOMMENDATIONS

#### 3.2.1 SCENARIO CANDIDATES

The data base consists of 112 impact survivable transport aircraft accidents which are grouped into three categories, namely: approach, landing, and rejected takeoff modes. The typical approach mode accident occurs as the aircraft impacts the ground while proceeding along the glide slope at approach speed. This is a very severe accident scenario as can be seen in Table 4-3, page 4-4. The fire and impact trauma fatalities are the largest of the three accident modes.

It is considered that the typical approach accident is not a practical candidate as a basis for aircraft design. The landing and rejected takeoff scenarios of Section 6 are proposed as potential scenario candidates which should be subjected to examination and analysis to determine the practicality of the magnitudes of the loads, accelerations, impact and failure sequence which result from these scenarios.

#### 3.2.2 ADVANCED MATERIALS

A survey of advanced materials and processes is given in Section 7. It is conceded that the new aluminum alloys should exhibit similar impact tolerance as aluminums that are in use today. However, questions about the behavior of metal matrix and advanced composites in hi-energy impact situations have not yet been answered.

It is recommended that a program should be initiated to study the following:

1. Post buckling behavior of laminated composite structure
2. Complex failure modes (under impact loading)
3. Material flammability
4. Thermal decomposition (i.e., noxious gases, smoke evaluation and human tolerance)
5. Service life degradation prior to an accident

The program to study the high energy impact tolerance potential of metal matrix and advanced composites could consist of the following steps:

- 1) Establish practical design composites concepts
- 2) Analyze the design concepts using material properties
- 3) Fabricate subcomponent specimens
- 4) Subject the specimens to test
- 5) Compare the test results with predictions and compare the impact behavior of the candidate materials with the baseline aluminum specimens.

The types of tests to be considered for this program are the following:

- A) "Head on collision" for which the specimen would resemble a section of fuselage
- B) "Vertical drop" for which the specimen would resemble the underbelly of an aircraft
- C) "Abrasion" with a specimen as for test B)
- D) "Sparking" with a specimen as for test B)

The advanced material candidates for semi-scale testing:

1. Aluminum for baseline
2. Graphite/epoxy composites
  - Rigidite 5208/T300 for baseline
  - CIBA #4/T300
  - BP 907/T300
3. Thermoplastic resin
  - Peek resin/T300
  - New resin
4. Two polyimide/graphite systems
5. Kevlar/epoxy
6. Boron/aluminum
7. Graphite/aluminum
8. Large aluminum castings

### 3.2.3 U. S. ARMY AIRCRAFT CRASH SURVIVAL DESIGN GUIDE

It is clear that overwhelming emphasis in the Design Guide is given to helicopters and to a lesser degree, light fixed wing aircraft. Therefore, it is recommended that a very worthwhile effort could consist of developing a commercial transport aircraft equivalent to the U. S. Army Design Guide.

### 3.2.4 HUMAN TOLERANCE TO IMPACT

Since the available human tolerance data is Air Force personnel oriented, it is recommended that a careful study to establish a definitive set of injury criteria for transport impact tolerance application be carried out. This would be an important contribution toward transport impact tolerance evaluation.

### 3.2.5 ANALYTICAL METHODS

It is recommended that workshops should be set up to provide opportunity for gaining experience in the use of KRASH, DYCAST and SOMLA for those that have not participated in their development.

A significant effort should be devoted to the formulation of simplified analysis approaches which serve preliminary design and parametric variation study purposes.

One concept to consider is the application of shaped acceleration pulses at the base of the occupant's seat. It would be necessary to first establish a proper set of pulses.

A second concept could involve modelling most of the aircraft by means of flexible mode shapes. The model would use non-linear elements below the fuselage floor and could account for moderate impact pulses. The structural model should contain less than 50 degrees of freedom and the execution CPU time should be less than 1,000 times real time.

### 3.2.6 TEST METHODS

It is recommended that a test program be carried out to:

- o Provide basic data for developing simplified methods of impact analysis.
- o Verify existing analysis methods and the proposed simplified methods.
- o Provide knowledge and visual evidence of aircraft structure failure in progress.

Tests performed with structural subsystem specimens provide the greatest promise for leading to improved impact tolerance. Structural components of many current aircraft are available at a reasonable cost from salvage yards.

The impact tolerance of an aircraft is primarily dependent on the performance of these three structural components:

- 1) Landing gear and wing
- 2) Fuselage underbelly
- 3) Seat and support structure

The types of tests to be performed on these specimens are listed and described in Section 12.2.4 and Appendix D.

## SECTION 4

### ACCIDENT DATA BASE

The accident data base was obtained from

1. NTSB data tapes called the "System of On-Line Analysis Retrieval of Accident Data (SOLARAD). This computer data bank has accident and incident data from the period 1964 to 1978 that are categorized and sorted.
2. ICAO and World Airline Accident Summaries

Two listings of jet aircraft accidents were extracted from SOLARAD tapes. One listing extracted all fatal accidents for jets of 27200 kg (60,000 lb.) and up. This produced an output of 92 accidents. The other listing extracted accidents with only serious injuries. This produced an output of 297 accidents.

Accidents which involved only minor damage, air turbulence, minor injury or were non-survivable were discarded. The remaining substantial damage, fatal/serious injury accidents comprise the accident data base of 112 accidents and are listed in Appendix A.

An impact-survivable accident in this analysis is defined as an accident in which all occupants did not receive fatal injuries as a result of impact forces imposed during the crash sequence. An accident is classified as a fatal accident if one or more occupants received fatal injuries. Substantial damage is damage which adversely affects the structural strength, performance, or flight characteristics of the aircraft and which would normally require replacement or major repair unless the accident results in destruction of the aircraft. Several fatal accidents involving an initial non-fatal occurrence resulting in substantial damage and a subsequent non-survivable impact or fatal event are included in the survivable or non-fatal categories because the damage resulting from the initial impact was of interest from an impact tolerance viewpoint and also because the subsequent impact or event might have been prevented had the effect of the initial damage been minimized.

Aircraft accidents occur on or off the airport during a landing, takeoff, taxi or parked mode. The taxi/park type of accident is generally not very serious and was eliminated from further consideration. Thus, the accident data base to be studied was organized into three categories according to the flight mode of the aircraft prior to the impact. These categories were

- 1) Approach
- 2) Landing
- 3) Rejected Takeoff (RTO)

Approach accidents occur while the aircraft is descending on approach before reaching the airport. This flight mode is generally characterized by flight along or near the glide slope with approach speed, power, flaps, and gross weight with landing gear down. Impact can be with trees, level or sloping ground, ditch, embankment, dike, water, vehicles, buildings or light support structures. These accidents are numbered 1-1 to 1-114 in Table A-1 of Appendix A.

Landing accidents occur when the aircraft touches down on or near the runway, and overruns or veers off the runway after touchdown. This flight mode is characterized by flared-out flight with landing speed, power, flaps, and gross weight with landing gear down. These accidents are numbered 2-0 to 2-113 in Table A-2 of Appendix A.

Takeoff accidents occur while the aircraft is moving on the runway for takeoff or after liftoff prior to retracting the landing gear and flaps. A tire or engine failure usually occurs. The wheel or engine braking action is thus reduced and asymmetrical, and the aircraft overruns the airport runway. These accidents are numbered 3-0 to 3-127 in Table A-3 Appendix A.

The data base includes principally domestic aircraft in the service of domestic and foreign airlines. This study applied only to transport category aircraft in commercial service certified to FAR PART 25.

Good documentation is needed for a useful study of an accident. NTSB has jurisdiction over domestic accidents but not those occurring in foreign countries. NTSB Blue Book accident reports was the principal source of information for this study. Since the availability of good documentation is so vital to the pursuit of this study, the well documented accidents were identified to reveal this. The identification system is shown in Table 4-1.

ACCIDENT CATEGORY	ACCIDENT IDENTIFICATION		TOTAL NUMBER
	WELL DOCUMENTED	BARE DOCUMENTATION	
APPROACH	1-1 TO 1-12	1-101 TO 1-114	26
LANDING	2-0 TO 2-15	2-101 TO 2-113	35
REJECTED TAKEOFF	3-0 TO 3-10	3-101 TO 3-127	44
TOTAL NUMBER	48	57	105

TABLE 4-1: ACCIDENT CATEGORY IDENTIFICATION AND QUALITY OF DOCUMENTATION

The Tenerife accident (March 27, 1977) is not included among the Rejected Takeoff accidents data base. This accident involved the ground collision of two Boeing 747 aircraft and is considered as non-survivable due to the destruction of the fuselage shell of both aircraft during the collision. The casualty figures for this accident are in Table 4-2.

AIRLINE	TOTAL ABOARD (T)	NONE/MINOR INJURY (N/M)	SERIOUS INJURY (S)	IMPACT TRAUMA FATALITY (I.T.)	FIRE FATALITY (F)
KLM	248	0	0	50	198
PAN AM	396	36	34	134	192

TABLE 4-2: TENERIFFE ACCIDENT, PASSENGERS AND CREW CASUALTY STATISTICS

World transport casualty statistics for survivable accidents occurring during the 1960 to 1980 period are given in Table 4-3.

ACCIDENT GROUP	NUMBER OF ACCIDENTS	NUMBER OF PASSENGERS AND CREW						
		TOTAL	NONE / MINOR	SERIOUS	FATALITIES			
					TOTAL	IMPACT TRAUMA	FIRE	DROWNING
1. APPROACH	27	2,113	550	287	1035	434	298	0
2. LANDING	33	3,058	1,581	352	421	157	227	0
3. TAKEOFF	49	4,798	3,601	352	379	92	146	78
TOTAL	109	10,069	5,732	991	1,835	683	671	78

FIGURE 4-3: INJURY SURVEY - SURVIVABLE ACCIDENTS - PERIOD 1960 TO 1980, COMMERCIAL TRANSPORT AIRCRAFT.

## SECTION 5

### CHARACTERISTICS OF IMPACT SCENARIO CANDIDATES

One of the principal objectives of this study was the development of generalized impact scenarios (GIS) representative of typical survivable aircraft accidents. The data base chosen for this development was the well documented accidents identified in Table 4-1.

The first step was to extract accident related data to show

- 1) a list of significant accident characteristics
- 2) the frequency of occurrence of the significant accident characteristics.
- 3) the relationship between the accident characteristics and the aircraft occupant injuries.
- 4) typical or average values for accident characteristics where appropriate.

For these purposes, a matrix of impact characteristics derived from the reference documents listed in Tables B-1, B-2 and B-3 was prepared for each of the three accident categories; approach, landing and takeoff and are presented in Appendix B. The approach and landing characteristics matrices (Tables B-1 and B-2) are similar and each contain 94 characteristics arranged in seven groups shown in Table 5-1.

The rejected takeoff matrix (Table B-3) contains 120 characteristics arranged in the seven groups also shown in Table 5-1.

CHARACTERISTIC GROUP		
	APPROACH & LANDING SCENARIOS	TAKEOFF SCENARIOS
1	PASSENGERS & CREW	PASSENGERS & CREW
2	SUBSYSTEMS	SUBSYSTEMS
3	APPROACH & IMPACT	RUNWAY TAKEOFF RUN
4	TERRAIN & AIRCRAFT SLIDE	RUNWAY OVERRUN & AIRCRAFT SLIDE
5	METEOROLOGICAL INFORMATION	METEOROLOGICAL INFORMATION

TABLE 5-1: ACCIDENT SCENARIO CHARACTERISTICS GROUPS

The following data is given in the bottom seven rows of each matrix.

- 1) the frequency of occurrence of the significant impact characteristics
- 2) the numbers of serious injuries, impact and fire fatalities for the accidents which experienced the given significant impact characteristic.

This accident frequency and injury data helped to provide some indication of the seriousness of each characteristic.

To facilitate the location of the information about an accident characteristic within the matrix and also to emphasize the importance of time during the fire and evacuation periods, some of the accident groups are listed chronologically. These are the third, fourth, fifth and sixth groups of those shown in Table 5-1.

The approach impact characteristics for thirteen scenario candidates are recorded in Table B-1. The serious structural failures and related results are shown in Table 5-2.

STRUCTURE	NUMBER OF ACCIDENTS	NUMBER OF INJURIES FOR ASSOCIATED ACCIDENTS		
		SERIOUS INJURIES (SI)	FATALITIES	
			IMPACT TRAUMA (I.T.F.)	FIRE (F.F.)
ENGINE SEPARATION	11	186	269	182
LANDING GEAR SEPARATION	10	168	163	144
TANK RUPTURE	7	159	257	164
FUSELAGE BREAKS	8	136	293	135
SEAT FAILURES	9	155	275	146

REFERENCE TABLE B-1

TABLE 5-2: APPROACH ACCIDENTS, CHARACTERISTICS & INJURY SUMMARIES

The average airspeed equals 146 Kn. and the average rate of descent equals 7.95 m/s (26.1 fps). There were ten fire accidents associated with 146 S.I.'s, 304 I.T.F.'s and 175 F.F.'s.

The aircraft generally impacts short of the runway by an average of 4485m (14,716 feet). There was a great variation in the landing terrain and obstacles such as light support structure, wooded ground, buildings, embarkment, dike, trees, marshland and ditch.

The landing category accident characteristics for nineteen scenario candidates are recorded in Table B-2 of Appendix B. The serious structural failures and related injury consequences are given in Table 5-3.

STRUCTURE	NUMBER OF ACCIDENTS	NUMBER OF INJURIES FOR ASSOCIATED ACCIDENTS		
		SERIOUS INJURIES (SI)	FATALITIES	
			IMPACT TRAUMA (I.T.F.)	FIRE (F.F.)
ENGINE SEPARATION	12	253	51	206
LANDING GEAR SEPARATION	12	156	13	184
TANK RUPTURE	7	93	58	182
FUSELAGE BREAKS	9	112	58	115
SEAT FAILURES	7	138	57	45

(REFERENCE TABLE B-2)

TABLE 5-3: LANDING CATEGORY ACCIDENTS, CHARACTERISTICS & INJURY SUMMARIES

The average airspeed equals 135 Kn and the average rate of descent equals 6 m/s (19.7 fps). In this category, there were 9 fire and 3 explosion accidents.

There were six impacts short of the runway by an average of 549m (1,800 feet). Seven of the landing category accidents resulted from runway overruns after the aircraft touchdown on the runway.

The landing category accident produced markedly less impact trauma fatalities than does the approach category accident. This probably results from the reduced touchdown speeds of the aircraft at impact.

The rejected takeoff (RTO) category accident characteristics for fourteen scenario candidates are recorded in Table B-3 in Appendix B. The serious structural failures and related results are shown in Table 5-4.

STRUCTURE	NUMBER OF ACCIDENTS	NUMBER OF INJURIES FOR ASSOCIATED ACCIDENTS		
		SERIOUS INJURIES (SI)	FATALITIES	
			IMPACT TRAUMA (I.T.F.)	FIRE (F.F.)
ENGINE SEPARATION	5	51	5	51
LANDING GEAR SEPARATION	7	140	3	59
TIRE FAILURE	6	139	3	48
TANK RUPTURE	8	138	8	49
FUSELAGE BREAKS	6	124	8	57
SEAT FAILURES	3	53	7	0

TABLE 5-4: RTO CATEGORY ACCIDENT, CHARACTERISTICS & INJURY SUMMARIES

The average maximum airspeed achieved during the takeoff run was 145 Kn. Due to braking procedures, the speeds, however, generally are less than 100 Kn when the impact occurs.

Nine RTO accidents involved a runway overrun. The average overrun distance equalled 574m (1,883 feet). The first fire truck arrival took an average of 2.75 minutes and the average fire was extinguished in an average of 8.75 minutes. The RTO category survivable accidents produced noticeably less numbers of impact trauma and fire fatalities than the approach and landing accident categories.

## SECTION 6

### GENERALIZED IMPACT SCENARIOS

Generalized Impact Scenarios (GIS) were developed for two accident categories defined in Section 4 (i.e., Landing and Rejected Takeoff).

These scenarios were developed from actual accident data as reported in NTSB Blue Books as well as reports of foreign government accident investigation agencies and the data accumulated in Appendix B from the aforementioned sources.

These GIS are vital for providing a basis for designing and testing future safety concept proposals. The GIS in this report were based on data from past accidents and may be satisfactory for existing aircraft.

Adjustment to these GIS may be required for aircraft designed in the future.

The elements of the Landing and Rejected Takeoff GIS are arranged in a chronological order. The subject matter of these elements are presented in Table 6-1. The Landing GIS have six elements whereas the Rejected Takeoff GIS are composed of three elements.

GENERALIZED IMPACT SCENARIOS		
ELEMENT NUMBER	CATEGORY	
	LANDING	REJECTED TAKEOFF
	METEOROLOGICAL DATA	
1	PERFORMANCE AT IMPACT	TAKEOFF RUN
2	PRE IMPACT PREPARATION	DECELERATION AND OVERRUN
3	LOCATION OF GROUND IMPACT	STRUCTURAL DAMAGE
4	STRUCTURAL DAMAGE	
5	SLIDE LENGTH	
6	SLIDE TIME	

TABLE 6-1: GENERALIZED IMPACT SCENARIO ELEMENTS

### 6.1 Generalized Landing Mode Accident Scenario (GLMAS)

The generalized landing mode accident scenario (GLMAS) consists of six chronologically arranged events that describe the principal scenario elements which influence the survivability of the aircraft occupants.

The six scenario elements were derived from the more serious landing accidents listed in Table B-2 of Appendix B. This table contains data for the scenario candidate accidents. These accidents are candidates by virtue of the amount of aircraft damage and injury as well as the availability of a comprehensive accident description.

## METEOROLOGICAL DATA

Average Air Temperature

= 15.6°C (60°F)

Light Condition: Hours of Light or Darkness

Heavy rain

Wind = 11.5 Kn

### 6.1.1 PERFORMANCE AT IMPACT

Flaps full down

The aircraft speed will be taken at 10 percent above  $V_{STALL}$  and should account for adverse ground winds of about 11.5 knots.

The rate of descent and relative ground airspeed were derived from the data of Table B-2 of Appendix B.

$$\text{Relative Ground Airspeed, } V_{RGA} = 1.14 V_{STALL} + 11.5 \text{ Kn}$$

$$\text{Vertical Rate of Descent} = 6.10 \text{ m/s (20 fps)}$$

### 6.1.2 PREIMPACT PREPARATION

This type of accident generally occurs with the crew fully prepared for a landing. It will be assumed that:

- A. The "FASTEN SAFETY BELT" sign is on.
- B. The crew has issued last minute landing and impact preparation instructions to the passengers.

### 6.1.3 LOCATION OF GROUND CONTACT

The landing type of accident generally touches down short of the runway or on the runway. The aircraft that land on the runway generally touch down several hundred meters beyond the runway threshold. Then, due to runway conditions or damage suffered at touchdown, the aircraft overruns the runway and impacts an embankment, building, or vehicle.

Two ground impact locations will be proposed.

- A. Short of the runway onto unprepared ground  
(Reference Table 6-2)

IMPACT OBSTRUCTION	TYPE OF INJURY	REF. ACCIDENTS
LANDED 102m (335') SHORT OF RWY, HARD LANDING 865m (2838') AIRCRAFT SLIDE, WRECKAGE SKIDDED OFF RWY	SEVERE S.I. SEVERE F.F.	2-1
IMPACTED TREES 1178m (3865') SHORT OF RWY. IMPACT GND 1106m (3629') SHORT OF RWY. AIRCRAFT SLID ON GND FOR 164m (539') AIRCRAFT IMPACTS ON LAVA EMBANKMENT	SEVERE F.F.	2-10

TABLE 6-2 OFF RUNWAY OBSTRUCTIONS, LANDING MODE ACCIDENTS

B. On the runway (Reference Table 6-3)

IMPACT OBSTRUCTION	TYPE OF INJURY	REF. ACCIDENTS
<p>TOUCHDOWN 60m (200') PAST RWY THRESHOLD.            SKIDDED OFF RUNWAY.            SLID ON BELLY FOR ABOUT 100m (300').            IMPACTED VEHICLE &amp; AND CONCRETE ABUTMENT.</p>	<p>SEVERE S.I.            SEVERE F.F.</p>	<p>2-0</p>
<p>IMPACT TAXIWAY 1219m (4000') PAST RWY THRESHOLD.            IMPACT TAIL FIRST.            AIRCRAFT SLID 610m (2000') AND STOPPED.</p>	<p>SEVERE S.I.</p>	<p>2-13</p>
<p>TOUCHDOWN 732m (2400') PAST RWY THRESHOLD.            OVERRUN RUNWAY FOR 34M (110') PLUNGED OVER A 12m (38 foot) EMBANKMENT</p>	<p>MODERATE S.I.</p>	<p>2-8</p>

TABLE 6-3: ON RUNWAY, LANDING MODE ACCIDENTS

6.1.4 STRUCTURAL DAMAGE (Reference Table 6-4)

	L'D'G ACCID IDENT	GEAR POS 'N	GEAR SEPARATED	ENG SEPARATED	WING SEPARATED	WING TANK RUPTURE	FUEL LINE RUPTURE	SEAT FAILURES	FUS BREAKS
A	2-1	DN	BOTH MAIN GEARS	#1	--	REMAINED INTACT	IN FUS. AT RIGHT MAIN GR.		--
	2-10	DN	NOSE GEAR FOLDED	ALL 4	--	NO. 4 MAIN WING TANK	--	NO PROBLEM	--
B	2-0	DN	BOTH MAIN	NUMBERS 2&4	--	LEFT WING ROOT	--	--	--
	2-13	UP	--	BOTH ON INITIAL IMPACT	NO	NO	--	92 PAX SEATS DAMAGED	CABIN INTACT FLOOR BUCKLED
	2-8	--	NOSE & BOTH MAIN	BOTH ENGINES & PYLONS	--	--	--	--	AFT FUS SEPAR- ATED

TABLE 6-4: AIRCRAFT STRUCTURAL DAMAGE, LANDING MODE ACCIDENTS

### 6.1.5 SLIDE LENGTH

These slide lengths will be associated with the accidents described in Item 3 entitled "Location of Ground Impact."

3(A) represents touchdowns short of the runway and

3(B) represents touchdowns on the runway

#### A. Touchdown Short of the Runway

<u>REFERENCE ACCIDENT</u>	<u>SLIDE LENGTH</u>	<u>DESCRIPTION</u>
2-1	865m (2838')	No obstacle impact at end of slide.
2-10	164m (539')	Aircraft impacts on a lava embankment at end of slide.

#### B. Touchdown On the Runway

<u>REFERENCE ACCIDENT</u>	<u>SLIDE LENGTH</u>	<u>DESCRIPTION</u>
2-0	100m (300')	Impacted vehicle and concrete abutment at end of slide.
2-13	610m (2000')	No obstacle impact at end of slide.
2-8	Overran Runway	Plunged over embankment.

### 6.1.6 SLIDE TIME

This is the time span, starting from ground impact, to when the aircraft comes to a stop. The slide time is a function of the average slide speed and the length of the slide.

Accidents 2-0 and 2-10:

The aircraft slides for a short distance.

The aircraft impacts an obstacle and comes to a halt.

The aircraft has experienced a small speed reduction.

$$T = \frac{\text{Slide Length}}{V_{RGA}} \times 1.944 \quad (\text{Sec.})$$

Accidents 2-1 & 2-13:

The aircraft slides on the runway for a long distance. The aircraft experiences a gradual reduction in speed and comes to a halt.

$$T = \frac{\text{Slide Length}}{\text{AVG } V_{RGA}} \times 1.944 \quad (\text{Sec.})$$

Accidents 2-8

The aircraft touched down about 800m past the runway threshold.

The aircraft was unable to slow satisfactorily and overran the departure end of the runway.

The aircraft impacted objects (hill, vehicle, building) outside the airport perimeter.

$$T = \frac{\text{Slide Length}}{\text{AVG } V_{RGA}} \times 1.944 \quad (\text{Sec.})$$

6.2 GENERALIZED REJECTED TAKEOFF MODE ACCIDENT SCENARIO (GRTMAS)

The generalized rejected takeoff mode accident scenario (GRTMAS) consists of three chronologically arranged events that describe the principal scenario elements which influence the survivability of the aircraft occupants.

The three scenario elements were derived from the more serious takeoff accidents listed in Table B-3 of Appendix B and the associated data. These accidents are candidates for development of a generalized takeoff mode accident scenario.

## Meteorological Data

Air Temperature = 1.2<sup>0</sup>C (34.2<sup>0</sup>F)  
Light Condition: Hours of Darkness  
Rain/Fog: Fog  
Ground Wind: 7.2 Kn (average)  
Icing: Freezing Drizzle

### 6.2.1 TAKEOFF RUN

Flap position = 12.5<sup>0</sup> (Table B-3)

Max. Airspeed relative to ground =  $V_{STALL} + 15 \text{ kn.}$   
=  $V_R$

#### A. Tire Failure (Ref. Accident 3-3)

The main landing gear wheels were locked from the start of the takeoff roll. Soft, moist, clear ice covered the runway surface. By 1300m from the start of takeoff, all the left hand tires are flat.

By 2600m all the right hand tires are flat.

$V_R$  is reached by 2800m

The aircraft reaches the end of the runway at 3100m and does not become airborne.

#### B. Collision on Runway (Ref. Accident 3-1)

The aircraft reached 145 kn at 1630m (5350') from the takeoff roll initiation point. The following pilot actions were taken:

power off  
Thrust reversers activated  
wheel brakes applied  
spoiler extended

Marked deceleration was felt at 1798m (5900'). The runway length was 2377m (7800').

C. Bird Ingestion (Ref. Accident 3-7)

The aircraft reach 100 kn airspeed during takeoff roll.

A flock of birds rose in front of the aircraft. The birds struck the aircraft. The pilot initiated the following action:

thrust levers moved to idle position  
thrust reversal was initiated  
heavy braking was applied

6.2.2 DECELERATION AND OVERRUN

A. Long Runway Overrun (Ref. Accident 3-3)

At 206m (675') beyond the runway, the aircraft passed through a wooden fence.

At 305m (1002') the aircraft contacted the structure supporting the ILS localizer facility.

At 823m (2700'), the aircraft crossed a 3.7m (12') deep ditch.

At 1036m (3400'), the main portion came to a halt.

B. Short Runway Overrun (Ref. Accident 3-1)

The aircraft overran the runway 68.6m (225') to the brow of a hill.

The aircraft became airborne momentarily.

The aircraft contacted the ground 20.4m (67') further down the embankment.

The main gear was sheared off and the nose wheel displaced rearward.

The aircraft slid and came to rest 128.3m (421') from the end of the runway.

C. Halted on The Airport (Ref. Accident 3-7)

The aircraft was decelerating

Number 3 engine disintegrated and caught fire.

Several tires and wheels disintegrated.

The aircraft approached the end of the runway at 40kn when it was steered onto a taxiway.

The right main gear collapsed.

### 6.2.3 STRUCTURAL DAMAGE

A. Long Runway Overrun (Ref. Accident 3-3)

The wreckage came to rest in an upright position.

The fuselage sustained a circumferential fracture aft of the wing trailing edge.

The main landing gear assemblies were detached from the aircraft.

The main landing gear tires were destroyed by friction milling during the takoff run.

The left wing was damaged following impact with the ILS structure.

The right wing tore loose at the ditch and a large quantity of fuel was released.

B. Short Runway Overrun (Ref. Accident 3-3)

The main landing gear was sheared.

The nose wheel was displaced rearward and forced the cabin floor upward .38m (15").

The fuselage upper structure was ruptured forward of the wing.

The right wing failed inboard of the No. 4 engine.

Engines Numbers 1 & 2 were partially separated from the wing.

C. Halted on the Airport (Ref. Accident 3-7)

The right main landing gear collapsed.

The left and center main gears had separated.

The right wing fuel tanks were ruptured first in the No. 3 fuel tank at about 7.62m (25') outboard of No. 3 engine. This was followed by penetration of the lower skin of the No. 2 fuel tank by parts of the No. 3 engine.

## SECTION 7

### ASSESSMENT OF ADVANCED MATERIALS

The demand for reduced life cycles costs for aircraft has created tremendous pressures to use light or more efficient materials and adopt new manufacturing processes. Ideally, these new materials and processes should not cause any added concern about the impact tolerance of the aircraft.

#### 7.1 Survey of Advanced Materials and Processes

The new materials to be considered can be grouped into three categories:

1. Aluminum Alloys
2. Metal Matrix Materials
3. Advanced Composites

The use of new fabrication techniques may significantly affect the impact tolerance of the aircraft. New processes to be considered are:

1. Bonding
2. Diffusion Bonded/Superplastic Formed (DB/SPF) Titanium
3. Large Castings
4. Filament Winding
5. Trapped Rubber

#### 7.2 Aluminum Alloys

There are several new aluminum alloys under active consideration. There should be no significant difference in impact tolerance for any of these. Aluminum alloys under consideration include the following:

1. 2224-T351
2. 2324-T391

3. 7010-T76
4. 7049-T76, T73
5. 7150-T6
6. 7175-T736
7. 7475-T6, T76, T73
8. CT90-T6, T7
9. CT91-T6, T7
10. Al-Li

### 7.3 Metal Matrix Materials

Two metal matrix materials have emerged as candidates for structural applications. These are Boron Carbide/Aluminum and Silicone Carbide coated Boron/Aluminum. Both of these materials may be superior to aluminum in a crash scenario. However, no test data under impact conditions exists. In any event, these materials will likely find application only in elevated temperature applications due to their high cost.

### 7.4 Advanced Composites

Advanced composite structure (primarily graphite/epoxy) is both the most promising new material application and the most controversial. Limited data are available.

Even though advanced composite laminates will burn, they do not melt appreciably. The burning of the graphite/epoxy composite would result in pyrolysis of the resin; the graphite fibers would survive but matrix cohesion and structural integrity would be degraded.

The use of graphite composites in commercial aircraft presents new considerations particularly with regard to impact tolerance. Designs and material modifications are now appearing to improve the durability and toughness of the composite structure. It will be of immense interest to

determine whether these improvement for relatively low energy impact will also show as improvement in the high energy impacts and crack propagation associated with a typical impact scenario. At best, however, it is difficult to envision a graphite (or Kevlar) reinforced organic matrix equivalent to the metal structure.

It is probable that the use of advanced composites in commercial aircraft may be avoided in some critical locations such as forward fuselage, main landing gear, etc. where high energy impact might jeopardize passenger safety.

Advanced composite materials are now being used in structural applications on a routine basis in military aircraft and will soon be applied in many areas on large commercial transports. Graphite/epoxy is the current leading material to offer lightweight, strong, rigid structure and, at the same time, offer the potential for low cost fabrication.

## 7.5 New Processes

Several new processes have shown promise for reducing the cost of manufacture. Some of these will affect the crashworthiness of the end item and some will not.

1. Bonding - Bonded structure can provide significant crack stopping which should be available at all impact energy levels.
2. Diffusion Bonded/Superplastic Formed Titanium - Superplastic Formed/Diffusion Bonded titanium sandwich is very stable under compression loading and exhibits exceptional resistance to damage from high impact forces. The construction possesses good general stability due to the ability to redistribute loads and dissipate energy. SPF/DB sandwich tends to crush rather than tear apart, absorbs energy, and sustains high crushing loads. These attributes provide increased impact tolerance when compared to conventional skin-stringer construction normally used in forward fuselage applications.

3. Large Castings - Large castings demonstrate efficiency by replacing built up sheet structure. The latter have greater energy absorbing capability. Consequently, the use of large castings may detract from impact tolerance.
4. Filament Winding - This technique produces composite parts at lower resin content than with autoclave curing. However, no tests have been found to date that would define either the resistance of a filament wound part to high energy impact or the effect of resin content.
5. Trapped Rubber - This process also tends to produce parts with lower resin content but insufficient data is available to define impact resistance with reduced resin content.

#### 7.6 Test Recommendations for Advanced Composites

All current and probable future matrix resins generally exhibit a low strain-to-failure characteristic behavior compared to metals. Extensive impact tolerance studies for metal aircraft structures have been conducted (Ref. 22, 23 and 24) but an investigation of the impact characteristics of composite airframe structures is needed and due to the common strain-to-failure characteristic will be generally applicable to whichever polymer matrix is used in the future.

The objectives of this impact investigation are the following:

1. Survey the literature to determine the existing data base on crash impact behavior of composites.
2. Review current analytical methods used for the design of impact tolerant airframe structures and assess their suitability for analysis of composite structure.
3. Develop the concept/problems that should be considered.

4. Outline the test needed to develop a design data base.
5. Consider the trade-off factors between concept selection, compatible manufacturing methods and various cost factors.

Analytical impact prediction methods should include structural evaluation, material characterization, and failure analysis. The impact environment needs to be defined from the literature in terms of expected strain rates, and the time sequence of events. Characterization of materials should be in terms of the energy absorption capabilities of laminates and cores.

This characterization should include the post-buckling behavior of the laminated composite structures. Failure analysis needs to include the complex failure modes of laminated structures for impact loading.

In addition, the analysis should be concerned with the structural aspects of flammability and the hazards associated with the thermal decomposition of polymeric composites during a post-impact fire. In particular, the noxious gas and smoke evolution during the polymer thermal decomposition should be related to human tolerance levels. Another issue affecting the response of a composite material structure in an impact environment is that of service life degradation prior to the impact.

Concepts for evaluation should include as a minimum:

1. Maintain a protective shell around the occupied area.
2. Provide for post-impact emergency egress.
3. Provide energy absorbing structure to reduce impact loads on the occupants.

4. Provide attachment structure to retain large loads and seats.
5. Eliminate strike hazards within the cabin.
6. Provide breakaway structure to prevent follow-on damage from engines or landing gear.
7. New "crack stopper" or other constructions and new resin matrix systems to minimize brittle failure modes.

There is almost a complete lack of data on the high energy impact resistance of advanced materials. It is becoming a matter of some urgency that such data be developed for advanced composites as well as other advanced materials.

Initial data could first be obtained by analytical means from basic material properties applied to structural design concepts. Subcomponent specimens incorporating these design concepts should then be fabricated and subjected to appropriate tests to provide a means of comparing rival concepts, to provide a means of confirming predictions and to accumulate semi-scale impact test data.

Candidate materials for these semi-scale impact tests are

1. Aluminum for the program baseline
2. Graphite/Epoxy Composites

Rigidite 5208/T300 for the composite baseline  
CIBA #4/T300 (Reference NASA Rept. 165677)  
BP907/T300 (Reference NASA Rept. 165677)

3. Thermoplastic Resin

PEEK resin with T300 graphite fiber  
A new resin from a new NASA program

4. Two polyimide/graphite systems to be selected
5. Kevlar/Epoxy
6. Boron Aluminum
7. Graphite Aluminum
8. Large Aluminum Castings

The large favorable material/subcomponent specimens should demonstrate the following properties:

1. The ability to dissipate large amounts of impact energy (i.e. exhibit a large area under the force/deflection diagram).
2. Exhibit resistance to abrasion damage during sliding motion when the material is in contact with surfaces of concrete, asphalt and unprepared ground variations of temperature and moisture conditions which may be significant.
3. Exhibit low tendencies to produce heat and electric sparks while sliding in contact with concrete, asphalt and unprepared ground.

There are at least four types of tests needed to demonstrate the adaptability of a material for impact applications. These tests are designed to simulate some element of an actual accident. The proposed test types are:

1. Head on Impact

The test is designed to represent a possible head on impact against a wall or building.

The test specimen would be in the form of a cylinder to represent three bays of a scaled down forward section of a fuselage. The specimens of the various materials must be of comparable strengths.

The specimen would be subjected to an axial load sufficient to cause buckling. The load would be gradually increased to promote continued buckling and collapse. Observations of force versus deflection and modes of failure would be made and recorded. The force/deflection data for all specimens would be normalized to ultimate strength to permit an equitable impact tolerance comparison to be made.

## 2. Vertical Drop

The purpose of this test is to demonstrate the energy absorption capability of a material system for the possible high rate of descent experienced in some accidents.

The portion of the fuselage structure that provides the cushioning for the excessive rate of descent situation is primarily below the floor. Thus, the test specimen would have the form of three bays of fuselage bounded above by the top of the fuselage and below by the fuselage lower outer skin.

The specimen would be subjected to loads applied perpendicular to the plane of the floor. The load would be gradually increased to promote buckling and then increased to cause continued buckling and progressive collapse.

The data to be recorded and the method of using the data is the same as for Test No. 1.

## 3. Abrasion

During an accident sequence, a fuselage underbelly may be subjected to abrasion. It is important that fuselage damage be kept to a minimum. Thus, a knowledge of the material resistance to abrasion is necessary.

An initial evaluation of the candidate materials could be accomplished with flat plate specimens acted upon by a rotating ring of abrasive material (concrete, asphalt or sand). The speed of the disc, the mean distance of travel and the applied pressure would be made to correspond to a typical impact scenario. The depth of the abraded groove would reveal the desired material evaluation.

#### 4. Sparking

An accident sequence may result in the aircraft sliding on its belly. This can lead to sparking as the wreckage passes over a concrete, asphalt or rocky surface which in turn may serve as an ignition source for spilled fuel. Materials which avoid this behavior are desirable.

A setup and test procedure similar to the "Abrasion Test" (Test No. 3) but with modifications could serve the purpose required here. The modifications consist of:

- a) Placing a container of fuel and spraying some fuel mist in the area where the sparks are expected.
- b) Arranging the typical meteorological conditions, as described in the generalized impact scenarios of Section 6, for the test environment.

Failure to pass this test may not rule out a composite material, since the addition of a modest amount of a benign material such as Dacron or Kevlar fiber could improve the properties of the basic material.

## SECTION 8

### EVALUATION OF THE "AIRCRAFT CRASH SURVIVAL DESIGN GUIDE"

In a project begun in 1965 and continuing to the present, periodically updated versions of the Crash Survival Design Guide have been published, the latest being USARTL-TR-79-22A through 22E. These reports have as their objective the presentation of the current state of the art in impact survival design for use by aircraft design engineers. The Design Guide information has influenced the establishment of certain Military Standards dealing with aircraft impact tolerance (MIL-STD-1290AV).

As an Army project, the Design Guide naturally concentrates on helicopters and light fixed-wing aircraft, but the design considerations covered are applicable in some degree to large transport aircraft as well.

Differences in the basis missions of combat versus civilian-transport aircraft serve to distinguish impact environments and structural design ranges. The combat aircraft is stronger and more maneuverable. The civilian transport is optimized for a very specific mission from which little deviation is expected and is designed with a high sensitivity to payload/structure weight ratio and to fuel consumption. Because the design strength of the civilian transport is lower, it would experience more structural damage than the military airplane in a crash at the same velocity. This is not to say, however, that occupant survivability would be lower in the transport.

The large transport fuselage is also a different type of structure, a semimonocoque shell of low strength but high strength-to-weight ratio, and with few areas of such concentrated strength as a frame structure would display.

Nevertheless, the Design Guide provides useful information for the transport designer in understanding the general nature of the impact phenomenon, in providing analysis and testing methods, and in setting out concepts and devices for improvement of impact tolerance of components.

The bulk of the evaluation for Volumes II and V inclusive is located in Appendix E. The evaluation concerns itself primarily with structural subjects such as design criteria, design methods, design data and energy absorbing concepts. Comments on data about human tolerance to aircraft impact which is contained in Volume III (Reference 3) is included in Section 9.

## 8.1 Conclusions

The Army Aircraft Crash Survival Design Guide is unique as a general aid to structural design for impact tolerance. It is clear that overwhelming emphasis is given to helicopters, although light, fixed-wing aircraft are also covered.

The main value of the Guide to the transport category airplane designer is in the illustration of methodology, and an important contribution is the definition of impact conditions in terms of idealized but specific acceleration vs time pulses. There is no justification at this time for the adoption of the quantitative properties of these pulses for civilian transports but it is essential that values for large transport impact eventually be established before rational structural design requirements can be evolved.

The degree of detail in treatments of various aspects of the structural design problems is somewhat uneven, with Volume IV being notable for comprehensiveness and sophistication in its treatment of design considerations for impact tolerant seats.

The questions of dynamic vs static requirements in design analysis and testing appear to be unsettled, but the development of static strength requirements in terms of bounds on load-deformation curves, based on

extensive dynamic response studies, is a feasible approach. The guide is also a handy source for particular design concepts and devices, particularly for energy absorbing "stroking" devices and for certain material properties.

Review of the Design Guide suggests that much could be gained from a project where the objective would be to set out a side-by-side comparison of the current requirements for civilian and military aircraft and in light of this to review the basis for differences, and to suggest testing and other research programs which might update the current requirements.

It is clear that a commercial transport equivalent to the U.S. Army Aircraft Crash Survival Design Guide would do much to centralize the location of the large quantities of data now in existence and expand its use in aircraft design practice.

## SECTION 9

### HUMAN TOLERANCE TO IMPACT

Many indices have been proposed for the purpose of giving some measure of the likelihood of occupant injury during an impact sequence. Several of the more prominent indices are discussed in Appendix F.

These indices include the Dynamic Response Index (DRI) and other spinal injury models, the Gadd Severity Index and the related Head Injury Criterion (HIC) of Federal Motor Vehicle Safety Standard 208. A brief discussion is given of leg injury criteria, of indices for "off axis" accelerations, of the shock spectrum approach, and of flailing-distance and volume-reduction indices.

#### 9.1 Conclusions

A number of injury criteria, both local and whole-body, have been proposed, although the experimental data base from which they have been drawn is extensive, there does not appear to be any comprehensive set of criteria which a design engineer could use with confidence in transport aircraft impact tolerance application. Criteria applicable to Air Force ejection seat design should not be carried over to the transport passenger who exhibits a wide range in age, size, weight, physical condition and degree of restraint. A careful study which results in a definitive set of injury criteria for transport impact application, would, although expensive, be an important contribution to the state of the art, without which a real evaluation of impact tolerance would be impossible.

## SECTION 10

### MERIT FUNCTIONS

The merit of a concept is a function of parameters that are intimate with the design objective of the concept. For each design or conceptual alternative, these parameters take on a specific set of magnitudes. These parameters can be combined into a single number which expresses the merit of the design. The best design among competing alternatives produces the largest merit value. The parameters fall into three categories: cost, effectiveness, and societal concern.

The cost element can be represented in one of two ways: acquisition cost, or direct operating cost. From the viewpoint of airline management, direct operating cost is the most desirable measure, since it includes the acquisition cost of each incremental change to the airplane. From the manufacturer's point of view he must know, with some precision, the magnitude of costs involved with proposed modifications. In any event, a baseline must be identified and its cost established so as to derive the effect of incremental changes.

Directing operating costs are derived by use of the Douglas Advanced Engineering Method, which represents a continuum of updating of the 1967 ATA Method. The major modifications made for updating include 1980 price levels, current operating practices, profiles and performance, and system attributes. The basic constituents of the direct operating cost (DOC) of aircraft are flight crew, cabin crew, airframe depreciation, engine depreciation, insurance, landing fees, airframe maintenance, engine maintenance, and fuel costs. A typical DOC schedule represents a single airplane with a representative type of operation.

Acquisition costs include the price of the aircraft, with estimates of proposed candidates for changes derived on a discrete basis. This means that proposed modifications to the baseline, such as changes in structures configurations,

have been reviewed as separate issues for each configuration. The development program, which includes also the type certification, has been summarized over a given quantity designated as a breakeven point. Cost elements used to derive a price are shown below:

- o Design Engineering
- o Fabrication
- o Assembly
- o Inspection
- o Tooling
- o Raw Materials and Purchased Parts
- o Instruments and Special Equipment
- o Product Support
- o Sustaining Engineering
- o Sustaining Tooling
- o Manufacturing Development
- o Planning
- o Flight Test
- o Laboratories
- o Propulsion
- o Miscellaneous

The nature of the study dictates very clearly that case examples have to be structured hypothetically, since quantities of airplanes must be assumed for amortization purposes and breakeven determinations. Other factors include use of new or existing aircraft, class of airplane, etc.

It is premature at this point to suggest structural safety concepts because a reliable analytical method is unavailable to perform dependable merit function studies. The evaluation of advanced composites through impact analysis and test described in Section 7 and the experience and data gained in the recommended analysis and component test effort of Sections 11 and 12 should help reveal structural concepts capable of improving passenger survivability.

## SECTION 11.0

### ANALYTICAL METHODS

It is contemplated in the future that analysis methods will be used in ascertaining the dynamic behavior of an aircraft under impact conditions. Two accomplishments are necessary for this to occur: (1) accepted impact scenarios and (2) adequate analytic prediction procedures. This latter category is of concern in this section.

#### 11.1 Analytical Requirements

Impact dynamic analysis methods for large transport aircraft are envisioned as a set of programs of differing complexity which serve a variety of purposes. These include (1) performing preliminary designs, (2) improving impact tolerant designs, (3) simulating accidents, (4) aiding in establishing impact criteria, (5) analyzing final designs, (6) providing properties for simpler programs and (7) verifying suitability of simpler procedures.

The intended purpose essentially dictates the requirements of the impact analysis method. For performing preliminary designs and parameter studies for impact tolerance improvements, it would be desirable to use a reasonably simplistic program which is relatively fast and inexpensive to run. Its accuracy need not be so stringent as to require a detailed reproduction of the actual response history, but it should give, for instance, a reasonable estimate of the peak accelerations to which an occupant is exposed. As an example, this type of program could begin with a defined set of acceleration impulses at the base of an occupant's seat.

Representative impulses for the indicated simple method can come from test data and/or analytical simulations of the complete aircraft using a more complex program, most likely of the hybrid type. This form of program incorporates a coarse model of the aircraft structure, preferably containing less than 300 degrees-of-freedom. The impulses to

be defined by this program are of sufficiently short duration to permit CPU times of the order of 10000 times real time. The hybrid program should also indicate the potential for wing fuel tank rupture, fuselage rupture, penetration of large masses into the fuselage and excessive volume change of the occupant's cabin. The hybrid program must be able to simulate both landing and ground run impact scenarios with starting routines appropriate to these conditions. Subsequent to the start, it should be able to handle nonlinear effects produced from large deflections and material inelasticity and permit the airplane to adequately interact with hard and soft surfaces of varying profile.

Within the hybrid category, but of simpler form, could be included a full airplane program which consists of flexible modes and nonlinear elements for the under part of the fuselage and landing gears. This program would be used for less severe impacts dominated by vertical impact. A program classified as simple, should contain less than 50 degrees of freedom for the structural model, but may be merged with simplified forms of occupant models. The execution CPU time should be less than 1000 times real time.

In order to operate the hybrid and simpler type programs, the nonlinear properties for any highly loaded structural element must be developed from test or an advanced analysis procedure of the finite element type. In order to serve this purpose, the finite element procedure must be able to handle large deflections and inelastic material behavior. It also should have the capacity to work with structural models containing in the order of 1000 degrees of freedom. A finite element program can be used to determine whether significant differences exist between static and dynamic properties. The CPU time for establishing dynamic properties can be as much as 100,000 times real time due to the short duration of real time simulation needed for this purpose.

## 11.2 Review of Existing Analysis Programs

Computer programs concerned with impact dynamic responses presently exist which have extensive histories of development. Three of these programs were given a limited review in the course of the study effort; namely, KRASH, DYCAST and SOMLA. The total airplane impact dynamics simulation program KRASH is well documented both technically and for usage (see References 13 and 14). The occupant-seat dynamic impact program SOMLA is similarly well documented (see References 11 and 12). The attributes of the finite element impact dynamics program DYCAST were mainly discerned from published papers (see, for example, Reference 10).

None of the above computer programs were run in the course of the review. Because of this, no comment can be made concerning the ability of these programs to predict with reasonable accuracy the impact dynamic responses of large transports. However, the literature (e.g., Reference 10) indicates that the KRASH and DYCAST programs can provide satisfactory response predictions for less complex airframe configurations and simple impact scenarios. Reasonable correlation has also been achieved between controlled experimental results and SOMLA program predictions when simple seat configurations are used. (Reference 9).

Since no work was done with these impact scenario computer programs, only subjective remarks can be made concerning the implementation of the considered programs. Adequate user documentation is a necessity for implementation. Both the KRASH and SOMLA programs are presently satisfactory in this respect (see previously cited references). SOMLA's limited scope along with its standardized occupant and seat models makes the set-up of the program relatively easy. The KRASH program utilizes a simplified airframe model composed of an open grid of beams. Although providing a documented explanation of the way to set the properties for the model's elements, the beginning user would have great difficulty in first defining the model for a large transport and then establishing the numerical properties of its elements. Extensive trials with the program by a devoted operator would be needed to surmount this difficulty.

Defining the model for the structure of a large transport is the most difficult step in implementing a finite element computer program such as DYCAST. The size and complexity of the large transport structure imposes considerable limitations on the modeling detail that can be used. Due to its involved nature, it does not appear that a finite element approach can be used for a complete large transport aircraft. Instead, the finite element procedures will most likely be limited to localized portions of the structure either for establishing properties or refining results obtained from more gross analyses.

Of the reviewed programs, only KRASH is potentially suitable for large transport airplane impact scenario simulations. The technical approach to the KRASH program satisfies many of the requirements mentioned in the previous section. Its limitations in dynamic degrees of freedom seems too restrictive for large transports. The running time of the program is satisfactory for scenarios in which the primary responses occur within 0.2 seconds after initiation of the impact sequence. The most difficult matter to discern is the modeling detail needed for large transport fuselages. There is no clear methodology for laying out the beam grid for the fuselage and then setting the properties for the beams. Given the grid, it appears that the properties of the beams are primarily set to approximate the stiffness characteristics of the original structure. It is not evident whether these same properties are satisfactory for obtaining an adequate internal stress state for failure determination. Large displacements are handled well in KRASH through the Eulerian formulation. The manner of accounting for inelastic effects by means of the KR factors appears to be reasonable and fits well into the hybrid concept of the KRASH program. Obtaining the data for these factors, however, may be a formidable task.

In KRASH, the impact sequence can only begin with the airplane in a landing attitude at touchdown. This should be generalized to permit the airplane to also assume a takeoff attitude at the start. The evolutionary nature of the impact responses precludes the consideration of arbitrary starting points during the impact sequence. The airplane during an impact sequence can be in contact with either hard or yielding

surfaces. KRASH contains a simple soil yielding model which in many respects fits well into the concept of the total program. It isn't apparent, however, that the plowing force should be prescribed independently of the yielding. The terrain over which the airplane operates in the KRASH program is defined by a linear varying or ramp type profile. Arbitrary profiles representing features as ditches or embankments are not covered. This situation should be relatively easy to remedy in the program.

In contrast to the corresponding weakness in KRASH, the strong point of the DYCAST program is the ability to follow the structure's internal stress behavior in sufficient detail for the assessment of the failure potential of the structure. In this regard, the seat finite element formulations in SOMLA needs improvement. Apart from this aspect, SOMLA handles the combination occupant-seat analysis quite well providing detailed graphics of the occupant's motions during the simulated impact condition. It would be desirable to extend SOMLA's analysis capability to cover coupled multi-occupant, multi-seat responses.

### 11.3 Analysis Recommendations

Experience with the predictive accuracy of analytical programs is most preferably gained by making comparisons of calculated results with those from controlled experiments. The latter, however, are sparse for helicopters and general aviation airplanes and essentially nonexistent for large transports. If the more elaborate impact dynamic programs such as DYCAST and KRASH can predict responses reasonably well for the former categories of air vehicles, then the predictions from these programs for large transports must serve as a reference until suitable experimental information can be obtained.

It is important that development continue on these advanced programs, particularly in the area of large transport structure modeling. The predictive performances should be further checked by comparisons between each other on actual transport designs, as well as on contrived structural models. Checking should also be made against experimental data obtained from relatively inexpensive impact tests of structural components. Modeling approaches for seats and occupants should be included in the structural modeling investigations. For organizations which may use the advanced programs but have not been participants in their development, workshops should be set-up to gain familiarity with these programs.

A significant effort should be devoted to the formulation of simplified analysis approaches which serve preliminary design and parametric variation study purposes. One concept to consider is the application of shaped acceleration pulses at the base of the occupant's seat. For this approach the primary activity would be in establishing the properties of a set of pulses. A second concept could involve modeling most of the airplane by means of flexible mode shapes. This model would use nonlinear elements below the fuselage floor and would be able to account for mild impacts. For preliminary structural design, it should be explored whether the results of this last model could be empirically scaled to higher impact conditions. Irrespective of the concept, the advanced analysis programs would be used to generate the data necessary for the development and verification of the simpler programs.

## SECTION 12

### TEST METHODS

An adequate test program is vital to assist in the search for and the developing of safety improvements.

Testing for impact tolerance improvement, from the point of view of structural response of a transport category airplane in an impact situation should be directed to achieving one or more of the following six objectives.

- o Determining Survivability Boundaries

This is the empirical determination of the parameter ranges within which an impact is survivable.

- o Characterizing Impact Conditions

The determination of external forces on the airplane to be expected at various impact speeds, angles, gross weights, terrain types, etc.

- o Identifying Structural Failure Modes

It is of extreme importance to know the manner in which structural subsystems will fail during the impact: plastic deformation, fracture, buckling, etc.; including the sequence of failures.

- o Determining Structural Properties

Besides known material properties (elastic modulus, stress-strain diagrams, etc.) it is of interest to have the ability to model a complex structure by a simple one such as a spring. Force-deflection characteristics of the complex structure are needed under static and dynamic conditions.

- o Evaluating Design Criteria

Dynamic tests of full scale systems and subsystems are needed in order to judge whether current static design criteria are reasonable and adequate.

- o Suggesting Design Improvements

Critical failure modes become apparent in a sequence of carefully observed tests. Then the designer can direct his attention to specific modes.

There are five types of tests reviewed in this section. Of these, which include total airplane, scale models, terrain, structural subsystems and simple structures, structural subsystems testing is the experimental approach which will provide the most useful information for enhancing impact tolerance. Distinct areas such as landing gear, fuselage and seats should be highlighted.

Considerable analysis and test planning will be necessary to ensure that tests will be run at maximum effectiveness. Static testing alone would be of limited value, and the parallel performance of static and dynamic tests of equivalent specimens would improve our understanding of dynamic failure modes and would enhance the capability of analytical prediction methods.

## 12.1 Review of Past Test Programs

A review of reports listed as References 15, 16, 17, 18, 19, 20, and 21 was carried out. References 15 and 16 report on the impact tests performed with full scale propeller transport aircraft that bear a close representation to the majority of the aircraft types being studied here. The material of References 17, 18, 19, 20 and 21 are of less direct interest since they apply to general aviation aircraft and scale testing.

Impact tests of full-scale aircraft have been performed in three areas. Helicopters have been drop tested to determine undercarriage impact response and crew G-loading. NASA has performed a large number of

pendulum swing drops with single and twin engined light airplanes. The only full scale impact tests of large transport aircraft were sponsored by the FAA and reported in 1965. There were two airplanes tested: a Douglas DC-7 (Ref. 15) and a Lockheed Constellation model 1649 (Ref. 16). Each test was run on the ground. The aircraft was guided into a series of barriers with a monorail nose landing gear guidance system. Instrumentation consisted of accelerometers, anthropomorphic dummies and motion picture cameras. The principal achievements of the tests were the verification of a method of producing a realistic impact environment and the production of useful records of acceleration vs time at various points on the aircraft and of records of subsystem failure modes. A number of restraint system experiments showed that occupant restraint systems enhance safety.

A review of the highlights of the impact test of a Douglas DC-7 aircraft (reported in Reference 16) is presented in Appendix C.

## 12.2 Recommendations for Future Tests

All of the conceivable testing in this area will be of one of the following types:

- o total airplane
- o scale model
- o terrain
- o structural subsystems
- o simple structures

Each of these types of tests has its own set of implications for cost, achievable objectives, and methodology.

### 12.2.1 Total Airplane Testing

For our purposes, the DC-7 and Constellation tests methodology could be utilized and updated with modern equipment, particularly in the application of telemetry techniques. Much of what would be learned, however, would be of a merely qualitative nature, and it is not clear that such information is not already available in the earlier reports and in actual data records. Structural dynamic information generated in such a test would be most useful for characterizing impact conditions, e.g., in learning of the duration and character of the accelerations experienced; and in substructural testing, e.g., correlating occupant/seat accelerations with floor accelerations. Some correlation of fuselage crushing with floor loading would be attempted, but the probability of success of such an experiment is doubtful because of the high degree of uncertainty inherent in measuring deformations.

In light of the expenses which would be involved in such a test it is unlikely that conducting one for structural dynamic testing purposes alone would be cost-effective.

### 12.2.2 Scale Model Testing

The utility of scale models in impact testing is small because of the uncertainty in scaling laws for structures undergoing gross deformation under impact conditions. This uncertainty exists because the physics of dynamic failure of materials is not well understood. Also a realistic model of a monocoque airplane structure would require such extreme detail in representation that the model would probably be more expensive than the full scale version. Accordingly, scale model testing generally should not be considered unless full scale tests are absolutely ruled out by lack of test facilities. This, however, does not seem to be the case.

### 12.2.3 Terrain Testing

An airplane impact involves deformation of both structure and ground, often with a noticeable plowing effect. Modeling the ground response by a spring and by a sliding friction coefficient appear to be necessary where analysis techniques of simulation are used, as in the Lockheed KRASH computer program. Determination of ground friction can be achieved through drag tests using a weighted rigid model. Experiments of the plowing effect cannot be devised without first developing scaling laws, probably based on momentum and fluid mechanics models.

### 12.2.4 Structural Subsystems

Static and dynamic testing of aircraft structural subsystems provides the greatest promise for improving impact tolerance. The following are the most promising substructures:

- landing gears
- seats
- fuselage sections

With landing gears the important questions involve breakaway loads and post-breakaway penetration of fuselage or wing, particularly with regard to fuel tank rupture. It is probable that landing gear design for breakaway will enhance overall survivability in a accident; that is, landing gears should not be as strong as possible: and high impact loads are probably better distributed over the fuselage underbelly.

Another factor to be considered is that the reliability of computer program analysis methods are still unproved as well as lengthy and expensive. Thus, for the purpose of providing a basis for developing a simplified method of analysis (as suggested in Sections 11.1 and 11.3) along with

improved accuracy, a test program has been outlined below and in Appendix D which is capable of providing basic impact data such as

- 1) Component load versus deflection measurements. (Acquiring load data for these tests may require a calibrated platform to receive the impact of the specimen in motion.)
- 2) Component failure modes (fuselage, wing, landing gear).
- 3) Structural member failure modes (stringer, ribs, frames).
- 4) Accelerometer load pulse plots.

The test program consists of three basic types of tests.

- 1) Landing gear and wing structure

- o Static test
- o Drop test onto unprepared ground
- o Drop test onto a cement runway

- 2) Fuselage underbelly

- o Static test
- o Drop test on underbelly on unprepared ground
- o Drop test on underbelly on concrete runway
- o Fuselage break drop test
- o Fuselage slide on unprepared ground
- o Fuselage slide of a concrete runway
- o Fuselage head on impact against a large tree or building.

- 3) Seat and support structure

- o Static test
- o Drop test
- o Mounted on sled in motion

Aircraft component tests were preferred due to the excessive expense of full scale complete aircraft tests. In order to obtain an indication of the range of desired data, aircraft components for test should be obtained from small, medium and large aircraft from salvage sources. Obviously, initial testing would be done with components fabricated from state of the art metal materials and methods. Future tests involving composite aircraft components would probably require components especially fabricated for this purpose due to unavailability of salvage specimens.

The initial tests would serve as data gathering exercises, whereas later tests could serve as analysis verification efforts as well.

The basic purpose for this program is to improve passenger survivability. These tests may also serve to reveal the need and provide methods to accomplish design improvements.

The conditions for these tests will be derived from the recommended critical generalized impact scenarios in Section 6.

#### 12.2.4.1 Landing gear impact tests of the following types may be performed.

- (A) Weighted wing section with gear impact against a bumper.  
Record possible penetration of wing.  
Measured loads at gear breakaway.  
The tests should be performed dynamically (at typical landing and slow-flight speeds) and "statically" (very slowly).  
Impact at various angles.

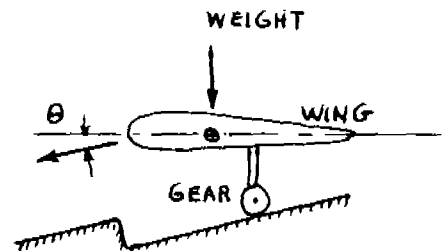

- (B) Weighted fuselage section with gear impact against a bumper.  
Record load-deflection history.  
Evaluate penetration of fuselage.  
Determine test strength of damaged fuselage.

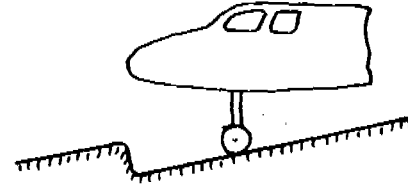

- (C) Drop test onto an incline plane  
(Reference Appendix D, Test 1.1.0, Figure D-1)

12.2.4.2 Fuselage drop tests will provide information about the modes of crushing of underbelly structure, and the force-deflection characteristics in the collapse. Static tests provide force-deflection characteristics. Probably a section containing a minimum of three bays will be needed in order to account for longitudinal buckling. (Reference Appendix D, Test 1.2.0, Figure D-2)

Fuselage drop tests will provide accelerations vs time at various floor points, at seats and at anthropomorphic dummies. (Reference Appendix D, Test 1.2.0, Figure D-3)

Shearing of the fuselage is a critical failure mode affecting survivability. Drop tests will determine the net impulse required to bring about a fuselage break. (Reference Appendix D, Test 1.2.0, Figure D-4)

12.2.4.3 Seat testing should be performed both statically and dynamically. Results will permit evaluation of current static load design criteria and determine occupant G loading at the point of seat failure. Seat tests should cover longitudinal, lateral and vertical accelerations. Sled tests, or, if feasible, drop tests would be performed. Multiple seat specimens should be used, as the strength and failure modes of multiple seat packages may differ considerably from those for single seats. (Reference Appendix D, Test 1.3.0)

Comparison with existing analytical techniques, such as the SOMLA code with seat capability, would be made.

12.2.5 Simple structural tests (i.e. tests on subcomponents such as beams or columns) are not recommended since they do not provide useful information on the impact behavior of airplanes and do not suffice to validate a computer program. In the latter case, even if accurate predictions were obtained there would be no assurance that the applied methodology would perform satisfactorily for more complex conditions.

## APPENDIX A

### ACCIDENT DATA BASE

This appendix summarizes the entire accident data base used in this study. The aircraft of the data base accidents are principally domestic aircraft certified to FAR Part 25 in the service of domestic and foreign airlines. The data base consists only of accidents judged to be impact survivable (i.e., in which all occupants did not receive fatal injuries as a result of impact forces imposed during the impact sequence). Table 4-1 gives an indication of the degree of documentation available with each accident record.

The accident data is presented in three tables according to the flight mode of the aircraft prior to the crash. These tables are:

Table A-1: Approach Accidents

Table A-2: Landing Accidents

Table A-3: Rejected Takeoff Accidents

TABLE A-1: IMPACT SURVIVABLE APPROACH ACCIDENTS

NO.	DATE M D Y	AIRCRAFT	LOCATION	AIRLINE	TYPE OF FLT.	PASSENGERS & CREW					FATALITIES			DESCRIPTION	REF.
						TOTAL	T	N/M	S	F	I.T.	FIRE	ORN		
1-1	11 8 65	B727	N. Constance, K.Y.	American	P	62	0	4	58					Pilots Failed to Monitor Altimeter	C: 1-0031
1-2	4 7 66	DC8	Auckland, NZ	Air New Zealand	T	5	0	3	2	2	-	-	-	Wing Tip Struck Ground. A/C Cartwheeled.	I: 1968-10
1-3	1 13 69	DC8-62	N. L.A. Calif.	SAS	P	45	13	17	15	-	-	15	-	A/C Flown into water. Fus. broke into 3 pieces. 2 sections sank. Wing section floated.	N: 70-14
1-4	5 18 72	DC9-31	Ft. Lauderdale, Fla.	Eastern	P	10	7	3	-	-	-	-	-	Failure from main gear. Tail section separated from A/C. 850 M skid on rwy. Aft fus. in flames.	N: 72-31
1-5	12 8 72	B737	Chicago, Ill.	United	P	61	7	11	43	18	25	-	-	A/C impacted trees, houses, utility pole cables & garages. In tense ctr sect fire.	N: 73-16
1-6	12 29 72	L1011	N. Miami, Fla.	Eastern	P	176	17	60	99	99	-	-	-	Descent into mud & water. Order of impact was Lwing, #1 eng., L Gr. Fus broke into 4 sections.	N: 73-14
1-7	11 27 73	DC9	Chattanooga, Tenn.	Delta	P	79	75	4	0	-	-	-	-	A/C struck dike & L wing separated from A/C. L eng. came to rest on rwy threshold	N: 74-13
1-8	12 17 73	DC10	Boston, Mass.	Iberia	P	167	163	4	0	-	-	-	-	Rt. Mgr. sheared at 30 M short of rwy threshold. Nose, ctr, LT M GR, engs. 1 & 3 separated in A/C slide.	N: 74-14
1-9	9 11 74	DC9-31	Charlotte, NC	Eastern	P	82	1	10	71	35	36	0	0	A/C struck trees, impacted cornfield, slid 300 M. Fire inside cabin during slide. Left wing broke in sections.	N: 75-09
1-10	6 24 75	B727	JFK	Eastern	P	124	0	12	112	87	25	0	0	Impacted into approach lites in thunderstorm. A/C destroyed by impact and fire.	N: 76-8
1-11	11 12 75	B727	Raleigh, NC	Easterr	P	139	138	1	0	-	-	-	-	Impacted Gnd. 85 M short of rwy. A/C lost M GRS & #3 eng. Bounced onto rwy & slide 1260 M	N: 76-15
1-12	3 13 79	B727	Doha Inter- national Airport	ALIA	P	64	4	15	45	25	20	-	-	Impacted Gnd 2050 M short of rwy. First impact with Ldg Gr up. Second impact in inverted pos'n. Slid into bldg. Fus. 3 mn sections. A/C fire.	I:

P:Pass  
T:TRAINING  
C:CARGO

A:ARB I:ICAO  
C:CAB N:NTSB  
D:DAC R:REF

TABLE A-1: IMPACT SURVIVABLE APPROACH ACCIDENTS

NO.	DATE M D Y	AIRCRAFT	LOCATION	AIRLINE	TYPE OF FLT.	PASSENGERS & CREW								DESCRIPTION	REF.
						TOTAL				FATALITIES					
						T	N/M	S	F	I.T.	FIRE	DRN	EVAC.		
1-101	4 28 68	DC8	Atlantic City, NJ			4	2	2	0	-	-	-	-	Go around. A/C rolled & yawed. Struck ground.	N (10009A)
1-102	4 3 66	DC8	Tokyo	CPA	P	72	0	8	64	32	32	-	-	850 M short, MGR whl struck lites 13 3. Crashed into seawall. A/C destroyed and caught fire on rwy.	I: 1970-6
1-103	5 3 67	DC8	Monrovia, Liberia	VARIG	P	90	16	23	51	11	40	0	0	A/C impacted gnd 1836M short of of rwy. A/C stopped after 259M slide. 4 houses damaged.	I: 1967-15
1-104	11 20 67	CV880	Constance, KY	TWA	P	82	0	13	69	69	-	-	-	Pilot misjudged Alt. Snow, severe impact, fire	N: TAPES
1-105	6 13 68	B707	Calcutta, India	PAN AM	P	63	49	8	6	-	-	-	-	A/C struck tree. Gnd. slide tore 4 engs.	R: (1)
1-106	8 2 68	DC8	Milan, Italy		P	95	-	-	13	-	-	-	-	Bad weather.	O: FILE
1-107	12 27 68	CV580	Chicago, Ill.	North Central	P	45	15	3	27	-	-	-	-	Stalled at 282 M above gnd. A/C struck hanger side in inverted position.	A: SUMRY
1-108	8 8 70	CV990	Acapulco, Mexico	Modern Air Tran.	C	8	0	8	0	-	-	-	-	A/C struck trees, aprch lites, small bldg. landed 183 M short of rwy.	N: 1-0051
1-109	6 7 71	CV580	New Haven, Conn.	Allegh'y	P	31	0	3	28	?	?	-	-	Landed about 1 mile short. Fire at impact. Wings separated. Fuel spill. Fuel intact. Explosion.	N: 1-0006
1-110	6 14 72	DC8	New Delhi, India		P	87	1	4	82	?	?	-	-		
1-111	10 30 75	DC9	Prague, Czech.		P	120	?	?	75	-	-	-	-	Instrument approach. Impact gnd. 8 km from rwy.	
1-112	3 4 77	DC8	Naimy, Niger	ONA	C	4	?	?	75					Instrument approach. Impact GND 8 KM from rwy.	
1-113	9 29 77	DC8	Kuala Lumpur, Malaysia	JAL	P	79	19	46	14	14	0	-	-	A/C Destroyed by impact & fire	O: File
1-114	12 23 78	DC9	Palmero, Sicily	Alitalia	P	129	?	?	108	?	0	?	-	Crashed in Water 4km from Rwy.	C: File

P:PASS  
T:TRAINING  
C:CARGO

A:ARB I:ICAO  
C:CAB N:NTSB  
D:DAC R:REF.

TABLE A-2: SURVIVABLE - IMPACT LANDING ACCIDENT (#2)

NO.	DATE M D Y	AIRCRAFT	LOCATION	AIRLINE	TYPE OF FLT.	PASSENGERS & CREW								DESCRIPTION	REF.
						TOTAL				FATALITIES					
						T	N/M	S	F	I.T.	FIRE	ORN	EVAC.		
2-0	7 11 61	DC8	Denver	United	P	114+8			17	0	17			During rollout skidded off rwy. Sheared MN gears. Slio on belly sideways. Struck truck & abutement. Fire #4 eng., fus. rt. side & lt. wing.	FAA-AM 70-16
2-0.1	7 1 65	B707	Kansas City, MO	CAL	P	66	12	0	0					Unable to stop after lng in rain. Went off end of rwy. Hit structure & blast mound.	C: 1-0019
2-1	11 11 65	B727	Salt Lake City, UT	United	P	91	9	35	43	-	43	-	-	Hard lndg. 102 M short of rwy. 4.7g v. M GR. sheared. A/C caught fire. Slid 865 M fus. fuel line ruptured by rt. gr. strt.	FAA-AM 70-16
2-1.1	8 8 68	B727	Boston, Mass	EAL	P	83	11	0	0					Hard lng. - broke LH M/G. Directional control maintained. Swerved off rwy. when velocity decreased.	N: 69-11
2-2	8 12 69	DC9	St. Thomas, VI.	Caribbean Atlantic	P	119	1	0	0	-	-	-	-	Overran rwy. 100 M, struck vehicles, came to rest in small buildings.	N: 70-23
2-3	5 2 70	DC9	N. St. Croix, VI.	ONA	P	63	29	11	23	-	-	23	-	Insufficient fuel. Open sea ditching. A/C intact. Floated for only 10 minutes.	N: 71-8
2-4	9 8 70	DC9	Louisville, KY	Delta	P	94	15	0	0	-	-	-	-	A/C touched down 47 M short of rwy. 2nd touch dn. tail first. A/C slid 1525 M Substantial damage	N: 71-15 D: File
2-5	9 15 70	DC8-62	JFK, NY	Alitalia	P	156	145	11	0	-	-	-	-	Hard Ldg. ground loop. 3 engs. separated from A/C. Fus. broke aft of wing.	N: 71-9
2-6	12 28 70	B727	St. Thomas, VI	Trans Caribbean	P	55	42	11	2	-	2	-	-	Hard Ldg. overran rwy. Fwd & aft fus. break. 2 fire fatalities. 1 fractured vertebrae.	N: 72-8
2-6.1	6 7 71	C580	New Haven, Conn.	All.	P	31	0	3	28	1	27	-	-	A/C below min. Alt. hit houses 1600 M short of rwy. Extensive fire.	N: SA-427
2-7	6 23 73	DC8-61	JFK, NY	Icelandic	P	128	120	8	0	-	-	-	-	Hard ldg. Spoilers inadvertently deployed 12 M above rwy. Impact tail first, short of rwy.	N: 73-20

P:PASS  
T:TRAINING  
C:CARGO

A:ARB I:ICAO  
C:CAB N:NTSB  
O:OAC R:REF.

TABLE A-2: SURVIVABLE - IMPACT LANDING ACCIDENT (#2)

NO.	DATE M D Y	AIRCRAFT	LOCATION	AIRLINE	TYPE OF FLT.	PASSENGERS & CREW								DESCRIPTION	REF.
						TOTAL				FATALITIES					
						T	N/M	S	F	I.T.	FIRE	DRN	EVAC.		
2-7.1	10 28 73	B737	Greensboro, NC	Piedmont	P	0	-	-	0	-	-	-	-	A/C landed long. Hydroplaning. overran end of rwy.	N: DCA 74-A-9
2-8	11 27 73	DC9	North Canton, Ohio	Eastern	P	26	10	16	0	-	-	-	-	Overran Rwy. Aft Fus. & 2 engs. separated from A/C. Wings intact. No fire.	N: 74-12
2-9	1 16 74	B707	L.A., CA	TWA	P	65	6	2	0	-	-	-	-	Nose Gr. first ldg. Nose gr. failed. Fire beneath fit. deck destroyed cockpit & cabin interior.	N: 74-10
2-10	1 30 74	B707	Pago Pago, Samoa	Pan Am	P	101	0	5	96	1	95	-	-	A/C impacted into trees 1180 M short of rwy. Slid 245 M A/C destroyed by impact & fire.	N: 74-15
2-11	4 5 76	B727	Ketchikan, Alas.	Alaska	P	50	38	11	1	1	-	-	-	Overran rwy. Impact in a ravine. Fus. brcke in 3 sections. A/C destroyed by impact & fire.	N: 76-20
2-12	4 27 76	B727	St. Thomas, VI.	American	P	88	32	19	37	18	19	-	-	Go around aborted. Overran rwy. by 315 M Stopped against bldg. Soon after overrun rt. wing ruptured & fire erupted.	N: 77-1 D: File
2-13	6 23 76	DC9	Philadelphia, PA	Allegheny	P	106	20	86	0	-	-	-	-	Aborted go around. Impacted taxi way & ldg. gr. retracted. A/C slid 610 M A/C destroyed by impact. No fire.	N: 78-2
2-14	4 4 77	DC9-31	N. Newhope, GA	Southern	P	85	1	22	62	38	24	-	-	Emergency ldg. on hwy. A/C struck trees, utility poles, gas station, vehicles.	N: 78-3
2-15	12 28 78	DC8	Portland, OR	United	P	189	158	23	10	10	-	-	-	A/C crashed 9.5 km short of airport. 475 M from first tree to end of slide. A/C struck trees, wire cables, 2 houses. Severe impact, no fire.	N: 79-07
2-101	4 7 64	B707	JFK, NY	Pan Am	P	145	129	16	0	-	-	-	-	Overran rwy. Major structural damage. No fire.	A: Summary
2-102	12 24 66	DC8	Mexico City, Mexico		P	109	101	8	0	-	-	-	-	Landed in dry lake.	Word Accident Summary
2-103	4 7 67	B727	Tampa, FL.	United	P	103	102	1	0	-	-	-	-	Wheels up ldg. Flt. engr. injured during evacuation.	N: Tape
2-104	6 3 68	B727	Flushing, NY	TWA	P	102	101	1	0	-	-	-	-	Struck approach lite pier. Pilot error	N: Tape

P:PASS  
T:TRAINING  
C:CARCO

A:ARB I:ICAO  
C:CAR N:NTSB  
D:DAC R:REF.

TABLE A-2: SURVIVABLE - IMPACT LANDING ACCIDENT (#2)

NO.	DATE M D Y	AIRCRAFT	LOCATION	AIRLINE	TYPE OF FLT.	PASSENGERS & CREW								DESCRIPTION	REF.
						TOTAL				FATALITIES					
						T	N/M	S	F	I.T.	FIRE	DRN	EVAC.		
2-105	5 1 69	CL44	Anchorage, Alas.	Mobile Oil	C	4	2	2	0	-	-	-	-	Hard ldg. Bounced. Wings separated from A/C. Fus. inverted. A/C destroyed by fire.	N: 3-3871
2-106	2 11 70	B707	Stockton, CA	Pan Am	T	7	6	1	0	-	-	-	-	Ran off end of rwy. Struck a 1 M ditch. No fire.	R: (1)
2-106.1	11 14 70	DC9	Huntington, W. VA.	South.	P	75		unknown						Aircraft descended at excessive rate below min. altitude. Crashed short of rwy. in wooded area	N: SA-422
2-107	5 18 72	DC9-31	Ft. Lauderdale, FL	Eastern	P	10	7	3	0	-	-	-	-	Hard Ldg. M GR failure. Tail sec. separated from A/C. Evacuation injuries.	N: 1-002
2-108	7 31 73	DC9	Boston, Mass	Delta	P	89	0	1	88	88	-	-	-	A/C impacted seawall. Wreckage scattered over area 75 M x 240 M. ILS approach.	N: 74-03
2-109	12 22 75	B707	Milan, Italy	TWA	P	122	119	3	0	-	-	-	-	Off rwy. landing.	N: Tape
2-110	3 31 75	B737	Casper, WY	Western	P	99	98	1	0	-	-	-	-	Collide with ditches.	N: Tape
2-111	3 3 78	DC8	Santiago, Spain	Iberia	P	222	170	52	0	-	-	-	-	Overran rwy. Came to rest in ravine.	I: Tape D: File
2-111.1	7 9 78	BAC111	Rochester, NY	Alleg.	P			unknown						Aircraft landed at excessive speed w/locked brakes. 3 tires failed and a/c went off rwy. Injuries unknown.	N: DCA-A- A017
2-112	9 20 78	DC10	Monrovia, Liberia		P	99	99	0	0	-	-	-	-	Overran rwy. Struck embankment	I: 11/78
2-113	10 7 79	DC8	Athens, Greece	Swissair	P	154	?	?	14	-	-	-	-	Overran rwy. Slid down embankment. A/C destroyed by fire.	D: File

P:PASS  
T:TRAINING  
C:CARGO

A:ARB I:ICAO  
C:CAB N:NTSB  
D:DAC R:REF.

TABLE A-3: IMPACT SURVIVABLE - REJECTED TAKEOFF ACCIDENTS (#3)

NO.	DATE M D Y	AIRCRAFT	LOCATION	AIRLINE	TYPE OF FLT.	PASSENGERS & CREW								DESCRIPTION	REF.
						TOTAL				FATALITIES					
						T	N/M	S	F	I.T.	FIRE	DRN	EVAC.		
3-0	11 23 64	B707	Rome, Italy	TWA	P	73	12	13	48	0	48	-	-	Overran rwy. #4 eng struck steam roll'r at 40 kts. Fuel line rupture. Fire. Rt. wing tip fuel spill & fire. Ctr. fus. tank fire & expl'n. etc.	FAA-AM-70-16
3-1	11 6 67	B707	Erlanger, KY	TWA	P	36	34	1	1	-	1	-	-	A/C overran rwy. rt. wing failed at #4 eng. Fire at wing separation. A/C destroyed.	N: 1-0029
3-1.1	12 26 68	B707	Achorage, Alas.	PAA			Unknown							Crashed just after liftoff. Severe lateral divergent oscillations with rt. wing contact gnd.	N: NA-86B
3-2	12 27 68	DC9	Sioux City, Iowa	Ozark	P	68	65	3	0	-	-	-	-	Initial climb. Airframe icing aborted T.O. overran rwy. 360 M fuel spillage. No fire.	N 70-20
3-2.1	1 5 70	OC990	Stockholm, Sweden	Span.	Ferry	10	1	4	5	5	-	-	-	A/C made planned 3-eng. T.O. Landed just after T/O beyond rwy. in woods. Fus broke into 5 sec.	Swedish Prel. Rept EC-BN651
3-3	11 27 70	DC8	Anchorage, Alas.	Capitol	P	229	133	49	47	1	46	-	-	Overran rwy. to 1050 M. Struck fence, ILS struc, 3.6 M deep ditch. Wings damaged, fuel spill, fire.	N: 72-12
3-3.1	8 13 72	B707	JFK, NY	JAT	P	186		0	0	-	-	-	-	A/C aborted T/O just prior to liftoff. Directional control good. Rolled just off rwy. Eng. fires.	N: A-0001
3-3.2	9 1 72	B747	JFK, NY	TWA	P	347		8	9	-	-	-	-	A/C had 2 flat tires while taxiing. Log. gear fire. Eng. no shutdown prior to evacuation.	N: ACC REP dtd 11-06-72
3-4	12 20 72	DC9-31	Chicago, ILL	North Central	P	45	26	9	10	-	10	-	-	Collided with CV880. Lost RT M GR. Failed. Nose & Lt. M GR at touchdown. Fire in aft. fus.	N: 73-15
3-5	6 20 73	OC8	Bangore, ME	ONA	P	261	258	3	0	-	-	-	-	Fire at RT M GR well during rollout. Evacuation injuries only.	N: 74-1
3-6	8 7 75	B727	Denver, Col.	Continental	P	134	119	15	0	-	-	-	-	Climbed to 30 M. Impacted rwy. 2nd impact after 160 M. A/C slid 400 M. Fus damage. No fire.	N: 76-14
3-7	11 12 75	OC10	JFK, NY	ONA	P	139	137	2	0	-	-	-	-	Seagull ingestion. #3 eng. disintegrated. Fires & wheels disint'd. Gr. failed, Fire destroyed A/C.	N: 76-19

P:PASS  
T:TRAINING  
C:CARGO

A:ARB I:ICAO  
C:CAB N:NTSB  
D:DAC R:REF.

TABLE A-3: IMPACT SURVIVABLE - REJECTED TAKEOFF ACCIDENTS (#3)

NO.	DATE M D Y	AIRCRAFT	LOCATION	AIRLINE	TYPE OF FLT.	PASSENGERS & CREW								DESCRIPTION	REF.
						TOTAL				FATALITIES					
						T	N/M	S	F	I.T.	FIRE	DRN	EVAC.		
3-8	11 16 76	DC9	Denver, Col.	Texas Inter- national	P	86	84	2	0	-	-	-	-	Overran rwy. to 320 M. Struck lite struct, two ditches, ILS screen. Severe impact & fire dmg	N: 77-10
3-9	3 1 78	DC10	LA, CA	Continental	P	200	167	31	2	0	2	-	-	Lt M GR collapsed. Lt wing fire. A/C Lt side destroyed. Evacua- tion injuries only.	N: 79-1
3-10	6 26 78	DC9	Toronto, Can.	Air Can.	P	107	59	46	2	2	-	-	-	A/C overran rwy to 140 M. A/C dropped into 15 M ravine. 2 fus breaks. Fuel spills. No fire	H80002
3-102	3 14 65	Caravelle	Ypsilanti, MI	United	P	54	53	1	0	-	-	-	-	Eng. failure. Evac. injuries.	N: Tape
3-102.1	9 13 65	C88C	Kansis City, MO	TWA	T			Unknown						A/C landed after T/O just beyond rwy. Hit tail, RT M/G first. Extensive fire.	N: 1-0021
3-102.2	9 27 65	CL44	Miami, Fla.	AER	C	10	0	4	6	6	-	-	-	A/C impacted at end of rwy. Att- empted T/O. Rotation not possi- ble due to control surf. locks.	N: DCA-76- AZ-005
3-103	9 8 67	B707	Frankfurt, GER	Pan Am	P	174	173	1	0	-	-	-	-	#3 eng. Disint'd. Rt. wing fire.	A: Sumry
3-104	11 22 67	B707	Honolulu, Hawaii	BOAC	P	52	51	1	0	-	-	-	-	No. 1 Eng. Disnt'd. Wing & Ldg. Gr. damaged. Fire under Rt. wing	A: Sumry
3-105	3 21 68	B727	Chicago, IL	United	C	3	2	1	0	-	-	-	-	Misused flaps. Collided with ditches.	N: 1-0023
3-106	4 8 68	B707	London, ENG	BOAC	P	127	84	38	5	-	5	-	-	No. 2 Eng. failed. Port wing tanks exploded. Fire.	A: Sumry
3-107	2 9 69	B727	Berlin, GER	Pan Am	P	116	114	2	0	-	-	-	-	Failure & Fire No. 3 Eng. 2 evacuation injuries.	R: (1)
3-108	6 24 69	C880	Moses Lake, Wash.	JAL	T	5	0	2	3	-	-	-	-	No. 4 eng. contacted rwy. A/C overran rwy. to 790 M. A/C de- stroyed by impact & fire.	R: (1)
3-109	4 19 70	DC8	Rome, Italy	SAS	P	65	53	12	0	-	-	-	-	No. 1 eng. disint'd, punctured ctr. wing tank. Fuel spill, fire, explosion, A/C destroyed.	R: (1)
3-110	6 9 70	DC-8F	Banqore, ME	Trans Caribbean	P	217	215	2	0	-	-	-	-	RT M LDG GR 2 tires blew. RT GR Fire. 2 serious evac'n injuries.	N: 1-0029
3-111	7 19 70	B737	Philadelphia, PA	United	P	61	60	1	0	-	-	-	-	No.1 eng. failed. A/C overran rwy 488 M. Substantial damage. No fire.	R: (1)

P:PASS  
T:TRAINING  
C:CARGO

A:ARB I:ICAO  
C:CAB N:NISB  
D:DAC R:REF.

A-8

TABLE A-3: IMPACT SURVIVABLE - REJECTED TAKEOFF ACCIDENTS (#3)

NO.	DATE	AIRCRAFT	LOCATION	AIRLINE	TYPE OF FLT.	PASSENGERS & CREW								DESCRIPTION	REF.
						TOTAL				FATALITIES					
						T	N/M	S	F	I.T.	FIRE	DRN	EVAC.		
3-111.1	9 8 70	DC8	JFK, NY	TIA	Ferry	11	0	0	11	11	-	-	-	Premature rotation to excessive nose-high attitude. A/C rolled w/lt wing contacting grd. ext. fire	N: 1-0011
3-112	7 30 71	B747	San Francisco, CA	Pan Am	P	218	199	19	0	-	-	0	-	A/C struck lite struct. Hydraulic Sys, M GR & Horiz. Stab. spars damaged. 17 evac'n injuries.	A: Sumry
3-113	1 21 72	DC9	N. Adana, Turkey		T	5	1	3	1	-	-	-	-		I: Sumry #34
3-114	11 8 72	DC8	Moscow, Russia	JAL	P	76	0	15	61	?	?	-	-	Impact sequence: tail first, then LT GR, #1 Eng, #2 Eng, LT wing tip. Wing fuel spill. A/C destroyed by impact & fire.	I: 1977 #2
3-115	1 30 73	DC9	Oslo, Norw.		P	33	0	0	0	-	-	-	-	Overran rwy. Sank in water.	I: 3/77
3-116	7 23 73	B707	Papeete, Tahiti		P	79	0	1	78	-	-	78	-	Initial climb. Ditched 3200 M from airport.	N: Tape
3-117	1 4 74	B727	Tampa, Fla.	United	P	118	117	1	0	-	-	-	-	M GR tire damage. No. 3 eng. ingested rubber. Evac'n inj. only.	R: (1)
3-118	2 7 74	DC8	LA, CA	UTA	P	161	160	1	0	-	-	-	-	Flat tire. Fire in LT M GR. Evac'n injuries only.	R: (1)
3-119	3 27 74	DC8-63	Anchorage, Alas.	World	P	233	232	1	0	-	-	-	-	Vibr'n during 1.0. run. Stopped on rwy. Fire in LT M GR well. Evac'n injuries only.	R: (1)
3-120	11 20 74	B747	Nairobi, Kenya	Lufthansa	P	157	78	20	59	-	-	-	-	A/C failed to gain alt. Crashed tail down in field near end of rwy. A/C des. by impact & fire.	A: Sumry
3-121	11 25 74	B707	Beirut, Lebanon	Pan Am	P	30	29	1	0	-	-	-	-	Eng. Fail. & Fire. Evac'n injuries only.	R: (1)
3-122	8 25 75	DC10	JFK, NY	American	P	231	228	3	0	-	-	-	-	Tire failure.	N: Tape
3-123	2 16 76	B727	Denver, Col.	Continental	P	120	119	1	0	-	-	-	-	Eng. Fail. Evac'n injur's only.	N: Tape
3-124	1 16 77	DC8	Baltimore, MD	Capitol	P	101	94	7	0	-	-	-	-	Eng. Fail. Evac'n injur's only.	N: Tape
3-125	8 19 77	DC10	Honolulu, HI	Philipp'e	P	267	265	2	0	-	-	-	-	Eng. Fail. Evac'n injur's only.	
3-126	10 2 77	DC8	Shannon, IRE	Capitol	P	159	142	17	0	-	-	-	-		N: Tape
3-127	2 9 79	DC9	Miami, Fla.	Eastern	T	5	4	1	0	-	-	-	-	A/C rolled & struck GND. Overran rwy 1500 M. Nose GR & RT wing separated from A/C.	I: 3-79 D: File

P: PASS  
T: TRAINING  
C: CARGO

A: ARB I: ICAO  
C: CAB N: NTSB  
D: DAC R: REF.

## APPENDIX B

### SCENARIO CANDIDATES ACCIDENT CHARACTERISTICS

This appendix contains listings of accident data from the well documented accidents which are listed in Table 4-1. The data is presented in three tables:

Table B-1: Approach Accidents - Characteristics and Associated Injuries

Table B-2: Landing Accidents - Characteristics and Associated Injuries

Table B-3: Takeoff Accidents - Characteristics and Associated Injuries

In these tables, the accident characteristics are grouped as indicated in Table 5-1. A brief analysis of these tables is given in Section 5 of this report.

TABLE B-1 : APPROACH ACCIDENTS, CHARACTERISTICS AND INJURIES

1 Accid. No.	2 A/C	3 PASSENGERS & CREW					7	8 Aircraft Damage	9 Subsystems						12	13
		T	S	F					10 Landing Gear							
				I.T.	Fire	Drwn			Separated From Aircraft	Tires Failed	Position		Safe Light			
											Up	Dn	Safe	Warning		
1-1	B727	62	4	29	29	0	Destroyed by Gnd Impact & Fire	-	-	X						
1-3	DC8-62	45	17	0	0	15	Destroyed by Water Impact	Nose & Main	-		X			X		
1-4	DC9-31	10	3	0	0	0	Impact Damage & Destroyed by Fire	Main	-		X					
1-5	B737	61	11	18	25	0	Destroyed by Impact & Fire	Nose & Rt. Main	-	X						
1-6	L1011	176	60	99	0	0	Destroyed by Impact	Nose & Lt. Main	-		X			X (Nose Gr)		
1-7	DC9	79	4	0	0	0	Destroyed	Nose & Main	-		X					
1-8	DC10	167	4	0	0	0	Substantial Damage	Rt. Main (Bounced) Nose & Ctr. Lt. Main	-		X					
1-9	DC9-31	82	10	35	36	0	Destroyed by Impact & Fire	Lt. Main Rt. Main Nose Gear	-		X					
1-10	B727	124	12	87	25	0	Destroyed by Impact & Fire	-	-		X					
1-11	B727	139	1	0	0	0	Substantial	Both Main	-							
1-12	B727	64	15	25	20	0	Impact Damage Nose & Ctr. Sects. Destroyed by Fire	-	-	X						
1-103	DC8	90	23	11	40	0	Destroyed by Gnd. Impact & Fire	Rt. Main	-		X					
Σ	12	1099	164	304	175	15										
No. of Serious(s) Injuries (S.I.)									168		30	168		77		
No. of Accidents									10		3	9		2		
No. of Serious Injuries/Accident									16.8		10	18.7		38.5		
No. of Impact Trauma Fatalities (I.T.F.)									163		72	232		99		
No. of Accidents									10		3	9		2		
No. of I.T.F./Accident									16.3		24	25.8		49.5		
No. of Fire Fatalities (F.F.)									144		74	144		15		
No. of Accidents									10		3	9		2		
No. of F.F./Accident									14.4		24.7	16.0		7.5		
Average																

B-2

TABLE B-1 : APPROACH ACCIDENTS, CHARACTERISTICS AND INJURIES

Accid. No.	14	15	16	17	18	19	20	21	22
	Engine		Wing		Subsystems			Electric System	Seats
	Power	Separated	Separated	Tank Ruptured	Fuel Line Ruptured	Hydraulic Line Ruptured	Hydraulic System		
1-1		1 & 3 Final Impact	-	-	-				
1-3		All 4 Eng.	-	-	-				2 Triple Seat Units
1-4	Idle	-	-	-	-				All 1st Class Seats Some Coach Seats
1-5	Full	1 & 2	-	-	-				Seat Leg Failures
1-6		1 & 3	Lt. Wing Demolished	Lt. Wing	Yes				Seat Leg Failures Energy Absorbing Support Structure
1-7		Lt. Eng.	Lt. Wing at Dike	-	At Eng. of Left Wing				
1-8		1 & 3	-	Lt. Wing	-				Captain's Seat Slid Back Aftr Embarkment Hit. Seats & Tracks Failed.
1-9		-	Lt. Wing Rt. Wing	Yes	-				Seats Failed. Forces Within Human Tolerance
1-10		1 & 3	Lt. Wing	Lt. Wing	Yes				Torn from Support Struct. During Last 180m of Slide
1-11		#3	-	-	-				
1-12		1 & 3	Severe Rt. Wing Damage	Yes	-				Detached & Twisted
1-103		Nos. 3 & 4	-	Yes	-				Seat & Belt Failures
No. of S.I.	186		101	159	111			35	155
No. of Accids.	11		5	7	4			1	9
No. of S.I./Acc.	16.9		20.2	22.7	27.8				17.2
No. of I.T.F.	269		247	257	186			0	275
No. of Accids.	11		5	7	4			1	9
No. of I.T.F./Accid.	24.5		49.2	36.7	46.5				30.6
No. of F.F.	182		81	164	68			43	146
No. of Accids.	11		5	7	4			1	9
No. of F.F./Acc.	16.5		16.2	23.4	17				16.2
Average									

TABLE B-1 : APPROACH ACCIDENTS, CHARACTERISTICS AND INJURIES

Accid. No.	23	24	25	26	27	28	29	30	31	32	33
	Subsystems			Approach and Impact							
	Flap Position	Cabin Emergency Lights		Airspeed	Rate of Descent	Last Heading	Angle of Attack	g Value	Descent Angle	Stall	Landing Severity
		On	Failed	KTS.	mps/fpm						
1-1	25°		-	147	3.2/625	270°	5° Nose Up	-			
1-3	Full 50° Down		X	155	8.8/1740	71°	Nose Up	1.5g VT (Small)			
1-4	50°		-	135/140	10.2/2000	70°	2.5° Nose Up	-		Yes	Hard Touchdown
1-5	37°		X	113	7.9/1550	-	30° Nose Up	-	4.5°	Yes	
1-6	18°		-	195	10.2/2000	180°	Nose Up	-			
1-7	25°		X Batteries Dispatched	122	4.8/950	-	-	2.0g Vert.			
1-8	50°		X	149	5.4/1060	318°	5.4° Nose Up	Struck Rwy. Hard			
1-9	50°		-	168	4.1/800	350°	-	-	4.5° (5.5° Bank)		
1-10	30°		-	123	7.6/1500	-	-	-			
1-11	30°		-	147	7.1/1400	229°	-	-			
1-12	25°		-	160	20.3/4000	-	10° Nose Up	-			
1-103	Full 30° Down		X	140	5.8/1150	047°	Nose Down	-	> 4.5°		
Avg.	35.4°										
No. of S.I.			94							14	
No. of Accids.			6	12	12					2	
No. of S.I./Acc.			15.7							7	
No. of I.T.F.			29							18	
No. of Accids.			6							2	
No. of I.T.F./Acc.			4.8							9	
No. of F.F.			108							25	
No. of Accids.			6							2	
No. of F.F./Acc.			18							12.5	
Average				146.4	8.0/1564						

TABLE B-1 : APPROACH ACCIDENTS, CHARACTERISTICS AND INJURIES

Accid.	34	35	36	37	38	39	40	41	42	43	44
	Short of Runway Threshold	Runway		Runway Surface	Light Support Struct.	Vehicle	Wooded Hillside	Buildings	Embankment	Dike	Trees
		On	Off								
1-1	3220m (10,560')		X				9.6° Up Slope				Initial Impact Rt. Wing
1-3	9650m (31,680')		X								
1-4		X									
1-5			X					Several			X
1-6	29000m (95,040')		X								
1-7	490m (1600')	Stopped 140m Beyond Threshold			490m (1600') Short					240m (785') Short	
1-8	150m (500')	Trail of Fire		Slope Prevented Fuel Puddles	150m (500') Short				Sheared Rt. Main Gear		
1-9	5310m (17,400')		X								X
1-10	730m (2400')		X		10 Nonfrangible Lite Towers						
1-11	86m (280')										
1-12	2050m (6660')							Tail First into Fire Station			
1-103	1836m (6023')		X					7			
Avg.	4500m (14,700')										
No. of S.I.		11	120		21		4	49	4	4	25
No. of Accids.		3	6		4	0	1	3	1	1	3
No. of S.I./Acc.		3.7	20		5.3		4	16.3	4	4	8.3
No. of I.T.F.		0	279		87		29	54	0	0	82
No. of Accids.		3	6		4	0	1	3	1	1	3
No. of I.T.F./Acc.		0	46.5		21.8		29	18	0	0	27.3
No. of F.F.		0	155		25		29	85	0	0	90
No. of Accids.		3	6		4	0	1	3	1	1	3
No. of F.F./Acc.		0	25.8		6.3		29	28.3	0	0	30
Average											

B-5

TABLE B-1 : APPROACH ACCIDENTS, CHARACTERISTICS AND INJURIES

Accid. No.	45	46	47	48	49	50	51	52
	Terrain & Aircraft Slide							
	Marshland	Ditch	Description	Wreckage Area	Deceleration	Total Distance	Total Time	
1-1			104m thru Lite Foliage. Stopped at Large Trees.			104m (340')		
1-3				381m x244m	Rapid			
1-4			900m (2950')			900m (2950')		
1-5								
1-6	Soft Mud Under 30 cm Water		488m (1600')			488m (1600')		
1-7			376m (1235')			376m (1235')		
1-8			914m (3000')			914m (3000')		
1-9		X	35m GR Impact Gnd. 60m Lt. Wing Tip Impact Gnd. 168m Wing Broke in Sec. 303m A/C Rest in Ravine			303m (995')		
1-10			No. 7 Tower. 8 & 9 Lt. Wing Damaged. 9-10 Struck Ground. 14-17 Fus. Disintegrated			457m (1500')		
1-11						1350m (4430')		
1-12			800m (2620')			800m (2600')		
1-103						260m (850')		
No. of S.I.								
No. of Accids.								
No. of S.I./Acc.						11		
No. of I.T.F.								
No. of Accids.								
No. of I.T.F./Acc.								
No. of Fire Fat.								
No. of Accids.								
No. of F.F./Acc.								
Average						619m (2030')		

TABLE B-1 : APPROACH ACCIDENTS, CHARACTERISTICS AND INJURIES

Accid.	53	54	55	56	57	58	59	60	61	62
	Meteorological Information									
	Time	Temp.	Dewpoint Temp.	Visibility	Light Condition	Snow Rain Fog	Winds	Gusts	Wind Shear	Icing
1-1	1901:27 est	13°C (56°F)	11°C (52°F)	-	Hours of Darkness	Rain 30 Sec. After Impact	13KTS 300°	17 KTS		
1-3	1921:30 pst	13°C (55°F)	11°C (52°F)	6437m (21,120')	Darkness	Light Rain and Fog	10 KTS 060°	NIL		
1-4	1521:00 edt	-	-	Poor	-	Heavy Rain Shower	12 KTS 130°			
1-5	1428:00 cst	-3°C (27°F)	-3°C (26°F)	1609m fog	Daylight Hours	-	6 KTS 250°			No
1-6	2342:00 est	22°C (72°F)	15°C (59°F)	16km Clear No Moon	Darkness	-	8 KTS 080°			
1-7	1851:00 est	-	-	3220m Poor	Darkness	Heavy Rain (Thunderstorm)	6 KTS. 160°		Yes	
1-8	1542:32 est	5°C (41°F)	3°C (38°F)	1207m (3960')	Daylight	Rain & Fog	10 KTS 310°		Yes 8 KTS Per 30m Alt.	
1-9	0733:58 edt	20°C (68°F)	19°C (66°F)	3200m Patcht Gnd. Fog	Daylight	Dense Fog	0 KTS			
1-10	1605:11 edt	25°C (77°F)	22°C (71°)	3220m (10,560')	Daylight Hours	Heavy Rain (Thunderstorm)	7 KTS. 210°	Blow. Hard N thru E	Yes + 15/30 KTS.	
1-11	2002:00 est	21°C (69°F)	18°C (65°)	Wall of Water	Night Darkness	Heavy Rain Fog	5 KTS. 190°	5 Kn 2.5 mps Down Draft		
1-12	2338:00 gmt	-	-	-	Night	Thunderstorm	-	-		
1-103	0256:00 gmt	28°C (75.2°F)	23°C (73.4°F)	8km (5 mi.)	Night	Fog Patches 050°	2 KTS. 050°			
						S R F				
No. of S.I.						0 8 5		34	20	
No. of Accids.		9			11		11	3	3	
No. of S.I./Acc.								11.3	6.7	
No. of I.T.F.								116	87	
No. of Accids.					11			3	3	
No. of I.T.F./Acc.								38.7	29	
No. of F.F.								54	25	
No. of Accids.					11			3	3	
No. of F.F./Acc.								18	8.3	
Average		16°C (60°F)	13°C (55°F)		Dark 7 Day 4		7.4 Kn	11kn		

TABLE B-2: LANDING ACCIDENTS, CHARACTERISTICS AND INJURIES

1	2	3	4	5	6	7	8	9	10	11	12	13
Accid. No.	A/C	Passengers and Crew					Aircraft Damage	Subsystems				
		T	S	Fatalities				Landing Gear				
				I.T.	Fire	Drwn		Separated From Aircraft	Tires Failed	Position		Safe Light
										Up	Dn.	Safe
2-0	DC8	122	33	0	17	0	Destroyed by Impact & Fire in 15 Min.	2 Main			X	
2-0.1	B707	66	0	0	0	0	Substantial Damage	Landing Gears				
2-1	B727	91	35	0	43	0	Destroyed by Gnd Impact & Fire	Both Main Gear	-		X	
2-1.1	B727	83	0	0	0	0	Substantial Damage	Left & Rt Main				
2-2	DC9	119	0	0	0	0	Nose Gear, Nose Sect., Wings & Fus.					
2-3	DC9	63	11	0	0	23	Remained Intact					
2-4	DC9-32	94	0	0	0	0						
2-5	DC-8-62	156	11	0	0	0	Beyond Economic Repair	RET. Main, Lt. Main & Nose				
2-6	B727	55	11	0	2	0	Destroyed by the Post Crash Fire	Rt. Main				
2-6.1	C580	31	3	1	27	0	Destroyed by Impact & Post Crash Fire	Nose Gr. Lt. Main			X	
2-7	DC-8-61	128	8	0	0	0		2 Main				
2-7.1	B737			0	0	0						
2-8	DC9	26	16	0	0	0	Substantial Damage Due to Impact	Nose & 2 Main				
2-9	B707	65	3	0	0	0	Fus. Destroyed by Postcrash Fire		Lt. Nose Gr. 1622m Past Threshold			
2-10	B707	101	5	1	95	0	Destroyed by Impact and Fire	Nose Gear Folded			X	
Σ	14	1200	103	2	184	23						

TABLE B-2: LANDING ACCIDENTS, CHARACTERISTICS AND INJURIES

1 Accid. No.	2 A/C	3 Passengers and Crew					7 Aircraft Damage	9 Separated From Aircraft	10 Tires Failed		11 Subsystems Landing Gear		12 Safe Light		13
		T	S	6 Fatalities					Position Up	Down	Safe	Warning			
				I.T.	Fire	Drwn									
2-11	B727	50	11	1	0	0	A/C Destroyed by Impact & Grd Fire	Nose & Main	No		X				
2-12	B727	88	19	18	19	0	A/C Destroyed		No		X				
2-13	DC-9-31	106	86	0	0	0	A/C Destroyed by Impact			X					
2-14	DC-9-31	85	22	38	24	0	A/C Destroyed				X				
2-15	DC-8	189	23	10	0	0	A/C Destroyed	Main			X		X		
$\Sigma$	19	1718	264	69	227	23									
No. of Accidents								12		1	8				
No. of Serious Injuries(s)								156		86	151				
No. of Impact Trauma Fatalities (I.T.)								13		0	69				
No. of Fire Fatalities (F.)								184		0	225				
Average															

TABLE B-2: LANDING ACCIDENTS, CHARACTERISTICS AND INJURIES

Accid. No.	14	15	16	17	18	19	20	21	22	23
	Subsystems									
	Engine Power	Engine Separated	Wing Separated	Wing Tank Rupture	Fus.	Fuel Line Rupture	Hydraulic Line	Hydraulic System	Electric System	Seats
2-0		No. 4 & 2		Left Wing Root	-					
2-0.1		3 Eng.	Intact & Not Separated	Fuel Fumes	3 Sect.					Some Partially Loose Seats. Few Failures
2-1	1/2 Throttle	#1	-	All Remained Intact		In Fus. at Right Main Gr		Ruptured Gen'r Leads @ Rt.M.Gr.		
2-1.1										
2-2										
2-3	Fuel Exhaust'n									
2-4						Buckles w/ Tail on Rwy				
2-5		#1, 3 & 4 During Rollout	Rt. Wing Root Damage	#4 Aux. Fuel Tank	Split Open Just Aft of Wing					
2-6			Rt. Wing Damaged but Did Not Separate							8 Broken Seats (5-10g at 30° to A/C)
2-6.1		X	Outb'd of the Nacelles	Yes						
2-7		No. 1			Lwr. RR Fus. Damaged	No. 1 Eng.				4 Pax Seats Collapsed
2-7.1										Aft Attendant Seat Failed
2-8		Both Eng. & Pylons			Aft Fus. Separated					
2-9							2 Nose Gr. Steering Lines			
2-10		All 4 Eng.		No. 4 Main Wing Tank						No Problem

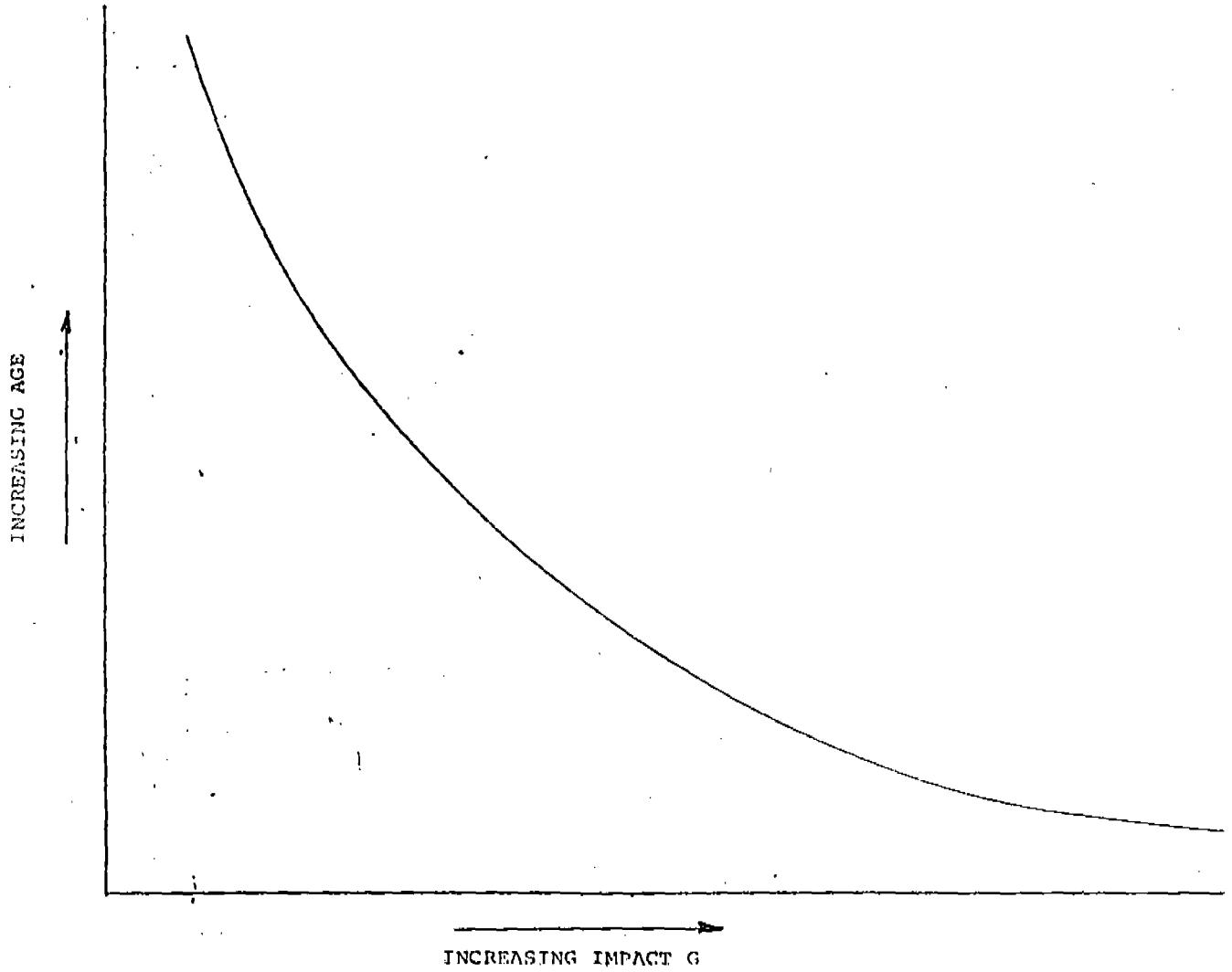

FIGURE F-5: IMPACT G TOLERANCE AS A FUNCTION OF AGE

## 7.0 Flailing Distance and Volume Reduction

An indicator of the possibility of impact of the occupant with hard structure in his vicinity is the surface defined by all the points which his extremities could reach. Thus a design concern is whether hard structure may be found within that surface. This can be decided without simulating impact dynamics.

An occupant response code will have the position of the occupant in an accident, and will indicate contacts which he makes. The computation of the contact forces on impact does not seem to be within the capacity of present-day occupant response programs.

When the occupant is surrounded by a defined structural surface, such as a cockpit, the reduction of its volume in an accident is another qualitative indicator of injury potential. Clearly a drastic volume reduction indicates certainty of injury, but there does not appear to be any quantitative means of generally correlating volume reduction and injury potential.

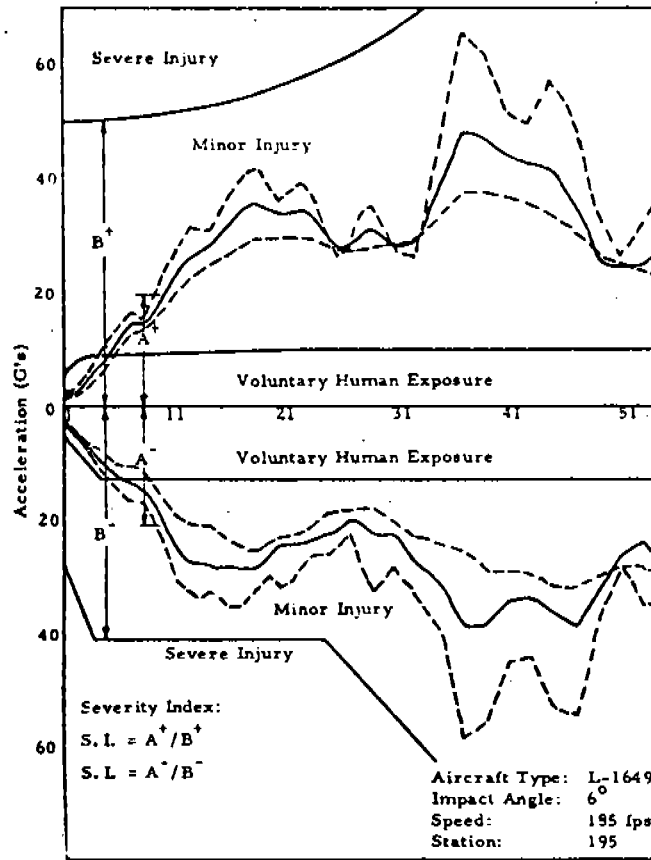

FIGURE F-4; SUPERPOSITION OF SHOCK SPECTRA AND HUMAN TOLERANCE TO OBTAIN SEVERITY INDEX (REFERENCE 7, FIGURE 8)

## 6.0 Shock Spectra

In 1967, Fitzgibbon and Vollmer\* proposed a method for measuring the severity of an impact acceleration transient, which is based on response spectra. The proposed severity index is the ratio of two functions: (1) the "shock spectrum" of the particular acceleration history and (2) a "human tolerance" curve of acceleration versus frequency. The human tolerance curves (Figure F-4) were derived from then-existing criteria for acceleration vs pulse duration. The shock spectra of a particular acceleration history is the graph versus frequency of the maximum acceleration response of a single degree of freedom system with that natural frequency (and prescribed damping ratio), when subjected to the input acceleration transient in question. Thus the ratio of these two spectra, itself a function of frequency, is a measure of the degree of "injury potential" in a particular impact pulse.

The shock spectra approach provides a means of making organized sense out of impact records, and would be of use in the development of design criteria for seats and other components. Because of its limitation to linear systems it seems to have been ignored in application to structures experiencing large deformation. But the idea of using a "severity index" which is the ratio of output acceleration spectrum (calculated in a simulation code or measured in an impact test) to an established "human tolerance spectrum" remains a viable and attractive approach.

---

D. D. Fitzgibbon and R. P. Vollmer, "Crash Loads Environment Study", FAA contract FA 66 WA-1511, Report DS-67-2 (1967).

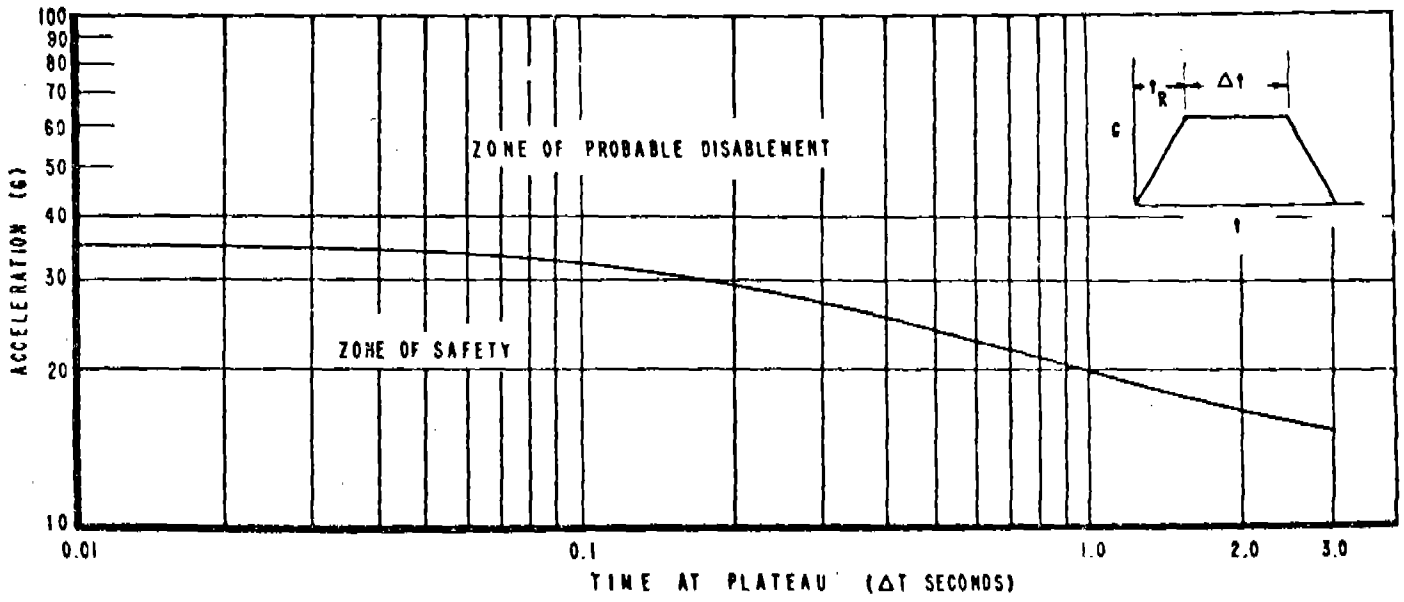

$\Delta t$ (SEC)	0-.03	.06	.084	.13	.15	.19	.22	.27	.32	.38	.45	.52	.61	.73	.87	1.0	1.22	1.5	1.92	2.45	3.0
G	35	34	33	32	31	30	29	28	27	26	25	24	23	22	21	20	19	18	17	16	15

REFERENCE MIL 9479B (USAF)

FIGURE F-3: ACCELERATION LIMIT ( $+G_{XL}$ ) (RISE TIME  $\geq$  .03 SEC)

5.0 Off-Axis Acceleration

There has been little if any study of injury tolerance in situations where the body acceleration vector does not lie along one of the principal (x, y, z) body axes, i.e., where the "G vector" has components  $G_x$ ,  $G_y$ ,  $G_z$  of which more than one is nonzero. The "natural" engineering approach would be a criterion based on vectorial combination of the relative injury measures in each direction:

$$\left[ \left( \frac{G_x}{G_{xL}} \right)^2 + \left( \frac{G_y}{G_{yL}} \right)^2 + \left( \frac{G_z}{G_{zL}} \right)^2 \right]^{1/2} < 1$$

where  $G_{xL}$ ,  $G_{yL}$ ,  $G_{zL}$  are limit allowable values for each direction.

The Air Force uses this criterion for ejection seat design, but modifies it in cases where  $G_z$  is positive (spinal compression) by replacing the z-component by the Dynamic Response Index:

$$\left[ \left( \frac{G_x}{G_{xL}} \right)^2 + \left( \frac{G_y}{G_{yL}} \right)^2 + \left( \frac{DRI}{DRI_L} \right)^2 \right]^{1/2} < 1$$

(MIL-S-9479B, USAF). For the limit values the specification is

$$DRI_L = \begin{cases} 18 & \text{if } |G_z / G_L| < \tan 5^\circ \\ 16 & \text{otherwise} \end{cases}$$

and the values  $G_{xL}$ ,  $G_{yL}$ ,  $G_{zL}$  depend upon their durations (Figure F-3 shows the relation for  $G_{xL}$ ).

This criterion has the advantage of simplicity of application but derives from an arbitrary means of combining the effects of orthogonal components of the nonorthogonal acceleration vector, which lacks experimental verification.

#### 4.0 Leg Injury Criteria

For the same reasons discussed above, transport impact study demands a criterion for tolerance of the lower leg to impact. Snyder's comprehensive survey\* states that only four studies are known and all are unpublished. Here also, the impact criterion would probably require occupant response dynamic analysis in order to define impact velocities and associated acceleration pulses..

\*R. G. Snyder, SAE 700398, p. 1400, Human Impact Tolerance"

The exponent  $n$  is a number greater than one, and when taken at 2.5 results in an injury criterion whereby an SI of 1000 gives the upper bound of survival and 700 predicts moderate injury. It is readily apparent that the severity index cannot be applied for long-duration acceleration histories, since it would indicate injury from very low levels of acceleration; e.g., fatality from 1000 sec at 1g.

The Head Injury Criterion (HIC) of Federal Motor Vehicle Safety Standard 208 is related to the SI but is somewhat more complicated in application.

$$HIC = \text{MAX} \left( \frac{1}{t_2 - t_1} \int_{t_1}^{t_2} \frac{a}{g} dt \right) \cdot (t_2 - t_1)$$

where  $t_1$  and  $t_2$  are any two points ( $t_2 > t_1$ ) in the acceleration history.

Head injury is probably of particular concern in impact studies of transport aircraft where passengers are restrained only by lap belts, and respond to airplane longitudinal deceleration by rotating the upper body about the restraint, impacting into facing seat backs. Application of head impact injury criteria would require use of an occupant response model to predict the skull-seatback impact velocity, as well as carefully constructed data base relating impact velocity to acceleration pulses experience in the head impact event. This data base would probably be obtained experimentally.

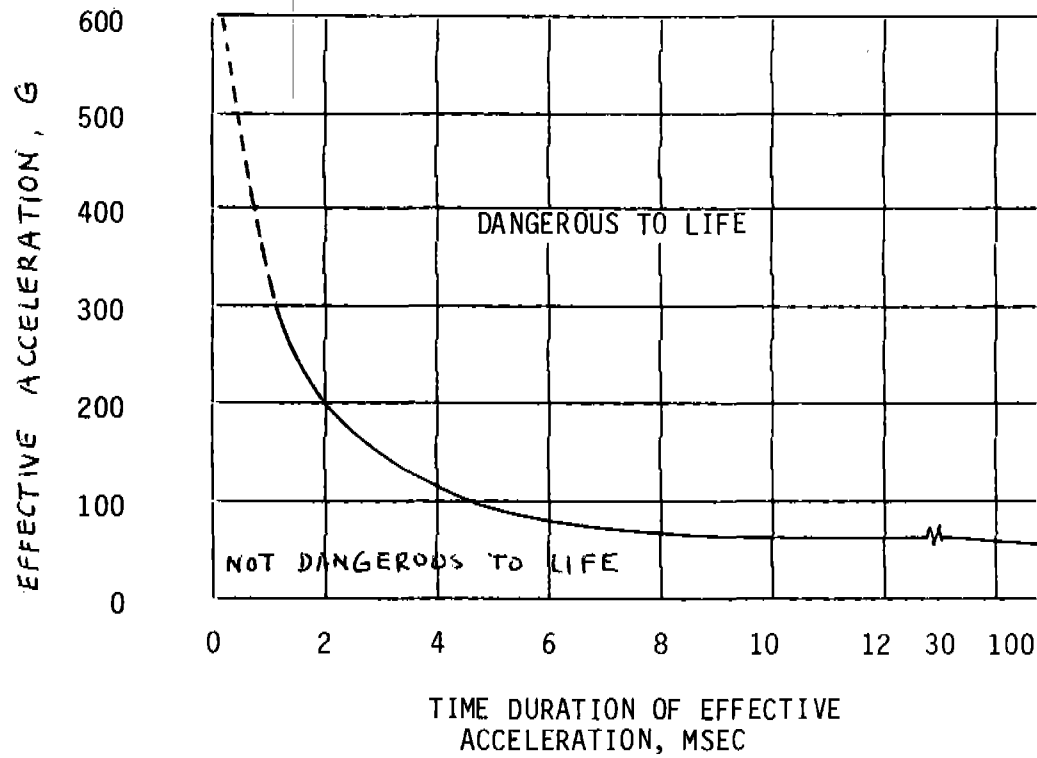

FIGURE F-2: WAYNE STATE TOLERANCE CURVE FOR THE HUMAN BRAIN IN FOREHEAD IMPACTS AGAINST PLANE, UNYIELDING SURFACES. (REFERENCE 2, FIGURE 15)

### 3.0 Head Injury Criteria

Studies of head impact tolerances have resulted in a number of injury criteria. Reference 1, Page 48 identifies four different types:

- peak G
- peak transmitted force
- Severity Index (SI)
- Head Injury Criterion (HIC)

The "Wayne Curve" has been developed at Wayne State University from extensive study with cadavers and animals. This criterion shown in Figure F-2 is intended to show impact tolerance for the human brain in forehead impacts against plane, unyielding surfaces. The tolerable level depends upon both acceleration and duration.

The Severity Index developed by Gadd is a single number which was proposed to account for the relatively higher dependence of injury on acceleration as against duration. From a history  $a(t)$  of head acceleration in impact from time  $t_0$  to time  $t_f$  (in seconds), the index is calculated by

$$SI = \int_{t_0}^{t_f} a/g^n dt$$

where  $a/g$  is the acceleration in g's.

## 2.0 Other Spinal Models

Elaboration on the principles underlying the Dynamic Response Index model leads to detailed, multi-degree-of-freedom models of the spine, with individual vertebra treated as rigid bodies connected by deformable elements. King and Prasad have developed a 78 degree of freedom model which simulates spinal motion in the mid sagittal plane (the body plane of "symmetry"). (J. Appl. Mech. 4, 3 546-550, 1974). Belytschko, et. al. have developed a three-dimensional model which includes vertebrae, pelvis, head and ribs. (USAF AMRL TR-76-10, 1976). Summaries of these two models are repeated by Laanenen in Reference 2, Page 67.

Used by themselves, these models promise much utility for predicting details of spinal response, but they would appear to require a fairly complex and sophisticated data base as well as a well-correlated means of inferring spinal injury potential from their output. It is not clear whether such means currently exist. Moreover, the demands made by multi-degree-of-freedom biomechanical subcomponent models upon computer core and processing time would tend to rule out their incorporation into general aircraft impact evaluation computer programs, at least at present.

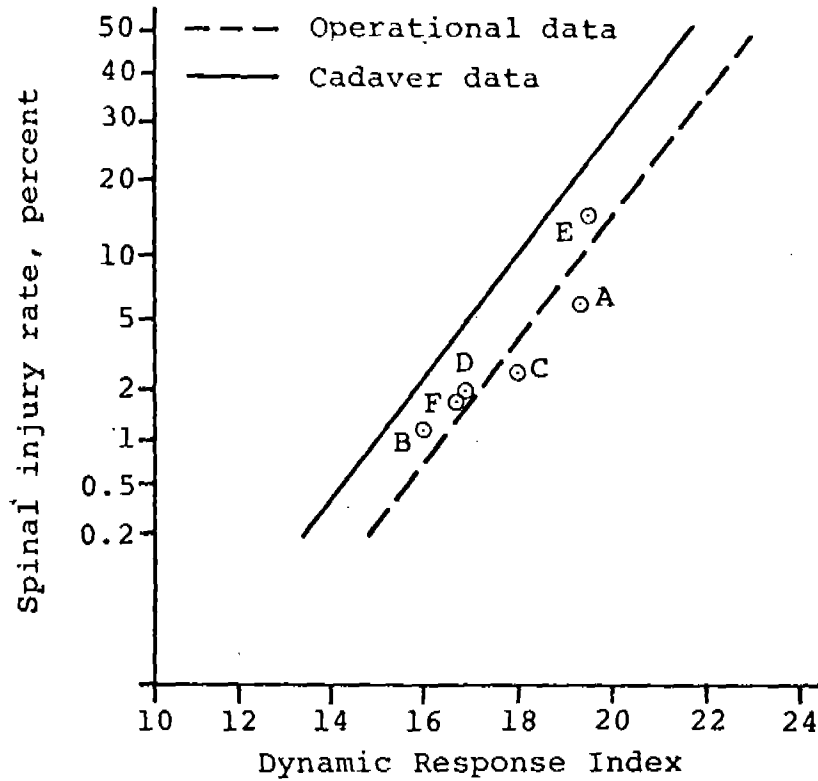

<u>Aircraft type</u>	<u>Nonfatal ejections</u>
A*	64
B*	62
C	65
D*	89
E	33
F	48

\*Denotes rocket catapult

FIGURE F-1: EXPERIMENTAL VERIFICATION OF DYNAMIC RESPONSE INDEX  
 (REFERENCE 2, PAGE 66)

The DRI model has been shown to correlate with spinal injury rate in aircraft seat ejection studies (Figure F-1). It has the advantages of simplicity and ease of incorporation into aircraft impact response computer programs of the finite element or lumped mass variety, such as KRASH, DYCAST, ACTION, SOMLA, etc.

For design of adjustable, upward, aircraft seat ejection systems, MIL-S-9479B (USAF) uses

$$\omega = 52.9 \text{ radius/sec.}$$

$$J = 0.224$$

In application of the Dynamic Response Index, it should be borne in mind that the model is useful in predicting spinal injury and compression loading, such as would be expected in seat ejection response or perhaps in aircraft impacts where the occupant is restrained by a shoulder harness. However, the typical airline passenger impact position (body folded forward, lap belt restraint) will usually develop extensional loading of the spine; and here DRI application may be questionable.

1.0 Dynamic Response Index (DRI)

The "Dynamic Response Index" is a simple measure of spinal injury severity resulting from short duration acceleration applied in the upward, vertical direction  $+G_z$  (to compress the spine). The index is the output of a one-degree-of-freedom spring-mass-damper oscillator whose parameters have been determined from vibration and impact tests of human subjects and cadavers. This model is embodied in a single equation

$$\ddot{\delta} + 2\zeta\omega\dot{\delta} + \omega^2\delta = \ddot{z}$$

governing the compressive deformation  $\delta$  of the vertebral column. The input  $z$  is the applied vertical acceleration (e.g., at the seat bucket). The parameters of the system are

$\omega$  , the natural frequency

$$\omega^2 = k/m \text{ where}$$

$k$  = stiffness

$m$  = mass

$\zeta$  = damping ratio

For a given input acceleration pulse  $\ddot{z}$ . The maximum deformation  $\delta_{\max}$  determines the Dynamic Response Index (DRI)

$$DRI = \frac{\omega^2 \delta_{\max}}{g}$$

where  $g$  is the gravitational acceleration  $9.81 \text{ m/s}^2$  ( $32.2 \text{ ft/sec.}^2$ ).

Thus the DRI is a measure of the peak acceleration response level.

## APPENDIX F

### HUMAN TOLERANCE TO IMPACT

This appendix contains a discussion of human tolerance limits to loads experienced in aircraft impacts. Indices and criteria applicable to spine loading and head impact are given prime concern. The tolerance test data appears to apply only to military personnel although Figure F-5 gives an indication of the variation of the tolerance limits for a wide range of ages for the flying public.

The discussion on human tolerance limits and index indicators covers the following:

- 1.0 Dynamic Response Index
- 2.0 Other Spinal Models
- 3.0 Head Injury Criteria
- 4.0 Leg Injury Criteria
- 5.0 Off-Axis Acceleration
- 6.0 Shock Spectra
- 7.0 Flailing Distance and Volume Reduction

TABLE E-3: STATIC LOAD REQUIREMENTS FOR  
ANCILLARY EQUIPMENT ATTACHMENTS  
(REFERENCE 3, PAGE 154)

Downward	50G
Upward	10G
Forward	35G
Aftward	15G
Sideward	25G

Static strength requirements for ancillary equipment and component attachments are specified in the Design Guide at Reference 3, Page 154 and Reference 4, Page 195. These static strength requirements, shown in Table E-3, are probably very conservative (Reference 4, Page 195) and if applied to items of substantial mass, "significant weight penalties may be incurred or the available supporting structure may not be capable of withstanding the anticipated loads" (Reference 3, Page 154). Probably a more realistic approach would be to lay down requirements in terms of maintaining attachment under specified base acceleration pulses. These would be satisfied by analysis or testing.

The Design Guide contains a sprinkling of tables and charts of very useful design data (an index of this could be very helpful for the designer).

Examples:

- o Crippling allowables for aluminum extrusions and formed sections, Reference 3, Page 216 and 217.
- o Material properties of selected flexible cellular polymers, Reference 4, Page 226 et seq.
- o Ignition conditions for abraded metal particles, Reference 3, Page 98.
- o Restraint webbing characteristics, Reference 4, Page 150.

Finally, the Guide contains an extensive but carefully selected list of references to technical works and each volume of the Guide is graced with an index.

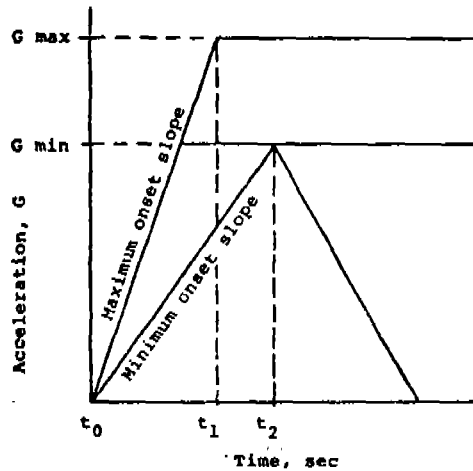

Test	Configuration	Parameter	Cockpit seats		Cabin seats	
			Qualification	R&D	Qualification	R&D
1	 Dummy inertial load	$t_1$ sec	0.036	0.020	.050	.028
		$t_2$ sec	0.051	0.051	.074	.074
		G min	46	46	32	32
		G max	51	51	37	37
		$\Delta v$ min, ft/sec	42	42	42	42
2a	 Utility and observation helicopters Dummy inertial load	$t_1$ sec	0.062	0.036	.062	.036
		$t_2$ sec	0.104	0.104	.104	.104
		G min	16	16	16	16
		G max	21	21	21	21
		$\Delta v$ min, ft/sec	30	30	30	30
2b	 Light fixed-wing, cargo and attack helicopters Dummy inertial load	$t_1$ sec	0.057	0.033	.057	.033
		$t_2$ sec	0.100	0.100	.100	.100
		G min	14	14	14	14
		G max	19	19	19	19
		$\Delta v$ min, ft/sec	25	25	25	25
3	 Dummy inertial load	$t_1$ sec	0.066	0.038	.081	.046
		$t_2$ sec	0.100	0.100	.127	.127
		G min	28	28	22	22
		G max	33	33	27	27
		$\Delta v$ min, ft/sec	50	50	50	50

FIGURE E-13: REQUIREMENTS OF DYNAMIC TESTS IF SUBSTITUTED FOR STATIC TESTS  
(REFERENCE 4, PAGE 189)

Design requirements for impact tolerant seats and for energy absorbing cargo restraint systems appear to be very specific: the load-deflection curves must have particular characteristics, as illustrated in Figure E-11. An acceptable design must have a load deflection curve which rises to the left of and above a specified "base curve", and which attains its ultimate load above a specified "minimum acceptable load curve". These loads are static loads, which have been determined from dynamic calculation based on specific input floor pulses (e.g. 30G peak triangular pulse of 15.2 m/s (50 ft/sec) velocity change in the cockpit and 24G peak with 15.2 m/s (50 ft/sec velocity) change in the cabin area for the forward load, (Reference 4 Page 169). The design requirements for cargo restraint are similar in form to those for seats. (Figure E-12).

The Design Guide recommends both static and dynamic seat testing and presents proposed test requirements as well as useful recommendations as to how the tests should be conducted (Reference 4, Pages 181-195). Figure E-13 shows the requirements for dynamic testing of seats. Requirements are also given for research/development which involve off-axis accelerations. Particular anthropomorphic dummies are to be used; with weights representing pilot/copilot or troop/gunner (with gear). For civilian transport applications, it would probably be necessary to modify the given values.

It is to be emphasized that the specific acceleration pulses probably cannot be carried over unchanged for use in transport aircraft design. As noted earlier, the large transport by its very size places a great deal of yielding structure between impact plane and floor; thus peak loads should probably be lower for the same impact defined in terms of velocity changes.

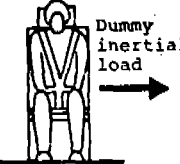
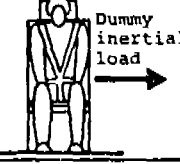
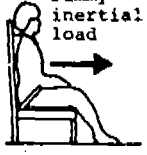
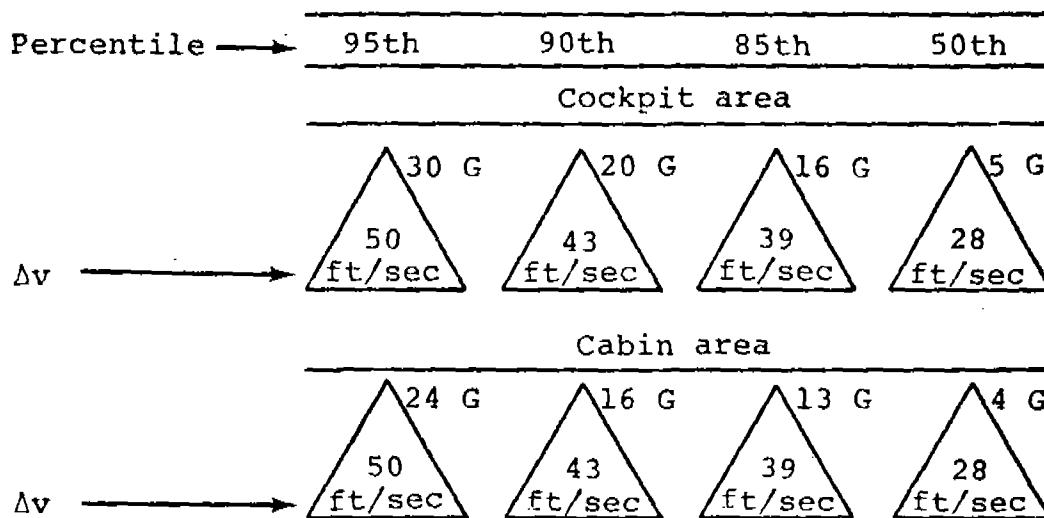

FIGURE E-10: AIRCRAFT FLOOR LONGITUDINAL PULSES FOR ROTARY - AND LIGHT FIXED-WING AIRCRAFT (REFERENCE 3, PAGE 160)

Various seat occupant computer programs are reviewed at Reference 4, Page 93 et seq., again without supplying much in the way of experimental verification.

Testing is discussed at Reference 3, Page 243 in the context of providing basic structural data for impact analysis. A study by Holmes and Colton (Reference 6, Pages 561-582) is reported which indicates that scale models can cut the cost of testing in half for prototype structures in the 1000-10000 lb range.

Volume IV of the Design Guide contains a detailed list of static test requirements for impact tolerant seats (Reference 4, Page 182) as well as requirements for dynamic tests if substituted for static tests (Reference 4 Pages 189 and 190). A useful list of references to ASMT test methods for flexible cellular plastics is provided at Reference 4 Page 228.

## 6.0 Design Requirements and Design Data

The design engineer's activity requires data in the form of material properties, geometries, conditions, and it also demands design objectives. To these ends, the Design Guide illustrates how these needs might be filled, and to what extent they remain unfilled. The "performance requirements" for impact tolerant structures (Table E-1) gives specific impact conditions which define the basis for design. Design impact velocity changes are provided, and it is specified that these velocity changes are assumed to occur on a rigid surface and with a triangular acceleration-time pulse shape. Generally, the pulse duration does not appear to be specified (and thus the peak acceleration level cannot be given), but this is reasonable since the duration depends to some extent on the particular structure involved. However, specific floor load pulses are given (Figure E-10) and this means that the designer of seats, cargo tie downs and other important protective systems has a basis to work from. It is noted that these are dynamic load conditions, rather than static. Static load requirements are specified for seats and cargo restraint systems, as discussed below.

## 5.0 Design Methods

Design techniques of various levels of sophistication and complexity appear in the Design Guide. Kinematics of the most elementary sort are described (Reference 3, Page 169) and applied to illustrate the properties of various idealized pulse shapes. Formulas and charts are provided which relate stopping distance to average deceleration (Reference 3, Page 182) and to peak accelerations for various pulse shapes (Reference 3, Page 190).

Elementary work-energy principles are derived (Reference 3, Page 174). These energy methods can be efficient and powerful means of gaining a basic understanding of impact phenomena as illustrated by analyses of earth plowing effects (Reference 3, Page 116) and of seat stroking (Reference 4, Pages 70-81). A useful formula for determining required seat stroke distance is given at Reference 4, Page 76.

Landing gear design methodology is described at Reference 3, Page 195. This discussion is rather elementary and neglects the fact that side loading which occurs during taxi is usually a critical design condition for the gear structure in large transport airplanes.

A number of digital computer programs for simulating structural response in the impact environment are reviewed briefly at Reference 3, Pages 225-242. Attention is given to KRASH, DYCAST and WRECKER (discussed elsewhere in this report) but little attempt is made to indicate the degree of confidence with which a design engineer could rely on them. For potential users of KRASH, a very important treatment of means of developing structural properties is given at Reference 3, Pages 203-224, but the intelligent use of impact simulation programs still appears to be rather an esoteric craft which can be learned only through long and painful experience. The Design Guide discussions, although somewhat obscure, is an important step in the direction of helping the average structural engineer in the use of these complex codes.

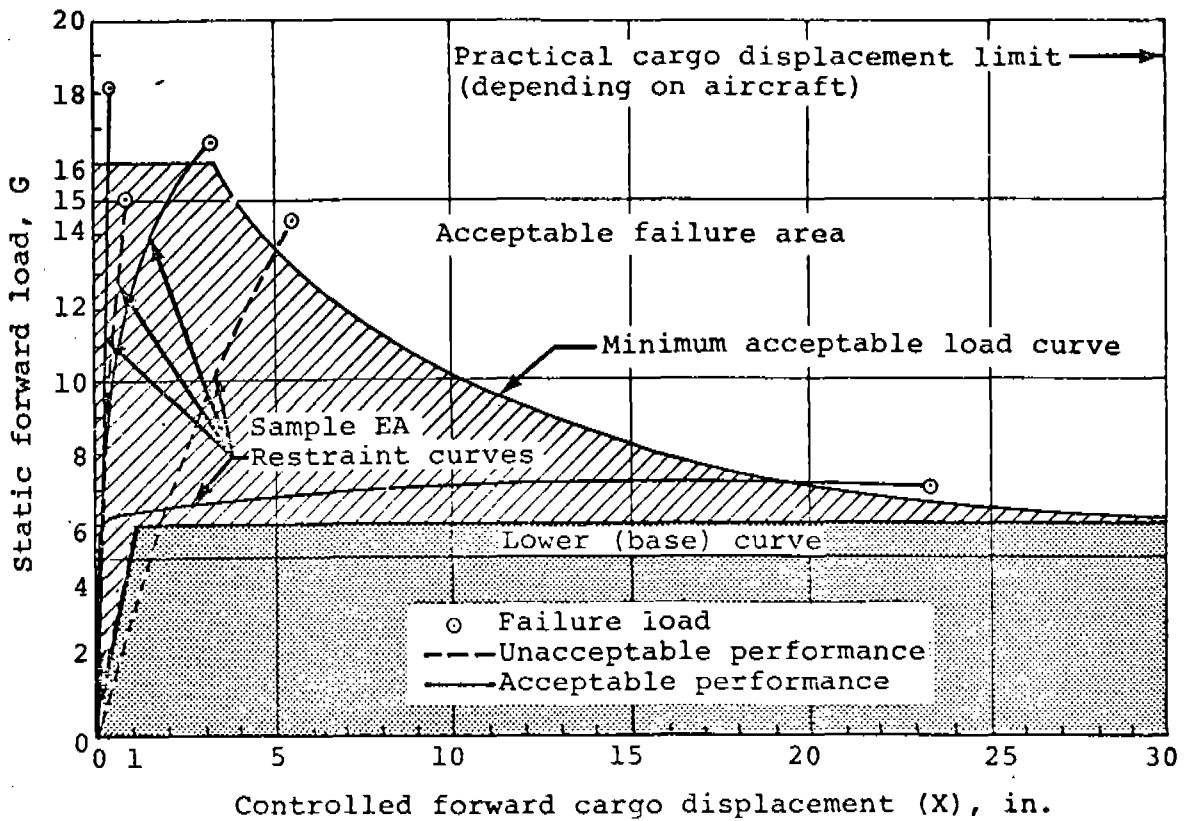
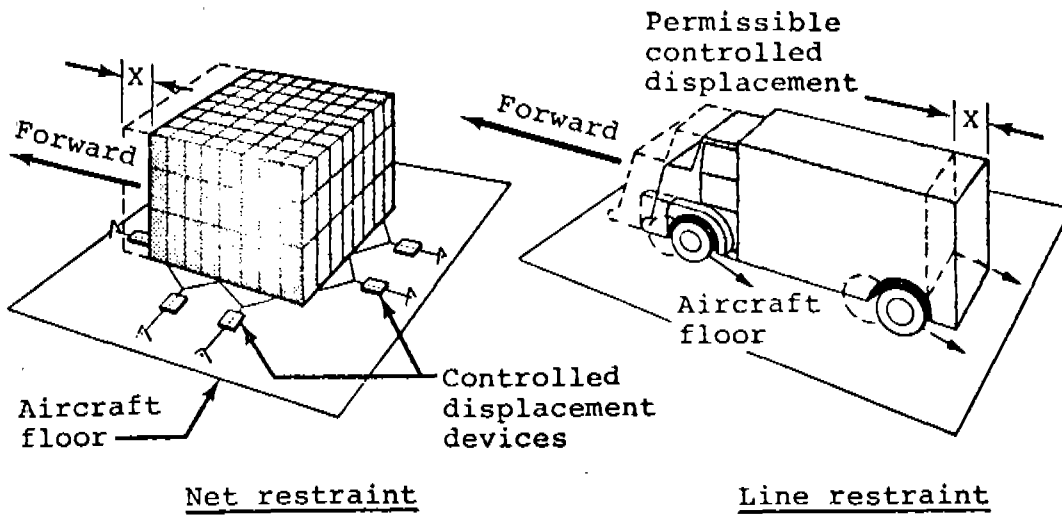

FIGURE E-12: LOAD-DISPLACEMENT REQUIREMENTS FOR ENERGY-ABSORBING CARGO RESTRAINT SYSTEMS (FORWARD LOADING OF ROTARY-WING AND FIXED-WING AIRCRAFT) (REFERENCE 3, PAGE 162)

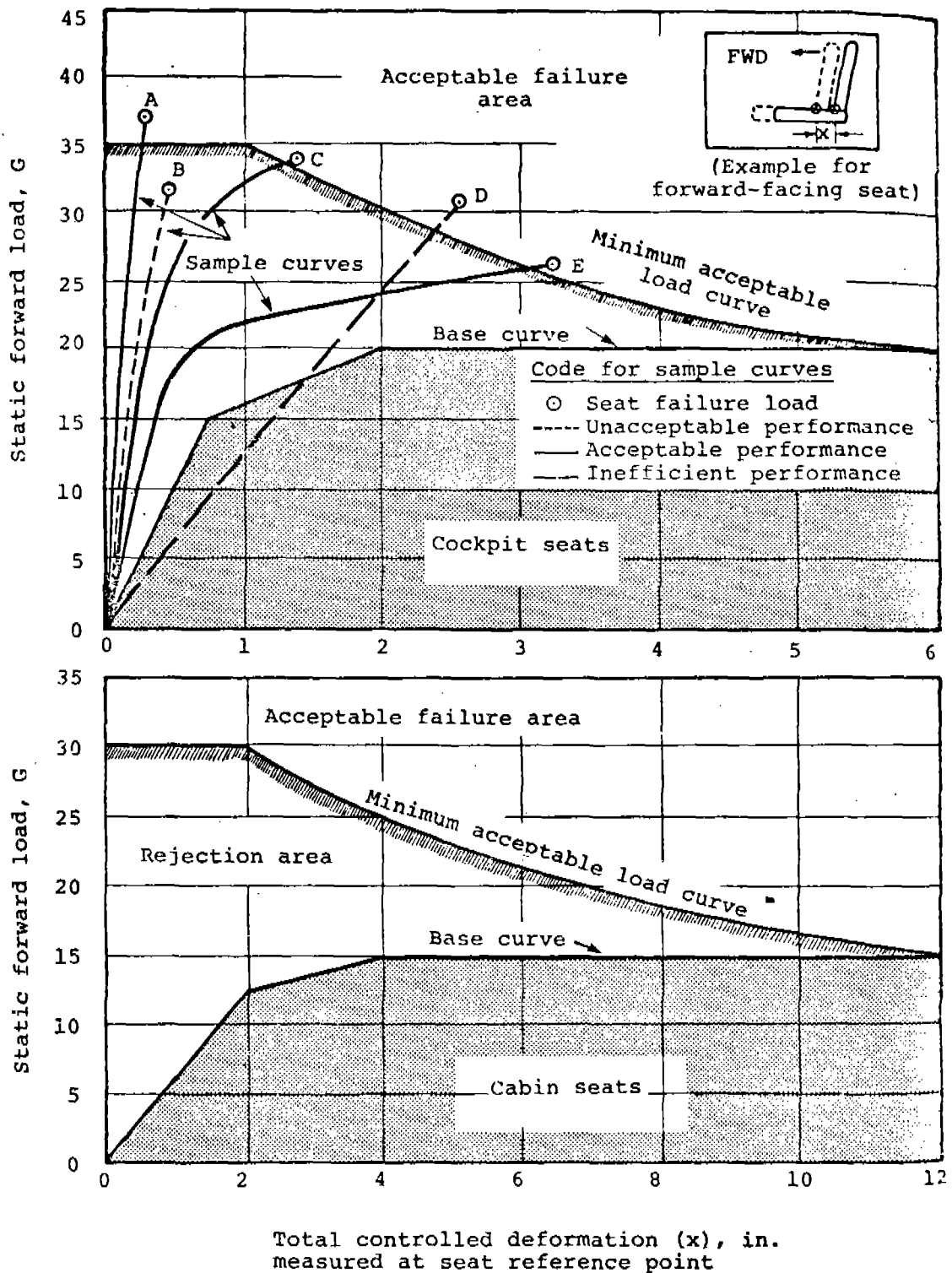
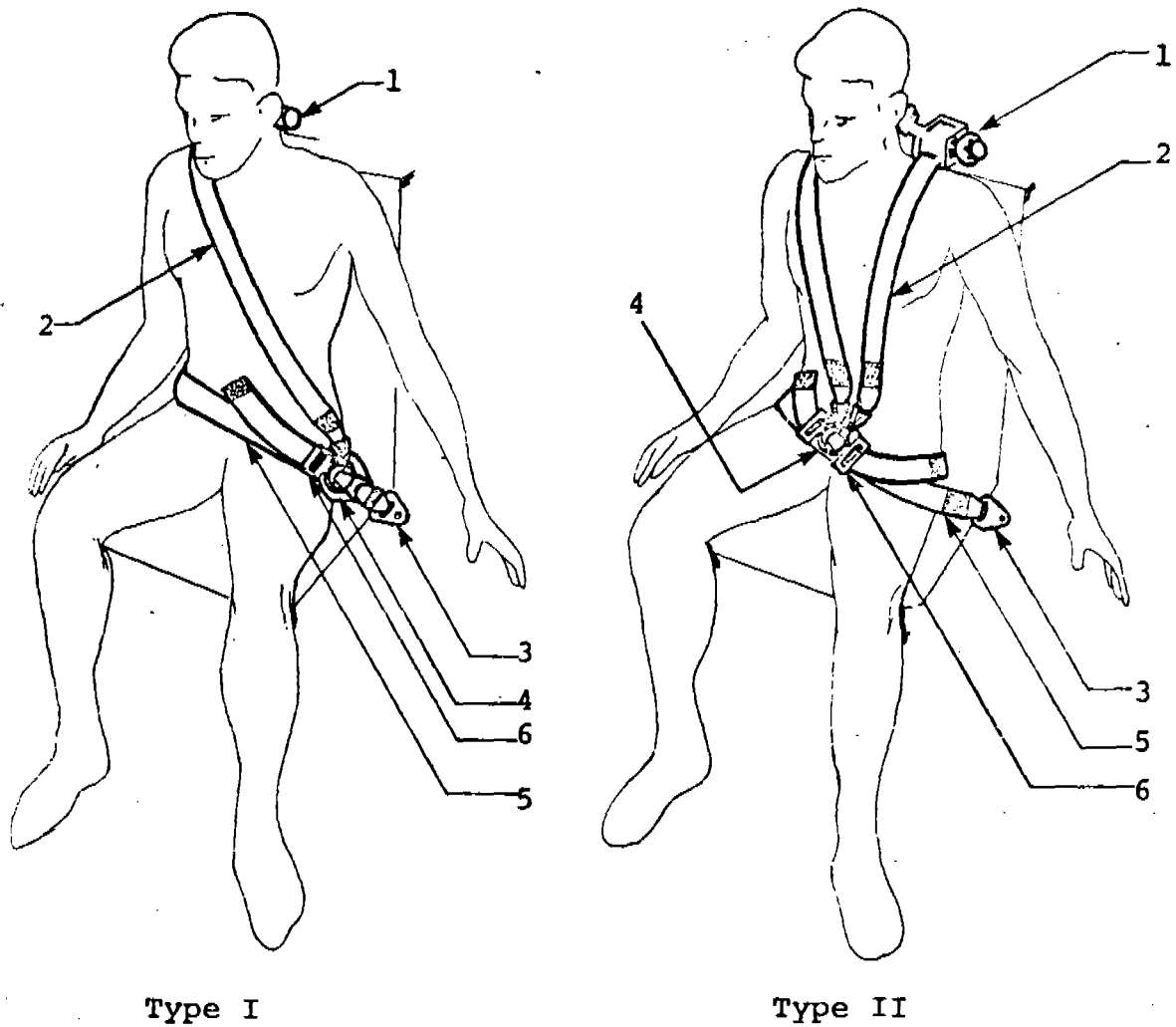

FIGURE E-11: SEAT FORWARD LOAD AND DEFLECTION REQUIREMENTS FOR ALL TYPES OF ARMY AIRCRAFT (FORWARD DESIGN PULSE)  
(REFERENCE 4, PAGE 170)



Type I

Type II

Item identity

1. Inertia reel
2. Shoulder strap
3. Lap belt anchor
4. Buckle with shoulder strap connection
5. Lap belt
6. Adjuster/fitting

FIGURE E-9: AIRCRAFT TROOP/PASSENGER RESTRAINT SYSTEMS  
 (REFERENCE 4, PAGE 135)

The Design Guide is mute on the subject of the relative merits of backward versus forward facing seats, a subject which clearly deserves the attention of engineers having a serious concern for the impact tolerance of transport aircraft.

Use of seat cushions for load alleviation appears to be impractical (Reference 4, Page 127); rather, their function should be to provide comfort and load distribution. Energy absorption considerations indicate that seat cushions of thickness rather less than those in current civilian aircraft are in order, because the motion of the pelvis relative to the seat bracket should be minimized (Reference 4 Page 128). Cushioning materials are recommended for the reduction of secondary impact injuries, in particular, head injury. These materials can serve to absorb energy as well as to distribute the impact from over a larger area (Reference 4, Page 219).

Restraint systems are treated in Section 7 of Reference 4 of the Design Guide. For troop/passenger seats the Guide recommends systems which include upper torso restraint (Figure E-9). These restraint systems should be designed to hold occupants in the 95th percentile survivable accident. Cargo restrain systems (nets and lines) are to sustain 90th percentile impacts, defined by a triangular impact pulse of 16 G peak (Reference 4, Page 161).

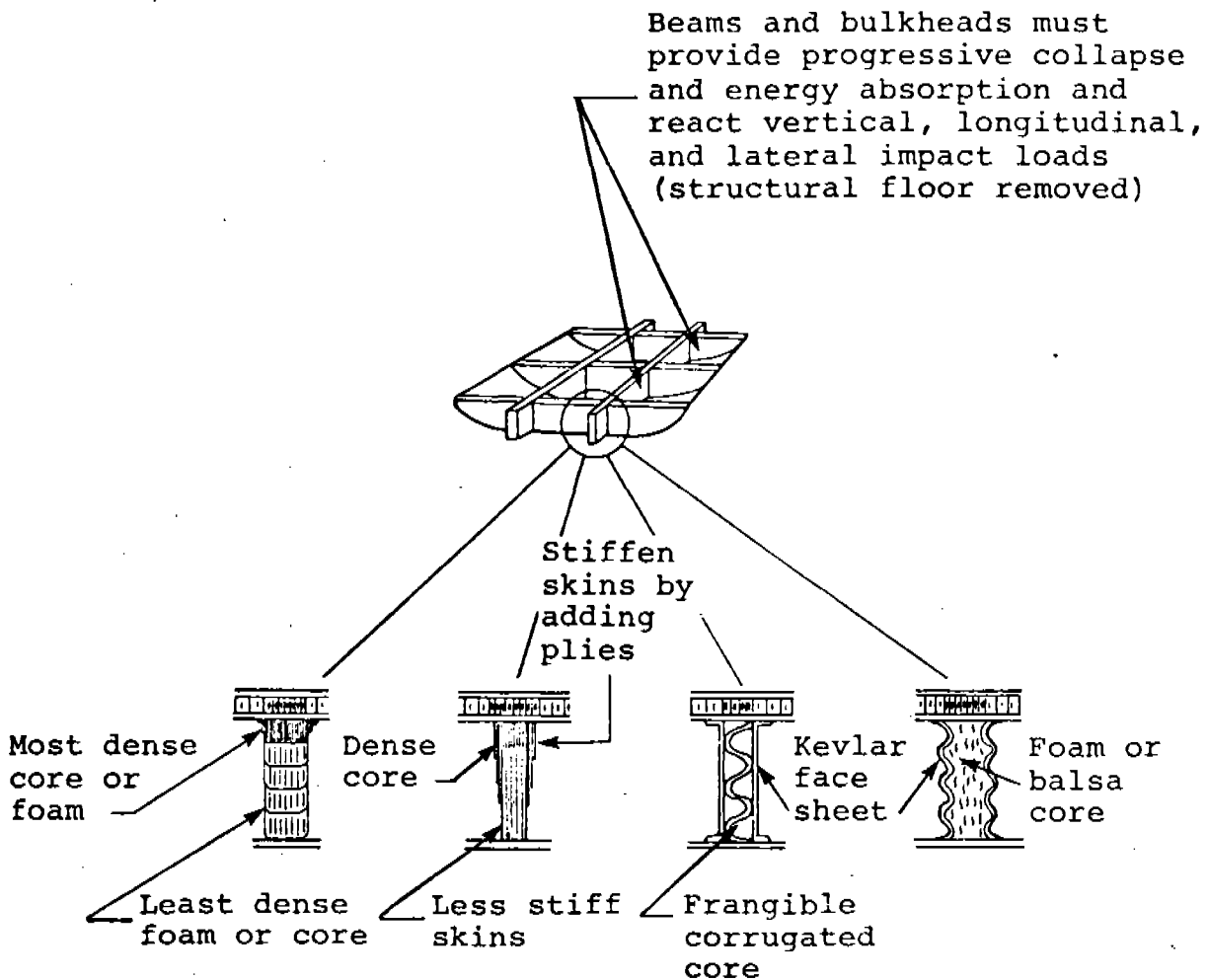

FIGURE E-8: ENERGY-ABSORPTION CONCEPTS - BEAMS AND BULKHEADS (VERTICAL IMPACT) (FROM REFERENCE 3, PAGE 91)

Deformation of joints is a serious concern in design of impact tolerant seats, and the Design Guide Volume IV (probably the best available work on seat design) devotes careful and rational attention to this problem. Inadequate performance of floor structure by excessive warpage, and of floor to seat connections by transmission of bending and torsion moments can void a well-designed seat. Figures (Reference 4, pages 56, 57, 58, 59, 60) illustrate concepts for joint design to effect release of moments or torques so as not to block the load alleviation devices which may be designed into the seat.

A review of design concepts for impact tolerant seats indicates that they should be designed as mechanisms as well as structure: their kinematics during impact response should be predictable. This means that floor and base structure should not deform substantially; the seat response should be a linkage motion with most links remaining rigid and the energy absorption function produced by specific links or connections. In particular all designs, specific hinges or struts absorb the energy by some form of plastic working of metal. Serious design problems are presented when force components are presented in all three principal directions and the stroking function may be impaired due to binding.

The seat design section of the Design Guide contains a comprehensive review of the use of "stroking" devices which have predictable load limiting and energy absorbing capabilities. It would appear that these devices, which already find application in all military crew seats, offer much potential for improving occupant protection.

The Design Guide addresses the problem of providing different load-limiting seat capability, depending on occupant weight, and indicates that this goal would be achieved by active or passive devices. Recommendation is made that variable limit-load energy absorbers be incorporated in all new (military) impact tolerant seat systems (Reference 4, Pages 92 and 93).

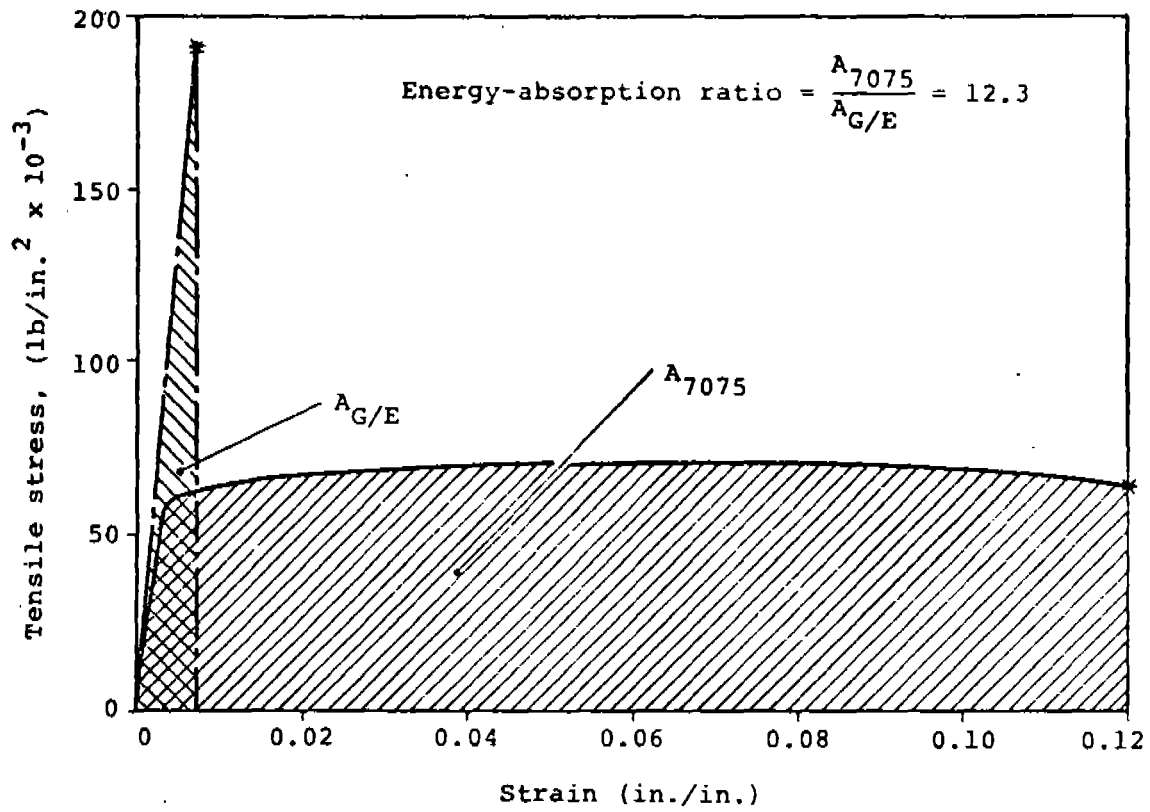
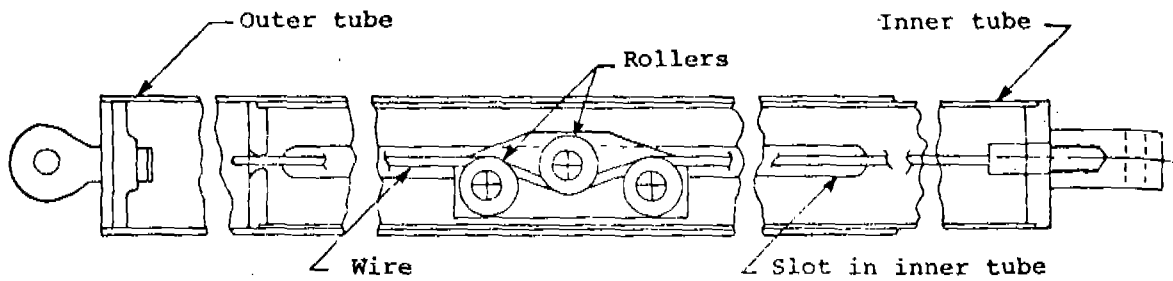
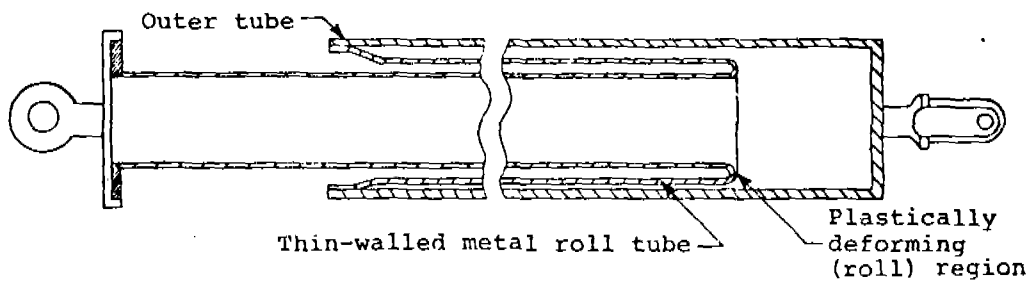

FIGURE E-7: STRESS-STRAIN RELATIONSHIP FOR ALUMINUM ALLOY (7075) and 0 DEGREES GRAPHITE/EPOXY COMPOSITE (REFERENCE 3, PAGE 85)



(a) Wire bending - absorbs energy by plastic bending of wire over rollers



(b) Inversion tube - absorbs energy by inverting a thin-walled tube

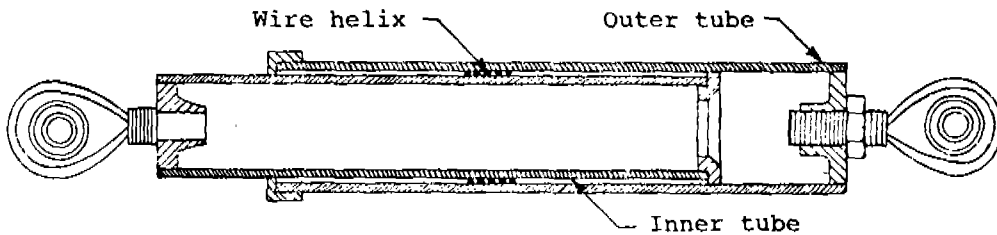

(c) Rolling torus - absorbs energy by rolling wire helix between concentric tubes

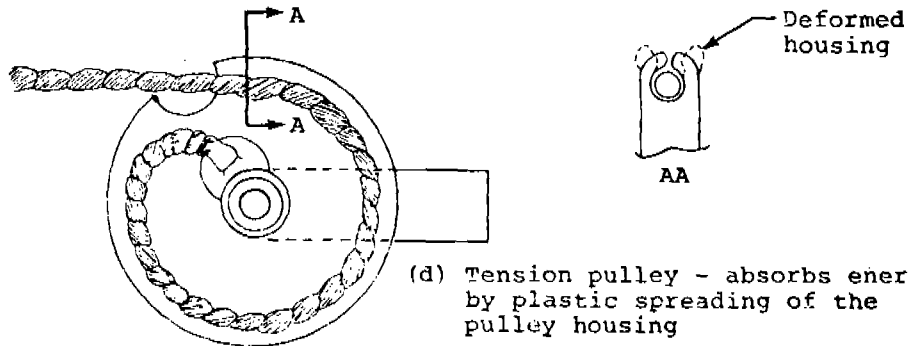

(d) Tension pulley - absorbs energy by plastic spreading of the pulley housing

FIGURE E-6: EXAMPLES OF ENERGY-ABSORBING DEVICES (REFERENCE 3, PAGE 100)

Kevlar straps maintain structural integrity and react side loads

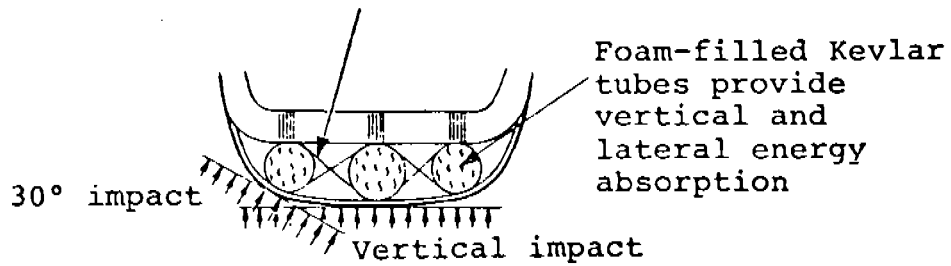

(a)

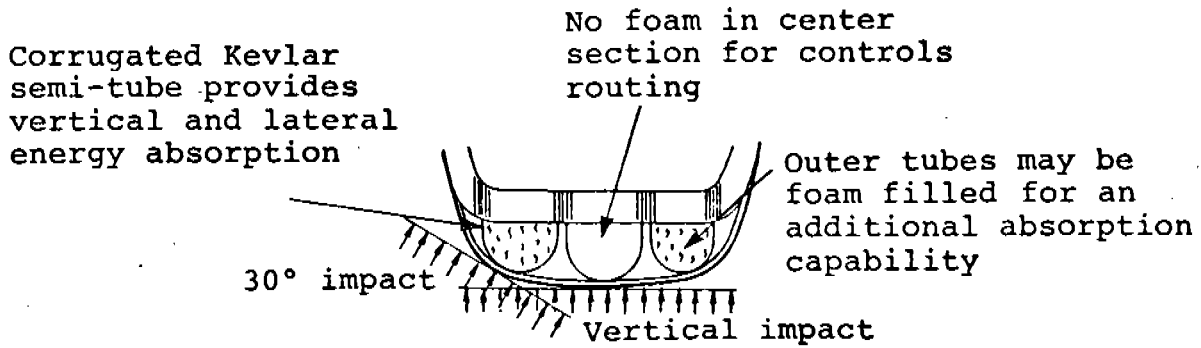

(b)

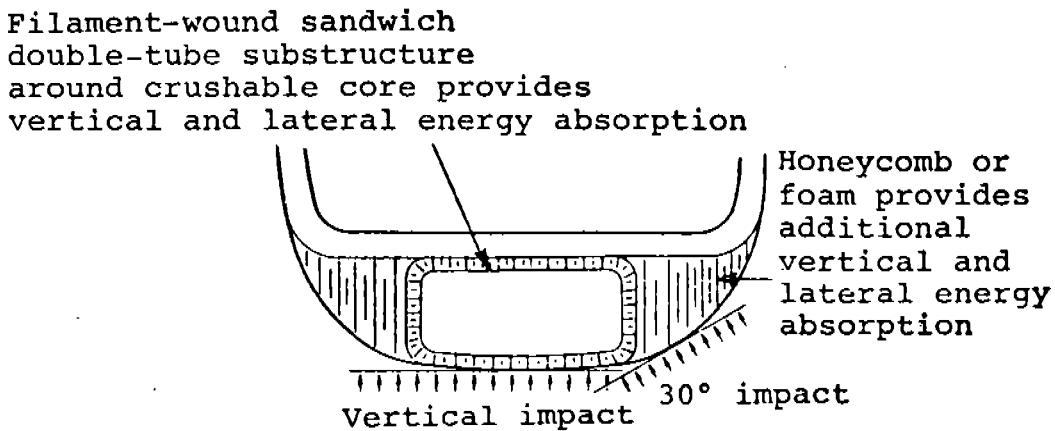

(c)

FIGURE E-5: ENERGY-ABSORPTION CONCEPTS - TUBULAR CONSTRUCTION (OBLIQUE VERTICAL IMPACT) (FROM REFERENCE 3, PAGE 92)

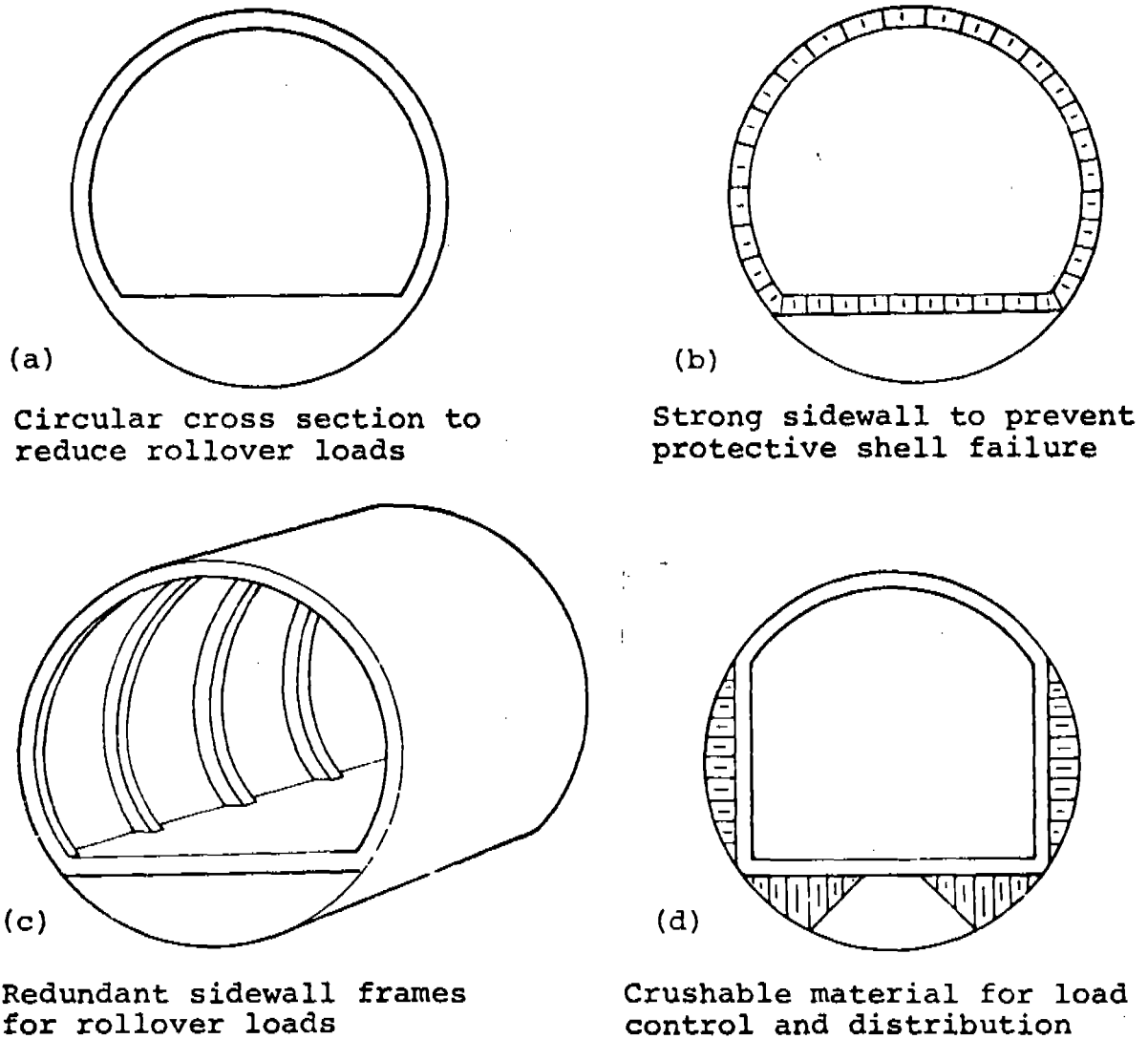

FIGURE E-4: FUSELAGE SIDEWALL CONCEPTS - LATERAL IMPACT  
(FROM REFERENCE 3, PAGE 94)

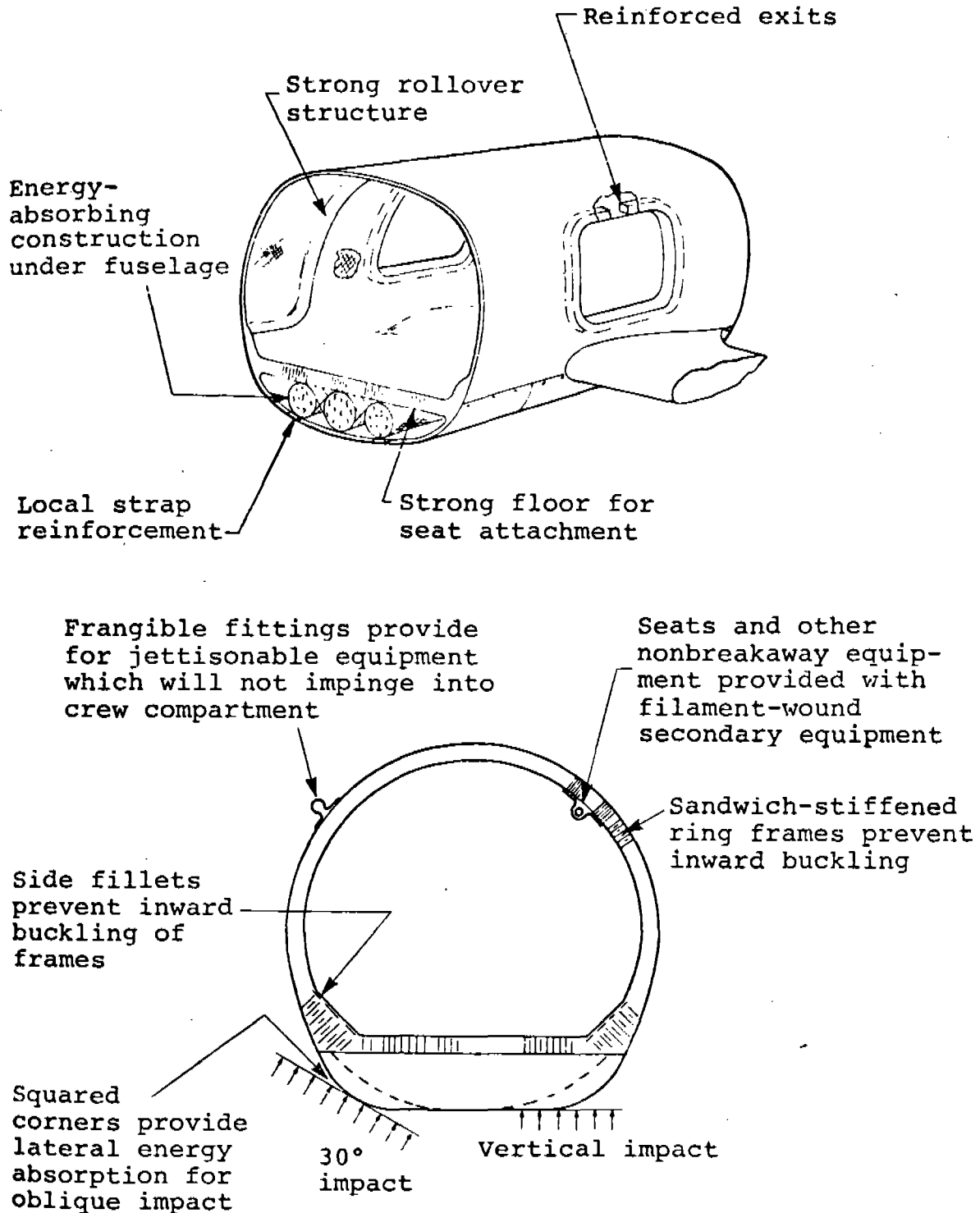

FIGURE E-3: OVERALL FUSELAGE CONCEPTS. (FROM REFERENCE 3, PAGE 89)

Various fuselage design concepts (illustrated in Figures E-3 and E-4) are directed toward reducing plowing, absorbing energy by crushing of the underbelly and keeping floor, sidewall and exits intact. In transports, use of foam and other types of reliable material (Figure E-5) would involve a very expensive reduction of cargo space. More appropriate would be consideration of concepts which utilize the energy absorbing capability of lower fuselage cargo.

Various energy absorbing devices are illustrated which involve metal working, (Figure E-6). These devices appear to be the most efficient from the point of view of specific energy absorption (energy absorbed per unit weight), but the unidirectional nature of their effectivity limits the potential areas of their application. The Design Guide notes that "some may be included in the primary aircraft structure to help control the deformation sequence during a crash; however, none are applicable for use as major structural members, such as beams," (Reference 3, Page 99) Essentially, these devices will find application as local limiting struts in seats and other restraint systems.

The Specific Energy Absorption (SEA) of materials is an important measure of their usefulness for structural crashworthiness. The material SEA, which is related to ductility, is the area under the stress strain diagram, divided by the specific weight. Figure E-7 illustrates the tremendous advantage of metal over composites. The Design Guide at Reference 3, Pages 81-97 contains a good overall discussion of the potential for composites in crashworthy design, and seems to show that the advantages which these materials offer in terms of strength-to-weight ratio are offset by their poor SEA capability. The Design Guide suggests use of components in crushable beams and bulkheads (Figure E-8) and in tubular items designed specifically for vertical impact energy absorption (Figure E-5).

The low capability of composites to resist and distribute concentrations of stress seems to require adjunct use of metals in joints and fastenings.

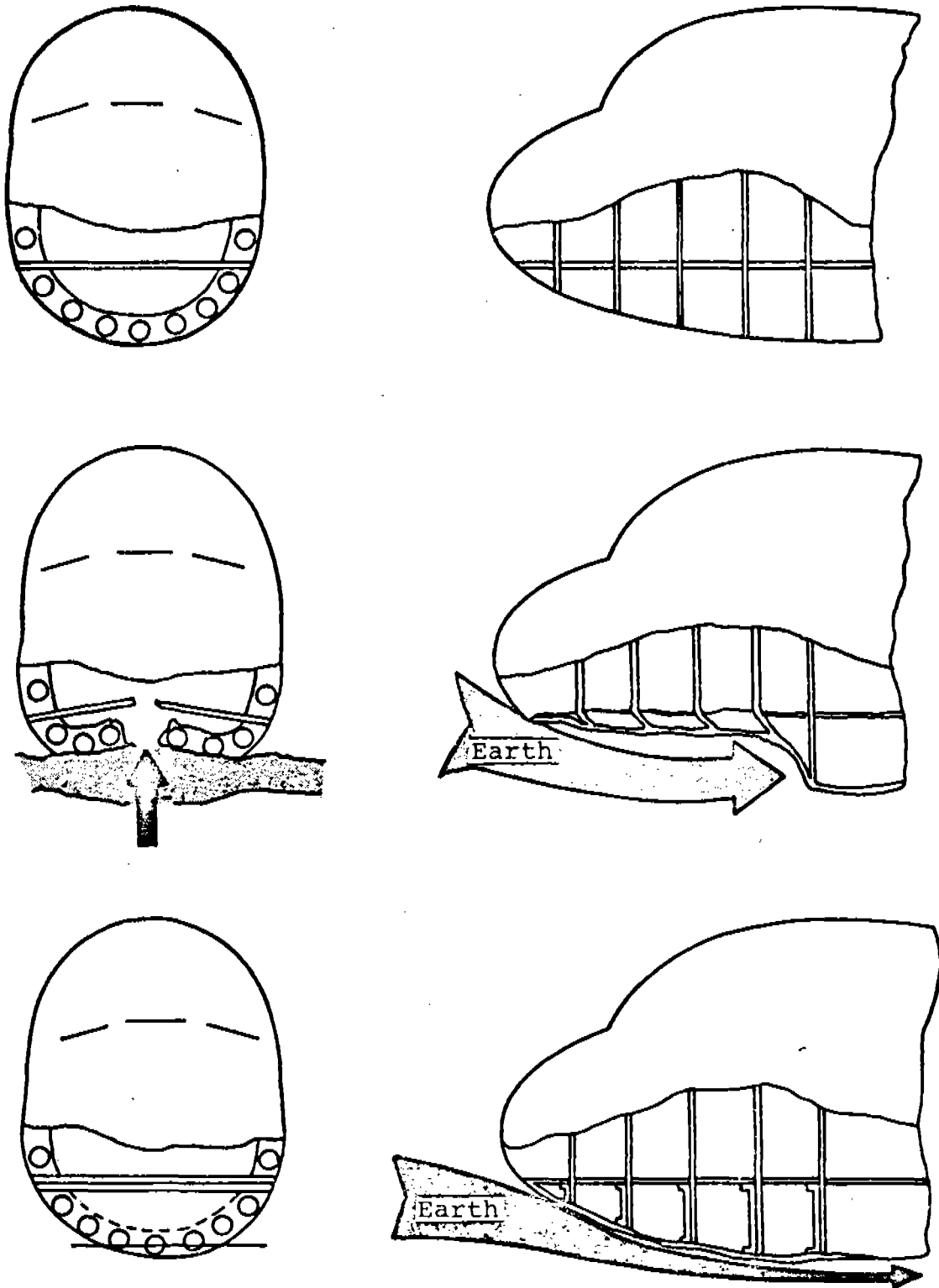

FIGURE E-2: METHOD OF REINFORCING NOSE STRUCTURE TO PROVIDE INCREASED RESISTANCE TO VERTICAL LOADS AND TO REDUCE EARTH SCOOPING (REFERENCE 3, PAGE 125)

where  $m_A$  is the aircraft mass,  $m_E$  the mass of scooped earth,  $V_0$  the initial impact velocity (longitudinal) and  $\Delta t$  the impact duration. Thus reducing  $m_E$  will reduce the acceleration. (The formula given is not valid for small  $m_E/m_A$  since the limit value is zero.) The Design Guide also gives a formula for  $m_E$ :

$m_E = KA V_0 \Delta t$  where  $K$  is constant and  $A$  is the cross section area of the earth gouge. This formula is given without any verification.

In any case, it is clear that earth scooping increases longitudinal loads. The Design Guide recommends a strong nose structure so as to prevent the formation of a "scoop", Figure (E-2). Actually, consideration of this design involves a tradeoff between on-runway and off-runway situations. For crash landings on the runway, which are probably the predominant type of survivable crash condition, designing for collapse of the lower fuselage is preferable to keeping it rigid.

A voltage control regulator failed in the onboard data recording system resulting in the loss of all electronic data in the onboard recorder. The telemetry system provided acceleration and force data from the cockpit. Two camera mounts failed allowing the cameras to point away from the intended fields of view.

INSTRUMENTATION: Sensors included the following:

- 35 acceleration vectors of fuselage and seats,
- 10 acceleration vectors of dummy pelvis (5 dummies),
- 6 pressure (fuel tanks),
- 13 seat leg loads
- 5 seat belt loads
- 1 velocity of aircraft
- 12 onboard cameras, and
- 13 exterior cameras

Recording media included one 14-channel FM-FM onboard tape recorder with battery power mounted in a protective box. Subcarrier oscillators were used to allow 7-channels of data to be recorded onto one channel of tape. Two tape channels were dedicated to tape speed compensation and test time/event correlation. Cockpit environmental data was gathered VIA a telemetry system. Cameras were operated at 200 and 500 frames/sec. Time correlation was provided by a 100 Hz., .01%, square wave recorded on tape. Correlation between onboard and exterior cameras was provided by flashbulb.

RESULTS: Aircraft velocity at impact was 15 knots faster than planned. The right main landing gear rebounded from its barrier and struck the right horizontal stabilizer, cutting off the outboard section. A blade from No. 3 engine propeller passed through the fuselage causing some structural weakening, damaging a camera mount, and ripping one of the forward facing seats apart. The fuselage broke during impact with the 8-degree hill. Both wings failed at the wingroots. The aircraft impacted the 20-degree hill about 10 feet from the summit and bounded over the hill. Final impact occurred at the foot of the hill about 860 feet from the main landing gear barriers. Several small fires occurred as a result of ruptured fuel and oil lines.

Biological Experiments

It is not believed that animal experiments would be useful in obtaining bone impact injury data applicable to human subjects. However, physiological responses such as cardiac and respiratory irregularities may indicate a closeness to physical incapacitation.

Rats could be used in a protected environment containing air bags or other energy absorbing material such that bone fractures due to hard impact would not occur. Electrocardiogram (EKG) and respiration data could be recorded during and following the impact test to (1) determine if physical incapacitation occurred and (2) to monitor the rate of recovery.

Special instrumentation for this type of measurement has been developed and is used regularly at this facility in fire tests and toxicity experiments. The onset of cardiac arrhythmia has been found to correlate very closely with physical incapacitation whether or not in the presence of toxic gas.

shown in Figure E-1 for a "load-limited seat". It is seen that the seat pan acceleration response and the occupant acceleration response curves oscillate about the limit-load factor. These dynamic overshoot phenomena require analysis by seat occupant response codes, and considerable testing in order to develop an effective seat design.

### 3.0 Impact Response

The Design Guide contains a general description of structural damage which frequently results in occupant injury (Reference 3, Page 51).

Longitudinal loads are first experienced by the forward and lower parts of the fuselage. Earth scooping enhances loads at the forward fuselage and often causes collapse. Breakup of more structure causes it to be pulled beneath the rest of the airplane and results in higher longitudinal acceleration than would be otherwise experienced. Landing gear is not effective in absorbing crash energy.

Vertical impact loads on the fuselage shell are enhanced by large mass items attached high on the fuselage. Excessively high impact loads limits for the lower fuselage structure will result in transmission of high vertical accelerations to occupant, causing compressive spinal injuries.

High lateral loading is a frequent occurrence in military helicopter accidents, but would probably be of less serious concern for large transports. An important design considerations is to restrain the occupant from contact with the fuselage shell.

Bending loads on the fuselage shell occur in impacts at high impact angles and cause rupture of the fuselage, exposing some occupants to direct contact with jagged metal and loss of restraint.

Floor buckling can reduce the effectiveness of seats. The energy-absorbing mechanisms of the seat (usually effected by some form of plastic yielding) should come into play neither too early nor too late in the impact sequence. A well-designed seat attempts to be load limiting, but the seat response depends upon the response of the occupant as well (Reference 4, Page 20). A typical picture of seat-occupant response is

#### 4.0 Concepts for Impact Tolerance Improvement

The Design Guide discusses a number of devices and concepts for structural design to improve impact tolerance.

Design for breakaway of wing and empennage under high impact loading is recommended so that the high forces otherwise needed to remove their kinetic energy during the impact need not be transmitted through the fuselage. This would tend to reduce the accelerations experienced by occupants. Wing removal also provides the means of leaving flammable fuels well behind the fuselage (Reference 3, Page 149).

Breakaway of landing gear has little effect on fuselage loading; the principal concern with gear breakaway is in controlling its trajectory in order to avoid penetration of fuel tanks.

Design considerations for fuel tanks are listed at Reference 3, Page 152. These are primarily concerned with reducing the likelihood of rupture.

Recommendation is made that large mass items be kept from position high in the fuselage so that sidewall collapse would be lessened and the possibility of the upper fuselage dropping upon occupants would be reduced (Reference 3, Page 133). In this regard, low-wing configurations should be more impact tolerant than high-wing configurations.

The analysis given in the Design Guide (Reference 3, Page 116) indicates the effect of earth plowing, where the crash involves the scooping of soft earth which is driven to the velocity of the aircraft. The effect on the average acceleration is said to be

$$a = \frac{m_E}{m_A + m_E} \cdot \frac{V_0}{\Delta t}$$

FIGURE E-1: TYPICAL SEAT PAN, DUMMY CHEST, AND DUMMY PELVIS RESPONSE TO VERTICAL IMPACT LOADING  
(FROM REFERENCE 4)

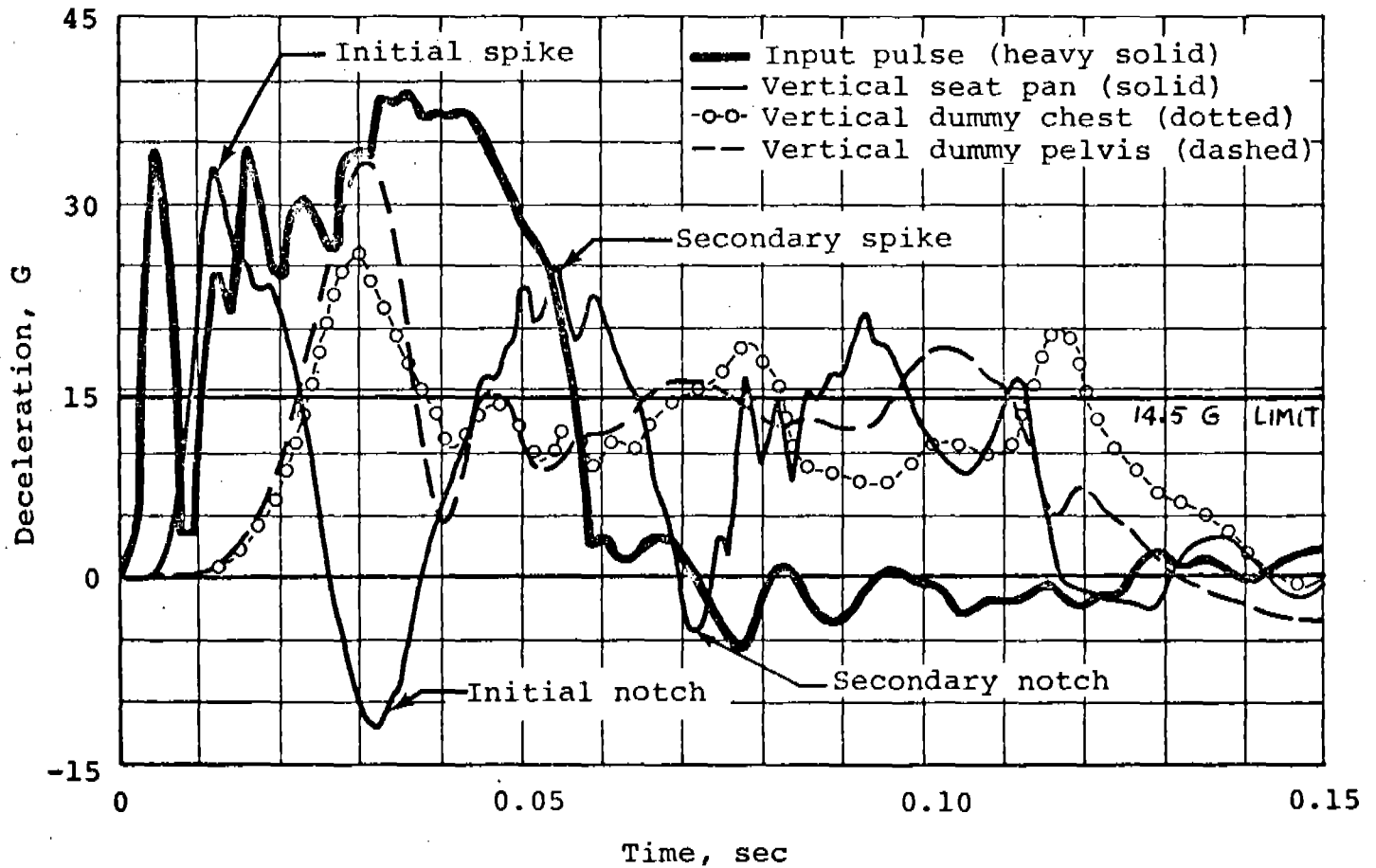

With the floor-acceleration-pulse-specifications approach, another essential ingredient where the occupant response is concerned is data for human tolerance level. As discussed elsewhere in this report, this data appears to be scattered, sometimes contradictory and usually limited to an idealized occupant (the army aviator). Nevertheless, it helps to define the designer's objective confining his job to provide occupant-protection devices to keep response within tolerable levels, given specified input accelerations.

In developing design requirements and procedures for civilian transport category airplanes, the starting points will be the same as those taken in the Design Guide. Overall definition of impact conditions will encompass either velocity changes (along with airplane attitude at impact and terrain conditions) or prescribed acceleration pulses. Actual values for transports must certainly be different from those for any helicopters, and must be established from the results of extensive test programs.

TABLE E-2: SUMMARY OF IMPACT CONDITIONS FOR HELICOPTERS AND  
LIGHT FIXED-WING AIRCRAFT DESIGN

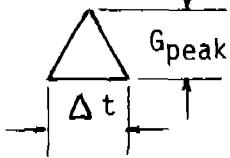
Impact Direction (Aircraft Axes)	Velocity Change, $\Delta v$ M/S (Ft/Sec)		Peak Acceleration (G)	Pulse Duration, $\Delta t$ (Sec)	Comments
Longitudinal (Cockpit)	15	(50)	30	0.104	Triangular deceleration pulse: 
Longitudinal (Cabin)	15	(50)	24	0.13	
Vertical	13	(42)	48	0.054	
Lateral	8	(25) <sup>a</sup>	16	0.097	t calculated from known or assumed values for $G_{peak}$ and $v$ : $\Delta t = \frac{2(\Delta v)}{g G_{peak}}$
	9	(30) <sup>b</sup>	18	0.104	

- a) Light fixed-wing aircraft, attack and cargo helicopters.  
b) Other helicopters.

(REFERENCE 3, PAGE 47)

TABLE E-1: PERFORMANCE REQUIREMENTS FOR STRUCTURAL IMPACT TOLERANCE

Impact direction	Impacted surface	Velocity differential (ft/sec)	Vehicle attitude limits	Percentage volume reduction	Other requirements	Data source
Longitudinal	Rigid	20		No hazard to pilot/copilot	Does not impede postcrash egress	Volume II
		40		15 max. length reduction for pass./troop compartment	Inward buckling of side walls should not pose hazards	MIL-STD-1290 Volume II
Lateral	Rigid	30	±20° Yaw	15 max. width reduction	Lateral collapse of occupied areas not hazardous. No entrapment of limbs.	MIL-STD-1290 Volume II
Vertical	Rigid	42	+25°/-15° Pitch ±20° Roll	15 max. height red. in pass./troop compartment	G loads not injurious to occupants	MIL-STD-1290 Volume II
Resultant	Rigid	50	Combination	As above for various components	Max. velocity changes: long. = 50 ft/sec vert. = 42 ft/sec <sup>a</sup> lat. = 30 ft/sec <sup>b</sup> 25 ft/sec <sup>b</sup>	MIL-STD-1290 Volume II
Rollover	Earth	-	90° sideward or 180° inverted or any intermediate angle	Minimal (door hatches etc. assumed to be non-load carrying)	Forward fuselage buried to depth of 2 in. (inverted or on side). Load uniformly distributed over forward 25% of occupied fuselage length. Can sustain 4 G without injury to seated and restrained occupants. All loading directions between normal and parallel to skin to be considered.	MIL-STD-1290
Rollover (post-impact)	Rigid		Two 360° rolls (max.)	15 max. volume reduction (5% desired)		MIL-STD-1290
Earth plowing & scooping (longitudinal)	Earth	-	-	-	Preclude plowing when forward 25% of fuselage has uniformly applied vertical load of 10 G and rearward load of 4 G or the ditching loads of MIL-A-008865A, whichever is the greatest.	MIL-STD-1290
Landing gear	Rigid	20	±10° Roll ±10° Pitch	None. Plastic deformation of gear and mounting system allowable	Aircraft deceleration at normal G.W. for impact with no fuselage to ground contact. All other A/C structural parts, except blades, should be flight-worthy following crash.	MIL-STD-1290
Landing gear	Sod	100 long. <sup>c</sup> 14 vert.	-5° Pitch ±10° Roll ±20° Yaw	15 max. volume reduction (5% desired)	No rollover, or if rollover occurs, two 360° rolls without fuselage crushing	MIL-STD-1290 Volume II

a) Light fixed-wing aircraft, attack and cargo helicopters.  
 b) Other helicopters.  
 c) Velocity at impact, not differential.

(REFERENCE 3, PAGE 56)

## 2.0 Crash Environment

There are various levels of generalization at which the definition of crash design conditions can be made. The principal approaches are two. At perhaps the most general level of abstraction, the "design impact" is defined in terms of velocity changes and terrain conditions; these limits are placed upon the structure response, in terms of volume reduction, maximizing G-loading experienced by occupants, maintenance of post impact egress, etc. The Design Guide (Reference 3, Page 56) contains a summary of such an approach under the heading of "Performance Requirements" (reproduced in Table E-1).

The second major point of departure for design definition is to provide acceleration pulse shapes for certain critical structural components, and to place design limits upon their dynamic response. This is an approach which is more in line with the tradition of specifications for aircraft structures, where usually the only significant difference being that dynamic rather than static loading is specified. The Design Guide contains a number of specifications of this type. For acceleration, input or idealized triangular pulses are imposed at the cabin floor level near the aircraft center of gravity. A summary is given in Table E-2 and the Design Guide recommends that these pulses be used for the design of restraint systems, seats, cargo restraint and other items inside the aircraft. The acceleration pulse conditions were derived by estimation from accident investigations of crashes over the periods 1960-65 and 1970-76.

## 1.0 Structural Design Philosophy

The latest version of the U.S. Army Aircraft Crash Survival Design Guide devotes a 270 page Volume III (Reference 3) to structural aspects of impact tolerance and Volume IV (Reference 4) to design of seats, restraints, litters and padding. The design philosophy expressed divides the protective function of the structure into two areas: (1) the landing gear, fuselage and outer structure are to absorb as much of the impact as possible while the fuselage maintains a protective shell about the occupants, within which no crushing takes place. (2) seats and restraint systems serve to keep the occupants within the protective shell and to limit accelerations imposed on the occupant during the impact sequence. A third function of structure is to reduce the likelihood of fire and toxic environment; this topic is treated generally in Volume 5 of the Design Guide, which is devoted to post impact survival. But from the viewpoint of protecting the occupant from impact load, the approach is simply and reasonably expressed: (1) reduce loadings before the occupant is subjected to them (2) protect from direct impact and have his seat and restraint system attenuate his accelerations.

## APPENDIX E

### REVIEW OF THE "AIRCRAFT CRASH SURVIVAL DESIGN GUIDE"

Volumes I to V of the "Aircraft Crash Survival Design Guide" listed as References 1 to 5 have been reviewed and much interesting data contained therein gave rise to the following comments. These comments are grouped into the following subjects.

- 1.0 Structural Design Philosophy
- 2.0 Impact Environment
- 3.0 Impact Response
- 4.0 Concepts for Impact Tolerance Improvement
- 5.0 Design Methods
- 6.0 Design Requirements and Design Data

### Photographic Coverage

Video tape recordings of the specimen at selected viewing angles will provide a low speed visual record of the test and to permit instant replay. The video tape system is too slow to capture the motion initiated at impact, therefore, high speed motion picture cameras will be required.

Motion picture cameras are available with frame rates from 2 frames/second to 11,000 frames/second. These cameras (16mm) will be located at selected viewing angles and at selected frames rates to provide redundant coverage. Cameras operating at high frame rates will be triggered to start recording at the time of impact (minus a time allowance for the film to reach constant speed). This is to assure that the camera does not run out of film before the specimen comes to rest.

A major problem with obtaining photocoverage at high frame rates, especially with color film, is that of providing enough light. Also, light reflections can obscure the scene. A tradeoff between frame rate and lighting will be necessary for each test. Light reflectons may be minimized by painting the specimen.

A grid line background will be provided on and near the specimen within the cameras field of view for use in data reduction.

Timing marks on the film will be provided with a 10,000 Hz., 0.005%, signal generator providing timing resolution up to 100 microseconds per "pip" depending upon frame rate.

Photographic stills will be taken before and after the test as appropriate to assess the amount of damage.

Onboard cameras may be required on fuselage tests to monitor selected seat and dummy motion to determine body flexures and contortions during primary and secondard impact.

### Displacement Measurements

A variety of transducers are available for the measurement of displacement. They include linear potentiometers, rotary potentiometers, strain-gaged bending beams, and linear differential transformers (LVDT).

### Acceleration Measurements

The majority of accelerometers will be tri-axial. This is necessary to accurately record the angular response of the component under test. It is particularly important for dummy accelerations to be recorded tri-axially because of the complex reorientation of the dummy relative to the restraint system during impact.

Load Measurements

Test loads will be measured with multi-channel strain gaged load cells. These units are calibrated in both tension and compression before installation on a test and at regular intervals thereafter. Accuracy of these units is within +1% of full range. Load cell rating will be selected to match maximum expected load as closely as possible to provide maximum sensitivity.

Strain Measurements

Metal foil, electrical resistance, epoxy backed strain gages will be used for strain measurement. Gage type will be selected to match the thermal characteristics of the material to which they are bonded. Gages will be wired in electrical bridge type circuits, using dummy gages for bridge completion as required by the type of gage installation. Gage circuit resistance will be measured and recorded for use in determining stress factors. Each gage installation will be photographed and the record filed in the library. Gages will then be encapsulated to provide protection against abuse and moisture.

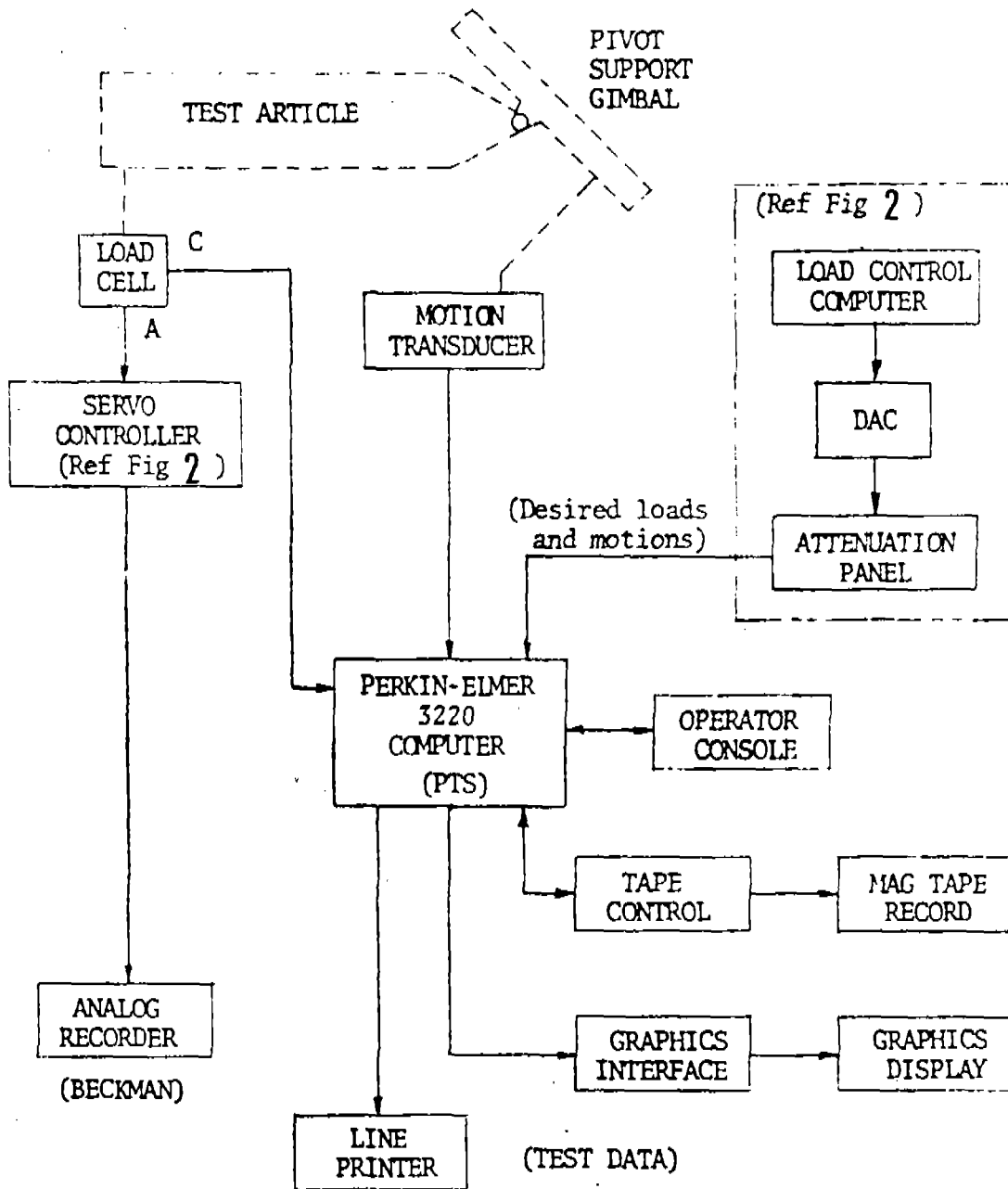

FIGURE D-7: FUNCTIONAL DIAGRAM - DATA ACQUISITION SYSTEM

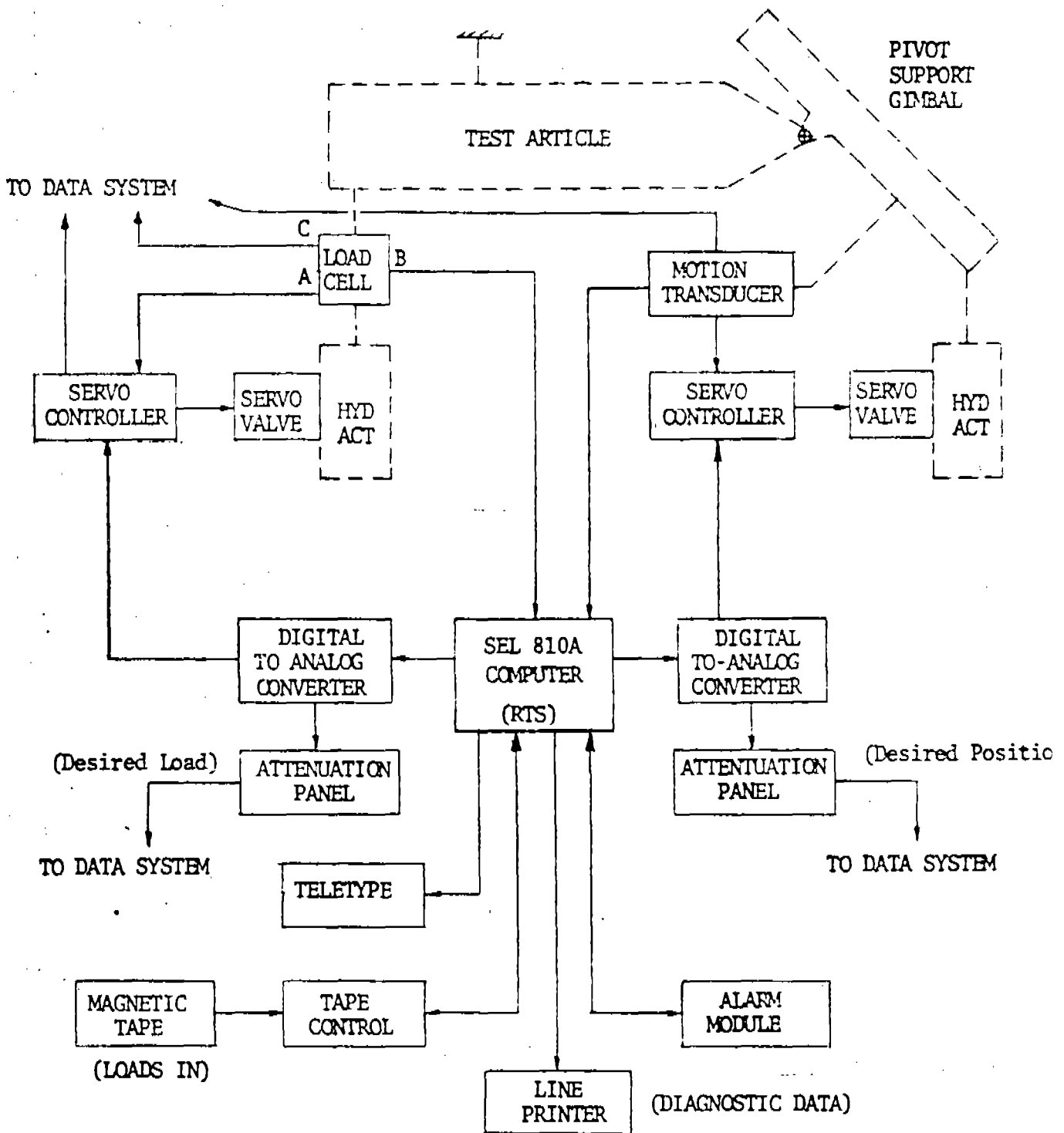

FIGURE D-6: FUNCTIONAL DIAGRAM - LOAD AND MOTION CONTROL SYSTEM

Static Tests

Some static tests may require load and motion control to determine the force-deflection characteristics of the specimen. A functional diagram of a typical load and motion control system utilizing the SEL 810A computer is shown in Figure D-6. Load control is accomplished by the computer acting through a closed loop hydraulic system for each loading actuator. A load command signal is summed with the load transducer response signal in the servo controller to produce an error signal. This error signal is used by the controller to drive the hydraulic flow control (servo) valve to produce zero error. Motion control is accomplished in a similar manner with the motion transducer.

The data acquisition function (Figure D-7) can be performed by Perkin-Elmer 3220 computer and 96 channels of signal conditioning in a unit called a Portable Test Station (PTS). This system can be used to acquire and process all quantitative data describing load, deflection and strain. All 96-channels may be continuously scanned by the computer at a rate of 50 KHz.

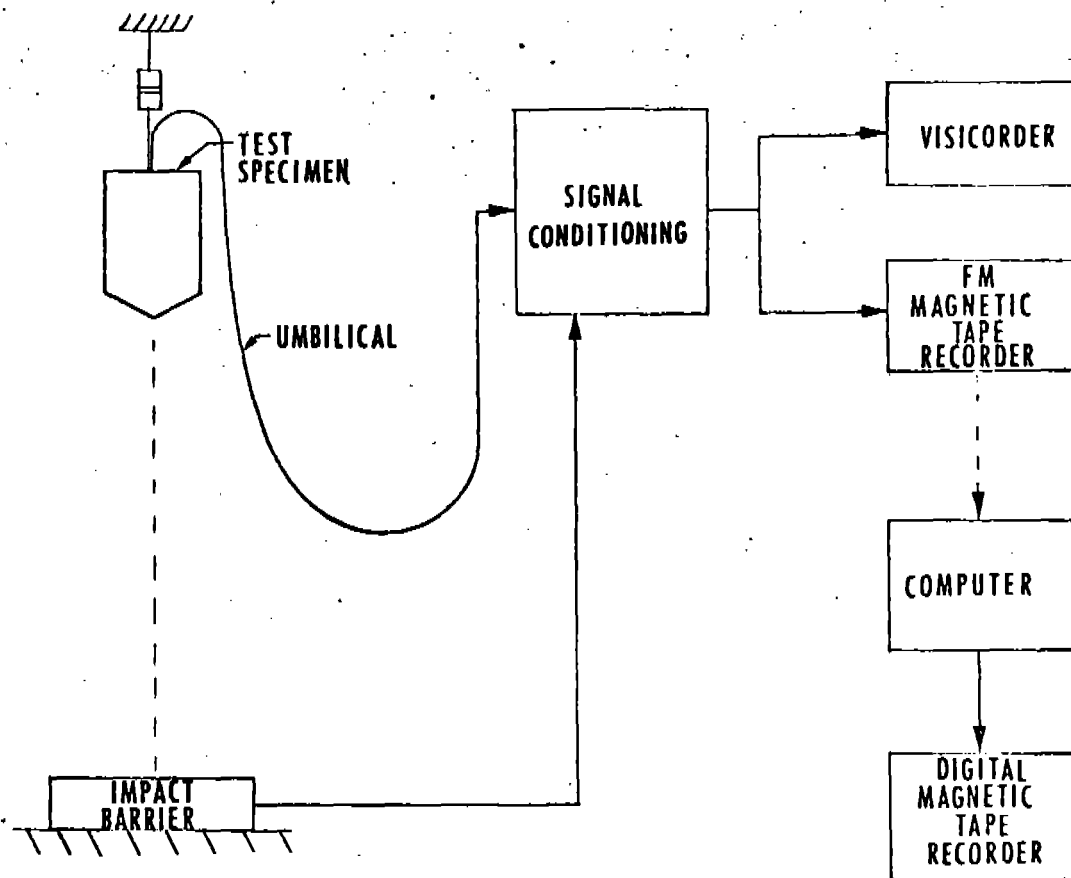

FIGURE D-5: DATA ACQUISITION SET-UP FOR IMPACT TESTS

## 2.0 Instrumentation

All tests which include planned damage to the test specimen are to be instrumented with double or triple redundancy to assure that, at least, the critical parameters are not lost due to instrumentation component failures. This will involve duplicate transducers, where feasible, duplicate umbilicals and completely isolated data recording systems. Data recording media will include a digital data system, an analog system including low frequency strip-chart recorders and high-frequency oscillographic recorders, and magnetic type systems for analog data. Umbilical cables, even with judicious use of data multiplexers, may not be desirable for use on some tests. In these cases data telemetry systems will be employed.

### Impact Tests

The method commonly used at this facility to record data from impact tests of short data duration with high data frequencies is shown schematically in Figure D-5. The test data is recorded simultaneously on oscillographic recorders and magnetic analog tape recorders. Following the test, the magnetic tape is played back at an appropriate speed reduction and the data is digitized and stored on digital magnetic tape for later use in data analysis. Oscillographic records are used to determine if the sensors were operating properly, and if the test conditions (velocity, attitude, etc.) were in the expected range. The digital data is used for computations, data presentation, and correlation with predicted responses.

Data to be recorded

Specimen description

Weight

Load orientation

Impact velocity

Floor or base accelerations

Accelerations at primary structural members

Strains at primary structural members

Motion picture records of impact sequence history

Sequence photographs of static response

Pre/post test photos.

## 1.3.0 SEAT TESTS (Ref. Tests 12.2.4.3)

Purposes

Evaluate current static load design criteria.

Correlate static and dynamic response characteristics.

Determine static load-deflection properties.

Specimens

Standard airline seats in two- or three-seat clusters.

Some specimens to include floor, tracks and brackets.

Test dummies.

Test SetupStatic

Loads to be applied in each of the three primary directions: down, forward and lateral, and in combinations.

Dynamic

Inertial loading to be applied by use of sled facility, or, if feasible, drop tower.

Data to be recorded

Specimen type

No. of bays

Weight

Drop height

Impact area configuration

material (California bearing ratio).

Accelerometer traces at various points

floor

seats

dummies

Pre and post impact still photos

Motion picture records.

Test setupStatic

Mount specimen in ground cutout.  
Apply loading through cables.

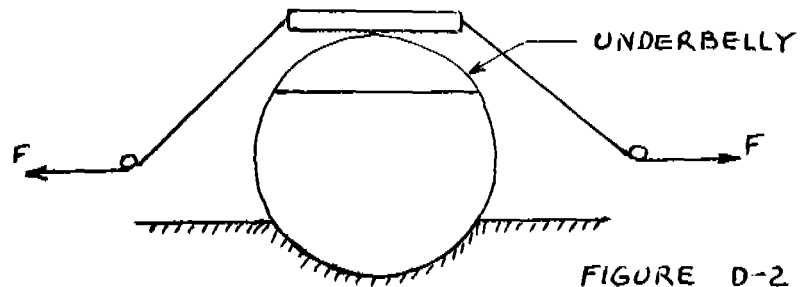

FIGURE D-2:  
FUSELAGE, STATIC CRUSH TEST

Dynamic

Drop tests.

Suspend specimen from sling.

FIGURE D-3:  
FUSELAGE DROP TEST

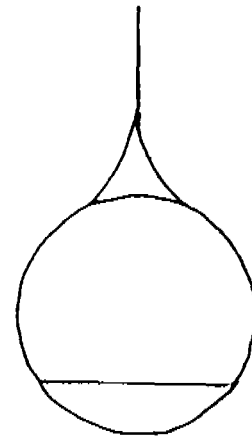

Step impact plane in some tests to study fuselage break.

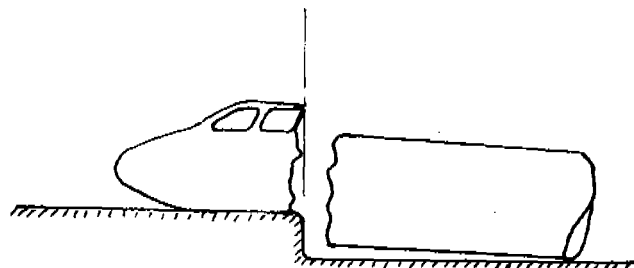

FIGURE D-4: FUSELAGE BREAK TEST

1.2.0 FUSELAGE TESTS (Ref. Test 12.2.4.2)Purposes

- o Determine static force-deflection characteristics.
- o Correlate with impact response.
- o Determine modes of crushing of underbelly structure.
- o Determine net impulse required to bring about a fuselage break.
- o Determine typical floor acceleration response to fuselage impact.
- o Determine typical seat and occupant acceleration response.

Specimen

- o Fuselage sections, each consisting of a minimum of three bays in order to account for longitudinal buckling, and containing:
  - o Complete floor structure.
  - o Seats.
  - o Anthropomorphic dummies (drop tests only).

Dynamic

Gear drop from drop tower.

Weights to simulate aircraft mass.

Impact onto inclined plane.

FIGURE D-1 :  
LANDING GEAR / WING  
DROP TEST

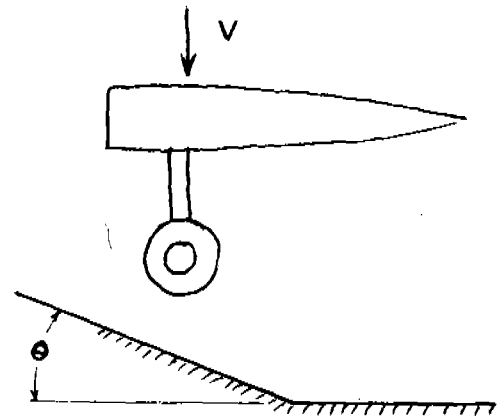
Data to be recorded

Specimen type

Weight

Drop height

Impact angle

Accelerometer traces

Strain gauge traces

Pre/post-impact photos

Motion picture records of failure sequence.

## 1.0 TESTS

1.1.0 Landing Gear Tests (Ref. Test 12.2.4.1)Purposes

- o Correlate static load-deflection characteristics and static strength with response under dynamic loading.
- o Determine degree of penetration of gear or supporting structure into wing or fuselage.
- o Obtain characteristic load pulse shapes at gear hard points.
- o Determine relationship between impact velocity and angle to acceleration response at various points on wing structure or within fuselage.

Specimens

- o Landing gear and supporting structure.
- o Attached wing section (from rear spar aft) or fuselage section to the extent feasible.

Test SetupStatic.

Load specimen on tower track until fracture or crushing failure occurs.

## APPENDIX D

### TEST PROGRAM

This appendix provides an outline of the details of some of the static and impact tests which are being recommended in Section 12 of the report to assist in the simplification and improvement of the accuracy of aircraft structure impact analyses.

Brief descriptions are given of test purpose, test specimens, test set-up and the data to be recorded. The tests outlined in Section 1 of this Appendix are

- 1.1.0 Landing Gear Tests
- 1.2.0 Fuselage Tests
- 1.3.0 Seat Tests

Instrumentation and usage is discussed in Section 2 of this appendix.

## Full-Scale Dynamic Crash Test of a Douglas DC-7 Aircraft (Reference 15)

OBJECTIVES: The purpose of the test was to obtain environmental data to study fuel containment, and to collect data on the behavior of various components aboard the aircraft. Separate experiments include the following:

1. Overall acceleration environment
2. Wing fuel spillage studies
3. Cockpit crew seat experiments
4. Cargo restraint experiments
5. Forward cabin fwd facing passenger seating experiment
6. Child restraint experiment
7. Wing center section forward facing passenger seating experiment, and kick-up load experiment
8. Aft facing passenger seating experiment
9. Galley equipment experiment
10. Air bag restraint experiment
11. Aft cabin fwd facing passenger seating experiment
12. Side facing passenger seating experiment

FACILITY: A special runway was constructed of soil-cement to support the weight of the aircraft during acceleration. A nose gear guide rail was constructed of a railroad rail laid on a reinforced concrete base. The craft was accelerated for a distance of 4000 Ft. reaching a velocity of 139 knots at impact. Impact barriers (in time sequence) were (1) special barriers to remove the landing gear, (2) an earthen mound for left wing impact and simulated trees for right wing impact, (3) an 8-degree slope for initial fuselage impact, and (4) a 20-degree slope for the final impact.

## APPENDIX C

### DC-7 IMPACT TEST

This appendix contains a review of the data in Reference 15 pertaining to the "Full Scale Dynamic Crash Test of a Douglas DC-7 Aircraft". This test and the test reported in Reference 16 were outstanding efforts to obtain impact data vital to assist in the search for safety improvements.

TABLE B-3: TAKEOFF ACCIDENTS, CHARACTERISTICS AND INJURIES

Accid. No.	65	66	67	68	69	70	71	72	73	74
	Meteorological Information									
	Time	Temp	Dewpoint Temp.	Visibility	Light Condition	Snow Rain Fog	Winds	Gusts	Wind Shear	Icing
3-0										
3-1	1841 e.s.t.	10C (34°F)	-70 (19°F)	24km (15mi.)	Darkness	No	190° 5kn			
3-1.1	0617 a.s.t.	-14C (6°F)	-17C (2°F)	3.2km ( mi.)		Fog	Calm			
3-2	0711 c.s.t.	-60C (22°F)	-70C (20°F)	3.2km (2 mi.)		Freezing Rain Fog	020° 13kn			on Wings 1.6mm Thick
3-2.1	2225 G.M.T.	-270C		2.5km		Fog Patches Gnd Snow	320° 3kns			No
3-3	1705 a.s.t.	-40C (24°F)	-50C (23°F)	8km (5 mi.)	Darkness	fog	060° 6kn			Light Free- zing Drizzle
3-3.1	0050 e.d.t.									
3-3.2	2121 e.d.t.									
3-4	1800:09 c.s.t.	20C (35°F)	10C (34°F)	4km 1/4 mi.		Fog				
3-5	0015 e.d.t.									
3-6*	1611:18 m.d.t.	290C (84°F)			Daylight	Rain	230° 12kns	Storm Outflow 5.5 m/s Down Draft	22 kn Tailwind	(60-90 kn
3-7	1310 e.s.t.			24km (15 mi.)	Daylight		160° 8kns			
3-8	1729:55 m.s.t.	40C (40°F)	-80C (17°F)	48km (30 mi.)			135° 7kns			
3-9	0925 p.s.t.	150C (59°F)	150C (59°F)	5km (3 mi.)	Night-time	Rain	140° 11kn	± 9kn		
3-10	0808 e.d.t.	180C	160C	3.2km (2 mi.)		Fog	140° 7kns			
						S R F				
No. of Accids.					3	2	1	3	6	
No. of S.I.					81	17				
No. of I.T.F.					1	0				
No. of F.F.					49	0				
Average		1.20C (34.2°F)	-1.40C (29.4°F)				7.2kn			

\*20 Kn headwind @ T/O

\*60 Kn tailwind shortly after T/O

TABLE B-3: TAKEOFF ACCIDENTS, CHARACTERISTICS AND INJURIES

Accid. No.	55	56	57	58	59	60	61	62	63	64
	Buildings	Hill	Trees	Steel Lite Stanchions	Wreckage Area	Overran Total Dist.	Runway Overrun & Aircraft Slide Description Terrain	Overran Speed	g	Crash Speed
3-0										
3-1		X				128m		59kn	+2.2g	
3-1.1	Small				L = 220m	1400m				
3-2			X			360m	Flat w/.56m Snow			
3-2.1			Tree Tops			1500m				
3-3	ILS Structure 300m End of Rwy					1036m			Modest	
3-3.1									Modest	
3-3.2										
3-4										
3-5						0		0		
3-6						608m	Flat 2nd Impact 41m Past Departure			126kn
3-7					L = 2580m W = 330m				Minor	
3-8	App. Lite Stanchions 120m End of Rwy				L = 260m W = 36m	320m (1050')			Minor	
3-9				Non Frangible		200m		68kn	1.22g	
3-10						183m			Severe Vertical 16g Fwd 19g Dn	.18 sec. .13 sec.
No. of Accids.	2	1	2							
No. of S.I.	51	1	7							
No. of I.T.F.	1	0	0							
No. of F.F.	46	1	0							
Average					574m		63.5kn			

TABLE B-3 TAKEOFF ACCIDENTS, CHARACTERISTICS AND INJURIES

Accid. No.	45	46	47		48	49	50	51	52	53	54						
	Roll After Impact		Runway Takeoff Run			Eng. Power	Ravine	Cabin	Ditch	Runway Overrun & Aircraft Slide Fence	Aircraft Slide Vehicles						
	Distance	Time Sec.	Rwy Surface	Rwy Surf Cond.													
3-0	240m	22	Concrete	Snow	Wrong Power Setting						Steam Roller						
3-1																	
3-1.1																	
3-2																	
3-2.1																	
3-3												No Snow	Dry Patches of Snow & Ice	2.4mm Ice	At ILS Struct. Impact	4m deep 800m from Rwy End	Wooden 200m End of Rwy
3-3.1																	
3-3.2																	
3-4												Remained on Airt.					
3-5																	
3-6																	
3-7			Concrete Asphalt Ungrooved														
3-8			Porous Friction Asphalt					2 Drain Ditches									
3-9			Asphalt Concrete Grooved	Wet													
3-10			Asphalt Concrete	Moist		46KIAS 16m											
No. of Accids.							1	2	2	1							
No. of S.I.							49	51	49	13							
No. of I.T.F.							1	1	1	0							
No. of F.F.							46	46	46	48							
Average																	

B-24

TABLE B-3: TAKEOFF ACCIDENTS - CHARACTERISTICS AND INJURIES

Accid. No.	34	35	36	37	38	39	40	41	42	43	44
	Rwy Length m	Max. Airspeed kn	Airspeed At Rwy Overrun	Flap Angle	Takeoff Heading	Rose Off Rwy	Stall	Impact on Rwy	Eng. Reverser	Wheel Brakes	Impact Vel. kn
3-0						No	No	Steam Roller			40
3-1	2380m	145kn				43m			Full Reverser	Max Braking	
3-1.1		175kn		0°		Yes 50m					
3-2	2010m	148		20°		Yes 8m	Yes				
3-2.1		(V <sub>1</sub> + 12) 145kn		27°							
3-3	L = 3320m W = 46m	152		23°						Brakes on During T/O Roll	
3-3.1		150kn				No					
3-3.2											
3-4		140kn				Yes		Collision With C880			
3-5		110kns	No Overrun			No					
3-6	L = 3500m W = 46m	(V <sub>2</sub> + 20) 157KIAS		15°		V <sub>2</sub> + 5kn 30m	Yes	Yes 120m Short			
3-7	L = 4440m W = 46m	100kns						Seagulls	Applied Engs. 1 & 2	Heavy Braking	
3-8	3050m	157kns		10°		No			Full Rev'r Applied to Abort T/O	Max. Braking to Abort T/O	
3-9	L = 3130m W = 46m	159kn		5°					RTO Full Reverse Thrust	RTO Applied Full Brakes	
3-10	2930m	149kns		0°		No			X	Full	
AVG	3100m										
No. of Accids.						4	2	4	5		
No. of S.I.						28	18	39	82		
No. of I.T.F.						0	0	0	2		
No. of F.F.						11	0	58	3		
Average		145		12.5°		33m					

TABLE B-3: TAKEOFF ACCIDENTS, CHARACTERISTICS AND INJURIES

24	25	26	27	28	29	30	31	32	33
Accid. No.	Subsystems		Emergency Lights		Explosion		Thrust Reverser	Spoilers	Slides
	Cabin Break	Fuselage Seats	On	Failed	Tank	Sec.			
3-0					Ctr. Fus. Rt. Ctr. Fus.	0 + 20 0 + 40	During T/O Roll		Fwd. Entry Door Reverse Installation
3-1	Wing L/E		X				All Engs.	Extended	Not Inflated
3-1.1	Fragmented								
3-2	Dented by Tree	Fwd. Flt. Attend't Seat Failed. 3 PAX Seats Failed	X						
3-2.1	Cockpit Separated. Extensive Damage. 5 Major Portions.	All but 20 Mid. Sec'n Seats Torn Loose from Tracks							
3-3	Fracture @ Wing T/E. Tail Sec. Came Off.	Flt. Attendent Seats Folded		X					
3-3.1									Inflated
3-3.2									
3-4	Upright on Rwy. Cockpit & Cabin Cutted by Fire			X					Main Did Not Inflate
3-5			X						Yes Some Difficulties
3-6	2 Breaks Aft of Cockpit Fwd of Engs	Remained Attached							
3-7			X				#3 Eng. In-operative		
3-8									
3-9							RTD Full Reverse Thrust		Failed Due to Radiant Heat
3-10	Broke into 3 Parts Wing L/E Press. Bulk'd	Most PAX Seats Failed Severe Seat Belt Injuries							
No. of Accids	6	3	4	2	1			1	5
No. of S.I.	124	53	9	58	13			1	57
No. of I.T.F.	8	7	0	1	0			0	0
No. of F.F.	57	0	1	56	48			1	61
Average									

TABLE B-3: TAKEOFF ACCIDENTS, CHARACTERISTICS AND INJURIES

14	15	16	17	18		19	20	21	22	23
Accid. No.	Landing Gear Braking	SUBSYSTEMS		Wing		Fuel Line Rupture	Hydraulic Line Rupture	Hydraulic System	Electric System	
		Engine Separated		Separated	Tank Rupture					
3-0	During T/O Roll		Impact w/Steam Roller				In the #4 NAC.			
3-1		1, 2 & 3			Rt. Wing					
3-1.1		1, 2, 3 & 4		Fragmented						
3-2		No	Ran for 2 Hr. After Accid.	No	Yes					
3-2.1		No. 1, 2, 3 & 4	#4 Blocked	1/2 Rt Wing 1/2 Lt Wing	Both Wings					
3-3	During T/O Roll			Yes Rt. Wing	Yes					
3-3.1										
3-3.2										
3-4										
3-5										
3-6		No			No	No				
3-7	Loss #2 Brake Sys. & 50% TO Reduction	#3	#3 Disintegrated		During Roll Off Rwy	At Eng. #3		#3 Sys Inoperative		
3-8					Lt. Wing Tank # Main Gr.					
3-9	Reduced Braking, 3 Failed Tires & Wet Rwy	No. 1			Left Wing Due to Lt Main Gr		Ruptured Brake			
3-10	Max. Braking				Main Lt.					
No. of Accids.	4	5		2	8	1	1	2	0	
No. of S.I.	95	51		53	138	13	31	0		
No. of I.T.F.	1	5		6	8	0	0	0		
No. of F.F.	96	51		46	49	48	2	0		
Average										

TABLE B-3: TAKEOFF ACCIDENTS, CHARACTERISTICS AND INJURIES

1 Accid. No.	2 A/C	3 Passengers and Crew		5 Fatalities			8 Aircraft Damage	9 Separated From Aircraft	10 Subsystems Landing Gear				12 Safe	13 Warning	
		4 T	5 S	6 I.T.	7 Fire	7 Drwn			10 Tires Failed	11 Position		12 Safe			13 Warning
										Up	Dn.				
3-0	B707	73	13	0	48	0	Cabin Destroyed				X				
3-1	B707	36	1	0	1	0	Destroyed in Gnd Slide & Fire	Main Gear			X				
3-1.1	B707			Non Survivable			Destroyed by Impact & Gnd Fire				X				
3-2	DC9	68	3	0	0	0	Destroyed in Impact			X					
3-2.1	C990	10	4	5	0	0	Destroyed in Impact	Still Attached		X					
3-3	DC-8-63F	229	49	1	46	0	Destroyed in Impact & Gnd Fire	Main Gear At Ditch	Due to Braking in T/O Roll		X				
3-3.1	B707	186	0	0	0	0					X				
3-3.2	B747	347	8 Evac.	0	0	0			2 Flat Tires		X				
3-4	DC-9-31	45	9	0	10	0	Destroyed by Impact & Fire	Nose & Main							
3-5	DC-8-63	261	3	0	0	0			Rt. Main						
3-6	B727	134	15	0	0	0	Substantial			X					
3-7	DC-10-30	139	2	0	0	0	A/C Destroyed by Impact & Fire	LT, RT & CTR.	3 Tires Dis-integrated						
3-8	DC-9-14	86	2	0	0	0	Severe Due to Impact & Fire	LT Main at Ditch			X				
3-9	DC-10-10	200	31 Evac.	0	2 Evac.	0	A/C LT Side Destroyed by Fire	Collapsed at Rwy End	3 Tires LT Main GR*						
3-10	DC-9-32	107	46	2	0	0	Destroyed by Impact	Folded Back	No. 3 Tire Failed		X		Due to Rubber Debris		
Σ	14	1921	186	8	107	0									
No. of Accidents									7	6	3	7			
No. of Serious Injuries(s)									140	139	22	119			
No. of Impact Trauma Fatalities (I.T.)									3	3	5	2			
No. of Fire Fatalities (F)									59	48	0	95			
Average															

\*1920m from departure end of Rwy.

TABLE B-2: LANDING ACCIDENTS, CHARACTERISTICS AND INJURIES

Accid. No.	57	58	59	60	61			62			63	64	65	66
	Time	Temp.	Dewpoint Temp.	Visibility	Meteorological Information			Snow Rain Fog	Winds	Gusts	Wind Shear	Icing		
2-11	0819 p.s.t.			Low	Daylight			Wet Rwy, Lt Snow, Fog	350° 6 kts Tail Wind	3 kts Tail Wind				
2-12	1510 a.s.t.	29°C (84°F)	23°C (73°F)	4 km (25 mi)	Daylight			Rain	120° 10kts	No				
2-13	1712 e.d.t.			762m (2500 ft)	Daylight			Heavy Rain	210° 35kts	Thunderstorm	Severe Horiz. & Vert.			
2-14	1619 e.s.t.				Daylight			Severe Rain & Hail	320° 28kts	50 kts				
2-15	1815 p.s.t.	-33°C (-28°F)	-24°C (-12°F)	24 km 15 mi.	Darkness				010° 11 kts					
					Day	Dark	S/H	R	F					
No. of Accids.					4	5	2	8	6			1		
No. of S.I.					63	79	33	137	44			86		
No. of I.T.F.					57	11	39	19	2			0		
No. of F.F.					45	138	24	114	27			0		
Average		15.7°C (60.2°F)	11°C (52°F)							11.3 kts	22 kts			

TABLE B-2: LANDING ACCIDENTS, CHARACTERISTICS AND INJURIES

Accid. No.	57	58	59	60	61 Meteorological Information						62	63	64	65	66
	Time	Temp.	Dewpoint Temp.	Visibility	Light Condition	Snow Rain Fog	Winds	Gusts	Wind Shear	Icing					
2-0	1130						7 KT Gnd. Wind from NE								
2-0.1	0529 c.s.t.	21°C (70°F)				Heavy Rain	070° 7 kts								
2-1	1752:12 MST	7° (44°F)	-3° (27°F)	40km (25mi)	Darkness	-	3kts 350°								
2-1.1	1436 e.d.t.			1830m (6000')		Rain	360° 10 kts								
2-2	1409 a.s.t.	27°C (81°F)	26° (78°F)			Rain Showers	8 KTS at at 120°								
2-3	1549 e.s.t.			600m (3/8 mi)		Rain									
2-4	2114 e.d.t.	26°C (79°F)	20°C (68°)	11 km (7 mi)	Nighttime		8 kts at at 310°								
2-5	1321 e.d.t.	23°C (73°F)	20°C (68°F)	6.4 km (4 mi)		Fog	4 kts 300°								
2-6	1442 a.s.t.	31°C (87°)		48.3 km (30 mi)	Daylight		10 kts 120°								
2-6.1	0950 e.s.t.			Poor		Fog									
2-7	0358 e.d.t.	18°C (64°F)	18°C (64°F)				185° 4.5 kts								
2-7.1	2222 e.s.t.					Heavy Rain Fog	Tailwind 10 kn	Turbulence							
2-8	2129 e.s.t.	14°C (58°F)	12°C (54°F)	2.4 km (1.5 mi)	Darkness	Light Rain Showers Fog	10 kts @ 160°								
2-9	0135 p.d.t.	11°C (52°F)		Lost Visu- al Reference		Low Cloud & Fog	5 kts @ 300°								
2-10	2341 a.s.s.t.				Darkness	Bad Rain Shower	22 kts -040°	35 kts							

B-18

TABLE B-2: LANDING ACCIDENTS, CHARACTERISTICS AND INJURIES

	49	50	51	52	53	54	55	56
	Terrain & Aircraft Slide							
Accid. No.	Marshland	Ditch m (ft)	Description	Debris Area m	Deceler'n	Slide		
						Total Distance	Total Time	
2-11		Below Rwy 12 (40)		L W 37x 76				
2-12			Debris Area Began at Embankment i.e. 612m Beyond 1st Touchdown					
2-13						600m (2000')		
2-14			Wing Struck Embankment 175m from Tree Top to Gnd. 385m Along Ground	L W 580m x 90m		380m (1260')		
2-15				L W 470m x 40m				
No. of Accids.		1						
No. of S.I.		11						
No. of I.T.F.		1						
No. of F.F.		0						
Average						360m (1185')		

TABLE B-2: LANDING ACCIDENTS, CHARACTERISTICS AND INJURIES

Accid. No.	49	50	51	52	53	54	55	56
	Terrain & Aircraft Slide							
	Marshland	Ditch m (ft)	Description	Debris Area m	Deceler'n	Slide		
						Total Distance	Total Time	
2-0						91m (300')		Skid Sideways Across 60m
2-0.1			Overshoot 137m					
2-1			865m for 27 Seconds .25g Longit'l Decelerat'n. Slid on Nose Gr. & Aft Fus.			865m (2838')		
2-2								A/C Fishtailed near end of Rwy
2-3		Yes						
2-4								A/C Stopped 1360m from Rwy Threshold
2-5								Ground Looped to the Left
2-6								
2-6.1						82m (270')		
2-7								
2-8								Hydroplaning A/C Left Rwy at 60 KIAS
2-9								
2-10						164m (539')		

TABLE B-2: LANDING ACCIDENTS, CHARACTERISTICS AND INJURIES

Accid. No.	36	37	38	39	40	41	42	43	44	45	46	47	48
	Dist. from Near End of Rwy	Short of Runway Threshold	Runway		Runway Surface	Light Support Structure	Vehicle	Wooded Hillside	Buildings	Embankment	Dike	Trees	Overran Far End of Rwy
2-11	1000m (3300')				Wet Rwy							Stumps	Into Ravine 210m Past Rwy Threshold
2-12	Initial Touchdown 850m		X			ILS Localizer Antenna	Destroyed Several Automobiles	Chain Link Perimeter Fence	Gas Stat'n Run Warehouse			Utility Poles	X
2-13	Tail First 1220m				Struck Ground Rt. of Rwy								
2-14					Landed on Hwy		Truck 5 Autos		Store Gasoline Station			Trees Utility Poles	Landed on Highway
2-15		X						Wooded Populated	2 Homes			6 Trees	
AVG.													
No. of Accids.			6	6		1	5	2	6	3	1	4	
No. of S.I.			112	160		19	85	34	67	40	33	61	
S.I./Accid.			18.7	26.7			17	17	11.2	13.3		15.3	
No. of I.T.F.			18	40		18	56	10	67	19	0	50	
I.T.F./Accid.			3.6	6.7			11.2	5	11.2	6.3		12.5	
No. of F.F.			81	43		19	62	2	70	114	17	119	
F.F./Accid.			13.5	7.2			12.4	1	11.7	38		29.8	
Average													



TABLE B-2: LANDING ACCIDENTS, CHARACTERISTICS AND INJURIES

Accid. No.	24	25	26		27	28	29	30		31	32	33	34	35
	Braking	Flap Position	Subsystems		Airspeed KTS	Rate of Descent m/s (fpm)	Last Heading	Approach and Impact		g Value	Descent Angle	Stall	Landing Severity	Bounced Back Into Air
			Cabin Emergency Lights On	Failed				Angle of Attack						
2-11		250			Excessive 145	7.1 (1400)		Insufficient Prelanding Preparation by Crew.						To Clear Gulley Service Road
2-12		250			*About 130K ● Touchdown									X
2-13		150			153			Nose Up 11°	+10g + Vert.					
2-14		500												6 Times
2-15			X		V <sub>s</sub>	Typ.								
AVG		42.5												
No. of Accids.			4	2										
No. of S.I.			42	35										
No. of I.T.F.			10	0										
No. of F.F.			0	43										
Average					135	6.0 (1180)								

\*Speed at Impact with Embankment May Not be Known. Speed at Impact May be Less than 130 KTS.

TABLE B-2: LANDING ACCIDENTS, CHARACTERISTICS AND INJURIES

Accid. No.	24	25	26		27	28	29	30		31	32	33	34	35
	Braking	Flap Position	Subsystems		Airspeed KTS	Rate of Descent	Last Heading	Approach Angle of Attack	Impact g Value	Descent Angle	Stall	Landing Severity	Bounced Back Into Air	
			Cabin Emergency Lights On	Failed										
2-0					Normal	Normal			Mild					
2-0.1	Wheels Brakes OK	Full Dn		X	Normal				4.8/-0.6g Peaks					
2-1		40°		X	123	10.2 m/s (2000 fpm)	-	-	4.7 g vert -1 to 6g Peaks					
2-1.1	Employed Full Reverse	Full Flaps			144		070°					Hard		
2-2	Loss of Braking (Full-thrust reversal)	50°			Above Norm. 135 kts									Bounce After Initial Touch down.
2-3					90 kts			50-60						
2-4	Engs. Would Not Reverse	50°		X	130 kts							Hard		Bounced Back Into Air
2-5	Reverse Thrust in Flight	50°			150 kts	High						Hard		
2-6					122 kts	3.3 m/s (650 fpm)			Hard					1. 15m 2. 9m
2-6.1		40°												Big Bounce
2-7		Full			129 kts	4.1 m/s (800 fpm)			Hard					
2-7.1				X	140 kts	4.1 m/s (800 fpm)								
2-8	Normal Rever. Thrust & Brks	50°		X	139 kts 27 Excess		Down Wind 8 Kts		High Vert.					
2-9	Braking Effec.	40°		X	147 kts	7.1 m/s (1400 fpm)			+4.60/-0.2					
2-10		50°			140 kts	7.5 m/s (1470 fpm)			Little Above Norm.					

TABLE B-2: LANDING ACCIDENTS, CHARACTERISTICS AND INJURIES

Accid. No.	14	15	16	17	18	19	20	21	22	23
	Subsystems									
	Engine Power	Engine Separated	Wing Separated	Wing Tank Rupture	Fus.	Fuel Line Rupture	Hydraulic Line	Hydraulic System	Electric System	Seats
2-11		No. 1	Rt. Wing							16 Seats Failed Compr. Buckling of Legs.
2-12				Yes	3 Parts					Several Seats Broke Loose
2-13		Both on Initial Impact	No	No	Cabin Intact. Floor Buckled. Tail Sec. Separated on Impact					92 of 100 Pax Seats were Damaged
2-14	Burn Out Both Eng. at 427m	Lt. Eng.	Both	Yes	5 Major Sec. Wind Shield Shattered by Hail					Most Seats Damaged. Compression Buckling. Separated from Tracks
2-15	All Eng. Flame Out	No. 2	Lt. Wing Rt. Wing		Cockpit Severe Tree Damage Pax Cabin Intact					
No. of Accids.		12	6	7	2	1	0	1	7	
No. of S.I.		253	81	93	43	3		35	136	
No. of I.T.F.		51	50	58	0	0		0	57	
No. of F.F.		206	53	182	43	0		43	45	
Average										