

COPY 1 2

DOT/FAA/CT-82/44

Light Aircraft Piston Engine Carburetor Ice Detector/Warning Device Sensitivity/Effectiveness

William Cavage
James Newcomb
Keith Biehl

FAA WJH Technical Center
Tech Center Library
Atlantic City, NJ 08405

June 1982

Final Report

This document is available to the U.S. public
through the National Technical Information
Service, Springfield, Virginia 22161.



US Department of Transportation
Federal Aviation Administration
Technical Center
Atlantic City Airport, N.J. 08405

DOT/FAA
CT-82/44

8/1
82/44



00007839

NOTICE

This document is disseminated under the sponsorship of the Department of Transportation in the interest of information exchange. The United States Government assumes no liability for the contents or use thereof.

The United States Government does not endorse products or manufacturers. Trade or manufacturer's names appear herein solely because they are considered essential to the object of this report.

1. Report No. DOT/FAA/CT-82/44		2. Government Accession No.		3. Recipient's Catalog No.	
4. Title and Subtitle LIGHT AIRCRAFT PISTON ENGINE CARBURETOR ICE DETECTOR/WARNING DEVICE SENSITIVITY/EFFECTIVENESS				5. Report Date June 1982	
				6. Performing Organization Code	
7. Author(s) William Cavage, James Newcomb, and Keith Biehl				8. Performing Organization Report No. DOT/FAA/CT-82/44	
9. Performing Organization Name and Address Federal Aviation Administration Technical Center Atlantic City Airport, New Jersey 08405				10. Work Unit No. (TRAIS)	
				11. Contract or Grant No. 184-320-130	
12. Sponsoring Agency Name and Address U.S. Department of Transportation Federal Aviation Administration Atlantic City Airport, New Jersey 08405				13. Type of Report and Period Covered Final June 1979 - October 1981	
				14. Sponsoring Agency Code	
15. Supplementary Notes					
16. Abstract A comprehensive test cell data collection and evaluation effort to review sensitivity and accuracy of "off-the-shelf" carburetor ice detection/warning devices for general aviation piston engine aircraft was conducted. Presented herein are results, observations, and conclusions drawn from over 150 hours of test cell engine carburetor ice operations on a Teledyne Continental Motors O-200A engine. Static sea level test cell engine operations were conducted to review carburetor ice detectors/warning devices sensitivity and accuracy during actual carburetor icing, determine internal carburetor ice accumulation locations, ascertain how ice formation propagates through the carburetor, observe carburetor performance during ice build-up and consider most advantageous location for a carburetor ice detector. Also presented is a review of the Federal Aviation Administration's carburetor accident/incident data relative to aircraft type, pilot qualifications, time of year and location by state where carburetor ice was a factor.					
17. Key Words General Aviation Light Aircraft Piston Engine Carburetor Ice Carburetor Ice Detection/Warning			18. Distribution Statement Document is available to the U.S. public through the National Technical Information Service, Springfield, Virginia 22161		
19. Security Classif. (of this report) Unclassified		20. Security Classif. (of this page) Unclassified		21. No. of Pages 90	22. Price

METRIC CONVERSION FACTORS

Approximate Conversions to Metric Measures

Symbol	When You Know	Multiply by	To Find	Symbol
LENGTH				
in	inches	2.5	centimeters	cm
ft	feet	30	centimeters	cm
yd	yards	0.9	meters	m
mi	miles	1.6	kilometers	km
AREA				
in ²	square inches	6.5	square centimeters	cm ²
ft ²	square feet	0.09	square meters	m ²
yd ²	square yards	0.8	square meters	m ²
mi ²	square miles	2.6	square kilometers	km ²
	acres	0.4	hectares	ha
MASS (weight)				
oz	ounces	28	grams	g
lb	pounds	0.45	kilograms	kg
	short tons (2000 lb)	0.9	tonnes	t
VOLUME				
tsp	teaspoons	5	milliliters	ml
Tbsp	tablespoons	15	milliliters	ml
fl oz	fluid ounces	30	milliliters	ml
c	cups	0.24	liters	l
pt	pints	0.47	liters	l
qt	quarts	0.95	liters	l
gal	gallons	3.8	liters	l
ft ³	cubic feet	0.03	cubic meters	m ³
yd ³	cubic yards	0.76	cubic meters	m ³
TEMPERATURE (exact)				
°F	Fahrenheit temperature	5/9 (after subtracting 32)	Celsius temperature	°C

* 1 in = 2.54 exactly. For other exact conversions and more detailed tables, see NBS Misc. Publ. 236, Units of Weights and Measures, Price \$2.25, SD Catalog No. C13.10:286.



Approximate Conversions from Metric Measures

Symbol	When You Know	Multiply by	To Find	Symbol
LENGTH				
mm	millimeters	0.04	inches	in
cm	centimeters	0.4	inches	in
m	meters	3.3	feet	ft
m	meters	1.1	yards	yd
km	kilometers	0.6	miles	mi
AREA				
cm ²	square centimeters	0.16	square inches	in ²
m ²	square meters	1.2	square yards	yd ²
km ²	square kilometers	0.4	square miles	mi ²
ha	hectares (10,000 m ²)	2.5	acres	
MASS (weight)				
g	grams	0.035	ounces	oz
kg	kilograms	2.2	pounds	lb
t	tonnes (1000 kg)	1.1	short tons	
VOLUME				
ml	milliliters	0.03	fluid ounces	fl oz
l	liters	2.1	pints	pt
l	liters	1.06	quarts	qt
l	liters	0.26	gallons	gal
m ³	cubic meters	35	cubic feet	ft ³
m ³	cubic meters	1.3	cubic yards	yd ³
TEMPERATURE (exact)				
°C	Celsius temperature	9/5 (then add 32)	Fahrenheit temperature	°F

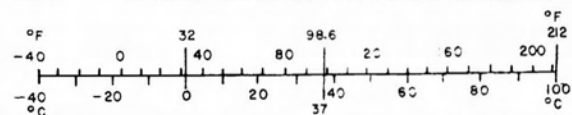

PREFACE

The Federal Aviation Administration Technical Center wishes to extend its appreciation to the following individuals/corporations which donated equipment, technical information and time during the fulfillment of this program test effort:

Mr. E. Zercher (Propellers)
Sensenich Corporation
Lancaster, Pennsylvania

Mr. R. Dunklau (Carburetors)
Marvel-Schebler Division of Borg-Warner Corporation
Decatur, Illinois

Mr. J. Kirwin (Carburetor)
Bendix Energy Control Division of Bendix Corporation
South Bend, Indiana

Mr. C. Kendall (Exhaust System)
Ken-Mor Aviation
Woodbine, New Jersey

Mr. F. Hale, and Mr. B. Rezy (Test Cell Equipment)
Teledyne Continental Motors
Mobile, Alabama

Mr. R. Cathers (Published Articles)
Aircraft Owners and Pilots Association
Washington, D.C.

Hr. H. Zeisloft (Data)
Experimental Aircraft Association
Oshkosh, Wisconsin

Mr. R. Newman (Data)
Crew Systems Consultants
Yellow Springs, Ohio

As addressed throughout this report, ice accumulation will commence at various times and locations with no change or degradation to engine performance. Hence, the reader should not expect to find explicit engineering data within this report which will pin-point exact cause or time when ice accumulation has commenced at a specific location. Due to the insidious nature of carburetor icing, data results were best derived by optical (video) observation which was largely utilized during test cell data acquisition on device sensitivity/effectiveness.

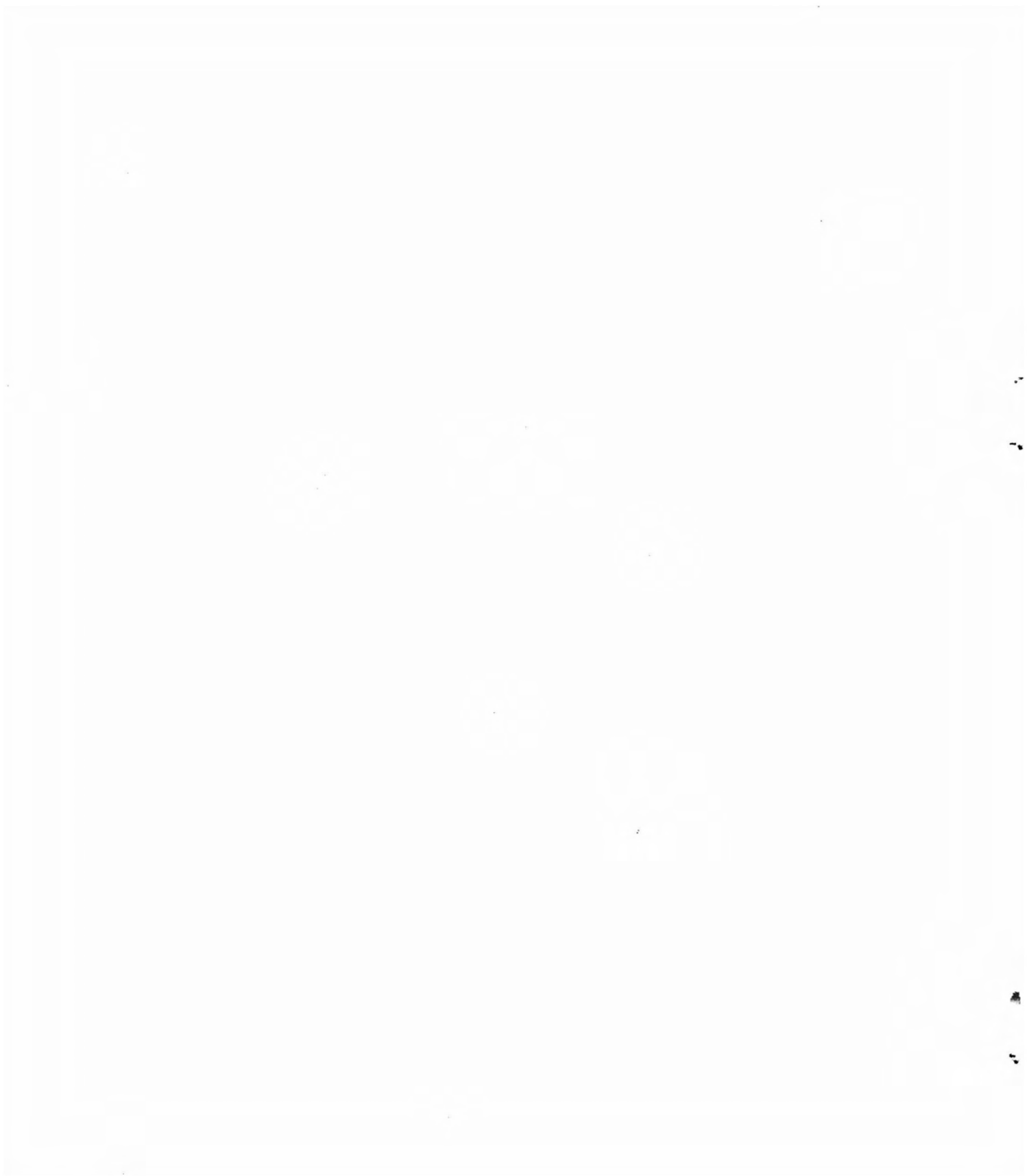

TABLE OF CONTENTS

	Page
INTRODUCTION	1
Purpose	1
Background	1
Objective	3
HISTORICAL DATA	3
Accidents/Incident Analysis	3
Related Factors	6
BASIC CONSIDERATIONS	18
Type of Ice	18
Formation Characteristics	18
Icing Parameters	18
Operational Characteristics	19
Cockpit Instrumentation	19
TEST CELL EQUIPMENT	22
Engine	22
Cooling System	22
Fuel System	23
Induction Air System	23
Ice Monitoring System	24
Data Acquisition System	26
ENGINE TEST SEQUENCE	26
Break-in Run	26
Baseline Tests	27
Test Probe 1 Carburetor Ice Detector System Test	27
Test Probe 2 Carburetor Ice Detector System Test	29
DISCUSSION	29
General Observations	32
CONCLUSIONS	33
Related Factors	33
General	34
Test Probe 1 Indicator System	34
Test Probe 2 Indicator System	35

TABLE OF CONTENTS (Continued)

	Page
APPENDICES	
Appendix A - Advisory Circular AC 20-113	
Appendix B - Carburetor Ice Bibliography	
Appendix C - "ARP" Supplemental Type Certificate	
Appendix D - Richter Supplemental Type Certificate	
Appendix E - Sample Test Data	
Appendix F - Test Cell Engine Installation	
Appendix G - Carburetor Ice Warning Devices	

LIST OF ILLUSTRATIONS

Figure		Page
1	Ministry of Transport - Canada	2
2	Carburetor Ice Detector Evaluation System	4
3	Carburetor Icing Occurances by Year	6
4	Carburetor Icing Accidents/Incidents by Month of Year (1976-1980)	15
5	Carburetor Icing Accidents/Incidents by Individual Month (1976-1980)	15
6	Carburetor Icing Accidents/Incidents From 1976 to 1980 by Hour (Private Rating)	16
7	Carburetor Icing Accidents/Incidents From 1976 to 1980 by Hour (Commercial Rating)	17
8	Test System Schematic	25
9	Carburetor Temperature Data Versus RPM	30
10	Idle Jet Pressure Versus RPM (No Ice)	31
11	Idle Jet Pressure Versus RPM (With Ice)	31

LIST OF TABLES

Table		Page
1	Test Parameters	5
2	Weather Conditions During Carburetor Icing Accidents/Incidents (1976-1980)	7
3	Phase of Flight During Carburetor Icing Accidents/Incidents (1976-1980)	7
4	Carburetor Icing Accidents/Incidents Report by Regions	8
5	Yearly Accident Totals by Pilot Certificate	9
6	Pilot Certificate/Rating for Carburetor Icing Accidents/ Incidents (1976-1980)	10
7	Carburetor Icing Accidents/Incidents by Aircraft Model (1976-1980)	11
8	Engine Test Sequence	28

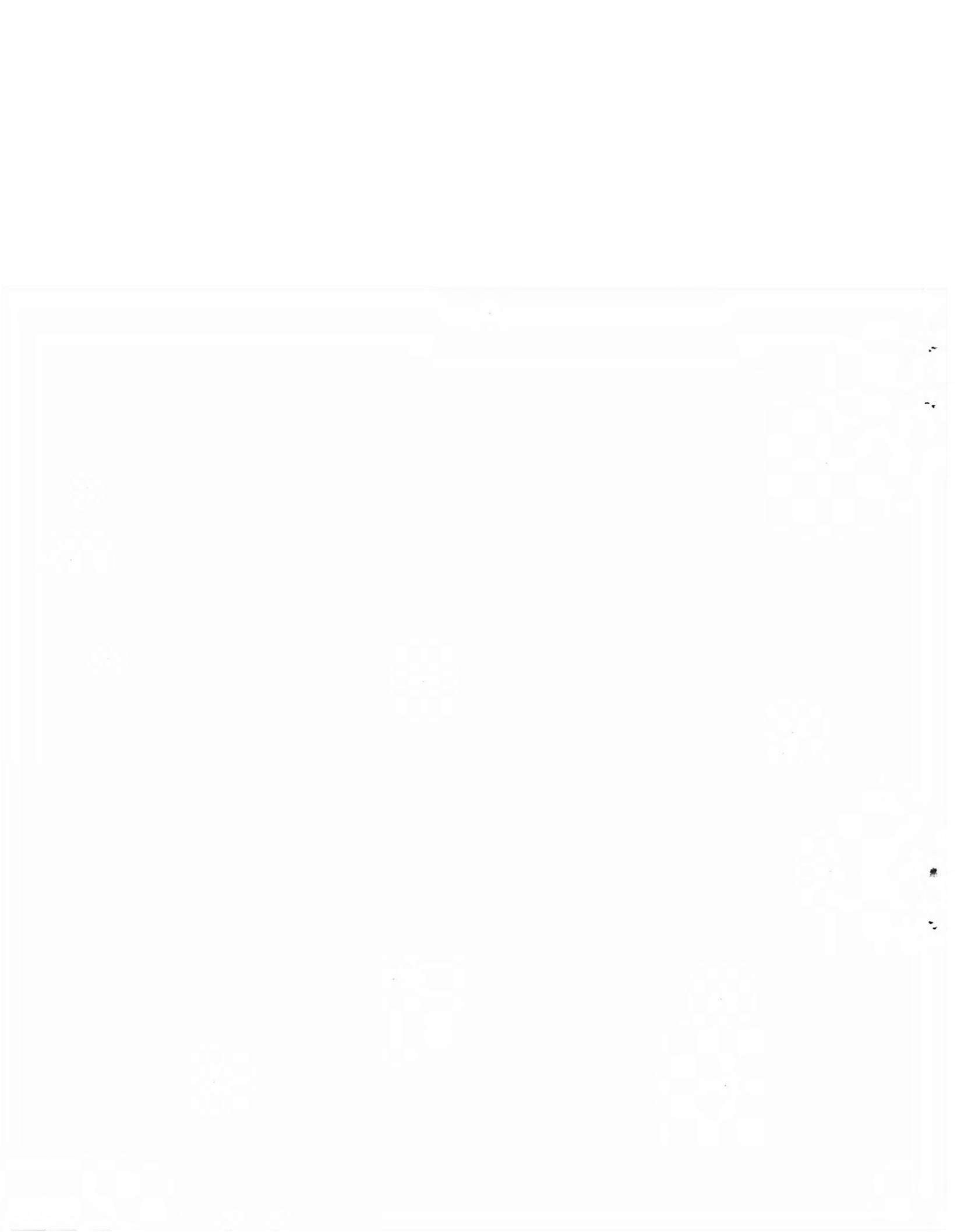

INTRODUCTION

PURPOSE.

The Federal Aviation Administration (FAA) Technical Center's propulsion effort is centered on the safety and reliability aspects of propulsion systems for both turbine and piston engines. The detailed planning and objectives of the FAA Technical Center's propulsion program is documented in an Engineering and Development Program Plan — Propulsion Safety Report, FAA-ED-18-5A, April, 1981. Aircraft piston engine safety and reliability is highlighted as an area of concern, particularly induction system problems associated with carburetor icing, induction system moisture ingestion, and carburetor antideicing. The detailed objective of this plan is to establish test cell engine operation during carburetor ice producing conditions, optically observe real-time carburetor icing operating conditions, and determine sensitivity of existing "off-the-shelf" carburetor ice detection equipment.

BACKGROUND.

Accident/incident data involving conditions conducive to carburetor/induction system icing as a cause/factor is available from the FAA computer system located in Kansas City, Missouri which contains both FAA and National Transportation Safety Board (NTSB) data. A review of this data reveals a substantial number of occurrences where carburetor icing was the "most probable cause" of general aviation engine failure while in flight. The term "most probable cause" is used due to difficulty in substantiating the insidious culprit which generally dissipates prior to examination of engine conditions.

Presently, on the aviation instrument market are items which propose to afford the pilot a warning when conditions conducive to carburetor icing are present. A problem which appeared in several accounts of carburetor icing incidents while using these available instruments was the fact that accuracy and sensitivity may be questionable.

The NTSB, FAA, Military, Foreign Aviation Agencies, and various pilot organizations have files full of technical reports and published articles dealing with carburetor icing accidents/incidents. The topic has been well researched and published, providing icing probability curves (figure 1) for pilot education to preclude a dangerous situation. Various individuals have directed their efforts toward developing cockpit instrumentation capable of warning the pilot of actual ice formation, or at least alerting them to the fact that carburetor conditions are conducive to ice formation (depending on atmospheric properties). Other individuals have pursued carburetor modification which will limit engine power loss during carburetor icing and prevent engine stoppage.

A review of various reports on carburetor icing reveal that pilots may be lured into a false sense of security while using carburetor ice detectors/warning devices. Reports have been published in monthly periodicals by individuals indicating that these off-the-shelf instruments may not have the accuracy and sensitivity required to provide adequate carburetor protection. When one reads the literature on available instruments, they may be led to believe that the FAA Supplemental Type Certification (STC) has certified the instrument as an accurate reliable cure-all to icing problems.

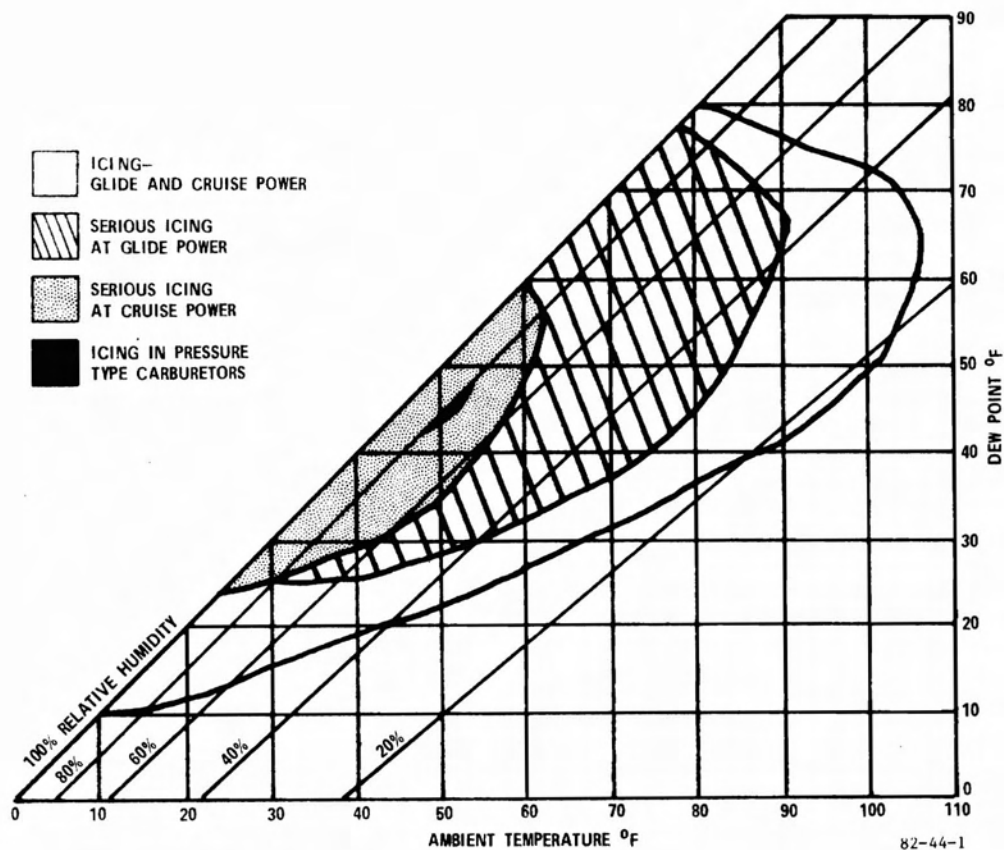

FIGURE 1. CARBURETOR ICING PROBABILITY CHART

Engine manufacturers are required to design and construct intake passages to minimize the danger of ice accretion, according to Federal Air Regulation (FAR) 33.35(b). Actual engine operation under carburetor icing conditions is not a requirement imposed on manufacturer by FAR's. In addition, the engine manufacturers point out that carburetor icing is a problem which must be scrutinized on an individual aircraft model installation basis. Therefore, engine manufacturers do little, if any, engine test cell work relative to carburetor icing problems. The final link in the carburetor icing chain is the aircraft manufacturer. As per FAR 23.929 and 23.1093, aircraft manufacturers are required to provide a means of increasing carburetor air temperature by 90° F. Actual aircraft/engine operation in carburetor icing condition is not imposed by the FAR's and the FAR's remain mute on the topic of ice detection equipment requirements as related to satisfactory engine operation. Some aircraft/engine manufacturers offer STC approved carburetor ice detection/warning equipment as optional instrumentation.

OBJECTIVE.

Based on the information obtained during the overall background review of carburetor icing problems, a program test plan was developed.

The objective of this program was:

1. Review FAA/NTSB computer files for carburetor icing accident/incident reports. Characterize:
 - a. Type of aircraft involved.
 - b. Location by state.
 - c. Time of year.
 - d. Type of pilot certificate held.
 - e. Total pilot experience.
 - f. Phase of flight.
 - g. Weather conditions.
2. Review commercial market and attempt to obtain a copy of each carburetor ice detector/warning device utilized on general aviation piston engine aircraft.
3. Establish test cell engine operation under known icing conditions and observe accuracy and sensitivity of off-the-shelf devices.
4. Determine internal carburetor locations where ice accumulation takes place.
5. Ascertain how ice formation propagates through the carburetor.
6. Determine carburetor operation during ice manifestation.
7. Determine proper location of the carburetor ice detection device to give desired information.

APPROACH. Through in-house FAA Technical Center test cell investigations, repeatable carburetor ice producing conditions were established during engine operation. With strategically positioned borescopes, actual internal carburetor ice formation/propagation was monitored/video recorded while engine performance parameters were recorded during actual engine operation. Figure 2 depicts carburetor instrumentation utilized for testing while table 1 contains a listing of all test parameters measured and recorded during test cell engine operation.

HISTORICAL DATA

ACCIDENTS/INCIDENT ANALYSIS.

The NTSB continues to indicate a number of accidents each year in which carburetor icing was reported or suspected. The NTSB data, together with the Technical Center's independent search of FAA's national computer data base; i.e., Accident/Incidents Data System (AIDS), were the basis for determining overall scope of the carburetor icing problem. For the purpose of this report, the AIDS was used since it contained NTSB and FAA data and was readily accessible. The AIDS data is compiled from aircraft registry, NTSB records, National Flight Data Center, Flight Standards National Field Office Safety Information tables, and reports submitted by field inspectors. Examples of information that may be obtained are: location, date, aircraft ratings, cause factors, contributing factors, number of fatalities, flying condition, etc. This data bank is accessible through United Computer Systems in Kansas City, Missouri, with current data available from 1976 to present.

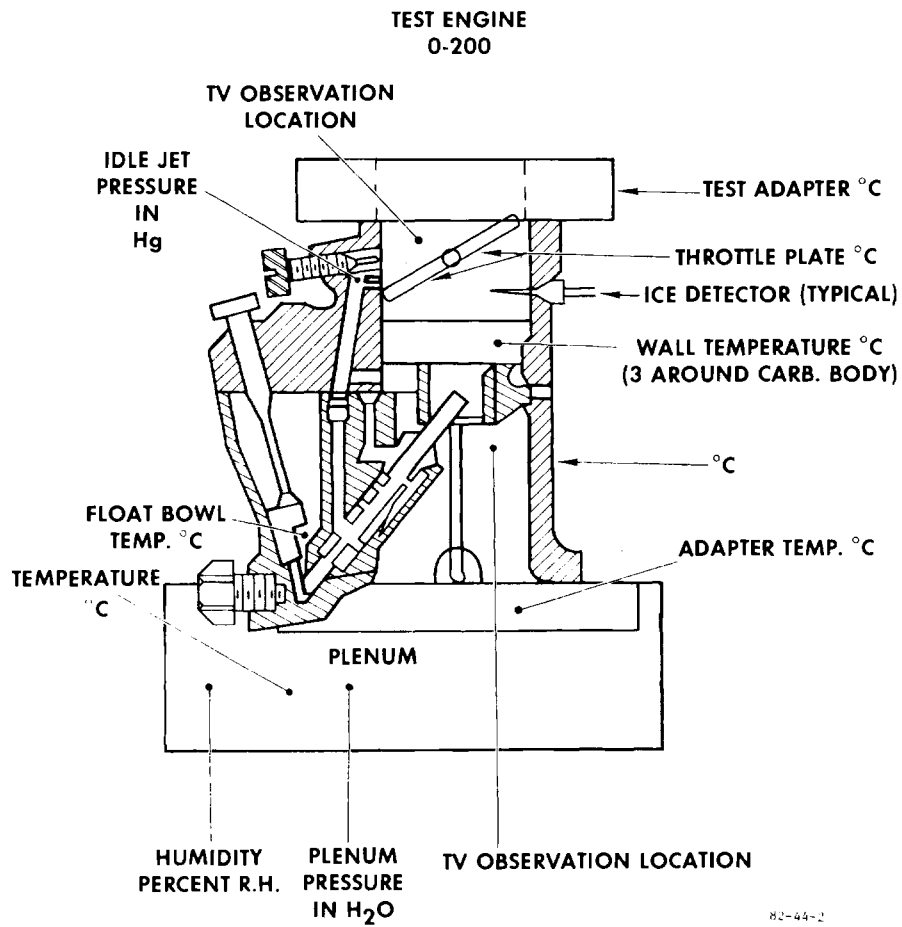

FIGURE 2. CARBURETOR ICE DETECTOR EVALUATION SYSTEM

TABLE 1. TEST PARAMETERS

Dew Point	°C	Oil Temperature	°C
Ice Indication	V DC	Carburetor Adapter Temperature	°C
Cowling Pressure	In. - H ₂ O	Cowling Air Temperature	°C
Plenum Pressure	In. - H ₂ O	Water Temperature	°C
Supply Air Pressure	PSIG	Test Cell Temperature	°C
Manifold Pressure	In.- Hg	Air Condition Outlet Air	°C
Oil Pressure	PSIG	Temperature	
Fuel Pressure	PSIG	Plenum Air Temperature	°C
Idle Jet Pressure	In.- Hg	Supply Air Temperature	°C
Torque	Ft-Lbs	Upper Throttle Plate Metal	°C
Engine Speed	RPM	Temperature	
		Lower Throttle Plate Metal	°C
		Temperature	
Cylinder Head Temperature #1	°C	Float Bowl Fuel Temperature	°C
Cylinder Head Temperature #2	°C	Carburetor Metal Temperature #1	°C
Cylinder Head Temperature #3	°C	Carburetor Metal Temperature #2	°C
Cylinder Head Temperature #4	°C	Carburetor Metal Temperature #3	°C
Exhaust Gas Temperature #1	°C	Carburetor Enclosure Air	°C
Exhaust Gas Temperature #2	°C	Temperature	
Exhaust Gas Temperature #3	°C	Fuel Filter Temperature	°C
Exhaust Gas Temperature #4	°C	Throttle Plate Position	% Travel

Analysis of the AIDS data indicates a substantial number of accidents/incidents are continuing to be encountered where carburetor ice was cited as a cause factor. Pilots with 150 flight hours or less are those most likely to be involved in carburetor icing reports. However, this does not preclude the veteran/advanced rated pilot from falling victim to the precarious culprit. A plot of carburetor icing reports, figure 3, suggests an upward trend in occurrences; however, additional data points are required to establish assignable cause.

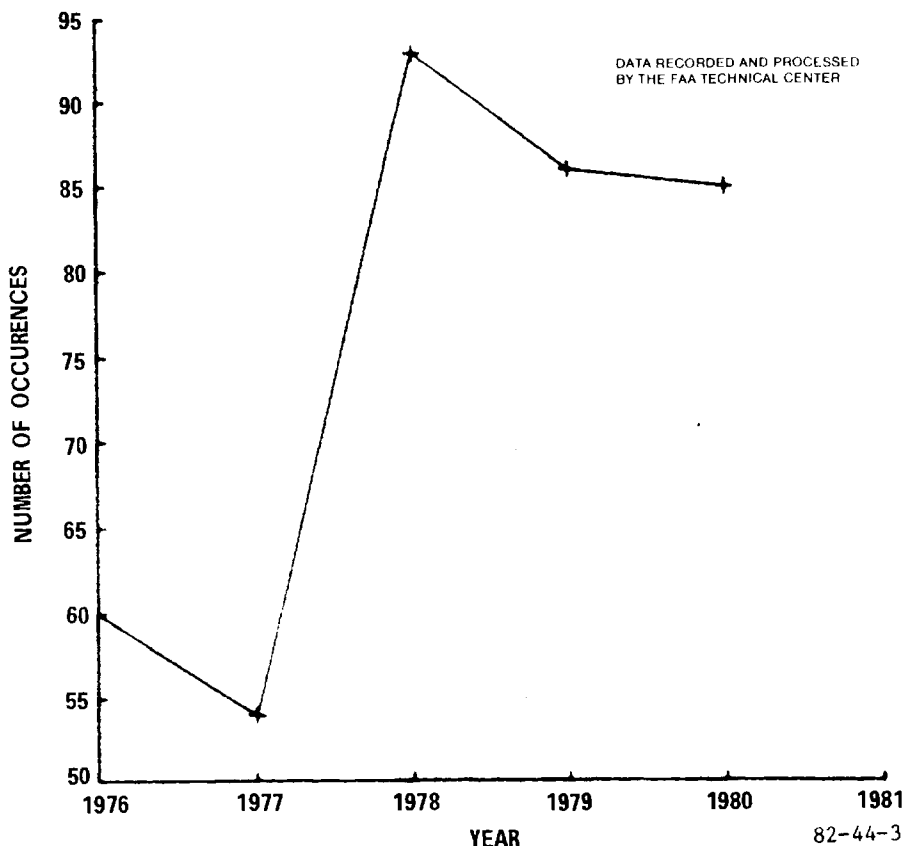

FIGURE 3. CARBURETOR ICING OCCURENCES BY YEAR

RELATED FACTORS.

The following related factors are presented relative to carburetor icing data bank reports. It is emphasized that no attempt has been made in this report to statistically analyze each factor or its relationship to the overall carburetor icing problem.

1. Weather conditions - Table 2
2. Phase of flight - Table 3
3. Occurrences by region - Table 4
4. Occurrences by rating - Tables 5 and 6
5. Occurrences by aircraft model - Table 7
6. Occurrences by month of year- Figures 4 and 5
7. Occurrences by pilot hours (private and commercial) - Figures 6 and 7

TABLE 2. WEATHER CONDITIONS DURING CARBURETOR ICING ACCIDENTS/INCIDENTS
(1976-1980)

<u>CONDITION</u>	<u>NUMBER</u>
Low Ceiling	7
Fog	14
Freezing Temperature	4
Heavy Freezing Rain	1
Heavy Snow	3
Light Freezing Rain	4
Light Snow	4
Light Rain	12
Weather Not a Factor	259
Thunderstorm	2
Wind	7
Unknown	2
Other	10
Total	329

TABLE 3. PHASE OF FLIGHT DURING CARBURETOR ICING ACCIDENTS/INCIDENTS
(1976-1980)

<u>PHASE OF FLIGHT</u>	<u>NUMBER</u>
Approach	59
Climb to Cruise	6
Cruise	159
Descent	6
Taxiing	2
Landing	14
Takeoff	66
Touch and go	2
Simulated Forced Landing	4
Practice Maneuver	1
Unknown	10
Total	329

TABLE 4. CARBURETOR ICING ACCIDENT/INCIDENT REPORT BY REGIONS

GREAT LAKES - TOTAL OCCURRENCES - 80

STATE	1976	1977	1978	1979	1980
MN	0	1	5	3	6
WI	1	4	3	2	4
IL	0	4	3	1	5
IN	1	2	4	2	2
OH	1	0	6	3	1
MICH	4	3	2	4	3
TOTAL	7	14	23	15	21

SOUTHWEST - TOTAL OCCURRENCES - 50

STATE	1976	1977	1978	1979	1980
NM	0	2	0	1	1
TX	2	3	7	6	6
OK	0	0	3	1	2
AR	0	0	1	2	5
LA	3	0	1	3	1
TOTAL	5	5	12	13	15

SOUTHERN - TOTAL OCCURRENCES - 37

STATE	1976	1977	1978	1979	1980
KY	1	1	0	1	1
NC	0	1	0	1	1
TN	1	0	1	1	0
SC	1	1	2	1	1
GA	1	1	1	2	1
FL	1	5	0	1	3
AL	1	0	1	1	0
MISS	0	0	1	0	1
TOTAL	6	9	6	8	8

ALASKAN - TOTAL OCCURRENCES - 25

STATE	1976	1977	1978	1979	1980
AK	3	3	6	6	7

NORTHWEST - TOTAL OCCURRENCES - 20

STATE	1976	1977	1978	1979	1980
WA	0	3	1	2	2
IC	1	0	1	3	1
OR	1	1	3	0	1
TOTAL	2	4	5	5	4

EASTERN - TOTAL OCCURRENCES - 45

STATE	1976	1977	1978	1979	1980
NY	6	2	6	1	4
PA	2	3	2	1	2
NJ	4	0	0	1	0
WV	1	0	0	0	1
MD	1	0	2	1	1
DE	0	0	1	0	1
VA	1	0	1	0	0
TOTAL	15	5	12	4	4

WESTERN - TOTAL OCCURRENCES - 39

STATE	1976	1977	1978	1979	1980
CA	6	3	7	4	10
NV	2	1	1	0	1
AZ	0	0	1	2	0
TOTAL	8	4	9	6	12

NEW ENGLAND - TOTAL OCCURRENCES - 15

STATE	1976	1977	1978	1979	1980
ME	0	0	0	1	2
MASS	4	1	2	0	0
CONN	1	0	0	3	0
VT	0	0	0	0	0
NH	1	0	0	0	0
RI	0	0	0	0	0
TOTAL	6	1	2	4	2

ROCKY MOUNTAIN - TOTAL OCCURRENCES - 15

STATE	1976	1977	1978	1979	1980
MT	3	0	0	0	1
ND	0	0	0	0	0
SD	0	1	1	0	0
WY	0	0	1	0	0
CO	1	3	0	0	0
W	0	0	1	1	1
TOTAL	4	4	3	1	3

CENTRAL - TOTAL OCCURRENCES - 9

STATE	1976	1977	1978	1979	1980
ID	0	0	0	0	0
MO	0	3	1	1	1
NE	0	1	1	1	0
KA	0	0	0	0	0
TOTAL	0	4	2	2	1

PACIFIC - TOTAL OCCURRENCES - 0

STATE	1976	1977	1978	1979	1980
HA	0	0	0	0	0

TABLE 5. YEARLY ACCIDENT TOTALS BY PILOT CERTIFICATE

	1976 NUMBER OF <u>ACCIDENTS/CERTIFICATES</u>		1977 NUMBER OF <u>ACCIDENTS/CERTIFICATES</u>		1978 NUMBER OF <u>ACCIDENTS/CERTIFICATES</u>	
STUDENT	9	188,801	10	203,501	13	204,874
PRIVATE	26	309,005	22	327,424	33	337,644
COMMERCIAL	21	187,801	21	188,763	30	185,833
AIRLINE TRANSPORT	5	45,072	1	50,149	5	55,881
UNKNOWN						

	1979 NUMBER OF <u>ACCIDENTS/CERTIFICATES</u>		1980 NUMBER OF <u>ACCIDENTS/CERTIFICATES</u>		TOTAL NUMBER OF <u>ACCIDENTS</u>
STUDENT	7	210,180	8	199,833	47
PRIVATE	34	343,276	46	357,479	161
COMMERCIAL	23	182,097	26	183,442	121
AIRLINE TRANSPORT	1	63,652	4	69,569	16
UNKNOWN			1		1

TABLE 6. PILOT CERTIFICATE/RATING FOR CARBURETOR ICING ACCIDENTS/
INCIDENTS 1976-1980

<u>CERTIFICATION</u>	<u>RATING</u>	<u>1976</u>	<u>1977</u>	<u>1978</u>	<u>1979</u>	<u>1980</u>
STUDENT	No Rating	9	10	13	7	8
PRIVATE	ASEL	25	19	28	29	42
PRIVATE	ASE ASES	0	2	3	1	2
PRIVATE	ASMEL	1	1	1	3	1
PRIVATE	RH ASEL	0	0	0	1	0
PRIVATE	UNKNOWN	0	0	1	0	1
COMMERCIAL	ASEL	9	8	6	5	6
COMMERCIAL	ASEL ASES	1	1	1	2	0
COMMERCIAL	ASMEL	10	10	8	4	5
COMMERCIAL	ASMEL ASES	2	0	0	1	1
COMMERCIAL	RH ASMEL	0	0	3	2	1
COMMERCIAL	RH	0	1	0	0	1
COMMERCIAL	ASMEL ASES	0	0	1	1	0
COMMERCIAL	RH ASEL	0	0	3	1	0
COMMERCIAL	G RH ASMEL	0	0	1	0	0
COMMERCIAL	G ASEL	0	1	0	0	0
COMMERCIAL	G ASEL ASES	0	0	0	0	1
COMMERCIAL	UNKNOWN	0	0	2	0	0
CERTIFIED FLIGHT INSTRUCTOR (CFI)	ASEL	0	0	1	1	1
CFI	ASMEL	0	0	4	3	1
CFI	ASMEL ASES	0	0	0	2	1
CFI	UNKNOWN	0	0	0	0	2
CFI	G RH ASMEL	0	0	0	1	0
AIRLINE TRANSPORT	ASEL	1	0	0	0	0
AIRLINE TRANSPORT	ASMEL	2	1	2	1	2
AIRLINE TRANSPORT	ASMEL ASMES	2	0	0	0	0
AIRLINE TRANSPORT	ASMEL ASES	0	0	1	0	0
AIRLINE TRANSPORT	RH ASMEL	0	0	1	0	0
AIRLINE TRANSPORT	UNKNOWN	0	0	0	0	2
AIRLINE TRANSPORT	ASMEL	0	0	1	0	0
FLIGHT INSTRUCTOR	ASMEL	0	0	0	0	0
UNKNOWN		0	0	0	0	1

RATING ABBREVIATIONS

ASEL - Aircraft Single Engine Land
 ASES - Aircraft Single Engine Sea
 AMEL - Aircraft Multi-Engine Land
 AMES - Aircraft Multi-Engine Sea
 ASMEL - Aircraft Single Multi-Engine Land
 ASMES - Aircraft Single Multi-Engine Sea
 RH - Rotorcraft
 G - Glider

TABLE 7. CARBURETOR ICING ACCIDENTS/INCIDENTS BY AIRCRAFT MODEL (1976-1980)

<u>AIRCRAFT MODEL</u>	<u>1976</u>	<u>1977</u>	<u>1978</u>	<u>1979</u>	<u>1980</u>	<u>TOTAL</u>
AA1A	0	1	0	0	0	1
AA1B	3	1	0	0	0	4
AA5	0	0	1	0	0	1
AA5A	0	1	0	0	0	1
AERSPRTQUAIL	0	0	0	0	1	1
A36	0	0	0	0	1	1
A9A	0	0	1	0	0	1
BABY LAKES	0	0	0	0	1	1
BC12D1	0	0	0	1	0	1
BEDEBD4	0	0	0	0	1	1
BL1265	1	0	0	0	0	1
BL65	0	1	0	0	0	1
BRCEZTLUI	0	0	0	0	1	1
B75NI	1	0	0	0	0	1
C23	0	0	0	1	0	1
C37	0	0	0	0	1	1
D C0657CRAFT	0	0	1	0	0	1
D36	0	0	1	0	0	1
F19	0	0	0	1	0	1
G-164A	0	0	1	0	1	2
G-164B	0	0	0	0	1	1
G-164C	1	0	0	1	0	2
G21A	0	0	0	0	1	1
HEADWIND	0	0	0	1	0	1
H18	0	0	0	0	1	1
J2MCCULH	0	0	1	0	0	1
J3C65	3	1	0	0	2	6
J5B	0	0	1	0	0	1
KR	0	1	0	0	0	1
L4B	1	1	0	0	0	2
M20C	0	1	0	0	0	1
M4T	0	0	1	0	0	1
M5235C	0	0	1	0	0	1
NAVION A	0	0	1	0	0	1
NAVION B	1	0	0	0	0	1
NAVION D	0	0	1	0	0	1
N253	0	0	1	0	0	1
PA11	0	0	1	0	0	1
PA12	3	0	1	0	0	4
PA16	1	0	0	0	0	1
PA18	0	0	1	1	1	3
PA18A	0	0	0	0	1	1
PA18 150	0	0	1	3	0	4
PA18 10150	0	0	1	0	1	2

TABLE 7. CARBURETOR ICING ACCIDENTS/INCIDENTS BY AIRCRAFT MODEL (1976-1980) (Continued)

<u>AIRCRAFT MODEL</u>	<u>1976</u>	<u>1977</u>	<u>1978</u>	<u>1979</u>	<u>1980</u>	<u>TOTAL</u>
G44A	0	0	0	1	0	1
PA22	0	1	0	0	1	2
PA22 150	0	0	0	0	1	1
PA22 160	0	0	2	0	0	2
PA23	1	2	0	1	0	4
PA23 160	0	0	0	1	0	1
PA24	0	2	0	0	0	2
PA24 250	1	0	1	0	0	2
PA24 400	1	0	0	0	0	1
PA25 235	0	1	2	4	2	9
PA28 A200	0	1	1	0	0	2
PA28 140	3	1	2	1	4	14
PA28 151	2	0	1	0	1	4
PA28 160	0	0	0	1	0	1
PA28 180	3	0	0	0	0	3
PA28 181	0	0	0	0	2	2
PA28 235	0	0	0	1	0	1
PA32 260	0	0	0	2	1	3
PA38 112	0	0	0	0	1	1
PT13D	0	1	0	0	0	1
PT19	0	0	0	0	1	1
PT26B	1	0	0	0	0	1
PA22 135	0	0	0	0	1	1
ROWN 175	1	0	1	0	0	2
RF5B	1	0	0	0	0	1
SA26	0	0	0	0	1	1
SCOOTER	0	0	1	0	0	1
SPORTS TERK	1	0	1	0	0	2
STITSSALLA	0	0	0	0	1	1
ST3KR	0	1	0	0	0	1
TC45B	0	0	1	0	0	1
UH12D	0	1	0	0	0	1
UH12E	0	0	0	0	1	1
UH12EL	0	0	0	0	1	1
UPF7	1	0	0	0	0	1
VARIEZE	0	0	0	0	0	1
V35	1	0	0	0	0	1
0561386	0	1	0	0	0	1
056577	1	0	0	0	0	1
108	1	0	0	0	0	1
1981	1	0	0	0	0	1
1082	0	1	0	0	0	1
11AC	0	0	0	0	1	1
120	0	1	1	0	1	3

TABLE 7. CARBURETOR ICING ACCIDENTS/INCIDENTS BY AIRCRAFT MODEL (1976-1980) (Continued)

<u>AIRCRAFT MODEL</u>	<u>1976</u>	<u>1977</u>	<u>1978</u>	<u>1979</u>	<u>1980</u>	<u>TOTAL</u>
140	0	0	0	1	0	1
15AC	0	0	1	0	0	1
A 150K	0	2	8	1	0	11
150	1	0	5	5	12	23
150C	0	1	0	0	1	2
150F	0	2	0	0	0	3
150FG	1	1	0	0	2	4
150H	0	1	0	1	0	2
150J	0	3	0	0	0	3
150K	1	0	0	0	0	1
150L	3	0	1	1	1	6
150M	1	2	1	3	3	10
152	0	0	0	4	5	9
170	0	0	0	0	1	1
170A	0	1	0	0	0	1
170B	0	0	0	1	0	1
172	1	0	3	5	0	9
172D	0	0	2	0	0	2
172E	0	1	0	0	0	1
172I	0	0	0	0	1	1
172K	1	0	0	0	0	1
172L	0	2	0	0	1	3
172M	2	0	2	2	2	8
175	0	0	0	1	0	1
175A	0	0	1	0	0	1
177	0	0	1	1	1	3
177A	0	1	0	0	0	1
177B	0	0	1	0	0	1
18 AAIRSPC	1	0	0	0	0	1
180	1	0	1	1	0	3
180E	1	0	1	0	0	2
180F	0	1	0	0	0	1
180H	0	1	0	0	0	1
180J	0	0	0	0	0	0
182	0	0	1	5	0	6
182A	0	0	0	0	1	1
182B	0	1	0	0	0	1
182C	0	0	0	0	1	1
182F	0	0	0	1	0	1
182H	0	0	7	0	0	7
182J	0	0	0	0	1	1
182K	0	0	0	1	0	1
182M	0	0	0	0	1	1
182N	1	0	0	1	0	2

TABLE 7. CARBURETOR ICING ACCIDENTS/INCIDENTS BY AIRCRAFT MODEL (1976-1980) (Continued)

<u>AIRCRAFT MODEL</u>	<u>1976</u>	<u>1977</u>	<u>1978</u>	<u>1979</u>	<u>1980</u>	<u>TOTAL</u>
182P	1	3	1	1	0	6
A185K	1	0	0	0	0	1
185	0	0	0	0	1	1
188 CESSNA	0	1	0	0	0	1
23 BEECH	0	0	0	0	1	1
305A	0	1	0	0	0	1
310	0	0	0	0	1	1
3105	1	0	0	0	0	1
415C	0	0	0	0	1	1
47B	0	0	0	1	0	1
47D1	2	0	0	1	0	3
47G2	0	0	0	1	0	1
47G3B1	0	0	1	0	0	1
47G4	0	0	0	1	0	1
47G4A	0	0	1	0	0	1
680E	0	0	2	0	0	2
7AC	1	2	2	1	0	6
7ACA	0	0	1	0	0	1
7ECA	1	1	0	0	0	2
7FC	0	0	0	0	1	1
7GCBC	1	0	0	1	0	0
7KCA	0	0	1	0	0	1
8A	0	0	1	1	0	2
95	1	2	0	0	0	3
95702FZ	0	1	0	0	0	1

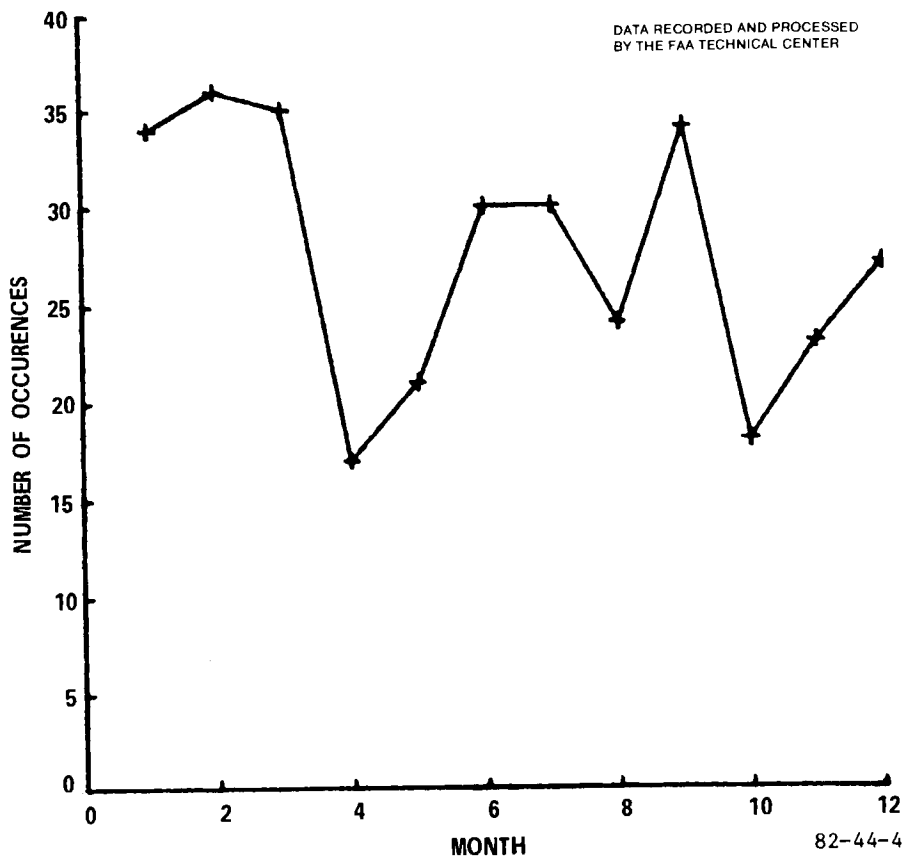

FIGURE 4. CARBURETOR ICING ACCIDENTS/INCIDENTS BY MONTH OF YEAR (1976-1980)

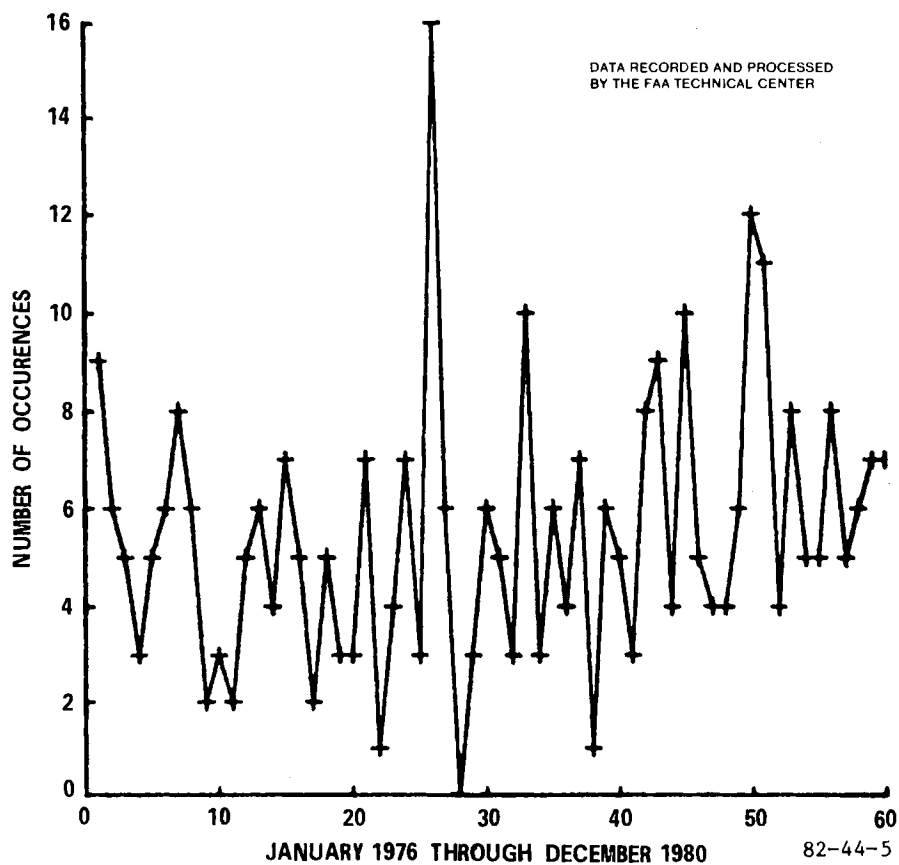

FIGURE 5. CARBURETOR ICING ACCIDENTS/INCIDENTS BY INDIVIDUAL MONTH (1976-1980)

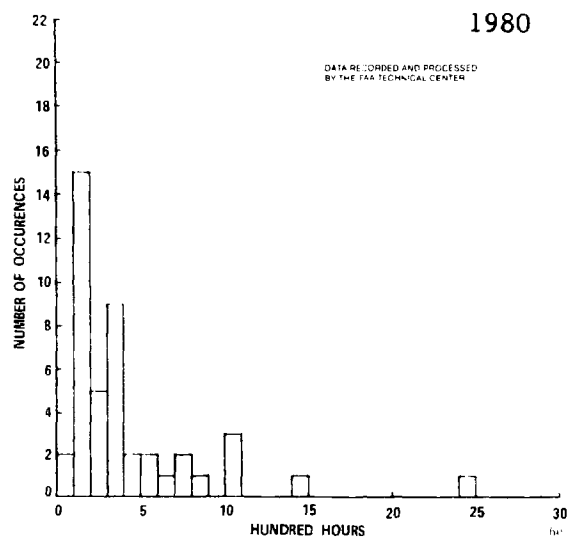
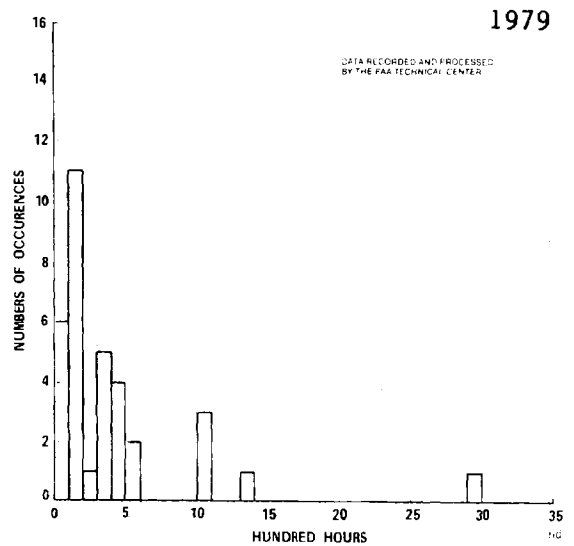
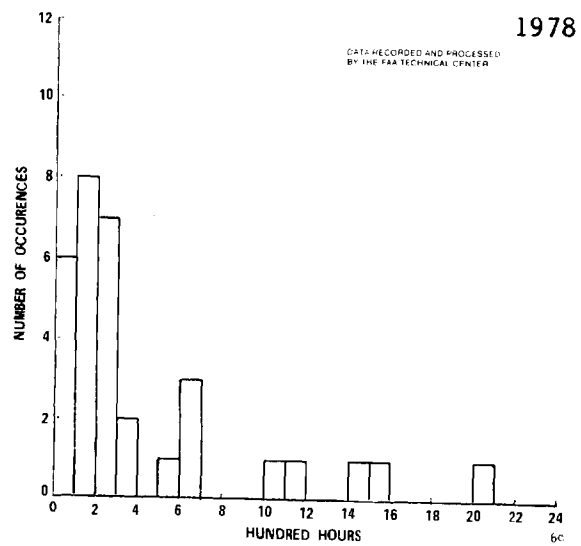
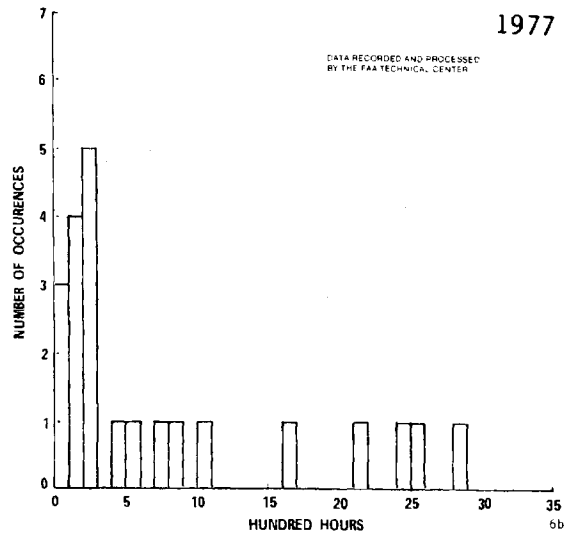
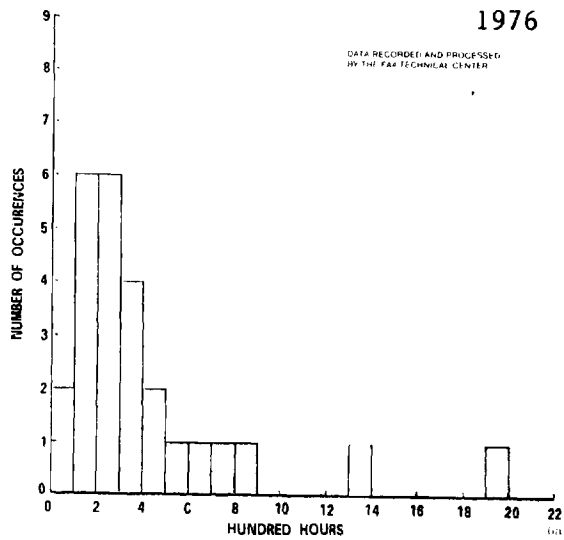

FIGURE 6. CARBURETOR ICING ACCIDENTS/INCIDENTS FROM 1976 TO 1980 BY HOUR (PRIVATE RATING)

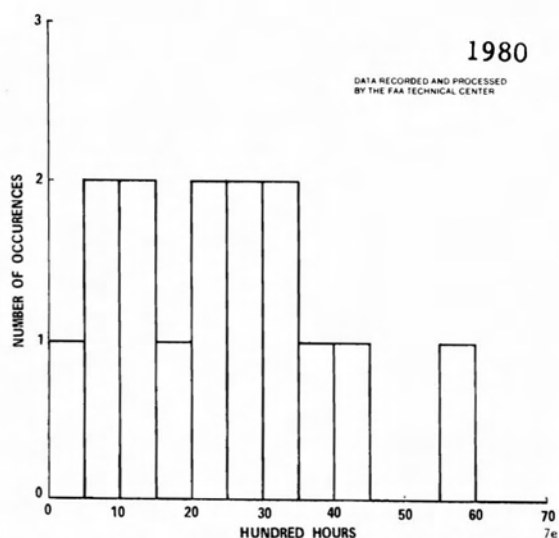
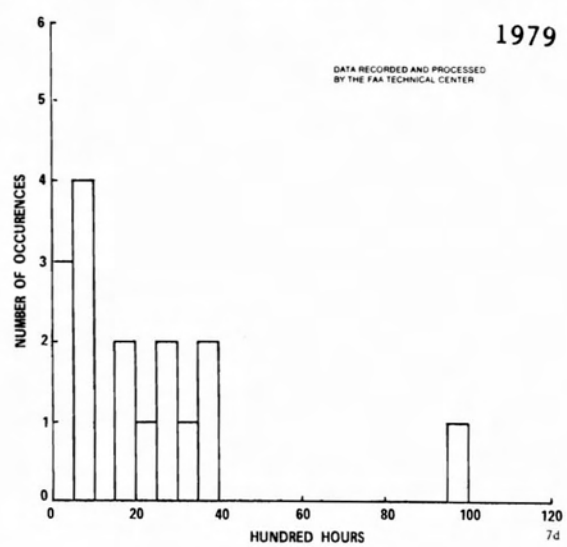
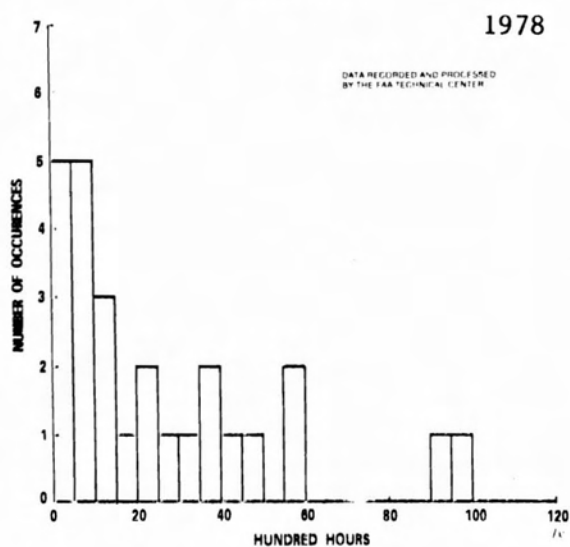
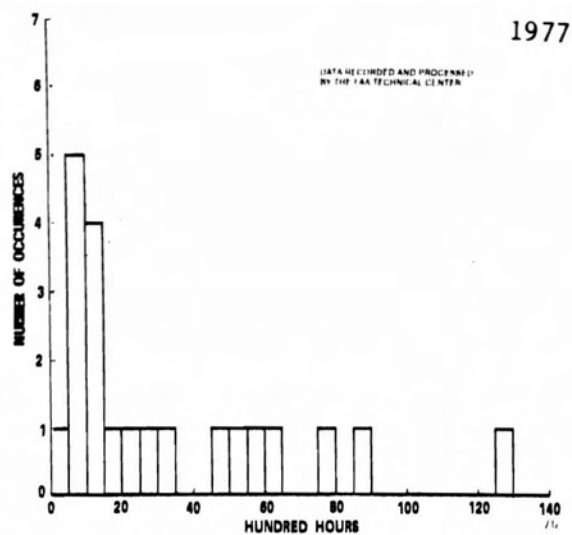
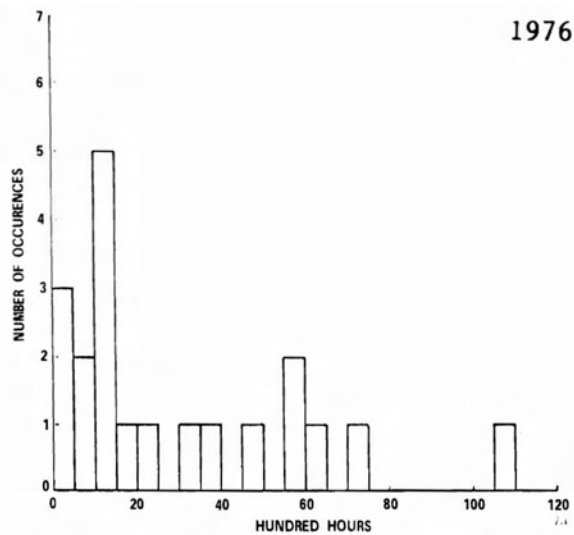

FIGURE 7. CARBURETOR ICING ACCIDENTS/INCIDENTS FROM 1976 TO 1980 BY HOUR (COMMERCIAL RATING)

BASIC CONSIDERATION

TYPES OF ICE.

Ice may form in the induction system and carburetor of reciprocating engines in the following ways:

1. Impact of water droplets in the induction air on surfaces whose temperature is below 32° F (0° C).
2. Cooling to below 32° F of the water vapor in induction air by expansion across throttle plate venturi. This expansion process produces a temperature drop which may approach 30° F.
3. As fuel is introduced into the carburetor airstream, water entrained or dissolved in the fuel is cooled to below 32° F.
4. Cooling of moisture-laden induction air to below 32° F due to fuel evaporation as fuel is introduced into the carburetor airstream.

When a liquid evaporates, a certain amount of heat transfer takes place which cools the surrounding environment. The maximum temperature drop with a stoichiometric mixture in piston engine aircraft carburetors will be approximately 37° F. As such, the total temperature drop through a carburetor may approach 70° F.

When aircraft operational characteristics are reviewed in relation to carburetor ice formation, the type of ice becomes insignificant, in the general sense. If a carburetor ice detector is to be accurate and sensitive, all types of carburetor ice should be detected regardless of cause. It should be noted that the issue is carburetor ice and not airframe ice which may block airflow through aircraft air inlet/air filter long before ice formation reaches the carburetor/carburetor ice detector.

FORMATION CHARACTERISTICS.

The initial anticipation for internal carburetor ice accumulation locations were primary or secondary venturi, main fuel jet housing, throttle plate and induction manifold downstream from the throttle plate. It was anticipated that these locations were not only the coldest positions within the carburetor induction system, but also areas where metal structures protrude into the airstream and as such, offer ice attachment. However, such locations did not always provide anticipated results as will be discussed in GENERAL OBSERVATIONS portion of report.

ICING PARAMETERS.

Factors/parameters which are critical for ice formation are carburetor air temperature/ambient air temperature, humidity and throttle plate angle. Throttle plate angle which relates to engine revolutions per minute (rpm) also relates to the amount of ambient air flowing through the engine. This interrelationship has the largest impact on carburetor metal temperature and as such, ice accumulation rate. Fuel temperature and mixture setting (rich/lean) were found to have an insignificant impact on ice formation, location, or rate.

Additional general carburetor/induction icing information is provided in appendix A. Additional carburetor/induction icing documentation bibliography is provided in Appendix B.

OPERATIONAL CHARACTERISTICS.

Most carburetor icing accident reports place final blame as pilot error, due to pilot in command of the aircraft having final authority and responsibility for the safe conduct of flight operations. While this is a true statement from the FAR standpoint, the question remains as to why the pilot allowed conditions to deteriorate to a point of no recovery.

Cockpit instrumentation, depending on aircraft configuration, which provide indications of aircraft/ engine performance deterioration are rpm, airspeed/altimeter, Exhaust Gas Temperature (EGT), and manifold pressure. As carburetor ice accumulation commences, engine RPM will gradually decay with a fixed pitch propeller and manifold pressure will decay with a constant speed propeller. This decay will be followed by a loss of airspeed if constant altitude is maintained, or a loss of altitude if aircraft trim is allowed to maintain constant airspeed. As noted under the GENERAL OBSERVATIONS portion of this report, ice accumulation generally produces mixture enrichment which leads to a reduction in EGT and is accompanied with a rough running engine.

Ice accumulation rate depends on atmospheric conditions, but generally is very steady and persistent. This brings about a steady change to aircraft/engine performance and as such, lends itself to catching the pilot unaware. Due to this steady change, some indications such as EGT change are difficult to detect, although not impossible.

It should be noted that although the mixture enrichment/EGT drop is the most common failure mode, there also exists a lean failure mode. This lean mode occurs far less often than the rich mode and is preceded by the rich mode conditions until ice formation causes a changeover.

With existing cockpit instrumentation available, it appears as though something is overlooked or misinterpreted. File data presented under historical data displays that, although most accidents/incidents occur to low-time student and private pilots, by no means are high time/ advanced rated pilots immune. Therefore, the big problem is proper interpretation of performance instrumentation in a timely manner that will allow appropriate corrective procedures to be implemented. Establishment of accurate, sensitive, more direct instrumentation, and/or establish carburetor induction systems which prevent engine stoppage due to ice, will assist in solving the problem.

COCKPIT INSTRUMENTATION.

STANDARD INSTRUMENTATION. Existing standard cockpit instrumentation is adequate to alert the pilot of a possible onset of carburetor ice formation. These instruments must be monitored for performance degradation which will appear once ice accumulation has progressed. Major drawbacks to present standard instrumentation are:

1. Pilots tend to overlook performance degradation to the point of near engine failure, hence, "Pilot Error."

2. At low power settings or prolonged periods of time at reduced power settings, adequate heat may not be available to overcome impact of ice accumulation.
3. Application of carburetor heat will momentarily cause an increase in engine roughness which entices the uninitiated pilot to turn off heat. Roughness is caused by water ingestion as ice melts, plus the application of heat causes enrichment of fuel-air mixture.
4. Performance degradation may not be caused by ice formation.
5. Performance degradation does not appear at initiation of ice formation, but rather after an accumulation has developed.
6. When carburetor temperature is well below freezing, there are times when the application of heat will make icing conditions worse, however, pilot doesn't always know when these conditions exist.

OPTIONAL INSTRUMENTATION. In addition to the standard cockpit instrumentation required by FAR's, there are optional instruments available on the market shelf which have been approved by the FAA on a no-hazard basis with the issuance of STCs for installation in type certificated aircraft. Such instruments are approved as optional equipment only and flight operations should not be predicated on their use. STC approval is not extended to other specific engines of the approved models on which other previously approved modifications are incorporated unless it is determined that the interrelationship between changes/modifications will introduce no adverse effect upon the airworthiness of that engine. Appendices C and D are examples of typical STC approvals.

Two off-the-shelf instruments which are commonly installed as carburetor ice detection/warning devices were evaluated within this report. For the purpose of this report these instruments are listed as Test Probe 1 and Test Probe 2.

Test Probe 1. The Test Probe 1 system is completely independent of temperature or pressure changes which do not affect detector operation except to melt away frost/ice accumulation. By means of a transistorized electrical circuit, a warning light mounted on the cockpit instrument panel, is actuated during blockage of light rays by frost/ice accumulation between the radiation source and the probe sensor, both of which are located inside the carburetor.

The panel mounted warning light also incorporates a sensitivity control which may be adjusted on the ground or in flight to regulate light activation. An optional warning horn may be included with system installation.

As discussed in the Test Probe 1 SYSTEM TESTS portion of this report, 18 separate test runs were performed in the static sea level engine test cell using Test Probe 1. Data compiled during test operations, which totaled 30.85 hours of engine operation, lead to the conclusion that the instrument is a useful cockpit item. There are some shortcomings inherent in Test Probe 1 system design/probe location as described in detailed in the ENGINE TEST SEQUENCE portion of this report; however, the following summarizes overall shortcomings:

1. System operation is sensitive to aircraft voltage fluctuation.

2. During some atmospheric conditions, the system has poor ice formation detection characteristics at low RPM settings (1400 and below) due to carburetor airflow characteristics.

3. STC addresses the existence of an aircraft flight manual supplement. However, no requirement exists to add such an equipment operational supplement to the aircraft flight manual when an ice detector probe is installed. This leaves the pilot/owner without full knowledge of proper equipment operation.

4. During actual carburetor frost/ice formation above 1400 rpm this system provides advance notice to the extent that some pilots may be led to disbelieve the warning signal.

Although the above mentioned shortcomings may appear to have serious connotations, it should not be construed that the instrument is useless. The Test Probe 1 carburetor ice detector is a valuable instrument for carburetor ice protection when used properly with correct interpretation as established by the manufacturers of such Probes.

Test Probe 2. The Test Probe 2 system is completely independent of pressure changes and air moisture content which do not affect warning device operation. This probe is a special small wire sensing coil of known resistance characteristics encapsulated in a thin wall shell with epoxy resin. The wire sensing coil resistance changes with carburetor air temperature. This resistance change is converted to temperature and displayed on the cockpit instrument panel. Such a system design is completely independent of pressure changes and air moisture content which do not affect warning device operation.

As indicated in the Test Probe 2 SYSTEM TESTS evaluation portion of this report, 13 separate test were performed in the static sea-level engine test cell. Data compiled during test operations, which totaled 22.06 hours of engine operation, lead to the conclusion that the instrument is a useful cockpit item if properly utilized as the manufacturer has recommended in the installation instructions. There are some shortcomings inherent in the Test Probe 2 system design/probe location as described in the ENGINE TEST SEQUENCE portion of this report; however, the following summarizes these shortcomings:

1. The instrument probe detects temperature only and does not detect moisture present to form ice.
2. The temperature probe does not see the coldest temperature inside the carburetor which occurs at the throttle plate.
3. The instrument probe does not see the effect of fuel flow mixing with airflow.
4. At low rpm settings such as 1400 and below, this probe does not provide accurate temperature indications due to carburetor airflow characteristics at probe location.
5. Installation instructions contain a section on pilot in-flight test procedures which should be utilized to verify cockpit instrument temperature indication when carburetor icing commences. This procedure is to be followed for

each aircraft installation so as to provide accurate information for that specific installation. STC does not require this procedure as a flight manual supplement which leaves the pilot/owner without full knowledge of proper equipment operation/indication.

Although these above mentioned shortcomings may seem to have serious connotations, it should not be construed that the instrument is useless. The Test Probe 2 carburetor temperature detector is a valuable instrument for carburetor ice protection when used properly with correct interpretation as established by the manufacturers of such Probes.

TEST CELL EQUIPMENT

ENGINE.

The test engine was a Teledyne Continental Motors zero time factory overhauled O-200A, naturally aspirated, overhead valve, air cooled, horizontally opposed, direct drive, and wet sump aircraft engine. The serial number was 231139-R with a bore and stroke of 4.06 inch x 3.88 inch for a total displacement of 201 cubic inches. The compression ratio was 7.0:1 with a firing order of 1-3-2-4.

The wet sump oil system had a 6-quart capacity with a standard gear type pump and no oil cooler. The engine contains hydraulic tappets while the cylinder walls/pistons are spray lubricated. Normal operational oil pressure was 30 to 60 pounds per square inch gage (psig).

The gravity feed fuel system produced 1.5 pounds per square inch (psi) at the carburetor inlet with a full tank of 50 gallons, 100 low-lead aviation gasoline. The carburetor system was a Marvel Schebler Model MA-3SPA, which had been especially instrumented for the test. A screen mesh fuel filter of the type used on DC-3 aircraft was installed in the system along with fuel system temperature and pressure probes at several locations.

The engine had a dual magneto, radio shielded ignition system where the right magneto fired the upper spark plugs and the left magneto fired the lower plugs. The magnetos were Slick Model 4201 with impulse couplings. Both magnetos drove clockwise, with a one-to-one drive ratio to the crank shaft and timed to 24° before top center (BTC).

COOLING SYSTEM.

The cooling system consisted of an air moving and heat unit, a pressure regulating and shutoff valve, an engine cooling hood, ducting and various pressure and temperature probes. The air moving and heating unit was self-contained with a 6,000 ft³/min (CFM) centrifugal blower; 20 Horsepower (HP), 3,600 rpm, 240 volt 3-phase, 60 hertz (Hz) motor. A one million British Thermal Unit (BTU) per hour burner using JP4 fuel with boiler, expansion tank and heat exchanger was also included.

A twenty-four-inch diameter sheet metal ducting with temperature and pressure probes was utilized to connect the air moving unit, pressure regulating and shutoff

valve, and 18-inch diameter flex duct which attached to the top of engine cooling hood. The pressure regulating and shutoff valve was a sheet metal tee with a set of louvers and regulating slide on the top to allow excess pressure/airflow to escape. The regulating portion had coarse and fine adjustment to allow for easy major settings and daily ambient changes, while the branch portion had shut-off louvers prior to the 18-inch engine ducting.

The engine cooling hood was a sheet metal box on top of the cylinders which converted the velocity of the cooling air into a pressure differential to move air across the cooling fins carrying away engine heat. The box had a total temperature probe and static ports to read cooling air pressure and temperature inside the hood assembly. There were high temperature rubber seals next to each cylinder to force air across the fins, rather than around them. The top of the hood was basically a transition section changing the 18-inch round flex duct to the shape of the cylinder box.

FUEL SYSTEM.

The fuel system consisted of a tank with sight gage, shut-off valve, fuel chiller, removable screen-type fuel filter with drain sump and the Marvel Schebler carburetor Model MA-3SPA.

The steel fuel tank had a 5-percent expansion space above the filler opening which contained a vented filler cap. A 3/8-inch type 304 stainless steel tube connected the tank to a manual shut-off valve followed by a normally closed 115 volt alternating current (a.c.) 9/32-inch orifice shut-off valve. The tubing connection at the fuel tank was approximately 1-inch above the tank bottom allowing room for water and sediment to remain on the bottom.

Next in line, the fuel system had an insulated tank heat exchanger. This insulated tank had a 3/8-inch fuel line coil around which ice was placed to cool fuel prior to fuel filter and carburetor inlet. The tank bottom had a water drain incorporated which allowed excess water to be removed. Fuel temperature was controlled manually by placing ice and water in heat exchanger tank and monitoring carburetor float bowl temperature.

The fuel filter was bolted to the engine mount back plate and had a thermocouple installed in a Swagelok™ fitting on filter body left side. A standard aircraft type quick drain was installed in the bottom of the filter to allow checking and removal of water and sediment. The carburetor instrumentation included two throttle plate temperatures, four metal temperatures and a float bowl temperature. Idle jet pressure and inlet fuel pressure were also instrumented. The carburetor was enclosed in a metal box to assist in controlling ambient temperature and simulate engine cowling conditions. There were openings in the box for throttle, mixture control, fuel line, instrumentation wires and tubes and to allow air to exhaust. After carburetor instrumentation and installation was completed, operational testing was accomplished to obtain data for engine performance correlation with performance data obtained during initial engine run-in checks. No performance degradation was noted as a result of extensive instrumentation.

INDUCTION AIR SYSTEM.

The induction air system consisted of two air source and conditioners, a humidity device, plenum chamber, carburetor heat valve, heat exchanger, and associated ducting.

The air sources were two 18,000 BTU per hour, 220 volt a.c. air conditioners ducted together with 6-inch flex line and a sheet metal tee. There were small sheet metal boxes on the air conditioner outlets that transition to the 6-inch duct. Thermocouples were mounted in the outlet boxes. When the engine was not running, the "fan-only" position on air conditioners pressurize the main plenum chamber to about 0.90 inches of water.

A specially designed humidity device which took a stream of water and broke it up with jets of air was used to supply moisture needed to make ice in the carburetor. The device included an air pressure gage and shut-off/regulating valve which controlled the shop air utilized to breakup the water stream, a rotormeter and shut-off valve to measure and regulate water flow and a water discharge tube located in the high pressure air jet path. This device could easily take ambient air or air-conditioned air to the saturation point by adjusting water flow rate.

The plenum chamber was a 2-foot sheet metal cube with legs, a 6-inch diameter inlet connection from the humidity device and two 3-inch outlets. There was a deflector plate at the 6-inch inlet to arrest any liquid water droplets and make them fall into the sump area. Also included were the temperature probe, pressure tap, dewpoint measuring ports, and sump area drain. The entire plenum was insulated to reduce ambient temperature effects on conditioned air.

The carburetor heat valve was tee-shaped with a remotely operated hydraulic slave system flapper valve and lever mechanism to allow either normal conditioned air or heated air to enter carburetor inlet. Carburetor heat was used between test points to heat and dry the engine induction system.

The heat exchanger, sometimes called a heater muff, was bolted to the exhaust pipes on the right side of the engine. When heat was selected, induction air would be drawn from the plenum chamber, around the exhaust pipes and into the carburetor inlet to melt any ice and dry the optical test probe. The heater muff inlet and outlet had 3-inch flexible tubing connecting the entire system from plenum to carburetor inlet.

ICE MONITORING SYSTEM.

The ice monitoring system consisted of two fiber optic borescopes, two cold light sources, two television (TV) cameras, one video cassette recorder, two TV monitors, and various adapters.

There were two 0.340-inch diameter fiber optic borescopes which had a 50-inch working length. One borescope had a forward viewing distal end while the other was side-viewing. Both were capable of 120° articulation in either direction from straight. A cold light source with two easily changed internal lamps, a brightness control knob, and operating on a 115-volt a.c. 2.5 amps accompanied each borescope. Both light sources were attached to a shock mounted plate to dampen engine vibration and, in addition, the carburetor bottom borescope light source was wired with a remote power switch for control room use while testing A.R.P. optical ice detector.

Each borescope optical end had a special adapter which allowed attachment to individual standard black and white television cameras. This assembly was then anchored to the same shock mounted plate utilized for borescope light sources. Each camera also required a separate remote power supply which was located in the control room. The distal end of each borescope mounted in separate adapters

specifically designed to fit below and above carburetor mounting flange and provide physical mounting of borescope probes while the bottom adapter also allowed flexing of the distal end.

A video cassette recorder was used to obtain a pictorial record of pertinent tests or conditions of a test. The video cassette recorder was normally attached to the bottom borescope to record bottom throttle plate view. The recorder could easily and quickly be shifted to the top borescope which provided viewing of either the top throttle plate area or the intake manifold.

Two TV monitors were used to view the test continually and check for ice buildup. The monitors allow for varying test conditions and obtain immediate feed-back, relative to data which should be recorded.

Figure 8 depicts overall instrumentation/installation equipment described above.

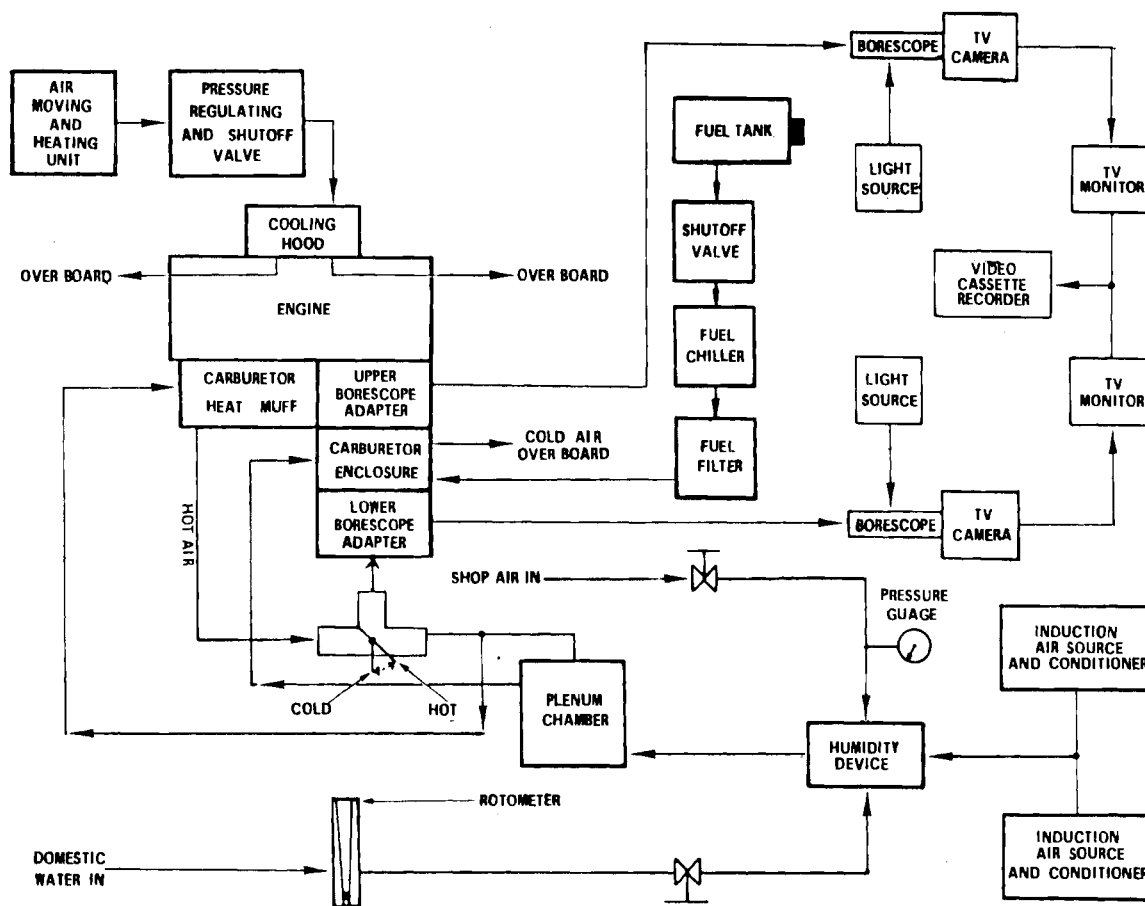

82-44-8

FIGURE 8. TEST SYSTEM SCHEMATIC

DATA ACQUISITION SYSTEM.

The data acquisition system used to collect the data was a NEFF instrument corporation series 620L analog data acquisition and control system. This system consists of a NEFF Series 400 Differential Multiplexer, a Digital Equipment Corporation PDP 11-04 computer, and a Kennedy Corporation Model 9000 tape transport.

The differential multiplexer was a complete high speed data acquisition subsystem. It contained a high speed solid state analog signal multiplexer that was capable of accepting 256 input channels, a programmable gain differential amplifier and an analog-to-digital converter. Signals acceptable to the differential multiplexer were thermocouples and analog voltages with full-scale readings ranging from 5 millivolts to 10.24 volts. Each channel had a 10Hz filter to reject superimposed noise and unwanted signal frequencies.

Control of the data acquisition was performed by the PDP11-04 computer which encompassed setting sampling rate (10kHz max), converting raw data into engineering units as established by operator, displaying eight different parameters on cathode ray tube (CRT) and writing data on Kennedy tape drive at a rate of 1600 bits per second. An alarm capability was installed to warn the engine operator when any parameter reached a critical value.

Thermocouple instrumentation utilized during test operations were calibrated to $\pm 0.5^\circ$ F, while data acquisition/computer system carried data readings to $\pm 0.0001^\circ$ F. This can be observed in the rapid sharp changes depicted in appendix E data plots.

ENGINE TEST SEQUENCE

BREAK-IN RUN.

The engine was purchased as a Teledyne Continental Motors factory rebuilt, zero time engine. A 50-hour break-in run was completed prior to a series of baseline tests to check engine performance. The baseline allowed comparison of icing runs with normal engine performance and a check for instrumentation placement and any related power deterioration.

The first 25 hours of operation was conducted with a non-detergent oil type Mil-C6529 Type II while the remainder of the testing was conducted with an Ashless Dispersent Aviation oil EE-80. Initially, oil was changed at 25 hours, again at the first 50-hour inspection and every 50-hours of subsequent operation.

Break-in testing started with an 800 to 1000 rpm setting. When oil temperature and cylinder-head temperature (CHT) showed a definite increase, rpm was set to 1200 and a manual data point taken. When oil temperature reached 70° F or greater, rpm was increased to 1800 and after a stabilization time, a magneto test was performed. The next series of steps paralleled a normal light plane operation. A full throttle takeoff run of about 5 minutes was accomplished followed by a power reduction to 2050 with manual data reading taken at each point. Finally, rpm was set at 1950 for a 20-to-30 minute steady-state condition, with data taken every 10 minutes, and then a 1200 rpm cooling condition was set followed by a decision to either enter a shutdown sequence or initiate another cycle.

The engine start, magneto check and a full power run was labeled Normal Startup Test (SUT).

BASELINE TESTS.

This test was initiated with a SUT. After full throttle condition data was taken, rpm was retarded to 2100 and engine allowed to stabilize. Computer data was taken continuously at 1 scan per minute while the engine was stabilizing. Manual data was taken at each point three minutes after point was set. After another minute or two, the next lower rpm was set. This sequence was repeated as per table 8 until all points were completed. When a full test was completed, 1200 RPM was selected and cooling air modulated to allow the engine to cool slowly. A 1000 rpm condition was selected, a magneto safety check accomplished, and then mixture control pulled to the off-position to stop engine. This was labeled Normal Shut-Down Test (SDT).

TEST PROBE 1 CARBURETOR ICE DETECTOR SYSTEM TESTS.

The initial series of Test Probe 1 tests were conducted with two main parameters in mind. First, it is very difficult to build ice at high rpm in a short period of time. Next, experience had previously shown that the throttle angle effects temperature readings in the location of the Test probe. This meant that rpm/throttle angle could effect the ice detection characteristics.

The optical ice monitoring system gave a very good picture below the throttle plate at all times, however, the picture above the throttle plate was poor at icing conditions. It was observed that high rpm ice tended to build out of the immediate view of the bottom borescope and borescope relocation would not solve this problem, therefore, 1800 rpm or below was selected to evaluate rate at which Test Probe 1 responded to ice.

The optical ice monitoring system utilized a cold light source, as discussed in TEST CELL EQUIPMENT portion of this report, to illuminate area being observed. A problem developed when Test Probe 1 ice detecting system testing commenced, since this system used light for its basic operating principal. With the bottom borescope light source operating, the illumination was such that the Test Probe 1 system would not function under any condition. To overcome this difficulty, a remote lower borescope light source power switch was installed in test cell control room test console which allowed test operator to control light source as desired. This enabled icing tests to be conducted with the borescope light source off, except for very brief moments to check for ice condition.

A series of ice detecting tests were performed in the sequence noted in table 8. After conducting a number of the tests, the Test Probe 1 system failed to detect ice at any condition. While trouble shooting the system, it was discovered that the power supply was putting out 14.5 volts direct current (V.d.c.) to the Test Probe 1 system. The sensitivity was reset to 12 V.d.c. and normal system operation commenced.

This led to the discovery that, if the Test Probe 1 sensitivity was set at one voltage and then operated at a lower voltage, the warning light would remain on at all times. If the sensitivity was set at one voltage and the Test Probe system operated at a much higher voltage the warning light would never come on even with very heavy ice. This voltage sensitivity was tested many times at different voltage variations and operational characteristics noted. If aircraft voltage

TABLE 8. ENGINE TEST SEQUENCE

NORMAL START-UP TEST (SUT)

800 to 1000 1200 1800 MAGNETO CHECK FULL THROTTLE POWER CHECK

NORMAL SHUT-DOWN TEST (SDT)

1200 cool down 1000 MAG SAFETY CHECK PULL MIXTURE OFF
 (SHUT COOLING AIR OFF WHEN CHT
 BELOW 300° F)

BREAK-IN TEST

SUT 2050 1950 1800 After 1800 either SDT or full
 throttle run then 2050 and
 repeat cycle

BASELINE TEST

SUT 2100 2050 1950 1850 1800 1500 1300 SDT

increases more than 0.75 V.d.c. above that which existed when Test Probe 1 sensitivity was set, ice detection accuracy decreased. When operating voltage increased approximately 2.25 V.d.c. above that which existed when the sensitivity was set, ice detection was next to nill. Another operational characteristic noted was the rate at which the sensitivity knob was adjusted. A very slow adjustment of the knob to desired position would leave the light accurate but extremely sensitive to frost formation. During these tests of characteristics, it was noted that best results were obtained when the sensitive knob was set at a medium rate and not fine tuned. It was also noted that as ice would build, the sensitivity could be reset until the warning light went out and the indicator would continue to function and provide a warning if ice continued to build. The Test Probe 1 ice detecting system can detect ice and be a very useful tool if instructions are followed and the operating limitations known.

TEST PROBE 2 CARBURETOR ICE DETECTING SYSTEM TESTS

The Test Probe 2 system testing was approached with limited practical knowledge of internal carburetor ice production and propagation, since this was the first system tested. Ice was produced at various rpms with several repeatable propagation patterns and rates with Test Probe 2 temperature indicator in and out of the caution arc. As test experience grew in the ice production area, it became apparent that the temperature probe being tested was not located in the coldest point in the carburetor. It was speculated that air around the probe stagnated at engine rpms of 1400 and below since actual air measurements could not be taken in the immediate vicinity of the probe. It was noted that visible ice could be accumulated on throttle plate at 1400 rpm and below while Test Probe 2 temperature indicator indicated outside of the yellow caution arc. Figure 9 contains a temperature plot indicating the temperature differential between the test probe temperature and internal carburetor temperatures. As engine rpm was increased above 1400, the indicator's caution arc became accurate relative to ice accumulation probability, however, temperature differentials continued. The Test Probe 2 temperature probe can be a useful tool to alert pilots of possible carburetor ice if operating instructions are followed and operating limitations are known.

DISCUSSION

As addressed in GENERAL OBSERVATIONS portion of this report, the carburetor idle jet pressure was useful in monitoring carburetor performance/sensitivity during ice accumulation and propagation. Figure 10 is an idle jet pressure plot versus rpm with pressure being measured in inches of mercury vacuum. Figure 10 was taken from the SUT of a Test Probe 1 test cycle, wherein slight idle jet pressure fluctuations which are evident at 900 and 1300 rpm are attributed to typical engine warm-up characteristics. The pressure fluctuation at 1800 rpm was typical during magneto operational check.

Figure 11 reflects idle jet pressure fluctuation during the entire Test Probe 1 test cycle initiated in figure 10. Large pressure fluctuations were typical during carburetor icing and were detected prior to engine performance degradation. During some large pressure fluctuations an idle jet vent was opened to check on possible alteration of engine performance characteristics. Whenever venting was initiated, idle jet pressure would return to near ambient. Exhaust emission analyzing equipment would better identify changes in engine performance characteristics due to such a venting operation.

DATA RECORDED AND PROCESSED
BY THE FAA TECHNICAL CENTER

- - TEST PROBE 2 TEMP.
- - CARBURETOR FLOAT BOWL TEMP.
- △ - THROTTLE PLATE LOWER TEMP.
- × - THROTTLE PLATE UPPER TEMP.
- * - THROTTLE PLATE PERCENT TRAVEL.

NOTE: CARBURETOR INLET TEMP. 59° F

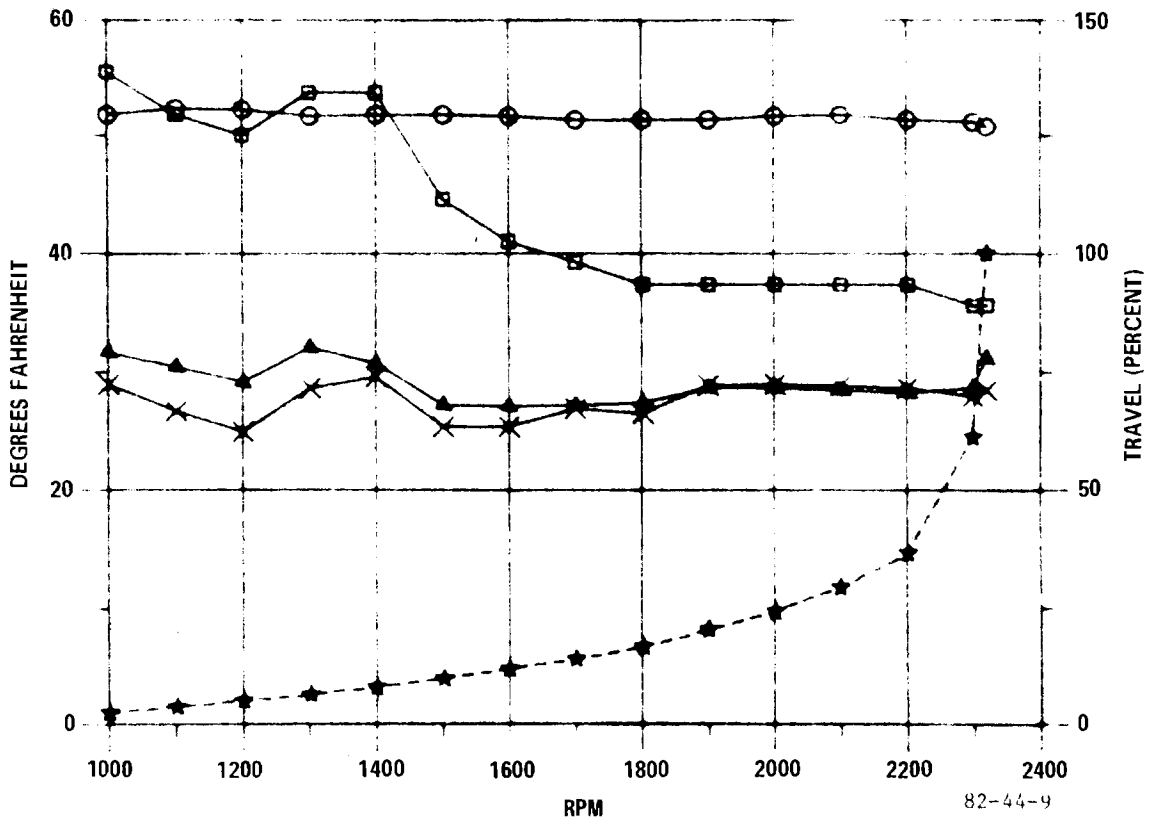

FIGURE 9. CARBURETOR TEMPERATURE DATA VERSUS RPM

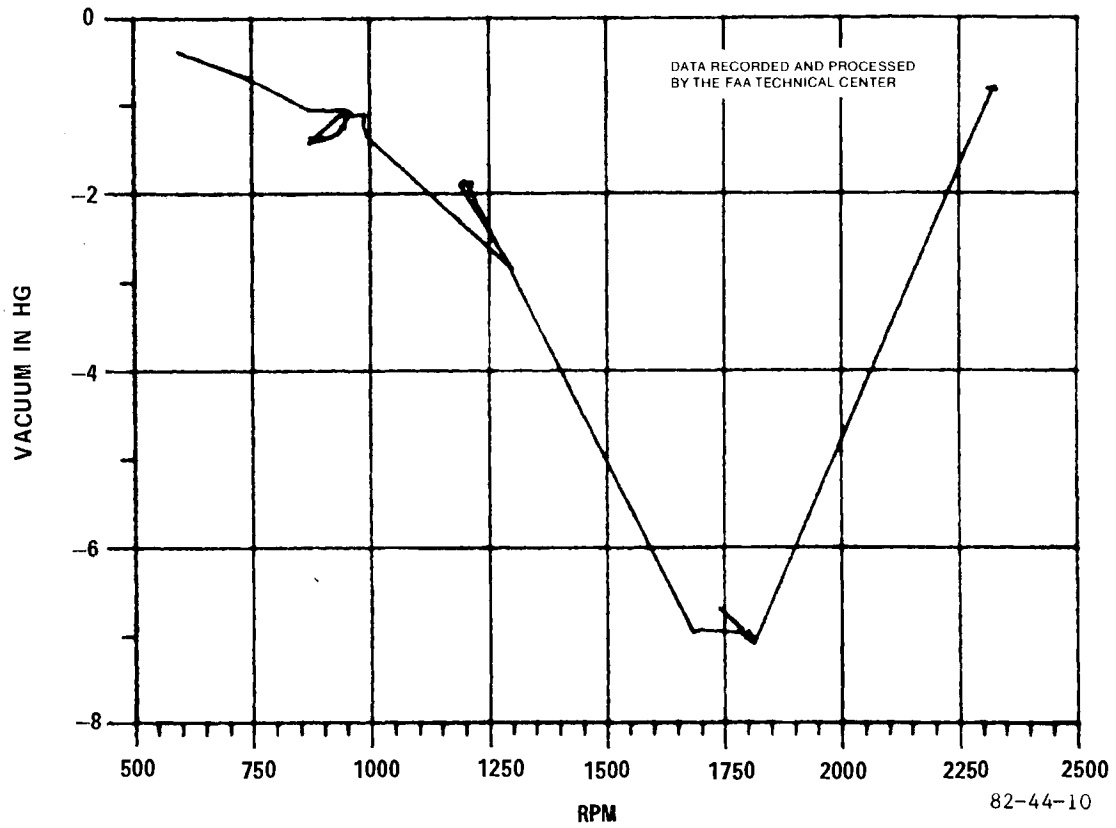

FIGURE 10. IDLE JET PRESSURE VERSUS RPM (NO ICE)

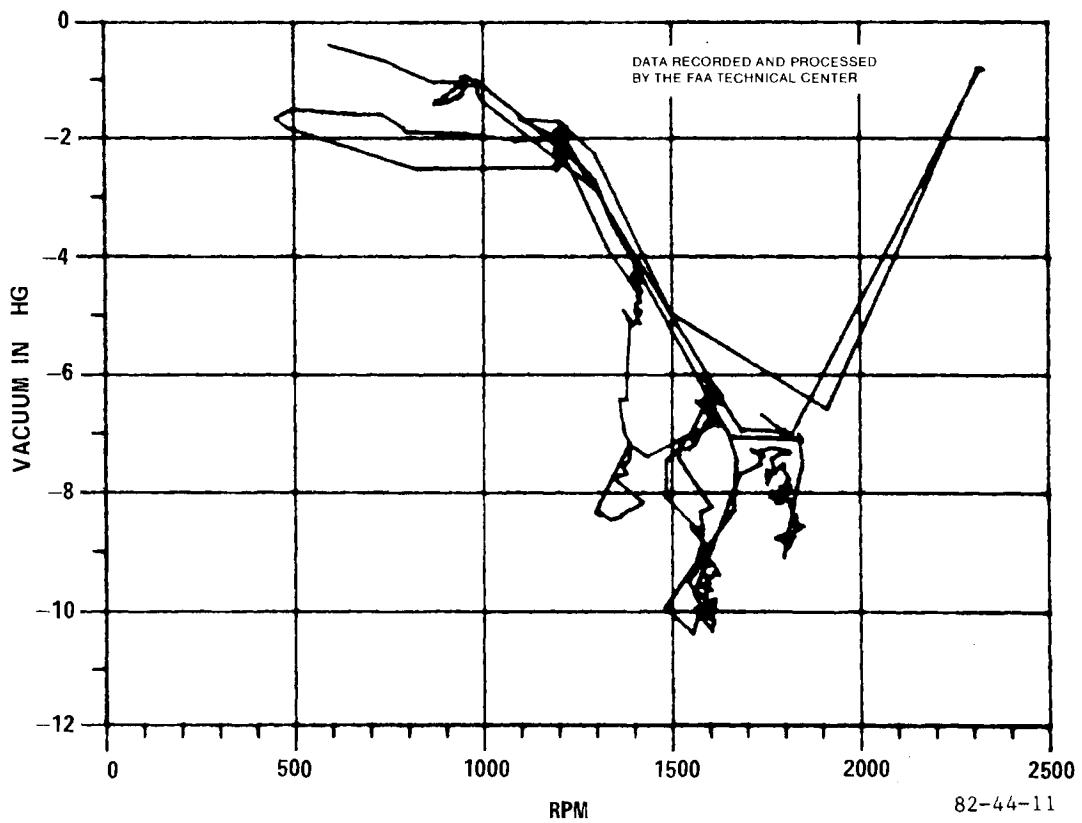

FIGURE 11. IDLE JET PRESSURE VERSUS RPM (WITH ICE)

Data collected during each engine test run was plotted as displayed in figures 10 and 11 as well as appendix E. Each parameter was plotted for the complete test run in two formats:

1. Individual parameter versus rpm for complete test run as displayed in figure 11.
2. Individual parameter versus 25-minute increments for complete test run as displayed in appendix E (figure E-5).

Appendix E test data is only a sample of the vast data obtained during the entire test program. For analysis purposes, each parameter listed in table 1 was plotted as mentioned above and reviewed for abnormalities.

Appendix F provides pictorial information relative to test cell engine installation.

GENERAL OBSERVATIONS.

1. Engine operation under carburetor icing conditions was accomplished at sea level conditions only.
2. Engine rpm in the test cell installation was a static condition. During actual in-flight operation, engine rpm would be 200-300 rpm higher for a given throttle plate angle. Such an increase in rpm with its corresponding increase in airflow would cause a slightly larger cooling effect inside the carburetor for a given throttle plate angle.
3. The static test cell engine installation without actual aircraft cowling and dynamic flight conditions allowed an engine heat transfer different from that imposed in-flight. The test cell installation did not allow the engine to dissipate heat as rapidly as in-flight, and hence, represents a conservative condition relative to icing.
4. Under static test cell operating conditions, engine rpm at times would drop from a given test point (1400, 1600, 1800, etc.) down to approximately 600 rpm. At that point in time, engine heat would cause ice to melt and allow the engine to accelerate without causing actual engine stoppage due to ice. However, in-flight conditions with flight loading on propeller would have caused engine stoppage.
5. A better understanding of carburetor ice accumulation effects on fuel-air ratio could have been obtained with the use of exhaust emission analyzer equipment. However, such test equipment was not available at time of test cell engine operation. Additional engine testing with emission equipment would better define the rich/lean failure modes.
6. The initial impact on carburetor performance as ice accumulation commences was a fluctuation of idle jet pressure below normal value. Such fluctuation would appear long before engine performance degradation commenced. Idle jet pressure became an accurate instrument for early detection of carburetor ice formation.

7. Additional "off-the-shelf" concepts/devices were becoming available, however, such equipment was not available at the FAA Technical Center during test cell engine operations. All known devices which are becoming available are listed in appendix G.

8. With over 150 hours of test cell engine operation, only two occasions were observed with any form of ice accumulation on the venturi (primary/secondary). These two occurrences were only light frost coverings and did not alter carburetor performance.

9. During one test cycle, throttle plate ice accumulated to a point that throttle movement was restricted and engine would not accelerate above 1900 rpm at which time engine stoppage would have occurred. Complete stoppage was alleviated by retarding throttle to 1200-1400 rpm at which point engine operation was acceptable. A cure for this 1900 rpm condition was obtained with:

- (a) full carburetor heat,
- (b) mixture left as set prior to problem, and
- (c) slowly exercise throttle with caution so as not to damage throttle plate or venturi area.

During this icing condition, ice built from throttle plate lower face straight down, parallel with and into the incoming airflow. After initial engine roughness which was corrected by setting a lean mixture, normal engine operation was noted until acceleration was attempted.

10. Based on video observations of actual carburetor ice accumulation, the best location for a carburetor ice detector/warning device would be on throttle plate.

11. Additional engine test work needs to be performed, relative to lean failure mode due to ice accumulation, to better understand the conditions.

12. Although total test time was short as compared to a year's operating time on an aircraft, dirt is not expected to interfere with the Test Probe 1 indicator light ray scatter technique between aircraft maintenance inspection requirements.

CONCLUSIONS

Related Factors.

Based on test cell instrumentation and test cycle data obtained as outlined in various portions of this report the following conclusions have been made.

1. Surprisingly, little moisture needs to be present in ambient air to initiate carburetor ice/frost formation. This may lead pilots to the assumption that carburetor ice is not their problem.

2. Carburetor ice accumulation commences on the throttle plate.

3. Small amounts of ice formation on the manifold side of the throttle plate next to the idle jet holes will have an immediate impact on idle jet pressure (vacuum).

4. When ice accumulation commences on the upstream throttle plate face, as it faces the incoming airstream, large amounts of ice may build up prior to performance degradation.

5. Little ice formation was noted on the carburetor venturi or the induction manifold above the carburetor.

6. Engine failure/stoppage modes due to ice accumulation are, excessive over rich mixture or excessive lean mixtures. The over rich mixture conditions are by far the most common.

7. Ice accumulation can build on throttle plate face to a point that throttle advancement and engine acceleration are impossible. This condition may occur with very little initial engine performance degradation until throttle advancement is attempted.

8. Primary and secondary venturi locations are not major ice accumulation positions.

General.

1. Existing standard cockpit instrumentation is adequate to detect carburetor ice formation. Aircraft/engine performance degradation will provide warning indications with sufficient time to correct deteriorating conditions prior to engine stoppage.

2. Pilot education during student training phase and biennial flight review needs to stress carburetor icing problems, detection indications and proper corrective procedures as specified by aircraft manufacturer in the approved aircraft flight manuals.

3. FAA/NTSB accident/incident data for engine failure/stoppage contain a large quantity of statements, "Cause Unknown." Many of these reports could quite conceivably be carburetor icing situations making the problem much larger than data reports indicate.

Test Probe 1 Indicator System.

1. Carburetor ice indicator was a useful instrument at rpms above 1,400.

2. The indicator probe does not feel the effects of fuel flow within the carburetor.

3. The carburetor throttle plate temperature is colder than the air temperature seen by the indicator probe.

4. There are some accuracy limitations when using this indication system which should be placed in aircraft flight manual such as observed at 1400 rpm and below.

5. When adjusting detector light sensitivity in-flight, care must be taken or accuracy of instrument will be nullified and pilot will not be aware of his adjustment error.

6. Although the above mentioned shortcomings may appear to have serious connotations, the instrument, when used properly, will provide valuable information.

Test Probe 2 Indicator System.

1. Carburetor air temperature indicator was useful at rpms above 1,400.
2. The air temperature probe does not feel the effects of moisture or fuel flow within the carburetor.
3. The carburetor throttle plate temperature is colder than the air temperature seen by the indicator probe.
4. There are some accuracy limitations when using this probe which should be placed in aircraft flight manual such as observed at 1400 rpm and below.
5. Although the above mentioned shortcomings may appear to have serious connotations, the instrument, when used properly, will provide valuable information.

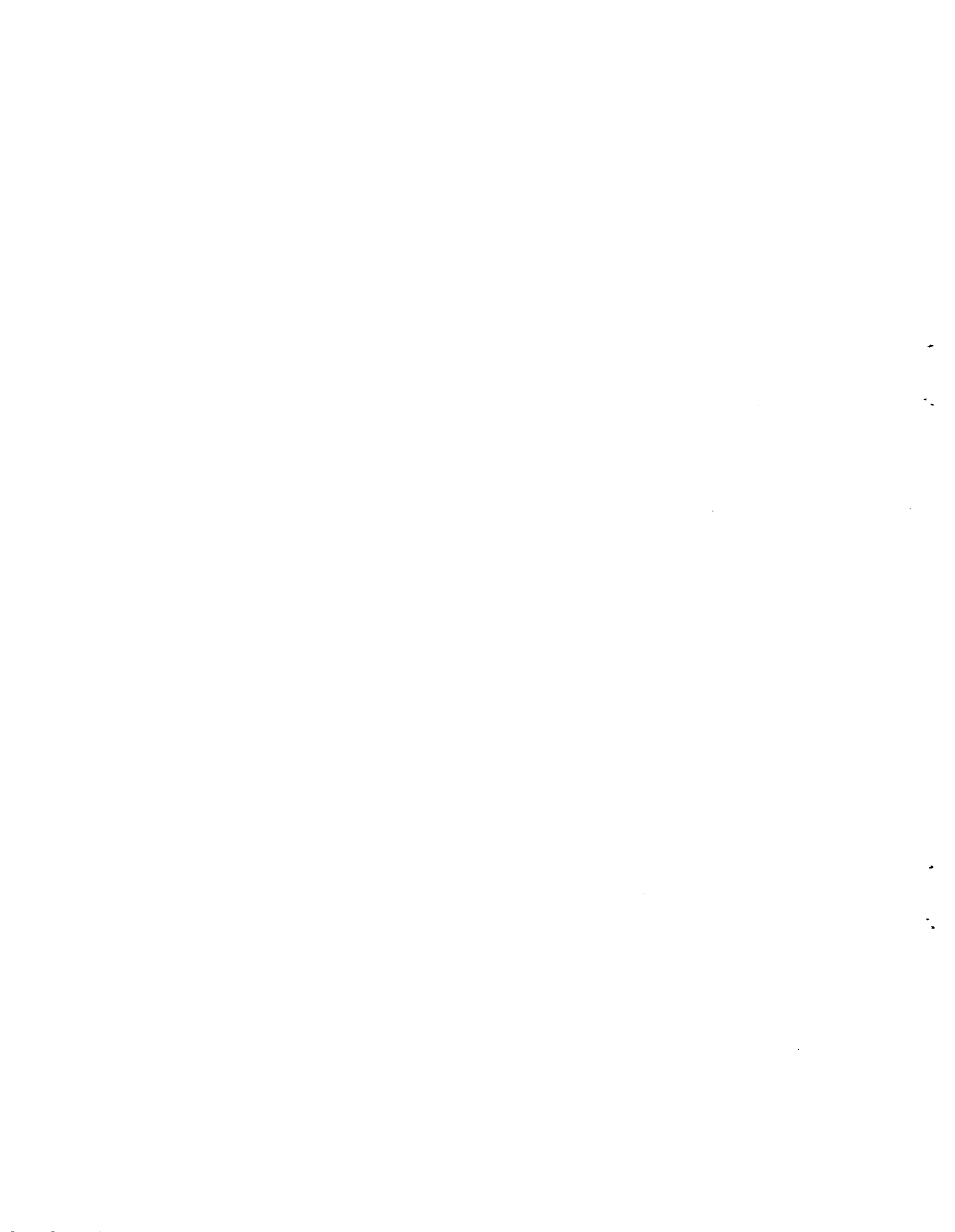

APPENDIX A

ADVISORY CIRCULAR AC NO: 20-113 DATED OCTOBER 22, 1981 SUBJECT:
PILOT PRECAUTIONS AND PROCEDURES TO BE TAKEN IN PREVENTING AIRCRAFT
RECIPROCATING ENGINE INDUCTION SYSTEM AND FUEL SYSTEM ICING PROBLEMS



AC 20-113

DATE 10/22/81

ADVISORY CIRCULAR



DEPARTMENT OF TRANSPORTATION
Federal Aviation Administration
Washington, D.C.

Subject: PILOT PRECAUTIONS AND PROCEDURES TO BE TAKEN IN PREVENTING
AIRCRAFT RECIPROCATING ENGINE INDUCTION SYSTEM AND FUEL SYSTEM
ICING PROBLEMS

1. PURPOSE. This circular provides information pertaining to aircraft engine induction system icing and the use of fuel additives to reduce the hazards of aircraft operation that may result from the presence of water and ice in aviation gasoline and aircraft fuel systems.
2. CANCELLATION. This Advisory Circular cancels AC 60-9 and 20-92.
3. RELATED READING MATERIAL.
 - a. Advisory Circular AC 20-24A, 4/1/67, Qualification of Fuels, Lubricants, and Additives.
 - b. Advisory Circular AC 20-29B, 1/18/72, Use of Aircraft Fuel Anti-Icing Additives.
 - c. Advisory Circular 20-73, 4/21/71, Aircraft Ice Protection.
 - d. National Research Council of Canada, Mechanical Engineering report LR-536, Aircraft Carburetor Icing Studies, July 1970.
 - e. Investigation of Icing Characteristics of Typical Light Airplane Engine Induction Systems, NACA TN No. 1790, February 1949.
 - f. Icing - Protection Requirements for Reciprocating Engine Induction Systems, NACA Technical Report No. 982, June 1949.
 - g. Various Aircraft Owners Handbooks, provided by the manufacturers.
 - h. Carburetor Ice in General Aviation, NTSB Special Report AAS-72-1.

Initiated by: AWS-140

4. BACKGROUND/DISCUSSION. Reciprocating engine icing conditions are a constant source of concern in aircraft operations since they can result in loss of power and, if not eliminated, eventual engine malfunction or failure. The different types of icing conditions are characterized as air induction system icing and aircraft fuel system icing. Because of a substantial number of aircraft accidents attributed to incidents involving such icing, it is important for a pilot to know the kinds of ice formation encountered, and the manner in which each is formed.

5. INDUCTION SYSTEM ICING. Induction system icing may be characterized as Impact Ice, Throttle Ice, and Fuel Vaporization Ice. Any one, or a combination of the three kinds of induction icing, can cause a serious loss of power by restricting the flow of the fuel/air mixture to the engine and by interference with the proper fuel/air ratio. Because induction icing accidents can be prevented by the pilot in virtually all cases, improved pilot awareness, attention, and adherence to recommended procedures should reduce accidents of this type.

a. Impact Ice - Impact ice is formed by moisture-laden air at temperatures below freezing, striking and freezing on elements of the induction system which are at temperatures of 32° F. or below. Under these conditions, ice may build up on such components as the air scoops, heat or alternate air valves, intake screens, and protrusions in the carburetor. Pilots should be particularly alert for such icing when flying in snow, sleet, rain, or clouds, especially when they see ice forming on the windshield or leading edge of the wings. The ambient temperature at which impact ice can be expected to build most rapidly is about 25° F., when the supercooled moisture in the air is still in a semiliquid state. This type of icing affects an engine with fuel injection, as well as carbureted engines. It is usually preferable to use carburetor heat or alternate air as an ice prevention means, rather than as a deicer, because fast forming ice which is not immediately recognized by the pilot may significantly lower the amount of heat available from the carburetor heating system. Additionally, to prevent power loss from impact ice, it may be necessary to turn to carburetor heat or alternate air before the selector valve is frozen fast by the accumulation of ice around it. When icing conditions are present, it is wise to guard against a serious buildup before deicing capability is lost. The use of partial heat for ice prevention without some instrumentation to gauge its effect may be worse than none at all under the circumstances. Impact icing is unlikely under extremely cold conditions, because the relative humidity is usually low in cold air and because such moisture as is present usually consists of ice crystals which pass through the air system harmlessly. The use of partial heat when the temperature is below 32° F. may, for example, raise the mixture temperature up to the danger range, whereas, full carburetor heat would bring it well above any danger of icing.

b. Throttle Ice - Throttle ice is usually formed at or near a partially closed throttle, typical of an off-idle or cruise power setting. This occurs when water vapor in the air condenses and freezes because of the cooling restriction caused by the carburetor venturi and the throttle butterfly valve. The rate of ice accretion within and immediately downstream from the carburetor venturi and throttle butterfly valve is a function of the amount of entrained moisture in the air. If this icing condition is allowed to continue, the ice may build up until it effectively throttles the engine. Visible moisture in the air is not necessary

for this type icing, sometimes making it difficult for the pilot to believe unless he is fully aware of this icing effect. The effect of throttle icing is a progressive decline in the power delivered by the engine. With a fixed pitch propeller this is evidenced by a loss in engine RPM and a loss of altitude or airspeed unless the throttle is slowly advanced. With a constant speed propeller, there will normally be no change in RPM but the same decrease in airplane performance will occur. A decrease in manifold pressure or exhaust gas temperature will occur before any noticeable decrease in engine and airplane performance. If these indications are not noted by the pilot and no corrective action is taken, the decline in engine power will probably continue progressively until it becomes necessary to retrim to maintain altitude; and engine roughness will occur probably followed by backfiring. Beyond this stage, insufficient power may be available to maintain flight; and complete stoppage may occur, especially if the throttle is moved abruptly.

c. Fuel Vaporization Ice - This icing condition usually occurs in conjunction with throttle icing. It is most prevalent with conventional float type carburetors, and to a lesser degree with pressure carburetors when the air/fuel mixture reaches a freezing temperature as a result of the cooling of the mixture during the expansion process that takes place between the carburetor and engine manifold. This does not present a problem on systems which inject fuel at a location beyond which the passages are kept warm by engine heat. Thus the injection of fuel directly into each cylinder, or air heated by a supercharger, generally precludes such icing. Vaporization icing may occur at temperatures from 32° F. to as high as 100° F. with a relative humidity of 50 percent or above. Relative humidity relates the actual water vapor present to that which could be present. Therefore, temperature largely determines the maximum amount of water vapor air can hold. Since aviation weather reports normally include air temperature and dewpoint temperature, it is possible to relate the temperature - dewpoint spread to relative humidity. As the spread becomes less, relative humidity increases and becomes 100% when temperature and dewpoint are the same. In general, when the temperature-dewpoint spread reaches 20° F. or less, you have a relative humidity of 50% or higher and are in potential icing conditions.

6. FUEL SYSTEM ICING. Ice formation in the aircraft fuel system results from the presence of water in the fuel system. This water may be undissolved or dissolved. One condition of undissolved water is entrained water which consists of minute water particles suspended in the fuel. This may occur as a result of mechanical agitation of free water or conversion of dissolved water through temperature reduction. Entrained water will settle out in time under static conditions and may or may not be drained during normal servicing, depending on the rate at which it is converted to free water. In general, it is not likely that all entrained water can ever be separated from fuel under field conditions. The settling rate depends on a series of factors including temperature, quiescence and droplet size.

a. The droplet size will vary depending upon the mechanics of formation. Usually, the particles are so small as to be invisible to the naked eye, but in extreme cases, can cause slight haziness in the fuel. Water in solution cannot be removed except by dehydration or by converting it through temperature reduction to entrained, then to free water.

b. Another condition of undissolved water is free water which may be introduced as a result of refueling or the settling of entrained water that collects at the bottom of a fuel tank. Free water is usually present in easily detectable quantities at the bottom of the tank, separated by a continuous interface from the fuel above. Free water can be drained from a fuel tank through the sump drains which are provided for that purpose. Free water frozen on the bottom of reservoirs, such as the fuel tanks and fuel filter, may render water drains useless and can later melt releasing the water into the system thereby causing engine malfunction or stoppage. If such a condition is detected, the aircraft may be placed in a warm hangar to reestablish proper draining of these reservoirs, and all sumps and drains should be activated and checked prior to any flying. Entrained water (i.e., water in solution with petroleum fuels) constitutes a relatively small part of the total potential water in a particular system, the quantity dissolved being dependent on fuel temperature and the existing pressure and the water solubility characteristics of the fuel. Entrained water will freeze in cold fuel and tend to stay in suspension longer since the specific gravity of ice is approximately the same as that of aviation gasoline.

c. Water in suspension may freeze and form ice crystals of sufficient size such that fuel screens, strainers, and filters may be blocked. Some of this water may be cooled further when the fuel enters carburetor air passages and causes carburetor metering component icing, when conditions are not otherwise conducive to this form of icing.

7. PREVENTION PROCEDURES.

a. Induction System Icing - To prevent accidents due to induction system icing, the pilot should regularly use heat under conditions known to be conducive to atmospheric icing and be alert at all times for indications of icing in the fuel system. The following precautions and procedures will tend to reduce the likelihood of induction system icing problems:

- (1) Periodically check the carburetor heat systems and controls for proper condition and operation.
- (2) Start the engine with the carburetor heat control in the COLD position to avoid possible damage to the system and a fire hazard because of a backfire while starting.
- (3) As a preflight item, check the carburetor heat effectiveness by noting the power drop (when heat is applied) on runup.
- (4) When the relative humidity is above 50 percent and the temperature is below 70° F., apply carburetor heat briefly immediately before takeoff, particularly with float type carburetors, to remove any ice which may have been accumulated during taxi and runup. Generally, the use of carburetor heat for taxiing is not recommended because of possible ingestion of foreign matter on some installations which have the unfiltered air admitted with the control in the HOT or ALTERNATE AIR positions.

10/22/81

AC 20-113

(5) Conduct takeoff without carburetor heat, unless extreme intake icing conditions are present.

(6) Remain alert for indications of induction system icing during takeoff and climb-out, especially when the relative humidity is above 50 percent, or when visible moisture is present in the atmosphere.

(7) With instrumentation such as carburetor or mixture temperature gauges, partial heat should be used to keep the intake temperature in a safe range. Without such instrumentation, full heat should be used intermittently as considered necessary.

(8) If induction system ice is suspected of causing a power loss, apply full heat or alternate air. Do not disturb the throttle until improvement is noted. Expect a further power loss momentarily and then a rise in power as the ice is melted.

(9) If the ice persists after a period with full heat, gradually advance the throttle to full power and climb at the maximum rate available to produce as much heat as possible. Leaning with the mixture control will generally increase the heat but should be used with caution as it may kill the engine under circumstances in which a restart is impossible.

(10) Avoid clouds as much as possible.

(11) As a last resort, and at the risk of catastrophic engine damage, a severely iced engine may sometimes be relieved by inducing backfiring with the mixture control. This is a critical procedure at best, should not be attempted with supercharged engines, and must be done with the carburetor heat control in the COLD position.

(12) Heat should be applied for a short time to warm the induction system before beginning a prolonged descent with the engine throttled and left on during the descent. Power lever advancement should be performed periodically during descent to assure that power recovery can be achieved. The pilot should be prepared to turn heat off after power is regained to resume level flight or initiate a go-around from an abandoned approach.

(13) The pilot should remember that induction system icing is possible, particularly with float type carburetors, with temperatures as high as 100° F. and the humidity as low as 50 percent. It is more likely, however, with temperatures below 70° F. and the relative humidity above 80 percent. The likelihood of icing increases as the temperature decreases (down to 32° F.) and as the relative humidity increases.

(14) General - When no carburetor air or mixture temperature instrumentation is available, the general practice with smaller engines should be to use full heat whenever carburetor heat is applied. With higher output engines, however, especially those with superchargers, discrimination in the use of heat

10/22/81

should be exercised because of the possible engine overheating and detonation hazard involved. In the case of pressurized aircraft, use of alternate or heated carburetor air may require depressurization of the passenger compartment. A pilot of an airplane equipped with a carburetor air or mixture temperature gauge should make it a practice to regulate his carburetor heat by reference to this indicator. In any airplane, the excessive use of heat during full power operations, such as takeoffs or emergency go-arounds, may result in serious reduction in the power developed, as well as the hazard of engine damage. It should be noted that carburetor heat is rarely needed for brief high power operations.

b. Fuel System Icing. The use of anti-icing additives for some piston-engine powered aircraft has been approved as a means of preventing problems with water and ice in aviation gasoline. Some laboratory and flight testing indicated that the use of hexylene glycol, certain methanol derivatives and ethylene glycol monomethyl ether (EGME) in small concentrations inhibit fuel system icing. These tests indicate that the use of EGME at a maximum 0.15% by volume concentration substantially inhibits fuel system icing under most operating conditions. The concentration of additives in the fuel is critical. Marked deterioration in additive effectiveness may result from too little or too much additive.

CAUTION: It should be recognized that the anti-icing additive is in no way a substitute or replacement for carburetor heat. Strict adherence to operating instructions involving the use of carburetor heat should be adhered to at all times when operating under atmospheric conditions conducive to icing.

c. CONCLUSIONS.

a. The evidence is clear that carburetor icing and aviation gasoline fuel system icing problems are prevented with proper use of aircraft carburetor air heat and by good housekeeping to eliminate water from gasoline and the aircraft fuel system.

b. Fuel anti-icing additives have been found to have a beneficial effect on the prevention of fuel system icing when properly blended in the fuel systems of aircraft powered by reciprocating engines.

c. Fuel anti-icing additives are not effective in preventing or reducing carburetor ice under all operating conditions and are no substitute for the necessity of carburetor heat or following prescribed flight manual operating procedures.

d. The effects and recommendations described in this circular are general in nature and appropriate to most certificated airplanes. The pilot should refer to all available operating instructions and placards pertaining to his airplane to determine whether any special consideration or procedures apply to its operation.

M. C. Beard
Director of Airworthiness

APPENDIX B
CARBURETOR ICE BIBLIOGRAPHY



APPENDIX B

CARBURETOR ICE BIBLIOGRAPHY

- Barnard, D. P. and Scott, E. H., Weather or Stall — Carburetor Icing Control, paper presented at SAE Annual Meeting, January 1959.
- Bass, E. L. and Smith, M., "Carburetor Icing," Shell Aviation News, 99, 1939, 19-23.
- Buck, R. N., Weather Flying, New York: MacMillan, 1970.
- Clothier, W. C., "Ice Formation in Carburetors," J. Royal Aeronautical Society, 39, 1935, 761-806.
- Coles, W. D., Laboratory Investigation of Ice Formation and Elimination in the Induction System of a Large Twin-Engine Cargo Aircraft, NASA-TN-1427, September 1947.
- Coles, W. D., Investigation of Icing Characteristics of Typical Light Airplane Engine Induction Systems, NASA-TN-1790, February, 1949.
- Coles, W. D., Rollin, V. G., and Mulholland, D. R., Icing Protection Requirement for Reciprocating Engine Induction Systems, NACA-TN-1993, June 1949; also cited as NACA-TR-982, June, 1949.
- Collins, R. L., "Why Engines Stop," Flying, December 1969, pp. 70-71.
- DeMuth, T. P., Jackson, H. R., and Test, L. J., Carburetor Icing Tests in the Laboratory and in Service, SAE Paper No. 448c, January, 1962.
- Diblin, J., "Induction System Icing," Flying, July 1971, pp. 82-83.
- Essex, H. A., Deicing of an Aircraft-Engine Induction System, NACA-WR-W-45, August 1943.
- Essex, H. A., Zlotowski, E. D., and Ellisman, C., Investigation of Ice Formation in the Induction System of an Aircraft Engine. I. Ground Tests, NACA-MR-E6B28, 1946.
- Essex, H. A., Ellisman, C., and Zlotowski, E. D., Investigation of Ice Formation in the Induction System of an Aircraft Engine. II. Flight Tests, NACA-MR-E6E16, 1946.
- Galvin, H. B., and Essex, H. A., Fluid Deicing Tests on A Chandler-Evans 1900CPB-3 Carburetor Mounted on a Pratt and Whitney R-1830-C4 Intermediate Rear Engine Section, NACA-WR-E-12, October 1944.
- Gardner, L., and Moon, G., Aircraft Carburetor Icing Studies, National Research Council of Canada DME-LR-536, July 1970.
- Gardner, L., Moon, G., and Whyte, R. B., Aircraft Carburetor Icing Studies, SAE Paper No. 710371, March 1971.
- U. von Glahn and Renner, C. E., Development of a Protected Air Scoop for the Reduction of Induction System Icing, NACA-TN-1134, September 1946.

Kimball, L. B., Icing Tests of Aircraft-Engine Induction Systems, NACA-WR-W-97, January 1943.

Neel, C. B., A Procedure for the Design of Air-Heated Ice-Prevention Systems, NACA-TN-3130, June 1954.

Newman, R. L., "Carburetor Ice: A Recurring Problem," National Association of Flight Instructors Newsletter, December 1977 pp 1-4.

Newman, R. L., Carburetor Ice: A Review, Office of General Aviation-FAA, TR-77-19, November 1977.

Newman, R. L., Flight Test Results of the Use of Ethylene Glycol Monomethyl Ether (EGME) As an Anti-Carburetor-Icing Fuel Additive, FAA, TR-79-9, July 1979.

Obermayer, R. W., and Roe, W. T., A Study of Carburetor/Induction System Icing in General Aviation Accidents, Manner System Sciences, NASA-CR-143835, March 1975.

Puccinelli, A. R., "The Venturi Could be Your Personal 'Ice Factory'" Aero Magazine, December 1976, pp. 22-23.

Richter, K., "Carburetor Heat: How to Use it," AOPA Pilot, December, 1959.

Richter, K., Carburetor Heat: How to Use It, SAE Paper No. 448b, January, 1962.

Schuel, H. J., and Burt, H. G., "New Tests on Carburetor Icing," Petroleum Refiner, November, 1960.

Skoglund, V. J., "Icing of Carburetor Air Induction Systems of Airplanes and Engines," J. Aeronautical Sciences, 8, 1941, 437-464.

Sparrow, S. W., Airplane Crashes: Engine Trouble — A Possible Explanation, NACA-TN-55, 1921.

Trammell, A., "What Can PFA-55MB Do For You," Flying, February 1967, pp. 44-45, 72.

Weick, F. E., "Powerplant Failures - Causes and Cures," Aviation Week, March 7, 1949, pp. 21-25.

Whisenhunt, G. B., Prevention of Ice Formation in Light Aircraft Induction Systems by Using Automatic Controls to Operate the Carburetor Air Heater, Thesis: Texas A&M University, August 1955.

Use of Carburetor Heat Control, Lycoming SI-1148A, December, 1967 Key Reprints from the AVCO Lycoming FLYER, AVCO Lycoming, issued irregularly.

Special Study: Carburetor Ice in Gejeral Aviation, NTSB-AAS-72-1, January, 1972.

Those Icy Fingers, The Aviation Consumer, January 1, 1980, Volume X, No. 1, pp. 11-15.

APPENDIX C

A.R.P. INDUSTRIES, INC. SUPPLEMENTAL TYPE CERTIFICATE



United States of America

Department of Transportation -- Federal Aviation Administration

Supplemental Type Certificate

23954EA-5

Number SA489EA

This certificate, issued to: Alfred R. Puccinelli
DER 1-145
36 Bay Drive East
Huntington, L.I. New York 11743

certifies that the change in the type design for the following product with the limitations and conditions
23/3;127/6

therefor as specified hereon meets the airworthiness requirements of Part of the Federal Aviation/
Civil Air
Regulations.

Original Product -- Type Certificate Number

Make: Normal, Utility and Acrobatic Category
Model: airplanes and helicopters equipped with engines
and carburetors as described below.

Description of Type Design Change: Installation of A.R.P. Industries, Inc. carburetor ice
detection system Models 107AP-12 or 107AP-24 in single and twin engine aircraft and
single engine helicopters powered by Continental, Franklin, and Lycoming type engines
equipped with Marvel-Schebler MA-2, MA-3, MA-3SPA, MA-4, MA-4-5, MA-6 and HA-6
series carburetors, in accordance with A.R.P. Industries, Inc. Kit Parts List 107AP-12 or
107AP-24 dated November 14, 1978.

Limitations and Conditions: This instrument is approved as optional equipment only and
flight operations should not be predicated on its use. It is used as an early warning device
for detecting formation of carburetor ice in accordance with A.R.P. Flight Manual
Supplement 107AP dated April 28, 1967.

This approval should not be extended to other specific airplanes of those models on which
other previously approved modifications are incorporated unless it is determined that
(See STC Continuation Sheet Page 2)

This certificate and the supporting data which is the basis for approval shall remain in effect until
revoked, suspended, rechecked, or a termination date is otherwise established by the Administrator of the
Federal Aviation Administration.

Date of application: November 11, 1966

Date received

Date of issuance: April 28, 1967

Date amended: June 25, 1968; June 11, 1971,
October 31, 1975, November 20, 1978

By direction of the Administrator



Raymond J. Borowski

(Signature)

RAYMOND J. BOROWSKI

Chief, Engineering & Manufacturing Branch
(Title)

Any alteration of this certificate punishable by a fine of not exceeding \$1,000, or imprisonment not exceeding 3 years, or both.

United States of America
Department of Transportation—Federal Aviation Administration
Supplemental Type Certificate
(Continuation Sheet)

Number SA489EA

Dated amended: November 20, 1978

Limitations and Conditions (cont.)

the interrelationship between this change and any of those other previously approved modifications will introduce no adverse affect upon the airworthiness of that airplane/helicopter.

NOTE: The Master Eligibility List of aircraft models previously attached to this STC has been deleted for administrative reasons.

END

Any alteration of this certificate is punishable by a fine of not exceeding \$1,000, or imprisonment not exceeding 3 years, or both.

FAA FORM 8110-2-1 (10-69)

This certificate may be transferred in accordance with FAR 21.47.

PAGE 2 OF 2 PAGES

AIRPLANE FLIGHT MANUAL SUPPLEMENT
ARP INDUSTRIES INC. ICE DETECTOR

STC No. SA 489 EA

MODEL 107AP-12,-24
107AP-R,-12,24

FAA APPROVED

S M Rose
W. Oleksak, Acting Chief,
Engineering & Manufacturing Branch

Date April 28, 1967

Date April 28, 1967

ARP INDUSTRIES INC.

Supplement to the applicable FAA approved Airplane Flight Manual for the installation of Carburetor Ice Detector P/N 107AP,-R

Warning; This instrument is approved as optional equipment only and flight operations should not be predicated on its use. Procedures listed herein on the use of carburetor heat are intended to supplement existing instructions.

GENERAL DESCRIPTION OF ICE DETECTOR SYSTEM

By means of a transistorized electrical circuit a warning light is actuated by the blockage of light rays by frost or ice between the radiation source and the probe sensor in the carburetor. This system is completely independent of temperature or pressure changes which do not effect the operation of the detector in any way except to melt away the frost or ice. In the absence of carburetor frost or ice the warning light automatically deenergizes.

OPERATIONAL ADJUSTMENTS AND INSTRUCTIONS

(a) Ground and flight sensitivity setting

Turn on the aircraft master switch and set the detector circuit breaker if installed. Turn on the detector power switch with the sensitivity set on O. The red warning light will come on. Turn the sensitivity up slowly until the red light goes out. This is the critical setting for ice detection and should be maintained at all times.

(b) Flight operation

After (a) above has been determined turn on the power switch and leave it on at all times in flight. To test circuit turn off power switch then on. The red light will flash on then off indicating all components are operating normally. If the red light comes on automatically it indicates the initial formation of frost or ice in the carburetor on the probe. Immediately apply carburetor heat(to both engines in a twin-engine airplane) until the red light goes out automatically. This indicates the ice has been removed from the carburetor. With a little experimentation with the amount of heat applied it can be determined just how little heat is required to keep the light out. This will result in more efficient engine operation under the existing atmospheric conditions. If the red light does not go out after approximately two minutes of heat application the cause may be due to too low a sensitivity setting. Turn up the sensitivity slightly and the light will go out. If it does not go out continue to apply heat until it does go out.

A. R. P. INDUSTRIES, INC.
36 BAY DRIVE E.
HUNTINGTON, N. Y. 11743

A. R. P. INDUSTRIES INC.
 CARBURETOR ICE DETECTOR 105 AP-12-24
 INSTALLATION INSTRUCTIONS 107 AP-12-24

A. R. P. INDUSTRIES, INC.
 100 W. 17th St. E.
 HUNTINGTON, N. Y. 11743

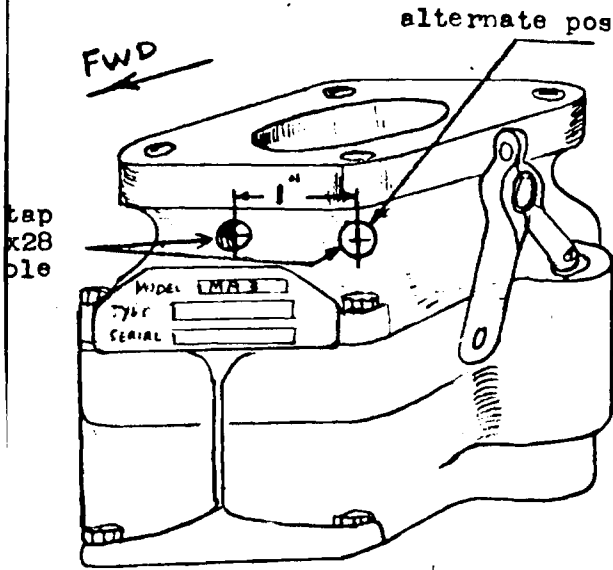

MARVEL SCHEBLER TYPE MA 3
 (4 cylinder engines)

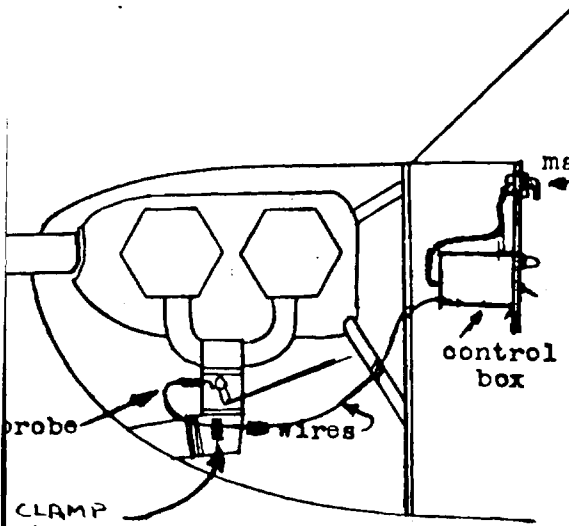
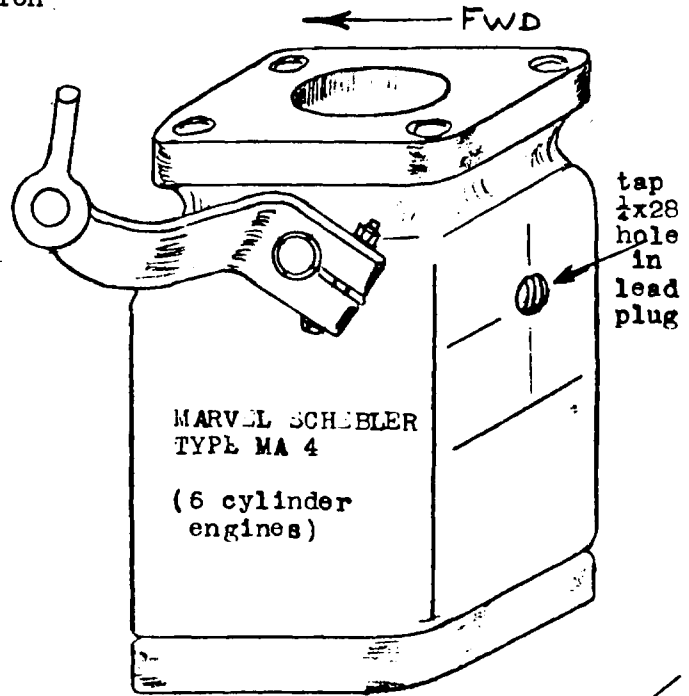

4 CYLINDER INSTALLATION.

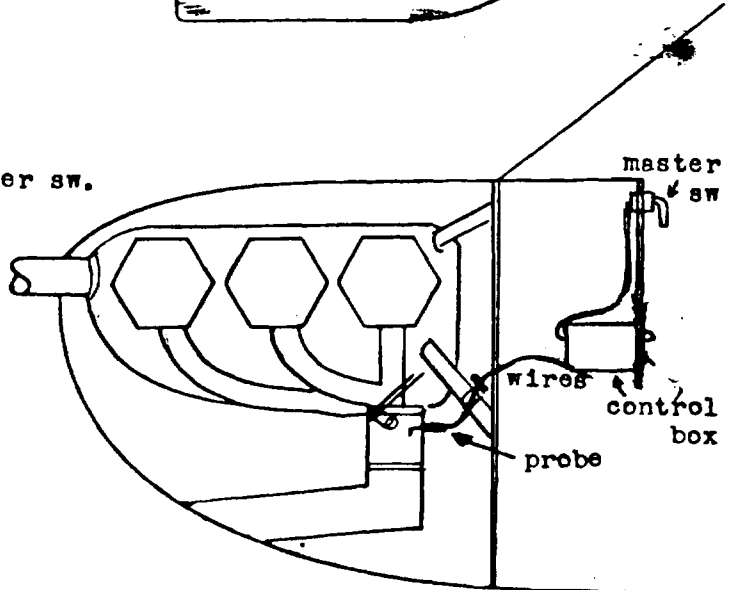

6 CYLINDER INSTALLATION

A.R.P. INDUSTRIES, INC.

36 BAY DRIVE E. • HUNTINGTON, N. Y. 11743 • TEL. • 516 • HA 7-1585

INSTALLATION INSTRUCTIONS

1. Remove or open up the engine cowling to allow access to the engine, carburetor and firewall.

2. Remove the plug in the carburetor housing just below the throttle valve. On 4 cylinder engines with Marvel-Schebler MA3 carb. the plug will be found on the forward side. On 6 cylinder engines with Marvel-Schebler MA4 carb. it is located on the rear. See page one for these instructions. If the carburetor has not been drilled and tapped for this plug remove the carburetor from the engine and drill out the lead plug. Tap this hole with a $\frac{1}{4}$ x 28 tap. Be careful to remove all burrs and chips from the interior of the carburetor.

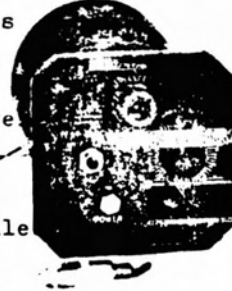

3. Open the throttle valve wide and carefully screw in the ice detector probe. Care must be taken not to bend the probe components. Install the lock washer and a proper number of shim washers so that when the probe is tightened the red dot on the probe housing will face down towards the ground. This will position the probe face into the carburetor air stream. The probe should be tightened by hand as tight as possible and then only $\frac{1}{4}$ turn additional by $\frac{3}{8}$ " short handle open end wrench. This is extremely important to prevent over-tightening which can over stress the threads in the carburetor.

4. At this time the electrical circuit may be installed to check the operation of the probe in the carburetor. The plus power red colored wire (this may also be a black wire with a fuse holder) must be connected to plus side of aircraft electrical power. This red wire is the power wire from the instrument case and not the probe red wire. In most aircraft the electrical system is plus with the negative battery post grounded to the airframe. This means the plus power wire can be connected to the circuit breaker or master switch. On aircraft with a positive ground the power wire must be reversed so that plus meets plus. Be sure the -12 detectors are installed on 12 Volt systems and the -24 on 24 Volt systems.

5. Connect the probe connectors to the instrument case connectors and check the probe operation as follows. Turn on the power switch. Turn the sensitivity control up from 0 slowly to approx 5 to 8 or more. The red light should come on at 0 and go out between 4 and 9. If this does not occur check the power supply and wires and connectors. Be sure the proper color wires from the probe are connected to the same color wires of the instrument.

6. Disconnect the connectors and install carburetor on the engine with the probe installed in the carburetor. Insert instrument cable thru firewall and replace fireproof grommets or putty. Reconnect the connectors. Clamp the probe cable with Adel clamps every 12" to the carburetor and airscoop and engine mount. Be sure to clamp the probe cable to the carburetor so that there will be no cable movement at the probe due to engine vibration. Allow at least 6 to 8 inches of slack between the clamping at the carburetor and the engine mount to allow for movement of the engine on the mount. Tape the connectors individually to prevent their touching and shorting out and to seal out oil and dirt.

R.P. INDUSTRIES, INC.

36 BAY DRIVE E. • HUNTINGTON, N. Y. 11743 • TEL. • 516 • HA 7-1585

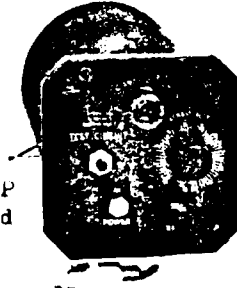
INSTALLATION INSTRUCTIONS CONTINUED

7. Mount the instrument case, if it is the model 105AP or 107AP, -R, M, on the instrument panel in the standard 3 1/4" opening with # 8-32 aluminum head (round) screws. Also use lock washers. The 105AP may be bracket mounted in a remote area with the red warning light positioned directly in front of the pilot (107AP-R) provided it is in reach of the pilot for adjustment of the sensitivity control. If it is the 107AP the rear of the box may be removed and it may be attached to the panel with # 10-32 screws, nuts and lock washers. Or small 24ST aluminum brackets may be installed on the sides of the rear section to mount it in a rectangular cut-out in the panel.

The ice detector is now ready for operational adjustment.

OPERATIONAL ADJUSTMENT

1. Turn on the aircraft master switch. Set the circuit breaker if such is installed. Turn on the ice detector power switch. With the sensitivity control set on 0 the red light will come on. Turn the control up slowly until the red light goes out. This is the setting for detecting frost and ice. The above is done with the engine off and with a normally charged battery. For increased sensitivity to the initial formation of frost the above procedure is repeated in flight by the pilot after he has leveled off and his generator or alternator charging rate has stabilised however this resetting is done only when extreme sensitivity is desired since the normal setting with the engine off affords at least a 3 minute warning before the engine is effected by too much carburetor ice.
2. To test the entire circuit and probe on the model 105AP push the push to test button switch with the detector operating and the red light out. The red light will flash on and go out when the button is released indicating all detector components are operating satisfactorily. The model 107AP may be tested (as well as the 105AP) by turning the power switch off then on during normal operation of the detector. The red light will flash on then off indicating all components are operating satisfactorily. Pushing the push to test button or turning the power switch off then on actually simulates ice on the probe.
3. The ice detectors should be turned on in flight at all times in air temperatures of 70 degrees or less.
4. With increasing time of operation on the engine a slight film of fuel residue may form on the probe which may result in a slight reduction of sensitivity at the original setting when the detector is first installed. This will be observed when it is required to set the sensitivity at an increasing higher setting as time goes on however the basic sensitivity of the detector is not reduced when adjusted as outlined above. If the sensitivity must be turned all the way up to 10 the probe must be removed for cleaning with a soft cloth and white gasoline.

APPENDIX D

RICHTER AERO EQUIPMENT, INCORPORATED SUPPLEMENTAL TYPE CERTIFICATE



United States of America
Department of Transportation — Federal Aviation Administration
Supplemental Type Certificate

Number SE1-201

This certificate, issued to Kenneth I. Richter
Richter Aero Equipment, Inc.
Essex, New York 12936

certifies that the change in the type design for the following product with the limitations and conditions therefor as specified hereon meets the airworthiness requirements of Part 3¹²³ & 13¹³³ of the Civil Air/ Federal Aviation Regulations.

Original Product — Type Certificate Number:

Make: See attached Engine Eligibility List

Model:

Description of Type Design Change:

Installation of the Richter Aero Equipment Type B-4 or B-5 Temperature Probe in Marvel Schebler Carburetor Models MA-2, MA-3, MA-3A, MA-3-SPA, MA-4, MA-4-5, MA-5, MA-6, MA-6AA, and HA-6 series and in Bendix Carburetor Models NA-S3B and NA-S3A1, in accordance with Richter Installation Bulletin No. 2 dated March 6, 1958, Bulletin No. 3 revised July 26, 1959, and Bulletin No. 4 dated June 28, 1961.

(See STC Continuation Sheet Page 2)

Limitations and Conditions:

1. Placard required on face of temperature gauge: "Maintain at least 5°C or 9°F above freezing during possible carburetor icing conditions."
Alternate Placard: "Keep needle out of yellow arc during possible carburetor icing conditions."

(See STC Continuation Sheet Page 2)

This certificate and the supporting data which is the basis for approval shall remain in effect until surrendered, suspended, revoked, or a termination date is otherwise established by the Administrator of the Federal Aviation Administration.

Date of application: May 6, 1958

Date issued:

Date of issuance: May 6, 1958

Date amended: 7/7/59, 8/11/61, 3/11/65, 9/20/77



By direction of the Administrator
Ralph L. Hare
(Signature)

RALPH L. HARE
Chief, Engineering & Manufacturing Branch
(Title)

Any alteration of this certificate is punishable by a fine of not exceeding \$1,000, or imprisonment not exceeding 3 years, or both.

This certificate may be transferred in accordance with FAR 21.47.

United States of America
Department of Transportation—Federal Aviation Administration
Supplemental Type Certificate
(Continuation Sheet)

Number SEI-201

Date amended: September 20, 1977

Description of Type Design Change: (con.)

This installation includes the Wac Line Inc. FLDX-N20350 temperature indicator as an alternate instrument in accordance with Richter wiring Bulletin No. 5 dated March 1, 1965.

Limitations and Conditions: (con.)

2. This approval should not be extended to other specific engines of these models on which other previously approved modifications are incorporated unless it is determined that the inter-relationship between this change and any of those other previously approved modifications will introduce no adverse affect upon the airworthiness of that engine.

ENGINE ELIGIBILITY LIST

AIRCOOLED MOTORS

FRANKLIN MODEL	T. C. NO.
4AC-150 Series	194
4AC-171 "	206
6A4-298 "	225
6ACT-298 "	"
6AL-315 "	234
6A4-145 "	238
6A4-150 "	"
6A4-165 "	"
6AG4-185 "	"
6A4-200 "	"
6A8-215 "	242
6V4-178 "	244
6V4-200 "	"
6V4-335 "	"
6VS-335-A "	1E2
6VS-335-B "	"
4A-235-B "	E6EA
6V-350-A "	E9EA
6V-350-B "	"

Any alteration of this certificate is punishable by a fine of not exceeding \$1,000, or imprisonment not exceeding 3 years, or both.

FAA FORM 8110-2-1 (10-69)

This certificate may be transferred in accordance with FAR 21.47.

PAGE 2 OF 4 PAGES

D

United States of America
 Department of Transportation—Federal Aviation Administration
Supplemental Type Certificate
 (Continuation Sheet)

Number SE1-201

Date amended: September 20, 1977

ENGINE ELIGIBILITY LIST (con.)

AIRCOOLED MOTORS

FRANKLIN MODEL	Series	T. C. NO.
6A-350-C	Series	E9EA
6A-350-D	"	"
6AS-350-A	"	E18EA
2A-120	"	E24EA

AVCO CORPORATION

LYCOMING MODEL	Series	T. C. NO.
0-145	Series	199 and 210
0-235	"	233
0-350	"	227
0-435	"	228
GO-435	"	"
0-290	"	229
0-320	"	274
0-340	"	277
VO-435	"	279
0-360	" (excl A1A, C2B, C2D)	286
HO-360-A1A only	"	"
VO-360	"	1E1
TO-360	"	E26EA
LTO-360	"	E26EA
0-540	"	295
VO-540-B&C	"	304
TVO-540-A1A	"	1E14

Any alteration of this certificate is punishable by a fine of not exceeding \$1,000, or imprisonment not exceeding 3 years, or both.

FAA FORM 8110-2-1 (10-69)

This certificate may be transferred in accordance with FAR 21.47.

PAGE 3 OF 4 PAGES

United States of America
 Department of Transportation—Federal Aviation Administration
Supplemental Type Certificate
 (Continuation Sheet)

Number SE1-201

Date amended: September 20, 1977

ENGINE ELIGIBILITY LIST (con.)

CONTINENTAL

MODEL	T. C. NO.
A-50 Series	190
A-65 "	205
A-75 "	213
A-80 "	217
C-75 "	233
C-85 "	233
C-115 "	236
C-125 "	"
E-165-2 only	246
E-185-2 only	"
C-90 Series	252
O-200 "	"
C-145 "	253
O-300 "	"
O-470-A,E,J,K,L,R,S,T,U only	273
GO-300 Series	298

RANGER

MODEL	T. C. NO.
6-440-C5	216

ROLLS ROYCE

MODEL	T. C. NO.
RR C90 Series	E3IN
RR O-300 "	E4IN
RR O-240-A	E11EU

..... E N D

Any alteration of this certificate is punishable by a fine of not exceeding \$1,000, or imprisonment not exceeding 3 years, or both.

FAA FORM 8110-2-1 (10-69)

This certificate may be transferred in accordance with FAR 21.47.

PAGE 4 OF 4 PAGES

SHORT FORM INSTALLATION INSTRUCTIONS
TYPE B-5 CARBURETOR AIR TEMPERATURE PROBE
RICHTER AERO EQUIPMENT, ESSEX, NEW YORK U.S.A.

1. DESCRIPTION OF INSTALLATION

As shown in Figure 1, installation consists of:

- (a) Mounting a temperature sensing probe (Richter Aero Equipment Model B-5) in the throat of the carburetor.
- (b) Mounting the carburetor temperature gauge on the shock mounted instrument panel. Gauge must have placard on face below instrument scale reading as follows: "Maintain at least 5° C or 9° F above freezing during possible carburetor icing conditions."
- (c) Electrically interconnecting the sensing probe and gauge with each other and the aircraft electrical system.

2. WEIGHT CHANGE

The installation of this instrument increases the empty weight of the airplane 1 lb. There is no appreciable change in the empty center of gravity.

3. INSTALLATION INSTRUCTIONS

A. Installation of temperature sensing probe in late series Marvel Schebler MA-4, MA4-5, and MA-6 carburetors provided with factory-tapped hole:

- (1) Unscrew threaded plug at position indicated by arrow.
- (2) Using one only .018" Shakeproof washer, screw probe into hole.
- (3) Hook up wires per wiring diagram with Burndy connectors furnished; slide insulating Teflon tubing over connectors and secure as shown in Fig. 5.

B. Installation of probe in carburetors not tapped at factory:

- (1) Remove carburetor.
- (2) Remove lead plug indicated by arrow in Fig. 1 by drilling out with 7/32" drill.
- (3) To provide seat for temperature probe, counterbore boss surrounding 7/32" hole with a 7/16" counterbore (with 7/32" pilot)
- (4) Thread 7/32" hole with a 1/4"-28 tap to receive the temperature probe.
- (5) Screw temperature probe into tapped hole. Determine the thickness of plain shim washer necessary in addition to the Shakeproof lock washer to prevent the end of the threaded portion of the temperature probe from protruding into the carburetor throat. (Fig. 3A, 3B). Either the .018 or .030 Shakeproof washer may be used alone; but when a shim washer is used there must be a Shakeproof between the shim washer and the Types temperature probe. For additional spacing, the shim washer can have another Shakeproof between it and the carburetor. Only one shim washer can be used. Carburetor wall thickness will vary on individual carburetors because of casting processes. No hard and fast rule in determining the correct amount of spacer washers may be used.

(over)

D 5

- (6) Blow all chips and filings out of carburetor and air box, and re-install on engine.
- (7) Hook up wires per wiring diagram, with Burndy connectors furnished; slide insulating Teflon tubing over connectors and secure with cord. (Refer to Fig. 5).

Installation Bulletin No. 3
Dated: July 26, 1959**INSTALLATION PROCEDURE FOR CARBURETOR AIR TEMPERATURE PROBE TYPE B-5**
This bulletin is in 7 parts covering installation and removal.**INSTALLATION INSTRUCTIONS:****Part 1. Mechanical Installation:**

- A. Carburetors provided with factory-tapped hole to accept B-5 probe: Marvel Schebler now furnishes some carburetors provided with a threaded brass plug in a 1/4 x 28 tapped hole instead of filling this drill-access hole with a lead plug.
- (1) Unscrew threaded plug at position indicated by arrow.
 - (2) Using one only .018 Shakeproof washer, screw probe into hole.
 - (3) Hook up wires per wiring diagram with Burndy connectors furnished; slide insulating Teflon tubing over connectors and secure as shown in Fig. 5.
- B. Carburetors not provided with factory-tapped hole: Adjacent to the butterfly valve in all Marvel-Schebler Ma2, MA3, MA4 and Ma4-5 series carburetors is a lead plug filling the access hole through which the idler jets were drilled on the far side of the carburetor barrel. This lead plug fills a stepped hole in the aluminum casting. The wall of the carburetor is approximately 1/4" thick at the boss in which this lead plug is inserted. These instructions describe a procedure by which this plug is removed, the hole enlarged and threaded so that the Type B-5 probe can be securely mounted at a point adjacent to the butterfly valve where it will accurately measure the temperature of the fuel-air mixture and thus warn of impending danger due to throttle valve icing.
- Step 1. Remove carburetor assembly from engine.
- Step 2. The installation kit for this unit includes a 7/16" aircraft counterbore, a 1/4 x 28 tap, and a 7/32 drill. Support the carburetor firmly under a drill press, and drill out the lead plug with the 7/32 drill. Drill slowly or limit the drill travel so the drill does not break through and plunge into the valve. It has been found helpful to put a small amount of putty over the inner end of the lead plug to keep metal chips out of the carburetor. If the drill does not go through the putty the problem of removing chips is simplified.
- Step 3. The counterbore pilot is inserted into the new hole, and the counterbore is then used lightly to create a flat surface at the outside of the hole. The function of the flat, which should be square with the hole, is to provide a locking surface for lock-washer between the carburetor and the probe.
- Step 4. Lubricate the 1/4 x 28 tap and tap out the hole.
- Step 5. Carefully remove all chips and metal shavings from the inside of the carburetor.
- Step 6. Apply thread lubricant to threaded portion of Type B-5 probe.
- Step 7. Screw the Type B-5 probe into the hole and note whether a portion of the threaded length protrudes into the inner barrel of the carburetor.
- Step 8. Remove the Type B-5 probe, and select from the special Shakeproof and flat spacing washers furnished a combination which will make the small diameter end of the probe start flush with the wall of the inner barrel of the carburetor. See drawing #3. The lock washers furnished should not be used stacked, that is, two at a time in this installation. Only one spacing washer can be used, and should be adjacent to the carburetor casting, with the lock washer adjacent to the locking flat on the Type B-5 probe. If necessary, lock washers can be used on both sides of the flat washer. If the probe does not reach all the way into the carburetor barrel, the counterbore can be used again to reduce the thickness of the casting slightly at the outside of the hole.

Part 2. ELECTRICAL WIRING INSTALLATION:

- A.** The most suitable gauge to be used in conjunction with the Type B-5 probe is a modified C-11 instrument, furnished in the complete kit supplied by Richter Aero Equipment. This is a bridge-type gauge of excellent construction, with the balancing resistance coils slightly changed to expand the scale in the vicinity of 0 C. This makes it easier to see the 5 C. spacing than on other gauges on which the separation of the graduations in the vicinity of 0 C. are difficult to discern readily. This gauge is furnished with appropriately colored segments to aid in instant reading. The required placard is furnished attached to the gauge as required by STC-SE 1-201.
- B.** Utilization with AN instruments. The resistance characteristics of the Richter Aero Equipment Type B-5 probe duplicate those of the AN 5525-1 and AN 5525-2 probes, having a resistance of 90.38 ohms at 0 degrees Centigrade or 32 degrees Fahrenheit. The B-5 probe can therefore be used for carburetor air temperature indication with any of the AN gauges designed to operate with the AN 5525-1 or AN 5525-2 probes. It is mandatory according to STC SE 1-201 that any gauge used must be placarded "Maintain at least 5° C or 9° F above freezing during possible carburetor icing conditions." The AN gauges that can be used, when placarded, in conjunction with the Richter Aero Equipment Type B-5 probe are as follows:
- AN-5790-6 Single electric thermometer indicator 12 or 24 volt. Range -70° C to +150° C 2 3/8" diameter requires 4 pin AN3106-14S-2S connector.
 - AN-5795-6 Dual electric thermometer indicator 12 or 24 volt. Range -70° C to +150° C 3 1/4" diameter. Requires 5 pin AN3106-14S-5S connector.
 - C-10 Single electric thermometer indicator 12 or 24 volt. Range -50° C to +50° C 3 1/4" diameter. Requires 4 pin AN3106-14S-2S connector. Dial marked "Free Air" must be placarded "Carburetor Air"
 - C-11 Single electric thermometer indicator 24 volt. Range 45° C to +45° C 2 3/8" diameter. Requires 3 pin AN3106-14S-1S connector. Dial marked "Free Air" must be placarded "Carburetor Air"
 - C-12 Single electric thermometer indicator 12 volt. Range -45° C to +45° C 2 3/8" diameter. Requires 3 pin AN3106-14S-1S connector. Dial marked "Free Air" must be placarded "Carburetor Air"
 - F-8 Single electric thermometer indicator 24 volt. Range -45° C to +45° C 2 3/8" diameter. Requires 3 pin AN3106-14S-1S connector. Dial marked "Carb. Temp. Mixt."
 - F-9 Single electric thermometer indicator 12 volt. Range -45° C to +45° C 2 3/8" diameter. Requires 3 pin AN3106-14S-1S connector. Dial marked "Carb. Temp. Mixt."
 - F-10 Dual electric thermometer indicator 24 volt. Range -45° C to +45° C 3 1/4" diameter. Requires 4 pin AN3106-14S-2S connector. Dial marked "Carb. Temp. Mixt."
- The use of millimeter-type gauges, such as the Weston 602 and 606 series is not recommended. This construction is sensitive to changes in the electrical system voltage. Tests have shown that a millimeter-type gauge will read 10° C higher on 12V than at 14V, so if generator or regulator fails, the temperature indication will be hazardously inaccurate. Bridge type gauges will indicate accurately with 1° C with only 2 volts in the system.

- Step 1.** Make up a cable to connect probe with gauge unit in instrument panel. Aircraft quality wire with a minimum gauge of 18 A. W. G. (.04"), well insulated, should be used. For installations requiring runs of more than ten feet,

a minimum of No. 16 (.051") should be used. The cable will consist of two conductors, and will terminate at the gauge end in the appropriate AN or lug connector to fit the indicator unit selected. At the end adjacent to the probe, each wire will be terminated with the Burndy YZ14-H Clasps furnished. These are installed with the appropriate indenting tool, care being taken to make the indentation on the opposite side of the connector from the seam. The insulation grip is then clamped down. The cable should be of ample length to reach from its terminus adjacent to the carburetor, via a grommeted aperture in the firewall to the terminal at the instrument. Some installers prefer to rig the engine side first, leaving excess wire at the panel which can be cut to length when the gauge is in place.

- Step 2. Connect cable to Type B-5 probe clamps and slide Teflon insulating tubing over connections. A slight tug on the wires will make the locking feature of these cable clamps operative. Plastic electrical tape, cord, or safety wire should be wound around the wire and tubing at each end of the tubing to prevent the tubing from sliding off the connectors.
- Step 3. The cable should be routed out of hot areas and should be supported so there is no excessive whip or vibration from the engine. Allow generous slack from the probe to the first support so that engine motion will not draw the wires tight. The wires leading into the probe are specially flexible to allow for vibration.
- Step 4. Draw free ends of cable through grommet in firewall. This can usually be an existing hole through which other wires are already routed. If a new hole is required, it should be of minimum possible diameter and should be provided with a fireproof grommet to prevent chafing and cutting the insulation on the wires. Route the cable, with appropriate supports, to the panel space provided for the gauge. Be sure that the cable does not and cannot affect the freedom of travel of controls behind the panel.
- Step 5. Attach free ends of cable to connector appropriate to instrument being used. Refer to attached wiring diagram for connections, which will depend on voltage, model of instrument, and number of engines. Connection to the aircraft electrical system should be made through 2 to 5 ampere fuse or 5 ampere trip-free circuit breaker.
- Step 6. Install gauge in panel cutout, attach connector to gauge. Test. Note: if the Type B-5 probe is being installed to replace another type of probe such as the AN5525, and the gauge already installed has colored limit markings, these markings should be changed to suit the more accurate readings made possible by the Type B-5 probe. The range between -4° F (-20° C) and 40° F ($+5^{\circ}$ C) can be marked with an orange arc.
- B. Utilization with Canadian instruments made by Sutton Horsley, Steps 1-4. Identical to above.
- Step 5. Attach free ends of cable to connector appropriate to instrument being used. Refer to attached wiring diagram for connections, which are different on certain Canadian-made indicators. Those made by Sutton-Horsley will be connected according to the diagrams so labeled.
- Step 6. Identical to above

Part 3. GROUND TEST

- A. The type B-5 probe, properly installed, should permit temperature readings within one degree Centigrade.
- Step 1. After installation of the complete system, with the engine still cold, the master switch should be turned on. The gauge should immediately register a temperature at or very near the prevailing outside temperature. (A Fahrenheit-Centigrade scale is included on one drawing for your convenience). This will vary if the carburetor is for any reason appreciably warmer or colder than the surrounding air. If the gauge registers much higher than the surrounding air, either there is a defective connection or wire introducing added resistance, or the gauge or probe is defective. If the gauge registers much lower than the surrounding air, there is a short circuit either in the probe, the cable, or the gauge, or power is not reaching the system.
- Step 2. In the event that the gauge readings vary substantially from outside air temperature, the gauge unit can be checked with another probe if available or with a 100 ohm precision resistor in place of the probe resistance. With the 100 ohm resistor the gauge should read approximately 27.5 degrees Centigrade or 81 degrees Fahrenheit. The probe may be checked on a Wheatstone bridge or precision ohm meter. It should have a resistance of 90.38 ohms at 0 degrees Centigrade or 32 degrees Fahrenheit. If it is inconvenient to test the probe at freezing, it may be tested at room temperature. The probe should read 97.31 ohms at 20 degrees Centigrade or 68 degrees Fahrenheit. With a difference of .35 ohm room temperature test level; that is, if the room temperature is, say, 5 degrees Fahrenheit less than 68 degrees Fahrenheit, then the resistance of the probe will be lower by $5 \times .2$ ohms; $97.31 - 1.00$, or 96.31 ohms, at 63 degrees Fahrenheit.
- Step 3. The engine should be started and the gauge observed during idling. There should be only a small change (usually a drop) in indicated temperature during idling. If the fuel supply is colder or warmer than the surrounding air temperature, this will be reflected in the reading.
- Step 4. The engine should be run up to cruise RPM at which time the gauge should indicate a temperature drop in the carburetor of approximately 15 degrees Centigrade or 26 degrees Fahrenheit. This will vary with different configurations of intake systems and the amount of manifold pressure which in turn controls the rate of expansion of the gas-air mixture in the carburetor.
- Part 4. SERVICE LIFE OF TYPE B-5 TEMPERATURE SENSING PROBE:
The Richter Aero Equipment Type B-5 Carburetor Temperature Probe is guaranteed for one year from date of purchase or 500 hours of operation, whichever comes first. It should be replaced when the wire leads fray at the point where they enter the potting compound at the outer end of the brass shell, or when damaged mechanically or electrically by accident. Otherwise it should remain serviceable as long as it reads correctly.
- Part 5. LIMITATIONS OF THE TYPE B-5 TEMPERATURE SENSING PROBE:
A. Electrical
The resistance characteristics of the sensing coil inside the tip of the unit have been made to correspond as nearly as possible to the AN scale. The special small wire that makes possible the very reduced size of the Type

B-5 probe has a resistance curve which matches the AN specifications exactly at 0 degrees Centigrade, and is accurate to within 1 degree Centigrade in the range from -15 degrees Centigrade to +15 degrees Centigrade (5 degrees to 59 degrees Fahrenheit). Above and below these figures the resistance curve of the Type B-5 deviates gradually from the AN curve, giving an error of -3 degrees Centigrade at 38 degrees Centigrade; that is, for an actual temperature of 38 degrees Centigrade an AN indicator used with the Type B-5 probe will indicate 35 degrees Centigrade. For the purpose for which the Type B-5 probe is intended, the measurement of carburetor air temperature, this error is of no real consequence. The important point is that the Type B-5 probe will sense the freezing point and its vicinity with greater accuracy than most airborne meters will indicate.

B. Mechanical

The materials used in the construction of the Type B-5 probe are the best obtainable and will successfully resist the effects of oil, water and gasoline, and heat and cold ranging from -104 degrees Centigrade to +200 degrees Centigrade (approximately -150 degrees Fahrenheit to +400 degrees Fahrenheit). The sensing coil is encapsulated in epoxy resin in a shell whose walls are .016 thick, sufficient to resist repeated back-fires, but thin enough to give nearly instant sensitivity to temperature change. Pliers should not be used on this more delicate probe end, but the rest of the unit can stand any normal handling. Tensile tests have shown that the lead-in wires require a pull of at least 90 pounds to pull them out of the shell. Since the combined tensile strength of the two lead-in wires is 100 pounds, the only possibility of strain trouble here is if insufficient slack is allowed between the probe and the first support of the wires.

→ Part 6.

A.

RECOMMENDED OPERATING INSTRUCTIONS FOR USE

It would be prudent for the pilot to determine his own operating procedure and limits on the basis of information obtained with his own plane under known carburetor icing conditions. A test procedure is described in Section B of Part 6 of these instructions. Airline flight engineer's manuals call for "the application of carburetor heat to an indicated level of 20 degrees Centigrade above freezing 3 minutes before entering visible moisture". Since most commercial aircraft are not provided with sensing probes as critically placed as the small size of the Type B-5 probe enables it to be, an approximate assumption of a 15 degree Centigrade (26 degree Fahrenheit) temperature drop must be made by the flight engineer or pilot of most models of transport aircraft. This means that standard practice actually amounts to carrying approximately 5 degrees Centigrade (9 degrees Fahrenheit) of heat above freezing as measured at the throttle valve, which is the most critical point. In practice we have found it sufficient to carry 5 degrees Centigrade of indicated heat above freezing under all but the most extraordinary conditions, such as might be encountered in a situation where the outside air temperature would be subject to suddenly extreme variation, or extreme icing conditions. Even under these circumstances if the pilot remains alert, he should be able to apply more heat and thus keep ahead of the situation. Constant monitoring of the gauge is required during possible icing conditions. Induction system icing can occur at several points, Fuel lines, pump, or screens can be blocked if there is water in the fuel and it freezes. The intake screen can become blocked with frozen moisture, either in the form of sleet or heavy snow. Elbows where the air box angles sharply can be rammed full of incident ice. And most commonly, the throttle valve can accumulate a rim of ice which, if allowed to develop unchecked,

will eventually grow to join a deposit which usually forms first on the wall of the carburetor barrel adjacent to the throttle valve, exactly at the point where the Type-5 probe is located. The alternate air supply via the carburetor heater will enable continued operation of the engine even when the intake screen is blocked, but if the obstruction at the throttle valve grows large enough to cut off much of the air supply, no alternate source is available, and engine failure will result. Experiments indicate that humidity is the controlling factor in the rate of icing. Therefore, the more humid the air, the more rapid the icing.

Attention is directed to Aviation Safety Releases Nos. 163, 261 and 338 concerning idling failure due in part to carburetor icing. Prudent use of the temperature information furnished by the Type B-5 probe should enable the average pilot to fly with greater security and economy, since full carburetor heat with its associated loss of power and performance will be required far less frequently. It will also furnish an immediate clue to the trouble if carburetor ice is responsible for a faltering engine. Since fuel induction system icing is the largest single cause of engine failure in light aircraft, the Type B-5 probe, properly used, should help to eliminate an important percentage of trouble from this source.

A collateral benefit derived from the use of information provided by the Type B-5 probe has come to light as a result of complaints about plug fouling in higher compression engines. A major spark plug manufacturer has found that lead deposits on the plugs in engines using higher octane gasoline are usually the result of inadequate volatilization of the antiknock compounds used to raise the octane rating of the fuel. Most such fuels contain tetraethyl lead, which if allowed to burn without an inhibitor, would form metallic lead oxide. Therefore another substance, ethylene dibromide, is added to the fuel along with the tetraethyl lead. The combustion product is lead bromide, a fine powder which is readily blown out the exhaust system. But gasoline has a lower vaporization temperature than ethylene dibromide, which in turn vaporizes more readily than tetraethyl lead. So if the mixture is too cold in the carburetor to vaporize all the fuel components properly, the tetraethyl lead may be concentrated in only a part of the engine, in the form of large, heavy droplets, and possibly separated from its inhibiting ethylene dibromide. During combustion, therefore, lead oxide may be formed. This lands on the lowest point in the cylinder, the lower plugs, which then foul out. To avoid this, it has been found that warming the fuel-air mixture in the carburetor will aid the volatilization of all the fuel elements together. Experiments have shown that an indicated temperature of about 5°C (9°F) above freezing measured at the throttle valve will assure proper volatilization, increasing plug life and engine reliability. Leaning the mixture to compensate for the slight richening due to heated carburetor air should result in fuel economy equal to or even better than that experienced when fuel is mixed with very cold air. This applies to cruise power conditions. For maximum power, the densest available, hence coldest, air is required.

→ B. Pilot In-Flight Test Procedure:

Pick a day or a flight level of known carburetor icing conditions. 50 to 58 degrees Fahrenheit (10 to 15 degrees Centigrade) with 60% or higher humidity is ideal. An engine is allowed to pick up carburetor ice at cruise RPM until the manifold pressure shows a drop of 1 inch or, on planes not equipped with manifold pressure gauges or constant speed propellers, the RPM drops 50 below normal in level flight. The carburetor heat control is then pulled on part way until the indicated temperature is plus 10 degrees Centigrade (50

degrees Fahrenheit). Engine performance should return to normal within 2 to 3 seconds. The carburetor can then be allowed to begin to ice again, and heat to the extent of 5 degrees Centigrade above freezing tried. If the engine clears promptly, the procedure should be repeated a degree lower each time until the engine no longer returns promptly to normal performance. This procedure should be followed separately for each engine, and it would be well to check at various power settings. By following this procedure the pilot will become familiar with the reading of the gauge under actual carburetor icing conditions and can establish his own operating margin. The final reading for the freeze point may in some cases be higher or lower than 0 degrees Centigrade (32 degrees Fahrenheit) depending principally on the configuration of the fuel intake system. But once the freeze point has been established, the pilot will have immediate information available concerning the risk of freezing temperature at the throttle valve, the point in the fuel induction system most likely to be affected.

- C. Value and Limitations of Temperature information provided by the Type B-5 probe:
 The indication does not supply information concerning the presence of sufficient moisture to form ice. This must still be judged by the pilot. Dew point indications given by air weather stations are a fair indicator of moisture in the air. The closer the dew point to the reported temperature, the higher the humidity. On the other hand it is quite possible to fly ice-free with temperature 30 to 50 degrees below freezing. Ice formation in carburetors seems to give its principal trouble at or near the actual freezing point, where moisture, condensing on cold metal, begins to build up a deposit, usually starting adjacent to the throttle valve exactly where the Type B-5 probe is located. Laboratory experiments have shown that under conditions of 100% humidity, ice will accumulate in the carburetor at temperatures from freezing down to 18°F (-8°C), possibly lower, as measured at the throttle valve. At lower temperatures moisture will be precipitated out of the air in the form of harmless crystals by the refrigerating effect of the expansion of the gas-air mixture into the manifold. It is this expansion - refrigeration effect that manufactures carburetor ice from moist air, so the pilot must be alert to keep the carburetor heat level above freezing during conditions of high humidity. If allowed through oversight to drop a degree or two below freezing, the partial use of carburetor heat could bring about exactly the kind of icing trouble this installation has been designed to avoid.

Part 7. REMOVAL INSTRUCTIONS

- A. Mechanical and electrical
- Step 1. With master switch OFF, unwind tapes or safety wires from insulating tubing over clamp connectors.
- Step 2. Slide tubing back away from clamps and disconnect.
- Step 3. Unscrew Type B-5 probe from carburetor. Carburetor need not be removed from engine.
- Step 4. Insert 1/4 x 28 plug in hole in carburetor. This plug should have a shoulder on the outer end to prevent its falling into the carburetor in flight. A 1/4 x 28 bolt, fully threaded, cut to 1/4 inch length would make a suitable plug. It should be either safety-wired or be furnished with a lock washer so it will not come out. Preferably it should just reach the inner barrel so as to leave a smooth contour on the inside of the carburetor. The plug should not project even slightly into the airstream. It does no harm to make the plug a little short, as a small depression at the hole will not affect fuel distribution.

- Step 5. Disconnect wiring from the bus.
- Step 6. If entire system is being removed, disconnect and remove gauge, remove cable through grommet. Plug hole if required.
- Step 7. If system is temporarily disconnected for replacement of either probe or gauge, disconnect power supply wire from the bus and PLACARD GAUGE: "Not Operating".

INSTALLATION OF RICHTER AERO EQUIPMENT TYPE B-5 PROBE
IN MARVEL-SCHEBLER CARBURETORS

STC SE1-201

FIG. 1 MODELS MA-2, MA-3, AND MA-4

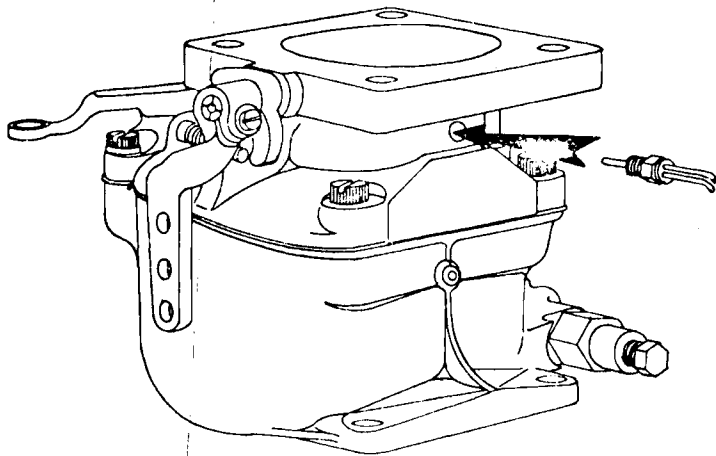
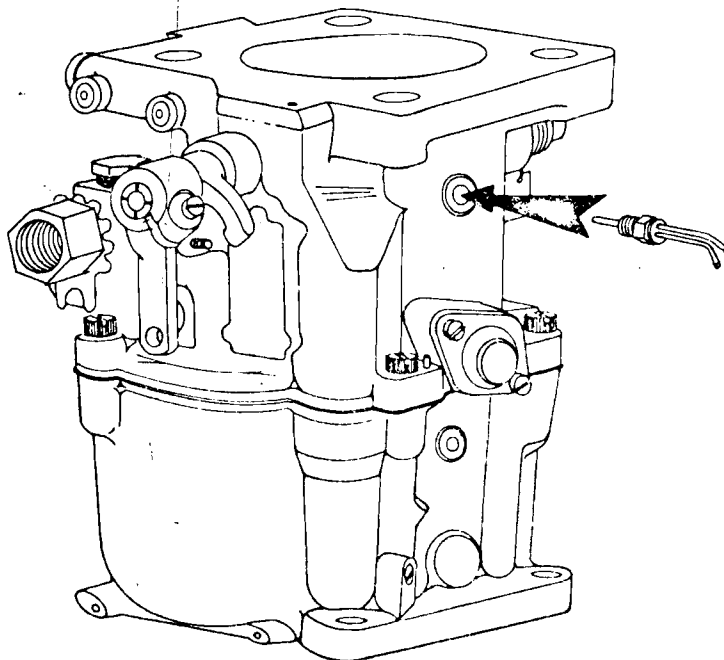

FIG. 2 MODEL MA-4-5



PROBE DEPTH INSIDE CARBURETOR

FIG. 3A

CORRECT

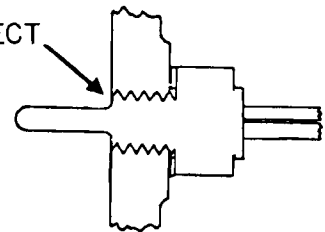

FIG. 3B

INCORRECT

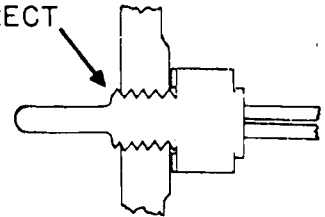

FIG. 4

CENTIGRADE -
FAHRENHEIT
CONVERSION SCALE

°C	°F
40	104
35	95
30	86
25	77
20	68
15	59
10	50
5	41
0	32
-5	23
-10	14
-15	5
-20	-4
°C	°F

FIG. 5
METHOD OF SECURING INSULATION



DESCRIPTIVE SHEET 10/63 1M

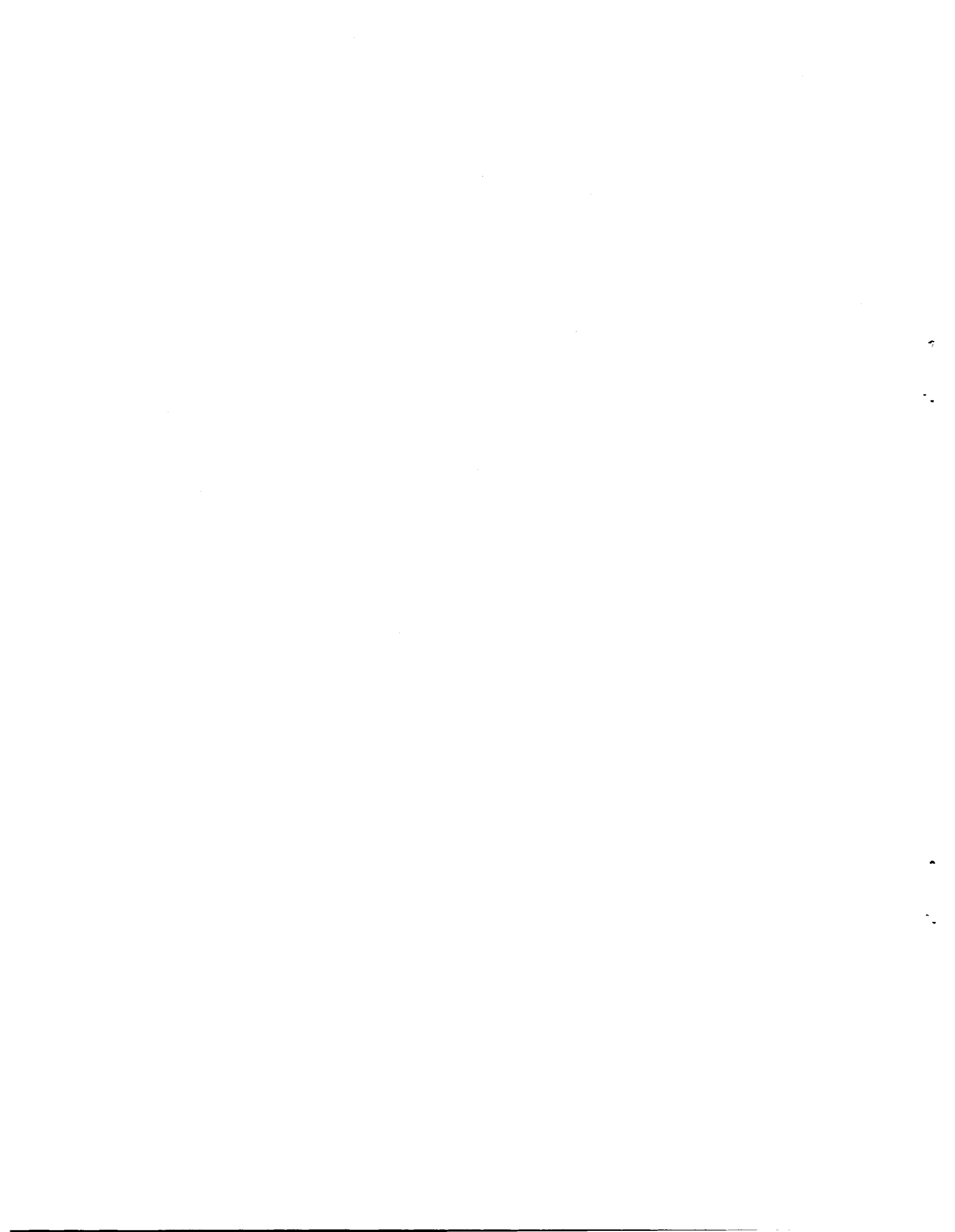

APPENDIX E
SAMPLE TEST DATA PLOTTING

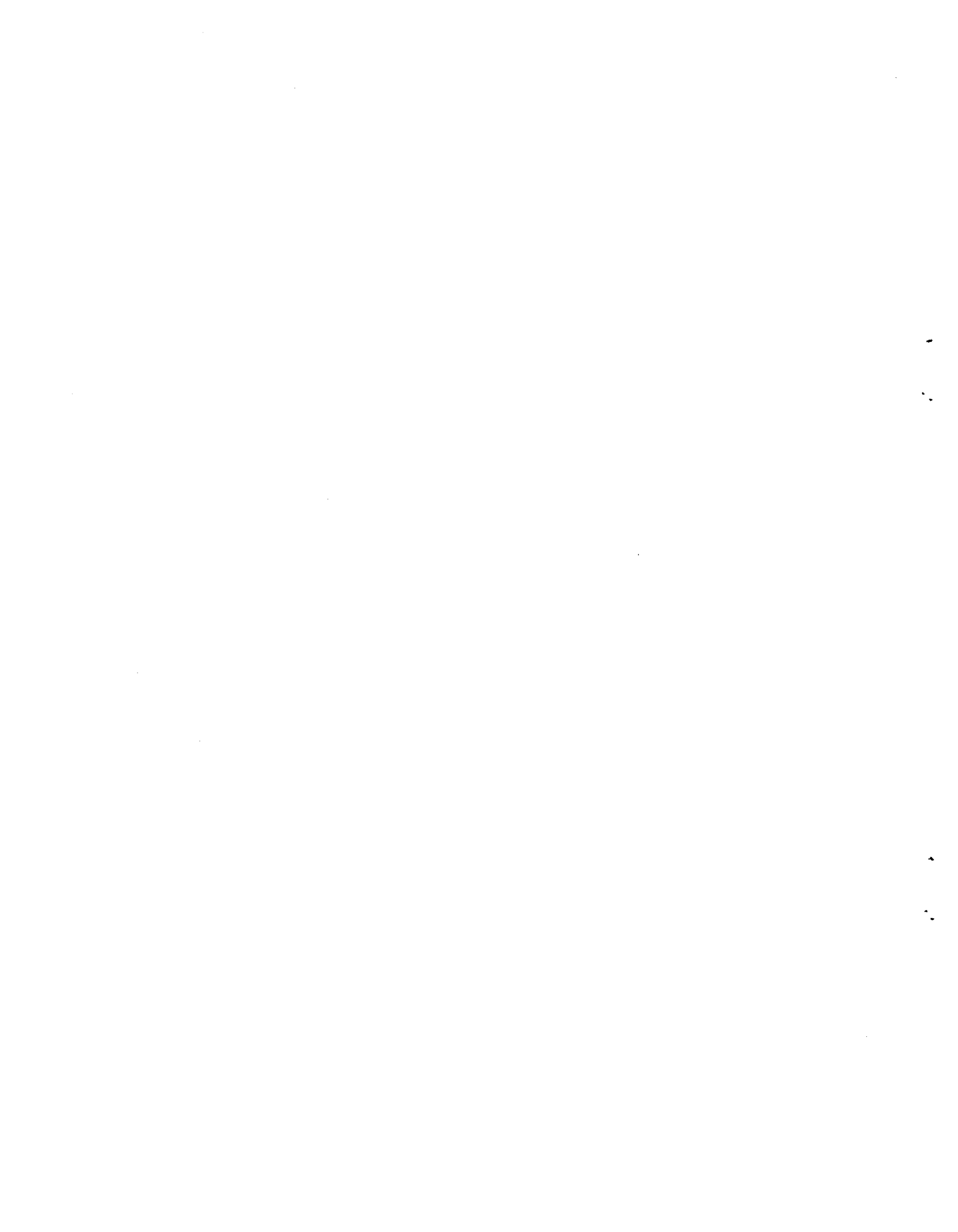

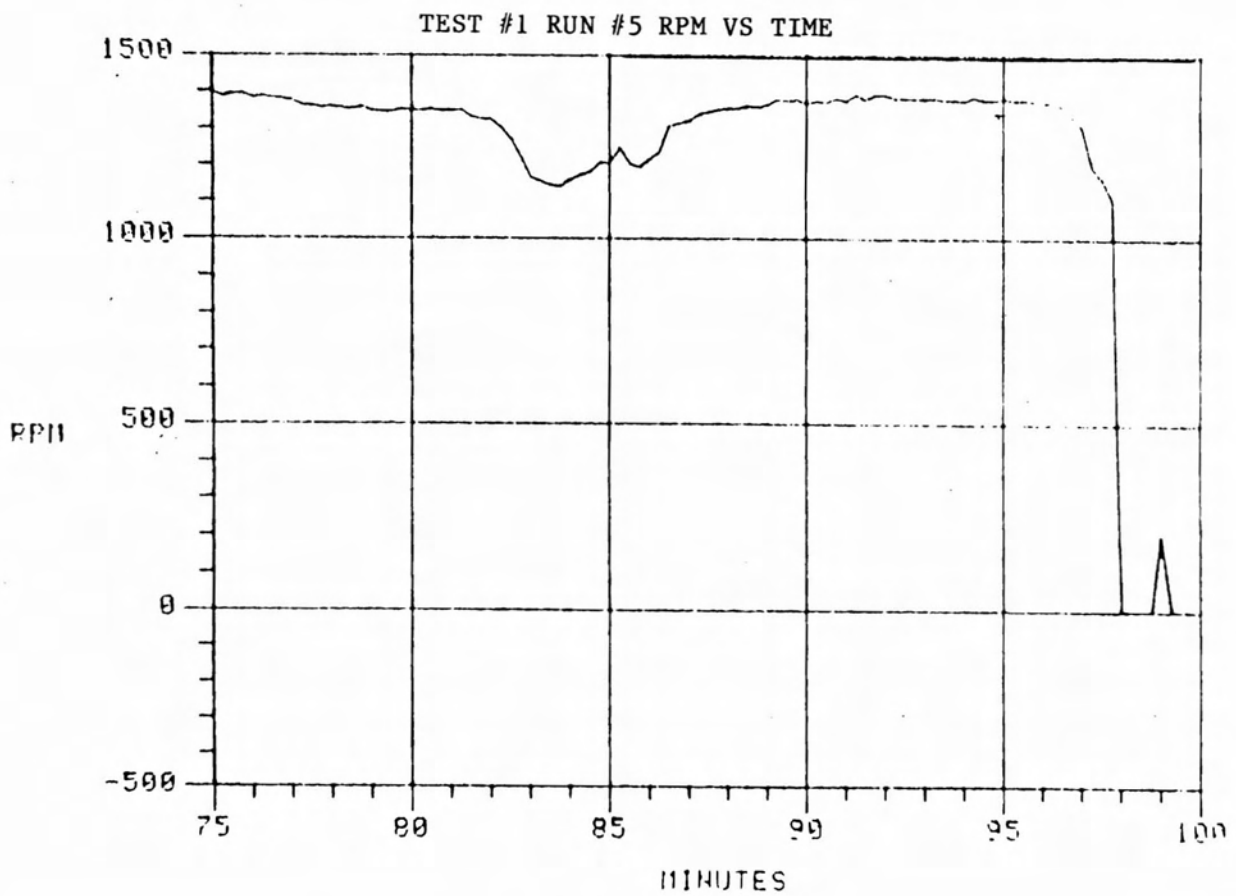
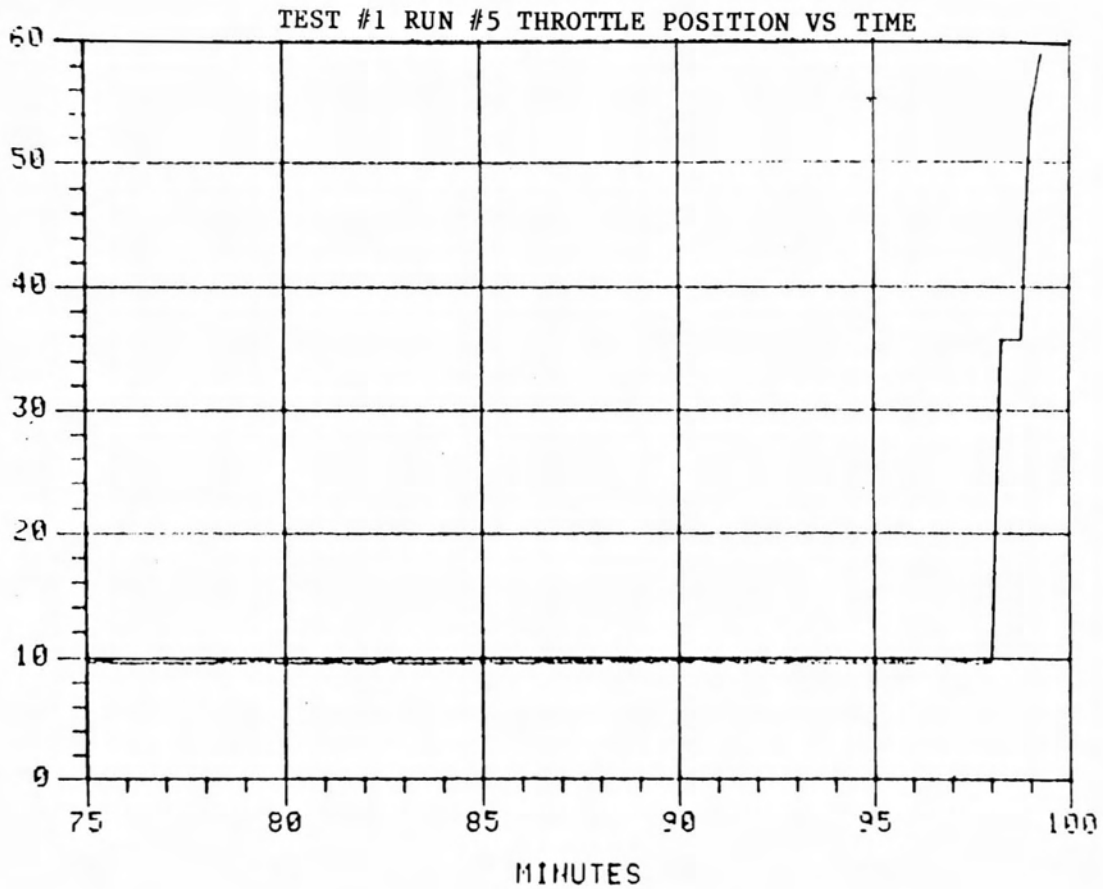

TEST #1 RUN #5 MANIFOLD PRESSURE VS TIME

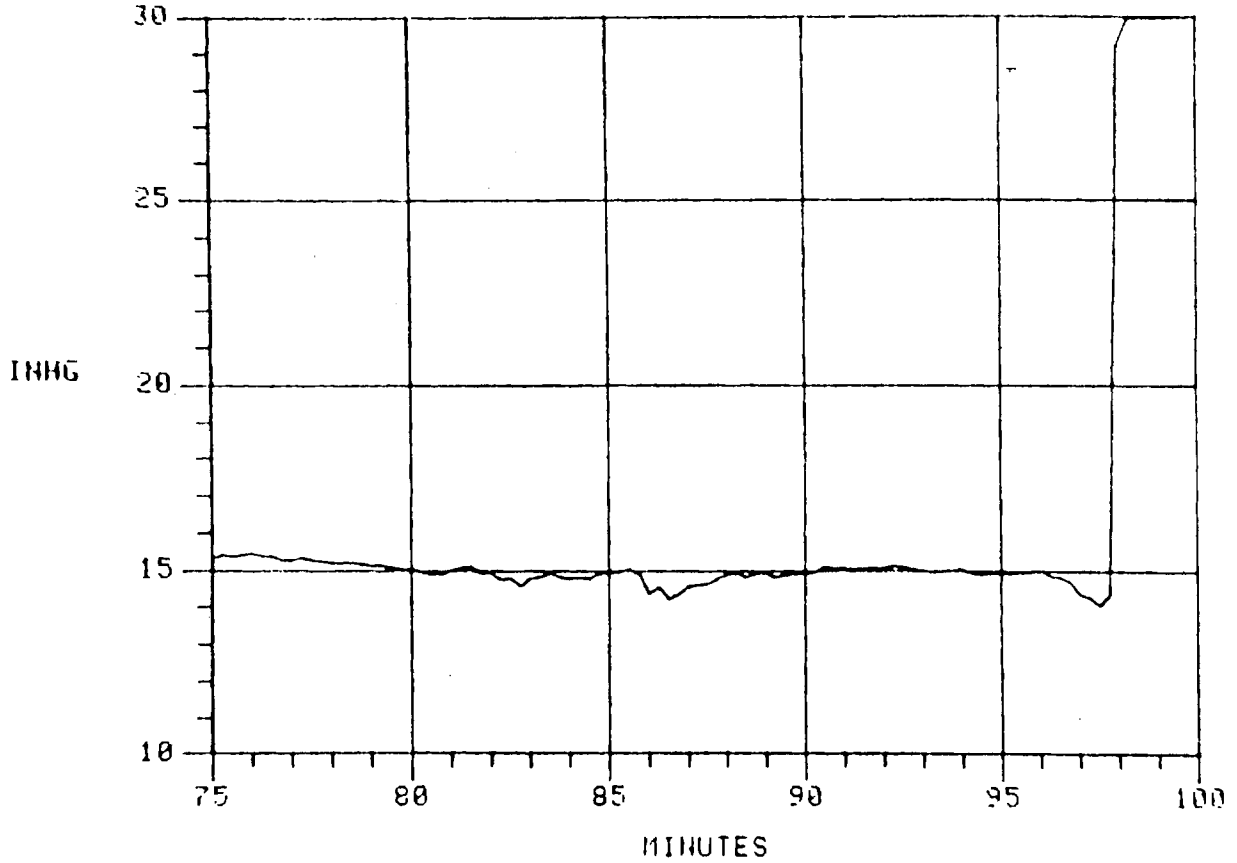

TEST #1 RUN #5 EGT #1 VS TIME

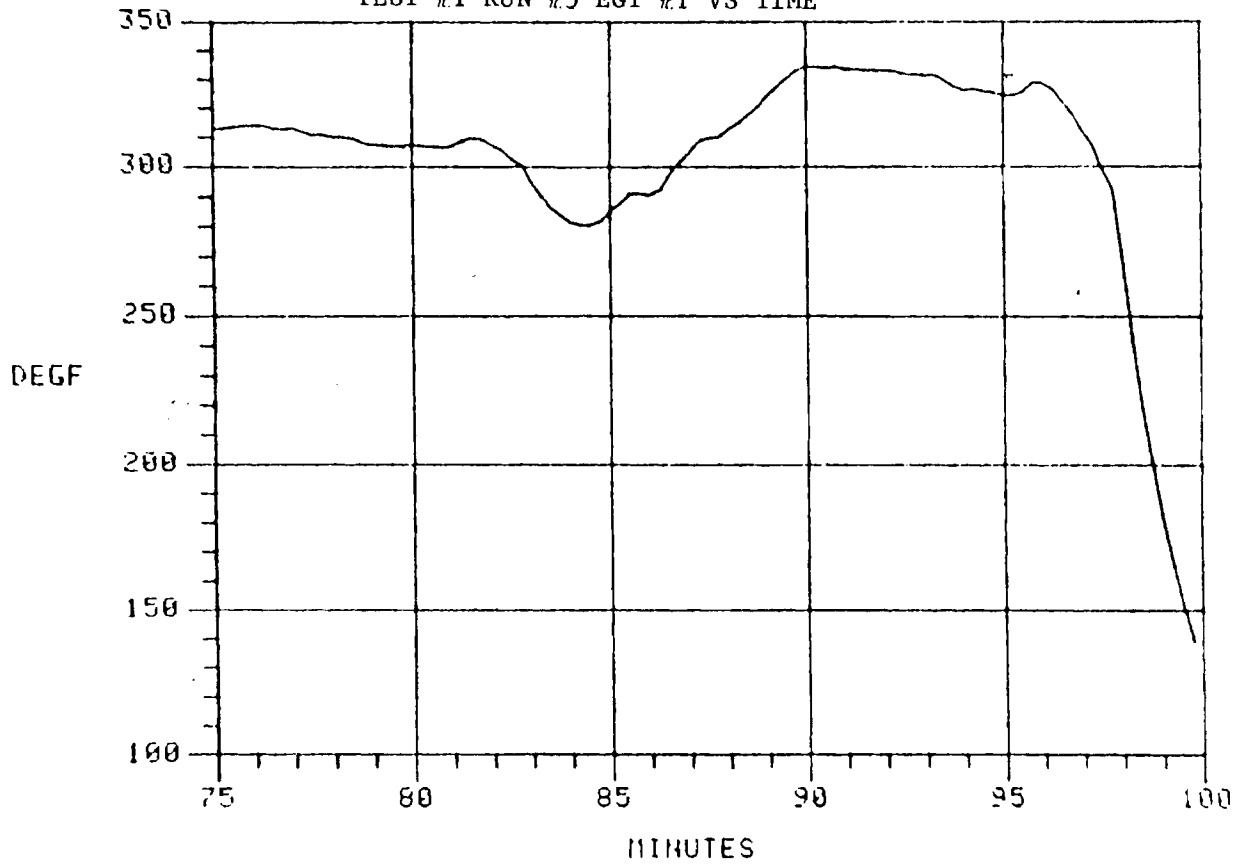

TEST #1 RUN #5 IDLE JET PRESSURE VS TIME

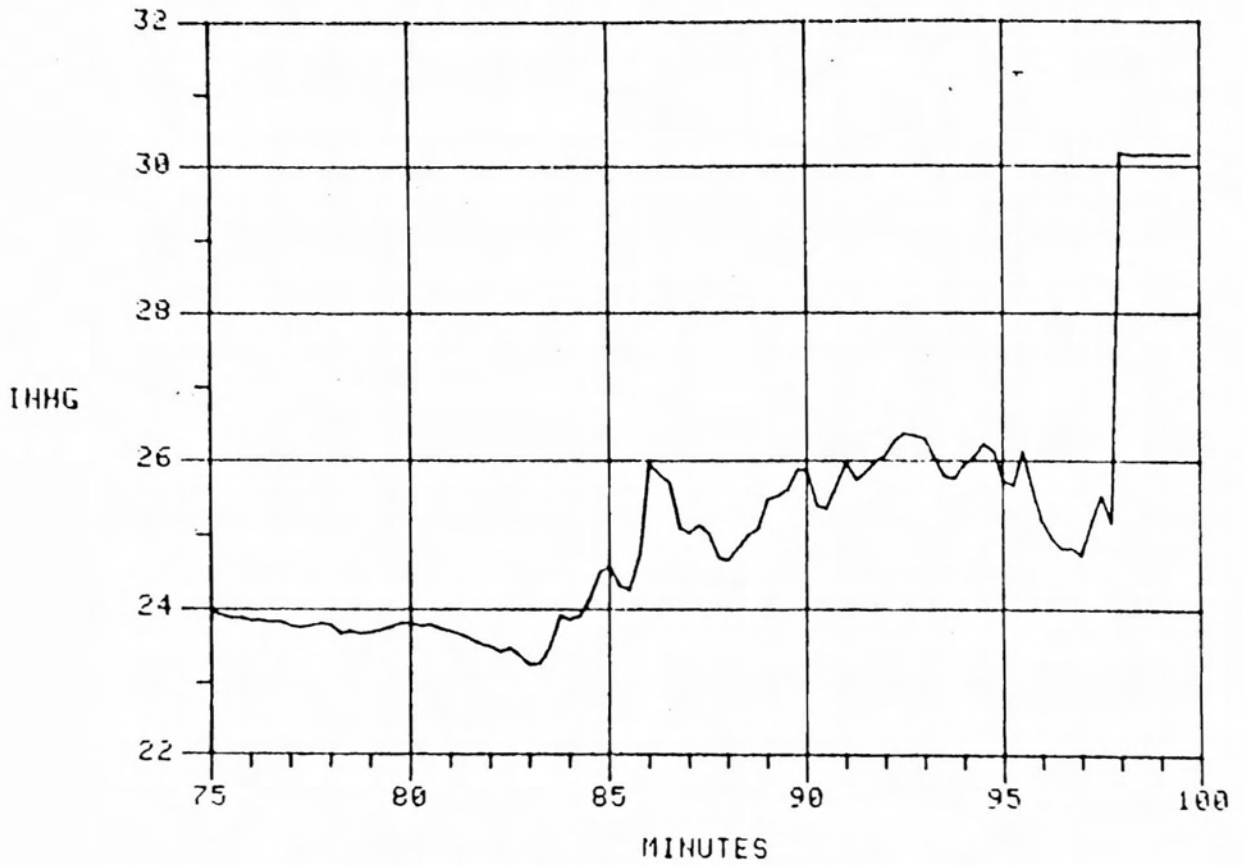

TEST #1 RUN #5 CARBURETOR ADAPTER TEMP VS TIME

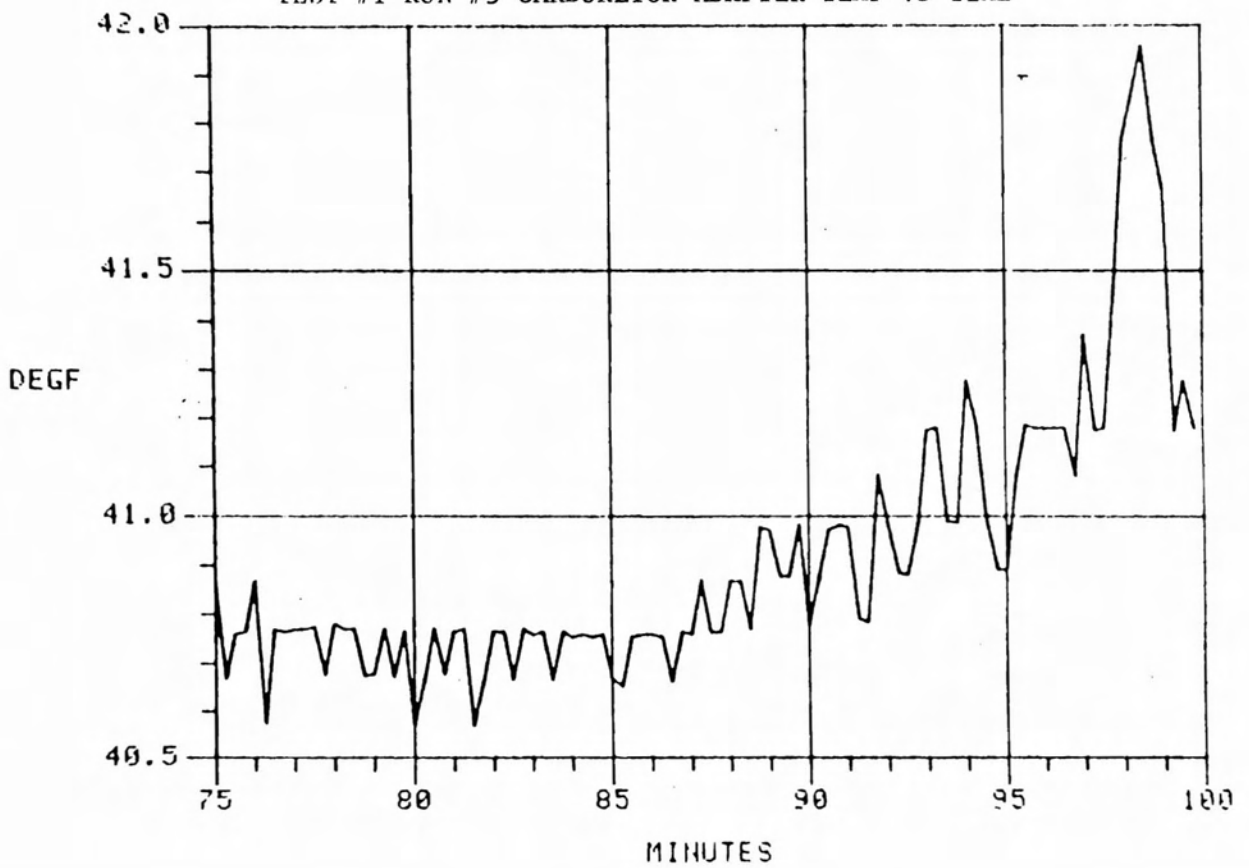

TEST #1 RUN #5 LOWER THROTTLE TEMP VS TIME

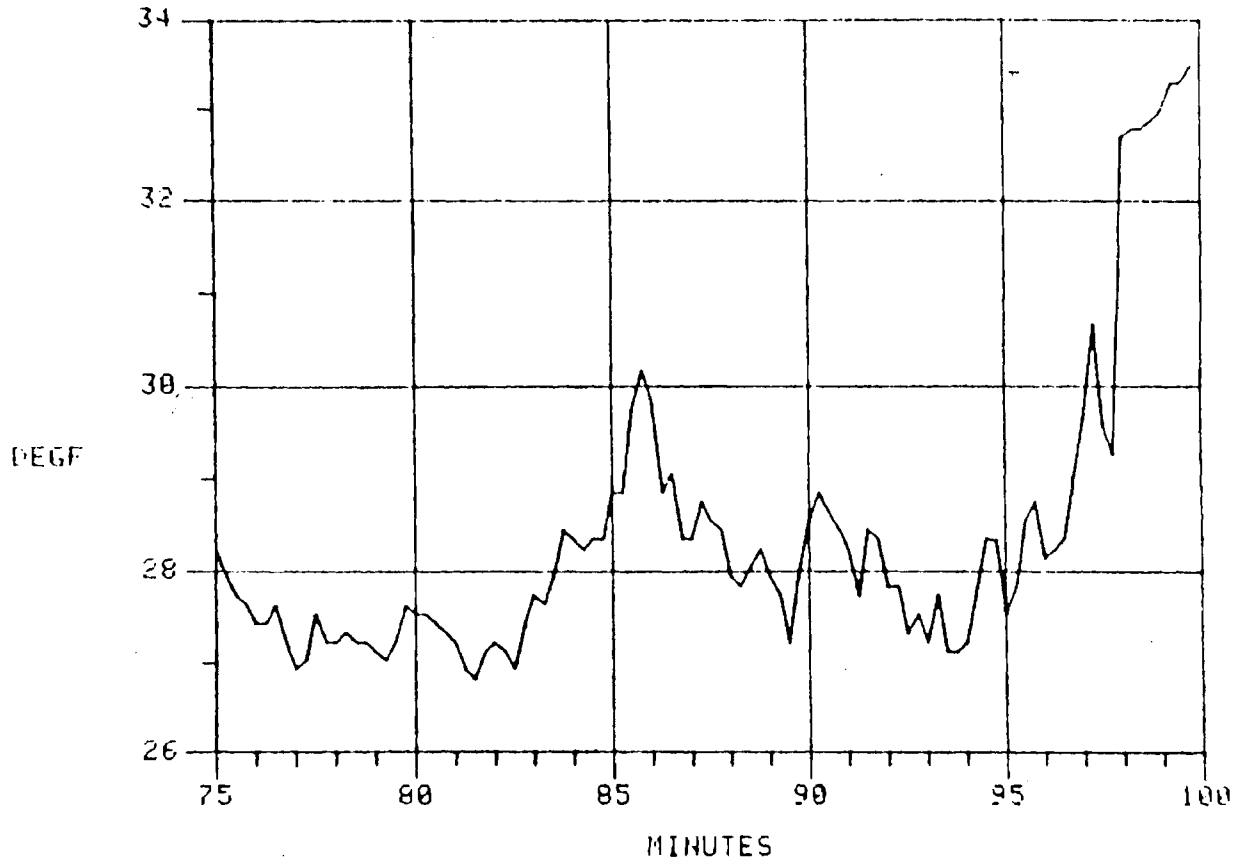

TEST #1 RUN #5 UPPER THROTTLE TEMP VS TIME

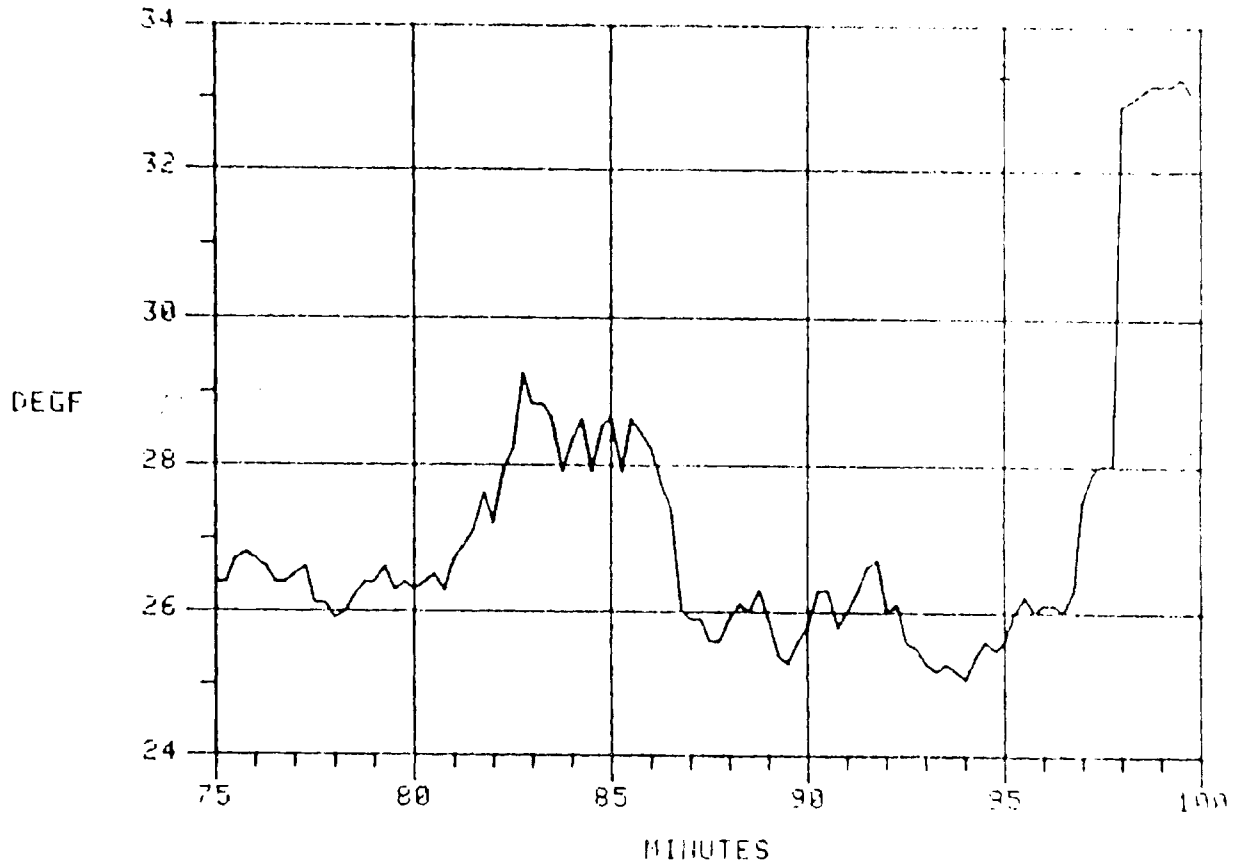

TEST #1 RUN #5 #1 METAL TEMP VS TIME

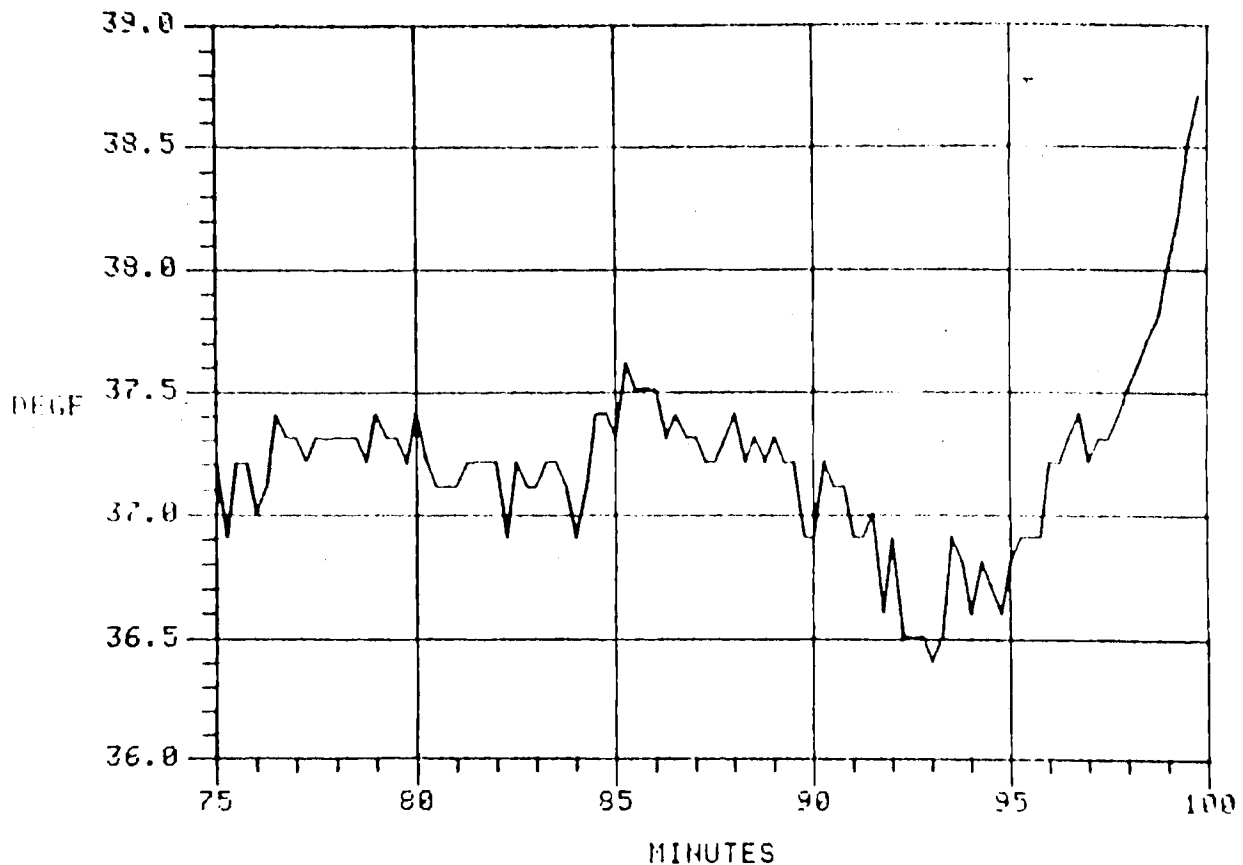

TEST #1 RUN #5 #2 METAL TEMP VS TIME

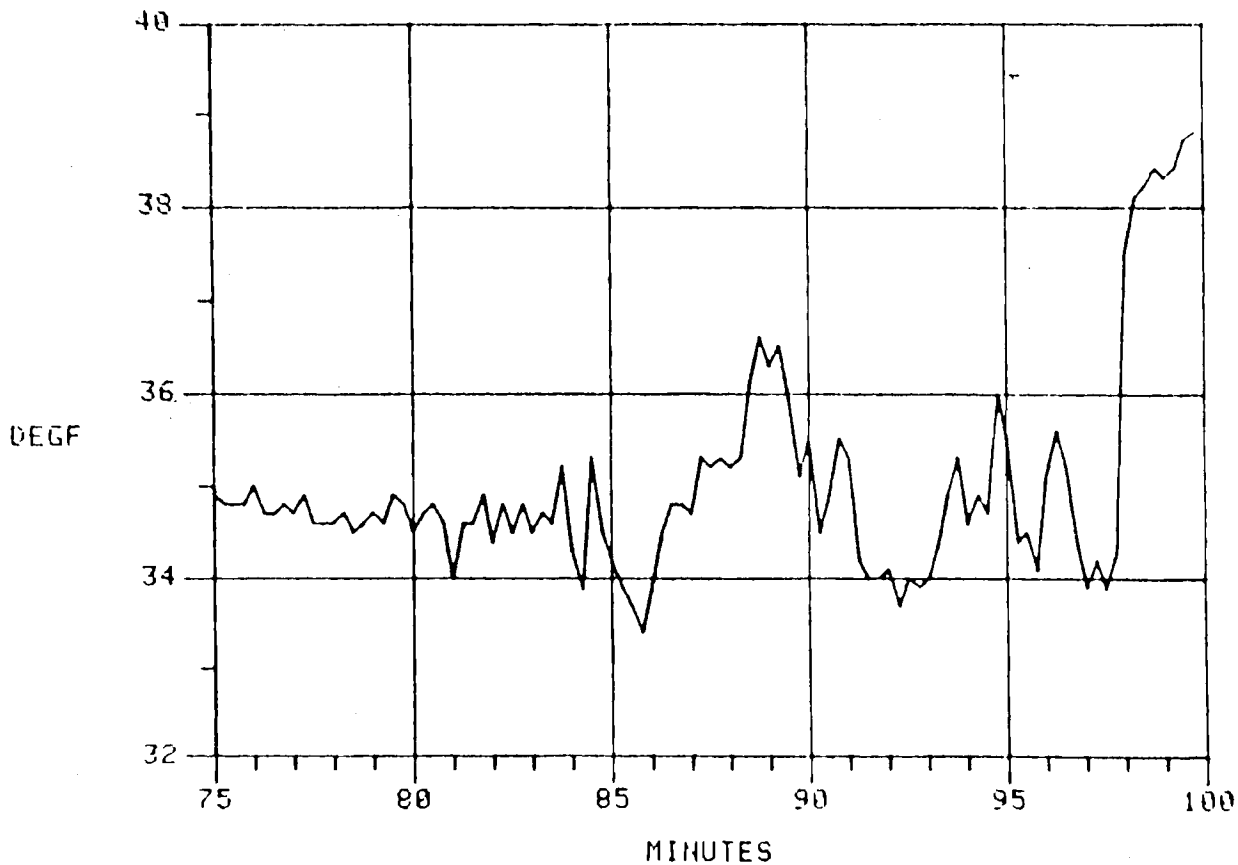

TEST #1 RUN #5 FUEL FILTER TEMP VS TIME

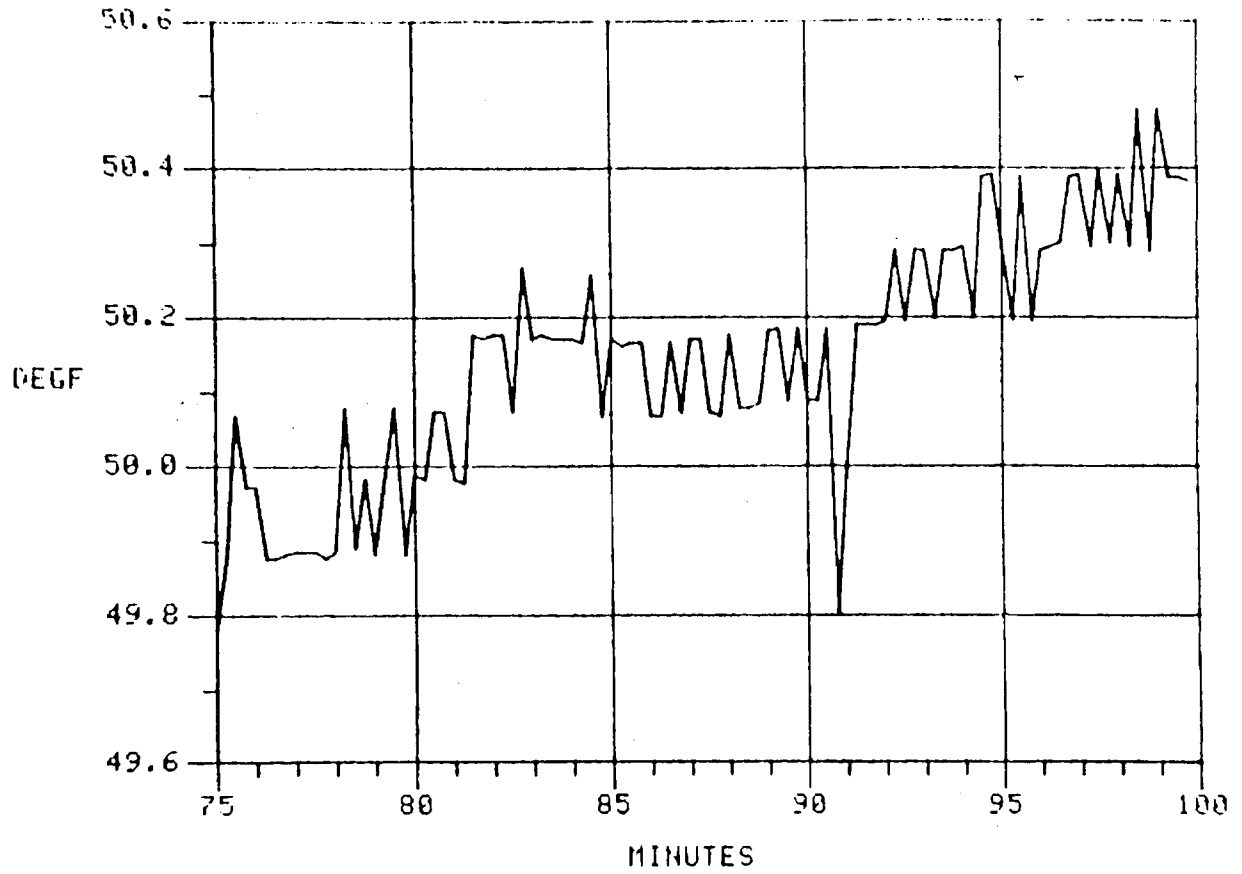

TEST #1 RUN #5 FLOAT BOWL TEMP VS TIME

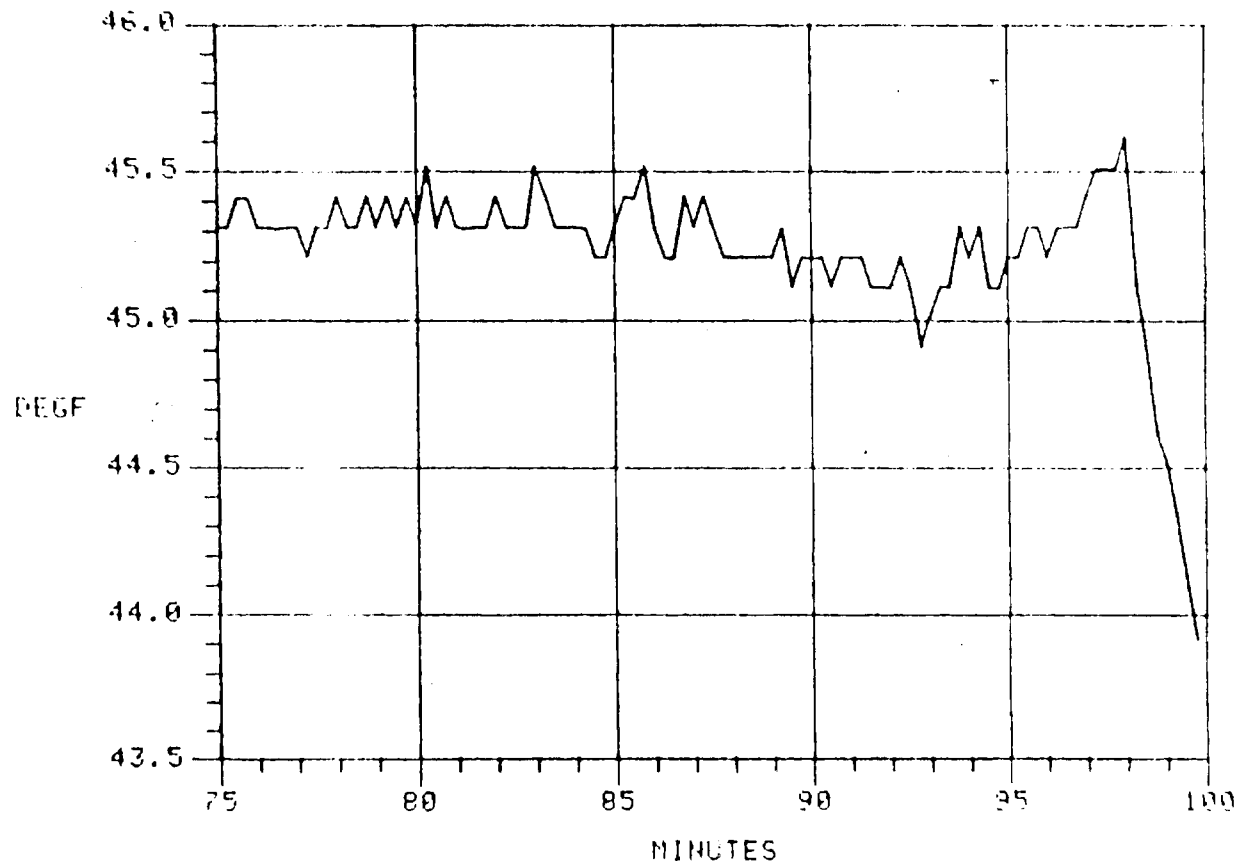

APPENDIX F

TEST CELL ENGINE INSTALLATION



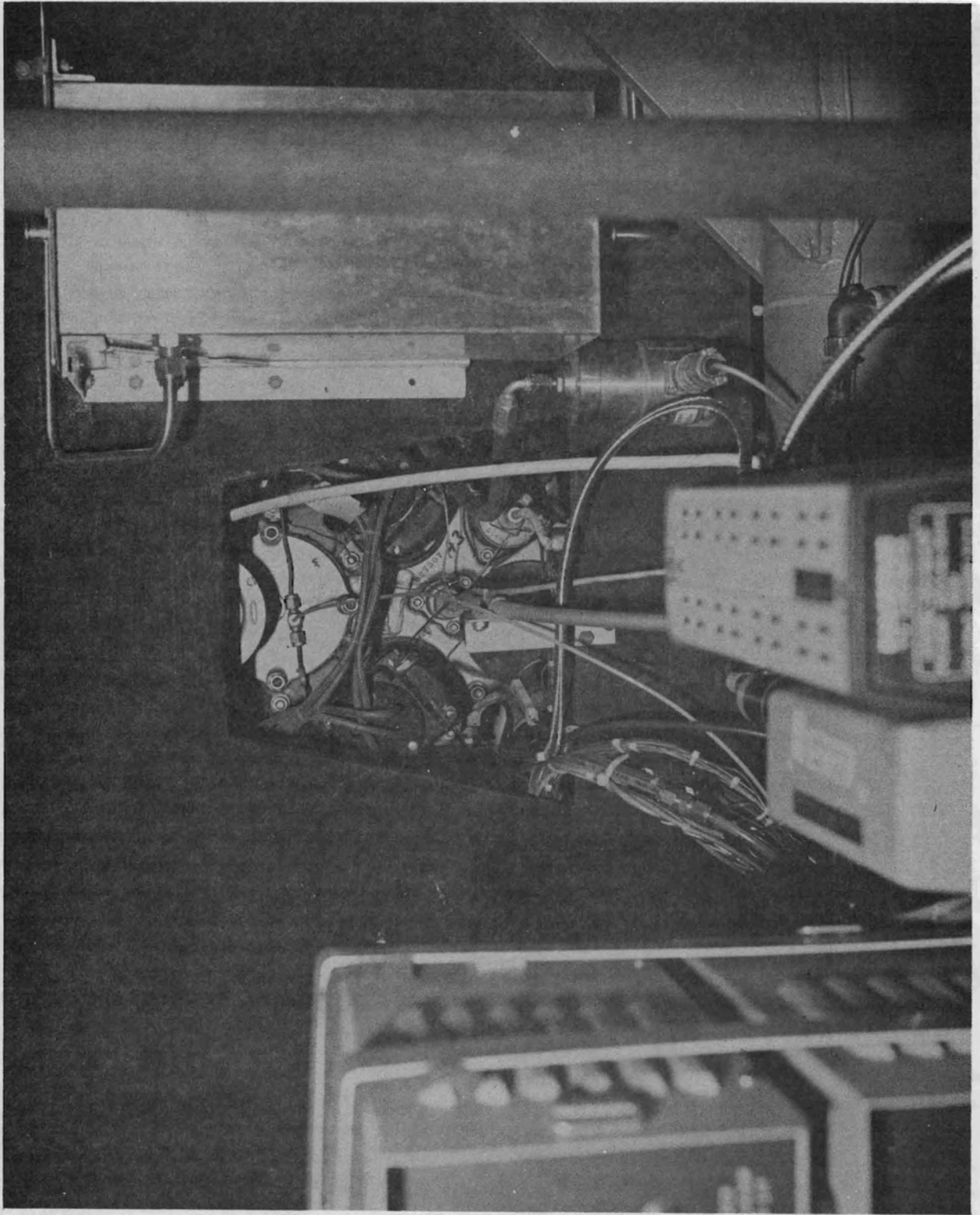

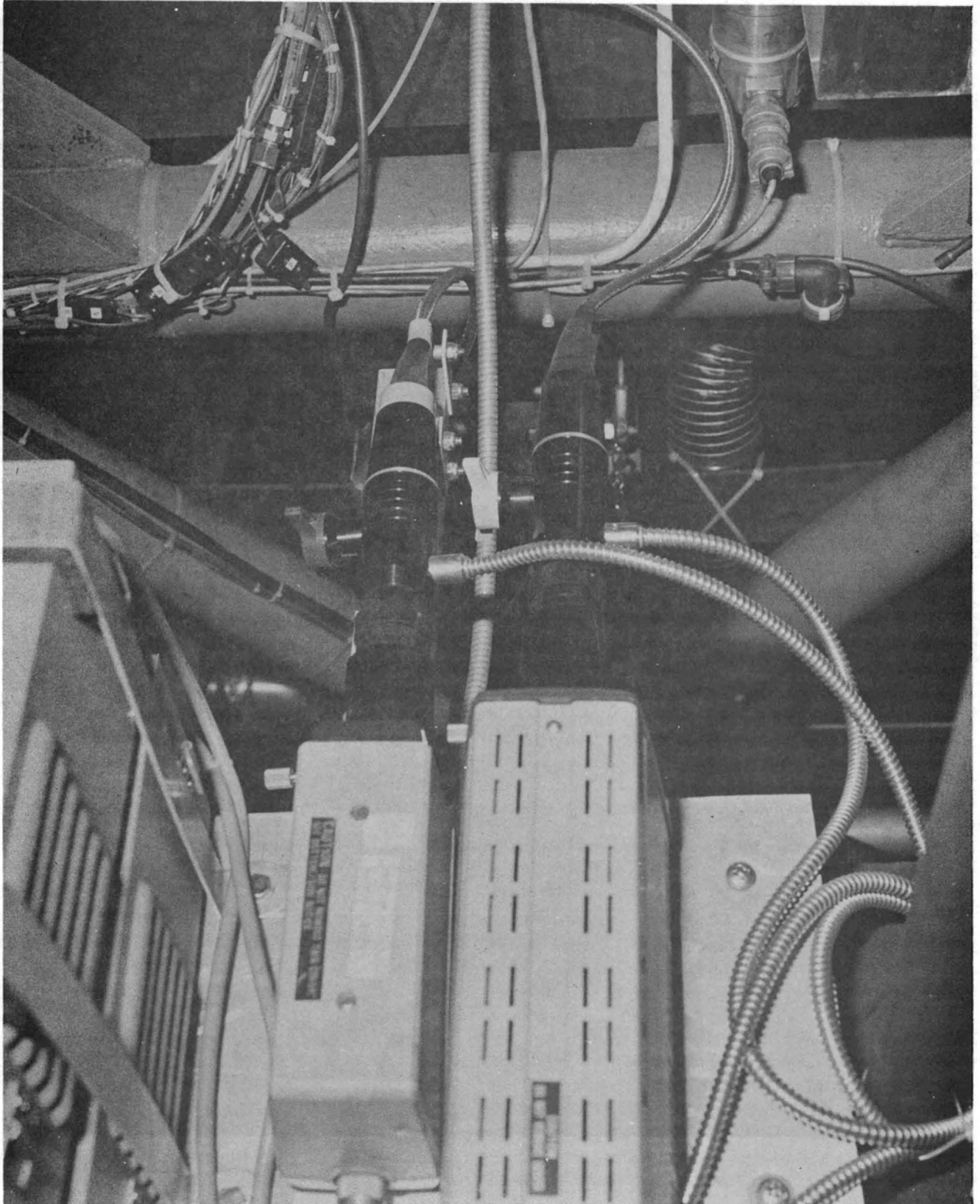

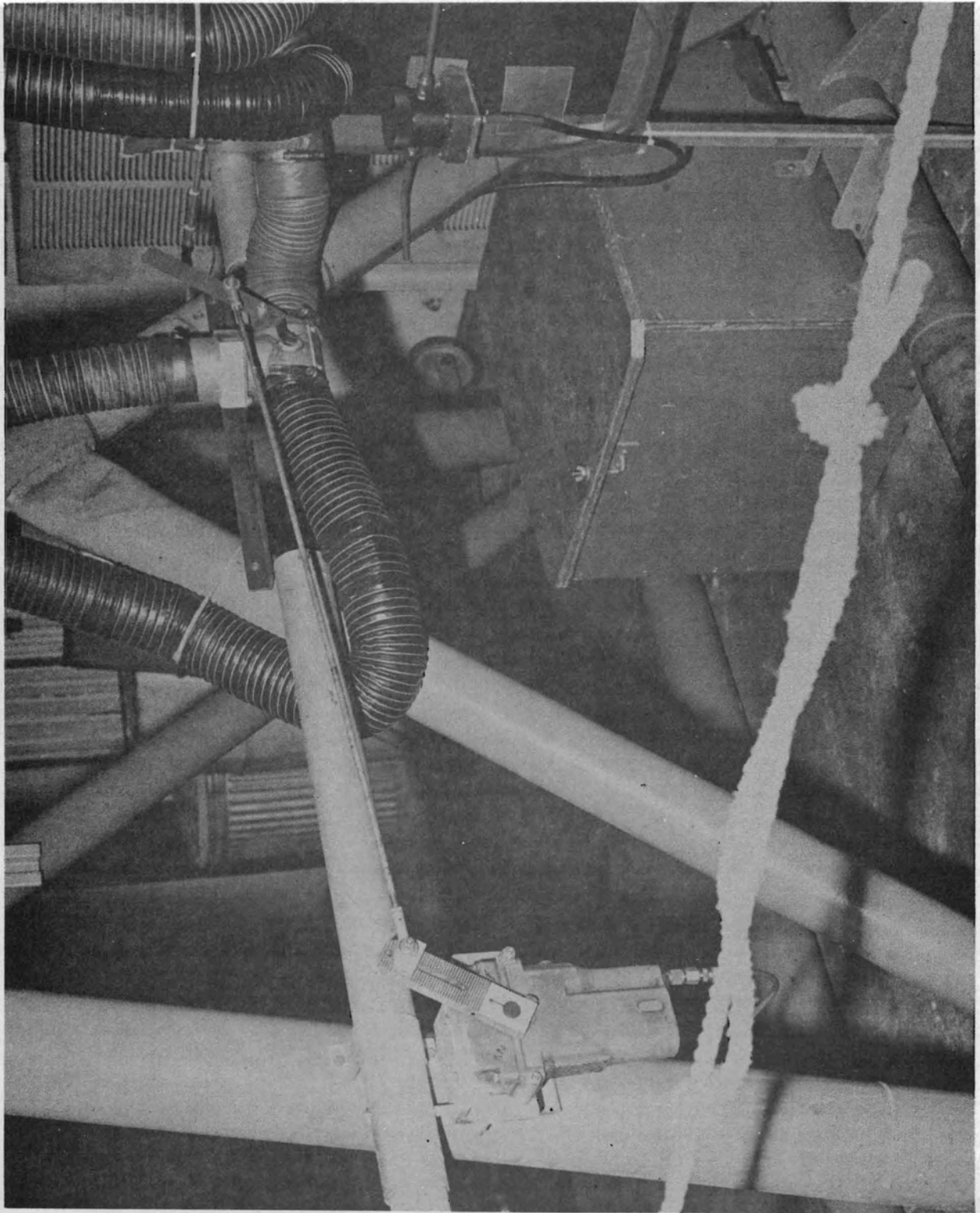

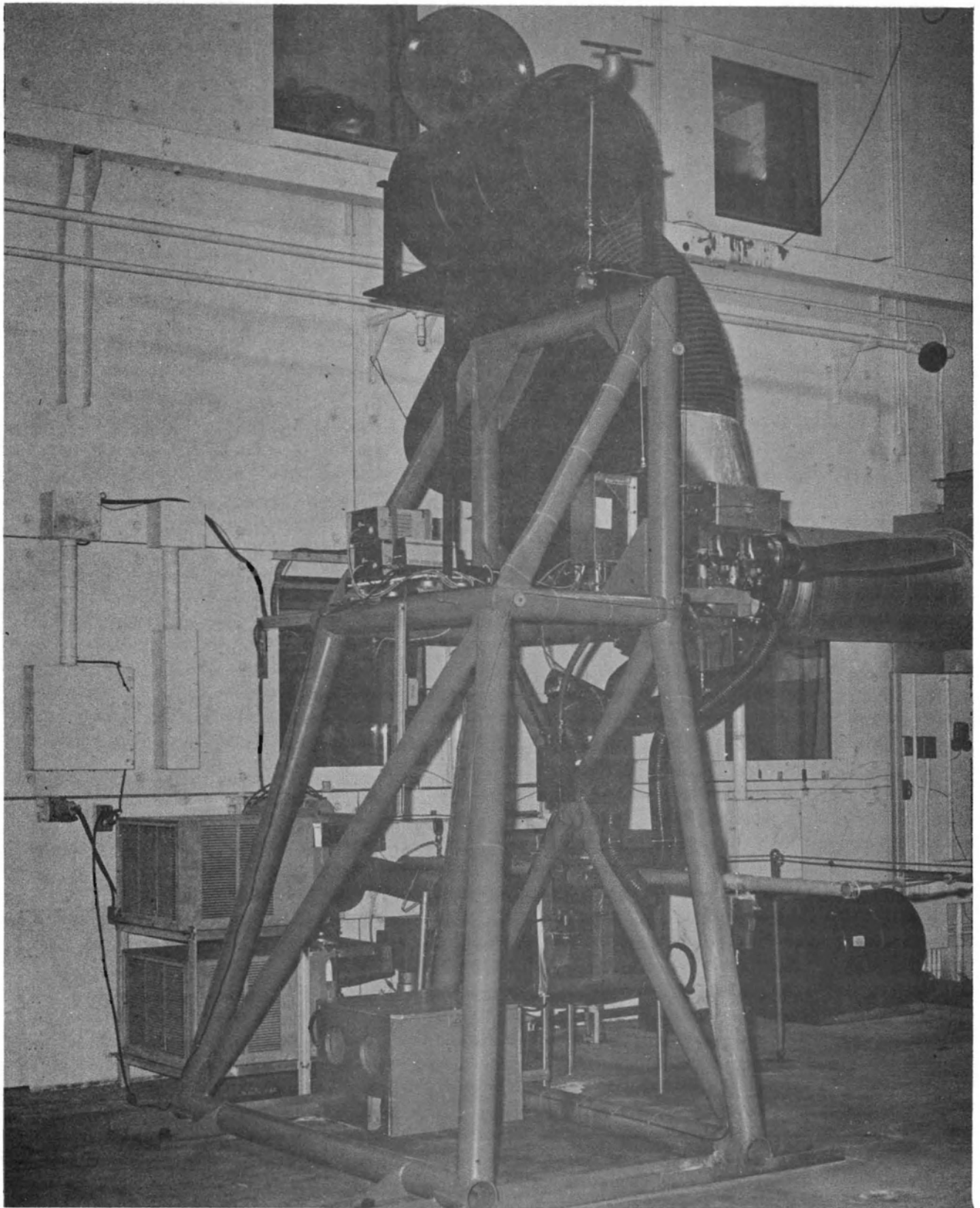

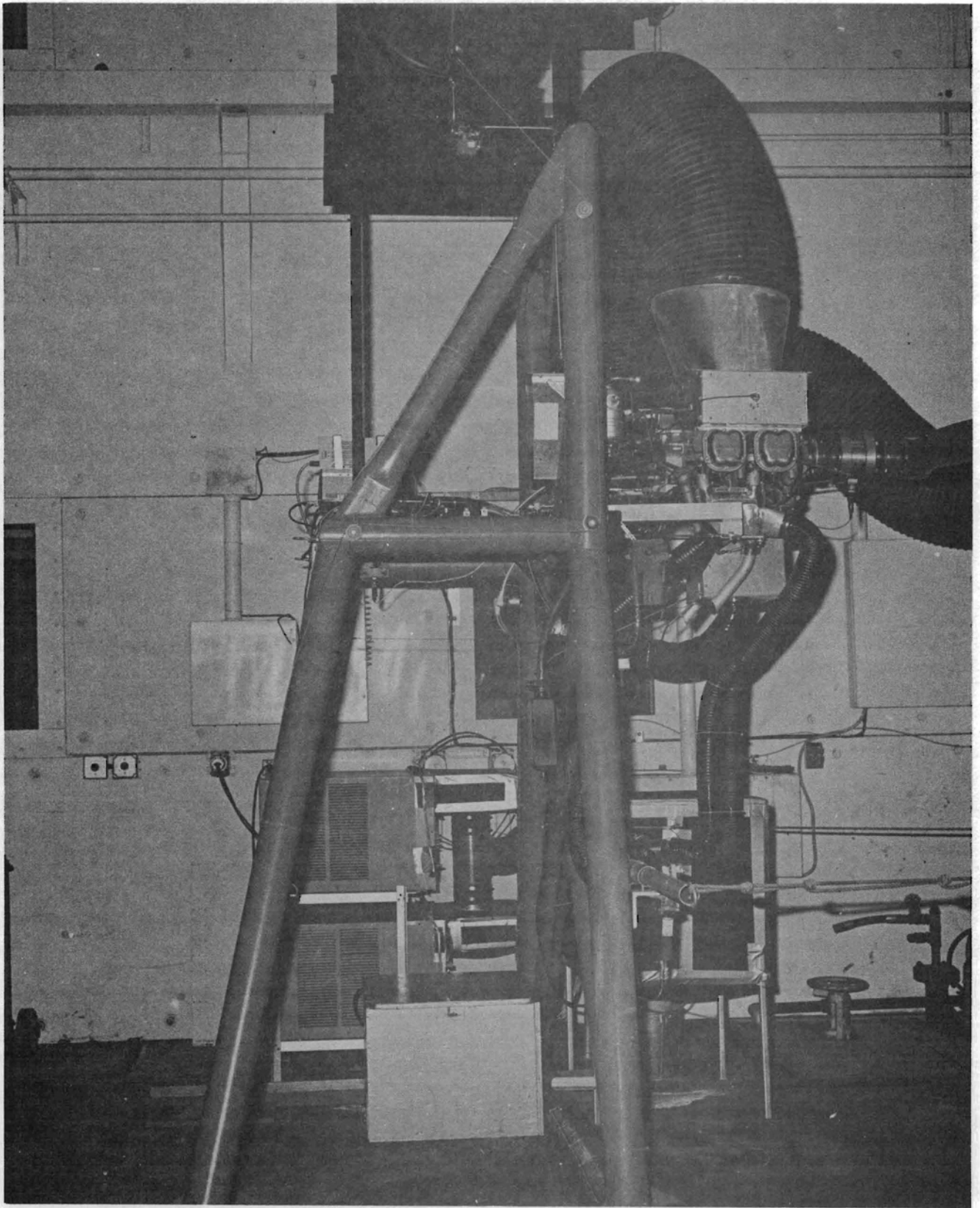



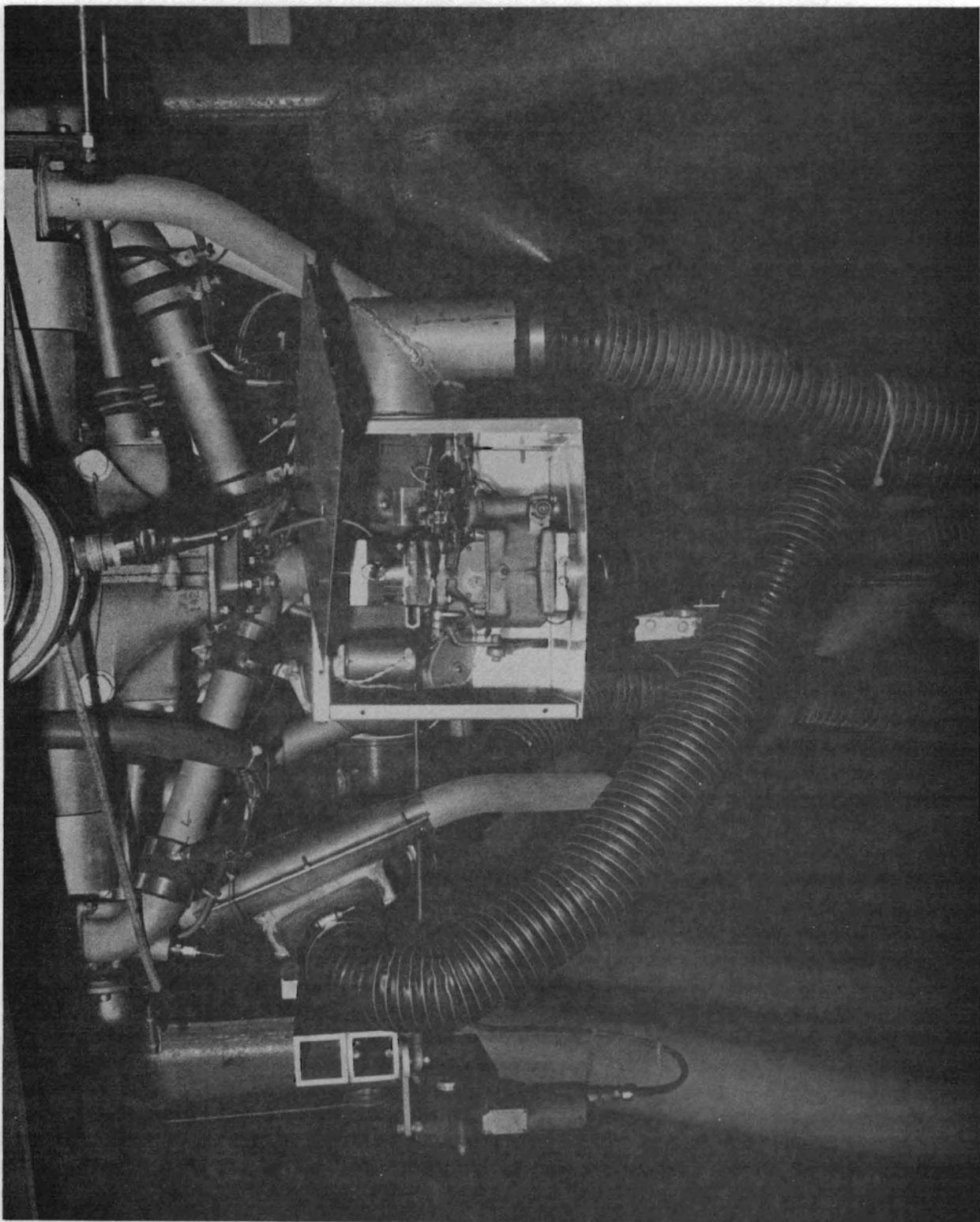

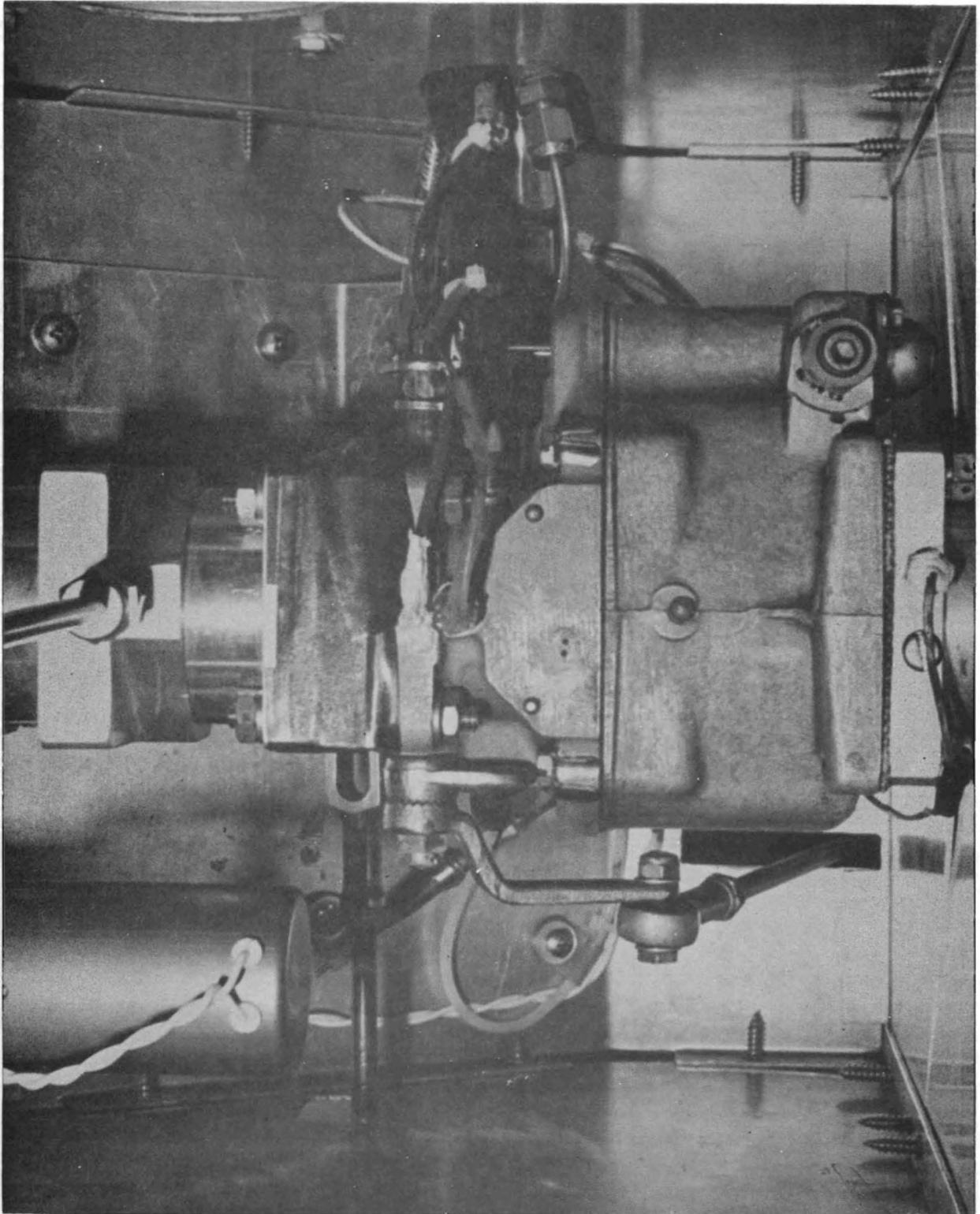

APPENDIX G

CARBURETOR ICE WARNING DEVICES

- a. Charles B. Shivers, Jr.
8928 Valleybrook Road
Birmingham, Alabama 35206
(telephone 205-833-7968)

This device is a carburetor modification to the throttle plate and accompanied with a cockpit indicator to provide warning of ice accumulation.

- b. Boldnor Electronics
Boldnor Farm
Nr. Yarmouth, I.O.W. England
(telephone 098-376-0268)

This device is a thin metal plate positioned between carburetor and induction manifold and accompanied with a cockpit indicator to provide warning of ice accumulation.

- c. Dataproducts
New England, Inc.
Barnes Park North
Wallingford, Connecticut 06492
(telephone 203-265-7151)

This device is still under development, however, it will be a throttle plate mounted ice detector accompanied with a cockpit indicator to provide warning of ice accumulation.

- d. A.R.P. Industries, Inc.
36 Bay Drive East
Huntington Long Island, New York 11743
(telephone 516-427-1585)

This device is a small light radiation source with a light sensor attached, all of which mounts in an existing 1/4-inch hole located in the carburetor venturi area. The light sensor connects via electric circuit to a cockpit mounted warning light, sensitivity control and optional warning horn.

- e. Richter Aero Equipment, Inc.
15194G Ridge Road
Essex, New York 12936
(telephone 518-963-7080)

This device is a small wire sensing coil of known resistance characteristics which change with temperature. The sensing coil mounts in an existing 1/4-inch hole located in carburetor venturi area. Attached to the coil via electric circuit is a cockpit mounted air temperature gage with color warning area and placard.

DOT/FAA
CT-82/44

Light aircraft piston engine
carburetor ice detector/warning
device sensitivity/effectiveness
/
00007839