

Handwritten scribbles and "COPY 1" stamp

DOT/FAA/CT-82/25

Plan View Display Modifications for the 9020 Replacement System

John J. Carr

**AVAILABLE IN
ELECTRONIC FORMAT**

FEDERAL AVIATION ADMINISTRATION

FEB 15 1983

TECHNICAL CENTER LIBRARY
ATLANTIC CITY, NJ 08405

October 1982

Final Report

This document is available to the U.S. public
through the National Technical Information
Service, Springfield, Virginia 22161.

**FAA WJH Technical Center
Tech Center Library
Atlantic City, NJ 08405**



US Department of Transportation
Federal Aviation Administration
Technical Center
Atlantic City Airport, N.J. 08405



DOT/FAA
CT-82/25

FAA TECHNICAL CENTER LIBRARY NJ

United State/Plan view display modificat

4/25



00007919

1. Report No. DOT/FAA/CT-82/25		2. Government Accession No.		3. Recipient's Catalog No.	
4. Title and Subtitle PLAN VIEW DISPLAY MODIFICATIONS FOR THE 9020 REPLACEMENT SYSTEM				5. Report Date October 1982	
				6. Performing Organization Code	
7. Author(s) John J. Carr				8. Performing Organization Report No. DOT/FAA/CT-82/25	
9. Performing Organization Name and Address Federal Aviation Administration Technical Center Atlantic City Airport, New Jersey 08405				10. Work Unit No. (TRAIS)	
				11. Contract or Grant No. 231-132-210	
12. Sponsoring Agency Name and Address U.S. Department of Transportation Federal Aviation Administration Technical Center Atlantic City Airport, New Jersey 08405				13. Type of Report and Period Covered Final May to October 1981	
				14. Sponsoring Agency Code	
15. Supplementary Notes					
16. Abstract This report describes the modifications that were made to a Plan View Display (PVD) which allowed it to be switched between the present National Airspace System (NAS) and a future 9020 Replacement (9020R) System. A second PVD was also modified and used to simulate the outputs of the 9020R System. The outputs of the simulated 9020R System were analog X and Y deflection signals, video unblanking, and brightness control bits. The PVD switch was controlled by a spare switch located on the front panel. The PVD was driven either in the normal manner by the present system or by the remote signals brought in from the 9020R simulator PVD. The R-controls were also switched between two different radar keyboard multiplexer (RKM) output connectors by means of an external relay box controlled by the front panel switch of the PVD. The switched PVD was driven over cable lengths of 20, 50, 70, and 100 feet. Line width and brightness measurements were taken and display patterns were observed at each of these lengths. Results were very good up to 70 feet and satisfactory up to 100 feet.					
17. Key Words 9020 Replacement System Plan View Displays Switch Modification National Airspace System			18. Distribution Statement Document is available to the U.S. public through the National Technical Information Service, Springfield, Virginia 22161		
19. Security Classif. (of this report) Unclassified		20. Security Classif. (of this page) Unclassified		21. No. of Pages 55	22. Price

TABLE OF CONTENTS

	Page
INTRODUCTION	1
Background	1
Purpose	1
DISCUSSION	1
Switch PVD	3
Driver PVD	3
TESTING	12
CONCLUSIONS	14
APPENDIX	

LIST OF ILLUSTRATIONS

Figure		Page
1	Test Setup	2
2	Modified A2 PCB — Switch PVD	4
3	Modified A5 PCB — Switch PVD	5
4	Lower Basket — Switch PVD	6
5	RKM Switch Box	7
6	Modified A2 PCB — Driver PVD	8
7	Modified A5 PCB — Driver PVD	9
8	Lower Basket — Driver PVD	10
9	Analog Line Drivers	11
10	Test Pattern Switch PVD — Internal	15
11	Test Pattern Driver PVD	16
12	Test Pattern Switch PVD — 50 Feet	17
13	Test Pattern Switch PVD — 100 Feet	18

LIST OF TABLES

Table		Page
1	List of Test Equipment	12
2	Line Width and Intensity Measurements for Various Cable Lengths	13

INTRODUCTION

BACKGROUND.

Consideration is presently being given to replacing the present National Airspace System (NAS) with a new updated system which will be referred to as the 9020 Replacement (9020R) System. A determination must be made as to what type of displays are to be used with the new system.

PURPOSE.

The purpose of this project was to investigate the possibility of using the Plan View Displays (PVD's) from the present NAS as displays for the 9020R System.

Two possibilities were considered: (1) using the PVD's permanently as simple monitors driven by analog X and Y deflection signals and video unblanking signals from the 9020R System, and (2) switching the PVD's back and forth between the two systems during the initial phase of the 9020R operation without causing system problems. The feasibility of driving the PVD's from the 9020R System over various lengths of cables was also to be determined.

DISCUSSION

Originally, transmitting analog X and Y deflection signals and the Z video signal was considered. This would have eliminated the controller's capability to adjust the brightness levels of various data classes. In order to maintain the present capabilities of the PVD, it was decided to transmit video unblanking signals and three-category enable bits along with the analog X and Y deflection signals.

Two PVD's were modified for this project. The first PVD, which will be referred to as the driver PVD, was modified to provide simulated signal outputs from the 9020R System. This PVD was driven by either the NAS or the En Route Radar Display Recording System (ERDIRS), and it was modified as described below to provide external analog X and Y deflection signals and video unblanking signals. The second PVD, which will be referred to as the switch PVD, was modified to display either the normal data received from the present NAS or the external data received from the 9020R simulator. Data were selected by means of a switch on the front panel of the PVD. The R-control interface was also switched between two output positions of the radar keyboard multiplexor (RKM) at the same time the data were switched, in order to demonstrate the effect on the present NAS. The R-control interface is used for communication between the RKM located in the NAS and the Keyboard, Quick Action Panel, Category and Function Key Panels, and the Radar Position Computer Readout Display (RCRD), which are located in the PVD. A photograph showing the test setup, including the two modified PVD's, the RKM switch box, and test equipment used to make measurements on the PVD's, is shown in figure 1. (A block diagram of the PVD modifications and interconnections is shown in figure A-1. A simplified drawing of the RKM switch is shown in figure A-2.)



82-25-1

81-2393

ATLANTIC CITY, NEW JERSEY

FIGURE 1. TEST SETUP

SWITCH PVD.

In the switch PVD, it was necessary to open a number of circuit connections on the Video Intensity Control — A2 Printed Circuit Board (PCB) — and on the Signal Pattern Correction — A5 PCB. These connections were rerouted through relays that were then used to switch in the simulated 9020R signals. The relays were mounted directly on the A2 and A5 PCB's. Line receivers, terminators, and input connectors were also mounted on the two PCB's. A spare switch located on the system status control panel of the PVD was wired in and used to control the relays mounted on the PCB's. Figures 2 and 3 show photographs of the two modified PCB's. A photograph of the lower basket of the switch PVD is shown in figure 4. An external box containing relays was connected between the R-control connector of the switch PVD and two RKM output connectors. This RKM switch box was used to switch the PVD R-controls to the other RKM output connector when the special front panel switch was activated. A photograph of the RKM switch box is shown in figure 5. (Figures A-5 and A-7 show schematics of the unmodified A2 and A5 PCB's. Schematics of the A2 and A5 PCB's, modified for the switch PVD, are shown in figures A-6 and A-8. Figure A-10 shows a schematic drawing of the switch box.)

DRIVER PVD.

In the driver PVD, it was required to output signals from the A2 and the A5 PCB's. No connections on the cards had to be opened. On the A2 PCB, signal points were connected to line drivers that were mounted on the card. The line driver outputs were wired to output connectors that were also mounted directly on the card. On the A5 PCB, the analog X and Y deflection signals were wired to output connectors that were mounted directly on the card. The analog line drivers were mounted on the PVD chassis above the lower basket and connected to the A2 PCB by coaxial cables. Figures 6 and 7 show photographs of the modified PCB's. A photograph of the lower basket of the driver PVD is shown in figure 8. The analog line driver box is located in the upper left corner of the photograph. Figure 9 shows a schematic drawing of the X and Y analog line drivers. (Schematics of the A2 and A5 PCB's, modified for the driver PVD, are shown in figures A-12 and A-13.)

The +5 volt power supply in the switch PVD, and the +5 volt and +15 volt power supplies in the driver PVD were used to provide power for the modifications. These supplies had adequate reserve power to meet the small additional requirements of the modifications.

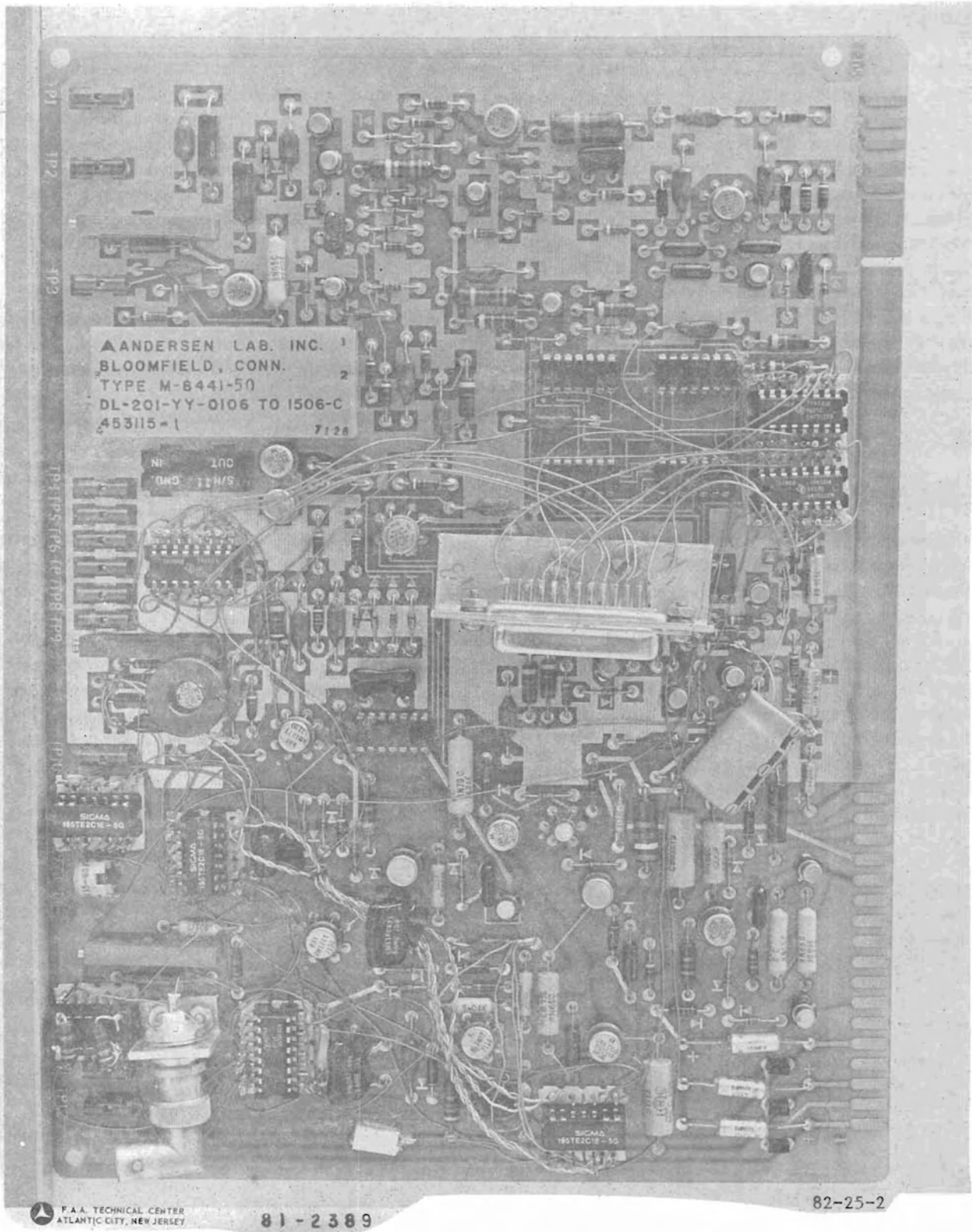

FIGURE 2. MODIFIED A2 PCB — SWITCH PVD

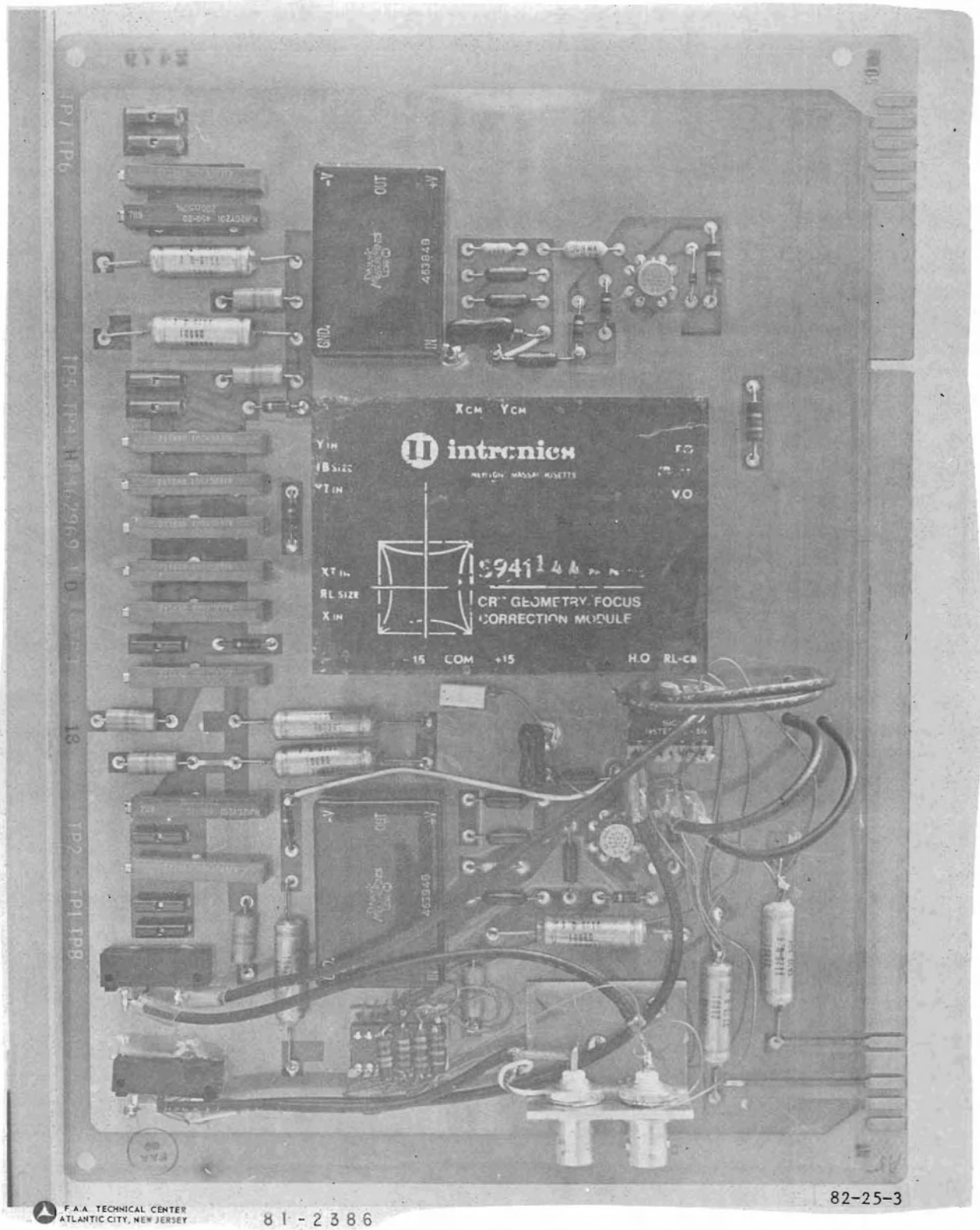

FIGURE 3. MODIFIED A5 PCB — SWITCH PVD

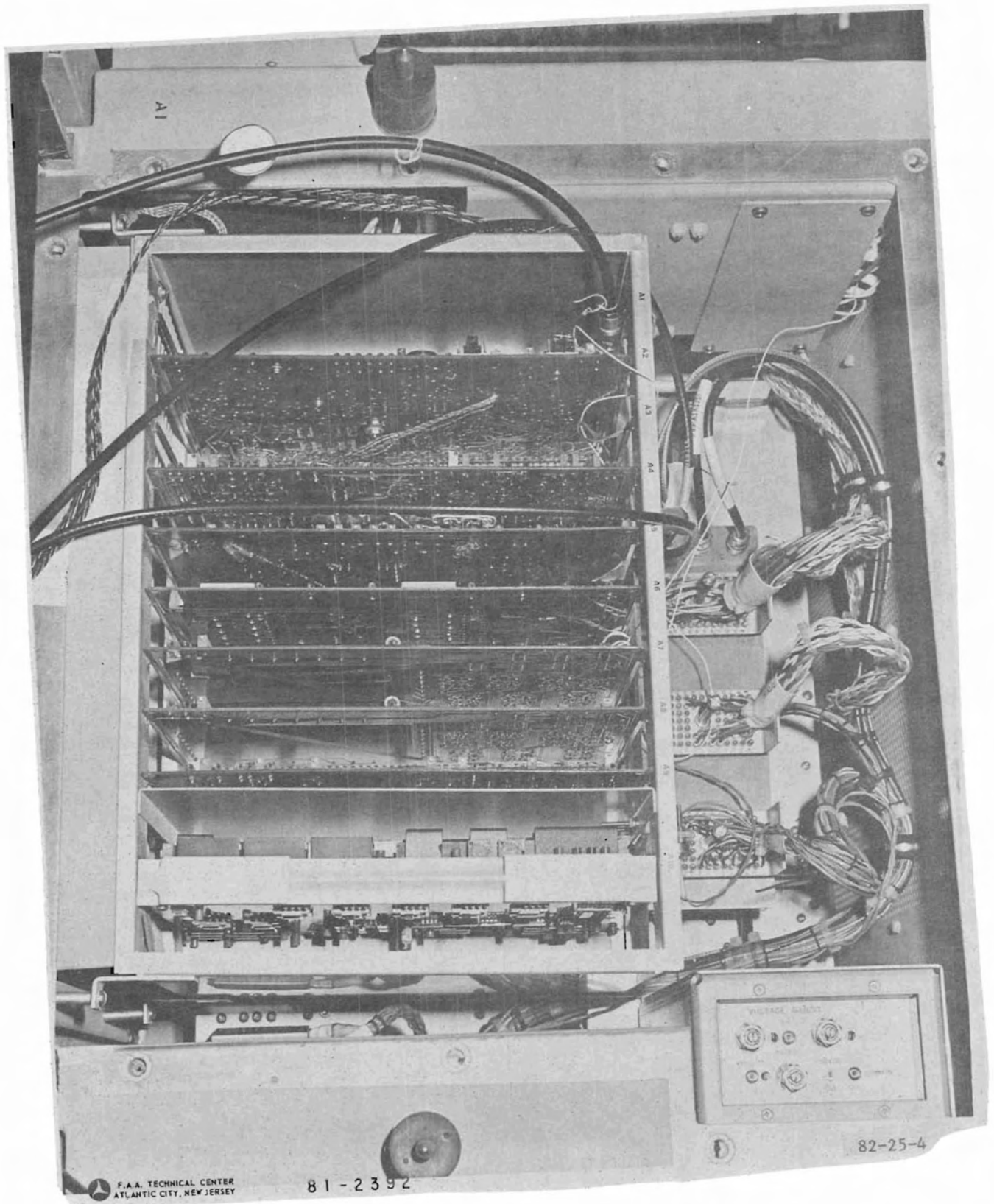
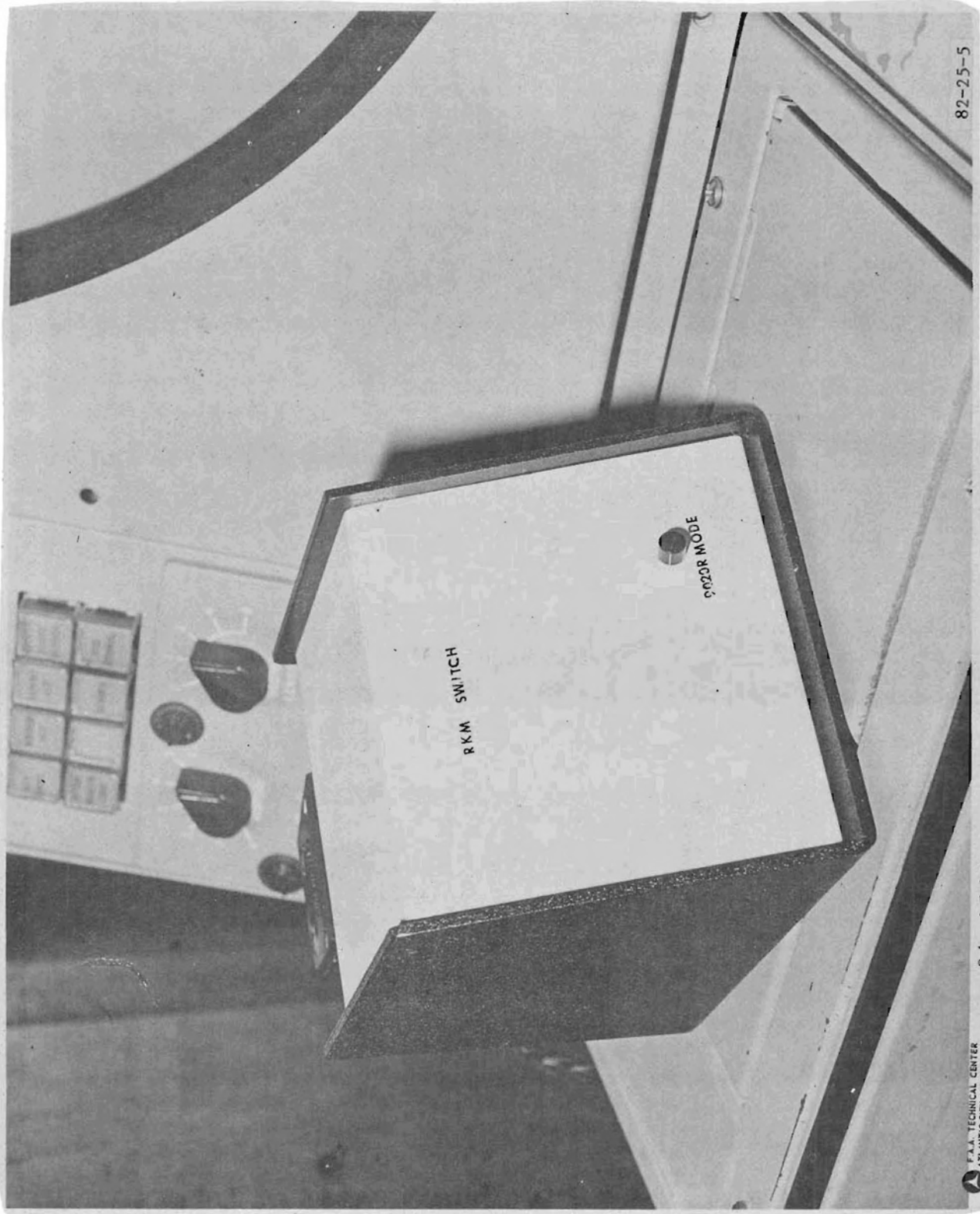

FIGURE 4. LOWER BASKET — SWITCH PVD



82-25-5

81-2390

EAAT TECHNICAL CENTER
ATLANTIC CITY, NEW JERSEY

FIGURE 5. RKM SWITCH BOX

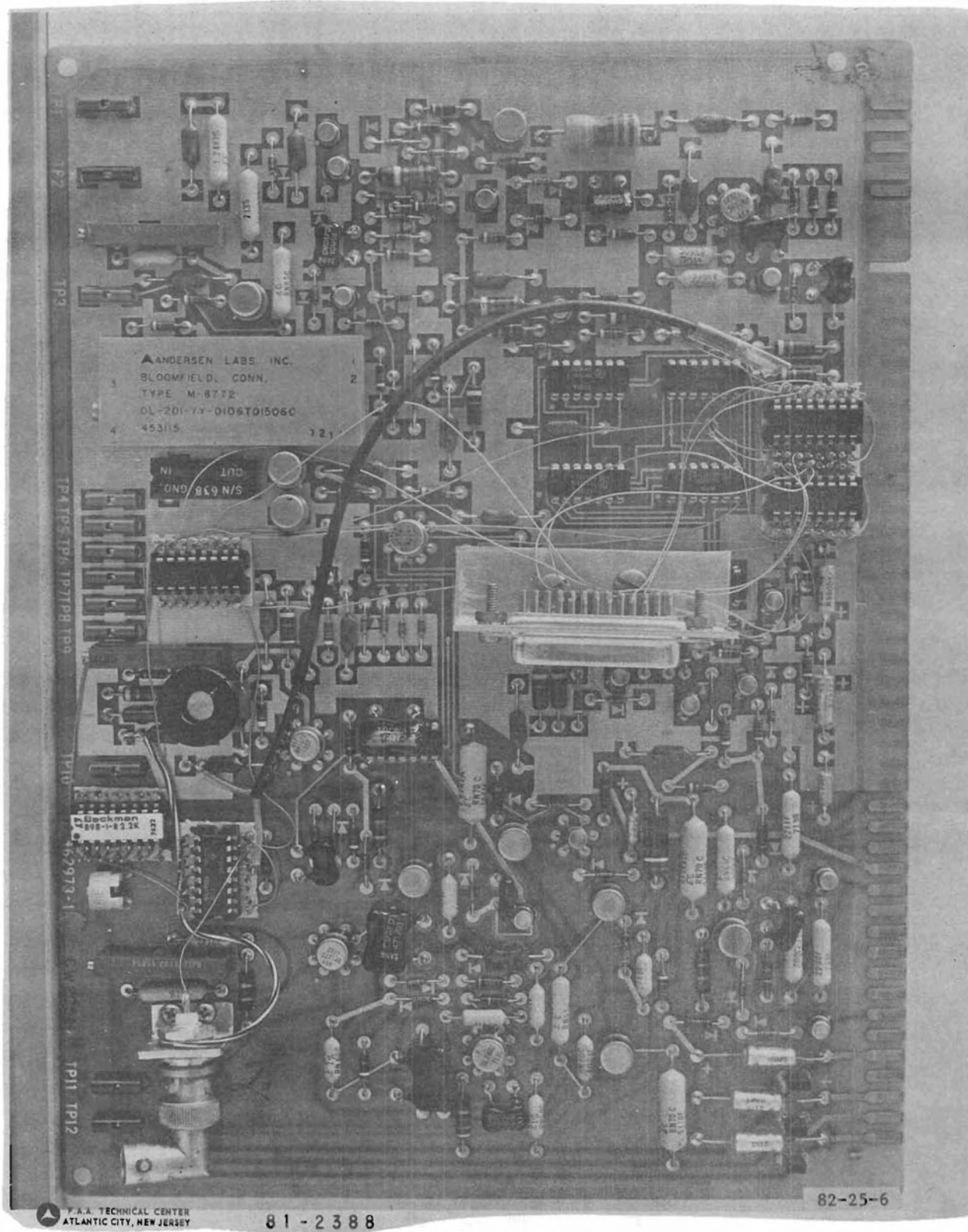

FIGURE 6. MODIFIED A2 PCB — DRIVER PVD

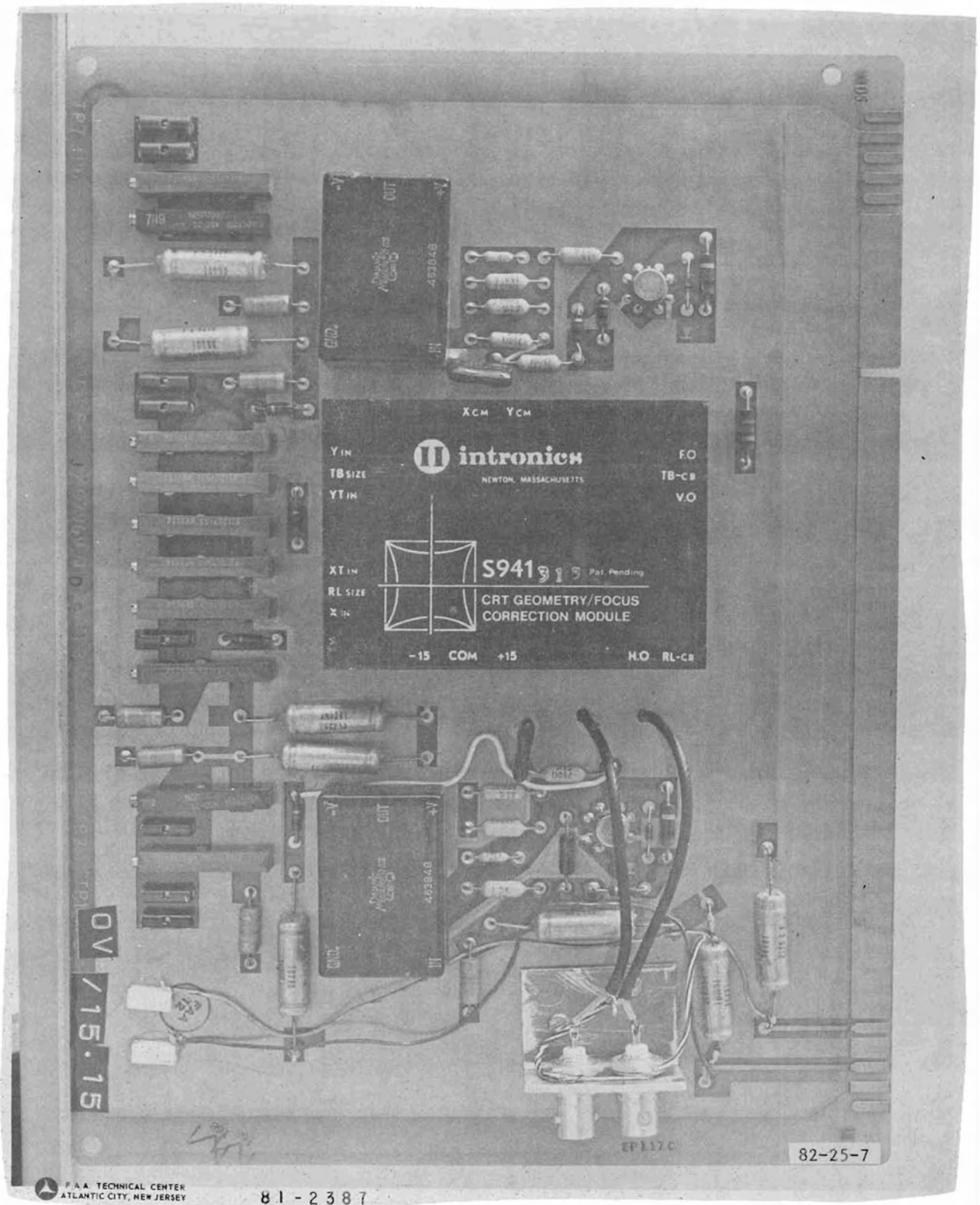

FIGURE 7. MODIFIED A5 PCB — DRIVER PVD

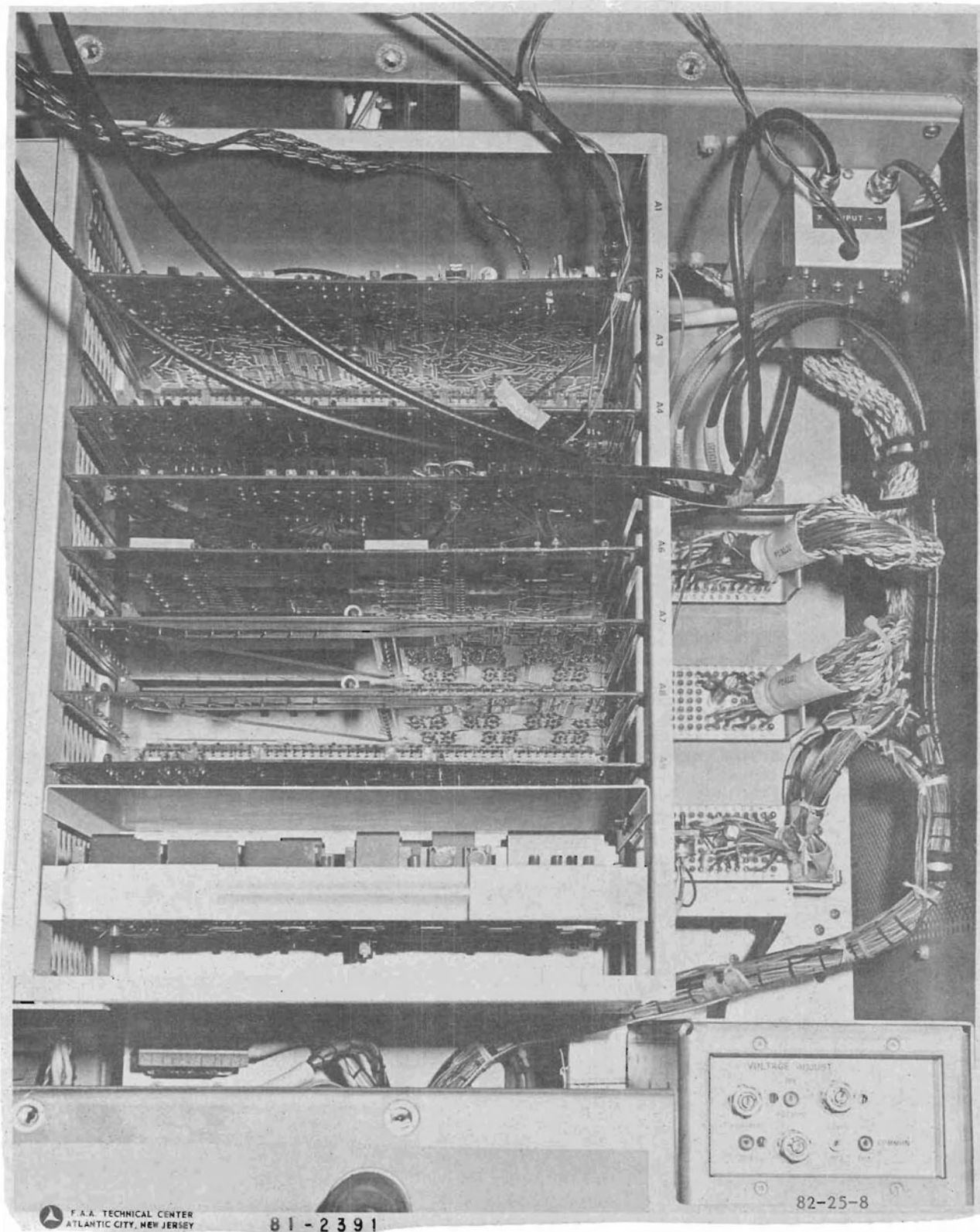
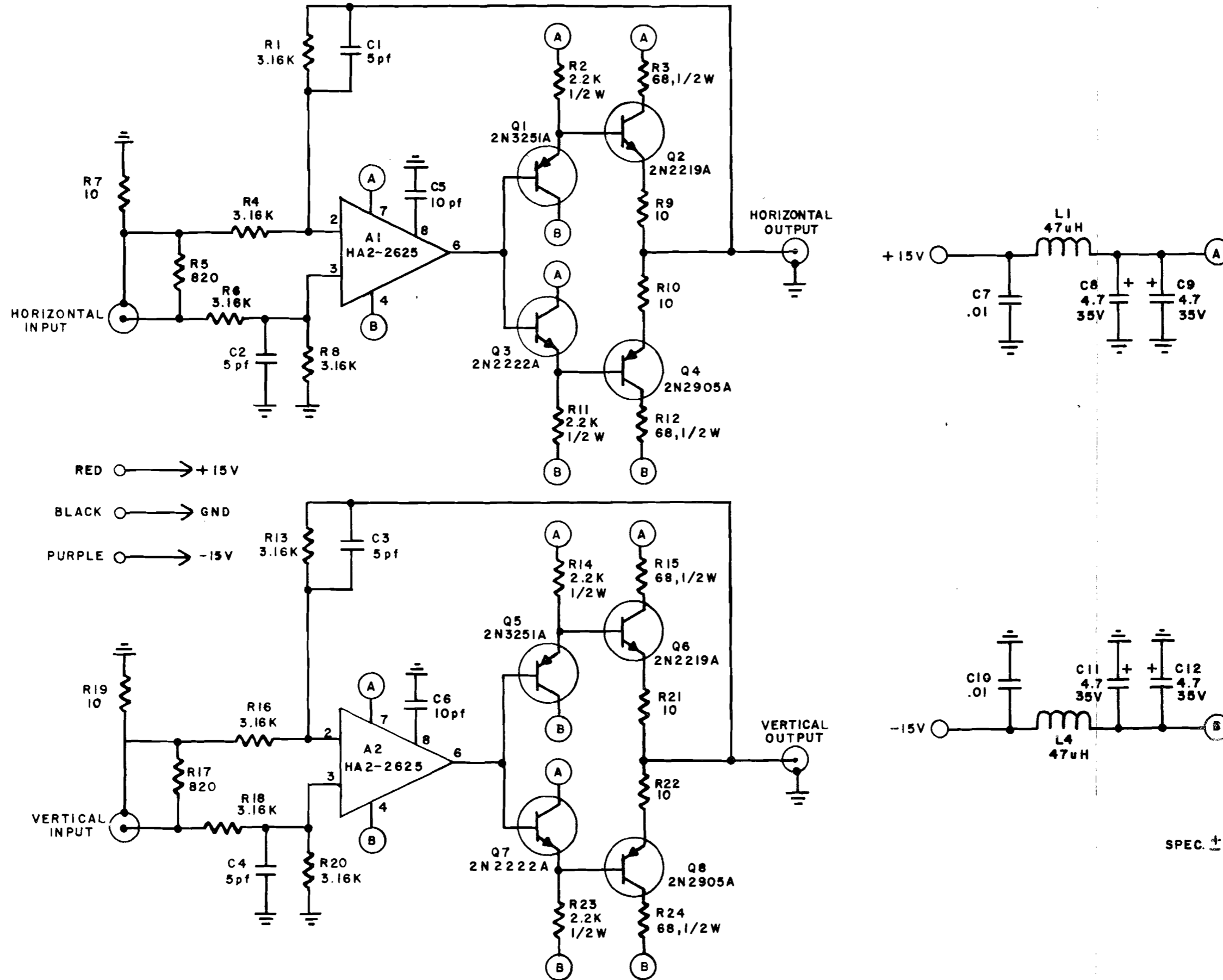

FIGURE 8. LOWER BASKET — DRIVER PVD



SPEC. ±8 VOLTS INTO 100 OHM COAX
(UG62/u) TERMINATED
7 MHZ BANDWIDTH
UNITY GAIN

FIGURE 9. ANALOG LINE DRIVERS

TESTING

The driver PVD and the switch PVD were located side by side. They were interconnected by four cables. The analog X and Y deflection signals were transmitted over two 100-ohm coaxial cables. A 75-ohm coaxial cable was used for the character unblanking signal connection. The category enable signals, vector unblanking signal, and character unblank enable signal were transmitted over twisted pair ribbon cable.

Cables of various lengths were used to conduct tests. Cable lengths of 20, 50, 70, and 100 feet were used. At each cable length, the data presented on the switch PVD were observed for legibility, jitter, or noise problems, missing data, and overall appearance. At each distance, line width and brightness measurements were made. Intensity was measured at the center of the display. Horizontal line width measurements were taken at the center and at the north and south ends of the display. Vertical line width measurements were taken at the center and at the east and west ends of the display. The on-line test pattern was displayed on the PVD and used when the measurements were taken.

The equipment used to take line width and brightness measurements was shown in figure 1. The equipment is listed in table 1. The line width and brightness measurements that were taken with various lengths of cable connections are listed in table 2.

TABLE 1. TEST EQUIPMENT

<u>Manufacturer</u>	<u>Model No.</u>	<u>Equipment</u>
Gamma Scientific Inc.	220	Standard Lamp Source
Gamma Scientific Inc.	220-1A	Luminance Standard Head
Gamma Scientific Inc.	700-10A	Photometric Microscope
Gamma Scientific Inc.	700-10-66	Scanning Micrometer Eyepiece
Gamma Scientific Inc.	700-10-4	Variable Aperture Photometric Lens
Gamma Scientific Inc.	700-10-39	Eyepiece
Gamma Scientific Inc.	2020-6	Photomultiplier Detector Assembly
Gamma Scientific Inc.	2020	Photometer
Weston	759	Foot Lambert Meter

TABLE 2. LINE WIDTH AND INTENSITY MEASUREMENTS FOR VARIOUS CABLE LENGTHS

<u>Line Position</u>	<u>Unswitched Mode</u>	Cable Length				<u>Unit</u>
		<u>20 (ft)</u>	<u>50 (ft)</u>	<u>70 (ft)</u>	<u>100 (ft)</u>	
North Horizontal	20.16	20.02	20.85	20.85	20.16	Mills
South Horizontal	18.07	18.57	18.07	18.76	18.77	Mills
West Vertical	17.38	18.07	18.07	20.55	20.16	Mills
East Vertical	19.46	19.46	19.46	19.07	19.77	Mills
Center Vertical	16.46	17.07	17.07	17.38	17.68	Mills
Center Horizontal	16.68	16.29	17.38	16.68	16.99	Mills
Intensity	50	50	50	50	50	Foot Lamberts

At distances of 20, 50, and 70 feet, any differences that may have existed were visibly indistinguishable compared to the unswitched mode. All of the data were legible and clear. There was no evidence of noise or jitter throughout the display.

At a distance of 100 feet, the overall appearance of the display was still similar. The characters were still clear and legible although there was some problem with the unblanking signal, causing a minute amount of character-stroke blanking. Also, some of the vector intersections did not meet exactly. While no attempt was made, these problems could probably be corrected by realigning the driver PVD.

At the 100-foot distance, there was a slight amount of jitter occasionally at several positions on the display.

When the switch PVD was cabled to 70 and 100 feet from the driver display, the overall size of the displayed data was reduced. This was easily corrected by adjusting the 200-ohm X and Y adjustment trimpots on the A5 PCB of the switch PVD.

When the switch PVD was switched between the NAS and the external input from the simulated 9020R, the R-control interface was switched between two different output connectors of the system RKM. The R-controls functioned in either position. When the PVD was switched, there was no impact on the NAS other than the single printouts listed in figure A-2.

Figure 10 shows a photograph of the test pattern on the switch PVD when it was being driven in the unswitched mode by the present NAS. Figure 11 is a photograph of the test pattern on the driver PVD. Figures 12 and 13 show the test pattern displayed on the switch PVD while it was being driven by the driver PVD (switched mode of operation) at distances of 50 and 100 feet.

CONCLUSIONS

The switch Plan View Display (PVD) operated very well up to 50 feet. At 70 feet, the display presentation was still very good. At 100 feet, the only major problem was an intermittent small amount of jitter a few places on the PVD screen.

The brightness and line widths of the display presentation were not affected significantly when driving the switch PVD at distances up to 100 feet.

The PVD's could be modified and switched back and forth between the present National Airspace System (NAS) and a future 9020 Replacement (9020R) System with no appreciable impact on the present NAS operation during the transition period.

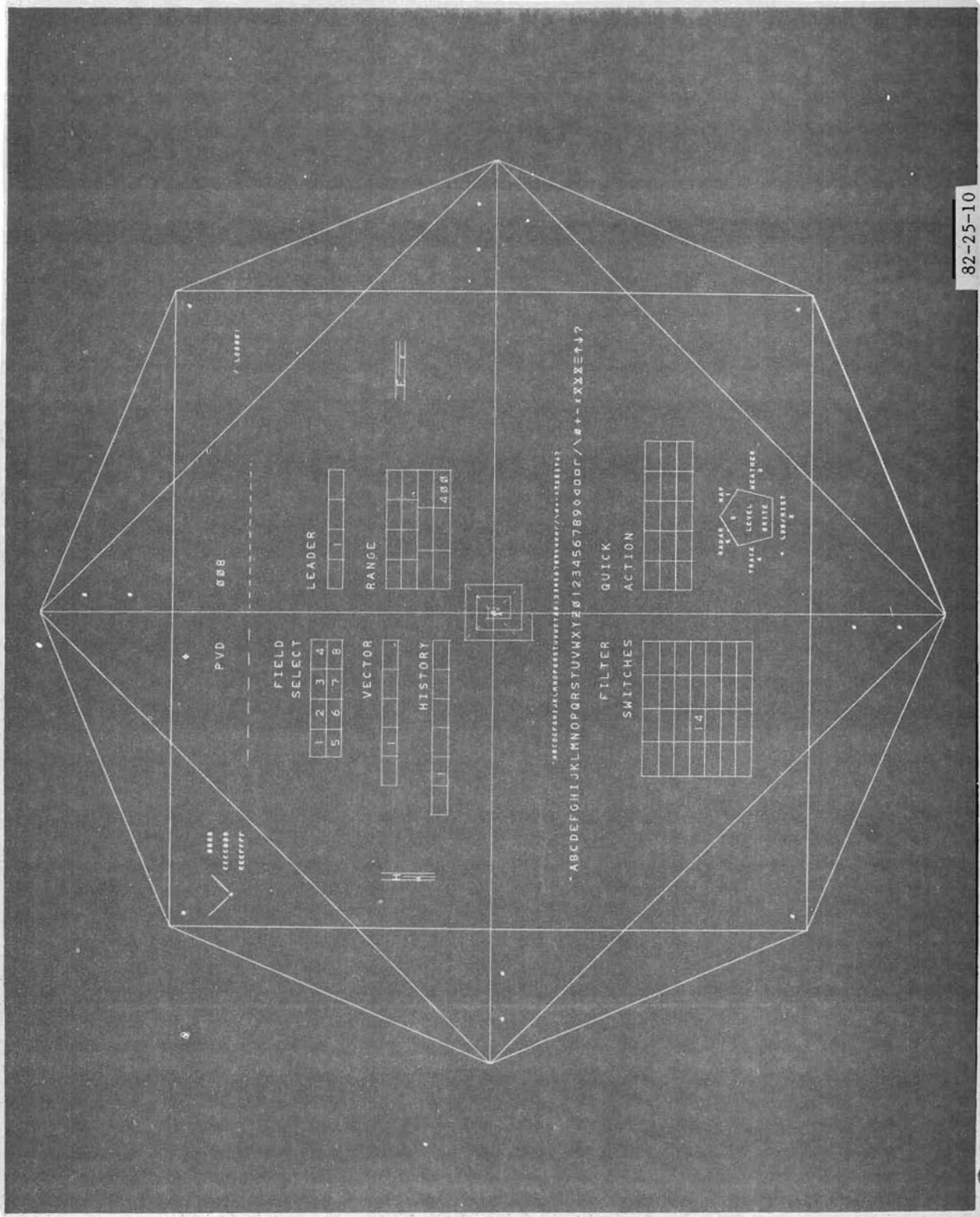

82-25-10

81-2384

F.A.A. TECHNICAL CENTER
ATLANTIC CITY, NEW JERSEY

FIGURE 10. TEST PATTERN SWITCH PVD — INTERNAL

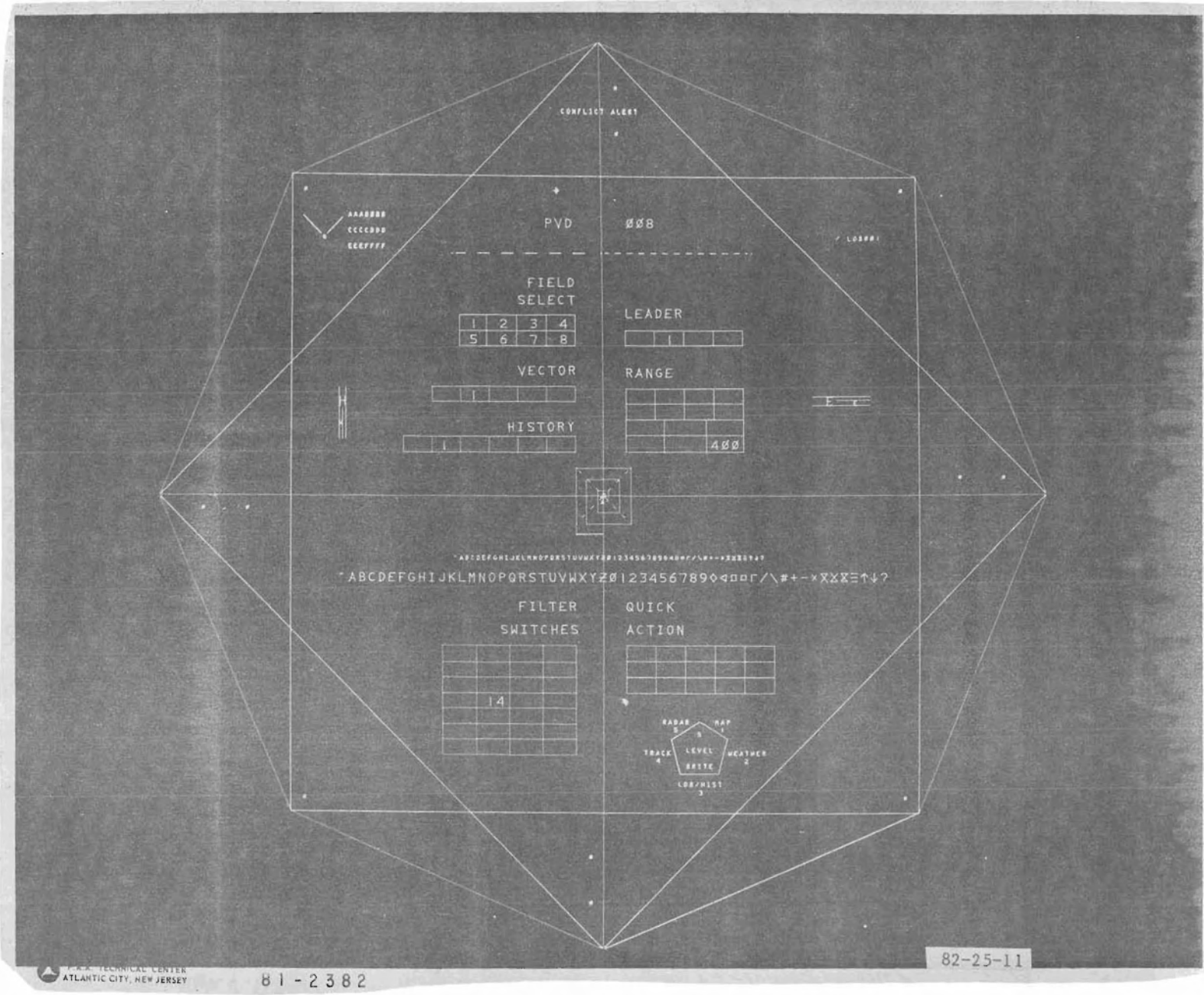
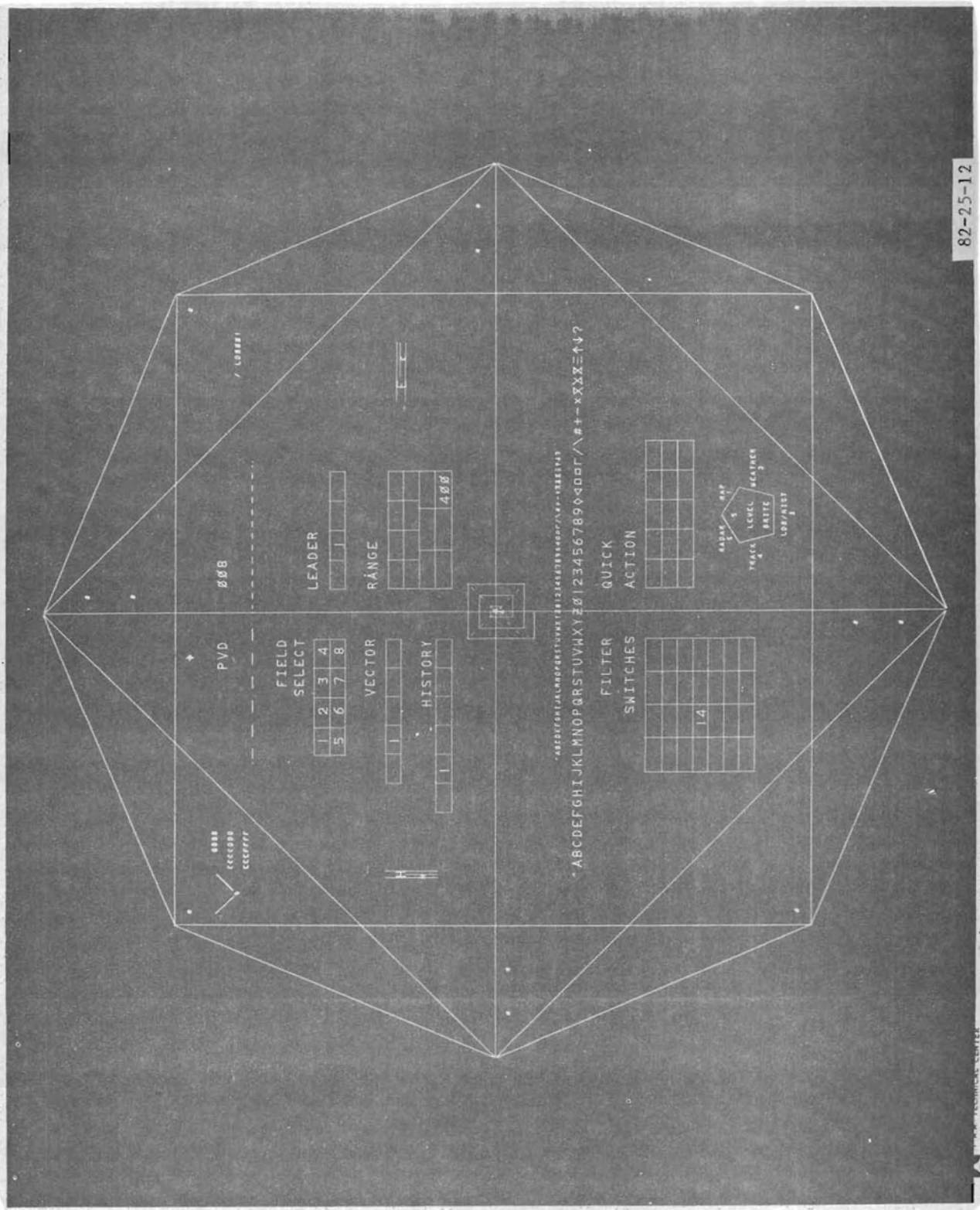

FIGURE 11. TEST PATTERN DRIVER PVD



82-25-12

81-2383

TECHNICAL CENTER
ATLANTIC CITY, NEW JERSEY

FIGURE 12. TEST PATTERN SWITCH PVD — 50 FEET

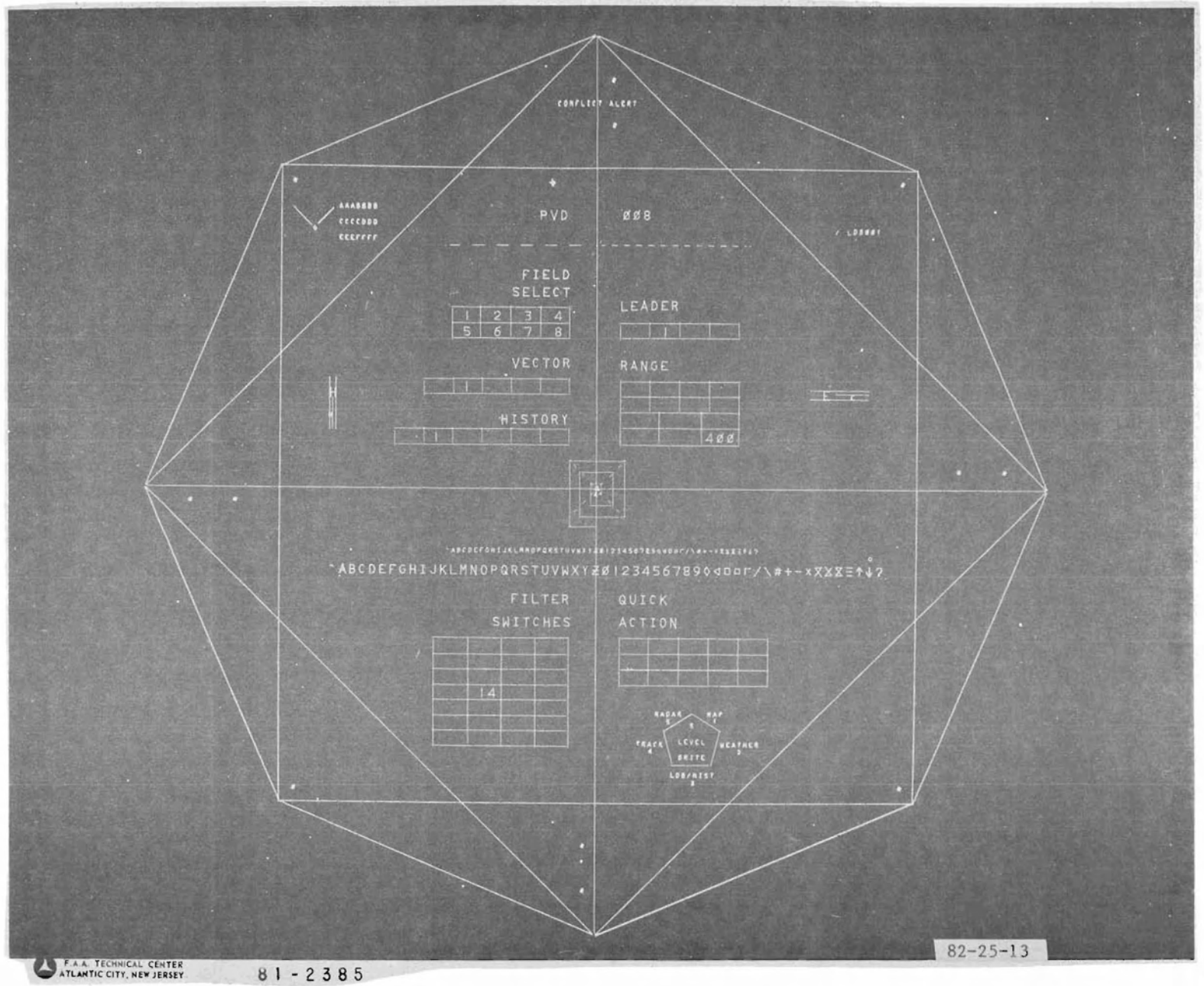

FIGURE 13. TEST PATTERN SWITCH PVD — 100 FEET

APPENDIX A

PVD MODIFICATION DOCUMENTATION

The Plan View Display (PVD) was modified to display either the normal data received from the present National Airspace System (NAS) or external analog X and Y deflection signals, video unblanking signals, and category bits from a future 9020 Replacement (9020R) System. Data are selected by means of a switch on the front panel of the PVD. The R-control interface is also switched.

A block diagram of the PVD modifications is shown in figure A-1. A simplified drawing of the radar keyboard multiplexor (RKM) switch is shown in figure A-2.

A spare switch located on the System Status Control Panel of the PVD was wired in and used to control relays mounted on the video intensity control printed circuit board (PCB) (A2), the signal pattern correction PCB (A2), and a circuit board located in the RKM switch box. These relays are used to switch the PVD back and forth between the two modes of operation.

Flush-mounted inverted integrated circuit (IC) sockets were used on the A2 and A5 PCB's. These sockets were glued to the component sides of the PCB's. Using this type of socket eliminated the need to drill holes for the socket pins. Small pieces of fiberboard were glued between the sockets and the PCB's. These were used as insulators.

The A2 PCB modification required four 14-pin IC sockets and four 16-pin IC sockets. The 16-pin IC sockets were three SN75115N and one SN75122N line receivers. The 14-pin IC sockets were three Sigma 195 TE-2CIE-56 relay IC sockets and one 14-pin header containing resistors. A BNC connector and a signal connector were also mounted on the A2 card using brackets and standoffs.

The A1 PCB modification required one 14-pin IC socket and one 16-pin IC socket for a sigma 195-TE-2CIE-56 relay and a header containing resistors. Two 200-ohm trimpots and two BNC connectors on a bracket were also mounted on the A1 PCB.

Photographs of the component sides of the modified A2 and A5 PCB's are shown in figures A-3 and A-4. Figures A-5 and A-6 show the schematic and layout of the video intensity control PCB before and after being modified. Figures A-7 and A-8 show the schematic and layout of the signal pattern correction PCB before and after being modified. By examining the drawings, it can be determined which connections should be opened and which connections should be made in order to complete the card modifications.

Figure A-9 shows a photograph of the RKM switch box. Figure A-10 shows the layout and wiring of the relay card which is mounted inside the box on standoffs. The relays are Sigma type 195 TE-2CIE-56. The "P" connector shown on sheet 3 of figure A-10 is an Amphenol Type 17-20250-1 (390). The "C" and "N" connectors are duplicates of the R-control connector on the PVD.

Figure A-11 shows the lower basket of the modified PVD. The three coaxial cables and the signal cable are brought out directly from the PCB's. In a field version, BNC connectors and a signal connector would be mounted on the PVD chassis. Short cables from these connectors to the PCB connectors would be used to bring the signals to the external PVD connectors.

Table A-1 contains an estimate of the manpower requirements for the PVD modification. Table A-2 contains a cost estimate for the PVD modification.

On the signal pattern correction PCB, all of the interconnections between the BNC connectors, the relay contacts, and the pincushion module inputs are made using coaxial cable.

On the video intensity PCB, the interconnections between the BNC connector, the relay contacts, and the line receiver are made using coaxial cable; and the interconnections between the signal connector, the relay contacts, and the line receivers are made using twisted pair wiring.

The output from the front panel switch used to switch the relays on the A2 and A5 PCB's is brought into the PCB's using test point receptacles that were mounted on the PCB's for this purpose. In a field version, this switch output would be brought into the PCB's by using spare pins on the back of the card cage.

Table A-3 contains the pin connections for the short cable that connects the RKM Switch Box to the R-control connector of the PVD.

TABLE A-1. PVD SWITCH MANPOWER ESTIMATE

A2 Card Modification	
A5 Card Modification	2 Man Days
PVD Modification	
RKM Switch Box Fabrication	
Cable RKM Box-PVD	2 Man Days
(3) Long and (3) Short Coaxial Cables	
(1) Long and (1) Short Signal Cable	1 Man Day
Total:	5 Man Days
If No Cable Assemblies:	4 Man Days

TABLE A-2. PVD SWITCH — PARTS LIST AND COST ESTIMATE

<u>Quantity</u>		<u>Unit Cost</u>	<u>Total Cost</u>
<u>A2 Card</u>			
6	Relays, Sigma Number 195TE-2CIE-5G,	\$13.45	\$80.70
6	SN75115N, Line Receivers	1.00	6.00
2	SN75122N, Line Receivers	1.00	2.00
1	IC Header with 75 Ohm, 2.2K Resistors		1.00
4	14-Pin IC Sockets	1.50	6.00
4	16-Pin IC Sockets	1.50	6.00
1	BNC Connector, Chassis Mount Recepticle	1.50	1.50
1	Plug, Amphenol type 17-20250-1(390)	2.37	2.37
<u>A5 Card</u>			
2	BNC Connectors, Chassis Mount Recepticle	1.50	3.00
2	Relays, Sigma Number 195TE-2CIE-5G	13.45	26.90
2	110 Ohm, 1 Watt Resistors	.10	.20
4	200-Ohm Trimpots	1.50	6.00
1	16-Pin IC Sockets	1.00	1.00
1	14-Pin IC Sockets	1.00	1.00
	Special Connector Brackets		20.00
	Miscellaneous Hardware		20.00
<u>PVD Connectors</u>			
3	BNC Connector, Chassis Mount Recepticle	1.50	4.50
1	Plug, Amphenol Type 17-20250-1(390)		<u>2.37</u>
	Total:		\$191.67

TABLE A-2. PVD SWITCH — PARTS LIST AND COST ESTIMATE (Continued)

<u>Quantity</u>		<u>Unit Cost</u>	<u>Total Cost</u>
<u>RKM Switch Box</u>			
8	Relays, Sigma Number 195TE-2CIE-5G,	\$13.45	\$107.60
6	14-Pin IC Sockets	1.50	9.00
1	Plug, Amphenol Type 17-20250-1(390)	2.37	2.37
2	Box Mount, Mate with RKM Cables	10.00	20.00
2	LED's	1.00	2.00
1	Lense Cap for LED		1.00
1	Bud Cabinet No. SC-12100		<u>12.25</u>
		Total:	\$154.22

A2 And A5 Card Cable Assemblies - One end of each hard wired to PVD chassis mounted connectors. The other end connected to A2 and A5 card connectors.

2	2 ft. RG 62/U Coax	\$1.37	\$4.11
3	BNC Plug Connector UG 260/U		1.00
1	2 ft. RG 59/U Coax		1.00
1	2 ft. Cable, Twisted Pair Alpha No. 3586/16		3.52
1	Connector, Amphenol 17-10250-1(390)		<u>.97</u>
1	Backshell, Amphenol 17-1372		
		Total:	\$10.60

TABLE A-2. PVD SWITCH — PARTS LIST AND COST ESTIMATE (Continued)

<u>Quantity</u>		<u>Unit Cost</u>	<u>Total Cost</u>
<u>Cable - RKM Switch Box to PVD</u>			
1	6 ft. Alpha No. 3586/16 Cable		\$3.00
1	Connector Amphenol 17-10250-1(390)		3.52
1	Backshell, Amphenol 17-1372		.97
1	Connector, Type 30194 PT05SE-14-15S		<u>10.00</u>
		Total:	\$17.49
<u>100 ft. Cable Assemblies to 9020R</u>			
2	RG 62/U Coaxial Cables		\$30.00
1	RG 59/U Coaxial Cables		15.00
6	BNC Plug Connectors UG 260/U	\$1.37	8.22
2	Connector, Amphenol 17-10250-1(390)	3.52	7.04
2	Backshell, Amphenol 17-1372	.97	1.94
1	Alpha No. 3586/16 Cable		<u>50.00</u>
		Total:	\$112.20

Total Cost (less external cable assemblies)

\$191.67 + \$154.22 + \$10.60 + \$17.49 = \$373.98

Total Cost (including external cable assemblies)

\$373.98 + \$112.20 = \$486.18

TABLE A-3. CABLE — RKM SWITCH BOX TO PVD

<u>RKM Switch Box Side</u>	<u>PVD Side</u>
Connector Amphenol 17-10250-1(390)	Mate to PVD
Backshell Amphenol 17-1372	R-Control Connector
<u>Pins</u>	<u>Pins</u>
1	M
2	N
3	C
4	D
5	A
6	B
7	E
8	F
9	G
10	H
12	P
11 (PVD Switch Input)	

Cable Length 6 Feet

Cable Type Alpha No. 3586/16

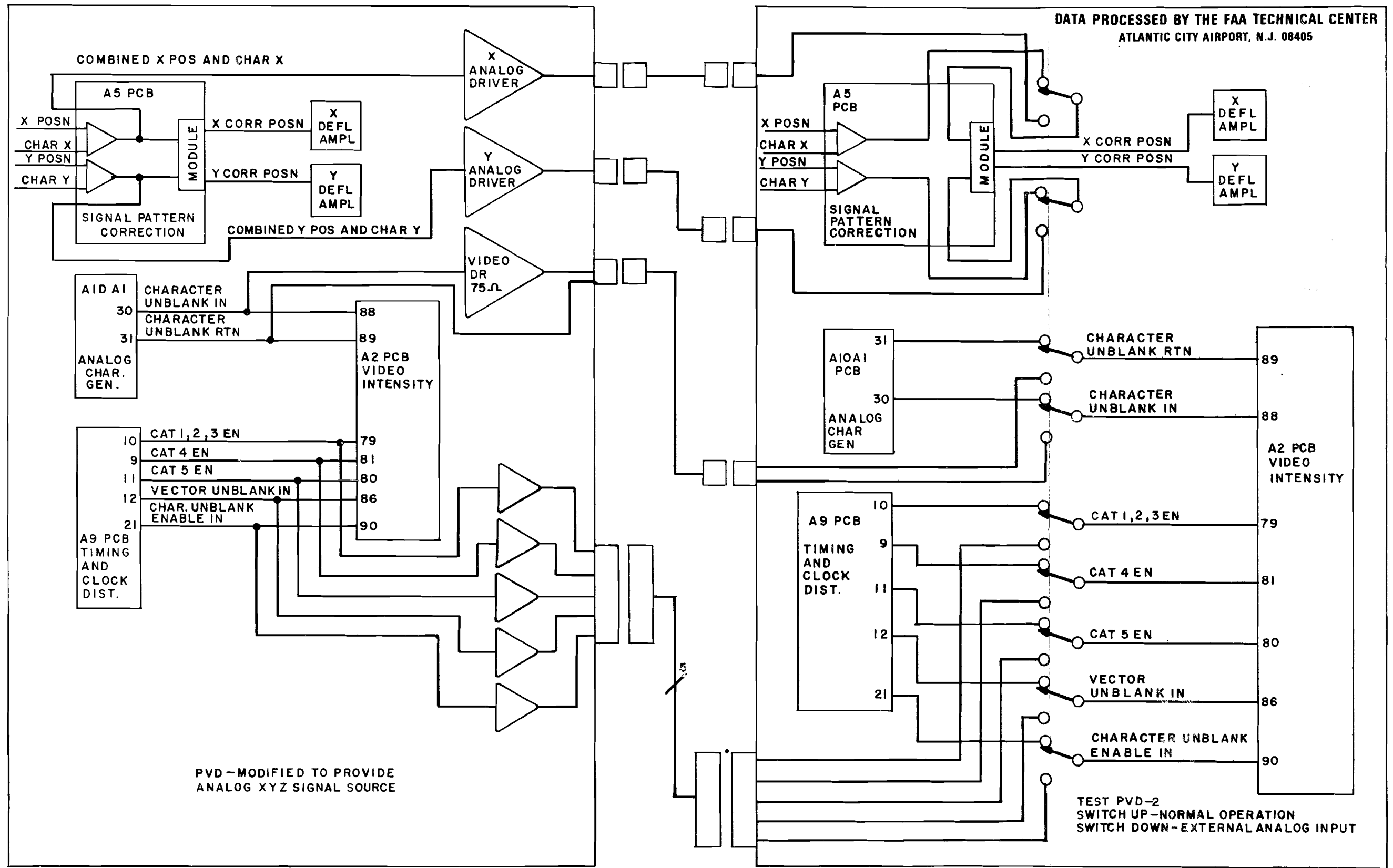
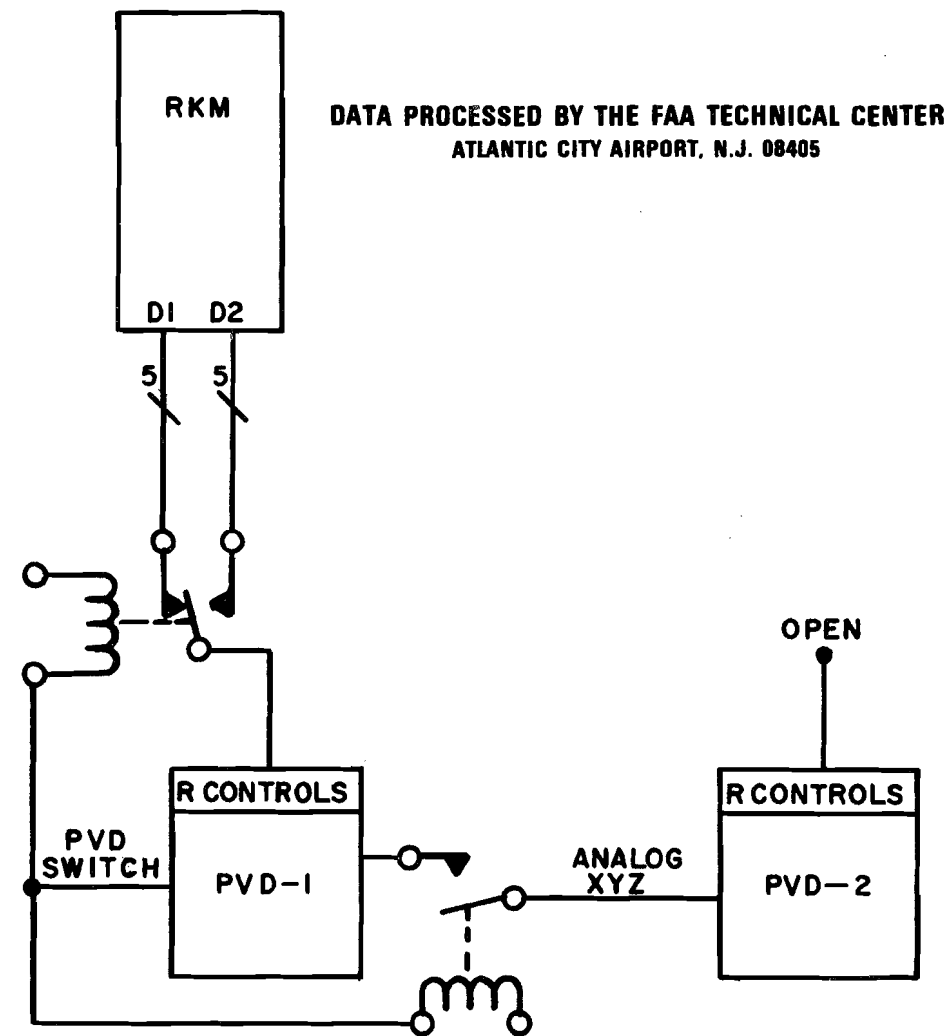

FIGURE A-1. OVERALL DIAGRAM OF PVD MODIFICATIONS



WHEN PVD-1 R-CONTROLS ARE SWITCHED TO RKM D2 POSITION:

- (a) ONE "CONSOLE-1 FAILURE" REPORT WILL BE PRINTED.
- (b) ONE "CONSOLE-2 ON" REPORT WILL BE PRINTED.

WHEN PVD-1 R-CONTROLS ARE SWITCHED BACK TO RKM D1 POSITION,

- (a) ONE "CONSOLE-ON" REPORT WILL BE PRINTED.
- (b) AND ONE "CONSOLE-2 FAILURE" REPORT WILL BE PRINTED.

FIGURE A-2. DIAGRAM OF RKM SWITCH

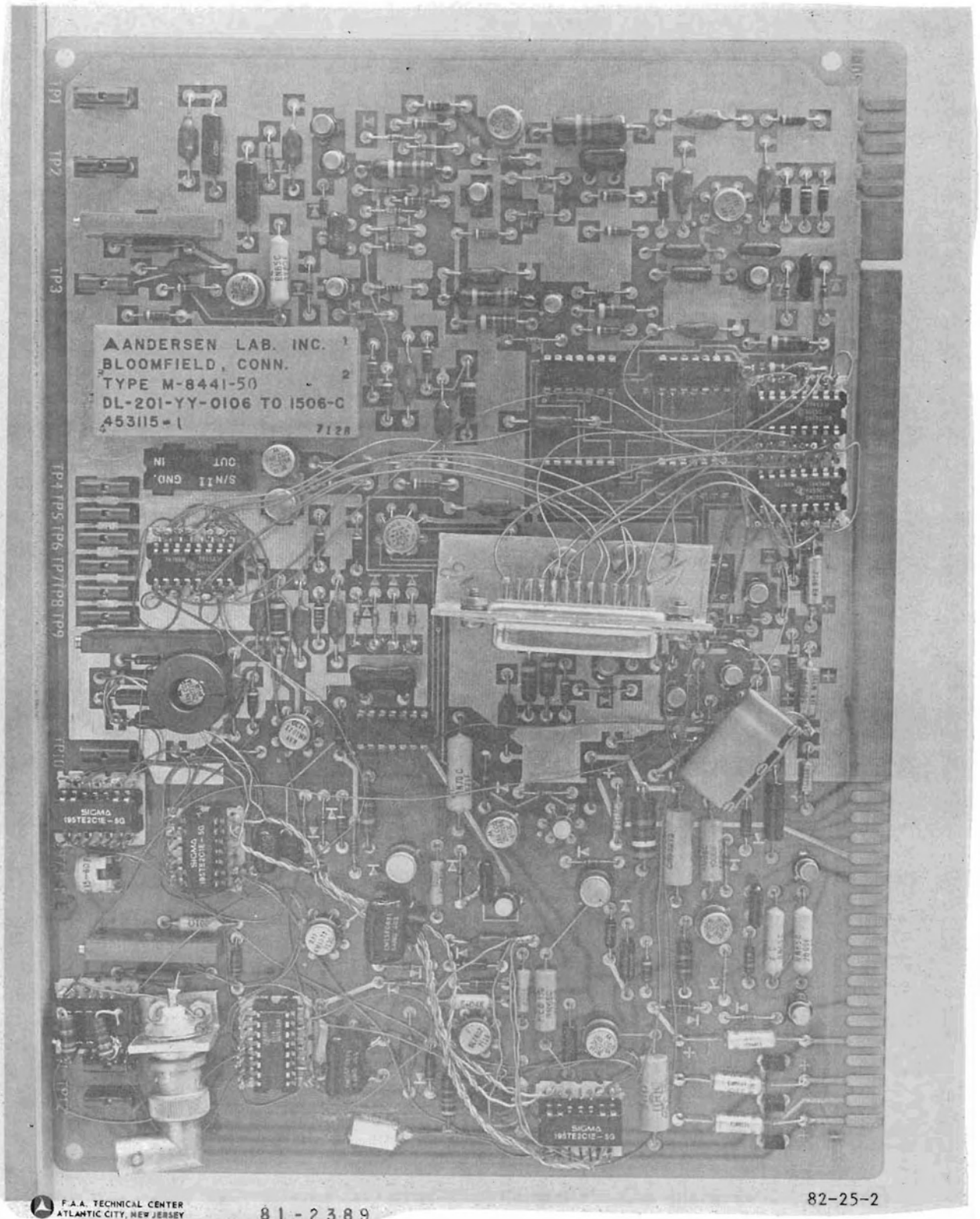

ANDERSEN LAB. INC. 1
BLOOMFIELD, CONN. 2
TYPE M-8441-50
DL-201-YY-0106 TO 1506-C
453115-1 7128

F.A.A. TECHNICAL CENTER
ATLANTIC CITY, NEW JERSEY

81-2389

82-25-2

FIGURE A-3. MODIFIED A2 PCB — SWITCH PVD

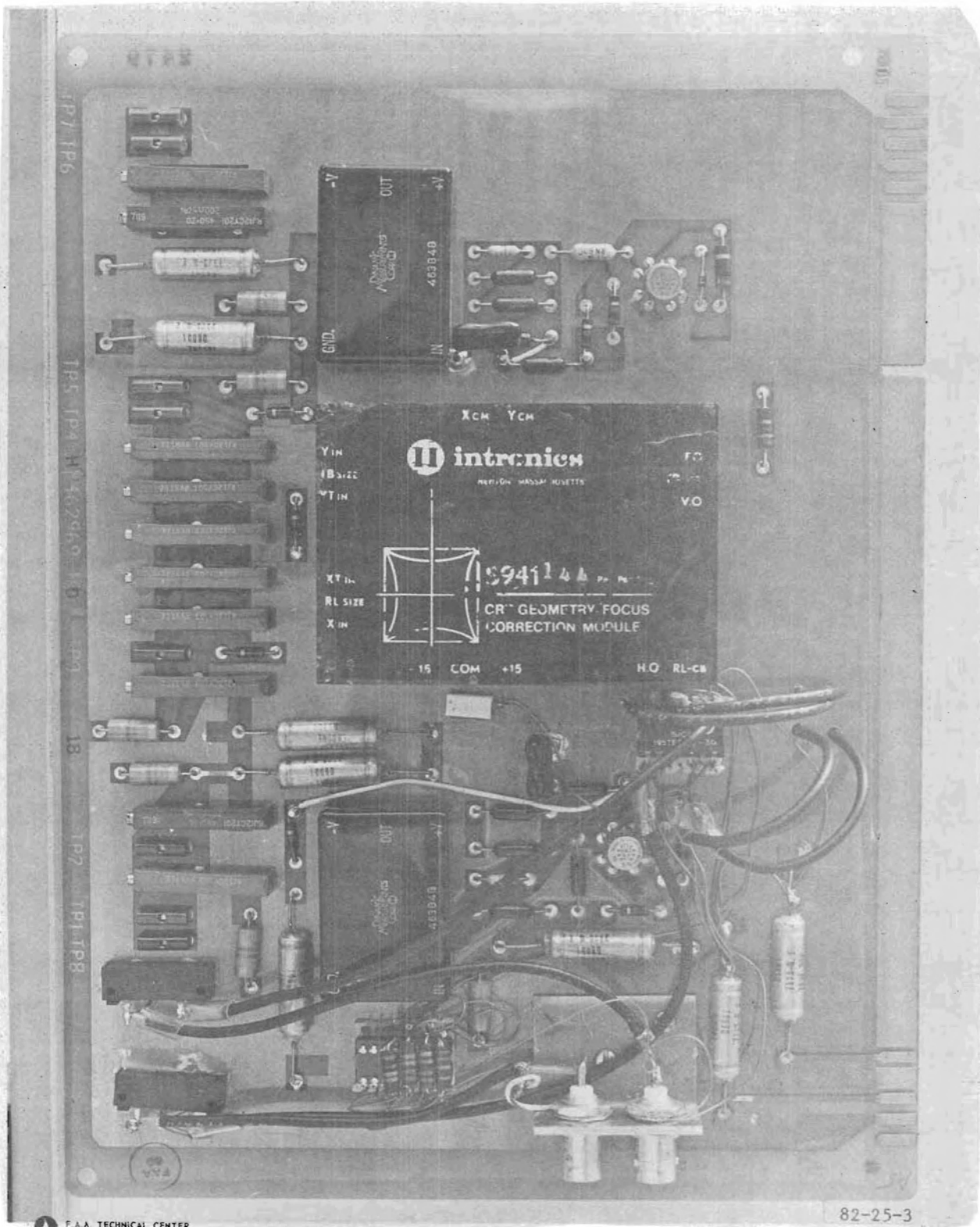

F.A.A. TECHNICAL CENTER
ATLANTIC CITY, NEW JERSEY

81-2386

82-25-3

FIGURE A-4. MODIFIED A5 PCB — SWITCH PVD

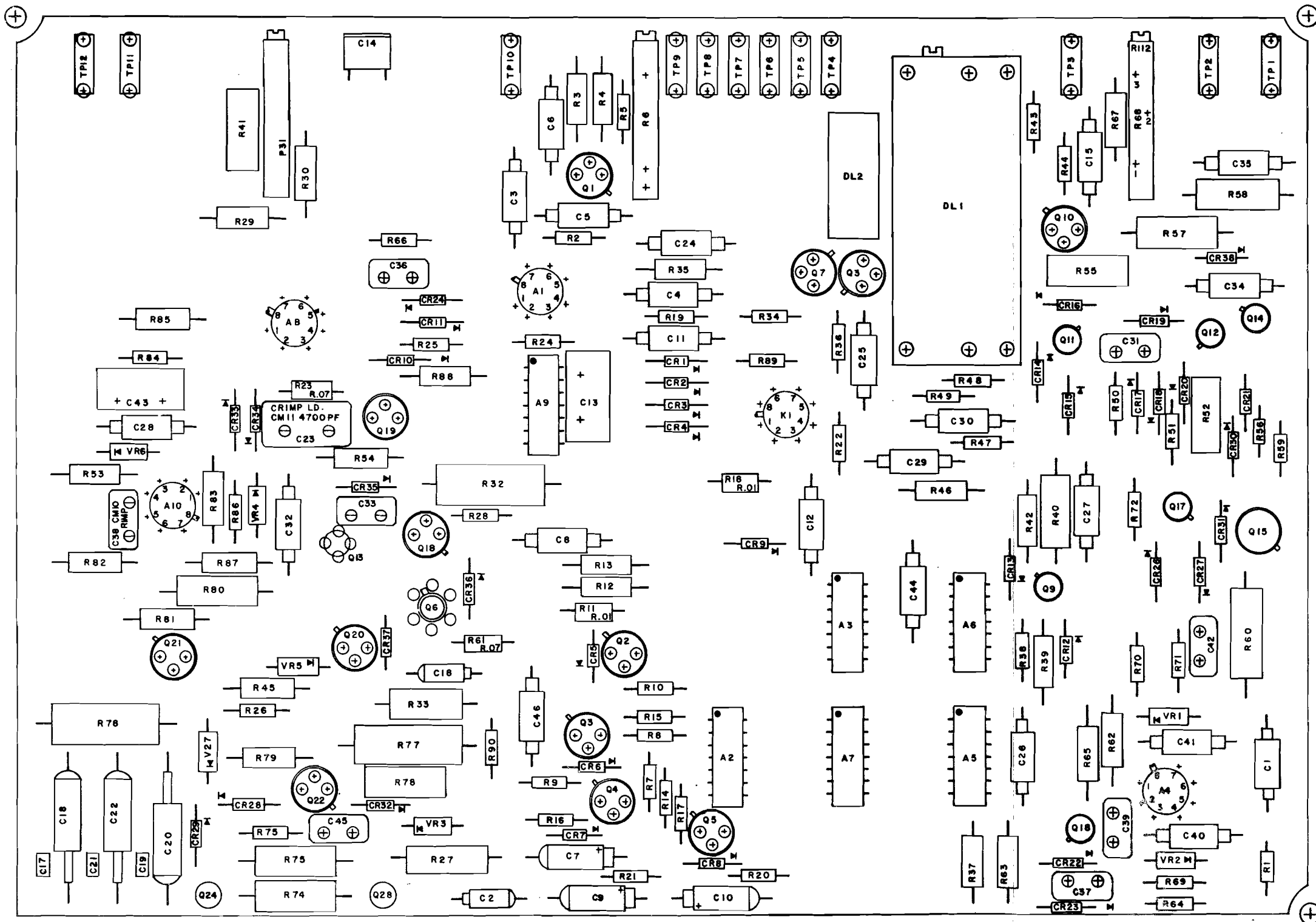

82-25-A-5a

FIGURE A-5. UNMODIFIED A-2 PCB (SHEET 1 OF 4)

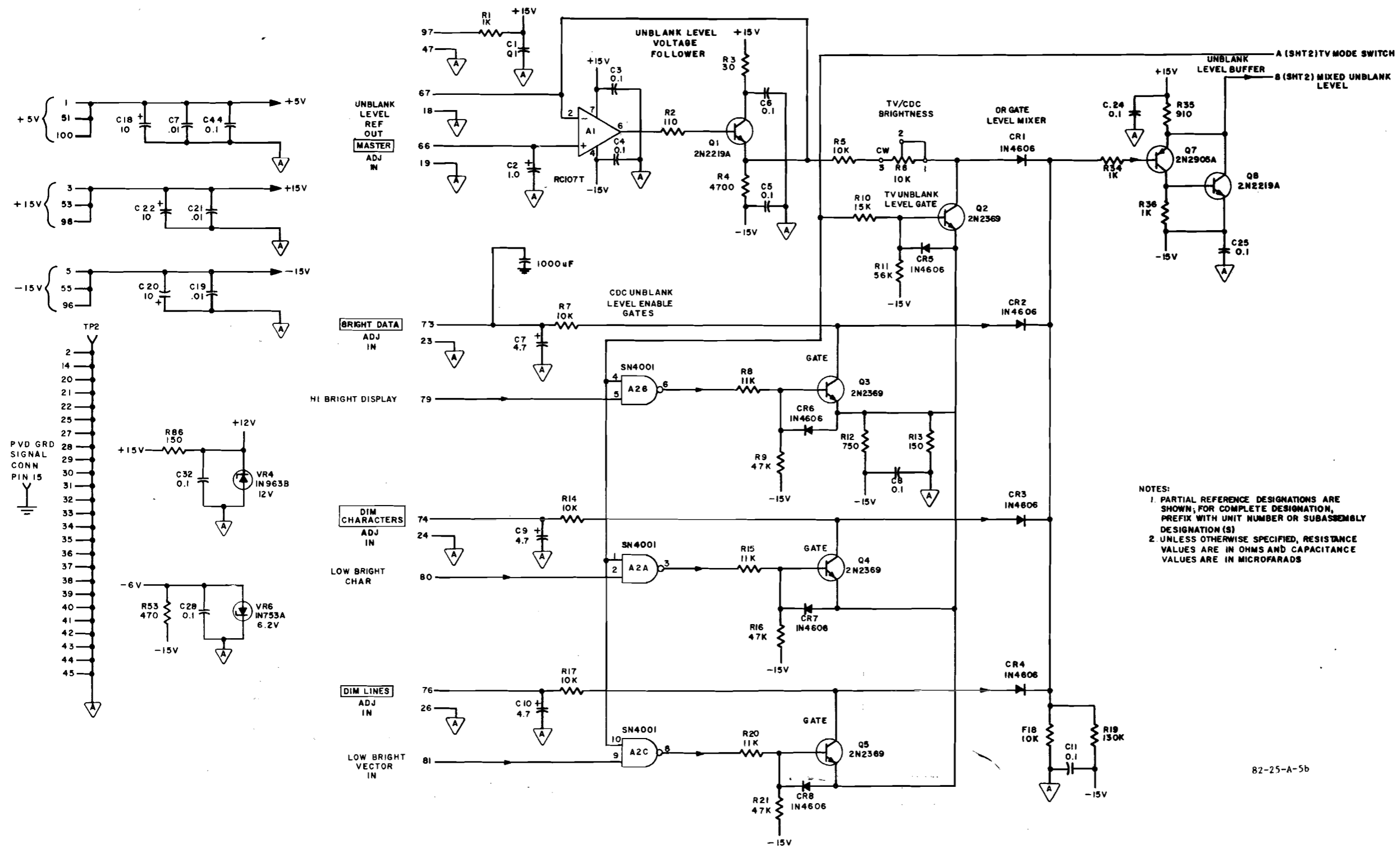

FIGURE A-5. UNMODIFIED A-2 PCB (SHEET 2 OF 4)

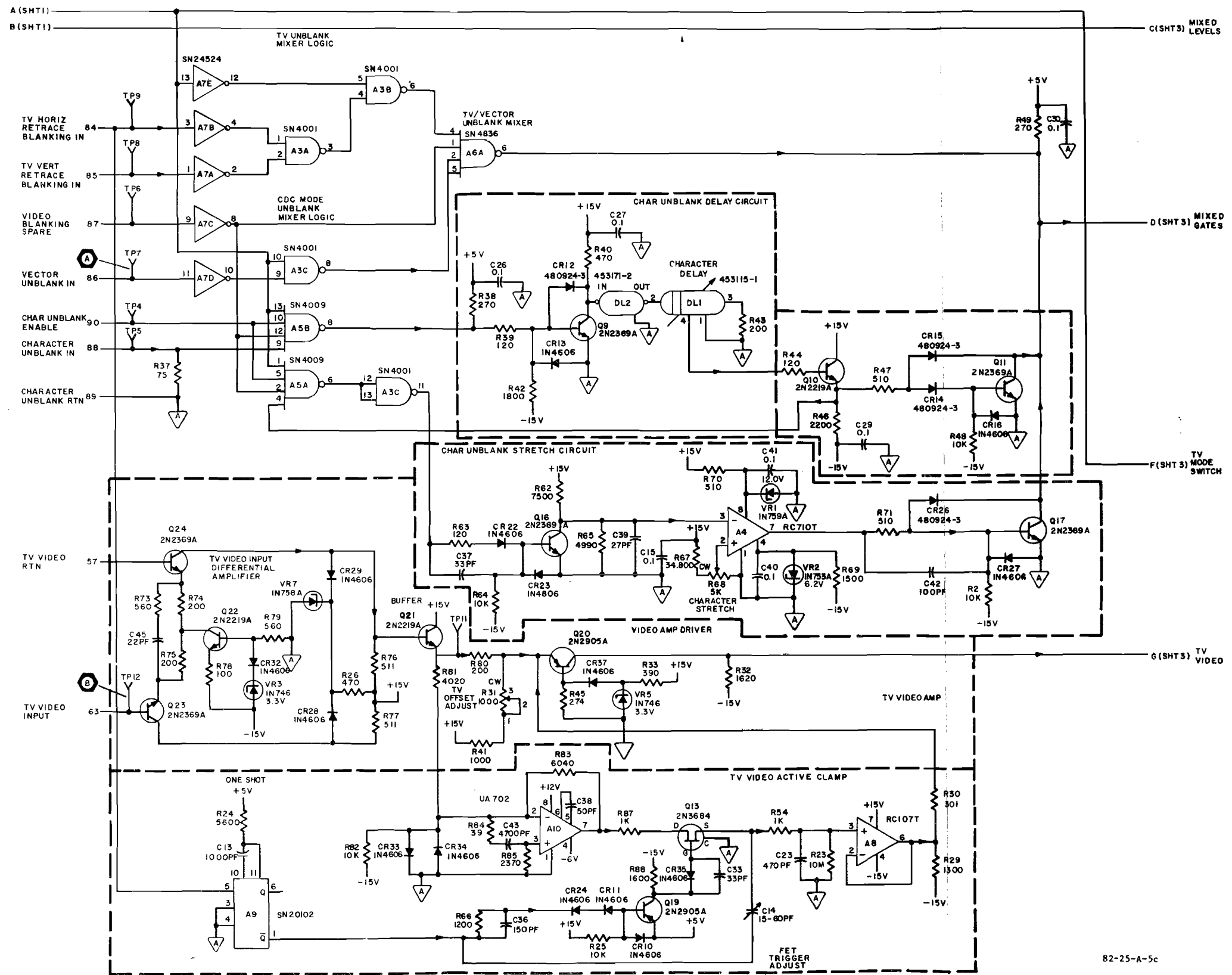

FIGURE A-5. UNMODIFIED A-2 PCB (SHEET 3 OF 4)

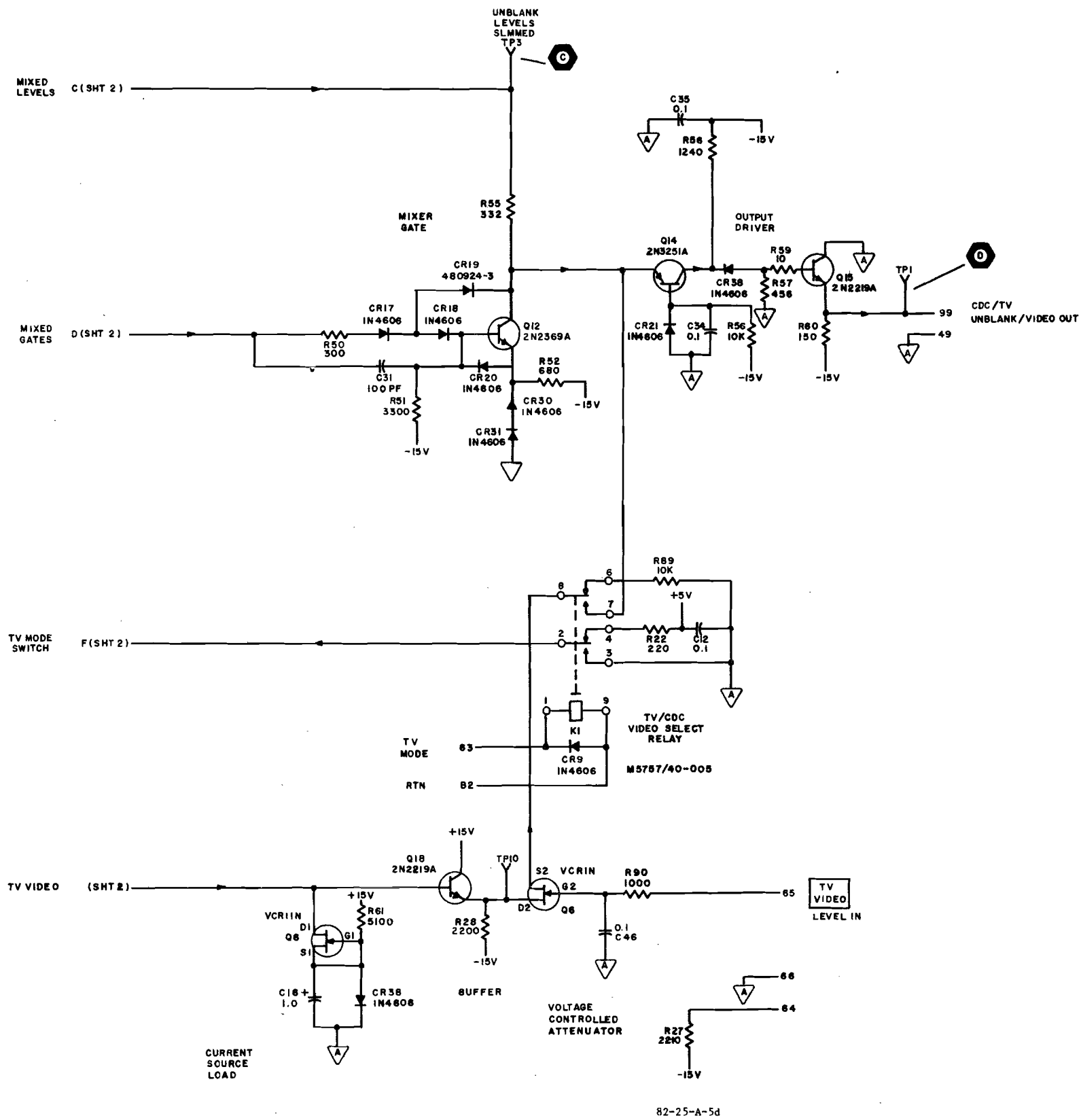
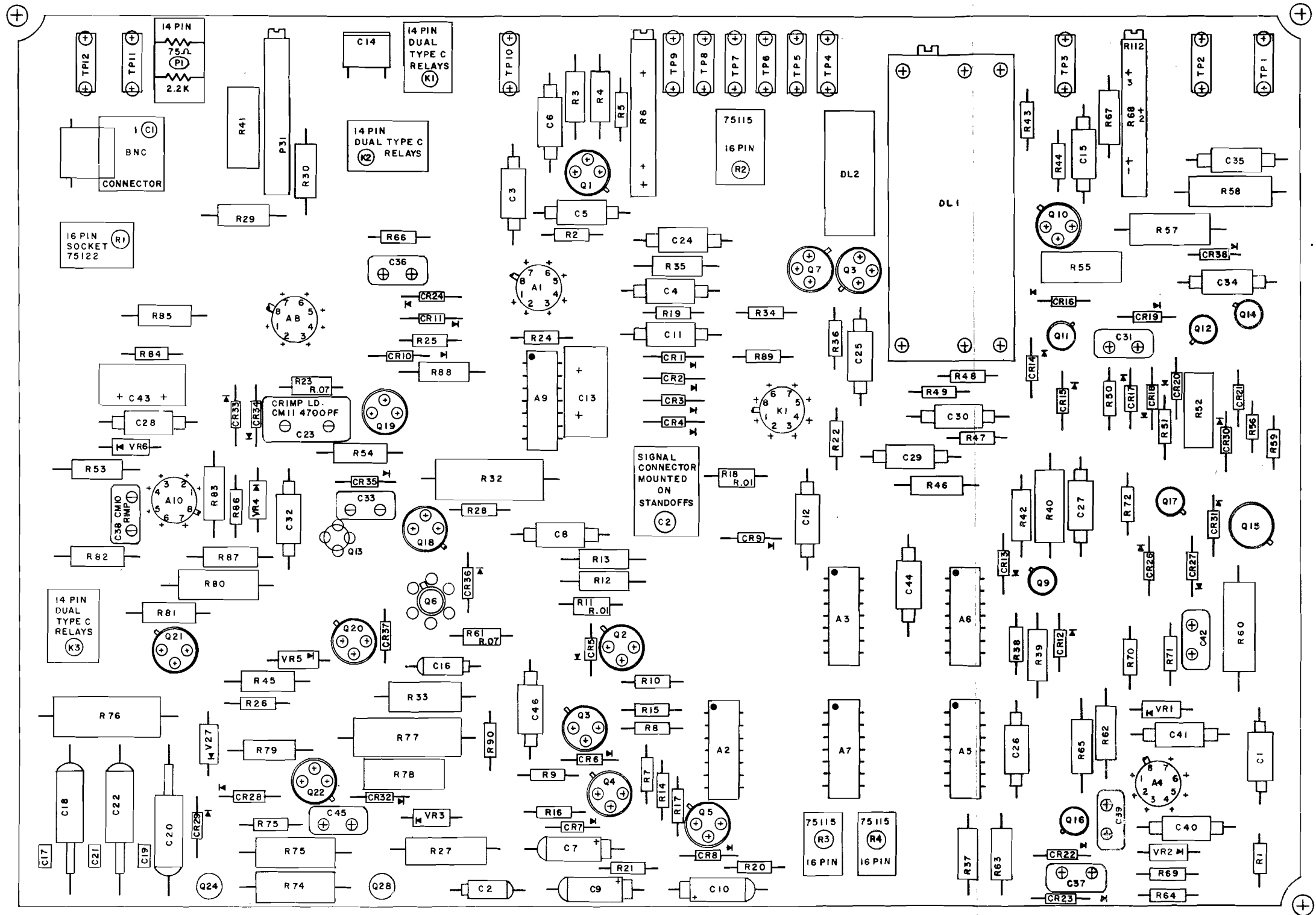
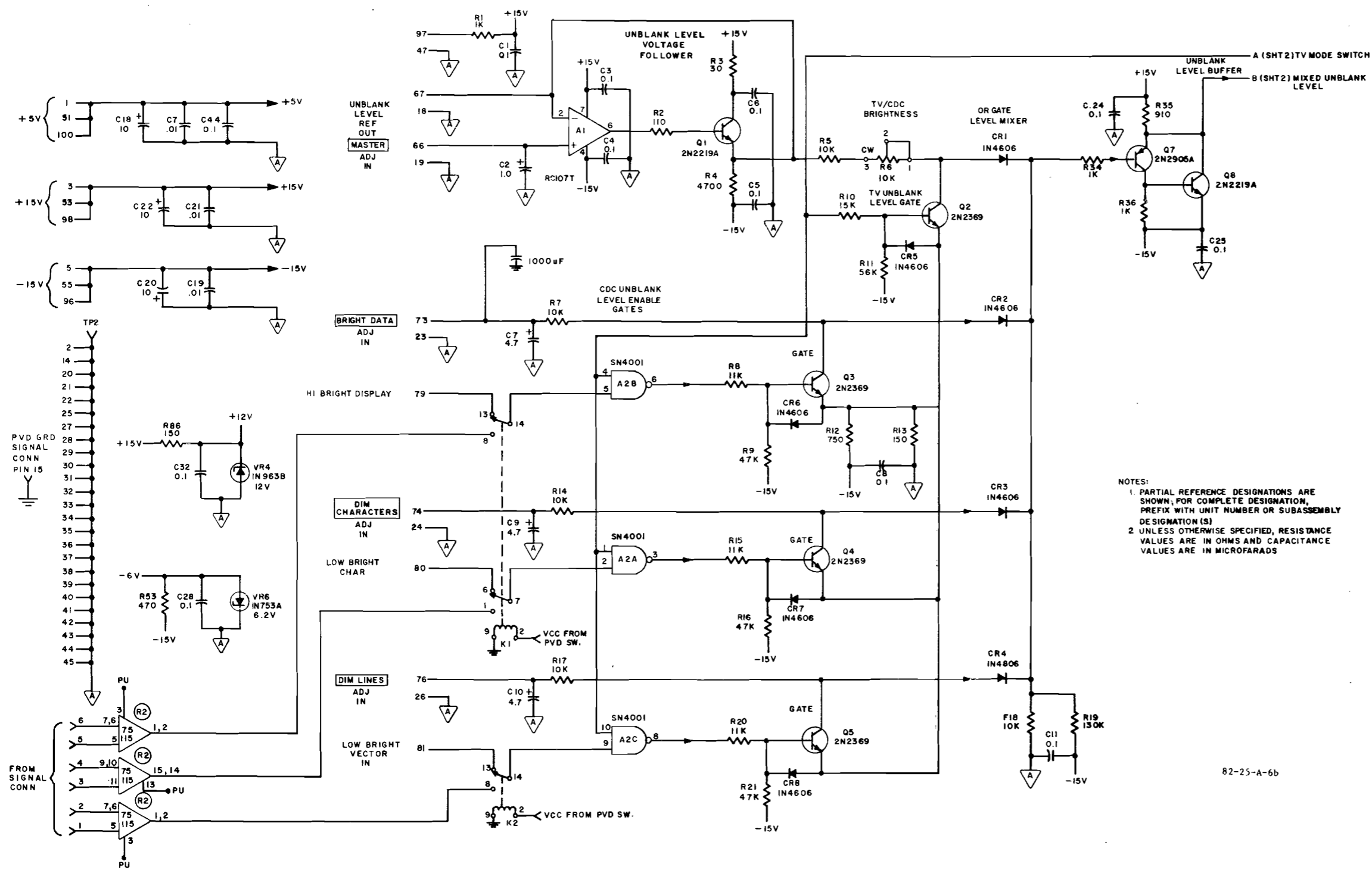

FIGURE A-5. UNMODIFIED A-2 PCB (SHEET 4 OF 4)



82-25-A-6a

FIGURE A-6. MODIFIED A2 PCB — SWITCH PVD (SHEET 1 OF 4)



82-25-A-6b

FIGURE A-6. MODIFIED A2 PCB — SWITCH PVD (SHEET 2 OF 4)

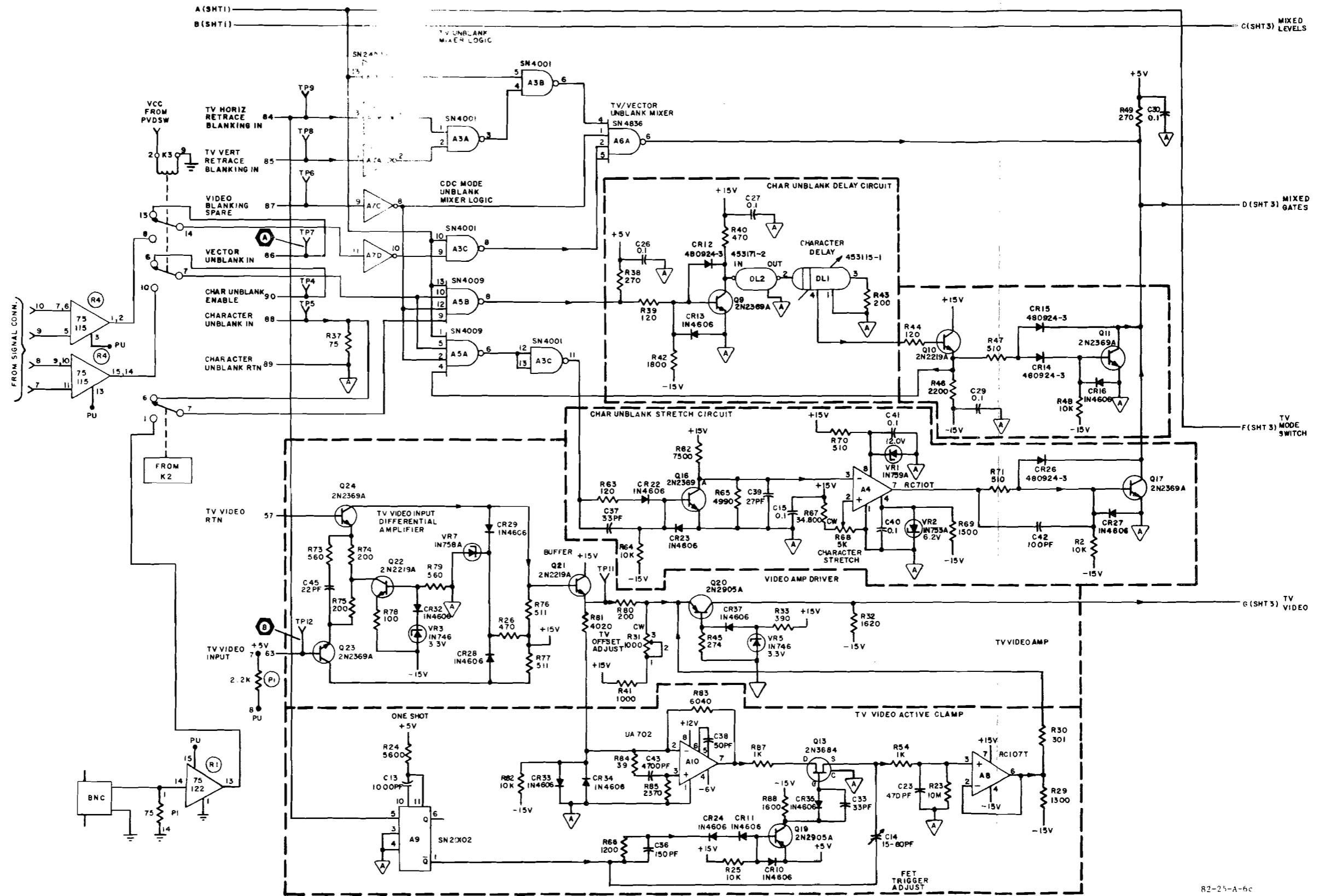
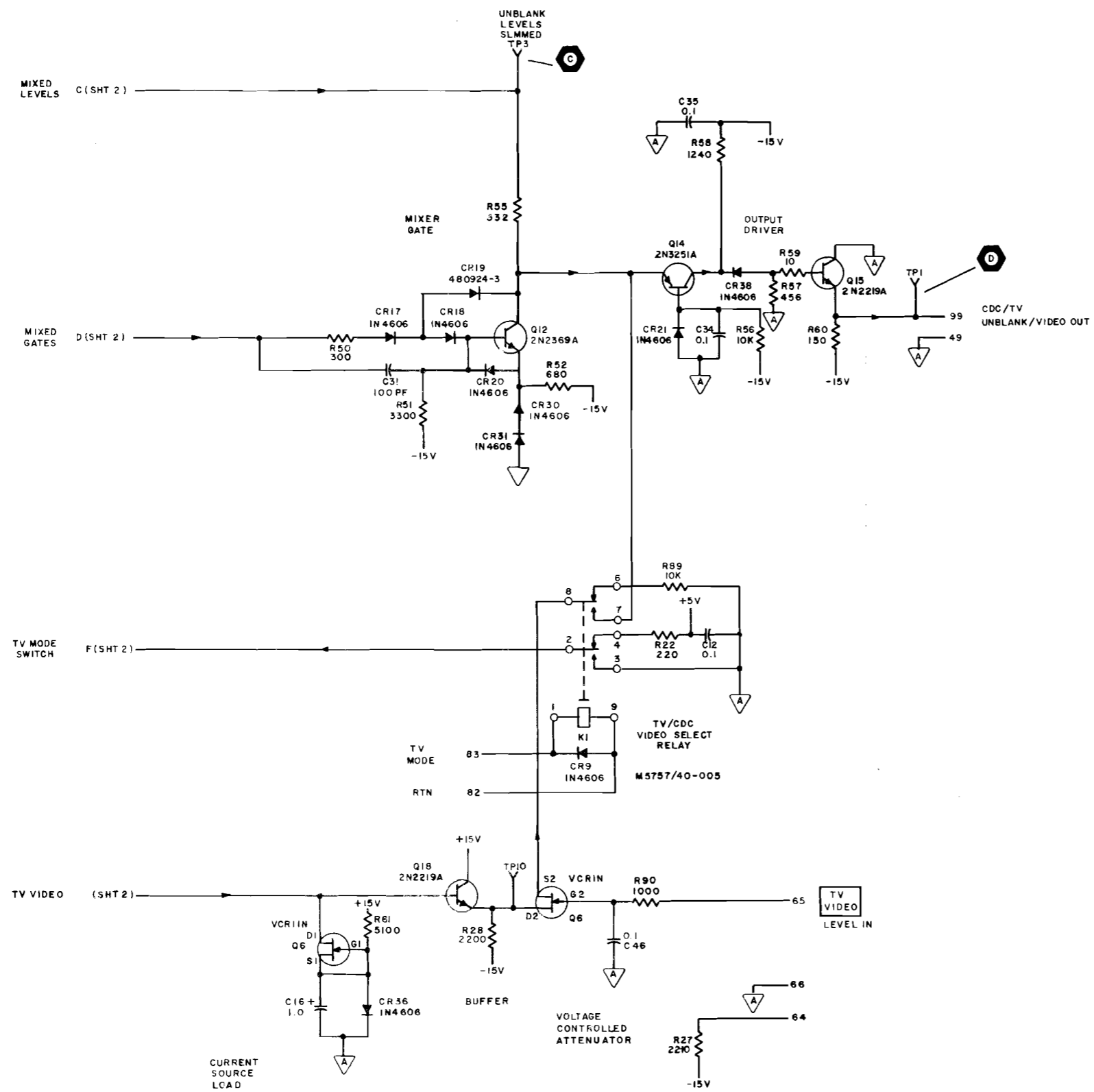

FIGURE A-6. MODIFIED A2 PCB — SWITCH PVD (SHEET 3 OF 4)



82-25-A-6d

FIGURE A-6. MODIFIED A2 PCB — SWITCH PVD (SHEET 4 OF 4)

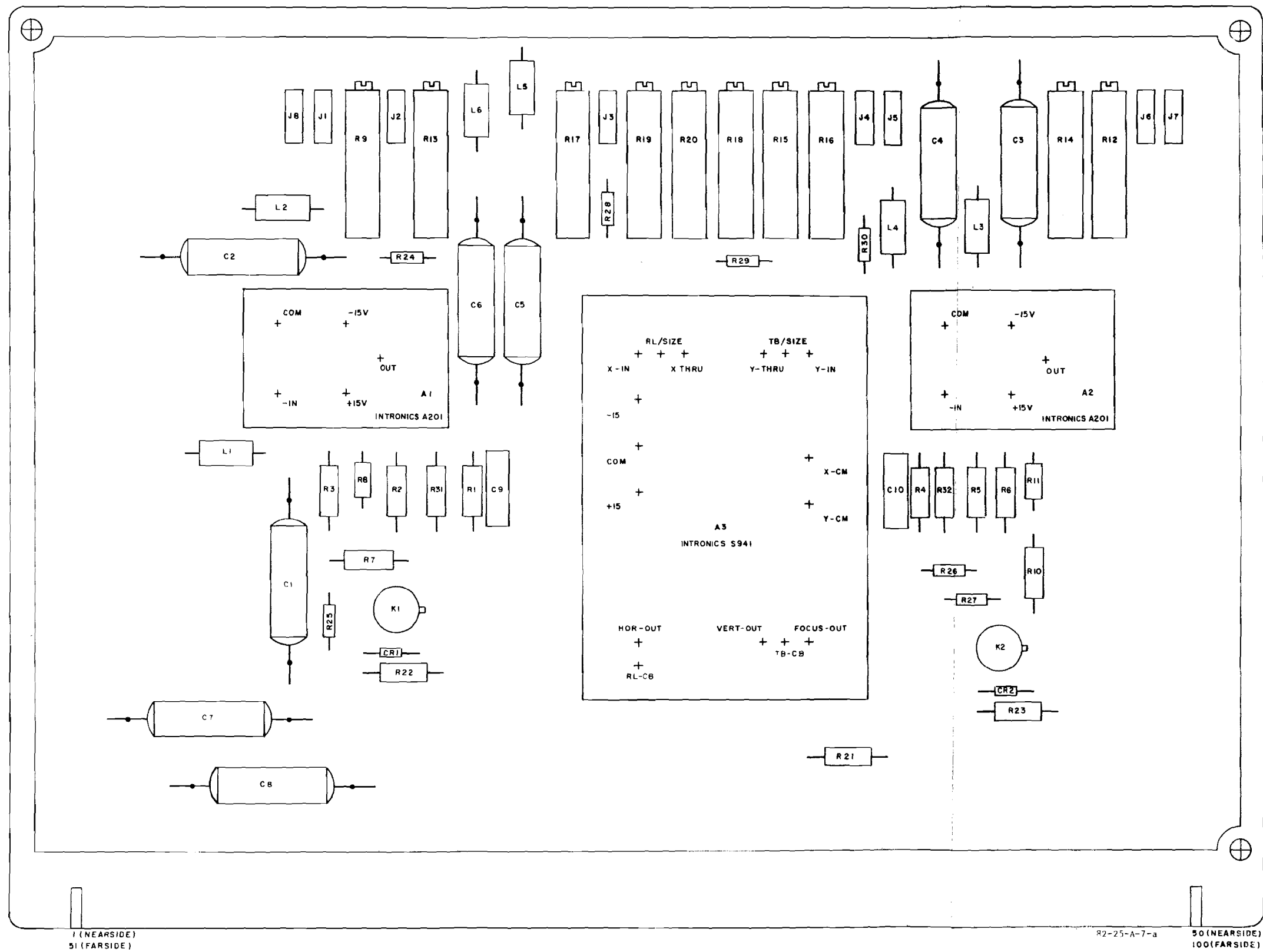
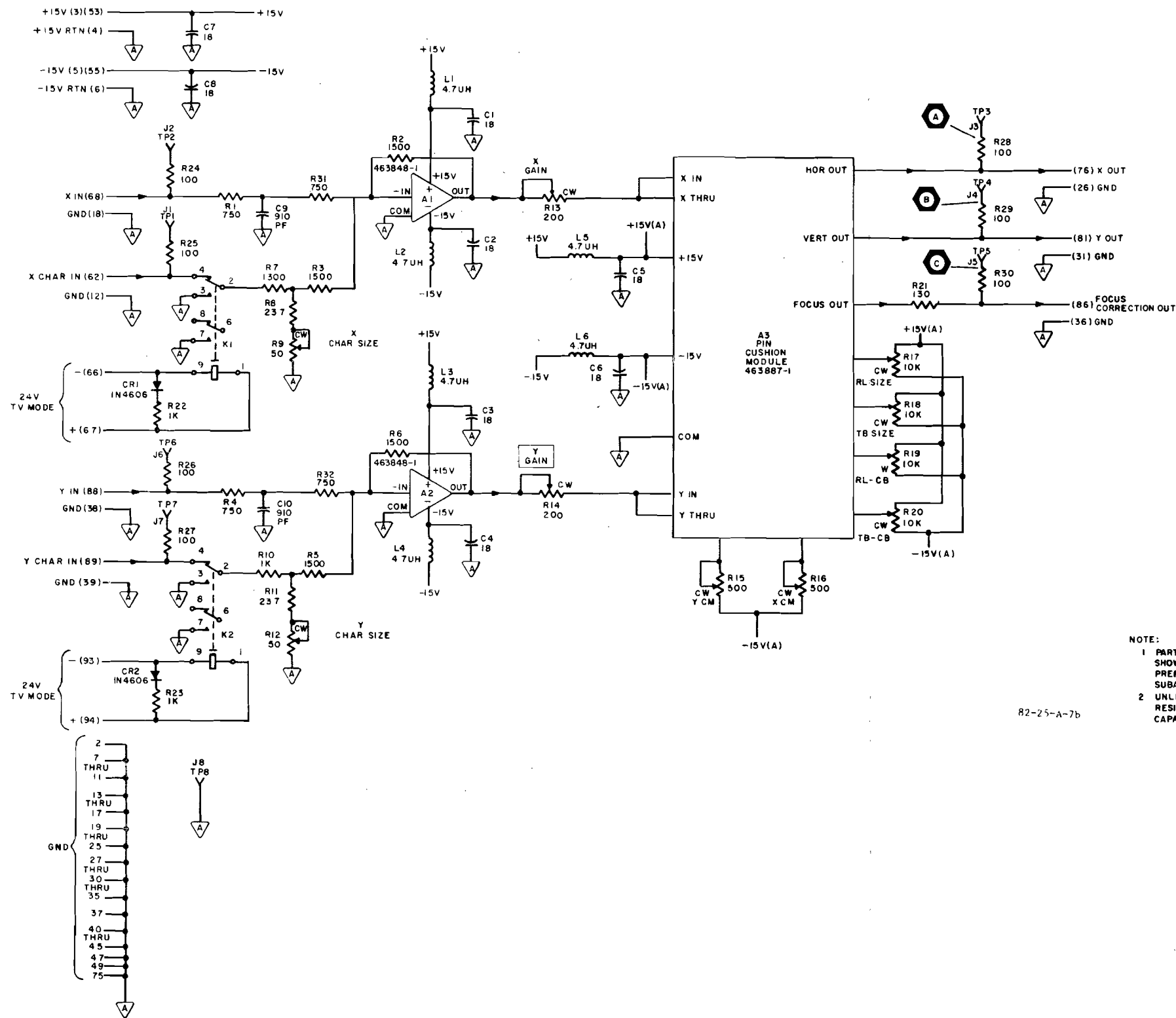

FIGURE A-7. UNMODIFIED A5 PCB (SHEET 1 OF 2)



R2-25-A-7b

FIGURE A-7. UNMODIFIED A5 PCB (SHEET 2 OF 2)

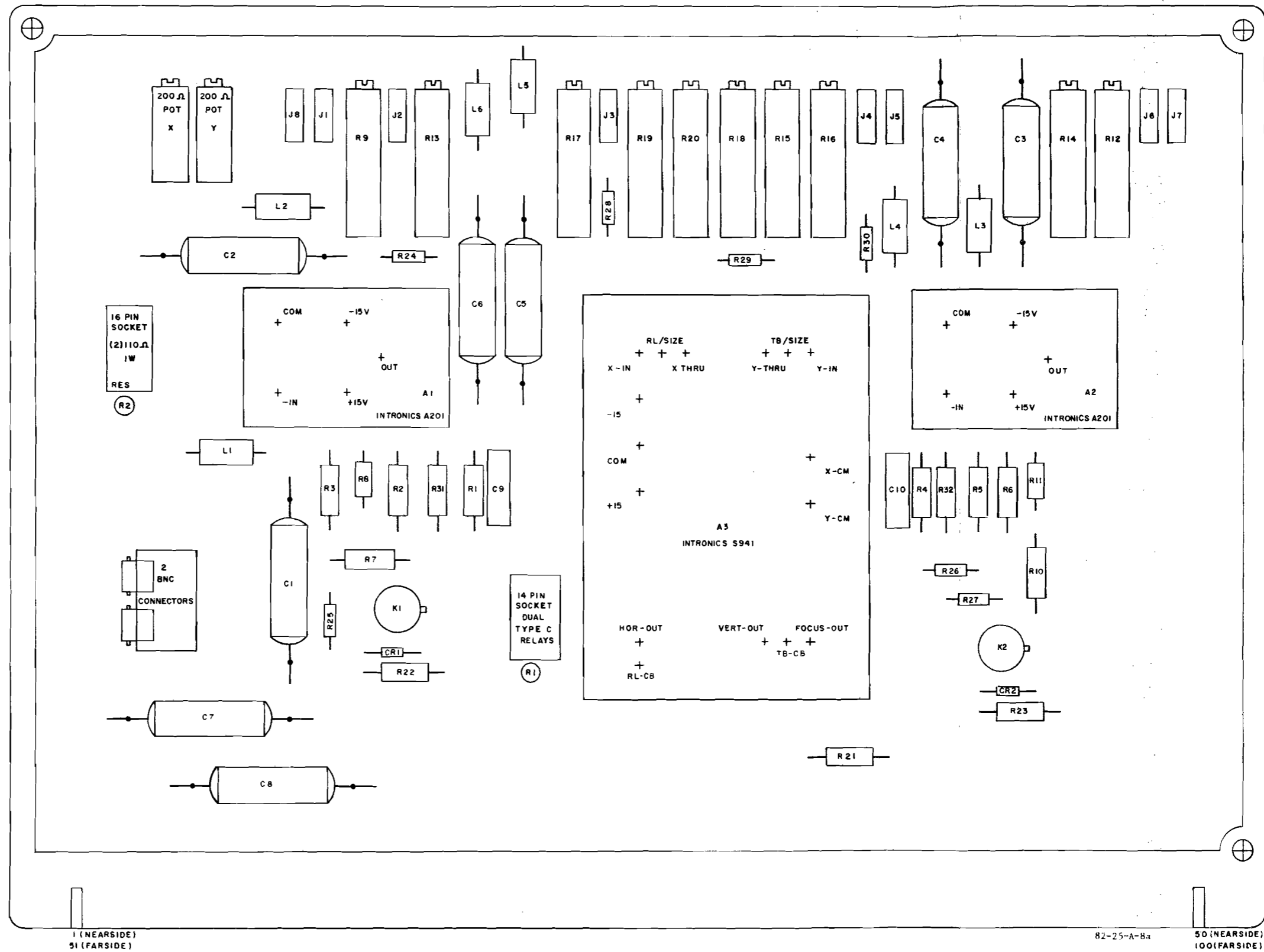
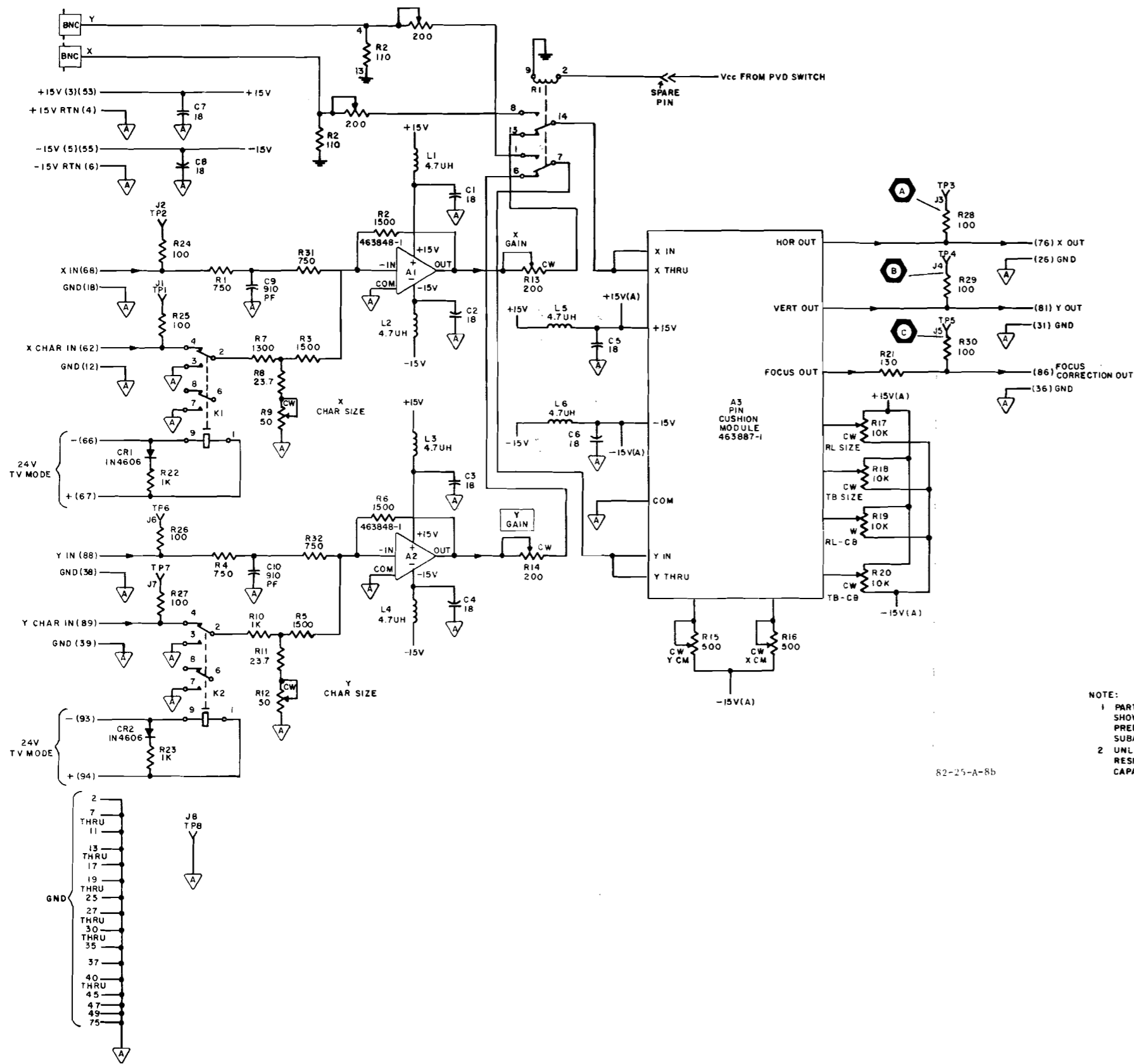

FIGURE A-8. MODIFIED A5 PCB — SWITCH PVD (SHEET 1 OF 2)



82-25-A-8b

NOTE:
 1 PARTIAL REFERENCE DESIGNATIONS ARE SHOWN, FOR COMPLETE DESIGNATION, PREFIX WITH UNIT NUMBER OR SUBASSEMBLY DESIGNATION (S)
 2 UNLESS OTHERWISE SPECIFIED RESISTANCE VALUES ARE IN OHMS AND CAPACITANCE VALUES ARE IN MICROFARADS.

FIGURE A-8. MODIFIED A5 PCB — SWITCH PVD (SHEET 2 OF 2)

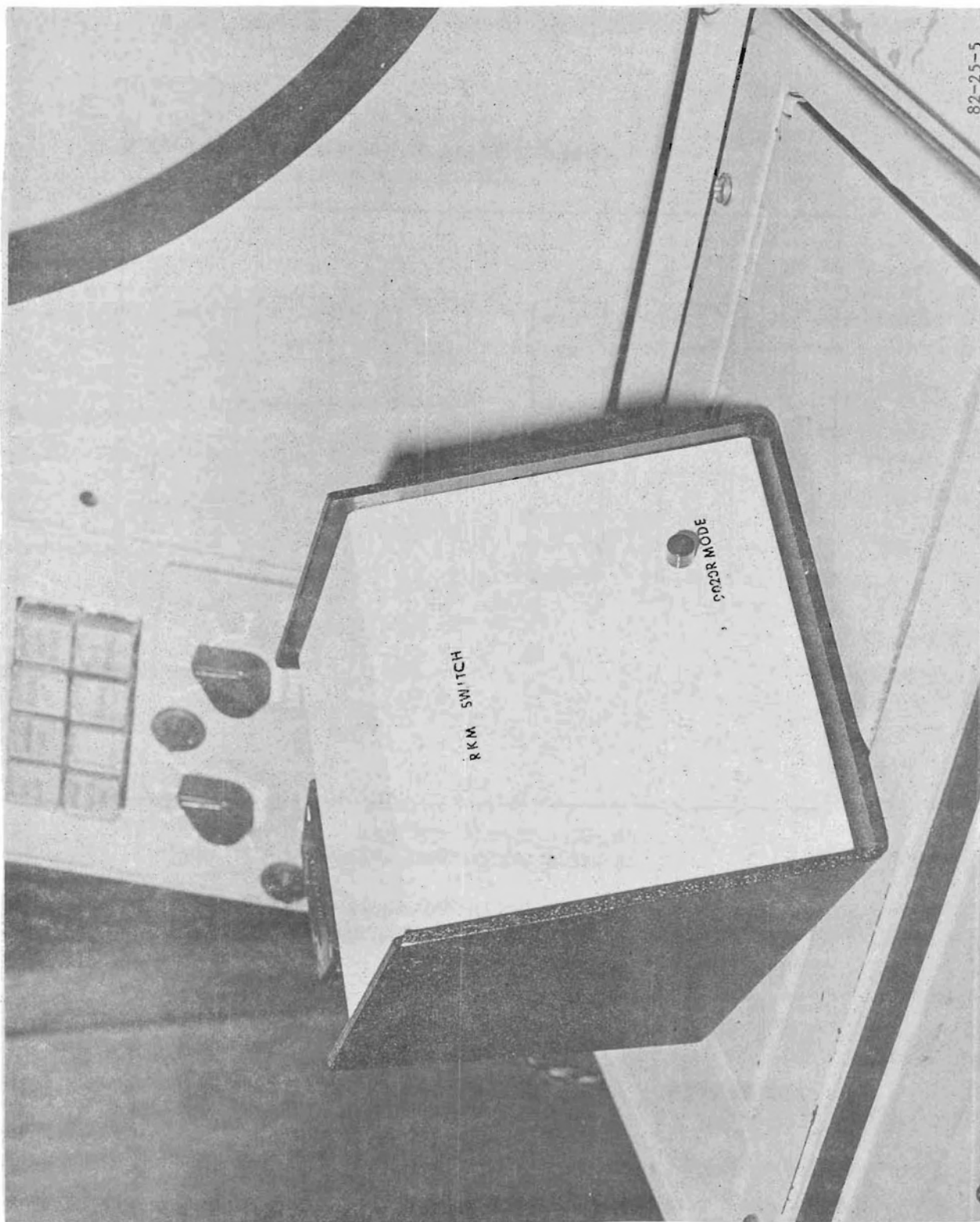

82-25-5

81-2390

F.A.A. TECHNICAL CENTER
ATLANTIC CITY, NEW JERSEY

FIGURE A-9. RKM SWITCH BOX

DATA PROCESSED BY THE FAA TECHNICAL CENTER
ATLANTIC CITY AIRPORT, N.J. 08406

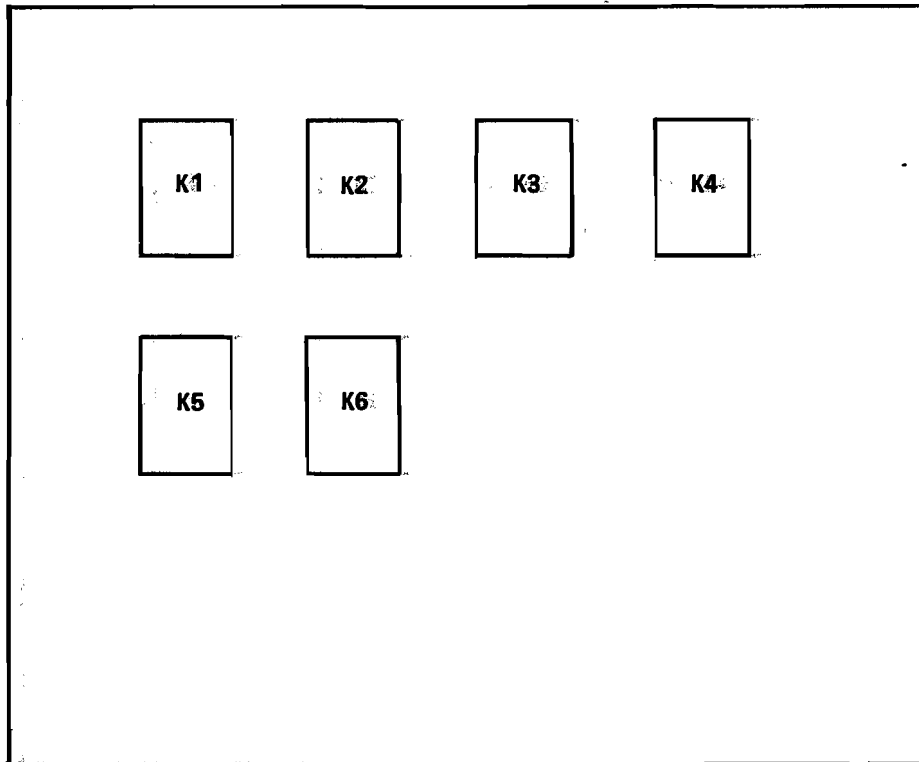

CIRCUIT BOARD -- TOP VIEW
RELAYS -- SIGMA 195TE-2C1E-5G

NOTE: RELAYS OVERHANG 14 PIN IC SOCKETS.
SPACE SOCKETS TO ALLOW SPACE FOR
RELAY INSERTION.

FIGURE A-10. RCM SWITCH BOX SCHEMATIC (SHEET 1 OF 3)

DATA RECORDED AND PROCESSED
BY THE FAA TECHNICAL CENTER

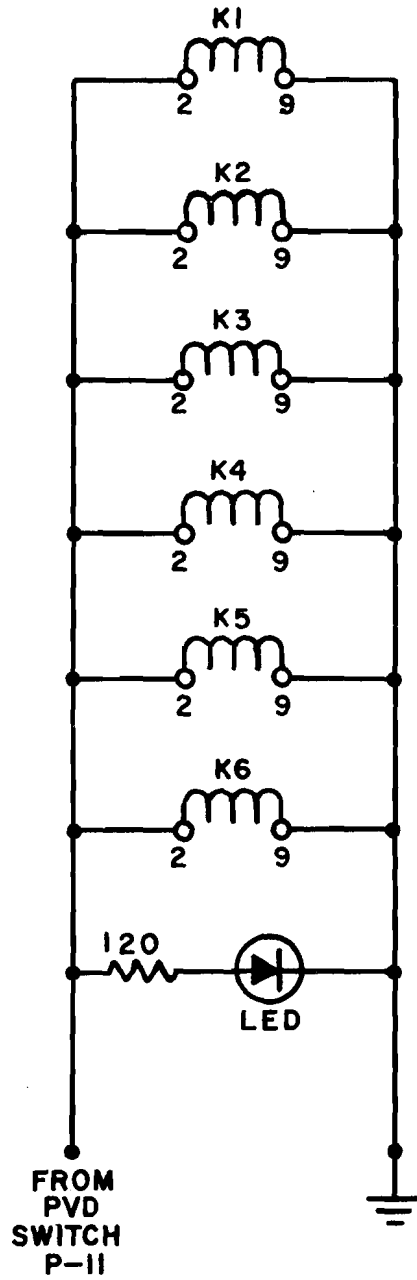

FIGURE A-10. RKM SWITCH BOX SCHEMATIC (SHEET 2 OF 3)

DATA PROCESSED BY THE FAA TECHNICAL CENTER
ATLANTIC CITY AIRPORT, N.J. 08405

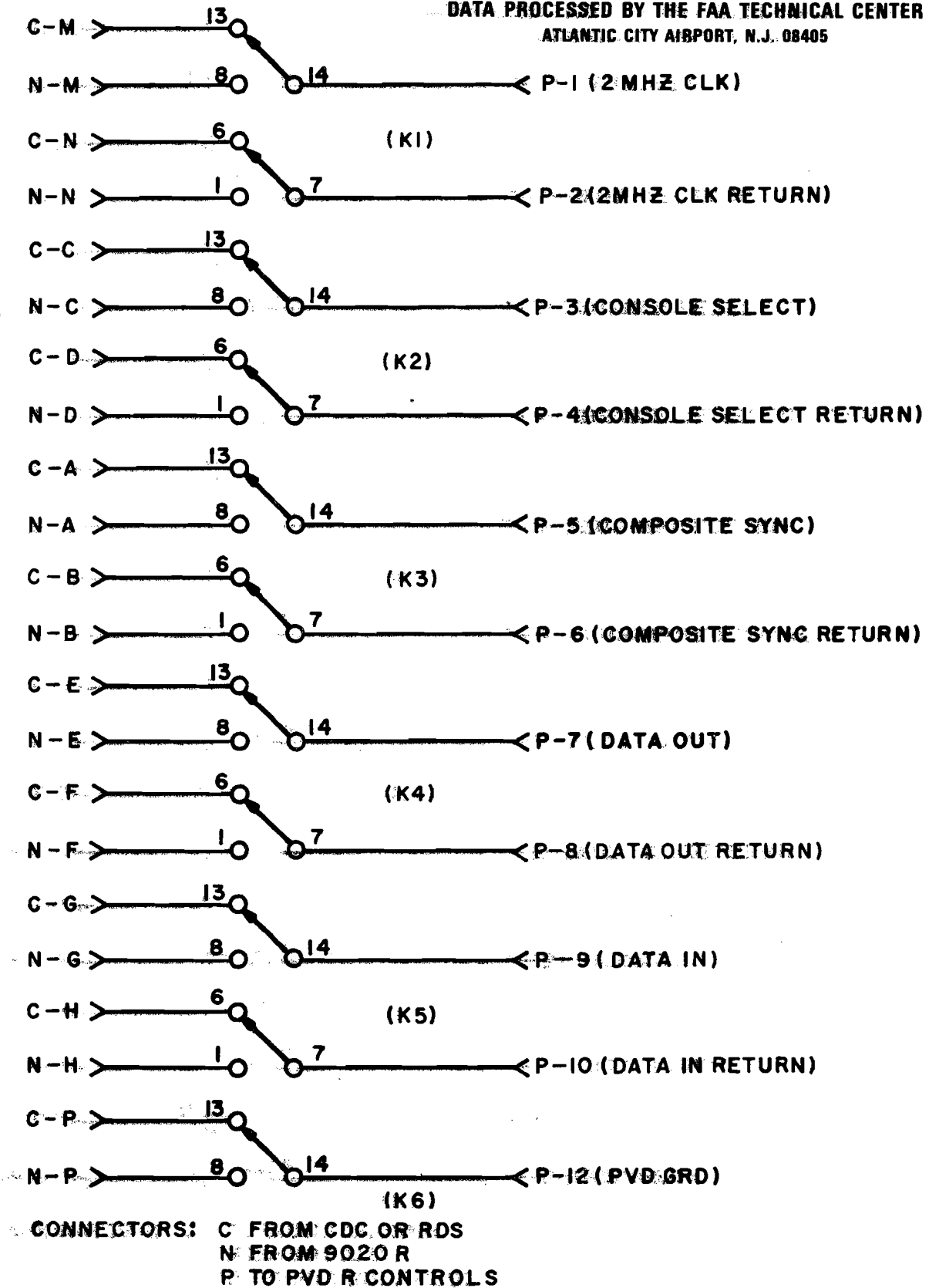

FIGURE A-10. RKM SWITCH BOX SCHEMATIC (SHEET 3 OF 3)

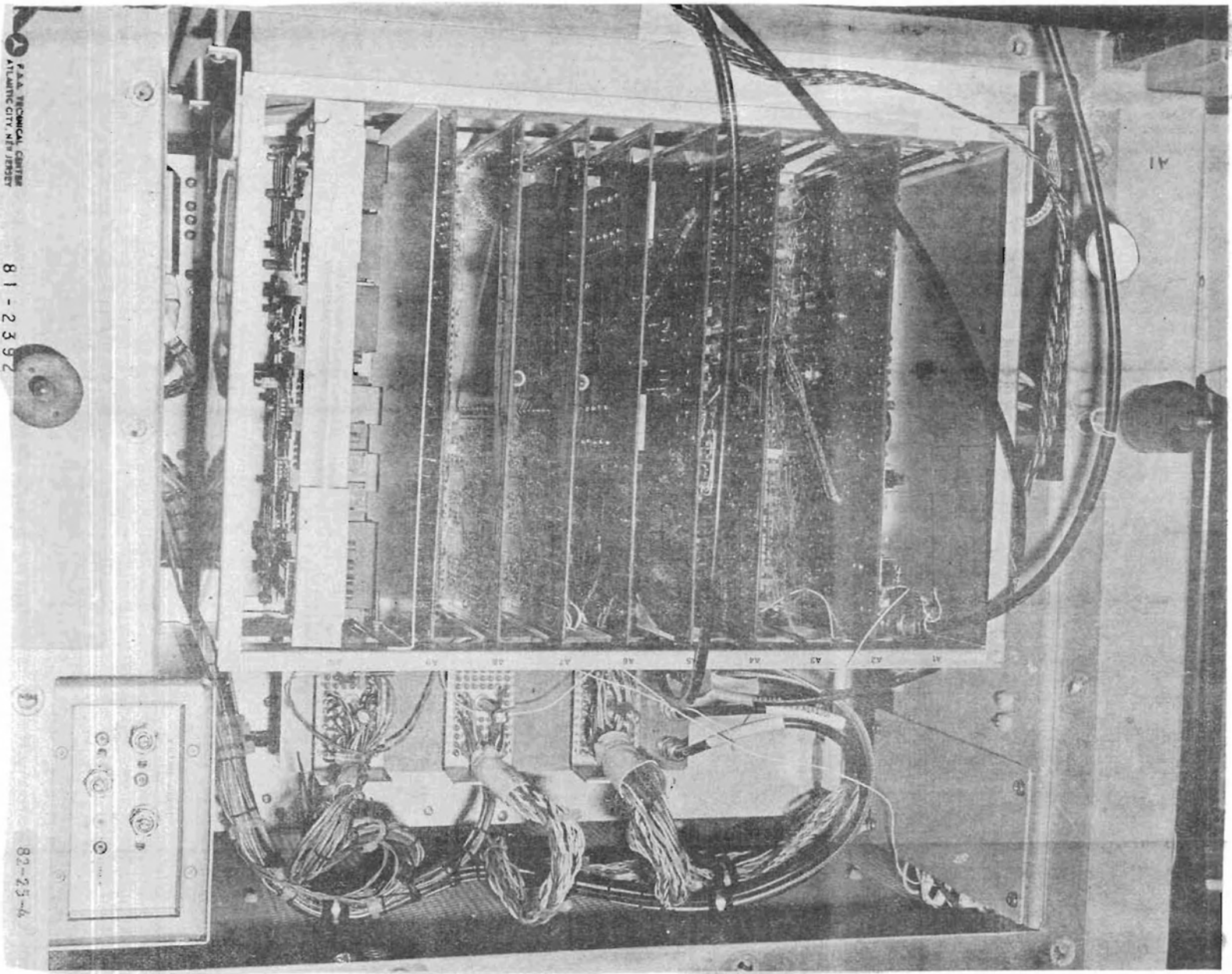
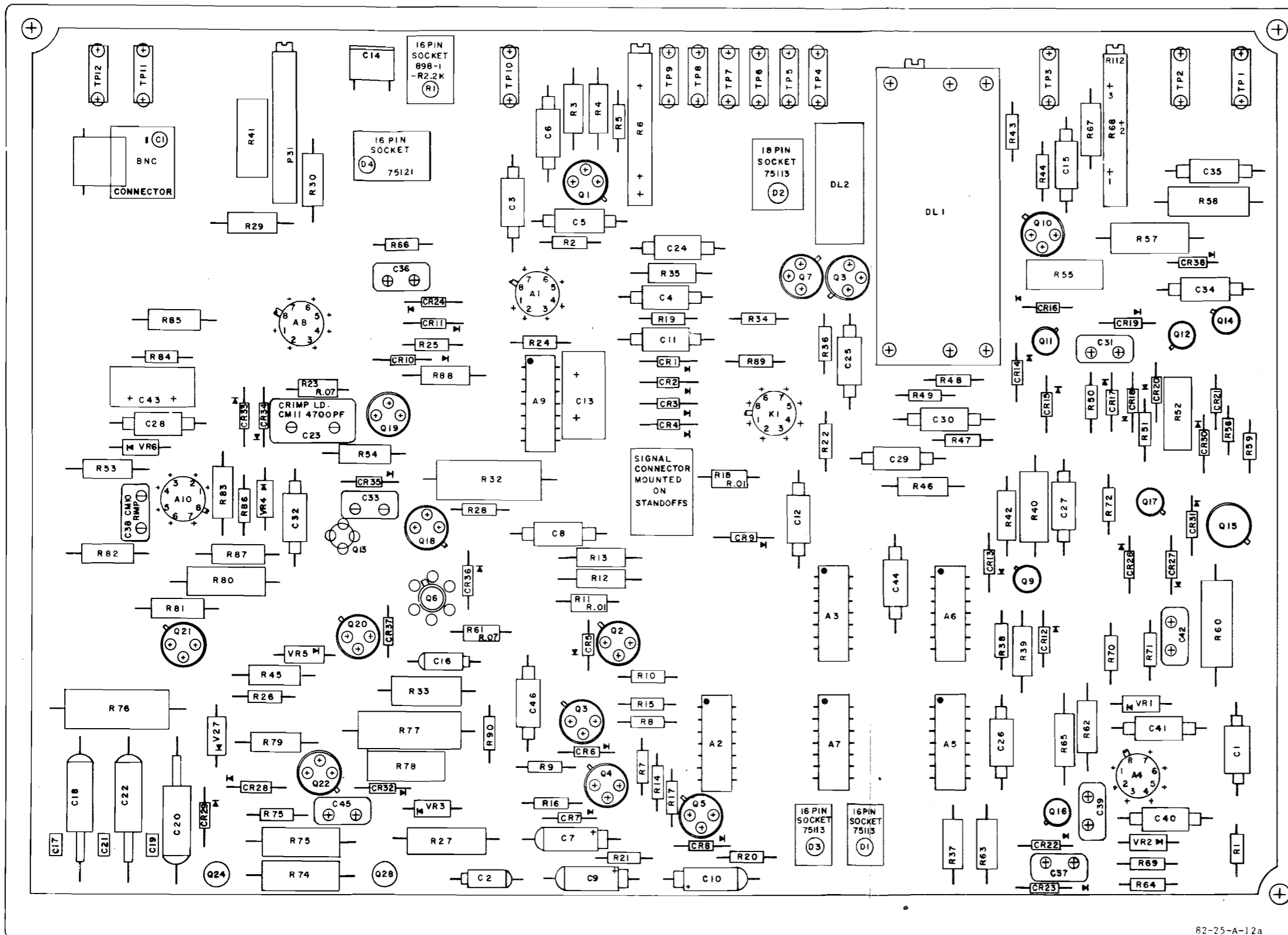

FIGURE A-11. LOWER BASKET — SWITCH PVD



82-25-A-12a

FIGURE A-12. MODIFIED A2 PCB — DRIVER PVD (SHEET 1 OF 4)

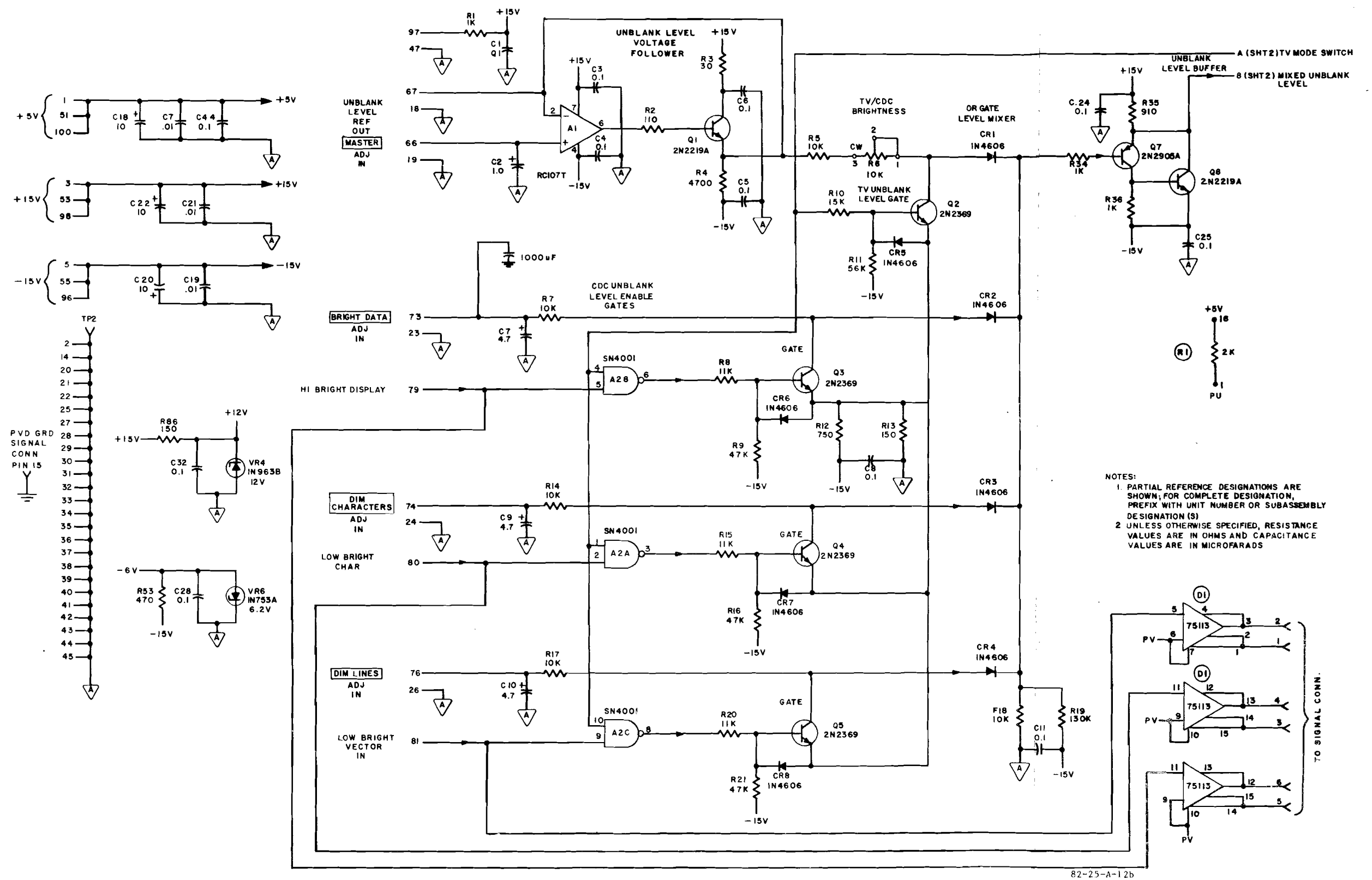
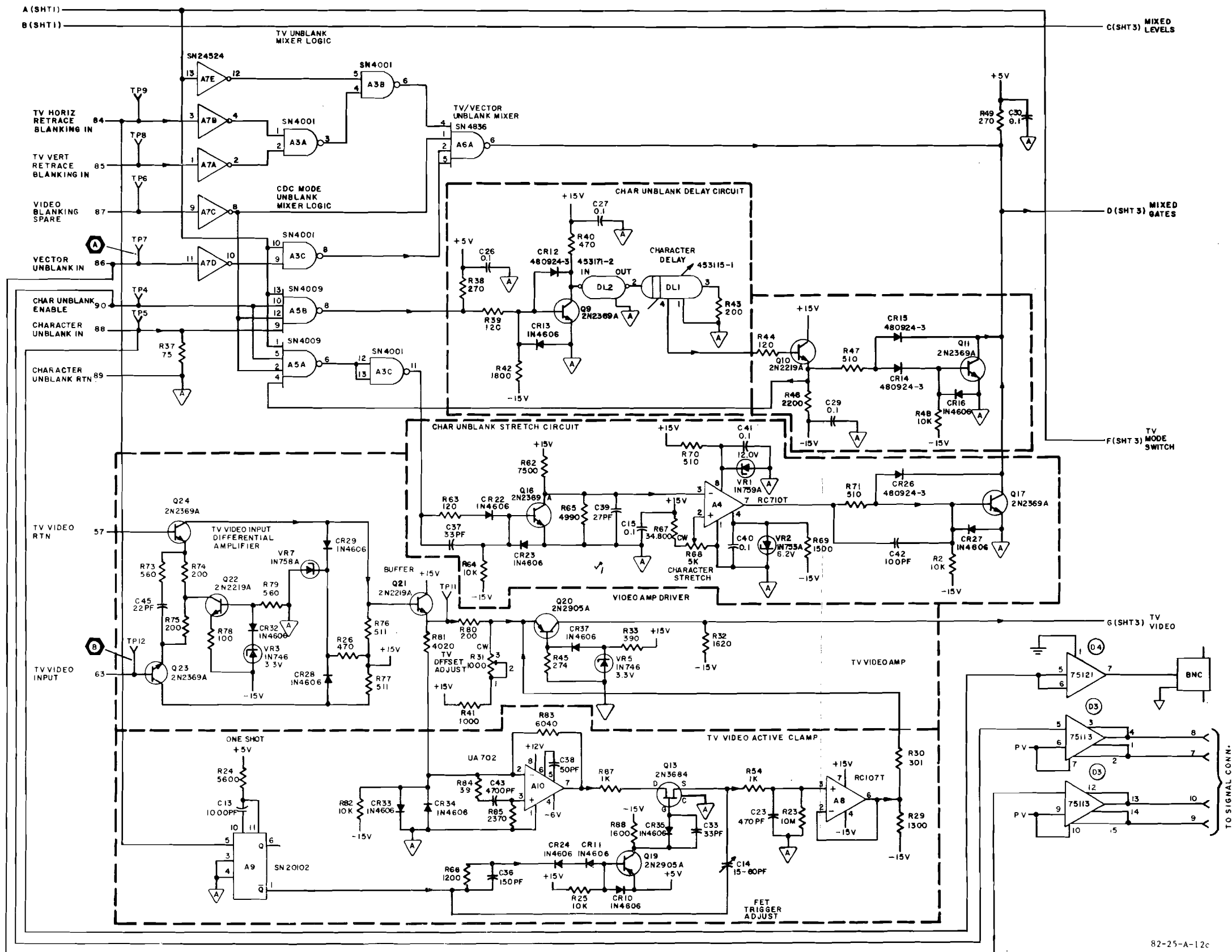

FIGURE A-12. MODIFIED A2 PCB — DRIVER PVD (SHEET 2 OF 4)



82-25-A-12c

FIGURE A-12. MODIFIED A2 PCB — DRIVER PVD (SHEET 3 OF 4)

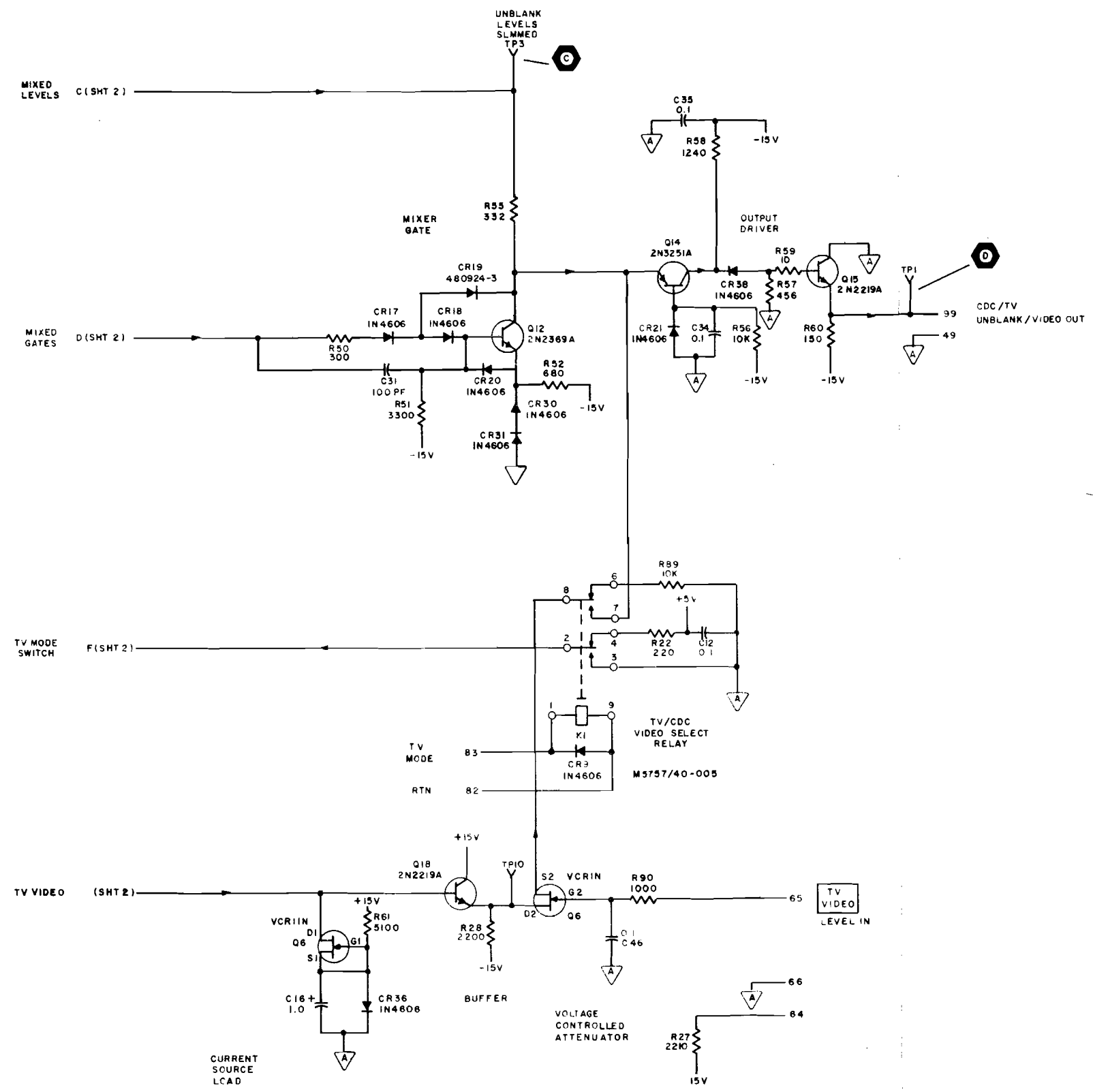

FIGURE A-12. MODIFIED A2 PCB -- DRIVER PVD (SHEET 4 OF 4)

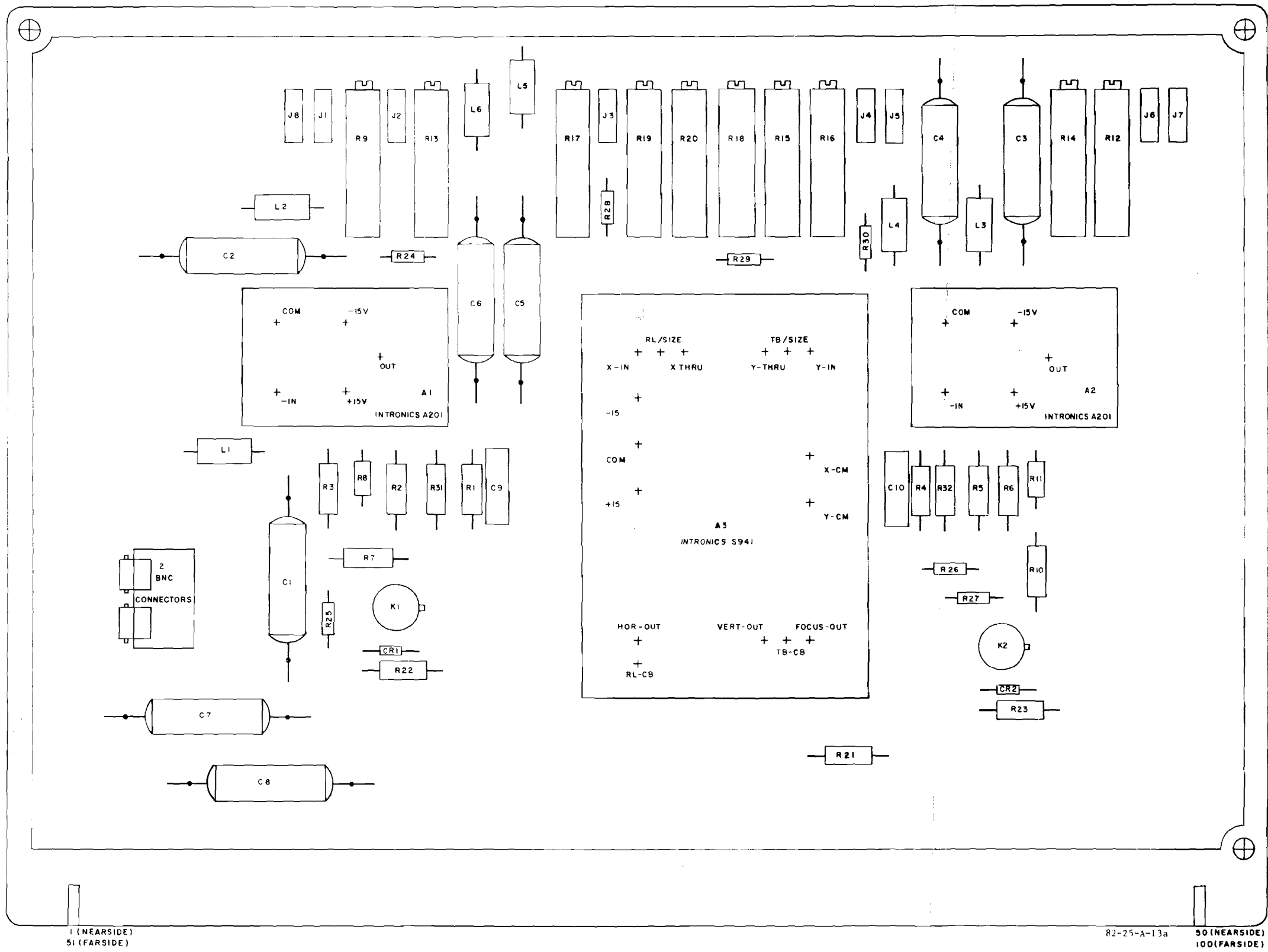

FIGURE A-13. MODIFIED A5 PCB — DRIVER PVD (SHEET 1 OF 2)

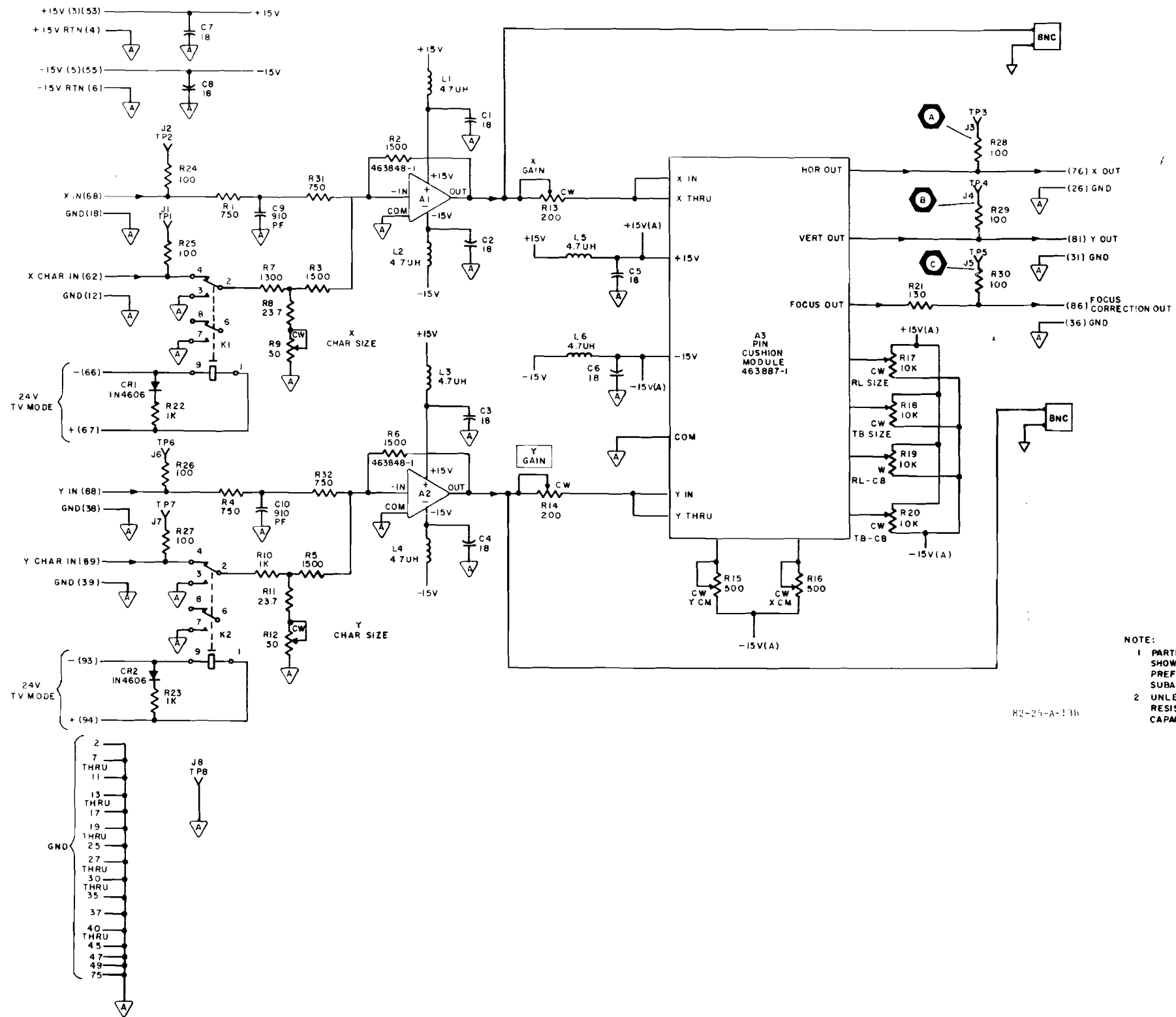

FIGURE A-13. MODIFIED A5 PCB — DRIVER PVD (SHEET 2 OF 2)