

COPY 1  
2

DOT/FAA/CT-82/30

# A Compendium of Lightning Effects on Future Aircraft Electronic Systems

Nickolus O. Rasch

FEDERAL AVIATION ADMINISTRATION

APR 20 1982

TECHNICAL CENTER LIBRARY  
ATLANTIC CITY, N.J. 08405

February 1982

Compendium

This document is available to the U.S. public through the National Technical Information Service, Springfield, Virginia 22161.



DOT/FAA  
CT-82/30



US Department of Transportation  
**Federal Aviation Administration**  
Technical Center  
Atlantic City Airport, N.J. 08405

FAA TECHNICAL CENTER LIBRARY NJ  
DOT/FAA/CT-82/30 c1  
United States/A Compendium of lightning e  
  
00008667

NOTICE

This document is disseminated under the sponsorship of the Department of Transportation in the interest of information exchange. The United States Government assumes no liability for the contents or use thereof.

The United States Government does not endorse products or manufacturers. Trade or manufacturer's names appear herein solely because they are considered essential to the object of this report.

1. Report No. DOT/FAA/CT-82/30		2. Government Accession No.		3. Recipient's Catalog No.	
4. Title and Subtitle A COMPENDIUM OF LIGHTNING EFFECTS ON FUTURE AIRCRAFT SYSTEMS				5. Report Date February 1982	
				6. Performing Organization Code	
7. Author(s) Nickolus O. Rasch				8. Performing Organization Report No. ACT-340	
9. Performing Organization Name and Address Federal Aviation Administration Technical Center Atlantic City Airport, New Jersey 08405				10. Work Unit No. (TRAIS)	
				11. Contract or Grant No. 182-340-100	
12. Sponsoring Agency Name and Address U.S. Department of Transportation Federal Aviation Administration Technical Center Atlantic City Airport, New Jersey 08405				13. Type of Report and Period Covered Final November 4-8, 1981	
				14. Sponsoring Agency Code	
15. Supplementary Notes					
16. Abstract  This publication is a composite of presentations given at the NASA-Langley Research Center/FAA Technical Center "Lightning Effects on Future Aircraft Systems Workshop" held on November 4-6, 1981, at the NASA-Langley Research Center Facility.  The presentations encompassed the full spectrum of lightning research from lightning phenomenology, lightning modeling, electromagnetic issues associated with composite materials, to the lightning/aircraft electromagnetic interaction analysis. Also included are a total of five presentations assessing the Digital System upset phenomenon.					
17. Key Words Triboelectrification Corona Stepped Leader Tortuous Channel			18. Distribution Statement Document is available to the U.S. public through the National Technical Information Service, Springfield, Virginia 22161		
19. Security Classif. (of this report) Unclassified		20. Security Classif. (of this page) Unclassified		21. No. of Pages 251	22. Price

## METRIC CONVERSION FACTORS

### Approximate Conversions to Metric Measures

Symbol	When You Know	Multiply by	To Find	Symbol
<b>LENGTH</b>				
in	inches	2.5	centimeters	cm
ft	feet	30	centimeters	cm
yd	yards	0.9	meters	m
mi	miles	1.6	kilometers	km
<b>AREA</b>				
in <sup>2</sup>	square inches	6.5	square centimeters	cm <sup>2</sup>
ft <sup>2</sup>	square feet	0.09	square meters	m <sup>2</sup>
yd <sup>2</sup>	square yards	0.8	square meters	m <sup>2</sup>
mi <sup>2</sup>	square miles	2.6	square kilometers	km <sup>2</sup>
	acres	0.4	hectares	ha
<b>MASS (weight)</b>				
oz	ounces	28	grams	g
lb	pounds	0.45	kilograms	kg
	short tons (2000 lb)	0.9	tonnes	t
<b>VOLUME</b>				
tsp	teaspoons	5	milliliters	ml
Tbsp	tablespoons	15	milliliters	ml
fl oz	fluid ounces	30	milliliters	ml
c	cups	0.24	liters	l
pt	pints	0.47	liters	l
qt	quarts	0.95	liters	l
gal	gallons	3.8	liters	l
ft <sup>3</sup>	cubic feet	0.03	cubic meters	m <sup>3</sup>
yd <sup>3</sup>	cubic yards	0.76	cubic meters	m <sup>3</sup>
<b>TEMPERATURE (exact)</b>				
°F	Fahrenheit temperature	5/9 (after subtracting 32)	Celsius temperature	°C

\*1 in = 2.54 (exactly). For other exact conversions and more detailed tables, see NBS Misc. Publ. 236, Units of Weights and Measures, Price \$2.25, SD Catalog No. C13.10:286.



### Approximate Conversions from Metric Measures

Symbol	When You Know	Multiply by	To Find	Symbol
<b>LENGTH</b>				
mm	millimeters	0.04	inches	in
cm	centimeters	0.4	inches	in
m	meters	3.3	feet	ft
m	meters	1.1	yards	yd
km	kilometers	0.6	miles	mi
<b>AREA</b>				
cm <sup>2</sup>	square centimeters	0.16	square inches	in <sup>2</sup>
m <sup>2</sup>	square meters	1.2	square yards	yd <sup>2</sup>
km <sup>2</sup>	square kilometers	0.4	square miles	mi <sup>2</sup>
ha	hectares (10,000 m <sup>2</sup> )	2.5	acres	
<b>MASS (weight)</b>				
g	grams	0.035	ounces	oz
kg	kilograms	2.2	pounds	lb
t	tonnes (1000 kg)	1.1	short tons	
<b>VOLUME</b>				
ml	milliliters	0.03	fluid ounces	fl oz
l	liters	2.1	pints	pt
l	liters	1.06	quarts	qt
l	liters	0.26	gallons	gal
m <sup>3</sup>	cubic meters	35	cubic feet	ft <sup>3</sup>
m <sup>3</sup>	cubic meters	1.3	cubic yards	yd <sup>3</sup>
<b>TEMPERATURE (exact)</b>				
°C	Celsius temperature	9/5 (then add 32)	Fahrenheit temperature	°F

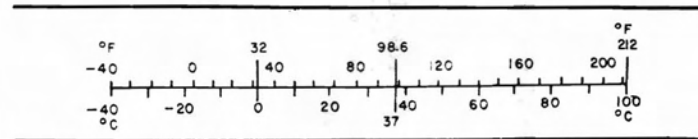

## PREFACE

The "Lightning Effects on Future Aircraft Electronic Systems" workshop, November 4-6, 1981, sponsored by the NASA-Langley Research Center in conjunction with the Federal Aviation Administration (FAA) Technical Center, provided an ideal vehicle for information exchange. This workshop provided regional and headquarters personnel with an insight into the magnitude of the problem, and the progress being accomplished through existing and future FAA programs.

Protection of electrical and electronic subsystems and equipments against the atmospheric electricity hazards constituted by lightning and static electricity must be taken into special account in the design of advanced technology aircraft. Two primary factors have contributed to an increased potential hazard to new generation aircraft: (1) The increasingly widespread use of digital microelectronic subsystems and/or avionic equipment which are inherently susceptible to upset and damage caused by electrical transients to implement flight and mission critical functions; and (2) the reduced electromagnetic shielding provided by many advanced structural materials. Present military and civil design guides and standards are being reviewed to assure adequate protection for new generation aircraft.

The NASA-Langley Research Center Electronic System Branch of the Flight Electronic Division was the host for this workshop; which is a major element in the FAA Technical Center's Advanced Integrated Flight Systems (AIFS) program. The AIFS program objectives are to acquire and disseminate data, enhance communications, and provide Aviation Standards, lead and/or certify regions airworthiness/certification personnel with a vehicle for information transfer in this highly technological area of lightning research as related to aircraft flight safety.

The personnel from the NASA-Langley Research Center Aircraft Electronic System Branch and their associates exhibited professionalism in the planning, assembling the technical experts and material, and conducting this workshop. It is with a deep and sincere sense of gratitude that we of the FAA would like to extend our appreciation to those persons for a job well done.



## TABLE OF CONTENTS

	Page
Lightning Effects Research Program - by Mr. Felix Pitts	1
Lightning Phenomenology - by Dr. M. Levine	5
Flight Experiment Definition and Summary - by Mr Felix Pitts	19
Data System Description - by Mr. Mitchel E. Thomas	29
Electromagnetic Sensors for Aircraft Lightning Reseach - by Mr. Klaus P. Zaepfel	39
Lightning Modeling - by Dr. M. Levine	51
Interpretation of In-Flight Test Data Approach, Problems and Outlook - by Dr. R. A. Perala	61
Corona and Streamer Effects - by Dr. R. A. Perala	76
An Analysis Method for the F-106 Direct Strike Data - by Dr. T. F. Trost	81
An Overview of the Electrical/Electromagnetic Impact of Advanced Composite Materials on Aircraft Design - by Dr. John C. Corbin, Jr.	91
Structural Application of Composite Materials and the Direct Effects of Lightning Strikes - by Mr. William E. Howell	155
Lightning Interaction Analysis - by Dr. Karl S. Kunz	171
Intermittent/Transient Faults in Digital Computers - by Dr. Gerald M. Masson	195
A Microprocessor-Based Upset Test Method - by Ms. Celeste M. Belcasto	213
Diagnostic Emulation Analysis--Need and Technique by Mr. Gerard E. Migneault	221
Digital System Hardware Description Technique Used in Emulation - by Mr. Robert M. Thomas, Jr.	231
The Need for Transient Data in a CARE III Reliability Analysis - by Mr. Salvatore J. Bavuso	241



LIGHTNING EFFECTS RESEARCH PROGRAM

by

Mr. Felix Pitts

Langley Research Center  
National Aeronautics and Space Administration

The current research program being pursued at the Langley Research Center on lightning and its effects on digital electronic systems will be presented.

**F106 USED IN LIGHTNING RESEARCH**



## LIGHTNING EFFECTS

- CURRENT TRANSPORT AIRCRAFT STRUCK ABOUT ONCE PER YEAR
  - ALUMINUM SKIN
  - HYDRAULIC/MECHANICAL PRIMARY CONTROLS
  - MOSTLY NUISANCE PROBLEMS CAUSED BY LIGHTNING
- FUTURE AIRCRAFT WILL EMPLOY
  - COMPOSITE STRUCTURE
  - DIGITAL AVIONICS/ELECTRONIC CONTROLSSUSCEPTIBLE TO DISTURBANCE  
POTENTIAL FOR UPSET
- NEED FOR FUTURE AIRCRAFT DESIGNS
  - BETTER UNDERSTANDING OF IN-FLIGHT LIGHTNING ENVIRONMENT
  - TECHNIQUES FOR ASSESSING DIGITAL SYSTEM PERFORMANCE IN LIGHTNING ENVIRONMENT

## LIGHTNING EFFECTS RESEARCH PROGRAM

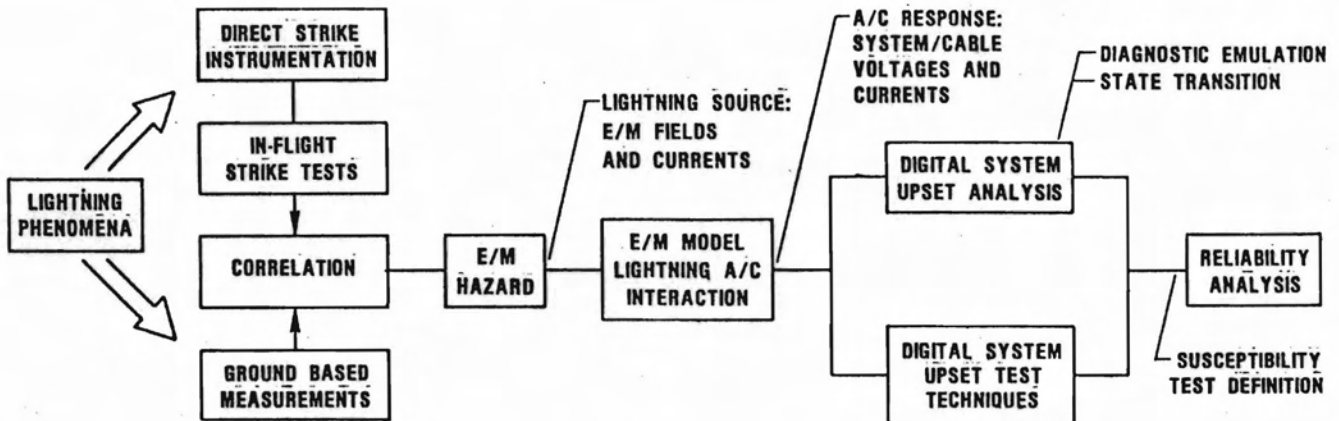



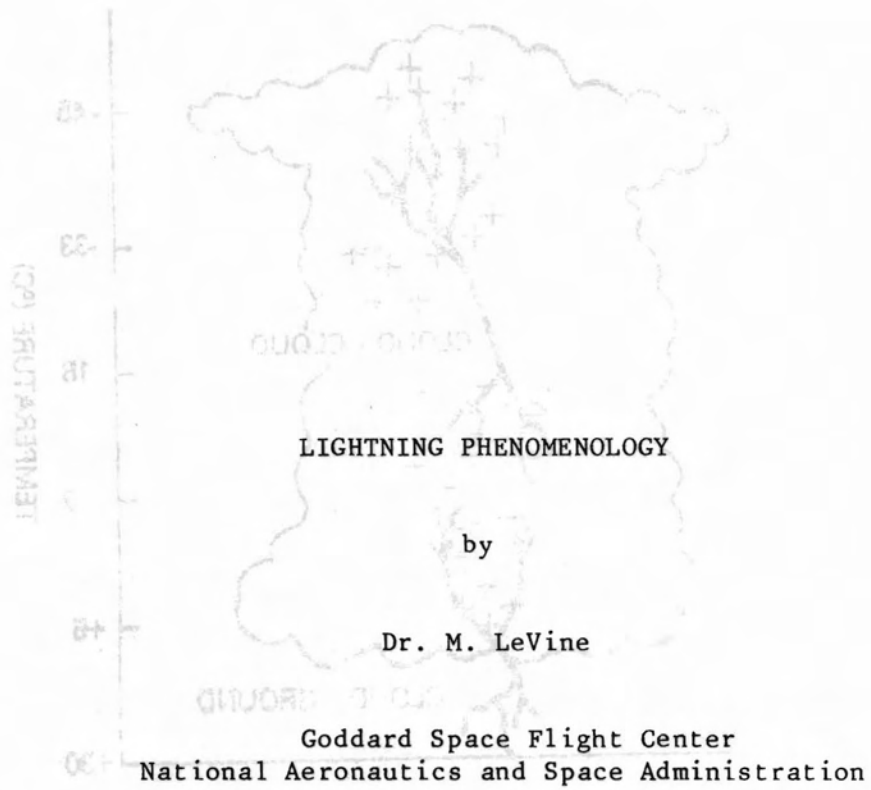

State-of-the-art of lightning knowledge: Theories of charge generation, the lightning discharge, stepped leaders, return strokes, fundamental electromagnetics of lightning, statistical distribution of lightning characteristics.

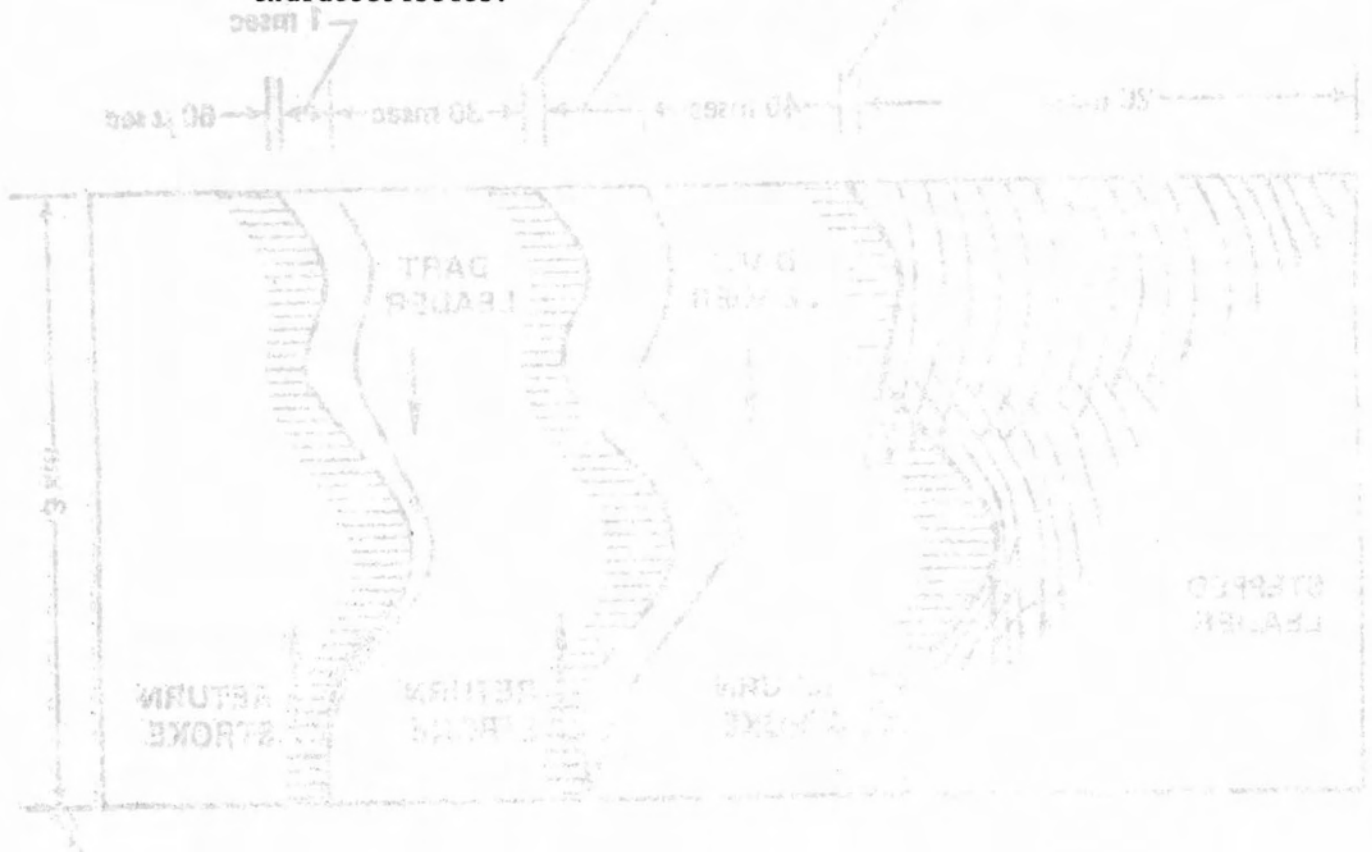

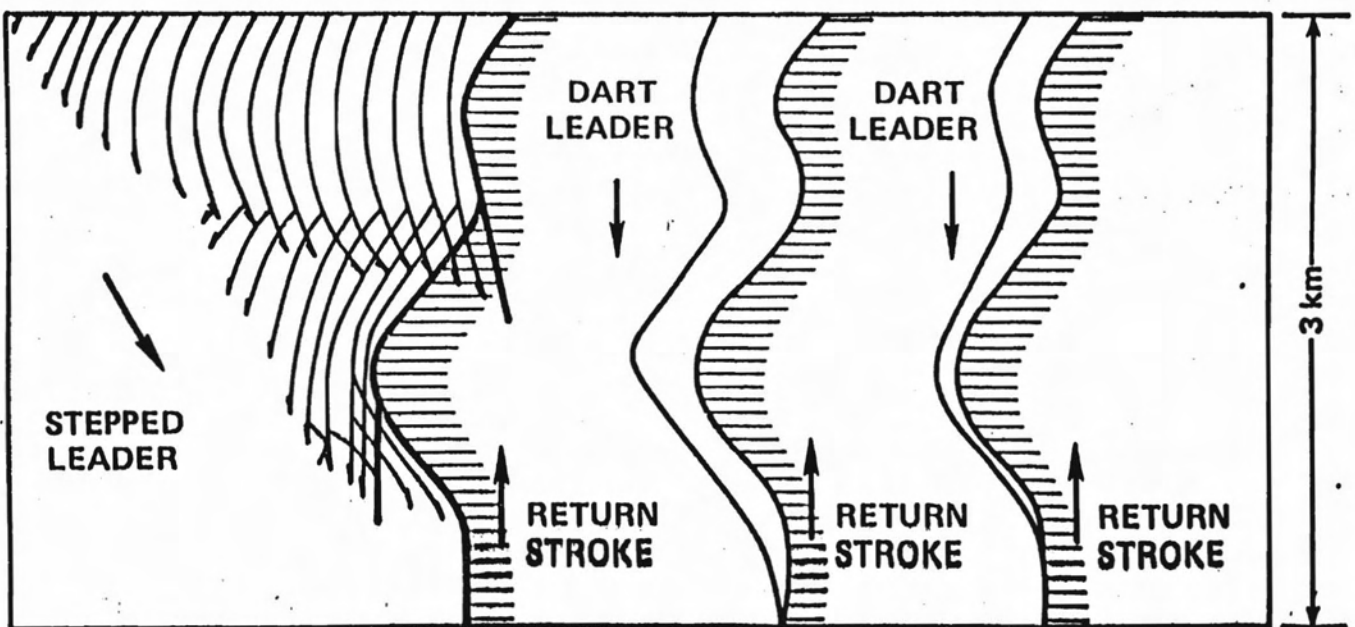
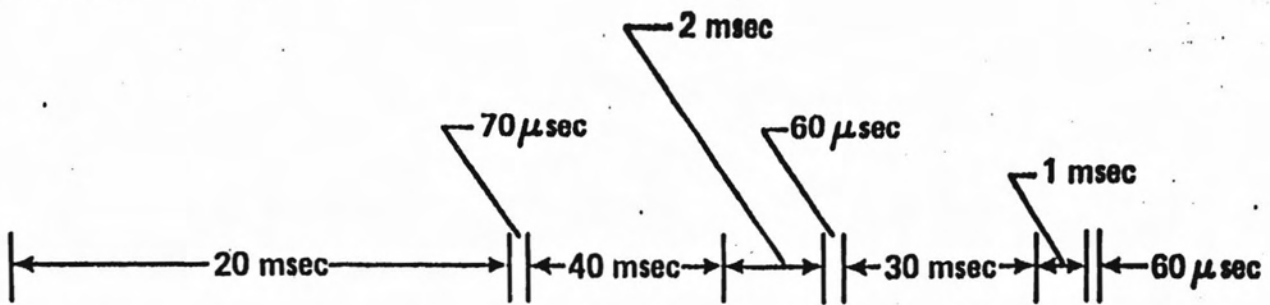
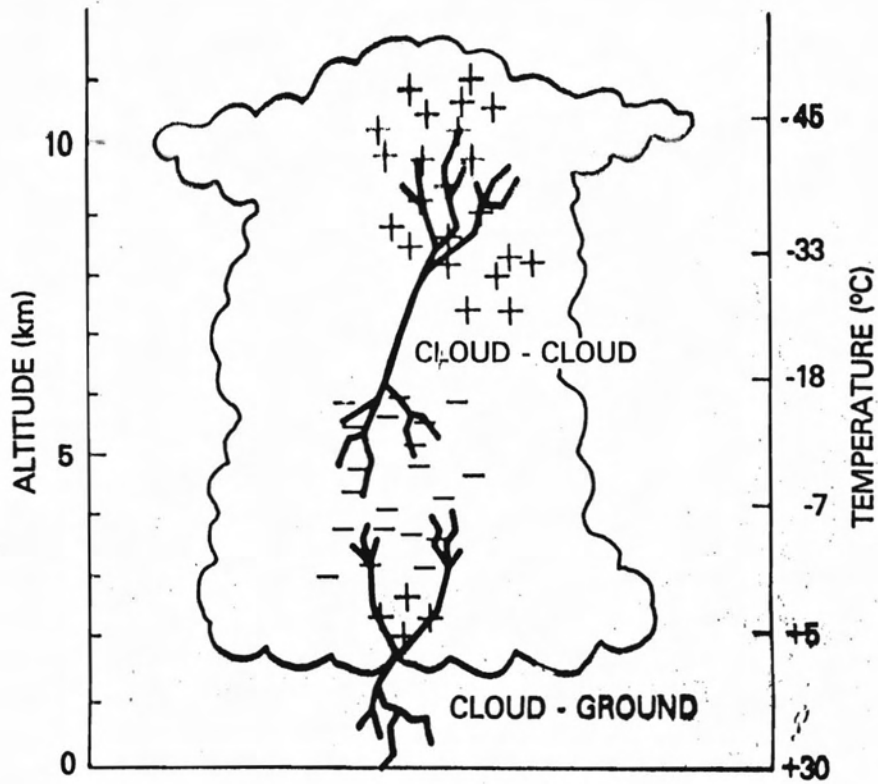

## CLOUD-TO-GROUND LIGHTNING PARAMETERS

	<u>MINIMUM*</u>	<u>REPRESENTATIVE</u>	<u>MAXIMUM*</u>
<b>STEPPED LEADER</b>			
LENGTH OF STEP (m)	3	50	200
TIME INTERVAL BETWEEN STEPS ( $\mu$ sec)	30	50	125
AVERAGE VELOCITY OF PROPAGATION OF STEPPED LEADER (m/sec)	$1.0 \times 10^5$	$1.5 \times 10^5$	$2.6 \times 10^6$
<b>DART LEADER</b>			
VELOCITY OF PROPAGATION (m/sec)	$1.0 \times 10^6$	$2.0 \times 10^6$	$2.1 \times 10^7$
<b>RETURN STROKE**</b>			
PEAK CURRENT (ka)		10-20	110
TIME TO HALF OF PEAK CURRENT ( $\mu$ sec)	10	40	250
CHANNEL LENGTH (km)	2	5	14
VELOCITY OF PROPAGATION (m/sec)	$2.0 \times 10^7$	$5.0 \times 10^7$	$1.4 \times 10^8$
<b>LIGHTNING FLASH</b>			
NUMBER OF STROKES PER FLASH	1	3-4	26
TIME INTERVAL BETWEEN STROKES (msec)	3	40	100
TIME DURATION OF FLASH (sec)	$10^{-2}$	0.2	2
CHARGE TRANSFERRED (coul)	3	25	90

\*THE WORDS MAXIMUM AND MINIMUM ARE USED IN THE SENSE THAT MOST MEASURED VALUES FALL BETWEEN THESE LIMITS.

\*\*FIRST RETURN STROKES HAVE SLOWER AVERAGE VELOCITIES OF PROPAGATION, SLOWER, CURRENT RATES OF INCREASE, LONGER TIMES TO CURRENT PEAK, AND GENERALLY LARGER CHARGE TRANSFER THAN SUBSEQUENT RETURN STROKES IN A FLASH.

# HISTORICAL PERSPECTIVE

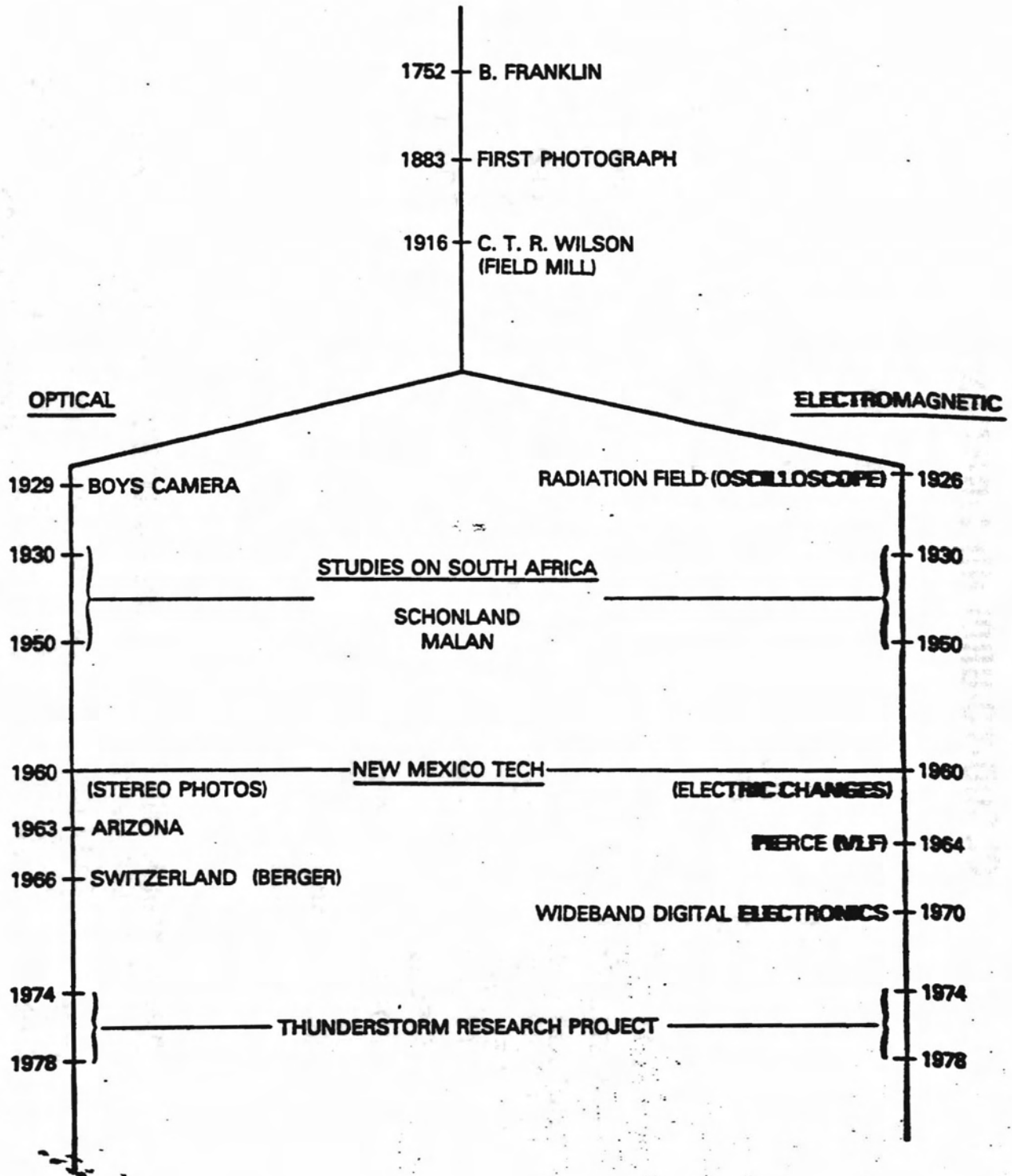

THE STREAK CAMERA

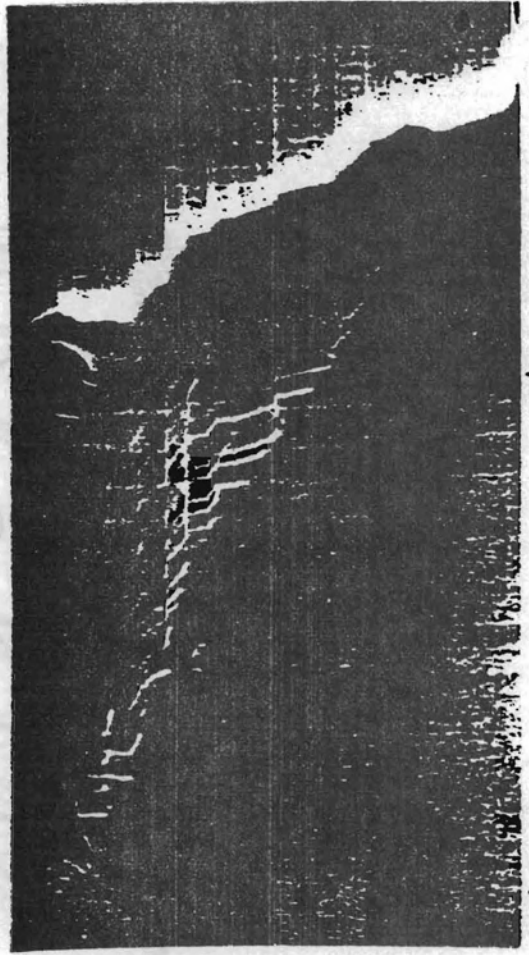
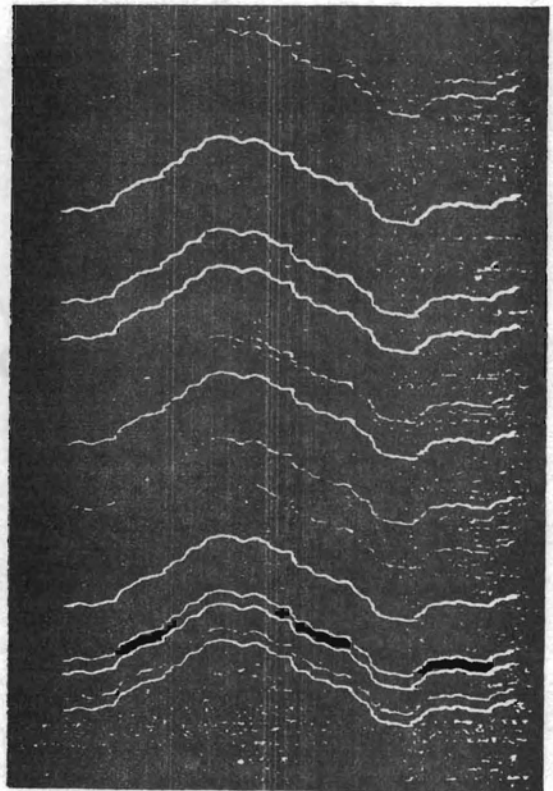
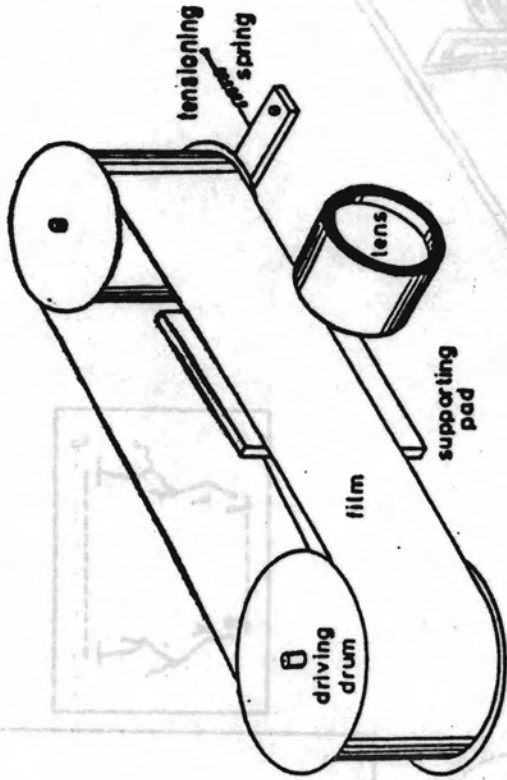

1 msec

THE BOYS' CAMERA

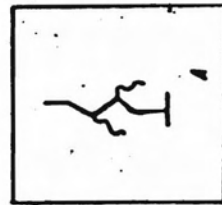
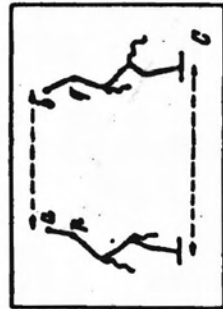
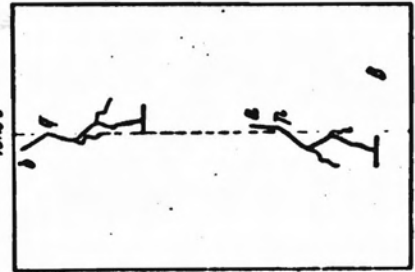
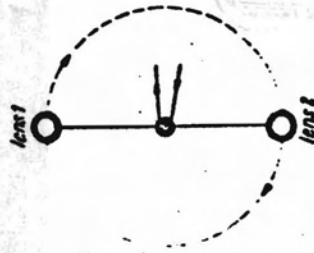
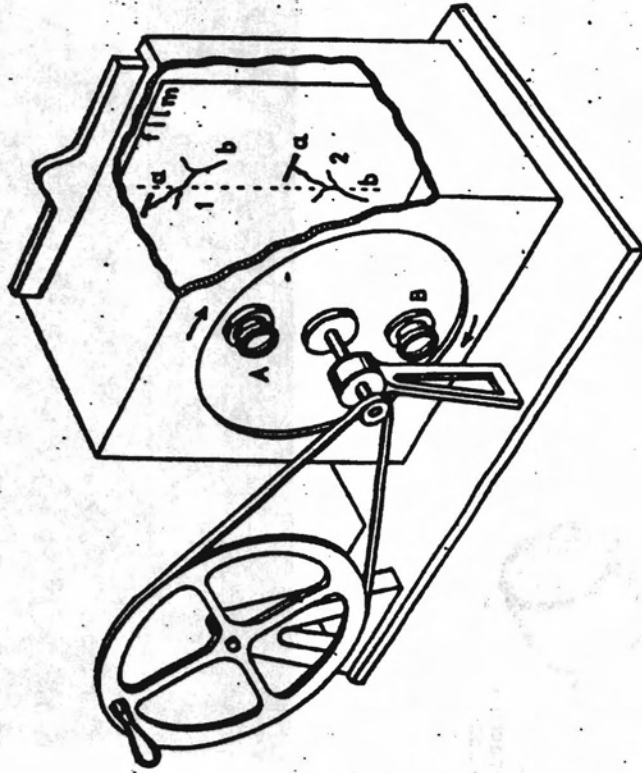

# FIELD MILL

METAL VANED WHEEL

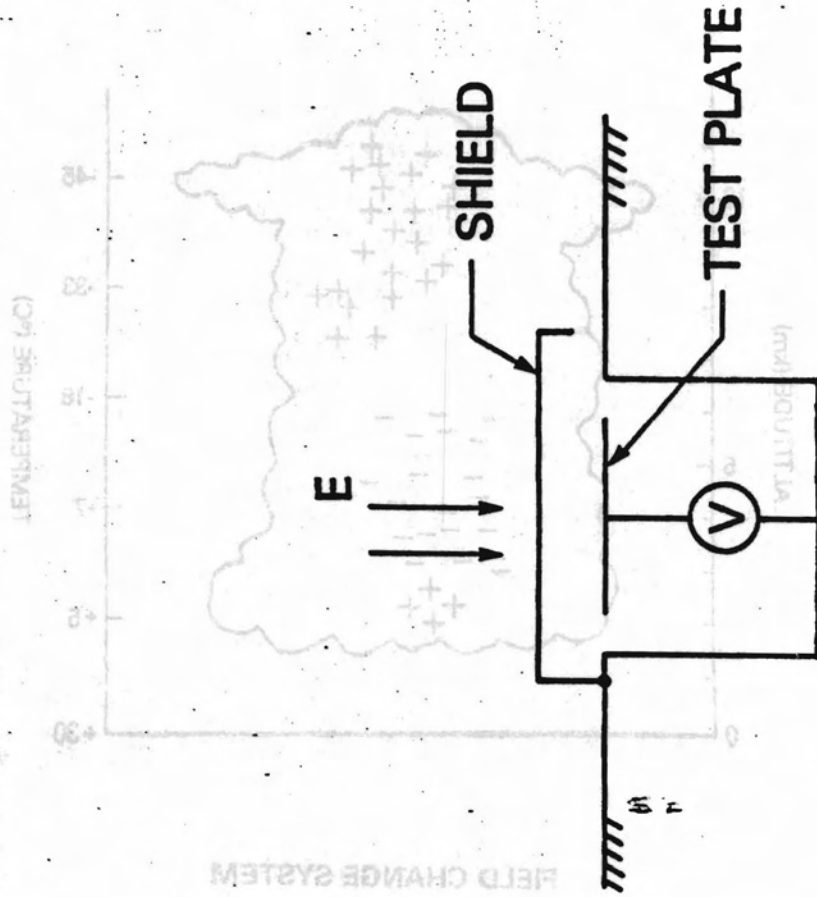
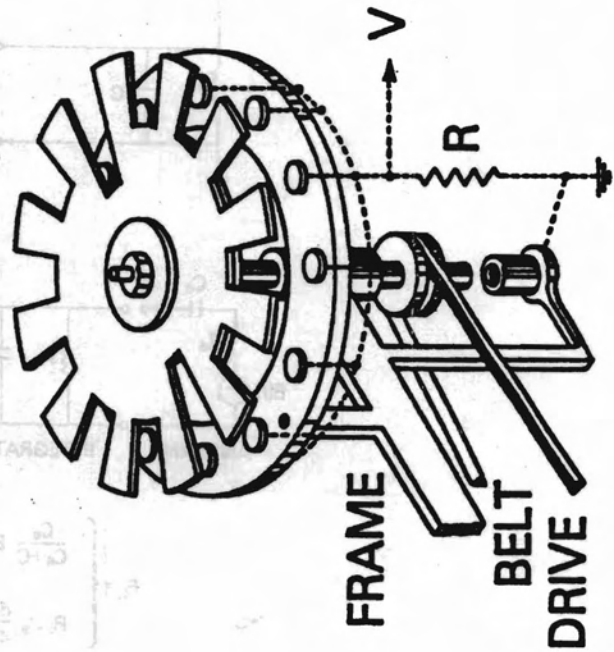

$$E_n = \frac{CV}{E_0A}$$

## DISTRIBUTION OF CHARGE IN A THUNDERCLOUD

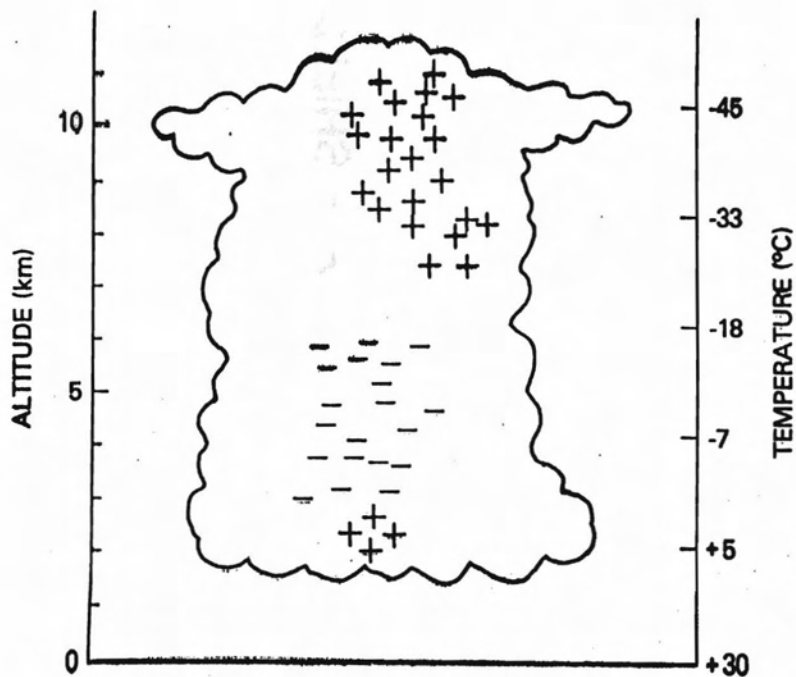

### FIELD CHANGE SYSTEM

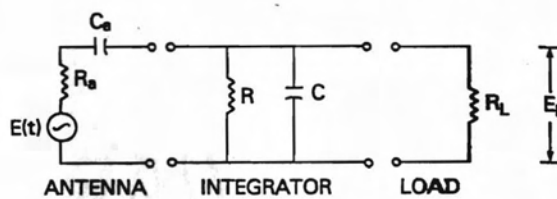
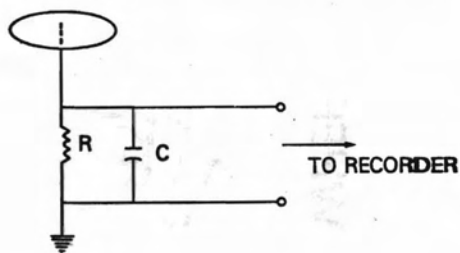

$$E_L = \begin{cases} \frac{C_a}{C_a + C} E & \text{INTEGRATOR} \\ R_L C_a \frac{dE}{dt} & \text{NO INTEGRATOR} \end{cases}$$

# SLOW ELECTRIC FIELD CHANGES

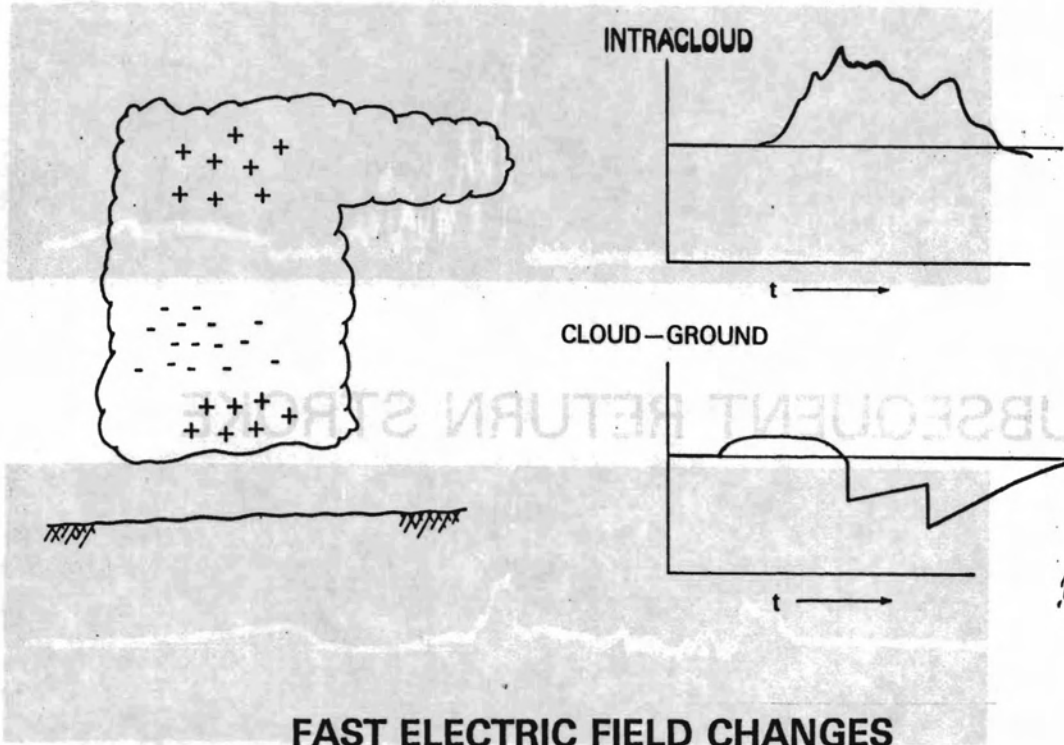

# FAST ELECTRIC FIELD CHANGES

LOW RESOLUTION

HIGH RESOLUTION

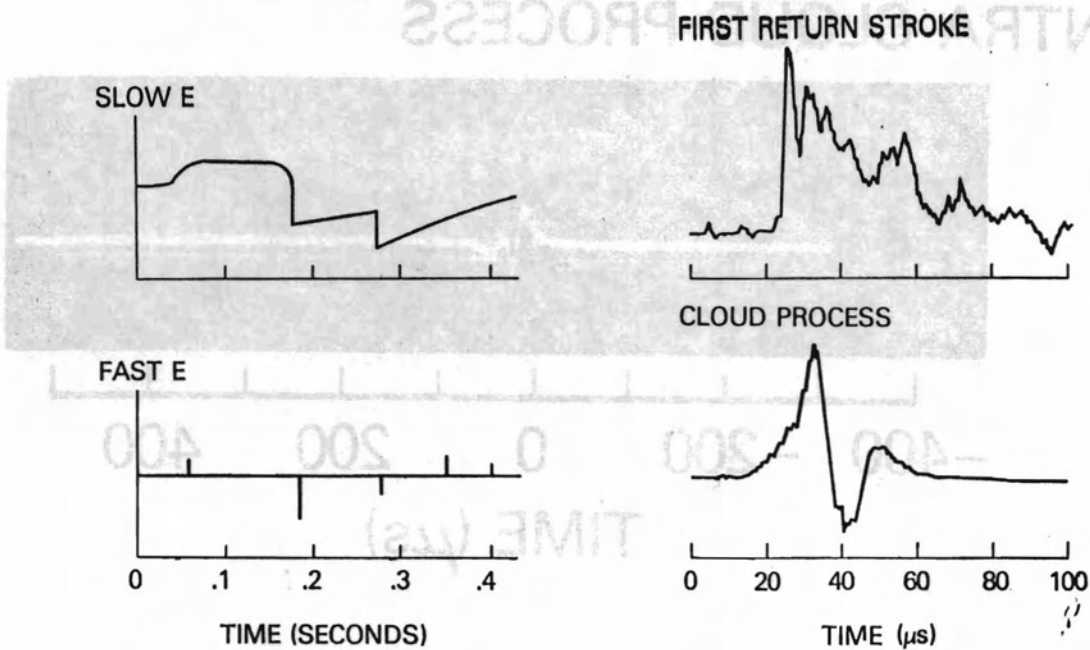

### FIRST RETURN STROKE

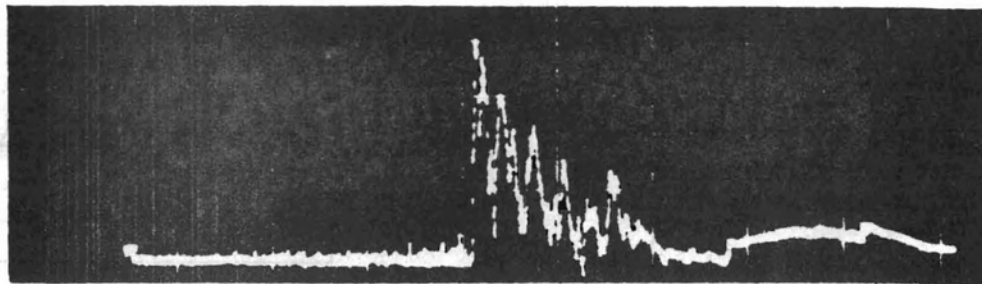

### SUBSEQUENT RETURN STROKE

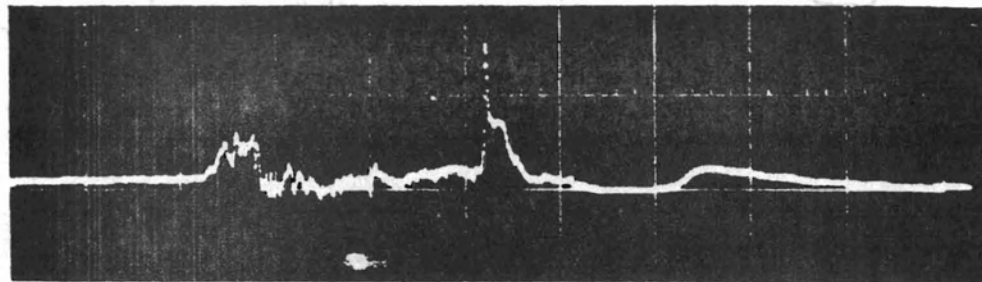

### INTRA CLOUD PROCESS

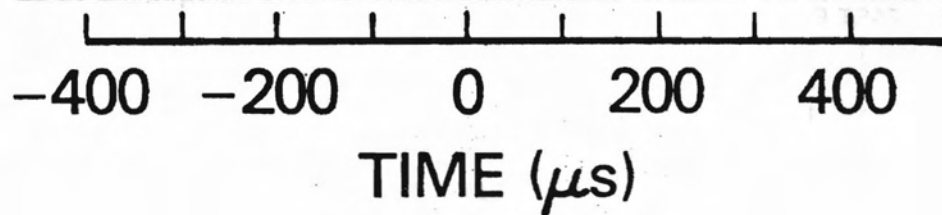
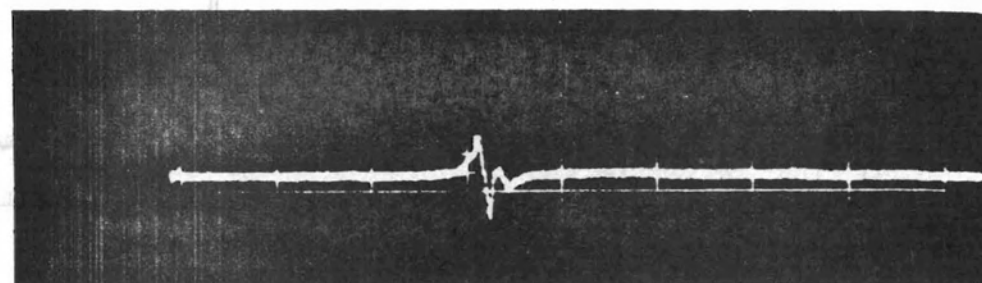

# RADIO RECEIVER

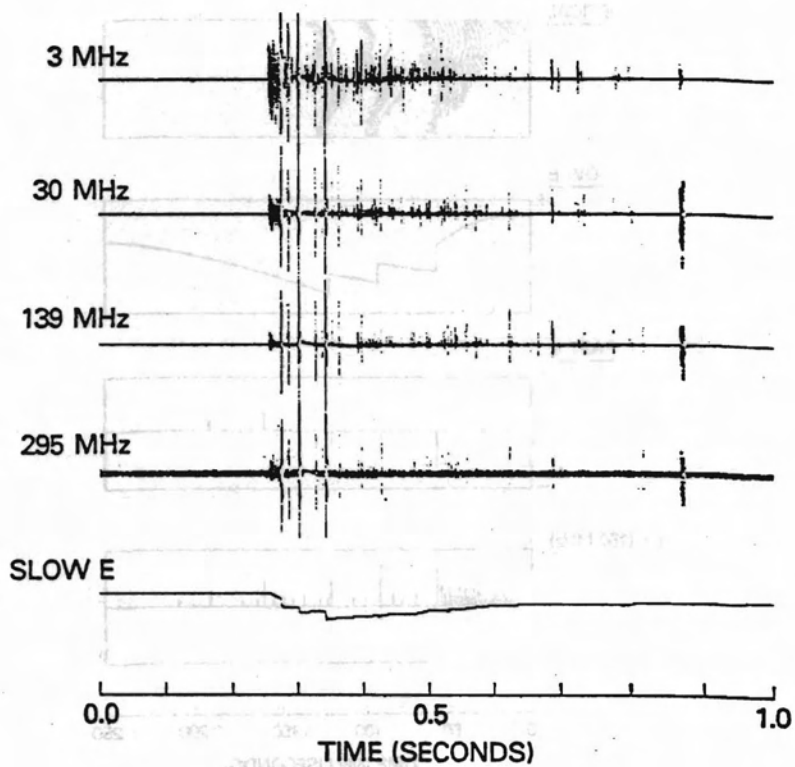
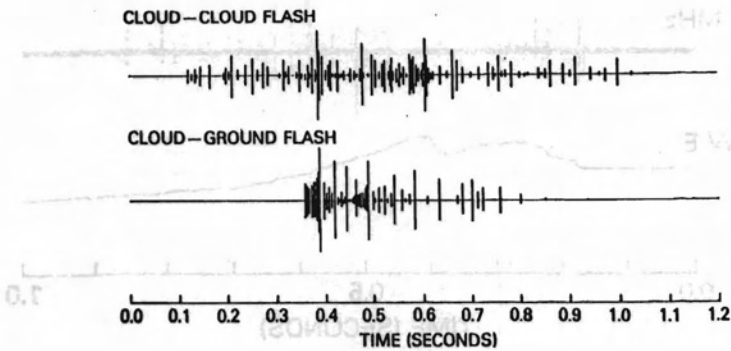
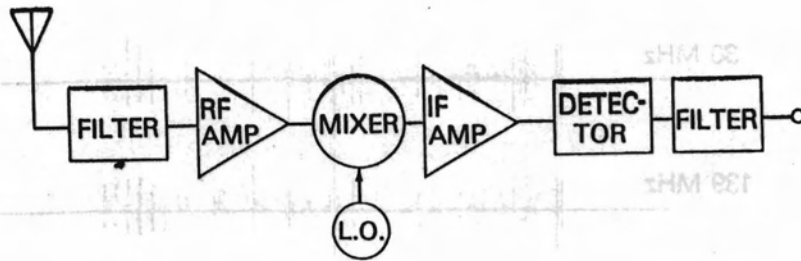

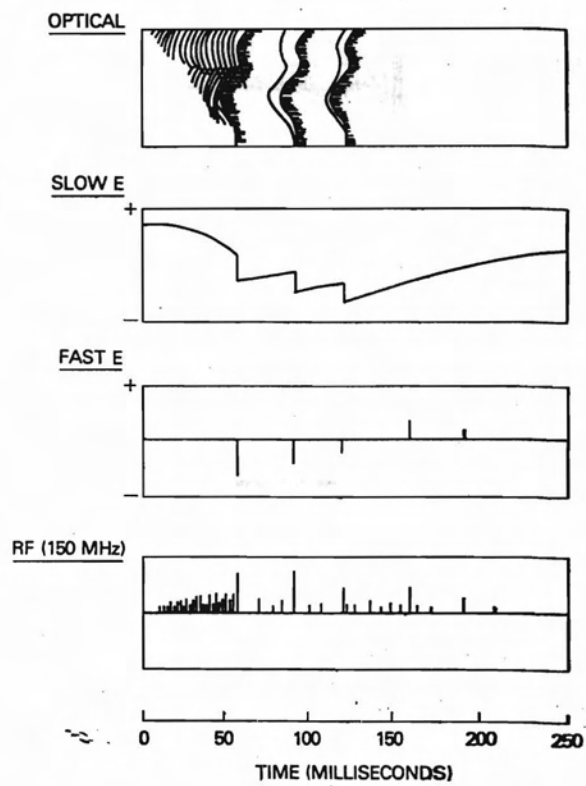
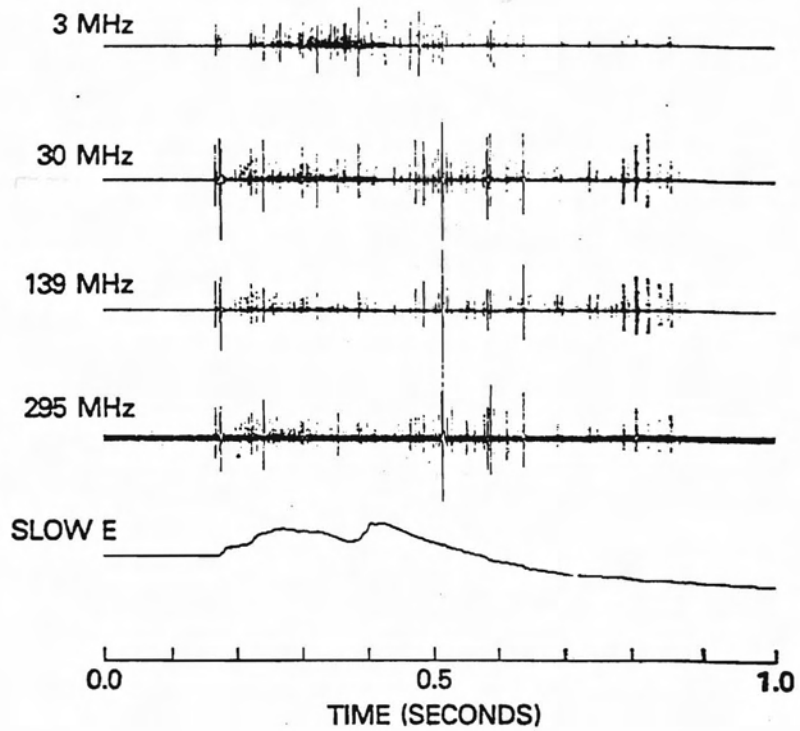

# MAPPING USING RF RADIATION

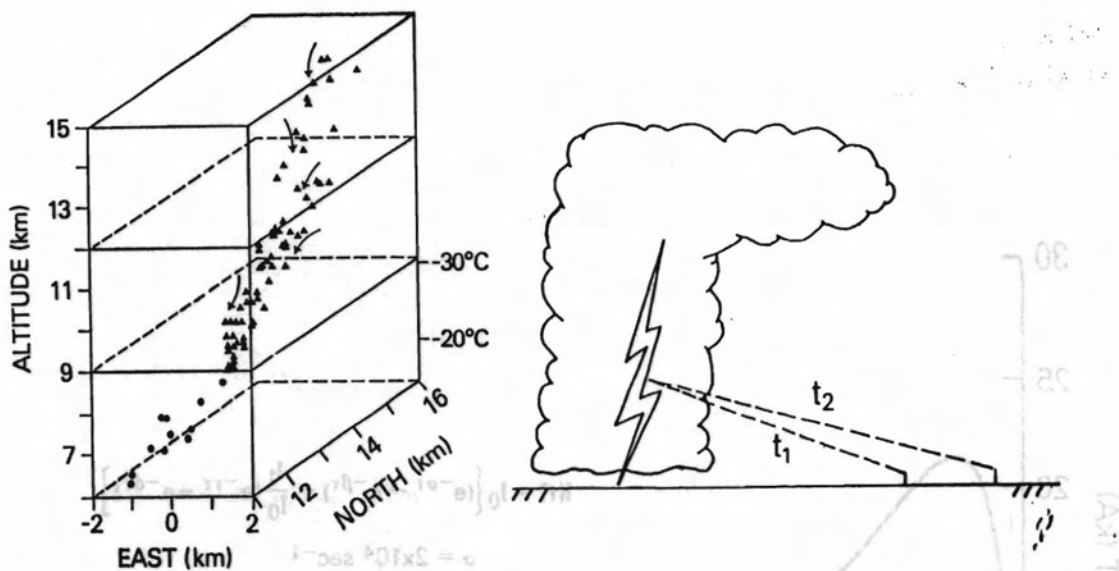

## CURRENT WAVEFORMS

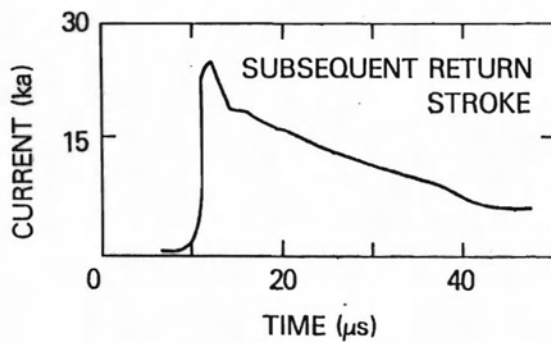
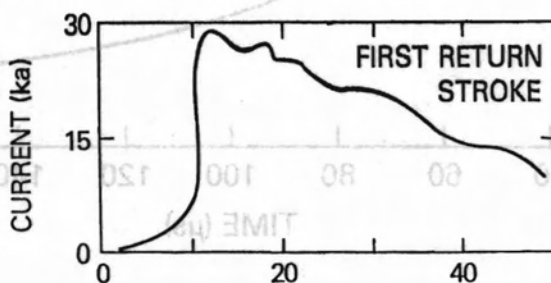

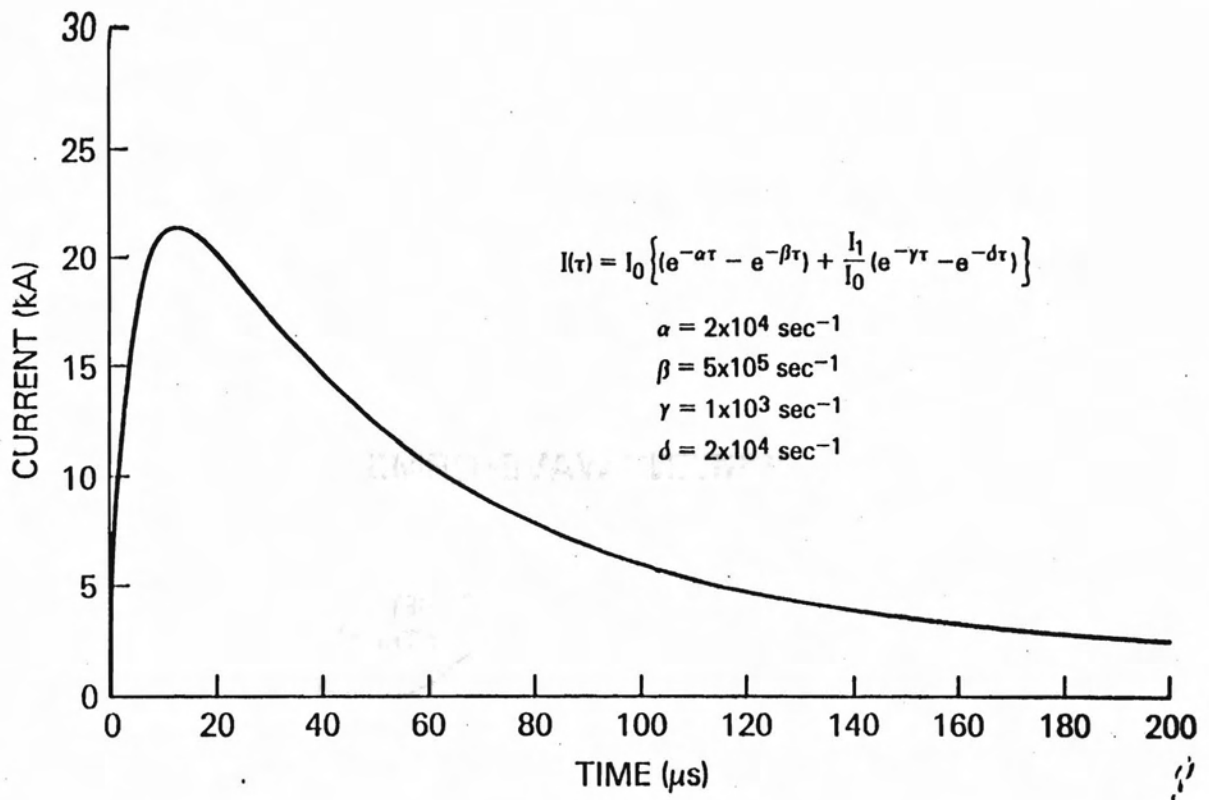

FLIGHT EXPERIMENT DEFINITION AND SUMMARY

by

Mr. Felix Pitts

Langley Research Center  
National Aeronautics and Space Administration

Description of NASA F-106B in-flight direct strike measurement program. Electromagnetic measurements, instrumentation concept, and results summary.

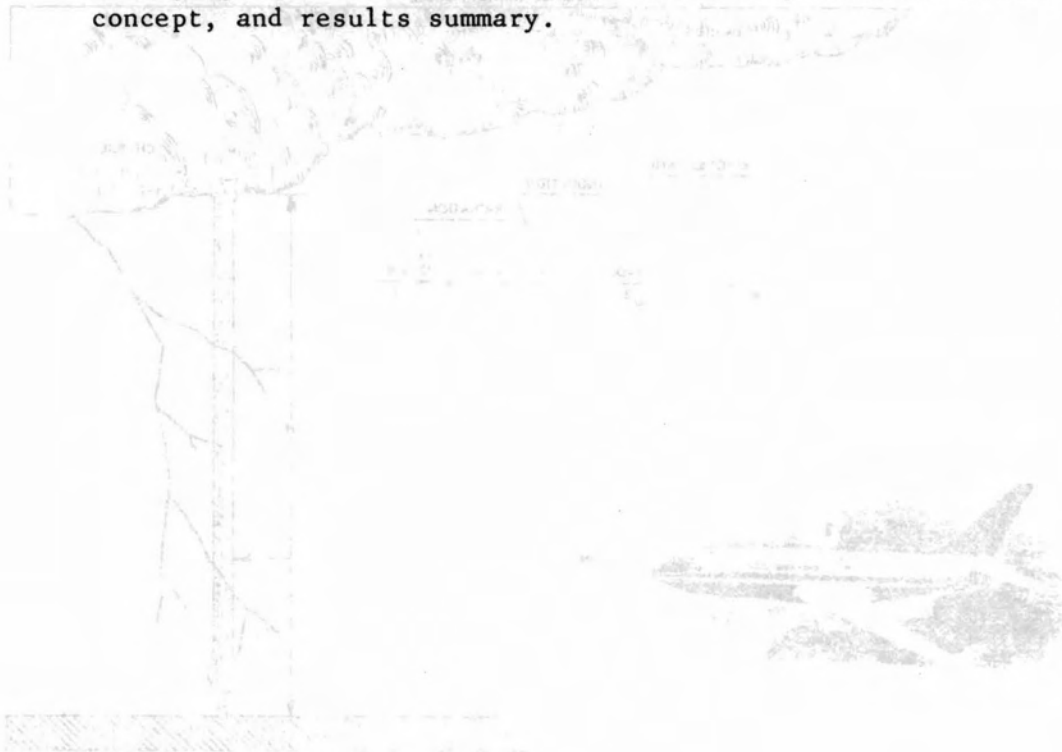

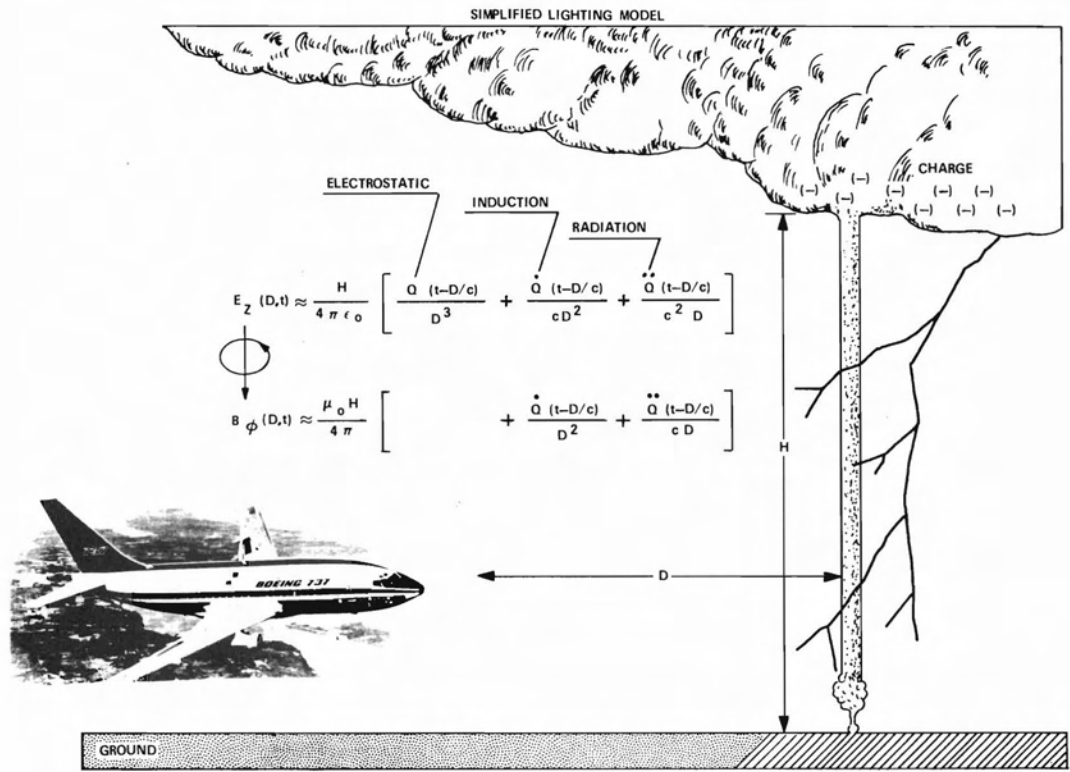
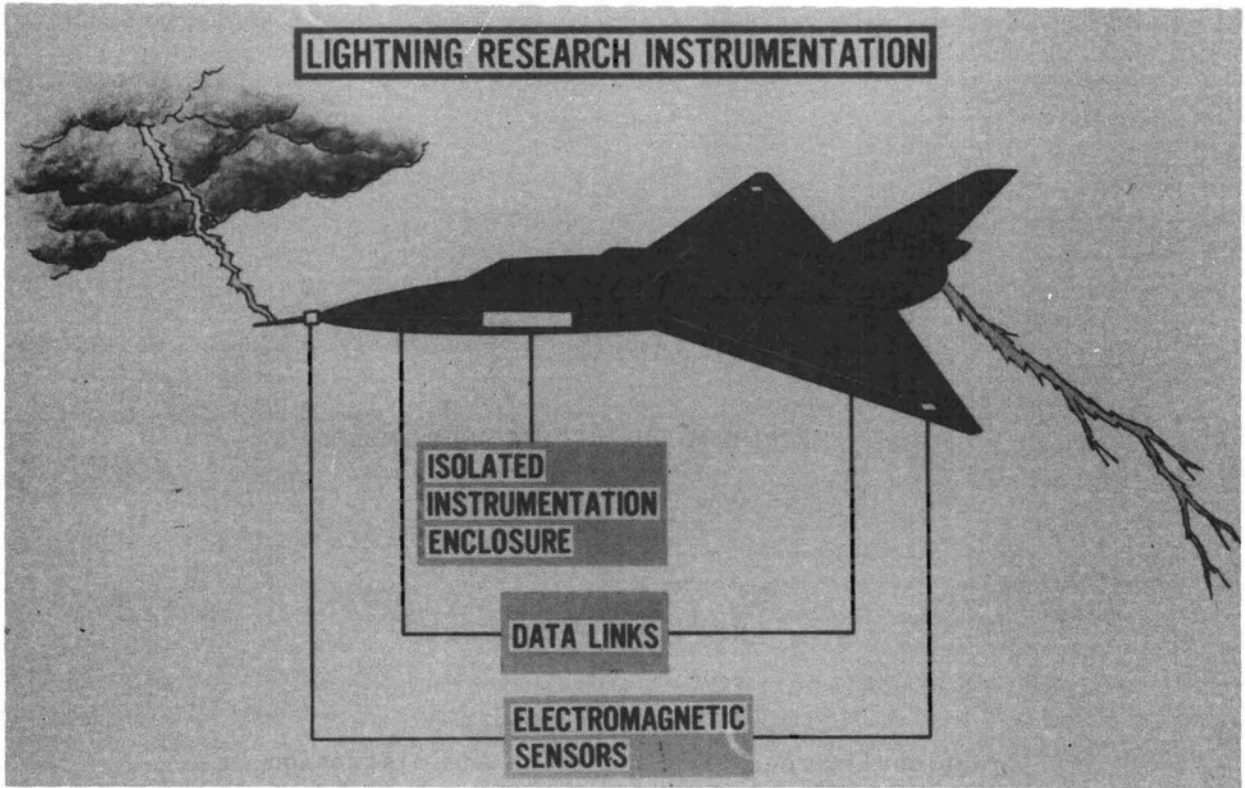

# MEASUREMENTS SUMMARY

MEASUREMENT LOCATIONS - 1980

<u>MEASUREMENT</u>	<u>SYMBOL</u>	<u>AMPLITUDE RANGE</u>	<u>SENSOR TYPE</u>
RATE OF CHANGE OF ELECTRIC FLUX DENSITY	$\dot{D}$	50 A/M <sup>2</sup>	FLUSH PLATE DIPOLE
RATE OF CHANGE OF MAGNETIC FLUX DENSITY	$\dot{B}$	2 X 10 <sup>4</sup> TESLA/SEC	MULTIGAP LOOP
RATE OF CHANGE OF CURRENT	$\dot{I}$	10 <sup>11</sup> A/SEC	INDUCTIVE CURRENT PROBE

# MEASUREMENTS SUMMARY

<u>MEASUREMENT</u>	<u>SYMBOL</u>	<u>DIMENSION</u>	<u>SENSOR TYPE</u>
• RATE OF CHANGE OF ELECTRIC FLUX DENSITY	$\dot{D}$	A/M <sup>2</sup>	FLUSH PLATE DIPOLE
• RATE OF CHANGE OF MAGNETIC FLUX DENSITY	$\dot{B}$	TESLA/SEC	MULTIGAP LOOP
• RATE OF CHANGE OF CURRENT	$\dot{I}$	A/SEC	INDUCTIVE CURRENT-PROBE
• ELECTRIC FIELD	E	V/M	FIELD MILL
• CURRENT	I	A	CURRENT TRANSFORMER

# MEASUREMENT LOCATIONS - 1980

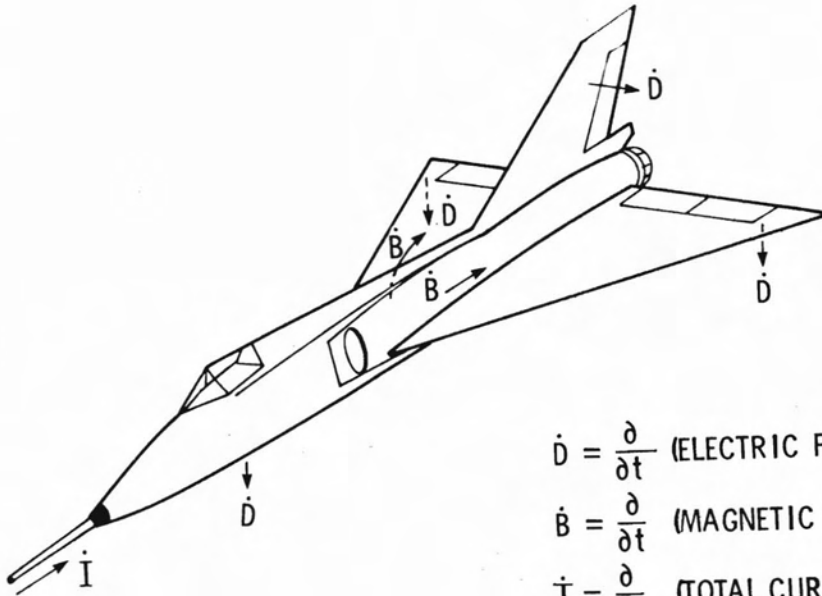

$$\dot{D} = \frac{\partial}{\partial t} \text{ (ELECTRIC FLUX DENSITY)}$$

$$\dot{B} = \frac{\partial}{\partial t} \text{ (MAGNETIC FLUX DENSITY)}$$

$$\dot{I} = \frac{\partial}{\partial t} \text{ (TOTAL CURRENT)}$$

1980 LIGHTNING OCCURRENCES

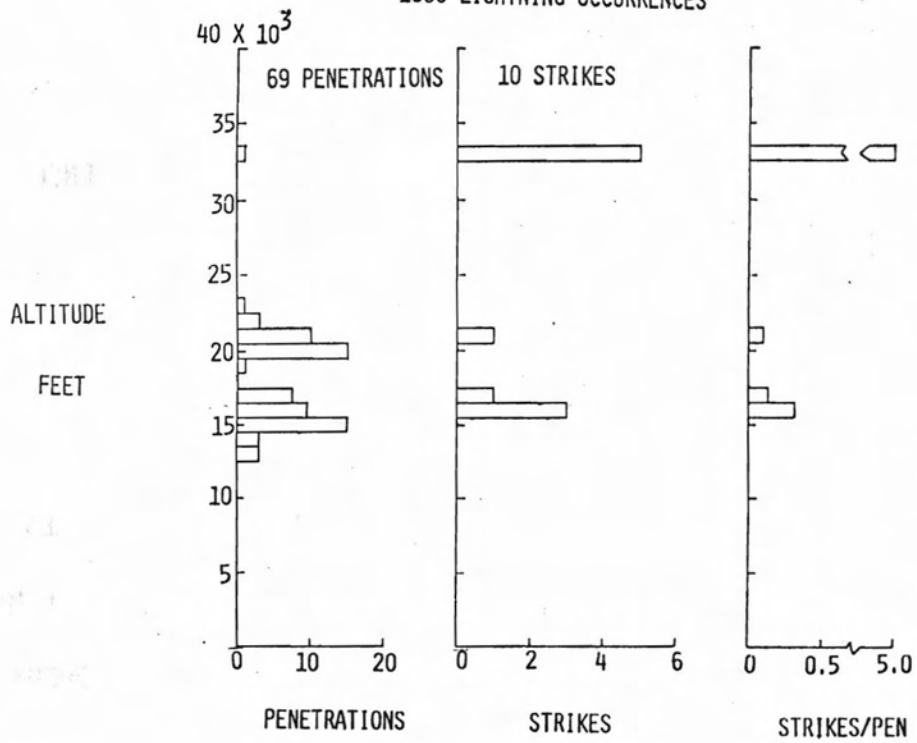

NASA  
L-79-5627

### INSTRUMENTATION SYSTEM

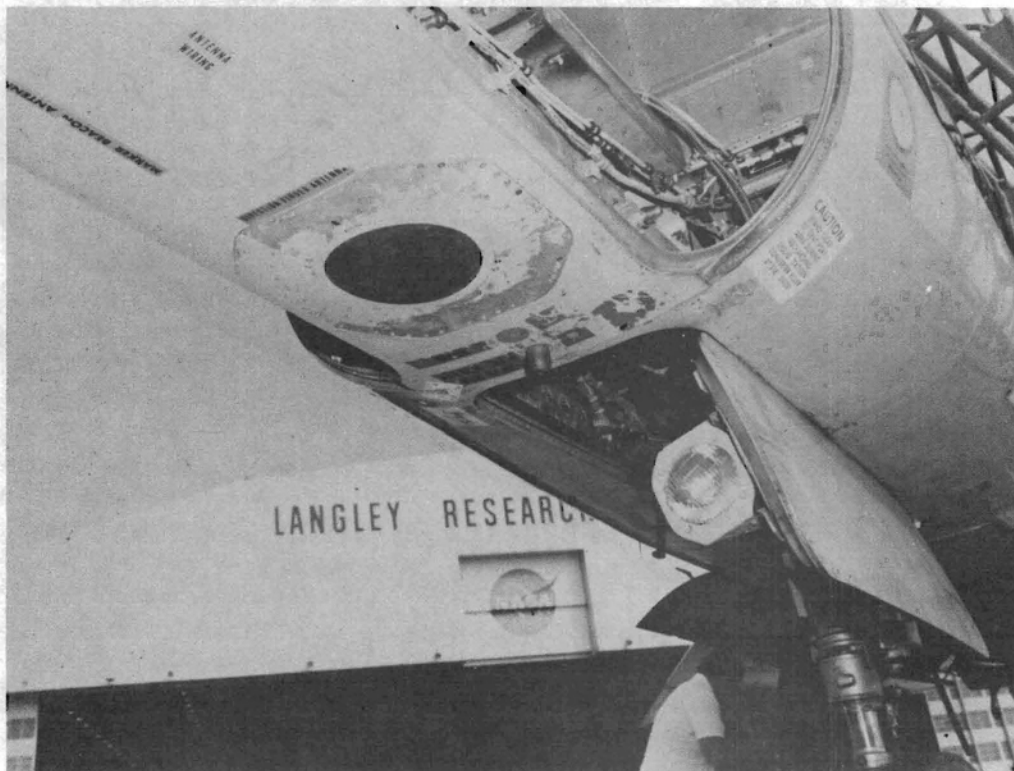
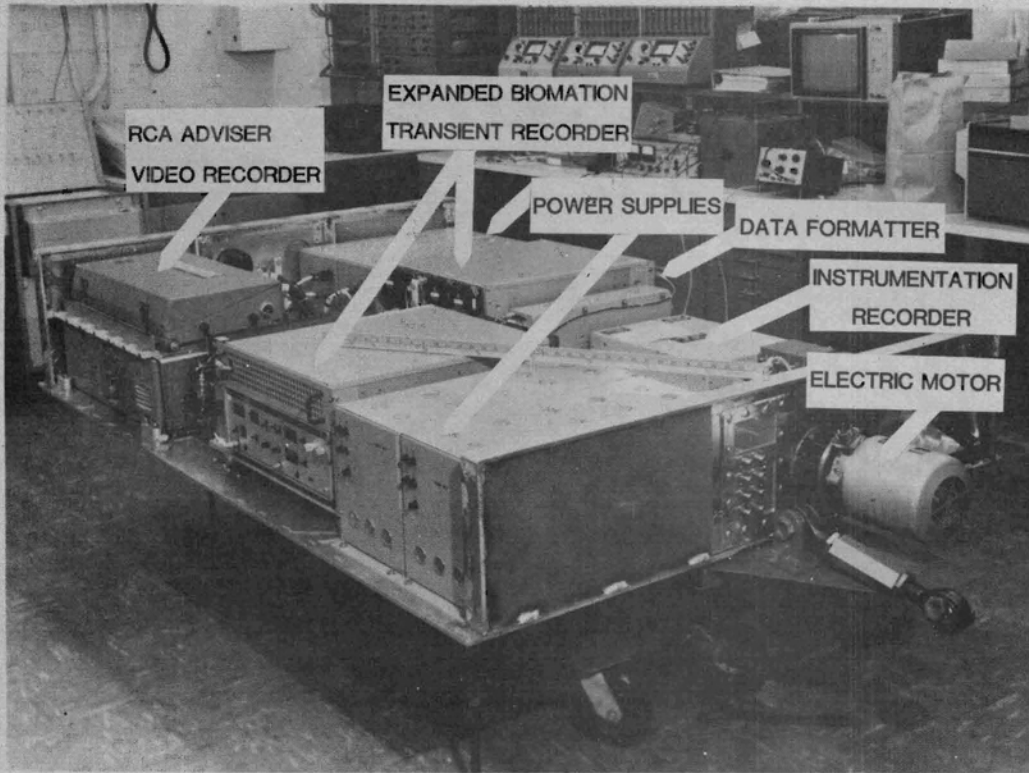

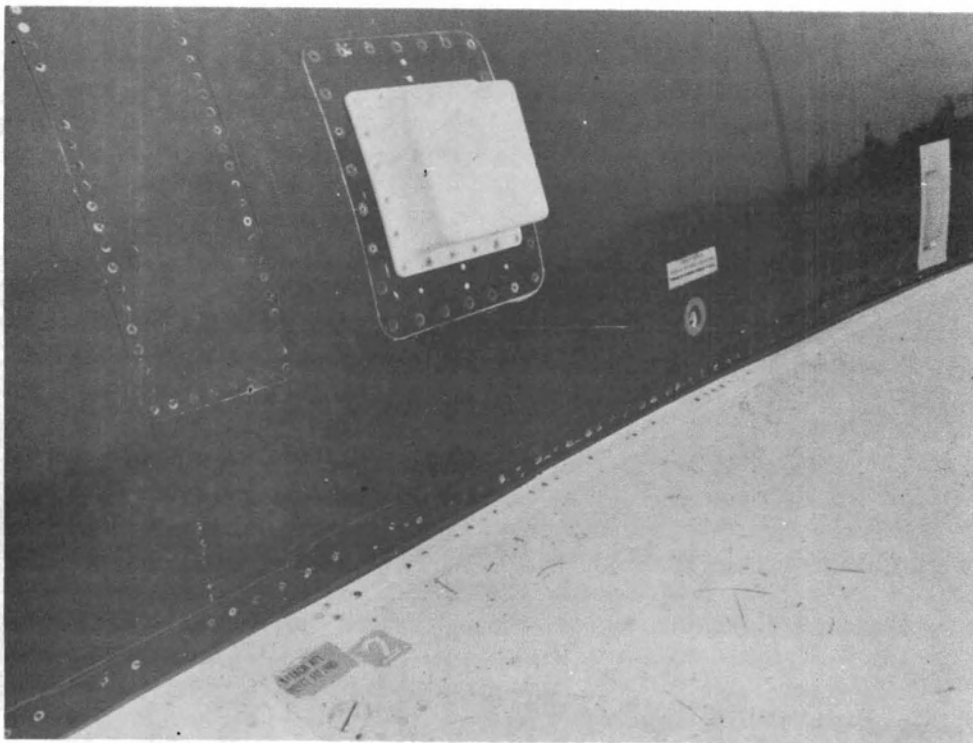
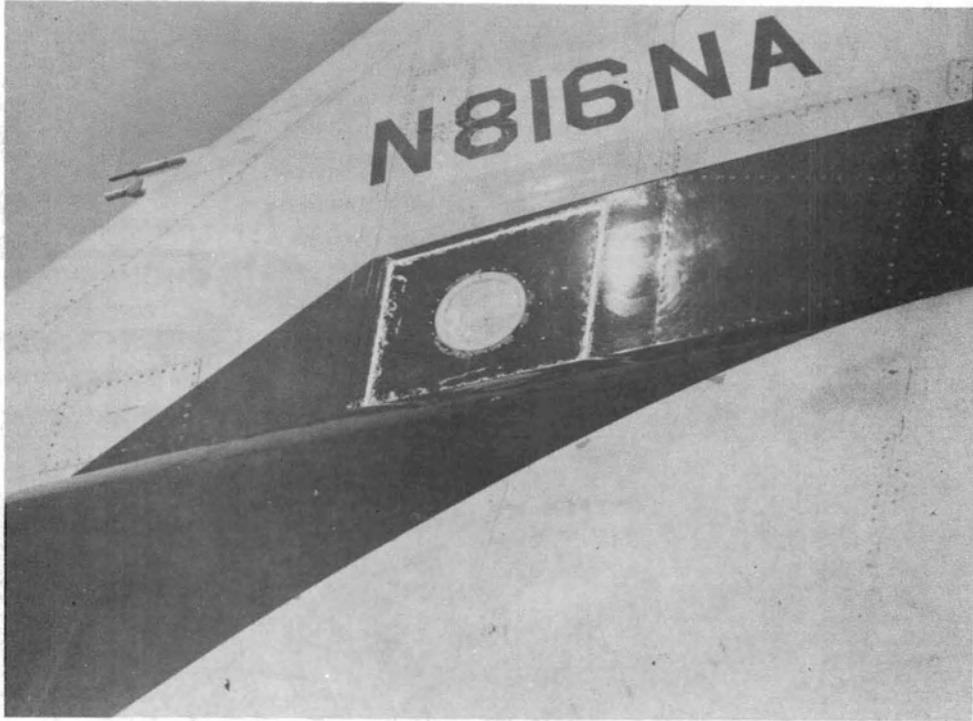

# TYPICAL DIRECT STRIKE LIGHTNING RESULTS

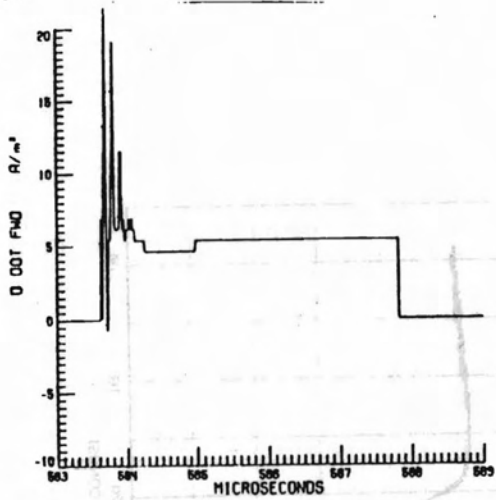

Fig. 10 D-dot sensor (flight #80-018).

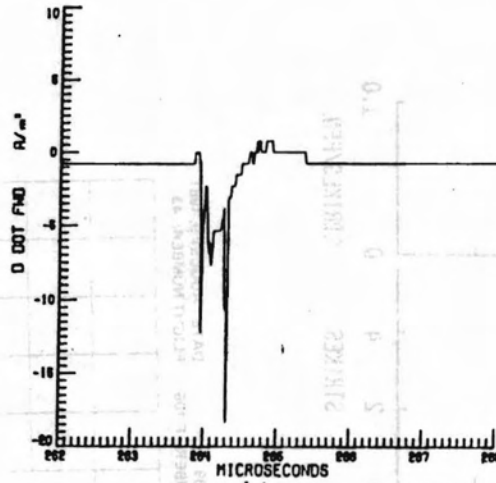

Fig. 11 D-dot sensor (flight #80-036).

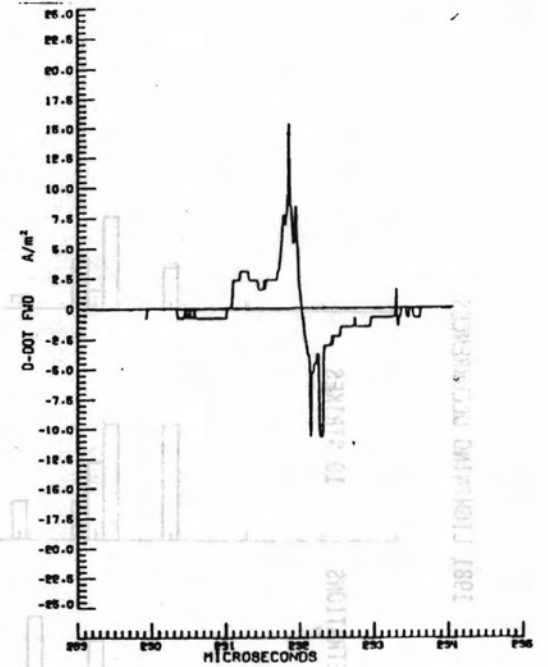

Fig. 12 D-dot sensor (flight #80-038).

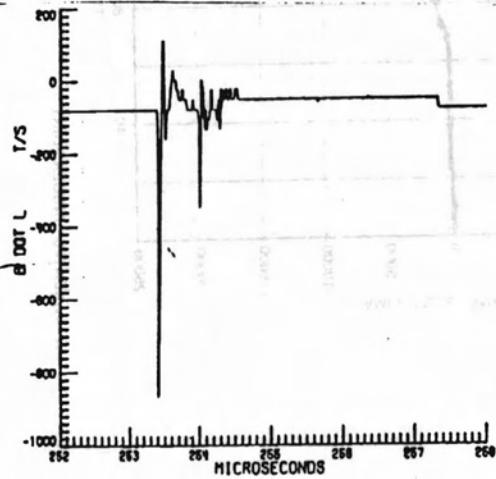

Fig. 13 B-dot sensor (flight #80-036).

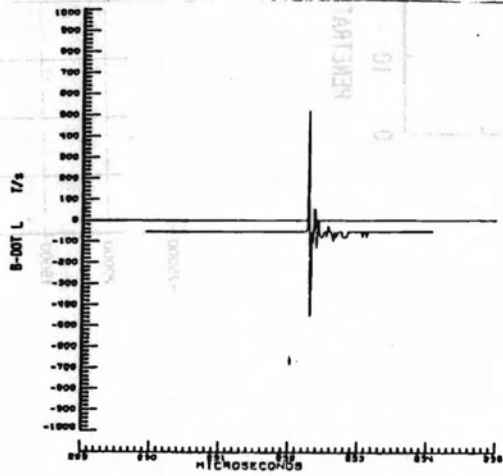

Fig. 14 B-dot sensor (flight #80-038).

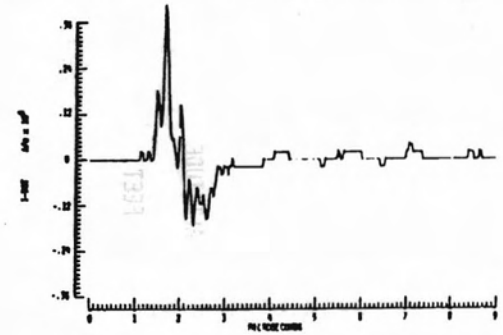
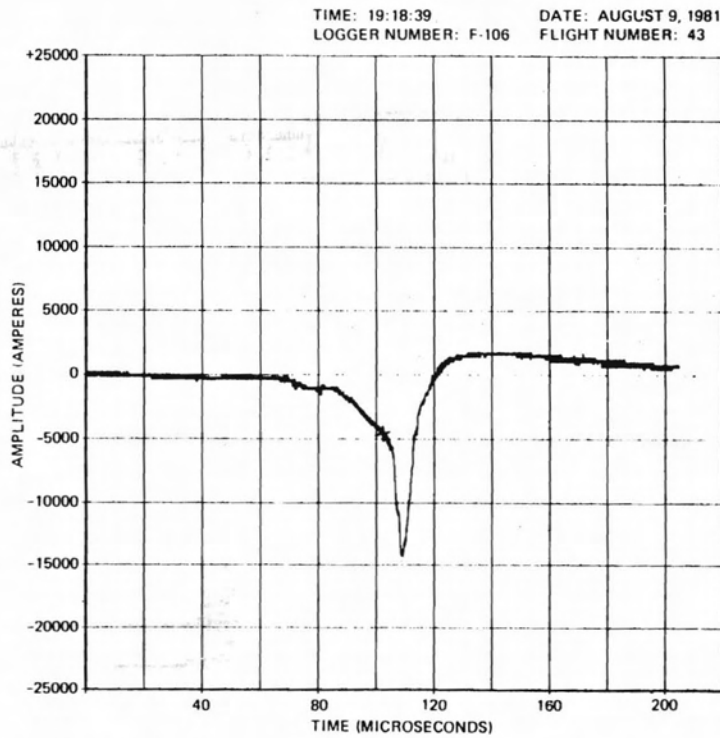
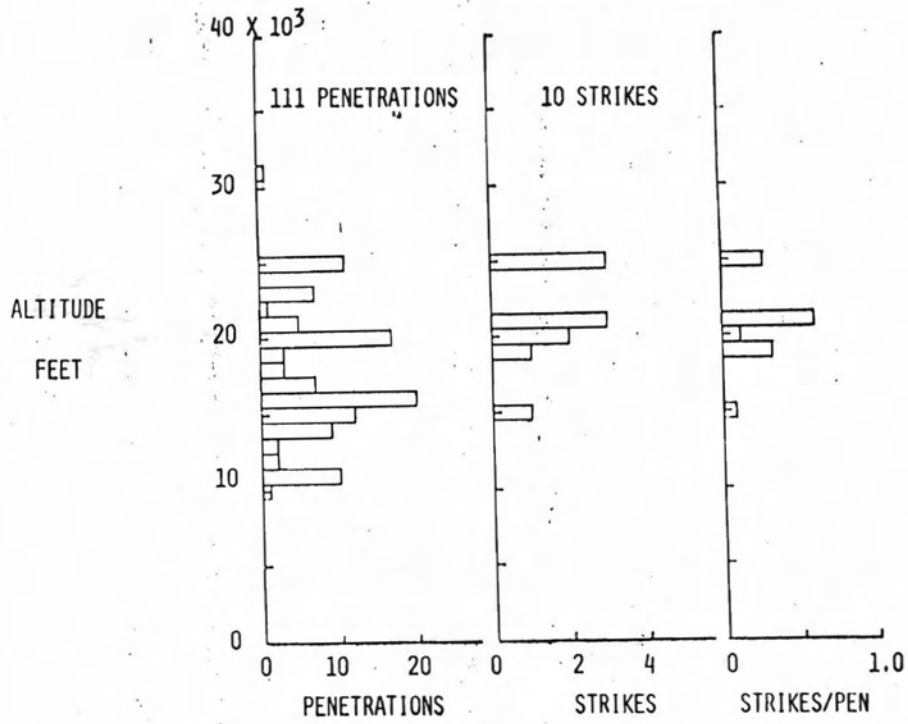

Fig. 15 I-dot sensor (flight #80-038).

26%

1981 LIGHTNING OCCURRENCES



X - INDICATES TRIGGER POINT

## DATA SUMMARY

### o 1980

- 19 FLIGHTS    69 STORM PENETRATIONS
- 10 STRIKES    17 TRANSIENTS: (7  $\dot{D}$ , 5  $\dot{B}$ , 5 I)
- RESULTS REPORTED:
  - NASA TM 81946 "1980 DIRECT STRIKE LIGHTNING DATA"
  - AIAA 81-0083 "E/M MEASUREMENT OF DIRECT LIGHTNING STRIKES TO A/C"

### o 1981

- 24 FLIGHTS    111 STORM PENETRATIONS
- 10 STRIKES    27 TRANSIENTS
  - 1 BOOM CURRENT (BOEING)
  - 16  $\dot{B}$ , 10  $\dot{D}$  (DISTANT)

### o MAXIMUM MEASURED VALUES

$\dot{D}$	30.5 A/m <sup>2</sup>	→	340 KV/0.1 $\mu$ S
$\dot{B}$	1160 T/s	→	2 KA/0.1 $\mu$ S
I	15 KA		

## OTHER F-106 LIGHTNING EXPERIMENTS

- ATMOSPHERIC CHEMISTRY EXPERIMENTS - LaRC
  - 1980 - SHOWED N<sub>2</sub>O ENHANCEMENT NEAR LIGHTNING
  - 1981 - SHOWED CO ENHANCEMENT NEAR LIGHTNING
- X-RAY EXPERIMENT - U. WASHINGTON
  - 1980 - SHOWED INCREASED COUNT NEAR LIGHTNING
  - 1981 - BEING EVALUATED
- OPTICAL SIGNATURE EXPERIMENT - NSSL
  - PROTOTYPE FOR ORBITAL LIGHTNING MAPPER
  - RESULTS BEING ANALYZED AT NSSL
- STORM SCOPE
  - TURBULENCE/LIGHTNING DO NOT ALWAYS CORRELATE
  - LIGHTNING LOCATIONS DISPLAYED TEND TO BE FURTHER FROM AIRCRAFT POSITION THAN RADAR CONTOURS (BUT AT SAME BEARING)
- BOEING DATA LOGGER
  - FIRST BOOM CURRENT RECORDED AUGUST 1981



IMPROVING THE PRESENTATION SYSTEM

WIDE BANDWIDTH FOR SUBMICROSECOND SIGNAL RESOLUTION

10 ns SAMPLE INTERVAL

### DATA SYSTEM DESCRIPTION

SCHEMATIC RECORDS FOR DEFINITION OF FULL LIGHTNING SCENARIO

IS THE ANALOG BANDWIDTH

Mr. Mitchel E. Thomas

ADDED ENCLOSURE

Langley Research Center  
National Aeronautics and Space Administration

FIBER OPTIC CONTROL

The research data-gathering system on the F-106B aircraft developed for in-flight measurement of direct and nearby lightning strike characteristics is described. Details of the design and performance are presented for system components including the digital transient recorders, wideband analog recorder, fiber optic control and diagnostic links, power system isolation, and system shielding.

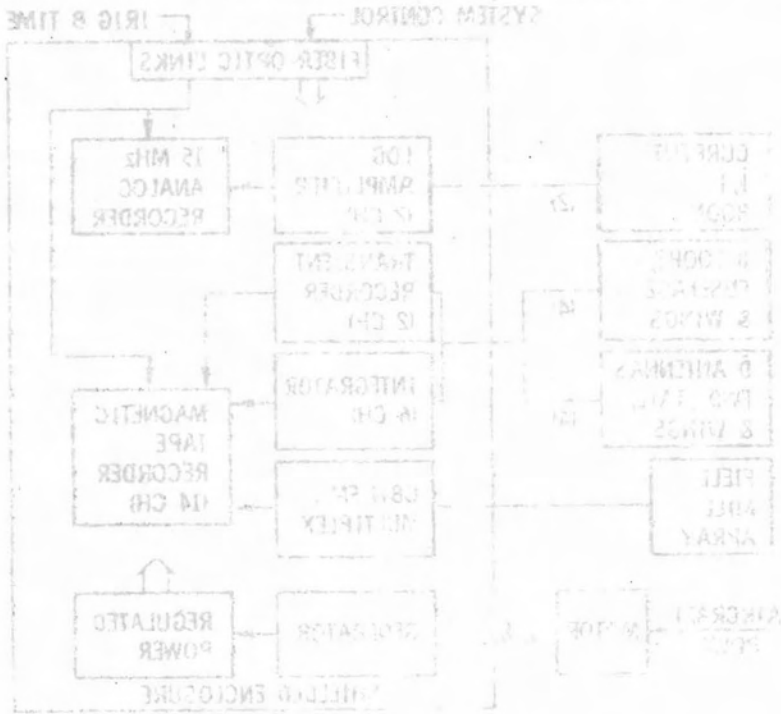

## LIGHTNING INSTRUMENTATION SYSTEM

- WIDE BANDWIDTH FOR SUBMICROSECOND SIGNAL RESOLUTION
  - 10 ns SAMPLE INTERVAL
- CONTINUOUS RECORDS FOR DEFINITION OF FULL LIGHTNING SCENARIO
  - 15 MHz ANALOG BANDWIDTH
- PROTECT AGAINST SPURIOUS RESPONSES (EMI)
  - SHIELDED ENCLOSURE
  - MOTOR-GENERATOR POWER ISOLATION
  - FIBER OPTIC CONTROL
- AUTOMATIC OPERATION

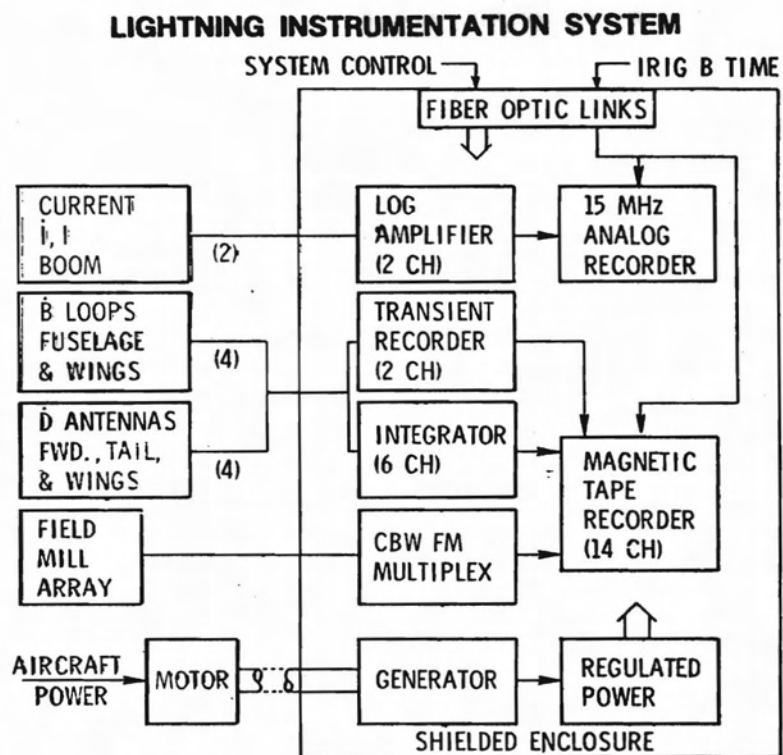

NASA  
L-79-5627

### INSTRUMENTATION SYSTEM

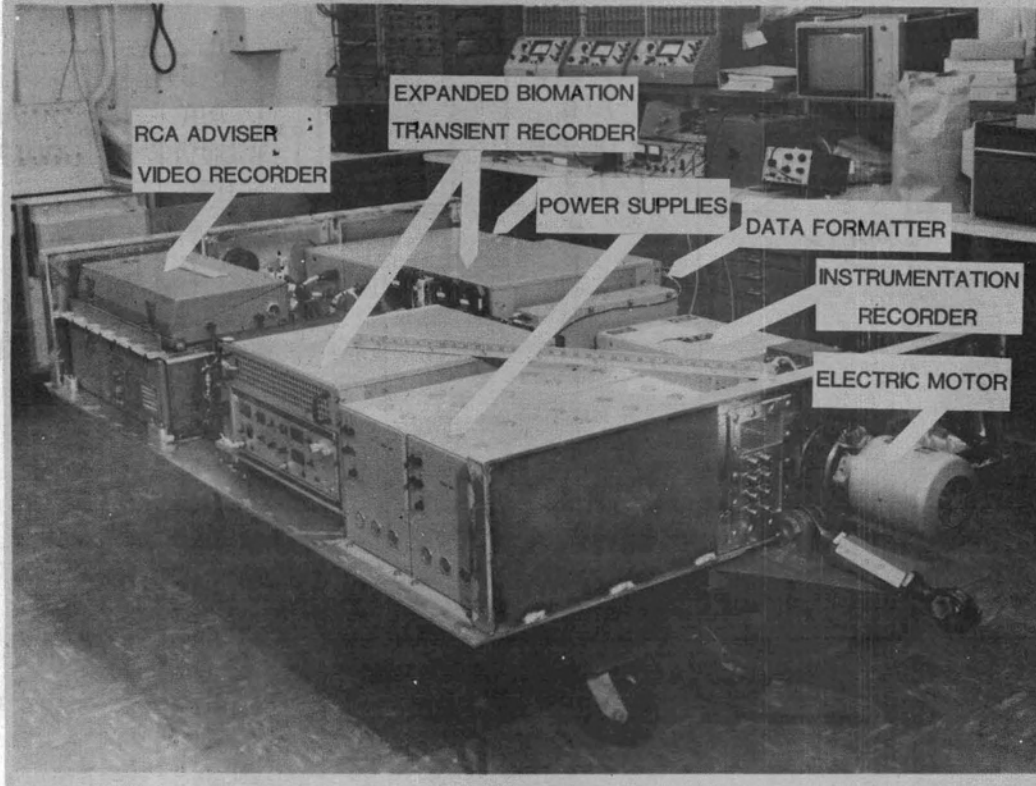

EXPANDED TRANSIENT WAVEFORM RECORDER FEATURES

### EXPANDED WAVEFORM RECORDER

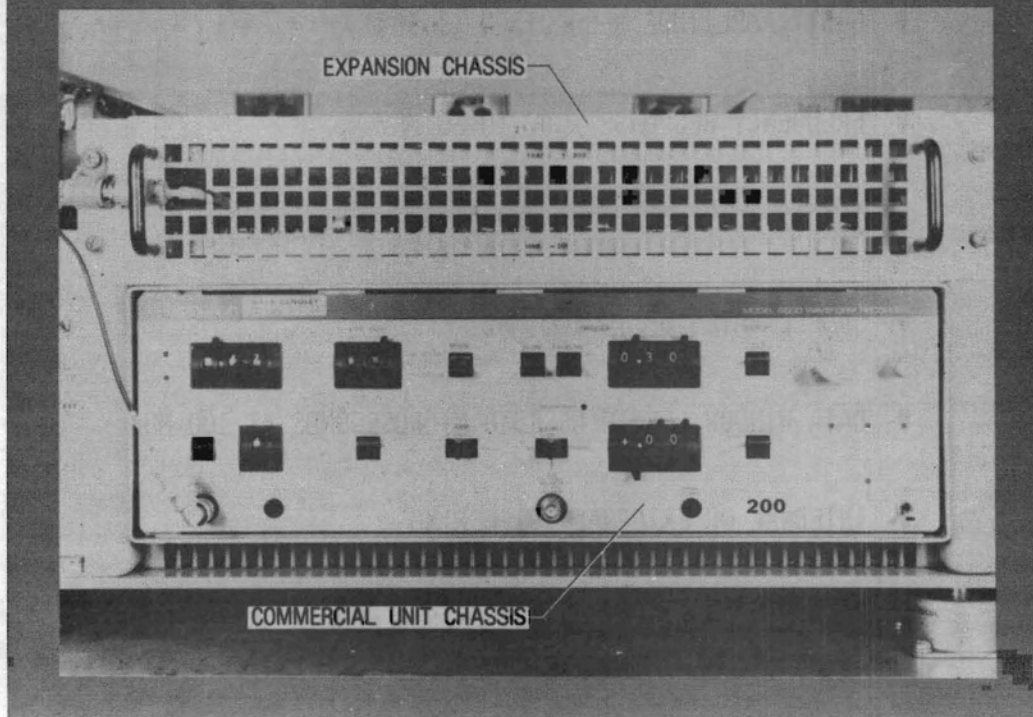

## TRANSIENT RECORDER

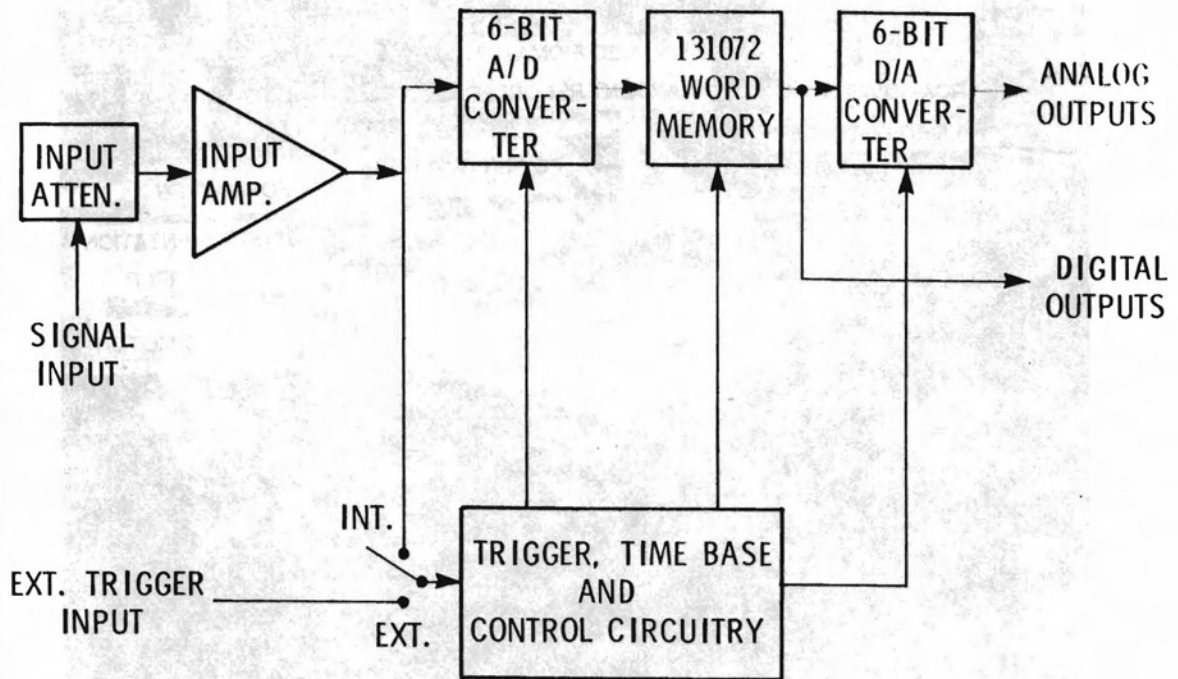

### EXPANDED TRANSIENT WAVEFORM RECORDER FEATURES

- 6-BIT AMPLITUDE RESOLUTION (1.56%)
- FREQUENCY RESPONSE - DC TO 50 MHz
- 131072 ( $2^{17}$ ) DATA WORD CAPACITY
- SAMPLE RATES UP TO 100 MHz
- DATA WINDOW LENGTH OF 1310 MICROSECONDS AT 100 MHz
- INTERNAL OR EXTERNAL TRIGGERING
- DATA WINDOW SELECTION WHICH IS BEFORE, DURING, OR AFTER TRIGGER EVENT

WIDE-BAND ANALOG RECORDER

VIDEO RECORD TECHNIQUES

LOW-LEVEL MODULATED CARRIER

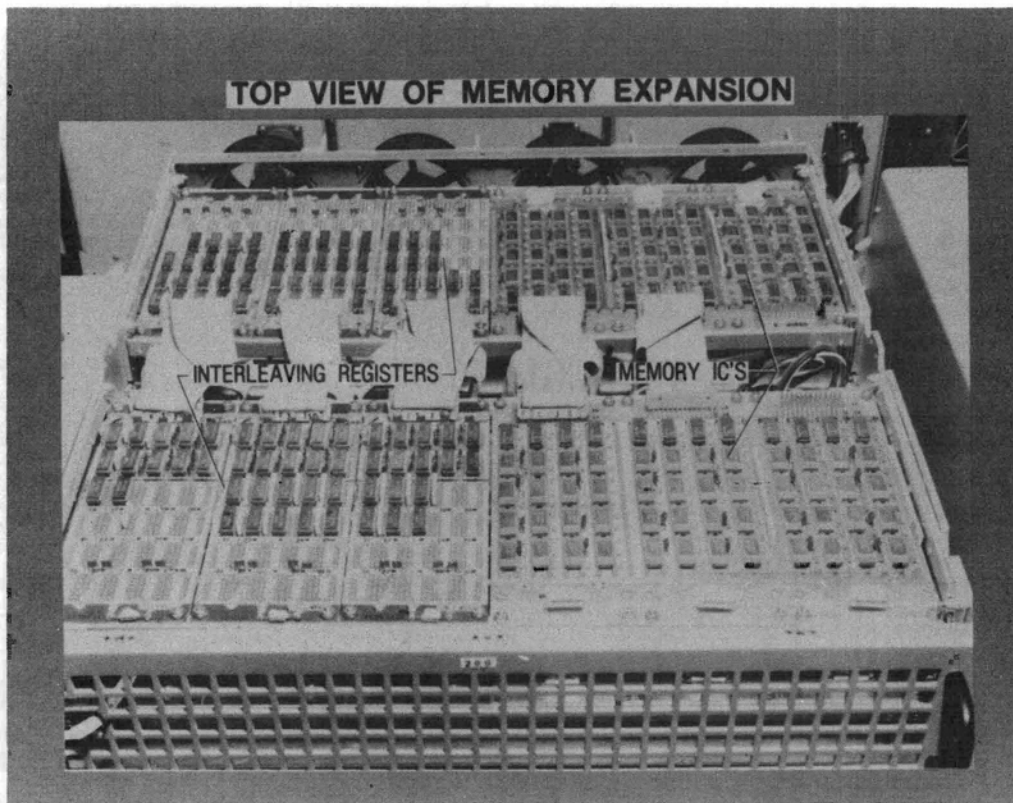

# WIDEBAND ANALOG RECORDER

- VIDEO RECORD TECHNIQUES
- FREQUENCY MODULATED CARRIER
- 10 Hz TO 15 MHz BANDWIDTH
- 12 MINUTES RECORD TIME
- 2 CHANNELS & 2 AUXILIARY

## LOGARITHMIC AMPLIFIER

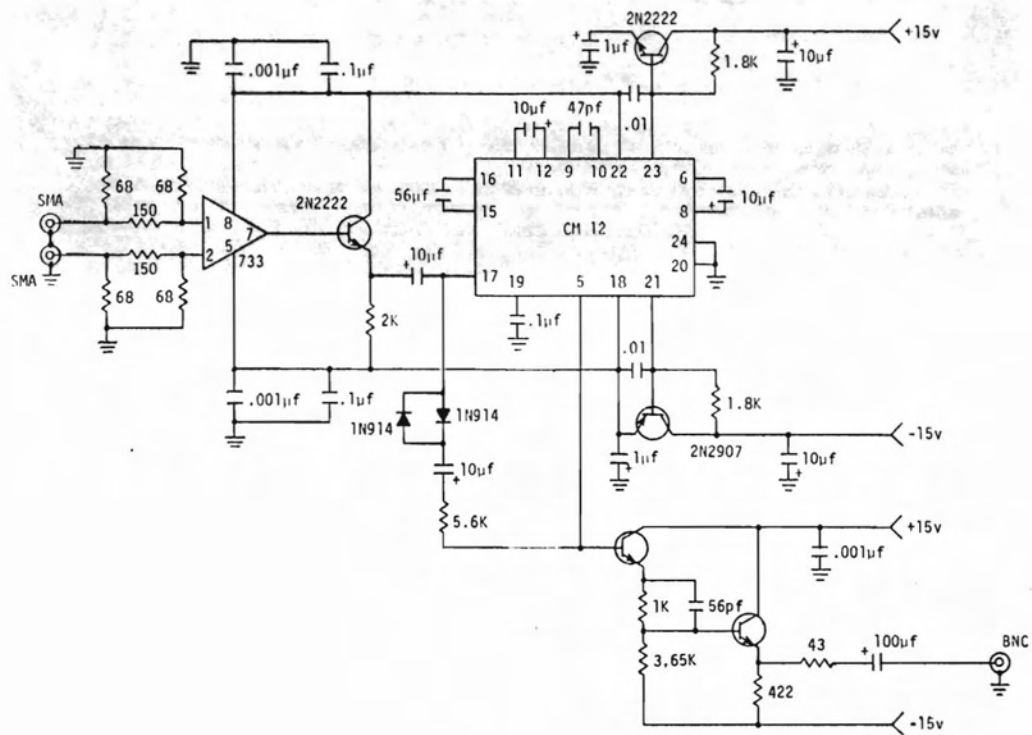

# COMPRESSION AMPLIFIER

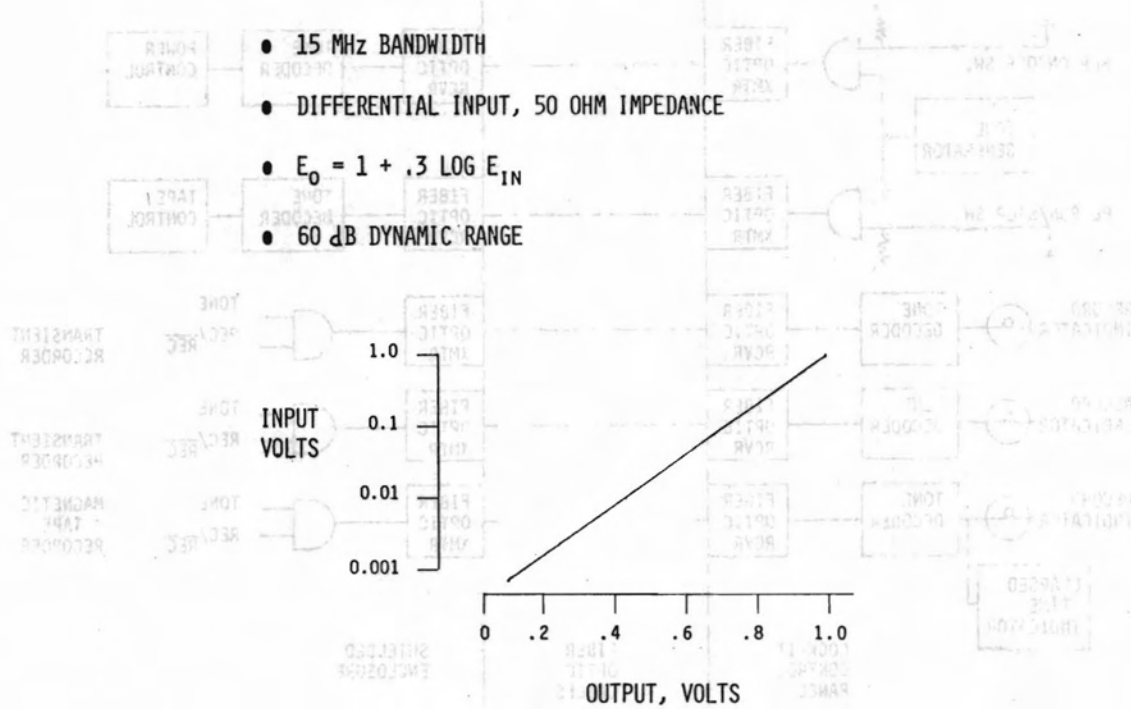

## SIMPLIFIED SHIELDING TOPOLOGY

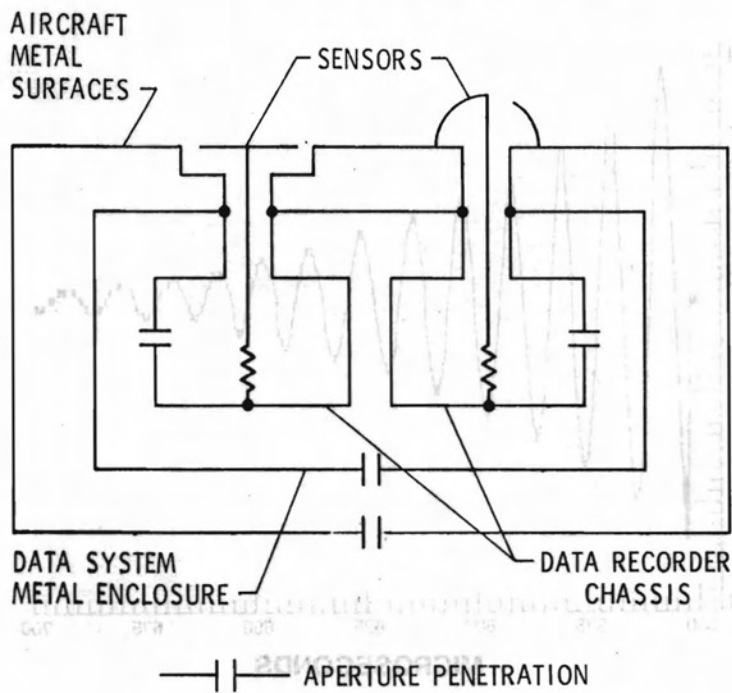

## LIGHTNING INSTRUMENTATION CONTROL

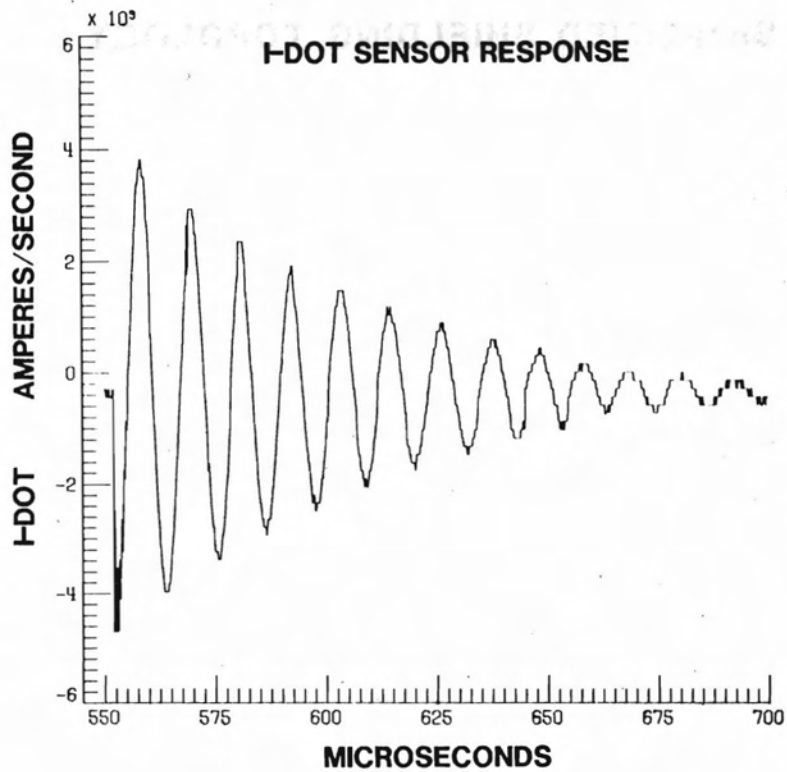
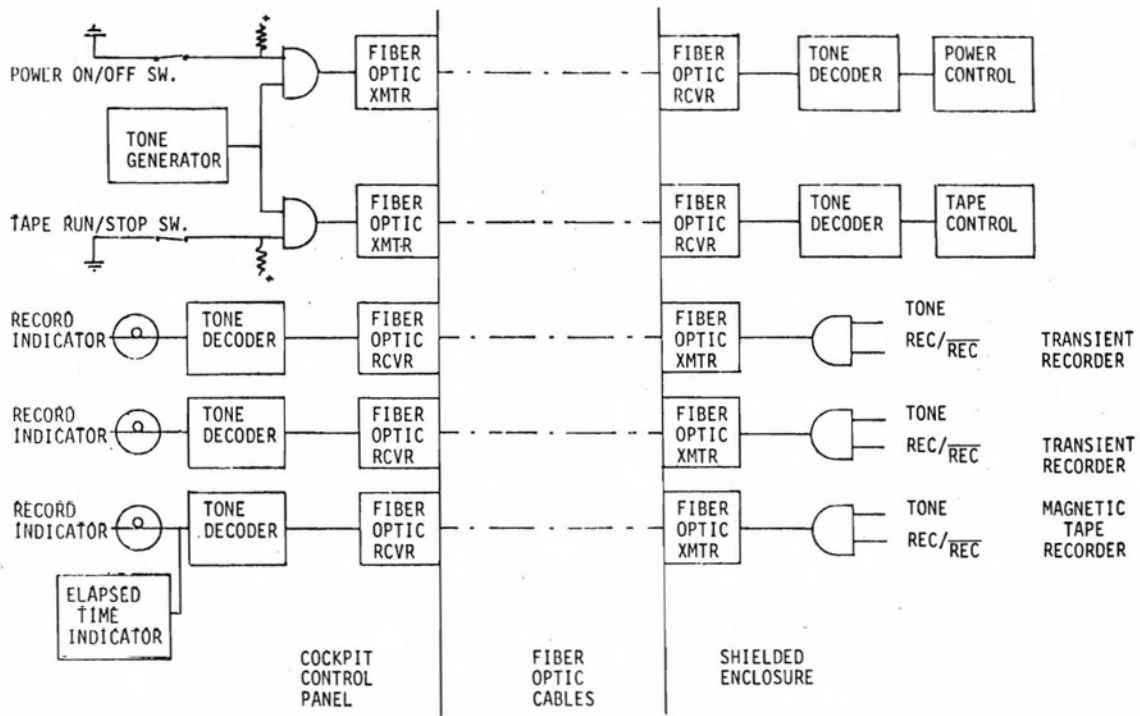

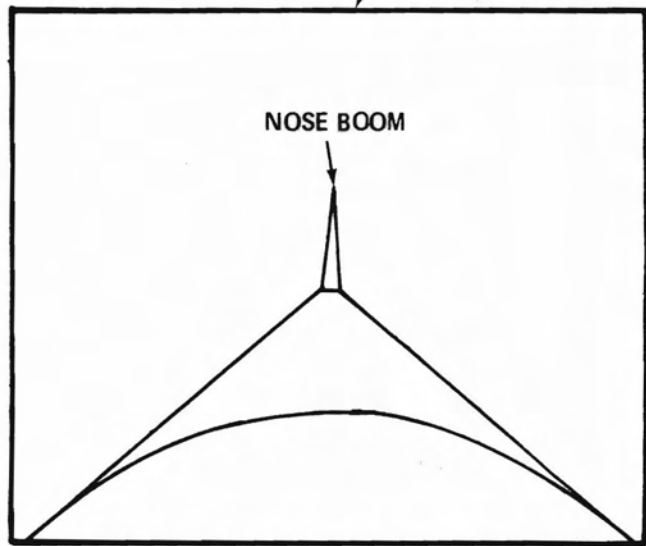
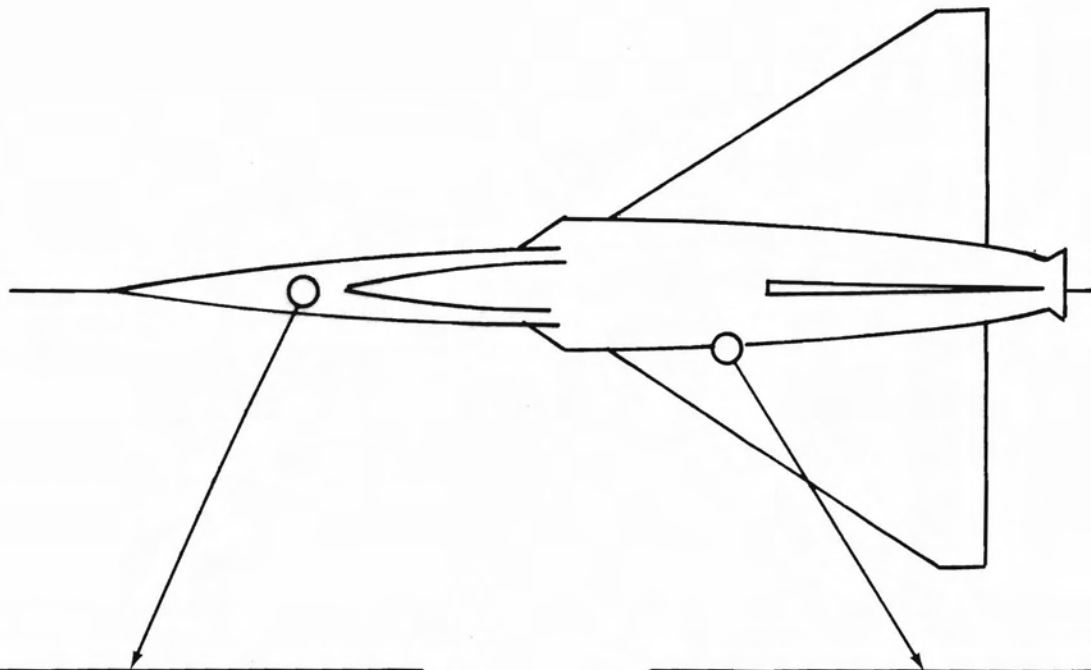

FORWARD - VIEWING CAMERA

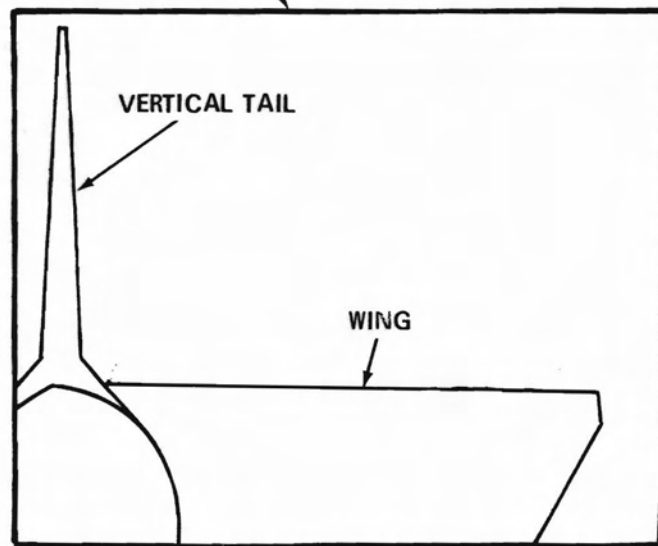

REARWARD - VIEWING CAMERA



# MEASUREMENT REQUIREMENTS

SENSOR OUTPUT	ELECTROMAGNETIC SENSORS FOR AIRCRAFT LIGHTNING RESEARCH	MEASUREMENT
> 100V	by	1
> 100V	Mr. Klaus P. Zaepfel	5
> 100V	Langley Research Center National Aeronautics and Space Administration	1

Electromagnetic sensors designed for measuring EM fields and currents during lightning strikes to the F-106B research aircraft are described. Sensor theoretical basis, performance, and parallel-plate transmission line used to check and calibrate these sensors are described.

# SENSOR CHARACTERISTICS

- DESIGN PRINCIPLES DEVELOPED BY AIR FORCE WEAPONS LAB FOR NEMP
- WIDE BANDWIDTH  $\approx 80 \text{ MHz}$  ( $f \geq 4.4 \text{ ns}$ )
- STIMPLE GEOMETRY: CALIBRATION BY RULER
- APPROXIMATELY 100 V OUTPUT FOR FULL-SCALE DIRECT STRIKE

## MEASUREMENT REQUIREMENTS

MEASUREMENT	FIELD CHANGE	SENSOR OUTPUT
$J_T$	$50\text{A/m}^2$ ( $\Delta E \approx 6 \times 10^5 \frac{\text{V}}{\text{m}}$ per $0.1\mu\text{s}$ )	$> 100\text{V}$
$\dot{B}$	$2 \times 10^4$ Tesla/s	$> 100\text{V}$
$\dot{i}$	10kA per $0.1\mu\text{s}$	$> 100\text{V}$

## SENSOR CHARACTERISTICS

- DESIGN PRINCIPLES DEVELOPED BY AIR FORCE WEAPONS LAB FOR NEMP
- WIDE BANDWIDTH:  $\geq 80$  MHz ( $t_R \leq 4.4$  ns)
- SIMPLE GEOMETRY: CALIBRATION BY RULER
- APPROXIMATELY 100 V OUTPUT FOR FULL-SCALE DIRECT STRIKE

## DEFINITIONS: ELECTRIC FIELDS

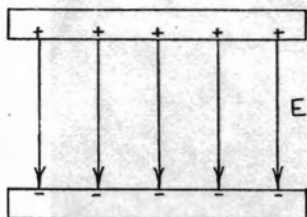

$E$ -FIELD, V/m  
(Electric Field Intensity)

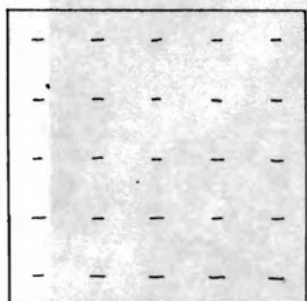

$D$ , C/m<sup>2</sup>  
(Electric Flux Density)

$\rho_s$ , C/m<sup>2</sup>  
(Surface Charge Density)

For flat plate,  $D = \rho_s$

$D = \epsilon E$  where  $\epsilon$  is  
permittivity of dielectric

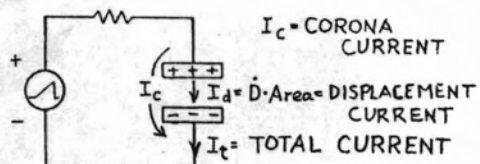

$I_c$  = CORONA  
CURRENT

$I_d = \dot{D} \cdot \text{Area}$  = DISPLACEMENT  
CURRENT

$I_t$  = TOTAL CURRENT

No Corona,  $I_t = \dot{D} \cdot \text{Area}$

In Corona,  $I_t = (J_c + \dot{D}) \text{Area}$   
 $= J_t \text{Area}$

## SENSOR FUNDAMENTALS

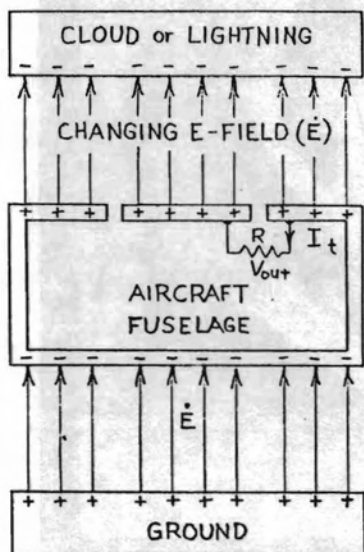

NO CORONA

$$\dot{D} = \epsilon \dot{E}$$

$$I_t = I_d = \dot{D} \cdot \text{AREA}$$

CORONA

$$I_t = (J_c + \dot{D}) \text{ AREA}$$

$$V_{out} = R I_t$$

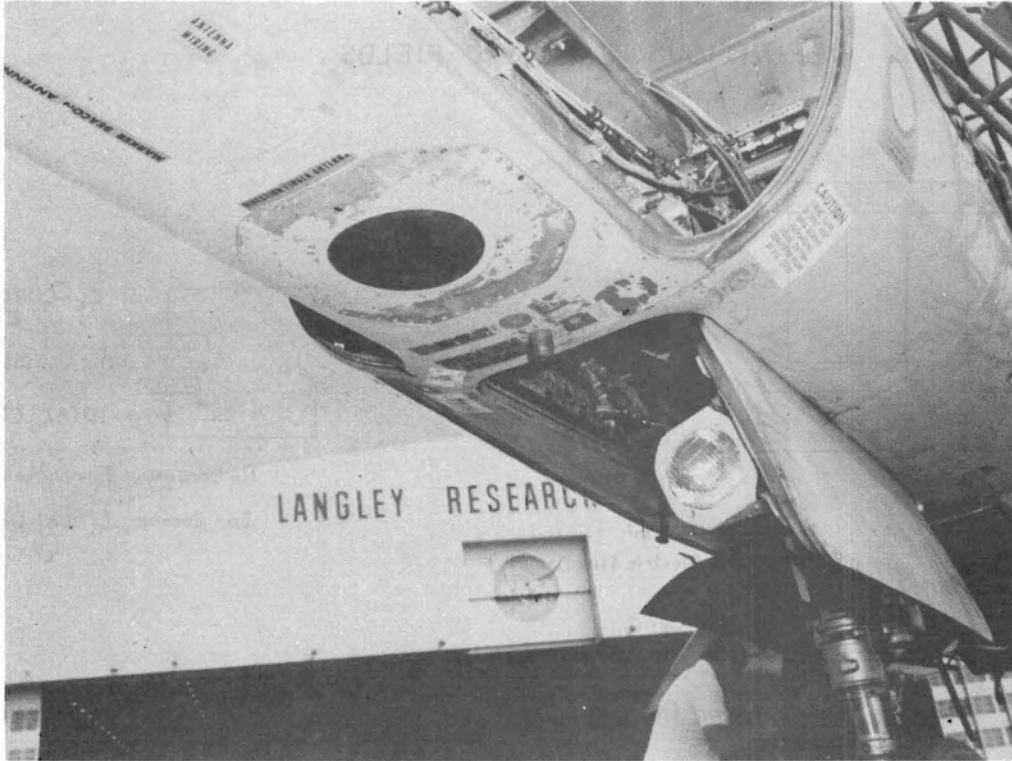

D-DOT SENSOR IN F-106 FUSELAGE PANEL

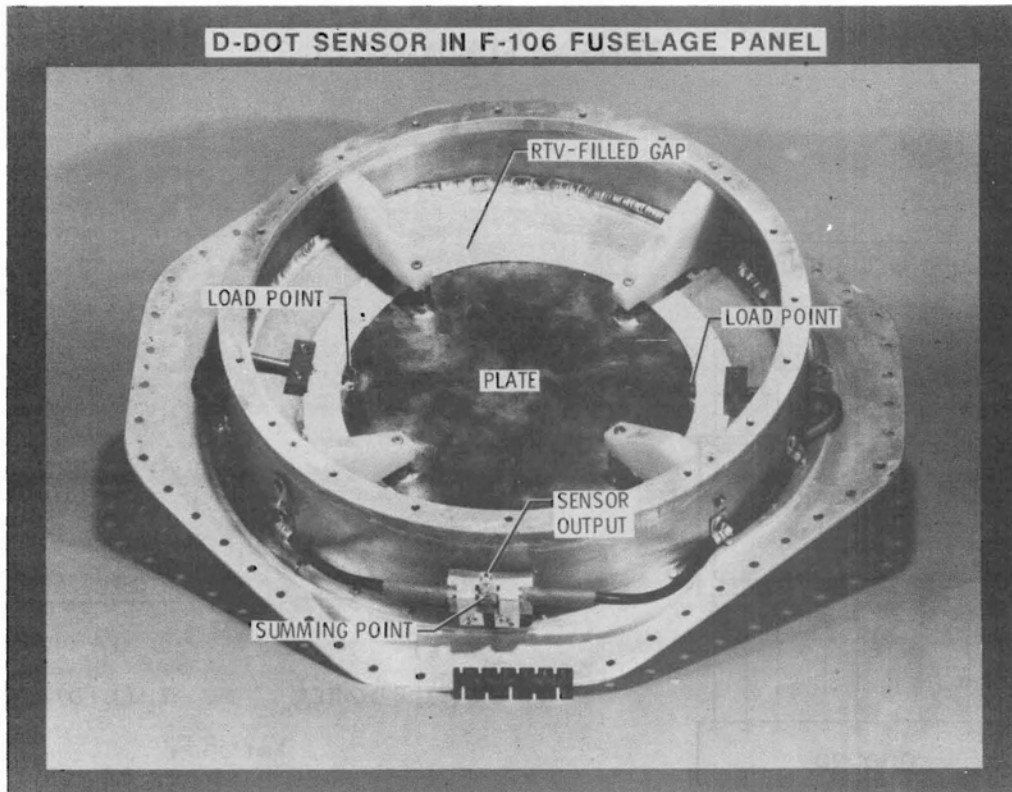

### J<sub>T</sub> SENSOR

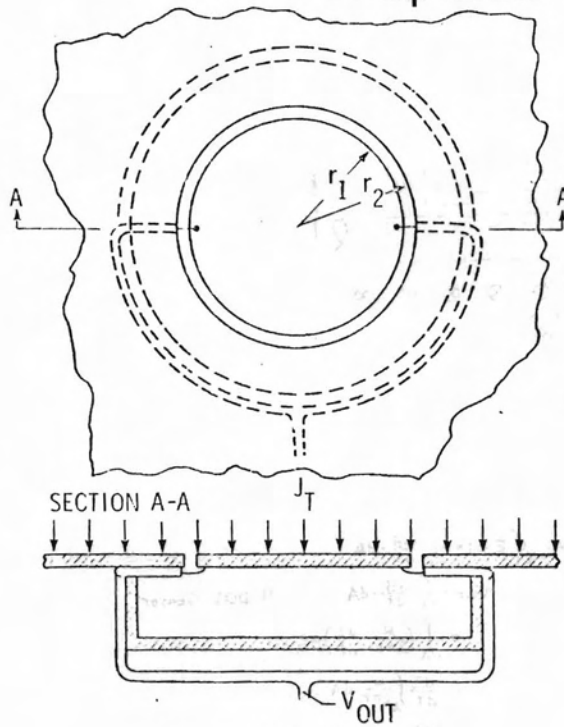

$$t_r = 2.2 RC, R = 50\Omega$$

$$t_{rt} = t_r + \text{PROPAGATION TIME}$$

$$V_{out} = A_J J_T R$$

$$= A_J (\dot{D} + J) R$$

$$A_J = \pi r^2, r^2 = r_1 r_2$$

### B-DOT SENSOR

### DEFINITION: MAGNETIC FIELDS

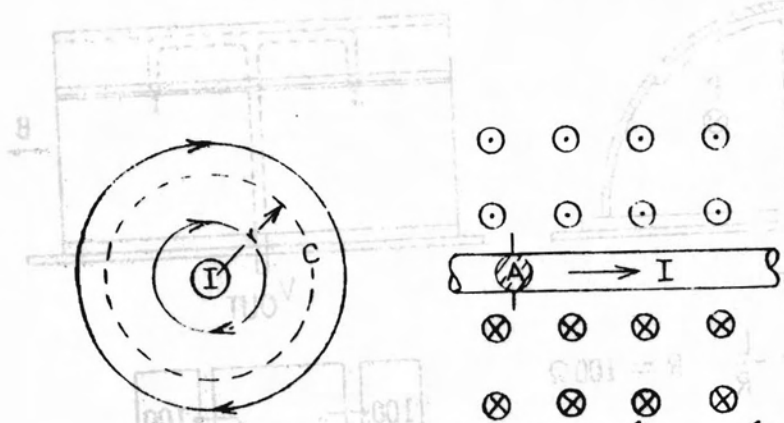

MAXWELL-AMPERE LAW:  $\oint_C \mathbf{H} \cdot d\mathbf{l} = \int_A \mathbf{J} \cdot d\mathbf{A}$

$$\frac{B}{\mu} 2\pi r = I$$

$$B = \frac{\mu}{2\pi r} I$$

$$H = \frac{B}{\mu}$$

## SENSOR FUNDAMENTALS

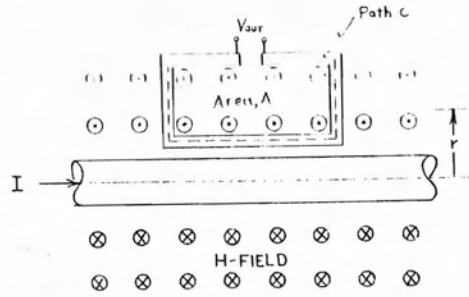

$$B = \frac{\mu}{2\pi r} I$$

MAXWELL-FARADAY LAW:  $\oint_C \mathbf{E} \cdot d\mathbf{l} = - \int_A \frac{d\mathbf{B}}{dt} \cdot d\mathbf{A}$

$V_{out} = - \int_A \frac{d\mathbf{B}}{dt} \cdot d\mathbf{A}$       B-DOT Sensor

$$= - \int_A \left( \frac{\mu}{2\pi r} \cdot \frac{dI}{dt} \right) dA$$

$$= - \frac{dI}{dt} \int_A \frac{\mu}{2\pi r} dA$$

$V_{out} = -M \dot{I}$ ,       $M = \frac{\mu}{2\pi} \int_A \frac{1}{r} dA$       I-DOT Sensor

## B-DOT SENSOR

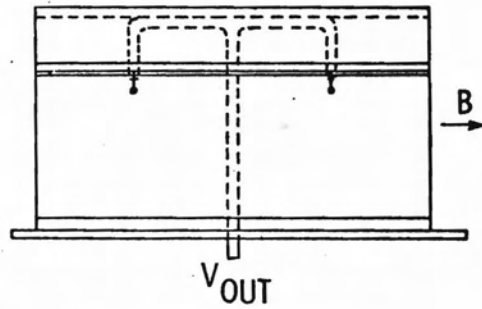
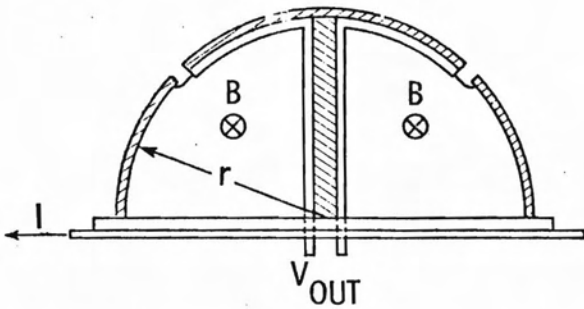

$$t_r = 2.2 \frac{L}{R}, \quad R = 100 \Omega$$

$$V_{out} = A_B \dot{B}$$

$$A_B \approx \frac{1}{2} \pi r^2$$

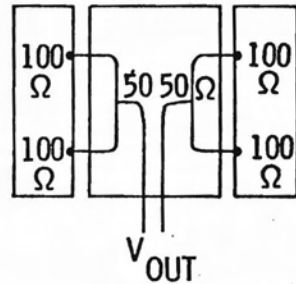

B-DOT SENSOR ON F-106 FUSELAGE PANEL

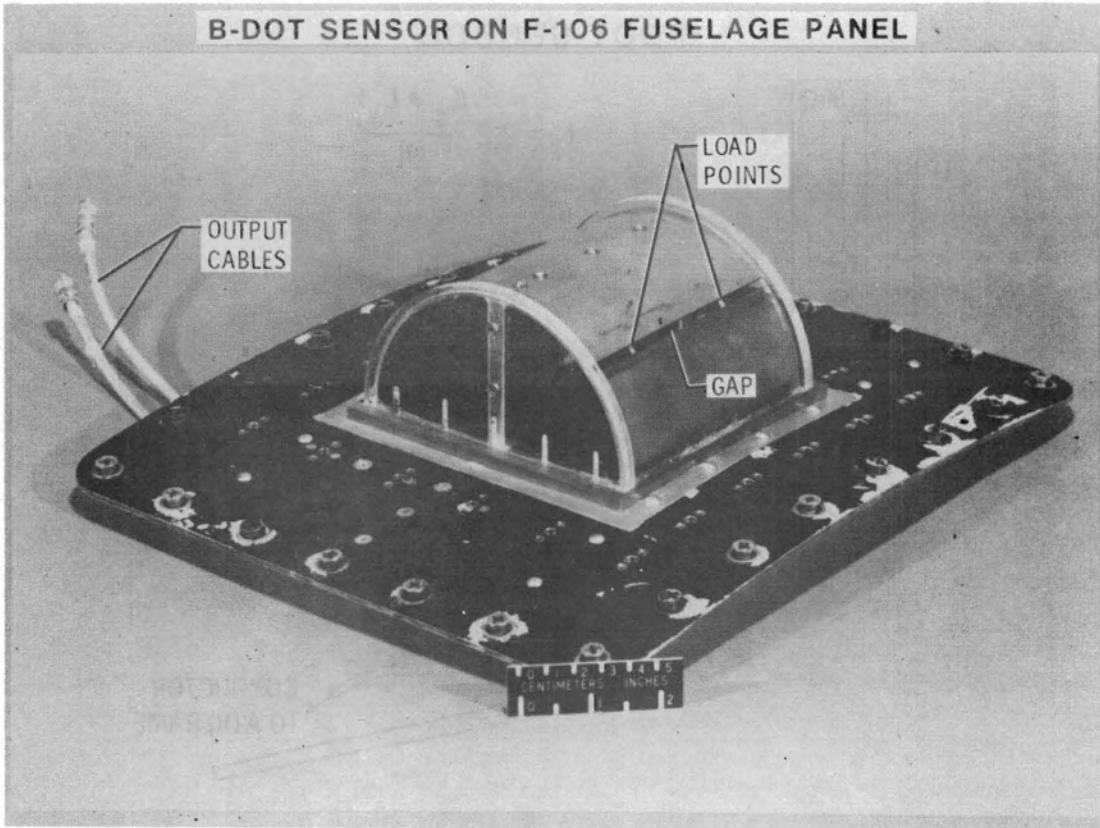

I-DOT SENSOR

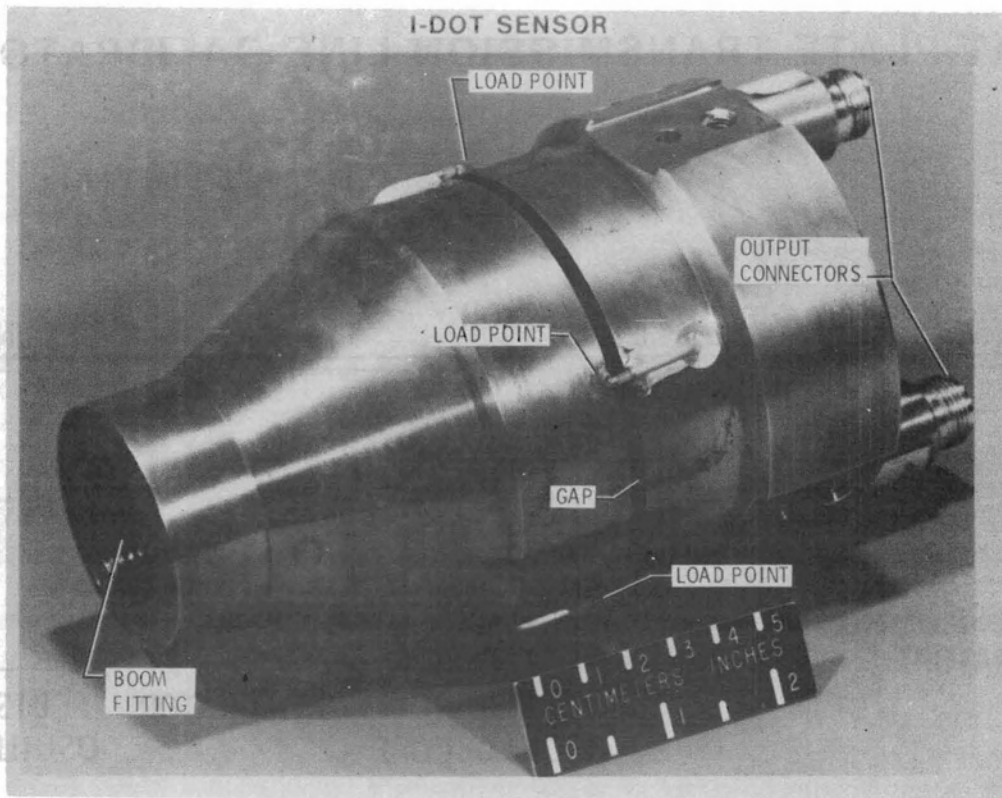

### I-DOT SENSOR

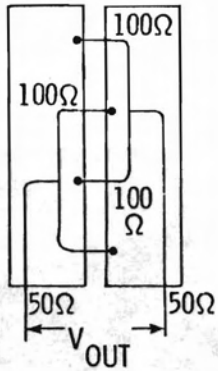

$$t_r = 2.2 \frac{(L_s + L_w)}{R}$$

$$V_{out} = M \dot{I}$$

$$M = \frac{\mu_0}{2\pi} w \ln \frac{a}{b}$$

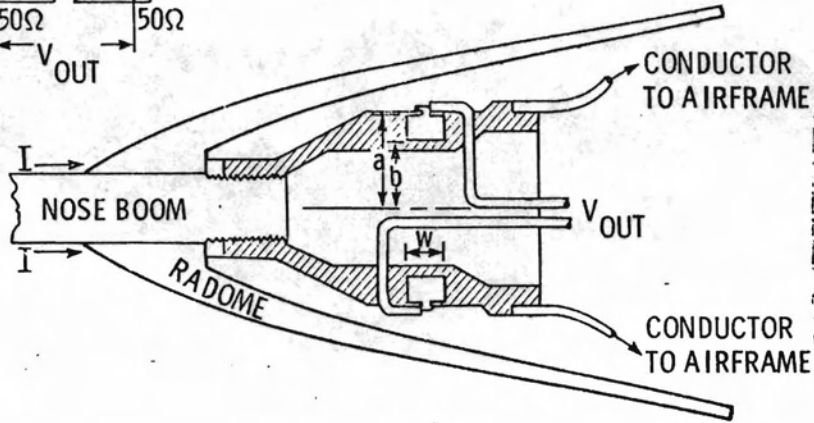

### FLAT-PLATE TRANSMISSION LINE CALIBRATOR

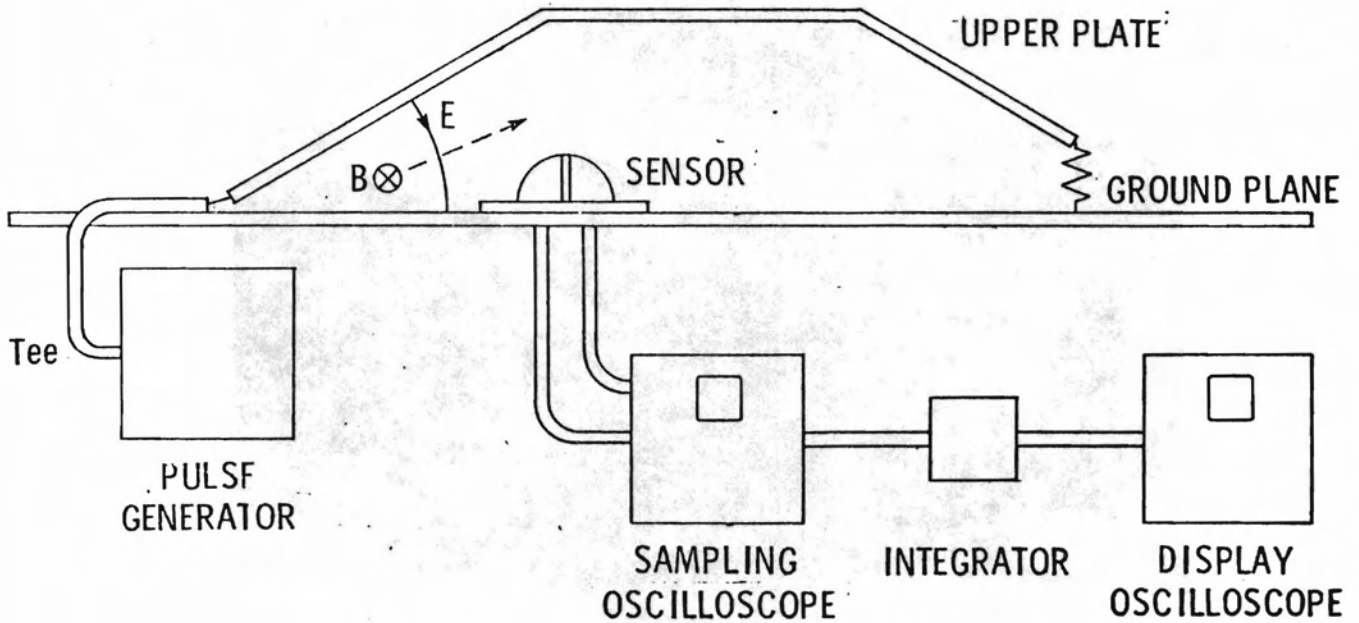

FLAT-PLATE TRANSMISSION LINE CALIBRATOR

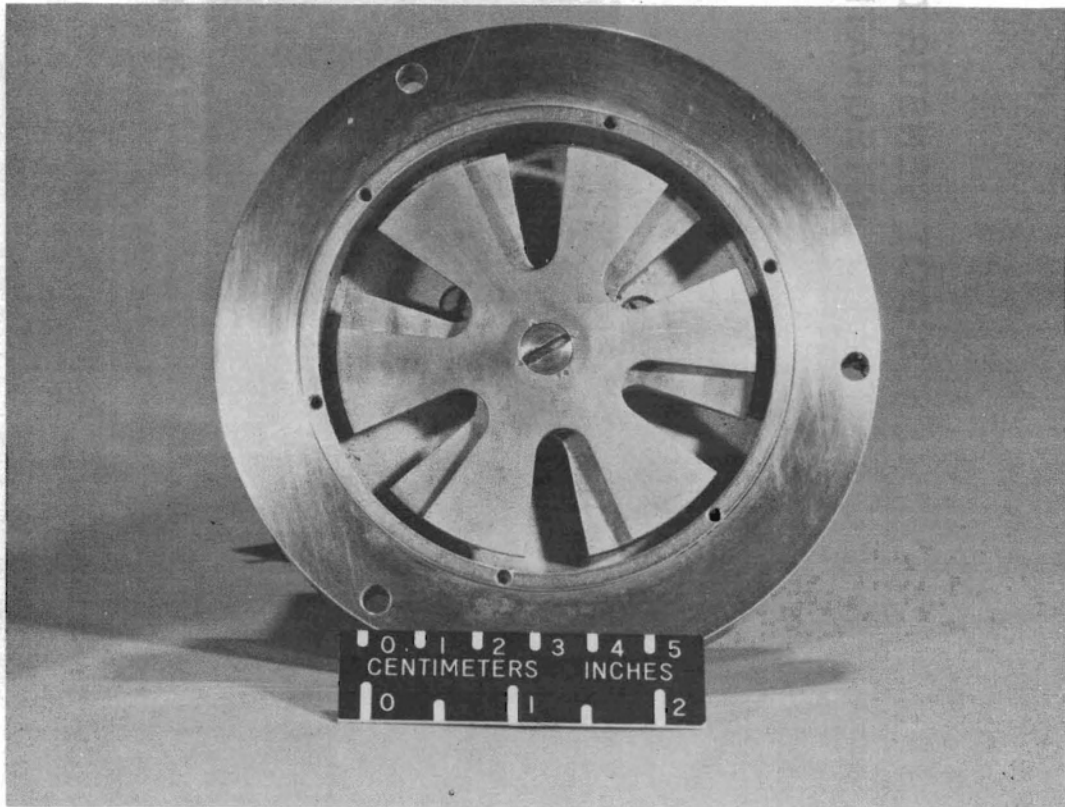
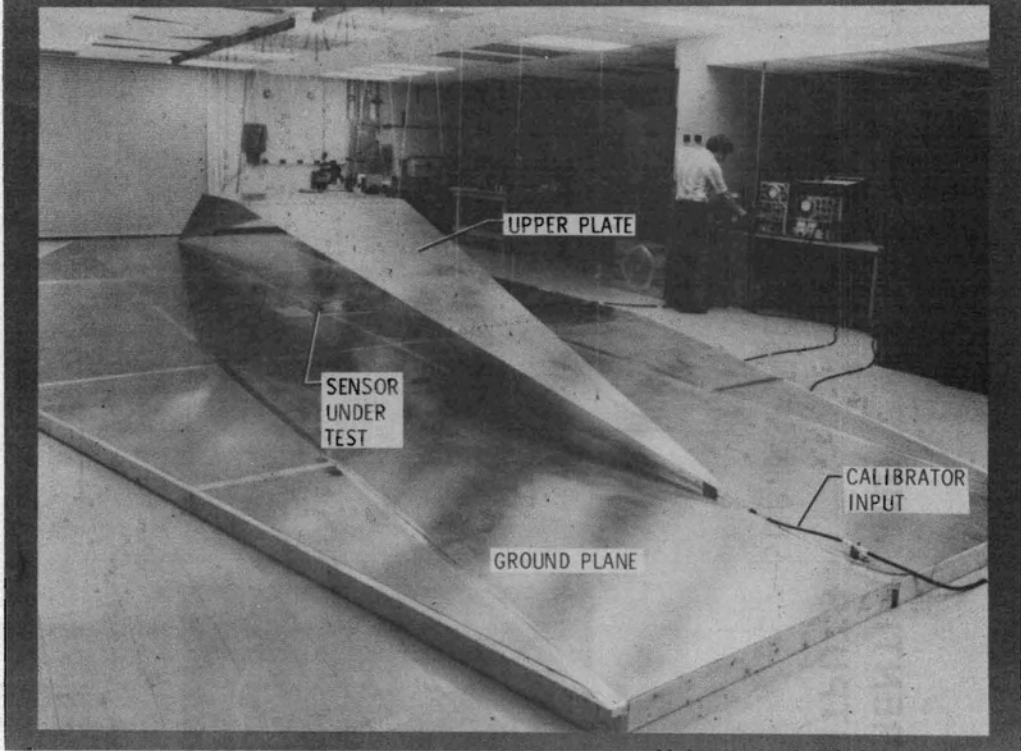

## B-DOT SENSOR DIFFERENTIAL AND INTEGRATED OUTPUTS

a: 200m V/div.

b:  $1.4 \times 10^{-10}$  V - s/div.

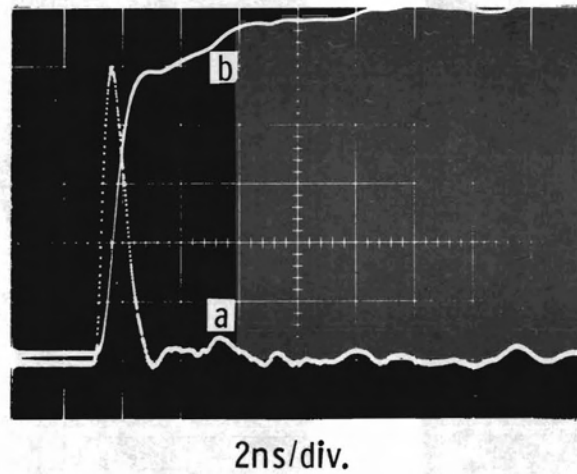

STEP RESPONSE

$v(t)$

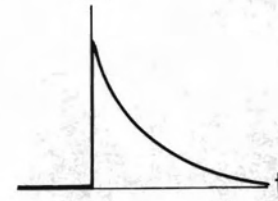

$$v(t) = \frac{RA_B B_0}{L} e^{-\frac{Rt}{L}} u(t)$$

INTEGRATED STEP RESPONSE

$$\int_{-\infty}^t v(t') dt'$$

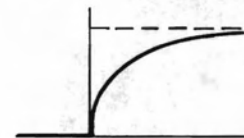

## SUMMARY OF SENSOR PARAMETERS

SENSOR	LOCATION	DESIGN	SENSITIVITY	RISETIME (10%-90%)
$J_T$	FUSELAGE/TAIL	CIRCULAR	$4.1 \times 10^{-2} \text{ m}^2$	2.4 ns
$J_T$	WINGS	RECTANGULAR	$2.7 \times 10^{-2} \text{ m}^2$	3.0 ns
B-DOT	FUSELAGE	2 GAPS, 4 LOAD POINTS	$5.7 \times 10^{-3} \text{ m}^2$	.85 ns
B-DOT	WINGS	1 GAP, 1 LOAD POINT	$5.5 \times 10^{-3} \text{ m}^2$	2.0 ns
I-DOT	RADOME	1 GAP, 4 LOAD POINTS	$2.1 \times 10^{-9} \text{ H}$	0.8 ns

### FIELD MILLS

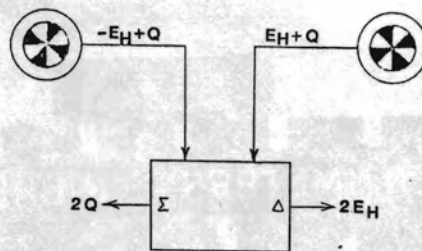
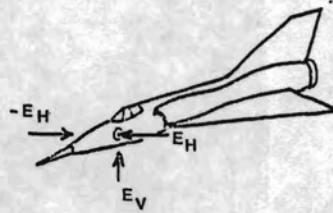

RESEARCH CENTER FOR THE STUDY OF THE HISTORY OF SCIENCE

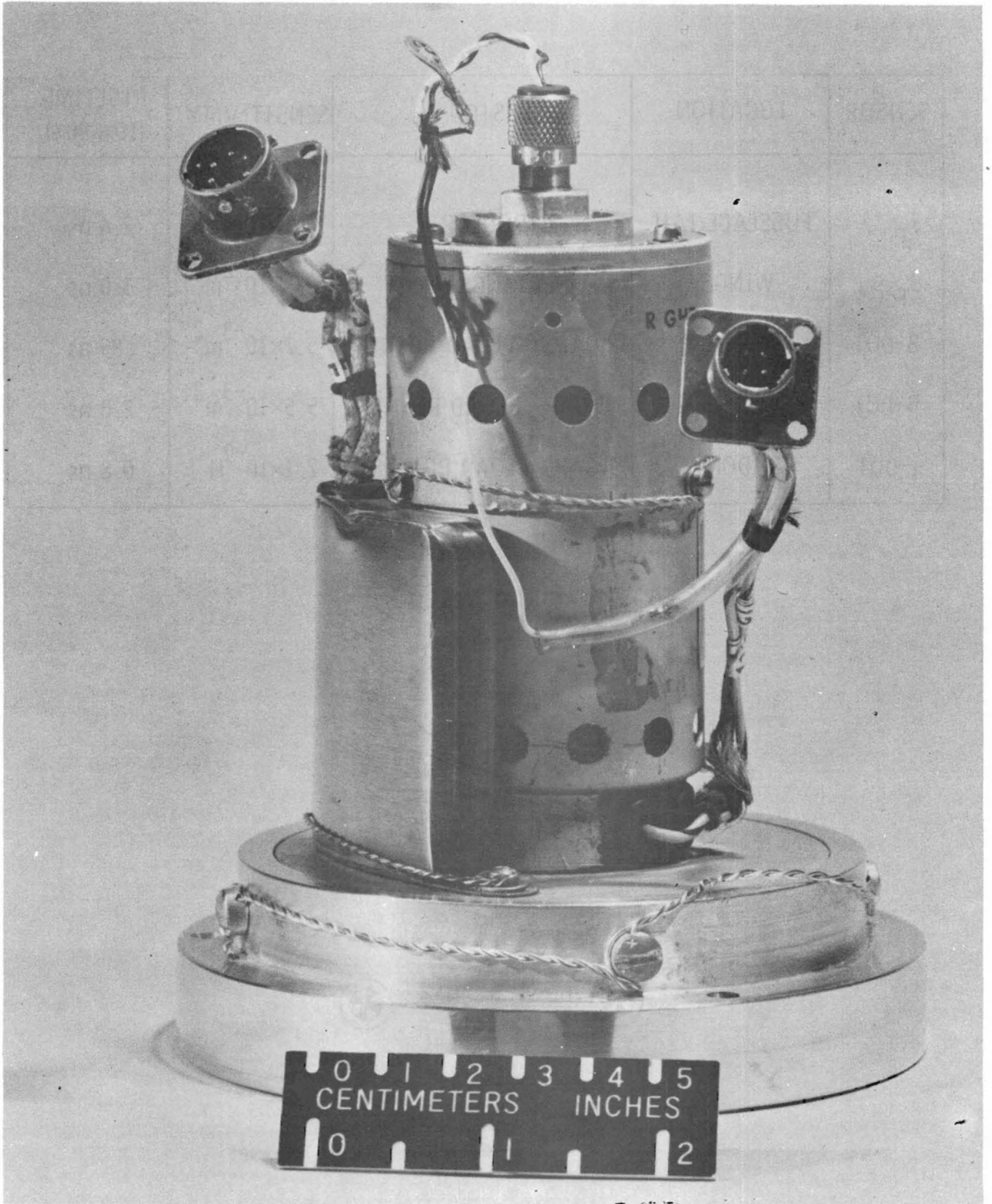

## LIGHTNING MODELING

by

Dr. M. LeVine

Goddard Space Flight Center  
National Aeronautics and Space Administration

The ground-based lightning measurements made at Wallops Flight Center concurrently with the in-flight direct strike measurements are described. Lightning mathematical model development to arrive at credible lightning models for use in induced effects electromagnetic coupling studies is discussed.

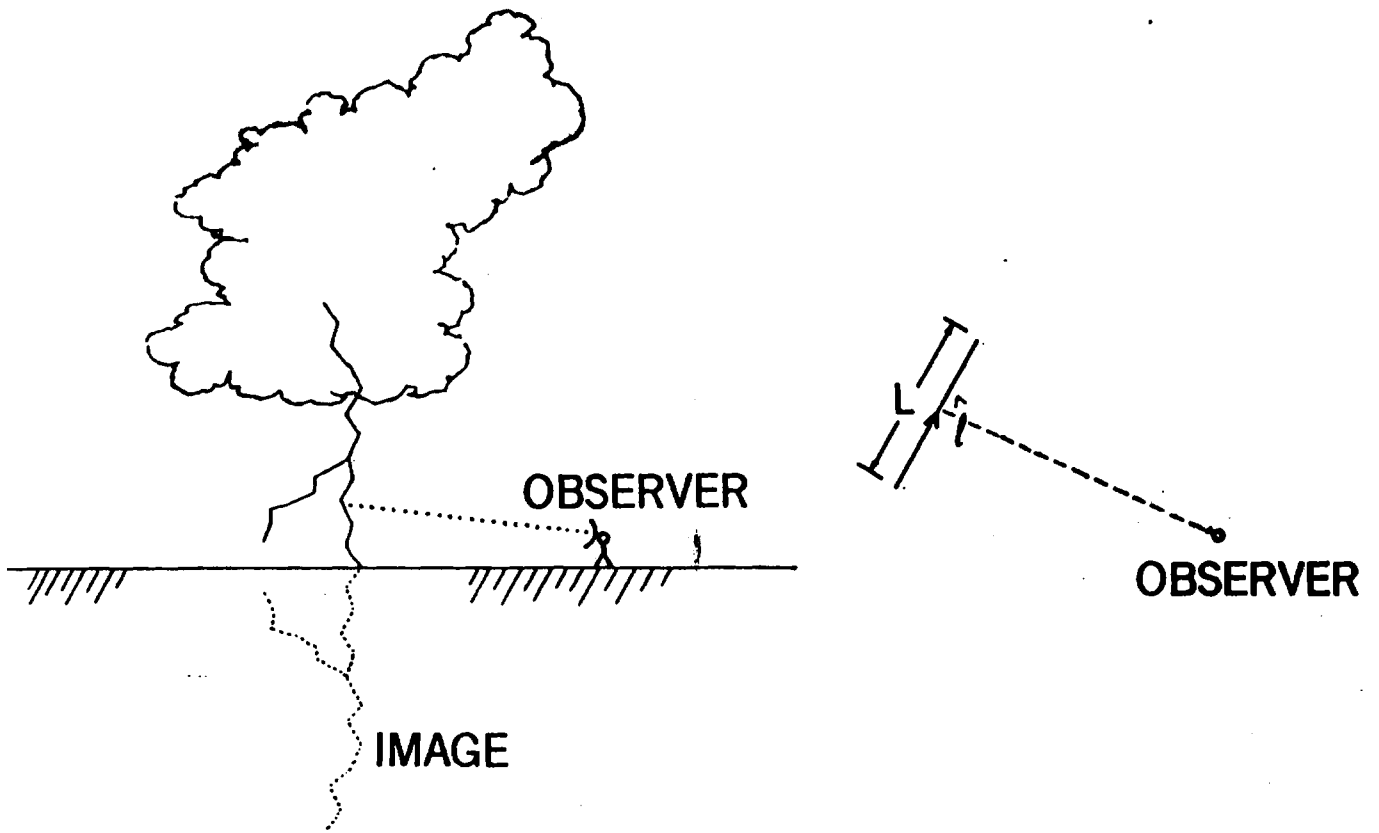

### CHANNEL GEOMETRY

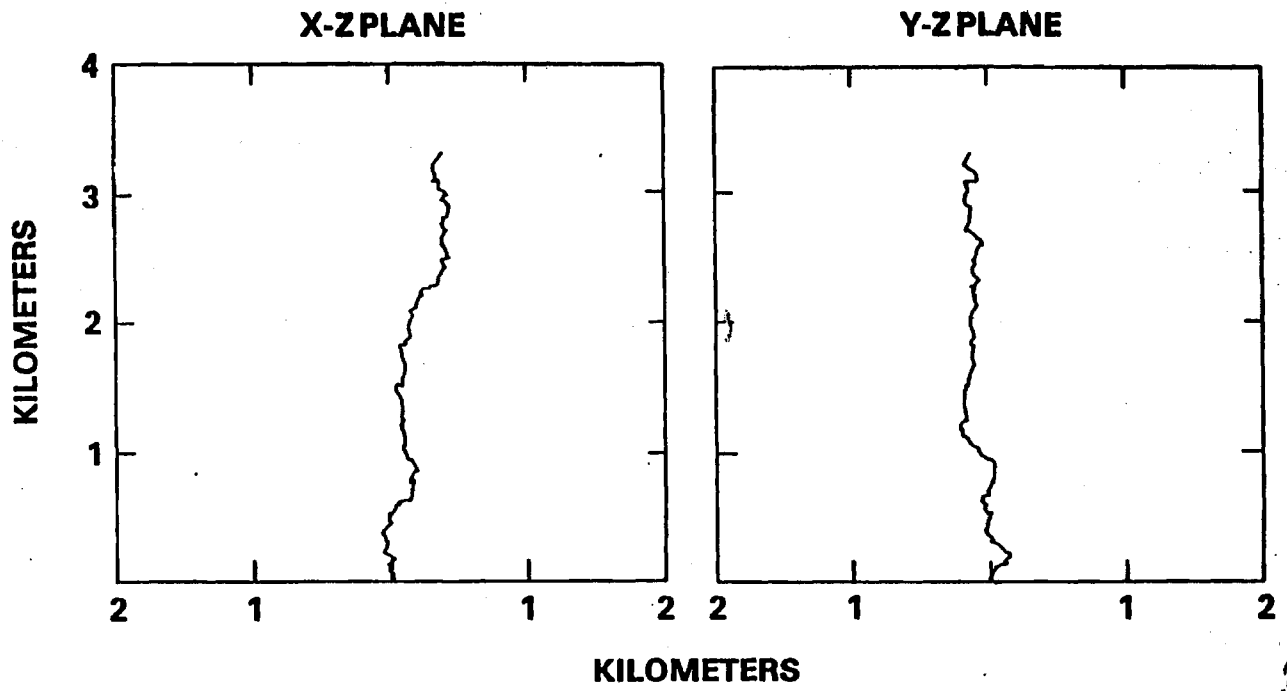

# CHANNEL GEOMETRY

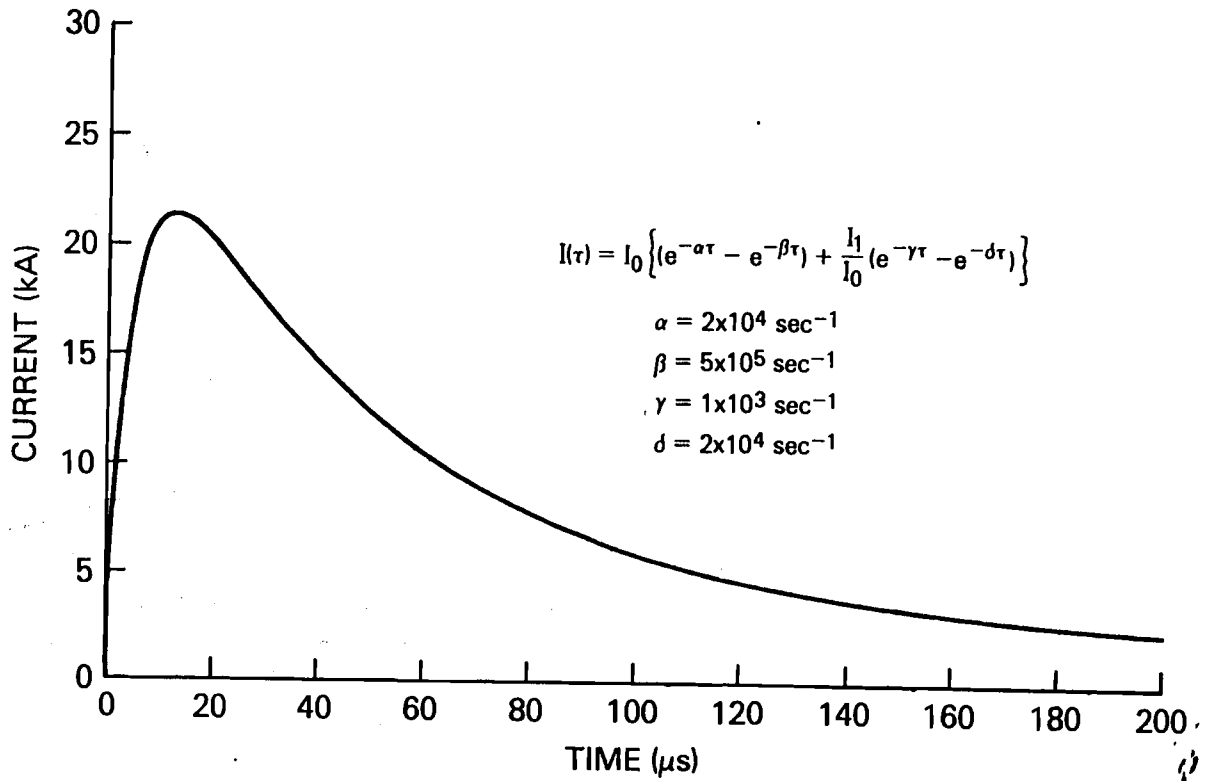
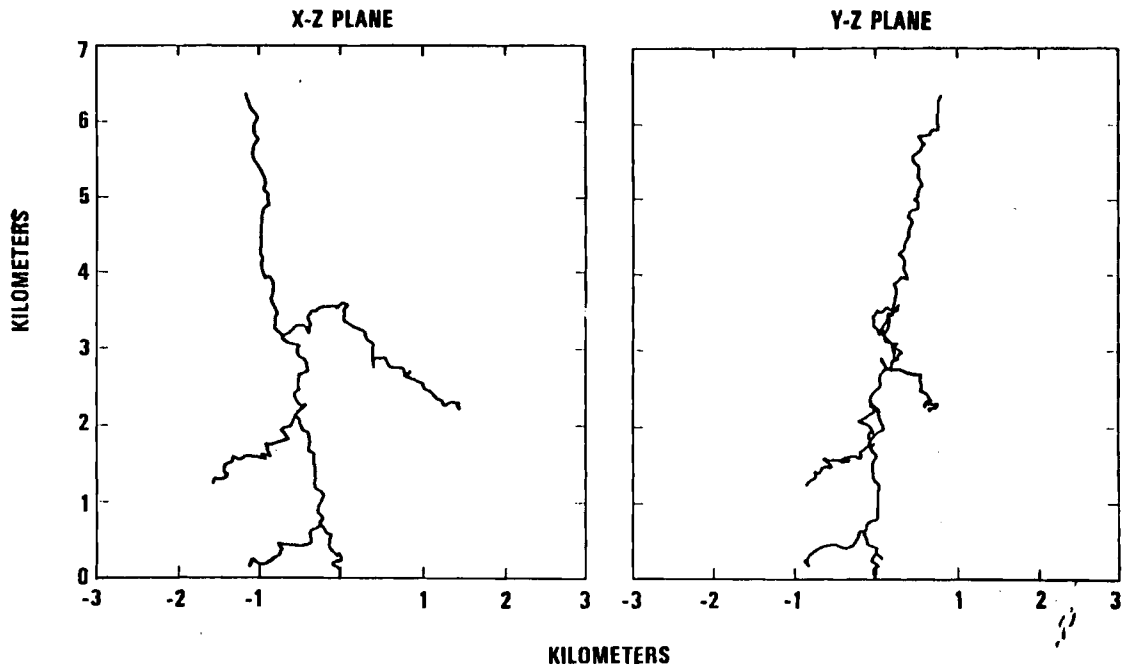

CHANNEL GEOMETRY

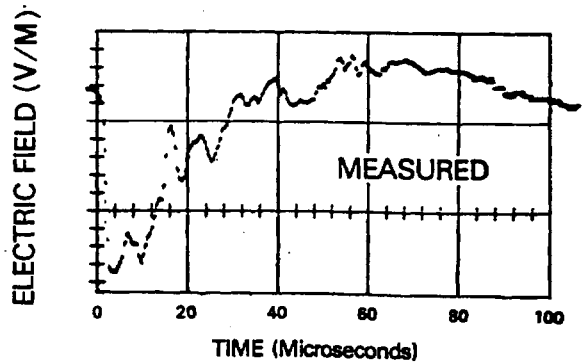
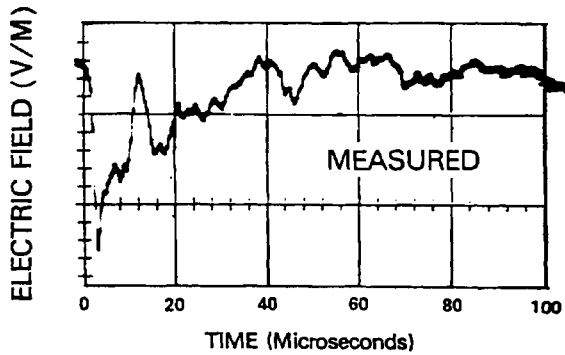
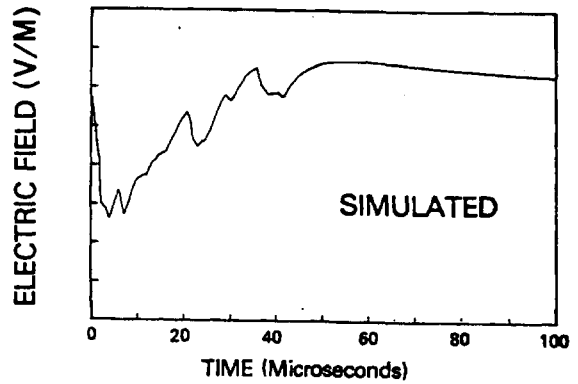
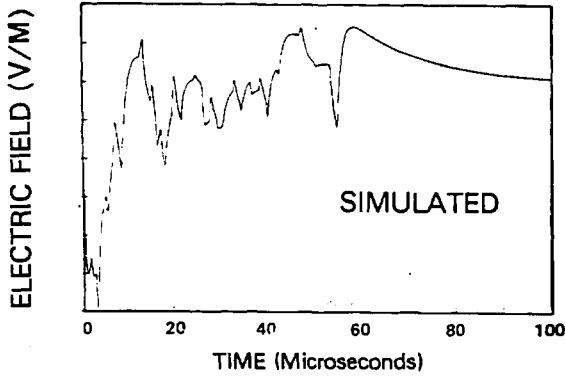
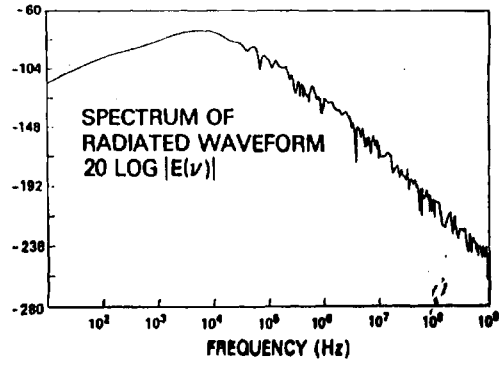
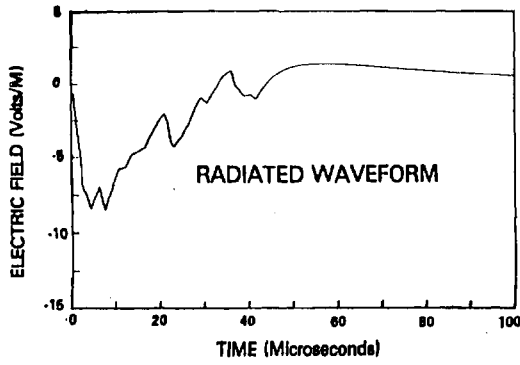
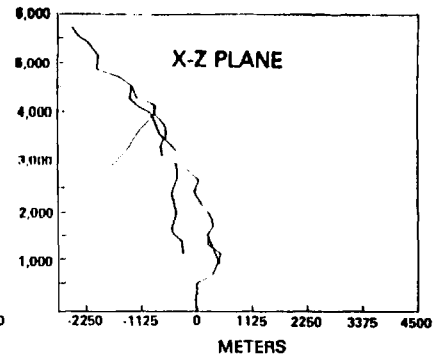
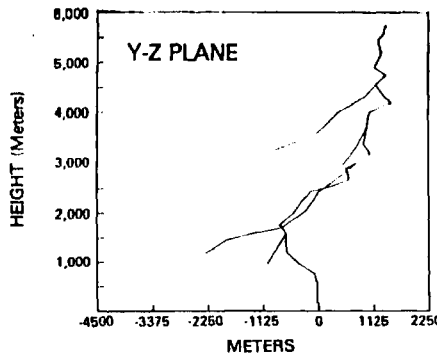

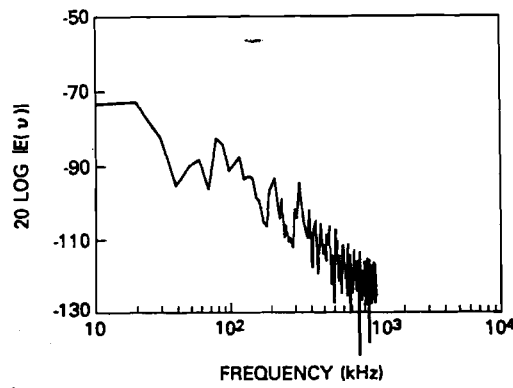
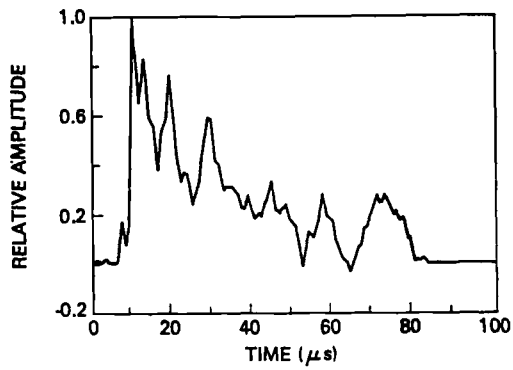
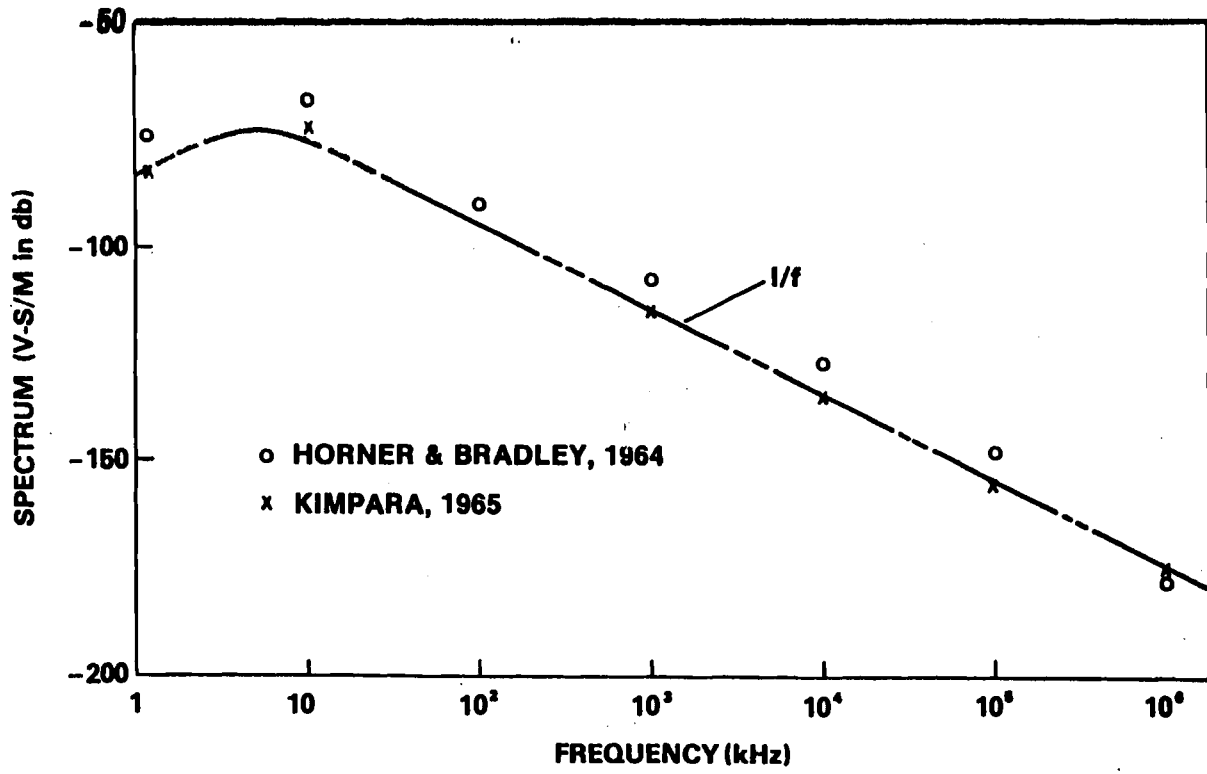

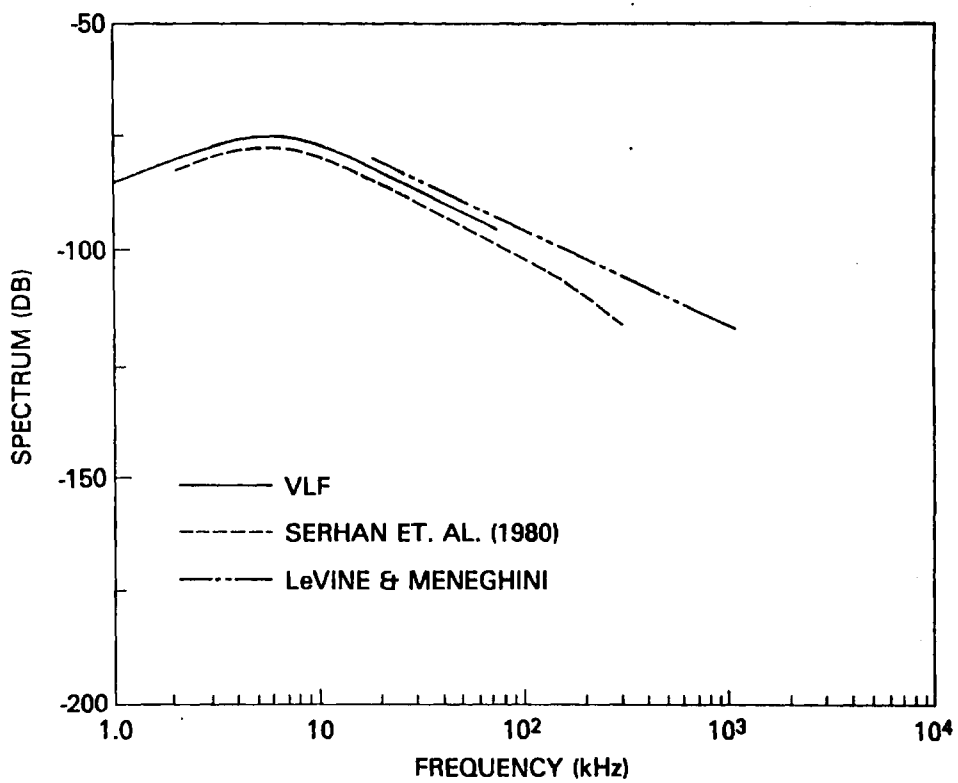
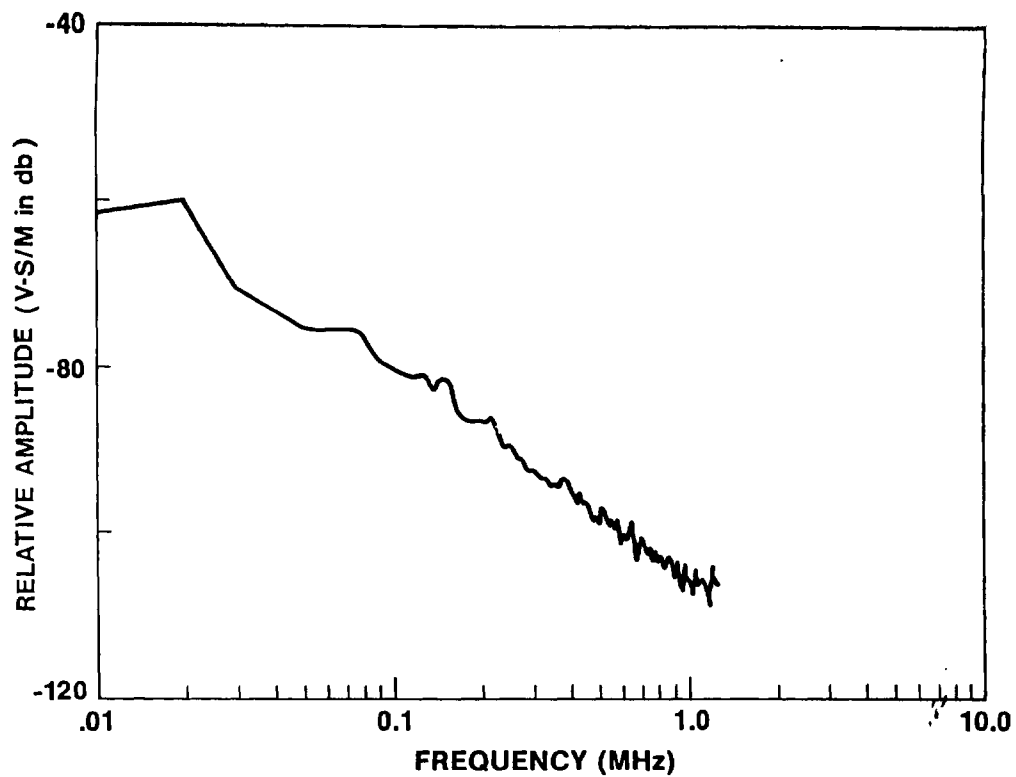

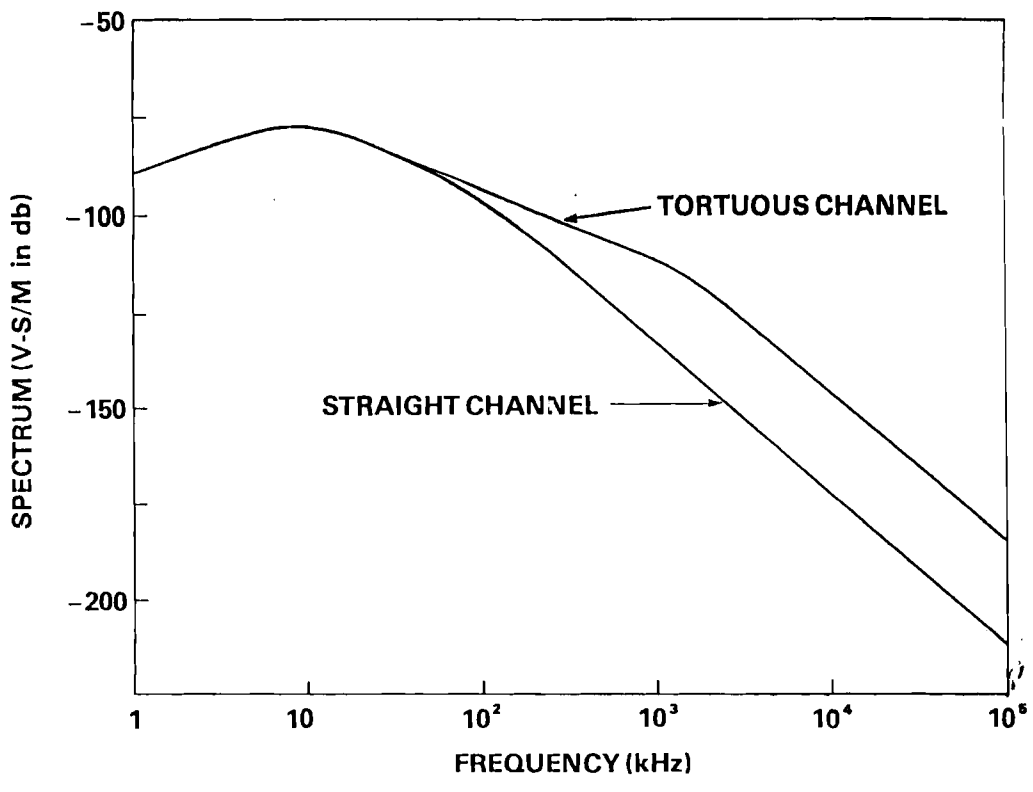
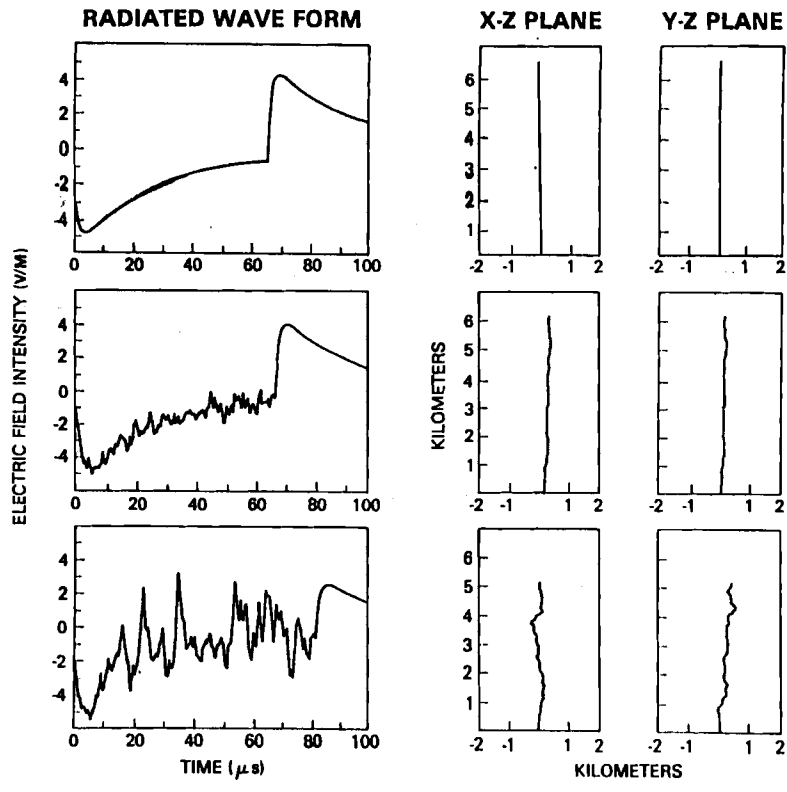

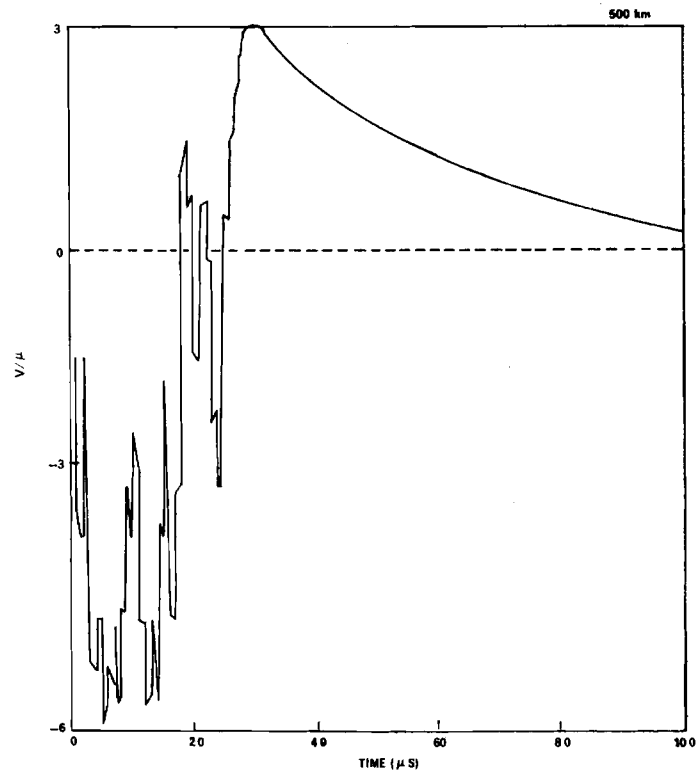
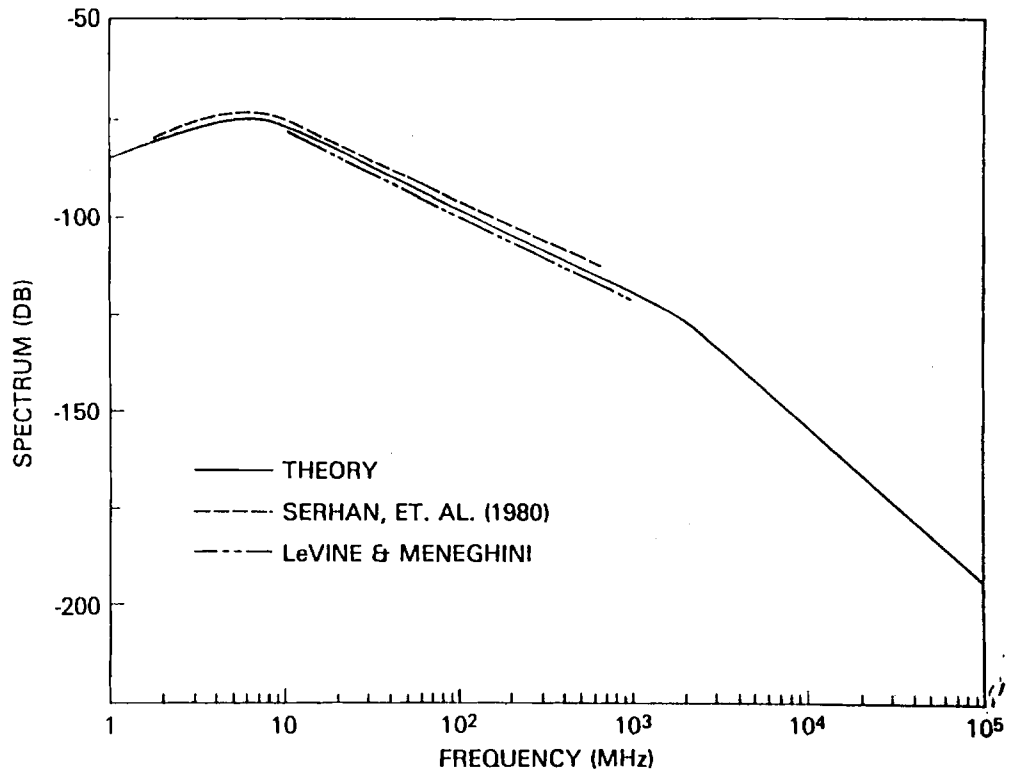

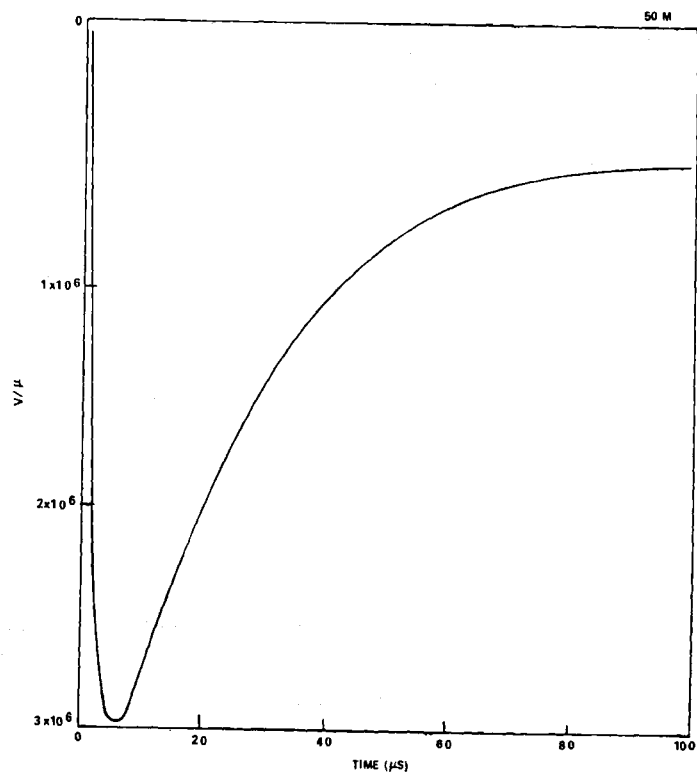
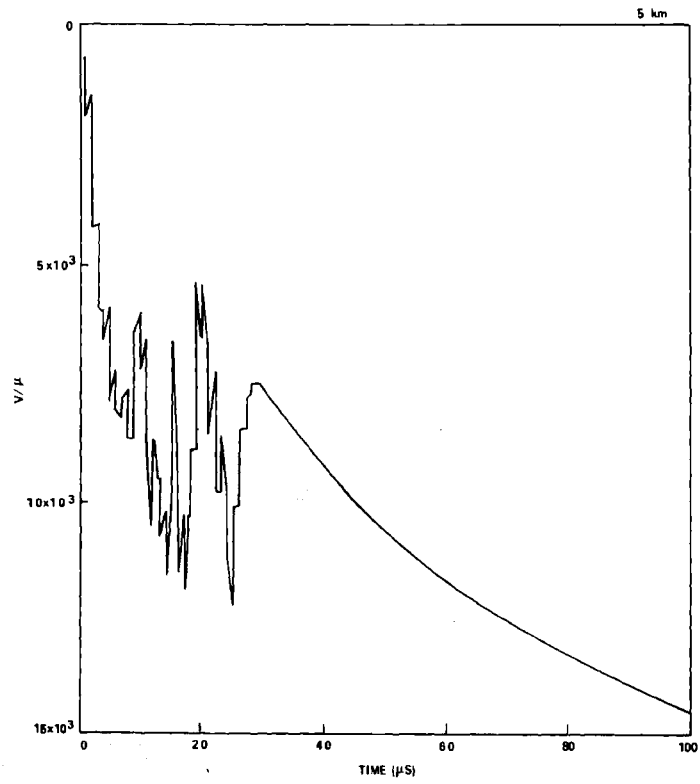

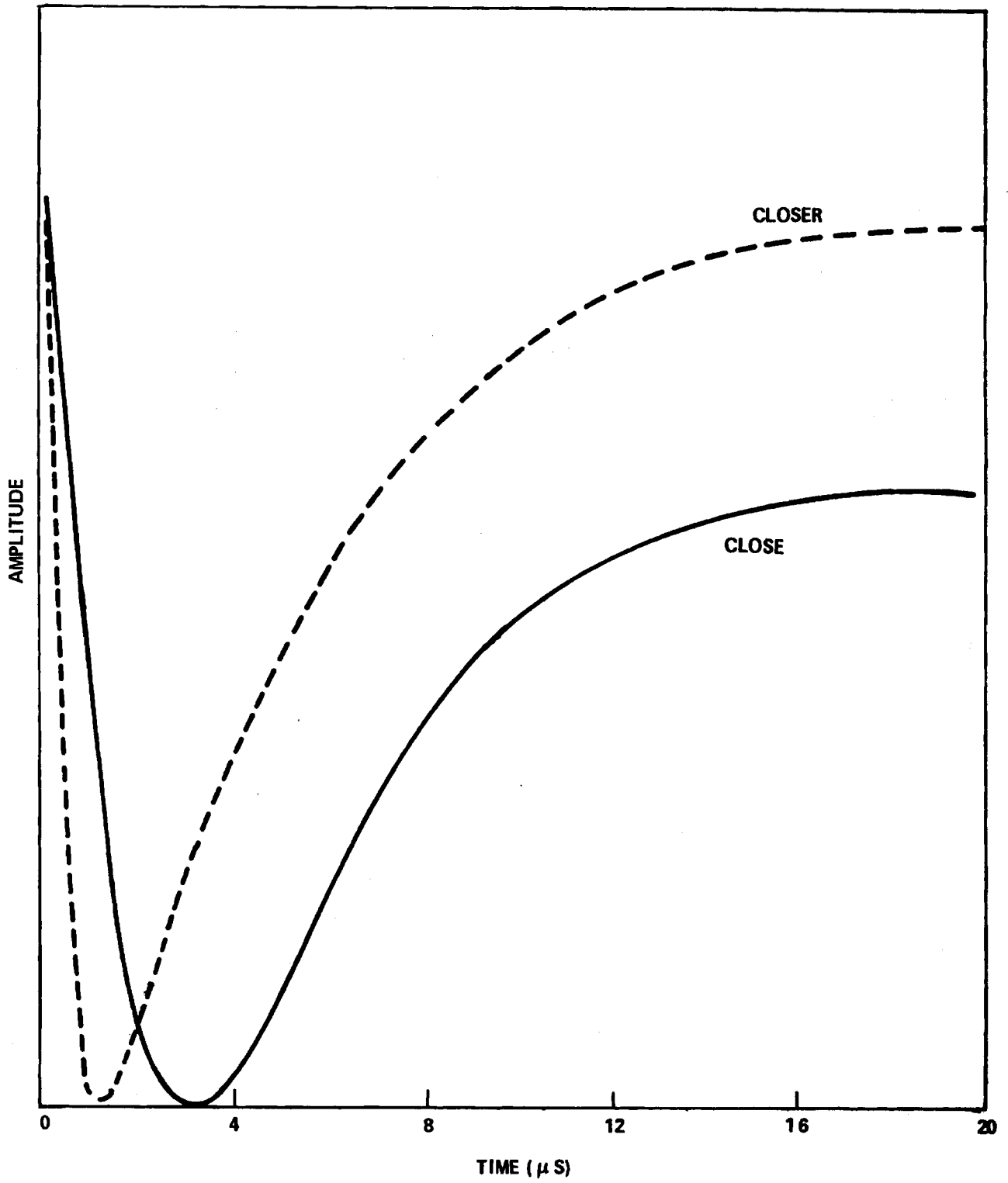

INTERPRETATION OF IN-FLIGHT TEST DATA APPROACH,  
PROBLEMS, AND OUTLOOK

by

Dr. R. A. Perala

Electromagnetic Applications, Incorporated

Discussion of the direct strike data interpretation problem and issues to be resolved. Review of lightning/aircraft interaction process and aircraft electrical resonance considerations. Approach for generalization of F-106 data to other aircraft classes.

## OUTLINE

- THE LIGHTNING/AIRCRAFT INTERACTION PROCESS
- THE NEED FOR IN-FLIGHT TEST DATA
- EXTENSION OF DATA TO OTHER AIRCRAFT
- LIGHTNING MODELING
- AIRCRAFT MODELING
- EXAMPLES

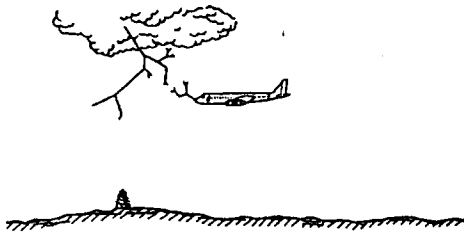

STEPPED LEADER APPROACHING AIRCRAFT

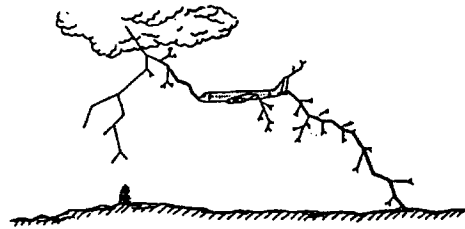

RETURN STROKE THROUGH THE AIRCRAFT

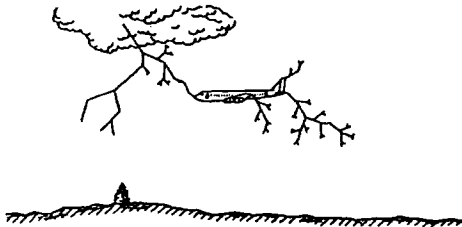

STEPPED LEADER ATTACHMENT AND CONTINUED  
PROPAGATION FROM AN AIRCRAFT

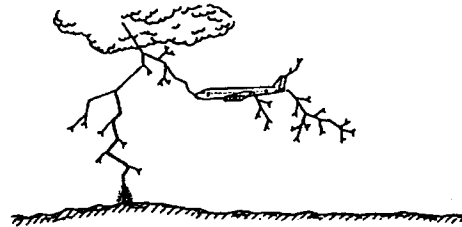

NO RETURN STROKE THROUGH THE AIRCRAFT

## LIGHTNING/AIRCRAFT INTERACTION DESCRIPTION

- AIRCRAFT IN LARGE STATIC ELECTRIC FIELD, 10-100 kV/M TYPICAL
- AIRCRAFT PROBABLY ALREADY CHARGED BY TRIBOELECTRIFICATION
- APPROACHING STEPPED LEADER GIVES LARGE E,  $\partial E/\partial t$
- WHEN E LARGE ENOUGH, AIRCRAFT STREAMERS
- STREAMER ATTACHES TO APPROACHING LEADER
- CHARGE FROM LEADER DEPOSITED ON AIRCRAFT AND ELEVATES ITS POTENTIAL
- WHEN ITS POTENTIAL IS HIGH ENOUGH, LEADER CONTINUES FROM AIRCRAFT TO DESTINATION
- STEPPED LEADER CURRENT FLOWS THROUGH AIRCRAFT UNTIL RETURN STROKE
- RETURN STROKE CURRENT LOWERS AIRCRAFT POTENTIAL
- AIRCRAFT IN CORONA DURING MUCH OF THIS TIME

### APPROACHING LEADER E FIELDS

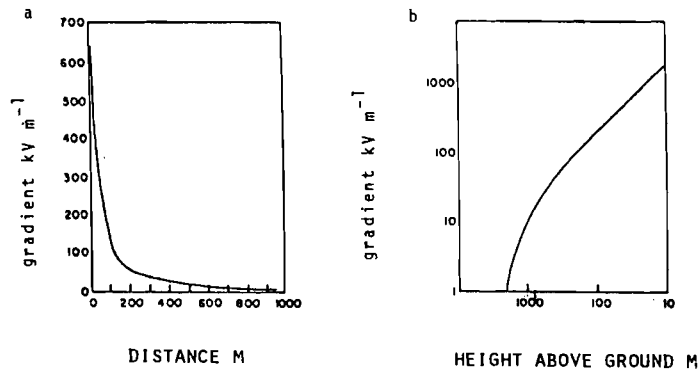

ELECTRIC GRADIENT BELOW LEADER CHANNEL: (a) AS FUNCTION OF HORIZONTAL DISTANCE AND (b) AS FUNCTION OF HEIGHT OF LEADER TIP ABOVE GROUND

ASSUME  $\frac{\partial E}{\partial t} = \frac{\partial E}{\partial h} \frac{\partial h}{\partial t}$  and  $\frac{\partial h}{\partial t} = 1.5 \times 10^5 \text{ m/sec}$

WE GET  $\frac{\partial E}{\partial t} = 1.2 \times 10^7$  at 1000 m  
 $= 1.5 \times 10^{10}$  at 10-20 m

## AIRCRAFT STREAMERING

- CURRENTS PROBABLY LESS THAN 100A, BASED ON GROUND STREAMER DATA
- WAVESHAPES: 10  $\mu$ sec RISETIMES
- NEGATIVE CHARGE ENTERING AIRCRAFT AT STREAMER POINT
- STREAMERING CAN OCCUR FROM CRITICAL POINTS
- STREAMERING INFLUENCED BY STATIC FIELD
- ELECTRIC FIELD ON AIRCRAFT REVERSES AT ATTACHMENT

## STEPPED LEADER CURRENT FLOW THROUGH AIRCRAFT

- AIRCRAFT NEEDS TO ACCUMULATE  $\geq 100$   $\mu$ C OF CHARGE FOR STEPPED LEADER TO CONTINUE ON FROM AIRCRAFT
- IF LEADER CURRENT IS 1000A RISING IN 100 ns, CHARGING TIME IS ABOUT 150 ns
- DURING THIS TIME AIRCRAFT NORMAL ELECTRIC FIELDS APPROACH 3 MV/m
- THIS GIVES  $\partial E/\partial t \approx 2 \times 10^{13}$  V/m/sec
- LEADER CURRENT CONTINUES THROUGH AIRCRAFT AND ELECTRIC FIELD STAYS CONSTANT AND CURRENT ASSUMES THE SLOWLY INCREASING ARC CURRENT UPON WHICH IS SUPERIMPOSED LEADER PULSE CURRENTS
- AIRCRAFT IS IN CORONA DURING THIS PHASE

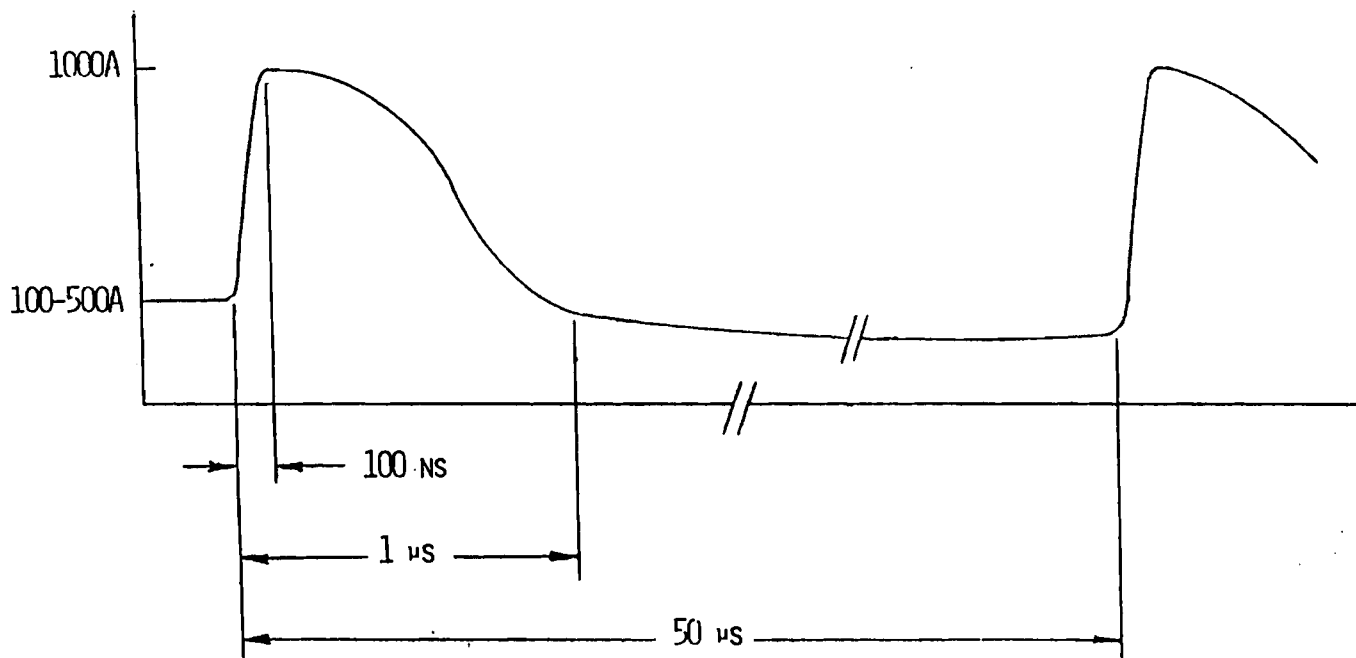

STEPPED LEADER CURRENTS

### J- AND K- CHANGES

J-CHANGES: SLOW, 100A CURRENTS

K-CHANGES: SEVERAL THOUSAND AMPS  
POSSIBLY 50 NS RISE TIMES

ISSUES OF INTEREST AND  
THE NEED FOR IN-FLIGHT TEST DATA

- ATTACHMENT PROCESS
  - WHAT ARE  $E$  AND  $\frac{\partial E}{\partial t}$  ?
  - HOW IMPORTANT ARE NONLINEAR (CORONA, STREAMERS) EFFECTS?
  - WHAT IS THE EQUIVALENT CIRCUIT OF THE LEADER (CHANNEL IMPEDANCE, NORTON CURRENT SOURCE)
- RETURN STROKE
  - WHAT ARE  $E$  AND  $\frac{\partial E}{\partial t}$  ?
  - WHAT ARE  $H$  AND  $\frac{\partial H}{\partial t}$  ?
  - HOW IMPORTANT ARE NONLINEAR EFFECTS?
  - WHAT IS THE RETURN STROKE EQUIVALENT CIRCUIT?
- NEARBY LIGHTNING: HOW IMPORTANT IS IT?
- HOW APPLICABLE ARE STATE OF THE ART LIGHTNING MODELS AT AIRCRAFT ALTITUDES?
  - MODELS SO FAR ARE BASED ON TERRESTRIAL OBSERVATIONS
  - MODELS HAVE NOT BEEN TESTED AT AIRCRAFT ALTITUDES
- OBTAIN DATA ON INTRACLOUD LIGHTNING
- HOW DOES THE AIRCRAFT INTERACT WITH LIGHTNING? IS THE LIGHTNING ENVIRONMENT ITSELF MODIFIED BY THE PRESENCE OF AN AIRCRAFT? IS IT DIFFERENT FOR DIFFERENT AIRCRAFT.

THE OBJECTIVE OF DATA INTERPRETATION

- WHAT ARE THE LIGHTNINGS THAT CAUSE THE F106B RESPONSES?  
(AN INVERSE PROBLEM)
- WHAT WOULD BE THE RESPONSE OF A DIFFERENT AIRCRAFT?
- CAN A METHODOLOGY BE DEVELOPED FOR EXTENDING IN-FLIGHT DATA FROM ANY AIRCRAFT TO ANY OTHER AIRCRAFT?

# APPROACH

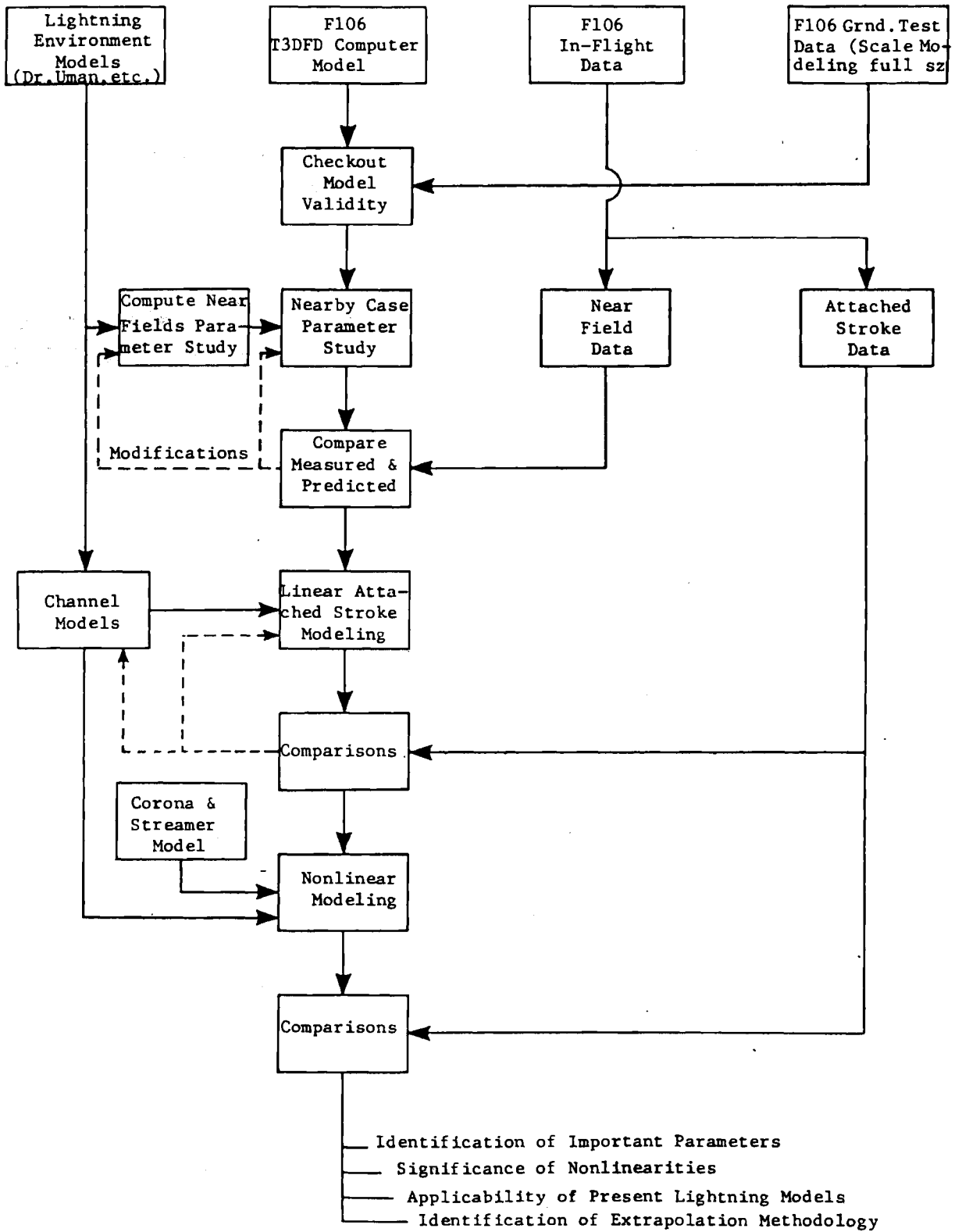

## IMPORTANCE OF NEAR MISS DATA

- INTERACTION CALCULATIONS CAN BE DONE LINEARLY, WITHOUT COMPLICATIONS INTRODUCED BY NONLINEARITIES
  
- DATA CAN BE USED TO INFER NEARBY LIGHTNING ELECTROMAGNETIC WAVEFORMS AT AIRCRAFT ALTITUDES TO CORRELATE WITH PREDICTIONS

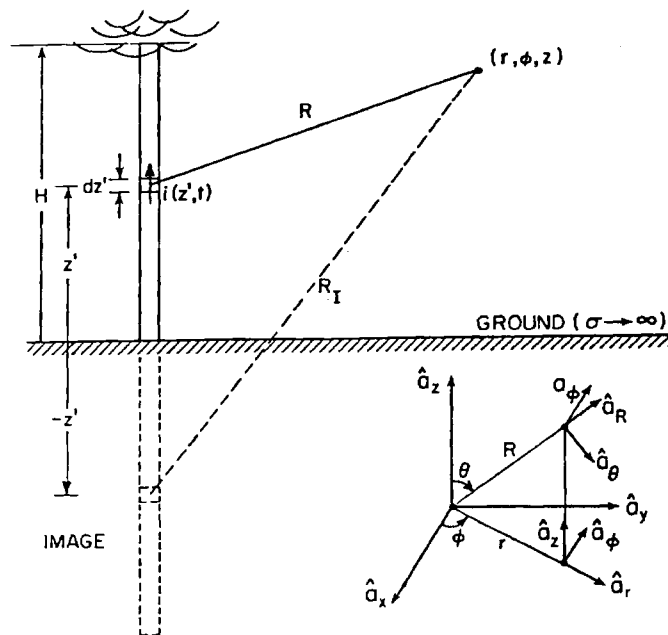

A DRAWING DEFINING ALL GEOMETRICAL PARAMETERS NEEDED IN THE CALCULATION OF ELECTRIC AND MAGNETIC FIELDS. (FROM UMAN)

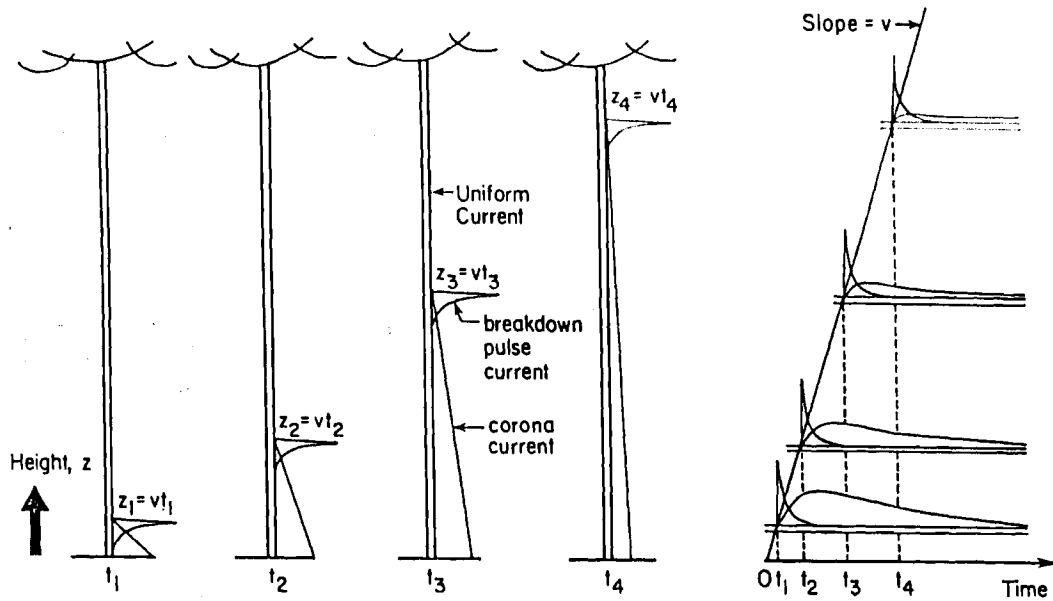

CURRENT DISTRIBUTION FOR THE MODEL OF LIN ET AL. (1980) IN WHICH THE BREAKDOWN PULSE CURRENT IS CONSTANT WITH HEIGHT. THE CONSTANT VELOCITY OF THE BREAKDOWN PULSE CURRENT IS  $v$ . CURRENT PROFILES ARE SHOWN AT FOUR DIFFERENT TIMES  $t_1$  THROUGH  $t_4$ , WHEN THE RETURN STROKE WAVEFRONT AND THE BREAKDOWN PULSE CURRENT ARE AT FOUR DIFFERENT HEIGHTS  $z_1$  THROUGH  $z_4$ , RESPECTIVELY. (FROM UMAN)

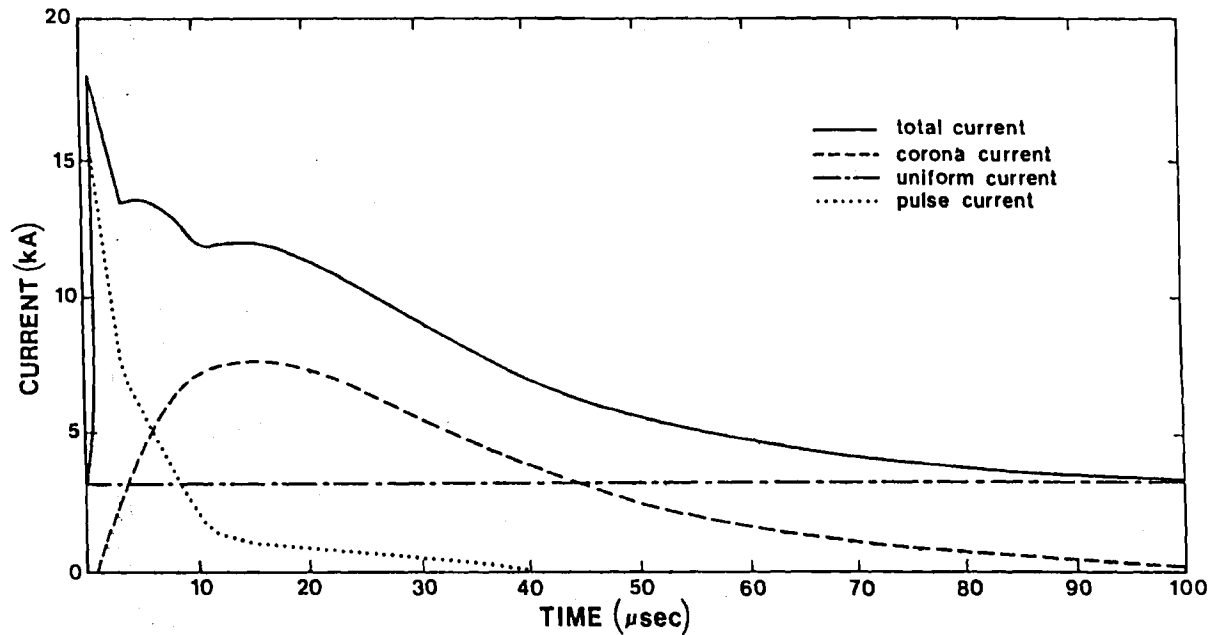

RETURN STROKE CURRENT COMPONENTS AT GROUND FOR A TYPICAL SUBSEQUENT STROKE CALCULATED FROM MEASURED ELECTRIC AND MAGNETIC FIELDS (FROM UMAN)

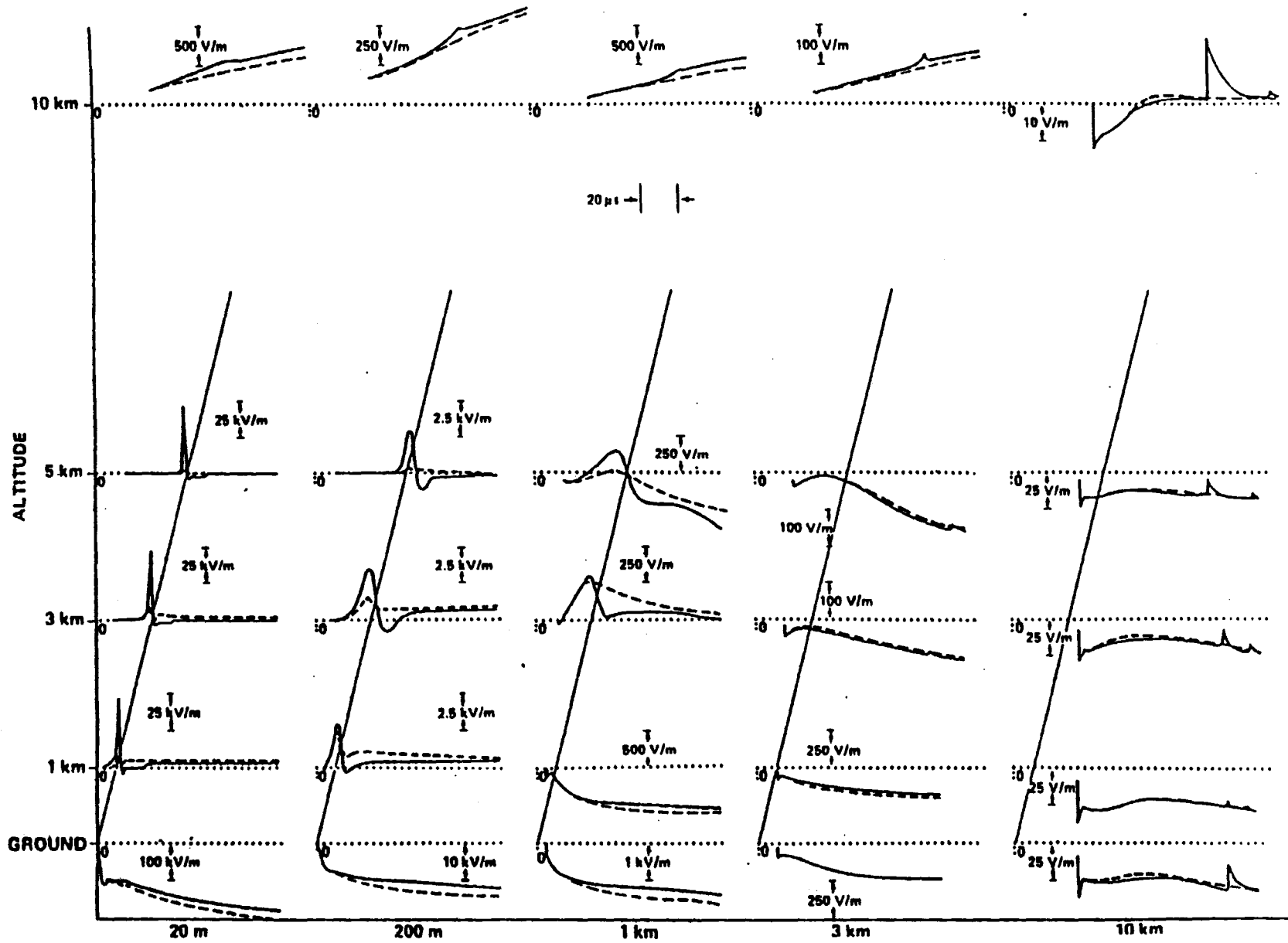

CALCULATED VERTICAL ELECTRIC FIELDS FOR A TYPICAL SUBSEQUENT RETURN STROKE (FROM UMAN)

17

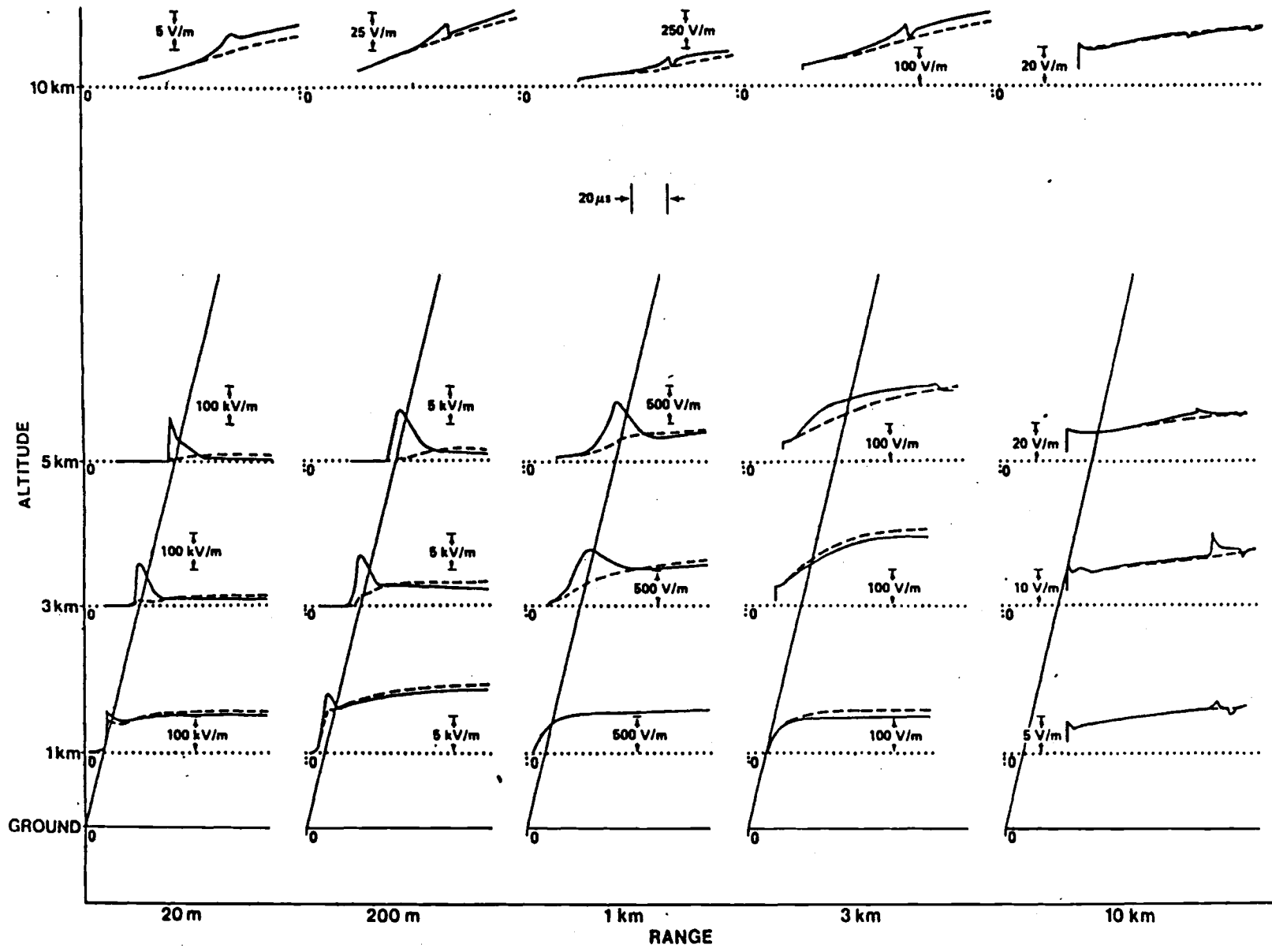

CALCULATED HORIZONTAL ELECTRIC FIELDS FOR A TYPICAL SUBSEQUENT RETURN STROKE (FROM UMAN)

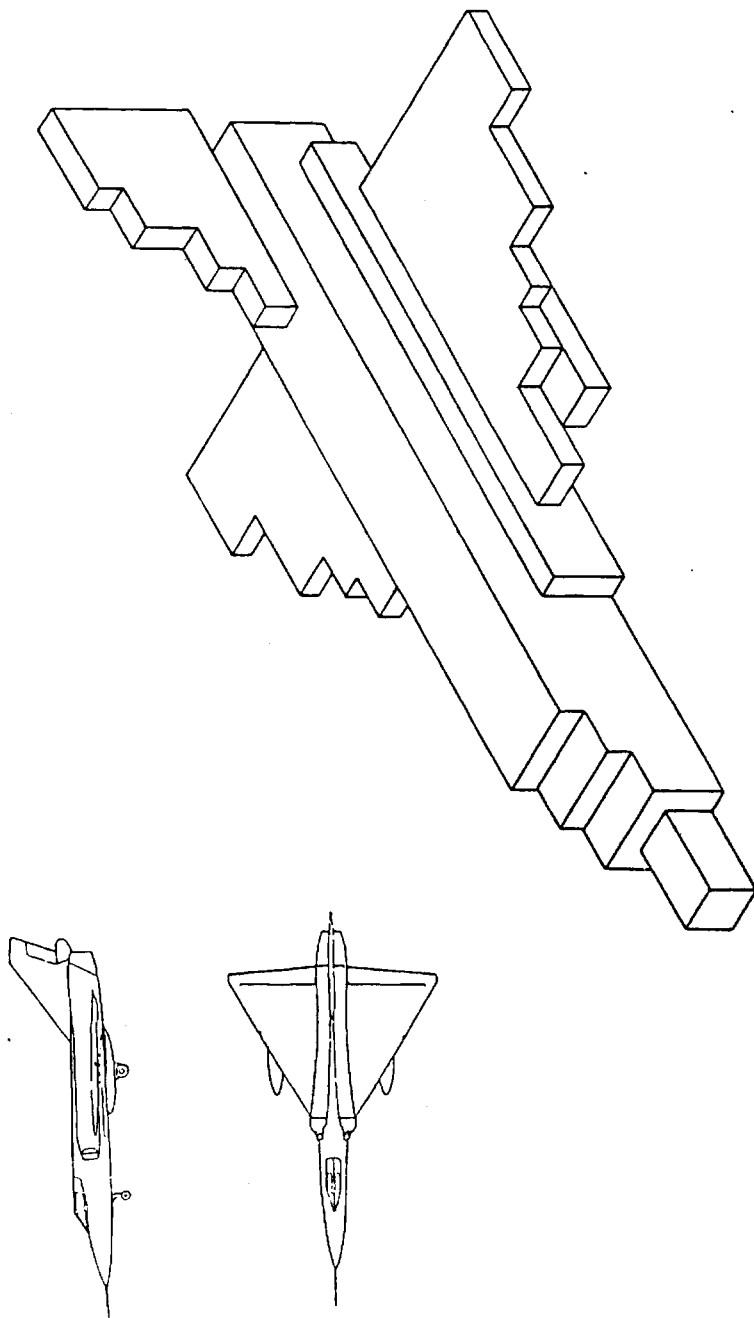

T3DFD MODEL OF F106B

ASSUMPTIONS: None  
 Maxwell's Equations

$$\begin{aligned}
 -u \frac{\partial H_x}{\partial t} &= \left( \frac{\partial E_z}{\partial y} - \frac{\partial E_y}{\partial z} \right) & H_x^n(i,j,k) &= H_x(x_0(i), y_0(j), z_0(k), t_H(n)) \\
 -u \frac{\partial H_y}{\partial t} &= \left( \frac{\partial E_x}{\partial z} - \frac{\partial E_z}{\partial x} \right) & H_y^n(i,j,k) &= H_y(x_0(i), y_0(j), z_0(k), t_H(n)) \\
 -u \frac{\partial H_z}{\partial t} &= \left( \frac{\partial E_y}{\partial x} - \frac{\partial E_x}{\partial y} \right) & H_z^n(i,j,k) &= H_z(x_0(i), y_0(j), z_0(k), t_H(n)) \\
 \epsilon \frac{\partial E_x}{\partial t} &= \sigma E_x - \left( \frac{\partial H_z}{\partial y} - \frac{\partial H_y}{\partial z} \right) - J_x & E_x^n(i,j,k) &= E_x(x_0(i), y_0(j), z_0(k), t_E(n)) \\
 \epsilon \frac{\partial E_y}{\partial t} &= \sigma E_y - \left( \frac{\partial H_x}{\partial z} - \frac{\partial H_z}{\partial x} \right) - J_y & E_y^n(i,j,k) &= E_y(x_0(i), y_0(j), z_0(k), t_E(n)) \\
 \epsilon \frac{\partial E_z}{\partial t} &= \sigma E_z - \left( \frac{\partial H_y}{\partial x} - \frac{\partial H_x}{\partial y} \right) - J_z & E_z^n(i,j,k) &= E_z(x_0(i), y_0(j), z_0(k), t_E(n))
 \end{aligned}$$

$x_0(i) = (i-1)\Delta x$  ,  $y_0(j) = (j-1)\Delta y$  ,  $z_0(k) = (k-1)\Delta z$  ,  $t_H(n) = (n-1)\Delta t$   
 $x(i) = (i-1/2)\Delta x$  ,  $y(j) = (j-1/2)\Delta y$  ,  $z(k) = (k-1/2)\Delta z$  ,  $t_E(n) = (n-1/2)\Delta t$

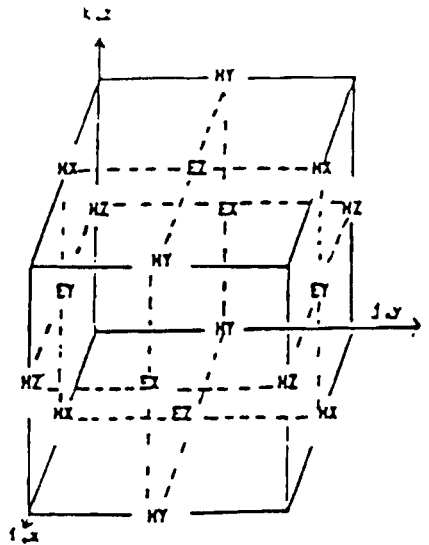

Finite Difference Equations (non-uniform grid allowed)

$$\begin{aligned}
 H_x^{n+1}(i,j,k+1) &= H_x^n(i,j,k+1) - \frac{\Delta t}{u} \left( \frac{E_z^n(i,j+1,k+1) - E_z^n(i,j,k+1)}{y(j+1) - y(j)} \right) + \frac{\Delta t}{u} \left( \frac{E_y^n(i,j+1,k+1) - E_y^n(i,j+1,k)}{z(k+1) - z(k)} \right) & \begin{cases} 1\epsilon[1,1,can] \\ J\epsilon[1,j,can-1] \\ k\epsilon[1,k,can-1] \end{cases} \\
 H_y^{n+1}(i+1,j,k+1) &= H_y^n(i+1,j,k+1) - \frac{\Delta t}{u} \left( \frac{E_x^n(i+1,j,k+1) - E_x^n(i+1,j,k)}{z(k+1) - z(k)} \right) - \frac{\Delta t}{u} \left( \frac{E_z^n(i+1,j,k+1) - E_z^n(i,j,k+1)}{x(i+1) - x(i)} \right) & \begin{cases} 1\epsilon[1,1,can-1] \\ J\epsilon[1,j,can] \\ k\epsilon[1,k,can-1] \end{cases} \\
 H_z^{n+1}(i+1,j+1,k) &= H_z^n(i+1,j+1,k) - \frac{\Delta t}{u} \left( \frac{E_y^n(i+1,j+1,k) - E_y^n(i,j+1,k)}{x(i+1) - x(i)} \right) + \frac{\Delta t}{u} \left( \frac{E_x^n(i+1,j+1,k) - E_x^n(i+1,j,k)}{y(j+1) - y(j)} \right) & \begin{cases} 1\epsilon[1,1,can-1] \\ J\epsilon[1,j,can-1] \\ k\epsilon[1,k,can] \end{cases} \\
 3 \cdot E_x^{n+1}(i,j,k) &= A \cdot E_x^n(i,j,k) - J_x - \left( \frac{H_y^{n+1}(i,j+1,k) - H_y^{n+1}(i,j,k)}{y_0(j+1) - y_0(j)} \right) - \left( \frac{H_z^{n+1}(i,j,k+1) - H_z^{n+1}(i,j,k)}{z_0(k+1) - z_0(k)} \right) & \begin{cases} 1\epsilon[1,1,can] \\ J\epsilon[1,j,can] \\ k\epsilon[1,k,can] \end{cases} \\
 -E_y^{n+1}(i,j,k) &= B \cdot E_y^n(i,j,k) - J_y + \left( \frac{H_x^{n+1}(i,j,k+1) - H_x^{n+1}(i,j,k)}{z_0(k+1) - z_0(k)} \right) - \left( \frac{H_z^{n+1}(i+1,j,k) - H_z^{n+1}(i,j,k)}{x_0(i+1) - x_0(i)} \right) & \begin{cases} 1\epsilon[1,1,can] \\ J\epsilon[1,j,can] \\ k\epsilon[1,k,can] \end{cases} \\
 3 \cdot E_z^{n+1}(i,j,k) &= A \cdot E_z^n(i,j,k) - J_z - \left( \frac{H_x^{n+1}(i+1,j,k) - H_x^{n+1}(i,j,k)}{x_0(i+1) - x_0(i)} \right) - \left( \frac{H_y^{n+1}(i,j+1,k) - H_y^{n+1}(i,j,k)}{y_0(j+1) - y_0(j)} \right) & \begin{cases} 1\epsilon[1,1,can] \\ J\epsilon[1,j,can] \\ k\epsilon[1,k,can] \end{cases}
 \end{aligned}$$

where  $A = \left( \frac{\epsilon}{\Delta z} - \frac{\sigma}{2} \right)$  ,  $B = \left( \frac{\epsilon}{\Delta z} + \frac{\sigma}{2} \right)$  ,  $J_x = J_x(z_H(n+1))$  ,  $J_y = J_y(z_H(n+1))$  ,  $J_z = J_z(z_H(n+1))$   
 all evaluated at desired  $\vec{r}$  component location

Externally supplied values are tangential electric fields on outer surface of problem space:

$$\begin{aligned}
 H_x^n(i,j,1) \quad , \quad H_y^n(i,j,1) \quad , \quad H_x^n(i,j,k_{can}+1) \quad , \quad H_y^n(i,j,k_{can}+1) & \quad \text{all } 1\epsilon[1,1,can] \quad , \quad J\epsilon[1,j,can] \\
 H_x^n(1,1,k) \quad , \quad H_y^n(1,1,k) \quad , \quad H_x^n(1,j_{can}+1,k) \quad , \quad H_y^n(1,j_{can}+1,k) & \quad \text{all } 1\epsilon[1,1,can] \quad , \quad k\epsilon[1,k,can] \\
 H_x^n(1,j,k) \quad , \quad H_y^n(1,j,k) \quad , \quad H_x^n(1_{can}+1,j,k) \quad , \quad H_y^n(1_{can}+1,j,k) & \quad \text{all } J\epsilon[1,j,can] \quad , \quad k\epsilon[1,k,can]
 \end{aligned}$$

### 3-D FINITE DIFFERENCE EQUATIONS IN RECTANGULAR COORDINATES SET UP WITH EXTERNALLY SUPPLIED H FIELDS

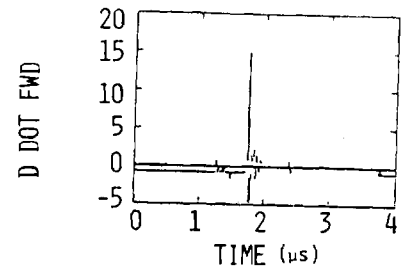
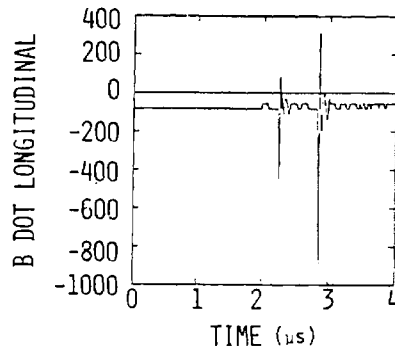
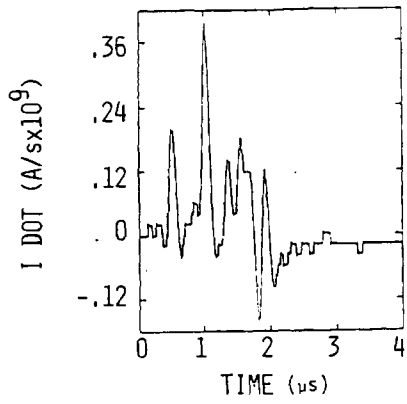

DATA FROM FLIGHT 80-038, RECORD 4

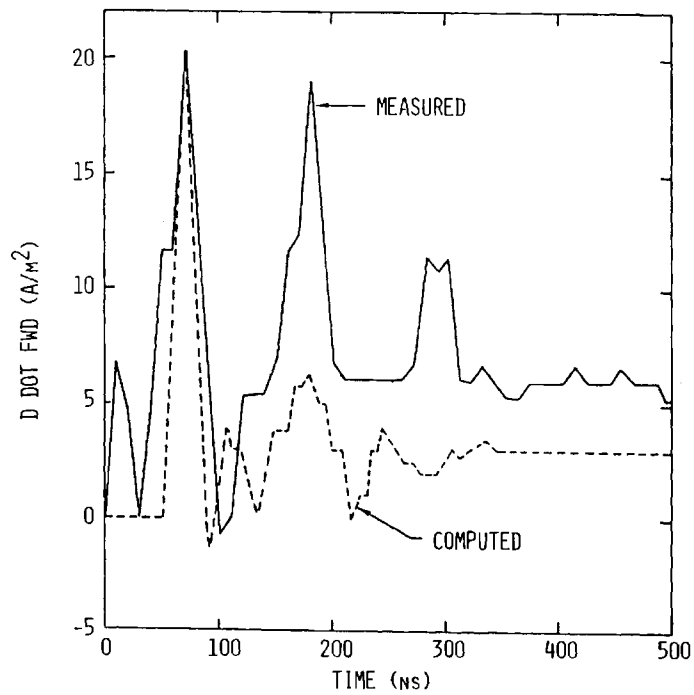

COMPARISON OF MEASURED RESPONSE (FLIGHT 80-18) AND COMPUTED WITH T3DFD AND A 30ns RISE TIME, 590 AMPERE STEP CURRENT SOURCE, NOSE TO TAIL.

CORONA AND STREAMER EFFECTS

by

Dr. R. A. Perala

Electromagnetic Applications, Incorporated

Description of possible corona effects on direct strike data, review of elements and state-of-the-art of corona modeling, and application of corona modeling to lightning/aircraft interaction. Corona to arc transition, importance, and modeling of streamers.

## DEFINITIONS

CORONA: A STATE OF THE GASEOUS CONDUCTION PREVIOUS TO ARC FORMATION

STREAMER: A CONDUCTING ARC CHANNEL EMANATING FROM A CORONA REGION

## CORONA: BASIC MECHANISM

- REQUIREMENT: FREE ELECTRONS ACCELERATED BY ELECTRIC FIELD

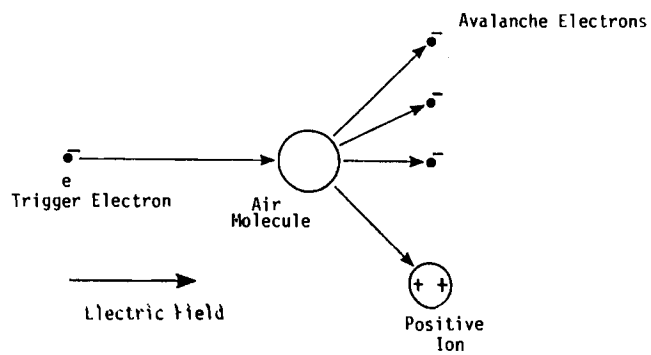

$$dn = \alpha ndx$$

n = Number of Electrons  
x = Distance  
 $\alpha$  = Townsend Ionization Coefficient

- SOURCE OF FREE (TRIGGER) ELECTRONS: BACKGROUND IONIZATION CAUSED BY COSMIC RAYS;  
 $\sim 2 \times 10^7$  ELECTRON-ION PAIRS/(m<sup>3</sup>-sec). THIS GIVES AMBIENT AIR CONDUCTIVITY  
 $\sim 10^{-13}$  mho/m.

## ELECTRON AND ION LOSS MECHANISMS

- ELECTRON ATTACHMENT TO NEUTRAL AIR MOLECULES TO FORM NEGATIVE IONS  
ATTACHMENT RATE  $\propto E$
- RECOMBINATION OF POSITIVE IONS AND ELECTRONS TO FORM NEUTRAL PARTICLES  
RECOMBINATION RATE  $\beta$
- RECOMBINATION OF POSITIVE AND NEGATIVE IONS  
RECOMBINATION RATE  $\gamma$

### AIR CHEMISTRY EQUATIONS FOR CORONA

$$\frac{dn_e(t)}{dt} + [\beta n_+(t) + \alpha_e - G] n_e(t) = Q(t),$$

$$\frac{dn_-(t)}{dt} + [\gamma n_+(t)] n_-(t) = \alpha_e n_e(t),$$

$$\frac{dn_+(t)}{dt} + [\beta n_e(t) + \gamma n_-(t)] n_+(t) = Q(t) + G n_e(t),$$

AIR CONDUCTIVITY  $\sigma = q (\mu_e n_e + \mu_i (n_- + n_+))$

- CONDUCTIVITY  $\sigma$  FEEDS BACK INTO MAXWELL'S EQUATIONS

$$\nabla \times \vec{E} = -\mu \frac{\partial \vec{H}}{\partial t}$$

$$\nabla \times \vec{H} = \epsilon \frac{\partial \vec{E}}{\partial t} + \sigma \vec{E}$$

- COEFFICIENTS  $G$ ,  $\alpha_e$ ,  $\mu_e$  IN TURN DEPEND UPON  $E$
- COEFFICIENTS ALSO DEPEND UPON HUMIDITY AND AIR PRESSURE

- IF WE ASSUME SPACE CHARGE NEUTRALITY

$$n_+ = n_e + n_-$$

- HOWEVER, SPACE CHARGE EFFECTS ARE IMPORTANT FOR CORONA, SO WE NEED TO INCLUDE:

$$\nabla \cdot \vec{J} + \frac{\partial \rho}{\partial t} = 0$$

$$\rho = (n_+ - n_- - n_e) q$$

$$\vec{J} = (n_+ \vec{V}_+ - n_- \vec{V}_- - n_e \vec{V}_e) q$$

ALSO NEED TO INCLUDE PARTICLE DYNAMICS

$$\vec{F}_s = q_s (\vec{E} + \vec{V}_s \times \vec{B}), \text{ s REFERS TO SPECIES}$$

RESULTS FOR A ROD-PLANE GAP.  
NUMERICAL RESULTS ASSUME SPACE CHARGE NEUTRALITY.

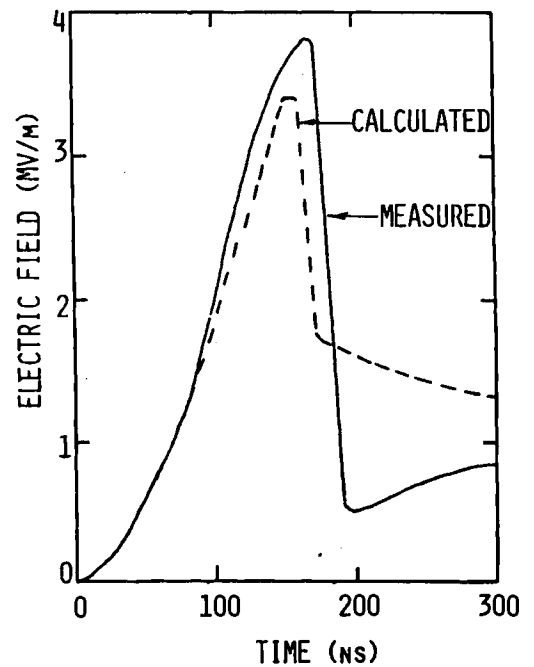
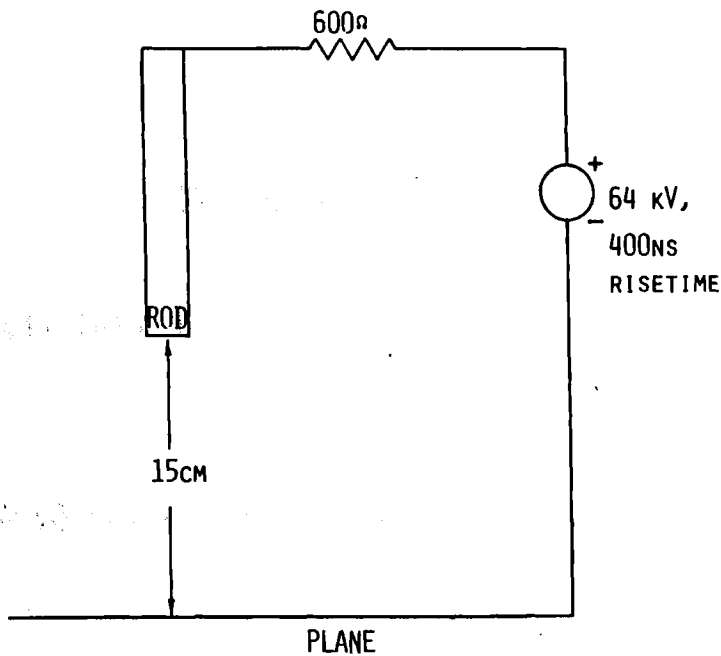

## EFFECTS OF NONLINEARITIES

- AIR CONDUCTIVITY MAY SHIELD APERTURES
- AIR BREAKDOWN MAY CAUSE INCREASES IN  $\frac{\partial E}{\partial t}$ , FOR EXAMPLE, AS INDICATED ON A PREVIOUS SLIDE
- AIRCRAFT COMPLEX RESONANT FREQUENCIES MAY CHANGE BECAUSE CORONA AND STREAMERS EFFECTIVELY EXTEND AIRCRAFT DIMENSIONS

## STREAMERS

- BASED ON GROUND MEASUREMENTS, AMPLITUDES LIMITED TO ~100 A
- NO MODEL BASED ON FIRST PRINCIPLES IS KNOWN TO EXIST FOR STREAMER FORMATION AND PROPAGATION
- AT PRESENT, MODELING IS PROBABLY BEST ACCOMPLISHED BY PRESCRIBING NONLINEAR CURRENT SOURCE REPRESENTATIONS

AN ANALYSIS METHOD FOR THE F-106 DIRECT STRIKE DATA

by

Dr. T. F. Trost

Texas Tech University

Summary of characteristics of electric and magnetic fields and currents measured during strikes. Description of laboratory modeling of direct strike fields and currents including test apparatus, airplane model, and data acquisition system. Comparison of model results with in-flight data: Resonances, attachment points, and waveforms. First order interpretation of in-flight data as a lightning input-aircraft response problem.

# F-106 DIRECT STRIKE DATA

## OBJECTIVES

- I. MEASURE STRENGTHS AND WAVEFORMS OF ELECTRIC AND MAGNETIC FIELDS ON AIRCRAFT
- II. INTERPRET WAVEFORMS
  - A. DETERMINE WHICH CHARACTERISTICS OF WAVEFORMS ARE DUE TO ELECTROMAGNETIC MODES OF AIRCRAFT/CHANNEL
  - B. INFER NATURE OF IONIZATION PROCESSES
  - C. STATE IMPLICATIONS OF MEASURED WAVEFORMS REGARDING COUPLING TO INTERIOR

### APPARATUS FOR AIRCRAFT-LIGHTNING MODELING

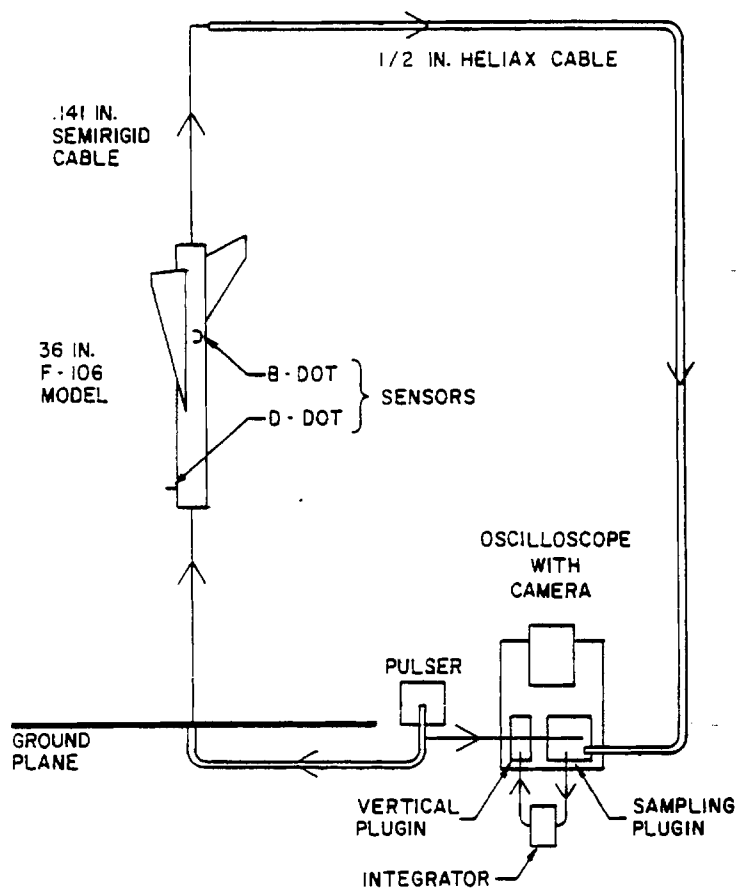

D-DOT AT NOSE

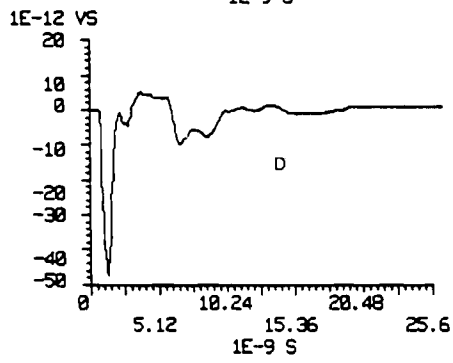
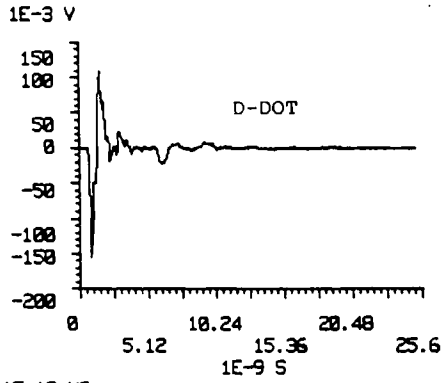

B-DOT AT FUSELAGE

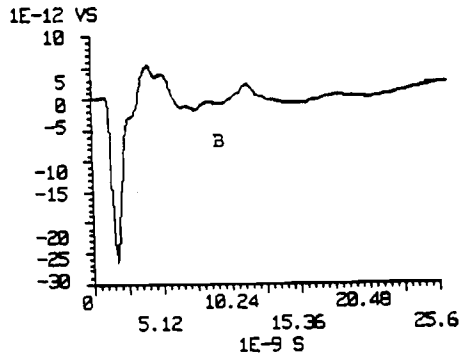
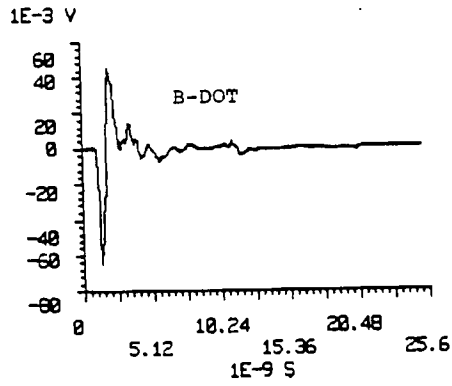

TRANSFER FUNCTIONS  
FOR THE F-106 MODEL

FREQUENCY DOMAIN DESCRIPTION

$$\text{TRANSFER FUNCTION} = \frac{\text{FOURIER TRANSFORM OF OUTPUT}}{\text{FOURIER TRANSFORM OF INPUT}}$$

INPUT: B-DOT NEAR LOWER WIRE  
OUTPUTS: D-DOT AT NOSE  
          B-DOT ON FUSELAGE OVER RIGHT WING  
          B-DOT AT VARIOUS LOCATIONS NEAR SURFACE  
          D-DOT AT VARIOUS LOCATIONS NEAR SURFACE

EXAMPLES OF TRANSFER FUNCTIONS

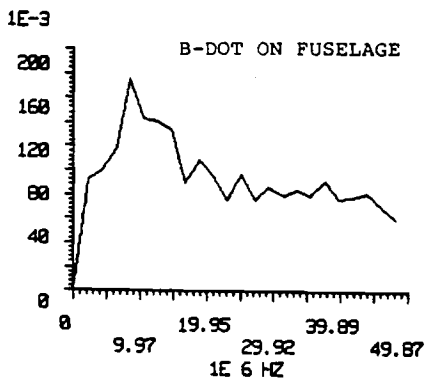
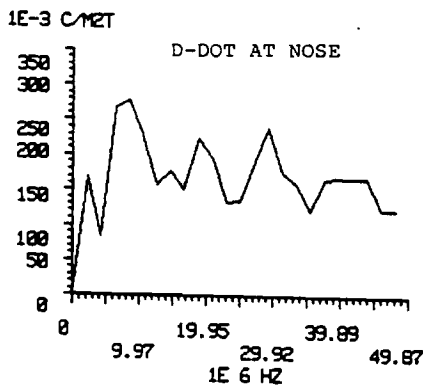

PRONY ANALYSIS OF FIELDS  
MEASURED ON THE MODEL

REPRESENT SENSOR OUTPUT WAVEFORMS AS FOLLOWS:

$$V(t) = \sum_{i=1}^N A_i e^{\sigma_i t} \cos(\omega_i t + \phi_i)$$

$$= \sum_{i=1}^{2N} R_i e^{s_i t}$$

$s_i = \sigma_i + j\omega_i$  ARE NATURAL FREQUENCIES OR POLES  
 $R_i$  ARE RESIDUES

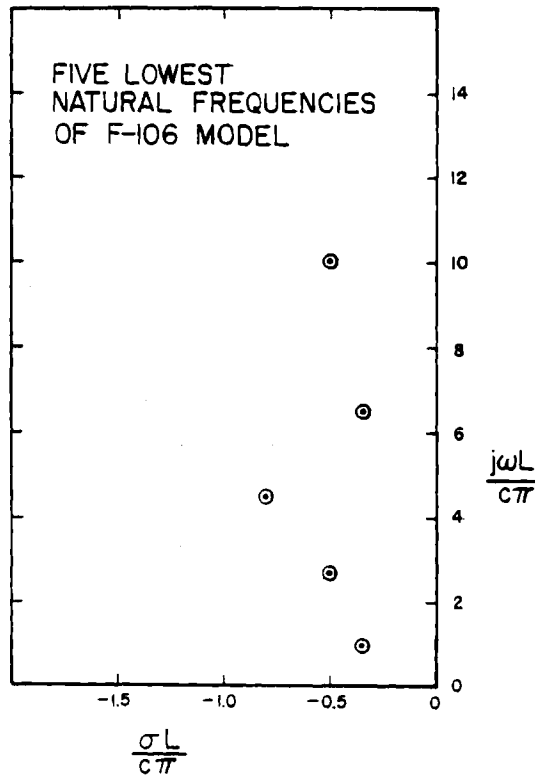

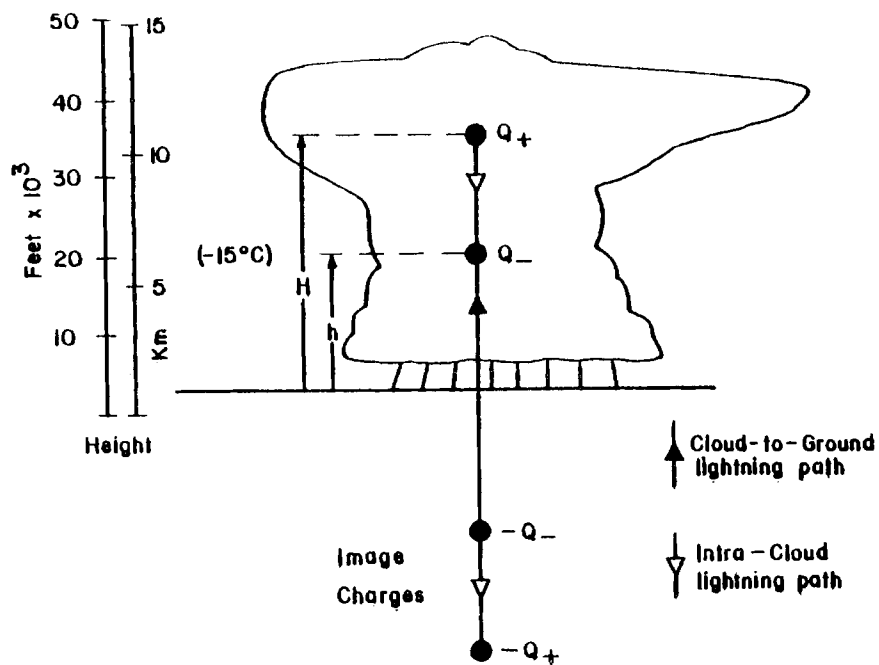

Model of thunderstorm charge distribution.

#### CHARACTERISTIC TIMES

CORONA CURRENT RISETIME (LABORATORY MEAS.)	10-50 ns
LIGHTNING CURRENT RISETIME (REMOTE ELECTRIC FIELD MEAS.)	30-8000 ns
PERIOD OF LOWEST ELECTROMAGNETIC MODE OF F-106 (LABORATORY SCALE MODEL MEAS.)	110 ns
TIME CONSTANT FOR CHARGING F-106 IN CHANNEL (ESTIMATE)	~250 ns
F-106 DIRECT STRIKE RISETIME OF B	20-40 ns
OF D	20-1000 ns

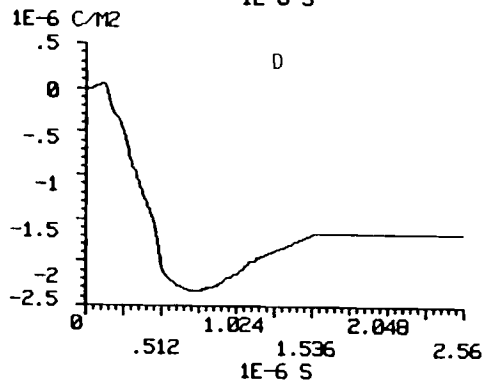
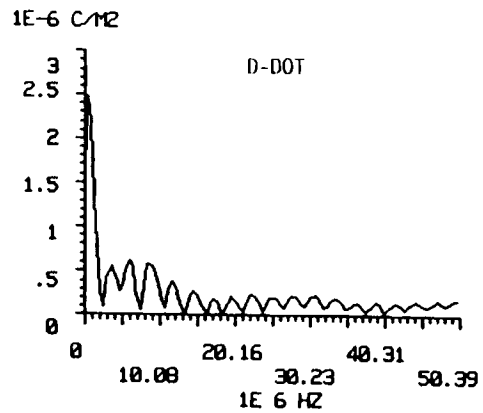
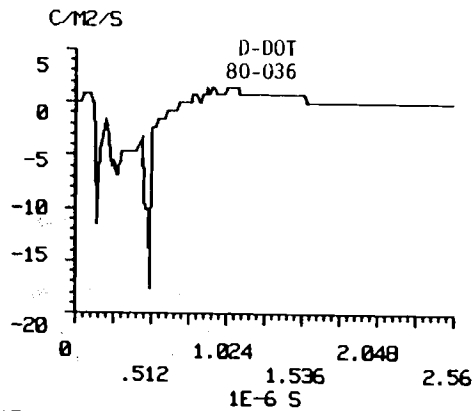
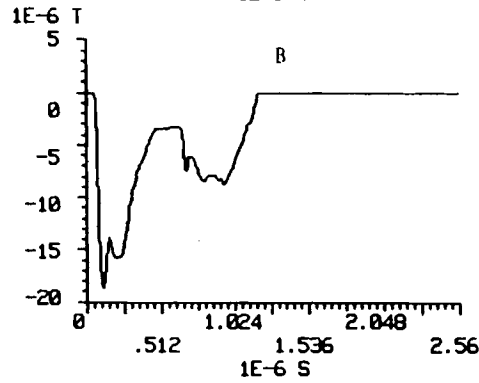
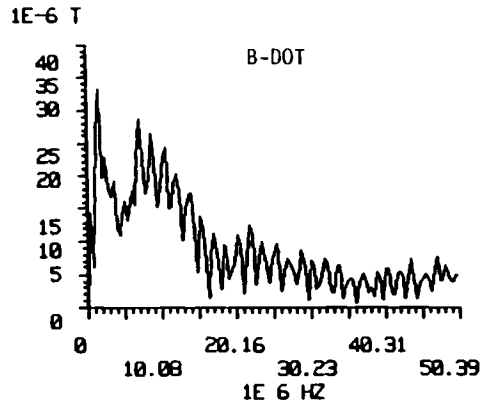
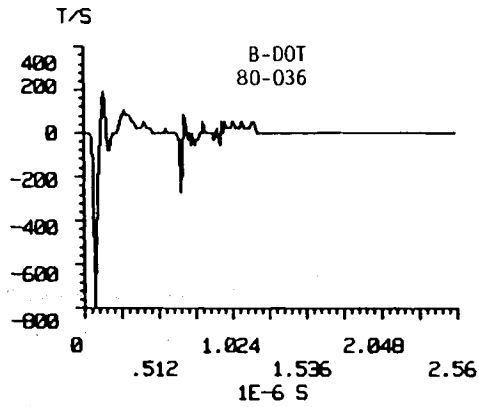

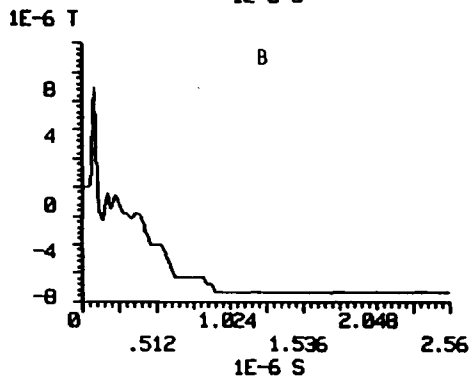
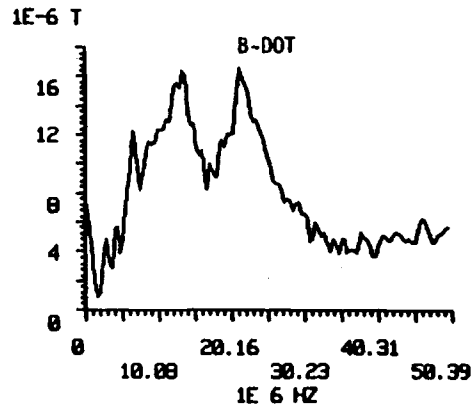
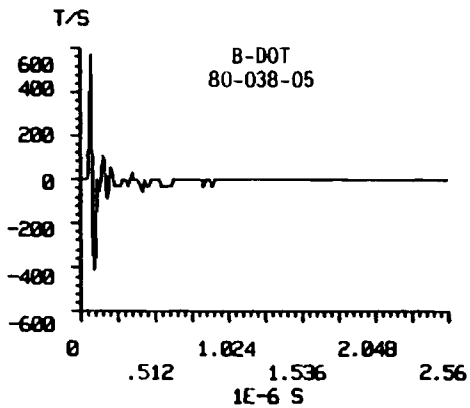
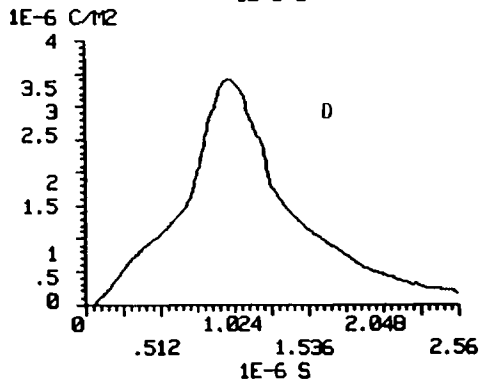
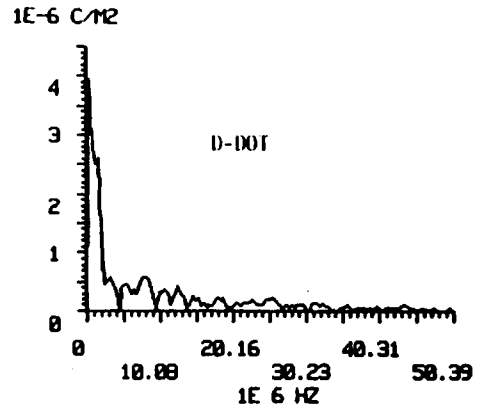
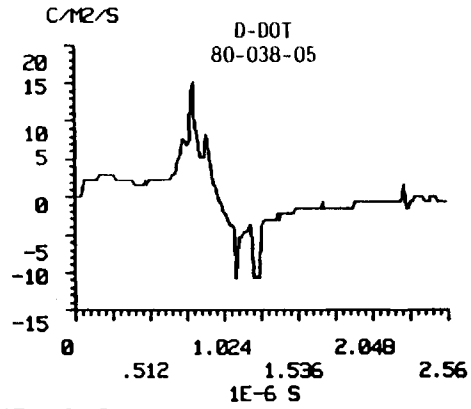

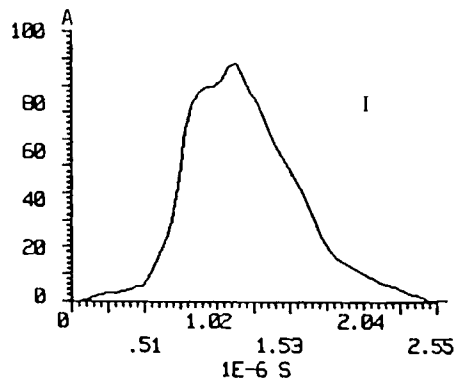
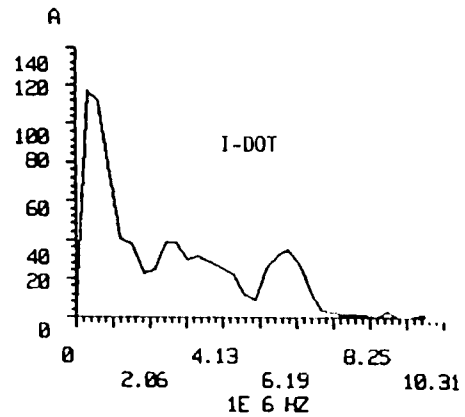
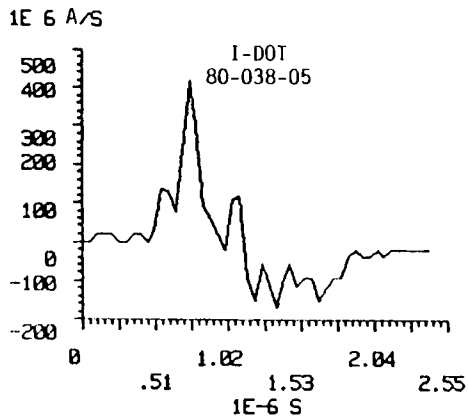

SOME RESULTS FROM COMPARISON  
OF MODEL AND IN-FLIGHT DATA

IN-FLIGHT FREQUENCY SPECTRUM PEAKS ARE IN  
GENERAL AGREEMENT WITH MODES OF MODEL  
AT 9MHZ AND 21 MHZ

SHOULD BE ABLE TO INFER SOME CHANNEL PROPERTIES  
FROM IN-FLIGHT SPECTRA

IN-FLIGHT D-DOT WAVEFORMS LONGER DURATION THAN  
B-DOT WHEREAS DURATIONS SAME ON MODEL



AN OVERVIEW OF THE ELECTRICAL/ELECTROMAGNETIC IMPACT OF  
ADVANCED COMPOSITE MATERIALS ON AIRCRAFT DESIGN

by

Dr. John C. Corbin, Jr.

Wright-Patterson Air Force Base

The impact of the application of composite structures in aircraft presented from the electromagnetic viewpoint. Fundamental electromagnetic differences between metal and composite aircraft are described and technology developments in shielding effectiveness, joint and fuel system design, and power system/equipment integration are reviewed.

# TRENDS IN AIRCRAFT DESIGN

---

FUEL ECONOMY - NEW ENGINE DESIGNS

- ACTIVE CONTROLS

REDUCED WEIGHT - LIGHTER STRUCTURES

- INCREASED PAYLOAD AND/OR  
RANGE

DIGITAL ELECTRONICS - HIGH DENSITY PACKAGING

- MICROMINIATURIZATION



- CRITICAL FLIGHT FUNCTIONS

# **ELECTROMAGNETIC (EM) ENVIRONMENTAL IMPACT**

---

- **ELECTRONICS MORE SUSCEPTIBLE TO FAILURE (PERMANENT DAMAGE OR TRANSIENT UPSET)**
  
- **CHARACTERISTICS OF THE AIRCRAFT SUBSTANTIALLY CHANGED**

# TECHNOLOGY TRENDS

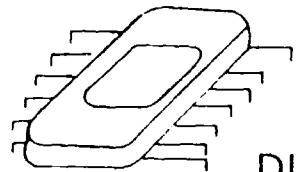
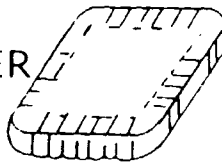
TUBES	DISCRETE TRANSISTORS	INTEGRATED CIRCUITS (IC)	LARGE SCALE INTEGRATED CIRCUITS (LSI)	VERY LARGE SCALE INTEGRATED CIRCUITS (VLSI)
 250V 1 WATT/ DEVICE	 TO-5 12V - 24V $10^{-1} - 10^{-2}$ WATTS/DEVICE	FLAT PACK  5V - 12V $10^{-2} - 10^{-3}$ WATTS/TRANS	 DIP 5V - 7V $10^{-3} - 10^{-4}$ WATTS/TRANS	CHIP CARRIER  1.5V - 3V $10^{-5} - 10^{-6}$ WATTS/TRANS
GLASS/ METAL/ CERAMIC	METAL/ CERAMIC	METAL/ CERAMIC/ EPOXY	METAL/ CERAMIC/ EPOXY	CERAMIC/ EPOXY
F-9, F-100, F-106	F-4, F-111	F-14, F-15	F-16, F-18	VSTOL, AFTI
ALUMINUM	ALUMINUM	ALUMINUM/ TITAN	GRAPHITE - EPOXY ALUMINUM	GRAPHITE - EPOXY ?
PRE - 1950'S	1950'S	1960'S	1970'S	1980'S

# EM FEATURES OF THE ALL-METAL AIRCRAFT

---

- SHIELDING OF 20 dB OR MORE BETWEEN THE EXTERNAL EM ENVIRONMENT AND INTERNAL AIRCRAFT ELECTRONICS
- READILY AVAILABLE “COMMON GROUND” RETURN PATHS FOR SIGNAL AND POWER
- A LOW RESISTANCE, HIGH CONDUCTIVITY OUTER SKIN FOR CARRYING DIRECT STRIKE LIGHTNING CURRENTS AND DISSIPATING PRECIPITATION STATIC CHARGES
- A RELATIVELY UNBROKEN COUNTERPOISE SYSTEM FOR AIRCRAFT ANTENNAS

# ELECTRICAL/ELECTRONIC SYSTEMS

---

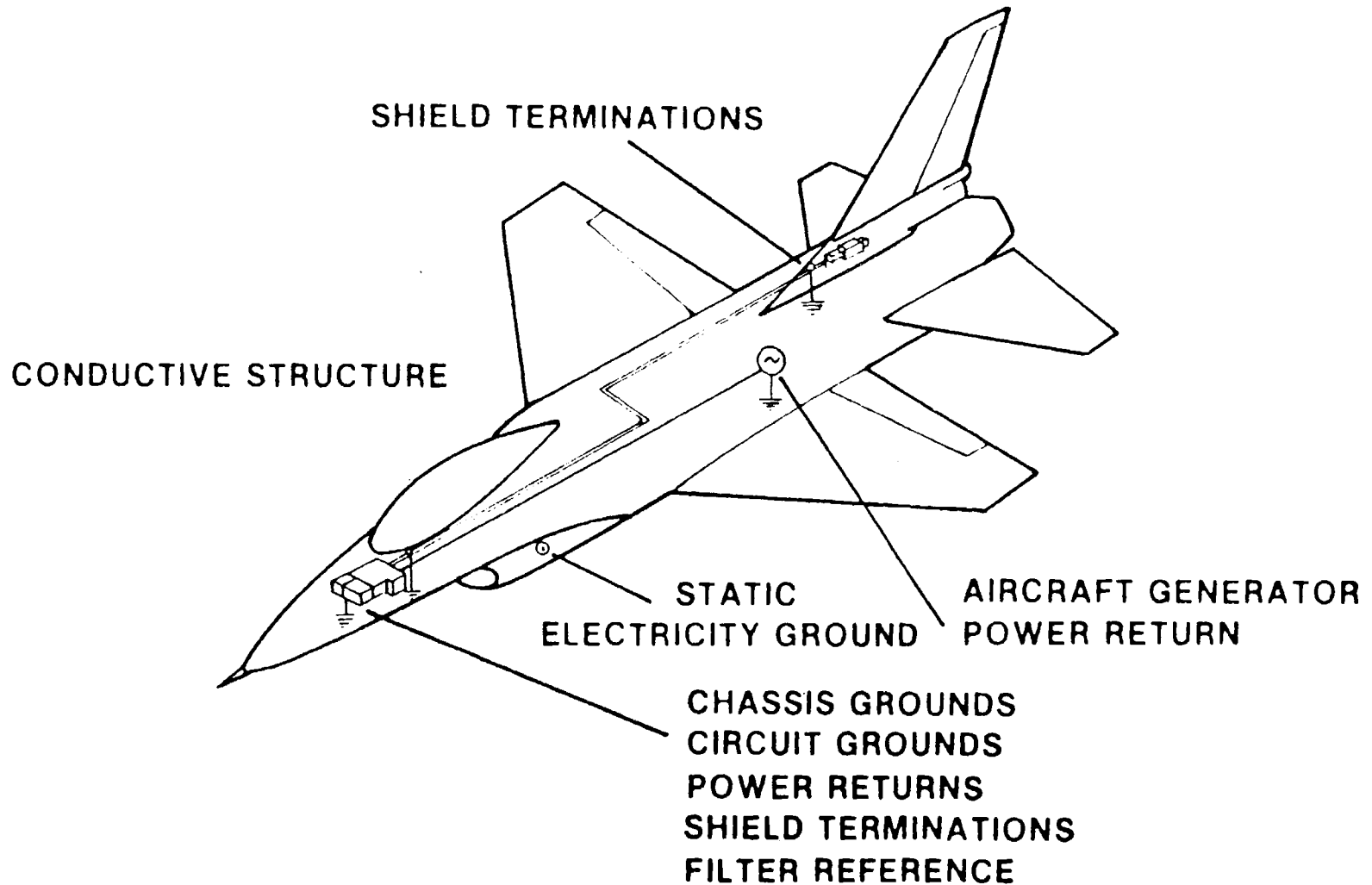

# ADVANCED COMPOSITE MATERIALS

---

- DEFINITION: FIBER-REINFORCED MATERIALS (FIBERS BONDED TO A MATRIX) HAVING PROPERTIES COMPARABLE OR SUPERIOR TO METALS AND FIBERGLASS
- FIBER/MATRIX SYSTEMS IN COMMON USAGE:
  - GRAPHITE/EPOXY
  - BORON/EPOXY
  - KEVLAR/EPOXY
  - HYBRIDS (CARBON, GLASS & KEVLAR)

## **AIRCRAFT APPLICATIONS**

---

- **YF-16 FORWARD FUSELAGE**
- **F/A 18 HORNET**
- **AV-8B V/STOL**
- **767**

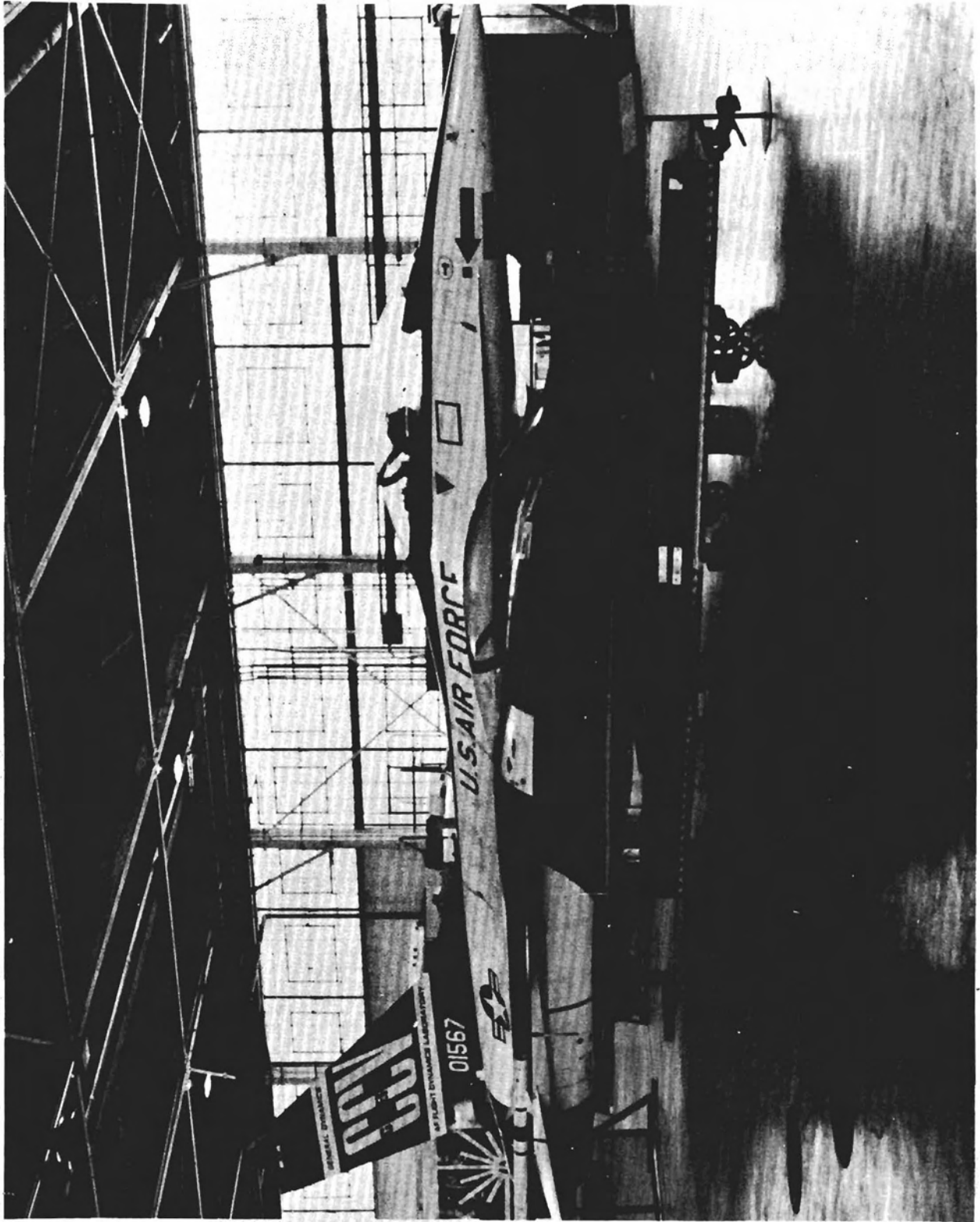

# F/A-18A MATERIALS DISTRIBUTION

100

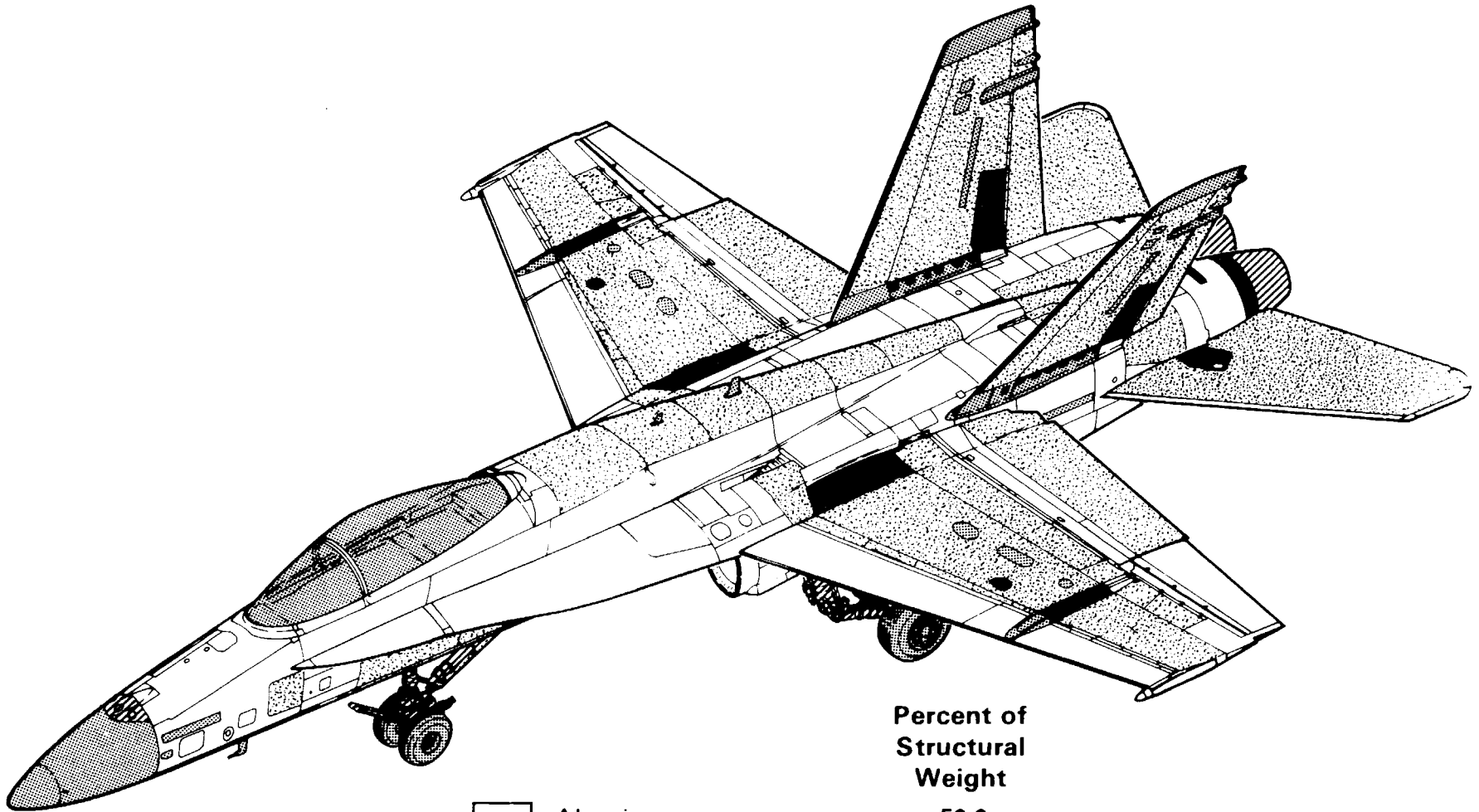



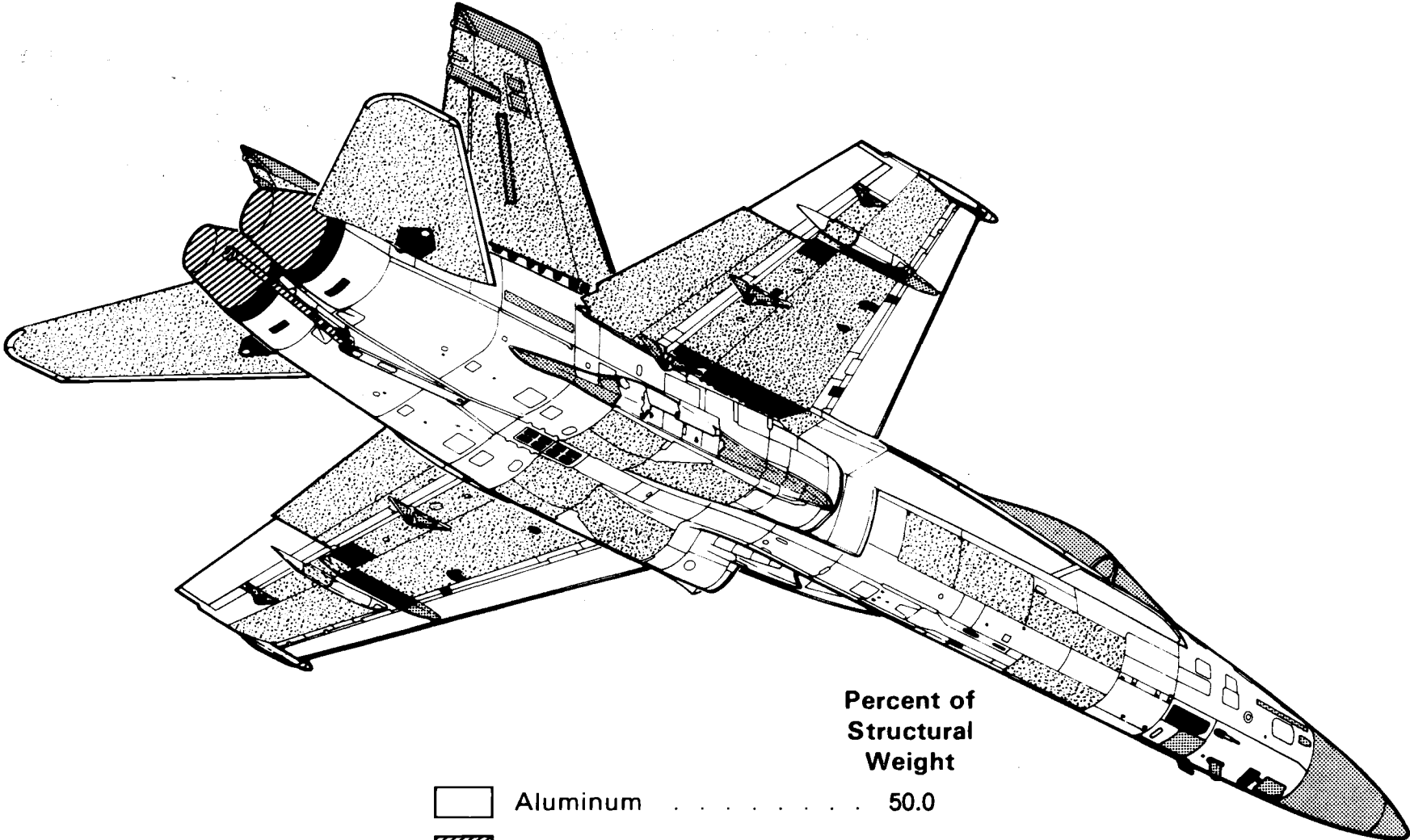

		Percent of Structural Weight
	Aluminum . . . . .	50.0
	Steel . . . . .	15.7
	Titanium . . . . .	13.0
	Graphite/Epoxy . . . . .	9.1
	Other . . . . .	12.2
		100.0



# F/A-18A MATERIALS DISTRIBUTION



Percent of Structural Weight

	Aluminum . . . . .	50.0
	Steel . . . . .	15.7
	Titanium . . . . .	13.0
	Graphite/Epoxy . . . . .	9.1
	Other . . . . .	12.2
		100.0

# AV-8B COMPOSITES APPLICATIONS

STRUCTURAL WEIGHT	
	GRAPHITE/EPOXY..... 26.3%
	ALUMINUM ..... 47.7%
	OTHER ..... 26.0%

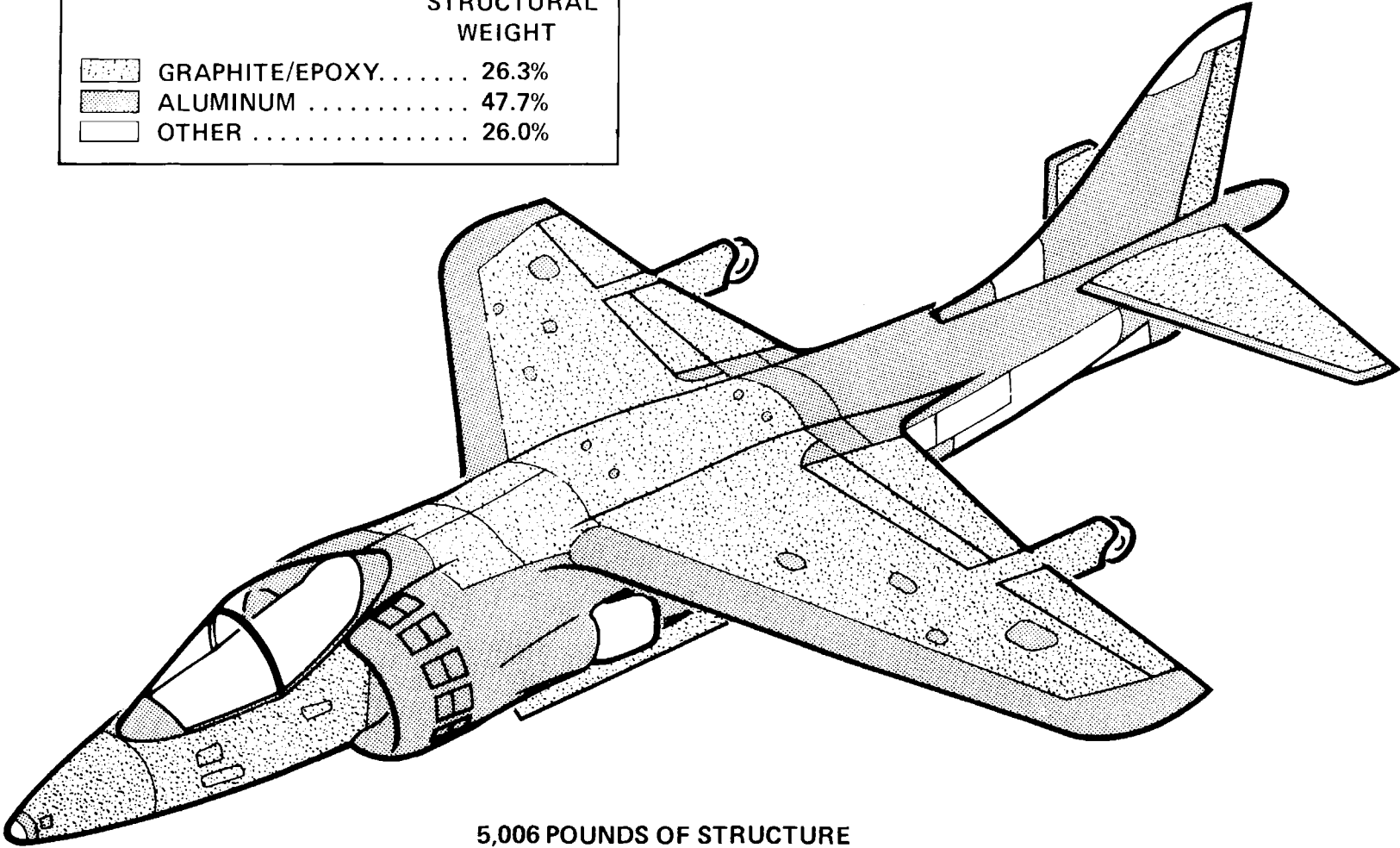

5,006 POUNDS OF STRUCTURE  
1,317 POUNDS OF GRAPHITE/EPOXY

767 NON METAL STRUCTURE

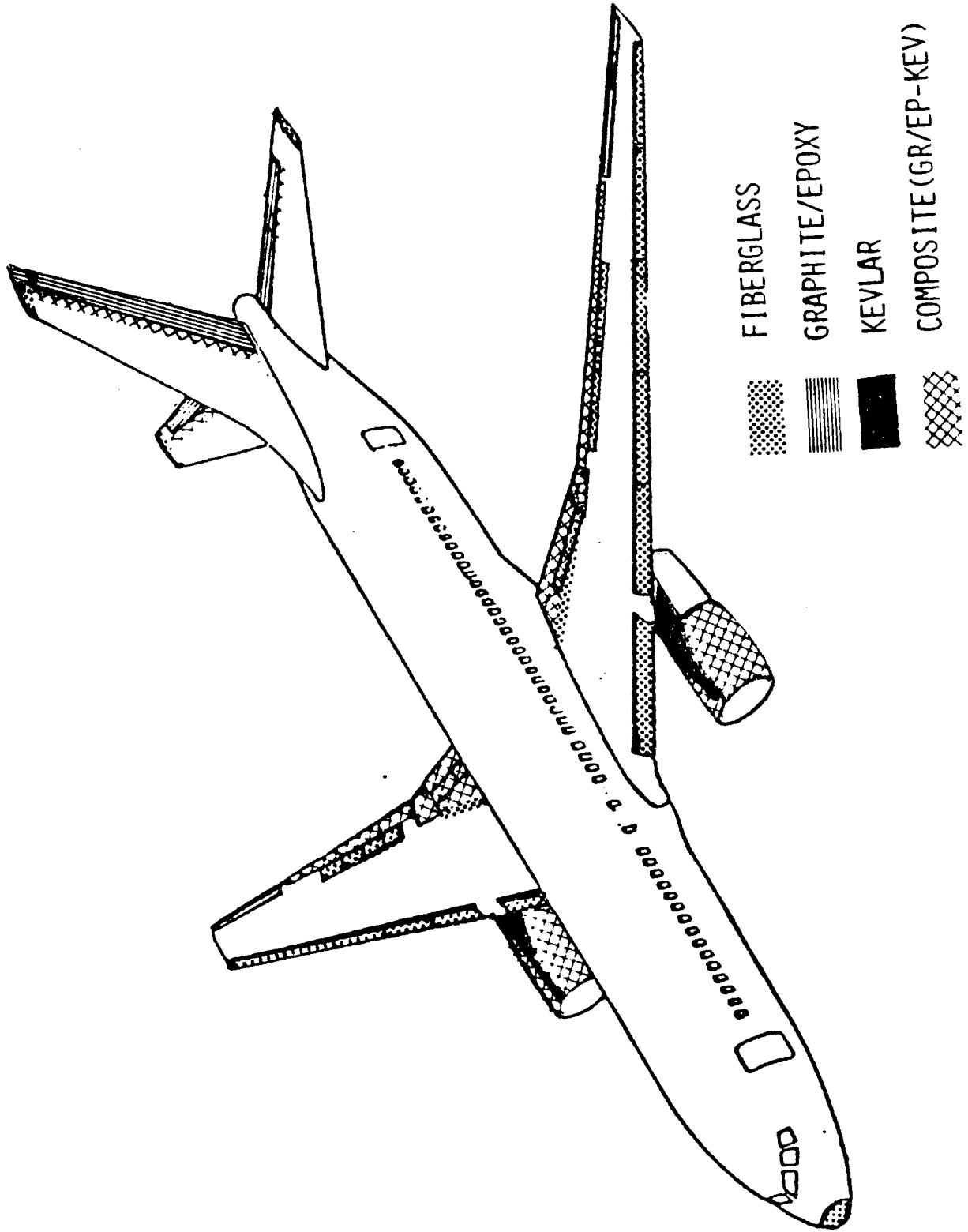

# 767 NON METAL STRUCTURE

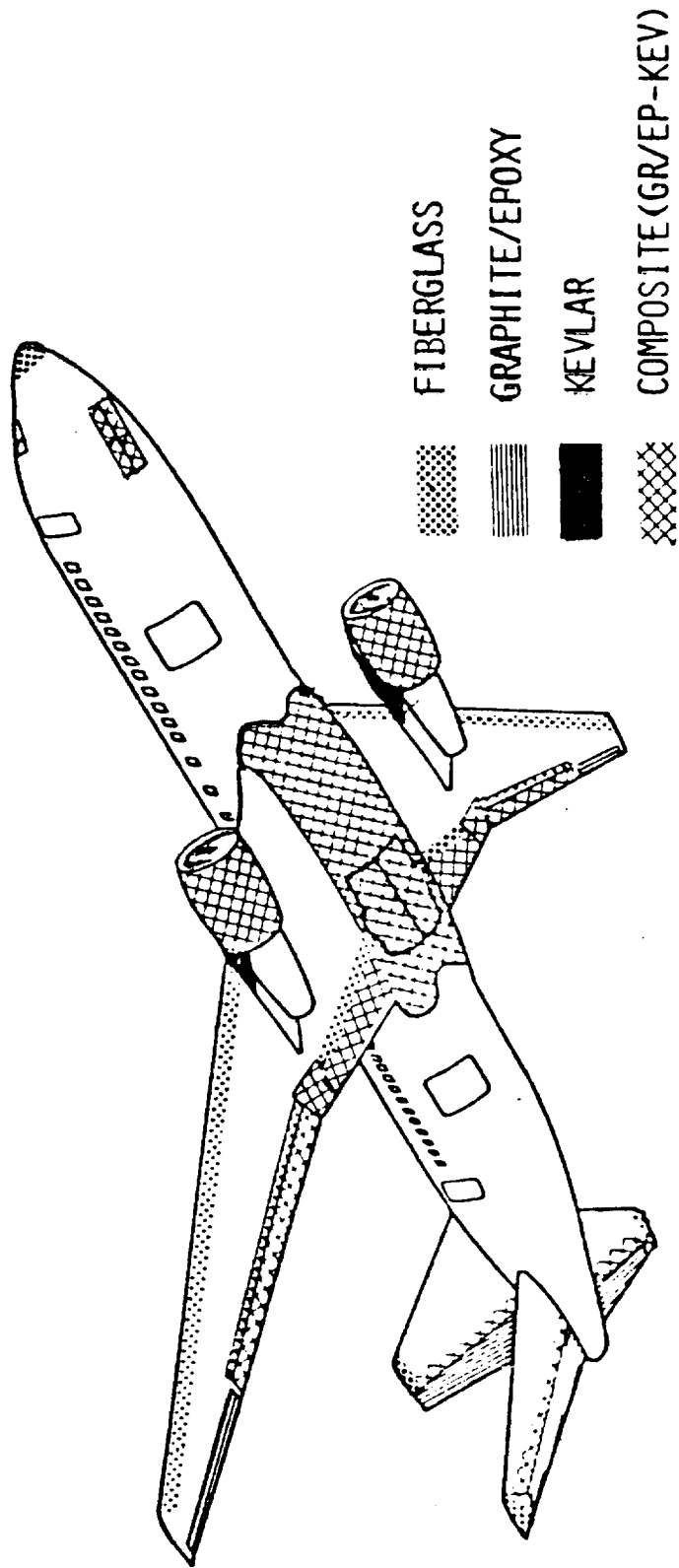

# AIR FORCE STUDY (1979)

---

- **SCOPE: ASSESS POTENTIAL ELECTRICAL/  
ELECTROMAGNETIC IMPACTS OF THE  
APPLICATION OF ADVANCED COMPOSITE  
MATERIALS TO AEROSPACE SYSTEMS**
- **OBJECTIVES: IDENTIFY POTENTIAL SUSCEPTIBILITIES  
OF SYSTEMS**

**DETERMINE IF EM ASPECTS ARE BEING  
FULLY CONSIDERED**

**DETERMINE IF EM PROGRAMS ARE  
IN BALANCE WITH STRUCTURAL  
PROGRAMS**

# CONDUCT OF STUDY

---

- QUESTIONNAIRE SENT TO GOVERNMENT AGENCIES & AEROSPACE CONTRACTORS
- VISITS & IN-DEPTH DISCUSSIONS AT SPECIFIC FACILITIES
- JOINT GOVERNMENT — INDUSTRY MEETING
- BRIEFINGS TO:

SAMSO  
AFWAL  
ASD  
RADC  
RAND

NASA  
NAVAL ASC  
AFSC (DL/SD)  
USAF (RD)  
DOD (USDR&E)

# SCOPE

---

- MATERIAL CLASS

METALLICS

CONDUCTIVE

GRAPHITE/EPOXIES

HIGH MODULUS (GY70 - SPECIAL,  
MISSILE & SPACECRAFT)

REDUCED  
CONDUCTIVITY

HIGH STRENGTH (T-300, AS -  
AIRCRAFT)

FIBER GLASS

DIELECTRIC

KEVLAR

# TOPICS

---

- IMPLEMENTATION ISSUES:
  - DESIGN CAPABILITY
  - DESIGN DATA
- DEVELOPMENT NEEDS
- E/EM CONCERNS
  - LIGHTNING EFFECTS (DIRECT/INDIRECT)
  - STATIC ELECTRIC EFFECTS
  - ANTENNA PERFORMANCE
  - RADAR CROSS-SECTION
  - ELECTROMAGNETIC INTERFERENCE (EMI)
  - ELECTROMAGNETIC COMPATIBILITY (EMC)
  - ELECTROMAGNETIC PULSE (EMP)
  - SYSTEM GENERATED EMP
  - POWER SYSTEM DESIGN
  - SPACE ENVIRONMENT EFFECTS
  - OTHER NUCLEAR EFFECTS

# SUMMARIZATION

109

	INSIGNIFICANT	MINOR	INTERMEDIATE	MAJOR	UNKNOWN	CONDUCTIVITY	TRANSFER IMPEDANCE	JOINT IMPEDANCE	GROUNDING
	I	II	III	IV	V	A	B	C	D
LIGHTING DIRECT EFFECT									
STRUCTURAL EFFECTS		X				X			
FUEL SYSTEM EFFECTS			X			X		X	X
LIGHTING INDIRECT EFFECTS			X			X	X	X	X
ANTENNA PERFORMANCE									
HF & LF			X					X	X
VHF -L BAND		X						X	X
ABOVE L BAND			X			X		X	
STATIC ELECTRICITY		X						X	
RADAR CROSS SECTION		X				X			
LOW RCS OBSERVABLE CASE			X					X	
EMI/EMC/EMP			X			X	X	X	X
POWER SUBSYSTEM			X			X		X	X
SYSTEM GENERATED EMP					X	X			
OTHER NUCLEAR EFFECTS					X				
SPACE ENVIRONMENTAL EFFECTS					X				

# LEADING CONCERNS

---

- LIGHTNING
  - SPARK FREE FUEL TANK DESIGN
  - INDIRECT EFFECTS (UPSET/DAMAGE)
- BONDING OF JOINTS AND SEAMS (EMI/EMC, EMP, SGEMP)
  - CORROSION CONTROL
  - ELECTRICAL DURABILITY (A/C AND SPACE)
  - STRUCTURAL/PRODUCIBILITY
- POWER SYSTEM GROUNDING
- HF AND LF ANTENNA TECHNOLOGY
- COMBINED SPACE ENVIRONMENT EFFECTS
- SPECIFIC DATA REQUIREMENTS
- TECHNOLOGY TRANSITION

# CONCERNS REFLECT

---

- MATERIAL PROPERTY DIFFERENCES:
  - REDUCED CONDUCTIVITY
    - REDUCED SURFACE CONDUCTIVITY
    - REDUCED SHIELDING
  - STRUCTURAL JOINT ELECTRICAL CONDUCTIVITY
  - ELECTROCHEMICAL POTENTIAL FOR CORROSION
- LIMITED DATA AND EXPERIENCE:
  - VARYING DEGREES OF CONCERN
  - SOME CONCERNS GENERIC

# CONCLUSIONS

---

- TECHNOLOGY DEVELOPMENT ESSENTIAL IN FIVE MAJOR AREAS:
  - JOINT DESIGN
  - FUEL SYSTEM DESIGN
  - POWER SYSTEM/EQUIPMENT INTEGRATION
  - SHIELDING EFFECTIVENESS
  - RADAR CROSS SECTION
- APPLICATION OF COMPOSITES TO AIRCRAFT IS LOW RISK
- ESTABLISHMENT OF TRI-SERVICE/NASA/FAA WORKING GROUP NEEDED FOR PROGRAM COORDINATION, DEVELOPMENT OF DESIGN GUIDES, HANDBOOKS, STANDARDS AND SPECIFICATIONS, AND DEVELOPMENT OF STANDARD ACCEPTED TEST METHODS FOR CRITICAL AREAS (SUCH AS SHIELDING EFFECTIVENESS)

# **McAIR ANALYSIS/TEST PROGRAM OF GRAPHITE EPOXY COMPOSITES**

---

- INHERENT SHIELDING
- PANEL SHIELDING
- PANEL/JOINT LEAKAGE
- PANEL JOINT IMPEDANCE
- FUSELAGE SHIELDING
- STATIC WING SHIELDING
- ANTENNA PERFORMANCE
- INTERMODULATION EFFECTS
- LIGHTNING EFFECTS

# INHERENT SHIELDING

---

- COAXIAL LINE FIXTURE (FIGURE 1)
- G/E WASHER SPECIMENS FROM 1, 2, 4, & 8 PLY PANELS
- CW SIGNAL INSERTED/RECEIVED SIGNAL MEASURED
- EFFECTIVE SHIELDING  $>60$  dB FROM 40 KHz - 1 GHz (FIGURE 2)
- SHIELDING PREDOMINANTLY BY REFLECTION

# COAXIAL FIXTURE

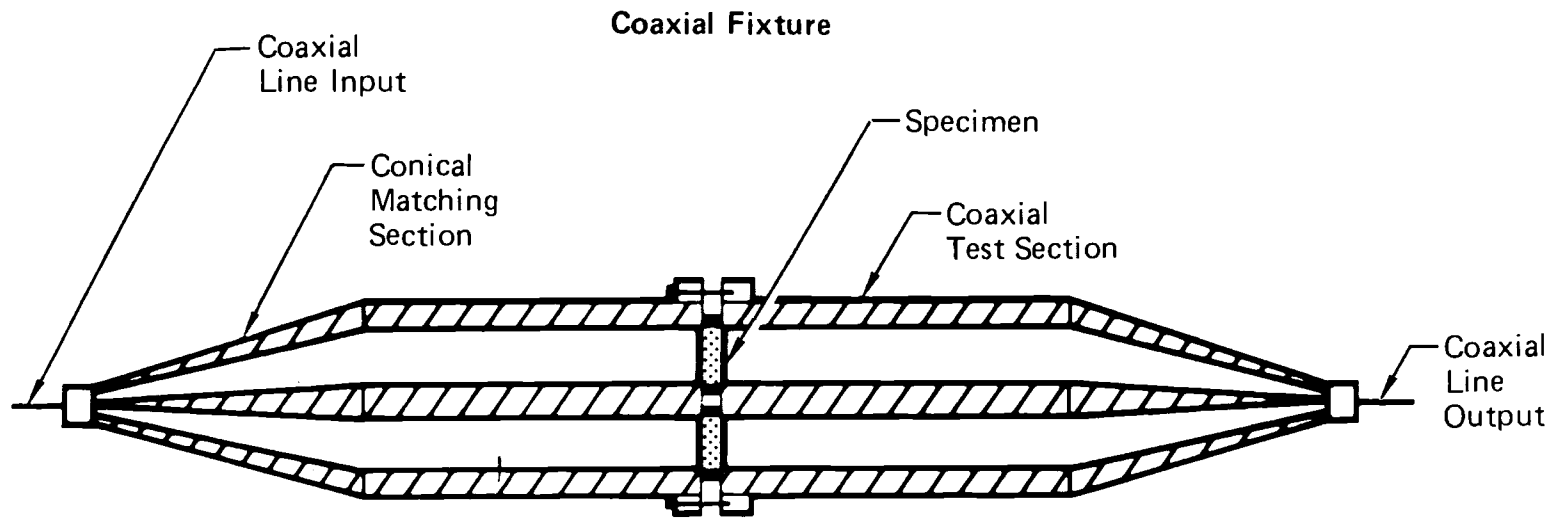

## Washer Specimen Mounting Detail

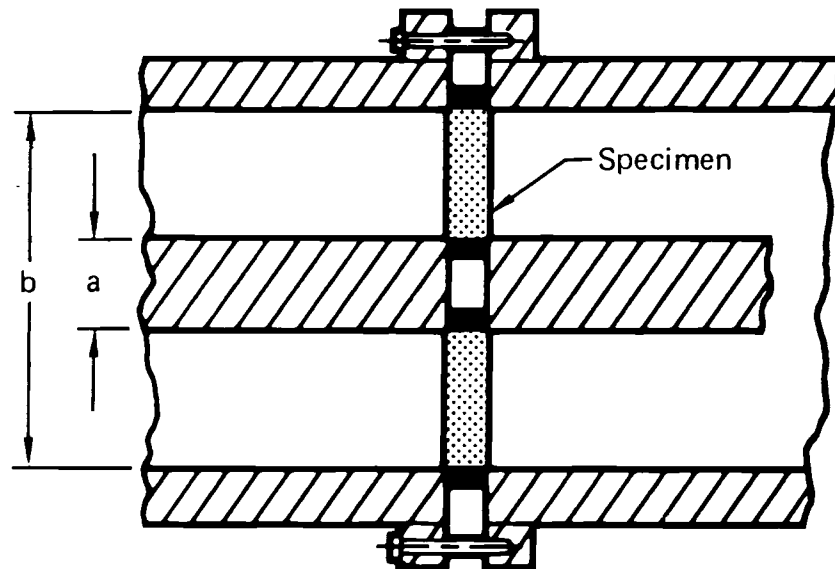

# PLANE WAVE SHIELDING MEASURED WITH COAXIAL LINE

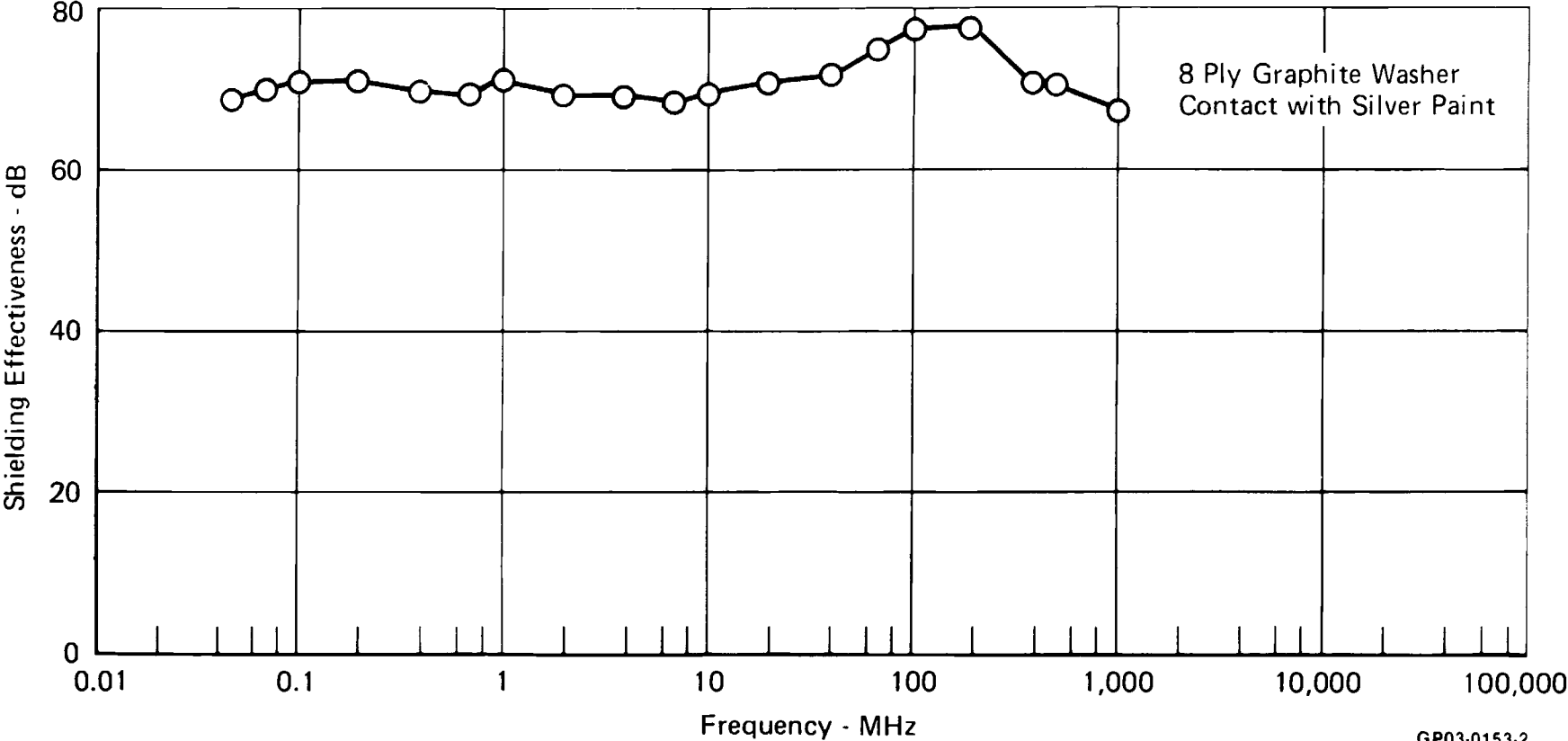

111

# PANEL SHIELDING

---

- VARIOUS THICKNESSES (1, 2, 4, & 8 PLY)
- VARIOUS CONSTRUCTION TYPES (MONOLYTHIC, HONEYCOMB, SYNTACTIC CORE)
- CUBICAL COPPER BOX FIXTURE (FIGURE 3)
- PLANE WAVE SOURCE (40 KHz - 20 GHz) - ROD ANTENNA SENSOR
- VARIOUS PANEL ATTACHMENTS
  - (a) CONTACT MOUNTING (FIGURE 4)
  - (b) CONDUCTIVE MOUNTING (EPOXY)
  - (c) FASTENER MOUNTING
  - (d) CONDUCTING FOIL MOUNTING (FIGURE 5)
  - (e) FINGER STOCK MOUNTING

CUBICAL BOX FIXTURE

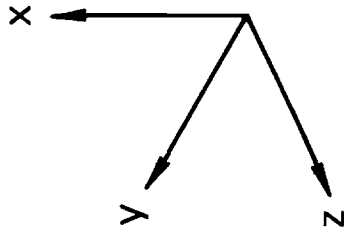
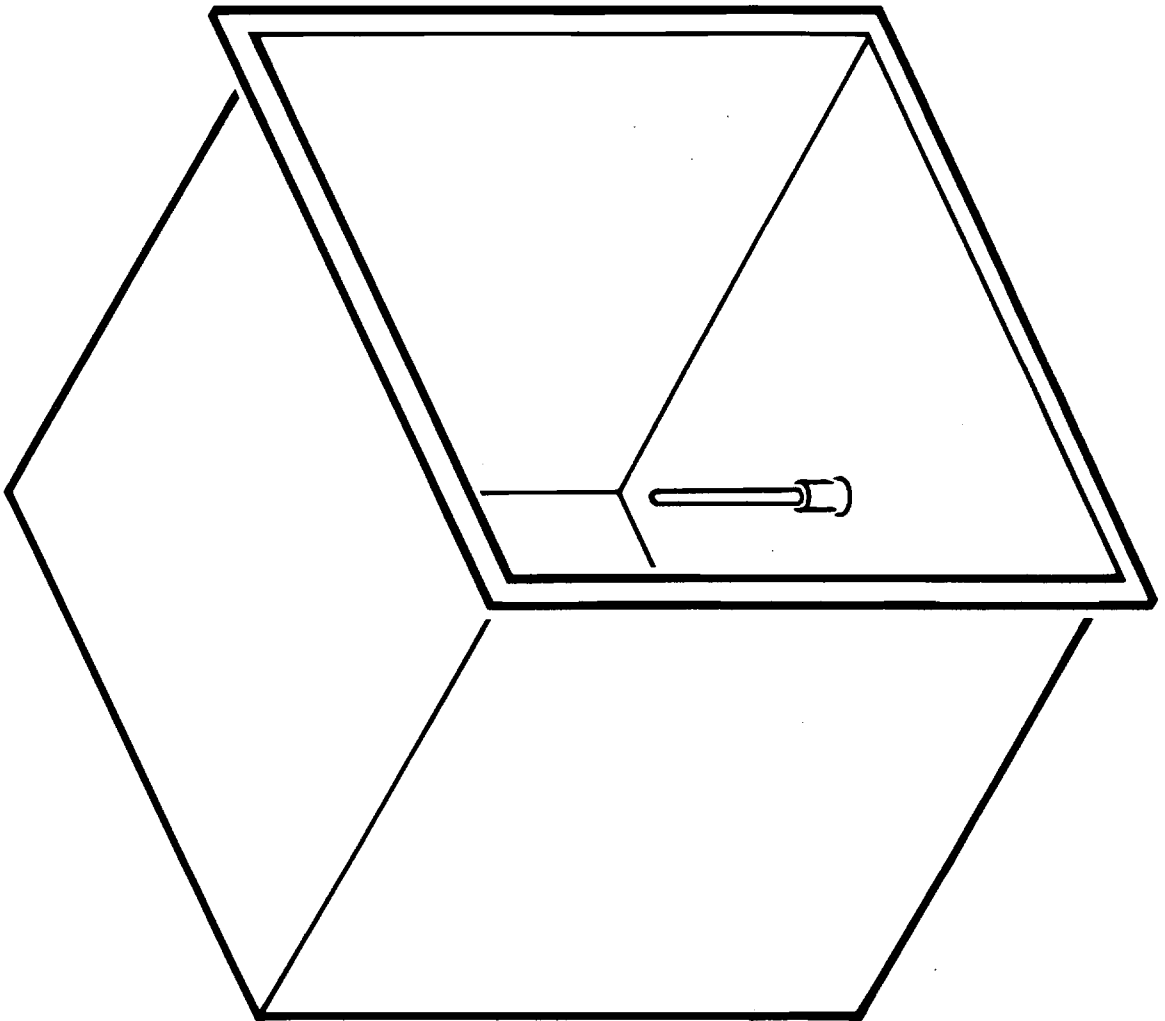

GP03-0153-3

# ELECTRIC FIELD SHIELDING FOR GRAPHITE PANELS ON BOX

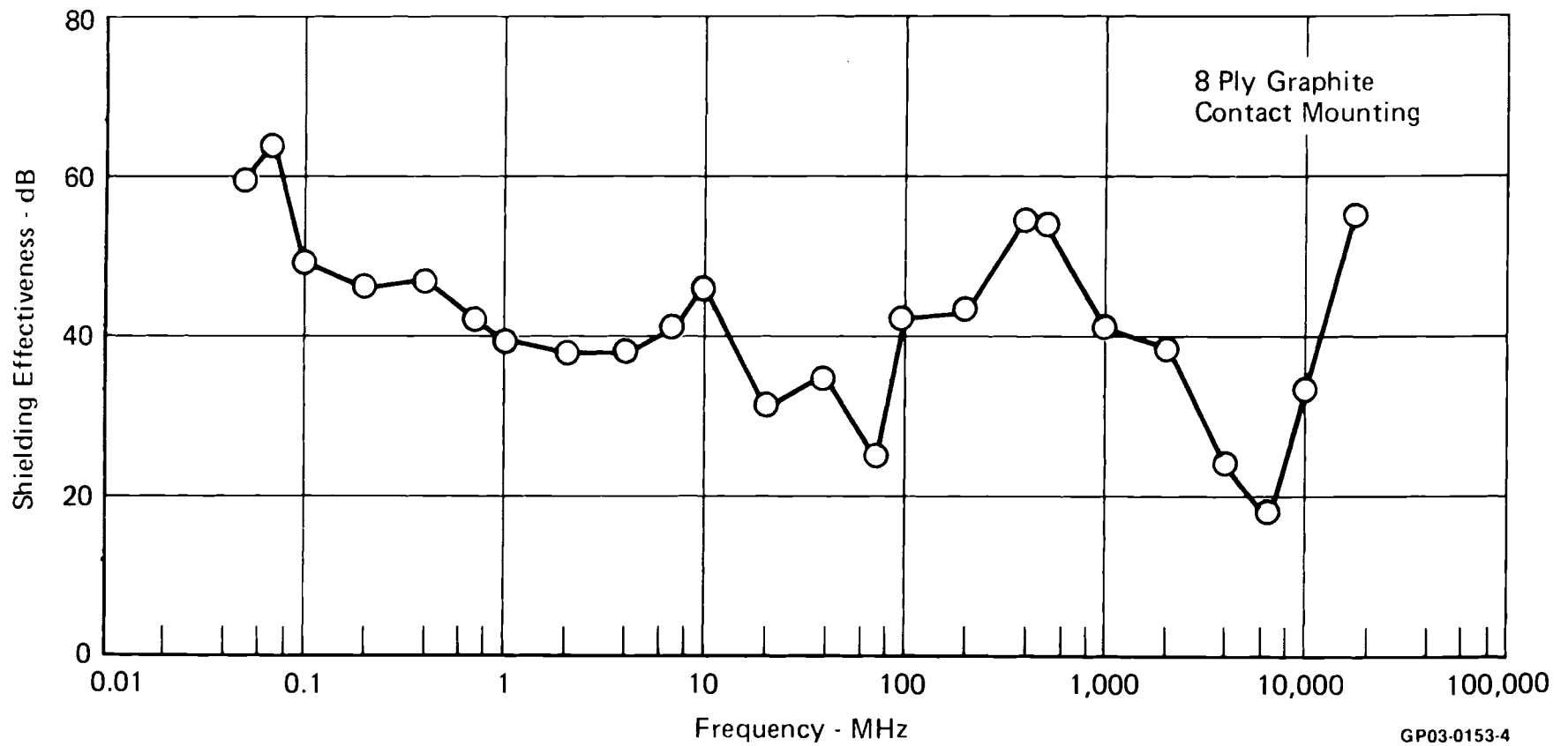

# ELECTRIC FIELD SHIELDING FOR GRAPHITE PANELS ON BOX (CAPACITIVELY COUPLED)

120

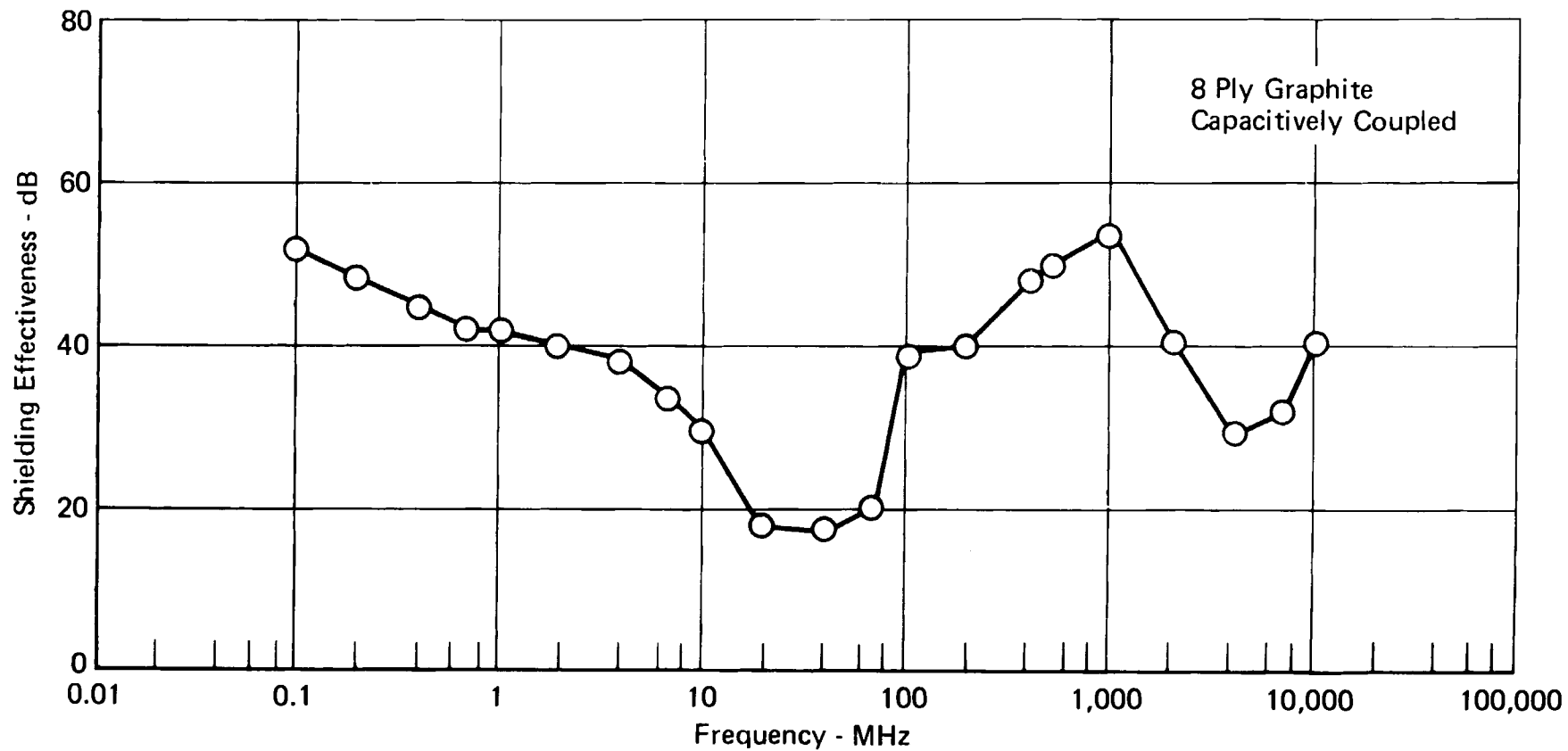

## PANEL/JOINT LEAKAGE TESTS

---

- 13 PANELS TESTED: 4 SOLID, 9 WITH JOINTS (TABLE 1)
- TEST FIXTURE (FIGURE 6)
- RELATIVE PERFORMANCE DATA (TABLE 2)
- CONCLUSIONS
  - TIN PLATING PROVIDED APPRECIABLE PROTECTION IMPROVEMENT THROUGH G/E SINGLE LAP SHEAR JOINTS
  - FINGER STOCKS MOST EFFECTIVE WHEN BONDING IS DESIRED BETWEEN A METALLIC PANEL AND A G/E PANEL
  - TIN PLATING INCREASES SHIELDING EFFECTIVENESS OF NON-JOINTED G/E PANEL

## EMI LEAKAGE TEST PANEL LIST

<u>CONF IGURATION IDENT.</u>	<u>CONF IGURATION</u>	<u>JOINT</u>	<u>JOINT SEAL CONFIGURATION</u>
A	G/E Tape Mat'l	None	None
B	G/E Cloth	None	None
C	Aluminum	None	None
D	G/E (Tin Plated)	None	None
G	G/E-Aluminum	Single Lap Shear	Form-In-Place (FIP) Seal
H	G/E-Aluminum	Single Lap Shear	Tin Plated-FIP Seal
J	G/E-Aluminum	Single Lap Shear	FIP Seal
K	G/E-Aluminum	Single Lap Shear	FIP Seal-Finger Stock
L	G/E-G/E	Single Lap Shear	Tin Plated
M	G/E-G/E	Double Lap Shear	Fay Seal
N	Aluminum-Aluminum	Double Lap Shear	Fay Seal
P	G/E-Aluminum	Single Lap Shear	FIP Seal-Finger Stock
R	G/E-G/E	Single Lap	Tin Plated-FIP Seal- Finger Stock

# TYPICAL TEST CONFIGURATIONS

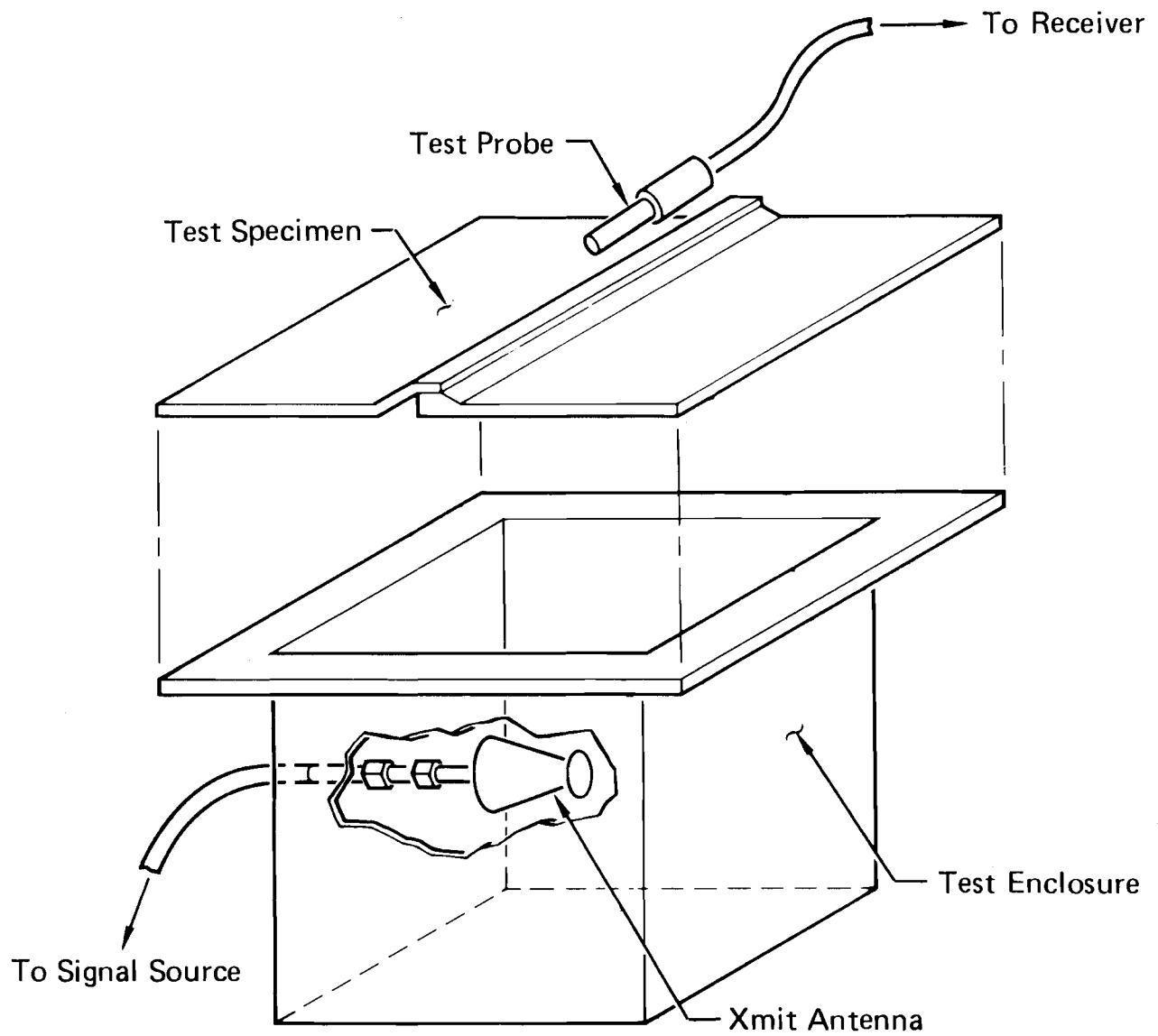

GP03-0153-8

**EMI TEST PANEL DATA**  
**RELATIVE PERFORMANCE OF PANELS WITH SEAMS**

Test	Panel Description	Seam Preparation (5)	Relative Performance	
			E	H
N	Aluminum-Aluminum	None Double Lap Shear (DLS)	100	97
L	Graphite/Epoxy Cloth - Graphite/ Epoxy Cloth	Tin Plated, Sealed	84	84
P	Aluminum - Graphite/Epoxy Cloth	Bonding Strip, Sealed	69	79
R	Graphite/Epoxy Cloth - Graphite/ Epoxy Cloth	Tin Plated, Bonding Strip Sealed	64	78
G	Aluminum - Graphite/Epoxy Cloth	Sealed	58	99
H	Aluminum - Graphite/Epoxy Cloth	Tin Plated, Sealed	49	96
M	Graphite/Epoxy Cloth - Graphite/ Epoxy Cloth	None (DLS)	50	4
K	Graphite/Epoxy Cloth - Graphite/ Epoxy Cloth	Bonding Strip, Sealed	37	55
J	Graphite/Epoxy Cloth - Graphite/ Epoxy Cloth	Sealed	10	68
C	(4) Aluminum		99	99
D	(4) Tin Plated, Graphite/Epoxy Cloth		95	89
A	(4) Graphite/Epoxy Tape		80	71
B	(4) Graphite/Epoxy Cloth		70	79

NOTES:

1. All panels show relationship to best panel whose value is 100
2. E (electric field)
3. H (magnetic field)
4. One piece panels (no seams)
5. Single lap shear (SLS) unless otherwise indicated
6. The seals are a formed-in-place rubber gasket used to prevent water leaks

## PANEL JOINT IMPEDANCE TESTS

---

- MEASURED JOINT BONDING RESISTANCE/IMPEDANCE AT FREQUENCIES FROM 14 KHz TO 500 KHz (FIGURE 7)
- TESTED SOLID AND JOINTED PANELS (TABLE 3)
- RATIO OF IMPEDANCES OF JOINT TO BULK MATERIAL TABULATED (TABLE 4)
- TIN SPRAYING AT THE JOINT INTERFACE IMPROVED RATIO

# ADJACENT GRAPHITE/EPOXY AND ALUMINUM LIGHTNING ATTACHMENT CHARACTERISTICS

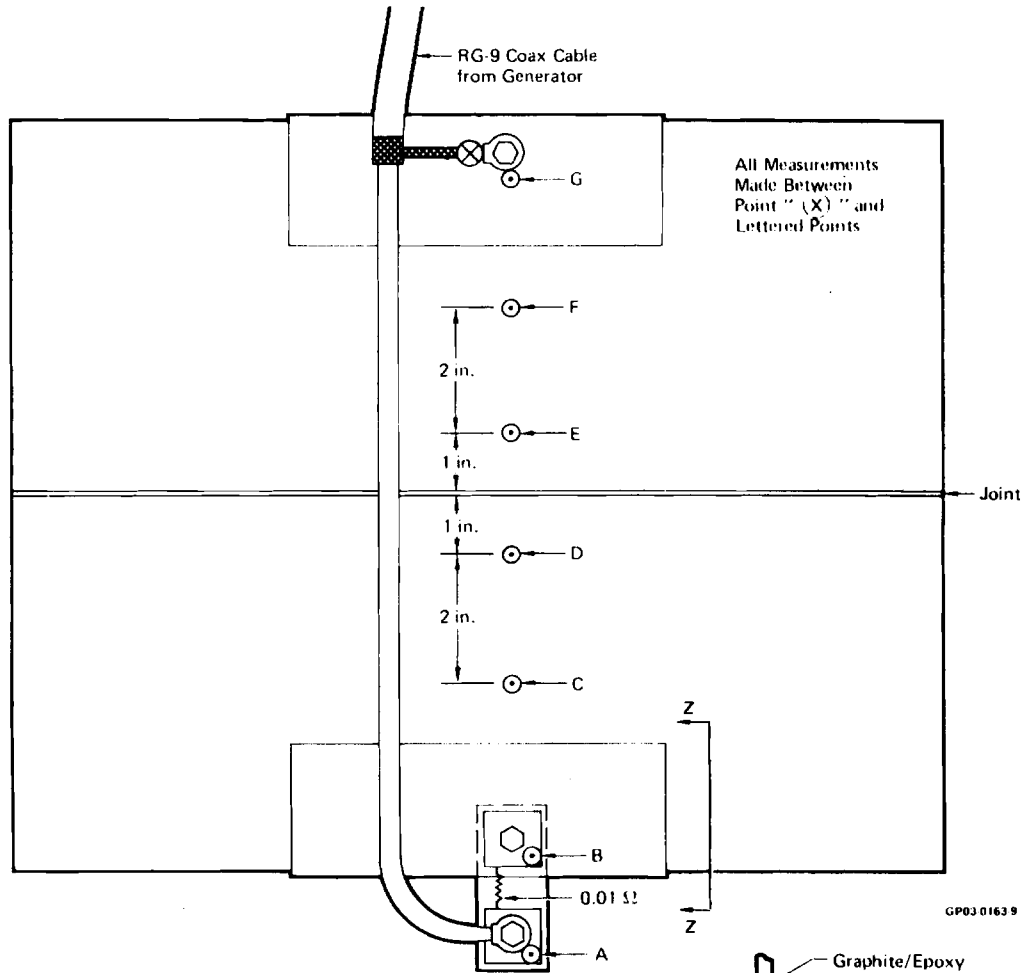

GP03 0163 9

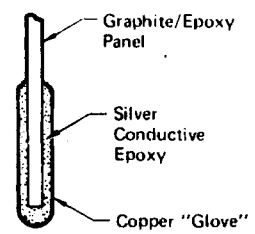

View Z-Z

## JOINT IMPEDANCE TEST PANEL LIST

<u>CONFIGURATION IDENT.</u>	<u>CONFIGURATION</u>	<u>JOINT</u>	<u>JOINT SEAL CONFIGURATION</u>
B	G/E	None	None
C	Aluminum	None	None
G	G/E-Aluminum	Single Lap Shear	2-Ply Cured Fiberglass
H	G/E-Aluminum	Single Lap Shear	Tin Plate & Form-In Place Seal
J	G/E-Aluminum	Single Lap Shear	Form-In-Place Seal
M	G/E-G/E	Double Lap Shear	Fay Seal
P	Aluminum-G/E	Single Lap Shear	Fip Seal-Finger Stock
R	G/E-G/E	Single Lap Shear	Tin Plate-Fip Seal-Finger Stock

## RATIO OF IMPEDANCES

<u>PANEL</u>	<u>TYPE</u>	D.C. RESISTANCE <u>(OHMS)</u>	Ratio of Joint-Impedance to Bulk Material			
			<u>14 KHz</u>	<u>42 KHz</u>	<u>112 KHz</u>	<u>500 KHz</u>
B	G/E Cloth	0.03	1.0	1.0	1.0	1.0
C	Aluminum	0.0	1.0	1.0	1.0	1.0
G	G/E-Alum SLS	0.013	2.3	2.4	2.1	2.8
H	G/E-Alum SLS	0.01	1.0	1.0	1.0	1.0
J	Al-G/E SLS	0.03	7.0	10.4	5.9	1.8
M	G/E DLS	0.41	42.5	42.5	42.5	30.0
P	G/E-Alum SLS	0.013	1.0	1.0	1.0	1.0
R	G/E SLS	0.012	1.0	1.0	1.0	1.0

# FUSELAGE SHIELDING

---

- COMPARED INDUCED VOLTAGES IN TYPICAL AVIONICS BAY FOR METAL AND G/E BOXES (FIGURE 8)
- TESTS CONDUCTED FROM 14 KHz TO 18 GHz
- TESTS CONDUCTED WITH IDENTICAL WIRE BUNDLES, LOAD TERMINATIONS, AND ROUTING LOCATION (FIGURE 9)
- OVER 100 DIFFERENT TEST CONFIGURATIONS (TYPICAL RESULTS SHOWN IN FIGURES 10 AND 11)
- TEST OF SIMULATED FUSELAGE STRUCTURE WITH ACCESS PANEL (FIGURE 12)
- CONCLUSION: LEAKAGE EFFECTS OF JOINTS FOR BOTH ALUMINUM AND G/E ARE DOMINANT FACTOR IN SHIELDING EFFECTIVENESS. LITTLE DIFFERENCE BETWEEN G/E AND ALUMINUM SHIELDING EFFECTIVENESS

# FORWARD FUSELAGE EMI TEST ARTICLE

130

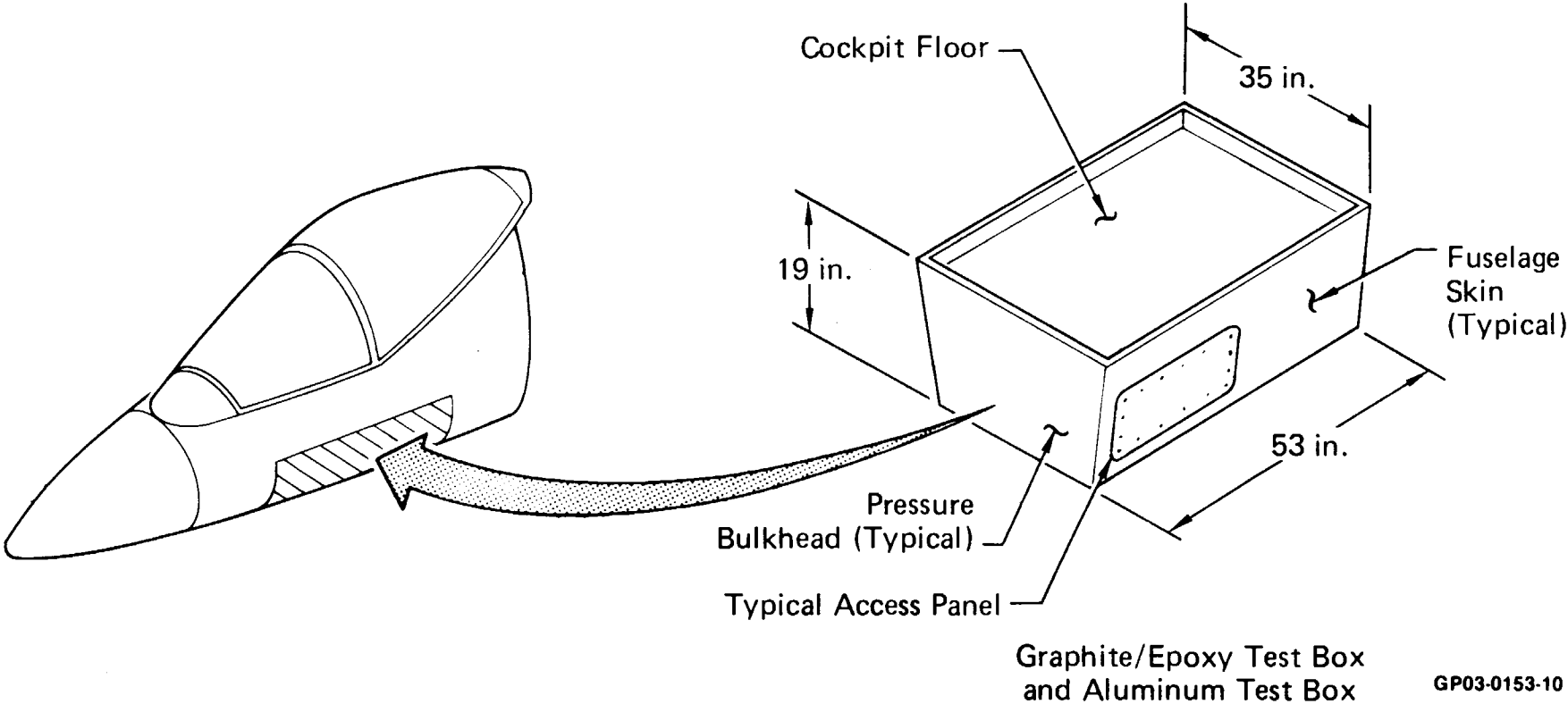

GP03-0153-10

# TRIMETRIC VIEW OF WIRE ROUTING

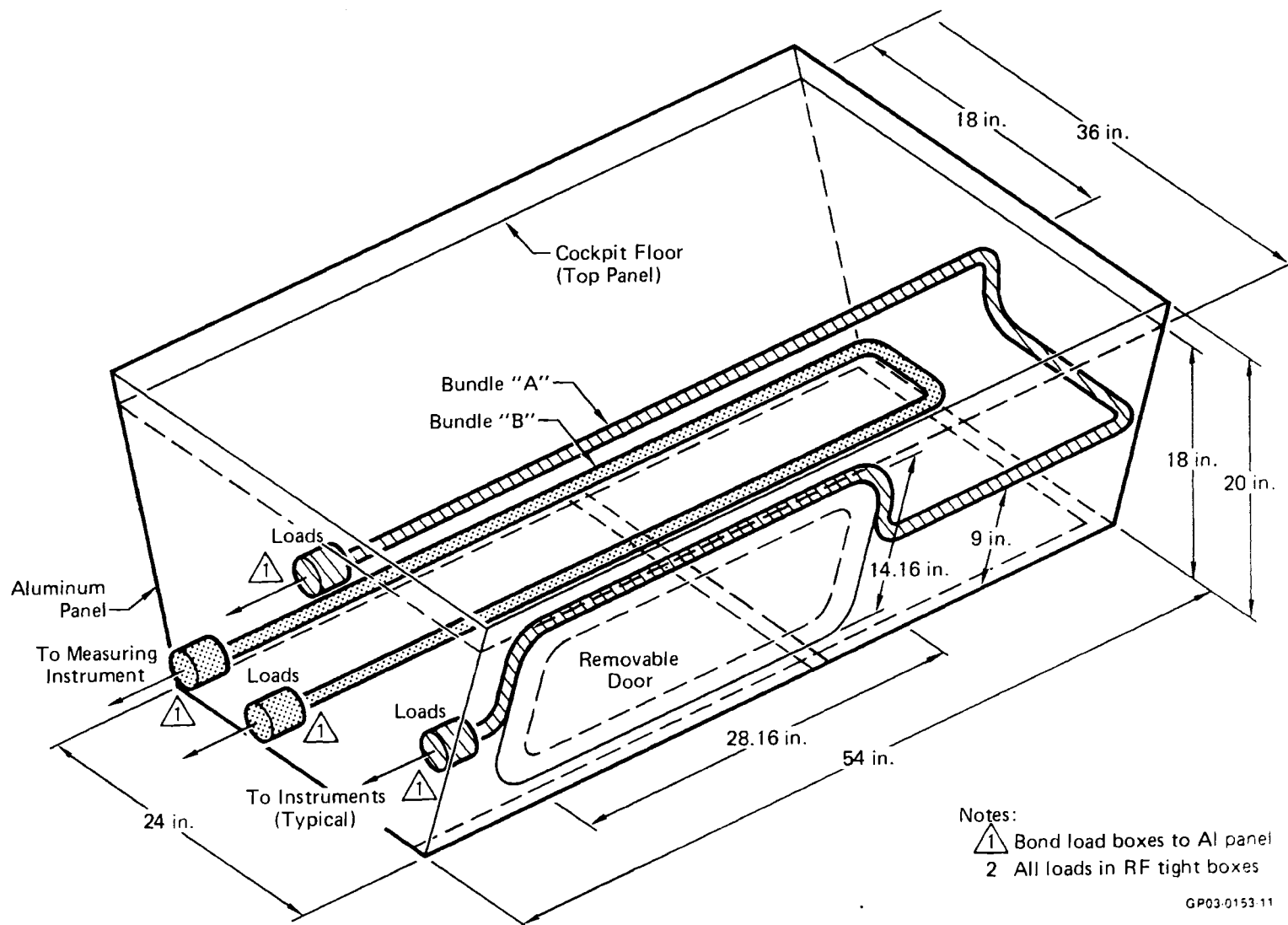

131

# INDUCED VOLTAGE ON SINGLE WIRE, 1 VOLT/METER FIELD

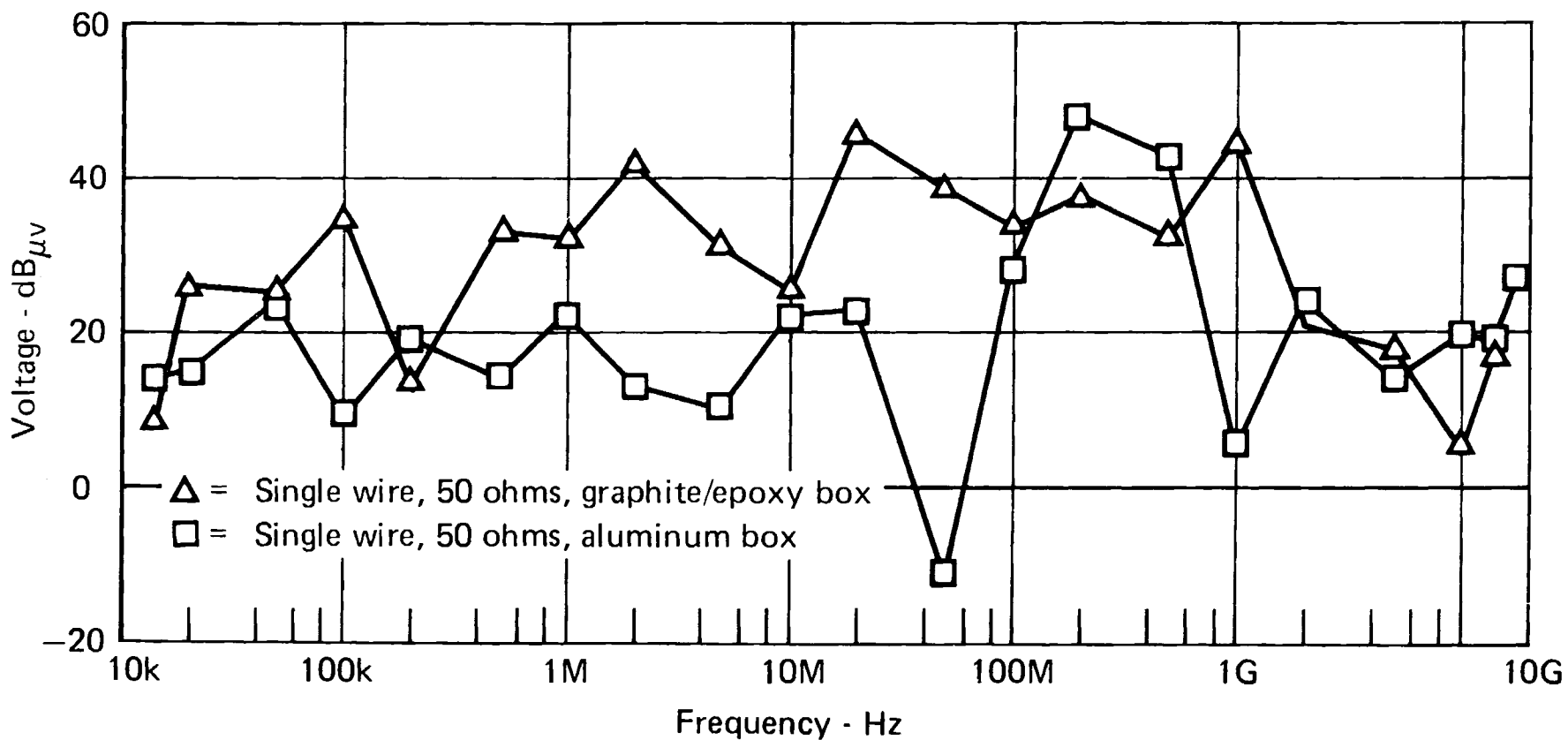

# INDUCED VOLTAGE ON TWISTED PAIR, 1 VOLT/METER FIELD

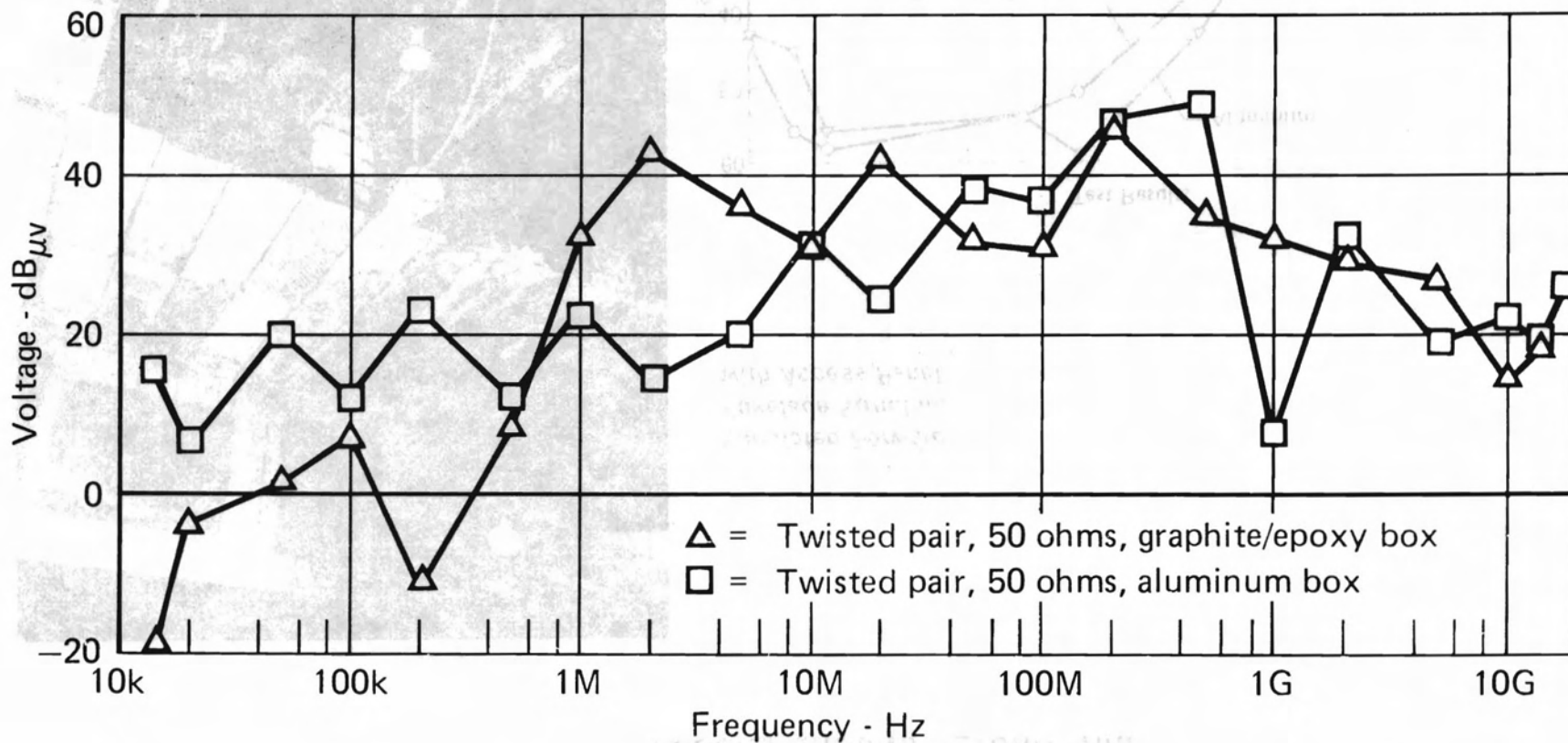

# SHIELDING OF ALUMINUM AND COMPOSITE FIXTURES RELATIVE TO EXPOSED GROUND RETURN WIRE

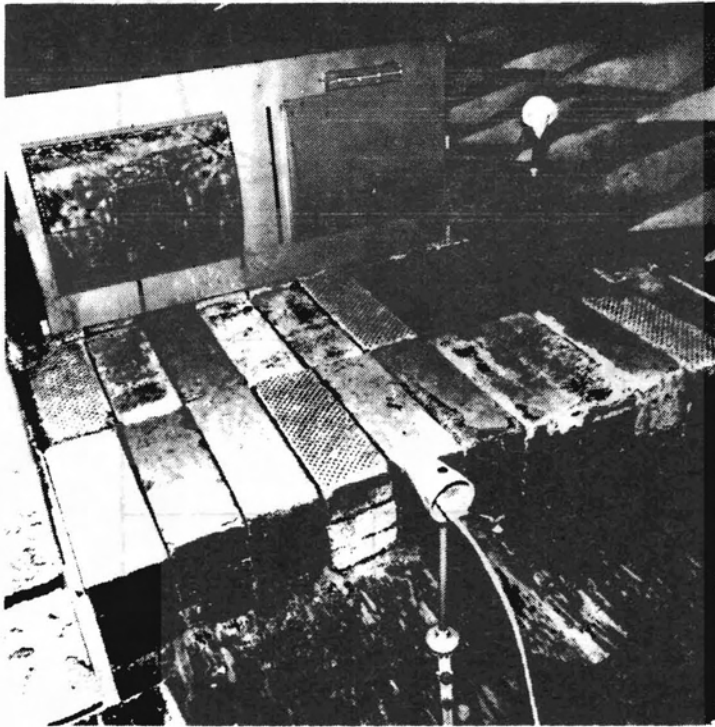

Test Setup

*Simulated Forward  
Fuselage Structure  
with Access Panel*

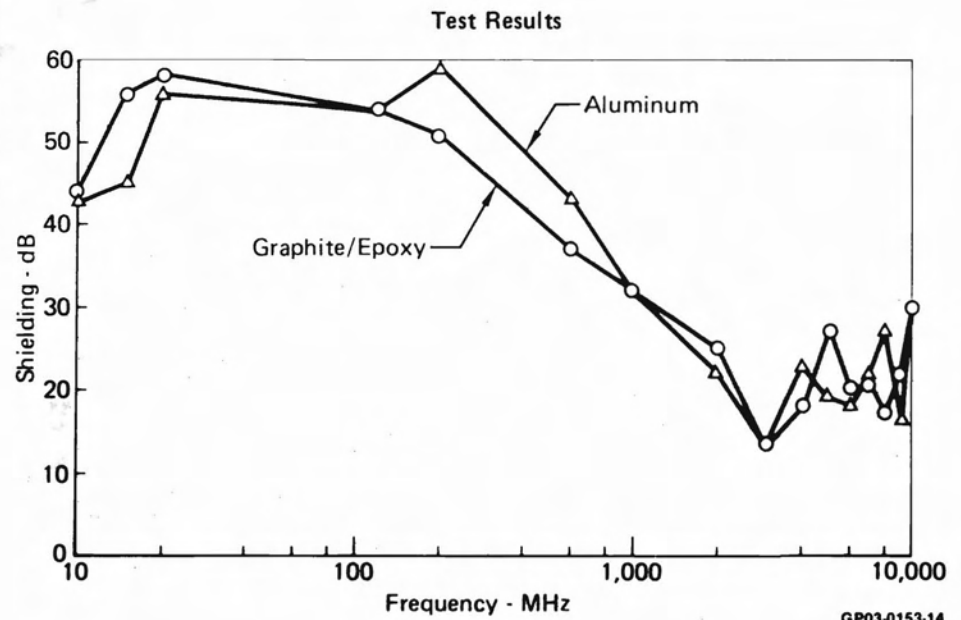

# SHIELDING EFFECTIVENESS OF AIRCRAFT STRUCTURES AGAINST MAGNETIC FIELDS

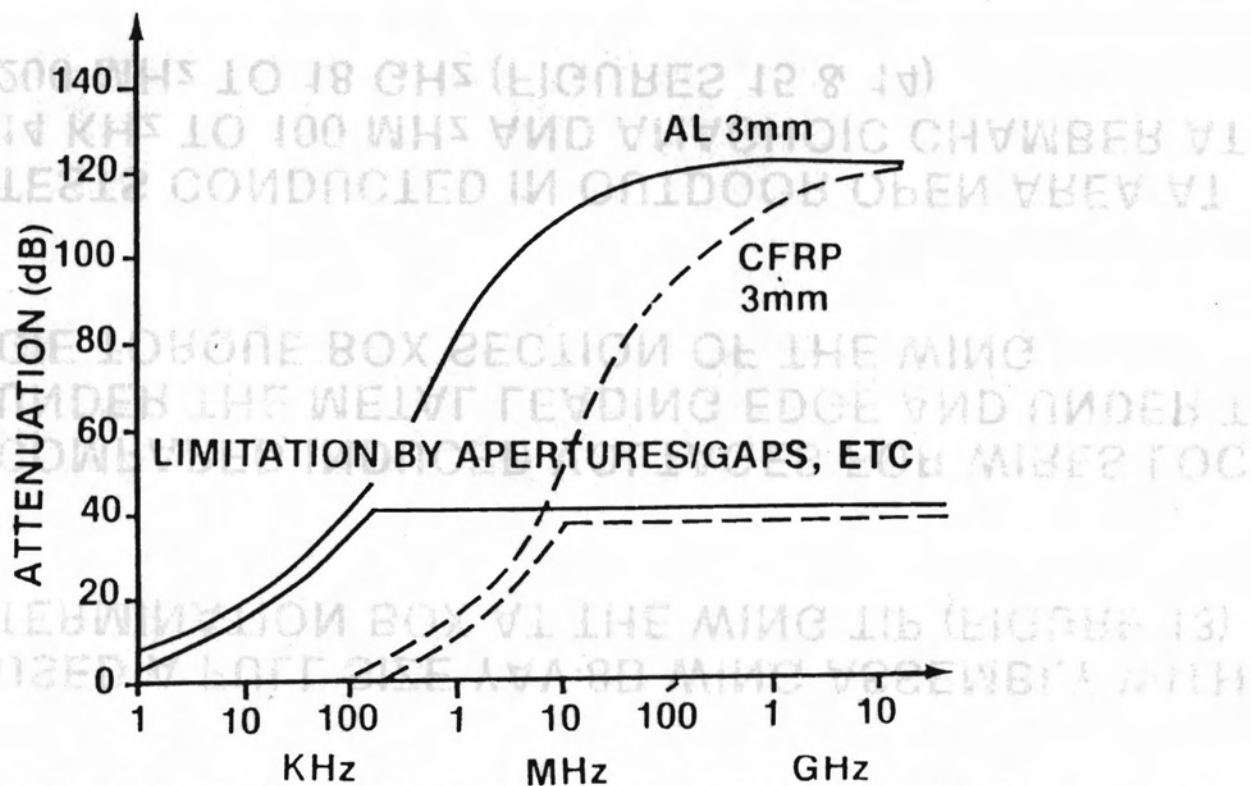

— TYP. METALLIC AIRCRAFT STRUCTURE

- - - TYP. CFRP AIRCRAFT STRUCTURE

## STATIC WING SHIELDING TESTS

---

- USED A FULL SIZE YAV-8B WING ASSEMBLY WITH TERMINATION BOX AT THE WING TIP (FIGURE 13)
- COMPARED INDUCED VOLTAGES FOR WIRES LOCATED UNDER THE METAL LEADING EDGE AND UNDER THE G/E TORQUE BOX SECTION OF THE WING
- TESTS CONDUCTED IN OUTDOOR OPEN AREA AT 14 KHz TO 100 MHz AND ANACHOIC CHAMBER AT 200 MHz TO 18 GHz (FIGURES 15 & 14)
- TESTS SHOWED G/E PROVIDES HIGH DEGREE OF SHIELDING; LITTLE DIFFERENCE IN INDUCED VOLTAGES ON SEPARATE WIRES

# EMI TEST ARTICLE

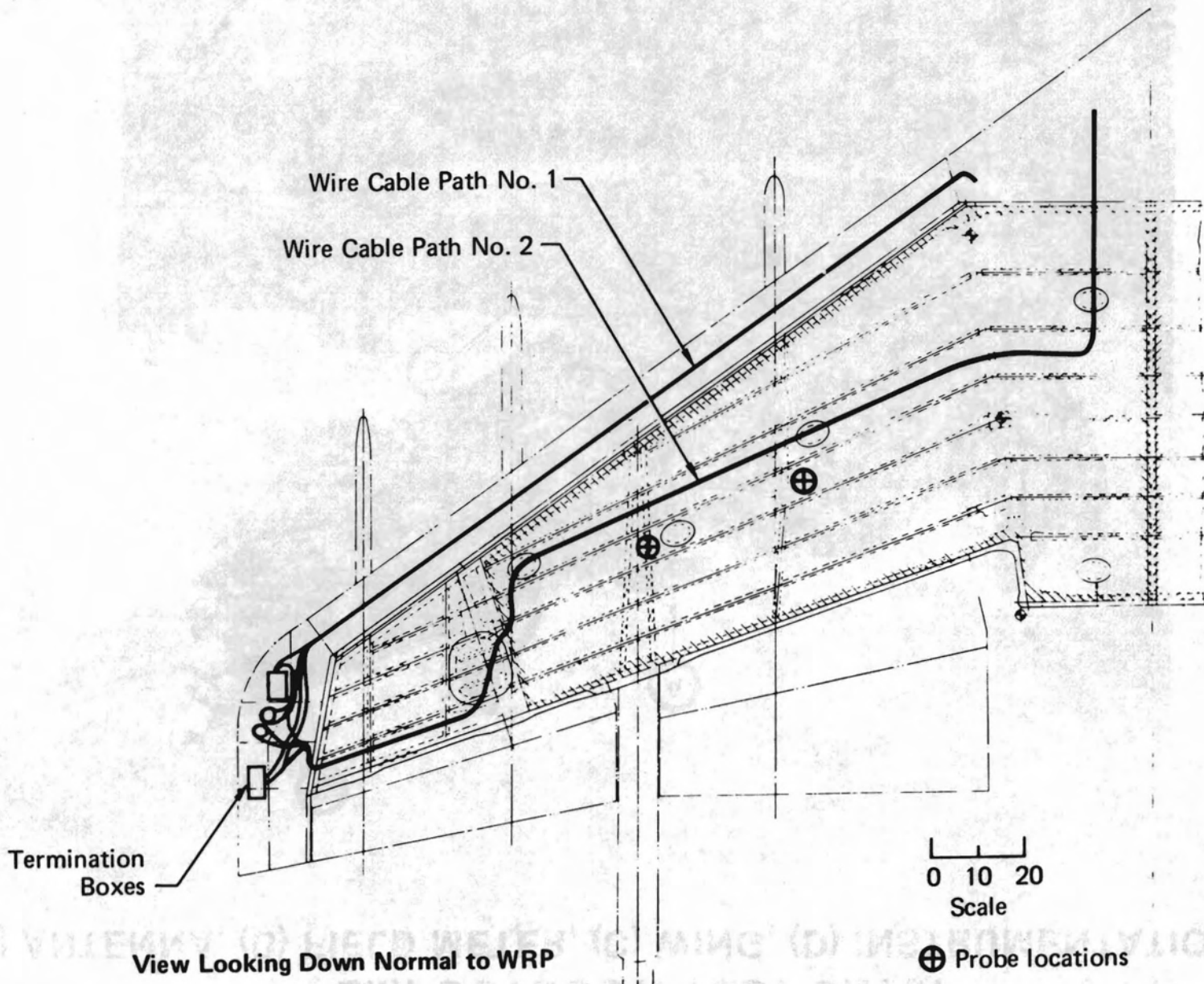

# EMI OUTDOOR TEST SETUP

(A) ANTENNA, (B) FIELD METER, (C) WING, (D) INSTRUMENTATION BOX

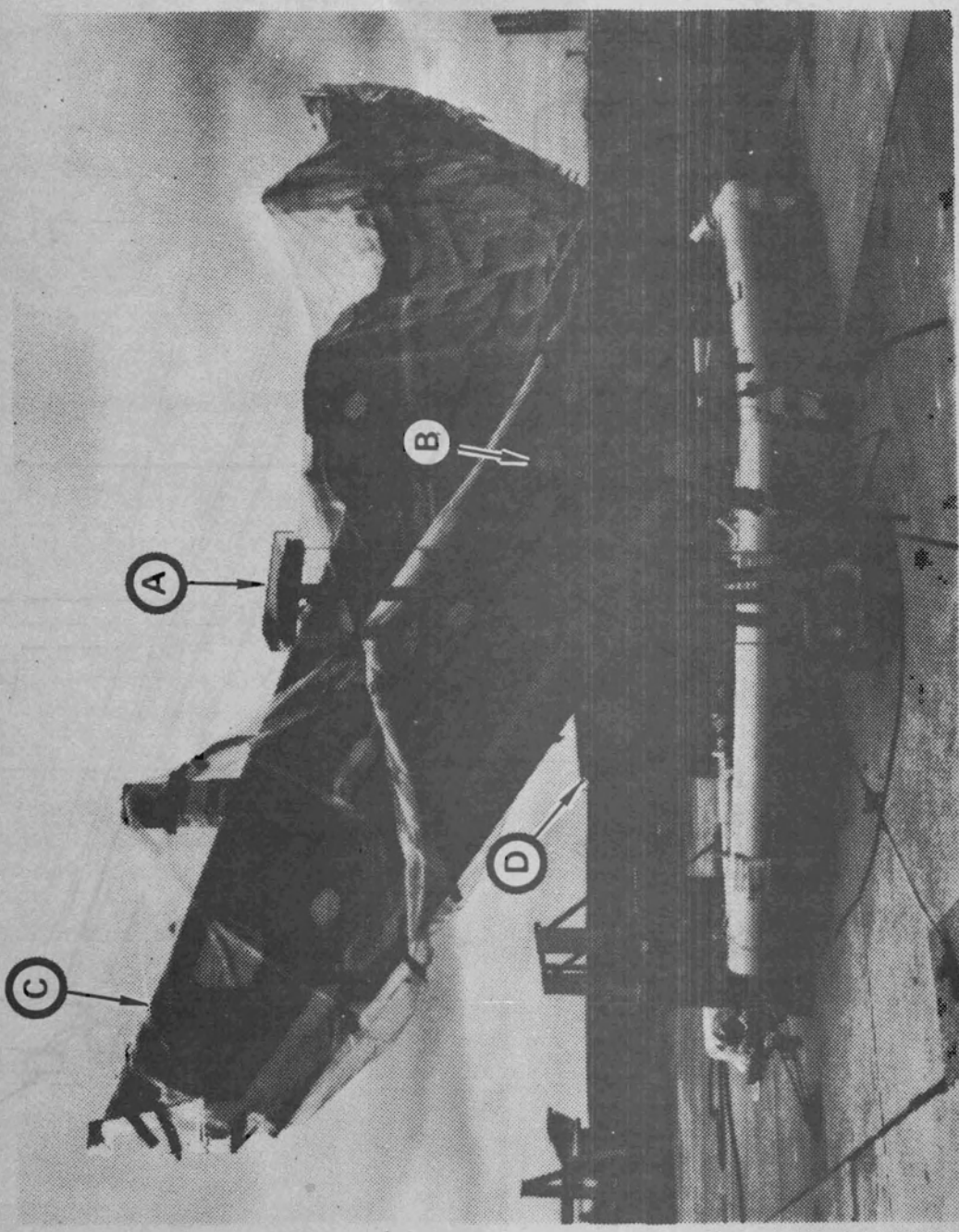

# EMI TEST SETUP IN ANECHOIC CHAMBER

(A) ANTENNA, (B) FIELD METER, (C) WING

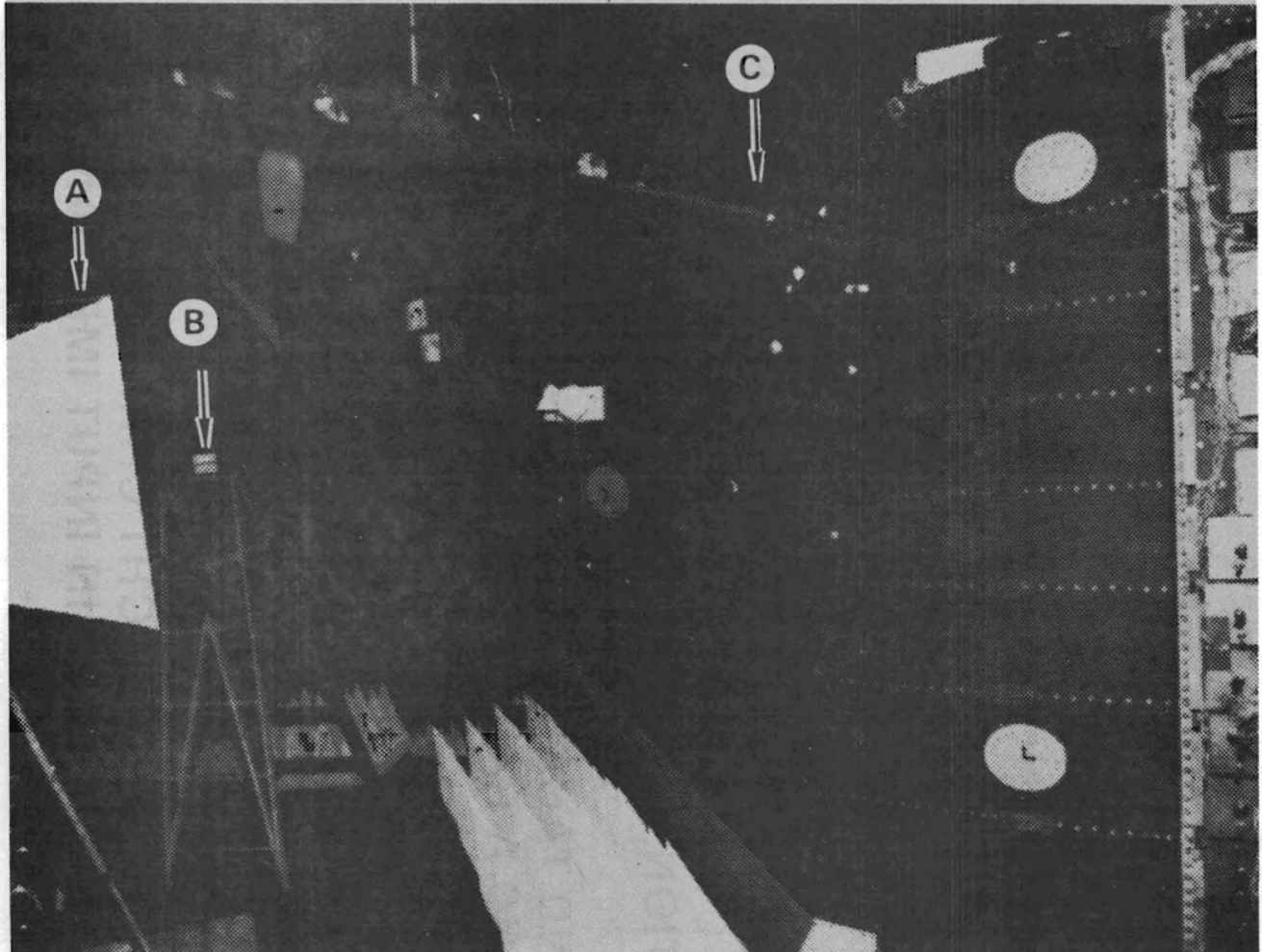

# ANTENNA PERFORMANCE TESTS

---

- PATTERN, GAIN, AND VSWR TESTS CONDUCTED
- USED VARIOUS TEST CONFIGURATIONS TO DETERMINE EFFECTS OF COMPOSITES, GROUND PLANE CONFIGURATION, AND TYPE OF ANTENNA MOUNT
- USED VHF AND TACAN BLADE ANTENNAS AT 400 MHz AND 1 GHz AND A RADAR BEACON STUB ANTENNA AT 10 GHz
- ONLY SMALL PATTERN AND GAIN CHANGES OBSERVED REGARDLESS OF GROUND PLANE OR BASE MOUNTING
- VSWR TESTS SHOWED SLIGHT CHANGES IN GAIN DUE TO SLIGHT CHANGES IN INPUT IMPEDANCE

## **INTERMODULATION EFFECTS**

---

- **CONCERN WITH INTERMODULATION EFFECTS (NONLINEAR JUNCTION) PRODUCED BY GRAPHITE FIBERS IN THE COMPOSITE MATRIX**
- **NO INTERMODULATION EFFECTS FOUND (NO HARMONICS GENERATED) FROM HIGH CURRENT LEVEL TESTS**

# LIGHTNING EFFECTS

---

- NO DAMAGE EXCEPT IN AREA OF ATTACHMENT POINT. THIN METALLIC COATINGS, SCREEN WIRE MESH, OR OTHER CONDUCTIVE LAYERS NEEDED TO SPREAD AND DISSIPATE THE LIGHTNING ENERGY
- ATTACHMENT ZONES FOR PARTIALLY COMPOSITE VEHICLE CAN BE DETERMINED FROM TESTS ON A METAL MODEL
- TESTS SHOWED NO MEASURABLE DIFFERENCE IN ATTACHMENT POINT BEHAVIOR BETWEEN METAL & G/E STRUCTURE (FIGURE 16)

## CIRCUIT AND PROBE ATTACHMENT POINTS

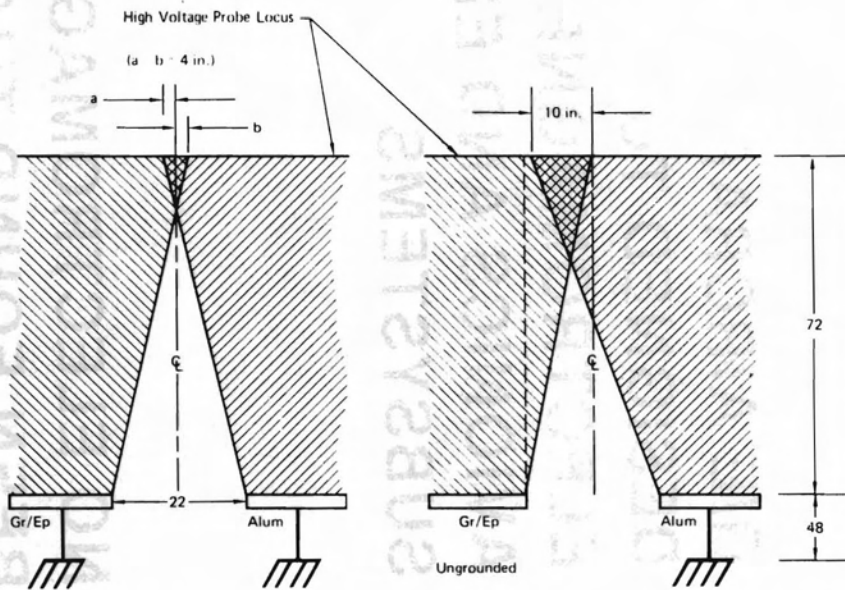
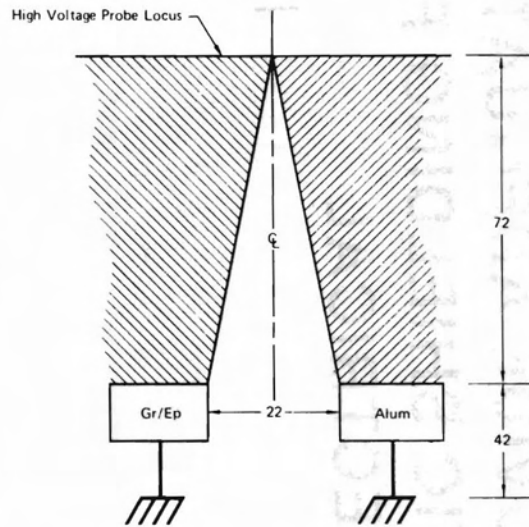

All dimensions in inches

GP03 0153 20

## OVERALL FINDINGS

---

- **G/E AIRCRAFT STRUCTURE CAN BE DESIGNED TO PROVIDE ADEQUATE ELECTROMAGNETIC SHIELDING FOR AVIONICS AND ELECTRICAL SUBSYSTEMS**
  
- **NO ELECTROMAGNETIC G/E ISSUE HAS BEEN FOUND THAT CANNOT BE HANDLED IN NORMAL AIRCRAFT DESIGN**

# **AV-8B COMPOSITE FORWARD FUSELAGE DEVELOPMENT PROGRAM**

**MDC REPORT A6398 (MAY 1980) - CONTRACT N00019-76-C-0666**

- **ASSESSED LIGHTNING PROTECTION DESIGN REQUIREMENTS FOR**

- **FORWARD FUSELAGE STRUCTURE**

- **AIRFRAME DOORS & PANELS**

- **ANTENNAS**

- **SENSOR PROBES**

- **FORMATION LIGHTS**

- **ELECTRICAL POWER**

- **AVIONICS**

# G/E PANELS AND COUPONS WITH BOLTED JOINTS

---

- THRESHOLD FOR STRENGTH DEGRADATION APPROX 20KA/INCH OF G/E WIDTH FOR PULSED PORTION OF LIGHTNING STROKE AND 150A FOR CONTINUING CURRENT PHASE (FIG 6-61 & 6-62)
- BOLTED JOINTS CAN CARRY RESTRIKE CURRENT AND ARE REMOVABLE WITHOUT HAVING TO DRILL OUT SCREWS
- CONDUCTIVE SURFACE COATING REQUIRED TO PREVENT LIGHTNING PENETRATION OF G/E TEST SPECIMENS (FIG 6-65)

## SIMPLIFIED BLOCK DIAGRAM OF LIGHTNING TEST SETUP

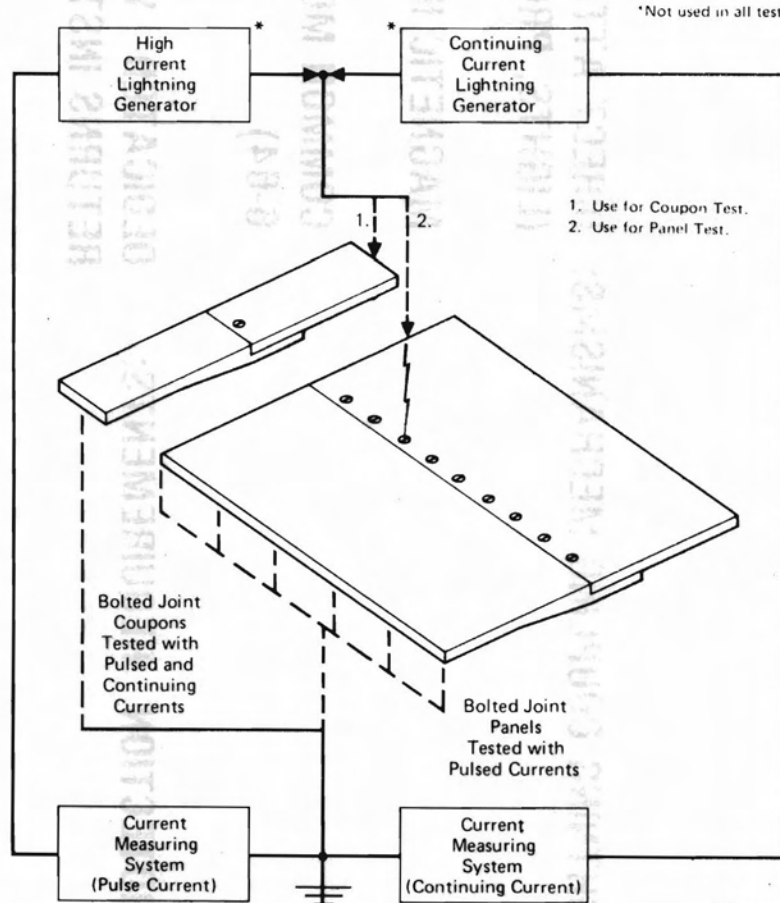
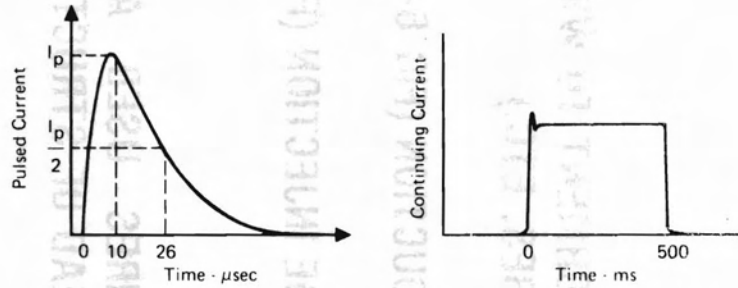

GP78-0348-7

# ELECTRICAL POWER

---

**LIGHTNING COUPLING MECHANISMS: DIRECT ATTACHMENT TO WIRING  
(LIGHTS, PROBES, ETC.)**

**MAGNETIC INDUCTION (FIG 6-63)**

**COMMON MODE INJECTION (FIG  
6-64)**

**PROTECTION REQUIREMENTS: DEDICATED WIRES USED AS POWER  
RETURNS INSTEAD OF STRUCTURE**

**INSTALLATION OF LIGHTNING  
ARRESTORS AT REMOTE POINTS OF  
POSSIBLE LIGHTNING ENTRY (LIGHTS,  
PROBES, ETC.)**

# MAGNETIC COUPLING OF LIGHTNING TO A RECEPTOR

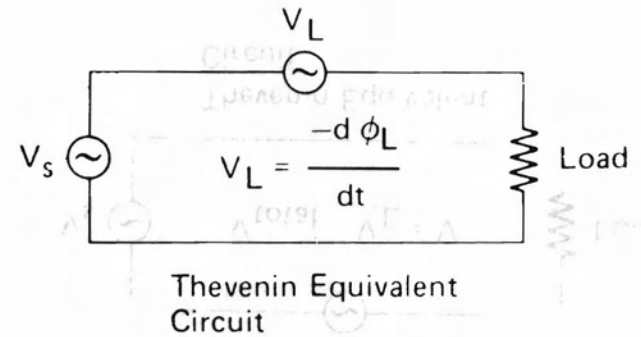
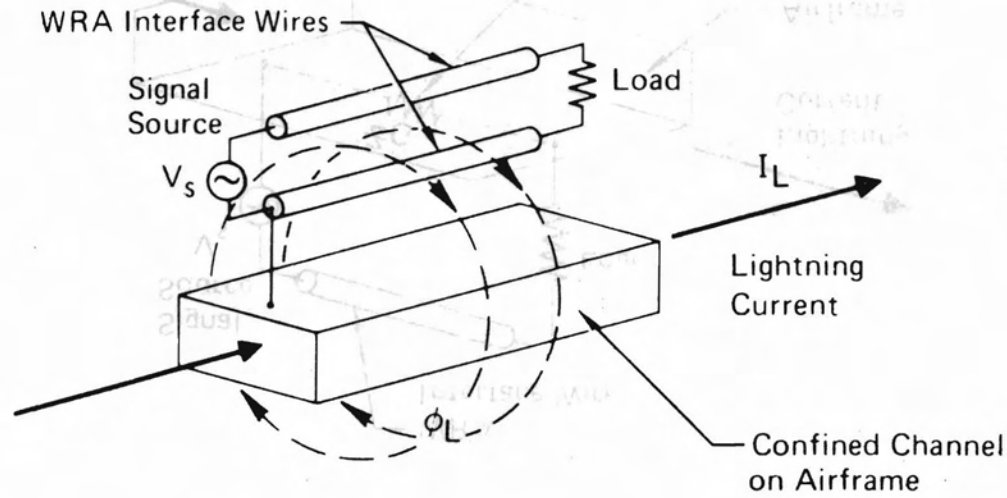

# COMMON MODE LIGHTNING COUPLING TO A RECEPTOR

150

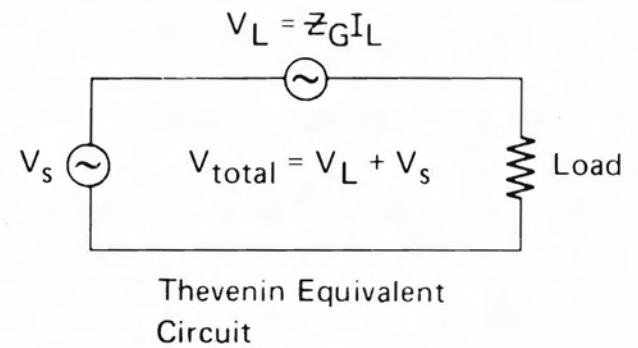
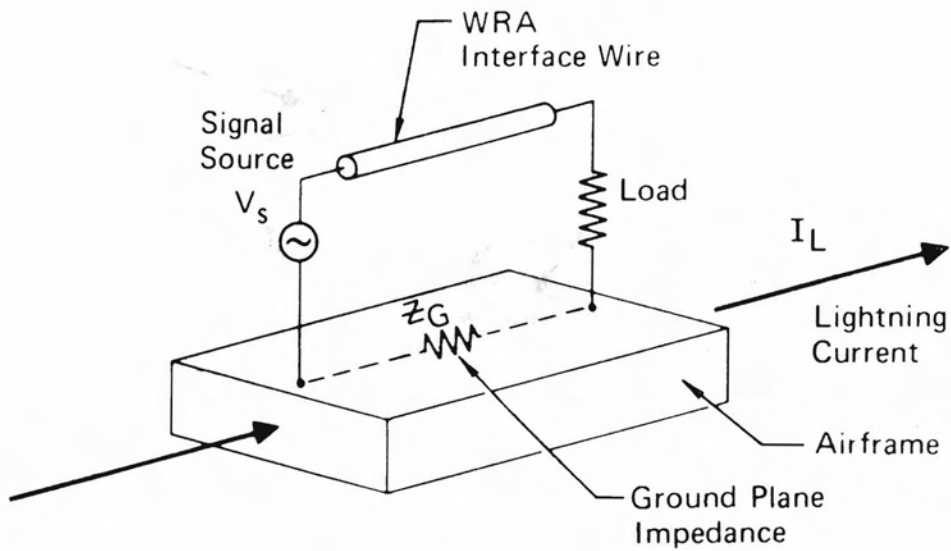

# BOEING STUDY PROGRAM

- **PROTECTION OF ADVANCED ELECTRICAL POWER SYSTEMS FROM ATMOSPHERIC ELECTROMAGNETIC HAZARDS (AF CONTRACT F33615-79-C-2006)**

- **PHASE I**

- **TASK 1 - THREAT ASSESSMENT**
- **TASK 2 - EVALUATION OF NORMAL DESIGN FOR INHERENT HARDNESS**
- **TASK 3 - ADD-ON PROTECTION DEVICE EVALUATION**

- **PHASE II**

- **TASK 4 - DESIGN GUIDE**

TRADE STUDY SUMMARY OF LIGHTNING PROTECTION TECHNIQUES

TYPE CIRCUIT (LOCATION)	SEVERE THREAT LEVEL	TYPE THREAT	INHERENT HARDENING TECHNIQUE	TRANSIENT LEVEL	TYPE OF ADDITIONAL PROTECTION REQUIRED AND TRANSIENT LEVEL			COMMENTS
					1	2	3	
METALLIC WING FIBER- GLASS LEAD- ING EDGE								
1. GENERATORS (ON WINGS)	200 KA	MAGNETIC COUPLING ON FEEDER	FEEDER ROUTED 2 INCHES ABOVE METALLIC SPAR	30 V	-	-	-	PROTECT FOR DIRECT ATTACH- MENT ONLY
2. POWER BUS (FUSELAGE)	200 KA	MAGNETIC COUPLING ON FEEDER	FEEDER ROUTED 2 INCHES ABOVE METALLIC SPAR	65 KV	FEEDER SHIELD: 5.4 KV; 295 V	TRANSZORB: 285 V	3 MIL FOIL ON*	SHIELDING COM- PARES PIGTAIL & CIRCUMFEREN- TIAL GROUNDING RESPECTIVELY.
3. WING TIP BEACON LIGHTS	200 KA	MAGNETIC COUPLING ON 20 GAUGE WIRES	ROUTE WIRES NEAR STRUCTURE	2.2 KV AT POWER BUS	WIRE SHIELD: 190 V	TRANSZORB: 285 V	3 MIL FOIL ON* WING: 10.V	TRANSZORBS MUST BE PARALLELED BACK TO BACK IN EACH CASE.
4. WINDSHIELD HEATERS	200 KA	CAPACITIVELY COUPLED ONTO HEATER ELEMENTS	LOCATION OF HEATER ELEMENTS	920 V AT POWER BUS	-	TRANSZORB: 285 V	-	OTHER SIMILAR PROTECTION DEVICES
COMPOSITE WING AND FUSELAGE								
1. GENERATORS (FUSELAGE)	200 KA	DIFFUSION COUPLING ON FEEDERS	MINIMIZED EXPOSED FEEDER	5.8 KV	CIRCUMFERENTIAL* GROUNDED FEEDER SHIELD: 320 V	TRANSZORB: 285 V	-	
2. POWER BUS	200 KA	DIFFUSION COUPLING ON FEEDERS	MINIMIZED EXPOSED FEEDER	2.5 KV	CIRCUMFERENTIAL* GROUNDED FEEDER SHIELD: 130 V	TRANSZORB: 285 V	-	

\* PREFERRED, DUE TO: 1. GREATEST PROTECTION  
2. WEIGHT  
3. RELIABILITY AND COST

# CONCLUSIONS

- ELECTRICAL POWER SYSTEMS IN COMPOSITE STRUCTURE AIRCRAFT CAN BE ADEQUATELY PROTECTED BY A COMBINATION OF STRUCTURAL SHIELDING, WIRE SHIELDING, AND VOLTAGE SUPPRESSION DEVICES
- THE IMPACT OF LIGHTNING ON ADVANCED COMPOSITE MATERIALS AND ADVANCED ELECTRICAL POWER SYSTEMS MUST BE ASSESSED EARLY IN THE DESIGN PHASE FOR NEW AIRCRAFT
- HARDWARE TESTING OF PROTOTYPE SYSTEMS SHOULD BE CONDUCTED TO VERIFY THE ASSESSMENT

# REFERENCES

---

1. COMPOSITE MATERIAL AIRCRAFT ELECTROMAGNETIC PROPERTIES AND DESIGN GUIDELINES, ARC REPORT NO. 50-5779, JANUARY 1981 (CONTRACT N00019-79-C-0634)
2. ELECTROMAGNETIC EFFECTS OF (CARBON) COMPOSITE MATERIALS UPON AVIONICS SYSTEMS, AGARD CONFERENCE PROCEEDINGS NO. 283, LISBON, PORTUGAL, 16-19 JUNE 1980
3. C. D. SKOUBY AND G. L. WEINSTOCK, TECHNIQUES IN THE DESIGN OF GRAPHITE EPOXY STRUCTURES FOR ELECTRICAL PERFORMANCE AND MAINTAINABILITY, FIFTH CONFERENCE ON FIBROUS COMPOSITES IN STRUCTURAL DESIGN, NEW ORLEANS, LOUISIANA, JAN 28, 1981
4. AV-8B COMPOSITE FORWARD FUSELAGE DEVELOPMENT PROGRAM (FINAL REPORT), MDC REPORT NO. A6398, MAY 1980 (CONTRACT N00019-76-C-0666)
5. PROTECTION OF ELECTRICAL SYSTEMS FROM EM HAZARDS, BOEING REPORT NO. D180-26154-2 (FINAL REPORT) AND D180-26154-3 (DESIGN GUIDE), OCTOBER 1981 (CONTRACT F33615-79-C-2006)  
AFWAL-TR-81-2117 and 2118
6. F. W. TORTOLANO, HYBRID COMPOSITES, DESIGN NEWS, SEP 21, 1981

STRUCTURAL APPLICATION OF COMPOSITE MATERIALS AND  
THE DIRECT EFFECTS OF LIGHTNING STRIKES

by

Mr. William E. Howell

Langley Research Center  
National Aeronautics and Space Administration

The direct effects of lightning strikes on composite materials and protection approaches will be described. Approaches to EMI shielding which maintain weight advantage and structural integrity over the life of the airframe will be discussed.

TEST	ACTIVITY	STRENGTH
NO.	MO. NO.	NO.
01	1010101010	101010
02		101010
03		101010
04	1010101010	101010

## SCOPE OF PRESENTATION

- o ADVANCED COMPOSITE MATERIALS
  
- o APPLICATIONS IN AIRCRAFT STRUCTURES
  
- o LANGLEY'S RESEARCH ON DIRECT EFFECTS OF LIGHTNING ON COMPOSITE STRUCTURES

## MATERIAL PROPERTIES

PROPERTIES					
MATERIAL	STRENGTH, KSI	MODULUS, X 10 <sup>3</sup> KSI	DENSITY, LB/IN. <sup>3</sup>	RESISTIVITY, OHM-CM	COST \$/LB
GRAPHITE-EPOXY	110-225	18	0.055	0.9-1.1x10 <sup>-4</sup>	30
KEVLAR-EPOXY	75-270	11	0.050	*	15
GLASS-EPOXY	75-200	6	0.070	*	10
ALUMINUM	55	10	0.101	2.8x10 <sup>-6</sup>	2

\* DIELECTRIC MATERIAL (NON-CONDUCTOR)

# COMPOSITE MATERIALS

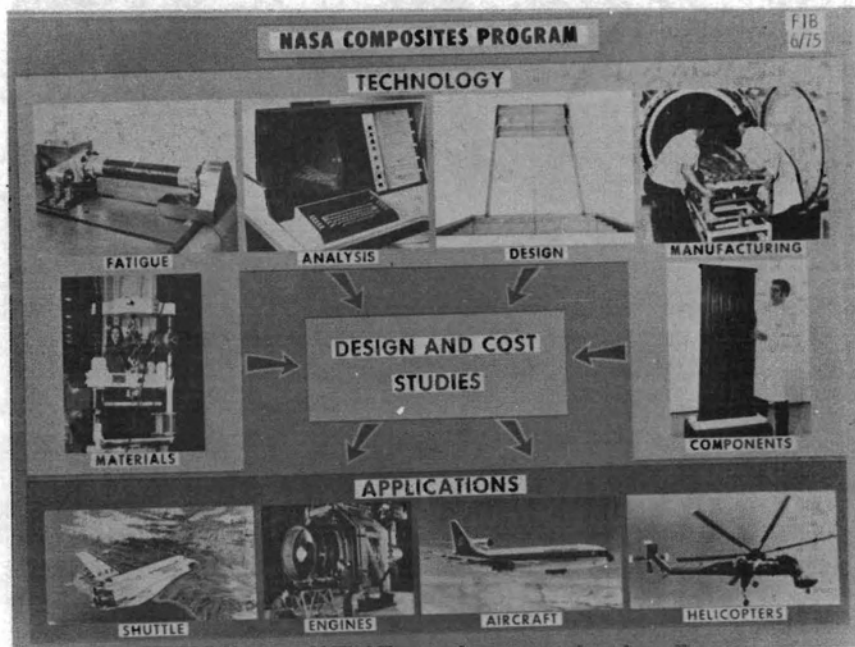
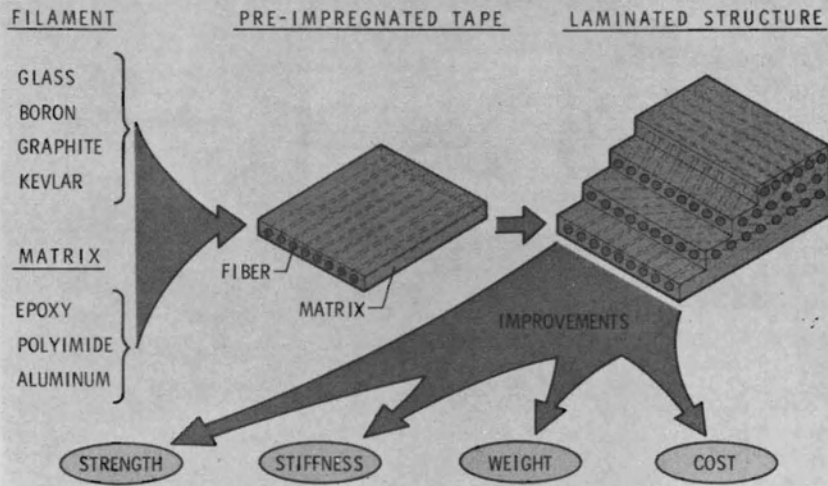

**BELL 206L HELICOPTER COMPOSITE COMPONENTS**



**FORWARD FAIRING**  
KEVLAR/EPOXY FABRIC  
STIFFENED FOAM SANDWICH  
MASS (kg) 2.31  
SIZE (m) 0.90 x 0.74

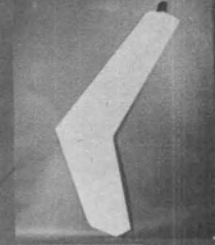

**VERTICAL FIN**  
GRAPHITE/EPOXY TAPE  
FIBER TRUSS CORE  
MASS (kg) 5.90  
SIZE (m) 1.98 x 0.50



**LITTER DOOR**  
KEVLAR/EPOXY FABRIC  
TWO SKINS - HOLLOW SECTION  
MASS (kg) 3.72  
SIZE (m) 1.17 x 0.66



**BAGGAGE DOOR**  
KEVLAR/EPOXY FABRIC  
HONEYCOMB SANDWICH  
MASS (kg) 1.41  
SIZE (m) 0.97 x 0.55



GRAPHITE-EPOXY SPOILERS FOR 737 COMMERCIAL FLIGHT SERVICE



FLIGHT SERVICE EVALUATION OF PRD-49/EPOXY PANELS ON LOCKHEED L-1011 AIRCRAFT

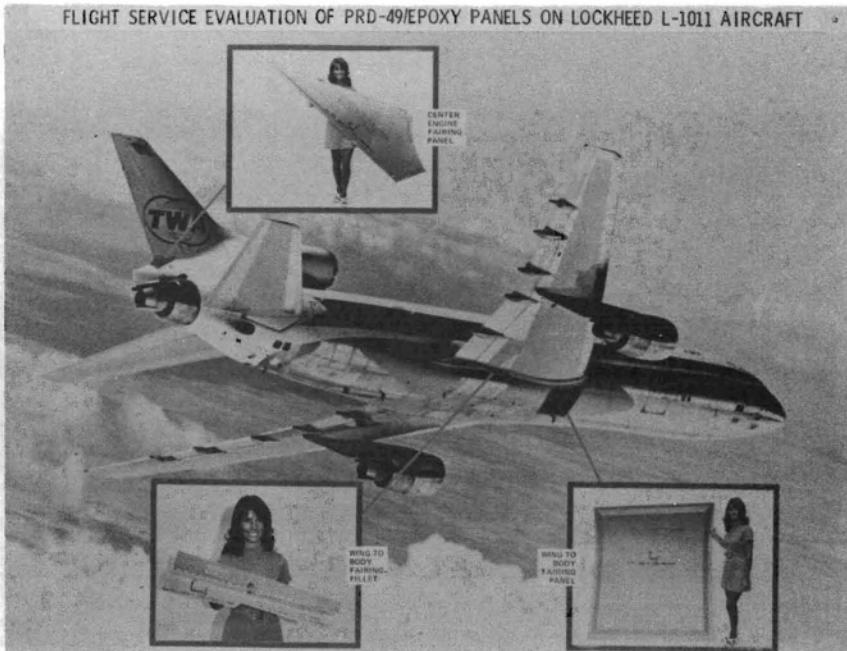

**ACEE**  
**COMPOSITE**  
**SECONDARY**  
**STRUCTURES**



**BOEING 727 COMPOSITE ELEVATOR**



**DOUGLAS DC-10 COMPOSITE RUDDER**



**LOCKHEED L-1011 COMPOSITE AILERON**

NASA  
168-78-95

**DC-10 COMPOSITE RUDDER**  
**LIGHTNING DAMAGE**



## BOEING 767 COMPOSITE STRUCTURE APPLICATIONS

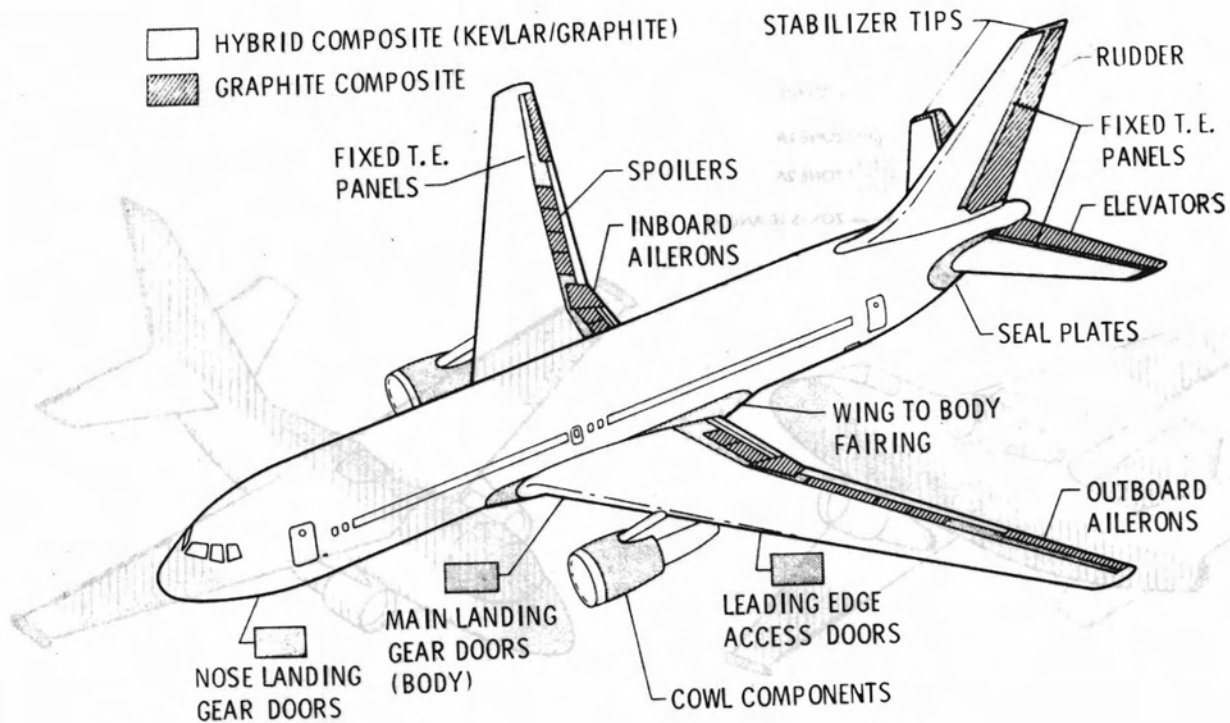

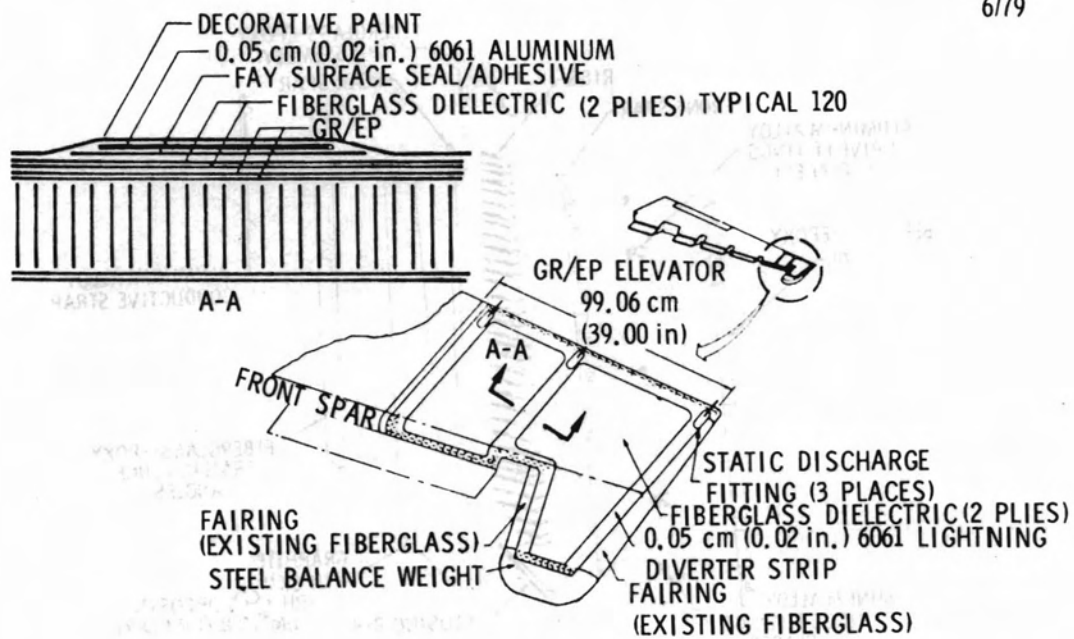

## LIGHTNING PROTECTION SYSTEM FOR 727 ELEVATOR

FAA7  
6179



# AIRCRAFT STRIKE ZONES

## LEGEND

-  ZONE 1A
-  ZONE 2A
-  ZONES 1B AND 2B

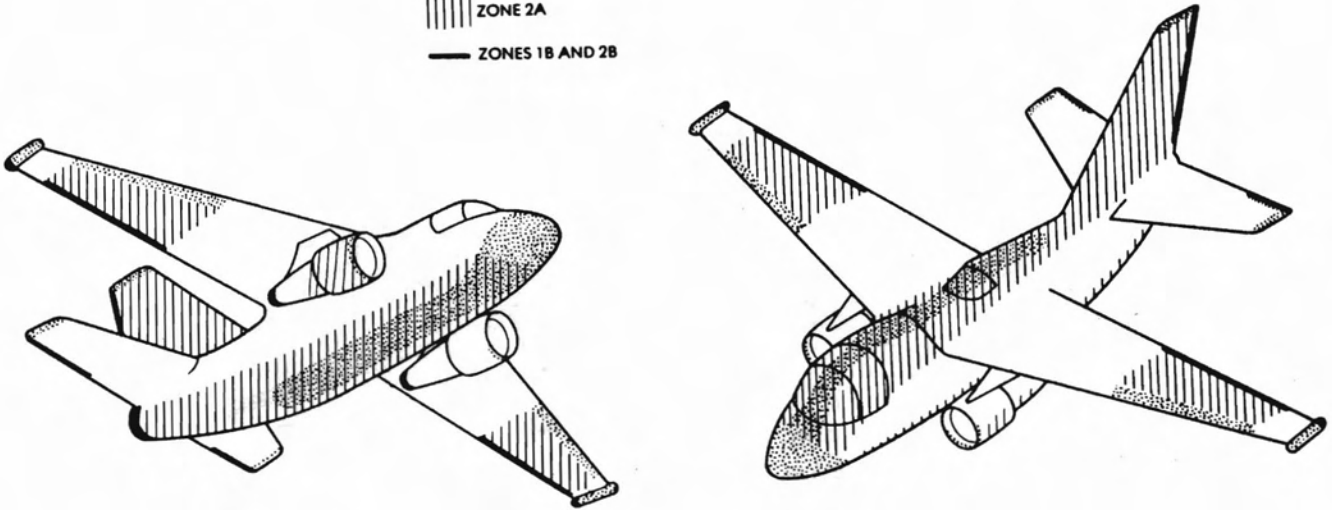

## GRAPHITE/EPOXY UPPER AFT RUDDER DOUGLAS DC-10

F3A  
5/76

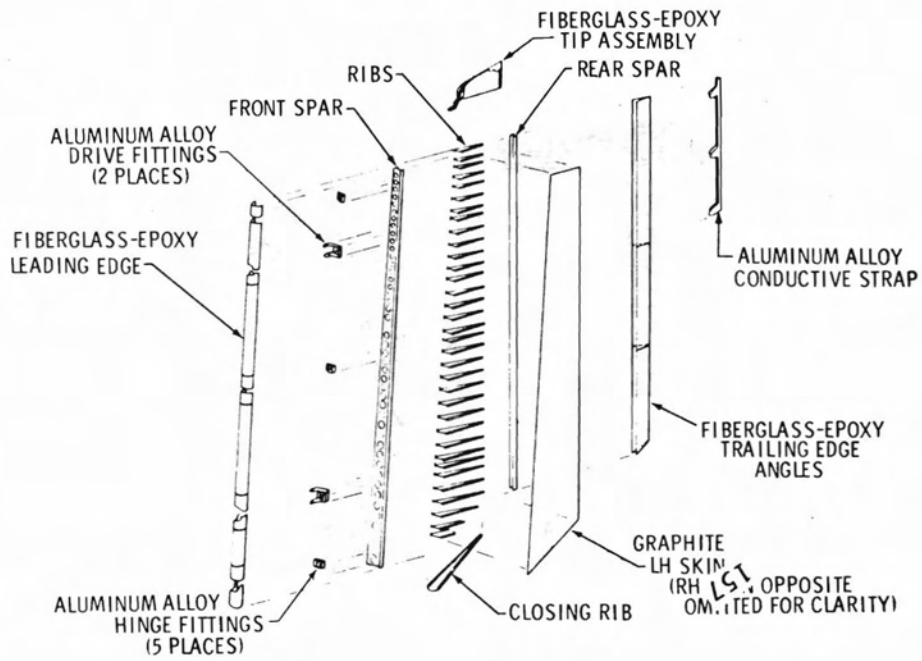

## B-727 GRAPHITE/EPOXY ELEVATOR

### LIGHTNING DAMAGE

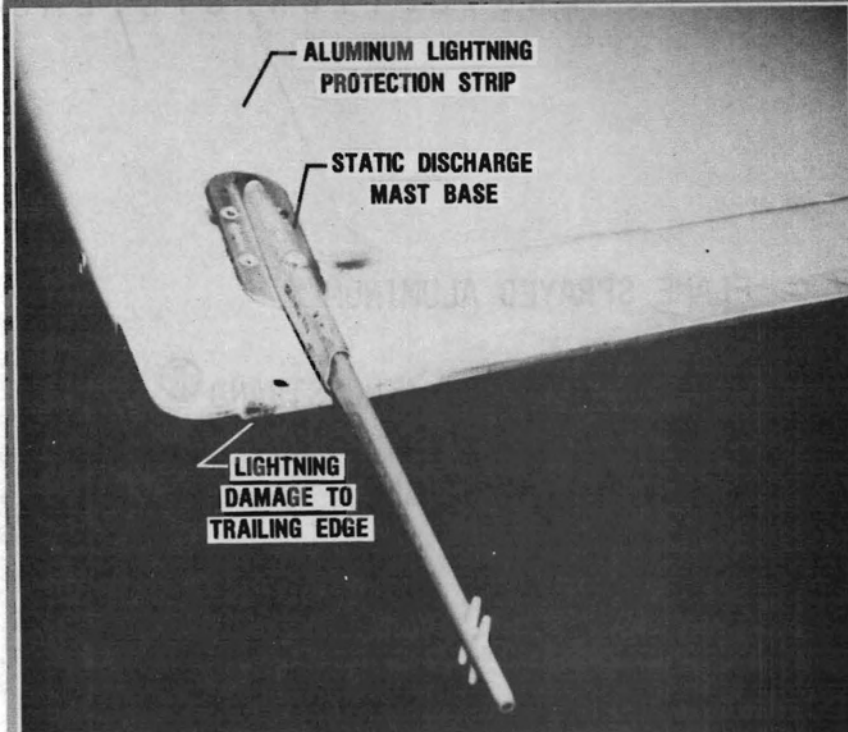

## LIGHTNING EFFECTS ON COMPOSITE STRUCTURES

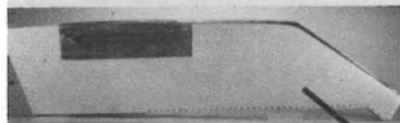

### VERTICAL FIN CAP

LENGTH 86 IN.

HEIGHT 19 IN.

WEIGHT 31 LB

### MATERIALS

KEVLAR 49 - EPOXY

GRAPHITE - EPOXY



F-106B RESEARCH AIRCRAFT

## EXAMPLE PROTECTION SYSTEMS

- o FLAME SPRAYED ALUMINUM
- o ALUMINIZED GLASS (THORSTRAND®)
- o ALUMINUM STRIPS/TAPE
- o METAL SCREEN OR WIRE MESH

### CERTIFICATION CURRENT TEST WAVEFORM COMPONENTS FOR EVALUATION OF DIRECT EFFECTS

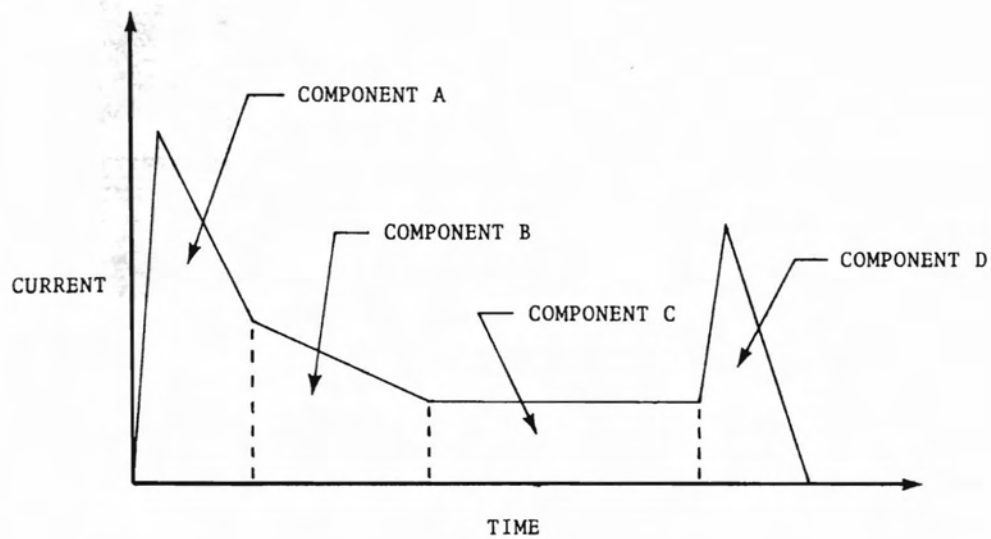

F-106B COMPOSITE FIN TIPS

- o KEVLAR-EPOXY WITH THORSTRAND®
- o GRAPHITE/EPOXY WITHOUT PROTECTION
- o GRAPHITE/EPOXY WITH FLAME SPRAYED ALUMINUM
- o KEVLAR/EPOXY WITH FLAME SPRAYED ALUMINUM

F-106B COMPOSITE FIN TIP ASSEMBLY

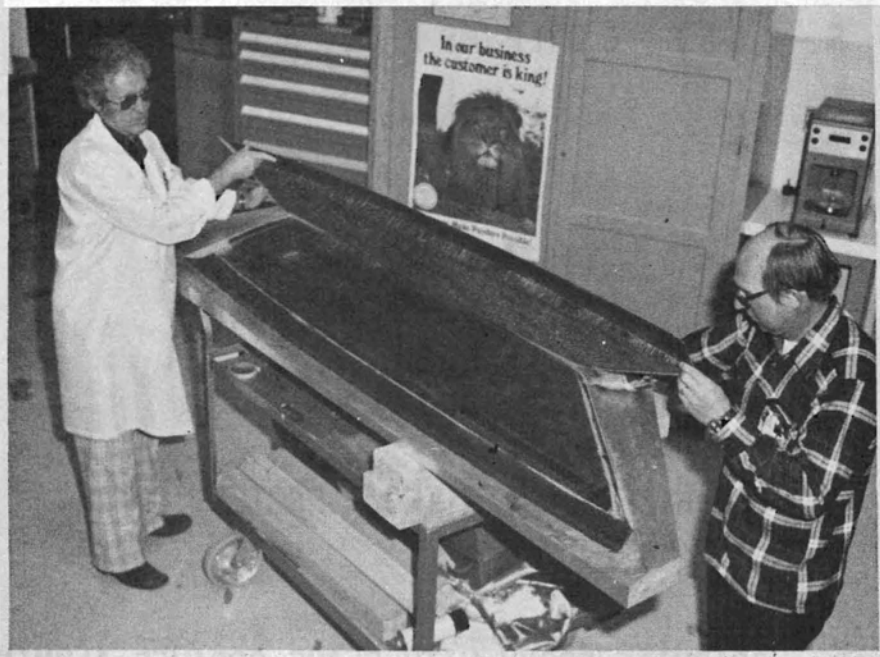

# EFFECT OF LIGHTNING ON KEVLAR/EPOXY WITH THORSTRAND

UNPAINTED

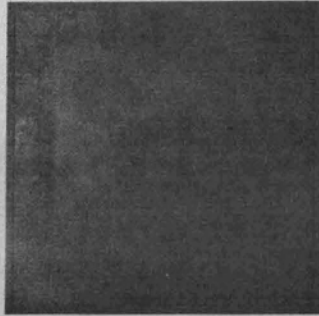

$i_p = 105 \text{ kA}$

ACTION INTEGRAL =  $0.82 \times 10^6 \text{ A}^2\text{-s}$

PAINTED

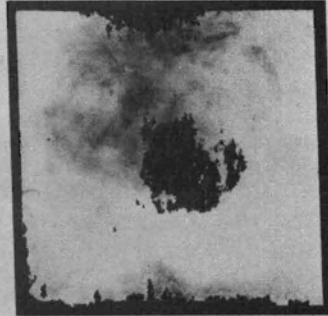

$i_p = 96 \text{ kA}$

ACTION INTEGRAL =  $0.47 \times 10^6 \text{ A}^2\text{-s}$

## EFFECTS OF LIGHTNING STRIKES ON COMPOSITE MATERIALS

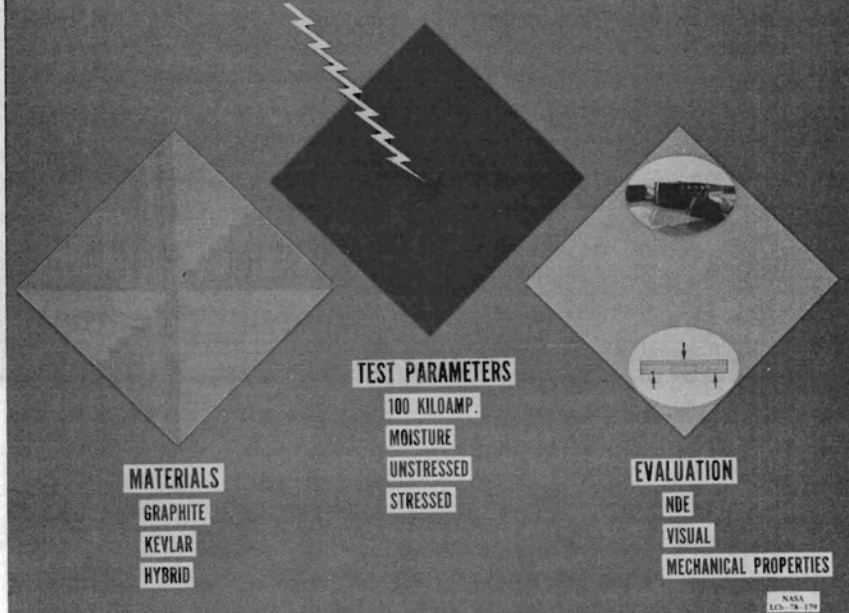



## CONCLUDING REMARKS

- o COMPOSITES EXHIBIT STRUCTURAL ADVANTAGES COMPARED TO METALS
  
- o EXCELLENT IN-SERVICE PERFORMANCE AND MAINTENANCE EXPERIENCE HAVE BEEN ACHIEVED WITH OVER 150 COMPOSITE COMPONENTS DURING 8 YEARS AND OVER 2 MILLION HOURS OF FLIGHT SERVICE WITH NO SIGNIFICANT DAMAGE FROM LIGHTNING STRIKES
  
- o EFFECTS OF LIGHTNING ON COMPOSITE MATERIALS AND LIGHTNING PROTECTION SYSTEMS ARE BEING EVALUATED
  
- o GROUND AND FLIGHT DATA BASE IS BEING DEVELOPED FOR THE ELECTRICAL SAFETY OF AIRCRAFT



## LIGHTNING INTERACTION ANALYSIS

by

Dr. Karl S. Kunz

Kunz Associates, Incorporated

Description of lightning interaction analyses and how they are performed including lightning model, aircraft geometry, interior equipment and cable layout, and modeling of interconnecting system. Sample direct strike problem and (generic) expected results. Overview of mathematical basis used in interaction analysis and description of finite difference method.

## WHAT IS A LIGHTNING INTERACTION ANALYSIS -

- A MATHEMATICAL TREATMENT OF THE PROPAGATION OF ELECTROMAGNETIC ENERGY FROM A LIGHTNING BOLT TO AN AIRCRAFT AND ON INTO SUSCEPTIBLE INTERIOR EQUIPMENT
- USES EXPERIMENTALLY DETERMINED CHARACTERISTICS AS THE INPUTS OF MATHEMATICAL MODELS
- PREDICTS RESPONSE LEVELS (VOLTAGE AND CURRENT) AT THE INPUTS (PINS) OF SUSCEPTIBLE EQUIPMENT
- ALLOWS UPSET/DAMAGE/FAILURE ASSESSMENTS TO BE MADE FOR THE SUSCEPTIBLE EQUIPMENT

## WHY A LIGHTNING INTERACTION ANALYSIS AND NOT JUST EXPERIMENT -

- EXPANDS ON EXPERIMENT
  - SOURCE VARIATIONS, AIRCRAFT MODIFICATIONS AND EQUIPMENT CAN BE ACCOMODATED
- INCREASES UNDERSTANDING
  - MODELING INCREASES UNDERSTANDING AS MODELS ARE REFINED AND MADE MORE ACCURATE
- EFFECTIVE
  - ANALYSIS CAN BE QUICKLY AND INEXPENSIVELY PERFORMED, WHILE ADEQUATE ACCURACY IS MAINTAINED

## HOW IS A LIGHTNING INTERACTION ANALYSIS PERFORMED -

- DEFINE SOURCE (DIRECT STRIKE, RADIATED FIELDS, ETC.), AIRCRAFT (707, 747, ETC.) AND POSSIBLY SUSCEPTIBLE EQUIPMENT (RADAR, NAVIGATIONAL EQUIPMENT, ETC.)
- OBTAIN RELEVANT EXPERIMENTAL DATA, SUCH AS
  - LIGHTNING TIME BEHAVIOR OR SPECTRUM
  - AIRCRAFT GEOMETRY AND CONSTRUCTION
  - INTERIOR EQUIPMENT AND CABLE LAYOUTS
  - ELECTRICAL PARAMETERS (CABLE SIZE, SHIELDING, IMPEDANCE, TERMINATIONS, ETC.)
  - DEVICE UPSET/DAMAGE/FAILURE THRESHOLDS AND MECHANISMS
- MODEL THE INTERCONNECTED SYSTEM OF SOURCE, AIRCRAFT AND EQUIPMENT
- SELECT A MATHEMATICALLY TRACTABLE REALIZATION OF THE MODEL
- CHECK THE MATHEMATICAL MODEL FOR COMPLETENESS AND VALIDITY (COMPARE PREDICTIONS WITH KNOWN EXPERIMENTAL RESULTS)
- PREDICT RESPONSES AT THE SELECTED SUSCEPTIBLE EQUIPMENT
- EXAMINE SENSITIVITY TO PARAMETER VARIATIONS (OPTIONAL "SAFETY" MEASURE)

TYPICAL PROBLEM

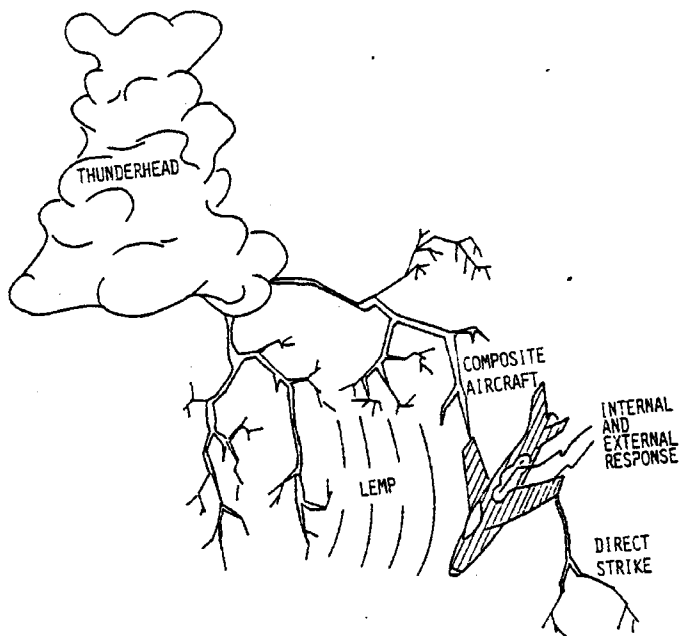

LIGHTNING DETAILS

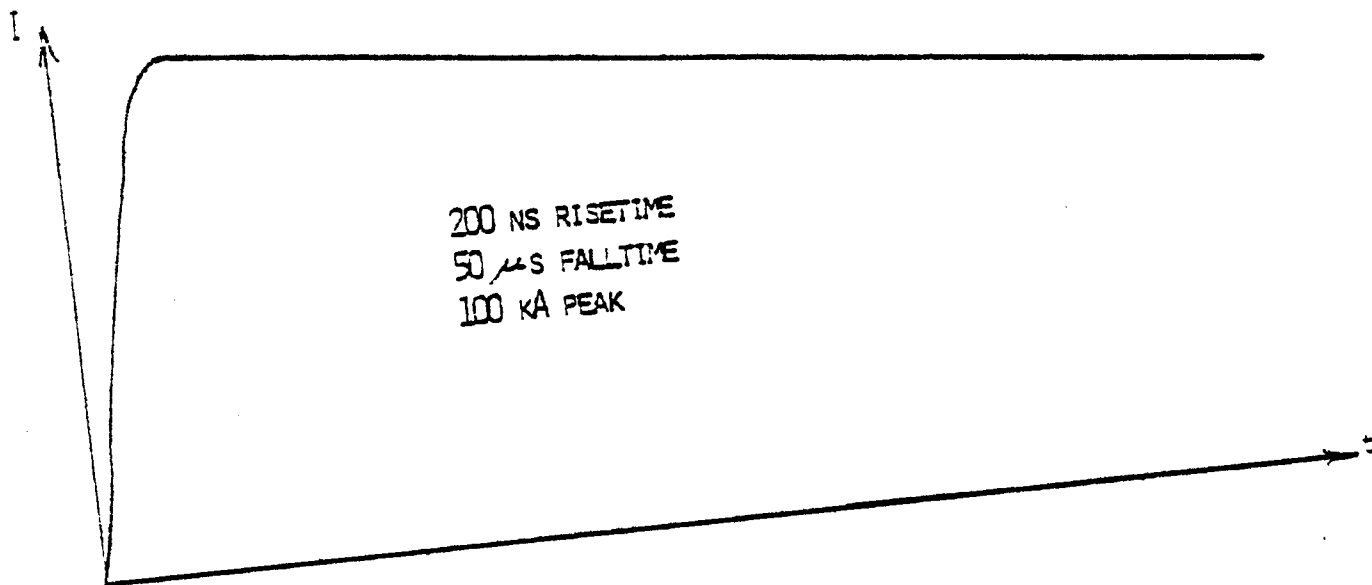

## AIRCRAFT DETAILS

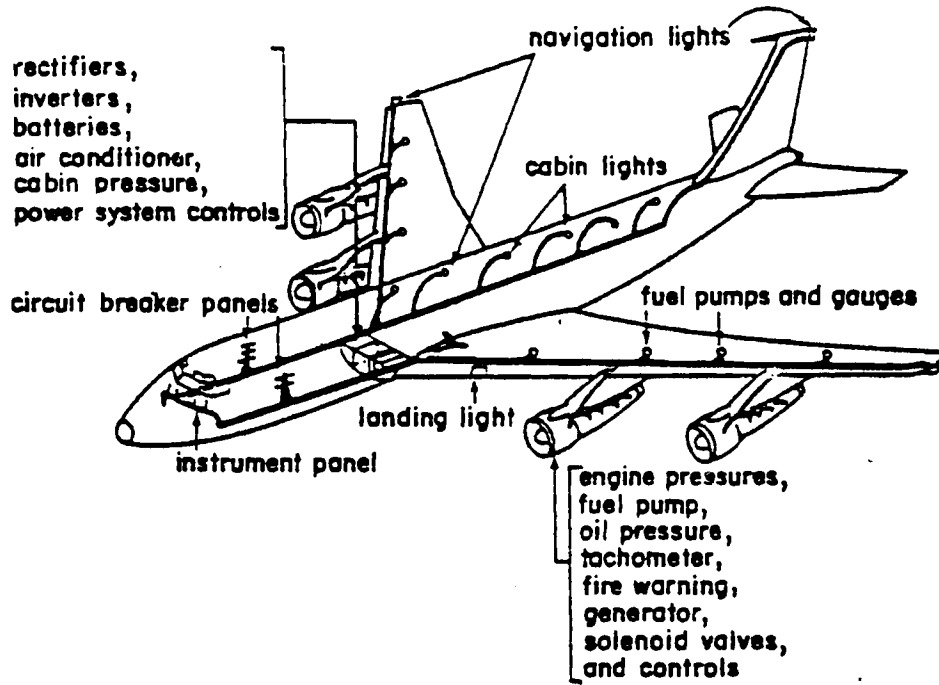

Typical elements and cabling associated with the aircraft power system.

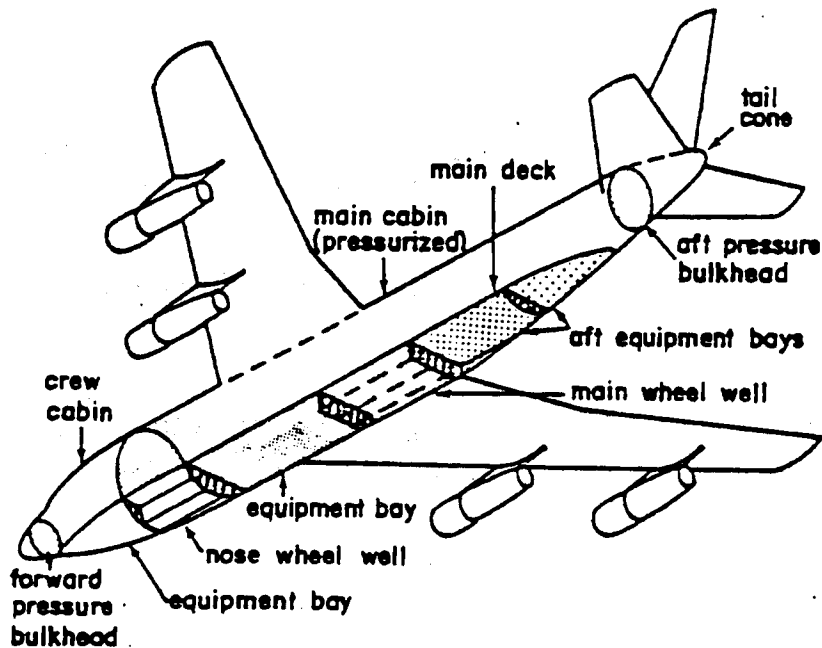

Elementary volumes within the aircraft.

## CABLE DETAILS

### CABLE TYPES (TRANSMISSION LINES)

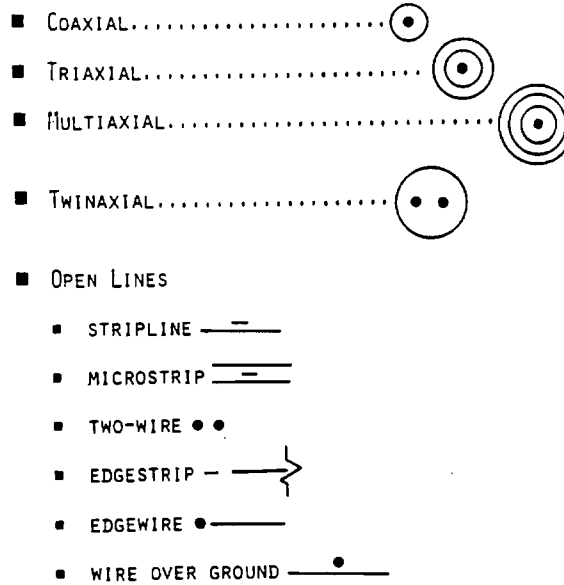

## MATHEMATICAL REALIZATION -

- GENERAL REQUIREMENTS -  
SOURCE X EXTERIOR RESPONSE X PENETRATION X INTERIOR  
RESPONSE X SHIELDING EFFECT = RESPONSE AT "PIN"
- EXTERIOR RESPONSE X PENETRATION X INTERIOR RESPONSE  
MOST DIFFICULT PART
- POSSIBLE APPROACHES (MAY BE COMBINED WITH TRANSMISSION  
LINE THEORY, BETHE SMALL HOLE THEORY, MULTIPLE RUNS, ETC.)
  - SIMPLE CANONICAL SHAPES
  - MoM THIN WIRE TYPE CODES (EFIE)
  - PATCH CODES (MFIE)
  - FINITE DIFFERENCE TECHNIQUES

# CANONICAL SHAPES

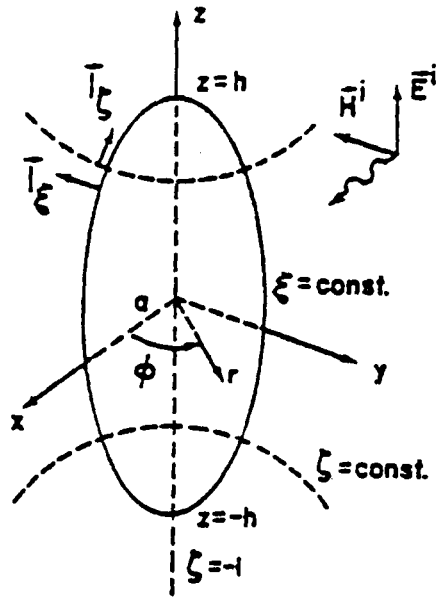

Plane wave broadside incident on a prolate spheroid.

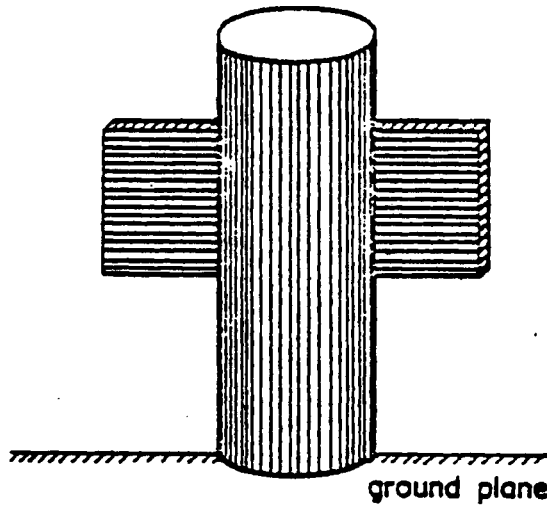
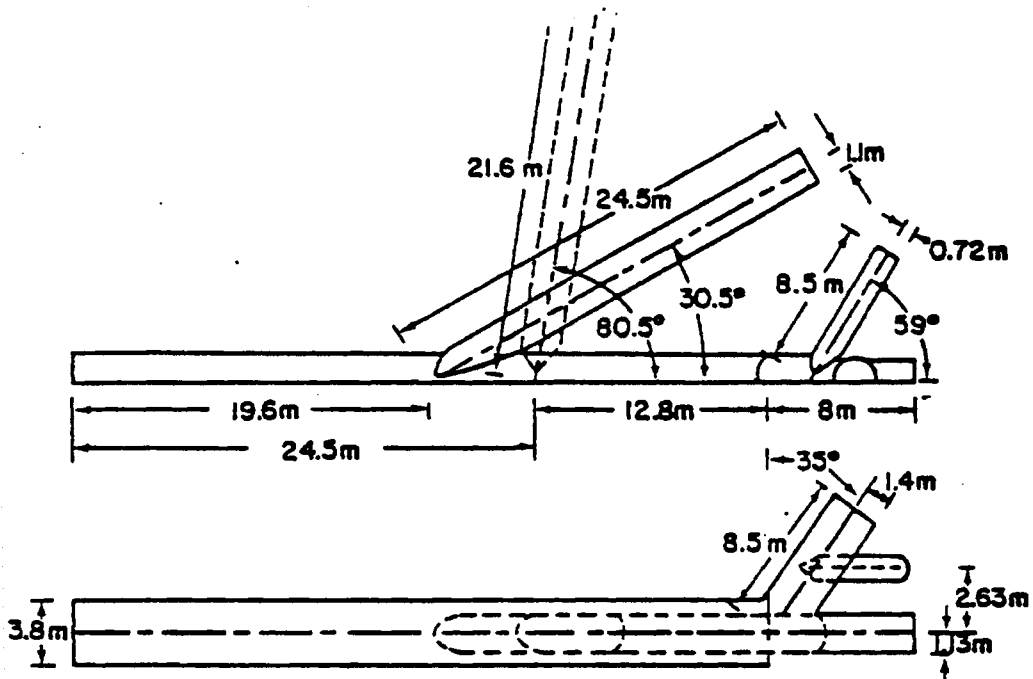
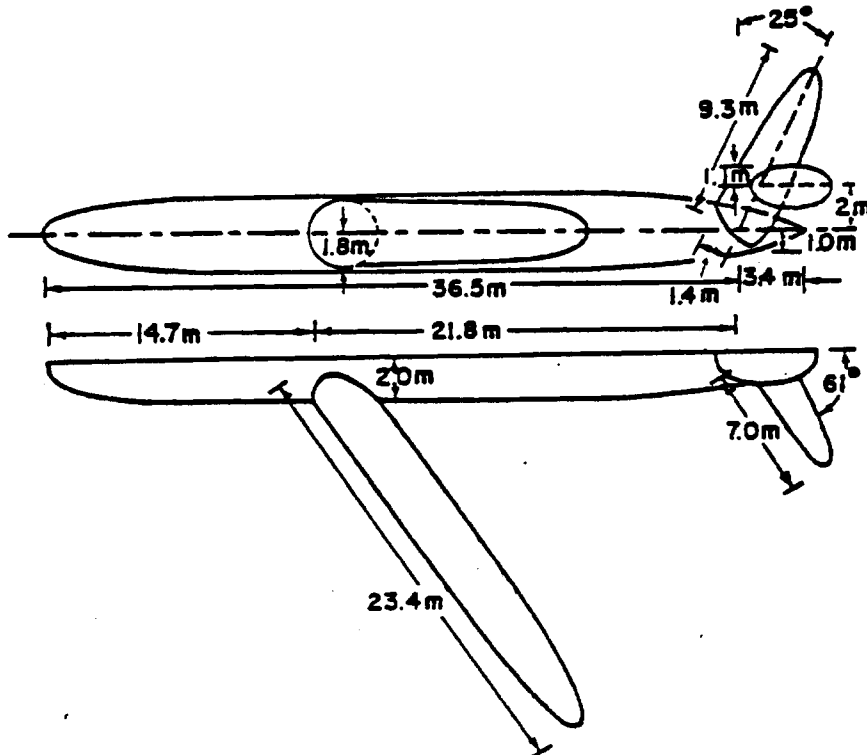

Diagram of flat plate crossed with an electrically thick cylinder.

WIRE MODEL/BOR'S



Stick (intersecting cylinders) model of the B-1 aircraft in the wings-forward and wings-swept configurations.



Body-of-revolution model of the EC-135 aircraft. Current zones are indicated with dotted lines.

# MoM

## Some Computational Aspects of Thin-Wire Modeling

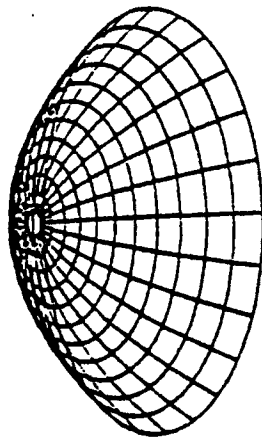

After POGGIO & MILLER [4.2]

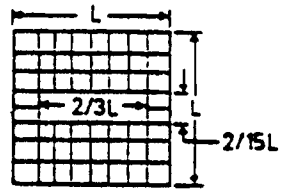

After MILLER & MORTON [4.20]

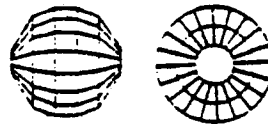

After RICHMOND [4.21]

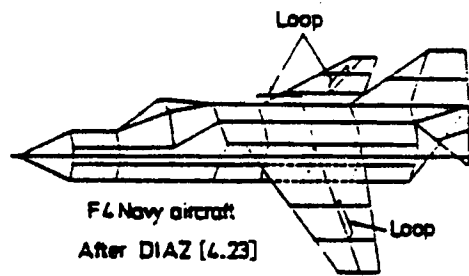

F4 Navy aircraft  
After DIAZ [4.23]

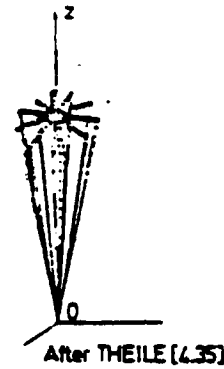

After THEILE [4.35]

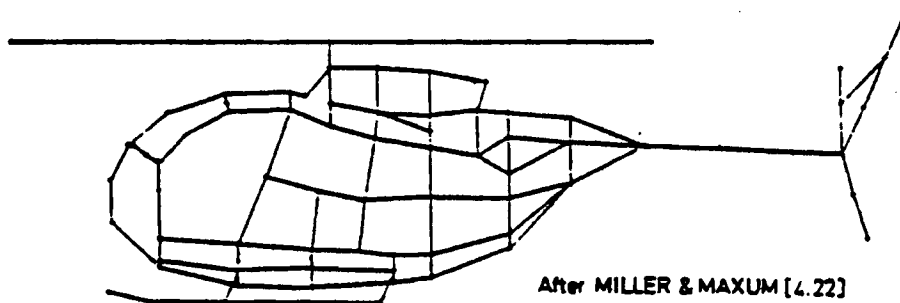

After MILLER & MAXUM [4.22]

Representative wire grid model structures

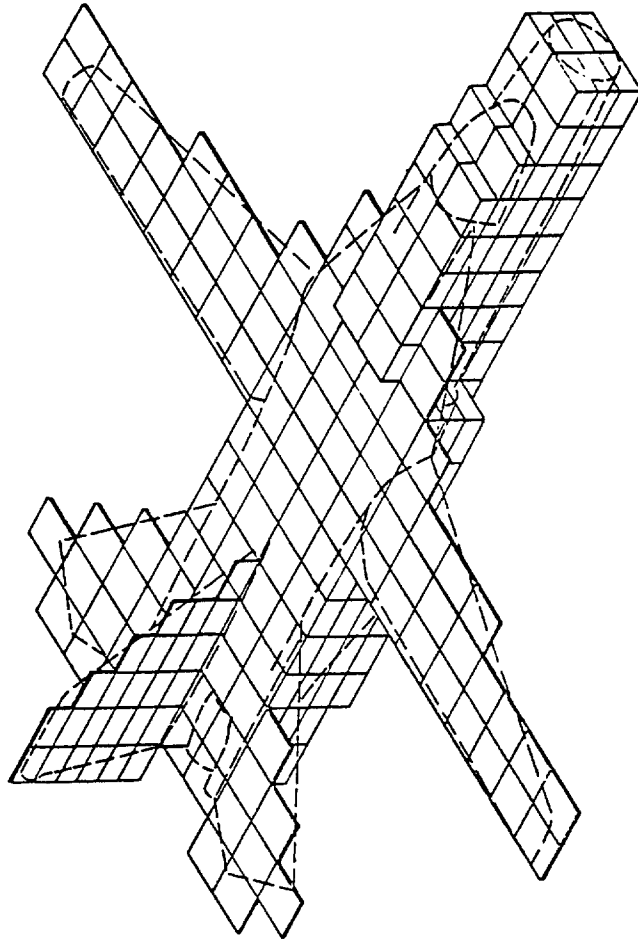

## FINITE DIFFERENCE METHOD -

- BASED ON BRUTE FORCE TIME STEPPING OF MAXWELL'S EQUATIONS
- INCORPORATES ANY MATHEMATICALLY EXPRESSIBLE SOURCE, I.E.  $I(t) = e^{-\alpha t} - e^{-\beta t}$
- ACCURATE EXTERIOR RESPONSE PREDICTIONS
- WITH EXPANSION TECHNIQUE CAN, ALSO, PERFORM INTERIOR RESPONSE PREDICTIONS AT REASONABLE COST
- CAN HANDLE COMPOSITES, AS WELL AS METAL AIRCRAFT PANELS

## DEFINITION OF THE FINITE DIFFERENCE APPROACH

Finite differencing consists of replacing continuous partial derivatives in P.D.E.'s with appropriate finite differences. For example:

$$\partial y \rightarrow \Delta(y_n) = y_{n+1} - y_n ; \quad \partial^2 y \rightarrow \Delta [\Delta(y_n)] = y_{n+2} - 2y_{n+1} + y_n ; \text{ etc.}$$

Finite differencing discretizes the P.D.E. and, hence, the problem being solved, i.e.

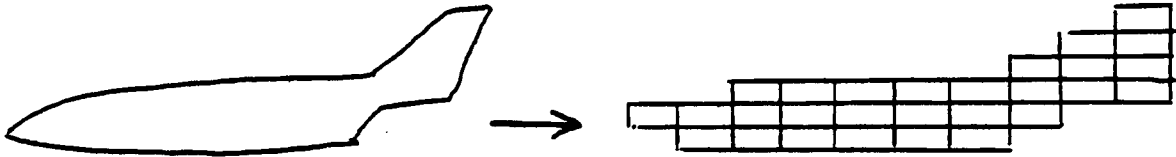

Finite differencing is, therefore, an approximation that in the limit of zero mesh size is exact.

Finite differencing does not require any special model of the problem to facilitate a solution, just the appropriate P.D.E. such as:

$$\frac{1}{\alpha} \frac{\partial T}{\partial \theta} = \nabla^2 T + Q/k \quad \text{or} \quad \left( \frac{\partial e_r}{\partial z} - \frac{\partial e_z}{\partial r} \right) = -\mu_0 \frac{\partial h_\phi}{\partial t}$$

(heat equation)

(portion of Maxwell Equations for thin scatterer in cylindrical coordinates)

## EVOLUTION OF PRECEEDING FINITE DIFFERENCE APPROACH TO EM

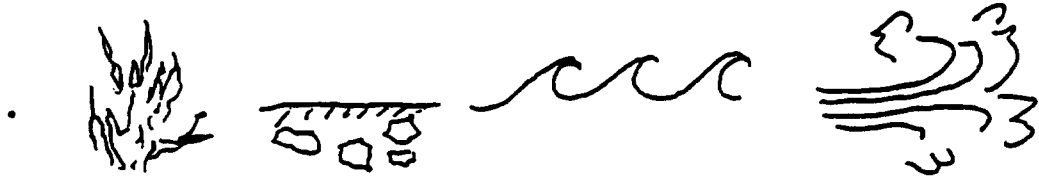

- The Maxwell Equations
- Classical Boundary Value Solutions
- Introduction of Computers/Computer Oriented Numerical Analysis
- Integral Equation Approaches (EFIE and MFIE)
- Finite Difference as presently applied to EM coupling
  - 1) feasibility of application to realistic problems -  
K.S. Lee - "Num. Sol. of Int. Bound. Val. Prob. Involving Maxwell's Equas. in Iso. Media", IEEE Transactions A and P, May, 1966.
  - 2) application in 2D to realistic problem with radiation boundary condition -  
D.E. Merewether - "Trans. Currents Induced on a Metallic Body of Rev. by an EM Pulse", IEEE Transactions on EMC, May, 1971.
  - 3) formulation of 3D code with radiation boundary condition -  
R. Holland - "THREDE: A Free-Field EMP Coupling and Scattering Code", Mission Research Corp., AMRC-R-95, Sept., 1976.

EVOLUTION - 2

- 4) application to complex scattering object with comparison to experiment -  
K.S. Kunz and K.M. Lee - "A Three-Dim. Finite-Diff. Solu. to the Ext. Response of an Aircraft to a Complex Transient EM Environment: Part 1 -The Method and Its Implementation and Part 2 - Comparison of Predictions and Measurements", IEEE Transactions on EMC, May, 1978.
- 5) expand subvolume in a second run for increased spatial and frequency resolution -  
K.S. Kunz and L.T. Simpson - "A Technique for Increasing the Resolution of Finite-Difference Solutions of the Maxwell Equations", IEEE Transaction on EMC November, 1981
- 6) generalize the 3D code to treat lossy dielectrics -  
R. Holland, L.T. Simpson and K.S. Kunz - "Finite-Difference Analysis of EMP Coupling to Lossy Dielectric Structures", IEEE Transactions on EMC, August, 1980.

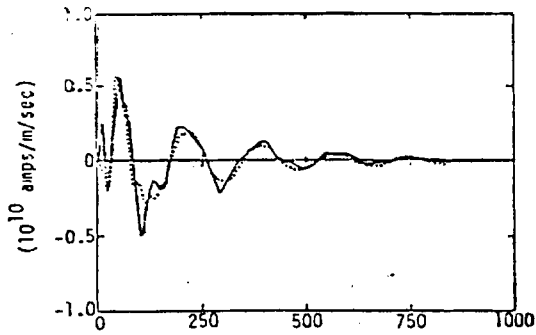

Fig. 17. T.P. R1,  $J_A(t)$ ,  $E \parallel$  Fuselage.

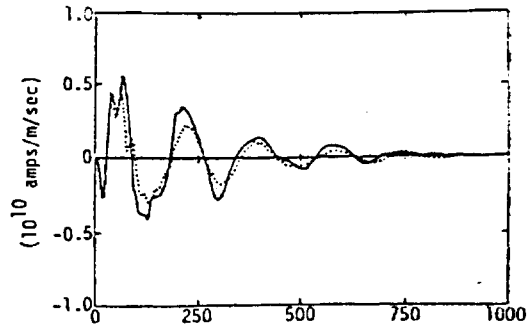

Fig. 21. T.P. 382,  $J_A(t)$ ,  $E \parallel$  Fuselage.

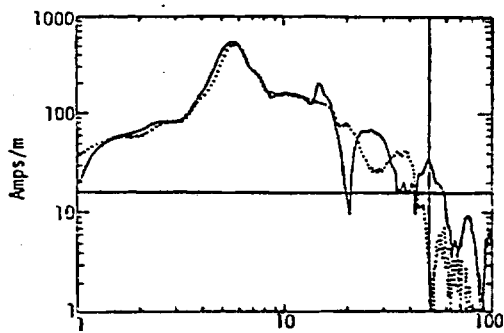

Fig. 18. T.P. R1,  $J_A(\omega)$ ,  $E \parallel$  Fuselage.

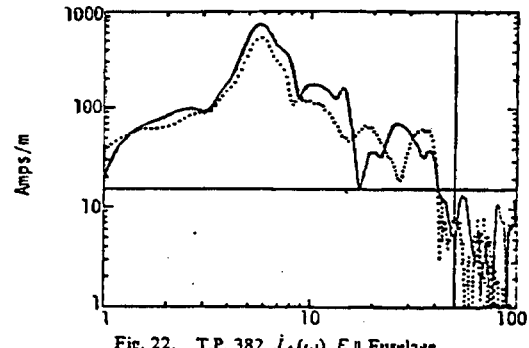

Fig. 22. T.P. 382,  $J_A(\omega)$ ,  $E \parallel$  Fuselage.

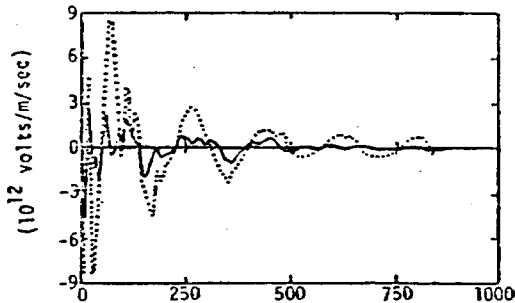

Fig. 19. T.P. R1,  $Q(t)$ ,  $E \parallel$  Fuselage.

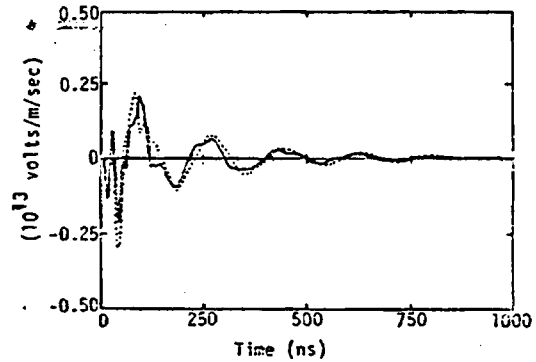

Fig. 23. T.P. 382,  $Q(t)$ ,  $E \parallel$  Fuselage.

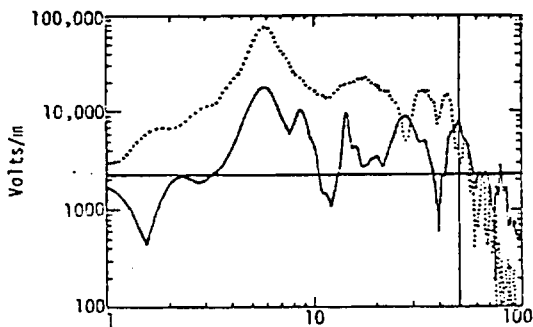

Fig. 20. T.P. R1,  $Q(\omega)$ ,  $E \parallel$  Fuselage.

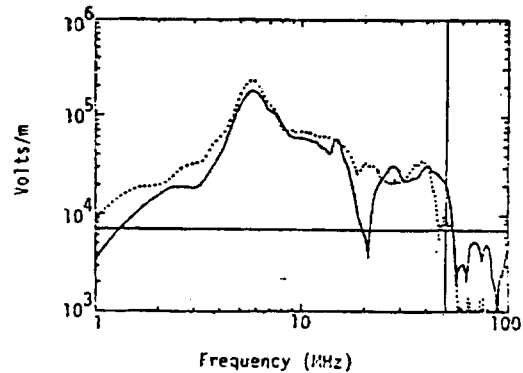

Fig. 24. T.P. 382,  $Q(\omega)$ ,  $E \parallel$  Fuselage.

SAMPLE PERFECTLY CONDUCTING A/C RESULTS

INCREASED RESOLUTION USING EXPANSION TECHNIQUE

- A/C UNEXPANDED -

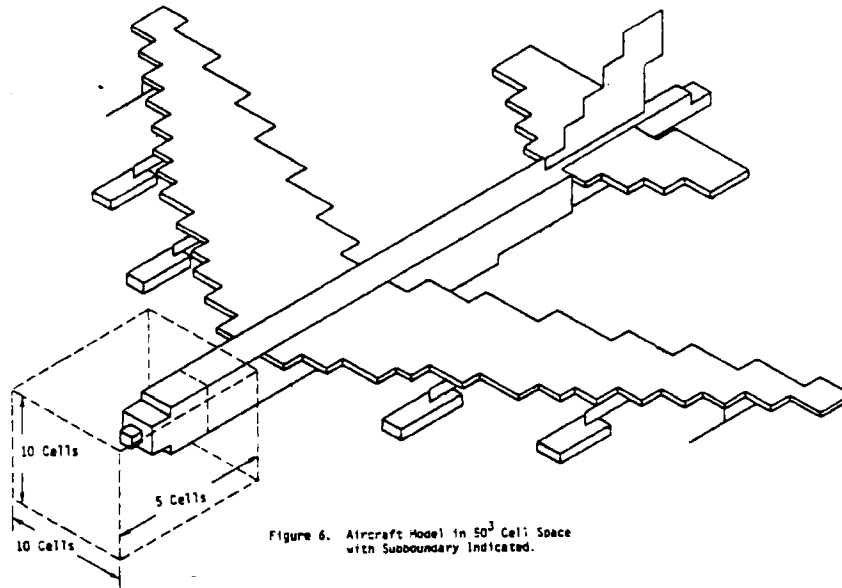

Figure 6. Aircraft Model in  $50^3$  Cell Space with Subboundary Indicated.

- A/C EXPANDED -

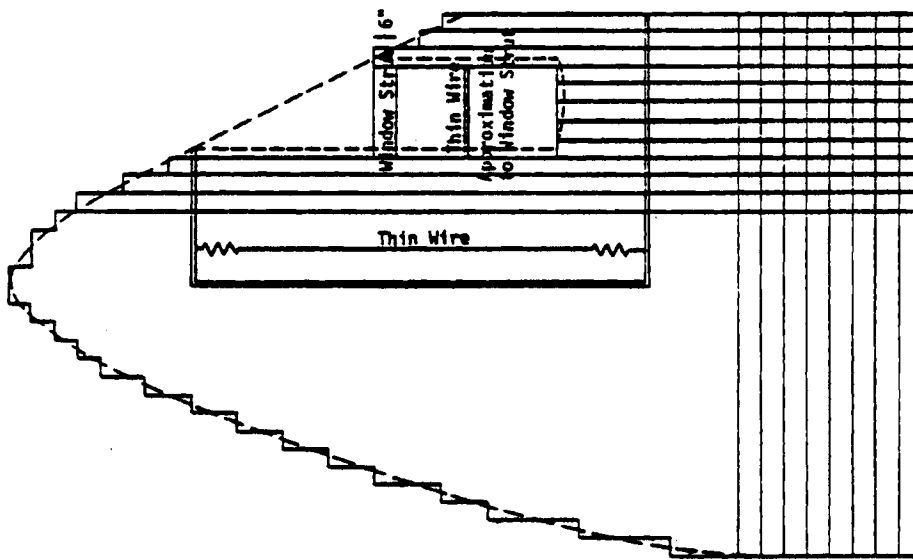

Figure 7. Expanded Run Showing Cockpit Area Detail.

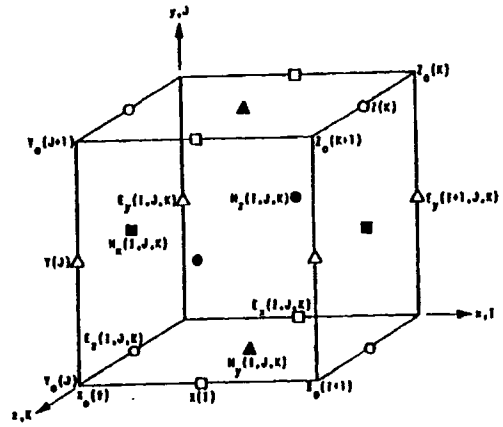

Fig. 1. Convention for imposing the (i, j, k) indexes on the (x, y, z) problem space, and location of the six field evaluation points in a typical cell.

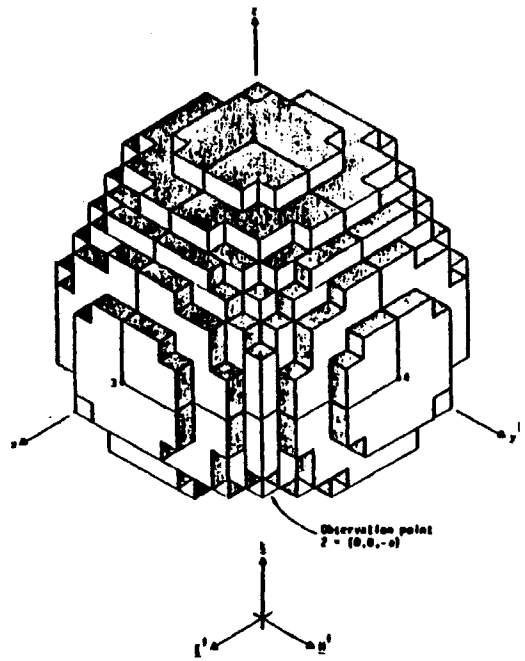

Fig. 2. THREDE model of a dielectric sphere with incident field and observation points indicated. The numbered observation points marked in this figure refer to the observation points cited in Figs. 3-20.

### LOSSY DIELECTRIC CAPABILITIES

The lossy-dielectric version of THREDE is based upon

$$\mu \frac{\partial H^i}{\partial t} + \sigma^* H^i = -\nabla \times E^i - \sigma^* H^i - (\mu - \mu_0) \frac{\partial H^i}{\partial t}$$

$$\epsilon \frac{\partial E^i}{\partial t} + \sigma E^i = \nabla \times H^i - \sigma E^i - (\epsilon - \epsilon_0) \frac{\partial E^i}{\partial t}$$

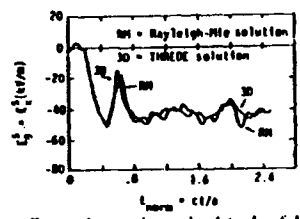

Fig. 3.  $E_\theta^i = +E_z^i$  at observation point 1 (pole of dark hemisphere) for  $\epsilon = 9\epsilon_0$ .

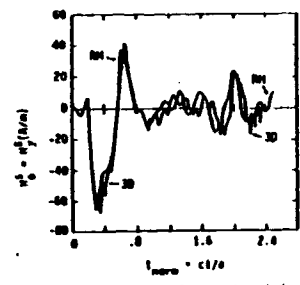

Fig. 4.  $H_\theta^i = +H_y^i$  at observation 1 for  $\epsilon = 9\epsilon_0$ .

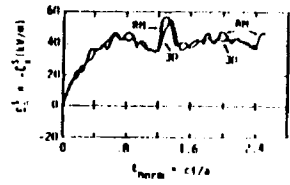

Fig. 5.  $E_\theta^i = -E_z^i$  at observation point 2 (pole of illuminated hemisphere) for  $\epsilon = 9\epsilon_0$ .

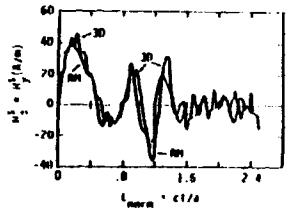

Fig. 6.  $H_\theta^i = +H_y^i$  at observation point 2 for  $\epsilon = 9\epsilon_0$ .

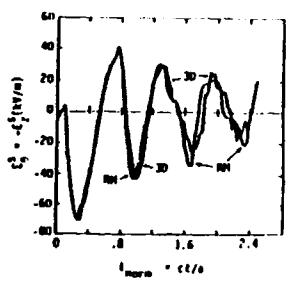

Fig. 7.  $E_\theta^i = -E_z^i$  at observation point 3 for  $\epsilon = 9\epsilon_0$ .

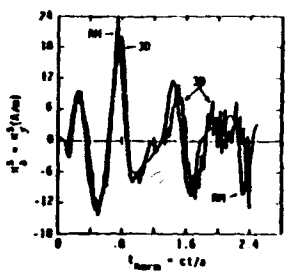

Fig. 8.  $H_\theta^i = +H_y^i$  at observation point 3 for  $\epsilon = 9\epsilon_0$ .

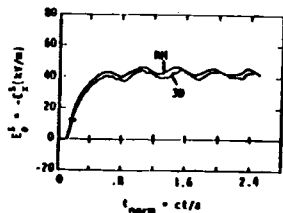

Fig. 9.  $E_{\theta}^i = -E_{\theta}^u$  at observation point 4 for  $\epsilon = 9\epsilon_0$ .

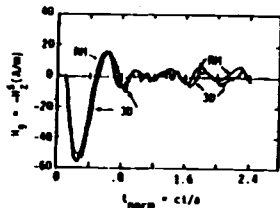

Fig. 10.  $H_{\theta}^i = -H_{\theta}^u$  at observation point 4 for  $\epsilon = 9\epsilon_0$ .

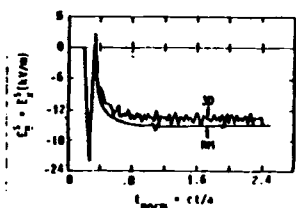

Fig. 11.  $E_{\theta}^i = +E_{\theta}^u$  (unfiltered) at observation point 1 (pole of dark hemisphere) for  $\epsilon = 2\epsilon_0$ .

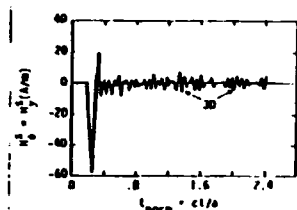

Fig. 12.  $H_{\theta}^i = +H_{\theta}^u$  (unfiltered) at observation point 1 for  $\epsilon = 2\epsilon_0$ .

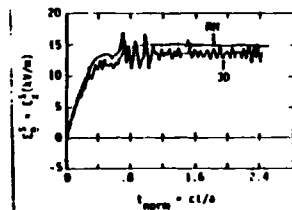

Fig. 13.  $E_{\theta}^i = -E_{\theta}^u$  (unfiltered) at observation point 2 (pole illuminated hemisphere) for  $\epsilon = 2\epsilon_0$ .

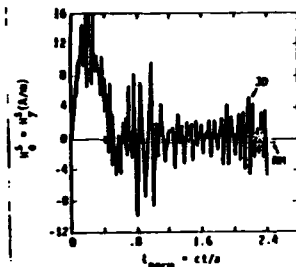

Fig. 14.  $H_{\theta}^i = +H_{\theta}^u$  (unfiltered) at observation point 2 for  $\epsilon = 2\epsilon_0$ .

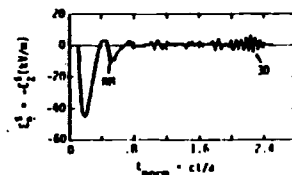

Fig. 15.  $E_{\theta}^i = -E_{\theta}^u$  (unfiltered) at observation point 3 for  $\epsilon = 2\epsilon_0$ .

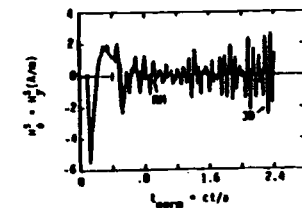

Fig. 16.  $H_{\theta}^i = +H_{\theta}^u$  (unfiltered) at observation point 3 for  $\epsilon = 2\epsilon_0$ .

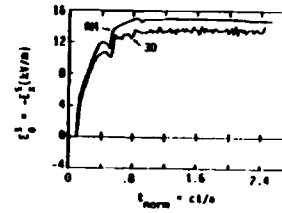

Fig. 17.  $E_{\theta}^i = -E_{\theta}^u$  (unfiltered) at observation point 4 for  $\epsilon = 2\epsilon_0$ .

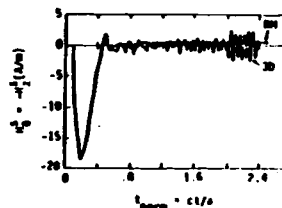

Fig. 18.  $H_{\theta}^i = -H_{\theta}^u$  (unfiltered) at observation point 4 for  $\epsilon = 2\epsilon_0$ .

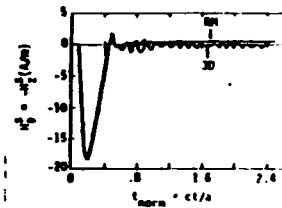

Fig. 19.  $H_{\theta}^i = +H_{\theta}^u$  ( $\omega_{c0} = 2.5 c/a$ ) at observation point 2 for  $\epsilon = 2\epsilon_0$ ; compare with the unfiltered result shown in Fig. 14.

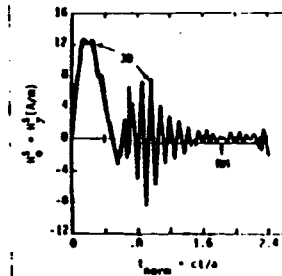
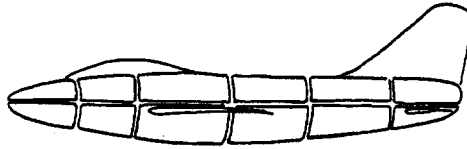

Fig. 20.  $H_{\theta}^i = -H_{\theta}^u$  ( $\omega_{c0} = 2.5 c/a$ ) at observation point 4 for  $\epsilon = 2\epsilon_0$ ; compare with the unfiltered result shown in Fig. 18.

INTERIOR COUPLING APPROACH



Contiguous Skin Model of the Aircraft for Diffusion Calculations



Perfectly Conducting Aircraft with Seams

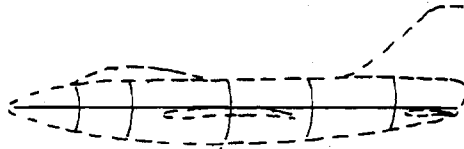

Complement of the Seam Model

ORIGINAL GEOMETRY

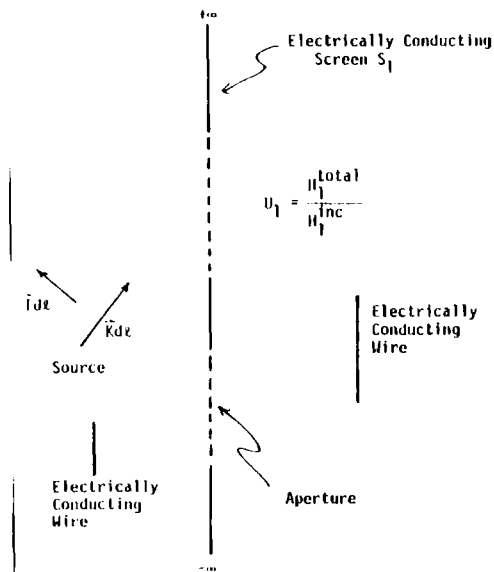

CONJUGATE/COMPLEMENT GEOMETRY

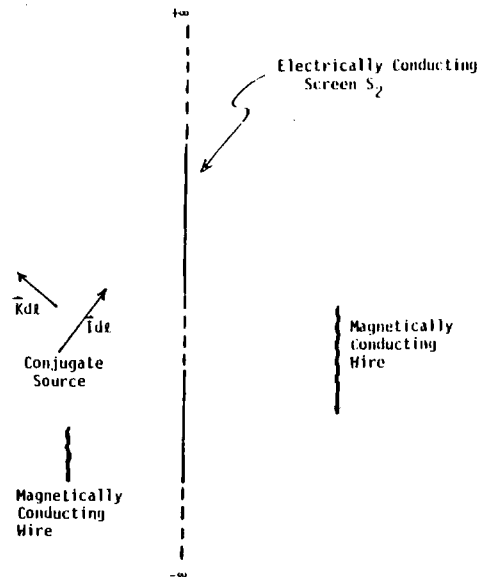

Original and Conjugate/Complement Geometry - Planar Screen Example

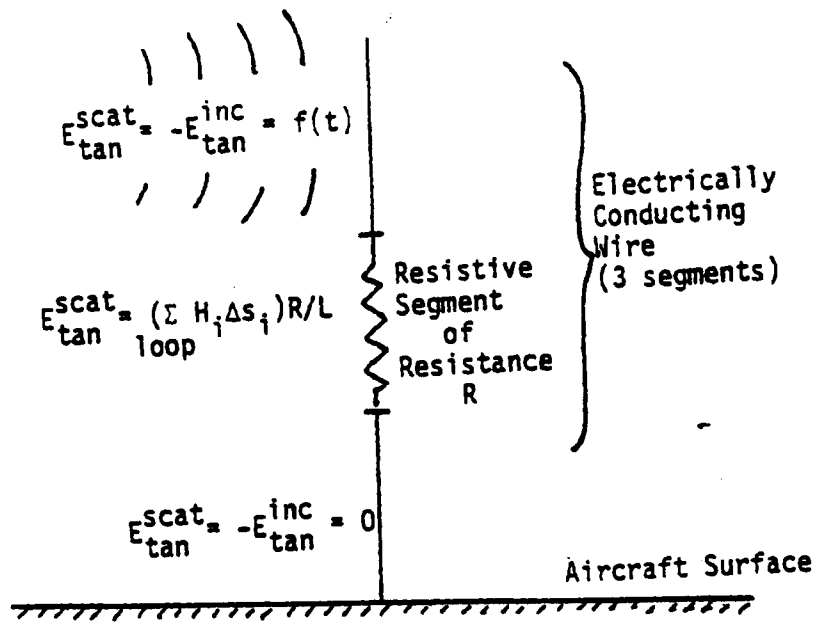

Lightning Channel Source

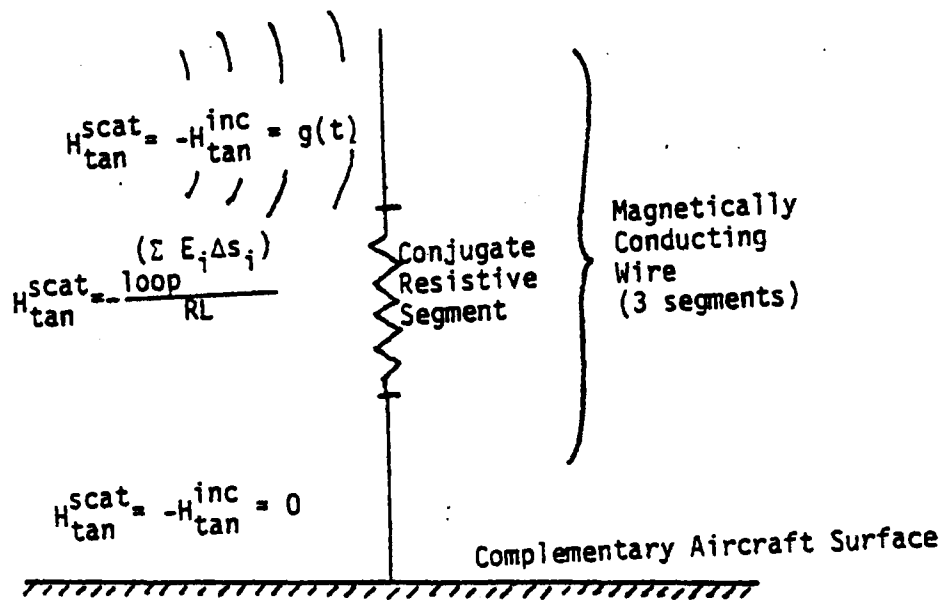

Conjugate Lightning Channel Source

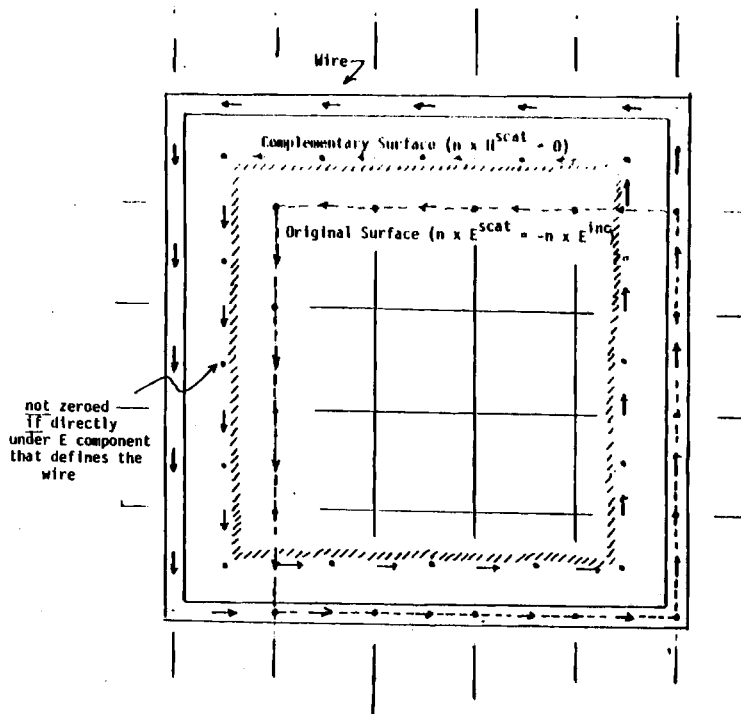

Finite Difference Formulation of the Complementary Aircraft Surface Showing the Half Cell Displacement and the Wire Model of the Seam Girdling the Surface

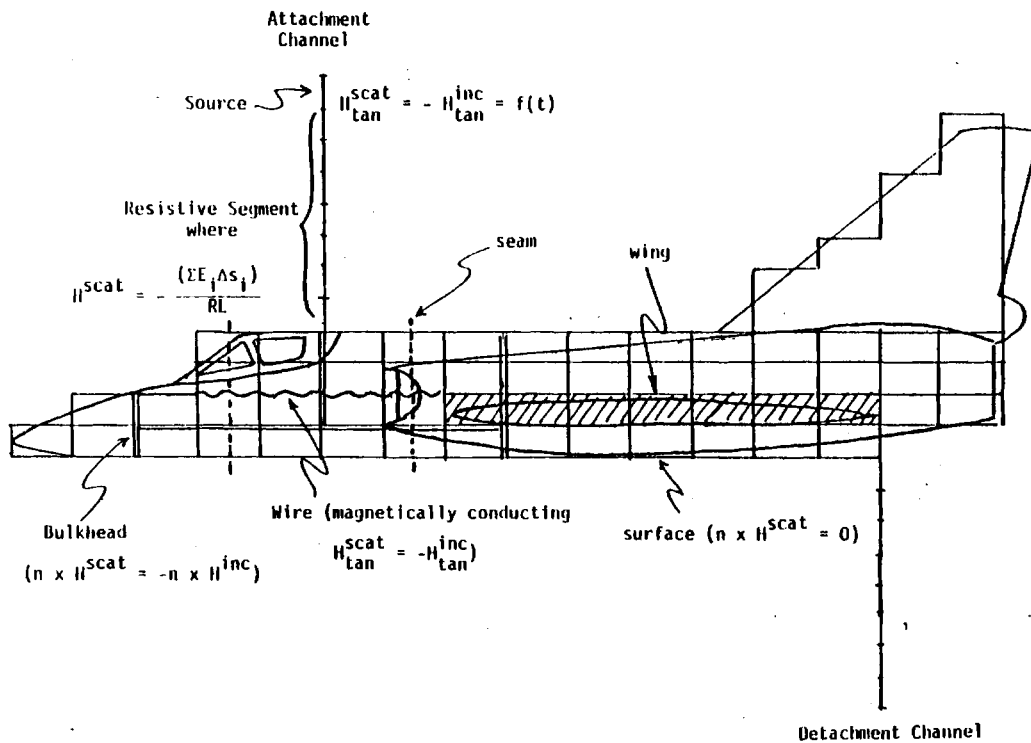

Couple Conjugate/Complement Geometry as Formulated for Finite Difference Applications

## PIN PREDICTIONS - SINGLE MULTILAYERED CABLE

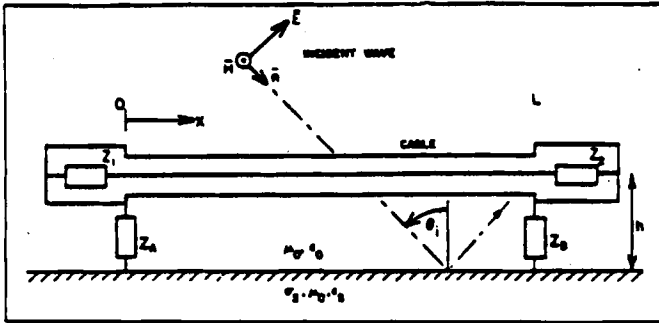

Model of aerial cables.

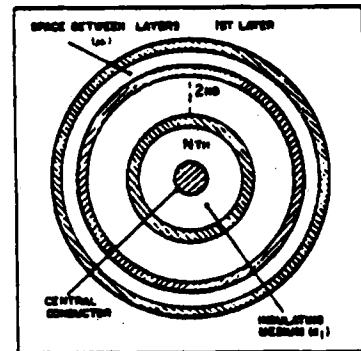

Model of shielded cables.

- USE F.D. TO FIND CURRENTS ALONG CABLE SHEATH,  $I_b$
- USE SURFACE TRANSFER IMPEDANCE,  $Z_T$ , AS DEFINED BY SCHELKUNOFF, TO FIND THE INTERIOR CURRENTS:

$$I_a(x) = \int_0^L G_{11}(x, x') \cdot Z_T \cdot I_b(x') dx' \quad *$$

WHERE  $G_{11}$  IS THE APPROPRIATE GREEN'S FUNCTION THAT INCORPORATES THE CORRECT BOUNDARY CONDITIONS FOR THE GEOMETRY AT HAND

- EVALUATE  $I_a(x = L)$  TO FIND THE CURRENT AT THE PIN
- EVALUATE THE VOLTAGE ACROSS THE DEVICE CONNECTED TO THE PIN,  $V_d$ , USING THE PIN CURRENT AND THE DEVICE'S IMPEDENCE  $Z_d$ , I.E.  $V_d = I_a(x = L)Z_d$ .

\*ONLY DIFFUSION THROUGH SHIELD CONSIDERED

## EXPECTED RESULTS -

- EXTERIOR RESPONSE - SIMILAR TO PERFECTLY CONDUCTING A/C RESPONSES
- INTERIOR CABLE RESPONSE, WIRE EXTERIOR - WEAKLY DAMPED SINUSOID, SEE BELOW
- PIN RESPONSE - SIMILAR TO WIRE EXTERIOR

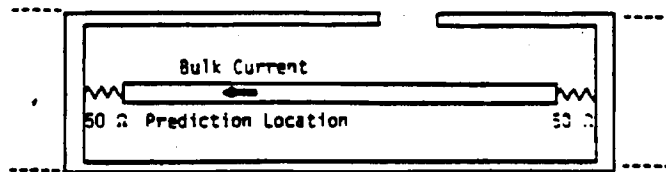

Interior Geometry of Expanded Region

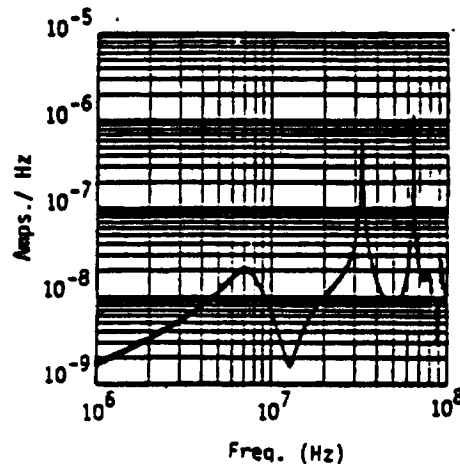
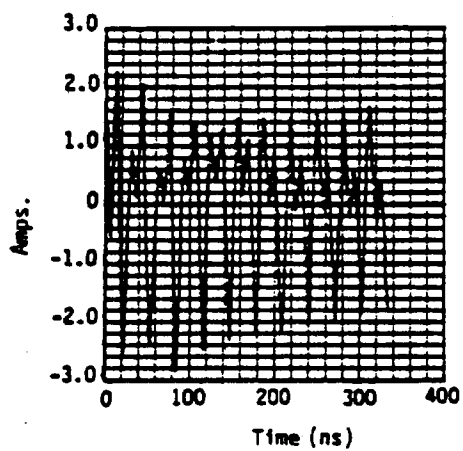

Sample of Predicted Results

## SUMMARY

### FEATURES

- ° Any fuselage exterior geometry can be modeled, including:
  - composites
  - conducting panels
  - mix of composite and metal
  
- ° Various coupling pathways can be modeled, including:
  - diffusion through composite panels
  - seams around panels
  - small apertures around doors/hatches/wheel wells, etc.
  - large apertures such as windows
  
- ° Detailed interior geometries can be treated, including:
  - individual wires with various terminations
  - surrounding "fill"
  - adjacent wires to within a cell size (~0.05m or ~2" at best)
  
- ° Fast risetime (~30-50ns) pulses can be easily incorporated
  
- ° Non-linear effects can be modeled
  - attachment points can be selected based on experience, while detachment points can be selected based on fields exceeding preset thresholds
  - interior arcing can be modeled similarly

## AREAS OF APPLICATION

- ° Exterior I and V response predictions as a function of:
  - position
  - A C construction (metal or composite or mix)
  - excitation source
  - attachment/detachment location
  
- ° Interior Responses
  - interior field levels
  - wire currents
  - transfer functions
  
- ° Hazard Assessment
  - induced current damage
  - field induced upset
  - fuel ignition from arcing
  
- ° Protection Measures Evaluation
  - field/charge and current penetration reduction  
(from covered seams, mesh across windows, etc.)
  - arc suppression  
(from cable rerouting, interior geometry changes, etc.)
  - protective device effects  
(depends on "threat" spectrum, device location, device operations, etc.)

INTERMITTENT/TRANSIENT FAULTS IN DIGITAL COMPUTERS

by

Dr. Gerald M. Masson

Johns Hopkins University

Need and objectives of digital system upset assessment methodology: The definition of upset. Description of approach being developed for assessing upset potential of digital systems. Upset model types and importance of burst error models; dominant importance of program transition models. Definition and use of system state probability transition matrix in upset analyses. Example of upset tolerant microcontroller.

## FAULT ANALYSIS

- \* FAULTS
  - PERMANENT
  - INTERMITTENT
  - TRANSIENT
  - I/T
- \* MODELS
  - STUCK-AT
- \* TESTS
  - DETECTION
  - LOCATION

## FAULT TOLERANCE

- \* DUPLEX SYSTEMS
  - ROLLBACK
- \* TMR SYSTEMS
  - ROLLAHEAD
- \* DIAGNOSABLE SYSTEMS
  - INTELLIGENT UNITS

## MICROPROCESSOR CONTROLLERS

- \* HARDWARE
  - CENTRAL PROCESSING UNIT (CPU)
  - READ-ONLY MEMORY (ROM)
  - READ/WRITE MEMORY (RAM)
  - INPUT/OUTPUT DEVICES (I/O)
  - SUPPORT LOGIC
- \* SOFTWARE
  - LOOKUP TABLES
  - CHARACTERIZATION
    - I. INPUT SENSORS SCANNED
    - II. DATA PROCESSING
    - III. CONTROL SIGNALS TO ACTUATORS

## FAULTS IN MICROPROCESSORS

- \* CPU TESTING
- \* RECOVERY STRATEGIES
  - DUPLICATION
  - TMR
  - WATCHDOG TIMER

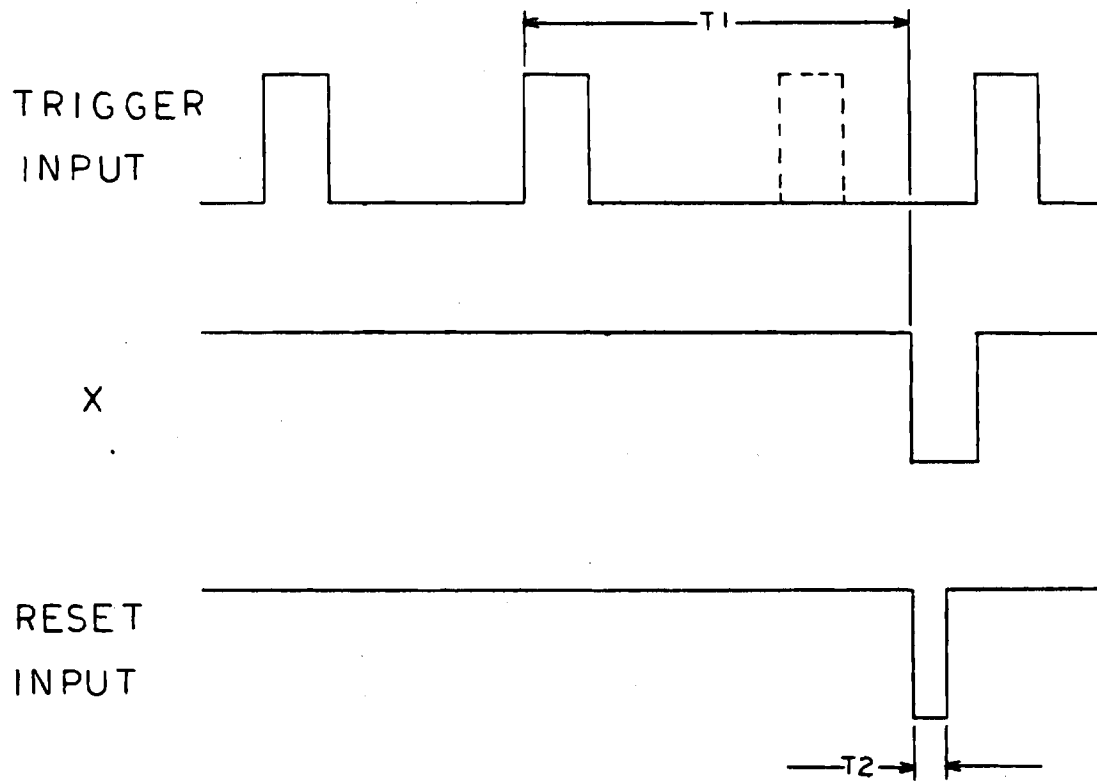
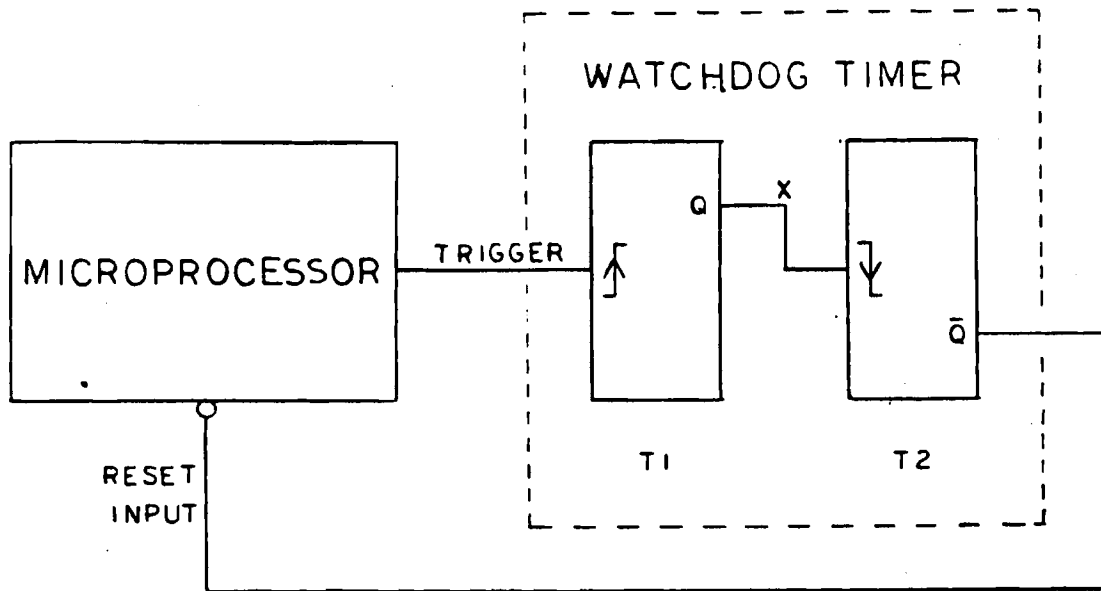

FIGURE 1. WATCHDOG TIMER

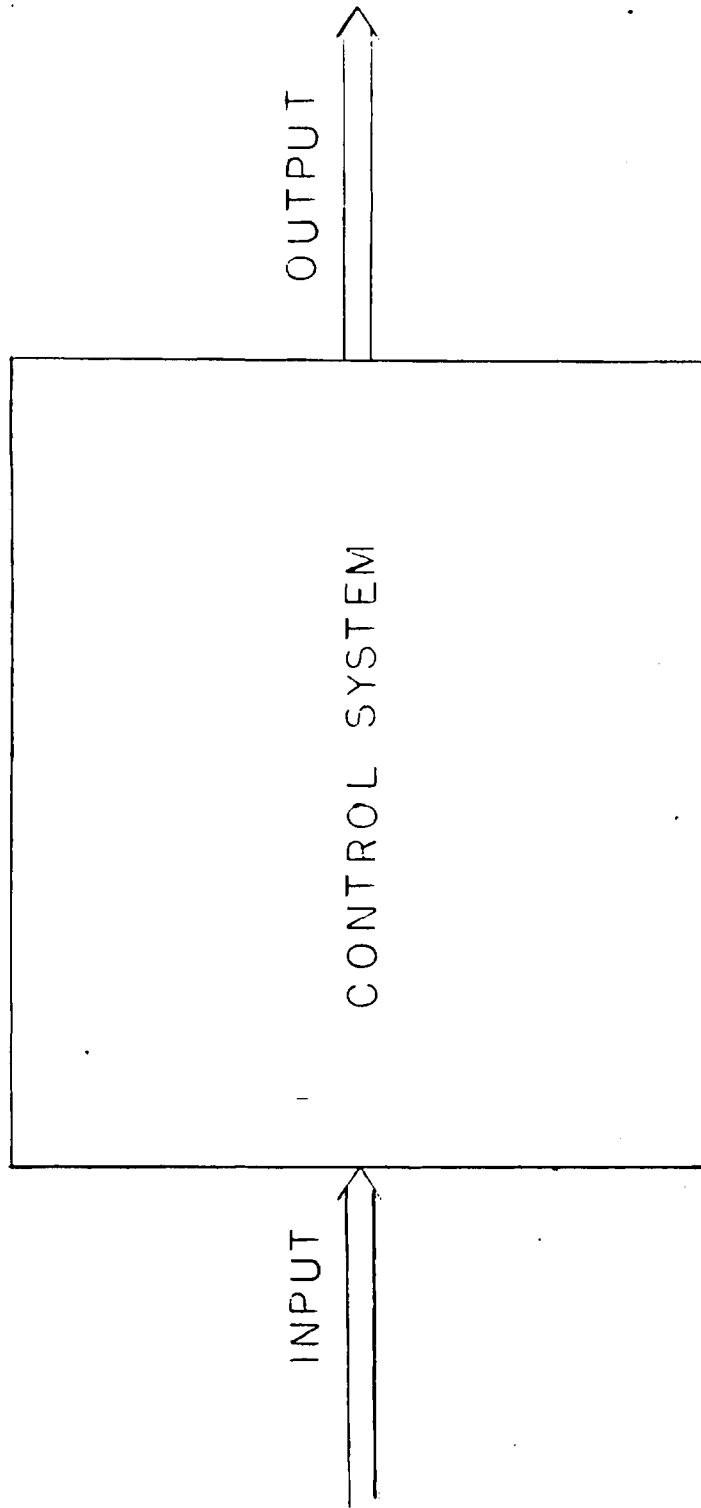

FIGURE 2. CONTROL SYSTEM CONSIDERED ALONE

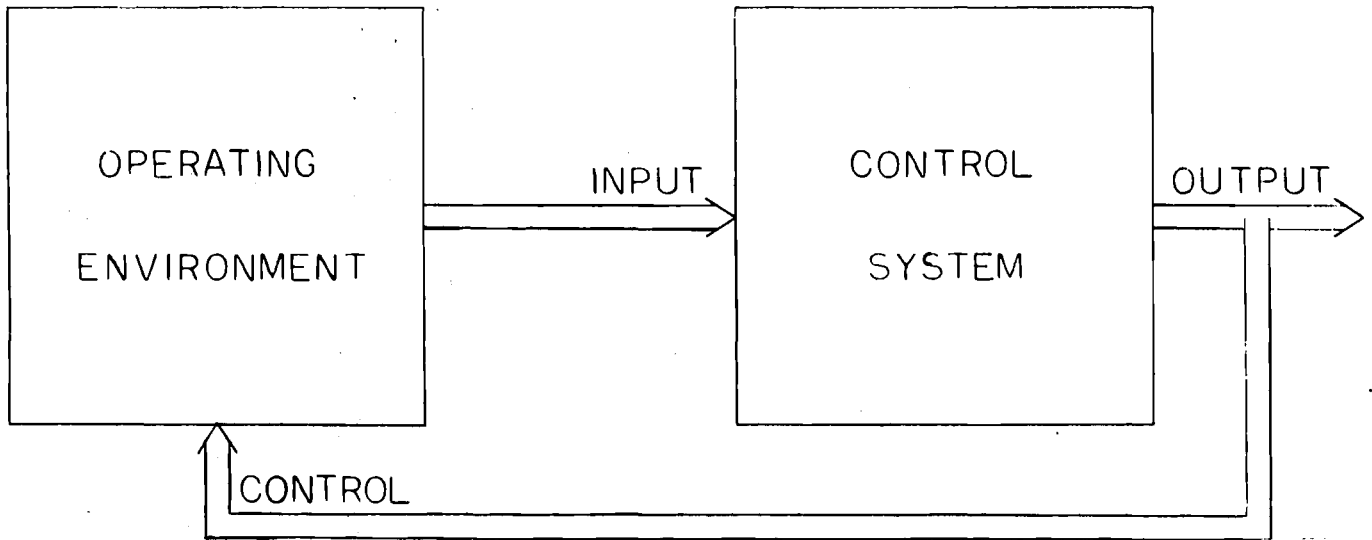

FIGURE 3. CONTROL SYSTEM SITUATED IN ITS ENVIRONMENT

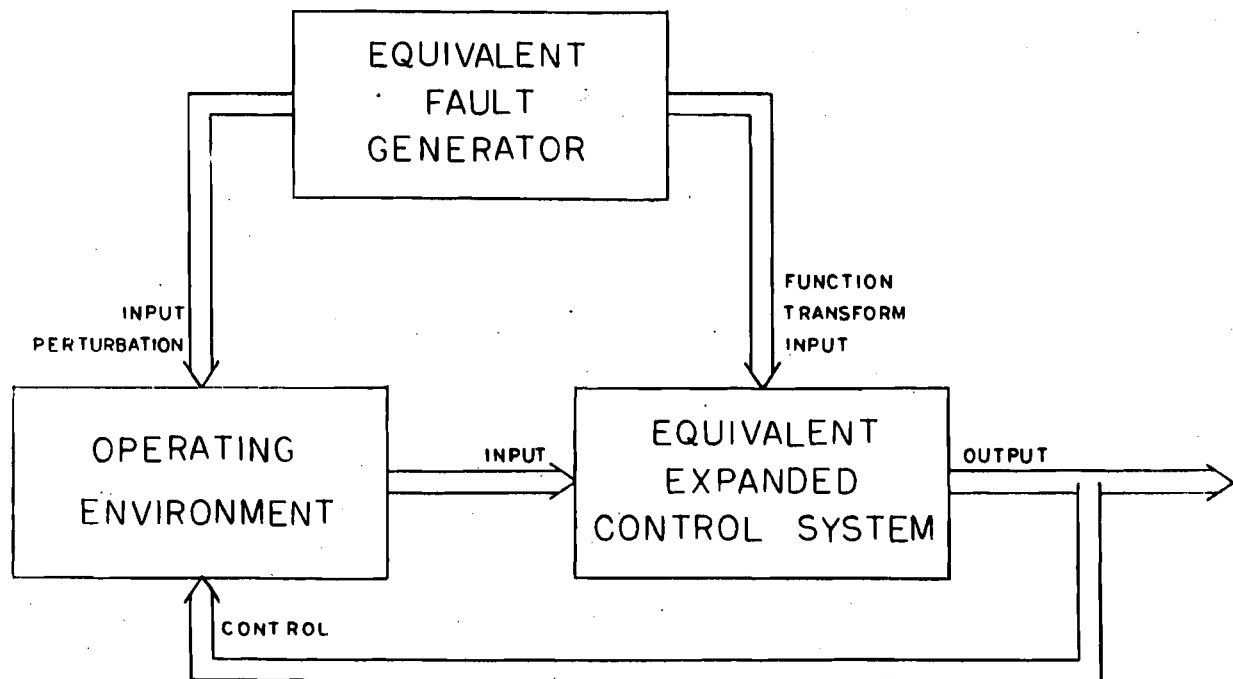

FIGURE 4. CONTROL SYSTEM SITUATED IN EQUIVALENT HOSTILE ENVIRONMENT

## FAULT/SYSTEM INTERACTION

- \* CONTROL SYSTEM INTERACTS WITH ENVIRONMENT
- \* INTERMITTENT/TRANSIENT FAULTS
  - SYSTEM "TRANSIENT" RESPONSE
  - SYSTEM "STEADY STATE" RESPONSE

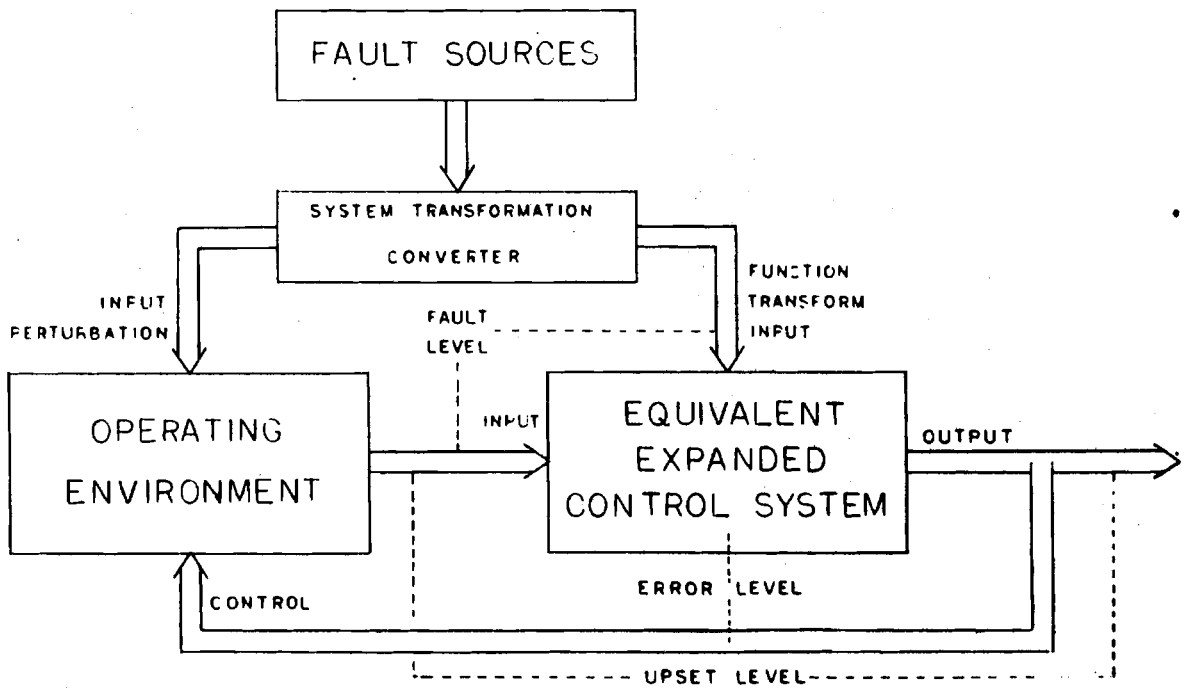

FIGURE 5. CONTROL SYSTEM SITUATED IN HOSTILE ENVIRONMENT

### FAULTS, ERRORS, AND UPSETS

- \* FAILURES
  - CIRCUIT LEVEL
  - ANALOG NATURE
- \* FAULTS
  - LOGICAL LEVEL
  - DIGITAL NATURE
  - LOGICAL DIFFERENCE AT FAULT SITE
- \* ERRORS
  - LOGICAL LEVEL
  - DIGITAL NATURE
  - DUE TO PROPAGATION OF FAULTS
  - LOSS OF SYNCHRONIZATION PROBLEM

NEW DEFINITION
- \* UPSETS
  - SYSTEM LEVEL
  - FUNCTIONAL NATURE
  - TRANSFER FUNCTION

### CONTAINMENT SETS

- \* A FINITE SET OF MUTUALLY EXCLUSIVE FUNCTIONAL STATES
- \* COVERS ALL POSSIBLE SYSTEM TRANSFER FUNCTIONS
- \* INCLUDES
  - VALID STATES
  - ERRONEOUS STATES

## CONTAINMENT SET TRANSITIONS

TRANSITION MATRIX:

$T = [p_{ij}]$ , WHERE  $p_{ij}$  IS THE PROBABILITY OF A TRANSITION FROM STATE  $j$  TO STATE  $i$ , GIVEN THAT AN ERROR HAS OCCURRED

$$L(K+1) = T L(K), \quad L(K) = \begin{bmatrix} P_0 \\ P_1 \\ \vdots \\ P_n \end{bmatrix}$$

$P_i(K)$  IS THE PROBABILITY OF BEING IN CONTAINMENT STATE  $L_i \in \{L\}$  AFTER  $K$  UPSETS

AFTER  $K$  UPSETS,

$$L(K) = T^K L(0)$$

## FAULT ANALYSIS AND SYSTEM VALIDATION

\* SINGLE UPSET ENVIRONMENT

-  $P_{11}$  OF  $T \begin{bmatrix} P_{ij} \end{bmatrix}$  OF MAJOR CONCERN

\* MULTIPLE UPSET ENVIRONMENT

-  $P_{11}$  OF  $T^K$  FOR LARGE  $K$  OF MAJOR CONCERN

\* EXAMPLE

$$T^* = \begin{bmatrix} 3/4 & 15/16 \\ 1/4 & 1/16 \end{bmatrix}, \quad T^{**} = \begin{bmatrix} 7/8 & 1/8 \\ 1/8 & 7/8 \end{bmatrix}$$

$$\lim_{K \rightarrow \infty} (T^*)^K = \begin{bmatrix} 15/19 & 15/19 \\ 4/19 & 4/19 \end{bmatrix}, \quad \lim_{K \rightarrow \infty} (T^{**})^K = \begin{bmatrix} 1/2 & 1/2 \\ 1/2 & 1/2 \end{bmatrix}$$

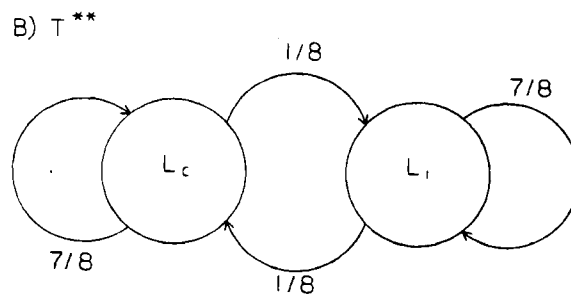
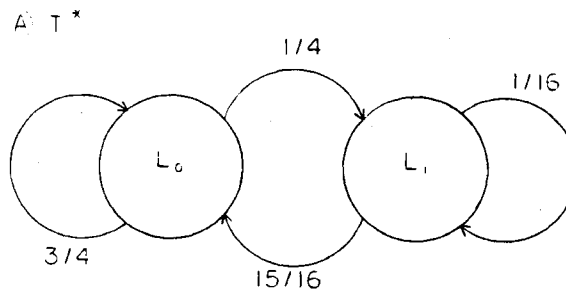

FIGURE 6. TWO 2-LOOP IMPLEMENTATIONS

## FAULT TOLERANCE

- \* CONTAINMENT SET AND TRANSITION MATRIX ANALYSIS PROVIDES FEEDBACK TO IMPROVE DESIGNS
- \* REMOVAL OF ERRONEOUS ELEMENTS FROM THE CONTAINMENT SET AUTOMATICALLY PROVIDES FAULT TOLERANCE

## CONTAINMENT SET FOR MICROPROCESSORS

### \* PROGRAM TYPES

- EXITING
- LOOPING

### \* TAKE THE CONTAINMENT SET TO CONSIST OF ALL POSSIBLE LOOP PROGRAMS

- INCLUDES VALID LOOPS
- INCLUDES ERRONEOUS LOOPS

GIVEN THE EXECUTION OF LOOP PROGRAM  $L_i \in \{L\}$ , UPSETS CAN  
BE CHARACTERIZED AS:

(1) DATA CHANGE --

DATA VALUES ARE MODIFIED, BUT EXECUTION  
REMAINS IN  $L_i$

(2) PROGRAM BUMP --

EXECUTION TEMPORARILY DIVERGES FROM  $L_i$  BUT  
EVENTUALLY RETURNS TO  $L_i$

(3) PROGRAM TRANSITION --

EXECUTION JUMPS FROM  $L_i$  TO  $L_j$ ,  $L_i \neq L_j$

PROGRAM TRANSITION = STEADY STATE OPERATIONAL DEVIATION  
TRANSITION INTO INVALID EMBEDDED LOOP = SYSTEM CRASH

	ADDRESS	CONTENTS
NORMAL EXECUTION	N	OP-CODE
ERRONEOUS EXECUTION	N+1	DATA
NORMAL EXECUTION	N	OP-CODE
ERRONEOUS EXECUTION	N+1	DATA 0
ERRONEOUS EXECUTION	N+2	DATA 1
ERRONEOUS EXECUTION	N	DATA TABLE
ERRONEOUS EXECUTION	N+1	DATA TABLE
.	.	.
.	.	.
.	.	.

FIGURE 7. ERRONEOUS LOOP INSTRUCTION EXECUTION

Result	Addr	Data	L0 Code	L1 Code	L2 Code	Other
L0	0000	00				NOP
.	.	.				.
.	.	.				.
.	.	.				.
L0	00C9	00				NOP
L0	00CA	3E	MVI A,0C3H			
L1	00CB	C3		JMP 0D3H		
L0	00CC	D3	OUT 0			
L0	00CD	00				NOP
L0	00CE	22	LXI H,0CFC3H			
L2	00CF	C3			JMP 0CFH	
L0	00D0	CF				RST 1
L0	00D1	00	NOP			
L0	00D2	32	STA 0CBC3H			
L1	00D3	C3		JMP 0CBH		
L0	00D4	CB				RSTV
L0	00D5	00	NOP			
L0	00D6	C3	JMP 0CAH			
L0	00D7	CA				JZ 0
L0	00D8	00				NOP
L0	00D9	00				NOP
.	.	.				.
.	.	.				.
.	.	.				.
L0	00FE	00				NOP
L0	00FF	C7				RST 0

Figure 8. An Erroneous Loop Example for the 8085

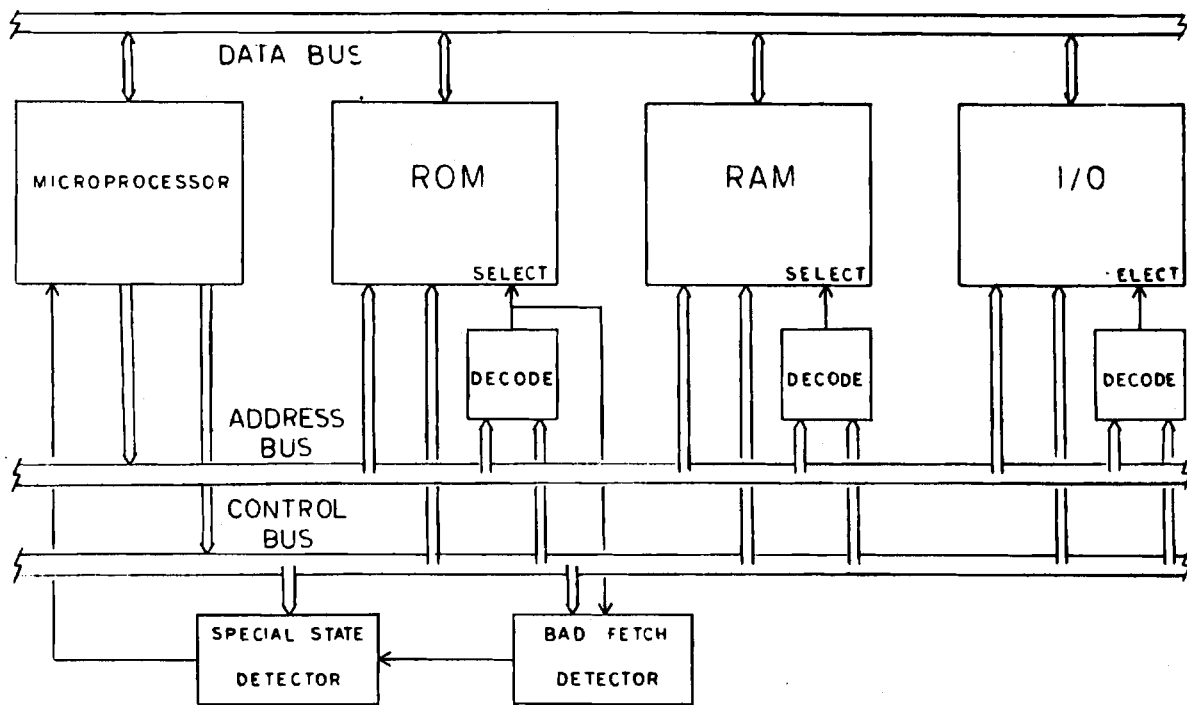

FIGURE 9. CONTROLLER WITH CONTAINMENT HARDWARE

### PROGRAM PATH DIVERTERS

#### \* HARDWARE

- CLOCK STOP
- HALT
- READY
- HOLD
- INTERRUPTS

#### \* SOFTWARE

- JUMP CATEGORY INSTRUCTIONS
- CALL CATEGORY INSTRUCTIONS
- RETURN CATEGORY INSTRUCTIONS  
(+ EFFECTS OF "UNDEFINED"  
INSTRUCTIONS)

\*\* A PROGRAM STRUCTURAL ANALYSIS IS MADE BASED ON PATH DIVERTERS \*\*

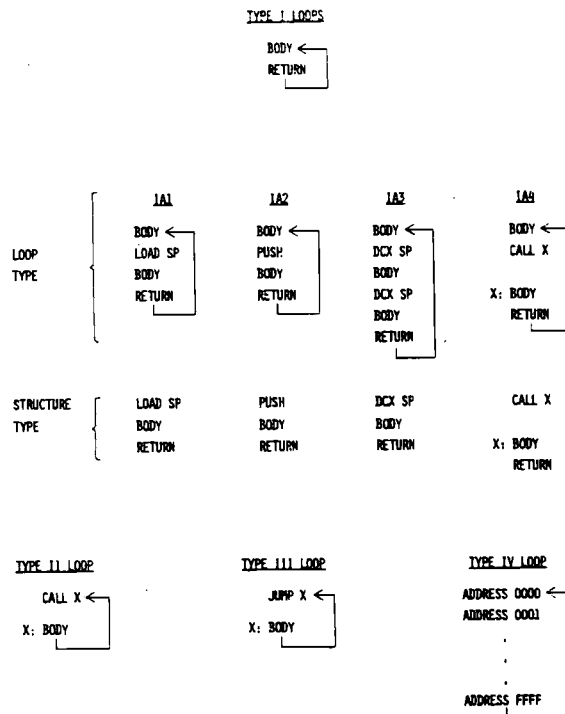

FIGURE 10. LOOP STRUCTURES

## FAULT TOLERANT CONTROLLER DESIGN RULES

### \* HARDWARE

- CONTINUOUS CLOCK
- UNCONDITIONAL INSTRUCTION EXECUTION  
(OP-CODE FETCH DETECTION)
- BAD FETCH DETECTOR  
(ROM RESTRICT MECHANISM)
- OPTIONAL SAFE ROM
- REQUIRES 2-3 INTEGRATED CIRCUITS

## TABLE I

### CRASH-PROOF SOFTWARE DESIGN RULES SUMMARY

1. PROGRAM EXECUTION FROM RAM IS PROHIBITED.
2. EXIT FROM TEMPORARY LOOPS MUST BE GUARANTEED.
3. STABLE LOOPS MUST INCLUDE A CALL TO A CHECK SUBROUTINE, WHICH GUARANTEES ALL ASSUMPTIONS THE PROGRAM REQUIRES FOR CONTINUED EXECUTION. (THESE INCLUDE ASSUMPTIONS ON I/O, INTERRUPTS, AND VARIABLES.)
4. RETURN FROM ALL POSSIBLE INTERRUPTS MUST BE GUARANTEED.
5. SUBROUTINES CANNOT CALL THEMSELVES.
6. SUBROUTINES CANNOT MODIFY THE STACK POINTER OR THE RETURN ADDRESS.
7. WITHIN SUBROUTINES, MEMORY STORE INSTRUCTIONS WHICH PERMIT A VARIABLE STORE ADDRESS MUST GUARANTEE THAT THE REGISTER USED AS THE ADDRESS POINTER CANNOT POINT TO THE STACK SPACE.
8. INSTEAD OF USING RET OR RCN INSTRUCTIONS, A JMP OR JCN TO A SPECIAL RETURN ROUTINE WHICH GUARANTEES THAT THE STACK POINTER POINTS WITHIN THE STACK SPACE BEFORE RETURNING MUST BE USED. (THE RETURN ROUTINE CONTAINS THE ONLY RET INSTRUCTION IN THE ENTIRE PROGRAM.)
9. A STACK WALL MUST BE ADDED. (LEAVE UNUSED ROM SPACE AS 00 OR FF.)
10. THE PCHL INSTRUCTION CANNOT BE USED.
11. EITHER A SAFE ROM MUST BE USED, OR ALL ERRONEOUS LOOPS AND ERRONEOUS CALLS TO ADDRESSES WHICH, WHEN CONSIDERED TO BE SUBROUTINES, DO NOT SATISFY EITHER RULE 5, 6, 7, OR 8 MUST BE REMOVED.

## FAULT TOLERANT CONTROLLER TEST SYSTEM

- \* NOISY POWER SUPPLY TEST SOURCE
- \* DUAL LED CONTROLLERS
- \* UNMODIFIED SOFTWARE
  - LED 1.1
  - LED 4.6
- \* CRASH-PROOF SOFTWARE
  - LED 2.2
  - LED 3.3
  - LED 3.4
  - LED 5.2
  - OVERHEAD

LED 2.2/LED 1.1 = 8.5 %

LED 5.2/LED 4.6 = 14 %

LED 3.3/LED 2.2 = 35 %

LED 3.3/LED 1.1 = 47 %

## SOFTWARE TOOLS

- \* DESIGN AIDS FOR FAULT TOLERANCE IMPLEMENTATION
- \* INTERACTIVE USE PROVIDES EFFECTIVE AND EFFICIENT DESIGN
- \* SAFE
  - PRODUCES SAFE ROM CONTENTS FROM SOURCE CODE
  - OUTPUT USED AS INPUT TO LOOP
- \* LOOP
  - LOCATES BANNED PROGRAM STRUCTURES
  - LOCATES ERRONEOUS LOOPS
  - PROVIDES CHECK ON INTENTIONAL LOOPS

LOOP ANALYSIS OF LED 1.1, PAGE 1

X LOOP LED1.1.OBJ LED1.1.SAFE

LOOP SEARCH? Y  
 ONLY VALID (V,v) OR ERRONEOUS (E,e) ? E  
 LOOP: ERRONEOUS  
 00FB F5 PSH PSW  
 00FC 00 NOP  
 00FD C3 F3 00 JMP 00F3  
 00F3 05 DCR B  
 00F4 CB RZ

LOOP SEARCH? N  
 LIST CALLS? Y  
 ONLY VALID (V,v) OR ERRONEOUS (E,e) ? E  
 LOOP: ERRONEOUS  
 036D FC 07 FB CM F807 [I/O]

LOOP: ERRONEOUS  
 0395 FC 0F FE CM FE0F [I/O]

LOOP SEARCH? N  
 LIST CALLS? N  
 LIST MEMORY STORES? Y  
 ONLY VALID (V,v) OR ERRONEOUS (E,e) ? V  
 LOOP: VALID  
 006A 77 MOV M,A

LOOP: VALID  
 00AC 34 INR M

LOOP: VALID  
 00F3 36 00 MVI M, 00

\*\*\* MAIN AND SWITCH SET AS ERRONEOUS \*\*\*

X LOOP LED1.1.OBJ LED1.1.SAFE

LOOP SEARCH? Y  
 ONLY VALID (V,v) OR ERRONEOUS (E,e) ? V  
 LOOP: VALID  
 009D CD EB 01 CALL 01EB  
 00A0 0D DCR C  
 00A1 C2 9D 00 JNZ 009D

LOOP: VALID  
 00F3 05 DCR B  
 00F4 C8 RZ  
 00F5 23 INX H  
 00F6 7E MOV A,M  
 00F7 23 INX H  
 00F8 FE F0 CPI F0  
 00FA C2 F5 00 JNZ 00F5  
 00FD C3 F3 00 JMP 00F3

LOOP: VALID  
 00F5 23 INX H  
 00F6 7E MOV A,M  
 00F7 23 INX H  
 00F8 FE F0 CPI F0  
 00FA C2 F5 00 JNZ 00F5

LOOP: VALID  
 00F3 05 DCR B  
 00F4 C8 RZ  
 00F5 23 INX H  
 00F6 7E MOV A,M

TABLE II  
LED Program Comparisons

<u>Program</u>	<u>Bytes (Hex)</u>	<u>Bytes (Dec)</u>	<u>Features</u>
LED 1.1	03BB	955	* Functional
LED 2.2	040C	1036	* Functional * Crash-proof
LED 3.3	0577	1399	* Functional * Crash-proof with SAFE ROM * State encode
LED 3.4	0578	1400	* Functional * Crash-proof * State encode
LED 4.6	039A	922	* Functional
LED 5.2	0419	1049	* Functional * Crash-proof

## CONCLUSIONS

- \* DIRECT APPLICATION TO MICROPROCESSOR CONTROLLERS
  - TRADE-OFFS
  - MEASUREMENTS
  - COMPARISON WITH WATCHDOG TIMER
  - LANGUAGE CONSIDERATIONS
    - ASSEMBLY LANGUAGE
    - COMPILED LANGUAGES
    - INTERPRETIVE LANGUAGES
  - CPU SELECTION REQUIREMENTS AND ARCHITECTURAL RECOMMENDATIONS
    - ROM RESTRICT MECHANISM
    - TEST MODES
    - UNDEFINED OP-CODES
- \* APPLICATION TO LARGE COMPUTER SYSTEMS
  - MONITORS
  - DIAGNOSABLE SYSTEMS
  - THEORY EXPANSION

A MICROPROCESSOR-BASED UPSET TEST METHOD

by

Ms. Celeste M. Belcastro

Langley Research Center  
National Aeronautics and Space Administration

Description of a microprocessor-based upset testing method employing transient waveforms randomly injected into a digital unit. Upset test data presented along with preliminary observations.

# OUTLINE

- BACKGROUND
- RESEARCH OBJECTIVES OF UPSET TESTING
- UPSET TEST DESIGN CRITERIA
- UPSET TEST HARDWARE IMPLEMENTATION
- PRELIMINARY OBSERVATIONS
- FUTURE PLANS

PROBLEM CAUSED BY LIGHTNING

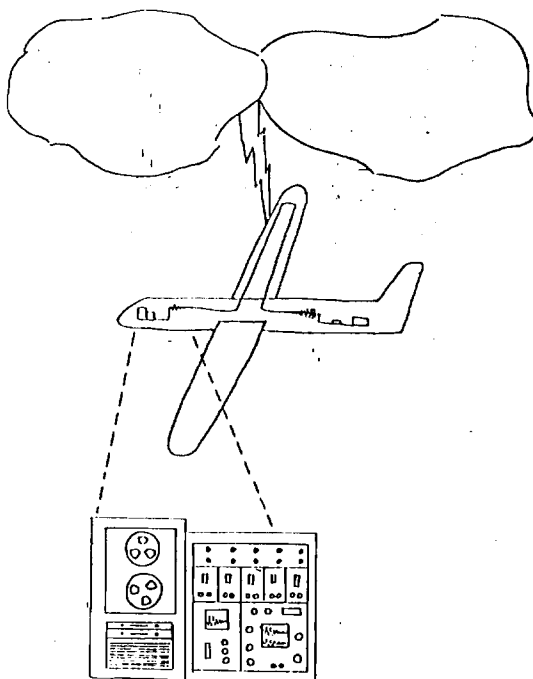

## INDUCED EFFECTS TESTING LEVELS

### ● SYSTEM AND SUBSYSTEM ASSESSMENT -

#### CABLE EXCITATION

- CHANGING MAGNETIC FIELD IN A COUPLING TRANSFORMER
- TRANSVERSE ELECTROMAGNETIC WAVES GENERATED ON PARALLEL-PLATE TRANSMISSION LINES

### ● INDIVIDUAL UNIT ASSESSMENT -

#### INTERFACE CIRCUIT INJECTION

- DIRECT APPLICATION OF TRANSIENT WAVEFORMS TO PIN CONNECTIONS

## RESEARCH OBJECTIVES

### ● SHORT RANGE

- DEVELOP A METHODOLOGY TO TEST A DIGITAL SYSTEM FOR UPSETS

### ● LONG RANGE

- CHARACTERIZE UPSET PHENOMENA
- DEVELOP DIGITAL FAULT SIGNATURES THAT MODEL UPSETS
  - DIAGNOSTIC EMULATION
  - UPSET VULNERABILITY ASSESSMENT

## UPSET TEST CRITERIA

- CHOOSE A CANDIDATE PROCESSOR/CONTROLLER
  
- INJECT TRANSIENT SIGNALS RANDOMLY
  - ENHANCE SIMULATION
  - AVOID SYNCHRONIZATION
  
- IDENTIFY PROCESSOR'S INTERNAL STATE WHEN INJECTION OCCURS
  - DETERMINE IF UPSET OCCURS INDEPENDENTLY OF PROCESSING STATE
  
- VARY THE TRANSIENT SIGNAL INJECTION POINT
  - DETERMINE IF UPSET SUSCEPTIBILITY IS UNIFORM THROUGHOUT THE PROCESSING SYSTEM
  
- OBTAIN BIT PATTERNS
  - DEVELOP FAULT SIGNATURES

### CANDIDATE PROCESSOR/CONTROLLER

INTEL  $\mu$ P UNIT -

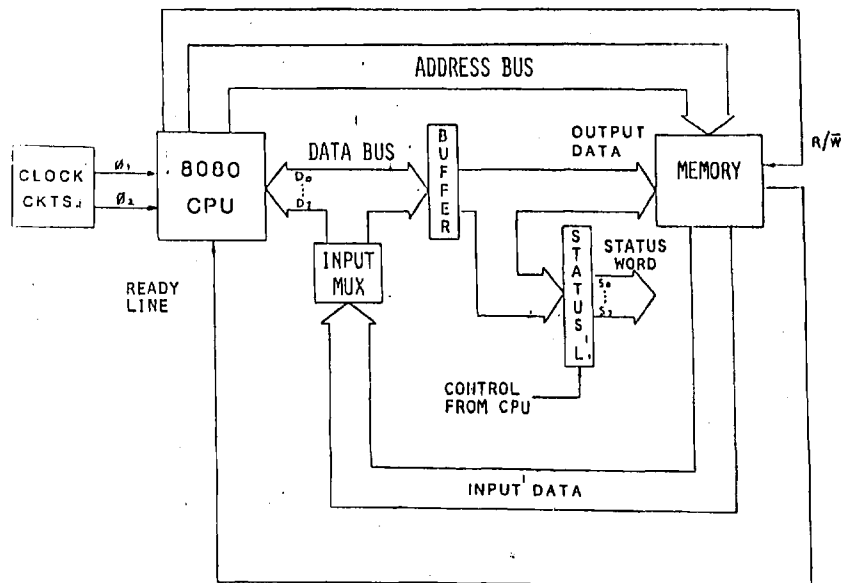

## PROGRAMMING HIERARCHY

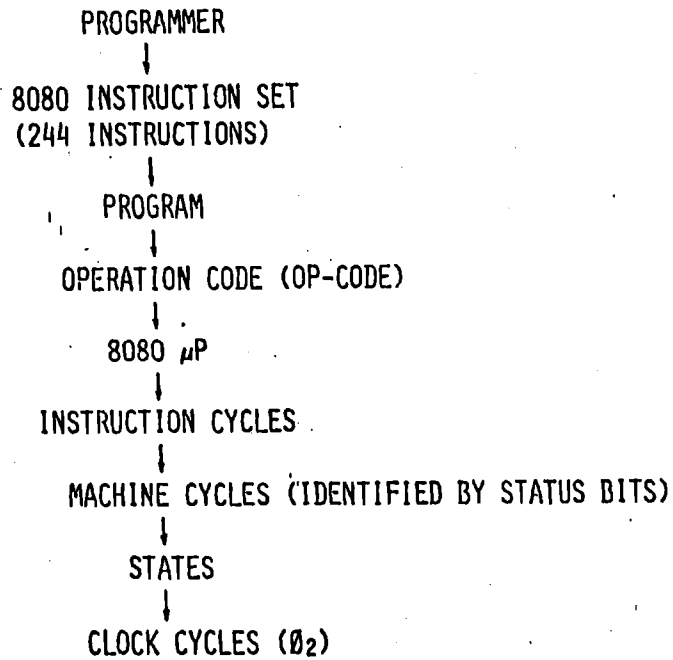

### MICROPROCESSOR MACHINE CYCLES

<u>TYPE OF MACHINE</u> <u>CYCLE</u>	<u>STATUS BITS</u>								<u>NO. OF CLOCK CYCLES</u>
	SZ	S6	S5	S4	S3	S2	S1	S0	
INSTRUCTION FETCH	1	0	1	0	0	0	1	0	4 OR 5
MEMORY READ	1	0	0	0	0	0	1	0	3
MEMORY WRITE	0	0	0	0	0	0	0	0	3 OR 4
STACK READ	1	0	0	0	0	1	1	0	3
STACK WRITE	0	0	0	0	0	1	0	0	3
INPUT	0	1	0	0	0	0	1	0	3
OUTPUT	0	0	0	1	0	0	0	0	3
INTERRUPT	0	0	1	0	0	0	1	1	5
HALT	1	0	0	0	1	0	1	0	3x
INTERRUPT WHILE HALT	0	0	1	0	1	0	1	1	5

## UPSET TEST CONFIGURATION

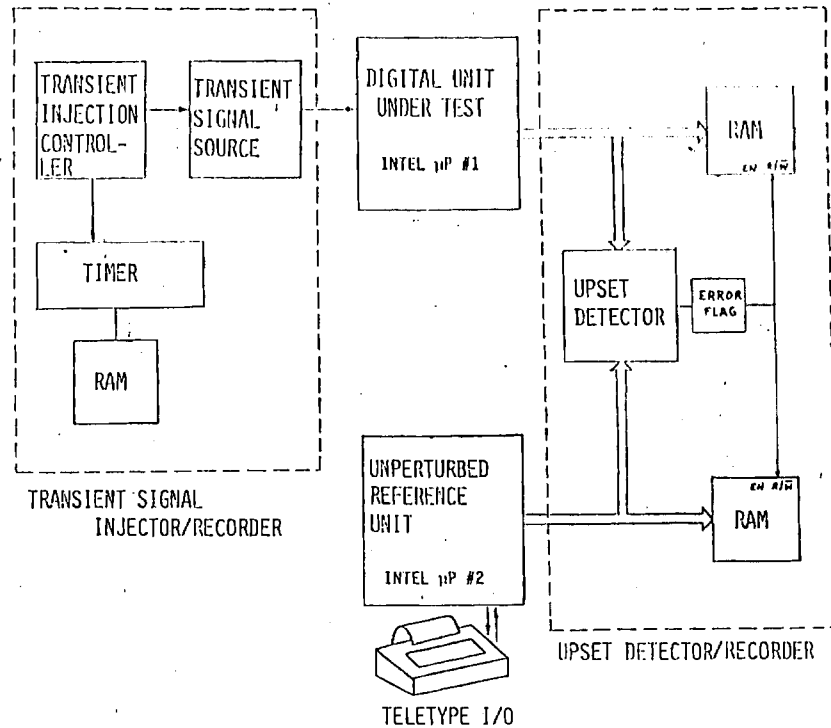

## LIGHTNING INDUCED EFFECTS WAVEFORMS

- DAMPED SINUSOID
- DECAYING EXPONENTIAL

### DAMPED SINUSOIDAL WAVEFORM

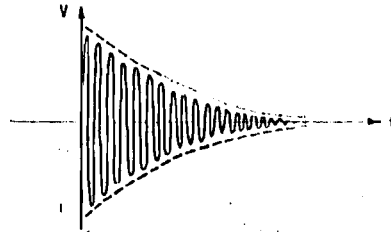

WAVEFORM	FREQUENCY	$t_r$ (ns)	$t_d$
1	1 MHz ( $\pm 20\%$ )	50 max	Amplitude decreases 25-50% in 4 cycles
2	10 MHz ( $\pm 20\%$ )	5 max	

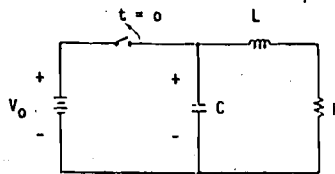

$$\frac{R}{2L} = -\frac{f n 0.5}{t_d}$$

$$C = \frac{1}{L \left[ 4\pi^2 f^2 + \left( \frac{R}{2L} \right)^2 \right]}$$

1 MHz

R = 68  $\Omega$   
L = 196  $\mu\text{H}$   
C = 129 pF

10 MHz

R = 47  $\Omega$   
L = 13.5  $\mu\text{H}$   
C = 18.7 pF

### DECAYING EXPONENTIAL WAVEFORM

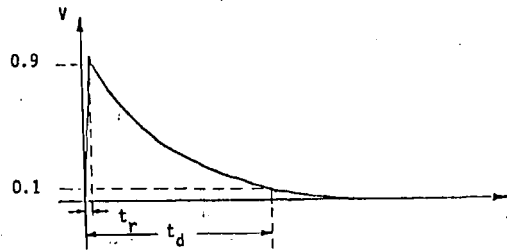

WAVEFORM	$t_r$ (ns)	$t_d$ ( $\mu\text{s}$ )
3	500 max	170 ( $\pm 20\%$ )
4	100 max	2 ( $\pm 20\%$ )

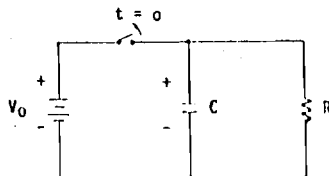

$$RC = \frac{t_d}{\ln 0.1}$$

$t_d = 170 \mu\text{s}$

R = 1.0 k $\Omega$   
C = 0.0068  $\mu\text{F}$

$t_d = 2 \mu\text{s}$

R = 1.8 k $\Omega$   
C = 470 pF

## PRELIMINARY OBSERVATIONS

- UPSET HAS BEEN INDUCED AND OBSERVED IN THE LABORATORY
  - UPSET DOES NOT OCCUR AFTER EACH TRANSIENT SIGNAL INJECTION
    - IMPLIES CORRELATION BETWEEN UPSET AND PROCESSING STATE
  
- NORMAL FUNCTION IS RESTORED BY RESETTING AND/OR REPROGRAMMING THE SYSTEM
  
- STATUS BIT SEQUENCES HAVE BEEN RECORDED THAT DO NOT CORRESPOND TO AN 8080 MACHINE CYCLE
  - IMPLIES UNDEFINED PROCESSING STATES BEING ENTERED

## FUTURE PLANS

- COMPLETE THE FOLLOWING UPSET TEST MATRIX

PIN LEVEL- PP CHIP	WAVEFORM 1	DATA BUS LINES
	WAVEFORM 2	ADDRESS BUS LINES
CONNECTOR	WAVEFORM 3	CONTROL LINES
LEVEL-	WAVEFORM 4	-----
CPU CARD		I/O LINES

- PERFORM A STATISTICAL ANALYSIS OF THE TIME DATA TO RELATE UPSET TO
  - INTERNAL STATE OF THE CANDIDATE PROCESSOR
  - TRANSIENT SIGNAL INJECTION POINT
  
- UTILIZE A SOFTWARE SIMULATION APPROACH TO DEVELOP FAULT SIGNATURES FROM THE STATUS BYTE DATA

DIAGNOSTIC EMULATION ANALYSIS--NEED AND TECHNIQUE

by

Mr. Gerard E. Migneault

Langley Research Center  
National Aeronautics and Space Administration

A brief description of the problem of determining failure modes will clarify the usefulness of emulation. The discussion will cover the relationship of complexity, definitional flaws, specific software dependent behavior and lumped parameter analytical models. Deterministic and stochastic application possibilities of emulation will be identified, as will implementation details — at the level of a conceptual scheme and in terms of supporting components. A sample application will be described. Future possible directions will be identified.

## CHARACTERISTICS OF FAULT TOLERANCE

- REDUNDANCY
  - ERROR DETECTION
  - CONTINUED OPERATION  
-- RECOVERY
  - INCREASED COMPLEXITY
- 
- SAFETY REQUIREMENT IMPLIES PROBABILITY OF SYSTEM FAILURE  
IN 10-HOUR FLIGHT LESS THAN ABOUT  $10^{-9}$
  - FAULT INTOLERANT SYSTEM  
WORST COMPONENT/DEVICE  
MTTF  $\sim 10^{10}$  HOURS  
NOT FEASIBLE TODAY
  - SYSTEM MUST TOLERATE FAULTS AND BE MAINTAINED

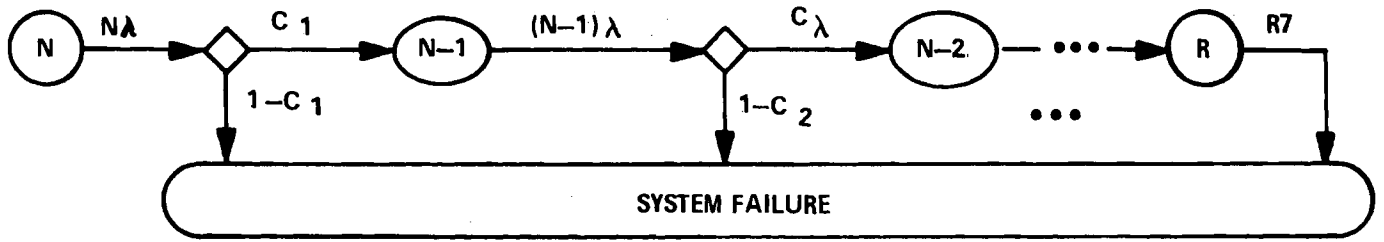

$$\frac{\text{SYSTEM MTF}}{\text{DEVICE MTF}} = \sum_{j=R}^N \frac{a^{N-j}}{j}$$

$$a = 1, \alpha_k = \prod_{k=1}^j C_k$$

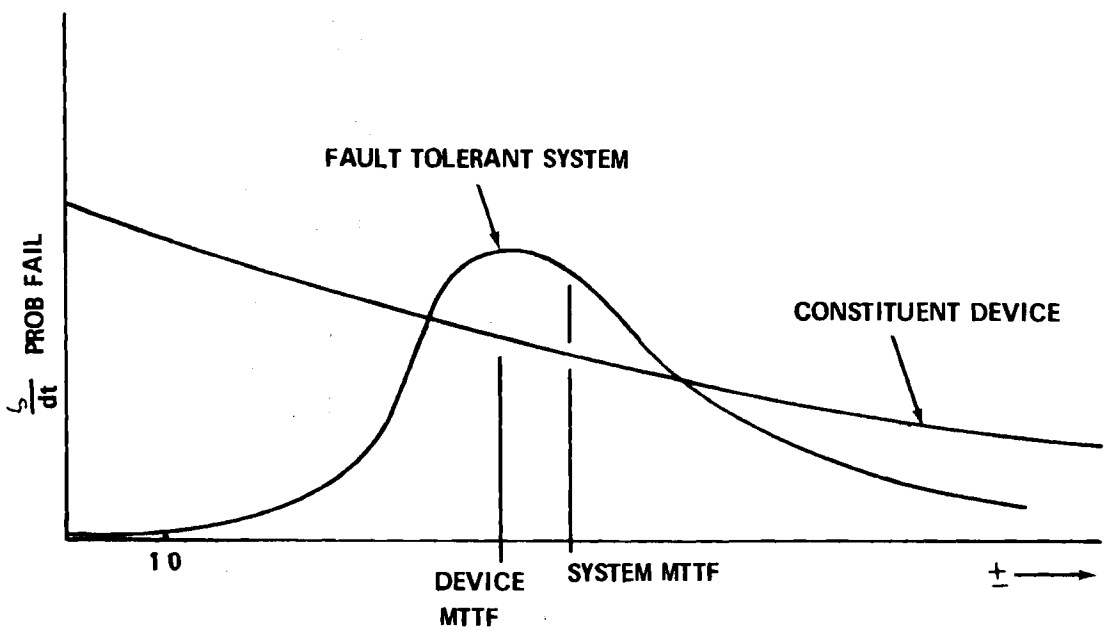

### MAINTAINED FAULT TOLERANT SYSTEM

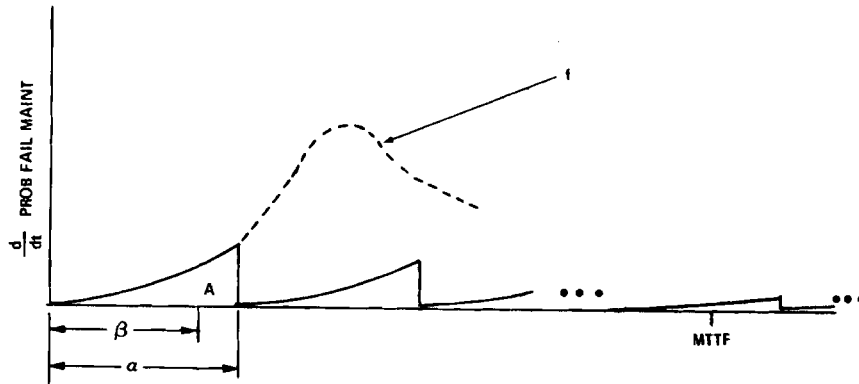

•  $MTTF_{MAINT} = \frac{a}{A} + \beta - a$   
 ~ 10 10 HOURS

$A = \int_0^a f(t)$

$\beta = \int_0^a t f(t)$

•  $MTTR_{EPAIR} \rightarrow \frac{DEVICE\ MTTF}{No.\ OF\ DEVICES}$

• ECONOMICS  $\rightarrow$  MULTIFUNCTION DEVICES

• MORE COMPLEXITY

### TOLERANCE OF DEFINITIONAL FLAWS SOFTWARE PRIME CULPRIT

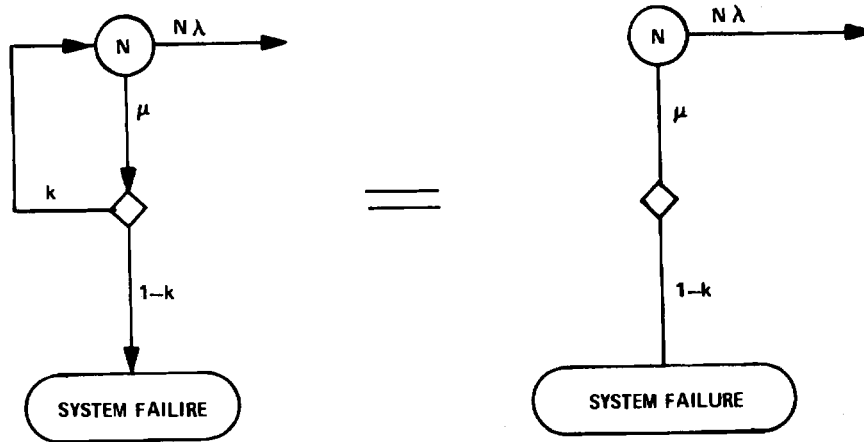

### TOLERANCE OF DEFINITIONAL FLAWS

SOFTWARE PRIME CULPRIT

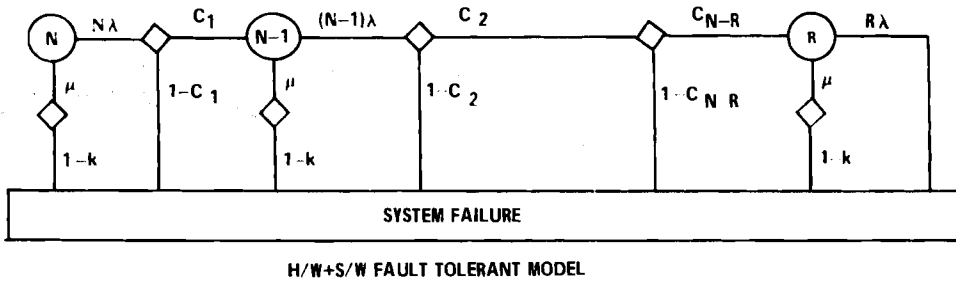

• ANALYTICAL SOLUTION TECHNIQUE

$$\text{PROB FAIL} = 1 - e^{-[N\lambda + \mu(1-k)]t} \sum_{l=0}^{N-R} \alpha_l \binom{N}{l} \left( \frac{\mu}{\lambda} \right)^l$$

• BUT

$$0.999999 < C_1 \leq 1$$

$$0.9999 < C_2 \leq 1$$

$$0 \leq \mu(1-k) \leq 0.000000001$$

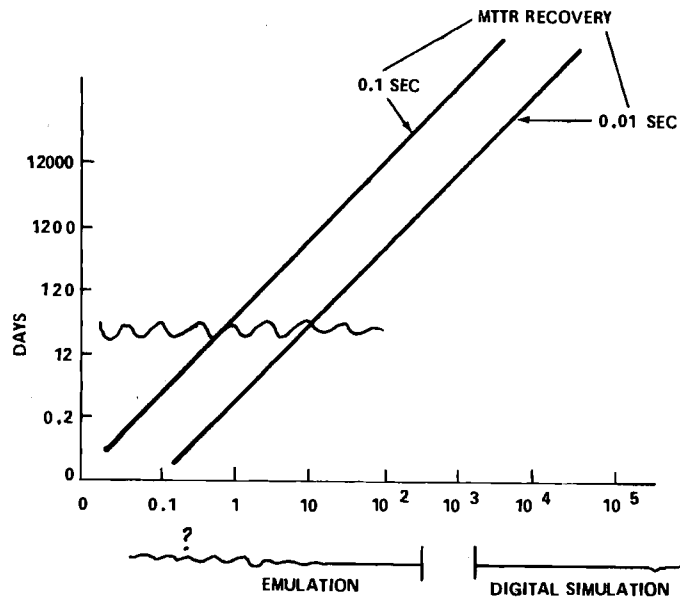

TEST DURATION FOR  $10^7$   
 FAULT INSERTIONS FOR  
 ~ 2000 GATE EQUIVALENTS CPU  
 WITH ARBITRARY MEMORY  
 AND SOFTWARE

## OBJECTIVE

DEVELOPMENT AND SPECIFICATION OF AN EMULATION TECHNIQUE FOR GENERATING STATISTICALLY SIGNIFICANT QUANTITIES OF FAILURE MODES EFFECTS DATA OF HIGHLY RELIABLE COMPUTER SYSTEMS

## JUSTIFICATION

- IN HIGHLY RELIABLE, FAULT TOLERANT SYSTEMS SYSTEM FAILURE MODES DUE TO DESIGN FLAWS BECOME SIGNIFICANT - PERHAPS DOMINANT
- CREDIBILITY OF ANALYTICAL RELIABILITY MODELS IS DEPENDENT UPON AMOUNT OF DATA FROM WHICH INPUT PARAMETERS ARE DERIVED
- HIGH RELIABILITY ( $10^{-9}$ ) OF SYSTEMS BEING ANALYZED PRECLUDES USE/LIFETIME TESTING OF ACTUAL SYSTEMS BECAUSE OF INORDINATELY LONG MTTF's
- NO OTHER MEANS IDENTIFIED TO ACQUIRE SUFFICIENT DATA FOR THE ABOVE.

## TECHNICAL APPROACH

- DEVELOPMENT OF FAST EMULATION ALGORITHMS CAPABLE OF SUPPORTING FAULT INSERTION
  - GATE LOGIC LEVEL
  - HYBRID LEVELS
    - GATE/CHIP/REGISTER/INSTRUCTION COMBINATIONS
- IMPLEMENTATION OF ALGORITHMS IN A HORIZONTALLY MICROPROGRAMMABLE COMPUTER AS AN ALGORITHM TEST BED WITH OPERATIONS SYSTEMS
- DEVELOPMENT AND SPECIFICATION OF NEEDED SUPPORT CAPABILITIES
  - META COMPILERS/ASSEMBLERS
  - DATA RECORDING CAPABILITIES
  - RUN TIME CONTROL FUNCTIONS
  - FAULT TABLE GENERATORS
  - H/W DESCRIPTION TRANSLATOR
  - ENVIRONMENT SIMULATOR/INTERFACING
  - DATA POST PROCESSORS
  - OPERATOR GRAPHICS

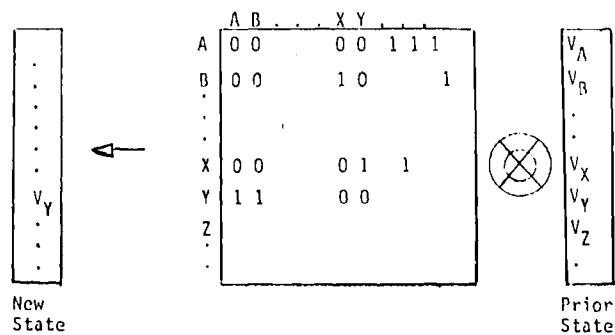
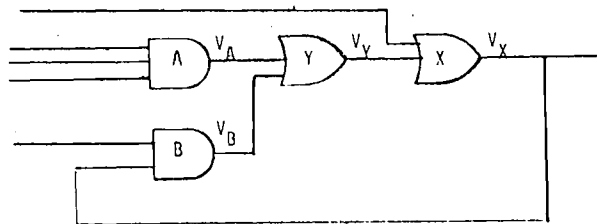
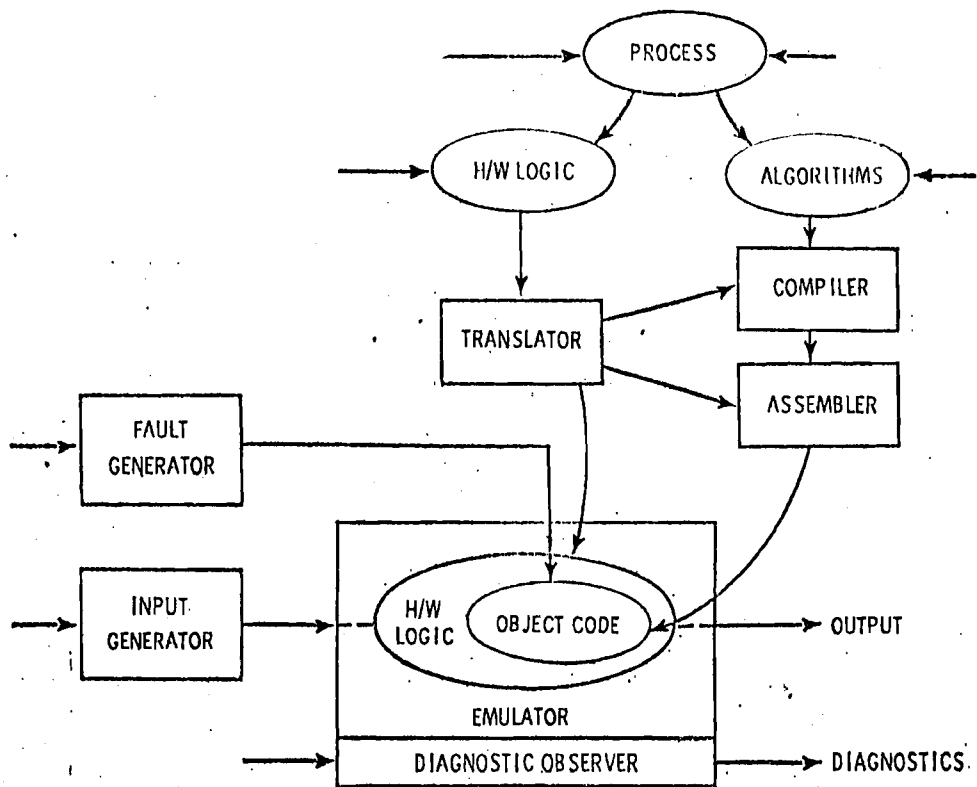

CONCEPTUAL EMULATION SCHEME

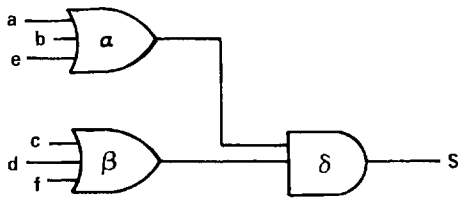
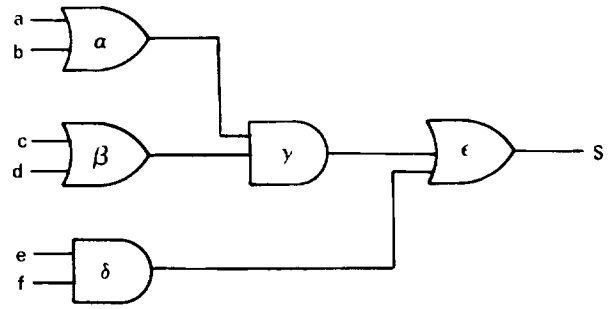
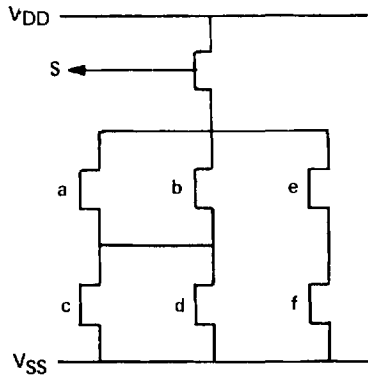

	a	b	c	d	e	f	$\alpha$	$\beta$	$\gamma$	$\delta$	$\epsilon$
$\alpha$	1	1	0	0	0	0	0	0	0	0	0
$\beta$	0	0	1	1	0	0	0	0	0	0	0
$\gamma$	0	0	0	0	0	0	1	1	0	0	0
S	0	0	0	0	1	1	0	0	0	0	0
$\epsilon$	0	0	0	0	0	0	0	0	1	1	0
S	0	0	0	0	0	0	0	0	0	0	1

### SAMPLE LATENT FAULT ANALYSIS

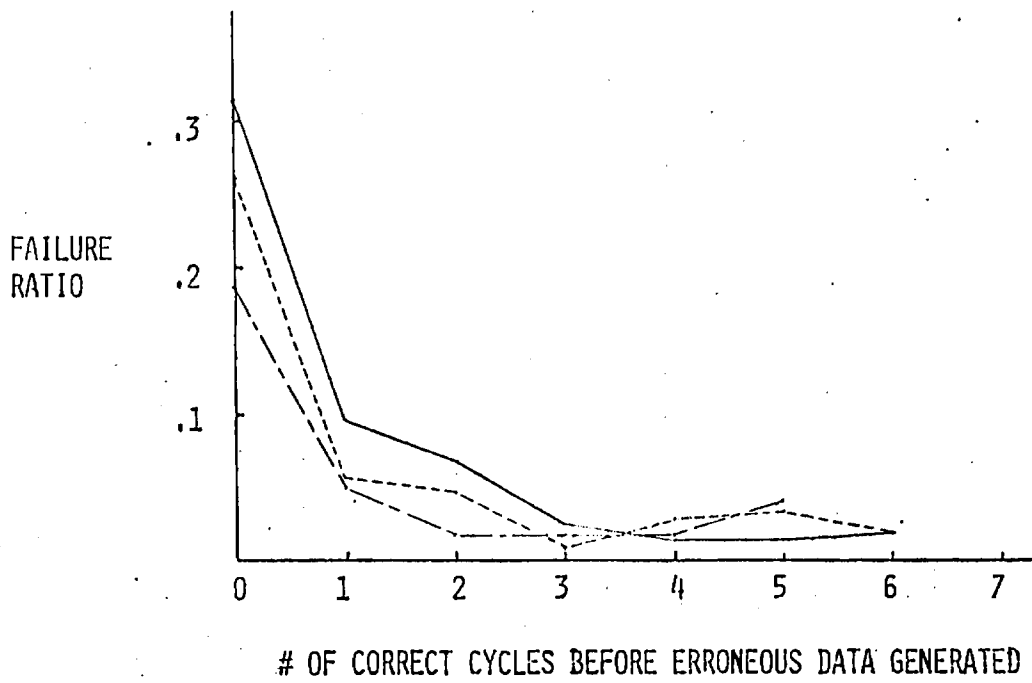

## DIAGNOSTIC EMULATION APPLICATIONS

### DETERMINISTIC:

- HARDWARE LOGIC DESIGN ANALYSIS.
- SOFTWARE DESIGN ANALYSIS.
- SYSTEM (H/W & S/W) EFFICIENCY/MISMATCH ANALYSIS.
- H/W/S/W/SYSTEM FAILURE MODES & EFFECTS ANALYSIS
- SYSTEM PERFORMANCE ANALYSIS IN A SIMULATED MISSION

## DIAGNOSTIC EMULATION APPLICATIONS

### STATISTICAL:

- LATENT FAULT ANALYSIS AND MODELING.
- COVERAGE DETERMINATION AND MODELING.
- TRANSIENT FAULT ANALYSIS.



DIGITAL SYSTEM HARDWARE DESCRIPTION TECHNIQUE USED IN EMULATION

by

Mr. Robert M. Thomas, Jr.

Langley Research Center  
National Aeronautics and Space Administration

A technique to translate a digital circuit description into the form required to emulate the circuit at the gate and flip-flop level is described. This technique, implemented as computer programs, takes as input a description of the integrated circuit and translates the description into tables for the emulation. Integrated circuit description language is described.

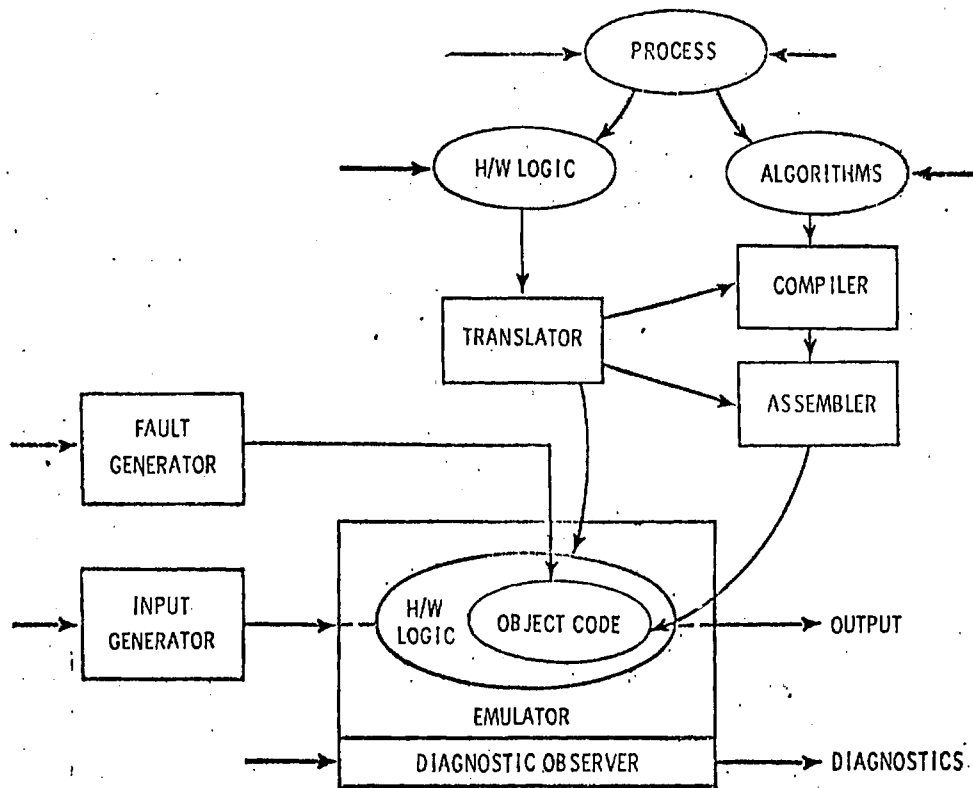

## OUTLINE

- HARDWARE DESCRIPTION LANGUAGE
- TRANSLATION
- FAULT GENERATION AND INSERTION

## HARDWARE DESCRIPTION LANGUAGE

SYSTEMATIC RULES FOR EXPRESSING HARDWARE LOGIC  
IN A FORM USABLE BY THE TRANSLATOR.

### SOURCE OF INFORMATION

#### SCHEMATICS

- INTEGRATED CIRCUIT TYPES
- INTERCONNECTIONS
- NAMES OF EACH IC

#### INTEGRATED CIRCUIT DATA SHEETS

- GATE/FLIP-FLOP MODELS

## HARDWARE DESCRIPTION LANGUAGE

### LANGUAGE ELEMENTS

GATE TYPES: AND, OR, NOT, NAND, NOR, EXCLUSIVE OR,  
EXCLUSIVE NOR

FLIP-FLOP TYPES: D, J-K, R-S, T

INTEGRATED CIRCUIT  
IDENTIFIERS: ALPHA-NUMERIC

INTEGRATED CIRCUIT  
CONNECTIONS: PIN TO PIN

# CHIP DESCRIPTION

```

$ CHIP DEFINITION $
TYPE !
POWER !
DESCRIPTION !
UNUSED PINS !
FUNCTIONS !
G-S =
G-A =
G-R =
G-C =
G-A' =
G-B' =
G-C' =
G-D 0 =
G-D 1 =
G-D 2 =
G-D 3 =
G-D 4 =
G-D 5 =
G-D 6 =
G-D 7 =
G-W (P-6) =
G-Y (P-5) =
END CHIP $

```

## LATCHED PARALLEL TO SERIAL CONVERTER SCHEMATIC

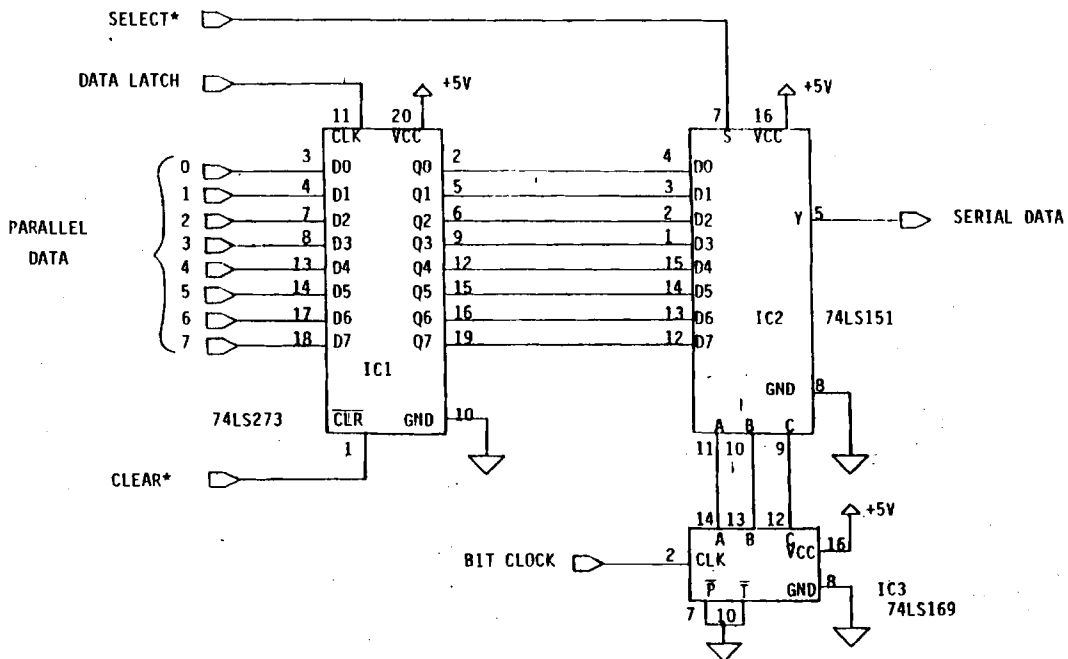

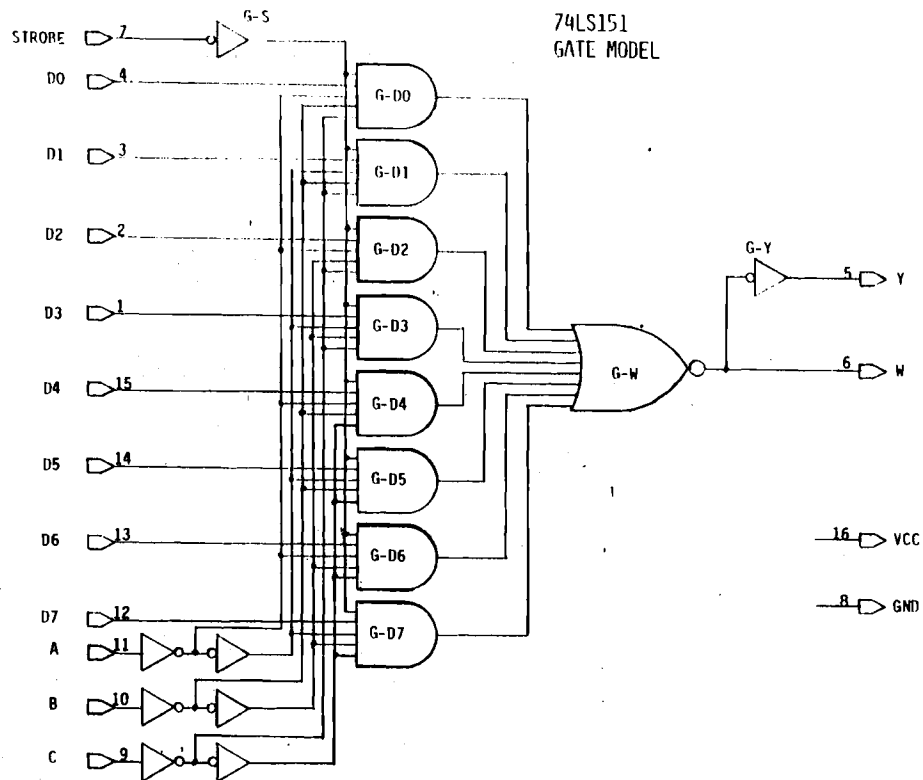

### CHIP DESCRIPTION FOR 74LS151

```

$ CHIP DEFINITION $
TYPE : SN54LS151
POWER : VCC = P-16, GND = P-8
DESCRIPTION : ONE OF EIGHT DATA SELECTORS MULTIPLEXERS.
UNUSED PINS : NONE
FUNCTIONS :
  G-S = NOT(P-7)
  G-A = AND(P-11)
  G-B = AND(P-10)
  G-C = AND(P-9)
  G-A' = NOT(G-A)
  G-B' = NOT(G-B)
  G-C' = NOT(G-C)
  G-D0 = AND(G-S, P-4, G-A', G-B', G-C')
  G-D1 = AND(G-S, P-3, G-A, G-B', G-C')
  G-D2 = AND(G-S, P-2, G-A', G-B, G-C')
  G-D3 = AND(G-S, P-1, G-A, G-B, G-C')
  G-D4 = AND(G-S, P-15, G-A', G-B', G-C)
  G-D5 = AND(G-S, P-14, G-A, G-B', G-C)
  G-D6 = AND(G-S, P-13, G-A', G-B, G-C)
  G-D7 = AND(G-S, P-12, G-A, G-B, G-C)
  G-W(P-6) = NOR(G-D0, G-D1, G-D2, G-D3, G-D4, G-D5, G-D6, G-D7)
  G-Y(P-5) = NOT(G-W)
$ END CHIP $

```

## INTEGRATED CIRCUIT NAME TABLE

<u>NAME</u>	<u>IC TYPE</u>
IC 1	74LS273
IC 2	74LS151
IC 3	74LS169

## INTEGRATED CIRCUIT CONNECTION TABLE

OUTPUT	DESTINATION	SIGNAL NAME (OPTIONAL)
IC 1-2	IC 2-4	
IC 1-5	IC 2-3	
IC 1-6	IC 2-2	
IC 1-9	IC 2-15	
IC 1-12	IC 2-14	
IC 1-15	IC 2-13	
IC 1-16	IC 2-12	
IC 1-19		
IC 2-5	OUTPUT CONNECTOR	SERIAL DATA
IC 3-14	IC 2-11	
IC 3-13	IC 2-10	
IC 3-12	IC 2-9	

## TRANSLATION PROCESS



## TRANSLATION PROCESS

CONVERT A PSEUDO ENGLISH CIRCUIT DESCRIPTION TO A  
PACKED BINARY ENCODED FORM REQUIRED BY THE EMULATION  
ALGORITHM

REJECT DESCRIPTION THAT DOES NOT FOLLOW PRECISELY  
THE HARDWARE DESCRIPTION LANGUAGE RULES

### EMULATION MATRIX

		SOURCE							
		G-S	G-A	G-B	G-C	G-A'	G-B'	G-C'	G-DO . . .
DESTINATION	G-S								
	G-A								
	G-B								
	G-C								
	G-A'		x						
	G-B'			x					
	G-C'								
	G-DO	x				x	x	x	
.									
.									
.									

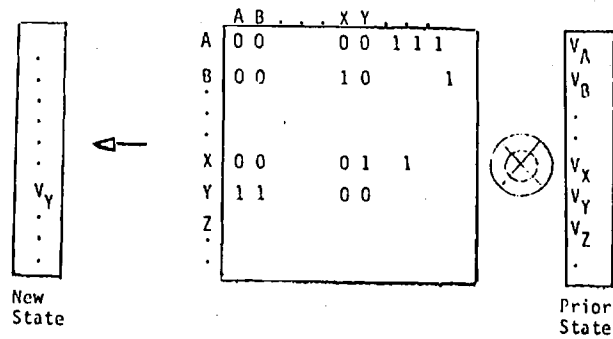
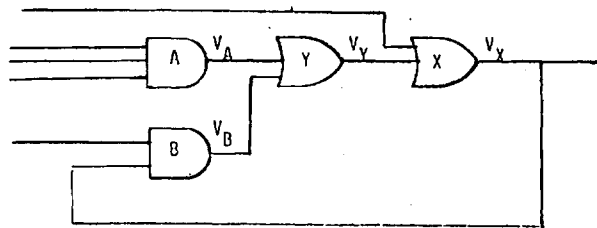

### CONCEPTUAL EMULATION SCHEME

## FAULT GENERATION AND INSERTION

### FAULT SELECTION

- MANUAL - SELECTED BY EXPERIMENTER
- AUTOMATIC - RANDOMLY SELECTED

### FAULT INSERTION

- MODIFY EMULATION MATRIX TO REFLECT FAULT

### FAULT OCCURRENCE

- INFORMATION TO EMULATION ALGORITHM AS TO WHEN FAULT OCCURS

## SUMMARY

### DEVELOPING THE TOOLS TO SUPPORT GATE/FLIP-FLOP LEVEL EMULATION OF DIGITAL COMPUTERS

- HARDWARE DESCRIPTION LANGUAGE
- TRANSLATOR PROGRAM
- FAULT GENERATOR PROGRAMS



THE NEED FOR TRANSIENT DATA IN A  
CARE III RELIABILITY ANALYSIS

by

Mr. Salvatore J. Bavuso

Langley Research Center  
National Aeronautics and Space Administration

The recently developed CARE III (Computer-Aided Reliability Estimation) computer program incorporates a transient/intermittent fault model that is mathematically accurate in contrast to many existing reliability evaluator programs which employ approximations for the transient/intermittent model. The CARE III transient/intermittent model will be discussed and compared to existing approximating models. Computational complexity arising from the use of the CARE III transient/intermittent model will also be addressed.

# ADVANCED RELIABILITY ASSESSMENT TECHNIQUES

OBJECTIVE: DEVELOP A CAPABILITY TO ASSESS THE RELIABILITY OF ANY FAULT-TOLERANT COMPUTER-BASED SYSTEM, INCLUDING EXECUTIVE SOFTWARE

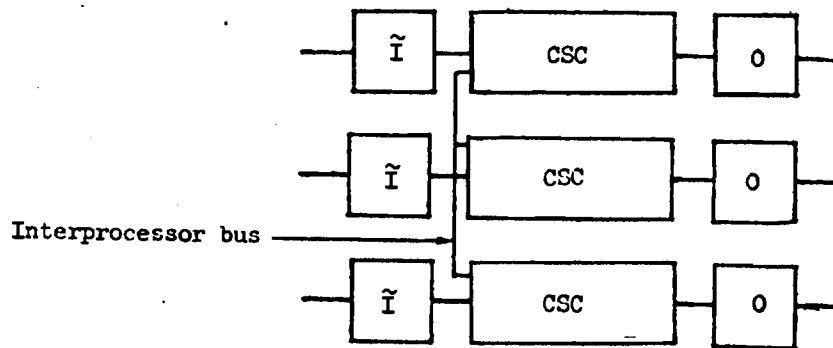

**Triplex computer architecture.**

$$S_1 = \bar{X}_1 X_2 X_3 + X_1 \bar{X}_2 X_3 + X_1 X_2 \bar{X}_3$$

(Two out of three channels operational)

$$S_0 = X_1 X_2 X_3$$

(All channels operational)

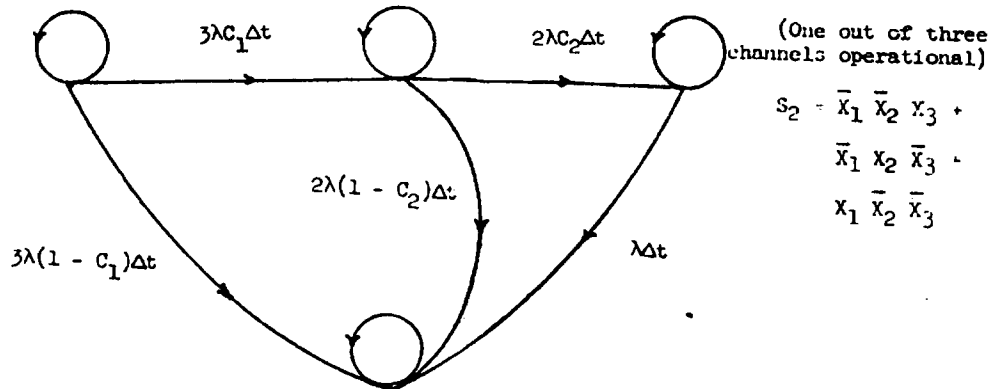

$$S_2 = \bar{X}_1 \bar{X}_2 X_3 + \bar{X}_1 X_2 \bar{X}_3 + X_1 \bar{X}_2 \bar{X}_3$$

$$S_3 = \bar{X}_1 \bar{X}_2 \bar{X}_3 + \bar{X}_1 X_2 \bar{X}_3 + X_1 \bar{X}_2 \bar{X}_3$$

(System failure)

**Markov state space model of triplex channel RCS.**

$$P_0(t + \Delta t) = P_0(t) - 3\lambda C_1 \Delta t P_0(t) - 3\lambda(1 - C_1) \Delta t P_0(t)$$

$$\lim_{\Delta t \rightarrow 0} \frac{P_0(t + \Delta t) - P_0(t)}{\Delta t} = \frac{dP_0(t)}{dt} = -3\lambda P_0(t)$$

$$\frac{dP_0(t)}{dt} = -3\lambda P_0(t)$$

$$\frac{dP_1(t)}{dt} = 3\lambda C_1 P_0(t) - 2\lambda P_1(t)$$

$$\frac{dP_2(t)}{dt} = 2\lambda C_2 P_1(t) - \lambda P_2(t)$$

$$\frac{dP_3(t)}{dt} = 3\lambda(1 - C_1)P_0(t) + 2\lambda(1 - C_2)P_1(t) + \lambda P_2(t)$$

where  $P_0$  is the probability of the system being in state  $S_0$ , that is

$$P_0 = P(S_0) \quad P_1 = P(S_1) \quad P_2 = P(S_2) \quad P_3 = P(S_3)$$

and the initial conditions are

$$P_0(0) = 1 \quad P_1(0) = P_2(0) = P_3(0) = 0$$

$$P_0(t) = e^{-3\lambda t}$$

$$P_1(t) = 3C_1(e^{-2\lambda t} - e^{-3\lambda t})$$

$$P_2(t) = 3C_1C_2(e^{-\lambda t} - 2e^{-2\lambda t} + e^{-3\lambda t})$$

$$P_3(t) = 1 - [P_0(t) + P_1(t) + P_2(t)]$$

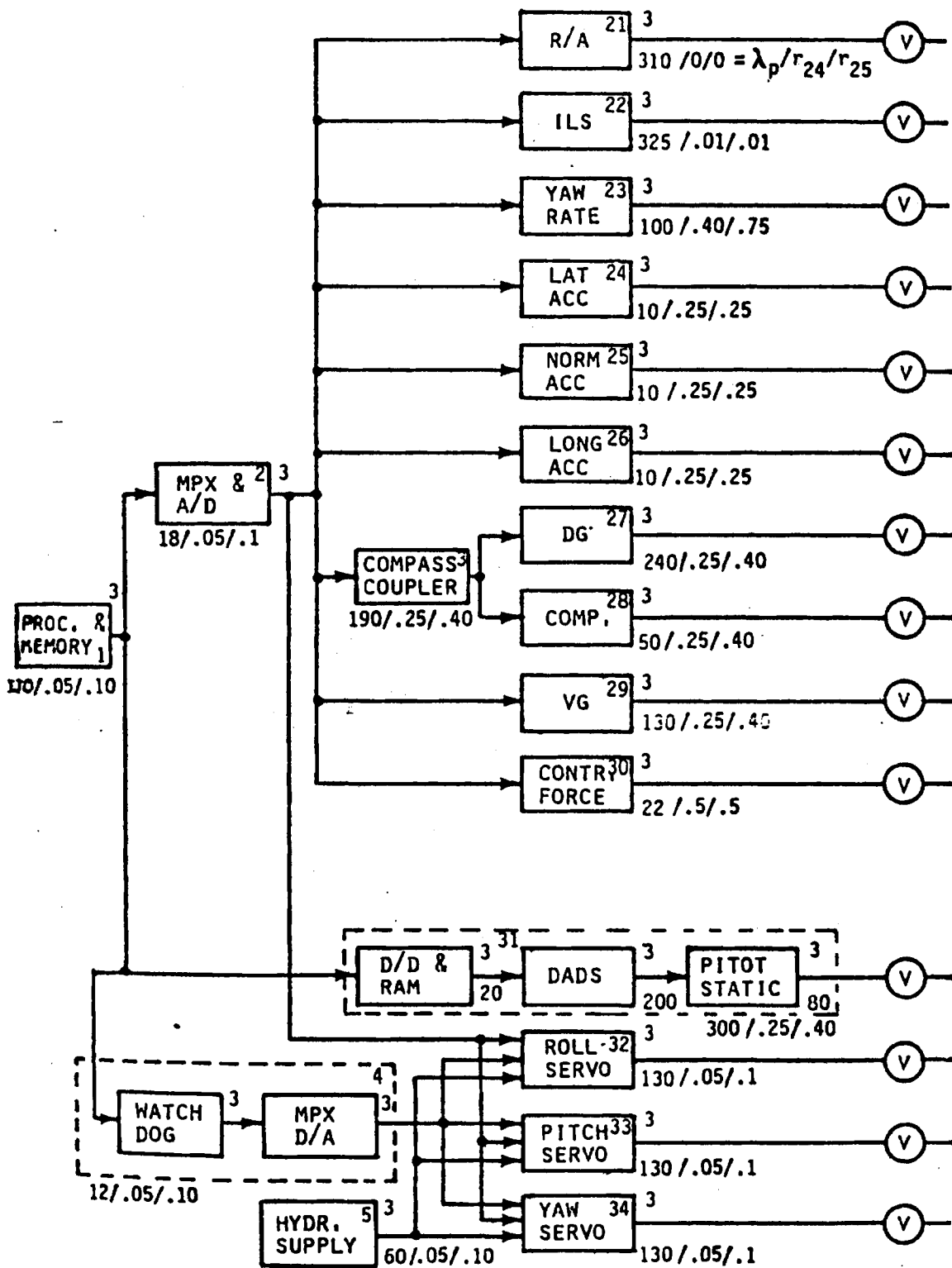

FOR CWS, DELETE R/A AND ILS

-Near-Term ARCS Dependency Tree

### DELINEATION OF HARDWARE AND SOFTWARE ANOMALIES

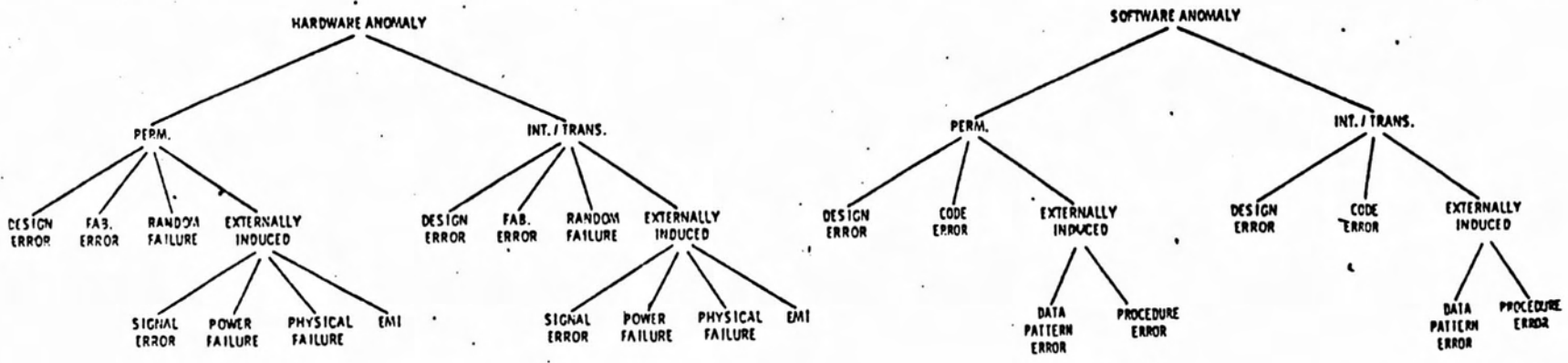

Delineation of hardware and software anomalies.

## NUMBER OF STATES NEEDED FOR A MARKOV MODEL

LET:  $n$  = NUMBER OF "COUPLED" STAGES

$k_i$  = NUMBER OF POSSIBLE FAULT TYPES IN  $i$ TH STAGE

$l_i$  = NUMBER OF POSSIBLE FAULT STATES/TYPE IN  $i$ TH STAGE

$m_i$  = NUMBER OF MODULE FAILURES THAT CAN BE TOLERATED  
IN THE  $i$ TH STAGE

THEN NUMBER OF SYSTEM STATES  $N$  IS

$$N = \prod_{i=1}^n \left[ \sum_{j=0}^{m_i} \binom{k_i l_i + j - 1}{j} \right]$$

E.g., If  $n = 4$  and  $k_i = 2$ ,  $l_i = 3$ ,  $m_i = 2$  for all  $i$ ,  $N = 614,656$

$$\text{CARE III } N = 2 \prod_{i=1}^n (m_i + 1) = 162$$

### CARE III APPROACH

- DEFINE SYSTEM STATE ONLY IN TERMS OF NUMBER OF EXISTING FAULTS
- INDEPENDENTLY EVALUATE TRANSITION PARAMETERS AS A FUNCTION OF DISTRIBUTION OF POSSIBLE FAULT TYPES AND STATES
- DETERMINE RELIABILITY USING KOLMOGOROV'S FORWARD DIFFERENTIAL EQUATIONS
- NUMBER OF STATES DRASTICALLY REDUCED;  
TRANSITION RATES NECESSARILY TIME-DEPENDENT

81 vs 614,656

# COMPUTER AIDED RELIABILITY ESTIMATION (CARE III)

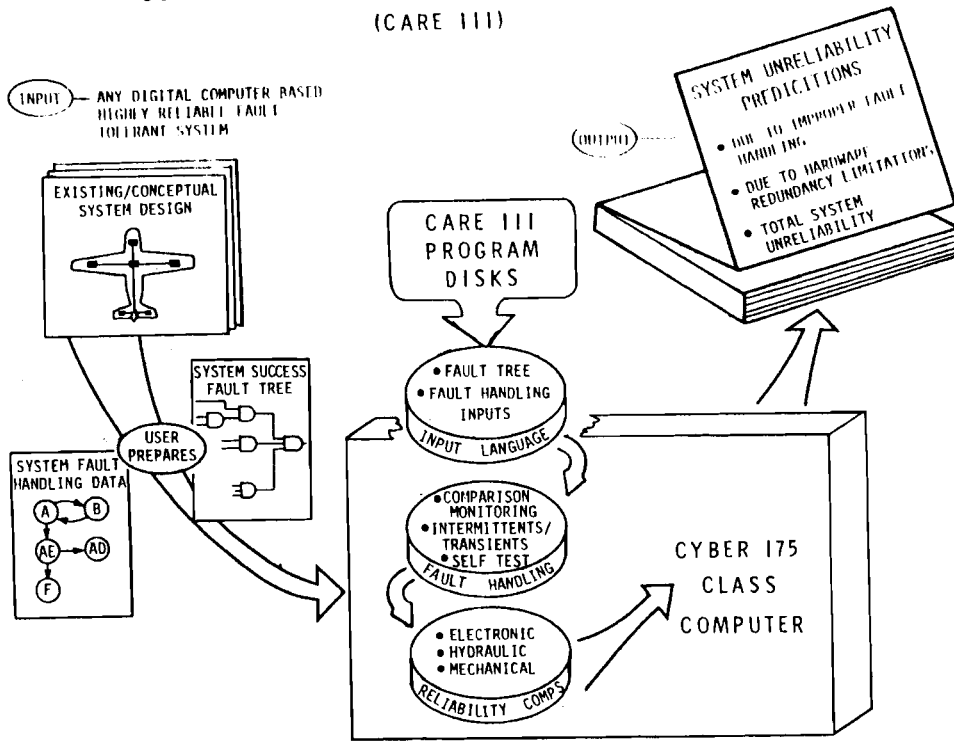

```

100- $FLTYP  NFTYPS=1,DEL=3,GE2,CUPRNT=T,DBLDF=5.0E-2,CUPL0T=TS
110- $STAGES NSTGES=2,N=10.5,M=2.2,IRLPCD=4,RLPLOT=TS
120- $FLTCAT NFCATS=2*1,JTYP(1,1)=1,JTYP(1,2)=1,
130-          RLM(1,1)=1.0E-4,RLM(1,2)=1.0E-58
140- $RNTIME FT=10.,SYSFLG=T,CPLFLG=TS
150- SIFT1 FAULT-TREE 7-1-81
160- 1 2 3 3
170- 3 0 1 2
180- SIFT1 CRITICAL-FAULT PAIRS
190- 1 15 16 18
200- 1 1 10
210- 2 11 15
220-16 2 1 2 3 4 5 6 7 8 9 10
230-17 2 11 12 13 14 15
240-18 0 16 17
    
```

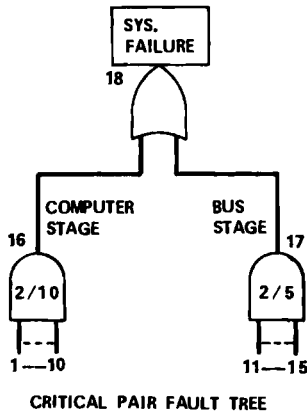
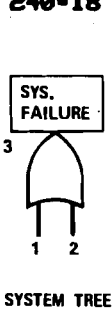

SYSTEM FAILS IF STAGE  
1 OR 2 FAILS OR A  
CRITICAL FAULT PAIR  
OCCURS.

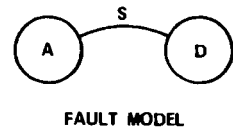

2 : : 5 BUS FORM  
A CRITICAL PAIR  
CAUSES A SYSTEM FAILURE

PERMANENT, TRANSIENT/INTERMITTENT FAULT ANALOG

	PERMANENT FAULT	TRANSIENT/INTERMITTENT FAULT
LOGICAL FAULT MODEL AFTER FAULT ARRIVAL	S-A-I/S-A-0 DETERMINISTIC: $\tau_F \leq \tau < \infty$	S-A-I/S-A-0 STOCHASTIC $\tau$ FOR DURATION OF S-A-I AND S-A-0 EXPONENTIAL: $f(t) = \alpha e^{-\alpha t}$
FAULT ARRIVAL MODEL		WEIBULL: $f(t) = w\lambda t^{w-1} e^{-\lambda t^w}$ EXPONENTIAL: $f(t) = \lambda e^{-\lambda t}$

TRANSIENT AND PERMANENT FAULTS  
CONVENTIONAL MARKOV MODEL  
2-UNIT SYSTEM

$\lambda_p$  = PERMANENT FAILURE RATE (ARRIVAL RATE)

$\lambda_T$  = TRANSIENT RATE (ARRIVAL RATE)

$1$  = PROPORTION OF TRANSIENTS THAT ARE MISTAKEN FOR PERMANENT FAILURES

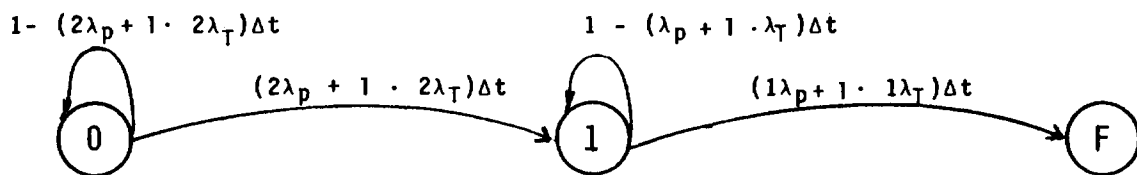

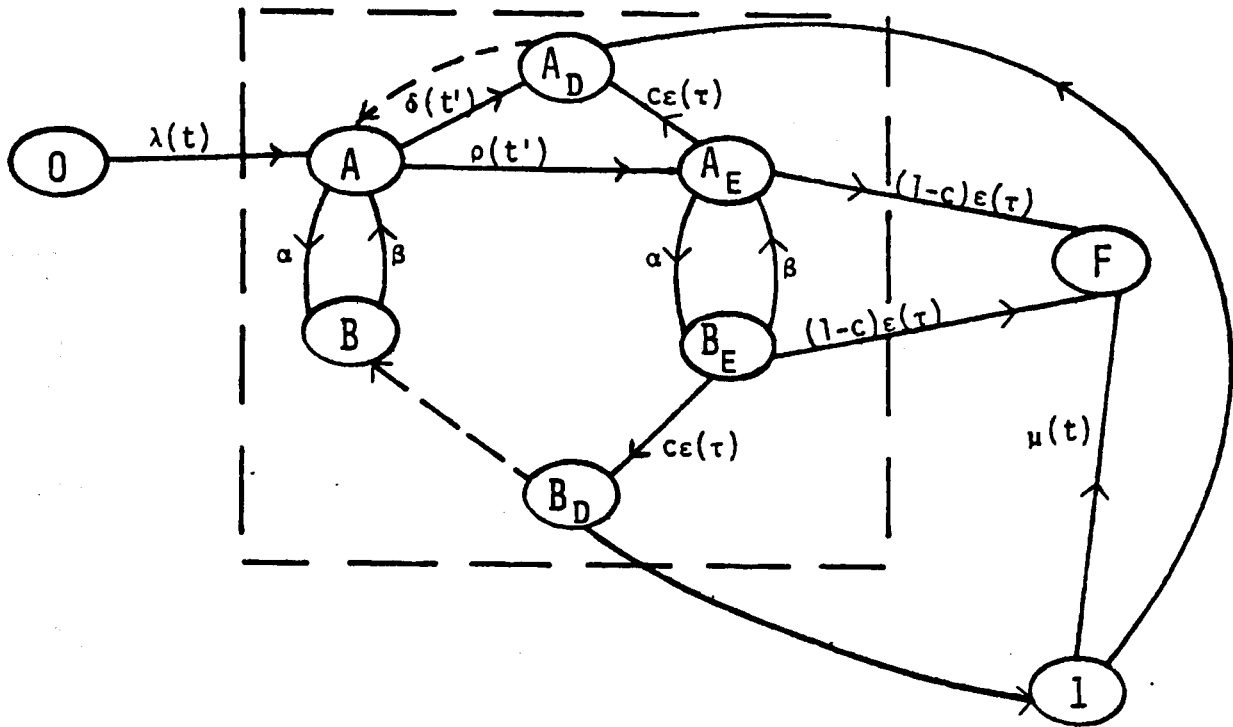

Overall reliability model of two-unit system.

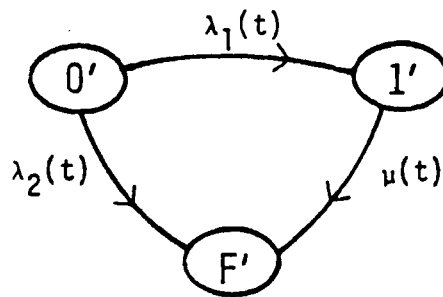

Aggregated reliability model for a two-unit system.

- System states defined by number of failed modules of each type
- Transition rates determined by averaging overall failure types and states

## SINGLE-FAULT MODEL EQUATIONS

	<u>VARIABLE</u>
$\phi(t) = \alpha e^{-\beta t} \int_0^t e^{-(\alpha-\beta)\tau} r(\tau) d(\tau) d\tau$	FEER(IT)
$P_a(t) = e^{-\alpha t} r(t) d(t) + \beta \int_0^t \phi(t-\tau) P_a(\tau) d\tau$	PA(IT)
$P_b(t) = \phi(t) + \beta \int_0^t \phi(t-\tau) P_b(\tau) d\tau$	PB1(IT)
$P_e(t) = \int_0^t e^{-\alpha\tau} \rho(\tau) d(\tau) e(t-\tau) d\tau + \beta \int_0^t \phi(t-\tau) P_e(\tau) d\tau$	PERR(IT)
$p_e(t) = e^{-\alpha t} \rho(t) d(t) + \beta \int_0^t \phi(t-\tau) p_e(\tau) d\tau$	PEAR(IT)
$p_e^-(t) = e^{-\alpha t} \delta(t) r(t) + \beta \int_0^t \phi(t-\tau) p_e^-(\tau) d\tau$	PNEAR(IT)
$P_f(t) = (1-C) \int_0^t p_e(\tau) \epsilon(t-\tau) d\tau$	PFLD(IT)
$\psi_A(t) = C \int_0^t p_e(\tau) \epsilon(t-\tau) \left( \frac{\beta + \alpha e^{-(\alpha+\beta)(t-\tau)}}{\alpha+\beta} \right) d\tau + p_e^-(t)$	PSIA(IT)
$\psi_B(t) = \frac{\alpha C}{\alpha+\beta} \int_0^t p_e(\tau) (1 - e^{-(\alpha+\beta)(t-\tau)}) \epsilon(t-\tau) d\tau$	PSIB(IT)

Double Fault Model

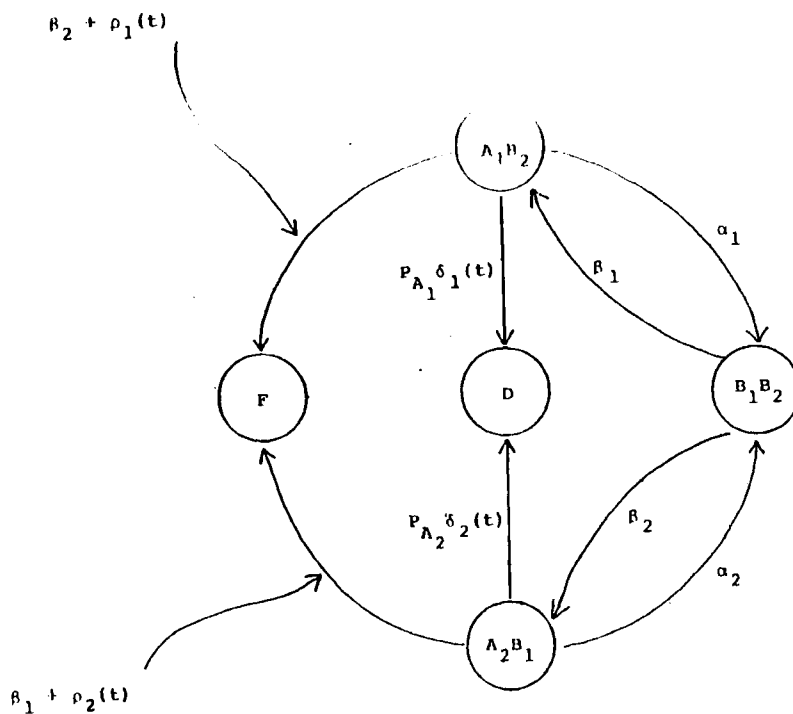

ADVANCED RELIABILITY ASSESSMENT DEVELOPMENT

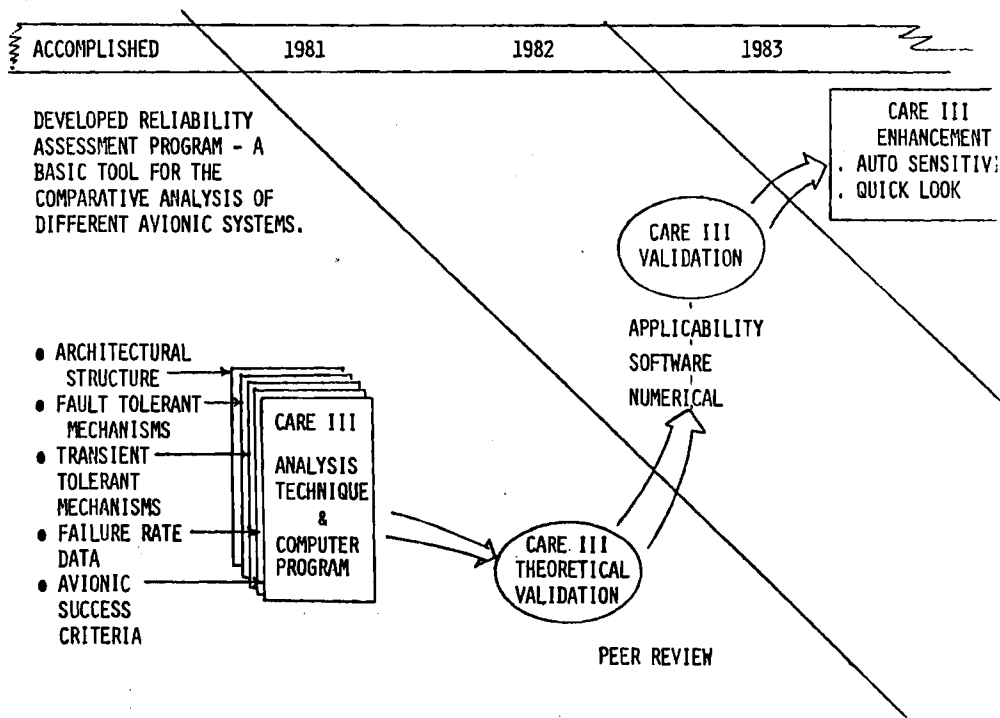

DOT/FAA  
CT-82/30 A Compendium of lightning  
effects on future aircraft  
electronic systems /  
00008667

---