

0310:10737946

CT
81
194A

TEST AND EVALUATION OF SOLID-STATE DOPPLER VERY HIGH FREQUENCY OMNIDIRECTIONAL (DVOR) DISTRIBUTOR ASSEMBLY

Wayne E. Bell

FEDERAL AVIATION ADMINISTRATION

MAR 73 1984

NATIONAL LIBRARY
OF AERONAUTICS AND SPACE



PROJECT PLAN ADDENDUM

March 1984

Prepared for
U. S. DEPARTMENT OF TRANSPORTATION
FEDERAL AVIATION ADMINISTRATION
TECHNICAL CENTER

Atlantic City Airport, New Jersey 08405

PREFACE

This document is an addendum to Project Plan "Test and Evaluation of Solid-State Doppler Very High Frequency Omnidirectional Range (DVOR) Distributor Assembly," No. DOT/FAA/CT-81/194, by Wayne Bell, dated February 1982.

TABLE OF CONTENTS

	Page
1. PROJECT DEFINITION	1
1.1 Purpose	1
1.2 Background	1
1.3 Technical Requirements	1
1.4 Test Procedures	1
2. GROUND TESTS	1
3. FLIGHT TESTS	2
4. DATA REDUCTION AND ANALYSIS	2
5. SCHEDULE	2
6. PRODUCT	2

1. PROJECT DEFINITION.

1.1 PURPOSE.

The purpose of this activity is to conduct tests with the second generation very high frequency omnidirectional range (VOR) equipment configured with a modified mechanical double sideband distributor (DSB) and 30 hertz (Hz) alternator.

1.2 BACKGROUND.

The Federal Aviation Administration (FAA) is in the process of replacing existing tube type very high frequency omnidirectional range tactical air navigational aid (VORTAC) and Doppler VOR facilities with new state-of-art solid-state equipment, referred to as second generation VOR/Doppler Very High Frequency Omnidirectional Range (DVOR). During a recent conversion several problem areas were encountered when trying to interface the mechanical distributor with the new equipment. Various solutions to these problems will be tested to determine/establish standard procedure for future DVOR conversions.

1.3 TECHNICAL REQUIREMENTS.

Ground measurements and flight tests involving variation in radiated power and near and far field phasing techniques will be conducted to determine their effects on course structure and stability. Data collection and analysis will be as per Doppler VOR Distributor Assembly (DVDA) Project Plan, No. DOT/FAA/CT-81/194, dated February 1982.

1.4 TEST PROCEDURES.

These tests will be conducted at the experimental DVOR site, building 188. The facility will be configured as a DSB Doppler (mechanical distributor) operating with the second generation VORTAC equipment. The 30 Hz amplitude modulation (AM) will be the 30 Hz direct mode of operation.

2. GROUND TESTS.

The 9960 Hz frequency modulation (FM) percent will be recorded at a radial distance of 500 and 150 feet from the center of the DVOR facility. Test setup in figure 1 will be utilized. A Yagi antenna, radiofrequency (RF) amplifier and detector will be used with monitor No. 1 and monitor No. 2 to provide a sample of the radiated signal. A Hewlett Packard model 7402 recorder will be used to record the FM percent modulation level for various phase adjustments.

Additional tests will be performed with the facility operating with a 10 to 50 watt linear amplifier in each sideband channel. The percent FM modulation will be measured/recorded at various azimuth locations around the DVOR facility.

3. FLIGHT TESTS.

Radial flights (225°, 270°, and 315°) at various altitudes with guidance provided by extended area instrumentation radar (EAIR) will be accomplished out to a distance of 40 nautical miles (nmi) to measure FM percent modulation with the station adjusted to various FM levels (see table 1). A modified flight inspection console utilizing a Bendix receiver with an oscillograph recorder will be used to obtain flight test recordings.

4. DATA REDUCTION AND ANALYSIS.

Data reduction and analysis will be in accordance with sections 4, 4.1, and 4.2 of the DVDA Project Plan.

5. SCHEDULE.

The estimated test schedule for each phase of this effort is shown in figure 2.

6. PRODUCT.

Test and evaluation support to evaluate second generation DVOR improvements. The results will be documented in a Technical Note.

TABLE 1. PLANNED FLIGHT TESTS

<u>Radials (deg)*</u>	<u>Altitude (ft/ASL)</u>	<u>Distance (nmi)</u>	<u>FM Level/Phase Adjustments (deg)</u>						
225	1,500	40	Optimum	-5.0	-10	-15	+5.0	+10	+15
225	5,999	40	Optimum	-5.0	-10	-15	+5.0	+10	+15
225	17,000	40	Optimum	-5.0	-10	-15	+5.0	+10	+15
270	1,500	40	Optimum	-5.0	-10	-15	+5.0	+10	+15
270	5,000	40	Optimum	-5.0	-10	-15	+5.0	+10	+15
270	17,000	40	Optimum	-5.0	-10	-15	+5.0	+10	+15
315	1,500	40	Optimum	-5.0	-10	-15	+5.0	+10	+15
315	5,000	40	Optimum	-5.0	-10	-15	+5.0	+10	+15
315	17,000	40	Optimum	-5.0	-10	-15	+5.0	+10	+15

*Data will be recorded on inbound and outbound radials.

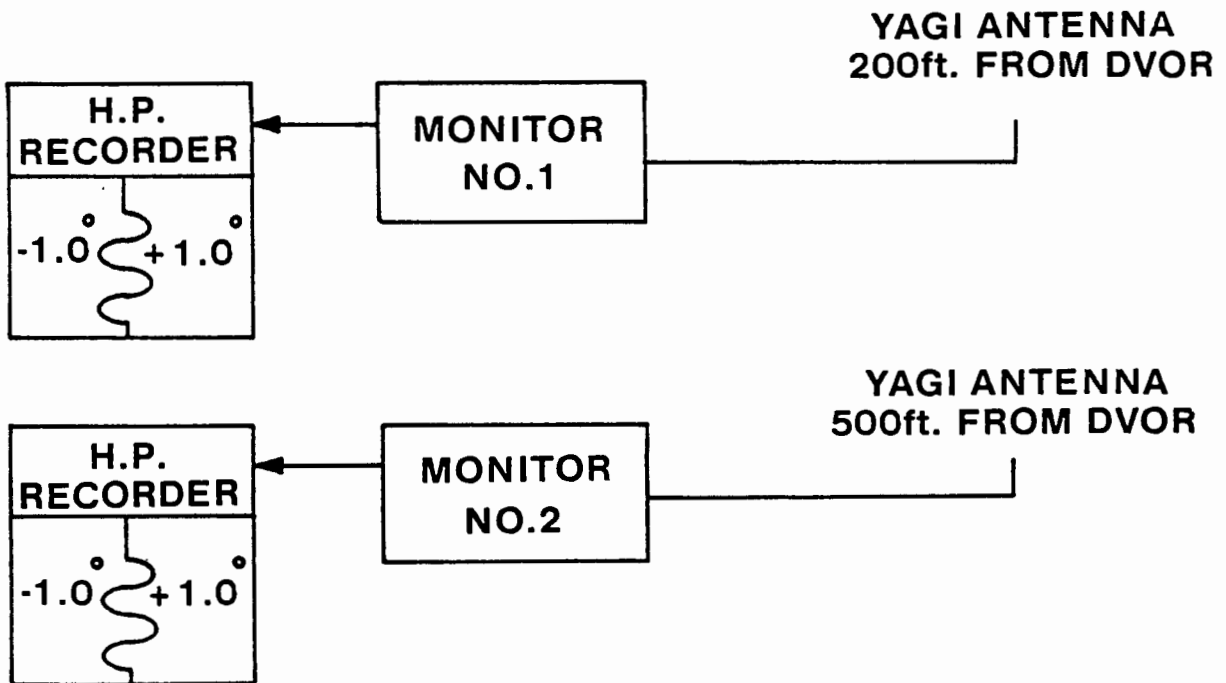
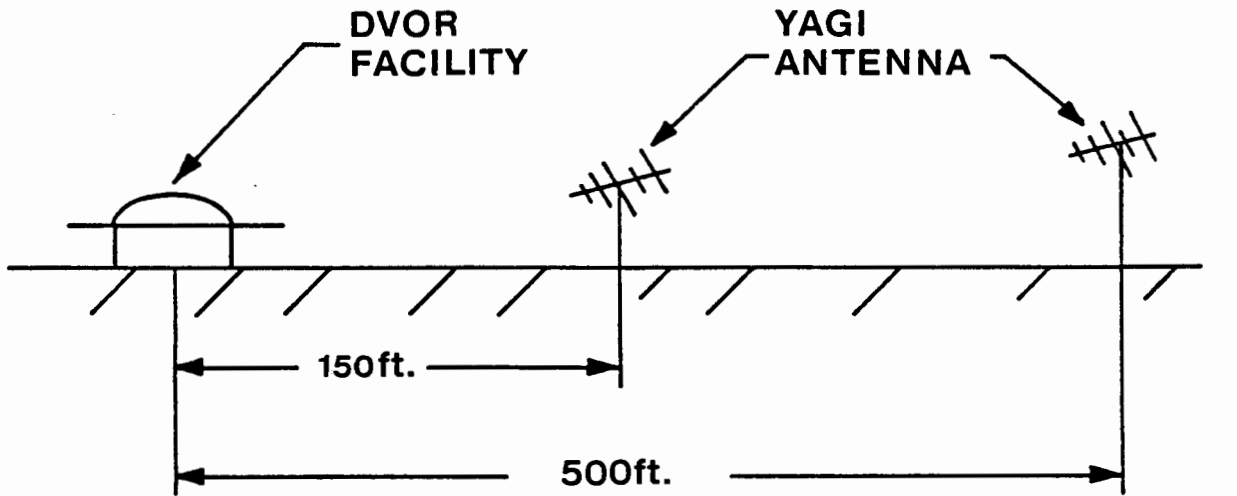

FIGURE 1. TEST SETUP TO MEASURE 9960 HZ PERCENT MODULATION

Milestone Schedule	Weeks From Project Start													
	1	2	3	4	5	6	7	8	9	10	11	12	13	14
Site Preparation	x	x	x											
Ground Tests				x	x									
Flight Tests Installation, Bldg. 188						x	x							
Power Tests								x	x					
Ground Tests										x				
Flight Tests											x			
Data Reduction and Report											x	x	x	x

FIGURE 2. SCHEDULE