

JOINT TRANSPORTATION RESEARCH PROGRAM

FHWA/IN/JTRP-2001/09

Final Report

VIRTUAL WEIGH STATION

**John Green
Andrew Nichols
Ed Allen
Luke Nuber
Jose Thomaz
Darcy Bullock
Guy Boruff
Jay Wasson
Mark Newland**

June 2002

Final Report

FHWA/IN/JTRP-2001/09

VIRTUAL WEIGH STATION

By

John G. Green
Graduate Research Assistant

Andrew Nichols
Graduate Research Assistant

Ed Allen, Luke Nuber
Undergraduate Research Assistant

Jose Thomaz
Database Analyst

And

Darcy Bullock
Professor of Civil Engineering

School of Civil Engineering
Purdue University

And

Guy Boruff
Indiana State Police

And

Jay Wasson
Indiana Department of Transportation

And

Mark Newland
Indiana Department of Transportation

Joint Transportation Research Program
Project No. C-36-17GGG
File No. 8-4-60
SPR-2481

The contents of this report reflect the views of the authors, who are responsible for the facts and the accuracy of the data presented herein. The contents do not necessarily reflect the views or policies of the Indiana State Police and the Indiana Department of Transportation. This report does not constitute a standard, specification, or regulation.

Purdue University
West Lafayette, IN 47907
June 2002

TECHNICAL REPORT STANDARD TITLE PAGE

1. Report No. FHWA/IN/JTRP-2001/09		2. Government Accession No.		3. Recipient's Catalog No.	
4. Title and Subtitle Virtual Weigh Station				5. Report Date June 2002	
				6. Performing Organization Code	
7. Author(s) John Green, Andrew Nichols, Ed Allen, Luke Nuber, Jose Thomaz,				8. Performing Organization Report No. FHWA/IN/JTRP-2001/09	
9. Performing Organization Name and Address Joint Transportation Research Program 1284 Civil Engineering Building Purdue University West Lafayette IN 47907-1284				10. Work Unit No.	
				11. Contract or Grant No. SPR-2481	
12. Sponsoring Agency Name and Address Indiana Department of Transportation State Office Building 100 North Senate Avenue				13. Type of Report and Period Covered Final Report	
				14. Sponsoring Agency Code	
15. Supplementary Notes Prepared in cooperation with the Indiana Department of Transportation and Federal Highway Administration.					
16. Abstract Overweight trucks shorten highway life and indirectly increase the costs of maintaining roads. Improved methods for enforcement of commercial vehicle weight laws may increase the number of overweight vehicles caught, thereby prolonging highway life. Improved enforcement may also reduce the number of illegally operating vehicles. This report describes the concept of using existing INDOT Weigh-In-Motion equipment, a laptop computer, and wireless communication equipment, to develop a virtual weigh station screening tool. The Virtual Weigh Station screening tool developed in this project allows officers to read the weights of vehicles crossing WIM scales, in real time, in their patrol cars. Giving officers this information increases the chances that the vehicles selected for weighing on portable scales are indeed overweight. This report documents the accuracy and precision evaluation performed on all the candidate WIM sites as well as the new infrastructure required to implement the Virtual Weigh Station concept. The report describes several cases where significantly overweight vehicles were identified and impounded. For example the procedures described in this report, resulted in the identifying the early morning hours as the best time for enforcement in Merrillville. As a result, on May 18, 2001 vehicles weighing 98,700 lbs and 100,600 lbs were stopped. Those vehicles were impounded and resulted in fines of \$1,625.00 and \$1,735.50, respectively. In February 2002, Commercial Vehicle Enforcement officers stopped ten trucks on US 24 near Fort Wayne using the virtual weigh station. Eight of the trucks were determined to be overweight and fined. The three heaviest trucks weighed 90,200 lbs, 90,900 lbs, and 91,100 lbs resulting in fines of \$1,099.50, \$1,169.50, and \$1,189.50, respectively. On April 12, 2002, another enforcement was conducted on I-65 near Merrillville. Three trucks were stopped based on the virtual weigh station data. One of the trucks weighed 87,400 lbs, resulting in a \$529.50 fine. The report concludes by making several recommendations designed to improve the quality of the WIM data and facilitate wide spread deployment by the Commercial Vehicle Enforcement Division.					
17. Key Words Commercial motor vehicle, weigh in motion, pavement damage			18. Distribution Statement No restrictions. This document is available to the public through the National Technical Information Service, Springfield, VA 22161		
19. Security Classif. (of this report) Unclassified		20. Security Classif. (of this page) Unclassified		21. No. of Pages	22. Price

Implementation Report

There is a need for real time monitoring of Weigh In Motion sites around the state and reporting of summary statistics on the web. For example the procedures described in this report, resulted in the identifying the early morning hours as the best time for enforcement in Merrillville. As a result, on May 18, 2001 vehicles weighing 98,700 lbs and 100,600 lbs were stopped. Those vehicles were impounded and resulted in fines of \$1,625.00 and \$1,735.50, respectively. In February 2002, Commercial Vehicle Enforcement officers stopped ten trucks on US 24 near Fort Wayne using the virtual weigh station. Eight of the trucks were determined to be overweight and fined. The three heaviest trucks weighed 90,200 lbs, 90,900 lbs, and 91,100 lbs resulting in fines of \$1,099.50, \$1,169.50, and \$1,189.50, respectively. On April 12, 2002, another enforcement was conducted on I-65 near Merrillville. Three trucks were stopped based on the virtual weigh station data. One of the trucks weighed 87,400 lbs, resulting in a \$529.50 fine.

In order to achieve a successful, wide scale deployment of the Virtual Weigh Station concept, on line data analysis procedures should be developed that permit rapid diagnosis of WIM calibration problems. This online diagnosis should have two components:

- Tabulation, by lane, of unclassified vehicles. The number of unclassified vehicles should not exceed 10% for any lane. The historical unclassified vehicle error rate should be presented in a format similar to that shown in Appendix E of this report. The memo in Appendix E identifies only 3 stations providing this level of accuracy in October 2000. Those stations were 4250, 5260, and 6260. All of those stations had only a WIM in a single lane.
- A crude evaluation of the accuracy and precision of a WIM can be estimated by looking at the distribution of the front axle weights. The thresholds shown in Appendix H provide a starting point for implementing a rigorous quality control program.

The following amendments to the INDOT WIM specification are suggested:

- ". . . documentation shall be furnished that completed installation confirms the ASTM pavement smoothness specification defined in the ASTM WIM standard E1318-94 at time of acceptance and possibly warranty smoothness for 2 years." This amendment is proposed because some of the recently completed WIM installations do not appear to conform to the required smoothness specification. Actually verifying conformance would require a lane closure.

- “. . . a vehicle used for calibrating a WIM shall travel across the WIM at the average speed of Class 9 trucks. Documentation of the average speed of Class 9 trucks shall be provided by WIM records for Class 9 trucks during a weekday from 9am to 4pm.” This amendment is proposed because one of the sources of calibration error was thought to be that calibration trucks were not always traveling at the prevailing speed of Class 9 trucks. In Merrillville that difference was about 10 mph.
- “. . . a vehicle used for calibration shall not be in violation of any Indiana laws.” This amendment is proposed because the truck used to calibrate the Merrillville WIM had a tandem load of 43,400 lbs. Subsequent discussion with IRD indicated this might cause calibration problems for lower axle weight vehicles.
- “. . . a WIM shall not be accepted by INDOT until telephone service has been operational for 30 consecutive days and the log files uploaded.” This amendment is proposed because it is very difficult to determine if a site is operating properly unless a month or so of data files, including rainy days, are uploaded and IRD error reports are run on the uploaded data.
- “. . . the panel shown in Figure J-1 with components, shown Figure J-2, shall be furnished and installed as part of WIM system.” This amendment is proposed so that all new WIMs will be accessible as a virtual scale as soon as they are turned on.

Regarding the use of WIMs for data collection purposes:

- Based upon the sensitivity analysis performed in Chapter 2, we believe a WIM should provide accurate axle weights within 6% (ASTM Type III) in order to effectively estimate ESALs used to compute pavement life. Based upon observations at new single load cell installations (4410 and 5130), it is not clear whether any of the current installed systems are calibrated to this accuracy. A detailed evaluation at all Single Load Cell Sites (4130, 4150, 4410, 4420, 5110, 5120, and 5130) should be conducted with Summer 2001 data, and field checks performed with Indiana Commercial Vehicle Enforcement Officers.
- Several of the older WIMs using Piezo technology are experiencing severe pavement distress and have likely reached the end their useful life. Those stations would be of little value to a virtual weigh station concept and are likely of little value for data collection. Consideration should be given to abandoning all Piezo WIM sites and perhaps all Bending Plate sites and devoting those additional resources to improved maintenance on the remaining sites.
- The WIMs that are most promising for the Virtual Weigh Station concept are the relatively new Single Load Cell installations. WIM 5110 on I-70 appears to hold some promise as a next Virtual Weigh Station site. However, some calibration and tuning will likely be required to eliminate some of the classification errors documented in this report.

Acknowledgements

This project was the idea of Dan Shamo, Jay Wasson, and Guy Boruff.

This study could not have been conducted without the close participation of the Indiana State Police. The efforts of Officers Deb Burkhart, Scott Fleming, Brian Nagle, Henry Davis, Gerald Young, Monty Buffum, Steve Baumgart, Jeff Ligget, and Sharon Branam were instrumental in the field verification and testing of the virtual weigh station concept.

Throughout this study Donn Klepinger, Larry Torrence, Phil Zurawski, and Scott MacCarthur provided field support and data archives necessary for several of the appendices. The figures in Appendix A are based upon Larry Torrence's files. The "Klepinger Scale" data in Appendix A was obtained from Donn Klepinger's qualitative site survey.

Finally, Rod Klashinsky from International Road Dynamics (IRD) provided the material for Appendix D as well as coordinated the field calibration and maintenance by Fred Kiesig.

Table of Contents

ACKNOWLEDGEMENTS	III
TABLE OF CONTENTS	IV
LIST OF FIGURES.....	VII
LIST OF TABLES.....	XV
1 INTRODUCTION	1
1.1 Definition of Overweight Problem.....	1
1.2 Laws and Statutes	2
1.3 Current Enforcement Procedures	3
1.3.1 “Port-of-Entry” Static Scales.....	3
1.3.2 Portable Scale Units	6
1.4 Scope of Project.....	8
2 IMPACT OF OVERWEIGHT VEHICLES	10
2.1 ESAL Computations.....	10
2.2 ESAL Spreadsheet	12
2.3 Analysis of Sensitivity to Vehicle Weights.....	16
3 EXISTING WIM RESOURCES	19
3.1 Existing Technologies	19
3.1.1 Piezoelectric Technologies	20
3.1.2 Single Load Cell.....	22
3.1.3 Bending Plates.....	23
3.2 Suitability of Existing WIM Scales in Indiana for use with the Virtual Weigh Station	25
3.3 WIM Scale Error Rates	27
3.4 Front Axle Histograms	28
3.5 Importance of WIM Accuracy.....	30
4 VIRTUAL WEIGH STATION SYSTEM	31
4.1 “In-cabinet” Radio / Antenna Panel Equipment.....	31

4.2	"In-vehicle" Equipment	32
4.3	Description of Road Runner Software Display	34
4.4	Procedure for System Use	35
4.5	Stored Data -- Log File	37
5	ENFORCEMENT DETAILS	38
5.1	Determination Procedure	38
5.2	Results from Analysis of February 2001 WIM Data on I-65 at Milepost 253.67	44
5.3	Summary of Enforcement Details	44
5.3.1	Summary of 8-10-00 Tests on I-65, near Lafayette, IN	45
5.3.2	Summary of the 1-04-01 Tests on I-74, near Covington, IN	45
5.3.3	Summary of the Enforcement Details on I-65, near Merrillville, IN	46
5.3.4	Summary of the Enforcement Details on US 24, near Fort Wayne, IN	50
5.3.5	Summary of the Enforcement Details on I-65, near Merrillville, IN	50
6	CONCLUSIONS	51
APPENDIX A	WIM STATION CONFIGURATION	54
APPENDIX B	EVALUATION OF COVINGTON WIM	99
APPENDIX C	DIVERSION ROUTES	102
APPENDIX D	INTERNATIONAL ROAD DYNAMICS COST SUMMARY MEMO	105
D.1	Kistler WIM	106
D.1.1	Common Configuration	107
D.1.2	Scheduled Maintenance	107
D.2	Single Load Cell Scale	108
D.2.1	Common Configuration	108
D.2.2	Scheduled Maintenance	109
D.3	Bending Plate Scale	109
D.3.1	Common Configuration	110
D.3.2	Scheduled Maintenance	110
D.4	Piezoelectric Sensors	111

D.4.1 Common Configuration	112
D.4.2 Scheduled Maintenance	112
D.5 Comparison of WIM Technology Accuracies and Costs	113
D.6 Maintenance/Performance Monitoring Approach	115
APPENDIX E SITE EVALUATION MEMO TO KIRK MANGOLD.....	117
E.1 Summary of Average Station Performance (All Lanes).....	123
E.2 Summary of Average Station Performance (Individual Lanes).....	129
APPENDIX F WIM CALIBRATION-JULY 2000.....	165
APPENDIX G MERRILLVILLE WIM TEST 3-23-01.....	200
APPENDIX H ASSESSMENT OF WIM ACCURACY AND PRECISION.....	203
APPENDIX I SUMMARY OF MERRILLVILLE ENFORCEMENT DETAIL.....	227
APPENDIX J AUTOCAD DRAWINGS	235
APPENDIX K SUMMARY OF SR 1 DATA (MARCH – MAY 2001) MEMO.....	238
APPENDIX L SUMMARY OF SR 1 DATA (MARCH – JULY 2001) MEMO.....	249
APPENDIX M SPECIFICATIONS FOR SR 1 PHOTO WIM MEMO	268
APPENDIX N SUMMARY OF US 24 DETAIL MEMO.....	274
APPENDIX O US 24 CALIBRATION ADJUSTMENT MEMO.....	279
APPENDIX P SUMMARY OF US 24 DATA (MARCH 2002) MEMO	282
APPENDIX Q SUMMARY OF I-65 ENFORCEMENT DETAIL MEMO.....	285
APPENDIX R EFFECTS OF ENFORCEMENT ON SR 1 MEMO	287
APPENDIX S SUMMARY OF BORMAN DATA (JANUARY-MARCH 2002) MEMO.....	289
APPENDIX T BIBLIOGRAPHY	294

List of Figures

Figure 1-1: Indiana State Police Commercial Vehicle Enforcement Division Officers Ligget, Boruff, and Buffum with INDOT official Jay Wasson in front of an illegally loaded (111,350-Lb) steel hauler, caught August 10, 2000.	2
Figure 1-2: Lowell, Indiana static scales on I-65 Southbound	4
Figure 1-3: Truck being weighed on Lowell static scales	5
Figure 1-4: Indiana State Police Motor Carrier Officer Monty Buffum records vehicle weights at the Lowell Scales....	5
Figure 1-5: Lowell scale weight display panel	6
Figure 1-6: Haenni WL 101 (portable) Wheel Load Scale	7
Figure 1-7: Weighing truck with Haenni scales	7
Figure 2-1: ESAL v. Axle Weights for Single and Tandem Axles	11
Figure 2-2: Screen capture of Microsoft EXCEL Spreadsheet, set up for calculation of Pavement Life.....	13
Figure 2-3: Screen Capture of Class 9 Vehicle ESAL sheet	14
Figure 2-4: Expected Life of Pavement for Various WIM Errors.....	17
Figure 2-5: Pavement Life Expectancy with 14% of vehicles 1.2 * Legal Limit.....	18
Figure 3-1: Piezoelectric WIM site configuration	20
Figure 3-2: Piezo-electric WIM in pavement on I-65 NB, near Lafayette, IN	21
Figure 3-3: A technician installs a piezo-electric sensor.....	21
Figure 3-4: Single Load Cell site configuration.....	22
Figure 3-5: Single load cells in each lane, I-74 WB, near Covington, IN	23
Figure 3-6: Front axle of truck passing over Bending Plate.....	24
Figure 3-7: Failed Bending Plate Installation at WIM 5450 Filled with Asphalt.....	24
Figure 3-8: Sample project record for a WIM scale installation	26
Figure 3-9: Station 4250, 1% Error in October 2000	28
Figure 3-10: Scatter plot for Front Axle loads by lane distribution for station 4110, July 2000	29
Figure 3-11: Histogram for Front Axle loads by lane distribution for station 4110, July 2000.....	29
Figure 4-1: Sample WIM “in-cabinet” computer output screen	31
Figure 4-2: Virtual Weigh Station System Hardware	33
Figure 4-3: Virtual Weigh Station Hardware Kit.....	33
Figure 4-4: Screen Capture of latest version of Road Runner software	35
Figure 4-5: Antenna at WIM Station 4410 on I-65 Northbound at Milepost 253.62	37
Figure 5-1: Overweight Northbound Lane 1, Class 9 Vehicles.....	43

Figure 5-2: Overweight Southbound Lane 1, Class 9 Vehicles	43
Figure 5-3: Driver Vehicle Inspection Report of Vehicle Impounded by ISP Officer Henry Davis on May 18, 2001, caught using the "In-vehicle" system – GVW was 98,700 Lbs (compared to 80,000 Lbs allowable)	47
Figure 5-4: Driver Vehicle Inspection Report of vehicle impounded by ISP Officer Henry Davis on June 01, 2001, caught using the "In-vehicle" system.....	48
Figure 5-5: Graphical Comparison of Combined WIM to Scale Weight.....	49
Figure A-1: Map of WIM sites in Indiana	56
Figure A-2: Schematic Key.....	58
Figure A-3: Station 4110 Four Lane Divided	59
Figure A-4: Station 4130 Six Lane Divided.....	60
Figure A-5: Station 4140 Four Lane Divided	61
Figure A-6: Station 4150 Four Lane Divided	62
Figure A-7: Station 4240 Four Lane Divided	63
Figure A-8: Station 4250 Four Lane Divided	64
Figure A-9: Station 4260 Four Lane Divided	65
Figure A-10: Station 4270 Four Lane Divided	66
Figure A-11: Station 4280 Four Lane Divided	67
Figure A-12: Station 4400 Six Lane Divided.....	68
Figure A-13: Station 4440 Six Lane Divided.....	70
Figure A-14: Station 5110 Four Lane Divided	71
Figure A-15: Station 5120 Four Lane Divided	72
Figure A-16: Station 5130 Four Lane Divided	73
Figure A-17: Station 5140 Four Lane Divided	74
Figure A-18: Station 5240 Four Lane Divided	75
Figure A-19: Station 5250 Four Lane Divided	76
Figure A-20: Station 5260 Four Lane Divided	77
Figure A-21: Station 5270 Four Lane Divided	78
Figure A-22: Station 5440 Four Lane Divided	79
Figure A-23: Station 5450 Four Lane Divided	80
Figure A-24: Station 5460 Six Lane Divided.....	81
Figure A-25: Station 5470 Six Lane Divided.....	82

Figure A-26: Station 5480 Six Lane Divided.....	83
Figure A-27: Station 5550 Four Lane Divided	84
Figure A-28: Station 6130 Four Lane Divided	85
Figure A-29: Station 6140 Four Lane Divided	86
Figure A-30: Station 6150 Four Lane Divided	87
Figure A-31: Station 6160 Four Lane Divided	88
Figure A-32: Station 6170 Four Lane Divided	89
Figure A-33: Station 6250 Four Lane Divided	90
Figure A-34: Station 6260 Four Lane Divided	91
Figure A-35: Station 6270 Four Lane Divided	92
Figure A-36: Station 6280 Two Lane Undivided.....	93
Figure A-37: Station 6290 Two Lane Undivided.....	94
Figure A-38: Station 6420 Four Lane Divided	95
Figure A-39: Station 7300 Four Lane Divided	96
Figure A-40: Station 7320 Four Lane Divided	97
Figure A-41: Station 7340 Four Lane Divided	98
Figure B-1: Comparison of Test Weights 01-04-01 at Covington WIM 5130.....	101
Figure C-1: Lowell Scale Diversion Routes	103
Figure C-2: Covington Scale Diversion Routes	104
Figure D-1: Common Configurations of Kistler Sensors.....	107
Figure D-2: Common Configuration of Single Load Cell Scale.....	108
Figure D-3: Common Configuration of Bending Plate Scale	110
Figure D-4: Common Configuration of Piezoelectric Sensor	112
Figure E-1: Error Rate at Station 4110.....	123
Figure E-2: Error Rate at Station 4130.....	123
Figure E-3: Error Rate at Station 4140.....	123
Figure E-4: Error Rate at Station 4150.....	123
Figure E-5: Error Rate at Station 4240.....	123
Figure E-6: Error Rate at Station 4250.....	123
Figure E-7: Error Rate at Station 4260.....	124
Figure E-8: Error Rate at Station 4270.....	124

Figure E-9: Error Rate at Station 4280	124
Figure E-10: Error Rate at Station 4400	124
Figure E-11: Error Rate at Station 4440	124
Figure E-12: Error Rate at Station 5110	124
Figure E-13: Error Rate at Station 5120	125
Figure E-14: Error Rate at Station 5130	125
Figure E-15: Error Rate at Station 5140	125
Figure E-16: Error Rate at Station 5240	125
Figure E-17: Error Rate at Station 5250	125
Figure E-18: Error Rate at Station 5260	125
Figure E-19: Error Rate at Station 5270	126
Figure E-20: Error Rate at Station 5440	126
Figure E-21: Error Rate at Station 5450	126
Figure E-22: Error Rate at Station 5460	126
Figure E-23: Error Rate at Station 5470	126
Figure E-24: Error Rate at Station 5480	126
Figure E-25: Error Rate at Station 5550	127
Figure E-26: Error Rate at Station 6130	127
Figure E-27: Error Rate at Station 6140	127
Figure E-28: Error Rate at Station 6150	127
Figure E-29: Error Rate at Station 6160	127
Figure E-30: Error Rate at Station 6170	127
Figure E-31: Error Rate at Station 6250	128
Figure E-32: Error Rate at Station 6260	128
Figure E-33: Error Rate at Station 6270	128
Figure E-34: Error Rate at Station 6280	128
Figure E-35: Error Rate at Station 6290	128
Figure E-36: Error Rate at Station 6420	128
Figure E-37: Error Rate of individual lanes at station 4110	129
Figure E-38: Error Rate of individual lanes at station 4130	130
Figure E-39: Error Rate of individual lanes at station 4140	131

Figure E-40: Error Rate of individual lanes at station 4150	132
Figure E-41: Error Rate of individual lanes at station 4240	133
Figure E-42: Error Rate of individual lanes at station 4250	134
Figure E-43: Error Rate of individual lanes at station 4260	135
Figure E-44: Error Rate of individual lanes at station 4270	136
Figure E-45: Error Rate of individual lanes at station 4280	137
Figure E-46: Error Rate of individual lanes at station 4400	138
Figure E-47: Error Rate of individual lanes at station 4440	139
Figure E-48: Error Rate of individual lanes at station 5110	140
Figure E-49: Error Rate of individual lanes at station 5120	141
Figure E-50: Error Rate of individual lanes at station 5130	142
Figure E-51: Error Rate of individual lanes at station 5140	143
Figure E-52: Error Rate of individual lanes at station 5240	144
Figure E-53: Error Rate of individual lanes at station 5250	145
Figure E-54: Error Rate of individual lanes at station 5260	146
Figure E-55: Error Rate of individual lanes at station 5270	147
Figure E-56: Error Rate of individual lanes at station 5440	148
Figure E-57: Error Rate of individual lanes at station 5450	149
Figure E-58: Error Rate of individual lanes at station 5460	150
Figure E-59: Error Rate of individual lanes at station 5470	151
Figure E-60: Error Rate of individual lanes at station 5480	152
Figure E-61: Error Rate of individual lanes at station 5550	153
Figure E-62: Error Rate of individual lanes at station 6130	154
Figure E-63: Error Rate of individual lanes at station 6140	155
Figure E-64: Error Rate of individual lanes at station 6150	156
Figure E-65: Error Rate of individual lanes at station 6160	157
Figure E-66: Error Rate of individual lanes at station 6170	158
Figure E-67: Error Rate of individual lanes at station 6250	159
Figure E-68: Error Rate of individual lanes at station 6260	160
Figure E-69: Error Rate of individual lanes at station 6270	161
Figure E-70: Error Rate of individual lanes at station 6280	162

Figure E-71: Error Rate of individual lanes at station 6290	163
Figure E-72: Error Rate of individual lanes at station 6420	164
Figure F-1: Station 4110, Class 9 Vehicles - Front Axle Load Distribution	166
Figure F-2: Station 4110, Class 9 Vehicles - Gross Vehicle Weight vs. Front Axle	166
Figure F-3: Station 4130, Class 9 Vehicles - Front Axle Load Distribution	167
Figure F-4: Station 4130, Class 9 Vehicles - Gross Vehicle Weight vs. Front Axle	167
Figure F-5: Station 4140, Class 9 Vehicles - Front Axle Load Distribution	168
Figure F-6: Station 4140, Class 9 Vehicles - Gross Vehicle Weight vs. Front Axle	168
Figure F-7: Station 4160, Class 9 Vehicles - Front Axle Load Distribution	169
Figure F-8: Station 4160, Class 9 Vehicles - Gross Vehicle Weight vs. Front Axle	169
Figure F-9: Station 4240, Class 9 Vehicles - Front Axle Load Distribution	170
Figure F-10: Station 4240, Class 9 Vehicles - Gross Vehicle Weight vs. Front Axle	170
Figure F-11: Station 4250, Class 9 Vehicles - Front Axle Load Distribution	171
Figure F-12: Station 4250, Class 9 Vehicles - Gross Vehicle Weight vs. Front Axle	171
Figure F-13: Station 4260, Class 9 Vehicles - Front Axle Load Distribution	172
Figure F-14: Station 4260, Class 9 Vehicles - Gross Vehicle Weight vs. Front Axle	172
Figure F-15: Station 4270, Class 9 Vehicles - Front Axle Load Distribution	173
Figure F-16: Station 4270, Class 9 Vehicles - Gross Vehicle Weight vs. Front Axle	173
Figure F-17: Station 4280, Class 9 Vehicles - Front Axle Load Distribution	174
Figure F-18: Station 4280, Class 9 Vehicles - Gross Vehicle Weight vs. Front Axle	174
Figure F-19: Station 4440, Class 9 Vehicles - Front Axle Load Distribution	175
Figure F-20: Station 4440, Class 9 Vehicles - Gross Vehicle Weight vs. Front Axle	175
Figure F-21: Station 5110, Class 9 Vehicles - Front Axle Load Distribution	176
Figure F-22: Station 5110, Class 9 Vehicles - Gross Vehicle Weight vs. Front Axle	176
Figure F-23: Station 5120, Class 9 Vehicles - Front Axle Load Distribution	177
Figure F-24: Station 5120, Class 9 Vehicles - Gross Vehicle Weight vs. Front Axle	177
Figure F-25: Station 5140, Class 9 Vehicles - Front Axle Load Distribution	178
Figure F-26: Station 5140, Class 9 Vehicles - Gross Vehicle Weight vs. Front Axle	178
Figure F-27: Station 5240, Class 9 Vehicles - Front Axle Load Distribution	179
Figure F-28: Station 5240, Class 9 Vehicles - Gross Vehicle Weight vs. Front Axle	179
Figure F-29: Station 5250, Class 9 Vehicles - Front Axle Load Distribution	180

Figure F-30: Station 5250, Class 9 Vehicles - Gross Vehicle Weight vs. Front Axle	180
Figure F-31: Station 5260, Class 9 Vehicles - Front Axle Load Distribution	181
Figure F-32: Station 5260, Class 9 Vehicles - Gross Vehicle Weight vs. Front Axle	181
Figure F-33: Station 5270, Class 9 Vehicles - Front Axle Load Distribution	182
Figure F-34: Station 5270, Class 9 Vehicles - Gross Vehicle Weight vs. Front Axle	182
Figure F-35: Station 5440, Class 9 Vehicles - Front Axle Load Distribution	183
Figure F-36: Station 5440, Class 9 Vehicles - Gross Vehicle Weight vs. Front Axle	183
Figure F-37: Station 5440, Class 9 Vehicles - Front Axle Load Distribution	184
Figure F-38: Station 5450, Class 9 Vehicles - Gross Vehicle Weight vs. Front Axle	184
Figure F-39: Station 5460, Class 9 Vehicles - Front Axle Load Distribution	185
Figure F-40: Station 5460, Class 9 Vehicles - Gross Vehicle Weight vs. Front Axle	185
Figure F-41: Station 5470, Class 9 Vehicles - Front Axle Load Distribution	186
Figure F-42: Station 5470, Class 9 Vehicles - Gross Vehicle Weight vs. Front Axle	186
Figure F-43: Station 5480, Class 9 Vehicles - Front Axle Load Distribution	187
Figure F-44: Station 5480, Class 9 Vehicles - Gross Vehicle Weight vs. Front Axle	187
Figure F-45: Station 5550, Class 9 Vehicles - Front Axle Load Distribution	188
Figure F-46: Station 5550, Class 9 Vehicles - Gross Vehicle Weight vs. Front Axle	188
Figure F-47: Station 6130, Class 9 Vehicles - Front Axle Load Distribution	189
Figure F-48: Station 6130, Class 9 Vehicles - Gross Vehicle Weight vs. Front Axle	189
Figure F-49: Station 6140, Class 9 Vehicles - Front Axle Load Distribution	190
Figure F-50: Station 6140, Class 9 Vehicles - Gross Vehicle Weight vs. Front Axle	190
Figure F-51: Station 6150, Class 9 Vehicles - Front Axle Load Distribution	191
Figure F-52: Station 6150, Class 9 Vehicles - Gross Vehicle Weight vs. Front Axle	191
Figure F-53: Station 6160, Class 9 Vehicles - Front Axle Load Distribution	192
Figure F-54: Station 6160, Class 9 Vehicles - Gross Vehicle Weight vs. Front Axle	192
Figure F-55: Station 6170, Class 9 Vehicles - Front Axle Load Distribution	193
Figure F-56: Station 6170, Class 9 Vehicles - Gross Vehicle Weight vs. Front Axle	193
Figure F-57: Station 6250, Class 9 Vehicles - Front Axle Load Distribution	194
Figure F-58: Station 6250, Class 9 Vehicles - Gross Vehicle Weight vs. Front Axle	194
Figure F-59: Station 6260, Class 9 Vehicles - Front Axle Load Distribution	195
Figure F-60: Station 6260, Class 9 Vehicles - Gross Vehicle Weight vs. Front Axle	195

Figure F-61: Station 6270, Class 9 Vehicles - Front Axle Load Distribution	196
Figure F-62: Station 6270, Class 9 Vehicles - Gross Vehicle Weight vs. Front Axle	196
Figure F-63: Station 6280, Class 9 Vehicles - Front Axle Load Distribution	197
Figure F-64: Station 6280, Class 9 Vehicles - Gross Vehicle Weight vs. Front Axle	197
Figure F-65: Station 6290, Class 9 Vehicles - Front Axle Load Distribution	198
Figure F-66: Station 6290, Class 9 Vehicles - Gross Vehicle Weight vs. Front Axle	198
Figure F-67: Station 6420, Class 9 Vehicles - Front Axle Load Distribution	199
Figure F-68: Station 6420, Class 9 Vehicles - Gross Vehicle Weight vs. Front Axle	199
Figure G-1: WIM #4410 Comparison to Portable Scales Test Results, 3-23-01	202
Figure H-1: Average Class 9 Front Axle Weight for All WIM Lanes	208
Figure H-2: Average Class 9 Front Axle Weight for WIM lanes with GVW < 32,000.....	217
Figure H-3: Average Class 9 Front Axle Weight for WIM Lanes with 32,000 < GVW < 70,000.....	220
Figure H-4: Average Class 9 Front Axle Weight for WIM lanes with GVW > 70,000.....	223
Figure I-1: March 29, 2001 – Merrillville Scale Detail (WIM 4410) – WIM v. Static graph	228
Figure I-2: May 8, 2001 – Merrillville Scale Detail (WIM 4410) – WIM v. Static graph	229
Figure I-3: May 15, 2001 – Merrillville Scale Detail (WIM 4410) – WIM v. Static graph.....	230
Figure I-4: May 18, 2001 – Merrillville Scale Detail (WIM 4410) – WIM v. Static graph.....	231
Figure I-5: May 21, 2001 – Merrillville Scale Detail (WIM 4410) – WIM v. Static graph.....	232
Figure I-6: May 23, 2001 - Merrillville Scale Detail (WIM 4410) - WIM v. Static graph	233
Figure I-7: May 31, 2001 - Merrillville Scale Detail (WIM 4410) - WIM v. Static graph	234
Figure J-1: Remote Radio Mounting Plate Drawing	236
Figure J-2: Remote Radio Mounting Assembly	237

List of Tables

Table 2-1: Load Equivalency Factors for various Single Axle and Tandem Weights	10
Table 2-2: Selected vehicle classes in various states of loading	15
Table 2-3: Expected Life of Asphalt Pavement for Various WIM Errors	16
Table 3-1: Summary of ASTM 1318-94 Type Code and Accuracy for Common WIM Technology	19
Table 5-1: Class 9 Vehicles, Feb 01 00:00:00 2001 TO Thu Mar 01 00:00:00 2001 - Station 4410, Northbound.....	39
Table 5-2: Class 9 Vehicles, Feb 01 00:00:00 2001 TO Thu Mar 01 00:00:00 2001 - Station 4420, Southbound	39
Table 5-3: February 2001, Northbound, Lane 1, Class 9 Vehicles exceeding 90,000lbs.	40
Table 5-4: February 2001, Northbound, Lane 2, Class 9 Vehicles exceeding 90,000 Lbs.	40
Table 5-5: February 2001, Northbound, Lane 3, Class 9 Vehicles exceeding 90,000 Lbs.	41
Table 5-6: February 2001, Southbound, Lane 1, Class 9 Vehicles exceeding 90,000 Lbs.	41
Table 5-7: February 2001, Southbound, Lane 2, Class 9 Vehicles exceeding 90,000 Lbs.	42
Table 5-8: Combined Results of Enforcement Details.....	49
Table A-1: WIM Sites of Indiana.....	55
Table A-2: List of Automatic Traffic Recording Sites in Indiana.....	57
Table A-3: List of Abbreviations Used	58
Table A-4: Klepinger Pavement Evaluation Scale, March 2001	58
Table A-5: Station 4110 Inventory	59
Table A-6: Station 4130 Inventory	60
Table A-7: Station 4140 Inventory	61
Table A-8: Station 4150 Inventory	62
Table A-9: Station 4240 Inventory	63
Table A-10: Station 4250 Inventory	64
Table A-11: Station 4260 Inventory	65
Table A-12: Station 4270 Inventory	66
Table A-13: Station 4280 Inventory	67
Table A-14: Station 4400 Inventory	68
Table A-15: Station 4440 Inventory	70
Table A-16: Station 5110 Inventory	71
Table A-17: Station 5120 Inventory	72
Table A-18: Station 5130 Inventory	73

Table A-19: Station 5140 Inventory	74
Table A-20: Station 5240 Inventory	75
Table A-21: Station 5250 Inventory	76
Table A-22: Station 5260 Inventory	77
Table A-23: Station 5270 Inventory	78
Table A-24: Station 5440 Inventory	79
Table A-25: Station 5450 Inventory	80
Table A-26: Station 5460 Inventory	81
Table A-27: Station 5470 Inventory	82
Table A-28: Station 5480 Inventory	83
Table A-29: Station 5550 Inventory	84
Table A-30: Station 6130 Inventory	85
Table A-31: Station 6140 Inventory	86
Table A-32: Station 6150 Inventory	87
Table A-33: Station 6160 Inventory	88
Table A-34: Station 6170 Inventory	89
Table A-35: Station 6250 Inventory	90
Table A-36: Station 6260 Inventory	91
Table A-37: Station 6270 Inventory	92
Table A-38: Station 6280 Inventory	93
Table A-39: Station 6290 Inventory	94
Table A-40: Station 6420 Inventory	95
Table A-41: Station 7300 Inventory	96
Table A-42: Station 7320 Inventory	97
Table A-43: Station 7340 Inventory	98
Table B-1: 01-04-01 Test of WIM System	100
Table D-1: WIM Technology Comparison	113
Table E-1: Acceptable Sites	118
Table E-2: Location of All WIM Stations	121
Table E-3: October 2000 Roadway Management Error Report.....	122
Table G-1: WIM #4410 Comparison to Portable Scales Test Results, 3-23-01.....	201

Table H-1: Average Class 9 Front Axle Weight for All WIM Lanes, Sorted by Front Axle Weight (33,689-10,398)...	204
Table H-2: Average Class 9 Front Axle Weight for All WIM Lanes, Sorted by Front Axle Weight (10,285-7,200).....	205
Table H-3: Average Class 9 Axle Weight for All WIM Lanes, Sorted by Front Axle Weight (6,310-1,001).....	206
Table H-4: Average Class 9 Axle Weight for All WIM Lanes, Sorted by Front Axle Weight (986-308).....	207
Table H-5: Average Class 9 Front Axle Weight for All WIM Lanes, Sorted by Number and Lane (4110-4280)	209
Table H-6: Average Class 9 Front Axle Weight for All WIM Lanes, Sorted by Number and Lane (4400-5460)	210
Table H-7: Average Class 9 Front Axle Weight for All WIM Lanes, Sorted by Number and Lane (5470-6250)	211
Table H-8: Average Class 9 Front Axle Weight for All WIM Lanes, Sorted by Number and Lane (6270-7340)	212
Table H-9: Average Class 9 Front Axle Weight for WIM lanes with GVW<32,000, Sorted by Site Number (4110-4400)	213
Table H-10: Average Class 9 Front Axle Weight for WIM lanes with GVW<32,000, Sorted by Site Number (5110- 5470).....	214
Table H-11: Average Class 9 Front Axle Weight for WIM lanes with GVW<32,000, Sorted by Site Number (5480- 6250).....	215
Table H-12: Average Class 9 Front Axle Weight for WIM lanes with GVW<32,000, Sorted by Site Number (6270- 7340).....	216
Table H-13: Average Class 9 Front Axle Weight for WIM lanes with 32,000<GVW<70,000, Sorted by Site Number (4110-5450)	218
Table H-14: Average Class 9 Front Axle Weight for WIM lanes with 32,000<GVW<70,000, Sorted by Site Number (5470-7340)	219
Table H-15: Average Class 9 Front Axle Weight for WIM lanes with GVW>70,000, Sorted by Site Number (4110- 5470).....	221
Table H-16: Average Class 9 Front Axle Weight for WIM lanes with GVW>70,000, Sorted by Site Number (5480- 7340).....	222
Table H-17: Acceptable Ranges for Front Axle Mean & Standard Deviation for Table H-18 and Table H-19.....	224
Table H-18: Evaluation of WIM Performance (Stations 4110-5240).....	225
Table H-19: Evaluation of WIM Performance (Stations 5250-7340).....	226
Table I-1: March 29, 2001 – Merrillville Scale Detail (WIM 4410) – WIM v. Static.....	228
Table I-2: May 8, 2001 – Merrillville Scale Detail (WIM 4410) – WIM v. Static.....	229
Table I-3: May 15, 2001 – Merrillville Scale Detail (WIM 4410) – WIM v. Static.....	230
Table I-4: May 18, 2001 – Merrillville Scale Detail (WIM 4410) – WIM v. Static.....	231

Table I-5: May 21, 2001 – Merrillville Scale Detail (WIM 4410) – WIM v. Static..... 232

Table I-6: May 23, 2001 - Merrillville Scale Detail (WIM 4410) - WIM v. Static 233

Table I-7: May 31, 2001 – Merrillville Scale Detail (WIM 4410) – WIM v. Static..... 234

1 Introduction

Overweight trucks shorten highway life and indirectly increase the costs of maintaining roads. Additionally, a study for the Oregon Department of Transportation found that a significant relationship exists between the rate of weight violations and a commercial carrier's accident rate [Eubanks, 1997]. Improvement in methods for enforcement of commercial vehicle weight laws may increase the number of overweight vehicles caught, thereby prolonging highway life. Improved enforcement may also reduce the number of illegally operating vehicles.

1.1 Definition of Overweight Problem

A highway is built to serve its function for a period of several years. This is called the road's design life. While transportation officials do plan and budget funds in the reference frame of time, the roads are actually designed according to a number of Equivalent Single Axle Loads, or ESAL, that can traverse the roadway before repairs or replacement is needed.

Problems arise when truck operators overload their vehicles. The amount of pavement life, measured in ESALs, consumed by the passage of a single truck increases dramatically as Gross Vehicular Weight (GVW) rises above the legal limits [IDOT, 1998]. To prevent the shortening of the roads' lifespans, the Indiana State Police enforces weight limits through the use of fixed-installation static scales and portable static scales.

By law, all commercial truck drivers must submit their vehicles for weighing if they traverse a section of roadway within which a static scale installation is located. Because there are a relatively small number of these expensive, permanent installations located in Indiana, Indiana State Police rely heavily upon the mobile scale units. Unfortunately, officers equipped with these portable scales currently have no tools to help them choose which trucks to weigh. While knowledge of truck driver behavior and accumulated experience help officers to choose vehicles for inspection, understandably, many of the trucks that officers select and weigh are within legal weight limits. Since the inspections take roughly 45 minutes to perform, this research is intended to increase the likelihood that a stopped vehicle is in fact overweight.



Figure 1-1: Indiana State Police Commercial Vehicle Enforcement Division Officers Ligget, Boruff, and Buffum with INDOT official Jay Wasson in front of an illegally loaded (111,350-Lb) steel hauler, caught August 10, 2000.

1.2 Laws and Statutes

While federal, state and local laws regulate commercial vehicles, the statutes pertaining to weight limits and loading configurations are primarily state laws. These weight laws are listed in Indiana Code 9-20-4. The Gross Vehicular Weight limit is described in **IC 9-20-4-1**.

“Sec. 1. (a) Except as provided in subsections (b) and (c), a person may not operate or cause to be operated upon an Indiana highway a vehicle or combination of vehicles having weight in excess of one (1) or more of the following limitations:

(1) The total gross weight, with load, in pounds of any vehicle or combination of vehicles may not exceed an overall gross weight on a group of two (2) or more consecutive axles produced by application of the following formula:

$$W = 500\{[(LN) \cdot (N - 1)] + 12N + 36\}$$

where W equals the overall gross weight on any group of two (2) or more consecutive axles to the nearest five hundred (500) pounds, L equals the distance in feet between the extreme of any group of two (2) or more consecutive axles, and N equals the number of axles in the group under consideration, except that two (2) consecutive sets of tandem axles may carry a gross load of thirty-four thousand (34,000) pounds each, providing the overall distance between the first and last axles of the consecutive sets of tandem axles is thirty-six (36) feet or more.

The overall gross weight limit, calculated under this subdivision, may not exceed eighty thousand (80,000) pounds.”

Individual axle group (tandem) limits are stated in this section as well.

“(2) The weight concentrated on the roadway surface from **any tandem axle group may not exceed the following:**

(A) Thirty-four thousand (34,000) pounds total weight.

(B) Twenty thousand (20,000) pounds on an individual axle in a tandem group,” [Access Indiana, 2000].

1.3 Current Enforcement Procedures

In Indiana, officers of the Commercial Vehicle Enforcement Division carry out enforcement of laws regarding trucks. More specifically, officers from this branch of the Indiana State Police regulate any commercial vehicle weighing greater than 10,000 lbs. The two primary methods used to check that vehicles are in compliance with weight limit statutes and regulations are “Port-of-Entry” static scales and portable scale units.

1.3.1 “Port-of-Entry” Static Scales

Following Federal policy suggestions, “Ports-of-Entry”, the first method that Indiana uses, is the operation of permanent, static scale installations. The Port-of-Entry concept directs that permanent scales be placed near state borders on high traffic volume routes, and only weigh trucks that have just entered the state. The idea is that if two neighboring states only operate installations weighing incoming vehicles, then redundancy will be avoided.

As a truck approaches a static scale installation from the highway, the operator is first directed whether the scale is “open” or “closed”. If the scale is “closed” (not in operation), the vehicle may proceed on the highway, uninterrupted. If the scale is “open”, then the truck enters the scale via an exit ramp.

At a modern station, such as the Lowell Scale on I-65, a Weigh-In-Motion (WIM) system along the ramp screens the trucks by weight, instructing the lighter weight vehicles to enter a scale bypass lane that sends the trucks back onto the highway. The trucks weighing close to their legally allowed limits (roughly within 10%) are directed to enter a lane that proceeds to the scales.

When a truck reaches the proper position on the scales, the Commercial Vehicle Enforcement Officer operating the installation inside the scale house flips a switch that changes the traffic signal controlling the scale lane to red (Figure 1-2). When the truck stops, if it is improperly positioned for a proper scale reading, the Commercial

Vehicle Enforcement Officer instructs the truck operator to adjust the position of his/her vehicle accordingly. When the vehicle is properly positioned, a weight reading is recorded.

If a vehicle is found to be overweight, either through exceeding the allowed gross vehicular weight or by surpassing the weight limit per axle tandem (or tridem), the truck operator is instructed to drive the truck to a detention lot. If laws were broken, citations may be issued. If the weight problem involves an overloaded axle, the driver may attempt to adjust the loading of the vehicle to become legal, and proceed back to the highway. However, if the truck exceeds GVW limits by a large enough margin (5000 Lbs for class 9 vehicles), the vehicle is impounded until part (or all) of the load is removed to make the vehicle legal.

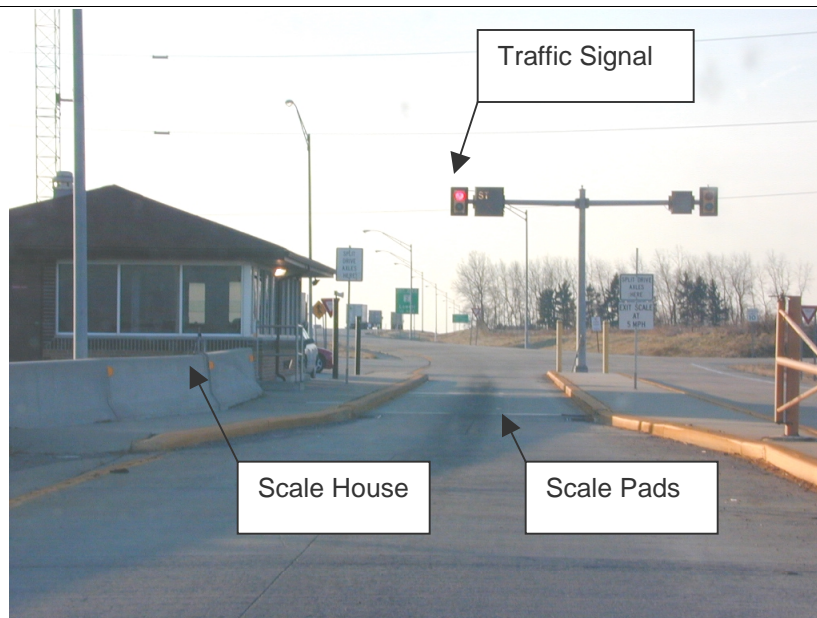

Figure 1-2: Lowell, Indiana static scales on I-65 Southbound

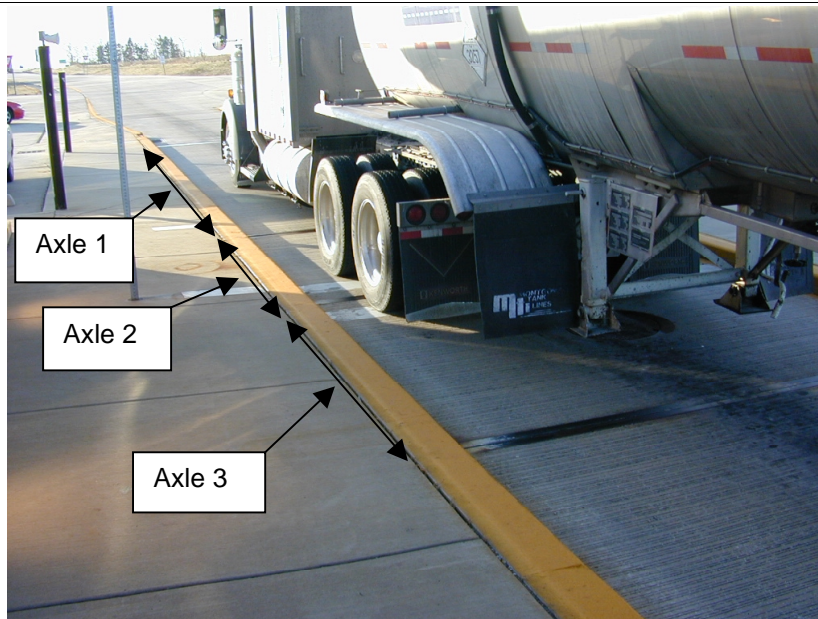

Figure 1-3: Truck being weighed on Lowell static scales



Figure 1-4: Indiana State Police Motor Carrier Officer Monty Buffum records vehicle weights at the Lowell Scales



Figure 1-5: Lowell scale weight display panel

1.3.2 Portable Scale Units

Because the Port-of-Entry permanent scales are located near Indiana's borders with other states, Indiana State Police deploy 46 portable scale crews to check the weights of vehicles in the interior of the state [FHWA, 2000]. Portable scale units are patrol cars usually equipped with four or six Haenni WL101 Wheel Load Scales (Figure 1-6).

The procedure for weighing trucks with portable scales is as follows. Officers observe traffic, select a suspected vehicle, and then lead it to a safe area for weighing. Individual axle weights are first determined by placing scales beneath a pair of wheels on the same axle of a vehicle. The measurements are added and recorded. Sheets of plywood, the same thickness as the scales, are placed under the wheels that are not currently being weighed to maintain the same cross-level and avoid shifting of the load. The truck is moved slightly, the scales are placed under the remaining wheels, and weights are recorded. When all of the axles have been weighed, the axle weights are summed to determine Drive Tandem Weight, trailer Tandem Weight, and Gross Vehicular Weight. If the vehicle is found to be out of compliance with weight laws, the drivers are either issued warnings or citations. If the vehicle is significantly overweight, the overloaded vehicle may be impounded until the weight is made legal through load repositioning (tandem axle weight violation) or offloading (GVW violation).

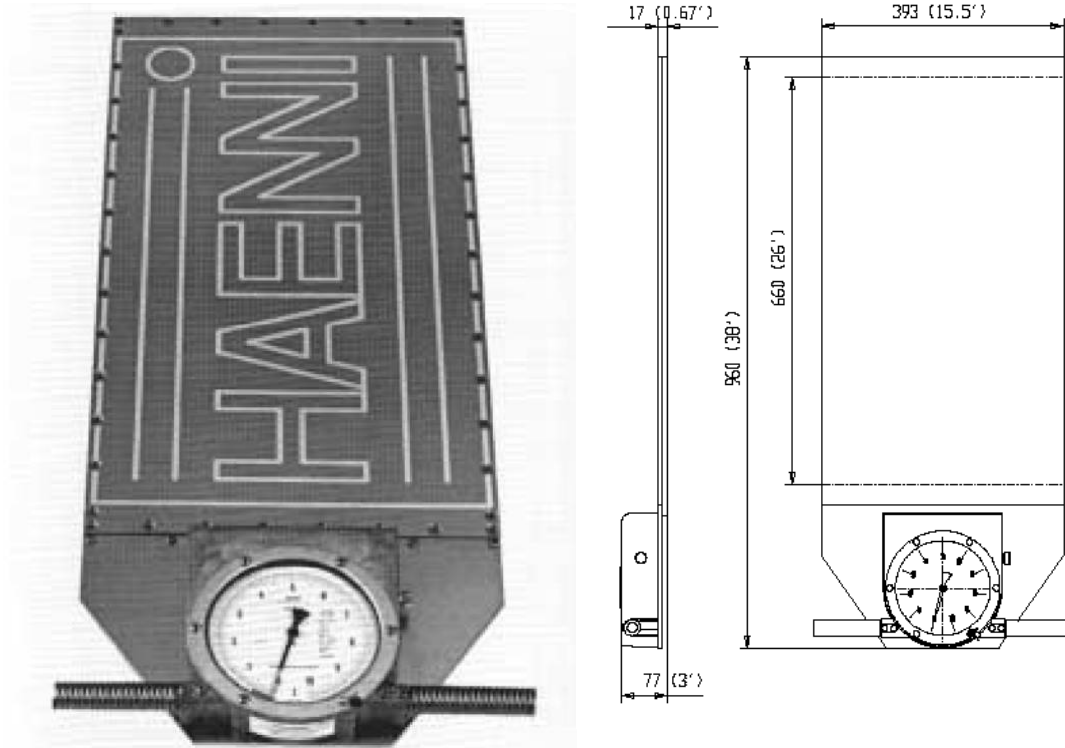

Figure 1-6: Haenni WL 101 (portable) Wheel Load Scale

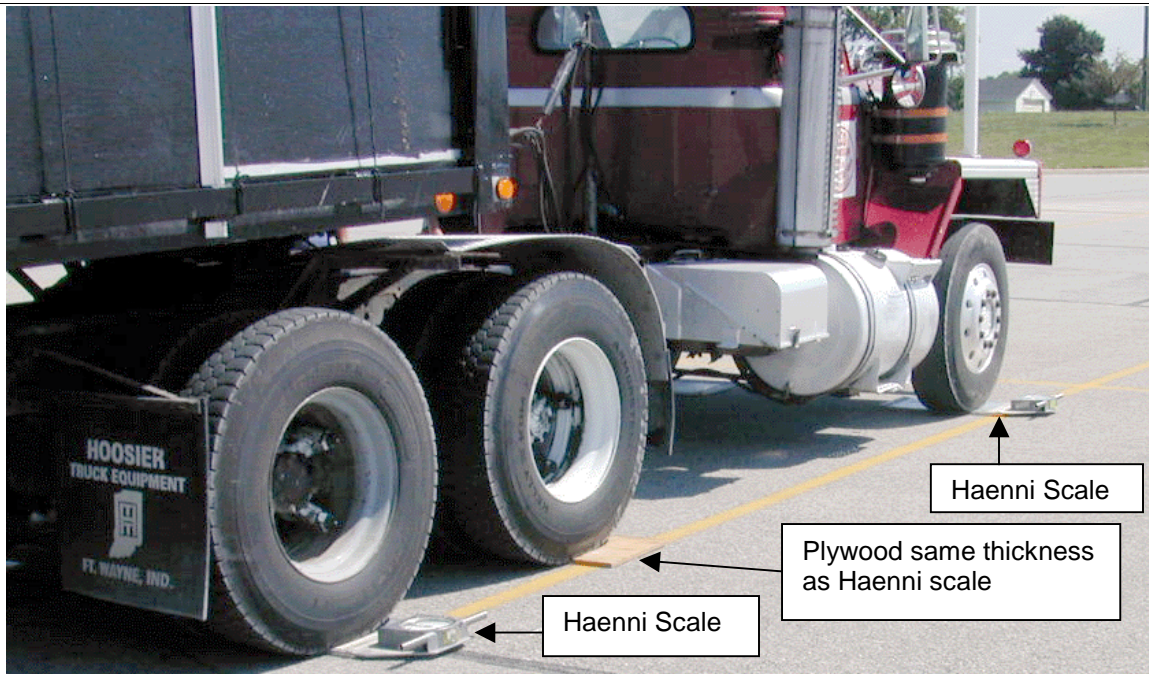

Figure 1-7: Weighing truck with Haenni scales

While the measurements obtained have been determined to be accurate enough for the issuing of citations, officers must rely upon their own intuition when choosing which vehicles to weigh. Because of the subjective nature of the current screening process, many legally loaded vehicles are weighed. More importantly, many overweight vehicles are not weighed because they do not usually exhibit characteristics that make it possible to identify them as being overweight.

1.4 Scope of Project

This project had five objectives:

- 1) To quantify impact of overweight vehicles. Chapter 2 discusses the spreadsheet model developed for this purpose.
- 2) To identify which of Indiana's existing WIM sites are currently operating accurately enough to be used with the "in-vehicle" laptop system (and which sites need repairs) and to demonstrate the importance of WIM accuracy in determining accumulated ESALs. Chapter 3 discusses these data analysis procedures.
- 3) To develop prototype "in-cabinet" and "in-vehicle" WIM screening equipment to improve enforcement efficiency. Chapter 4 describes the necessary WIM cabinet components and the virtual weigh station software run in the vehicle called Road Runner.
- 4) To develop procedures to determine the best times for ISP to schedule enforcement details so that scarce resources are used as efficiently as possible. Chapter 5 shows some tabulations illustrating peak times for enforcement.
- 5) To document the impact of the virtual WIM on enforcement. Chapter 5 describes several details. Chapter 6 proposes several items that should be pursued to deploy the virtual weigh station concept in a manner that will maximize impact.

In addition, this report contains the following Appendices:

Appendix A: Tables and figures describing the location and features of existing WIMs. Because WIMs are constantly being upgraded, the reader is cautioned that this appendix is only a snapshot of the current WIM system statewide.

Appendix B: Tables and graphs from Covington WIM #5130 evaluation. Subsequent analysis by Donn Klepinger found system did not meet INDOT specifications and the vendor was contacted.

Appendix C: Diversion routes envisioned for trucks diverting around WIMs on I-65 and I-74. Locations of Scale Houses are also shown.

Appendix D: Cost summary information provided by International Road Dynamics.

Appendix E: Site evaluation memo sent to Kirk Mangold based upon classification error rates.

Appendix F: Tabulation of front axle loads from July 2000 used to screen for scale accuracy.

Appendix G: Summary of Merrillville WIM test.

Appendix H: Summary table and graph of front axle data from Appendix F.

Appendix I: Summary sheets from Merrillville enforcement details.

Appendix J: Drawings of panels to be installed in INDOT cabinets to enable the Virtual Weigh Station Concept.

Appendix K: Memo summarizing the data obtained from the SR 1 WIM for March – May 2001.

Appendix L: Memo summarizing the data obtained from the SR 1 WIM for March – July 2001.

Appendix M: Memo summarizing the specifications for the video aspect of the SR 1 WIM.

Appendix N: Memo summarizing the enforcement details conducted on US 24 in February 2002.

Appendix O: Memo summarizing the calibration adjustment for the US 24 WIM.

Appendix P: Memo summarizing the data obtained from the US 24 WIM for March 2002.

Appendix Q: Memo summarizing the enforcement detail conducted on I-65 near Merrillville in April 2002.

Appendix R: Memo summarizing the effects of the SR 1 WIM installation on truck volumes.

Appendix S: Memo summarizing the data obtained from the I-80/I-94 WIM for January - March 2002.

Appendix T: List of references in this research.

2 Impact of Overweight Vehicles

Overweight vehicles have a significant effect on pavement life. Because the relationship between vehicular weight and pavement life consumption is non-linear, one significantly overweight truck can do as much damage as all of the automobiles that traverse the same section of road in a day. Improperly distributed loads can also cause more damage to a roadway than a similar vehicle with the same load properly distributed. Therefore, to more accurately describe the effects of vehicles on pavement life, consumption is described in terms of Equivalent Single Axle Loads (ESALs), rather than Gross Vehicular Weight.

2.1 ESAL Computations

Design by ESALs is a straightforward concept, but needs to be explained. While vehicles that travel over Interstate Highways vary widely in appearance and operating capabilities, at least one property remains the same across all makes and classes – they all have pairs of wheels, connected by an axle, that transfer loads to the roadway running surface.

The standard weight for a single-axle ESAL is assumed to be 18,000 Lbs., and roads are designed to accept the loading cycles of a set number of ESALs before the road fails due to fatigue. For Interstate highways like I-65 in Indiana, an average design number of ESAL is around 50,000,000. Table 2-1 shows ESALs for various axle weights. Figure 2-1 illustrates the ESALs for both single axle and tandem weights [Huang, 1997].

Weight (Lbs)	Single Axle ESAL Factor	Tandem ESAL Factor	Weight (Lbs)	Single Axle ESAL Factor	Tandem ESAL Factor	Weight (Lbs)	Single Axle ESAL Factor	Tandem ESAL Factor
1000	0.00002		18000	1.00	0.07730	35000	12.50	1.23
2000	0.00018		19000	1.24	0.09710	36000	13.93	1.38
3000	0.00072		20000	1.51	0.12060	37000	15.50	1.53
4000	0.00209		21000	1.83	0.14800	38000	17.20	1.70
5000	0.00500		22000	2.18	0.180	39000	19.06	1.89
6000	0.01043		23000	2.58	0.217	40000	21.08	2.08
7000	0.01960		24000	3.03	0.260	41000	23.27	2.29
8000	0.03430		25000	3.53	0.308	42000	25.64	2.51
9000	0.05620		26000	4.09	0.364	43000	28.22	2.75
10000	0.08770	0.00688	27000	4.71	0.426	44000	31.00	3.00
11000	0.13110	0.01008	28000	5.39	0.495	45000	34.00	3.27
12000	0.189	0.01440	29000	6.14	0.572	46000	37.24	3.55
13000	0.264	0.01990	30000	6.97	0.658	47000	40.74	3.85
14000	0.360	0.02700	31000	7.88	0.753	48000	44.50	4.17
15000	0.478	0.03600	32000	8.88	0.857	49000	48.54	4.51
16000	0.623	0.04720	33000	9.98	0.971	50000	52.88	4.86
17000	0.796	0.06080	34000	11.18	1.095			

Table 2-1: Load Equivalency Factors for various Single Axle and Tandem Weights

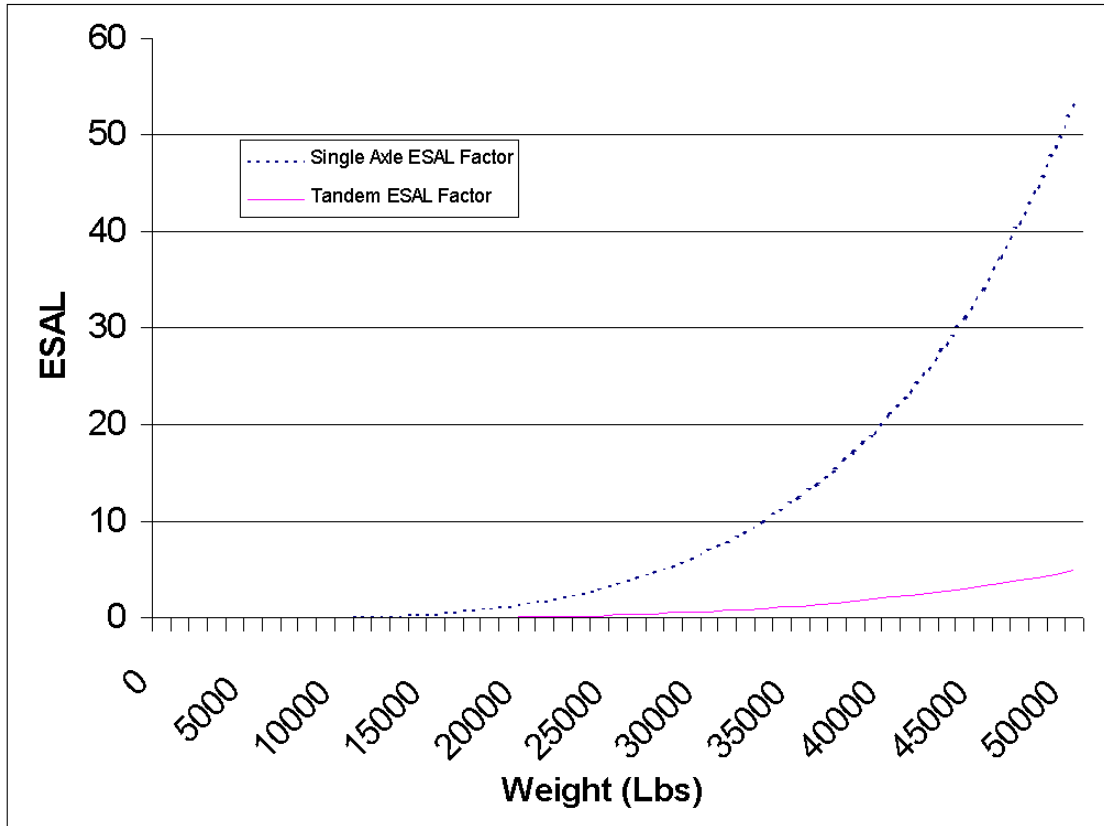

Figure 2-1: ESAL v. Axle Weights for Single and Tandem Axles

The formula used by many engineers for designing asphalt highway pavements was developed by the Asphalt Institute [Huang, 1997]. It is,

$$ESAL = f_d \times G_{jt} \times AADT_i \times 365 \times N_i \times F_{ei}$$

Where:

ESAL = Equivalent Single Axle Loads

f_d = design lane factor

G_{jt} = growth factor for a given growth rate "j", and design period "t"

$AADT_i$ = first year annual average daily traffic for axle category "i"

N_i = number of axles on each vehicle in category "i"

F_{ei} = load equivalency factor for axle category "i"

The following sets of example calculations illustrate the procedure for applying this formula. The example assumes the following data:

Passenger Cars (1000 Lb per axle)	= 50%
2-axle Single-unit Trucks (5000 Lb per axle)	= 30 %
3-axle Single Unit Trucks (7500 Lb per axle)	= 20%
AADT	= 12,000
Design Period	= 20 years
% Truck volume on design lane	= 45%

Solution:

$$ESAL = f_d \times G_{jt} \times AADT \times 365 \times N_i \times F_{ei}$$

Growth factor = 29.78 (Compound growth rate for 20 years at 4% growth)

Load equivalency factors per axle:

Passenger cars	= 0.00002	(Table 2-1)
2-axle Single-unit Trucks	= 0.00500	(Table 2-1)
3-axle Single Unit Trucks	= 0.01960	(Table 2-1)

Number of accumulated ESAL in the design lane:

$$\text{Passenger cars} = 0.45 \times 29.78 \times 12,000 \times 0.50 \times 365 \times 2 \times 0.00002 = 1174$$

$$\text{2-axle Single-unit Trucks} = 0.45 \times 29.78 \times 12,000 \times 0.30 \times 365 \times 2 \times 0.005 = 176,089$$

$$\text{3-axle Single Unit Trucks} = 0.45 \times 29.78 \times 12,000 \times 0.20 \times 365 \times 3 \times 0.0196 = 690,269$$

$$\text{Total} = 866,358 \text{ ESAL}$$

2.2 ESAL Spreadsheet

Performing ESAL calculations can be quite cumbersome when many highway alternatives are considered. This is especially true when the complete number of vehicle classes defined by the State of Indiana is considered in the calculations. Spreadsheet computer applications, such as Microsoft's EXCEL, can simplify the task, and reduce the amount of time necessary by considerable amounts.

Figure 2-2 is a screen-capture of an EXCEL spreadsheet configured to account for vehicle classes two through thirteen (accounting for the majority of traffic traversing I-65). Each class of vehicle is represented by several

states of loading that may be expected in a random sampling of vehicles. Indiana State Police Commercial Vehicle Enforcement Division Officers Monty Buffum and Steve Baumgart have provided data for approximate Gross Vehicular Weights (GVW) and individual axles of each class.

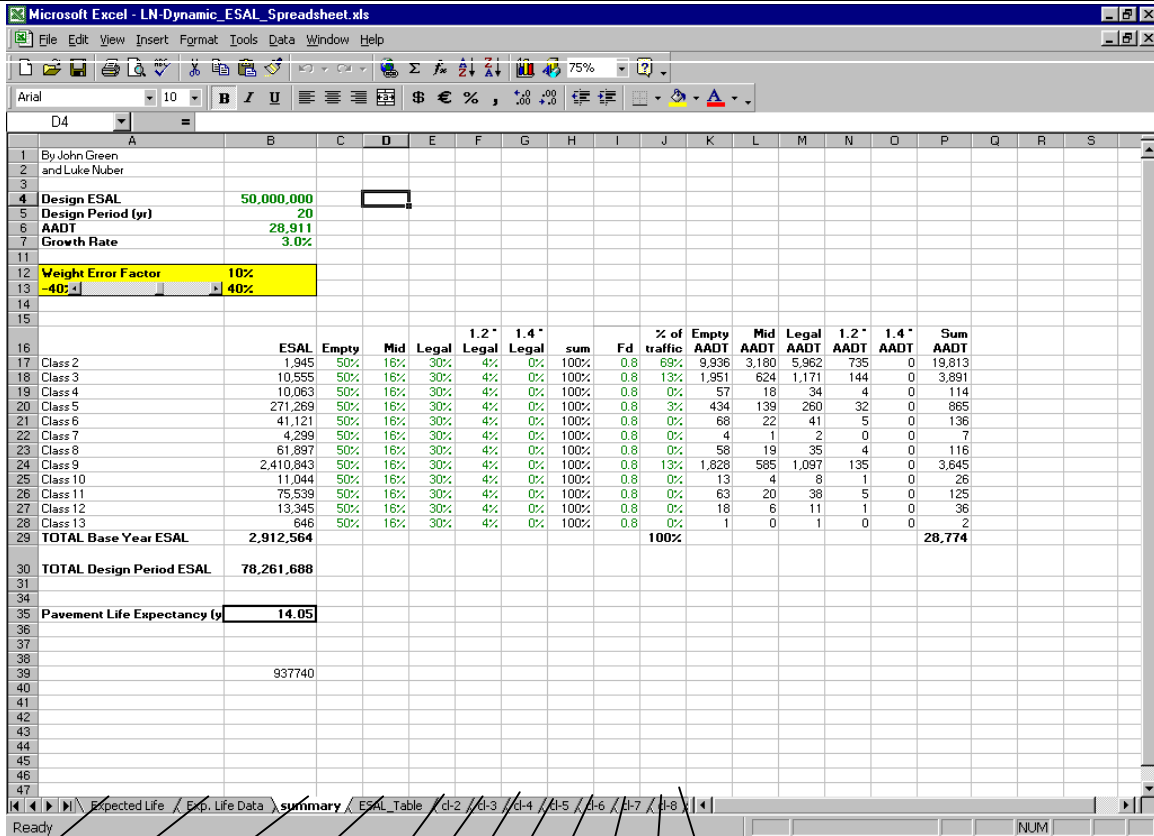

(1) (2) (3) (4) (5) (6) (7) (8) (9) (10) (11) (12) Tabs for Classes 9-13 not shown

Figure 2-2: Screen capture of Microsoft EXCEL Spreadsheet, set up for calculation of Pavement Life

The first page (Figure 2-2, item 1), Expected Life, of the spreadsheet shows a graph comparing the pavement life versus the Weight Error Factor (Figure 2-4). The resulting curve produced by connecting the data points shows that a logarithmic relationship exists between the two. From the graph, it can be determined that, for a particular traffic scenario, a small error of 10% in calculation of accumulated ESALs may cause the pavement life estimate to be off by more than 25%.

The second page (Figure 2-2, item 2), Expected Life Data, lists in tabular form results of pavement life expectancy produced by iterations of the spreadsheet program. Examining only the range varying from 80% to 120% of actual GVW, iterations show that pavement life varies accordingly from 39 to 10 years.

The third page (Figure 2-2, item 3), Summary, summarizes the information calculated by the spreadsheet, contains areas for designers to input information regarding Design ESAL, Design Period (in years), AADT, and Growth Rate. Additionally, information in other areas, which are shown in light gray, can be altered to represent the actual mix of traffic if precise data is available. At the bottom of the Summary page results reporting the Total Base Year ESAL, Total Design Period ESAL, and Pavement Life Expectancy (in years), are shown.

The fourth page (Figure 2-2, item 4), ESAL Table, is a data table that the summary sheet calculations refer to for individual axle ESAL factors. This table was taken from *Traffic and Highway Engineering* by Garber & Hoel [Garber, 1988]. The remaining pages in the spreadsheet contain information unique to each individual class of vehicles (Figure 2-2, items 5-12). Once again, the summary sheet is where the calculations are performed and the unique class sheets are only used for formula reference.

The screenshot shows a Microsoft Excel spreadsheet titled "Darcy_TrafficModel_10-03-00.xls". The active sheet is "ESAL Table" and the selected cell is H15. The spreadsheet contains the following data:

Class 9 Vehicle					
					
Axle Weights					
	Empty	Midrange	Legal	1.2*Legal	1.4*Legal
Axle 1	8,000	10,000	12,000	14,400	20,160
Axle 2	4,000	10,500	17,000	20,400	28,560
Axle 3	4,000	10,500	17,000	20,400	28,560
Axle 4	4,500	10,750	17,000	20,400	28,560
Axle 5	4,500	10,750	17,000	20,400	28,560
Total	25,000	52,500	80,000	96,000	134,400
ESAL Equiv					
	Empty	Midrange	Legal	1.2*Legal	1.4*Legal
Axle 1	0.03430	0.08770	0.01890	0.36000	1.51000
Axle 2	0.0021	0.0877	0.7960	1.5100	5.3900
Axle 3	0.0021	0.0877	0.7960	1.5100	5.3900
Axle 4	0.0021	0.0877	0.7960	1.5100	5.3900
Axle 5	0.0021	0.0877	0.7960	1.5100	5.3900
Total	0.04266	0.4385	3.2029	6.4000	23.0700
AADT by Category					
	1,120	358	672	67	22
365	365	365	365	365	365
Fd	0.75	0.75	0.75	0.75	0.75
Base Year ESAL	13,080	43,022	589,205	117,734	141,465
TOTAL YEARLY ESAL 904,507					

Figure 2-3: Screen Capture of Class 9 Vehicle ESAL sheet

What the ESAL spreadsheet illustrates is that increasing the weights of vehicles to overweight levels, especially for classes nine and greater, significantly reduces pavement life. The relationship for increasing weights

and ESAL is not a linear function. As use of the ESAL spreadsheet shows, increasing the weights of all non-automobiles (trucks) by 25% more than doubles the ESALs consumed.





	Vehicle Class		Empty	Midrange	Legal	1.2*Legal	1.4*Legal
	2	Weight (lbs)	2,000	3,000	4,000	4,800	6,720
		ESAL	0.000	0.000	0.000	0.000	0.001
	3	Weight (lbs)	5,000	8,000	11,000	13,200	18,480
		ESAL	0.001	0.003	0.015	0.030	0.122
	4	Weight (lbs)	28,000	30,000	32,000	38,400	53,760
		ESAL	1.088	1.371	1.529	3.390	11.490
	5	Weight (lbs)	11,000	21,500	32,000	38,400	53,760
		ESAL	0.015	0.298	1.529	3.390	11.490
	6	Weight (lbs)	20,000	34,000	48,000	57,600	80,640
		ESAL	0.050	0.094	2.019	4.020	15.450
	7	Weight (lbs)	27,000	47,500	68,000	81,600	95,200
		ESAL	0.131	1.414	5.860	11.290	20.790
	8	Weight (lbs)	26,000	47,000	68,000	81,600	114,240
		ESAL	0.066	0.454	3.529	7.050	25.430
	9	Weight (lbs)	25,000	52,500	80,000	96,000	134,400
		ESAL	0.043	0.439	3.203	6.400	23.070
	10	Weight (lbs)	35,000	57,500	80,000	96,000	134,400
		ESAL	0.070	0.453	1.892	4.268	15.800
	11	Weight (lbs)	36,000	58,000	80,000	96,000	134,400
		ESAL	0.124	0.244	3.203	6.400	23.070
	12	Weight (lbs)	42,000	61,000	80,000	96,000	134,400
		ESAL	0.134	0.538	1.627	3.185	12.910
	13	Weight (lbs)	50,000	65,000	80,000	96,000	134,400
		ESAL	0.168	0.393	0.581	2.136	8.530

Table 2-2: Selected vehicle classes in various states of loading

2.3 Analysis of Sensitivity to Vehicle Weights

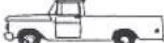
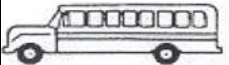
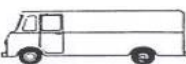
One of the most powerful uses of this spreadsheet is to evaluate the impact variations in WIM accuracy or vehicle mix have on estimated pavement life. For the example in Table 2-3, when the expected life is 20 years, we see that a WIM that overestimates the axle weight by 5% overestimates the life expectancy of the pavement by 3.1 years. Similarly, a WIM that underestimates the axle weight by 5% underestimates the life expectancy of the pavement by almost 4 years.

Weight Error Factor	Expected Life	Weight Error Factor	Expected Life	Weight Error Factor	Expected Life	Weight Error Factor	Expected Life
-40%	72.95	-20%	39.36	1%	19.49	21%	9.59
-39%	71.6	-19%	38.58	2%	18.81	22%	9.26
-38%	69.4	-18%	37.27	3%	18.15	23%	8.92
-37%	67.39	-17%	36.06	4%	17.72	24%	8.68
-36%	66.01	-16%	35.18	5%	16.9	25%	8.3
-35%	63.5	-15%	33.57	6%	16.34	26%	7.98
-34%	61.52	-14%	32.49	7%	15.9	27%	7.75
-33%	60.2	-13%	31.71	8%	15.34	28%	7.47
-32%	58.27	-12%	30.69	9%	14.47	29%	7.27
-31%	56.47	-11%	29.6	10%	14.05	30%	6.91
-30%	54.19	-10%	28.25	11%	13.72	31%	6.69
-29%	53.18	-9%	27.61	12%	13.25	32%	6.46
-28%	51.37	-8%	26.59	13%	12.75	33%	6.23
-27%	49.68	-7%	25.69	14%	12.4	34%	6.03
-26%	48.62	-6%	25.08	15%	11.9	35%	5.79
-25%	46.53	-5%	23.98	16%	11.44	36%	5.57
-24%	45.15	-4%	23.1	17%	11.41	37%	5.4
-23%	44.22	-3%	22.57	18%	10.73	38%	5.21
-22%	42.68	-2%	21.75	19%	10.35	39%	5.02
-21%	41.25	-1%	21.04	20%	9.86	40%	4.84

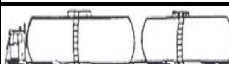
Table 2-3: Expected Life of Asphalt Pavement for Various WIM Errors

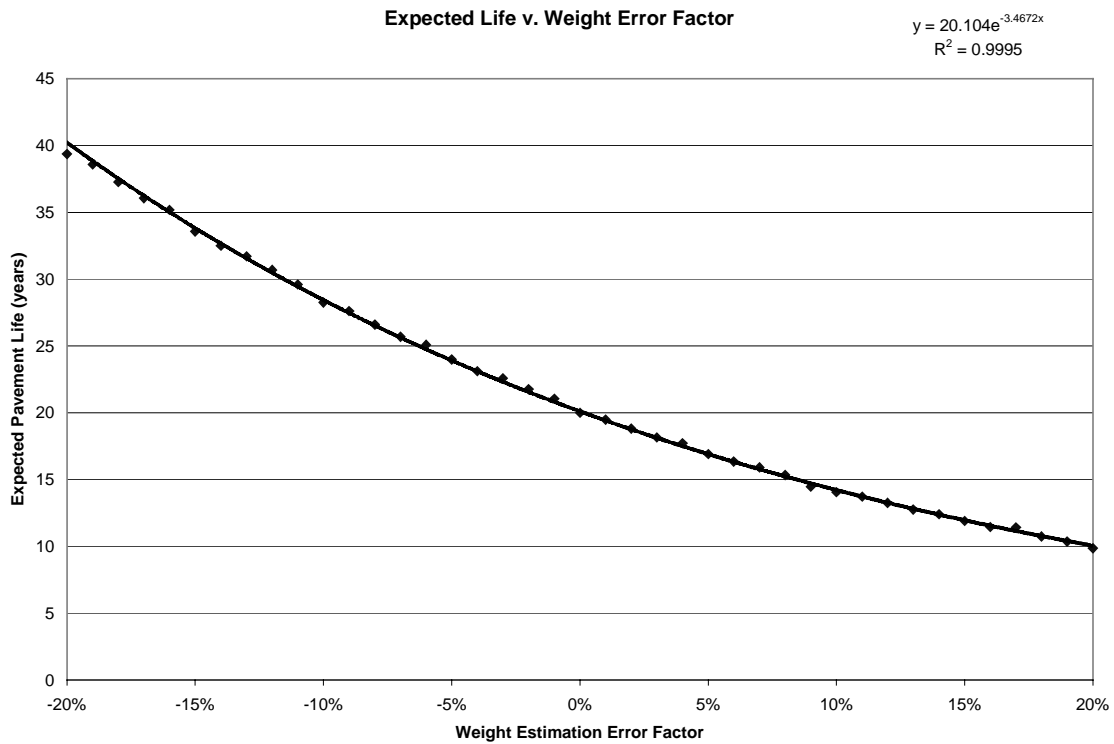

Figure 2-4: Expected Life of Pavement for Various WIM Errors

Since a typical section of interstate rehabilitation can cost roughly \$ 1,000,000 to \$4,000,000/ lane / mile, it is very important to obtain as accurate axle weight estimates as possible so that maintenance activities can be efficiently programmed.

Also, to estimate the impact overweight vehicles have on the life expectancy of pavement, consider the example from Figure 2-5. If the percentage of overweight vehicles is increased to 14%, the pavement life expectancy decreases from 20 years to 16.6 years.

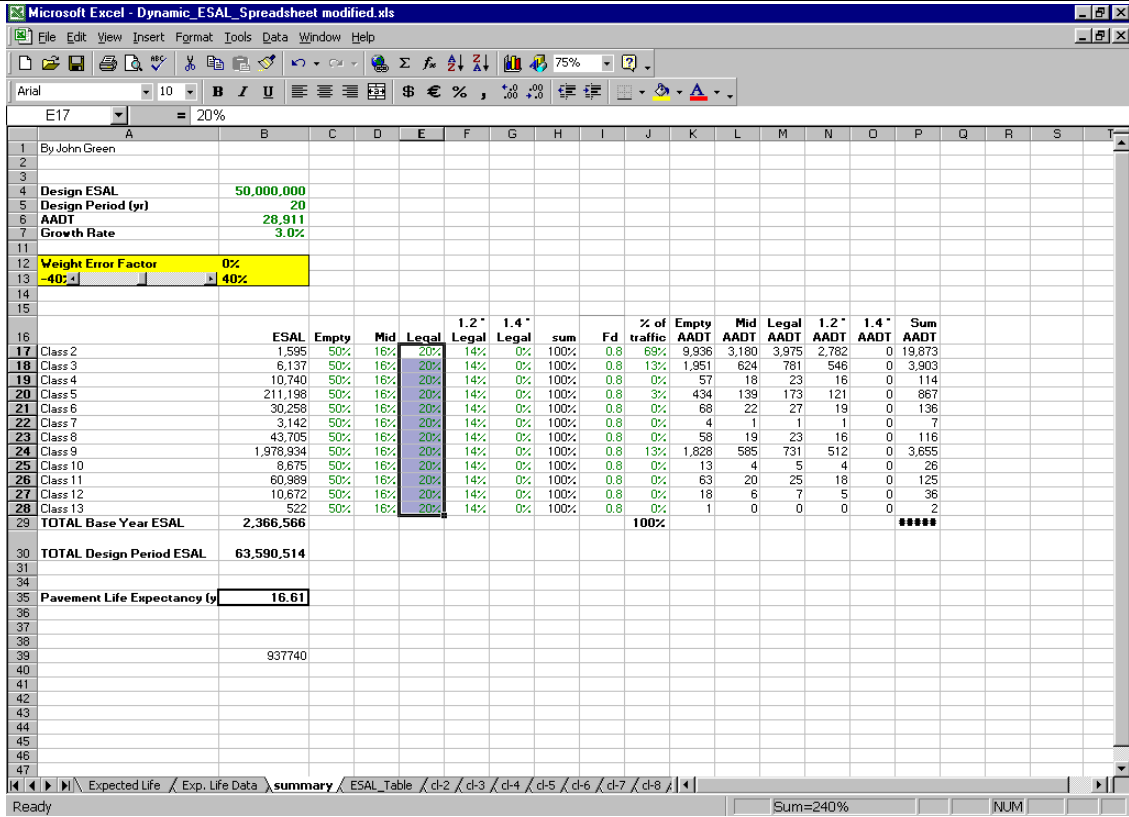

Figure 2-5: Pavement Life Expectancy with 14% of vehicles 1.2 * Legal Limit

3 Existing WIM Resources

Indiana has employed WIM scales for data collection purposes for over 10 years. The goal of this project is to determine if these existing devices could be used to screen overweight trucks. This chapter reviews the technology used by WIMs and their relative accuracy levels.

3.1 Existing Technologies

There are currently 3 different Weigh-In-Motion technologies commonly employed in the pavements of Indiana's highways. They are Piezo-electric sensors, Single Load Cells, and Bending Plate scales. The Kistler technology is not currently used in Indiana, but is used in Illinois. Of these three WIM scale types, Piezo-electric sensors cost the least, but unfortunately, also produce the least accurate results. The error rates that can be expected for each of the technologies are shown in Table 3-1. [Bushman, 1998]. Appendix D was provided by Rod Klashinsky of IRD and summarizes the estimated costs and perceived accuracies of the available technologies.

Technology	ASTM Type	GVW Accuracy
Piezo	2	15%
Bending Plate, Kistler	1	10%
Load Cell	3	6%

Table 3-1: Summary of ASTM 1318-94 Type Code and Accuracy for Common WIM Technology

Technology : Piezoelectric

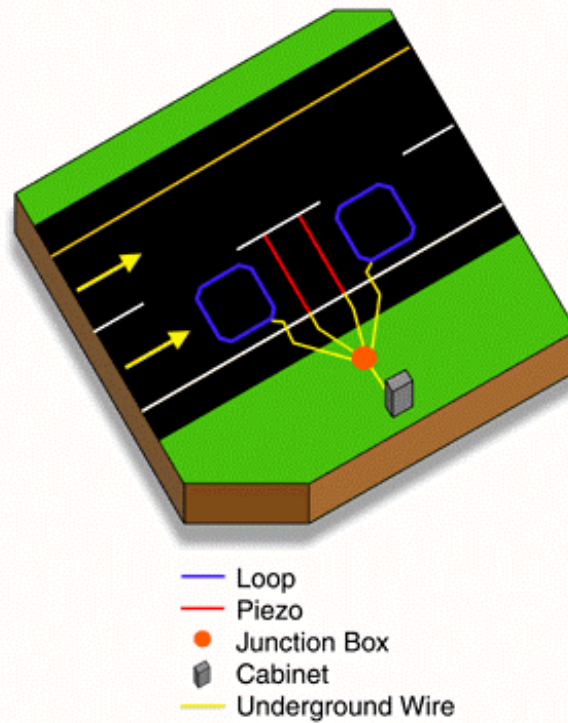

Figure 3-1: Piezoelectric WIM site configuration

3.1.1 Piezoelectric Technologies

At the heart of a piezoelectric sensor is a copper wire, surrounded by a piezoelectric material. When a vehicle passes over the sensor, the wire deforms slightly, and an electric charge is produced. The degree and characteristics of the electric charge are then analyzed to determine the weight of the vehicle.

Figure 3-1 shows the typical sensor configuration for a Piezo installation. Figure 3-2 shows a photograph of a failed Piezo installation in the northbound lane of I-65 at WIM site 5450. Figure 3-3 shows a photograph of a technician installing a Piezo sensor.



Figure 3-2: Piezo-electric WIM in pavement on I-65 NB, near Lafayette, IN



Figure 3-3: A technician installs a piezo-electric sensor

Technology : Single Load Cell

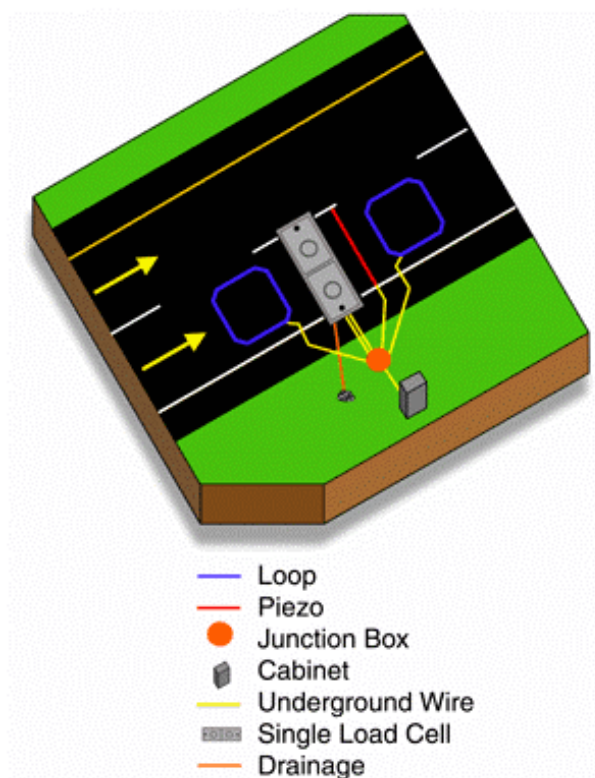

Figure 3-4: Single Load Cell site configuration

3.1.2 Single Load Cell

The Single Load Cell technology is believed to be the most accurate WIM weighing technology currently used in Indiana. It is also perhaps the most expensive of the technologies on a per site basis. Figure 3-4 shows the sensor configuration of a single load cell installation. Figure 3-5 shows a photograph of an installation on I-74 in the eastbound direction at station 5130.

The Single Load Cell (WIM) Scale consists of two interconnected weighing platforms, situated side-by-side, covering one lane of traffic. Each platform has one hydraulic load cell inside it that measures half the weight of a vehicle passing over it. Weights recorded by each weighing platform are then combined to produce axle weights and ultimately GVW.



Figure 3-5: Single load cells in each lane, I-74 WB, near Covington, IN

3.1.3 Bending Plates

A Bending Plate Scale consists of two steel platforms placed next to each other, covering an entire lane of traffic. When a vehicle moves across the steel plates, strain gauges attached to the plates determine the amount that they deform. The strains of each steel platform are then analyzed to determine the weight of the vehicle.

Bending Plates have been in use for a long time in Indiana. However, the cost of a Bending Plate installation is comparable with a Single Load Cell site, while the accuracy is almost as poor as experienced with Piezo sensors (Table 3-1). Figure 3-6 shows a photograph of a bending plate installation. Figure 3-7 shows a photograph of a failed bending plate installation at station 5450 filled in with asphalt.



Figure 3-6: Front axle of truck passing over Bending Plate



Figure 3-7: Failed Bending Plate Installation at WIM 5450 Filled with Asphalt

3.2 Suitability of Existing WIM Scales in Indiana for use with the Virtual Weigh Station

Appendix A contains records for each WIM scale site in Indiana. Figure 3-8 is a sample record for a multi-lane scale installation in operation in Indiana on an interstate highway (I-65). There are two parts to each record -- a figure on the top of the page showing the physical lane configuration, and a table at the bottom of each page detailing the equipment in each lane, the suitability for Virtual Weigh Station operations, and the date (if known) of the last scale calibration. The July 2000 and October 2000 suitability dates provide the following information:

- October 2000 – Suitability is based upon classification error data provided in Appendix E and Section 3.3.
- July 2000 – Suitability is based upon front axle accuracy data provided in Appendices F, H, Section 3.4, and summarized in Table H-18 and Table H-19.

The following section details the data that supports these entries. The last row of the table is a numerical evaluation of the site performance by Donn Klepinger in the winter of 2001. This is documented in Table A-4 and is referred to in this report as the Klepinger scale.

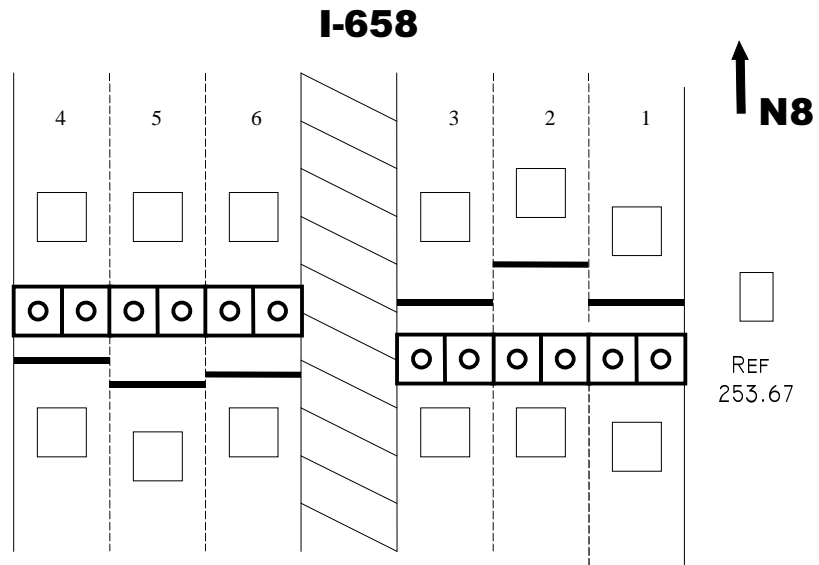

Figure A-13: Stations 4410 & 4420 Six Lane Divided

	Lane 1	Lane 2	Lane 3	Lane 4	Lane 5	Lane 6
WIM	X	X	X	X	X	X
Classification						
Sensor	SLC	SLC	SLC	SLC	SLC	SLC
Pavement	C	C	C	C	C	C
Suitable for VWS 7/00	NO DATA	NO DATA	NO DATA	NO DATA	NO DATA	NO DATA
Suitable for VWS 10/00	NO DATA	NO DATA	NO DATA	NO DATA	NO DATA	NO DATA
Suitable for VWS 2/01						
Klepinger Scale	6-	6-	6-	6-	6-	6-
Calibration Dates						

Table A-15: Stations 4410 and 4420 Inventory

Figure 3-8: Sample project record for a WIM scale installation

3.3 WIM Scale Error Rates

WIM accuracy is dependent upon three factors: pavement smoothness, vehicle dynamics, and the integrity of the WIM system [Bergen, 1997]. Errors due to vehicle dynamics are typically isolated to liquid loads, vehicles changing lanes, and peculiar loads. Pavement condition and WIM systematic errors are a much bigger concern.

Since INDOT has approximately 40 stations, an early decision in the project was to select several potential sites at which the Virtual Weigh Station system would be tested. The normal procedure that Indiana uses to test and calibrate its WIM scales involves running a standard vehicle of known weight (determined by weighing on the closest static scale installation) over the same WIM scale many times. With each passage of the known-weight vehicle, the WIM produced weight is recorded, and a technician adjusts a factor in the "In-cabinet" computer controlling the WIM scale. When the technician feels that the WIM readings are sufficiently accurate, 10 passes are made with the same truck to verify the repeatability of the system. Once this is verified, the procedure is ended and the WIM scale is considered calibrated. Because the standard procedure is time intensive, for this project it was decided that an alternative method needed to be developed to determine the level of accuracy at which the WIM scales operate.

In consultation with IRD, the vendor decided that to properly test the Virtual Weigh Station system it would be desirable to use WIM scales operating with less than 10% of the vehicle records unclassified. As a starting point, it was decided to examine the error rates for all stations during a week. The team was able to obtain reports produced between January 1998 and October 2000 that list the "best" weekly error rates for all the stations (composite error rate calculated over all lanes and for individual lanes). Figure 3-9 shows an example graph of the historical classification error rate of station 4250. Based upon analysis of this data (which is found in Appendix E) as of October 2000, 8 stations were reporting all lanes within the proposed tolerance level of 10% or less error. Appendix E summarizes this information in a memo and Figure E-1 through Figure E-36.

Further analysis of these stations was performed on a lane-by-lane basis. In that analysis, individual lanes were analyzed and only three stations (4250, 5260, 6260) had all lanes operating with less than 10% classification error.

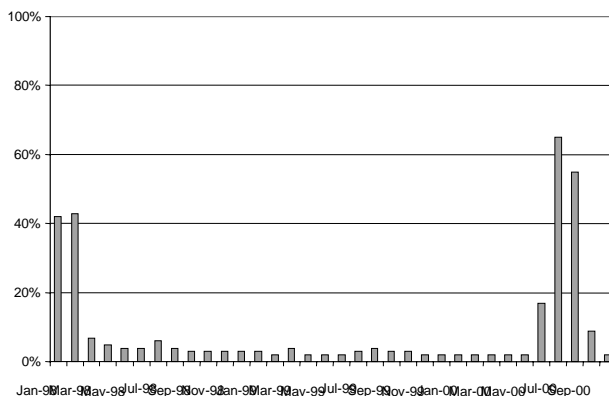

Figure 3-9: Station 4250, 1% Error in October 2000

3.4 Front Axle Histograms

The previous section discussed a screening procedure based on classification errors, but did not consider the accuracy of the axle weights. To evaluate the WIM scales' axle weight error, the front axle weights of all class 9 trucks on all WIM scales during July 2000 were tabulated [Dahlin, 1992]. The weights and configurations of commercial vehicles vary widely. Most of this variation can be attributed to the trailer and load. Previous researchers have reported that front axle weights are relatively uniform for class 9 trucks.

In light of this similarity, one would expect that if a scale were operating correctly, the front axles of most trucks crossing a weigh station would fall within this 9,000-Lb to 12,000-Lb range. This method was applied to the data gathered in July 2000 from the WIM sites in the state of Indiana. For each WIM site two graphs were plotted – a scatter plot of each valid (non-error) front axle weight record for the month, and a histogram constructed with 1500-lb intervals. The graphs were then subjectively judged for data “closeness of fit” to the predicted averages. This is how the “Suitability for VWS 7/00” row in each station record in Appendix A was determined. For example, Figure 3-10 and Figure 3-11 illustrate that the front axle data for lane 3 is clustered around 28,000 lbs. Such data indicate that weight data for lane 3 are probably not valid. In contrast, the data for lane 1 is clustered around a more believable 10,000 lbs, but appear to have too much dispersion.

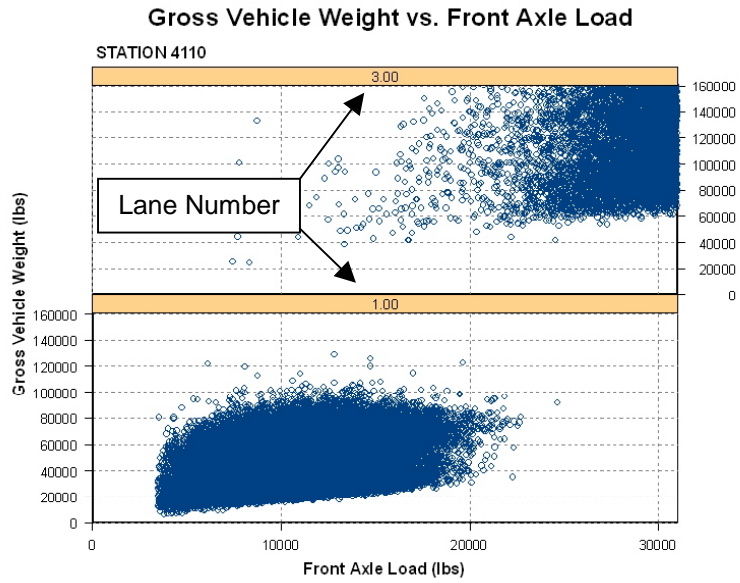

Figure 3-10: Scatter plot for Front Axle loads by lane distribution for station 4110, July 2000

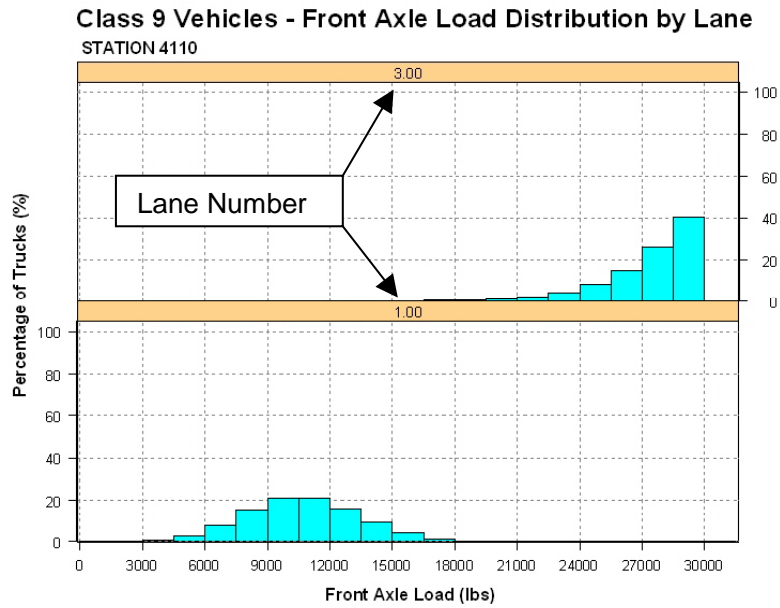

Figure 3-11: Histogram for Front Axle loads by lane distribution for station 4110, July 2000

3.5 Importance of WIM Accuracy

The importance of accurate WIM measurements for planning and design purposes cannot be understated. As demonstrated in chapter two, error rates of a relatively small 10% can cause pavement life estimates to be in error by almost 50%. When a pavement designed to last 20 years needs to be reconstructed in 14 years, both budgetary and political questions may arise. Therefore it is in the best interests of agencies operating WIMs to ensure that WIM scales produce highly accurate data. This is accomplished through preventative maintenance and calibration on a regular basis.

Resources expended to keep WIM sites operating at levels of high accuracy would serve the additional purpose of increasing the utility of the virtual WIM system. Accurate WIM data would increase the likelihood that vehicles chosen for weighing by portable scale by Commercial Vehicle Enforcement officers are in fact overweight. This would increase the effectiveness of scale enforcement research and serve to reduce the number of overweight trucks that lead to premature pavement failure.

4 Virtual Weigh Station System

The concept of using existing INDOT Weigh-In-Motion equipment, a laptop computer, and wireless communication equipment, to develop a virtual weigh station system was proposed for deployment in Indiana by Guy Boruff, Dan Shamo, and Jay Wasson in 1998. This project provided a mechanism for developing and testing the concept. The Virtual Weigh Station screening tool allows officers to read the weights of vehicles crossing WIM scales, in real time, in their patrol cars. Giving officers this information increases the chances that the vehicles selected for weighing on portable scales are indeed overweight.

4.1 “In-cabinet” Radio / Antenna Panel Equipment

Potentially, all of the existing WIM sites providing accurate weight data in Indiana can be used for weight enforcement details with the virtual weigh station system. For one of the existing WIM sites to be utilized, a radio modem needs to be installed in the WIM scale cabinet, and an antenna installed nearby. Close proximity is necessary because “line-of-sight” radios were employed. A listing of the current WIM sites in Indiana and a map of the sites are included in Appendix A (Table A-1 and Figure A-1).

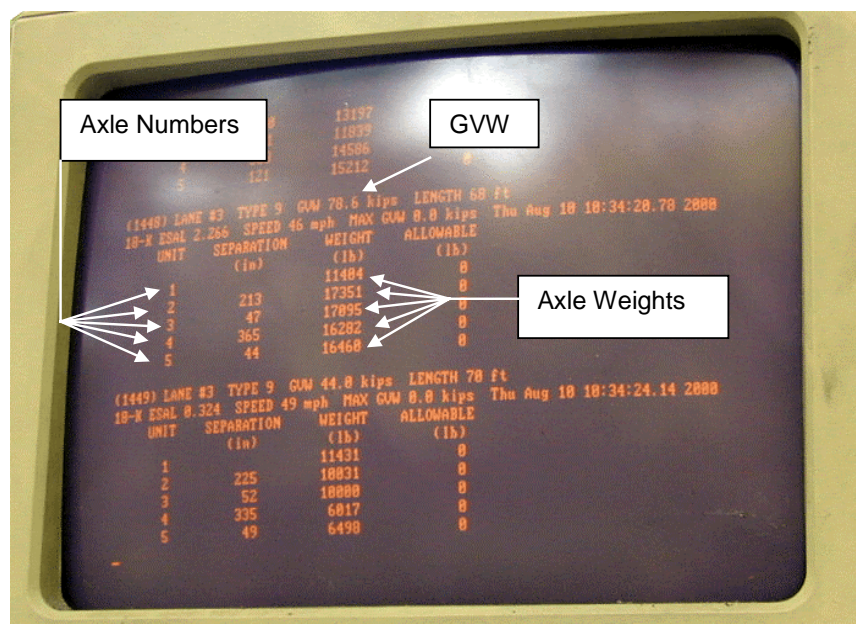

Figure 4-1: Sample WIM “in-cabinet” computer output screen

Located in Appendix J are two AutoCAD drawings. Figure J-1 depicts the dimensions of a metal plate needed to attach the Radio Modem to the inside of the WIM cabinet. Figure J-2 shows the modem and equipment used to provide the wireless connection in the WIM controller cabinets. This panel provides a wireless link to a laptop so that the information available at the cabinet WIM (Figure 4-1) is available to the Commercial Vehicle Enforcement Officer in their vehicle.

4.2 “In-vehicle” Equipment

The “in-vehicle” equipment needed for operation with the virtual weigh station system consists of a laptop computer (on which the Road Runner software is installed) connected to a Gina radio modem. The prototype equipment developed for this project is depicted in Figure 4-2. The prototype materials are portable – note the magnetic antenna and cushioned briefcase. After the Road Runner software was completely debugged, it was installed on all of the laptops located in the Indiana State Police Commercial Vehicle Enforcement Division patrol cars. Three hardware kits were assembled and given to CVE to use to connect to the WIM stations. A hardware kit is shown in Figure 4-3. The kit contains a radio modem, magnet-mount antenna, power cable, antenna cable, and serial cable. All of the equipment fits into a durable case and can be closed while being transferred between vehicles.



Figure 4-2: Virtual Weigh Station System Hardware



a. Open Case



b. Closed Case

Figure 4-3: Virtual Weigh Station Hardware Kit

4.3 Description of Road Runner Software Display

Figure 4-4 shows a screen-capture of the current configuration of the Road Runner software. The menus located at the top of the window allow the system user to connect to the WIM station and clear the screen. Within the communications menu, the user can choose a method of connection to the WIM station – either through a direction connection with wireless link, or through a dialup modem, ostensibly to check status of the system from an offsite location. The communication port to be used can also be selected. The “disconnect” button in this menu terminates the connection between the laptop and WIM. The “clear screen” menu button resets the output window that occupies the bottom half of the screen.

The first column from the left lists properties of the current vehicular record. “Date” and “time” are self-explanatory. “Record” lists the record number assigned by the WIM station so that individual vehicle information may be referenced later. “Lane” tells in which traffic lane the vehicle is traveling. “Axles” gives the number of axles that a vehicle has. “Class”, “Length”, “Speed”, and “GVW” also are self-explanatory.

The second column lists the individual axle weights for the current vehicle. If the vehicle has fewer axles than axle boxes, surplus axle boxes contain zeroes.

In the top right region of the window, the user can set the GVW limit threshold and enable and disable lanes and vehicle classes to view in the window. Since the primary intended use for the Road Runner system is as a tool for enforcement of commercial vehicle weight laws, the available class choices are limited to classes 7, 8, and 9. Additionally, the user has the option to select and view “All Classes” of vehicles. This option is not recommended for high volume traffic areas, because in high volume conditions the system may experience slight delays in listing vehicle records. When the threshold is exceeded, the computer running the software beeps and displays the weight in red text on a black background. The vehicle record, class, lane, and GVW are then logged in the “Violators” list in the middle right side of the window.

The bottom half of the screen logs the vehicle records obtained while the software is running. Fields shown in the bottom half include Date, Time, Record, Lane, Class, and GVW. In heavy traffic, a vehicle record may appear for only a second before the next record replaces it. The bottom half is intended to allow the user to examine any record data that he or she may have missed in its listing in the “current” position.

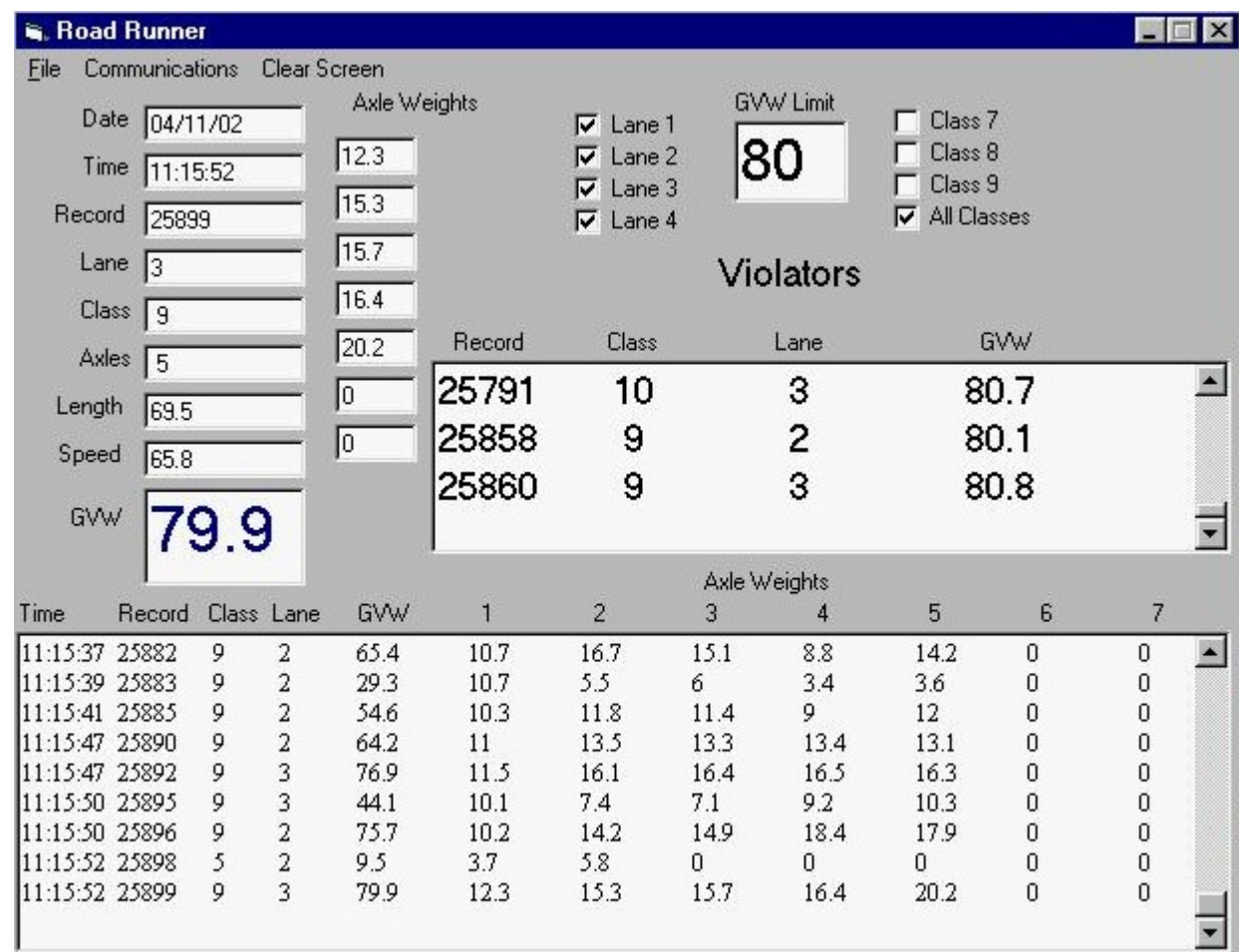

Figure 4-4: Screen Capture of latest version of Road Runner software

4.4 Procedure for System Use

A Commercial Vehicle Enforcement Division Officer in a vehicle equipped with the Road Runner wireless WIM system may use the existing WIM installation by locating his/her vehicle within an approximate one-mile radius of the antenna and within direct sight of the antenna. Figure 4-5 shows a picture of the antenna mounted at station 4410 on I-65 east. If the WIM installation covers traffic in two directions (for example, the Merrillville, Indiana WIMs #4410 and #4420), the officer needs to set the direction of interest in the cabinet before operating the system. Once these conditions have been met, the officer turns on the system in the vehicle and runs the software program to start observing vehicular weights.

When the Roadrunner software starts up, the user needs to establish communication. This can be done through a serial or modem connection.

Once a connection is established, the default threshold setting of 0.0 Kips will cause all vehicles crossing the WIM to register as overweight. To change the GVW limit threshold, the user must type in a higher number in the GVW limit box to set the overweight threshold to a higher weight, such as 80.0 kips (80,000 Lbs). While 80.0 kips is the legal GVW limit for class 9 vehicles, a higher or lower threshold may be more useful. Due to the dynamic nature of vehicles in motion – certain loads may cause vehicles to “bounce”. Bouncing vehicles may register slightly higher (or lower) than actual weights as they cross the WIM scales.

Another default setting of the Road Runner software that can be easily changed is class of vehicle selected. When the program starts, records for all classes of vehicles will be shown on the display. In the current software version, users have the option to choose to view either all classes or any combination of vehicle classes 7, 8, and/or 9. To change this setting, the user only needs to pick clearly labeled check boxes for the desired classes.

When a vehicle crosses the WIM whose GVW is greater than the current threshold, a warning tone is sounded and the box displaying the GVW increases in size and the GVW of the vehicle is shown in red numbers on a black background. If the officer chooses to chase the vehicle, due to the physical distances involved in catching the suspected vehicle, radio contact will probably be lost between the WIM cabinet and the “in-vehicle” system. After the officer inspects and weighs the vehicle with portable scales, radio contact needs to be reestablished. This is accomplished by closing the program and restarting it when the officer is back in position near the WIM. Once in position, with the system running again, the officer can again observe vehicular weights.



Figure 4-5: Antenna at WIM Station 4410 on I-65 Northbound at Milepost 253.62

4.5 Stored Data -- Log File

As an additional feature, the Road Runner software produces log files. Every vehicle record that the “in-vehicle” system receives from the WIM scale is stored in a log file, named according to the date that the system is in use. These log files are text files which can be analyzed easily with common spreadsheet software programs later. These files are in addition to the data that is continually logged in the WIM cabinet.

5 Enforcement Details

An important question for management of any organization is how to best employ scarce resources. This is especially true for the Commercial Vehicle Enforcement Division of the Indiana State Police. A goal of this project was to develop a quick method to determine when the greatest numbers of overweight vehicles operate. Presumably, if given this information, coordinators could schedule work shifts to produce the greatest impact on overweight vehicle interception operations. In a study of enforcement operations in several states, it was determined that in areas where enforcement is visible and regular, GVW violations can be lower than 1% [Taylor et al., 1999].

5.1 Determination Procedure

The times when Indiana State Police Commercial Vehicle Enforcement officers can be the most effective were determined by analyzing data already collected by the WIM sites and used for maintenance and planning purposes. Some states, such as California, already use WIM data to schedule enforcement hours [Bergen, 1998]. The assumption was made that Indiana State Police Commercial Vehicle Enforcement officers would have the highest probability of catching overweight vehicles when the greatest numbers of these overweight vehicles were operating. Therefore, enforcement details should be scheduled at these times to have the greatest impact.

Computer data files for an individual WIM site, covering the four weeks of February 2001, were analyzed. Table 5-1 and Table 5-2 show a portion of the traffic count results reported for the entire month of February 2001 for the WIM Stations 4410 (Northbound) and 4420 (Southbound), at Milepost 253.67 on I-65. While the February data was selected, the same procedure can be applied to any 4-week period. Table 5-1 and Table 5-2 show the overweight violations reported by the IRD software in a strict axle and GVW threshold. However, since there were some calibration problems at that site in February, to be conservative, only Class 9 vehicles that exceeded 90,000 lbs were considered "overweight". The number of trucks that weighed more than 90,000 lbs was calculated using a spreadsheet and the occurrences of the violations are tabulated in Table 5-3 through Table 5-7.

Status	Lane Number							
	1	1	2	2	3	3	All	All
	Count	%	Count	%	Count	%	Count	%
Legal	52,793	70.9	38,118	87.8	567	78	91,478	77.2
Overweight	21,425	28.8	5,077	11.7	151	20.8	26,653	22.5

Table 5-1: Class 9 Vehicles, Feb 01 00:00:00 2001 TO Thu Mar 01 00:00:00 2001 - Station 4410, Northbound

Status	Lane Number							
	1	1	2	2	3	3	All	All
	Count	%	Count	%	Count	%	Count	%
Legal	66,967	89.5	39,529	80.5	376	92.6	106,872	77.2
Overweight	7,733	10.3	9,437	19.2	25	6.2	17,195	13.8

Table 5-2: Class 9 Vehicles, Feb 01 00:00:00 2001 TO Thu Mar 01 00:00:00 2001 - Station 4420, Southbound

Counting overweight records and comparing the total amounts listed in each hourly group revealed the times when the most overweight vehicles operated. Table 5-3 through Table 5-7, Figure 5-1 and Figure 5-2 were constructed using this data. As was expected, most of the overweight vehicles were in Lane 1. Table 5-3, Table 5-4, and Table 5-5 show the number of Class 9 vehicles that exceeded 90,000 lbs, sorted by hour and day of week for lanes 1, 2, and 3 in the northbound direction. The Northbound lane 1 data is shown graphically in Figure 5-1. Similarly, Table 5-6 and Table 5-7 show the number of Class 9 vehicles that exceeded 90,000 lbs, sorted by hour and day of week for the Southbound direction (a negligible amount were observed in Lane 3), while Figure 5-2 shows the Southbound lane 1 data graphically.

Hour	Sunday	Monday	Tuesday	Wednesday	Thursday	Friday	Saturday
0	2	25	20	13	31	24	6
1	4	31	26	19	27	35	3
2	4	28	25	20	40	42	8
3	2	39	23	25	41	46	9
4	8	34	33	42	37	47	6
5	0	33	26	24	26	45	9
6	6	29	21	19	25	30	8
7	8	35	14	24	17	16	14
8	13	36	29	27	33	39	14
9	5	29	29	19	28	34	5
10	8	28	36	34	29	35	9
11	9	31	29	18	16	23	14
12	13	33	23	26	28	22	19
13	13	29	22	23	23	20	7
14	9	26	22	34	22	15	9
15	10	18	19	15	20	10	6
16	10	18	18	22	17	7	8
17	12	16	14	13	14	6	8
18	8	18	23	9	19	5	7
19	18	20	19	18	24	9	2
20	21	23	19	16	33	9	1
21	16	29	18	13	32	10	8
22	23	27	18	21	33	8	7
23	30	22	22	18	27	4	1
Total	252	657	548	512	642	541	188

Table 5-3: February 2001, Northbound, Lane 1, Class 9 Vehicles exceeding 90,000lbs.

Hour	Sunday	Monday	Tuesday	Wednesday	Thursday	Friday	Saturday
0	0	0	2	1	0	1	0
1	0	1	0	0	0	0	0
2	0	0	0	0	0	1	1
3	0	0	0	0	0	0	0
4	0	0	1	0	2	2	0
5	0	0	1	0	1	1	0
6	0	1	1	0	0	0	0
7	0	0	0	0	1	1	0
8	0	0	0	1	2	0	1
9	0	0	0	2	3	1	1
10	0	0	0	0	2	0	2
11	0	1	1	0	2	0	3
12	2	1	0	0	1	0	1
13	1	0	0	1	1	1	1
14	0	0	0	0	0	2	2
15	0	0	0	1	4	0	1
16	0	1	1	0	1	0	0
17	0	0	0	0	0	0	0
18	0	0	0	1	0	0	0
19	0	0	1	0	0	0	0
20	0	0	0	0	0	1	0
21	1	0	0	0	0	0	0
22	1	0	0	0	0	1	0
23	0	1	0	0	0	0	0
Total	5	6	8	7	20	12	13

Table 5-4: February 2001, Northbound, Lane 2, Class 9 Vehicles exceeding 90,000 Lbs.

Hour	Sunday	Monday	Tuesday	Wednesday	Thursday	Friday	Saturday
0	0	0	0	0	0	0	0
1	0	0	0	0	0	0	0
2	0	0	0	0	0	0	0
3	0	0	0	0	0	0	0
4	0	0	0	1	0	0	0
5	0	0	0	0	0	0	0
6	0	0	0	0	0	0	0
7	0	0	0	0	0	0	0
8	0	0	0	0	0	0	0
9	0	0	0	0	0	0	0
10	0	0	0	0	0	0	0
11	0	0	0	0	0	0	0
12	0	0	0	0	1	0	0
13	0	0	0	0	0	0	0
14	0	0	0	0	0	0	0
15	0	0	0	0	0	0	0
16	0	0	0	0	0	0	0
17	0	0	0	0	0	0	0
18	0	0	0	0	0	0	0
19	0	0	0	0	0	0	0
20	0	0	0	0	0	0	0
21	0	0	0	0	0	0	0
22	1	0	0	0	0	0	0
23	0	0	0	0	0	0	0
Total	1	0	0	1	1	0	0

Table 5-5: February 2001, Northbound, Lane 3, Class 9 Vehicles exceeding 90,000 Lbs.

Hour	Sunday	Monday	Tuesday	Wednesday	Thursday	Friday	Saturday
0	0	0	0	0	2	2	0
1	0	0	0	1	1	0	0
2	0	0	0	0	1	0	1
3	1	0	1	0	1	0	0
4	0	2	1	2	0	0	0
5	0	4	3	1	3	1	2
6	1	0	0	1	1	1	0
7	0	1	1	1	1	0	0
8	0	3	2	0	0	1	0
9	0	1	0	0	2	2	0
10	1	0	0	1	0	0	1
11	0	1	3	0	1	0	0
12	0	1	2	1	0	1	0
13	0	0	0	3	1	1	2
14	0	1	0	2	0	1	1
15	0	0	1	0	2	0	0
16	0	0	0	1	3	1	1
17	0	0	0	0	0	2	2
18	0	0	0	1	2	0	3
19	1	2	0	1	1	0	1
20	2	0	3	0	0	0	0
21	3	2	1	0	0	0	1
22	2	2	1	5	0	7	1
23	0	0	1	0	0	4	2
Total	11	20	20	21	22	24	18

Table 5-6: February 2001, Southbound, Lane 1, Class 9 Vehicles exceeding 90,000 Lbs.

Hour	Sunday	Monday	Tuesday	Wednesday	Thursday	Friday	Saturday
0	2	0	1	1	1	0	0
1	0	1	2	1	0	0	0
2	0	0	0	1	0	0	0
3	0	0	0	0	0	0	0
4	0	0	0	0	1	0	0
5	0	1	1	1	0	0	1
6	0	0	0	0	0	0	0
7	1	0	0	0	0	0	0
8	0	0	0	0	1	0	0
9	0	1	0	0	0	0	0
10	0	0	0	0	0	0	0
11	0	0	1	1	0	0	0
12	1	0	1	0	1	1	0
13	0	2	2	0	0	1	3
14	0	0	2	1	0	0	2
15	0	0	0	0	0	0	2
16	1	1	1	0	0	0	1
17	0	0	1	2	0	0	0
18	1	1	1	2	2	0	0
19	0	0	1	0	0	2	0
20	0	1	1	0	0	3	0
21	0	0	2	0	0	1	1
22	0	1	1	1	0	3	0
23	0	1	1	0	1	0	0
Total	6	10	19	11	7	11	10

Table 5-7: February 2001, Southbound, Lane 2, Class 9 Vehicles exceeding 90,000 Lbs.

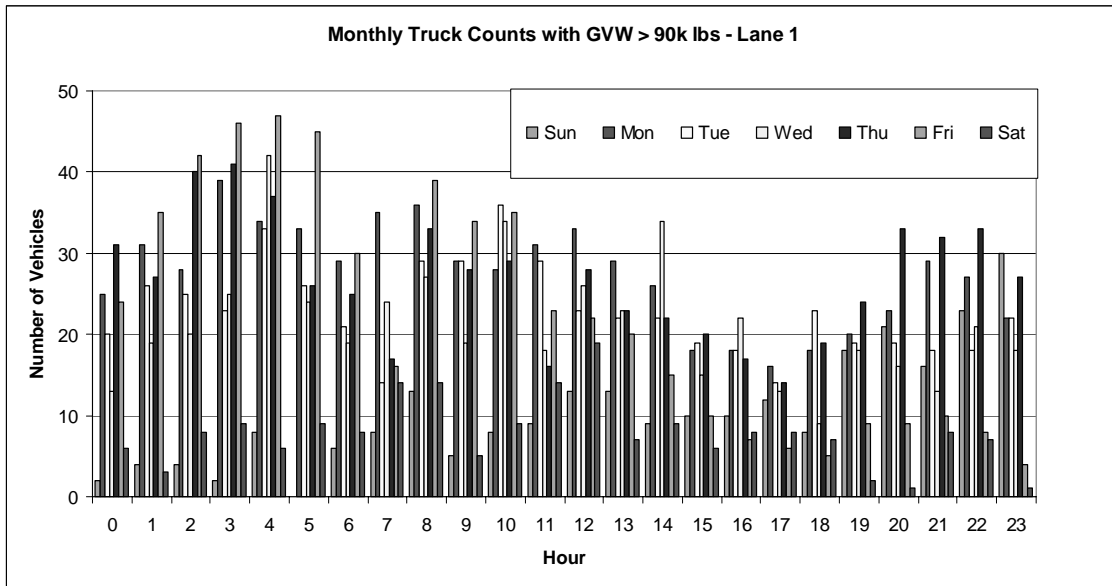

Figure 5-1: Overweight Northbound Lane 1, Class 9 Vehicles

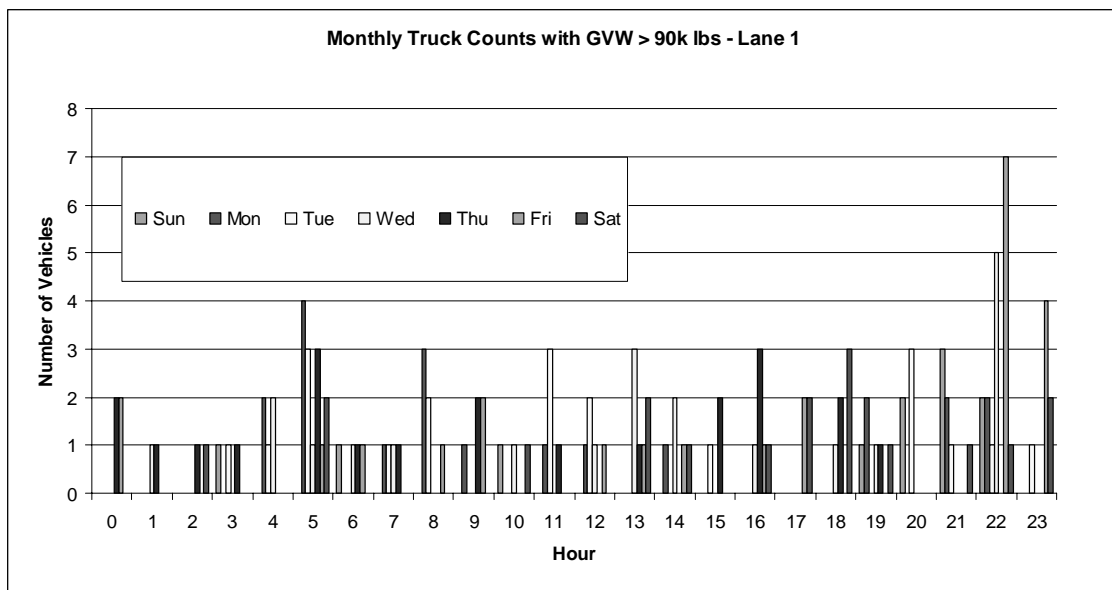

Figure 5-2: Overweight Southbound Lane 1, Class 9 Vehicles

5.2 Results from Analysis of February 2001 WIM Data on I-65 at Milepost 253.67

Careful examination of the tables produces several conclusions about February 2001 traffic:

- Overall, 22.5% of the Northbound and 13.8% of the Southbound Class 9 traffic was considered overweight.
- A total of 3414 out of 91,478 (3.7%) Class 9 vehicles exceeded 90,000 lbs in the northbound direction during February 2001.
- A total of 210 out of 106,872 (0.2%) Class 9 vehicles exceeded 90,000 lbs in the southbound direction during February 2001.
- The morning Friday hours in the Northbound direction, say from 2am to 6am, appear to be when most 90,000lb+ vehicles pass the WIM (see Table 5-3). Since there were 4 weeks in this reporting period, during those periods about 10-11 trucks per hour were over 90,000 lbs.
- Mondays and Thursdays are when the largest number of northbound 90,000lb+ vehicles pass the WIM.

Similar analyses were performed for the WIMs on SR 1, US 24, and I-80/I-94. The results are summarized in the memos in Appendix K, Appendix L, Appendix P, and Appendix S.

It is widely recognized that overweight violation rate is inversely related to enforcement visibility [Taylor et al., 2000]. Therefore, the effectiveness of specific detail times and locations should decrease over time as commercial vehicle operators become aware of scheduled operations. When portable-scale detail effectiveness lessens noticeably (or sooner), current WIM traffic data should be gathered and analyzed. In this way, enforcement officers are likely to be in the areas where and when they may intercept the most overweight vehicles.

5.3 Summary of Enforcement Details

Several field studies were conducted with the virtual WIM equipment throughout its development. A first test was performed on August 10, 2000 on I-65 at WIM 5450 to test the theory that overweight vehicles could be identified in moderate traffic conditions as they passed over a WIM scale. On January 04, 2001 tests were conducted on I-74 near Covington, Indiana to determine if the prototype "in-vehicle" equipment and Road Runner software were working properly, and to learn if the discrepancies between WIM-recorded GVW and actual (weigh station static-scale-recorded) GVW would be prohibitive for virtual WIM system use. Once the prototype virtual WIM system was

complete, it was tested under actual field enforcement conditions on March 23, May 08, May 15, May 18, May 21, and May 23 of 2001. The following text summarizes those details.

5.3.1 Summary of 8-10-00 Tests on I-65, near Lafayette, IN

INDOT Official Jay Wasson, and Indiana State Police Officers Guy Boruff, Monty Buffum, and Jeff Ligget performed the first Weigh-In-Motion detail on August 19, 2000. This detail was run at WIM scale #5450 to determine if overweight vehicles could be identified in moderate traffic conditions as they passed over a WIM scale.

The procedure employed was straightforward. Weights were observed on the monitor in the WIM computer cabinet (Figure 4-1). When overweight vehicles crossed the WIM scales the information was communicated to Indiana State Police Commercial Vehicle Enforcement Officers in patrol cars. The selected vehicles were chased, escorted out of traffic, and weighed using Haenni WL101 portable static scales. The WIM data weights were compared to the actual, static scale weights, and it was determined that the vehicles selected for weighing were indeed the trucks selected using the WIM. It was during this detail that the 111,350-Lb, overweight vehicle in Figure 1-1 was caught.

5.3.2 Summary of the 1-04-01 Tests on I-74, near Covington, IN

Tests were performed on January 04, 2001 primarily to test the performance of the prototype virtual WIM equipment, and secondarily to test the accuracy of the WIM scale #5130 on I-74, which is approximately 10 miles West of the Covington, IN static scale installation. Indiana State Police Officers Monty Buffum, Steve Baumgart, Jeff Ligget, and Sharon Branam, and Purdue University researchers John Green and Ed Allen performed the study.

With the prototype "in-vehicle" equipment inside, a patrol car was positioned near WIM scale #5130 to select and record the weights of vehicles from eastbound traffic. After weights for the vehicle were recorded, a physical description of the vehicle was then radioed to the group members inside the Covington Scale house. When a vehicle matching a description forwarded by the detail near the WIM scale was weighed by the static scales, its individual axle weights and GVW were recorded. Later the data was compared and analyzed to determine accuracy.

The weights of 24 vehicles were compared using the WIM and Covington Weigh Station static scales, representing classes of vehicles 7 through 10 (classes of commonly overweight vehicles). The data collected is shown in Table B-1. A scatter plot graph comparing WIM weights to actual (Covington Scale) weights is shown in Figure B-1. After that detail was completed, it was found that it did not meet INDOT accuracy specifications. Subsequent work by the vendor involved closing a lane to repair a splice and adding additional filtering to get rid of noise. Because a very high level of compliance was observed here, no further details were scheduled.

5.3.3 Summary of the Enforcement Details on I-65, near Merrillville, IN

The completed prototype virtual WIM system was tested to determine its effectiveness in actual enforcement conditions on March 23, May 08, May 15, May 18, May 21, May 23, and May 31 of 2001. The procedure employed for each day of testing was the same. All of the details were performed on I-65 (Northbound) near Merrillville, IN to test the accuracy of WIM site #4410 and identifying overweight vehicles. The detail teams variously involved Indiana State Police Officers Deb Burkhart, Henry Davis, Scott Fleming, Scott Nagle, and Gerald Young, and Purdue University Researchers John Green and Ed Allen.

The procedure involved observing the weights of vehicles until one registered as overweight on the Road Runner software (on the "in-vehicle" computer) as it crossed the WIM scale heading north. The patrol car using the virtual WIM system then chased the suspected overweight vehicle and escorted it off of the Interstate.

Once off the Interstate, the vehicle was led to a safe location where it was weighed with Haenni static scales. After the individual axle weight and GVW measurements were obtained, appropriate enforcement actions were taken. In the cases of legally operating vehicles, the truck drivers were allowed to leave unhindered. Drivers of those vehicles found to be in violation of one or more Federal and/or State law were given either warnings or issued citations, depending on the severity of their violations. In several cases, the vehicles were found to be so grossly overweight that the vehicles were impounded with the appropriate local authorities. A copy of the report issued to one such vehicle is shown in Figure 5-3.

The actual individual axle weights and GVW of the vehicle were then recorded and compared to determine WIM accuracy. This information was then relayed to a WIM technician from International Road Dynamics, who adjusted factors within the "in-cabinet" WIM system software in an attempt to better calibrate the WIM scale. The combined results of each test are shown in Table 5-8 and in Figure 5-4. Additionally, the results of each enforcement detail are located in Appendix I. When the calibration adjustments were made, the patrol returned to a spot on the shoulder of I-65 to observe and await the next suspected overweight vehicle. As you can see from Figure 5-4, there is a large scatter in the data for this station. Subsequent investigation by IRD has indicated that there is a bad load cell in lane 1. Both load cells in lane 1 were replaced on May 31, 2001.



	Indiana State Police Commercial Vehicle Enforcement Division 5252 Decatur Blvd., Suite J Indianapolis, IN 46241 (317)615-7373	DRIVER VEHICLE INSPECTION REPORT Report #: INAC700009 Date: 05/18/01 Time Started: 01:00 Time Ended: 01:41 Insp. Level: 2 (Walk-Around Inspection)																																																		
ICC: [REDACTED] DOT #: [REDACTED] Fax #: [REDACTED]	Driver: [REDACTED] License: [REDACTED] DOB: [REDACTED] State #: [REDACTED] Cargo: [REDACTED]	State: [REDACTED]																																																		
Location: I65 NB Highway: [REDACTED] Shipper: [REDACTED]	MilePost: 253MM County: LAKE	Origin: [REDACTED] Destination: [REDACTED] Shipping Paper #: [REDACTED]																																																		
VEHICLE IDENTIFICATION <table border="0" style="width: 100%; border-collapse: collapse;"> <thead> <tr> <th style="text-align: left;">Unit</th> <th style="text-align: left;">Type</th> <th style="text-align: left;">Make</th> <th style="text-align: left;">Yr</th> <th style="text-align: left;">Company</th> <th style="text-align: left;">License</th> <th style="text-align: left;">State</th> <th style="text-align: left;">CVSA #</th> <th style="text-align: left;">HAZARDOUS MATERIALS HM Code/Class</th> <th style="text-align: left;">Qty</th> <th style="text-align: left;">Wst</th> </tr> </thead> <tbody> <tr> <td>1</td> <td>TT</td> <td>PTRB</td> <td>85</td> <td>43</td> <td>[REDACTED]</td> <td>[REDACTED]</td> <td></td> <td></td> <td></td> <td></td> </tr> <tr> <td>2</td> <td>ST</td> <td>MCKT</td> <td>96</td> <td>mt43</td> <td>[REDACTED]</td> <td>[REDACTED]</td> <td></td> <td></td> <td></td> <td></td> </tr> </tbody> </table>	Unit	Type	Make	Yr	Company	License	State	CVSA #	HAZARDOUS MATERIALS HM Code/Class	Qty	Wst	1	TT	PTRB	85	43	[REDACTED]	[REDACTED]					2	ST	MCKT	96	mt43	[REDACTED]	[REDACTED]																							
Unit	Type	Make	Yr	Company	License	State	CVSA #	HAZARDOUS MATERIALS HM Code/Class	Qty	Wst																																										
1	TT	PTRB	85	43	[REDACTED]	[REDACTED]																																														
2	ST	MCKT	96	mt43	[REDACTED]	[REDACTED]																																														
BRAKE ADJUSTMENTS Axle # Right Left Chamber																																																				
VIOLATIONS <table border="0" style="width: 100%; border-collapse: collapse;"> <thead> <tr> <th style="text-align: left;">Violation Code</th> <th style="text-align: left;">St</th> <th style="text-align: left;">Unit</th> <th style="text-align: left;">OOS</th> <th style="text-align: left;">Citation #</th> <th style="text-align: left;">Verify</th> <th style="text-align: left;">Violations Discovered</th> </tr> </thead> <tbody> <tr> <td>395.8(f)(1)</td> <td></td> <td>D</td> <td>N</td> <td>warning</td> <td>N</td> <td>Log book not current, last entry at 14:30 on 05/17/01</td> </tr> <tr> <td>9-20-4-1</td> <td>X</td> <td>D</td> <td>N</td> <td></td> <td>N</td> <td>Overweight Axles drv tandems 37,700/34,00</td> </tr> <tr> <td>9-20-4-1</td> <td>X</td> <td>D</td> <td>N</td> <td></td> <td>N</td> <td>Overweight spread axle 50,100/40,00</td> </tr> <tr> <td>9-20-4-1</td> <td>X</td> <td>D</td> <td>N</td> <td>i078448</td> <td>N</td> <td>Overweight Gross(98,700/80,000</td> </tr> <tr> <td>9-18-2-19</td> <td>X</td> <td>D</td> <td>N</td> <td></td> <td>N</td> <td>Failure to carry registration traile</td> </tr> </tbody> </table>											Violation Code	St	Unit	OOS	Citation #	Verify	Violations Discovered	395.8(f)(1)		D	N	warning	N	Log book not current, last entry at 14:30 on 05/17/01	9-20-4-1	X	D	N		N	Overweight Axles drv tandems 37,700/34,00	9-20-4-1	X	D	N		N	Overweight spread axle 50,100/40,00	9-20-4-1	X	D	N	i078448	N	Overweight Gross(98,700/80,000	9-18-2-19	X	D	N		N	Failure to carry registration traile
Violation Code	St	Unit	OOS	Citation #	Verify	Violations Discovered																																														
395.8(f)(1)		D	N	warning	N	Log book not current, last entry at 14:30 on 05/17/01																																														
9-20-4-1	X	D	N		N	Overweight Axles drv tandems 37,700/34,00																																														
9-20-4-1	X	D	N		N	Overweight spread axle 50,100/40,00																																														
9-20-4-1	X	D	N	i078448	N	Overweight Gross(98,700/80,000																																														
9-18-2-19	X	D	N		N	Failure to carry registration traile																																														
ACCIDENT/INCIDENT # : PROJECT CODE : OT : RD																																																				
IN ACCORDANCE WITH 49 CFR-396.9(d), SHOULD ANY VIOLATIONS BE NOTED, COMPLETE THIS CERTIFICATION AND RETURN TO THE POLICE AGENCY ABOVE WITHIN FIFTEEN (15) DAYS. BY DOING SO, YOU VERIFY AND ACKNOWLEDGE ALL NOTED VIOLATIONS AND THE COMPLETION OF EFFECTIVE CORRECTIVE MEASURES.																																																				
Signature of Carrier Official: X _____ Date: _____																																																				
<table border="0" style="width: 100%; border-collapse: collapse;"> <tr> <td style="width: 30%;">Report Prepared By:</td> <td style="width: 20%;">Badge #:</td> <td style="width: 30%;">Copy Received By:</td> <td style="width: 20%;"></td> </tr> <tr> <td>HENRY DAVIS</td> <td>5146</td> <td>[REDACTED]</td> <td></td> </tr> <tr> <td>X _____</td> <td></td> <td>X _____</td> <td></td> </tr> </table>											Report Prepared By:	Badge #:	Copy Received By:		HENRY DAVIS	5146	[REDACTED]		X _____		X _____																															
Report Prepared By:	Badge #:	Copy Received By:																																																		
HENRY DAVIS	5146	[REDACTED]																																																		
X _____		X _____																																																		
<div style="text-align: right;">Page #: 1 Last Page</div>																																																				

Figure 5-3: Driver Vehicle Inspection Report of Vehicle Impounded by ISP Officer Henry Davis on May 18, 2001, caught using the “In-vehicle” system – GVW was 98,700 Lbs (compared to 80,000 Lbs allowable)



Indiana State Police
Commercial Vehicle Enforcement Division
 5252 Decatur Blvd., Suite J
 Indianapolis, IN 46241
 (317)615-7373

DRIVER VEHICLE INSPECTION REPORT
 Report #: INAC700022
 Date: 06/01/01
 Time Started: 04:50 Time Ended: 06:06
 Insp. Level: 2 (Walk-Around Inspection)

Driver: [REDACTED]
 License #: [REDACTED]
 DOB: [REDACTED] State: [REDACTED]
 State #: [REDACTED]
 Cargo: [REDACTED]
 DOT #: [REDACTED]
 Fax #: [REDACTED]

ICC [REDACTED]
 Phone #: [REDACTED]

Location: 61ST AVE MilePost: [REDACTED]
 Highway: [REDACTED] County: [REDACTED]
 Shipper: [REDACTED]

Origin: WHEELING, WV
 Destination: GARY, IN
 Shipping Paper #: [REDACTED]

VEHICLE IDENTIFICATION

Unit	Type	Make	Yr	Company	License	State	CVSA #
1	TT	FRHT	98	9307	[REDACTED]	[REDACTED]	
2	ST	RITZ	00	9307a	[REDACTED]	[REDACTED]	

HAZARDOUS MATERIALS

HM Code/Class	Qty	Wst

BRAKE ADJUSTMENTS
 Axle #
 Right
 Left
 Chamber

VIOLATIONS

Violation Code	St	Unit	OOS	Citation #	Verify	Violations Discovered
395.8(k)(2)		D	Y	1078362	N	Log book not current, last entry at 1:00pm on 05/30/01
395.8(k)(2)		D	Y	WARNING	N	Driver failing to retain previous 7 days logs
9-20-4-1	X	D	N	1078361	N	Overweight Gross(392.2W C.F.R.)126,500/80,00
9-20-4-1	X	D	N		N	Overweight Axle(s)(392.2W C.F.R) 54,600/34000
9-20-4-1	X	D	N		N	Overweight spreadAxle(s)(392.2W C.F.R) 59,200/34,000
9-18-2-19	X	D	N		N	Failure to carry Original IRP Cab Card (392.2 C.F.R)
8-2.1-24-21	X	D	N		N	No Company Signs (b-t express inc
8-2.1-14-20	X	D	N		N	NoSingle State Registration (b-t express)
6-6-4.1-12	X	D	N		N	No or Expired Fuel Tax Permit (392.2 C.F.R) b-t express
392.16		D	N		N	Failing to use seat belt while operating CMV
392.2		D	N		N	no lease agreement (b-t express)

ACCIDENT/INCIDENT # : PROJECT CODE : OT : RD

Pursuant to title 49 CFR-395.13(c) and (d) [REDACTED] is considered OOS until 2:00 PM 06/01/01. No motor carrier shall require or permit a driver, nor shall any driver placed OOS drive any CMV until all terms of the OOS order has been fulfilled. OOS at:

IN ACCORDANCE WITH 49 CFR-396.9(d), SHOULD ANY VIOLATIONS BE NOTED, COMPLETE THIS CERTIFICATION AND RETURN TO THE POLICE AGENCY ABOVE WITHIN FIFTEEN (15) DAYS. BY DOING SO, YOU VERIFY AND ACKNOWLEDGE ALL NOTED VIOLATIONS AND THE COMPLETION OF EFFECTIVE CORRECTIVE MEASURES.

Signature of Carrier Official: X _____ Date: _____

Report Prepared By:
 HENRY DAVIS
 X _____

Badge #:
 5146

Copy Received By:
 [REDACTED]
 X _____

Page #: 1
 Last Page

Figure 5-4: Driver Vehicle Inspection Report of vehicle impounded by ISP Officer Henry Davis on June 01, 2001, caught using the "In-vehicle" system.

Description	Record #	Axle 1	Axle 1	Tandem 1	Tandem 1	Tandem 2	Tandem 2	GVW WIM	GVW Scale	Error	%Err
		WIM	Scale	WIM	Scale	WIM	Scale				
CL9/L2	008679	11,200	11,600	28,300	30,000	31,700	30,900	71,200	72,500	-1,300	-2%
CL9/L1	010093	11,800	11,900	33,200	32,800	30,400	31,300	75,400	76,000	-600	-1%
CL9/L1	011130	11,100	10,200	33,700	33,100	36,000	32,900	80,800	76,200	4,600	6%
CL9/L1	012132	12,500	12,200	33,100	32,200	32,200	31,000	77,800	75,400	2,400	3%
CL9/L1	013522	12,500	12,700	31,100	32,100	35,600	32,400	79,200	77,200	2,000	3%
CL9/L3	015038	12,600	12,200	33,500	32,800	33,400	32,400	79,600	77,300	2,300	3%
CL9/L1	016548	10,400	11,100	35,000	29,000	38,700	35,400	84,000	75,400	8,600	11%
CL9/L2	017419	11,100	11,500	31,100	32,400	33,400	34,200	75,700	78,100	-2,400	-3%
CL9/L1	018261	9,200	9,000	46,400	38,700	41,600	37,200	97,200	84,800	12,400	15%
CL9/L1 - Freight Box	021143	11,500	11,750	33,500	32,400	35,500	32,800	82,600	76,950	5,650	7%
CL9/L1 - Freight Box	022494	10,800	10,700	34,100	35,300	36,900	32,800	81,800	78,800	3,000	4%
CL9/L2 - Grain	026191	11,600	12,700	34,400	39,800	37,400	41,300	83,400	93,800	-10,400	-11%
CL9/L1 - Steel Coil	003003	10,900	11,400	44,300	32,500	29,200	32,400	84,500	76,300	8,200	11%
CL9/L1 - Container	005352	11,000	11,400	34,100	34,900	33,700	32,800	78,800	79,100	-300	0%
CL9/L1 - Freight Box	005360	11,600	12,500	32,700	35,200	33,000	31,700	77,300	79,400	-2,100	-3%
CL7/L1 - 4-Axle Dump	004050	19,100	19,100	75500*	50100*	0	0	93,400	69,200	24,200	35%
CL9/L1 - Short Dump	009810	9,400	10,200	36,300	27,900	45,500	35,100	91,200	73,200	18,000	25%
CL9/L1 - Short Dump	011336	9,400	10,400	33,000	31,100	43,300	39,300	85,700	80,800	4,900	6%
CL9/L2 - Spread Axle	000500	9,800	10,900	32,500	37,700	48,000	50,100	90,400	98,700	-8,300	-8%
CL9/L2 - Spread Axle	001244	10,900	11,800	34,400	38,600	46,300	50,200	91,500	100,600	-9,100	-9%
CL9/L1 - Freight Box	001844	11,100	12,200	37,300	35,300	35,200	33,100	83,600	80,600	3,000	4%
CL9/L1 - Freight Box	002984	9,700	11,200	37,900	36,600	36,100	31,300	83,700	79,100	4,600	6%
CL7/L1 - 4-Axle Dump	009184	11,100	13,650	60,700	50,100*	0	0	71,900	63,750	8,150	13%
CL9/L1 - Short Dump	010944	8,800	9,650	31,000	25,800	35,400	32,450	75,300	67,900	7,400	11%
CL9/L1 - Short Dump	012501	8,600	9,950	31,800	27,350	39,000	31,600	79,400	68,900	10,500	15%
CL9/L1 - Grain Hauler	013812	9,300	10,650	38,000	40,200	38,300	38,750	85,500	89,600	-4,100	-5%
CL9/L1 - Steel Hauler	015951	8,300	8,450	33,500	33,250	38,900	34,000	80,800	75,700	5,100	7%
CL9/L1 - Tanker	010490	11,000	11,750	34,300	31,900	35,500	33,100	80,700	76,750	3,950	5%
CL9/L1 - Steel Hauler	000493	10,500	9,700	38,000	36,600	32,700	37,100	81,200	83,400	-2,200	-3%
CL9/L1 - Timber Hauler	001301	12,500	11,800	36,800	40,700	36,700	34,100	86,200	86,600	-400	0%
CL9/L1 - Steel Hauler	002706	13,800	12,700	47,700	54,600	51,600	59,200	113,200	126,500	-13,300	-11%

Table 5-8: Combined Results of Enforcement Details

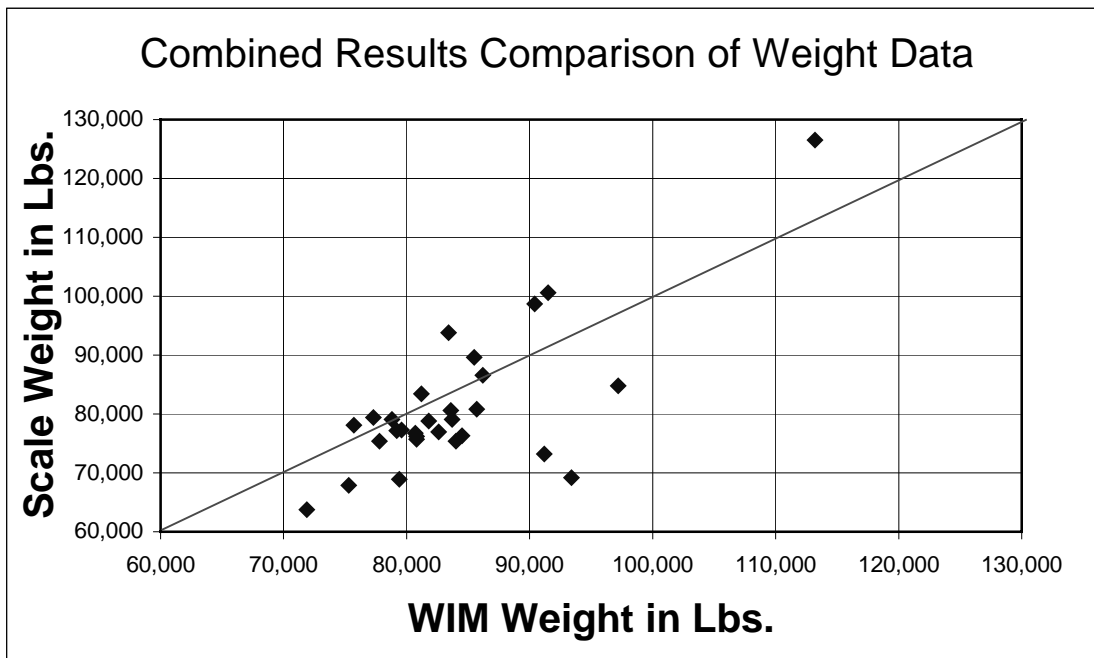

Figure 5-5: Graphical Comparison of Combined WIM to Scale Weight

5.3.4 Summary of the Enforcement Details on US 24, near Fort Wayne, IN

On September 18, 2001, an enforcement was conducted at the WIM on US 24. Six trucks were stopped and weighed on the pulloff areas located to the east and west of the WIM. One truck was found to be overweight and was placed out of service because of a fuel leak. A summary of this detail can be found in the memo in Appendix N.

After the software was installed on the CVE laptops and the hardware kits provided, the CVE officers conducted enforcement details at their own discretion. CVE officers periodically monitored the US 24 WIM beginning in February 2002. During the month of February, ten trucks were pulled over and weighed. Seven of the ten trucks were found to be in violation of weight limit laws. Based on the data collected, the calibration factors in the WIM station were adjusted by -7.7% in the eastbound direction and $+3.9\%$ in the westbound direction. A summary of the enforcement detail and calibration adjustment can be found in the memo in Appendix O.

5.3.5 Summary of the Enforcement Details on I-65, near Merrillville, IN

An enforcement detail was conducted at the WIM on I-65 near Merrillville on April 12, 2002. Three trucks were pulled over and weighed. All three were determined to be overweight and issued fines. A summary of the enforcement can be found in the memo in Appendix Q.

6 Conclusions

There is a need for real-time monitoring of Weigh In Motion sites around the state and reporting of summary statistics on the web. For example, Table 5-3 through Table 5-5, Figure 5-1 and Figure 5-2 resulted in identifying the early morning hours as the best time for enforcement in Merrillville. As a result, on May 18, 2001 vehicles weighing 98,700 lbs and 100,600 lbs were stopped. Those vehicles were impounded and resulted in fines of \$1,625.00 and \$1735.00 respectively. In February 2002, Commercial Vehicle Enforcement officers stopped ten trucks on US 24 near Fort Wayne using the virtual weigh station. Eight of the trucks were determined to be overweight and fined. The three heaviest trucks weighed 90,200 lbs, 90,900 lbs, and 91,100 lbs resulting in fines of \$1,099.50, \$1,169.50, and \$1,189.50, respectively. On April 12, 2002, another enforcement was conducted on I-65 near Merrillville. Three trucks were stopped based on the virtual weigh station data. One of the trucks weighed 87,400 lbs, resulting in a \$529.50 fine. There is an urgent need to perfect the tools and procedures of the Virtual Weigh Station concept so that these tools can be deployed statewide. To support that objective, the following points should be considered:

- Online data analysis procedures should be developed that permit rapid diagnosis of WIM calibration problems. This online diagnosis should have two components:
 - Tabulation, by lane, of unclassified vehicles. The number of unclassified vehicles should not exceed 10% for any lane. The historical unclassified vehicle error rate should be presented in a format similar to Figure E-53. The memo in Appendix E identifies only 3 stations providing this level of accuracy in October 2000. Those stations were 4250, 5260, and 6260. All of those stations had only a WIM in a single lane.
 - A crude evaluation of the accuracy and precision of a WIM can be estimated by looking at the distribution of the front-axle weights. The thresholds shown in Table H-17 provide a starting point for constructing tables similar to Table H-18 and Table H-19.
 - A relative comparison of all front axles means should be performed on a monthly basis using a plot similar to Figure H-1 constructed for data in Table H-1 through Table H-4.
- The wireless communication link is reasonably reliable with the radios shown in Appendix J. However, in the Merrillville area occasional interference will interrupt communications for up to 30 seconds. Some considerations may be given to using more sophisticated radios with a frequency hopping scheme. One radio system that might be considered is manufactured by California Microwave. It is currently used by INDOT in closed loop traffic signal systems.
- At larger WIM installations where more than 4 lanes are being monitored, the IRD system uses separate processing units. As a result, not all lanes can be connected simultaneously via a single radio link. The

current procedure is to manually move the cable between systems. Some further study of the most appropriate procedure for handling this should be performed.

The following amendments to the INDOT WIM specification are suggested:

- “. . . documentation shall be furnished that completed installation confirms the ASTM pavement smoothness specification defined in the ASTM WIM standard E1318-94 at time of acceptance and possibly warrant smoothness for 2 years.” This amendment is proposed because some of the recently completed WIM installations do not appear to confirm to the required smoothness specifications. Actually verifying conformance would require a lane closure.
- “. . . a vehicle used for calibrating a WIM shall travel across the WIM at the average speed of Class 9 trucks. Documentation of the average speed of Class 9 trucks shall be provided by WIM records for Class 9 trucks during a weekday from 9am to 4pm.” This amendment is proposed because one of the sources of calibration error was thought to be that calibration trucks were not always traveling at the prevailing speed of Class 9 trucks. In Merrillville that difference was about 10 mph.
- “. . . a vehicle used for calibration shall not be in violation of any Indiana laws.” This amendment is proposed because the truck used to calibrate the Merrillville WIM had a tandem load of 43,400 lbs. Subsequent discussion with IRD indicated this might have caused calibration problems for lower axle weight vehicles.
- “. . . a WIM shall not be accepted by INDOT until telephone service has been operational for 30 consecutive days and the log files uploaded.” This amendment is proposed because it is very difficult to determine if a site is operating properly unless a month or so of data files, including rainy days, are uploaded and IRD error reports are run on the uploaded data.
- “. . . the panel shown in Figure J-1 with component, shown in Figure J-2, shall be furnished and installed as part of WIM system.” This amendment is proposed so that all new WIMs will be accessible as a virtual scale as soon as they are turned on.

Regarding the use of WIMs for data collection purposes:

- Based upon the sensitivity analysis performed in Chapter 2 (Table 2-3 and Figure 2-4), we believe a WIM should provide accurate axle weights within 6% (ASTM Type III) in order to effectively estimate ESALs used to compute pavement life. Based upon observations at new single load cell installations (4410 and 5130), it is not clear whether any of the current installed systems are calibrated to this accuracy. A detailed evaluation at all Single Load Cell Sites (4130, 4150, 4410, 4420, 5110, 5120, and 5130) should be

conducted with Summer 2001 data, and field checks performed with Indiana Commercial Vehicle Enforcement Officers.

- Several of the older WIMs using Piezo technology are experiencing severe pavement distress and have likely reached the end of their useful life. Those stations would be of little value to a virtual weigh station concept and are likely of little value for data collection. Consideration should be given to abandoning all Piezo WIM sites and perhaps all Bending Plate sites and devoting those additional resources to improved maintenance on the remaining sites.
- The WIMs that are most promising for the Virtual Weigh Station concept are the relatively new Single Load Cell installations. For example, from Table H-18, WIM 5110 on I-70 appears to hold some promise. However, some calibration and tuning will likely be required to eliminate some of the classification errors shown in Figure E-48.

On a concluding note, the “online data analysis” procedure recommended needs to also include checks in the standard IRD report and be highly automated so they can be performed on a daily or weekly basis.

Finally, the diversion route study and the video capture portion of this project have not been performed to date. A revised work plan is currently being developed to address these proposed tasks.

Appendix A WIM Station Configuration

Station	Type	Ref. Marker	Location	Side
4110	WIM	218.38	ON I-65 3.64 MILES N OF SR 114	NB
4130	WIM	038.03	ON I-94 1.92 MILES W OF US 20/35	EB
4140	WIM	068.26	ON I-69 4.16 MILES N OF SR 18	SB
4150	WIM	137.88	ON I-69 2.53 MILES S OF SR 4	SB
4240	WIM	035.30	ON SR 49 1.58 MILES S OF US 6	NB
4250	WIM	065.18	ON SR 2 2.84 MILES W OF US 20	WB
4260	WIM	216.98	ON US 31 0.66 MILES S OF SR 10	NB
4270	WIM	087.62	ON US 24 4.49 MILES W OF SR 115	WB
4280	WIM	100.16	ON US 27/33 6.26 MILES S OF I-469	SB
4400	WIM	013.40	ON I-80/94 1.56 MILES E OF I-65	WB
4410	WIM	253.67	ON I-65 0.70 MI N OF US 30 (NB)	NB
4420	WIM	253.67	ON I-65 0.70 MI N OF US 30 (SB)	NB
4440	WIM	005.96	ON I-80/94 0.89 MILES E OF SR 912 (CLINE)	EB
4900	WIM	032.01	ON I-80/90 0.97 MI E OF SR 49	WB
4910	WIM	071.60	ON I-80/90 0.49 MI W OF US 31	WB
4920	WIM	079.42	ON I-80/90 2.61 MI W OF SR 933	WB
5110	WIM	107.98	ON I-70 4.33 MILES E OF SR 9	EB
5120	WIM	079.09	ON I-65 1.00 MILES S OF SR 252	SB
5130	WIM	004.84	ON I-74 0.60 MILES E OF SR 63	WB
5140	WIM	155.49	ON I-70 0.52 MILES W OF US 40	EB
5240	WIM	199.87	ON US 41 1.27 MILES S OF SR 18	SB
5250	WIM	096.70	ON SR 37 2.84 MILES S OF SR 45 SB	SB
5260	WIM	172.25	ON SR 37 1.18 MILES S OF SR 238	SB
5270	WIM	000.54	ON SR 332 0.54 MILES E OF I-69	WB
5440	WIM	007.52	ON I-70 0.68 MILES E OF US 41	WB
5450	WIM	175.94	ON I-65 0.78 MILES N OF SR 25	NB
5460	WIM	010.02	ON I-465 (W. SIDE) 0.70 MILES N OF I-70	SB
5470	WIM	102.54	ON I-65 0.65 MILES S OF Southport Rd.	NB
5480	WIM	042.41	ON I-465 (E. SIDE) 0.97 MILES S OF US 36	SB
5550	WIM	125.65	ON US 31 2.27 MILES N OF I-465	NB
6130	WIM	002.16	ON I-164 0.75 MILES W OF Green River Rd.	WB
6140	WIM	027.92	ON I-64 1.53 MILES W OF I-164 / SR 57	EB
6150	WIM	054.82	ON I-64 1.22 MILES E OF SR 161	EB
6160	WIM	116.96	ON I-64 0.98 MILES W OF SR 62/64	EB
6170	WIM	169.77	ON I-74 0.82 MILES E OF US 52	EB
6250	WIM	012.51	ON SR 62 2.58 MILES E OF SR 69	WB
6260	WIM	018.72	ON SR 66 0.97 MILES W OF SR 65	EB
6270	WIM	047.65	ON SR 66 2.97 MILES W OF SR 161	WB
6280	WIM	024.11	ON US 50 2.34 MILES E OF SR 257	EB
6290	WIM	137.40	ON US 50 1.08 MILES W OF US 421 NB	WB
6420	WIM	004.63	ON I-65 0.89 MILES S OF I-265	SB

Table A-1: WIM Sites of Indiana

Figure A-1

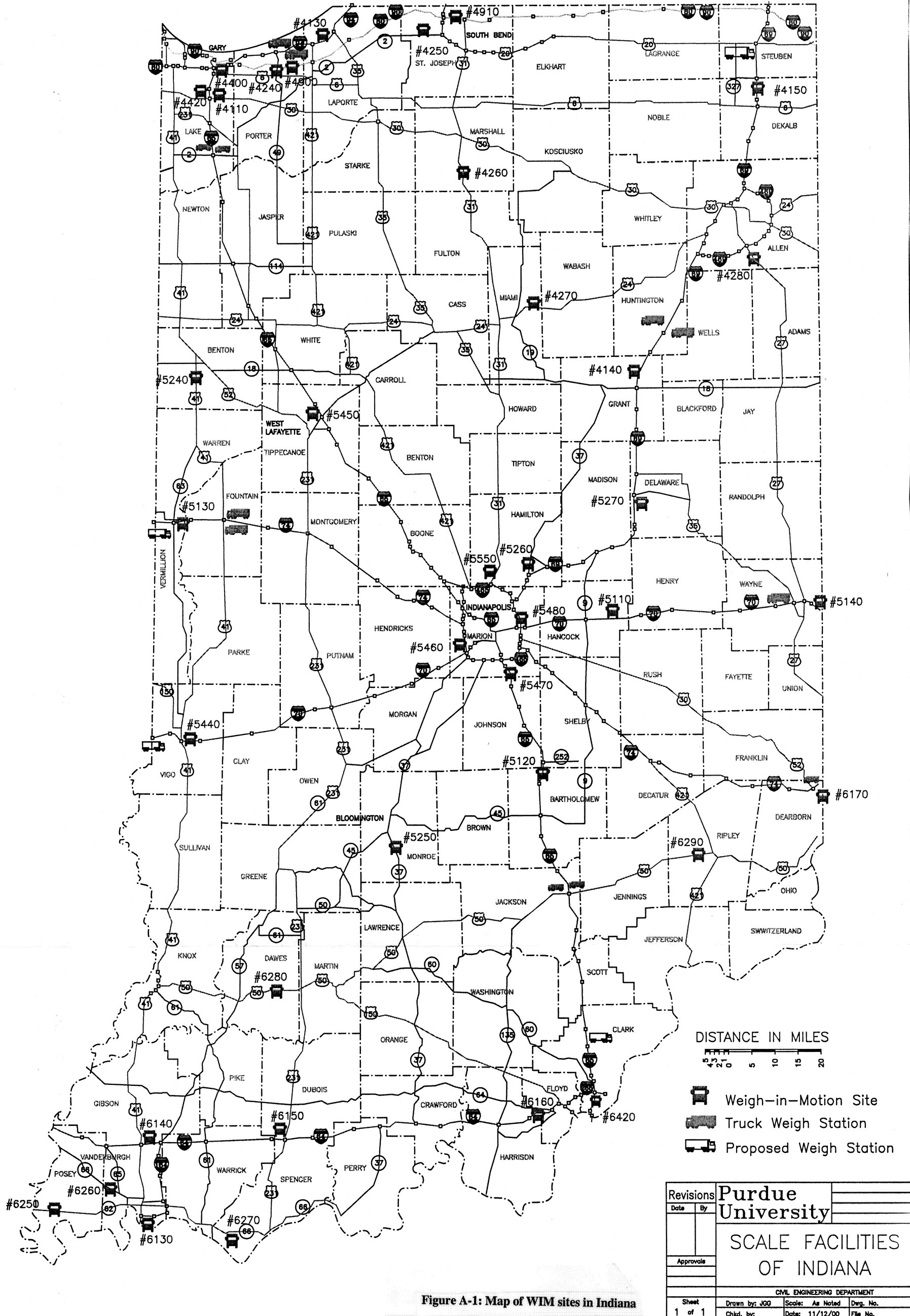

Figure A-1: Map of WIM sites in Indiana

Station #:	Route #:	Location:	Ref. Mkr.:	County:	District:	Sub-district:
0101	052-US	ON US 52/231 1.52 MILES W OF US 231 SB	041.67	TIPPECANOE	CRAWFORDSVILLE	FOWLER
0102	231-US	ON US 231 2.78 MILES N OF SR 28	196.03	TIPPECANOE	CRAWFORDSVILLE	CRAWFORDSVILLE
0103	136-US	ON US 136 4.23 MILES E OF SR 25 SB	031.31	MONTGOMERY	CRAWFORDSVILLE	CRAWFORDSVILLE
0104	065-I	ON I-65 1.46 MILES S OF SR 267	131.89	BOONE	CRAWFORDSVILLE	FRANKFORT
0105	041-US	ON US 41 5.63 MILES S OF I-70	104.22	VIGO	CRAWFORDSVILLE	TERRE HAUTE
0106	070-I	ON I-70 3.22 MILES E OF SR 59	025.80	CLAY	CRAWFORDSVILLE	TERRE HAUTE
0107	042-SR	ON SR 42 0.81 MILES E OF SR 59	012.21	CLAY	CRAWFORDSVILLE	TERRE HAUTE
0108	065-I	ON I-65 1.98 MILES S OF SR 18	185.95	WHITE	CRAWFORDSVILLE	FOWLER
0109	074-I	ON I-74 1.54 MILES W OF I-465	071.76	MARION	CRAWFORDSVILLE	CRAWFORDSVILLE
0201	120-SR	ON SR 120 0.92 MILES W OF SR 13	013.85	ELKHART	FORT WAYNE	GOSHEN
0202	006-US	ON US 6 0.94 MILES W OF SR 15	093.56	ELKHART	FORT WAYNE	GOSHEN
0203	015-SR	ON SR 15 0.88 MILES N OF US 30	060.03	KOSCIUSKO	FORT WAYNE	WARSAW
0204	069-I	ON I-69 1.92 MILES N OF SR 14	107.19	ALLEN	FORT WAYNE	FORT WAYNE
0205	930-SR	ON SR 930 3.06 MILES W OF I-469	010.39	ALLEN	FORT WAYNE	FORT WAYNE
0206	069-I	ON I-69 0.65 MILES N OF SR 5	078.18	HUNTINGTON	FORT WAYNE	BLUFFTON
0207	124-SR	ON SR 124 3.86 MILES E OF SR 3	041.01	WELLS	FORT WAYNE	BLUFFTON
0208	101-SR	ON SR 101 1.28 MILES S OF US 224	039.79	ADAMS	FORT WAYNE	BLUFFTON
0209	069-I	ON I-69 2.52 MILES S OF SR 4	137.89	DEKALB	FORT WAYNE	ANGOLA
0301	009-SR	ON SR 9 0.71 MILES N OF SR 32 EB	073.07	MADISON	GREENFIELD	GREENFIELD
0302	032-SR	ON SR 32 0.69 MILES E OF SR 9	107.69	MADISON	GREENFIELD	GREENFIELD
0303	035-US	ON US 35 0.80 MILES N OF SR 32	044.51	DELAWARE	GREENFIELD	ALBANY
0304	001-SR	ON SR 1 0.31 MILES S OF SR 32 EB	084.53	RANDOLPH	GREENFIELD	ALBANY
0305	037-SR	ON Old SR 37 1.96 MILES S OF I-465	161.93	MARION	GREENFIELD	INDIANAPOLIS
0306	465-I	ON I-465 0.72 MILES N OF I-69	036.15	MARION	GREENFIELD	INDIANAPOLIS
0307	465-I	ON I-465 0.60 MILES S OF US 40 EB	046.26	MARION	GREENFIELD	INDIANAPOLIS
0308	040-US	ON US 40 4.91 MILES E OF SR 9	103.27	HANCOCK	GREENFIELD	GREENFIELD
0309	031-US	ON US 31 1.16 MILES S OF I-465	106.07	MARION	GREENFIELD	INDIANAPOLIS
0310	044-SR	ON SR 44 4.32 MILES W OF SR 3	051.05	RUSH	GREENFIELD	GREENFIELD
0311	065-I	ON I-65 S OF LAFAYETTE RD	119.67	MARION	GREENFIELD	INDIANAPOLIS
0312	465-I	ON I-465 0.85 MILES E OF I-65	052.39	MARION	GREENFIELD	INDIANAPOLIS
0401	080-I	ON I-80/94 1.55 MILES E OF I-65	013.39	LAKE	LaPORTE	GARY
0402	020-US	ON US 20 0.12 MILES W OF SR 520	036.48	PORTER	LaPORTE	LaPORTE

Table A-2: List of Automatic Traffic Recording Sites in Indiana

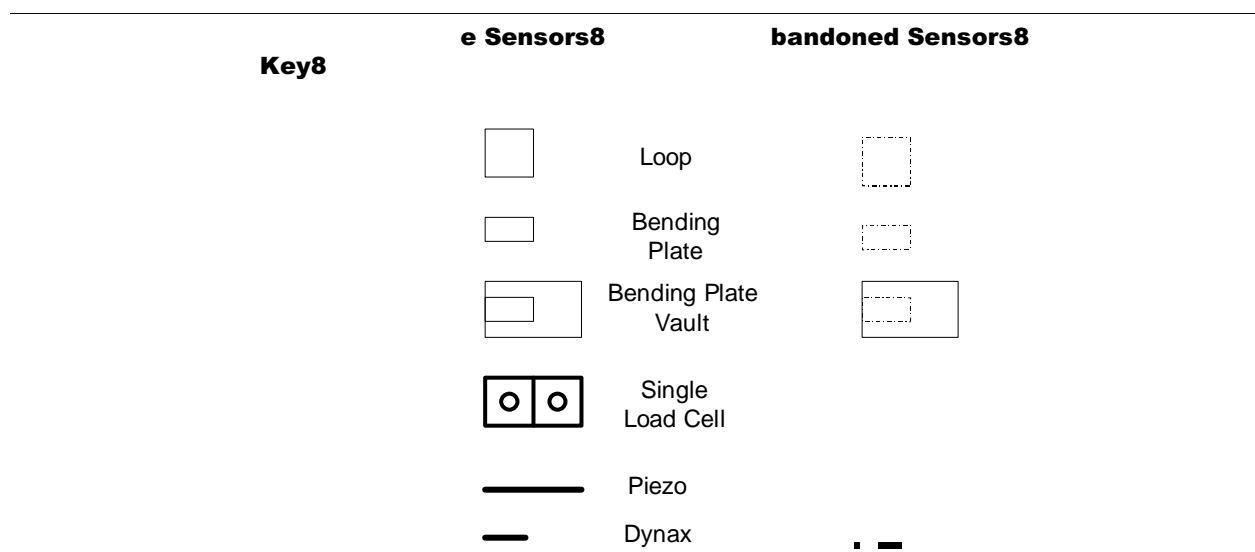

Figure A-2: Schematic Key

Piezo	=	Piezo-Electric Sensor
SLC	=	Single Load Cell
CLS	=	Classification Only
BP	=	Bending Plate
BP-V	=	Bending Plate Vault
C	=	Concrete Pavement
A	=	Asphalt Pavement

Table A-3: List of Abbreviations Used

1	=	Road and Sensors Bad
2	=	Road Determination / Sensor Determination
3	=	Road Cracking
4	=	Sensors O.K.
5	=	Sensors in Road in Good Shape
6	=	Ideal Conditions
+	=	Slightly Higher
-	=	Slightly Lower

Table A-4: Klepinger Pavement Evaluation Scale, March 2001

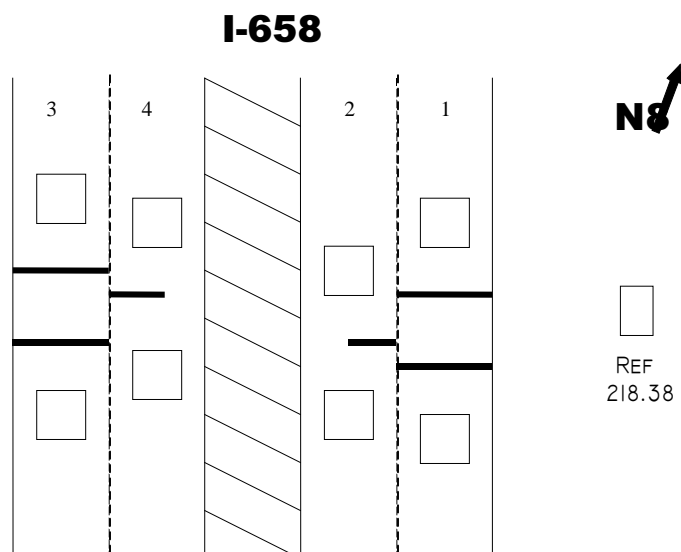

Figure A-3: Station 4110 Four Lane Divided

	Lane 1	Lane 2	Lane 3	Lane 4
WIM	X		X	
Classification		X		X
Sensor	PIEZO	CLS	PIEZO	CLS
Pavement	C	C	C	C
Suitable for VWS 6/00 (F. Axle)	YES		NO	
Suitable for VWS 10/00 (Class.)	YES		NO	
Suitable for VWS 3/01 (F. Axle)	NO		NO	
Klepinger Scale	4	4	4	4
Calibration Dates	3-22-99, 8-12-99			

Table A-5: Station 4110 Inventory

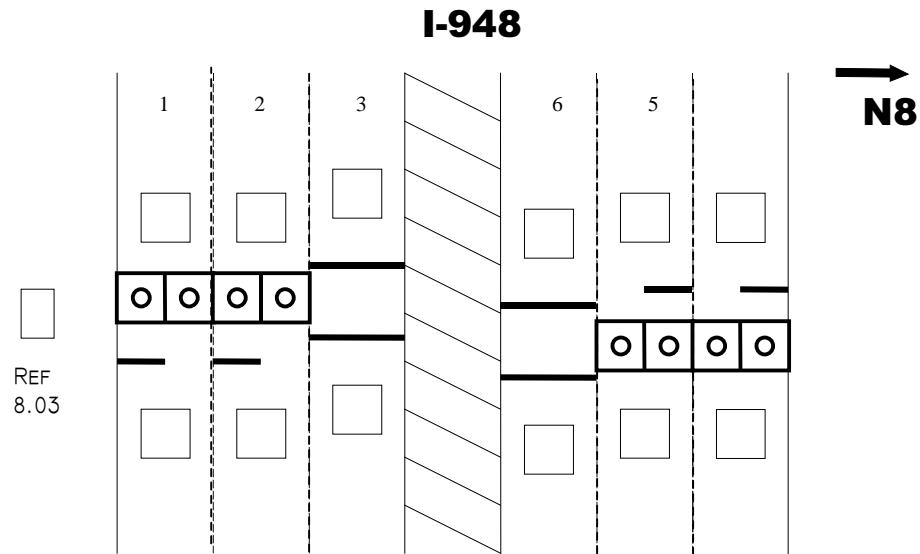

Figure A-4: Station 4130 Six Lane Divided

	Lane 1	Lane 2	Lane 3	Lane 4	Lane 5	Lane 6
WIM	X	X	X	X	X	X
Classification						
Sensor	SLC	SLC	PIEZO	SLC	SLC	PIEZO
Pavement	C	C	C	C	C	C
Suitable for VWS 6/00 (F. Axle)	YES	YES	NO	NO	YES	NO
Suitable for VWS 10/00 (Class.)	NO	NO	YES	NO	NO	YES
Suitable for VWS 3/01 (F. Axle)	YES	YES	NO	NO	NO	NO
Klepinger Scale	5	5	5	5	5	5
Calibration Dates						

Table A-6: Station 4130 Inventory

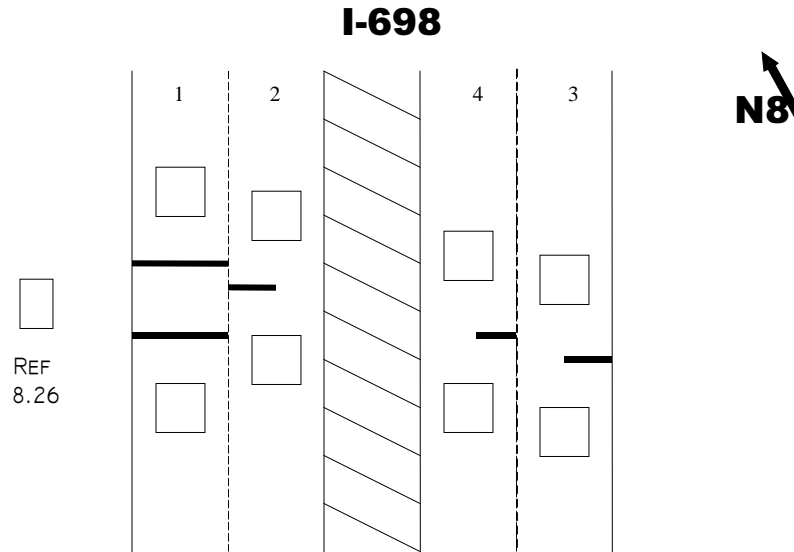

Figure A-5: Station 4140 Four Lane Divided

	Lane 1	Lane 2	Lane 3	Lane 4
WIM	X			
Classification		X	X	X
Sensor	PIEZO	CLS	CLS	CLS
Pavement	C	C	C	C
Suitable for VWS 6/00 (F. Axle)	NO			
Suitable for VWS 10/00 (Class.)	NO			
Suitable for VWS 3/01 (F. Axle)	YES			
Klepinger Scale	4	4	4-	4-
Calibration Dates	1-15-98, 7-15-99, 11-30-00			

Table A-7: Station 4140 Inventory

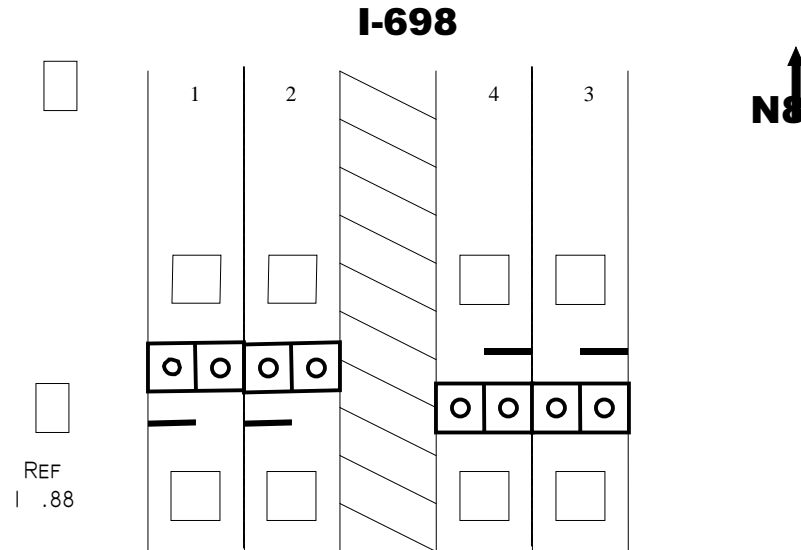

Figure A-6: Station 4150 Four Lane Divided

	Lane 1	Lane 2	Lane 3	Lane 4
WIM	X	X	X	X
Classification				
Sensor	SLC	SLC	SLC	SLC
Pavement	C	C	C	C
Suitable for VWS 6/00 (F. Axle)	NO	YES	YES	NO
Suitable for VWS 10/00 (Class.)	YES	NO	YES	NO
Suitable for VWS 3/01 (F. Axle)	NO	NO	NO	NO
Klepinger Scale	4+	5-	5-	5-
Calibration Dates	11-27-00			

Table A-8: Station 4150 Inventory

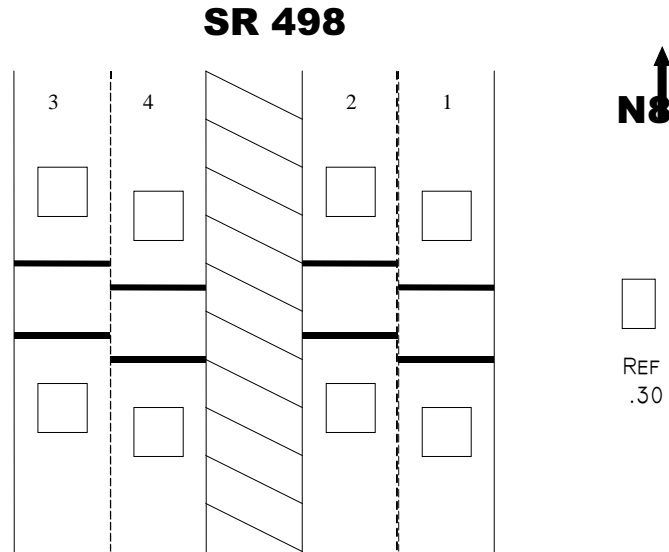

Figure A-7: Station 4240 Four Lane Divided

	Lane 1	Lane 2	Lane 3	Lane 4
WIM	X	X	X	X
Classification				
Sensor	PIEZO	PIEZO	PIEZO	PIEZO
Pavement	A	A	A	A
Suitable for VWS 6/00 (F. Axle)	NO DATA	NO DATA	NO DATA	NO DATA
Suitable for VWS 10/00 (Class.)	NO DATA	NO DATA	NO DATA	NO DATA
Suitable for VWS 3/01 (F. Axle)	NO DATA	NO DATA	NO DATA	NO DATA
Klepinger Scale				
Calibration Dates	OUT OF SERVICE			

Table A-9: Station 4240 Inventory

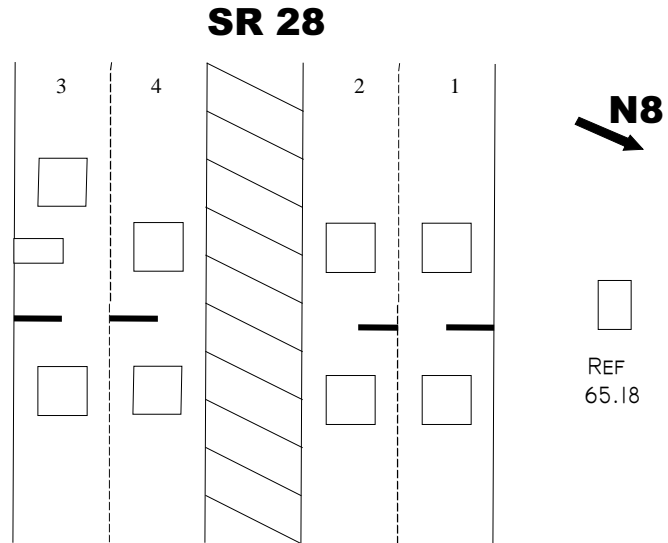

Figure A-8: Station 4250 Four Lane Divided

	Lane 1	Lane 2	Lane 3	Lane 4
WIM			X	
Classification	X	X		X
Sensor	CLS	CLS	BP	CLS
Pavement	A	A	A	A
Suitable for VWS 6/00 (F. Axle)			NO	
Suitable for VWS 10/00 (Class.)			YES	
Suitable for VWS 3/01 (F. Axle)			NO	
Klepinger Scale	3+	3-	3+	3-
Calibration Dates	3-24-99			

Table A-10: Station 4250 Inventory

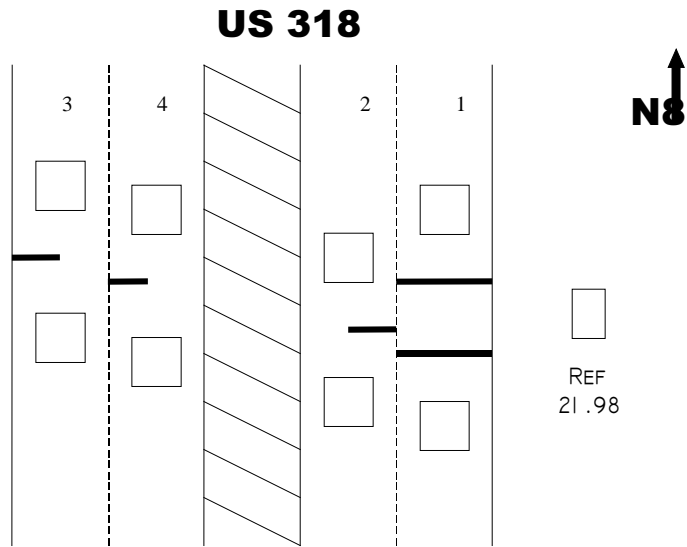

Figure A-9: Station 4260 Four Lane Divided

	Lane 1	Lane 2	Lane 3	Lane 4
WIM	X			
Classification		X	X	X
Sensor	PIEZO	CLS	CLS	CLS
Pavement	A	A	A	A
Suitable for VWS 6/00 (F. Axle)	NO			
Suitable for VWS 10/00 (Class.)	YES			
Suitable for VWS 3/01 (F. Axle)	NO			
Klepinger Scale	2+	3+	3	3+
Calibration Dates	3-23-99			

Table A-11: Station 4260 Inventory

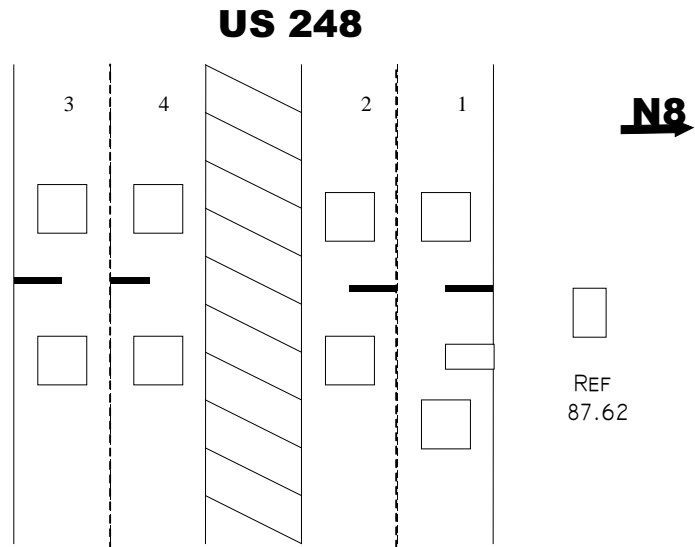

Figure A-10: Station 4270 Four Lane Divided

	Lane 1	Lane 2	Lane 3	Lane 4
WIM	X			
Classification		X	X	X
Sensor	BP	CLS	CLS	CLS
Pavement	A	A	A	A
Suitable for VWS 6/00 (F. Axle)	YES			
Suitable for VWS 10/00 (Class.)	NO			
Suitable for VWS 3/01 (F. Axle)	NO			
Klepinger Scale	3-	2+	4	4
Calibration Dates	6-01-98, 4-08-99, 11-29-00			

Table A-12: Station 4270 Inventory

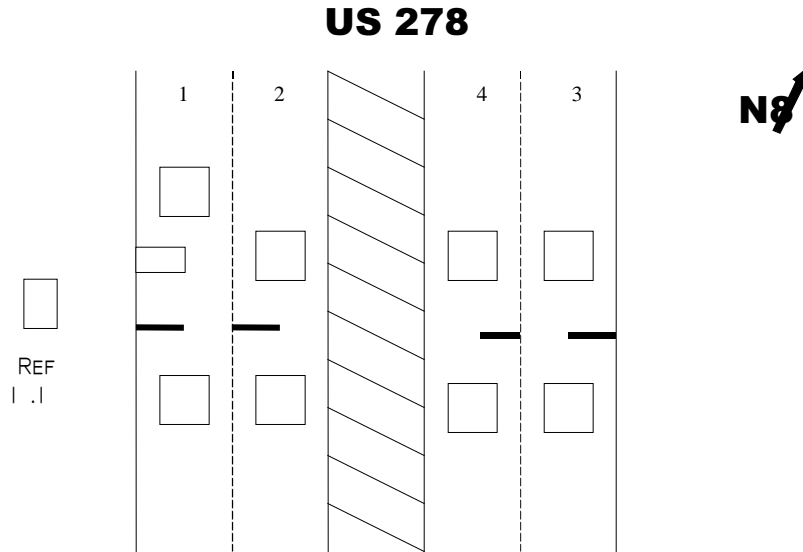

Figure A-11: Station 4280 Four Lane Divided

	Lane 1	Lane 2	Lane 3	Lane 4
WIM	X			
Classification		X	X	X
Sensor	BP	CLS	CLS	CLS
Pavement	A	A	A	A
Suitable for VWS 6/00 (F. Axle)	YES			
Suitable for VWS 10/00 (Class.)	NO			
Suitable for VWS 3/01 (F. Axle)	YES			
Klepinger Scale	3+	3+	3	3
Calibration Dates	3-26-90, 11-28-00			

Table A-13: Station 4280 Inventory

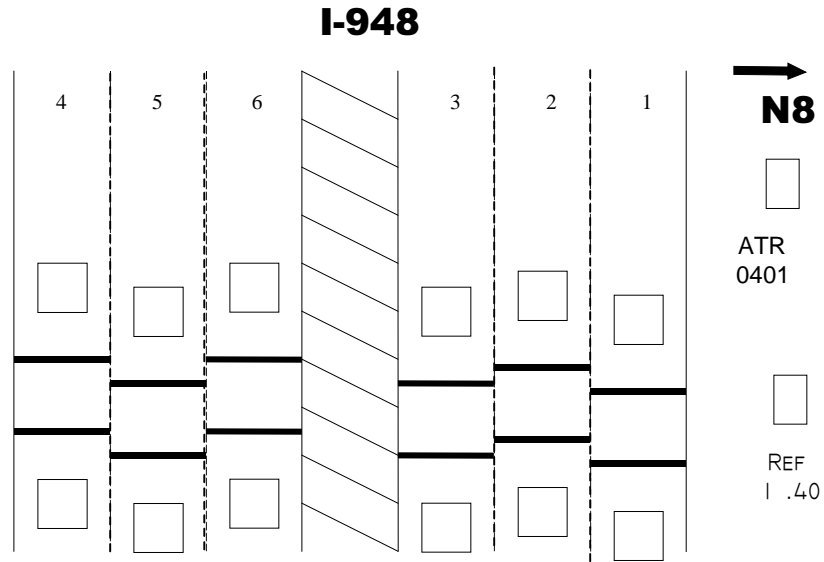

Figure A-12: Station 4400 Six Lane Divided

	Lane 1	Lane 2	Lane 3	Lane 4	Lane 5	Lane 6
WIM	X	X	X	X	X	X
Classification						
Sensor	PIEZO	PIEZO	PIEZO	PIEZO	PIEZO	PIEZO
Pavement	A	A	A	A	A	A
Suitable for VWS 6/00 (F. Axle)	NO DATA	NO DATA	NO DATA	NO DATA	NO DATA	NO DATA
Suitable for VWS 10/00 (Class.)	YES	YES	NO	YES	YES	NO
Suitable for VWS 3/01 (F. Axle)	NO	NO	NO	NO	YES	NO
Klepinger Scale	5	5	5	4-	4	4+
Calibration Dates						

Table A-14: Station 4400 Inventory

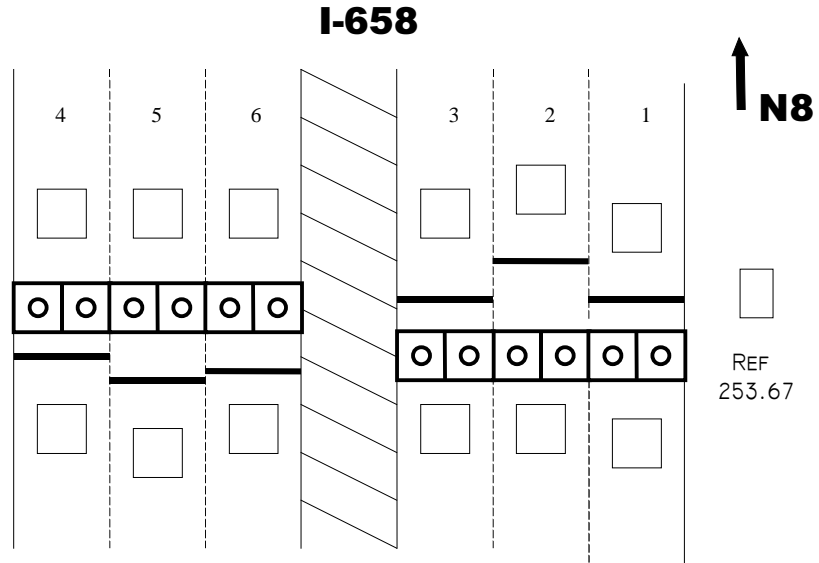

Figure A-13: Stations 4410 & 4420 Six Lane Divided

	Lane 1	Lane 2	Lane 3	Lane 4	Lane 5	Lane 6
WIM	X	X	X	X	X	X
Classification						
Sensor	SLC	SLC	SLC	SLC	SLC	SLC
Pavement	C	C	C	C	C	C
Suitable for VWS 6/00 (F. Axle)	NO DATA	NO DATA	NO DATA	NO DATA	NO DATA	NO DATA
Suitable for VWS 10/00 (Class.)	NO DATA	NO DATA	NO DATA	NO DATA	NO DATA	NO DATA
Suitable for VWS 3/01 (F. Axle)	NO DATA	NO DATA	NO DATA	NO DATA	NO DATA	NO DATA
Klepinger Scale	6-	6-	6-	6-	6-	6-
Calibration Dates						

Table A-15: Stations 4410 and 4420 Inventory

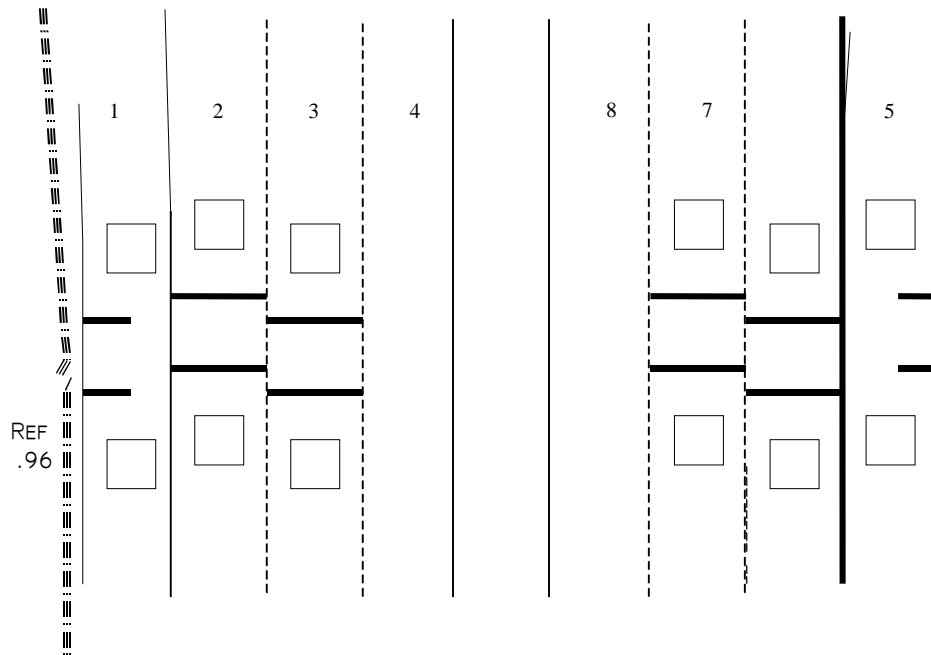

Figure A-13: Station 4440 Six Lane Divided

	Lane 1	Lane 2	Lane 3	Lane 4	Lane 5	Lane 6	Lane 7	Lane 8
WIM		X	X	X		X	X	X
Classification	X				X			
Sensor	CLS	PIEZO	PIEZO	PIEZO	CLS	PIEZO	PIEZO	PIEZO
Pavement	C	A	A	A	C	A	A	A
Suitable for VWS 6/00 (F. Axle)		NO DATA	NO DATA	NO DATA		NO DATA	NO DATA	NO DATA
Suitable for VWS 10/00 (Class.)		NO DATA	NO DATA	NO DATA		NO DATA	NO DATA	NO DATA
Suitable for VWS 3/01 (F. Axle)		NO DATA	NO DATA	NO DATA		NO DATA	NO DATA	NO DATA
Klepinger Scale	5	2	2	3	5	2+	2	4
Calibration Dates								

Table A-15: Station 4440 Inventory

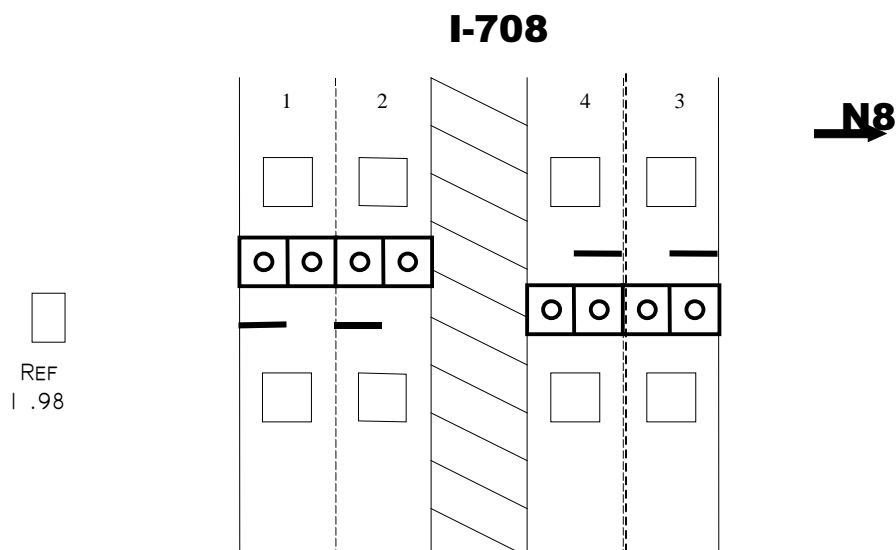

Figure A-14: Station 5110 Four Lane Divided

	Lane 1	Lane 2	Lane 3	Lane 4
WIM	X	X	X	X
Classification				
Sensor	SLC	SLC	SLC	SLC
Pavement	A	A	A	A
Suitable for VWS 6/00 (F. Axle)	NO	YES	NO	NO
Suitable for VWS 10/00 (Class.)	YES	NO	YES	NO
Suitable for VWS 3/01 (F. Axle)	YES	YES	YES	YES
Klepinger Scale	3	3	3+	3+
Calibration Dates	01-13-98			

Table A-16: Station 5110 Inventory

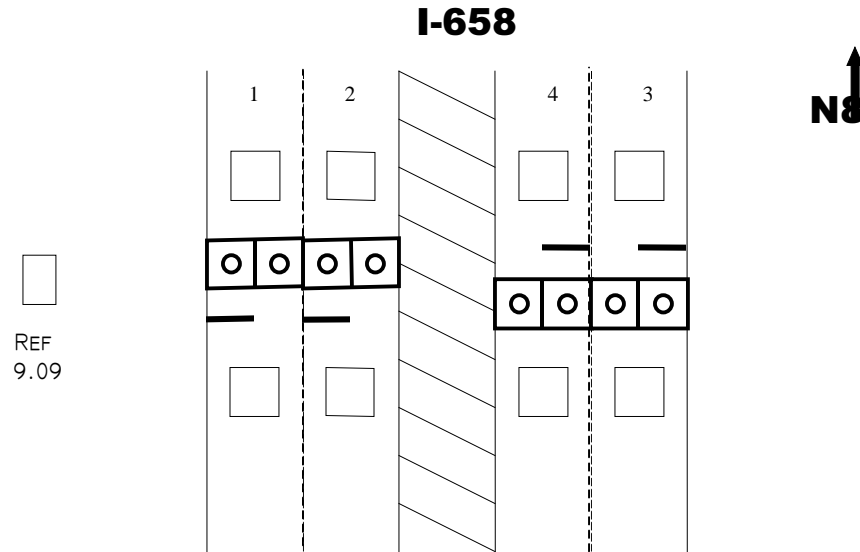

Figure A-15: Station 5120 Four Lane Divided

	Lane 1	Lane 2	Lane 3	Lane 4
WIM	X	X	X	X
Classification				
Sensor	SLC	SLC	SLC	SLC
Pavement	A	A	A	A
Suitable for VWS 6/00 (F. Axle)	NO	NO	YES	NO
Suitable for VWS 10/00 (Class.)	NO	YES	NO	NO
Suitable for VWS 3/01 (F. Axle)	NO	NO	NO	NO
Klepinger Scale	2	4-	3+	3+
Calibration Dates				

Table A-17: Station 5120 Inventory

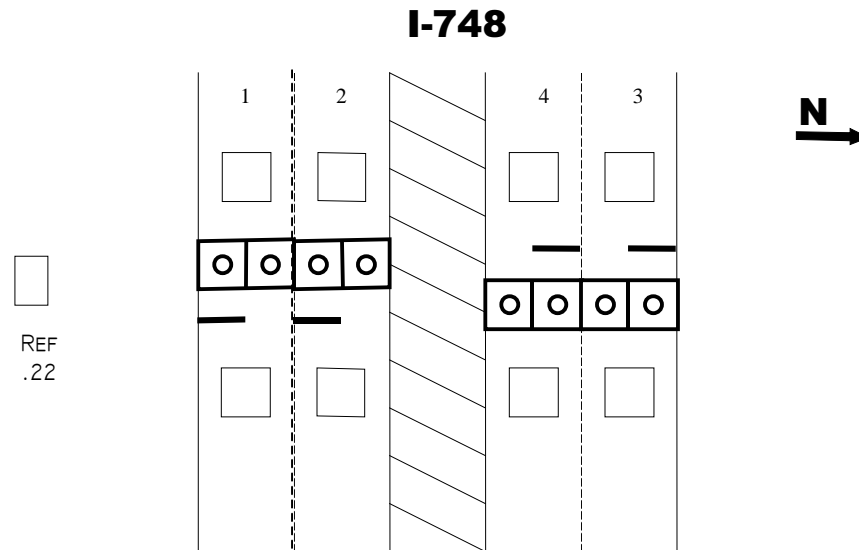

Figure A-16: Station 5130 Four Lane Divided

	Lane 1	Lane 2	Lane 3	Lane 4
WIM	X	X	X	X
Classification				
Sensor	SLC	SLC	SLC	SLC
Pavement	C	C	C	C
Suitable for VWS 6/00 (F. Axle)	NO DATA	NO DATA	NO DATA	NO DATA
Suitable for VWS 10/00 (Class.)	YES	NO	NO	NO DATA
Suitable for VWS 3/01 (F. Axle)	NO DATA	NO DATA	NO DATA	NO DATA
Klepinger Scale	6-	6-	5+	5+
Calibration Dates				

Table A-18: Station 5130 Inventory

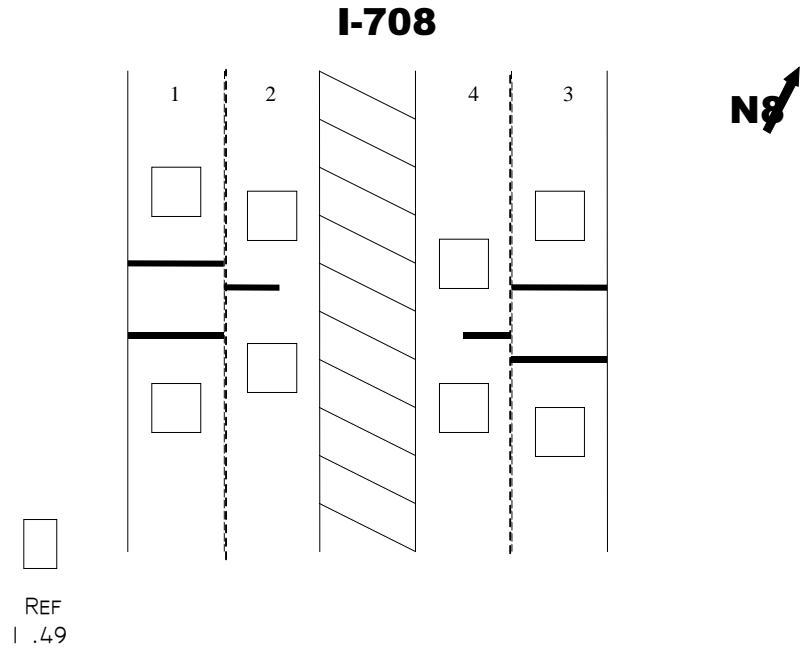

Figure A-17: Station 5140 Four Lane Divided

	Lane 1	Lane 2	Lane 3	Lane 4
WIM	X		X	
Classification		X		X
Sensor	PIEZO	CLS	PIEZO	CLS
Pavement	A	A	A	A
Suitable for VWS 6/00 (F. Axle)	NO		NO	
Suitable for VWS 10/00 (Class.)	YES		YES	
Suitable for VWS 3/01 (F. Axle)	NO		NO	
Klepinger Scale	3-	3	2+	3-
Calibration Dates	02-26-99			

Table A-19: Station 5140 Inventory

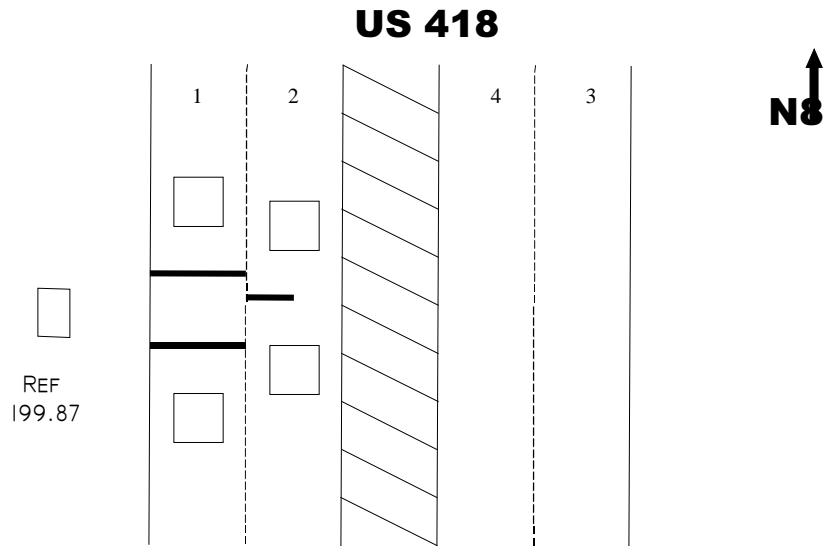

Figure A-18: Station 5240 Four Lane Divided

	Lane 1	Lane 2	Lane 3	Lane 4
WIM	X			
Classification		X		
Sensor	PIEZO	CLS		
Pavement	C	C	A	A
Suitable for VWS 6/00 (F. Axle)	NO		NO	NO
Suitable for VWS 10/00 (Class.)	YES		N/A	N/A
Suitable for VWS 3/01 (F. Axle)	NO			
Klepinger Scale	3+	4-	N/A	N/A
Calibration Dates				

Table A-20: Station 5240 Inventory

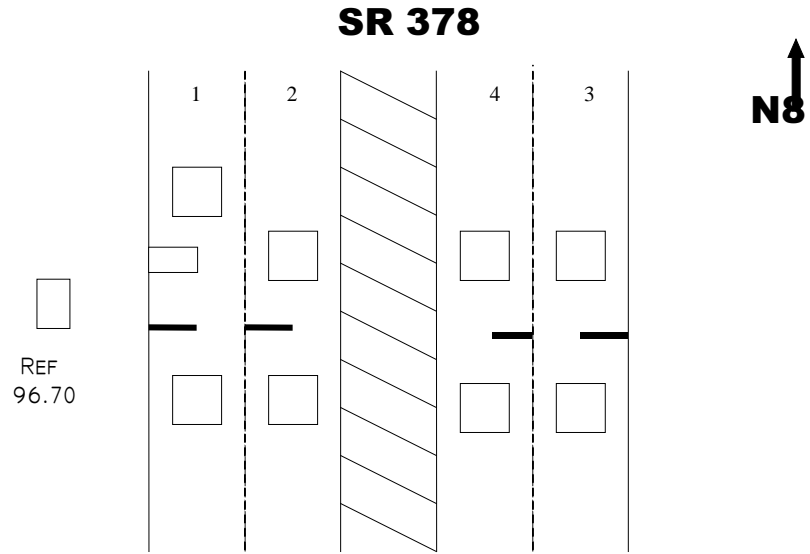

Figure A-19: Station 5250 Four Lane Divided

	Lane 1	Lane 2	Lane 3	Lane 4
WIM	X			
Classification		X	X	X
Sensor	BP	CLS	CLS	CLS
Pavement	C	C	C	C
Suitable for VWS 6/00 (F. Axle)	NO			
Suitable for VWS 10/00 (Class.)	NO			
Suitable for VWS 3/01 (F. Axle)	YES			
Klepinger Scale	3+	3+	3+	3+
Calibration Dates	3-25-99			

Table A-21: Station 5250 Inventory

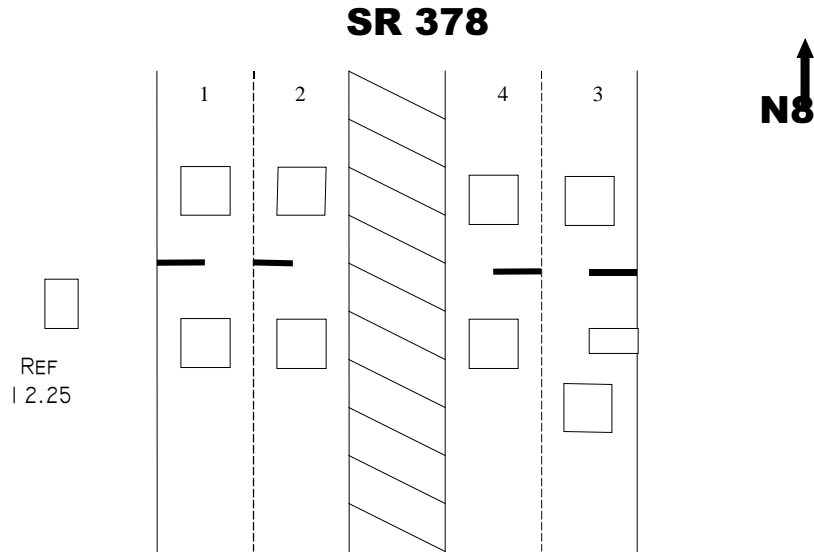

Figure A-20: Station 5260 Four Lane Divided

	Lane 1	Lane 2	Lane 3	Lane 4
WIM			X	
Classification	X	X		X
Sensor	CLS	CLS	BP-V	CLS
Pavement	A	A	A	A
Suitable for VWS 6/00 (F. Axle)			NO DATA	
Suitable for VWS 10/00 (Class.)			YES	
Suitable for VWS 3/01 (F. Axle)			NO DATA	
Klepinger Scale	5-	5-	5	5
Calibration Dates	02-27-99, 10-26-99			

Table A-22: Station 5260 Inventory

SR 3328

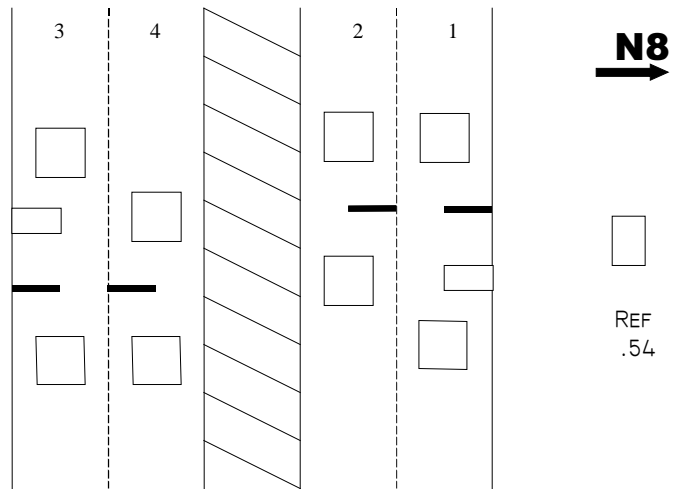

Figure A-21: Station 5270 Four Lane Divided

	Lane 1	Lane 2	Lane 3	Lane 4
WIM	X		X	
Classification		X		X
Sensor	BP	CLS	BP	CLS
Pavement	C	C	C	C
Suitable for VWS 6/00 (F. Axle)	NO DATA		NO DATA	
Suitable for VWS 10/00 (Class.)	NO		NO	
Suitable for VWS 3/01 (F. Axle)	NO DATA		NO DATA	
Klepinger Scale	3+	3+	4-	4
Calibration Dates				

Table A-23: Station 5270 Inventory

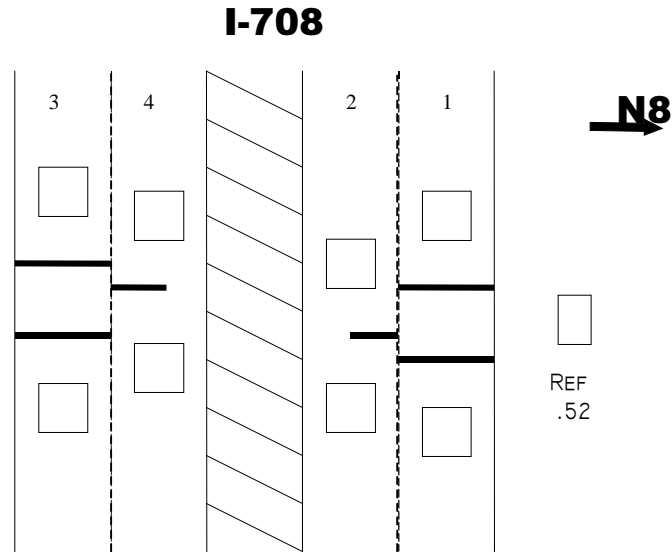

Figure A-22: Station 5440 Four Lane Divided

	Lane 1	Lane 2	Lane 3	Lane 4
WIM	X		X	
Classification		X		X
Sensor	PIEZO	CLS	PIEZO	CLS
Pavement	A	A	A	A
Suitable for VWS 6/00 (F. Axle)	NO DATA		NO	
Suitable for VWS 10/00 (Class.)	YES		NO	
Suitable for VWS 3/01 (F. Axle)	NO DATA		NO	
Klepinger Scale	2+	3-	3-	2+
Calibration Dates	3-18-99, 11-29-00			

Table A-24: Station 5440 Inventory

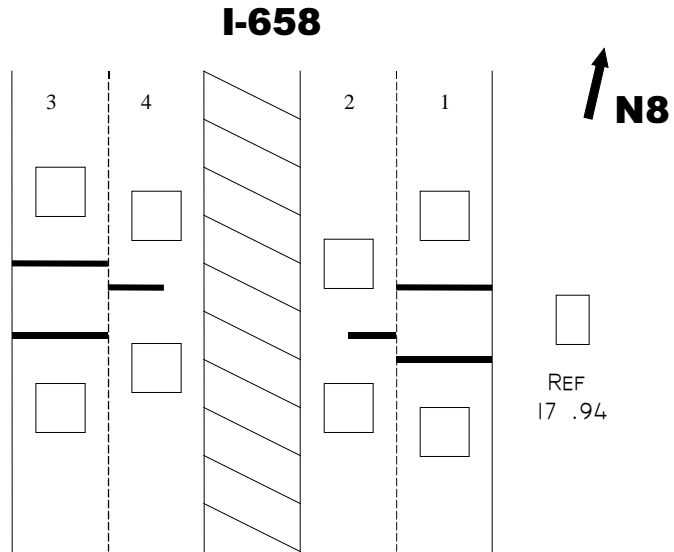

Figure A-23: Station 5450 Four Lane Divided

	Lane 1	Lane 2	Lane 3	Lane 4
WIM	X		X	
Classification		X		X
Sensor	PIEZO	CLS	PIEZO	CLS
Pavement	A	A	A	A
Suitable for VWS 6/00 (F. Axle)	NO		NO	
Suitable for VWS 10/00 (Class.)	NO		NO	
Suitable for VWS 3/01 (F. Axle)	NO		NO	
Klepinger Scale	1	3	3	3
Calibration Dates	3-19-99			

Table A-25: Station 5450 Inventory

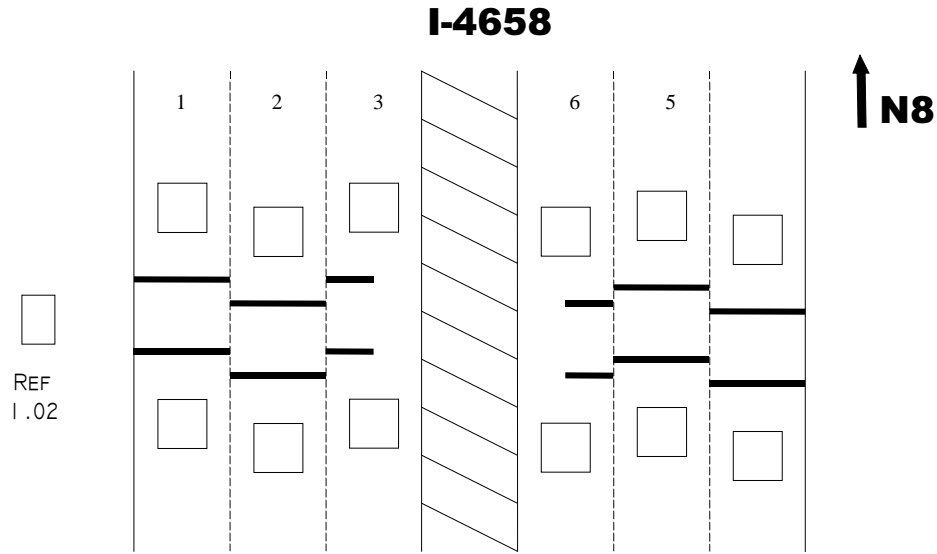

Figure A-24: Station 5460 Six Lane Divided

	Lane 1	Lane 2	Lane 3	Lane 4	Lane 5	Lane 6
WIM	X	X		X	X	
Classification			X			X
Sensor	PIEZO	PIEZO	CLS	PIEZO	PIEZO	CLS
Pavement	A	A	A	A	A	A
Suitable for VWS 6/00 (F. Axle)	NO	NO DATA		NO DATA	NO DATA	
Suitable for VWS 10/00 (Class.)	NO	NO		NO	NO	
Suitable for VWS 3/01 (F. Axle)	NO	NO DATA		NO DATA	NO DATA	
Klepinger Scale	3-	3-	3+	3	3	3+
Calibration Dates						

Table A-26: Station 5460 Inventory

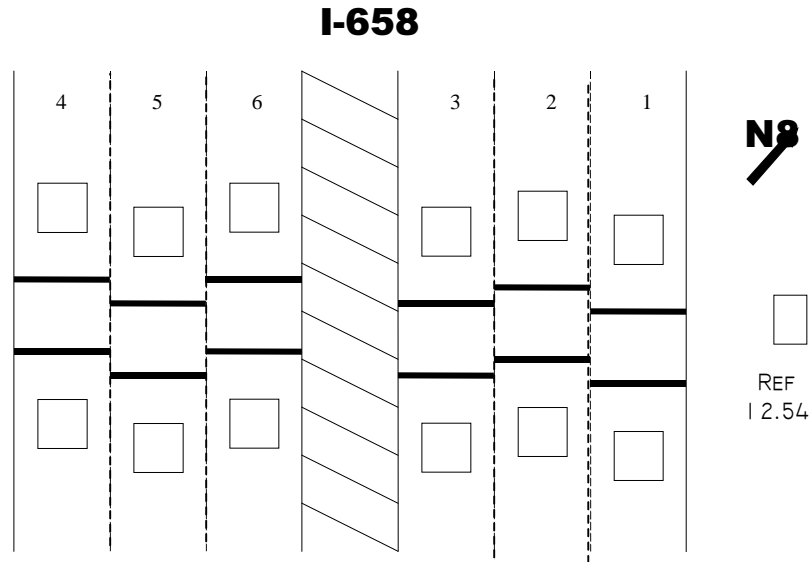

Figure A-25: Station 5470 Six Lane Divided

	Lane 1	Lane 2	Lane 3	Lane 4	Lane 5	Lane 6
WIM	X	X	X	X	X	X
Classification						
Sensor	PIEZO	PIEZO	PIEZO	PIEZO	PIEZO	PIEZO
Pavement	A	A	A	A	A	A
Suitable for VWS 6/00 (F. Axle)	NO	NO	NO	NO	NO	NO
Suitable for VWS 10/00 (Class.)	YES	YES	YES	NO	YES	YES
Suitable for VWS 3/01 (F. Axle)	NO	NO	NO	NO	NO	NO
Klepinger Scale	3+	3+	3+	4-	4-	4-
Calibration Dates						

Table A-27: Station 5470 Inventory

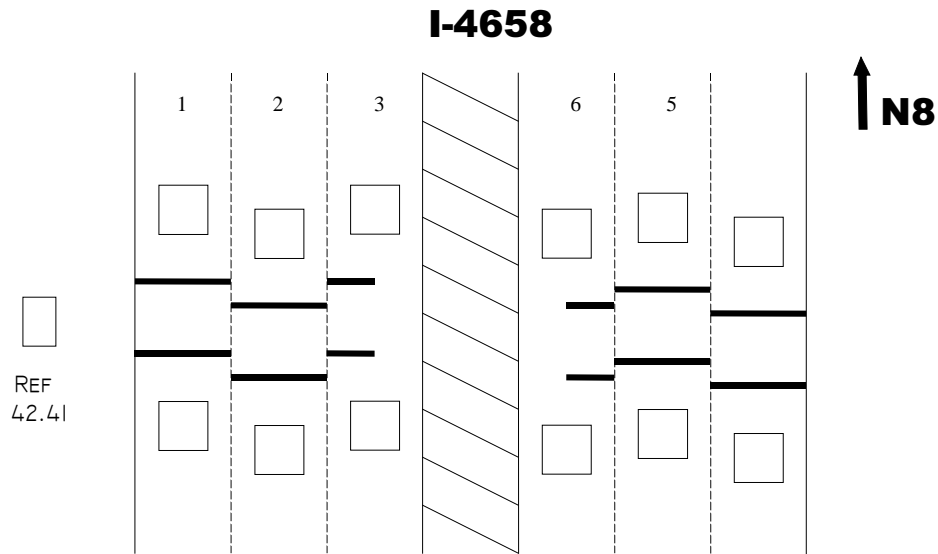

Figure A-26: Station 5480 Six Lane Divided

	Lane 1	Lane 2	Lane 3	Lane 4	Lane 5	Lane 6
WIM	X	X		X	X	
Classification			X			X
Sensor	PIEZO	PIEZO	CLS	PIEZO	PIEZO	CLS
Pavement	C	C	C	C	C	C
Suitable for VWS 6/00 (F. Axle)	NO	NO		NO	NO	
Suitable for VWS 10/00 (Class.)	NO	NO		NO	YES	
Suitable for VWS 3/01 (F. Axle)	NO	NO		NO	NO	
Klepinger Scale	2	3+	5	2	3-	5
Calibration Dates						

Table A-28: Station 5480 Inventory

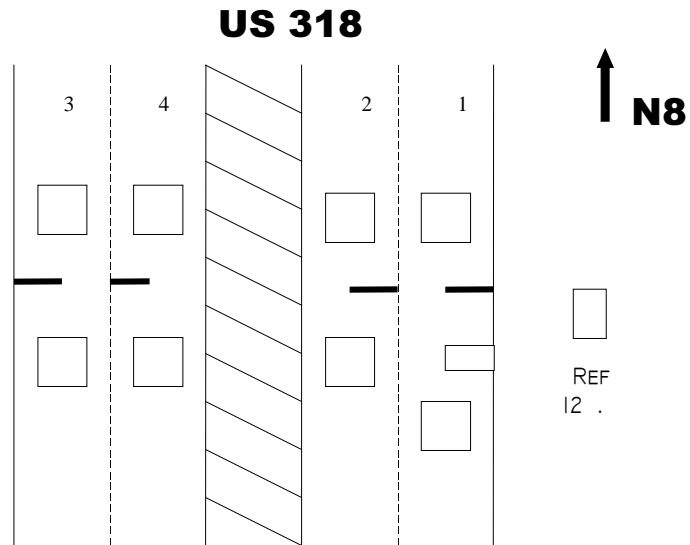

Figure A-27: Station 5550 Four Lane Divided

	Lane 1	Lane 2	Lane 3	Lane 4
WIM	X	X	X	X
Classification				
Sensor	PIIEZO	PIEZO	PIEZO	PIEZO
Pavement	A	A	A	A
Suitable for VWS 6/00 (F. Axle)	NO	NO	NO	NO
Suitable for VWS 10/00 (Class.)	NO	NO	NO	NO
Suitable for VWS 3/01 (F. Axle)	NO	NO	NO	NO
Klepinger Scale	6	6	6	6
Calibration Dates	01-29-01, 02-28-01			

Table A-29: Station 5550 Inventory

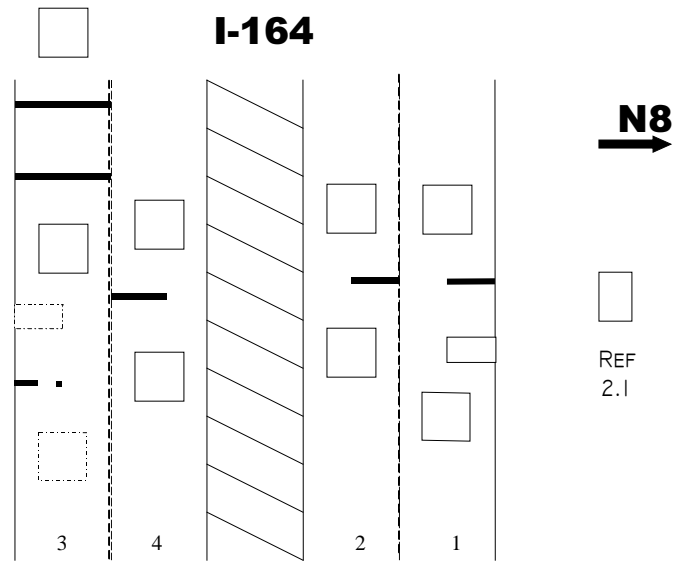

Figure A-28: Station 6130 Four Lane Divided

	Lane 1	Lane 2	Lane 3	Lane 4
WIM	X		X	
Classification		X		X
Sensor	PIEZO	CLS	PIEZO	CLS
Pavement	A	A	A	A
Suitable for VWS 6/00 (F. Axle)	NO DATA		NO DATA	
Suitable for VWS 10/00 (Class.)	NO		NO	
Suitable for VWS 3/01 (F. Axle)	NO DATA		NO DATA	
Klepinger Scale	4+	4+	3+	4-
Calibration Dates	3-17-98, 02-05-99			

Table A-30: Station 6130 Inventory

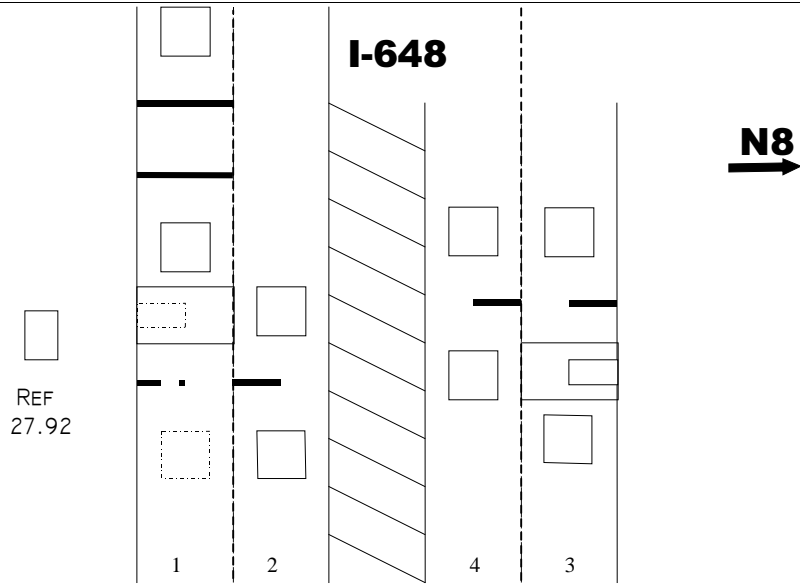

Figure A-29: Station 6140 Four Lane Divided

	Lane 1	Lane 2	Lane 3	Lane 4
WIM	X		X	
Classification		X		X
Sensor	PIEZO	CLS	BP-V	CLS
Pavement	A	A	A	A
Suitable for VWS 6/00 (F. Axle)	NO		NO	
Suitable for VWS 10/00 (Class.)	NO		NO	
Suitable for VWS 3/01 (F. Axle)	NO		NO	
Klepinger Scale	4+	4+	4+	4+
Calibration Dates				

Table A-31: Station 6140 Inventory

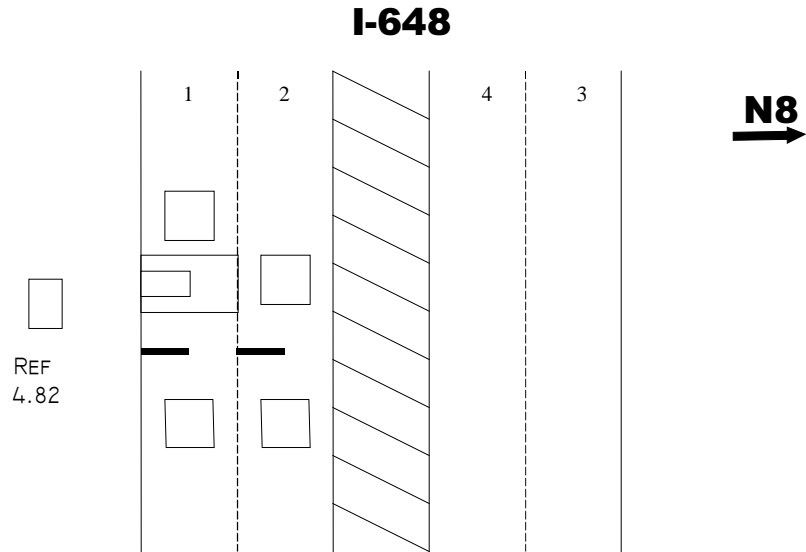

Figure A-30: Station 6150 Four Lane Divided

	Lane 1	Lane 2	Lane 3	Lane 4
WIM	X			
Classification		X		
Sensor	BP-V	CLS		
Pavement	A	A	A	A
Suitable for VWS 6/00 (F. Axle)	YES		N/A	N/A
Suitable for VWS 10/00 (Class.)	NO		N/A	N/A
Suitable for VWS 3/01 (F. Axle)	NO		N/A	N/A
Klepinger Scale	3+	4+	N/A	N/A
Calibration Dates	11-12-97, 02-17-98, 02-09-99			

Table A-32: Station 6150 Inventory

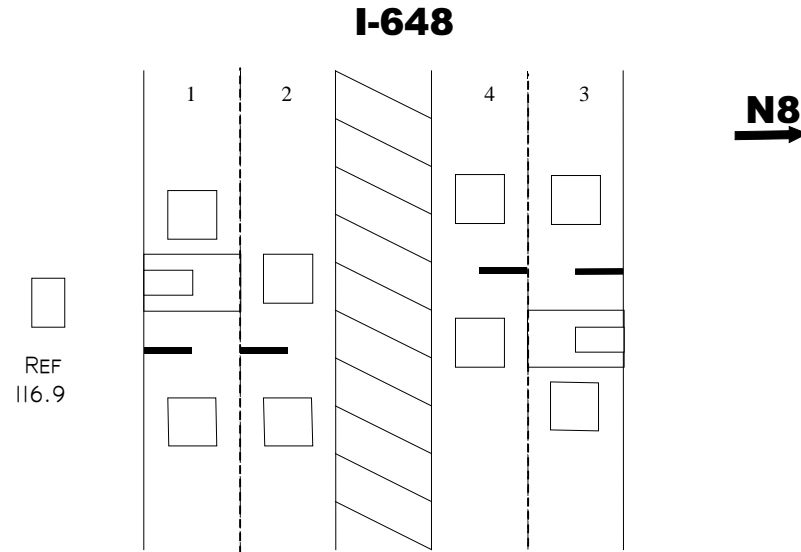

Figure A-31: Station 6160 Four Lane Divided

	Lane 1	Lane 2	Lane 3	Lane 4
WIM	X		X	
Classification		X		X
Sensor	BP	CLS	BP	CLS
Pavement	C	C	C	C
Suitable for VWS 6/00(F. Axle)	NO		NO	
Suitable for VWS 10/00 (Class.)	NO		NO	
Suitable for VWS 3/01 (F. Axle)	NO		NO	
Klepinger Scale	2	3	1	2+
Calibration Dates	02-12-99			

Table A-33: Station 6160 Inventory

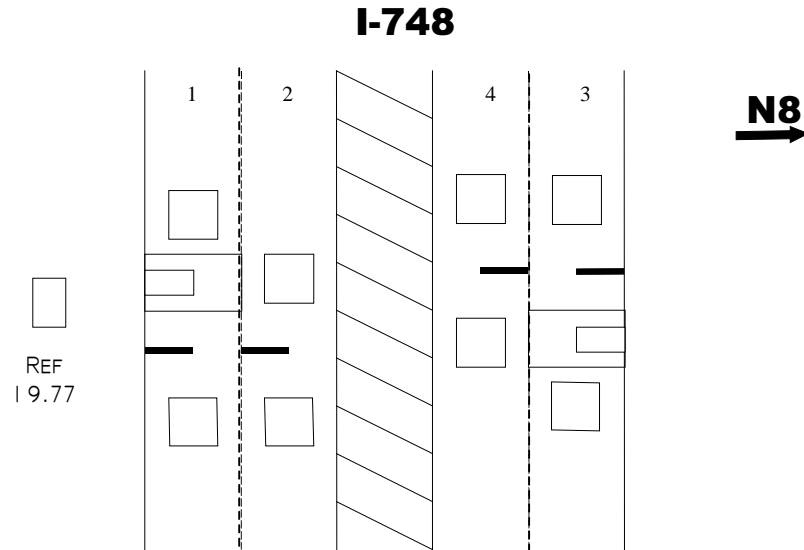

Figure A-32: Station 6170 Four Lane Divided

	Lane 1	Lane 2	Lane 3	Lane 4
WIM	X		X	
Classification		X		X
Sensor	PIEZO	CLS	BP-V	CLS
Pavement	A	A	A	A
Suitable for VWS 6/00 (F. Axle)	NO		NO	
Suitable for VWS 10/00 (Class.)	YES		NO	
Suitable for VWS 3/01 (F. Axle)	NO		YES	
Klepinger Scale	5	5+	5	5+
Calibration Dates	3-13-98, 3-30-99			

Table A-34: Station 6170 Inventory

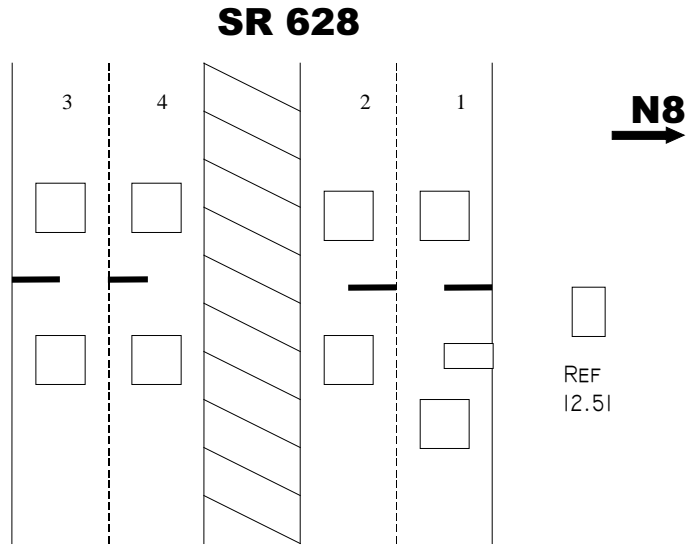

Figure A-33: Station 6250 Four Lane Divided

	Lane 1	Lane 2	Lane 3	Lane 4
WIM	X			
Classification		X	X	X
Sensor	BP	CLS	CLS	CLS
Pavement	C	C	C	C
Suitable for VWS 6/00 (F. Axle)	NO			
Suitable for VWS 10/00 (Class.)	NO			
Suitable for VWS 3/01 (F. Axle)	NO			
Klepinger Scale	5	5	5	5
Calibration Dates	3-15-98, 01-04-99			

Table A-35: Station 6250 Inventory

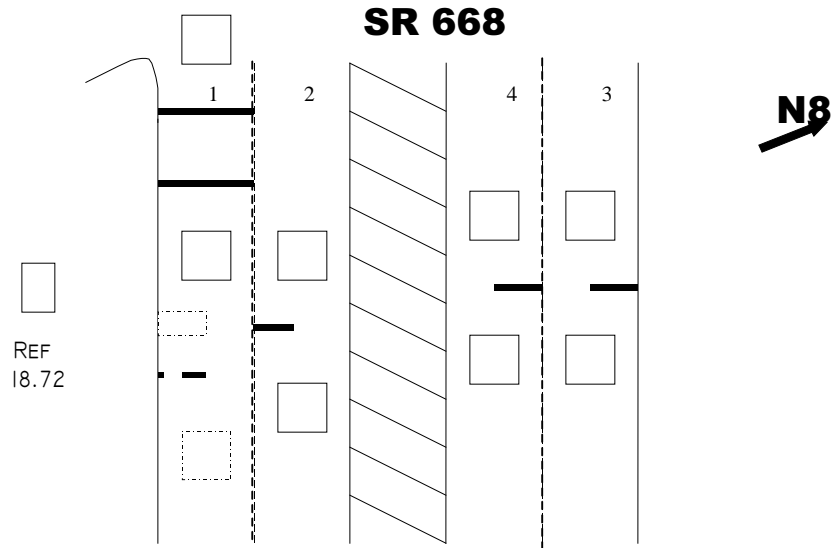

Figure A-34: Station 6260 Four Lane Divided

	Lane 1	Lane 2	Lane 3	Lane 4
WIM	X			
Classification		X	X	X
Sensor	PIEZO	CLS	CLS	CLS
Pavement	C	C	C	C
Suitable for VWS 6/00 (F. Axle)	NO DATA			
Suitable for VWS 10/00 (Class.)	YES			
Suitable for VWS 3/01 (F. Axle)	NO DATA			
Klepinger Scale	3-	3	3	3
Calibration Dates	3-19-98, 01-04-99			

Table A-36: Station 6260 Inventory

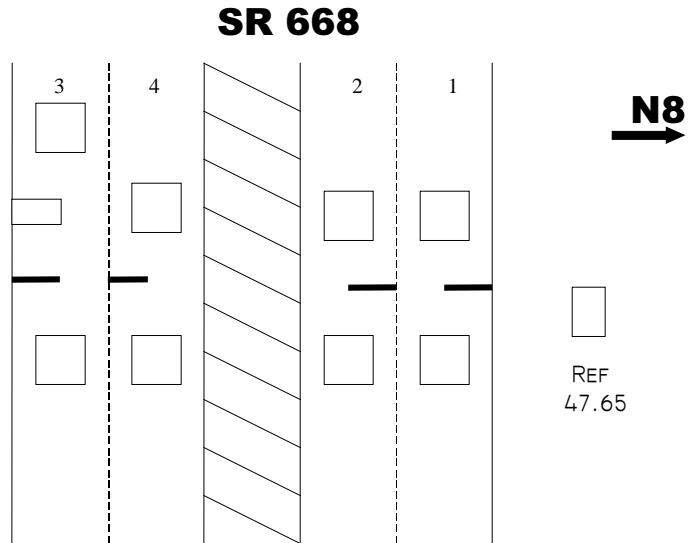

Figure A-35: Station 6270 Four Lane Divided

	Lane 1	Lane 2	Lane 3	Lane 4
WIM			X	
Classification	X	X		X
Sensor	CLS	CLS	BP	CLS
Pavement	A	A	A	A
Suitable for VWS 6/00 (F. Axle)			NO	
Suitable for VWS 10/00 (Class.)			YES	
Suitable for VWS 3/01 (F. Axle)			NO	
Klepinger Scale	3	3	3-	2+
Calibration Dates	11-13-97, 02-11-98, 02-10-99			

Table A-37: Station 6270 Inventory

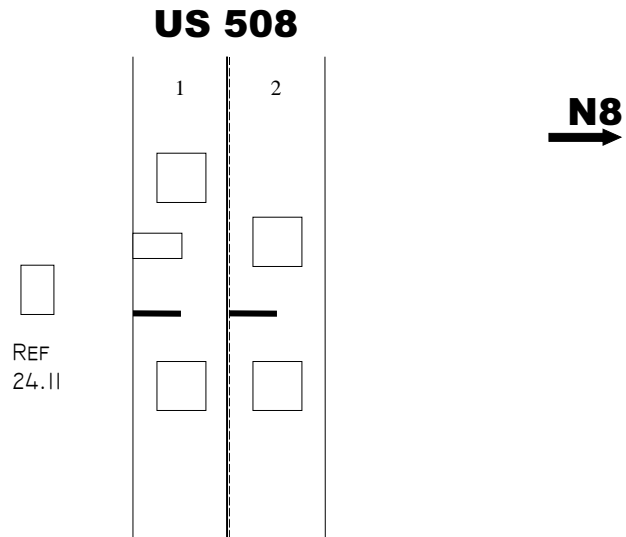

Figure A-36: Station 6280 Two Lane Undivided

	Lane 1	Lane 2
WIM	X	
Classification		X
Sensor	BP	CLS
Pavement	A	A
Suitable for VWS 6/00 (F. Axle)	NO	
Suitable for VWS 10/00 (Class.)	NO	
Suitable for VWS 3/01 (F. Axle)	NO	
Klepinger Scale	2+	2+
Calibration Dates	10-08-97, 3-26-99, 4-23-99	

Table A-38: Station 6280 Inventory

US 508

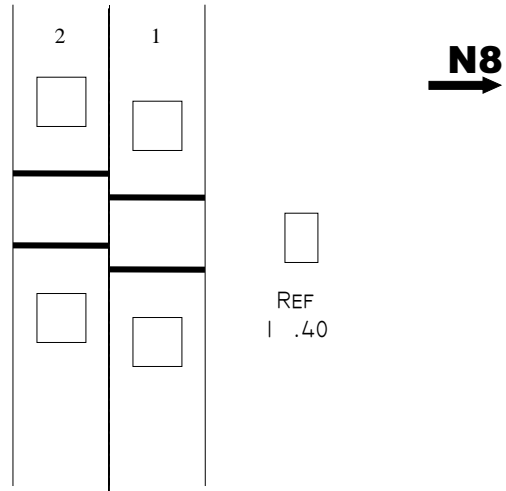

Figure A-37: Station 6290 Two Lane Undivided

	Lane 1	Lane 2
WIM	X	X
Classification		
Sensor	PIEZO	PIEZO
Pavement	A	A
Suitable for VWS 6/00 (F. Axle)	NO	NO
Suitable for VWS 10/00 (Class.)	NO	NO
Suitable for VWS 3/01 (F. Axle)	NO	NO
Klepinger Scale	4	4-
Calibration Dates	01-16-98, 3-04-99	

Table A-39: Station 6290 Inventory

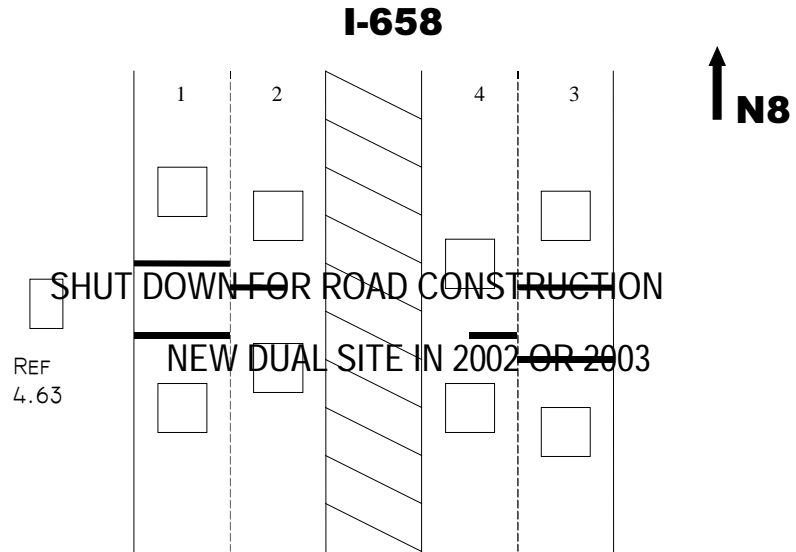

Figure A-38: Station 6420 Four Lane Divided

	Lane 1	Lane 2	Lane 3	Lane 4
WIM				
Classification				
Sensor				
Pavement				
Suitable for VWS 7/00				
Suitable for VWS 10/00				
Suitable for VWS 2/01				
Klepinger Scale				
Calibration Dates				

Table A-40: Station 6420 Inventory

I-80/90 Toll Road8

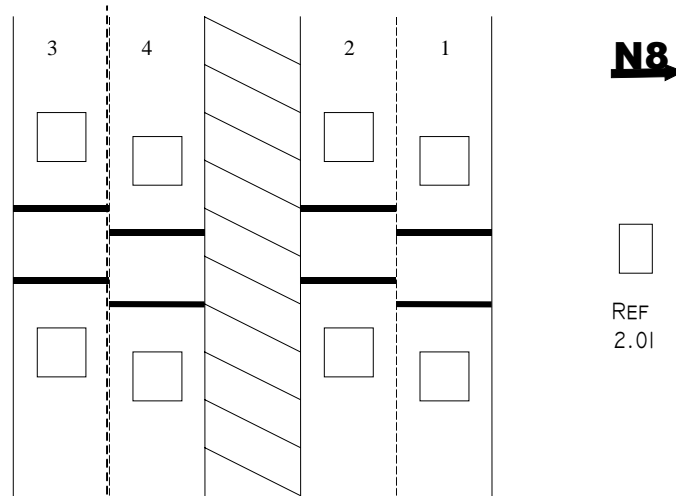

Figure A-39: Station 7300 Four Lane Divided

	Lane 1	Lane 2	Lane 3	Lane 4
WIM	X	X	X	X
Classification				
Sensor	PIEZO	PIEZO	PIEZO	PIEZO
Pavement	C	C	C	C
Suitable for VWS 6/00 (F. Axle)	NO DATA	NO DATA	NO DATA	NO DATA
Suitable for VWS 10/00 (Class.)	NO DATA	NO DATA	NO DATA	NO DATA
Suitable for VWS 3/01 (F. Axle)	NO	NO	YES	NO
Klepinger Scale				
Calibration Dates				

Table A-41: Station 7300 Inventory

I-80/90 Toll Road8

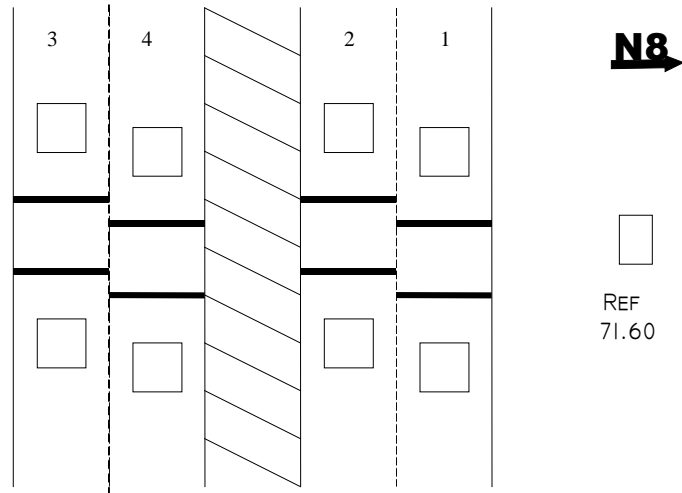

Figure A-40: Station 7320 Four Lane Divided

	Lane 1	Lane 2	Lane 3	Lane 4
WIM	X	X	X	X
Classification				
Sensor	PIEZO	PIEZO	PIEZO	PIEZO
Pavement	C	C	C	C
Suitable for VWS 6/00 (F. Axle)	NO DATA	NO DATA	NO DATA	NO DATA
Suitable for VWS 10/00 (Class.)	NO DATA	NO DATA	NO DATA	NO DATA
Suitable for VWS 3/01 (F. Axle)	YES	YES	NO	NO
Klepinger Scale				
Calibration Dates				

Table A-42: Station 7320 Inventory

I-80/90 Toll Road8

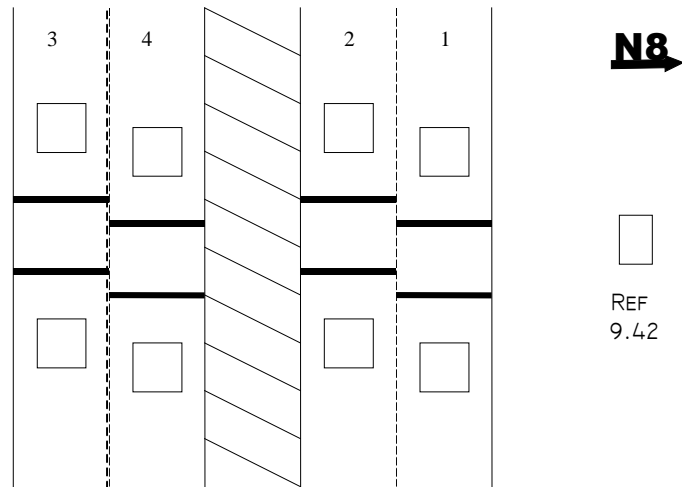

Figure A-41: Station 7340 Four Lane Divided

	Lane 1	Lane 2	Lane 3	Lane 4
WIM	X	X	X	X
Classification				
Sensor	PIEZO	PIEZO	PIEZO	PIEZO
Pavement	C	C	C	C
Suitable for VWS 6/00 (F. Axle)	NO DATA	NO DATA	NO DATA	NO DATA
Suitable for VWS 10/00 (Class.)	NO DATA	NO DATA	NO DATA	NO DATA
Suitable for VWS 3/01 (F. Axle)	YES	NO	NO	NO
Klepinger Scale				
Calibration Dates				

Table A-43: Station 7340 Inventory

Appendix B Evaluation of Covington WIM

January 4, 2001
I-74 Scale
WIM 5130

Record #	Ed Allen GVW WIM	John Green GVW Scale	Error	%Error
3221	81,800	79,360	2,440	3%
3332	81,600	77,860	3,740	5%
3355	50,700	50,640	60	0%
3400	33,000	38,840	-5,840	-15%
3452	70,200	74,520	-4,320	-6%
3532	56,900	59,800	-2,900	-5%
3579	46,700	48,080	-1,380	-3%
3771	66,100	30,580	35,520	116%
3810	80,900	77,660	3,240	4%
3970	73,900	72,280	1,620	2%
4030	51,700	58,780	-7,080	-12%
4083	79,000	77,900	1,100	1%
4205	28,100	33,980	-5,880	-17%
4376	82,700	76,780	5,920	8%
4409	75,500	74,720	780	1%
4475	81,800	77,760	4,040	5%
4521	80,700	76,320	4,380	6%
4558	44,900	46,280	-1,380	-3%
4595	80,700	78,560	2,140	3%
4648	37,500	39,480	-1,980	-5%
4707	31,000	33,680	-2,680	-8%
4760	75,700	75,100	600	1%
4804	78,600	78,420	180	0%
4839	62,500	65,380	-2,880	-4%

Table B-1: 01-04-01 Test of WIM System

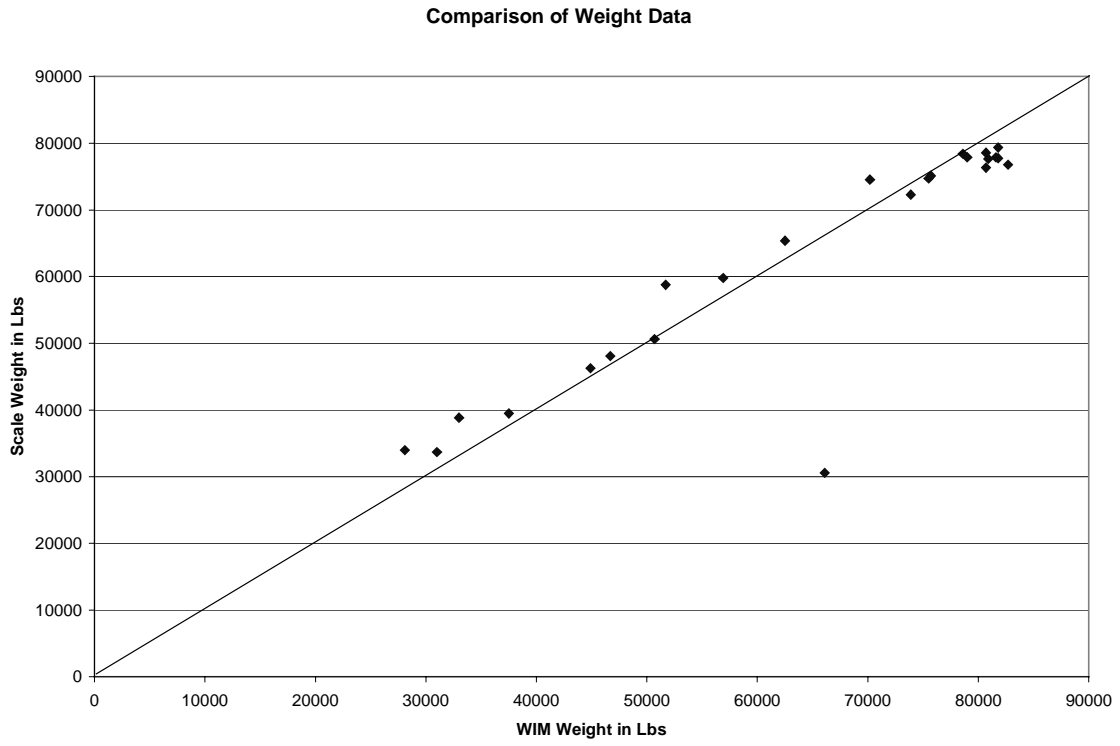

Figure B-1: Comparison of Test Weights 01-04-01 at Covington WIM 5130

Appendix C Diversion Routes

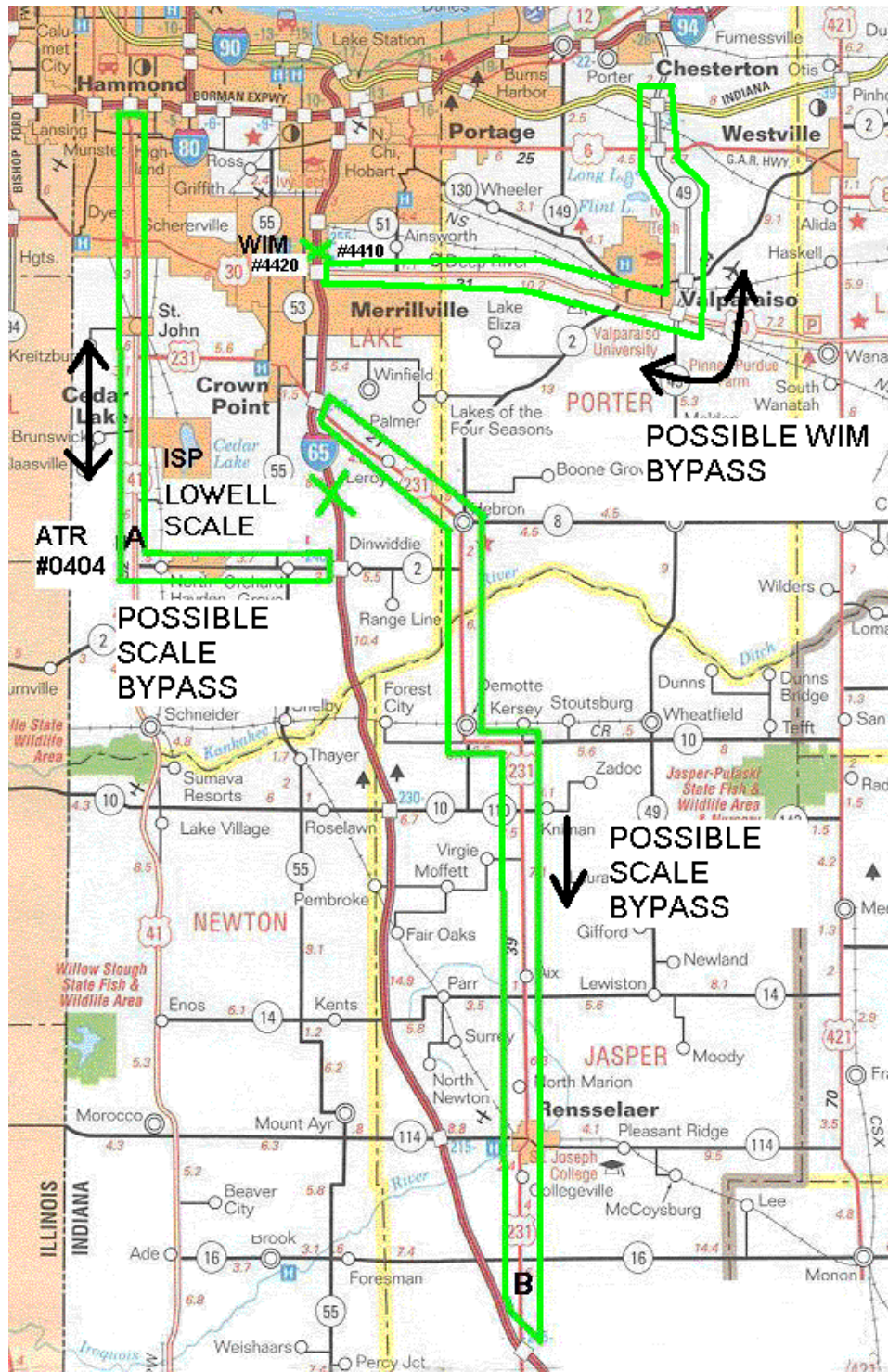

Figure C-1: Lowell Scale Diversion Routes

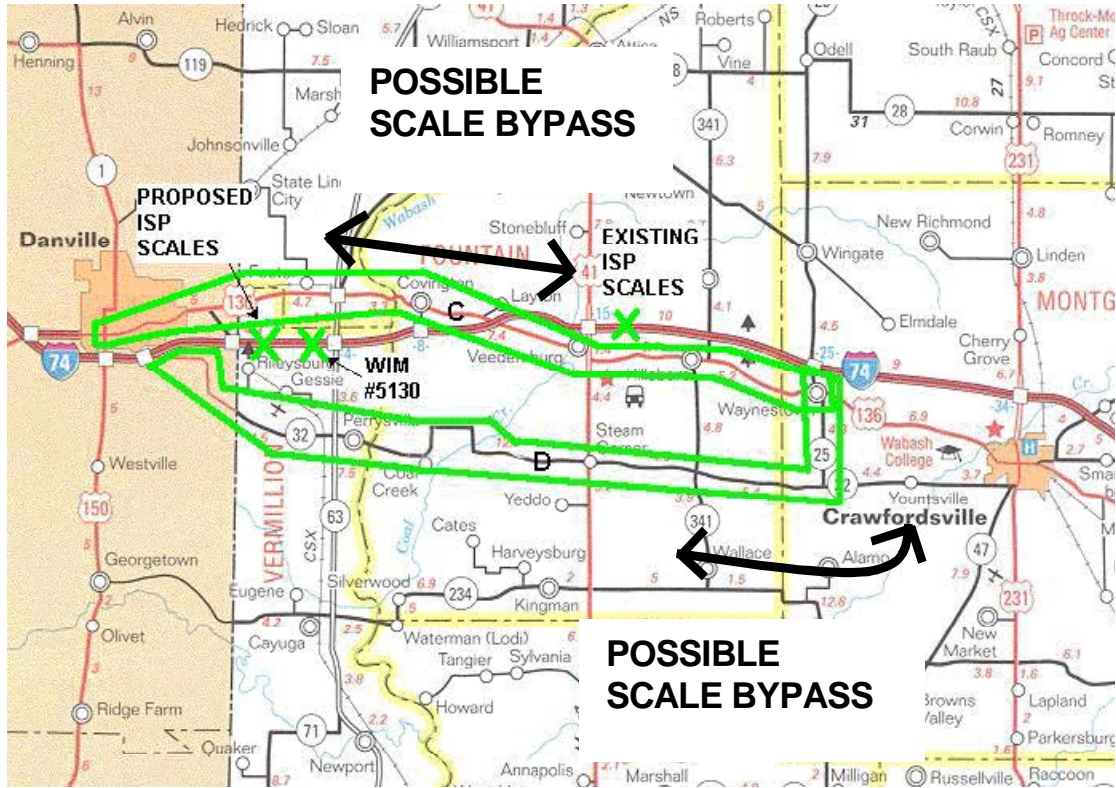

Figure C-2: Covington Scale Diversion Routes

Appendix D International Road Dynamics Cost Summary Memo

D.1 Kistler WIM

The Kistler WIM consists of a light metal profile in the middle of which quartz disks are fitted under preload. When force is applied to the sensor surface the quartz disks yield an electric charge proportional to the applied force through piezoelectric effect. This electric charge is converted by a charge amplifier into a proportional voltage that can then be further processed as required.

The sensors can be installed in combination with other traffic detectors like induction loops, switching cables, etc. Kistler WIM sensors are easy to install both individually and in groups for comprehensive recording over a wide roadway. Typically, four one-meter-long (39.4") sensors are required to cover one typical lane width of approximately 12 feet.

Installation begins by making a relatively small cut in the road into which the sensor will be installed. The size of the cut varies depending on the sensor being installed, but is generally 2.25" deep and 3" wide. The sensor is placed in the sawcut and secured in place by a fast curing grout.

A complete lane installation consisting of eight sensors and two loops can be accomplished in less than a day, including curing time.

When properly installed and calibrated, the Kistler WIM system should be expected to provide gross vehicle weights that are within 10% of the actual vehicle weight for 95% of the trucks measured.

D.1.1 Common Configuration

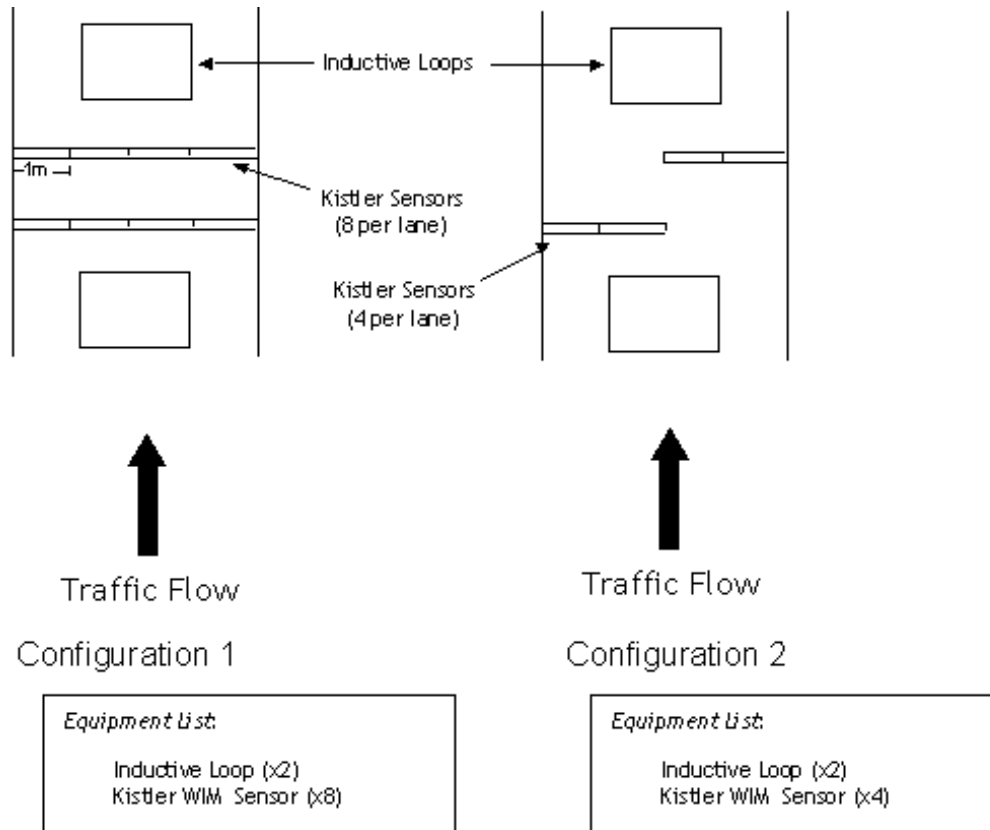

Figure D-1: Common Configurations of Kistler Sensors

D.1.2 Scheduled Maintenance

At six (6) Month intervals the following Scheduled Maintenance should be performed to ensure continual sensor operation:

- Visually inspect the Kistler sensor installation.
- Ensure no cracks are forming in grout or surrounding pavement.
- Ensure seal between grout and pavement.
- Maintain the installation of the grout.
- Maintain all Kistler sensor cable splices as required.
- Visually inspect the BNC connector and replace if required.
- Measure the resistance and voltage output of the sensor.

D.2 Single Load Cell Scale

The Single Load Cell Scale consists of two (2) weighing platforms with a surface size of 6' by 3'2", placed adjacent to each other to fully cover a normal 12' traffic lane. A single hydraulic load cell is installed at the center of each platform to measure the force applied to the scales. The load measurements are recorded and analyzed by the system electronics to determine the axle loads.

The installation of a single load cell scale requires the use of a concrete vault. The roadway is cut and excavated to form a pit. The frame is positioned in place and then is cast into the concrete to form a secure and durable foundation for the scale. The size of the vault required is slightly large, measuring 165" by 58" by 38".

The Single Load Cell scale is typically installed in a lane with two inductive loops and an axle sensor to provide vehicle length and axle spacing information. Installing a complete lane of scales, loops and axle sensor can be accomplished in 3 days.

When properly installed and calibrated, the Single Load Cell WIM system should be expected to provide gross vehicle weights that are within 6% of the actual vehicle weight for 95% of the trucks measured.

D.2.1 Common Configuration

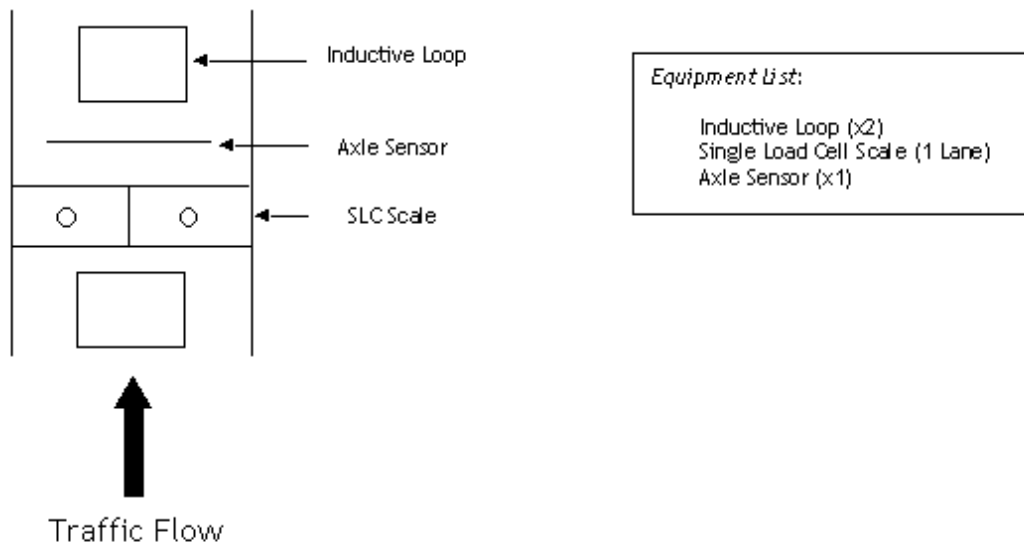

Figure D-2: Common Configuration of Single Load Cell Scale

D.2.2 Scheduled Maintenance

At six (6) month intervals the following scheduled maintenance should be performed to ensure continued scale operation:

- Visually inspect the scale installation.
- Maintain installation of the concrete vault.
- Maintain the slot between the concrete vault and the existing roadway with loop sealant.
- Remove the load cell from the load cell cavity, retorque the four (4) mounting bolts in the load cell cavity, check the splice, replace the antifreeze in the load cell cavity, replace the load cell, load cell hatch, secure and reseal load cell hatch.
- Retorque and/or replace the eight (8) mounting bolts as required.
- Replace all frost plugs as required.
- Maintain the installation of the silicon sealant between the scale and frame.
- Maintain all splices in junction boxes as required.
- Measure the signal cable resistance of the scale.
- Recalibrate the scale.

D.3 Bending Plate Scale

The Bending Plate scale consists of two steel platforms, which are each 2' by 6', placed adjacent to each other to cover a 12' lane. The steel plate is instrumented with strain gages at critical points to measure the strain in the plate as a tire or axle passes over. The measured strain is analyzed to determine the axle load. The Bending Plate scale is typically installed in a lane with two inductive loops and an axle sensor to provide vehicle length and axle spacing information.

There are two basic installation methods for a Bending Plate scale. In concrete roadways of sufficient depth, a shallow excavation is made in the surface of the road (Quick Installation). The scale frame is anchored into place using anchoring bars and epoxy. In asphalt roads or thin concrete roads, it is necessary to install a concrete foundation for support of the frame (Vault Installation). The roadway is cut and excavated to form a pit of 30" deep by 4'10" wide by 13'10" long. The frame is positioned in place and then is cast into concrete to form a secure and durable foundation for the scale.

Installing a complete lane of scales, loops and axle sensor can be accomplished in a day using the shallow excavation method and in 3 days using the concrete vault.

When properly installed and calibrated, the Bending Plate WIM system should be expected to provide gross vehicle weights that are within 10% of the actual vehicle weight for 95% of the trucks measured.

D.3.1 Common Configuration

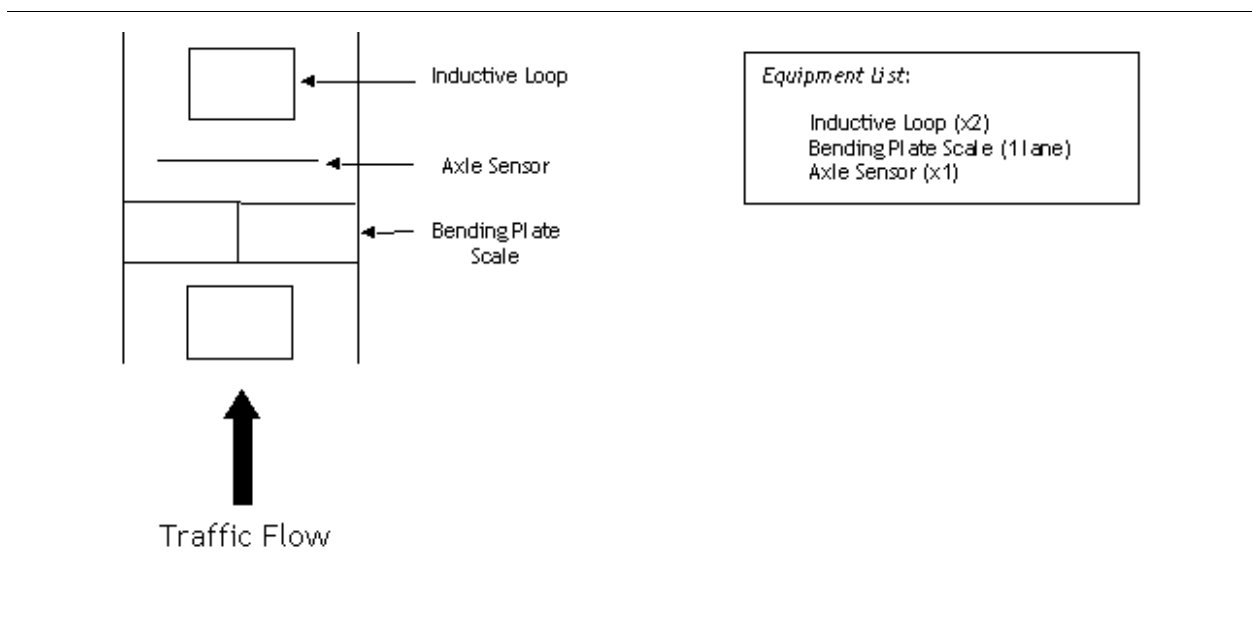

Figure D-3: Common Configuration of Bending Plate Scale

D.3.2 Scheduled Maintenance

Quick Installation (No concrete vault)

At six (6) month intervals the following scheduled maintenance should be performed to ensure continued scale operation:

- Visually inspect the scale installation.
- Maintain installation of the epoxy material
- Re-torque and/or replace stainless steel cap screws.
- Replace frost plugs as required.
- Maintain installation of the silicon seal.
- Maintain all splices in the junction boxes as required.
- Measure signal cable resistance of scale.

- Recalibrate the scales.

Vault Installation

At six (6) month intervals the following scheduled maintenance should be performed to ensure continued scale operation:

- Visually inspect the scale installation.
- Maintain installation of the concrete vault.
- Maintain the slot between the concrete vault and the existing roadway with loop sealant.
- Re-Torque and/or replace stainless steel cap screws.
- Replace frost plugs as required.
- Maintain installation of the silicon seal.
- Maintain all splices in the junction boxes as required.
- Measure signal cable resistance of scale.
- Recalibrate the scales.

D.4 Piezoelectric Sensors

The basic construction of the typical sensor consists of a copper strand, surrounded by a piezoelectric material, which is covered by a copper sheath. When pressure is applied to the piezoelectric material an electrical charge is produced. The sensor is actually embedded in the pavement and the load is transferred through the pavement. The characteristics of the pavement will therefore affect the output signal. By measuring and analyzing the charge produced, the sensor can be used to measure the weight of a passing tire or axle group.

For a complete data collection system, it is common to install two inductive loops and two piezoelectric sensors in each lane, which is being monitored. Installation begins by making a relatively small cut in the road into which the sensor will be installed. The size of the cut varies depending on the sensor being installed, but is generally 1" to 2" deep and 1" to 2" wide. The sensor is placed in the sawcut and secured in place by a fast curing grout.

A complete lane installation consisting of two sensors and two loops can be accomplished in less than a full day, including curing time.

When properly installed and calibrated, a piezoelectric WIM system should be expected to provide gross vehicle weights that are within 15% of the actual vehicle weight for 95% of the trucks measured.

D.4.1 Common Configuration

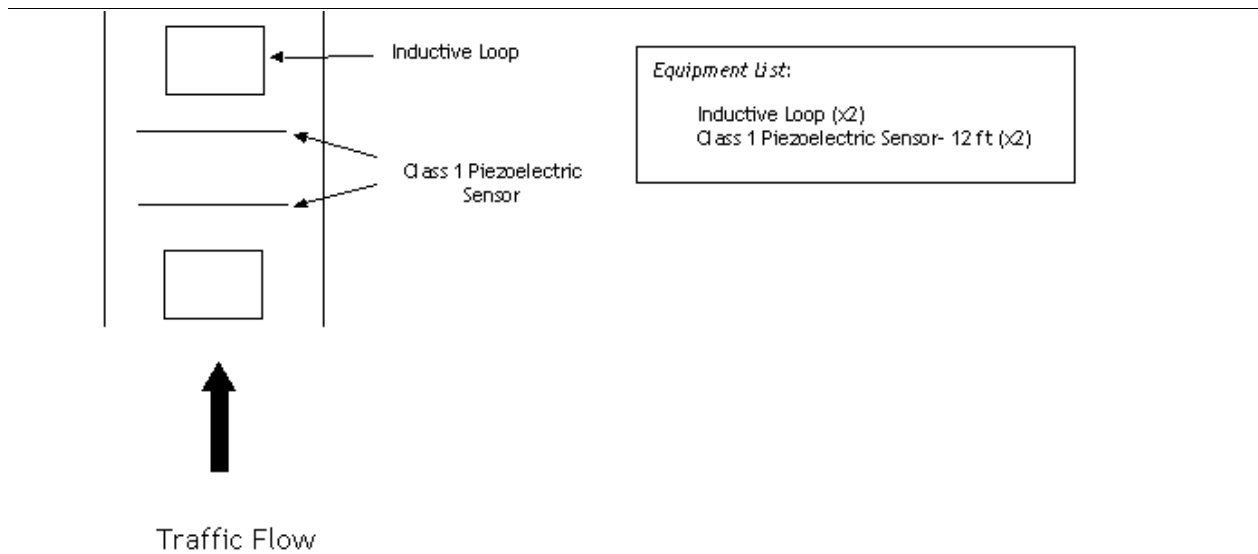

Figure D-4: Common Configuration of Piezoelectric Sensor

D.4.2 Scheduled Maintenance

At six (6) Month intervals the following Scheduled Maintenance should be performed to ensure continual sensor operation:

- Visually inspect the piezo installation.
- Maintain the installation of the grout.
- Maintain all piezo cable splices as required.
- Visually inspect the BNC connector and replace if required.
- Measure the resistance and voltage output of the sensor.

D.5 Comparison of WIM Technology Accuracies and Costs

In order to evaluate which technology is most appropriate, the cost of each technology must also be considered. However, there are many factors to include in the cost of a WIM technology beyond equipment cost or the installation cost. Other factors to consider include the expected life, maintenance cost and replacement costs.

The life cycle costing was carried over a twelve-year period. For comparison, the equipment and installation costs will be for the in-road equipment only. The cost of the electronics, cabinet, power supply, telephone connection, and road preparation are assumed to be relatively constant, regardless of technology use and are not included in these estimates. The initial installation includes the equipment supply, installation by a local contractor, installation supervision and calibration by a vendor representative and traffic control during installation and curing. Installation costs are dependent on site conditions and local market rates.

The equipment included for each type of WIM technology is displayed in the individual configurations shown previously. The Quick installation (no vault) has been included for the Bending Plate scale comparison. The Kistler configuration included in the comparison is seen in *Configuration 1*, previously displayed.

	Kistler	Single Load Cell	Bending Plate	Piezoelectric
Accuracy (GVW) (95% confidence level)	2 σ =10%	2 σ =6%	2 σ =10%	2 σ =15%
Service Life	6 years	20 years	6 years	4 years
Initial Budgetary Equipment Cost	\$ 20,500 /lane	\$39,000 /lane	\$8,000 /lane	\$2,500 /lane
Initial Budgetary Installation Cost	\$12,000 /lane	\$20,800 /lane	\$13,500 /lane	\$6,500 /lane
Life Cycle Cost (over 12 year period)	\$7,500 /year/lane	\$6,200 /year/lane	\$6,400 /year/lane	\$4,750 /year/lane

Table D-1: WIM Technology Comparison

Note:

- * Prices shown are ESTIMATED only.
- * All monetary values in USD.
- * Life cycle costing carried out over a twelve-year period.
- * Kistler Accuracy stated for Configuration 1.
- * No Vault installation used in cost comparison of Bending Plate.

- * All accuracies stated at a 95% confidence level.
- * Initial Budgetary installation costs include materials to install and physical installation.

D.6 Maintenance/Performance Monitoring Approach

The following are a number of suggested maintenance monitoring approaches, depending on the level of service desired.

- Current Method – Data collection group completes reports every one (1) to three (3) months. At this time they identify any errors, which indicates that maintenance.
- Scheduled Performance Monitoring by INDOT – INDOT would carry out daily, weekly or monthly maintenance checks and they would prepare summary reports. Within these reports, the client could look for irregularities in % errors, % un-classed vehicles, vehicle volume or % of vehicle types.
- Scheduled Performance Monitoring by IRD – same as listed for INDOT in above item.
- Self-Diagnostics – Change system software, so software looks for high % errors or vehicle volume irregularities. The system would phone out when problems detected.

Standard IRD Maintenance Form

Customer Recommended Maintenance For IRD Weigh-In-Motion (WIM) Systems. Preventative Maintenance Service as identified below should be performed at six (6) month intervals.

In-Road WIM Sensors:

- All WIM Sensors
 - Test response levels, signal level and lead cables
 - Verify sensor performance and reliability
 - Adjust calibration factors as required
- Single Load Cell Scales
 - Maintain installation of concrete vault
 - Maintain silicone seal around perimeter of the weigh pads
 - Tighten or replace damaged hardware and frost plugs as required
 - Remove and replace single load cell hatch and perform visual inspection of single load cell and lightning protection
 - Add antifreeze to single load cell scale as required
- Bending Plates

- Maintain installation of concrete vault or epoxy
- Maintain silicone seal around the perimeter of the weigh pads
- Tighten or replace damaged hardware and frost plugs as required
- Piezo Sensors
 - Maintain installation of grout
- Kistler Sensors
 - Maintain installation of grout
 - Maintain seal

Other In-Road Sensors:

- All In-Road Sensors
 - Test response levels, signal level and lead cables
 - Verify sensor performance and reliability
- Dynax Sensors
 - Maintain installation of concrete vault or epoxy
 - Tighten or replace damaged hardware and frost plugs as required
- Loops
 - Maintain installation of loop sealant

Electronics Interface and System Computers:

- Clean interior and exterior of all components
- Remove, clean and inspect all printed circuit boards
- Maintain all electrical connectors, cables and components
- Test and verify control and sequence of operation of interface components

Appendix E Site Evaluation Memo to Kirk Mangold

To: Kirk Mangold
 From: Darcy Bullock
 Date: February 2, 2001
 Subject: Weigh in Motion Data Analysis, Update III

As you are aware, Mark Newland requested that I supply him with information concerning the impact of overweight vehicles on Indiana roads. Since INDOT has approximately 40 stations, we mutually decided to initially examine only about 25% of the stations. The week of January 15, 2001, I forwarded Mark a list of selected stations (Table E-1) and requested data for those stations during July 2000. On January 17, 2001, Philip Zurawski forwarded me data for the July 9-16, 2000 period. Table E-1 summarized that data. Information obtained from Roy Czinku at IRD indicated that the error rate should be less 10%. Preliminary review of that data showed that all stations exceeded that recommended standard (Table E-1).

No.	M.P.	Location	Legal	Over	Error
4140	068.26	I-69 4.16 MILES N OF SR 18	61.7	1.4	36.9
4150	137.88	I-69 2.53 MILES S OF SR 4	68.4	18.0	13.6
4260	216.98	US 31 0.66 MILES S OF SR 10	81.7	0.0	18.3
5110	107.98	I-70 4.33 MILES E OF SR 9	71.0	14.0	15.0
5450	175.94	I-65 0.78 MILES N OF SR 25	36.5	13.8	49.7
5460	010.02	I-465 (W. SIDE) 0.70 MILES N OF I-70	65.1	0.5	34.4
5480	042.41	I-465 (E. SIDE) 0.97 MILES S OF US	67.6	3.7	28.7
6160	116.96	I-64 0.98 MILES W OF SR 62/64	14.1	3.6	82.3
6280	024.11	ON US 50 2.34 MILES E OF SR 257	60.8	0.0	39.2
6290	137.40	US 50 1.08 MILES W OF US 421 NB	54.8	11.2	34.0
6420	004.63	I-65 0.89 MILES S OF I-265	74.6	7.7	17.7

Table E-1: Acceptable Sites

On January 19, 2001, we decided to examine the error rates for all stations (Table E-2) during a week in July and week in November. Phil Zurawski provided some additional data for the entire months of July and November. However, because of limitations of the reporting program, some of the data sets were too large for the IRD reporting program to produce monthly reports. Instead, Phil had to produce daily reports for some of the more active sites (For Example Station 4150). Those reports were too voluminous to analyze quickly.

On January 23, 2001, we visited Don Klepinger and Larry Torrance at Roadway Management and learned that some error reports were available from them. We were able to obtain reports produced between January 1998 and October 2000 that list the “best” weekly error rates for all the stations (composite error rate calculated over all lanes and for individual lanes). An example of that data is shown in Table E-3. Figure E-1 to Figure E-36 on the following pages graphically depict that data we obtained from Roadway Management that summarized the performance across all lanes.

A preliminary scan of the data suggests the following stations were running within the expected accuracy range as of October 2000:

- Station 4250, 1% Error
- Station 4270, (borderline) 7% Error
- Station 5140, 5% Error
- Station 5260, 2% Error
- Station 5470, 5% Error
- Station 6170, (borderline) 8% Error
- Station 6260, 2% Error
- Station 6270, 3% Error

As we understand it, the source of these errors is the “best” week of a monthly report¹. If that is the case, some of these borderline stations may not be performing acceptably during other weeks in the month. An example transient problem masked by this type of reporting would be a bad loop detector splice that performs fine during dry weather, but fails during wet weather.

After reviewing the data further, we determined that because the errors shown in Figure E-1 through Figure E-36 are the average across all lanes, there is the possibility of averaging out significant errors in individual lanes. On February 2, 2001 we prepared graphs shown in Figure E-37 through Figure E-72. After reviewing those graphs we have determined the following stations have individual lanes experiencing error rates higher than that proposed by Roy Czinku:

- Station 4270: Lane 1 errors (Figure E-44) have crept up to 13% as of October 2000.
- Station 5140: Lane 1 errors (Figure E-51) have crept up to 11% as of October 2000.

¹ This fact needs to be checked to understand the exact procedure for producing these reports.

- Station 5470: Lane 4 errors (Figure E-59) have crept up to 16% as of October 2000.
- Station 6170: Lane 3 errors (Figure E-66) have crept up to 12% as of October 2000.
- Station 6270: Lane 4 errors (Figure E-69) have declined some (Sept was 12%), but are at 10%.

Based upon this additional analysis, as of October 2000 (Table E-3), the following stations are the only ones reporting all lanes within the tolerance proposed by Roy Czinku

- Station 4250, 1% Error. Reviewing the individual lane errors shown in Figure E-42, this station appears to have been very reliable since January 1998, except for a few isolated problems in past years.
- Station 5260, 2% Error. Reviewing the individual lane errors shown in Figure E-54, this station appears to have been very reliable since November 1999 when long-term problems with Lane 3 appear to have been corrected. Unfortunately, this cabinet was recently hit by a car and is currently out of service.
- Station 6260, 2% Error. Reviewing the individual lane errors shown in Figure E-68, this station has been reliable since September 1998, recently experienced very high errors rates this past summer, but September 2000 showed improvement and by October 2000 the errors rates were all below 5%. Since October 2000 is our latest data, this station should probably be reexamined to see if it continues to stay within expected error tolerances.

Station	County	Location
4110	Jasper	I65 NB MM 218.4
4130	LaPorte	I94 EB MM 38.0
4140	Grant	I69 SB MM 68.3
4150	Dekalb	I69 SB MM 137.9
4240	Porter	SR 49 NB RM 35.3
4250	LaPorte	SR 2 WB RM 65.2
4260	Marshall	US 31 NB RM 217.0
4270	Miami	US 24 WB RM 87.6
4280	Adams	US 27 SB RM 100.2
4400	Lake	I80 / I94 WB MM 13.3
4410	Lake	I65 NB MM 253.7
4420	Lake	I65 NB MM 253.7
4440	Lake	I80 / I94 EB MM 6.0
5110	Hancock	I70 EB MM 108.0
5120	Shelby	I65 SB MM 79.1
5130	Vermillion	I74 EB MM 4.8
5140	Wayne	I70 EB MM 155.5
5240	Benton	US 41 SB RM 199.9
5250	Monroe	SR 37 SB RM 96.7
5260	Hamilton	SR 37 SB RM 172.0
5270	Delaware	SR 332 WB RM 0.5
5440	Vigo	I70 WB MM 7.5
5450	Tippecanoe	I65 NB MM 175.9
5460	Marion	I465 SB MM 10.0
5470	Marion	I65 NB MM 102.5
5480	Marion	I465 SB MM 42.4
5550	Hamilton	US 31 NB RM 125.6
6130	Vanderburgh	I164 WB MM 2.2
6140	Gibson	I64 EB MM 27.9
6150	Spencer	I64 EB MM 54.8
6160	Floyd	I64 EB MM 117.0
6170	Dearborn	I74 EB MM 169.8
6250	Posey	SR 62 WB RM 12.5
6260	Vanderburgh	SR 66 EB RM 18.7
6270	Spencer	SR 66 WB RM 47.6
6280	Daviess	US 50 EB RM 24.1
6290	Ripley	US 50 WB RM 137.4
6420	Clark	I65 SB MM 4.8

Table E-2: Location of All WIM Stations

WEIGH-IN-MOTION												
ERROR REPORT FOR 10/15 THRU 10/21												
October 2000												
SITE - CITY	ROUTE	LANES WITH WIM	ALL	ERROR RATES								
				1	2	3	4	5	6	7	8	
4110 - RENSSELAER **	I-65	4	3	16%	2%	18%	28%	16%	XX	XX	XX	XX
4130 - MICHIGAN CITY **	I-94	6	1 2 3 4 5 6	39%	14%	42%	6%	85%	40%	5%	XX	XX
4140 - MARION ***	I-69	4	1	12%	25%	1%	3%	8%	XX	XX	XX	XX
4150 - ANGOLA **	I-69	4	12 34	15%	4%	27%	2%	71%	XX	XX	XX	XX
4240 - VALPARAISO *	SR-49	4		42%	#####	#####	16%	100%	XX	XX	XX	XX
4250 - LAPORTE	SR-2	4	3	1%	1%	1%	1%	1%	XX	XX	XX	XX
4260 - PLYMOUTH *	US-31	4	1	10%	1%	1%	22%	6%	XX	XX	XX	XX
4270 - WABASH ***	US-24	4	1	7%	13%	1%	2%	1%	XX	XX	XX	XX
4280 - FORT WAYNE	US-27	4	1	13%	26%	3%	5%	6%	XX	XX	XX	XX
4400 - LAKE STATION **	I-80/94E	6	1 2 3 4 5 6	17%	9%	10%	68%	2%	4%	16%	XX	XX
4440 - GARY *	I-80/94W	8	2 3 4 6 7 8	58%	32%	47%	#####	99%	49%	76%	61%	20%
5110 - GREENFIELD ***	I-70	4	12 34	23%	9%	19%	4%	91%	XX	XX	XX	XX
5120 - EDINBURGH **	I-65	4	12 34	39%	22%	8%	37%	100%	XX	XX	XX	XX
5130 - COVINGTON ***	I-74	4	1 3	#####	#####	#####	#####	#####	XX	XX	XX	XX
5140 - RICHMOND **	I-70	4	1 3	5%	11%	3%	2%	3%	XX	XX	XX	XX
5240 - FOWLER	US-41	2	1	9%	10%	3%	XX	XX	XX	XX	XX	XX
5250 - BLOOMINGTON ***	SR-37	4	1	35%	89%	3%	3%	1%	XX	XX	XX	XX
5260 - NOBLESVILLE ***	SR-37	4	3	2%	2%	0%	4%	3%	XX	XX	XX	XX
5270 - MUNCIE ***	SR-332	4	1 3	#####	#####	#####	#####	#####	XX	XX	XX	XX
5440 - TERREHAUTE ***	I-70	4	1 3	15%	10%	37%	20%	3%	XX	XX	XX	XX
5450 - LAFAYETTE ***	I-65	4	1 3	25%	18%	15%	97%	33%	XX	XX	XX	XX
5460 - INDPLS WEST **	I-465	6	12 45	57%	34%	71%	47%	90%	79%	4%	XX	XX
5470 - SOUTHPORT ***	I-65	6	12 4	5%	2%	6%	3%	16%	2%	1%	XX	XX
5480 - INDPLS EAST **	I-465	6	12 45	43%	42%	53%	40%	42%	6%	35%	XX	XX
5550 - CARMEL *	US-31	4	1	#####	#####	#####	#####	#####	XX	XX	XX	XX
6130 - EVANSVILLE/S *	I-164	4	1 3	48%	71%	1%	100%	1%	XX	XX	XX	XX
6140 - EVANSVILLE/N ***	I-64	4	1 3	25%	18%	3%	40%	13%	XX	XX	XX	XX
6150 - DALE	I-64	2	1	48%	48%	#####	XX	XX	XX	XX	XX	XX
6160 - NEW ALBANY ***	I-64	4	1 3	64%	98%	1%	82%	1%	XX	XX	XX	XX
6170 - WEST HARRISON **	I-74	4	1 3	8%	7%	4%	12%	5%	XX	XX	XX	XX
6250 - MOUNT VERNON *	SR-62	4	1	15%	35%	2%	1%	7%	XX	XX	XX	XX
6260 - EV'ILLE 66W *	SR-66	4	1	2%	1%	1%	4%	3%	XX	XX	XX	XX
6270 - HATFIELD 66E ***	SR-66	4	3	3%	4%	1%	1%	10%	XX	XX	XX	XX
6280 - WASHNGTN SOW *	US-50	2	1	32%	32%	#####	XX	XX	XX	XX	XX	XX
6290 - VERSAILLES 50E *	US-50	2	1 2	100%	100%	100%	XX	XX	XX	XX	XX	XX
6420 - JEFFERSNVILLE **	I-65	4	1 3	#####	#####	#####	#####	#####	XX	XX	XX	XX
C CONSTRUCTION												
* NO WEIGHTS RECORDED												
** WEIGHTS APPEAR HIGH						SHRP LANE						
*** WEIGHTS APPEAR LOW												
##### - NO REPORT AVAILABLE												

4400 - ERROR REPORT FROM 10/20 to 10/21.

Table E-3: October 2000 Roadway Management Error Report

E.1 Summary of Average Station Performance (All Lanes)

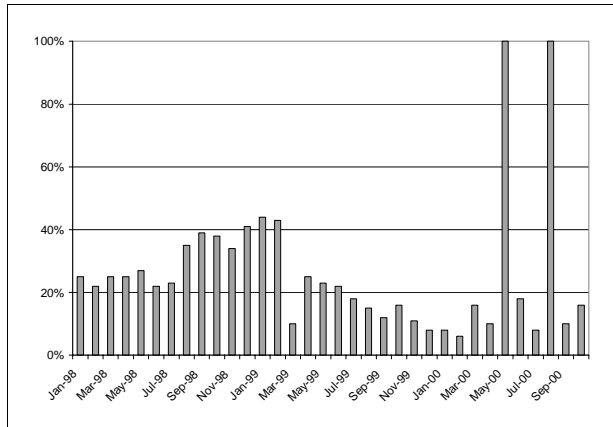

Figure E-1: Error Rate at Station 4110

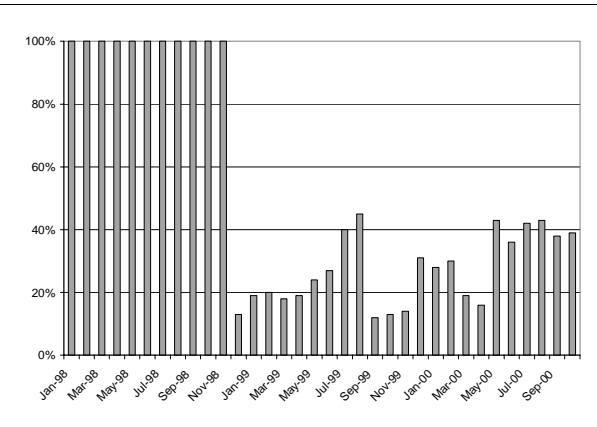

Figure E-2: Error Rate at Station 4130

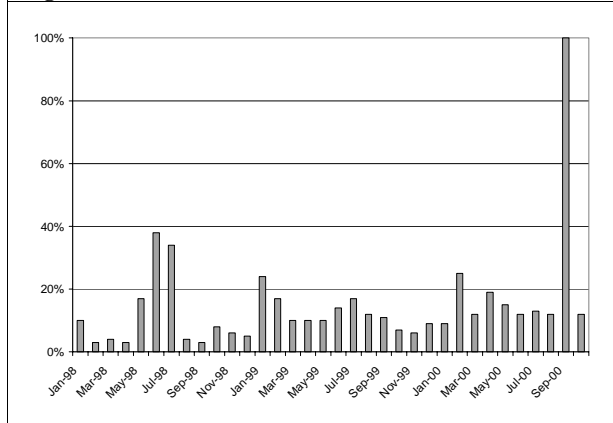

Figure E-3: Error Rate at Station 4140

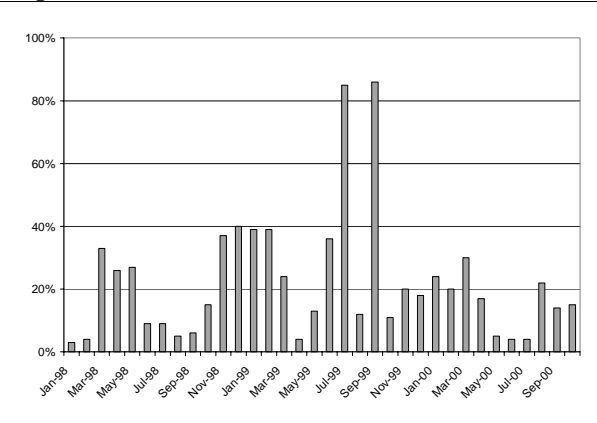

Figure E-4: Error Rate at Station 4150

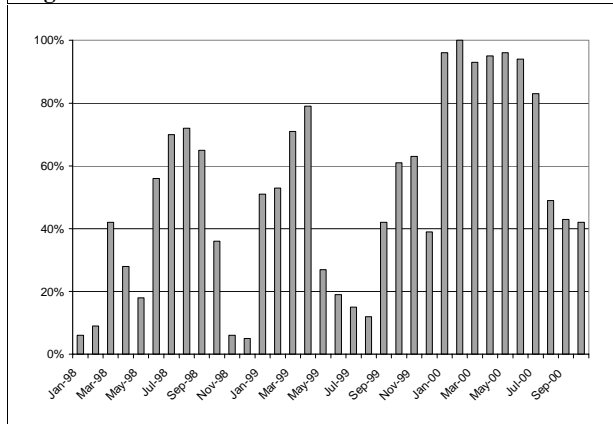

Figure E-5: Error Rate at Station 4240

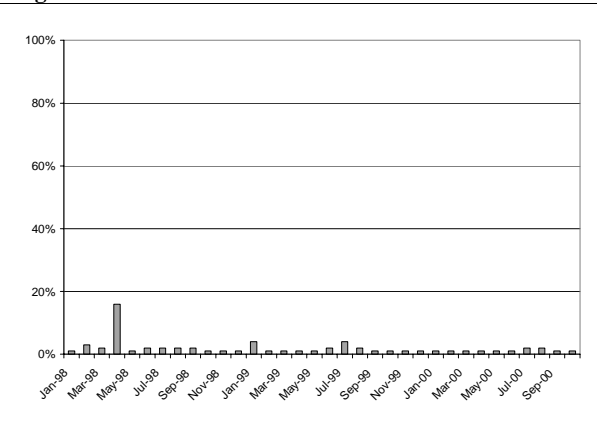

Figure E-6: Error Rate at Station 4250

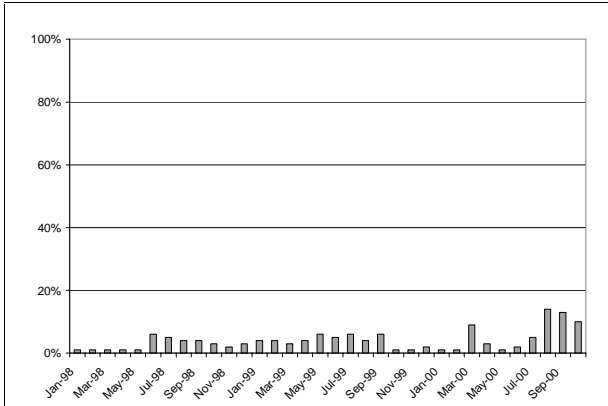

Figure E-7: Error Rate at Station 4260

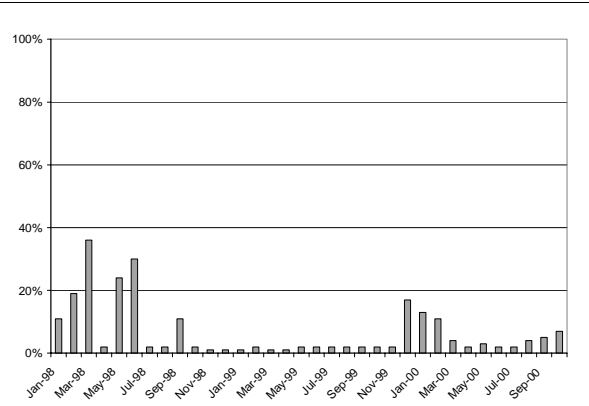

Figure E-8: Error Rate at Station 4270

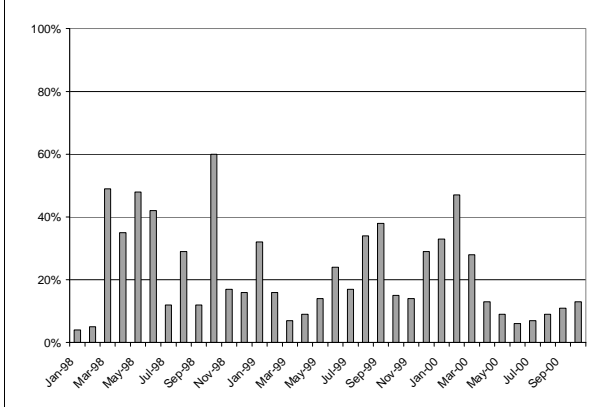

Figure E-9: Error Rate at Station 4280

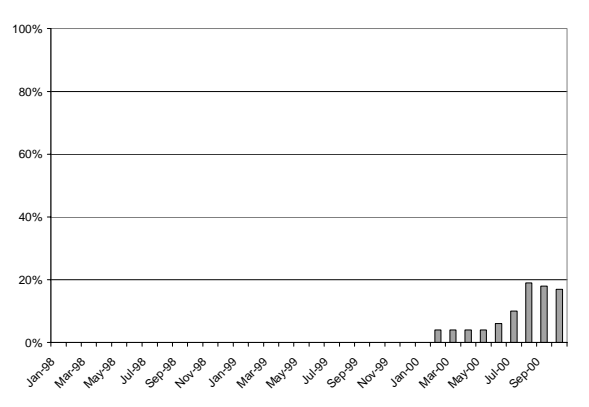

Figure E-10: Error Rate at Station 4400

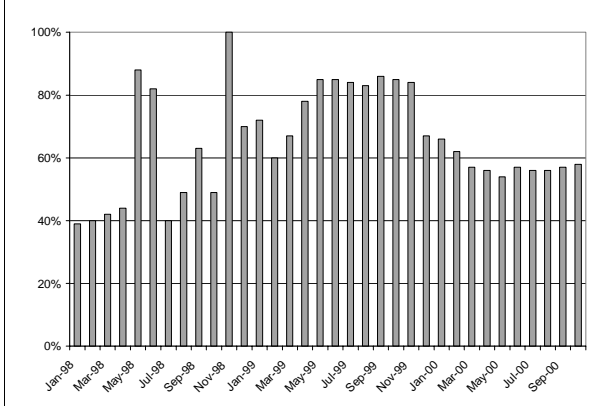

Figure E-11: Error Rate at Station 4440

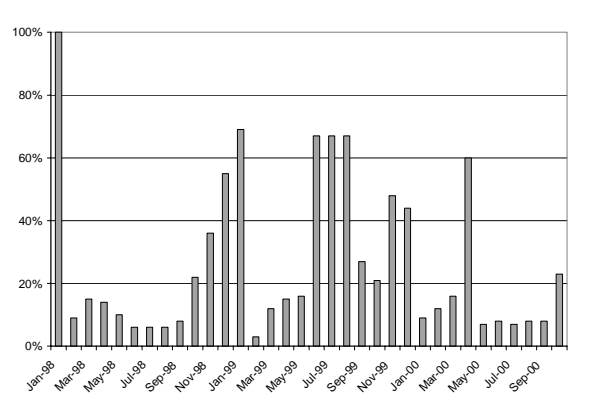

Figure E-12: Error Rate at Station 5110

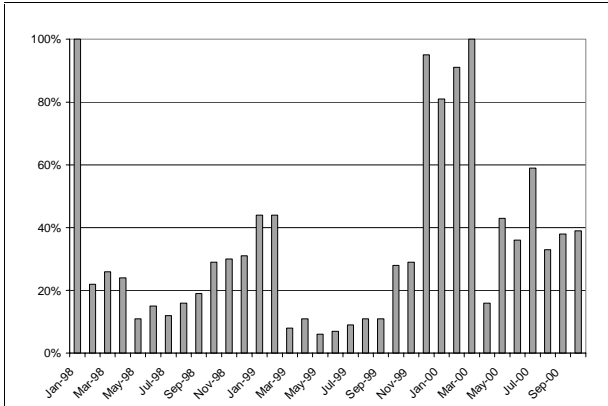

Figure E-13: Error Rate at Station 5120

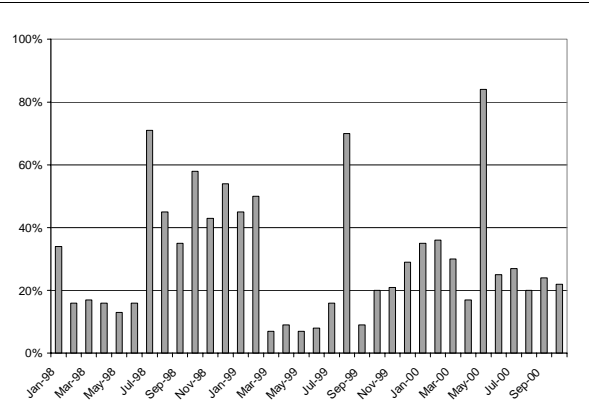

Figure E-14: Error Rate at Station 5130

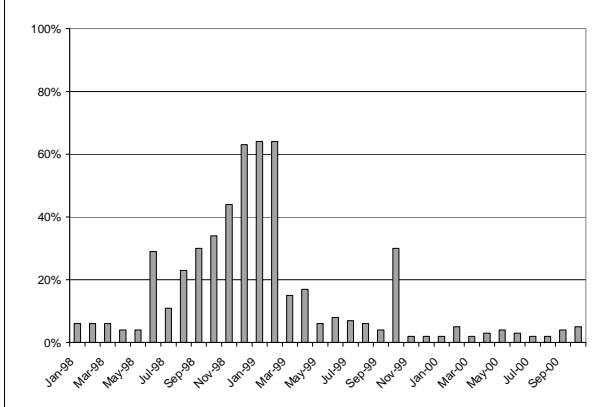

Figure E-15: Error Rate at Station 5140

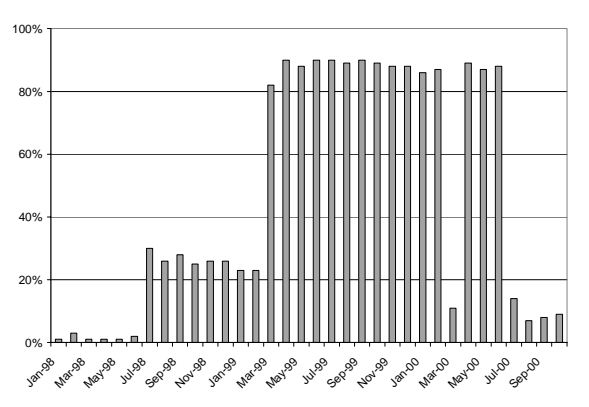

Figure E-16: Error Rate at Station 5240

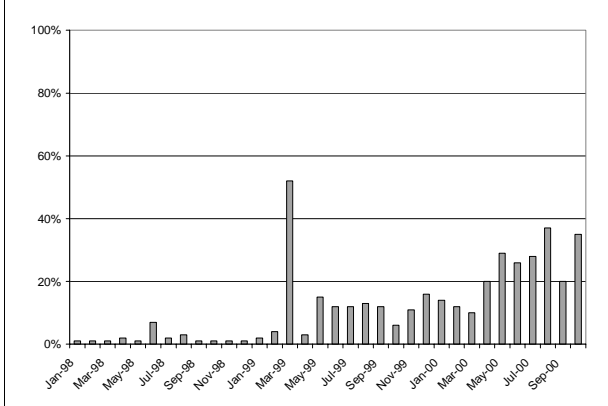

Figure E-17: Error Rate at Station 5250

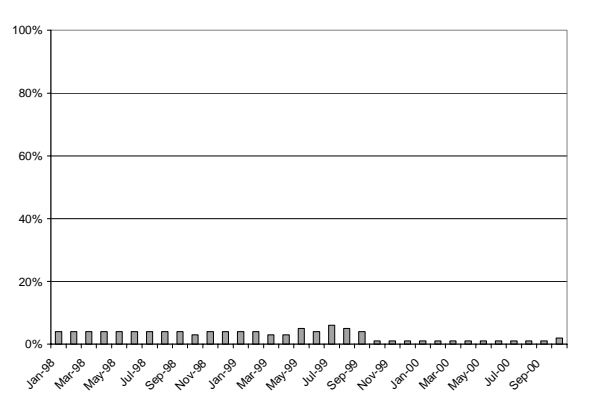

Figure E-18: Error Rate at Station 5260

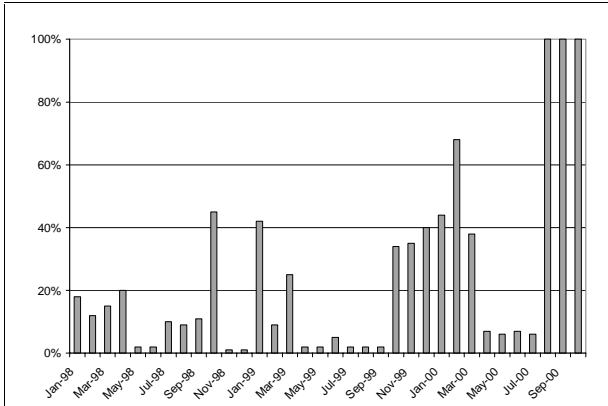

Figure E-19: Error Rate at Station 5270

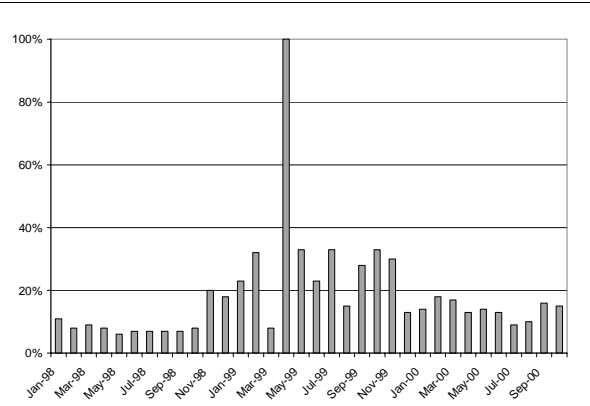

Figure E-20: Error Rate at Station 5440

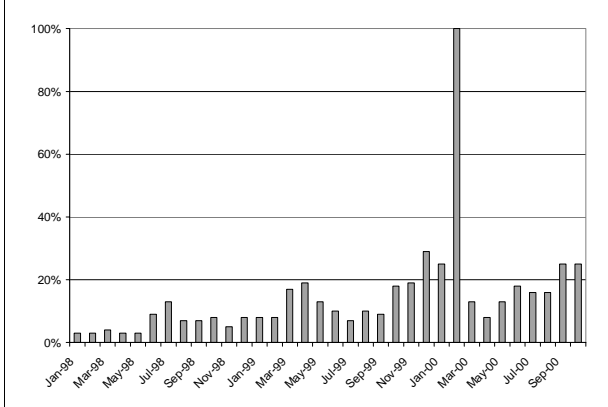

Figure E-21: Error Rate at Station 5450

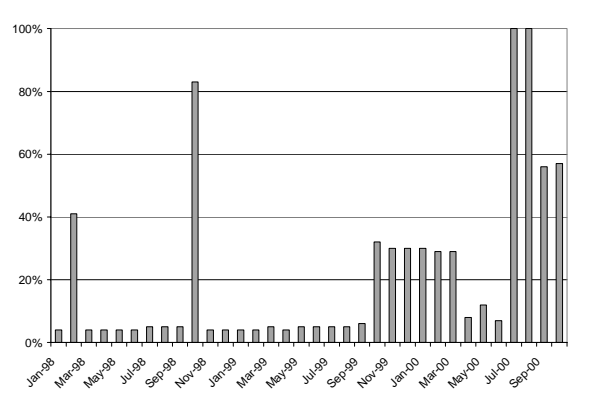

Figure E-22: Error Rate at Station 5460

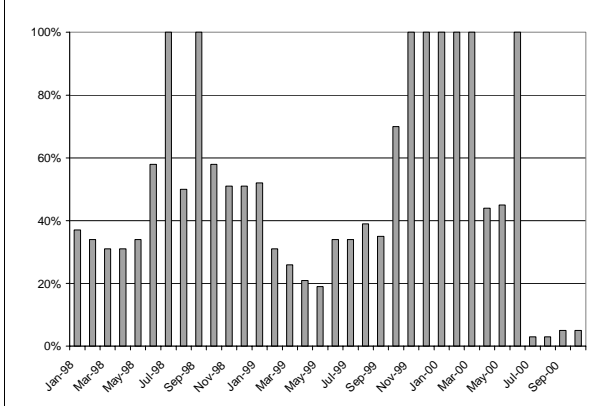

Figure E-23: Error Rate at Station 5470

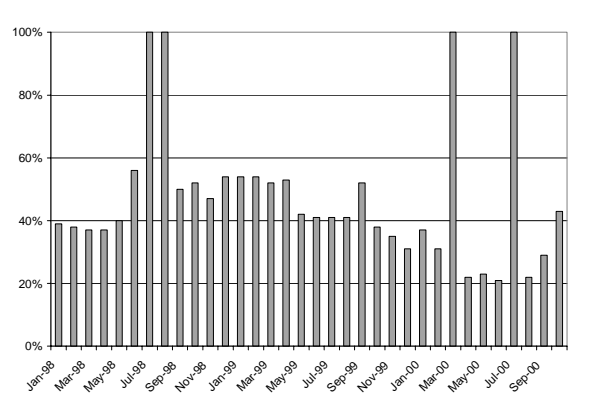

Figure E-24: Error Rate at Station 5480

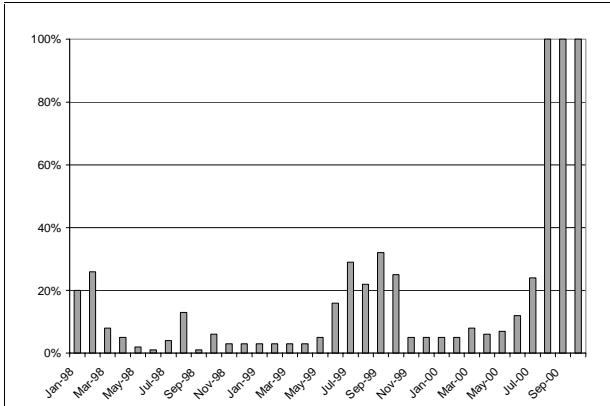

Figure E-25: Error Rate at Station 5550

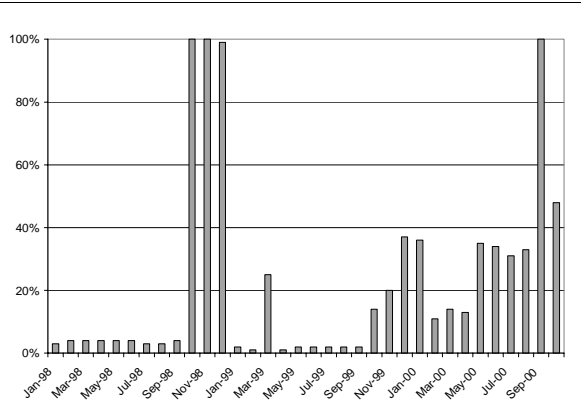

Figure E-26: Error Rate at Station 6130

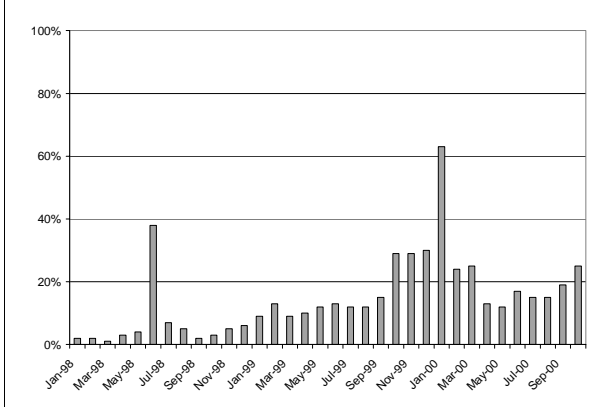

Figure E-27: Error Rate at Station 6140

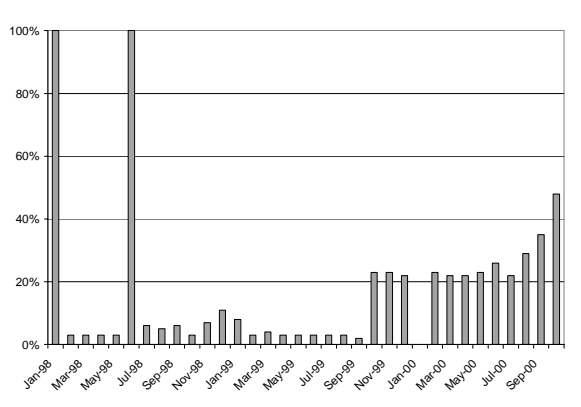

Figure E-28: Error Rate at Station 6150

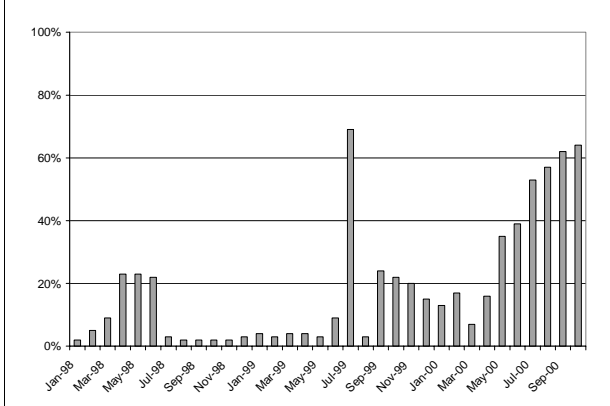

Figure E-29: Error Rate at Station 6160

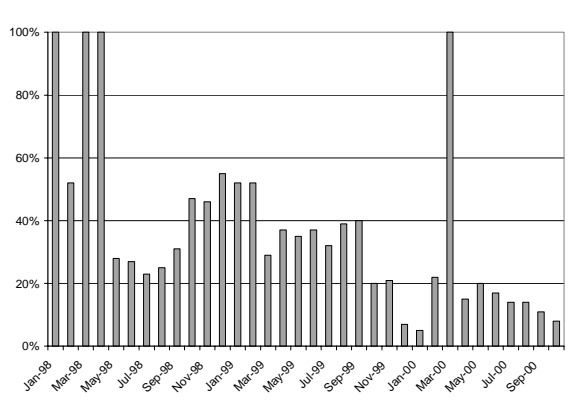

Figure E-30: Error Rate at Station 6170

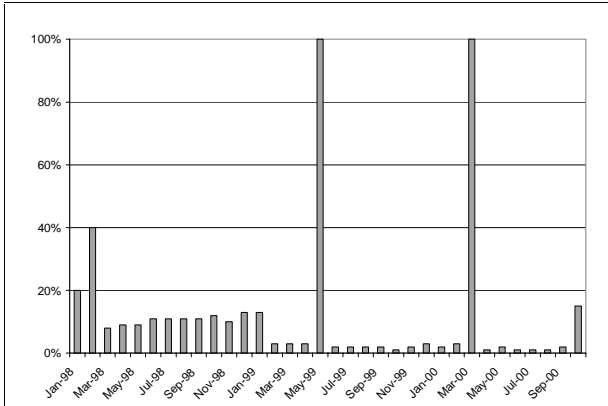

Figure E-31: Error Rate at Station 6250

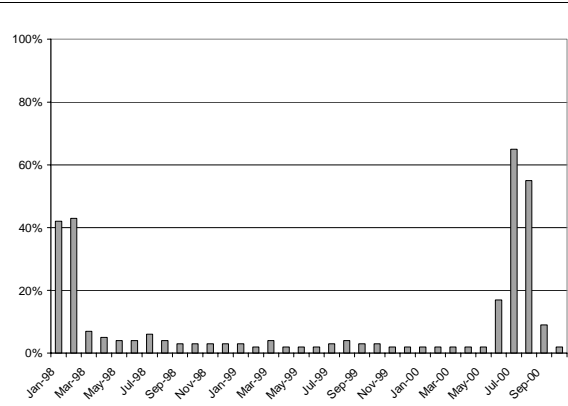

Figure E-32: Error Rate at Station 6260

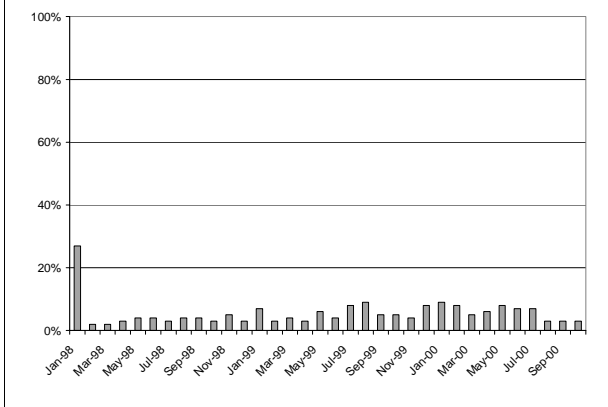

Figure E-33: Error Rate at Station 6270

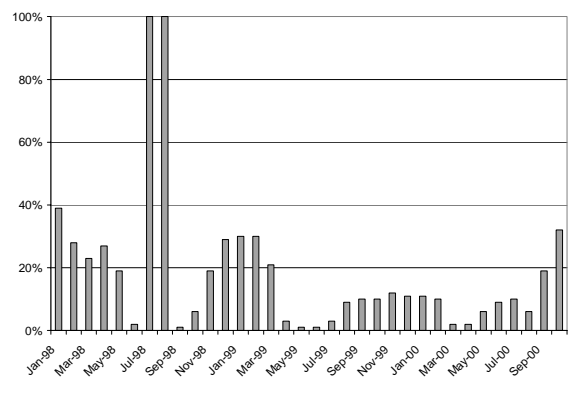

Figure E-34: Error Rate at Station 6280

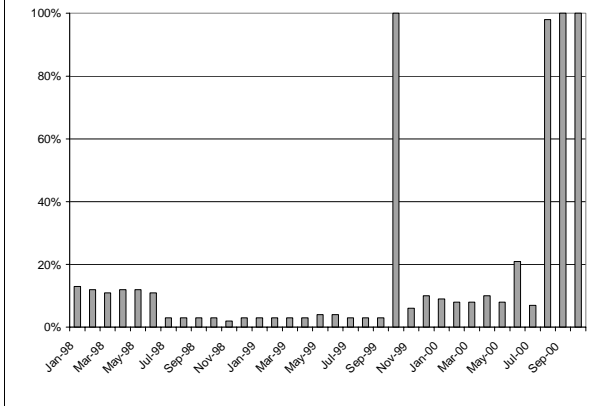

Figure E-35: Error Rate at Station 6290

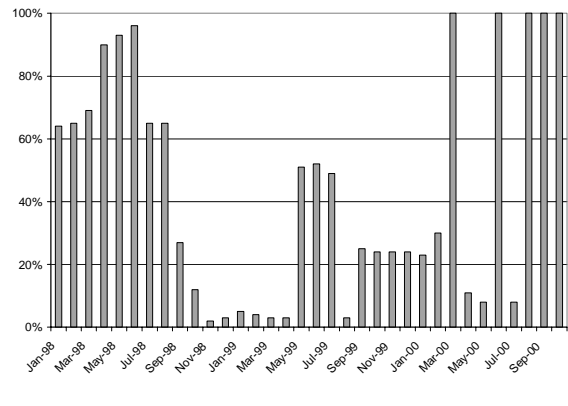

Figure E-36: Error Rate at Station 6420

E.2 Summary of Average Station Performance (Individual Lanes)

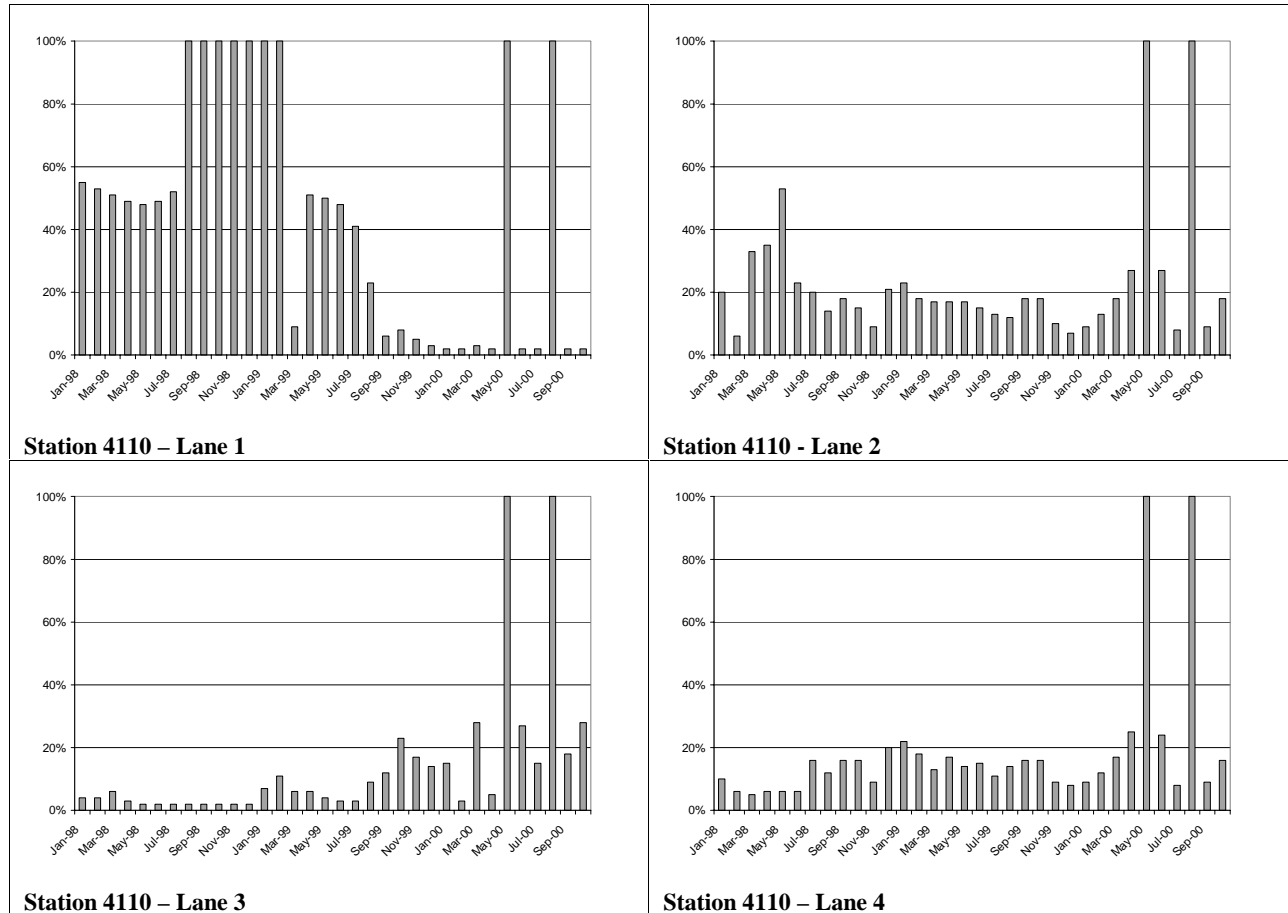

Figure E-37: Error Rate of individual lanes at station 4110

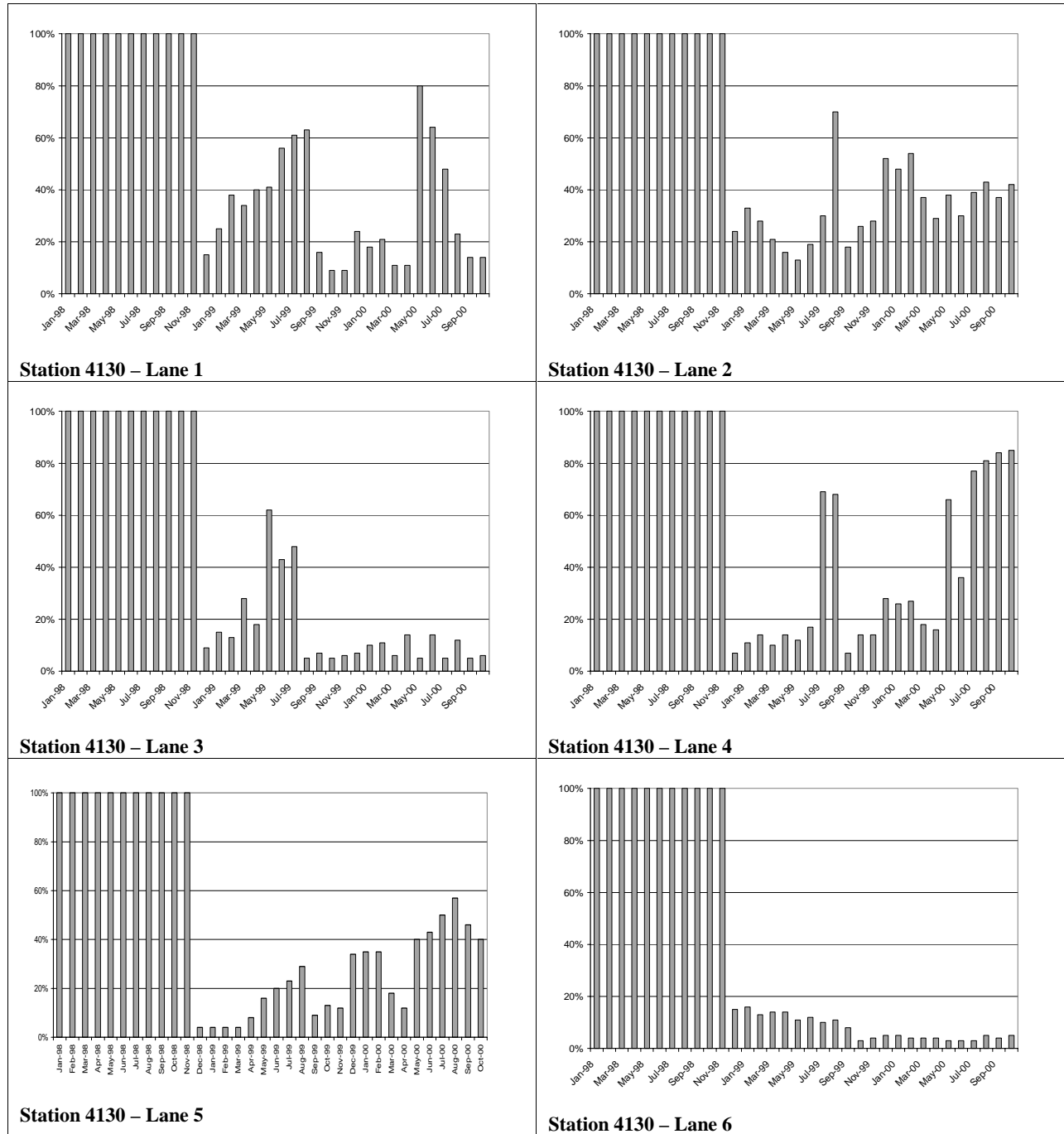

Figure E-38: Error Rate of individual lanes at station 4130

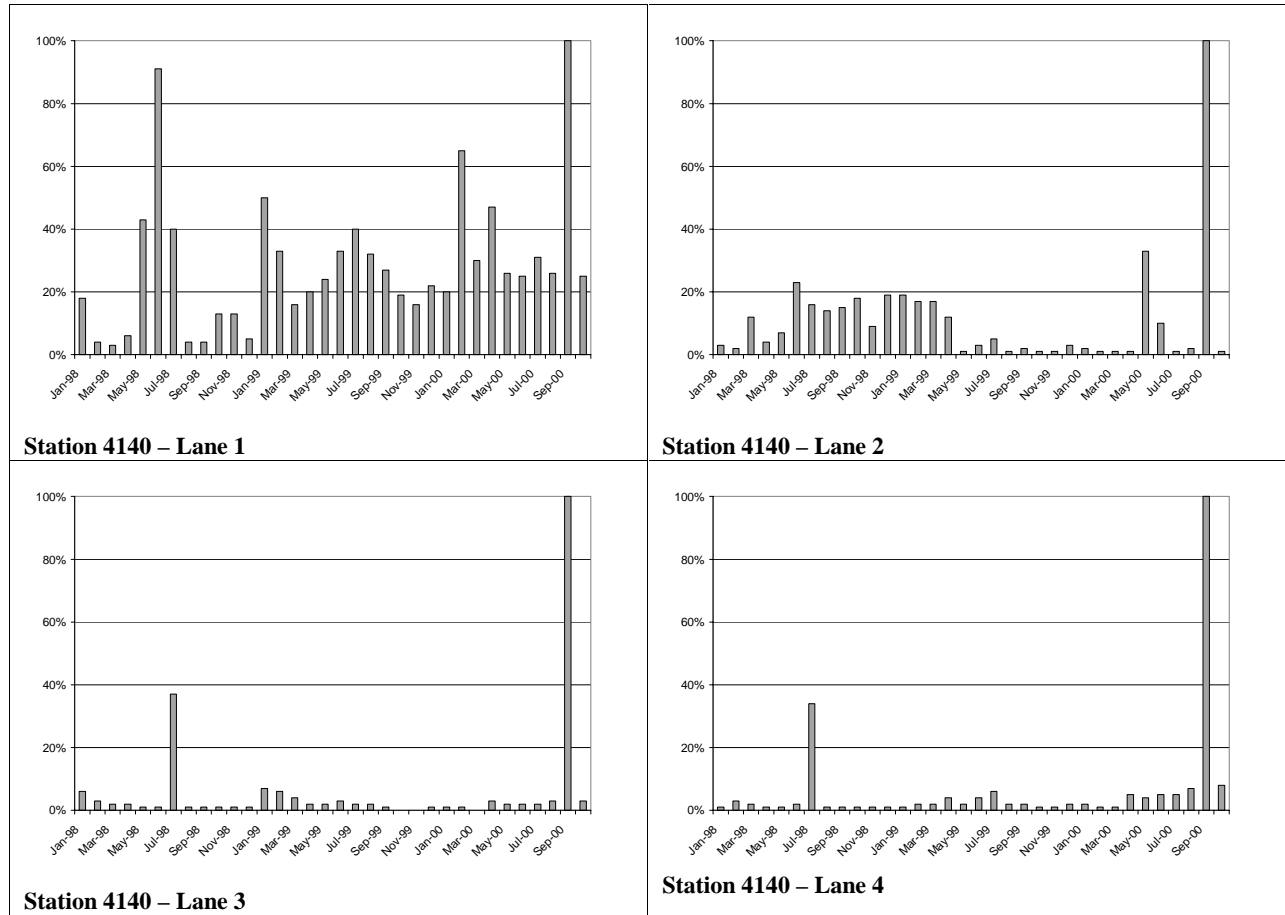

Figure E-39: Error Rate of individual lanes at station 4140

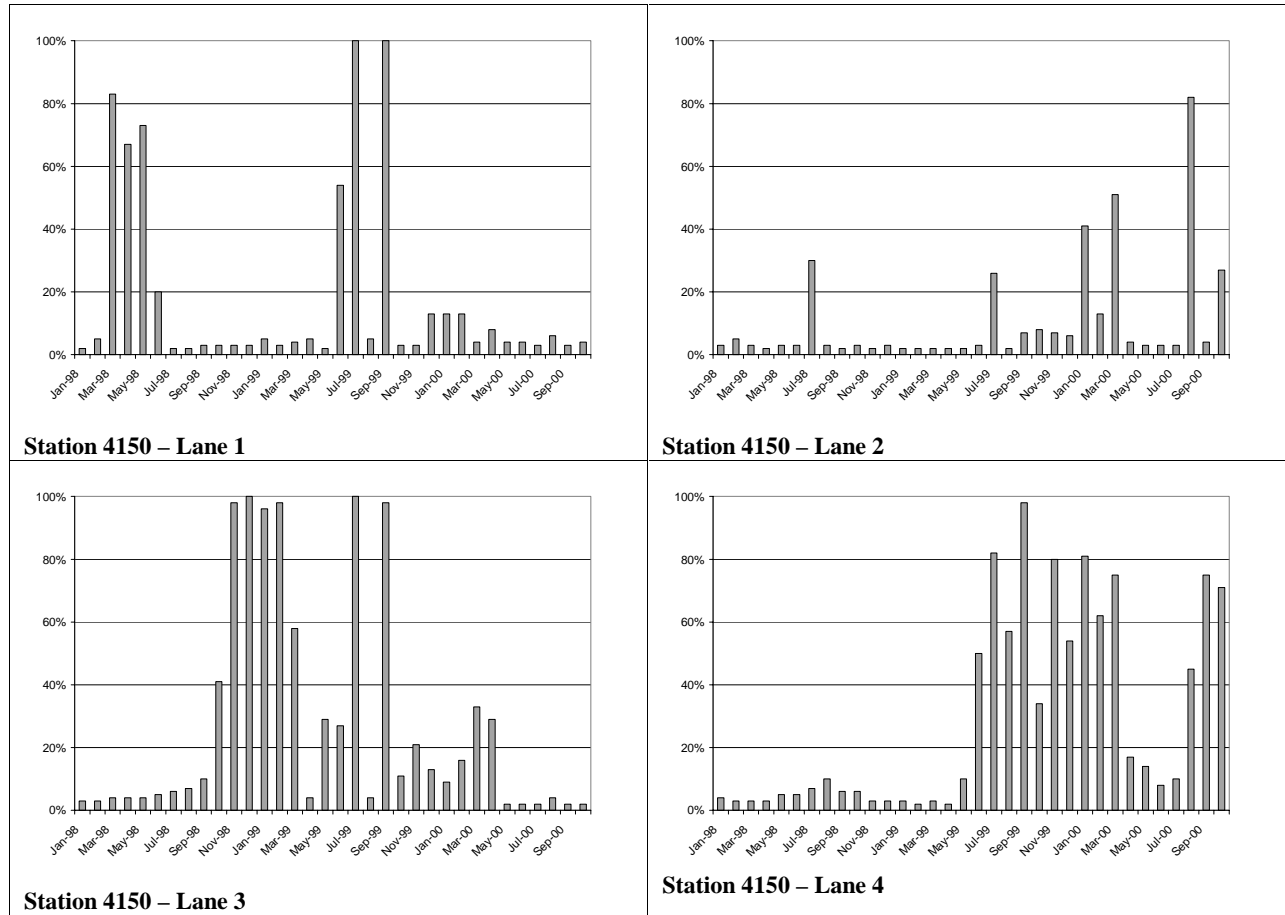

Figure E-40: Error Rate of individual lanes at station 4150

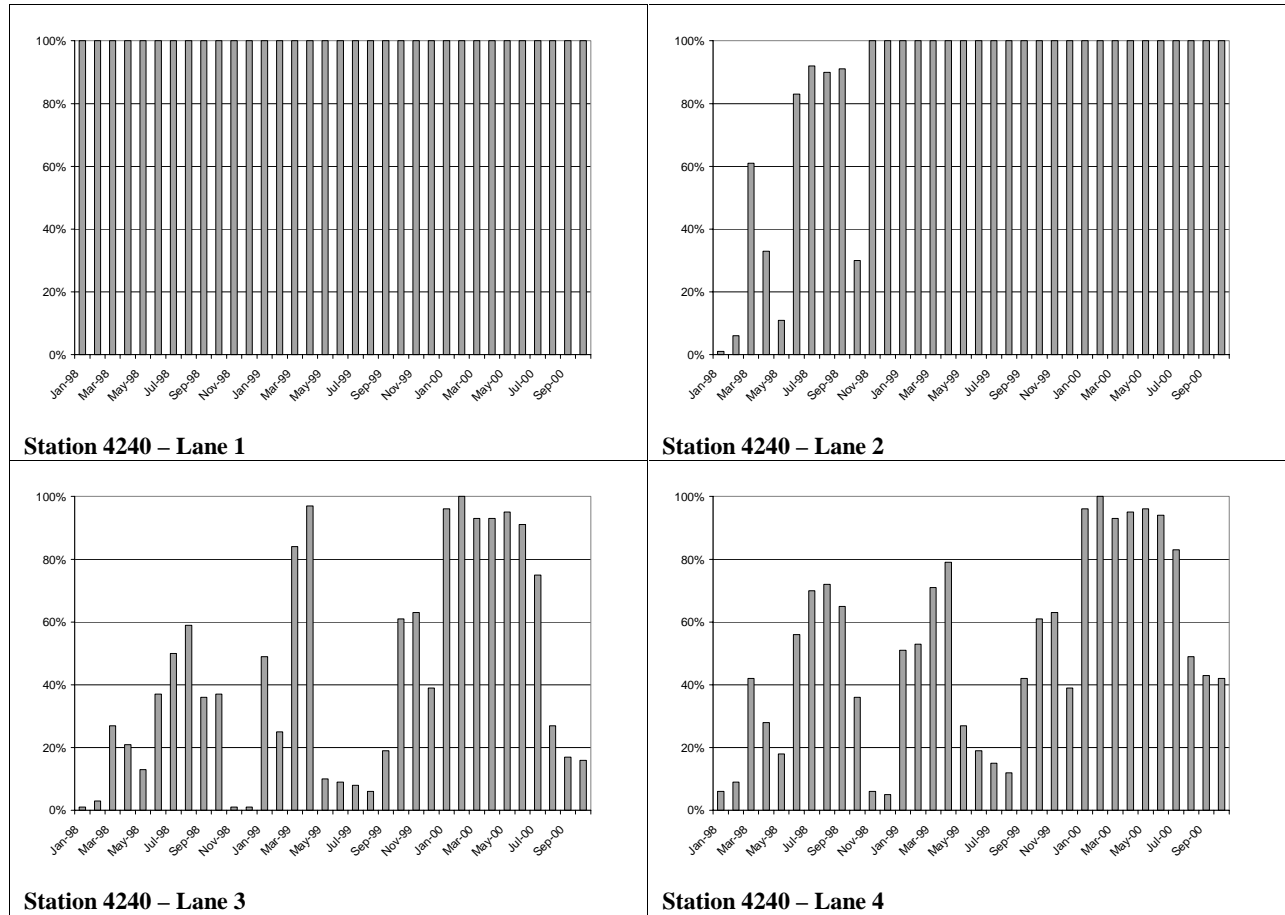

Figure E-41: Error Rate of individual lanes at station 4240

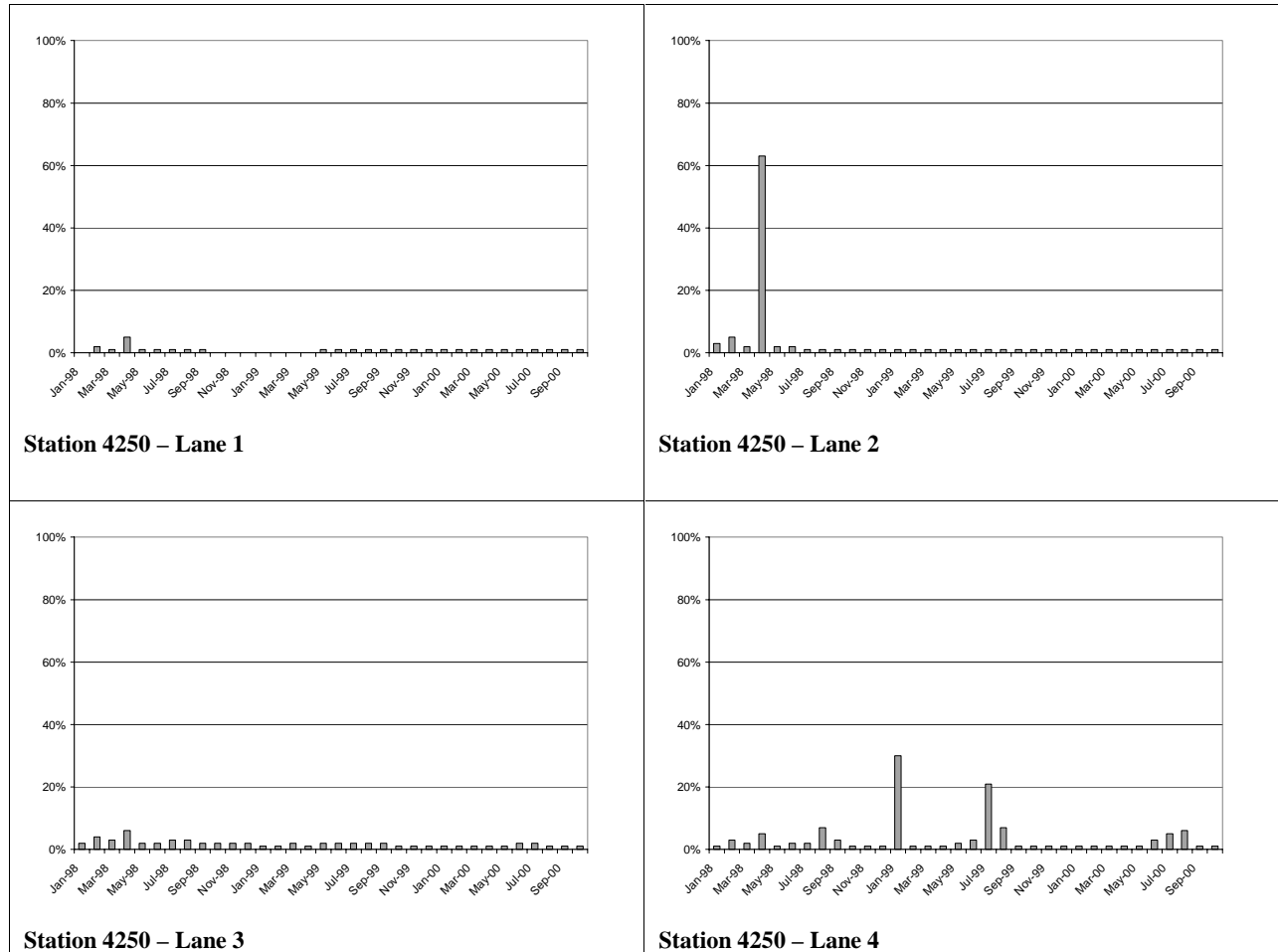

Figure E-42: Error Rate of individual lanes at station 4250

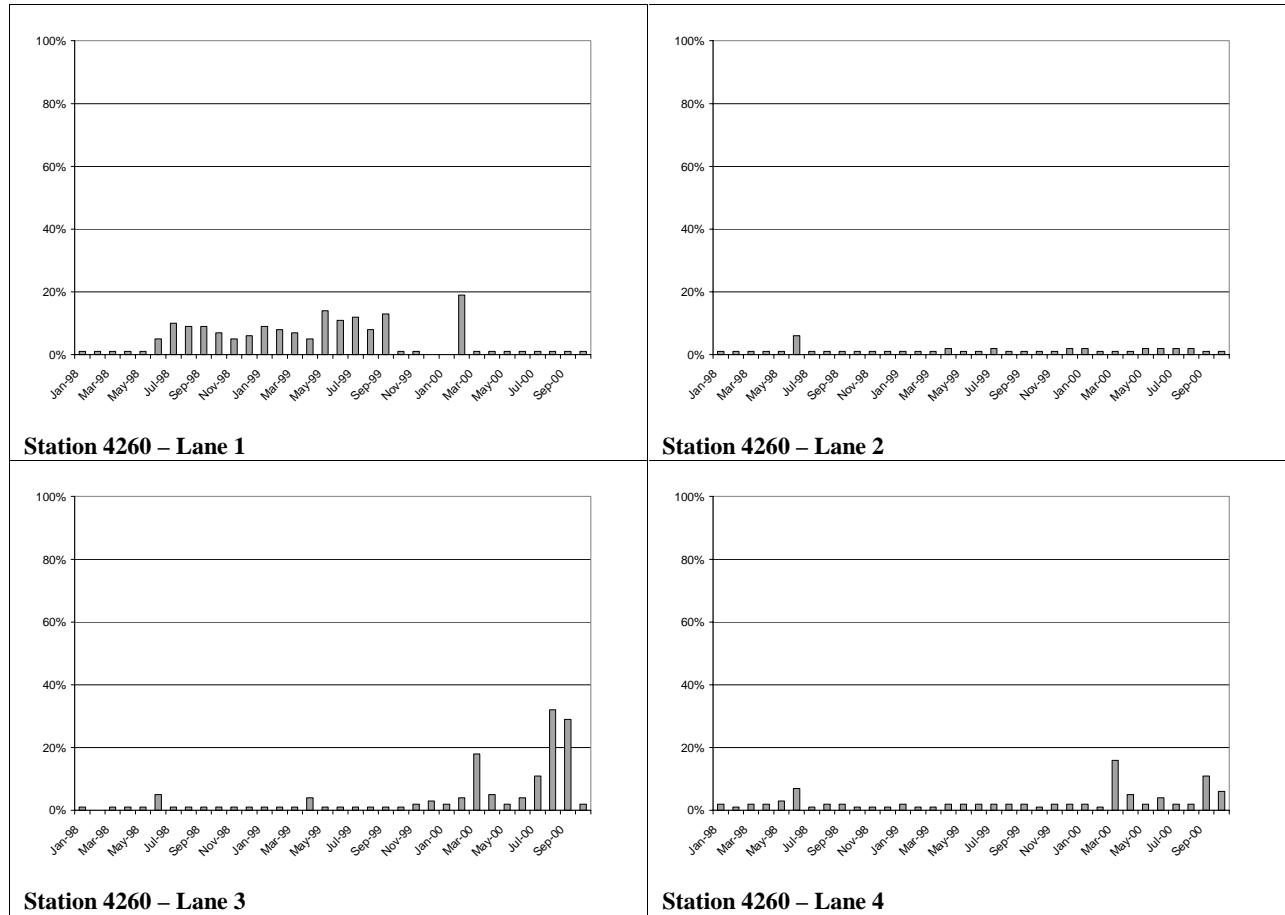

Figure E-43: Error Rate of individual lanes at station 4260

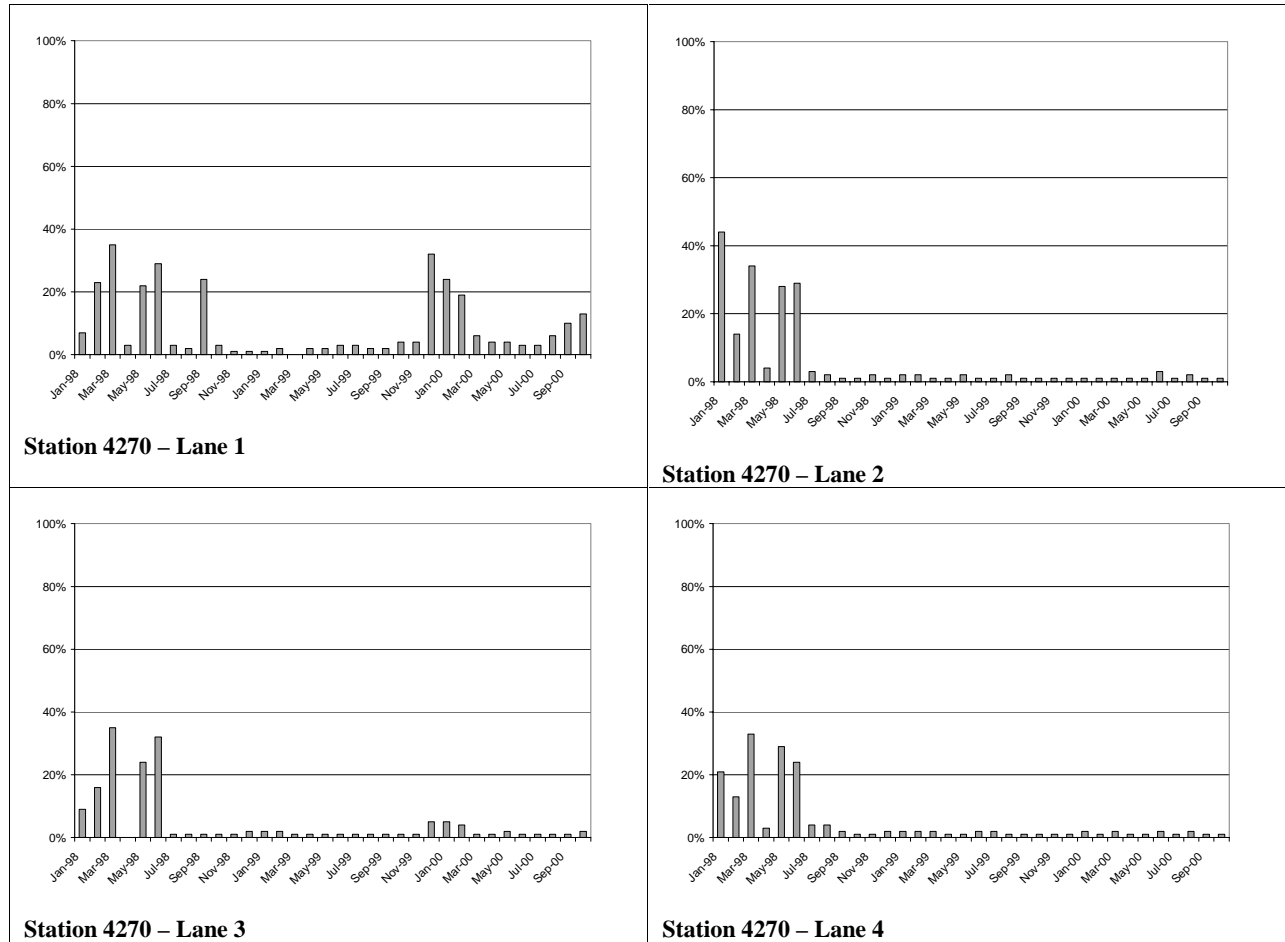

Figure E-44: Error Rate of individual lanes at station 4270

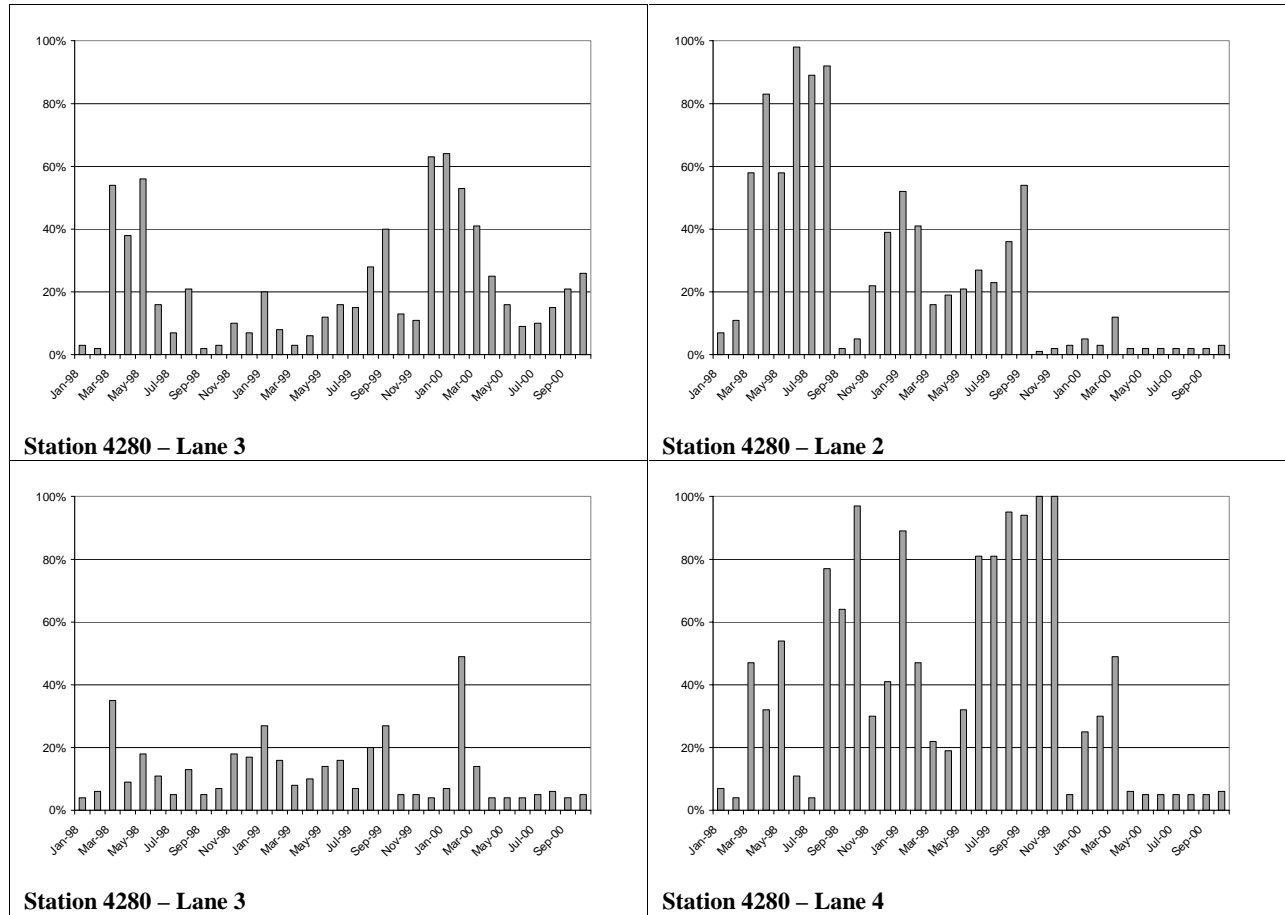

Figure E-45: Error Rate of individual lanes at station 4280

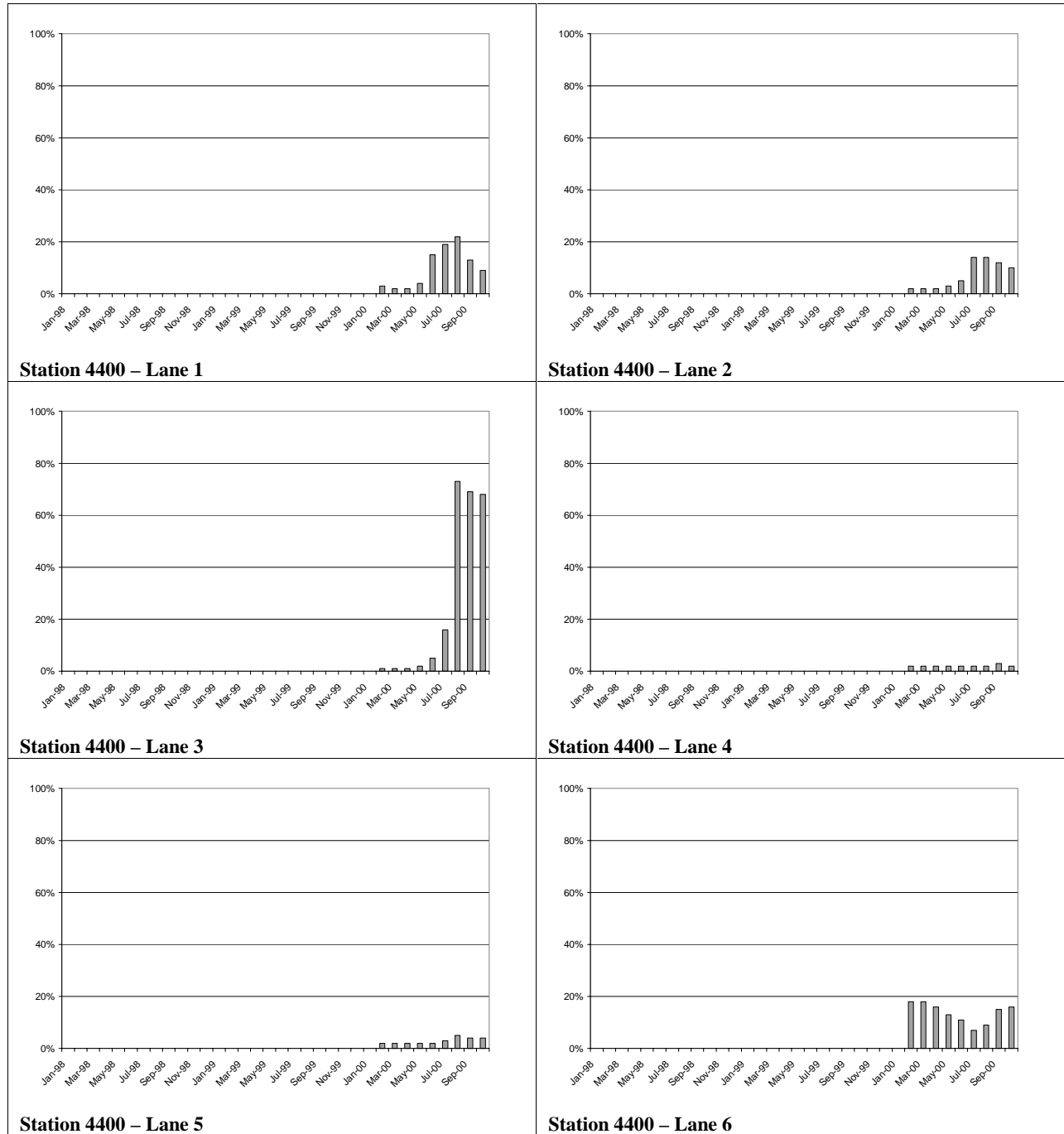

Figure E-46: Error Rate of individual lanes at station 4400

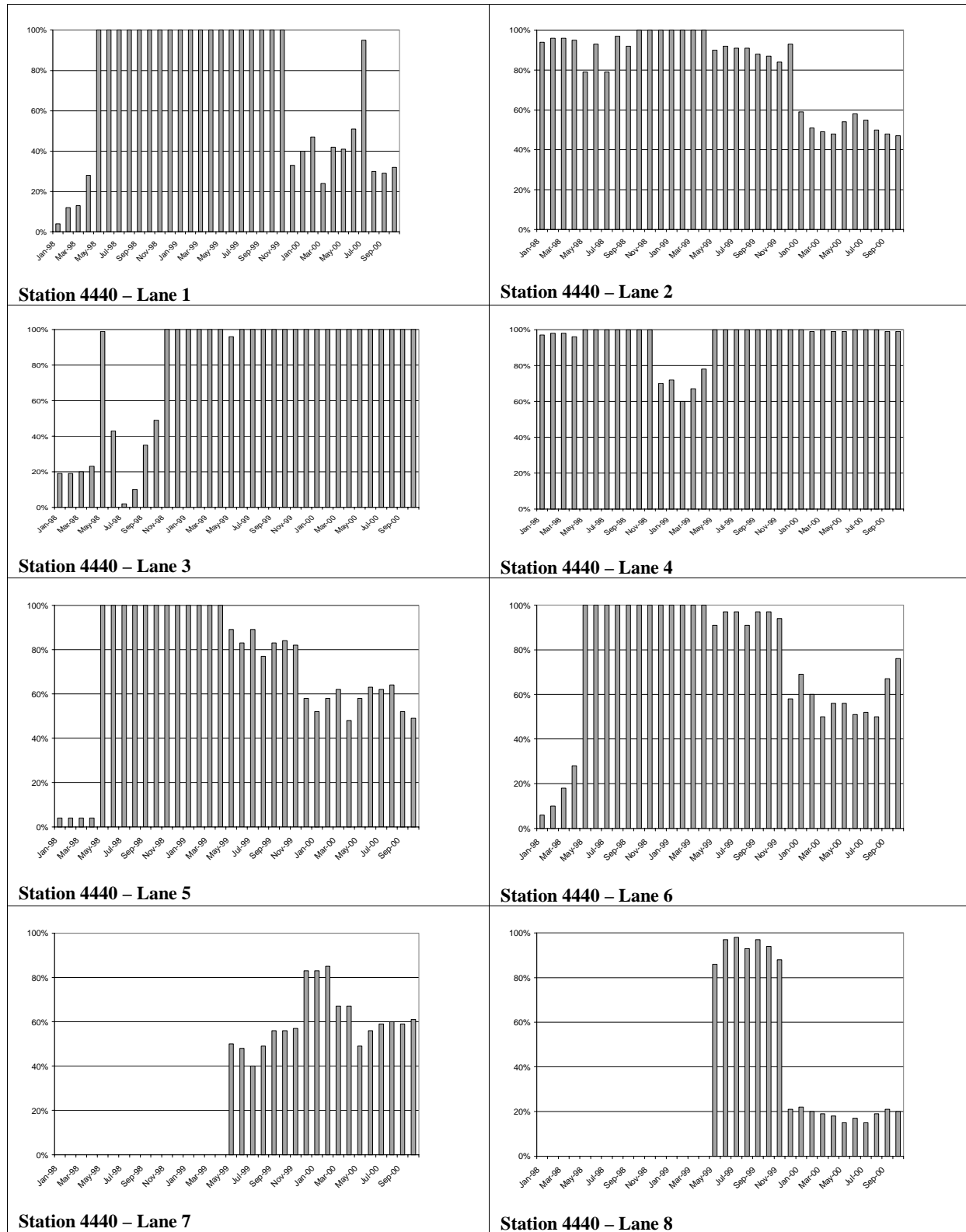

Figure E-47: Error Rate of individual lanes at station 4440

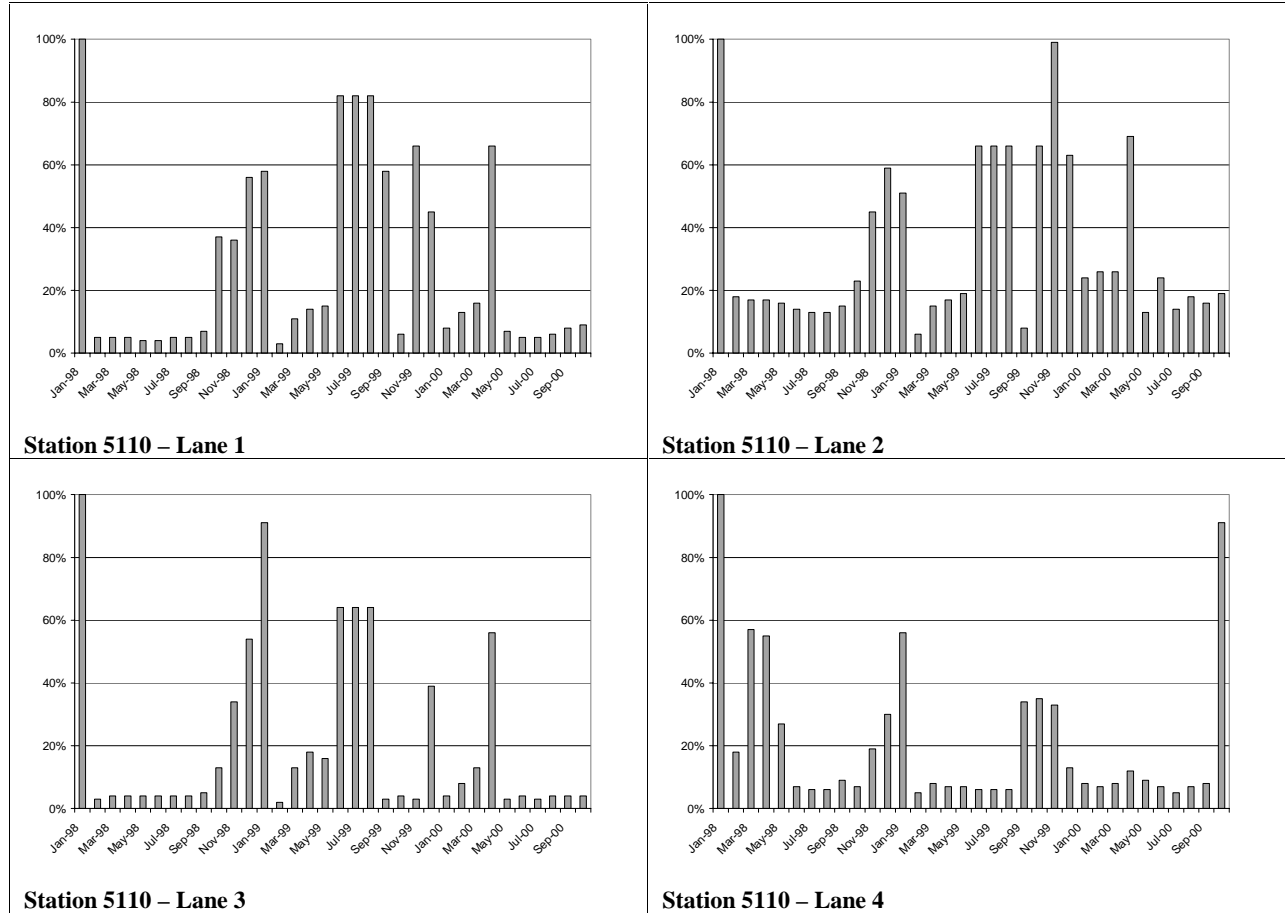

Figure E-48: Error Rate of individual lanes at station 5110

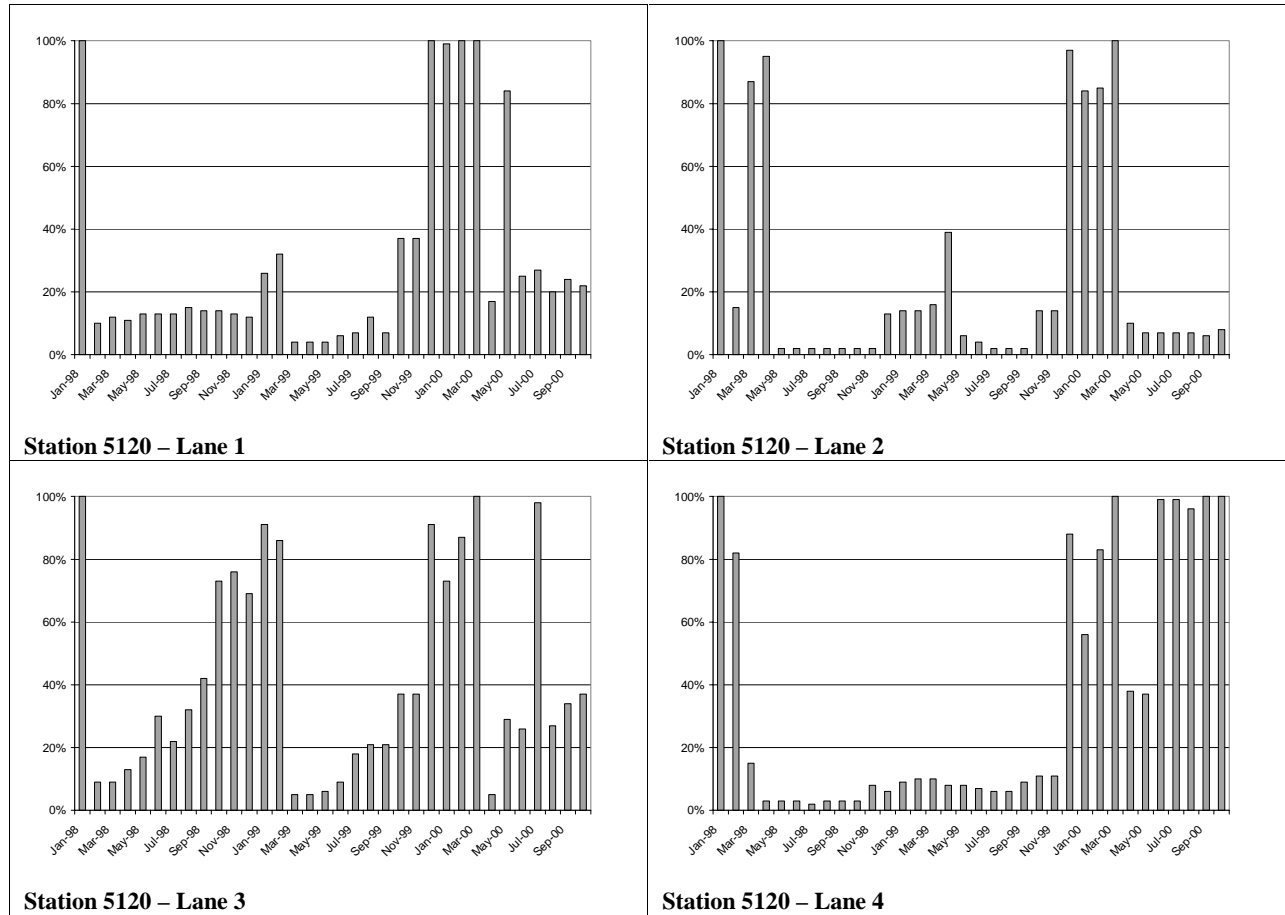

Figure E-49: Error Rate of individual lanes at station 5120

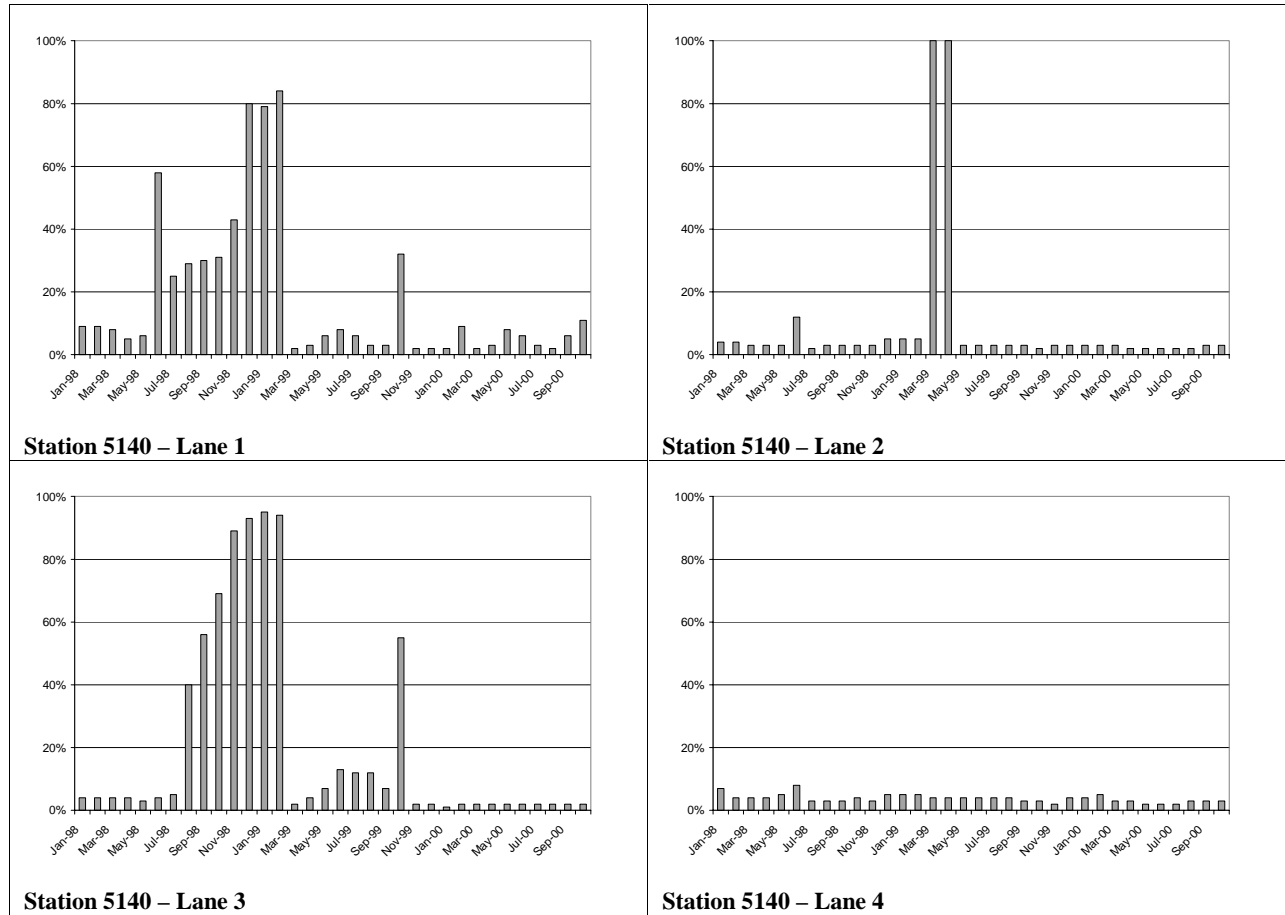
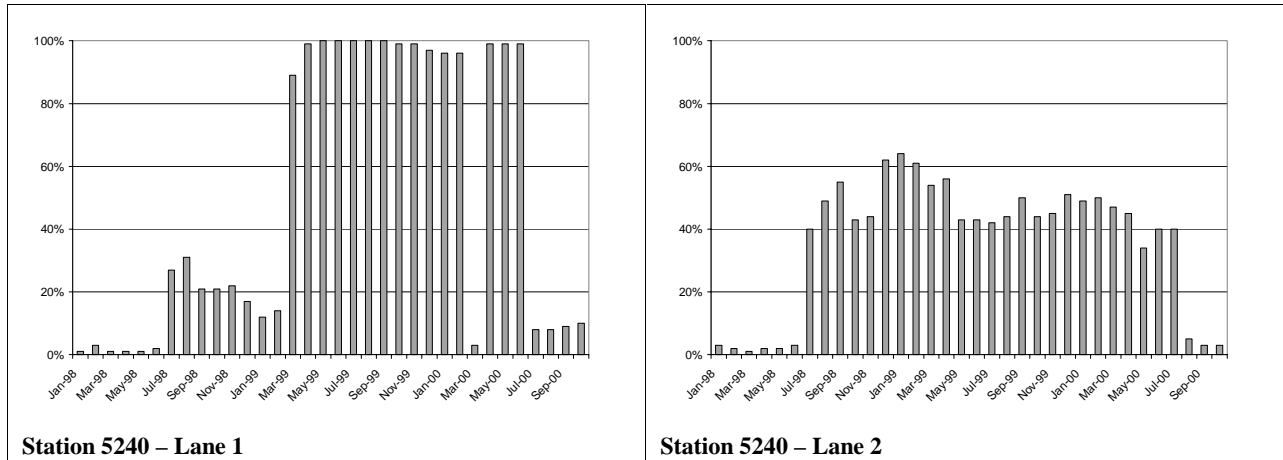

Figure E-51: Error Rate of individual lanes at station 5140



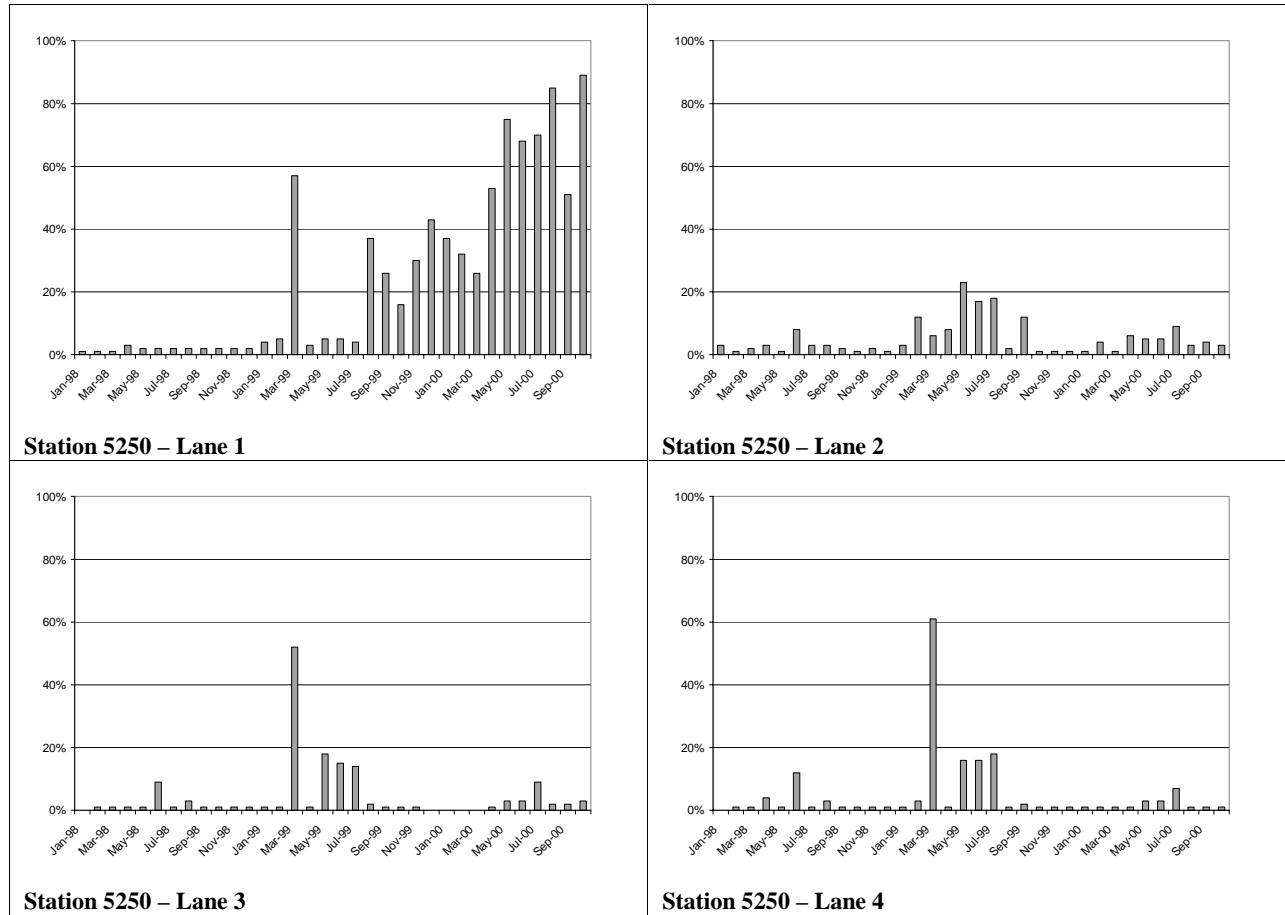

Figure E-53: Error Rate of individual lanes at station 5250

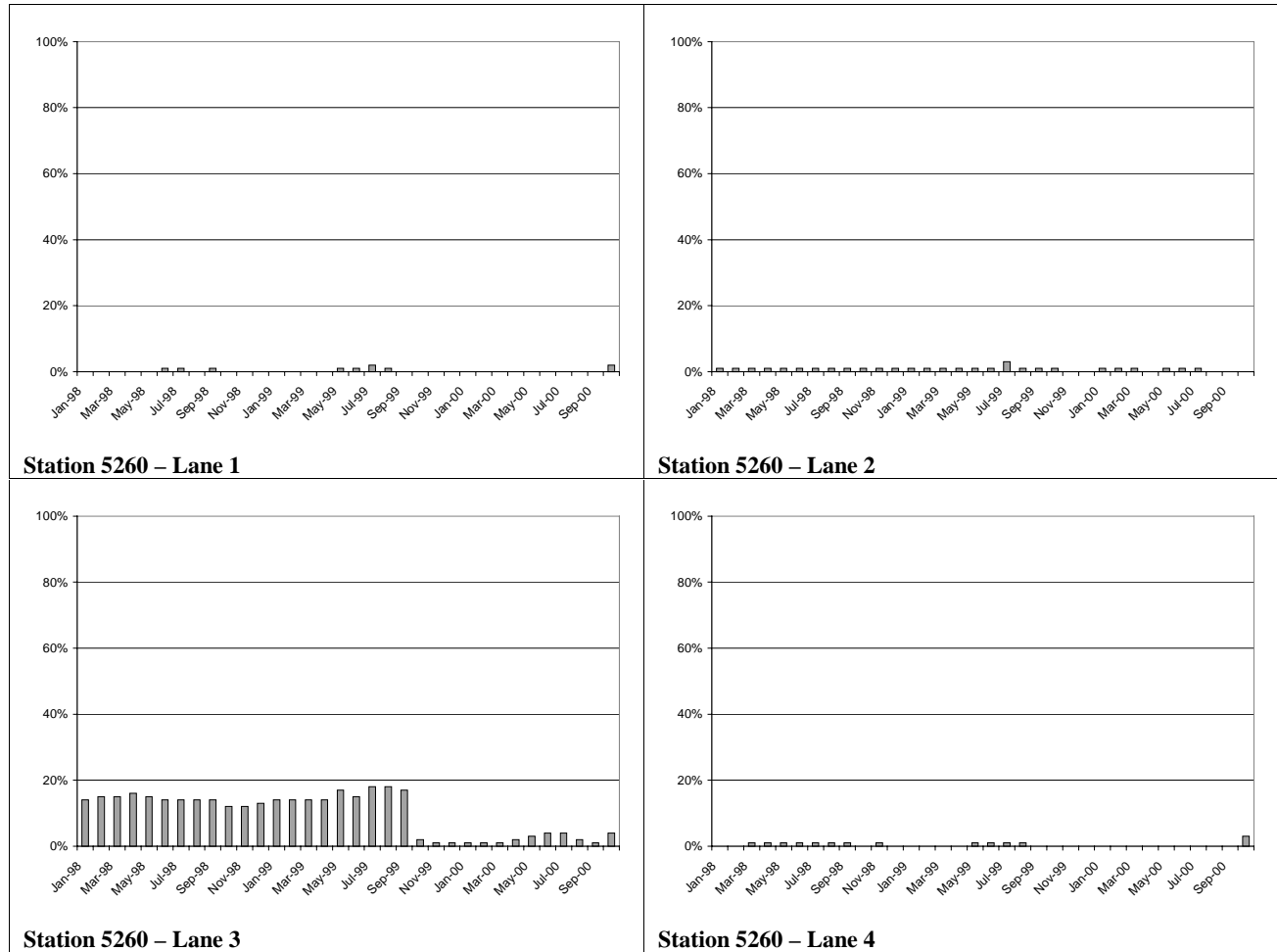

Figure E-54: Error Rate of individual lanes at station 5260

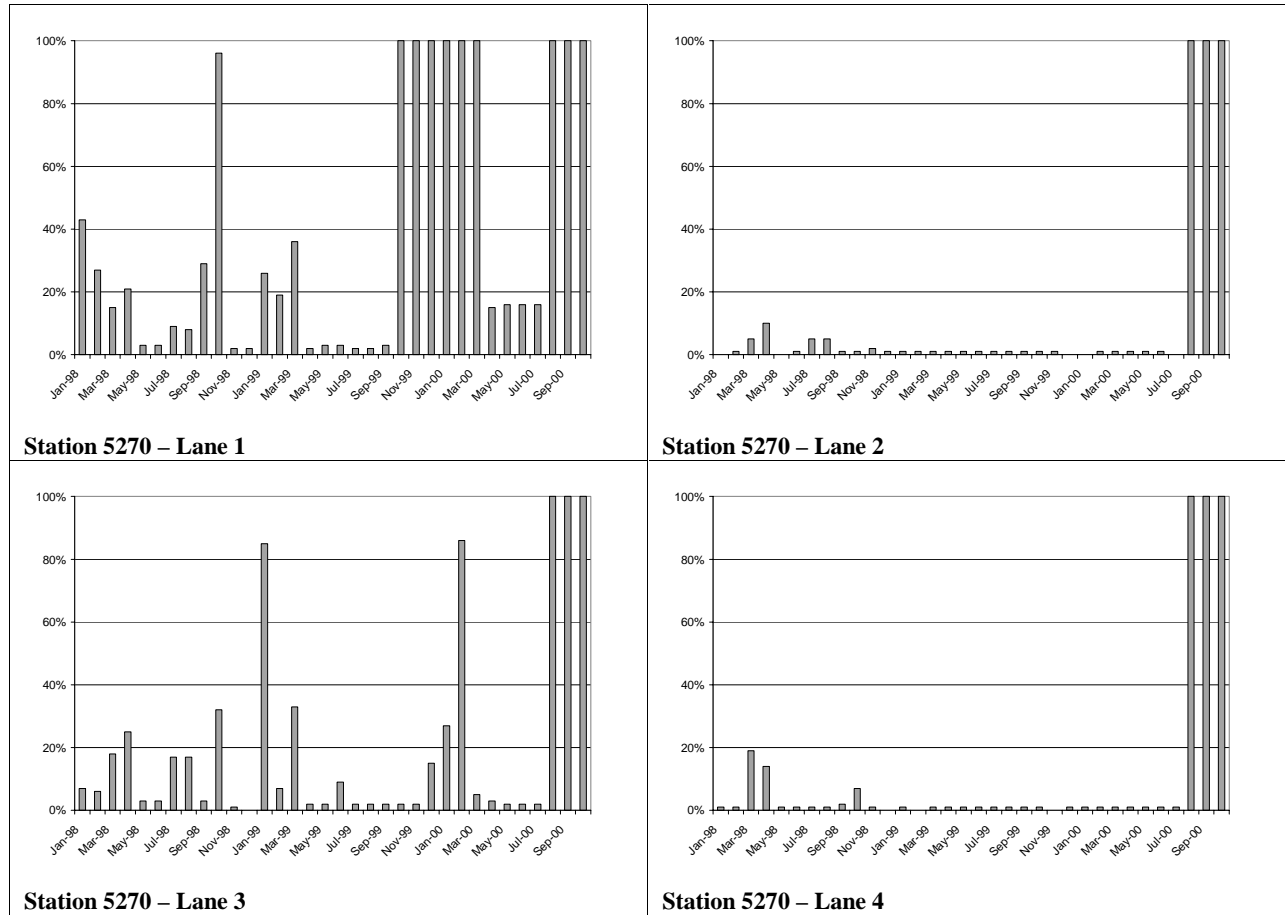

Figure E-55: Error Rate of individual lanes at station 5270

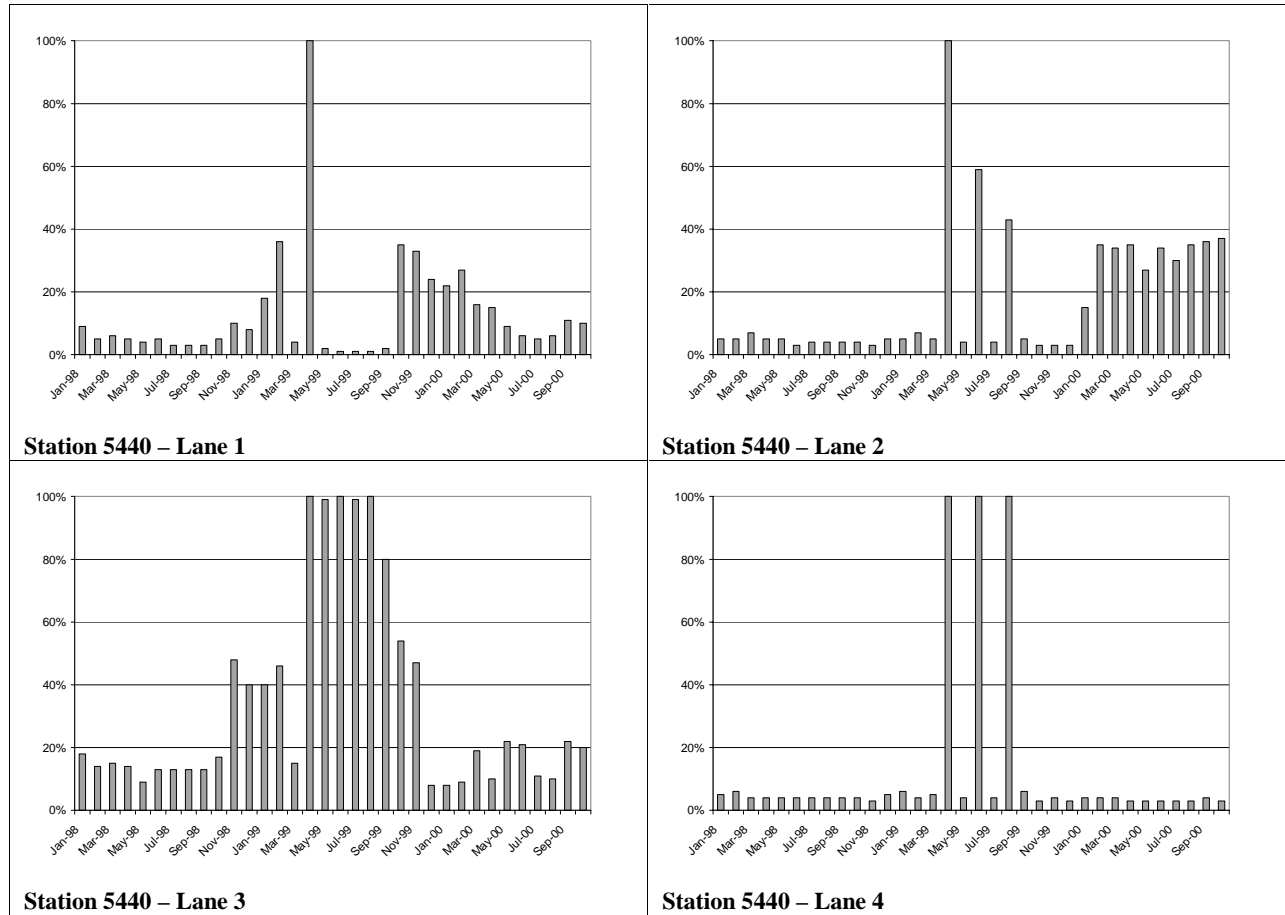

Figure E-56: Error Rate of individual lanes at station 5440

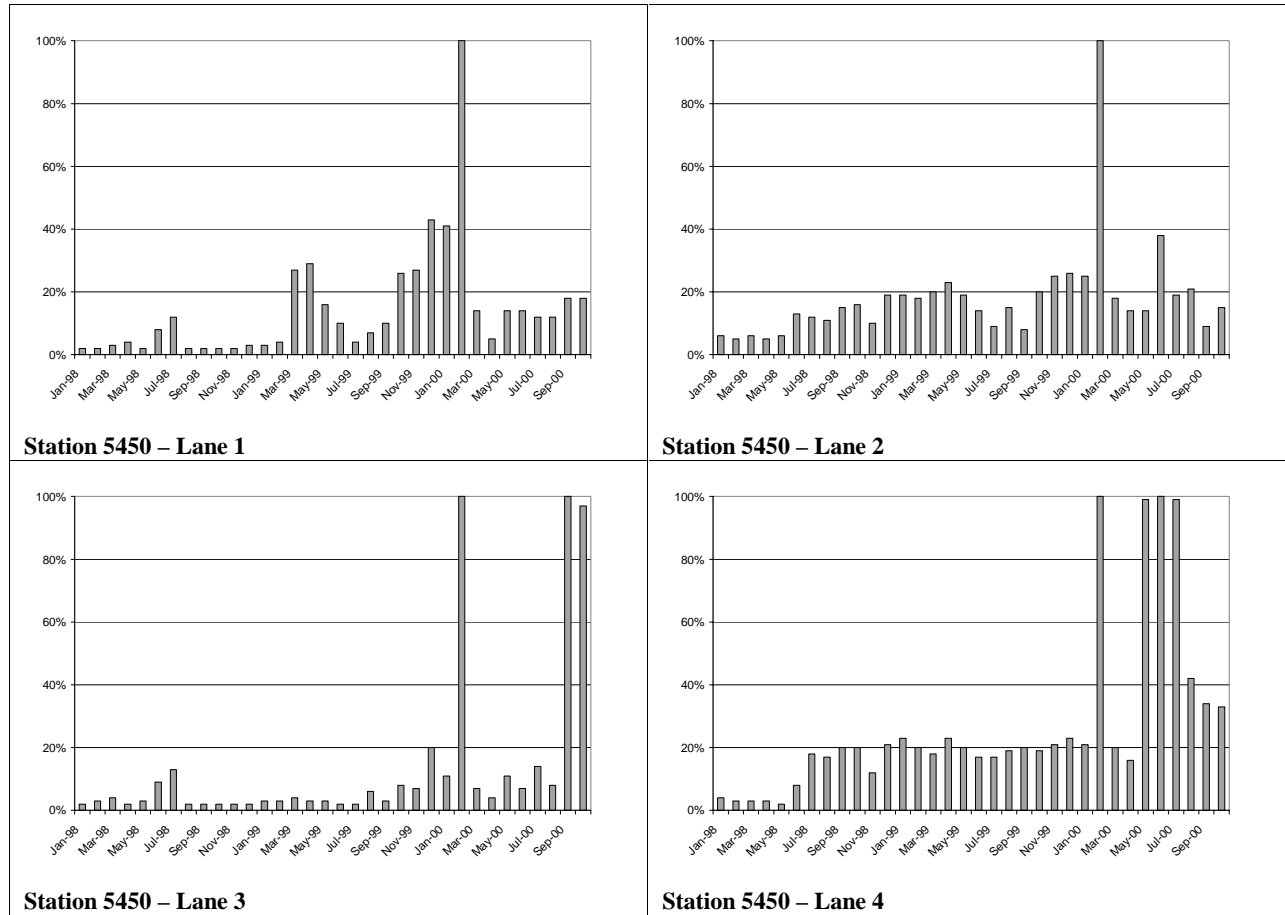

Figure E-57: Error Rate of individual lanes at station 5450

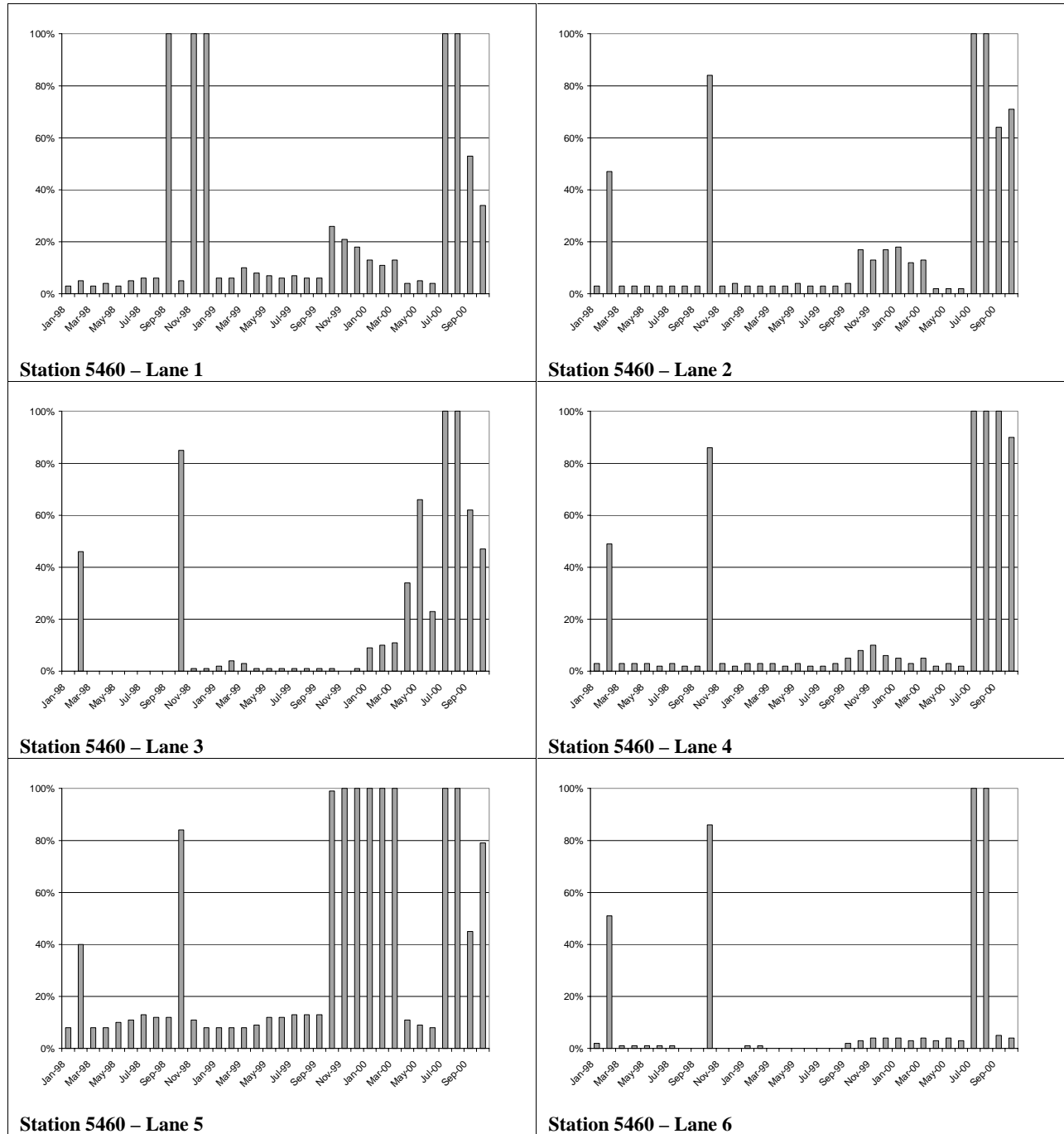

Figure E-58: Error Rate of individual lanes at station 5460

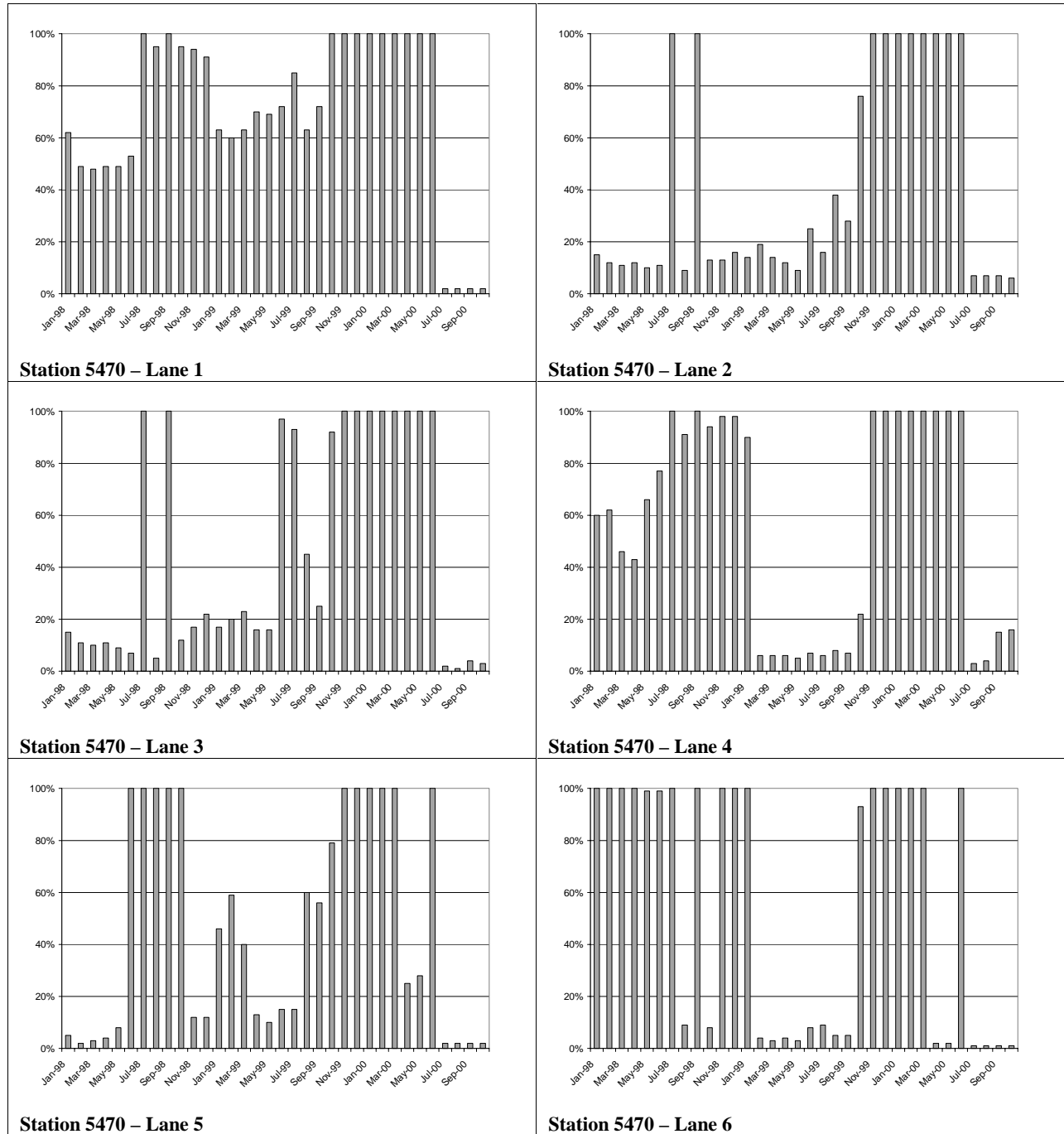

Figure E-59: Error Rate of individual lanes at station 5470

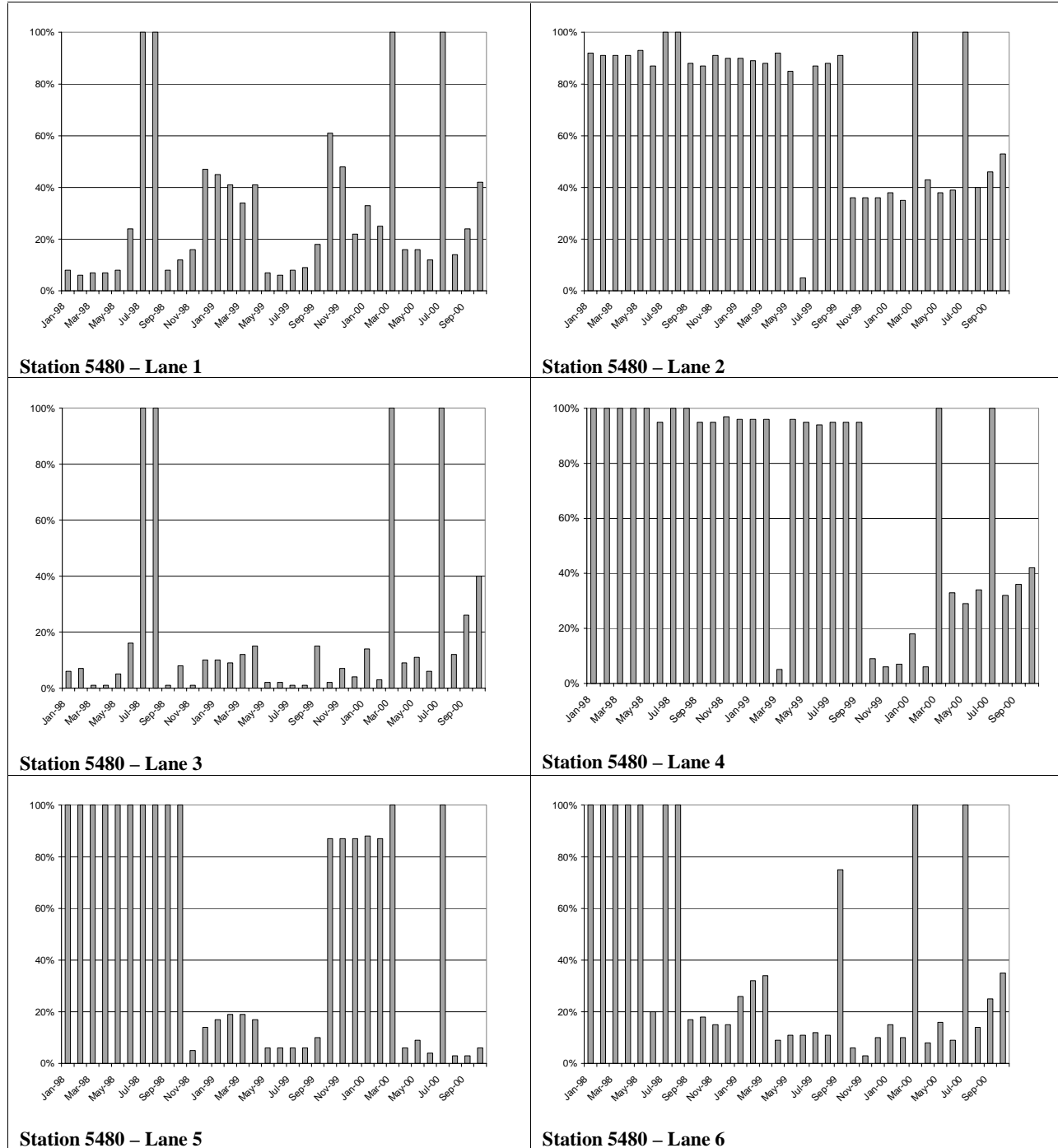

Figure E-60: Error Rate of individual lanes at station 5480

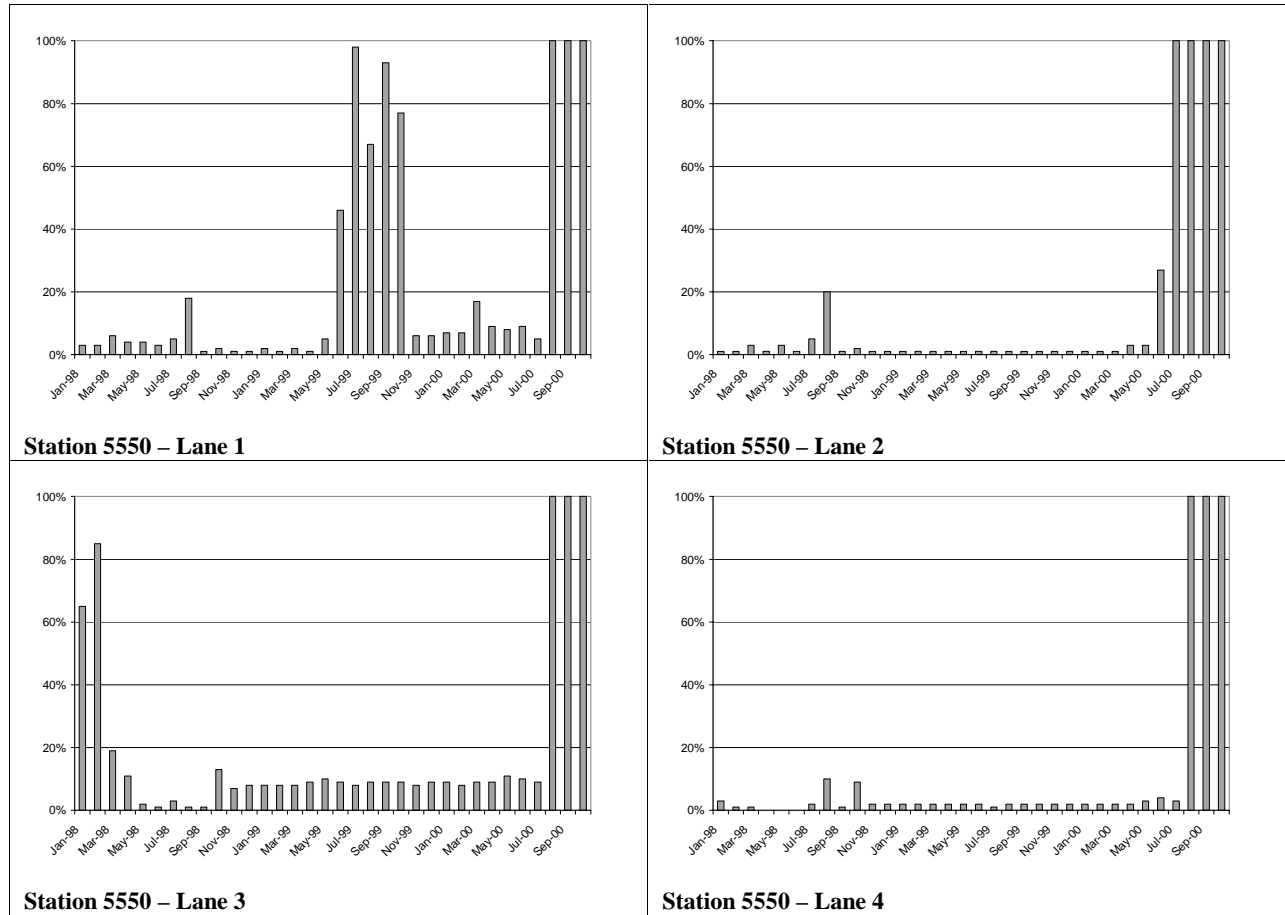

Figure E-61: Error Rate of individual lanes at station 5550

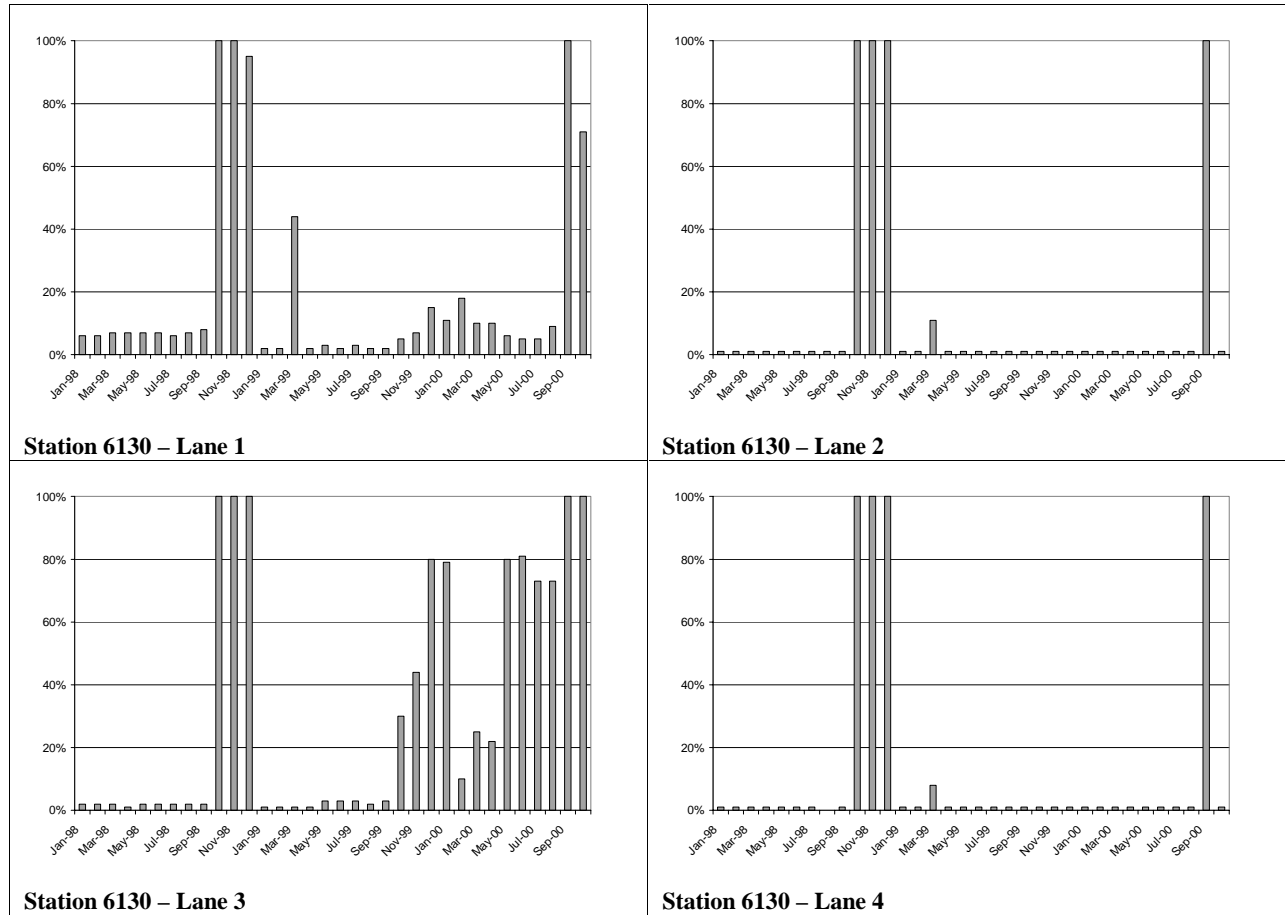

Figure E-62: Error Rate of individual lanes at station 6130

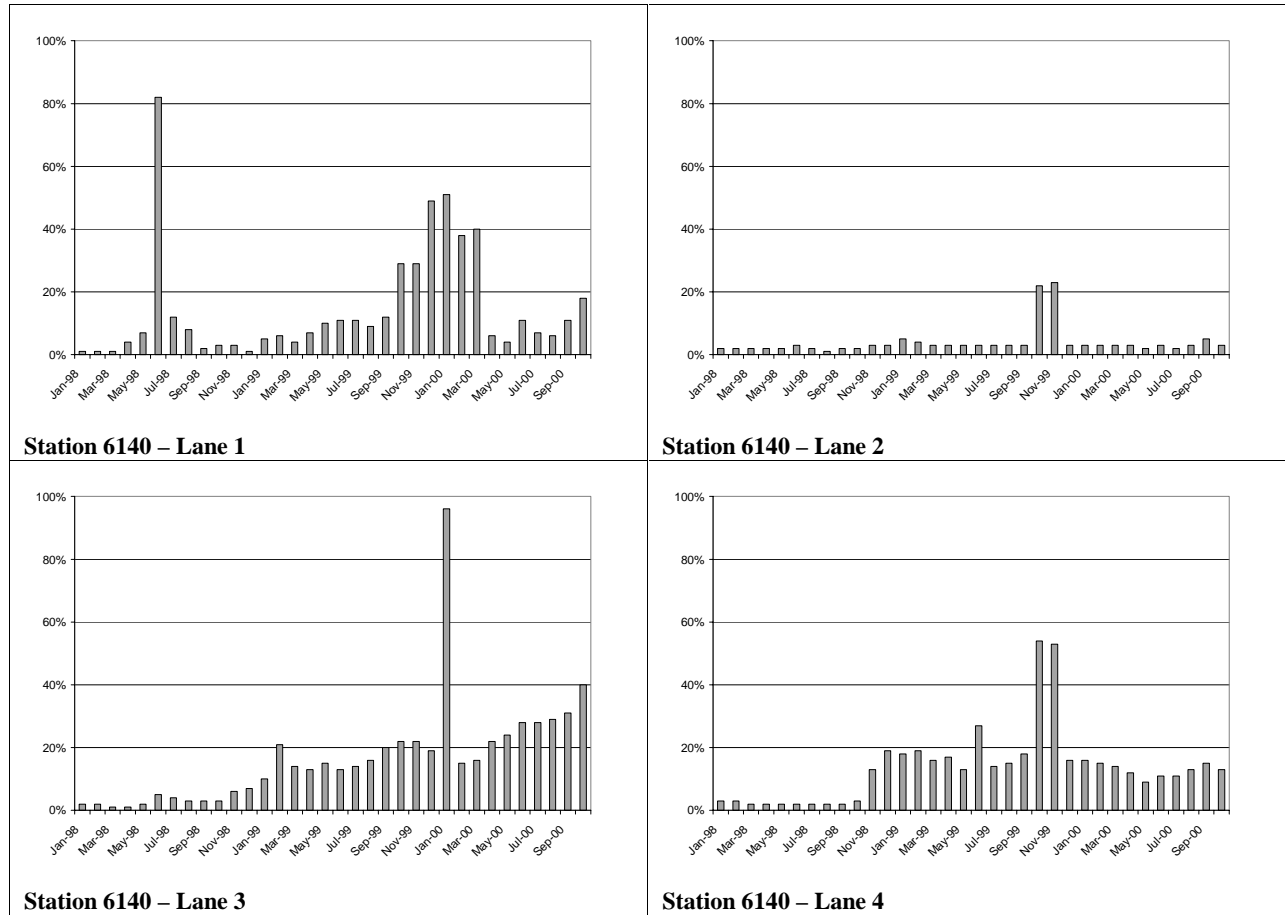

Figure E-63: Error Rate of individual lanes at station 6140

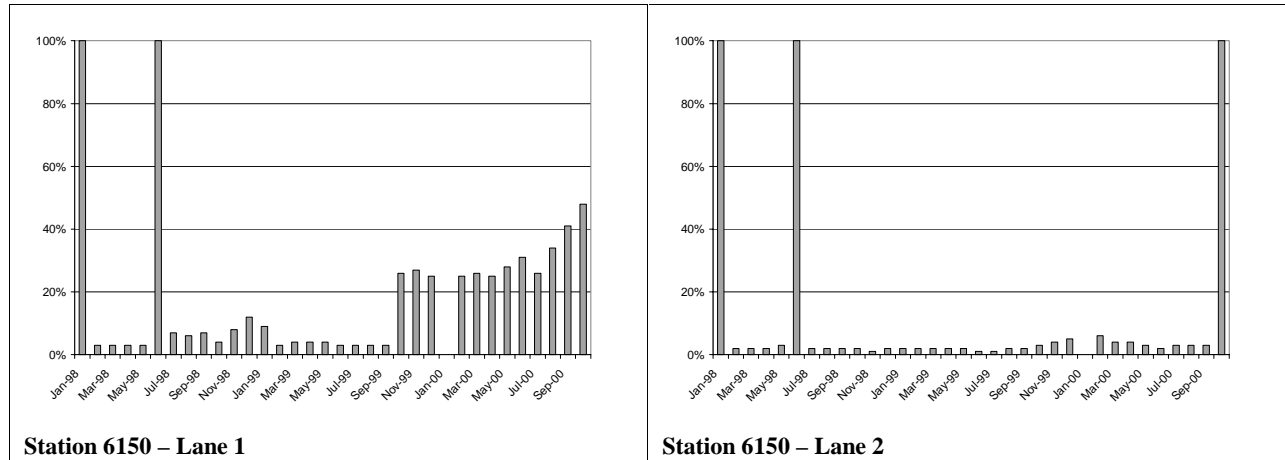

Figure E-64: Error Rate of individual lanes at station 6150

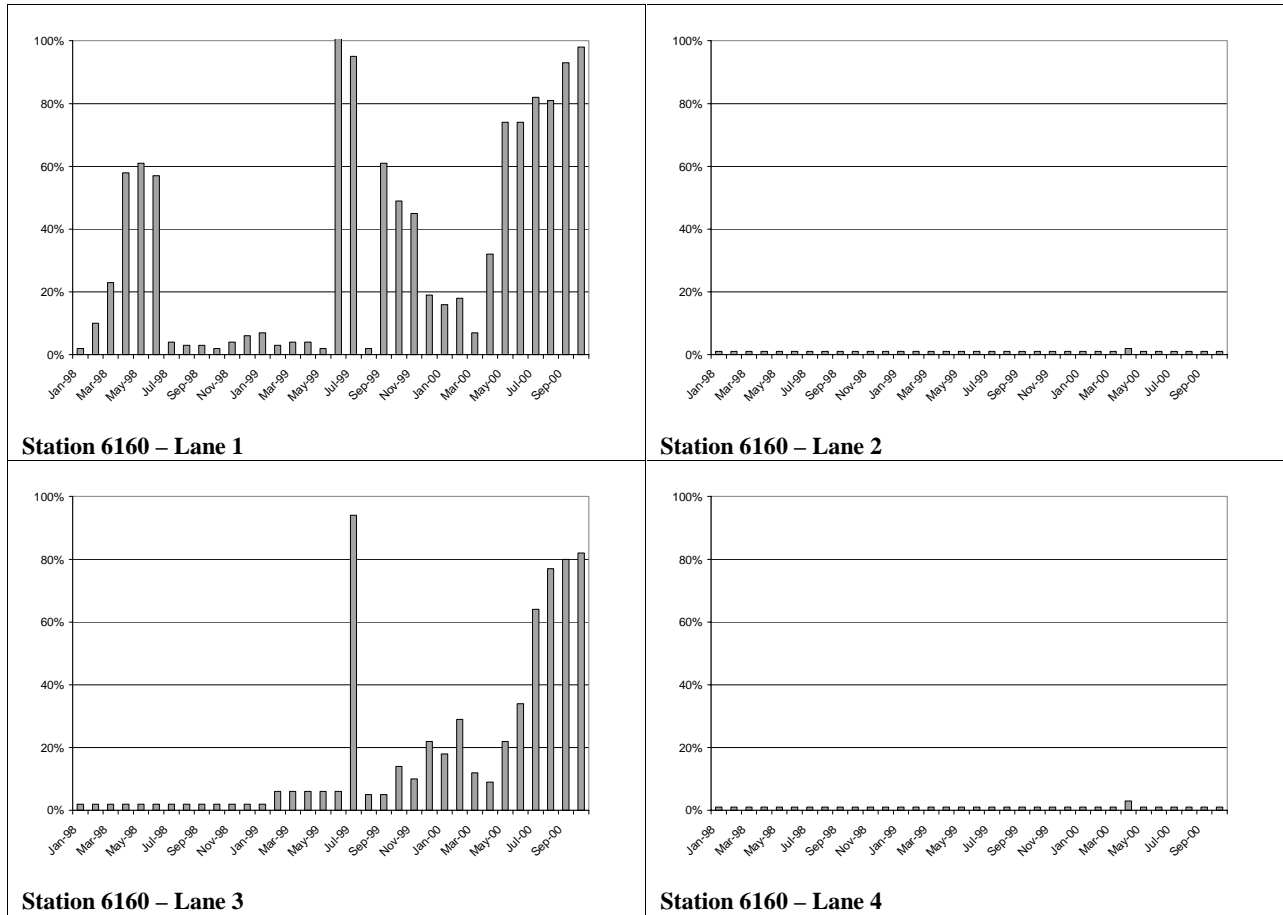

Figure E-65: Error Rate of individual lanes at station 6160

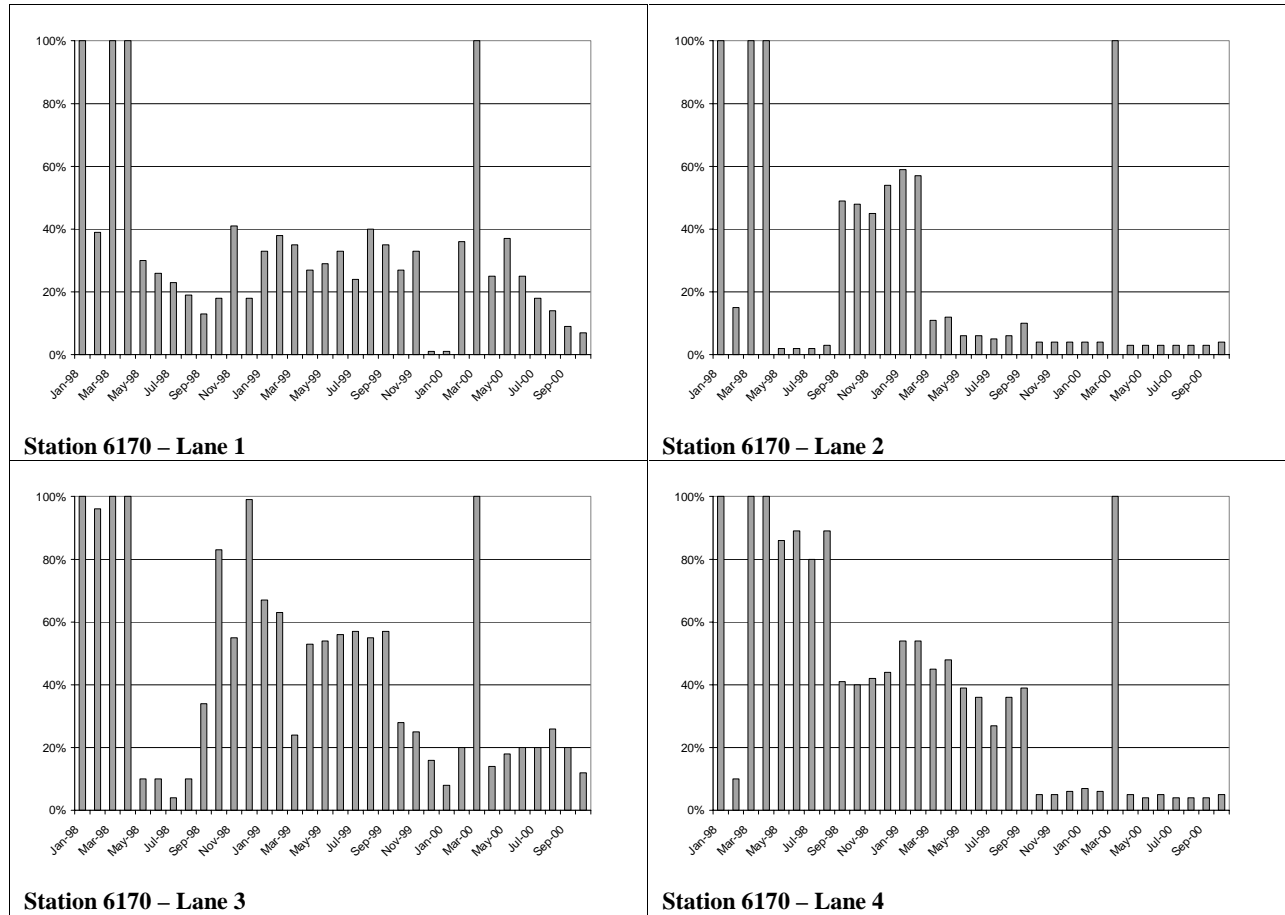

Figure E-66: Error Rate of individual lanes at station 6170

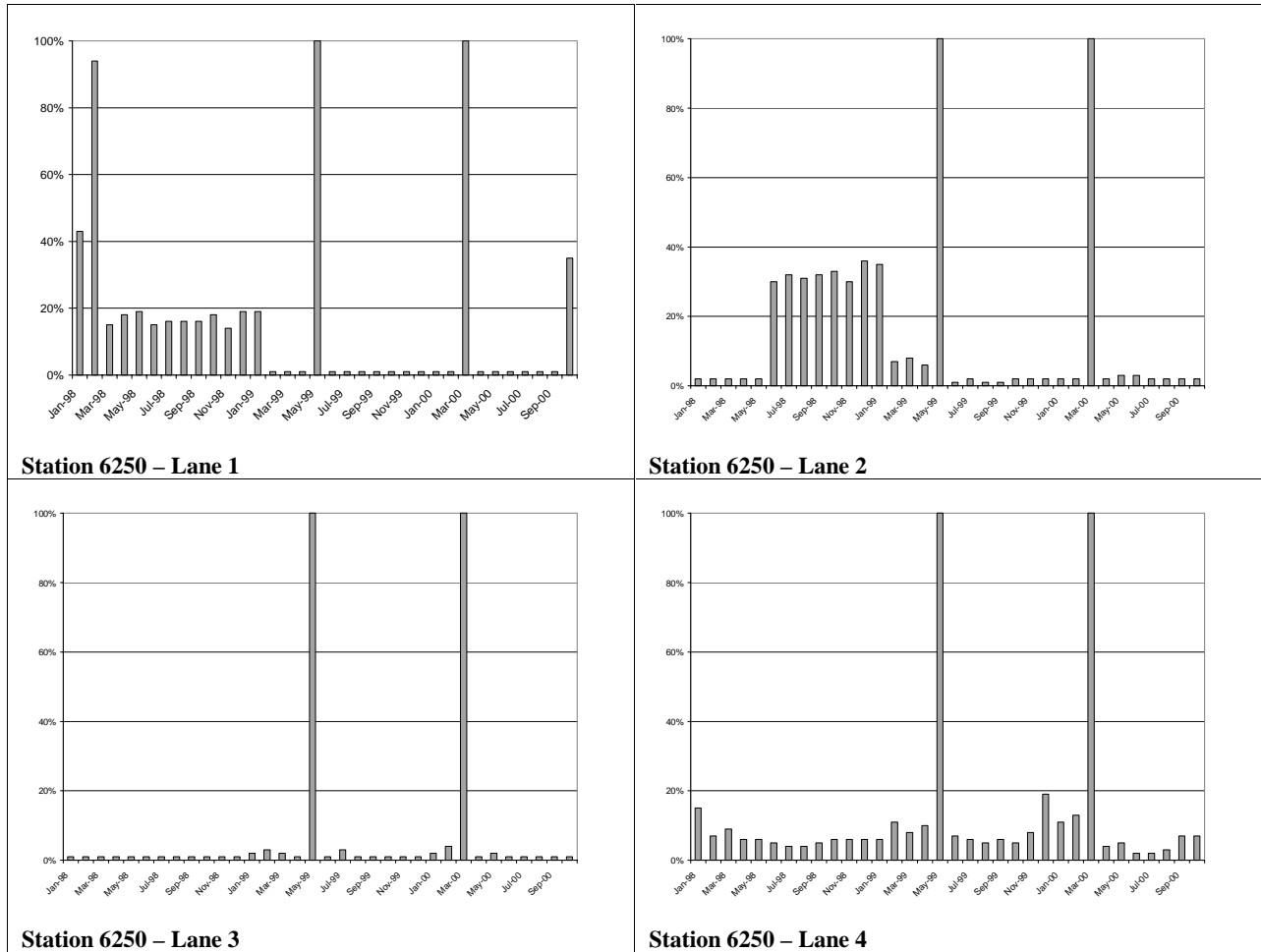

Figure E-67: Error Rate of individual lanes at station 6250

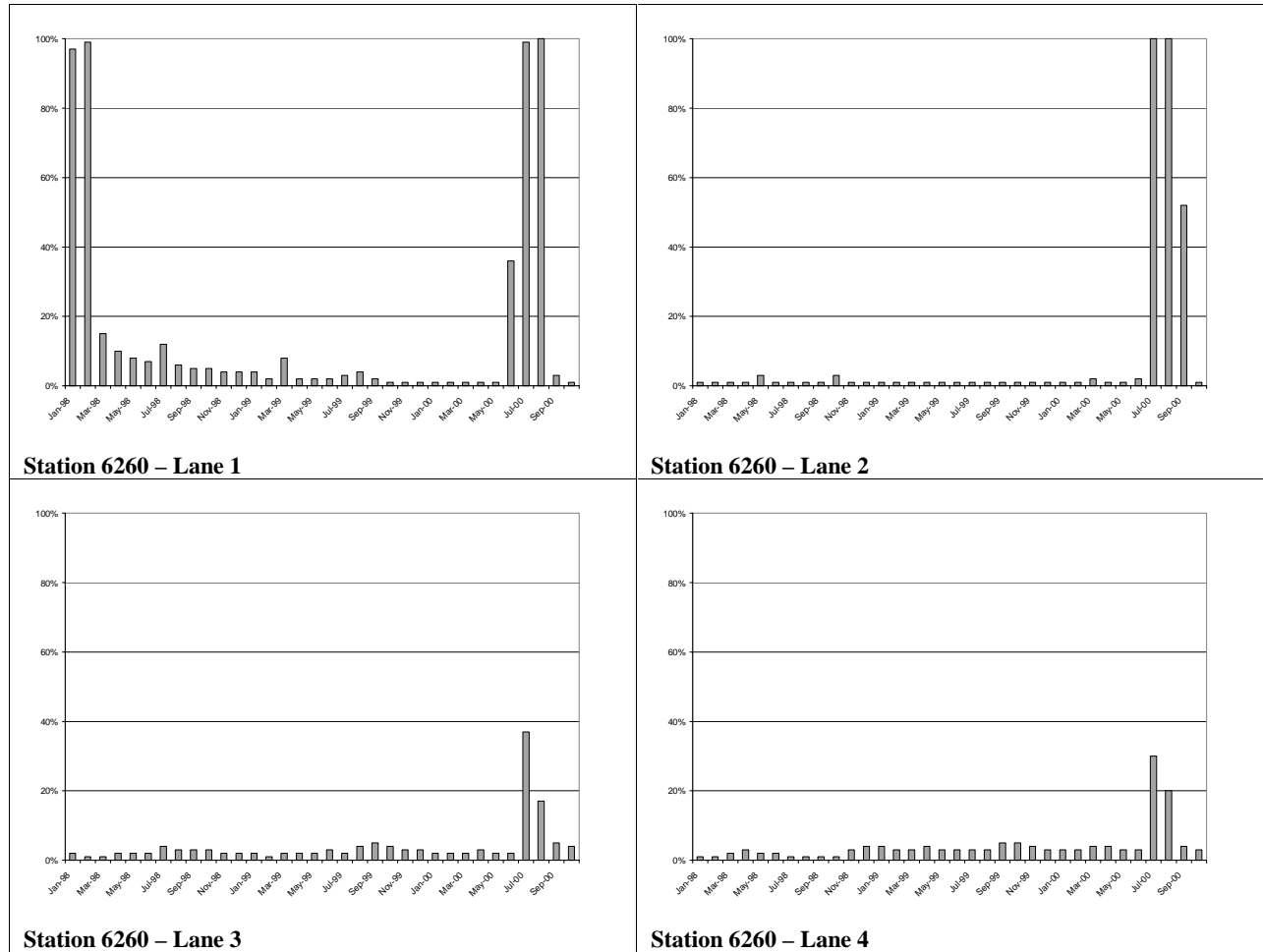

Figure E-68: Error Rate of individual lanes at station 6260

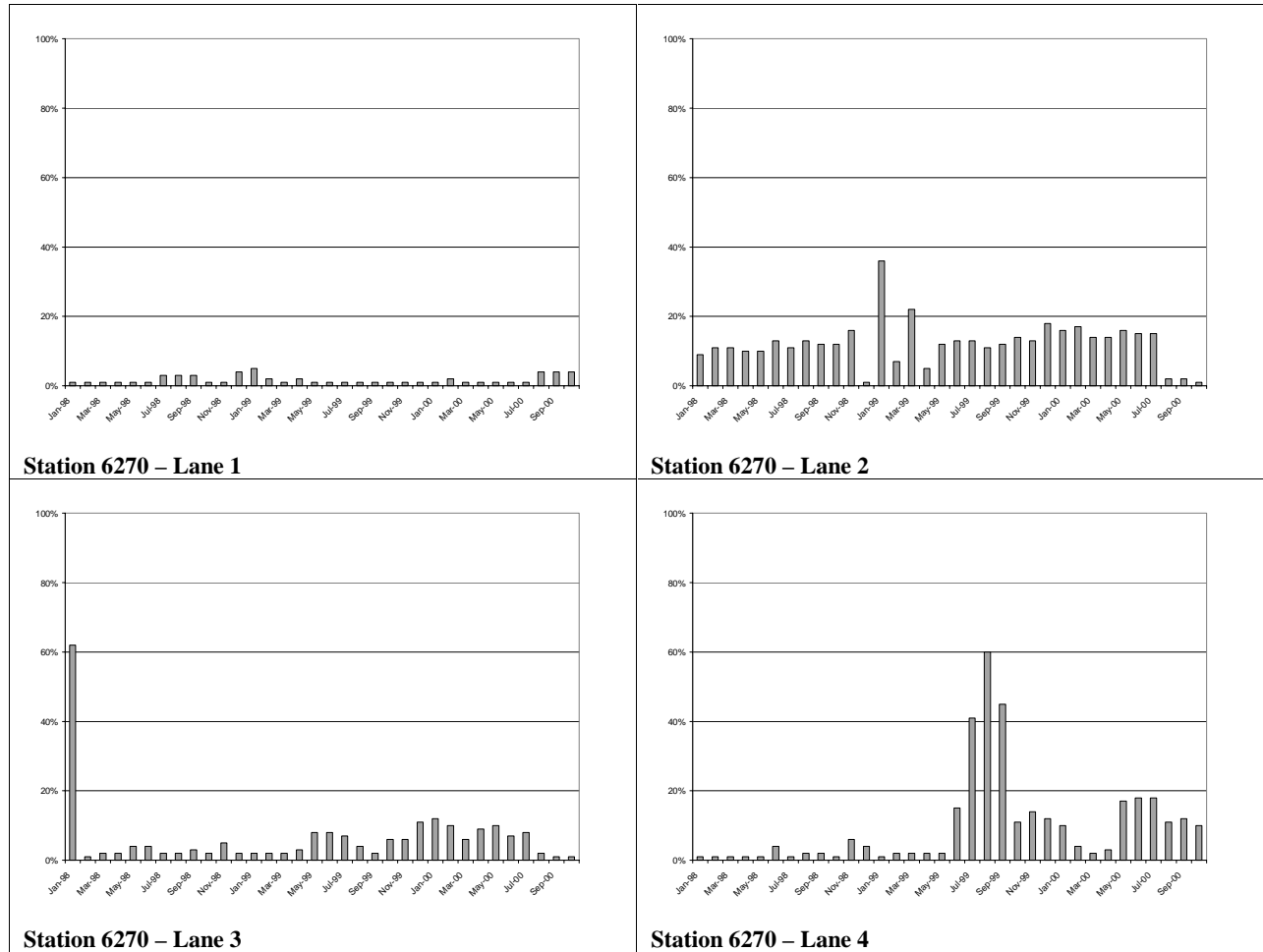

Figure E-69: Error Rate of individual lanes at station 6270

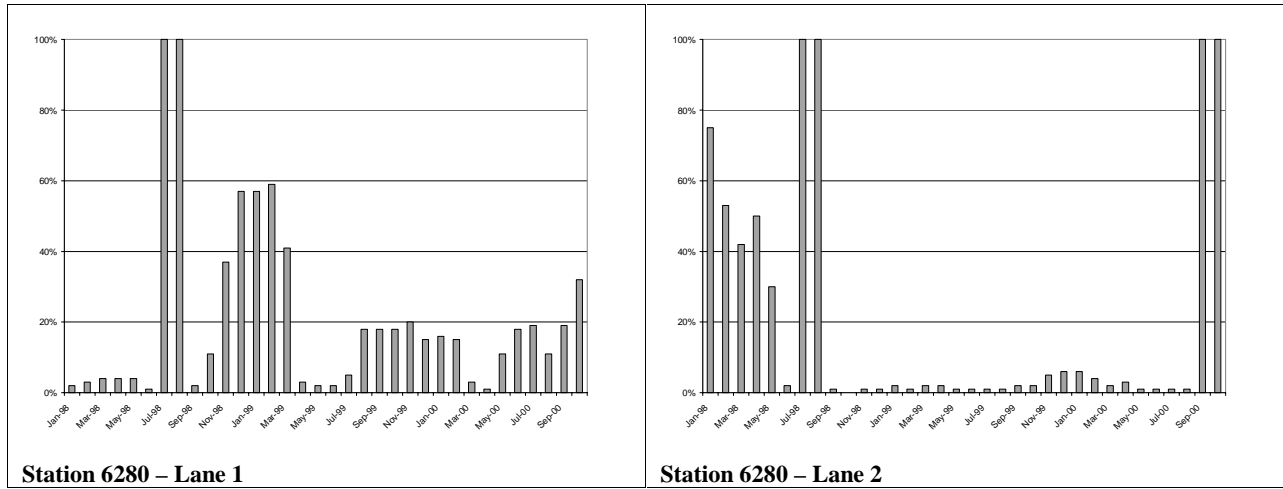

Figure E-70: Error Rate of individual lanes at station 6280

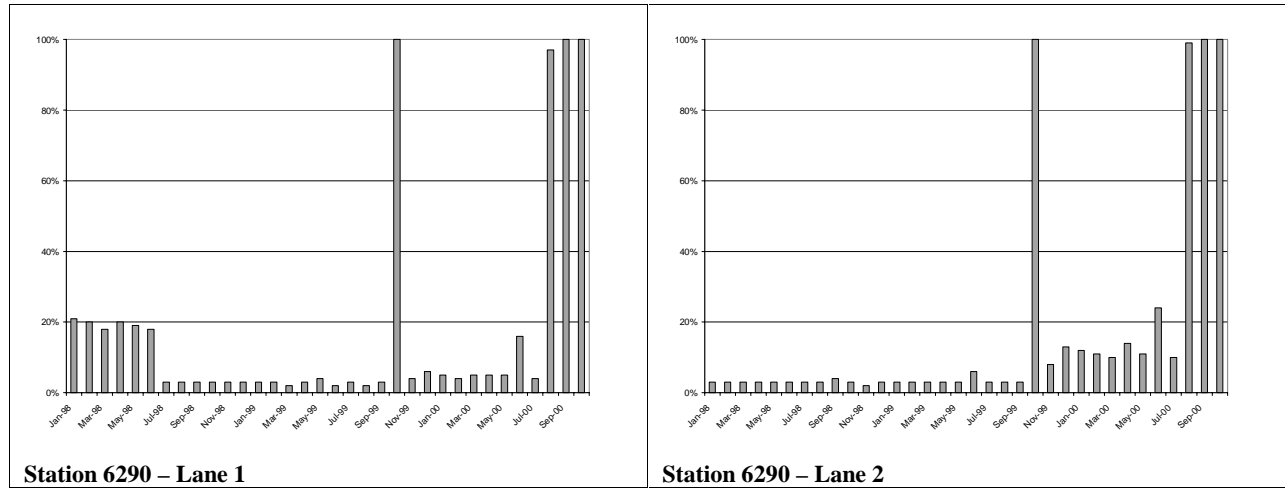

Figure E-71: Error Rate of individual lanes at station 6290

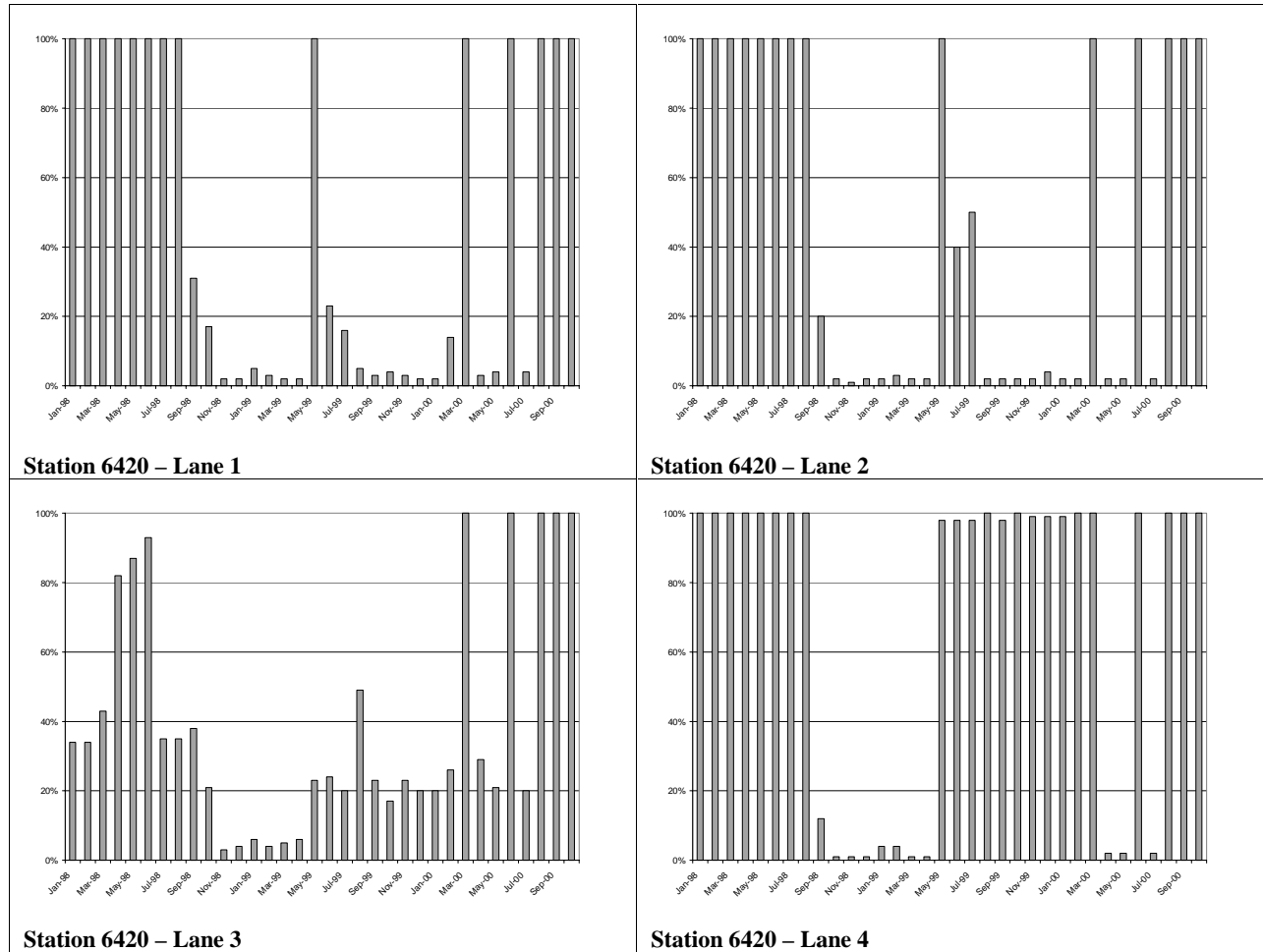

Figure E-72: Error Rate of individual lanes at station 6420

Appendix F WIM Calibration-July 2000

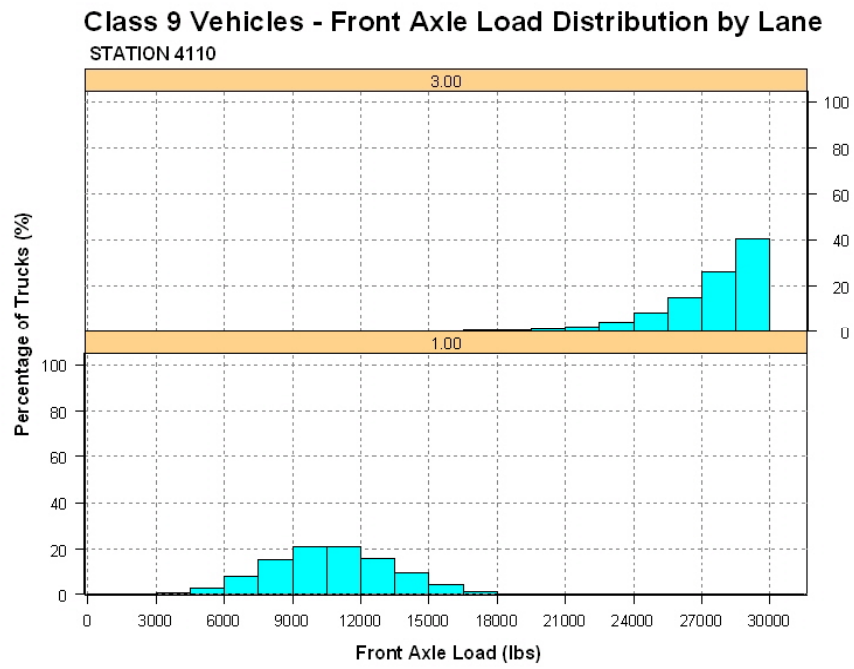

Figure F-1: Station 4110, Class 9 Vehicles - Front Axle Load Distribution

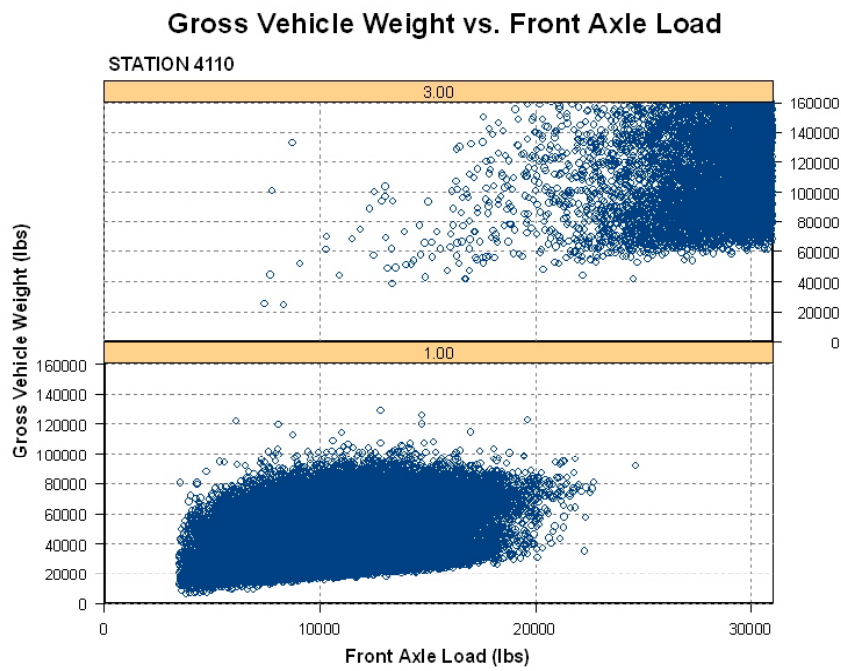

Figure F-2: Station 4110, Class 9 Vehicles - Gross Vehicle Weight vs. Front Axle

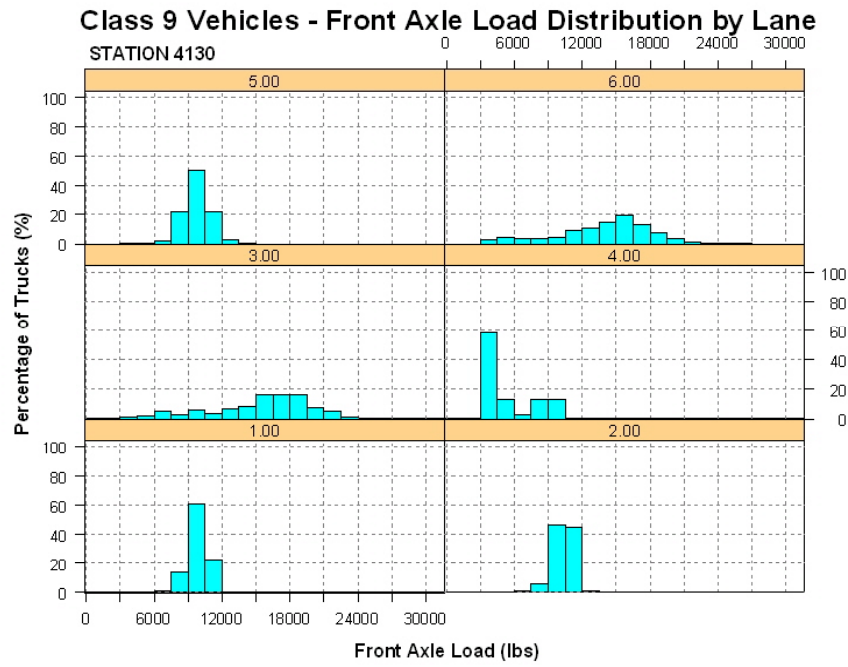

Figure F-3: Station 4130, Class 9 Vehicles - Front Axle Load Distribution

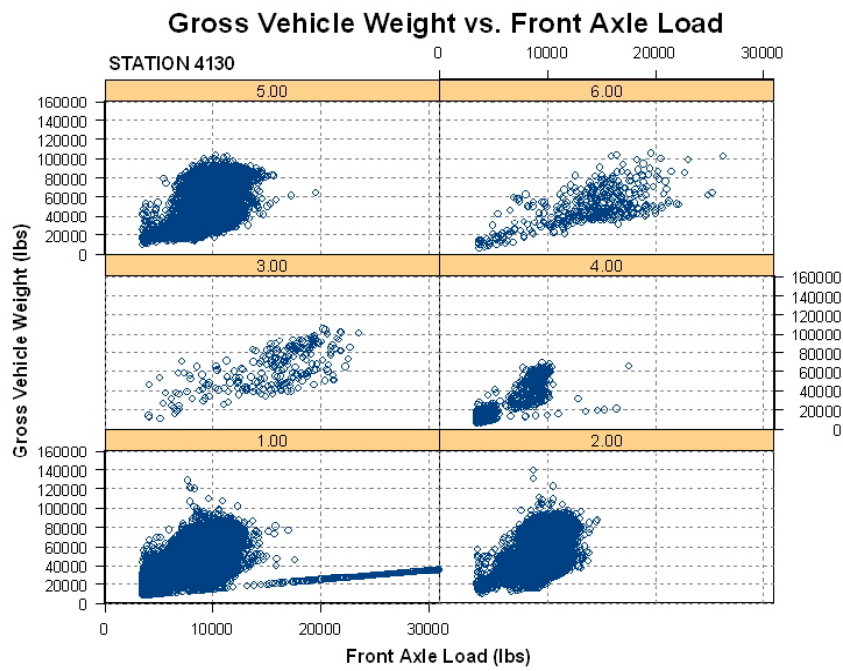

Figure F-4: Station 4130, Class 9 Vehicles - Gross Vehicle Weight vs. Front Axle

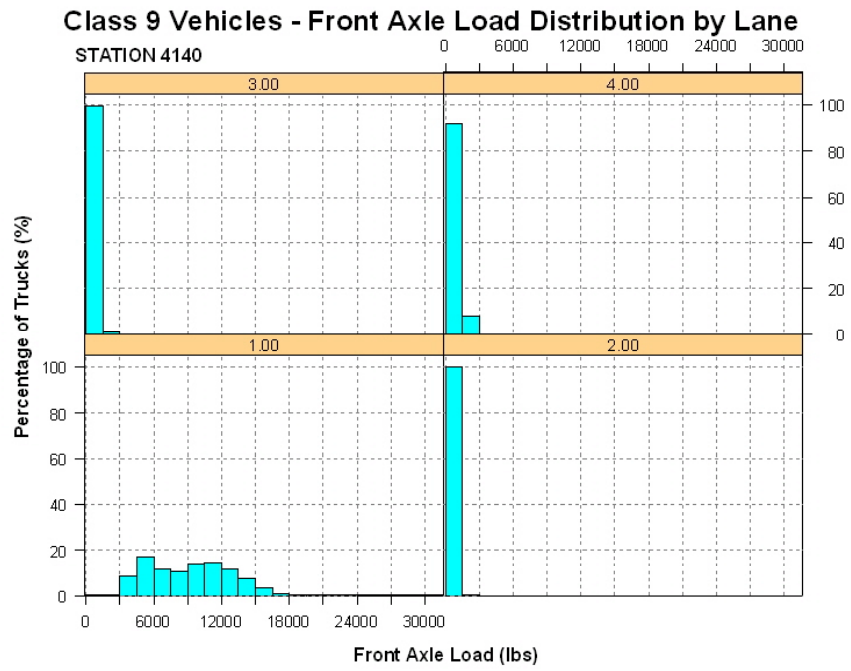

Figure F-5: Station 4140, Class 9 Vehicles - Front Axle Load Distribution

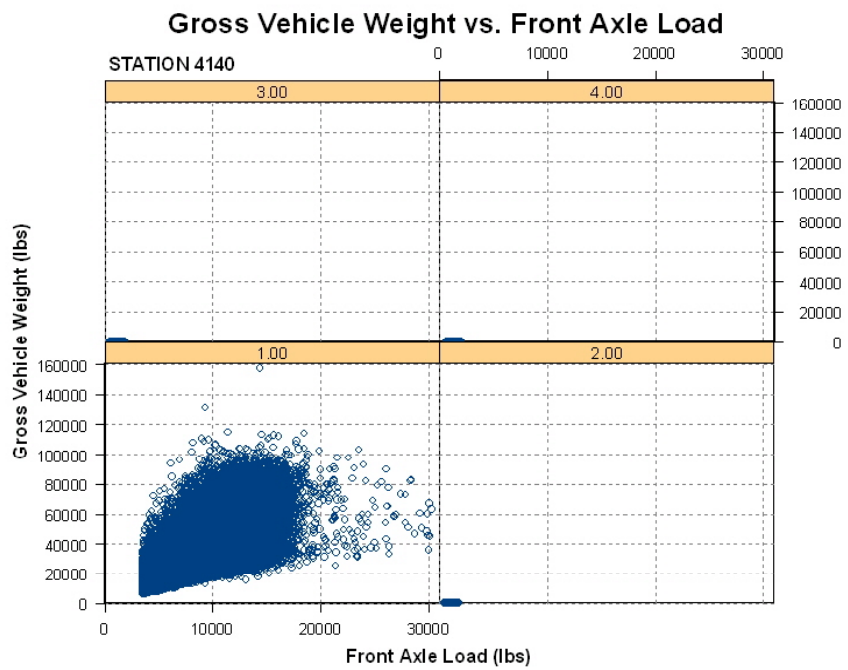

Figure F-6: Station 4140, Class 9 Vehicles - Gross Vehicle Weight vs. Front Axle

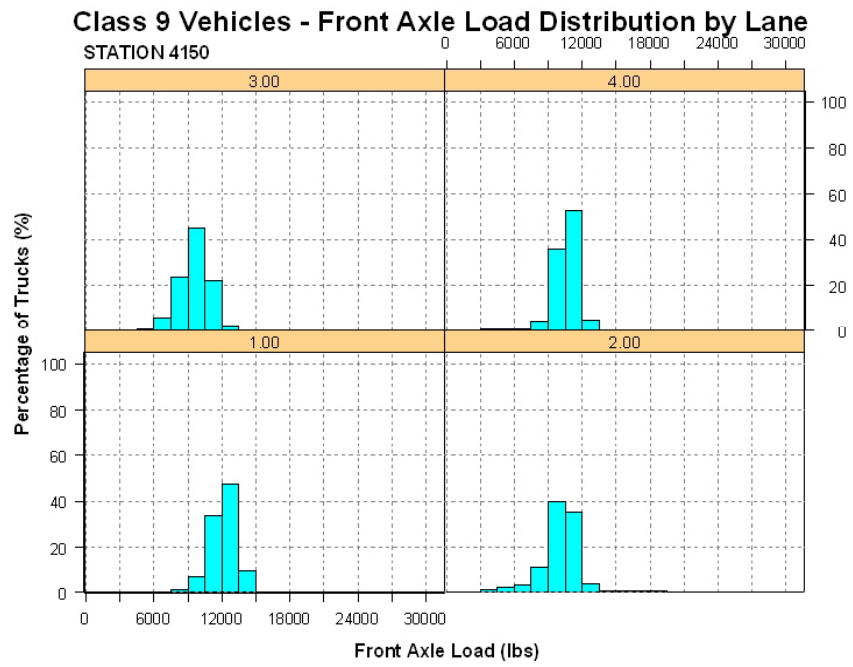

Figure F-7: Station 4160, Class 9 Vehicles - Front Axle Load Distribution

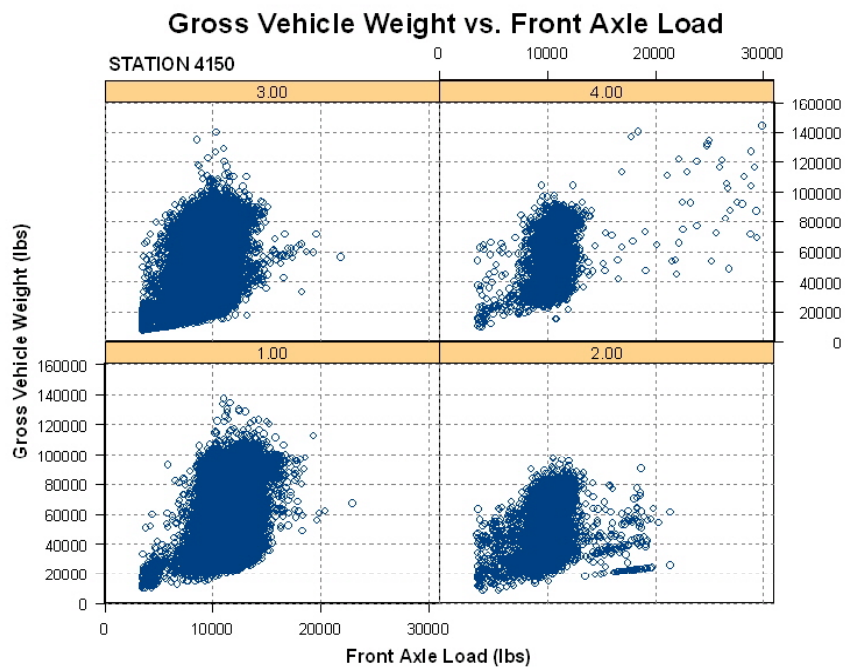

Figure F-8: Station 4160, Class 9 Vehicles - Gross Vehicle Weight vs. Front Axle

Class 9 Vehicles - Front Axle Load Distribution by Lane
STATION 4240

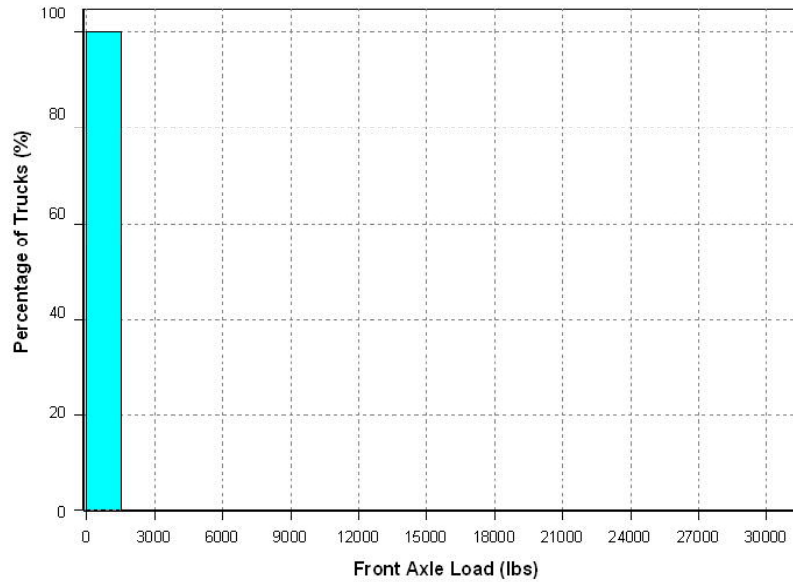

Figure F-9: Station 4240, Class 9 Vehicles - Front Axle Load Distribution

Gross Vehicle Weight vs. Front Axle Load

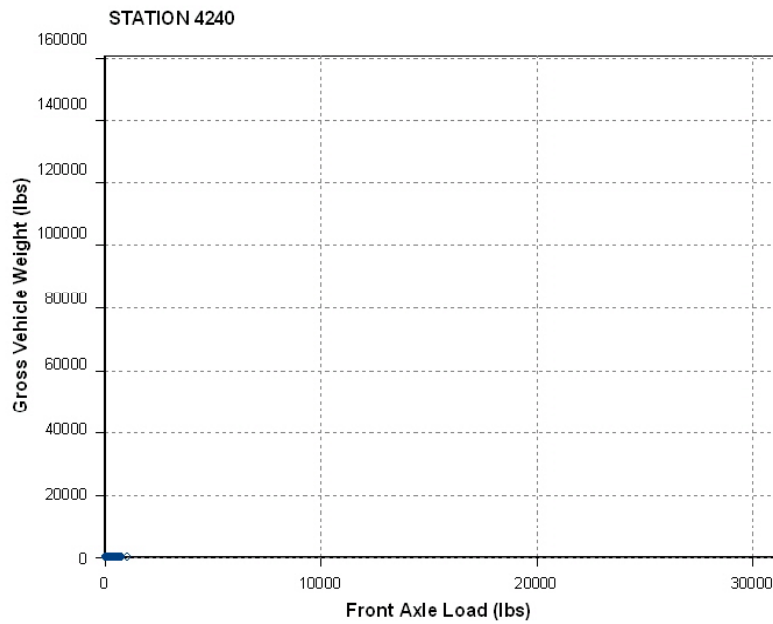

Figure F-10: Station 4240, Class 9 Vehicles - Gross Vehicle Weight vs. Front Axle

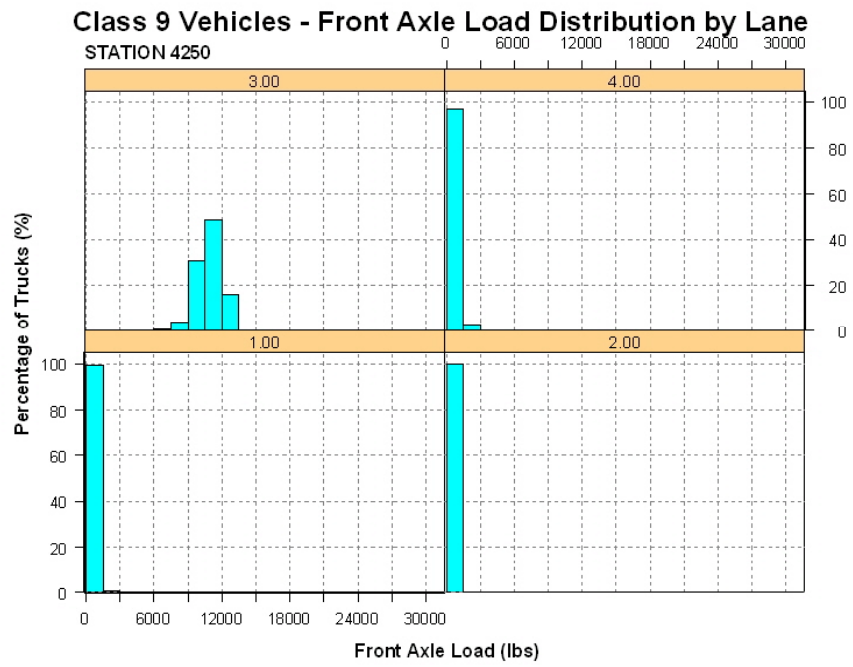

Figure F-11: Station 4250, Class 9 Vehicles - Front Axle Load Distribution

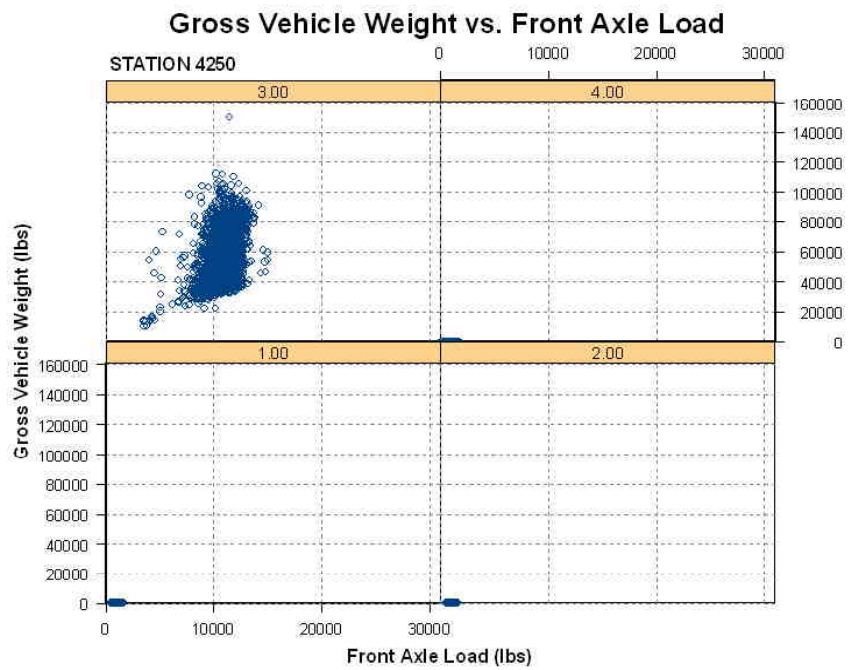

Figure F-12: Station 4250, Class 9 Vehicles - Gross Vehicle Weight vs. Front Axle

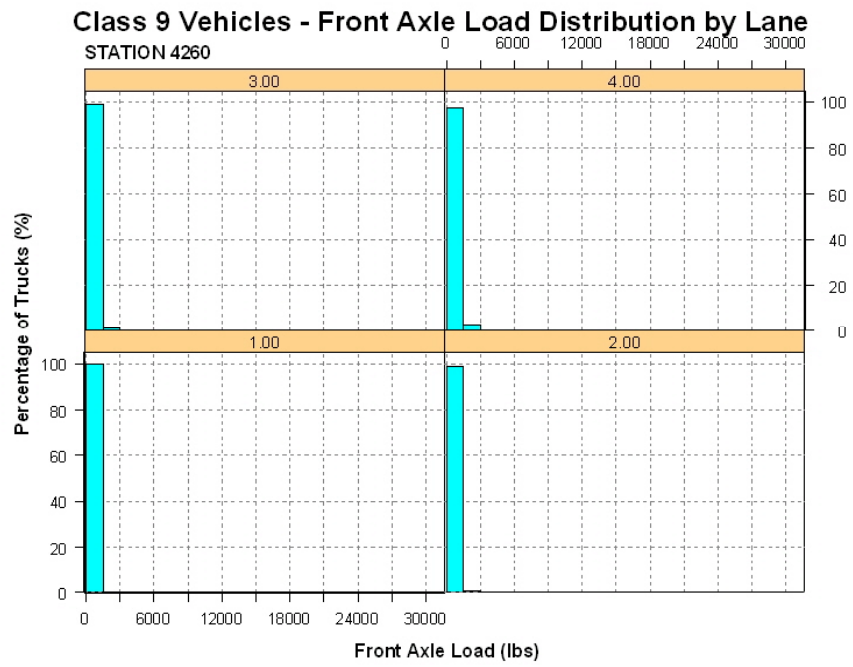

Figure F-13: Station 4260, Class 9 Vehicles - Front Axle Load Distribution

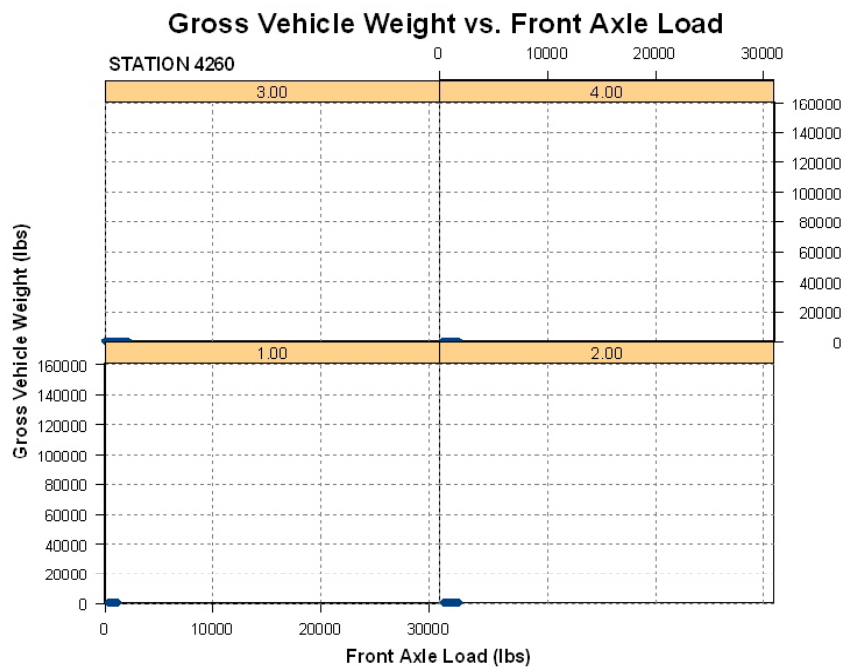

Figure F-14: Station 4260, Class 9 Vehicles - Gross Vehicle Weight vs. Front Axle

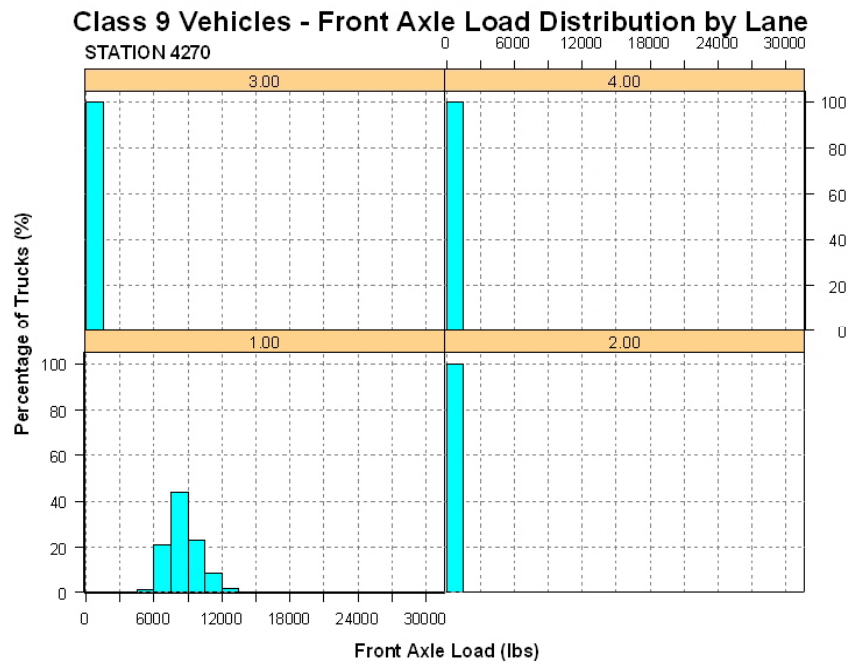

Figure F-15: Station 4270, Class 9 Vehicles - Front Axle Load Distribution

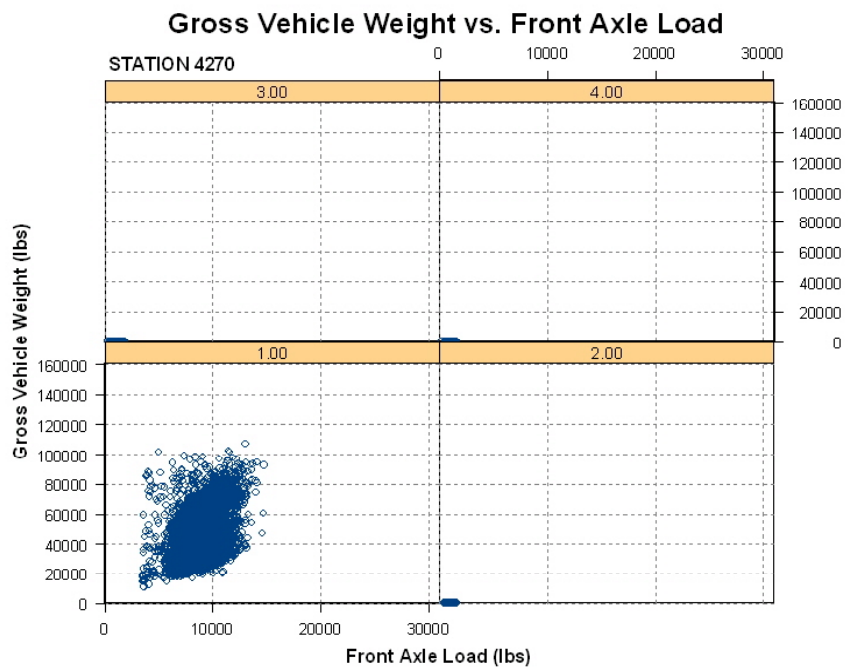

Figure F-16: Station 4270, Class 9 Vehicles - Gross Vehicle Weight vs. Front Axle

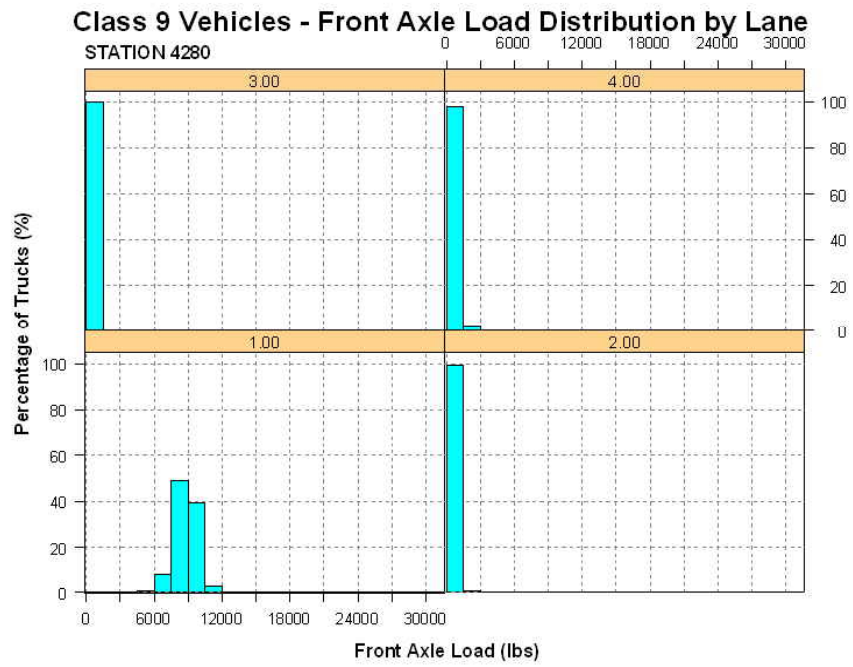

Figure F-17: Station 4280, Class 9 Vehicles - Front Axle Load Distribution

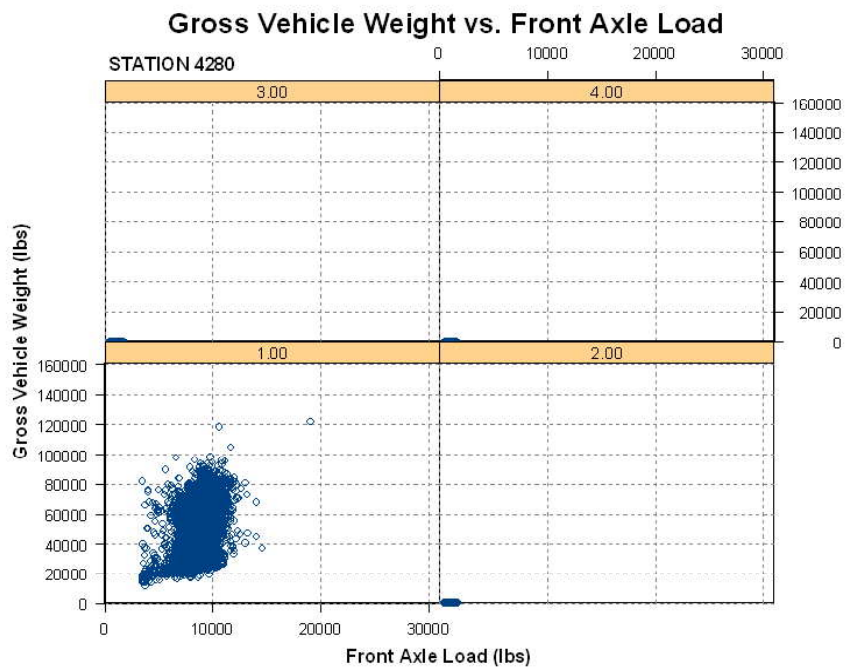

Figure F-18: Station 4280, Class 9 Vehicles - Gross Vehicle Weight vs. Front Axle

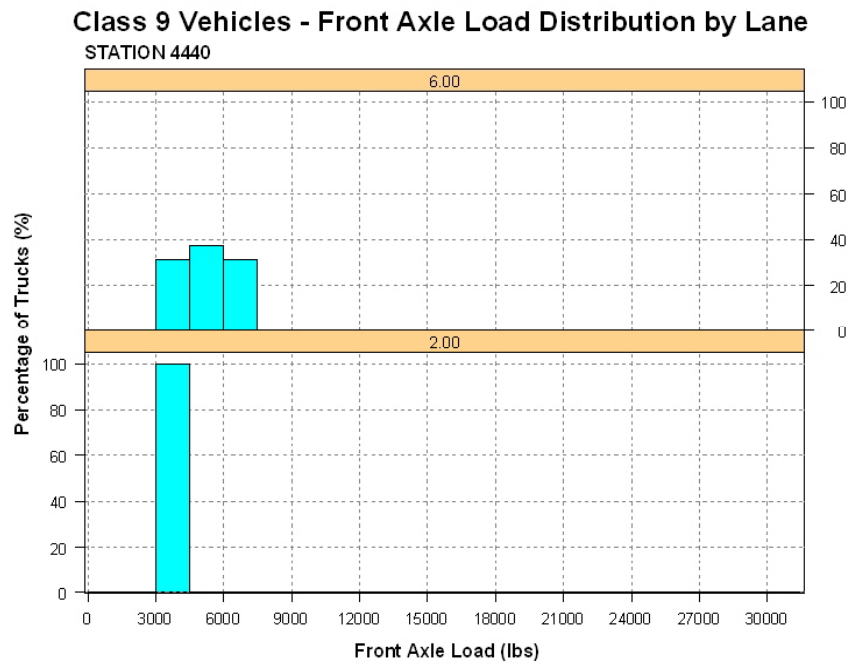

Figure F-19: Station 4440, Class 9 Vehicles - Front Axle Load Distribution

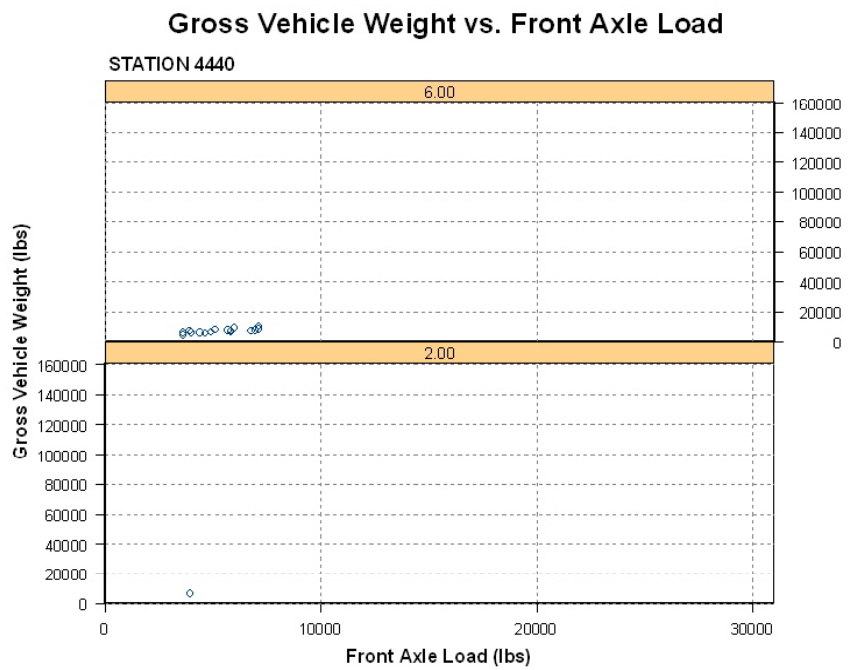

Figure F-20: Station 4440, Class 9 Vehicles - Gross Vehicle Weight vs. Front Axle

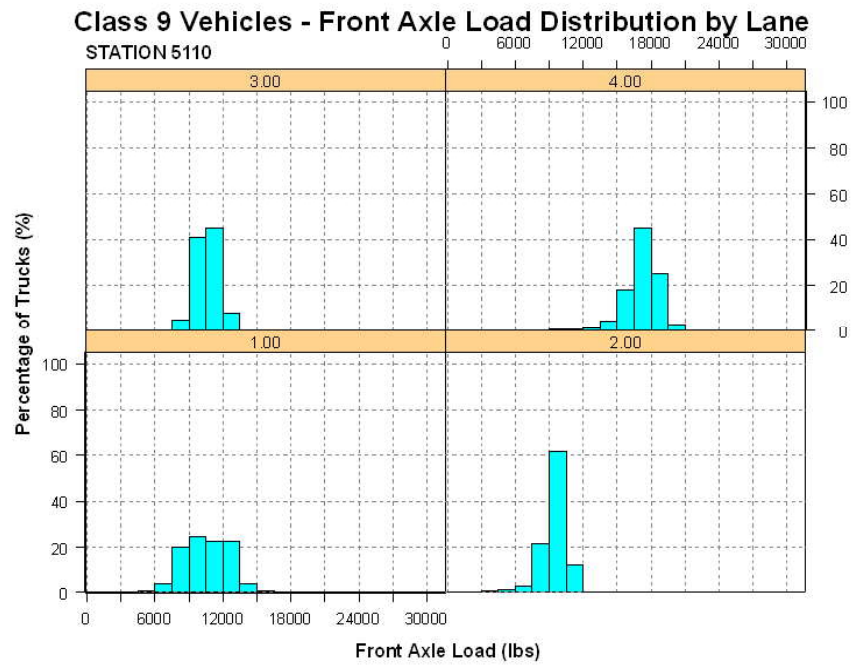

Figure F-21: Station 5110, Class 9 Vehicles - Front Axle Load Distribution

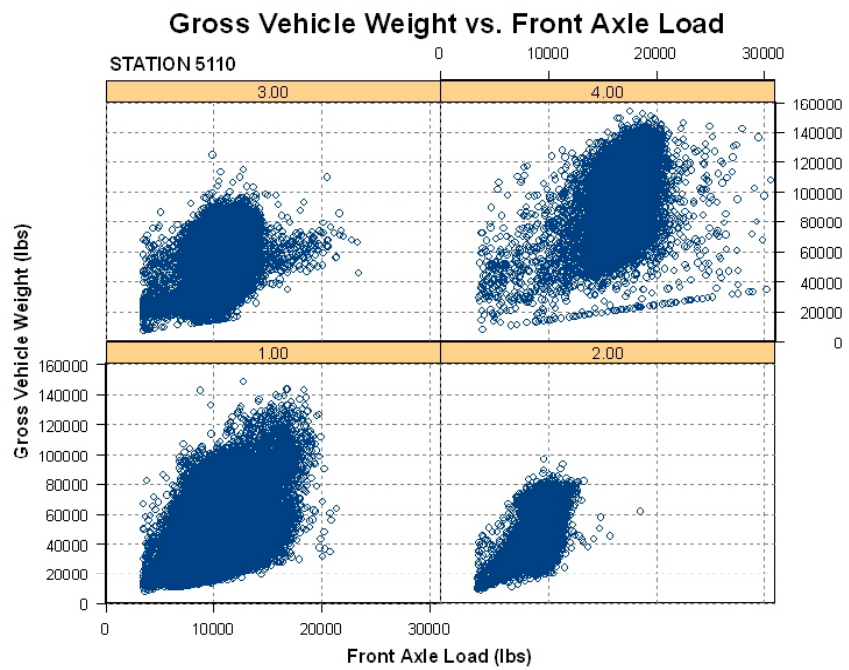

Figure F-22: Station 5110, Class 9 Vehicles - Gross Vehicle Weight vs. Front Axle

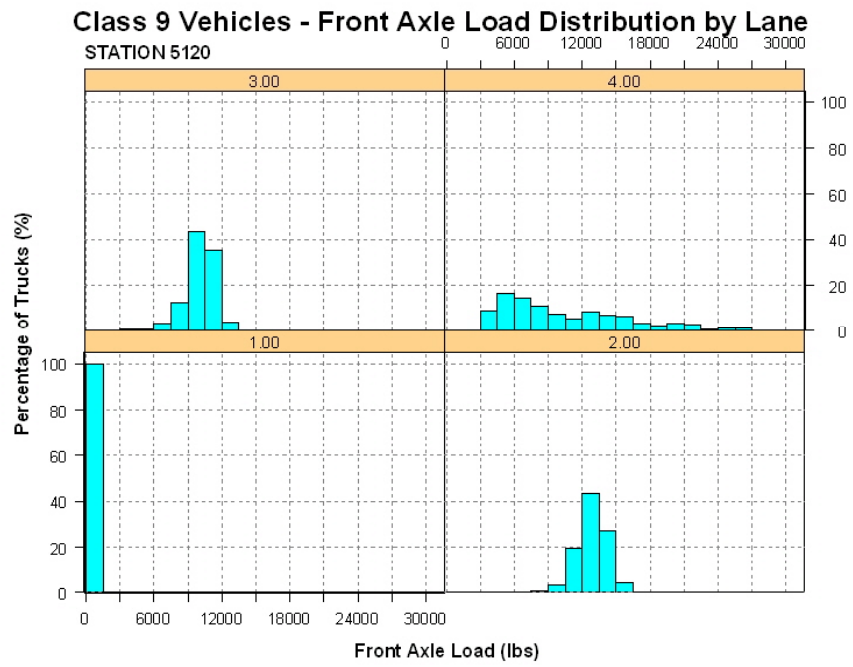

Figure F-23: Station 5120, Class 9 Vehicles - Front Axle Load Distribution

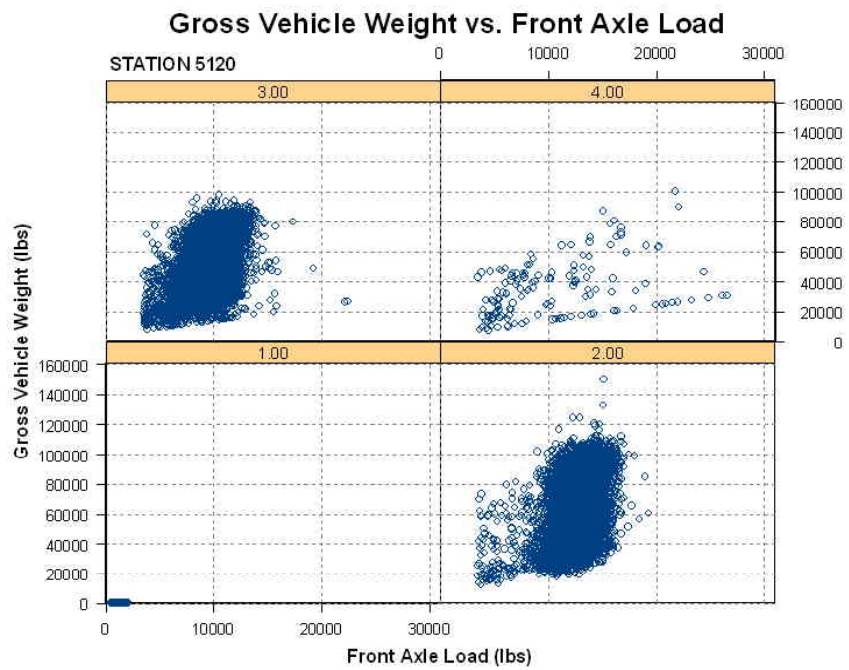

Figure F-24: Station 5120, Class 9 Vehicles - Gross Vehicle Weight vs. Front Axle

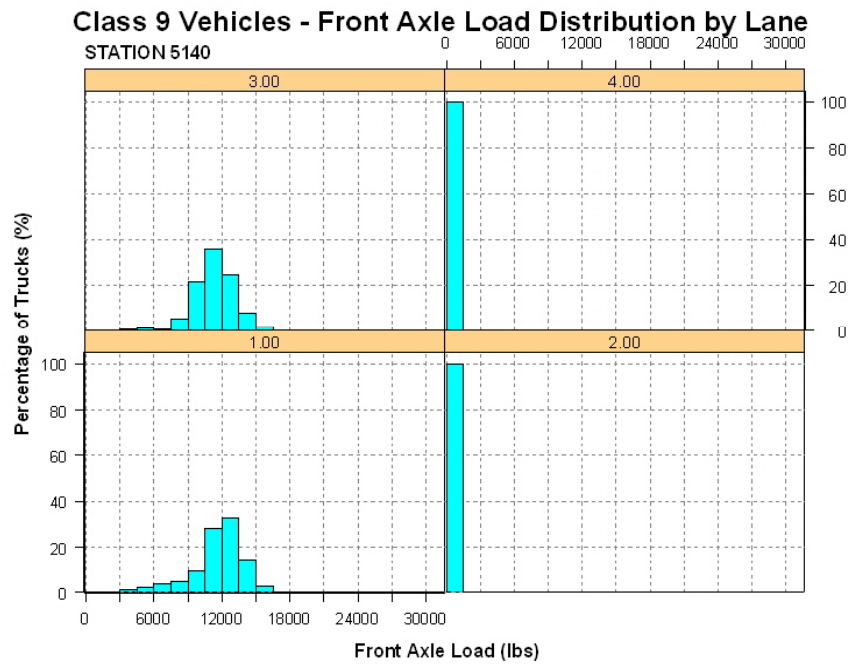

Figure F-25: Station 5140, Class 9 Vehicles - Front Axle Load Distribution

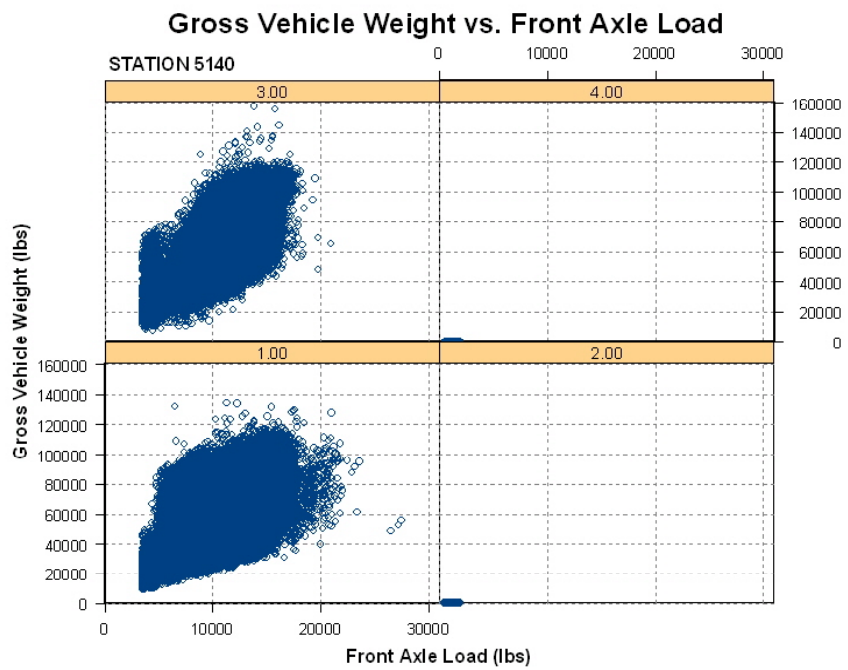

Figure F-26: Station 5140, Class 9 Vehicles - Gross Vehicle Weight vs. Front Axle

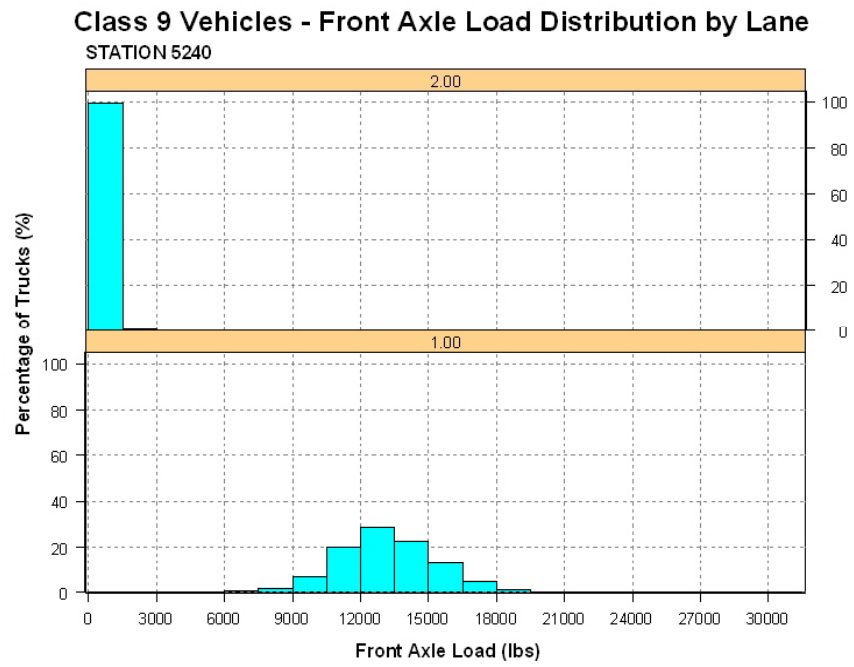

Figure F-27: Station 5240, Class 9 Vehicles - Front Axle Load Distribution

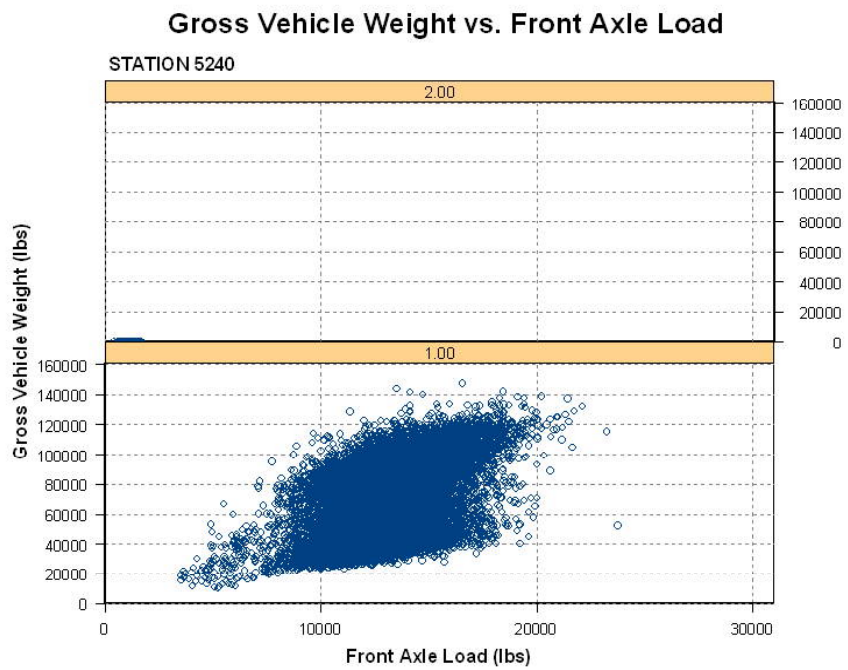

Figure F-28: Station 5240, Class 9 Vehicles - Gross Vehicle Weight vs. Front Axle

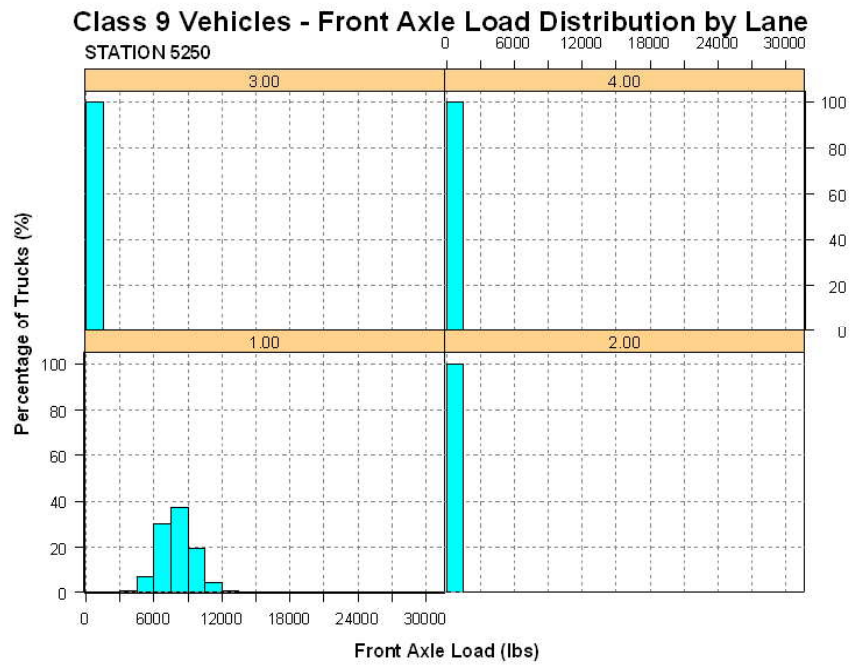

Figure F-29: Station 5250, Class 9 Vehicles - Front Axle Load Distribution

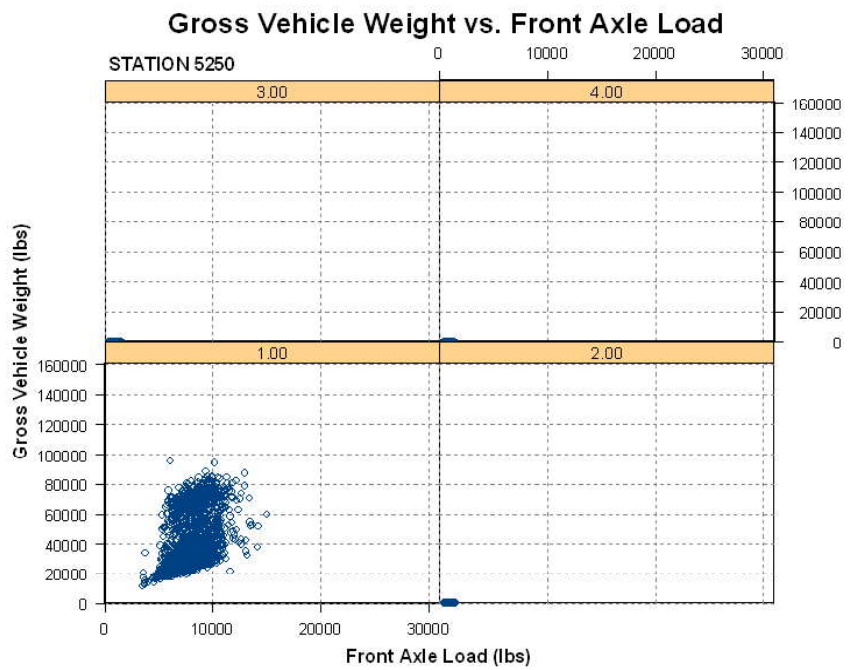

Figure F-30: Station 5250, Class 9 Vehicles - Gross Vehicle Weight vs. Front Axle

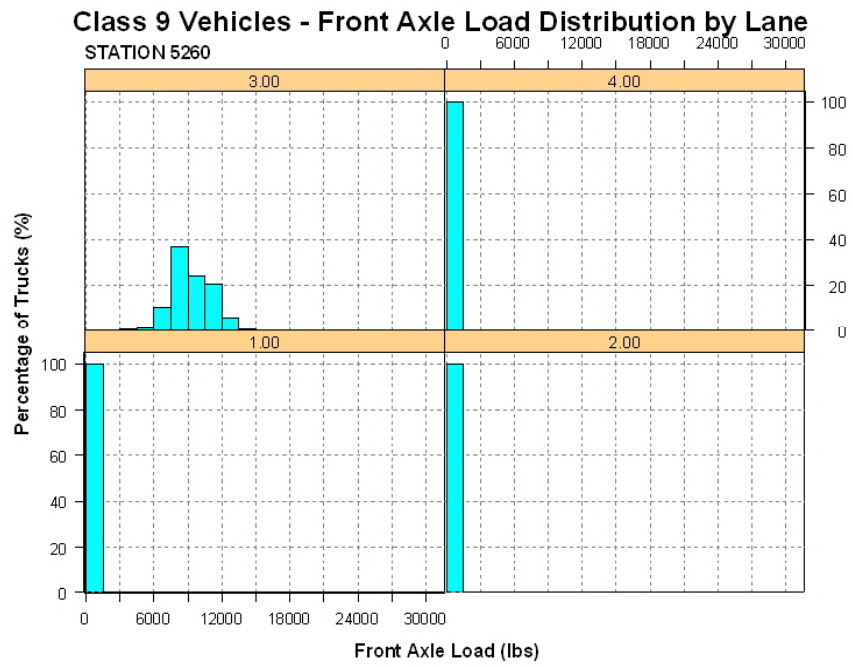

Figure F-31: Station 5260, Class 9 Vehicles - Front Axle Load Distribution

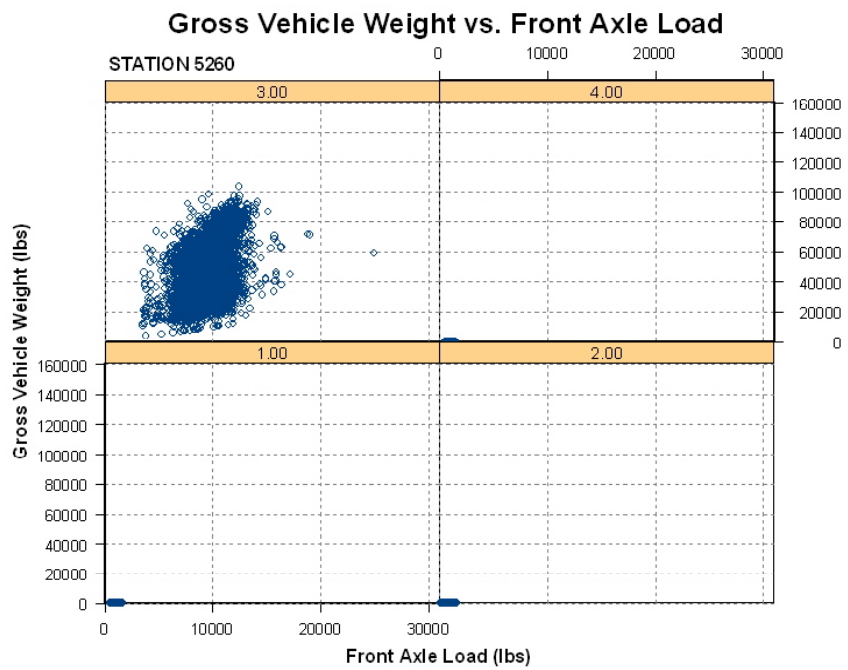

Figure F-32: Station 5260, Class 9 Vehicles - Gross Vehicle Weight vs. Front Axle

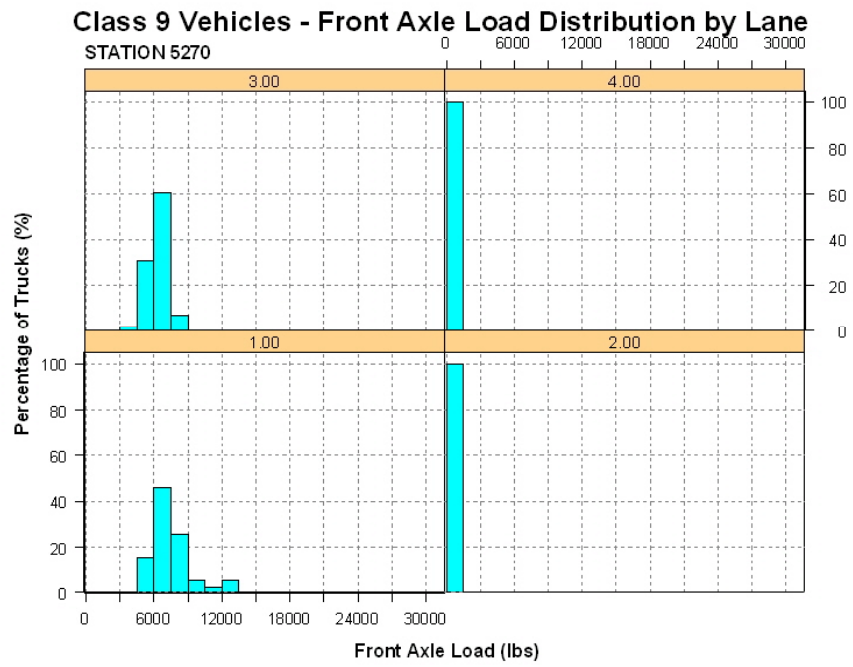

Figure F-33: Station 5270, Class 9 Vehicles - Front Axle Load Distribution

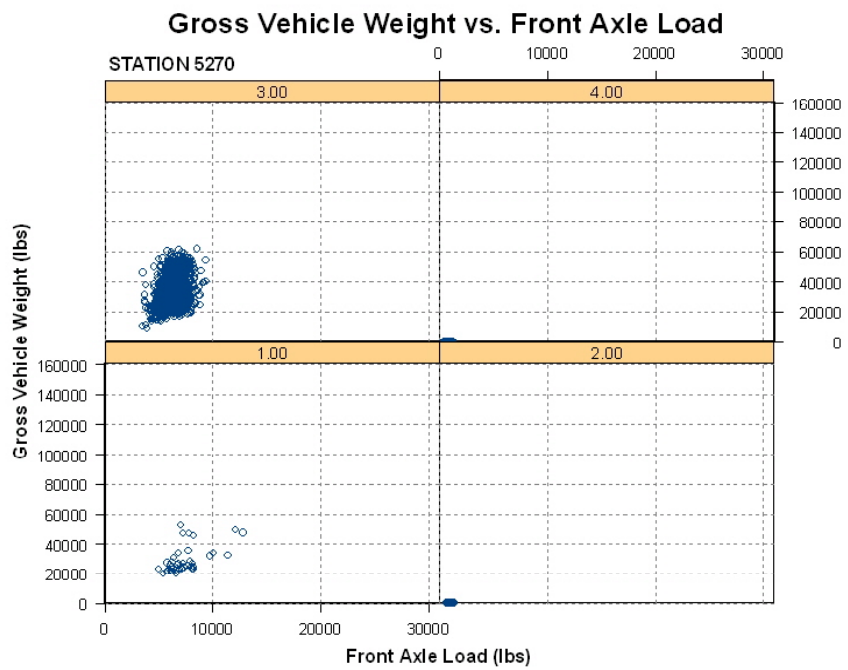

Figure F-34: Station 5270, Class 9 Vehicles - Gross Vehicle Weight vs. Front Axle

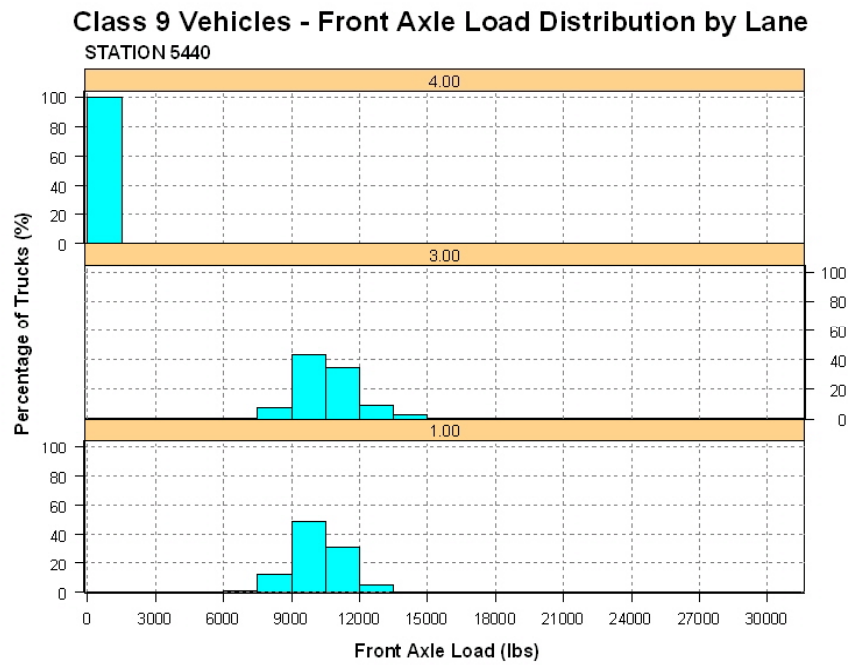

Figure F-35: Station 5440, Class 9 Vehicles - Front Axle Load Distribution

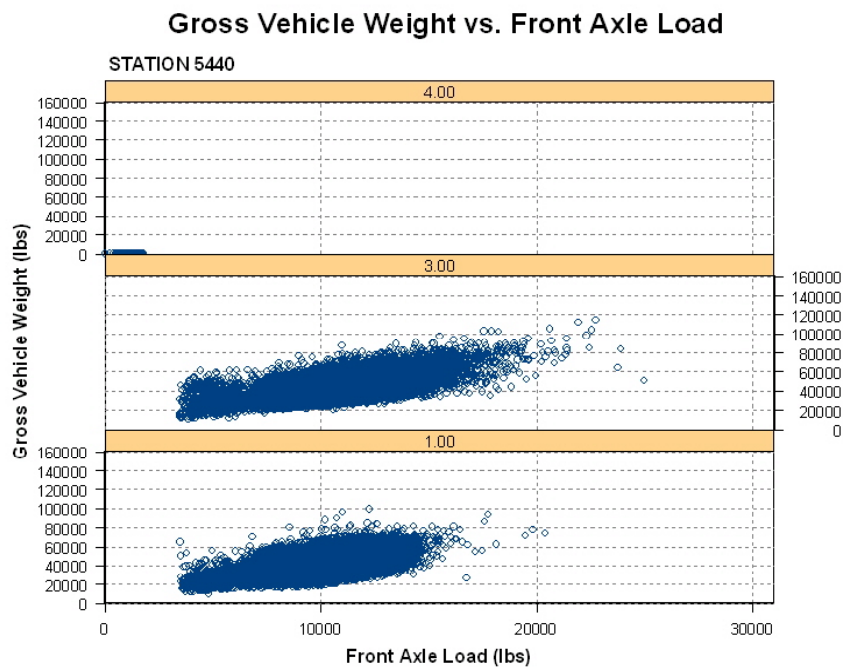

Figure F-36: Station 5440, Class 9 Vehicles - Gross Vehicle Weight vs. Front Axle

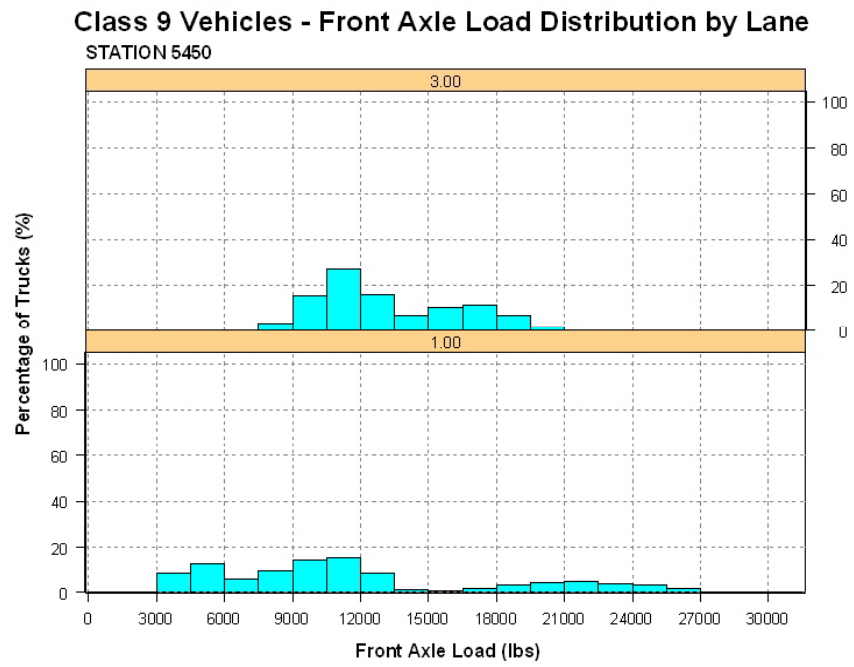

Figure F-37: Station 5440, Class 9 Vehicles - Front Axle Load Distribution

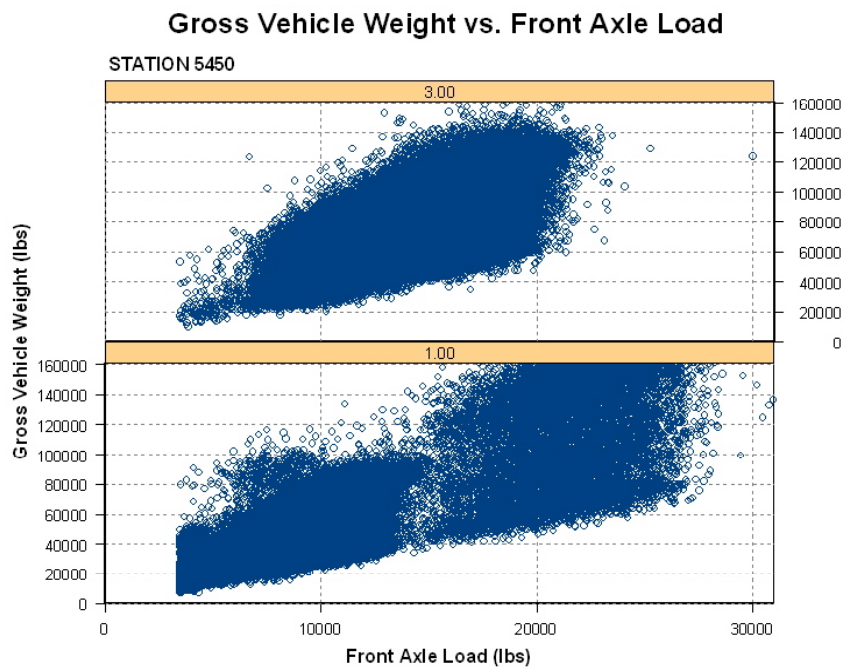

Figure F-38: Station 5450, Class 9 Vehicles - Gross Vehicle Weight vs. Front Axle

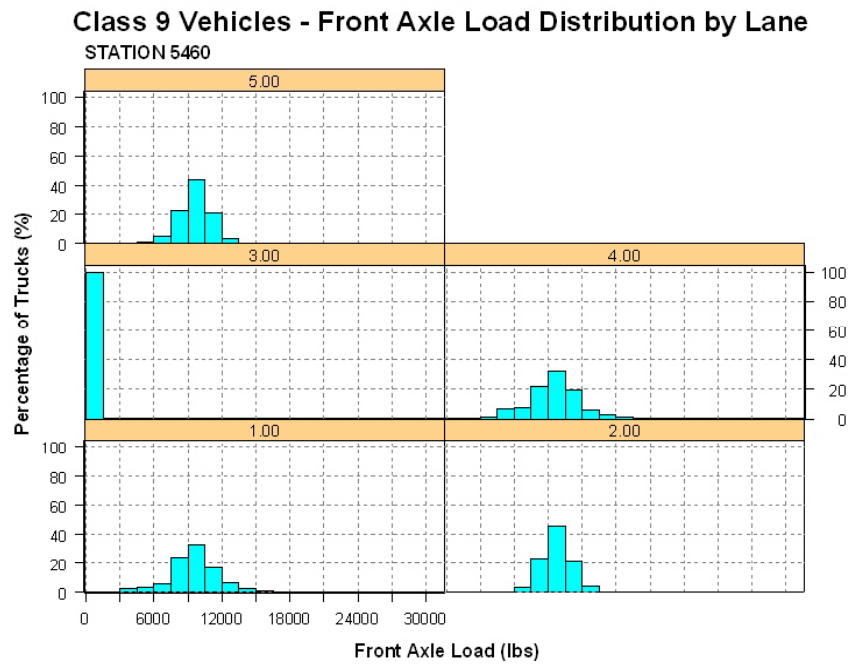

Figure F-39: Station 5460, Class 9 Vehicles - Front Axle Load Distribution

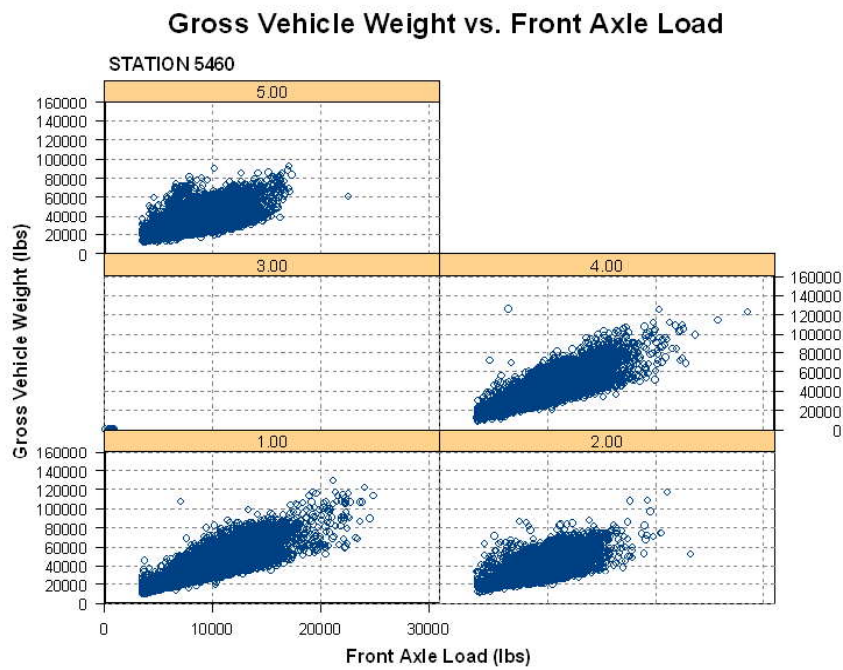

Figure F-40: Station 5460, Class 9 Vehicles - Gross Vehicle Weight vs. Front Axle

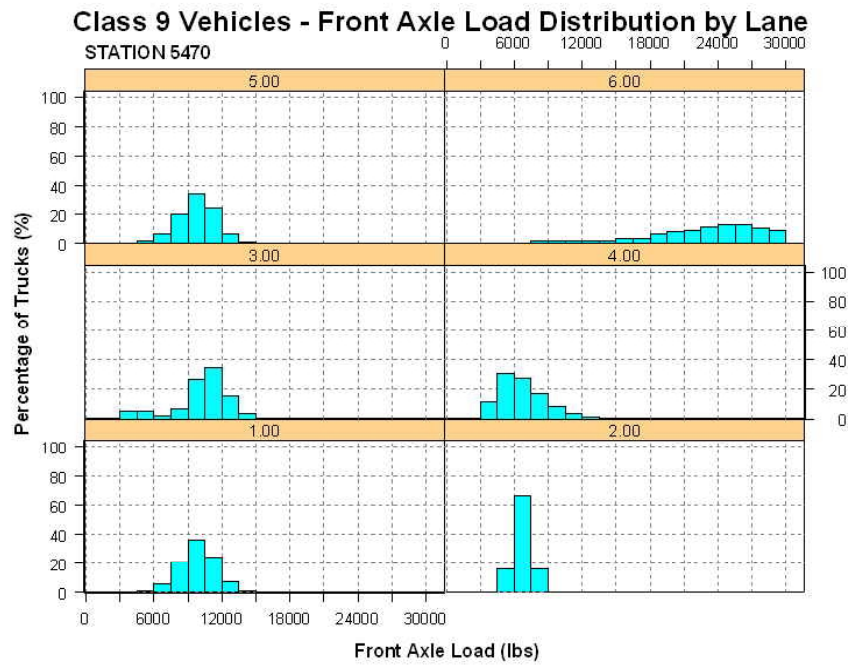

Figure F-41: Station 5470, Class 9 Vehicles - Front Axle Load Distribution

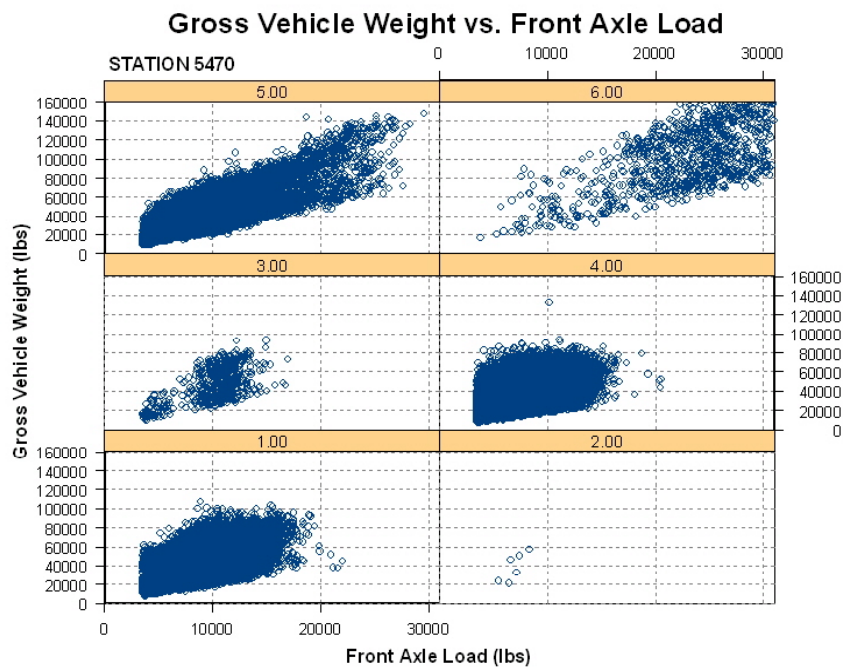

Figure F-42: Station 5470, Class 9 Vehicles - Gross Vehicle Weight vs. Front Axle

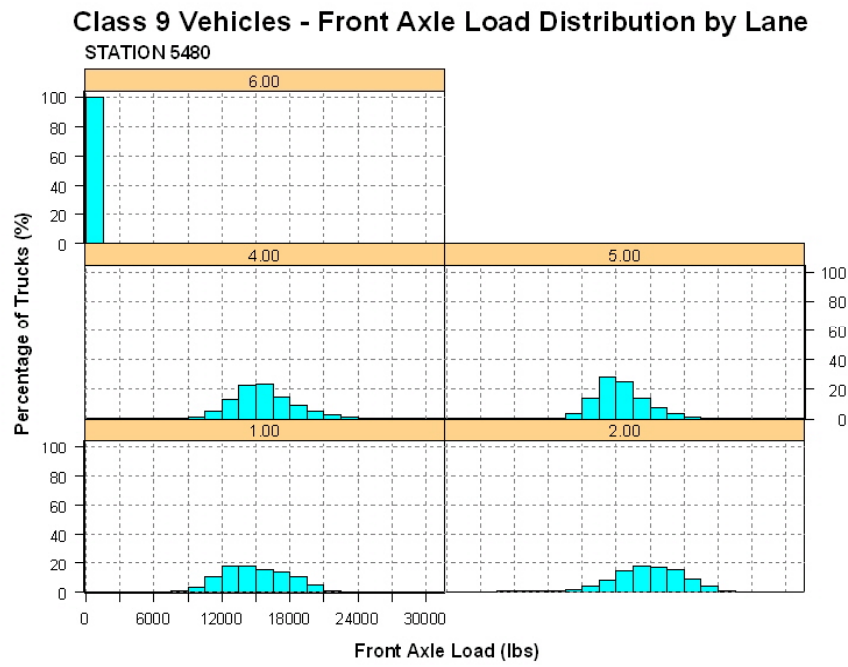

Figure F-43: Station 5480, Class 9 Vehicles - Front Axle Load Distribution

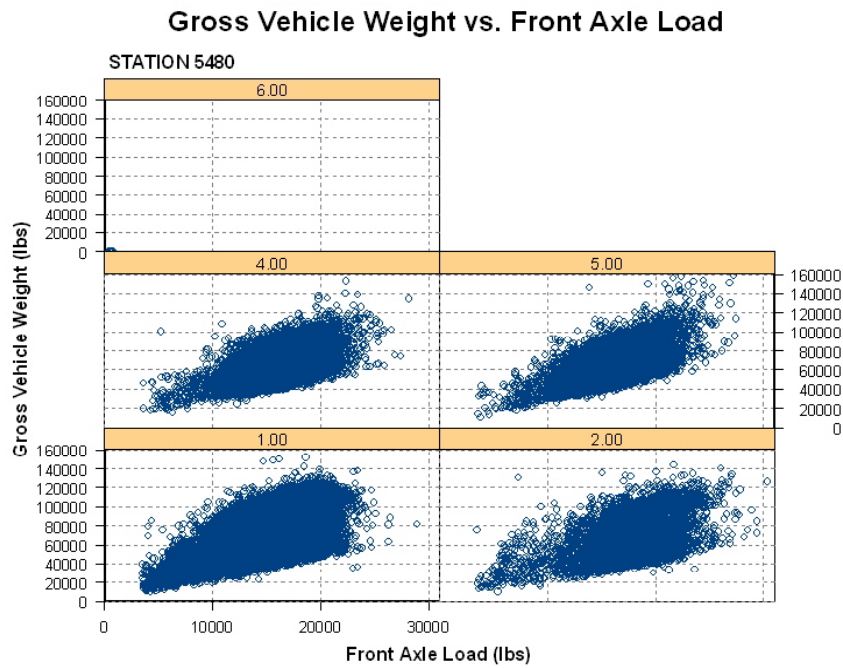

Figure F-44: Station 5480, Class 9 Vehicles - Gross Vehicle Weight vs. Front Axle

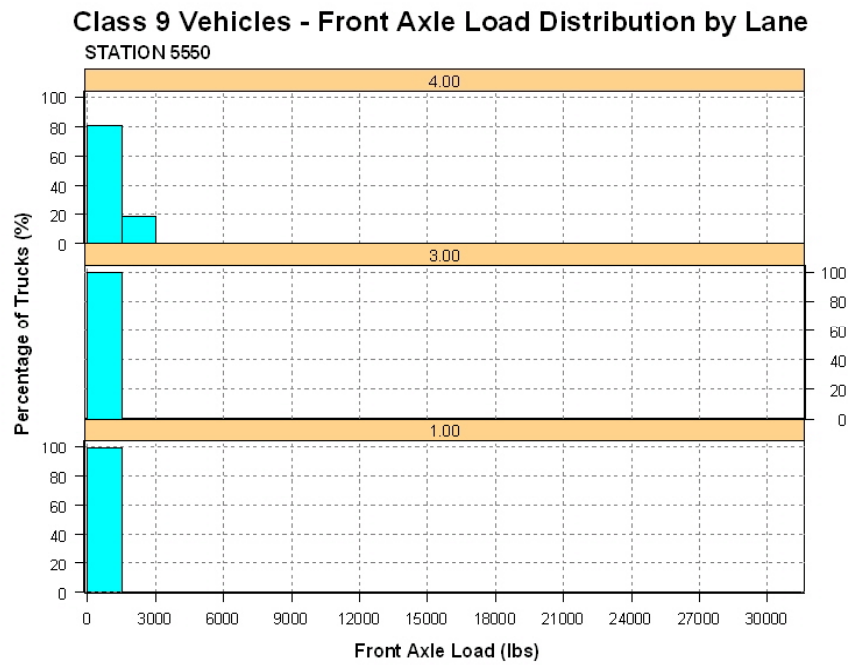

Figure F-45: Station 5550, Class 9 Vehicles - Front Axle Load Distribution

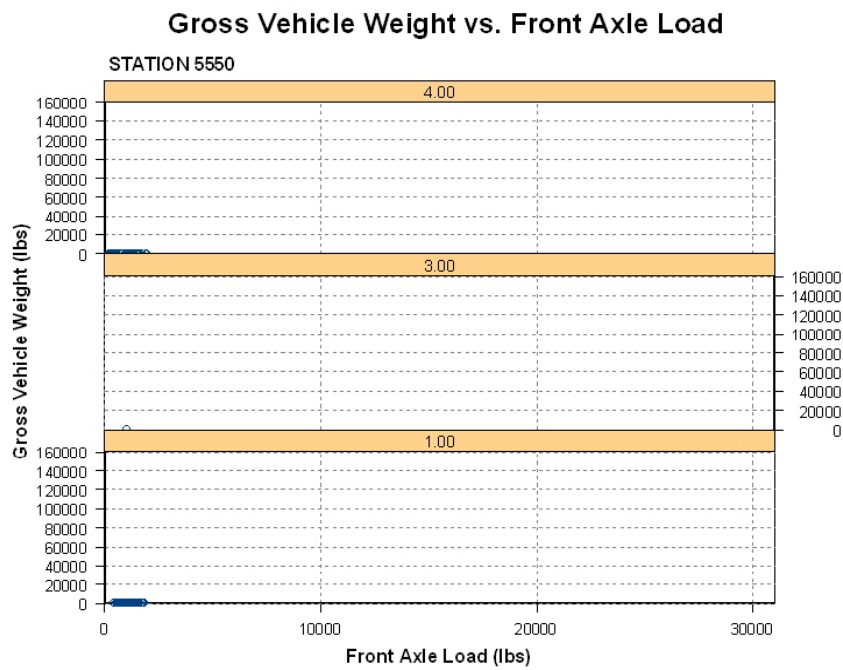

Figure F-46: Station 5550, Class 9 Vehicles - Gross Vehicle Weight vs. Front Axle

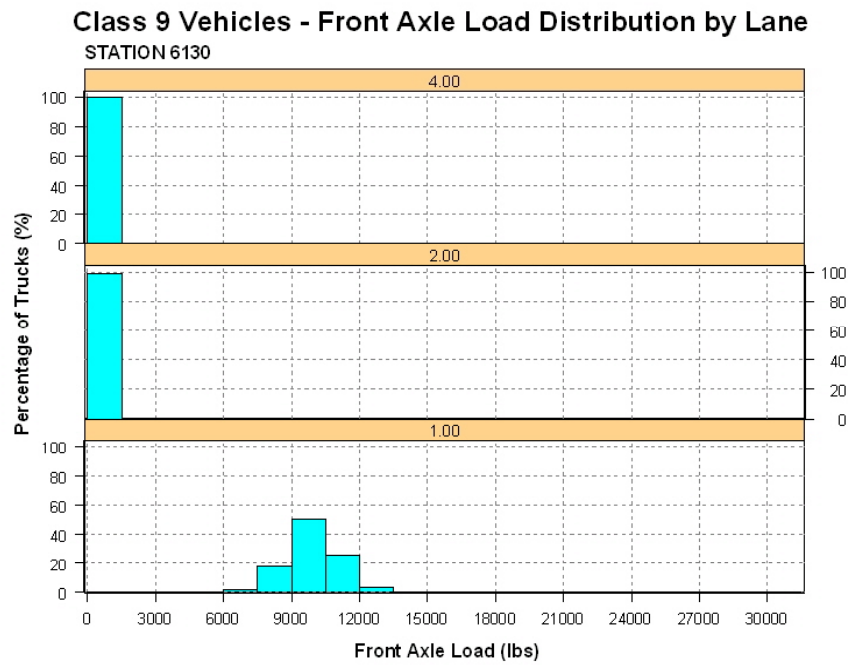

Figure F-47: Station 6130, Class 9 Vehicles - Front Axle Load Distribution

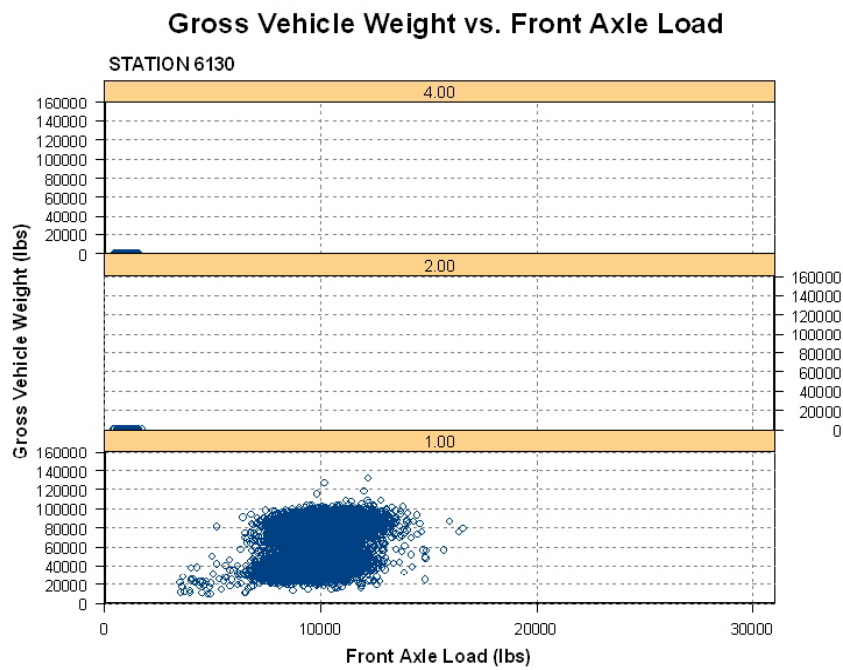

Figure F-48: Station 6130, Class 9 Vehicles - Gross Vehicle Weight vs. Front Axle

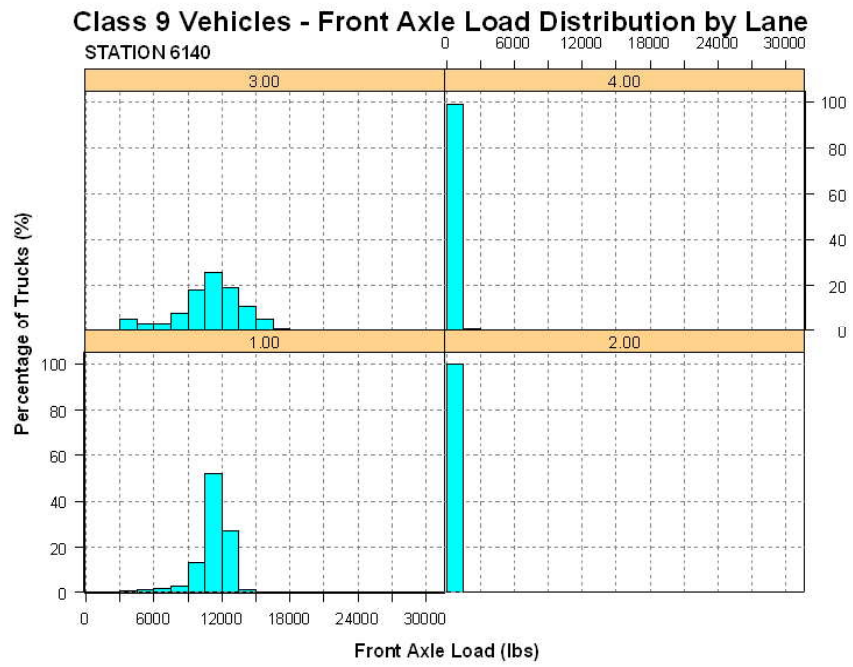

Figure F-49: Station 6140, Class 9 Vehicles - Front Axle Load Distribution

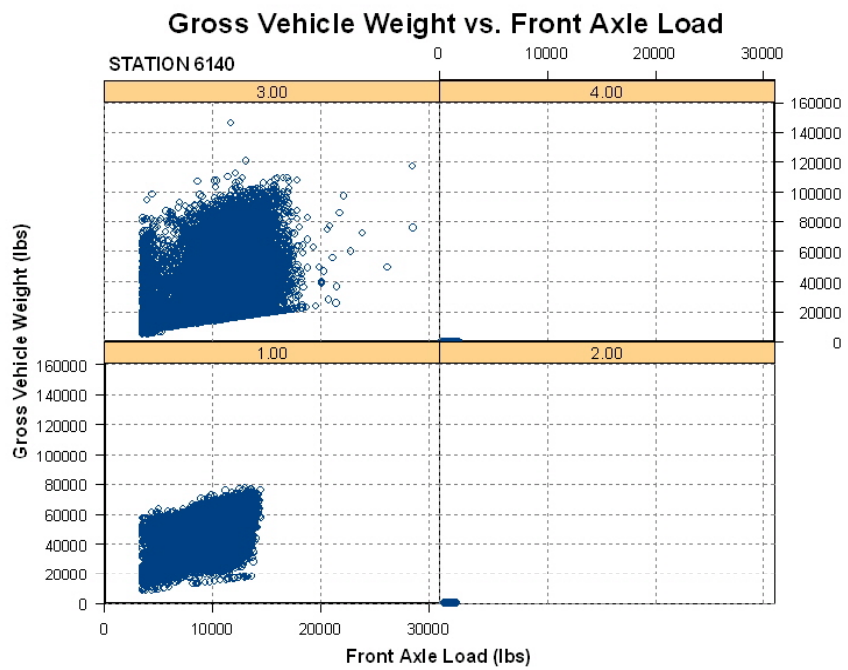

Figure F-50: Station 6140, Class 9 Vehicles - Gross Vehicle Weight vs. Front Axle

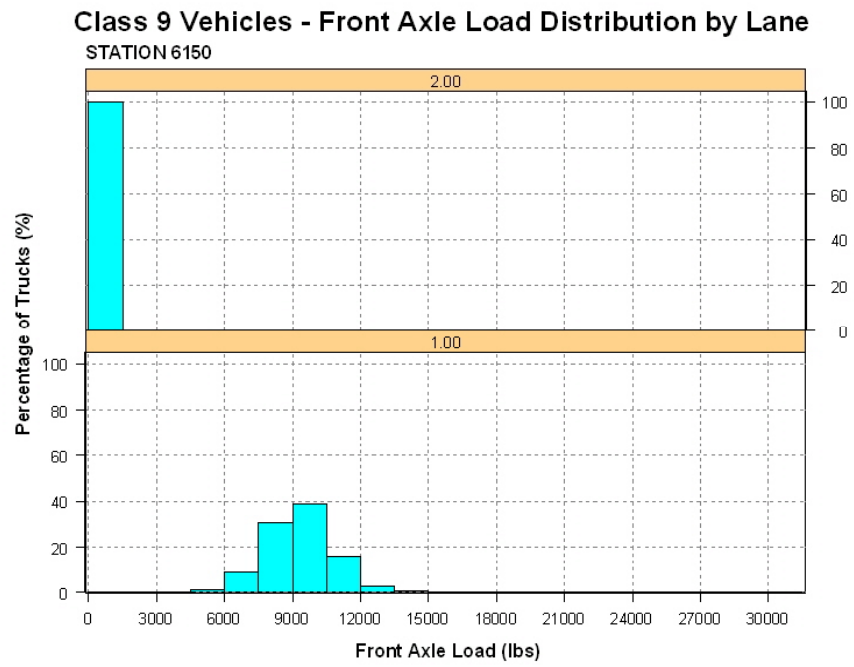

Figure F-51: Station 6150, Class 9 Vehicles - Front Axle Load Distribution

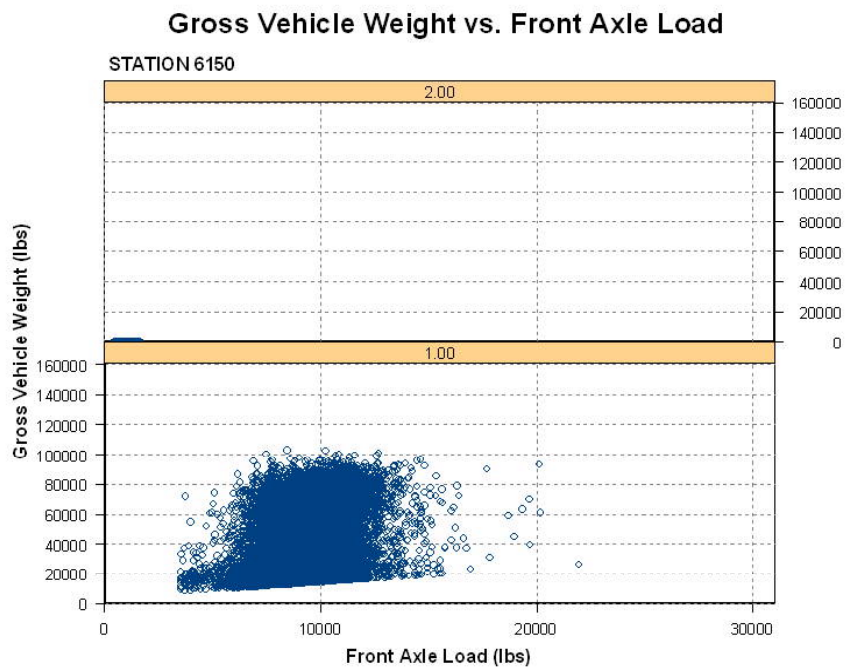

Figure F-52: Station 6150, Class 9 Vehicles - Gross Vehicle Weight vs. Front Axle

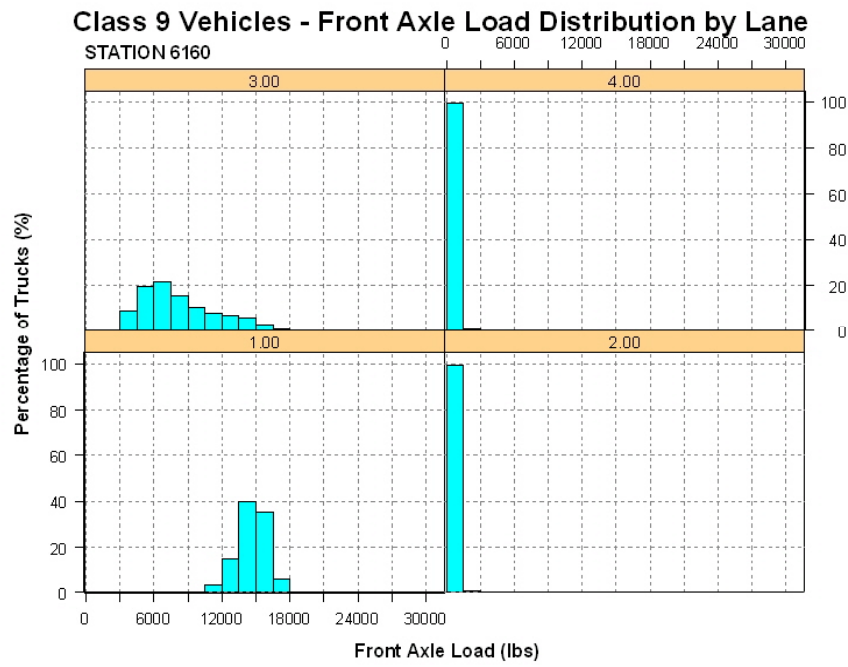

Figure F-53: Station 6160, Class 9 Vehicles - Front Axle Load Distribution

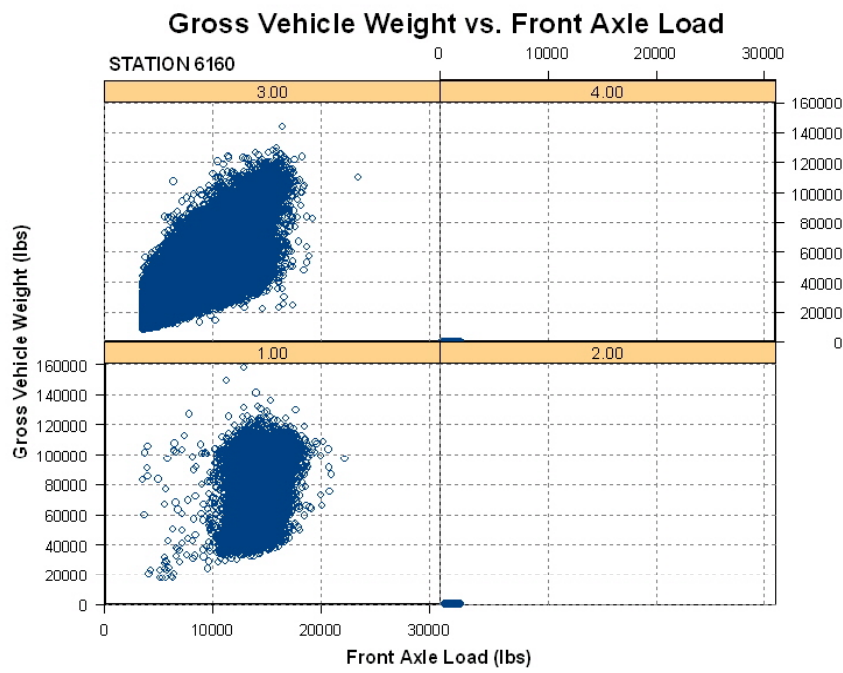

Figure F-54: Station 6160, Class 9 Vehicles - Gross Vehicle Weight vs. Front Axle

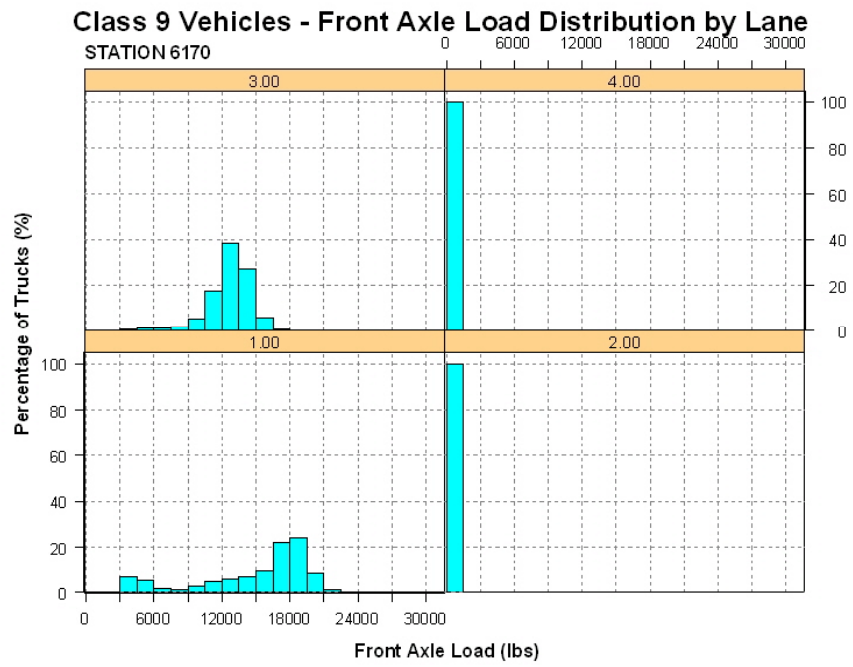

Figure F-55: Station 6170, Class 9 Vehicles - Front Axle Load Distribution

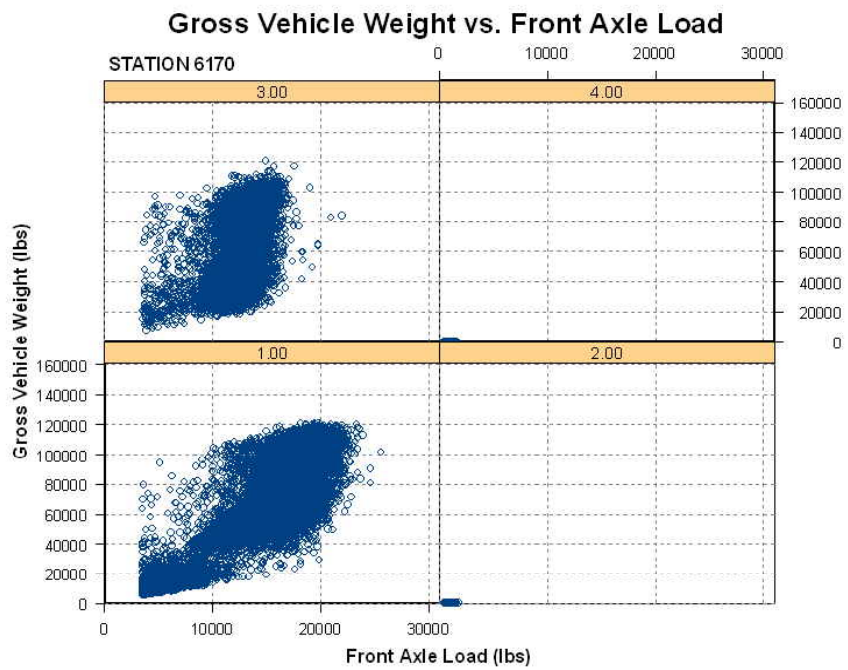

Figure F-56: Station 6170, Class 9 Vehicles - Gross Vehicle Weight vs. Front Axle

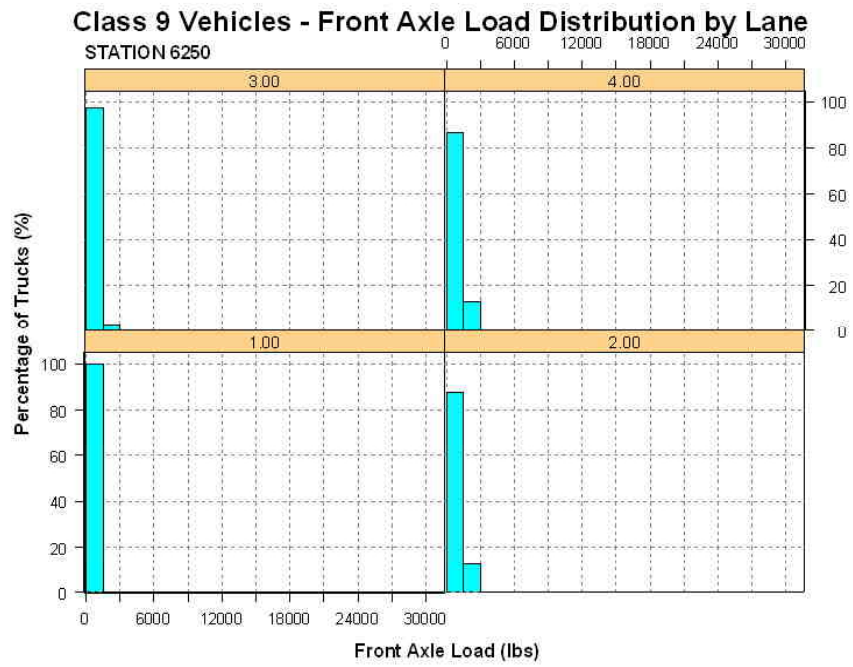

Figure F-57: Station 6250, Class 9 Vehicles - Front Axle Load Distribution

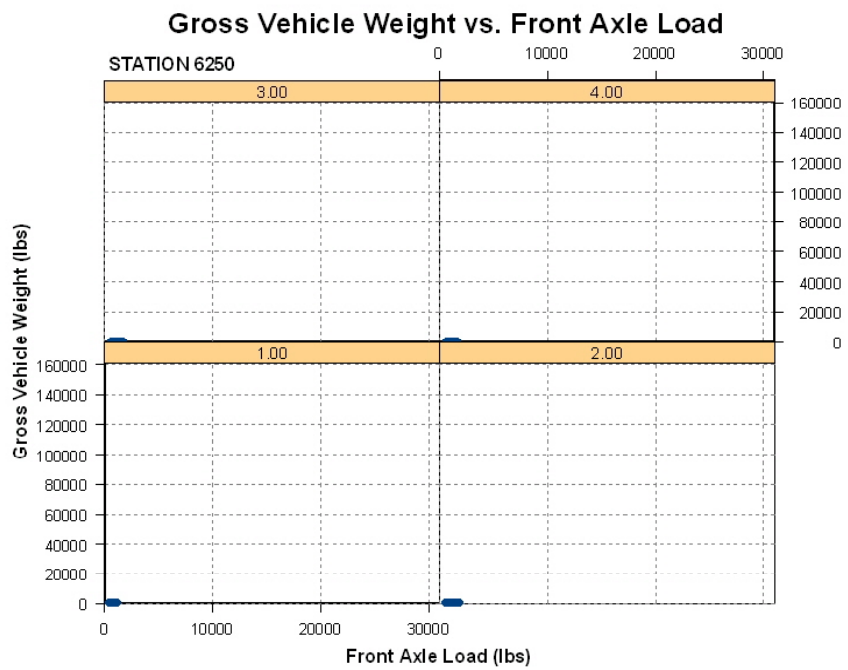

Figure F-58: Station 6250, Class 9 Vehicles - Gross Vehicle Weight vs. Front Axle

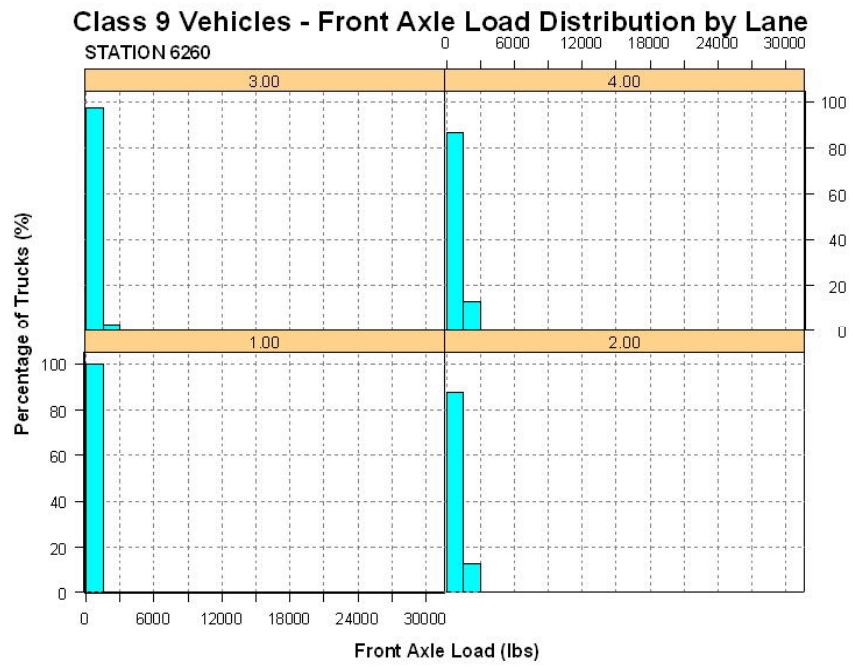

Figure F-59: Station 6260, Class 9 Vehicles - Front Axle Load Distribution

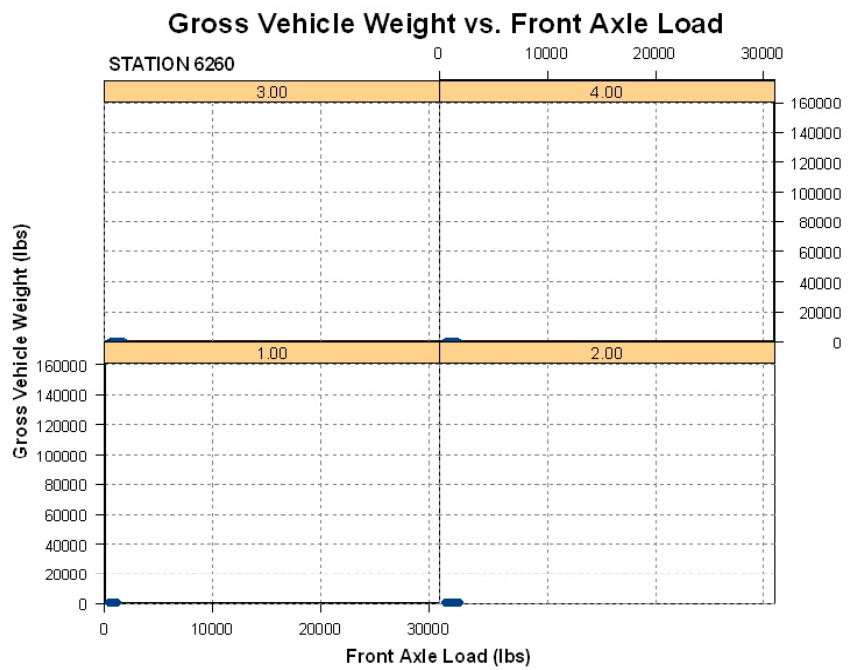

Figure F-60: Station 6260, Class 9 Vehicles - Gross Vehicle Weight vs. Front Axle

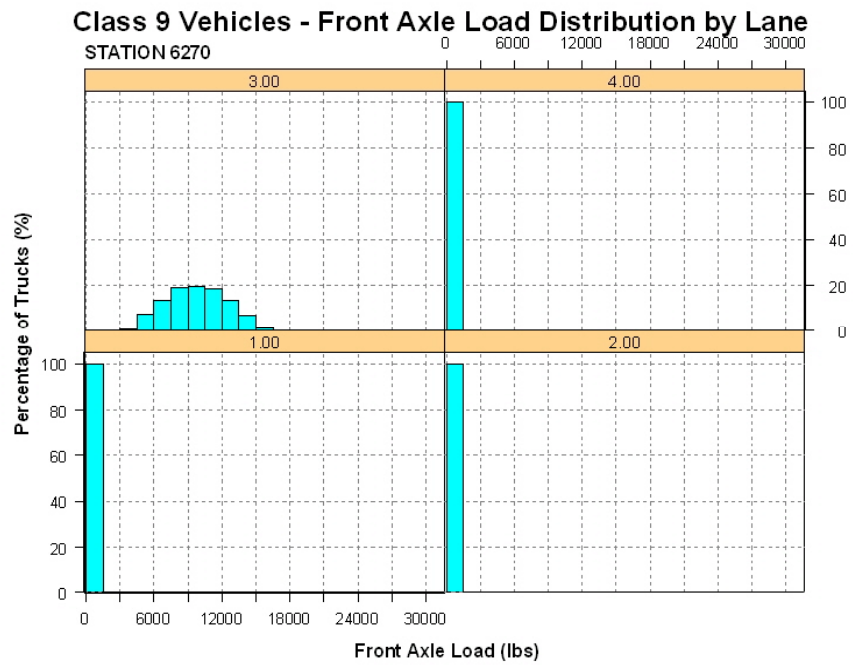

Figure F-61: Station 6270, Class 9 Vehicles - Front Axle Load Distribution

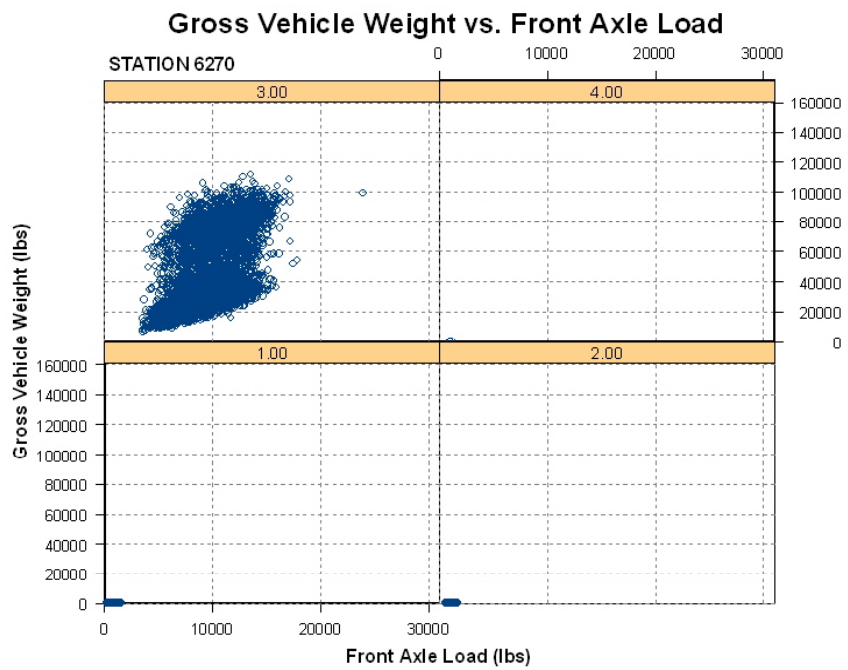

Figure F-62: Station 6270, Class 9 Vehicles - Gross Vehicle Weight vs. Front Axle

Class 9 Vehicles - Front Axle Load Distribution by Lane
STATION 6280

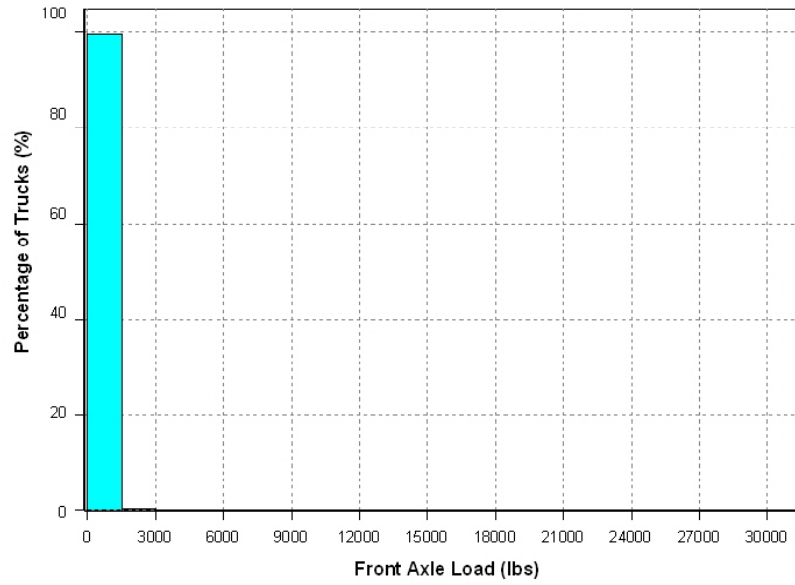

Figure F-63: Station 6280, Class 9 Vehicles - Front Axle Load Distribution

Gross Vehicle Weight vs. Front Axle Load

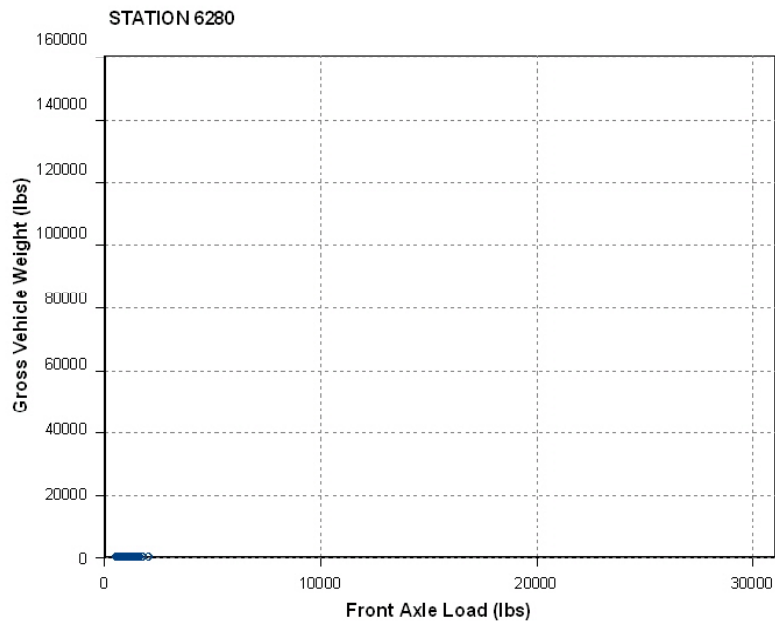

Figure F-64: Station 6280, Class 9 Vehicles - Gross Vehicle Weight vs. Front Axle

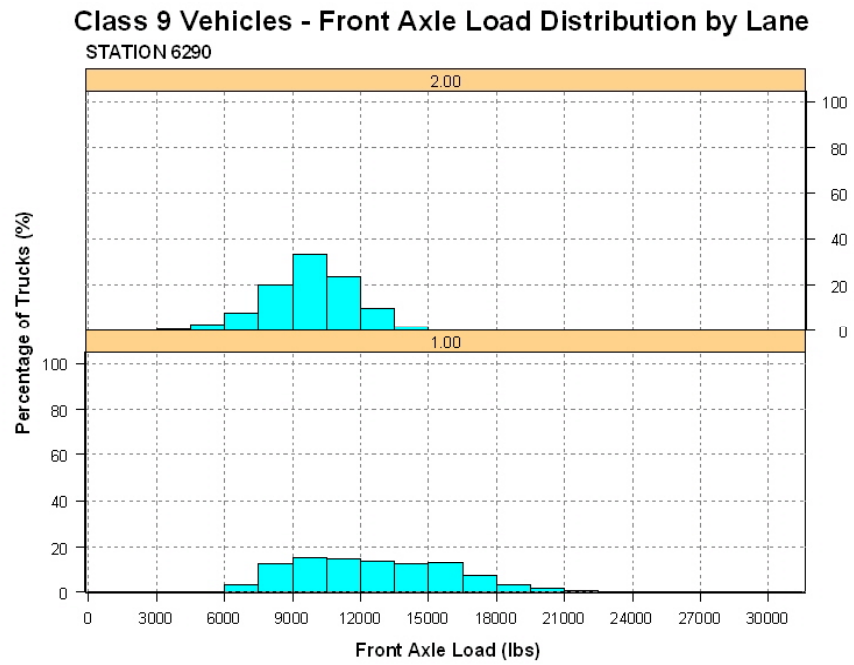

Figure F-65: Station 6290, Class 9 Vehicles - Front Axle Load Distribution

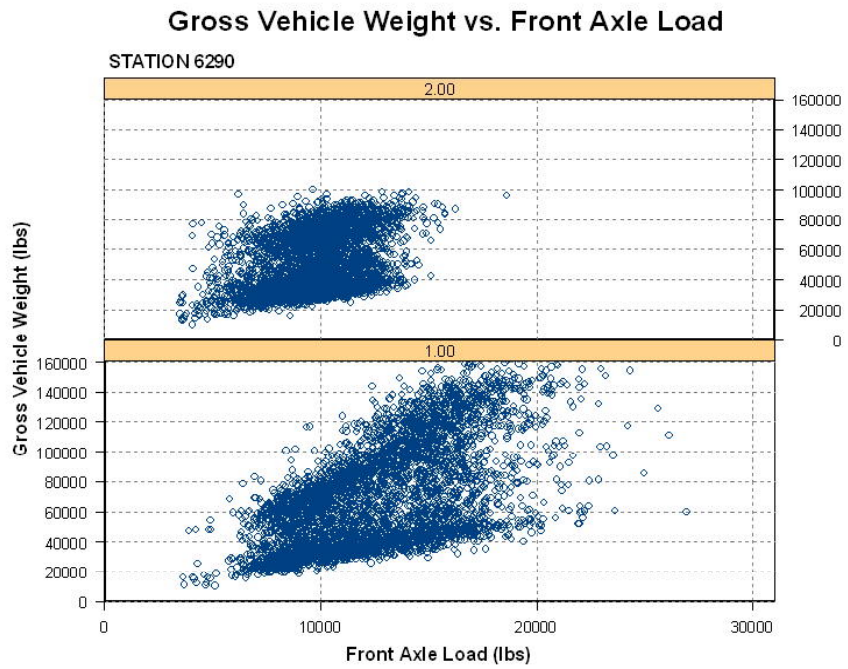

Figure F-66: Station 6290, Class 9 Vehicles - Gross Vehicle Weight vs. Front Axle

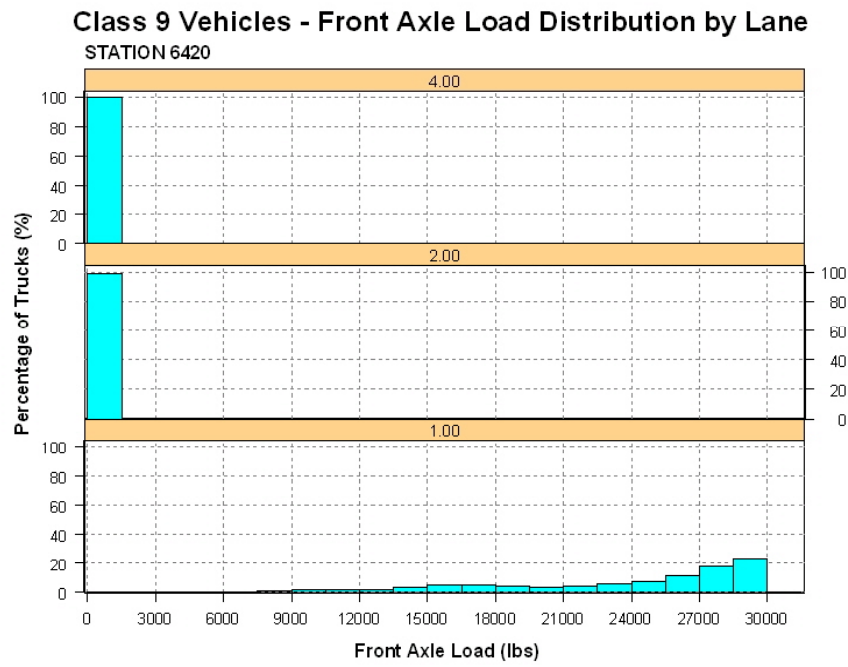

Figure F-67: Station 6420, Class 9 Vehicles - Front Axle Load Distribution

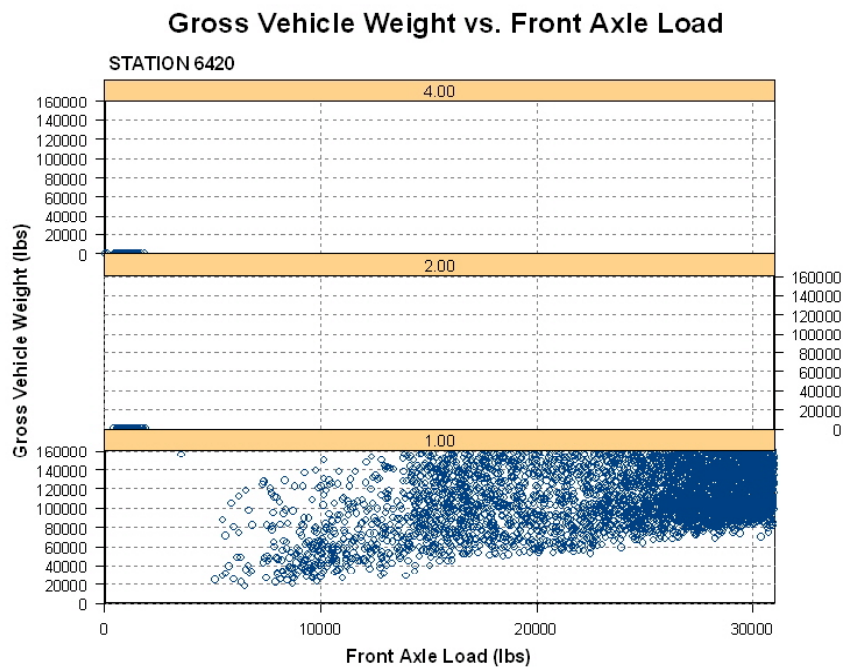

Figure F-68: Station 6420, Class 9 Vehicles - Gross Vehicle Weight vs. Front Axle

Appendix G Merrillville WIM Test 3-23-01

3/23/01
Station #4410
NB

Record	Time	Lane		Axle 1	Axle 2	Axle 3	Axle 4	Axle 5	GVW	% Error
8679	7:32 AM	2	WIM	11.2	14.4	13.9	16.5	15.2	71.2	
			Portable	11.6	15.2	14.8	14.9	16.0	72.5	
									-1.3	-1.79%
10093	8:15 AM	1	WIM	11.8	16.4	16.8	15.5	14.9	75.4	
			Portable	11.9	16.8	16.0	15.8	15.5	76.0	
									-0.6	-0.79%
11130	8:46 AM	1	WIM	11.1	16.8	16.9	16.6	19.4	80.8	
			Portable	10.2	16.3	16.8	16.5	16.4	76.2	
									4.6	6.04%
12132	9:18 AM	1	WIM	12.5	16.6	16.5	15.5	16.7	77.8	
			Portable	12.2	15.9	16.3	14.0	17.0	75.4	
									2.4	3.18%
13522	10:06 AM	1	WIM	12.5	15.4	15.7	15.3	20.3	79.2	
			Portable	12.7	15.8	16.3	14.7	17.7	77.2	
									2.0	2.59%
15038	10:54 AM	3	WIM	12.6	17.3	16.2	16.7	16.7	79.6	
			Portable	12.2	16.2	16.6	15.4	17.0	77.3	
									2.3	3.04%
16548	11:42 AM	1	WIM	10.4	17.8	17.2	19.5	19.2	84.0	
			Portable	11.1	14.4	14.6	18.2	17.2	75.4	
									8.7	11.48%
17419	12:08 PM	2	WIM	11.1	15.5	15.6	16.7	16.7	75.7	
			Portable	11.5	16.3	16.1	17.7	16.5	78.1	
									-2.3	-3.01%
18261	12:33 PM	1	WIM	9.2	23.9	22.5	22.1	19.5	97.2	
			Portable	9.0	19.1	19.6	20.7	16.5	84.8	
									12.5	14.69%

Table G-1: WIM #4410 Comparison to Portable Scales Test Results, 3-23-01

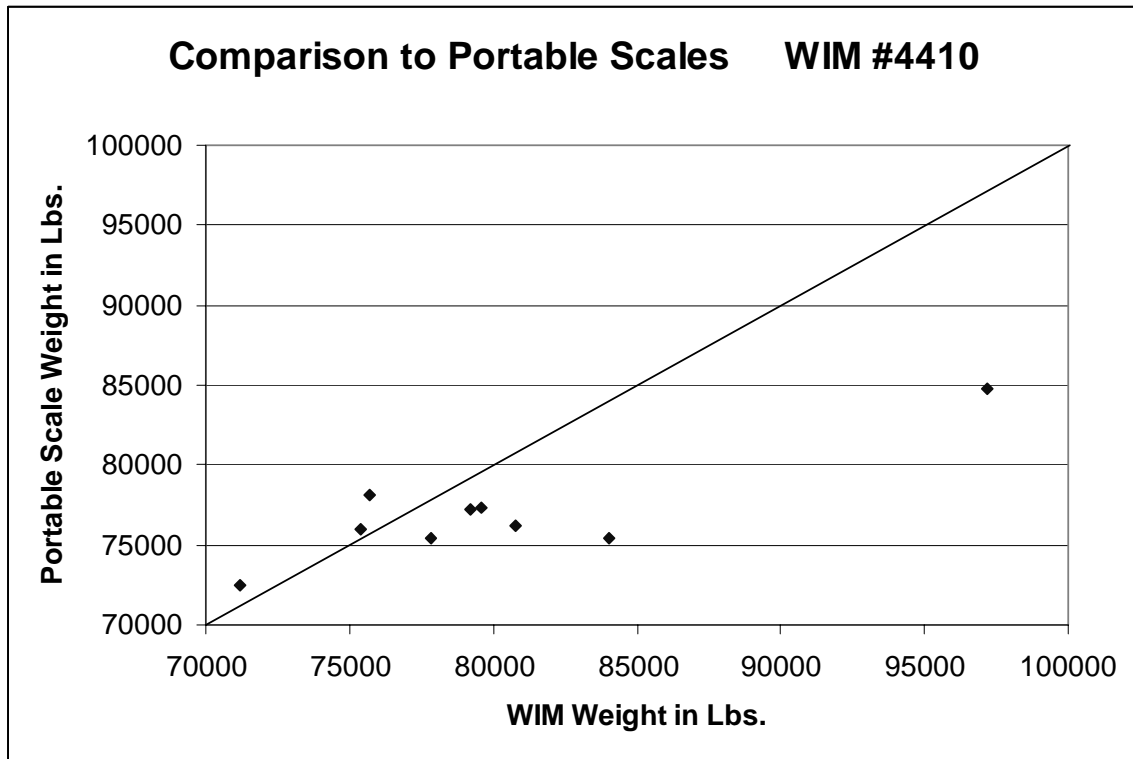

Figure G-1: WIM #4410 Comparison to Portable Scales Test Results, 3-23-01

Appendix H Assessment of WIM Accuracy and Precision

STE	Lane	Mar-01			Jun-00			Front Axle Load	Vehicle Count
		Front Axle Load (lbs)		Vehicle Count	Front Axle Load (lbs)		Vehicle Count	2000-2001 %change	%change
		Mean	StdDev		Mean	StdDev			
4110	3	33,689	5,256	15,359	37,733	5,803	63,524	-11%	-76%
4260	1	16,702	5,759	20,048	697	126	20,599	2296%	-3%
5480	2	16,004	3,641	4,581	17,618	3,742	5,103	-9%	-10%
6140	3	14,710	2,672	34,753	10,943	2,939	18,125	34%	92%
4150	1	14,262	1,634	71,305	12,036	1,235	60,581	18%	18%
6160	1	14,184	1,831	54,036	14,630	1,376	23,011	-3%	135%
5560	3	13,552	6,341	8,412	1,034		1	1211%	841100%
5560	1	13,315	6,572	8,252	1,039	188	6,951	1157%	19%
6270	3	13,132	2,040	9,069	9,765	2,606	5,010	35%	81%
5480	4	12,739	4,050	5,639	15,507	2,854	8,570	-18%	-34%
6290	1	12,648	3,636	8,602	12,626	3,452	4,510	0%	91%
5440	3	12,179	2,063	95,105	10,550	1,450	79,340	15%	20%
5120	2	12,002	1,702	9,353	12,816	1,436	14,418	-6%	-35%
6280	1	11,677	1,711	8			0		
4400	1	11,609	4,546	153,922					
4150	2	11,350	1,462	6,574	10,174	1,938	5,881	12%	12%
4130	3	11,241	4,423	227	15,436	4,339	229	-27%	-1%
4400	2	11,135	5,714	62,392					
5470	6	11,025	3,445	962	23,876	6,038	1,087	-54%	-12%
7340	4	10,975	3,147	5,097					
4400	5	10,928	2,657	175,245					
4250	3	10,915	1,261	3,863	10,867	1,186	3,733	0%	4%
5450	3	10,869	2,612	116,942	13,189	3,035	104,500	-18%	12%
4150	3	10,693	1,235	62,193	9,586	1,336	60,064	12%	4%
4130	6	10,517	4,149	459	14,007	4,260	388	-25%	16%
4150	4	10,498	1,377	7,211	10,669	1,623	6,286	-2%	15%
4400	4	10,492	2,621	164,704					
4280	1	10,486	1,286	8,743	8,794	998	13,513	19%	-35%
5120	4	10,461	1,474	9,799	10,850	6,234	146	-4%	6521%
5470	3	10,442	2,854	496	10,280	2,484	544	2%	-9%
4270	1	10,419	1,749	11,799	8,540	1,430	9,423	22%	25%
4130	2	10,401	1,016	10,640	10,305	964	41,091	1%	-74%
7300	4	10,338	2,249	11,982					

Table H-1: Average Class 9 Front Axle Weight for All WIM Lanes, Sorted by Front Axle Weight (33,689-10,398)

SITE	Lane	Mar-01			Jun-00			Front Axle 2000-2001 % change	Vehicle % change
		Front Axle Load (lbs)		Vehicle Count	Front Axle Load		Vehicle Count		
		Mean	StdDev		Mean	StdDev			
5110	4	10,285	882	22,418	17,109	2,045	22,565	-40%	-1%
7340	3	10,170	2,435	38,795					
7300	3	10,139	1,915	108,307					
7320	2	10,126	2,244	13,202					
5140	3	10,108	1,967	29,827	11,307	1,867	130,393	-11%	-77%
6150	1	10,047	5,609	19,801	9,315	1,519	19,216	8%	3%
7320	3	10,030	2,844	98,022					
7300	2	10,026	2,396	11,612					
4400	6	10,023	2,563	963					
7340	2	9,938	2,149	3,567					
7300	1	9,909	4,169	96,923					
7320	1	9,858	2,440	103,988					
7340	1	9,846	2,446	43,214					
5470	5	9,837	1,686	56,871	9,982	2,299	53,099	-2%	7%
5240	1	9,826	1,716	18,437	13,143	2,191	16,875	-25%	9%
5140	1	9,822	1,613	31,483	11,654	2,329	138,734	-16%	-77%
5470	1	9,685	1,657	91,327	9,849	1,763	80,961	-2%	13%
5470	4	9,651	2,746	89,824	6,720	2,012	78,858	44%	14%
4130	1	9,626	1,127	2,859	9,958	2,049	89,487	-3%	-97%
6170	1	9,561	3,894	38,425	15,031	4,905	29,667	-36%	30%
4140	1	9,548	1,038	2	9,219	3,642	45,343	4%	-100%
7320	4	9,539	5,497	11,569					
5250	1	9,517	1,300	9,434	8,031	1,501	2,148	19%	339%
5450	1	9,421	2,357	98,597	11,816	6,300	50,021	-20%	97%
6160	3	9,419	3,508	45,576	8,265	3,221	25,878	14%	76%
5550	2	9,213	4,440	763			0		
6170	3	9,022	1,572	26,349	12,663	2,002	8,889	-29%	196%
5110	2	8,803	1,087	23,747	9,450	1,100	18,382	-7%	29%
5110	3	8,771	931	116,346	10,599	1,102	130,871	-17%	-11%
5550	4	8,716	5,373	200	967	527	53	801%	277%
6290	2	8,700	4,067	6,604	9,809	1,891	4,190	-11%	58%
5480	1	8,533	3,016	19,092	14,921	3,104	34,134	-43%	-44%
5110	1	8,406	1,444	128,723	10,565	1,996	131,252	-20%	-2%
4110	1	8,245	2,105	17,046	10,742	2,680	106,734	-40%	-1%
4130	4	7,581	2,270	29,648	5,465	2,317	1,351		
5120	3	7,361	4,036	77,728	10,057	1,387	18,170		
6250	1	7,200	983	5,619	764	134	7,861		

Table H-2: Average Class 9 Front Axle Weight for All WIM Lanes, Sorted by Front Axle Weight (10,285-7,200)

SITE	Lane	Mar-01			Jun-00			Front Axle Load 2000-2001 % change	Vehicle Count % change
		Front Axle Load (lbs)		Vehicle Count	Front Axle Load (lbs)		Vehicle Count		
		Mean	StdDev		Mean	StdDev			
4400	3	6,310	1,722	24					
6140	1	5,783	1,774	51,296	11,184	1,564	43,679	-48% 17%	
5460	1	5,657	2,307	3	9,608	2,401	25,704	-41% -100%	
5470	2	5,563	3,053	6	6,926	973	6	-20% 0%	
6250	4	1,272	211	508	1,272	206	654	0% -22%	
6250	2	1,259	203	849	1,260	209	770	0% 10%	
4280	4	1,202	258	22	1,138	188	566	6% -96%	
5120	1	1,200	208	10,203	1,086	185	58,264	11% -83%	
6140	4	1,177	172	2,388	1,173	182	2,346	0% 2%	
6160	4	1,153	174	6,730	1,148	179	7,181	0% -6%	
4280	2	1,147	191	941	1,139	183	789	1% 19%	
4260	4	1,138	227	968	1,138	211	1,217	0% -21%	
5140	4	1,137	162	6,960	1,139	166	27,282	0% -75%	
6160	2	1,134	168	5,587	1,139	170	5,517	0% 1%	
5140	2	1,132	160	3,642	1,137	156	20,005	0% -82%	
4260	2	1,119	204	1,988	1,115	200	2,303	0% -14%	
4140	4	1,112	162	8,320	1,263	180	4,482	-12% 86%	
6150	2	1,110	168	2,337	1,117	172	3,005	-1% -22%	
5440	4	1,105	140	29,102	1,105	147	29,568	0% -2%	
6250	3	1,102	244	5,709	1,136	198	7,359	-3% -22%	
4250	4	1,094	218	164	980	330	199	12% -18%	
6140	2	1,082	157	3,259	1,103	157	3,282	-2% -1%	
5240	2	1,078	187	973	1,107	192	1,070	-3% -9%	
4270	2	1,070	176	636	1,057	181	584	1% 9%	
5450	4	1,062	155	9			0		
4140	3	1,052	173	57,643	1,127	192	43,630	-7% 32%	
4270	4	1,049	186	192	1,064	187	460	-1% -58%	
4250	2	1,044	211	305	1,030	198	269	1% 13%	
4270	3	1,038	176	8,382	1,045	182	8,356	-1% 0%	
4250	1	1,033	205	3,902	1,041	200	1,850	-1% 111%	
6130	4	1,025	159	1,064	1,073	169	2,187	-5% -51%	
6130	2	1,003	157	650	1,106	187	1,517	-9% -57%	
5250	2	1,001	179	1,229	985	181	1,573	2% -22%	

Table H-3: Average Class 9 Axle Weight for All WIM Lanes, Sorted by Front Axle Weight (6,310-1,001)

SITE	Lane	Mar-01			Jun-00			Front Axle Load	Vehicle Count
		Front Axle Load (lbs)		Vehicle Count	Front Axle Load (lbs)		Vehicle Count	2000-2001 % change	% change
		Mean	StdDev		Mean	StdDev			
4140	2	986	145	8,530	1,048	152	5,534	-6%	54%
6170	2	962	157	3,244	994	168	4,639	-3%	-30%
5250	4	958	173	1,074	958	176	1,039	0%	3%
5260	2	935	175	607	932	262	647	0%	-6%
5260	1	928	171	6,097	1,012	183	5,935	-8%	3%
6170	4	916	168	2,637	983	175	3,631	-7%	-27%
5250	3	894	152	4,011	866	158	7,391	3%	-46%
4130	5	805	132	1,424	9,750	1,185	42,626	-92%	-97%
5480	3	766	150	144			0		
5460	6	695	149	678			0		
5480	6	676	150	254	657	109	32	3%	694%
5460	3	308	352	45	674	102	445	-54%	-90%

Table H-4: Average Class 9 Axle Weight for All WIM Lanes, Sorted by Front Axle Weight (986-308)

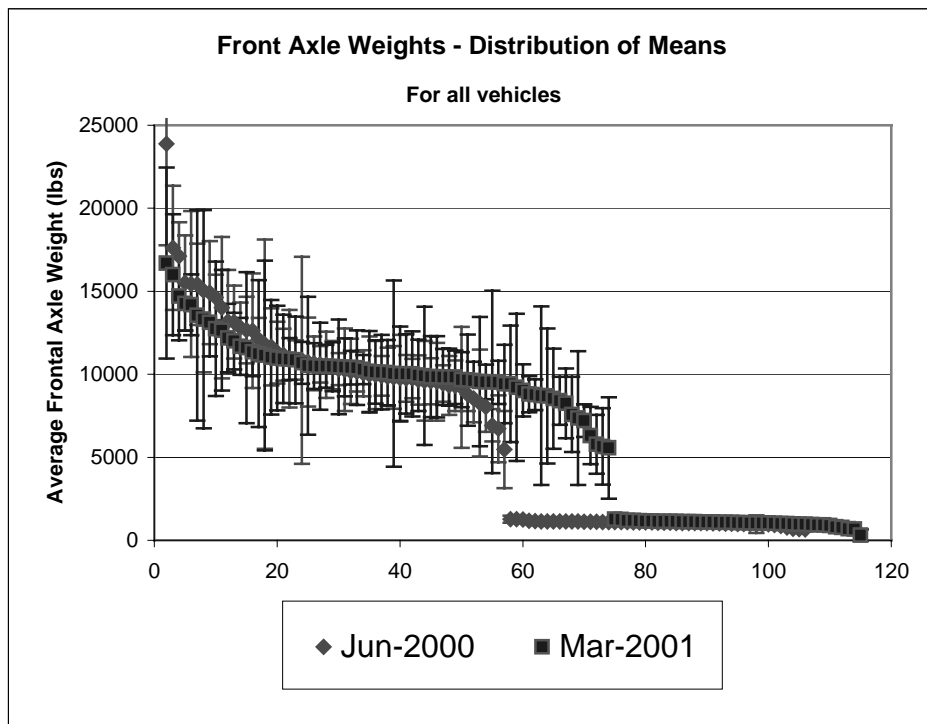

Figure H-1: Average Class 9 Front Axle Weight for All WIM Lanes

SITE	Lane	Mar-01			Jun-00			Front Axle Load	Vehicle Count
		Front Axle Load (lbs)		Vehicle Count	Front Axle Load (lbs)		Vehicle Count	2000-2001 % change	% change
		Mean	StdDev		Mean	StdDev			
4110	1	8,245	2,105	17,046	10,742	2,680	106,734	-23%	-84%
4110	3	33,689	5,256	15,359	37,733	5,803	63,524	-11%	-76%
4130	1	9,626	1,127	2,859	9,958	2,049	89,487	-3%	-97%
4130	2	10,401	1,016	10,640	10,305	964	41,091	1%	-74%
4130	3	11,241	4,423	227	15,436	4,399	229	-27%	-1%
4130	4	7,581	2,270	29,648	5,465	2,317	1,351	39%	2095%
4130	5	805	132	1,424	9,750	1,185	42,626	-92%	-97%
4130	6	10,517	4,149	459	14,007	4,260	395	-25%	16%
4140	1	9,548	1,038	2	9,219	3,642	45,343	4%	-100%
4140	2	986	145	8,530	1,048	152	5,534	-6%	54%
4140	3	1,052	173	57,643	1,127	192	43,630	-7%	32%
4140	4	1,112	162	8,320	1,263	180	4,482	-12%	86%
4150	1	14,262	1,634	71,305	12,096	1,295	60,581	18%	18%
4150	2	11,350	1,462	6,574	10,174	1,968	5,881	12%	12%
4150	3	10,693	1,265	62,198	9,586	1,386	60,064	12%	4%
4150	4	10,498	1,377	7,211	10,659	1,623	6,286	-2%	15%
4250	1	1,033	205	3,902	1,041	200	1,850	-1%	111%
4250	2	1,044	211	305	1,030	198	269	1%	13%
4250	3	10,915	1,261	3,863	10,867	1,186	3,733	0%	4%
4250	4	1,094	218	164	980	330	199	12%	-18%
4260	1	16,702	5,759	20,048	697	126	20,599	2296%	-3%
4260	2	1,119	204	1,988	1,115	200	2,303	0%	-14%
4260	4	1,138	227	968	1,138	211	1,217	0%	-21%
4270	1	10,419	1,749	11,799	8,540	1,430	9,423	22%	25%
4270	2	1,070	176	636	1,057	181	584	1%	9%
4270	3	1,038	176	8,382	1,045	182	8,356	-1%	0%
4270	4	1,049	186	192	1,064	187	460	-1%	-58%
4280	1	10,486	1,286	8,743	8,794	998	13,513	19%	-35%
4280	2	1,147	191	941	1,139	183	789	1%	19%
4280	4	1,202	258	22	1,138	188	566	6%	-96%

Table H-5: Average Class 9 Front Axle Weight for All WIM Lanes, Sorted by Number and Lane (4110-4280)

SITE	Lane	Mar-01			Jun-00			Front Axle 2000-2001 % change	Vehicle % change
		Front Axle Load (lbs)		Vehicle Count	Front Axle Load (lbs)		Vehicle Count		
		Mean	StdDev		Mean	StdDev			
4400	1	11,609	4,546	153,922					
4400	2	11,135	5,714	62,392					
4400	3	6,310	1,722	24					
4400	4	10,492	2,621	164,704					
4400	5	10,928	2,657	175,245					
4400	6	10,023	2,563	963					
5110	1	8,406	1,444	128,723	10,565	1,996	131,252	-20%	-2%
5110	2	8,803	1,087	23,747	9,450	1,100	18,382	-7%	29%
5110	3	8,771	931	116,346	10,599	1,102	130,871	-17%	-11%
5110	4	10,285	882	22,418	17,109	2,045	22,565	-40%	-1%
5120	1	1,200	208	10,203	1,086	185	58,264	11%	-83%
5120	2	12,002	1,702	9,353	12,816	1,496	14,418	-6%	-35%
5120	3	7,361	4,036	77,728	10,057	1,387	18,170	-27%	328%
5120	4	10,461	1,474	9,799	10,850	6,234	148	-4%	6521%
5140	1	9,822	1,613	31,483	11,654	2,329	138,734	-16%	-77%
5140	2	1,132	160	3,642	1,137	156	20,005	0%	-82%
5140	3	10,108	1,967	29,827	11,307	1,867	130,393	-11%	-77%
5140	4	1,137	162	6,960	1,139	166	27,282	0%	-75%
5240	1	9,826	1,716	18,437	13,143	2,191	16,875	-25%	9%
5240	2	1,078	187	973	1,107	192	1,070	-3%	-9%
5250	1	9,517	1,300	9,434	8,031	1,501	2,148	19%	339%
5250	2	1,001	179	1,229	985	181	1,573	2%	-22%
5250	3	894	152	4,011	866	158	7,391	3%	-46%
5250	4	958	173	1,074	958	176	1,039	0%	3%
5260	1	928	171	6,097	1,012	183	5,935	-8%	3%
5260	2	935	175	607	932	262	647	0%	-6%
5440	3	12,179	2,063	95,105	10,550	1,450	79,340	15%	20%
5440	4	1,105	140	29,102	1,105	147	29,568	0%	-2%
5450	1	9,421	2,357	98,597	11,816	6,300	50,021	-20%	97%
5450	3	10,869	2,612	116,942	13,189	3,095	104,500	-18%	12%
5450	4	1,062	155	9					
5460	1	5,657	2,307	3	9,608	2,401	25,704	-41%	-100%
5460	3	308	352	45	674	102	445	-54%	-90%
5460	6	695	149	678					

Table H-6: Average Class 9 Front Axle Weight for All WIM Lanes, Sorted by Number and Lane (4400-5460)

SITE	Lane	Mar-01			Jun-00			Front Axle Load	Vehicle Count
		Front Axle Load (lbs)		Vehicle Count	Front Axle Load (lbs)		Vehicle Count	2000-2001 % change	% change
		Mean	StdDev		Mean	StdDev			
5470	1	9,685	1,657	91,327	9,849	1,763	80,961	-2%	13%
5470	2	5,563	3,053	6	6,926	973	6	-20%	0%
5470	3	10,442	2,854	496	10,280	2,484	544	2%	-9%
5470	4	9,651	2,746	89,824	6,720	2,012	78,858	44%	14%
5470	5	9,837	1,686	56,871	9,982	2,299	53,099	-2%	7%
5470	6	11,025	3,445	962	23,876	6,098	1,087	-54%	-12%
5480	1	8,533	3,016	19,092	14,921	3,104	34,134	-43%	-44%
5480	2	16,004	3,641	4,581	17,618	3,742	5,103	-9%	-10%
5480	3	766	150	144					
5480	4	12,739	4,050	5,639	15,507	2,854	8,570	-18%	-34%
5480	6	676	150	254	657	109	32	3%	694%
5550	1	13,315	6,572	8,252	1,059	188	6,951	1157%	19%
5550	2	9,213	4,440	763					
5550	3	13,552	6,341	8,412	1,034		1	1211%	841100%
5550	4	8,716	5,373	200	967	527	53	801%	277%
6130	2	1,003	157	650	1,106	187	1,517	-9%	-57%
6130	4	1,025	159	1,064	1,073	169	2,187	-5%	-51%
6140	1	5,783	1,774	51,296	11,184	1,564	43,679	-48%	17%
6140	2	1,082	157	3,259	1,103	157	3,282	-2%	-1%
6140	3	14,710	2,672	34,753	10,943	2,939	18,125	34%	92%
6140	4	1,177	172	2,388	1,173	182	2,346	0%	2%
6150	1	10,047	5,609	19,801	9,315	1,519	19,216	8%	3%
6150	2	1,110	168	2,337	1,117	172	3,005	-1%	-22%
6160	1	14,184	1,831	54,036	14,630	1,376	23,011	-3%	135%
6160	2	1,134	168	5,587	1,139	170	5,517	0%	1%
6160	3	9,419	3,508	45,576	8,265	3,221	25,878	14%	76%
6160	4	1,153	174	6,730	1,148	179	7,181	0%	-6%
6170	1	9,561	3,894	38,425	15,031	4,905	29,667	-36%	30%
6170	2	962	157	3,244	994	168	4,639	-3%	-30%
6170	3	9,022	1,572	26,349	12,663	2,002	8,889	-29%	196%
6170	4	916	168	2,637	983	175	3,631	-7%	-27%
6250	1	7,200	983	5,619	764	134	7,861	842%	-29%
6250	2	1,259	203	849	1,260	209	770	0%	10%
6250	3	1,102	244	5,709	1,136	198	7,359	-3%	-22%
6250	4	1,272	211	508	1,272	206	654	0%	-22%

Table H-7: Average Class 9 Front Axle Weight for All WIM Lanes, Sorted by Number and Lane (5470-6250)

SITE	Lane	Mar-01			Jun-00			Front Axle Load	Vehicle Count
		Front Axle Load (lbs)		Vehicle Count	Front Axle Load (lbs)		Vehicle Count	2000-2001 % change	% change
		Mean	StdDev		Mean	StdDev			
6270	3	13,132	2,040	9,069	9,765	2,606	5,010	35%	81%
6280	1	11,677	1,711	8					
6290	1	12,648	3,636	8,602	12,626	3,452	4,510	0%	91%
6290	2	8,700	4,067	6,604	9,809	1,891	4,190	-11%	58%
7300	1	9,909	4,169	96,923					
7300	2	10,026	2,396	11,612					
7300	3	10,139	1,915	108,307					
7300	4	10,398	2,249	11,982					
7320	1	9,858	2,440	103,988					
7320	2	10,126	2,244	13,202					
7320	3	10,030	2,844	98,022					
7320	4	9,539	5,497	11,569					
7340	1	9,846	2,446	43,214					
7340	2	9,938	2,149	3,567					
7340	3	10,170	2,435	38,795					
7340	4	10,975	3,147	5,097					

Table H-8: Average Class 9 Front Axle Weight for All WIM Lanes, Sorted by Number and Lane (6270-7340)

SITE	Lane	Mar-01			Jun-00			Front Axle Load	Vehicle Count
		Front Axle Load (lbs)		Vehicle Count	Front Axle Load (lbs)		Vehicle Count	2000-2001 % change	% change
		Mean	StdDev		Mean	StdDev			
4110	1	7,596	1,922	7,323	9,672	2,458	32,451	-22%	-77%
4110	3	6,199		1	7,879	617	2	-21%	-50%
4130	1	9,133	1,166	636	9,382	2,174	13,005	-3%	-95%
4130	2	8,486	2,071	209	8,428	1,744	1,307	1%	-84%
4130	3	6,437	2,441	51	7,126	2,188	16	-10%	219%
4130	4	6,521	1,764	14,441	4,452	1,425	1,050	47%	1275%
4130	5	805	132	1,424	8,780	1,076	8,413	-91%	-83%
4130	6	6,761	2,145	167	7,267	2,896	59	-7%	183%
4140	1	8,814		1	7,089	2,842	21,151	24%	-100%
4140	2	986	145	8,530	1,048	152	5,534	-6%	54%
4140	3	1,052	173	57,643	1,127	192	43,630	-7%	32%
4140	4	1,112	162	8,320	1,263	180	4,482	-12%	86%
4150	1	10,663	3,142	746	10,944	1,789	6,432	-3%	-88%
4150	2	9,529	2,200	530	9,367	2,497	1,322	2%	-60%
4150	3	9,831	1,378	12,468	8,808	1,349	17,785	12%	-30%
4150	4	8,726	1,961	463	9,391	1,708	635	-7%	-27%
4250	1	1,033	205	3,902	1,041	200	1,850	-1%	111%
4250	2	1,044	211	305	1,030	198	269	1%	13%
4250	3	8,243	1,893	93	8,063	1,991	80	2%	16%
4250	4	1,094	218	164	980	330	199	12%	-18%
4260	1	9,548	1,727	1,954	697	126	20,599	1270%	-91%
4260	2	1,119	204	1,988	1,115	200	2,303	0%	-14%
4260	4	1,138	227	968	1,138	211	1,217	0%	-21%
4270	1	8,952	1,161	1,660	7,900	1,116	3,345	13%	-50%
4270	2	1,070	176	636	1,057	181	584	1%	9%
4270	3	1,038	176	8,382	1,045	182	8,356	-1%	0%
4270	4	1,049	186	192	1,064	187	460	-1%	-58%
4280	1	9,361	1,138	1,159	8,208	998	3,649	14%	-68%
4280	2	1,147	191	941	1,139	183	789	1%	19%
4280	4	1,202	258	22	1,138	188	566	6%	-96%
4400	1	6,379	1,504	13,013					
4400	2	6,637	2,420	10,952					
4400	3	6,016	1,617	17					
4400	4	7,202	1,903	30,140					
4400	5	7,529	1,962	15,667					
4400	6	6,803	2,034	77					

Table H-9: Average Class 9 Front Axle Weight for WIM lanes with GVW<32,000, Sorted by Site Number (4110-4400)

SITE	Lane	Mar-01			Jun-00			Front Axle Load	Vehicle Count
		Front Axle Load (lbs)		Vehicle Count	Front Axle Load (lbs)		Vehicle Count	% change	% change
		Mean	StdDev		Mean	StdDev			
5110	1	7,700	1,505	22,966	9,373	1,871	22,982	-18%	0%
5110	2	8,016	1,037	4,343	8,168	1,549	2,081	-2%	109%
5110	3	8,232	940	23,000	9,608	1,162	13,337	-14%	73%
5110	4	8,197	1,681	575	11,258	6,111	136	-27%	323%
5120	1	1,200	208	10,203	1,086	185	58,264	11%	-83%
5120	2	10,050	1,996	768	11,187	1,885	1,094	-10%	-30%
5120	3	3,980	3,814	34,478	9,126	1,602	3,505	-56%	884%
5120	4	9,855	1,462	2,948	9,598	6,204	71	3%	4052%
5140	1	8,756	1,443	4,966	6,982	2,430	6,834	25%	-27%
5140	2	1,132	160	3,642	1,137	156	20,005	0%	-82%
5140	3	7,117	1,633	1,568	6,473	2,091	2,463	10%	-36%
5140	4	1,137	162	6,960	1,139	166	27,282	0%	-75%
5240	1	8,937	1,587	5,455	10,285	2,038	921	-13%	492%
5240	2	1,078	187	973	1,107	192	1,070	-3%	-9%
5250	1	8,432	1,022	2,368	7,382	1,229	1,054	14%	125%
5250	2	1,001	179	1,229	985	181	1,573	2%	-22%
5250	3	894	152	4,011	866	158	7,391	3%	-46%
5250	4	958	173	1,074	958	176	1,039	0%	3%
5260	1	928	171	6,097	1,012	183	5,935	-8%	3%
5260	2	935	175	607	932	262	647	0%	-6%
5440	3	8,879	1,852	2,448	9,382	1,284	10,627	-5%	-77%
5440	4	1,105	140	29,102	1,105	147	29,568	0%	-2%
5450	1	7,918	1,692	26,771	5,863	2,100	10,970	35%	144%
5450	3	7,609	1,889	6,333	8,948	1,564	1,989	-15%	218%
5450	4	1,062	155	9					
5460	1	5,657	2,307	3	7,667	1,889	8,103	-26%	-100%
5460	3	308	352	45	674	102	445	-54%	-90%
5460	6	695	149	678					
5470	1	8,759	1,572	27,627	8,816	1,626	22,777	-1%	21%
5470	2	4,333	563	5	5,982	709	2	-28%	150%
5470	3	6,669	2,743	91	7,684	2,849	127	-13%	-28%
5470	4	8,405	2,110	24,104	6,034	1,679	41,076	39%	-41%
5470	5	8,607	1,694	12,228	8,683	1,680	14,891	-1%	-18%
5470	6	6,717	2,321	136	8,755	2,636	20	-23%	580%

Table H-10: Average Class 9 Front Axle Weight for WIM lanes with GVW<32,000, Sorted by Site Number (5110-5470)

SITE	Lane	Mar-01			Jun-00			Front Axle Load	Vehicle Count
		Front Axle Load (lbs)		Vehicle Count	Front Axle Load (lbs)		Vehicle Count	2000-2001 % change	% change
		Mean	StdDev		Mean	StdDev			
5480	1	6,728	2,031	6,712	8,800	2,564	857	-24%	683%
5480	2	10,349	3,801	352	9,510	3,707	163	9%	116%
5480	3	766	150	144					
5480	4	10,411	4,730	401	7,953	2,364	83	31%	383%
5480	6	676	150	254	657	109	32	3%	694%
5550	1	9,110	3,050	2,265	1,059	188	6,951	760%	-67%
5550	2	7,180	1,856	405					
5550	3	8,670	2,328	1,888	1,034	.	1	739%	188700%
5550	4	6,337	2,568	127	967	527	53	555%	140%
6130	2	1,003	157	650	1,106	187	1,517	-9%	-57%
6130	4	1,025	159	1,064	1,073	169	2,187	-5%	-51%
6140	1	5,119	1,192	29,665	8,980	2,684	2,152	-43%	1279%
6140	2	1,082	157	3,259	1,103	157	3,282	-2%	-1%
6140	3	10,177	4,108	1,651	10,160	3,129	7,404	0%	-78%
6140	4	1,177	172	2,388	1,173	182	2,346	0%	2%
6150	1	6,725	2,641	5,196	8,879	1,452	9,461	-24%	-45%
6150	2	1,110	168	2,337	1,117	172	3,005	-1%	-22%
6160	1	9,347	2,703	183	7,173	2,492	25	30%	632%
6160	2	1,134	168	5,587	1,139	170	5,517	0%	1%
6160	3	6,783	2,060	13,769	6,030	1,886	8,736	13%	58%
6160	4	1,153	174	6,730	1,148	179	7,181	0%	-6%
6170	1	7,281	2,251	15,014	5,201	1,785	4,386	40%	242%
6170	2	962	157	3,244	994	168	4,639	-3%	-30%
6170	3	8,249	1,607	4,224	10,679	2,576	1,084	-23%	290%
6170	4	916	168	2,637	983	175	3,631	-7%	-27%
6250	1	6,856	858	3,370	764	134	7,861	797%	-57%
6250	2	1,259	203	849	1,260	209	770	0%	10%
6250	3	1,102	244	5,709	1,136	198	7,359	-3%	-22%
6250	4	1,272	211	508	1,272	206	654	0%	-22%

Table H-11: Average Class 9 Front Axle Weight for WIM lanes with GVW<32,000, Sorted by Site Number (5480-6250)

SITE	Lane	Mar-01			Jun-00			Front Axle Load	Vehicle Count
		Front Axle Load (lbs)		Vehicle Count	Front Axle Load (lbs)		Vehicle Count		
		Mean	StdDev		Mean	StdDev		2000-2001 % change	% change
6270	3	10,611	1,820	467	8,176	2,107	2,015	30%	-77%
6280	1	10,853	1,834	4					
6290	1	8,803	1,709	1,453	8,847	1,598	594	-1%	145%
6290	2	5,979	2,331	2,964	8,541	1,690	898	-30%	230%
7300	1	7,971	1,792	25,939					
7300	2	8,568	2,379	3,107					
7300	3	8,820	1,814	15,204					
7300	4	7,994	2,586	2,183					
7320	1	8,398	2,221	24,402					
7320	2	8,368	2,396	2,406					
7320	3	8,501	1,949	14,947					
7320	4	6,908	1,868	3,322					
7340	1	8,606	2,108	9,491					
7340	2	8,633	2,193	1,048					
7340	3	8,846	1,772	5,993					
7340	4	7,542	2,657	465					

Table H-12: Average Class 9 Front Axle Weight for WIM lanes with GVW<32,000, Sorted by Site Number (6270-7340)

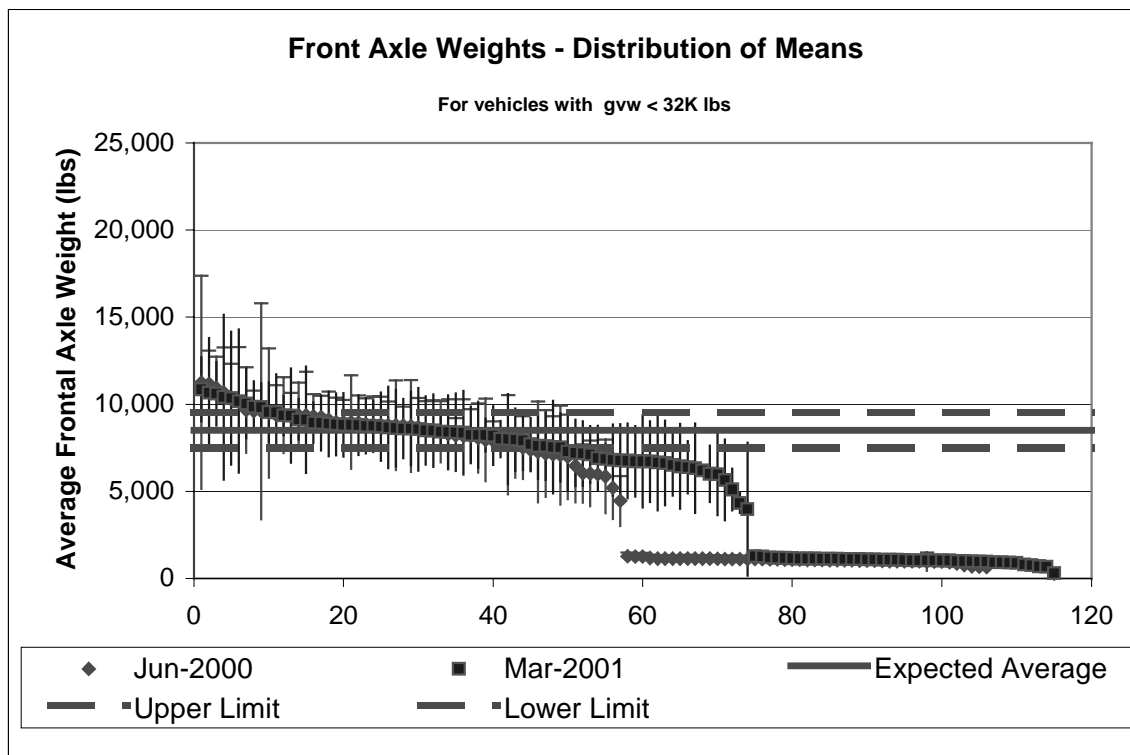

Figure H-2: Average Class 9 Front Axle Weight for WIM lanes with GVW < 32,000

SITE	Lane	Mar-01			Jun-00			Front Axle Load 2000-2001 % change	Vehicle Count % change
		Front Axle Load (lbs)		Vehicle Count	Front Axle Load (lbs)		Vehicle Count		
		Mean	StdDev		Mean	StdDev			
4110	1	8,704	2,092	9,562	11,051	2,575	67,113	-21%	-86%
4110	3	26,716	3,684	382	26,460	4,802	522	1%	-27%
4130	1	9,678	1,045	1,914	10,004	2,118	66,910	-3%	-97%
4130	2	10,236	1,032	5,545	10,181	884	23,275	1%	-76%
4130	3	11,581	3,267	136	14,500	3,956	121	-20%	12%
4130	4	8,303	2,070	13,744	8,998	969	301	-8%	4466%
4130	6	12,061	3,100	254	14,744	3,173	277	-18%	-8%
4140	1	10,282		1	10,677	3,097	20,224	-4%	-100%
4150	1	13,905	1,526	34,670	12,032	1,146	32,067	16%	8%
4150	2	11,328	1,312	4,049	10,259	1,841	3,474	10%	17%
4150	3	10,709	1,117	33,339	9,674	1,244	28,295	11%	18%
4150	4	10,426	1,224	4,704	10,595	1,217	3,655	-2%	29%
4250	3	10,743	1,067	2,670	10,722	1,025	2,818	0%	-5%
4270	1	10,319	1,522	7,975	8,724	1,326	5,464	18%	46%
4280	1	10,434	1,134	4,429	8,960	864	8,890	17%	-50%
5110	1	8,522	1,281	104,164	10,203	1,762	78,057	-17%	33%
5110	2	8,959	1,006	18,840	9,544	900	14,074	-6%	34%
5110	3	8,895	873	92,610	10,609	1,008	97,829	-16%	-5%
5110	4	10,226	795	16,486	15,760	3,039	3,507	-35%	370%
5120	2	11,696	1,615	4,615	12,605	1,443	6,833	-7%	-33%
5120	3	9,877	1,110	32,497	10,089	1,239	10,645	-2%	205%
5120	4	10,497	1,368	5,128	11,037	5,466	68	-5%	7441%
5140	1	9,735	1,427	22,518	11,262	2,122	68,457	-14%	-67%
5140	3	9,657	1,720	18,354	10,779	1,717	61,972	-10%	-70%
5240	1	10,131	1,590	12,565	12,673	1,948	7,268	-20%	73%
5250	1	9,674	1,112	5,283	8,501	1,447	884	14%	498%
5440	3	11,566	1,723	50,001	10,697	1,322	68,218	8%	-27%
5450	1	9,476	1,953	58,173	9,993	3,732	21,131	-5%	175%
5450	3	10,387	2,351	69,714	11,760	2,332	49,069	-12%	42%

Table H-13: Average Class 9 Front Axle Weight for WIM lanes with 32,000<GVW<70,000, Sorted by Site Number (4110-5450)

SITE	Lane	Mar-01			Jun-00			Front Axle Load	Vehicle Count
		Front Axle Load (lbs)		Vehicle Count	Front Axle Load (lbs)		Vehicle Count	2000-2001 % change	% change
		Mean	StdDev		Mean	StdDev			
5470	1	10,005	1,478	60,646	10,157	1,573	55,304	-2%	10%
5470	2	11,709		1	7,398	719	4	58%	-75%
5470	3	10,945	2,138	285	10,908	1,710	352	0%	-19%
5470	4	9,889	2,509	59,102	7,433	2,051	37,339	33%	58%
5470	5	10,002	1,454	40,043	10,236	1,804	36,618	-2%	9%
5470	6	11,116	2,685	595	16,403	4,862	146	-32%	308%
5480	1	8,951	2,720	10,757	14,299	2,832	18,313	-37%	-41%
5480	2	15,649	3,062	2,464	16,924	3,373	2,816	-8%	-13%
5480	4	12,554	3,359	4,720	14,839	2,514	5,642	-15%	-16%
6140	1	6,474	1,757	20,660	11,292	1,389	41,353	-43%	-50%
6140	3	14,499	2,300	16,384	11,344	2,720	8,567	28%	91%
6150	1	9,347	4,420	10,979	9,561	1,442	7,110	-2%	54%
6160	1	13,582	1,733	25,082	14,112	1,308	8,412	-4%	198%
6160	3	9,409	3,096	20,574	8,296	2,700	12,303	13%	67%
6170	1	10,188	3,412	19,549	14,275	3,002	8,319	-29%	135%
6170	3	8,910	1,510	16,104	12,497	1,780	3,805	-29%	323%
6270	3	12,561	1,763	3,970	10,266	2,295	1,638	22%	142%
6290	1	12,760	3,272	3,890	11,974	3,067	2,021	7%	93%
6290	2	10,038	3,582	2,752	9,871	1,734	2,411	2%	14%
7300	1	9,656	3,094	56,360					
7300	2	10,332	2,098	7,069					
7300	3	10,174	1,794	73,728					
7300	4	10,728	1,733	8,081					
7320	1	10,051	2,281	63,010					
7320	2	10,252	1,961	7,894					
7320	3	10,002	2,534	69,934					
7320	4	8,793	2,724	6,690					
7340	1	9,957	2,289	26,911					
7340	2	10,316	1,767	2,286					

Table H-14: Average Class 9 Front Axle Weight for WIM lanes with 32,000<GVW<70,000, Sorted by Site Number (5470-7340)

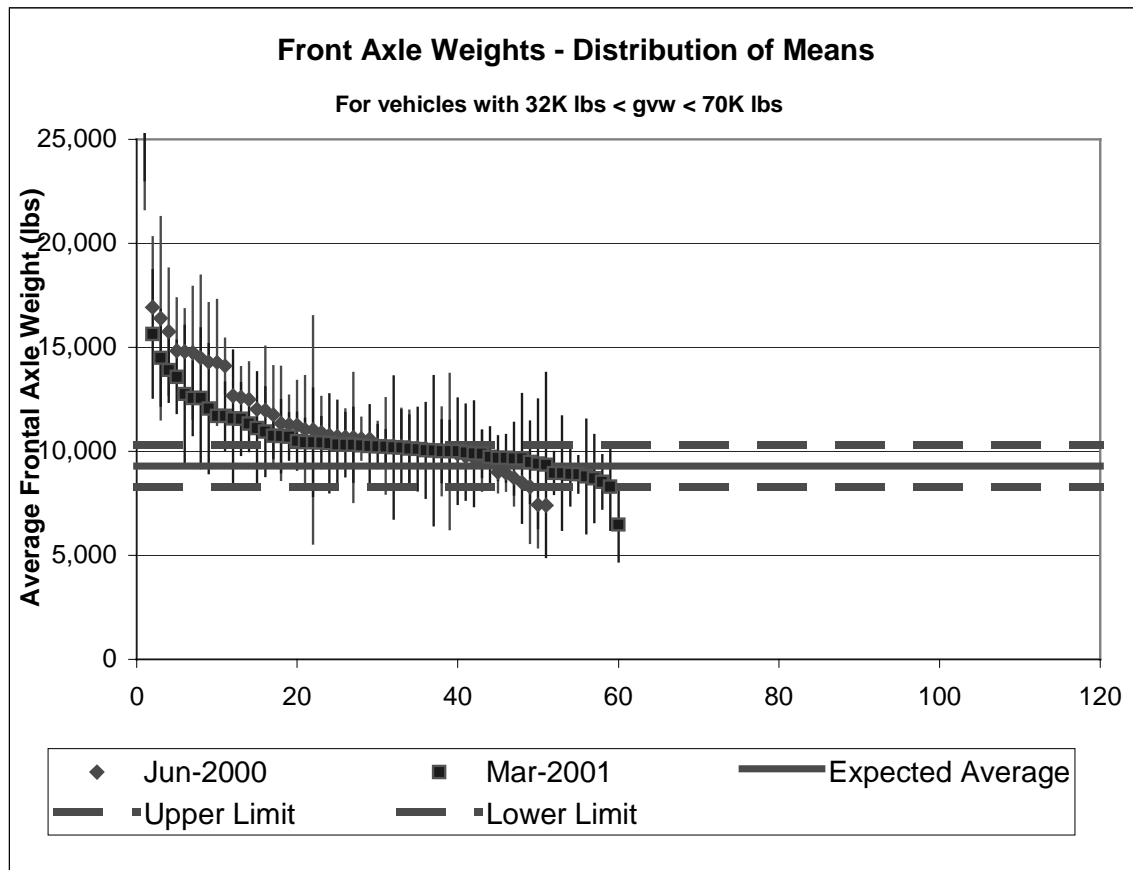

Figure H-3: Average Class 9 Front Axle Weight for WIM Lanes with 32,000 < GVW < 70,000

SITE	Lane	Mar-01			Jun-00			Front Axle Load	Vehicle Count
		Front Axle Load (lbs)		Vehicle Count	Front Axle Load (lbs)		2000-2001 % change		
		Mean	StdDev		Mean	StdDev			
4110	1	10,558	2,115	161	12,682	2,771	7,170	-17%	-98%
4110	3	33,868	5,164	14,976	37,827	5,716	63,000	-11%	-76%
4130	1	10,322	1,091	309	10,414	896	9,572	-1%	-97%
4130	2	10,670	771	4,886	10,628	752	16,509	0%	-70%
4130	3	16,207	3,589	40	18,112	2,551	92	-11%	-57%
4130	4	11,266	1,975	1,463					
4130	6	16,706	2,715	38	17,288	2,690	59	-3%	-36%
4150	1	14,682	1,510	35,889	12,526	1,087	22,082	17%	63%
4150	2	11,879	1,050	1,995	10,883	1,108	1,085	9%	84%
4150	3	11,317	1,065	16,391	10,400	1,163	13,984	9%	17%
4150	4	11,066	1,151	2,044	11,178	1,966	1,996	-1%	2%
4250	3	11,560	1,197	1,100	11,625	987	835	-1%	32%
4270	1	11,913	1,786	2,164	10,383	1,737	614	15%	252%
4280	1	10,973	1,264	3,155	9,474	1,123	974	16%	224%
5110	1	10,977	3,736	1,593	12,408	1,346	30,213	-12%	-95%
5110	2	9,642	1,156	564	10,053	819	2,227	-4%	-75%
5110	3	10,019	1,010	736	11,218	1,027	19,705	-11%	-96%
5110	4	10,691	601	5,357	17,401	1,530	18,922	-39%	-72%
5120	2	12,736	1,281	3,970	13,312	1,200	6,491	-4%	-39%
5120	3	10,595	1,076	10,753	10,784	1,054	4,020	-2%	168%
5120	4	11,391	1,283	1,723	19,317	5,666	9	-41%	19044%
5140	1	11,638	1,296	3,999	12,580	1,730	63,443	-8%	-94%
5140	3	11,416	1,495	9,905	11,983	1,540	65,958	-5%	-85%
5240	1	12,268	1,399	417	13,839	2,043	8,686	-11%	-95%
5250	1	10,494	1,140	1,783	9,312	1,403	210	13%	749%
5440	3	13,087	1,981	42,656	15,330	2,361	495	-15%	8517%
5450	1	12,134	2,542	13,653	17,609	5,702	17,920	-31%	-24%
5450	3	12,194	2,396	40,895	14,659	2,990	53,442	-17%	-24%
5470	1	11,696	1,600	3,054	12,090	1,921	2,880	-3%	6%
5470	3	12,107	1,729	120	11,952	1,393	65	1%	85%
5470	4	12,074	4,226	6,618	10,277	2,413	443	18%	1394%
5470	5	11,664	1,232	4,600	16,312	4,216	1,590	-29%	189%
5470	6	13,328	3,388	231	25,389	4,890	921	-48%	-75%

Table H-15: Average Class 9 Front Axle Weight for WIM lanes with GVW>70,000, Sorted by Site Number (4110-5470)

SITE	Lane	Mar-01			Jun-00			Front Axle Load	Vehicle Count
		Front Axle Load (lbs)		Vehicle Count	Front Axle Load (lbs)		2000-2001 % change		
		Mean	StdDev		Mean	StdDev		Vehicle Count	
5480	1	13,225	2,071	1,623	16,032	2,817	14,964	-18%	-89%
5480	2	17,628	3,043	1,765	19,161	3,073	2,124	-8%	-17%
5480	4	16,226	6,472	518	17,052	2,630	2,845	-5%	-82%
6140	1	11,349	1,636	971	12,851	913	174	-12%	458%
6140	3	15,366	2,342	16,718	12,040	2,379	2,154	28%	676%
6150	1	16,924	6,169	3,626	10,211	1,406	2,645	66%	37%
6160	1	14,739	1,690	28,771	14,941	1,283	14,574	-1%	97%
6160	3	12,670	2,844	11,233	12,222	2,418	4,839	4%	132%
6170	1	15,253	4,204	3,862	17,943	1,760	16,962	-15%	-77%
6170	3	9,866	1,319	6,021	13,358	1,586	4,000	-26%	51%
6270	3	13,875	1,919	4,632	11,519	2,238	1,357	21%	241%
6290	1	14,230	3,422	3,259	14,507	3,011	1,895	-2%	72%
6290	2	13,633	3,246	888	10,932	1,722	881	25%	1%
7300	1	14,319	6,799	14,624					
7300	2	11,675	2,180	1,436					
7300	3	11,042	1,867	19,375					
7300	4	11,898	1,600	1,718					
7320	1	11,274	2,245	16,576					
7320	2	11,242	1,959	2,902					
7320	3	11,918	3,955	13,141					
7320	4	18,356	9,505	1,557					
7340	1	11,132	2,688	6,812					
7340	2	12,099	2,182	233					
7340	3	11,515	3,527	7,006					
7340	4	12,746	3,031	1,774					

Table H-16: Average Class 9 Front Axle Weight for WIM lanes with GVW>70,000, Sorted by Site Number (5480-7340)

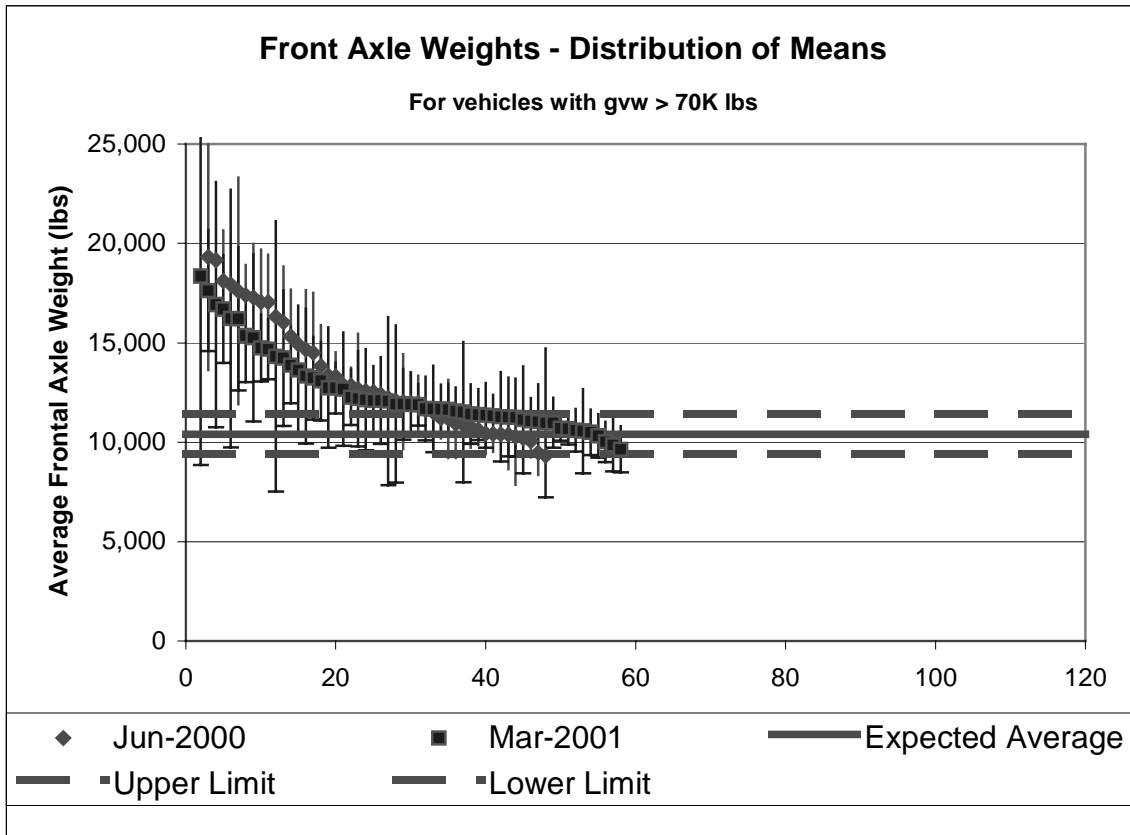

Figure H-4: Average Class 9 Front Axle Weight for WIM lanes with GVW > 70,000

	GVW Range	Front Axle Mean		Front Axle Standard Deviation
		Lower Limit	Upper Limit	Upper Limit
Range 1	GVW < 32,000	7,500	9,500	1,329
Range 2	32,000 < GVW < 70,000	8,300	10,300	1,500
Range 3	GVW > 70,000	9,400	11,400	1,500

Table H-17: Acceptable Ranges for Front Axle Mean & Standard Deviation for Table H-18 and Table H-19

Site	Lane	March, 2001						June, 2000						I.R.D. Sensor Report for April 01, 2001
		Out-of-Range Front Axle Mean			Out-of-Range Front Axle Standard			Out-of-Range Front Axle Mean			Out-of-Range Front Axle Standard			
		1	2	3	1	2	3	1	2	3	1	2	3	
4110	1				X	X	X	X	X	X	X	X	X	Piezo #3 & Dynax 1&2 need to be replaced.
	3	X	X	X	ND	X	X		X	X		X	X	
4130	1										X	X		SLC PM & all Dynax Need to be replaced.
	2				X						X			
	3	X	X	X	X	X	X	X	X	X	X	X	X	
	4	X	X		X	X	X	X	ND	ND	X		ND	
	5	X	ND	ND		ND	ND		ND	ND		ND	ND	
	6	X	X	X	X	X	X	X	X	X	X	X	X	
4140	1			ND	ND	ND	ND	X	X	ND	X	X	ND	All sensors ok.
4150	1	X	X	X	X		X	X	X	X				SLC PM & Dynax Need to be replaced.
	2	X	X	X	X					X	X			
	3	X	X		X					X				
	4		X		X		X			X			X	
4240	1	ND	ND	ND	ND	ND	ND	ND	ND	ND	ND	ND	ND	NO DATA
	2	ND	ND	ND	ND	ND	ND	ND	ND	ND	ND	ND	ND	
	3	ND	ND	ND	ND	ND	ND	ND	ND	ND	ND	ND	ND	
	4	ND	ND	ND	ND	ND	ND	ND	ND	ND	ND	ND	ND	
4250	3		X	X	X				X	X	X			Lane 3 Dynax needs to be replaced.
4260	1	X	X	ND	X	X	ND	X	X	ND		X	ND	All Dynax need to be replaced.
4270	1		X	X		X	X						X	All Dynax need to be replaced.
	2	X	ND	ND		ND	ND	X	ND	ND		ND	ND	
	3	X	ND	ND		ND	ND	X	ND	ND		ND	ND	
	4	X	ND	ND		ND	ND	X	ND	ND		ND	ND	
4280	1		X											NB Dynax need to be replaced.
4400	1	X	ND	ND	X	ND	ND	ND	ND	ND	ND	ND	ND	Piezo #s 3, 6, 14 Need to be replaced.
	2	X	ND	ND	X	ND	ND	ND	ND	ND	ND	ND	ND	
	3	X	ND	ND	X	ND	ND	ND	ND	ND	ND	ND	ND	
	4	X	ND	ND	X	ND	ND	ND	ND	ND	ND	ND	ND	
	5		ND	ND	X	ND	ND	ND	ND	ND	ND	ND	ND	
	6	X	ND	ND	X	ND	ND	ND	ND	ND	ND	ND	ND	
5110	1				X		X			X	X	X		SLC PM
	2										X			
	3							X						
	4				X			X	X	X	X	X	X	
5120	1	X	ND	ND	X	ND	ND	X	ND	ND		ND	ND	SLC PM
	2	X	X	X	X	X		X	X	X	X			
	3	X			X						X			
	4	X	X		X			X	X	X	X	X	X	
5130	1	ND	ND	ND	ND	ND	ND	ND	ND	ND	ND	ND	ND	NO DATA
	2	ND	ND	ND	ND	ND	ND	ND	ND	ND	ND	ND	ND	
	3	ND	ND	ND	ND	ND	ND	ND	ND	ND	ND	ND	ND	
	4	ND	ND	ND	ND	ND	ND	ND	ND	ND	ND	ND	ND	
5140	1			X	X			X	X	X	X	X	X	Piezo #3 needs to be replaced.
	3	X		X	X	X		X	X	X	X	X	X	
5240	1			X	X	X		X	X	X	X	X	X	Temp. Sensor to be replaced.

Table H-18: Evaluation of WIM Performance (Stations 4110-5240)

Site	Lane	March, 2001						June, 2000						I.R.D. Sensor Report for April 01, 2001	
		Out-of-Range Front Axle Mean			Out-of-Range Front Axle Standard			Out-of-Range Front Axle Mean			Out-of-Range Front Axle Standard				
		1	2	3	1	2	3	1	2	3	1	2	3		
5250	1							X			X				Site ok.
5270	1	ND	ND	ND	ND	ND	ND	ND	ND	ND	ND	ND	ND	ND	Site ok.
	3	ND	ND	ND	ND	ND	ND	ND	ND	ND	ND	ND	ND	ND	
5440	1	ND	ND	ND	ND	ND	ND	ND	ND	ND	ND	ND	ND	ND	Upstream loop in lane 1 needs to be replaced. All Dynax need to be replaced. All piezo sensors need to be checked.
	3		X	X	X	X	X		X	X					
5450	1		X	X	X	X	X	X		X	X	X	X	X	Site ok.
	3		X	X	X	X	X		X	X	X	X	X	X	
5460	1	X	ND	X	X	ND	X		ND	X	X	ND	X	X	All piezo & Dynax need to be replaced.
	2	ND	ND	ND	ND	ND	ND	ND	ND	ND	ND	ND	ND	ND	
	4	ND	ND	ND	ND	ND	ND	ND	ND	ND	ND	ND	ND	ND	
	5	ND	ND	ND	ND	ND	ND	ND	ND	ND	ND	ND	ND	ND	
5470	1			X	X		X			X	X	X	X	X	Site ok.
	2	X	X	ND			ND	ND	X	X	ND			ND	
	3	X	X	X	X	X	X		X	X		X	X	X	
	4			X	X	X	X	X	X	X	X	X	X	X	
	5			X	X	X	X		X	X	X	X	X	X	
	6	X	X	X	X	X	X		X	X	X	X	X	X	
5480	1	X	X	X	X	X	X		X	X	X	X	X	X	Site to be rebuilt.
	2	X	X	X	X	X	X	X	X	X	X	X	X	X	
	4	X	X	X	X	X	X		X	X	X	X	X	X	
	5	ND	ND	ND	ND	ND	ND	ND	ND	ND	ND	ND	ND	ND	
5550	1		X	ND	X	X	ND	X	X	ND		X	ND	ND	Site ok. Loops need to be re-sealed (topped off) & piezo #7 needs to be replaced.
	2	X	X	ND	X	X	ND	ND	X	ND	ND	X	ND	ND	
	3		X	ND	X	X	ND	X	X	ND	ND	X	ND	ND	
	4	X	X	ND	X	X	ND	X	X	ND	X	X	ND	ND	
6130	1	ND	ND	ND	ND	ND	ND	ND	ND	ND	ND	ND	ND	ND	Conduit under road is blocked.
	3	ND	ND	ND	ND	ND	ND	ND	ND	ND	ND	ND	ND	ND	BP & Dynax need to be replaced.
6140	1	X	X			X	X		X	X	X	X	X	X	Site ok.
	3	X	X	X	X	X	X	X	X	X	X	X	X	X	NB Vault needs to be ground down.
6150	1	X		X	X	X	X					X			Site ok.
6160	1		X	X	X	X	X	X	X	X	X	X	X	X	Dynax needs to be replaced.
	3	X		X	X	X	X	X	X	X	X	X	X	X	
6170	1	X		X	X	X	X	X	X	X	X	X	X	X	Site ok.
	3			X	X	X	X	X	X	X	X	X	X	X	
6250	1	X	ND	ND		ND	ND	X	ND	ND		ND	ND	ND	Dynax need to be replaced.
6260	1	ND	ND	ND	ND	ND	ND	ND	ND	ND	ND	ND	ND	ND	BP needs to be checked.
6260	1	ND	ND	ND	ND	ND	ND	ND	ND	ND	ND	ND	ND	ND	NO DATA
6270	3	X	X	X	X	X	X	X		X	X	X	X	X	Dynax need to be replaced.
6280	1	X	X	ND	X	X	ND	ND	X	ND	ND	X	ND	ND	Site to be rebuilt.
6290	1		X	X	X	X	X	X	X	X	X	X	X	X	Site ok.
	2	X		X	X	X	X	X		X	X	X	X	X	
7300	1			X	X	X	X	ND	ND	ND	ND	ND	ND	ND	Site ok.
	2		X	X	X	X	X	ND	ND	ND	ND	ND	ND	ND	
	3			X	X	X	X	ND	ND	ND	ND	ND	ND	ND	
	4		X	X	X	X	X	ND	ND	ND	ND	ND	ND	ND	
7320	1				X	X	X	ND	ND	ND	ND	ND	ND	ND	Piezo #7 needs to be replaced.
	2				X	X	X	ND	ND	ND	ND	ND	ND	ND	
	3			X	X	X	X	ND	ND	ND	ND	ND	ND	ND	
	4	X		X	X	X	X	ND	ND	ND	ND	ND	ND	ND	
7340	1				X	X	X	ND	ND	ND	ND	ND	ND	ND	Piezos need to be patched.
	2		X	X	X	X	X	ND	ND	ND	ND	ND	ND	ND	
	3			X	X	X	X	ND	ND	ND	ND	ND	ND	ND	
	4		X	X	X	X	X	ND	ND	ND	ND	ND	ND	ND	

Table H-19: Evaluation of WIM Performance (Stations 5250-7340)

Appendix I Summary of Merrillville Enforcement Detail

John Green Officer Deb Burkhart Officer Scott Fleming Officer Brian Nagle									
Description	Axle 1 WIM	Axle 1 Scale	Tandem 1 WIM	Tandem 1 Scale	Tandem 2 WIM	Tandem 2 Scale	GVW WIM	GVW Scale	Action Taken
CL9/L2	11,200	11,600	28,300	30,000	31,700	30,900	71,200	72,500	None
CL9/L1	11,800	11,900	33,200	32,800	30,400	31,300	75,400	76,000	None
CL9/L1	11,100	10,200	33,700	33,100	36,000	32,900	80,800	76,200	None
CL9/L1	12,500	12,200	33,100	32,200	32,200	31,000	77,800	75,400	None
CL9/L1	12,500	12,700	31,100	32,100	35,600	32,400	79,200	77,200	None
CL9/L3	12,600	12,200	33,500	32,800	33,400	32,400	79,600	77,300	None
CL9/L1	10,400	11,100	35,000	29,000	38,700	35,400	84,000	75,400	Tandem warning (34,000 legal)
CL9/L2	11,100	11,500	31,100	32,400	33,400	34,200	75,700	78,100	Tandem warning (34,000 legal)
CL9/L1	9,200	9,000	46,400	38,700	41,600	37,200	97,200	84,800	GVW ticket (80,000 legal) & tandem ticket (34,000 legal) issued

Table I-1: March 29, 2001 – Merrillville Scale Detail (WIM 4410) – WIM v. Static

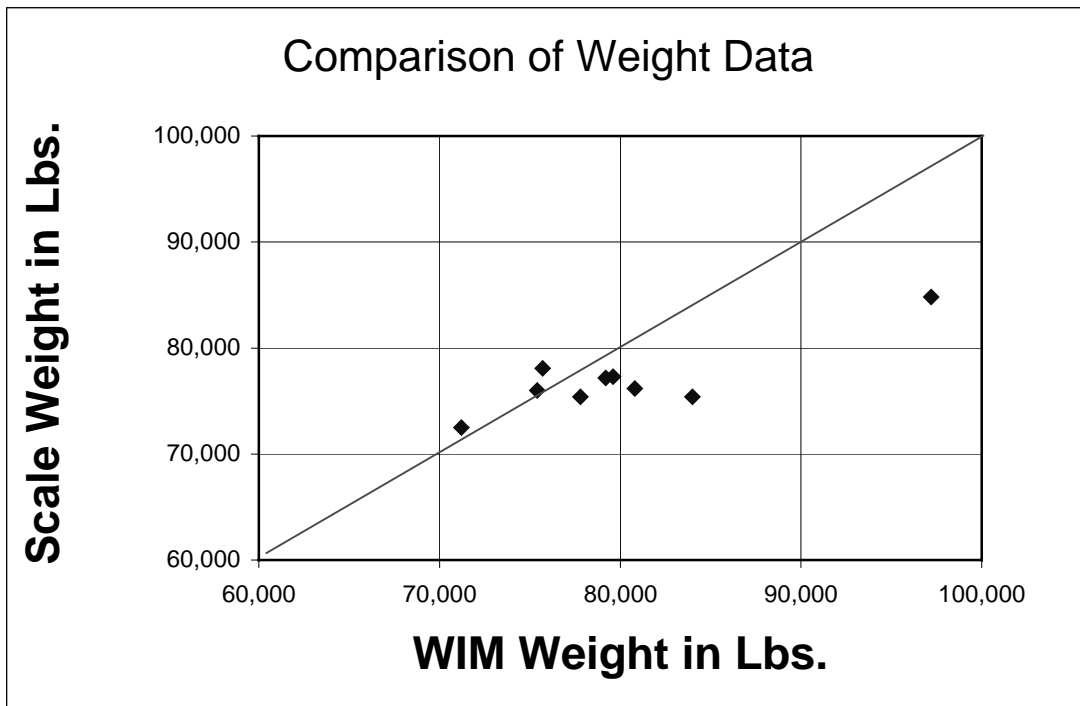

Figure I-1: March 29, 2001 – Merrillville Scale Detail (WIM 4410) – WIM v. Static graph

Ed Allen John Green Officer Henry Davis Officer Gerald Young									
Description	Axle 1 WIM	Axle 1 Scale	Tandem 1 WIM	Tandem 1 Scale	Tandem 2 WIM	Tandem 2 Scale	GVW WIM	GVW Scale	Action Taken
CL9/L1 Freight Box	11,500	11,750	33,500	32,400	35,500	32,800	82,600	76,950	none
CL9/L1 Freight Box	10,800	10,700	34,100	35,300	36,900	32,800	81,800	78,800	none
CL9/L2 Grain	11,600	12,700	34,400	39,800	37,400	41,300	83,400	93,800	GVW ticket (80,000 legal) issued, tandem warning (34,000 legal)
CL9/L1 Steel Coil	10,900	11,400	44,300	32,500	29,200	32,400	84,500	76,300	none
CL9/L1 Container	11,000	11,400	34,100	34,900	33,700	32,800	78,800	79,100	Tandem warning (34,000 legal)
CL9/L1 Freight Box	11,600	12,500	32,700	35,200	33,000	31,700	77,300	79,400	Tandem warning (34,000 legal)

Table I-2: May 8, 2001 – Merrillville Scale Detail (WIM 4410) – WIM v. Static

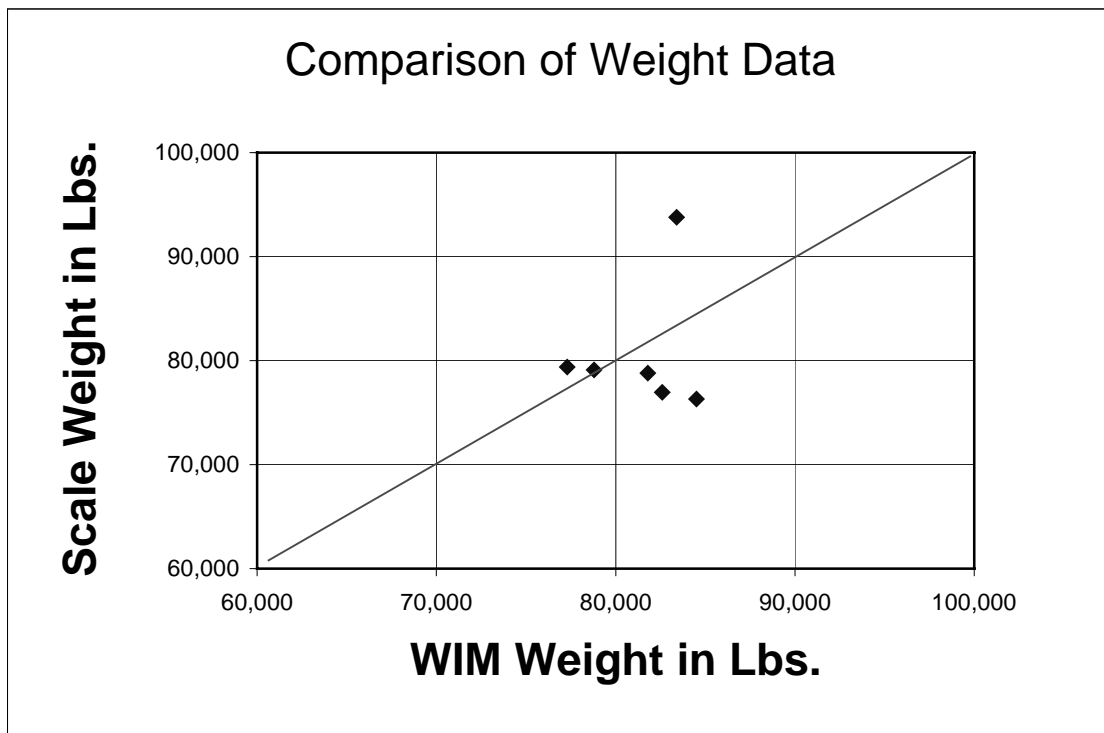

Figure I-2: May 8, 2001 – Merrillville Scale Detail (WIM 4410) – WIM v. Static graph

Ed Allen John Green Officer Gerald Young * = tridem									
Description	Axle 1 WIM	Axle 1 Scale	Tandem 1 WIM	Tandem 1 Scale	Tandem 2 WIM	Tandem 2 Scale	GVW WIM	GVW Scale	Action Taken
CL7/L1 4-Axle Dump	19,100	19,100	75,500*	50,100*	0	0	93,400	69,200	GVW ticket (68,000 legal) issued
CL9/L1 Short Dump	9,400	10,200	36,300	27,900	45,500	35,100	91,200	73,200	Tandem warning (34,000 legal)
CL9/L1 Short Dump	9,400	10,400	33,000	31,100	43,300	39,300	85,700	80,800	Tandem ticket (34,000 legal), GVW warning (73,280 legal)

Table I-3: May 15, 2001 – Merrillville Scale Detail (WIM 4410) – WIM v. Static

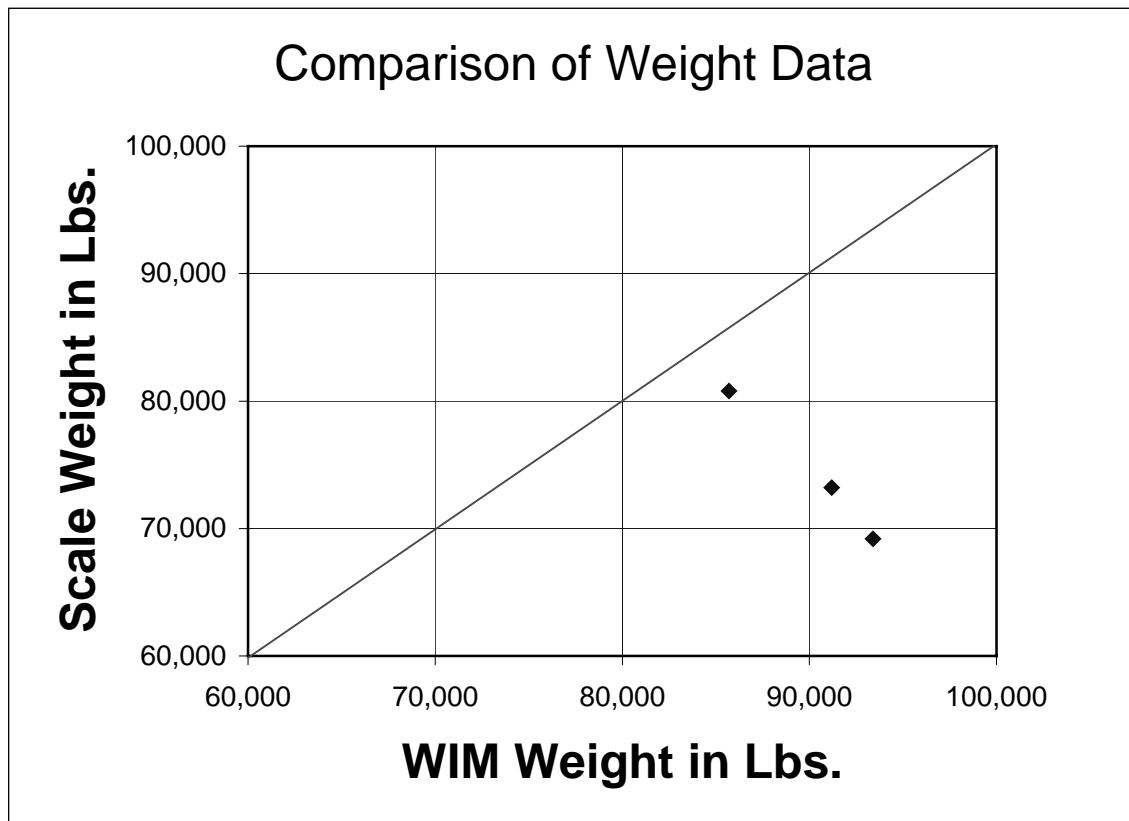

Figure I-3: May 15, 2001 – Merrillville Scale Detail (WIM 4410) – WIM v. Static graph

John Green Officer Henry Davis									
* = Spread Axle trailers allow 40,000 tandem on trailer									
Description	Axle 1 WIM	Axle 1 Scale	Tandem 1 WIM	Tandem 1 Scale	Tandem 2 WIM	Tandem 2 Scale	GVW WIM	GVW Scale	Action Taken
CL9/L2 Spread Axle	9,800	10,900	32,500	37,700	48,000	50,100	90,400	98,700	Vehicle Impounded, GVW (80,000 legal) & Tandem (40,000*) Ticket
CL9/L2 Spread Axle	10,900	11,800	34,400	38,600	46,300	50,200	91,500	100,600	Vehicle Impounded, GVW (80,000 legal) & Tandem (40,000*) Ticket
CL9/L1 Freight Box	11,100	12,200	37,300	35,300	35,200	33,100	83,600	80,600	Tandem ticket (34,000 legal), GVW warning (80,000 legal)
CL9/L1 Freight Box	9,700	11,200	37,900	36,600	36,100	31,300	83,700	79,100	Tandem ticket (34,000 legal)

Table I-4: May 18, 2001 – Merrillville Scale Detail (WIM 4410) – WIM v. Static

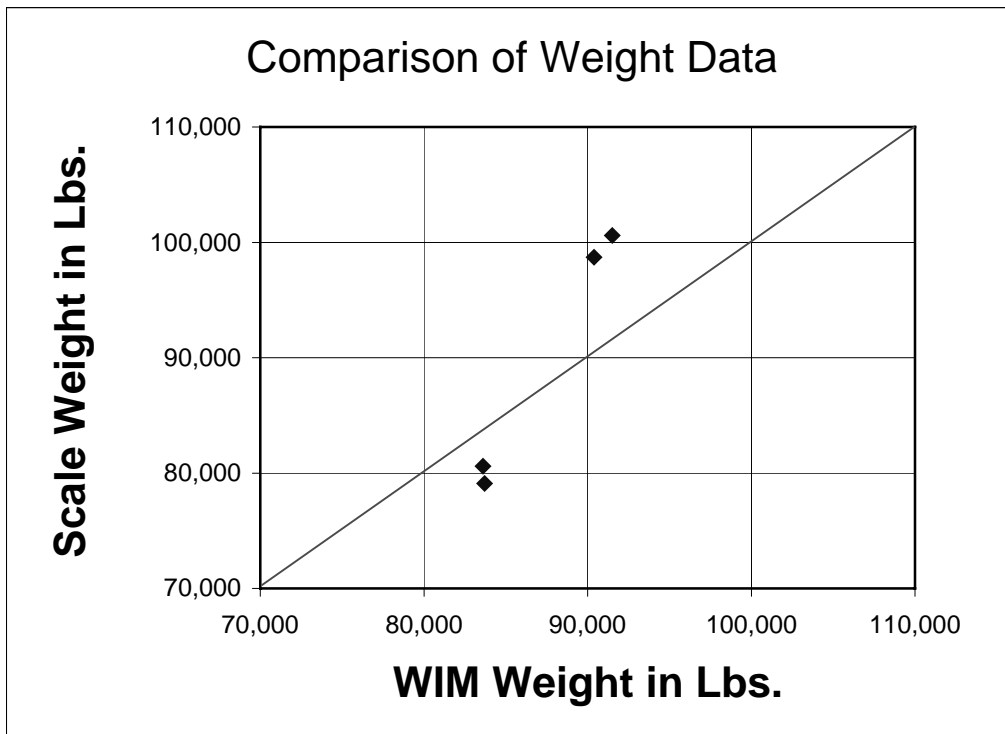

Figure I-4: May 18, 2001 – Merrillville Scale Detail (WIM 4410) – WIM v. Static graph

Ed Allen John Green Officer Deb Burkhart									* = Tridem
Description	Axle 1 WIM	Axle 1 Scale	Tandem 1 WIM	Tandem 1 Scale	Tandem 2 WIM	Tandem 2 Scale	GVW WIM	GVW Scale	Action Taken
CL7/L1 4-Axle Dump	11,100	13,650	60,700	50,100*	0	0	71,900	63,750	Verbal Tridem (50,000) Warning
CL9/L1 Short Dump	8,800	9,650	31,000	25,800	35,400	32,450	75,300	67,900	None
CL9/L1 Short Dump	8,600	9,950	31,800	27,350	39,000	31,600	79,400	68,900	None
CL9/L1 Grain Hauler	9,300	10,650	38,000	40,200	38,300	38,750	85,500	89,600	Tandem ticket (34,000 legal), GVW ticket (80,000 legal)
CL9/L1 Steel Hauler	8,300	8,450	33,500	33,250	38,900	34,000	80,800	75,700	None

Table I-5: May 21, 2001 – Merrillville Scale Detail (WIM 4410) – WIM v. Static

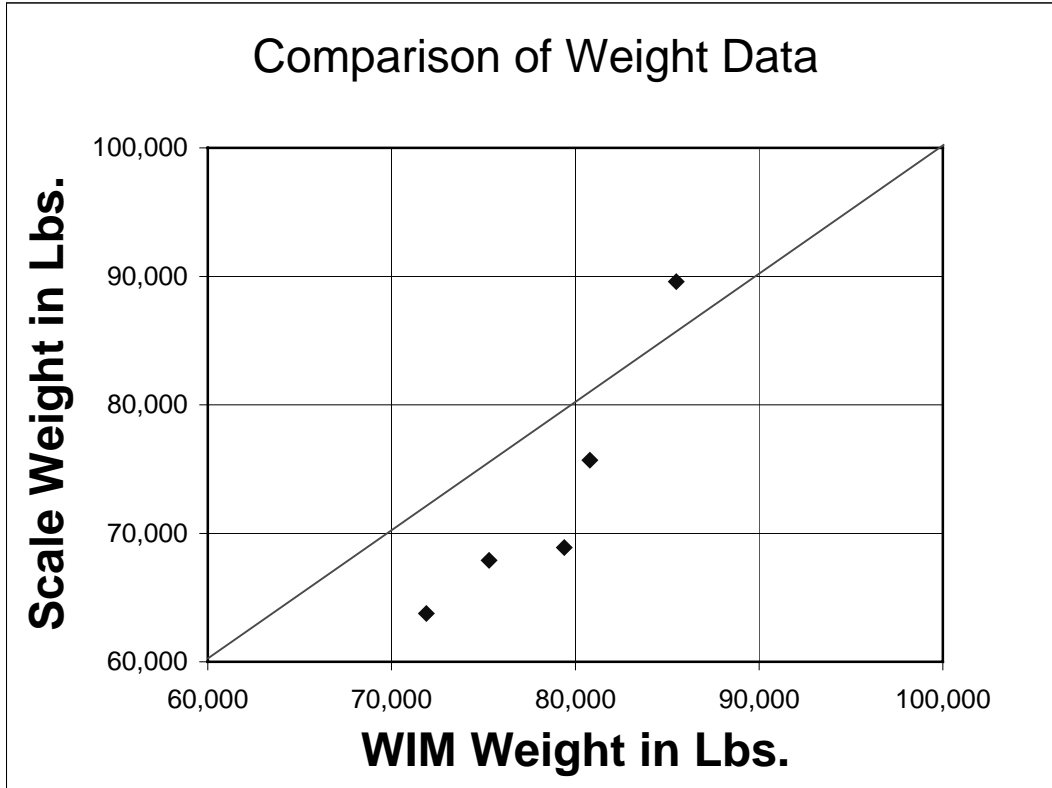

Figure I-5: May 21, 2001 – Merrillville Scale Detail (WIM 4410) – WIM v. Static graph

John Green Officer Deb Burkhart									
Description	Axle 1 WIM	Axle 1 Scale	Tandem 1 WIM	Tandem 1 Scale	Tandem 2 WIM	Tandem 2 Scale	GVW WIM	GVW Scale	Action Taken
CL9/L1 Tanker	11,000	11,750	34,300	31,900	35,500	33,100	80,700	76,750	None

Table I-6: May 23, 2001 - Merrillville Scale Detail (WIM 4410) - WIM v. Static

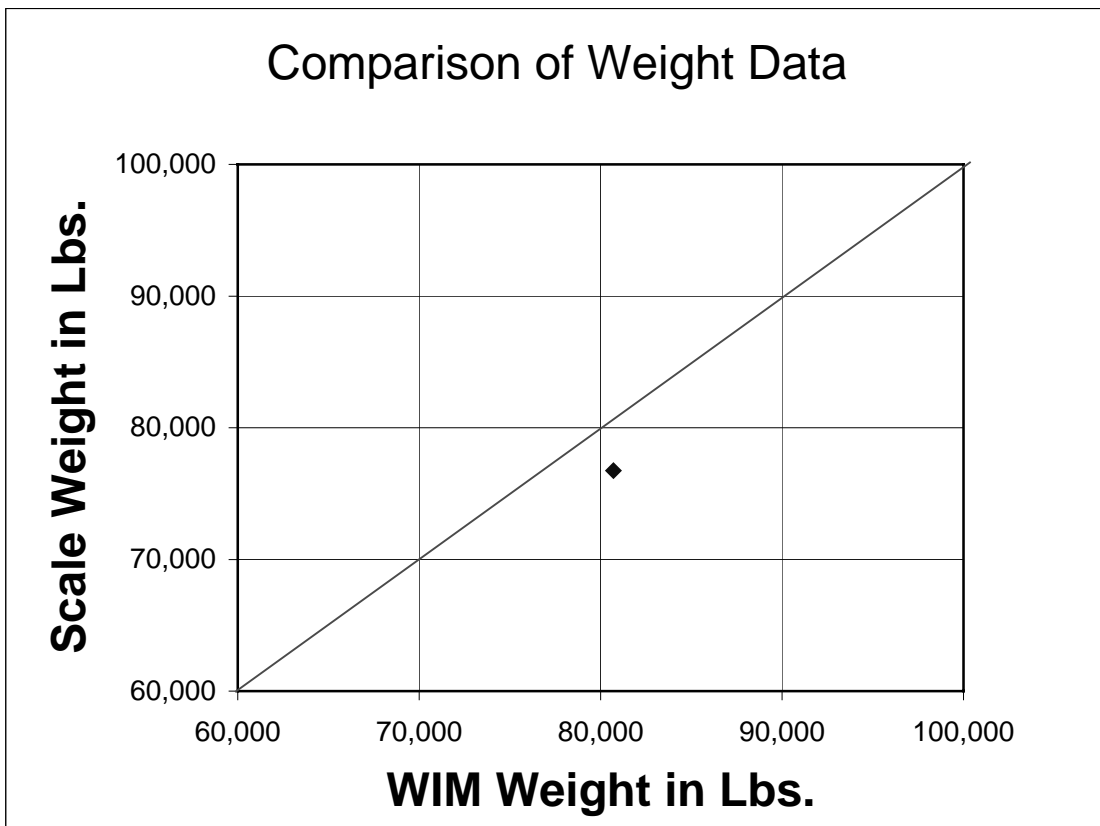

Figure I-6: May 23, 2001 - Merrillville Scale Detail (WIM 4410) - WIM v. Static graph

Ed Allen John Green Officer Henry Davis									
Description	Axle 1 WIM	Axle 1 Scale	Tandem 1 WIM	Tandem 1 Scale	Tandem 2 WIM	Tandem 2 Scale	GVW WIM	GVW Scale	Action Taken
CL9/L1 Steel Hauler	10,500	9,700	38,000	36,600	32,700	37,100	81,200	83,400	Vehicle Impounded, GVW and Tandem ticket
CL9/L1 Timber Hauler	12,500	11,800	36,800	40,700	36,700	34,100	86,200	86,600	Vehicle Impounded, GVW and Tandem ticket
CL9/L1 Steel Hauler	13,800	12,700	47,700	54,600	51,600	59,200	113,200	126,500	Vehicle Impounded, GVW and Tandem ticket

Table I-7: May 31, 2001 – Merrillville Scale Detail (WIM 4410) – WIM v. Static

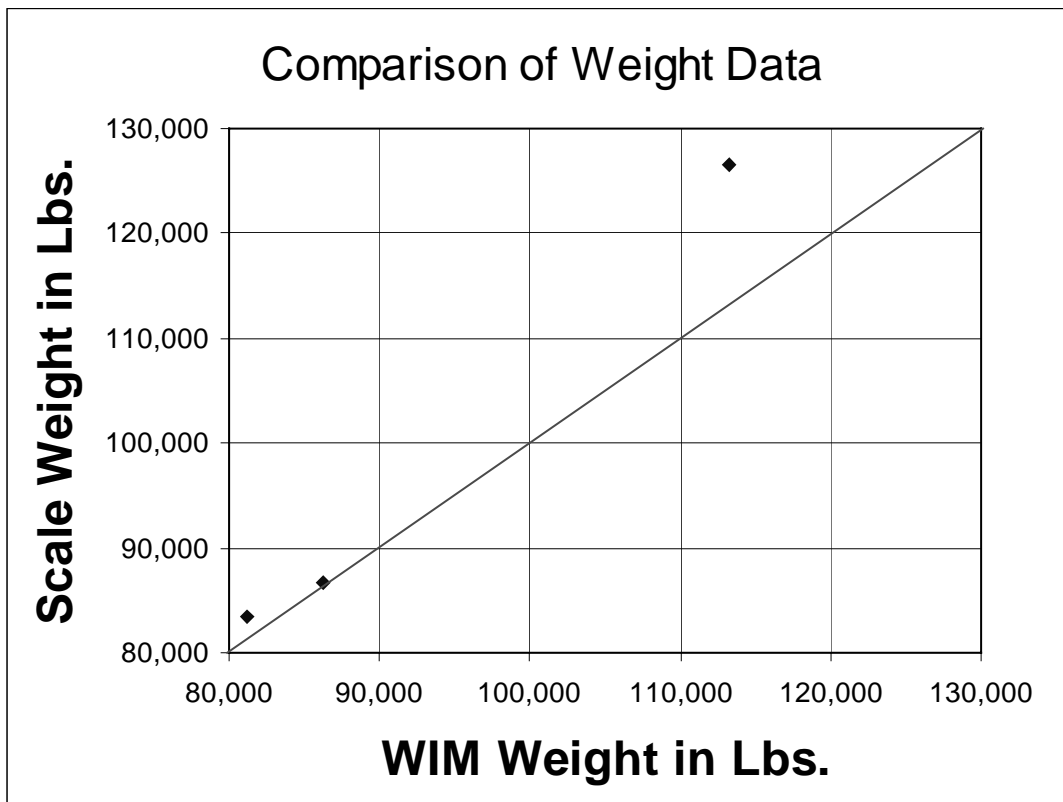
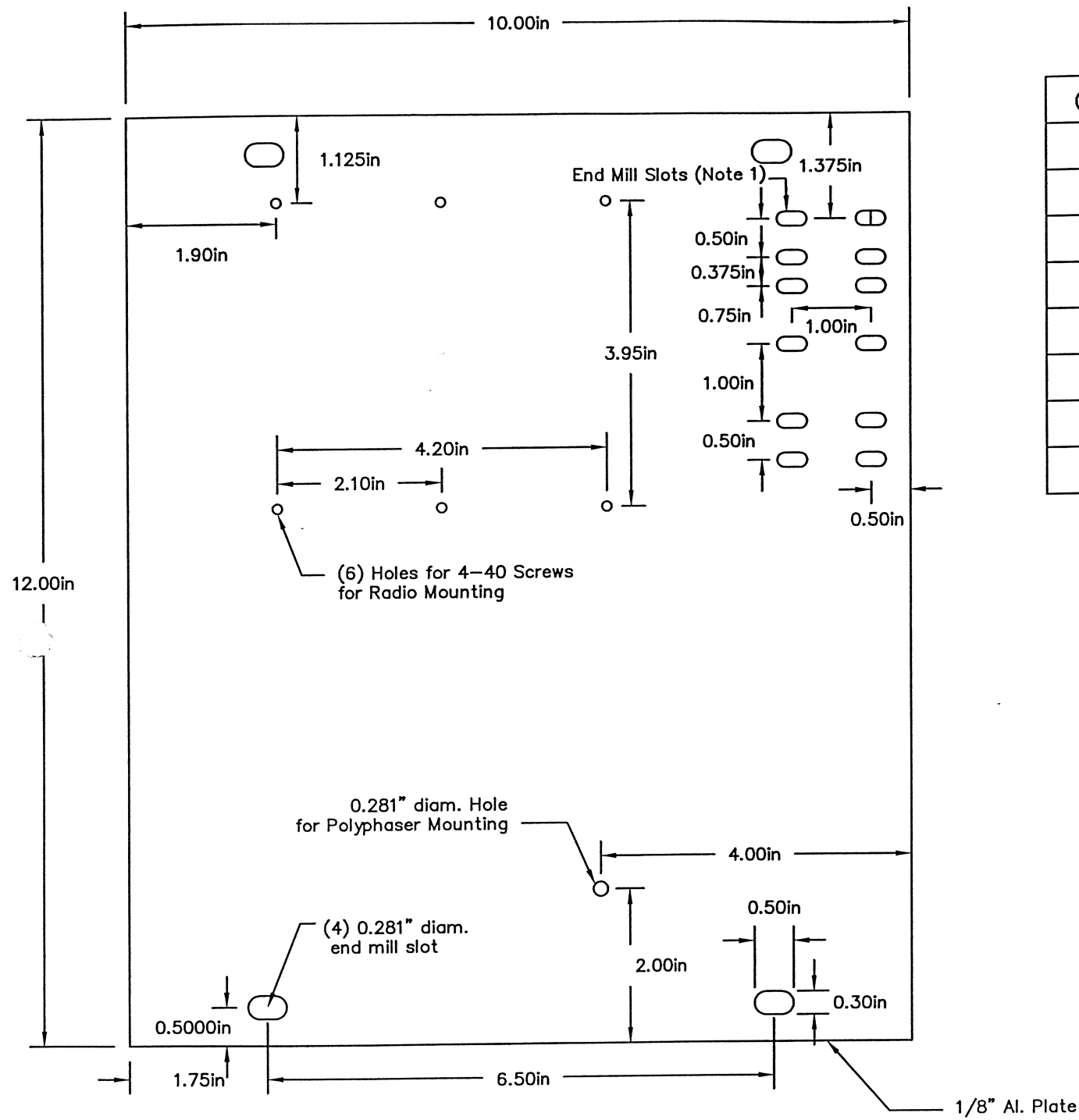

Figure I-7: May 31, 2001 - Merrillville Scale Detail (WIM 4410) - WIM v. Static graph

Appendix J AutoCad Drawings

Figure J-1



Qty.	Part No.	Description
4	Spring Loaded Toggle Nuts	Nuts with Springs to Mount in Traffic Box
4	1/4" Bolts	Bolts for Traffic Box Brackets
6	4-40 Screws 3/8" LG	Brass Screws for Radio Mounting
1	1/4" Straight Head Bolt	Screw to Mount Polyphaser
1	1/4" Nut	Nut for Polyphaser Bolt
1	1/4" Washer	Washer for Polyphaser Bolt

Note 1) End Mill Slots are nominally 3/16" X 3/8"

Figure J-2

RS-232 Cable

Male DB9 Connector (Mate w/Female on Gina)	Female DB9 Connector (Mate w/Male on IRD WIM)
2	2
3	3
5	5
6	6
7	7
8	8, 20

Qty.	Part No.	Description
1	GINA 6000NV-5T	Extended Temperature Radio Modem
1	IS-50NX-C2	PolyPhaser, Lightning Arrestor
1	30-2000	Flex. Extension Cable
1	30-0040	Omni Antenna
As Needed	LMR 400	Coax Antenna Cable

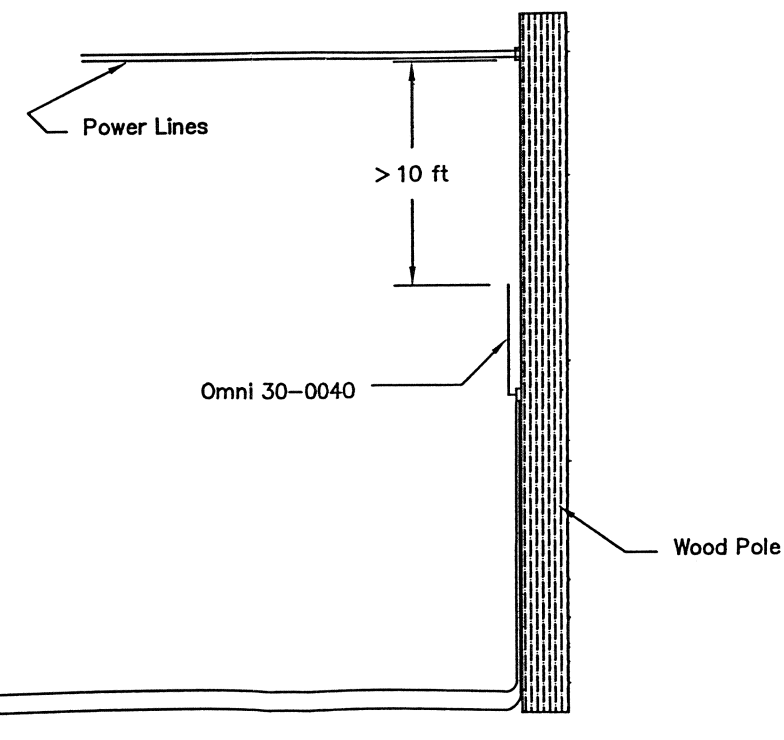
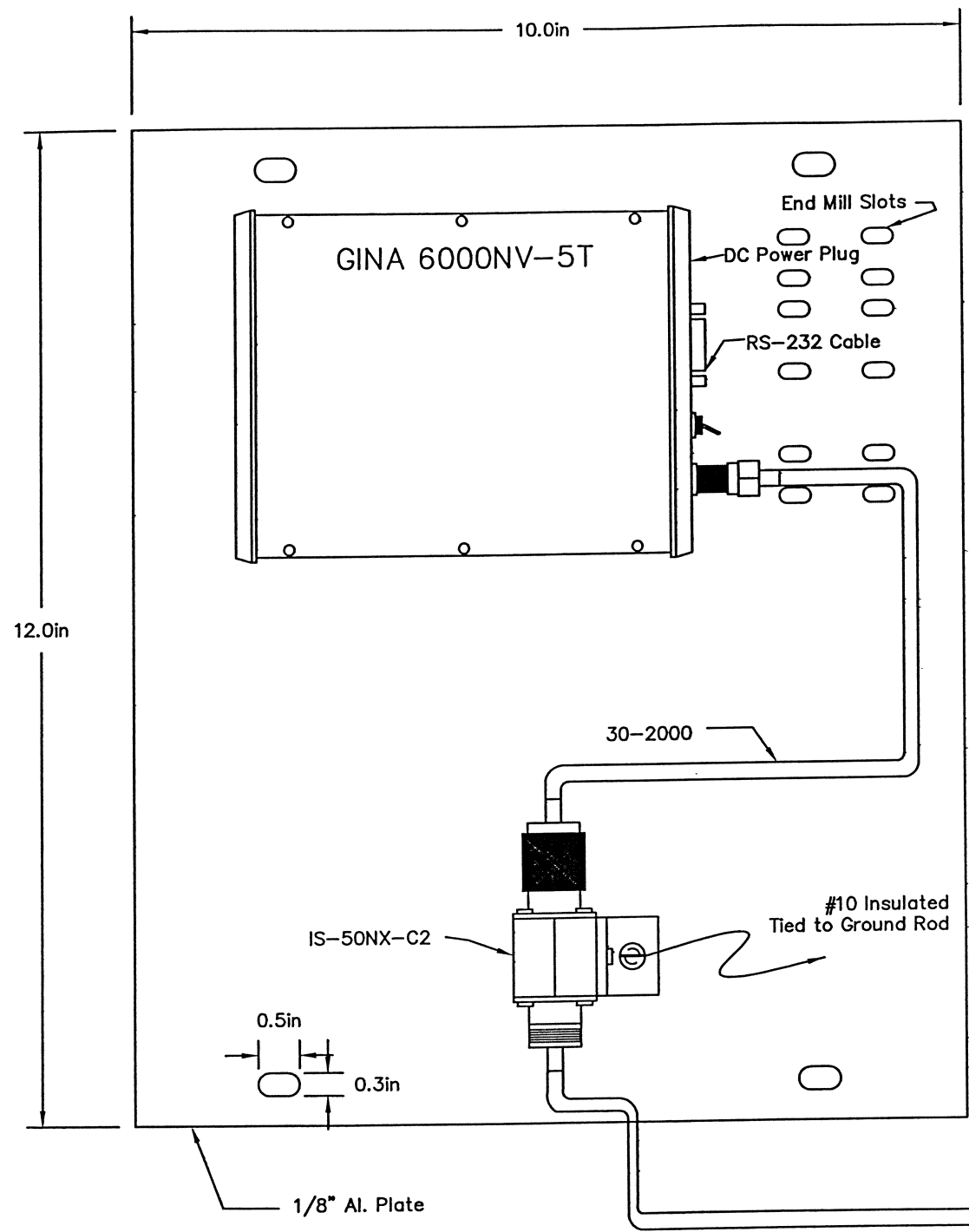

1284 Civil Engineering Bldg.
West Lafayette, IN 47907

Remote Radio
Mounting Assembly

PURDUE
UNIVERSITY

JAR/DMB JAR/JG

Appendix K Summary of SR 1 Data (March – May 2001) Memo

To: Mark Newland, Guy Boruff
 From: Darcy Bullock, Jose Thomaz
 Date: June 25, 2001
 Subject: Summary of SR 1 Weigh In Motion Data from March 18 to May 30, 2001.

As you are aware, you requested that we tabulate the data obtained from the SR 1. The raw data files for this analysis were downloaded from the SR 1 site by Steve Rowlands of Mettler-Toledo. Steve emailed us the data he downloaded during April, May and June approximately every 20 days. Those data files covered the period March 18 to May 30, 2001 and were parsed for Class 9 trucks. Based upon the data we extracted, I offer the following comments:

- The Class 9 truck traffic is approximately evenly split, with slightly more Northbound Class 9 trucks. Tables 1 and 2 report the total Southbound Class 9 traffic during the period was 9455 and the total Northbound Class 9 traffic was 10,059.
- In our June 12, 2001 memo, we reported that during that period, the WIM recorded 2.8 % of the Southbound traffic had GVW's exceeding 80,000 lbs and 0.1% of the Northbound traffic had GVW's exceeding 80,000 lbs. At the request of Guy Boruff we went back and examined the data for over axle and over tandem. That data is now also tabulated in Tables 1 and 2. Somewhat surprisingly, it shows that **11% of the Southbound Class 9 vehicles have overweight tandems. This is more the 5 times the number of Northbound Class 9 vehicles that were measured overweight on their tandem.**
- Figure 1 shows the distribution of Southbound Class 9 volume with Wednesday generally having the highest number and Saturday the lowest.
- Figure 2 shows the number of Southbound Class 9 vehicles with GVW's exceeding 80,000lbs for each day during the study period.
- Figure 3 shows the same general distribution of Northbound Class 9 vehicles.
- Figure 4 shows much fewer Northbound overweight vehicles then shown in Figure 2.
- Figures 5 and 6 shows the average hourly distribution of all Southbound Class 9 vehicles and those Class 9 vehicles with GVW's exceeding 80,000 lbs. Figure 7 and 8 show similar graphs for the Northbound traffic.
- Since there appears to be substantially more Southbound vehicles with GVW's exceeding 80,000 lbs, we examined the Front axle statistics. Figure 9 shows virtual identical histograms for both the Northbound and Southbound lanes. Table 3 shows very similar average front axle weights. In fact, the average Northbound front axle weight is slightly higher then the average Southbound front axle so there does not appear to be any evidence that the Northbound Class 9 vehicles are weighing light (or Southbound weighing heavy). However, in order to verify this, several Class 9 trucks should be stopped and their static weight compared to the WIM.
- We examined the distribution of GVW's for both the Northbound and Southbound directions. Figure 10 shows the histogram from 0 to 100,000lbs, Figure 11 shows the same data with the histogram zoomed in on the just the tail near 80,000 lbs. From these histograms, one can see that the Northbound Class 9 traffic is skewed such that there is a substantial number of vehicles with GVW's just under 80,000 lbs, but very few exceeding 80,000 lbs (Table 2). In contrast, the Southbound Class 9 traffic is more evenly distributed, but approximately 258 (Table 1) Class 9 vehicles during the period exceed 80,000 lbs.
- From inspecting the raw data, 5 Southbound Class 9 vehicles exceeded 90, 000 lbs during this period. Those GVW's were 94900, 92020, 90820, 90480, 90380 and occurred on May 30, May 11, May 6, April 10, and March 20' respectively. Although the heaviest GVW's are the most recent, Figure 2 does not appear to show any evidence that the number of Class 9 vehicles with GVW's exceeding 80,000 lbs is increasing.
- Figures 12 and 13 show the histograms for axle and tandem weights during this period.

- **Figure 14** shows the histograms by the time of day the overweight tandems were observed at the South bound station. **In comparison to over GVW South bound vehicles shown in Figure 6, it appears that a detail targeting over tandem trucks might be reasonably successful since there are several hours where on average more then 1 truck per hour per day is overweight on their tandem.**

Table 1: SR 1 WIM Station, Southbound.

	March 18-31, 2001	April 1-30, 2001	May 1-30, 2001	Total
Total Class 9 Vehicles	1776	3649	3772	9197
Class 9 Vehicles with GVW>80k	68	117	73	258
Class 9 Vehicles with an Axle > 20k	12	21	17	50
Class 9 Vehicles with a Tandem > 34k	232	416	441	1089
% Overweight GVW	3.8%	3.2%	1.9%	2.8%
% Over Axle	0.7%	0.6%	0.4%	0.5%
% Over Tandem	13.1%	11.4%	11.7%	11.8%

Table 2: SR 1 WIM Station, Northbound.

	March 18-31, 2001	April 1-30, 2001	May 1-30, 2001	Total
Total Class 9 Vehicles	2018	4066	3971	10,045
Class 9 Vehicles with GVW>80k	1	7	6	14
Class 9 Vehicles with an Axle > 20k	1	4	1	6
Class 9 Vehicles with a Tandem > 34k	39	91	72	202
% Overweight GVW	0.0%	0.2%	0.2%	0.1%
% Over Axle	0.0%	0.1%	0.0%	0.1%
% Over Tandem	1.9%	2.2%	1.8%	2.0%

Table 3: Average Front Axle and GVW Weights.

Lane	Average Front Axle Load (lbs)	St.Dev. Front Axle Load (lbs)	Average GVW (lbs)	St.Dev. GVW (lbs)
Southbound	10,190	1,259	57,822	15,340
Northbound	10,508	1,159	55,886	15,271

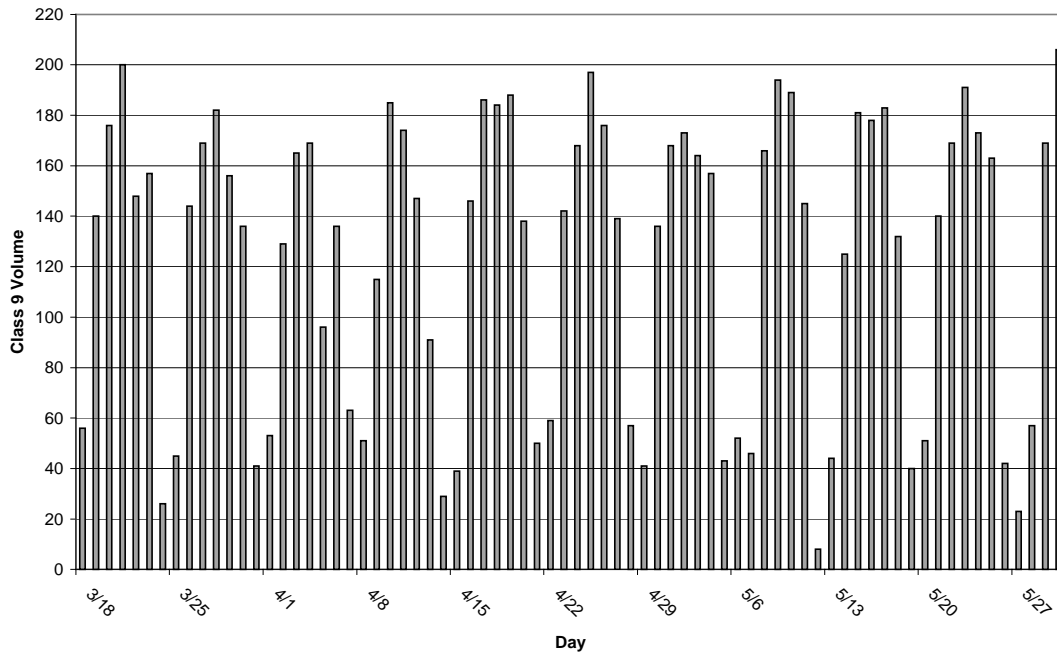

Figure 1: Southbound Class 9 Volume on SR 1 for March 18 to May 30, 2001

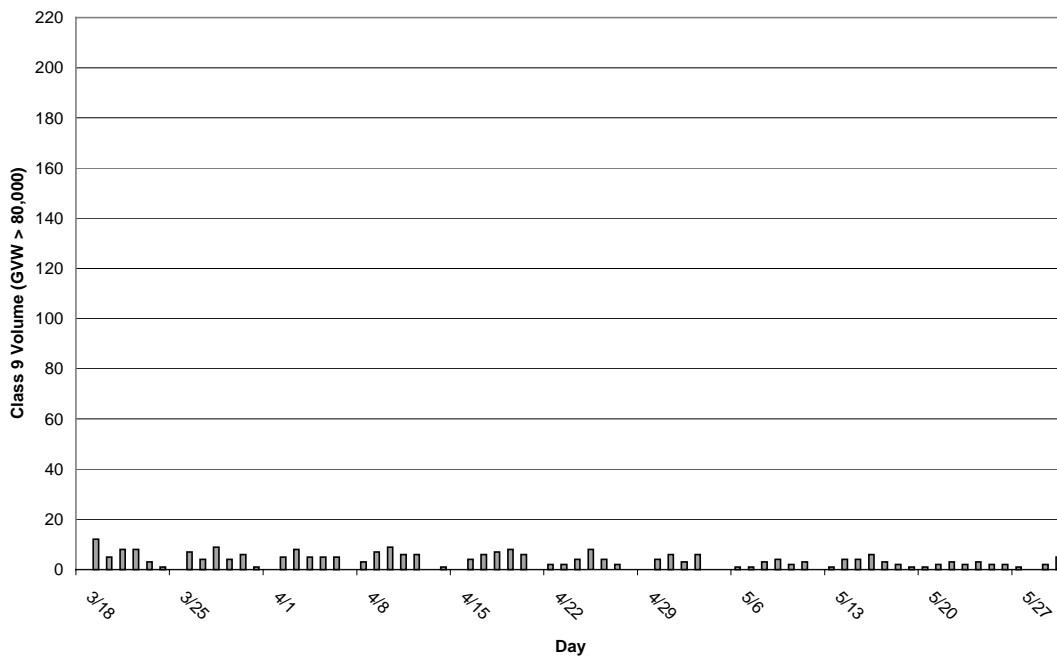

Figure 2: Southbound Class 9 Volume on SR 1 with GVW>80,000lbs for March 18 to May 30, 2001

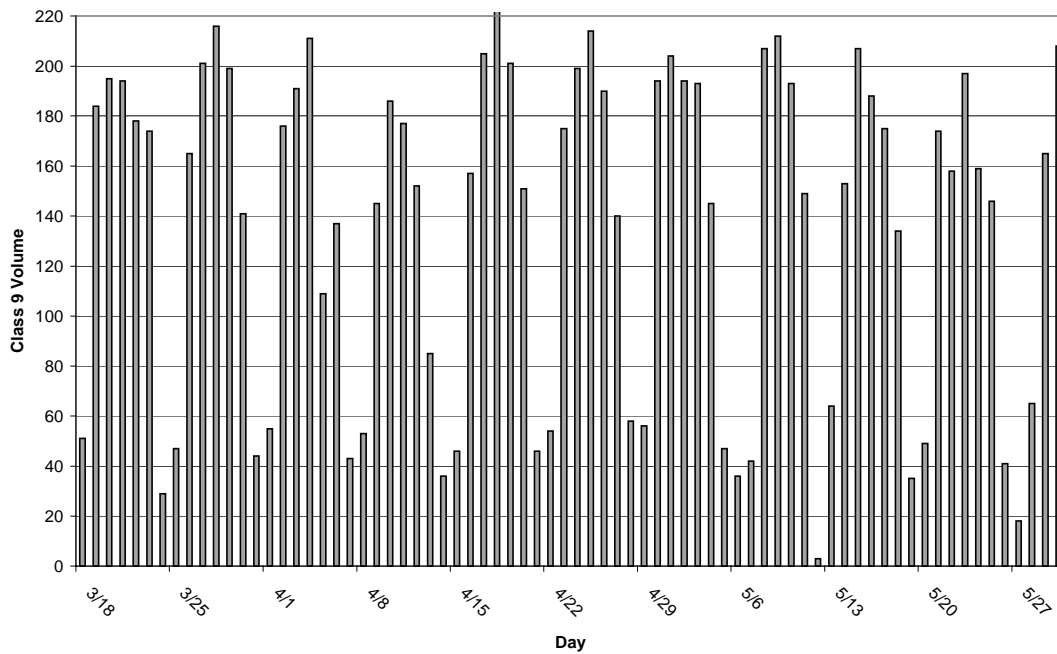

Figure 3: Northbound Class 9 Volume on SR 1 for March 18 to May 30, 2001

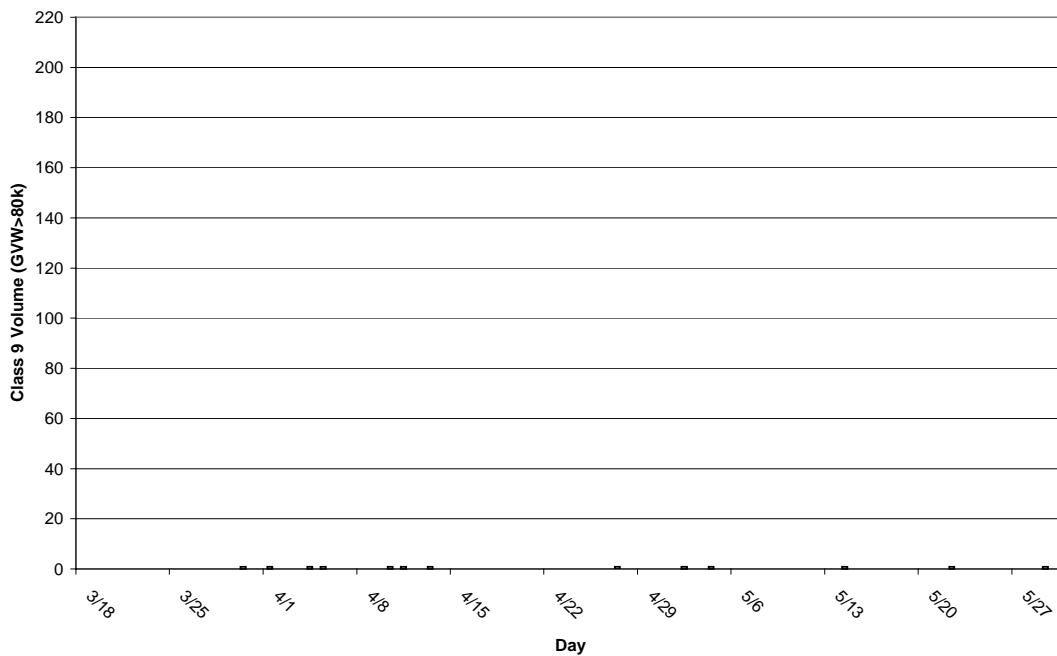

Figure 4: Northbound Class 9 Volume on SR 1 with GVW > 80,000 lbs for March 18 to May 30, 2001

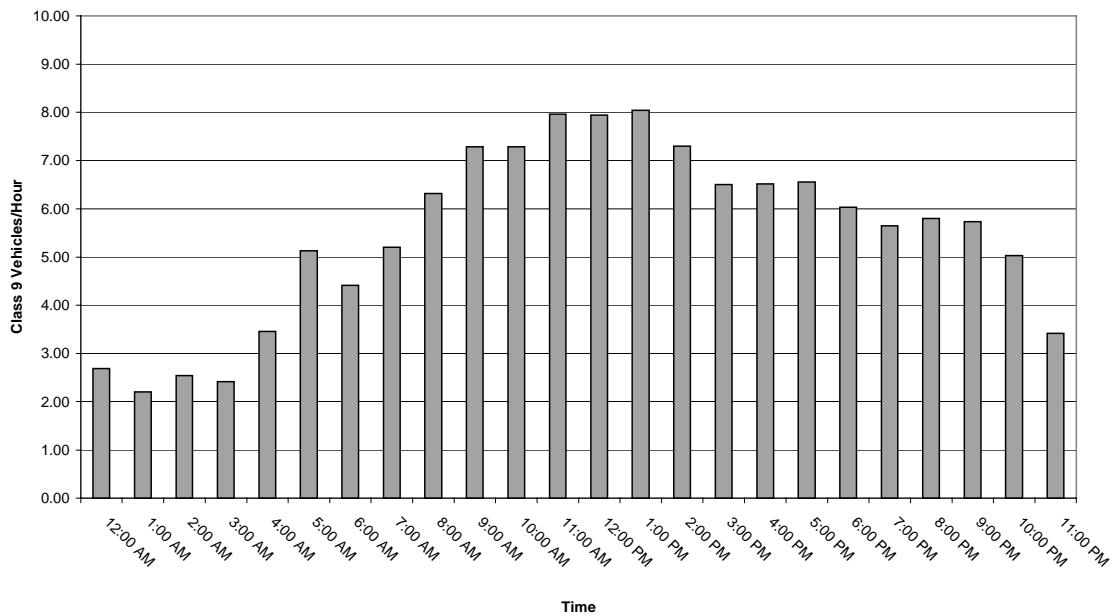

Figure 5: Average Hourly Southbound Class 9 Volume on SR 1 for March-May, 2001

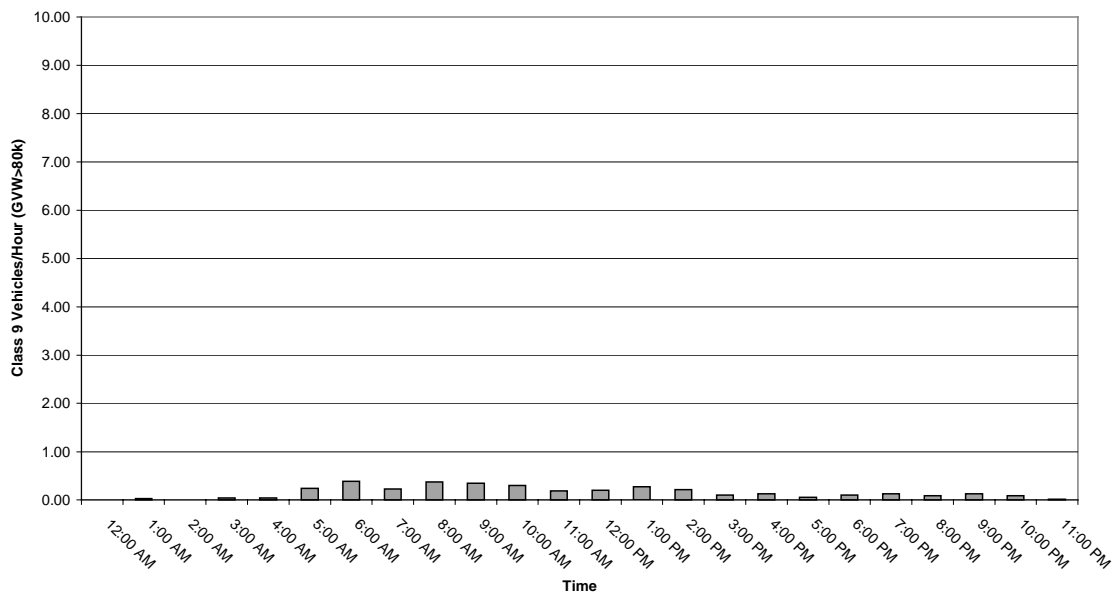

Figure 6: Average Hourly Southbound Class 9 Volume with GVW>80,000 on SR 1 for March-May, 2001

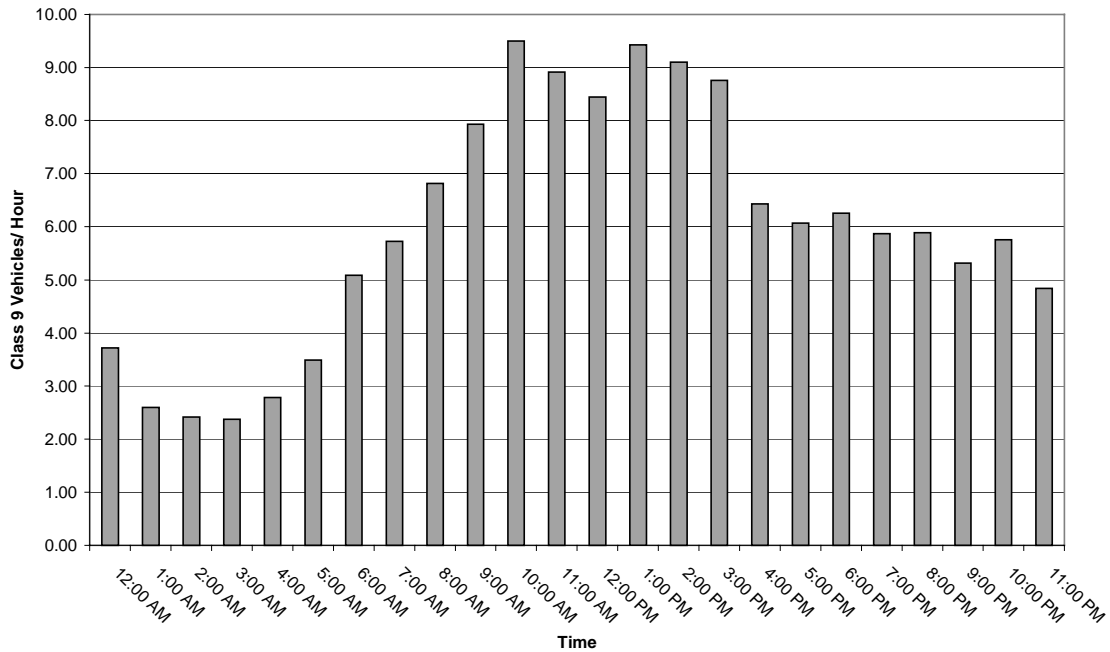

Figure 7: Average Hourly Northbound Class 9 Volume on SR 1 for March-May, 2001

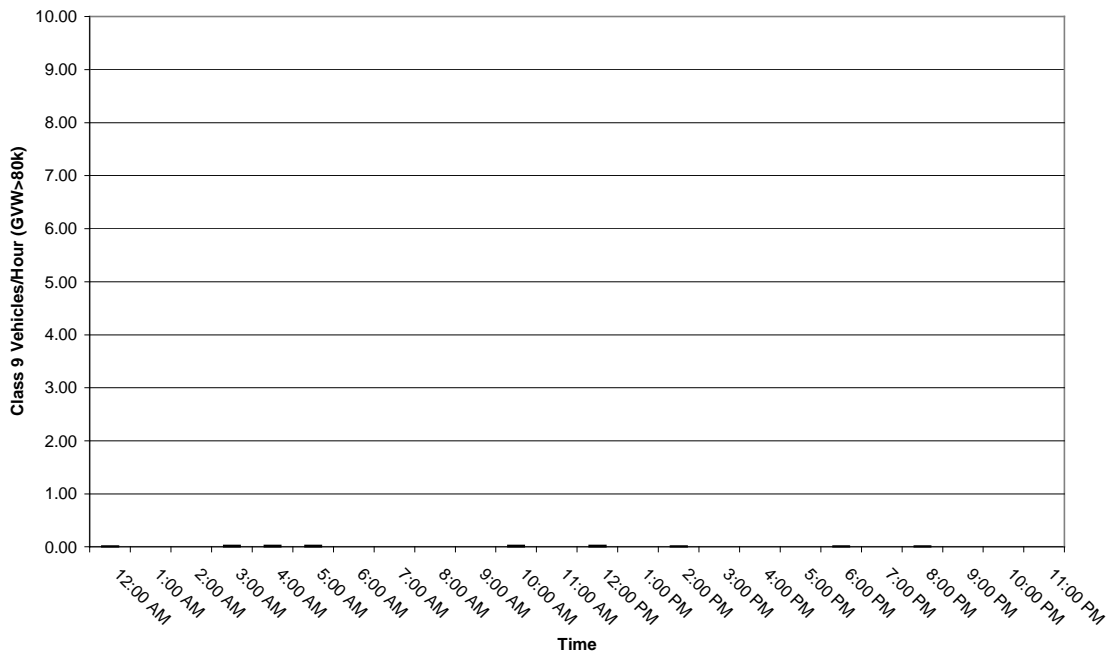

Figure 8: Average Hourly Northbound Class 9 Volume with GVW>80,000 on SR 1 for March-May, 2001

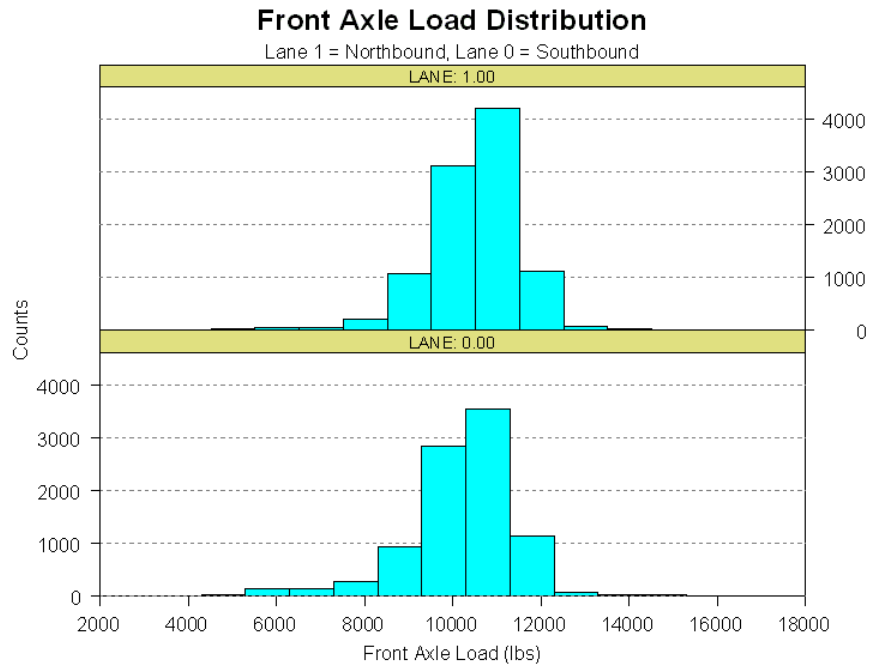

Figure 9: Average Class 9 Front Axle Weight Distribution on SR 1 for March-May, 2001

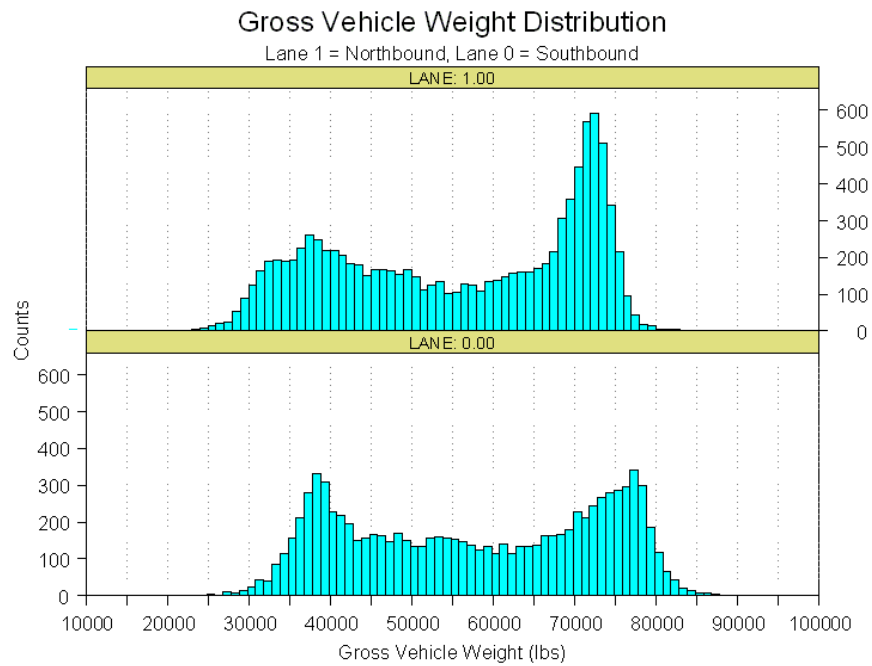

Figure 10: Distribution of Class 9 GVW, March 18-May 30, 2001.

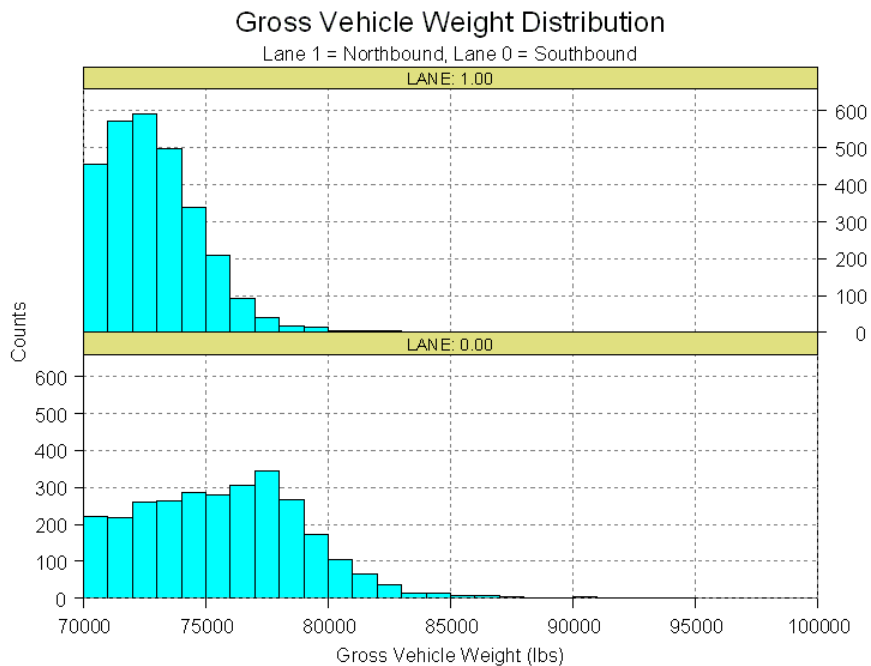

Figure 11: Distribution of Class 9 GVW, Zoomed in graph of same data shown in Figure 10.

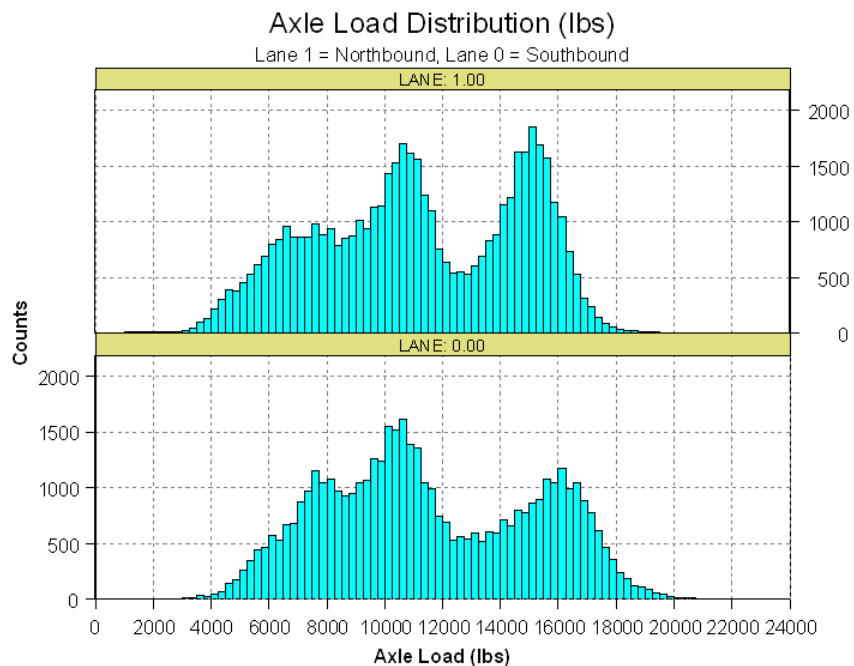

Figure 12: Distribution of Class 9 Axle Weight, March 18-May 30, 2001.

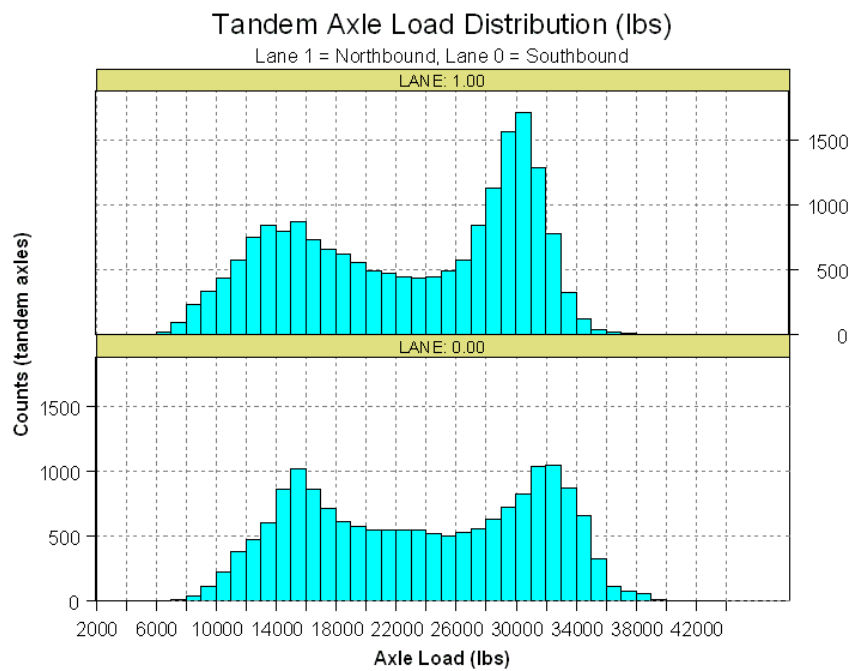

Figure 13: Distribution of Class 9 Tandem Weight, March 18-May 30, 2001.

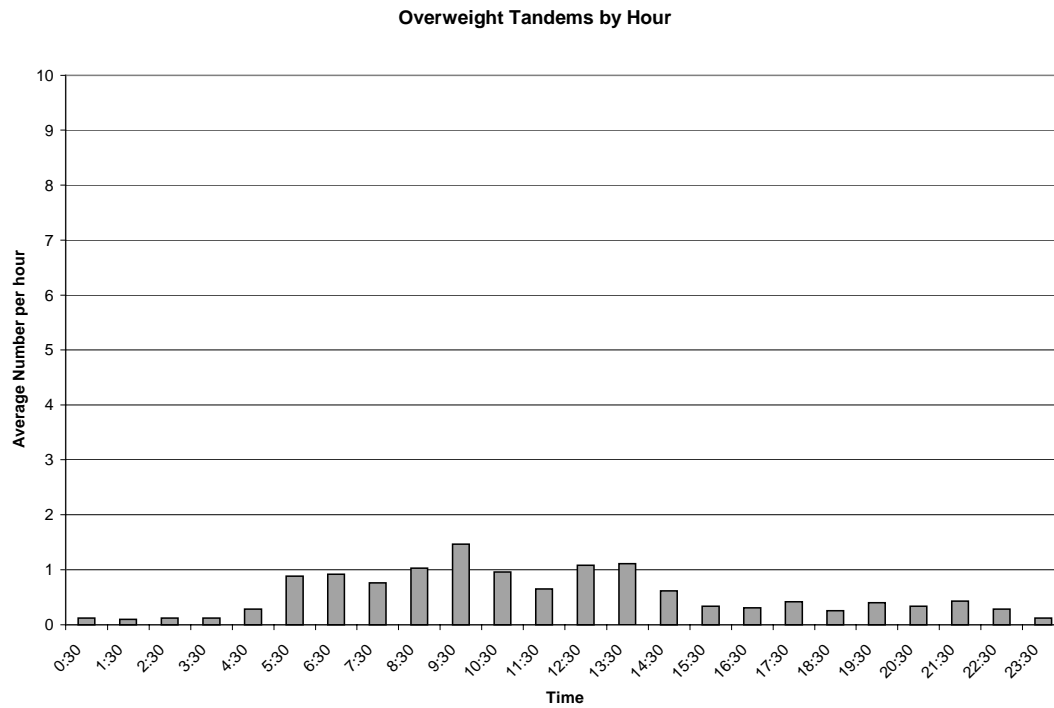

Figure 14: Distribution of Southbound Class 9 Tandem Over weights by hour, March-May, 2001.

Appendix L Summary of SR 1 Data (March – July 2001) Memo

To: Mark Newland, Guy Boruff

From: Darcy Bullock, Jose Thomaz, Andrew Nichols

Date: September 12, 2001

Subject: Summary of SR 1 Weigh In Motion Data

March 18 – May 2001

As you are aware, you requested that we tabulate the data obtained from the SR 1. The raw data files for this analysis were downloaded from the SR 1 site by Steve Rowlands of Mettler-Toledo. Steve emailed us the data he downloaded during April, May and June approximately every 20 days. Those data files covered the period March 18 to May 30, 2001 and were parsed for Class 9 trucks. Based upon the data we extracted, I offer the following comments:

- The Class 9 truck traffic is approximately evenly split, with slightly more Northbound Class 9 trucks. Table 1 and Table 2, columns 1, 2, and 3 report the total Southbound Class 9 traffic during the period was 9455 and the total Northbound Class 9 traffic was 10,059.
- In our June 12, 2001 memo, we reported that during that period, the WIM recorded 2.8 % of the Southbound traffic had GVW's exceeding 80,000 lbs and 0.1% of the Northbound traffic had GVW's exceeding 80,000 lbs. At the request of Guy Boruff we went back and examined the data for over axle and over tandem. That data is now also tabulated in Table 1 and Table 2, columns 1, 2, and 3. Somewhat surprisingly, it shows that **11% of the Southbound Class 9 vehicles have overweight tandems. This is more the 5 times the number of Northbound Class 9 vehicles that were measured overweight on their tandem.**
- Figure 1 shows the distribution of Southbound Class 9 volume with Wednesday generally having the highest number and Saturday the lowest.
- Figure 2 shows the number of Southbound Class 9 vehicles with GVW's exceeding 80,000lbs for each day during the study period.
- Figure 3 shows the same general distribution of Northbound Class 9 vehicles.
- Figure 4 shows much fewer Northbound overweight vehicles then shown in Figure 2.
- Figure 5 and Figure 6 shows the average hourly distribution of all Southbound Class 9 vehicles and those Class 9 vehicles with GVW's exceeding 80,000 lbs. Figure 7 and Figure 8 show similar graphs for the Northbound traffic.
- Since there appears to be substantially more Southbound vehicles with GVW's exceeding 80,000 lbs, we examined the Front axle statistics. Figure 9 shows virtual identical histograms for both the Northbound and Southbound lanes. Table 3 shows very similar average front axle weights. In fact, the average Northbound front axle weight is slightly higher then the average Southbound front axle so there does not appear to be any evidence that the Northbound Class 9 vehicles are weighing light (or Southbound weighing heavy). However, in order to verify this, several Class 9 trucks should be stopped and their static weight compared to the WIM.
- We examined the distribution of GVWs for both the Northbound and Southbound directions. Figure 10 shows the histogram from 0 to 100,000lbs, Figure 11 shows the same data with the histogram zoomed in on the just the tail near 80,000 lbs. From these histograms, one can see that the Northbound Class 9 traffic is skewed such that there are a substantial number of vehicles with GVW's just fewer than 80,000 lbs, but very few exceeding 80,000 lbs (Table 2). In contrast, the Southbound Class 9 traffic is more evenly distributed, but approximately 258 (Table 1) Class 9 vehicles during the period exceed 80,000 lbs.
- From inspecting the raw data, 5 Southbound Class 9 vehicles exceeded 90, 000 lbs during this period. Those GVW's were 94900, 92020, 90820, 90480, 90380 and occurred on May 30, May 11, May 6, April 10, and March 20' respectively. Although the heaviest GVW's are the most recent, Figure 2 does not appear to show any evidence that the number of Class 9 vehicles with GVW's exceeding 80,000 lbs is increasing.

- Figure 12 and Figure 13 show the histograms for axle and tandem weights during this period.
- Figure 14 shows the histograms by the time of day the overweight tandems were observed at the South bound station. **In comparison to over GVW South bound vehicles shown in Figure 6, it appears that a detail targeting over tandem trucks might be reasonably successful since there are several hours where on average more than 1 truck per hour per day is overweight on their tandem.**

June-July 2001

- The overall volume of Class 9 vehicles in both directions was approximately the same with 7,035 Southbound and 7,587 Northbound during June and July.
- The monthly volumes decreased by nearly 300 vehicles between June and July in both directions, as detailed in Table 1 and Table 2. In the Northbound direction, the volumes decreased monthly over the period from April to July.
- The number of Class 9 vehicles with gross vehicle weights greater than 80,000 lbs during the June-July period was 9 in the Northbound direction, but was 103 in the Southbound direction.
- In the Southbound direction, the number of GVW overweights continued to decrease over the period of analysis from 117 in April to 36 in July, as shown in Table 1.
- **In the Southbound direction, the percentage of overweight GVW, axle, and tandems has steadily decreased from April to July, as shown in Table 1.**
- In June and July the number of overweight tandems is still more frequent than the overweight axles and GVW in both directions, with the Southbound direction having the higher rate of overweights overall.
- The maximum GVW in the Southbound direction was 95,560 lbs and the max in the Northbound direction was 92,320 lbs (Table 4).
- The average front axle and GVW between the April-May period (Table 3) and the June-July period (Table 4) remained consistent for each direction.
- The time of day with the highest average number of Southbound overweight tandems is 9:00 – 9:59 AM for both March-May (Figure 14) and June-July (Figure 27).
- The following data were missing for this period:
- GVW > 80k 6/4, 6/21, 6/29, 7/4, 7/21, 7/29
- Axle > 20k 6/4, 6/5, 6/9, 6/15, 6/18, 6/19, 6/21, 6/22, 6/24, 6/29, 7/4, 7/5, 7/9, 7/15, 7/18, 7/19, 7/21, 7/22, 7/24, 7/29, 7/31

Table 1: SR 1 WIM Station, Southbound.

	March 18-31, 2001	April 2001	May 2001	June 2001	July 2001	Total
Total Class 9 Vehicles	1776	3649	3772	3659	3376	16232
Class 9 Vehicles with GVW>80k	68	117	73	67	36	361
Class 9 Vehicles with an Axle > 20k	12	21	17	16	9	75
Class 9 Vehicles with a Tandem > 34k	232	416	441	379	283	1751
% Overweight GVW	3.8%	3.2%	1.9%	1.8%	1.1%	2.2%
% Over Axle	0.7%	0.6%	0.4%	0.4%	0.3%	0.5%
% Over Tandem	13.1%	11.4%	11.7%	10.4%	8.4%	10.8%

Table 2: SR 1 WIM Station, Northbound.

	March 18-31, 2001	April 2001	May 2001	June 2001	July 2001	Total
Total Class 9 Vehicles	2018	4066	3971	3970	3617	17642
Class 9 Vehicles with GVW>80k	1	7	6	7	2	23
Class 9 Vehicles with an Axle > 20k	1	4	1	2	4	12
Class 9 Vehicles with a Tandem > 34k	39	91	72	65	48	315
% Overweight GVW	0.0%	0.2%	0.2%	0.2%	0.0%	0.1%
% Over Axle	0.0%	0.1%	0.0%	0.0%	0.1%	0.1%
% Over Tandem	1.9%	2.2%	1.8%	1.6%	1.3%	1.8%

Table 3: Average Front Axle and GVW Weights March 18-May 2001

Lane	Average Front Axle Load (lbs)	St.Dev. Front Axle Load (lbs)	Average GVW (lbs)	St.Dev. GVW (lbs)
Southbound	10,190	1,259	57,822	15,340
Northbound	10,508	1,159	55,886	15,271

Table 4: Average Front Axle and GVW Weights June-July 2001

Lane	Average Front Axle Load (lbs)	St.Dev. Front Axle Load (lbs)	Max Front Axle Load (lbs)	Average GVW (lbs)	St.Dev. GVW (lbs)	Max GVW (lbs)
Southbound	10,020	1,213	15560	56,703	15,019	95560
Northbound	10,530	1,164	19460	55,512	15,091	92320

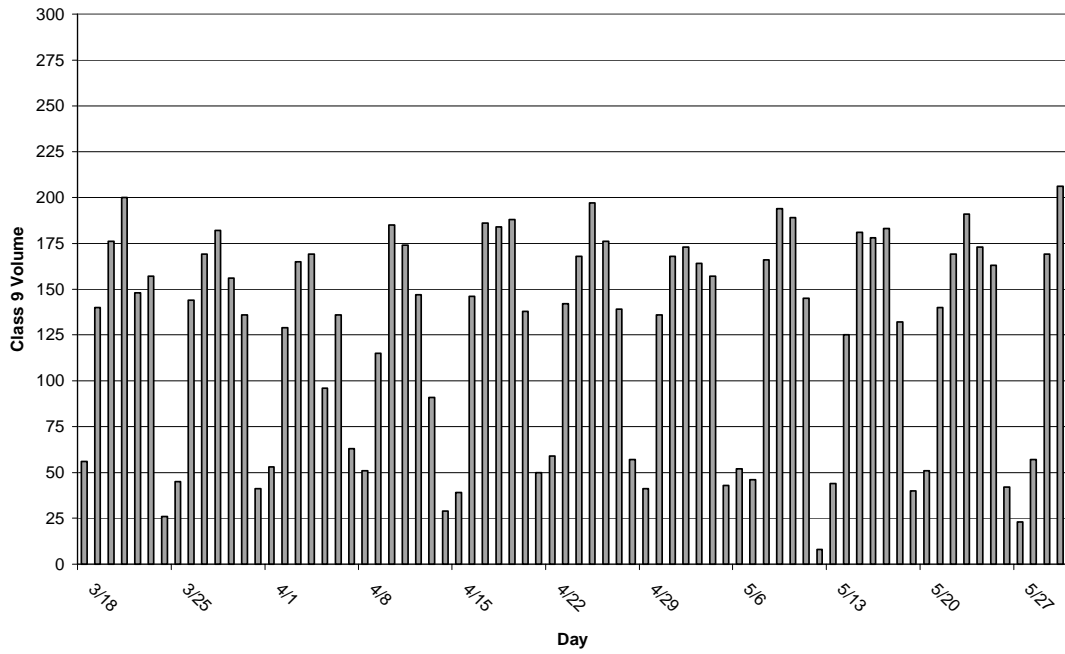

Figure 1: Southbound Class 9 Volume on SR 1 for March 18 to May 2001

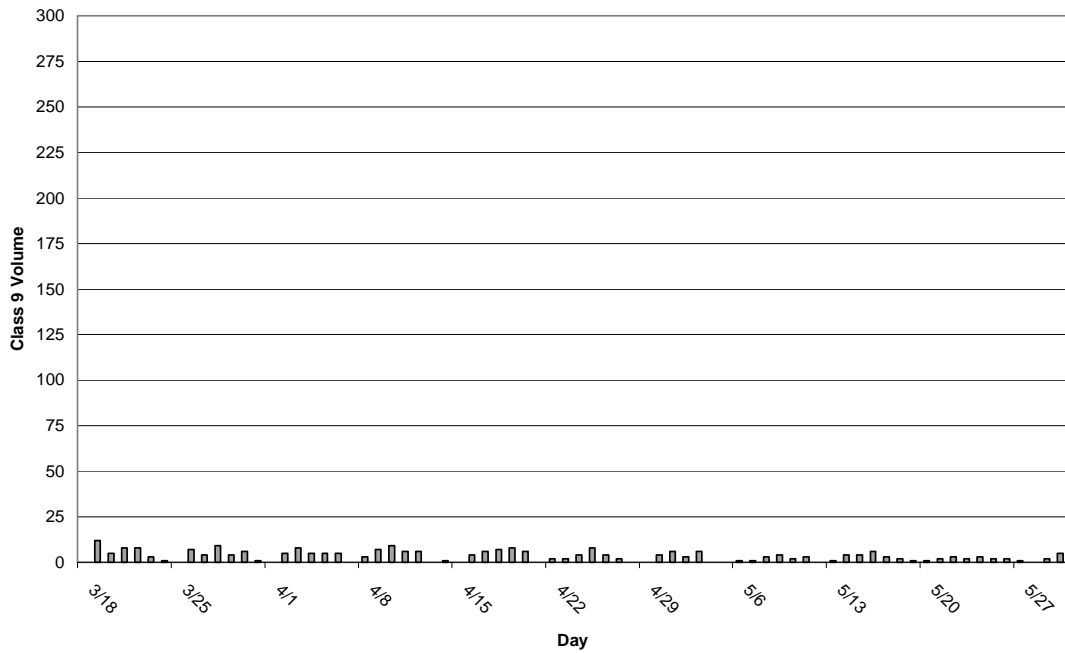

Figure 2: Southbound Class 9 Volume on SR 1 with GVW > 80,000 for March 18 to May 2001

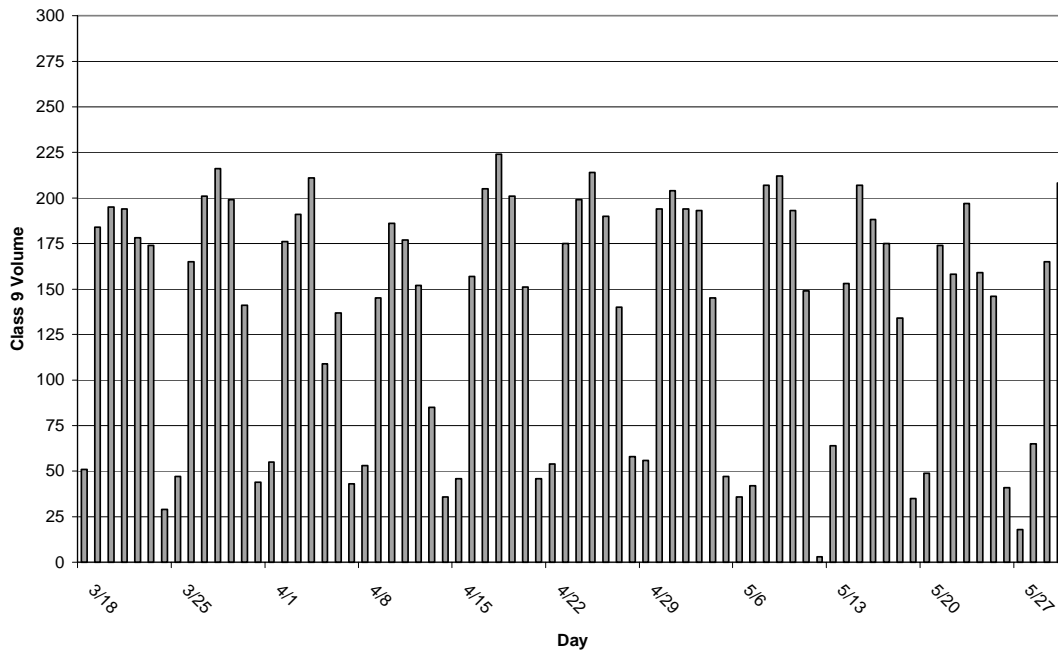

Figure 3: Northbound Class 9 Volume on SR 1 for March 18 to May 2001

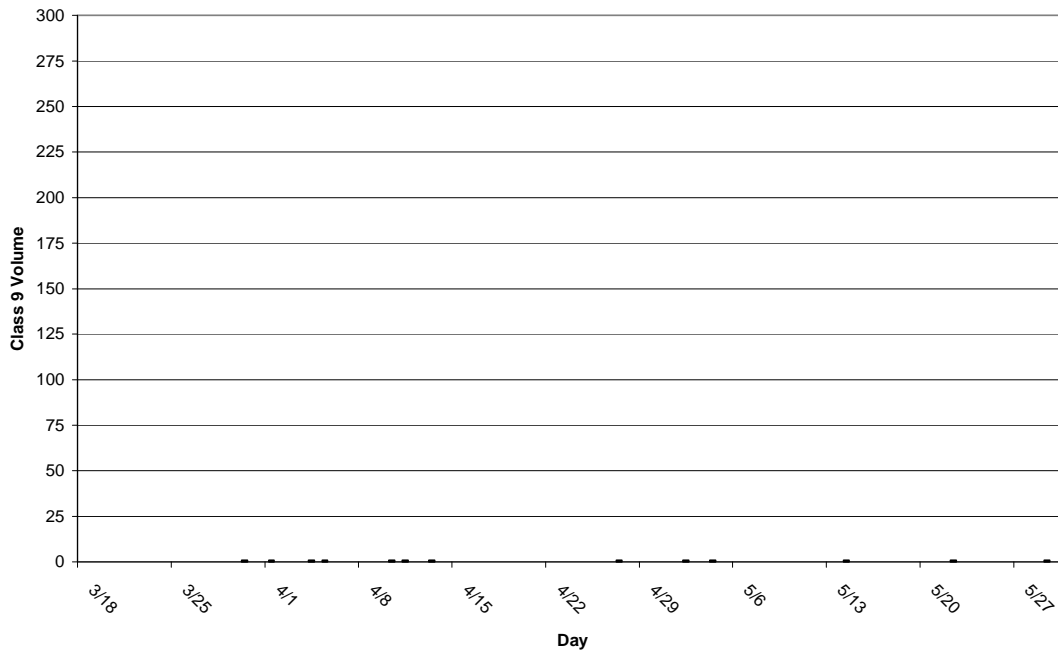

Figure 4: Northbound Class 9 Volume on SR 1 with GVW>80,000 for March 18 to May 2001

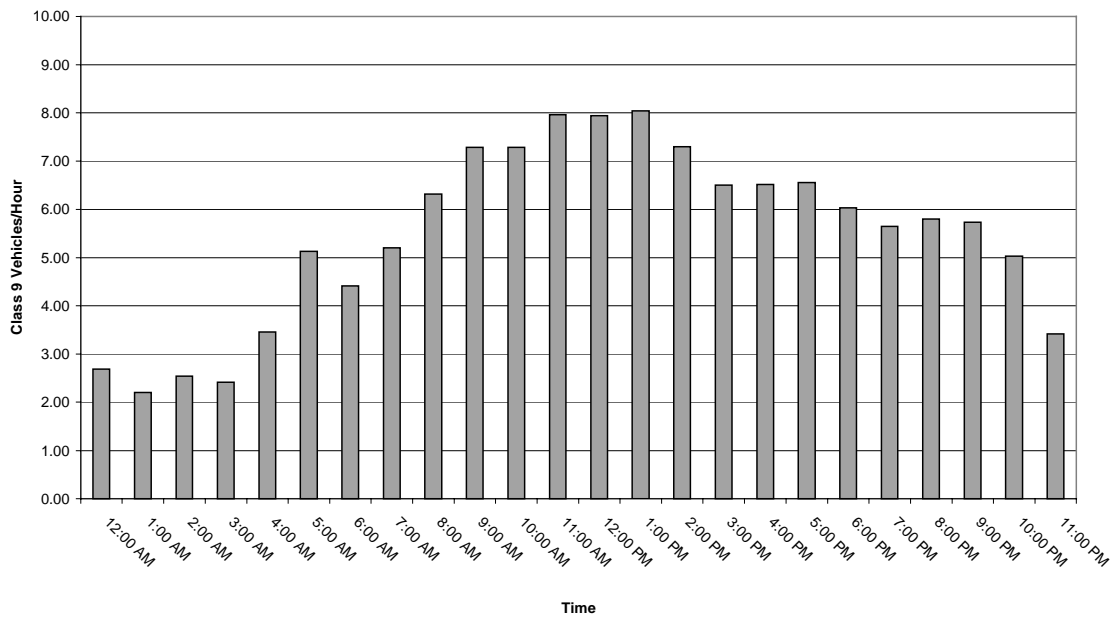

Figure 5: Average Hourly Southbound Class 9 Volume on SR 1 for March 18 to May 2001

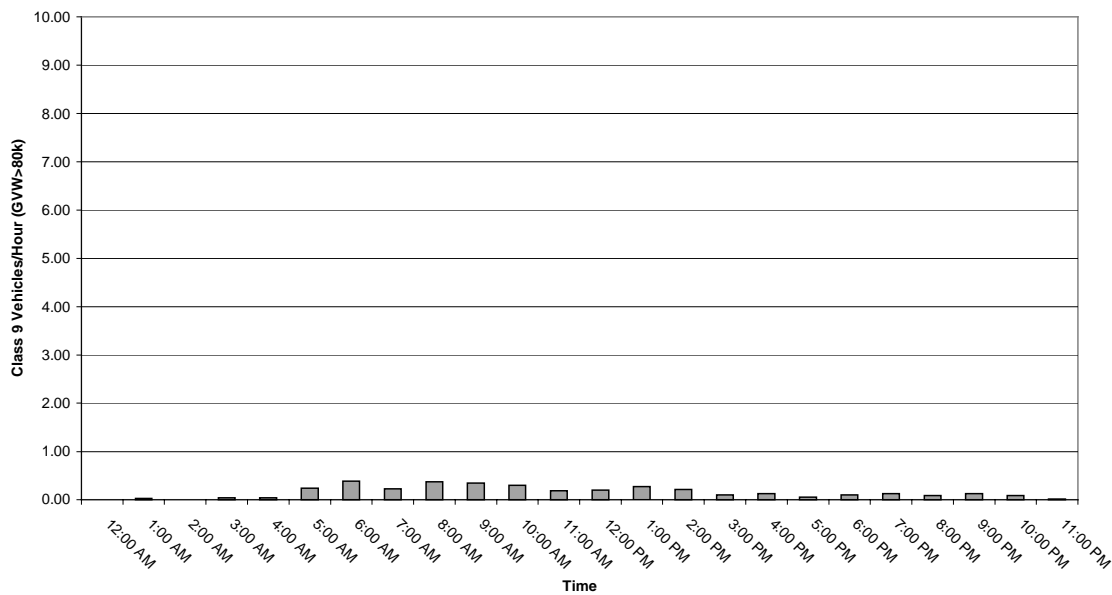

Figure 6: Average Hourly Southbound Class 9 Volume with GVW>80,000 on SR 1 for March 18 to May 2001

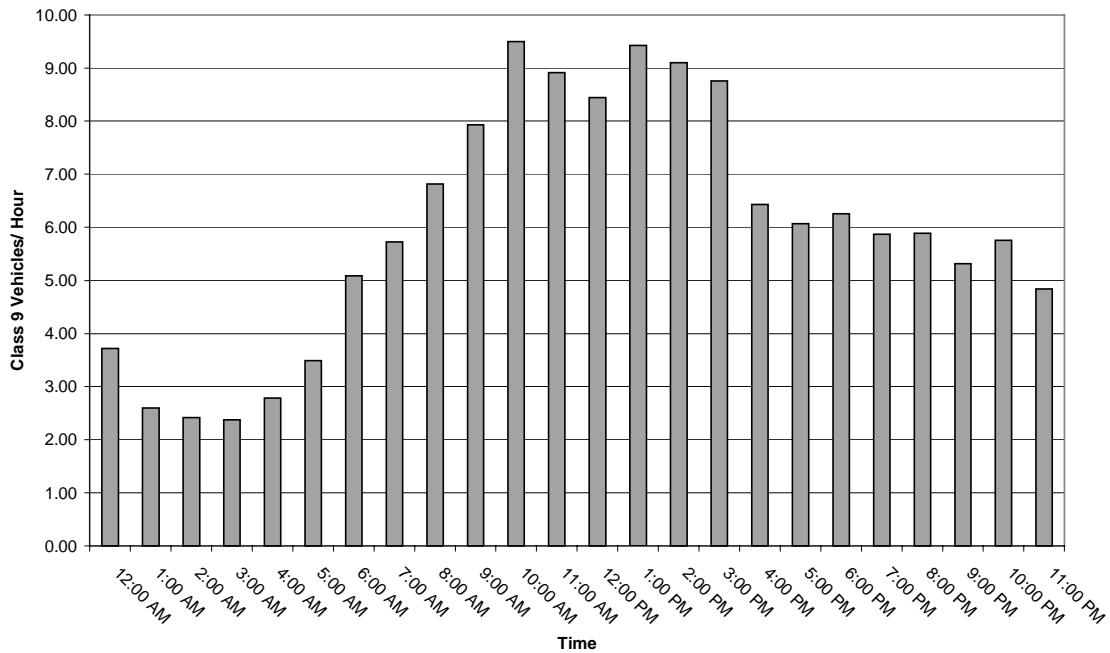

Figure 7: Average Hourly Northbound Class 9 Volume on SR 1 for March18 to May 2001

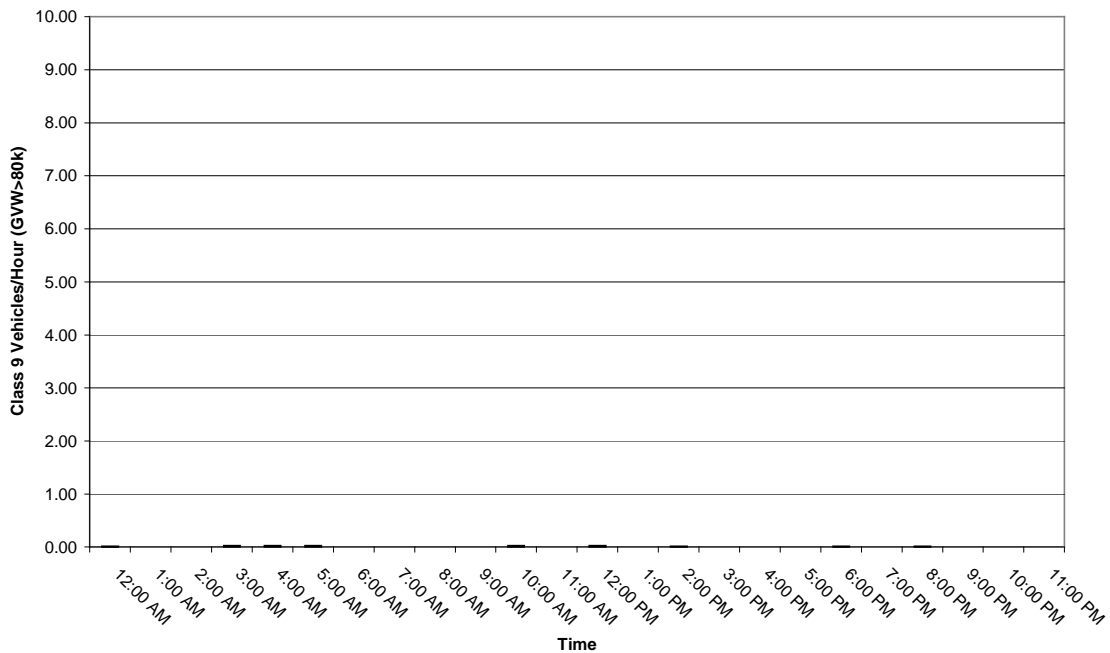

Figure 8: Average Hourly Northbound Class 9 Volume with GVW>80,000 on SR 1 for March 18 to May 2001

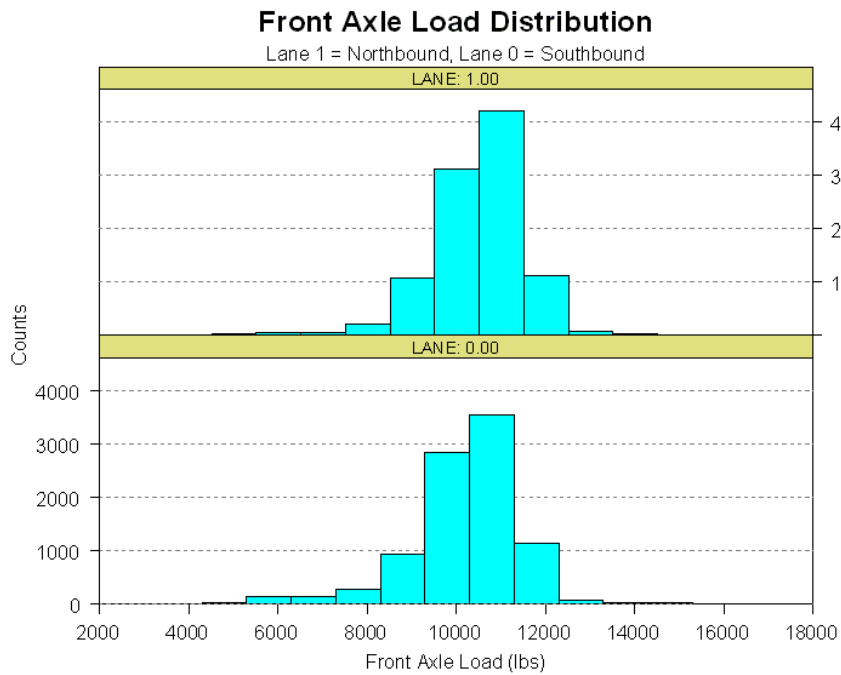

Figure 9: Average Class 9 Front Axle Weight Distribution on SR 1 for March 18 to May 2001

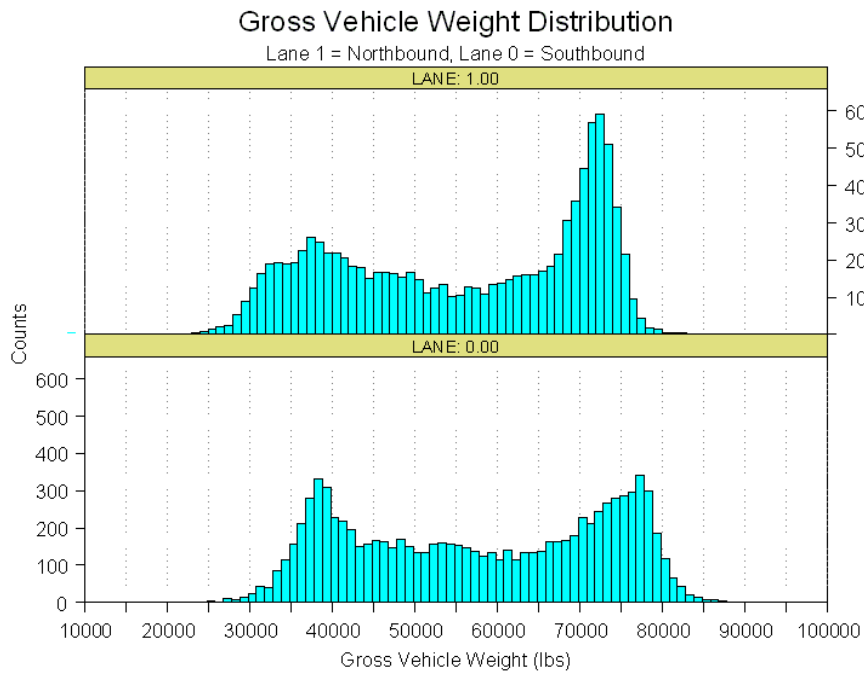

Figure 10: Distribution of Class 9 GVW, March 18 to May 2001

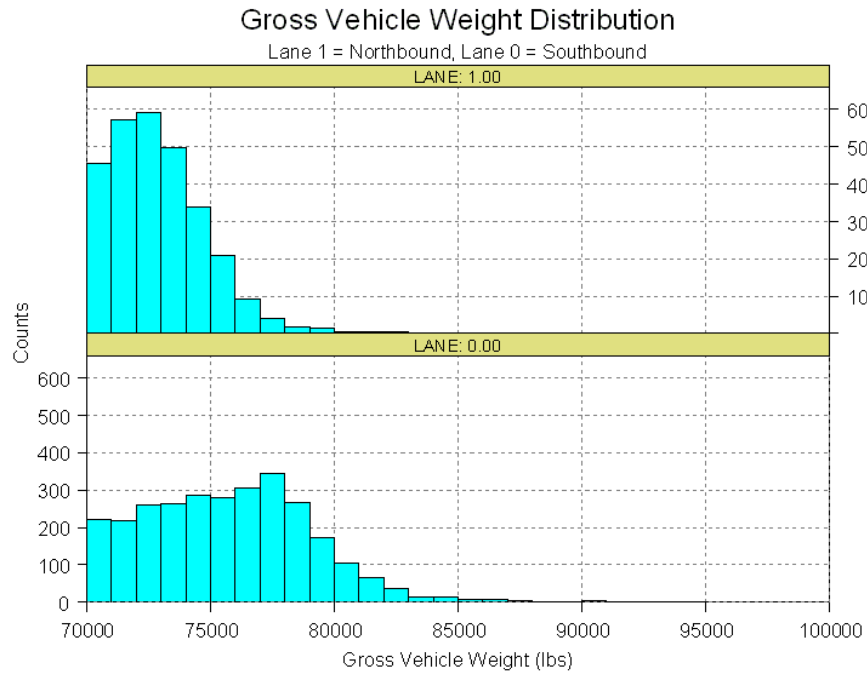

Figure 11: Distribution of Class 9 GVW, Zoomed in graph of same data shown in Figure 10 Figure

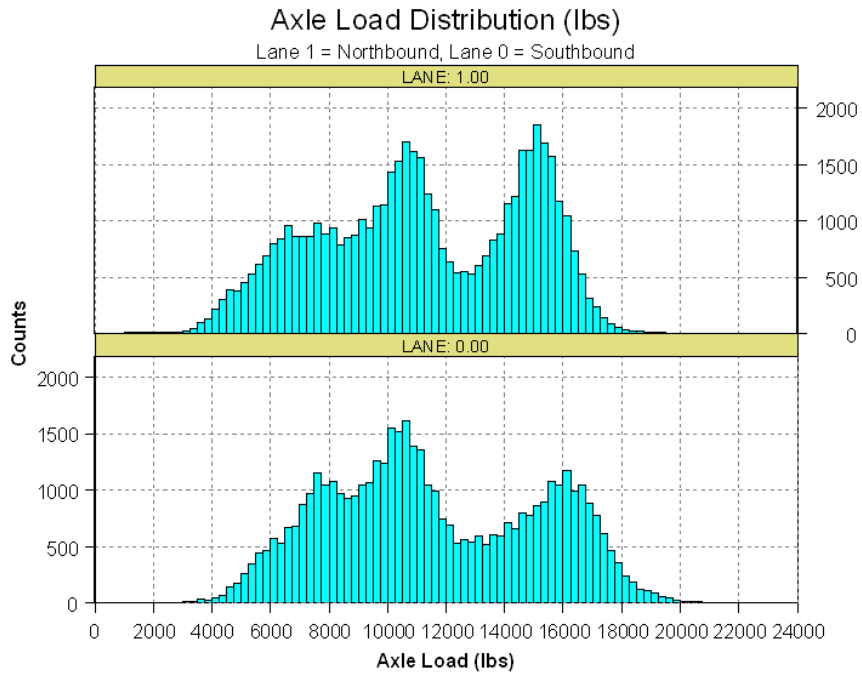

Figure 12: Distribution of Class 9 Axle Weight, March 18 to May 2001

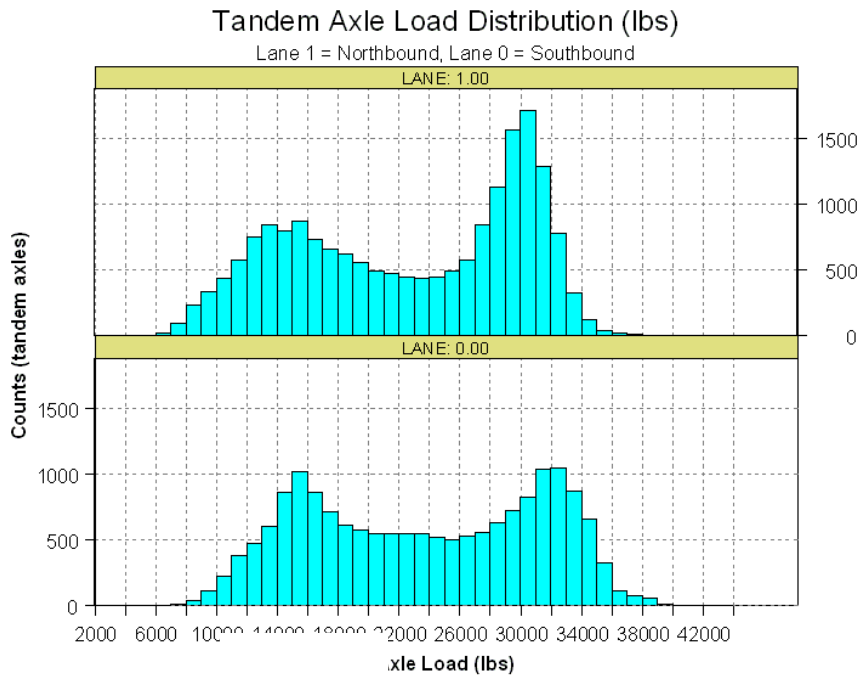

Figure 13: Distribution of Class 9 Tandem Weight, March 18 to May 2001

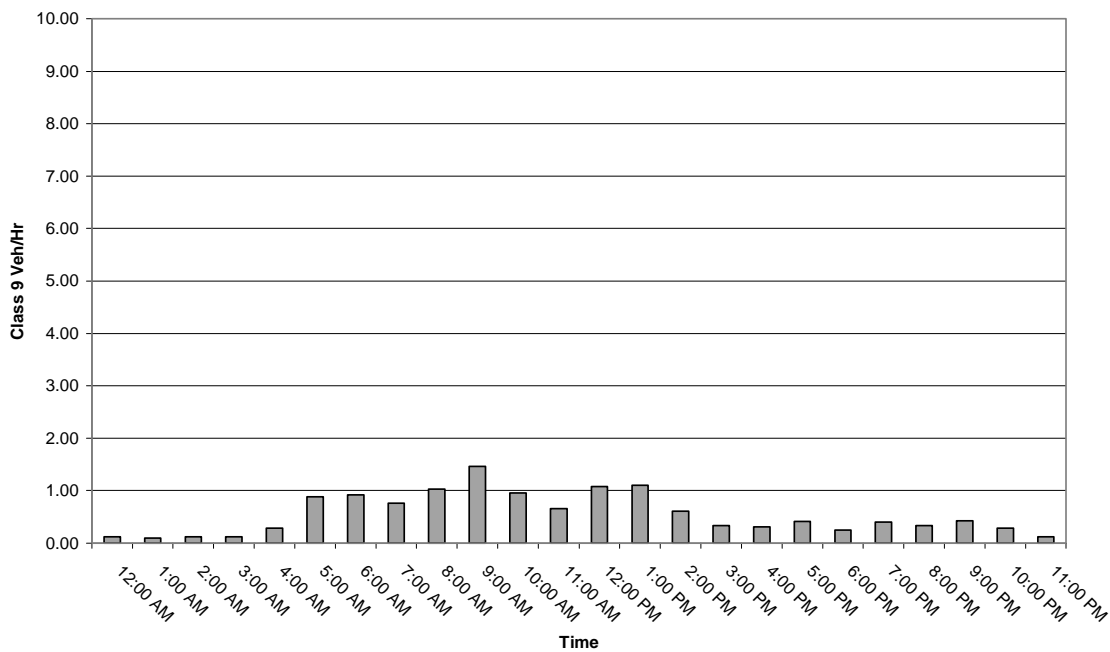

Figure 14: Average Hourly Southbound Class 9 Volume with Tandem>34,000 on SR1 for March 18 to May 2001

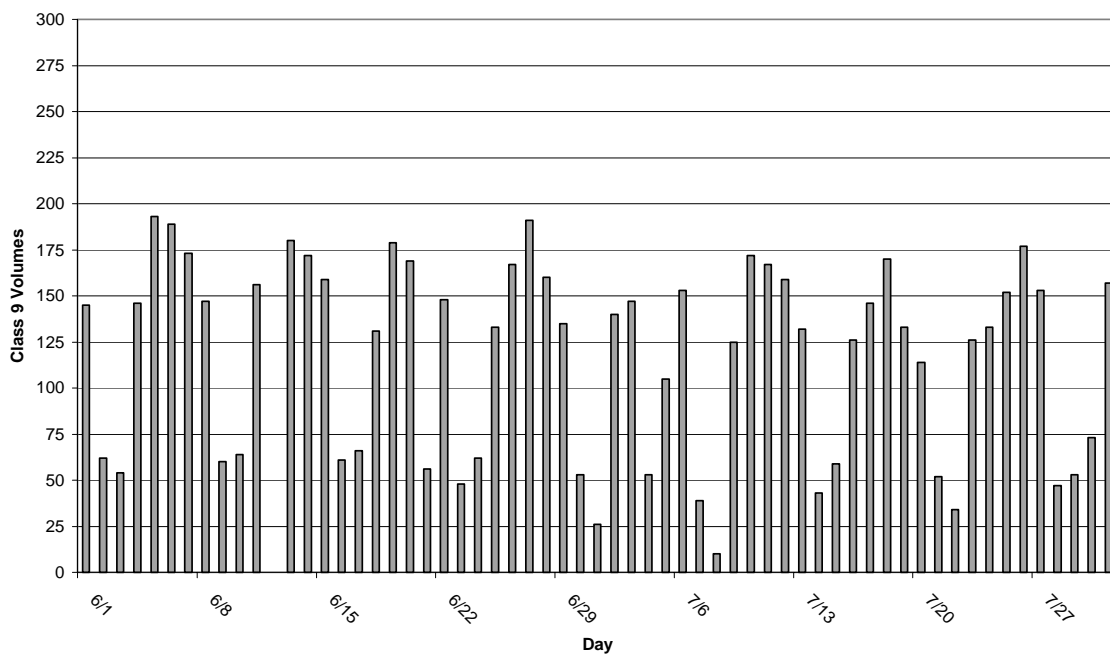

Figure 15: Southbound Class 9 Volume on SR 1 for June-July 2001

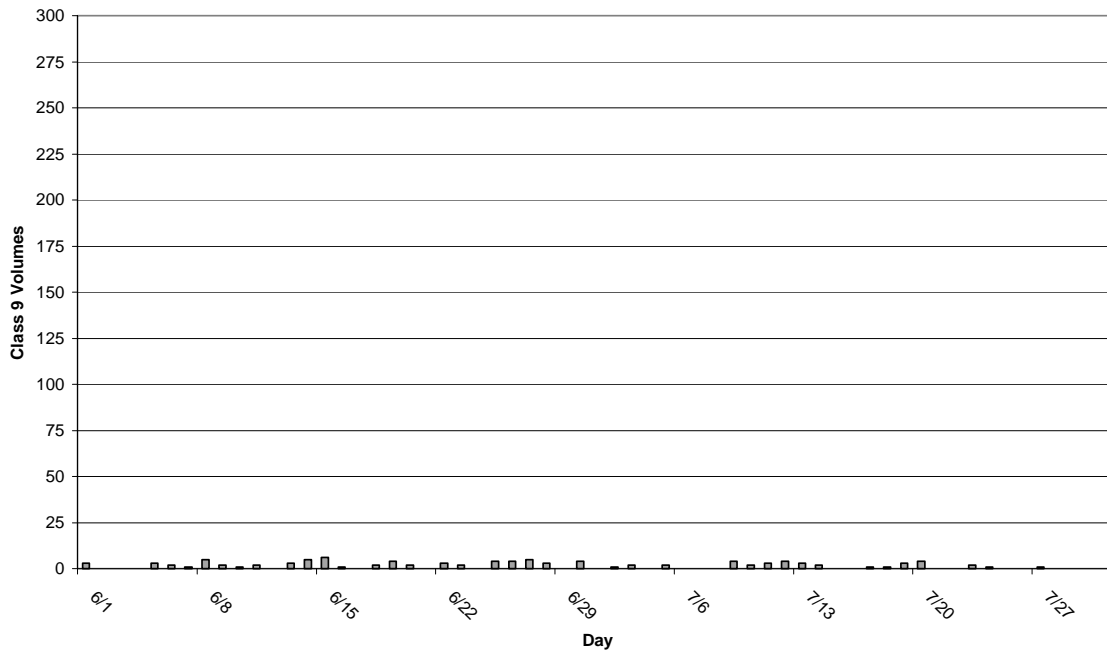

Figure 16: Southbound Class 9 Volume on SR 1 with GVW>80,000 for June-July 2001

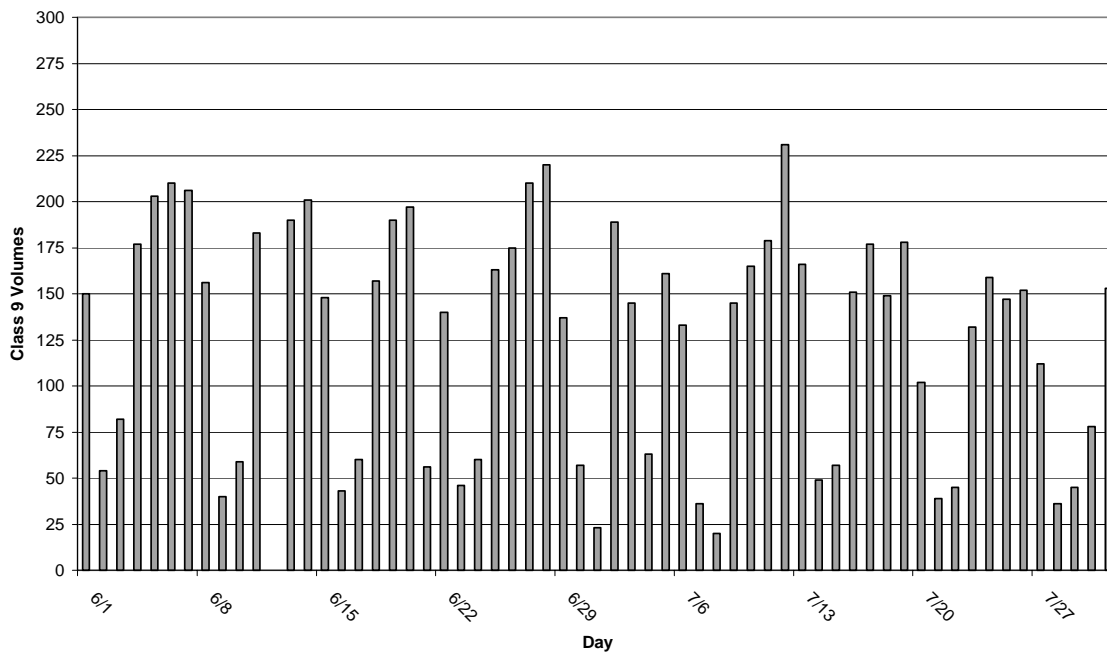

Figure 17: Northbound Class 9 Volume on SR 1 for June-July 2001

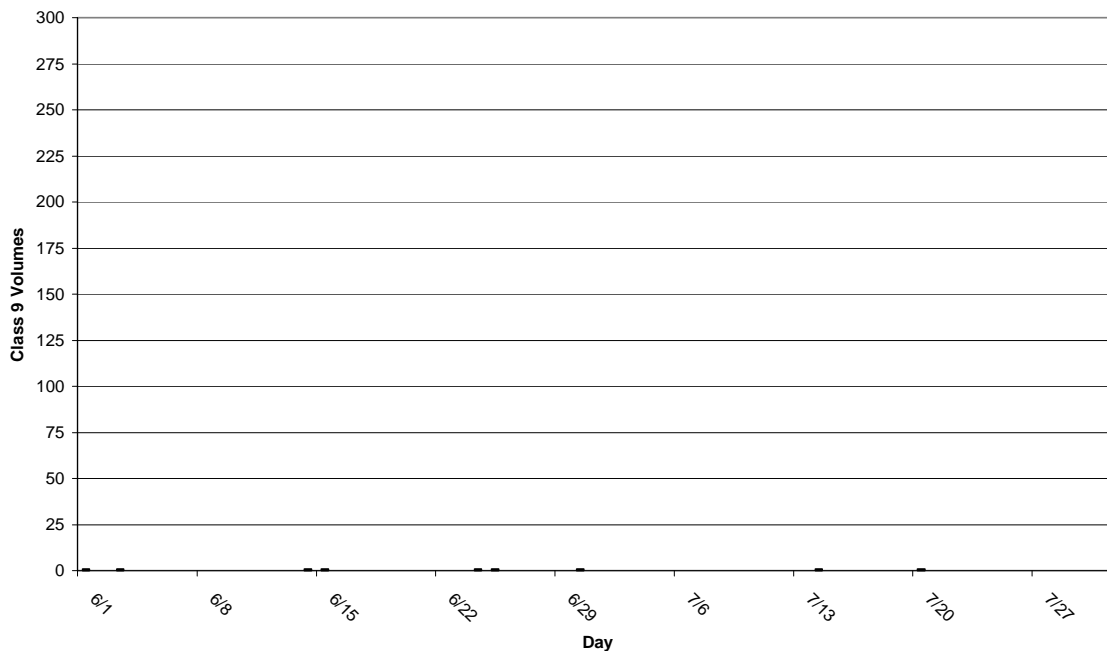

Figure 18: Northbound Class 9 Volume on SR 1 with GVW>80,000 for June-July 2001

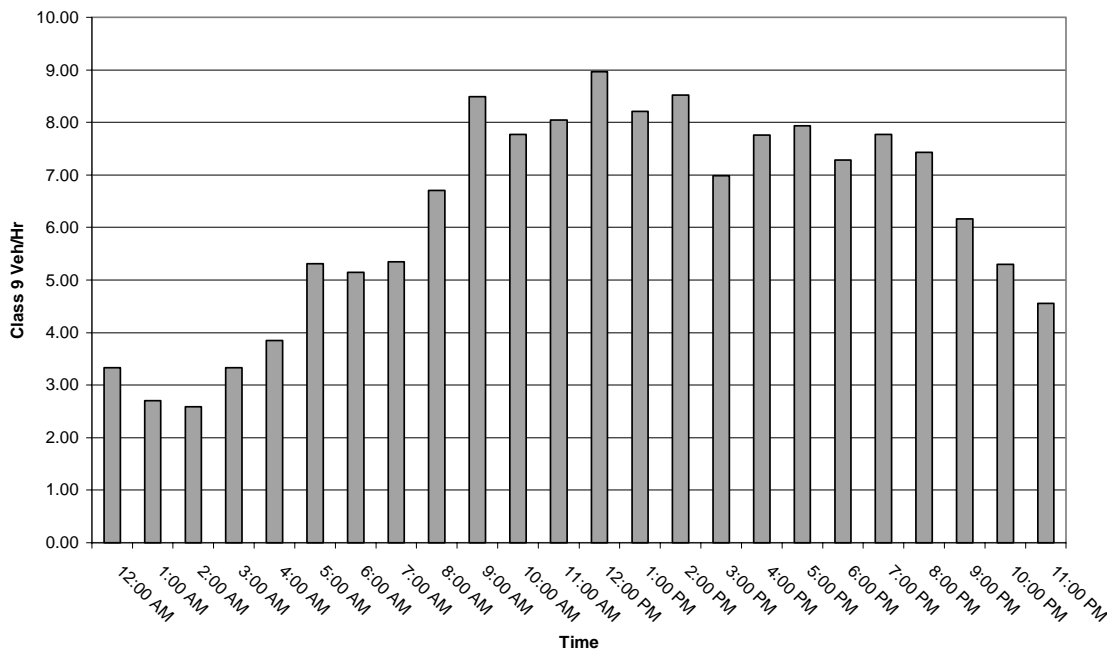

Figure 19: Average Hourly Southbound Class 9 Volume on SR 1 for June-July 2001

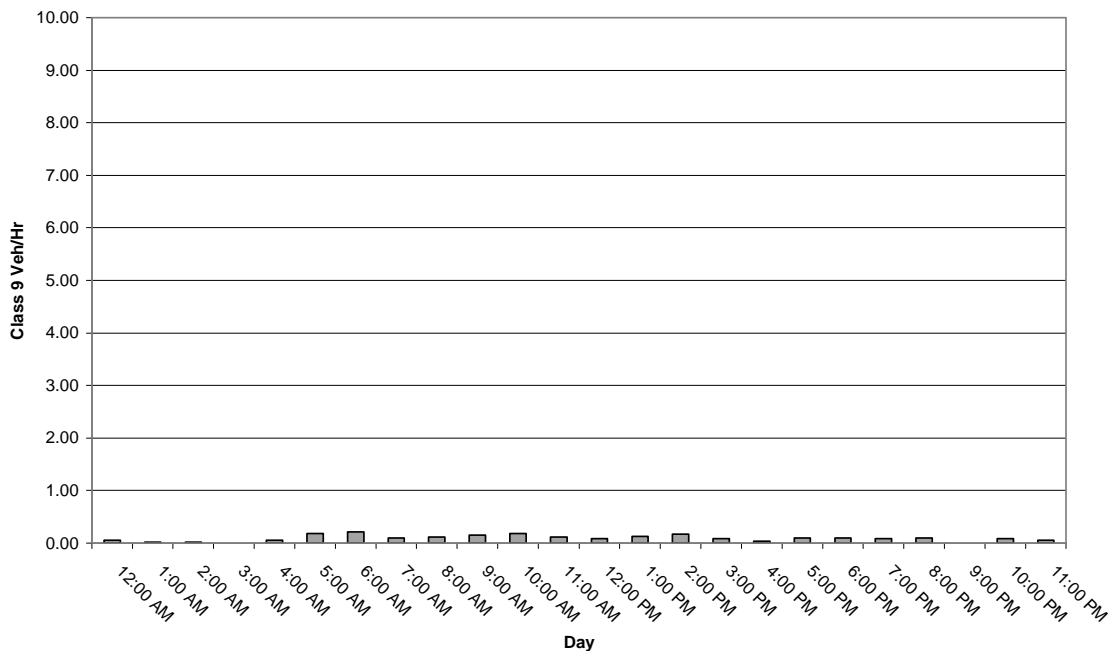

Figure 20: Average Hourly Southbound Class 9 Volume with GVW>80,000 on SR 1 for June-July 2001

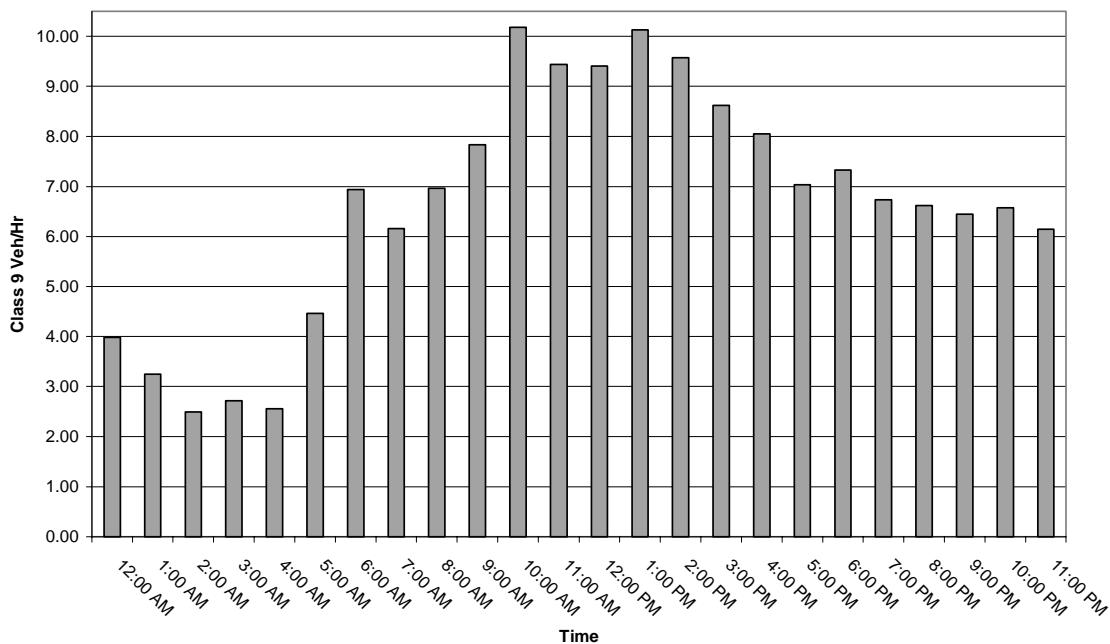

Figure 21: Average Hourly Northbound Class 9 Volume on SR 1 for June-July 2001

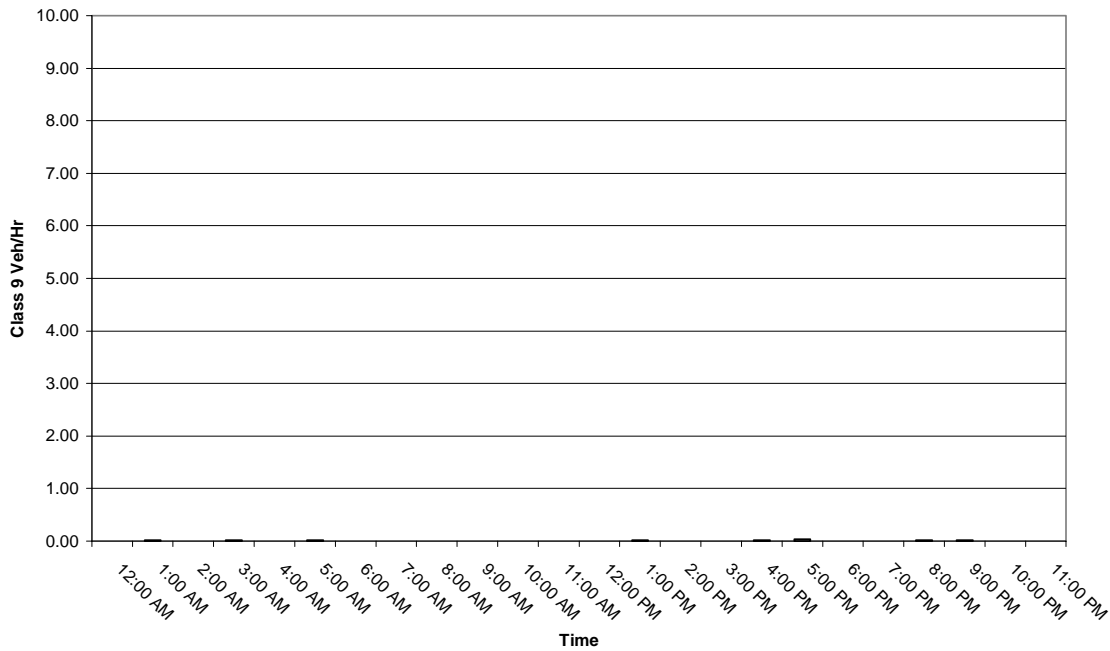

Figure 22: Average Hourly Northbound Class 9 Volume with GVW>80,000 on SR 1 for June-July 2001

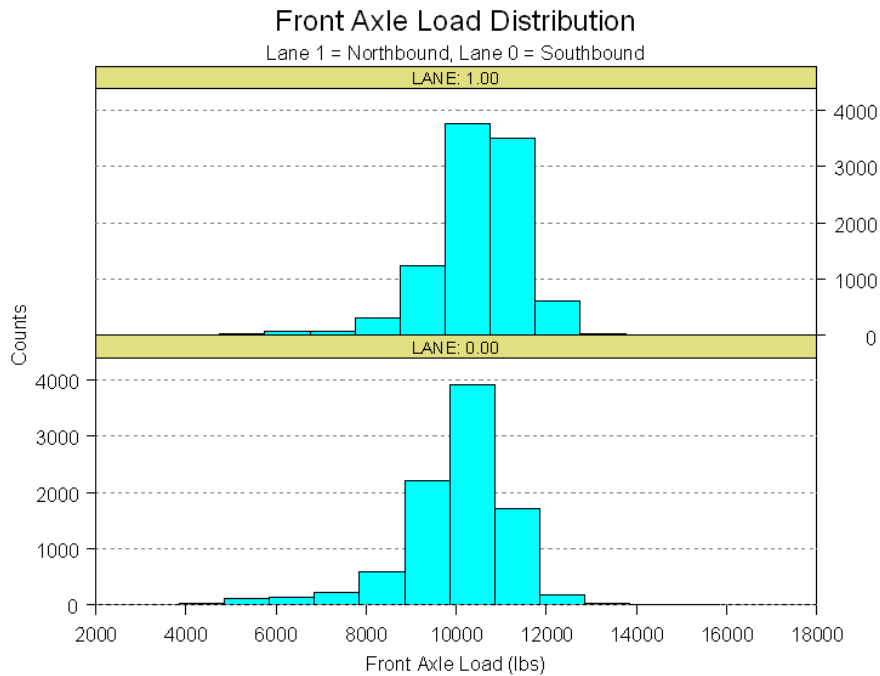

Figure 23: Average Class 9 Front Axle Weight Distribution on SR 1 for June-July 2001

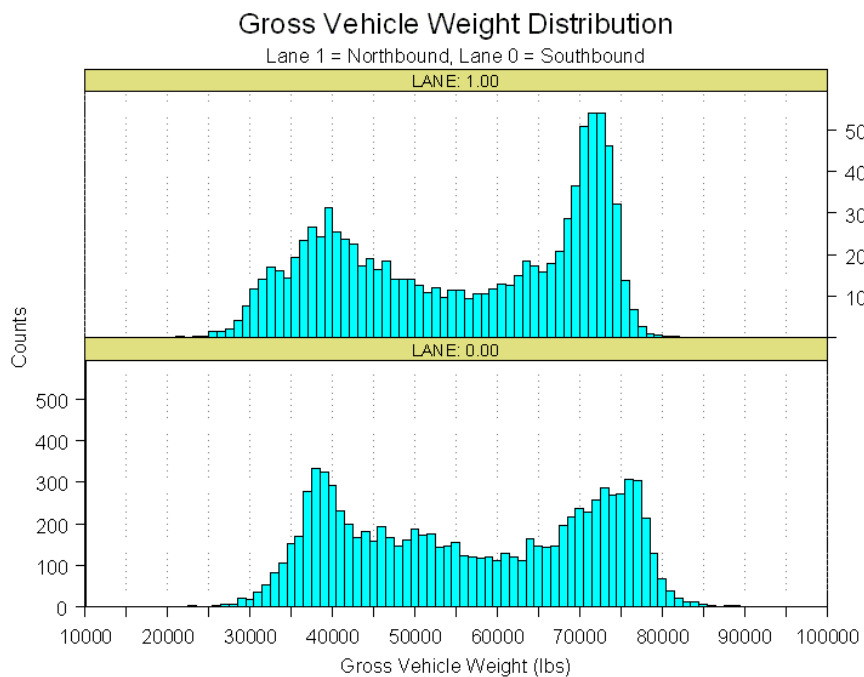

Figure 24: Distribution of Class 9 GVW, June-July 2001

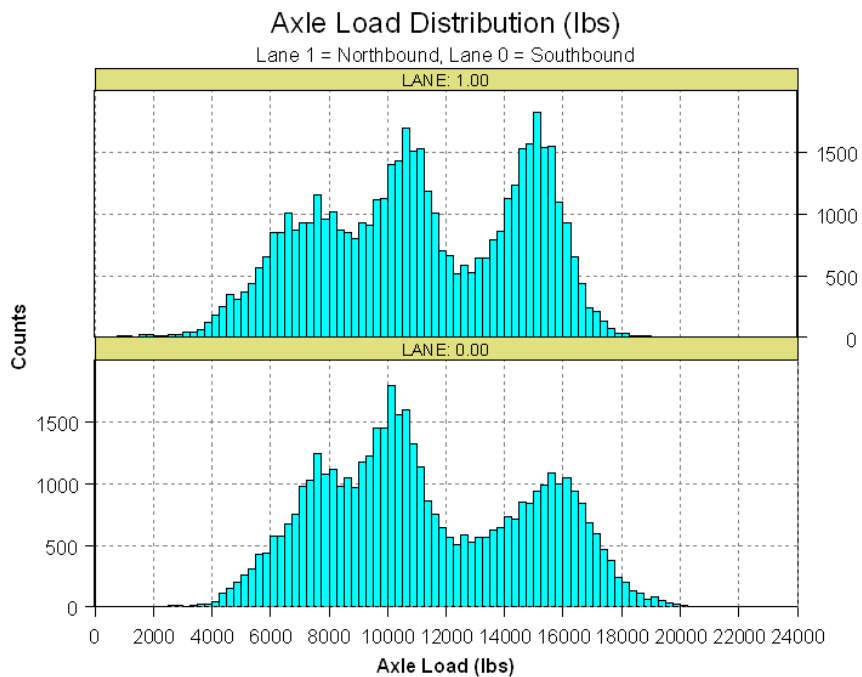

Figure 25: Distribution of Class 9 Axle Weight, June-July 2001

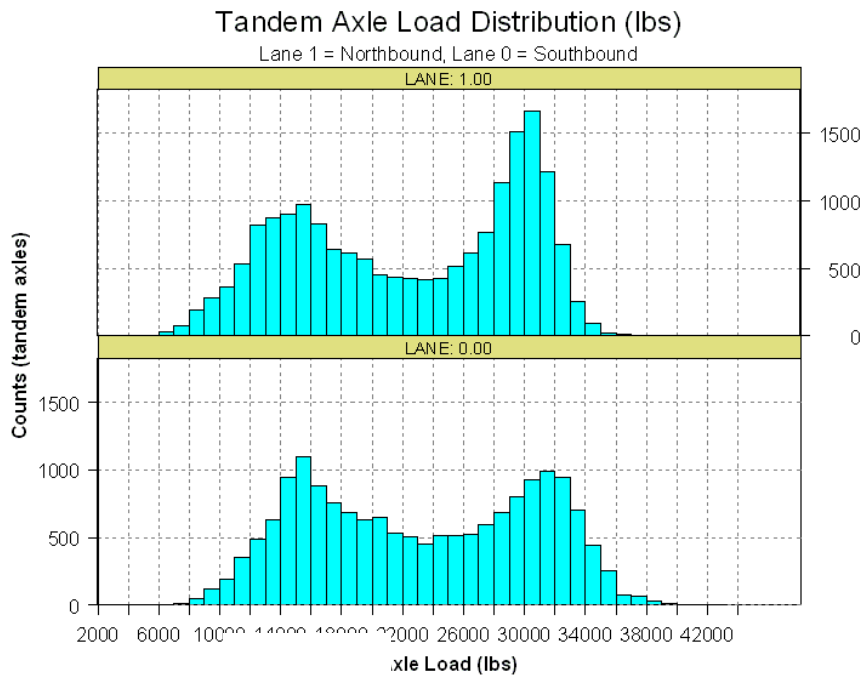

Figure 26: Distribution of Class 9 Tandem Weight, June-July 2001

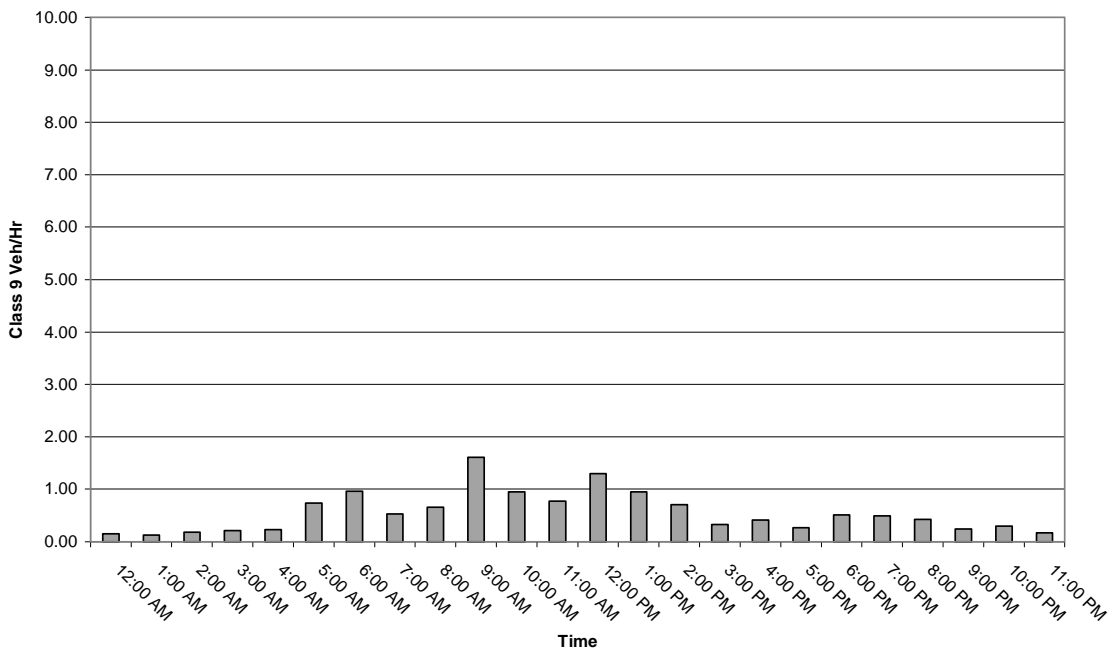

Figure 27: Average Hourly Volume of Southbound Class 9 Tandem > 34,000 on SR1 for June-July 2001

Appendix M Specifications for SR 1 Photo WIM Memo

To: Mark Newland
 From: Darcy Bullock and Andrew Nichols
 Date: September 17, 2001
 Subject: Draft Scope of Work for SR 1 Video Capture Installation on SR 1 south of I-74.

Background: Due to the high volume of trucks traveling on SR1, a weigh-in-motion site was recently installed in the northbound and southbound lanes. Tables 1 and 2 summarize data recently collected at this site. This site serves as a test site for Indiana State Police Commercial Vehicle Enforcement activities. The information from the weigh-in-motion station will be used by the ISP/CVE to determine which trucks may be overweight so they can stop them to statically weigh them.

Table 1: SR 1 WIM Station, Southbound.

	March 18-31, 2001	April 1-30, 2001	May 1-30, 2001	Total
Total Class 9 Vehicles	1776	3649	3772	9197
Class 9 Vehicles with GVW>80k	68	117	73	258
Class 9 Vehicles with an Axle > 20k	12	21	17	50
Class 9 Vehicles with a Tandem > 34k	232	416	441	1089
% Overweight GVW	3.8%	3.2%	1.9%	2.8%
% Over Axle	0.7%	0.6%	0.4%	0.5%
% Over Tandem	13.1%	11.4%	11.7%	11.8%

Table 2: SR 1 WIM Station, Northbound.

	March 18-31, 2001	April 1-30, 2001	May 1-30, 2001	Total
Total Class 9 Vehicles	2018	4066	3971	10,045
Class 9 Vehicles with GVW>80k	1	7	6	14
Class 9 Vehicles with an Axle > 20k	1	4	1	6
Class 9 Vehicles with a Tandem > 34k	39	91	72	202
% Overweight GVW	0.0%	0.2%	0.2%	0.1%
% Over Axle	0.0%	0.1%	0.0%	0.1%
% Over Tandem	1.9%	2.2%	1.8%	2.0%

Concept: It has been decided that the most beneficial information that the weigh-in-motion site could provide to the ISP/CVE officer is a picture of the truck along with the weight information of that truck. In order to collect the data at the site, two cameras need to be installed to capture the image of each southbound truck. One camera shall be used to capture the entire truck cab and part of the trailer. The second camera shall be used to capture a zoomed image of the side of trucks to provide information specifically identifying the truck. The southbound direction has approximately 12% of the Class 9 trucks traveling in that direction were observed to have overweight tandems. It would be desirable to determine if a significant number of these trucks were run by the same trucking company and/or hauling the same commodity.

The wood utility pole on which the cameras will be mounted will be supplied by INDOT. The equipment described in this document will be purchased by Purdue University and transferred to INDOT.

Specifications:

1. Camera Installation

Two cameras shall be installed on a wood utility pole located within the INDOT right-of-way. The installation shall conform to the following specifications:

- The pole shall be on the west side of SR1 and will be approximately 20' above ground level. The vendor will determine the specific height at which the cameras will be mounted. The pole shall be installed within the INDOT right of way. The exact pole location and height will be determined by a field inspection with members of INDOT, Purdue University, and the vendor present.
- Lightning protection and environmental specifications for both cameras shall be provided. Shop drawings showing proposed lighting arrestor equipment and installation details shall be submitted to Purdue University for approval by Purdue and INDOT 10 days before proceeding with installation.
- Power/data/video connections shall be supplied to the cameras via an underground conduit from the cabinet.
- Appropriate cables shall be selected to prevent electrical noise from adversely impacting the data/video signals.
- Cameras shall be installed within weatherproof housings.
- The cameras and cables shall be installed in a manner that will discourage theft and vandalism. Ideally cameras will be installed in a "dome" type enclosure.

2. Computer System

The data will exist on the computer in the existing cabinet and shall conform to the following specifications:

- The computer shall run the Windows 2000 operating system.
- The computer shall be capable of storing up to 200,000 images.
- A single dial up modem will be used to access all functions remotely such as:
 - To configure which images will be logged by vehicle class and violation.
 - To set overweight threshold for logging images.
 - To download images with WIM superimposed on image.
 - To download standard WIM data similar to that currently available for remote download on existing DOS based system.
- The logged image filename shall have the precise time encoded such that one can directly associate an image with the detailed WIM record. For example, 140607.020.jpg would correspond to the WIM record obtained at time 14:06:07 and 20 milliseconds shown in Figure 1.
- The logged images shall be stored in folders corresponding to the date (MM_DD_YYYY).
- The system shall be configurable to log data for all vehicles.

- The system shall be configurable to log annotated pictures for the user-defined vehicle classes.
- The system shall be configurable to log annotated pictures for the following user-defined violations:
 - Check for GVW violations on selected classes and annotate captured picture accordingly.
 - Check for Tandem violations on selected classes and annotate captured picture accordingly.
 - Check for Axle violations on selected classes and annotate captured picture accordingly.
 - Check for Bridge violations on selected classes and annotate captured picture accordingly.
 - Check for Speed violations on selected classes and annotate captured picture accordingly.
- For testing purposes, it shall be configurable to log images (with WIM data overlaid) of all vehicles.

3. Logged Image

The information required on the image stored in the database is shown in Figure 1. The actual layout of the information on the screen may be changed subject to INDOT's approval. Descriptions for each field are listed below.

1. Traveling direction of vehicle – NB or SB
2. Vehicle Class
3. Vehicle Speed in miles per hour
4. Gross Vehicle Weight in pounds
5. Axle Weight in pounds
6. Axle Spacing in inches
- 7a. Check box for speed violation (threshold set by user)
- 7b. Check box for GVW violation (threshold set by user)
- 7c. Check box for axle violation on Axle 1 (threshold set by user)
- 7d. Check box for axle violation on Axle 2 (threshold set by user)
- 7e. Check box for axle violation on Axle 3 (threshold set by user)
- 7f. Check box for axle violation on Axle 4 (threshold set by user)
- 7g. Check box for axle violation on Axle 5 (threshold set by user)
8. Date (MM/DD/YY) and Time (HH:MM:SS) (this information shall be obtained from the actual WIM system so that records will be synchronized)

Figure 1. Image of Compliant Truck

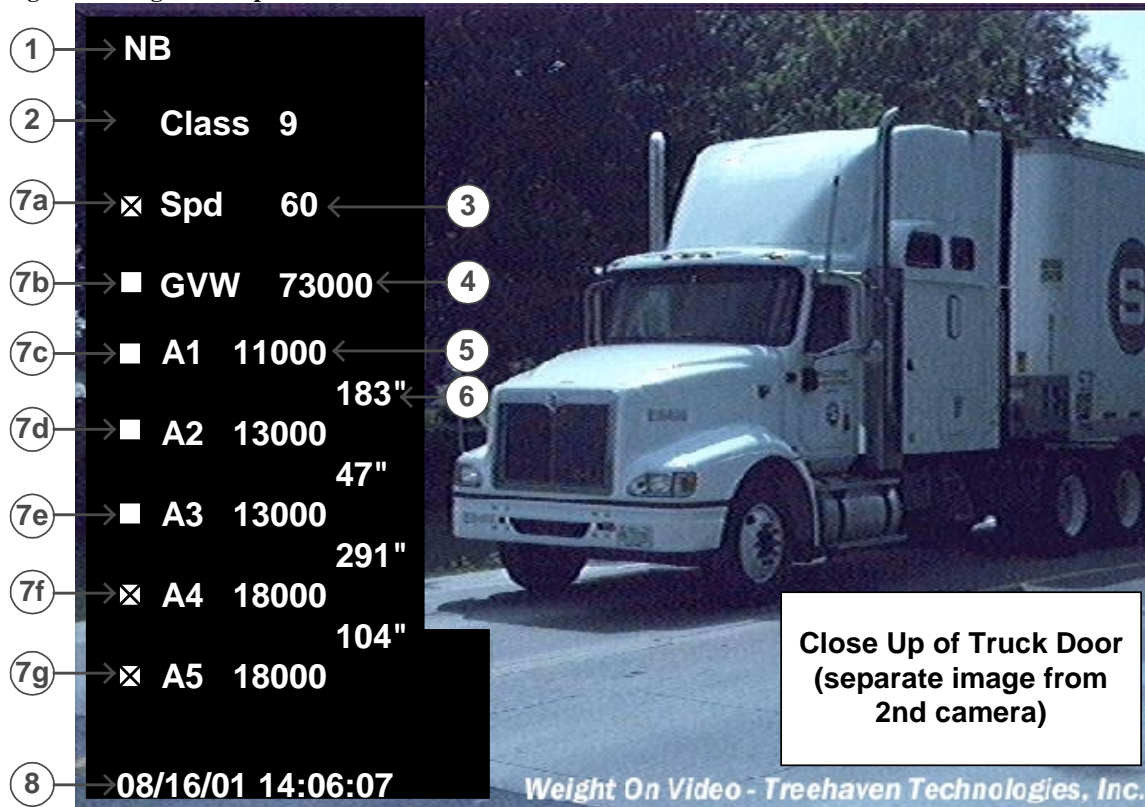

Violations will be indicated on the image in the following manner:

- Speed violations will be denoted with an 'X' in box 7a.
- GVW violations will be denoted with an 'X' in box 7b.
- Single axle violations will be denoted with an 'X' in the corresponding box(es) 7c, 7d, 7e, 7f, 7g.
- Tandem axle violations will be denoted with an 'X' in the corresponding box(es) 7d & 7e, 7f & 7g.
- Bridge violations will be denoted with an 'X' in boxes 7d, 7e, 7f, 7g.

4. Documentation

- Manuals for all installed equipment shall be furnished to INDOT.
- As built plans shall be furnished to INDOT including (but not limited to) utility pole location, utility pole height, camera height, aerial wire paths, conduit paths, camera vendor and part numbers, cable vendor(s) and part number, connector vendor(s) and part numbers, and weatherproofing accessories for cameras and electrical connectors.

5. Acceptance Terms

All parts of the above specifications must be observed to be operational for 30 continuous days. If specifications are not met during the 30 day test period, the test period must be restarted. The invoicing shall be as follows:

- 30% due net 45 days from shipment.
- 30% due net 45 days from installation of equipment
- 15% due net 45 days from set-up/training
- 25% due net 45 days from completion of above described test

Appendix N Summary of US 24 Detail Memo

To: Mark Newland, Guy Boruff
 From: Darcy Bullock, Andrew Nichols
 Subject: US 24 Detail on September 18, 2001
 Date: September 26, 2001

On September 18th, 2001 Officer Monty Buffum arranged a detail at the US 24 WIM sight (designated WIM site 2400 by INDOT) East of Fort Wayne to test the wireless communication link, laptop software, and WIM accuracy. Andrew Nichols from Purdue accompanied Officer Buffum. The following table summarizes the six samples that were obtained.

Table 1. Summary of Vehicles Weighed

Record #	Direction	Speed	GVW WIM	GVW Scale	Error	%Error
3090	EB	45	84,100	78,850	5,250	7%
3269	EB	52	88,300	79,300	9,000	11%
3316	EB	52	83,600	80,640	2,960	4%
3530	WB	46	83,200	85,800	-2,600	-3%
3876	WB	55	73,200	76,150	-2,950	-4%
3996	WB	46	82,000	81,050	950	1%

The following actions were taken on the six vehicles selected for weighing statically.

- 3090 Released
- 3269 Released
- 3316 Released
- 3530 Overweight ticket and placed out of service because of fuel leak
- 3876 Released
- 3996 Released



Figure 1: WIM monitoring site.



Figure 2: WIM scales (during construction ~July 2001).



Figure 3: WIM load cell.



Figure 4: Truck inspection site.



Figure 5: Truck inspection site.

Appendix O US 24 Calibration Adjustment Memo

To: Fred Keisig
 From: Darcy Bullock, Andrew Nichols
 Date: April 10, 2002
 Subject: US 24 Virtual Weigh Station Enforcement Data Analysis

February 2002

The data below was collected at the US 24 WIM (station 2400) during February 2002 by ISP Commercial Vehicle Enforcement officers. The trucks' weights were observed as they crossed the scales using the virtual weigh station equipment and software. The trucks that were reported overweight by the scales were pulled over by the officer and weighed using portable scales. The officer recorded the gross vehicle weight reported by the WIM and the by portable scales. The graphs below show the data recorded by the officer in each direction, as well as a proposed percentage adjustment to the weights.

Based on this data, it is proposed that the EB lane be adjusted -7.7% and the WB lane be adjusted $+3.9\%$.

Table 1: Westbound US 24 WIM Station Data Collected

Date	Time	WIM	Adjusted	Portable	Violation
02/05/2002	8:53 AM	81,600	84,763	79,150	None
02/18/2002	5:45 PM	89,900	93,384	91,100	Over GVW/Over Axle
02/21/2002	2:06 PM	83,200	86,425	90,200	Over GVW/Over Tandem
02/21/2002	2:06 PM	80,500	83,620	90,900	Over GVW/Over Tandem
02/22/2002	11:24 AM	80,200	83,309	80,800	Warning Over GVW

Table 2: Eastbound US 24 WIM Station Data Collected

Date	Time	WIM	Adjusted	Portable	Violation
02/05/2002	10:50 AM	87,000	80,262	76,200	None
02/20/2002	4:20 PM	88,500	81,646	78,900	Over Tandem
02/22/2002	10:50 AM	82,000	75,650	79,800	Warning Over Axle
02/22/2002	12:20 PM	81,000	74,727	80,980	Warning Over GVW
02/22/2002	12:51 PM	85,000	78,417	77,180	None

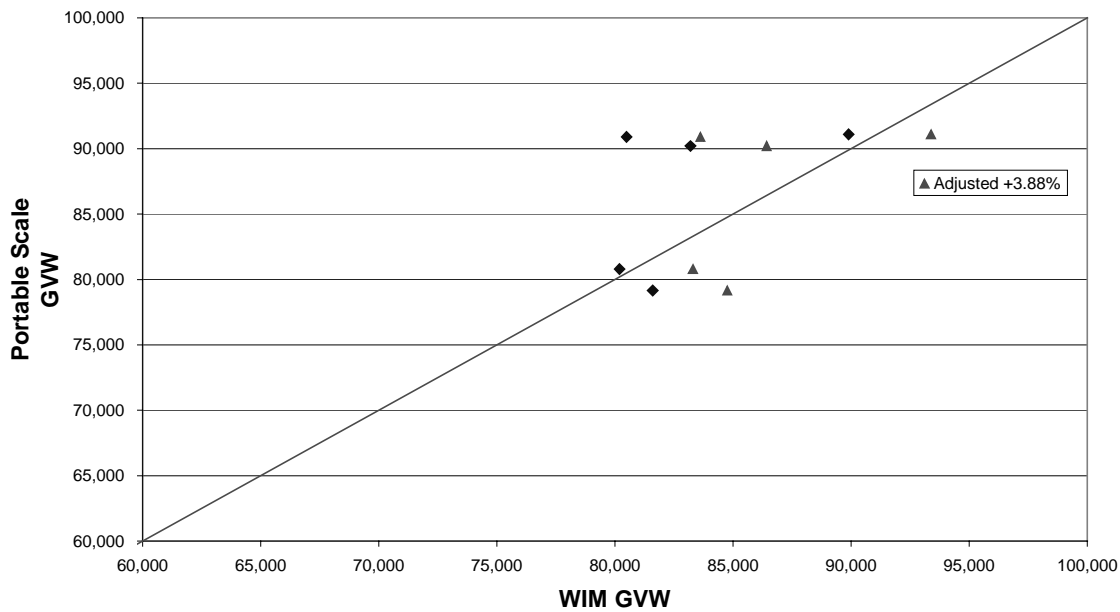

Figure 1: Westbound US 24 WIM Station Data Accuracy Plot & Calibration Adjustment

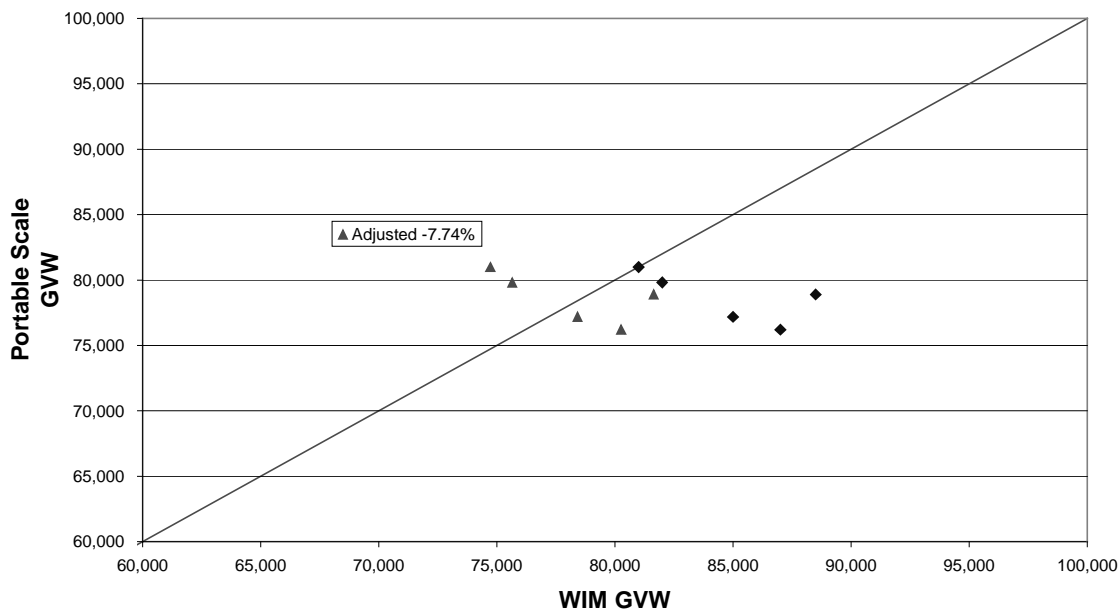

Figure 2: Eastbound US 24 WIM Station Data Accuracy Plot & Calibration Adjustment

Appendix P Summary of US 24 Data (March 2002) Memo

To: Guy Boruff
 From: Darcy Bullock, Andrew Nichols
 Date: April 11, 2002
 Subject: US 24 March 2002 Data Analysis

This document contains an analysis of the weigh-in-motion data from March 2002 at USR 24 near Fort Wayne. Figure 1 shows the average Class 9 volume with Gross Vehicle Weight exceeding 80,000 lbs by hour of the day. Figure 2 shows the average Class 9 volume with GVW exceeding 80,000 lbs by day of the week. Figure 3 shows the total Class 9 volume with GVW exceeding 80,000 lbs for each day of the month.

IRD will have the scales recalibrated by Saturday, April 13. The recalibration is based on the data collected during the February enforcement details. The EB values reported in these graphs account for the adjustment factor of -7.8% (WIM weighing heavy). The WB values were not adjusted in these graphs, but will be recalibrated by $+3.9\%$ (WIM weighting light).

In general, the WB direction has a higher volume of overweight trucks. According to Figure 1, the time periods with the highest number of overweight trucks is 8:00am – 10:00am, 11:00am-12:00pm. According to Figure 2, the day with the highest number of overweight trucks is Wednesday.

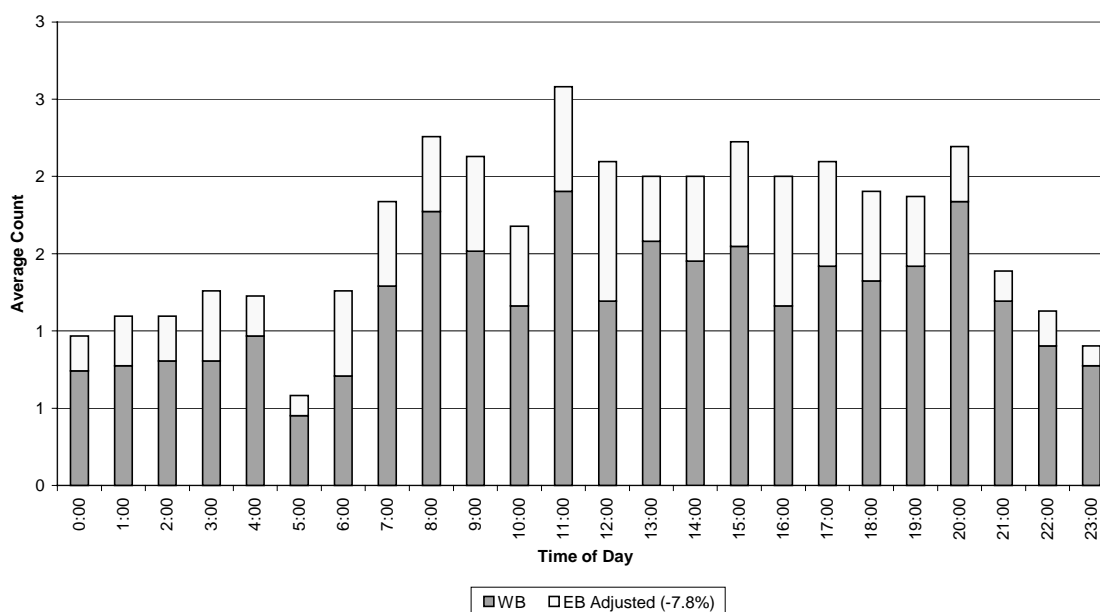

Figure 1: Average Hourly Class 9 Volume on US 24 with GVW Exceeding 80,000 lb (adjusted)

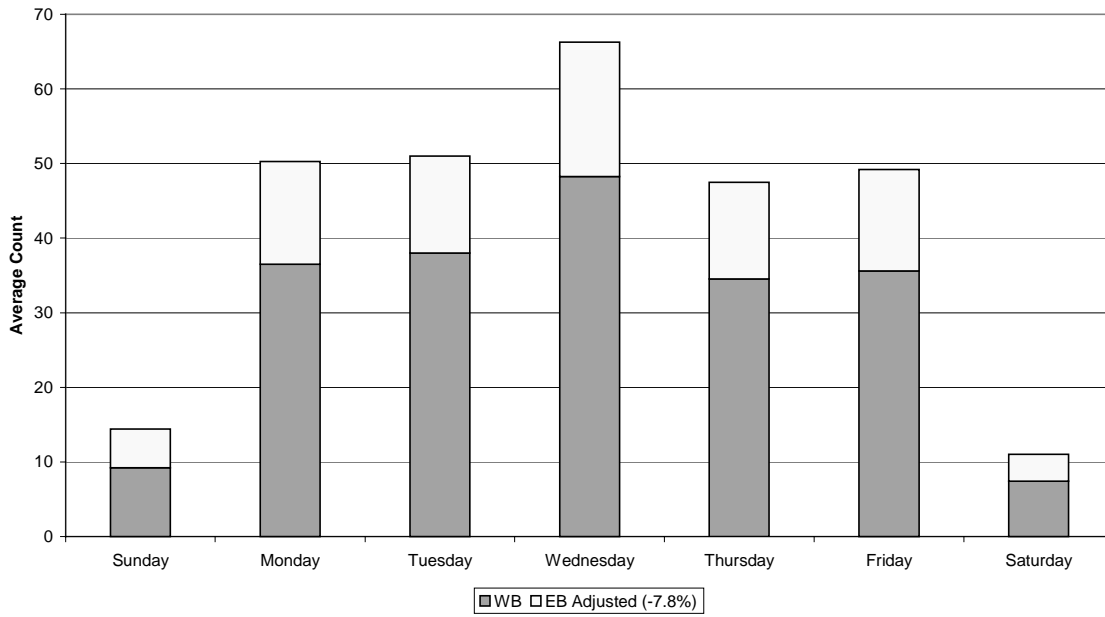

Figure 2: Average Daily Class 9 Volume on US 24 with GVW Exceeding 80,000 lb (adjusted)

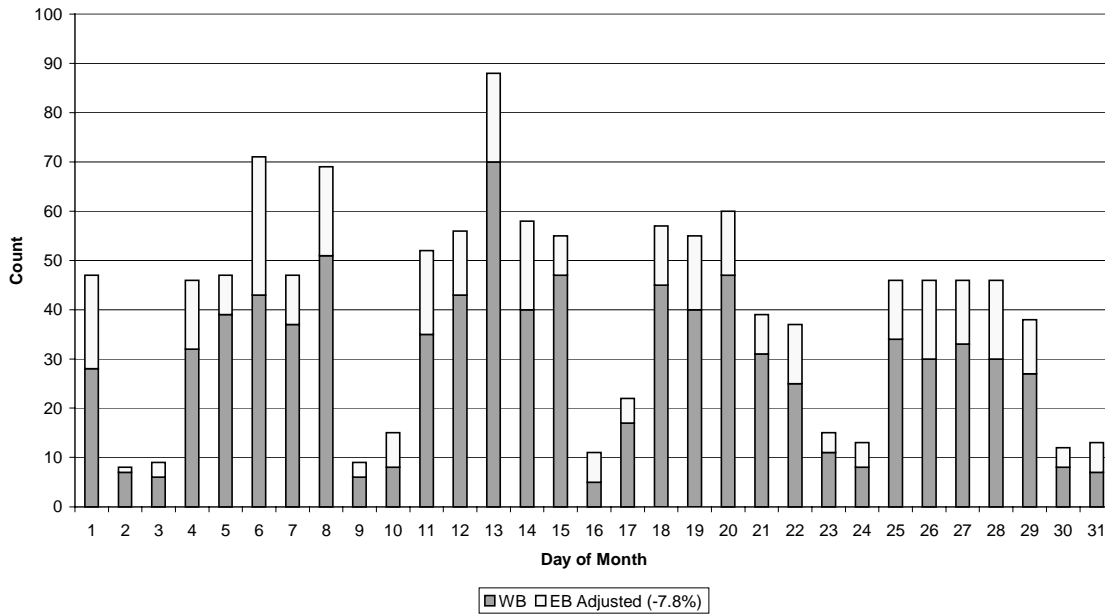

Figure 3: Daily Class 9 Volume on US 24 with GVW Exceeding 80,000 lb (adjusted)

Appendix Q Summary of I-65 Enforcement Detail Memo

To: Guy Boruff
 From: Darcy Bullock, Andrew Nichols
 Date: April 25, 2002
 Subject: I-65 Merrillville WIM Enforcement Details

April 12, 2002

An enforcement detail was conducted at the I-65 Northbound WIM station in Merrillville on April 12, 2002 by ISP Commercial Vehicle Enforcement Officers Williams, Young, Nagle, Kunstek, and Fleming. The detail was conducted between 7:00AM and 10:00AM. The trucks' weights were observed by Officer Young as they crossed the WIM scales using the virtual weigh station equipment and software. The trucks that were reported overweight by the WIM scales were pulled over on Exit 255 (61st Avenue) and weighed using certified portable scales in an unused parking lot. The graph and table below show the truck weights and violations.

Table 1. Northbound I-65 WIM Station Data Collected April 12, 2002

Time	Lane	WIM	Portable	Violation
7:47 AM	2	80,400 lb	77,800 lb	Warning Overweight Tandem 400lb, No Seatbelt, Log Book Not Current, Out-of-Service
8:01 AM	2	81,400 lb	88,200 lb	Overweight GVW, Out-of-Service
8:09 AM	1	82,900 lb	87,400 lb	Overweight GVW Fine: \$529.50

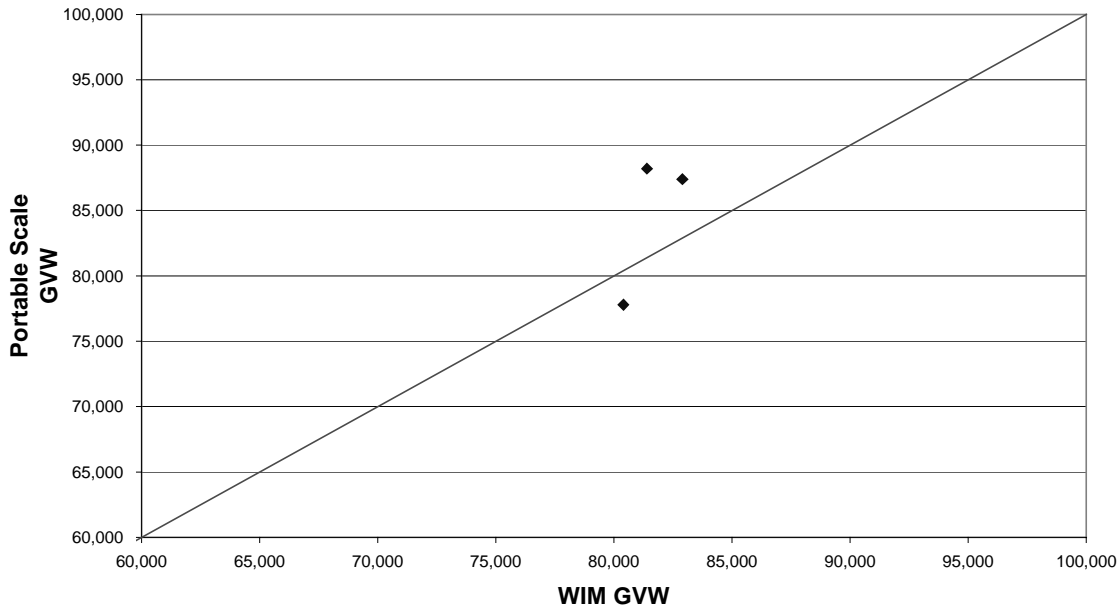

Figure 1: Northbound I-65 WIM Station Data Accuracy Plot

Appendix R Effects of Enforcement on SR 1 Memo

To: Barry Partridge
 From: Darcy Bullock
 CC: Kumares Sinha
 Date: May 14, 2002
 Subject: State Route 1 WIM Data

As requested by Commissioner Nicol today, I have reviewed our memo from September 12, 2001 (attached) summarizing the data from April, May, June, and July 2001 at the SR 1 weigh-in-motion (WIM) sight. The WIM system became active in early March and we began receiving data on March 18th. Table 1 below summarizes the percent reduction between April 2001 and July 2001, specific vehicle counts are contained in the attached September 12, 2001 memo.

One word of caution, these are raw counts and could reflect seasonal variation in truck traffic. I will plan on tabulating a comparison between 2001 and 2002 data after July 2002 (when we will have 4 consecutive months a year later) and transmit that information to you.

	% Reduction in South bound	% Reduction in North bound
Total Class 9 Vehicles	7%	11%
Class 9 Vehicles with GVW>80k	69%	71%
Class 9 Vehicles with an Axle > 20k	57%	0%
Class 9 Vehicles with a Tandem > 34k	32%	47%
% Overweight GVW	66%	68%
% Over Axle	50%	0%
% Over Tandem	26%	41%

Table 1: Comparison of April 2001 with July 2001 Data.

Appendix S Summary of Borman Data (January-March 2002) Memo

To: Guy Boruff
 From: Darcy Bullock, Andrew Nichols
 Date: May 31, 2002
 Subject: Borman WIM Data Summary January 16 – March 31, 2002

January 16 – March 31, 2002

The tables and figures below summarize the data collected by the WIM sites on I-80/I-94 in Gary. According to the data in Table 1, there are a higher number of overweight class 9 trucks in the eastbound direction than there are in the westbound direction, even though the truck volumes are similar. As shown in Table 2, the average front axle weights for both WIMs are very close with relatively small standard deviations. This provides some indication that the WIMs are operating well. The highest rate of overweight trucks in both directions occurs between noon and 4pm shown in Figure 1 and Figure 2. Tuesdays and Wednesdays also see the highest rate of overweight activity shown in Figure 3 and Figure 4. Figure 5 and Figure 6 show the actual number of overweight trucks for each day in the time period between January 16 and March 31.

Table 1: Summary of Class 9 Vehicle Data January 16 – March 31, 2002

	EB (4000)		WB (4010)	
	Total	% of Total	Total	% of Total
Class 9 Vehicles	1,101,434	--	1,082,450	--
GVW > 80k	58,419	5.30%	15,509	1.43%
GVW > 90k	1,673	0.15%	1,001	0.09%
GVW > 100k	326	0.03%	210	0.02%
Axle > 20k	22,392	2.03%	8,922	0.82%
Axle > 30k	109	0.01%	44	0.00%
Tandem > 34k	186,809	16.96%	102,664	9.48%
Tandem > 50k	297	0.03%	244	0.02%

Table 2: Summary of Class 9 Vehicle Data January 16 – March 31, 2002

	EB	WB
Avg Front Axle	10,579	10,446
Std Dev Front Axle	1,027	930
Max Front Axle	32,300	20,200
Avg GVW	56,428	54,491
Std Dev GVW	18,433	17,386
Max GVW	140,500	128,899
Max Tandem	70,600	65,400

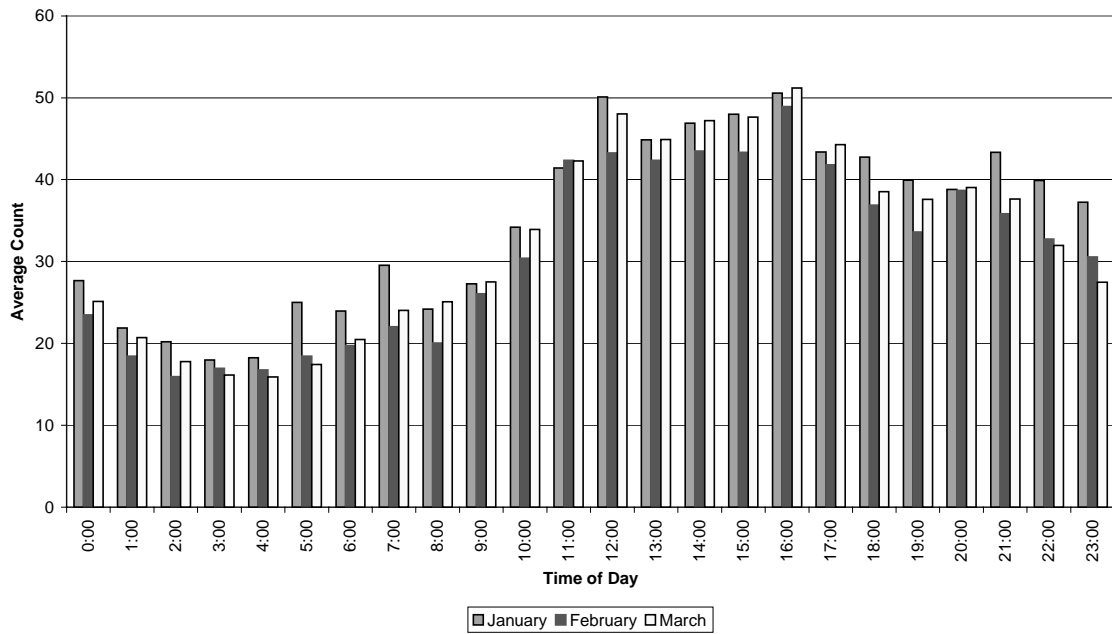

Figure 1: Eastbound Average GVW Violations by Hour

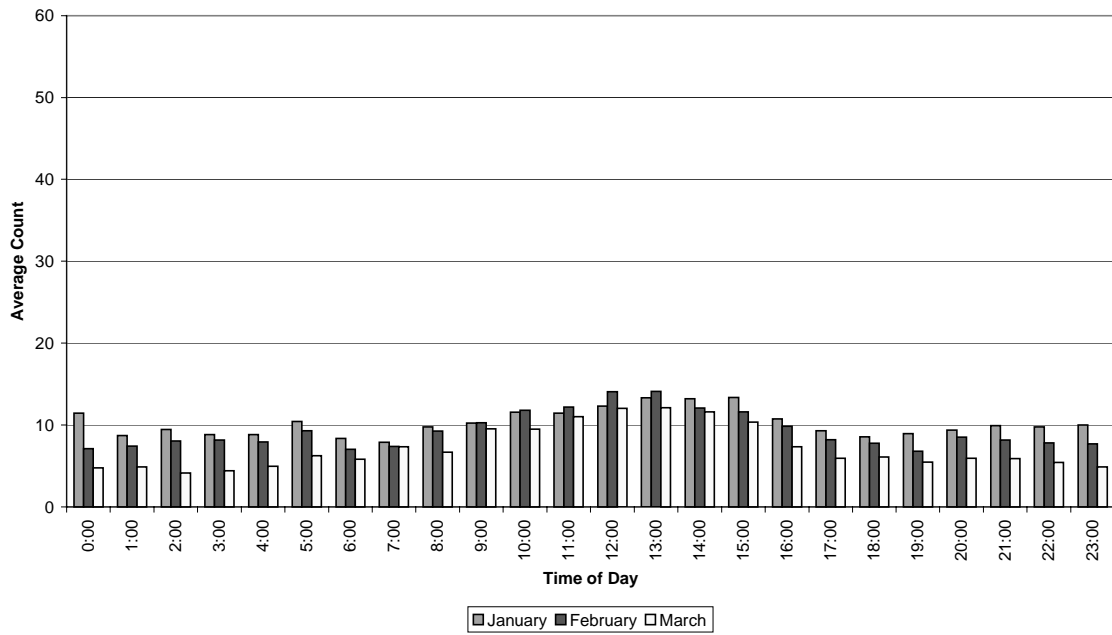

Figure 2: Westbound Average GVW Violations by Hour

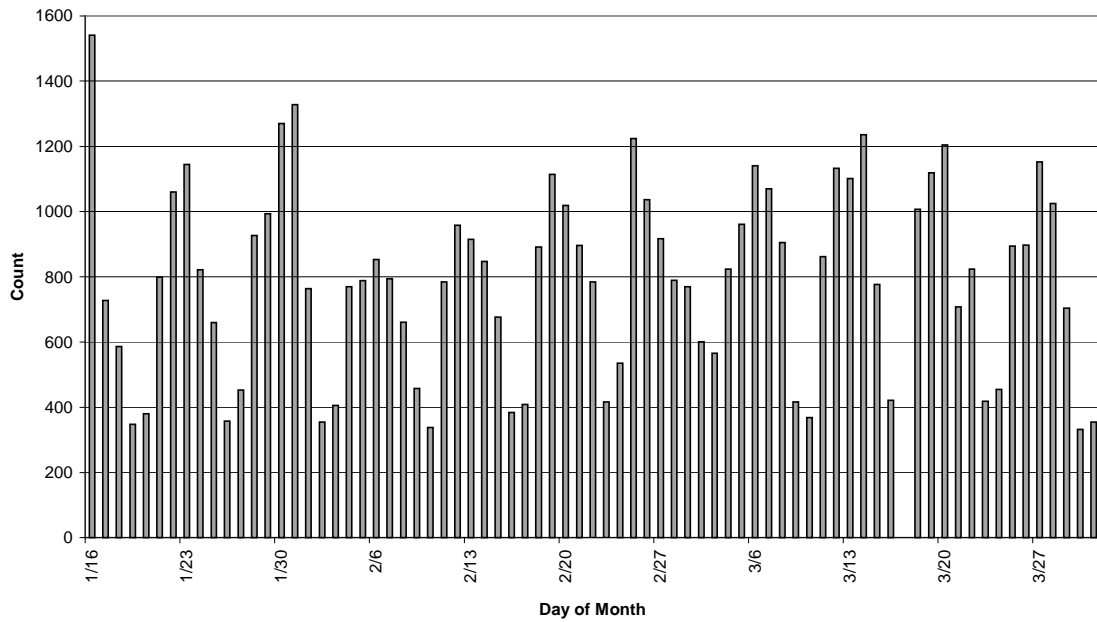

Figure 3: Eastbound GVW Violations by Day of the Month

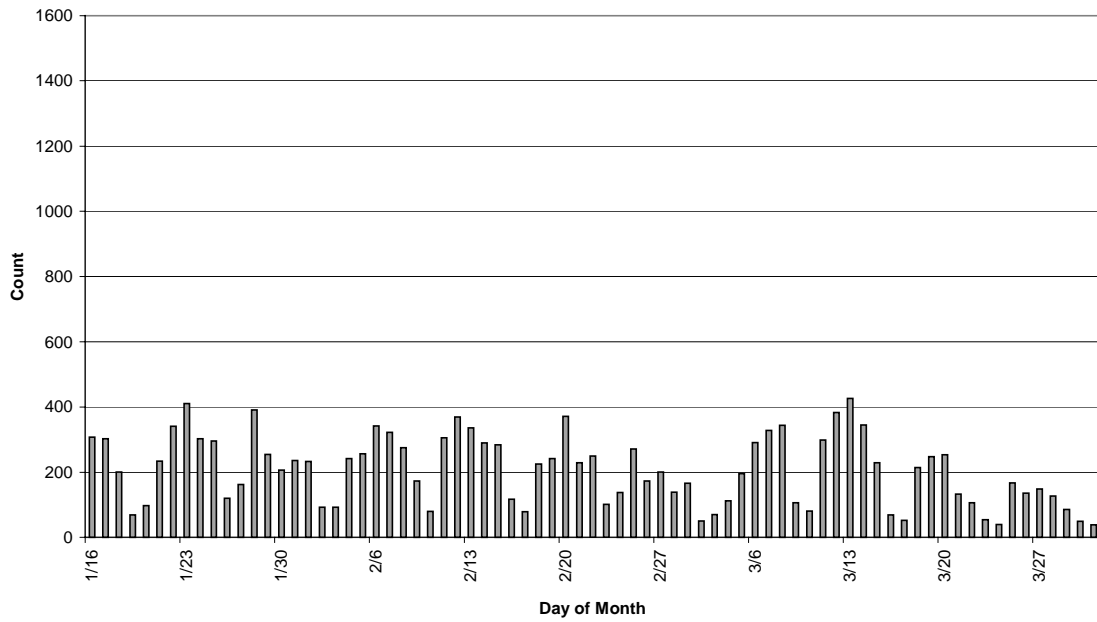

Figure 4: Westbound GVW Violations by Day of the Month

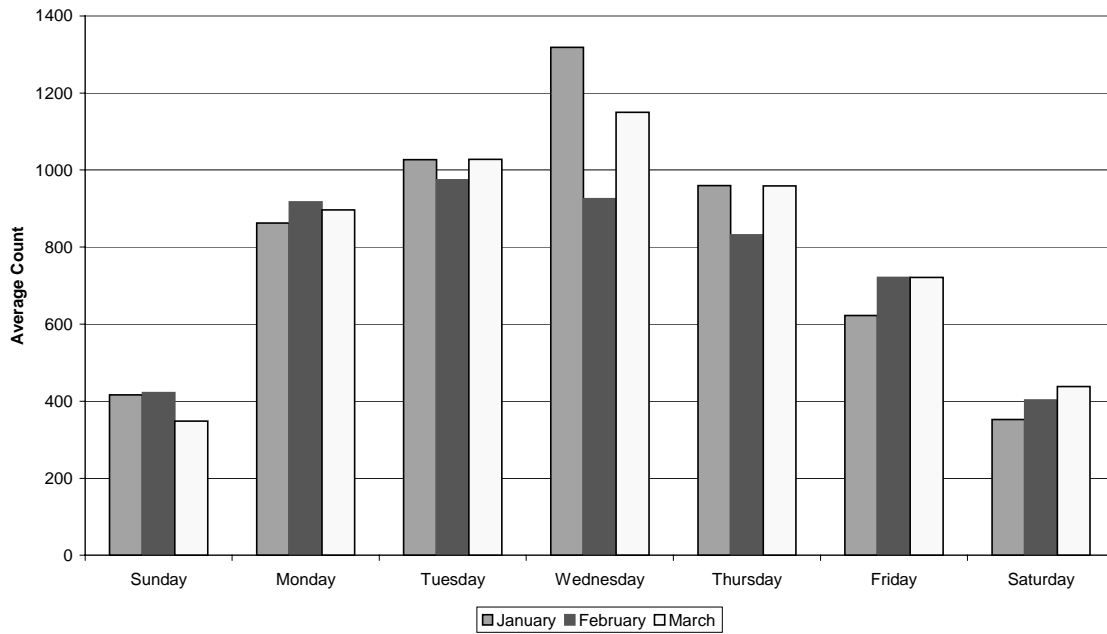

Figure 5: Eastbound Average GVW Violations by Day of the Week

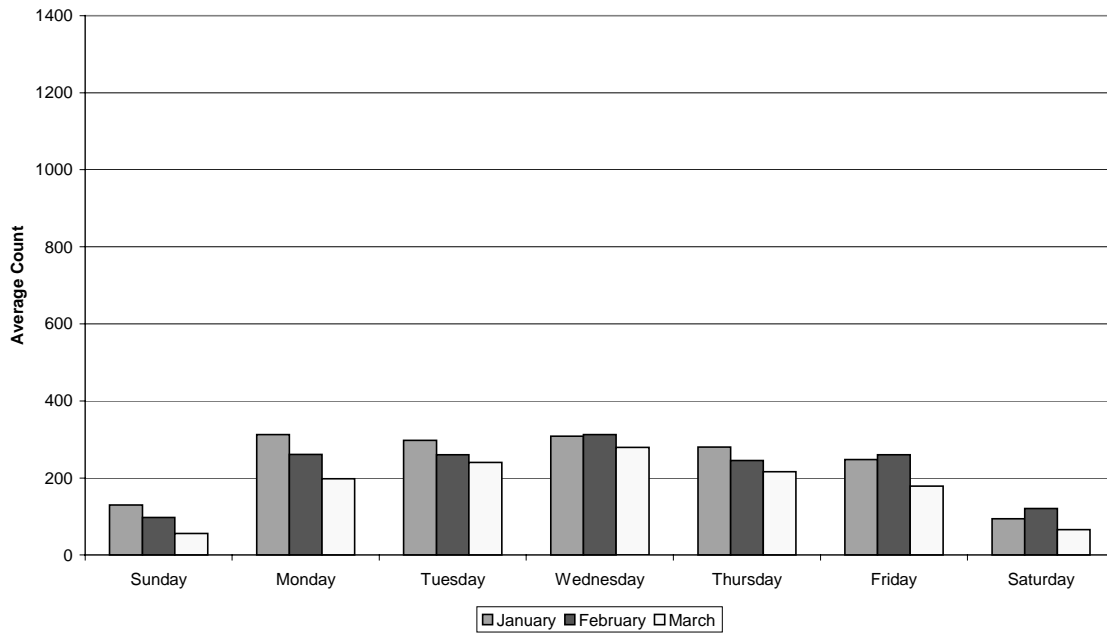

Figure 6: Westbound Average GVW Violations by Day of the Week

Appendix T Bibliography

Access Indiana. 2000. <http://www.state.in.us/legislative/ic/2000/title9/ar20/ch4.html>

Alavi, Papagiannakis, et al. Performance Evaluation of Piezoelectric Weigh-In-Motion Sensors Under Controlled Field Loading Conditions. Washington, DC: Transportation Research Board, January 2001.

Bergan, Berthelot, and Taylor. Effect of Weigh-In-Motion Accuracy on Weight Enforcement Efficiency. Saskatoon, SK, Canada: International Road Dynamics, March 1997.

Bergen, Lindgren, et al. Preserving Highway Infrastructure Using Weigh-In-Motion. Saskatoon, SK, Canada: International Road Dynamics, November, 1998.

Bushman and Pratt. Weigh-In-Motion Technology – Economics and Performance. Charlotte, North Carolina: NATMEC, 1998.

Dahlin, Curtis. A Proposed Method for Calibration Weigh-In-Motion Systems and for Monitoring that Calibration Over Time. Washington, DC: Transportation Research Board, January 1992.

Eubanks and Broadwell. Safety Records of Weight Violating Motor Carriers. Salem, Oregon: Oregon Department of Transportation Motor Carrier Transportation Branch, September 30, 1997.

FHWA & Ohio State Highway Patrol. Size and Weight Workshop Meeting Summary. Truck Size and Weight Workshop. Columbus, Ohio, October 2000.

Garber and Hoel. Traffic and Highway Engineering. St. Paul, Minnesota: West Publishing Company, 1998.

Huang, Yang. Pavement Analysis and Design. Englewood Cliffs, New Jersey: Prentice Hall, 1993.

Illinois Department of Transportation. Truck Size and Weight Report. Springfield, Illinois: June, 1998.

Ott, Weston, and Papagiannakis, A. WIM Data QA Based on 3-S2 Steering Axle Load Analysis. Washington DC: Transportation Research Board, January 1996.

Taylor, Bergan and Lindgren. A Summary of Vehicle Overloading, Safety, and Non-Compliance. Saskatoon, SK, Canada: International Road Dynamics, September, 1999.

Taylor, Bergan, et al. "Heavyweight Safety." Traffic Technology International. Annual Review 2000, January 2000. 234-237.

"Keeping Overweight Trucks from Getting A-Weigh." Texas Transportation Researcher. Volume 35, Number 3 (1999).