

Report No. FAA-CT-81-60

FAA WJH Technical Center  
00090944

CF  
81  
60  
COPY 1

**DISCRETE ADDRESS BEACON SYSTEM (DABS)  
SOFTWARE SYSTEM  
RELIABILITY MODELING AND PREDICTION**

**EVALUATION ASSOCIATES, INC.  
GSB BLDG., 1 BELMONT AVE.  
BALA CYNWYD, PA. 19004**

**Contract No. DTFA03-80-C-00028**



FEDERAL AVIATION

JUL 81

TECHNICAL CENTER LIBRARY  
ATLANTIC CITY, N.J. 08405

**FINAL REPORT**

**JUNE 1981**

Document is available to the U.S. public through  
the National Technical Information Service,  
Springfield, Virginia 22161.

Prepared for  
**U. S. DEPARTMENT OF TRANSPORTATION  
FEDERAL AVIATION ADMINISTRATION  
TECHNICAL CENTER  
Atlantic City Airport New Jersey 08405**

#### NOTICE

This document is disseminated under the sponsorship of the Department of Transportation in the interest of information exchange. The United States Government assumes no liability for the contents or use thereof.

The United States Government does not endorse products or manufacturers. Trade or manufacturer's names appear herein solely because they are considered essential to the object of this report.

Technical Report Documentation Page

1. Report No. FAA-CT-81-60	2. Government Accession No.	3. Recipient's Catalog No.	
4. Title and Subtitle DISCRETE ADDRESS BEACON SYSTEM (DABS) SOFTWARE SYSTEM RELIABILITY MODELING AND PREDICTION		5. Report Date June 1981	
		6. Performing Organization Code	
7. Author(s)		8. Performing Organization Report No. FAA-CT-81-60	
9. Performing Organization Name and Address Evaluation Associates, Inc. GSB Bldg., 1 Belmont Ave. Bala Cynwyd, Pa. 19004		10. Work Unit No. (TRAIS)	
		11. Contract or Grant No. DTFA03-80-C-00028	
12. Sponsoring Agency Name and Address U.S. Department of Transportation Federal Aviation Administration Technical Center Atlantic City Airport, New Jersey 08405		13. Type of Report and Period Covered Final January 1979 - June 1980	
		14. Sponsoring Agency Code	
15. Supplementary Notes			
16. Abstract  This report contains the results of a pilot study accomplished to demonstrate the ability to determine the magnitude of software reliability encountered in large-scale computer-based equipment. The engineering model of the Discrete Address Beacon System (DABS) currently undergoing development was used as the subject. Based on software failure and test time data, a software reliability model was developed for the engineering model of DABS and used to measure software reliability and its growth during the debugging process. The software reliability model was merged with the hardware reliability model into a DABS system model suitable for prediction. The Mean Time Between Failures (MTBF) determined by this study applies only to an early version of the software associated with the engineering model of the DABS. The report also includes recommendations for the specification of software reliability and the modification to the failure reporting system.			
17. Key Words DABS Software Reliability MTBF		18. Distribution Statement Document is available to the U.S. public through the National Technical Information Service, Springfield, Virginia 22161	
19. Security Classif. (of this report) Unclassified	20. Security Classif. (of this page) Unclassified	21. No. of Pages 63	22. Price

## TABLE OF CONTENTS

	<u>Page</u>
1.0 Executive Summary	1
1.1 Objective	1
1.2 Background	1
1.3 Significant Findings	3
2.0 Description of DABS Computer Software, Testing and Data Base	7
2.1 Description of DABS Computer Software and Its Testing	7
2.2 DABS Software Data Base	10
3.0 Approach to Software Reliability Modeling	14
3.1 Theoretical Software Reliability Model	14
3.2 Data Analysis	15
4.0 Reliability Evaluation of DABS Software Modules	17
4.1 Reliability Evaluation of the Communication Module	17
4.2 Reliability Evaluation of the Performance Monitoring Module	20
4.3 Reliability Evaluation of Message Routing and Data Link Processing Modules	20
4.4 Reliability Evaluation of Data Extraction Module	25
4.5 Reliability Evaluation of Channel Management Module	25
4.6 Reliability Evaluation of Network Management Module	25
4.7 Reliability Evaluation of MTD and RDAS Modules	31
4.8 Reliability Evaluation of System Software Module	31
4.9 Reliability Evaluation of the Surveillance Processing Module	37
5.0 Integrated DABS Hardware and Software Reliability Model	40
5.1 Software Subsystem Reliability Model	40
5.2 DABS Integrated System (Hardware and Software) Relia- bility Model	41
Appendix A. Review and Critique of the Available Hardware Reliability Model and the Hardware Reliability Pre- diction for the DABS	45
Appendix B. A Recommended Software Reliability Failure Reporting System for DABS	48
Appendix C. Listing of DABS Software Trouble Reports	52

## LIST OF FIGURES

<u>Figure</u>		<u>Page</u>
1	DABS Functional Block Diagram	8
2	DABS Software Independent Task/Processor Organization	9
3	DABS Software Test Baseline	11
4	Communication Module - Reliability Growth Model	19
5	Performance Monitor Module - Reliability Growth Model	22
6	Message Routing & Data Link Modules - Reliability Growth Model	24
7	Data Extraction Module - Data Plot	27
8	Channel Management Module - Data Plot	29
9	Network Management - Data Plot	32
10	MTD & RDAS Modules - Data Plot	34
11	System Software Module - Reliability Growth Model	36
12	Surveillance Module - Reliability Growth Model	39
B-1	DABS Trouble Report/Change Proposal	49
B-2	DABS Trouble Report/Change Proposal Update Worksheet	50

## LIST OF TABLES

<u>Table</u>		<u>Page</u>
1	Chargeable DABS Software Failures	13
2	Chargeable Failures Reported During the Prediction Interval	16
3	Communication Module - Reliability Data Summary	18
4	Performance Monitoring Module - Reliability Data Summary	21
5	Message Routing and Data Link Modules - Reliability Data Summary	23
6	Data Extraction Module - Reliability Data Summary	26
7	Channel Management Module - Reliability Data Summary	28
8	Network Management - Reliability Data Summary	30
9	MTD & RDAS Modules - Reliability Data Summary	33
10	System Software Module - Reliability Data Summary	35
11	Surveillance Module - Reliability Data Summary	38
12	Summary of Software Reliability Predictions	42
13	Summary of Module Critical Error Rates	43

## 1. EXECUTIVE SUMMARY.

### 1.1 OBJECTIVE.

The Federal Aviation Administration (FAA) uses mathematical models to measure and predict the reliability of hardware. FAA engineering specifications for systems under development contain reliability requirements, usually in terms of mean-time-between-failures (MTBF), for the hardware portions of these systems. However, recently procured systems contain computers with copious amounts of software. It has been the experience of the data processing community that failures of such systems are not confined to hardware. Software which has been debugged and in use for many years has been known to cause system failure. Consequently the FAA initiated this pilot study to determine the magnitude of the software reliability problem in one system currently in development. Study objectives were the following:

- Develop a software reliability model for the Discrete Address Beacon System (DABS) and make a software reliability prediction.

- Review and critique the available hardware reliability model and the hardware reliability prediction for DABS.

- Integrate/evolve the software and hardware reliability models into a DABS system model and make a system reliability prediction.

- Compare the predicted systems reliability value versus the specified value. Make applicable recommendations for reliability improvement of the system.

- Recommend a software reliability failure reporting system for the DABS.

### 1.2 BACKGROUND.

The objectives cited above were accomplished by grouping related objectives and tasks according to importance as defined by Mr. G. Apostolakis, head of the Reliability Engineering Section at the FAA Technical Center. As stated by Mr. Apostolakis, the primary concern of the FAA is the study of DABS software reliability--how it could be measured, modeled, predicted and how it could be incorporated with the hardware into an integrated software/hardware reliability model for DABS. The results of this study are contained in the body of this report, Sections 2 through 5. Of secondary concern are 1) the review and critique of the DABS hardware reliability model and prediction, and 2) a recommended software reliability failure reporting system for

the DABS. A brief critique of the DABS hardware reliability model is contained in Appendix A to this report. Because the FAA already has a failure reporting system for DABS software, a review of the procedures and forms was made. Recommendations for improvement are contained in Appendix B to this report.

The DABS software reliability was modeled using test time and failure data obtained from the testing of the sensors at three test sites--FAA Technical Center, Elwood and Clementon, N.J. Based on tests conducted between February 1979 and June 1980, reliability measurements were made for nine software modules which comprise the DABS mission software. Maintenance and off-line software were not modeled. Also not modeled was the Automatic Traffic Advisory and Resolution Service (ATARS) module because of its interim status.

Reliability prediction models for software modules were derived and then verified by matching predictions of error rate with software test data collected during July, August and September of 1980. Measurements of software reliability obtained from the models were combined with hardware reliability predictions (prepared by FAA) to obtain an integrated DABS reliability prediction model.

Unfortunately, there is no concensus in the literature pertaining to the definitions of commonly used terms such as bugs, errors, faults and failures. A few definitions are presented here to provide the reader some insight into those terms and concepts of software reliability.

- Software bugs, errors and faults will be considered to be synonymous. They denote latent defects present in software due to coding errors, misunderstanding of the required logic on the part of the programmer, incorrect algorithms or other programming errors.

- A software failure occurs when certain combinations of input parameters, input commands, input options or input data exercise the defective part of the program. Under a large variety of circumstances, one may consider these inputs to be random sets from all possible inputs. These random sets of inputs, in turn, cause random failures in the corresponding outputs. The random output failures may be analyzed statistically and thus constitute the basis for the concept of reliability as applied to software failures.

- Software reliability is the probability that a given software program will operate without failure for a specified time in a specified environment.

### 1.3 SIGNIFICANT FINDINGS.

1. The DABS has a measured overall MTBF of 252 hours; 575 hours MTBF for the hardware and 448 hours for the software. Only critical failures, those which dramatically reduce system capability, were counted in computing the MTBFs of hardware and software.

This achieved MTBF is far short of the 1000-hour MTBF specified in the engineering requirements. It is recognized that the required MTBF of 1000 hours was intended for application only to hardware, but even if the software is ignored the system does not now meet its reliability requirement. If all chargeable software failures were included in the calculation, software MTBF would decrease to 81 hours and the system MTBF would decrease to 71 hours. These measurements are based on a total of 5386 software test hours during which 354 errors were observed and evaluated.

It should be recognized that DABS is undergoing development testing and that its reliability is expected to increase as improvements are incorporated. Also, the transition from a test or debugging scenario to an operational scenario should noticeably improve the measured MTBF of the software. Much of the software testing at the Technical Center was geared toward pushing the system to its specified operational limits (e.g., capacity testing, multiple correlations, crossing tracks). The system was tested using a multitude of input environments and many of the reported errors were discovered as a result of testing using input environments which would not ordinarily be encountered in an operational scenario.

2. A critical software failure will frequently have a far greater effect on system operation than a computer hardware failure because critical software failures cause a significant or complete loss of system capability; that is, they defeat the hardware redundancy built into the system. In the event of computer failure the system can recover by using a spare computer; however, critical software failures result in either complete system failure or reduced performance which does not meet specification. From a reliability point of view, partial system operation is considered to be a failed condition because no reliability requirements are specified for alternate (degraded) modes of operation.

It is recommended that the FAA investigate the design of fault-tolerant software for DABS. The software could be designed to sense critical software failures (watchdog logic or audits) which would recover the system in much the same fashion as a computer failure by causing an automatic re-initialization of the system.

3. The Duane reliability growth model which has been used extensively to model the growth of hardware reliability and more recently to model the growth of software reliability as well, fits the known history of DABS software. Of the nine software modules in DABS, the Duane model accurately predicts reliability and rate of reliability growth of five modules. The modules and their rate of reliability growth models are:

Communication:  $\lambda_{\Sigma} = .174 T^{-.503}$   
Measured MTBF at end of study: 976 hours

Performance Monitoring:  $\lambda_{\Sigma} = .1403 T^{-.419}$   
Measured MTBF at end of study: 494 hours

Message Routing & Data Link:  $\lambda_{\Sigma} = .3467 T^{-.645}$   
Measured MTBF at end of study: 2400 hours

System Software:  $\lambda_{\Sigma} = 5.689 T^{-.863}$   
Measured MTBF at end of study: 2588 hours

Surveillance:  $\lambda_{\Sigma} = .1067 T^{-.3071}$   
Measured MTBF at end of study: 207 hours

where  $\lambda_{\Sigma}$  = cumulative error rate (number of chargeable errors/total test hours) and T = cumulative test hours. Of the remaining modules, the data were either too sparse to evaluate the parameters of the model or too erratic to determine whether module reliability is improving.

The parameters appearing as exponents of T indicate the rate of MTBF growth (MTBF = 1/error rate), which is usually a measure of management pressure to find and correct errors. The rates shown are all within the range typically encountered but they vary more than usual. This suggests that testing, debugging and integration efforts have not been applied uniformly in the DABS program. Some modules have received much more attention than others.

4. Based on hardware reliability measurements reported in Report No. FAA-RD-80-36, "Discrete Address Beacon System (DABS) Baseline Test and Evaluation," April 1980, DABS hardware MTBF growth rate, albeit using a small sample, was calculated to be  $\alpha = .36$ . Projections of hardware MTBF improvement using  $\alpha = .36$  and software MTBF improvement using  $\alpha = .52$  show that the DABS software/hardware system will achieve its 1000-hour MTBF requirement after 49 additional months of testing. At that time hardware MTBF will be approximately 1650 hours and software MTBF will be approximately 2500 hours if the growth rate continues.

The models predict that if no changes are made in the present reliability improvement efforts, software errors will still constitute 10 percent of total system errors (based on 1000-hour hardware MTBF) after  $50 \times 10^6$  software test hours (test time needed to achieve software MTBF = 10,000 hours).

The following actions are recommended to speed up the reliability improvement of the DABS system:

- Increase the intensity of the software test program to conduct well planned non-random testing such as the identification and evaluation of degraded as well as complex inputs to software modules.

- Automatically identify/isolate access of the code with low input/output traffic; check all jump statements.

- Conduct failure modes, effects and criticality analyses of hardware elements which contribute most to unreliability--antenna, transmitter, receiver and processor. These elements which have no redundancy in the single channel sensor could be improved through the identification of failure modes and their elimination through corrective action.

- The reliability engineering department of the FAA Technical Center should continue to monitor the progress of the software test, participate in configuration management and include estimates of software reliability in DABS predictions.

5. Analysis of the test data for the purpose of measuring reliability and its growth showed that the error rates of most software modules changed appreciably during the test. Several causes are postulated:

- a) As noted in Figure 4, the nearly constant error rate of the communication module for 900 test hours is followed by a rapidly declining error rate. This pattern is characteristic of an early test period in which the software package was not tested with the intensity needed to identify and correct errors. Subsequent testing then resulted in the identification and elimination of more errors at a significantly higher rate.

- b) Software test personnel are sometimes reluctant to document errors as they are observed because they believe that continuation of the test and analyses of results are more important tasks. Consequently, failures may be documented en masse several weeks or months after they occur, usually at the completion of the test. Such perturbations to the model may require several additional data points to effect smoothing.

c) Neither the Duane nor any other model which assumes a continuously decreasing error rate with time can predict significantly large perturbations due to mass introductions of software modifications at "release" points. These can either increase or decrease an error rate. Abrupt termination of a debugging process will also significantly reduce the observed error rate.

6. The FAA should endeavor to include software as well as hardware elements in future reliability models for DABS and other computer aided systems. Reliability requirements of future systems, which are often set by systems requirements analyses, should also include the reliability of the software. Measured reliability of the system will then be realistic since it will apply to software and hardware.

## 2. DESCRIPTION OF DABS COMPUTER SOFTWARE, TESTING AND DATA BASE.

### 2.1 DESCRIPTION OF DABS COMPUTER SOFTWARE AND ITS TESTING.

As described by Dr. C. M. Applewhite in "Disbributed Computer Architecture For The Discrete Address Beacon System," the purpose of DABS is to provide highly reliable tracking and collision avoidance support for DABS-equipped aircraft. Control of DABS is provided by software operating in a ground based distributed computer network interfaced to a beacon radar. Each DABS aircraft is assigned a unique identification (discrete address) associated with its DABS transponder. Recognition of a beacon interrogation is keyed to the discrete address of each particular aircraft such that a unique data link with minimum interference can be established between the computer network and each aircraft. The software subsystem maintains a track update on each aircraft, predicts potential conflict situations and controls the scheduling of the beacon radar. Data to support aircraft tracking is gathered via uplink interrogations and downlink responses of aircraft positional data. Traffic data and maneuver advisories are provided to the pilots via the uplink in the event the computer subsystem predicts a potential conflict situation. Telephone line data links between sensors facilitate coordination among adjacent sensors with overlapping airspace responsibilities.

DABS surveillance capability is designed to be completely compatible with the present Air Traffic Control Radar Beacon System (ATCRBS) and thus can be introduced gradually and economically without major operational or procedural change. Since DABS uses monopulse direction finding, the system also provides improved surveillance coverage for ATCRBS equipped aircraft at a reduced interrogation rate.

In addition to the requirements given above, the software system is required to respond to computer hardware failures by reconfiguring the system and maintaining system integrity, to monitor system status indicators, to send status messages to ATC maintenance facilities and to collect performance data for the sensor. A functional block diagram which highlights some of the DABS features is shown in Figure 1. The architecturally distributed, molecular software is shown in Figure 2.

No special tests were run expressly to provide data, solely for reliability analysis. Consequently, the running time and errors generated during debugging, checkout and operation of the DABS sensors at FAA Technical Center, Elwood and Clementon, N.J., were used to formulate the software reliability model and measure achieved reliability and growth rate. The DABS software was tested formally and informally. At the FAA Technical Center, initial testing was conducted by running

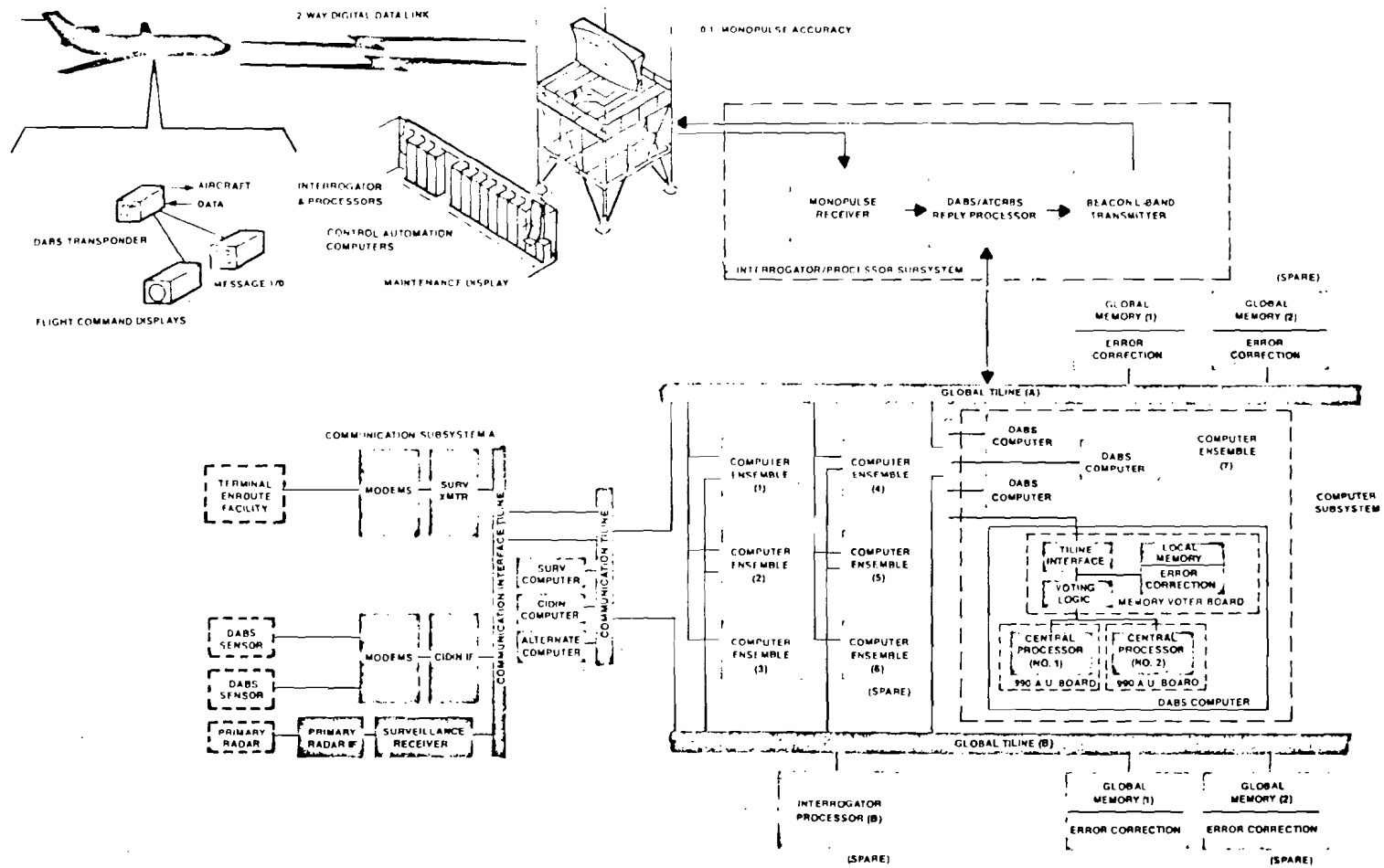

Figure 1. DABS Functional Block Diagram

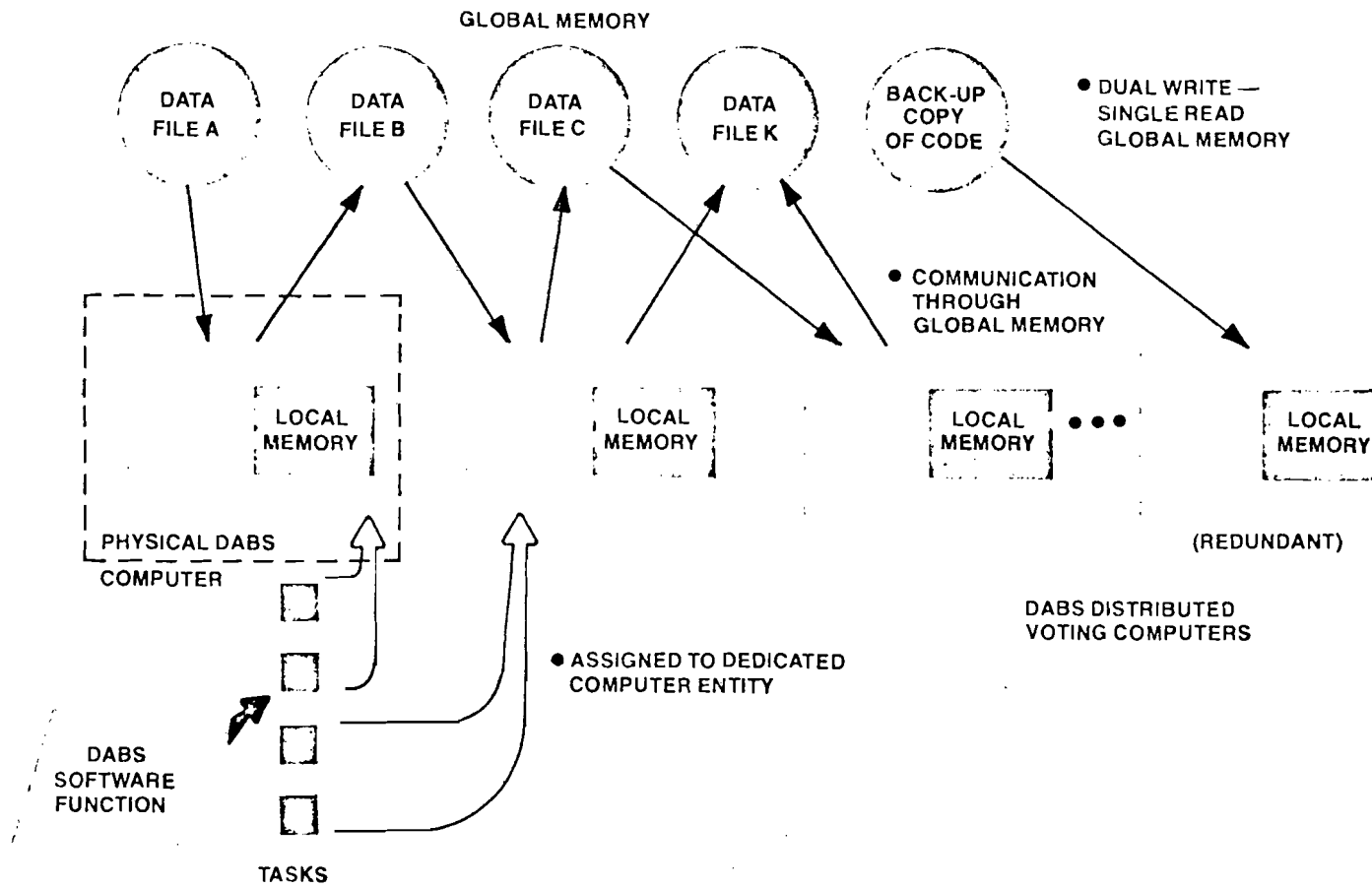

Figure 2. DABS Software Independent Task/Processor Organization

the system. Maximum specified values of targets and fruit rates (replies to interrogations from other sensors) were simulated to test DABS software and hardware. The test program uncovered coding errors, timing and interrupt faults.

## 2.2 DABS SOFTWARE DATA BASE.

The software test time base is shown in Figure 3. The figure contains monthly estimates of software test time for three facilities where testing occurred--FAA Technical Center, Elwood and Clementon, NJ. Beginning in October 1979 the test time is the scheduled software test time for each test site. Prior to October, software test times were based on estimates obtained from Messrs. M. Holtz, DABS Program Manager, and J. Simpfenderfer, T. I. Technical Representative. The figure also shows the time phasing of the testing of the various DABS software modules. It shows, for example, that channel management, surveillance and data extraction were considered to be undergoing test from the beginning of the test, whereas network management was not tested until all three sensors were on-line in October 1979.

An additional three months of test data (1790 hours) accrued during July, August, and September 1980. This time period constituted a small controlled sample from DABS testing to be used to verify reliability predictions made using the data base described above. This procedure is described in Section 3 of this report.

Software errors discovered during the test programs were reported on trouble reports. A brief description of the reporting system, including a sample form, is given in Appendix B to this report.

The DABS software error data base consists of 354 trouble reports (TR) which document program stops, errors, enhancements and change proposals. Not all supply adequate information for reliability analysis. Software design engineers at Texas Instruments reviewed each TR and its associated follow-up documentation and classified the TRs with respect to severity. Chargeable errors which were used to measure software reliability were classified as critical (1) or non-critical (2). Those not chargeable were classified other (3) or no count (4). The following definitions were applied.

### Chargeable Errors:

1. Critical - An error in the software which causes a significant or total loss of operational system capability.
2. Non-Critical (Major) - An error in the software which causes an erroneous response in the operational system. An error in this classification may not be recognized as such by a trained observer due to the self-repair inherent in the system.

Calendar Yr. Month	← 1979 →												← 1980 →					Total Hours	
	0	1	2	3	4	5	6	7	8	9	10	11	12	1	2	3	4		5
FAA Technical Center Hrs/Mo.		140	140	140	140	140	140	140	140	155	170	182	184	211	184	284	191	203	2,884
Elwood Hrs/Mo.							48	48	48	100	120	146	187	171	171	219	143	155	1,556
Clementon Hrs/Mo.										50	100	161	157	98	76	121	84	99	946
Total Hrs/Mo.		140	140	140	140	140	188	188	188	305	390	489	528	480	431	624	418	457	5,386

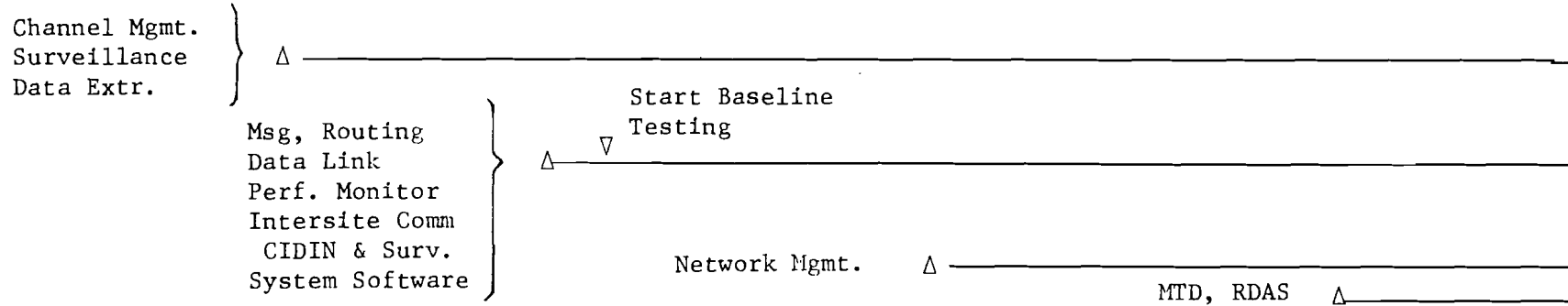

Figure 3. DABS Software Test Baseline

Non-Chargeable Errors:

3. Other (Minor) - An error which has no measurable effect on the operational system or is of unknown cause at this time (hardware/software/cockpit). Errors of unknown causes would be charged against the DABS system rather than the software.

4. No Count - A trouble report which was erroneously attributed to software errors. In addition, change proposals, enhancements, duplicate trouble reports and "cockpit errors" are included.

A summary of chargeable errors is presented in the matrix in Table 1. Only software modules identified in the table were included in the reliability analysis. Other software modules which are off-line analysis tools or are used during maintenance or pre-initialization were not modeled because they are not part of the mission software. The ATARS module which will eventually constitute a large portion of the DABS software subsystem cannot be analyzed now because it is being rewritten and is not scheduled for extensive testing until Spring of 1981. A computer listing of all DABS trouble reports is contained in Appendix C.

Table 1. Chargeable DABS Software Failures

		<u>SYS</u>	<u>MTD RDAS</u>	<u>COMM</u>	<u>PM</u>	<u>MR&amp; DL</u>	<u>NM</u>	<u>CM</u>	<u>DEX</u>	<u>SURV</u>	<u>F</u>
1979	FEB							1		8	9
	MAR									0	0
	APR									1	1
	MAY	4		1	3	1		1		4	14
	JUN	1		1	0					2	4
	JUL	3		1	2	2			1	3	12
	AUG	2		1	0					1	4
	SEP	4		1	1	1		1		2	10
	OCT	1		0	5		3			2	11
	NOV	1		0	0		0		1	1	3
	DEC	0		0	1		6	1		2	10
1980	JAN	0		1	1		2	1		2	7
	FEB	1		3	0		4	2		2	12
	MAR	0		1	0	2	3	2		3	11
	APR	0	1	1	4	1	3	2		2	14
	MAY	1	1		2		1	3		4	12
	JUN	0	1		1		0			2	4
		18	3	11	20	7	22	14	2	41	138

### 3. APPROACH TO SOFTWARE RELIABILITY MODELING.

#### 3.1 THEORETICAL SOFTWARE RELIABILITY MODEL.

The reliability growth model introduced by Duane in 1964 and more recently expounded by Codier, has found wide acceptance by reliability engineers. It is simple to use and it is applicable to both continuous and discrete data cases. Its wide applicability to diverse hardware test programs and more recently to software test data prompted its use here.

Using data from several different types of hardware test programs as a basis, Duane plotted cumulative failure rate ( $\lambda_{\Sigma}$ ) vs. total operating time (t) and observed a linear relationship between  $\log(\lambda_{\Sigma})$  and  $\log(T)$  for each equipment. This relationship is characterized by the model:

$$\lambda_{\Sigma} = KT^{-\alpha} \quad \text{where,}$$

$\lambda_{\Sigma}$  = cumulative failure rate

K = a model parameter to be estimated (represents  $\lambda$  at T=1)

T = total operating hours, cycles or missions

$\alpha$  = Growth rate to be estimated.

Duane presents a method for estimating the model parameter directly from the data plotted on log-log paper. The growth parameter can be obtained by calculating the slope of the line. The location parameter is also obtained directly from the plot as the value for  $\lambda_{\Sigma}$  at T = 1. K can be interpreted as the initial or zero-age failure rate. For software, it is a function of program complexity, size, its maturity relative to the state-of-the-art and other variables.

The curve is more sensitive to the exponent  $\alpha$  than to K. The exponent reflects the intensity with which reliability improvement is pursued; it nearly always lies between .2 and .5, the average being close to .3.

In addition to information regarding cumulative failure rates, the predicted failure rate at any point in time; i.e., instantaneous failure rate  $\lambda_t$ , can also be estimated from the following equation where F = total failures and all other variables have been previously defined.

$$\begin{aligned} \lambda_t &= \frac{\partial F}{\partial T} = \frac{\partial}{\partial T} (\lambda_{\Sigma} T) = \frac{\partial}{\partial T} (KT^{-\alpha} T) \\ &= (1-\alpha)KT^{-\alpha} = (1-\alpha)\lambda_{\Sigma} \end{aligned}$$

Thus, program progress can be modeled using cumulative information and can be continuously monitored using the current information.

### 3.2 DATA ANALYSIS.

The operating time and error data base for each software module was analyzed to provide inputs into the Duane model. Using chargeable errors and test time the cumulative error rate  $\lambda_{\Sigma} = \text{total failures} / \text{total time}$  was calculated for each month in which at least 1 error was reported. The data were plotted in accordance with the Duane growth curve requirements and model parameters were estimated if growth were evident.

The modeling process generated a model of cumulative error rate,  $\lambda_{\Sigma} = KT^{-\alpha}$ , and a model of instantaneous error rate,  $\lambda_t = (1-\alpha)\lambda_{\Sigma}$ . The reciprocals of error rates are the MTBFs, cumulative and instantaneous respectively. In addition, MTBCF, i.e., mean time between critical (severity class 1) failures, values were calculated where applicable.

For the modules where reliability improvement was evident, the models were used as predictive tools to estimate the error rate during future testing. In this analysis the future consisted of the 1790 test hours during July, August and September of 1980. Results of the predictions were then compared to actual data. The analysis of the COM module (Section 4.1) serves as a detailed example of the process. For information purposes, Table 2 contains a listing of chargeable errors written during the prediction test interval.

Table 2. Chargeable Failures Reported During the Prediction Interval

<u>Report Number</u>	<u>Date of Error</u>	<u>Module</u>	<u>Severity</u>
M0002	7/10/80	CM	1
N0066	7/11/80	MTD	2
S0317	7/16/80	PM	2
S0319	7/16/80	PM	2
S0320	7/16/80	PM	1
S0321	7/18/80	SYS	1
S0326	7/20/80	COMM	2
S0328	7/23/80	SURV	2
S0330	7/24/80	CM	2
S0331	7/24/80	SYS	2
S0333	7/24/80	SURV	1
N0072	8/11/80	SURV	2
S0334	8/ 4/80	COMM	2
S0335	8/ 4/80	COMM	2
S0337	8/ 4/80	COMM	2
S0338	8/ 4/80	COMM	2
M0004	9/29/80	SURV	2
M0005	9/29/80	SURV	2
M0006	9/29/80	SURV	2
M0008	9/29/80	SURV	2
M0014	9/29/80	DEX	2
S0358	9/15/80	SYS	2

#### 4. RELIABILITY EVALUATION OF DABS SOFTWARE MODULES.

##### 4.1 RELIABILITY EVALUATION OF THE COMMUNICATION MODULE.

The Communications (COM) Module includes the surveillance and CIDIN communications programs which control and monitor transfer of data between a sensor and external facilities. The reliabilities of other software in the intersite communications package were not modeled because the software is associated with off-line and maintenance processing and is not part of the mission software.

The COM module was tested for 4966 hours during which 11 chargeable errors were reported (see Table 3). Only 4091 test hours along with the 11 errors were used to construct the growth model because the data base was terminated at the last reported failure in accordance with the rules of model construction. Results of the model generation and reliability predictions follow.

The model which describes cumulative error rate is  $\lambda_{\Sigma} = .174 T^{-.503}$  where  $\lambda_{\Sigma}$  = cumulative error rate and T = cumulative test hours. For example, at the time of the last reported error (T = 4091 hr.) the model predicts  $\lambda_{\Sigma} = .00265$  error/hr. or 377 hr. MTBF. The measured error rate at T = 4091 hr. was .0027 error/hr. or 372 hr. MTBF. When used as a predictive tool to extrapolate beyond the time limits of the data base to T = 6756 hours,  $\lambda_{\Sigma} = .174 (6756)^{-.503} = .00206$  error/hr. or 485 hours MTBF. The time interval between 4091 hours and 6756 hours (2665 hours) includes the last 875 hours of test without a reported failure and 1790 hours of test during the prediction interval. Because the model predicted a cumulative error rate of .00206 error/hr. at T = 6756 hr., the expected number of cumulative errors was calculated from:  $F = \lambda_{\Sigma} \cdot T = .00206 \text{ error/hr.} \cdot 6756 \text{ hr.} = 139$  errors. Because 11 errors had already been reported within 4091 test hours, the remaining 2.9 errors represent a prediction to be compared with the observed results. In fact, five chargeable errors were reported against the COM module, a number which is well within the limits of statistical variation. Figure 4 contains a graph of the model.

The model which describes instantaneous error rate and MTBF is  $\lambda_t = .0865 T^{-.503}$ . It represents the rate at which errors are systematically being identified and removed from the COM module at time T hours. For example, at T = 6756 hours,  $\lambda_t = .0865 (6756)^{-.503} = .00102$  error/hr. or 976 hr. MTBF. The value of  $\lambda_t$  at T = 6756 has the significance that if the test correction process were to cease at T = 6756 hours, the error rate of the COM module would no longer decrease, but would become constant at  $\lambda = .00102$  error/hr. or 976 hr. MTBF.

Table 3. Communication Module - Reliability Data Summary

Month	Monthly Test Hrs (T)	Monthly Errors (F)	Cumulative Test Hrs. ( $T_{\Sigma}$ )	Cumulative Errors ( $F_{\Sigma}$ )	Cumulative Error/Hr ( $\lambda_{\Sigma}$ )	Average Time Between Errors (MTBF $_{\Sigma}$ )
1979 Feb						
Mar						
Apr						
May	140	1	140	1	.0071	140
June	140	1	280	2	.0071	140
July	188	1	468	3	.0064	156
Aug	188	1	656	4	.0061	164
Sept	188	1	844	5	.0059	169
Oct	305	0	1149			
Nov	390	0	1539			
1979 Dec	489	0	2028			
1980 Jan	528	1	2556	6	.0023	426
Feb	480	3	3036	9	.003	337
Mar	431	1	3467	10	.0029	347
Apr	624	1	4091	11	.0027	372
May	418		4509			
June	457		4966			
July						
Aug	1790					
Sept			6756			

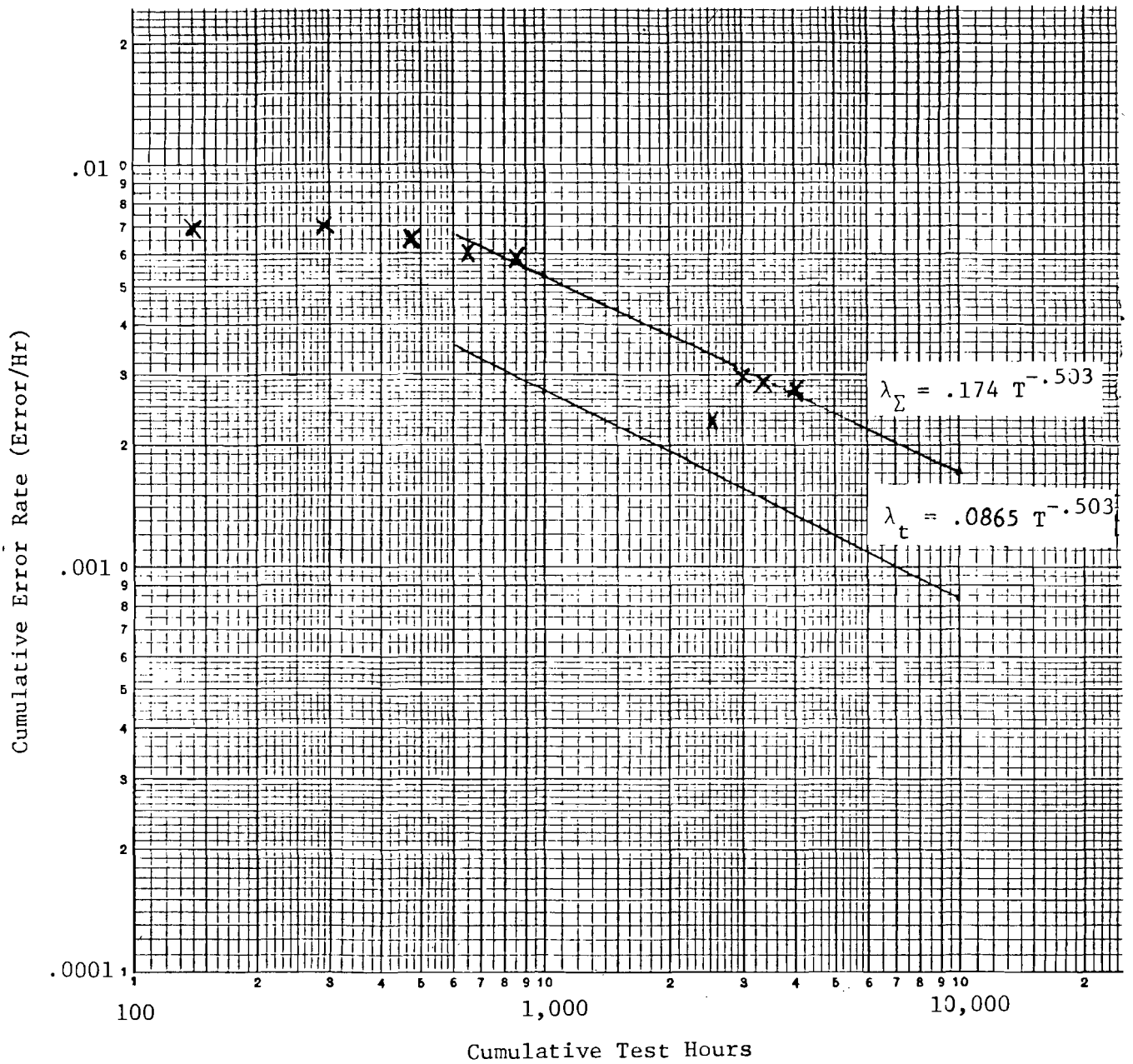

Figure 4. Communication Module - Reliability Growth Model

#### 4.2 RELIABILITY EVALUATION OF THE PERFORMANCE MONITORING MODULE.

The Performance Monitoring (PM) module, a portion of intrasite communications, is responsible for gathering and analyzing status of the sensor and the transmission of status messages to external facilities.

As reported in Table 4, the PM software was tested for 4966 hours during which 20 chargeable errors were reported. Of the chargeable errors, five were classified as critical. Figure 5, which contains the reliability growth curve for the PM module shows that the module experienced a decreasing error rate throughout the test except for minor fluctuations. The cumulative error rate model,  $\lambda_{\Sigma} = .1403T^{-.419}$ , gives  $\lambda_{\Sigma} = .00348$  error/hr. at  $T = 6756$  hours. This translates into 3.5 expected errors during the time of the test interval used for prediction purposes. Because 3 chargeable errors were reported during the 1790 test hours of the prediction interval, there is close agreement and acceptance of the model.

The instantaneous error rate model,  $\lambda_t = .0815T^{-.419}$ , predicts that  $\lambda = .00203$  error/hr. at  $T = 6756$  which is equivalent to 494 hours MTBF.

#### 4.3 RELIABILITY EVALUATION OF MESSAGE ROUTING AND DATA LINK PROCESSING MODULES.

The Message Routing (MR) software is responsible for routing incoming messages to the appropriate software module. Data Link (DL) processing manages uplink and downlink messages to/from participating DABS equipped aircraft. MR & DL software were tested together and form a single software module for the purpose of reliability analysis.

Table 5 contains the time and error data used to generate the reliability growth curve shown in Figure 6. Using the cumulative growth model,  $\lambda_{\Sigma} = .3467 T^{-.645}$ ,  $\lambda_{\Sigma} = .00117$  error/hr. at  $T = 6756$  hours. The model predicts the occurrence of 7.9 errors throughout the test of 6756 hours. Because 7 errors were reported during the initial test phases, 0.9 errors were predicted to occur during the prediction test interval. Actually, no failures were reported during the 1790 hours of additional test, a value within acceptable statistical variation.

The instantaneous error rate model,  $\lambda_t = .123T^{-.645}$ , predicts  $\lambda_t = .000417$  error/hour or 2400 hours MTBF at  $T = 6756$  hours.

Table 4. Performance Monitoring Module - Reliability Data Summary

Month	Monthly Test Hrs (T)	Monthly Errors (F)	Cumulative Test Hrs. ( $T_{\Sigma}$ )	Cumulative Errors ( $F_{\Sigma}$ )	Cumulative Error/Hr ( $\lambda_{\Sigma}$ )	Average Time Between Errors ( $MTBF_{\Sigma}$ )
1979 Feb						
Mar						
Apr						
May	140	3	140	3	.0214	47
June	140	0	280			
July	188	2	468	5	.0107	93
Aug	188	0	656			
Sept	188	1	844	6	.0071	141
Oct	305	5	1149	11	.0096	104
Nov	390	0	1539			
1979 Dec	489	1	2028	12	.0059	169
1980 Jan	528	1	2556	13	.0051	196
Feb	480		3036			
Mar	431		3467			
Apr	624	4	4091	17	.0042	238
May	418	2	4509	19	.0042	238
June	457	1	4966	20	.0040	250
July						
Aug	1790					
Sept			6756			

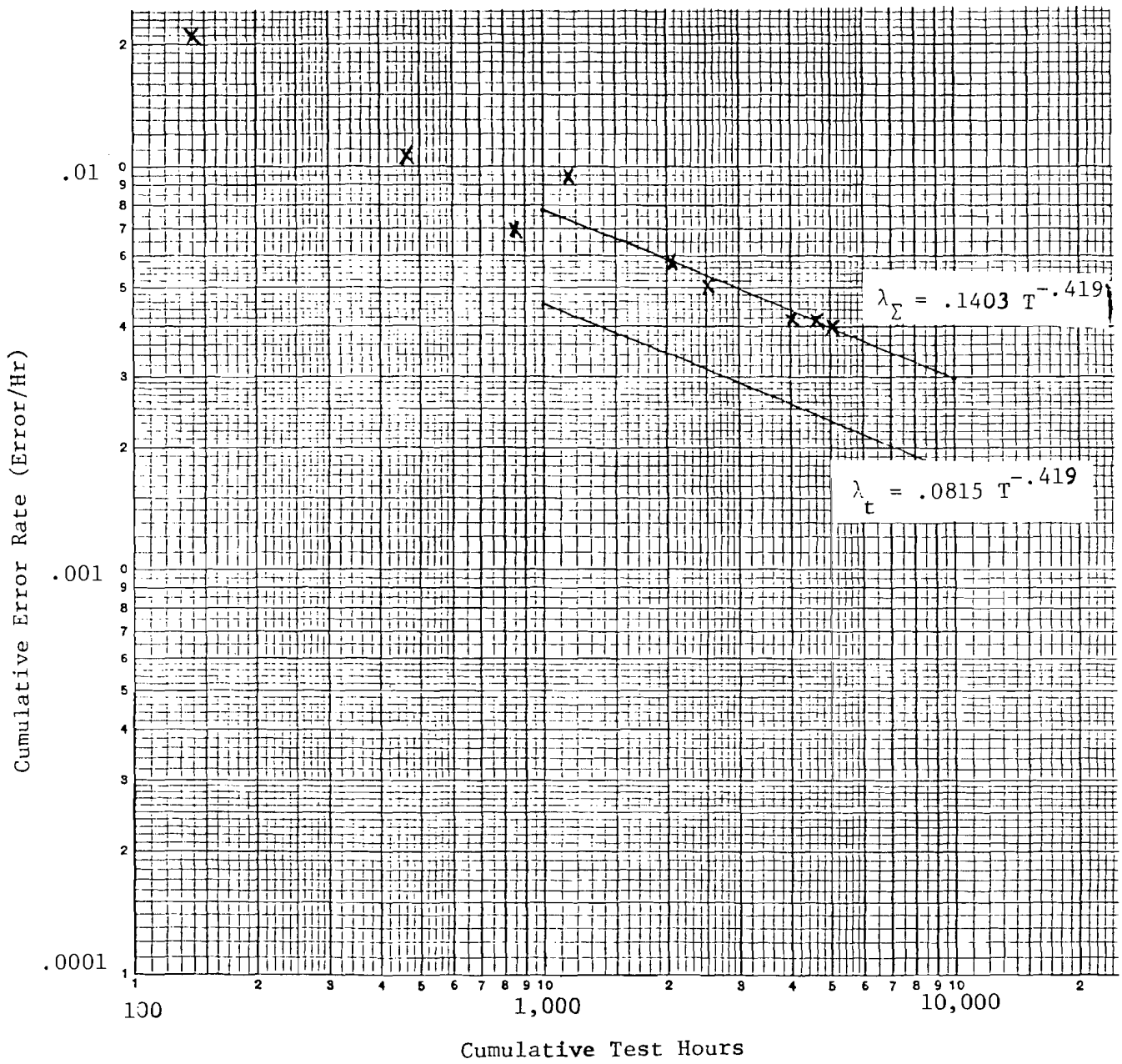

Figure 5. Performance Monitor Module - Reliability Growth Model

Table 5. Message Routing and Data Link Modules - Reliability Data Summary

Month	Monthly Test Hrs (T)	Monthly Errors (F)	Cumulative Test Hrs. ( $T_{\Sigma}$ )	Cumulative Errors ( $F_{\Sigma}$ )	Cumulative Error/Hr ( $\lambda_{\Sigma}$ )	Average Time Between Errors (MTBF $_{\Sigma}$ )
1979 Feb						
Mar						
Apr						
May	140	1	140	1	.0071	141
June	140		280			
July	188	2	468	3	.0064	156
Aug	188		656			
Sept	188	1	844	4	.0047	213
Oct	305		1149			
Nov	390		1539			
1979 Dec	489		2028			
1980 Jan	528		2556			
Feb	480		3036			
Mar	431	2	3467	6	.0017	588
Apr	624	1	4091	7	.0017	588
May	418		4509			
June	457		4966			
July						
Aug	1790					
Sept			6756			

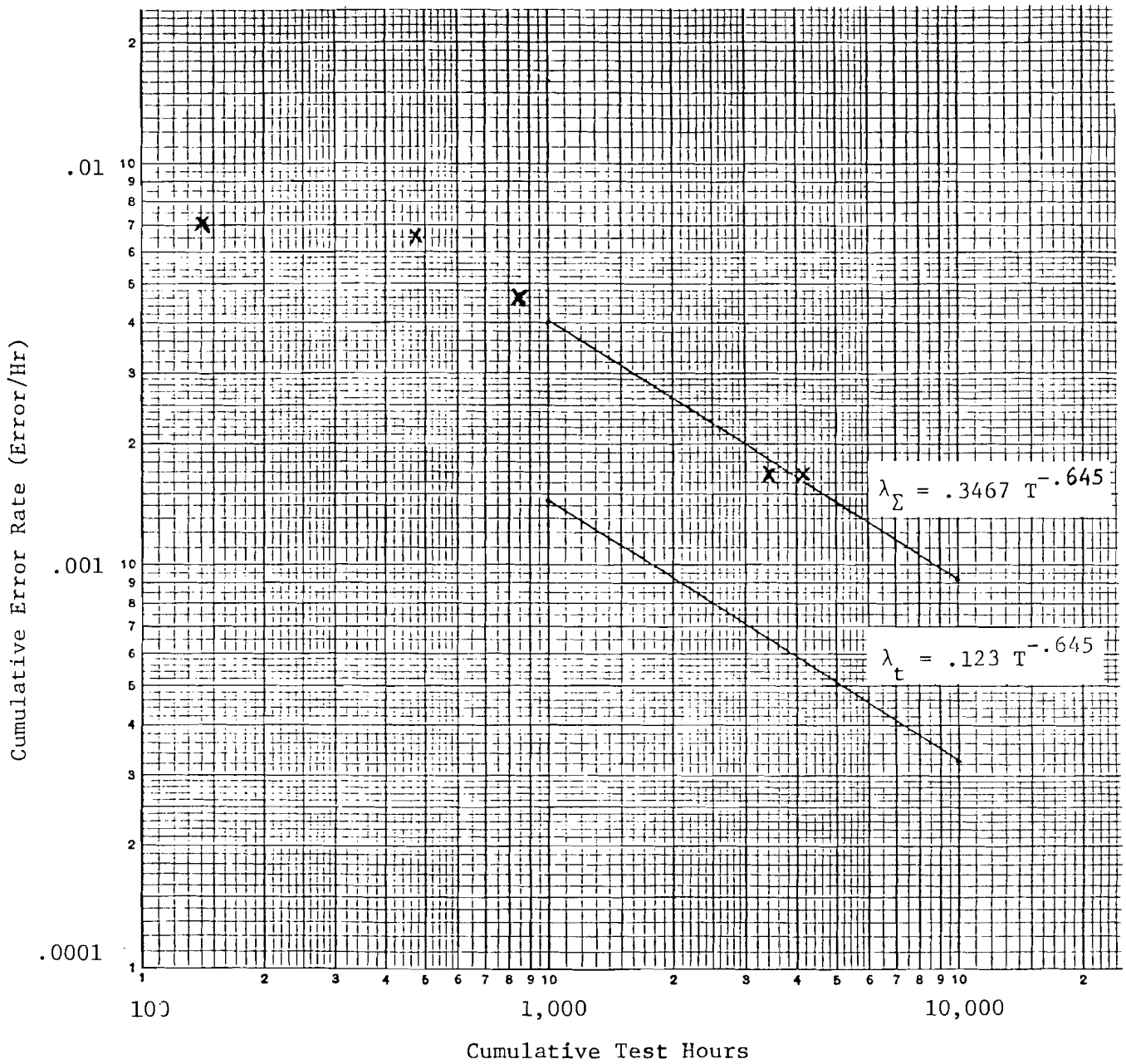

Figure 6. Message Routing and Data Link Modules - Reliability Growth Model

#### 4.4 RELIABILITY EVALUATION OF DATA EXTRACTION MODULE.

Included in this evaluation are data from the portion of the Data Extraction (DEX) module which is associated with data collection; i.e., on-line real time extraction of performance data from the DABS data base and its recording on magnetic tape. Playback, quick-look and extended analysis software are used off-line and are not part of the mission software.

As seen in Table 6 and Figure 7, the DEX module is very reliable. Only two chargeable errors were reported in 5386 test hours for an MTBF of 2693 hours or an error rate of .000371 error/hr. One of the errors was classified as critical. Too few data are available to generate a reliability trend curve. It can be seen however, that the error rate is decreasing which implies that the instantaneous MTBF is greater than 2693 hours. There was one error reported against DEX software during the prediction test interval.

#### 4.5 RELIABILITY EVALUATION OF CHANNEL MANAGEMENT MODULE.

Channel Management (CM) regulates all activity on the RF channel, scheduling the aircraft interrogations and corresponding listening periods to ensure that communications and surveillance tasks are accomplished for each aircraft.

The CM module has been characterized by T. I. software designers as the most complex of the DABS software modules primarily because of its logical structure. Its measured reliability is among the lowest. During 5386 hours of test, 14 chargeable errors were reported for an error rate of .0026 error/hr. or 385 hours MTBF. Table 7 contains cumulative time and error data for CM. The data plot in Figure 8 shows that no trend analysis is possible because of the abrupt changes in slope of the curve. In fact, during the test period between 2500 hr. and 5000 hr. CM error rate increased from .0016 error/hr. to .0028 error/hr. Subsequent testing indicates a reversal of the trend because the error rate appears to be decreasing in the prediction interval between 4929 hours and 7176 hours. Consequently, for prediction purposes the cumulative error rate  $\lambda_{\Sigma} = \text{total errors}/\text{total hours} = .0026 \text{ error/hr.}$  will be used.

#### 4.6 RELIABILITY EVALUATION OF NETWORK MANAGEMENT MODULE.

Network Management (NM) is a portion of intrasite communications responsible for communication of surveillance data to and from other sensors.

Table 8 contains the data used in the reliability analysis of the NM software. Based on a total of 4122 test hours and 22 chargeable errors

Table 6. Data Extraction Module - Reliability Data Summary

Month	Monthly Test Hrs (T)	Monthly Errors (F)	Cumulative Test Hrs. ( $T_{\Sigma}$ )	Cumulative Errors ( $F_{\Sigma}$ )	Cumulative Error/Hr ( $\lambda_{\Sigma}$ )	Average Time Between Errors (MTBF $_{\Sigma}$ )
1979 Feb	140		140			
Mar	140		280			
Apr	140		420			
May	140		560			
June	140		700			
July	188	1	888	1	.0011	909
Aug	188		1076			
Sept	188		1264			
Oct	305		1569			
Nov	390	1	1959	2	.0010	1008
1979 Dec	489		2448			
1980 Jan	528		2976			
Feb	480		3456			
Mar	431		3887			
Apr	624		4511			
May	418		4929			
June	457		5386			
July						
Aug	1790					
Sept			7176			

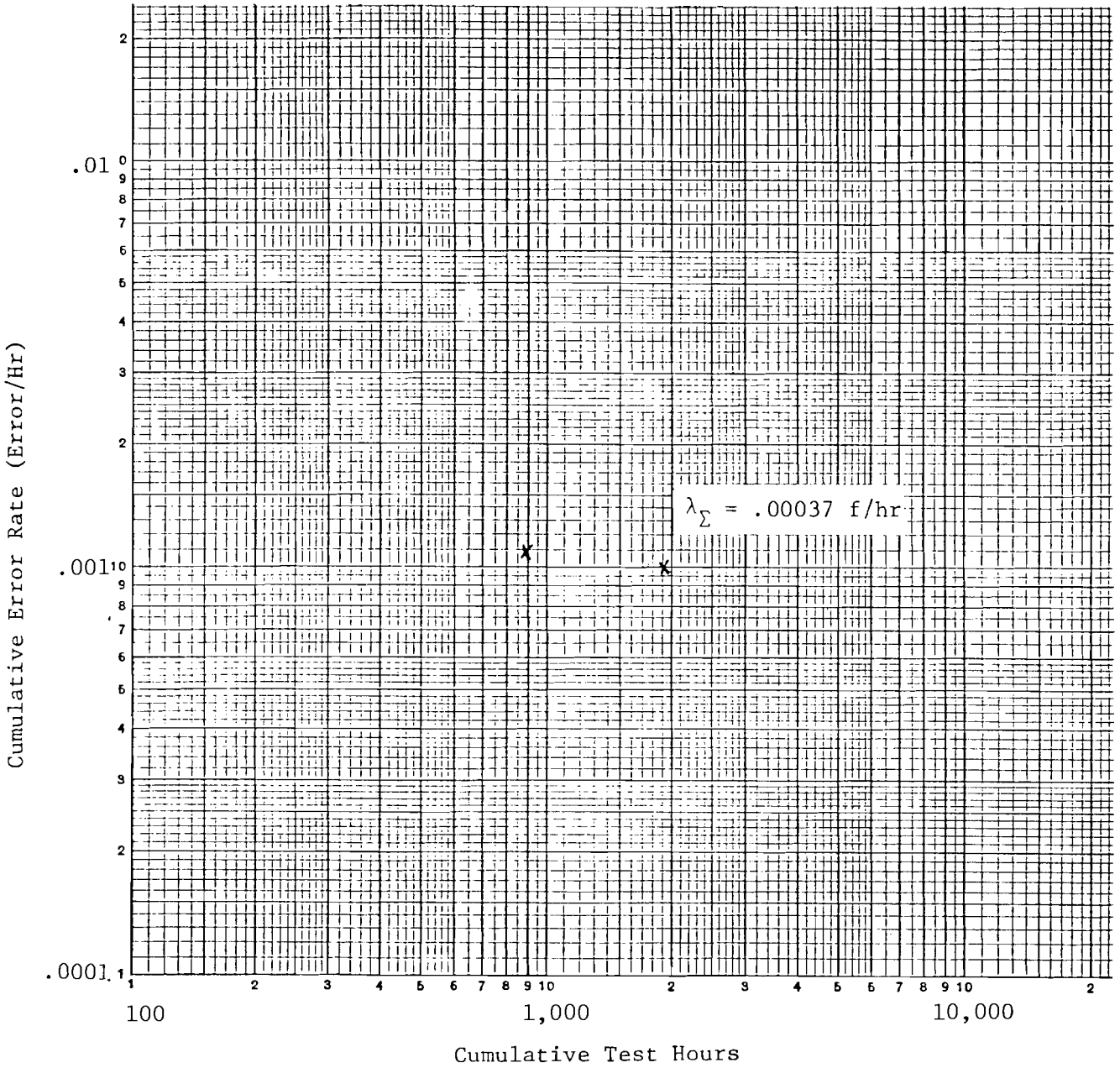

Figure 7. Data Extraction Module - Data Plot

Table 7. Channel Management Module - Reliability Data Summary

Month	Monthly Test Hrs (T)	Monthly Errors (F)	Cumulative Test Hrs. ( $T_{\Sigma}$ )	Cumulative Errors ( $F_{\Sigma}$ )	Cumulative Error/Hr ( $\lambda_{\Sigma}$ )	Average Time Between Errors (MTBF $_{\Sigma}$ )
1979 Feb	140	1	140	1	.00714	140
Mar	140		280			
Apr	140		420			
May	140	1	560	2	.0036	278
June	140		700			
July	188		888			
Aug	188		1076			
Sept	188	1	1264	3	.0024	417
Oct	305		1569			
Nov	390		1959			
1979 Dec	489	1	2448	4	.0016	625
1980 Jan	528	1	2976	5	.0017	588
Feb	480	2	3456	7	.002	500
Mar	431	2	3887	9	.0023	435
Apr	624	2	4511	11	.0024	417
May	418	3	4929	14	.0028	357
June	457		5386			
July						
Aug	1790					
Sept			7176			

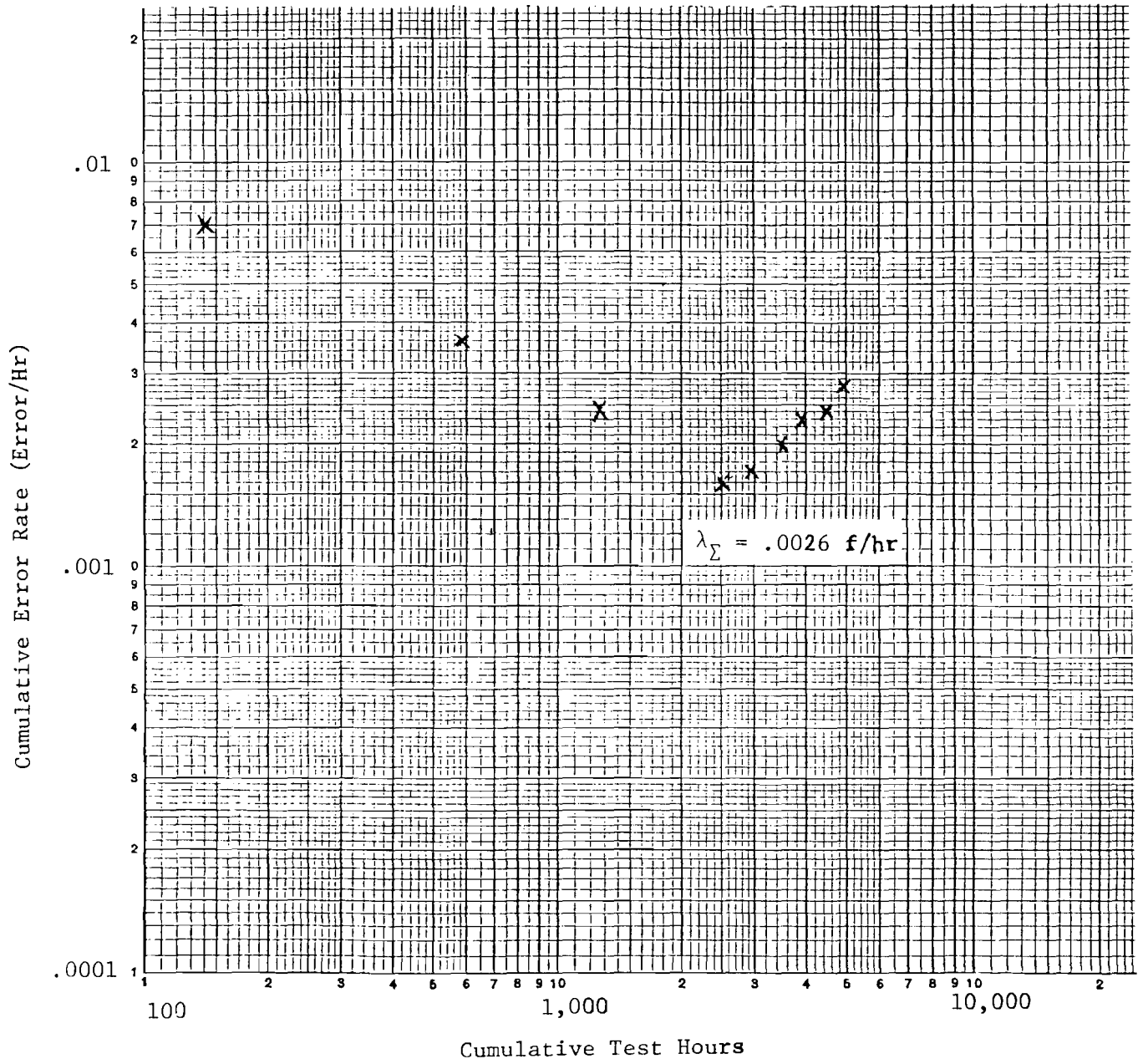

Figure 8. Channel Management Module - Data Plot

Table 8. Network Management - Reliability Data Summary

Month	Monthly Test Hrs (T)	Monthly Errors (F)	Cumulative Test Hrs. ( $T_{\Sigma}$ )	Cumulative Errors ( $F_{\Sigma}$ )	Cumulative Error/Hr ( $\lambda_{\Sigma}$ )	Average Time Between Errors (MTBF $_{\Sigma}$ )
1979 Feb						
Mar						
Apr						
May						
June						
July						
Aug						
Sept						
Oct	305	3	305	3	.0098	102
Nov	390	0	695			
1979 Dec	489	6	1184	9	.018	56
1980 Jan	528	2	1712	11	.0064	156
Feb	480	4	2192	15	.0068	147
Mar	431	3	2623	18	.0069	145
Apr	624	3	3247	21	.0065	154
May	418	1	3665	22	.0060	167
June	457	0	4122			
July						
Aug	1790		5912			
Sept						

NM cumulative error rate was measured to be  $\lambda_{\Sigma} = 22/4122 = .00534$  error/hr. or 187 hours MTBF. NM software has been characterized as moderately complex; it has the highest predicted error rate of the DABS software modules which were studied. Although its error rate appears to be decreasing (see Figure 9), there are not sufficient current data to support trend analysis. Data reported during the prediction test interval also indicate a decreasing error rate trend. During 1790 hours of test there were no reported errors. However, a large portion of the apparent reliability improvement may be due to a lessening of the severity of the test environment. The formal NM test which was run to demonstrate compliance with operational requirements had been completed in June 1980. Consequently the NM software may have been operating in reduced data and requirements environments during the July to September time frame.

#### 4.7 RELIABILITY EVALUATION OF MTD AND RDAS MODULES.

The Moving Target Detector (MTD) and Radar Data Acquisition Subsystem (RDAS) programs are integral to the sensor track software which is required to acquire and track DABS and ATRBS aircraft.

As noted in Table 9, the MTD and RDAS module was tested for only 3 months resulting in 1499 test hours and 3 chargeable errors for an error rate of .002 error/hr. or 500 hours MTBF. The data in Figure 10 show a constant error rate, with a slight increasing trend which is influenced by the paucity of data. During the prediction test interval no errors were reported against the MTD and RDAS module.

#### 4.8 RELIABILITY EVALUATION OF SYSTEM SOFTWARE MODULE.

System (SYS) software refers to all the software required to calibrate and initialize DABS and recover from hardware failures. SYS also contains standardized software support utilities.

As noted in Table 10, SYS was tested for 4966 hours with 18 reported chargeable errors. Fourteen (14) of the errors occurred within the first 844 hours of test which resulted in a high error rate during early testing followed by a rapidly decreasing error rate. This is shown graphically in Figure 11. Because SYS code resides in every computer and much of it is replicated, the code is tested more thoroughly. More of the logical paths are exercised with a higher probability of encountering a logical "bug." This may account for the extremely high growth rate of .863.

The cumulative error rate model,  $\lambda_{\Sigma} = 5.689T^{-.863}$ , predicts that  $\lambda_{\Sigma} = .00281$  error/hr. at  $T = 6756$  hours. This is equivalent to a

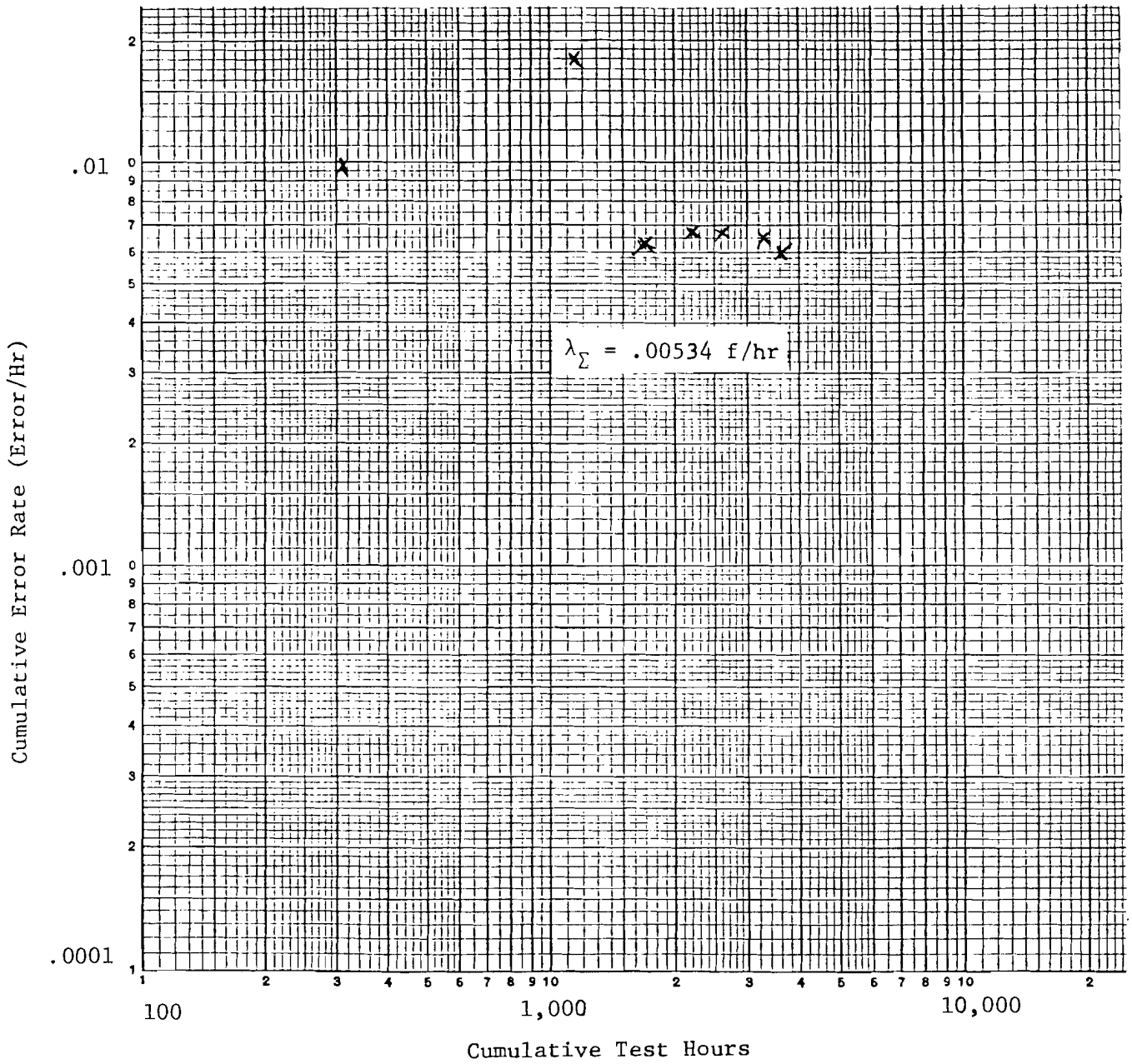

Figure 9. Network Management - Data Plot

Table 9. MTD and RDAS Modules - Reliability Data Summary

Month	Monthly Test Hrs (T)	Monthly Errors (F)	Cumulative Test Hrs. ( $T_{\Sigma}$ )	Cumulative Errors ( $F_{\Sigma}$ )	Cumulative Error/Hr ( $\lambda_{\Sigma}$ )	Average Time Between Errors (MTBF $_{\Sigma}$ )
1979 Feb						
Mar						
Apr						
May						
June						
July						
Aug						
Sept						
Oct						
Nov						
1979 Dec						
1980 Jan						
Feb						
Mar						
Apr	624	1	624	1	.0016	625
May	418	1	1042	2	.0019	526
June	457	1	1499	3	.002	500
July						
Aug	1790					
Sept						

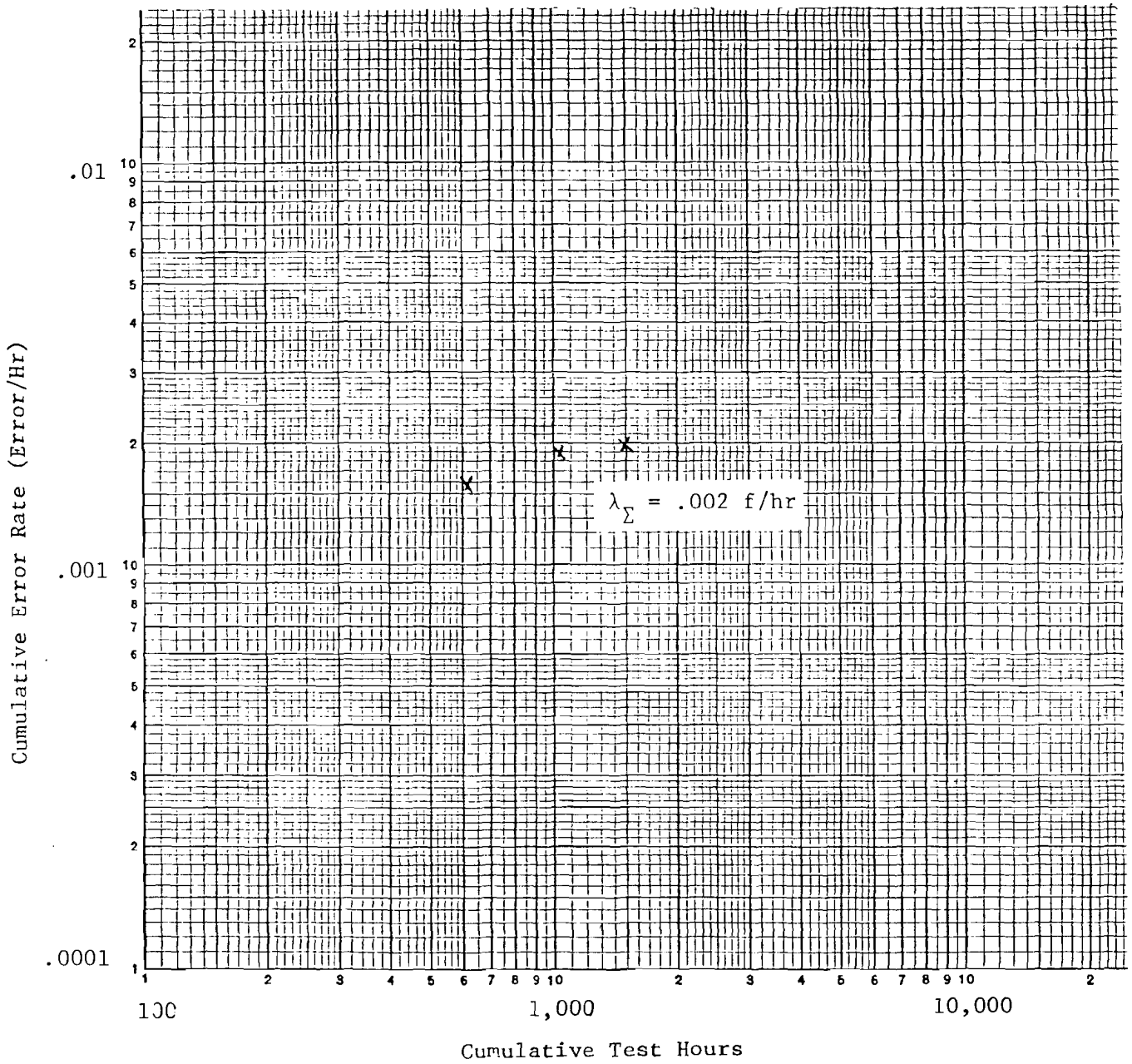

Figure 10. MTD & RDAS Modules - Data Plot

Table 10. System Software Module - Reliability Data Summary

Month	Monthly Test Hrs (T)	Monthly Errors (F)	Cumulative Test Hrs. ( $T_{\Sigma}$ )	Cumulative Errors ( $F_{\Sigma}$ )	Cumulative Error/Hr ( $\lambda_{\Sigma}$ )	Average Time Between Errors ( $MTBF_{\Sigma}$ )
1979 Feb						
Mar						
Apr						
May	140	4	140	4	.029	34
June	140	1	280	5	.018	56
July	188	3	468	8	.017	59
Aug	188	2	656	10	.015	67
Sept	188	4	844	14	.017	59
Oct	305	1	1149	15	.013	77
Nov	390	1	1539	16	.010	100
1979 Dec	489	0	2028			
1980 Jan	528	0	2556			
Feb	480	1	3036	17	.0056	179
Mar	431	0	3467			
Apr	624	0	4091			
May	418	1	4509	18	.004	250
June	457	0	4966			
July						
Aug	1790					
Sept			6756			

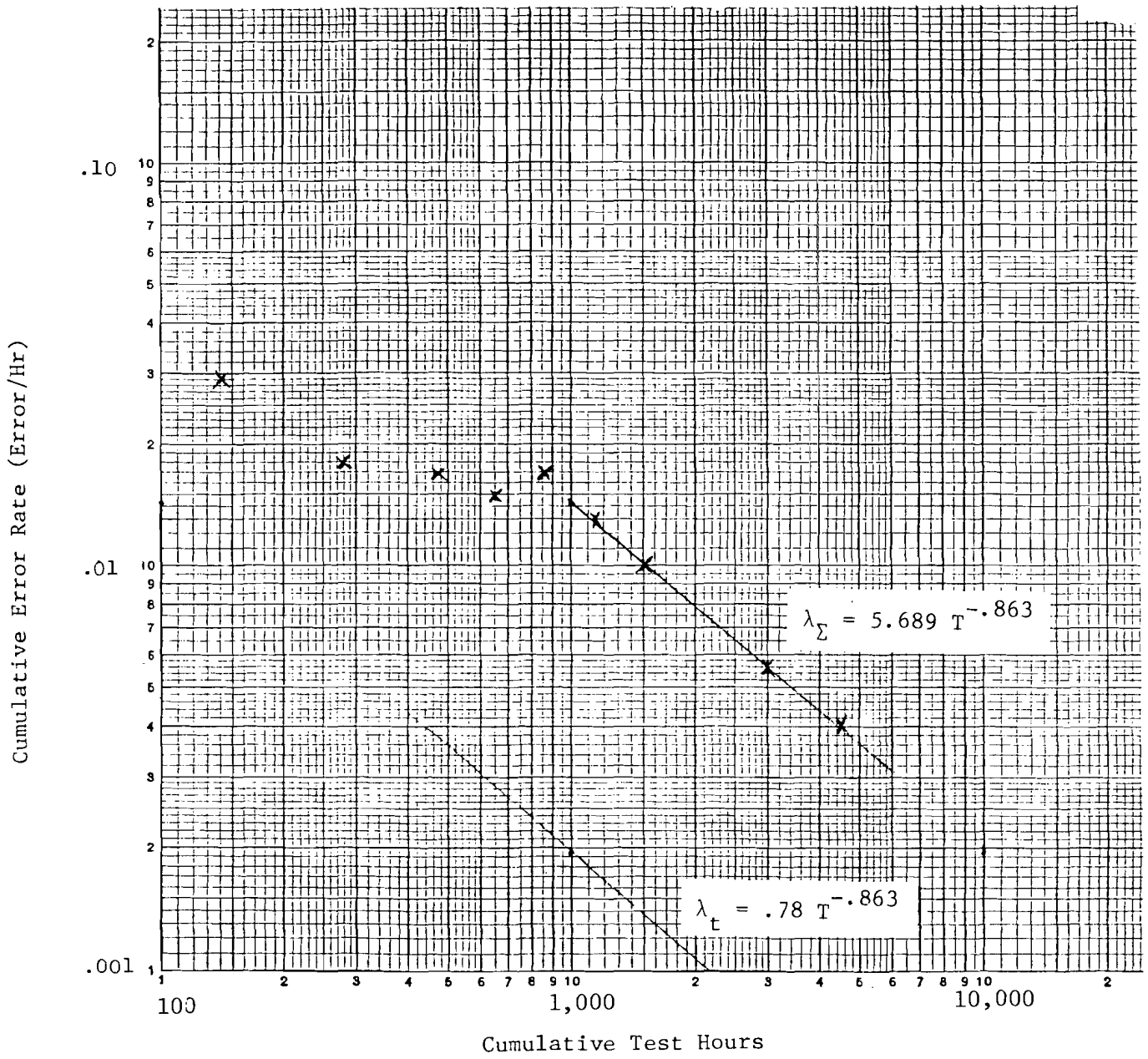

Figure 11. System Software Module - Reliability Growth Model

prediction that one error will occur during the prediction test interval. Three chargeable errors were reported, a number which is quite high. The occurrence of three or more errors when only one is expected should occur no more than 8 percent of the time. Therefore, the prediction is marginally acceptable.

The instantaneous error rate of .000386 error/hr. at  $T = 6756$  hours was predicted using the model  $\lambda_t = .78T^{-.863}$ . Based on the above comparison between predicted and actual numbers of failures, the instantaneous failure rate is expected to be somewhat optimistic.

#### 4.9 RELIABILITY EVALUATION OF THE SURVEILLANCE PROCESSING MODULE.

The Surveillance (SURV) processing module is responsible for tracking targets, correlating radar reports with beacon reports or tracks and for maintaining the surveillance file.

The SURV module accrued 5386 hours of test during which 41 chargeable errors were reported. Its cumulative error rate at  $T = 5386$  was .0076 error/hr. or 131 hours MTBF. The data used in the reliability analysis is contained in Table 11. Figure 12 displays the reliability growth model. It should be noted that the SURV module exhibited decreasing error rates, but at different rates. The change in slope of the curve may be attributed to variations in the test environment, to delays in documenting the errors or to delays in implementing corrective action. All three situations have been identified as causative factors which perturb reliability growth models. Note that the growth curve was generated using weighted least squares which stresses current data. The slope of the line favors the current trend rather than the overall trend.

Based on the cumulative growth model,  $\lambda_\Sigma = .1067T^{-.3071}$ , the predicted  $\lambda_\Sigma$  at  $T = 7176$  hours is .006983 error/hr. which is equivalent to a total of 50.1 expected errors. This implies a prediction of 9.1 errors during the 1790-hour prediction test interval. Seven (7) errors were reported against the SURV module, a number which compares favorably with the prediction.

The instantaneous growth model,  $\lambda_t = .0739T^{-.3071}$ , predicts an error rate of .00484 error/hr. or 207 hours MTBF at  $T = 7176$  test hours.

Table 11. Surveillance Module - Reliability Data Summary

Month	Monthly Test Hrs (T)	Monthly Errors (F)	Cumulative Test Hrs. ( $T_{\Sigma}$ )	Cumulative Errors ( $F_{\Sigma}$ )	Cumulative Error/Hr ( $\lambda_{\Sigma}$ )	Average Time Between Errors (MTBF $_{\Sigma}$ )
1979 Feb	140	8	140	8	.0571	18
Mar	140	0	280	8		
Apr	140	1	420	9	.0214	47
May	140	4	560	13	.0232	43
June	140	2	700	15	.0214	47
July	188	3	888	18	.0203	49
Aug	188	1	1076	19	.018	56
Sept	188	2	1264	21	.017	59
Oct	305	2	1569	23	.015	67
Nov	390	1	1959	24	.013	77
1979 Dec	489	2	2448	26	.011	91
1980 Jan	528	2	2976	28	.009	111
Feb	480	2	3456	30	.0086	116
Mar	431	3	3887	33	.0085	118
Apr	624	2	4511	35	.0078	128
May	418	4	4929	39	.0079	127
June	457	2	5386	41	.0076	132
July						
Aug	1790					
Sept			7176			

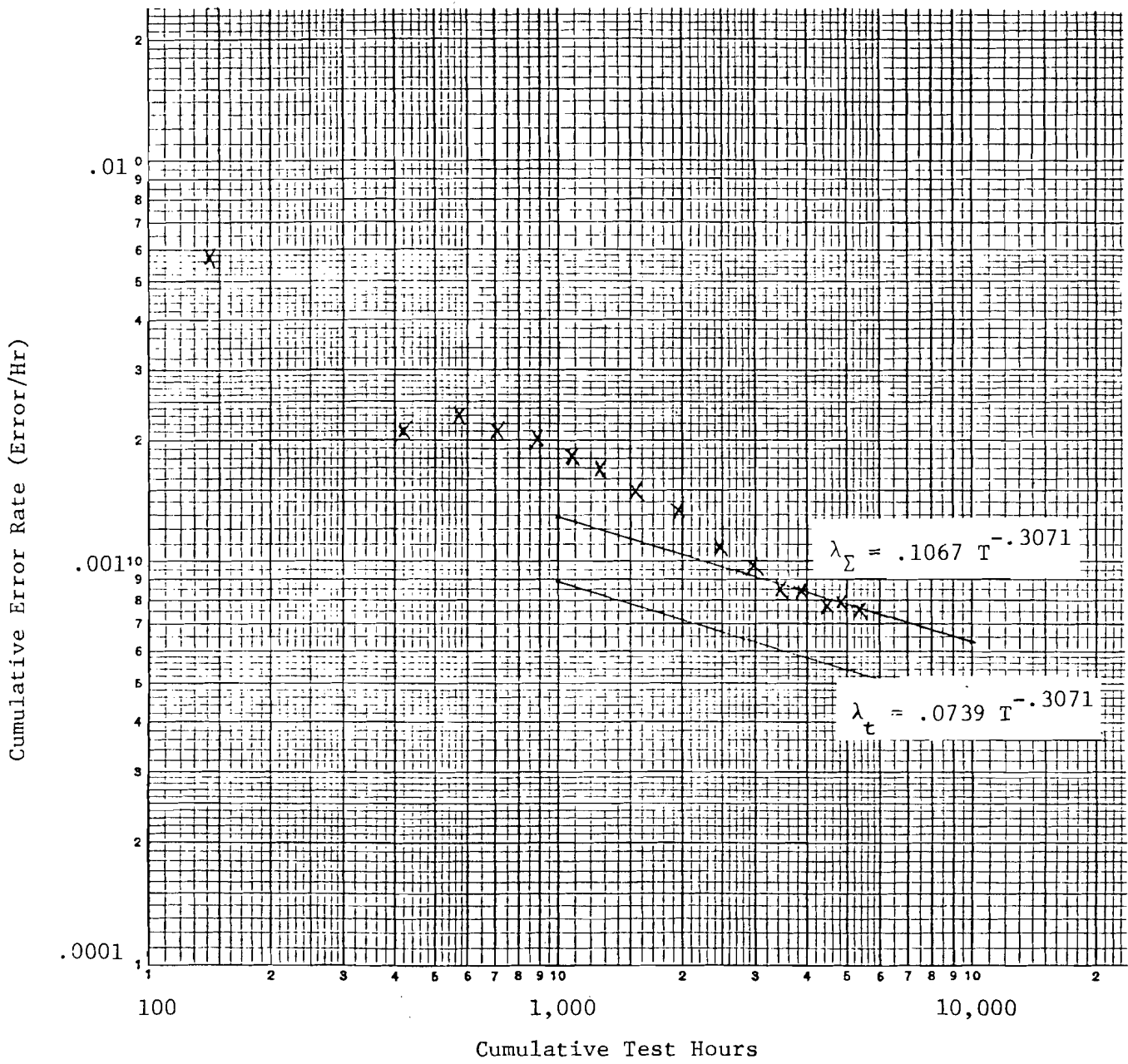
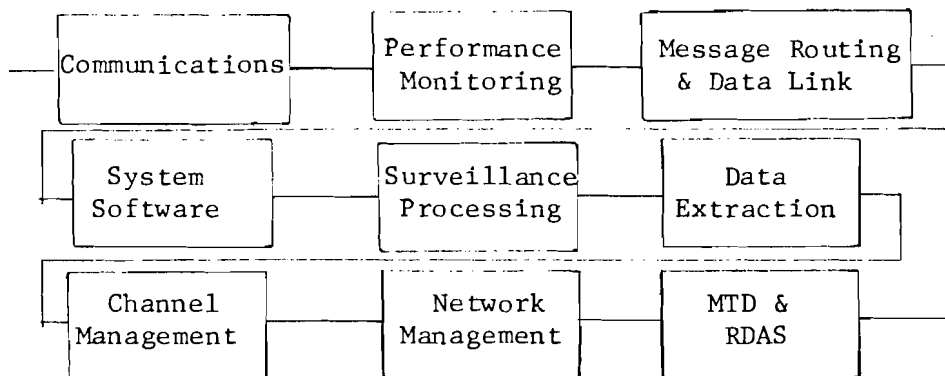

Figure 12. Surveillance Module - Reliability Growth Model

## 5. INTEGRATED DABS HARDWARE AND SOFTWARE RELIABILITY MODEL.

### 5.1 SOFTWARE SUBSYSTEM RELIABILITY MODEL.

The reliability block diagram of the DABS software is



The reliability model which corresponds to the above block diagram is

$$R_{S.W.} = \prod_{i=1}^9 R_i$$

where  $R_{S.W.}$  = Reliability of the software subsystem  
 $R_i$  = Reliability of each module,  $i=1, 9$

It was noted in Section 4 of this report that the reliability growth model used to measure DABS software reverts to a constant failure rate model at the conclusion of the test/analyze/fix process underway during a test program. Therefore, the reliability model for operational software is identical to the reliability model used by the FAA to model hardware reliability. It is characterized by an exponential distribution of times between errors or it may be stated as a Poisson distribution of the number of errors within a specified time interval.

Using terminology similar to that used by the FAA in the hardware reliability model,

$$\lambda_{S.W.} = \sum_{i=1}^N \lambda_i$$

where  $\lambda_{S.W.}$  = error rate of the total software program  
 $\lambda_i$  = error rate of a software module for  $i=1, 9$ .

As noted earlier, the error rates of the modules are changing because of the results of debugging the software. Therefore, the reliability prediction will be made in terms of accumulated software test time. A summary of reliability predictions for the DABS software modules is presented in Table 12. In summary, it states that a chargeable error will occur within the DABS software every 53 test hours. For comparison purposes, Table 13 contains a summary of module critical error rates.

It was noted earlier that the error rate of a module may improve dramatically once the module is removed from a test environment. An improvement factor of 5 was noted by the author in a similar study. It is not implied that the same factor is applicable to DABS software, but if it were, the time between chargeable errors would increase to only 265 hours.

The software reliability model makes no provision for software repair in the event of failure. The DABS system is structured to provide reconfiguration in the event of certain hardware failures. Critical software failures will generally fail the system. Also, redundancy features of hardware do not apply to software. If two redundant processors encounter the same logical software error, and if the error is critical, both processors and therefore the computer will fail.

## 5.2 DABS INTEGRATED SYSTEM (HARDWARE AND SOFTWARE) RELIABILITY MODEL.

The reliability block diagram which combines hardware with software elements of DABS is

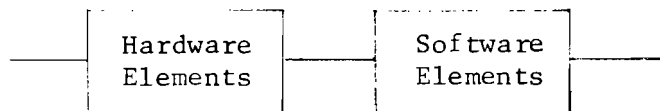

The reliability model is  $R_{H.W.} \times R_{S.W.} = R_{DABS}$ .

Translated into the effective failure rate ( $\lambda_{EFF}$ ) model used by FAA,  $\lambda_{DABS} = \lambda_{EFF}(\text{Hardware}) + \lambda(\text{Software})$ . Based on data contained in Report No. FAA-RD-80-36, "Discrete Address Beacon System (DBAS) Baseline Test and Evaluation", by M. Holtz,  $\lambda_{EFF} = .001736$  failure/hr.

Table 12. Summary of Software Reliability Predictions

<u>Software Module</u>	<u>Reliability Predictions</u>		
	<u>Number of Errors Within Prediction Interval</u>	<u>Number of Errors/ Test Hour</u>	<u>Average Time Between Errors</u>
Communications	2.9	.001020	976
Performance Monitor	3.5	.002030	494
Message Routing & Data Link	0.9	.000417	2400
System Software	1	.000386	2588
Surveillance Processing	9.1	.004840	207
Data Extraction	No Prediction	.00037	2703
Channel Management	No Prediction	.00260	385
Network Management	No Prediction	.00534	187
MTD & RDAS	No Prediction	.00200	500
TOTAL		.019	53

Table 13. Summary of Module Critical Error Rates

<u>Software Module</u>	<u>Test Hours</u>	<u>Number of Critical Errors</u>	<u>Critical Error Rate - Critical Error/Hr.</u>
COM	4966	5	.001
PM	4966	5	.001
MR & DL	4966	0	--
DEX	5386	1	.00019
CM	5386	4	.00074
NM	4122	2	.000485
MTD & RDAS	1499	1	.000667
SYS	4966	7	.0014
SURV	5386	6	.00111
			<hr/>
			.00662

Note: During July, August and September of 1980, 4 critical errors were reported during 1790 hours of test. The error rate of .00223 error/hr is equivalent to MTBCF of 448 hours.

Using all chargeable software errors,  $\lambda_{\text{DABS}} = .001736 + .019 =$   
.020736 failure/hr. or 48 hours MTBF. Using only critical software  
errors,  $\lambda_{\text{DABS}} = .001736 + .00223 = .003966$  fail/hr. or 252 hours MTBF.

## APPENDIX A

### Review and Critique of the Available Hardware Reliability Model and the Hardware Reliability Prediction for the DABS

FAA Report No. FAA-NA-78-31, "Plan for the Reliability and Maintainability Evaluation of the Discrete Address Beacon (DABS) Engineering Laboratory Models," contains the hardware reliability model and reliability prediction for the DABS. The report also addresses the failure reporting, data collection, data processing system and the criteria which will be used to evaluate (measure) hardware reliability of engineering laboratory models.

The critique presented herein addresses only those portions of the report which deal with the DABS hardware reliability models and the reliability prediction. Review and critique of the failure data collection, processing and analysis procedures are outside the scope of this task.

The FAA report describes the construction and use of a series of Einhorn equations (models) which transform mean-time-between-failure (MTBF) and mean-time-to-repair (MTTR) of an equipment into effective failure rate ( $\lambda_{EFF}$ ) for the equipment. In addition, a method is provided by which effective failure rates of 2 or more equipments may be combined to produce a subsystem effective failure rate. The models of the DABS subsystems are well prepared and documented. The comments which follow address minor points of the modeling process and several major topics which were not addressed in the report, but which might be candidates for inclusion in a revision to the document.

#### GENERAL COMMENTS:

1. The predicted mean-time-between-failures (MTBF) of a single channel sensor is 774 hours, a value considerably lower than the 1,000 hours specified in the engineering requirement. There is nothing in the document to indicate that appropriate improvements such as redesign or use of high reliability parts will be employed to improve system reliability. As stated in Report No. FAA-RD-80-36, DABS measured MTBF is 575 hours but is increasing. The FAA should monitor test results closely, continue to measure system MTBF during development testing and implement effective corrective actions to improve system MTBF to meet the specification.
2. The state diagram technique used to model DABS hardware reliability appears to generate  $\lambda_{EFF}$  which is pessimistic. Significant terms in the calculation of  $\lambda_{EFF}$  are obtained by multiplying the failure rate of a specific hardware configuration by the probability of failure in the configuration for the entire anticipated mission. However, the

most likely time of failure for equipments having MTBF >> mission time is near the midpoint of the mission. Hence, the calculated probabilities of failure are nearly doubled.

3. The report should contain a brief but complete description of the DABS mission. A complete reliability evaluation plan should describe the anticipated mission or a standardized mission which will be used for reliability measurement. Mission identification should identify and describe all mission phases, their duration and anticipated environments. The results of the mission analysis should then be merged with the results of a systems analysis which then identifies the full complement of equipment, including reliability block diagrams, which will be used to measure reliability during each mission phase. Also included are alternate modes of operation and success/failure criteria.

4. The reliability equations are very general and optimistic because they include the probability of repairing equipments without considering the number of repairmen, number of spares or administrative delays which may prolong maintenance time. The FAA equations are applicable only if an infinite number of spares and repairmen are instantly available at each operational site. If reasonable constraints were placed on the above model parameters, predicted reliability would decrease.

5. The FAA report specifically states that "special reliability tests" will not be conducted and that objectives of the reliability and maintainability (R&M) evaluation can be achieved using FAA performance tests. It should be recognized that not all performance tests will be applicable to the measurement of DABS R&M. The report should contain the results of an analysis of the anticipated test program which would describe the quantity and quality of the anticipated data and why the data can be used for R&M measurement.

6. The "estimation" of equipment MTBF should include the calculation of confidence intervals for equipment and system MTBF; i.e., an interval which contains the true but unknown MTBF with stated probability.

#### SPECIFIC COMMENTS:

1. Page 28 Second Paragraph

Per this paragraph. A statistical test will be performed to determine if the exponential distribution is appropriate to describe time to failure and time to repair data. The report should describe alternative statistical techniques for data analysis if the exponential distribution fails to adequately describe these time data. This is especially important for time to repair which is often modeled using the log-normal distribution.

2. Pages 39/40

The reliability block diagram for two redundant equipments with a switch is

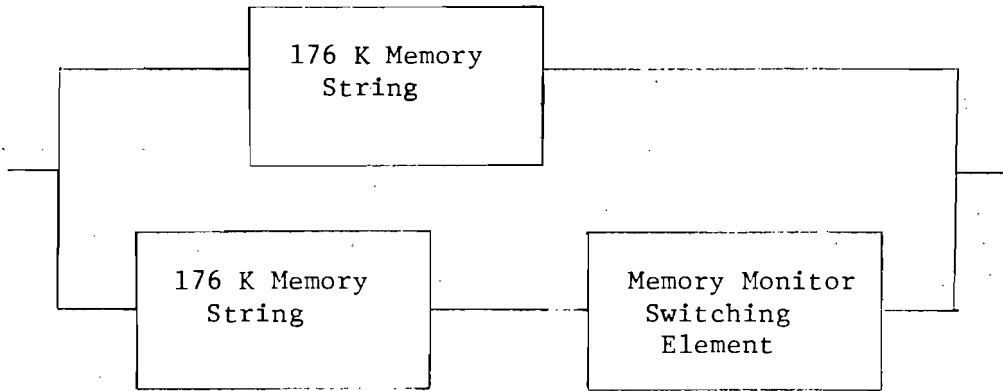

The reliability model for the above system is

$$R = e^{-\lambda t} + R_{\text{SWITCH}} (\lambda t) e^{-\lambda t}$$

where  $\lambda$  = failure rate of 176 K memory string  
 $t$  = mission duration  
 $R_{\text{SWITCH}}$  = reliability of switching element

3. Titles of Figures 1, 2, 4 and 12

These figures are titled "reliability models" but a more appropriate title is "reliability block diagram." The reliability model is usually defined as the equation which transforms MTBF into probability of success.

## APPENDIX B

### A Recommended Software Reliability Failure Reporting System for DABS

The FAA currently uses the DABS Trouble Report/Change Proposal (Figure B-1) to document software errors. Additional analysis and follow-up are documented on DABS Trouble Report/Change Proposal Update Worksheet (Figure B-2). While the reporting system was not structured specifically to provide data suited for reliability analysis, the forms do provide most of the required information when completed in accordance with the Trouble Report Users Guide.

The difficulties encountered when using DABS Trouble Reports (TR) were primarily lack of completeness and lack of error classification. These weaknesses in the present system can be corrected by instituting an editorial review of the software errors as TRs are initiated, completed and classified. A glaring weakness in the procedure can be corrected by ensuring that the TRs contain the date of occurrence of the error as well as the date of TR initiation. It is recommended that a representative of the reliability engineering group participate in the editorial review because much of the data are needed for reliability analysis purposes.

As soon as error follow-up identifies causes for the initiation of a TR it should be classified with regard to CATEGORY and SEVERITY. With regards to CATEGORY, the following definitions are recommended for use by FAA.

<u>Error Source Code</u>	<u>Error Source</u>	<u>Description</u>
0	Requirements	Source of problem is changing, ill conceived or poorly stated performance requirement.
1	Design	Source of problem is in preliminary or detailed design.
2.	Coding	Source of problem is an error in implementing the design or code.
3.	Maintenance	Source of problem is an error introduced in process of trying to fix a previous error.
4.	Not Known	Source of error not known.

DABS TROUBLE REPORT/CHANGE PROPOSAL			
FOR ORIGINATOR USE			
ORIGINATOR	ORIGINATING INSTALLATION	DATE	
		MO	DA YI
SOFTWARE		CHANGE PROPOSAL <input type="checkbox"/>	
PRODUCT IDENTIFIER	VERSION	TROUBLE REPORT <input type="checkbox"/>	
PART NUMBER	REVISION		
PRIORITY <input type="checkbox"/> CRITICAL <input type="checkbox"/> VERY IMPORTANT <input type="checkbox"/> IMPORTANT <input type="checkbox"/> CAUSES INCONVENIENCE <input type="checkbox"/> INTERESTING			
GENERAL DESCRIPTION			
CHECK APPLICABLE BOXES <input type="checkbox"/> ATC INTERFACE AFFECTED <input type="checkbox"/> LISTING ATTACHED <input type="checkbox"/> INSTALLATION SYSTEM PATCHED. NO. = _____ <input type="checkbox"/> TEMPORARY ECN INSTALLED <input type="checkbox"/> ATTACHMENTS <input type="checkbox"/> HARDWARE PART FAILURE <input type="checkbox"/> OTHER			
FOR INVESTIGATING ACTIVITY ONLY			
PROPOSED SOLUTION/COMMENTARY			
FOR JCCB USE ONLY			
PRIORITY	APPROVAL		
ASSIGNED ACTIVITY		YES	NO
TROUBLE RPT NO.	LOCAL MGR _____	<input type="checkbox"/>	<input type="checkbox"/>
CHANGE PROP. NO.	CCB CHRMN _____	<input type="checkbox"/>	<input type="checkbox"/>
COMMENTS			

WHITE, PINK, BLUE - CONFIG MGMT  
 NA FORM 6365-1 (7-79)

YELLOW - RETAINED BY ORIGINATOR

Figure B-1. DABS Trouble Report/Change Proposal

**DABS TROUBLE REPORT/CHANGE PROPOSAL UPDATE WORKSHEET**

INTER AT LEAST ONE OF THE FOLLING TO IDENTIFY REPORT		
REPORT FORM NO. _____	CHANGE PROPOSAL NO. _____	TROUBLE REPORT NO. _____
SHORT DESCRIPTION		
SOLUTION/COMMENTARY		
MODULES CHANGED (SW MODULE NAME, HW PART NUMBER)		
INSTALLATIONS AFFECTED		
OTHER FORMS INITIATED		
ECN _____ _____ _____	DCN _____ _____ _____	
CHANGE TEST RESULTS <input type="checkbox"/> SW CHANGE PROPOSED DOES NOT CORRECT PROBLEM <input type="checkbox"/> SW CHANGE TESTED AND READY FOR SYSTEM TEST (SCMR ATTACHED) <input type="checkbox"/> HW CORRECTION DOES NOT SOLVE PROBLEM <input type="checkbox"/> HW FIX TESTED AND READY FOR IMPLEMENTATION (ECN ATTACHED)		
TROUBLE CATEGORY <input type="checkbox"/> H--HARDWARE PROBLEM <input type="checkbox"/> S--SOFTWARE PROBLEM <input type="checkbox"/> D--DOCUMENTATION PROBLEM <input type="checkbox"/> E--DESIGN PROBLEM <input type="checkbox"/> R--NEW REQUIREMENT		

NA FORM 6365-2 (7-79)

Figure B-2. DABS Trouble Report/Change Proposal Update Worksheet

Errors should also be classified as to type:

<u>Error Type Code</u>	<u>Type of Software Errors</u>
A	Computational
B	Logic Errors
C	Data Input Errors
D	Data Handling Errors
E	Data Output Errors
F	Interface Errors
G	Data Definition Errors
H	Data Base Errors
I	Operational Errors
J	Other
K	Documentation Errors
X	Trouble Report Rejection

Trouble reports should be classified as with regard to SEVERITY in accord with the following definitions:

Chargeable Errors:

1. Critical - An error in the software which causes a significant or total loss of operational system capability.
2. Non-Critical (Major) - An error in the software which causes an erroneous response in the operational system. An error in this classification may not be recognized as such by a trained observer due to the self repair inherent in the system.

Non-Chargeable Errors:

3. Other (Minor) - An error which has no measurable effect on the operational system or are of unknown cause at this time (hardware/software/cockpit). Errors of unknown cause would be charged against the DABS system rather than the software.
4. No Count - A trouble report which was erroneously attributed to software errors. In addition, change proposals, enhancements, duplicate trouble reports and "cockpit errors" are included.

APPENDIX C

LISTING OF DABS SOFTWARE TROUBLE REPORTS

\*\*\* TR PROCESSING PROGRAM (TRPP) VER 1 01 09 34 44 07/07/00 PAGE 2\*\*\*

SOFTWARE TROUBLE REPORTS - DAB007 SHEET 1							
TR#	CHG PROP #	INIT	DESCRIPTION	PROD	PART NO.	OPEN	ST#
70001			FAA SET CAP BITS IN ARIES	DAB004	EXT	##11/20/78	1
70002			FAA MISC EXTDED ANALY PRBLMS	DAB004	EXT	##01/11/79	1
70004			FAA CAN'T HNDL 48 A/C/BEAM	DAB004	SURV	##01/20/79	1
70003			FAA DX: SHRT & LNG DABS REPLIES	DAB004	DEX	##01/20/79	1
70006			FAA UNIQUE CODE FLAG	DAB004	SURV	##02/09/79	1
70007			FAA HISTORY FIRMNESS =3	DAB004	SURV	02/07/79	OC
70008			FAA VEL REASONABLE CODING ERR	DAB004	SURV	02/09/79	OC
70009			FAA BAD DABS ID ON MTNC DISPLAY	DAB004	SURV	##02/11/79	1
70010			FAA 48 A/C BEAM COULD NOT HANDLED	DAB005	CM	02/11/79	OC
70011			FAA ALT FLAG IN SURV FL NOT UPD	DAB004	SURV	02/11/79	OC
70012			FAA C-BITS ALT GRAY CODE CHECK	DAB004	SURV	02/11/79	OC
70013			FAA VEL REASONABLENESS PROBLEM	DAB004	SURV	02/11/79	OC
70014			FAA ASSOC ZONE BOUNDARIES CALC	DAB004	SURV	02/11/79	OC
70015			FAA ALT MISS COUNT NOT UPDATED	DAB004	SURV	02/22/79	OC
70016			FAA ONLY 3 CORRELATIONS ALLOWED	DAB004	SURV	02/23/79	OC
70017			FAA FILTER BY ID	DAB005	EXT	##02/23/79	1
71251			FAA ANAL DISAGREE WITH DISPLAY	DAB004	EXT	##03/01/79	1
71252			FAA ARIES AZIMUTH UNIT HRDWARE	DAB004	CM	03/01/79	OC
71256			FAA INCORR DABS REPLY CLASS	DAB004	EXT	##04/01/79	1
71257			FAA SURV FILE EXTRACT LOSSES	DAB004	DEX	##04/12/79	1
71258			FAA FALSE TRACK STARTS	DAB004	SURV	04/18/79	OC
71370	DS-S-0001-0001		00RADAR RANGE MASK FOR NAFEC	DAB006	SA	##05/14/79	11
73892	DS-S-0002-0002		00NAFEC REFLECTOR FILE	DAB006	SA	##05/14/79	11
73893	DS-S-0003-0003		00NAFEC OPEN ARRAY CAL CURVE	DAB006	SA	##05/14/79	11
73897			FWF 60 NM RADAR RANGE MSK-NAFEC	DAB006	SA	##05/14/79	1
73901			FWF NAFEC SITE ADAPTATION	DAB006	SA	##05/14/79	1
73902	DS-S-0004-0004		00NAFEC SITE ADAPTATION	DAB006	SA	##05/14/79	11
73904	DS-S-0005-0005		00NAFEC SITE ADAPTATION	DAB006	SA	##05/14/79	11
71371	DS-S-0006-0006		00BAD LINK FOR COLD START	DAB006	SYS	##05/18/79	11
71259			FAA 2 TKS FOR 1 A/C	DAB006	SURV	05/18/79	OC
71260			FAA ATRCBS MISSING REPLIES @NM	DAB006	SURV	05/18/79A	OC
71373	DS-S-0007-0007		00TILINE T.O. IN CP4 OF ENS.	DAB006	SYS	##05/18/79	11
73817			FS TILINE T.O. ON CP4 ALL TLS	DAB006	SYS	##05/17/79	1
71372	DS-S-0008-0008		01BAD LINK FOR SXGMBX	DAB006	SYS	##05/17/79	11
73899	DS-S-0009-0001		01NAFEC COVERAGE MAP	DAB006	SA	##05/17/79	11
71374	DS-S-0010-0001		02UNABLE TO ROLL CALL DABS	DAB006	SA	##05/18/79	11
73894	DS-S-0011-0003		01NEW NAFEC MONDPULSE TABLE	DAB006	SA	##05/18/79	11
73895	DS-S-0012-0008		02ELWOOD BACK-BACK MOND. TBL	DAB006	SA	##05/18/79	11
73900			SNS NAFEC COVERAGE MAP UPDATE	DAB006	SA	##05/18/79	1
73876			JAS BACK/BACK ELWOOD ARIES S.A.	DAB006	SA	##05/20/79	1
73878			SNS IPC STATUS BIT OR'D INTO ID	DAB006	PM	##05/20/79	1
73896			FWF ELWOOD F.A.T. MOND. TABLE	DAB006	SA	##05/23/79	1
73903			SNS ELWOOD FAT SITE ADAPTATION	DAB006	SA	##05/23/79	1
73905			SNS ELWOOD FAT SITE ADAPTATION	DAB006	SA	##05/23/79	1
73877	DS-S-0013-0009		00BACK/BACK ELWOOD LIVE S.A.	DAB006	SA	##05/24/79	11
73879	DS-S-0014-0010		00ALEC NOT WORKING	DAB006	CM	##05/24/79	11
73880	DS-S-0015-0011		00RED MESSAGE TILINE TIMEOUT	DAB006	PM	##05/24/79	11
73881	DS-S-0016-0012		00ASS/COR LOSING NON-DISCRETE	DAB006	SURV	##05/24/79	11
73882	DS-S-0017-0013		00INCREASE LIMITS ON RELAY LP	DAB006	MR	##05/24/79	11
73883			SNS INCONSISTENT SA RELAY TABLE	DAB006	SA	##05/24/79	1

SOFTWARE TROUBLE REPORTS - DAB00?

SHEET 2

ITR#	CHG PRDP #	INIT	DESCRIPTION	PRUD	PART NO.	OPEN	ST#
23884			JAS NOT TRACKING DABS	DAB006	SA	##05/24/79	1
23885	DS-S-0018-0006		02PROGRAM OVERLAYING DATA	DAB006	SURV	##05/24/79	11
23886			SNS ADJUST ELWOOD CPME PARAMTRS	DAB006	SA	##05/24/79	1
23907	DS-S-0019-0014		00N2GS PATCH TO SC022X	DAB006	COMM	##05/24/79	11
21375			SNS EXCLUDE EXTERNAL CPME'S	DAB006	SA	##05/24/79	1
23888	DS-S-0032-0022		00DOUBLE DISS OF LATE REP.	DAB006	SURV	05/23/79W	7
23887			FWF TAT BROKEN BY SPARE CP FAIL	DAB006	SYS	05/23/79	0C
23889			FWF WWV OVERRIDE HANGS WMSTART	DAB006	SYS	##05/23/79	1
23890	DS-S-0020-0013		01RELAY PATH FIX	DAB006	MR	##05/23/79	11
23891	DS-S-0021-0015		00NEW COMM A/B DRIVER	DAB006	DRV	##05/23/79	11
23898			FWF BACK OUT SCN #3878	DAB006	PM	##05/23/79	1
23906	DS-S-0022-0016		00NEW CIDIN DRIVER	DAB006	DRV	##05/23/79	11
23908	DS-S-0023-0017		00FIRST CP FAILURE	DAB006	SYS	##05/23/79	11
23909	DS-S-0049-0035		01FIRST CP FAIL CHECKIN TBL	DAB006	SYS	##05/23/79	11
23910			SNS UPDATE ELWOOD CPME LOC.	DAB006	SA	##06/01/79	1
23911			FWF ENABLE ELWOOD LINK SWITCH	DAB006	SA	##06/01/79	1
23912	DS-S-0024-0009		01BACK FACE ANTENNA OFFSET	DAB006	SA	##06/01/79	11
23913	DS-S-0053-0066		00IPC BLK DATA FOR ELWOOD, CLE	DAB006	SA	##06/01/79	11
23914	DS-S-0025-0018		00PART. UPDATE FOR IPC PARMS	DAB006	SA	##06/01/79	11
23916	DS-S-0026-0015		01COMM A/B DRIVER CORRECTION	DAB006	DRV	##06/01/79	11
23824			DEG + P O UNIT ASSMNTS PRE INIT	DAB006	SYS	##06/01/79	1
21261	DS-S-0033-0023		00SCEN. GEN. 3 DEG. TURN RATE	DAB006	EXT	##06/13/79	1
23827			FJS LVL3 IMP/COMM INTERRUPTS	DAB006	SYS	06/13/79	0C
23920	DS-S-0034-0024		00NEW VERSION OF SC022X	DAB006	COMM	##06/13/79	11
23826			SAB UPDATE BACKFACE PROCESSING	DAB006	SURV	06/13/79W	0S
23915			FAA LOSS OF ATRCBS TARGETS	DAB006	SURV	##06/21/79	1
23922			DEG CAN'T S. A. RADAR RANGE MSK	DAB006	SA	06/21/79	0C
21262			FAA TRCKALERT-CONE OF SILENCE	DAB006	NM	06/22/79S	0S
23828			SAB RNGE MSK BACKFACE SCHED	DAB006	CM	06/23/79	0C
23763			SH BAD FORMAT IN PRINT	DAB006	EXT	06/23/79	0C
23941	DS-S-0027-0019		00ELWOOD BASELINE SITE ADAPT.	DAB006	SA	##07/01/79	11
23942	DS-S-0028-0009		02ELWOOD BASELINE SITE ADAPT.	DAB006	SA	##07/01/79	11
23943	DS-S-0029-0020		00ELWOOD BASELINE SITE ADAPT.	DAB006	SA	##07/01/79	11
23944	DS-S-0030-0021		00ELWOOD BASELINE SITE ADAPT.	DAB006	SA	##07/01/79	11
21264	DS-S-0035-0025		00RADAR ONLY DISSEMINATION	DAB006	SURV	##07/01/79	3
23945			SNS PHY COMP. ID USED FOR INT.	DAB006	SYS	07/01/79	0C
23946			SNS SYSTEM RELOAD RE CIDIN PROT	DAB006	COMM	07/01/79G	0S
21263	DS-S-0036-0026		00RADAR ONLY COLLIMATION	DAB006	SURV	07/01/79W	7
21265	DS-S-0037-0027		00I & P FAILURE RECOVERY	DAB006	SYS	07/01/79F	5S
23764			BR RE-RELEASE ASSOC/CORR CODE	DAB006	SURV	##07/01/79	1
21266			FAA DABS MESS RPTS IN ERROR	DAB006	SURV	##07/13/79	1
21268			FAA UNSATIS ATRCBS CPME	DAB006	SURV	##07/13/79	1
23959			JAS CONVERT TO DAB006.4	DAB006	-----	##07/13/79	1
23961			JAS DELETION OF OLD FILES	DAB006	-----	##07/13/79	1
23958	DS-S-0038-0028		00OVERFLOW CNTR NOT INCREMENT	DAB006	DL	##07/17/79	11
23960	DS-S-0039-0029		00WRG FLK SETTING FOR FLK 2	DAB006	PM	07/17/79S	5S
23964	DS-S-0040-0030		00CTR-DEF RES LISTS WRONG	DAB006	ATAR	*07/17/79M	10
23965	DS-S-0041-0031		00PERF MONITOR PROBES	DAB006	-----	07/18/79	5N
23963	DS-S-0042-0032		00WRG LOCAL BLK DATA	DAB006	SURV	##07/18/79	11
23967	DS-S-0043-0033		000-ADDRESS LIST UPDATED	DAB006	MR	07/18/79	5C

SOFTWARE TROUBLE REPORTS - DAB007

SHEET 3

TR#	CHG PROP #	INIT	DESCRIPTION	PROD	PART NO.	OPEN	ST#
Z3829			SH NO MESSAGE FILTER	DAB007	AML	07/27 79	0C
Z3966	DS-S-0095-0065	00ATCRBS	CODE VALID INCORR	DAB006	SURV	##07/27 79	11
Z3030			TM INCORR ARGU DESCRPTN NFC	DAB006	AML	07/27 79	0C
Z3934			JAS TAPE STATUS ERROR	DAB006	DEX	07/27 79	0C
Z3935	DS-S-0044-0034	00CHANNEL	MGMT-THETA-1/2 PHN	DAB006	CM	07/27 79	5C
Z1271			FAA PERFORMANCE MONITOR	DAB006	PM	##07/27 79	1
Z1272	DS-S-0048-0035	00CHANNEL	MANAGEMENT IN 1 ENS	DAB006	SYS	##07/27 79	11
Z1273	DS-S-0050-0036	00FAILURE/RECOVERY	- DPMS	DAB006	SYS	##07/27 79	11
Z1274	DS-S-0051-0037	00FAILURE/RECOVERY	- PERF MON	DAB006	SYS	##07/27 79	3
Z3936			JAS NO REJECT MESS TRK DROP	DAB006	DL	07/31 79	0C
Z3837			BM MSK WORD LGTH IN CASOUX	DAB006	DEX	07/31 79W	05
Z3937			JWH LEVEL 3 STATUS LOST	DAB006	SYS	08/01 79	0C
Z3949	DS-S-0031-0018	01ELWOOD	SITE ADAPT	DAB006	SA	##08/02 79	11
Z3948	DS-S-0047-0015	04COMM A/B DR.	-CAPACITY RUN	DAB006	DRV	##08/02 79	11
Z3939	DS-S-0046-0015	03COMM A/B DR.	-4B BEAM RUN	DAB006	DRV	##08/02 79	11
Z3938	DS-S-0045-0015	02COMM A/B DR.	-16 SCAN ADJMNT	DAB006	DRV	##08/02 79	11
Z3846			JO BLIP SCAN INC REL REPORTS	DAB006	AML	08/03 79	0C
Z3845			JO TRCKLIFE ERR TRCK ANALYSIS	DAB006	AML	08/03 79	0C
Z3842			JO RANGE, AZIMUTH ERR WIDE P. D.	DAB006	AML	08/03 79	0C
Z3844			JO ERRORS-BLPSCN, TRK ANAL, LIFE	DAB006	AML	08/03 79	0C
Z3848	DS-S-0160-0082	00INTEGER	DIVIDE - TQCKUX	DAB006	DRV	08/03 79	5C
S0001			BEG 6 SEC RESPOND ON ENG. MSG.	DAB006	COMM	08/10 79	0C
S0002			BEG MSG DROP-AFTER NEGGS ERR REC.	DAB006	COMM	08/10 79	0C
S0009			PV BD SA1A4 CAN'T BE DELETED	DAB006	SYS	##08/23 79	1
S0011			JAS GARBAGE ROLL-CALL REPLY	DAB006	DEX	*08/31 79W	7
S0012			JAS TRANSIENT TAPE ERROR	DAB006	SYS	08/31 79F	05
S0013	DS-S-0053-0039	00DABS R. C.	LOST T&E TESTING	DAB006	SURV	08/30 79	4
S0014			JAS SOME DABS R. C NOT RESPOND	DAB006	SURV	08/30 79W	05
S0015	DS-S-0054-0040	00PRBLM DABS	T&E TESTING	DAB006	CM	##08/30 79	3
S0016	DS-S-0055-0041	00CAL CURVE	FOR CLEMENTON	DAB006	SA	##09/04 79	11
S0017			BEG CIDIN STOPS WHEN ATC FAILS	DAB006	COMM	09/07 79	0C
S0018	DS-S-0056-0042	00FAILURE OF	PRIMARY STANDBY	DAB006	SYS	##09/10 79	11
S0019	DS-S-0057-0043	00NOT DETECTING	ENS FAILURE	DAB006	SYS	##09/10 79	11
S0022	DS-S-0058-0044	00TAPE OFF-LINE	ERRGR RECOV.	DAB006	SYS	##09/10 79	11
S0024	DS-S-0059-0045	00CLEMENTON	SITE ADAPTATION	DAB006	SA	##09/10 79	11
S0028	DS-S-0060-0046	00ARIES CAL	CURVE AT ELWOOD	DAB006	SA	##09/10 79	11
S0029	DS-S-0061-0047	00USER	DEFINITION	DAB006	DEX	##09/11 79	11
S0031	DS-S-0071-0049	00CHANNEL	SELECT PROBLEM 'B'	DAB006	SYS	##09/12 79	11
S0036	DS-S-0075-0053	00DESIGN	REVIEW FOR Z. C. T.	DAB006	SURV	09/14 79	5L
S0037			BVW ASSDC INDEX DISEMINATED	DAB006	SURV	09/14 79	0C
S0038	DS-S-0094-0066	00ASSOC	ZONE WINDOWS PROB.	DAB006	SURV	09/14 79W	5S
S0039	DS-S-0062-0048	00NEEDED	UPGRADES	DAB007	-----	##09/15 79	11
S0040	DS-S-0063-0048	01NEEDED	UPDATING	DAB007	SA	##09/15 79	11
S0041	DS-S-0064-0048	02FLOCK	CHANGES	DAB007	ATARS	##09/15 79	11
S0042	DS-S-0065-0048	03INITIALIZED	ARRAYS	DAB007	PM	##09/15 79	11
S0043	DS-S-0066-0048	04CHG	SIZE, INIT.	DAB007	SA	##09/15 79	11
S0044	DS-S-0076-0054	00COMM	A CHAR. NOT TRANS.	DAB006	DL	##09/15 79	11
S0045	DS-S-0067-0049	05DELETE	"FIXROMX"	DAB007	SYS	##09/15 79	11
S0046	DS-S-0068-0049	06"TERESX"	USER ADDED	DAB007	ATARS	##09/15 79	11
S0047	DS-S-0069-0048	07ADD	'TMSG LX' AS A USER	DAB007	MR	##09/15 79	11

SOFTWARE TROUBLE REPORTS - DAB007

SHEET 4

TRM	CHG	PROP #	INIT	DESCRIPTION	PRUD	PART NO.	OPEN	ST
50048	DS-S	0070-0048		00DIFLTL SEV. USERS	DAB007	NM	##09/21/79	11
50049	DS-S	0077-0055		00MUST BUILD COV MAP SITES 2,3	DAB006	SA	##09/21/79	11
50050	DS-S	0078-0048		0970 ADD COMMONS TO 'TERESX'	DAB007	AFARS	##09/21/79	11
50032	DS-S	0072-0050		00CREATE SITE ADAPT SITE 3	DAB006	SA	##09/21/79	11
50033	DS-S	0073-0051		00CREATL SITE ADAPT SITE 3	DAB006	SA	##09/21/79	11
50034	DS-S	0074-0052		00CREATE SITE ADAPT SITE 3	DAB006	SA	##09/21/79	11
50051	DS-S	0079-0056		00CURVEY RANGE CHG FOR SITE 3	DAB006	SA	##09/21/79	11
50052	DS-S	0080-0048		10CHANGE SOURCE - DAB007	DAB007	DRV	##09/21/79	11
50053	DS-S	0081-0048		11CHANGE VARIABLE - DAB007	DAB007	CM	##09/21/79	11
50054	DS-S	0082-0057		00CHNG FRAME TABLE FOR SITE 2	DAB006	SA	##09/21/79	11
50058	DS-S	0084-0048		12CHANGE BLOCK DATA 'CDTYPX'	DAB007	SYS	##09/21/79	11
50060	DS-S	0085-0048		13IMPROPER FLOCK SETTINGS	DAB007	DEX	##09/21/79	11
50086	DS-S	0091-0048		15RELEASE 7 COLDSTART	DAB007	SYS	##09/21/79	11
50063	DS-S	0090-0062		00AC POWER >15 SEC DOESN'T WK	DAB006	SYS	##09/21/79	11
50061	DS-S	0086-0059		00STORAGE YELLOW ST. PROBLEM	DAB006	PM	##09/21/79	11
50067	DS-S	0158-0038		00NEED TO INSERT PATCHES	DAB007	SYS	10/01/79	5C
50068	DS-S	0008-0048		14CIDIN COM(SCO22X) HAS A BUG	DAB007	CUMM	##10/01/79	1
50070	DS-S	0089-0061		00MUST GENERATE M-SITE MAPS	DAB006	SA	##10/01/79	11
50062	DS-S	0087-0060		00TPTXIX SOME BIAS NOT RESTRD	DAB006	PM	##10/01/79	11
50001			JD	MISSING F/B BIT	DAB006	SURV	10/01/79	0C
50002			JD	TIME UPDATED @ SCAN RATE	DAB006	SURV	10/01/79	0C
50003			JD	ELWOOD F/B BIT INCORRECT	DAB006	SURV	10/01/79	0C
50102	DS-S	0092-0063		00MULTIPLE CANCEL DATA PRBLM	DAB006	NM	##10/01/79	11
50103	DS-S	0009-0069		00 BVW VARIABLE NAME MISSPELL	DAB006	AFARS	##10/01/79	11
50107	DS-S	0094-0064		00MIXUPEXT SENSOR A & B	DAB006	PM	##10/01/79	11
50100	DS-S	0100-0070		00DROPCK FAILURE	DAB006	AFARS	##10/11/79	11
50106			PMV	BRD 13A1A18 PROBLEM	DAB006	SYS	10/11/79	0C
50108	DS-S	0097-0067		00BAD TRK # IN CX REQUEST	DAB007	NM	##10/11/79	11
50112	DS-S	0197-0084		00ASSOCIATE/CORRELATE PROBLM	DAB006	SURV	*10/11/79	5S
50113	DS-S	0002-0072		00IPC DOES NOT COME UP	DAB006	PM	##10/11/79	11
50114	DS-S	0101-0071		00EXCESS BIT COUNT OF 16	DAB006	PM	##10/11/79	11
50115	DS-S	0104-0074		00PROB SETTING ATCRBS ID	DAB006	NM	##10/11/79	11
50117	DS-S	0098-0068		00ATCRBS LOGIC CONFLICT	DAB006	AFARS	##10/11/79	11
50118	DS-S	0103-0073		00 CPME OUTRAGEOUS INDICES	DAB006	PM	##10/22/79	11
50123	DS-S	0095-0067		00TRACK REQUESTING DATA PRBLM	DAB007	NM	##10/22/79	11
50131	DS-S	0096-0067		01 MODIFY NETWORK MGMT	DAB007	NM	##10/22/79	11
50133	DS-S	0109-0076		00MODIFY COMM DRIVER	DAB006	DRV	##10/31/79	11
50134	DS-S	0106-0067		03 COMMON & FLOCK CHANGES	DAB007	NM	##10/31/79	11
50136	DS-S	0105-0075		00 AZMUTH BIAS	DAB006	SA	##11/01/79	11
50135	DS-S	0110-0048		17CORRECT TILINE TIMEOUT	DAB007	SA	##11/01/79	11
50137	DS-S	0111-0048		18UPDATE COMM BLOCK	DAB007	DEX	##11/01/79	11
50139	DS-S	0127-0048		25FAILURE TELEPHONE LINES	DAB007	PM	##11/11/79	11
50140	DS-S	0112-0048		19ADD TIME & SCAN MARKERS	DAB007	NM	##11/11/79	11
50142			JAS	DUMP OF PROC 0	DAB007	DEX	11/11/79	0C
50057	DS-S	0125-0048		26ADDITION OF USERS	DAB007	---	##11/11/79	11
24331	DS-S	0129-0048		29 ADDITION MTD/RDAS	DAB007	MTD	11/21/79	5C
50143	DS-S	0113-0048		20TEST MESSAGES PATH WRONG	DAB007	NM	##11/21/79	11
50144	DS-S	0114-0067		05IPC MARK CORRECTION	DAB007	SA	##11/31/79	11
50145	DS-S	0115-0067		06MULT TRK INITIATIONS	DAB007	SURV	##11/31/79	11
50146	DS-S	0116-0067		07CREATION NEW CAL CURVE	DAB007	SA	##11/31/79	11

SUBWARE TROUBLE REPORTS - DAB00?

SHEET 5

TR#	CHG	PROP #	INIT	DESCRIPTION	PROD	PART NO.	OPEN	ST:
50109	DS-S	0108-0067	04	INTERFACE PROBLEM	DAB007	SURV	##12/07 79 11	
50147	DS-S	0117-0067	00	ATCHBUS PROBLEM	DAB007	SURV	##12/07 79 11	
50148	DS-S	0118-0067	09	CHANGES TO CHANNEL MGMT	DAB007	CM	##12/07 79 11	
00001	DS-S	0147-0017	00	REG RELEASE ERROR	DAB007		*12/07 79M10	
50151	DS-S	0119-0048	21	CORRECTION NETWORK MESSAGES	DAB007	NM	##12/07 79 11	
50152	DS-S	0120-0067	10	BAD DESTINATION MESSAGES	DAB007	PM	##12/17 79 11	
50153	DS-S	0121-0048	11	IMPLEMENT CHANGE ATARS	DAB007	ATARS	*12/17 79M10	
50158	DS-S	0123-0048	24	ILLEGAL SENSOR STATUS	DAB007	NM	##12/17 79 11	
50154	-	SNS		CALL REPLIES LOCKOUT	DAB007	NM	##12/17 79 1	
50156	DS-S	0122-0048	23	TRK COORDINATION MESSAGE	DAB007	NM	*12/17 79M10	
50157	-	SNS		FADE OF MIZPAH	DAB007	SURV	##12/17 79 1	
50159	DS-S	0148-0003	00	CONDITIONS REMOTE DATA	DAB007	NM	12/17 79M10	
50161	DS-S	0124-0048	25	NM 2-1 TRANSITION	DAB007	NM	##12/17 79 11	
50163	-	SNS		DABS TARGETS OUTSIDE COV.	DAB007	NM	##12/17 79 1	
50184	DS-S	0138-0067	16	CHANGED LCF FILES	DAB007		-----##01/27 80 11	
50149	DS-S	0131-0067	11	INCORRECT ACTRBS REPLY A EL	DAB007	SURV	##12/07 79 11	
50179	DS-S	0137-0067	15	NUMBER OF CONN SENSORS = 0	DAB007	PM	##01/17 80 11	
50169	DS-S	0135-0067	14	ALL CALL-TO-COAST DATA REGU.	DAB007	NM	##01/07 80 11	
50175	DS-S	0136-0048	31	DATA STOP WITH ZERO ID	DAB007	NM	##01/17 80 11	
50180	DS-S	0140-0048	33	REQ. FOR PRIM. IN CENT. CELL	DAB007	NM	*01/17 80S 5S	
50174	DS-S	0139-0048	32	NET MGT HI CON TEST	DAB007	NM	##01/07 80 3	
50167	DS-S	0133-0067	13	MULTISITE ADAPTATION	DAB007	SA	##01/07 80 11	
50165	DS-S	0141-0048	34	OVERLOAD COMM & DAAT FACIL.	DAB007	NM	##12/27 79 11	
50166	DS-S	0134-0048	30	CHECKS FOR UNLK LOCKED FILED	DAB007	NM	##12/27 79 11	
50164	DS-S	0132-0067	12	LOST DABS DUE TO DAAT	DAB007	NM	##12/37 79 11	
N0004	DS-S	0130-0078	00	INCORR ROLL-CALL REPLIES	DAB006	CM	##12/27 79 11	
50188	DS-S	0154-0009	00	ATCRBS TRACK HANG	DAB007	SURV	01/27 80W 7	
50189	DS-S	0165-0019	00	FRONT/BACK RADAR RANGE MASK	DAB007	CM	*01/27 80 5C	
S0255				BG LOSS OF DATA ON MULTI DISS.	DAB007	COMM	01/27 80G 0S	
N0005	DS-N	0004-0036	00	INC. BIT IN SURVEILL. FILE	DAB007	SURV	01/17 80W 7	
S0193	DS-S	0146-0003	00	ERROR IN DOWNLINK ELM PROC	DAB007	CM	02/07 80W 7	
S0194	DS-S	0145-0002	00	LOSING ALL-CALL SYNC	DAB007	CM	02/07 80M10	
S0195	DS-S	0144-0001	00	BAD BIAS REGISTER	DAB007	SYS	02/07 80W 5S	
S0187	DS-S	0142-0079	00	UPDATED CAL CURVES	DAB007	SA	01/27 80M10	
N0006	DS-N	0001-0048	35	SOFTWR TESTS FOR MBL & MBH	DAB007	SURV	01/17 80M10	
S0202	DS-A	0001-0001	00	IMPLEMENT INTERIM ATARS	DAB008	ATARS	*02/07 80M10	
N0007	DS-S	0169-0023	00	REQUESTED SOFTWR CHNGS	DAB007	MTD	02/07 80B 5S	
S0208	DS-S	0150-0005	00	LOCAL SENSOR SECONDARY	DAB007	NM	02/17 80W 7	
S0207	DS-S	0149-0003	00	SYSTEM SPECIAL MODE FLAG	DAB007	NM	02/17 80W 7	
N2001				BK RESTARTING ARIES	DAB006	SURV	02/27 80B 0S	
S0217				JS LOSS OF ATCRBS TARGETS	DAB007	SURV	02/07 80W 0S	
S0210				SS ATCRBS REM TRK DATA PASSED	DAB007	NM	02/27 80S 0S	
S0213	DS-S	0152-0006	00	INCORR DISSEM OF CIDIN MSGS	DAB007	COMM	02/27 80G 5S	
S0212	DS-S	0151-0005	00	HI PRI COMM BUFF BACK-UP	DAB007	COMM	02/27 80G 5S	
S0214	DS-S	0153-0007	00	CIDIN FAIL TO CHK ZERO VALUED	DAB007	COMM	02/27 80G 5S	
S0190	DS-S	0154-0008	00	CHANGING EXT DATA STREAMS	DAB007	NM	##01/27 80 3	
N0008	DS-N	0003-0008	00	CHANNEL MGT INTERROG SPAC	DAB007	SA	*01/27 80M10	
T0001	DS-U	0001-0084	00	TRACK ALERT MESSAGE	DAB006	NM	*02/17 80S 4S	
S0244	DS-S	0157-0037	00	INCORR LINK SWITCH CONTR	DAB007	SA	03/07 80G 5S	
S0218	DS-S	0156-0010	00	COMPILE ERRDR IN DAB008 RELD	DAB007	SYS	*02/27 80M 5S	

SOFTWARE TROUBLE REPORTS - DAB007 SHEET 6

ITRM	CHG PROP #	INIT	DESCRIPTION	PROD	PART NO.	OPEN	ST:
N0009	DS-N-0006-0011	00	TEST 28, RUN 4 LOCKOUT PROB	DAB007	NM	03/17 805	5S
N0010		JD	DABS LOCKOUT PROB	DAB007	NM	##03/17 80	1
N0011	DS-N-0008-0012	00	NAFEC REQ FOR PRIMARY	DAB007	NM	03/17 80	4
N0012		JD	PCPF STILL SET	DAB007	NM	##03/17 80	1
N0013	DS-N-0009-0014	00	EXTRA PROCESS-SPEC MODE	DAB007	NM	*03/17 80	4N
N0026		JD	SF UPDATE	DAB007	NM	##03/21 80	1
N0027	DS-N-0009-0003	00	COMM RESPONSE PROBLEM	DAB007	DL	##03/21 80	3
S0251	DS-S-0162-0013	00	UNCONNECTED SENSOR FLAD	DAB007	NM	03/21 805	5S
S0257	DS-S-0161-0012	00	DISABLE AI REQUEST	DAB007	NM	03/21 805	5S
S0249	DS-D-0164-0016	00	INCR BIAS REG SET IN CIDIND	DAB007	COMM	03/17 805	5S
S0254	DS-S-0163-0015	00	SITE ADAPTATION UPGRADES	DAB007	SA	03/21 805	5S
N0016		RS	TRANSMITTER OVERLOAD ON ELMD	DAB007	CM	03/21 805	0S
N1006		RS	MCU PARITY ERROR	DAB007	PM	03/18 805	0S
N0015		RS	TARGET REPTS	DAB007	SURV	03/21 805	0S
N0017	DS-S-0166-0020	00	SENSOR STOPS INTERROGATING	DAB007	CM	03/21 80	5C
N0019	DS-N-0015-0028	00	LOSS OF DATALINK MSG-AIRCR	DAB007	DL	*03/21 80	4N
N0020	DS-N-0016-0028	00	LOSS OF DATALINK MSG	DAB007	DL	*03/21 80	4N
N0021		RS	DISSEMINATING "A" CODE	DAB007	SURV	03/21 80A	0S
N0022		RS	COR OF FRUIT REPLIES	DAB007	SURV	*03/21 80	2
N0023		RS	DISSEM OF ALT OF ZERO	DAB007	SURV	03/21 80A	0S
N0024		RS	LOSS OF REPTS TO ATC FACIL	DAB007	SURV	03/21 80A	0S
N0025		RS	BAD REPTS BEING DISSEM	DAB007	SURV	03/21 80A	0S
S0260	DS-S-0164-0016	00	NM HANG PROXIMITY TEST	DAB007	NM	04/02 805	5S
A0001	DS-A-0002-0016	00	ATARS VSL DESIGN ERROR	DAB007	ATARS	04/03 80	5A
A0002	DS-A-0003-0017	00	ERROR IN ATARS SIMULATOR	DAB007	ATARS	04/03 80	2
A0003	DS-A-0004-0018	00	ATARS EPOCH CYCLE CHANGE	DAB007	ATARS	04/03 80	5A
S0141		FF	3 COMP FAIL CAUSES 4TH FAIL	DAB006	SYS	11/14 79F	0S
N0028	DS-N-0017-0029	00	CODE SWAPPING LOGIC WRONG	DAB007	SURV	*04/08 80W	5S
N0042		RS	DOUBLE DABS REPORTS GEN	DAB007	SURV	04/02 80A	0S
N0043		RS	INCREASE OF ATCRBS TRACKS	DAB007	SURV	04/07 80W	0S
N0032		JD	S.F. TIME	DAB007	SURV	*03/31 80	2
S0268		FF	UPDATED RADAR REINF. BIT	DAB007	SURV	04/15 805	0S
S0269	DS-S-0194-0010	00	IMPROVED SITE ADAPT TECH	DAB008	SYS	*04/16 80F	5S
N0036		JD	UNEXPECTED PRIMARY REQUEST	DAB007	NM	*04/16 80	3
N0037	DS-N-0013-0026	00	INLIST CLEAR	DAB007	NM	*04/15 805	5S
N0038		BS	SENSOR DROPPED INTERROCAT	DAB007	CM	04/16 80W	0S
N0035		JD	COMM PROBLEM	DAB007	DL	04/11 805	0S
S0270		BW	SITE AD. FOR LOD TAP CONSOLE	DAB008	SA	*04/16 80	1
N0034	DS-N-0014-0027	00	SMF PROBLEM	DAB007	NM	*04/11 80	4N
N0031		JD	FAADAB CELL CHANGE	DAB007	NM	##03/31 80	1
N0033		JD	CONNECTIVITY PROBLEM	DAB007	NM	##04/11 80	1
N0030		JD	S.F. UPDATE	DAB007	SURV	##04/23 80	1
N0029		JD	USF PROBLEM	DAB007	NM	##04/11 80	1
S0271	DS-S-0167-0022	00	NEW CAL CURVE - ELWOOD	DAB007	SA	04/16 80W	5S
S0264	DS-S-0166-0021	00	IPC M SITE ADJ SITE DEF	DAB007	SA	04/08 80W	5S
N0040	DS-N-0010-0009	00	SYMBOLS DISAPPEAR FROM STC	DAB007	RDAS	*04/22 805	5S
S0279	DS-S-0193-0009	00	COLD START-GMBILD ON TAPE	DAB008	SYS	*04/24 80F	5S
N0039		EM	RADAR ONLY DROPOUT ON STC	DAB007	RDAS	##04/22 80	1
S0250	DS-S-0177-0006	00	MGDIFY CM RTNS	DAB007	CM	04/22 80	5C
S0272	DS-S-0176-0005	00	ERROR IN DISSEM. -MODE 4	DAB007	SURV	04/22 80	5C

SOFTWARE TROUBLE REPORTS - DAB007

SHEET 7

TR#	CHG PROP #	INIT	DESCRIPTION	PRDD	PART NO	OPEN	ST#
S0274	DS-S-0175-0004	00	SURV TRANSMIT ERR - MODE 4	DAB007	COMM	04/21 80	5C
S0273	DS-S-0174-0003	00	HANG IN COURSE SCREEN	DAB007	PM	04/21 80	5C
S0275	DS-S-0172-0001	00	HANG ON MISSING BRD	DAB007	PM	04/21 80	5C
S0276	DS-S-0173-0002	00	BAD BIAS REG	DAB007	PM	04/21 80	5C
S0277	DS-S-0170-0024	00	REMOTE DATA ACTIVE FLAG	DAB007	NM	*04/21 80S	5S
S0278	DS-S-0171-0002	00	NOTIFY ATARS OF ATC SENSER	DAB008	PM	*04/21 80S	5S
S0280		JS	LOST SURV. DUR. ELM UPLINK	DAB007	CM	*04/21 80	2
S0282		BG	ELM 209 SCENARIO PROBLEM	DAB007	CM	05/01 80G	0S
A0004	DS-A-0005-0002	00	PROC. SKIPPED-ATCRBS/ATCRBS	DAB008	ATARS	*05/01 80W	7
S0287	DS-S-0180-0007	00	PM & MODE 4	DAB007	PM	*05/01 80W	7
S0291	DS-S-0187-0025	00	PREMATURE DATA REQ. CANC.	DAB007	NM	*05/11 80S	5S
N0044		JD	MESSAGE EXPIRATION	DAB007	DL	#05/01 80	1
N0045		JD	COMM SCENARIO PROBLEM	DAB007	DL	05/01 80G	0S
C0002		JD	ZENITH CONE PROBLEM	DAB007	SURV	*05/11 80	2
A0007	DS-A-0008-0006	00	RESPONSIVE GENERATOR	DAB008	ATARS	*05/11 80	5N
A0006	DS-A-0007-0005	00	DETECTOR DATA	DAB008	ATARS	*05/11 80	5N
A0005	DS-A-0006-0004	00	CEM DATA	DAB008	ATARS	*05/11 80	5N
C0003	DS-C-0001-0011	00	RDAS WEATHER REPORTS	DAB007	MTD	*05/11 80W	7
C0004		JD	RADAR REPORT DISSEMINATION	DAB007	SURV	*05/11 80	1
N0046		WS	ATCRBS FRUIT REJECTION	DAB007	SURV	05/11 80A	0S
N0047		WS	ATCRBS FRUIT REJECTION	DAB007	SURV	05/11 80A	0S
S0296		SS	INCORRECT DABS TRACK INIT.	DAB007	SURV	05/21 80E	0S
N0049		JD	ALL-CALL LOCKOUT PROBLEM	DAB007	NM	#05/11 80	1
N0050		JD	USF PROBLEM	DAB007	NM	*05/11 80E	5S
N0051		JD	SENSOR STATUS PROBLEM	DAB007	AML	#05/11 80	1
N0052		JD	AC-ACQUIRE PROBLEM	DAB007	NM	05/11 80S	0S
N0053		JD	DATA REQUEST	DAB007	NM	*05/11 80	3
A0008	DS-A-0009-0007	00	ALTITUDE DATA IN MESSAGES	DAB008	ATARS	*05/11 80	5N
N0054		JD	ANTENNA FACE PROBLEM	DAB008	SURV	*05/11 80	2
N0057		CC	ATCRBS RADAR RANGE MASK	DAB007	CM	#05/21 80	1
S0297	DS-S-0190-0009	00	ILLEGAL OP CODE	DAB007	CM	*05/21 80W	7
S0295	DS-S-0191-0010	00	NOT HANDLING ILLEGAL OP	DAB007	SYS	*05/21 80W	7
N0060		WS	COMMAND ERROR	DAB007	DEX	*06/01 80	1
A0009	DS-A-0010-0008	00	DETECT AND RESOLUTION CHNG	DAB008	ATARS	*05/21 80	5N
N0059		LM	DAAT INITIATION	DAB007	NM	#05/21 80	1
S0283	DS-S-0196-0001	00	ATC FAILURE MESSAGES	DAB008	PM	*05/01 80S	5S
S0303		WS	ATCRBS PROCESSING	DAB007	SURV	06/04 80W	0S
N1025		EM	INCORRECT V.R. WEA. MAP	DAB007	-----	*06/11 80P	0S
N0055		CC	WWVB SYNCHRONIZATION	DAB007	-----	*05/21 80L	0S
N0058		LM	REFLECTOR FILES	DAB007	-----	*05/21 80	0N
S0305		BW	SIZE OVERFLOW FOR SSOOAX	DAB008	ATARS	*06/01 80W	0S
S0219		BW	DABCOB CHANGES	DAB008	-----	*02/21 80	2
S0310		BW	INCORRECT BLOCK DATA INIT	DAB008	PM	*06/11 80H	0S
S0309		MB	ATCRBS CORR AT NM	DAB007	SURV	*06/11 80A	0S
N1023		EM	NO RADAR FALSE TGTS	DAB007	SURV	*06/11 80E	0S
S0304		MF	DATABASE KLUDGE	DAB008	MTD	*06/04 80M	5S
A0010		NB	PROX MESSAGE	DAB008	ATARS	*05/21 80	5N
S0306		MF	CHANGED LCF	DAB008	-----	*06/01 80M	5S
S0301		BG	ELM TRANSPONDER PROBLEMS	DAB007	-----	*05/21 80	0N
S0300		BG	ELM PROBLEMS	DAB007	CM----	*05/21 80	2

SOFTWARE TROUBLE REPORTS - DAB007 SHEET 8

TR#	CHG	PROP #	INIT	DESCRIPTION	PROD	PART NO	OPEN	ST
N0063				WG SFN TESTS COASTS	DAB007	SURV	*06/18	JCCB OS
N0062				WG ARIES SCENARIO PROBLEM	DAB007	SURV	*06/18	BOB OS
A0011				NB 2-MANEUVER CONFLICT	DAB008	ATARS	*06/18	BO ON
S0308				LH SENSOR INTERNAL DELAYS	DAB007	SA	*06/27	BOH OS

STATUS CODE SUMMARY

STATUS	DESCRIPTION	NUMBER
00	TROUBLE REPORT SUBMITTED	79
01	LOCAL MANAGER DISAPPROVED. CLOSED	57
02	AWAITING JCCB ACTION	8
03	JCCB DISAPPROVED. CLOSED	8
04	JCCB PLACED ON HOLD	7
05	JCCB APPROVED AND ASSIGNED	55
06	CHANGE FAILED - RETURN TO JCCB	0
07	CHANGE RELEASED TO STAGING LIBRARY	13
08	CHANGE FAILED I & T	0
09	AWAITING APPROVAL FOR BASELINE	0
10	JCCB APPROVED FOR BASELINE	10
11	CHANGE IN BASELINE. CLOSED	117
--	INVALID STATUS CODE ASSIGNED	0
	TOTAL	354