

FAA WJH Technical Center  
00090943

# **VERY HIGH FREQUENCY (VHF) MULTICOUPLER TESTS**

**Albert J. Rehmann**



**FINAL REPORT**

**FEBRUARY 1982**

Document is available to the U.S. public through  
the National Technical Information Service,  
Springfield, Virginia 22161.

**Prepared for**

**U.S. DEPARTMENT OF TRANSPORTATION  
FEDERAL AVIATION ADMINISTRATION  
TECHNICAL CENTER  
Atlantic City, N.J. 08405**

#### NOTICE

This document is disseminated under the sponsorship of the Department of Transportation in the interest of information exchange. The United States Government assumes no liability for the contents or use thereof.

The United States Government does not endorse products or manufacturers. Trade or manufacturer's names appear herein solely because they are considered essential to the object of this report.

Technical Report Documentation Page

1. Report No. DOT/FAA/CT-81/62		2. Government Accession No.		3. Recipient's Catalog No.	
4. Title and Subtitle  VERY HIGH FREQUENCY (VHF) MULTICOUPLER TESTS				5. Report Date February 1982	
				6. Performing Organization Code ACT-100	
7. Author(s)  Albert J. Rehmann				8. Performing Organization Report No.  DOT/FAA/CT-81/62	
9. Performing Organization Name and Address Federal Aviation Administration Technical Center Atlantic City Airport, New Jersey 08405				10. Work Unit No. (TRAIS)	
				11. Contract or Grant No. 219-151-200	
12. Sponsoring Agency Name and Address U.S. Department of Transportation Federal Aviation Administration Technical Center Atlantic City Airport, New Jersey 08405				13. Type of Report and Period Covered  Final Report March - April 1981	
				14. Sponsoring Agency Code	
15. Supplementary Notes					
16. Abstract  This report describes tests conducted on two commercially available very high frequency (VHF) multicouplers to determine if they could meet a set of proposed specifications. The multicouplers met all proposed specifications except the intermodulation distortion requirements.					
17. Key Words Multicoupler Tests			18. Distribution Statement Document is available to the U.S. public through the National Technical Information Service, Springfield, Virginia 22161		
19. Security Classif. (of this report) Unclassified		20. Security Classif. (of this page) Unclassified		21. No. of Pages 31	22. Price

## METRIC CONVERSION FACTORS

### Approximate Conversions to Metric Measures

Symbol	When You Know	Multiply by	To Find	Symbol
<b>LENGTH</b>				
in	inches	*2.5	centimeters	cm
ft	feet	30	centimeters	cm
yd	yards	0.9	meters	m
mi	miles	1.6	kilometers	km
<b>AREA</b>				
in <sup>2</sup>	square inches	6.5	square centimeters	cm <sup>2</sup>
ft <sup>2</sup>	square feet	0.09	square meters	m <sup>2</sup>
yd <sup>2</sup>	square yards	0.8	square meters	m <sup>2</sup>
mi <sup>2</sup>	square miles	2.6	square kilometers	km <sup>2</sup>
	acres	0.4	hectares	ha
<b>MASS (weight)</b>				
oz	ounces	28	grams	g
lb	pounds	0.45	kilograms	kg
	short tons (2000 lb)	0.9	tonnes	t
<b>VOLUME</b>				
tsp	teaspoons	5	milliliters	ml
Tbsp	tablespoons	15	milliliters	ml
fl oz	fluid ounces	30	milliliters	ml
c	cups	0.24	liters	l
pt	pints	0.47	liters	l
qt	quarts	0.95	liters	l
gal	gallons	3.8	liters	l
ft <sup>3</sup>	cubic feet	0.03	cubic meters	m <sup>3</sup>
yd <sup>3</sup>	cubic yards	0.76	cubic meters	m <sup>3</sup>
<b>TEMPERATURE (exact)</b>				
°F	Fahrenheit temperature	5/9 (after subtracting 32)	Celsius temperature	°C

\*1 in = 2.54 (exactly). For other exact conversions and more detailed tables, see NBS Misc. Publ. 286, Units of Weights and Measures, Price \$2.25, SD Catalog No. C13.10:286.



### Approximate Conversions from Metric Measures

Symbol	When You Know	Multiply by	To Find	Symbol
<b>LENGTH</b>				
mm	millimeters	0.04	inches	in
cm	centimeters	0.4	inches	in
m	meters	3.3	feet	ft
m	meters	1.1	yards	yd
km	kilometers	0.6	miles	mi
<b>AREA</b>				
cm <sup>2</sup>	square centimeters	0.16	square inches	in <sup>2</sup>
m <sup>2</sup>	square meters	1.2	square yards	yd <sup>2</sup>
km <sup>2</sup>	square kilometers	0.4	square miles	mi <sup>2</sup>
ha	hectares (10,000 m <sup>2</sup> )	2.5	acres	
<b>MASS (weight)</b>				
g	grams	0.035	ounces	oz
kg	kilograms	2.2	pounds	lb
t	tonnes (1000 kg)	1.1	short tons	
<b>VOLUME</b>				
ml	milliliters	0.03	fluid ounces	fl oz
l	liters	2.1	pints	pt
l	liters	1.06	quarts	qt
l	liters	0.26	gallons	gal
m <sup>3</sup>	cubic meters	35	cubic feet	ft <sup>3</sup>
m <sup>3</sup>	cubic meters	1.3	cubic yards	yd <sup>3</sup>
<b>TEMPERATURE (exact)</b>				
°C	Celsius temperature	9/5 (then add 32)	Fahrenheit temperature	°F

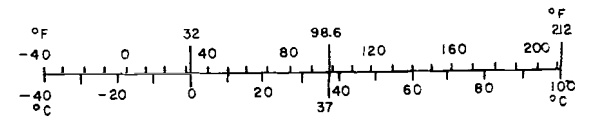

## TABLE OF CONTENTS

	Page
INTRODUCTION	1
Purpose	1
Background	1
DISCUSSION	1
General Description of Tests	1
Passive Multicoupler Tests	1
Active Multicoupler Tests	2
SUMMARY OF RESULTS	6
CONCLUSIONS	6
RECOMMENDATIONS	8
REFERENCES	8
APPENDIX	

## LIST OF ILLUSTRATIONS

Figure		Page
1	Proposed Passive Transmitter/Receiver Coupler Specifications	9
2	Proposed Active Receiver Coupler Specifications	9
3	Passive Multicoupler Input/Output VSWR Tests	10
4	Passive Multicoupler Insertion Loss Tests	11
5	Passive Multicoupler Isolation Tests	12
6	Receiver Antenna Input Impedance Test Setup	12
7	Receiver Input VSWR Versus Frequency, Center Frequency 118.00 MHz	13
8	Receiver Input VSWR Versus Frequency, Center Frequency 127.60 MHz	14
9	Receiver Input VSWR Versus Frequency, Center Frequency 136.00 MHz	15
10	Active Multicoupler Input VSWR Test Setup	16
11	Locus Multicoupler, Input VSWR Versus Frequency	17
12	Locus Multicoupler, Output VSWR Versus Frequency	18
13	Active Multicoupler Gain and Bandwidth Test Setup	19
14	Locus Multicoupler, Gain Versus Frequency	20
15	Locus Multicoupler, Output Isolation	21
16	Active Multicoupler Intermodulation Distortion Test Setup	22
17	Active Multicoupler Noise Figure Test Setup	22

## LIST OF TABLES

Table		Page
1	Intermodulation Distortion Test Results	4
2	Multicoupler Dynamic Range	4
3	Receiver Sensitivity	6
4	Passive VHF Multicoupler Parameters	7
5	Active VHF Multicoupler Parameters	7

## LIST OF ACRONYMS

AAF	Airway Facilities Service
dB	decibel
dBm	decibels above 1 milliwatt
HP	Hewlett-Packard
IF	intermediate frequency
kHz	kilohertz
MHz	megahertz
MTBF	mean time between failures
mW	milliwatts
RF	radiofrequency
UHF	ultra high frequency
V	volts
Vac	volts alternating current
Vdc	volts direct current
VHF	very high frequency
VSWR	voltage standing wave ratio
W	watts

## INTRODUCTION

### PURPOSE.

The purpose of this task was to support an Airway Facilities Service (AAF) national procurement of radiofrequency (RF) multicouplers. The information contained in this report will directly support the specification for this procurement.

### BACKGROUND.

Project 066-221-850, Test and Evaluation of Air/Ground Communications Multicouplers, had been previously performed at the Technical Center and a set of proposed multicoupler specifications was prepared and provided to AAF-430, Communications Systems Branch. (Copies of these proposed specifications are shown as figures 1 and 2.) AAF-430 is presently planning a national buy of multicouplers and requested additional information to support the proposed specifications and procurement. A new series of tests were designed and conducted on a TRW passive multicoupler, part No. 800740, and a Locus active multicoupler, model MC-241A. These multicouplers had been previously procured and are considered representative of commercially available multicouplers. The results of these tests are discussed in this report.

## DISCUSSION

### GENERAL DESCRIPTION OF TESTS.

Tests were performed on two very high frequency (VHF) multicouplers, one passive and one active. The passive multicoupler was a TRW VHF multicoupler, part No. 800740, and the active unit was a Locus model MC-241A. The following test equipment were used in performing these tests:

Hewlett-Packard (HP) power meter, model 463A

HP power sensor, model 8482H

HP audio generator, model 200AB

HP SWR meter, model 415E

Alford slotted line assembly consisting of:

Alford slotted line, type 1026C-6, 100 to 3000 megahertz (MHz)

Alford taper reducer, type 1122C

Alford taper reducer, type 1122D

Alford tuned probe, type 2162X, 30 to 235 MHz

HP signal generator, model 8660

HP signal generator, model 8640

Tektronix mainframe oscilloscope with 7L13 spectrum analyzer plug-in, model 7904

HP recorder, model 7004B X-Y

Narda directional coupler, model MD 3020A

Texcan tunable bandpass filter, part No. 3VF95/190-5AA

Texcan tunable bandpass filter, part No. 5VF95/190-5AA

### PASSIVE MULTICOUPLER TESTS.

The passive multicoupler tests were conducted using a GRT-21 transmitter, serial No. 22286, as the signal source. The transmitter output (nominally 10 watts (W)) was fed through two 3 decibel (dB) attenuators (6 dB total) to the equipment being tested. This was done to isolate the equipment under test from variations in transmitter output impedance. No high power tests of this multicoupler were conducted.

The passive multicoupler consists essentially of a tuned cavity for each

output port. When these cavities are tuned at or near the same frequency, interaction occurs. For this reason, the passive multicoupler tests were conducted with one cavity tuned to the reference frequency and the other tuned at least 2 MHz away from it.

Three tests were conducted on the TRW VHF multicoupler, part No. 800740, serial No. 102:

1. Input/output voltage standing wave ratio (VSWR)
2. Insertion loss
3. Port-to-port isolation

Figures 3, 4, and 5 show the test configurations used and the test results for each of these tests.

The input/output impedances of the multicoupler were not measured since they can be calculated from the VSWR. For the worse case VSWR of 1.22:1, the calculated port impedances were 61 or 41 ohms. (A given VSWR can result from load impedances either above or below the line impedance. See appendix.)

#### ACTIVE MULTICOUPLER TESTS.

A total of nine tests were conducted to determine the performance of the Locus multicoupler, model MC-241A, serial No. 01. Eight tests were measurements of the coupler parameters and one test was a measurement of the antenna terminal input impedance of the receivers used in the tests. All tests and their descriptions are delineated as follows:

1. Receiver antenna input impedance
2. Multicoupler input VSWR
3. Multicoupler output VSWR
4. Multicoupler gain and bandwidth
5. Multicoupler output isolation

6. Multicoupler intermodulation distortion

7. Multicoupler dynamic range

8. Multicoupler noise figure

9. Receiver performance with multicoupler

Test descriptions for these nine tests follow.

RECEIVER ANTENNA INPUT IMPEDANCE. During preliminary coupler testing it was noted that the multicoupler input VSWR became excessive when the coupler outputs were unterminated. This motivated investigation of the input VSWR of several GRR-23 receivers.

Each receiver was tuned according to TI 6620.2A (reference 1) prior to testing. The test setup is shown in figure 6, and the resulting graphs are shown in figures 7, 8, and 9. Note that the receiver input VSWR exceeds 5:1 at frequencies more than 1 MHz away from the receiver's center frequency.

MULTICOUPLER INPUT VSWR. The test setup is shown in figure 10 and test results are shown in figure 11. For the first test of the input VSWR the coupler outputs were loaded with three receivers and five 50-ohm terminations. The receiver frequencies were 118.0, 127.6, and 136.0 MHz.

The effect of the receiver VSWR on the multicoupler input VSWR is apparent in figure 11, plot A. All coupler outputs were then terminated in 50 ohms and the VSWR was swept, figure 11, plot B. For the final test of this group all coupler output ports were unterminated and the VSWR was swept, figure 11, plot C.

MULTICOUPLER OUTPUT VSWR. The test setup is the same as that used in the previous test, except that the RF generator output was injected into one of the coupler output ports. The

coupler output VSWR was swept with five ports (including the input) terminated in 50 ohms and three ports terminated with test receivers. The effect of the receiver VSWR on the coupler output VSWR is not as pronounced as it was on the coupler input VSWR. The coupler output VSWR was swept again with all ports terminated in 50 ohms and again with all ports open. Figure 12 is a plot of the results of all three tests.

MULTICOUPLER GAIN AND BANDWIDTH. The test setup for gain and bandwidth tests is shown in figure 13. The coupler gain versus frequency plot is shown in figure 14. Only one curve is shown, but this is representative of the performance of each output. (Note: The Narda directional coupler had been used in previous tests and was left in for convenience.)

MULTICOUPLER OUTPUT ISOLATION. The test setup was the same as that used to sweep the multicoupler output VSWR, except that one of the terminated output ports is used as the observation port. The curves in figure 15 show the extremes of coupler isolation for different combinations of output loading and injection and observation port location. The conditions for each curve are listed in figure 15.

To reduce the possibility of interference caused by intermodulation of receiver local oscillator leakage and incoming RF, the multicoupler output isolation specification should be increased to 40 dB. This is a realistic specification because both multicouplers tested were able to meet it over the VHF band.

MULTICOUPLER INTERMODULATION DISTORTION. The test setup for the intermodulation distortion tests is shown in figure 16.

The bandpass filters were used in this test to prevent intermodulation distortion from developing in the spectrum analyzer front end. The multicoupler intermodulation was measured with input signal levels of +10 decibels above 1 milliwatt (dBm). The test results are contained in table 1. When the generator outputs were reduced to 0 dBm, all intermodulation products were below -70 dBm.

Signal levels of +10 dBm would be the RF levels received from a 10 W transmitter with about 20-foot separation between transmitting and receiving antennas, assuming 0 dB antenna gain. A 0 dBm received signal level would result from about 60-foot separation between antennas. Any transmitter and receiver antenna gains would add to the received signal levels.

MULTICOUPLER DYNAMIC RANGE. The test setup is that used in the "Multicoupler Gain and Bandwidth" test (test 4). The resulting data are shown in table 2. The multicoupler compression at the +16 dBm input level is less than 1 dB.

MULTICOUPLER NOISE FIGURE. The noise figure measurement was made using the 3 dB additional noise method. The test setup for this noise figure test is shown in figure 17. The test was performed by first measuring the noise figure of the test receiver, then measuring the noise figure of the multicoupler/test receiver combination. The difference in the measurements gives the noise added to the receiver intermediate frequency (IF) output by the multicoupler. The actual noise figure of the multicoupler was calculated using Friss' formula (reference 2) for cascaded noisy amplifiers.

TABLE 1. INTERMODULATION DISTORTION TEST RESULTS

Generator Output Frequency (MHz)	<u>Intermodulation</u>		<u>Harmonics</u>	
	Frequencies (MHz)	Level (dBm)	Frequencies (MHz)	Level (dBm)
120	115	-48	240	-34
			245	-28
125	130	-47	250	-30
125	120	-50	250	-35
			255	-30
130	135	-50	260	-40

Note: Input signal level was +10 dBm for all tests.

TABLE 2. MULTICOUPLER DYNAMIC RANGE

<u>Power In (dBm)</u>	<u>Power Out (dBm)</u>
-110	-108.0
-90	-91.0
-70	-70.5
-50	-51.6
-20	-20.9
-10	-10.8
0	+0.49
+10	+10.3
+16	+16.54

Friss' formula for noisy cascaded amplifiers:

$$F_t = F_1 + \frac{F_2 - 1}{A_1} \quad (1)$$

Where:

$F_t$  = total noise figure (receiver plus multicoupler) expressed as a ratio,

$F_1$  = multicoupler noise figure expressed as a ratio,

$F_2$  = receiver noise figure expressed as a ratio, and

$A_1$  = multicoupler gain expressed as a ratio.

Therefore:

$$F_1 = F_t - \frac{(F_2 - 1)}{A_1} \quad (2)$$

and

$$NF_1 = 10 \text{ Log } F_1 = 10 \text{ Log } \left( F_t - \frac{(F_2 - 1)}{A_1} \right) \quad (3)$$

Measured values were:

<u>Frequency</u>	<u>Receiver Noise Figure</u>		<u>Total Noise Figure</u>		<u>Multicoupler Gain</u>
127.6	dB = 7.0	$F_2 = 5.01$	dB = 8.55	$F_t = 7.16$	dB = 0.4 $A_1 = 1.1$
136.0	dB = 9.0	$F_2 = 7.94$	dB = 9.90	$F_t = 9.77$	dB = 0.4 $A_1 = 1.1$

Example for 127.6 MHz:

$$F_1 = 7.16 - \frac{5.01 - 1}{1.1}$$

$$F_1 = 3.51$$

$$NF_1 = 10 \text{ Log } 3.51 = 5.46 \text{ dB}$$

The derived noise figure for the Locus multicoupler data for the two frequencies measured are:

127.6 MHz/5.46 dB  
 136.0 MHz/5.39 dB

RECEIVER PERFORMANCE WITH MULTICOUPLER.

The overall performance of the multicoupler was evaluated by measuring the receiver sensitivity with and without the multicoupler and comparing the results. The sensitivity of the receiver is the input level required to produce a ratio of 10 dB signal plus noise-to-noise. The test results are shown in table 3. Note that the receiver tuned to 136 MHz demonstrates improved sensitivity with the multicoupler in the circuit. Further investigation showed the improvement was due to better impedance matching of the receiver to a 50-ohm source by the multicoupler.

SUMMARY OF RESULTS

The proposed specifications for passive and active multicouplers (figures 1 and 2) lists the important parameters for these multicouplers. To summarize the results of the tests described herein,

tables 4 and 5 compare the specification parameters to the worse case parameter values obtained in the multicoupler tests. Table 4 lists the parameters for the passive multicoupler; table 5 lists them for the active multicoupler.

CONCLUSIONS

1. The multicouplers tested met the proposed specifications except for the intermodulation distortion requirement. However, some parts of the proposed specifications should be revised (see "Recommendations" section).
2. The passive multicouplers exhibited less isolation and increased insertion loss when the cavities were tuned less than 2 MHz from each other.
3. A passive multicoupler should not be used in an operational environment unless the assigned frequencies are at least 2 MHz apart.

TABLE 3. RECEIVER SENSITIVITY

<u>Frequency (MHz)</u>	<u>Rx Only</u>		<u>Rx with Coupler</u>	
	<u>V</u>	<u>dBm</u>	<u>V</u>	<u>dBm</u>
Rx1 118	1.3	-104.7	1.4	-104
Rx2 127.6	1.15	-105.8	1.15	-105.8
Rx3 136	1.3	-104.7	1.25	-105

TABLE 4. PASSIVE VHF MULTICOUPLER PARAMETERS

<u>Parameter</u>	<u>Proposed Specification</u>	<u>TRW 800740 Worse Case</u>
Input/Output VSWR	2.0:1 max	1.22:1
Insertion Loss	2.0 dB max	1.75 dB
Port-to-Port Isolation at 2 MHz Separation	30.0 dB min	50.2 dB
Input/Output Impedance	50 ohms nominal	41-61 ohms*

\*Calculated from VSWR

TABLE 5. ACTIVE VHF MULTICOUPLER PARAMETERS

<u>Parameter</u>	<u>Proposed Specification</u>	<u>Locus MC-241A Worse Case</u>
Input/Output VSWR	1.6:1 max	1.37:1 <sup>(1)</sup>
Port-to-Port Isolation	30 dB min	40 dB <sup>(1)</sup>
Gain	2 dB $\pm$ 2 dB	+0.4 dB 0.0 dB
Noise Figure	8 dB max	5.5 dB
Third Order Intermodulation	Better than -60 dB	-70 dB <sup>(2)</sup> -57 dB <sup>(3)</sup>
RF Input Level	+10 dBm max	+16 dBm <sup>(4)</sup>

Notes:

- (1) With all ports terminated.
- (2) With 0 dBm signal generator output level.
- (3) With +10 dBm signal generator output level.
- (4) Less than 1 dB compression at +16 dBm.

## RECOMMENDATIONS

1. The specification port-to-port isolation should be changed to 40 dB on both the passive and active multicouplers, with all ports terminated.
2. For the active multicoupler, the input signal level for the intermodulation distortion requirements should be specified. From table 4, the intermodulation level was -57 dB for input signals of +10 dBm, and -70 dB for input signals of 0 dBm.
3. For the passive multicoupler specification, the tuning separation for the two outputs should not be less than 2 MHz.

## REFERENCES

1. ITT, Transmitting Set, Radio AN/GRT-21 and AN/GRT-22, Instruction Book, Vol. 1, Unified Industries Inc., May 13, 1977.
2. Carlson, B. A., Communications Systems - An Introduction to Signals and Noise for Electrical Communications, McGraw-Hill, 1968.

Frequency Range	VHF 118 MHz to 136 MHz UHF 225 MHz to 400 MHz
Input/Output Impedance	50 Ohms Nominal
Input/Output VSWR	2.0:1 Maximum
Number of Output Ports	2 Minimum
Port-to-Port Isolation	30 dB at 2 MHz Separation
Insertion Loss	2.0 dB Maximum
RF Input Levels	100 Watts Maximum
RF Input/Output Connectors	Type N Female

FIGURE 1. PROPOSED PASSIVE TRANSMITTER/RECEIVER COUPLER SPECIFICATIONS

Frequency Range	VHF 118 MHz to 136 MHz UHF 225 MHz to 400 MHz
Input/Output Impedance	50 Ohms Nominal
Input/Output VSWR	1.6:1 Maximum
Number of Output Ports	8 Minimum
Port-to-Port Isolation	30 dB Minimum
Gain	2 dB $\pm$ 2 dB
Noise Figure	8 dB Maximum
Third Order Intermodulation Levels	60 dB Down Minimum
Spurious Radiations	80 dB Below Input Signal Levels
RF Input Levels	+10 dBm Maximum
Service Life	25,000 Hours (180,000 Goal) MTBF
Power Input	115 Vac $\pm$ 10 V/26 Vdc $\pm$ 4 V

FIGURE 2. PROPOSED ACTIVE RECEIVER COUPLER SPECIFICATIONS

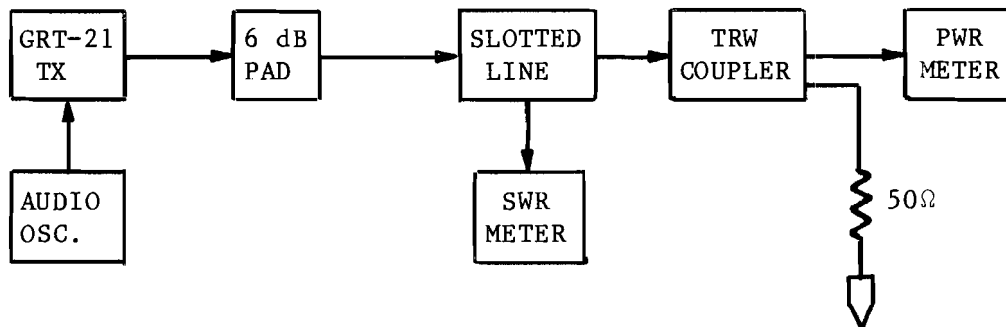

Frequency (MHz)	Input VSWR	Output VSWR		Input Power (Watts)
	Port B	Port 1	Port 2	
118	1.18/1	1.1/1	1.02/1	2.51
127	1.08/1	1.04/1	1.22/1	2.51
136	1.04/1	1.04/1	1.02/1	2.51

NOTES:

1. Drawing shows test configuration for input VSWR measurements. For output VSWR measurements the signal was fed into port 1 or 2. All unused ports were terminated.
2. The power meter was used both as a 50-ohm termination, and as a check on configuration integrity.

FIGURE 3. PASSIVE MULTICOUPLER INPUT/OUTPUT VSWR TESTS

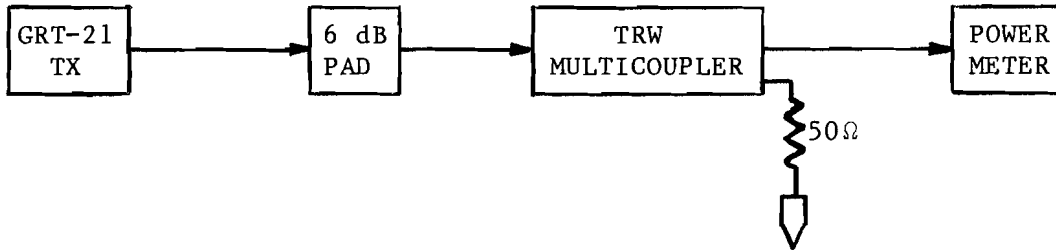

FORWARD INSERTION LOSS

Frequency (MHz)	Port	Power In/Power Out (Watts)	Loss (dB)
118	B/1	2.55/1.71	1.74
	B/2	2.55/1.72	1.71
127	B/1	2.50/1.74	1.57
	B/2	2.50/1.68	1.73
136	B/1	2.50/1.70	1.67
	B/2	2.50/1.67	1.75

REVERSE INSERTION LOSS

Frequency (MHz)	Port	Power In/Power Out (Watts)	Loss (dB)
118	1/B	2.55/1.78	1.56
	2/B	2.55/1.77	1.59
127	1/B	2.51/1.77	1.52
	2/B	2.51/1.77	1.52
136	1/B	2.50/1.74	1.57
	2/B	2.50/1.67	1.75

FIGURE 4. PASSIVE MULTICOUPLER INSERTION LOSS TESTS

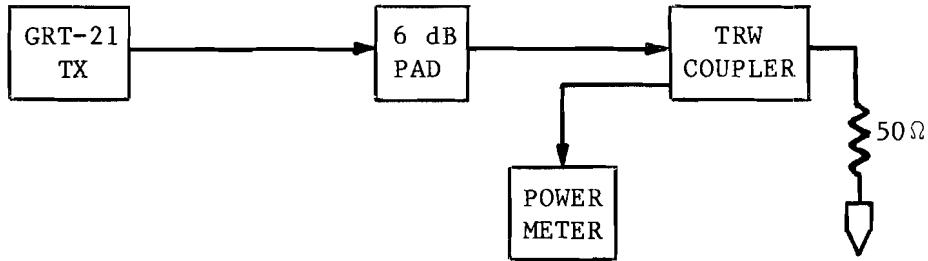

Frequency (MHz)	Power In Port 1 (Watts)	Power Out Port 2 (mW)	Isolation (dB)
118	2.5	+2 MHz = 0.016	51.9
		-2 MHz = 0.015	52.2
127	2.5	+2 MHz = 0.013	52.8
		-2 MHz = 0.024	50.2
136	2.5	+2 MHz = 0.013	52.8
		-2 MHz = 0.018	51.4

Note: Power out port was tuned 2 MHz above and below transmitter frequency.

FIGURE 5. PASSIVE MULTICOUPLER ISOLATION TESTS

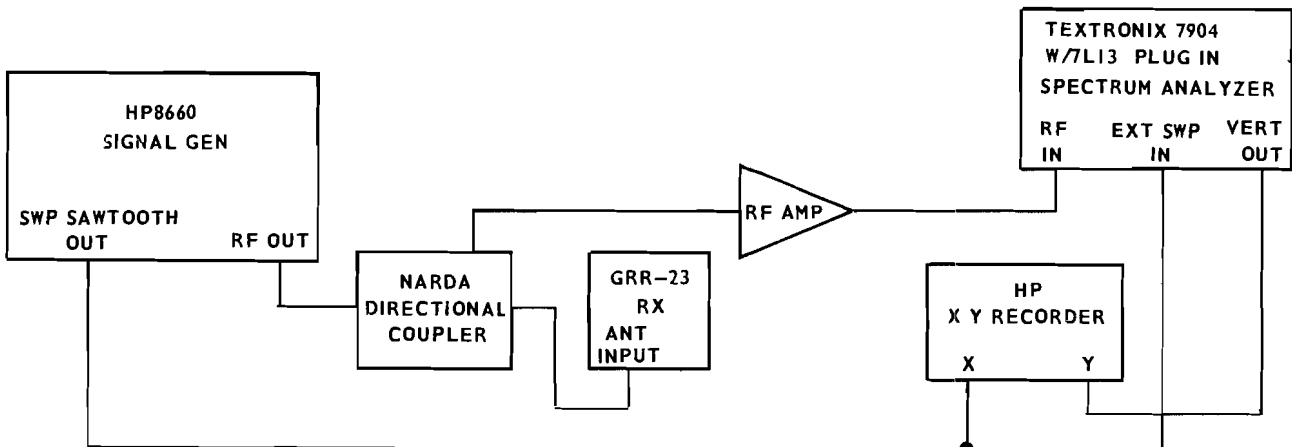

81-62-6

FIGURE 6. RECEIVER ANTENNA INPUT IMPEDANCE TEST SETUP

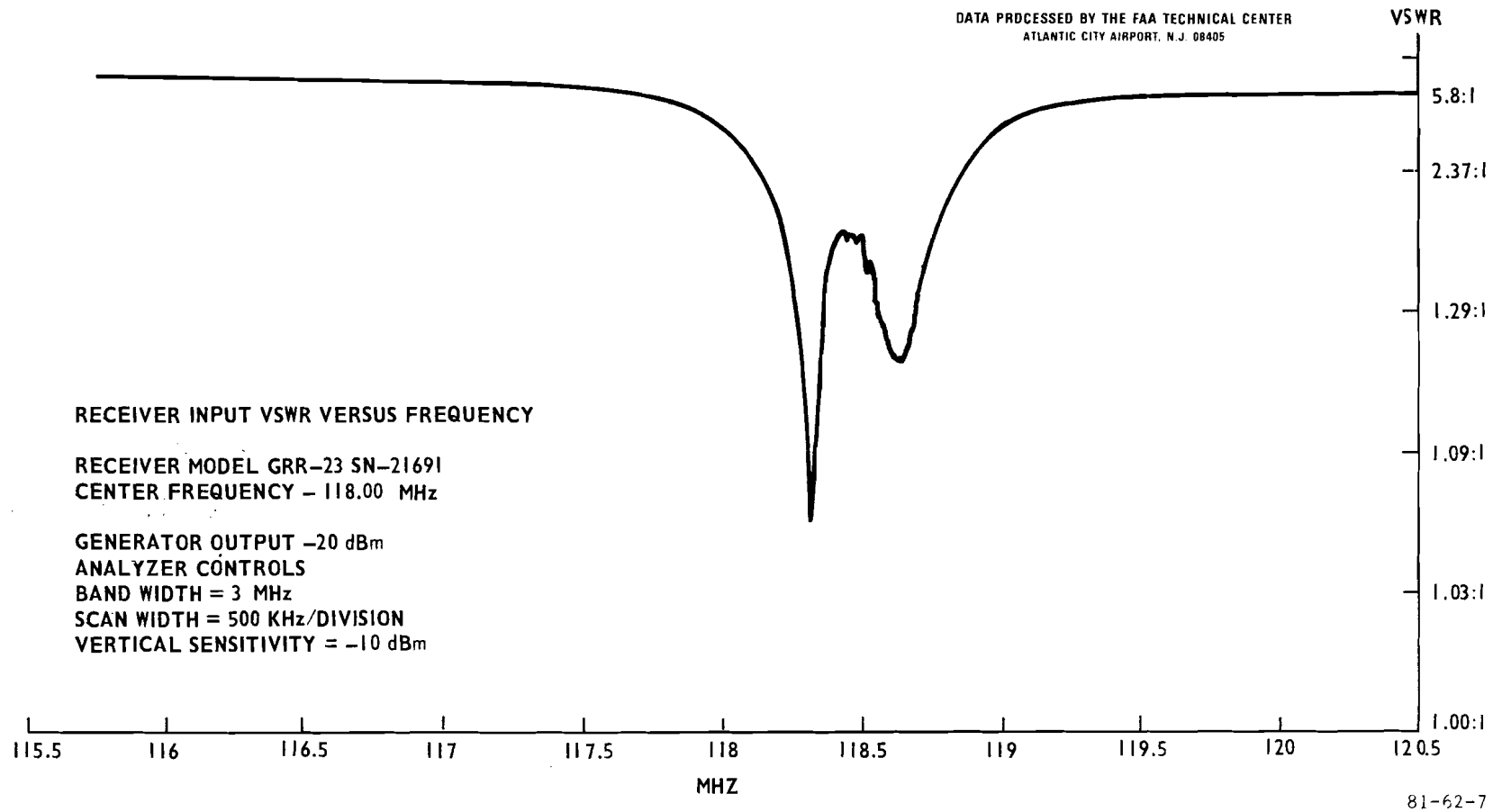

FIGURE 7. RECEIVER INPUT VSWR VERSUS FREQUENCY, CENTER FREQUENCY 118.00 MHZ

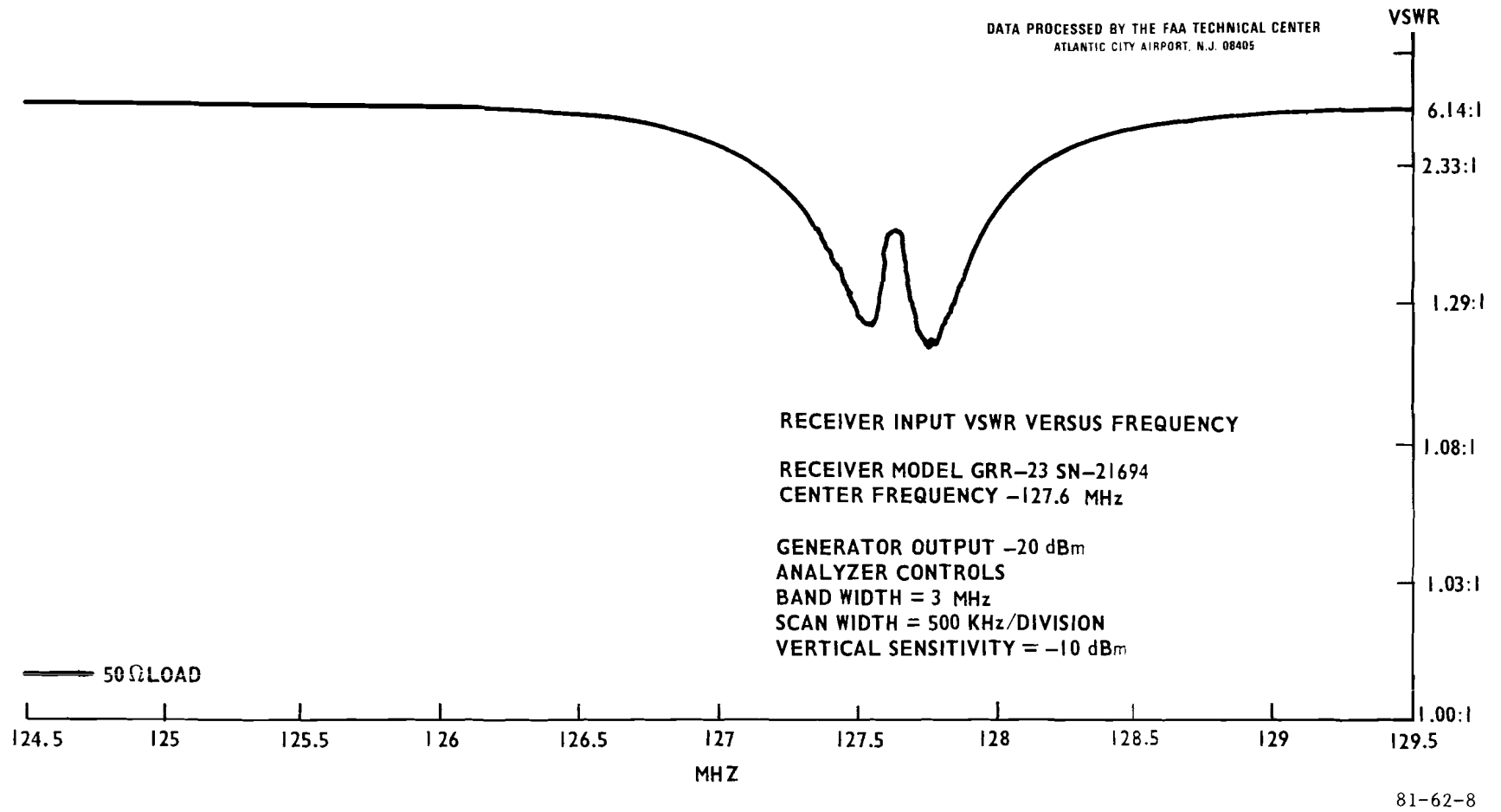

FIGURE 8. RECEIVER INPUT VSWR VERSUS FREQUENCY, CENTER FREQUENCY 127.60 MHZ

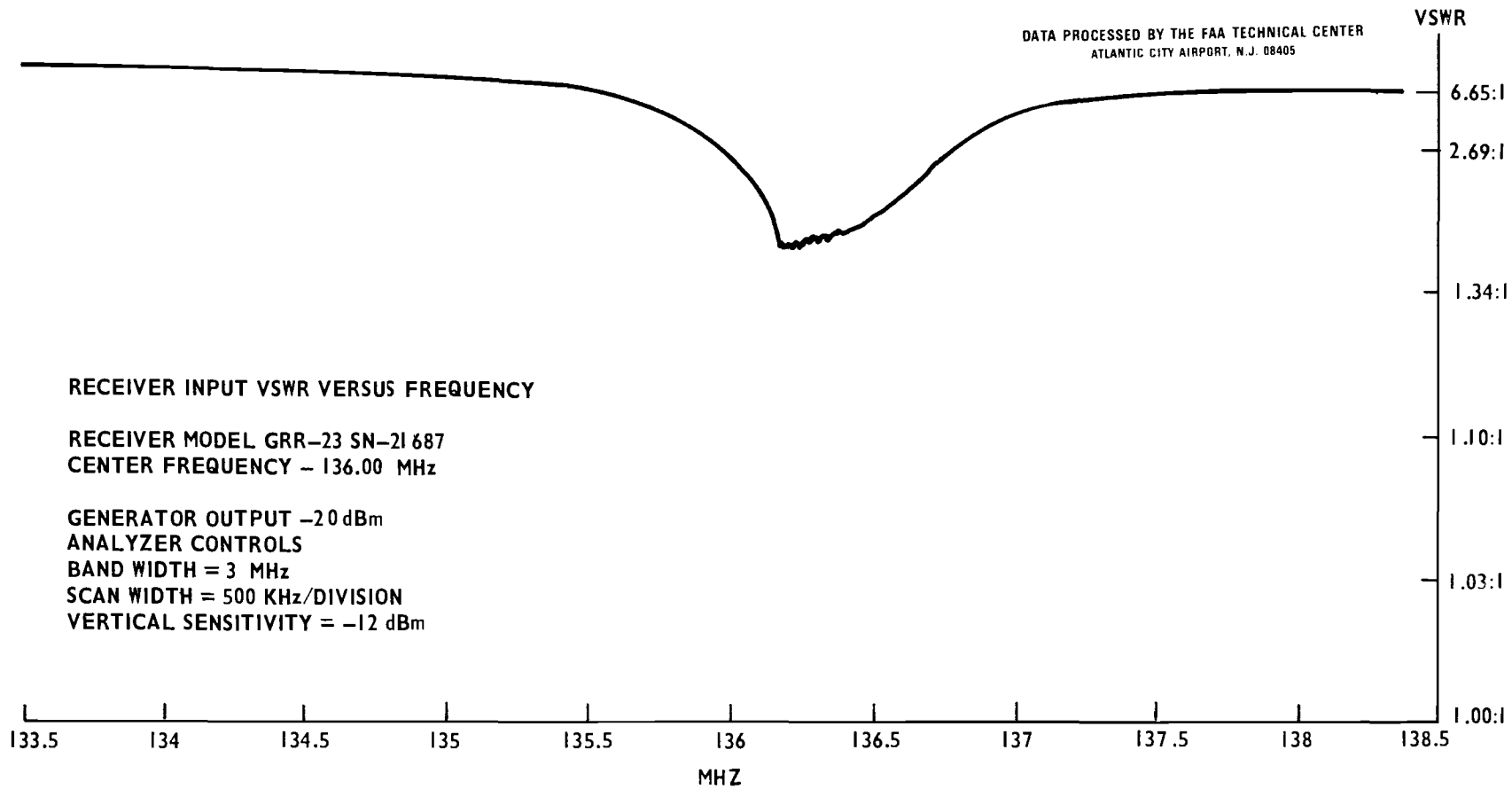
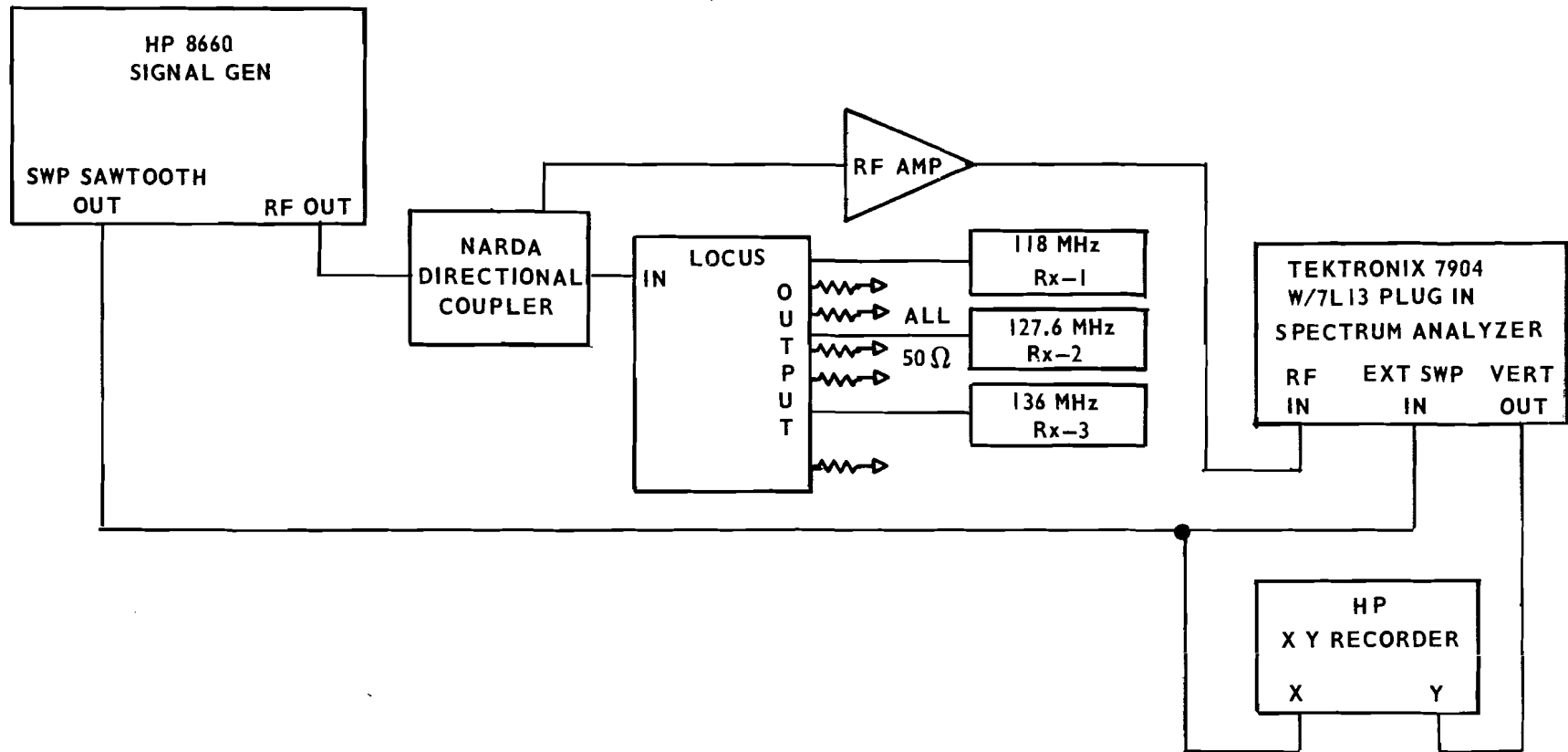
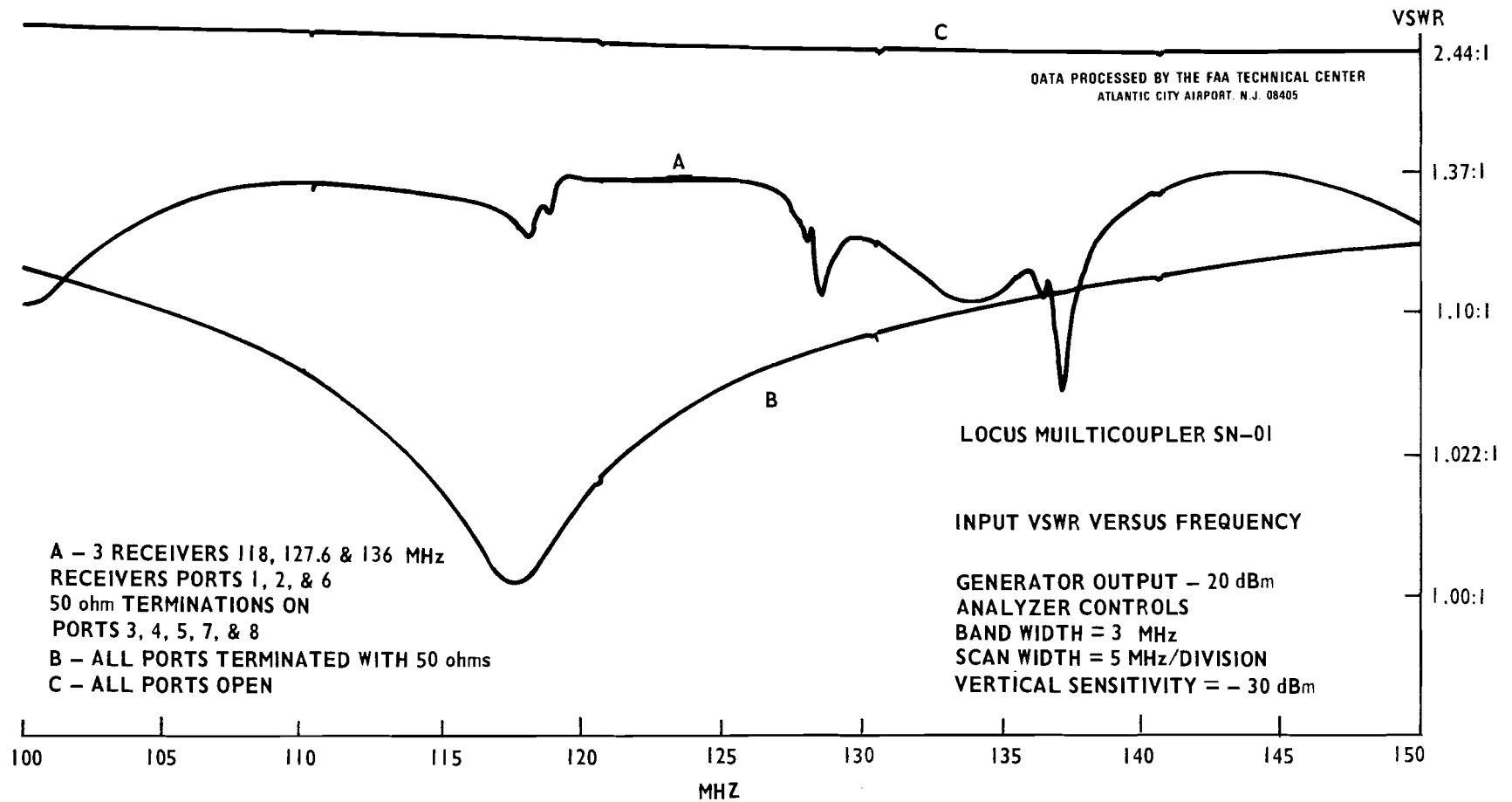

FIGURE 9. RECEIVER INPUT VSWR VERSUS FREQUENCY, CENTER FREQUENCY 136.00 MHz



81-62-10

FIGURE 10. ACTIVE MULTICOUPLER INPUT VSWR TEST SETUP



81-62-11

FIGURE 11. LOCUS MULTICOUPLER, INPUT VSWR VERSUS FREQUENCY

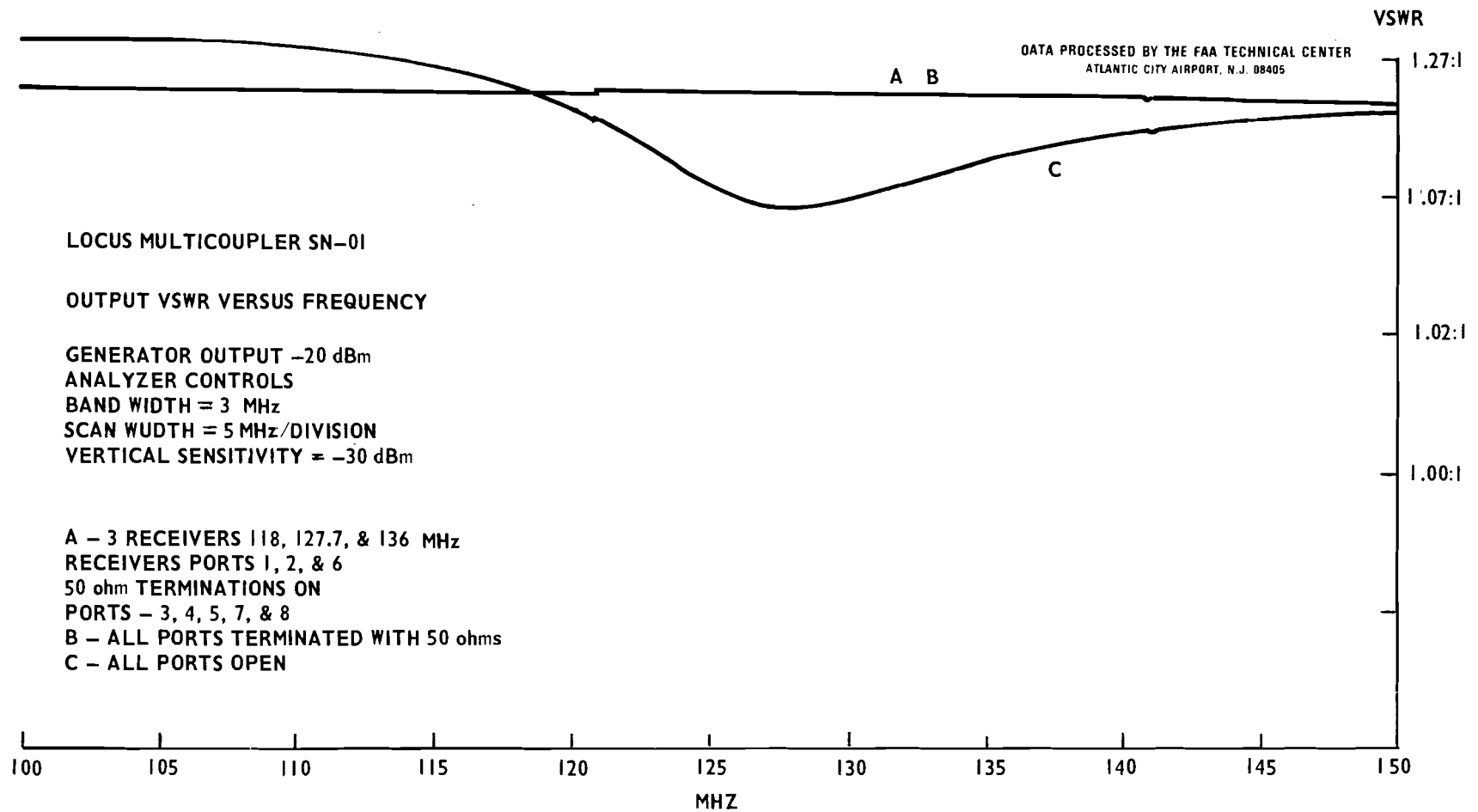

FIGURE 12. LOCUS MULTICOUPLER, OUTPUT VSWR VERSUS FREQUENCY

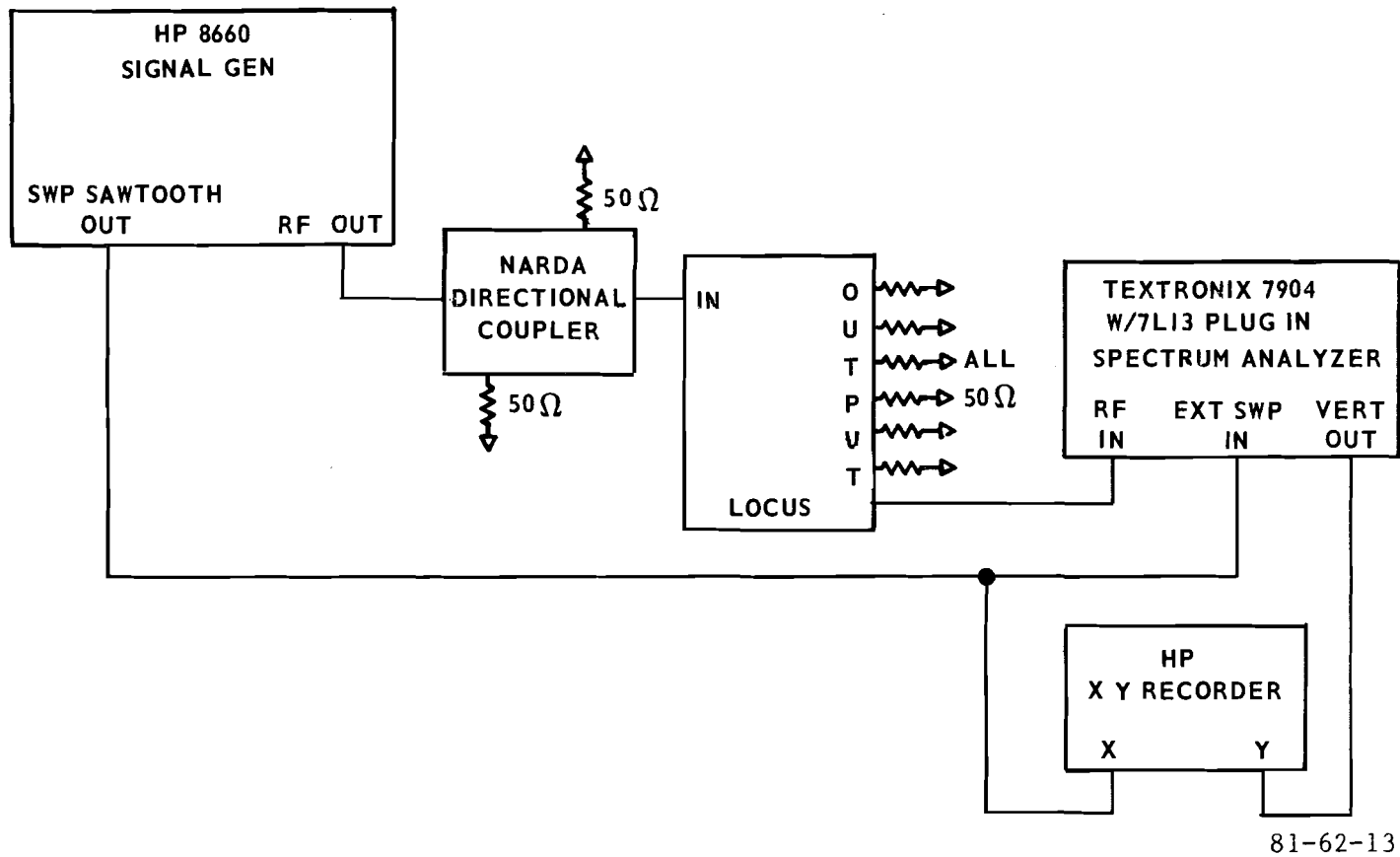

FIGURE 13. ACTIVE MULTICOUPLER GAIN AND BANDWIDTH TEST SETUP

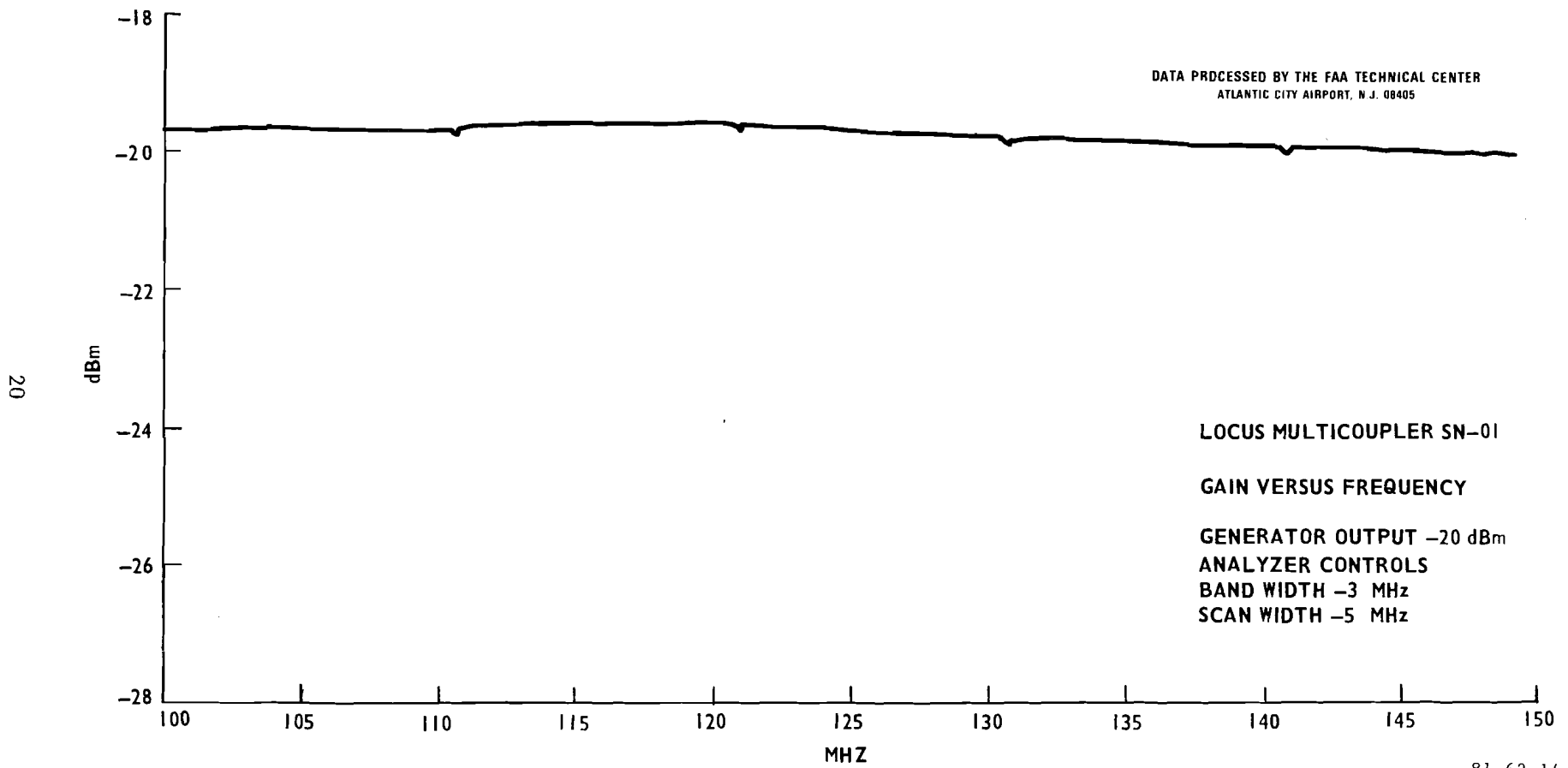

FIGURE 14. LOCUS MULTICOUPLER, GAIN VERSUS FREQUENCY

DATA PROCESSED BY THE FAA TECHNICAL CENTER  
ATLANTIC CITY AIRPORT, N.J. 08405

LOCUS MULTICOUPLER SN -01

OUTPUT ISOLATION IN dB

ANALYZER CONDITIONS  
BAND WIDTH = 3 MHz  
SCAN WIDTH = 5 MHz  
VERTICAL SENSITIVITY 10 dB/DIVISION  
GENERATOR OUTPUT 0 dBm

INJECTION PORT No. 1  
OBSERVATION PORT No. 8

A - ALL PORTS UNTERMINATED  
B - PORTS 2, 7, & 8  
RECEIVERS  
ALL OTHER PORTS 50 ohms  
C - SAME AS B EXCEPT  
PORT 5 INJECTION PORT  
PORT 6 OBSERVATION PORT

21

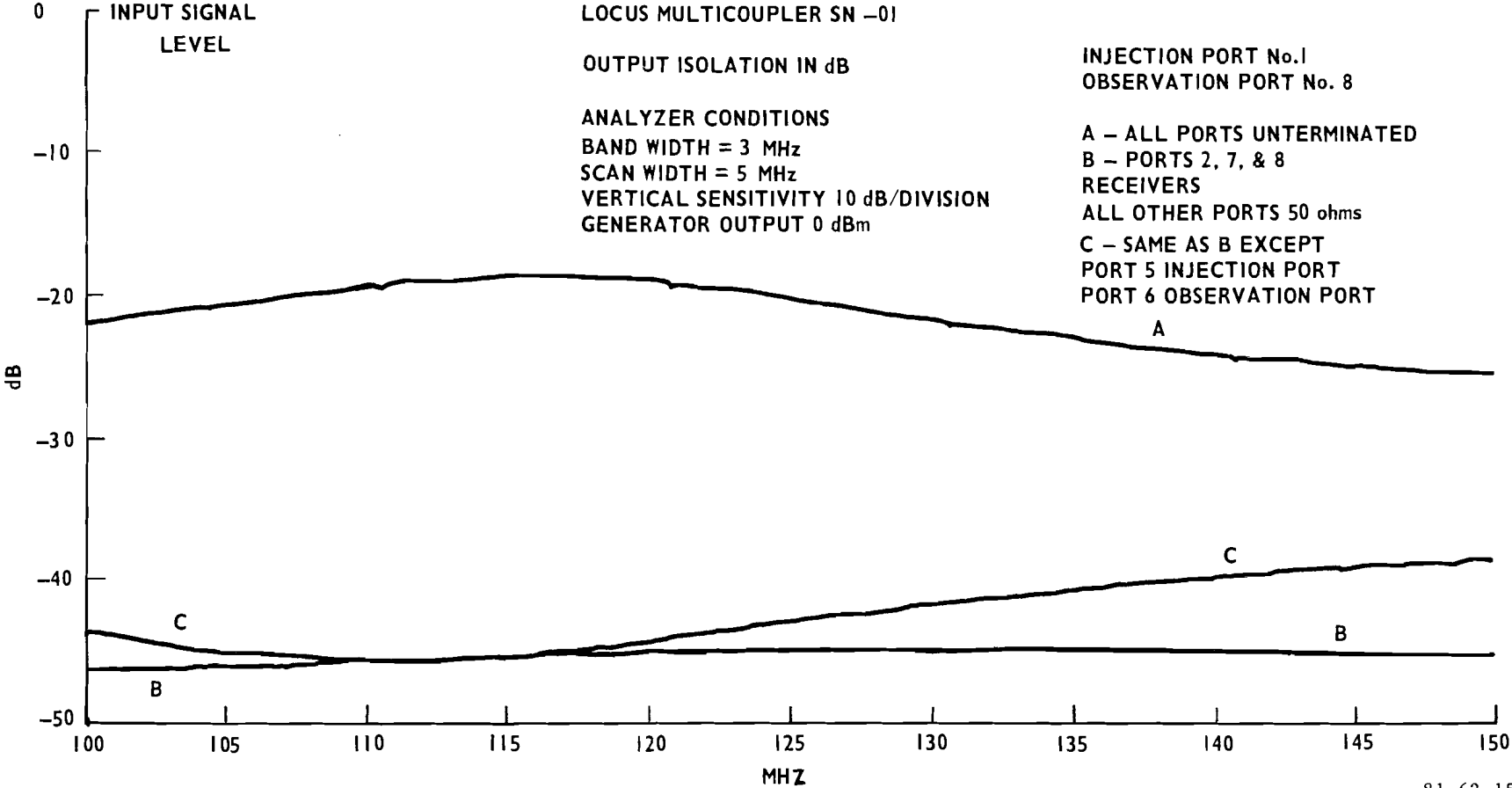

81-62-15

FIGURE 15. LOCUS MULTICOUPLER, OUTPUT ISOLATION

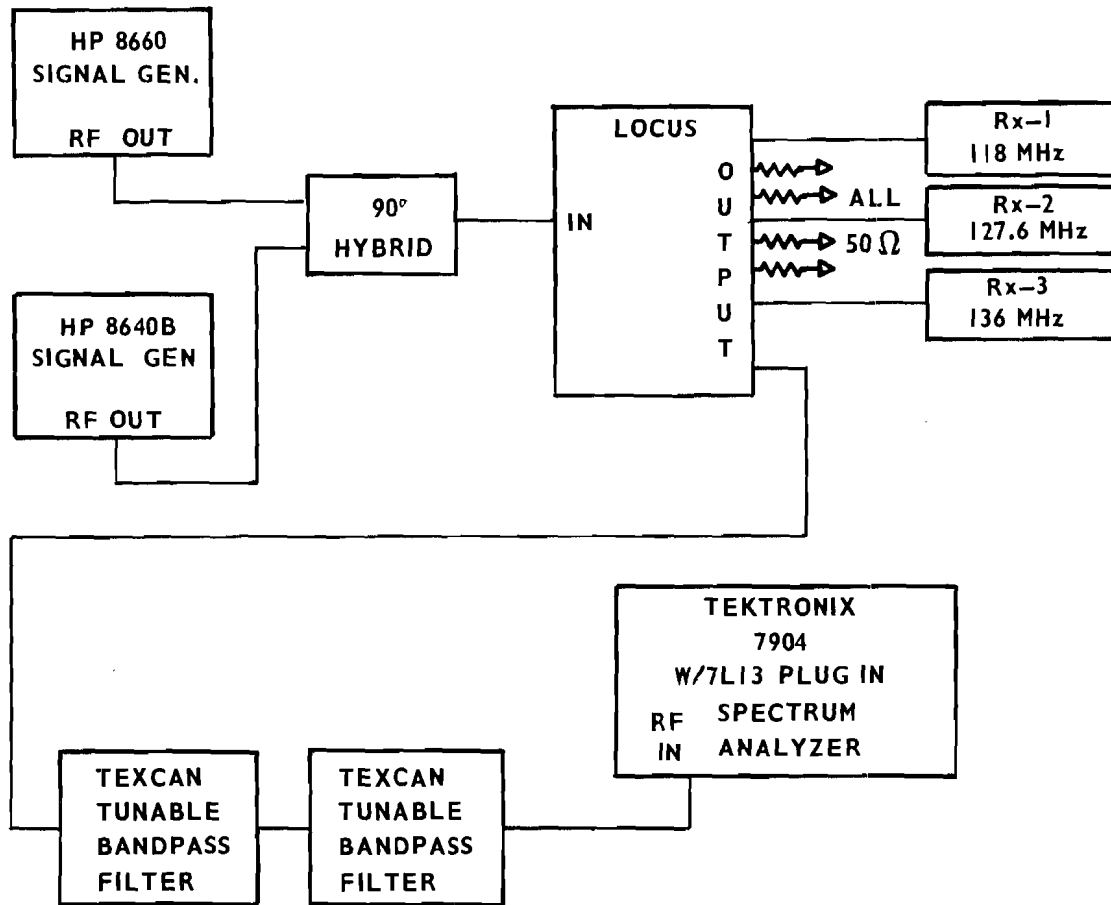

81-62-16

FIGURE 16. ACTIVE MULTICOUPLER INTERMODULATION DISTORTION TEST SETUP

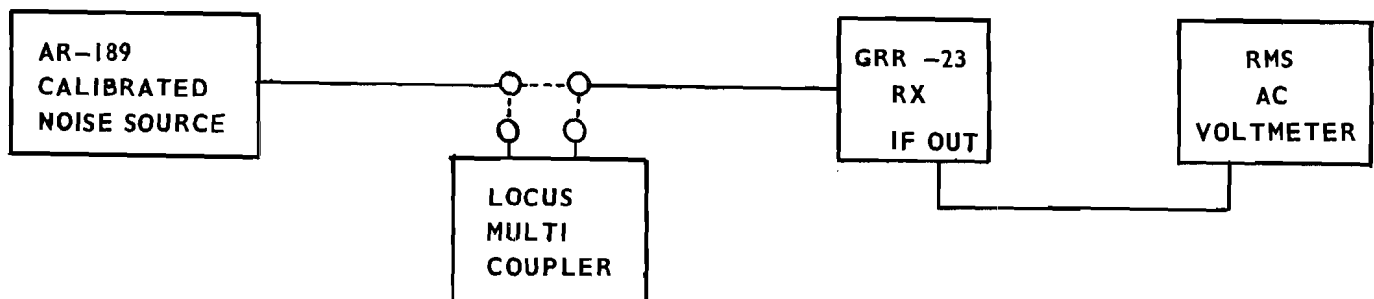

81-62-17

FIGURE 17. ACTIVE MULTICOUPLER NOISE FIGURE TEST SETUP

## APPENDIX

Calculation of load impedance from measured voltage standing wave ratio (VSWR) and known line impedance (when the phase angle is not known).

Symbols used:

$S = \text{VSWR}$

$V_R = \text{Voltage Reflection Coefficient}$

$V_F = \text{Forward Voltage}$

$V_R = \text{Reflected Voltage}$

$Z_L = \text{Load Impedance}$

$Z_0 = \text{Line Impedance}$

Basic relationships:

$$S = \frac{V_{\text{MAX}}}{V_{\text{MIN}}} = \frac{V_F + V_R}{V_F - V_R} \quad (\text{A-1})$$

$$\rho = \frac{V_R}{V_F} = \frac{Z_L - Z_0}{Z_L + Z_0} \quad (\text{A-2})$$

$$S = \frac{1 + \rho}{1 - \rho} \quad (\text{A-3})$$

$$\therefore S = \frac{1 + \left| \frac{Z_L - Z_0}{Z_L + Z_0} \right|}{1 - \left| \frac{Z_L - Z_0}{Z_L + Z_0} \right|} \quad (\text{A-4})$$

Note that two values of  $Z_L$  will provide a solution to this equation.

For  $Z_L > Z_0$ :

$$S = \frac{1 + \frac{Z_L - Z_0}{Z_L + Z_0}}{1 - \frac{Z_L - Z_0}{Z_L + Z_0}} \quad (\text{A-5})$$

$$S = \frac{Z_L}{Z_0} \quad (\text{A-6})$$

$$Z_L = S (Z_0) \quad (\text{A-7})$$

For  $Z_L < Z_0$ :

$$S = \frac{1 + \frac{Z_0 - Z_L}{Z_0 + Z_L}}{1 - \frac{Z_0 - Z_L}{Z_0 + Z_L}} \quad (\text{A-8})$$

$$S = \frac{Z_0}{Z_L} \quad (\text{A-9})$$

$$Z_L = \frac{1}{S} (Z_0) \quad (\text{A-10})$$

Thus two values of  $Z_L$  can give the same VSWR.

$$Z_L = S (Z_0) \text{ FOR } Z_L > Z_0 \quad (\text{A-11})$$

$$Z_L = \frac{1}{S} (Z_0) \text{ FOR } Z_L < Z_0 \quad (\text{A-12})$$