

**COPY 1,**  
**Report No. FAA-CT-81-50-1**

FAA WJH Technical Center  
00090947

**MLS PERFORMANCE ASSESSMENT  
TASK IV  
VOLUME 1: EVALUATION PROCEDURES AND  
EQUIPMENT DESIGN.**

**Robert W. Lilley  
Richard H. McFarland  
Walter D. Phipps**

**Avionics Engineering Center  
Department of Electrical Engineering  
Ohio University  
Athens, Ohio 45701**

**FEDERAL AVIATION ADMINISTRATION**

**SEP 18 1981**

**TECHNICAL CENTER LIBRARY  
ATLANTIC CITY, N.J. 08405**



**FINAL REPORT**

**DECEMBER 1980**

Document is available to the U.S. public through  
the National Technical Information Service,  
Springfield, Virginia 22161.

Prepared for →

**U. S. DEPARTMENT OF TRANSPORTATION  
FEDERAL AVIATION ADMINISTRATION  
TECHNICAL CENTER  
Atlantic City Airport, N.J. 08405**

## NOTICE

**This document is disseminated under the sponsorship of the Department of Transportation in the interest of information exchange. The United States Government assumes no liability for the contents or use thereof.**

1. Report No. <b>81-50-1</b> <del>FAA-CT-81-182, Vol. 1</del>	2. Government Accession No.	3. Recipient's Catalog No.	
4. Title and Subtitle <b>MLS PERFORMANCE ASSESSMENT Task IV</b> <b>VOLUME 1: EVALUATION PROCEDURES AND EQUIPMENT DESIGN</b>		5. Report Date <b>December 1980</b>	6. Performing Organization Code
7. Author(s) <b>Robert W. Lilley, Richard H. McFarland, Walter D. Phipps</b>		8. Performing Organization Report No. <b>EER 47-2</b>	
9. Performing Organization Name and Address <b>Avionics Engineering Center</b> <b>Department of Electrical Engineering</b> <b>Ohio University</b> <b>Athens, Ohio 45701</b>		10. Work Unit No.	11. Contract or Grant No. <b>DOT-FA79NA-6030</b>
12. Sponsoring Agency Name and Address <b>U.S. Department of Transportation</b> <b>Federal Aviation Administration</b> <b>Technical Center</b> <b>Atlantic City, New Jersey</b>		13. Type of Report and Period Covered <b>Final Report - Task IV</b>	
14. Sponsoring Agency Code			
15. Supplementary Notes			
16. Abstract  Preliminary flight-check procedures and system tolerances for the Microwave Landing System (MLS) are presented. A data-collection and recording package for use in light-aircraft measurement of MLS parameters in support of the System Test and Evaluation Program (STEP) is included containing a ground reference system, digital telemetry link airborne MLS sensor unit and system computation/display element.			
17. Key Words <b>Microwave Landing System, MLS, STEP Program, standards, tolerances, flight-check, position reference, light-aircraft, navaid flight check, digital telemetry, theodolite</b>		18. Distribution Statement <b>This document is available to the U.S. public through the National Technical Information Service, Springfield, Virginia 22161</b>	
19. Security Classif. (of this report) <b>Unclassified</b>	20. Security Classif. (of this page) <b>Unclassified</b>	21. No. of Pages <b>76</b>	22. Price

## TABLE OF CONTENTS

	<u>PAGE</u>
List of Figures	iii
List of Tables	iv
I. INTRODUCTION	1
II. FLIGHT EVALUATION PROCEDURES AND TOLERANCES	1
A. Engineering Flight-Check Methodology and Procedures	1
B. Preliminary Standards and Tolerances	2
1. Channel Specifications	2
2. Beam Patterns	4
3. Scan Frequency	4
4. RF Power and Coverage	4
5. Structure	9
6. Reference Datum	11
7. DME Accuracy	11
C. Minimization of Time and Costs for Flight Checks	11
III. MLS EVALUATION AND DATA-COLLECTION SYSTEM	13
A. General	13
B. Measurement System Outline	15
1. Operational Configurations	15
2. Size, Weight, and Power	15
3. Physical Construction; Appearance	15
C. Ground Reference Element	20
1. Measurement Technique	20
2. Ground Tracker Description	23
3. Tracker Placement Notes	29
4. Range Sensor and Data Link	29
5. Ground Telemetry Processor	33
D. Airborne Measurement Element	40
1. MLS Receiver and Antenna Installation	40
2. Airborne Telemetry Processor	40
E. System Data Processing and Control Element	49
IV. RECOMMENDATIONS FOR FUTURE WORK	52
V. ACKNOWLEDGEMENTS	53
VI. BIBLIOGRAPHY	53
VII. APPENDIX	65
A. Results of Review of Available Ground Reference Elements	65

## TABLE OF CONTENTS (CONTINUED)

	<u>PAGE</u>
B. Experimental Activity in Support of System and Procedures Design	65
1. Theodolite Motorized Tracking Tests	65
2. Acquisition Motor Drive Simulation	68
3. Preliminary Ranger Demonstration	71
C. Summary of Design Review Meetings	71
1. Briefing: August 11, 1980, FAA, Washington, D. C.	71
2. Briefing: November 25, 1980, FAA, Washington, D. C.	74

## LIST OF FIGURES

		<u>PAGE</u>
Figure 2-1.	Approach Azimuth Coverage.	7
Figure 2-2.	Approach Elevation Coverage.	8
Figure 3-1.	Beech Bonanza A-36.	14
Figure 3-2.	MLS Data-Collection System - Configuration 1.	16
Figure 3-3.	MLS Data-Collection System - Configuration 2.	17
Figure 3-4.	Physical Layout, Configuration 1.	21
Figure 3-5.	Physical Layout, Configuration 2.	22
Figure 3-6.	Ground Reference System Components Pictorial.	24
Figure 3-7.	Motor Drive Circuitry.	25
Figure 3-8.	Optical Shaft Encoder.	26
Figure 3-9.	Theodolite Modifications.	27
Figure 3-10.	Joystick Controller.	28
Figure 3-11.	Mini-Ranger System.	31
Figure 3-12.	Range Console Front Panel.	32
Figure 3-13.	Ground Telemetry Processor - Pictorial.	35
Figure 3-14.	Ground Telemetry Processor - Block Diagram.	36
Figure 3-15.	Cabling - Mini-Ranger.	38
Figure 3-16.	Cabling - Theodolite and Joystick to Ground Telemetry Processor.	39
Figure 3-17.	Airborne System Pictorial.	41
Figure 3-18.	Receiver Control Panel.	42
Figure 3-19.	Pilot Display.	43
Figure 3-20.	Planned Antenna Locations, BE-36 Aircraft.	45

## LIST OF FIGURES (CONTINUED)

		<u>PAGE</u>
Figure 3-21.	MLS System Interconnect Diagram.	46
Figure 3-22.	Airborne Telemetry Processor.	47
Figure 3-23.	Tektronix 4052.	50
Figure 7-1.	Theodolite Motor Drive Test Bed.	69
Figure 7-2.	Theodolite Drive Motor Mount with Shaft Coupling for Encoder or Potentiometer.	70
Figure 7-3.	Pattern B: Mini-Ranger Output.	72
Figure 7-4.	DC-3 Aircraft with Mini-Ranger Antenna Boom-Mounted Beneath Cabin.	73

## LIST OF TABLES

Table 2-1.	Flight Paths; Initial Evaluations.	3
Table 2-2.	Flight Paths; Periodic Evaluations.	3
Table 3-1.	Size and Weight of Units.	18
Table 3-2.	Power Consumption.	19
Table 3-3.	Expected Theodolite Tracking Rates.	30
Table 3-4.	Required Mating Connectors for MMR.	34
Table 3-5.	Mating Connectors for MLS Receivers (Bendix Corp.).	44
Table 6-1.	MLS Index, Numerical.	54
Table 6-2.	MLS Index, Word in Context.	55
Table 7-1.	Reference System Comparisons.	66

## I. INTRODUCTION

The Microwave Landing System (MLS) System Test and Evaluation Program (STEP) provides a means for development of system standards and tolerances, flight-check procedures and data collection and processing capabilities for cost-effective measurement. This report describes results of a design study relating to these standards, procedures and measurement techniques. The report is presented in two volumes; Volume 1 is the design study report, and Volume 2 gives results of a computer literature search, the goal of which is to make available abstracts of available MLS literature for reference during the design study and for future efforts.

Preliminary flight-check procedures and measurement tolerances are related to ICAO SARPS and FAA requirements, using past experience with ILS system measurement and maintenance and recent MLS measurement missions performed by FAA as guides. The goal is to minimize flight time while obtaining complete system examination, to maximize cost-effectiveness.

The design for an MLS data-collection and recording package, suitable for use in a light aircraft, is presented. This package permits on-site data processing and graphic output of MLS parameters, corrected for antenna and ground reference system locations. Either the theodolite reference system designed into the package may be used, or external telemetry data may be introduced for combination with airborne MLS observations.

Volume 1 contains a bibliography/index of literature currently available, plus summaries of design review meetings held during the task activity.

## II. FLIGHT EVALUATION PROCEDURES AND TOLERANCES

A. Engineering Flight-Check Methodology and Procedures. The absolute proofing of MLS air navigation signals must necessarily be done by probing the airspace. One logical question which must be answered is, "What is the time and space frequency with which the system must be evaluated to insure safety margins commensurate with, or better than contemporary navigation capability?" The discussion which follows will outline a program for development of procedures and tolerances, using as example system parameters the characteristics of the Basic Narrow MLS.

Clearly, signals at the infinity of points in the three-dimensional volume of interest to potential users cannot all be measured. This has been true in the past with ILS, VOR, and NDB, and will be even more true with MLS. Costs of fuel and flight time in particular strongly motivate conservation in exploring and measuring in the large volume where the MLS signals will be used.

A necessary condition for the signals to be correct in space is that the signals as measured at appropriate ground check points be correct. All discussions of flight-check measurements are predicated on ground measurements having given indications that the signals being generated and radiated are correct. This preparatory work is important to insure conservation of resources, particularly the relatively expensive flight-data collection time.

In principle, it must be determined that the MLS signal at the infinitum of points contained in a sector of space is providing the correct guidance information. The bounds for the coverage sector as defined in ER-700-08C for this STEP work will be considered to be 15 nm,  $\pm 40^\circ$  for the coverage extremes. This sector will be checked for the various quantities and parameters listed later in Paragraph B of this section.

As with most measurement processes involving the real world, compromise must be effected but only in such a way that the fundamental issues of safety and reliability are not subject to question. The assurance must be provided by the flight measurements that incorrect navigation information appearing at any point will always be detectable through measurement, and either a check made at that point to ascertain the true problem or an inferential measurement made to ascertain whether the prescribed tolerances are or are not exceeded.

The tables which follow outline one method of probing the sector volume of concern to the MLS operation. Flight profiles will be specified that allow, with a reasonable amount of flight time, a complete and statistically sound set of engineering data, from which the quality or correctness of the MLS signals for the whole space can be inferred. Technically sound inferential approaches are designed for maximum certainty with minimum flight time expended.

The basis for confidence that the recommended measurements will indeed provide sufficient information to determine that the system is performing safely is that in some measure they are derived from techniques used for years in engineering and operation flight checks on the ILS and STEP. Phase I data collection in part has found such measurements to produce conclusive and satisfactory information for evaluation.

B. Preliminary Standards and Tolerances. The reference which at this time is considered the foundation for establishing MLS standards and tolerances is ICAO AN-WP/5099, Section 3.11, which presents MLS characteristics. Of principal concern for the STEP work in particular are those items which follow. The experience gained in the STEP effort will probably be used to modify the numerical values to be more consistent, if possible, with safety and operational reality.

1. Channel Specifications. Noise generated by coherent radiation on the channel of interest shall not be greater than -95 dBm. The operating radio frequency of the radiated signal shall not vary more than plus or minus 10 kHz from the assigned frequency. The frequency stability shall be such that there is no more than a plus or minus 50 Hz deviation from the nominal frequency when measured over a one-second interval.

Further, the transmitted signal shall be such that, during the transmission time, the mean power density above a height of 600 meters (2000 feet) shall not exceed  $-100.5 \text{ dBW/m}^2$  for angle guidance and  $-95.5 \text{ dBW/m}^2$  for data, as measured in a 150 kHz bandwidth centered 840 kHz or more from the nominal frequency.

PATTERN	FLIGHT TRACK	ALTITUDE, ELEVATION, DIRECTION	RANGE
B	RADIALS 40° L 20° L 0° G 20° R 40° R	2000 AGL ↓	15 nm → 0 ↓
D	ORBIT ± 40°	5000', 6° CW 5000', 6° CCW 3000', 3° CW 3000', 3° CCW 2000', 2° CW 2000', 2° CCW 1000', 1° CW 1000', 1° CCW	-- -- -- -- -- -- -- --
A	APPROACH CENTERLINE	6° 3°	10 → 0

Table 2-1. Flight Paths; Initial Evaluations.

PATTERN	FLIGHT TRACK	ALTITUDE, ELEVATION, DIRECTION	RANGE
B	RADIALS 40 L 0 40 L	2000 AGL ↓	15nm → 0
D	ORBIT ± 40°	5000', 6° CCW 3000', 3° CCW 1000', 1° CCW	-- -- --
A	APPROACH CENTERLINE	3°	10 → 0

Table 2-2. Flight Paths; Periodic Evaluations.

2. Beam Patterns. The -10 dB points on the beam envelope shall be displaced from the beam center by at least 0.7 beamwidth, but not more than 0.9° beamwidth.

3. Scan Frequency. Each function transmitted shall be repeated at an average rate as follows:

FUNCTION	AVERAGE FUNCTION RATE (HZ)
APPROACH AZIMUTH GUIDANCE	13.0
HIGH RATE APPROACH AZIMUTH GUIDANCE	39.0
BACK AZIMUTH GUIDANCE	6.5
APPROACH ELEVATION GUIDANCE	39.0
FLARE ELEVATION GUIDANCE	39.0

The timing accuracy of each listed event including jitter shall be the specified nominal value plus or minus 2 microseconds. The timing jitter shall be less than 1 microsecond RMS.

4. RF Power and Coverage.

a. General. Coverage is met where the power density of any of the radiated signals has any value between the minimum specified in the table below. The power density for DPSK, clearance and angle guidance signals shall be at least the following values under all operational weather conditions at any point within coverage.

Function	DPSK Signals dBW/m <sup>2</sup>	Angle Signals (dBW/m <sup>2</sup> )			Clearance Signals (dBW/m <sup>2</sup> )
		1°	2°	3°	
Approach Azimuth Guidance	-89.5	-88.0	-85.5	-82.0	-88.0
High Rate Approach Azimuth Guidance	-89.5	-88.0	-88.0	-86.8	-88.0
Back Azimuth Guidance	-81.0	-79.5	-77.0	-73.5	-88.0
Approach Elevation Guidance	-89.5	-88.0	-88.0	N/A	N/A

The power density of the approach azimuth angle guidance signals shall be greater than that specified by at least:

- (1) 15 dB at the approach reference datum;
- (2) 5 dB at 2.5 meters (8 feet) above the runway surface, at the MLS datum point, or at the farthest point of the runway centerline which is in line of sight of the azimuth antenna.

b. Azimuth. The approach azimuth ground equipment shall provide guidance information in at least the following volumes of space:

(1) Horizontally within a sector plus or minus 40 degrees about the runway centerline originating at the MLS datum point and extending in the direction of the approach to 20 nautical miles from the runway threshold.

(2) Vertically between:

(a) A conical surface originating 2.5 meters (8 feet) above the runway centerline at threshold inclined at 0.9 degree above the horizontal, and

(b) A conical surface originating at the azimuth ground equipment antenna inclined at 15 degrees above the horizontal to a height of 6000 meters (20,000 feet).

Where intervening obstacles penetrate the 0.9 degree surface, it is intended that guidance need not be provided at less than line-of-sight heights.

(3) Horizontally within a sector 45 meters (150 feet) each side of the runway centerline beginning at the stop end and extending parallel with the runway centerline in the direction of the approach to join the approach region.

(4) Vertically between:

(a) A horizontal surface which is 2.5 meters (8 feet) above the farthest point of the runway centerline which is in line of sight of the azimuth antenna; and

(b) A conical surface originating at the azimuth ground equipment antenna inclined at 20 degrees above the horizontal up to a height of 600 meters (2000 feet).

The lower level of the coverage in the runway region is 2.5 meters (8 feet) above the runway centerline.

The approach azimuth ground equipment shall provide guidance information vertically to 30 degrees above the horizontal.

The minimum proportional guidance sector shall be plus or minus 10 degrees about the runway centerline. Where the proportional guidance sector provided is less than the minimum lateral coverage,  $\pm 40^\circ$  for 20 nm, clearance guidance shall be provided to maintain the overall coverage sector. (See Figure 2-1)

c. Elevation. The approach elevation ground equipment shall provide proportional guidance information in at least the following volume of space:

(1) Laterally with a sector originating at the MLS datum point which is at least equal to the proportional guidance sector provided by the approach azimuth ground equipment.

(2) Longitudinally from 75 meters (250 feet) from the MLS datum point in the direction of the approach to 20 nautical miles from threshold.

(3) Vertically within the sector bounded by:

(a) A surface which is the locus of points 2.5 meters (8 feet) above the runway;

(b) A conical surface originating at the MLS datum point and inclined 0.9 degree above the horizontal; and

(c) A conical surface originating at the MLS datum point and inclined 7.5 degrees above the horizontal up to a height of 6000 meters (20,000 feet).

When the physical characteristics of the approach region prevent the achievement of the standards under (1), (2), and (3b) above, it is intended that guidance need not be provided below a conical surface originating at the elevation antenna and inclined 0.9 degree above the line of sight.

The approach elevation ground equipment should provide guidance to angles greater than 7.5 degrees above the horizontal when necessary to meet operating requirements.

The flare elevation ground equipment shall provide proportional guidance information in at least the following volume of space:

(1) Horizontally over the runway surface and within a sector of plus and minus 10 degrees about the runway centerline originating at a point on the runway 760 meters (2500 feet) from threshold and extending to 5 nautical miles from threshold in the direction of the approach. (See Figure 2-2)

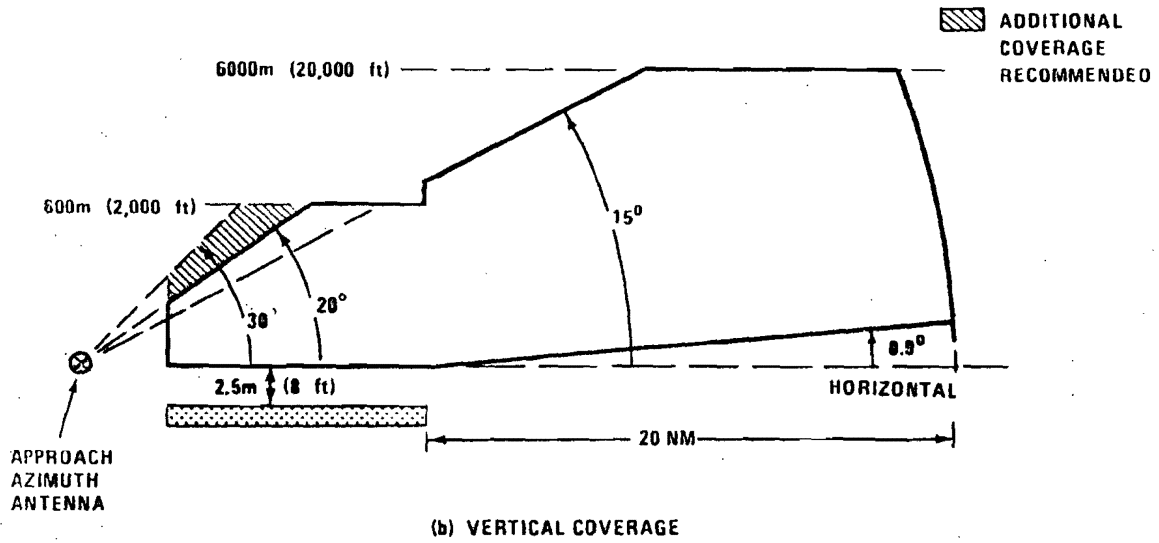
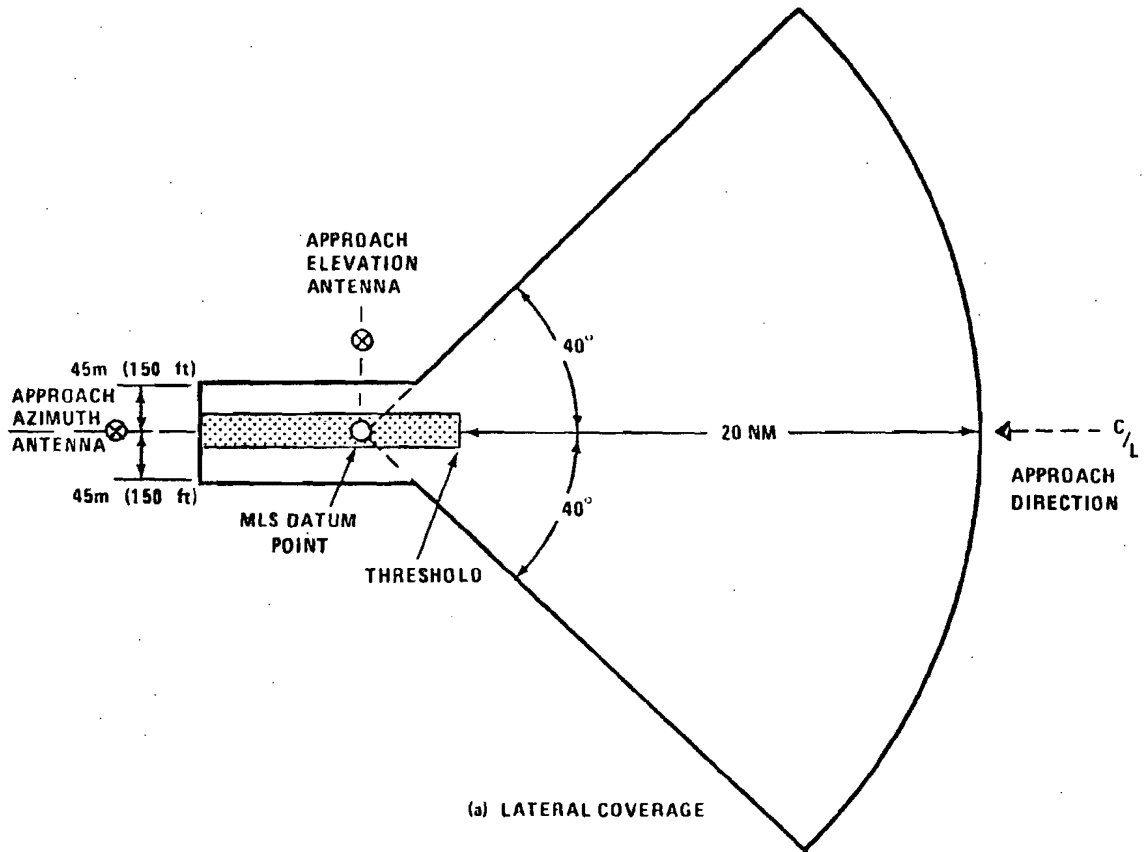

Figure 2-1. Approach Azimuth Coverage.

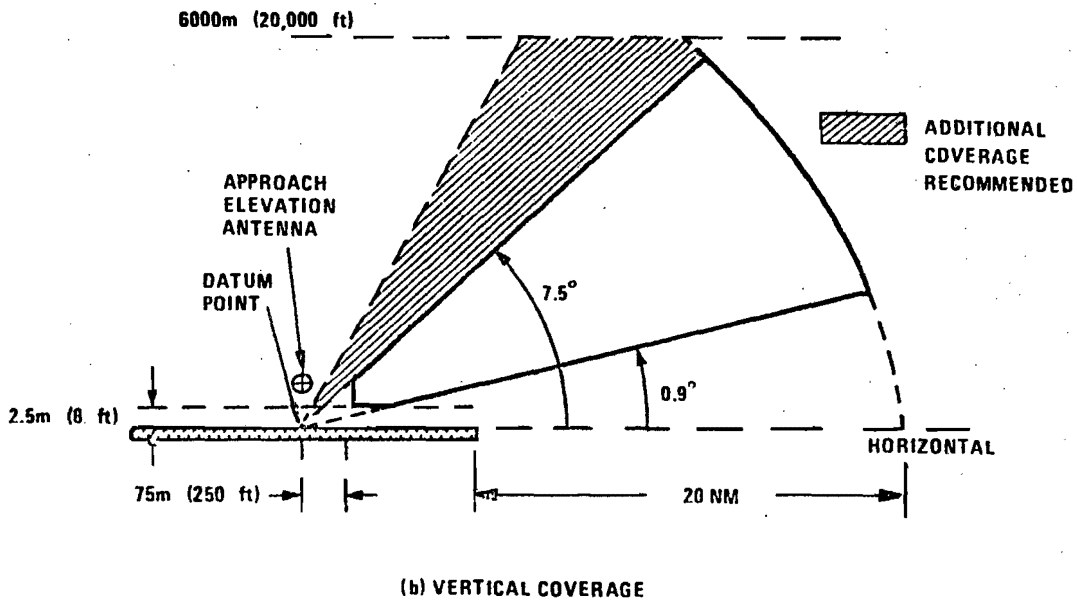
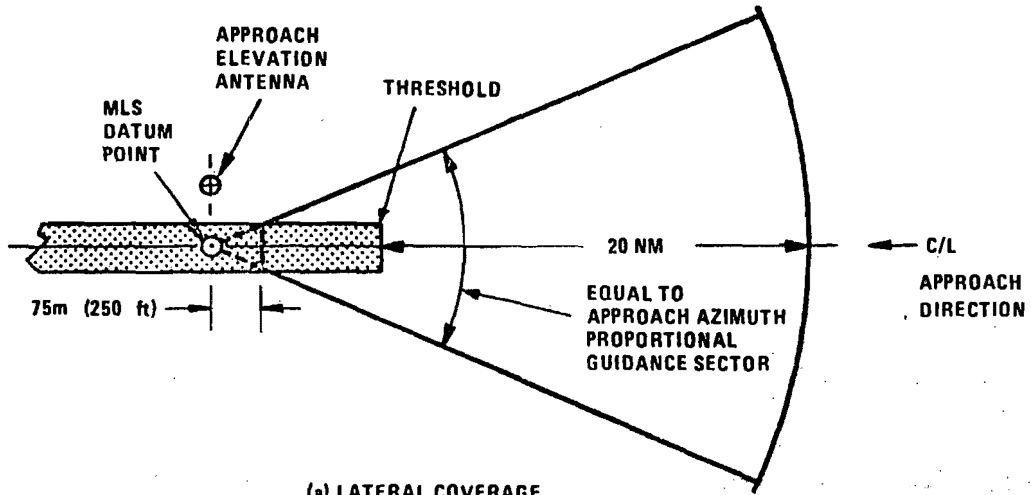

Figure 2-2. Approach Elevation Coverage.

5. Structure.

a. Azimuth. At the approach reference datum, the approach azimuth function shall provide performance as follows:

- (1) The PFE shall not be greater than plus or minus 6 meters (20 feet).
- (2) The PFN shall not be greater than plus or minus 3.5 meters (11.5 feet).
- (3) The CMN shall not be greater than plus or minus 3.2 meters (10.5 feet) or 0.1 degree, whichever is less.

At the approach reference datum, the PFE shall not be greater than plus or minus 4 meters (13.5 feet).

The approach azimuth angular PFE, PFN and CMN shall be allowed to degrade linearly to the limits of coverage as follows:

(1) With distance - The PFE limit and PFN limit, expressed in angular terms at 20 nautical miles from the runway threshold along the extended runway centerline is 2 times the value specified at the approach reference datum. The CMN limit, expressed in angular terms at 10 nautical miles from the reference datum along the extended runway centerline is 1.3 times the value specified at the approach reference datum.

(2) With azimuth angle - The PFE limit and PFN limit, expressed in angular terms at plus or minus 40 degrees azimuth angle is 1.5 times the value on the extended runway centerline at the same distance from the approach reference datum. The CMN limit, expressed in angular terms at plus or minus 40 degrees azimuth angle is 1.3 times the value on the extended runway centerline at the same distance from the approach reference datum.

(3) With elevation angle - The PFE limit and PFN limit shall not degrade up to an elevation angle of 9 degrees. The PFE limit and PFN limit expressed in angular terms at an elevation angle of 15 degrees from the approach azimuth antenna phase center is 2 times the value permitted below 9 degrees at the same distance from the approach reference datum and the same azimuth angle. The CMN limit shall not degrade with elevation angle.

b. Elevation. At the approach reference datum the approach elevation function shall provide performance as follows:

- (1) The PFE shall not be greater than plus or minus 0.6 meters (2 feet).
- (2) The PFN shall not be greater than plus or minus 0.4 meters (1.3 feet).
- (3) The CMN shall not be greater than plus or minus 0.3 meters (1 foot).

The approach elevation angular PFE, PFN and CMN shall be allowed to degrade linearly to the limits of coverage as follows:

- (1) With distance - The PFE limit and PFN limit, expressed in angular terms at 20 nautical miles from the runway threshold on the minimum glide path is 0.2 degree. The CMN limit, expressed in angular terms at 10 nautical miles from the reference datum on the minimum glide path is 1.3 times the value specified at the approach reference datum.
- (2) With azimuth angle - The PFE limit and PFN limit expressed in angular terms at plus or minus 40 degrees azimuth angle is 1.3 times the value on the extended runway centerline at the same distance from the approach reference datum. The CMN limit, expressed in angular terms at plus or minus 40 degrees azimuth angle is 1.3 times the value on the extended runway centerline at the same distance from the approach reference datum.
- (3) With elevation angle - For elevation angles above the minimum glide path or 3 degrees, whichever is less and up to the maximum of the proportional guidance coverage and at the locus of points directly above the approach reference datum the PFE limit, PFN limit and the CMN limit expressed in angular terms shall be allowed to degrade linearly such that at an elevation angle of 15 degrees the limit is 2 times the value specified at the reference datum. In no case shall the CMN directly above the reference datum exceed plus or minus 0.07 degree. For other regions of coverage within the angular sector from an elevation angle equivalent to the minimum glide path up to the maximum angle of proportional coverage the degradations with distance and azimuth angle specified in (1) and (2) shall apply.
- (4) For elevation angles below 60 percent of the minimum glide path and down to the limit of coverage is a conical surface originating at the MLS datum point and inclined 0.9 degree above the horizontal, and at the locus of points directly below the approach reference datum the PFE limit, the PFN limit and the CMN limit expressed in angular terms, shall be allowed to increase linearly to 6 times the value at the approach reference datum. For other regions of coverage within the angular sector from an elevation angle equivalent to 60 percent of the minimum glide path angle value, and down to the limit of coverage, the degradation with distance and azimuth angle specified in (1) and (2) shall apply. In no case shall the PFE be allowed to exceed 0.8 degree, or the CMN be allowed to exceed 0.4 degree.

The limit expressed in angular terms on the linear degradation of the PFE limit, the PFN limit and the CMN limit at angles below 60 percent of the minimum glide path and down to the limit of coverage is to be 3 times the value permitted at the approach reference datum. For other regions of coverage within the angular sector from an elevation angle equivalent to the minimum glide path and down to the limit of coverage, the degradation with distance and azimuth angle specified in (1) and (2) shall apply. The PFE should not exceed 0.35 degree, and the CMN should not exceed 0.2 degree.

6. Reference Datum. The MLS approach reference datum. The height shall be 15 meters (50 feet). A tolerance of plus 3 meters (10 feet) shall be permitted.

When ILS and MLS simultaneously serve the same runway, the ILS and minimum MLS glide paths should be coincident over the threshold within a tolerance of one meter (3 feet).

7. DME Accuracy. The DME portion of the MLS shall provide longitudinal/positional accuracies (2 sigma probability) of 600 feet in the normal mode. Accuracy of the precision mode shall be (2 sigma) of 100 feet.

The DME/M equipment should, whenever possible, provide indicated zero range to the pilot at the touchdown point in order to satisfy current operational requirements.

One major item for consideration when developing standards and tolerances is the regard for the wide range of performance characteristics of the various aircraft that can be logically expected to use the MLS. Control motion noise for one aircraft may be path following noise for another. Standards must be set to protect all users. At this early development stage of the MLS, and in spite of a long history of ILS, there has been little technical work done on establishing bounds on the allowable numerical values for safe operation of a facility. Because of this fact alone, values which are recommended in this report must be considered tentative. As a result of STEP experience, it is reasonable to expect refinement to be made. Results of a recommended later study would complement the STEP findings and allow technically defensible numerical values to be established.

C. Minimization of Time and Costs for Flight Checks. Although the service volume for the MLS is larger than for ILS, there will be good technical justification for reducing the flight-check time requirements for the periodic checks. One justification is that the boundary between the near and far fields is close enough to the physical antenna that far-field measurements can be made by means of ground checks. Ground checking outside of the accepted range of the criterion  $2D^2/\lambda$  provides for far-field measurements and evaluation with only modest equipment requirements. Another justification is that factors affecting performance in the far field and not detectable with ground checks should be identifiable visually.

If one wishes to think of the classical textbook closed surface surrounding the radiating source, then, assuming a far-field requirement, a great area of this surface can be examined using ground probes. Accordingly, the only sources of derogation must be beyond the probes in the environment. This forces scrutiny of the environment for surfaces which would reflect the microwave energy. Fortunately, good scrutiny does not involve use of an aircraft and can be accomplished in several ways, ways which can be used to cross-check each other in certain instances.

Once engineering, commissioning and perhaps early periodic checks have been successfully completed, it is conceivable that flight checks can be reduced to a standard intercept and normal approach-to-landing profile. The standard intercept will allow a look at the critical below-path structure, and the approach will confirm path structure which had been observed previously. Changes from earlier documentation would be justification for an increased number of flight patterns.

Documentation of previous data on approach-zone and environmental scrutiny become two very critical items of the flight check. One will note that these are not items of great contemporary concern in the flight-check operation. Performance assurance for the MLS should include these. Modern digital data storage, transmission, and processing make this realistic, and requirements for documenting system performance for maintenance and accident investigation make it almost essential.

The flight-check operation should routinely store the digital flight record and allow call-up for review and automatic quantitative comparison. A readout should be provided that allows the flight inspector to make a judgment as to whether additional flight measurements are necessary. In most cases it would be expected that more would not be necessary. This assumes, of course, that the maintenance, monitoring and ground checks have produced evidence that the system is within tolerance limits.

With the possible advent of flight-check data being processed principally on the ground, the historical data for comparison can be made available on a telephone line or through cassette storage. This type of operation is well within the current state of the art.

Environmental surveillance procedures need to be formalized and made more specific and rigorous. At present, should a large hangar begin to appear on the airdrome, most ILS workers would raise questions, but there is no procedure for determining whether it will be accommodated electromagnetically. The following are suggestions for formalizing the process.

Each airport would have a survey accomplished, or a previous survey confirmed as being current, and this information would be stored in computer memory. Any changes to the buildings, structures, or topography should be identified through any or several of the following means:

1. Visual observation.
2. Engineering drawings that would be circulated formally from airport commissions and involved architects.
3. Periodic photographic acquisitions of the airport panorama.

These then would be entered into the mathematical model used to predict multipath effects for MLS. Should the model predict effects, then flight measurements must be committed to identify the actual in-flight signal conditions.

The rigor of a good surveillance scheme will serve to give protection from physical features derogating signal quality. The key will be to make full use of modern data storage and retrieval capabilities. One can conceive that after data acquisition and input, the remaining activities could be automated. Human qualities do not lend themselves well to surveillance activities and this may be a good reason as to why this approach has not been used in the past. With contemporary and future data processing capability, the problem of performing surveillance for significant physical world disturbances become basically an implementation matter.

### III. MLS EVALUATION AND DATA-COLLECTION SYSTEM

A. General. The MLS evaluation and data-collection system consists of four major elements; (1) the ground tracker, (2) the telemetry link, (3) the MLS sensor element and (4) system control and data processing. These four elements may be interconnected in a variety of configurations for support of specific MLS measurement missions. The system is all-digital in design, and has been configured for transport and use with a light aircraft of the Beech Bonanza A-36 variety, shown in Figure 3-1. This aircraft provides low-cost flight evaluation at normal approach speeds.

The evaluation and data-collection system is designed to exhibit flexibility both at the operational level and in future growth or alteration. The telemetry link is served at both ends by microprocessor-based control units, which permit software data formatting, operation of a variety of standard peripheral devices, and alteration of measurement sequence or selection of inputs.

In general, system elements are interconnected using standard interface specifications. EIA RS-232 is used wherever possible, permitting convenient testing or monitoring of data flow using standard computer terminal and display devices. The IEEE-488 bus is used for the primary data connection to the system computer. This bus provides high-speed data transfer with live interrupt capability, and interfaces with many off-the-shelf computer devices. One non-standard serial interface is provided, for use with the FAA laser tracker unit, converting bi-phase serial data to parallel TTL logic levels for system use.

The emphasis on software control throughout the evaluation and data-collection system, and the provision of standard data communications interfaces permits future growth or mission-dependent measurements to be made with a minimum of cost and effort. System physical design emphasizes the light-aircraft installation which is planned; exchange of one power inverter will permit operation in other aircraft which use the 28 VDC power standard. Of course, appropriate antenna installations must be provided for MLS angle and DME, communications and the ranging element. Major system components, selected during this study, are: The Motorola Mini-Ranger III (TM), to provide slant range to the aircraft to  $\pm 6$  feet plus an integral digital data link; the Warren Knight WK-83 theodolite, modified for motor drive and digital shaft outputs, with resolution to  $0.01^\circ$  and expected operational accuracy of  $0.03$ - $0.04^\circ$  in azimuth and elevation. Modifications to the theodolite do not degrade manufacturers' stated accuracy of 20 seconds of arc in azimuth and 40 seconds of arc in elevation. The Tektronix (TM) 4052 computer combines processor, mass storage and graphics display in one unit.



Figure 3-1. Beech Bonanza A-36.

## B. Measurement System Outline.

1. Operational Configurations. There are two possible operational configurations available. The computer, with its attendant data tape storage and hard-copy unit, may be placed either in the aircraft (Configuration 1) or on the ground (Configuration 2). The accuracy and integrity of the data are identical in either case. The choice of configuration can be based upon the mission requirements, the convenience of the operator and the location of any additional observers. A block diagram of Configuration 1 is shown in Figure 3-2. The computer communicates with the Airborne Telemetry Processor (ATP) to obtain MLS, and ground reference data, and to control the pilot display.

Configuration 2 is shown in Figure 3-3. In this case, the computer is connected to the Ground Telemetry Processor (GTP). The tape unit and the hard-copy unit follow the computer to either location, but all other equipment is unchanged in location and function. Only software changes need be made to alter the configuration, and these are entered during set-up from the computer's cartridge tape unit. Data lines are standard throughout the system.

2. Size, Weight, and Power. Table 3-1 lists approximate size and weight for the individual units that will comprise the MLS data system. Total volume is approximately 23 cubic feet and total weight will be approximately 465 pounds.

Power requirements are given in Table 3-2. When using light aircraft, it will be necessary to utilize load management techniques to hold power consumption within acceptable limits. A total of approximately 50 amp at 14 v may be used aboard typical aircraft.

3. Physical Construction; Appearance. The physical construction of the MLS data system will be patterned after the Ohio University Minilab, used successfully for the ILS measurements over the past  $3\frac{1}{2}$  years in support of FAA research and engineering. This unit has met all its design goals and, after several hundred hours of ILS data collection, has proven to be rugged and reliable. Fabrication techniques employed by Ohio University stress the following areas:

a. Modularity - This applies both on a large and small scale. On the small scale, individual power supplies are in modular form. This decreases the number of spare parts required. On a large scale, individual units of the data system are self-contained. The tape unit will contain the tape transport, the formatting circuitry, and the power supplies, for example.

b. Ease of Maintenance - All mechanical layout is done with emphasis on the ability to repair items quickly and easily. All circuitry will be accessible by hinged doors, removable tops, and slide-out chassis as applicable.

c. Ease of Installation - All units employed in the airborne package will be attached to platforms which will slide onto existing seat rails. Connectors, cables, and mounting mechanisms will be accessible without removing equipment.

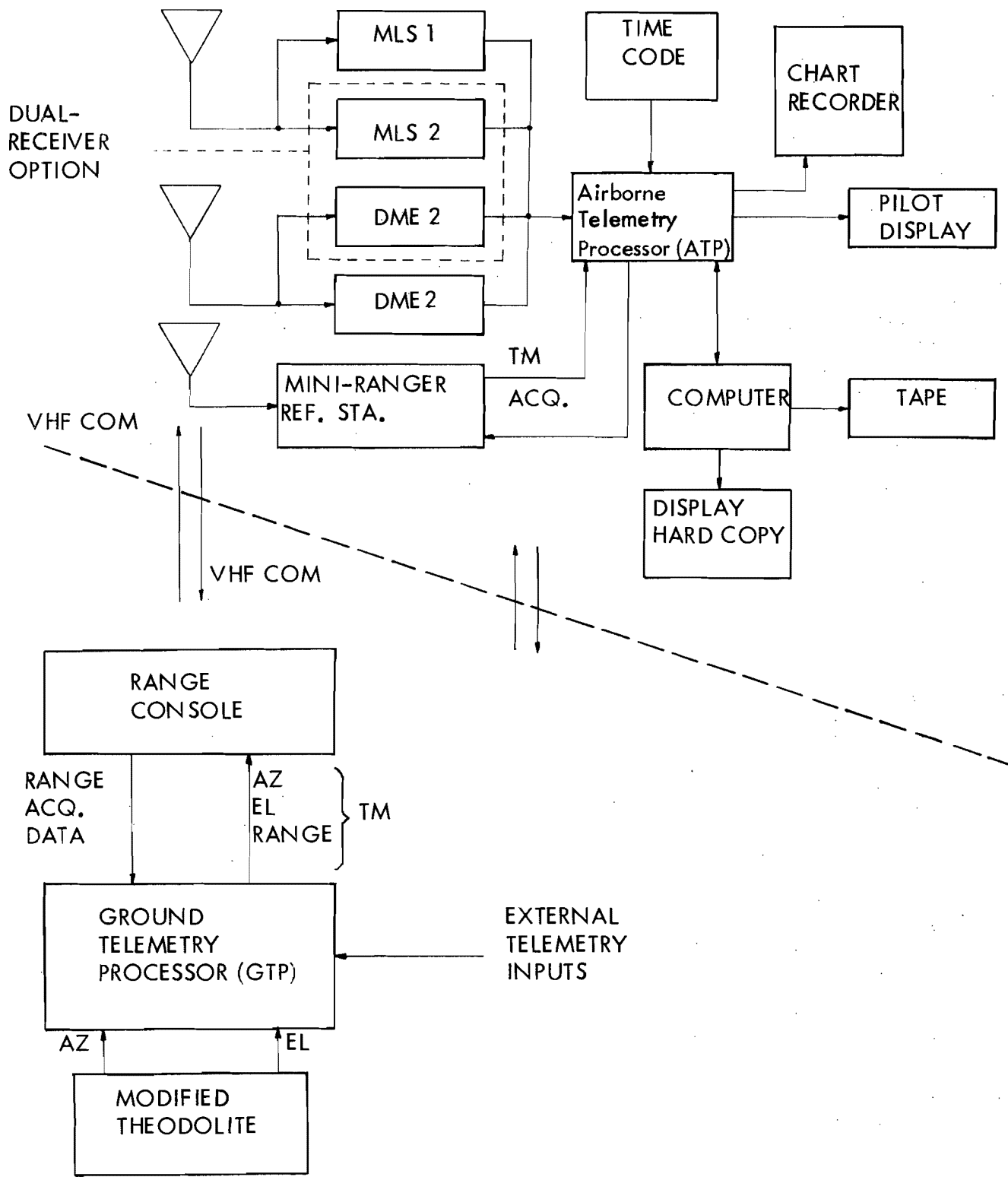

Figure 3-2. MLS Data-Collection System - Configuration 1.

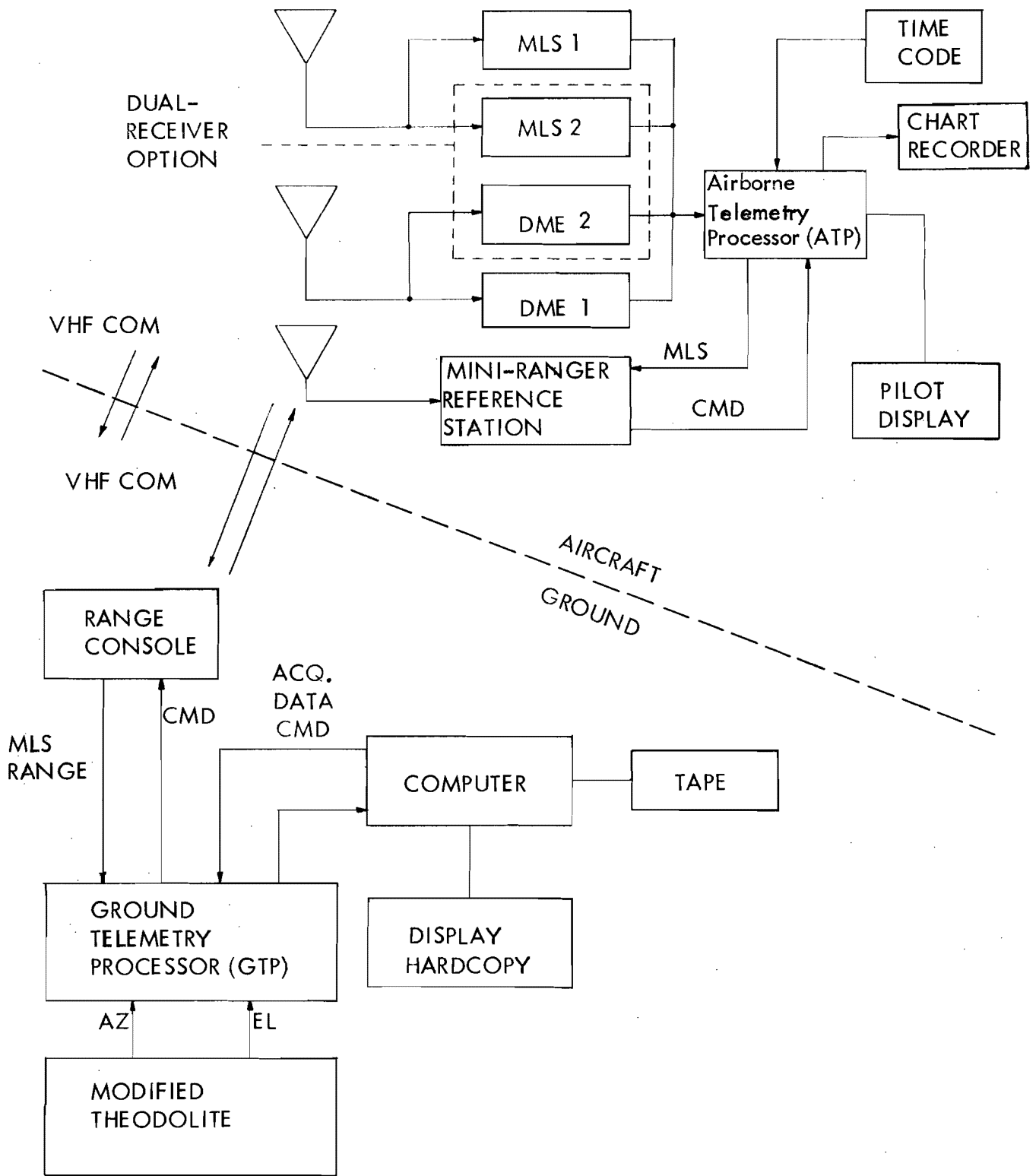

Figure 3-3. MLS Data-Collection System - Configuration 2.

	Size	Weight
Tektronix 4052 Minicomputer	14" high x 19" wide x 33" deep	68 lb.
Tektronix 4611 Hard Copy	12" high x 16" wide x 26" deep	45 lb.
Power Inverter 115V, Sinewave	7" high x 19" wide x 13" deep	95 lb.
Airborne Telemetry Processor	9" high x 20" wide x 18" deep	25 lb.
Ground Telemetry Processor	9" high x 20" wide x 18" deep	25 lb.
3M-HCD75 Tape Unit	8" high x 20" wide x 18" deep	30 lb.
Motorola Mini-Ranger Range Console	6" high x 17" wide x 18" deep	32 lb.
Mini-Ranger Transmitter/Receiver (2)	12" high x 8" wide x 6" deep	10 lb.
Warren-Knight-83 Theodolite and Case	22" high x 19" wide x 15" deep	48 lb.
MLS/DME Receiver Pallet	24" high x 6" wide x 16" deep	35 lb.
Control Head Pallet	12" high x 6" wide x 16" deep	6 lb.
Power Inverter 115V, 400 Hz	4" high x 6" wide x 6" deep	9 lb.
Pilots Display	2" high x 8" wide x 6" deep	3 lb.
Pallets and Mounting Framework	-----	20 lb.
Linseis Penless Recorder	5" high x 18" wide x 18" deep	40 lb.

Table 3-1. Size and Weight of Units.

	115 V 60 Hz	Converted 14 V. D.C. Aircraft Load (See Note 1)
Tektronix 4052 Computer	300 W	400 W
Tektronix 4611 Hard Copy	350 W	465 W
Linseis Penless Recorder	85 W	113 W
Airborne Telemetry Processor (ATP)	100 W	133 W
ATP VHF Communications (Transmit)	80 W	60 W
Ground Telemetry Processor	100 W	(X)
Bendix Angle Receiver	(X)	60 W (Note 2)
3M-HCD75 Tape Recorder	88 W	117 W
Cooling Fans	(X)	24 W
Bendix DME Receiver	(X)	120 W (Note 2)
Miniranger Remote Unit	13 W	18 W

(1) These figures allow for a typical efficiency of 75% in the 60 Hz and 400 Hz inverters and the +5V, +12V, and -12V switching regulators.

(2) Requires 115V, 400 Hz at 55 VA. 10 VA additional used for cooling fan on the angle receiver.

(X) Not applicable.

Table 3-2. Power Consumption.

The ATP, GTP, and the 3M-HCD75 data cartridge will be built into standard 19" equipment cabinets such as the Zero Manufacturing Company VIP-170816 or similar. The MLS Receiver, DME Receiver, and associated control heads will be mounted in open frame cabinets, while the computer, hard-copy unit and power inverters will retain their commercial packaging.

The physical layout of the various packages for Configuration 1 is shown in Figure 3-4. This conceptual drawing demonstrates the approximate layout when installed in a Beechcraft A-36. In this configuration, the ground package will consist of the theodolite, Motorola Mini-Ranger, and the GTP.

Figure 3-5 shows the ground package layout in Configuration 2. In this case, the airborne package will consist of the ATP, the MLS/DME receiver complex, the Mini-Ranger remote unit, and an optional chart recorder for immediate recording of raw analog CDI and flag events for the pilot. The large, 115 VAC sine-wave inverter used in the aircraft for Configuration 1 is no longer required, and the copilot seat may be retained for use by an observer or safety pilot. A smaller, square-wave inverter may now be used, to drive the Airborne Telemetry Processor and the analog chart recorder.

### C. Ground Reference Element.

1. Measurement Technique. After consideration of a variety of position-measuring methods and devices (See Appendix, Section A), it was decided to investigate further the modification of a standard optical theodolite for digital angle outputs, and to add a radio-ranging subsystem to complete the position measurement. Additionally, consideration of motor-driven theodolite axes, with a joystick controller for operator convenience, was begun. Subsequent tests (Appendix, Section B.1) produced encouraging results using the motor drive. Laboratory experimentation was begun to determine parameters of computer control for aircraft acquisition (Appendix B.2).

The Motorola Mini-Ranger III (TM) device was obtained for demonstration (Appendix, Section B.3) and was found to operate much as expected. Project team members were impressed with the degree to which the manufacturer supports the Mini-Ranger product in the field.

Based upon the availability of suitable ranging equipment and the acceptable accuracy and range obtainable from the manually-operated optical theodolite, plus the desirable portability of this ground tracker system, the theodolite/ranger method has been chosen as the preferred method.

In operation, the ground tracker will generate a complete position message for transmission to the MLS measurement system computer, to be combined with observed MLS data received at the flight-evaluation aircraft. Azimuth and elevation angles, plus range, will be available every 15 msec.

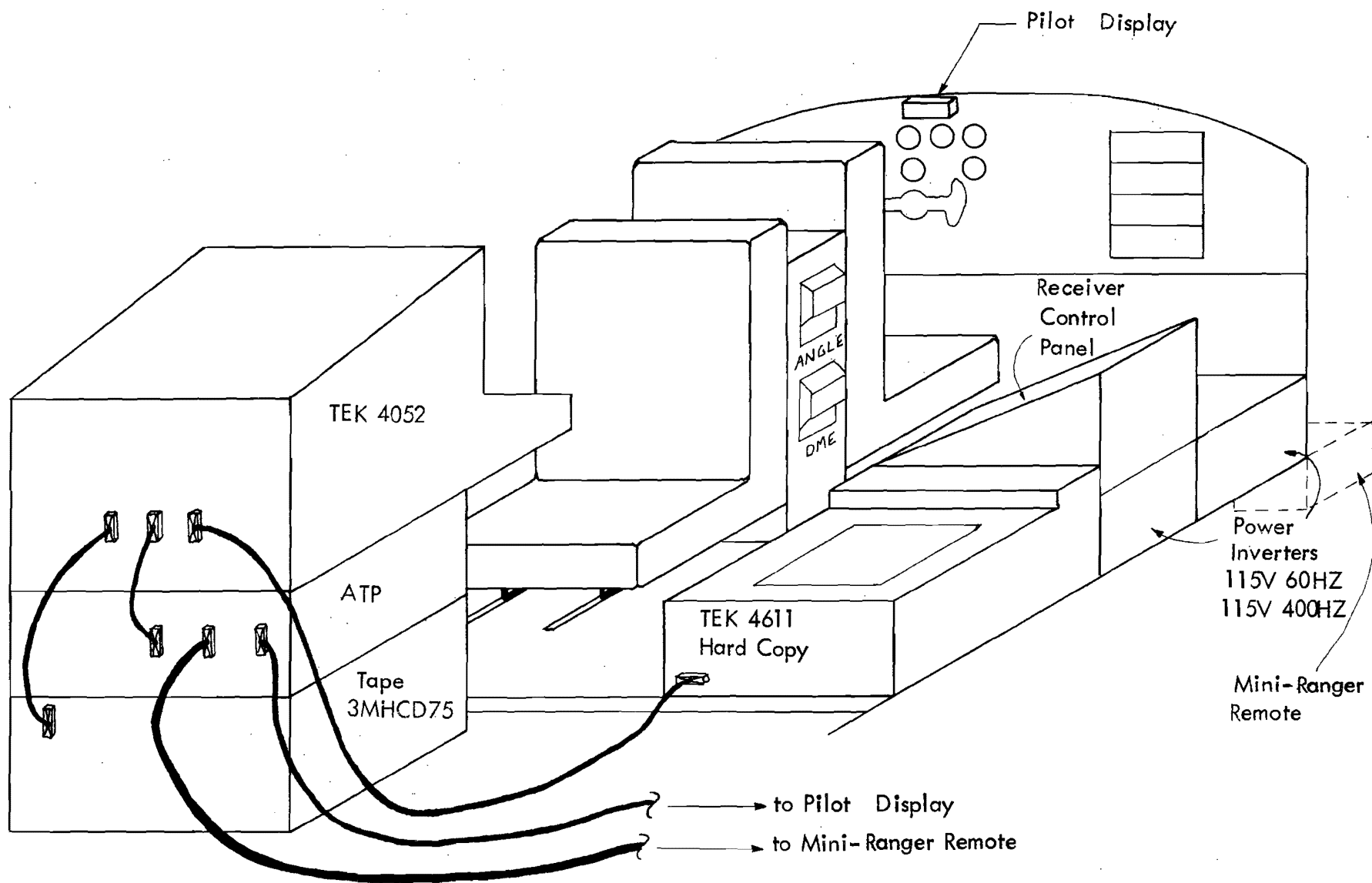

Figure 3-4. Physical Layout, Configuration 1.

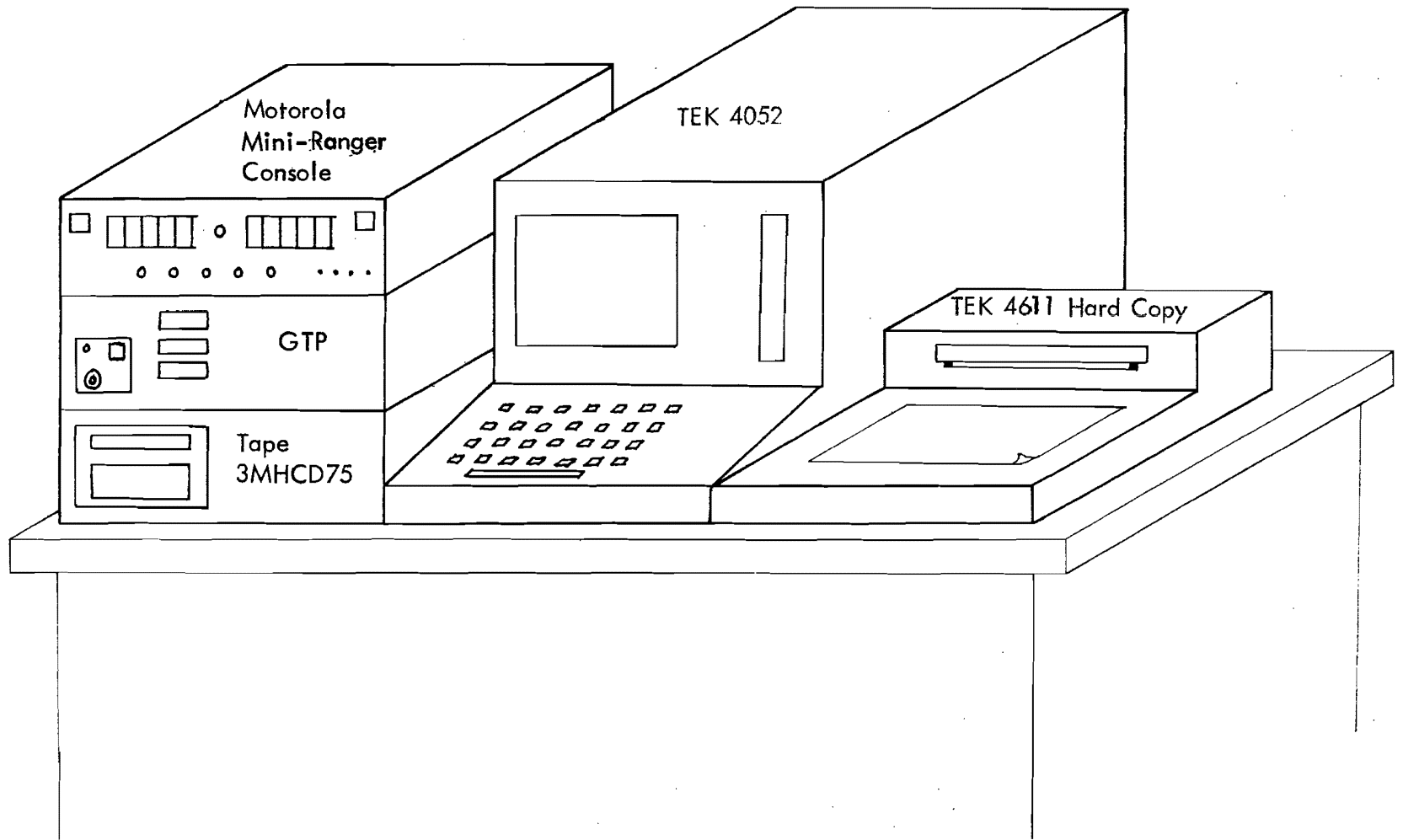

Figure 3-5. Physical Layout, Configuration 2.

2. Ground Tracker Description. Figure 3-6 is a pictorial of the Ground Reference System and the required unit-to-unit interconnections. The three elements of the Ground Reference System are the theodolite and theodolite control, the Mini-Ranger, and the Ground Telemetry Processor. These elements provide precise azimuth, elevation, and range data which will allow computation of the aircraft's true three-dimensional position.

The theodolite is a modified Warren-Knight WK-83. The azimuth and elevation drive shafts have been altered to permit mounting of Portescap 28PL219 motors and gear trains. The aircraft is tracked by means of a joystick. Displacement of the joystick introduces a voltage to the motor drive circuitry causing the theodolite to move in response. The rate of movement of the theodolite is proportional to the joystick displacement. The motor drive system is therefore a "velocity-controlled" system as opposed to a "position-controlled" system. A block diagram of the theodolite motor drive circuitry is given in Figure 3-7. The back-emf of the motor is sensed by the feedback element and is used to control the amplifier. This allows precise control of the motor at very low speeds and prevents sudden surges when motor direction is reversed. The motor is fitted with a 100 pulse-per-revolution optical shaft encoder. This encoder (see Figure 3-8) serves two purposes. First, it provides information on the shaft position. The output of the optical encoder is two square waves with 90° phase separation. The direction of the shaft revolution can be determined by which square wave is leading the other. The amount of shaft revolution is determined by counting. Second, the output of the optical encoder can be used as an improved feedback sensor. A short-duration, high energy pulse can be applied to the motor to overcome its initial inertia. The pulse can be applied until the motor starts to move. The point at which the motor begins to move is easily determined by watching for transitions on the optical encoder output. Since the optical encoder is attached to the non-g geared motor output, ahead of the gear train, it will be moving approximately 100 times faster than the theodolite shaft. Thus, the motor can be started and the speed stabilized before any perceptible motion occurs on the theodolite shaft.

The theodolite is further modified to provide a mount for the Mini-Ranger antenna. While the theodolite operator is tracking the aircraft, the antenna will automatically be aimed in the proper direction. A pictorial of the proposed theodolite modifications is shown in Figure 3-9.

A pictorial of the joystick controller is shown in Figure 3-10. This unit will be mounted to the theodolite tripod or to an external support. It provides all the functions necessary for the theodolite operator. Event marks can be entered by a pushbutton switch for transmission over the data link. VHF communications are supported by headset and microphone connections and a push-to-talk switch.

A Go/No-Go switch informs the pilot via an annunciator lamp on the pilot display that a valid track is in progress. This will reduce the need for VHF communications traffic. Finally, an acquisition mode switch disables the joystick and allows the theodolite to be directed by the processor in the GTP. The theodolite can then be automatically

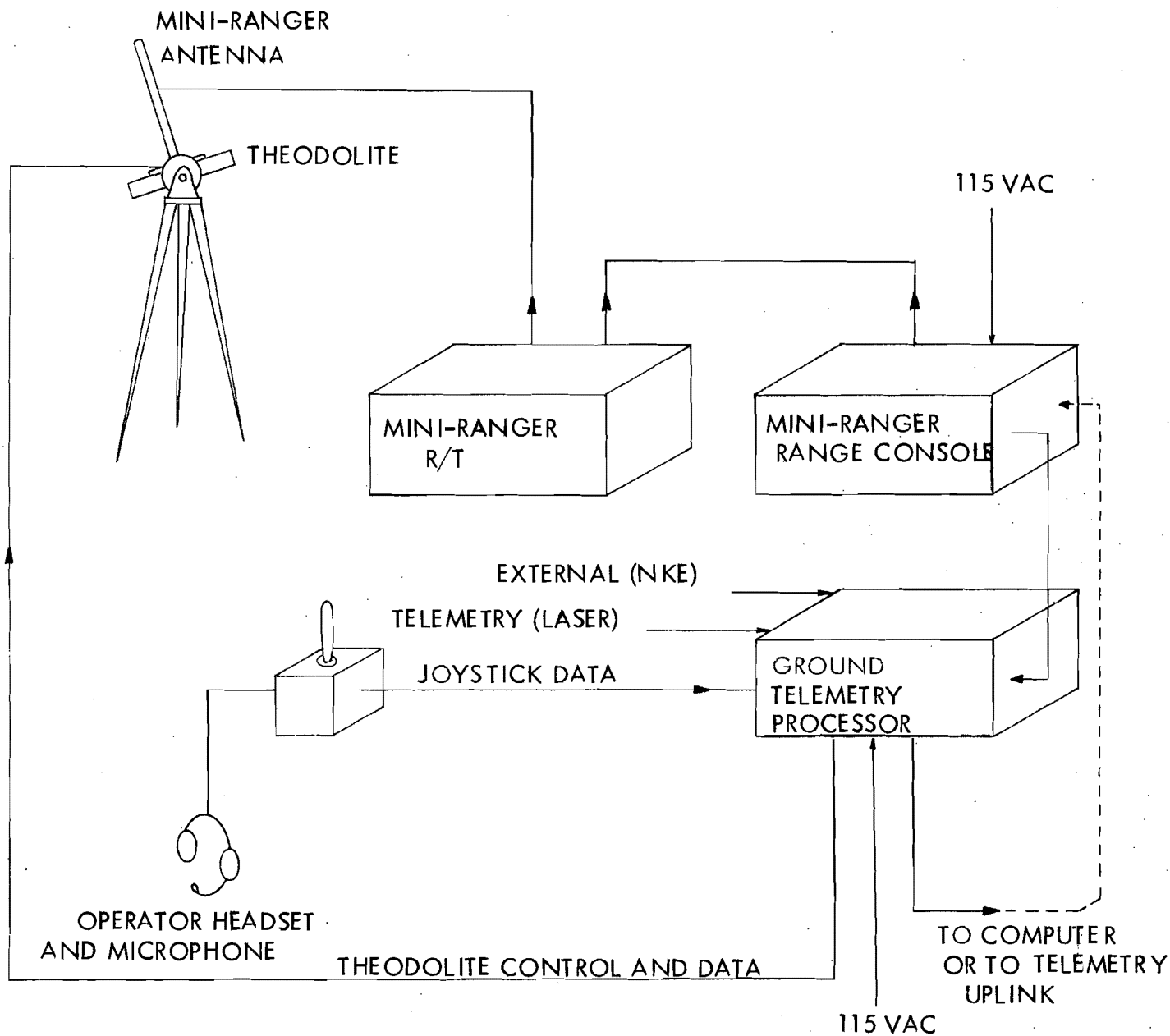

Figure 3-6. Ground Reference System Components Pictorial.

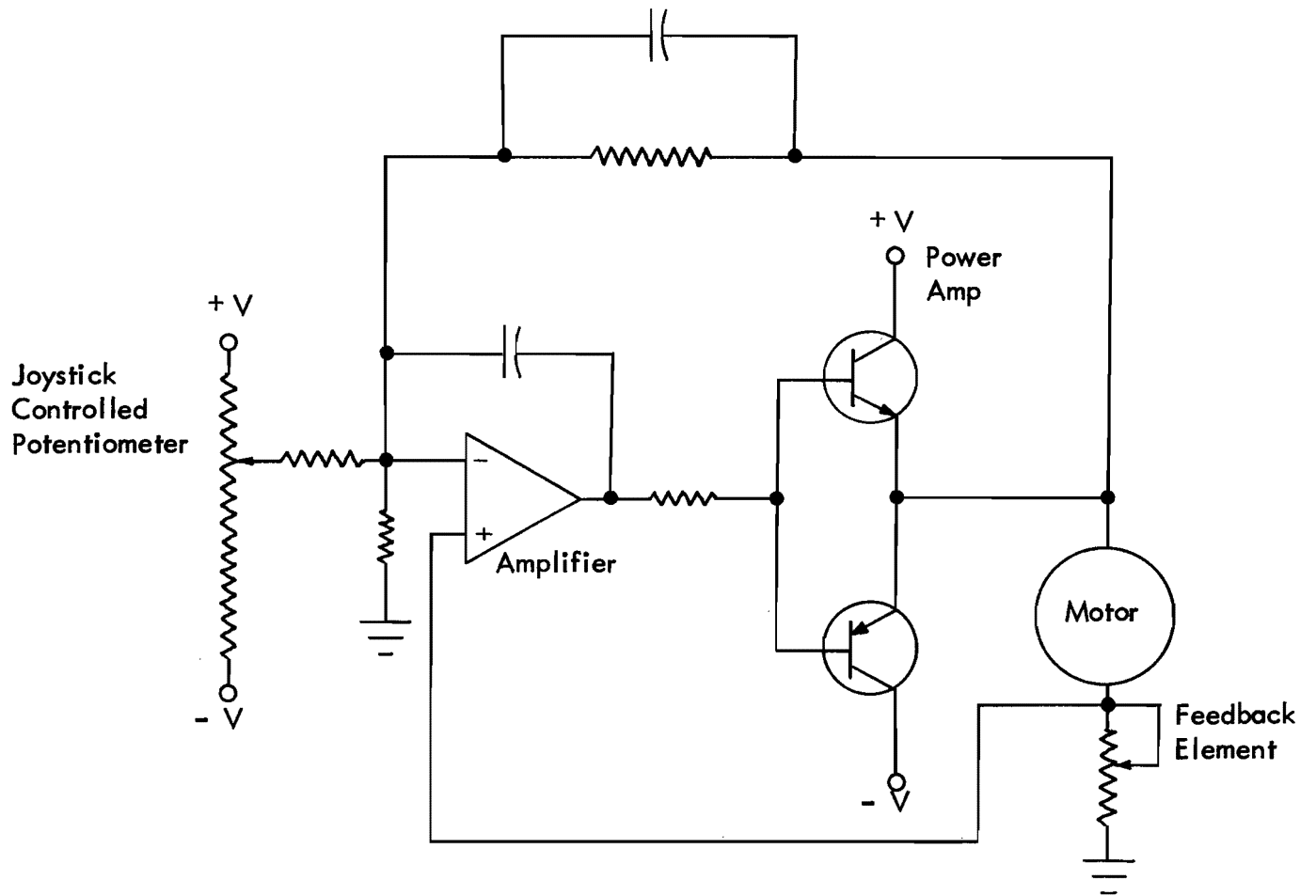

Figure 3-7. Motor Drive Circuitry.

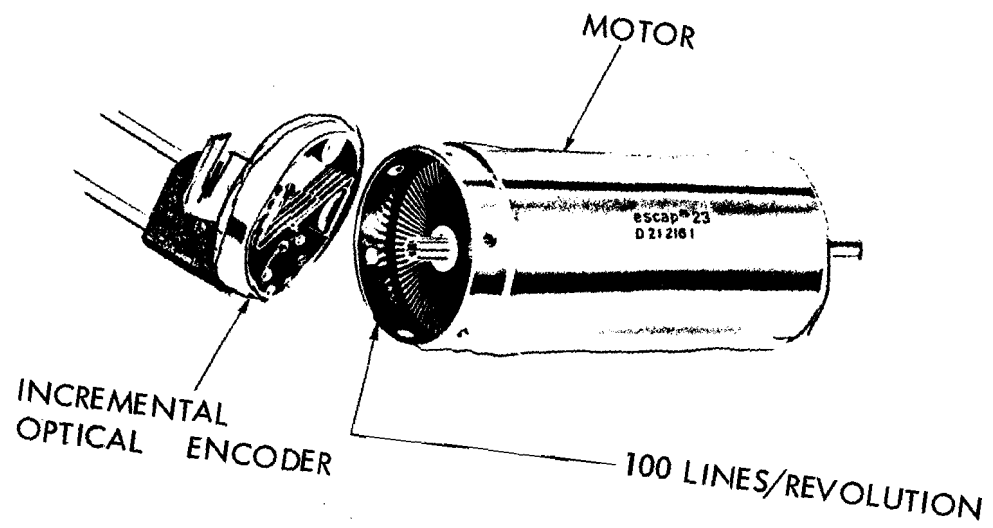

Figure 3-8. Optical Shaft Encoder.

ADDED AMPHENOL  
18-1P; 10-PIN PLUG

ADD MOUNT FOR  
MINIRANGER ANTENNA

RF  
CABLE

THE ODOLITE  
CONTROL CABLE

ADD 0.01°  
SHAFT ENCODER  
ADD MOTOR

ADD 0.01°  
SHAFT ENCODER  
ADD MOTOR

Figure 3-9. Theodolite Modifications.

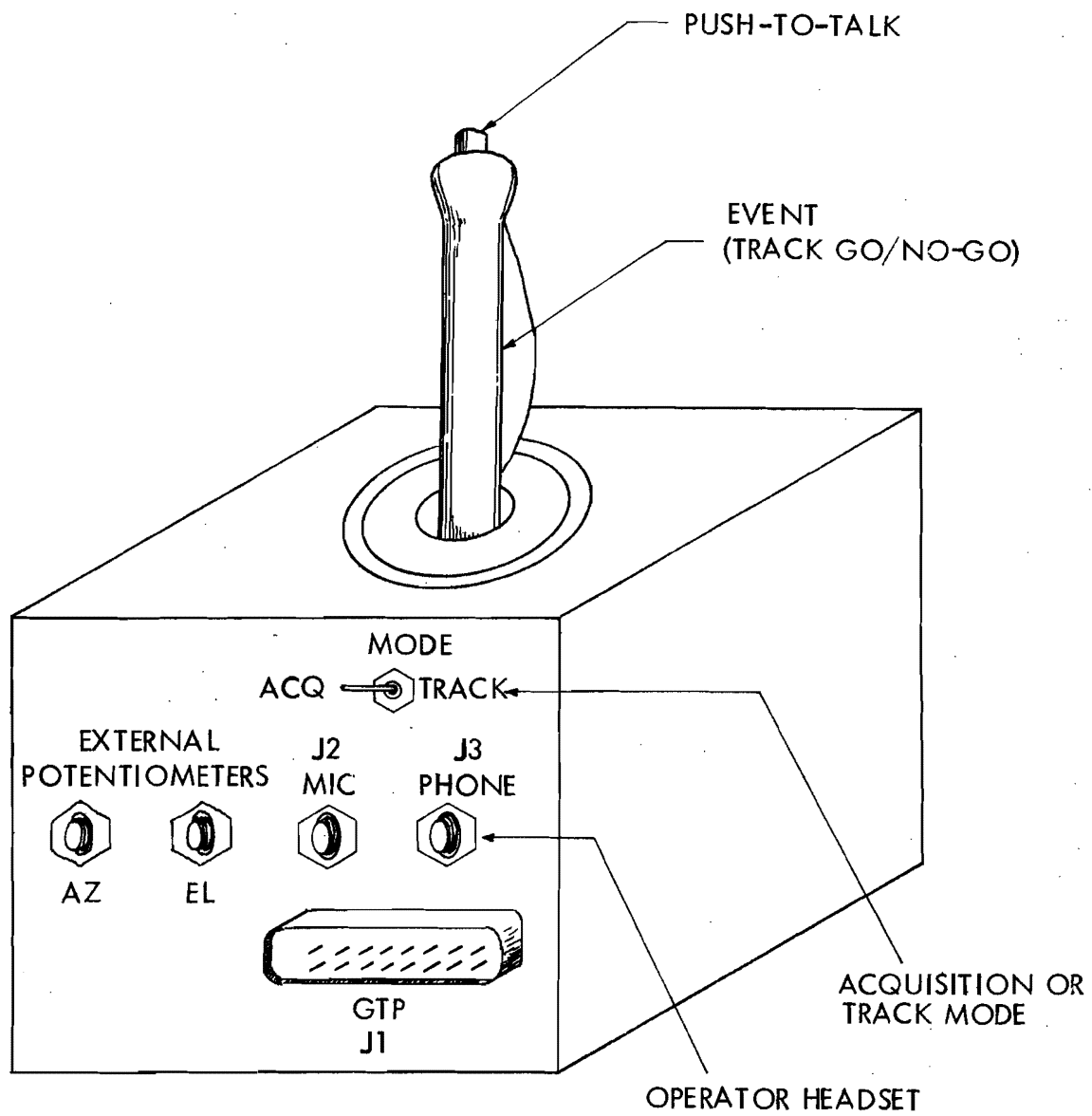

Figure 3-10. Joystick Controller.

steered to the computed position of the aircraft. This will allow acquisition at greater distances than is manually possible. Additionally, it will keep the Mini-Ranger antenna pointed in the correct direction for telemetry of airborne measurements when the aircraft is too far away to be visible. This mode would generally find use in usable-distance runs.

3. Tracker Placement Notes. The theodolite can be placed in almost any reasonable location on the airdrome, since the telemetered position of the aircraft can be corrected by the computer before it is used for calculation and display. This eliminates the need to place the theodolite in a specific position with respect to the navaid antenna as is necessary now. It is only necessary to measure the chosen location carefully so the computer will have the proper values to perform the coordinate-conversion corrections. The only considerations necessary for choosing the theodolite site are the tracking rates and the accuracy requirements for the various flight paths. The motorized theodolite is designed to provide continuous tracking in both axes, providing essentially instantaneous azimuth and elevation angles on demand. (A manual theodolite is operated at high tracking rates by releasing the gear drive of the appropriate axis and shifting rapidly the theodolite ahead of the aircraft. The operator then sends an event mark when the aircraft passes through the crosshairs.) This is not feasible with the motors and optical encoders because the stored shaft position information would be invalid if the theodolite gears were released. The motorized theodolite has a design goal of tracking at a rate of up to two degrees per second. This is sufficient to track the expected flight patterns. If unforeseen flight patterns require higher tracking rates, it will be necessary either to install a lower gear ratio on the motors (with a corresponding loss in low-speed control), disengage the affected axis and discard the angular data obtained from that axis, or move the theodolite to a more favorable location. Table 3-3 shows examples of calculated tracking rates for various projected flight patterns at DCA.

4. Range Sensor and Data Link. The range sensor element of the ground reference system is the Motorola Mini-Ranger III (MMR). The MMR provides the required range accuracy ( $\pm 2$  meters) necessary to test the MLS, and additionally provides a data link which can be used to telemeter the ground reference system data to the aircraft. The MMR consists of a receiver-transmitter assembly and antenna, a range console, and a reference station with antenna. A pictorial of the MMR complement is shown in Figure 3-11. The MMR operates on the principle of pulsed radar. A ground-based receiver-transmitter interrogates an airborne reference station. The reference station replies, and the elapsed time between the interrogation and the reply is used to determine range. The range console is capable of alternately interrogating two reference stations. A pictorial of the range console is given in Figure 3-12. When incorporated into the Ground Reference System, the MMR will be used in the Navigation mode. In this mode, both channels of the range console interrogate the same reference station. This doubles the range sampling rate and likewise doubles the maximum possible data transfer rate.

The MMR transmits a three-pulse sequence each interrogation. The spacing between the first and second pulses is used by the reference station to see if it is being interrogated. This spacing varies from 59  $\mu$ sec to 88  $\mu$ sec. Each three-pulse sequence (PRF) requires 1.14 msec. The range console averages five PRF's before updating the range so that each

1. Pattern A, Centerline,  $6^\circ$  Path, 200 feet/sec.
  - a. Theodolite at Az site:
    - $\dot{A}_z$   $0^\circ/\text{sec.}$  average.
    - $\dot{E}_l$  Less than  $.1^\circ/\text{sec.}$ , but with only 2.1 ft. resolution.
  - b. Theodolite at runway edge, abeam El site: (Runway width = 200')
    - $\dot{A}_z$   $1.4^\circ/\text{sec.}$  at threshold.
    - $\dot{E}_l$   $1.1^\circ/\text{sec.}$  at threshold.
2. Off-Angle Pattern A,  $+40^\circ$  azimuth,  $6^\circ$  path, 200 feet/sec.
  - a. Theodolite at runway edge, abeam El site:
    - $\dot{A}_z$   $2.4^\circ/\text{sec.}$  abeam threshold.
3. Pattern B, Centerline, 1000 ft. AGL, 200 feet/sec.
  - a. Theodolite at runway edge, abeam El site:
    - $\dot{A}_z$  Less than  $0.1^\circ/\text{sec.}$  at limit of El coverage.
    - $\dot{E}_l$   $1.4^\circ/\text{sec.}$  at limit of El coverage.
4. Pattern C,  $\perp$  cut, 1000 ft. AGL, 200 feet/sec.
  - a. Theodolite at runway edge, abeam El site:
    - $\dot{A}_z$  Less than  $1.91^\circ/\text{sec.}$  at any distance greater than 1 mile from theodolite.
    - $\dot{E}_l$   $0^\circ/\text{sec.}$  average.

**Conclusion:** It is felt that corrected measurements may be obtained for both  $\dot{A}_z$  and  $\dot{E}_l$  on normal flight-check flight paths with the theodolite located abeam the El site, as close as possible to centerline, for paths up to threshold. Inside threshold, azimuth rates quickly increase.

Table 3-3. Expected Theodolite Tracking Rates.

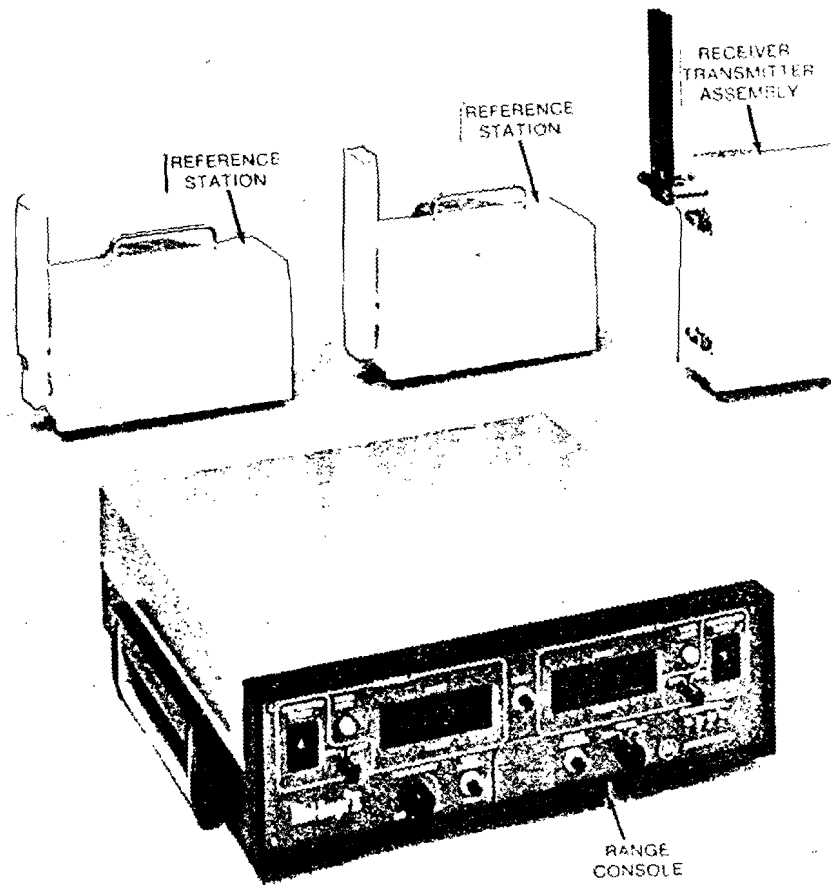
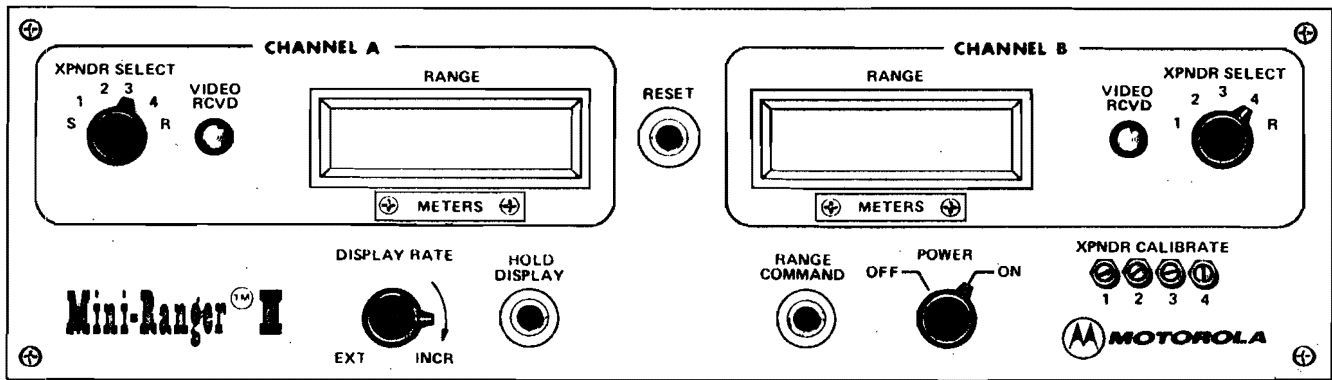
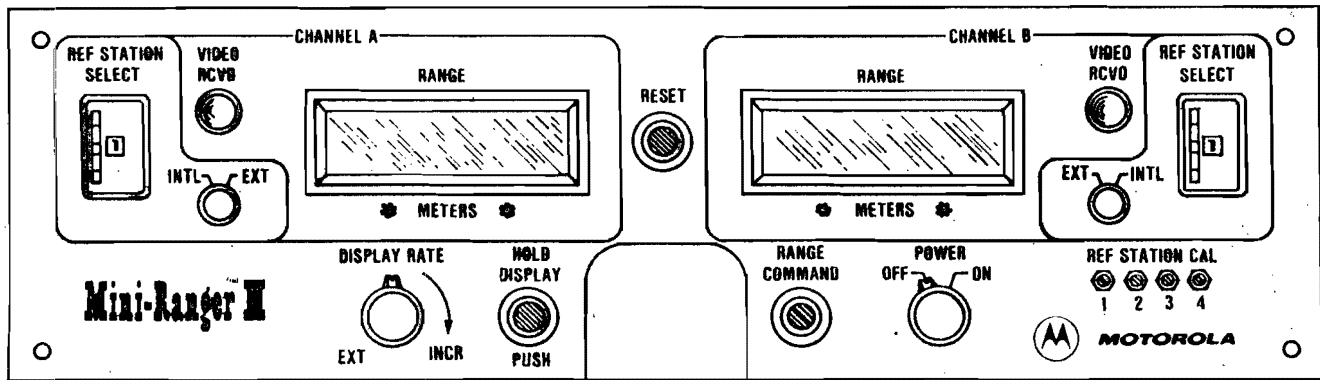

Figure 3-11. Mini-Ranger III System.



Early Model



Late Model

Figure 3-12. Range Console Front Panel.

new range is computed every 5.7 msec.

Addition of the data link is accomplished by adding a fourth pulse to each PRF. This additional pulse requires a longer time for each PRF so each PRF now requires 1.5 msec per PRF. The position of the fourth pulse relative to the third pulse is determined by the data being transmitted. Eight bits of the desired data are loaded into a down counter at the appropriate time. When the counter counts down to zero, the "carry" pulse becomes the encoded data pulse. Thus, the binary weighing of the data determines the pulse position (in time) of the fourth pulse. This position is decoded into four bits of data at the other end of the data link. Four bits (or one "frame") are transmitted every PRF. The data is transmitted in 32-bit words so that eight PRF's are required for each word. Additionally, a start frame is added to the beginning of every word and a checksum frame is appended to the end of every word. A complete data transmission requires ten frames or 15 msec. This allows the data link to maintain an effective transmission rate of 2133 baud.

The data link accepts and outputs only ASCII encoded data. Each data message to or from the data link must adhere to the following format:

STX (Start of Text) ASCII Code 02  
Eight data frames (ASCII Codes for 0-9 or A-F)  
ETX (End of Text) ASCII Code 06

Required mating connectors for the MMR are listed in Table 3-4.

5. Ground Telemetry Processor. The ground telemetry processor (GTP) is one of two similar units, located at each end of the Motorola Mini-Ranger's integral digital data link. The GTP, as was shown in context in Figure 3-6, provides data communications and control services for the theodolite angular sensor and its control unit, for the ranging subsystem and for the system computer, when located on the ground (Configuration 2). The GTP also permits input of data from external sources such as independent position-reference systems. The pictorial, Figure 3-13, shows planned front-panel layout for the GTP, illustrating operator features.

Digitized theodolite angles and ranging subsystem output are displayed for operator reference and system set-up. Four status lights are available, to indicate theodolite "no-go" status and acquisition mode, wherein the theodolite is driven by MLS-derived data to the aircraft's current position. The operator's VHF communications transceiver is included in the GTP to avoid additional packaging and cabling, and the operator has switches to select the use of theodolite or external telemetry and theodolite operational mode.

Figure 3-14 gives the block diagram of the GTP. A microprocessor provides logical control of data paths, control and display functions. An IEEE-488 bus controller chip provides the link to the system computer, when located on the ground, and a standard serial UAR/T (universal asynchronous receiver/transmitter) interfaces the GTP and the telemetry data link. Range data are captured from the Mini-Ranger outputs

DATA LINK MATING CONNECTORS:

RANGE CONSOLE - RS232

Connector Type: M24308 - 1 - 3

Mating Connectors: M24308 - 3 - 3

Pin Assignments: 1 - Ground

2 - RS232 IN (from peripheral to Data Link)

3 - RS232 OUT (from Data Link to peripheral)

5 - Clear to Send

6 - Data Set Ready

7 - Signal Ground

8 - Received Line Signal Detector

20 - Data Terminal Ready

Pins 5, 6, 8 & 20 are jumpered together  
Pins 1 & 7 are jumpered together

MOBILE STATION - 6 pin circular

Connector Type: MS3114E10 - 6S

Mating Connector: MS3116F10 - 6P

Pin Assignments: 1 - Ground

2 - SDI (from peripheral to Data Link)

3 - SDO (from Data Link to peripheral)

Table 3-4. Required Mating Connectors for MMR.

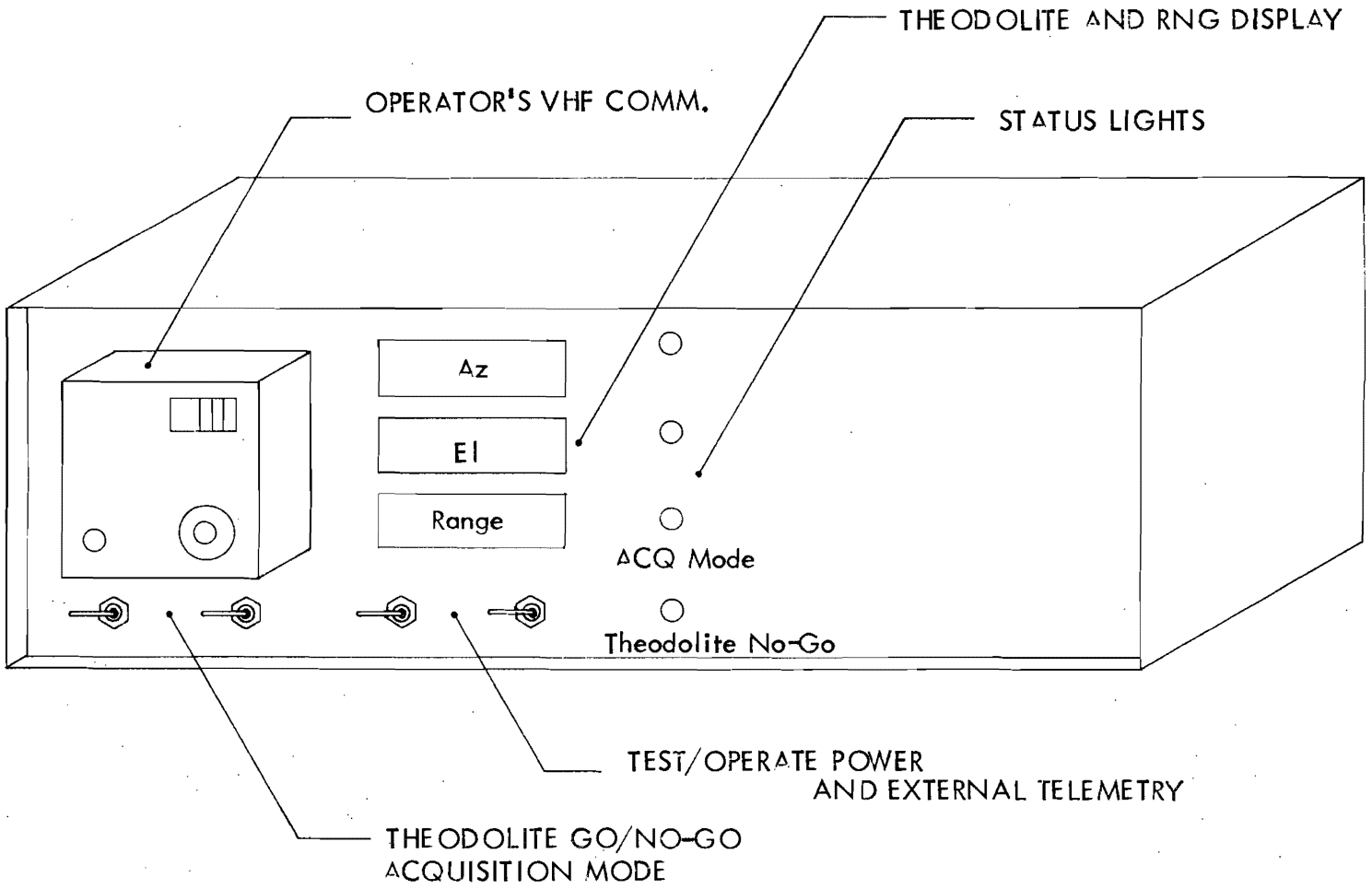

Figure 3-13. Ground Telemetry Processor - Pictorial.

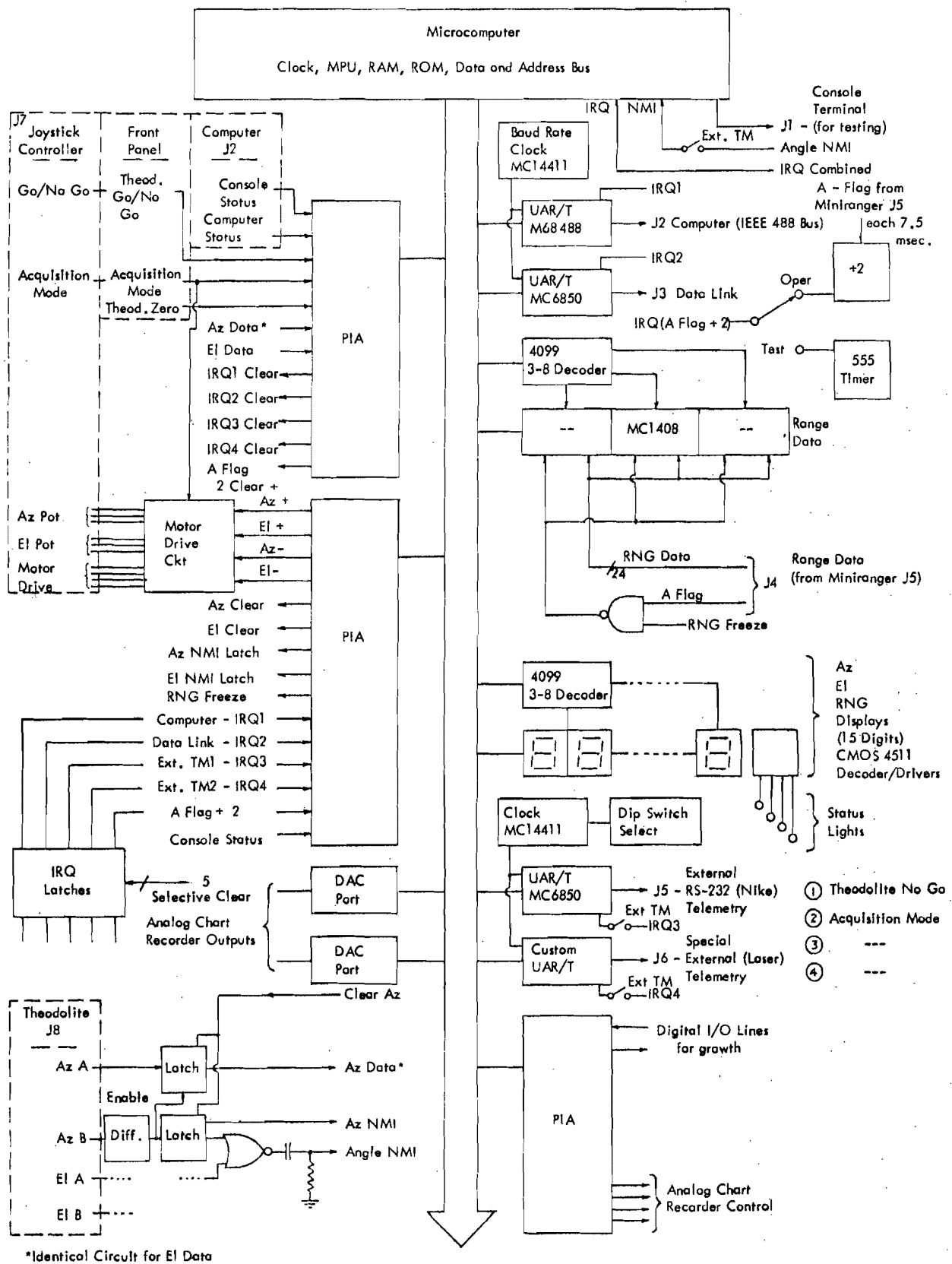

Figure 3-14. Ground Telemetry Processor - Block Diagram.

every 15 msec by latching the parallel digital data available at the ranger's back panel. The latch signal is provided by the ranger itself, and this signal (the "A-flag") also provides an interrupt to the GTP processor, permitting synchronization with ranger and data-link functions. A set of output latches receives data from the microprocessor bus, decodes the BCD data and drives 7-segment, incandescent displays for range, azimuth and elevation. One 4-bit latch drives the status lights for front-panel display. External telemetry inputs are serviced by appropriate serial input circuitry. For RS-232 standard inputs, a UAR/T chip is provided, with adjustable baud rate. For specialized external sources, such as the FAA laser tracker, a custom interface is provided to convert serial bi-phase synchronous data to parallel data for input to the microcomputer data bus.

Two digital-analog converter chips provide outputs for the system chart recorder, when it is desired to utilize this unit at the ground tracker location. Generally, this use will occur when the system computer is located in the aircraft and it is desired simultaneously to view the output data on the ground.

A variety of digital signal lines is made available through peripheral interface adaptors (PIAs) for system control. Since the GTP is driven to perform its various services by external-world stimuli, a software-controlled interrupt process is implemented through single-bit latches with computer-controlled read and clear functions. The software may then assign interrupt priority as required by the ongoing process. Latch circuitry also serves to connect the theodolite incremental shaft encoders to the GTP processor, which performs the angular additions and subtractions to maintain a digital representation of theodolite position at all times. The microcomputer also controls theodolite drive motors in acquisition mode, driving the optics to a position in space based upon corrected MLS data. Generally, acquisition mode would be used to aid the operator in finding the aircraft for tracking. Experience shows that gains in range of over one nautical mile can result from this machine-aided acquisition.

The GTP provides an input/output port for a standard computer terminal operating on the RS-232 standard interface. This port, for use in laboratory testing and calibration prior to field work, permits access to the microcomputer monitor routine, which supervises single-step operation, diagnostic routines, and can operate modified software using a temporary random-access memory (RAM) card. The RAM memory can be downloaded from a host computer, on which resident assembler and simulator programs provide software development and alteration capabilities.

Figures 3-15 and 3-16 give cabling details for the ground tracker system, including the GTP, and are included for reference.

It will be noted in the presentation of the airborne telemetry processor (ATP), in Section III.D.2 of this report, that the ATP and GTP designs are similar. In fact, it is planned to use maximum common I/O and interface circuitry for the two units, to minimize maintenance problems and spares requirements. Major differences will be in software.

Miniranger Chan A  
BCD - J5

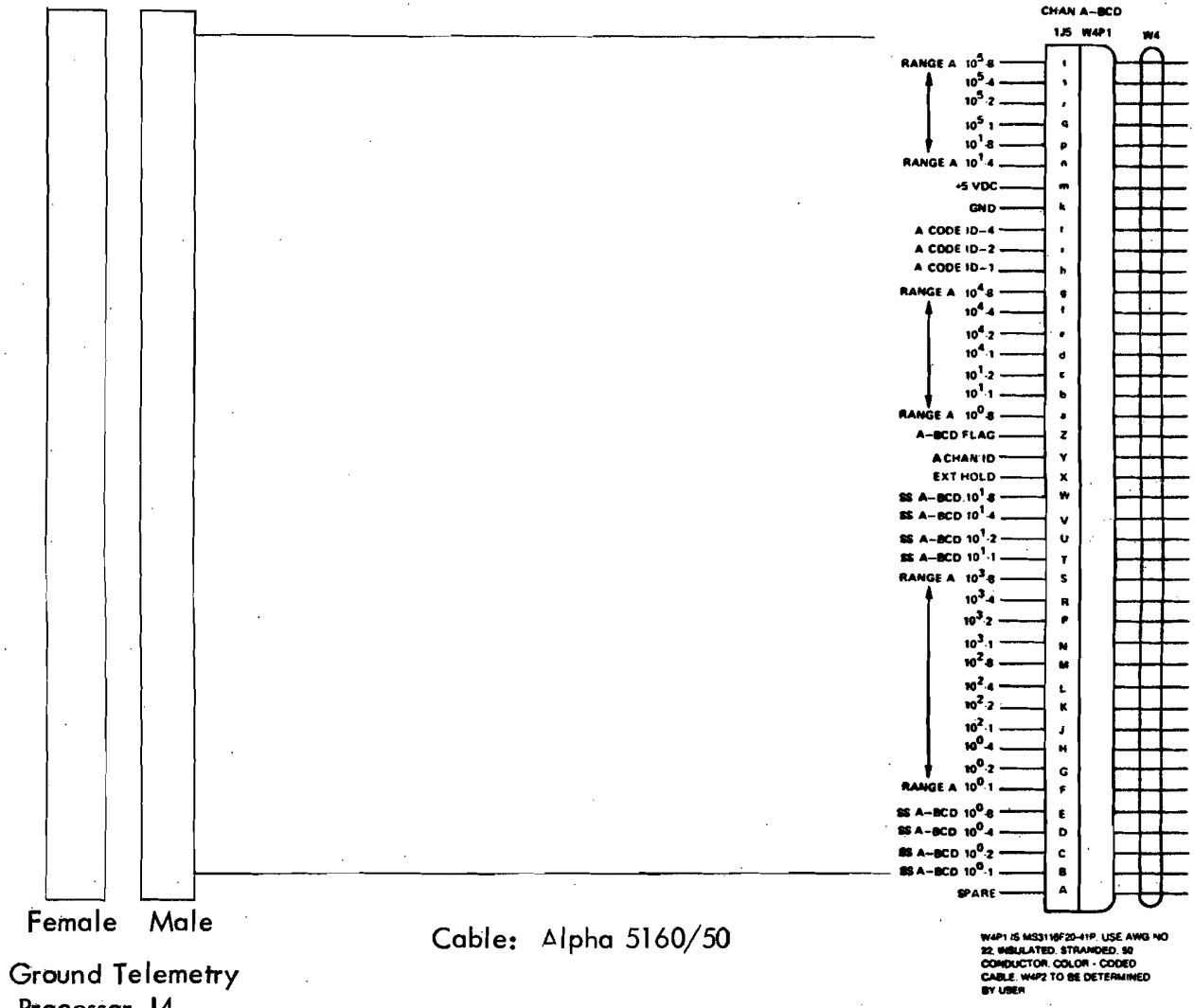

Ground Telemetry  
Processor J4  
17-90500-16\*  
17-80500-16

Range Flag and Output

Miniranger

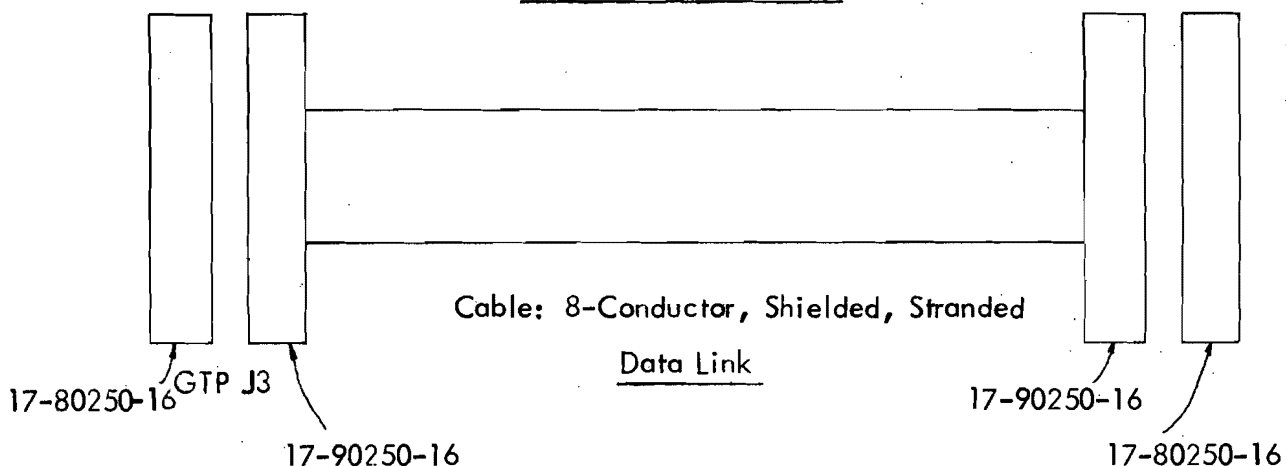

\* Connector is Amphenol "MIN RAC 17"

Figure 3-15. Cabling - Mini-Ranger.

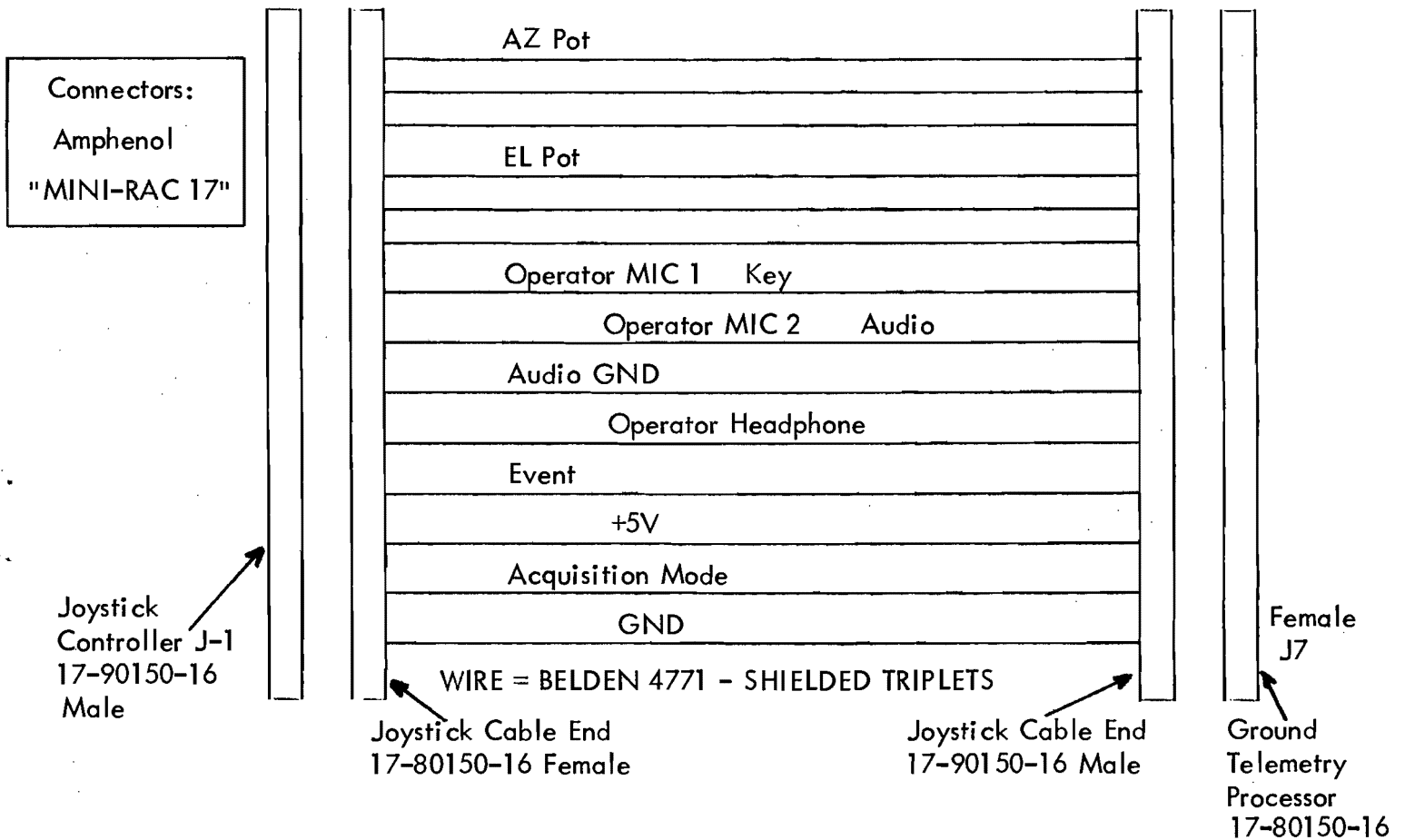
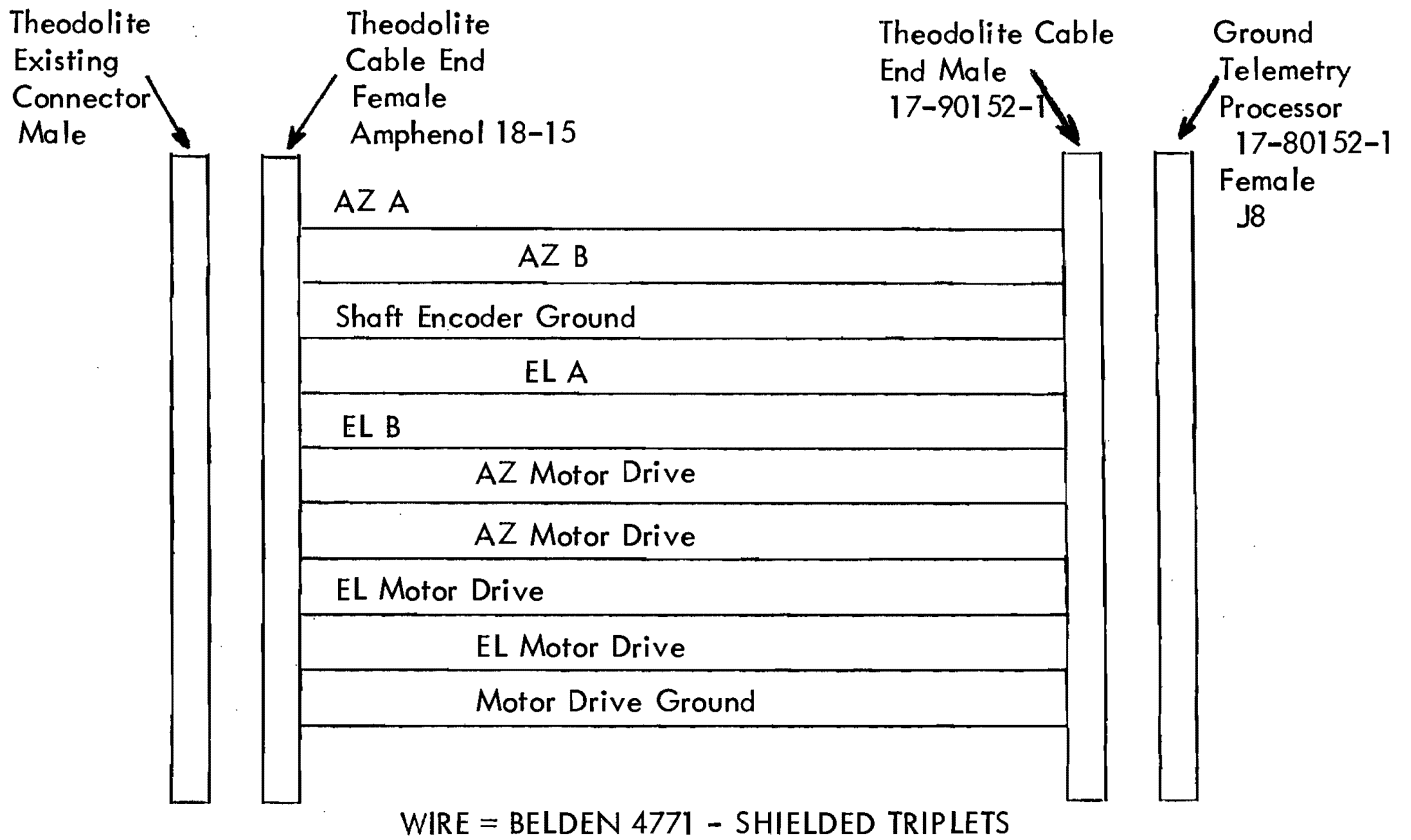

Figure 3-16. Cabling - Theodolite and Joystick to Ground Telemetry Processor.

## D. Airborne Measurement Element.

1. MLS Receiver and Antenna Installation. Figure 3-17 is a pictorial of the MLS receiver complement along with the signal flow lines demonstrating the unit-to-unit interconnections. In the Beechcraft A-36 installation, the DME interrogator and the MLS angle receiver will be mounted in the space between the front left and center left seats. The control panel will be mounted in the space between the right front and right center seats. A pictorial of the receiver control panel is given in Figure 3-18. In this position, the displays and controls will be accessible to both the pilot and panel operator if necessary. Additionally, the pilot will have a small control and display unit mounted on the aircraft instrument panel and will receive MLS crosspointer information on an existing CDI movement. This pictorial is given in Figure 3-19. The approximate layout of this equipment after installation in the A-36 was shown in Figure 3-4. The location of the equipment is critical only to the point of keeping the coaxial antenna lines as short as possible. Antenna placement on the aircraft must be done with care to avoid shadowing, so that possible antenna placement determines, to some extent, the location of various equipment items. Figure 3-20 shows the approximate antenna locations that have been chosen for the A-36.

None of the equipment requires forced-air cooling, provided there is sufficient space between and around each unit. The presence of convection current obstructions or proximity to a major heat source such as a power inverter will probably require the addition of a fan.

Mounting of the MLS receiver is very straightforward. The shockmounts for both receivers are equipped with vibration isolators and are available from the manufacturer. It is recommended that one-inch clearance be allowed in every direction around the receivers to allow free movement on the shockmounts.

A complete system interconnect diagram is given in Figure 3-21. The cable assemblies must be fabricated by the installer. The manufacturer recommends the acquisition of two special crimping tools for this purpose. Interconnecting the MLS receiver complement requires several different types of mating connectors. A complete list of the required connectors along with part numbers is given in Table 3-5. Other cable assemblies are necessary to interface the MLS receiver complement to the Ohio University evaluation and data-collection system. These assemblies will generally be connected either by Amphenol MS or "Mini-RAC 17" connectors as appropriate.

2. Airborne Telemetry Processor. The airborne telemetry processor (ATP), which was shown pictorially in Figure 3-17, provides software-controlled interface services among the MLS receivers, pilot display, telemetry link to and from the ground, and the airborne time code generator. When the system computer is located in the aircraft, the airborne telemetry processor also provides the link between the computer and the remainder of the system.

Figure 3-22 presents a block diagram of the ATP, showing overall control by a commercially-available microprocessor with addition of peripheral controllers to permit

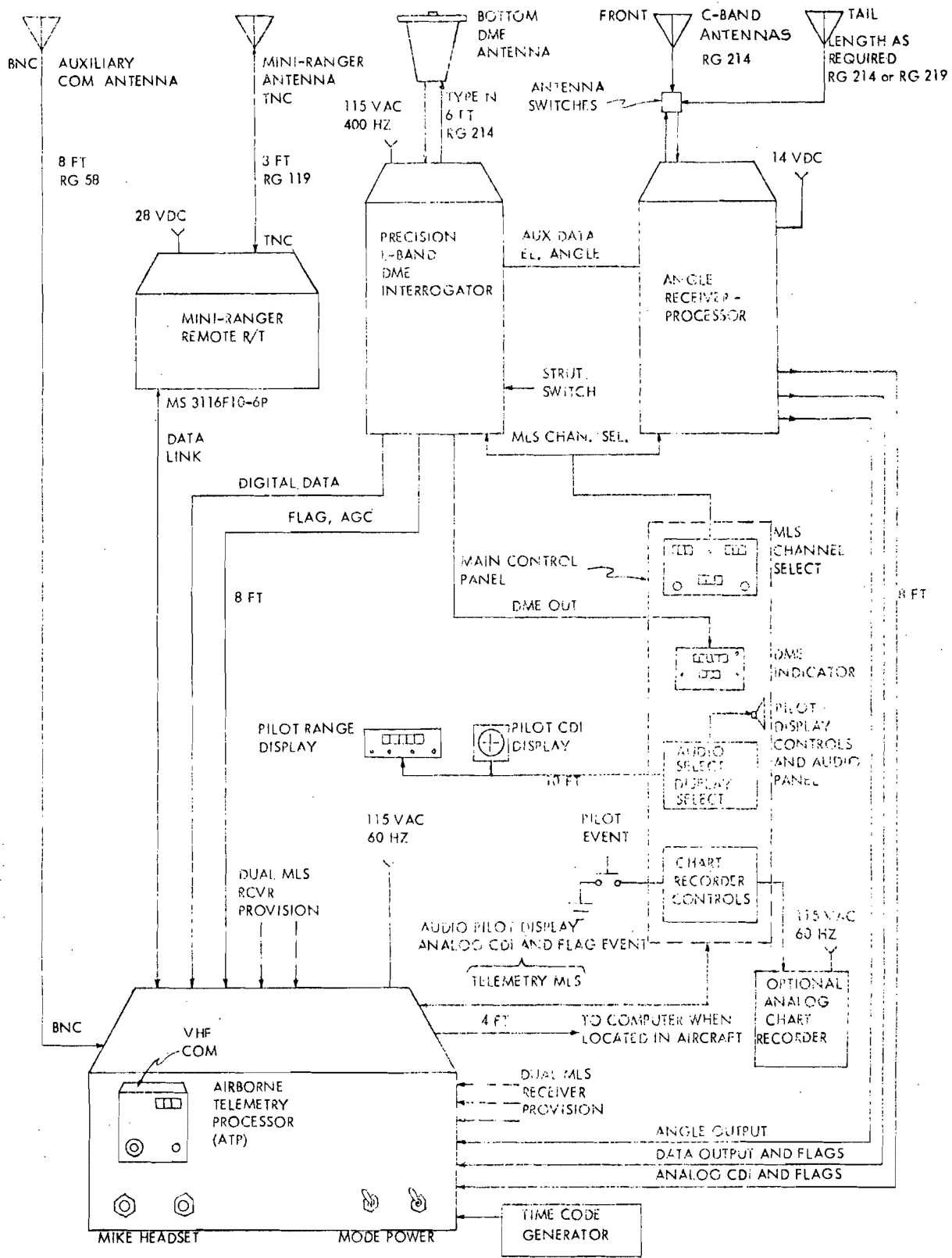

Figure 3-17. Airborne System Pictorial.

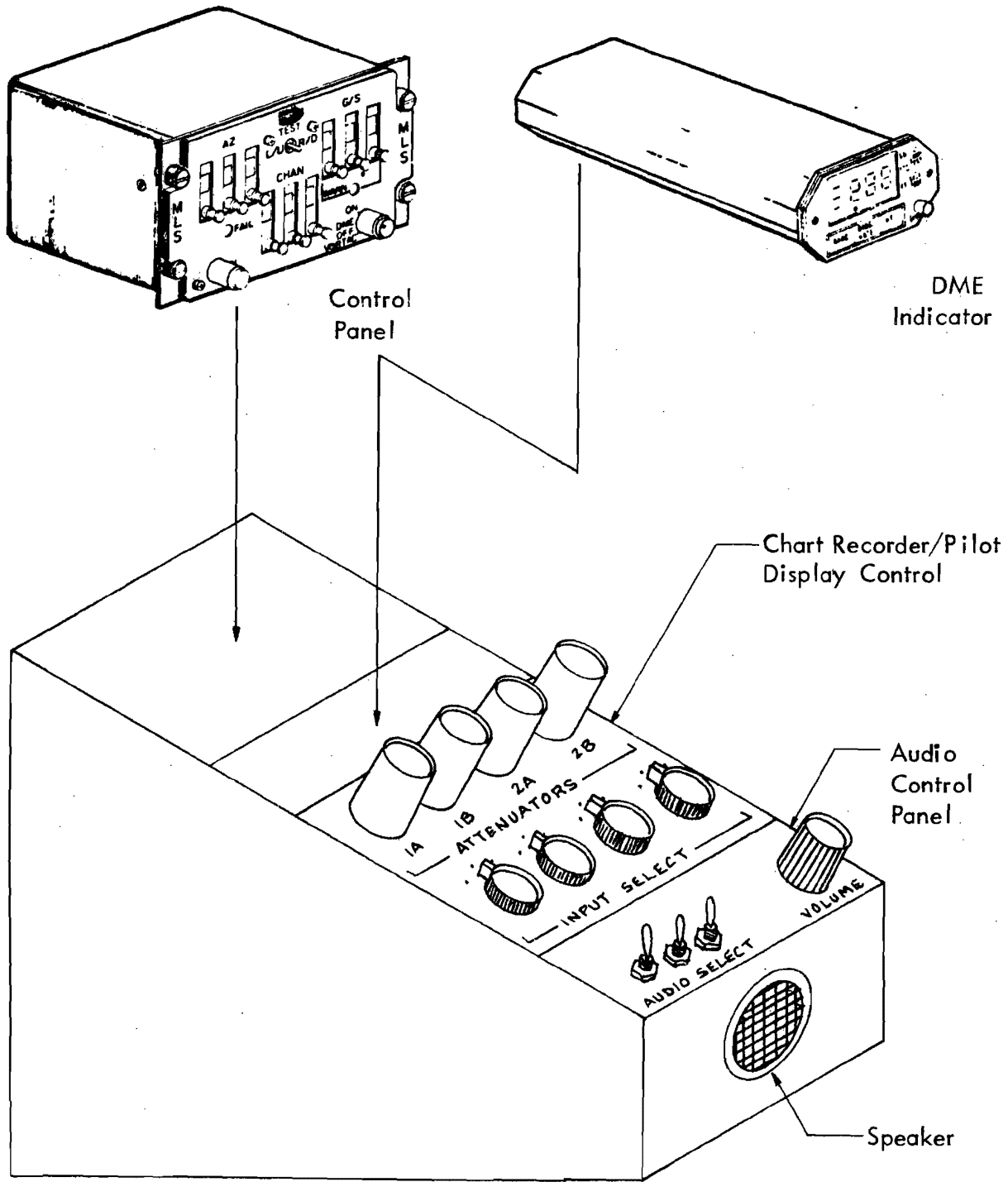

Figure 3-18. Receiver Control Panel.

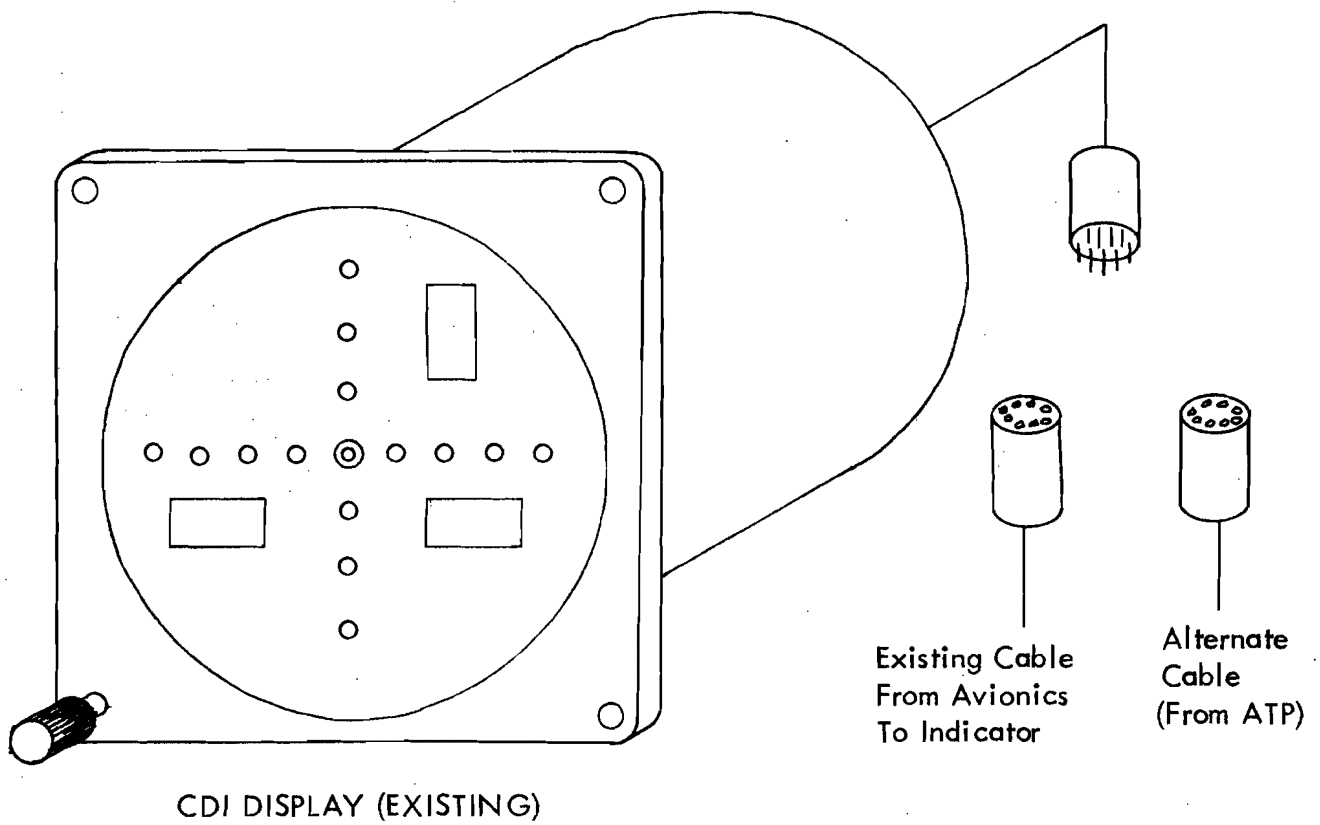
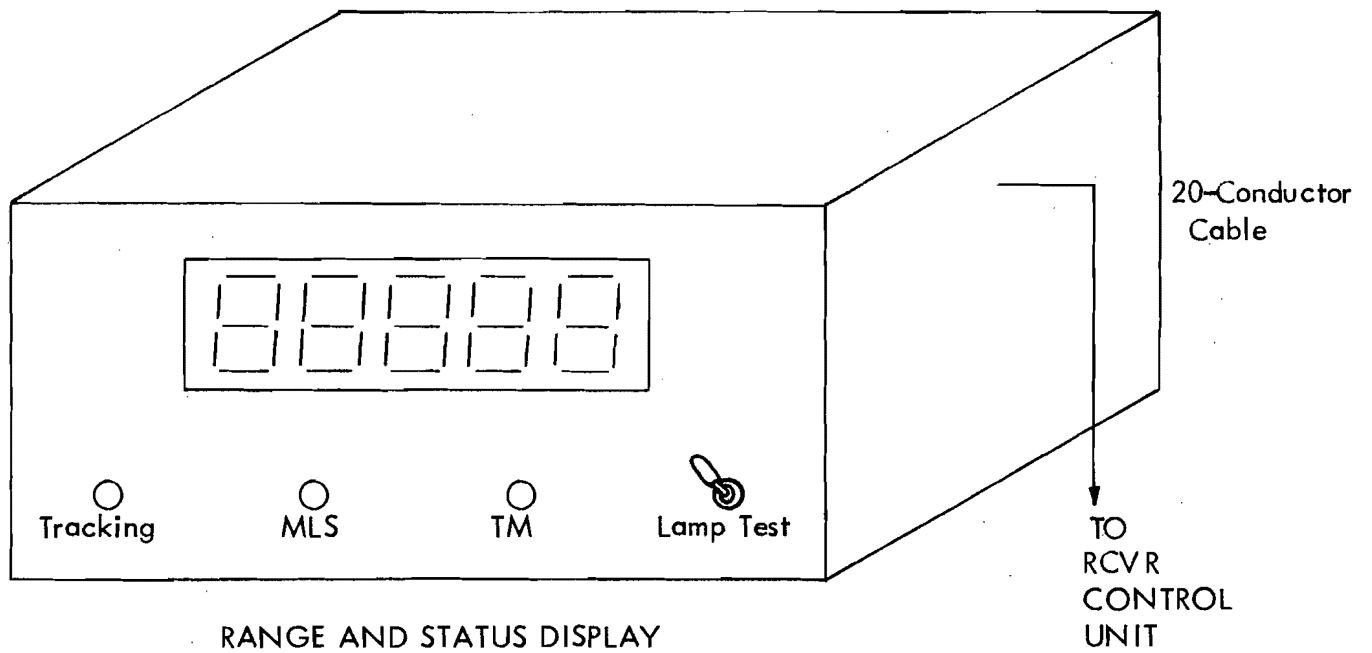
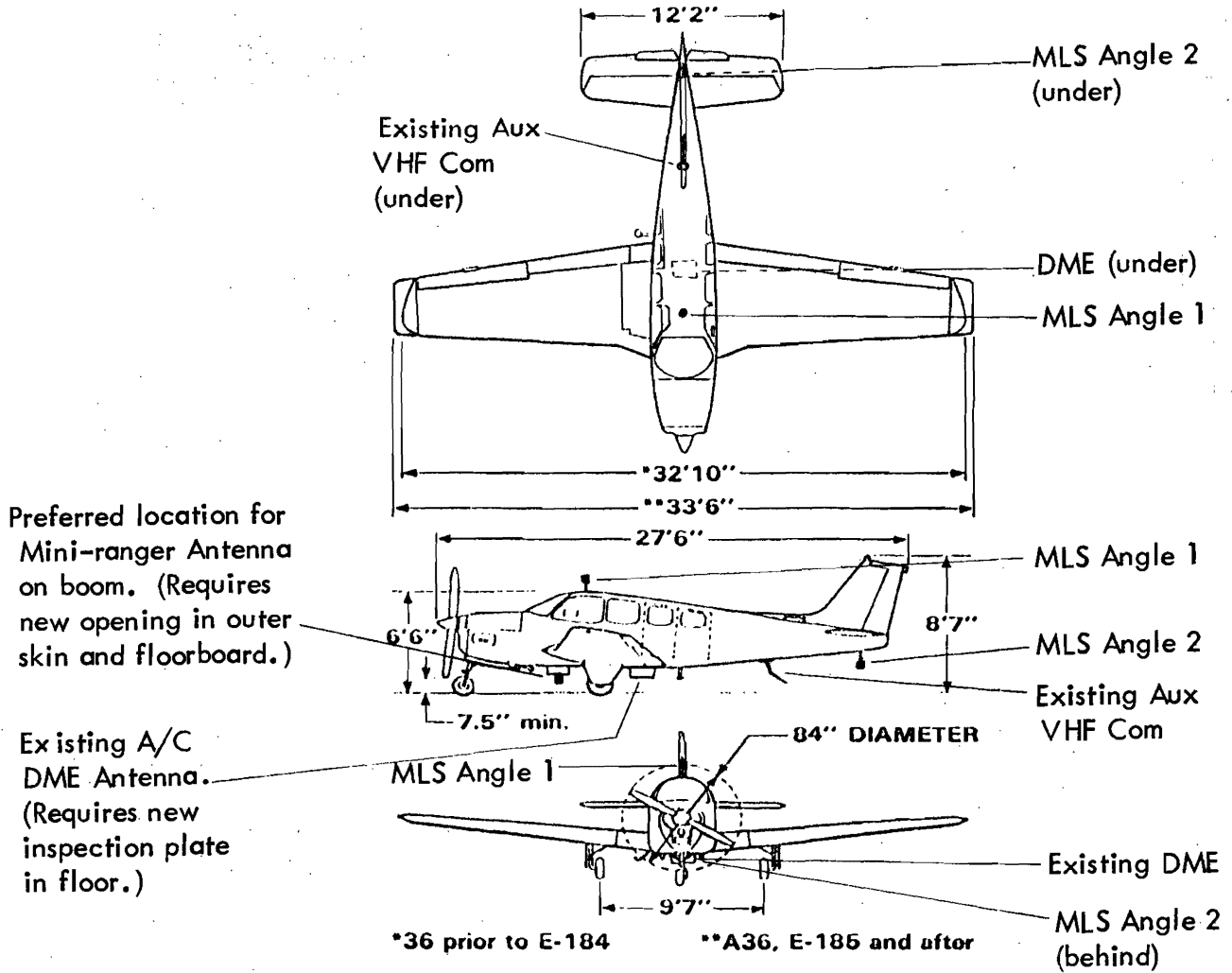

Figure 3-19. Pilot Display.

CONNECTOR DESIGNATION	MATING CONNECTOR	FUNCTION	CONNECTED TO
MLS Receiver	AMP RM2P-C2S-106P-00-01-020 with Cannon CM2 insert	Main, rear	MLS Shockmount
Control Unit	Cannon DD50S-C33-F92	Control	MLS Angle Receiver
Aux Unit	Cannon DA15S-C33-F92	Aux Data	MLS Angle Receiver
Switching Module	Type UG-21D/U	Ant Switching	MLS C-Band Antenna
Latching Relay	Type N	Ant Switching	DME Antennas
DME Unit	Cannon DPXZMA AC3S67S-33B-0019	Main	DME Shockmount
DME Indicator	MS 3116F-16-26S	Indicator	DME Interrogator

Table 3-5. Mating Connectors for MLS Receivers (Bendix Corp.).

**BEECHCRAFT Bonanza 36, A36  
E-1 thru E-926**



February 1980

Figure 3-20. Planned Antenna Locations, BE-36 Aircraft.  
(Figure from Beech Aircraft, Inc., Pilot's Operating Handbook)



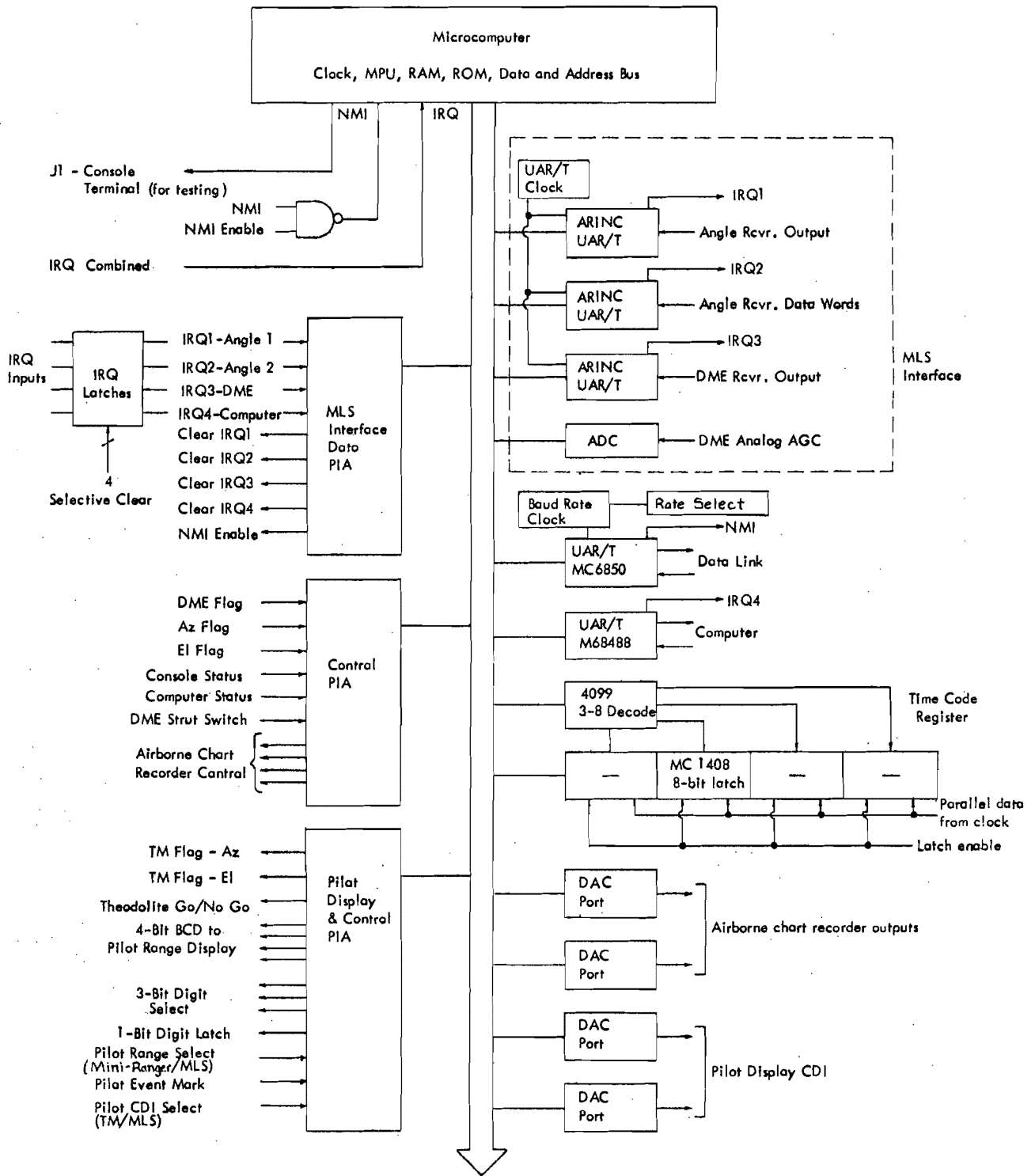

Figure 3-22. Airborne Telemetry Processor - Block Diagram.

communication with the other system elements. The MLS receivers are connected by means of ARINC UAR/T chips, now commercially available. These chips provide 32-bit data buffering, microprocessor interrupt and address/data selection. The chips accept 32-bit ARINC data directly from the MLS receivers and provide 8-bit parallel bytes to the microprocessor bus. The MLS receiver interface hardware may be duplicated, to permit a dual-receiver system.

The ATP performs no manipulations upon MLS data content. Rather, the unit steers the data to appropriate destinations for processing, display or recording. Since the ATP is transparent to data content, the system computer must decode data identification bits and determine the correct use for the observation. With this system characteristic, it is possible to utilize existing modification for the MLS angle receiver which provides amplitude outputs, necessary for usable-distance measurements. It is only necessary to inform the system computer that such data are now to be processed. No other system changes are required, once the modified receiver is placed in the airborne receiver rack.

The telemetry data link is connected via standard UAR/T, with effective data rate of 2133 baud, asynchronous, full-duplex. The system computer, when located in the aircraft, interfaces via IEEE-488 bus controller.

Two digital-analog converters are provided, for output of analog CDI information derived from the ground tracker position to the pilot display. DME analog AGC may be selected by software for measurement at the output of an analog-digital converter.

Airborne time may be provided to the measurement system using a time-code generator, for which a 32-bit latch register is provided on the microprocessor bus. The inclusion of such a clock permits real-time merging of external telemetry data and airborne MLS observations. Experimentation with single-chip timing circuitry is underway, to determine cost-effectiveness.

Two additional digital-analog converters are available for control of the airborne chart recorder. This recorder is anticipated for use in the aircraft when the system computer and recording devices are on the ground (Configuration 2) for pilot and observer data output in the aircraft. In Configuration 1, with the computer and hard-copy devices in the aircraft, this chart recorder is not required, but may be used on the ground, for data output to observers or measurement team members.

The microprocessor software includes a system monitor, which may be activated for test purposes by attachment of a standard computer terminal. These tests, which would generally be done in the laboratory prior to a field measurement mission, would include processor diagnostics and I/O port checks. Temporary addition of random-access memory cards will facilitate software development or modification, with final operative software placed in read-only memory for field use.

Figure 3-22 also shows the large number of individual digital signals necessary for control of ATP functions. Since the unit is fully interrupt-driven by the peripheral devices

in the aircraft, suitable software-controlled interrupt latches are required. Digital flags from the MLS receivers and various ATP status bits are handled by the Control PIA (peripheral interface adaptor). MLS receiver interrupts are handled through the MLS interface PIA, along with airborne chart recorder control. Pilot display and control functions including CDI flags, ground tracker status, range display and event mark are served by the Pilot Display PIA. Spare digital input/output lines are included in all three PIA devices for future needs.

E. System Data Processing and Control Element. The microcomputer-based ground telemetry processor and airborne telemetry processor units discussed earlier in this report were introduced as software-controlled system elements. They provide specific services for ground tracker, airborne sensor and telemetry link operations. In the larger system sense, however, these processors are dedicated to their assigned tasks, and are reconfigured only through reprogramming prior to a measurement mission. The data processing and control element, presented below, is the source for computational services relating to data merges and recording, computation of corrected aircraft position during data-collection run, and display of output data. The computer is also assigned the task of computing theodolite positioning data during acquisition activities, utilizing received MLS data when available, or operator commands if necessary. For many mission scenarios, the acquisition mode may permit continuous tracking of the aircraft during the outbound portion of a flight, permitting immediate tracking to begin at the completion of the inbound turn.

Using the airborne telemetry processor and the data uplink (for the configuration with the computer on the ground), the computer provides computed crosspointer "CDI" values for selected desired flight paths. For example, on a Pattern C (perpendicular cut), the vertical needle is driven by a combination of range and azimuth, and the horizontal needle receives computer results from range and elevation to form a commanded path for the pilot. Such commands available in the cockpit serve to regularize flight tracks, permitting additional data stability from run to run.

The computer records MLS and tracker data, including system flags such as "theodolite no-go", to permit complete post-flight analysis. In real time, numerical and/or graphical outputs are provided for operator and experimenter use. Using the data uplink, the computer may provide corrected data outputs in an aircraft chart recorder even though the computer and primary displays are located on the ground. This data would be interleaved with uplink command data sent to the pilot display.

The data processing and control element consists of a central computer, controlling the primary data recorder (a magnetic tape cartridge unit), alphanumeric and graphic outputs for operator and experimenter use, video hard-copy, and such other input/output devices as are required for specific missions. Considerations of processor speed, standard and optional features and size/weight/power tradeoffs has led to the choice of the Tektronix 4052 unit, pictured in Figure 3-23. This unit utilizes a 16-bit, bit-slice processor for speed and precision. The keyboard, graphics or alphanumeric display, and a cartridge tape unit for systems software are all built into the single package. Hard-copy output is included, as is RS-232 and GPIB (IEEE-488) communications ports. For applica-

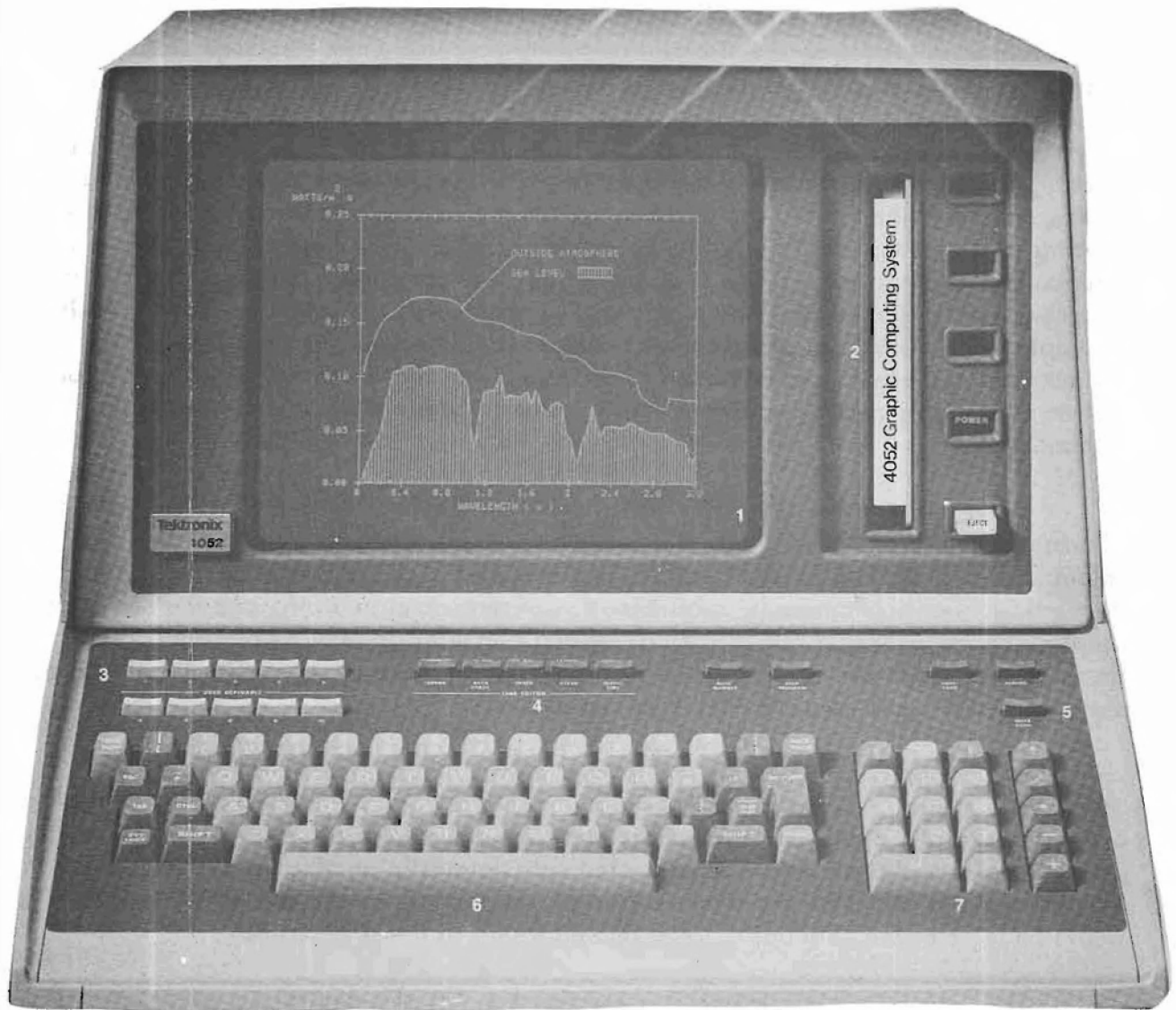

Figure 3-23. Tektronix 4052.

tion to the MLS data collection and recording system, the addition of a high-capacity cartridge tape recorder such as the 3M- HCD75 and a video hard-copy device, such as the Tektronix 4611 completes the configuration. The processing and control element interchanges data with other system elements through the GPIB interface, connected to either the airborne or ground telemetry units. Cartridge tape control and data are transferred by RS-232 link.

The Tektronix 4052 may be obtained with significant programming services already available. The plotting package, for example, is well-developed and convenient to use. Availability of such software packages reduces programming time and allows concentration of effort on the MLS task, rather than on system control routines.

Coordinate conversion software will be modified from FAA Technical Center routines, and PFE/CMN/PFN filtering routines will be produced. Operator interface software will emphasize the "hierarchical menu" approach, to maximize flexibility while maintaining convenience. Provisions for repeatable site parameter data entry and such constants as aircraft antenna parallax will permit storage of these values for recall and possible modification for specific missions; it will not be necessary to repeat antenna location data for a particular site, for example, so long as the data remains constant from mission to mission.

Although the computer will be providing data outputs on site both in real time and near-real time (between runs), additional programs will be provided for use in post-flight analysis. Data may be transferred to a host computer for large-scale processing or data-banking. Host data may be downloaded to the system computer for replotting or reanalysis. In this mode, the system computer, connected to a host machine via the RS-232 port, operates as an intelligent terminal, with added graphics and hard-copy capabilities. Thus, the system computer serves the data collection and processing process even when field measurement exercises are not being carried out.

The discussion of the data processing and control element has emphasized specific hardware, chosen after review and demonstration of a variety of currently-available computing systems. The discussion is intended to outline the required functions of this system element; developments in the small-computer industry may very well permit added flexibility of choice as final design and fabrication of the system proceed.

#### IV. RECOMMENDATIONS FOR FUTURE WORK

Some recommendations have been formulated based on the reported work. These recommendations are believed consistent with an orderly evolution and implementation of microwave landing system operation.

1. Implement a study to identify numerical values of tolerance limits which will accommodate all classes of user aircraft. An important part of the study would be the involvement of simulation to assess flight performance with respect to numerical values which are candidates for system tolerances.

2. Conduct a study which will examine the feasibility of physical world data-logging for environs of airports. From this study, evolve a detailed plan for using this information with the MLS math models to predict multipath and possible out-of-tolerance conditions such that augmented flight checks should be conducted for measuring actual effects on signal quality.

3. An investigation should be performed to identify critical areas for location of aircraft with respect to the MLS transmitting antennas. It is important to define carefully the specific areas where aircraft taxiing and parking must be prohibited. The approach to defining the areas should be through the use of mathematical modeling to predict maximum course perturbations given aircraft size, location, and orientation with respect to the antenna. A contour map can then be drawn for the airport showing the maximum perturbation produced on the MLS course for each given isopleth. Critical areas can be derived directly from the contours once decisions are made concerning maximum allowable perturbations. It would be well to confirm the accuracy of the plots of predicted values by measuring selected points at a typical MLS STEP site.

4. Continued effort should be given to refining the numerical values used in this report and elsewhere as tolerances for MLS operation. Measurements from the STEP program will be a rich source of data and this should be used to the greatest possible extent in obtaining values that confirm established numerical values or suggest changes that are consistent with continued or increased safety yet providing for greater utilization of the MLS.

## V. ACKNOWLEDGEMENTS

The authors acknowledge assistance given by members of the FAA Technical Center staff, with their suggestions and comments based upon earlier experience with MLS prototypes. Personnel at the Bendix Corporation facility at Towson, Maryland were especially helpful in relation to MLS receiver characteristics.

Mohammed Jamil, a technician on the Avionics Engineering Center staff, provided the tracker system comparisons and supported experimental work with laboratory fabrication. Engineer James Nickum and student intern Thomas Zumwalde performed the literature search and indexing operations. Student intern David Bernard produced the motor drive test unit.

## VI. BIBLIOGRAPHY

The literature search conducted early in the MLS Performance Assessment task has resulted in the collection indexed on the following pages. For ease of access, the word-in-context format has been used to display available literature, in Tables 6-1 and 6-2.

The search process is a continuous one, with the bibliography included here representing those materials available to date. In addition to the published literature, computer programs, meeting notes and records of personal conversations provide references in support of the design effort.

Sources include the Lockheed DIALOG computer search service, FAA representatives, consulting firms and equipment manufacturers associated with the MLS effort.

Volume 2 of this report contains abstracts of available literature pertaining to MLS.

\*MLS1\* TECH RPT STUDY AND ANALYSIS OF SC-117, NATIONAL AND USAF PLANS FOR A NEW LANDING SYSTEM MITCHELL SYSTEMS JULY 1972  
 \*MLS2\* ABSTRACTS M.L.S. DIALOG ABSTRACTS  
 \*MLS4\* TECH RPT EXTRACT FROM PRELIMINARY ICAD SARPS: APPENDIX 1 TO THE REPORT ON AGENDA ITEM 1 APPENDIX P  
 \*MLS3\* TECH RPT ADDITIONAL TESTS ON PHASE 3 RECEIVERS CALSPAN TN-1 JAN. 1977  
 \*MLS5\* TECH RPT EXTRACT FROM PRELIMINARY ICAD SARPS: APPENDIX 2 TO THE REPORT ON AGENDA ITEM 1 APPENDIX C  
 \*MLS6\* TECH RPT EXTRACT FROM PRELIMINARY ICAD SARPS APPENDIX 2 TO THE REPORT ON AGENDA ITEM 1  
 \*MLS7\* MLS MULTIPATH STUDIES, PHASE 3, FINAL REPORT, VOL. I: DEVELOPMENT AND VALIDATION OF MODEL FOR MLS TECHNIQUES.  
 \*MLS8\* TECH RPT ESTIMATE OF MLS SHADOWING , CRITICAL AREAS AND AIRPORT BUILDING RESTRICTIONS MTR-8947 THE MITRE CORP. MAY 1975  
 \*MLS9\* TECH RPT TRSB CRITICAL AREAS STUDIES PT. I REFLECTION EFFECTS LINCOLN LABS NOV. 5, 1975  
 \*MLS10\* TECH RPT MLS MULTIPATH STUDIES, VOL. III: APPLICATION OF MULTIPATH MODEL TO KEY MLS PEPF. ISSUES LINCOLN LABS. FEB. 1976  
 \*MLS11\* TECH RPT TRACKER PERFORMANCE , AVAILABILITY AND DEGRADATION  
 \*MLS12\* TECH RPT MULTIPATH AND PERFORMANCE TESTS OF TRSB RECEIVERS CALSPAN TN-6 FEB. 1976  
 \*MLS13\* TECH RPT FLIGHT TEST DATA FOR MULTIMODE DIGITAL PROCESSOR CALSPAN TN-16 DEC 1979  
 \*MLS14\* TECH RPT OCA MLS ADDITIONAL NOTE DEC. 11, 1979  
 \*MLS15\* TECH RPT A NEW GUIDANCE SYSTEM FOR APPROACH AND LANDING RADIO TECHNICAL COMMISSION FOR AERONAUTICS DEC. 1970  
 \*MLS16\* TECH RPT MICROWAVE LANDING SYSTEM APPLICATIONS AND BENEFITS MTR698 MITRE CORP. JULY 1975  
 \*MLS17\* TECH RPT NATIONAL PLAN FOR DEVELOPMENT OF THE MICROWAVE LANDING SYSTEM FAA-ED-37-2A F.A.A. JUNE 1978  
 \*MLS18\* TECH RPT U.S. MLS DEVELOPMENT PROGRAM SYMPOSIUM D.O.T./F.A.A. JUNE 1973  
 \*MLS19\* TECH RPT MLS MULTIPATH STDS. PHASE 3 OVERVIEW AND PROPAGATION MODEL VALIDATION/REFINEMENT STDS. LINCOLN LABS. APR. 1979  
 \*MLS20\* TECH RPT MLS MULTIPATH STDS. PHASE 3 DEVELOPMENT AND VALIDATION OF MODEL FOR MLS TECHNIQUES LINCOLN LABS. FEB. 1980  
 \*MLS21\* TECH RPT CURVED APPROACH PATH STUDY FAA-ED-72-143 COLLINS RADIO CORP./F.A.A. APRIL 1973  
 \*MLS22\* ABSTRACT MICRO STRIP ANTENNAS JOHN C. HOWELL LANGLEY RESEARCH CENTER JULY 1974  
 \*MLS23\* TECH RPT DUAL BAND AIRBORNE ANTENNA STUDY U.S. ARMY ELECTRONICS COMMAND/UNIV. OF MICHIGAN MAY, 1974  
 \*MLS24\* JOURNAL MICROWAVE LANDING SYSTEM ARP-700 F.A.A.  
 \*MLS25\* MANUAL MANUAL ON TESTING OF RADIO NAVIGATION AIDS INTERNATIONAL CIVIL AVIATION ORG. 1972 THIRD EDITION VOL II  
 \*MLS26\* TECH RPT MLS MULTIPATH STUDIES , MATHEMATICAL MODELS AND VALIDATION LINCOLN LABS. FEB. 25, 1976 VOL. I  
 \*MLS27\* TECH RPT MLS PHASE III BASIC NARROW AND SMALL COMM CONFIG. FINAL RPT VOL. I APPENDIX MLS-RCR-R-2801-1 JUNE 1978  
 \*MLS28\* ENG REQ FAA ENGINEERING REQ. MLS FOR BASIC CONFIG. FAA-ER-700-01 FEB. 1975  
 \*MLS29\* ENG REQ FAA ENGINEERING REQ. MLS SIGNAL FORMAT AND SYSTEM LEVEL FUNCTIONAL REQ. FAA-ER-700-09C MAY 10 1979  
 \*MLS30\* TECH RPT MLS FLIGHT CHECK PROCEDURE AT PHILADELPHIA INTERNATIONAL AIRPORT, MAY 29 1980.  
 \*MLS31\* TECH RPT MLS FLIGHT CHECK PROCEDURE AT WASHINGTON NATIONAL AIRPORT, MARCH 6, 1979.  
 \*MLS32\* TECH RPT. GUIDANCE ACCURACY CONSIDERATIONS FOR THE MLS PDME, R.J. KELLY, E.F.C. LABERGE NAVIGATION SPRING 1980  
 \*MLS33\* MAINT MAN MINI RANGER DATA PROCESSOR MAINT. MANUAL, 68-P02526F MOTOROLA NOV. 15, 1978  
 \*MLS34\* INSTR. MAN MLS AIRBORNE SUBSYSTEM BASIC CONFIGURATION INSTR. MANUAL, 1.B.1157 BENDIX JUNE 1976  
 \*MLS35\* MAINT. MAN MLS ONE PRECISION INTERROGATOR SYSTEM MAINT. MANUAL, 1.B.1157B APRIL 1977  
 \*MLS36\* OPER. MAN MINI RANGER DATA PROCESSOR OPERATION & INSTR. MANUAL, 64-P02525F MOTOROLA JUNE 1 1978  
 \*MLS37\* TECH RPT. TEST AND EVALUATION OF TEXAS INSTRUMENTS SMALL COMM. MLS, FINAL RPT MAY 1980  
 \*MLS38\* ENGR. REQ NON-FEDERAL NAVIGATION FACILITIES PROPOSED MLS REQUIREMENTS, FEDERAL REGISTER VOL. 45 NO. 175 SEPT 9 1980  
 \*MLS39\* TEST SERVICE TEST AND EVALUATION PROGRAM (STEP) FOR MLS, FEB. 26, 1979  
 \*MLS40\* OPER. MAN OPERATION AND INSTALLATION MANUAL FOR MINI RANGER III SYSTEM, MOTOROLA APRIL 1 1977  
 \*MLS41\* TECH. DEVELOPMENT OF MICROWAVE LANDING SYSTEM IMPLEMENTATION CRITERIA FINAL RPT. JUNE 1974  
 \*MLS42\* TECH RPT MLS ENGINEERING FLIGHT TEST RESULTS WASHINGTON NATIONAL AIRPORT TM-SA-3-80-6 VITRO LABS SEPT. 1980  
 \*MLS43\* TECH RPT COORDINATE CONVERSION FOR WASHINGTON NATIONAL INSTALLATION MLS-SE-00 LABERGE JUNE 23, 1980  
 \*MLS44\* TECH RPT RE-EVALUATION OF THE EFFECTS OF MLS GUIDANCE ERRORS ON COORDINATE ACCURACY MLS-SE-004 LABERGE JULY 31, 1980  
 \*MLS45\* TEST PLAN WASHINGTON NATIONAL TEST PLAN WP-ROW00725 MITRE NOV 1980  
 \*MLS46\* AN ANALYSIS OF THE REQ FOR AND THE BENEFITS AND COST OF THE NATIONAL MLS EXEC SUMM RPT NO. FAA-EM-80-7 JUNE 1980  
 \*MLS47\* AN ANALYSIS OF THE REQ FOR AND THE BENEFITS AND COST OF THE NATIONAL MLS VOL. I RPT NO. FAA-EM-80-7 JUNE 1980  
 \*MLS48\* AN ANALYSIS OF THE REQ FOR AND THE BENEFITS AND COST OF THE NATIONAL MLS VOL. II RPT NO. FAA-EM-80-7 JUNE 1980  
 \*MLS49\* MICROWAVE LANDING SYSTEM TRANSITION PLAN DRAFT OCTOBER 20 1980

Table 6-1. MLS Index, Numerical.

R JULY 1974 \*MLS22\* ABSTRACT MICRO STRIP ANTENNAS JOHN Q. HOWELL LANGLEY RESEARCH CENTE  
 \*MLS2\* ABSTRACTS M.L.S. DIALOG ABSTRACTS  
 \*MLS2\* ABSTRACTS M.L.S. DIALOG ABSTRACTS  
 E NAVIGATION SPRING 1980 \*MLS32\* TECH RPT. GUIDANCE ACCURACY CONSIDERATIONS FOR THE MLS PDWF, R.J. KELLY, S.F.C. LAHERG  
 E-EVALUATION OF THE EFFECTS OF MLS GUIDANCE ERRORS ON COORDINATE ACCURACY MLS-SE-004 LAHERGE JULY 31, 1980 \*MLS44\* TECH RPT P  
 \*MLS3\* TECH RPT ADDITIONAL TESTS ON PHASE 3 RECEIVERS CALSPAN TN-1 JAN. 1977  
 \*MLS14\* TECH RPT OCA MLS ADDITIONAL NOTE DEC.11, 1979  
 E SYSTEM FOR APPROACH AND LANDING RADIO TECHNICAL COMMISSION FOR AERONAUTICS DEC. 1970 \*MLS15\* TECH RPT A NEW GUIDANC  
 EXTRACT FROM PRELIMINARY ICAD SARPS: APPENDIX 1 TO THE REPORT ON AGENDA ITEM 1 APPENDIX B \*MLS4\* TECH RPT  
 EXTRACT FROM PRELIMINARY ICAD SARPS: APPENDIX 2 TO THE REPORT ON AGENDA ITEM 1 APPENDIX C \*MLS5\* TECH RPT  
 EXTRACT FROM PRELIMINARY ICAD SARPS APPENDIX 2 TO THE REPORT ON AGENDA ITEM 1 \*MLS6\* TECH RPT  
 \*MLS25\* MANUAL MANUAL ON TESTING OF RADIO NAVIGATION AIDS INTERNATIONAL CIVIL AVIATION ORG. 1972 THIRD EDITION VOL II  
 JAN MAY, 1974 \*MLS23\* TECH RPT DUAL BAND AIRBORNE ANTENNA STUDY U.S. ARMY ELECTRONICS COMMAND/UNIV. OF MICH  
 TX JUNE 1976 \*MLS34\* INSTR. MAN MLS AIRBORNE SUBSYSTEM BASIC CONFIGURATION INSTR. MANUAL, I.B.1157 BENDI  
 \*MLS2\* TECH RPT ESTIMATE OF MLS SHADOWING ,CRITICAL AREAS AND AIRPORT BUILDING RESTRICTIONS MTP-6847 THE MITRE CORP. MAY 1975  
 ECH RPT MLS FLIGHT CHECK PROCEDURE AT PHILADELPHIA INTERNATIONAL AIRPORT, MAY 29 1980. \*MLS20\* T  
 LS31\* TECH RPT MLS FLIGHT CHECK PROCEDURE AT WASHINGTON NATIONAL AIRPORT, MARCH 6, 1979. \*MLS42\*  
 TECH RPT MLS ENGINEERING FLIGHT TEST RESULTS WASHINGTON NATIONAL AIRPORT TM-SA-3-RD-6 MITRE LABS SEPT. 1980 \*MLS42\*  
 M LITCHEFORD SYSTEMS JULY 1972 \*MLS1\* TECH RPT STUDY AND ANALYSIS OF SC-117, NATIONAL AND USAF PLANS FOR A NEW LANDING SYSTE  
 LS EXEC SUMM RPT NO. FAA-EM-80-7 JUNE 1980 \*MLS46\* AN ANALYSIS OF THE REQ FOR AND THE BENEFITS AND COST OF THE NATIONAL M  
 LS VOL. I RPT NO. FAA-EM-80-7 JUNE 1980 \*MLS47\* AN ANALYSIS OF THE REQ FOR AND THE BENEFITS AND COST OF THE NATIONAL M  
 LS VOL. II RPT NO. FAA-EM-80-7 JUNE 1980 \*MLS48\* AN ANALYSIS OF THE REQ FOR AND THE BENEFITS AND COST OF THE NATIONAL M  
 1974 \*MLS23\* TECH RPT DUAL BAND AIRBORNE ANTENNA STUDY U.S. ARMY ELECTRONICS COMMAND/UNIV. OF MICHIGAN MAY, 1974  
 \*MLS22\* ABSTRACT MICRO STRIP ANTENNAS JOHN Q. HOWELL LANGLEY RESEARCH CENTER JULY 1974  
 \*MLS4\* TECH RPT EXTRACT FROM PRELIMINARY ICAD SARPS: APPENDIX 1 TO THE REPORT ON AGENDA ITEM 1 APPENDIX B \*MLS4\* TECH RPT EXTRACT FROM P  
 RELIMINARY ICAD SARPS: APPENDIX 1 TO THE REPORT ON AGENDA ITEM 1 APPENDIX C \*MLS5\* TECH RPT EXTRACT FROM P  
 \*MLS5\* TECH RPT EXTRACT FROM PRELIMINARY ICAD SARPS: APPENDIX 2 TO THE REPORT ON AGENDA ITEM 1 APPENDIX C \*MLS5\* TECH RPT EXTRACT FROM P  
 RELIMINARY ICAD SARPS: APPENDIX 2 TO THE REPORT ON AGENDA ITEM 1 APPENDIX C \*MLS5\* TECH RPT EXTRACT FROM P  
 \*MLS6\* TECH RPT EXTRACT FROM PRELIMINARY ICAD SARPS APPENDIX 2 TO THE REPORT ON AGENDA ITEM 1  
 FEB. 1976 \*MLS10\* TECH RPT MLS MULTIPATH STUDIES, VOL.II: APPLICATIONS AND BENEFITS MTR6938 MITRE CORP. JULY 1975  
 \*MLS16\* TECH RPT MICROWAVE LANDING SYSTEM APPROACH AND LANDING RADIO TECHNICAL COMMISSION FOR AERONAUTICS DEC  
 \*MLS15\* TECH RPT A NEW GUIDANCE SYSTEM FOR APPROACH PATH STUDY FAA-RD-72-143 COLLINS RADIO COMP./F.A.A. APR. 1979  
 . 1970 \*MLS21\* TECH RPT CURVED APPROACH PATH STUDY FAA-RD-72-143 COLLINS RADIO COMP./F.A.A. APR. 1979 \*MLS19\* TECH RPT MLS MULTIPATH STDS. PHASE 3 OVERV  
 1973 \*MLS21\* TECH RPT CURVED APPROACH PATH STUDY FAA-RD-72-143 COLLINS RADIO COMP./F.A.A. APRIL 1977 \*MLS35\* MAINT. MA  
 IFW AND PROPAGATION MODEL VALIDATION/REFINEMENT STDS. LINC.LABS. APRIL 1977 \*MLS40\* OPER. MAN OPERAT  
 N MLS ONE PRECISION INTERROGATOR SYSTEM MAINT. MANUAL, I.B.1157B APRIL 1 1977 \*MLS21\* TECH RPT CUR  
 ION AND INSTALLATION MANUAL FOR MINI RANGER III SYSTEM, MOTOROLA APRIL 1973  
 VED APPROACH PATH STUDY FAA-RD-72-143 COLLINS RADIO COMP./F.A.A. ARD-700 F.A.A.  
 \*MLS24\* JOURNAL MICROWAVE LANDING SYSTEM AREAS AND AIRPORT BUILDING RESTRICTIONS MTP-6847 THE MITRE CORP. MA  
 Y 1975 \*MLS8\* TECH RPT ESTIMATE OF MLS SHADOWING ,CRITICAL AREAS STUDIES PT.1 REFLECTION EFFECTS LINCOLN LABS NOV.5, 1975  
 \*MLS9\* TECH RPT TWSB CRITICAL AREAS AND AIRPORT BUILDING RESTRICTIONS MTP-6847 THE MITRE CORP. MA  
 \*MLS23\* TECH RPT DUAL BAND AIRBORNE ANTENNA STUDY U.S. ARMY ELECTRONICS COMMAND/UNIV. OF MICHIGAN MAY, 1974  
 \*MLS11\* TECH RPT TRACKER PERFORMANCE , AVAILABILITY AND DECEPTION \*MLS25\* MANJA  
 I MANUAL ON TESTING OF RADIO NAVIGATION AIDS INTERNATIONAL CIVIL AVIATION ORG. 1972 THIRD EDITION VOL II  
 MICHIGAN MAY, 1974 \*MLS23\* TECH RPT DUAL BAND AIRBORNE ANTENNA STUDY U.S. ARMY ELECTRONICS COMMAND/UNIV. OF  
 -P-2801-1 JUNE 1978 \*MLS27\* TECH RPT MLS PHASE III BASIC NARROW AND SMALL COMM CONFIG. FINAL RPT VOL. I BENDIX MLS-BCD  
 \*MLS28\* ENG REQ FAA ENGINEERING REQ. MLS FOR BASIC CONFIG. FAA-ER-700-01 FEB. 1975 \*MLS27\* TECH RPT MLS PHASE III  
 \*MLS34\* INSTR. MAN MLS AIRBORNE SUBSYSTEM BASIC CONFIGURATION INSTR. MANUAL, I.B.1157 BENDIX JUNE 1976 \*MLS27\* TECH RPT ML  
 BASIC NARROW AND SMALL COMM CONFIG. FINAL RPT VOL. I BENDIX MLS-BCD-R-2901-1 JUNE 1978 \*MLS27\* TECH RPT ML  
 S PHASE III BASIC NARROW AND SMALL COMM CONFIG. FINAL RPT VOL. I BENDIX MLS-BCD-R-2801-1 JUNE 1978 \*MLS27\* TECH RPT ML  
 S AIRBORNE SUBSYSTEM BASIC CONFIGURATION INSTR. MANUAL, I.B.1157 BENDIX JUNE 1976 \*MLS34\* INSTR. MAN ML  
 \*MLS16\* TECH RPT MICROWAVE LANDING SYSTEM APPLICATIONS AND BENEFITS MTR6938 MITRE CORP. JULY 1975  
 JUNE 1980 \*MLS46\* AN ANALYSIS OF THE REQ FOR AND THE BENEFITS AND COST OF THE NATIONAL MLS EXEC SUMM RPT NO. FAA-EM-80-7  
 NE 1980 \*MLS47\* AN ANALYSIS OF THE REQ FOR AND THE BENEFITS AND COST OF THE NATIONAL MLS VOL. I RPT NO. FAA-EM-80-7 JU  
 JUNE 1980 \*MLS48\* AN ANALYSIS OF THE REQ FOR AND THE BENEFITS AND COST OF THE NATIONAL MLS VOL. II RPT NO. FAA-EM-80-7 J  
 TECH RPT ESTIMATE OF MLS SHADOWING ,CRITICAL AREAS AND AIRPORT BUILDING RESTRICTIONS MTR-6847 THE MITRE CORP. MAY 1975 \*MLS8\*

Table 6-2. MLS Index, Word in Context.

\*MLS3\* TECH RPT ADDITIONAL TESTS ON PHASE 3 RECEIVERS CALSPAN TN-1 JAN. 1977

LS12\* TECH RPT MULTIPATH AND PERFORMANCE TESTS OF 1PSR RECEIVERS CALSPAN TN-6 EPT. 1976

MLS13\* TECH RPT FLIGHT TEST DATA FOR MULTIMODE DIGITAL PROCESSOR CALSPAN TN-16 DEC 1979

2\* ABSTRACT MICRO STRIP ANTENNAS JOHN Q. HOWELL LANGLEY RESEARCH CENTER JULY 1974

\*MLS37\* TECH RPT MSL FLIGHT CHECK PROCEDURE AT PHILADELPHIA INTERNATIONAL AIRPORT, MAY 29 1990.

\*MLS31\* TECH RPT MSL FLIGHT CHECK PROCEDURE AT WASHINGTON NATIONAL AIRPORT, MARCH 6, 1979.

MANUAL MANUAL ON TESTING OF RADIO NAVIGATION AIDS INTERNATIONAL CIVIL AVIATION ORG. 1972 THIRD EDITION VOL II

\*MLS21\* TECH RPT CURVED APPROACH PATH STUDY FAA-RD-72-143 COLLINS RADIO COMP./F.A.A. APRIL 1973

\*MLS27\* TECH RPT MSL PHASE III BASIC NARROW AND SMALL COMM. MSL, FINAL RPT VOL. I BENDIX MSL-BCD-R-2801-1 JUNE 1978

\*MLS37\* TECH RPT. TEST AND EVALUATION OF TEXAS INSTRUMENTS SMALL COMM. MSL, FINAL RPT MAY 1990

TECH RPT DUAL BAND AIRBORNE ANTENNA STUDY U.S. ARMY ELECTRONICS COMMAND/UNIV. OF MICHIGAN MAY, 1-74

1 A NEW GUIDANCE SYSTEM FOR APPROACH AND LANDING RADIO TECHNICAL COMMISSION FOR AERONAUTICS DEC. 1970

TECH RPT CURVED APPROACH PATH STUDY FAA-RD-72-143 COLLINS RADIO COMP./F.A.A. APRIL 1973

\*MLS27\* TECH RPT MSL PHASE III BASIC NARROW AND SMALL COMM. MSL, FINAL RPT VOL. I BENDIX MSL-BCD-R-2801-1 JUNE 1978

\*MLS28\* ENG REQ FAA ENGINEERING REQ. MSL FOR BASIC CONFIG. FAA-ER-700-01 FEB. 1975

\*MLS34\* INSTR. MAN MSL AIRBORNE SUBSYSTEM BASIC CONFIGURATION INSTR. MANUAL, I.R.1157 BENDIX JUNE 1976

10N SPRING 1980

JUNE 23, 1980

D LABERGE JUNE 23, 1980

TECH RPT RE-EVALUATION OF THE EFFECTS OF MSL GUIDANCE ERRORS ON CRITICAL AREAS AND AIRPORT BUILDING RESTRICTIONS MTR-6847 THE MITRE CORP. MAY 1975

\*MLS32\* TECH RPT. GUIDANCE ACCURACY CONSIDERATIONS FOR THE MSL PDME, R.J. KELLY, E.F.C. LABERGE NAVIGAT

\*MLS43\* TECH RPT COORDINATE CONVERSION FOR WASHINGTON NATIONAL INSTALLATION MSL-SE-0

\*MLS43\* TECH RPT COORDINATE CONVERSION FOR WASHINGTON NATIONAL INSTALLATION MSL-SE-0

TECH RPT RE-EVALUATION OF THE EFFECTS OF MSL GUIDANCE ERRORS ON CRITICAL AREAS AND AIRPORT BUILDING RESTRICTIONS MTR-6847 THE MITRE CORP. MAY 1975

\*MLS44\* TECH RPT ESTIMATE OF MSL SHADOWING CRITICAL AREAS AND AIRPORT BUILDING RESTRICTIONS MTR-6847 THE MITRE CORP. JULY 1975

\*MLS46\* AN ANALYSIS OF THE REQ FOR AND THE BENEFITS AND COST OF THE NATIONAL MSL EXEC SIMM RPT NO. FAA-EM-80-7 JUNE 1980

\*MLS47\* AN ANALYSIS OF THE REQ FOR AND THE BENEFITS AND COST OF THE NATIONAL MSL VOL. I RPT NO. FAA-EM-80-7 JUNE 1980

\*MLS48\* AN ANALYSIS OF THE REQ FOR AND THE BENEFITS AND COST OF THE NATIONAL MSL VOL. II RPT NO. FAA-EM-80-7 JUNE 1980

41\* TECH. DEVELOPMENT OF MICROWAVE LANDING SYSTEM IMPLEMENTATION CRITERIA FINAL RPT. JUNE 1974

CONCP. MAY 1975

\*MLS8\* TECH RPT ESTIMATE OF MSL SHADOWING CRITICAL AREAS AND AIRPORT BUILDING RESTRICTIONS MTR-6847 THE MITRE CORP. MAY 1975

\*MLS9\* TECH RPT TRSR CRITICAL AREAS STUDIES PT.1 REFLECTION EFFECTS LINCOLN LABS NOV.5,

APRIL 1973

\*MLS21\* TECH RPT CURVED APPROACH PATH STUDY FAA-RD-72-143 COLLINS RADIO COMP./F.A.A.

\*MLS13\* TECH RPT FLIGHT TEST DATA FOR MULTIMODE DIGITAL PROCESSOR CALSPAN TN-16 DEC 1979

\*MLS33\* MAINT MAN MINI RANGER DATA PROCESSOR MAINT. MANUAL, 68-02526F MOTOROLA NOV. 15, 1978

\*MLS36\* OPER. MAN MINI RANGER DATA PROCESSOR OPERATION & INSTR. MANUAL, 68-02525F MOTOROLA JUNE

\*MLS14\* TECH RPT DCA MSL ADDITIONAL NOTE DEC.11, 1979

I 1978

T FLIGHT TEST DATA FOR MULTIMODE DIGITAL PROCESSOR CALSPAN TN-16 DEC 1979

\*MLS14\* TECH RPT DCA MSL ADDITIONAL NOTE DEC.11, 1979

APPROACH AND LANDING RADIO TECHNICAL COMMISSION FOR AERONAUTICS DEC. 1970

\*MLS11\* TECH RPT TRACKER PERFORMANCE, AVAILABILITY AND DESCRIPTION

\*MLS7\* MSL MULTIPATH STUDIES, PHASE 3, FINAL REPORT, VOL. I: DEVELOPMENT AND VALIDATION OF MODEL FOR MSL TECHNIQUES.

E 1978

\*MLS17\* TECH RPT NATIONAL PLAN FOR DEVELOPMENT OF THE MICROWAVE LANDING SYSTEM FAA-ED-07-2A F.A.A. JUN

\*MLS18\* TECH RPT U.S. MSL DEVELOPMENT PROGRAM SYMPOSIUM D.O.T./F.A.A. JUNE 1973

AL RPT. JUNE 1974

\*MLS41\* TECH. DEVELOPMENT OF MICROWAVE LANDING SYSTEM IMPLEMENTATION CRITERIA FIN

\*MLS2\* ABSTRACTS M.L.S. DIGITAL ABSTRACTS

\*MLS13\* TECH RPT FLIGHT TEST DATA FOR MULTIMODE DIGITAL PROCESSOR CALSPAN TN-16 DEC 1979

\*MLS35\* MAINT. MAN MSL ONE PRECISION INTERROGATOR SYSTEM MAINT. MANUAL, I.R.1157R APRIL 19

77

\*MLS49\* MICROWAVE LANDING SYSTEM TRANSITION PLAN DRAFT OCTOBER 20 1980

OF MICHIGAN MAY, 1974

\*MLS23\* TECH RPT DUAL BAND AIRBORNE ANTENNA STUDY U.S. ARMY ELECTRONICS COMMAND/UNIV

1980

\*MLS20\* TECH RPT MSL MULTIPATH STDS. PHASE 3 DEVELOPMENT AND VALIDATION OF MODEL FOR MSL TECHNIQUES LIN. LABS. FEB.

DIO NAVIGATION AIDS INTERNATIONAL CIVIL AVIATION ORG. 1972 THIRD EDITION VOL II

\*MLS9\* TECH RPT TRSB CRITICAL AREAS STUDIES PT.1 REFLECTION EFFECTS LINCOLN LABS NOV.5, 1975

BERGE JULY 31, 1980

\*MLS44\* TECH RPT RE-EVALUATION OF THE EFFECTS OF MSL GUIDANCE ERRORS ON COORDINATE ACCURACY MSL-SE-004 LA

\*MLS23\* TECH RPT DUAL BAND AIRBORNE ANTENNA STUDY U.S. ARMY ELECTRONICS COMMAND/UNIV. OF MICHIGAN MAY, 1974

B. 1975

\*MLS28\* ENG REQ FAA ENGINEERING REQ. MSL FOR BASIC CONFIG. FAA-ER-700-01 FE

DITIONAL REQ. FAA-ER-700-08C MAY 10 1979

\*MLS29\* ENG REQ FAA ENGINEERING REQ. MSL SIGNAL FORMAT AND SYSTEM LEVEL FUN

FAA-ER-700-08C MAY 10 1979

\*MLS28\* ENG REQ FAA ENGINEERING REQ. MSL FOR BASIC CONFIG. FAA-ER-700-01 FEB. 1975

\*MLS29\* ENG REQ FAA ENGINEERING REQ. MSL SIGNAL FORMAT AND SYSTEM LEVEL FUNCTIONAL REQ.

-80-6 VITRO LABS SEPT. 1980 \*MLS42\* TECH RPT MLS ENGINEERING FLIGHT TEST RESULTS WASHINGTON NATIONAL AIRPORT TM-SA-3  
 NTS, FEDERAL REGISTER VOL. 45 NO. 175 SEPT 8 1980 \*MLS39\* ENGR. REQ NON-FEDERAL NAVIGATION FACILITIES PROPOSED MLS REQUIREME  
 T MULTIPATH AND PERFORMANCE TESTS OF INSTR RECEPTORS CALSPAN TN-6 EPT. 1976 \*MLS12\* TECH RP  
 \*MLS44\* TECH RPT RE-EVALUATION OF THE EFFECTS OF MLS GUIDANCE ERRORS ON COORDINATE ACCURACY MLS-SE-004 LABERGE JULY 31, 1980  
 TRICIONS MTR-6847 THE MITRE CORP. MAY 1975 \*MLS8\* TECH RPT ESTIMATE OF MLS SHADOWING CRITICAL AREAS AND AIRPORT BUILDING RES  
 \*MLS37\* TECH RPT. TEST AND EVALUATION OF TEXAS INSTRUMENTS SMALL COMM. MLS, FINAL RPT MAY 1980  
 \*MLS39\* TEST SERVICE TEST AND EVALUATION PROGRAM (STEP) FOR MLS, FEB. 26, 1979  
 PACY MLS-SE-004 LABERGE JULY 31, 1980 \*MLS44\* TECH RPT RE-EVALUATION OF THE EFFECTS OF MLS GUIDANCE ERRORS ON COORDINATE ACCU  
 SIS OF THE REQ FOR AND THE BENEFITS AND COST OF THE NATIONAL MLS EXEC SUMM RPT NO. FAA-EM-80-7 JUNE 1980 \*MLS46\* AN ANALY  
 ENDA ITEM 1 APPENDIX B \*MLS4\* TECH RPT EXTRACT FROM PRELIMINARY ICAD SARPS: APPENDIX 1 TO THE REPORT ON AG  
 ENDA ITEM 1 APPENDIX C \*MLS5\* TECH RPT EXTRACT FROM PRELIMINARY ICAD SARPS: APPENDIX 2 TO THE REPORT ON AG  
 NDA ITEM 1 \*MLS6\* TECH RPT EXTRACT FROM PRELIMINARY ICAD SARPS APPENDIX 2 TO THE REPORT ON AG  
 RT NATIONAL PLAN FOR DEVELOPMENT OF THE MICROWAVE LANDING SYSTEM FAA-ED-07-2A F.A.A. JUNE 1978 \*MLS17\* TECH R  
 \*MLS21\* TECH RPT CURVED APPROACH PATH STUDY FAA-RD-72-143 COLLINS RADIO COMM./F.A.A. APRIL 1973  
 \*MLS28\* ENGR REQ FAA ENGINEERING REQ. MLS FOR BASIC CONFIG. FAA-ER-700-01 FEB. 1975  
 \*MLS28\* ENGR REQ FAA ENGINEERING REQ. MLS FOR BASIC CONFIG. FAA-ER-700-01 FEB. 1975  
 REQ. FAA-ER-700-08C MAY 10 1979 \*MLS29\* ENGR REQ FAA ENGINEERING REQ. MLS SIGNAL FORMAT AND SYSTEM LEVEL FUNCTIONAL  
 INFERING REQ. MLS SIGNAL FORMAT AND SYSTEM LEVEL FUNCTIONAL REQ. FAA-ER-700-08C MAY 10 1979 \*MLS29\* ENGR REQ FAA ENG  
 AND THE BENEFITS AND COST OF THE NATIONAL MLS EXEC SUMM RPT NO. FAA-EM-80-7 JUNE 1980 \*MLS46\* AN ANALYSIS OF THE REQ FOR  
 FOR AND THE BENEFITS AND COST OF THE NATIONAL MLS VOL. I RPT NO. FAA-EM-80-7 JUNE 1980 \*MLS47\* AN ANALYSIS OF THE REQ  
 OR AND THE BENEFITS AND COST OF THE NATIONAL MLS VOL. II RPT NO. FAA-EM-80-7 JUNE 1980 \*MLS48\* AN ANALYSIS OF THE REQ F  
 175 SEPT 8 1980 \*MLS38\* ENGR. REQ NON-FEDERAL NAVIGATION FACILITIES PROPOSED MLS REQUIREMENTS, FEDERAL REGISTER VOL. 45 NO.  
 PPLICATION OF MULTIPATH MODEL TO KEY MLS PERP. ISSUES LINCOLN LABS. FEB. 1976 \*MLS10\* TECH RPT MLS MULTIPATH STUDIES, VOL. II: AP  
 3 DVLPMT AND VALIDATION OF MODEL FOR MLS TECHNIQUES LINCOLN LABS. FEB. 1980 \*MLS20\* TECH RPT MLS MULTIPATH STDS. PHASE  
 IPATH STUDIES, MATHEMATICAL MODELS AND VALIDATION LINCOLN LABS. FEB. 25, 1976 VOL. I \*MLS24\* TECH RPT MLS MULT  
 ENG REQ FAA ENGINEERING REQ. MLS FOR BASIC CONFIG. FAA-ER-700-01 FEB. 1975 \*MLS28\*  
 \*MLS39\* TEST SERVICE TEST AND EVALUATION PROGRAM (STEP) FOR MLS, FEB. 26, 1979  
 REGISTER VOL. 45 NO. 175 SEPT 8 1980 \*MLS39\* ENGR. REQ NON-FEDERAL NAVIGATION FACILITIES PROPOSED MLS REQUIREMENTS, FEDERAL R  
 EQ NON-FEDERAL NAVIGATION FACILITIES PROPOSED MLS REQUIREMENTS, FEDERAL REGISTER VOL. 45 NO. 175 SEPT 8 1980 \*MLS38\* ENGR. P  
 CHNIQUES. \*MLS7\* MLS MULTIPATH STUDIES, PHASE 3, FINAL REPORT, VOL. 1: DEVELOPMENT AND VALIDATION OF MODEL FOR MLS TE  
 LS27\* TECH RPT MLS PHASE III BASIC NARROW AND SMALL COMM CONFIG. FINAL RPT VOL. I BENDIX MLS-80D-R-2801-1 JUNE 1978 \*M  
 H RPT. TEST AND EVALUATION OF TEXAS INSTRUMENTS SMALL COMM. MLS, FINAL RPT MAY 1980 \*MLS37\* TFC  
 DEVELOPMENT OF MICROWAVE LANDING SYSTEM IMPLEMENTATION CRITERIA FINAL RPT. JUNE 1974 \*MLS41\* TECH.  
 1979 \*MLS13\* TECH RPT FLIGHT TEST DATA FOR MULTIMODE DIGITAL PROCESSOR CALSPAN TN-16 DEC  
 9 1980. \*MLS30\* TECH RPT MLS FLIGHT CHECK PROCEDURE AT PHILADELPHIA INTERNATIONAL AIRPORT, MAY 2  
 9. \*MLS31\* TECH RPT MLS FLIGHT CHECK PROCEDURE AT WASHINGTON NATIONAL AIRPORT, MARCH 6, 197  
 LABS SEPT. 1980 \*MLS42\* TECH RPT MLS ENGINEERING FLIGHT TEST RESULTS WASHINGTON NATIONAL AIRPORT TM-SA-3-80-6 VITRO  
 \*MLS29\* ENGR REQ FAA ENGINEERING REQ. MLS SIGNAL FORMAT AND SYSTEM LEVEL FUNCTIONAL REQ. FAA-ER-700-08C MAY 10 1979 \*MLS29\*  
 ENG REQ FAA ENGINEERING REQ. MLS SIGNAL FORMAT AND SYSTEM LEVEL FUNCTIONAL REQ. FAA-ER-700-08C MAY 10 1979 \*MLS29\*  
 FOR AERONAUTICS DEC. 1970 \*MLS15\* TECH RPT A NEW GUIDANCE SYSTEM FOR APPROACH AND LANDING RADIO TECHNICAL COMMISSION  
 C. LABERGE NAVIGATION SPRING 1980 \*MLS32\* TECH RPT. GUIDANCE ACCURACY CONSIDERATIONS FOR THE MLS PDME, R.J. KELLY, E.F.  
 1980 \*MLS44\* TECH RPT RE-EVALUATION OF THE EFFECTS OF MLS GUIDANCE ERRORS ON COORDINATE ACCURACY MLS-SE-004 LABERGE JULY 31,  
 \*MLS22\* ABSTRACT MICRO STRIP ANTENNAS JOHN Q. HOWELL LANGLEY RESEARCH CENTER JULY 1974  
 \*MLS4\* TECH RPT EXTRACT FROM PRELIMINARY ICAD SARPS: APPENDIX 1 TO THE REPORT ON AGENDA ITEM 1 APPENDIX B  
 \*MLS5\* TECH RPT EXTRACT FROM PRELIMINARY ICAD SARPS: APPENDIX 2 TO THE REPORT ON AGENDA ITEM 1 APPENDIX C  
 \*MLS6\* TECH RPT EXTRACT FROM PRELIMINARY ICAD SARPS APPENDIX 2 TO THE REPORT ON AGENDA ITEM 1  
 -80D-R-2801-1 JUNE 1978 \*MLS27\* TECH RPT MLS PHASE III BASIC NARROW AND SMALL COMM CONFIG. FINAL RPT VOL. I BENDIX MLS  
 S40\* OPER. MAN OPERATION AND INSTALLATION MANUAL FOR MINI RANGER III SYSTEM, MOTOROLA APRIL 1 1977 \*ML  
 \*MLS41\* TECH. DEVELOPMENT OF MICROWAVE LANDING SYSTEM IMPLEMENTATION CRITERIA FINAL RPT. JUNE 1974  
 77 \*MLS40\* OPER. MAN OPERATION AND INSTALLATION MANUAL FOR MINI RANGER III SYSTEM, MOTOROLA APRIL 1 19  
 \*MLS43\* TECH RPT COORDINATE CONVERSION FOR WASHINGTON NATIONAL INSTALLATION MLS-SE-00 LABERGE JUNE 23, 1980  
 I.R.1157 BENDIX JUNE 1976 \*MLS34\* INSTR. MAN MLS AIRBORNE SUBSYSTEM BASIC CONFIGURATION INSTR. MANUAL, I.B.1157 BENDIX JUNE 1976  
 \*MLS34\* INSTR. MAN MLS AIRBORNE SUBSYSTEM BASIC CONFIGURATION INSTR. MANUAL, I.B.1157 BENDIX JUNE 1976  
 \*MLS36\* OPER. MAN MINI RANGER DATA PROCESSOR OPERATION INSTR. MANUAL, 68-PO2525F MOTOROLA JUNE 1 1978  
 \*MLS37\* TECH RPT. TEST AND EVALUATION OF TEXAS INSTRUMENTS SMALL COMM. MLS, FINAL RPT MAY 1980

Table 6-2. (Continued).

\*MLS25\* MANUAL MANUAL ON TESTING OF RADIO NAVIGATION AIDS INTERNATIONAL CIVIL AVIATION ORG. 1972 THIRD EDITION VOL II  
 \*MLS30\* TECH RPT MLS FLIGHT CHECK PROCEDURE AT PHILADELPHIA INTERNATIONAL AIRPORT, MAY 29 1980.  
 \*MLS35\* MAINT. MAN MLS DME PRECISION INTERROGATOR SYSTEM MAINT. MANUAL, I.B.1157B APRIL 1977  
 STUDIES, VOL.II: APPLICATION OF MULTIPATH MODEL TO KEY MLS PERF. ISSUES LINC. LABS. FEB. 1976 \*MLS10\* TECH RPT MLS MULTIPATH  
 FROM PRELIMINARY ICAO SARPS: APPENDIX 1 TO THE REPORT ON AGENDA ITEM 1 APPENDIX B \*MLS4\* TECH RPT EXTRACT  
 FROM PRELIMINARY ICAO SARPS: APPENDIX 2 TO THE REPORT ON AGENDA ITEM 1 APPENDIX C \*MLS5\* TECH RPT EXTRACT  
 FROM PRELIMINARY ICAO SARPS: APPENDIX 2 TO THE REPORT ON AGENDA ITEM 1 \*MLS6\* TECH RPT EXTRACT  
 \*MLS3\* TECH RPT ADDITIONAL TESTS ON PHASE 3 RECEIVERS CALSPAN TN-1 JAN. 1977 \*M  
 \*MLS22\* ABSTRACT MICRO STRIP ANTENNAS JOHN Q. HOWELL LANGLEY RESEARCH CENTER JULY 1974  
 \*MLS24\* JOURNAL MICROWAVE LANDING SYSTEM ARD-700 F.A.A.  
 TIONAL AND USAF PLANS FOR A NEW LANDING SYSTEM LITCHFORD SYSTEMS JULY 1972 \*MLS1\* TECH RPT STUDY AND ANALYSIS OF SC-117, NA  
 VE LANDING SYSTEM APPLICATIONS AND BENEFITS MTR6938 MITRE CORP. JULY 1975 \*MLS1\* TECH RPT MICROW  
 RACT MICRO STRIP ANTENNAS JOHN Q. HOWELL LANGLEY RESEARCH CENTER JULY 1974 \*MLS22\* ABST  
 OF MLS GUIDANCE ERRORS ON COORDINATE ACCURACY MLS-SE-004 LABERGE JULY 31, 1980 \*MLS44\* TECH RPT RE-EVALUATION OF THE EFFECTS  
 DEVELOPMENT OF THE MICROWAVE LANDING SYSTEM FAA-ED-07-2A F.A.A. JUNE 1978 \*MLS17\* TECH RPT NATIONAL PLAN FOR  
 B\* TECH RPT U.S. MLS DEVELOPMENT PROGRAM SYMPOSIUM D.O.T./F.A.A. JUNE 1973 \*MLS1  
 AND SMALL COMM CONFIG. FINAL RPT VOL. I BENDIX MLS-RCD-R-2801-1 JUNE 1978 \*MLS27\* TECH RPT MLS PHASE III BASIC NARROW  
 RNE SUBSYSTEM BASIC CONFIGURATION INSTR. MANUAL, I.B.1157 BENDIX JUNE 1976 \*MLS34\* INSTR. MAN MLS AIRRO  
 ER DATA PROCESSOR OPERATION C INSTR. MANUAL, 68-PO2526F MOTOROLA JUNE 1 1978 \*MLS36\* OPER. MAN MINI RANG  
 I OF MICROWAVE LANDING SYSTEM IMPLEMENTATION CRITERIA FINAL RPT. JUNE 1974 \*MLS41\* TECH. DEVELOPME  
 INVERSION FOR WASHINGTON NATIONAL INSTALLATION MLS-SE-00 LABERGE JUNE 23, 1980 \*MLS43\* TECH RPT COORDINATE C  
 EFITS AND COST OF THE NATIONAL MLS EXFC SUMM RPT NO. FAA-EM-80-7 JUNE 1980 \*MLS46\* AN ANALYSIS OF THE REQ FOR AND THE BEN  
 BENEFITS AND COST OF THE NATIONAL MLS VOL. I RPT NO. FAA-EM-80-7 JUNE 1980 \*MLS47\* AN ANALYSIS OF THE REQ FOR AND THE  
 BENEFITS AND COST OF THE NATIONAL MLS VOL. II RPT NO. FAA-EM-80-7 JUNE 1980 \*MLS48\* AN ANALYSIS OF THE REQ FOR AND THE R  
 TECH RPT. GUIDANCE ACCURACY CONSIDERATIONS FOR THE MLS DOME, P.J. KELLY, E.F.C. LABERGE NAVIGATION SPRING 1980 \*MLS32\* T  
 MLS MULTIPATH STUDIES, VOL.III: APPLICATION OF MULTIPATH MODEL TO KEY MLS PERF. ISSUES LINC. LABS. FEB. 1976 \*MLS10\* TECH RPT  
 NCE ACCURACY CONSIDERATIONS FOR THE MLS DOME, P.J. KELLY, E.F.C. LABERGE NAVIGATION SPRING 1980 \*MLS32\* TECH RPT. GUIDA  
 DINATE CONVERSION FOR WASHINGTON NATIONAL INSTALLATION MLS-SE-00 LABERGE JUNE 23, 1980 \*MLS43\* TECH RPT COOR  
 EFFECTS OF MLS GUIDANCE ERRORS ON COORDINATE ACCURACY MLS-SE-004 LABERGE JULY 31, 1980 \*MLS44\* TECH RPT RE-EVALUATION OF THE  
 RPT TRSB CRITICAL AREAS STUDIES PT.1 REFLECTION EFFECTS LINCOLN LABS NOV.5, 1975 \*MLS9\* TECH  
 II: APPLICATION OF MULTIPATH MODEL TO KEY MLS PERF. ISSUES LINC. LABS. FEB. 1976 \*MLS10\* TECH RPT MLS MULTIPATH STUDIES, VOL.  
 OVERVIEW AND PROPAGATION MODEL VALIDATION/REFINEMENT STDS. LINC.LABS. APR. 1979 \*MLS19\* TECH RPT MLS MULTIPATH STDS. PHASE 3  
 PHASE 3 DVLPMT AND VALIDATION OF MODEL FOR MLS TECHNIQUES LINC. LABS. FEB. 1980 \*MLS20\* TECH RPT MLS MULTIPATH STDS.  
 S MULTIPATH STUDIES , MATHEMATICAL MODELS AND VALIDATION LINCOLN LABS. FEB.25, 1976 VOL.I \*MLS26\* TECH RPT ML  
 IGH TEST RESULTS WASHINGTON NATIONAL AIRPORT TM-SA-3-80-6 VITRO LABS SEPT. 1980 \*MLS42\* TECH RPT MLS ENGINEERING FL  
 STUDY AND ANALYSIS OF SC-117, NATIONAL AND USAF PLANS FOR A NEW LANDING SYSTEM LITCHFORD SYSTEMS JULY 1972 \*MLS1\* TECH RPT  
 \*MLS15\* TECH RPT A NEW GUIDANCE SYSTEM FOR APPROACH AND LANDING SYSTEM APPLICATIONS AND BENEFITS MTR6938 MITRE CORP. JULY 1  
 975 \*MLS16\* TECH RPT MICROWAVE LANDING SYSTEM ARD-700 F.A.A.  
 \*MLS17\* TECH RPT NATIONAL PLAN FOR DEVELOPMENT OF THE MICROWAVE LANDING SYSTEM FAA-ED-07-2A F.A.A. JUNE 1978  
 \*MLS24\* JOURNAL MICROWAVE LANDING SYSTEM ARD-700 F.A.A.  
 \*MLS41\* TECH. DEVELOPMENT OF MICROWAVE LANDING SYSTEM IMPLEMENTATION CRITERIA FINAL RPT. JUNE 1974  
 \*MLS49\* MICROWAVE LANDING SYSTEM TRANSITION PLAN DRAFT OCTOBER 20 1980  
 \*MLS22\* ABSTRACT MICRO STRIP ANTENNAS JOHN Q. HOWELL LANGLEY RESEARCH CENTER JULY 1974  
 MLS29\* ENG REQ FAA ENGINEERING REQ. MLS SIGNAL FORMAT AND SYSTEM LEVEL FUNCTIONAL REQ. FAA-EP-700-08C MAY 10 1979 \*  
 , VOL.II: APPLICATION OF MULTIPATH MODEL TO KEY MLS PERF. ISSUES LINC. LABS. FEB. 1976 \*MLS10\* TECH RPT MLS MULTIPATH STUDIES  
 ASE 3 OVERVIEW AND PROPAGATION MODEL VALIDATION/REFINEMENT STDS. LINC.LABS. APR. 1979 \*MLS19\* TECH RPT MLS MULTIPATH STDS. PH  
 STDS. PHASE 3 DVLPMT AND VALIDATION OF MODEL FOR MLS TECHNIQUES LINC. LABS. FEB. 1980 \*MLS20\* TECH RPT MLS MULTIPATH  
 S9\* TECH RPT TRSB CRITICAL AREAS STUDIES PT.1 REFLECTION EFFECTS LINCOLN LABS NOV.5, 1975 \*ML  
 H RPT MLS MULTIPATH STUDIES , MATHEMATICAL MODELS AND VALIDATION LINCOLN LABS. FEB.25, 1976 VOL.I \*MLS26\* TEC  
 YSIS OF SC-117, NATIONAL AND USAF PLANS FOR A NEW LANDING SYSTEM LITCHFORD SYSTEMS JULY 1972 \*MLS1\* TECH RPT STUDY AND ANAL  
 ROLA NOV. 15, 1978 \*MLS33\* MAINT MAN MINI RANGER DATA PROCESSOR MAINT. MANUAL, 68-PO2526F MOTOROLA NOV. 15, 1978  
 .1157B APRIL 1977 \*MLS35\* MAINT. MAN MLS DME PRECISION INTERROGATOR SYSTEM MAINT. MANUAL, I.B  
 \*MLS35\* MAINT. MAN MLS DME PRECISION INTERROGATOR SYSTEM MAINT. MANUAL, I.B.1157B APRIL 1977  
 NOV. 15, 1978 \*MLS33\* MAINT MAN MINI RANGER DATA PROCESSOR MAINT. MANUAL, 68-PO2526F MOTOROLA N



ANALYSIS OF THE REQ FOR AND THE BENEFITS AND COST OF THE NATIONAL  
DIES, PHASE 3, FINAL REPORT, VOL. I: DEVELOPMENT AND VALIDATION OF  
TECH RPT MLS MULTIPATH STUDIES, VOL. II: APPLICATION OF MULTIPATH  
19\* TECH RPT MLS MULTIPATH STDS. PHASE 3 OVERVIEW AND PROPAGATION  
0\* TECH RPT MLS MULTIPATH STDS. PHASE 3 DVLPT AND VALIDATION OF  
\*MLS26\* TECH RPT MLS MULTIPATH STUDIES, MATHEMATICAL  
\* MAINT MAN MINI RANGER DATA PROCESSOR MAINT. MANUAL, 68-P02526F  
MINI RANGER DATA PROCESSOR OPERATION & INSTR. MANUAL, 68-P02525F  
AN OPERATION AND INSTALLATION MANUAL FOR MINI RANGER III SYSTEM,  
MLS SHADOWING, CRITICAL AREAS AND AIRPORT BUILDING RESTRICTIONS  
S16\* TECH RPT MICROWAVE LANDING SYSTEM APPLICATIONS AND BENEFITS  
\*MLS13\* TECH RPT FLIGHT TEST DATA FOR  
IDATION OF MODEL FOR MLS TECHNIQUES.  
S PERF. ISSUES LINC. LABS. FEB. 1976 \*MLS7\* MLS  
\*MLS10\* TECH RPT MLS \*MLS10\* TECH RPT MLS  
\*MLS10\* TECH RPT MLS MULTIPATH STUDIES, VOL. II: APPLICATION OF  
1976 \*MLS12\* TECH RPT  
\*MLS20\* TECH RPT MLS  
\*MLS26\* TECH RPT MLS  
\*MLS19\* TECH RPT MLS  
\*MLS27\* TECH RPT MLS PHASE III BASIC  
\*MLS1\* TECH RPT STUDY AND ANALYSIS OF SC-117,  
0-07-24 F.A.A. JUNE 1978 \*MLS17\* TECH RPT  
\*MLS31\* TECH RPT MLS FLIGHT CHECK PROCEDURE AT WASHINGTON  
\*MLS42\* TECH RPT MLS ENGINEERING FLIGHT TEST RESULTS WASHINGTON  
\*MLS43\* TECH RPT COORDINATE CONVERSION FOR WASHINGTON  
\*MLS45\* TEST PLAN WASHINGTON  
S46\* AN ANALYSIS OF THE REQ FOR AND THE BENEFITS AND COST OF THE  
S47\* AN ANALYSIS OF THE REQ FOR AND THE BENEFITS AND COST OF THE  
S48\* AN ANALYSIS OF THE REQ FOR AND THE BENEFITS AND COST OF THE  
N VOL II \*MLS25\* MANUAL MANUAL ON TESTING OF RADIO  
RACY CONSIDERATIONS FOR THE MLS PDME, R.J. KELLY, F.F.C. LABERGE  
VOL. 45 NO. 175 SEPT 8 1980 \*MLS38\* ENGR. REQ NON-FEDERAL  
RPT STUDY AND ANALYSIS OF SC-117, NATIONAL AND USAF PLANS FOR A  
SION FOR AERONAUTICS DEC. 1970 \*MLS15\* TECH RPT A  
\*MLS14\* TECH RPT OCA MLS ADDITIONAL  
TRSR CRITICAL AREAS STUDIES PT. I REFLECTION EFFECTS LINCOLN LABS  
AN MINI RANGER DATA PROCESSOR MAINT. MANUAL, 68-P02526F MOTOROLA  
MLS45\* TEST PLAN WASHINGTON NATIONAL TEST PLAN WP-80W00725 MITRE  
\*MLS49\* MICROWAVE LANDING SYSTEM TRANSITION PLAN DRAFT  
P02525F MOTOROLA JUNE 1 1978 \*MLS36\* OPR. MAN  
TEM, MOTOROLA APRIL 1 1977 \*MLS40\* OPR. MAN  
DLA APRIL 1 1977 \*MLS40\* OPR. MAN  
ON TESTING OF RADIO NAVIGATION AIDS INTERNATIONAL CIVIL AVIATION  
S. APR. 1979 \*MLS19\* TECH RPT MLS MULTIPATH STDS. PHASE 3  
\*MLS21\* TECH RPT CURVED APPROACH  
\*MLS32\* TECH RPT. GUIDANCE ACCURACY CONSIDERATIONS FOR THE MLS  
IPATH STUDIES, VOL. II: APPLICATION OF MULTIPATH MODEL TO KEY MLS  
\*MLS11\* TECH RPT TRACKER  
\*MLS12\* TECH RPT MULTIPATH AND  
\*MLS3\* TECH RPT ADDITIONAL TESTS ON  
\*MLS7\* MLS MULTIPATH STUDIES,  
\*MLS19\* TECH RPT MLS MULTIPATH STDS.  
\*MLS20\* TECH RPT MLS MULTIPATH STDS.  
IX MLS-BCD-R-2801-1 JUNE 1978 \*MLS27\* TECH RPT MLS

MLS VOL. II RPT NO. FAA-EM-80-7 JUNE 1980 \*MLS48\* AN A  
MODEL FOR MLS TECHNIQUES. \*MLS7\* MLS MULTIPATH STU  
MODEL TO KEY MLS PERF. ISSUES LINC. LABS. FEB. 1976 \*MLS10\*  
MODEL VALIDATION/REFINEMENT STDS. LINC. LABS. APR. 1979 \*MLS  
MODEL FOR MLS TECHNIQUES LINC. LABS. FEB. 1980 \*MLS2  
MODELS AND VALIDATION LINCOLN LABS. FEB. 25, 1976 VOL. I  
MOTOROLA NOV. 15, 1978 \*MLS33  
MOTOROLA JUNE 1 1978 \*MLS36\* OPR. MAN  
MOTOROLA APRIL 1 1977 \*MLS40\* OPR. M  
MTP-6847 THE MITRE CORP. MAY 1975 \*MLS8\* TECH RPT ESTIMATE OF  
MTR6938 MITRE CORP. JULY 1975 \*ML  
MULTIMODE DIGITAL PROCESSOR CALSPAN TN-16 DEC 1979  
MULTIPATH STUDIES, PHASE 3, FINAL REPORT, VOL. I: DEVELOPMENT AND VAL  
MULTIPATH STUDIES, VOL. II: APPLICATION OF MULTIPATH MODEL TO KEY ML  
MULTIPATH MODEL TO KEY MLS PERF. ISSUES LINC. LABS. FEB. 1976  
MULTIPATH AND PERFORMANCE TESTS OF TRSB RECEIVERS CALSPAN TN-6 EPT.  
MULTIPATH STDS. PHASE 3 DVLPT AND VALIDATION OF MODEL FOR MLS TECH  
MULTIPATH STUDIES, MATHEMATICAL MODELS AND VALIDATION LINCOLN LABS  
MULTIPATH STDS. PHASE 3 OVERVIEW AND PROPAGATION MODEL VALIDATION/RE  
NARROW AND SMALL COMM CONFIG. FINAL RPT VOL. I BENDIX MLS-BCD-R-280  
NATIONAL AND USAF PLANS FOR A NEW LANDING SYSTEM LITCHFIELD SYSTEMS  
NATIONAL PLAN FOR DEVELOPMENT OF THE MICROWAVE LANDING SYSTEM FAA-E  
NATIONAL AIRPORT, MARCH 6, 1979.  
NATIONAL AIRPORT TM-SA-3-80-6 VITRO LABS SEPT. 1980  
NATIONAL INSTALLATION MLS-SF-90 LABERGE JUNE 23, 1980  
NATIONAL TEST PLAN WP-80W00725 MITRE NOV 1980  
NATIONAL MLS EXEC SJMM RPT NO. FAA-EM-80-7 JUNE 1980 \*ML  
NATIONAL MLS VOL. I RPT NO. FAA-EM-80-7 JUNE 1980 \*ML  
NATIONAL MLS VOL. II RPT NO. FAA-EM-80-7 JUNE 1980 \*ML  
NAVIGATION AIDS INTERNATIONAL CIVIL AVIATION ORG. 1972 THIRD EDITIO  
NAVIGATION SPRING 1980 \*MLS32\* TECH RPT. GUIDANCE ACCU  
NAVIGATION FACILITIES PROPOSED MLS REQUIREMENTS, FEDERAL REGISTER  
NEW LANDING SYSTEM LITCHFIELD SYSTEMS JULY 1972 \*MLS1\* TECH  
NEW GUIDANCE SYSTEM FOR APPROACH AND LANDING RADIO TECHNICAL COMMIS  
NOTE DEC. 11, 1979  
NOV. 5, 1975 \*MLS9\* TECH RPT  
NOV. 15, 1978 \*MLS33\* MAINT M  
NOV 1980  
OCTOBER 20 1980  
\*MLS36\* OPR. MAN MINI RANGER DATA PROCESSOR OPERATION & INSTR. MANUAL, 68-  
\*MLS40\* OPR. MAN OPERATION AND INSTALLATION MANUAL FOR MINI RANGER III SYS  
OPERATION & INSTR. MANUAL, 68-P02525F MOTOROLA JUNE 1 1978  
OPERATION AND INSTALLATION MANUAL FOR MINI RANGER III SYSTEM, MOTOR  
ORG. 1972 THIRD EDITION VOL II \*MLS25\* MANUAL MANUAL  
OVERVIEW AND PROPAGATION MODEL VALIDATION/REFINEMENT STDS. LINC. LAB  
PATH STUDY FAA-PD-72-143 COLLINS RADIO COMP./F.A.A. APRIL 1973  
PDME, R.J. KELLY, E.F.C. LABERGE NAVIGATION SPRING 1980  
PERF. ISSUES LINC. LABS. FEB. 1976 \*MLS10\* TECH RPT MLS MULT  
PERFORMANCE, AVAILABILITY AND DECRYPTION  
PERFORMANCE TESTS OF TRSB RECEIVERS CALSPAN TN-6 EPT. 1976  
PHASE 3 RECEIVERS CALSPAN TN-1 JAN. 1977  
PHASE 3, FINAL REPORT, VOL. I: DEVELOPMENT AND VALIDATION OF MODEL F  
PHASE 3 OVERVIEW AND PROPAGATION MODEL VALIDATION/REFINEMENT STDS.  
PHASE 3 DVLPT AND VALIDATION OF MODEL FOR MLS TECHNIQUES LINC. LA  
PHASE III BASIC NARROW AND SMALL COMM CONFIG. FINAL RPT VOL. I BEND

\*MLS30\* TECH RPT MLS FLIGHT CHECK PROCEDURE AT PHILADELPHIA INTERNATIONAL AIRPORT, MAY 29 1980.  
 J.A.A. JUNE 1978 \*MLS17\* TECH RPT NATIONAL PLAN FOR DEVELOPMENT OF THE MICROWAVE LANDING SYSTEM FAA-ED-07-2A F  
 \*MLS45\* TEST PLAN WASHINGTON NATIONAL TEST PLAN WP-80W00725 MITRE NOV 1980  
 \*MLS45\* TEST PLAN WASHINGTON NATIONAL TEST PLAN WP-80W00725 MITRE NOV 1980  
 \*MLS49\* MICROWAVE LANDING SYSTEM TRANSITION PLAN DRAFT OCTOBER 20 1980  
 \*MLS1\* TECH RPT STUDY AND ANALYSIS OF SC-117, NATIONAL AND USAF PLANS FOR A NEW LANDING SYSTEM LITCHFORD SYSTEMS JULY 1972  
 APPENDIX B \*MLS35\* MAINT. MAN MINI RANGER DATA PRECISION INTERROGATOR SYSTEM MAINT. MANUAL, I.B.1157B APRIL 1977  
 APPENDIX C \*MLS4\* TECH RPT EXTRACT FROM PRELIMINARY ICAO SARPS: APPENDIX 1 TO THE REPORT ON AGENDA ITEM 1 A  
 \*MLS5\* TECH RPT EXTRACT FROM PRELIMINARY ICAO SARPS: APPENDIX 2 TO THE REPORT ON AGENDA ITEM 1 A  
 \*MLS6\* TECH RPT EXTRACT FROM PRELIMINARY ICAO SARPS APPENDIX 2 TO THE REPORT ON AGENDA ITEM 1  
 \*MLS30\* TECH RPT MLS FLIGHT CHECK PROCEDURE AT PHILADELPHIA INTERNATIONAL AIRPORT, MAY 29 1980.  
 \*MLS31\* TECH RPT MLS FLIGHT CHECK PROCEDURE AT WASHINGTON NATIONAL AIRPORT, MARCH 6, 1979.  
 \*MLS13\* TECH RPT FLIGHT TEST DATA FOR MULTIMODE DIGITAL PROCESSOR CALSPAN TN-16 DEC 1979  
 \*MLS33\* MAINT MAN MINI RANGER DATA PROCESSOR MAINT. MANUAL, 68-P02526F MOTOROLA NOV. 15, 1978  
 \*MLS36\* OPER. MAN MINI RANGER DATA PROCESSOR OPERATION & INSTR. MANUAL, 68-P02525F MOTOROLA JUNE 1 197  
 \*MLS18\* TECH RPT U.S. MLS DEVELOPMENT PROGRAM SYMPOSIUM D.O.T./F.A.A. JUNE 1973  
 \*MLS39\* TEST SERVICE TEST AND EVALUATION PROGRAM (STEP) FOR MLS, FEB. 26, 1979  
 \*MLS19\* TECH RPT MLS MULTIPATH STDS. PHASE 3 OVERVIEW AND PROPAGATION MODEL VALIDATION/REFINEMENT STDS. LINC.LABS. APR. 1979  
 1980 \*MLS38\* ENGR. REQ NON-FEDERAL NAVIGATION FACILITIES PROPOSED MLS REQUIREMENTS, FEDERAL REGISTER VOL. 45 NO. 175 SEPT 8  
 OPER. MAN MINI RANGER DATA PROCESSOR OPERATION & INSTR. MANUAL, 68-P02525F MOTOROLA JUNE 1 1978 \*MLS36\* OP  
 \*MLS33\* MAINT MAN MINI RANGER DATA PROCESSOR MAINT. MANUAL, 68-P02526F MOTOROLA NOV. 15, 1978  
 \*MLS15\* TECH RPT A NEW GUIDANCE SYSTEM FOR APPROACH AND LANDING RADIO TECHNICAL COMMISSION FOR AERONAUTICS DEC. 1970  
 \*MLS21\* TECH RPT CURVED APPROACH PATH STUDY FAA-RD-72-143 COLLINS RADIO COMP./F.A.A. APRIL 1973  
 EDITION VOL II \*MLS25\* MANUAL MANUAL ON TESTING OF RADIO NAVIGATION AIDS INTERNATIONAL CIVIL AVIATION ORG. 1972 THIRD  
 978 \*MLS32\* MAINT MAN MINI RANGER DATA PROCESSOR MAINT. MANUAL, 68-P02526F MOTOROLA NOV. 15, 1  
 & JUNE 1 1978 \*MLS26\* OPER. MAN MINI RANGER DATA PROCESSOR OPERATION & INSTR. MANUAL, 68-P02525F MOTOROL  
 \*MLS40\* OPER. MAN OPERATION AND INSTALLATION MANUAL FOR MINI RANGER III SYSTEM, MOTOROLA APRIL 1 1977  
 \*MLS3\* TECH RPT ADDITIONAL TESTS ON PHASE 3 RECEIVERS CALSPAN TN-1 JAN. 1977  
 \*MLS12\* TECH RPT MULTIPATH AND PERFORMANCE TESTS OF TRSB RECEIVERS CALSPAN TN-6 EPT. 1976  
 MULTIPATH STDS. PHASE 3 OVERVIEW AND PROPAGATION MODEL VALIDATION/REFINEMENT STDS. LINC.LABS. APR. 1979 \*MLS19\* TECH RPT MLS  
 \*MLS9\* TECH RPT TRSB CRITICAL AREAS STUDIES PT.1 REFLECTION EFFECTS LINCOLN LABS NOV.5, 1975 \*MLS38\* ENGR. REQ NON-F  
 FEDERAL NAVIGATION FACILITIES PROPOSED MLS REQUIREMENTS, FEDERAL REGISTER VOL. 45 NO. 175 SEPT 8 1980 \*MLS4\*  
 TECH RPT EXTRACT FROM PRELIMINARY ICAO SARPS: APPENDIX 1 TO THE REPORT ON AGENDA ITEM 1 APPENDIX B \*MLS5\*  
 TECH RPT EXTRACT FROM PRELIMINARY ICAO SARPS: APPENDIX 2 TO THE REPORT ON AGENDA ITEM 1 APPENDIX C \*MLS6\*  
 \* TECH RPT EXTRACT FROM PRELIMINARY ICAO SARPS APPENDIX 2 TO THE REPORT ON AGENDA ITEM 1 \*MLS6\*  
 FS. \*MLS7\* MLS MULTIPATH STUDIES, PHASE 3, FINAL REPORT, VOL. 1: DEVELOPMENT AND VALIDATION OF MODEL FOR MLS TECHNIQ  
 975 \*MLS28\* ENG REQ FAA ENGINEERING REQ FAA ENGINEERING REQ. MLS FOR BASIC CONFIG. FAA-ER-700-01 FEB. 1  
 \*MLS28\* ENG REQ FAA ENGINEERING REQ. MLS FOR BASIC CONFIG. FAA-ER-700-01 FEB. 1975  
 \*MLS29\* ENG REQ FAA ENGINEERING REQ. MLS SIGNAL FORMAT AND SYSTEM LEVEL FUNCTIONAL REQ. FAA-ER-700-  
 \*MLS29\* ENG REQ FA  
 \*MLS29\* ENG REQ FAA ENGINEERING REQ. MLS SIGNAL FORMAT AND SYSTEM LEVEL FUNCTIONAL REQ. FAA-ER-700-08C MAY 10 1979  
 \*MLS29\* ENG REQ FA  
 A ENGINEERING REQ. MLS SIGNAL FORMAT AND SYSTEM LEVEL FUNCTIONAL REQ. FAA-ER-700-08C MAY 10 1979 \*MLS29\* ENG REQ FA  
 FEDERAL REGISTER VOL. 45 NO. 175 SEPT 8 1980 \*MLS38\* ENGR. REQ NON-FEDERAL NAVIGATION FACILITIES PROPOSED MLS REQUIREMENTS, F  
 NO. FAA-EM-80-7 JUNE 1980 \*MLS46\* AN ANALYSIS OF THE REQ FOR AND THE BENEFITS AND COST OF THE NATIONAL MLS EXEC SUMM RPT  
 FAA-EM-80-7 JUNE 1980 \*MLS47\* AN ANALYSIS OF THE REQ FOR AND THE BENEFITS AND COST OF THE NATIONAL MLS VOL. I RPT NO  
 O. FAA-EM-80-7 JUNE 1980 \*MLS48\* AN ANALYSIS OF THE REQ FOR AND THE BENEFITS AND COST OF THE NATIONAL MLS VOL. II PPT N  
 \*MLS38\* ENGR. REQ NON-FEDERAL NAVIGATION FACILITIES PROPOSED MLS REQUIREMENTS, FEDERAL REGISTER VOL. 45 NO. 175 SEPT 8 1980 \*  
 \*MLS22\* ABSTRACT MICRO STRIP ANTENNAS JOHN Q. HOWELL LANGLEY RESEARCH CENTER JULY 1974  
 ESTIMATE OF MLS SHADOWING ,CRITICAL AREAS AND AIRPORT BUILDING RESTRICTIONS MTR-6847 THE MITRE CORP. MAY 1975 \*MLS8\* TECH RPT  
 980 \*MLS42\* TECH RPT MLS ENGINEERING FLIGHT TEST RESULTS WASHINGTON NATIONAL AIRPORT TN-SA-3-80-6 VITRO LABS SEPT. 1  
 LANDING SYSTEM LITCHFORD SYSTEMS JULY 1972 \*MLS1\* TECH RPT STUDY AND ANALYSIS OF SC-117, NATIONAL AND USAF PLANS FOR A NEW  
 N AGENDA ITEM 1 APPENDIX B \*MLS4\* TECH RPT EXTRACT FROM PRELIMINARY ICAO SARPS: APPENDIX 1 TO THE REPORT O  
 \*MLS3\* TECH RPT ADDITIONAL TESTS ON PHASE 3 RECEIVERS CALSPAN TN-1 JAN. 1977  
 \*MLS5\* TECH RPT EXTRACT FROM PRELIMINARY ICAO SARPS: APPENDIX 2 TO THE REPORT O  
 \*MLS6\* TECH RPT EXTRACT FROM PRELIMINARY ICAO SARPS APPENDIX 2 TO THE REPORT O  
 N AGENDA ITEM 1 APPENDIX C \*MLS6\* TECH RPT EXTRACT FROM PRELIMINARY ICAO SARPS APPENDIX 2 TO THE REPORT O  
 AGENDA ITEM 1 \*MLS6\* TECH RPT EXTRACT FROM PRELIMINARY ICAO SARPS APPENDIX 2 TO THE REPORT O  
 RESTRICTIONS MTR-6847 THE MITRE CORP. MAY 1975 \*MLS8\* TECH RPT ESTIMATE OF MLS SHADOWING ,CRITICAL AREAS AND AIRPORT BUILDING

NOV. 5, 1975  
 KEY MLS PERFORM. ISSUES LINC. LABS. FEB. 1976  
 PPT. 1976  
 DEC 1979  
 COMMISSION FOR AERONAUTICS DEC. 1970  
 F CORP. JULY 1975  
 AA-ED-07-2A F.A.A. JUNE 1978  
 ATION/REFINEMENT STDS. LINC. LABS. APR. 1979  
 MLS TECHNIQUES LINC. LABS. FEB. 1980  
 A.A. APRIL 1973  
 UNIV. OF MICHIGAN MAY, 1974  
 LIN LABS. FEB. 25, 1976 VOL. I  
 I BENDIX MLS-BCD-R-2801-1 JUNE 1978  
 TECH RPT MLS PHASE III BASIC NARROW AND SMALL COMM CONFIG. FINAL RPT VOL. I BENDIX MLS-BCD-R-2801-1 JUNE 1978  
 T, MAY 29 1980.  
 H 6, 1979.  
 F.F.C. LABERGE NAVIGATION SPRING 1980  
 L RPT MAY 1980  
 TEST AND EVALUATION OF TEXAS INSTRUMENTS SMALL COMM. MLS, FINAL RPT MAY 1980  
 DEMENT OF MICROWAVE LANDING SYSTEM IMPLEMENTATION CRITERIA FINAL RPT. JUNE 1974  
 TM-SA-3-80-6 VITRO LABS SEPT. 1980  
 SE-00 LABERGE JUNE 23, 1980  
 TE ACCURACY MLS-SC-004 LABERGE JULY 31, 1980  
 REQ FOR AND THE BENEFITS AND COST OF THE NATIONAL MLS EXEC SUMM RPT NO. FAA-EM-80-7 JUNE 1980  
 THE REQ FOR AND THE BENEFITS AND COST OF THE NATIONAL MLS VOL. I RPT NO. FAA-EM-80-7 JUNE 1980  
 HE REQ FOR AND THE BENEFITS AND COST OF THE NATIONAL MLS VOL. II RPT NO. FAA-EM-80-7 JUNE 1980  
 \*MLS44\* TECH RPT EXTRACT FROM PRELIMINARY ICAO SARPS: APPENDIX 1 TO THE REPORT ON AGENDA ITEM 1 APPENDIX B  
 \*MLS55\* TECH RPT EXTRACT FROM PRELIMINARY ICAO SARPS: APPENDIX 2 TO THE REPORT ON AGENDA ITEM 1 APPENDIX C  
 \*MLS56\* TECH RPT EXTRACT FROM PRELIMINARY ICAO SARPS APPENDIX 2 TO THE REPORT ON AGENDA ITEM 1  
 TES PROPOSED MLS REQUIREMENTS, FEDERAL REGISTER VOL. 45 NO. 175 SEPT 8 1980  
 TEST RESULTS WASHINGTON NATIONAL AIRPORT TM-SA-3-90-6 VITRO LABS SEPT. 1980  
 \*MLS39\* TEST SERVICE TEST AND EVALUATION PROGRAM (STEP) FOR MLS, FEB. 26, 1979  
 47 THE MITRE CORP. MAY 1975 \*MLS8\* TECH RPT ESTIMATE OF MLS SHADOWING ,CRITICAL AREAS AND AIRPORT BUILDING RESTRICTIONS \*IF-68  
 0 1979 \*MLS29\* ENG REQ FAA ENGINEERING REQ. MLS SIGNAL FORMAT AND SYSTEM LEVEL FUNCTIONAL REQ. FAA-EP-700-08C MAY 1  
 78 \*MLS27\* TECH RPT MLS PHASE III BASIC NARROW AND SMALL COMM CONFIG. FINAL RPT VOL. I BENDIX MLS-BCD-R-2801-1 JUNE 19  
 \*MLS37\* TECH RPT. TEST AND EVALUATION OF TEXAS INSTRUMENTS SPRING 1980  
 ERATIONS FOR THE MLS PDME, R.J. KELLY, F.F.C. LABERGE NAVIGATION \*MLS32\* TECH RPT. GUIDANCE ACCURACY CONSID  
 STDS. LINC. LABS. APR. 1979 \*MLS19\* TECH RPT MLS MULTIPATH STDS. PHASE 3 OVERVIEW AND PROPAGATION MODEL VALIDATION/REFINEMENT  
 DS. PHASE 3 OVERVIEW AND PROPAGATION MODEL VALIDATION/REFINEMENT STDS. LINC. LABS. APR. 1979 \*MLS19\* TECH RPT MLS MULTIPATH ST  
 NC. LABS. FEB. 1980 \*MLS20\* TECH RPT MLS MULTIPATH STDS. PHASE 3 DVLPMT AND VALIDATION OF MODEL FOR MLS TECHNIQUES LI  
 \*MLS39\* TEST SERVICE TEST AND EVALUATION PROGRAM (STEP) FOR MLS, FEB. 26, 1979  
 MODEL FOR MLS TECHNIQUES. \*MLS22\* ABSTRACT MICRO STRIP ANTENNAS JOHN Q. HOWELL LANGLEY RESEARCH CENTER JULY 1974  
 \*MLS7\* MLS MULTIPATH STUDIES,PHASE 3, FINAL REPORT, VOL. 1:DEVELOPMENT AND VALIDATION OF  
 SUES LINC. LABS. FEB. 1976 \*MLS9\* TECH RPT TRSB CRITICAL AREAS STUDIES,PT.1 REFLECTION EFFECTS LINCOLN LABS NOV.5, 1975  
 1976 VOL.1 \*MLS10\* TECH RPT MLS MULTIPATH STUDIES, VOL.11: APPLICATION OF MULTIPATH MODEL TO KEY MLS PERFORM. ISSUES LINC. LABS. FEB. 25,  
 DING SYSTEM LITCHFORD SYSTEMS JULY 1972 \*MLS26\* TECH RPT MLS MULTIPATH STUDIES , MATHEMATICAL MODELS AND VALIDATION LINCOLN LABS. FEB. 25,  
 \*MLS1\* TECH RPT STUDY AND ANALYSIS OF SC-117, NATIONAL AND USAF PLANS FOR A NEW LAN  
 \*MLS21\* TECH RPT CURVED APPROACH PATH STUDY FAA-RD-72-143 COLLINS RADIO COMP./F.A.A. APRIL 1973  
 \*MLS23\* TECH RPT DUAL BAND AIRBORNE ANTENNA STUDY U.S. ARMY ELECTRONICS COMMAND/UNIV. OF MICHIGAN MAY, 1974  
 1976 \*MLS34\* INSTR. MAN. MLS AIRBORNE SUBSYSTEM BASIC CONFIGURATION INSTR. MANUAL, I.B.1157 BENDIX JUNE 1  
 F THE REQ FOR AND THE BENEFITS AND COST OF THE NATIONAL MLS EXEC SUMM RPT NO. FAA-EM-80-7 JUNE 1980 \*MLS46\* AN ANALYSIS O  
 \*MLS18\* TECH RPT U.S. MLS DEVELOPMENT PROGRAM SYMPOSIUM D.O.T./F.A.A. JUNE 1973

Table 6-2. (Continued).

AND ANALYSIS OF SC-117, NATIONAL AND USAF PLANS FOR A NEW LANDING SYSTEM LITCHFORD SYSTEMS JULY 1972 \*MLS1\* TECH RPT STUDY A  
 NAUTICS DEC. 1970 \*MLS15\* TECH RPT A NEW GUIDANCE SYSTEM FOR APPROACH AND LANDING RADIO TECHNICAL COMMISSION FOR AERO  
 TECH RPT NATIONAL PLAN FOR DEVELOPMENT OF THE MICROWAVE LANDING SYSTEM APPLICATIONS AND BENEFITS MTR6938 MITRE CORP. JULY 1975  
 \*MLS16\* TECH RPT MICROWAVE LANDING SYSTEM FAA-ED-07-2A F.A.A. JUNE 1978 \*MLS17\*  
 \*MLS24\* JOURNAL MICROWAVE LANDING SYSTEM APD-700 F.A.A.  
 \*MLS29\* ENG REQ FAA ENGINEERING REQ. MLS SIGNAL FORMAT AND SYSTEM LEVEL FUNCTIONAL REQ. FAA-ER-700-08C MAY 10 1979  
 \*MLS35\* MAINT. MAN MLS DME PRECISION INTERROGATOR SYSTEM MAINT. MANUAL, I.B.11578 APRIL 1977  
 UPER. MAN OPERATION AND INSTALLATION MANUAL FOR MINI RANGER III SYSTEM, MOTOROLA APRIL 1 1977 \*MLS40\*  
 \*MLS41\* TECH. DEVELOPMENT OF MICROWAVE LANDING SYSTEM IMPLEMENTATION CRITERIA FINAL RPT. JUNE 1974  
 \*MLS49\* MICROWAVE LANDING SYSTEM TRANSITION PLAN DRAFT OCTOBER 20 1980  
 -117, NATIONAL AND USAF PLANS FOR A NEW LANDING SYSTEM LITCHFORD SYSTEMS JULY 1972 \*MLS1\* TECH RPT STUDY AND ANALYSIS OF SC  
 A NEW LANDING SYSTEM LITCHFORD SYSTEMS JULY 1972 \*MLS4\* TECH RPT EXTRACT FROM PRELIMINARY ICAO SARPS: APPENDIX 1 TO THE REP  
 JPT ON AGENDA ITEM 1 APPENDIX B \*MLS3\* TECH RPT ADDITIONAL TESTS ON PHASE 3 RECEIVERS CALSPAN TN-1 JAN. 19  
 77 \*MLS5\* TECH RPT EXTRACT FROM PRELIMINARY ICAO SARPS: APPENDIX 2 TO THE REP  
 JPT ON AGENDA ITEM 1 APPENDIX C \*MLS4\* TECH RPT EXTRACT FROM PRELIMINARY ICAO SARPS APPENDIX 2 TO THE REP  
 RT ON AGENDA ITEM 1 \*MLS9\* TECH RPT ESTIMATE OF MLS SHADOWING , CRITICAL AREAS AND AIRPORT BUT  
 LANDING RESTRICTIONS MTR-6947 THE MITRE CORP. MAY 1975 \*MLS9\* TECH RPT TPSB CRITICAL AREAS STUDIES PT.1 REFLECTION EFFECTS LINCOL  
 N LABS NOV.5, 1975 \*MLS10\* TECH RPT MLS MULTIPATH STUDIES, VOL.II: APPLICATION OF MULTIPATH MO  
 DEL TO KEY MLS PRF. ISSUES LINC. LABS. FEB. 1976 \*MLS11\* TECH RPT TPACKER PERFORMANCE , AVAILABILITY AND DESCRIPTION  
 TN-6 EPT. 1976 \*MLS12\* TECH RPT MULTIPATH AND PERFORMANCE TESTS OF TRSB RECEIVERS CALSPAN  
 N-16 DEC 1979 \*MLS13\* TECH RPT FLIGHT TEST DATA FOR MULTIMODE DIGITAL PROCESSOR CALSPAN T  
 \*MLS14\* TECH RPT DCA MLS ADDITIONAL NOTE DEC.11, 1979  
 ICAL COMMISSION FOR AERONAUTICS DEC. 1970 \*MLS15\* TECH RPT A NEW GUIDANCE SYSTEM FOR APPROACH AND LANDING RADIO TECHN  
 MITRE CORP. JULY 1975 \*MLS16\* TECH RPT MICROWAVE LANDING SYSTEM APPLICATIONS AND BENEFITS MTR6938  
 TEM FAA-ED-07-2A F.A.A. JUNE 1978 \*MLS17\* TECH RPT NATIONAL PLAN FOR DEVELOPMENT OF THE MICROWAVE LANDING SYS  
 1973 \*MLS18\* TECH RPT U.S. MLS DEVELOPMENT PROGRAM SYMPOSIUM D.O.T./F.A.A. JUNE  
 VALIDATION/REFINEMENT STDS. LINC.LABS. APR. 1979 \*MLS19\* TECH RPT MLS MULTIPATH STDS. PHASE 3 OVERVIEW AND PROPAGATION MODEL  
 FOR MLS TECHNIQUES LINC. LABS. FEB. 1980 \*MLS20\* TECH RPT MLS MULTIPATH STDS. PHASE 3 DVLPT AND VALIDATION OF MODEL  
 P./F.A.A. APRIL 1973 \*MLS21\* TECH RPT CURVED APPROACH PATH STUDY FAA-RO-72-143 COLLINS RADIO COM  
 MANU/JUNIV. OF MICHIGAN MAY, 1974 \*MLS23\* TECH RPT DUAL BAND AIRBORNE ANTENNA STUDY U.S. ARMY ELECTRONICS COM  
 LINCOLN LABS. FEB.25, 1976 VOL.I \*MLS26\* TECH RPT MLS MULTIPATH STUDIES , MATHEMATICAL MODELS AND VALIDATION  
 T VOL. I APPNDIX MLS-ROD-R-2901-1 JUNE 1978 \*MLS27\* TECH RPT MLS PHASE III BASIC NARROW AND SMALL COMM CONFIG. FINAL RP  
 IREPORT, MAY 29 1980. \*MLS30\* TECH RPT MLS FLIGHT CHECK PROCEDURE AT PHILADELPHIA INTERNATIONAL A  
 MARCH 6, 1979. \*MLS31\* TECH RPT MLS FLIGHT CHECK PROCEDURE AT WASHINGTON NATIONAL AIRPORT,  
 ELLY, E.F.C. LABERGE NAVIGATION SPRING 1980 \*MLS32\* TECH RPT. GUIDANCE ACCURACY CONSIDERATIONS FOR THE MLS PDME, R.J. K  
 FINAL RPT MAY 1980 \*MLS37\* TECH RPT. TEST AND EVALUATION OF TEXAS INSTRUMENTS SMALL COMM. MLS,  
 IA FINAL RPT. JUNE 1974 \*MLS41\* TECH. DEVELOPMENT OF MICROWAVE LANDING SYSTEM IMPLEMENTATION CRITER  
 REPORT TM-SA-3-80-6 VITRO LABS SEPT. 1980 \*MLS42\* TECH RPT MLS ENGINEERING FLIGHT TEST RESULTS WASHINGTON NATIONAL AI  
 MLS-SF-00 LABERGE JUNE 23, 1980 \*MLS43\* TECH RPT COORDINATE CONVERSION FOR WASHINGTON NATIONAL INSTALLATION  
 COINATE ACCURACY MLS-SE-004 LABERGE JULY 31, 1980 \*MLS44\* TECH RPT RE-EVALUATION OF THE EFFECTS OF MLS GUIDANCE ERRORS ON COO  
 \*MLS45\* TEST PLAN WASHINGTON NATIONAL TECHNICAL COMMISSION FOR AERONAUTICS DEC. 1970 \*MLS1  
 5\* TECH RPT A NEW GUIDANCE SYSTEM FOR APPROACH AND LANDING RADIO TECHNIQUES LINC. LABS. FEB. 1980 \*MLS20\* TECH RPT ML  
 FINAL REPORT, VOL. 1: DEVELOPMENT AND VALIDATION OF MODEL FOR MLS TEST DATA FOR MULTIMODE DIGITAL PROCESSOR CALSPAN TN-16 DEC 1979  
 S MULTIPATH STDS. PHASE 3 DVLPT AND VALIDATION OF MODEL FOR MLS \*MLS37\* TECH RPT. TEST AND EVALUATION OF TEXAS INSTRUMENTS SMALL COMM. MLS, FINAL RPT  
 MAY 1980 \*MLS39\* TEST SERVICE TEST SERVICE TEST AND EVALUATION PROGRAM (STEP) FOR MLS, FEB. 26, 1  
 77 \*MLS39\* TEST SERVICE TEST AND EVALUATION PROGRAM (STEP) FOR MLS, FEB. 26, 1979  
 PT. 1980 \*MLS42\* TECH RPT MLS ENGINEERING FLIGHT TEST RESULTS WASHINGTON NATIONAL AIRPORT TM-SA-3-80-6 VITRO LABS SE  
 \*MLS45\* TEST PLAN WASHINGTON NATIONAL TEST PLAN WP-80W00725 MITRE NOV 1980  
 1972 THIRD EDITION VOL II \*MLS25\* MANUAL MANUAL ON TESTING OF RADIO NAVIGATION AIDS INTERNATIONAL CIVIL AVIATION ORG.  
 \*MLS3\* TECH RPT ADDITIONAL TESTS ON PHASE 3 RECEIVERS CALSPAN TN-1 JAN. 1977  
 \*MLS12\* TECH RPT MULTIPATH AND PERFORMANCE TESTS OF TRSB RECEIVERS CALSPAN TN-6 EPT. 1976  
 \*MLS37\* TECH RPT. TEST AND EVALUATION OF TEXAS INSTRUMENTS SMALL COMM. MLS, FINAL RPT MAY 1980

OF RADIO NAVIGATION AIDS INTERNATIONAL CIVIL AVIATION ORG. 1972 THIRD EDITION VOL II \*MLS25\* MANUAL MANUAL ON TESTING  
 \*MLS11\* TECH RPT TRACKER PERFORMANCE, AVAILABILITY AND DESCRIPTION  
 \*MLS49\* MICROWAVE LANDING SYSTEM TRANSITION PLAN DRAFT OCTOBER 20 1980  
 V.5, 1975 \*MLS9\* TECH RPT TPSR CRITICAL AREAS STUDIES PT.1 REFLECTION EFFECTS LINCOLN LABS NO  
 \*MLS12\* TECH RPT MULTIPATH AND PERFORMANCE TESTS OF TPSR RECEIVERS CALSPAN TN-6 FPT. 1976 \*MLS23\* TECH RP  
 T DUAL BAND AIRBORNE ANTENNA STUDY U.S. ARMY ELECTRONICS COMMAND/UNIV. OF MICHIGAN MAY, 1974 \*MLS7\* MIS  
 \*MLS1\* TECH RPT STUDY AND ANALYSIS OF SC-117, NATIONAL AND USAF PLANS FOR A NEW LANDING SYSTEM LITCHFORD SYSTEMS JULY 1972  
 MULTIPATH STUDIES, PHASE 3, FINAL REPORT, VOL. 1: DEVELOPMENT AND VALIDATION OF MODEL FOR MLS TECHNIQUES. \*MLS19\* TE  
 CH RPT MLS MULTIPATH STDS. PHASE 3 OVERVIEW AND PROPAGATION MODEL VALIDATION/REFINEMENT STDS. LINC. LABS. APR. 1979  
 \*MLS20\* TECH RPT MLS MULTIPATH STDS. PHASE 3 DVLPMT AND VALIDATION OF MODEL FOR MLS TECHNIQUES LINC. LABS. FEB. 1980  
 \*MLS26\* TECH RPT MLS MULTIPATH STUDIES, MATHEMATICAL MODELS AND VALIDATION LINCOLN LABS. FEB. 25, 1976 VOL. I  
 ING FLIGHT TEST RESULTS WASHINGTON NATIONAL AIRPORT TM-SA-3-80-6 VITRO LABS SEPT. 1980 \*MLS42\* TECH RPT MLS ENGINEER  
 \*MLS7\* MLS MULTIPATH STUDIES, PHASE 3, FINAL REPORT, VOL. 1: DEVELOPMENT AND VALIDATION OF MODEL FOR MLS TECHNIQUES.  
 LABS. FEB. 1976 \*MLS10\* TECH RPT MLS MULTIPATH STUDIES, VOL. II: APPLICATION OF MULTIPATH MODEL TO KEY MLS PERF. ISSUES LINC  
 GATION AIDS INTERNATIONAL CIVIL AVIATION ORG. 1972 THIRD EDITION VOL II \*MLS25\* MANUAL MANUAL ON TESTING OF RADIO NAVI  
 , MATHEMATICAL MODELS AND VALIDATION LINCOLN LABS. FEB. 25, 1976 VOL. I \*MLS26\* TECH RPT MLS MULTIPATH STUDIES  
 RPT MLS PHASE III BASIC NARROW AND SMALL COMM CONFIG. FINAL RPT VOL. I BENDIX MLS-BCD-R-2801-1 JUNE 1978 \*MLS27\* TECH  
 VIGATION FACILITIES PROPOSED MLS REQUIREMENTS, FEDERAL REGISTER VOL. 45 NO. 175 SEPT 9 1980 \*MLS38\* ENGR. REQ NON-FEDERAL NA  
 SIS OF THE REQ FOR AND THE BENEFITS AND COST OF THE NATIONAL MLS VOL. I RPT NO. FAA-EM-80-7 JUNE 1980 \*MLS47\* AN ANALY  
 SIS OF THE REQ FOR AND THE BENEFITS AND COST OF THE NATIONAL MLS VOL. II RPT NO. FAA-EM-80-7 JUNE 1980 \*MLS48\* AN ANALY  
 \*MLS31\* TECH RPT MLS FLIGHT CHECK PROCEDURE AT WASHINGTON NATIONAL AIRPORT, MARCH 6, 1979.  
 \*MLS42\* TECH RPT MLS ENGINEERING FLIGHT TEST RESULTS WASHINGTON NATIONAL AIRPORT TM-SA-3-80-6 VITRO LABS SEPT. 1980  
 \*MLS43\* TECH RPT COORDINATE CONVERSION FOR WASHINGTON NATIONAL INSTALLATION MLS-SF-00 LAFARGE JUNE 23, 1980  
 \*MLS45\* TEST PLAN WASHINGTON NATIONAL TEST PLAN WP-80W00725 MITRE NOV 1980

## VII. APPENDIX

A. Results of Review of Available Ground Reference Elements. Project team members obtained manufacturers' literature, and briefings on a variety of precision position reference systems. The comparisons given in Table 7-1, on the following pages, provide information on the Australian system, which has been used by FAA, the German IFIS system and the French Minilir system. The FAA/Ohio University measurement system which is the subject of this report is also summarized for comparison.

The choice of a theodolite two-axis angle measurement plus C-band range-measurement device was made based on cost, size, weight and flexibility parameters. While such a reference system is a manual-tracking system requiring good visibility, the benefits obtained from continuous track-while-ranging operation and the provision of an integral, bidirectional data link to the aircraft are significant. Airborne equipment to accomplish the reference position measurement task is minimal. Since the use of a light aircraft with low operating cost is anticipated, the size, weight, power consumption and complexity of a platform-mounted projector or searchlight on the aircraft is infeasible.

By provision of the programmable bidirectional data link, inclusion of data from external position reference or timing sources is possible, along with flexibility of location of measurement and processing elements for the total navaid measurement system. It also provides for a theodolite acquisition mode, by downlinking MLS measurements to the theodolite position for motor drive operation.

### B. Experimental Activity in Support of System and Procedures Design.

1. Theodolite Motorized Tracking Tests. Preliminary tests on the motor-driven theodolite were conducted at the Ohio University Airport on December 12, 1980. The target aircraft was a Piper Cherokee 180. Weather conditions were clear, ten-mile visibility, with light to moderate chop. Test patterns flown included three low approaches (Pattern A's), a level pass (Pattern B) at an altitude of 1000 feet AGL, and a perpendicular cut (Pattern C) at a distance of five miles from the threshold and an altitude of 1800 feet AGL. The theodolite was located 240 feet off centerline and 830 feet from threshold. The tracking tests were performed both by experienced and inexperienced manual theodolite operators.

For these initial tests, the theodolite was equipped with azimuth and elevation motors with 150:1 azimuth gear ratio and 200:1 in elevation. Motor drive was derived from a "joystick" controller, with joystick displacement from center proportional to motor speed in both axes. No spring-return feature was present on the controller.

Tracking of the Pattern B and Pattern C runs were observed judgmentally to be significantly improved over manual theodolite tracks. During the Pattern B, it was possible to keep the crosshairs centered on the aircraft until the aircraft had exceeded ten degrees theodolite elevation. Manual tracks are usually terminated at only four degrees eleva-

	AUSTRALIAN	GERMAN	FRENCH	OHIO UNIVERSITY
Tracking Concept	Automatic optical tracking Two at a time (Tracker has TV system)	Infrared tracker - Two axis stabilized tracking lamp	Infrared tracker Two axis Halogen lamp on A/C servoed	Manual optical tracking - Two axis at a time, Radio theodolite (RTT & Ranger)
Ground Equipment	Vidicon camera, Az gear box, Elev. gear box, telemetry R/T, Electronic processing unit Tripod	IFIS servo Platform, Tripod, Infrared tracker, Ground electronic unit, VHF Tx	Turret, IR unit, Encoding unit, VHF Tx, Tripod	Theodolite, Ground telemetry processor, Miniranger console, Miniranger Tx
Aircraft Equipment	Gyro stabilized lamp, Telemetry RX/Demod, Chart Recorder	Airborne Electronics unit, Servoed lamp, Recorder	Projector, Relay unit, Data restitution & processing unit, Recorder, Projector control unit	Airborne telemetry processor, Miniranger remote, Pilots display, Power supply
Functions Available				
Az	Yes	Yes	Yes	Yes
EI	Yes	Yes	Yes	Yes
Range	--	A/C DME	--	Yes
Coverage				
EI	-3° to + 30°	-3° to + 30°	-10° to + 70°	-19° to + 90°
Az	± 180°	> 360°	± 186°	360°
0 → 5 nm	Yes	Yes	Yes	Yes
5 → 10 nm	--	Yes	Yes	Yes
10 → 20 nm	--	--	--	Night Tracking
Weather Restrictions	Requires Good Visibility	None Specified	Requires Good Visibility	Requires Good Visibility

Table 7-1. Reference System Comparisons.

	AUSTRALIAN	GERMAN	FRENCH	OHIO UNIVERSITY
Accuracy Az El Range	0.01° 0.01° --	+ 0.02° + 0.02° --	+ 0.0025° + 0.0025° --	0.03° 0.05° + 6 ft.
Recording Capability	N/S	Yes	Yes	Tape and Hard- Copy Graphics
Power Supply A/C Eqpt.	28 V D.C. 115V/400 Hz 1000 W (Lamp)	28 V D.C. 115V/400 Hz 1067 W (Search Light)	28 V 115V/400 Hz 600 W (Lamp)	14 V D.C. 365 W
Cost	Tracker Aus \$89000 Telemetry Eqpt. Aus \$8500	DM 474500 DM 93800 DM 18700 DM 3600	\$250000	\$80000
Construction	Non-modular	Non-modular	Non-modular	Modular
Physical Characteristic				
Volume Grnd Eqpt.	0.31 m <sup>3</sup>	0.35 m <sup>3</sup>	1.1 m <sup>3</sup> (excludes tripod)	.34 m <sup>3</sup>
Volume A/C Eqpt.	0.13 m <sup>3</sup> (ex- cludes lamp & recorder)	0.05 m <sup>3</sup> (ex- cludes search light & recorder)	N/S	0.12 m <sup>3</sup>
Weight Grnd Eqpt.	109.5 Kg	144.5 Kg	100 Kg	52 Kg 23 Kg (Complete system including all MLS receivers, power supplies, com- puter and I/O)
Weight A/C Eqpt.	3.7 Kg (ex- cludes lamp & recorder)  Tracker only	24 Kg (ex- cludes search light & recorder)  Tracker only	N/S  Tracker Only	

Table 7-1. (Continued).

tion due to the time between event marks becoming too short for the operator to maintain track. An additional advantage of the motorized theodolite is the continuous track, compared to the comparatively few data points possible in manual mode. Similar improvement was found in the Pattern C. Manual operation typically provides an event mark only every five degrees azimuth. The continuous tracking provided by the motor-driven theodolite provides data for all azimuth values. The operator is required only to track the aircraft and not necessarily be cognizant of the azimuth values.

The results for Pattern A runs were not as consistent as has been experienced with manual theodolite operation, but the theodolite operator indicated that he only needed more practice, and a modified mount for the joystick, to solve the problem.

The next step will be to optimize the motor drive. Since these tests were only preliminary concept demonstrations, all materials used to implement the motor drives were limited to those on hand. The motors were of marginal torque and the gear ratios (150:1 azimuth and 200:1 elevation) were too low. It was not possible to track the aircraft during Pattern A runs closer than 500 feet from threshold, due to the rapid azimuth slew rate. More powerful motors and the proper gear ratios will be installed on the theodolite along with integral optical shaft encoders.

The next test will include investigation of velocity feedback from the shaft encoders to permit better motor control.

It is concluded from these preliminary observations that the motor-driven theodolite offers major advantages for landing systems measurement in terms of continuity of data and operator convenience. Subjective results suggest that data quality will improve with appropriate gear ratios and controller mounting.

2. Acquisition Motor Drive Simulation. Using parts on hand, a test bed for digital control of theodolite motors has been assembled. Figure 7-1 shows a general view of the unit, while Figure 7-2 gives a close-up of the motor mount and its associated shaft coupler.

The intent of the test bed is to permit convenient algorithm development for motor control in theodolite acquisition mode, where the theodolite is driven by MLS inputs to a position near the current aircraft position. An existing KIM-1 microcomputer and necessary power supplies provides the digital control of motor signals. The KIM-1 can be loaded from cassette tape, or downloaded from the Ohio University IBM System/370 computer. Either the integral keyboard or a standard computer terminal may be used for program control.

To simulate feedback from theodolite shaft encoders, the test motor will initially be outfitted with a precision potentiometer whose voltage is returned to the computer via a 10-bit analog-to-digital converter. Software will then generate simulated rate inputs for the motor drive routines. When the actual shaft encoder for the theodolite becomes available, it may be attached via the motor's shaft coupling.

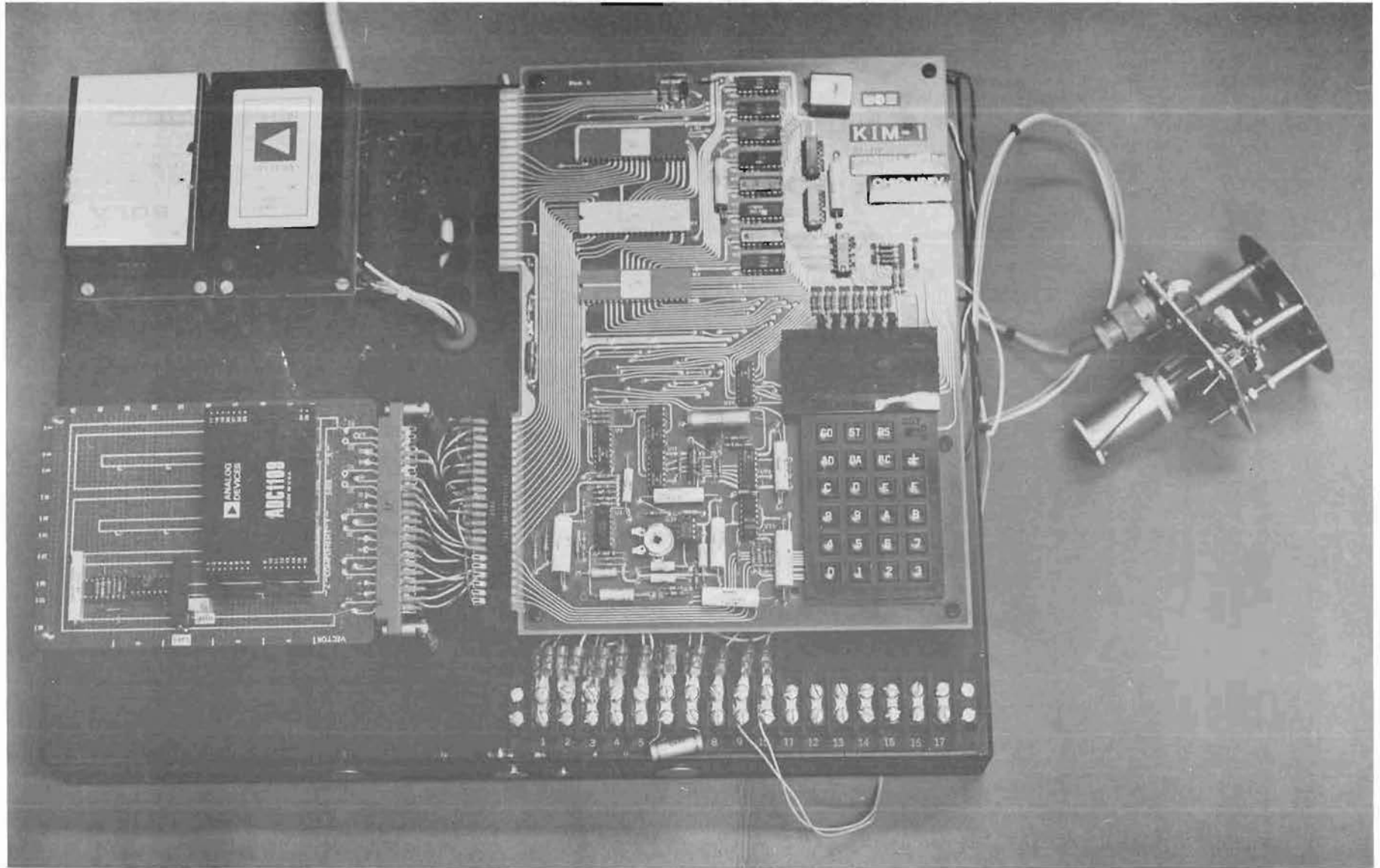

Figure 7-1. Theodolite Motor Drive Test Bed.  
(Photograph by J. Nickum).

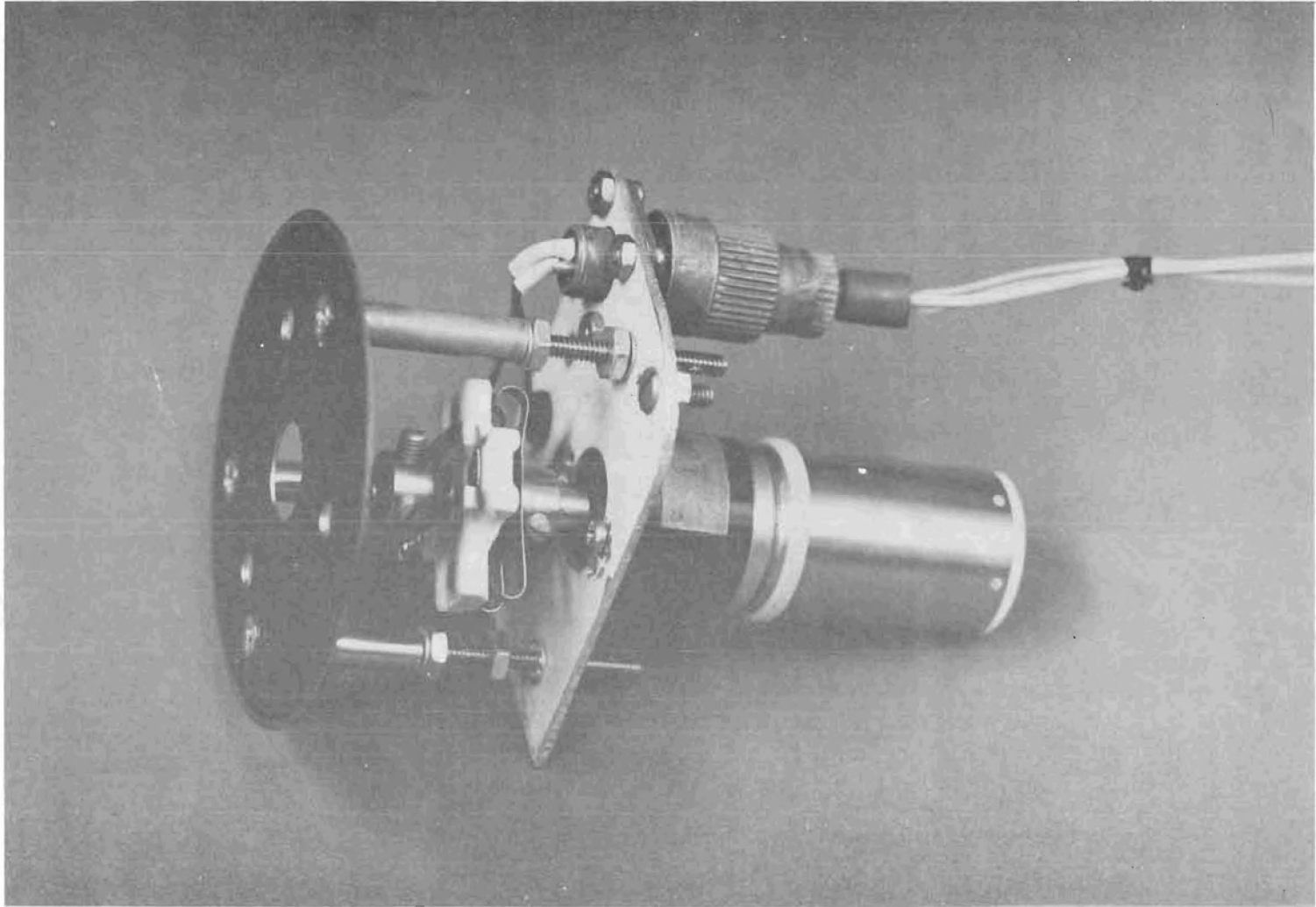

Figure 7-2. Theodolite Drive Motor Mount with Shaft Coupling for Encoder or Potentiometer.  
(Photograph by J. Nickum).

Digital signals will then be returned directly to the computer from the encoder.

As initially configured, this test fixture permits investigation of bidirectional motor control via pulse-width modulation (PWM), with or without velocity feedback. Later addition of digital-to-analog converter chips for proportional or pulse-amplitude modulation motor control will be accomplished, if proven necessary by the PWM tests.

3. Preliminary Ranger Demonstration. The Motorola Mini-Ranger (TM) unit was demonstrated in flight and on the ground at Ohio University. Results were consistent with expectations, and discussions with Motorola personnel answered questions concerning Mini-Ranger data-link operations and data rates. It now appears that the Mini-Ranger will provide the required range accuracy ( $\pm 2$  meters) and data-link transfers (at rates approaching 2400 baud) for a successful ground reference/telemetry system with minimal airborne installations.

Figure 7-3 shows Mini-Ranger graphical output from a Pattern B pass at 1000 ft. AGL, parallel to Runway 24 at Ohio University Airport. Ground reference stations were located just south of the runway and at a point approximately five miles north of the runway, as indicated by the two points labeled "01". The flight proceeded inbound over the UNI NDB, five miles from threshold, with the flight path directed over the reference station on the airport.

Event marks taken over the UNI NDB showed good repeatability. However, as the missing triangle marks indicate in Figure 7-3, data was lost during the overflight of the reference station. This was expected and was, in fact, one purpose for the flight. The aircraft (DC-3 N7AP), was equipped with the Motorola omniazimuthal antenna, mounted below the cabin on a one-foot boom (see Figure 7-4), and the ground antenna was an identical omniazimuthal antenna, approximately six feet above ground level. Data loss shown in Figure 7-3 is the result of the restrictions on vertical pattern ( $\pm 15^\circ$ ) applied to both antennas.

In the operational tracking system, it is planned to use a directional antenna mounted on the theodolite and steered as the theodolite tracks the aircraft. This antenna gain will permit use of a hemispherical antenna, if necessary, aboard the aircraft to avoid vertical pattern problems.

### C. Summary of Design Review Meetings.

1. Briefing: August 11, 1980, FAA, Washington, D. C. Ohio University project team members presented preliminary system outlines, indicating cost and utility tradeoffs among ground reference system types. A ground tracker consisting of a standard theodolite, modified for digital azimuth and elevation outputs, plus a Motorola Mini-ranger (TM), was proposed. The concept of a flexible, software-controlled system, able to provide on-site data processing and display either in the aircraft or on the ground, was introduced.

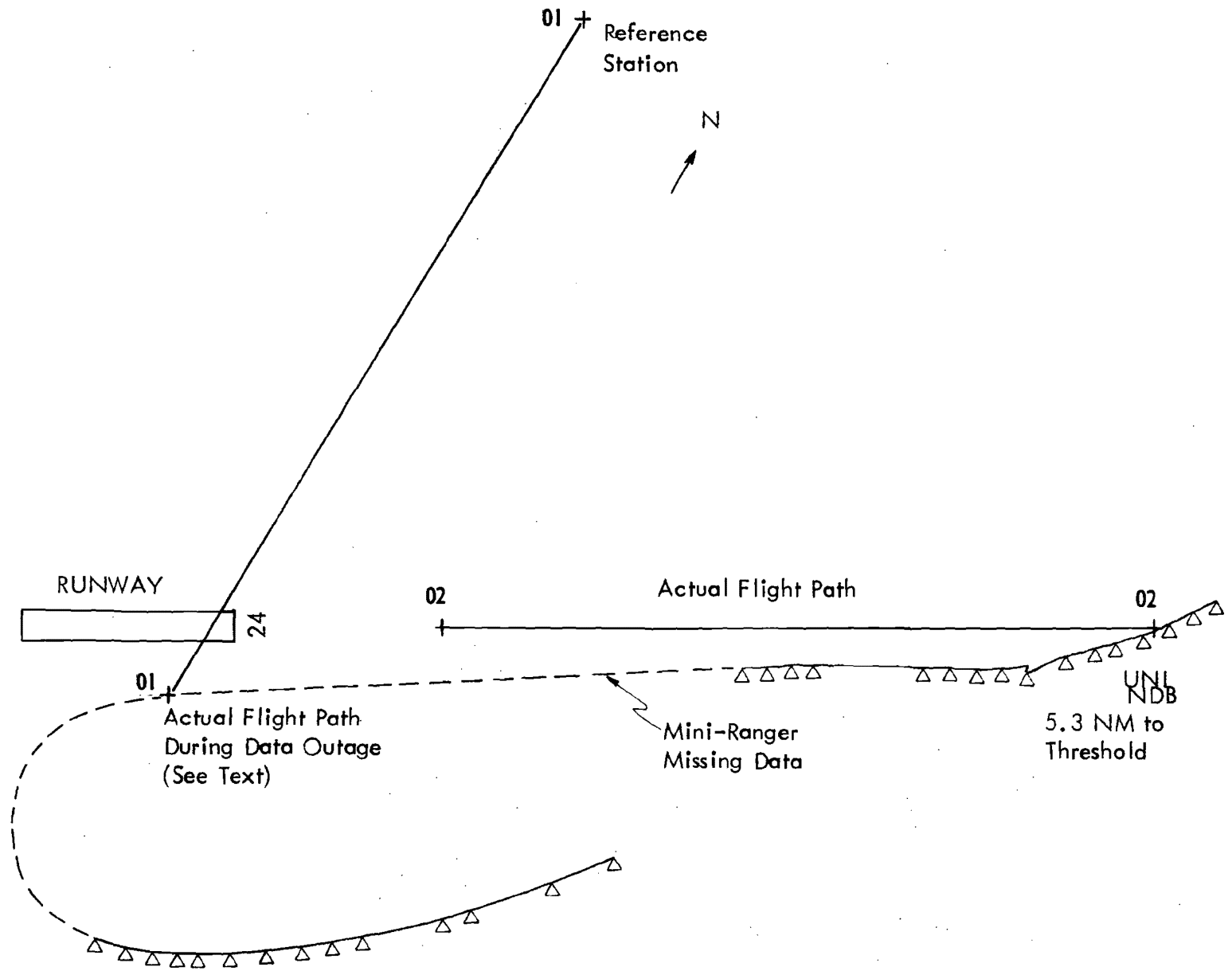

Figure 7-3. Pattern B: Mini-Ranger Output.



Figure 7-4. DC-3 Aircraft with Mini-Ranger Antenna Boom-Mounted Beneath Cabin.

FAA personnel commented on their concern that output data be in merged form; that is, that tracker and airborne MLS data not require a post-flight merge in a separate process. The merge process discussion brought about consideration of the need for data simultaneity between tracker and MLS observations. Ohio University team members agreed to study this problem further and determine whether precision time-code generation and subsequent data transfer with the time-stamp would be required. The idea of time synchronization using detailed knowledge of system processing delays was discussed briefly.

2. Briefing: November 25, 1980, FAA, Washington, D. C. Ohio University project team members presented the MLS evaluation and data-collection system to FAA representatives, with emphasis on the details of the ground tracker. Overall system block diagrams were discussed, together with details of theodolite modifications and expected tracking rates given specific theodolite locations with respect to the approach path. The planned design for the ground telemetry processor and its inter-connection with the Motorola Mini-Ranger were presented.

Questions and comment centered upon

a. System flexibility to permit data recording and display in the aircraft or on the ground.

The system provides this flexibility.

b. Provision of analog CDI traces in the aircraft for those cases where main data recording and display is on the ground.

Provision for analog chart recording in the aircraft of either raw MLS CDI or computed CDI based on ground position-reference data has been included.

c. Provision for dual MLS receiver capability.

Dual receiver capability has been included in the airborne processor design, but the Mini-ranger data link will be unable to transmit two full data streams to the ground in real time. Therefore, the dual capability requires the system computer and data recording system to be in the aircraft (Configuration 1). Additionally, space, weight and power considerations may preclude dual-receiver capability in the Beech A-36 aircraft. Larger aircraft could accommodate the dual-receiver unit.

d. Provision of a separate cartridge tape playback unit to transfer flight data to 9-track, standard computer magnetic tape.

Design of such a device is relatively uncomplicated. Budget considerations may, however, delay procurement of the necessary hardware and the technician time required to fabricate the unit, until primary system costs are better known.

e. Consideration of operation of the airborne system in the absence of ground tracker data.

The system, as designed, permits this operation without ground tracker information. Uncorrected MLS data are collected, and may be displayed as numerical or graphical outputs, based only upon time, or on operator event marks.

f. Concern was voiced regarding theodolite tracker range, and the consequent need for external telemetry inputs from the NIKE radar or FAA Laser Tracker.

The system has been designed to accept inputs from both the NIKE and the laser tracker, when required. It is acknowledged that the optical theodolite is restricted in range and by weather conditions. The cost/performance considerations favor the theodolite, however, for this evaluation system, since it will find application at a variety of MLS sites where radar or laser trackers are not available.

g. Comment was made regarding available MLS data-processing software produced by consulting firms during MLS development.

Project team members requested FAA obtain this software, so that applicable portions may be included in the planned system, avoiding duplicated software development.

The FAA Technical Center has provided project members with data-processing software which will be helpful in this respect.

h. Concern was voiced over Ohio University's plan to insure data simultaneity through calibration of system delays, rather than through use of time-code generators. Especially worrisome was the synchronization of airborne MLS observations with NIKE or laser tracker data.

Provision has been made in the telemetry processors for time-code input, allowing a time-stamp to be applied to each observation. The clocks would be set

manually before a flight mission, physically moved to the aircraft and tracker for the flight.

Study and experimentation with other means of insuring data simultaneity will continue, to determine whether successful results may be obtained with less data transfer and system cost.