

COPY 1
2

EFFECT OF THERMAL RADIATION ON THE INTEGRITY OF PRESSURIZED AIRCRAFT EVACUATION SLIDES AND SLIDE MATERIALS

Louis J. Brown Jr.
Eldon B. Nicholas

FEDERAL AVIATION ADMINISTRATION

APR 16 1981

TECHNICAL CENTER LIBRARY
ATLANTIC CITY, N.J. 08405



FINAL REPORT

MARCH 1981

Document is available to the U.S. public through
the National Technical Information Service,
Springfield, Virginia 22161.

Prepared for
U. S. DEPARTMENT OF TRANSPORTATION
FEDERAL AVIATION ADMINISTRATION
TECHNICAL CENTER
Atlantic City Airport, N.J. 08405



NOTICE

This document is disseminated under the sponsorship of the Department of Transportation in the interest of information exchange. The United States Government assumes no liability for the contents or use thereof.

The United States Government does not endorse products or manufacturers. Trade or manufacturer's names appear herein solely because they are considered essential to the object of this report.

AD-A08-179

Technical Report Documentation Page

1. Report No. FAA-CT-81-28		2. Government Accession No.		3. Recipient's Catalog No.	
4. Title and Subtitle EFFECT OF THERMAL RADIATION ON THE INTEGRITY OF PRESSURIZED AIRCRAFT EVACUATION SLIDES AND SLIDE MATERIALS				5. Report Date March 1981	
				6. Performing Organization Code	
7. Author(s) Louis J. Brown Jr. and Eldon B. Nicholas				8. Performing Organization Report No. FAA-CT-81-28	
9. Performing Organization Name and Address Federal Aviation Administration Technical Center Atlantic City Airport, New Jersey 08405				10. Work Unit No. (TRAIS)	
				11. Contract or Grant No. 181-350-320	
12. Sponsoring Agency Name and Address U.S. Department of Transportation Federal Aviation Administration Technical Center Atlantic City Airport, New Jersey 08405				13. Type of Report and Period Covered Final May 1979 to September 1980	
				14. Sponsoring Agency Code	
15. Supplementary Notes					
16. Abstract Seventeen full-scale fire tests were conducted to examine the effect of thermal radiation from a large fuel fire on the integrity of pressurized aircraft evacuation slides. Urethane nylon, aluminized urethane nylon, neoprene nylon, aluminized neoprene nylon, and aluminized neoprene Kevlar slides were tested at various distances from a 30- by 30-foot fire pit. Heat flux at the slide, inflation pressure, and air temperature were measured and motion pictures and photographs were taken during these full-scale tests. At an average heat flux level of 1.5 Btu/ft ² -second (sec) (15 feet from edge of fire pit) inservice evacuation slides failed in a nonseam area in 23 to 32 seconds. With an aluminized coating applied to the airholding surfaces, the time failure increased by more than a factor of two at the same test condition. A laboratory test method, suitable for materials qualification, was developed that exposes an evacuation slide material to a preselected radiant heat flux and pressure. Tests were conducted on new materials submitted by slide and material manufacturers, and material samples taken from the undamaged areas of full-scale test slides. A good correlation was demonstrated between the failure times measured in full-scale and laboratory tests.					
17. Key Words Aircraft Evacuation Slides Full-Scale Tests Laboratory Tests Heat Flux Pressure			18. Distribution Statement Document is available to the U.S. public through the National Technical Information Service, Springfield, Virginia 22161		
19. Security Classif. (of this report) Unclassified		20. Security Classif. (of this page) Unclassified		21. No. of Pages 79	22. Price

METRIC CONVERSION FACTORS

Approximate Conversions to Metric Measures

Symbol	When You Know	Multiply by	To Find	Symbol
LENGTH				
in	inches	*2.5	centimeters	cm
ft	feet	30	centimeters	cm
yd	yards	0.9	meters	m
mi	miles	1.6	kilometers	km
AREA				
in ²	square inches	6.5	square centimeters	cm ²
ft ²	square feet	0.09	square meters	m ²
yd ²	square yards	0.8	square meters	m ²
mi ²	square miles	2.6	square kilometers	km ²
	acres	0.4	hectares	ha
MASS (weight)				
oz	ounces	28	grams	g
lb	pounds	0.45	kilograms	kg
	short tons (2000 lb)	0.9	tonnes	t
VOLUME				
tsp	teaspoons	5	milliliters	ml
Tbsp	tablespoons	15	milliliters	ml
fl oz	fluid ounces	30	milliliters	ml
c	cups	0.24	liters	l
pt	pints	0.47	liters	l
qt	quarts	0.95	liters	l
gal	gallons	3.8	liters	l
ft ³	cubic feet	0.03	cubic meters	m ³
yd ³	cubic yards	0.76	cubic meters	m ³
TEMPERATURE (exact)				
°F	Fahrenheit temperature	5/9 (after subtracting 32)	Celsius temperature	°C

* 1 in = 2.54 (exactly). For other exact conversions and more detailed tables, see NBS Misc. Publ. 286, Units of Weights and Measures, Price \$2.25, SD Catalog No. C13.10:286.



Approximate Conversions from Metric Measures

Symbol	When You Know	Multiply by	To Find	Symbol
LENGTH				
mm	millimeters	0.04	inches	in
cm	centimeters	0.4	inches	in
m	meters	3.3	feet	ft
m	meters	1.1	yards	yd
km	kilometers	0.6	miles	mi
AREA				
cm ²	square centimeters	0.16	square inches	in ²
m ²	square meters	1.2	square yards	yd ²
km ²	square kilometers	0.4	square miles	mi ²
ha	hectares (10,000 m ²)	2.5	acres	
MASS (weight)				
g	grams	0.035	ounces	oz
kg	kilograms	2.2	pounds	lb
t	tonnes (1000 kg)	1.1	short tons	
VOLUME				
ml	milliliters	0.03	fluid ounces	fl oz
l	liters	2.1	pints	pt
l	liters	1.06	quarts	qt
l	liters	0.26	gallons	gal
m ³	cubic meters	35	cubic feet	ft ³
m ³	cubic meters	1.3	cubic yards	yd ³
TEMPERATURE (exact)				
°C	Celsius temperature	9/5 (then add 32)	Fahrenheit temperature	°F

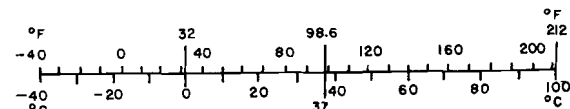

PREFACE

The authors would like to acknowledge the assistance of Messrs. Richard Johnson, Ross Glidewell, and Charles Huber in the varying activities of test equipment fabrication, instrumentation, testing, and data analysis. Grateful thanks are extended to Mr. Samuel Zinn for his helpful advice and useful discussions throughout this test program.

The cooperation of the following evacuation slide manufacturers made this study possible: Air Cruisers Company, Belmar, New Jersey; American Safety Inflatables Division, Miami, Florida; B. F. Goodrich Company, Akron, Ohio; Sargent Industries, Pico Division, City of Industry, California.

TABLE OF CONTENTS

	Page
INTRODUCTION	1
Purpose	1
Background	1
Experimental Objectives	2
DISCUSSION	2
General Approach	2
Equipment Description	2
Test Measurements	5
TEST RESULTS AND ANALYSIS	8
Full-scale	8
Laboratory	25
Correlation	37
SUMMARY OF RESULTS	40
Full-Scale	40
Laboratory	40
CONCLUSIONS	42
RECOMMENDATIONS	43
REFERENCES	43
APPENDICES	
A. Proposed Laboratory Test Method for Aircraft Inflatable Evacuation Slide/Slide Raft Materials	
B. Heat Flux and Pressure Plots for Full-Scale Tests	

LIST OF ILLUSTRATIONS

Figure		Page
1	Slide Attachment Tower	3
2	Diagram of Full-Scale Test Set-Up	4
3	Evacuation Slide Material Laboratory Testing Apparatus	6
4	Full-Scale Fire Test Set-up; Test 5	7
5	Urethane Nylon Slide Smoking During Test; Test 3B	12
6	Catastrophic Failure of Urethane Nylon Slide; Test 8A	14
7	Neoprene Nylon Seam Failure; Test 11	16
8	Aluminized Neoprene Kevlar Seam Failure; Test 12	17
9	Neoprene Kevlar Seam Failure; Test 14	18
10	Aluminized Urethane Nylon With Stenciling Showing; Test 16B	19
11	Urethane Nylon Non-Seam Failure; Test 16A	21
12	Aluminized Urethane Nylon Slide Failure During Test; Test 16B	22
13	Aluminized Urethane Nylon Slide Failure During Test; Test 17	23
14	Aluminized Urethane Nylon Seam Slippage; Test 19	24
15	Aluminized Neoprene Nylon Seam Failure; Test 20	26
16	Neoprene Nylon Seam Failure; Test 22	27
17	The Effect of Reflective Coating Thicknesses	30
18	Time Versus Pressure for an Uncoated and Aluminized Urethane Nylon Fabric	32
19	Heat Flux Versus Time to Initial Pressure Loss	33
20	Heat Flux Versus Time to Initial Pressure Loss	35
21	Heat Flux Versus Time to Initial Pressure Loss	39

LIST OF TABLES

Table		Page
1	Summary of Test Conditions	9
2	Summary of Urethane Nylon Full-Scale Tests	10
3	Summary of Neoprene Full-Scale Tests	11
4	Summary of Urethane Coated Fabrics	28
5	Laboratory Repeatability Tests	31
6	Summary of Neoprene Coated Fabrics	34
7	Summary of Urethane Coated Slide Fabrics from Full-Scale Test Slides	36
8	Summary of Neoprene Coated Slide Fabrics from Full-Scale Test Slides	38
9	Laboratory/Full-Scale Correlation	41

INTRODUCTION

PURPOSE.

The purpose of this project was to measure and study the integrity of pressurized evacuation slide materials exposed to thermal radiation during small-scale tests of material samples in the laboratory and full-scale outdoor pool fire tests of complete slides.

BACKGROUND.

During an impact-survivable crash, passenger egress can be threatened by an external fuel fire. Intense heat and flame from such a fire can cause loss of potential passenger exit routes. The primary vehicle for passenger egress is the inflatable evacuation slide which has been greatly improved, resulting in shortened escape times, since its introduction into airline service over 25 years ago.

The inflatable portion of current slides and slide/rafts are constructed of either urethane nylon or neoprene nylon materials. The elastomeric coatings of these materials are known to have inherently low melting temperatures (275° F -360° F) in comparison to temperatures produced by a fuel fire (2000° F). At present, Federal Regulations require evacuation slide materials be tested for flame resistance in accordance with Federal Aviation Regulation (FAR) 25.853 (Part b).

There are currently no Federal Aviation Administration (FAA) requirements for slide material resistance to thermal radiation. A slide deployed in a post-crash fire environment can be subjected to thermal radiation without flame contact. The structural integrity of an inflatable evacuation slide is dependent upon the maintenance of adequate internal pressurization. If substantial damage occurs to the airholding portion of the slide, inflation pressure will

escape rapidly, rendering the slide unuseable.

The National Transportation Safety Board (NTSB) investigation of the Continental DC-10 accident at Los Angeles International Airport (reference 1) concluded that fuel fire radiation caused the forward right escape slide/raft to fail, without direct flame contact, before all passengers and crew members had evacuated the airplane. This early finding prompted the FAA Technical Center (formerly the National Aviation Facilities Experimental Center (NAFEC)) to conduct a preliminary assessment of the fire protection characteristics of various evacuation slide materials (reference 2). This cursory study included both small-scale tests in the laboratory and outdoor pool fire tests. The findings indicated that a thin coating of aluminum paint provided a significant improvement in the thermal radiation resistance of a slide material. Good correlation was also established between the failure time of slide materials measured in a crude laboratory test, hurriedly developed for the study and outdoor fire exposure tests. The laboratory test utilized an electric radiant heater to expose pressurized samples configured into 3-inch diameter cylinders. The time from the initial thermal exposure to fabric failure, indicated by a loss in pressure, was well defined by a pressure transducer trace in these experiments. However, the setup time required for these tests, particularly for the fabrication of the cylindrical samples, was lengthy and cumbersome. The quick reaction nature of the study limited the outdoor tests to large flat samples, not actual pressurized slides, exposed to thermal radiation from a fuel fire. This study also did not include the testing of seams.

Based on the conclusions and recommendations from the quick reaction study, a more comprehensive program was initiated at the Technical Center to further

investigate the radiant heat resistance of slide materials.

EXPERIMENTAL OBJECTIVES.

The primary objectives of this program were fourfold: (1) design and develop a laboratory test method for measuring the integrity of pressurized evacuation slide materials exposed to thermal radiation; (2) develop a practical and lightweight coating to be used for retrofitting inservice evacuation slides; (3) examine and foster the development of advanced materials that are resistant to radiant heat and suitable for use in the fabrication of evacuation slides; and (4) determine the heat resistance acceptance criteria for slide materials.

DISCUSSION

GENERAL APPROACH.

The general approach taken was to test slide and slide/raft materials for resistance to radiant heat under both full-scale and laboratory conditions. The laboratory test used in the quick reaction study was chosen as a basis for the new laboratory test method. The lab apparatus was modified and made more precise and simple to operate. A contract was awarded to B. F. Goodrich (reference 3) to develop a reflective coating for retrofitting inservice slides and slide/rafts. Laboratory tests were performed on candidate materials for use in the manufacture of new slides as well as on samples taken from the undamaged sections of slides used in full-scale tests.

At various stages during the project, pressurized slides were subjected to thermal radiation produced by a large fuel fire. Baseline tests involved a series of L-1011 urethane nylon slides and DC-10 neoprene nylon slides. Similar slides were protected with an

aluminized coating and tested. An aluminized neoprene Kevlar 737 slide and a neoprene Kevlar tube section were also tested. The purpose of these full-scale tests was to establish the failure modes under the most realistic conditions possible, and to provide full-scale data for comparison with data from the new laboratory test method.

EQUIPMENT DESCRIPTION.

Full-scale tests were conducted at the airport fire test site utilizing a 30- by 30-foot fire pit filled with JP-4 fuel. Two towers were fabricated with galvanized pipe and positioned equidistant on opposite sides of the fire pit (see figures 1 and 2). Girt bar assemblies allowed for slide attachment to simulate a door sill height of 15 feet above the ground. These towers were constructed with wheels for ease in repositioning to obtain various heat fluxes as a function of distance from the pit. Three calorimeters (Hy-cal model C-1300 A) were used to measure the incident heat flux upon each slide. Two calorimeters were mounted on stands for placement near the middle and foot of each slide.

The third calorimeter was mounted on the tower near the top of the slide. A pressure transducer (Dynisco model PT305-15) was connected to each slide inflation chamber to continuously monitor internal pressure during the tests. The calorimeter and pressure transducer data were recorded on a Honeywell Oscillograph model 1858. Six chromel-alumel thermocouples were positioned adjacent to each calorimeter (three for each slide). Thermocouple data was collected at 5-second intervals on an Esterline Angus recorder model D2020. The oscillograph and temperature recorder were located in an instrumentation van approximately 100 feet from the fire pit. During later tests, an additional thermocouple was positioned to measure either sliding surface temperature or underside temperature in

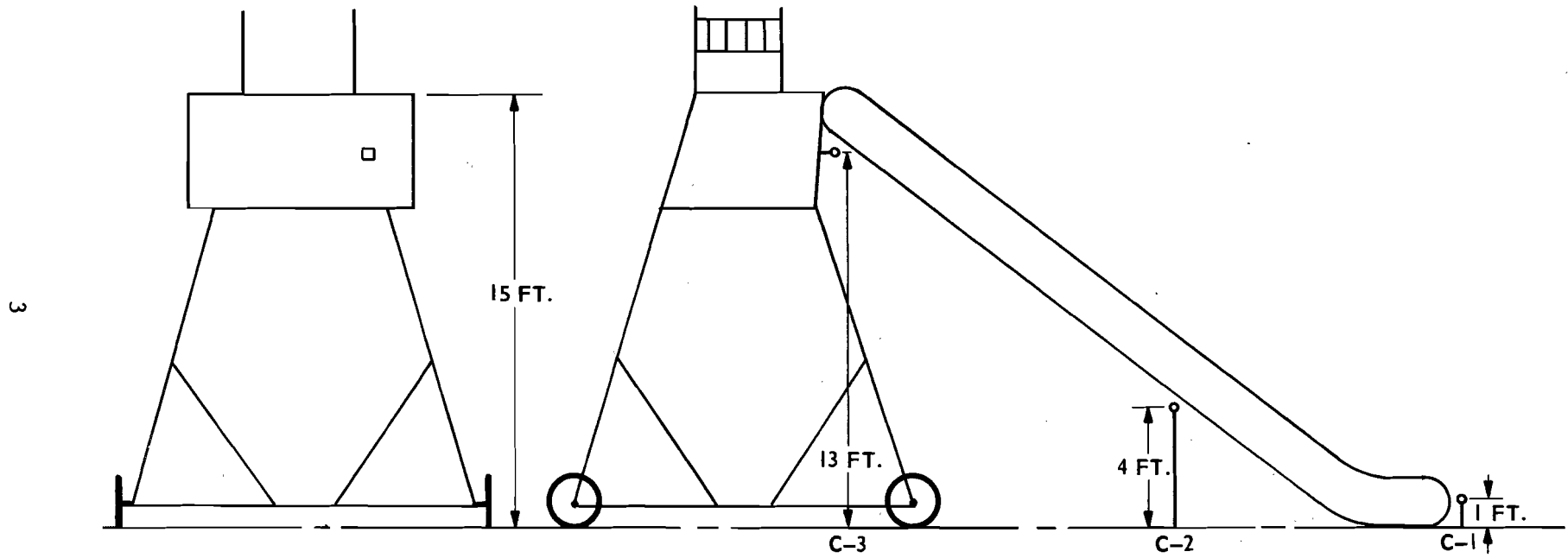

3

81-28-1

FIGURE 1. SLIDE ATTACHMENT TOWER

P

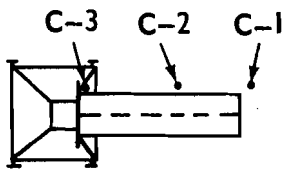
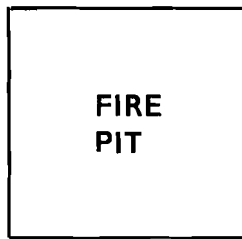
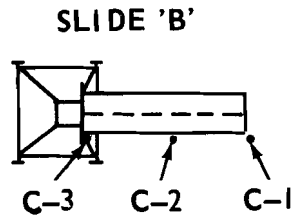

SLIDE 'A'

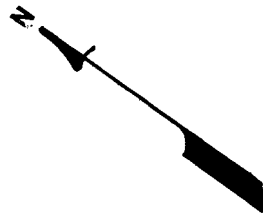

P = PHOTO & TV



81-28-2

FIGURE 2. DIAGRAM OF FULL-SCALE TEST SET-UP

the air pocket near the top of the slide. Due to the limited availability of slides, later tests consisted of only one slide per test.

Early morning tests were chosen to minimize the effects of wind which influence fire plume behavior. The inflation systems were removed from each slide prior to testing. A gasoline-powered portable air compressor was used to inflate the slides to nominal pressure. Test visual documentation was provided by two clock-equipped instrumentation motion picture cameras, two "still" cameras, three color video cameras, and one mobile motion picture documentary camera.

The laboratory apparatus developed during this study to determine the resistance of pressurized evacuation slide and slide/raft materials subjected to radiant heat is shown in figure 3. The sample is fastened to the open end of a cylinder and is pressurized for the test. An electric furnace irradiates the specimen surface. A 0-5 Btu/foot (ft)²-second (sec) calorimeter is used for calibrating the irradiance level of the furnace and establishing the required distance from the furnace to the surface of the test specimen. A digital millivolt meter records the output of the calorimeter and a Honeywell model 19642 strip chart potentiometer recorder monitors the pressure and temperature on the test specimen.

A more complete description of the apparatus and its operation can be found in a proposed American Society for Testing and Materials (ASTM) laboratory test method (appendix A).

TEST MEASUREMENTS.

A set routine was followed in preparing for and conducting each full-scale test. First, the fire pit was filled with water to a depth that sufficiently covered the concrete base. Approximately 100 gallons of JP-4 fuel per

minute of desired burn time was then pumped from a fuel tanker truck into the pit. The slides were pressurized to a nominal value specified by the manufacturer. Calorimeter cooling water was turned on and lines were checked for proper water flow. With all instruments operational, a horn was sounded to signal the start of the test. After 20 seconds elapsed (start-up time required for movie and video coverage), the fuel in the pit was ignited and the timing clocks were started. The slides designated as "A" and "B" (see figure 4) were located on the left and right sides of the pit, respectively, as viewed from the camera position. When both slides had visually collapsed, the fire was extinguished by the Airport Fire Department utilizing light water foam. The failure modes of the slides were documented after each test with motion picture, still, and video cameras. For all of the full-scale tests, the average heat flux from 15 seconds (time required for fire to become fully developed) until time of initial pressure loss was determined.

Measurements from the laboratory test apparatus included incident thermal radiation on the test sample, temperature of the unexposed surface (back side) of the sample, and time to initial pressure loss (time when a decrease in the cylinder pressure is first noted). Test materials included samples with and without seams, and with and without heat reflective coatings.

The desired heat flux exposure condition was set, by varying the distance of the calorimeter from the opening of the radiant heat furnace until the desired setting was achieved, and then setting the surface of the test specimen (after pressurization) to that same distance.

Back side surface temperature was measured with a 22-gauge iron constantan thermocouple attached to the inside of the pressure cylinder, adjusted so that the thermocouple bead touched (without

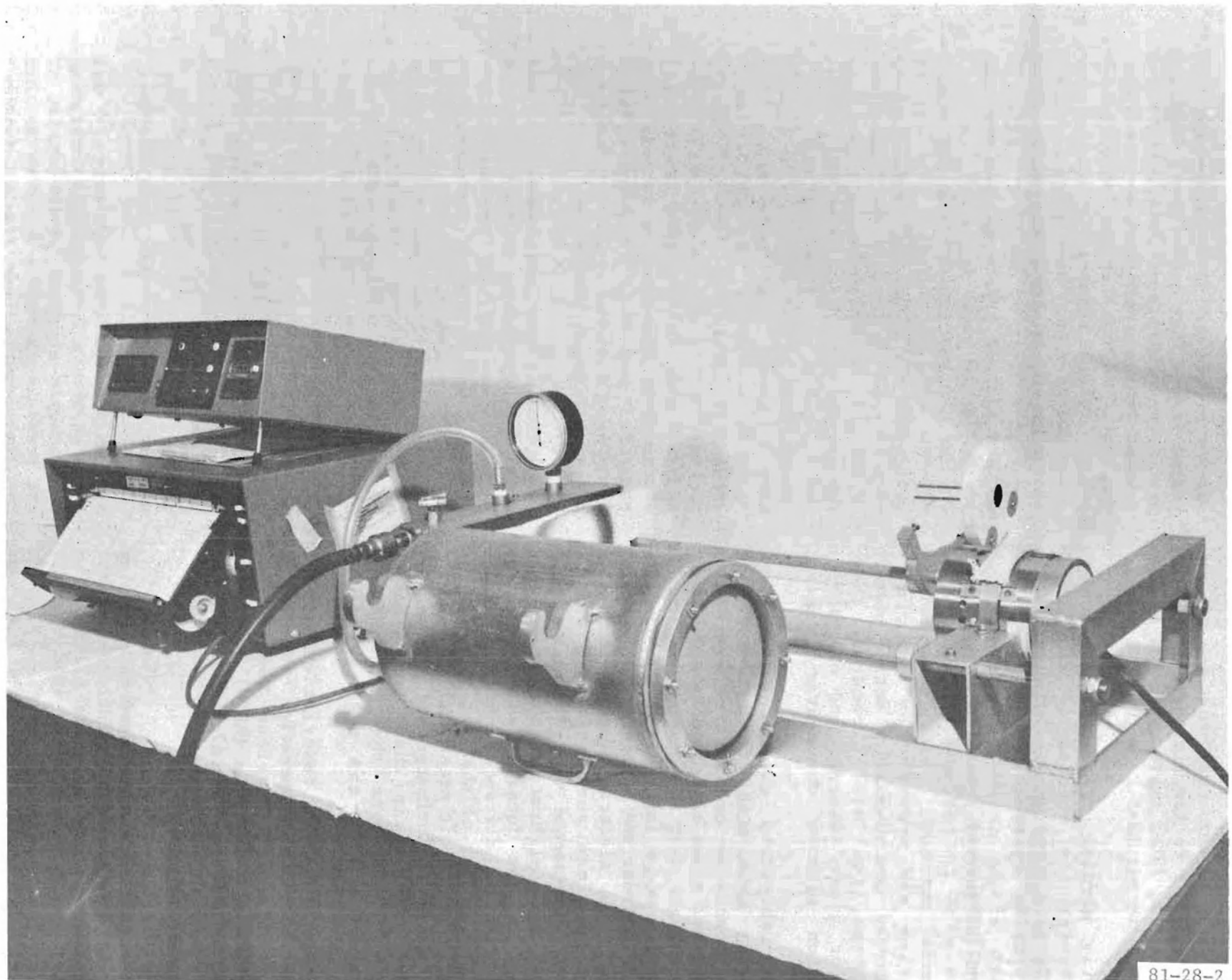

81-28-2

FIGURE 3. EVACUATION SLIDE MATERIAL LABORATORY TESTING APPARATUS



81-26-3

FIGURE 4. FULL-SCALE FIRE TEST SET-UP; TEST 5

pressure) the approximate center of the test specimen.

TEST RESULTS AND ANALYSIS

FULL-SCALE.

Seventeen full-scale tests were conducted utilizing complete evacuation slides or tube sections (see tables 1, 2, and 3). Baseline tests were performed with urethane nylon and neoprene nylon slides. Two urethane nylon and two neoprene nylon slides were prepared and tested with the B. F. Goodrich aluminized coating. An additional urethane nylon slide was prepared and tested with an Air Cruisers aluminized coating. A neoprene Kevlar tube section and an aluminized neoprene Kevlar slide were also tested. Appendix B-1 contains heat flux and inflation pressure profiles for each test.

A description of the full-scale tests are given in the following paragraphs.

Test 3: Two urethane nylon double lane slides were positioned at a distance of 15 feet from the edge of the fire pit. Slide "A" was inflated to 2.65 pounds per square inch gage (psig) and slide "B" was inflated to 2.5 psig. Five hundred gallons of JP-4 fuel were added to the pit and ignited (fuel quantity used in all full-scale tests).

At 27 seconds into the test and at a peak pressure of 3.13 psig, slide "A" blew out catastrophically in a nonseam area near the center of the tube facing the fire. The peak heat flux was recorded by the medium height calorimeter (1.6 Btu/ft²-sec at 27 seconds, see figure B-1). The highest "average" (defined as the average heat flux over the time interval from 15 seconds (developed fire) to the time of initial pressure loss) heat flux also occurred at this location (1.51 Btu/ft²-sec).

At 27 seconds into the test and a peak pressure of 3.0 psig, slide "B" began to leak pressure from a nonseam area near the center of the tube facing the fire (see figure 5). At 52 seconds, slide "B," after having leaked down to 0.38 psig, blew out. The heat flux levels recorded by the medium height calorimeter were practically identical to those measured for slide "A" at the same location (see figure B-2).

Test 5: Two urethane nylon double-lane slides were positioned at a distance of 20 feet from the fire pit (see figure 4). Both slides were inflated to 2.5 psig.

As shown in figure B-3, at between 70 and 80 seconds into the test, slide "A" gradually began to lose pressure after having reached a peak pressure of 3.33 psig. At 91 seconds and a pressure of 3.13 psig, the pressure began to decrease more rapidly from the seam above the aspirator at the top of the tube facing the fire. By 110 seconds, slide "A" had leaked down to 0.2 psig. The peak heat flux for the top calorimeter was 1.1 Btu/ft²-sec at 91 seconds; however, the highest heat flux was recorded by the medium height calorimeter.

Slide "B" gradually began to lose pressure between 60 and 65 seconds. At 71 seconds, slide "B" began to lose pressure from a seam above the aspirator at the top of the tube facing the fire. By 120 seconds, slide "B" had leaked down to 0.43 psig. Thus, both slides developed major failures at a seam above the aspirator.

Test 7: One urethane nylon double-lane slide was positioned at a distance of 25 feet from the fire pit. The slide was inflated to 2.5 psig. The slide did not fail over the test duration. The pressure increased throughout the test to a peak of 4.0 psig at 240 seconds. At this time the fire began to diminish

TABLE 1. SUMMARY OF TEST CONDITIONS

Test Number	Date	Time	Air Temp. (°F)	Wind Dir.	Wind Knots	Dew Point (°F)	JP-4 Amount (Gal)	Distance (Feet)		Slide Description	Coating Applied By	Comments
3 A	11/6/79	0610	36	010	03	34	500	15	Double	Lane Urethane Nylon		
B	11/6/79	0610	36	010	03	34	500	15	Double	Lane Urethane Nylon		
5 A	11/9/79	0603	48	200	03	46	500	20	Double	Lane Urethane Nylon		
B	11/9/79	0603	48	200	03	46	500	20	Double	Lane Urethane Nylon		
7 A	11/16/79	0603	44	250	09	36	500	25	Double	Lane Urethane Nylon		
8 A	11/20/79	0602	38	00	00	38	500	22.5	Single	Lane Urethane Nylon		
B	11/20/79	0602	38	00	00	38	500	12.5	Double	Lane Urethane Nylon		
10 A	5/8/80	0526	53	360	06	49	500	15	Double	Lane Neoprene Nylon		
11 A	5/9/80	0526	42	300	07	36	500	20	Double	Lane Neoprene Nylon		
12 A	5/13/80	0525	63	220	07	60	600	15	Single	Lane Neoprene Kevlar (Aluminized)		Pres. Relief Value Plugged
14 A	5/15/80	0527	46	330	05	43	500	15	Tube	Section Neoprene Kevlar		
16 A	6/25/80	0431	62	220	04	61	500	15	Double	Lane Urethane Nylon BFG		
B	6/25/80	0431	62	220	04	61	500	15	Single	Lane Urethane Nylon (BF Goodrich Aluminized)		
17 A	6/26/80	0428	57	not recorded		57	500	15	Double	Lane Urethane Nylon (Air Cruisers Aluminized)	Air Cruisers	
19 A	7/24/80	0507	64	010	04	04	500	20	Double	Lane Urethane Nylon (BF Goodrich Aluminized)	FAA	Light Coating
20 A	7/25/80	0511	56	300	03	53	500	20	Single	Lane Neoprene Nylon (BF Goodrich Aluminized)	FAA	
22 A	7/27/80	0512	64	00	00	63	600	20	Double	Lane Neoprene Nylon (BF Goodrich Aluminized)	FAA	

TABLE 2. SUMMARY OF URETHANE NYLON FULL-SCALE TESTS

Test Number	Lanes		Aluminized		Hi AV H. F. ⁽⁴⁾ Btu/ft ² -5	Time Leaked (Second)	Fail Mode Blew Out	Fail Type & Location			Pressure		Coated By	
	Single	Double	No	Yes				Base	Middle	Top	Initial	Peak		
3 A		X	X		1.51M ⁽⁵⁾		27		Nonseam		2.65	3.13		
3 B		X	X		1.53M		27		Nonseam		2.5	3.0		
5 A		X	X		1.12M		91			Seam	2.5	3.33		
5 B		X	X		1.10M		71			Seam	2.5	3.5		
7		X	X		0.66B ⁽⁶⁾				No fail in 240 seconds			2.5	4.0	
8 A	X		X		0.94M			84	Seam		2.5	4.1		
8 B		X	X		1.59M		27		Nonseam		2.5	3.05		
16 A		X	X		1.35M		32		Nonseam		2.1	3.0		
16 B	X			BFG ⁽²⁾	1.54T ⁽⁷⁾		71			Seam	2.35	3.5	BFG	
17		X (C) ⁽¹⁾		AC ⁽³⁾	1.92T		26		Nonseam		2.45	3.0	AC	
19		X (C)		BFG	1.22M		58			Seam	2.5	Data Loss	FAA ⁽⁸⁾	

(1) C - Canted

(2) BFG - B. F. Goodrich

(3) AC - Air Cruiser

(4) Hi Av H. F. - Highest Average Heat Flux

(5) M - Middle
 (6) B - Base
 (7) T - Top

Calorimeter Locations

(8) FAA - Federal Aviation Administration

TABLE 3. SUMMARY OF NEOPRENE FULL-SCALE TESTS

Test Number	Material	Lanes		Aluminized		Hi Av H. F. (5) Btu/ft ² -5	Time Leaked (Second)	Fail Mode Blew out	Fail Type and location			Pressure	
		Single	Double	No	Yes				Base	Middle	Top	Initial	Peak
10 upper ⁽¹⁾ lower ⁽²⁾	Nylon		X	X		1.79M ⁽⁶⁾		23		Nonseam		2.75	3.15
	Nylon		X	X		1.79M		28		Nonseam		2.2	2.8
11 upper lower	Nylon		X	X		1.16M		58		Seam		2.3	3.55
	Nylon		X	X		0.86*(7)		206		Seam		3.0	3.75
12	Kevlar	X				AS ⁽³⁾		68			Seam	2.04	5.05
14	Kevlar	(tube section)		X		1.75T ⁽⁸⁾		44			Seam	1.9	4.65
20	Nylon	X				BFG ⁽⁴⁾		49		Seam		3.35	4.1
22 upper lower	Nylon		X			BFG		104		Seam		2.75	3.85
	Nylon		X			BFG		106		Seam		2.35	3.75

*estimated

(1) upper }
(2) lower } Dual Section Slide

(3) AS - American Safety

(4) BFG - B. F. Goodrich

(5) Hi Av H. F. - Highest Average Heat Flux

(6) M - Middle }
(7) * Estimated } Calorimeter Location

(8) T - Top



81-28-4

FIGURE 5. URETHANE NYLON SLIDE SMOKING DURING TEST; TEST 3B

in intensity as the remaining fuel was consumed (figure B-5). The fire was then extinguished and the pressure in the slide gradually returned to 2.5 psig. The only damage to the slide was the "ungluing" of a nonairholding filler strip between the upper evacuee retaining tube ("armrest") and the main tube on the side facing the fire. The heat flux histories were very similar for the three calorimeters, with an average value for the low, medium, and high calorimeters of 0.66 Btu/ft²-sec, 0.62 Btu/ft²-sec, and 0.63 Btu/ft²-sec, respectively. Thus, this test demonstrated that inservice urethane nylon slides could withstand radiative heat at a distance of 25 feet from a major fuel fire (0.6 - 0.7 Btu/ft²-sec); and subsequent tests were conducted closer to the fire in order to compare the heat resistance of different material systems under conditions producing failure.

Test 8: In order to more closely define and bracket the heat failure conditions, test 8 consisted of one urethane nylon single-lane slide at 22-1/2 feet (slide "A") and one urethane nylon double-lane slide at 12-1/2 feet (slide "B") from the fire pit. Slides "A" and "B" were inflated to 2.5 psig.

At 27 seconds into the test, slide "B," having reached a peak pressure of 3.05 psig, began to lose pressure rapidly from a nonseam area near the center of the tube facing the fire. By 40 seconds, slide "B" had leaked down to 0.15 psig. The onset of failure and heating conditions were similar to that of slide "A" in test 3, yet the loss of pressure was gradual compared to the abrupt loss (blowout) evidenced in test 3.

At 84 seconds into the test, slide "A" blew out catastrophically (see figure 6) at a seam approximately 2 feet below the aspirator on the tube facing the fire. The pressure had increased to 4.1 psig at the point of failure.

The heating history and onset of failure was similar to test 5 (20-foot distance from fire), but the failure was abrupt, contrasted to the more gradual leakage witnessed in test 5. The test results appear to be more consistent in terms of the time to the onset of pressure loss rather than the pressure leakage rate.

Test 10: One neoprene nylon double-lane, dual inflation chamber slide was positioned at a distance of 15 feet from the fire pit. The upper and lower chambers were inflated to 2.75 psig and 2.2 psig, respectively. An additional thermocouple was attached to the underside of the sliding surface near the top of the slide.

At 23 seconds into the test, the upper chamber blew out catastrophically in a nonseam area approximately 3 feet from the foot of the slide.

The slide remained taut, however, because of the support provided by the inflated lower chamber. The lower chamber began to rapidly lose pressure at 28 seconds from a nonseam area on the support cushion suspended below the lower tube facing the fire, and the pressure leaked down to 0.1 psig by 35 seconds. The peak heat flux was recorded by the medium height calorimeter at 1.8 Btu/ft²-sec at 15 seconds. The temperature rise on the underside of the sliding surface was only 28° F by 28 seconds into the test, indicating that insignificant heat accumulation occurred in this area. This test demonstrated that the dual chamber design can provide an additional safety margin with regard to maintaining slide erection in a fire environment.

Test 11: One neoprene nylon double-lane dual inflation chamber slide was positioned at a distance of 20 feet from the fire pit (in order to examine the behavior of neoprene at a less severe heating condition than test 10). The upper and lower chambers were inflated to 2.3 psig and 3.0 psig, respectively.



FIGURE 6. CATASTROPHIC FAILURE OF URETHANE NYLON SLIDE; TEST 8A

At 58 seconds into the test, the upper chamber blew out catastrophically on a seam area facing the fire near the base of the slide. The blowout shifted the base of the slide approximately 3 feet further away from the fire pit. Also at 58 seconds, the lower chamber began losing pressure, perhaps from the shock caused by failure of the upper chamber. The loss of pressure was very gradual (figure B-9) in contrast to the experiences of previous tests. By 206 seconds, the lower chamber had leaked down from a peak pressure of 3.75 psig at 58 seconds to 3.25 psig, and blew out catastrophically on a seam area near the base of the slide (see figure 7). The medium height calorimeter recorded the peak heat flux and the highest average heat flux, 1.4 Btu/ft²-sec and 1.16 Btu/ft²-sec, respectively. It was estimated that the heat flux near the base of the slide dropped approximately 0.3 Btu/ft²-sec after failure of the upper chamber.

Test 12: One aluminized Kevlar single-lane slide was positioned at a distance of 15 feet from the fire pit. The slide was inflated to 2.04 psig. An additional thermocouple was attached to the underside of the sliding surface as in test 10. The pressure relief valve on the slide had been plugged by the manufacturer and had inadvertently remained so throughout the test.

At 68 seconds into the test, the slide blew out catastrophically on a seam approximately 3 feet below the top of the tube facing the fire (see figure 8). At the time of failure, the inflation pressure had increased to over 5 psig, higher than in previous experiments, and possibly because of the inoperative pressure relief valve. Wind conditions caused the fire to bend toward the slide, producing a higher heat flux than in previous tests, which peaked at 2.4 Btu/ft²-sec at 68 seconds for the medium height calorimeter (figure B-10). The temperature rise for the underside of the sliding surface, which was

insignificant in previous tests, was 134° F by 68 seconds.

Test 14: One neoprene Kevlar slide tube section was positioned at a distance of 15 feet from the fire pit and inflated to 1.9 psig. Since there was no pressure relief valve installed on the tube section, a 1/4-inch copper dump line with a valve was fastened to the tube section to provide some manual pressure regulation during the test. This measure for relieving pressure later proved to be inadequate.

At 44 seconds into the test, the tube section reached a peak pressure of 4.65 psig and blew out catastrophically on a seam near the top of the tube facing the fire (see figure 9). The peak heat flux was recorded by the top calorimeter at 1.9 Btu/ft²-sec at 30 seconds and was much higher at this location than at the lower levels (figure B-11). As in test 12, wind conditions caused the fire to bend toward the tube section, producing a higher heat flux than measured in the earlier tests at the same distance from the fire. Despite the higher radiative exposure, the Kevlar proved more heat resistant than urethane or neoprene.

Test 16: A urethane nylon double-lane slide was positioned at a distance of 15 feet from the fire pit (slide "A"). For comparison purposes, an aluminized urethane nylon single-lane slide was positioned at the same distance on the opposite side of the fire pit (slide "B"). B. F. Goodrich sprayed their aluminized coating to slide "B." During the aluminization coating process, B. F. Goodrich masked off the stenciling below the aspirator, leaving the original urethane nylon exposed (see figure 10). Thus, the stenciled area was left unprotected. Slides "A" and "B" were inflated to 2.1 psig and 2.35 psig, respectively.

At 32 seconds into the test, the uncoated slide ("A") began leaking pressure from a nonseam area in the



81-28-6

FIGURE 7. NEOPRENE NYLON SEAM FAILURE; TEST 11

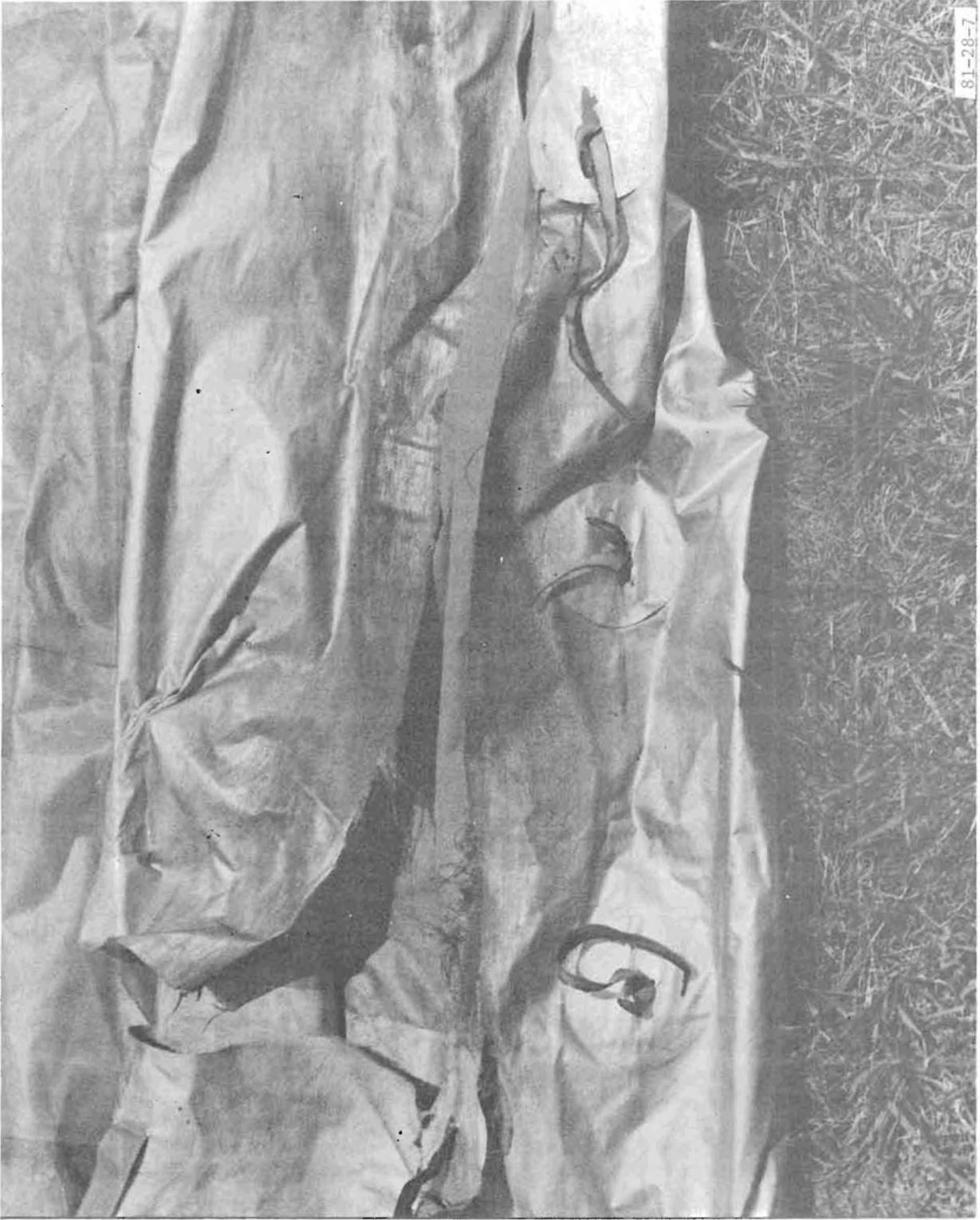

FIGURE 8. ALUMINIZED NEOPRENE KEVLAR SEAM FAILURE; TEST 12

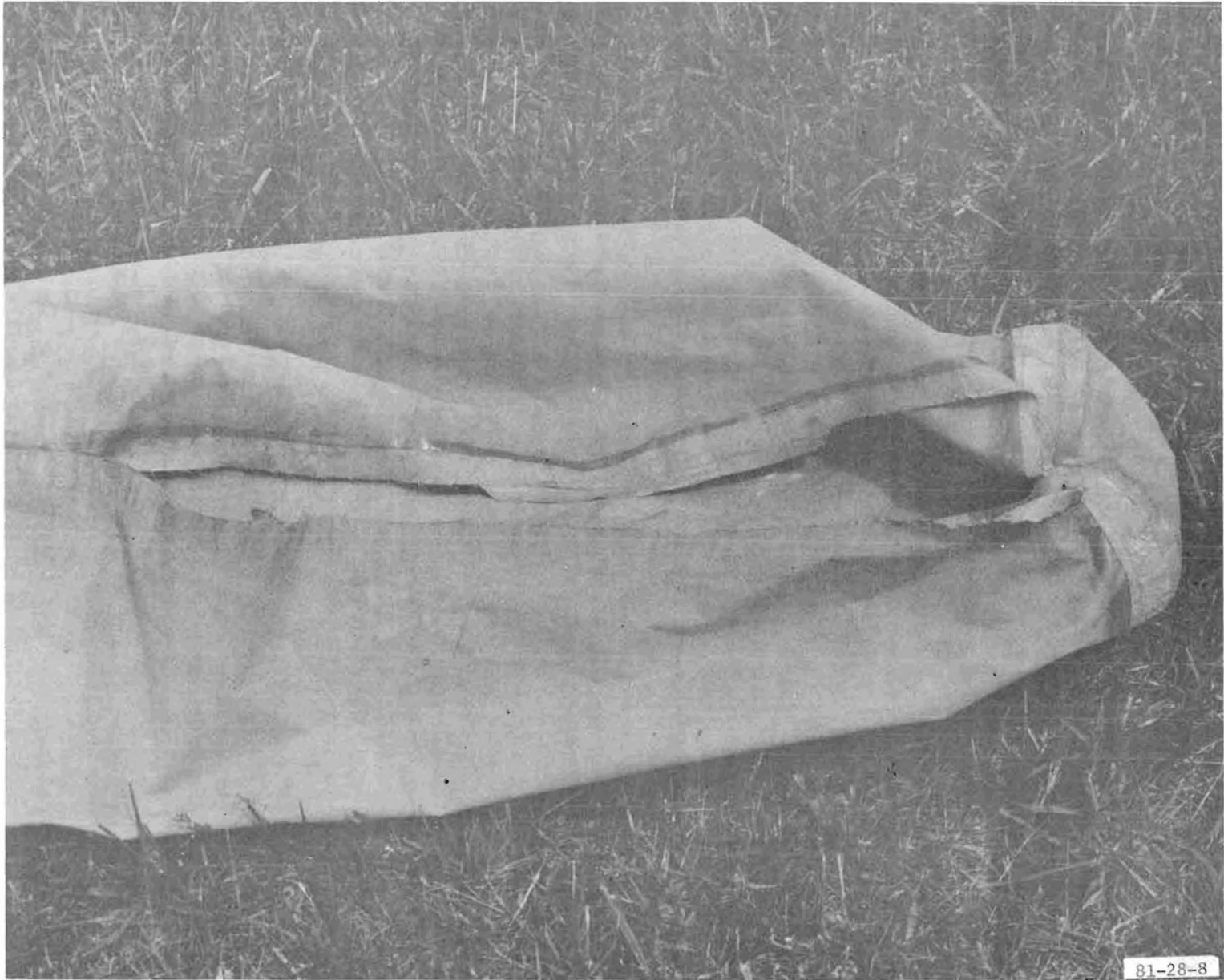

FIGURE 9. NEOPRENE KEVLAR SEAM FAILURE; TEST 14



FIGURE 10. ALUMINIZED URETHANE NYLON WITH STENCILING SHOWING; TEST 16B

middle of the tube facing the fire. By 64 seconds, at a pressure of 0.5 psig, the uncoated slide blew out in a nonseam area approximately 3 feet below the aspirator on the tube facing the fire (see figure 11). The measured radiative heat flux levels are shown in figure B-12. Although the heat flux values are slightly less than in test 3, which also exposed a double-lane urethane nylon slide at 15 feet from the fire, the onset of failure from this test is consistent with test 3.

The aluminized slide did not begin leaking pressure until 64 seconds into the test, exactly two times as long as the uncoated slide. The initial leakage which was gradual (figure B-13) was from a seam above the aspirator on the tube facing the fire. At 71 seconds, a more rapid leakage occurred from the non-aluminized, nonseam stenciled area below the aspirator facing the fire (see figure 12). By 80 seconds, slide "B" had leaked down to 0.25 psig. As shown in figure B-12, the heat flux levels impinging on the aluminized slide ("B") were higher than on the unprotected slide ("A"). Thus, one might surmise that, notwithstanding the unprotected stenciled area, had the aluminized slide been subjected to precisely the same radiation as the unprotected slide, the improvement would have been even greater. Again, wind conditions caused the fire to bend slightly toward the top of slide "B," producing a higher heat flux.

Test 17: An aluminized urethane nylon double-lane canted slide was positioned at a distance of 15 feet from the fire pit. The slide was prepared by Air Cruisers with their own aluminized coating. This coating was applied with a roller as opposed to the spraying operation used by B. F. Goodrich. The slide was successfully repacked by Air Cruisers in its original container and without any problem. Thus, the additional coating thickness did not prevent repacking of the slide into its

original container nor interfere with the deployment of the slide. The slide was inflated to 2.45 psig for the fire test.

At 26 seconds into the test, the slide began to lose pressure rapidly from a nonseam area in the middle of the tube facing the fire. At 35 seconds, the slide leaked down to 0.15 psig and blew out approximately 2 feet below the aspirator in a nonseam area (see figure 13). The earlier than expected failure (see test 16) appeared to result from the unusually high heat flux levels, which were greater than in any of the previous tests (figure B-14).

Wind conditions caused the fire to bend toward the top of the slide, producing a higher heat flux.

Test 19: One aluminized, urethane nylon double-lane, canted slide was positioned at a distance of 20 feet from the fire pit. The slide was sprayed with the B. F. Goodrich aluminized coating by FAA Technical Center personnel. The slide was inflated to 2.5 psig. Unfortunately, pressure transducer data were lost shortly after the start of the test. A thermocouple was attached to the top side of the sliding surface near the top of the slide.

At 58 seconds into the test, seam slippage occurred near the top of the slide on a rounded corner of the upper retaining tube ("armrest") (see figure 14). The slide visually began to collapse at 85 seconds. The peak heat fluxes for the low, medium, and high calorimeters were 1.75 Btu/ft²-sec, 1.65 Btu/ft²-sec, and 1.25 Btu/ft²-sec, respectively (figure B-15). The average heat fluxes for the low, medium, and high calorimeters were 1.2 Btu/ft²-sec, 1.22 Btu/ft²-sec, and 0.85 Btu/ft²-sec, respectively (refer to appendix B-15). This test indicated that seam failure limited the potential heat resistance improvements provided by an aluminized coating applied to a

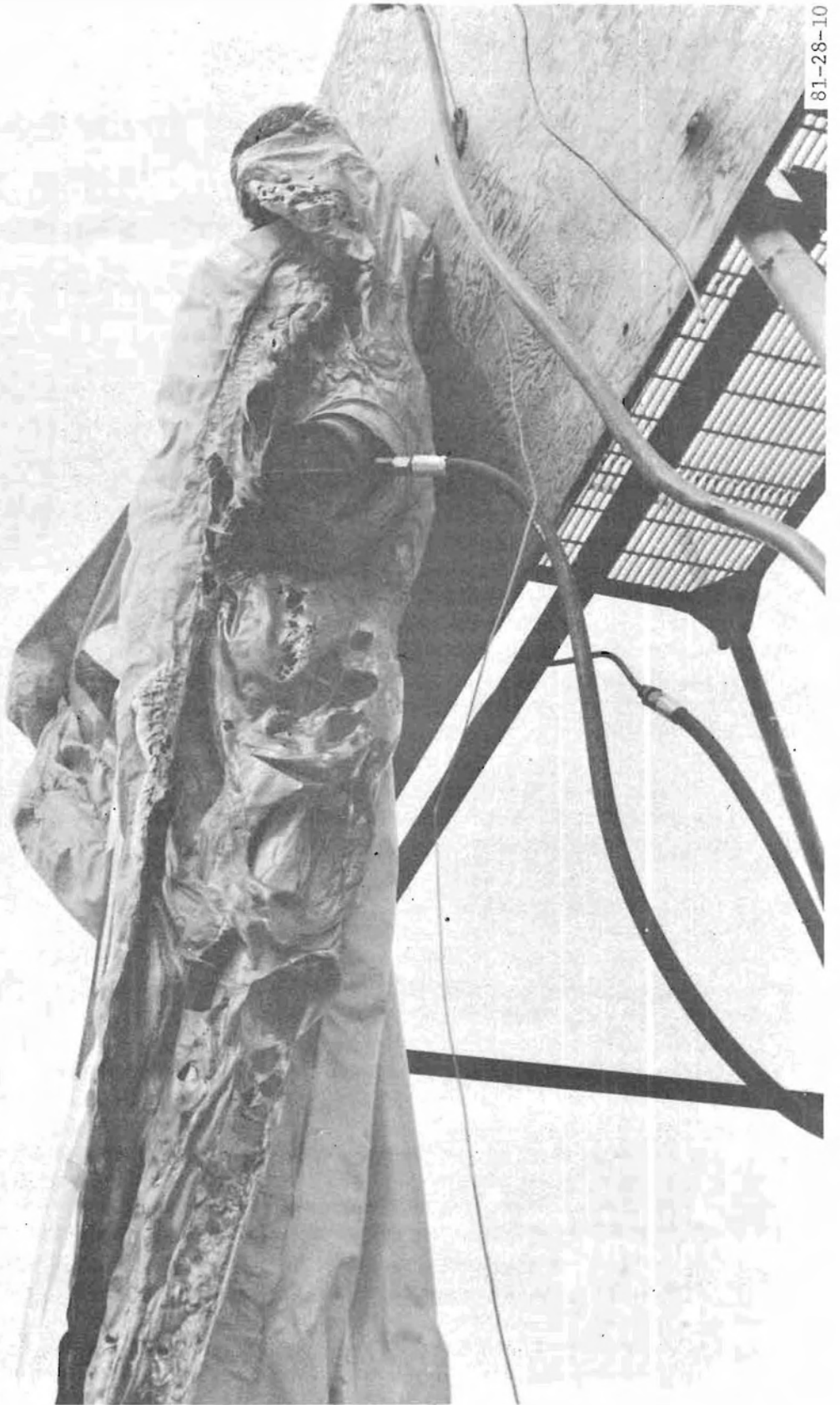
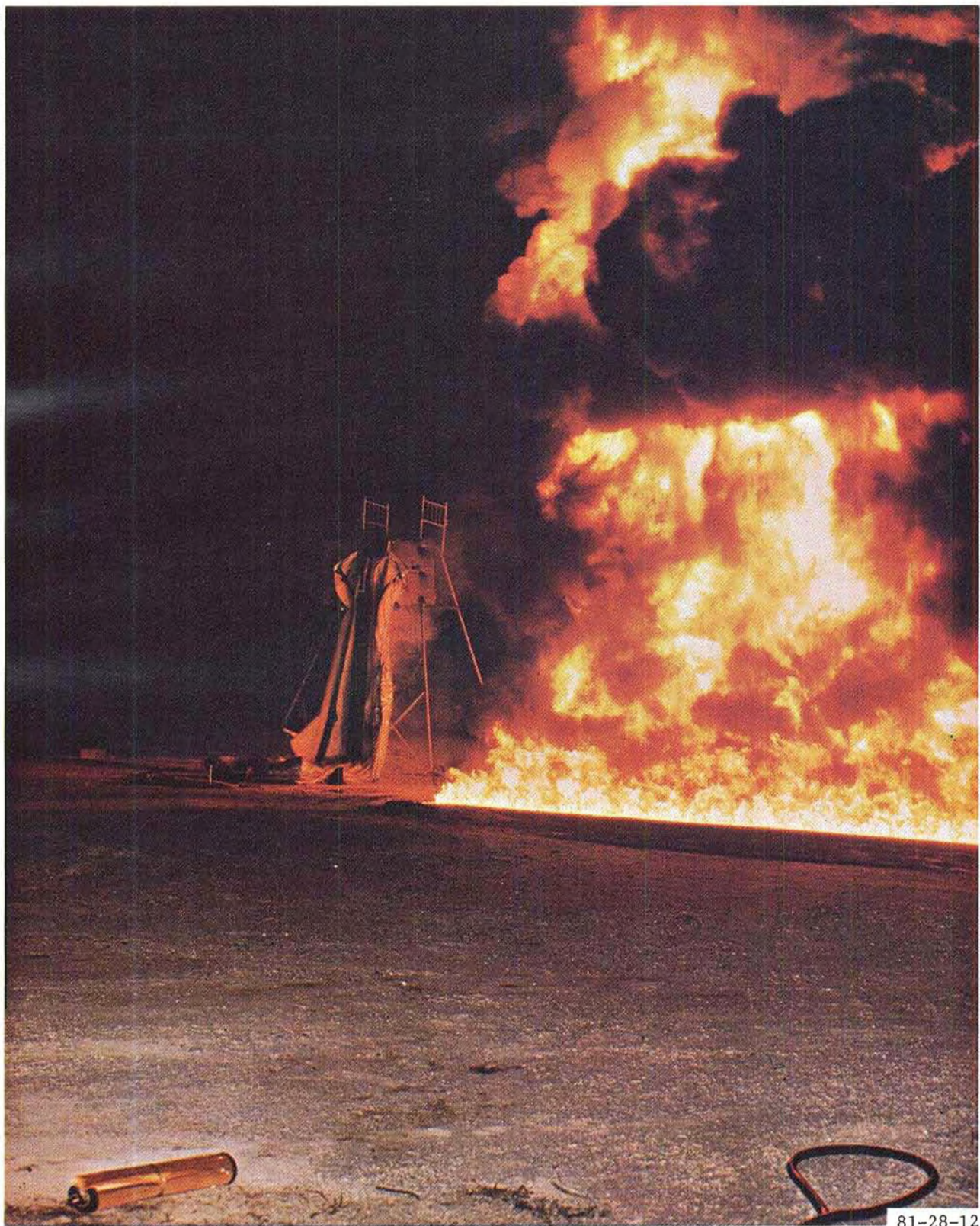

FIGURE 11. URETHANE NYLON NONSEAM FAILURE; TEST 16A



81-28-11

FIGURE 12. ALUMINIZED URETHANE NYLON SLIDE FAILURE DURING TEST; TEST 16B



81-28-12

FIGURE 13. ALUMINIZED URETHANE NYLON SLIDE FAILURE DURING TEST; TEST 17



FIGURE 14. ALUMINIZED URETHANE NYLON SEAM SLIPPAGE; TEST 19

complete evacuation slide. No visible damage was noted in the nonseam middle and base areas, although the average heat fluxes at these locations were higher than at the top of the slide. The temperature rise for the top side of the sliding surface was 90° F by 58 seconds.

Test 20: One aluminized neoprene nylon single-lane slide was positioned at a distance of 20 feet from the fire pit. The slide was sprayed with the B. F. Goodrich aluminized coating by FAA Technical Center personnel. The slide was inflated to 3.35 psig. An additional thermocouple was attached to the top side of the sliding surface as in test 19.

At 49 seconds into the test, the slide reached a peak pressure of 4.1 psig and blew out catastrophically on a seam near the base of the tube facing the fire (see figure 15). The peak heat fluxes for the low, medium, and high calorimeters were 0.9 Btu/ft²-sec, 0.8 Btu/ft²-sec, and 1.1 Btu/ft²-sec, respectively, all recorded at 45 seconds (figure B-16). At these heat flux levels, it was expected that the aluminized neoprene nylon slide would have resisted the fire for a longer period of time. No visible radiant heat damage was noted in the middle and top areas of the slide, in spite of the highest heat flux levels at the top of the slide. Other seam areas near the base of the slide also showed no visible radiant heat damage. It was therefore concluded that the seam in the failure area contained some sort of flaw. The temperature rise for the top side of the sliding surface was 47° F by 49 seconds.

Test 22: An aluminized neoprene nylon double-lane, dual inflation chamber slide was positioned at a distance of 20 feet from the fire pit. The slide was sprayed with the B. F. Goodrich aluminized coating by FAA Technical Center personnel. The upper and lower chambers were inflated to 2.75 psig and 2.35

psig, respectively. An additional thermocouple was attached to the top side of the sliding surface as in test 19.

At 69 seconds into the test, the non-airholding structural stabilizer peeled away from the upper tube, exposing a nonaluminized pressurized area of the slide to direct radiant heat. The exposed yellow area immediately began to smoke. At 104 seconds, the upper chamber blew out catastrophically on a nonaluminized seam near the middle of the tube facing the fire (see figure 16). At 106 seconds, the lower chamber began to lose pressure rapidly from a nonaluminized seam near the middle of the tube facing the fire (figure B-17). As shown in appendix B-17, the heat flux histories for the three calorimeters were very similar and the "average" values were identical for all practical purposes. No visible radiant heat damage was noted in the aluminized areas of the slide; the temperature rise for the top side of the sliding surface was 24° F by 55 seconds. Sliding surface temperature then leveled off for the remainder of the test.

LABORATORY.

Tables 4 through 8 are a compilation of the laboratory tests conducted during this program. Information contained in these tables include: (1) a description of the base fabric; (2) whether a reflective coating was applied; (3) whether the test specimen was plain or a seam; (4) material weight in ounces per square yard; (5) material thickness; (6) heat flux exposure; (7) cylinder pressure; (8) temperature on the back surface of the specimen at the time of initial pressure loss; and (9) time to initial pressure loss.

NEW URETHANE COATED FABRICS. Table 4 summarizes the results of tests on new urethane coated fabrics, including fabrics with various types of reflective coatings applied to the exposed surface.

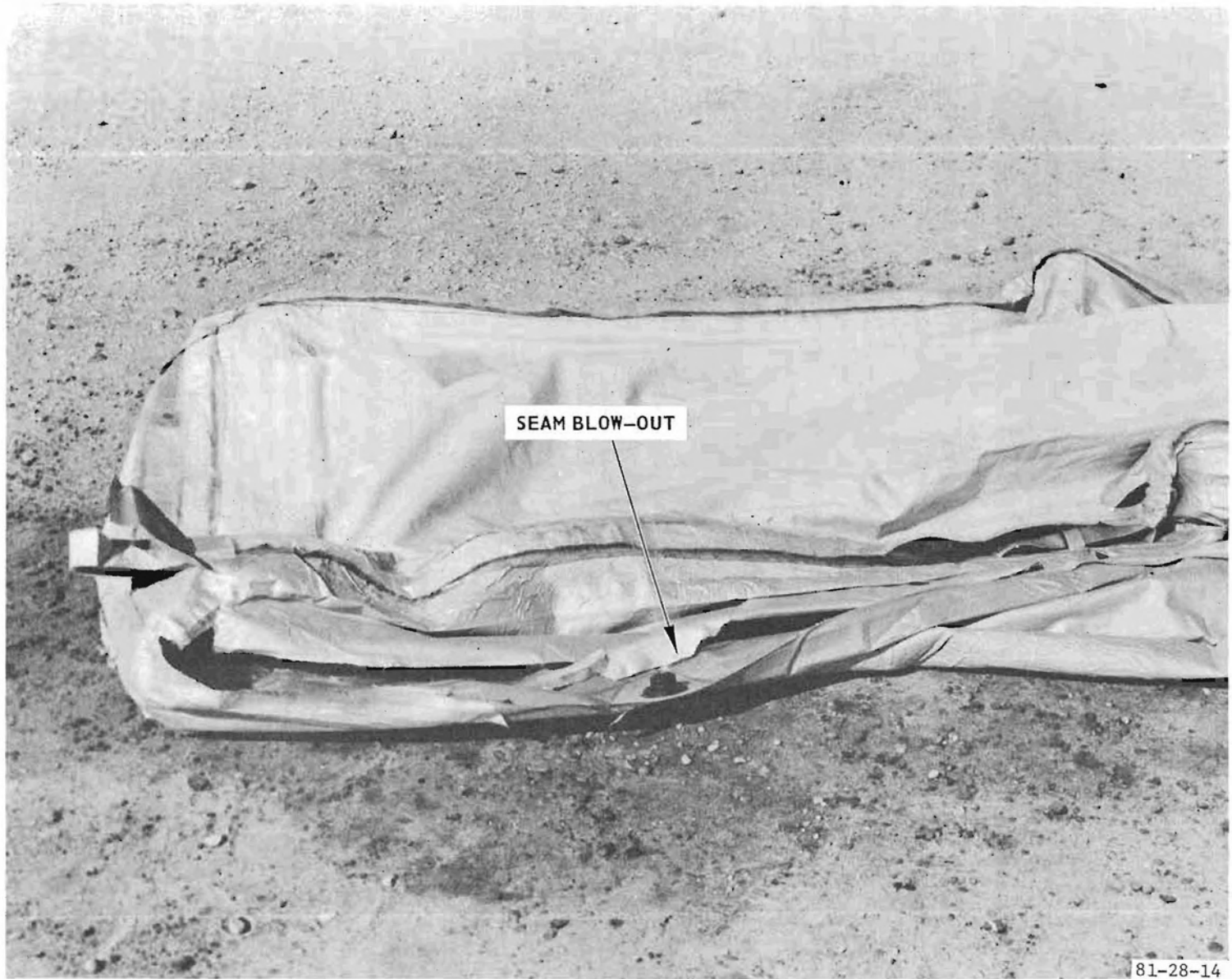
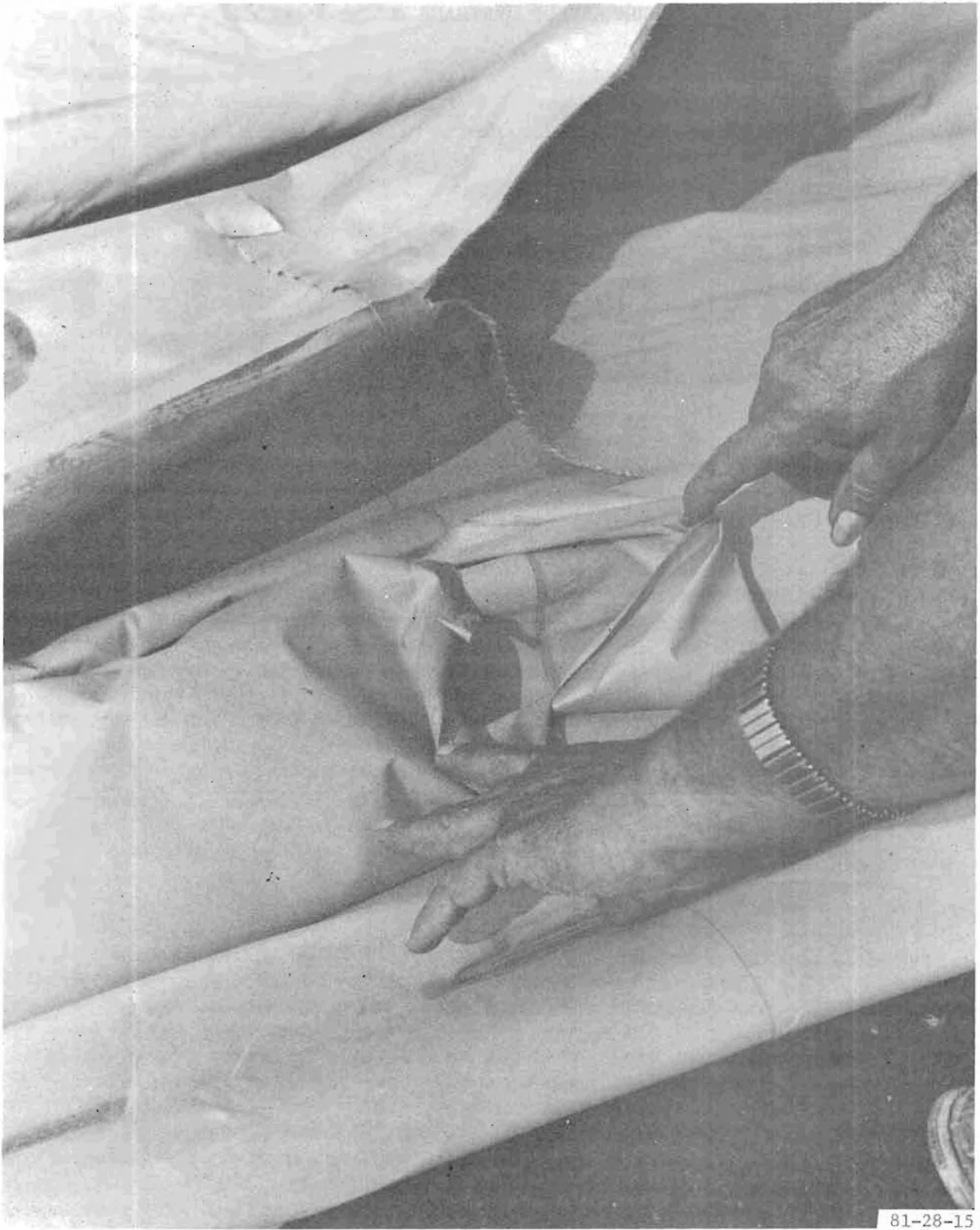

FIGURE 15. ALUMINIZED NEOPRENE NYLON SEAM FAILURE; TEST 20



81-28-15

FIGURE 16. NEOPRENE NYLON SEAM FAILURE; TEST 22

TABLE 4. SUMMARY OF URETHANE COATED FABRICS

Fabric	Reflective Coating	Seam	No Seam	Material Weight (oz/yd ²)	Material Thickness (in)	Heat Flux Btu/ft ² -sec	Cylinder Pressure (psig)	Temperature At Time Of Initial Pressure Loss (°F)	Time For Initial Pressure Loss (sec)	
Dacron	None		x	7.13	0.011	2	5	NA	7	
	None		x	7.32	0.011	2	5	NA	6	
	Aluminum		x	10.58	0.013	2	5	NA	10	
	Aluminum		x	9.59	0.013	2	5	NA	29	
	White		x	7.68	0.013	2	5	NA	7	
	White		x	9.62	0.013	2	5	NA	8	
	Chrome		x	7.55	0.011	2	5	NA	125	
	Chrome		x	7.84	0.013	2	5	NA	110	
Kevlar	None		x	6.43	0.008	2	2.5	163	7	
	None		x	6.43	0.008	1.5	2.5	197	12.5	
	None		x	6.43	0.008	1.0	2.5	218	30.	
	None		x	6.60	0.008	2	2.5	181	8.5	
	Aluminum		x	5.99	0.007	2	2.5	112	6	
	Aluminum		x	5.99	0.007	1.5	2.5	126	8.5	
	Aluminum		x	5.99	0.007	1.0	2.5	144	16.3	
	Aluminum		x	6.3	0.007	2	2.5	144	7.5	
	Aluminum		x	NA	NA	2	2.5	126	6.3	
	Nylon	None		x	9.0	0.011	1.5	2.5	NA	28
Nylon	None		x	9.0	0.011	2.2	2.5	136	10.5	
	None		x	9.0	0.011	2.2	2.5	211	9.5	
	None		x	8.1	NA	2.5	2	NA	10	
	None		x	8.1	NA	2.0	2	NA	14	
	None		x	8.1	NA	1.5	2	NA	26	
	Nylon 3.9 single ply	None		x	8.8	0.011	2.0	2.5	225	13
	Nylon 1.4 - 2.0 double ply	None		x	8.3	0.011	2.0	2.5	207	10.5
Nylon 3.9 single ply	None		x	7.5	0.011	2.0	2.5	204	10.5	
Nylon 3.0 - 3.3 single ply	None		x	7.7	0.013	2.0	2.5	145	5.5	
Nylon 3.9 single ply	None		x	8.4	0.010	2.0	2.5	214	13.5	
Nylon	Aluminized Mylar		x	NA	0.013	2.3	5	NA	540	
	Aluminized Mylar		x	NA	0.013	4.5	10	NA	At start of test	
	Aluminized Kapton		x	NA	0.019	4.5	5	NA	At start of test	
	Aluminized Kapton		x	NA	0.019	2.2	5	NA	At start of test	
	Al/urethane		x	NA	NA	2.2	2.5	233	19	
	Al/urethane		x	NA	NA	2.2	2.5	238	20	
	Al/urethane		x	NA	NA	2.2	2.5	233	18.5	
	Al/urethane		x	NA	NA	2.2	2.5	233	19.5	
	Al/urethane		x	NA	NA	2.2	2.5	218	16.5	
	Al/urethane		x	NA	NA	2.2	2.5	221	18	
	Al/urethane		x	NA	NA	2.2	2.5	191	11	
	Al/urethane		x	NA	NA	2.2	2.5	197	11	
	Aluminum		x	NA	NA	2.5	2.0	NA	22	
Aluminum		x	NA	NA	2.0	2.0	NA	55		
Aluminum		x	NA	NA	1.5	2.0	NA	>600		
Nylon 3.0 - 3.3 single ply	Aluminum		x	8.7	0.014	2.0	2.5	133	7.5	
	Aluminum		x	6.8	0.012	2.0	2.5	136	7.0	
Nylon 3.9 single ply	Aluminum		x	8.3	0.011	2.0	2.5	216	20	
	Aluminum		x	7.7	0.011	2.0	2.5	194	16	
Nylon	Al/light coat ⁽¹⁾		x	8.83	0.011	2.0	2.5	259	32	
			x	8.83	0.011	1.5	2.5	244	132	
			x	8.83	0.011	1.0	2.5	216	>600	
Nylon	Al/medium coat ⁽²⁾		x	9.18	0.012	2.0	2.5	253	* 63	
			x	9.18	0.012	1.5	2.5	236	192	
			x	9.18	0.012	1.25	2.5	220	>600	
Nylon	Al/heavy coat ⁽³⁾		x	9.42	0.013	2.0	2.5	253	84	
			x	9.42	0.013	1.5	2.5	221	294	
			x	9.42	0.013	1.4	2.5	217	>600	

NOTE: (1) Light coat = 1 spray coat
(2) Medium coat = 2 spray coats
(3) Heavy coat = 3 spray coats
Uncoated = 8.74

Figure 17 shows the effect of reflective coating thickness, by percent weight increase, on the heat resistance of a urethane nylon slide fabric. Time to initial pressure loss increases from 27 seconds for the noncoated material to approximately 210 seconds for a 5-percent weight increase over the base fabric weight (approximately 2 spray coats).

The repeatability of the laboratory apparatus was determined by performing five replicate tests at 1.5 Btu/ft²-sec and 2.5 psig on both non-reflective and aluminized (B. F. Goodrich KE 7620 paint) coated urethane nylon fabrics. The laboratory apparatus is very repeatable and more so than many standardized fire tests. The coefficients of variation for the time to initial pressure loss for the non-coated and aluminized coated samples were 2.9 percent and 2.2 percent, respectively (see table 5). As shown in figure 18, the advantage of a lightweight aluminized coating on the ability of a slide fabric to retain pressure can be very significant in a laboratory test environment. For the aluminized fabric the decrease in pressure at the time of failure is extremely small compared to the uncoated material. It should be noted that the results of figure 18 are with an aluminized fabric prepared by the fabric supplier, and heat resistance of this material is much greater than when the aluminized coating is applied "in the field" (figure 17).

Figure 19 shows the effect of heat flux, base fabric and aluminization, on the time to initial pressure loss. For urethane nylon at 1.5 Btu/ft²-sec, the time-to-failure was increased from 26 seconds for the noncoated material to over 600 seconds for a new material with a reflective coating. This reflective coating was applied by the manufacturer in the finished fabric. At the same heat flux, the improvement provided by aluminization was much less significant for the Kevlar fabric, as shown

in figure 18B. Only 4 seconds in useful time was gained by aluminization of Kevlar.

NEW NEOPRENE COATED FABRICS. Table 6 summarizes the laboratory test results on new coated fabrics. Figure 20 is a comparison of the difference between neoprene nylon and neoprene Kevlar materials with and without an aluminized reflective coating. These results alone and compared with figure 19 provide several important findings. All other factors being the same, neoprene coated materials are equal or superior to urethane counterparts in terms of heat resistance and ability to retain pressure. This difference is most pronounced for the Kevlar fabric. Clearly, neoprene coated Kevlar is substantially more heat resistant than urethane coated Kevlar. Figure 20 also illustrates that aluminization of neoprene nylon provides a greater proportional improvement in heat resistance than does aluminization of neoprene Kevlar.

SAMPLES FROM FULL-SCALE TEST SLIDES. Samples were taken from the undamaged part of the slides after full-scale tests for evaluation in the laboratory. This included samples from slides as they are presently used without any reflective coatings and slides that had been coated with an aluminum paint (B. F. Goodrich KE 7620) under consideration as a retrofit coating. This series of tests included samples with and without seams.

Table 7 contains the laboratory test results on samples taken from urethane nylon slides tested full-scale. Laboratory tests at 1.5 Btu/ft²-sec on slide samples taken from test 3 indicated a seam failure at 27 seconds and a nonseam sample failure at 22 seconds. Thus, at this condition the reinforcement of material at the seam provides a slight benefit or longer time to failure. These laboratory predictions agree very well with the full-scale test results (see figures B-1 and

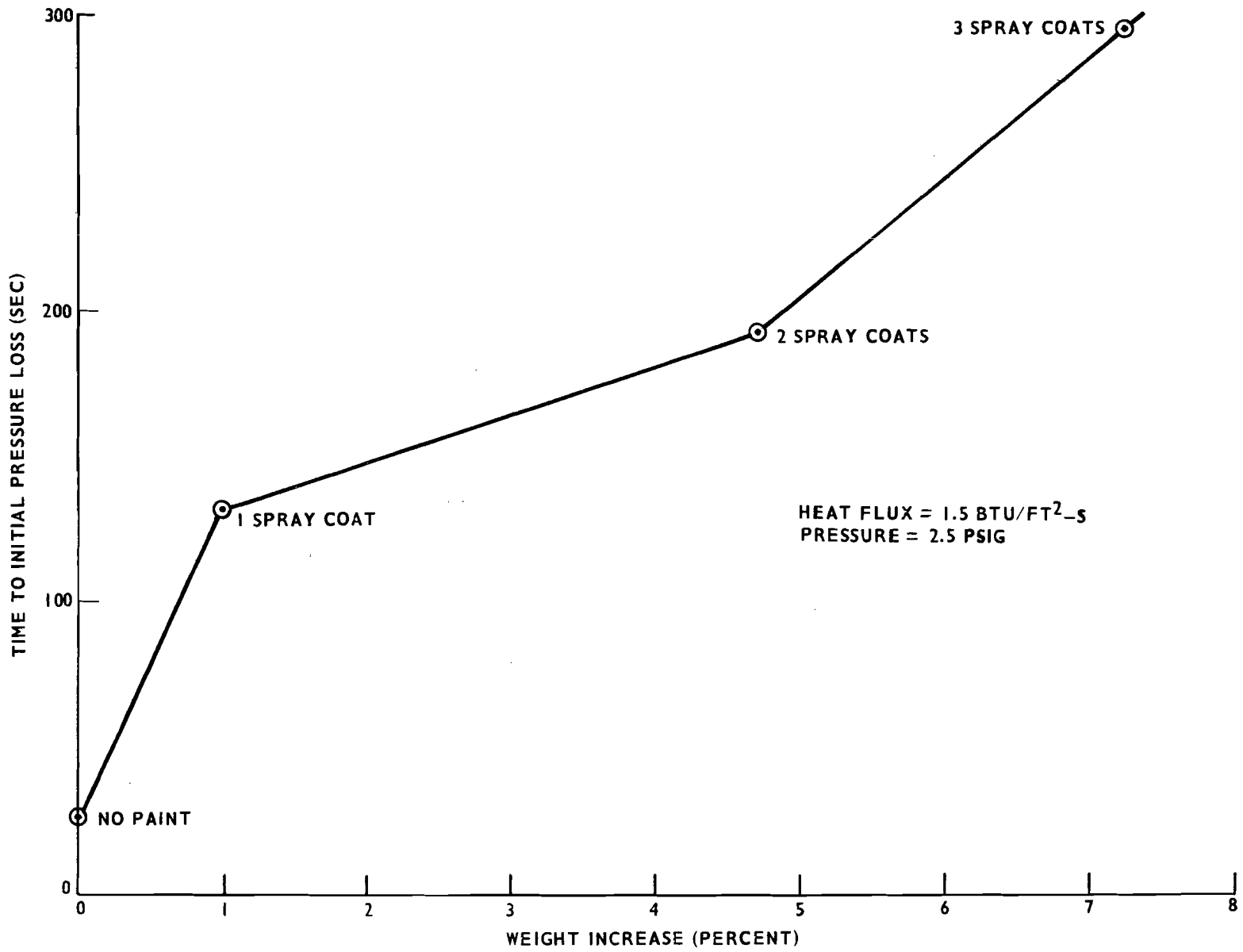

FIGURE 17. THE EFFECT OF REFLECTIVE COATING THICKNESSES

Table 5. LABORATORY REPEATABILITY TESTS

For Coated and Uncoated Evacuation Slide Materials
 Urethane Nylon Tested at 1.5 Btu/ft²-sec, 2.5 psig

<u>Test Number</u>	<u>Time to Initial Pressure Loss (seconds)</u>	<u>Temperature (°F)</u>
1	31.5	167.0
2	30.5	170.0
3	30.5	168.0
4	32.5	170.0
5	30.5	173.0
Average	31.5	169.6
Standard Deviation	0.89	2.30
Coefficient of Variation	2.9 percent	1.4 percent

Aluminized Urethane Nylon Tested at 1.5 Btu/ft²-sec, 2.5 psig

<u>Test Number</u>	<u>Time to Initial Pressure Loss (seconds)</u>	<u>Temperature (°F)</u>
1	105.0	167.0
2	105.0	170.0
3	110.0	170.0
4	108.0	168.0
5	105.0	171.0
Average	106.0	169.2
Standard Deviation	2.3	1.64
Coefficient of Variation	2.2 percent	1.0 percent

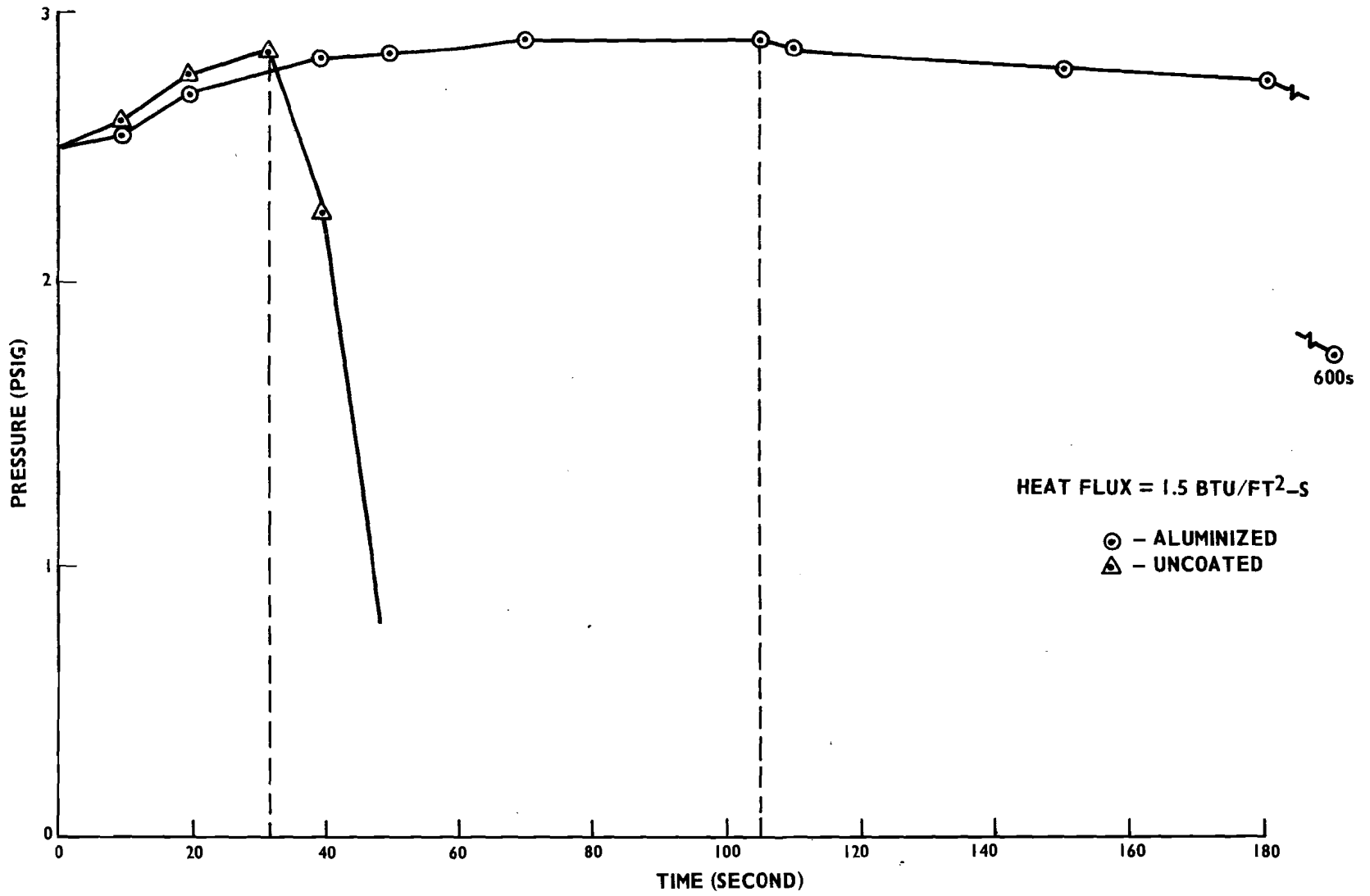

FIGURE 18. TIME VERSUS PRESSURE FOR AN UNCOATED AND ALUMINIZED URETHANE NYLON FABRIC

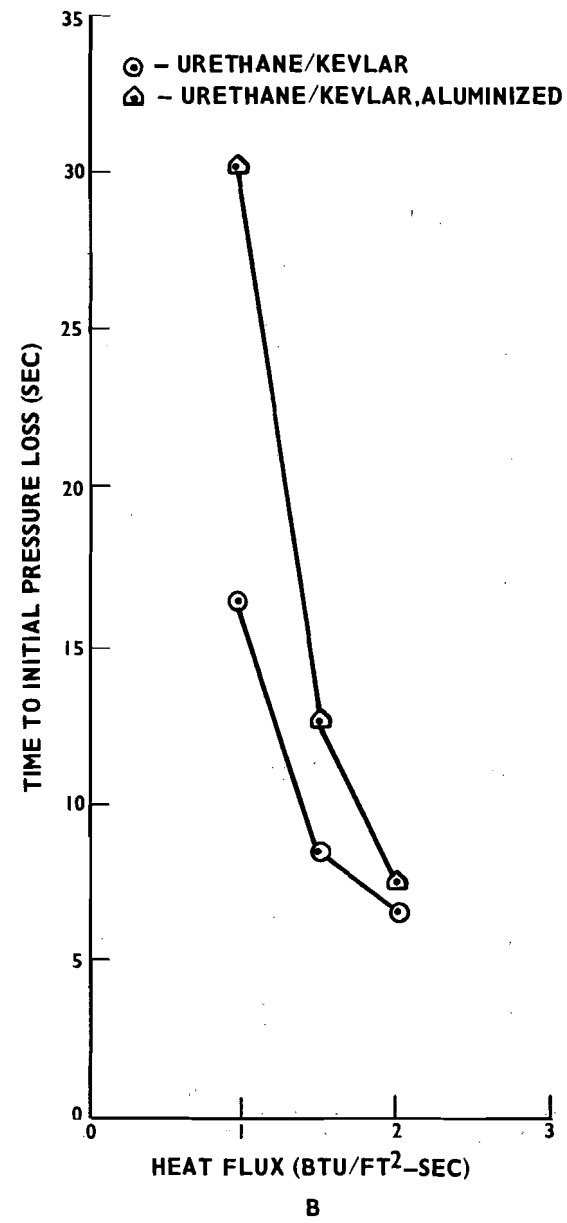
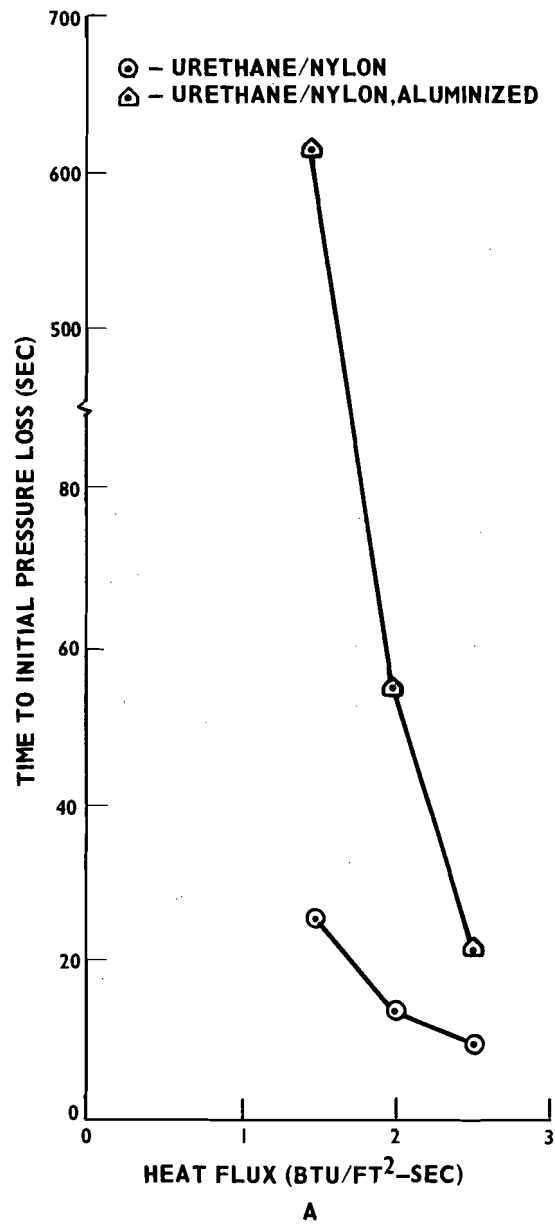

FIGURE 19. HEAT FLUX VERSUS TIME TO INITIAL PRESSURE LOSS

TABLE 6. SUMMARY OF NEOPRENE COATED FABRICS

Fabric	Reflective Coating	Seam	No Seam	Material Weight (oz/yd ²)	Material Thickness (in)	Heat Flux Btu/ft ² -sec	Cylinder Pressure (psig)	Temperature At Time of Initial Pressure Loss (°F)	Time For Initial Pressure Loss (sec)
Kevlar	None		x	7.0	NA	2.5	2	NA	24
			x	7.0	NA	2.0	2	NA	160
			x	7.0	NA	1.5	2	NA	456
Kevlar	Aluminum		x	8.5	NA	2.5	2	NA	185
			x	8.5	NA	2.0	2	NA	306
			x	8.5	NA	1.5	2	NA	>600
			x	8.5	NA	2.5	2.5	341	100
			x	6.0	0.007	2.0	2.5	328	>600
Kevlar 2.2 single ply	Aluminum		x	6.0	0.007	2.0	2.5	328	>600
Kevlar 2.2 single ply	N/u aluminum		x	NA	0.007	2.0	2.5	278	24
Kevlar 2.2 single ply	None		x	7.3	0.008	2.0	2.5	333	110
Nylon 3.0 - 3.3 single ply	None		x	8.0	0.011	2.0	2.5	213	13.5
Nylon 1.4 - 2.0 double ply	None		x	8.5	0.010	2.0	2.5	208	11.2
Nylon 3.9 single ply	None		x	9.3	0.011	2.0	2.5	216	14
Nylon 1.4 - 2.0 double ply	None		x	NA	NA	2.0	2.5	199	10.25
Nylon 1.4 - 2.0 double ply	Aluminum		x	NA	NA	2.0	2.5	253	74
Nylon	None		x	8.4	NA	2.5	2.0	NA	8
			x	8.4	NA	2.0	2.0	NA	12
			x	8.4	NA	1.5	2.0	NA	18
Nylon	Aluminum		x	10.1	0.011	3.0	2.5	279	45
			x	10.1	0.011	2.7	2.5	289	306
			x	10.1	0.011	2.5	2.5	276	>600
			x	10.1	0.011	2.0	2.5	259	>600
			x	10.1	0.011	1.5	2.5	235	>600
			x	NA	0.012	4.5	10.0	NA	32
Nylon	Aluminized Mylar		x	NA	0.012	4.5	5	NA	>900
			x	NA	0.012	2.3	5	NA	>900
			x	NA	0.017	4.5	5	NA	858
Nylon	Aluminized Kapton		x	NA	0.017	4.5	5	NA	858
			x	NA	0.017	2.2	5	NA	>980

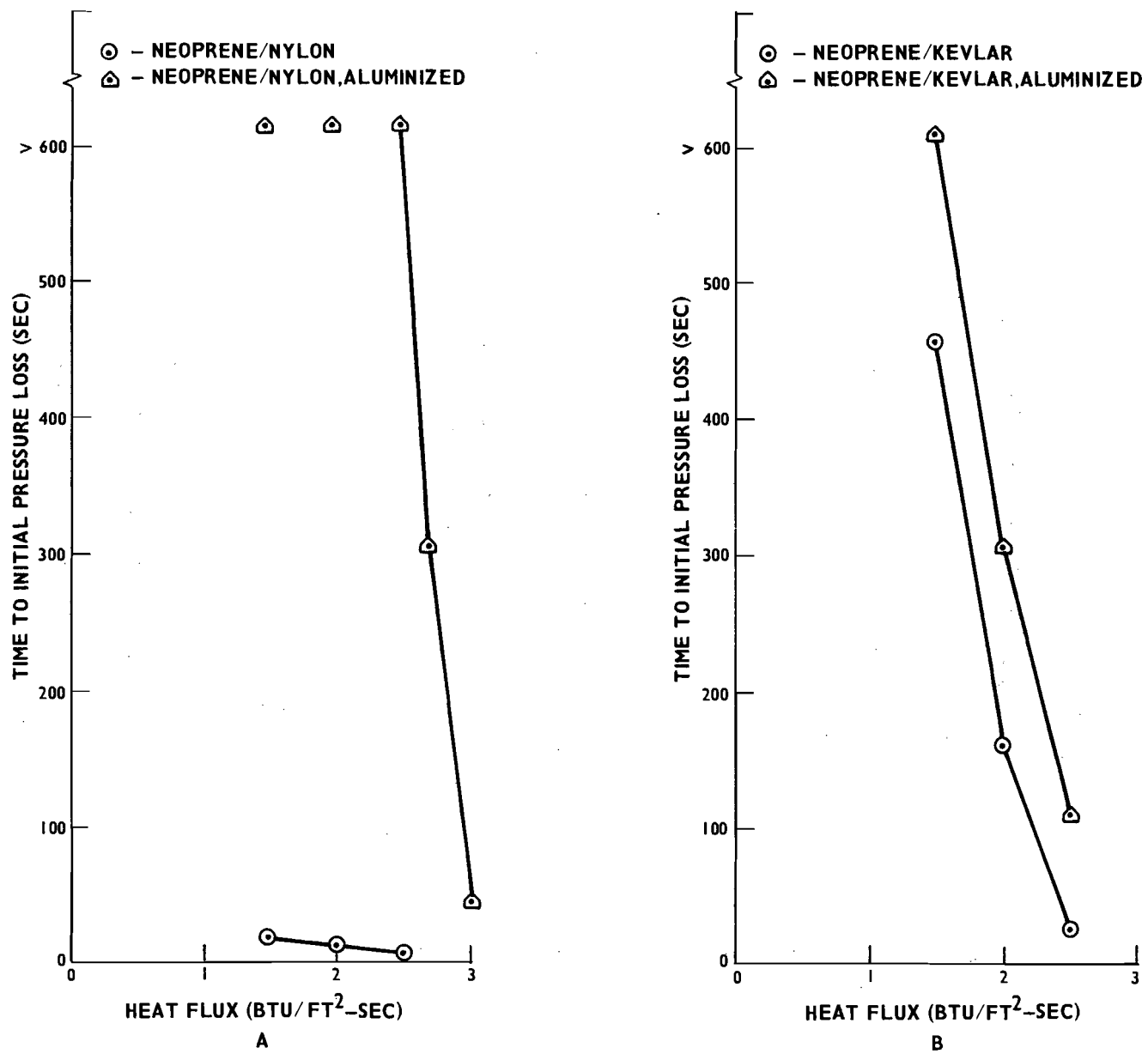

FIGURE 20. HEAT FLUX VERSUS TIME TO INITIAL PRESSURE LOSS

TABLE 7. SUMMARY OF URETHANE COATED SLIDE FABRICS FROM FULL-SCALE TEST SLIDES

Fabric and Test Number	Reflective Coating	Seam	No Seam	Material Weight (oz/yd ²)	Material Thickness (in)	Heat Flux Btu/ft ² -sec	Cylinder Pressure (psig)	Temperature At Time Of Initial Pressure Loss (°F)	Time For Initial Pressure Loss (sec)
Nylon Test 3B	None		x	9.0	0.011	1.5	2.5	NA	23
Nylon Test 3A	None		x	9.0	0.011	1.5	2.5	NA	22
Nylon Test 3A	None	x		9.0	0.011	1.5	2.5	NA	27
Nylon Test 16B	Aluminum		x	8.3	0.012	1.5	2.5	239	78
			x	8.3	0.012	1.4	2.5	153	148
			x	8.3	0.012	1.0	2.5	204	>600
Nylon Test 16B	Aluminum	x		8.3	0.012	1.6	2.5	202	51
		x		8.3	0.012	1.5	2.5	193	72
		x		8.3	0.012	1.0	2.5	193	95
Nylon Test 17	Aluminum		x	8.91	0.012	1.75	2.5	147	35.5
	Aluminum		x	8.91	0.012	1.5	2.5	258	105
	Aluminum		x	8.91	0.012	1.0	2.5	217	179
	Aluminum	x		8.91	0.012	1.75	2.5	176	46
	Aluminum	x		8.91	0.012	1.5	2.5	207	63.5
	Aluminum	x		8.91	0.012	1.25	2.5	197	72
	Aluminum	x		8.91	0.012	1.0	2.5	215	159
Nylon Test 16A	None	x		8.57	0.012	1.55	2.5	256	27.7
Nylon Test 19	Aluminum		x	7.89	0.011	1.75	2.5	275	78
			x	7.89	0.011	1.65	2.5	156	111
			x	7.89	0.011	1.5	2.5	263	198
			x	7.89	0.011	1.15	2.5	234	>600
		x		7.89	0.011	1.75	2.5	167	30
		x		7.89	0.011	1.65	2.5	143	32.8
		x		7.89	0.011	1.5	2.5	177	37
		x		7.89	0.011	1.15	2.5	175	52.5
		x		7.89	0.011	1.08	2.5	197	51.8

B-2). Figure 21A shows the effect of heat flux on the failure time of aluminized urethane nylon samples, with and without seams. It is evident that the weakest part of an aluminized urethane nylon slide is the seam. Figure 21B shows a similar comparison for aluminized neoprene nylon materials. (Table 8 is a tabulation of laboratory test results on samples taken from neoprene coated slides evaluated full-scale.) It is significant that the failure profile for the seam and nonseam samples of aluminized neoprene nylon are practically identical. Figure 21 demonstrates the benefit of aluminized neoprene nylon as compared to aluminized urethane nylon. Laboratory tests at 1.5 Btu/ft²-sec on neoprene nylon slide samples show seam failure occurring at 27 seconds. Sample without a seam lasted 17 seconds before initial pressure loss.

Nonaluminized neoprene Kevlar samples from a prototype slide were also tested in the laboratory. At 1.5 Btu/ft²-sec the seam failed at 195 seconds, while the nonseam sample lasted for 540 seconds before initial pressure loss. When the heat flux was raised to 1.85 Btu/ft²-sec, there was no significant difference between the seam and nonseam data obtained, 95 and 106 seconds, respectively.

Aluminized neoprene Kevlar samples from the prototype slide, tested at 1.5 Btu/ft²-sec lasted for over 600 seconds in both the seam and nonseam configuration. A seam tested on this material at 2.0 Btu/ft²-sec, held pressure for 492 seconds and the nonseam sample started losing pressure at 528 seconds. At 2.8 Btu/ft²-sec a seam and nonseam sample failed at 29 and 32 seconds, respectively.

CORRELATION.

URETHANE NYLON. Full-scale test results indicated that urethane nylon slides failed at 27 seconds in a nonseam area

when exposed to an "average" radiant heat flux of 1.5 Btu/ft²-sec. This heat flux corresponded to a distance of 15 feet from the fire pit under zero wind conditions. Laboratory test results at 1.5 Btu/ft²-sec showed that urethane nylon nonseam and seam samples failed in 22 and 27 seconds, respectively. Thus, the laboratory and full-scale test results on urethane nylon slide fabrics were in good agreement as were the results on aluminized slides. Full-scale test results indicated that a urethane nylon slide, with the B. F. Goodrich KE 7620 aluminized coating applied to airholding surfaces, failed on a seam in 64 seconds at an "average" radiant heat flux of approximately 1.5 Btu/ft²-sec. Laboratory test results showed that aluminized urethane nylon seam samples failed in 72 seconds when exposed to a radiant heat flux of 1.5 Btu/ft²-sec. Laboratory tests of nonseam samples failed in 198 seconds when exposed to the same heat flux, confirming the seam failure mode evidenced in full-scale tests.

NEOPRENE NYLON. Full-scale test results indicated that a neoprene nylon slide failed in 23 seconds at a nonseam area when exposed to an average radiant heat flux of 1.5 Btu/ft²-sec, while laboratory results on a comparable sample tested at 1.5 Btu/ft²-sec failed in 17 seconds. Laboratory tests of seam samples failed in 27 seconds when exposed to the same heat flux. Full-scale tests were not conducted in the 1.5 Btu/ft²-sec range for an aluminized neoprene nylon slide. Laboratory test results showed that aluminized neoprene nylon seam samples failed in 366 seconds when exposed to a radiant heat flux of 1.5 Btu/ft²-sec, and nonseam samples did not fail in 600 seconds at the same heat flux. Full-scale test results (tests 20 and 22) at 1.0 Btu/ft²-sec failed much earlier than would have been predicted, based on the laboratory test method. It was possible that the early full-scale

TABLE 8. SUMMARY OF NEOPRENE COATED SLIDE FABRICS FROM FULL-SCALE TEST SLIDES

Fabric and Test Number	Reflective Coating	Seam		Material Weight (oz/yd ²)	Material Thickness (in)	Heat Flux Btu/ft ² -sec	Cylinder Pressure (psig)	Temperature At Time of Initial Pressure Loss °F	Time For Initial Pressure Loss (sec)
		Seam	No Seam						
Kevlar Test 14	None		x	7.6	0.008	2.0	2.5	341	86
			x	7.6	0.008	1.85	2.5	335	101
			x	7.6	0.008	1.85	2.5	332	112
Kevlar Test 14	None	x		7.6	0.008	2.0	2.5	345	82
		x		7.6	0.008	1.85	2.5	336	95
		x		7.6	0.008	1.5	2.5	308	195
Kevlar Test 12	Aluminum		x	8.4	0.010	2.8	3.5	349	29
			x	8.4	0.010	2.5	2.5	312	352
			x	8.4	0.010	2.0	2.5	312	492
			x	8.4	0.010	1.5	2.5	269	>600
			x	8.4	0.010	1.5	2.5	276	>600
Nylon Test 10	None		x	7.9	0.009	1.5	2.5	178	21
			x	7.9	0.009	1.5	2.75	162	12
Nylon Test 10	None		x	7.9	0.009	1.5	2.5	174	22
			x	7.9	0.009	1.5	3.0	269	32
Nylon Test 11	None		x	7.9	0.009	1.4	2.5	263	28
			x	7.9	0.009	1.25	2.5	277	>600
			x	7.9	0.009	1.05	2.5	259	>600
			x	7.9	0.009	1.15	2.5	267	138
Nylon Test 20	Aluminum		x	7.74	0.009	1.75	2.5	260	35.5
			x	7.74	0.009	1.65	2.5	164	81
			x	7.74	0.009	1.5	2.5	261	>600
			x	7.74	0.009	1.15	2.5	233	>600
			x	7.74	0.009	1.0	2.5	173	>600
Nylon Test 20	Aluminum		x	7.74	0.009	1.75	2.5	251	72
			x	7.74	0.009	1.65	2.5	215	90
			x	7.74	0.009	1.5	2.5	244	366
			x	7.74	0.009	1.4	2.5	251	>600
			x	7.74	0.009	1.15	2.5	220	>600
			x	7.74	0.009	1.0	2.5	205	>600

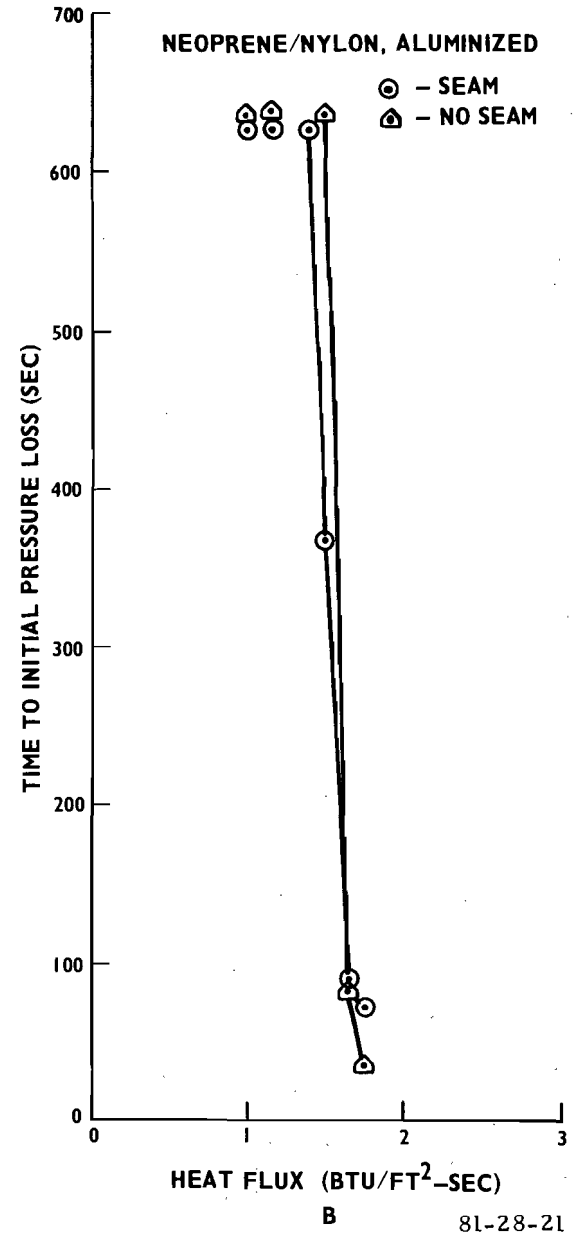
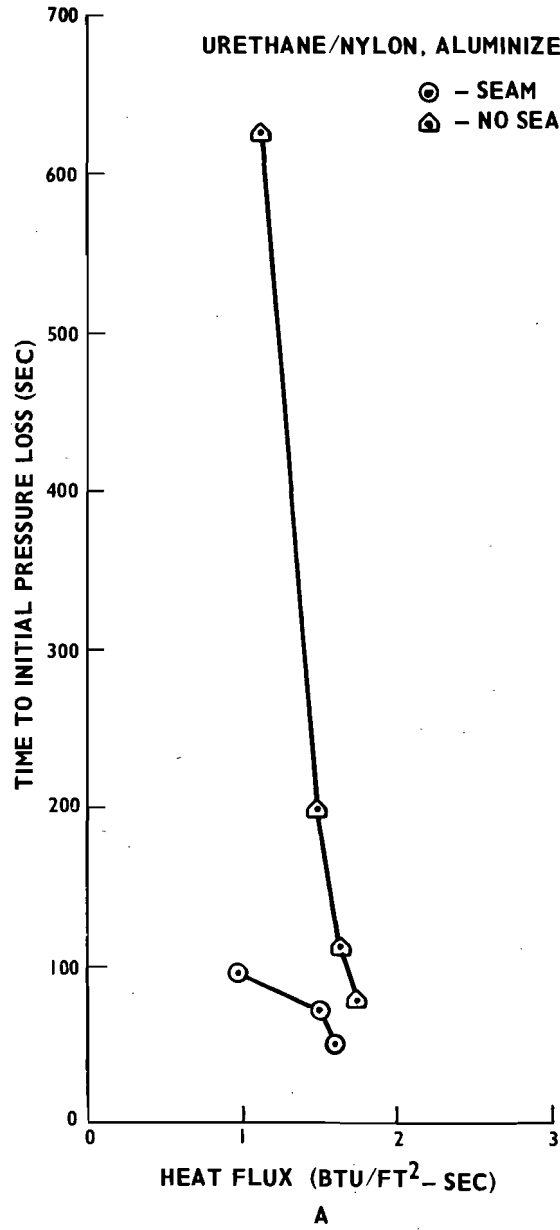

FIGURE 21. HEAT FLUX VERSUS TIME TO INITIAL PRESSURE LOSS

test method. It was possible that the early full-scale test failure of an aluminized neoprene nylon prototype slide was due to a flaw in the seam, since a slide will fail at its weakest point. With the exception of aluminized neoprene nylon seams, all full-scale test data correlated well with laboratory test results. This good agreement is due, at least in part, to the selection of time to initial pressure loss as the end point measurement, which obviates scaling problems due to thermal radiation exposure areas versus inflation volume ratio.

A summary of the laboratory/full-scale test results comparison are contained in table 9.

SUMMARY OF RESULTS

FULL-SCALE.

1. Full-scale test results (tests 3A, 3B, 8B, 10, and 16A) indicated that inservice evacuation slides (yellow urethane nylon or yellow neoprene nylon) failed in 20 to 30 seconds in a nonseam area, when exposed to an average radiant heat flux of 1.5 Btu/ft²-sec. This heat flux corresponds to a distance of 15 feet from the edge of a 30- by 30-foot fuel fire during zero wind conditions.

2. Full-scale test results (tests 5A, 5B, and 10) indicated that inservice evacuation slides (yellow urethane nylon or yellow neoprene nylon) failed in 60 to 80 seconds on a seam when exposed to an average heat flux of 1.0 Btu/ft²-sec. This heat flux corresponds to a distance of 20 feet from the edge of a 30- by 30-foot fuel fire during zero wind conditions.

3. Full-scale test results (test 16B) indicated that an aluminized urethane nylon slide failed on a seam in 64 seconds when exposed to an average heat flux of 1.5 Btu/ft²-sec.

4. Full-scale tests results indicated that an aluminized neoprene nylon slide (test 20) failed unexpectedly early on a seam when exposed to an average heat flux of 1.0 Btu/ft²-sec (possibly due to a flaw in a seam). However, little radiant heat damage was noted on other areas of the slide compared to a non-aluminized slide exposed to the same heat flux level.

5. Full-scale test results indicated that an aluminized neoprene Kevlar slide failed on a seam in 68 seconds (test 12) when exposed to an average heat flux of 1.88 Btu/ft²-sec (possibly due to overpressure from a plugged relief valve). A yellow neoprene Kevlar tube section failed on a seam in 44 seconds (test 14) when exposed to an average heat flux of 1.75 Btu/ft²-sec. (also possibly due to inadequate pressure relief).

6. The temperature of the top and underside sliding surface was recorded for some tests. Temperature rise did not appear to be significant for these tests.

7. With exception of the Kevlar tests, pressure rise did not appear to have hastened the failure time of the full-scale slide tests.

LABORATORY.

1. The laboratory test apparatus that was developed to measure the integrity of slide fabrics subjected to radiative heating exhibited excellent within-laboratory repeatability for both aluminized and nonaluminized urethane nylon fabrics. The coefficients of variation of the time to initial pressure loss were 2.2 percent and 2.9 percent, respectively.

2. Laboratory tests demonstrated that the B. F. Goodrich KE 7620 aluminum coating applied to the exposed surface of a new urethane nylon fabric, at a coating thickness corresponding to 5

TABLE 9. LABORATORY/FULL-SCALE CORRELATION

1.5 BTU /ft ² -sec.		URETHANE NYLON		NEOPRENE NYLON	
		YELLOW	ALUMINIZED	YELLOW	ALUMINIZED
FULL SCALE	SEAM (seconds)	25 - 30	70 - 75	23 - 28	NA
LAB SCALE	SEAM (seconds)	35 - 40	70 - 75	30 - 35	365 - 370
	NON-SEAM (seconds)	20 - 25	195 - 200	20 - 25	+600

percent of the base fabric weight, will increase the time to initial pressure loss from 27 seconds to 210 seconds at 1.5 Btu/ft²-sec.

3. Urethane nylon materials with the aluminum pigment included in the urethane coating by the materials manufacturer can increase the time to initial pressure loss from 27 seconds to over 600 seconds at 1.5 Btu/ft²-sec.

4. The urethane Kevlar fabric exhibited poor heat resistance, and application of an aluminized coating only provided a relatively slight improvement in heat resistance.

5. New neoprene nylon aluminized materials show a significant increase in heat resistance at 1.5 Btu/ft²-sec over the nonaluminized material (600 seconds versus 18 seconds for time to initial pressure loss).

6. New neoprene Kevlar fabrics are more heat resistant than neoprene nylon fabrics.

7. Seam and nonseam urethane nylon slide samples fail at practically the same time at 1.5 Btu/ft²-sec (27 seconds and 22 seconds, respectively).

8. Aluminized urethane nylon slide seam samples fail at 72 seconds, nonseam samples fail at 198 seconds.

9. Neoprene nylon slide seam samples are more heat resistant at 1.5 Btu/ft²-sec than nonseam samples (27 seconds versus 17 seconds for time to initial pressure loss).

10. Nonaluminized and aluminized neoprene Kevlar samples were found to always fail earlier at seams than on the plain material.

CONCLUSIONS

1. Inservice slides can fail prematurely when exposed to radiant heat alone from a fuel fire (no flame contact).

2. An aluminized reflective coating on the exposed surface of a slide fabric significantly improves the airholding qualities upon exposure to radiant heat.

3. Under radiant heat exposure conditions, new neoprene Kevlar fabrics are far superior to other materials presently used for slide fabrication.

4. Laboratory and full-scale tests demonstrate that after the retrofit application of a reflective aluminum coating to an evacuation slide, failure of the slide from radiative heating originates at the seam.

5. Adhesives that are presently used for seam fabrication appear to limit the potential improvements in heat resistance provided by new and aluminized slide materials.

6. The laboratory test method is a valid procedure for evaluating the heat resistance of slide materials subjected to thermal radiation as evidenced by the good correlation with full-scale test results and excellent repeatability within a laboratory.

RECOMMENDATIONS

It is recommended that:

1. B. F. Goodrich KE 7620 aluminized paint or an equivalent be considered for retrofit application on inservice slide/slide rafts in the United States (U. S.) Transport aircraft fleet.
2. The laboratory test method developed during this study be adopted as Federal Aviation Administrations (FAA) standard for evaluation of the radiative heat resistance of evacuation slide materials.
3. A round robin series of tests be conducted with the laboratory test method by various laboratories to determine the precision of the test method within different laboratories and between laboratories.
4. Full-scale tests be performed on newly fabricated slides constructed of advanced materials, especially both uncoated and aluminized neoprene Kevlar and alumnized neoprene nylon, in order to resolve the inconsistent laboratory and full-scale test results for these materials.

REFERENCES

1. Aircraft Accident Report, - Continental Airline DC-10, Los Angeles International Airport, Los Angeles, California, NTSB - AAR-79-1, March 1, 1978.
2. Geyer, G., Brown, L., Neri, L., and O'Neill, J., Preliminary Assessment of the Integrity of Aircraft Evacuation Slide Material When Exposed to Thermal Radiation, FAA-NA-78-41-LR, June 1978.
3. Cole, R., and Sims, G., Aluminized Coating Study for Retrofitting Slide Materials, FAA-CT-81-151, November 1980.

APPENDIX A

PROPOSED LABORATORY TEST METHOD FOR AIRCRAFT INFLATABLE EVACUATION SLIDE/ SLIDE RAFT MATERIALS

1. SCOPE.

1.1 This method is intended for use in determining the resistance of aircraft inflatable evacuation slide/slide raft materials to radiant heat.

1.2 This standard should be used to measure and describe the properties of materials, products, or assemblies in response to heat and flame under controlled laboratory conditions and should not be used to describe or appraise the fire hazard or fire risk of materials, products, or assemblies under actual fire conditions. However, results of this test may be used as elements of a fire risk assessment which takes into account all of the factors which are pertinent to an assessment of the fire hazard of a particular end use.

2. SIGNIFICANCE.

2.1 The useful time of an aircraft inflatable evacuation slide/slide raft is dependent on the ability of the coated fabric to hold air pressure when exposed to radiant heat from a fuel fire.

2.2 This method provides a laboratory test procedure for measuring and comparing the resistance to loss of air pressure through coated fabric material specimens of small size that are intended for use in the manufacture of aircraft inflatable slides and slide rafts.

3. APPARATUS.

3.1 The test apparatus shall be essentially as shown in figures A-1 through A-6 and shall include the following.

3.2 The pressure cylinder and specimen holder as shown in figures A-1, A-2, and A-5 consists of a 7-inch (178 millimeter (mm)) outside dimensions (O.D.) by 6 1/2-inch (165mm) inside dimensions (I.D.) by 12-inch (305mm) long aluminum tube. On one end of the tube is welded a 1/2-inch (13mm) thick aluminum plate, drilled and tapped for a 1/4-inch (6mm) NPT to facilitate air and pressure recording hookups. On the other end of the tube a 7-inch (178mm) O.D. by 5 1/2-inch (140mm) I.D. ring of 1/2-inch (13mm) thick aluminum is welded. This ring is drilled and tapped for 1-32 by 7/8-inch (22mm) long studs. Another ring 6 3/4-inch (172mm) O.D. by 5 1/2-inch (140mm) I.D. by 1/2-inch (13mm) thick aluminum ring and two neoprene rubber gaskets with matching clearance holes to fit over the studs provide a means for clamping and sealing the test specimens in place. Hinges and adjustable stops are welded to the sides of the cylinder, shown in figures A-2 and A-6.

3.3 An electric furnace, figure A-7 with a 3-inch (76mm) diameter opening shall be used to provide a constant irradiance on the specimen surface. The standard NSB smoke chamber radiant heat furnace, available from Superpressure Inc., 8030 Gorgia Avenue, Silver Springs, Maryland 20910, is recommended.

3.4 A 0-5 Btu/ft²-sec Hy-Cal™ calorimeter, model C-1300-A, available from Hy-Cal Engineering, 12105 Los Nietos Road, Sante Fe Springs, California 90670, is used. The calorimeter is

mounted in a 4 1/2-inch (114mm) diameter by 3/4-inch (19mm) thick insulating block and is hinged to one of the sliding bars of the framework. The surface of the calorimeter is flush with the surface of the insulating block and centered with the furnace. See figures A-1 and A-6.

3.5 The pressure cylinder, calorimeter and furnace are mounted on a framework as detailed in figures 1 and 6. Adjustable sliding stops are located on each of the bars for setting the cylinder and calorimeter at the desired distance from the opening of the furnace.

3.6 Compressed air is connected to the cylinder through a needle valve attached to the end of the framework. A tee on the outlet side of the valve provides for a 0-5 psig pressure gage, transducer and flexible tube to supply air to the rear plate of the pressure cylinder (figures A-3 and A-4.)

3.7 The outputs of the calorimeter and pressure transducer are measured and recorded using a recording potentiometer or other suitable instrument capable of measurement of the range required.

4. TEST SPECIMEN AND CONDITIONING.

4.1 Test specimens 7 inches (178mm) in diameter with 1/4-inch (6mm) holes punched in the material to match the studs in the pressure cylinder are cut from the material to be tested.

4.2 Specimens shall be conditioned at 70° F and 50 percent relative humidity for at least 24 hours prior to testing.

4.3 All tests shall be conducted in a draft free room or enclosed space.

5. TEST PROCEDURE.

5.1 Turn on radiant heat furnace and other required instrumentation. Allow 1/2 to 3/4 hour to stabilize heat output and instrumentation warmup.

5.2 Adjust transformer to produce a radiant heat flux of 2 Btu/ft²-sec when the calorimeter is positioned 1 1/2 inches (38mm) in front of the radiant heat furnace.

5.3 Find the location in front of the furnace for the desired test heat flux. This is done by sliding the calorimeter on the horizontal bar and fixing the position with the sliding stop provided. Swing the calorimeter out of position.

5.4 Mount the specimen on the open end of the cylinder with a neoprene gasket on each side of the specimen. Place the aluminum ring on the studs and tighten the nuts so that an airtight seal is made.

5.5 Pressurize the cylinder to the desired test pressure. Check for leakage.

5.6 Check the distance from the radiant heat furnace to the surface of the test specimen. This distance is the same as the distance to the surface of the calorimeter.

5.7 Place the calorimeter in front of the radiant heat furnace and record the heat flux. Remove calorimeter.

5.8 Place the pressure cylinder and test specimen in front of the radiant heat furnace. Start timer or note starting time on the recorder.

5.9 Pressure is monitored from the time the specimen is placed in front of the furnace until initial pressure loss is observed.

6. REPORT.

6.1 Useful time of a material is the time that the material is exposed to the radiant heat until initial pressure loss.

7. PRECISION AND ACCURACY.

7.1 Each testing agency has the responsibility of judging the acceptance of its own results. The precision of the results is a function of the procedures and the equipment utilized as well as compliance to the materials specifications.

7.2 As soon as sufficient data have been obtained a more definitive statement on precision and accuracy will be included.

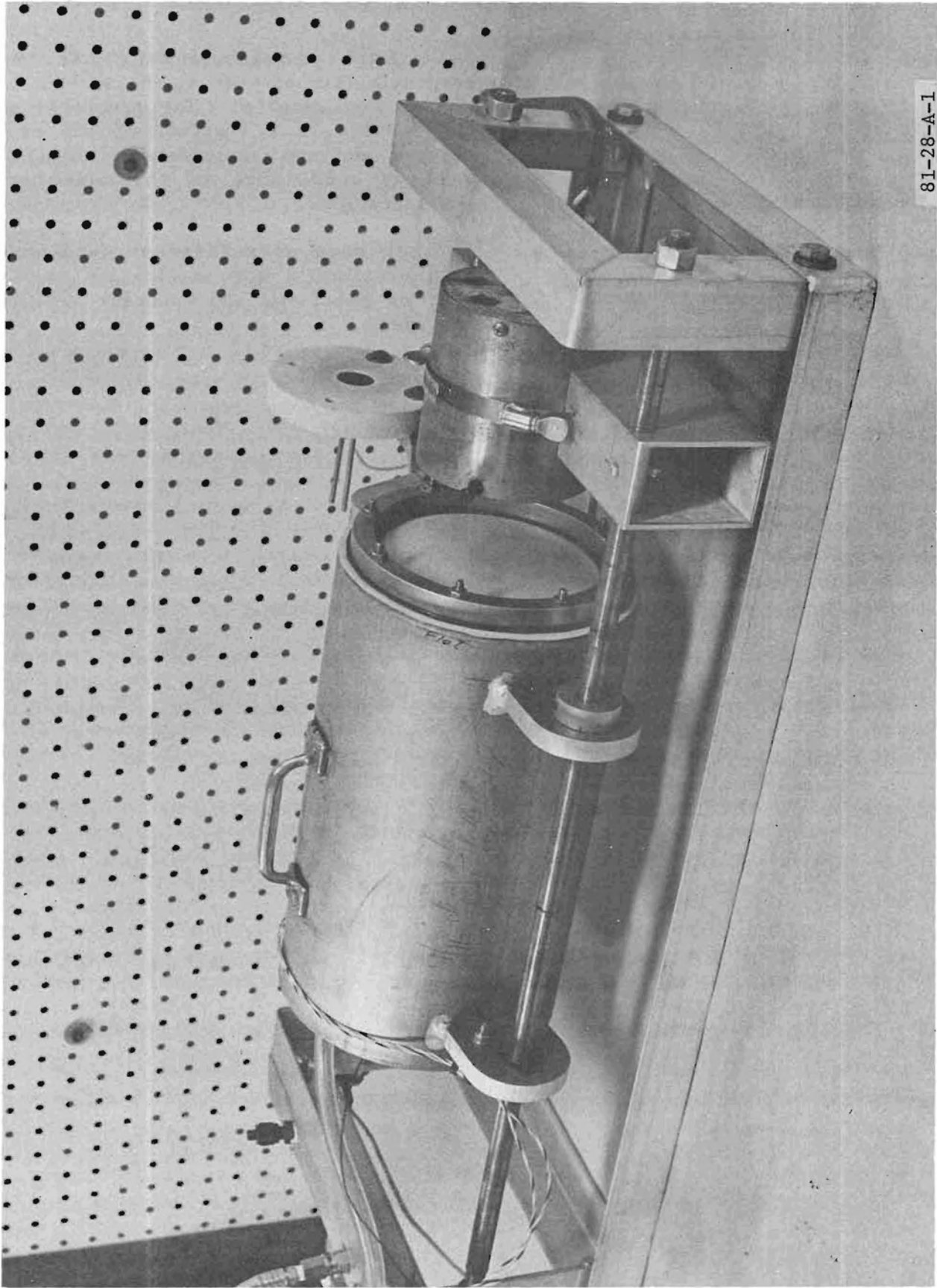

81-28-A-1

FIGURE A-1. SLIDE/SLIDE RAFT MATERIAL TEST APPARATUS

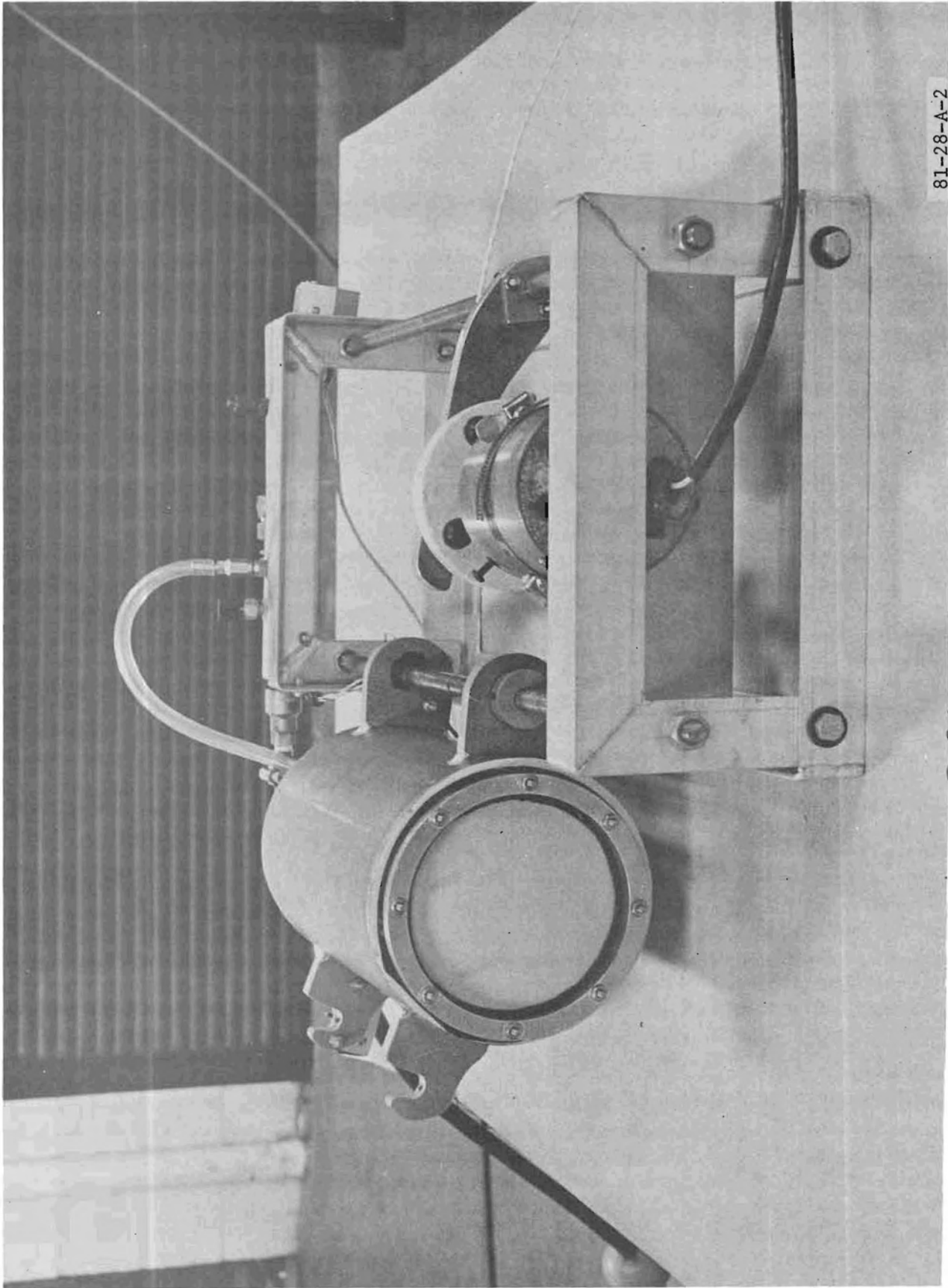

FIGURE A-2. SLIDE/SLIDE RAFT MATERIAL TEST SIDE VIEW

A-6

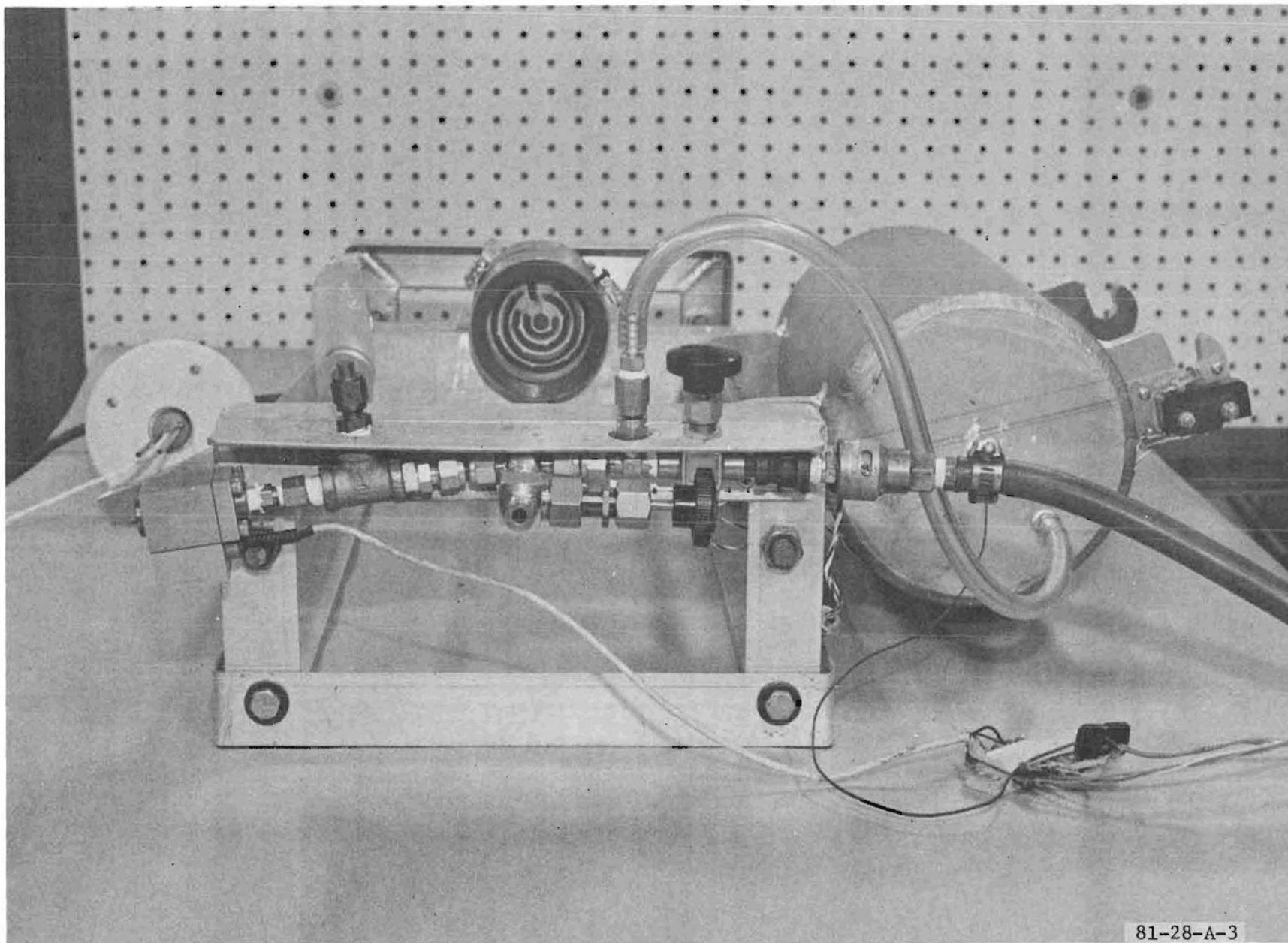

FIGURE A-3. SLIDE/SLIDE RAFT MATERIAL TEST FRONT VIEW

A-7

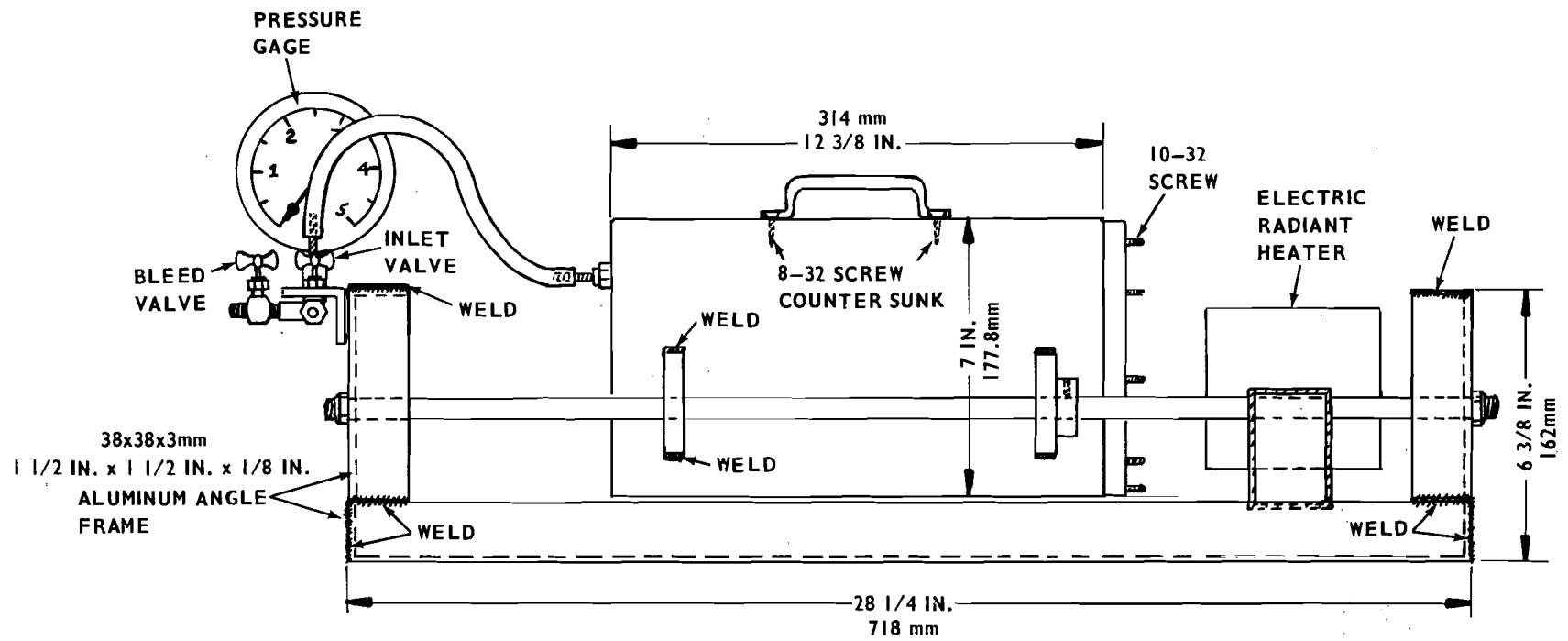

FIGURE A-4. LABORATORY TEST (FRONT VIEW)

A-8

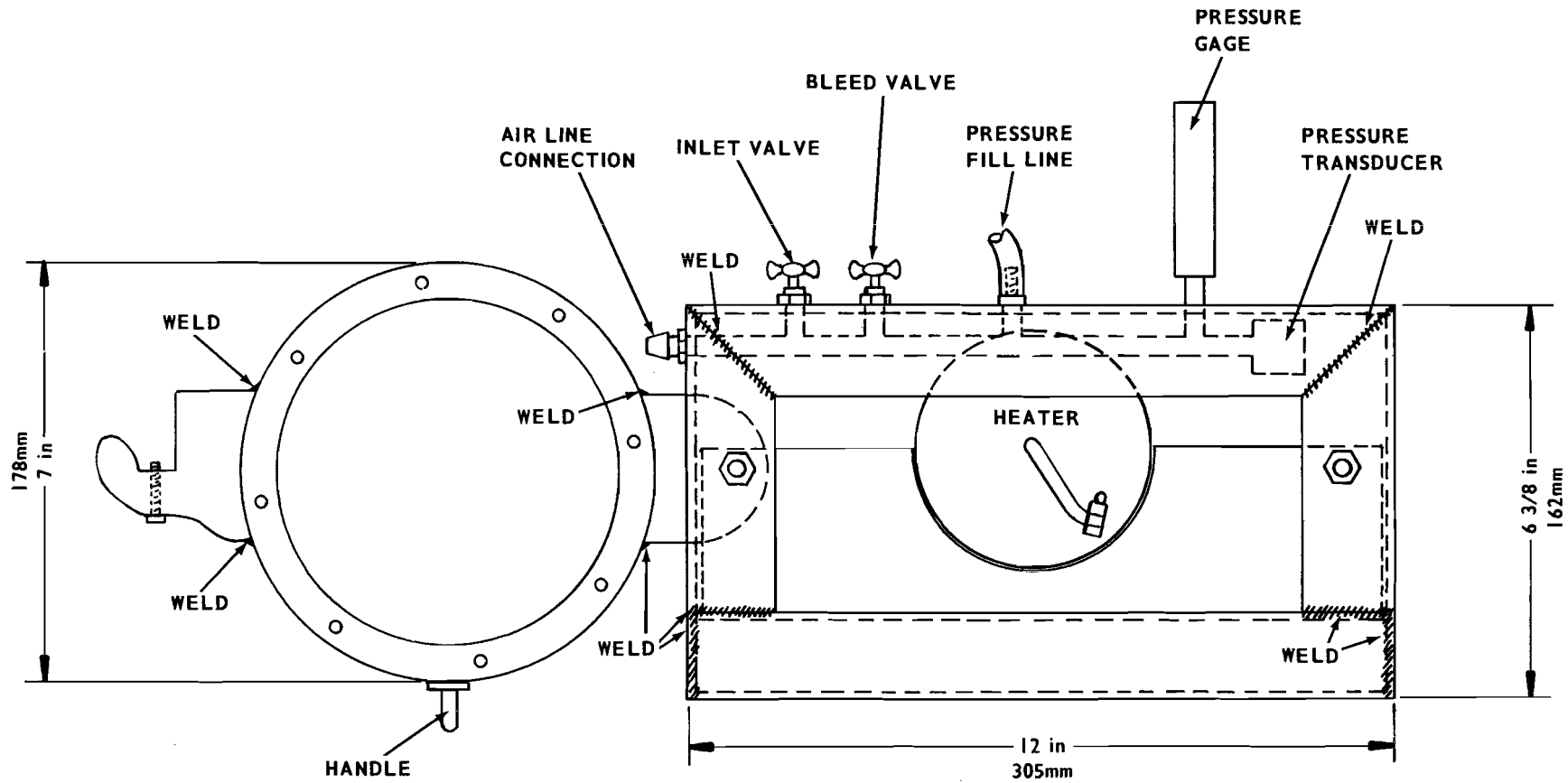

FIGURE A-5. LABORATORY TEST (SIDE VIEW)

A-9

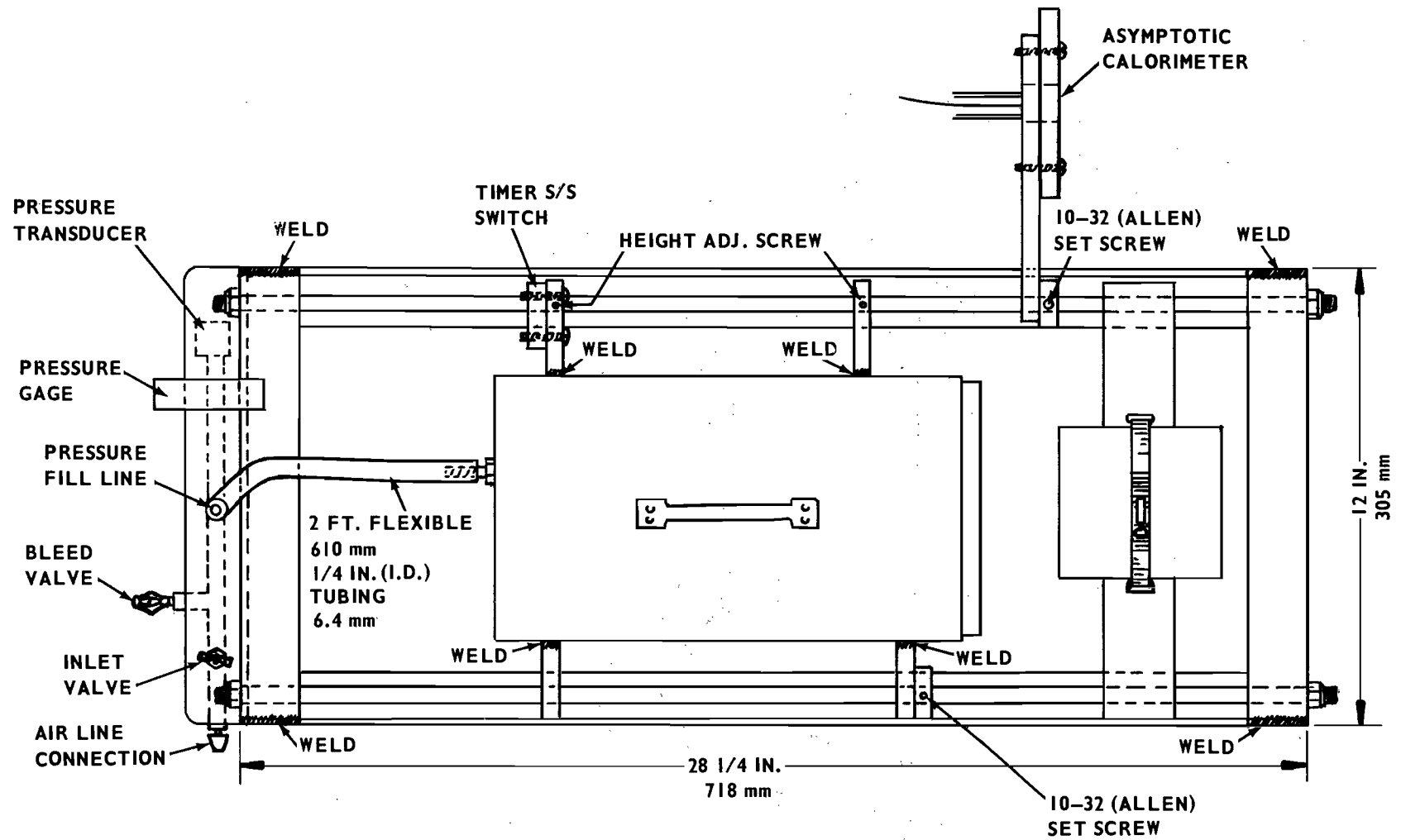
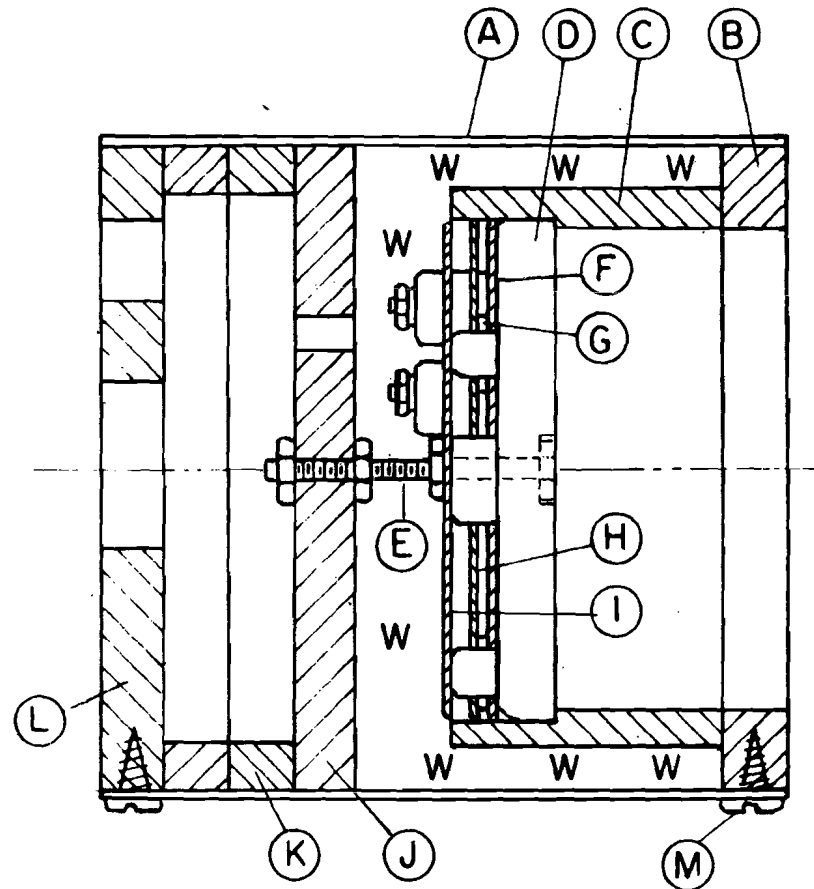

FIGURE A-6. LABORATORY TEST (TOP VIEW)



- | | | |
|----------------------------|---|------------------------|
| A - STAINLESS STEEL TUBE | F - ASBESTOS PAPER GASKET | J - ASBESTOS BOARD |
| B - ASBESTOS BOARD | G - STAINLESS STEEL SPACING WASHERS (3) | K-ASBESTOS BOARD |
| C - CERAMIC TUBE | H - STAINLESS STEEL REFLECTOR | L-ASBESTOS BOARD COVER |
| D - HEATING ELEMENT, 525 W | I - STAINLESS STEEL REFLECTOR | M-SHEET METAL SCREWS |
| E - STAINLESS STEEL SCREW | W-PYREX GLASS WOOL | |

FIGURE A-7. FURNACE SECTION

APPENDIX B

HEAT FLUX AND PRESSURE PLOTS FOR FULL-SCALE TESTS

B-1

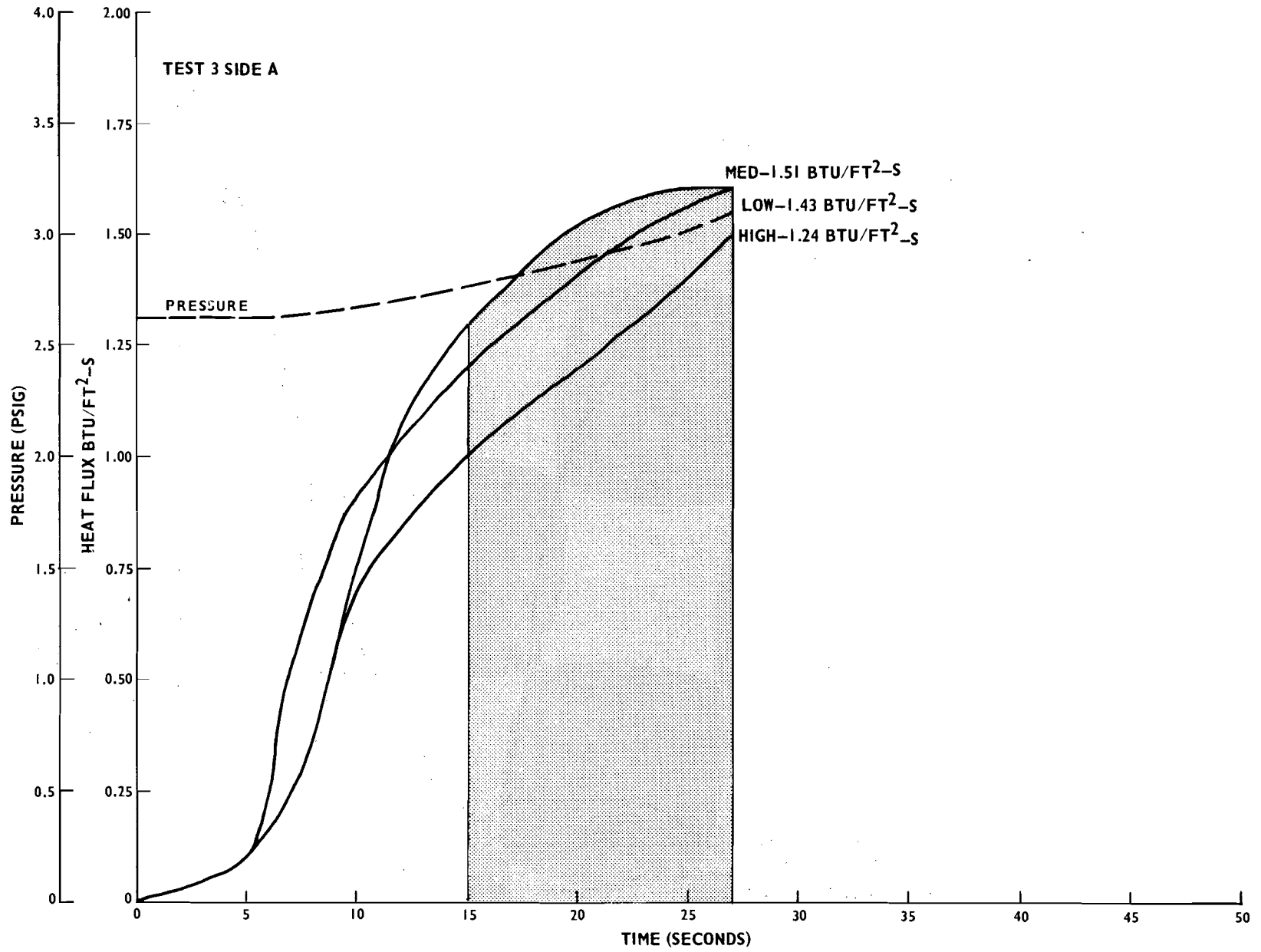

FIGURE B-1. HEAT FLUX AND PRESSURE PLOTS FOR FULL-SCALE TESTS (TEST 3, SIDE A)

B-2

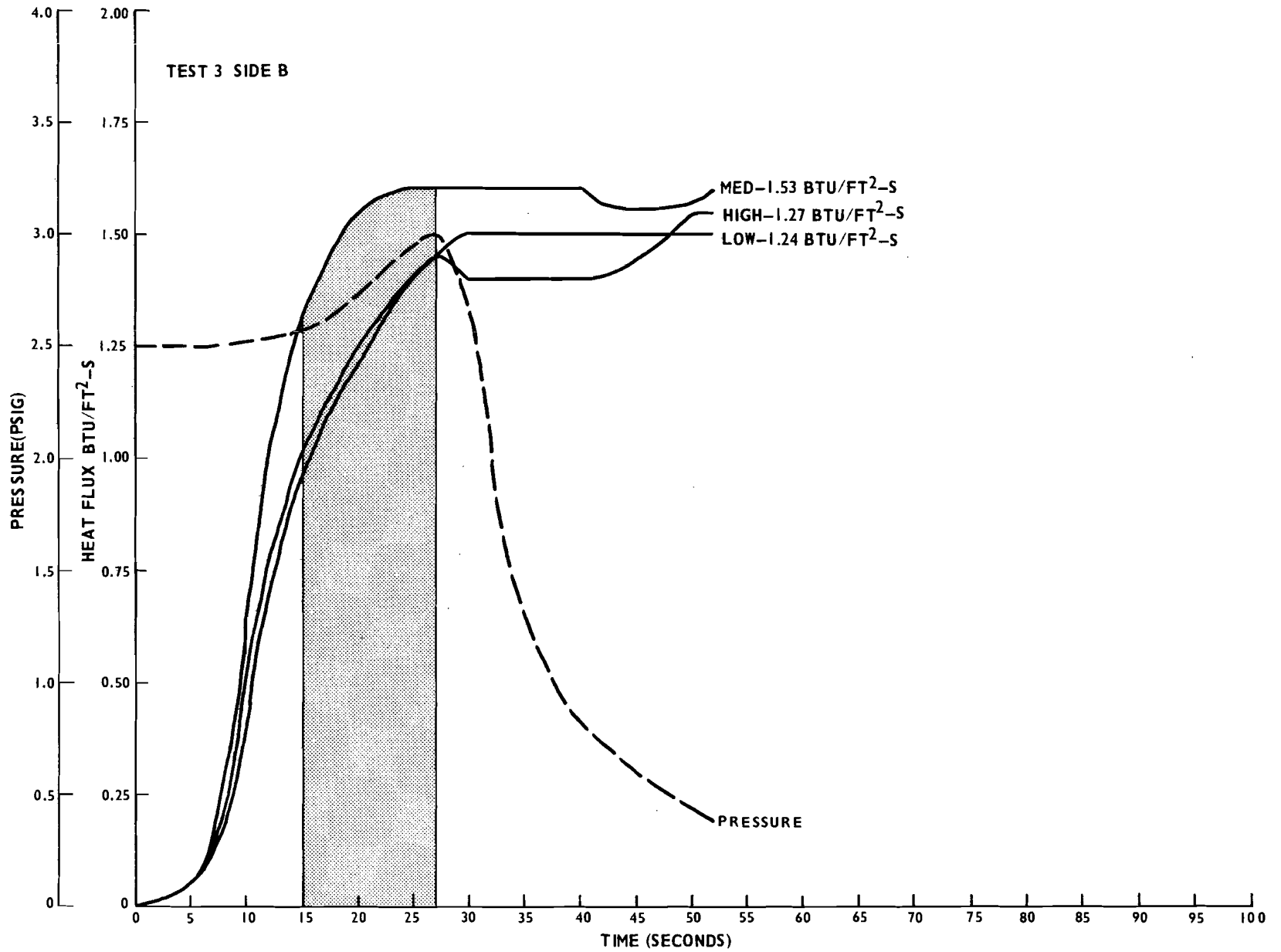

FIGURE B-2. HEAT FLUX AND PRESSURE PLOTS FOR FULL-SCALE TESTS (TEST 3, SIDE B)

B-3

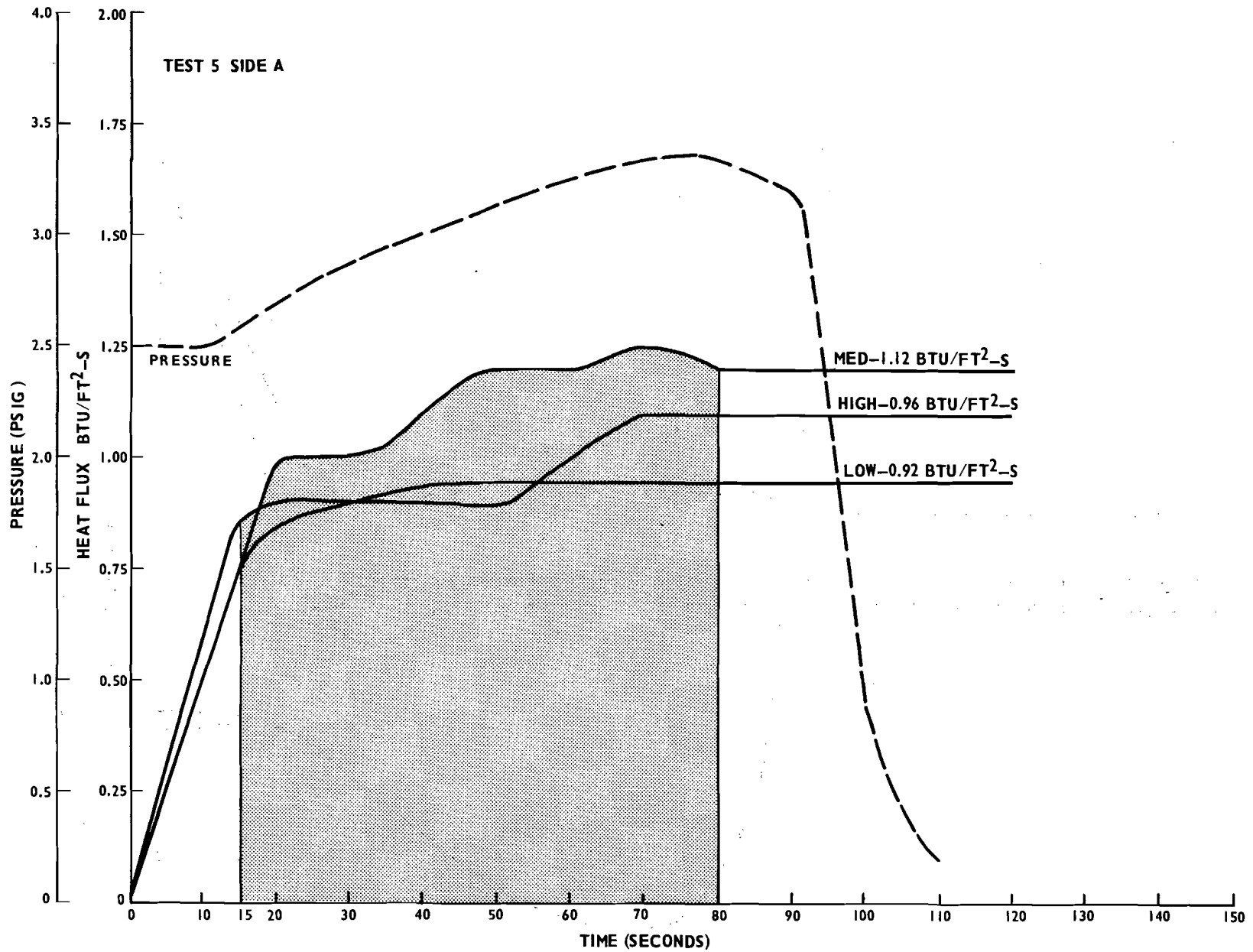

FIGURE B-3. HEAT FLUX AND PRESSURE PLOTS FOR FULL-SCALE TESTS (TEST 5, SIDE A)

B-4

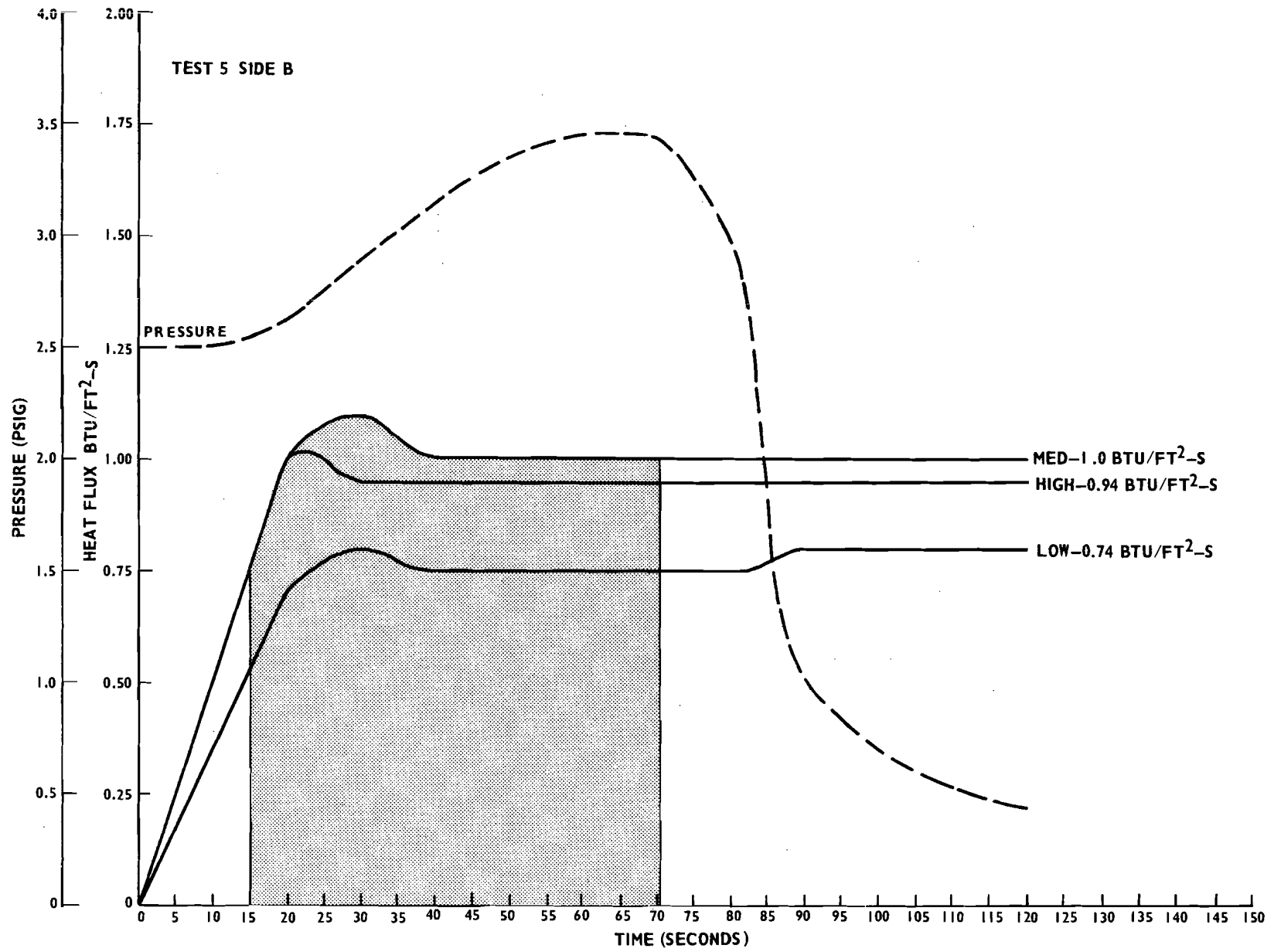

FIGURE B-4. HEAT FLUX AND PRESSURE PLOTS FOR FULL-SCALE TESTS (TEST 5, SIDE B)

B-5

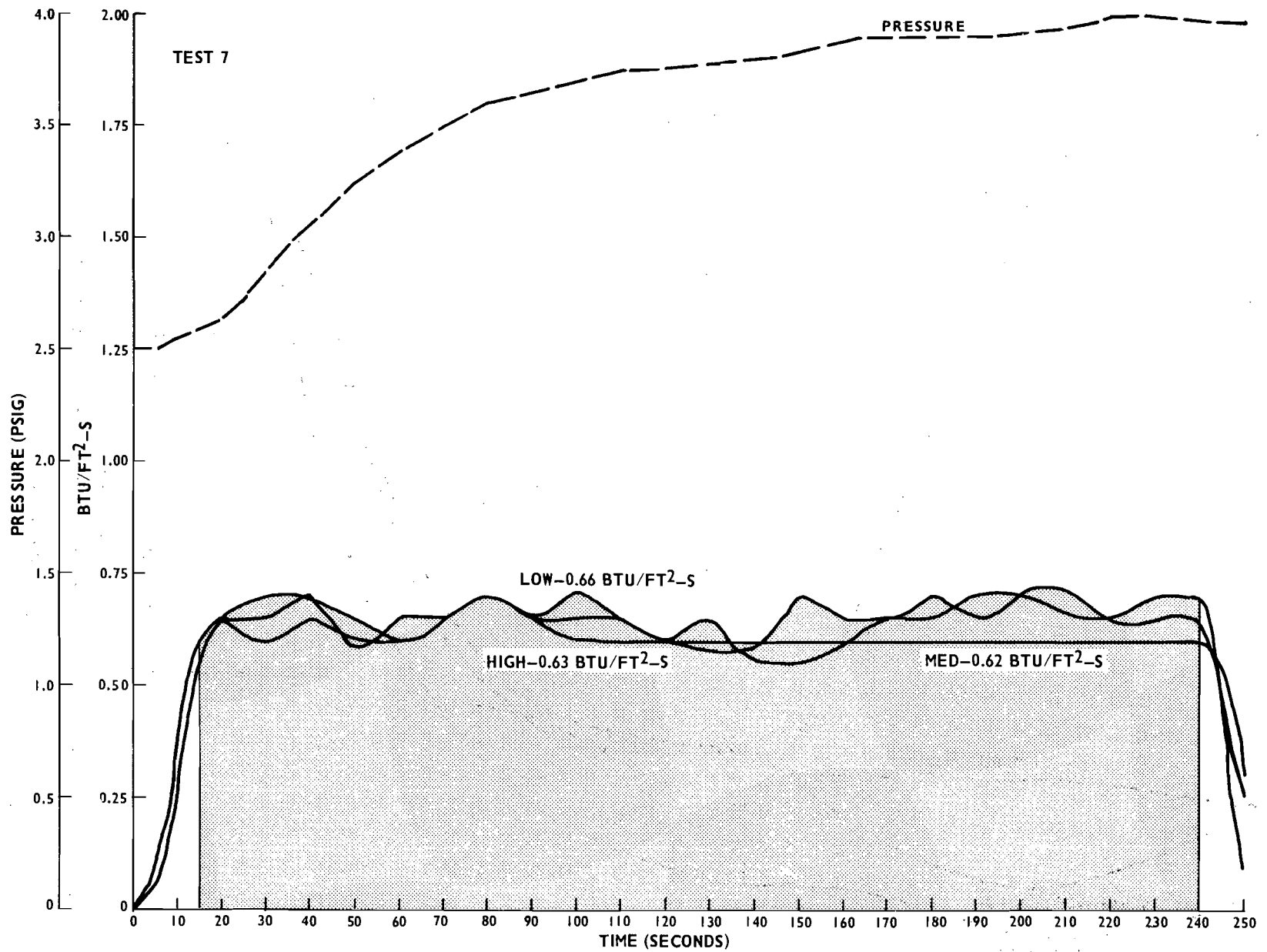

FIGURE B-5. HEAT FLUX AND PRESSURE PLOTS FOR FULL-SCALE TESTS (TEST 7)

B-6

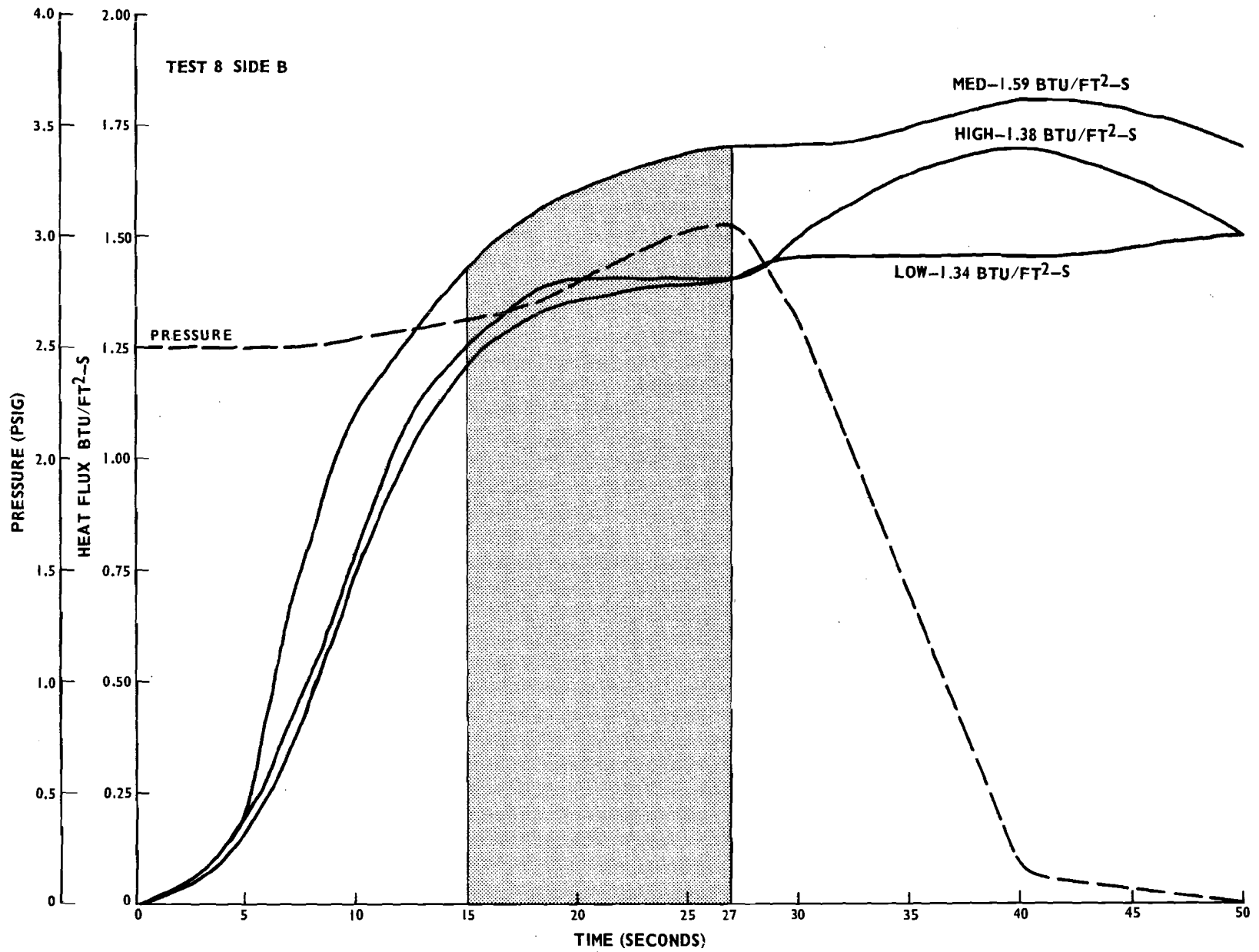

FIGURE B-6. HEAT FLUX AND PRESSURE PLOTS FOR FULL-SCALE TESTS (TEST 8, SIDE B)

B-7

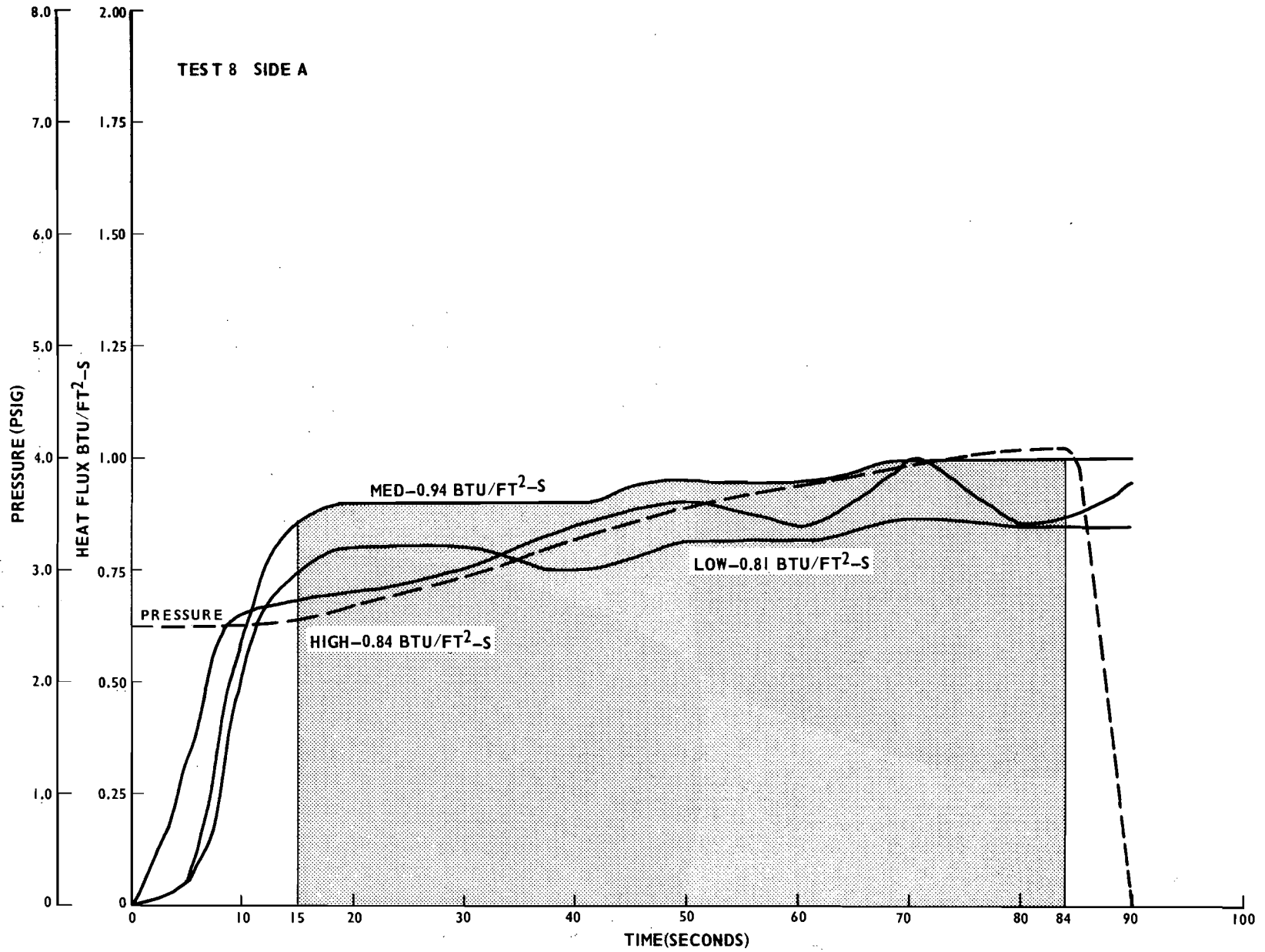

FIGURE B-7. HEAT FLUX AND PRESSURE PLOTS FOR FULL-SCALE TESTS (TEST 8, SIDE B)

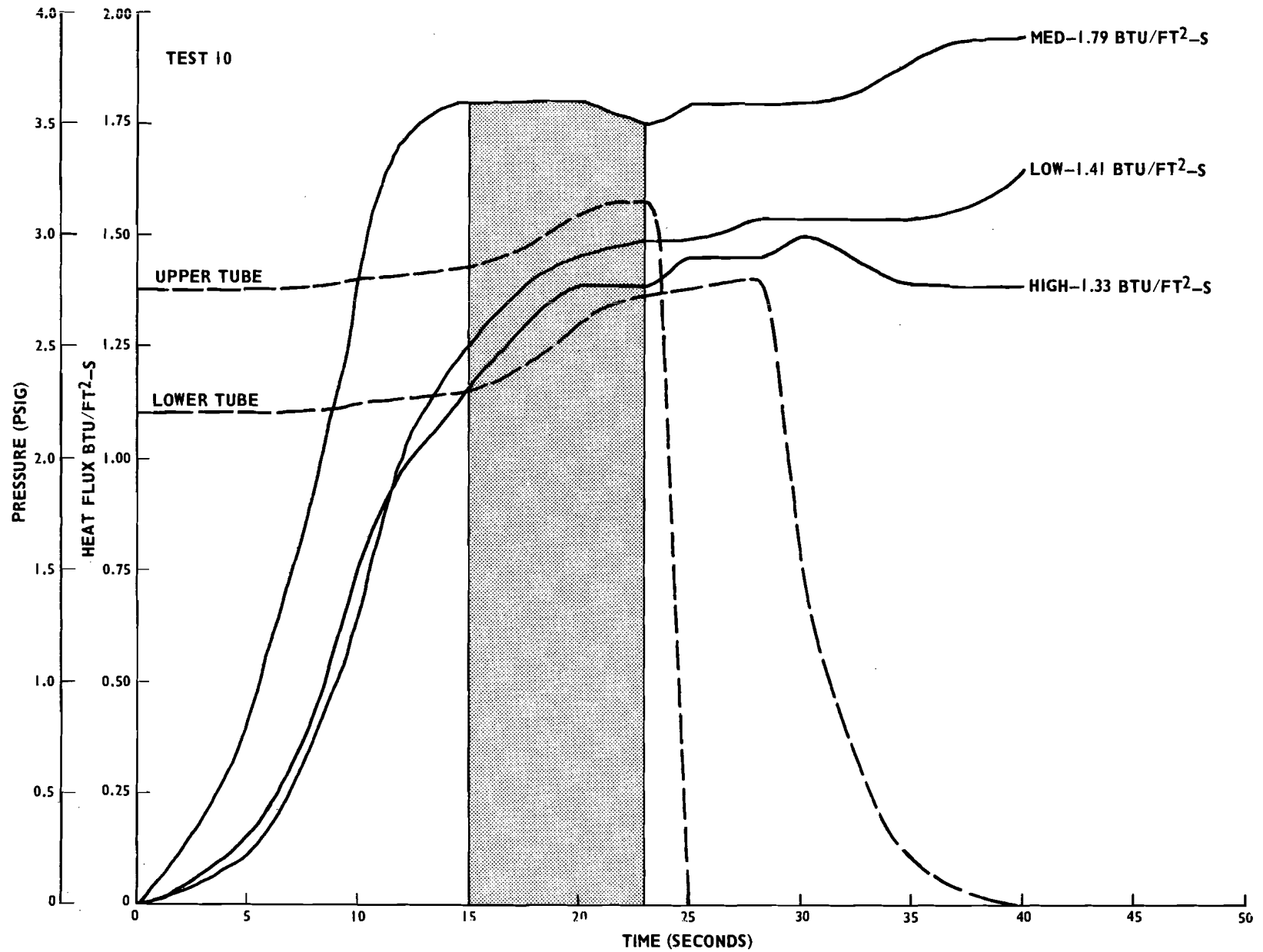

FIGURE B-8. HEAT FLUX AND PRESSURE PLOTS FOR FULL-SCALE TESTS (TEST 10)

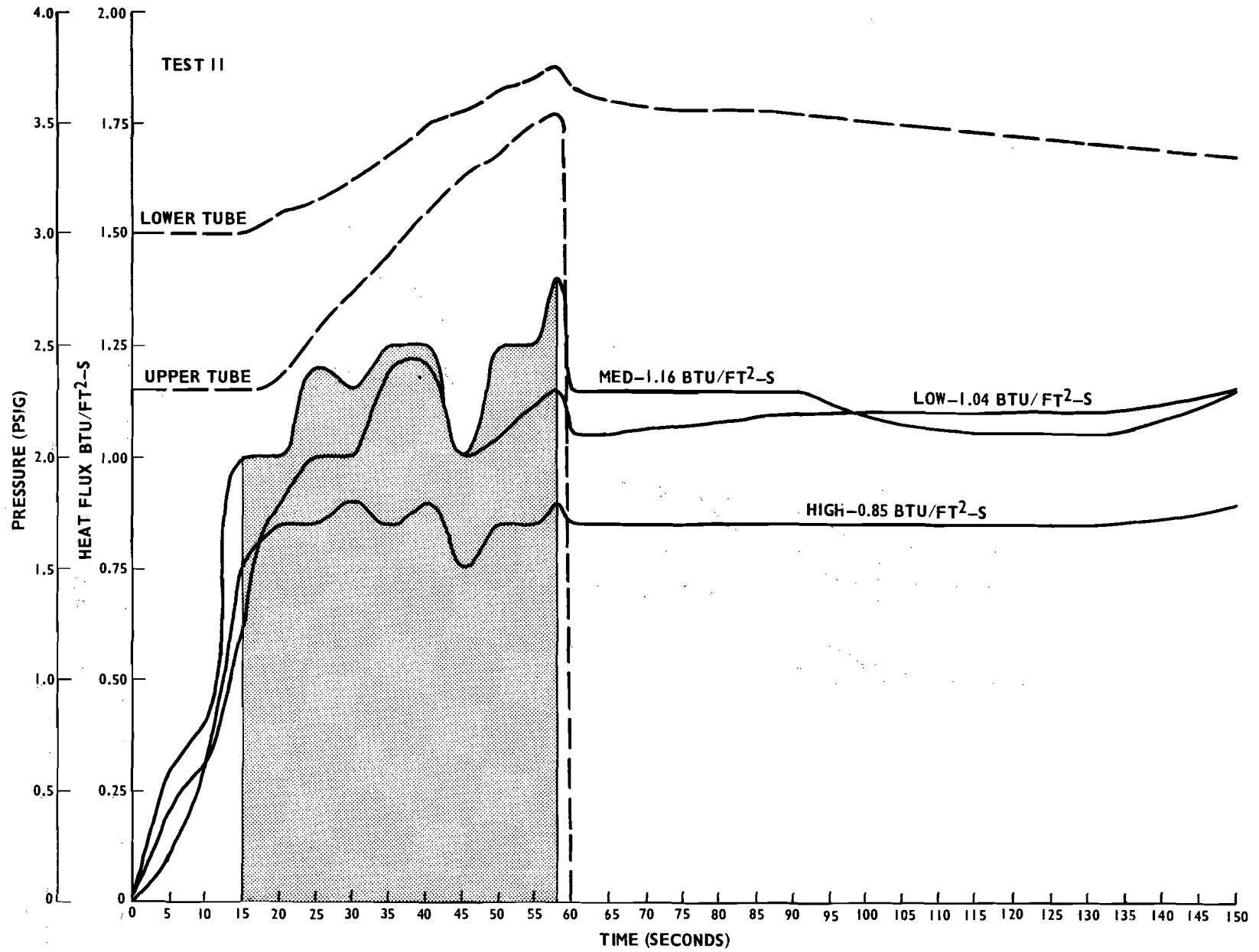

FIGURE B-9. HEAT FLUX AND PRESSURE PLOTS FOR FULL-SCALE TESTS (TEST 11)

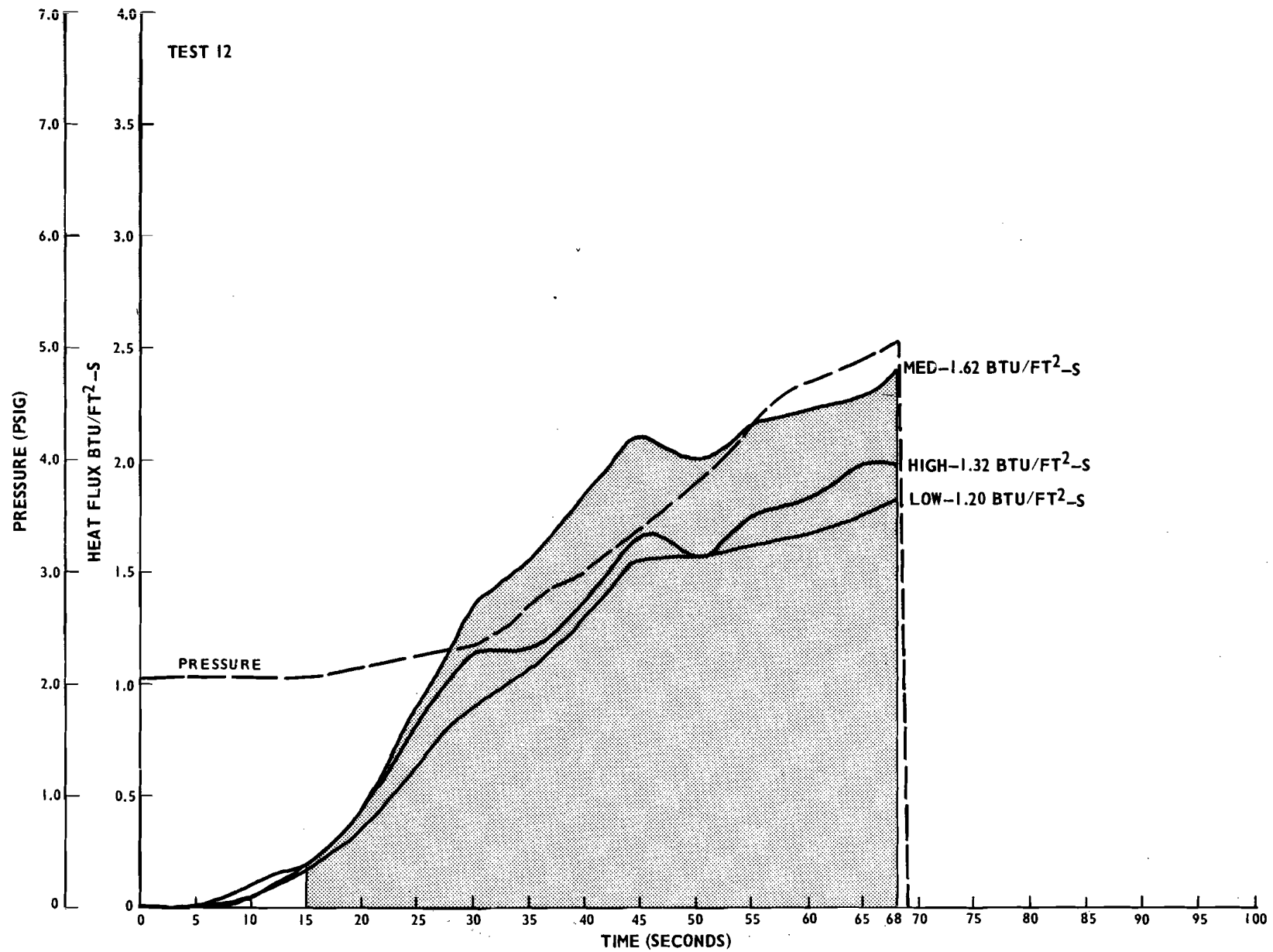

FIGURE B-10. HEAT FLUX AND PRESSURE PLOTS FOR FULL-SCALE TESTS (TEST 12)

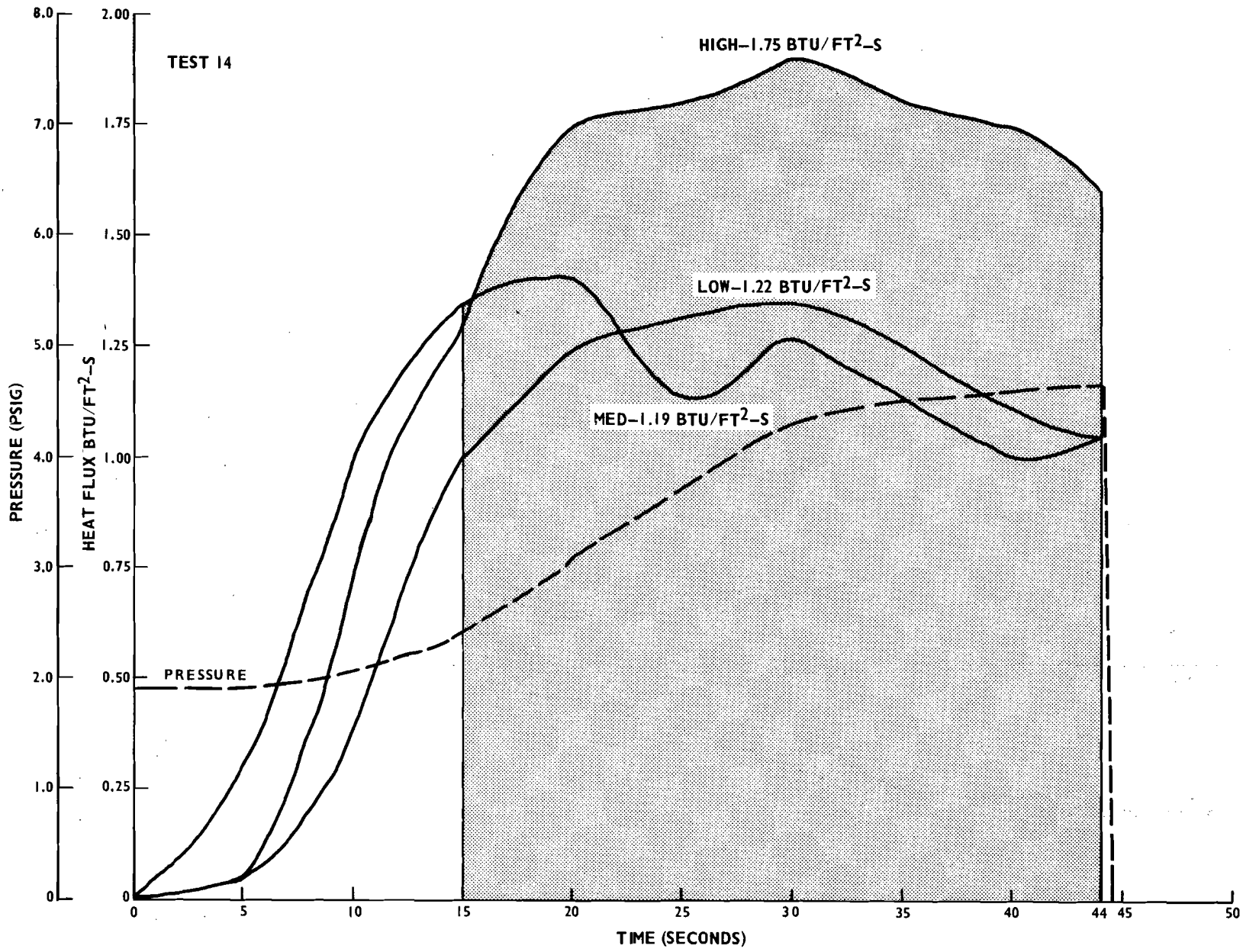

FIGURE B-11. HEAT FLUX AND PRESSURE PLOTS FOR FULL-SCALE TESTS (TEST 14)

B-12

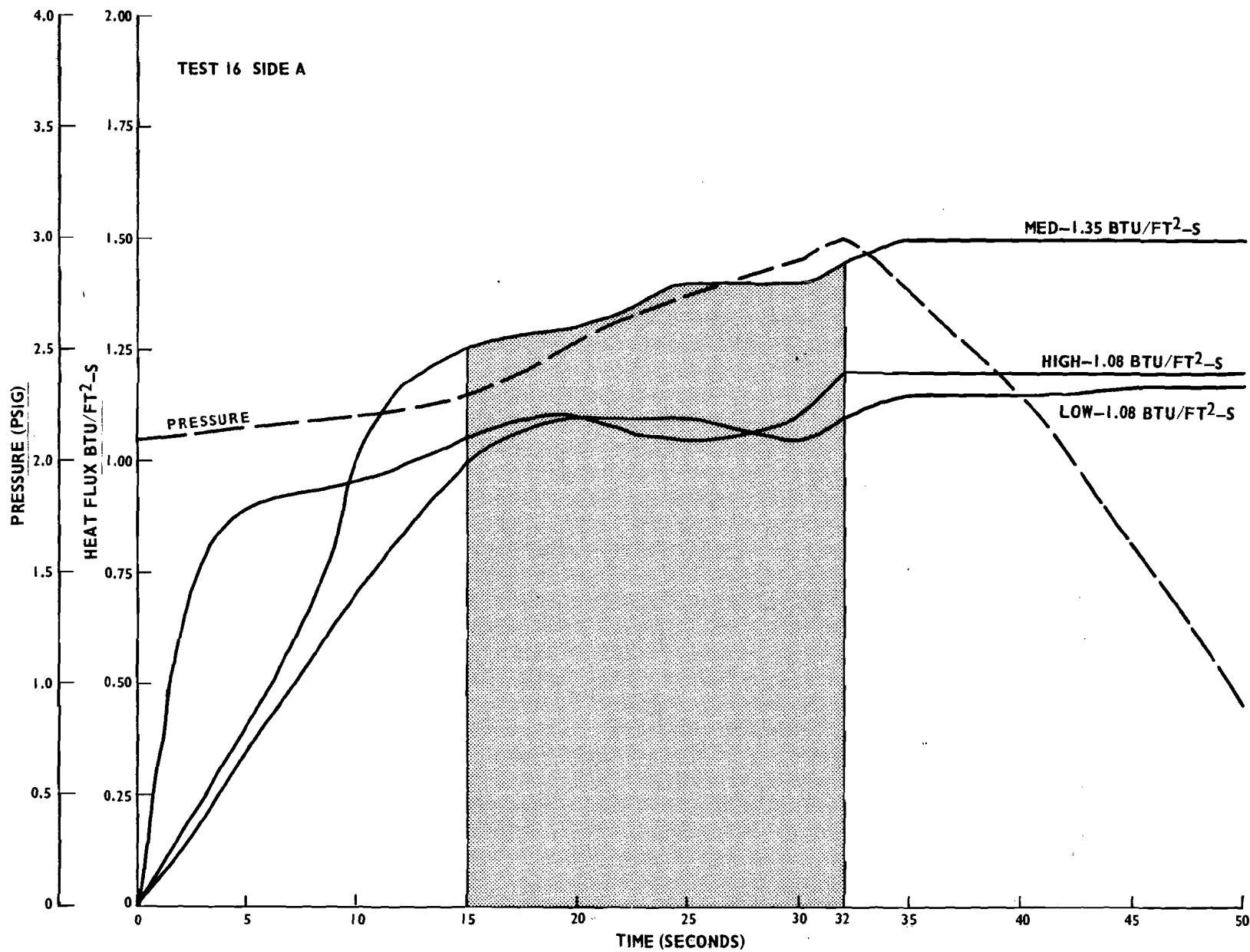

FIGURE B-12. HEAT FLUX AND PRESSURE PLOTS FOR FULL-SCALE TESTS (TEST 16, SIDE A)

B-13

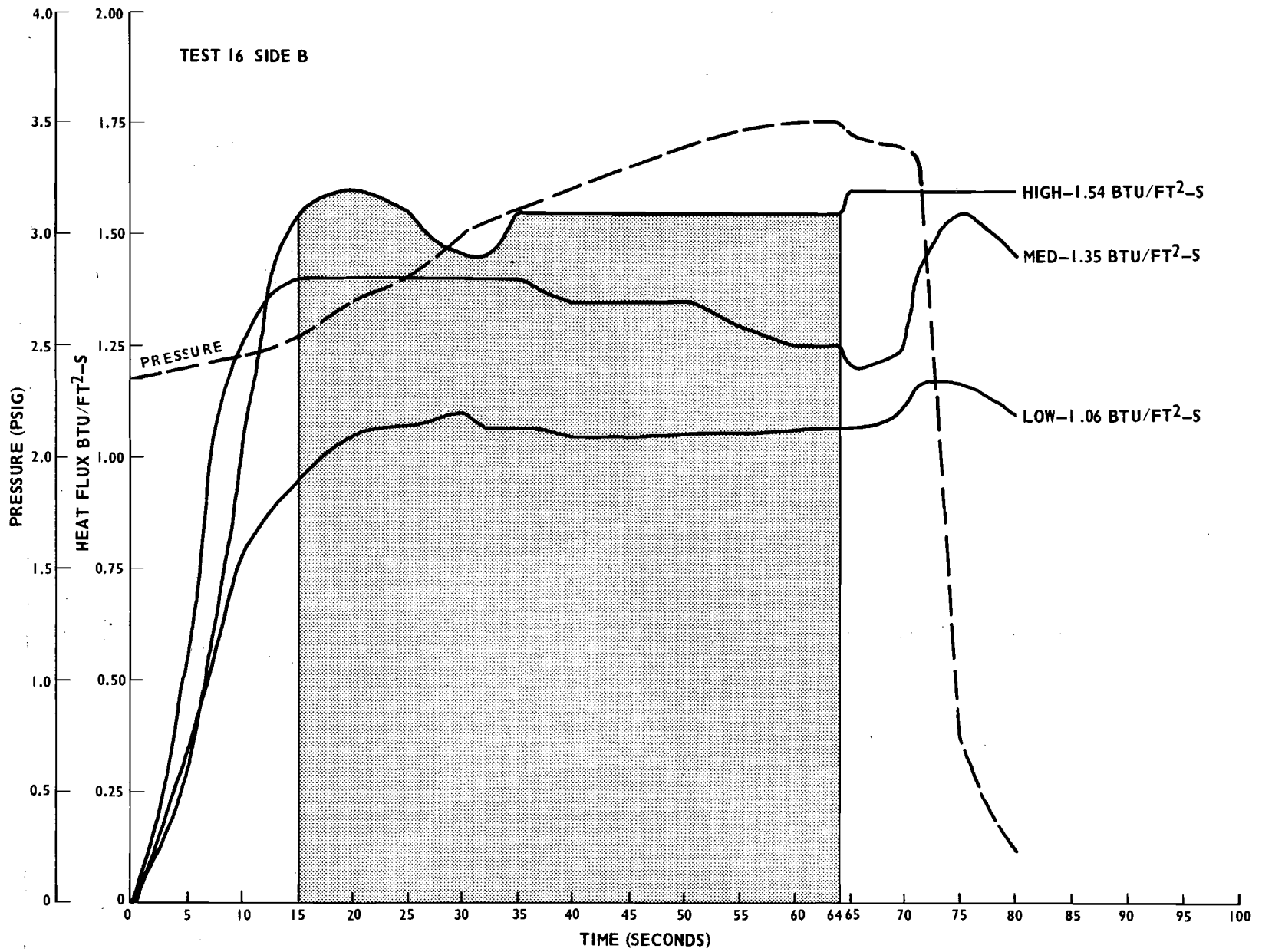

FIGURE B-13. HEAT FLUX AND PRESSURE PLOTS FOR FULL-SCALE TESTS (TEST 16, SIDE B)

B-14

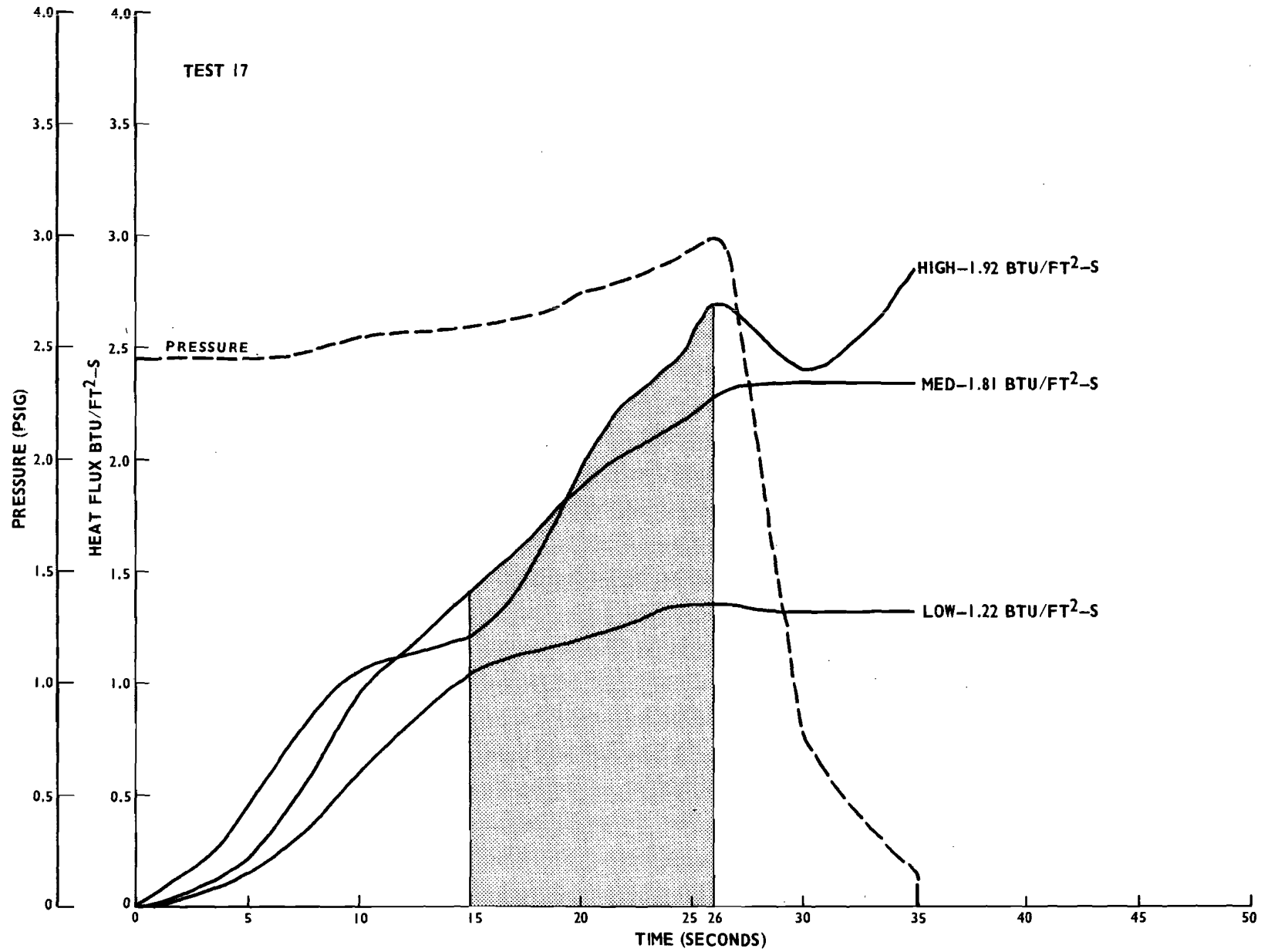

FIGURE B-14. HEAT FLUX AND PRESSURE PLOTS FOR FULL-SCALE TESTS (TEST 17)

B-15

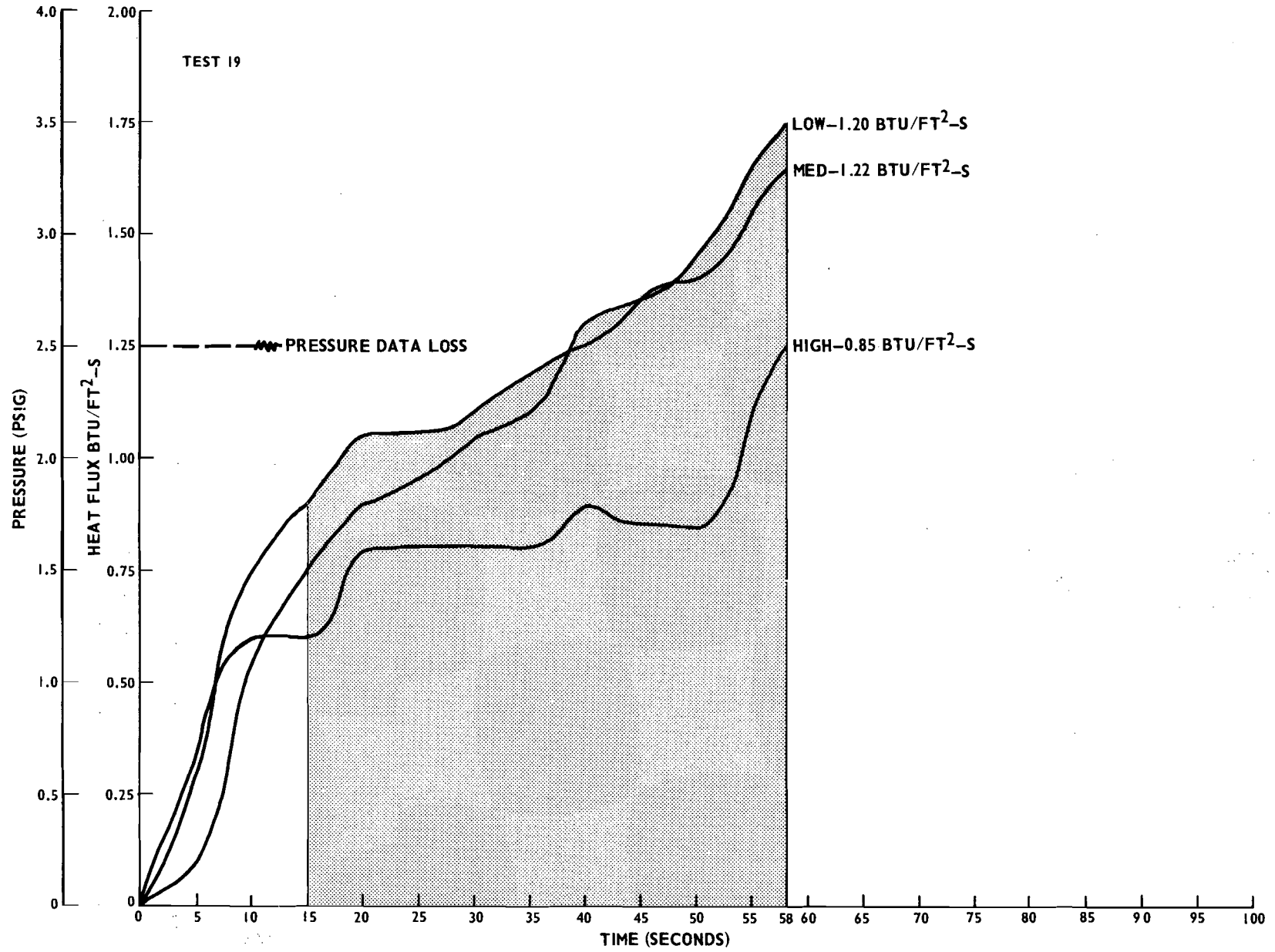

FIGURE B-15. HEAT FLUX AND PRESSURE PLOTS FOR FULL-SCALE TESTS (TEST 19)

B-16

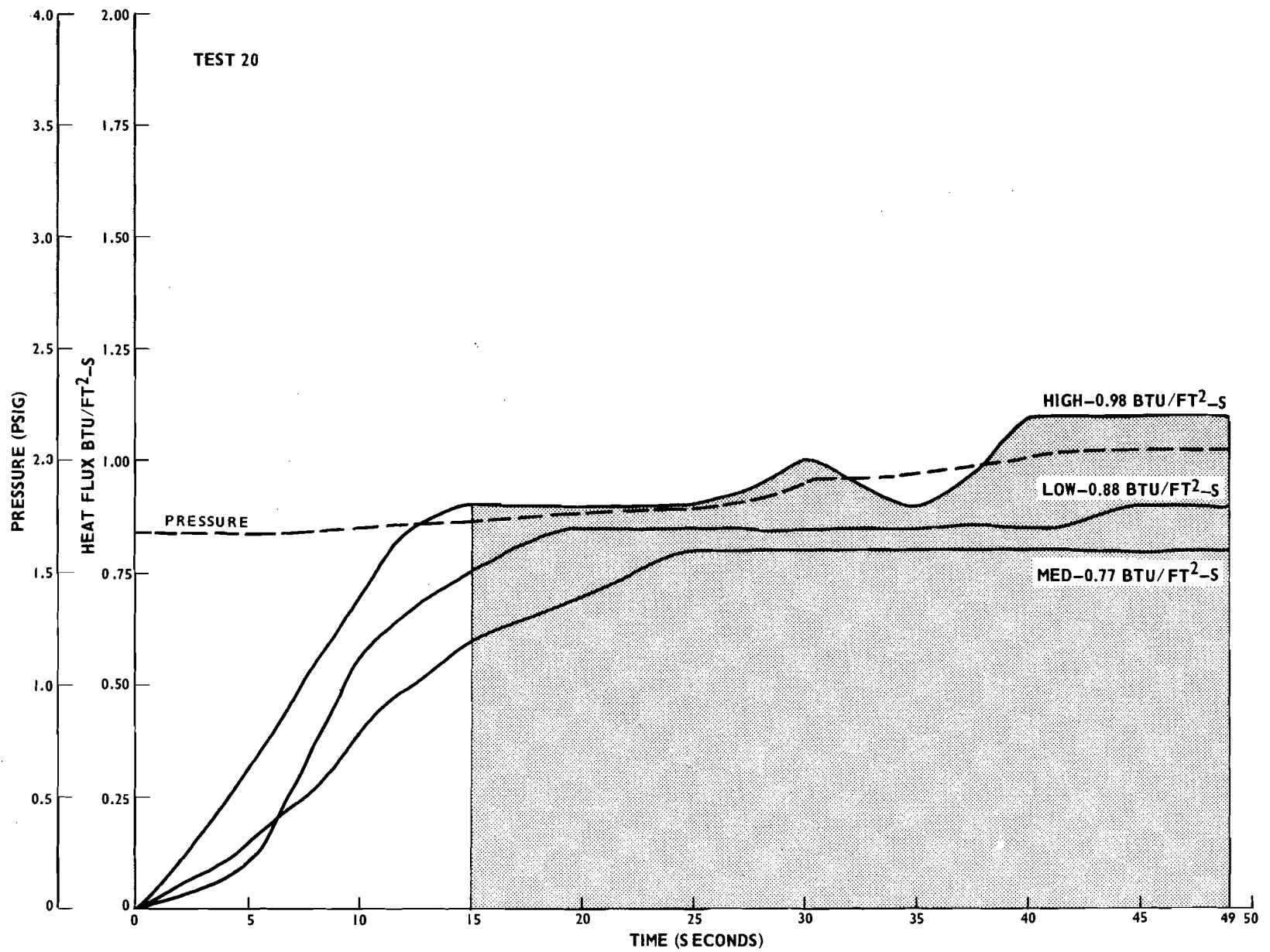

FIGURE B-16. HEAT FLUX AND PRESSURE PLOTS FOR FULL-SCALE TESTS (TEST 20)

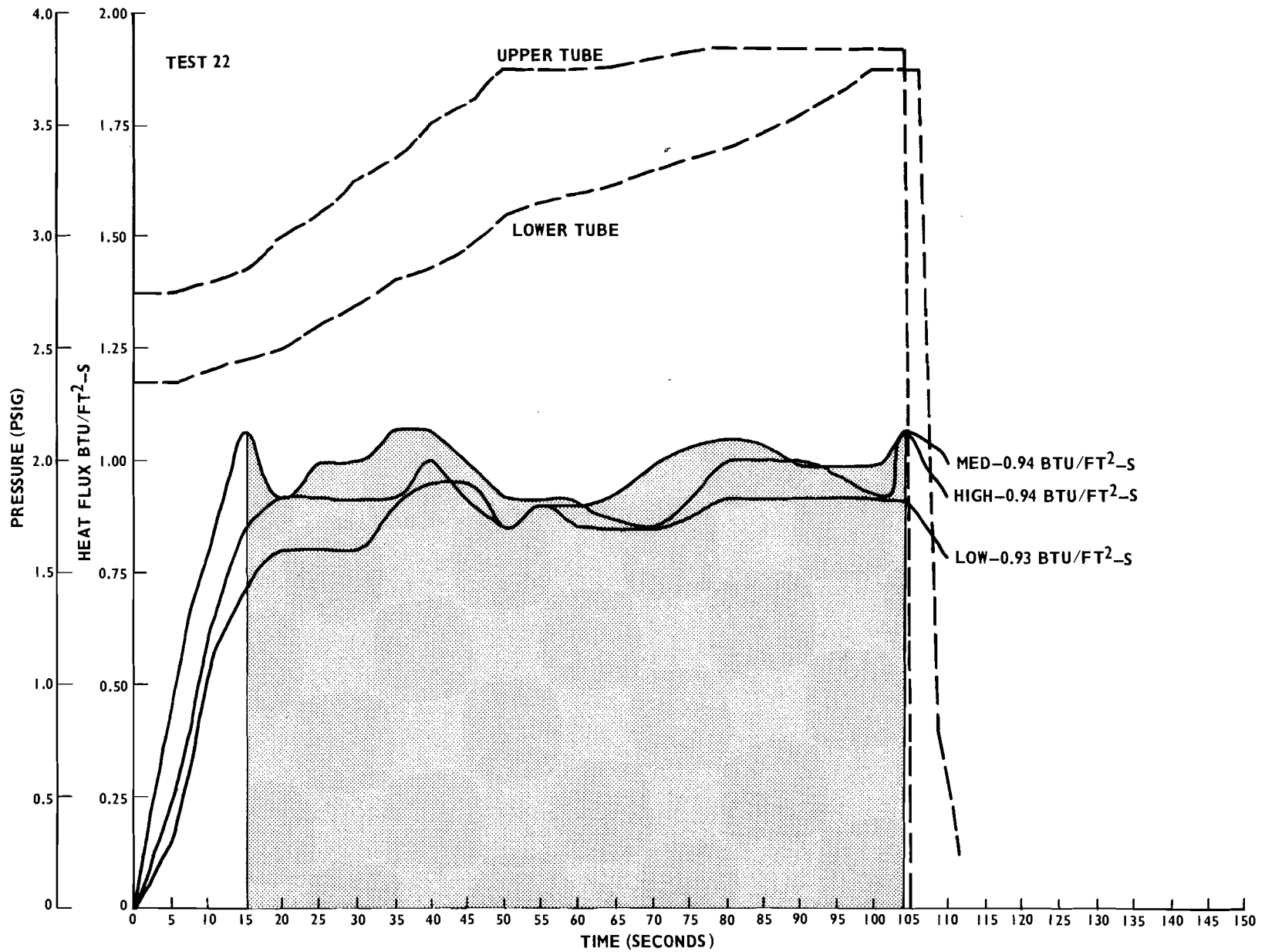

FIGURE B-17. HEAT FLUX AND PRESSURE PLOTS FOR FULL-SCALE TESTS (TEST 22)