

Report No. FAA-CT-81-18

COPY 1

CF6-50 ENGINE EMISSIONS TESTING WITH TRAVERSE PROBE

TECHNICAL CONTRIBUTORS

T. F. Lyon
D. W. Bahr

GENERAL ELECTRIC COMPANY
AIRCRAFT ENGINE BUSINESS GROUP
CINCINNATI, OHIO 45215

FEDERAL AVIATION ADMINISTRATION
JUL 27 1981
TECHNICAL CENTER LIBRARY
ATLANTIC CITY, N.J. 08403



FINAL REPORT

MAY 1981

Document is available to the U.S. public through
the National Technical Information Service,
Springfield, Virginia 22161.

Prepared for
U. S. DEPARTMENT OF TRANSPORTATION
FEDERAL AVIATION ADMINISTRATION
TECHNICAL CENTER
Atlantic City Airport, N.J. 08405

1. Report No. FAA-CT-81-18	2. Government Accession No.	3. Recipient's Catalog No.	
4. Title and Subtitle CF6-50 Engine Emissions Testing with Traverse Probe		5. Report Date January 1981	
		6. Performing Organization Code	
7. Author(s) T.F. Lyon, D.W. Bahr		8. Performing Organization Report No. R81AEG213	
		10. Work Unit No.	
9. Performing Organization Name and Address General Electric Company Aircraft Engine Business Group Cincinnati, Ohio 45215		11. Contract or Grant No. DOT-FA79NA-6010	
		13. Type of Report and Period Covered Final Report May 1979 to November 1980	
12. Sponsoring Agency Name and Address U.S. Department of Transportation Federal Aviation Administration Technical Center Atlantic City Airport, New Jersey 08405		14. Sponsoring Agency Code 201-521-160	
		15. Supplementary Notes	
16. Abstract The variation in emissions over the exhaust area of a General Electric CF6-50 model engine was investigated in order to determine the requirements for a representative sample. The emission measurements were made in a systematic pattern of 120 sample points using a traversing probe system. These data were used to develop detailed emission profiles at three power levels. At idle power, variations over the exhaust area are attributed to the particular fueling pattern used in current CF6-50 model engines. At higher power levels, where uniform fueling is employed, emission levels are more uniform and are characterized by a slightly peaked radial profile. Average values from the 120-point traverse were compared with selected 12-point averages in the EPA prescribed cruciform patten. Generally good agreement between the two averages was obtained.			
17. Key Words (Suggested by Author(s)) Aircraft Engine Emissions CF6-50 Emissions Gas Turbine Combustion Traverse Probe Tests Emissions Variability		18. Distribution Statement This document is available to the public through the National Technical Information Service, Springfield, Virginia 22161	
19. Security Classif. (of this report) Unclassified	20. Security Classif. (of this page) Unclassified	21. No. of Pages	22. Price*

* For sale by the National Technical Information Service, Springfield, Virginia 22161

METRIC CONVERSION FACTORS

Approximate Conversions to Metric Measures

Symbol	When You Know	Multiply by	To Find	Symbol
LENGTH				
in	inches	*2.5	centimeters	cm
ft	feet	30	centimeters	cm
yd	yards	0.9	meters	m
mi	miles	1.6	kilometers	km
AREA				
in ²	square inches	6.5	square centimeters	cm ²
ft ²	square feet	0.09	square meters	m ²
yd ²	square yards	0.8	square meters	m ²
mi ²	square miles	2.6	square kilometers	km ²
	acres	0.4	hectares	ha
MASS (weight)				
oz	ounces	28	grams	g
lb	pounds	0.45	kilograms	kg
	short tons (2000 lb)	0.9	tonnes	t
VOLUME				
tsp	teaspoons	5	milliliters	ml
Tbsp	tablespoons	15	milliliters	ml
fl oz	fluid ounces	30	milliliters	ml
c	cups	0.24	liters	l
pt	pints	0.47	liters	l
qt	quarts	0.95	liters	l
gal	gallons	3.8	liters	l
ft ³	cubic feet	0.03	cubic meters	m ³
yd ³	cubic yards	0.76	cubic meters	m ³
TEMPERATURE (exact)				
°F	Fahrenheit temperature	5/9 (after subtracting 32)	Celsius temperature	°C

*1 in = 2.54 (exactly). For other exact conversions and more detailed tables, see NBS Misc. Publ. 286, Units of Weights and Measures, Price \$2.25, SD Catalog No. C13.10:286.



Approximate Conversions from Metric Measures

Symbol	When You Know	Multiply by	To Find	Symbol
LENGTH				
mm	millimeters	0.04	inches	in
cm	centimeters	0.4	inches	in
m	meters	3.3	feet	ft
m	meters	1.1	yards	yd
km	kilometers	0.6	miles	mi
AREA				
cm ²	square centimeters	0.16	square inches	in ²
m ²	square meters	1.2	square yards	yd ²
km ²	square kilometers	0.4	square miles	mi ²
ha	hectares (10,000 m ²)	2.5	acres	
MASS (weight)				
g	grams	0.035	ounces	oz
kg	kilograms	2.2	pounds	lb
t	tonnes (1000 kg)	1.1	short tons	
VOLUME				
ml	milliliters	0.03	fluid ounces	fl oz
l	liters	2.1	pints	pt
l	liters	1.06	quarts	qt
l	liters	0.26	gallons	gal
m ³	cubic meters	35	cubic feet	ft ³
m ³	cubic meters	1.3	cubic yards	yd ³
TEMPERATURE (exact)				
°C	Celsius temperature	9/5 (then add 32)	Fahrenheit temperature	°F

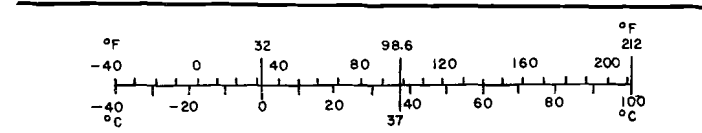

TABLE OF CONTENTS

<u>Section</u>		<u>Page</u>
1.0	INTRODUCTION	1
2.0	SUMMARY	2
3.0	ENGINE EMISSION TEST SETUP	4
	3.1 CF6-50 Engine Description	4
	3.2 Test Vehicle Configuration	6
	3.3 Traverse Probe Sampling System	8
	3.4 Emission Analysis System	16
	3.5 Emission Data Reduction Procedures	20
4.0	TRAVERSE PROBE EMISSION TESTS	21
	4.1 Test Procedure	21
	4.2 Engine Test Data	22
	4.3 Emission Test Data	25
5.0	CONCLUSIONS	54
	REFERENCES	55
	APPENDIX	56

LIST OF ILLUSTRATIONS

<u>Figure</u>		<u>Page</u>
1.	General Electric CF6-50 High Bypass Turbofan Engine.	5
2.	CF6-50 Fuel Nozzle Configuration - Aft Looking Forward.	7
3.	Traverse Probe System.	9
4.	Sample Ports for Traverse Probe.	10
5.	CF6-50 Primary Nozzle Configuration and Radial Sampling Locations for Traverse Probe.	11
6.	Sampling System Schematic.	12
7.	Wiring Schematic for Sampling System Sequencing Switches.	14
8.	Traverse Probe System Mounted Behind CF6-50 Engine in Test Cell.	17
9.	Traverse Probe Sampling Orifices in Position to Sample CF6-50 Exhaust.	18
10.	Emissions Analysis System.	19
11.	Fuel-Air Distribution at Idle Power.	28
12.	CO Concentration Distribution at Idle Power.	29
13.	HC Concentration Distribution at Idle Power.	30
14.	NO _x Concentration Distribution at Idle Power.	31
15.	Fuel-Air Distribution at 30 Percent Power.	33
16.	CO Distribution at 30 Percent Power.	34
17.	HC Distribution at 30 Percent Power.	35
18.	NO _x Concentration Distribution at 30 Percent Power.	36
19.	Fuel-Air Ratio Distribution at 85 Percent Power.	37
20.	CO Concentration Distribution at 85 Percent Power.	38
21.	NO _x Distribution at 85 Percent Power.	39
22.	Radial Profiles of Fuel-Air Ratio, CO, HC, and NO _x Concentration at Idle Power and for Selected Circumferential Locations. V and N Indicate Vent Tube (R=3.1 in.) and Exhaust Nozzle (R=18.0) Radii.	41
23.	Radial Profiles of Fuel-Air Ratio, CO, HC, and NO _x Concentration at 30 Percent Power and for Selected Circumferential Locations. V and N Indicate Vent Tube (R=3.1 in.) and Exhaust Nozzle (R=18.0) Radii.	42

LIST OF ILLUSTRATIONS (Concluded)

<u>Figure</u>		<u>Page</u>
24.	Radial Profiles of Fuel-Air Ratio, CO, HC, and NO _x Concentrations at 85 Percent Power and for Selected Circumferential Locations. V and N Indicate Vent Tube (R=3.1 in.) and Exhaust Nozzle (R=18.0) Radii.	43
25.	Hydrocarbon Concentration Isopleths at Idle Power (Aft Looking Forward).	44
26.	Carbon Monoxide Concentration Isopleths at Idle Power (Aft Looking Forward).	46
27.	Fuel-Air Ratio Isopleths at Idle Power (Aft Looking Forward). All Measured Levels Outside Contours are Between 0.010 and 0.012.	47
28.	Typical Exit Temperature Profile Characteristics of the CF6-50 Combustor.	52

LIST OF TABLES

<u>Table</u>		<u>Page</u>
1.	Valve Sequencing for Traverse Probe System.	15
2.	Engine Test Data.	23
3.	Jet A Fuel Analysis.	24
4.	Summary of Data from 120 Point Traverse.	26
5.	Comparison of Cruciform Average and 120 Point Traverse Average.	48

1.0 INTRODUCTION

The measurement of emission levels from aircraft gas turbine engines is influenced, at least to some extent, by the number and location of the sampling points over the exhaust area. Severe concentration gradients in the exhaust may require either that a large number of sampling points be employed, or that a smaller number of sampling points be very carefully selected so as to obtain an accurate average level of emissions. In either case, a knowledge of the variation of relevant concentrations over the exhaust area is required in order to verify that the selected sampling pattern produces an average emission level which closely approximates the overall emission level of the engine being tested.

The Environmental Protection Agency (EPA) has established test procedures for emission measurements of aircraft gas turbine engines. The procedure guards against a biased sample by requiring that evidence be provided to show that the sampling system being used provides a representative sample. Such evidence may be obtained by using a moving or traversing probe system to obtain emission data at closely spaced intervals over the engine exhaust area.

The purpose of the test program reported herein is to measure the variation in concentrations of carbon monoxide (CO), carbon dioxide (CO₂), hydrocarbons (HC), and oxides of nitrogen (NO_x) over the core exhaust area of a General Electric CF6-50 model engine, and to use these data to develop emission profiles of the exhaust at several engine power levels.

This program is part of an ongoing effort by the FAA to establish a broad data base from which regulations can be established to assure compliance with EPA aircraft emission standards.

2.0 SUMMARY

The emission levels of a CF6-50 engine were measured, using a traversing probe system developed for this program. Measurements were taken in a circular pattern consisting of 5 radial locations and 24 circumferential locations for a total of 120 sample points at each of three engine power levels. The resulting emission data are presented in this report as circumferential profiles, radial profiles, and, in some cases, as contour maps.

The variations in concentrations over the exhaust area were found to have certain characteristics which are associated with particular design features of the current production CF6-50 engine. At idle power, a localized rich region in the exhaust was observed. This rich zone is caused by locally higher fuel flow near the ignitors in the combustor, and results in low CO and HC concentrations and high NO_x concentrations at this location. Large variations in HC concentrations were observed at idle power. These variations are apparently associated with the bleed fuel flow that is incorporated into 14 of the 30 fuel nozzles of the combustion system. The purpose of this bleed fuel flow is to prevent stagnation and possible decomposition of the fuel within these fuel nozzles at the low power engine operating conditions where uniform fueling around the combustor is not used.

In general, except for the rather large variations in HC concentration at idle power, the emission levels were found to be quite uniform over the exhaust area. At high power levels, the measured variations in fuel-air ratio and CO and NO_x concentrations were characterized by modestly peaked radial profiles, while HC concentration variations were insignificant. These peaked radial profiles are due to the turbine inlet temperature profile which is similarly shaped due to turbine rotor design requirements.

The EPA-specified 12-point cruciform sampling pattern was found to provide a good average sample for the CF6-50 engine, in spite of the large variation in HC concentration at idle power. Based on the results of this study, it is concluded that, for modern high pressure ratio engines with annular combustors and with nonmixed core and fan streams, the EPA 12-point cruciform pattern should produce a representative average sample provided that the

fueling pattern is uniform in the combustor. For other types of combustion systems or if the fueling pattern is nonuniform at some operating conditions, the emission variations across the nozzle should be determined to assure that the selected sampling pattern does not give a biased result.

3.0 ENGINE EMISSION TEST SETUP

The engine emission tests with the traverse probe were run in Evendale Development Test Cell No. 2 on CF6-50 Engine 455-507/19. The tests performed on August 15 and 18, 1980, consisted of a detailed 120-point traverse of the engine exhaust for CO, CO₂, HC, and NO_x at each of three power settings (ground idle, 30%, and 85%).

This section describes the CF6-50 engine used in these tests, along with the emissions sampling and analysis system, and emission data reduction procedures.

3.1 CF6-50 ENGINE DESCRIPTION

The CF6 engine family consists of twin-spool, high bypass turbofan engines used principally to power large, wide-body commercial transports. The CF6 combines high bypass ratio with high component efficiency and increased turbine operating temperatures to produce low operating costs, low sound levels, low smoke, and high performance.

The CF6-50 engine series used for the emission tests in the present program, is a high thrust version of the CF6. A typical CF6-50 installation is shown in Figure 1. The CF6-50 has a single-stage fan and three-stage low pressure compressor which are driven by a four-stage low pressure turbine through a shaft concentric with the core engine. The core engine consists of a 14-stage axial flow compressor with variable stators, an annular combustor, and a two-stage air cooled turbine.

The combustor configuration used in production CF6-50 engines is a high performance design with low exit temperature pattern factors, low pressure loss, high combustion efficiency, and low smoke emissions at all operating conditions. This annular combustor contains 30 pressure-atomizing, duplex-type fuel nozzles and two ignitors. Axial swirlers in the combustor dome, one for each fuel nozzle, provide the intense mixing of fuel and air required for good combustion stability and low smoke. The current production CF6-50 combustion system is equipped with smoke abatement features, but not with

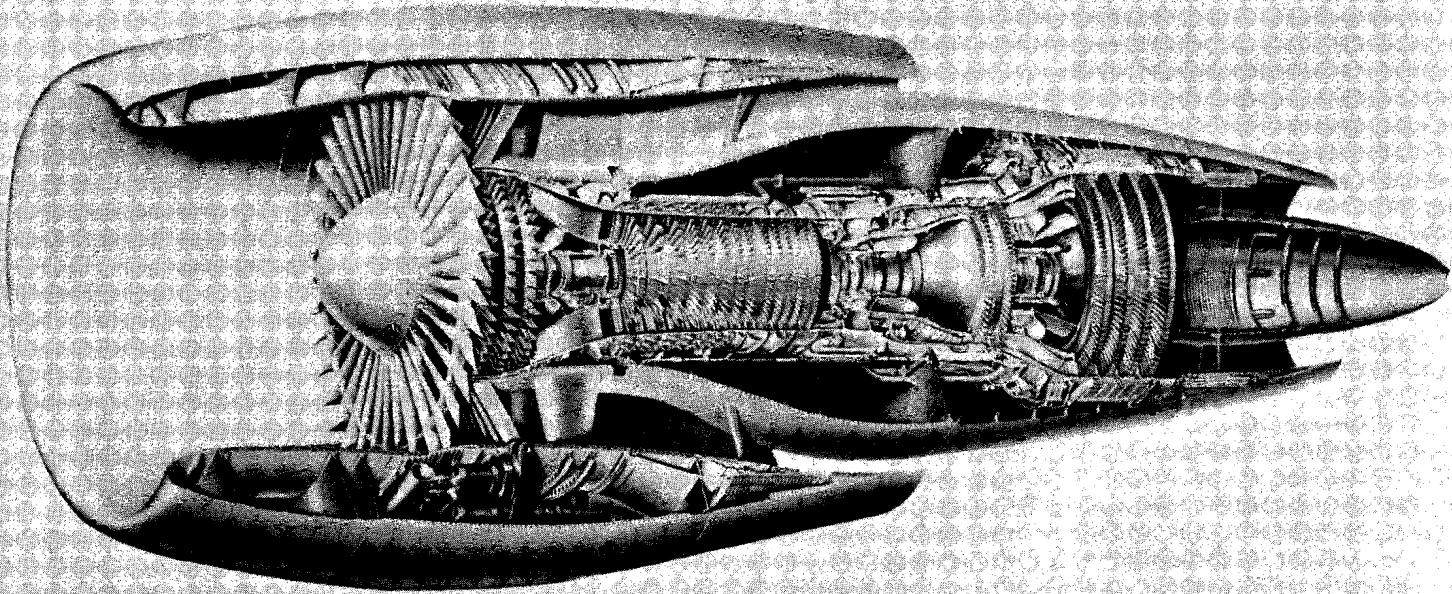

FIGURE 1. GENERAL ELECTRIC CF6-50 HIGH BYPASS TURBOFAN ENGINE.

features which would be required to meet the currently proposed EPA standards for gaseous emissions (Reference 1).

The CF6-50 engine series (50,000-pound thrust class) has a wide range of applications which include the three-engine McDonnell Douglas DC-10 Series 30 long range trijet, the two-engine Airbus A300B, and the four-engine Boeing 747. The military version of the CF6-50, designated the F103, is being produced for the Boeing E-4A command post version of the 747 aircraft and has been flown in the Boeing YC-14 short takeoff and landing vehicle.

3.2 TEST VEHICLE CONFIGURATION

CF6-50 Engine 455-507 is one of several factory engines which are used for development testing. For the engine emission tests, this engine was equipped with a fixed, conical primary exhaust nozzle, which is the type generally used for factory acceptance testing. This nozzle differs from the flight-type nozzle, which has a larger centerbody extending some distance aft of the exhaust plane.

This test engine was equipped with an improved combustor, currently in development. This new combustor configuration has several features which have been incorporated mainly to improve combustor durability. The emission characteristics of this development combustor are quite similar to those of the current production combustor configuration. The fuel nozzles were standard production parts (P/N 9119M60) consisting of 16 nozzles with both primary and secondary flow systems and 14 nozzles with secondary flow only. As shown in Figure 2, the fuel nozzles are arranged in an alternating pattern, except at the ignitor location where three adjacent fuel nozzles with primary and secondary flow systems are located. The fuel nozzles are sized so that, at ground idle speed, only the primary flow systems are open, resulting in an alternate burning arrangement. This feature was adopted in order to improve the engine starting characteristics. Secondary valve opening is scheduled so that, at high power conditions, fuel flow is essentially the same from all nozzles. This is necessary to create the required uniform temperature distribution at the turbine inlet plane.

- ⊗ FUEL NOZZLE WITH PRIMARY AND SECONDARY FLOW (16)
- FUEL NOZZLE WITH ONLY SECONDARY FLOW (14)
- ↑ IGNITOR LOCATION

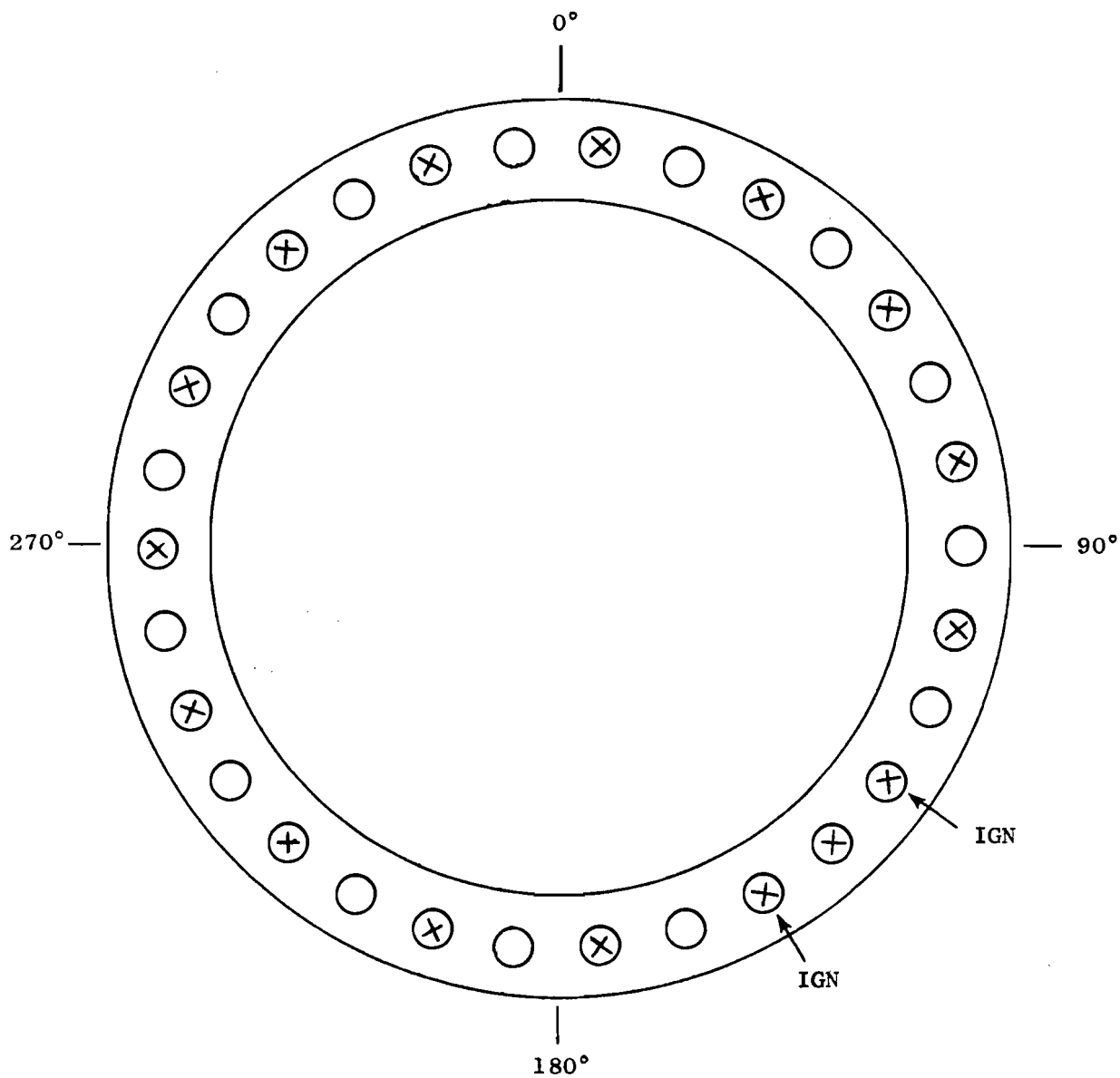

FIGURE 2. CF6-50 FUEL NOZZLE CONFIGURATION (AFT LOOKING FORWARD).

3.3 TRAVERSE PROBE SAMPLING SYSTEM

The traverse probe system was originally designed and fabricated by General Electric for use in CF6-50 engine tests on Phase III of the NASA Experimental Clean Combustor Program (Ref. 2). For the present program, the system was modified to obtain individual samples from 40 locations over the exhaust area of the core engine. The capability was retained for rotation over 45 degrees about the engine centerline.

A sketch of the traverse probe system is shown in Figure 3. The probe assembly consists of eight probe arms mounted to a rotatable ring. The ring is eight feet in diameter and is sized to clear the fan stream of the CF6-50 engine. Each probe arm contains five sample orifices, with each of the 40 orifices connected to a separate solenoid valve. The 40 valves are mounted in four boxes, which are fastened directly to the rotatable ring. The valve outlets are connected to two manifolds (20 to each manifold) which are in turn connected to the electrically heated, flexible sample lines "A" and "B".

Each orifice is connected to the corresponding solenoid valve by stainless steel tubing within a steam jacket (Figure 4). The steam jacket is clamped to the probe arm. The orifices are evenly spaced to span the distance between the sump vent tube and the core exhaust nozzle of the CF6-50 engine, as shown in Figure 5.

Figure 6 is a schematic of the entire sampling system, showing the sample flowpath from the orifices to the gas analysis system. The two lines from the manifolds on the probe system are each connected to a separate purge valve and analyzer valve in such a way that a sample from one orifice can be analyzed while the line from an orifice in the other manifold is purged. This feature resulted in saving of considerable test time by minimizing the time required for sample system equilibration.

Operation of the valving system may be illustrated by reference to Figure 6. With orifice valves 11 and 31 open, analyzer valve 1 and purge valve B open, the sample from orifice 11 is routed up to the analyzer while the line from orifice 31 is purged. After analysis of the sample from orifice 11, orifice valve 11 would be closed and 16 opened, while orifice

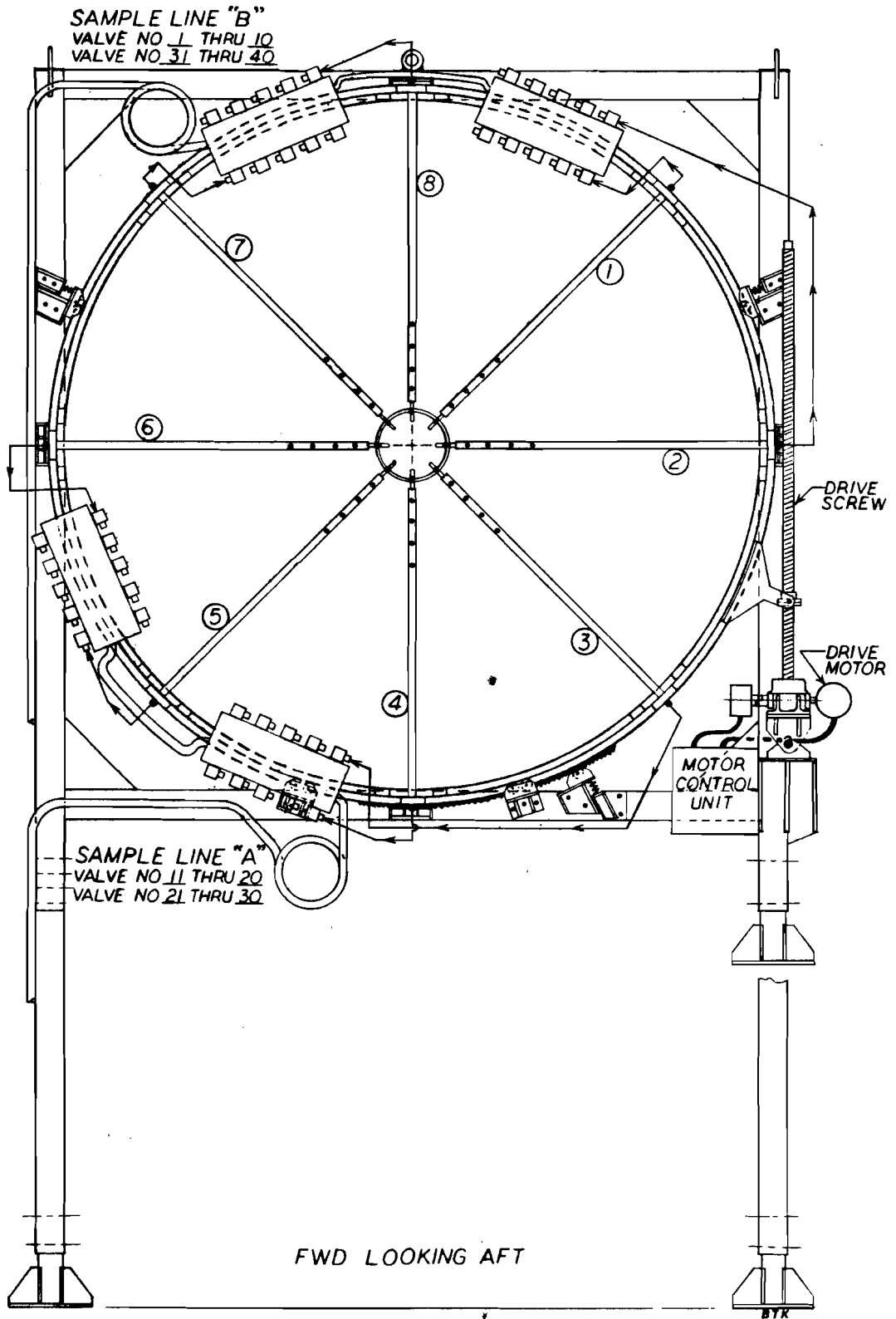

FIGURE 3. TRAVERSE PROBE SYSTEM.

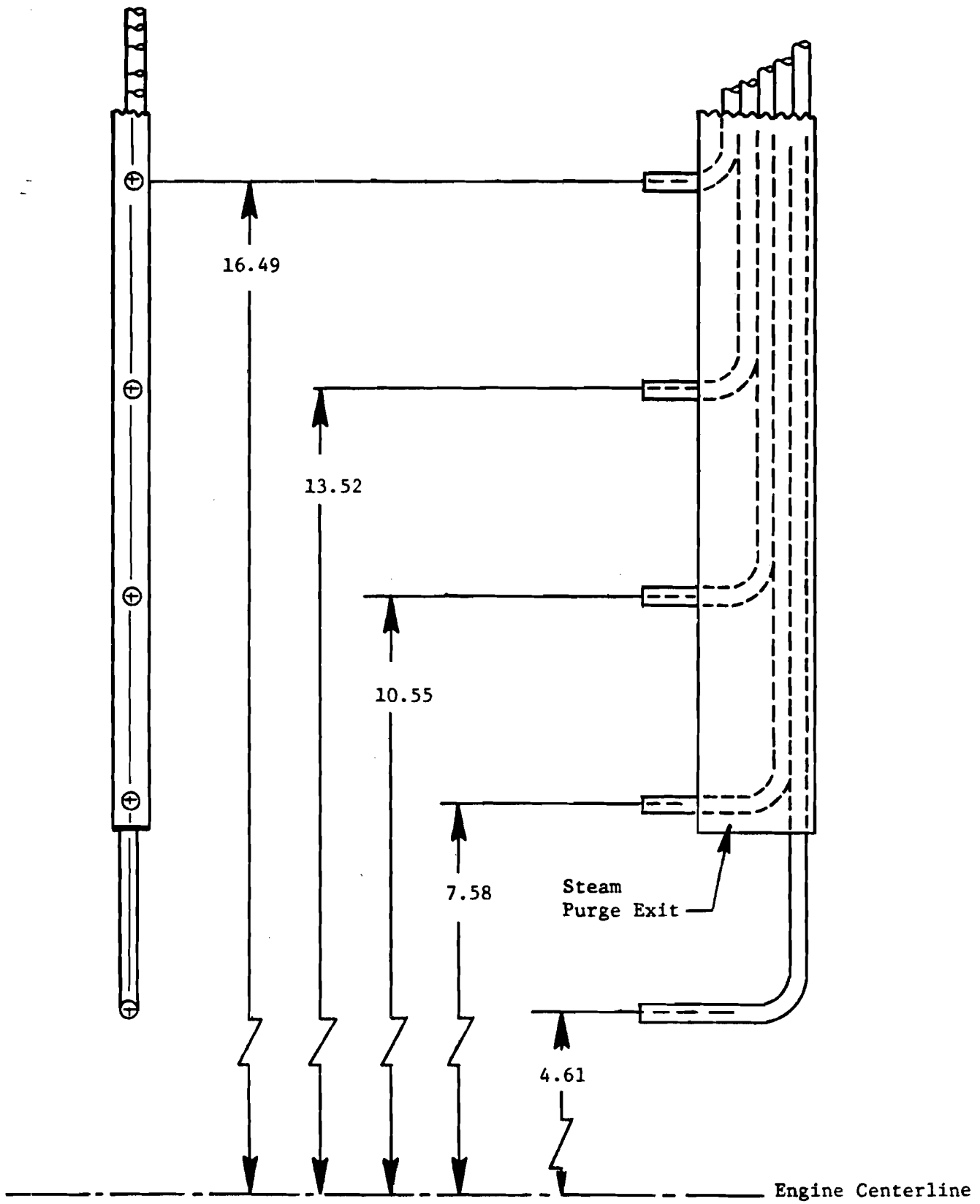

FIGURE 4. SAMPLE PORTS FOR TRAVERSE PROBE.

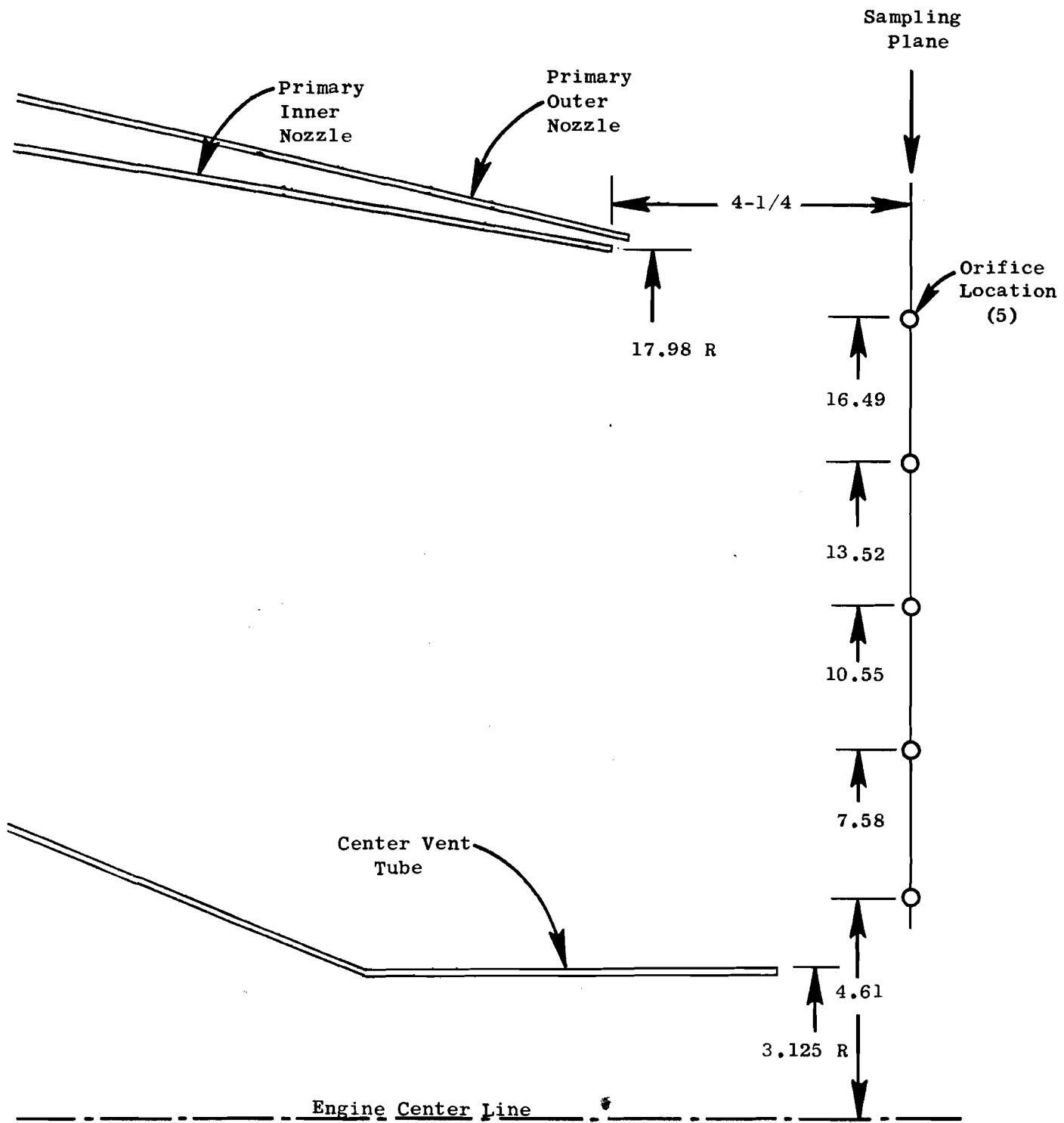

FIGURE 5. CF6-50 PRIMARY NOZZLE CONFIGURATION AND RADIAL SAMPLING LOCATIONS FOR TRAVERSE PROBE.

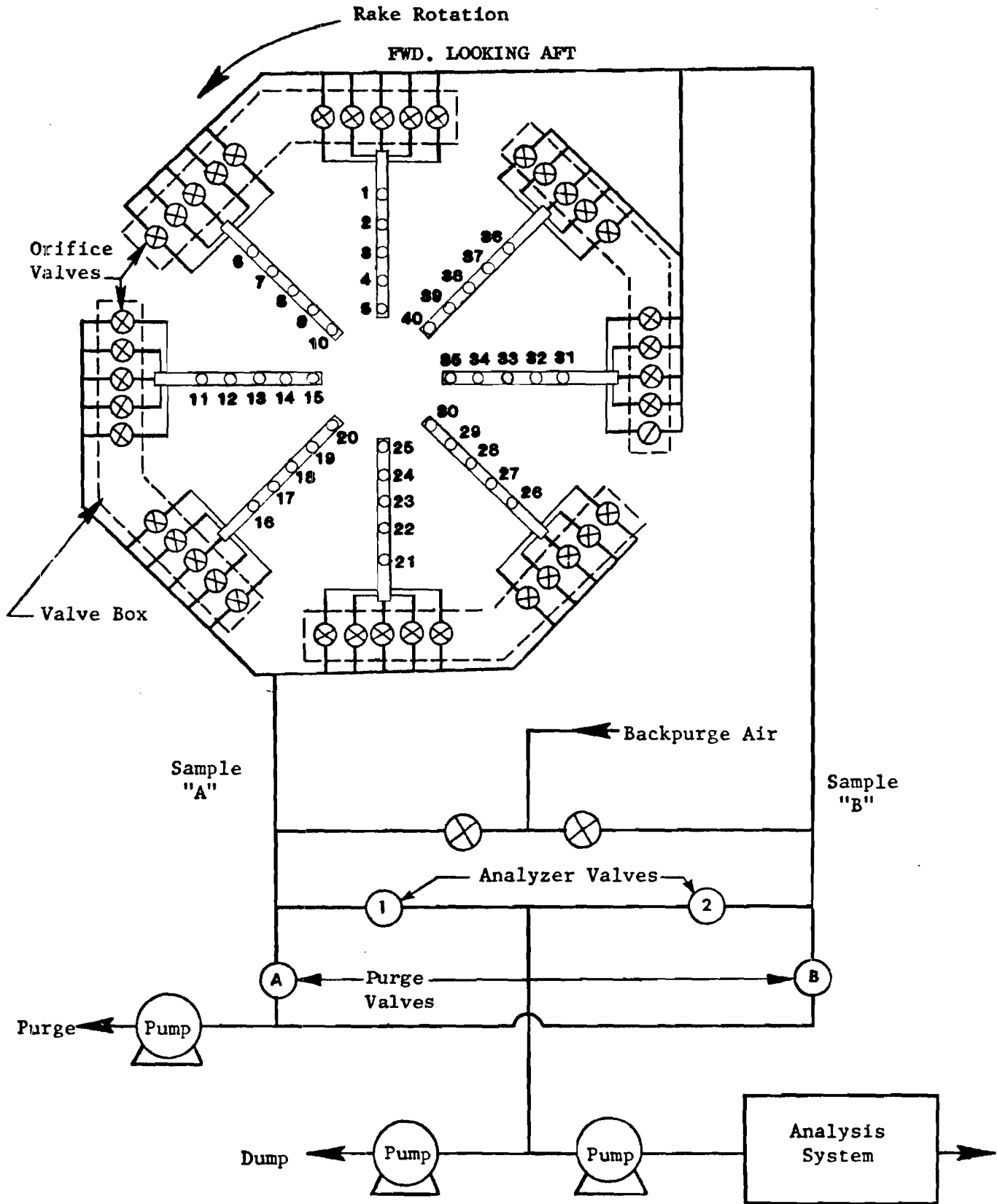

FIGURE 6. SAMPLING SYSTEM SCHEMATIC.

valve 31 remained open, analyzer valve 1 closed and 2 opened, purge valve B closed and A opened. With this valve positioning, the sample from orifice 31 is analyzed and the line from orifice 16 is purged. This sequence of valve manipulation is continued until all 40 orifices have been sampled.

It might be noted that the sequence of valve operation requires 40 steps, each of which consists in opening four selected valves while all other valves remain in their normally closed positions. The four valves consist of two orifice valves, one analyzer valve, and one purge valve. In the 40 steps, a particular orifice valve remains open for two consecutive steps, while an analyzer and a purge valve open on alternate steps.

The sequence of valve operation is controlled by two rotary switches with three gangs each, wired as shown in Figure 7. Switch A controls 20 orifices and switch B the remaining 20. With switch A in position 21, voltage is applied to the wiper of switch B. Gang 1 of each switch controls the analyzer and purge valves, gang 2 activates valves connected to manifold A, and gang 3 activates valves connected to manifold B.

Clockwise rotation of the switches results in the sampling sequence shown in Table 1. This sequence is such that successive samples are taken from opposite sides of the sampling pattern, and the outer orifices are sampled first.

The main ring assembly on the traverse probe system (Figure 3) rotates on a system of rollers. Two roller assemblies bear the weight of the ring, while two additional spring loaded roller assemblies aid in maintaining alignment of the ring. A separate system of four roller assemblies contacts the bearing ring located behind the main ring and bear the axial load due to the drag of the rakes in the exhaust stream.

Rotation of the main ring assembly is accomplished through a linear actuator consisting of a rotating screw and traveling nut. The screw is driven by a one-horsepower electric motor and a total linear travel of 43 inches produces 45 degree angular rotation.

The indicator assembly provides an angular position indication. A rack is brazed to the main ring assembly and engages a gear coupled to a potentiometer so that potentiometer rotation is proportional to ring rotation. The

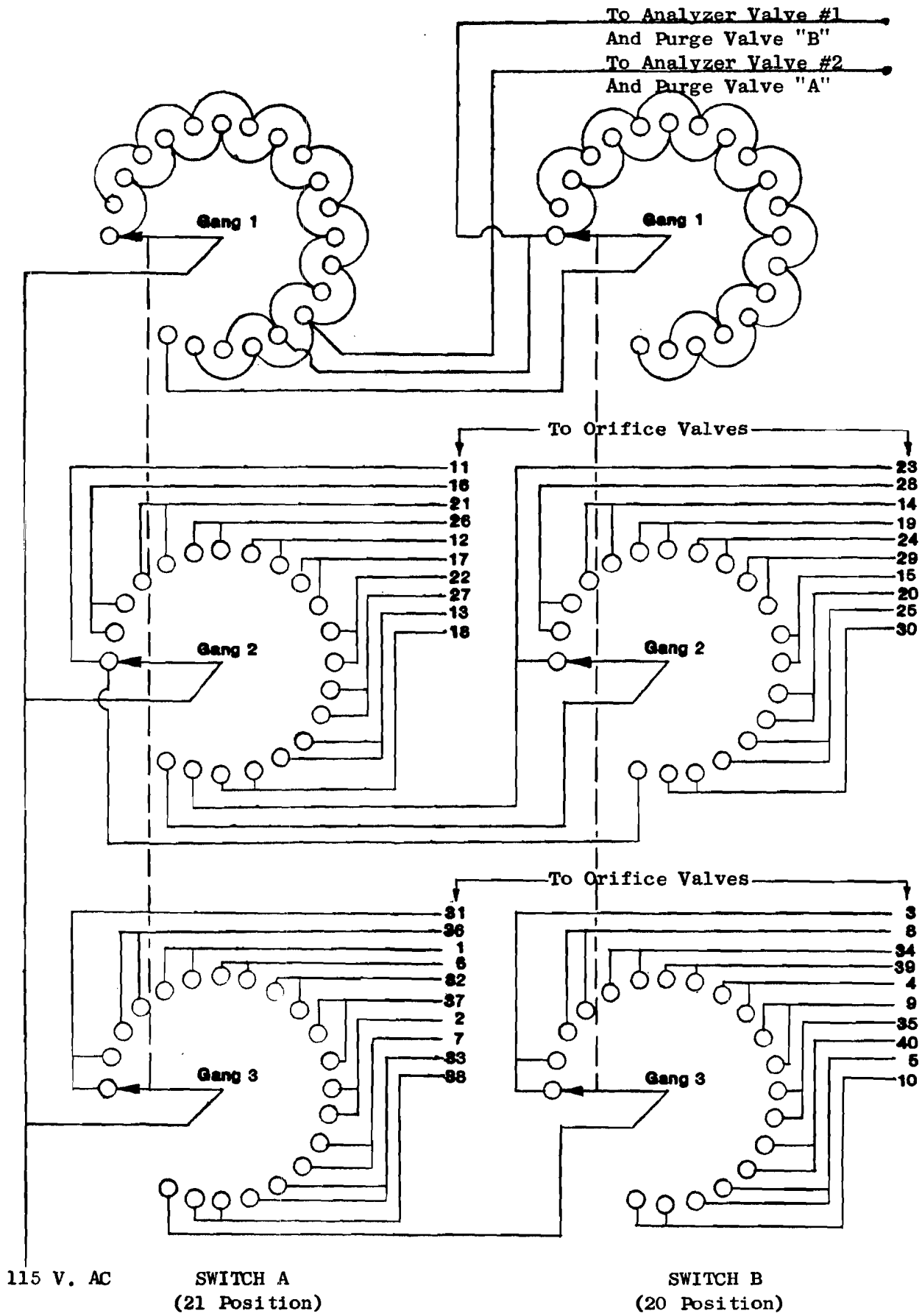

FIGURE 7. WIRING SCHEMATIC FOR SAMPLING SYSTEM SEQUENCING SWITCHES.

TABLE 1. VALVE SEQUENCING FOR TRAVERSE PROBE SYSTEM.

<u>Switch Position</u>		<u>Orifice To Gas Analyzer</u>	<u>Orifice To Purge</u>	<u>Open Analyzer Valve</u>	<u>Open Purge Valve</u>
<u>A</u>	<u>B</u>				
1	-	11	31	1	B
2	-	31	16	2	A
3	-	16	36	1	B
4	-	36	21	2	A
5	-	21	1	1	B
6	-	1	26	2	A
7	-	26	6	1	B
8	-	6	12	2	A
9	-	12	32	1	B
10	-	32	17	2	A
11	-	17	37	1	B
12	-	37	22	2	A
13	-	22	2	1	B
14	-	2	27	2	A
15	-	27	7	1	B
16	-	7	13	2	A
17	-	13	33	1	B
18	-	33	18	2	A
19	-	18	38	1	B
20	-	38	23	2	A
21	1	23	3	1	B
21	2	3	28	2	A
21	3	28	8	1	B
21	4	8	14	2	A
21	5	14	34	1	B
21	6	34	19	2	A
21	7	19	39	1	B
21	8	39	24	2	A
21	9	24	4	1	B
21	10	4	29	2	A
21	11	29	9	1	B
21	12	9	15	2	A
21	13	15	35	1	B
21	14	35	20	2	A
21	15	20	40	1	B
21	16	40	25	2	A
21	17	25	5	1	B
21	18	5	30	2	A
21	19	30	10	1	B
21	20	10	11	2	A

potentiometer output is connected to a digital voltmeter on the control panel, and the voltage is selected so that the meter reads the rake position directly in degrees.

Figure 8 shows the traverse probe system mounted behind the engine in the test cell. The cell augmentor is in the background. Parts of the traverse probe system may be identified by reference to Figure 3. Figure 9 is a view showing the traverse probe sampling orifices and the CF6-50 core engine exhaust nozzle.

3.4 EMISSION ANALYSIS SYSTEM

The sample gas is pumped to the gas analysis system as indicated in Figure 6. The analysis system consists of four separate instruments, manufactured by Beckman Instruments, Inc. The CO (Model 865) and CO₂ (Model 864) analyzers are nondispersive infrared instruments. The NO/NO_x analyzer is a Model 951 heated chemiluminescent analyzer with thermal converter, and the HC analyzer is a Model 402 flame ionization instrument. These instruments conform to the EPA requirements for measurement of emissions from aircraft gas turbine to engines as specified in Title 40, Code of Federal Regulations, Part 87 (Ref. 1).

As shown in Figure 10, two standard relay racks house the four gas analyzers along with the readout devices, flowmeters, flow control valves, and solenoid operated calibration gas valves. Two double-pen recorders provide a permanent and continuous record of the instrument outputs. The actual test values are more quickly and conveniently read from a digital millivoltmeter which is switched from one analyzer output to the other.

The gaseous emission analyzers were calibrated with certified mixtures of propane in air, CO, and CO₂ in nitrogen, and NO in nitrogen. Each analyzer was calibrated with four separate mixtures in concentrations such as to cover the range of concentrations of gas samples from the engine. Each calibration gas was certified by the vendor to an accuracy of 2 percent of the concentration. In addition, the calibration gases were compared at General Electric to Standard Reference Material (SRM) mixtures which are obtained from the National Bureau of Standards and are certified accurate within 1 percent. A complete calibration was performed before and after each engine

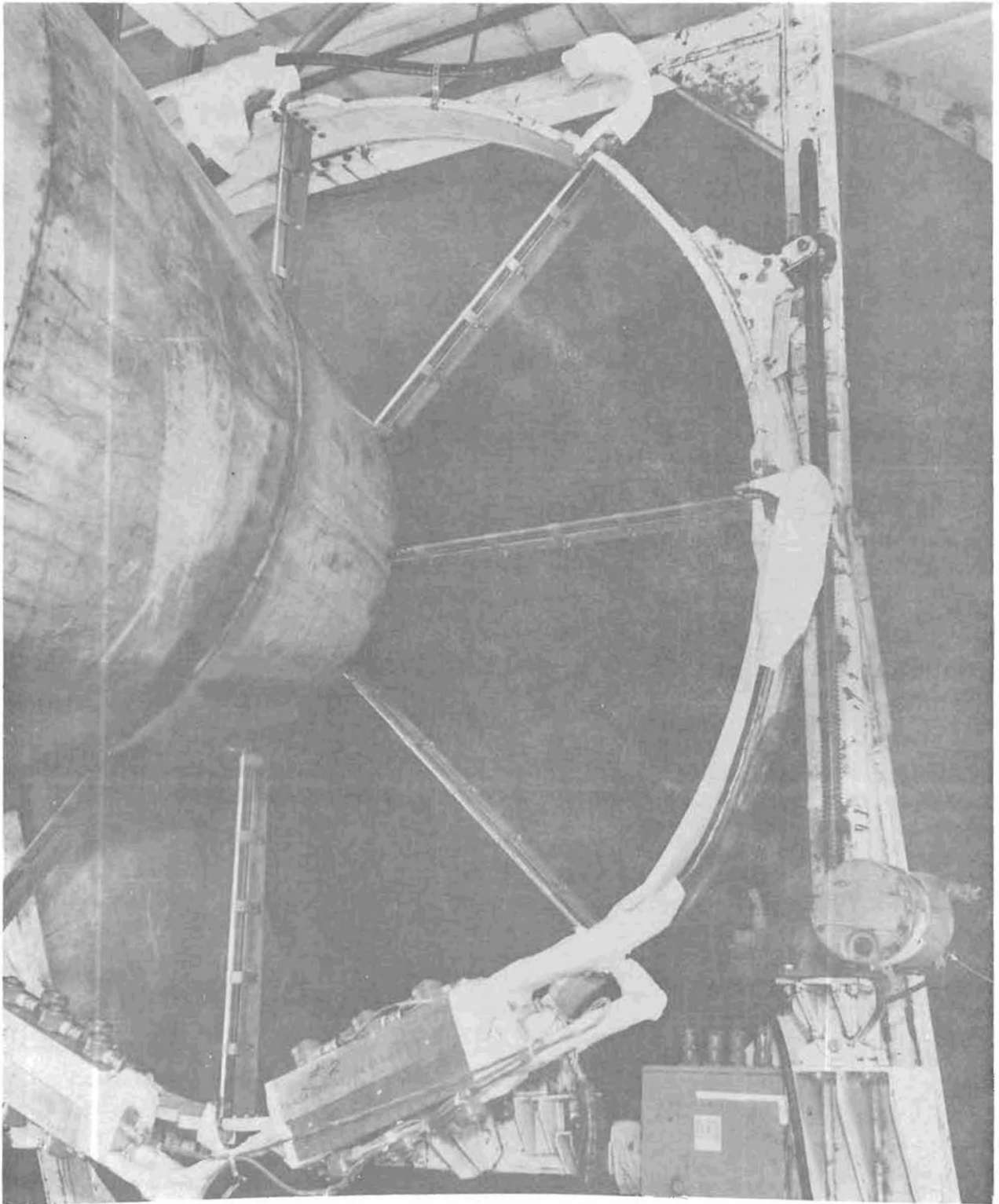

FIGURE 8. TRAVERSE PROBE SYSTEM MOUNTED BEHIND CF6-50 ENGINE IN TEST CELL.

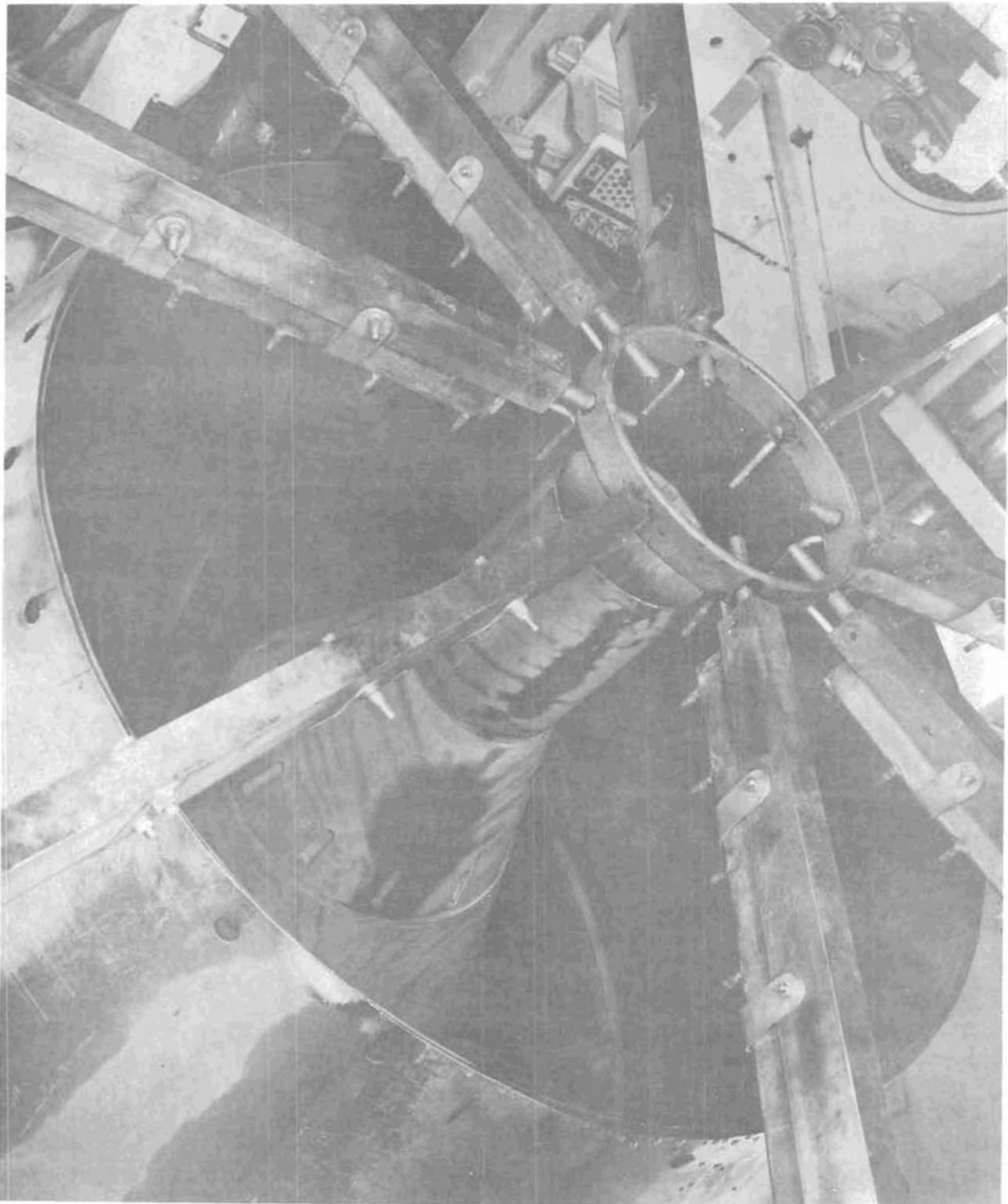

FIGURE 9. TRAVERSE PROBE SAMPLING ORIFICES IN POSITION TO SAMPLE CF6-50 EXHAUST.



FIGURE 10. EMISSIONS ANALYSIS SYSTEM.

test. During the course of each test, the zero and span on each instrument were checked at approximately one-hour intervals.

3.5 EMISSION DATA REDUCTION PROCEDURES

For each individual gas sample obtained, concentrations of CO, CO₂, HC, and NO_x were calculated from the output of each analyzer along with the analyzer calibration data. Since an ice trap was used in the sample line before the CO and CO₂ analyzers, the concentrations of CO and CO₂ are semi-dry (contain 0.6% water vapor). Samples to the HC and NO_x analyzers are not dried and thus are "wet"; i.e., they contain the true exhaust water vapor concentration.

From the concentrations of the four species, emission indices, fuel-air ratio, and combustion efficiency were calculated for each sample. The calculation procedure used for these parameters is consistent with the method given in SAE ARP1256A (Reference 3). One exception to the SAE procedure was that the HC emission index is calculated as methane, as specified by the EPA (Reference 1) rather than as fuel, as per the SAE procedure.

The emission parameters (concentrations, emission indices, etc.) are stored in the time-share computer system along with the circumferential and radial location of each sample. These data can be accessed and used to construct data tables or used in various kinds of computer plotting routines.

4.0 TRAVERSE PROBE EMISSION TESTS

The emission tests were run on August 15, 1980 (idle and 30% power) and on August 18, 1980 (85% power), with a complete 120-point traverse made at each power condition. Jet A fuel was used for all tests. This section of the report describes the emission test procedure and presents the test data.

4.1 TEST PROCEDURE

From 3 to 4 hours of continuous engine operation were required at each power setting. The longer time was needed at idle power where the HC analysis required additional time for equilibration following the very large changes in HC concentrations. The same throttle setting was maintained throughout each test since it was decided that this was the best way to minimize the effects of changes in ambient conditions during a particular test run. The normal ground idle power setting (approximately 6300 rpm corrected core speed) was used for the idle test point. Corrected fan speed settings of 2309 and 3477 rpm were used for the 30 and 85% power settings, respectively. These latter speeds correspond to the specified thrust settings, as determined by the most recent CP6-50C2 engine cycle, based on production engine performance.

The normal test procedure involved first the calibration of the analysis instrumentation as well as heat-up and checkout of the sampling system. The engine was then started and operational checks were made. This was followed by acceleration to the appropriate power setting and stabilization at that setting. Following engine stabilization, emission readings were started. With the probe system in its initial position, the 40 orifices were each sampled in the sequence shown in Table 1. The ring structure was then rotated 15 degrees and the sequence was repeated. The structure was then rotated an additional 15 degrees and the sequence was repeated a third time for a total of 120 samples.

During the emission sampling, a complete reading of engine parameters was made on the Automatic Data Handling (ADH) system at approximately 1/2-

hour intervals. Span and zero checks of the emission analysis instruments were made at approximately one-hour intervals.

4.2 ENGINE TEST DATA

A summary of important engine test parameters is given in Table 2. A list of nomenclature for this table follows:

XNL	(rpm)	-	fan speed
XNH	(rpm)	-	core speed
FN	(lb)	-	net thrust
FNK	(lb)	-	corrected net thrust
BARO	(psia)	-	barometric pressure
HUM	(gr/lb)	-	humidity
T ₂	(° F)	-	engine inlet temperature
P ₂	(psia)	-	engine inlet pressure
W ₂	(pps)	-	engine airflow
T ₃	(° F)	-	combustor inlet temperature
P ₃	(psia)	-	combustor inlet pressure
W ₃₆	(pps)	-	combustor airflow
WFE	(pph)	-	engine fuel flow
FAR4		-	fuel-air ratio at combustor exit
FAR8		-	fuel-air ratio at core exhaust nozzle
Fuel T.	(° F)	-	fuel temperature at fuel flow meter
FMP	(psia)	-	fuel manifold pressure

All engine test parameters listed in Table 2 are measured or corrected values except for W₃₆, FAR4, and FAR8 which are calculated based on analysis of core engine performance.

As may be noted in Table 2, engine operation was quite stable throughout the idle and 30% power test points. However, near the completion of the 85% power test point, a rainshower occurred. This was accompanied by a decrease in ambient temperature, which resulted in an increase in engine fuel flow and thrust.

Fuel analysis results are given in Table 3 and compared to the Jet A specification. The analysis was performed in the Evendale Plant fuels lab

TABLE 2. ENGINE TEST DATA.

CF6-50 Traverse Probe Tests - ESN 455-507/19 - Jet A Fuel - Cell 2

Date	PWR	Time of Day	ADH Rdg.	XNL (rpm)	XNH (rpm)	FN (lb)	FNK (lb)	Baro (psis)	HUM (gr/lb)	T ₂ (° F)	P ₂ (psia)	W ₂ (pps)	T ₃ (° F)	P ₃ (psia)	W ₃₆ (pps)	WFE (pph)	FAR4	FAR8	Fuel T. (° F)	FMP (psia)	
8/15/80	GIDL	13:58	240	835	6465	1763	1800	14.414	96	74.8	14.397	273.6	336.6	42.8	29.3	1447	0.01390	0.01136	77.9	260	
		14:30	241	836	6470	1755	1792	14.411	96	75.9	14.395	268.5	337.7	42.8	29.3	1447	0.01392	0.01137	78.2	260	
		15:00	242	836	6468	1758	1795	14.407	95	75.3	14.392	269.5	337.9	42.8	29.3	1447	0.01390	0.01136	78.0	260	
		15:30	243	836	6468	1754	1791	14.406	95	75.7	14.390	258.7	337.9	42.8	29.3	1442	0.01385	0.01132	78.2	260	
		16:03	244	835	6467	1755	1793	14.400	91	75.7	14.384	261.2	338.0	42.7	29.3	1442	0.01387	0.01134	78.2	260	
		16:31	245	836	6469	1760	1799	14.395	91	75.7	14.378	269.2	338.2	42.8	29.2	1447	0.01393	0.01138	77.9	260	
		17:01	246	836	6472	1752	1790	14.398	92	76.1	14.383	271.6	338.5	42.8	29.2	1447	0.01393	0.01138	78.4	260	
		17:30	247	835	6467	1753	1791	14.402	92	76.3	14.386	274.6	338.8	42.7	29.2	1447	0.01394	0.01140	78.5	260	
		Average	---	---	836	6468	1756	1794	14.404	94	75.7	14.388	268.4	338.0	42.8	29.3	1446	0.01391	0.01136	78.2	260
		8/15/80	30%	19:37	249	2354	8880	15072	15511	14.407	85	75.3	14.289	815.6	704.1	162.9	97.8	5543	0.01594	0.01303	77.9
20:05	250			2357	8880	15171	15621	14.409	85	74.3	14.273	815.0	703.7	163.5	98.1	5575	0.01597	0.01305	77.5	440	
20:35	251			2360	8880	15231	15679	14.414	84	73.8	14.276	817.8	702.7	164.1	98.5	5607	0.01601	0.01308	77.2	440	
21:10	252			2361	8880	15273	15714	14.418	84	73.6	14.284	819.6	702.4	164.2	98.5	5609	0.01600	0.01309	76.3	440	
21:38	253			2360	8880	15271	15707	14.424	84	73.8	14.288	817.5	703.0	164.3	98.6	5610	0.01599	0.01307	76.9	440	
22:00	254			2361	8880	15271	15705	14.426	84	73.8	14.290	816.1	702.5	164.3	98.6	5608	0.01599	0.01307	76.9	440	
Average	---			2359	8880	15214	15656	14.416	84	74.1	14.283	816.9	703.1	163.9	98.4	5592	0.01598	0.01307	77.0	440	
9/18/80	85%			12:06	259	3537	10129	39781	41433	14.454	115	85.8	14.110	1271	1019	336.4	171.8	15674	0.02576	0.02105	84.0
		12:30	260	3528	10129	39479	41124	14.454	115	86.7	14.108	1266	1020	333.9	170.4	15597	0.02585	0.02112	84.9	775	
		13:02	261	3532	10129	39554	41226	14.447	115	87.1	14.100	1266	1021	335.8	171.5	15607	0.02569	0.02099	86.2	775	
		13:37	262	3527	10129	39223	40878	14.442	115	88.5	14.101	1260	1022	333.6	170.6	15443	0.02556	0.02089	86.8	775	
		14:13	263	3563	10129	40851	42599	14.447	123	80.6	14.093	1292	1016	345.9	176.9	16074	0.02568	0.02099	85.2	775	
		14:46	264	3608	10131	42489	44335	14.452	105	74.1	14.084	1322	1022	356.7	181.3	16825	0.02616	0.02138	81.9	775	
		Average	---	3549	10129	40230	41933	14.449	115	83.8	14.099	1280	1020	340.4	173.8	15870	0.02578	0.02107	84.8	775	

TABLE 3. JET A FUEL ANALYSIS.

Sample No. 9536

Sample Date 8/15/80

Cell 2

Engine CF6-50 455-507/19

	<u>Fuel Sample</u>	<u>Specification ASTM D 1655-79</u>	
		<u>Min</u>	<u>Max</u>
Specific Gravity	0.8090	0.7753	0.8398
Net Heat of Combustion, Btu/lb	18,559	18,400	-
Hydrogen, % by wt.	13.94	-	-
Sulfur, % by wt.	0.080	-	0.3
Hydrogen to Carbon atom ratio	1.932	-	-

by standard analytical methods. Specific gravity was measured by the hydrometer method (ASTM D 1298), net heat of combustion by precision bomb (ASTM D 2382), hydrogen by the lamp method (ASTM D 1018), and sulfur by the lamp method (ASTM D 1266).

4.3 EMISSION TEST DATA

A complete tabulation of emission data from the 120-point traverse at each of the three power settings is given in the Appendix to this report. This tabulation includes concentrations and emission indices (EI) for CO, HC, and NO_x, along with fuel-air ratio and combustion efficiency.

Table 4 gives a summary of emission data from each of the 120-point traverses. Included in this tabulation are the average values, standard deviation, and coefficient of variation. The coefficient of variation (CV%) is the standard deviation divided by the average, expressed in percent. Also listed in Table 4 are area-weighted averages and, for emission indices, the overall average. The overall average emission level (EI) is calculated from the average concentrations while the average EI is the average of the individual values. It might be noted that the area-weighted averages in Table 4 are generally higher than the corresponding average. This is due to the fact that the radial profiles are generally peaked toward the outside as will be shown in a later section of this report, while the sampling points are evenly spaced along a radius. The fuel-air ratio calculated from engine parameters (average FAR8 in Table 2) is also listed in Table 4. This value is in excellent agreement (within 3%) of the area-weighted gas sample fuel-air ratio at all power levels.

4.3.1 Circumferential Distribution

Fuel-air ratio, concentrations, and EI's have been plotted against circumferential sample location at each radial position. In these plots, circumferential position is measured in degrees clockwise, aft looking forward. It should be noted that previous sketches of the traverse probe (Figures 3 and 6) were forward looking aft.

TABLE 4. SUMMARY OF DATA FROM 120-POINT TRAVERSE.

Power Setting	Parameter	Avg.	Std. Dev.	CV%	Area Weighted Avg.	Overall Avg.	Engine FAR8
Idle	CO, ppm	768.9	49.0	6.4	776.0	-	0.01136
	HC, ppm	913.2	247.9	27.1	912.5	-	
	NO _x , ppm	14.9	1.9	12.8	15.2	-	
	EICO	64.7	6.65	10.3	64.3	64.3	
	EIHC	46.1	13.4	29.1	45.4	45.4	
	EINO _x	2.12	0.11	5.2	2.12	2.13	
	FAR	0.01150	0.00093	8.1	0.01169	0.01150	
30%	CO, ppm	32.6	7.2	22.1	33.1	-	0.01307
	HC, ppm	5.6	5.1	91	6.2	-	
	NO _x , ppm	78.0	4.6	5.9	78.8	-	
	EICO	2.39	0.56	23.4	2.40	2.38	
	EIHC	0.24	0.22	92	0.27	0.24	
	EINO _x	9.72	0.36	3.7	9.71	9.71	
	FAR	0.01316	0.00063	4.8	0.01331	0.01316	
85%	CO, ppm	23.5	4.1	17.4	22.8	-	0.02107
	HC, ppm	0.61	0.54	88.5	0.59	-	
	NO _x , ppm	277.4	17.0	6.1	279.6	-	
	EICO	1.09	0.20	18.3	1.05	1.09	
	EIHC	0.02	0.02	100	0.02	0.02	
	EINO _x	22.46	1.01	4.5	22.48	22.47	
	FAR	0.02053	0.00078	3.8	0.02068	0.02053	
CV% = 100 x Std. Dev./Avg.							

Examination of these circumferential profiles reveals some interesting characteristics, particularly at idle power. Figure 11 shows the circumferential fuel-air ratio distribution at idle power and indicates rather uniform fuel-air ratio, except for the peak near 255°, and a slight radial trend, with fuel-air ratio increasing with radial distance from the center. The fuel-air ratio peak is apparently due to the three adjacent fueled nozzles at the ignitors in the otherwise alternate fueled configuration (see Figure 2). The fueled nozzle locations are indicated in Figure 11. The peak in the fuel-air ratio is displaced about 90° clockwise from its location at 138° in the combustor, due to the overall rotation of the exhaust which occurs in passing through the clockwise rotating low pressure and high pressure turbines.

Figure 12 shows the circumferential variation in CO concentration. The overall variation in CO is from a minimum of 627 ppm to a maximum of 872 ppm. The minimum CO concentration occurs at an angular location of about 225° which corresponds to the location of the maximum fuel-air ratio. As is the case with the fuel-air ratio, considerably greater changes in CO concentration occur at the outer radial positions as compared to the inner positions.

Figure 13 shows the circumferential variation in HC concentration at idle power. As with CO, the minimum in HC concentration occurs near 225° where the fuel-air ratio is a maximum. The relative variation in HC is much larger than either CO or fuel-air ratio with overall variation from 285 to 1553 ppm. Examination of the Figure 13 data points reveals an apparent cyclical variation with three maxima and minima around the circumference. In addition, the maxima and minima at one radial location are displaced clockwise with respect to the maxima and minima at the next larger radial location. This holds true for all except the inner radial location where maxima and minima are not discernible.

Figure 14 shows the NO_x circumferential distribution at idle power level. The overall variation is similar to that of fuel-air ratio (Figure 11) with the rather prominent peak at 225°. The fuel-air ratio maximum due to the three adjacent fueled nozzles at idle power level thus results in a corresponding maximum in NO_x concentration, and minima in CO and HC. The plots of

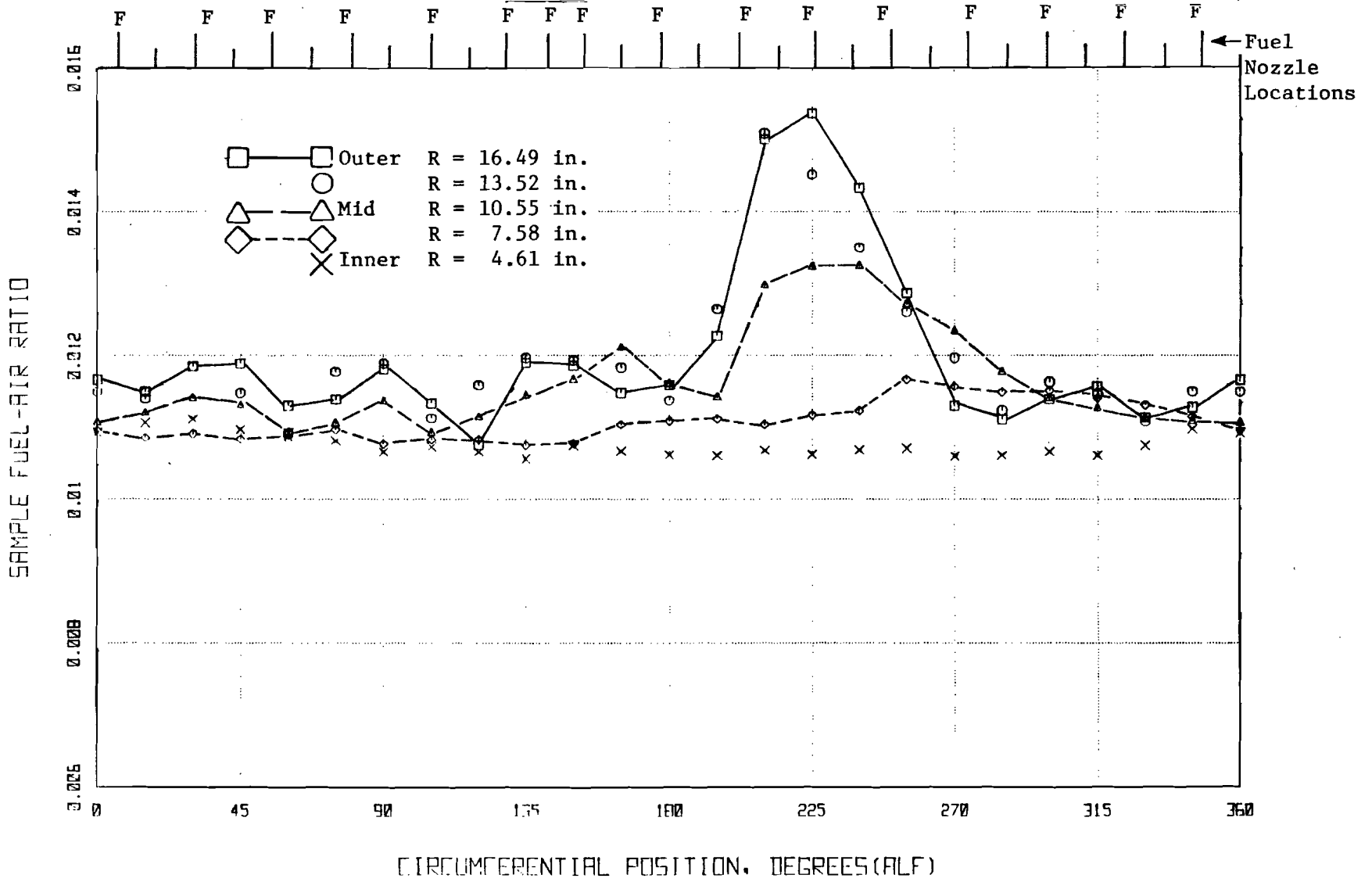

FIGURE 11. FUEL-AIR DISTRIBUTION AT IDLE POWER.

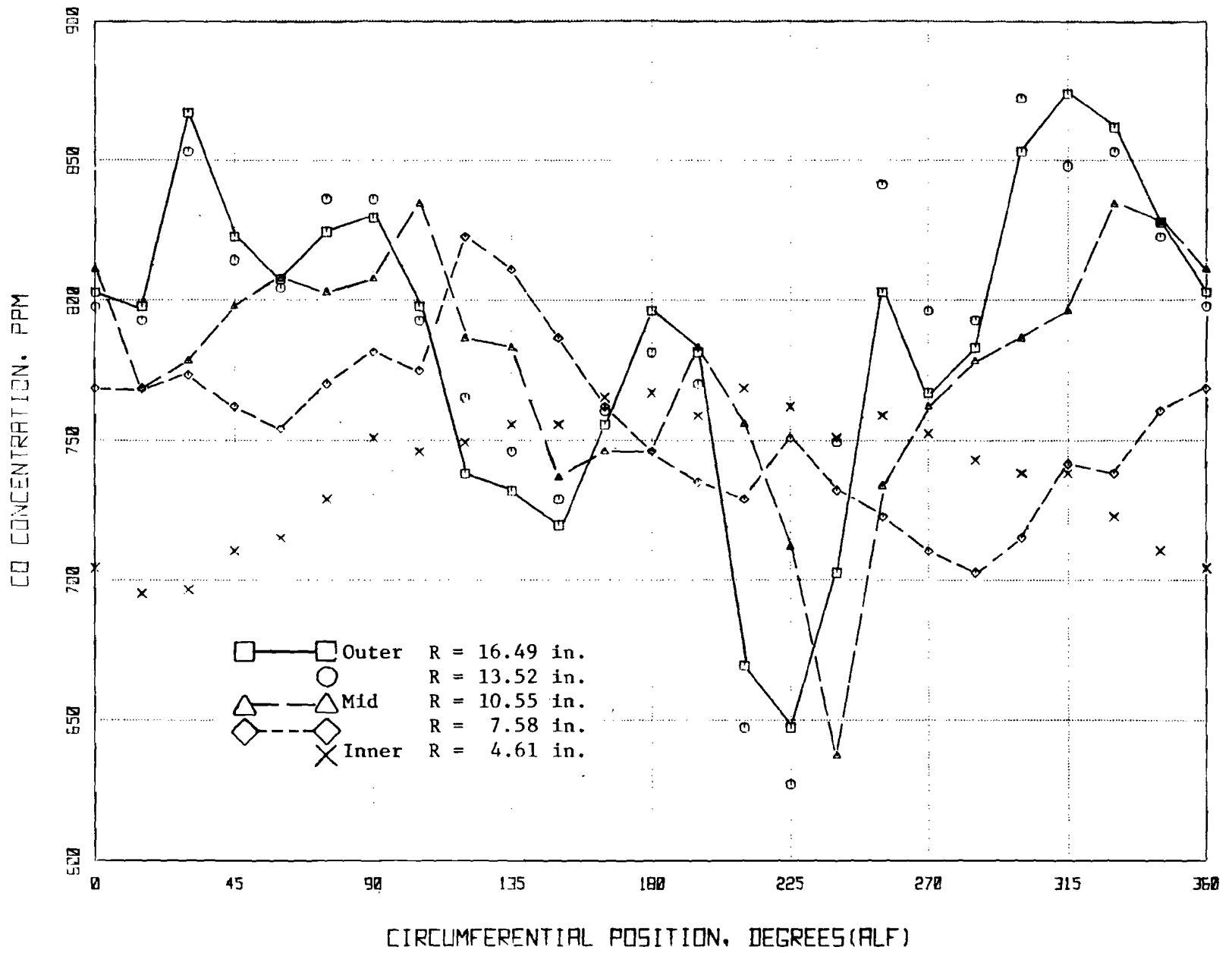

FIGURE 12. CO CONCENTRATION DISTRIBUTION AT IDLE POWER.

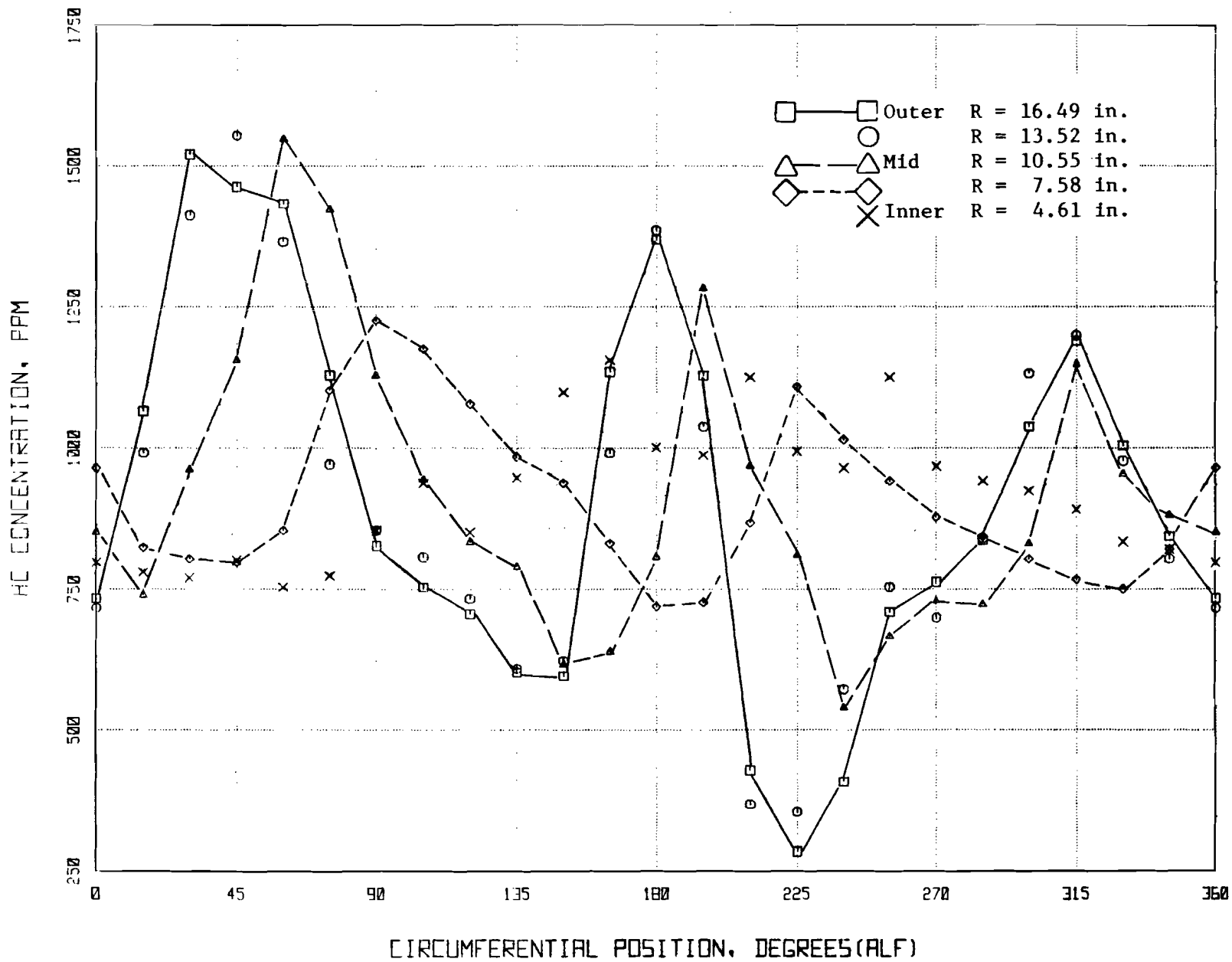

FIGURE 13. HC CONCENTRATION DISTRIBUTION AT IDLE POWER.

EI against circumferential location show generally the same variation as the corresponding concentration and thus the EI plots are not presented here.

Figure 15 shows the circumferential variation in fuel-air ratio at 30% power level. No features are apparent except for the slight radial profile which peaks somewhat outside the radial center. Both the CO and HC concentration distribution at 30% power level (Figures 16 and 17) contain maxima near 180° but no reason for this is apparent, and no significant variation in fuel-air ratio occurs at this location. Figure 18 shows the circumferential variation in NO_x concentration at 30% power. No significant circumferential features are noted, and the radial trend is similar to that of fuel-air ratio.

Figure 19 shows the circumferential variation in fuel-air ratio at 85% power. The overall distribution is quite uniform, with coefficient of variation only 3.8% for the entire 120-point traverse. Much of the overall variation is due to the characteristic radial profile which peaks somewhat outside the radial center. Figure 20 shows the circumferential variation in CO concentration at 85% power. The distribution is quite uniform with no significant features. Figure 21 shows the circumferential variation in NO_x concentration at 85% power. No significant circumferential features are apparent and the radial profile is similar to that of the fuel-air ratio.

4.3.2 Radial Distribution

Fuel-air ratio and concentrations have been plotted against radial position (inches from engine centerline) at selected circumferential locations. The circumferential locations selected were at 45°, 135°, 225° and 315° clockwise, aft looking forward. These locations were chosen so as to closely examine the radial variation at idle power near the peak in the circumferential fuel-air distribution which was located near 225°. In addition, these four circumferential locations coincide with the positions of the four arms on the standard General Electric CF6 manifolded sampling rake, which was used in a previously conducted FAA-sponsored program (Reference 4).

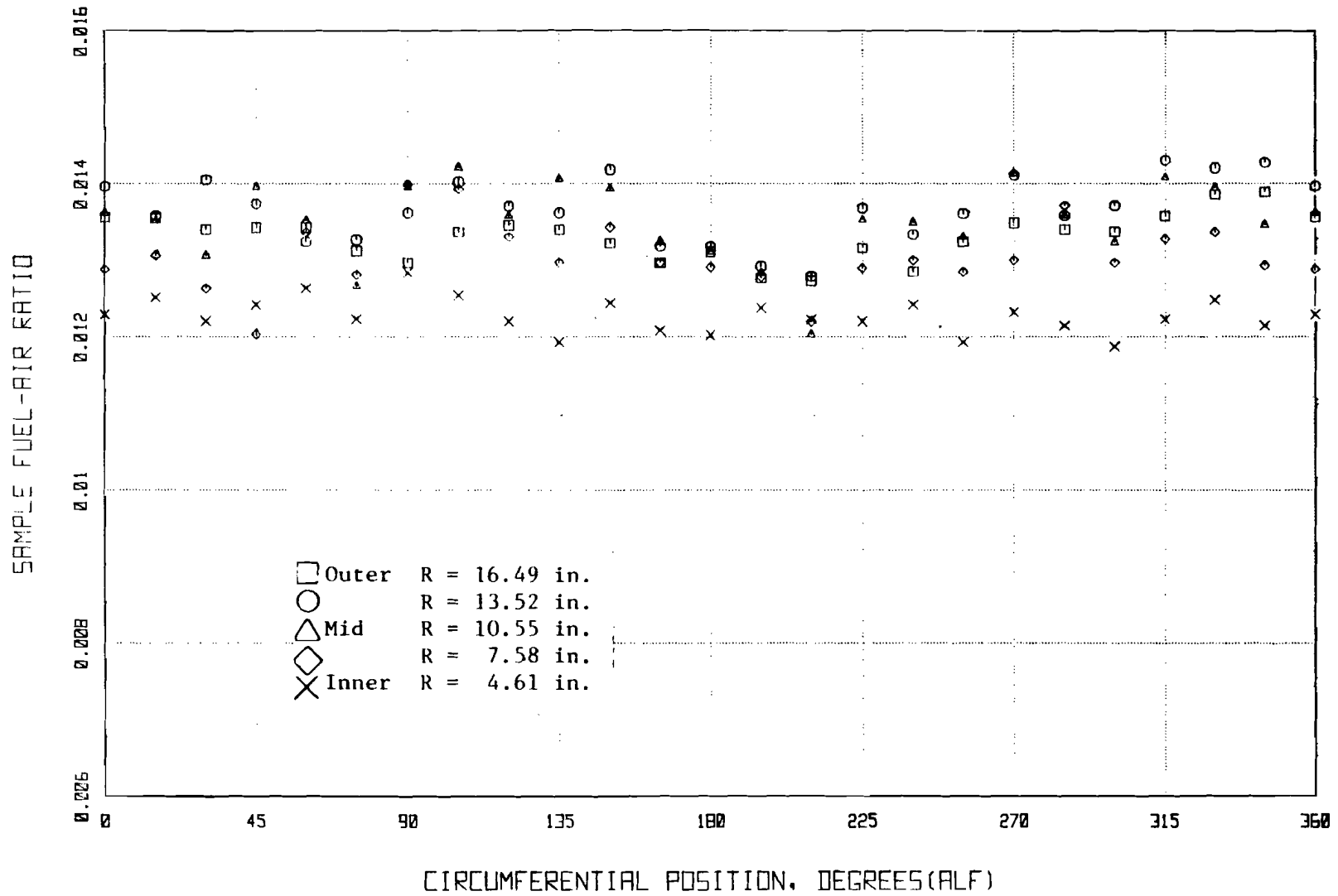

FIGURE 15. FUEL-AIR DISTRIBUTION AT 30 PERCENT POWER.

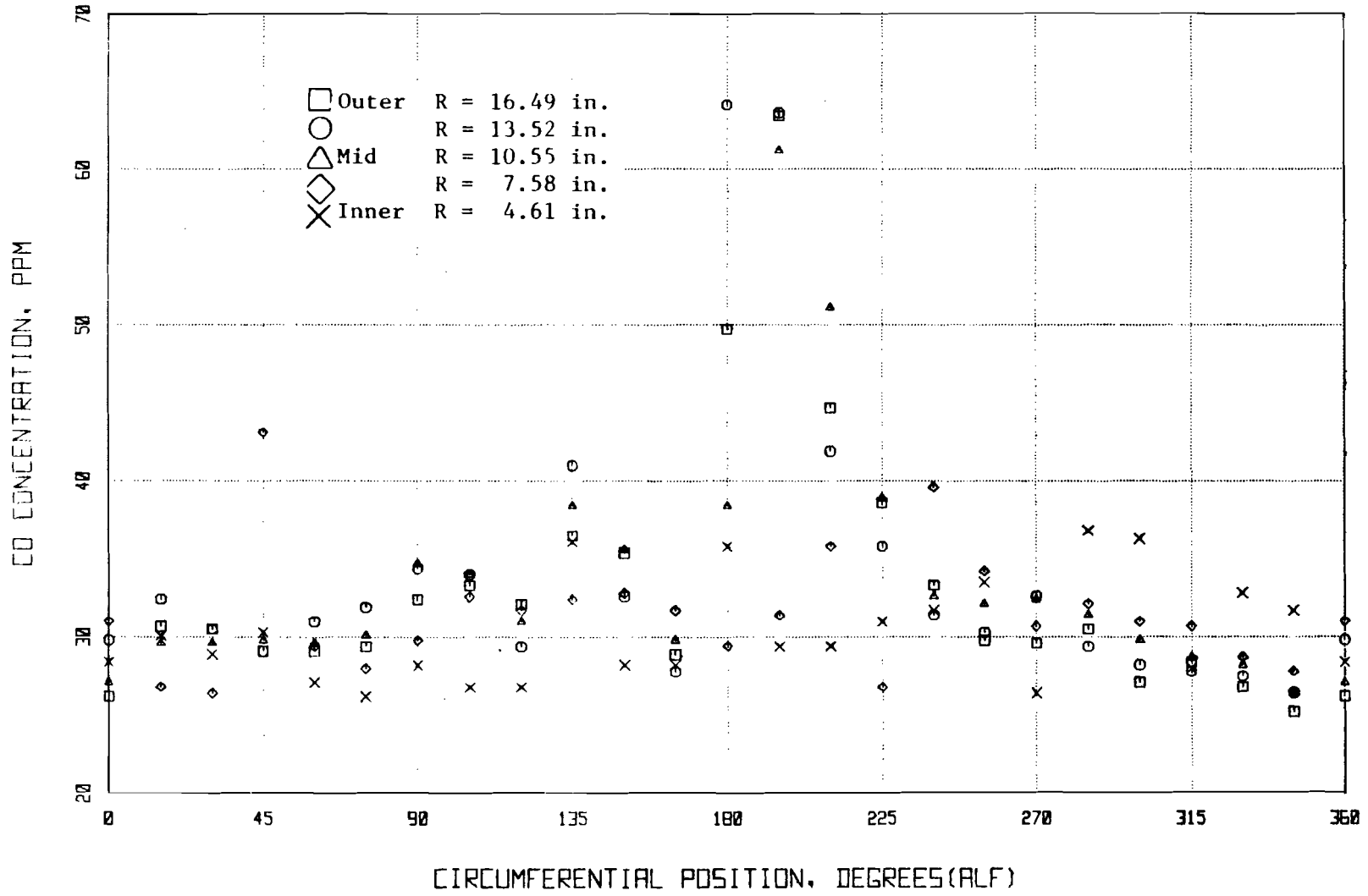

FIGURE 16. CO DISTRIBUTION AT 30 PERCENT POWER.

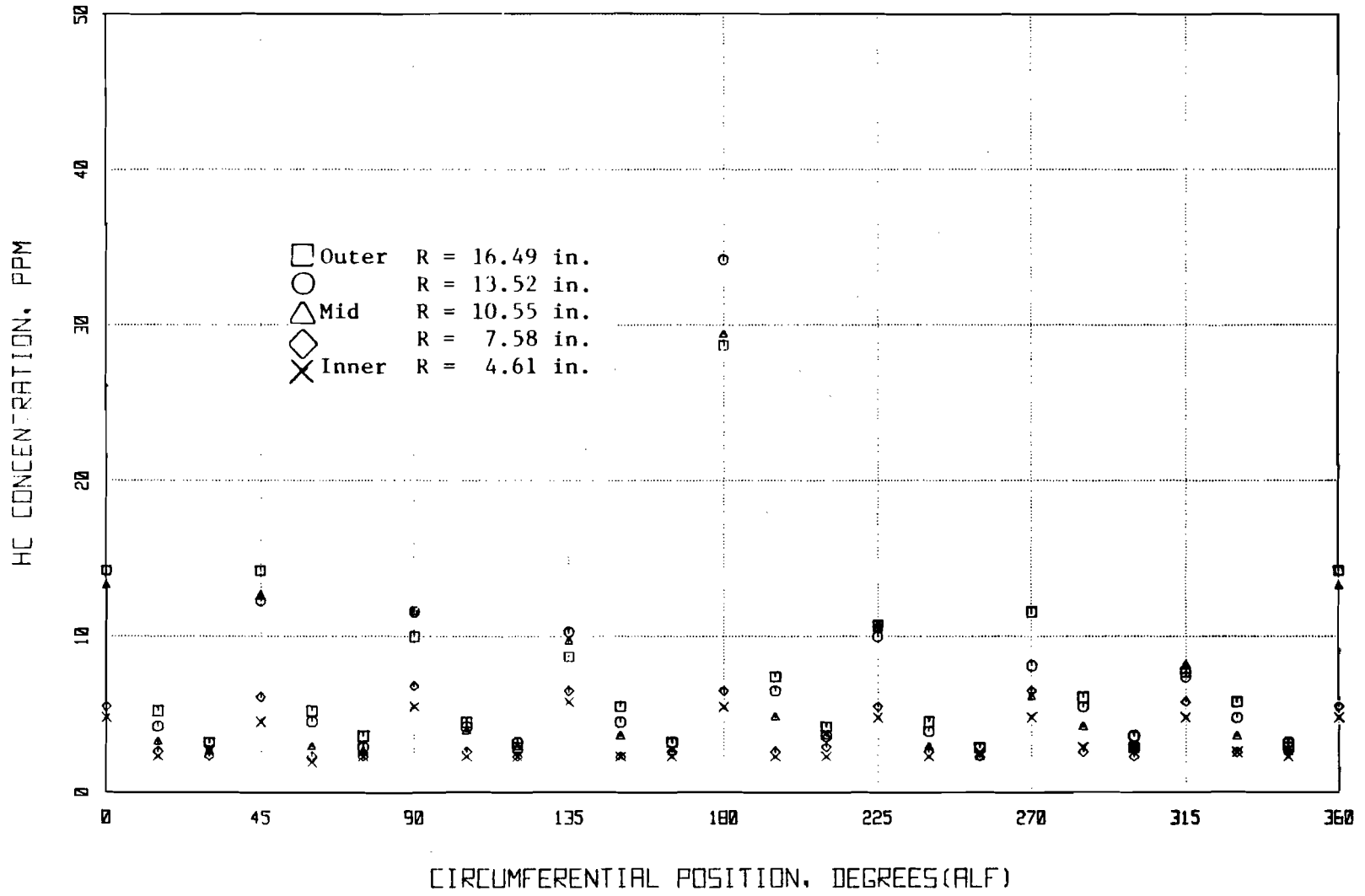

FIGURE 17. HC DISTRIBUTION AT 30 PERCENT POWER.

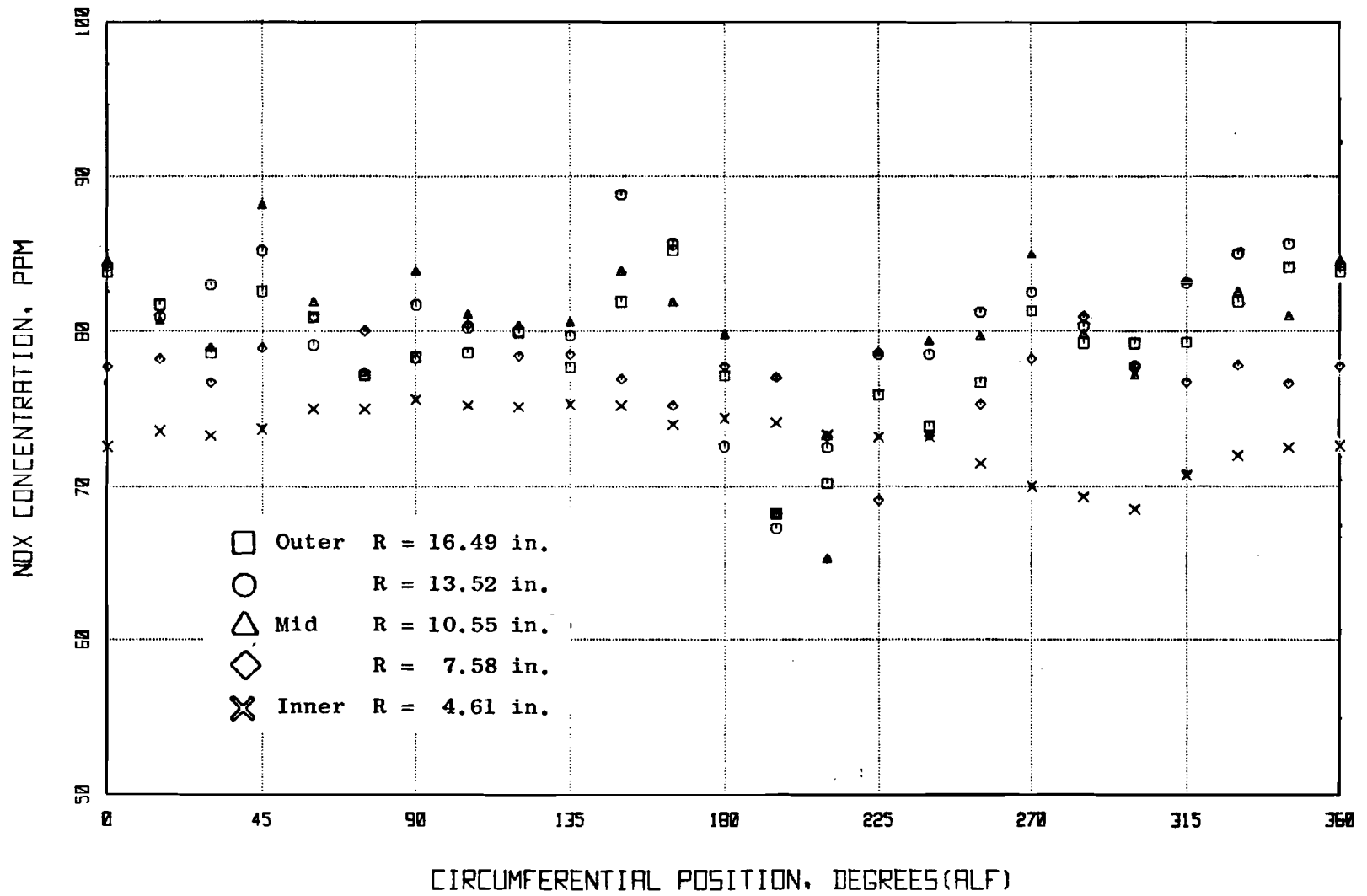

FIGURE 18. NO_x CONCENTRATION DISTRIBUTION AT 30 PERCENT POWER.

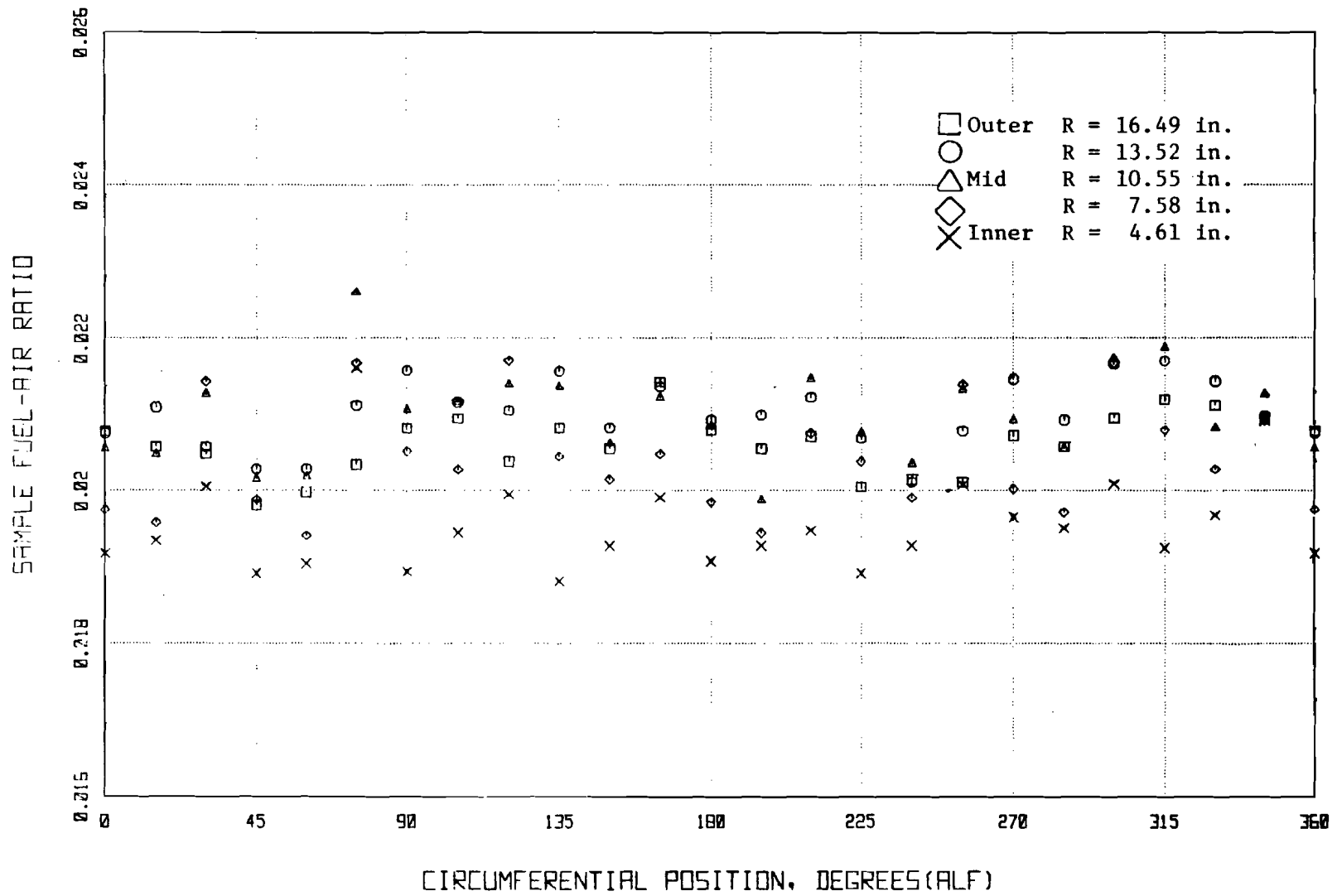

FIGURE 19. FUEL-AIR RATIO DISTRIBUTION AT 85 PERCENT POWER.

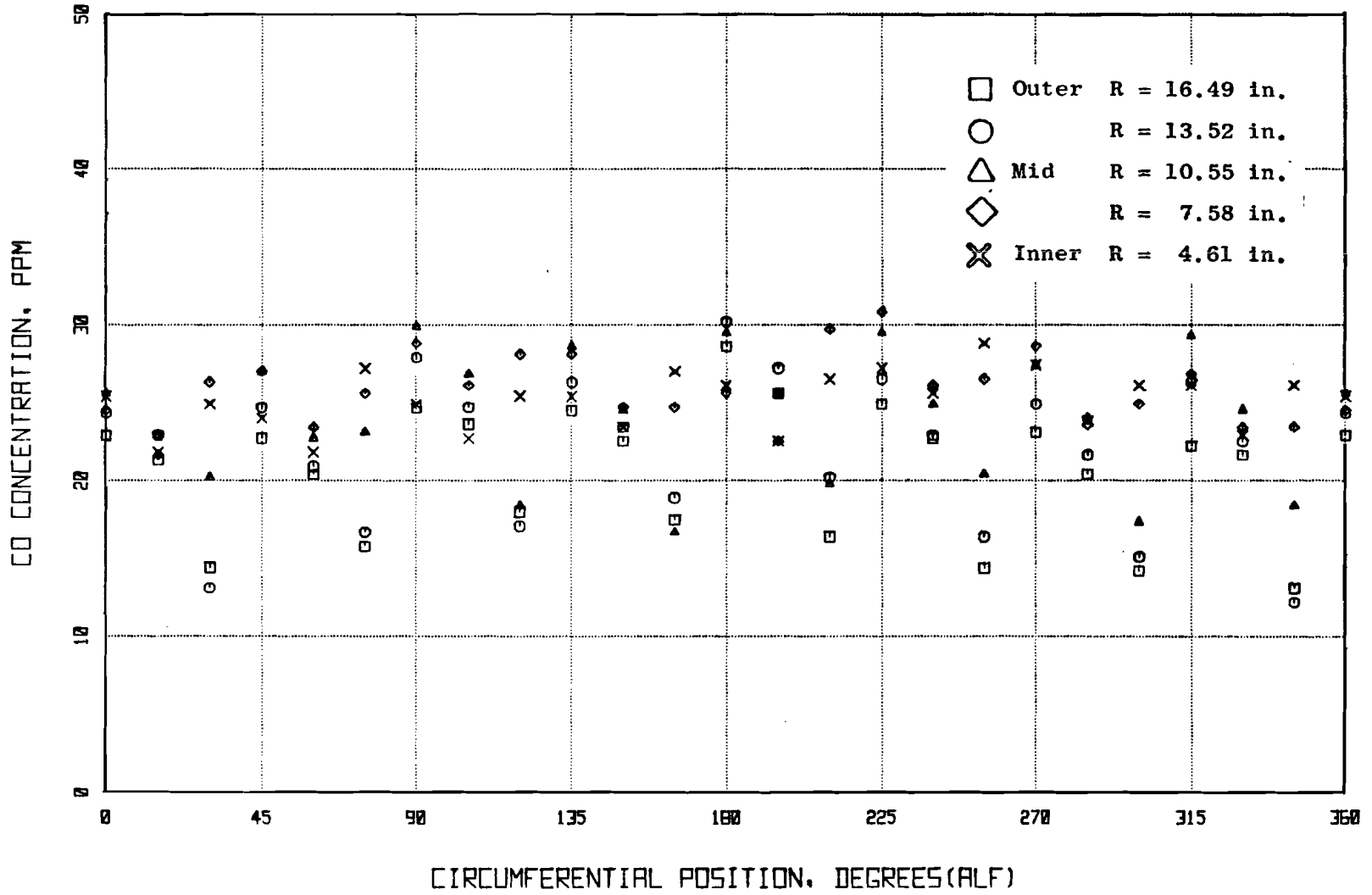

FIGURE 20. CO CONCENTRATION DISTRIBUTION AT 85 PERCENT POWER.

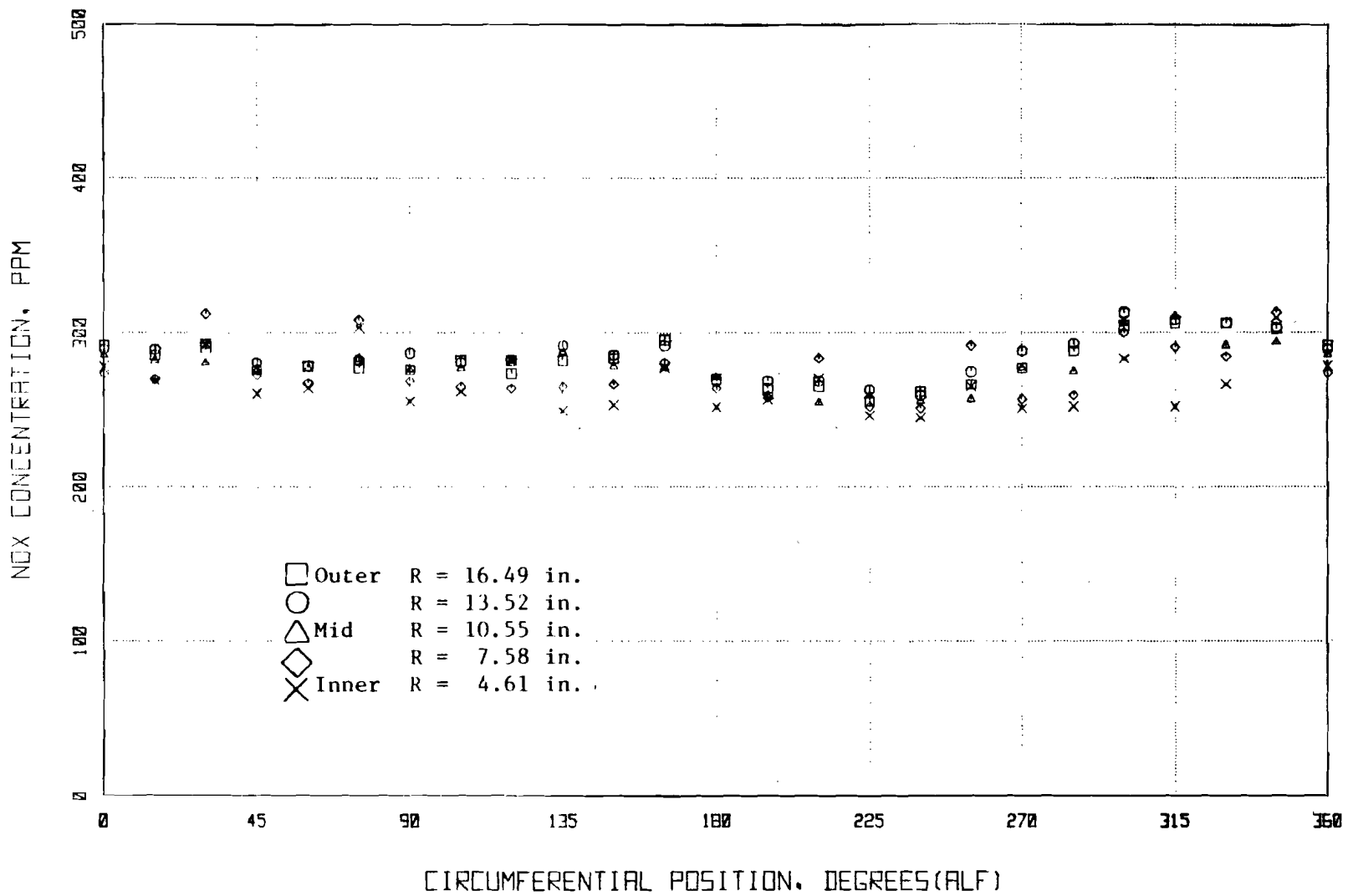

FIGURE 21. NO_x DISTRIBUTION AT 85 PERCENT POWER.

Figure 22 shows radial profiles of fuel-air ratio and pollutant concentrations at idle power level and at the four selected circumferential locations. Fuel-air ratio is relatively constant at each circumferential location except at the 225° location where the fuel-air ratio increases sharply with radial distance from the engine centerline. As noted previously, the variation in this area is due to the combustor fueling pattern which results in a corresponding increase in NO_x concentration and a decrease in CO and HC. In general, CO is relatively constant, as had been noted on the circumferential plots, while wide variations occur in HC. Except at 225°, the HC variations are apparently not associated with variations in fuel-air ratio.

Figure 23 shows the radial profiles at the 30% power level. Few significant features are noted on these plots except for the tendency for the fuel-air profiles to peak somewhat outside of the radial midpoint, and a similar tendency in NO_x concentration. The variation in CO and HC appear not to be related to the fuel-air ratio variation, except for the 45° location where the minimum in fuel-air ratio at the 7.5-inch radial position may be associated with the CO peak at the same position.

In Figure 24, the radial profiles are plotted for the 85% power level. Here the peaked fuel-air profiles are most obvious, with the maximum consistently occurring between 10 and 14 inches radially. The NO_x profiles are similar to the fuel-air profiles both in relative magnitude and in the location of the maximum. The CO profiles are also peaked but the maxima are generally somewhat inboard of the corresponding peak in fuel-air ratio.

4.3.3 Concentration and Fuel-Air Ratio Isopleths at Idle Power

As was noted in previous sections of this report, large variations in fuel-air ratio, CO and HC over the exhaust area occurred only at idle power. In order to more graphically illustrate these variations, contour maps have been prepared. Figure 25 shows the iso-concentration plot for HC at idle power. The three maxima which were observed in the circumferential plot (Figure 13) appear as lobes on the isopleth at 45°, 180° and 315°. The trough at 220° is coincident with the CO trough and the fuel-air ratio peak.

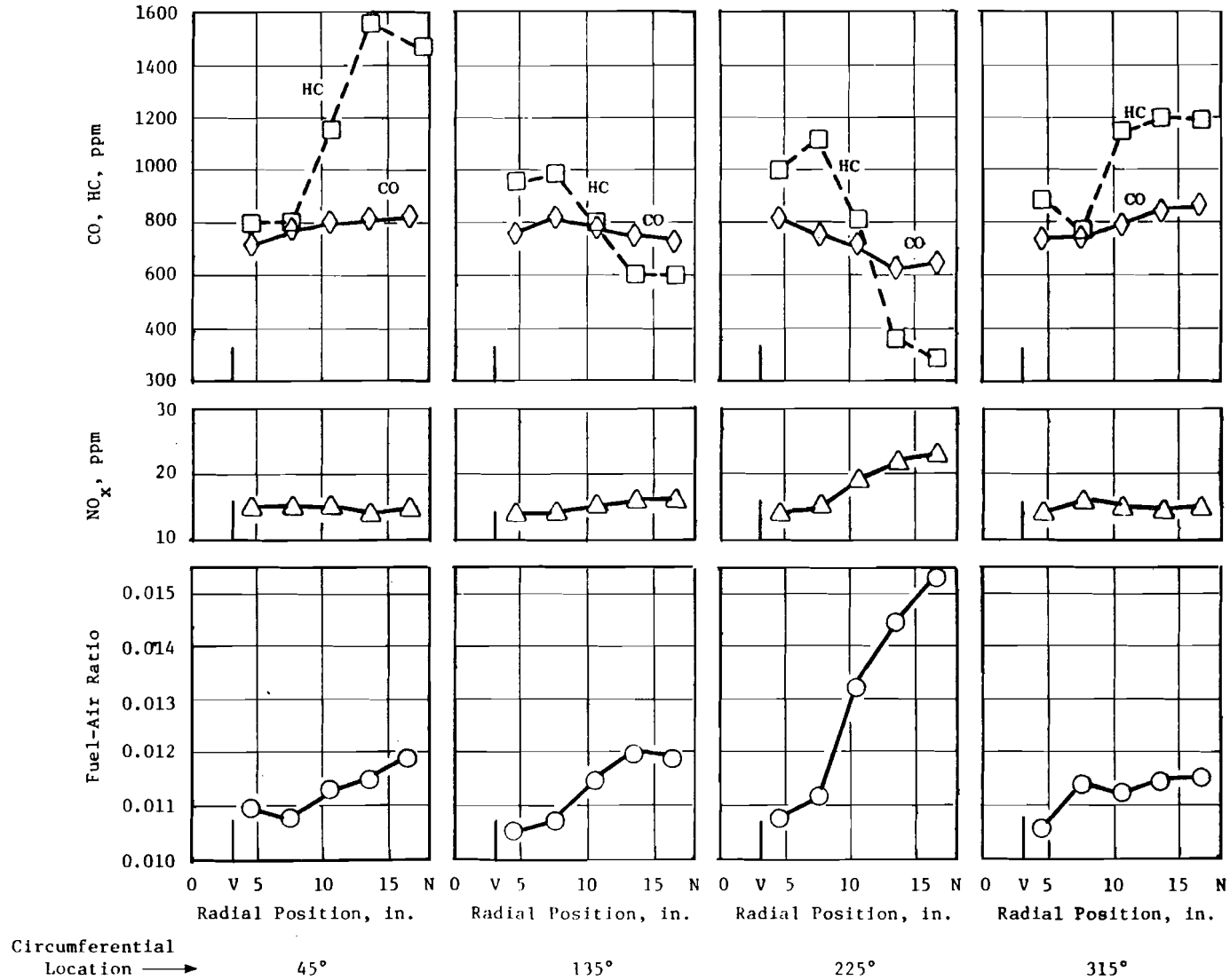

FIGURE 22. RADIAL PROFILES OF FUEL-AIR RATIO, CO, HC, AND NO_x CONCENTRATIONS AT IDLE POWER AND FOR SELECTED CIRCUMFERENTIAL LOCATIONS. V AND N INDICATE VENT TUBE (R = 3.1 IN.) AND EXHAUST NOZZLE (R = 18.0 IN.) RADII.

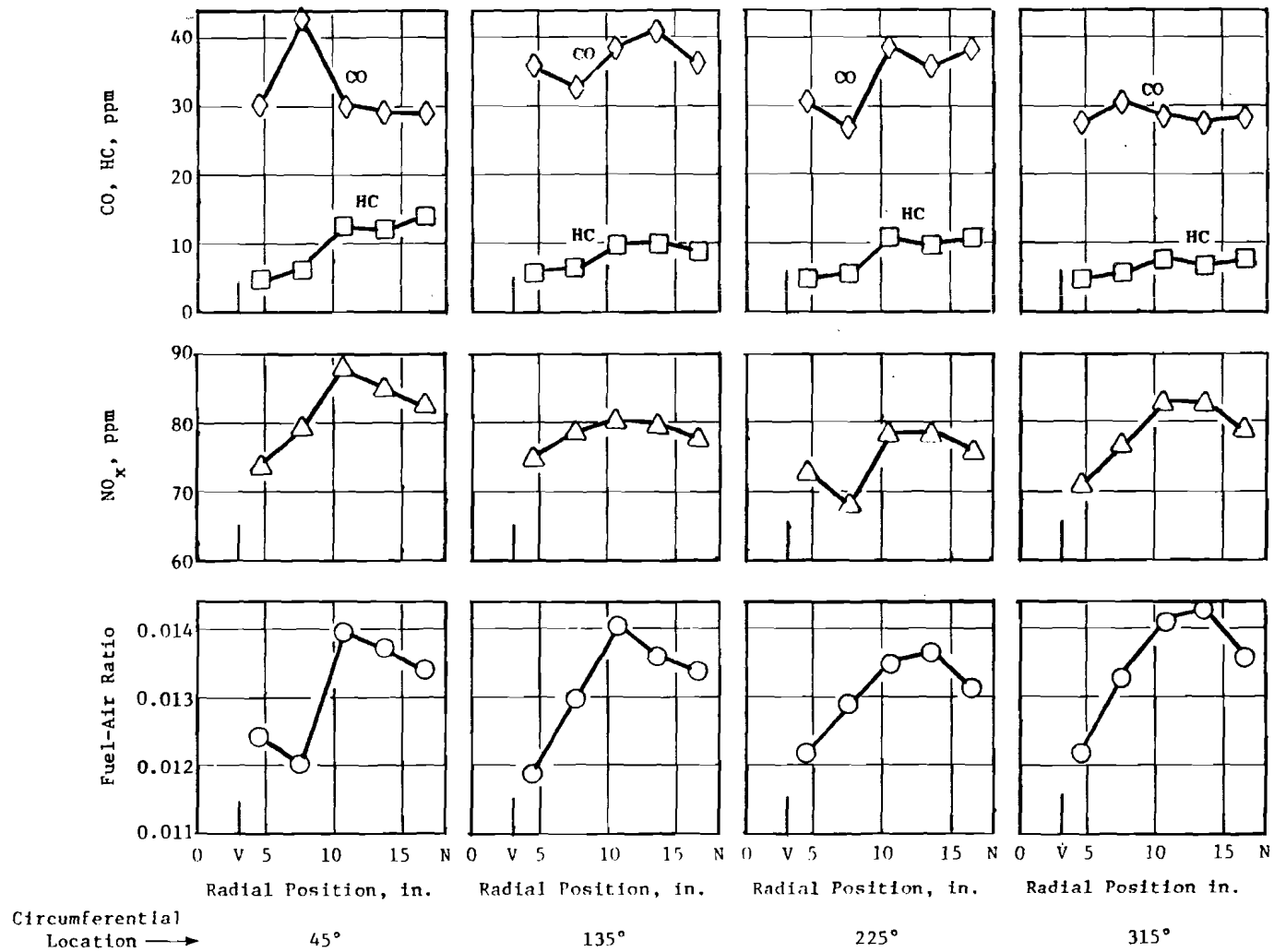

FIGURE 23. RADIAL PROFILES OF FUEL-AIR RATIO, CO, HC, AND NO_x CONCENTRATIONS AT 30% POWER AND FOR SELECTED CIRCUMFERENTIAL LOCATIONS. V AND N INDICATE VENT TUBE (R = 3.1 IN.) AND EXHAUST NOZZLE (R = 18.0 IN.) RADII.

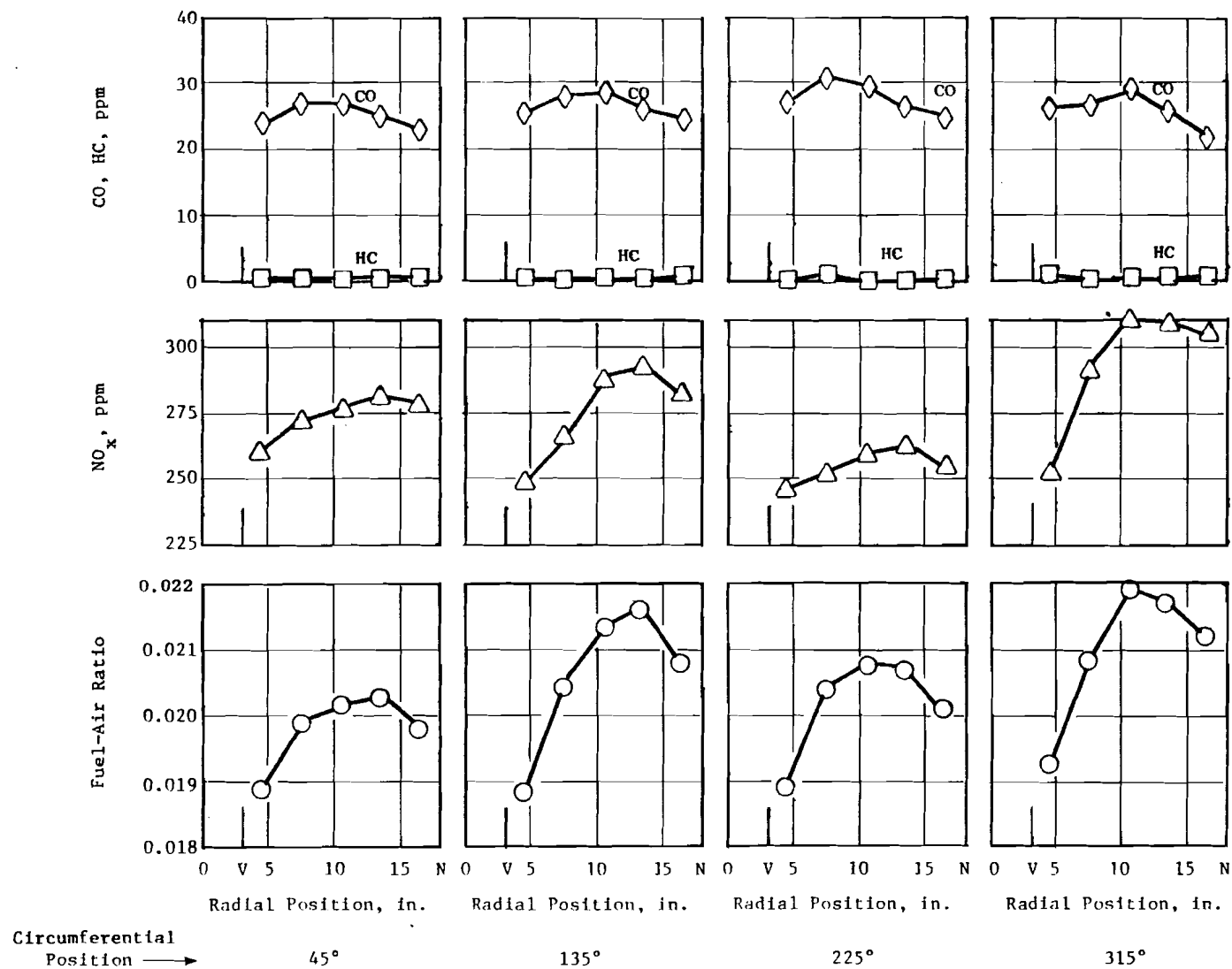

FIGURE 24. RADIAL PROFILES OF FUEL-AIR RATIO, CO, HC, AND NO_x CONCENTRATIONS AT 85% POWER AND FOR SELECTED CIRCUMFERENTIAL LOCATIONS. V AND N INDICATE VENT TUBE (R = 3.1 IN.) AND EXHAUST NOZZLE (18.0 IN.) RADII.

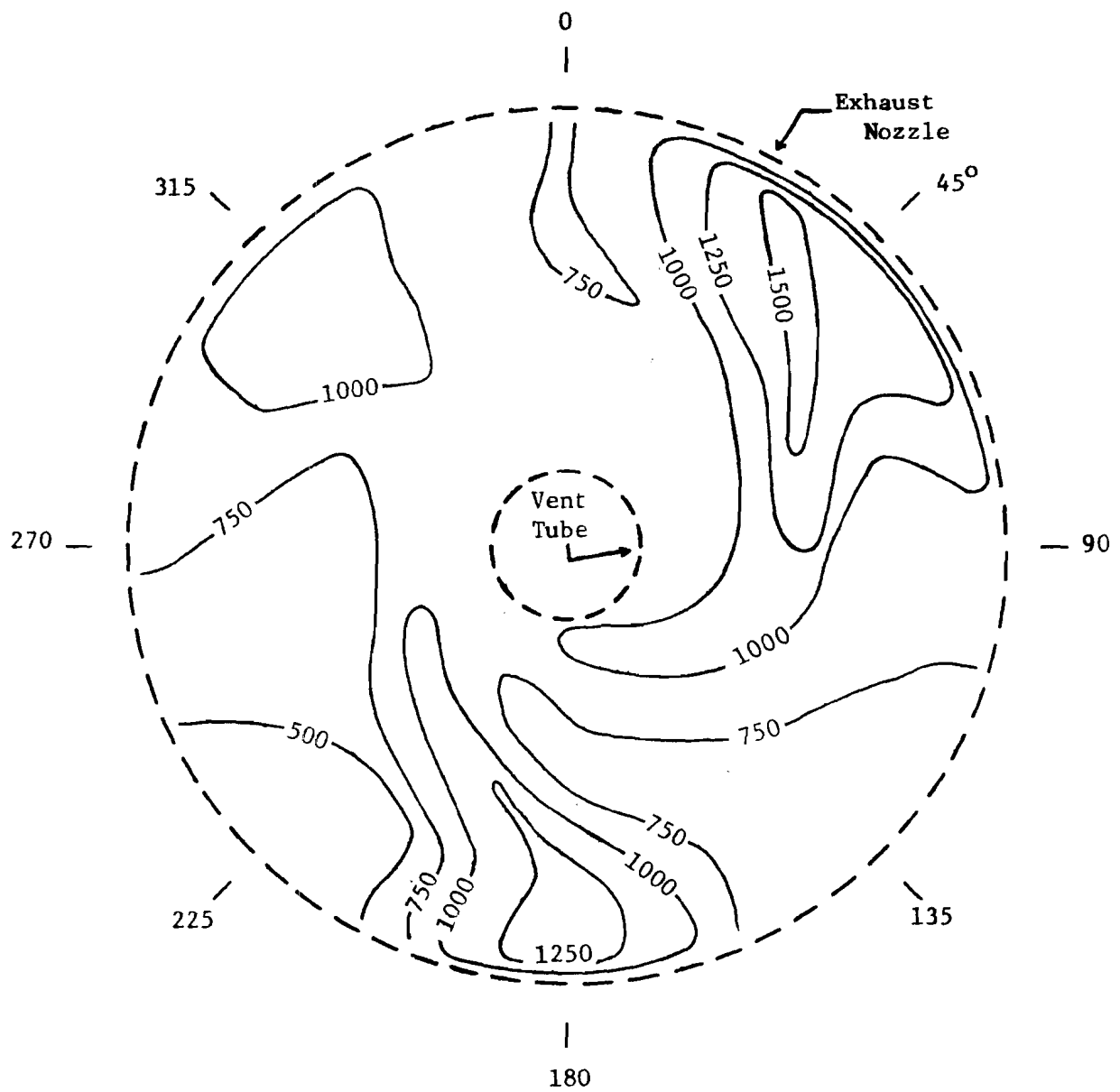

FIGURE 25. HYDROCARBON CONCENTRATION ISOPLETHS AT IDLE POWER (AFT LOOKING FORWARD).

The lobes have the appearance of spreading inward and clockwise from the regions of maximum concentration. The clockwise spreading is in the direction of engine rotation. It might be noted that, near the exhaust nozzle, very rapid changes in HC concentration occur where the core stream mixes with fan air. Thus, the isopleths would be very closely spaced in this region.

Figure 26 shows the CO concentration isopleths at idle power. The general features of this map are similar to the HC map although the overall variation in CO is much smaller. As with the HC map, there are three prominent lobes and one trough. There is, however, an additional lobe near 260° which does not appear on the HC map.

Figure 27 shows fuel-air ratio contours at idle power level. This plot is devoid of features except for the single lobe which is coincident with the CO and HC troughs. As noted previously, the fuel-air ratio peak is due to the asymmetric fueling pattern in the combustor resulting from three adjacent fueled nozzles at the ignition in an otherwise alternately fueled pattern. In Figure 27, except within the two isopleths shown, all other measured fuel-air ratios were between 0.010 and 0.012.

4.3.4 Cruciform Comparison

In order to determine if the cruciform sampling pattern is appropriate for obtaining a representative emissions sample from the CF6-50 engine, selected 12-point samples were averaged and compared to the 120-point traverse average. The area-weighted traverse average was considered to be the most accurate average engine value. The cruciform average was obtained by taking three samples from each of four arms spaced 90° apart. Six such averages could be obtained from the 120-sample points, with the additional constraint that the three samples on a particular radius be those closest to the centers of three equal areas. The radial locations closest to the centers of three equal areas were at 16.49, 13.52 and 7.58 inches.

Table 5 compares the cruciform averages with the corresponding area-weighted average from the 120-point traverse for each of the six orientations of the cruciform (0, 15, 30, 45, 60 and 75°). The cruciform sample is in general agreement with the 120-point area-weighted average. For CO con-

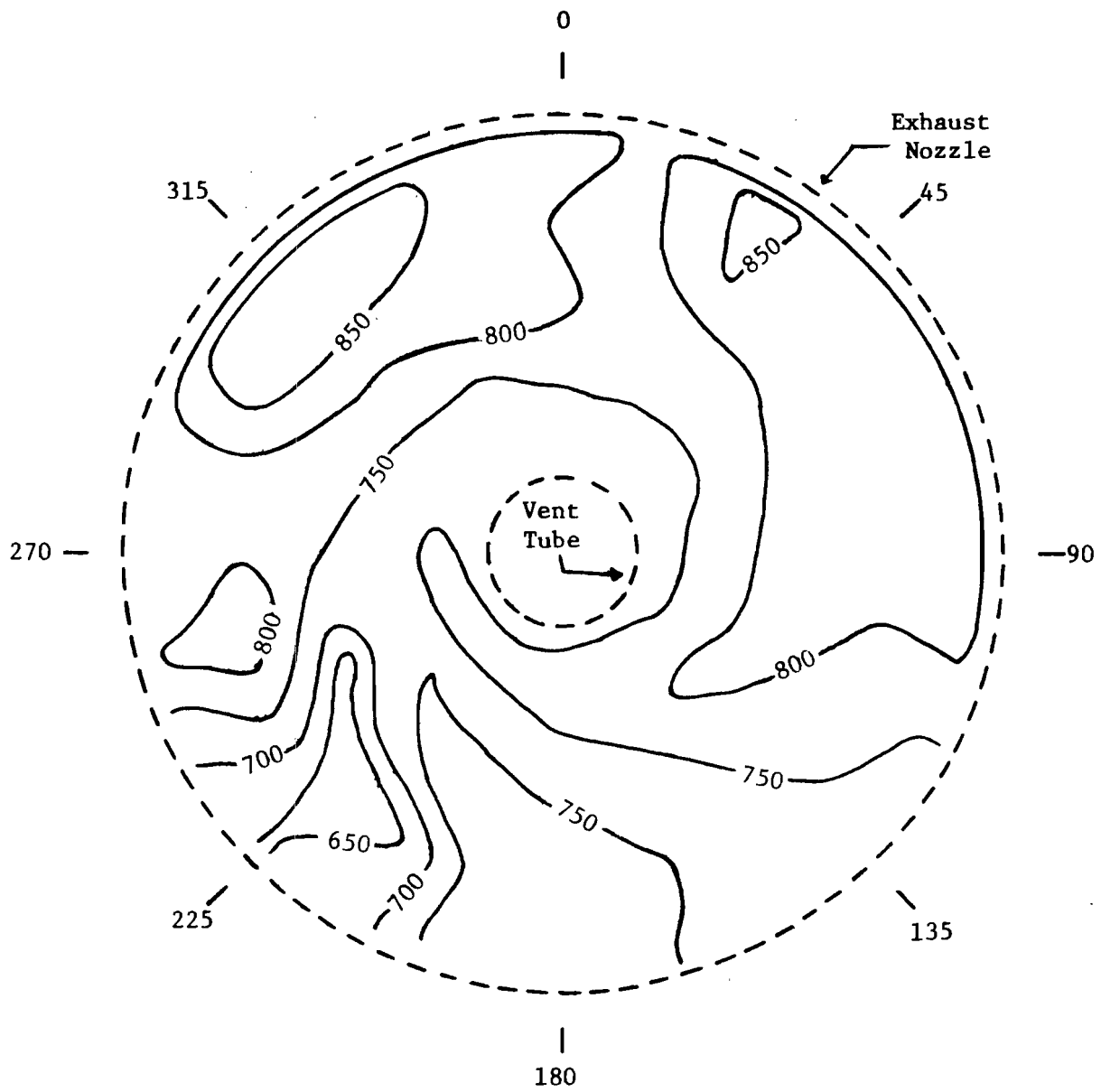

FIGURE 26. CARBON MONOXIDE CONCENTRATION ISOPLETHS AT IDLE POWER (AFT LOOKING FORWARD).

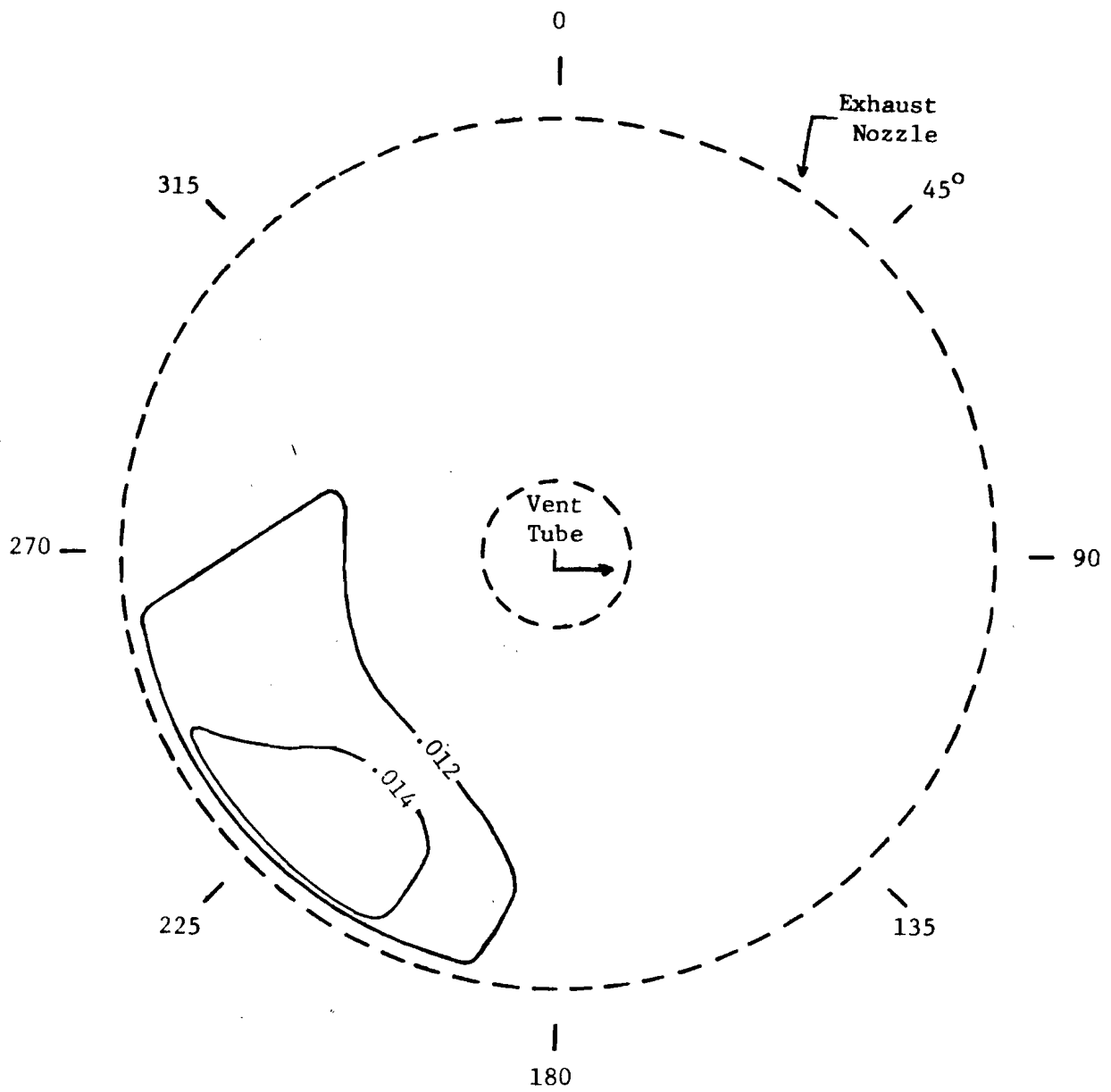

FIGURE 27. FUEL-AIR RATIO ISOPLETHS AT IDLE POWER (AFT LOOKING FORWARD). ALL MEASURED LEVELS OUTSIDE CONTOURS ARE BETWEEN 0.010 AND 0.012.

TABLE 5. COMPARISON OF CRUCIFORM AVERAGE AND 120-POINT TRAVERSE AVERAGE.

Power Level	Angle of Cruciform Degrees	FAR			CO			HC			NO _x		
		CA	AWA	$\frac{CA-AWA}{AWA} \times 100$ %	CA ppm	AWA ppm	$\frac{CA-AWA}{AWA} \times 100$ %	CA ppm	AWA ppm	$\frac{CA-AWA}{AWA} \times 100$ %	CA ppm	AWA ppm	$\frac{CA-AWA}{AWA} \times 100$ %
Idle	0	0.01146	0.01169	-1.9	784.4	776.0	+1.1	927.9	912.5	+1.7	15.05	15.20	-1.0
	15	0.01141	0.01169	-2.4	774.1	776.0	+0.2	919.0	912.5	+0.7	14.76	15.20	-2.9
	30	0.01195	0.01169	+2.2	775.4	776.0	+0.1	907.6	912.5	-0.5	15.23	15.20	+0.2
	45	0.01203	0.01169	+2.9	764.7	776.0	-1.5	909.2	912.5	-0.4	14.90	15.20	-2.0
	60	0.01169	0.01169	0	769.8	776.0	-0.8	878.0	912.5	-3.8	15.20	15.20	0
	75	0.01163	0.01169	-0.5	790.5	776.0	+1.9	919.0	912.5	+0.7	14.61	15.20	-3.9
30%	0	0.01340	0.01331	+0.7	35.0	32.6	+7.3				79.4	78.8	+0.8
	15	0.01339	0.01331	+0.6	36.7	32.6	+12.5				77.7	78.8	-1.4
	30	0.01319	0.01331	-0.9	32.4	32.6	-0.5				77.3	78.8	-1.9
	45	0.01334	0.01331	+0.2	33.3	32.6	+2.2				78.8	78.8	0
	60	0.01346	0.01331	+1.1	31.5	32.6	-3.5				79.9	78.8	+1.4
	75	0.01326	0.01331	-0.4	29.3	32.6	-10.2				80.0	78.8	+1.5
85%	0	0.02066	0.02068	-0.1	26.18	22.8	+14.8				275.8	279.6	-1.4
	15	0.02049	0.02068	-0.9	23.43	22.8	+2.8				275.2	279.6	-1.6
	30	0.02105	0.02068	+1.8	19.79	22.8	-13.2				287.5	279.6	+2.8
	45	0.02063	0.02068	-0.2	25.90	22.8	+13.6				278.5	279.6	+0.4
	60	0.02035	0.02068	-1.6	22.88	22.8	+0.4				277.3	279.6	-0.8
	75	0.02096	0.02068	+1.4	18.77	22.8	-17.7				290.6	279.6	+3.9

CA = 12 point cruciform average
AWA = Area weighted average from 120 point traverse (See Table 4)

centrations at 30% and 60% power, the percentage deviation is quite large at certain orientations even though the absolute deviation is only a few ppm. The HC concentration at 30% and 85% power are so low that comparison of the two averages is not meaningful and the data are therefore omitted from the table.

It should be noted in Table 5 that, at idle power, the maximum deviation in fuel-air ratio averages occurs at the 45° orientation of the cruciform, since at that position the peak in the fuel-air ratio is included in the cruciform average. It might also be noted that the HC concentration cruciform averages at idle are quite representative in spite of the very large variations in individual sample values. This is due to the fact that high values on one cruciform arm tend to be balanced by low values on the arm located in the 180° opposite position.

Although EI's are not listed in Table 5, the relative value can be inferred by reference to the fact that the EI equation includes a term which is the concentration divided by fuel-air ratio. The total relative deviation in EI is thus the concentration relative deviation minus the relative deviation in fuel-air ratio. Based on the absolute value of the combined deviations, the most favorable orientation of the cruciform for CO at idle power is 60° (-0.8% deviation in EI) while the least favorable is 45° (-4.4% deviation in EI). For HC at idle, the best orientation is 75° (+1.2% deviation in EI) and the worst is 60° (-3.8% deviation in EI). For NO_x at 85% power, the best orientation of the cruciform is 45° (+0.6% deviation in EI) and the worst is 75° (2.5% deviation in EI). On an overall basis, there is but slight improvement in EI to be obtained by optimizing the cruciform orientation. If equal importance is given to idle CO and HC measurement and 85% NO_x measurement, then the 60° orientation would appear to be the best choice and the 45° orientation the worst choice. It should be emphasized that this conclusion applies to the particular engine used for these tests since another engine might have somewhat different concentration distribution.

4.3.5 Discussion

This investigation of the variations in exhaust composition across the nozzle exit plane of the CF6-50 engine has revealed several significant

features. The circumferential fuel-air ratio distribution at idle is characterized by a single rich region which is coincident with, and is the cause of, the minimum in the CO and HC concentration distribution, and the maximum in NO_x concentration. It is quite apparent that this effect is due to the idle fueling pattern in which there are three adjacent fueled nozzles in a pattern where all other nozzles are alternately fueled. The relative "richness" of this region may be judged by noting that 3 of 4 adjacent nozzles are fueled in the richer region and 2 of 4 adjacent nozzles are fueled in the remainder of the combustor. The circumferential location of this rich region at the exhaust plane is displaced approximately 90° clockwise from its location within the combustor. This displacement is in the direction of, and is due to, the flow of exhaust through the six turbine stages. Thus, the cause of the maximum in fuel-air ratio at idle, and the consequent effect on CO, HC, and NO_x, is characteristic of the current production CF6-50 fuel nozzle configuration.

The overall variation in HC is relatively much larger than in either CO or fuel-air ratio, and contains three maxima which are fairly evenly spaced around the exhaust nozzle area. The large overall variation in HC is apparently associated with the bleed flow in the unfueled nozzles. The purpose of this small bleed flow is to prevent stagnation and possible decomposition of the fuel within the fuel nozzle at the low power engine operating conditions. This bleed flow at idle is more than sufficient to account for all of the HC emissions, if none of the bleed flow burns. This is because the total bleed flow is approximately 10% of the total fuel flow at idle, and the average HC EI is 46 lb per 1000 lb of fuel. The fuel entering the combustor as bleed flow will either burn or not burn, depending on whether the mixing processes within the combustor expose the fuel to favorable combustion conditions before reactions are completely quenched by dilution and cooling air. This situation might result in large variations in HC concentration. Similar large variations at idle power have been noted in previous CF6-50 emissions studies at General Electric where a limited amount of traverse probe data was obtained. The overall HC variation at idle power thus seems to be associated with the small bleed fuel flow, but the cause of the three maxima in HC is not apparent.

It should be noted that low CO/HC emissions combustor designs of the CF6-50 engine currently under development do not utilize bleed flow in the fuel nozzles.

As engine power is increased from idle, the fuel-air ratio, CO and NO_x radial profiles tend toward a pronounced peaked shape with the maxima near the radial midpoint, as illustrated in Figure 24. Also with increasing engine power, the relative flow between fuel nozzles becomes more uniform until at high power levels the flow to each nozzle becomes nearly equal. This results in a quite uniform circumferential distribution of all species. This overall trend at high power results from certain design requirements of the modern gas turbine engine. In order to obtain long life in hot section parts, the overall temperature level must be compatible with the hardware design and the temperature profile must be carefully controlled to avoid local high temperature regions. The overall airflow pattern within the combustor results in a temperature distribution at the turbine inlet which is quite uniform circumferentially and which is slightly peaked toward the center of the annular space. An illustration of this carefully tailored temperature profile is shown in Figure 28 where typical test results on a CF6-50 combustor are presented. The general shape of the profiles in Figure 28 is similar to the emissions profiles at 85% power shown in Figure 24. As a result of the practical engine design considerations cited above, it might be expected that all modern, high pressure ratio engines with annular combustors would tend to have uniform distribution of exhaust species at the higher power levels.

Comparison of the 12-point cruciform average with the 120-point area-weighted traverse average indicates that, for the current CF6-50 engine configuration, the EPA-specified cruciform sampling pattern will give values within 1 to 5% of the 120-point average, depending on the angular orientation of the cruciform. Although the EPA has not defined the criteria for showing that a sample is "representative," it seems logical that a representative sample would be one in which the sampling error is comparable to the inaccuracies introduced by other factors such as measurement system errors, test-to-test variation, and engine-to-engine variation. It would

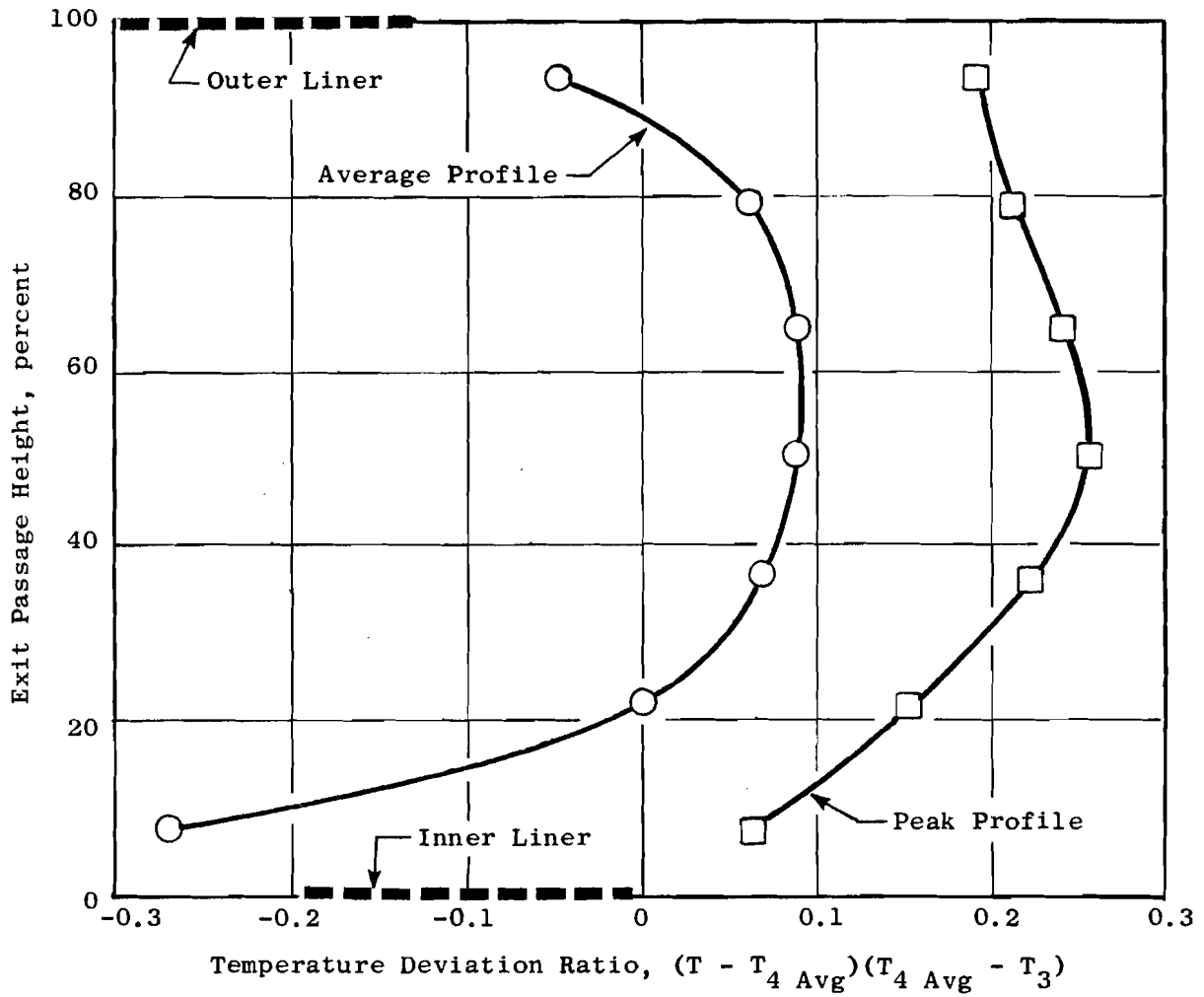

FIGURE 28. TYPICAL EXIT TEMPERATURE PROFILE CHARACTERISTICS OF THE CF6-50 COMBUSTOR.

seem that sampling errors of a few percent are not large compared with reasonable estimates of these other causes of data inaccuracy.

It is worth noting that one of two situations must apply: either the variation in concentrations is rather randomly distributed across the exhaust area, or there is a definite pattern in the concentration distribution. If the variation is random, then sampling error will be improved by additional sampling points. If there is a definite pattern in the distribution, then care must be exercised to avoid a sampling pattern which would result in biasing of the results. For example, a four-lobed distribution could result in considerable sampling error if a cruciform rake were employed. In any case, detailed traverse data is most useful in establishing that the chosen sampling pattern will result in a representative average sample.

5.0 CONCLUSIONS

From the measurement of exhaust composition variation over the nozzle exit plane of the CF6-50 engine, the following conclusions are drawn:

1. The fueling pattern of the current CF6-50 combustor at idle power causes a locally rich region in the exhaust at about 225° angular position (aft looking forward) and a corresponding maximum in NO_x and minimum in CO and HC concentrations.
2. The large overall variation in HC concentration at idle is apparently associated with the fuel nozzle bleed flow used at low power operating conditions in alternately positioned nozzles.
3. At higher power levels, the fuel-air ratio, CO, and NO_x variation is quite uniform circumferentially and the radial profile tends to be peaked with a maximum near the radial midpoint. This radial profile is a result of the turbine inlet temperature profile which is similarly shaped as a result of practical engine design considerations.
4. In general, for modern high pressure ratio engines with annular combustors and with nonmixed core and fan streams, the EPA-specified cruciform sampling pattern should be adequate for sampling the core engine exhaust, provided that the fueling pattern is uniform within the combustor.
5. For other types of combustion systems or if the fueling pattern is nonuniform, an investigation of the concentration distribution should be made to assure that the selected sampling pattern does not give a biased result.

REFERENCES

1. "Control of Air Pollution from Aircraft and Aircraft Engines - Proposed Amendments to Standards," U.S. EPA, Federal Register, Vol. 43, p. 12615, March 24, 1978.
2. C.C. Gleason and D.W. Bahr, "Experimental Clean Combustor Program," Phase III Final Report, NASA CR-135384 (June 1, 1979).
3. SAE Aerospace Recommended Practice, "Procedure for the Continuous Sampling and Measurement of Gaseous Emissions from Aircraft Turbine Engines," ARP 1256A (Revised 10/1/80).
4. T.F. Lyon, W.J. Dodds, and D.W. Bahr, "Determination of Pollutant Emissions Characteristics of General Electric CF6-6 and CF6-50 Model Engines," Report No. FAA-EE-80-27 (March 1980).

APPENDIX

This appendix gives a complete tabulation of emissions data for the traverse probe tests of the CF6-50 engine. Three separate tables are given: Table A1 lists data at the idle power setting, Table A2 at the 30% power setting, and Table A3 at the 85% power setting. Each table consists of six pages, with the first three pages giving CO, CO₂, HC, and NO_x concentrations along with rake positions (traverse ring position; 0, 15, or 30° clockwise rotation), switch A and B position (refer to Table 1), and the circumferential and radial position of the sample point. The last three pages on each table give the emission indices, fuel-air ratio, and combustion efficiency. The average, standard deviation, and area weighted average of each parameter is also given. In addition, the overall average for emission indices and fuel-air ratio is listed.

TABLE A1. EMISSIONS DATA FOR 120-POINT TRAVERSE AT IDLE POWER.

TEST - FAA DETAIL TRAV CF6-50 DATE - 8/15/80
 CELL - 2 RUN - 1 FUEL - JETA
 CAL TIME = 1115 HUM = 94.0 FUEL H/C = 1.92

R06 240 POINT IDL

RAKE POS	SWITCH		ACTUAL GAS ANALYSIS				POSITION	
	A	B	CO SEMI-DRY (PPM)	CO2 SEMI-DRY (PCT)	HC WET (PPM)	NOX WET (PPM)	CIRCUM (DEG)	RADIAL (IN)
0	6	1	802.7	2.31	733.18	16.2	0	16.49
15	6	1	797.7	2.24	1064.62	15.3	15	
30	6	1	866.8	2.26	1519.93	13.8	30	
0	8	1	822.6	2.22	1463.02	14.6	45	
15	8	1	807.6	2.16	1432.89	13.7	60	
30	8	1	824.3	2.21	1128.23	13.6	75	
0	1	1	829.3	2.33	826.92	15.6	90	
15	1	1	797.7	2.24	753.27	14.8	105	
30	1	1	738.3	2.13	706.40	13.0	120	
0	3	1	732.0	2.38	602.62	15.7	135	
15	3	1	719.6	2.38	595.92	15.6	150	
30	3	1	755.7	2.24	1134.93	13.9	165	
0	5	1	796.1	2.23	1369.28	14.5	180	
15	5	1	781.4	2.40	1128.23	16.2	195	
30	5	1	669.5	3.07	428.53	21.0	210	
0	7	1	647.4	3.16	284.57	23.1	225	
15	7	1	702.7	2.92	408.44	21.1	240	
30	7	1	802.7	2.57	709.75	16.9	255	
0	2	1	766.9	2.24	763.31	14.3	270	
15	2	1	783.0	2.19	836.97	13.9	285	
30	2	1	853.0	2.22	1037.84	13.3	300	
0	4	1	873.7	2.24	1188.49	14.8	315	
15	4	1	861.6	2.17	1004.36	13.8	330	
30	4	1	827.6	2.22	843.66	13.3	345	

TABLE A1. EMISSIONS DATA FOR 120-POINT TRAVERSE AT IDLE POWER (CONTINUED).

0	14	1	797.7	2.28	716.44	15.0	0	13.52
15	14	1	792.8	2.23	990.97	14.9	15	
30	14	1	853.0	2.28	1412.80	14.6	30	
0	16	1	814.3	2.19	1553.41	14.0	45	
15	16	1	804.3	2.09	1365.93	13.0	60	
30	16	1	836.0	2.31	970.88	14.8	75	
0	9	1	836.0	2.35	853.71	15.5	90	
15	9	1	792.8	2.19	806.84	14.4	105	
30	9	1	765.3	2.30	733.18	14.5	120	
0	11	1	746.2	2.40	609.31	15.8	135	
15	11	1	728.9	2.39	622.70	15.7	150	
30	11	1	760.5	2.33	990.97	14.9	165	
0	13	1	781.4	2.19	1386.02	14.4	180	
15	13	1	770.1	2.49	1037.24	16.8	195	
30	13	1	647.4	3.09	368.27	22.1	210	
0	15	1	627.1	2.97	354.87	22.0	225	
15	15	1	749.4	2.72	572.49	18.8	240	
30	15	1	841.1	2.51	753.27	16.8	255	
0	10	1	796.1	2.38	699.70	15.6	270	
15	10	1	792.8	2.21	840.32	14.3	285	
30	10	1	872.0	2.26	1131.58	13.9	300	
0	12	1	847.9	2.22	1198.54	14.5	315	
15	12	1	853.0	2.16	977.58	13.6	330	
30	12	1	822.6	2.27	803.49	14.5	345	
0	21	2	810.9	2.18	850.36	14.8	0	10.55
15	21	2	768.5	2.22	739.88	14.9	15	
30	21	2	778.2	2.24	960.84	15.3	30	
0	21	4	797.7	2.19	1155.02	15.0	45	
15	21	4	807.6	2.06	1546.72	12.8	60	
30	21	4	802.7	2.11	1422.84	13.3	75	
0	17	1	807.6	2.21	1128.23	14.4	90	
15	17	1	834.3	2.13	944.10	13.1	105	
30	17	1	786.3	2.19	833.62	14.2	120	
0	19	1	783.0	2.26	790.10	14.8	135	
15	19	1	736.7	2.33	616.01	14.6	150	
30	19	1	746.2	2.42	639.44	15.8	165	
0	21	1	746.2	2.30	806.84	15.3	180	
15	21	1	783.0	2.21	1282.23	14.2	195	
30	21	1	755.7	2.57	967.53	17.7	210	
0	21	3	711.9	2.65	810.18	18.9	225	
15	21	3	637.2	2.69	539.01	19.0	240	
30	21	3	733.6	2.55	666.23	17.9	255	
0	18	1	762.1	2.46	729.84	16.8	270	
15	18	1	778.2	2.34	723.14	15.0	285	
30	18	1	786.3	2.25	830.27	14.8	300	
0	20	1	796.1	2.19	1148.32	14.9	315	
15	20	1	834.3	2.18	954.14	13.7	330	
30	20	1	827.6	2.18	880.49	14.0	345	

TABLE A1. EMISSIONS DATA FOR 120-POINT TRAVERSE AT IDLE POWER (CONTINUED).

0	21	10	768.5	2.14	964.19	15.1	0	7.58
15	21	10	768.5	2.14	823.58	14.0	15	
30	21	10	773.3	2.15	803.49	13.7	30	
0	21	12	762.1	2.14	796.79	14.8	45	
15	21	12	754.1	2.15	853.71	14.3	60	
30	21	12	770.1	2.13	1101.45	13.6	75	
0	21	5	781.4	2.08	1225.32	13.9	90	
15	21	5	774.9	2.09	1175.10	13.5	105	
30	21	5	822.6	2.10	1078.01	13.9	120	
0	21	7	810.9	2.09	984.27	13.8	135	
15	21	7	786.3	2.11	937.40	13.3	150	
30	21	7	762.1	2.18	830.27	13.7	165	
0	21	9	746.2	2.20	719.79	14.8	180	
15	21	9	735.2	2.21	726.49	14.3	195	
30	21	9	728.9	2.18	867.10	14.0	210	
0	21	11	750.9	2.18	1108.14	15.0	225	
15	21	11	732.0	2.20	1014.40	14.6	240	
30	21	11	722.7	2.30	940.75	15.1	255	
0	21	6	710.4	2.29	877.14	15.7	270	
15	21	6	702.7	2.28	843.66	14.8	285	
30	21	6	715.0	2.28	803.49	14.9	300	
0	21	8	741.5	2.26	766.66	15.6	315	
15	21	8	738.3	2.24	749.92	14.8	330	
30	21	8	760.5	2.20	820.23	14.2	345	
0	21	18	704.2	2.16	796.79	15.0	0	4.61
15	21	18	695.1	2.19	780.05	15.1	15	
30	21	18	696.6	2.21	770.01	14.0	30	
0	21	20	712.4	2.17	800.14	15.1	45	
15	21	20	715.0	2.16	753.27	14.8	60	
30	21	20	728.9	2.14	773.36	13.5	75	
0	21	13	750.9	2.09	853.71	14.8	90	
15	21	13	746.2	2.10	937.40	14.2	105	
30	21	13	749.4	2.09	850.36	13.6	120	
0	21	15	755.7	2.06	947.45	14.0	135	
15	21	15	755.7	2.09	1098.10	13.8	150	
30	21	15	765.3	2.06	1155.02	12.6	165	
0	21	17	766.9	2.07	1001.01	13.7	180	
15	21	17	758.9	2.07	987.62	13.5	195	
30	21	17	768.5	2.07	1124.88	12.5	210	
0	21	19	762.1	2.07	994.32	13.8	225	
15	21	19	750.9	2.09	964.19	13.8	240	
30	21	19	758.9	2.08	1124.88	12.3	255	
0	21	14	752.5	2.07	967.53	13.7	270	
15	21	14	743.0	2.08	940.75	13.3	285	
30	21	14	738.3	2.09	924.01	12.8	300	
0	21	16	738.3	2.08	890.53	13.8	315	
15	21	16	722.7	2.12	833.62	13.9	330	
30	21	16	710.4	2.17	820.23	13.6	345	
AVG			768.9	2.26	913.19	14.9		
STD DEV			49.0	0.21	247.89	1.9		
AREA WT AVG			776.0	2.30	912.48	15.2		

TABLE A1. EMISSIONS DATA FOR 120-POINT TRAVERSE AT IDLE POWER (CONTINUED).

RAKE POS	SWITCH		CALCULATED EMISSIONS LEVELS				F/A SAMPLE	COMB EFF
	A	B	CO	HC (AS CH4)	NO	NOX		
			◆◆◆◆◆◆◆◆	LBS/1000	LBS FUEL	◆◆◆◆◆◆◆◆		
0	6	1	66.10	35.96		2.28	0.01166	95.33
15	6	1	66.66	52.96		2.19	0.01150	93.84
30	6	1	70.30	73.39		1.91	0.01185	91.98
0	8	1	66.48	70.41		2.02	0.01189	92.33
15	8	1	68.70	72.50		1.99	0.01130	92.09
30	8	1	69.52	56.63		1.95	0.01139	93.45
0	1	1	67.42	40.05		2.16	0.01181	94.94
15	1	1	67.57	37.98		2.13	0.01134	95.12
30	1	1	65.99	37.54		1.98	0.01076	95.20
0	3	1	59.09	28.99		2.17	0.01190	96.10
15	3	1	58.28	28.76		2.16	0.01186	96.14
30	3	1	63.24	56.52		1.99	0.01148	93.61
0	5	1	66.01	67.57		2.06	0.01159	92.59
15	5	1	61.14	52.62		2.16	0.01227	94.00
30	5	1	42.72	16.40		2.31	0.01500	97.58
0	7	1	40.33	10.64		2.48	0.01536	98.13
15	7	1	47.00	16.36		2.43	0.01432	97.48
30	7	1	59.89	31.62		2.16	0.01286	95.85
0	2	1	65.19	38.62		2.07	0.01130	95.12
15	2	1	67.74	43.07		2.06	0.01111	94.67
30	2	1	71.96	52.10		1.92	0.01139	93.79
0	4	1	72.59	58.77		2.09	0.01157	93.20
15	4	1	74.33	51.54		2.03	0.01114	93.78
30	4	1	70.49	42.76		1.94	0.01123	94.64

TABLE A1. EMISSIONS DATA FOR 120-POINT TRAVERSE AT IDLE POWER (CONTINUED).

0	14	1	66.63	35.63	2.14	0.01150	95.35
15	14	1	66.83	49.72	2.14	0.01140	94.12
30	14	1	69.18	68.22	2.03	0.01185	92.45
0	16	1	68.16	77.37	2.01	0.01142	91.62
15	16	1	70.90	71.56	1.95	0.01091	92.12
30	16	1	68.24	47.20	2.06	0.01177	94.20
0	9	1	67.53	41.09	2.13	0.01189	94.85
15	9	1	68.46	41.45	2.12	0.01113	94.80
30	9	1	63.45	36.20	2.06	0.01159	95.37
0	11	1	59.83	29.14	2.17	0.01197	96.07
15	11	1	58.65	29.86	2.16	0.01193	96.04
30	11	1	61.73	47.92	2.06	0.01183	94.39
0	13	1	65.98	69.63	2.07	0.01138	92.41
15	13	1	58.46	47.00	2.18	0.01264	94.55
30	13	1	41.07	14.02	2.41	0.01508	97.32
0	15	1	41.33	14.04	2.49	0.01451	97.31
15	15	1	53.22	24.31	2.29	0.01350	96.64
30	15	1	64.09	34.25	2.19	0.01260	95.53
0	10	1	63.84	33.44	2.14	0.01197	95.60
15	10	1	67.81	42.77	2.09	0.01124	94.70
30	10	1	72.06	55.67	1.97	0.01163	93.48
0	12	1	71.04	59.76	2.08	0.01147	93.15
15	12	1	73.91	50.38	2.01	0.01109	93.90
30	12	1	68.73	39.97	2.07	0.01150	94.92
0	21	2	70.41	43.92	2.19	0.01107	94.54
15	21	2	65.92	37.77	2.18	0.01120	95.18
30	21	2	65.55	48.17	2.21	0.01141	94.28
0	21	4	67.82	58.42	2.17	0.01131	93.34
15	21	4	71.57	81.44	1.93	0.01085	91.25
30	21	4	69.81	73.57	1.98	0.01106	91.98
0	17	1	68.35	56.81	2.08	0.01136	93.47
15	17	1	73.45	49.42	1.97	0.01092	93.99
30	17	1	67.84	42.79	2.06	0.01114	94.70
0	19	1	65.74	39.49	2.12	0.01144	95.03
15	19	1	60.67	30.22	2.06	0.01166	95.96
30	19	1	59.20	30.25	2.15	0.01210	95.99
0	21	1	61.72	39.74	2.17	0.01161	95.10
15	21	1	65.89	64.20	2.03	0.01142	92.88
30	21	1	55.92	42.74	2.24	0.01297	94.92
0	21	3	51.60	35.08	2.35	0.01323	95.75
15	21	3	46.13	23.32	2.36	0.01324	96.90
30	21	3	55.37	30.01	2.32	0.01271	96.10
0	18	1	59.31	33.87	2.23	0.01233	95.67
15	18	1	63.51	35.16	2.09	0.01177	95.46
30	18	1	66.24	41.63	2.12	0.01141	94.33
0	20	1	67.89	58.26	2.16	0.01127	93.35
15	20	1	72.03	49.00	2.02	0.01113	94.06
30	20	1	71.71	45.38	2.08	0.01109	94.38

TABLE A1. EMISSIONS DATA FOR 120-POINT TRAVERSE AT IDLE POWER (CONCLUDED).

0	21	10	67.41	50.30	2.26	0.01096	94.05
15	21	10	68.03	43.35	2.12	0.01086	94.64
30	21	10	68.13	42.10	2.06	0.01091	94.75
0	21	12	67.57	42.01	2.23	0.01084	94.77
15	21	12	66.35	44.67	2.14	0.01093	94.57
30	21	12	67.50	57.40	2.03	0.01097	93.43
0	21	5	69.77	65.02	2.12	0.01077	92.72
15	21	5	68.80	62.01	2.04	0.01083	93.00
30	21	5	73.01	56.87	2.11	0.01083	93.35
0	21	7	72.52	52.32	2.11	0.01075	93.76
15	21	7	70.15	49.72	2.03	0.01078	94.04
30	21	7	66.37	43.01	2.03	0.01104	94.71
0	21	9	64.64	37.10	2.18	0.01109	95.27
15	21	9	63.53	37.35	2.11	0.01112	95.27
30	21	9	63.46	44.90	2.09	0.01104	94.62
0	21	11	64.62	56.72	2.20	0.01117	93.56
15	21	11	62.63	51.63	2.14	0.01123	94.05
30	21	11	59.49	46.12	2.12	0.01167	94.60
0	21	6	58.97	43.36	2.23	0.01157	94.85
15	21	6	58.75	41.99	2.11	0.01149	94.98
30	21	6	59.69	39.94	2.12	0.01151	95.14
0	21	8	62.42	38.42	2.24	0.01141	95.20
15	21	8	62.71	37.91	2.14	0.01131	95.24
30	21	8	65.55	42.06	2.08	0.01115	94.81
0	21	18	61.91	41.66	2.25	0.01093	94.93
15	21	18	60.35	40.29	2.24	0.01107	95.09
30	21	18	60.18	39.58	2.07	0.01112	95.15
0	21	20	62.25	41.71	2.26	0.01097	94.92
15	21	20	62.95	39.45	2.22	0.01092	95.10
30	21	20	64.79	40.87	2.04	0.01082	94.93
0	21	13	67.74	45.78	2.27	0.01066	94.44
15	21	13	66.88	49.94	2.16	0.01073	94.10
30	21	13	67.62	45.61	2.09	0.01066	94.46
0	21	15	68.82	51.27	2.18	0.01056	93.94
15	21	15	67.58	58.36	2.11	0.01075	93.35
30	21	15	68.99	61.87	1.94	0.01067	93.01
0	21	17	69.43	53.86	2.11	0.01062	93.70
15	21	17	68.78	53.19	2.08	0.01061	93.77
30	21	17	69.17	60.17	1.92	0.01068	93.15
0	21	19	69.04	53.52	2.13	0.01062	93.74
15	21	19	67.59	51.58	2.12	0.01068	93.94
30	21	19	68.15	60.03	1.88	0.01071	93.19
0	21	14	68.28	52.17	2.12	0.01060	93.87
15	21	14	67.35	50.67	2.06	0.01061	94.02
30	21	14	66.61	49.55	1.96	0.01066	94.14
0	21	16	66.90	47.96	2.13	0.01061	94.27
15	21	16	64.62	44.31	2.12	0.01075	94.64
30	21	16	62.20	42.72	2.03	0.01098	94.83
AVG			64.70	46.06	2.12	0.01150	94.43
OVERALL AVG			64.26	45.43	2.13	0.01150	94.55
STD DEV			6.65	13.38	0.11	0.00093	1.28
AREA WT AVG			64.32	45.43	2.12	0.01169	94.55

TABLE A2. EMISSIONS DATA FOR 120-POINT TRAVERSE AT 30 PERCENT POWER.

TEST - FFA DETAIL TRAV CF6-50 DATE - 8/15/80
 CELL - 2 RUN - 1 FUEL - JETA
 CAL TIME = 1115 HUM = 84.0 FUEL H/C = 1.92

RDG 249 POINT 30

RAKE POS	SWITCH		ACTUAL GAS ANALYSIS				POSITION	
	A	B	CO SEMI-DRY (PPM)	CO2 SEMI-DRY (PCT)	HC MET (PPM)	NOX MET (PPM)	CIRCUM (DEG)	RADIAL (IN)
0	6	1	26.2	2.87	14.21	83.8	0	16.49
15	6	1	30.7	2.87	5.17	81.7	15	
30	6	1	30.5	2.84	3.23	78.6	30	
0	8	1	29.1	2.84	14.21	82.6	45	
15	8	1	29.1	2.84	5.17	80.9	60	
30	8	1	29.4	2.78	3.55	77.1	75	
0	1	1	32.4	2.74	10.01	78.3	90	
15	1	1	33.3	2.83	4.52	78.6	105	
30	1	1	32.1	2.85	2.91	79.9	120	
0	3	1	36.5	2.84	8.72	77.7	135	
15	3	1	35.4	2.80	5.49	81.9	150	
30	3	1	28.9	2.74	3.23	85.2	165	
0	5	1	49.7	2.77	28.74	77.1	180	
15	5	1	63.4	2.70	7.43	68.2	195	
30	5	1	44.7	2.69	4.20	70.2	210	
0	7	1	38.6	2.78	10.66	75.9	225	
15	7	1	33.3	2.72	4.52	73.9	240	
30	7	1	29.8	2.80	2.91	76.7	255	
0	2	1	29.6	2.86	11.62	81.3	270	
15	2	1	30.5	2.84	6.14	79.2	285	
30	2	1	27.1	2.83	2.91	79.2	300	
0	4	1	28.4	2.88	7.75	79.3	315	
15	4	1	26.8	2.93	5.81	81.9	330	
30	4	1	25.2	2.94	2.91	84.1	345	

TABLE A2. EMISSIONS DATA FOR 120-POINT TRAVERSE AT 30 PERCENT POWER (CONTINUED).

0	14	1	29.8	2.95	14.21	84.2	0	13.52
15	14	1	32.4	2.88	4.20	80.9	15	
30	14	1	30.5	2.97	3.23	83.0	30	
0	16	1	29.1	2.91	12.27	85.2	45	
15	16	1	31.0	2.80	4.52	79.1	60	
30	16	1	31.9	2.81	2.91	77.2	75	
0	9	1	34.4	2.88	11.62	81.7	90	
15	9	1	34.0	2.97	4.20	80.2	105	
30	9	1	29.4	2.90	3.23	80.0	120	
0	11	1	41.0	2.88	10.33	79.7	135	
15	11	1	32.6	3.00	4.52	88.8	150	
30	11	1	27.8	2.79	3.23	85.6	165	
0	13	1	64.1	2.78	34.23	72.6	180	
15	13	1	62.6	2.73	6.46	67.3	195	
30	13	1	41.9	2.71	3.55	72.5	210	
0	15	1	35.8	2.90	10.01	78.5	225	
15	15	1	31.4	2.82	3.87	78.5	240	
30	15	1	30.3	2.88	2.91	81.2	255	
0	10	1	32.6	2.99	8.07	82.5	270	
15	10	1	29.4	2.88	5.49	80.3	285	
30	10	1	28.2	2.90	3.55	77.7	300	
0	12	1	27.8	3.03	7.43	83.1	315	
15	12	1	27.5	3.01	4.84	85.0	330	
30	12	1	26.4	3.02	3.23	85.6	345	
0	21	2	27.1	2.88	13.24	84.5	0	10.55
15	21	2	29.6	2.86	3.23	80.6	15	
30	21	2	29.6	2.76	2.58	78.9	30	
0	21	4	29.8	2.95	12.59	88.1	45	
15	21	4	29.6	2.86	2.91	81.8	60	
30	21	4	30.1	2.68	2.58	77.3	75	
0	17	1	34.7	2.95	11.62	83.8	90	
15	17	1	34.0	3.01	3.87	81.0	105	
30	17	1	31.0	2.88	2.91	80.3	120	
0	19	1	38.4	2.97	9.69	80.5	135	
15	19	1	35.6	2.95	3.55	83.8	150	
30	19	1	29.8	2.80	2.58	81.8	165	
0	21	1	38.4	2.77	29.38	79.7	180	
15	21	1	61.2	2.71	4.84	68.2	195	
30	21	1	51.1	2.54	3.55	65.2	210	
0	21	3	38.6	2.86	10.66	78.6	225	
15	21	3	32.6	2.86	2.91	79.3	240	
30	21	3	32.1	2.82	2.26	79.6	255	
0	18	1	32.4	2.99	6.14	84.9	270	
15	18	1	31.4	2.88	4.20	79.8	285	
30	18	1	29.8	2.80	2.91	77.1	300	
0	20	1	28.7	2.98	8.07	83.2	315	
15	20	1	28.2	2.95	3.55	82.5	330	
30	20	1	26.4	2.85	2.58	80.9	345	

TABLE A2. EMISSIONS DATA FOR 120-POINT TRAVERSE AT 30 PERCENT POWER (CONTINUED).

0	21	10	31.0	2.72	5.49	77.7	0	7.58
15	21	10	26.8	2.76	2.58	78.2	15	
30	21	10	26.4	2.67	2.26	76.7	30	
0	21	12	43.1	2.54	6.14	78.9	45	
15	21	12	29.4	2.83	2.26	80.9	60	
30	21	12	28.0	2.71	2.26	80.0	75	
0	21	5	29.8	2.96	6.78	78.2	90	
15	21	5	32.6	2.95	2.58	80.4	105	
30	21	5	31.7	2.82	2.26	78.4	120	
0	21	7	32.4	2.74	6.46	78.5	135	
15	21	7	32.8	2.84	2.26	76.9	150	
30	21	7	31.7	2.74	2.58	75.2	165	
0	21	9	29.4	2.73	6.46	77.7	180	
15	21	9	31.4	2.71	2.58	77.0	195	
30	21	9	35.8	2.58	2.91	73.2	210	
0	21	11	26.8	2.73	5.49	69.1	225	
15	21	11	39.6	2.75	2.58	73.3	240	
30	21	11	34.2	2.72	2.26	75.3	255	
0	21	6	30.7	2.75	6.46	78.2	270	
15	21	6	32.1	2.90	2.58	80.9	285	
30	21	6	31.0	2.74	2.26	77.8	300	
0	21	8	30.7	2.81	5.81	76.7	315	
15	21	8	28.7	2.83	2.58	77.8	330	
30	21	8	27.8	2.74	2.58	76.6	345	
0	21	18	28.4	2.60	4.84	72.6	0	4.61
15	21	18	30.1	2.65	2.26	73.6	15	
30	21	18	28.9	2.58	2.58	73.3	30	
0	21	20	30.3	2.63	4.52	73.7	45	
15	21	20	27.1	2.67	1.94	75.0	60	
30	21	20	26.2	2.59	2.26	75.0	75	
0	21	13	28.2	2.72	5.49	75.6	90	
15	21	13	26.8	2.65	2.26	75.2	105	
30	21	13	26.8	2.58	2.26	75.1	120	
0	21	15	36.1	2.52	5.81	75.3	135	
15	21	15	28.2	2.63	2.26	75.2	150	
30	21	15	28.2	2.56	2.26	74.0	165	
0	21	17	35.8	2.54	5.49	74.4	180	
15	21	17	29.4	2.62	2.26	74.1	195	
30	21	17	29.4	2.59	2.26	73.3	210	
0	21	19	31.0	2.58	4.84	73.2	225	
15	21	19	31.7	2.63	2.26	73.2	240	
30	21	19	33.5	2.52	2.58	71.5	255	
0	21	14	26.4	2.61	4.84	70.0	270	
15	21	14	36.8	2.57	2.91	69.3	285	
30	21	14	36.3	2.51	2.91	68.5	300	
0	21	16	28.0	2.59	4.84	70.7	315	
14	21	16	32.8	2.64	2.58	72.0	330	
30	21	16	31.7	2.57	2.26	72.5	345	
AVG			32.6	2.79	5.56	78.0		
STD DEV			7.2	0.13	5.11	4.6		
AREA WT AVG			33.1	2.82	6.22	78.8		

TABLE A2. EMISSIONS DATA FOR 120-POINT TRAVERSE AT 30 PERCENT POWER (CONTINUED).

PMS	FAKE SWITCH		CD	CALCULATED EMISSIONS LEVELS		NOX	F/R	COMB
	A	B		HC/RS (CH4)	LBS/1000 LBS FUEL			
0	6	1	1.85	0.60	10.14	0.01356	99.90	
15	6	1	2.17	0.22	9.89	0.01355	99.93	
30	6	1	2.18	0.14	9.63	0.01340	99.94	
0	8	1	2.08	0.60	10.09	0.01343	99.90	
15	8	1	2.08	0.22	9.88	0.01343	99.93	
30	8	1	2.15	0.15	9.64	0.01312	99.94	
0	1	1	2.39	0.44	9.89	0.01297	99.91	
15	1	1	2.39	0.19	9.65	0.01337	99.93	
30	1	1	2.29	0.12	9.74	0.01346	99.94	
0	3	1	2.61	0.37	9.51	0.01340	99.91	
15	3	1	2.57	0.24	10.17	0.01322	99.92	
30	3	1	2.14	0.14	10.78	0.01297	99.94	
0	5	1	3.62	1.25	9.64	0.01311	99.81	
15	5	1	4.76	0.33	8.76	0.01277	99.86	
30	5	1	3.37	0.19	9.05	0.01273	99.90	
0	7	1	2.81	0.46	9.46	0.01316	99.89	
15	7	1	2.46	0.20	9.43	0.01285	99.92	
30	7	1	2.16	0.13	9.50	0.01324	99.94	
0	2	1	2.10	0.49	9.89	0.01349	99.91	
15	2	1	2.18	0.26	9.70	0.01340	99.93	
30	2	1	1.94	0.12	9.72	0.01337	99.94	
0	4	1	2.01	0.33	9.53	0.01353	99.92	
15	4	1	1.96	0.24	9.70	0.01336	99.94	
30	4	1	1.74	0.12	9.93	0.01339	99.95	

TABLE A2. EMISSIONS DATA FOR 120-POINT TRAVERSE AT 30 PERCENT POWER (CONTINUED).

0	14	1	2.05	0.58	9.89	0.01396	99.90
15	14	1	2.28	0.18	9.77	0.01358	99.93
30	14	1	2.08	0.13	9.70	0.01405	99.94
0	16	1	2.03	0.51	10.18	0.01374	99.91
15	16	1	2.24	0.20	9.79	0.01324	99.93
30	16	1	2.30	0.13	9.54	0.01327	99.94
0	9	1	2.42	0.49	9.64	0.01362	99.90
15	9	1	2.32	0.17	9.38	0.01402	99.93
30	9	1	2.05	0.13	9.58	0.01371	99.94
0	11	1	2.88	0.43	9.60	0.01362	99.90
15	11	1	2.20	0.18	10.28	0.01418	99.93
30	11	1	2.02	0.14	10.65	0.01318	99.94
0	13	1	4.66	1.48	9.03	0.01318	99.76
15	13	1	4.72	0.29	8.54	0.01292	99.86
30	13	1	3.14	0.16	9.29	0.01279	99.91
0	15	1	2.51	0.42	9.41	0.01368	99.91
15	15	1	2.26	0.17	9.65	0.01334	99.93
30	15	1	2.13	0.12	9.79	0.01361	99.94
0	10	1	2.21	0.33	9.60	0.01411	99.92
15	10	1	2.07	0.23	9.70	0.01358	99.93
30	10	1	1.97	0.15	9.30	0.01371	99.94
0	12	1	1.86	0.30	9.54	0.01430	99.93
15	12	1	1.86	0.20	9.82	0.01420	99.94
30	12	1	1.77	0.13	9.85	0.01427	99.95
0	21	2	4.90	0.56	10.18	0.01362	99.91
15	21	2	2.10	0.14	9.78	0.01352	99.94
30	21	2	2.17	0.11	9.90	0.01306	99.94
0	21	4	2.05	0.52	10.35	0.01396	99.91
15	21	4	2.10	0.12	9.93	0.01352	99.94
30	21	4	2.28	0.12	10.01	0.01266	99.94
0	17	1	2.38	0.48	9.85	0.01396	99.90
15	17	1	2.29	0.16	9.36	0.01421	99.93
30	17	1	2.19	0.12	9.70	0.01358	99.94
0	19	1	2.62	0.39	9.40	0.01406	99.90
15	19	1	2.45	0.15	9.88	0.01393	99.93
30	19	1	2.16	0.11	10.13	0.01324	99.94
0	21	1	2.81	1.28	9.97	0.01311	99.82
15	21	1	4.57	0.22	8.72	0.01283	99.87
30	21	1	4.08	0.17	8.87	0.01203	99.89
0	21	3	2.75	0.45	9.53	0.01353	99.90
15	21	3	2.31	0.12	9.65	0.01349	99.94
30	21	3	2.31	0.10	9.81	0.01331	99.94
0	18	1	2.19	0.25	9.85	0.01414	99.93
15	18	1	2.22	0.18	9.64	0.01358	99.93
30	18	1	2.16	0.13	9.55	0.01324	99.94
0	20	1	1.95	0.33	9.70	0.01402	99.93
15	20	1	1.94	0.15	9.70	0.01395	99.94
30	20	1	1.88	0.11	9.86	0.01346	99.95

TABLE A2. EMISSIONS DATA FOR 120-POINT INVERSE AT 50 PERCENT POWER (CONCLUDED).

0	21	10	2.31	0.24	9.89	0.01288	99.92
15	21	10	1.97	0.11	9.81	0.01306	99.94
30	21	10	2.00	0.10	9.96	0.01263	99.94
0	21	12	3.44	0.29	10.74	0.01203	99.89
15	21	12	2.11	0.10	9.92	0.01337	99.94
30	21	12	2.10	0.10	10.24	0.01281	99.94
0	21	5	2.04	0.28	9.17	0.01399	99.93
15	21	5	2.24	0.11	9.47	0.01393	99.94
30	21	5	2.28	0.10	9.66	0.01331	99.94
0	21	7	2.39	0.28	9.93	0.01297	99.92
15	21	7	2.34	0.10	9.39	0.01343	99.94
30	21	7	2.34	0.11	9.51	0.01297	99.94
0	21	9	2.18	0.29	9.87	0.01291	99.92
15	21	9	2.36	0.12	9.87	0.01278	99.93
30	21	9	2.82	0.14	9.83	0.01220	99.92
0	21	11	1.99	0.24	8.77	0.01290	99.93
15	21	11	2.92	0.11	9.25	0.01300	99.92
30	21	11	2.55	0.10	9.61	0.01285	99.93
0	21	6	2.27	0.28	9.86	0.01300	99.92
15	21	6	2.25	0.11	9.68	0.01371	99.94
30	21	6	2.29	0.10	9.84	0.01297	99.94
0	21	8	2.22	0.25	9.43	0.01328	99.93
15	21	8	2.06	0.11	9.55	0.01337	99.94
30	21	8	2.06	0.11	9.71	0.01293	99.94
0	21	18	2.22	0.23	9.63	0.01229	99.93
15	21	18	2.31	0.10	9.64	0.01251	99.94
30	21	18	2.27	0.12	9.84	0.01220	99.94
0	21	20	2.34	0.21	9.72	0.01242	99.93
15	21	20	2.06	0.09	9.73	0.01263	99.94
30	21	20	2.05	0.11	10.04	0.01223	99.94
0	21	13	2.11	0.24	9.64	0.01284	99.93
15	21	13	2.05	0.10	9.83	0.01254	99.94
30	21	13	2.11	0.11	10.03	0.01220	99.94
0	21	15	2.90	0.28	10.34	0.01193	99.91
15	21	15	2.18	0.10	9.90	0.01244	99.94
30	21	15	2.24	0.11	10.04	0.01208	99.94
0	21	17	2.86	0.26	10.13	0.01202	99.91
15	21	17	2.27	0.10	9.81	0.01238	99.94
30	21	17	2.30	0.11	9.82	0.01223	99.94
0	21	19	2.44	0.23	9.83	0.01220	99.92
15	21	19	2.45	0.10	9.66	0.01242	99.93
30	21	19	2.70	0.12	9.82	0.01193	99.93
0	21	14	2.05	0.22	9.31	0.01232	99.93
15	21	14	2.90	0.14	9.35	0.01214	99.92
30	21	14	2.93	0.14	9.45	0.01187	99.92
0	21	16	2.20	0.23	9.47	0.01223	99.93
14	21	16	2.52	0.12	9.46	0.01248	99.93
30	21	16	2.50	0.11	9.78	0.01214	99.93
AVG			2.39	0.24	9.72	0.01316	99.92
DWERALL	AVG		2.38	0.24	9.71	0.01316	99.92
STD DEV			0.56	0.22	0.36	0.00063	0.03
AREA WT	AVG		2.40	0.27	9.71	0.01331	99.92

TABLE A3. EMISSIONS DATA FOR 120-POINT TRAVERSE AT 85 PERCENT POWER.

TEST - FFA DETAIL TRAV CF6-50 DATE - 8/18/80
 CELL - 2 RUN - 2 FUEL - JETA
 CAL TIME = 730 HUM = 115.0 FUEL H/C = 1.92

RDG 259 POINT 85

RAKE POS	SWITCH		ACTUAL GAS ANALYSIS				POSITION	
	A	B	CO SEMI-DRY (PPM)	CO2 SEMI-DRY (PCT)	HC WET (PPM)	NOX WET (PPM)	CIRCUM (DEG)	RADIAL (IN)
0	6	1	22.9	4.42	0.97	291.6	0	16.49
15	6	1	21.3	4.37	0.65	285.6	15	
30	6	1	14.4	4.35	0.32	290.4	30	
0	8	1	22.7	4.21	0.65	275.9	45	
15	8	1	20.4	4.24	0.97	278.3	60	
30	8	1	15.8	4.32	0.32	277.1	75	
0	1	1	24.7	4.43	1.61	275.9	90	
15	1	1	23.6	4.45	0.	282.0	105	
30	1	1	18.0	4.33	0.32	273.5	120	
0	3	1	24.5	4.43	0.97	282.0	135	
15	3	1	22.5	4.37	0.	283.2	150	
30	3	1	17.5	4.56	0.	295.2	165	
0	5	1	28.6	4.42	0.65	269.9	180	
15	5	1	25.6	4.37	0.32	263.9	195	
30	5	1	16.4	4.40	0.	265.1	210	
0	7	1	24.9	4.26	0.32	255.4	225	
15	7	1	22.7	4.28	0.65	261.5	240	
30	7	1	14.4	4.27	0.	266.3	255	
0	2	1	23.1	4.40	1.61	277.1	270	
15	2	1	20.4	4.37	0.32	288.0	285	
30	2	1	14.2	4.45	0.65	304.8	300	
0	4	1	22.2	4.51	0.97	306.1	315	
15	4	1	21.6	4.49	0.32	306.1	330	
30	4	1	13.1	4.45	0.32	302.4	345	

TABLE A3. EMISSIONS DATA FOR 120-POINT TRAVERSE AT 85 PERCENT POWER (CONTINUED).

0	14	1	24.3	4.41	0.65	289.2	0	13.52
15	14	1	22.9	4.48	0.97	289.2	15	
30	14	1	13.1	4.37	0.65	292.8	30	
0	16	1	24.7	4.31	0.32	280.7	45	
15	16	1	20.9	4.31	1.29	278.3	60	
30	16	1	16.7	4.49	0.65	282.0	75	
0	9	1	27.9	4.59	0.32	286.8	90	
15	9	1	24.7	4.50	0.65	280.7	105	
30	9	1	17.1	4.48	0.	282.0	120	
0	11	1	26.3	4.59	0.32	291.6	135	
15	11	1	23.4	4.43	0.65	285.6	150	
30	11	1	18.9	4.54	0.	291.6	165	
0	13	1	30.2	4.45	0.32	268.7	180	
15	13	1	27.2	4.46	0.65	268.7	195	
30	13	1	20.2	4.51	0.	268.7	210	
0	15	1	26.5	4.40	0.32	262.7	225	
15	15	1	22.9	4.27	0.97	259.1	240	
30	15	1	16.4	4.42	0.32	274.7	255	
0	10	1	24.9	4.56	0.65	288.0	270	
15	10	1	21.6	4.45	0.97	292.8	285	
30	10	1	15.1	4.61	0.32	313.3	300	
0	12	1	26.3	4.62	0.65	308.5	315	
15	12	1	22.5	4.56	0.65	306.1	330	
30	12	1	12.2	4.46	0.32	303.6	345	
0	21	2	25.6	4.37	0.32	285.6	0	10.55
15	21	2	22.9	4.35	1.29	282.0	15	
30	21	2	20.2	4.52	0.65	280.7	30	
0	21	4	27.0	4.28	0.32	275.9	45	
15	21	4	22.7	4.29	1.29	277.1	60	
30	21	4	23.1	4.31	0.32	283.2	75	
0	17	1	29.9	4.48	0.32	275.9	90	
15	17	1	26.8	4.50	1.29	277.1	105	
30	17	1	18.4	4.55	0.32	282.0	120	
0	19	1	28.6	4.54	0.32	288.0	135	
15	19	1	24.5	4.38	1.29	278.3	150	
30	19	1	16.7	4.51	0.32	277.1	165	
0	21	1	29.5	4.43	0.	271.1	180	
15	21	1	25.6	4.22	1.29	259.1	195	
30	21	1	19.8	4.56	0.32	254.2	210	
0	21	3	29.5	4.41	0.	259.1	225	
15	21	3	24.9	4.32	0.97	255.4	240	
30	21	3	20.4	4.54	0.32	256.7	255	
0	18	1	27.4	4.45	0.32	277.1	270	
15	18	1	24.0	4.37	1.61	274.7	285	
30	18	1	17.3	4.62	0.65	306.1	300	
0	20	1	29.3	4.65	0.65	310.9	315	
15	20	1	24.5	4.43	1.61	291.6	330	
30	20	1	18.4	4.52	0.65	294.0	345	

TABLE A3. EMISSIONS DATA FOR 120-POINT TRAVERSE AT 85 PERCENT POWER (CONTINUED).

0	21	10	24.5	4.19	0.	273.5	0	7.58
15	21	10	21.6	4.16	1.61	269.9	15	
30	21	10	26.3	4.56	0.	312.1	30	
0	21	12	27.0	4.22	0.32	272.3	45	
15	21	12	23.4	4.12	1.61	267.5	60	
30	21	12	25.6	4.61	0.	308.5	75	
0	21	5	28.8	4.36	0.	268.7	90	
15	21	5	26.1	4.31	0.97	265.1	105	
30	21	5	28.1	4.62	0.	263.9	120	
0	21	7	28.1	4.35	0.	265.1	135	
15	21	7	24.7	4.28	1.29	266.3	150	
30	21	7	24.7	4.35	0.	280.7	165	
0	21	9	25.6	4.22	0.	263.9	180	
15	21	9	22.5	4.13	1.29	257.9	195	
30	21	9	29.7	4.41	0.	283.2	210	
0	21	11	30.8	4.33	0.97	251.8	225	
15	21	11	26.1	4.23	1.29	250.6	240	
30	21	11	26.5	4.55	0.	291.6	255	
0	21	6	28.6	4.25	0.32	256.7	270	
15	21	6	23.6	4.19	1.61	259.1	285	
30	21	6	24.9	4.61	0.32	300.0	300	
0	21	8	26.8	4.42	0.32	290.4	315	
15	21	8	23.4	4.31	1.61	284.4	330	
30	21	8	23.4	4.45	0.32	313.3	345	
0	21	18	25.4	4.07	0.32	278.3	0	4.61
15	21	18	21.8	4.11	1.61	268.7	15	
30	21	18	24.9	4.26	0.	292.8	30	
0	21	20	24.0	4.02	0.32	260.3	45	
15	21	20	21.8	4.04	1.61	263.9	60	
30	21	20	27.2	4.59	0.	303.6	75	
0	21	13	24.9	4.02	0.65	255.4	90	
15	21	13	22.7	4.13	1.61	261.5	105	
30	21	13	25.4	4.24	0.	282.0	120	
0	21	15	25.4	4.00	0.65	249.4	135	
15	21	15	23.4	4.09	1.29	253.0	150	
30	21	15	27.0	4.23	0.	277.1	165	
0	21	17	26.1	4.05	0.32	251.8	180	
15	21	17	22.5	4.09	1.29	256.7	195	
30	21	17	26.5	4.14	0.	269.9	210	
0	21	19	27.2	4.02	0.32	245.8	225	
15	21	19	25.6	4.09	1.29	244.6	240	
30	21	19	28.8	4.27	0.	265.1	255	
0	21	14	27.4	4.17	0.97	250.6	270	
15	21	14	23.8	4.14	1.94	251.8	285	
30	21	14	26.1	4.27	0.	283.2	300	
0	21	16	26.1	4.09	0.97	251.8	315	
15	21	16	22.9	4.18	1.94	266.3	330	
30	21	16	26.1	4.45	0.	309.7	345	
AVG			23.5	4.36	0.61	277.4		
STD DEV			4.1	0.17	0.54	17.0		
AREA WT AVG			22.8	4.40	0.59	279.6		

TABLE A3. EMISSIONS DATA FOR 120-POINT TRAVERSE AT 85 PERCENT POWER (CONTINUED).

RAKE POS	SWITCH		CALCULATED EMISSIONS LEVELS				F/A SAMPLE	COMB EFF
	A	B	CO	HC (AS CH4) LBS/1000	NO LBS FUEL	NOX		
0	6	1	1.05	0.03		23.33	0.02078	99.97
15	6	1	0.99	0.02		23.07	0.02058	99.98
30	6	1	0.67	0.01		23.58	0.02048	99.98
0	8	1	1.09	0.02		23.14	0.01981	99.97
15	8	1	0.97	0.03		23.15	0.01998	99.97
30	8	1	0.74	0.01		22.64	0.02024	99.98
0	1	1	1.13	0.04		22.04	0.02082	99.97
15	1	1	1.07	0.		22.38	0.02095	99.98
30	1	1	0.84	0.01		22.31	0.02038	99.98
0	3	1	1.12	0.03		22.52	0.02082	99.97
15	3	1	1.04	0.		22.91	0.02055	99.98
30	3	1	0.78	0.		22.93	0.02142	99.98
0	5	1	1.31	0.02		21.59	0.02079	99.97
15	5	1	1.19	0.01		21.35	0.02055	99.97
30	5	1	0.75	0.		21.28	0.02071	99.98
0	7	1	1.18	0.01		21.18	0.02005	99.97
15	7	1	1.07	0.02		21.57	0.02015	99.97
30	7	1	0.68	0.		22.01	0.02011	99.98
0	2	1	1.06	0.05		22.24	0.02072	99.97
15	2	1	0.95	0.01		23.26	0.02058	99.98
30	2	1	0.65	0.02		24.20	0.02095	99.98
0	4	1	1.00	0.03		24.03	0.02119	99.97
15	4	1	0.97	0.01		24.10	0.02112	99.98
30	4	1	0.59	0.01		24.01	0.02095	99.99

TABLE A3. EMISSIONS DATA FOR 120-POINT TRAVERSE AT 85 PERCENT POWER (CONTINUED).

0	14	1	1.11	0.02	23.17	0.02075	99.97
15	14	1	1.03	0.03	22.81	0.02109	99.97
30	14	1	0.61	0.02	23.66	0.02058	99.98
0	16	1	1.16	0.01	23.01	0.02028	99.97
15	16	1	0.98	0.04	22.81	0.02028	99.97
30	16	1	0.75	0.02	22.21	0.02112	99.98
0	9	1	1.23	0.01	22.13	0.02157	99.97
15	9	1	1.11	0.02	22.08	0.02116	99.97
30	9	1	0.77	0.	22.28	0.02105	99.98
0	11	1	1.16	0.01	22.50	0.02156	99.97
15	11	1	1.07	0.02	22.81	0.02082	99.97
30	11	1	0.84	0.	22.72	0.02136	99.98
0	13	1	1.37	0.01	21.36	0.02092	99.97
15	13	1	1.23	0.02	21.29	0.02099	99.97
30	13	1	0.91	0.	21.06	0.02122	99.98
0	15	1	1.22	0.01	21.12	0.02068	99.97
15	15	1	1.03	0.03	21.41	0.02011	99.97
30	15	1	0.75	0.01	21.98	0.02078	99.98
0	10	1	1.10	0.02	22.33	0.02146	99.97
15	10	1	0.98	0.03	23.28	0.02092	99.97
30	10	1	0.66	0.01	24.07	0.02166	99.98
0	12	1	1.15	0.02	23.66	0.02170	99.97
15	12	1	1.00	0.02	23.77	0.02143	99.98
30	12	1	0.55	0.01	24.07	0.02098	99.99
0	21	2	1.19	0.01	23.10	0.02055	99.97
15	21	2	1.06	0.04	22.89	0.02048	99.97
30	21	2	0.90	0.02	21.97	0.02126	99.98
0	21	4	1.27	0.01	22.76	0.02015	99.97
15	21	4	1.07	0.04	22.82	0.02018	99.97
30	21	4	0.97	0.01	20.88	0.02259	99.98
0	17	1	1.35	0.01	21.80	0.02106	99.97
15	17	1	1.20	0.04	21.79	0.02116	99.97
30	17	1	0.82	0.01	21.93	0.02139	99.98
0	19	1	1.27	0.01	22.43	0.02136	99.97
15	19	1	1.13	0.04	22.45	0.02062	99.97
30	19	1	0.75	0.01	21.73	0.02122	99.98
0	21	1	1.34	0.	21.62	0.02085	99.97
15	21	1	1.23	0.04	21.65	0.01988	99.97
30	21	1	0.88	0.01	19.71	0.02146	99.98
0	21	3	1.35	0.	20.76	0.02075	99.97
15	21	3	1.17	0.03	20.87	0.02035	99.97
30	21	3	0.91	0.01	20.03	0.02132	99.98
0	18	1	1.25	0.01	22.03	0.02092	99.97
15	18	1	1.11	0.05	22.23	0.02055	99.97
30	18	1	0.76	0.02	23.44	0.02173	99.98
0	20	1	1.27	0.02	23.66	0.02187	99.97
15	20	1	1.12	0.04	23.29	0.02082	99.97
30	20	1	0.82	0.02	23.01	0.02126	99.98

TABLE A3. EMISSIONS DATA FOR 120-POINT TRAVERSE AT 85 PERCENT POWER (CONCLUDED).

0	21	10	1.18	0.	23.01	0.01975	99.97
15	21	10	1.05	0.05	22.90	0.01958	99.97
30	21	10	1.17	0.	24.23	0.02143	99.97
0	21	12	1.29	0.01	22.76	0.01928	99.97
15	21	12	1.15	0.05	22.88	0.01941	99.97
30	21	12	1.12	0.	23.70	0.02167	99.97
0	21	5	1.34	0.	21.77	0.02052	99.97
15	21	5	1.22	0.03	21.73	0.02028	99.97
30	21	5	1.23	0.	20.24	0.02170	99.97
0	21	7	1.31	0.	21.55	0.02045	99.97
15	21	7	1.17	0.04	21.97	0.02015	99.97
30	21	7	1.15	0.	22.79	0.02048	99.97
0	21	9	1.23	0.	22.09	0.01935	99.97
15	21	9	1.10	0.04	22.02	0.01945	99.97
30	21	9	1.36	0.	22.69	0.02075	99.97
0	21	11	1.44	0.03	20.54	0.02032	99.96
15	21	11	1.25	0.04	20.91	0.01991	99.97
30	21	11	1.18	0.	22.68	0.02139	99.97
0	21	6	1.36	0.01	21.31	0.02002	99.97
15	21	6	1.14	0.05	21.83	0.01971	99.97
30	21	6	1.09	0.01	23.05	0.02167	99.97
0	21	8	1.22	0.01	23.23	0.02079	99.97
15	21	8	1.10	0.05	23.31	0.02028	99.97
30	21	8	1.06	0.01	24.91	0.02092	99.97
0	21	18	1.26	0.01	24.09	0.01918	99.97
15	21	18	1.07	0.05	23.06	0.01935	99.97
30	21	18	1.18	0.	24.27	0.02005	99.97
0	21	20	1.21	0.01	22.84	0.01892	99.97
15	21	20	1.09	0.05	23.00	0.01905	99.97
30	21	20	1.20	0.	23.40	0.02160	99.97
0	21	13	1.25	0.02	22.38	0.01895	99.97
15	21	13	1.11	0.05	22.33	0.01945	99.97
30	21	13	1.21	0.	23.49	0.01995	99.97
0	21	15	1.29	0.02	22.00	0.01882	99.97
15	21	15	1.15	0.04	21.79	0.01928	99.97
30	21	15	1.29	0.	23.12	0.01991	99.97
0	21	17	1.30	0.01	21.91	0.01908	99.97
15	21	17	1.11	0.04	22.10	0.01928	99.97
30	21	17	1.30	0.	23.01	0.01948	99.97
0	21	19	1.37	0.01	21.57	0.01892	99.97
15	21	19	1.27	0.04	21.07	0.01928	99.97
30	21	19	1.36	0.	21.94	0.02002	99.97
0	21	14	1.33	0.03	21.19	0.01965	99.97
15	21	14	1.16	0.06	21.44	0.01951	99.97
30	21	14	1.24	0.	23.43	0.02008	99.97
0	21	16	1.29	0.03	21.72	0.01925	99.97
15	21	16	1.11	0.06	22.48	0.01968	99.97
30	21	16	1.19	0.	24.62	0.02092	99.97
AVG			1.09	0.02	22.46	0.02053	99.97
OVERALL AVG			1.09	0.02	22.47	0.02053	99.97
STD DEV			0.20	0.02	1.01	0.00078	0.01
APER WT AVG			1.05	0.02	22.48	0.02062	99.97