

Handwritten: COPY 1
Handwritten: 2

WING SPILLAGE TESTS USING ANTIMISTING FUEL

Robert F. Salmon

FEDERAL AVIATION ADMINISTRATION
FEB 18 1981

TECHNICAL CENTER LIBRARY
ATLANTIC CITY, N.J. 08405



FINAL REPORT

FEBRUARY 1981

Document is available to the U.S. public through
the National Technical Information Service,
Springfield, Virginia 22161.

Prepared for

**U. S. DEPARTMENT OF TRANSPORTATION
FEDERAL AVIATION ADMINISTRATION
TECHNICAL CENTER
Atlantic City Airport, N.J. 08405**

United State/Wing spillage tests using a

4
81



00008136

//

NOTICE

This document is disseminated under the sponsorship of the Department of Transportation in the interest of information exchange. The United States Government assumes no liability for the contents or use thereof.

The United States Government does not endorse products or manufacturers. Trade or manufacturer's names appear herein solely because they are considered essential to the object of this report.

1. Report No. FAA-CT-81-11		2. Government Accession No.		3. Recipient's Catalog No.	
4. Title and Subtitle WING SPILLAGE TESTS USING ANTIMISTING FUEL				5. Report Date February 1981	
				6. Performing Organization Code	
7. Author(s) Robert F. Salmon				8. Performing Organization Report No. FAA-CT-81-11	
9. Performing Organization Name and Address Federal Aviation Administration Technical Center Atlantic City Airport, New Jersey 08405				10. Work Unit No. (TRAIS)	
				11. Contract or Grant No. 181-520-100	
12. Sponsoring Agency Name and Address U.S. Department of Transportation Federal Aviation Administration Atlantic City Airport, New Jersey 08405				13. Type of Report and Period Covered Final March 1979 - November 1980	
				14. Sponsoring Agency Code	
15. Supplementary Notes					
16. Abstract Fuel spillage tests were conducted to evaluate the performance of an antimisting fuel (FM-9 with glycol/amine carrier fluid) in a simulated crash environment. The results of the tests are: (1) FM-9 when compared with neat Jet A afforded flammability protection even under test conditions which resulted in a "fail" for the FM-9; (2) 0.3% 80°F FM-9 provided excellent fire resistance at air-shearing velocities up to 125 knots; (3) spillage rates from 20 to 60 gallons per second yielded similar results; (4) fuel temperature impacted the antimisting performance of the fuel, 47° fuel and 110°F fuel provided fire resistance at air-shearing velocities of 133 and 116 knots, respectively; (5) additive concentration affected fire resistance performance with 0.2 percent and 0.35 percent providing protection at air-shearing velocities of 99 knots and 142 knots, respectively; (6) MK40 rockets used as an ignition source did not alter the basic fire resistance properties of the fuel; (7) the height above the ground of the fuel release point did not affect the test results; (8) the discharge orifice shape did not affect the tests results; (9) engine fuel ingestion tests indicated that fuel quantity ingested was the governing factor as to whether engine surge occurs; (10) deceleration tests indicated that the safety range of FM-9 is about 30 knots higher in deceleration tests versus steady-state spillage tests.					
17. Key Words Antimisting Modified fuels Post-crash fire Fuel mist flammability Rheology			18. Distribution Statement Document is available to the U.S. public through the National Technical Information Service, Springfield, Virginia 22161		
19. Security Classif. (of this report) Unclassified		20. Security Classif. (of this page) Unclassified		21. No. of Pages 48	22. Price

METRIC CONVERSION FACTORS

Approximate Conversions to Metric Measures

Symbol	When You Know	Multiply by	To Find	Symbol
LENGTH				
in	inches	2.5	centimeters	cm
ft	feet	30	centimeters	cm
yd	yards	0.9	meters	m
mi	miles	1.6	kilometers	km
AREA				
in ²	square inches	6.5	square centimeters	cm ²
ft ²	square feet	0.09	square meters	m ²
yd ²	square yards	0.8	square meters	m ²
mi ²	square miles	2.6	square kilometers	km ²
	acres	0.4	hectares	ha
MASS (weight)				
oz	ounces	28	grams	g
lb	pounds	0.45	kilograms	kg
	short tons (2000 lb)	0.9	tonnes	t
VOLUME				
tsp	teaspoons	5	milliliters	ml
Tbsp	tablespoons	15	milliliters	ml
fl oz	fluid ounces	30	milliliters	ml
c	cups	0.24	liters	l
pt	pints	0.47	liters	l
qt	quarts	0.95	liters	l
gal	gallons	3.8	liters	l
ft ³	cubic feet	0.03	cubic meters	m ³
yd ³	cubic yards	0.76	cubic meters	m ³
TEMPERATURE (exact)				
°F	Fahrenheit temperature	5/9 (after subtracting 32)	Celsius temperature	°C

*1 in = 2.54 (exactly). For other exact conversions and more detailed tables, see NBS Misc. Publ. 286, Units of Weights and Measures, Price \$2.25, SD Catalog No. C13.10:286.

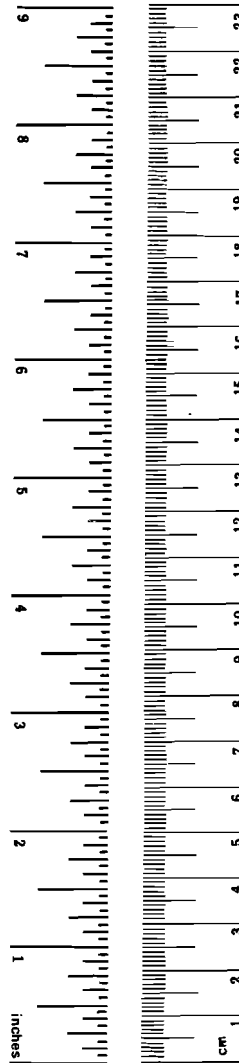

Approximate Conversions from Metric Measures

Symbol	When You Know	Multiply by	To Find	Symbol
LENGTH				
mm	millimeters	0.04	inches	in
cm	centimeters	0.4	inches	in
m	meters	3.3	feet	ft
m	meters	1.1	yards	yd
km	kilometers	0.6	miles	mi
AREA				
cm ²	square centimeters	0.16	square inches	in ²
m ²	square meters	1.2	square yards	yd ²
km ²	square kilometers	0.4	square miles	mi ²
ha	hectares (10,000 m ²)	2.5	acres	
MASS (weight)				
g	grams	0.035	ounces	oz
kg	kilograms	2.2	pounds	lb
t	tonnes (1000 kg)	1.1	short tons	
VOLUME				
ml	milliliters	0.03	fluid ounces	fl oz
l	liters	2.1	pints	pt
l	liters	1.06	quarts	qt
l	liters	0.26	gallons	gal
m ³	cubic meters	35	cubic feet	ft ³
m ³	cubic meters	1.3	cubic yards	yd ³
TEMPERATURE (exact)				
°C	Celsius temperature	9/5 (then add 32)	Fahrenheit temperature	°F

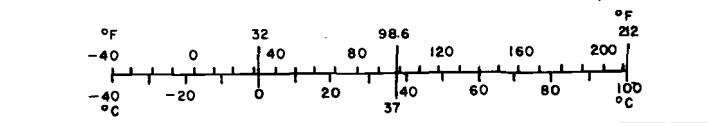

TABLE OF CONTENTS

	Page
INTRODUCTION	1
Purpose	1
DISCUSSION	1
Test Design	1
Facility Description	1
RESULTS	18
General	18
Test Results	23
CONCLUSIONS	42
REFERENCES	44
APPENDIX	

LIST OF ILLUSTRATIONS

Figure		Page
1	Aircraft Population vs Landing Speed	2
2	Wing Spillage Test Facility	3
3	Augmentor Air Velocity at Horizontal Centerline (21 feet Aft)	5
4	Augmentor Air Velocity at Horizontal Centerline (57 feet Aft)	6
5	Augmentor Air Velocity at Horizontal Centerline (93 feet Aft)	7
6	Augmentor Velocity Decline vs. Distance Aft of Exit	8
7	Fuel Spillage System Schematic	9
8	Fuel Spillage vs. Time (20 gallons per second)	10
9	Fuel Spillage vs. Time (60 gallons per second)	11
10	Ignition System Schematic	13
11	Aft Torch Ignition System Schematic	14
12	Photo Sequence of Test No. 64	16
13	Photo Sequence of Test No. 63	17
14	Fireball Silhouettes of Test No. 64	19
15	Fireball Silhouettes of Test No. 63	20
16	Effective Fireball Radius vs. Time (No.64)	21
17	Effective Fireball Radius vs. Time (No.63)	22
18	Jet A Baseline Test Results	25
19	Group 2 Results (Velocity)	26
20	Group 3 Results (Spillage)	27
21	Group 4 Results (Fuel Temperature)	29
22	Group 5 Results (Fuel Additive Concentration)	30
23	Group 6 Rocket Exhaust Silhouettes	32
24	Group 7 Results (Ground Level Effects)	34

LIST OF ILLUSTRATIONS (Continued)

Figure		Page
25.	Group 8 Orifice Configurations	35
26	Group 8 Results (Orifice Configuration)	36
27	Engine Ingestion Photo Sequence	38
28	Group 10 Results (Deceleration)	41
29	Group 10 Deceleration Calibration	43

LIST OF TABLES

Table		Page
1	Test Control Sequence	12
2	Test Summary	24

INTRODUCTION

The Federal Aviation Administration (FAA) initiated a program in July 1978, to evaluate the performance of an antimisting fuel when it is released into a high speed airstream. This was to simulate the phenomena which occurs when an aircraft crashes, rupturing wing tanks and releasing fuel as the aircraft decelerates to a stop. Impact survivable crashes have resulted in fatalities due to fires which develop from air sheared fuel mist that ignites in an almost explosive manner when exposed to an ignition source or from fuel pool fires ignited by a mist fire.

The definition of "survivable crash" is open to discussion; however, for this program it is considered to be a crash which occurs at speeds as high as 145 knots. A fuel which would resist misting and explosive ignition, and propagation at this speed would provide protection at normal landing speeds for approximately 99 percent of the current commercial carriers (figure 1).

PURPOSE.

The effort described in this report is intended to develop information and techniques which would predict and evaluate the performance of an antimisting fuel in a crash situation. Essentially, it describes the test facilities and techniques designed and developed to simulate the fuel spillage which would occur in a crash for evaluation of the effectiveness of the antimisting agent. The "typical" crash, which one could simulate on a full-scale basis by crashing aircraft, is extremely expensive. Many variables enter into the crash situation and sorting out these variables is time consuming and expensive. The wing-spillage test was designed to develop a correlation between a full-scale crash and a controlled large spillage simulation of the various parameters which enter into a

full-scale crash. This report describes the effort and the results obtained from this work.

DISCUSSION

TEST DESIGN.

The wing-spillage tests were planned to evaluate the parameters pertinent to the flammability resistance of antimisting fuel when the antimisting fuel is released into an airstream simulating a ruptured wing tank during a crash. These parameters include the following:

1. Baseline tests with neat Jet A fuel
2. Air-shearing velocity
3. Fuel-spillage rate
4. Fuel and air temperature
5. Additive concentration in the fuel
6. Ignition location and intensity
7. Height of wing rupture above ground
8. Rupture (orifice) configuration
9. Aft-mounted engine ingestion of spilled fuel
10. Deceleration impact on spillage characteristics

FACILITY DESCRIPTION.

The facility consists of a simulated airfoil with a fuel-spillage system and a high volume, medium velocity, external wind tunnel. The major components include: an augmentor, a turbofan engine, a fuel delivery system, an airfoil section, an ignition system, and instrumentation for monitoring and controlling the tests.

AUGMENTOR. Figure 2 is an illustration of the facility design which consists of a 30-inch diameter primary airstream duct which supplies unvitiated fan air developed by a TF 33 engine. This duct releases the fan air through a square nozzle into the throat of a bellmouth.

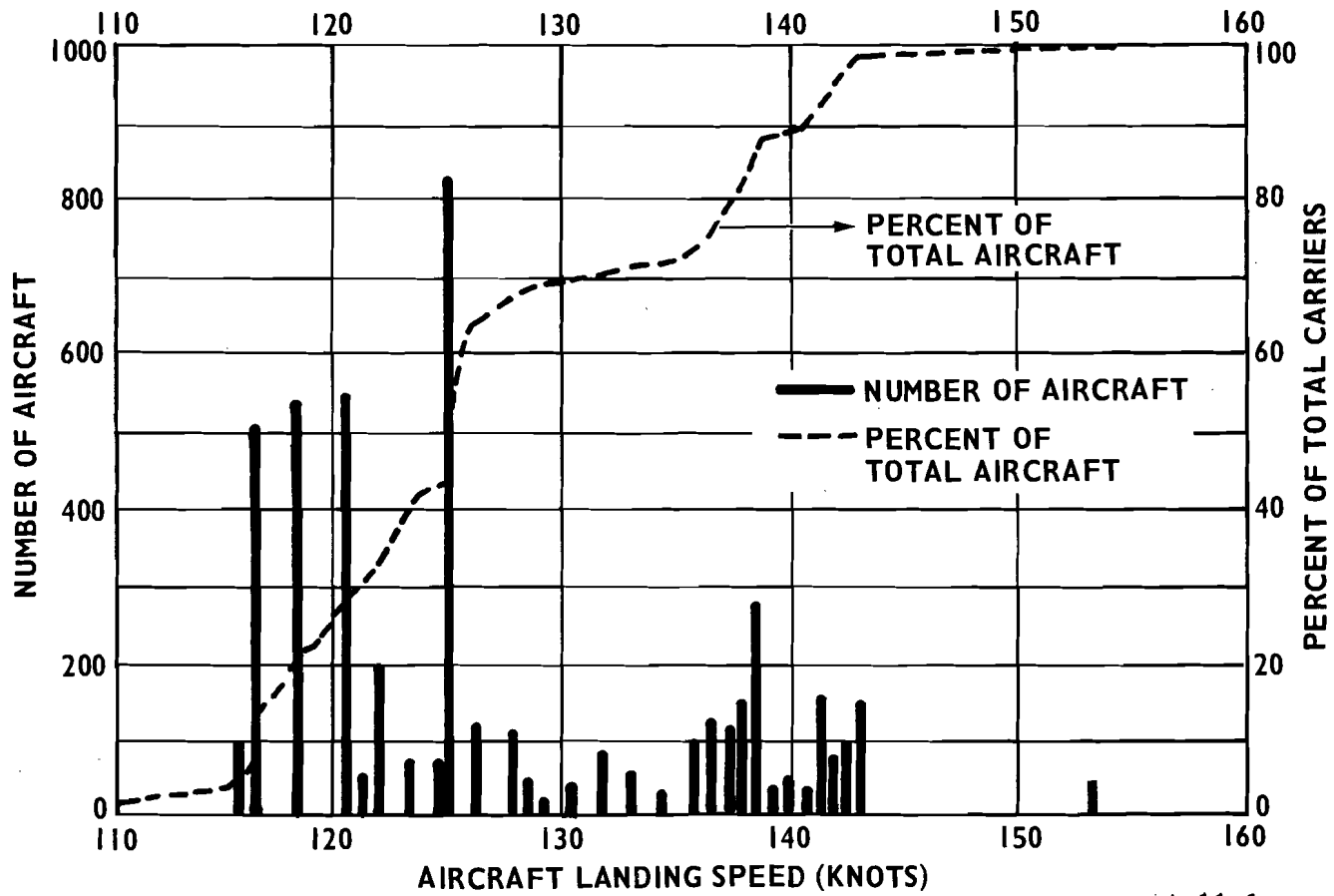

81-11-1

FIGURE 1. AIRCRAFT POPULATION VS. LANDING SPEED

3

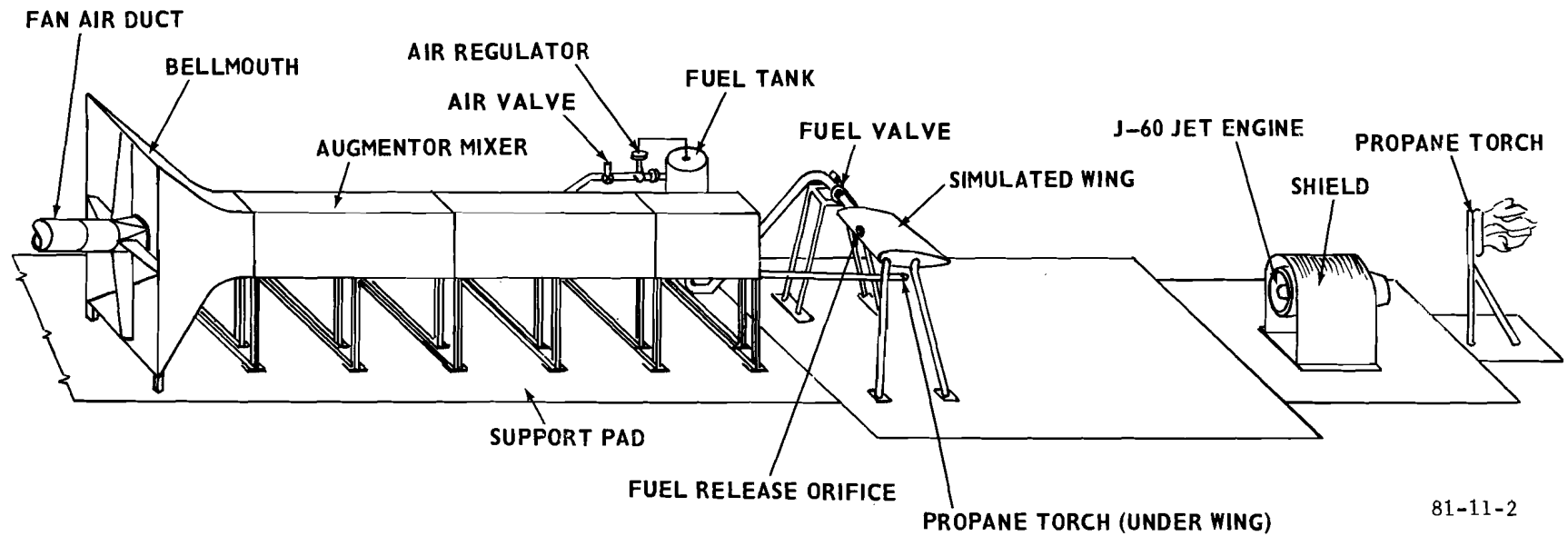

81-11-2

FIGURE 2. WING SPILLAGE TEST FACILITY

The bellmouth, a 20-foot by 20-foot square which reduces to a 69-inch square, is designed to act as a collector for the augmentation of the primary airstream. At 95 percent of the rated power of the TF 33 engine, the primary airstream delivers approximately 200 pounds/second of air at a nominal pressure 1.6 times the ambient atmosphere. The primary airstream discharge velocity at this condition is about 550 knots through the square nozzle. An additional airflow of approximately 400 pounds/second is induced into the bellmouth. The two airstreams mix through a 50-foot long, square mixing duct.

The velocity profile across the exit face of the duct is shown in figure 3. Calibrations of the facility were made at the outset of the program. Adjustments to correct for the slight deviation from the ideal symmetrical profile were considered unwarranted. Figures 4 and 5 show similar airstream calibrations at points 3 feet and 6 feet aft of the point where the figure 3 calibration was made. These figures and figure 6 show the rate of decline of airstream velocity as a function of distance from the augmentor exit.

A simulated wing is located 16 feet aft of the augmentor exit. At the leading edge of the wing is an orifice plate which regulates the fuel spillage rate during a test.

The effective air-shearing velocity acting on the fuel is the sum of its release velocity and the counter-flowing airstream velocity. For example, when the fuel velocity is 16 knots forward and the nominal air velocity is 130 knots, the fuel which extends approximately 7 feet forward of the orifice actually experiences an air-shearing velocity which is the sum of the two stream velocities at that point (figure 6). In this example, the fuel would be subjected to a 131 knot air-shearing force (115-knot air + 16-knot fuel).

FUEL-SPILLAGE SYSTEM. The fuel-spillage system design consists of a tank, piping, valves, gauges, and thermocouples as shown in figure 7. Prior to a test, the fuel is pressurized and is moved through the 12-inch diameter piping up to the face of a 12-inch butterfly valve (valve A) set in the closed position. Beyond the butterfly valve are 14 feet of 12-inch diameter pipe which ducts the fuel to the release point located at the projected center line of the augmentor airstream, 16 feet aft of the exit plane of the augmentor. The fuel tank is pressurized using air regulated to a range of 10 to 18 inches of mercury above ambient. The regulator is sized to assure a sufficient flow of air to maintain essentially constant pressure (± 1 inHg) in the tank as the fuel level in the tank declines during a test. This pressure variation, shown in figure 8, results in approximately ± 1.2 knots variation in fuel velocity. Calibrations of the effectiveness and accuracy of this approach are shown in figures 8 and 9, which show the buildup of the flow rate, the steady flow-spillage rate for approximately 4 seconds, and the declining flow rate as the test concludes. Fuel, when released, is expelled forward through the orifice in the leading edge of the simulated wing, counter to the airstream flow. Typically, to release 20 gallons per second (gal/sec) through a 4 1/4-inch diameter orifice requires a driving gauge pressure of 14 inHg. This pressure pushes the fuel approximately 8 feet forward of the release point against a 120- to 140-knot airstream. To vary the spillage rate, the orifice size is changed while maintaining the same driving pressure.

IGNITION SYSTEM. Several different ignition sources were used in the tests reported herein. These include (1) a steadily burning propane torch providing a flame about 5 feet long and 6 inches in diameter in still air, and (2) a similar torch which intermittently burned a regulated volume of propane

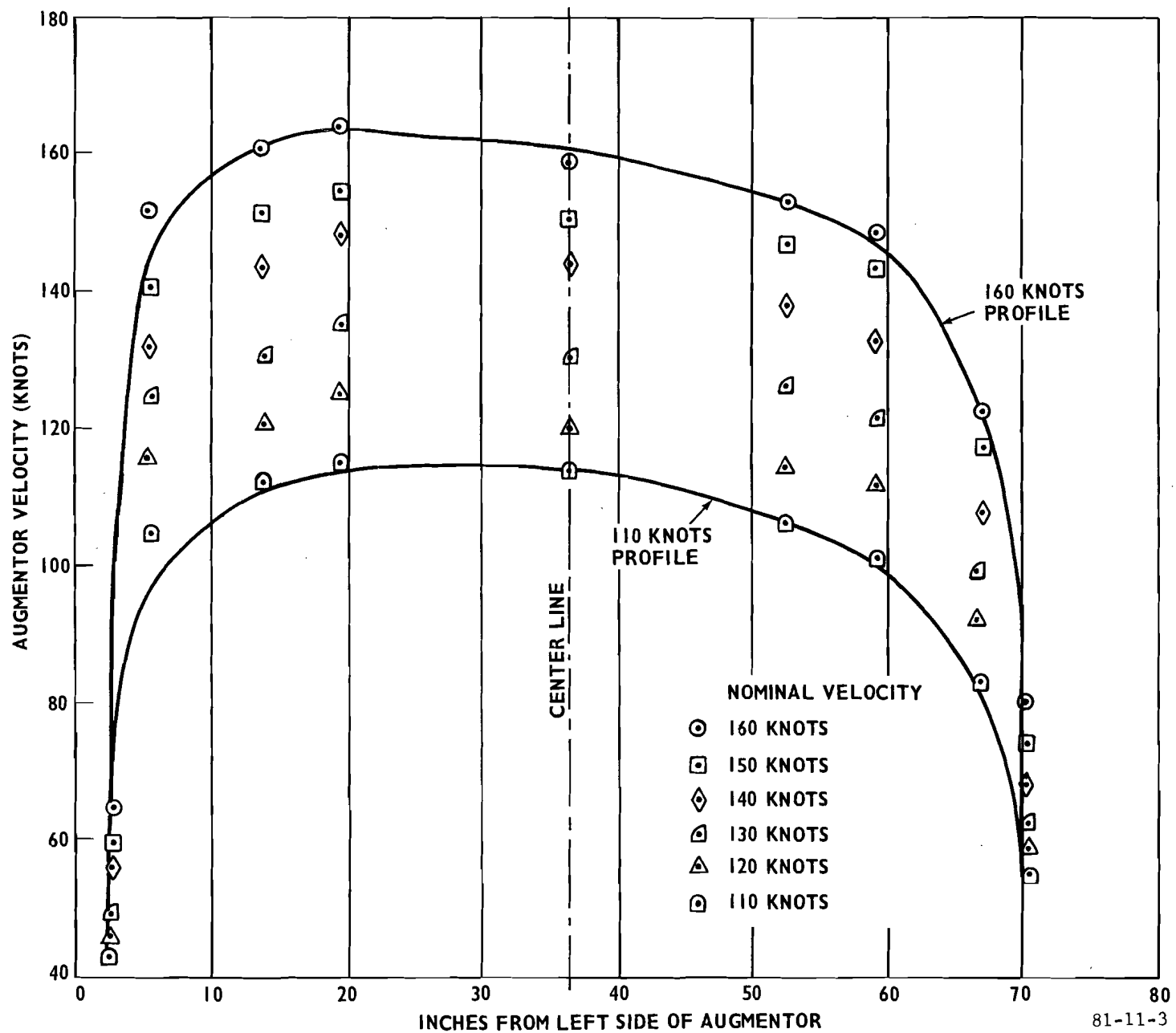

FIGURE 3. AUGMENTOR AIR VELOCITY AT HORIZONTAL CENTERLINE (21 FEET AFT)

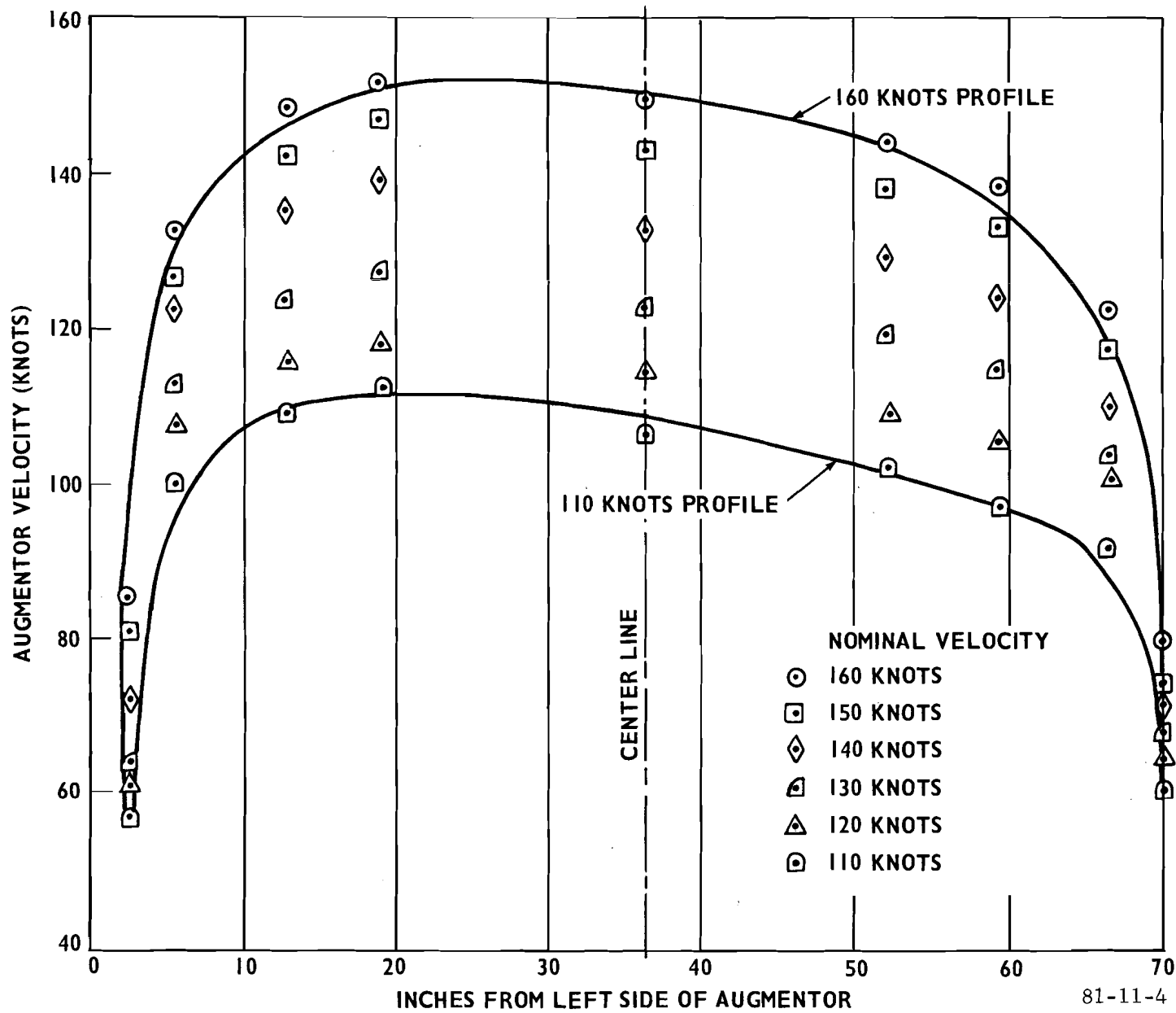

FIGURE 4. AUGMENTOR AIR VELOCITY AT HORIZONTAL CENTERLINE (57 FEET AFT)

81-11-4

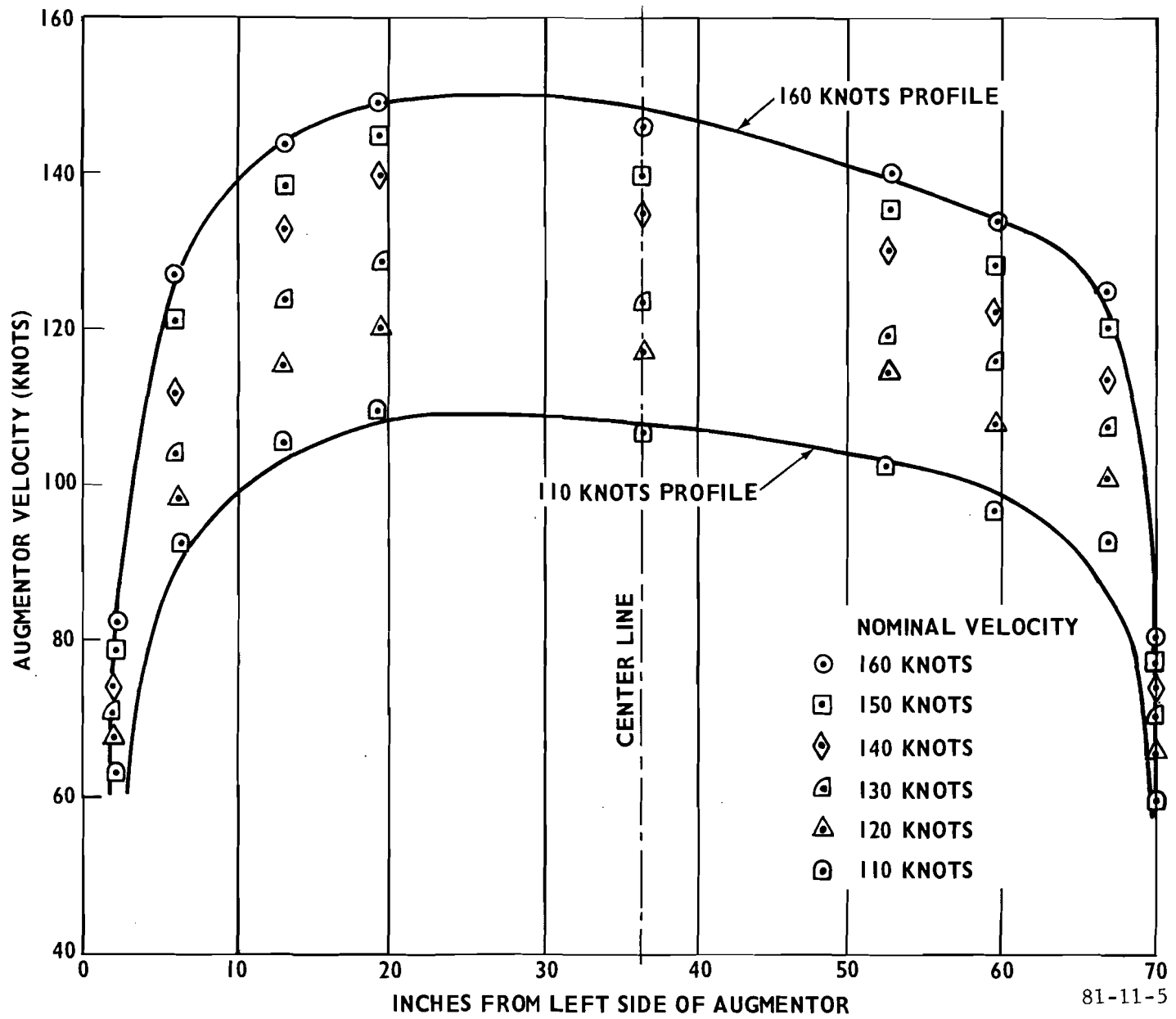

FIGURE 5. AUGMENTOR AIR VELOCITY AT HORIZONTAL CENTERLINE (93 FEET AFT)

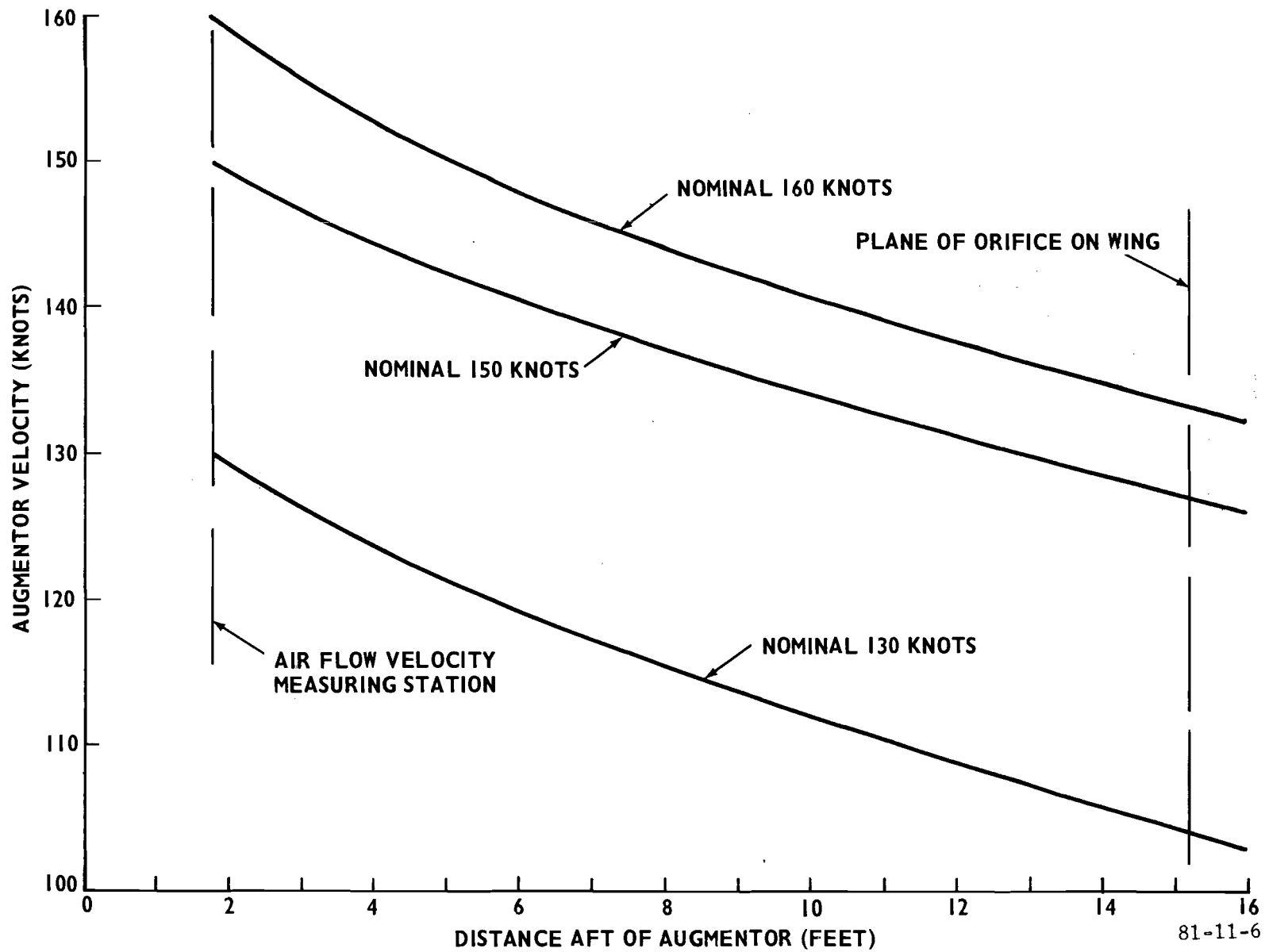
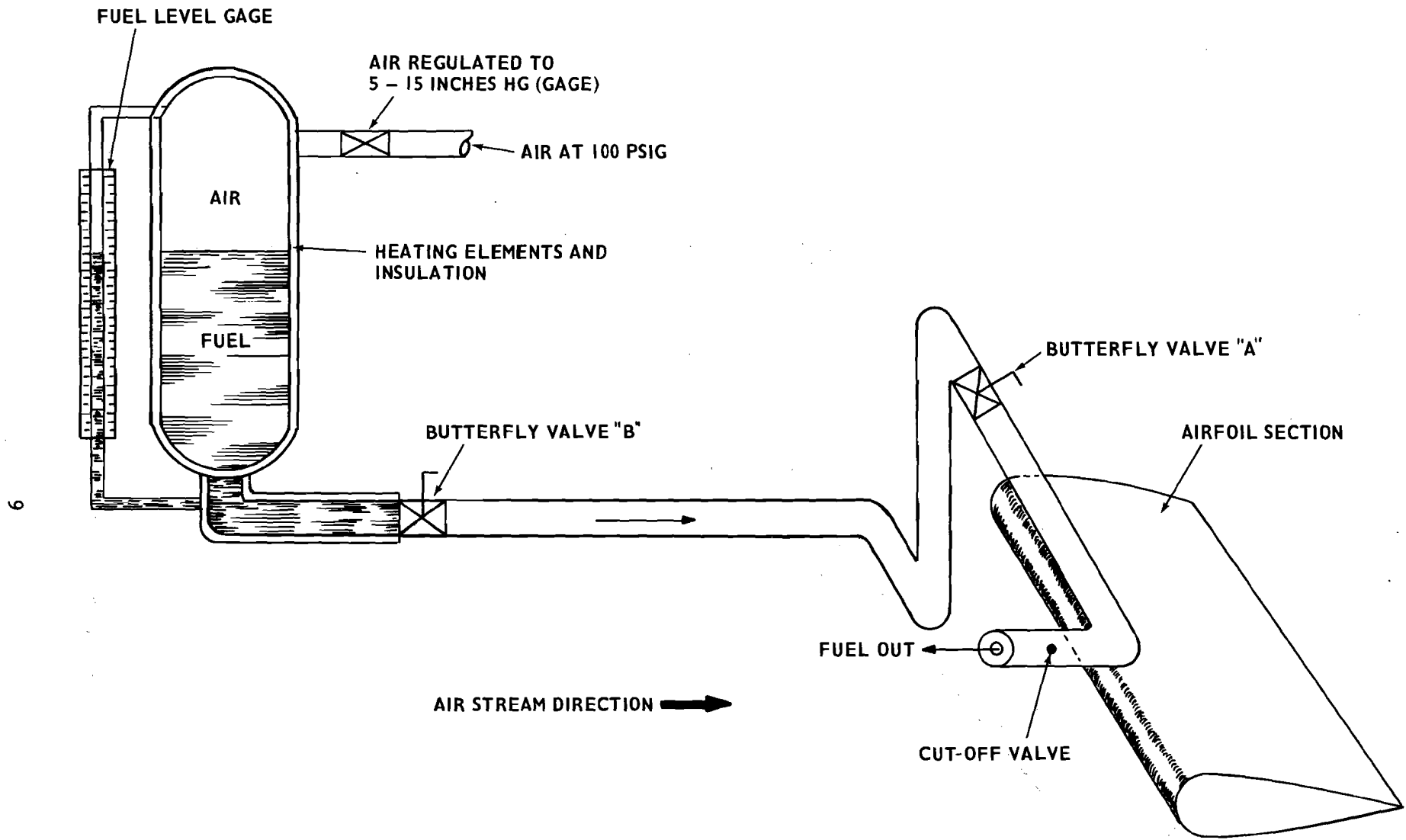

FIGURE 6. AUGMENTOR VELOCITY DECLINE VS. DISTANCE AFT OF EXIT



81-11-7

FIGURE 7. FUEL SPILLAGE SYSTEM SCHEMATIC

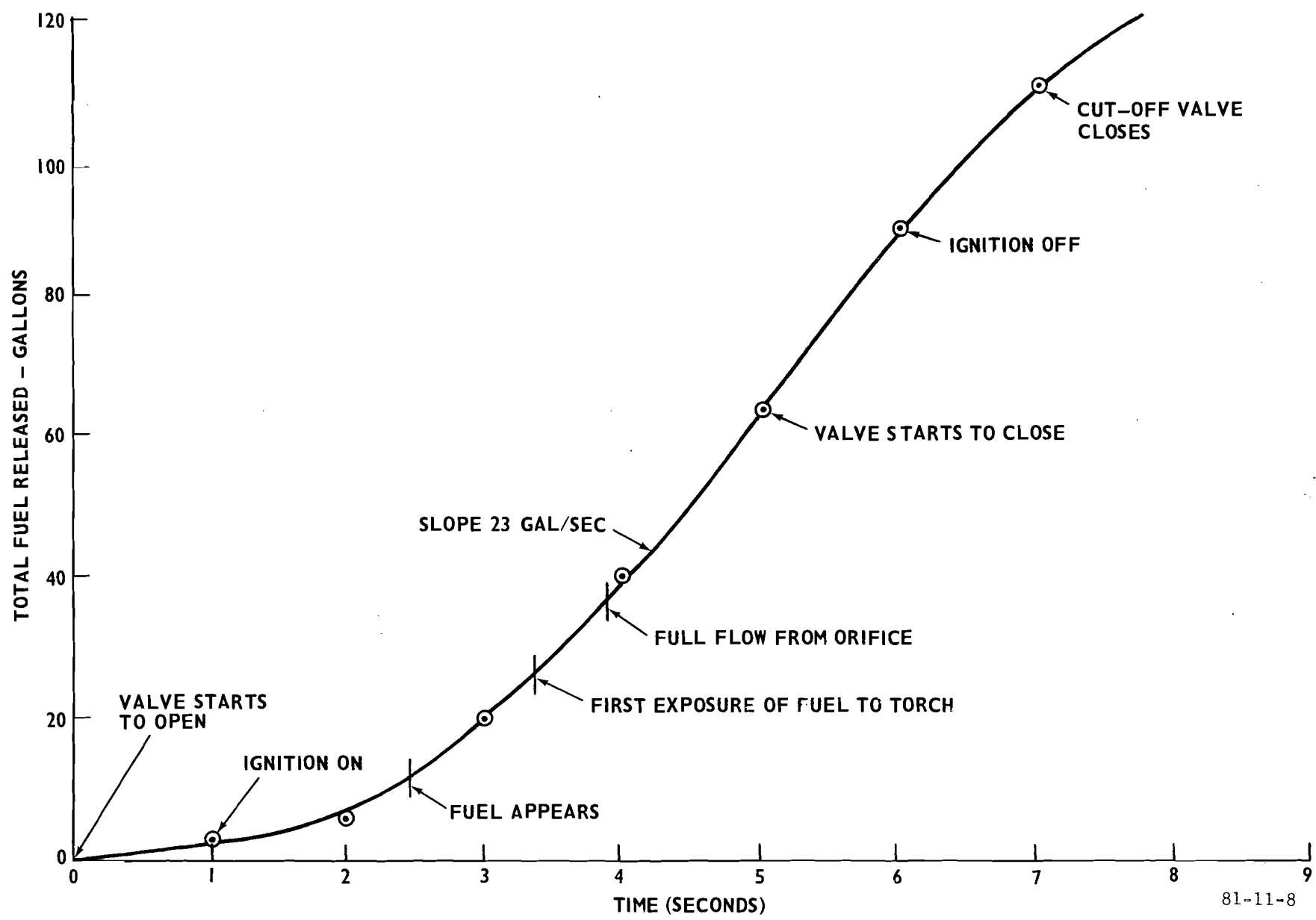

FIGURE 8. FUEL SPILLAGE VS. TIME (20 GALLONS PER SECOND)

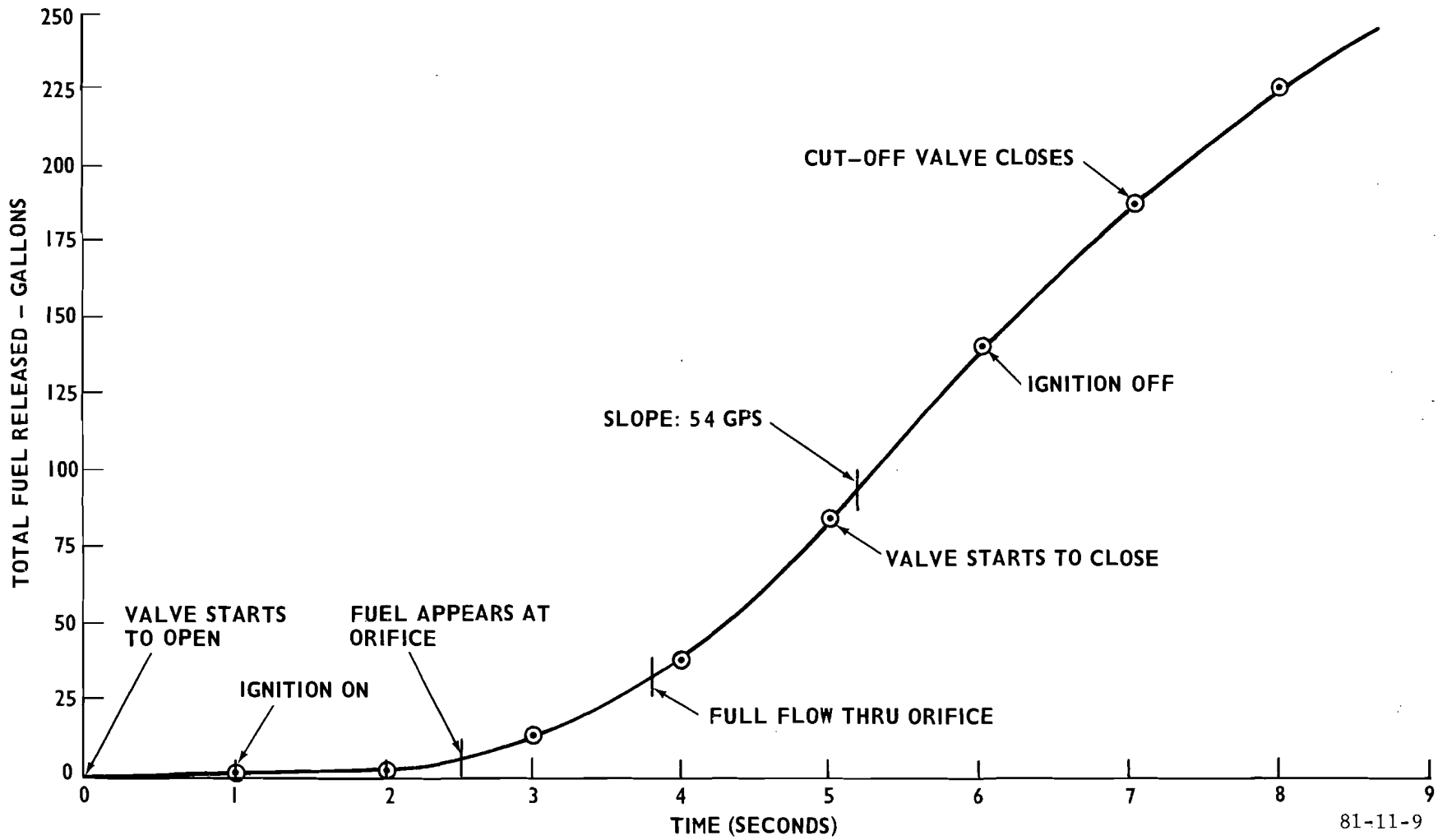

FIGURE 9. FUEL SPILLAGE VS. TIME (60 GALLONS PER SECOND)

(17.5 cubic inches at 40 pounds per second) for about 1/2 second, interspersed with no flame for 1 second. These torches were located 3 feet under the wing and 4.5 feet aft of the fuel release point, along the projected vertical centerline of the augmentor airstream. The propane torch temperatures were approximately 1100° F. A propane torch was also used in special tests where a direct comparison of Jet A and FM-9 was required for demonstration purposes. In these tests, the torch was located 40 feet aft of the fuel-release point. This was done to reduce the possibility of facility damage when testing Jet A. In other special tests, the ignition source was a cluster of MK40 rockets (Mighty Mouse rocket motors) located in a stand 40 feet aft of the fuel release point, 5 feet below the projected horizontal centerline of the augmentor airstream and along the projected vertical centerline of the airstream. A cluster of five rockets, each rocket having a burn period of 1.5 seconds and ignition overlap of 1/2 a second were used. (Thus, all five

rockets would be burned in a total time period of 5.5 seconds). The temperature of this ignition source was in the 3000° F range. A fourth ignition source used in the tests were J60 turbojet engines located 40 feet aft of the fuel release point in the vertical centerline of the augmentor airflow and 5 feet below the horizontal centerline of the flow. The engines were operated on Jet A fuel at 75 percent and 95 percent power during these tests. Figures 10 and 11 are schematics of the ignition sources used in the various tests.

INSTRUMENTATION AND TEST PROCEDURE.
Basic tests conducted during the program were of 5-second duration. In analyzing the test requirements, it was recognized that the transient nature of the operation would necessitate a quick response data acquisition system and a means of conducting tests in a repetitive manner. To assure uniformity in the conduct of the test, the various operations were actuated by an automatic sequencer which performed the operations as shown in table 1.

TABLE 1. TEST CONTROL SEQUENCE

<u>Time</u>	<u>Operation Number</u>	<u>Operation</u>
-5 Sec	1	Sequence Initiating Warning Lights On
-3 Sec	2	Instrumentation on (Cameras, Data Acquisition, Recorders)
0	3	Fuel Valve starts to Open (Start of Test)
1	4	Ignition on (*1, *2)
5 Sec	5	Fuel Valve starts to Close
6 Sec	6	Ignition Off (End of Test)
7 Sec	7	Fuel Cut-Off Valve Closes

Notes:

* (1) When J60 ingestion tests were conducted, the J60 engine was stabilized at the 75 percent or 95 percent power before starting the automatic sequencer. If no flameout occurred, the engines continued at the pre-set power while the sequencer controlled operations were completed. At the conclusion of a test, the J60 engine was then manually shut down.

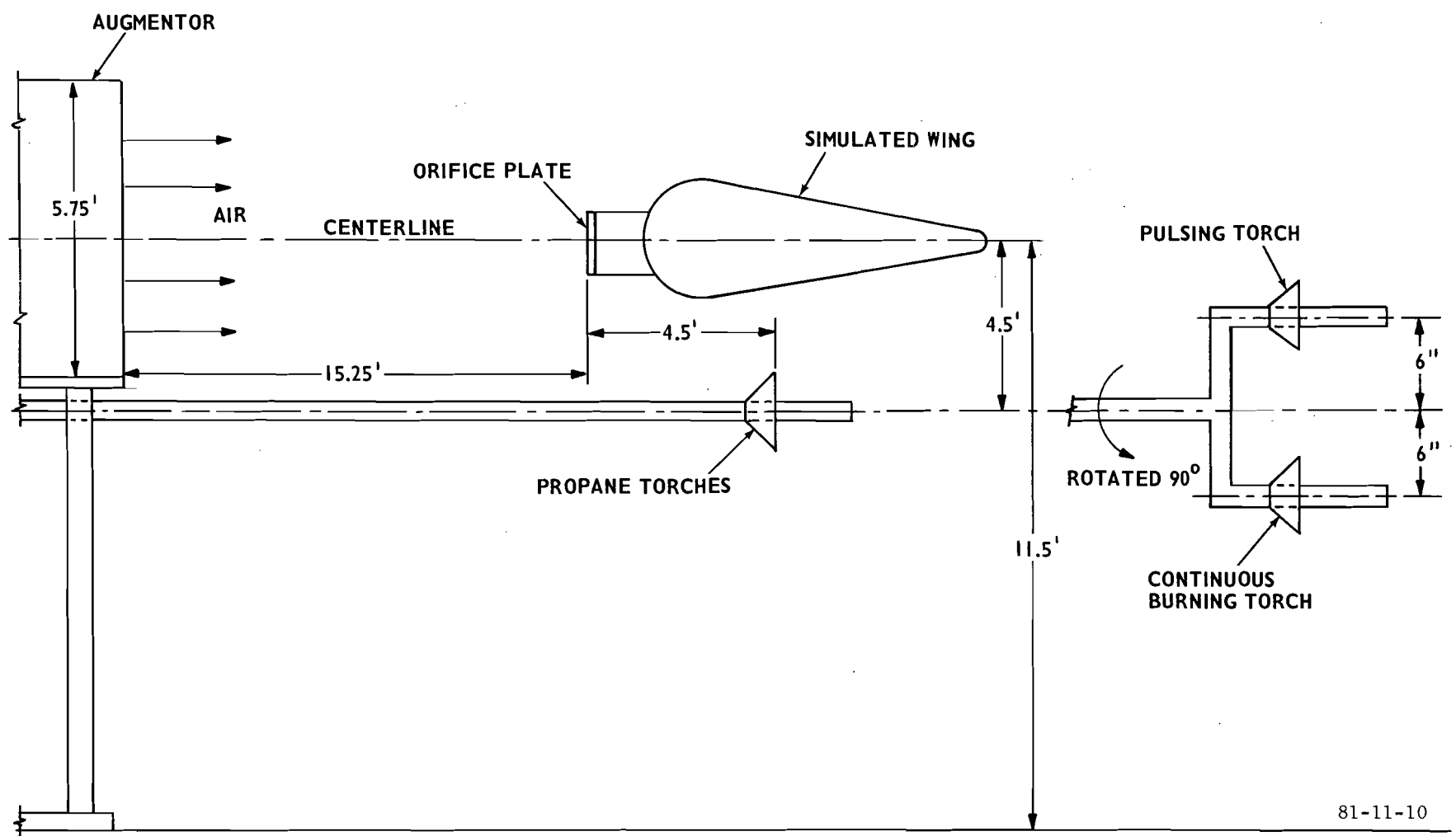

FIGURE 10. IGNITION SYSTEM SCHEMATIC

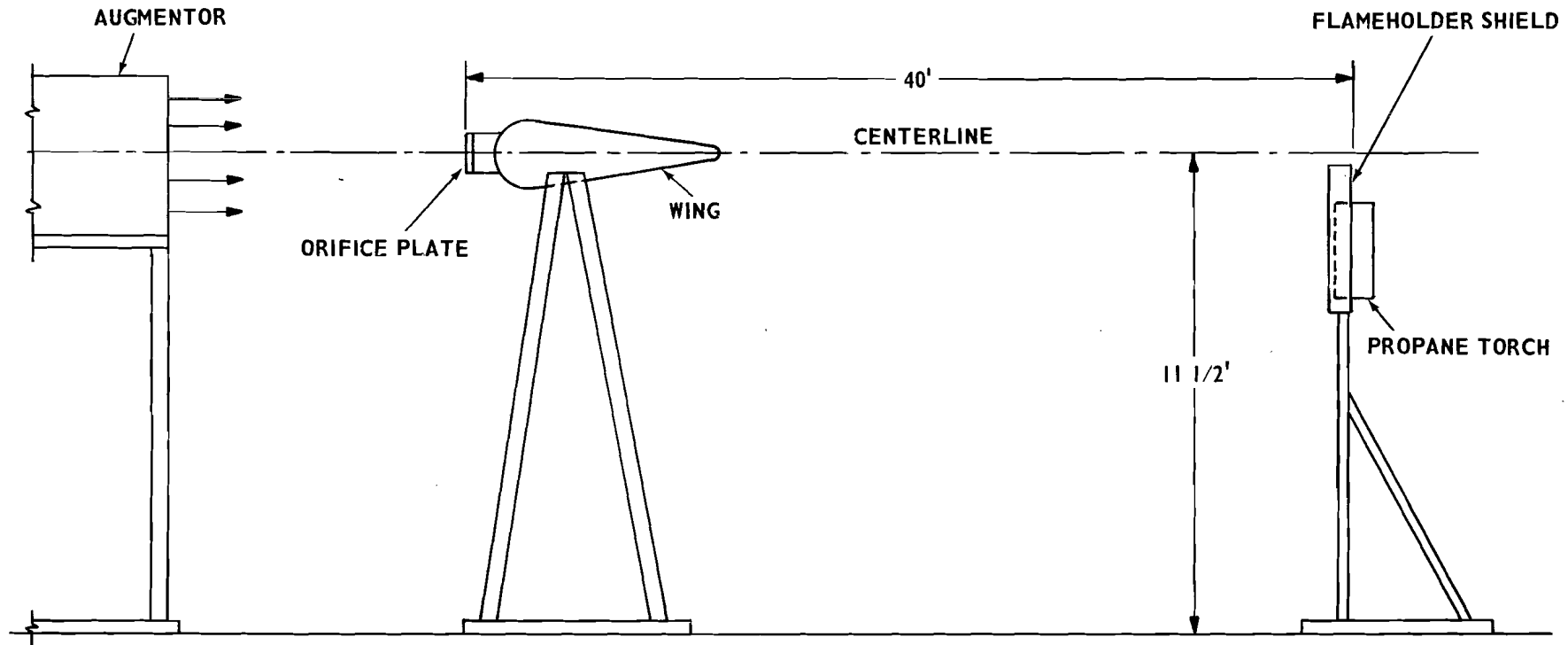

FIGURE 11. AFT TORCH IGNITION SYSTEM SCHEMATIC

*(2) When a propane torch was located 40 feet aft of the leading edge of the wing (during several special tests), the torch was ignited prior to the start of the tests and was not incorporated in the sequencer.

The instrumentation which supported the test operation consisted of (1) temperature measurements of the fuel in the tank and in the 12-inch pipe leading to the orifice, (2) pressure measurements of air in the fuel tank, (3) total and static pressure measurements of the augmentor airstream, (4) ambient atmospheric pressure and temperature, and (5) the total temperature of the augmentor airstream. In addition to this, measurements of TF 33 engine parameters such as N_1 and N_2 rotor speed, exhaust gas temperature, and fuel-flow were also recorded.

Pre-test preparations included loading the fuel in the tank, pressurizing the tank, priming the fuel up to the 12-inch butterfly valve (valve A), and bleeding air trapped ahead of the fuel. The desired air-shearing velocity for each test was controlled by monitoring the centerline augmentor air velocity using a pitot/static probe at the augmentor horizontal and vertical centerline 21 inches aft of the augmentor exit. The pitot probe supplied inputs to a 0-15 inch H_2O , bourdon tube type differential pressure gauge (Magnehelic). This was used for visual monitoring of the air velocity. The differential pressure was read on the gauge and was simultaneously recorded on the data acquisition system during a test. The automatic test sequencer was activated when the augmentor airspeed stabilized at the target speed for a test. Photographic coverage, the primary source of data collection, included the rate of flow of fuel from the fuel tank, the variation in air pressure in the fuel tank during fuel discharge, and three different high-speed views of the test itself as it proceeded. These three views were the prime source of information on the performance of the fuel during a test. The three views were as follows:

1. Close-up view of the wing and ignition source; 500 frames per second.

2. Overall view of the test scene encompassing the augmentor exit, the wing, ignition sources and 150 feet aft of the fuel release point; 200 frames per second.

3. Close-up, 3/4 view looking forward at the wing and the ignition source; 200 frames per second.

These views were selected to provide as much information as possible about the relative droplet size of the fuels, the density of the spray, the exposure to ignition, the actual exposure time of fuel-to-ignition, and the qualitative overall view of the test scene. Camera speeds were selected to provide this information in the most appropriate manner. Figure 12 displays sequence photographs of the type of fire and flame development recorded by the number 2 camera view described above. This figure shows a relatively small fire development. Figure 13 shows the sequential development of a large fire.

DATA ANALYSIS. In the previous paragraph it was pointed out that the photographic coverage was a prime source of the information obtained from the tests. Analysis procedures were developed from the photographic coverage to quantify the flammability of the fuel during a test. Impressions of the test result immediately after a test were highly subjective and a more precise analysis system was developed to provide a more objective method for characterizing a test as either pass, marginal, or fail. To do this, the overall test view films, similar to those shown in figures 12 and 13, were analyzed. Using known distances



A



B

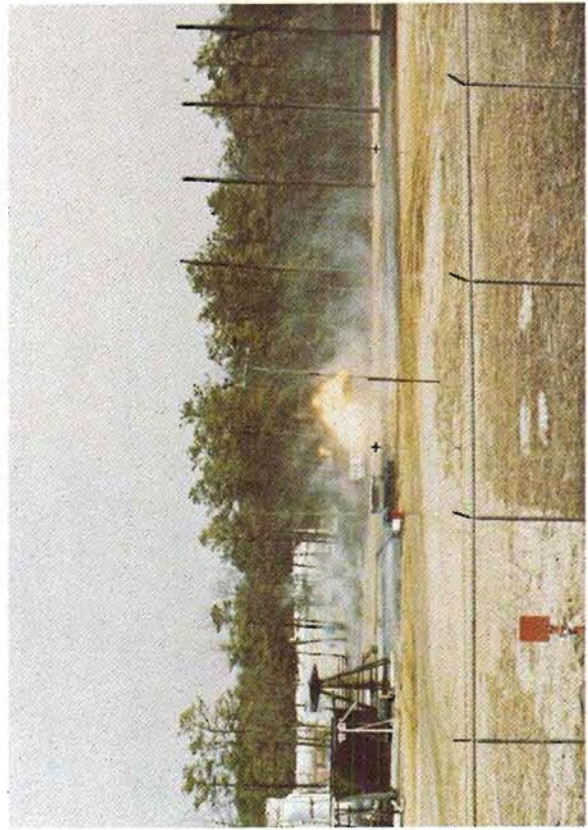

C

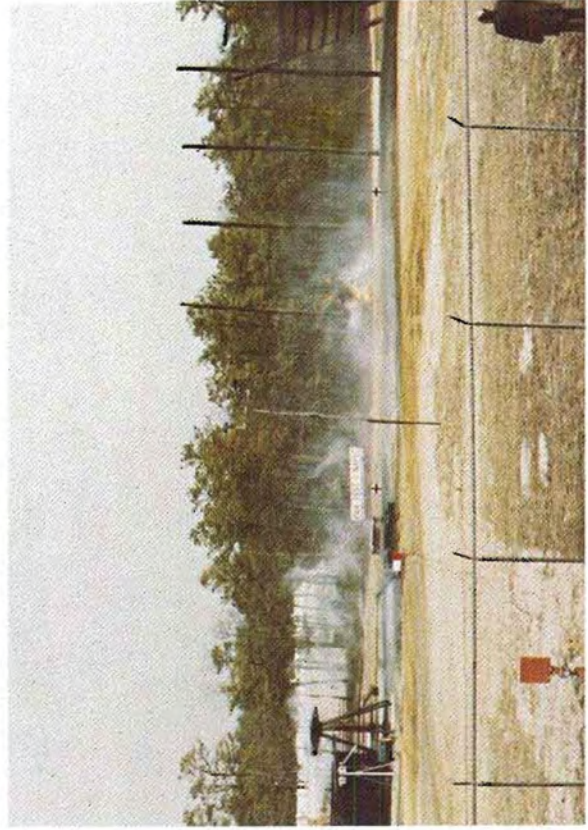

D

81-11-12

FIGURE 12. PHOTO SEQUENCE OF TEST NO. 64



A



B



C



D

81-11-13

FIGURE 13. PHOTO SEQUENCE OF TEST NO. 63

and time, the size of a fire could be measured in two dimensions. Film speed yielded a measurement of the rate of fire growth. This analysis procedure was conducted as follows:

1. The film was projected on a backdrop incorporating significant reference points relative to known dimensions.

2. When a fireball or a fire started, the outline silhouette of the fire was drawn on the backdrop and labeled area number 1.

3. The film was examined every 10 frames, or at 1/20th of a second intervals, and a silhouette was drawn and numbered sequentially at each such interval.

4. This process was continued for each 1/20th of a second until either the fire extinguished itself or it became involved with the ground which acted as a stationary flameholder.

For purposes of clarity, each silhouette shown in figures 14 and 15 was drawn in a different color. The areas of the fire silhouettes were measured using a planimeter. With known reference distances, the actual fire area was computed at each time interval. The fire area was converted to an equivalent circle and the circle radius was computed. The result of this process was a tabulation of time versus equivalent fireball radius. Figure 16 is a plot of the data obtained in this way. This particular curve indicates that the rate of fire growth in the fuel laden airstream is 5.2 feet per second (test No. 64).

A more volatile fire growth rate is shown in figure 17, where the growth rate is 20.1 feet/second (test No. 63). Figures 16 and 17 represent data obtained from the test sequences shown in figures 12 and 13, respectively.

Using this procedure for measuring the relative flammability of the fuel during a test, the levels of the original pass, marginal, or fail designations were established basing the judgment of these labels on experience and extensive reviews of the films. A test was designated "pass" when the effective fireball radius growth rate was less than 11 feet/second, the "marginal" rate was between 11 and 20 feet/second and the "fail" region was above 20 feet/second. The 11 feet/second growth rate was selected as a cut-off point for the "pass" test because up to that level any fireball which developed would not grow into a sizable ground fire and would be self-extinguishing. The 21 feet/second growth rate was considered to be in the "fail" region. At that level, the fire was expanding rapidly and upon contact with the ground a very large ground fire would develop. The arbitrary cut-off points are somewhat disputable, but it should be recognized that this is an attempt to put a scalar quantity to rather intangible characteristics. All data reported herein consistently reflect the above measurements and designations.

RESULTS

GENERAL.

The overall object of the program was to evaluate the antimisting fuel flammability characteristics when subjected to test conditions considered representative of the ranges experienced in impact survivable crashes. The specific variables which were investigated include the following:

1. Jet A baseline tests
2. Air-shearing velocity
3. Fuel-spillage rate
4. Fuel and air temperature
5. Fuel additive concentration

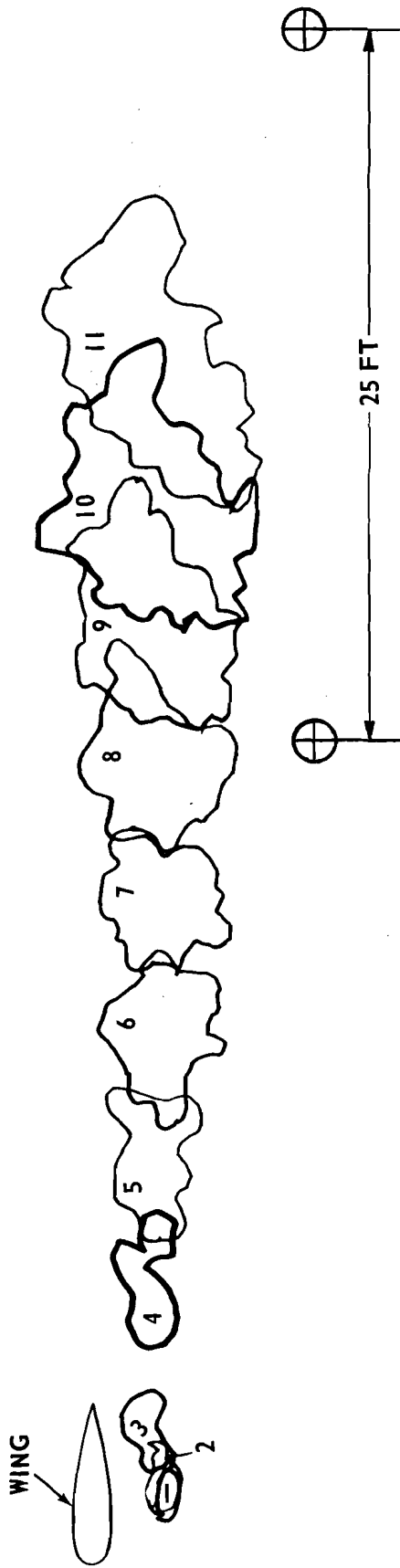
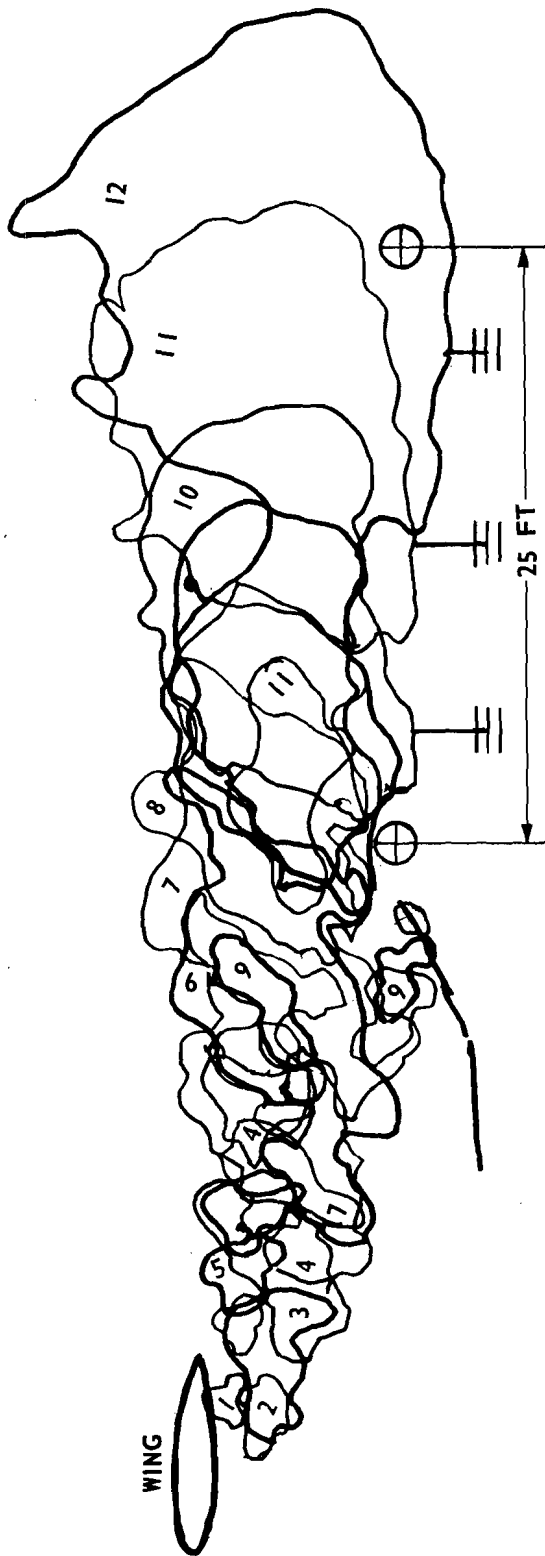

FIGURE 14. FIREBALL SILHOUETTES OF TEST No. 64



81-11-15

FIGURE 15. FIREBALL SILHOUETTES OF TEST No. 63

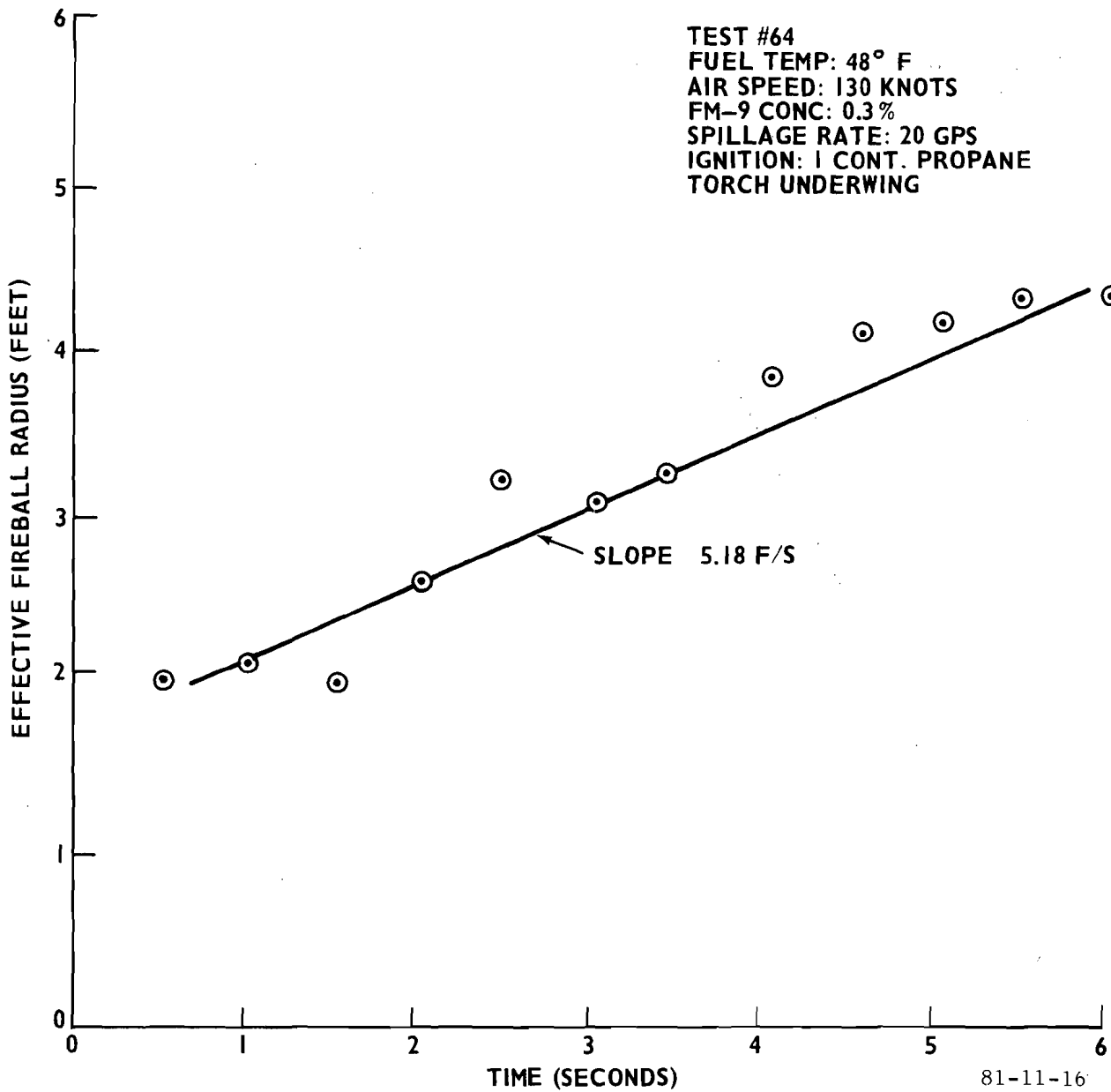

FIGURE 16. EFFECTIVE FIREBALL RADIUS VS. TIME (NO. 64)

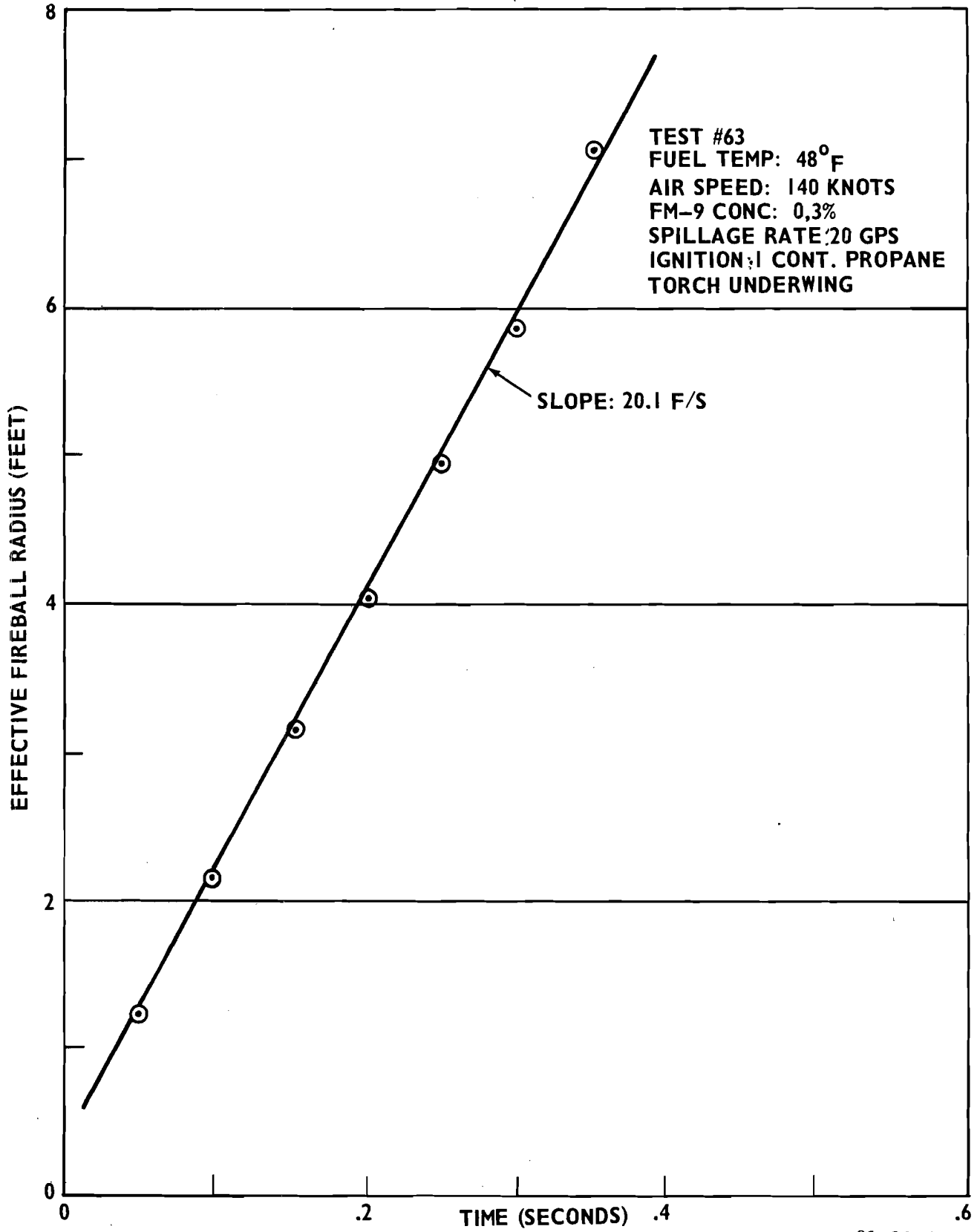

FIGURE 17. EFFECTIVE FIREBALL RADIUS VS. TIME (NO. 63)

81-11-17

6. Ignition location and intensity
7. Height of wing rupture above ground
8. Rupture (orifice) configuration
9. Engine ingestion of spilled fuel
10. Deceleration impact on spillage characteristics

Table 2 and the appendix summarizes these parameters and outlines the ranges of variables covered for each group.

TEST RESULTS.

The test results will be discussed in numerical order for each of the groups listed. This will permit a clearer understanding of the impact of each of the variables on the antimisting performance of the fuel.

Group 1 (Jet A Baseline Tests). At the outset of the program it was recognized that a baseline had to be established which would define the type of fire that would take place when using a neat Jet A fuel. Two such tests were conducted with spillage rates of 20 and 60 gal/sec. The configuration for these tests was the same as that used during the typical underwing continuous burning propane torch ignition tests. The fuel in each case was released into a 130-knot airstream and upon the first exposure to ignition the misted Jet A lit off in an almost explosive manner. The fire expanded in all directions and propagated forward to the spillage release point, even to the most forward point that the fuel reached as it moved against the counterflowing airstream. The severity of the fires resulting from these tests posed a threat to the wing-spillage facility and after the initial tests, Jet A was not tested again with the ignition source under the wing.

The analysis of the film produced the results shown in figure 18. It indicates that the fireball radius growth rates were 48 feet/second and 80 feet/second for 20 and 60 gal/sec

spillage rates, respectively. These values are at least twice as high as those which are measured when a "fail" designation is applied to a modified fuel. It should be recognized that modified fuel failures, which occurred during the tests reported herein, are less severe in intensity, nonexplosive in nature, and in no instance did flame progress forward against an airstream as high as 130 knots. For this reason, it is felt that even a "failed" FM-9 provides a degree of safety in a crash situation which neat Jet A can not match.

Group 2: (Air Velocity). The group 2 tests dealt with antimisting fuel using an additive concentration of 0.3 percent by weight in Jet A, 20 gal/sec spill rate, 80° F ±3° fuel temperature, a continuous burning propane torch located under the wing as the ignition source, with the only planned variable for the tests being the air-shearing velocity. The results of these tests are shown in figure 19, a plot of air-shearing velocity versus fire growth rate (obtained from the silhouetted film data). A line of "pass" and "fail" is drawn across the curve at the growth rate of 10 feet/second and 20 feet/second, respectively. Using this scaling procedure, 0.3 percent concentration fuel at 80° F provided protection up to a speed of 125 knots.

Group 3: (Spillage Rate). The group 3 tests dealt with antimisting fuel at a concentration of 0.3 percent by weight, 80° F ±3° fuel temperature, a continuous burning propane torch located under the wing as the ignition source, spillage rates from 20 to 60 gal/sec, and air speeds ranging from 120 to 150 knots. The results of these tests are shown in figure 20. Twenty gal/sec, 40 gal/sec, and 60 gal/sec data lines indicate that the spill rate had only a minor impact on the flammability resistance characteristics of the fuel. The effect amounts to a shift in the

TABLE 2. TEST SUMMARY

<u>Group No.</u>	<u>Type Of Test</u>	<u>Fuel Condition</u>	<u>Fuel Concentration</u>	<u>Fuel Spill Rate gal/sec</u>	<u>Air Velocity</u>	<u>Ignition Source</u>
1	Baseline	Constant Temperature $\approx 80^{\circ}$ F	Neat Jet A	20 To 60	130 Knots	Continuous Propane
2	Air Velocity	Constant Temperature $\approx 80^{\circ}$ F	0.3%	20	Ranging From Full Pass To Full Fail	Same
3	Fuel Spillage Rate	Constant Temperature $\approx 80^{\circ}$ F	.3%	20 To 60	Same	Same
4	Fuel & Air Temperature	40° F To 110° F	.3%	20	Same	Same
5	Fuel Additive Concentration	Constant Temperature $\approx 80^{\circ}$ F	.2% To .4%	20	Same	Same
6	Ignition Location & Intensity	Constant Temperature $\approx 80^{\circ}$ F	.3%	20	Same	Continuous Propane and Rockets
7	Height Of Wing Rupture Above Ground	Constant Temperature $\approx 80^{\circ}$ F	.3%	20	Same	Same
8	Rupture Orifice Configuration	Constant Temperature $\approx 80^{\circ}$ F	.3%	20 To 60	Same	Same
9	Engine Ingestion Of Spilled Fuel	Constant Temperature $\approx 80^{\circ}$ F	.3%	20 To 60	Same	J60 Turbojet
10	Deceleration Tests	Constant Temperature $\approx 80^{\circ}$ F	.3%	20 To 60	Same	J60 Turbojet and Continuous Propane

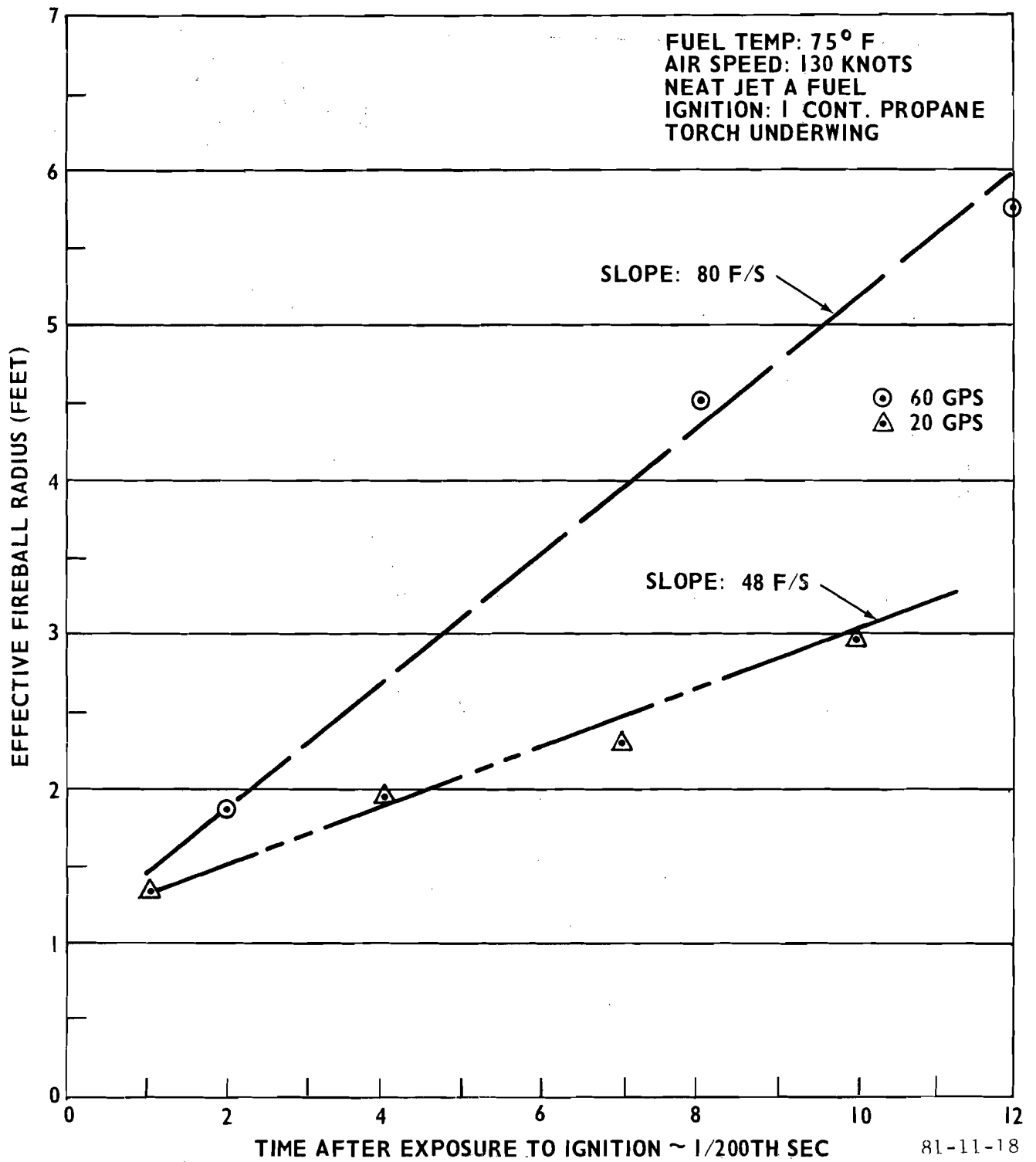

FIGURE 18. JET A BASELINE TEST RESULTS

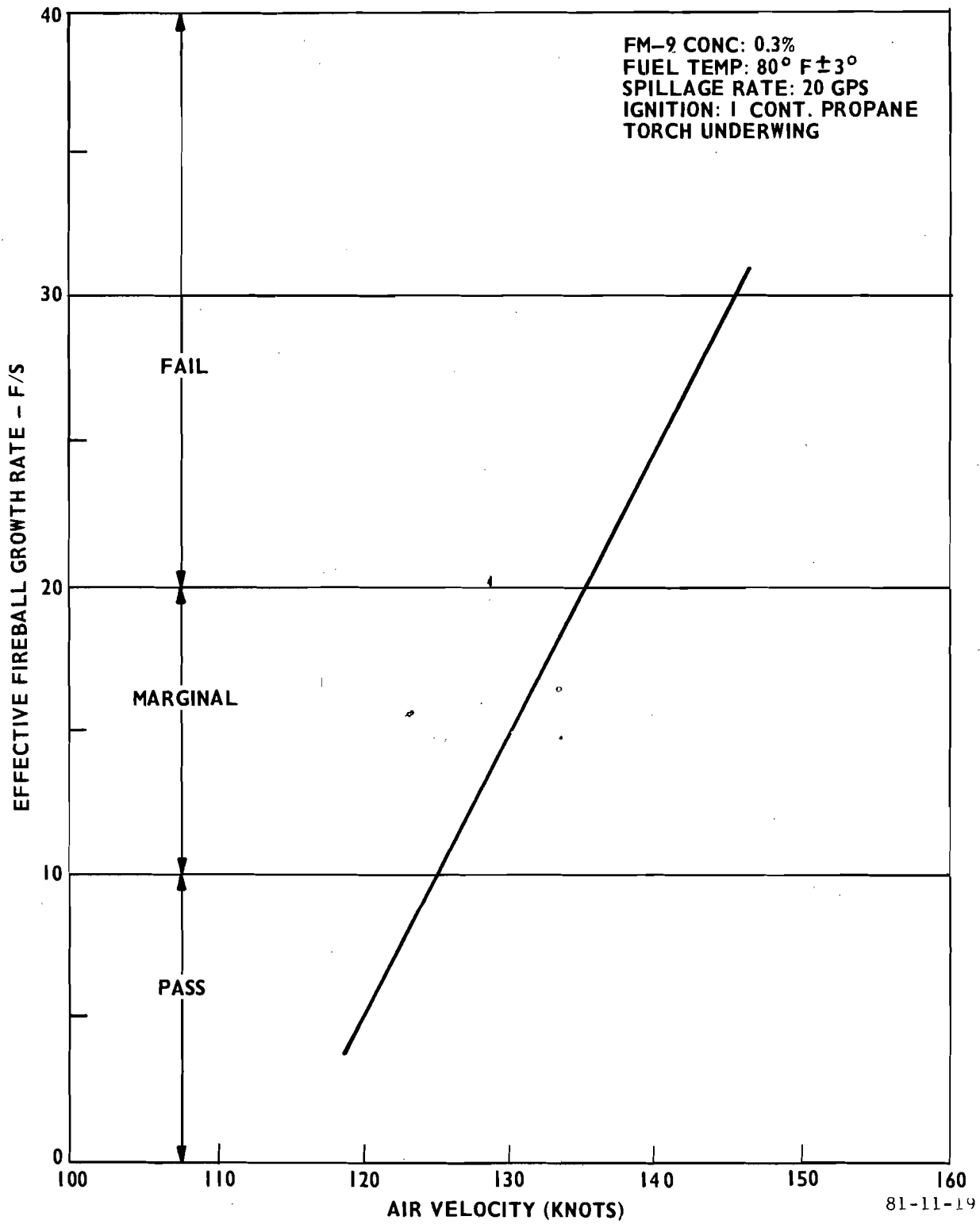

FIGURE 19. GROUP 2 RESULTS (VELOCITY)

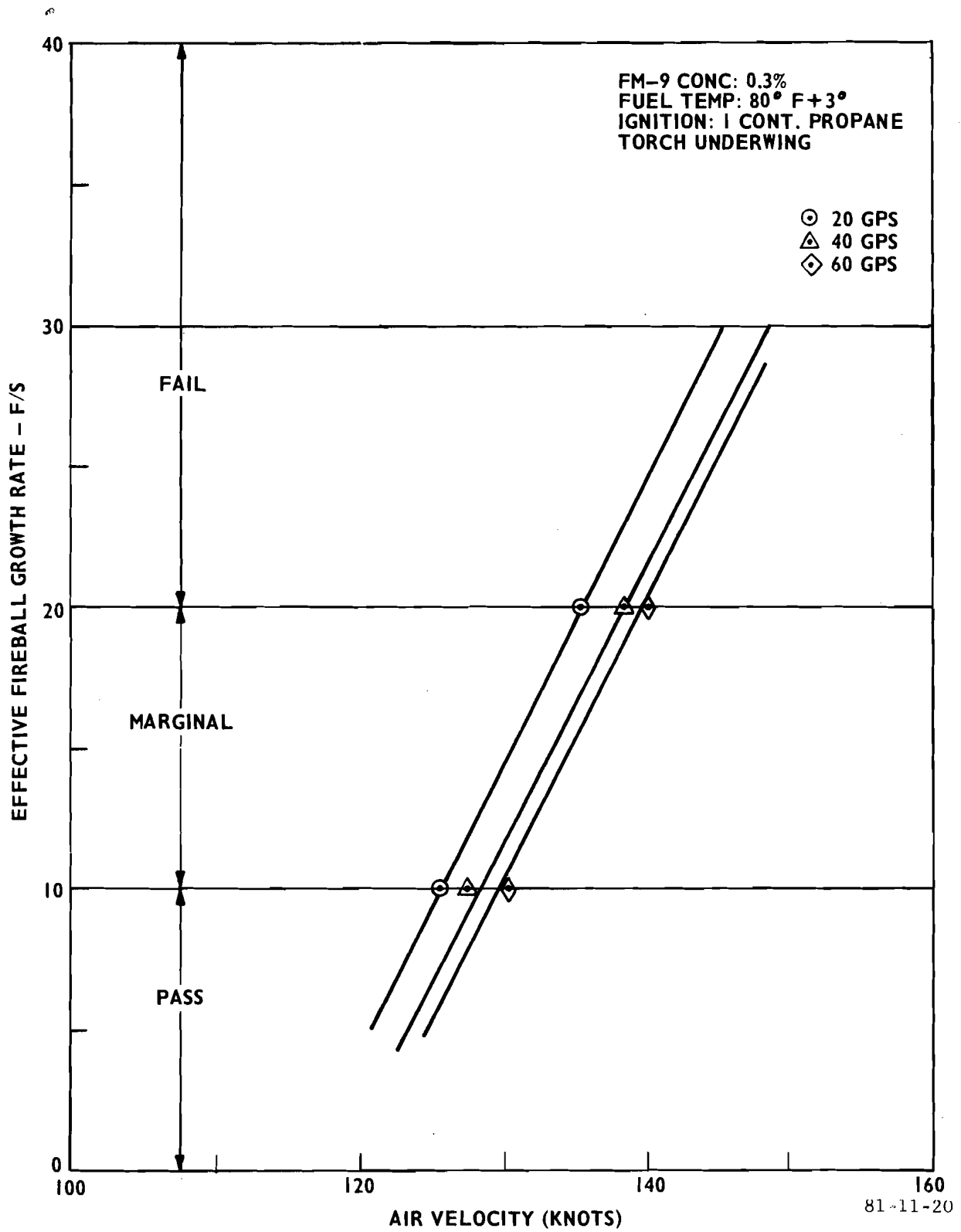

FIGURE 20. GROUP 3 RESULTS (SPILLAGE)

"pass" region from 125 to 130 knots as the spillage rate varied from 20 to 60 gal/sec. The 5-knot shift in the "pass" regime could be explained by the fact that the fuel/air ratio in the region of the propane torch is richer at the 60-gal/sec spillage rate. It is possible that the 60 gal/sec test would yield results identical to the 20 gal/sec test if the torch were located at some point further back from the present location and where the fuel/air ratio would be similar to that obtained during a 20 gal/sec test.

Group 4: (Fuel Temperature). The group 4 tests dealt with antimisting fuel at an additive concentration of 0.3 percent by weight, a 20 gal/sec spill rate, a continuous burning propane torch located under the wing as the ignition source, fuel temperatures varying from 47° F to 110° F, and air speeds varying from 110 to 160 knots. The results of these tests are shown in figure 21, a plot of air velocity versus fire growth rate at various fuel temperatures. A line of "pass" and "fail" is drawn across the curve at the 10 and 20 feet/second levels, respectively. The 0.3 percent concentration fuel experiences a measurable reduction in flammability resistance as a function of fuel temperature with 47° F fuel safe at 133 knots while the 110° F fuel was safe only as high as 116 knots.

Group 5: (Fuel Additive Concentration). The group 5 tests dealt with antimisting fuel with a range of fuel additive concentrations from 0.2 to 0.4 percent by weight, a 20 gal/sec spill rate, a continuous burning propane torch located under the wing as the ignition source, an 80° F $\pm 3^\circ$ fuel temperature, and air speeds varying from 90 to 200 knots. It should also be pointed out, in discussing fuel concentration, that the fuels received during the course of the tests were ordered from the factory by nominal additive concentration levels. Problems of quality control of the additive concentration occurred during some of the earlier tests.

Nominal 0.3 percent additive fuel was received at 0.26 percent or as high as 0.33 percent. This problem was overcome during the later tests wherein the tolerance was ± 0.01 percent on a nominal 0.3 percent fuel. When test results differed between earlier and later tests, the later tests were felt to be more accurate and are the results reported herein. These results are shown in figure 22 (air velocity versus fire growth rate at various fuel additive concentration levels). A "pass" and "fail" line is again drawn on the graph at the 10 feet/second and 20 feet/second levels, respectively. At the low additive concentration level of 0.2 percent, the fuel is "safe" up to a level of 99 knots while 0.35 percent fuel is "safe" at 142 knots.

Group 6: (Ignition Location and Intensity). The group 6 tests dealt with antimisting fuel at an additive concentration of 0.3 percent by weight, a 20 gal/sec spill rate, an 80° F $\pm 3^\circ$ fuel temperature, air shearing velocities from 110 to 160 knots and various ignition source configurations consisting of a continuously burning propane torch, an intermittently burning propane torch, a cluster of MK40 (Mighty Mouse) rockets, and J60 turbojet engines. (The J60 engine tests are discussed separately in group 9 of this report.) The sources were located at various points in and around the fuel mist test cloud. The continuously and intermittently burning torches were located 3 feet under the wing and 4.5 feet aft of the fuel release point. The intermittent torch was eliminated early in the program, as it did not provide information which was not already attainable with the continuously burning torch.

The MK40 rockets were mounted in a cluster of five, located 40 feet aft of the wing-spillage release point. This particular aspect of the testing was undertaken to provide information on the fuel performance under conditions which were comparable to those present during

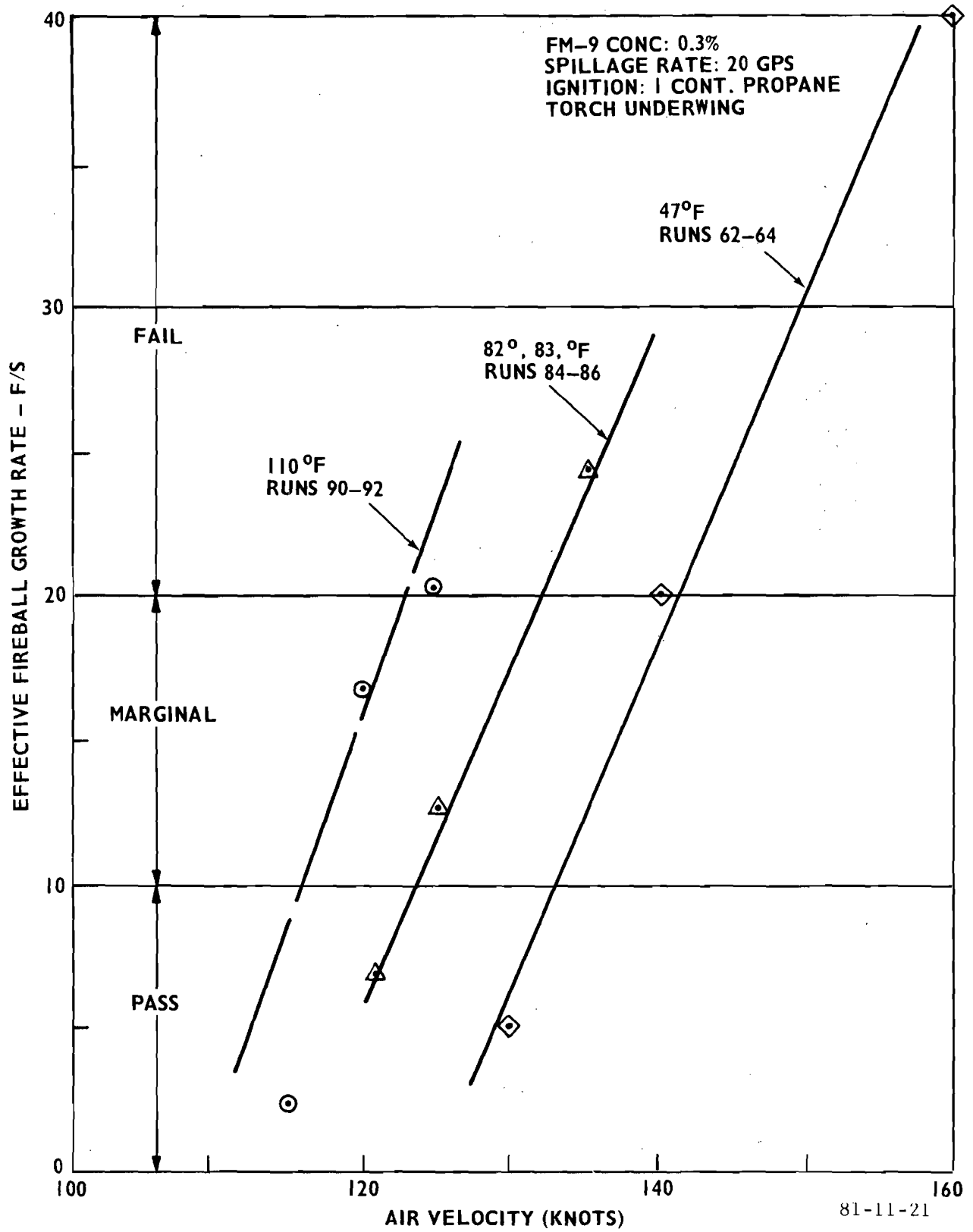

FIGURE 21. GROUP 4 RESULTS (FUEL TEMPERATURE)

30

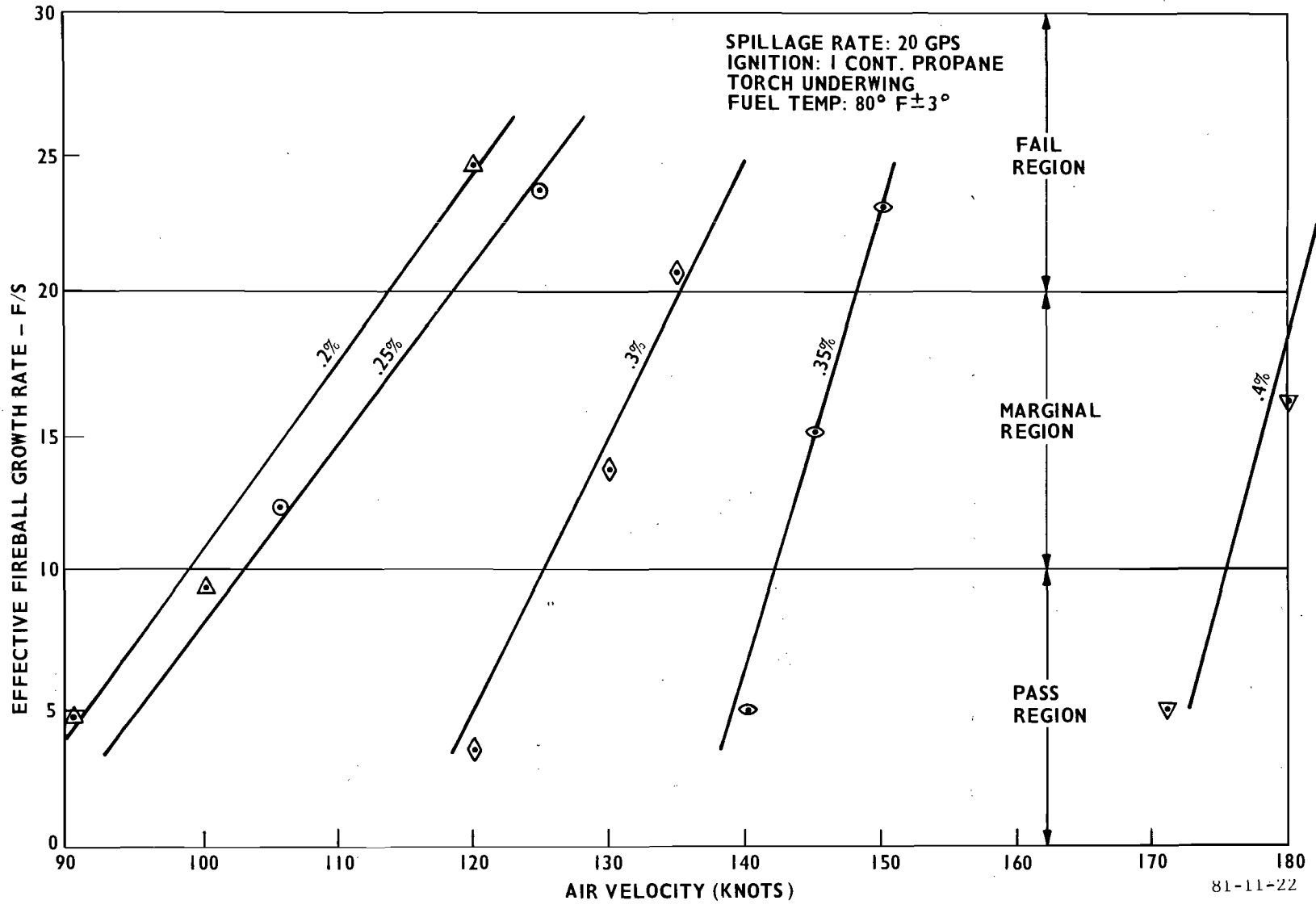

FIGURE 22. GROUP 5 RESULTS (FUEL ADDITIVE CONCENTRATION)

large-scale crash tests at the Naval Air Engineering Center (NAEC) at Lakehurst, New Jersey, and to evaluate the impact of ignition sources (in this case, rockets) at a position where turbine engines would be located on an aft engine powered aircraft. The NAEC clusters mounted on the aft sides of the aircraft fuselage to simulate engine heat sources. One of the differences between the tests described herein and the NAEC crash tests is the duration of the exposure time of the airsheared fuel to the rocket exhaust heat. At NAEC, the rockets moved with the aircraft and the fuel that was exposed to the rocket exhaust heat was exposed only as the rocket moved through the slower moving airborne fuel. Fuel released by the impact, decelerated more rapidly than the aircraft because of the mass/inertia differences. For example, in the NAEC tests, the time period that a portion of fuel which has been sheared at 130 knots is exposed to the rocket exhaust would be on the order of 0.1 second due to the speed differential between aircraft and fuel. In the wing-spillage tests at the Technical Center, the duration of the exposure for a 130 knots air-sheared fuel would be 0.3 second or more, due to the fact that the rockets are stationary and the airborne fuel, although sheared at 130 knots, is moving at about 40 knots in the vicinity of the rockets (40 feet aft of the fuel release point). Thus, from the viewpoint of length of exposure time, the wing-spillage tests with rocket ignition are considered to be more severe than the NAEC crash tests with rockets. The results of these wing-spillage rocket tests are discussed in the following paragraphs.

The fuel carried by the airstream into the immediate area of the rocket exhaust burned and enlarged the exhaust plume. The flame enlargement rate was moderate in nature and did not expand beyond the confines of the enlarged augmentor airstream (figure 23). The type of fire which developed during these tests was unlike the typical results obtained with the forward torch,

inasmuch as the flame did not detach itself from the rocket and float back with the moving airstream. The fire would be self-extinguishing when the rocket motor shut down. Shutdowns occurred during tests despite the fact that the rockets were sequenced to burn for 1.5 seconds with 0.5 second overlap between successive firings. As a rocket burned out, the exhaust flame would die and as the next rocket started up, there was a finite time when no flame appeared at the exhaust. In the course of these tests, this type of rocket sequence firing occurred consistently. The only time a flame would persist when the rocket motor was not burning was when the fire was attached to the ground or when the rocket protective housing acted as a flameholder. This flameholder effect could be significant in a crash situation. Fuel spilling from a wing could adhere to an aft engine nacelle or horizontal stabilizer and, if exposed to a flame from an engine surge, this fuel could burn and remain burning as the aircraft decelerated to a stop. However, with modified fuel, it would not be burning in an environment where a combustible mist of fuel would be present and thus would not result in an explosive fire.

Throughout this test series, there was no instance of flame propagation from the rocket exhaust forward to the wing-spillage point. Variations in airstream velocity appeared to have a negligible impact on the fires which occurred during these tests.

Group 7: (Height of Wing Rupture Above Ground). The group 7 tests dealt with antimisting fuel at an additive concentration of 0.3 percent by weight, a 20 gal/sec spill rate, an 80° F ±3° fuel temperature, a continuous burning propane torch located under the wing as the ignition source, a range of air-shearing velocities from 110 to 160 knots, and three different ground level distances relative to the fuel-spillage release point. These three distances were: the normal release distance above

ROCKET TEST

120 KNOTS .3% 20 GPS
1/40 TH SEC INTERVALS

32

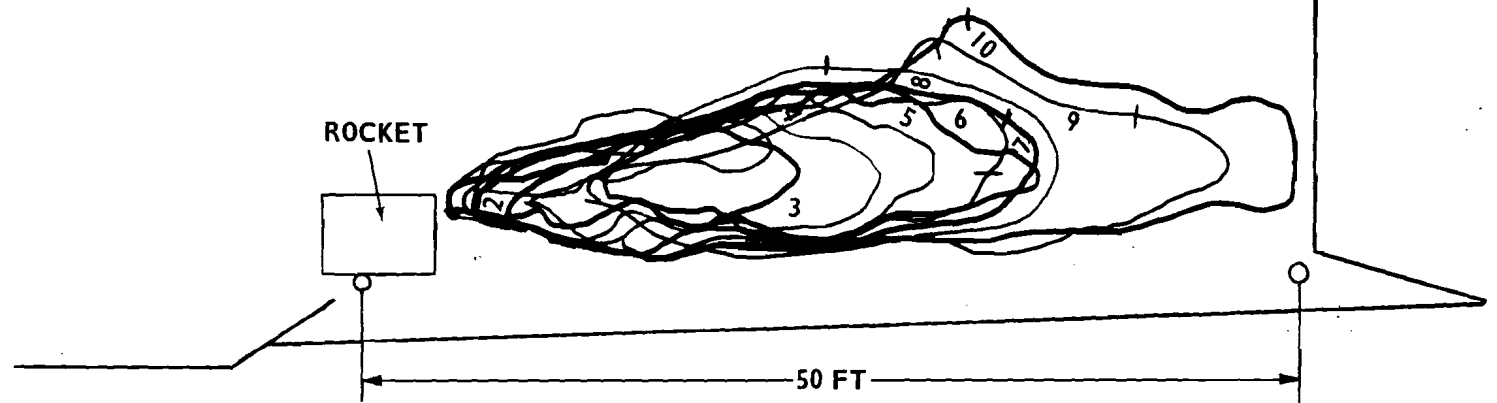

81-11-23

FIGURE 23. GROUP 6 ROCKET EXHAUST SILHOUETTES

the ground of 11 1/2 feet, an artificial ground level located 4 1/2 feet below the fuel release point, and an artificial ground level 7 feet below the fuel release point. The results of these tests did indicate some effect, under certain conditions, on the performance of the fuel due to the height above-ground of the fuel release point.

Initial testing was conducted using the artificial deck, mounted 4 1/2 feet below the wing with a stiffening angle iron projecting 1 inch above the surface of the simulated ground at the aft end of the deck. This projection acted as a barrier collecting released fuel. Fuel was accumulated on the deck by this projection. It was then secondarily blown up from an essentially zero velocity by the airstream. This action on the initially air-sheared fuel represented a secondary or additional shearing degradation. The overall effect was a reduction in flammability resistance of 15 knots. When the projection was removed, the fuel was no longer subjected to this double shearing action and it performed essentially as it would at the normal height above the ground. Thus, the tests indicated that altering the distance above the ground from which the antimisting fuel was released did not change the flammability resistance characteristics of the fuel when no secondary shearing action took place (figure 24).

Group 8: (Rupture Orifice Configuration). The group 8 tests dealt with antimisting fuel at an additive concentration of 0.3 percent by weight, an 80° F ±3° fuel temperature, a continuous burning propane torch located under the wing as an ignition source, a range of air shearing velocities from 110 to 160 knots, and six different rupture orifice configurations to control the fuel-spillage rate and the mechanical shearing effect created by the orifice shape and size.

The types of orifices can be divided into two general categories:

(1) Circular orifices; 3-inch diameter, 4 1/4-inch diameter, 6-inch diameter, and 7 3/4-inch diameter (both flat plates and conical openings).

(2) Rectangular and slotted orifices:

(a) 6 x 9 inches (1 each with horizontal slot)

(b) 1 1/2 x 3 3/4 inches (3 each with vertical slots)

(c) 1 1/2 x 6 inches (1 each with vertical slot)

The first category was designed to provide spillage rates ranging from 10 to 60 gal/sec using a constant tank pressure as the working head. In order to determine whether the orifice inlet characteristics degraded the fuel, similarly sized conical orifices and flat plate orifices were tested. Figure 25 shows the two types of orifices used when varying spillage rates. The second category was designed to develop varying degrees of mechanical shear forces on the fuel as it came through the orifice. These were designed as flat plates with high wetting surface to volume ratios. The three-slotted orifice plate was designed for 20 gal/sec spillage and had a wetted surface length of 31.50 inches. A comparable flow rate using the 4 1/4-inch diameter orifice has a wetted surface length of 13.25 inches. The slotted configuration also exposed a much larger surface area of spilled fuel to the counter-flowing airstream. Both these factors were examined to determine if the fuel was more severely degraded with this configuration than if it was released through a smooth circular orifice. The results of these tests are shown in figure 26, where air shearing velocity versus the flame growth rate is plotted. Curves for the different orifice configurations are shown and it is apparent that the discharge configuration had only a minimal impact on the results obtained during a test.

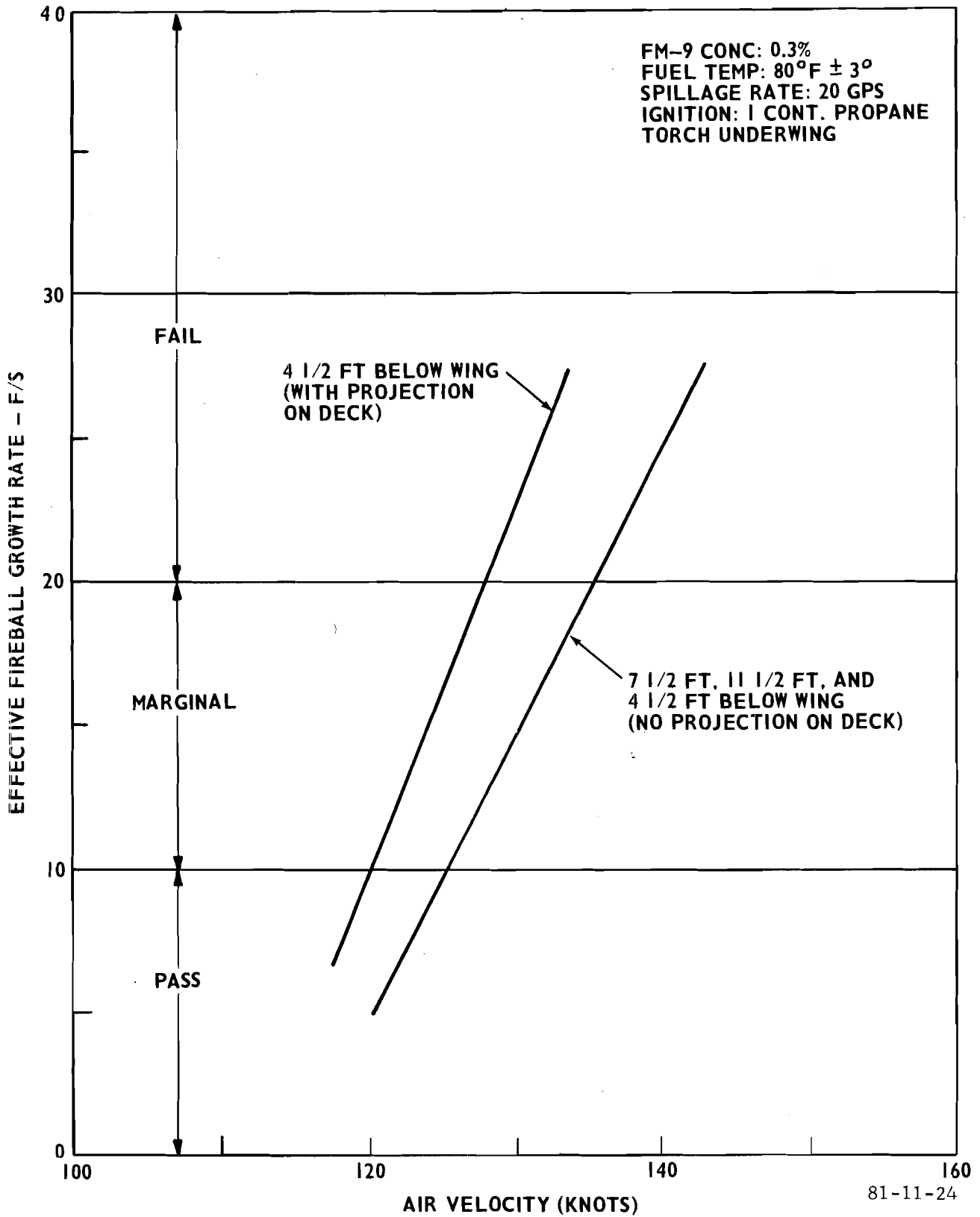
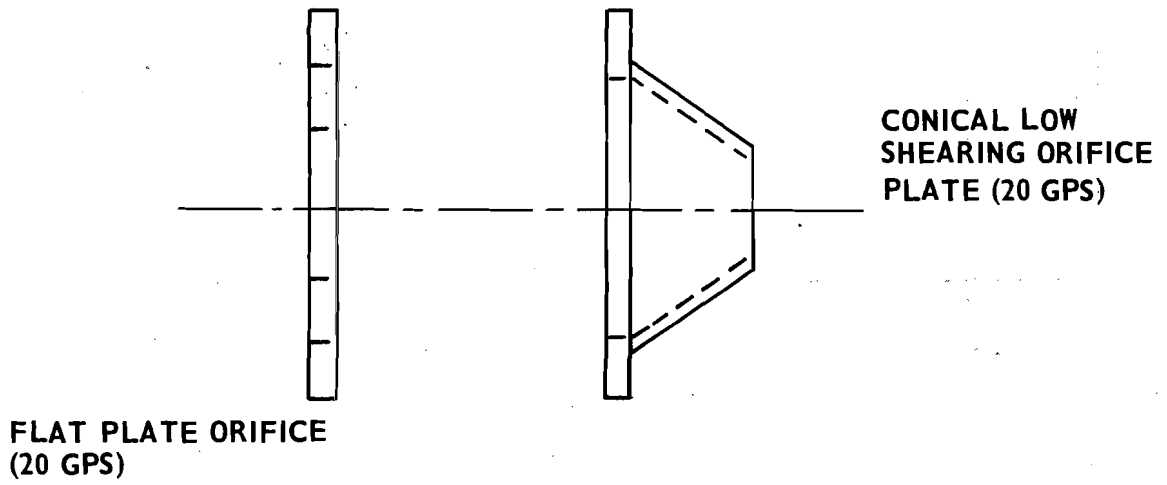
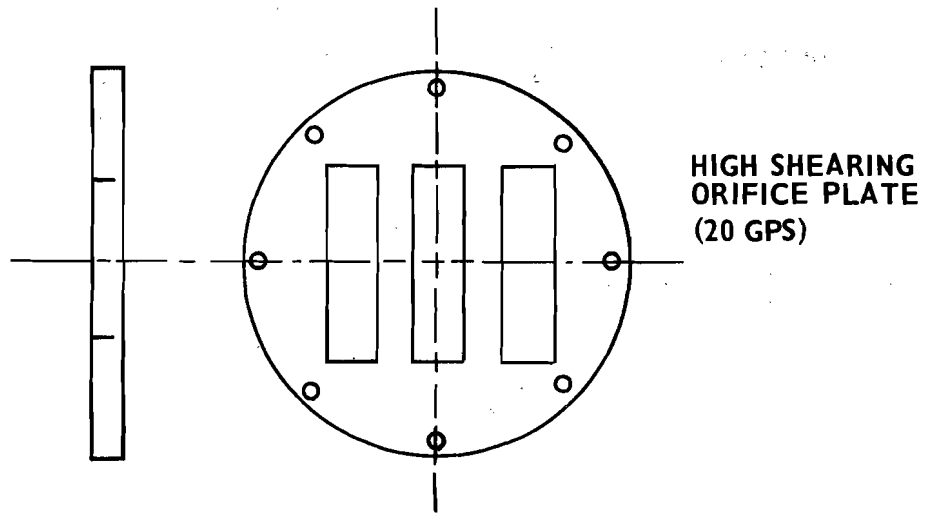

FIGURE 24. GROUP 7 RESULTS (GROUND LEVEL EFFECTS)



CATEGORY I



CATEGORY 2

81-11-25

FIGURE 25. GROUP 8 ORIFICE CONFIGURATIONS

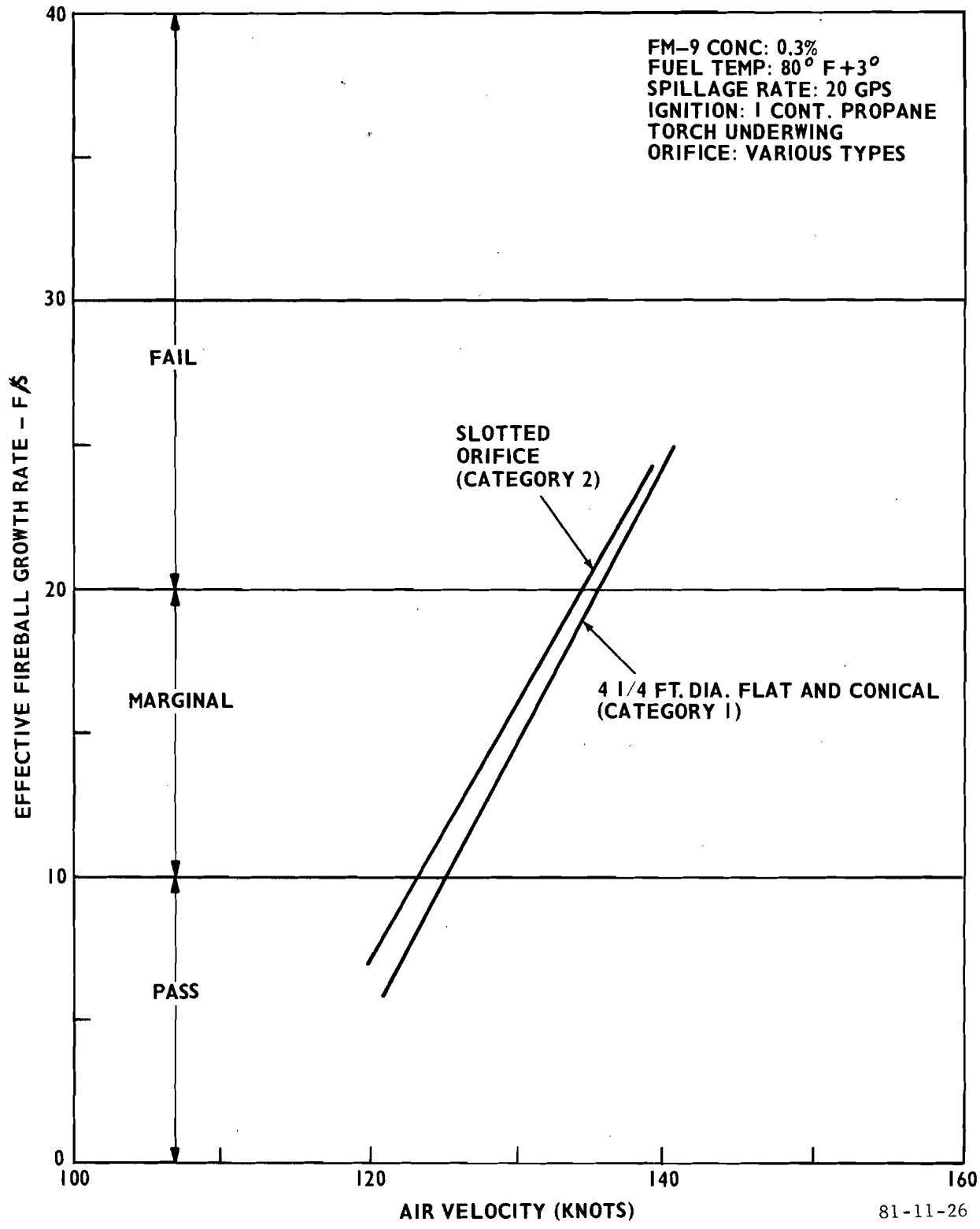

FIGURE 26. GROUP 8 RESULTS (ORIFICE CONFIGURATION)

Using a 4 1/4-inch diameter flat plate or a 4 1/4-inch conical orifice yielded essentially the same results for the flammability envelope. This is probably due to the fact that the velocity across the orifice is rather low and the wetted surface to volume ratio is also low. In order to increase the contrast of wetted surface to volume, the slotted configuration in category 2, shown in figure 25 was tested. This also yielded essentially the same results as that obtained with a 4 1/4-inch orifice. It is apparent that on the scale which these tests were conducted, the governing factor for flame resistance at a constant additive concentration and temperature is the air-shearing velocity.

One other aspect of the orifice tests dealt with the question of relative speeds of the two moving streams, i.e., air and fuel. In these tests, the fuel-spillage rate was held constant at 20 gal/sec, using orifices of 3-inch, 4 1/4-inch and 6-inch diameter. The fuel velocity ranged from 32 to 8 knots. The airstream velocity was set at speeds which would provide a constant net air/fuel velocity shearing force of 120, 130, and 140 knots. The results of these tests indicated that the relative-shearing velocity is the governing factor in the antimisting performance of this fuel. A high-velocity fuel stream, counterflowing into a low-velocity airstream, performs in a manner similar to a low-velocity fuel stream, counterflowing into a high-velocity airstream when the sum of the two velocities are equal.

Group 9: (Engine Ingestion of Spilled Fuel). The group 9 tests dealt with antimisting fuel at an additive concentration of 0.3 percent by weight, an 80° F ±3° fuel temperature, a range of air-shearing velocities from 110 to 150 knots, and J60 turbojet engines operating at 75 and 95 percent power and acting as an ignition source. The engine inlet was located 40 feet aft

of the fuel release point at the projected vertical centerline of the augmentor exit and 5 feet below the projected horizontal centerline of the augmentor exit.

The procedure used in these tests was as follows:

1. The J60 engine was stabilized at the desired power.
2. The augmentor airspeed was set at the target velocity and stabilized.
3. The automatic sequencer which controls the fuel spillage system instrumentation, timing, and photography was started (see notes on table 1.)

The testing indicated that when the engine ingested relatively low quantities of airborne fuel, there was no marked change in performance. This was seen at the outset of each test. However, when a dense cloud of fuel was ingested (when the full-spillage rate was achieved), the engine surged violently, with flames torching at the exhaust, the inlet and the compressor bleed. In cases when the engine did not flameout from the violence of the surge, there were repeated surges (as many as 10) during a 3- or 4-second period. When flameout did not occur, the test would be completed and the J60 would continue to operate after the spilled fuel no longer was being ingested. If the surges caused an engine flameout, there was no reignition either from residual internal flames or hot metal surfaces (see figure 27).

The J60 engine does not have continuous ignition under ordinary operating conditions. Most civil aircraft do not utilize continuous ignition, but some engines employ it during descent or during operations in inclement weather. For this reason, it was considered relevant to conduct a series of "igniters on" tests. These tests produced the same type of results



A

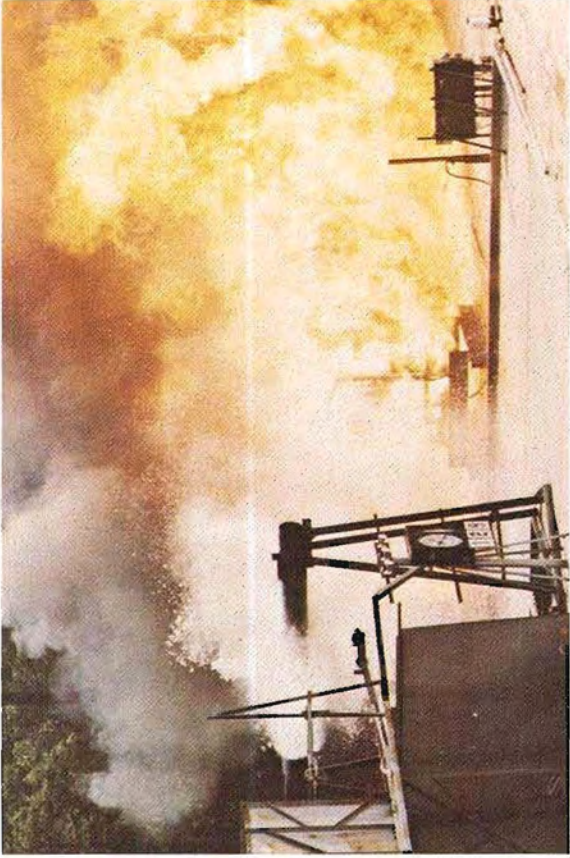

B



C



D

81-11-27

FIGURE 27. ENGINE INGESTION PHOTO SEQUENCE

as those obtained with the "igniters off." With the igniters on, the engine did not flameout; however, the compressor failed during an "igniters on" test at 95 percent engine power. This failure resulted in an engine seizure and occurred after a prolonged series of violent surges.

The only apparent difference in results obtained during fuel ingestion test was that the severity of the engine surges was greater at the 95 percent power versus the 75 percent power.

The controlling factor in the engine ingestion tests appeared to be the quantity of fuel ingested. The air-shearing forces acting to degrade the fuel did not determine whether engine surge or flameout would occur.

One of the ancillary results of these tests is that the fuel does not appear to be prone to hot engine surface ignition. Whenever a flameout occurred there was no reignition of modified fuel either on hot external or internal engine surfaces. It was noted, however, that the tendency of the fire to progress forward toward the spill release point of the fuel is greater when high shearing forces (higher air velocities) have acted on the fuel. The likelihood of forward flame propagation is governed by the flame propagation rate relative to the airstream velocity.

Group 10: (Deceleration Tests).

The group 10 tests dealt with anti-misting fuel at an additive concentration of 0.3 percent by weight, a 20 gal/sec spill rate, an 80° F \pm 3° fuel temperature, two types of ignition, and air-shearing velocities which decreased during a test from 170 to 60 knots and 110 to 60 knots, according to a predetermined schedule. These tests were designed to simulate a crash situation, wherein fuel is initially released into the air as the aircraft impacts (at 130 knots, for example). As it progresses through the crash sequence

and decelerates, the spilled fuel is sheared at progressively lower velocities. All tests described in groups 1 through 9 dealt with essentially constant air-shearing velocities acting on the spilled fuel. That type of situation is considered to be more severe than a real crash situation wherein the velocity of the aircraft decreases as the aircraft comes to rest.

In order to understand the connection between wing-spillage deceleration tests and the NAEC large-scale crash tests, a review of the NAEC tests, references 1 and 2, is worthwhile.

The dynamics of an NAEC type crash are as follows:

1. The aircraft is released from the pusher cart and rolls freely along the crash path at the targeted crash velocity.

2. The aircraft wing impacts the mechanism which opens up the leading edge of the wing, thus permitting the fuel to spill out into the air.

3. The initial release of the fuel is at the velocity of the aircraft plus the hydraulic ram velocity of the fuel. This hydraulic ram, based on films of the NAEC tests, imparts a velocity to the spilled fuel which does not exceed 10 knots forward, relative to the aircraft. Thus, if the aircraft is moving at 130 knots, the actual air shearing velocity acting on the fuel would not exceed 140 knots. This differential (10 knots) equates to an average longitudinal force of approximately 1/2 g (acceleration of gravity) acting on the fuel. Accelerometers located at various points aboard the aircraft during the NAEC tests indicated instantaneous horizontal deceleration peaks as high as 15 g's. However, the shortlived nature of these peaks did not appear to have an impact on the fuel-spillage rate during a test, based on an analysis of the photographic coverage of the test.

4. As the aircraft moves down the crash path, the velocity declines and the aircraft comes to rest in 8 seconds.

5. Along the crash path stationary ignition sources are located to assure that the spilled fuel has sufficient exposure to potential ignition sources. This is essentially the sequence during the NAEC tests and it is apparent that only a small portion of any spilled fuel experiences air-shearing forces in excess of 125 knots (considered the "pass" region for 0.3 FM-9). Assuming uniform deceleration occurs during the 8-second crash (130 knots to zero knots in 8 seconds or 16.25 knots per second average deceleration), the spilled fuel experiences air-shearing forces of 140 to 125 knots for a period of 0.92 seconds. These deceleration assumptions are reasonable based on film analyses of the NAEC tests. After that time, the air shearing velocity acting on the fuel is less than 125 knots. If the initially sheared fuel does ignite, it would burn but it would shortly be exhausted, since the fuel being released after the first 0.92 second would be resistant to fire development and propagation (based on tests reported herein for 80° F ±3° percent FM-9). In addition, any fire resulting from an initial ignition would be left behind the aircraft (experience in the wing spillage tests indicate that an airborne modified fuel "mist" when exposed to a large fireball does not propagate against an airstream whose velocity is as low as 50 knots).

The group 10 tests, therefore, are a partial simulation of the dynamics occurring in the NAEC crash tests. In these tests, the airspeed was set at a predetermined velocity. At a time which was determined by augmentor system calibrations, the air velocity was reduced uniformly at a declining rate of 14 knots per second. Fuel spilled from the wing into the airstream and was sheared and carried past the ignition source. The two types of ignition

sources used during these tests were the continuous burning propane torch and the J60 engine operating at 95 percent power. The results of these tests are discussed in the following paragraphs.

1. Underwing Ignition — Deceleration tests using the standard ignition system (underwing continuous burning propane torch) were conducted at airspeeds as high as 170 knots. The character of the fireball development during these tests was comparable to the type of development which occurred during constant airspeed tests at velocities 30 knots lower. In these tests, the fireballs which separated from the torch and developed, all took place in the first 0.5 second after full exposure of the fuel to the ignition source. The initial rate of fireball growth in the first 0.05 second after light-off was large, up to 24 feet/second radius growth rate. This rate declined steadily and after 0.1 second the growth rate stabilized between 5 and 12 feet/second for about 0.15 second. From that point until the end of the test, the fireball size remained about constant or declined.

Figure 28 shows the characteristic curves derived from three successive fireballs which developed as the airspeed declined.

It should be noted that these plots indicate a second degree curve in contrast to the first degree curves developed from data obtained during steady-state tests. Figure 28 is based on a test wherein the initial airspeed was 170 knots. The time at the instant that the first fireball appeared was 3.28 seconds after the start of the test or at about the moment of full exposure of fuel to the torch (figure 28). At that moment, the augmentor was delivering air at a velocity of 165 knots and the velocity was declining at a rate of 20 knots per second. The second fireball appeared 0.18 second

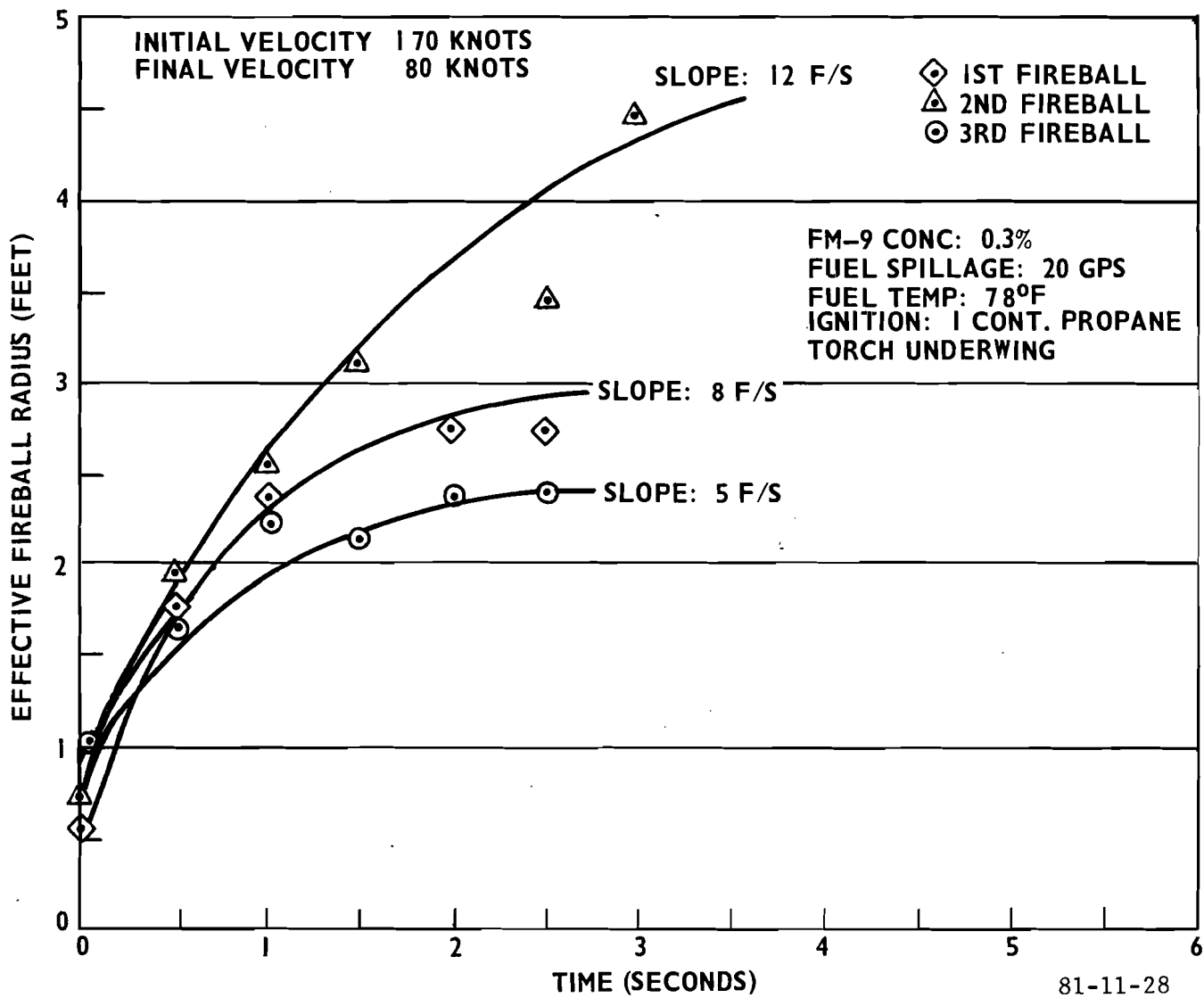

FIGURE 28. GROUP 10 RESULTS (DECELERATION)

after the first fireball, and the third fireball appeared 0.12 second after that. No further developing fireballs appeared after the first three. There is a certain randomness in a fire test of this type which should be discussed in this context. In steady-state tests, covered in groups 1 through 9, a typical fireball development would occur for a borderline "fail" situation approximately 1.20 seconds after exposure of the fuel to the torch. All the proper conditions of fuel, air, and droplet size must be present to initiate the fireball. Prior to the appearance of a fully developed fireball, flashes of fire and small self-extinguishing fireballs usually appear. The air-stream velocity in those type tests remains constant and typically during the 4 seconds of full spillage and ignition exposure, the proper conditions for fireball development occur.

In contrast, in a deceleration test, the probability is small for the right conditions for fireball development at a steady-state borderline "fail" air velocity. This is probably the reason that the higher "pass" velocity takes place during deceleration tests. Additionally, the full development of the fireball is retarded in deceleration tests because the declining air-shearing velocity produces coarser and coarser fuel droplets which are more and more resistant to flame propagation. The deceleration tests indicate that the "pass" level for steady-state tests of antimisting fuel is conservative and in an actual decelerating crash situation the "pass" level could be 30 knots higher.

2. Turbine Engine Ignition — Deceleration tests using a J60 engine for an ignition source resulted in engine surges whenever a sufficient quantity of fuel was ingested. The high ingestion rate started at about the 3.7 seconds point in the test sequence and continued for about 4 more seconds. At the moment of initial full fuel

spillage, the augmentor air velocity was at the target velocity and the deceleration was just beginning. During the following 4 seconds, the air velocity declined at approximately 14 knots per second. A calibration curve for a deceleration test which started at 130 knots is shown in figure 29. Superimposed on the curve is the marker which shows the moment when full fuel spillage occurs during a 20 gal/sec spillage test. Results of these deceleration tests were similar to steady-state engine ingestion tests wherein the J60 engine could tolerate low levels of ingestion but would surge at high levels. Air shearing the fuel at different speeds did not appear to affect the results of the tests. Fuel sheared at 130 knots and fuel sheared at 80 knots when ingested in sufficient quantities caused engine surges.

CONCLUSIONS

1. Neat Jet A mist burned in an explosive manner and the rate of fireball growth is significantly greater than that of antimisting fuel.
2. Three tenths percent FM-9 at 80° fuel temperature provides fuel mist fire protection at crash speeds up to 125 knots.
3. Fuel spillage rate does not significantly affect the antimisting performance of the fuel.
4. Fuel temperature affects the antimisting performance of FM-9 with low-temperature fuel performing effectively at higher crash speeds than high-temperature fuel.
5. The higher the additive concentration of FM-9, the higher the air-shearing velocity at which the fuel can perform effectively in an antimisting manner.

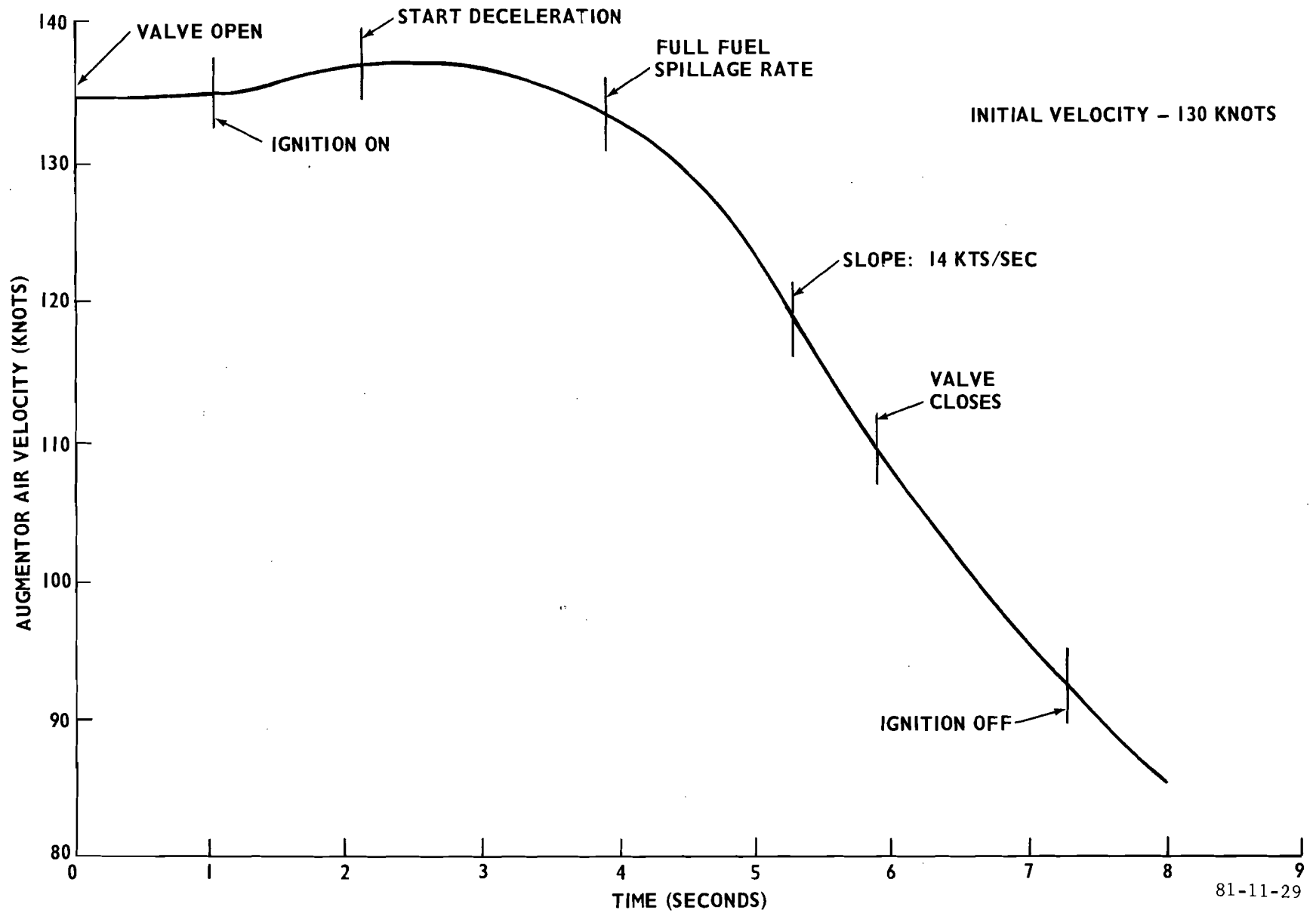

81-11-29

FIGURE 29. GROUP 10 DECELERATION CALIBRATION

6. The height-above-ground of the fuel release point had no significant bearing on the effectiveness of the fuel as an antimisting system.

7. The major agent acting on the FM-9 fuel during a crash is the relative-shearing velocity; the shape of the tank rupture does not impact the results.

8. The controlling factor for FM-9 fuel mist fire protection as influenced by crash speed and fuel release rate is the relative air-to-fuel shearing velocity.

9. FM-9 fuel when ingested by an operating engine will cause engine surge and possibly flameout; however, flames produced by the surging engine will not propagate forward through the airborne fuel cloud.

10. FM-9 fuel mist fire protection is significantly greater when subjected to a decreasing air-shearing velocity than when subjected to a constant velocity air shear.

REFERENCES

1. Zagarella, A., Full-Scale Aircraft Crash Tests of Anti-Misting Kerosene, Interim Report No. NAEC-TR-183, August 1980.

2. Ahlers, R. H., Full-Scale Aircraft Crash Tests of Modified Jet Fuel, Technical Report No. FAA-RD-72-13, U.S. Department of Transportation, Federal Aviation Administration, Washington, D.C., January 1977.

Test No.	Group No.	Test Type	Fuel Type	Spill Rate	Remarks
1A	1	Baseline	Neat Jet A	20 gps	Std Config
2A	1	Baseline	Neat Jet A	60 gps	Std Config
1	2 & 5	Velocity	FM-9, 0.4%	20 gps	Std Config
2					
3					
4					
5					
6					
7					
8					
9					
10			FM-9, 0.27%		
11					
12			FM-9, 0.333%		
13					
14					
15					
16			FM-9, 0.3%		
17					
18					
19	3	Spill Rate		60 gps	
20	3			60 gps	
21	3			60 gps	
22	3 & 8	Orifice & Spill Rate		20 gps	
23					
24					
25					
26					
27					
28	8	Orifice	0.3%	20 gps	Std Config
29	8	Orifice	0.3%	20 gps	Std Config
30	7 & 3	Height above Ground and Spill Rate	0.3%	20 gps	Std Config
31					
32	5	Concentration	0.2%	20 gps	
33	5				
34	5				
35	5				
36	3 & 5	Concentration	0.2%	40 gps	
37	3 & 5	Spill Rate	0.2%	40 gps	
38	6	Ignition	0.2%	20 gps	
39	7 & 3	Height above Ground and Spill Rate	0.3%	60 gps	
40	6	Ignition	0.3%	20 gps	
41	7	Height Above Ground	0.3%	20 gps	
42					
43					
44					
45					
46					
47					
48					
49	6 & 5	Ignition & Concentration	0.3%	20 gps	Std Config
50	6 & 5		0.3%	20 gps	
51	6 & 5	Ignition	2.5%	20 gps	
52					
53					
54	6	Ignition	0.3%	20 gps	Rockets
55			0.3%	20 gps	
56					
57					
58					
59	2	Velocity			NAEC Test Fuel
60	2	Velocity			NAEC Test Fuel
61	2	Velocity			NAEC Test Fuel
62	4	Temp			Std Config
63					
64					
65					
66					
67					
68	8	Orifice	0.3%	20 gps	
69	8	Orifice	0.3%	20 gps	
70	8	Orifice	0.3%	20 gps	
71	2 & 5	On Velocity & Concentration	0.3%	20 gps	NAEC Test Fuel With Dye
72					
73					
74			0.25%		
75			0.25%		
76			0.3%		
77			0.3%		
78			0.3%		
79			0.25%		
80			0.25%		
81			0.25%		
82	4	Temp	0.3%	20 gps	Std Config
83					
84					
85					
86					
87					
88					
89					
90					
91					
92					
93					
94					
95					
96					
97					
98					
99					
100					
101					
102	8 & 3	Spill Rate	0.3%	40 gps	
103		Orifice			
104					
105					
106	6	Ignition	0.3%	20 gps	
107	6	Ignition	0.3%	20 gps	
108					Demonstration
109 (DB11)	Demo	Demo	Jet A	0.35%	20 gps
110 (DB12)	Demo	Demo	Jet A	"	"
111 (DB13)	Demo	Demo	Jet A	0.35%	20 gps
112	2 & 5	Concentration & Velocity	0.3%	20 gps	Std Config
113					
114					
115					
116					
117					
118 (DB14)	Demo	Demo	Jet A	0.35%	20 gps
118 (DB15)	Demo	Demo	0.3%	20 gps	J60 Ignition
119					
120					
121					
122					
123					
124					
125					J60 Ignition
126		Deceleration & Ingestion	0.3%	20 gps	
127					
128					
129					
130					
131					
132					
133	9	Ingestion	0.3%	20 gps	Igniters On
134	9	Ingestion	0.3%	20 gps	Igniters On
135	4	Temperature	0.3%	20 gps	100°F Fuel
136	4	Temperature	0.3%	20 gps	100°F Fuel
137	4	Temperature	0.3%	20 gps	100°F Fuel
138	10	Deceleration	0.3%	20 gps	Std Config
139	10	Deceleration	0.3%	20 gps	
140	10	Deceleration	0.3%	20 gps	
141	2	Velocity	0.3%	20 gps	