

Report No. FAA-CT-81-5

*Copy 1*  
*DFW*

FAA WJH Technical Center  
00091023

# SUMMARY OF TRANSPONDER DATA MAY 1979 THROUGH NOVEMBER 1979

FEDERAL AVIATION ADMINISTRATION

Max Greenberg

JUN 15 1983

TECHNICAL CENTER LIBRARY  
ATLANTIC CITY, N.J. 08405



DATA REPORT

FEBRUARY 1981

Document is available to the U.S. public through  
the National Technical Information Service,  
Springfield, Virginia 22161.

Prepared for  
**U. S. DEPARTMENT OF TRANSPORTATION**  
FEDERAL AVIATION ADMINISTRATION  
TECHNICAL CENTER  
Atlantic City Airport, N.J. 08405

#### NOTICE

This document is disseminated under the sponsorship of the Department of Transportation in the interest of information exchange. The United States Government assumes no liability for the contents or use thereof.

The United States Government does not endorse products or manufacturers. Trade or manufacturer's names appear herein solely because they are considered essential to the object of this report.

Technical Report Documentotio Page

1. Report No. FAA-CT-81-5		2. Government Accession No.		3. Recipient's Catalog No.	
4. Title and Subtitle SUMMARY OF TRANSPONDER DATA MAY 1979 THROUGH NOVEMBER 1979				5. Report Date February 1981	
				6. Performing Organization Code	
7. Author(s) Max Greenberg				8. Performing Organization Report No. FAA-CT-81-5	
9. Performing Organization Name and Address Federal Aviation Administration Technical Center Atlantic City Airport, New Jersey 08405				10. Work Unit No. (TRAIS)	
				11. Contract or Grant No. 031-241-830	
12. Sponsoring Agency Name and Address U.S. Department of Transportation Federal Aviation Administration Technical Center Atlantic City Airport, New Jersey 08405				13. Type of Report and Period Covered Data Report May through November 1979	
				14. Sponsoring Agency Code	
15. Supplementary Notes					
16. Abstract <p>The purpose of this effort was to determine the performance characteristics of air traffic control radar beacon transponders in an operational environment in general aviation aircraft. A transponder performance analyzer (TPA) was developed at the Federal Aviation Administration Technical Center to measure performance parameters of transponders installed in aircraft. The TPA was installed in a bus for mobility and simulates an air traffic control beacon interrogator (ATCBI) to facilitate measurement of 15 transponder parameters in approximately 30 seconds. A standard gain horn antenna is utilized to couple the signals between the TPA bus and the aircraft. Transponder data were collected at six different geographic locations resulting in more than 690 samples of general aviation transponders. Results show that 42 percent of the transponders met all measured parameters. This is a slight improvement over the 1977/1978 data and is attributed to inclusion of data collected at general aviation airports in the Atlanta area. It is recommended that a study be conducted to determine the effects of transponder performance on the air traffic control systems (Automated Radar Terminal System (ARTS) and National Airspace System (NAS)) by individually varying each of the 15 parameters outside of their specification limits.</p>					
17. Key Words Transponder Air Traffic Control Beacon			18. Distribution Statement Document is available to the U.S. public through the National Technical Information Service, Springfield, Virginia 22161		
19. Security Classif. (of this report) Unclassified		20. Security Classif. (of this page) Unclassified		21. No. of Pages 27	22. Price

## METRIC CONVERSION FACTORS

### Approximate Conversions to Metric Measures

Symbol	When You Know	Multiply by	To Find	Symbol
<b>LENGTH</b>				
in	inches	2.5	centimeters	cm
ft	feet	30	centimeters	cm
yd	yards	0.9	meters	m
mi	miles	1.6	kilometers	km
<b>AREA</b>				
in <sup>2</sup>	square inches	6.5	square centimeters	cm <sup>2</sup>
ft <sup>2</sup>	square feet	0.09	square meters	m <sup>2</sup>
yd <sup>2</sup>	square yards	0.8	square meters	m <sup>2</sup>
mi <sup>2</sup>	square miles	2.6	square kilometers	km <sup>2</sup>
	acres	0.4	hectares	ha
<b>MASS (weight)</b>				
oz	ounces	28	grams	g
lb	pounds	0.45	kilograms	kg
	short tons (2000 lb)	0.9	tonnes	t
<b>VOLUME</b>				
tsp	teaspoons	5	milliliters	ml
Tbsp	tablespoons	15	milliliters	ml
fl oz	fluid ounces	30	milliliters	ml
c	cups	0.24	liters	l
pt	pints	0.47	liters	l
qt	quarts	0.95	liters	l
gal	gallons	3.8	liters	l
ft <sup>3</sup>	cubic feet	0.03	cubic meters	m <sup>3</sup>
yd <sup>3</sup>	cubic yards	0.76	cubic meters	m <sup>3</sup>
<b>TEMPERATURE (exact)</b>				
°F	Fahrenheit temperature	5/9 (after subtracting 32)	Celsius temperature	°C

### Approximate Conversions from Metric Measures

Symbol	When You Know	Multiply by	To Find	Symbol
<b>LENGTH</b>				
mm	millimeters	0.04	inches	in
cm	centimeters	0.4	inches	in
m	meters	3.3	feet	ft
m	meters	1.1	yards	yd
km	kilometers	0.6	miles	mi
<b>AREA</b>				
cm <sup>2</sup>	square centimeters	0.16	square inches	in <sup>2</sup>
m <sup>2</sup>	square meters	1.2	square yards	yd <sup>2</sup>
km <sup>2</sup>	square kilometers	0.4	square miles	mi <sup>2</sup>
ha	hectares (10,000 m <sup>2</sup> )	2.5	acres	
<b>MASS (weight)</b>				
g	grams	0.035	ounces	oz
kg	kilograms	2.2	pounds	lb
t	tonnes (1000 kg)	1.1	short tons	
<b>VOLUME</b>				
ml	milliliters	0.03	fluid ounces	fl oz
l	liters	2.1	pints	pt
l	liters	1.06	quarts	qt
l	liters	0.26	gallons	gal
m <sup>3</sup>	cubic meters	35	cubic feet	ft <sup>3</sup>
m <sup>3</sup>	cubic meters	1.3	cubic yards	yd <sup>3</sup>
<b>TEMPERATURE (exact)</b>				
°C	Celsius temperature	9/5 (then add 32)	Fahrenheit temperature	°F

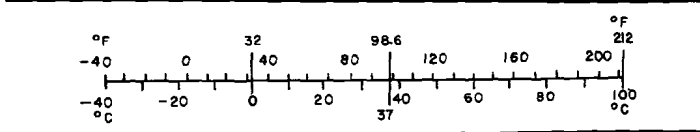

\* 1 in = 2.54 (exactly). For other exact conversions and more detailed tables, see NBS Misc. Publ. 286, Units of Weights and Measures, Price \$2.25, SD Catalog No. C13.10:286.

## TABLE OF CONTENTS

	Page
INTRODUCTION	1
Purpose	1
Background	1
Transponder Performance Analyzer	1
Data Collection	2
Data Samples	2
Parameters Measured	2
Test Procedures	2
RESULTS	4
COMPARATIVE ANALYSIS	7
SUMMARY	7
REFERENCES	9

## LIST OF ILLUSTRATIONS

Figure		Page
1	Transponder Performance Analyzer Bus	10
2	Interior of TPA Bus (Left Center)	11
3	Interior of TPA Bus (Left Forward)	12
4	Interior of TPA Bus (Right Center)	13
5	TPA Block Diagram	14
6	Positioning Aircraft	15
7	Computer Printout Sample	16
8	Dead Time ( $\mu s$ ) (690 Samples, 1979)	17
9	Suppression Time ( $\mu s$ ) (690 Samples, 1979)	17
10	Reply Power (dBm) (690 Samples, 1979)	18
11	Frequency (MHz) (690 Samples, 1979)	18
12	F <sub>1</sub> Pulse Width (ns) (690 Samples, 1979)	19
13	F <sub>2</sub> Pulse Width (ns) (690 Samples, 1979)	19
14	Sensitivity (-dBm) (690 Samples, 1979)	20
15	Delay Time Difference (ns) (690 Samples, 1979)	20
16	Reply Jitter (ns) (690 Samples, 1979)	21
17	Mode A Time Delay ( $\mu s$ ) (690 Samples, 1979)	21
18	Mode C Time Delay ( $\mu s$ ) (690 Samples, 1979)	22
19	F <sub>1</sub> -F <sub>2</sub> Spacing ( $\mu s$ ) (690 Samples, 1979)	22

LIST OF TABLES

Table		Page
1	Test Parameters	3
2	Percentage of Transponders Meeting Standards	5
3	Percentage of Transponders Meeting "N" of the 15 Standards	6
4	Percentage of Transponders Meeting Standards (1977/1978 Versus 1979)	8
5	Percentage of Transponders Meeting "N" of the 15 Standards (1977/1978 Versus 1979)	8

## INTRODUCTION

### PURPOSE.

The purpose of this effort was to determine the performance characteristics of transponders in general aviation aircraft in an operational environment.

### BACKGROUND.

At the request of the Airway Facilities Service (AAF) and the Systems Research and Development Service (SRDS), the Federal Aviation Administration (FAA) Technical Center was commissioned to provide data from general aviation aircraft transponders in calendar year 1979. This report is essentially the continuation of Report No. FAA-RD-79-56 (reference 1).

### TRANSPONDER PERFORMANCE ANALYZER.

GENERAL DESCRIPTION. The transponder performance analyzer (TPA) is an automated mobile test system capable of testing many transponders while operating in the aircraft or in a laboratory bench mode of operation. The TPA is fully self-contained and housed in a bus (figure 1) for mobility. The equipment consists of a modified AN/UPX-14 beacon transmitter/receiver, directional horn antenna, voltage control (digital) PIN diodes, pulse mode generator (PMG), radiofrequency (RF) control unit, reply processor, digital clock, computer buffer, minicomputer with magnetic tape and disk storage, a display terminal with hard copy printer, and other elements for timing (e.g., control and analog-to-digital (A/D) conversions). (See figures 2, 3, and 4.)

TPA OPERATION AND PROCEDURES. The minicomputer issues commands to the PMG, which establishes the pulse rate and spacing between interrogation pulses. The PMG also triggers the transmitter, which generates a low level of RF power. The control of the pulse rate and pulse spacing is utilized in measurement

of transponder dead time, suppression time, decode accuracy, and other characteristics. The amplitude of the RF is controlled by voltage variable attenuators that feed the horn antenna. The horn antenna transmits and receives all the RF pulses between the TPA and test aircraft. The transponder reply is processed through the receiver intermediate frequency (IF) amplifiers and various circuits for measurement of pulse amplitude, width, and spacing and then recorded on magnetic tape for data reduction and future analysis. A 100-megahertz (MHz) clock is used to measure the pulse width, spacing, and timing. A cathode ray tube (CRT) provides a visual output during the test. A thermal printer provides a hard copy printout for immediate assessment. Figure 5 is the TPA Block Diagram.

In the ramp test procedure, the TPA bus is located alongside the taxiway and the aircraft under test is positioned over a calibrated reference mark (figure 6). The aircraft pilot is requested to turn on the transponder and squawk a specified code. The test requires approximately 30 seconds. When the aircraft transponder antenna is over the reference mark, the free-space attenuation, horn antenna gain, environmental conditions, and cable losses are accounted for in amplitude dependent measurements such as transponder power output and sensitivity. The computer software automatically controls interrogation signal amplitude, spacing, and rate and records the transponder response to the interrogation signals. Typical processed reply characteristics are shown on the computer printout (figure 7). The TPA calibration and test procedures use the United States (U.S.) National Aviation Standard for the IFF Mark X (SIF)/Air Traffic Control Radar Beacon System Characteristics (reference 2); The Radio Technical Commission for Aeronautics (RTCA) "Minimum Performance Standards Airborne ATC Transponder Equipment Testing Procedures" (reference 3); and RTCA "Minimum Operational Characteristics-Airborne ATC Transponder

Systems" (reference 4) for guidance and control of test signal characteristics and measurements of transponder response.

#### DATA COLLECTION.

The 1979 data collection included five air shows/fly-ins and two general aviation airports in the Atlanta, Georgia, area. The air shows were selected based on expected number of aircraft, geographic area, travel requirements, and other considerations. The two general aviation airports were included at the request of the FAA Southern Region. Air shows selected were:

Reading, Pa.	(air show)	May 1979
Dayton, Ohio	(air show)	July 1979
White Lake, N.Y.	(air show)	Aug 1979
Opa-Locka, Fla.	(fly-in)	Oct 1979
Kissimmee, Fla.	(air show)	Nov 1979
Atlanta, Ga.*	(fly-in)	Nov 1979

\*(DeKalb and Fulton County Airports)

#### DATA SAMPLES.

More than 700 aircraft were interrogated in 1979 by the TPA bus at the various air shows and fly-ins. Of these, 690 were considered valid samples for compiling statistics. The invalid samples were the result of duplication of tests by the same aircraft at another air show or daily return to the same show. Duplicate data were automatically discarded during data reduction. Another cause for invalid data was aircraft movement from the calibrated reference point before the data collection process was completed. It is noted that all data samples were from voluntary participants in the program.

#### PARAMETERS MEASURED.

Transponder test parameters are listed in table 1. The parameter values are recorded as a function of interrogation signal conditions and represent the average value for a number of

interrogations at each condition. The test results are automatically compared with the national standards (defined in reference 2) and an output provided for operator use. The data are also recorded on magnetic tape for further analysis.

#### TEST PROCEDURES.

A very high frequency (VHF) communication channel was assigned by frequency management prior to the air show/fly-in date. This information, along with other general information about the TPA, was utilized in Notices to Airmen (NOTAM's), Automatic Terminal Information Service (ATIS), brochures, and handouts for advance publicity. In addition, signs directed the aircraft towards the TPA bus testing area and parking facilities. Once communication was established, the volunteer pilot was directed by a member of the TPA team to the calibrated mark on the taxiway (figure 6) and advised to operate his transponder on a specified discrete code. When the personnel in the TPA bus detected reply signals from the transponder, they entered the aircraft tail number and reply frequency via the CRT keyboard.

The directional antenna (horn) used to couple the signal between the aircraft transponder antenna and the TPA bus is a Scientific Atlanta standard gain horn, model 12-0.9. Calibration and dimensions for the horn are taken from the Naval Research Laboratory (NRL) Report No. 4433. The nominal gain at 1.0 gigahertz (GHz) is 13.7 decibels (dB). The E and H plane nominal beam widths are 35 and 40 degrees, respectively. The average height from the ground to the general aviation transponder antennas is approximately 30 inches. The horn is set at that height. A coupling factor due to height variation is taken into consideration as part of the measurement tolerance (reference 5, pages 48 and 49). The distance of 50 feet between horn and aircraft antenna is used for separation and clearance

TABLE 1. TEST PARAMETERS

<u>Characteristics</u>	<u>Specification</u>	<u>Measurement Tolerance</u>	<u>Remarks</u>
1. Dead Time	No greater than 125 $\mu$ s		
2. Suppression Time	35 $\pm$ 10 $\mu$ s		
3. Reply Power	At least 48.5 dBm not more than 57 dBm	$\pm$ 3 dB*	For aircraft operating below 15,000 feet.
4. Frequency	1090 $\pm$ 3 MHz		
5. F <sub>1</sub> Pulse Width	450 $\pm$ 100 ns	$\pm$ 20 ns	
6. F <sub>2</sub> Pulse Width	450 $\pm$ 100 ns	$\pm$ 20 ns	
7. Sensitivity	69 -77 dBm	$\pm$ 3 dB*	
8. Delay Time Diff.	Not to exceed 200 ns	$\pm$ 50 ns	Delay variations between modes (e.g., A, C)
9. Reply Jitter	Not to exceed 100 ns	$\pm$ 10 ns	
10. Mode A Delay	3 $\pm$ 0.5 $\mu$ s		
11. Mode C Delay	3 $\pm$ 0.5 $\mu$ s		
12. F <sub>1</sub> - F <sub>2</sub> Spacing	20.3 $\pm$ 0.1 $\mu$ s	$\pm$ 20 ns	
13. SLS Decode Accur.	2.0 $\pm$ 0.15 $\mu$ s		Interval between P <sub>1</sub> P <sub>2</sub>
14. Mode A Decode Accur.	8.0 $\pm$ 0.2 $\mu$ s		Interval between P <sub>1</sub> P <sub>3</sub>
15. Mode C Decode Accur.	21.0 $\pm$ 0.2 $\mu$ s		Interval between P <sub>1</sub> P <sub>3</sub>

\*Measurement error and/or antenna coupling factor include variations due to antenna height, lobing, reflections, etc.

purposes and is taken into account during calibration. Calibration of the TPA electronics utilizes the state-of-the-art test equipment and a reference transponder. The reference transponder is measured for the 15 parameters directly by the TPA equipment (bench test), and the parameter values recorded for comparison purposes.

The reference transponder and antenna are then placed over the calibration mark on the taxiway and the measurements repeated. The transponder is interrogated as in normal operation and the TPA equipment adjusted by offset voltages and computer parameters to produce the same readings as previously recorded from the bench test. This procedure accounts for coupling factors such as free-space attenuation, ground effects (i.e., lobing, reflections, and shielding), cable losses, power level settings, gain of the horn, etc.

## RESULTS

Measurements of the 15 parameters from all 690 samples obtained in 1979 were compared to the standards. Table 2 indicates the percentage of transponders meeting the standards for the 15 characteristics measured at the individual shows and fly-ins as well as composite data for 1979. A measurement tolerance is also indicated to allow for possible measurement error and/or antenna coupling. These are taken into consideration in the calculation of power output and sensitivity.

Table 3 shows the percentages of transponders which met some number of the standards where the parameter number varies from 1 to 15. Figures 8 through 19 are the composite data (690 samples) for each of the individual parameters for a total of 10,350 measurements.

From table 2 it is noted that approximately 14 to 16 percent failed to meet standards for reply power, sensitivity,

delay time difference, bracket pulse spacing, and mode C decode accuracy. Examination of table 3 composite data shows only 42 percent of the 690 transponders tested met all 15 parameters; that is, 58 percent failed at least one parameter. Thirty-five percent failed at least two parameters and 21 percent failed at least three parameters. This does not necessarily mean the transponders will not work in the normal ATC environment, but it does mean marginal performance. For example, power exceeding specification would simply be detected at longer ranges. Greater sensitivity could also result in detection at longer ranges, but could also result in "ring-around" (transponder would respond at many or all azimuths). Reduced power and/or sensitivity would result in only shorter range detection and would not function satisfactorily in long range operation. The other parameters could have varying effects depending on what direction and how much the parameter is out. The possible causes for the transponders being out of specification are lack of, or deficiency of, maintenance. It is suspected that many of the transponders are not checked and calibrated as required by regulation. Secondly, the transponders may be checked and certified on the basis of bench checks which would not include the antenna and associated couplings. This could affect the power and sensitivity of the transponders performance.

It is also noted that the data in this report includes data collected at Peach Tree/DeKalb and Fulton County Airports, Atlanta, Georgia. The Atlanta data indicate slightly better performance than the air show data. This is attributed to the greater number of trainer and executive business type aircraft tested as compared with the air show data samples. It is probable the maintenance/calibration schedules for these aircraft would be better than the privately owned aircraft because of cost and tax write-offs.

TABLE 2. PERCENTAGE OF TRANSPONDERS MEETING STANDARDS

CHARACTERISTICS	Reading (66)		Dayton (128)		White Lake (56)		Opa-Lock (167)		Kissimmee (165)		Atlanta (108)		Composite (690)		No. A/C
	Meas.* Toler. %	Spec. %	Meas.* Toler. %	Spec. %	Meas.* Toler. %	Spec. %	Meas.* Toler. %	Spec. %	Meas.* Toler. %	Spec. %	Meas.* Toler. %	Spec. %	Meas.* Toler. %	Spec. %	
1. Dead Time		100.00		100.00		98.21		100.00		99.39		99.07		99.57	687
2. Suppression Time		92.42		96.87		87.50		92.81		93.94		99.44		93.62	646
3. Reply Power	25.76	74.24	28.12	89.06	32.14	83.93	37.72	85.03	18.18	76.97	34.26	90.74	29.13	83.77	578
4. Frequency		95.45		89.06		89.29		95.81		95.15		91.67		93.33	644
5. F <sub>1</sub> Pulse Width	4.55	87.88	4.69	92.19	1.79	91.07	4.19	88.62	4.85	88.48	2.78	94.44	4.06	90.29	623
6. F <sub>2</sub> Pulse Width	3.03	86.36	10.16	94.53	5.36	92.86	2.99	93.41	1.21	89.70	6.48	94.44	4.60	92.17	636
7. Sensitivity	22.73	74.24	27.34	87.50	28.57	85.71	34.73	87.43	44.85	89.70	21.30	87.04	32.02	86.52	597
8. Delay Time Diff.	0.0	87.88	1.56	87.50	1.79	82.14	1.20	86.83	3.64	83.64	1.85	89.81	1.88	86.38	596
9. Reply Jitter	4.55	93.94	3.12	89.84	0.00	91.07	5.39	95.21	4.24	93.33	4.63	96.30	4.06	93.48	645
10. Mode A Delay		89.39		93.75		82.14		92.22		86.67		95.37		90.58	625
11. Mode C Delay		87.88		94.53		83.93		95.81		91.52		93.52		92.46	638
12. F <sub>1</sub> F <sub>2</sub> Spacing	4.55	81.82	4.69	83.59	7.14	78.57	8.38	85.63	4.85	83.03	1.85	90.74	5.36	84.49	583
13. SLS Decode Accur.		84.85		88.28		92.86		85.03		93.33		91.67		88.84	613
14. Mode A Decode Accur.		93.94		89.84		85.71		95.21		93.94		93.52		92.46	638
15. Mode C Decode Accur.		96.97		80.47		80.36		85.63		83.64		87.96		84.78	585

\*Measurement Tolerance provides for measurement error and/or antenna coupling factor including variations due to antenna height, lobing, shielding, reflections, etc.

TABLE 3. PERCENTAGE OF TRANSPONDERS MEETING "N" OF THE 15 STANDARDS

"N" Standards Out of 15	Reading (66)		Dayton (128)		White Lake (56)		Opa-Loca (167)		Kissimmee (165)		Atlanta (108)		Composite (690)	
	No. A/C	%	No. A/C	%	No. A/C	%	No. A/C	%	No. A/C	%	No. A/C	%	No. A/C	%
15	24	36.36	46	35.94	20	35.71	63	37.72	77	46.67	60	55.56	289	41.88
14	38	57.58	83	64.84	33	58.93	109	65.27	109	66.06	79	73.15	451	65.36
13	52	78.79	104	81.25	40	71.43	136	81.44	126	76.36	91	84.26	548	79.42
12	56	84.85	113	88.28	43	76.79	151	90.42	137	83.03	96	88.89	595	86.23
11	58	87.88	121	94.53	47	83.93	156	93.41	145	87.88	102	94.44	627	90.87
10	59	89.39	124	96.87	51	91.07	162	97.01	149	90.30	105	97.22	649	94.06
9	61	92.42	125	97.66	53	94.64	166	99.40	158	95.76	106	98.15	669	96.96
8	66	100.00	126	98.44	53	94.64	167	100.00	162	98.18	107	99.07	681	98.70
7	66	100.00	127	99.22	55	98.21	167	100.00	163	98.79	108	100.00	686	99.42
6	66	100.00	128	100.00	56	100.00	167	100.00	164	99.39	108	100.00	689	99.86
5	66	100.00	128	100.00	56	100.00	167	100.00	165	100.00	108	100.00	690	100.00
4	66	100.00	128	100.00	56	100.00	167	100.00	165	100.00	108	100.00	690	100.00
3	66	100.00	128	100.00	56	100.00	167	100.00	165	100.00	108	100.00	690	100.00
2	66	100.00	128	100.00	56	100.00	167	100.00	165	100.00	108	100.00	690	100.00
1	66	100.00	128	100.00	56	100.00	167	100.00	165	100.00	108	100.00	690	100.00
0	66	100.00	128	100.00	56	100.00	167	100.00	165	100.00	108	100.00	690	100.00

## COMPARATIVE ANALYSIS

The number of data samples collected for this reporting effort was 690, which is approximately 0.7 percent of the estimated 100,000, plus transponders installed in general aviation aircraft. Transponder data collected in FAA-RD-79-56 (reference 1) is approximately 1 percent (roughly 1,000 samples) and can be compared with the above. Tables 4 and 5 show the difference between the two sampling periods.

Table 5 shows the percentage of transponders meeting at least "N" of the 15 standards (composite) for both 1977/1978 and 1979. It can be seen that in 1977/1978 approximately 36 percent met 15 out of 15; 61 percent met 14 out of 15; 79 percent met 13 out of 15; and 88 percent met 12 out of 15. In 1979, 42 percent met 15 out of 15; 65 percent met 14 out of 15; 79 percent met 13 out of 15; and 86 percent met 12 out of 15. The 1979 data as compared with the 1977/1978 data are very similar.

Again, the two most commonly out-of-specification parameters are reply power and sensitivity, which are also the two most difficult parameters to measure. This is due to the variables and conditions previously discussed: ground effect and antenna coupling/orientation (lobing, reflections, shielding, etc.). Therefore, an additional 3 dB was allowed under the heading "Meas. Toler. %," in tables 2 and 4 and figures 10 and 14 for reply power and sensitivity measurements. This 3 dB, or grey area, where the measurement tolerance percent is indicated, shows a greater percentage in tolerance than those for pulse width, jitter, delay, and  $F_1 -$

$F_2$  spacing. An example in table 4, under composite for reply power, shows that 83.77 percent met the specification out of 690 transponders, of which 29.13 percent were in this grey area as indicated under "Meas. Toler. %." The same applies for sensitivity, wherein, 86.52 percent met the specification, of which 32.02 percent were in the grey area. Measurement tolerance for pulse width, jitter, and delay are relatively small due to electronic equipment and test equipment error. These tolerances are negligible, as indicated in table 2. Other areas that appear to have a higher out-of-specification parameter are  $F_1 - F_2$  spacing and mode C decode accuracy.

## SUMMARY

1. Only 42 percent of the 690 transponders tested in 1979 met national standards for all 15 test parameters, or conversely, 58 percent failed at least 1 of the 15 parameters tested. Thirty-five percent failed at least two parameters, and 21 percent failed at least three parameters.
2. Further, there is no significant difference between the 1977/1978 performance level and the 1979 level when the Atlanta data are excluded. There is only a 6 percent improvement when the Atlanta data are included.
3. The percentage of transponders out of specification would have a significant impact on the air traffic control environment in terms of reduced range, intermittent or no target detection, and ring-around.

TABLE 4. PERCENTAGE OF TRANSPONDERS MEETING STANDARDS (1977/1978 VERSUS 1979)

<u>Characteristics</u>	<u>Composite 1977/1978 (965)</u>		<u>Composite 1979 (690)</u>	
	<u>Meas.* Toler. %</u>	<u>Spec. %</u>	<u>Meas.* Toler. %</u>	<u>Spec. %</u>
1. Dead Time		97.6		99.57
2. Suppression Time		92.1		93.26
3. Reply Power	22.69	83.1	29.13	83.77
4. Frequency		92.5		93.33
5. F <sub>1</sub> Pulse Width	5.08	89.3	4.06	90.29
6. F <sub>2</sub> Pulse Width	4.77	87.5	4.60	92.17
7. Sensitivity	24.14	78.1	32.02	86.52
8. Delay Time Diff.	2.38	92.8	1.88	86.33
9. Reply Jitter	3.73	93.7	4.06	93.48
10. Mode A Delay		96.0		90.58
11. Mode C Delay		95.8		92.46
12. F <sub>1</sub> F <sub>2</sub> Spacing	5.38	88.8	5.36	84.49
13. SLS Decode Accur.		90.1		88.84
14. Mode A Decode Accur.		89.2		92.46
15. Mode C Decode Accur.		82.3		84.78

\*Measurement Tolerance provides for measurement error and/or antenna coupling factor including variations due to antenna height, lobing, shielding, reflections, etc.

TABLE 5. PERCENTAGE OF TRANSPONDERS MEETING "N" OF THE 15 STANDARDS (1977/1978 VERSUS 1979)

<u>"N" Standards Out of 15</u>	<u>Composite 1977/78 (965)</u>		<u>Composite 1979 (690)</u>	
	<u>No. A/C</u>	<u>%</u>	<u>No. A/C</u>	<u>%</u>
15	348	36.1	289	41.88
14	590	61.2	451	65.36
13	760	78.8	548	79.42
12	852	88.3	595	86.23
11	910	94.3	627	90.87
10	935	96.9	649	94.06
9	944	97.83	669	96.96
8	954	98.87	681	98.70
7	958	99.28	686	99.42
6	960	99.49	689	99.86
5	962	99.7	690	100.00
4	963	99.8	690	100.00
3	964	99.9	690	100.00
2	965	100.00	690	100.00
1	965	100.00	690	100.00
0	965	100.00	690	100.00

REFERENCES

1. Greenberg, M., Summary of Transponder Data, June 1977 through August 1978, FAA-RD-79-56, August 1979.
2. U.S. National Aviation Standard for the IFF Mark X(SIF)/Air Traffic Control Radar Beacon System Characteristics, No. 1010.51A, August 3, 1971.
3. Minimum Performance Standards Airborne ATC Transponder Equipment, Radio Technical Commission for Aeronautics, DO-150, March 17, 1972.
4. Minimum Operational Characteristics-Airborne ATC Transponder Systems, Radio Technical Commission for Aeronautics, DO-144, March 12, 1970.
5. Transponder Test Program, Federal Aviation Administration, FAA-RD-72-30, April 12, 1971.

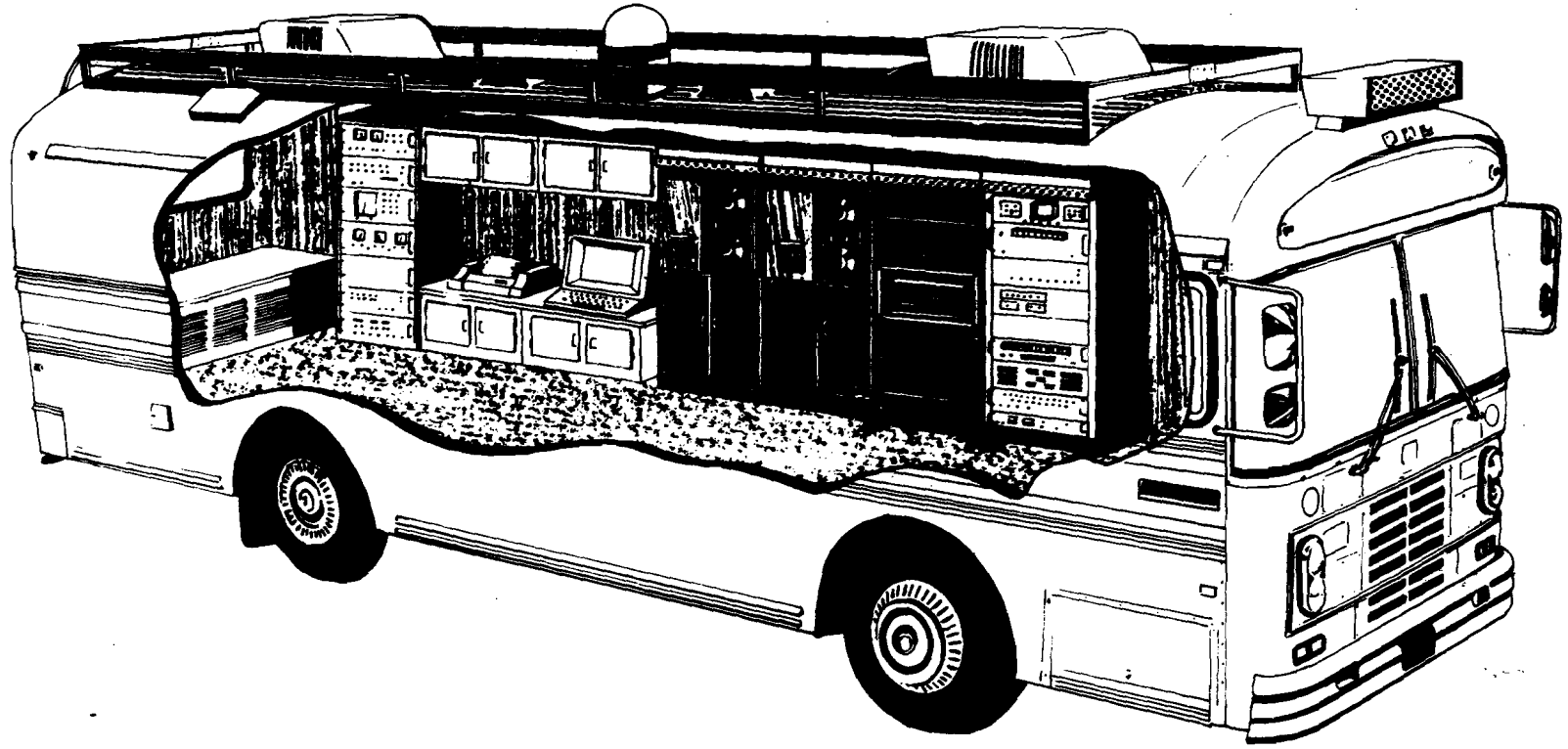

81-5-1

FIGURE 1. TRANSPONDER PERFORMANCE ANALYZER BUS

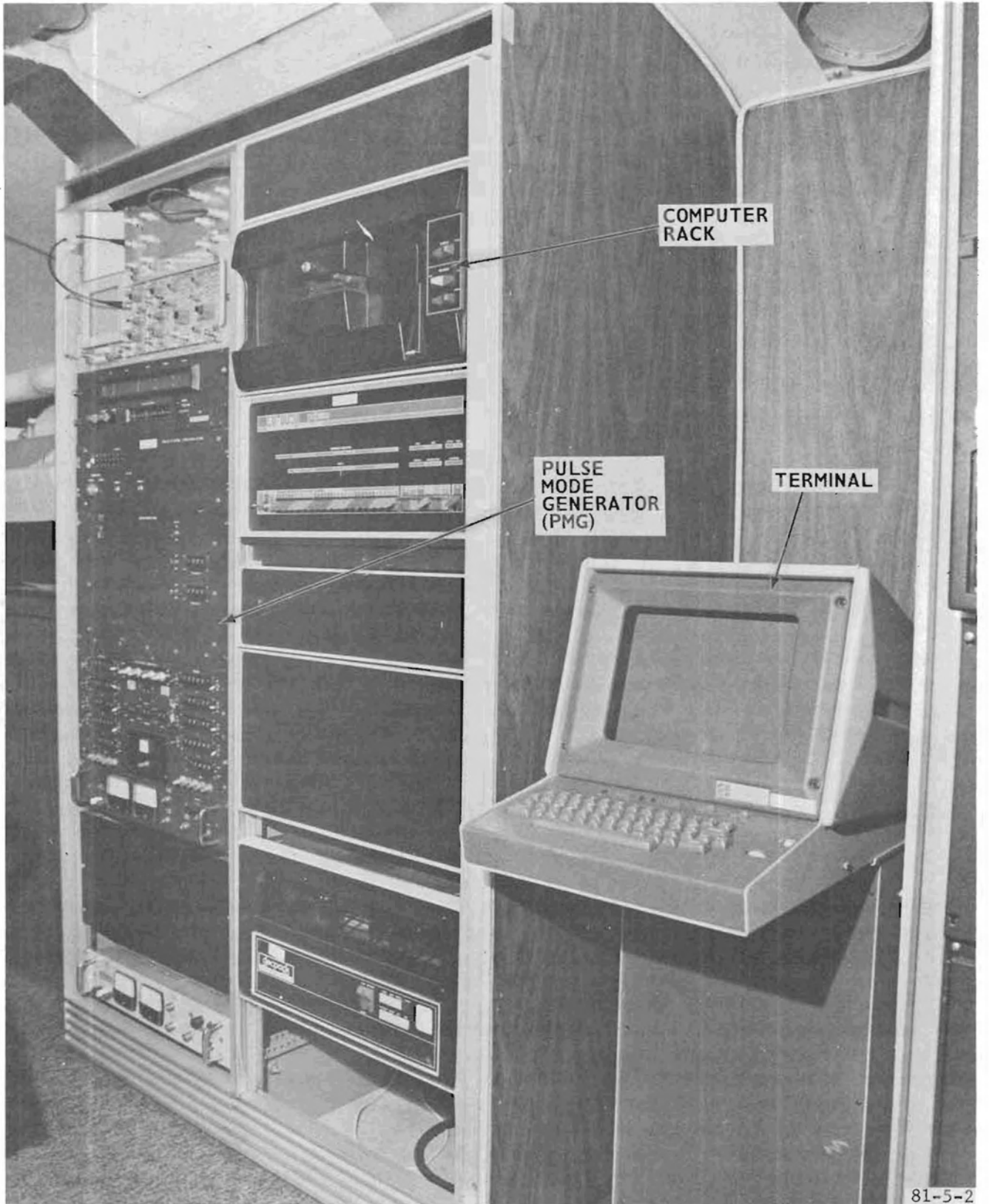

81-5-2

FIGURE 2. INTERIOR OF TPA BUS (LEFT CENTER)



FIGURE 3. INTERIOR OF TPA BUS (LEFT FORWARD)

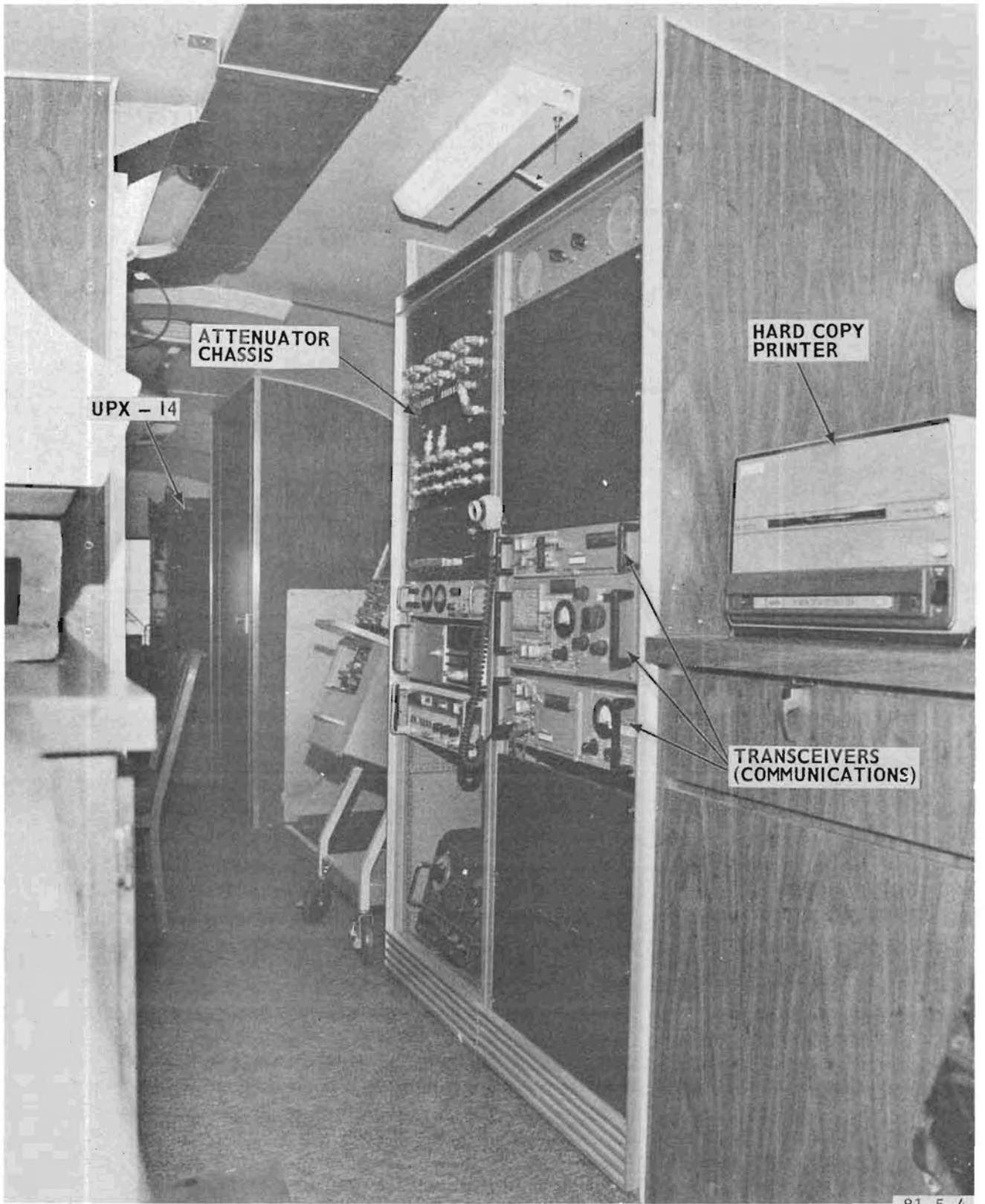
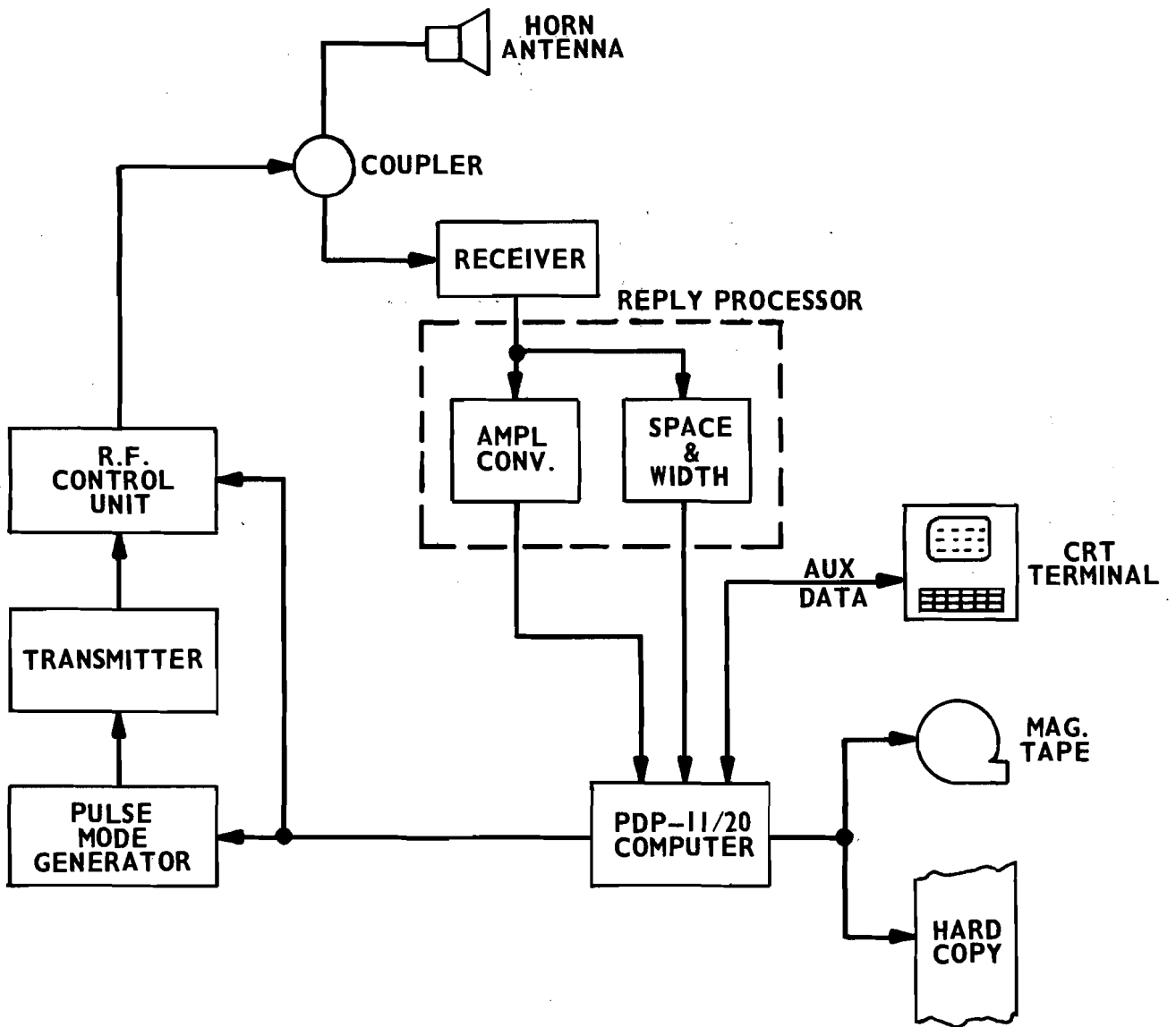
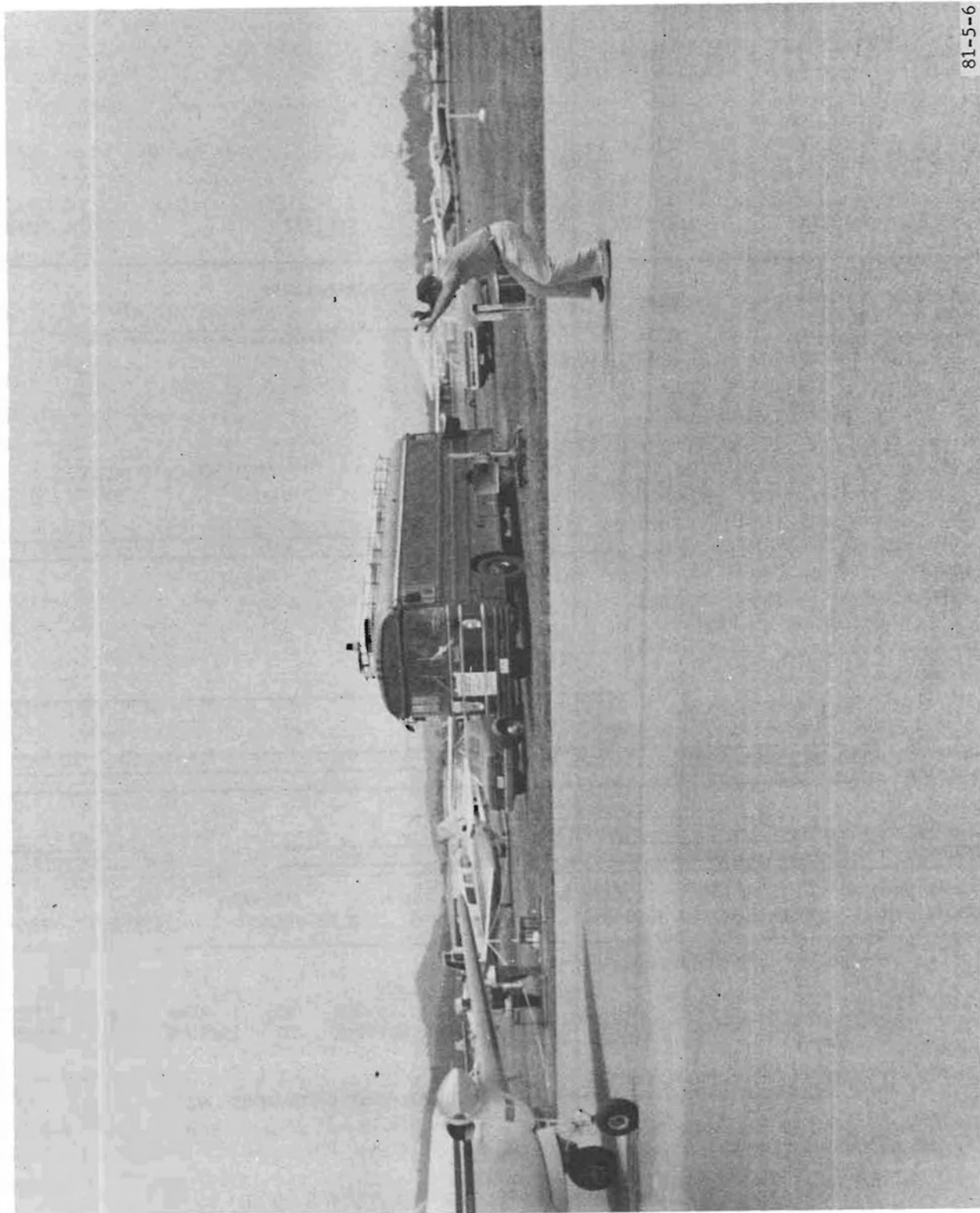

FIGURE 4. INTERIOR OF TPA BUS (RIGHT CENTER)



81-5-5

FIGURE 5. TPA BLOCK DIAGRAM



81-5-6

FIGURE 6. POSITIONING AIRCRAFT

A-C ID. N56313  
 TEST NO. 27.0

A-C TYPE  
 XPNDR TYPE

CODE:7777  
 ALT: 0

FREQ: 1090 MHZ  
 FOWER DBM

DATE: 9-JUNE-75  
 LOCATION: READING  
 TAPE ID: 004575  
 FILE NO: 000001

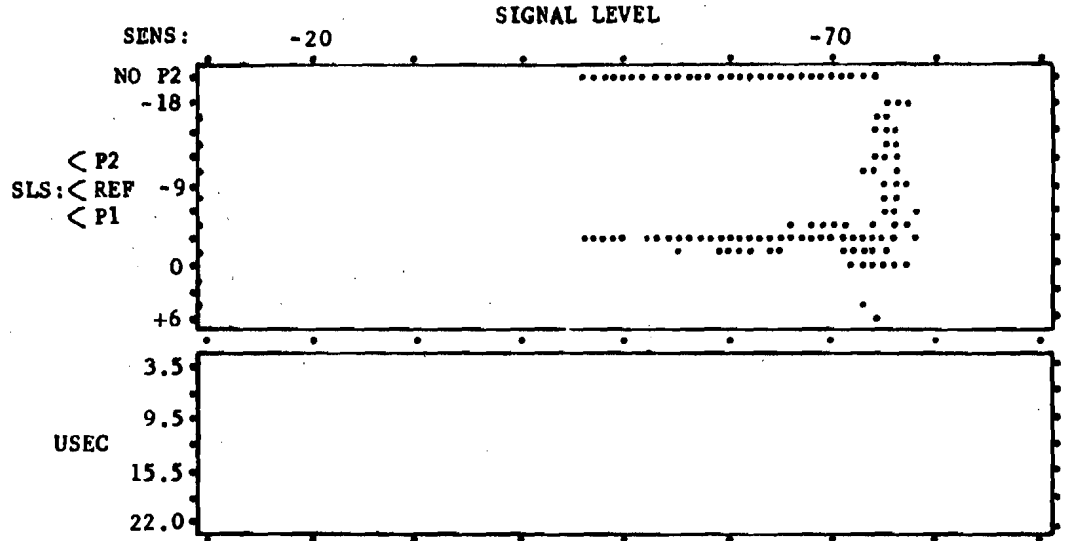

ECHO  
 SUPP

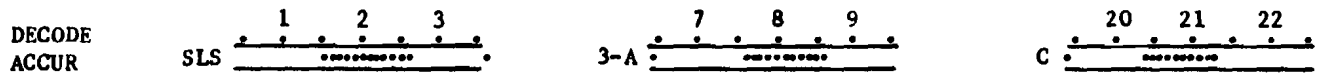
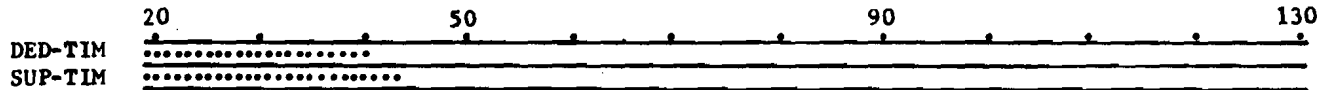

F1-F2 SPACING: 20.27 USEC. WIDTH: 470 , 460 NS. PWR OUT: 41.3, 40.6 DBM  
 DELAY TIME: MODE 3-A: 3.10 USEC. MODE C: 2.85 USEC JITTER: 190 NSEC

AVERAGE CODE PULSE SPACING IN NANoseconds

ACT	ACT	ACT	ACT	ACT	ACT
A1: 28500K	A2: 57200K	A4: 86300K	B1: 116100K	B2: 144200K	B4: 173300K
C1: 14000K	C2: 42900K	C4: 71600K	D1: 129800K	D2: 158800K	D4: 187700K

COMMENTS:

COURTESY OF THE FAA TECHNICAL CENTER, ATLANTIC CITY AIRPORT, N.J.

81-5-7

FIGURE 7. COMPUTER PRINTOUT SAMPLE

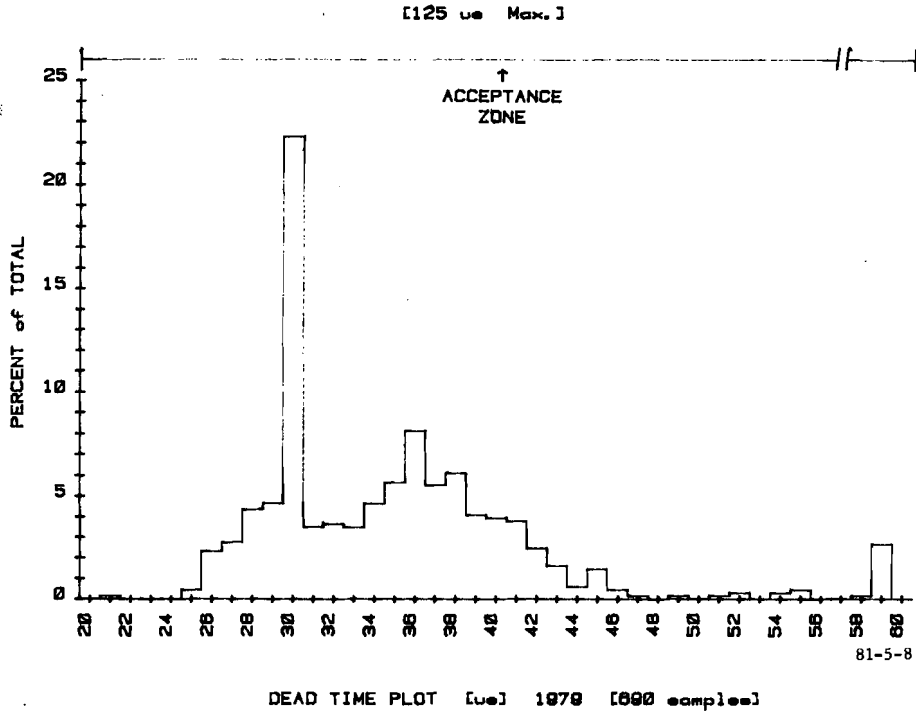

FIGURE 8. DEAD TIME ( $\mu\text{s}$ ) (690 SAMPLES, 1979)

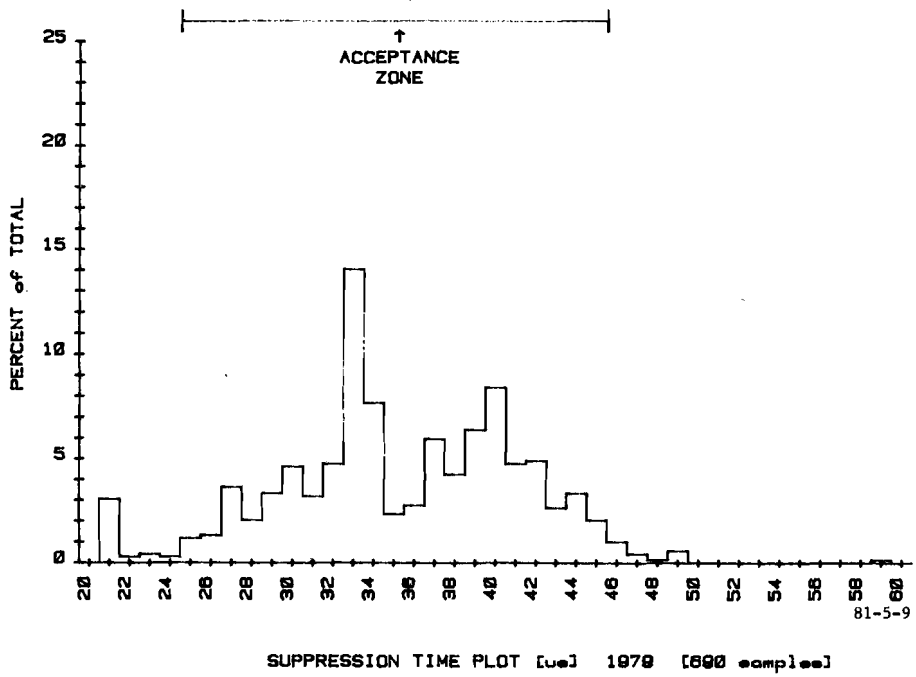

FIGURE 9. SUPPRESSION TIME ( $\mu\text{s}$ ) (690 SAMPLES, 1979)



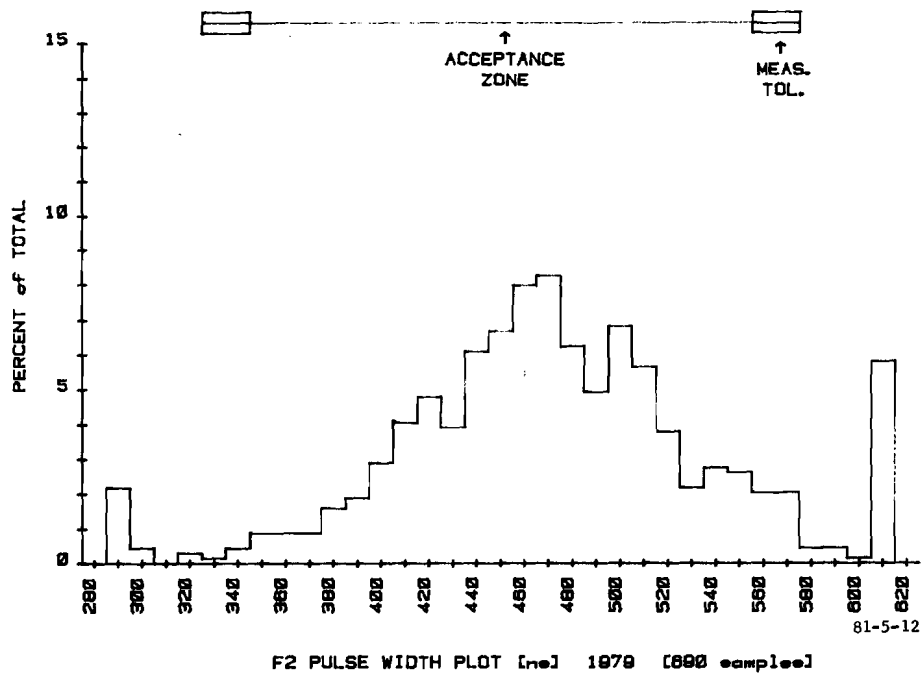

FIGURE 12. F<sub>1</sub> PULSE Width (ns) (690 SAMPLES, 1979)

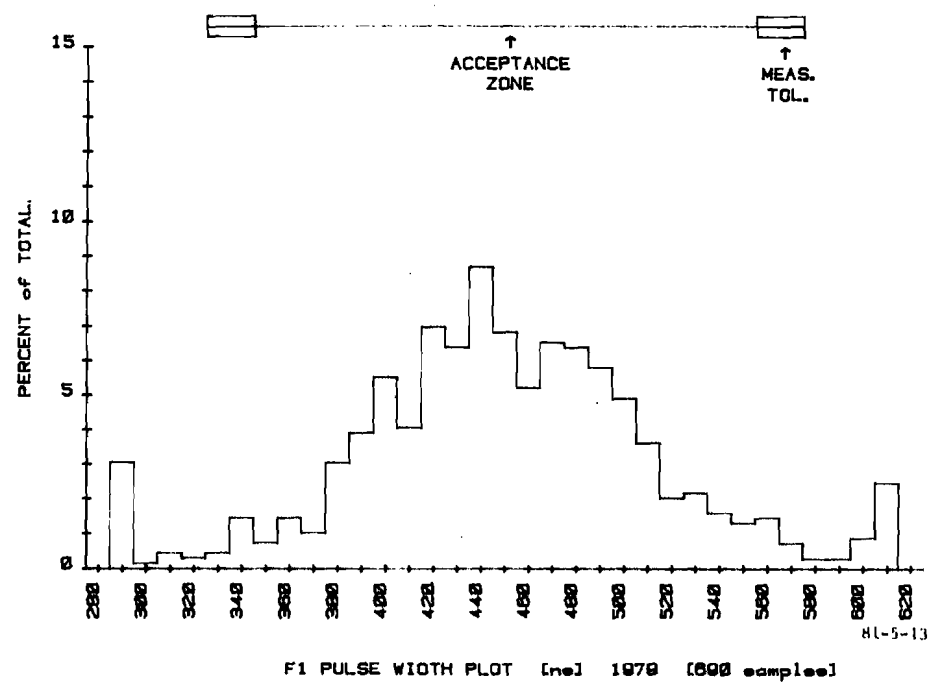

FIGURE 13. F<sub>2</sub> PULSE WIDTH (ns) (690 SAMPLES, 1979)

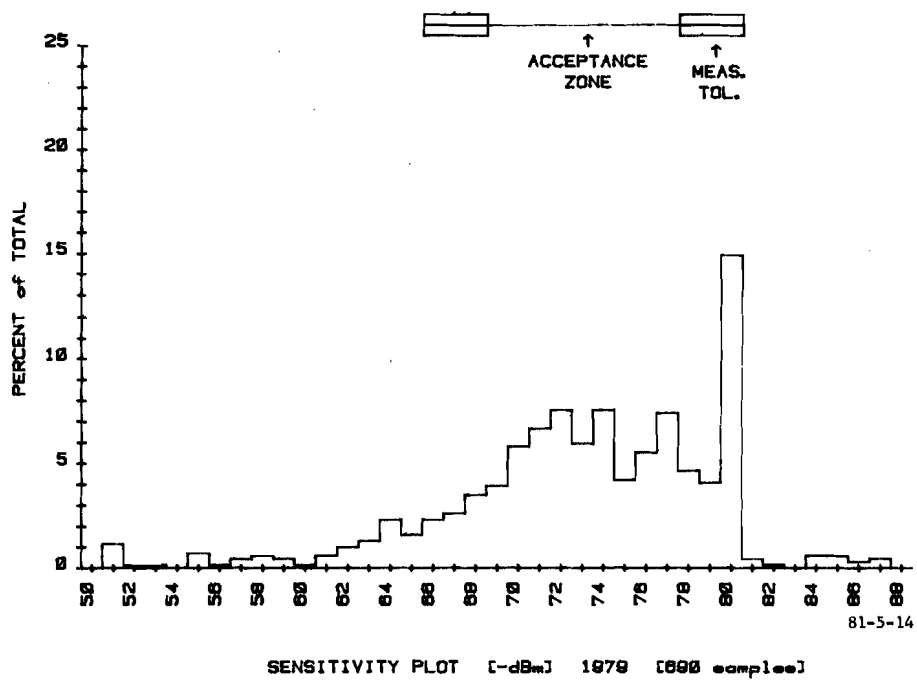

FIGURE 14. SENSITIVITY (-dBm) (690 SAMPLES, 1979)

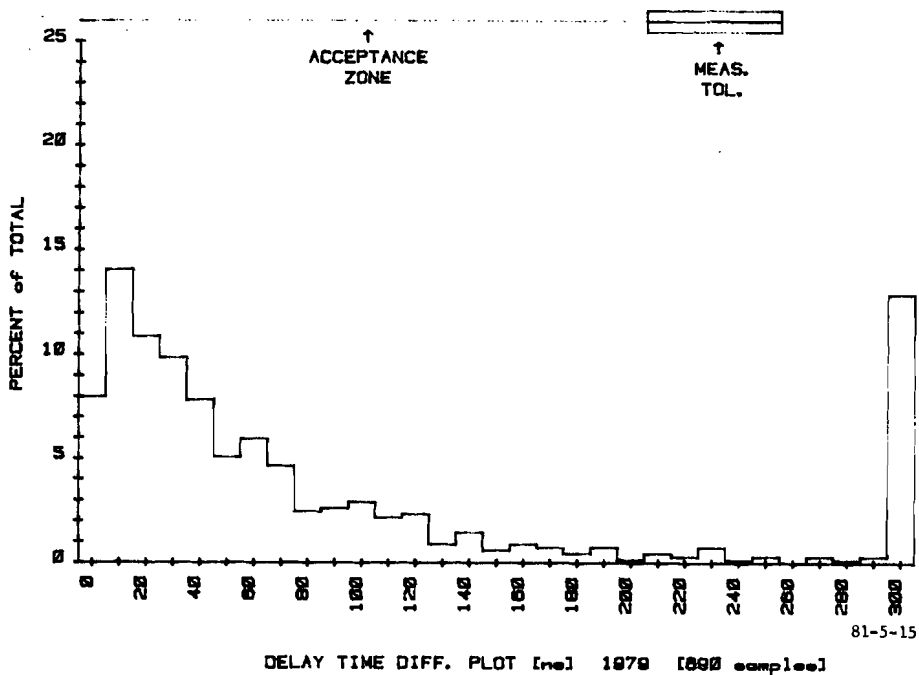

FIGURE 15. DELAY TIME DIFFERENCE (ns) (690 SAMPLES, 1979)

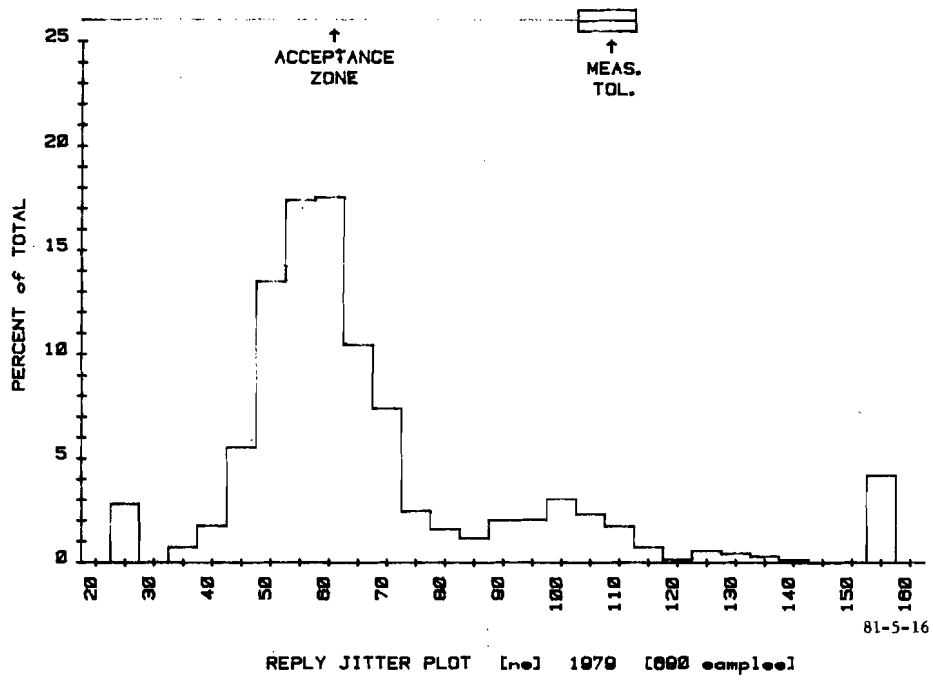

FIGURE 16. REPLY JITTER (ns) (690 SAMPLES, 1979)

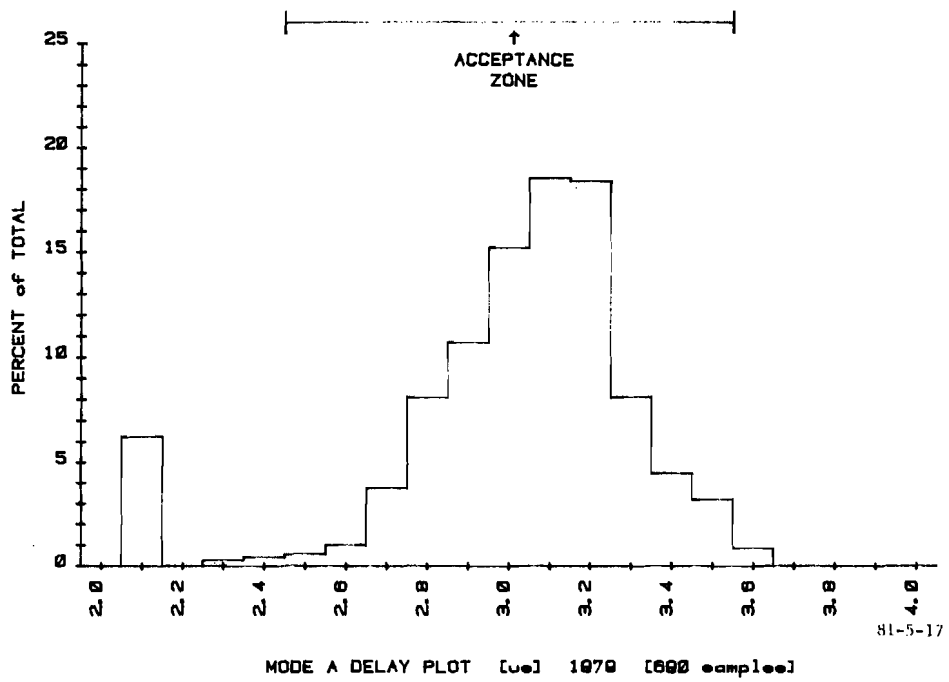

FIGURE 17. MODE A TIME DELAY ( $\mu s$ ) (690 SAMPLES, 1979)

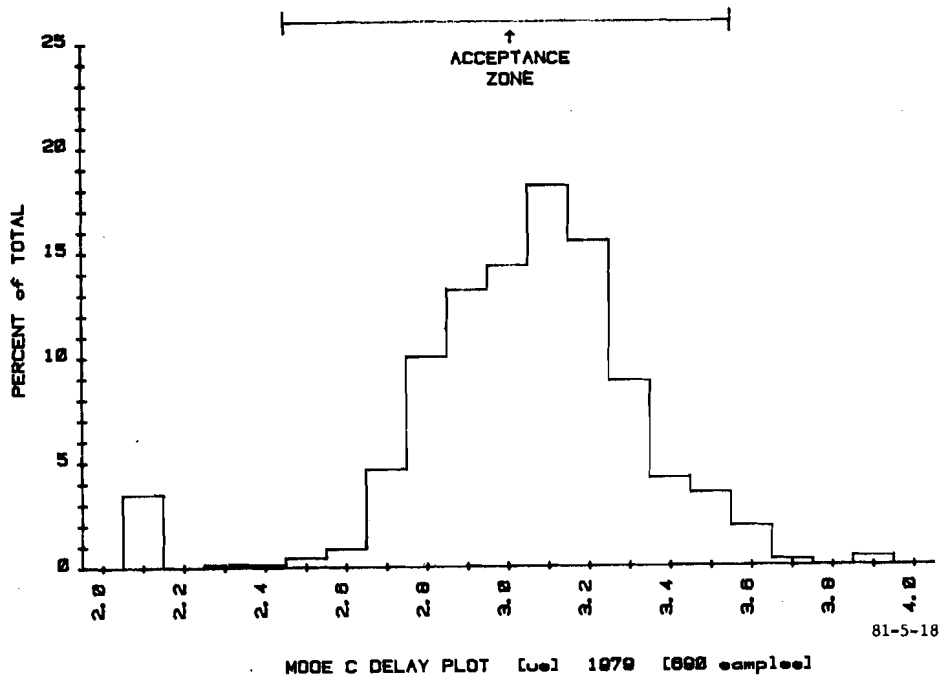

FIGURE 18. MODE C TIME DELAY ( $\mu s$ ) (690 SAMPLES, 1979)

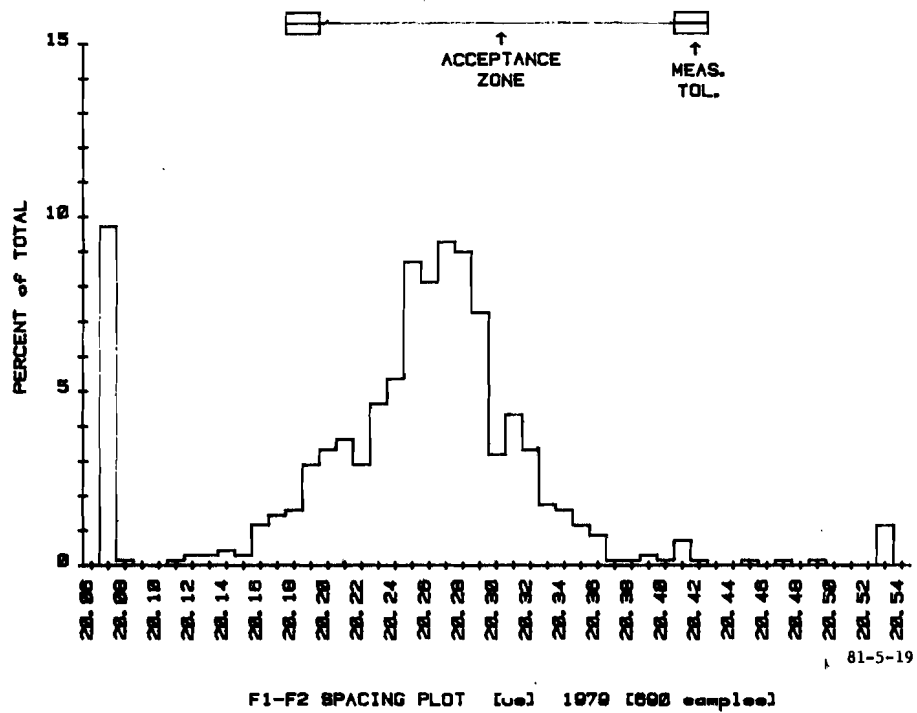

FIGURE 19.  $F_1 - F_2$  SPACING ( $\mu s$ ) (690 SAMPLES, 1979)