

Report No. FAA-RD-80-125-II
FAA-CT-80-51-II

COPY 1
80
51
11

ACTIVE BEACON COLLISION AVOIDANCE LOGIC EVALUATION: VOLUME II, COLLISION AVOIDANCE (BCAS) THREAT PHASE

A. Adkins
J. Thomas
B. Billmann
J. Windle

FEDERAL AVIATION ADMINISTRATION TECHNICAL CENTER
Atlantic City Airport, N.J. 08405



FEDERAL AVIATION ADMINISTRATION
NOV 2 1981
TECHNICAL CENTER LIBRARY
ATLANTIC CITY, N.J. 08405

FINAL REPORT

SEPTEMBER 1981

Document is available to the U.S. public through
the National Technical Information Service,
Springfield, Virginia 22161.

Prepared for
U. S. DEPARTMENT OF TRANSPORTATION
FEDERAL AVIATION ADMINISTRATION
Systems Research & Development Service
Washington, D. C. 20590



00007391

NOTICE

This document is disseminated under the sponsorship of the Department of Transportation in the interest of information exchange. The United States Government assumes no liability for the contents or use thereof.

The United States Government does not endorse products or manufacturers. Trade or manufacturer's names appear herein solely because they are considered essential to the object of this report.

Technical Report Documentation Page

1. Report No. FAA-RD-80-125-II		2. Government Accession No.		3. Recipient's Catalog No.	
4. Title and Subtitle ACTIVE BEACON COLLISION AVOIDANCE LOGIC EVALUATION: VOLUME II, COLLISION AVOIDANCE (BCAS) THREAT PHASE				5. Report Date September 1981	
				6. Performing Organization Code	
7. Author(s) A. Adkins, J. Thomas, B. Billmann, and J. Windle				8. Performing Organization Report No. FAA-CT-80-51-II	
9. Performing Organization Name and Address Federal Aviation Administration Technical Center Atlantic City Airport, New Jersey 08405				10. Work Unit No. (TRAIS)	
				11. Contract or Grant No. 052-241-320	
12. Sponsoring Agency Name and Address U.S. Department of Transportation Federal Aviation Administration Systems Research and Development Service Washington, D.C. 20590				13. Type of Report and Period Covered Final April 1979 - June 1980	
				14. Sponsoring Agency Code	
15. Supplementary Notes					
16. Abstract The purpose of this project was to evaluate and refine the April 1979 version of the Beacon Collision Avoidance System (BCAS) logic prior to Active BCAS prototype flight testing. The April 1979 version of the BCAS logic added changes to support multiple aircraft conflict resolution, Conflict Indicator Register (CIR) interfacing and new surveillance logic interfacing. The results of the first phase of the Active BCAS logic, evaluating the Air Traffic Control Radar Beacon System (ATCRBS) threat phase, identified several improvements that should be made to the BCAS logic. These improvements were incorporated into the logic prior to beginning the second phase, the BCAS equipped threat phase. The second phase was conducted from September to November 1979 and was designed to evaluate the BCAS performance against BCAS equipped threats. The results are presented in this report. Several logic improvements have been identified. These changes have been implemented in both the threat logic and the BCAS command coordination logic (CIR logic). In general, BCAS performance for equipped threats was not as sensitive to vertical rate tracker noise as in the ATCRBS threat case. Resolution performance has been improved through a reduction in undesirable BCAS alarms and by reducing excessive separation with the inclusion of a projected vertical miss distance (VMD) filter for equipped threats. A better method of selecting threat volume parameters has been incorporated. Coordination logic changes include the elimination of the generation of false alarms when dropping commands, the addition of the proper procedures for coordination during a threat logic hit-miss-hit sequence, and the deletion of the appropriate CIR rows when a consecutive number of missing reports occur.					
17. Key Words Collision Avoidance BCAS Conflict Indicator Register Vertical Miss Distance			18. Distribution Statement Document is available to the U.S. public through the National Technical Information Service, Springfield, Virginia 22161		
19. Security Classif. (of this report) Unclassified		20. Security Classif. (of this page) Unclassified		21. No. of Pages 60	22. Price

METRIC CONVERSION FACTORS

Approximate Conversions to Metric Measures

Symbol	When You Know	Multiply by	To Find	Symbol
LENGTH				
in	inches	2.5	centimeters	cm
ft	feet	30	centimeters	cm
yd	yards	0.9	meters	m
mi	miles	1.6	kilometers	km
AREA				
in ²	square inches	6.5	square centimeters	cm ²
ft ²	square feet	0.09	square meters	m ²
yd ²	square yards	0.8	square meters	m ²
mi ²	square miles	2.6	square kilometers	km ²
	acres	0.4	hectares	ha
MASS (weight)				
oz	ounces	28	grams	g
lb	pounds	0.45	kilograms	kg
	short tons (2000 lb)	0.9	tonnes	t
VOLUME				
tsp	teaspoons	5	milliliters	ml
Tbsp	tablespoons	15	milliliters	ml
fl oz	fluid ounces	30	milliliters	ml
c	cups	0.24	liters	l
pt	pints	0.47	liters	l
qt	quarts	0.95	liters	l
gal	gallons	3.8	liters	l
ft ³	cubic feet	0.03	cubic meters	m ³
yd ³	cubic yards	0.76	cubic meters	m ³
TEMPERATURE (exact)				
°F	Fahrenheit temperature	5/9 (after subtracting 32)	Celsius temperature	°C

Approximate Conversions from Metric Measures

Symbol	When You Know	Multiply by	To Find	Symbol
LENGTH				
mm	millimeters	0.04	inches	in
cm	centimeters	0.4	inches	in
m	meters	3.3	feet	ft
m	meters	1.1	yards	yd
km	kilometers	0.6	miles	mi
AREA				
cm ²	square centimeters	0.16	square inches	in ²
m ²	square meters	1.2	square yards	yd ²
km ²	square kilometers	0.4	square miles	mi ²
ha	hectares (10,000 m ²)	2.5	acres	
MASS (weight)				
g	grams	0.035	ounces	oz
kg	kilograms	2.2	pounds	lb
t	tonnes (1000 kg)	1.1	short tons	
VOLUME				
ml	milliliters	0.03	fluid ounces	fl oz
l	liters	2.1	pints	pt
l	liters	1.06	quarts	qt
l	liters	0.26	gallons	gal
m ³	cubic meters	35	cubic feet	ft ³
m ³	cubic meters	1.3	cubic yards	yd ³
TEMPERATURE (exact)				
°C	Celsius temperature	9/5 (then add 32)	Fahrenheit temperature	°F

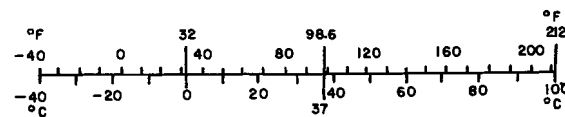

* 1 in = 2.54 (exactly). For other exact conversions and more detailed tables, see NBS Misc. Publ. 286, Units of Weights and Measures, Price \$2.25, SD Catalog No. C13.10286.

TABLE OF CONTENTS

	Page
INTRODUCTION	1
Purpose	1
Background	1
Objective	1
Phased Evaluation Concept	2
Unequipped Intruder Phase	2
Equipped Threat Phase	2
Multiple Intruder Phase	2
Error-Degraded Performance Phase	3
Scope	3
EVALUATION PROCEDURES	3
General	3
BCAS Performance Standards	4
Description of the CIR	4
RESULTS	6
General	6
Resolution Logic	6
Impact of Alpha-Beta Vertical Tracking on Resolution of Encounters with BCAS Equipped Threats	6
Early Command Removal Due to Overestimates of the Tracked Vertical Rate	8
Excessive Separation Due to Lack of Projected Vertical Miss Distance Filtering	10
Setting of High Altitude and Ultrahigh Altitude Threat Volume Parameters	13
Radar Altimeter Descent Command Inhibit Feature	13
General Performance for Linear Encounters	25
Proper Command Sense Choice Procedures for Equipped Threats in Performance Level 2 Areas	29
Coordination Logic	33
CIR Interface Logic Performance	33
Improper Deletion of CIR Rows Following Missed BCAS Surveillance Reports	39
CONCLUSIONS	44
REFERENCES	45
APPENDIX	
A - Chronology of Algorithm Deficiencies	

LIST OF ILLUSTRATIONS

Figure		Page
1	Conflict Indicator Register Data Structure	5
2	Improper Sense Selection for Vertically Accelerating ATCRBS Threats	7
3	Vertical Divergence Projection Function ($P(-R/\dot{R})$)	8
4	Vertical Profile of Geometry Which Results in Early Command Removal	9
5	Basic Geometry for Vertical Miss Distance Filtering Evaluation	11
6	DRACT Modification — VMD Filter Addition	13
7	Vertical Separation Performance With VMD Filter for Equipped Threats	15
8	TROACT Modification — Elimination of the Setting of Parameter Values	16
9	Parallel ILS Encounter	17
10	Descent Commands Not Inhibited by Radar Altimeter (Intruder Equipped — Parallel ILS)	18
11	Descent Commands Inhibited by Radar Altimeter (Intruder Equipped — Parallel ILS)	19
12	Command Duration Comparison	20
13	Descent Commands Not Inhibited by Radar Altimeter (Intruder Unequipped — Parallel ILS)	20
14	Descent Commands Inhibited by Radar Altimeter (Intruder Unequipped — Parallel ILS)	21
15	Basic Geometry for ILS Encounter With Level Flight Crossing Intruder	22
16	Descent Commands Not Inhibited by Radar Altimeter (Intruder Unequipped — 30° Crossing Angle)	23
17	Descent Commands Inhibited by Radar Altimeter (Intruder Unequipped — 30° Crossing Angle)	23
18	Descent Commands Not Inhibited by Radar Altimeter (Intruder Equipped — 30° Crossing Angle)	24

LIST OF ILLUSTRATIONS (Continued)

Figure		Page
19	Descent Commands Inhibited by Radar Altimeter (Intruder Equipped — 30° Crossing Angle)	25
20	Basic Geometry for Level BCAS and Equipped Vertically Maneuvering Intruder	26
21	Performance Against Equipped Descending Intruders	27
22	Performance Against Equipped Climbing Intruders	27
23	Crossing Angle Effect on Equipped Descending Intruder Performance	28
24	Crossing Angle Effect on Equipped Climbing Intruder Performance	28
25	Basic Geometry for Equipped Intruder Vertically Maneuvering Evaluation	30
26	Results for Equipped Intruder Vertically Maneuvering Evaluation	30
27	Vertical Separation for Aircraft Maneuvering at Low Vertical Rates	31
28	Crossing Angle Effect on Vertical Separation Performance	31
29	Vertical Separation Performance for Horizontally Maneuvering Threats	32
30	Conditions Leading to Reduced Performance Against Equipped Threats in Performance Level 2 Regions	33
31	DRACT Logic Modification To Properly Select Sense for Performance Level 2 Equipped Threats	34
32	False Threat Generation in Conflict Indicator Register	36
33	RCV Modification — Command Presence Check	37
34	DRACT Modification — Hit-Miss-Hit Problem (First Solution)	40
35	DRACT Modification — Hit-Miss-Hit Problem (Second Solution)	41

LIST OF ILLUSTRATIONS (Continued)

Figure		Page
36	Original TRIACT Logic	42
37	TRIACT Logic Modification — Delay Intruder State Vector Deletion	43

LIST OF TABLES

Table		Page
1	Results With no Vertical Miss Distance Filtering of Threats	12
2	Separation With VMD Filter Modification	14
3	Sequence of Events Resulting in Separation Loss	35
4	KHIT Sequence Which Prevents Command Coordination	38

LIST OF ACRONYMS AND BCAS ALGORITHM TERMS

- A - Absolute value of the relative tracked altitude of the intruder
- A BIT - ATARS Service Bit used in the CIR
- ALFAZ - Alpha-beta vertical position tracking constant (0.4)
- ADOT - Tracked relative vertical rate of intruder
- AGL - Above ground level
- ALIM - Altitude threshold for choice of positive commands (470 feet)
- ALPC - Lower boundary of high altitude airspace (18,000 feet)
- ALUH - Lower boundary of ultrahigh altitude airspace (29,000 feet)
- ASEPH - High altitude positive command threshold (670 feet)
- ASEPU - Ultra high altitude positive command threshold (770 feet)
- ATARS - Automatic Traffic Advisory and Resolution Service
- ATCRBS - Air Traffic Control Radar Beacon System
- BCAS - Beacon Collision Avoidance System
- B BIT - BCAS responsibility bit in the Conflict Indicator Register
- C BIT - ATARS responsibility bit in the Conflict Indicator Register
- CIR - Conflict Indicator Register
- CMDSAV - Previous command selection Array (threat dependent); same composition as D FIELD
- CMDTRT - Command portion of BCAS coordination advisory message sent to equipped threats (10 bits in length; same composition as D FIELD)
- COMCOMP (BCAS) - Function subroutine which checks a received CMDTRT for compatibility with each row of own CIR
- COORD - The logic subroutine which prepares CMDTRT messages, performs logic bookkeeping of threats with active commands, and performs command coordination and command validity checks
- D FIELD - CIR row maneuver intent field (10 bits)
- D1 - Horizontal command presence bit
 - D2 - Positive horizontal command bit
 - D3 - Horizontal sense bit
 - D4 - Vertical command presence bit

D5 - Positive vertical command bit
D6 - VSL bit
D7 - Vertical sense bit
D8 - Multiple threat bit
D9 - Coordination failure bit
D10 - Command display bit

DMOD - Modification distance applied to tracked range (1, 0.5, or 0.1 nmi)

DISPLA - BCAS subroutine used to generate command displays

DRACT - The logic subroutine that uses CAS logic intruder tracks to detect and resolve single threats

E - CIR row BCAS coordination in progress bit

ID - The threat identity field in the CIR row (DABS identity)

INDEX - BCAS threat logic performance level based on own aircraft track file

KHIT - Hit counter for conflict detection; an element of the intruder track file

LTACS - Time of last ATARS message (CIR row dependent)

LTBCS - Time of last BCAS message (CIR row dependent)

MTENT - Equipped intruder's indicated maneuver intent due to own aircraft

OWNTENT - Own aircraft's maneuver intent; an element of the intruder track file; same composition as the D FIELD

P(•) - Vertical divergence projection function

Performance Level - The setting of CAS logic sensitivity through parameter threshold selection. The selection can be based on range and altitude information provided by an RBX or accomplished manually by the pilot

PLINT - Indicated performance level of an equipped intruder; an element of the intruder track file

R - Tracked range to the intruder; an element of the intruder tracked file and CIR threat block data for an ATRCBS threat

RBX - Radar Beacon Transponder; the ground hardware designed to interface with aircraft equipped with Active BCAS

RCV - The subroutine that receives and manipulates BCAS interrogations from other BCAS aircraft

RCVD - An element of the BCAS threat interrogation message that indicates if last row of the CIR has been received

RD - Tracked range rate of the intruder; an element of the intruder track file and CIR threat block data for an ATRBS threat

RINNER - Range threshold between performance level 2 and performance level 3 regions (2 nmi)

ROUTER - Range threshold between performance level 3 and performance level 4 region (15 nmi)

RTRANS - Range to nearest RBX in track

RZ - Tracked relative altitude of intruder

RZD - Tracked relative vertical rate of intruder

SLEVEL - Performance level value received through the RBX

TAUV - Tracked time to coaltitude (-A/ADOT)

TCMD - Time of command selection for this intruder; an element of the intruder track file

TCUR - Internal clock time; an element of the own aircraft track file

TDATA - Time of latest track update; an element of the own aircraft track file

TDROP - Number of consecutive missed surveillance reports required to delete intruder state vector (10)

THETA - Bearing to intruder; an element of the threat track block in the CIR row; not used in Active BCAS

THDOT - Bearing rate for intruder; an element of the threat track block in the CIR row; not used in Active BCAS

TIC - Threat correlation subroutine used to find proper row in CIR

TMIN - Minimum time for command display (5 seconds)

TREPT - Time of latest surveillance report (intruder dependent); an element of the intruder track file

TRIACT - Threat logic intruder tracking subroutine

TROACT - Threat logic own aircraft tracking subroutine

TRTRU - Tracked time to minimum range (-R/Ṙ)

TV1 - Time delay to respond to commands (8 seconds)

TVPCMD - Look-ahead time for altitude detection (30 or 35 seconds)

TVPESEC - Look-ahead time for altitude resolution (30 to 35 seconds)

VMD - Projected vertical miss distance

Z - Reported altitude of the intruder; an element of the threat track block for an ATRBS threat in the CIR row

ZD - Reported altitude rate of the intruder; an element of the threat track block for an ATRBS threat in the CIR row

ZDESEN - Altitude for automatic selection of performance level 5 (10,000 feet)

ZDINT - Tracked intruder vertical rate; an element of the intruder track file

ZDOWN - Own aircraft tracked vertical rate; an element of the own aircraft track file

ZINT - Tracked altitude of the intruder; an element of the intruder track file

ZOWN - Own aircraft tracked altitude; an element of the own aircraft track file

ZRINT - Surveillance mode C report for the intruder; an element of the intruder track file

ZROWN - Surveillance mode C report for the own aircraft; an element of the own aircraft track file

ZTHR - Immediate altitude threshold used in threat detection (750 feet)

ZTHRH - High altitude airspace altitude threshold used in threat detection (850 feet)

ZTHRU - Ultra high altitude airspace altitude threshold used in threat detection (950 feet)

INTRODUCTION

PURPOSE.

This document presents an evaluation of Active Beacon Collision Avoidance System (BCAS) logic performance for BCAS equipped threats. The research was conducted using simulation to identify and correct areas of weak BCAS resolution performance prior to prototype flight testing of an active BCAS system. The research was not intended to substitute simulation results for live flight results. However, many encounter scenarios that are impossible to consider in live flight testing were closely analyzed and documented. Fast-time simulation also provides a standard for measuring flight test results. This report reviews the logic performance for the April 1979 Collision Avoidance Logic, reference 1, as modified with changes described in references 2 and 3.

BACKGROUND.

On three separate occasions real-time simulations of BCAS logic have been conducted at the Federal Aviation Administration (FAA) Technical Center, using the Air Traffic Control Simulation Facility (ATCSF). The first two simulations evaluated the impact of the Full BCAS logic on the air traffic controller in two different terminal air traffic control (ATC) environments. The terminal environments simulated were the Chicago (O'Hare), Illinois, and Knoxville (McGhee-Tyson), Tennessee, terminal areas. The results of these simulations were reported in references 4 and 5. The third simulation in the ATCSF assessed the impact of an interim version of the Active BCAS on the controller in the Knoxville terminal area, the same environment that was used in the Full BCAS testing.

The results of this prototype testing are reported in reference 6. The interim Active BCAS logic was also used in the air carrier simulations conducted by Aeronautical Radio, Incorporated (ARINC) (reference 7). In order to enable the BCAS logic to properly coordinate commands among aircraft in multiple aircraft encounters and Discrete Address Beacon System (DABS)/Automatic Traffic Advisory and Resolution Service (ATARS) sites, the MITRE Corporation developed the concept of a Conflict Indicator Register (CIR). The CIR is the aircraft's repository of conflict information. The CIR permits Active BCAS resolution of encounters involving BCAS or Air Traffic Control Radar Beacon System (ATCRBS) equipped aircraft in a multiple aircraft conflict. The use of the CIR to control and coordinate the BCAS command presentations necessitated extensive changes to the interim Active BCAS logic concepts. Changes were necessary to interface the collision avoidance algorithms with the CIR and to provide for resolution of multiple encounter scenarios. To meet these new requirements, MITRE Corporation developed the Active BCAS logic found in reference 1. Numerous improvements were made to Active BCAS logic for ATCRBS threats. The improvements include better ATCRBS sense choice logic and modifications to limit the effect of the noise in the vertical rate tracker. The results of the ATCRBS threat phase were reported in reference 3.

OBJECTIVES.

The primary objective of the research documented in this report is the evaluation of the Active BCAS collision avoidance logic performance for BCAS equipped threats. Additional objectives of the research were:

1. Identification of logic deficiencies which result in poor performance.
2. Testing of logic modifications designed to address areas of poor performance.
3. Validation of the interface between the collision avoidance logic and the coordination (CIR) logic.
4. Functional evaluation of the BCAS-to-BCAS portion of the coordination logic.

Secondary objectives included the testing of optional logic features such as the inhibiting of descent commands with radar altimeter information.

PHASED EVALUATION CONCEPT.

The evaluation of Active BCAS performance was conducted in four sequential phases. The phased concept permits a structured approach to the overall logic evaluation. The detection and resolution logic for unequipped intruders (ATCRBS threats) is evaluated prior to the evaluation of the coordination protocol logic for equipped intruders. Similarly, the command coordination procedures have to be checked prior to the evaluation of the multiple aircraft resolution logic. The division of the evaluation activities into distinct phases allows for the updating of the collision avoidance algorithms in a highly controlled manner. Logic deficiencies detected during one phase can be corrected before proceeding to the next phase. This limits the impact of detected logic deficiencies on subsequent phases. The results of the first phase, the unequipped intruder phase or Mode C, was presented in volume I. The results of the equipped threat phase is presented in this volume. The results of remaining phases will be presented in subsequent volumes.

UNEQUIPPED INTRUDER PHASE. The first phase of the evaluation activities assessed Active BCAS collision avoidance algorithm performance for unequipped intruders. Initially the logic performance is checked against unequipped intruders in simple linear encounters. The scenarios are designed to become progressively more complex. Final stages of the evaluation of unequipped intruder performance includes encounters in which both the BCAS aircraft and the intruder are maneuvering vertically and/or horizontally.

Although the CIR is not required to coordinate commands in this phase, the ability of the CIR to properly locate and correlate ATCRBS threat block data is subjected to a thorough review.

EQUIPPED THREAT PHASE. The second phase of the research investigates Active BCAS performance for BCAS equipped threats. The CIR coordination logic must function properly in this stage. As in the initial phase, equipped intruder performance is first measured against simple linear encounters. The complexity is then increased to include scenarios in which both aircraft are maneuvering vertically and/or horizontally.

MULTIPLE INTRUDER PHASE. The error-free data analysis activities culminate in this phase. In the multiple intruder phase, performance is measured in a two-intruder (three-aircraft) environment. The equipped status of the intruders is varied so that all possible intruder equipment combinations are analyzed. This phase stresses the threat correlation and multiple aircraft conflict resolution logic. The results from all the phases form the basis for comparison of the error-degraded logic performance in the final phase.

ERROR-DEGRADED PERFORMANCE PHASE. The final phase calls for the evaluation of the Active BCAS collision avoidance algorithm performance in an error-degraded environment. The logic input measures of altitude and range are degraded through the autoregressive modeling of own and intruder altitude and range measurements. Additionally, the impact of delayed intruder track establishment and missing intruder track reports are modeled. A sensitivity study identifies how these error characteristics affect the BCAS logic.

SCOPE.

This phase of the evaluation measures the performance of the Active BCAS collision avoidance logic against BCAS equipped intruders. More than 15,000 aircraft conflicts were simulated during the evaluation. In this phase, the BCAS air-to-air coordination procedures, identified in reference 1, were simulated. The BCAS/ATARS logic interfaces were not coded for this phase of the evaluation.

This report identifies the results of the BCAS equipped threat phase of the Active BCAS logic evaluation. A chronology of logic deficiencies and the logic modifications to correct the deficiencies is presented in appendix A of this report. The appendix refers the reader to a specific page number in the report where each logic deficiency is described in detail. Throughout the report BCAS algorithm terms, as they exist in the documented logic, were used. The definitions of these terms are shown on page viii.

EVALUATION PROCEDURES

GENERAL.

The evaluation of Active BCAS logic requires the interfacing of two highly inter-related algorithms. The first is the Fast-Time Encounter Generator (FTEG) or simulation algorithm which controls the operation of the model in fast-time and performs the data reduction and reporting tasks. (The description of the FTEG is included in reference 3.) The second is the BCAS algorithm which represents the Aircraft Separation Assurance (ASA) system under evaluation. (The description of the BCAS algorithm and interface software is described in reference 3.) The FTEG controls the execution of several subprograms to model the flight profiles of aircraft as they interact with the BCAS logic. It also supports the reconstruction of all encounters identifying pertinent BCAS variables, commands issued, and aircraft positions on a second-by-second basis. These data define the performance characteristics of the BCAS logic for defined scenario conditions and allow an evaluation based on a stated set of performance standards. The evaluation of BCAS logic performance is made against a wide range of paired aircraft and multiple encounter conditions. Evaluations are made in both error-free and error-degraded environments. The composition of encounter conditions against which BCAS performance was substandard were identified, and, where necessary, recommendations for logic changes were made. Extensive testing was conducted to ensure effective algorithm performance.

BCAS PERFORMANCE STANDARDS.

The basic BCAS logic performance requirements are:

1. BCAS should generate alarms for conflicting aircraft in a timely fashion to ensure at least 300 feet of vertical separation at the closest point of approach (CPA). For paired encounter conditions BCAS should not reduce the already existing vertical separation between aircraft at CPA.
2. Separation should be generated without exposing a BCAS aircraft to a set of contradictory commands.
3. All conflicting aircraft which are BCAS equipped, including multiple conflicts, should receive mutually compatible commands.
4. BCAS commands should not cause excessive vertical deviations in the presence of adequate preexisting separation. Generation of separation in excess of 1,000 feet vertically may indicate unsatisfactory algorithm performance.

Certain logic deficiencies in the coordination logic did not affect BCAS separation performance. However, logic performance was considered poor when the coordination procedures were grossly inefficient in the housekeeping of the CIR data field storage areas.

DESCRIPTION OF THE CIR.

The CIR is used to coordinate maneuver intent with other BCAS aircraft and to function as the communication interface with ATARS. The CIR also serves as the repository of own aircraft maneuver intentions for all threats. The resolutions for each individual threat are stored in the CIR, one threat resolution per row. The CIR is read by the multiple aircraft resolution logic in order to generate a BCAS command in a multiple threat situation.

The CIR threat row and message structure simulated is shown in figure 1. The structure is the same as that described in reference 1. The composition of each row generally was the same as that described in the original logic document. Since only BCAS-to-BCAS coordination was evaluated, some fields which are strictly associated with BCAS-to-ATARS coordination were not used. The fields not used included the ATARS service bit field, the LTACS field, and the ATRBS threat track block elements, bearing (THETA) and bearing rate (THDOT). These threat block elements were not used since Active BCAS cannot obtain bearing information on a threat. Some portions of the coordination logic which are used strictly to interface with ATARS were not coded into the test bed system. As a result, only the portions of the CIR logic required to perform BCAS-to-BCAS coordination were evaluated.

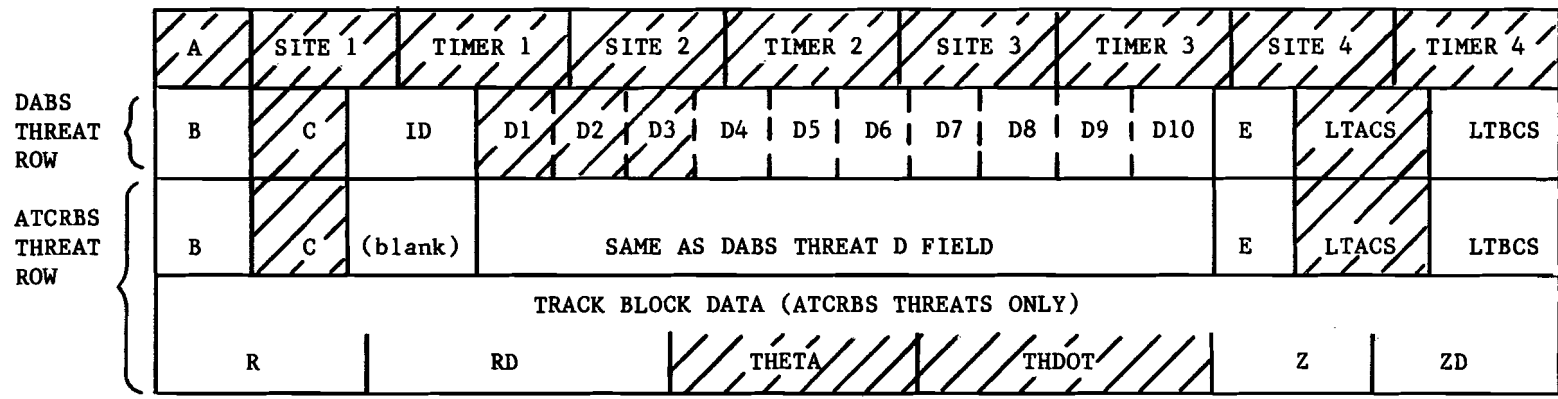

DEFINITIONS OF FIELDS AND BITS

- | | | | |
|-----------|---|---------|---------------------------------|
| A | ATARS SERVICE BIT | Z | ALTITUDE OF ATCRBS THREAT |
| SITE 1-4 | ATARS SITE ID | ZD | ALTITUDE RATE OF ATCRBS THREAT |
| TIMER 1-4 | TIME OF LAST UPDATE FROM SITE I | D FIELD | MANEUVER INTENT FIELD (10 BITS) |
| B | BCAS RESPONSIBILITY | D1 | HORIZONTAL COMMAND PRESENCE BIT |
| C | ATARS RESPONSIBILITY | D2 | POSITIVE HORIZONTAL COMMAND BIT |
| ID | DABS IDENTIFICATION | D3 | HORIZONTAL SENSE BIT |
| E | BCAS COORDINATION IN PROGRESS | D4 | VERTICAL COMMAND PRESENCE BIT |
| LTACS | TIME OF LAST ATARS MESSAGE FOR THIS ROW | D5 | POSITIVE VERTICAL COMMAND BIT |
| LTBCS | TIME OF LAST BCAS MESSAGE FOR THIS ROW | D6 | VSL BIT |
| R | RANGE TO ATCRBS THREAT | D7 | VERTICAL SENSE BIT |
| RD | RANGE RATE TO ATCRBS THREAT | D8 | MULTIPLE THREAT BIT |
| THETA | BEARING TO ATCRBS THREAT | D9 | COORDINATION FAILURE BIT |
| THDOT | BEARING RATE TO ATCRBS THREAT | D10 | COMMAND DISPLAY BIT |

 FIELD NOT USED IN ACTIVE BCAS-TO-BCAS COORDINATION

FIGURE 1. CONFLICT INDICATOR REGISTER DATA STRUCTURE

RESULTS

GENERAL.

Active BCAS logic performance for equipped threats was generally good. Areas of marginal performance are reviewed in this section. Discussion of the results first reviews resolution logic performance. Deficiencies in the coordination logic are then presented.

RESOLUTION LOGIC.

This section describes the performance of the conflict resolution logic for conflicts involving two BCAS equipped aircraft. This analysis was conducted in an error-free environment. The following subsections will describe the analysis in detail.

IMPACT OF ALPHA-BETA VERTICAL TRACKING ON RESOLUTION OF ENCOUNTERS WITH BCAS EQUIPPED THREATS. The Active BCAS logic relies heavily on the BCAS-tracked vertical rates of ZDOWN and ZDINT to resolve conflicts. The performance of the vertical tracker is poor at low vertical rates 700 feet per minute (ft/min) or less. The Active BCAS logic selects the command maneuver sense based on a projected relative vertical miss distance (VMD) of the aircraft. The unequipped threat logic uses a 35-second maximum projection, and equipped threat logic uses an 8-second projection; therefore, the oscillations in the tracked vertical rates (and corresponding oscillation in VMD) pose less sense selection problems in BCAS equipped threat encounters.

Errors occur in the tracked vertical rates of an aircraft during vertical acceleration. The tracker does not immediately recognize the change in the vertical rate, due to the acceleration. Even when it recognizes the change, the tracked values oscillate around the true rate prior to stabilizing.

Volume I of this report identified problems in resolving conflicts with vertically accelerating ATCRBS threats. Figure 2 identifies the scenarios which were most critical. When the intruder is BCAS equipped, BCAS logic performance is considerably better. Since the sense selection in the equipped intruder case is based on a vertical position projection of only 8 seconds instead of 35 seconds, the incorrect sense choice (climb for the level flight BCAS in figure 2) occurs much less frequently than when the intruder is unequipped. Additionally, simulation has shown that even when the level flight BCAS selects a climb sense, this is properly coordinated and the descending BCAS intruder receives a descent command. Simulation showed that BCAS-generated vertical separation exceeded 250 feet at CPA even when the incorrect sense choice was made.

For a level flying BCAS aircraft, the $\alpha - \beta$ tracked vertical rate oscillations often cause undesirable cyclic vertical speed limit (VSL) alarms. In such cases, the problem can be resolved by incorporating an additional check on the tracked vertical rate of the own BCAS aircraft. If the BCAS aircraft vertical rate (in absolute value) is less than a nominal value of 300 ft/min, VSL advisories should not be issued. A negative advisory of the proper sense should be issued.

A. SENCE SELECTION

1. INTRUDER IN CONSTANT RATE DESCENT
2. INTRUDER TRACKED TO PASS BELOW BCAS
3. CLIMB/NO DESCENT SENSE SELECTED

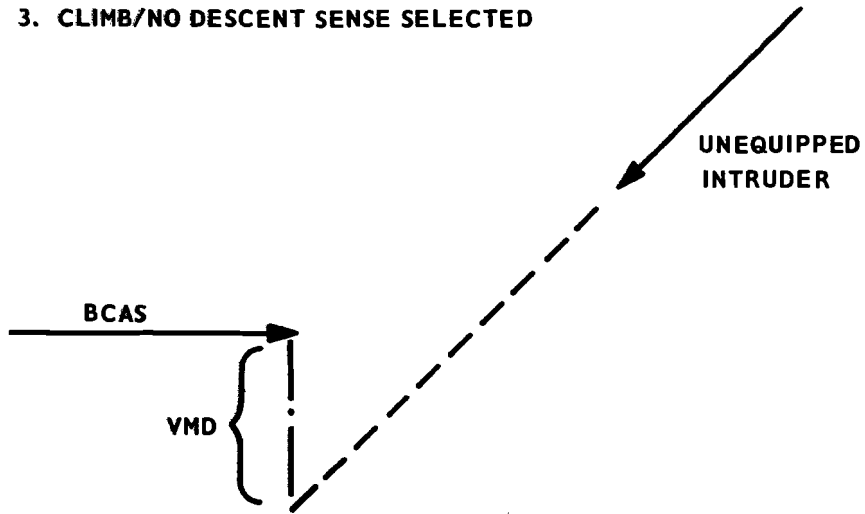

B. INITIAL COMMAND

1. DUE TO LARGE PROJECTED VERTICAL MISS (VMD) POSITIVE COMMAND IS NOT REQUIRED
2. NO DESCENT COMMAND ISSUED

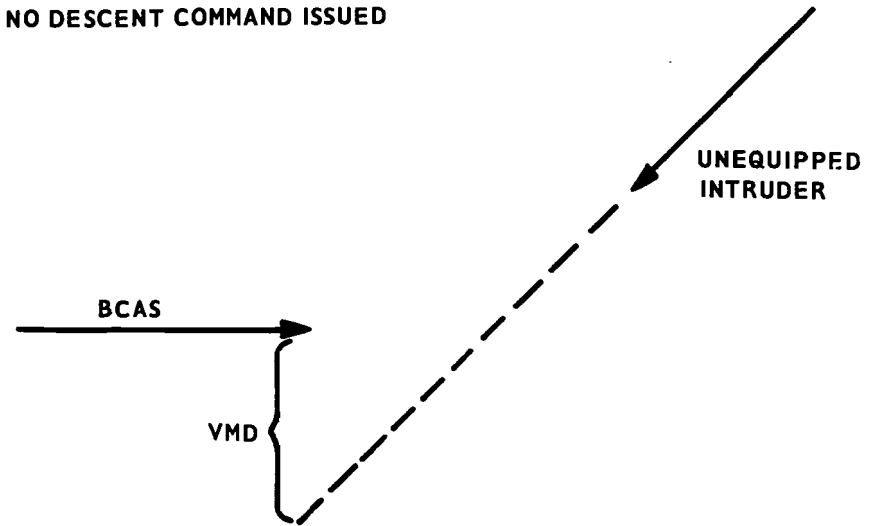

C. INTRUDER MANEUVERS

1. INTRUDER BEGINS TO LEVEL OFF ABOVE BCAS
2. REDUCTION IN VMD CAUSED NEGATIVE COMMAND TO TRANSITION TO POSITIVE COMMAND
3. CLIMB COMMAND ISSUED

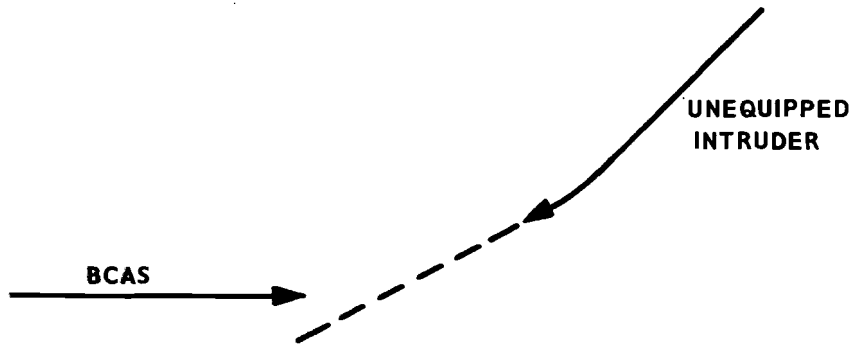

D. RESULTS

1. BCAS RESPONDS TO CLIMB COMMAND AND CLIMBS TOWARD LEVEL INTRUDER

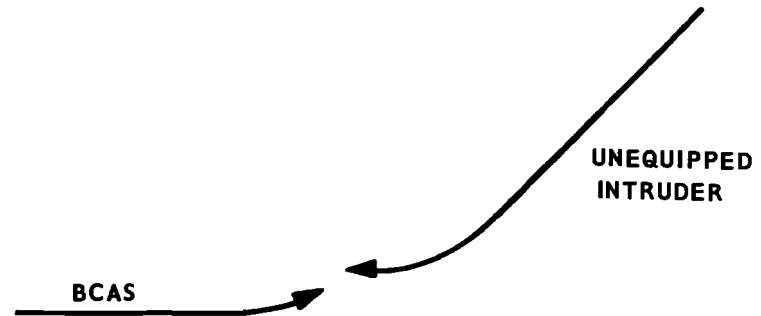

80-51-15

FIGURE 2. IMPROPER SENCE SELECTION FOR VERTICALLY ACCELERATING ATRBS THREATS

EARLY COMMAND REMOVAL DUE TO OVERESTIMATES OF THE TRACKED VERTICAL RATE. The threat detection logic uses a vertical divergence prediction function, $P(-R/\dot{R})$, to determine vertical separation when the tracked relative vertical rate is positive (vertical separation is increasing). The function, $P(-R/\dot{R})$, is designed to underestimate the vertical separation at CPA by reducing the projected time to CPA; that is, the vertical separation is only projected for $P(-R/\dot{R})$ seconds instead of $-R/\dot{R}$ seconds. Figure 3 presents a graph of $P(-R/\dot{R})$.

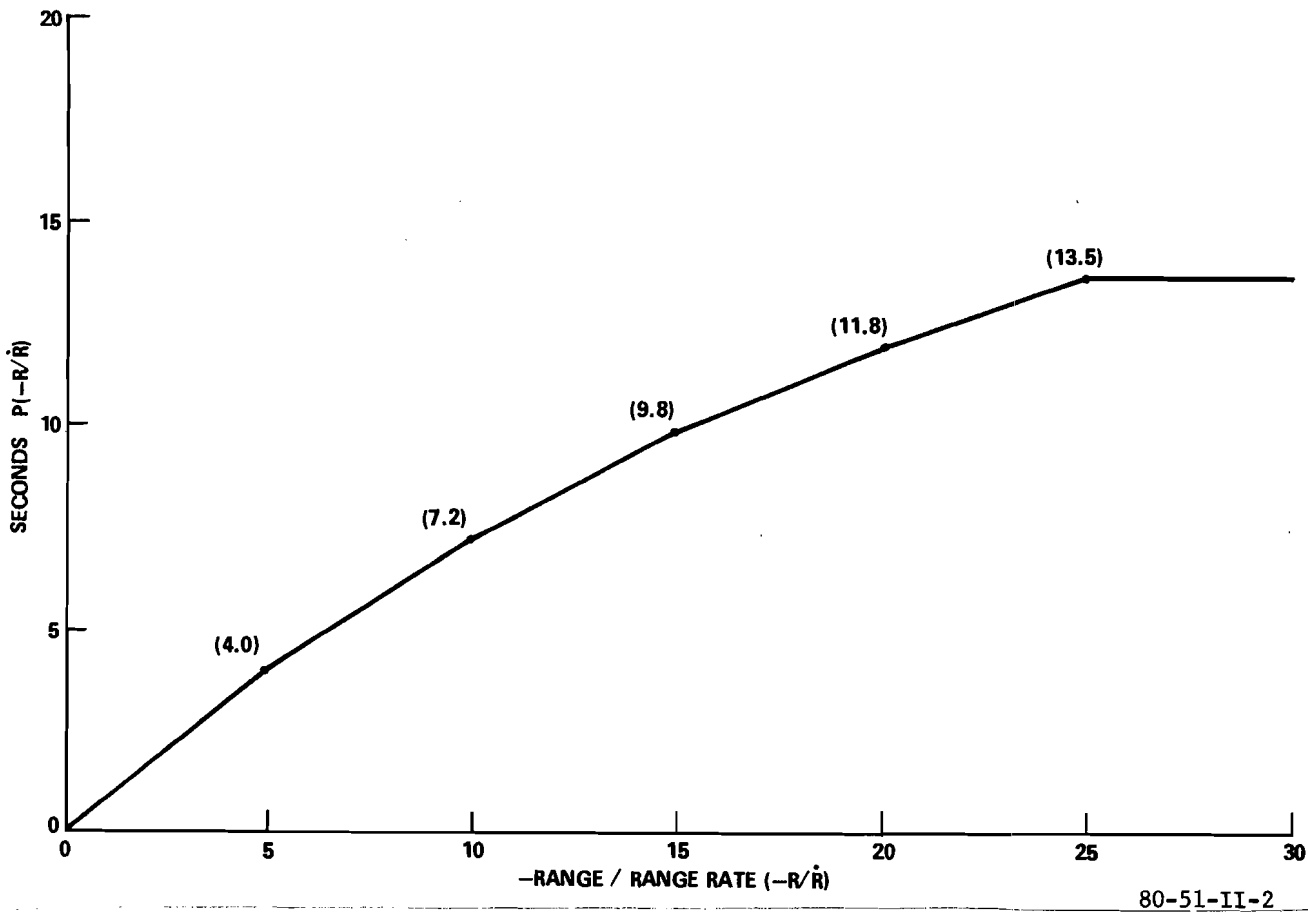

80-51-II-2

FIGURE 3. VERTICAL DIVERGENCE PROJECTION FUNCTION ($P(-R/\dot{R})$)

The problem with the projected vertical divergence logic is the error that can exist in the tracked relative vertical rate, ADOT. The error is especially large when coaltitude aircraft ($\Delta Z \leq 470$ feet) respond to complementary positive BCAS commands. Figure 4 shows the vertical profile and sequential BCAS command pattern which resulted for a pair of BCAS aircraft. The planned encounter conditions were:

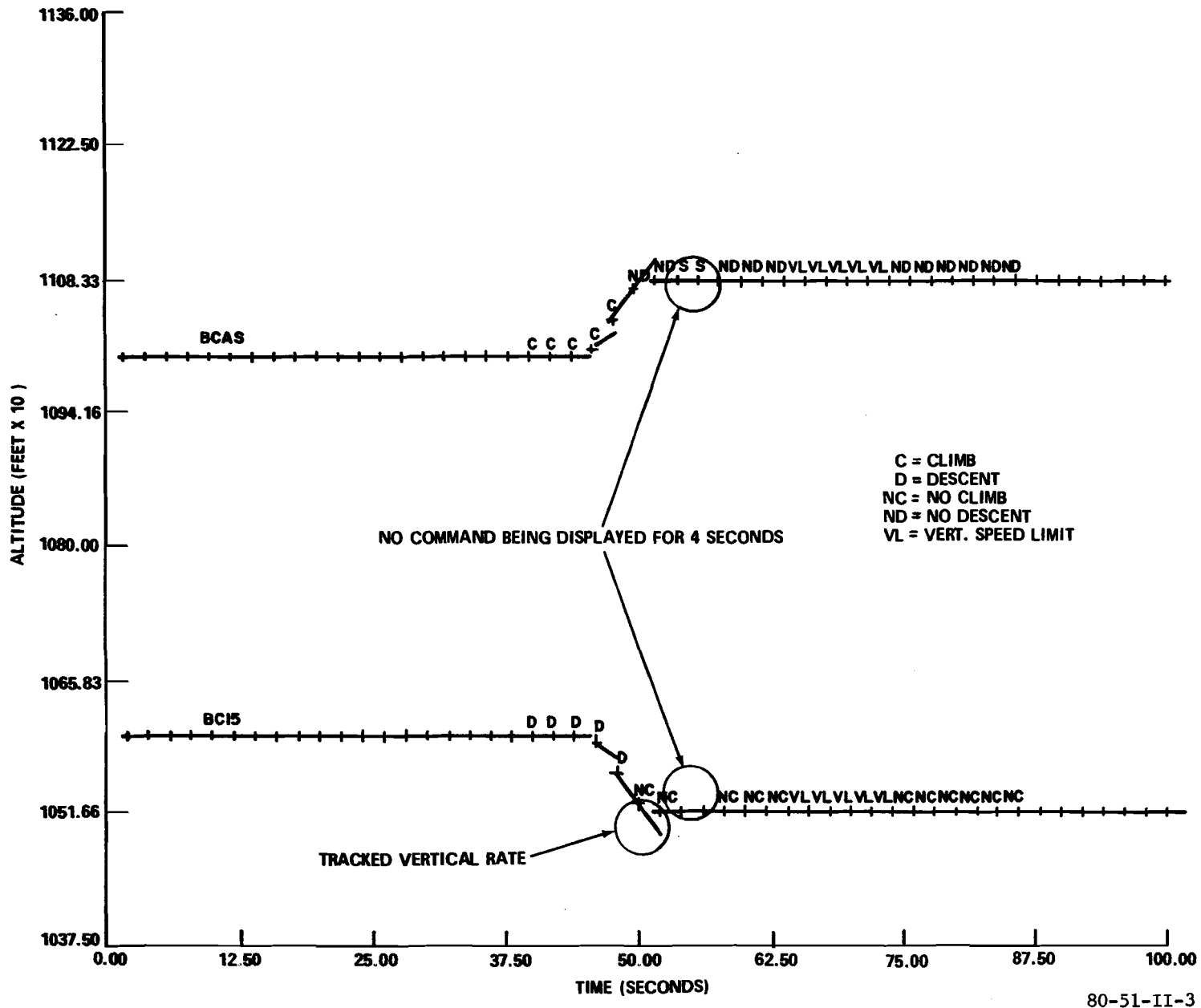

FIGURE 4. VERTICAL PROFILE OF GEOMETRY WHICH RESULTS IN EARLY COMMAND REMOVAL

	<u>BCAS</u>	<u>BC15</u>
Velocity	180 kns.	150 kns.
Vertical Rate	0 ft/sec	0 ft/sec
Crossing Angle	180° (head on)	
Planned Vertical Separation	400 feet	
Planned Horizontal Separation	0 feet	

Forty seconds prior to CPA, complementary climb and descent commands are displayed. Six seconds later, the aircraft begins to respond. After 10 seconds, the predicted vertical separation is greater than 470 feet, and the tracked vertical separation rate is positive. This results in the positive commands changing to negative commands. Four seconds later the tracked vertical rates indicate a high vertical separation rate (the magnitude of the rate is apparent from the angle of the vertical velocity vector). The overestimation in the separation rate due to the error in the vertical rate trackers causes the projected vertical miss distance at CPA to be larger than 750 feet, the threshold for commands. As a result, no commands are displayed from the 53rd to the 57th second. Once the vertical rate trackers have stabilized, the complementary negative and/or VSL advisories reappear and continue until the range rate becomes positive on the 86th second. The P(-R/R) function is the original weighted divergence projection function that was used with prototype Full BCAS logic that assumed a 4-second update rate.

One method of eliminating the early command removal is to require the threat volume for command removal to be larger than the volume for threat declaration. However, a better method of controlling the early removal of commands, and at the same time limiting early transition in the severity of commands, is to use the current vertical separation rather than a predicted separation when aircraft are separating vertically but still inside the threat volume.

In the example, the complementary negative commands are removed 28 seconds prior to CPA only to reappear 24 seconds prior to CPA. If the current vertical separation was used instead of predicted separation using a P(-R/R) projection, no oscillations in the complementary negative commands would have occurred.

EXCESSIVE SEPARATION DUE TO LACK OF PROJECTED VERTICAL MISS DISTANCE FILTERING.

Figure 5 presents the paired aircraft encounter geometry used in this analysis. The planned vertical separation was varied from -4,500 feet to 3,500 feet in increments of 500 feet. Table 1 indicates the wide range of VMD's over which BCAS alarms occurred with the original logic which had no VMD filtering. Even when the planned vertical separation at CPA was -4,500 feet, BCAS alarms still resulted.

Review of the resolution logic shows that the excessive alarm volume is due to the lack of a projected VMD filter in the equipped intruder conflict resolution logic. The reduction in vertical separation (which occurred in some cases), found in table 1, is due to the 8-second vertical position projection in the equipped intruder conflict resolution logic. The 8-second projection causes a sense choice to be selected that does not take advantage of the already existing large-planned vertical separation.

The current logic generates alarms whenever TAUR < 30 seconds and time to coalitude, TAUUV, is less than 30 seconds. On figure 2-3(c) of reference 1, the logic sets the projected VMD to the current relative vertical separation, A, when

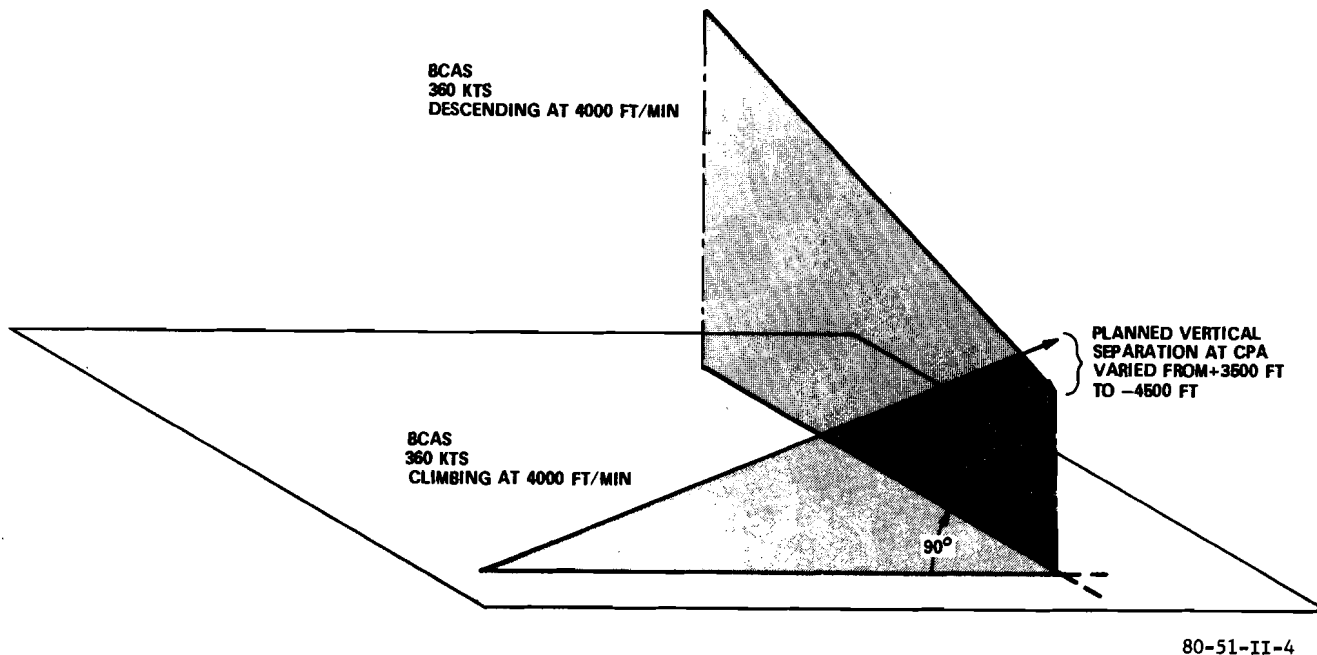

FIGURE 5. BASIC GEOMETRY FOR VERTICAL MISS DISTANCE FILTERING EVALUATION

the intruder is equipped. Following these calculations, the logic proceeds directly to resolution without considering the magnitude of VMD.

In order to reduce the threat volume based on VMD, a change in the logic was made as shown in figure 6. Previous analysis has shown that the VMD projection based on TVPCMD was conservative, especially for equipped intruders. Therefore, the VMD filter proposed in figure 6 uses an -R/R (TRTRU) second projection. The encounter conditions shown in figure 5 were repeated. Table 2 summarizes the results. To ensure the suggested logic change did not result in significant reduction in vertical separation for planned vertical separations in the critical region between -1,000 feet and 1,000 feet, additional tests were performed. The same encounter conditions were repeated and the planned vertical separation varied in 100-foot increments between -1,000 and 1,000 feet. The results of this analysis are plotted in figure 7. Although a slight loss in separation occurred for planned vertical separations of -900 and -1,000 feet, the resulting separation remained well above 300 feet.

The Active BCAS logic should be changed to incorporate VMD filtering for equipped threats. The results show that VMD filtering will reduce the excessive threat volume and reduce the number of unnecessary alarms.

TABLE 1. RESULTS WITH NO VERTICAL MISS DISTANCE FILTERING OF THREATS

<u>Planned Vertical Separation (feet)</u>	<u>Command for Descending BCAS Aircraft</u>	<u>Length of Command (seconds)</u>	<u>Resulting Vertical Separation (feet)</u>
3,500	ND	5	3,500
3,000	ND	8	3,032
2,500	-2,000	11	2,729
2,000	-2,000	10	2,400
1,500	-2,000	12	2,033
1,000	ND	16	1,786
500	-2,000	23	1,386
0	-2,000	26	1,163
-500	-1,000	29	1,096
-1,000	ND	23	891
-1,500	C	12	436
-2,000	ND	14	1,493
-2,500	ND	14	933
-3,000	C	11	370
-3,500	C	30	420
-4,000	NC	16	4,000
-4,500	D	5	4,517

Legend

ND - no descent
 NC - no climb
 -2,000 feet - limit descent to 2000 feet/minute
 -1,000 feet - limit descent to 1000 feet/minute
 C - climb
 D - descend

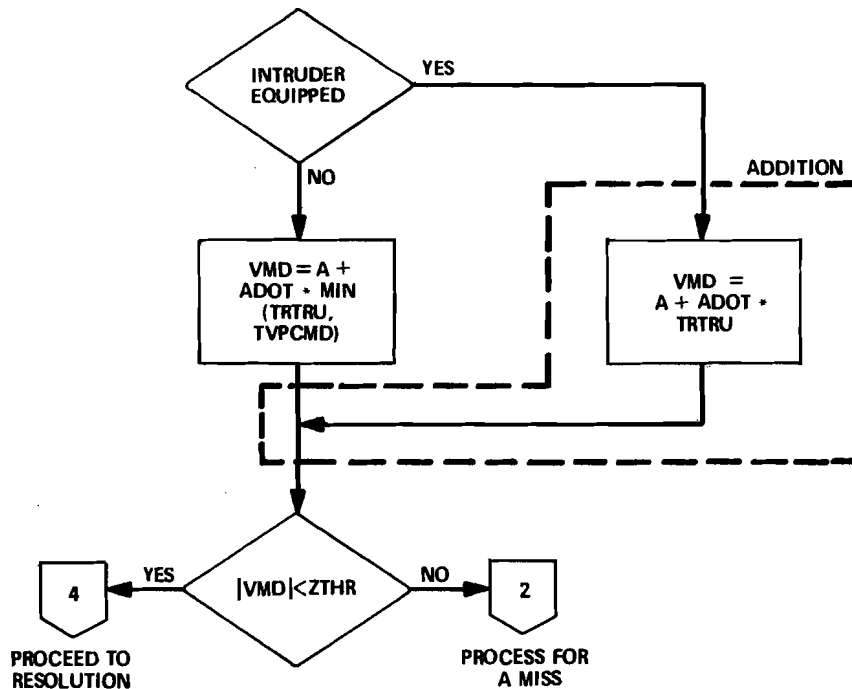

NOTE: SEE FIGURE 2-3(C) IN REFERENCE 1.

80-51-II-5

FIGURE 6. DRACT MODIFICATION — VMD FILTER ADDITION

SETTING OF HIGH ALTITUDE AND ULTRAHIGH ALTITUDE THREAT VOLUME PARAMETERS. In reference 1, the high altitude and ultrahigh altitude values of the threat volume parameters ALIM and ZTHR are set in TROACT logic. The logic, as shown in figure 8, will set threat alarm threshold ALIM and ZTHR to the high altitude or ultrahigh altitude values once the own aircraft has climbed above 18,000 feet (ALPC) or 29,000 feet (ALUH), respectively. The problem that exists is that once the own aircraft begins a descent for landing, the current logic does not reset ALIM or ZTHR to the smaller threshold values associated with low altitude or terminal area airspace.

It is recommended that only INDEX values be set in TROACT logic. DRACT logic sets all threat volume parameter values except ALIM and ZTHR based on the INDEX value of the own aircraft and intruder if BCAS equipped. This is done in an attempt to ensure that both aircraft are using the same threat volume to declare each other a threat. However, with the current value of ALIM and ZTHR being set in TROACT, each aircraft in a conflict pair could be using different threat volumes. It is recommended that ALIM and ZTHR values be set in DRACT along with the other logic parameter values. When either aircraft's INDEX value is 5, ALIM and ZTHR will be set using the higher altitude of the two aircraft in question. (This logic was added in the January 11, 1980, draft of Logic Revisions - Change 17.)

RADAR ALTIMETER DESCENT COMMAND INHIBIT FEATURE. The Active BCAS logic utilizes radar altimeter information, when it is available, to prevent BCAS aircraft from

TABLE 2. SEPARATION WITH VMD FILTER MODIFICATION

<u>Planned Vertical Separation (feet)</u>	<u>Command for Descending BCAS Aircraft</u>	<u>Length of Command (seconds)</u>	<u>Resulting Vertical Separation (feet)</u>
3,500	NO COMMAND		3,500
3,000	NO COMMAND		3,000
2,500	NO COMMAND		2,500
2,000	NO COMMAND		2,000
1,500	NO COMMAND		1,500
1,000	-2,000 VSL	5	1,000
500	-2,000 VSL	11	959
0	-2,000 VSL	17	866
-500	-1,000 VSL	20	856
-1,000	ND	21	685
-1,500	C	16	2,345
-2,000	NO COMMAND		2,000
-2,500	NO COMMAND		2,500
-3,000	NO COMMAND		3,000
-3,500	NO COMMAND		3,500
-4,000	NO COMMAND		4,000
-4,500	NO COMMAND		4,500

Legend

ND - no descent
 NC - no climb
 -2,000 feet - limit descent to 2,000 feet/minute
 -1,000 feet - limit descent to 1,000 feet/minute
 C - climb
 D - descend
 VSL - vertical speed limit

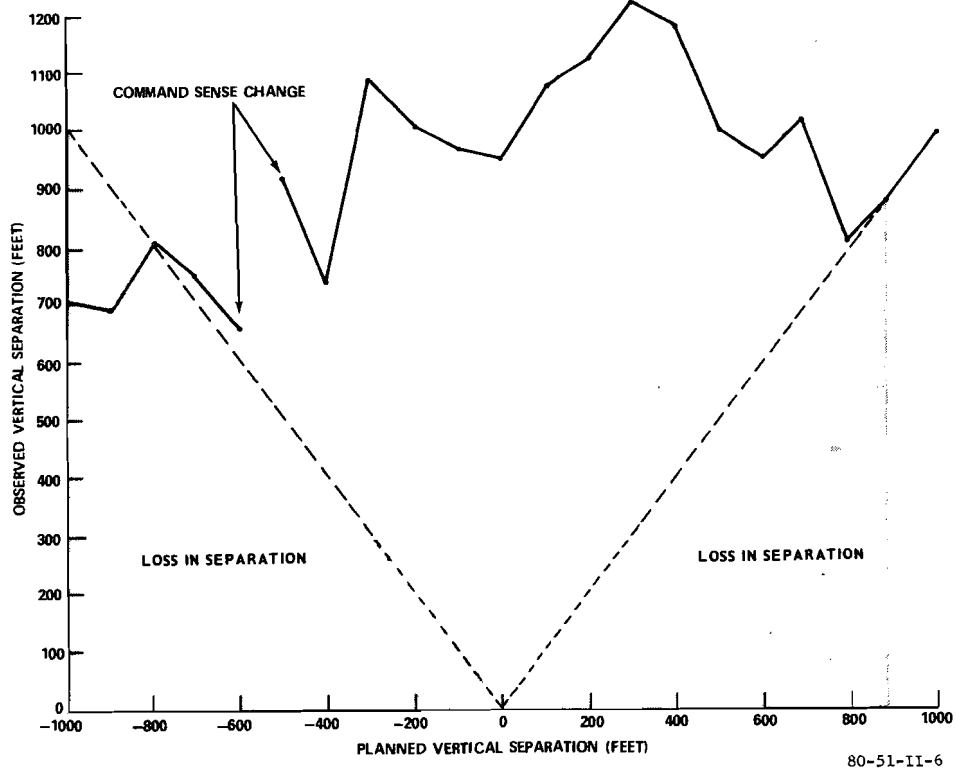

FIGURE 7. VERTICAL SEPARATION PERFORMANCE WITH VMD FILTER FOR EQUIPPED THREATS

descending into the ground in response to BCAS descent commands. When radar altimeter information indicates the altitude of the BCAS aircraft is less than 500 feet above ground level (AGL), any descent command that is being displayed is converted to a no-climb command. Experimentation was conducted to determine if the radar altimeter descent command inhibit feature is required. Furthermore, the experimentation attempted to verify if the 500 feet AGL region, in which descent commands are inhibited, is an adequate region. The effect on BCAS-generated separation, caused by the descent command inhibit feature, was also analyzed.

Two different encounter geometries were analyzed. Both the geometries had the primary BCAS aircraft descending on a 2.92° Instrument Landing System (ILS) glide slope. In both cases, the encounters were arranged so that the vertical CPA was planned to occur when the primary BCAS aircraft was 200 feet AGL on the ILS glide slope. During the investigation, the planned vertical miss distance of the intruder at CPA was varied from 100 feet below (-100 feet) to 1,000 feet above (+1,000 feet) the primary BCAS aircraft. This aircraft is called the primary BCAS aircraft to distinguish it from the intruder when the intruder is also BCAS equipped. For this analysis, equipped aircraft responded with a $1/4$ g acceleration to an escape velocity of 1,000 feet per minute (ft/min).

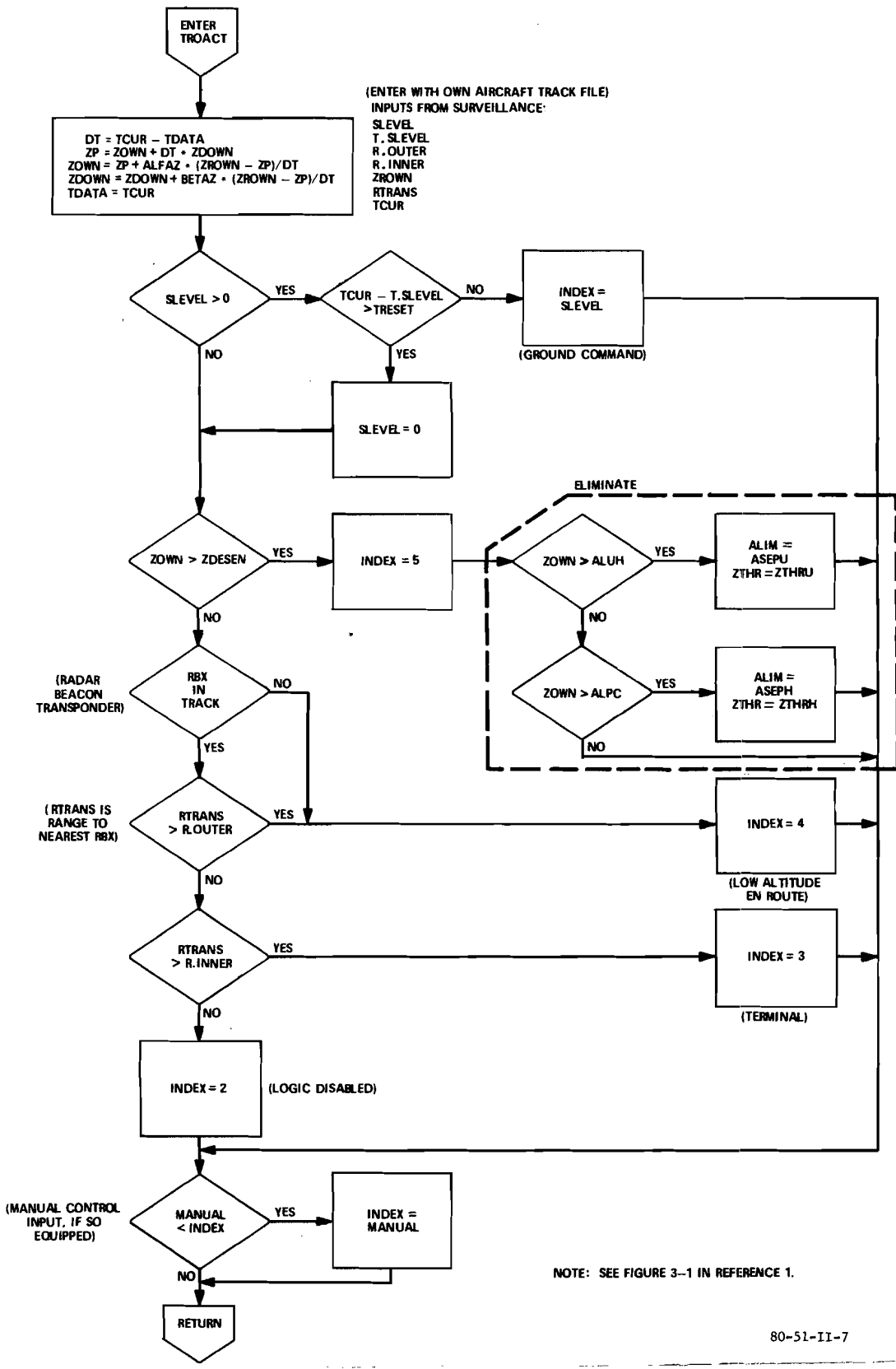

FIGURE 8. TROACT MODIFICATION — ELIMINATION OF THE SETTING OF PARAMETER VALUES

Parallel ILS Encounter — Intruder Equipped. The first geometry investigated was the highly likely condition of the intruder overtaking the primary BCAS aircraft while on a parallel ILS approach. Figure 9 depicts the conditions of this encounter. The results when the intruder is also BCAS equipped will be reviewed first. The results in terms of change in the vertical separation and the altitude (AGL) at the maximum deviation below the glide slope are presented as a function of the planned vertical separation at CPA in figures 10 and 11. Figure 10 presents the results when descent commands are not inhibited by radar altimeter information. The ground level is assumed to be 0 feet and is shown by the dashed horizontal line. The resulting separation curve identifies the vertical separation at CPA that resulted following BCAS alarms. When positive descent commands occurred, the terrain clearance that resulted following the positive descent command is also plotted.

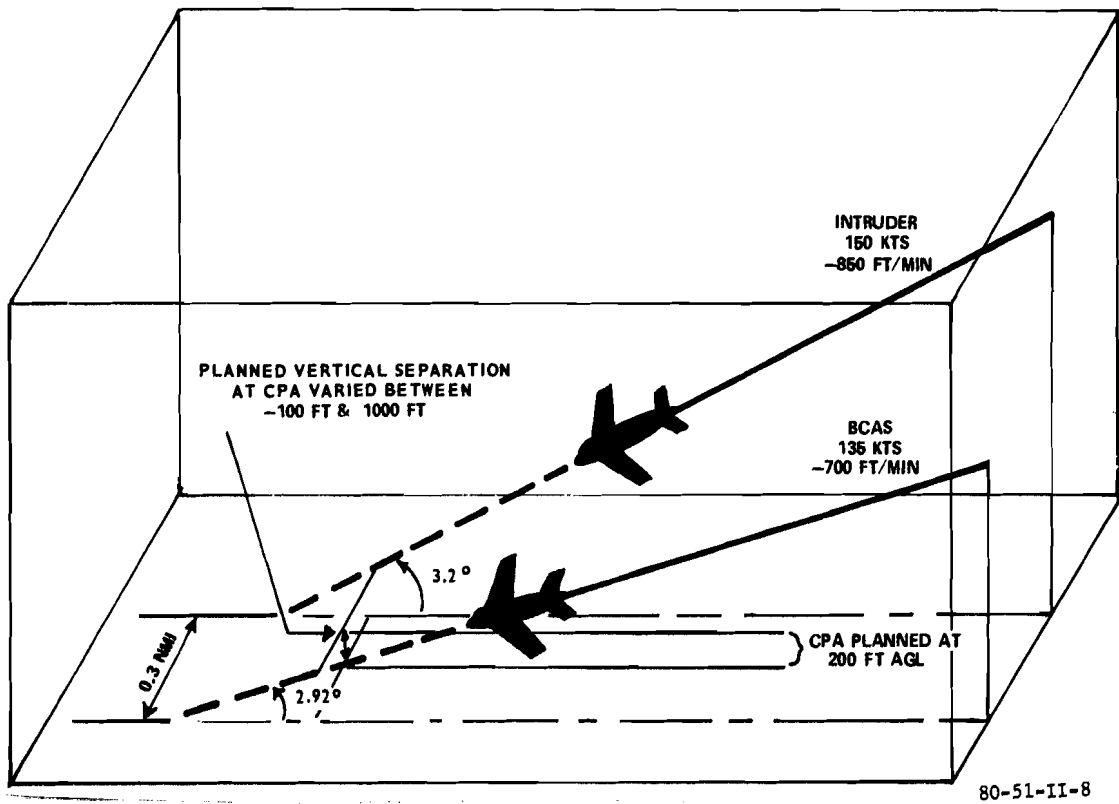

FIGURE 9. PARALLEL ILS ENCOUNTER

When the planned vertical separation was -100 feet, the primary BCAS aircraft received a climb command. Since climb commands are unaffected by radar altimeter information, the resulting separation was the same regardless of whether or not descent commands were being inhibited. For the cases in which the descent commands were not inhibited (figure 10), the closest ground proximity was 86 feet and occurred when the planned vertical separation was +100 feet. For this condition, the primary BCAS aircraft was forced to descend to 86 feet AGL in response to the BCAS descent command. The primary BCAS aircraft received descent commands when the planned vertical separation ranged from 0 to +400 feet. For planned vertical separations which exceeded +400 feet, positive descent commands did not occur. The primary BCAS aircraft received a no-climb command and the intruder received a variety of VSL's or a no-descent command.

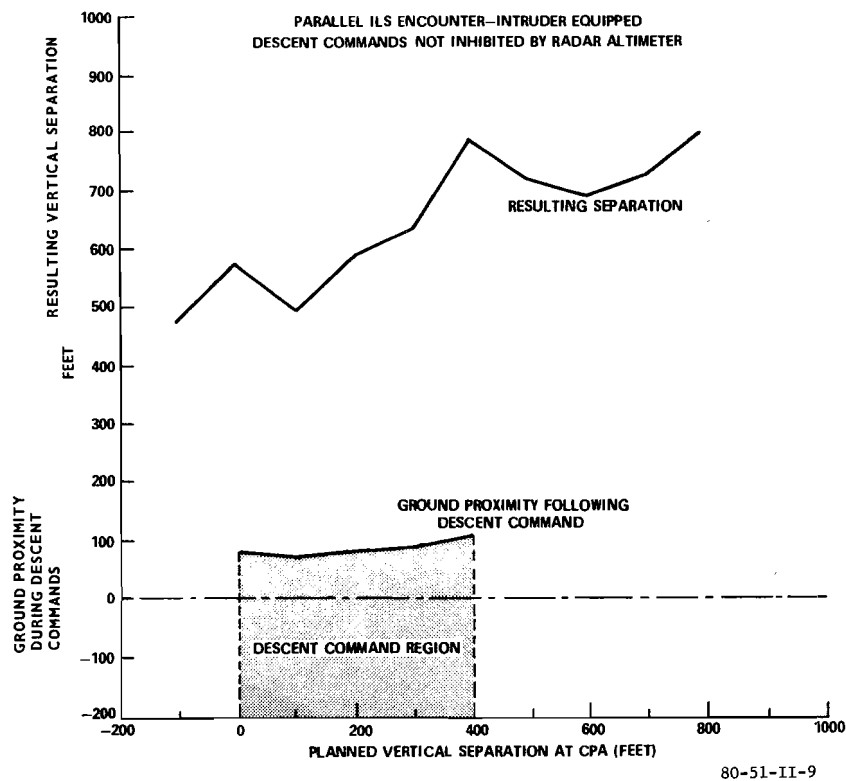

FIGURE 10. DESCENT COMMANDS NOT INHIBITED BY RADAR ALTIMETER (INTRUDER EQUIPPED — PARALLEL ILS)

When the descent commands were inhibited, as shown in figure 11, the primary BCAS aircraft did not receive a descent command for any planned vertical separation. No deviations below the glide slope occurred because BCAS resolution did not call for any positive commands until after the primary BCAS aircraft had descended below 500 feet AGL. As a result, the descent command inhibit feature caused the primary aircraft to only receive no-climb commands. For all planned vertical separations, the resulting separation was more than adequate, since the intruder created the increase in the separation by its response to the climb commands it received.

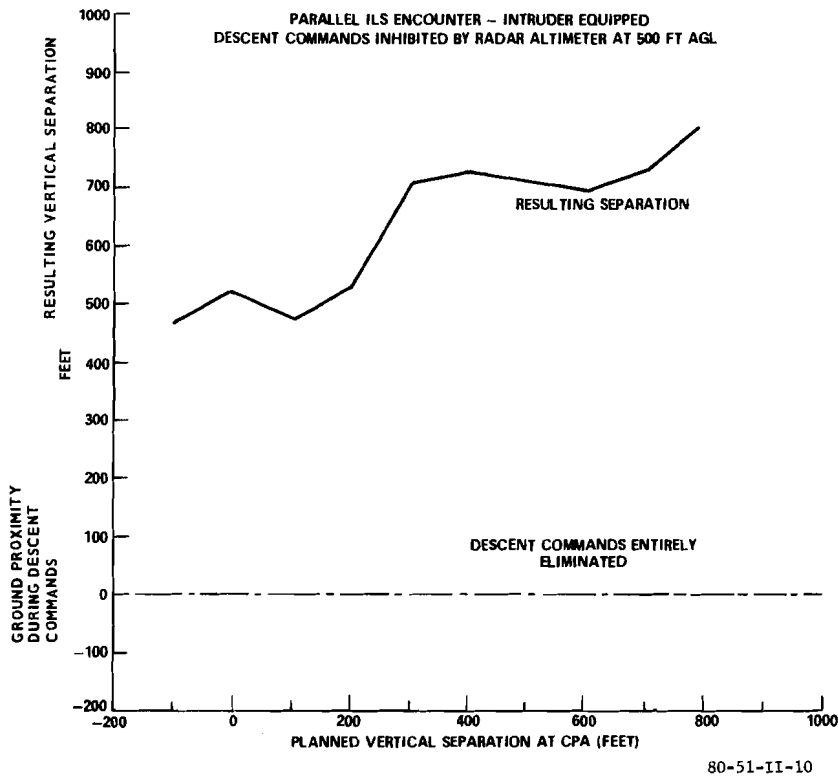
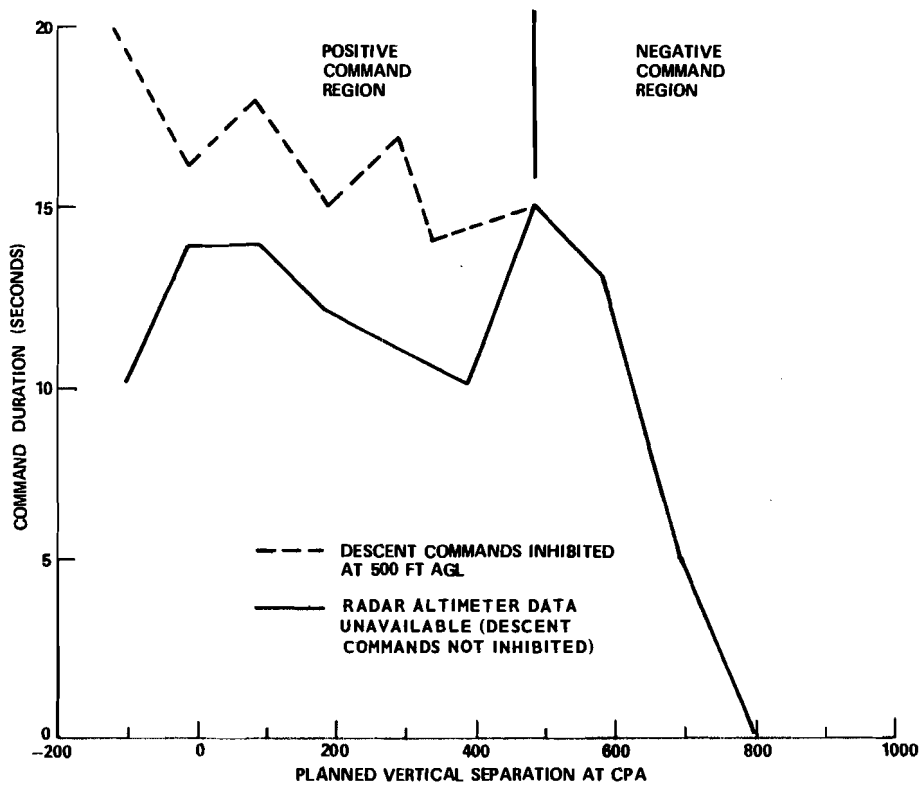

FIGURE 11. DESCENT COMMANDS INHIBITED BY RADAR ALTIMETER (INTRUDER EQUIPPED — PARALLEL ILS)

In some cases, the separation was larger when inhibited descent commands were compared to the cases where the descent commands were uninhibited. This seems to say that more separation occurred in some cases, even though only one aircraft (the intruder) was maneuvering. This strange result was investigated. In figure 12, the analysis of the command lengths showed that in the positive command region the command durations for the cases, where descent commands were inhibited, were always longer than when the descent commands were not inhibited. The greatest increase in separation (95 feet) for cases where the descent commands were inhibited occurred when the planned vertical separation was 300 feet. For this case, the command duration was 6 seconds longer than when the descent commands were not inhibited.

Parallel ILS Encounter — Intruder Unequipped. The parallel ILS encounter was repeated with an unequipped intruder. Figure 13 depicts the results when descent commands were not inhibited by radar altimeter information. The results indicate that numerous descent commands occurred that would have driven the primary BCAS aircraft into the ground. When the intruder was unequipped, positive descent commands occurred when the planned vertical separation ranged between +100 feet and +500 feet.



80-51-II-11

FIGURE 12. COMMAND DURATION COMPARISON

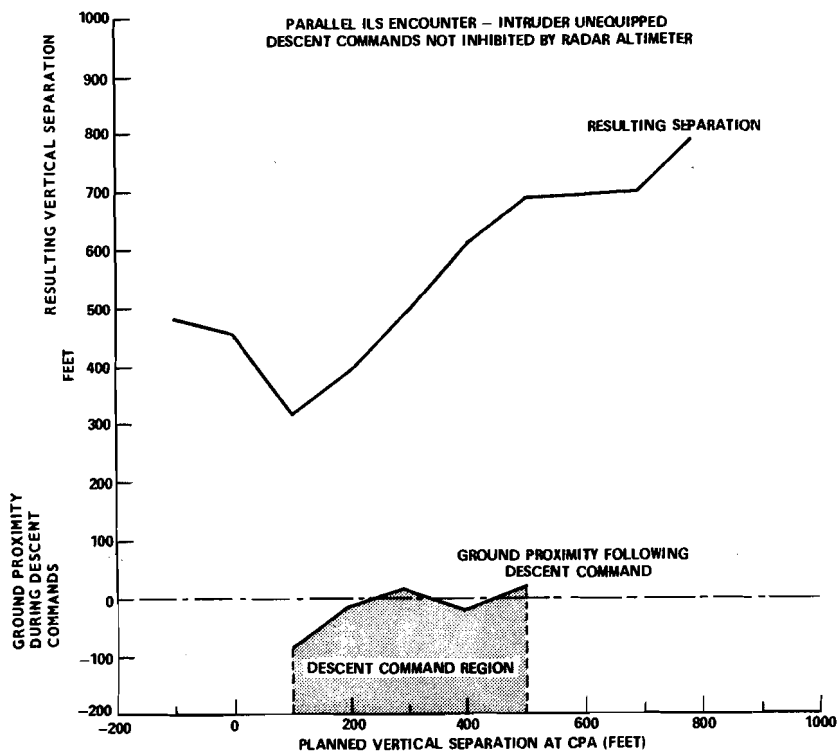

80-51-II-12

FIGURE 13. DESCENT COMMANDS NOT INHIBITED BY RADAR ALTIMETER (INTRUDER UNEQUIPPED — PARALLEL ILS)

When the intruder is unequipped, the only way the separation can be increased is with the movement of the BCAS aircraft. Hence, the descent commands are longer in duration than when the intruder was equipped (figure 10) and less terrain clearance results. For +100 feet planned vertical separation, a descent command forced the BCAS aircraft to descend to 96 feet below ground level. On five out of six cases which resulted in descent commands, the BCAS aircraft would have been forced to descend to less than 20 feet AGL.

Figure 14 presents the separation results when the descent commands are inhibited by radar altimeter information. Since the intruder is unequipped and all descent commands were inhibited and changed to no-climb commands by the radar altimeter information, no increase in separation was generated.

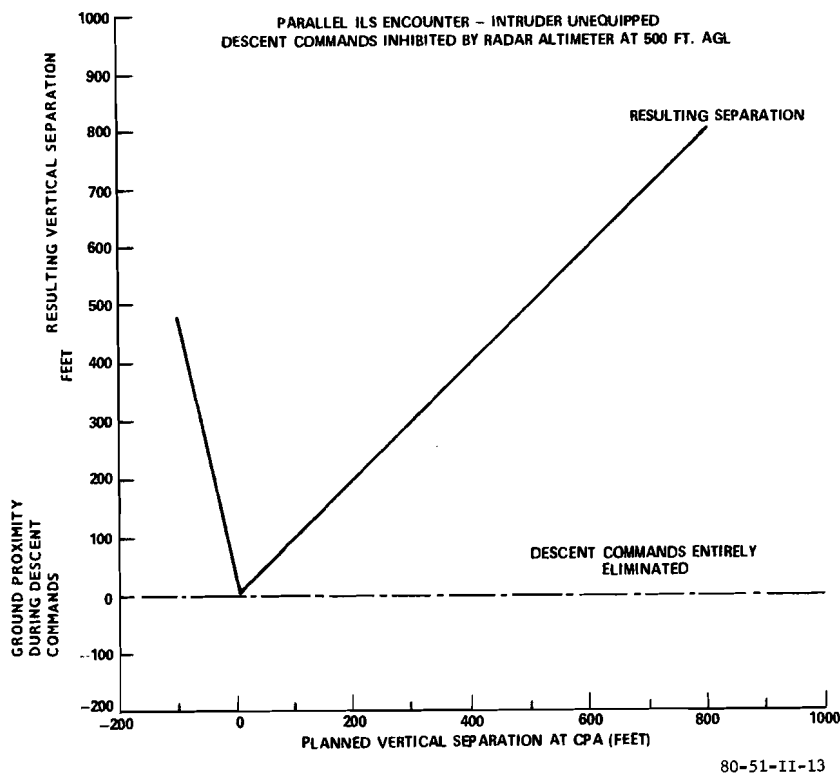

FIGURE 14. DESCENT COMMANDS INHIBITED BY RADAR ALTIMETER (INTRUDER UNEQUIPPED — PARALLEL ILS)

Level Flight ILS Crossing Encounter — Intruder Unequipped. The second geometry analyzed involved a level flight crossing intruder. The encounter was designed to represent an intruder aircraft wandering through the ILS final approach course. Figure 15 presents the encounter geometry. When the intruder was unequipped, the BCAS aircraft was forced to make large deviations below the glide slope in response to long duration BCAS descent commands. The results are shown in figure 16. On two occasions, when the planned vertical separation was +200 and +300 feet, the BCAS aircraft would have been forced into the ground in response to BCAS descent commands.

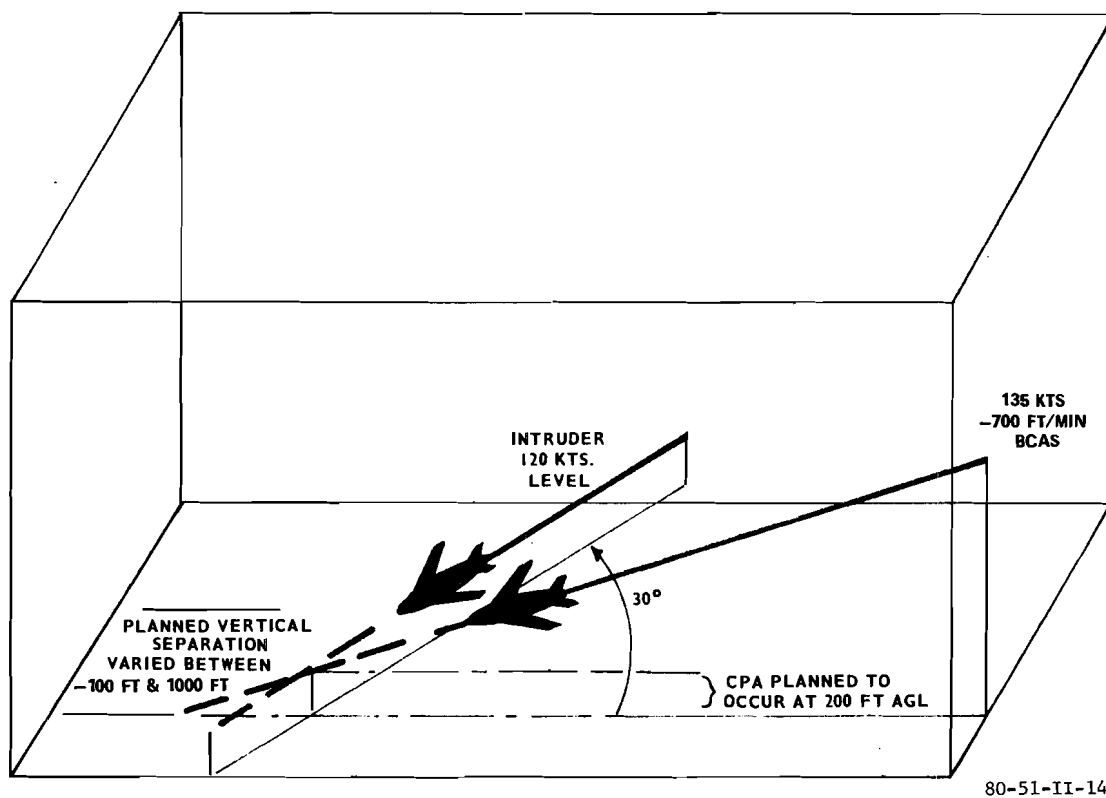

FIGURE 15. BASIC GEOMETRY FOR ILS ENCOUNTER WITH LEVEL FLIGHT CROSSING INTRUDER

When the descent commands were inhibited below 500 feet AGL, figure 17 shows the resulting separation and ground proximity that occurred. Even though descent commands were inhibited at 500 feet AGL, some descent commands occurred prior to the BCAS aircraft descending to 500 feet AGL.

As a result of inhibiting descent commands, a significant increase in terrain clearance (250 to 350 feet) occurred without appreciably affecting vertical separation when compared to the results shown in figure 16. The descent commands which initially did occur were changed to no-climb commands as the BCAS aircraft descended through 500 feet AGL. In responding to this command change, the BCAS aircraft was able to stop its descent at least 198 feet AGL in all cases. The response model required 7 seconds for the BCAS aircraft to stop its descent and level off. A faster response to the no-climb command (0.25 g vertical acceleration was used in this analysis) would have provided more terrain clearance. In general, the inhibiting of descent commands at 500 feet AGL provided 300 feet or more terrain clearance.

As the crossing angle was increased beyond 30°, the increase in the range rate caused earlier alarm initiation resulting in descent commands occurring over a smaller range of planned vertical separations. Since the alarms occurred earlier in the scenario and the BCAS aircraft was descending from above, the unequipped intruder sense choice logic resulted in climb sense commands more often. For crossing angles greater than 120°, no-descent commands were observed regardless of the planned vertical separation.

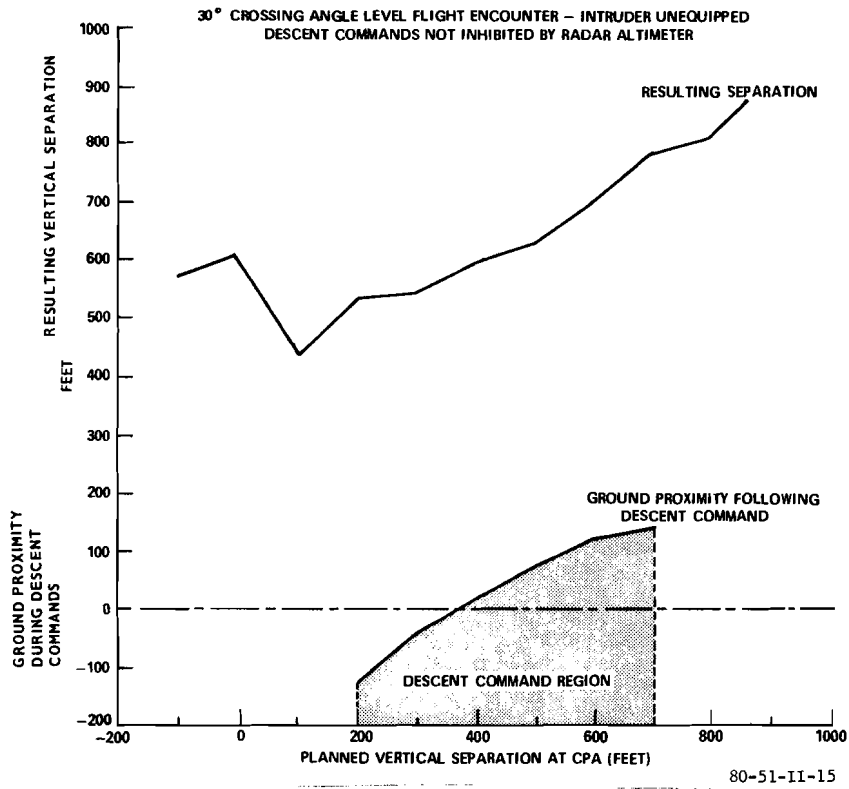

FIGURE 16. DESCENT COMMANDS NOT INHIBITED BY RADAR ALTIMETER (INTRUDER UNEQUIPPED — 30° CROSSING ANGLE)

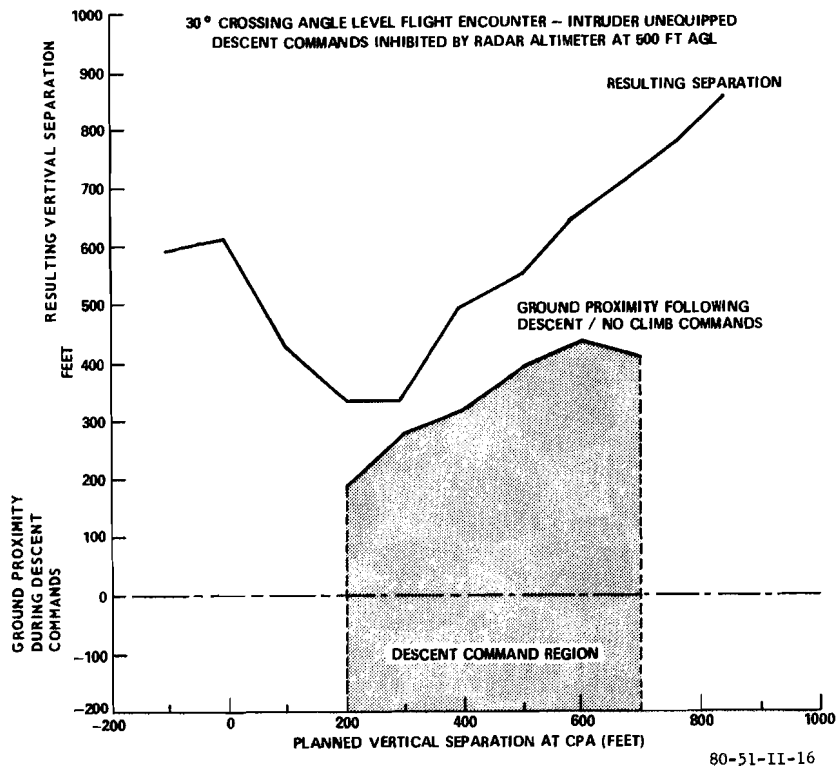

FIGURE 17. DESCENT COMMANDS INHIBITED BY RADAR ALTIMETER (INTRUDER UNEQUIPPED — 30° CROSSING ANGLE)

Level Flight ILS Crossing Encounter — Intruder Equipped. For these conditions, when descent commands were not inhibited (figure 18) they occurred for planned vertical separations ranging from +400 to +800 feet. The different region for descent commands, when compared to the unequipped intruder results (figure 16), occurs because different sense choice logic is used in the case of the equipped intruder. The ground proximity throughout the descent command region approximated 300 feet AGL. The increase in ground proximity, when compared to the unequipped case, occurred because both aircraft were now responding to BCAS commands which shortened the command duration.

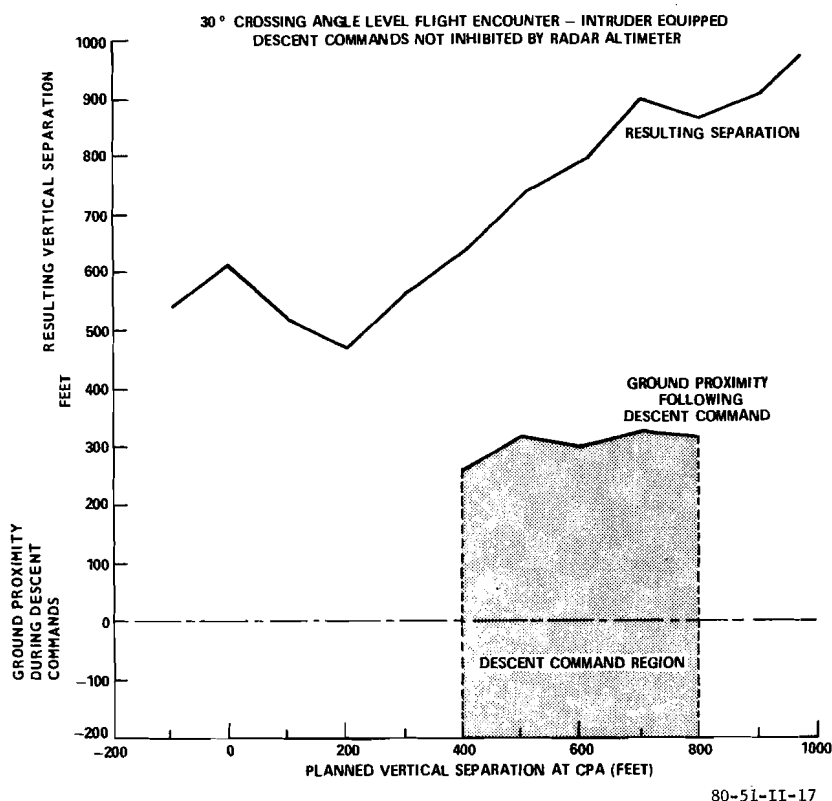

FIGURE 18. DESCENT COMMANDS NOT INHIBITED BY RADAR ALTIMETER (INTRUDER UNEQUIPPED — 30° CROSSING ANGLE)

Figure 19 presents the results when the descent commands were inhibited for the primary BCAS aircraft. Positive descent commands occurred when the planned vertical separation ranged from +400 to +800 feet. Deviations below the glide slope occurred because initial descent commands were generated while the primary BCAS aircraft was still above 500 feet AGL. In all cases, the inhibiting of descent commands by radar altimeter information at 500 feet AGL permitted ample time for the BCAS aircraft to stop its descent with adequate terrain clearance. In no case did the descent commands cause the primary BCAS aircraft to descend below 300 feet AGL.

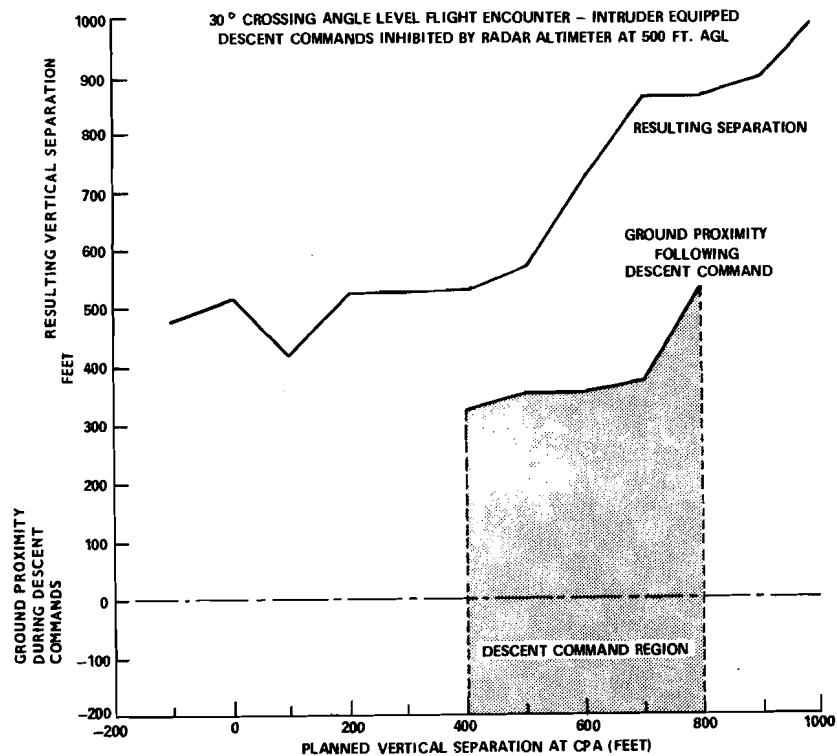

FIGURE 19. DESCENT COMMANDS NOT INHIBITED BY RADAR ALTIMETER (INTRUDER EQUIPPED — 30° CROSSING ANGLE)

The results, especially for the parallel ILS encounters, indicate that descent commands should be inhibited in some region when radar altimeter information is available. Without the inhibiting of descent commands, long-duration descent commands could cause the BCAS aircraft to descend into the ground. The current region for inhibiting descent commands, 500 feet AGL and below, is adequate. For the parallel ILS case, no descent commands occurred for the primary BCAS aircraft because it had already descended to below 500 feet AGL when BCAS resolution called for a descent command. Although descent commands occurred before the primary BCAS aircraft had descended to 500 feet AGL during the crossing encounter, sufficient time remained for the BCAS aircraft to level off. Generally, the BCAS aircraft was able to stop the descent with at least 300 feet or more terrain clearance. This was observed despite a slow no-climb response by the BCAS aircraft.

The only drawback with the descent inhibit feature occurred on the parallel ILS encounter when the intruder was unequipped. Since no positive commands occurred until after the BCAS aircraft had descended below 500 feet AGL, no increase in separation resulted.

GENERAL PERFORMANCE FOR LINEAR ENCOUNTERS. The analysis of linear encounters with BCAS threats focuses on geometries in which one aircraft is level and the other is climbing or descending. The basic geometry investigated is presented in figure 20. The encounters were replicated with the planned vertical separation at CPA and the

aircraft vertical rates being incrementally varied. Figures 21 and 22 show the achieved vertical separation at CPA for 90° crossing angles. The pilot response delay was held constant at 5 seconds, and aircraft maneuvers were limited to 0.5 g acceleration and a maximum response rate of 500 feet per minute. Aircraft velocities were 300 knots. The planned horizontal separation at CPA was 0 feet.

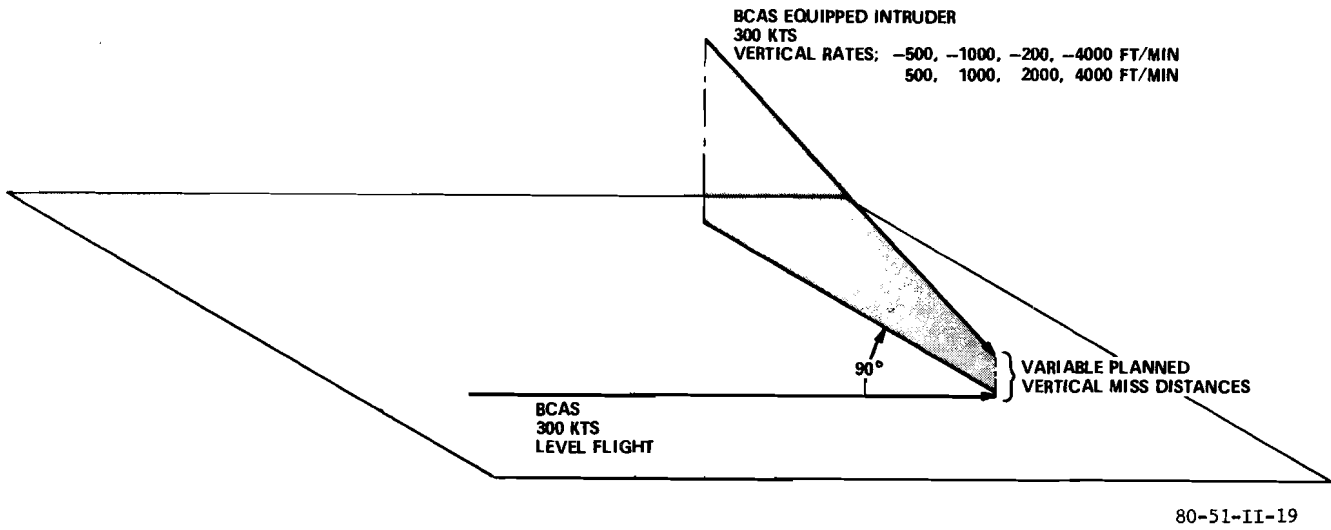

FIGURE 20. BASIC GEOMETRY FOR LEVEL BCAS AND EQUIPPED VERTICALLY MANEUVERING INTRUDER

The analysis did not uncover any major discrepancies. In general, the performance was adequate. The algorithm's built-in bias (8-second look-ahead time) for stratifying equipped threats (higher aircraft climb and lower aircraft descend) is evident. This strong stratification bias is evident at high vertical rates (2,000 and 4,000 ft/min) when there is a large negative planned vertical separation (-500 to -1,000 feet). In these cases, the achieved separation is less than the planned vertical separation but greater than 300 feet.

On some occasions for high vertical rates and large planned vertical separations, short duration positive commands are issued at or after CPA. These commands are of no major benefit and do not increase separation; however, they do not detract from BCAS performance.

Using the same encounter conditions depicted in figure 20, figures 23 and 24 show the impact of crossing angle on the resulting vertical separation. The planned vertical separation was held constant at 0 feet while the crossing angle was varied. The resulting vertical separation is fairly constant over the observed range of crossing angles. Crossing angles of 30° and 60° (intruder approaching from the rear at the 5 and 4 o'clock position) show some deviation. This is due to the slower horizontal closure rate for these crossing angles. Tail chase situations are not examined in this section.

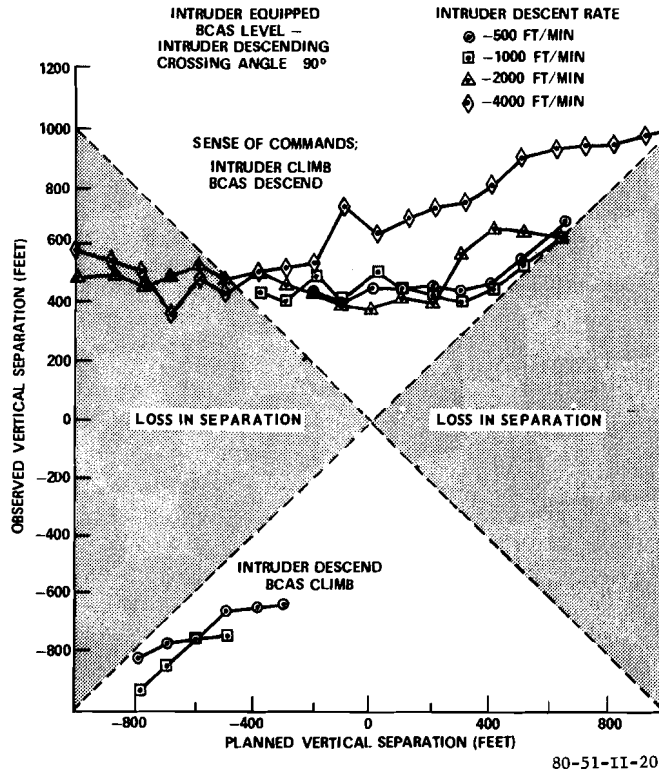

FIGURE 21. PERFORMANCE FOR EQUIPPED DESCENDING INTRUDERS

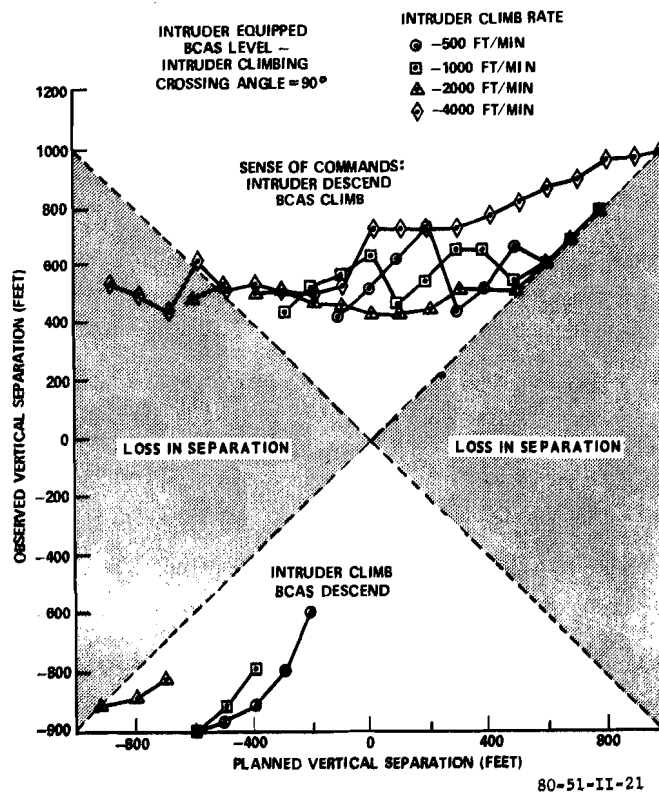

FIGURE 22. PERFORMANCE FOR EQUIPPED CLIMBING INTRUDERS

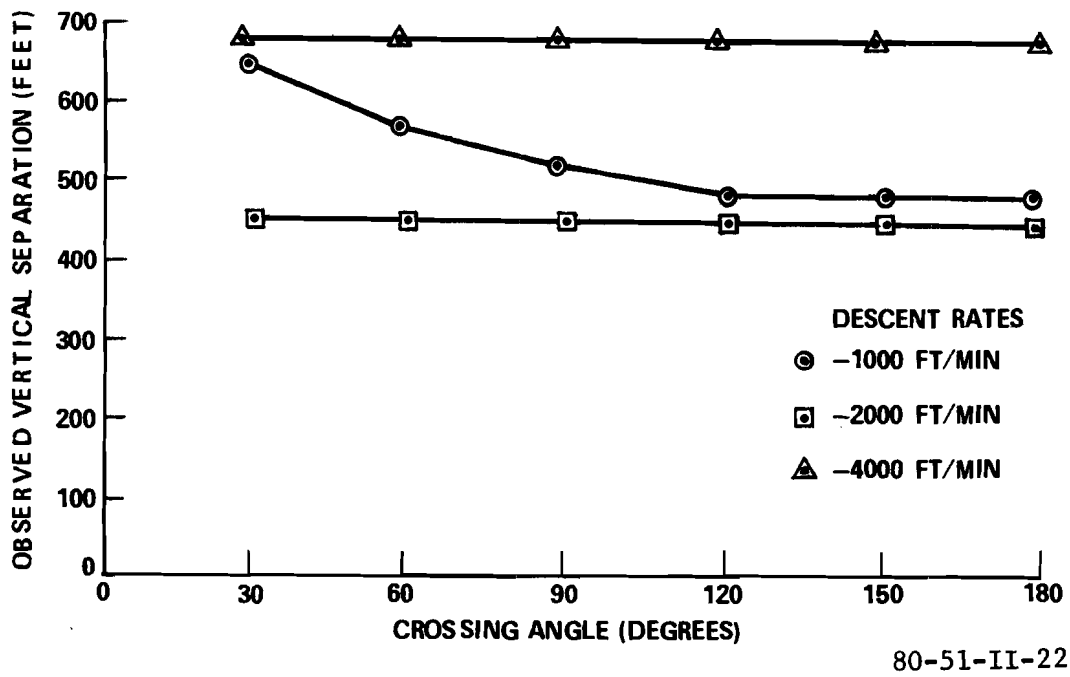

FIGURE 23. CROSSING ANGLE EFFECT ON EQUIPPED DESCENDING INTRUDER PERFORMANCE

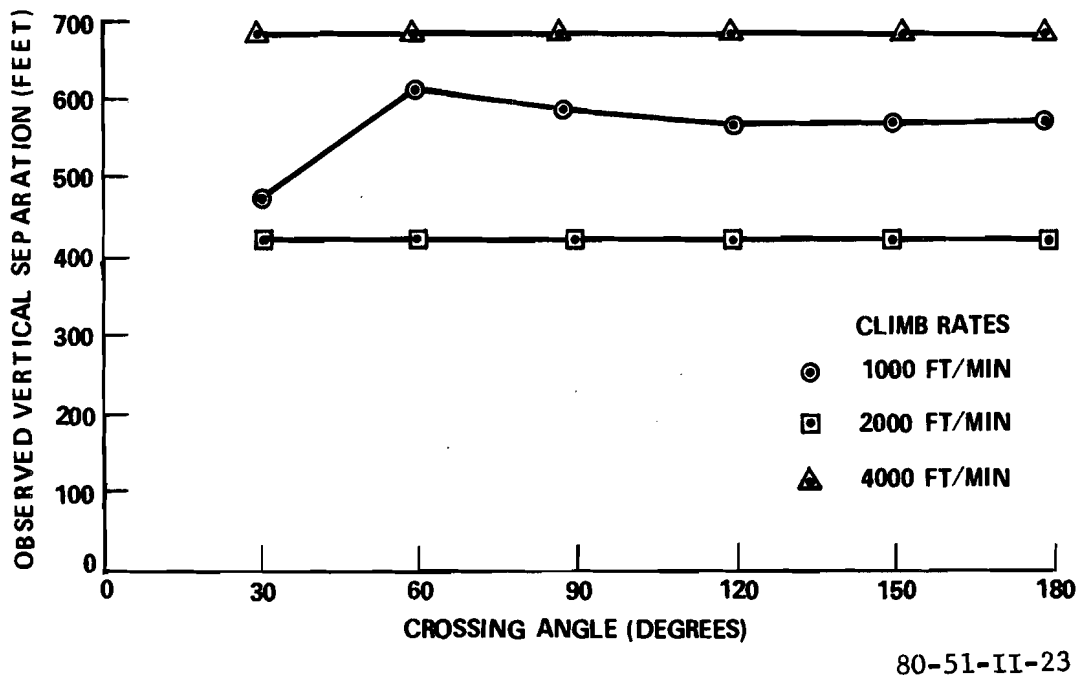

FIGURE 24. CROSSING ANGLE EFFECT ON EQUIPPED CLIMBING INTRUDER PERFORMANCE

Low Vertical Rate Performance. With the original B tracker, the relative error (error/true measurement) in the vertical tracker is high for low vertical rates (<700 ft/min); therefore, the largest errors in projected vertical miss distance occur at low vertical rates. In this section, the performance of Active BCAS resolution of BCAS equipped intruders with low vertical rates is discussed. The basic encounter conditions for this analysis are shown in figure 25.

Figure 26 presents the results for the conditions shown in figure 25. Negative values of planned vertical separation indicate that altitude crossing would occur prior to CPA. For planned vertical separations between -1,000 and -900 feet, both aircraft received noneffective VSL's (i.e., the VSL did not affect the aircraft's vertical profile). Between -900 and -600 feet planned vertical separation, a slight increase in vertical separation is achieved with short-duration negative commands. In the range -600 to -200 feet, both aircraft received positive commands (primary BCAS — climb; equipped intruder — descend) of various durations which significantly increase the vertical separation. Between -200 and 400 feet planned vertical separation, the sense of the positive commands is reversed. The primary BCAS aircraft receives a descent command, and the equipped intruder receives a climb command. Noneffective VSL alarms occurred with planned vertical separations as large as 1,100 feet.

The effect of crossing angle was again analyzed. Holding the planned vertical separation constant at 300 feet, the crossing angle was varied from 30° to 330° in 30° increments. Figure 27 shows the results of this analysis. The smallest increase in separation resulted for low crossing angles. Figures 26 and 27 show that the algorithm performance for simultaneous vertical maneuvers by equipped aircraft is excellent.

Horizontally Maneuvering Performance. The encounter conditions used in the analysis of Active BCAS performance for horizontally maneuvering threats are shown in figure 28. Figure 29 presents a plot of observed vertical separation as a function of the time-from-turn rollout to CPA. The results indicate that the observed vertical separation always exceeded 300 feet. The increase in separation for times between 20 and 30 seconds prior to CPA occurs because when durations are greater than 30 seconds the horizontal maneuver by the intruder is completed prior to BCAS commands being generated. When the time-from-turn rollout to CPA is less than 20 seconds, initial detection and command generation occur prior to or during the horizontal maneuver by the intruder aircraft.

The analysis is conducted for simultaneous climbs only. The results for simultaneous descents cannot be any worse than the simultaneous climb results. The analysis is conducted for very conservative aircraft response characteristics. Any increase in the aircraft response characteristic will result in better performance.

PROPER COMMAND SENSE CHOICE PROCEDURES FOR EQUIPPED THREATS IN PERFORMANCE LEVEL 2 AREAS. Improvements to Active BCAS logic performance, identified in reference 2, include the tracking of intruders by equipped aircraft in performance level 2 areas. The original logic described in reference 1 did not permit tracking of intruders by BCAS aircraft in performance level 2 areas. While the BCAS command resolution is still prevented for BCAS aircraft in performance level 2 areas, the modification which permits tracking of intruders for these BCAS aircraft is highly desirable. Since tracking can proceed, the BCAS aircraft would be subjected to a minimal BCAS command delay (when a command is required) upon exiting from performance level 2 areas.

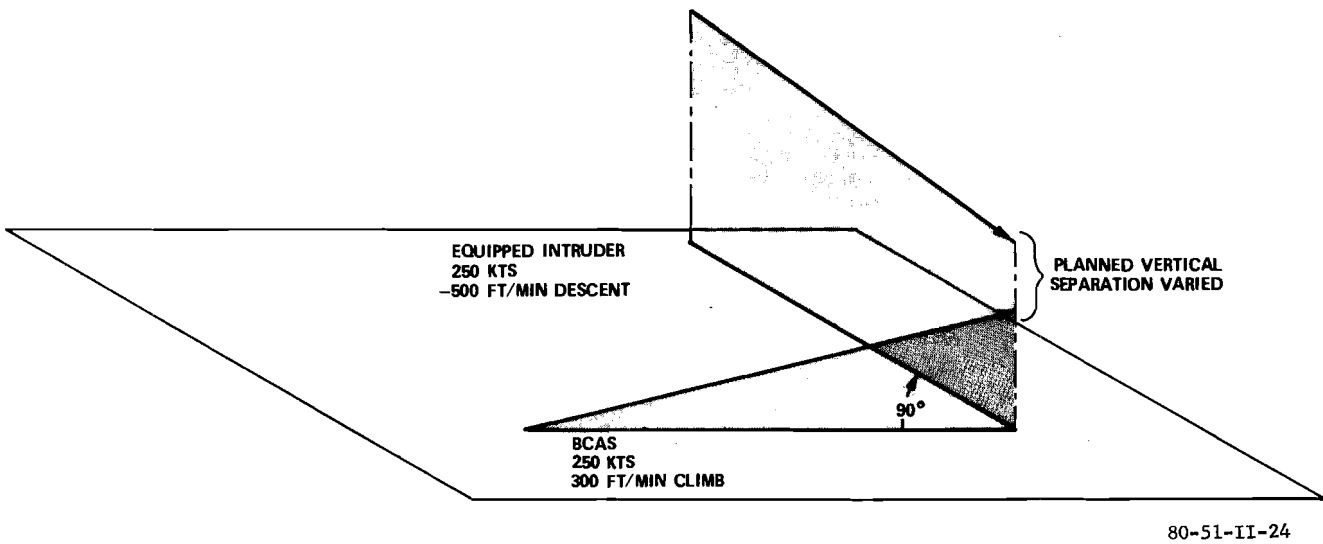

FIGURE 25. BASIC GEOMETRY FOR EQUIPPED INTRUDER VERTICALLY MANEUVERING EVALUATION

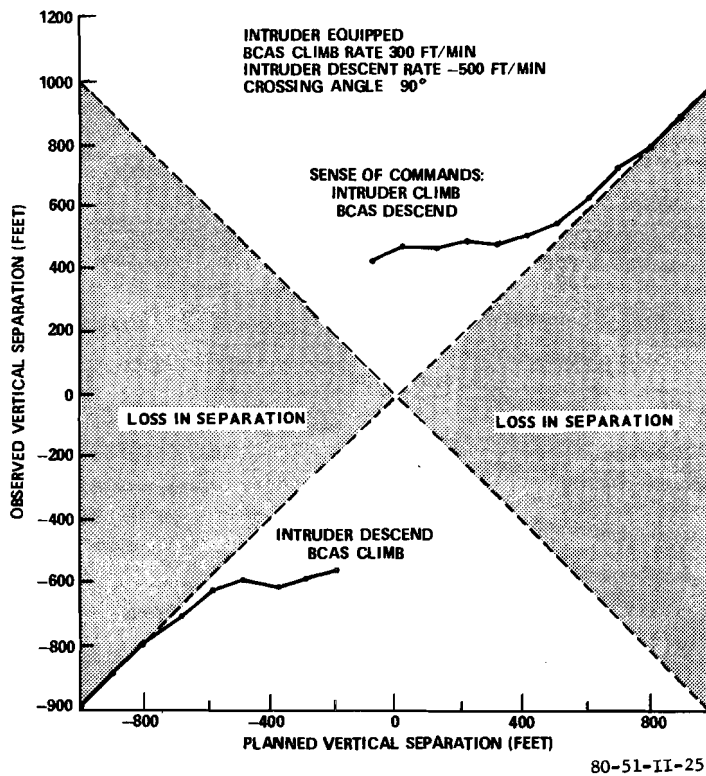

FIGURE 26. RESULTS FOR EQUIPPED INTRUDER VERTICALLY MANEUVERING EVALUATION

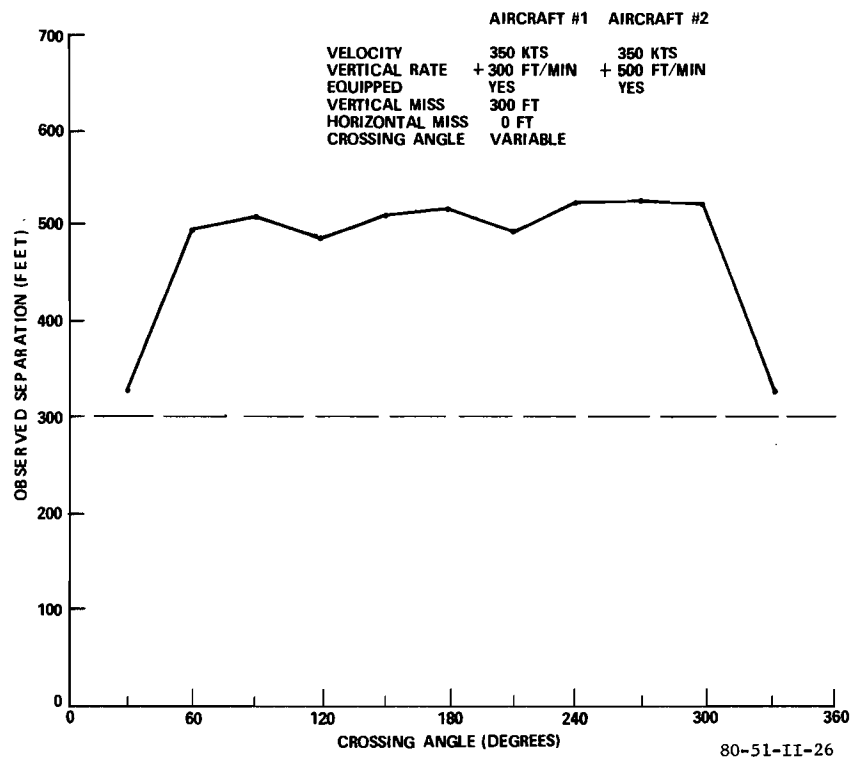

FIGURE 27. VERTICAL SEPARATION FOR AIRCRAFT MANEUVERING AT LOW VERTICAL RATES

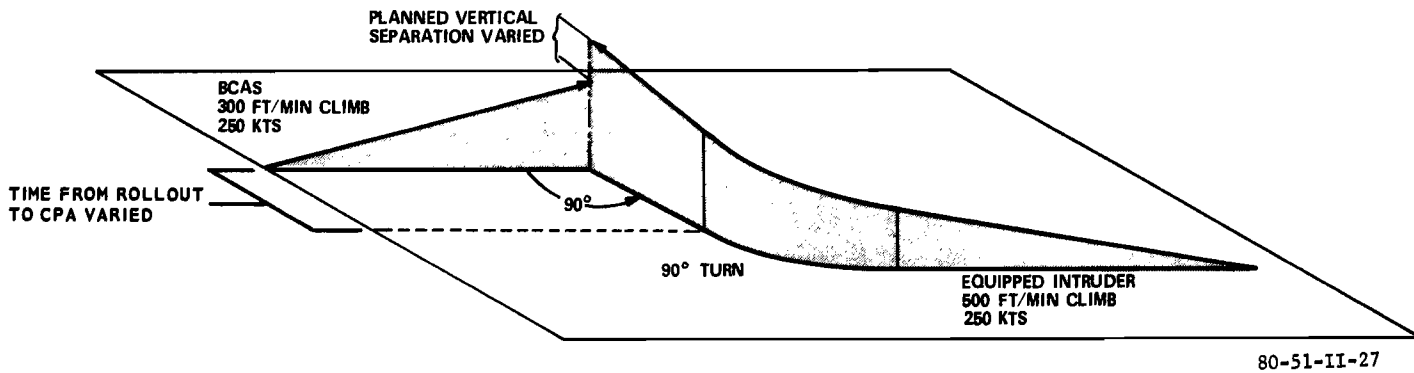

FIGURE 28. CROSSING ANGLE EFFECT ON VERTICAL SEPARATION PERFORMANCE

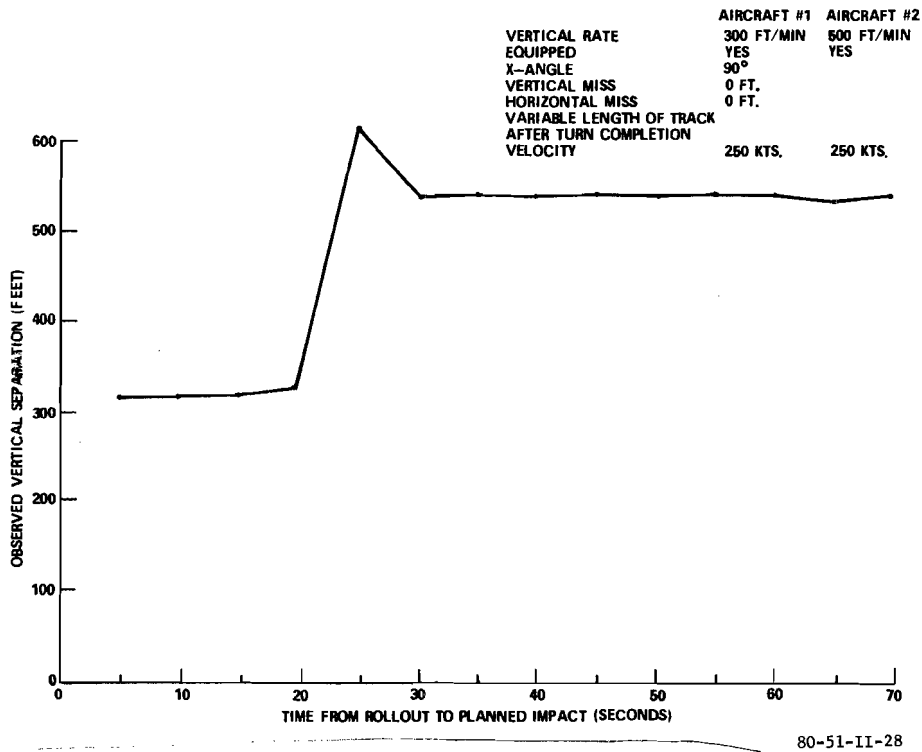

FIGURE 29. VERTICAL SEPARATION PERFORMANCE FOR HORIZONTALLY MANEUVERING THREATS

Improvements in logic performance for BCAS aircraft in performance level 2 regions has led to possible degradation in BCAS performance for equipped aircraft outside performance level 2 regions. The scenario conditions, where degradation in performance may occur, are shown in figure 30. With previous logic, BCAS 2 would not have responded to an interrogation by BCAS 3. As a result, BCAS 3 would consider BCAS 2 to be unequipped. The new logic, however, permits BCAS 2 to continue to track and respond to interrogations while in performance area 2, but BCAS 2 does not receive any BCAS commands. The problem is that BCAS 3 identifies BCAS 2 as being equipped and determines sense, assuming BCAS 2 will respond to a command. The correct procedure is for BCAS 3 to use unequipped sense choice logic for BCAS threats in performance level 2 areas.

The threat logic intruder track files contain the performance level of equipped threats. The variable is called PLINT. A simple modification of DRAC logic shown in figure 31 can be made. This change will treat equipped threats in performance level 2 areas as unequipped and properly select sense. If BCAS 2 subsequently exits performance level 2 areas, no problem exists since it would have to coordinate its intent with BCAS 3 which already has a command established.

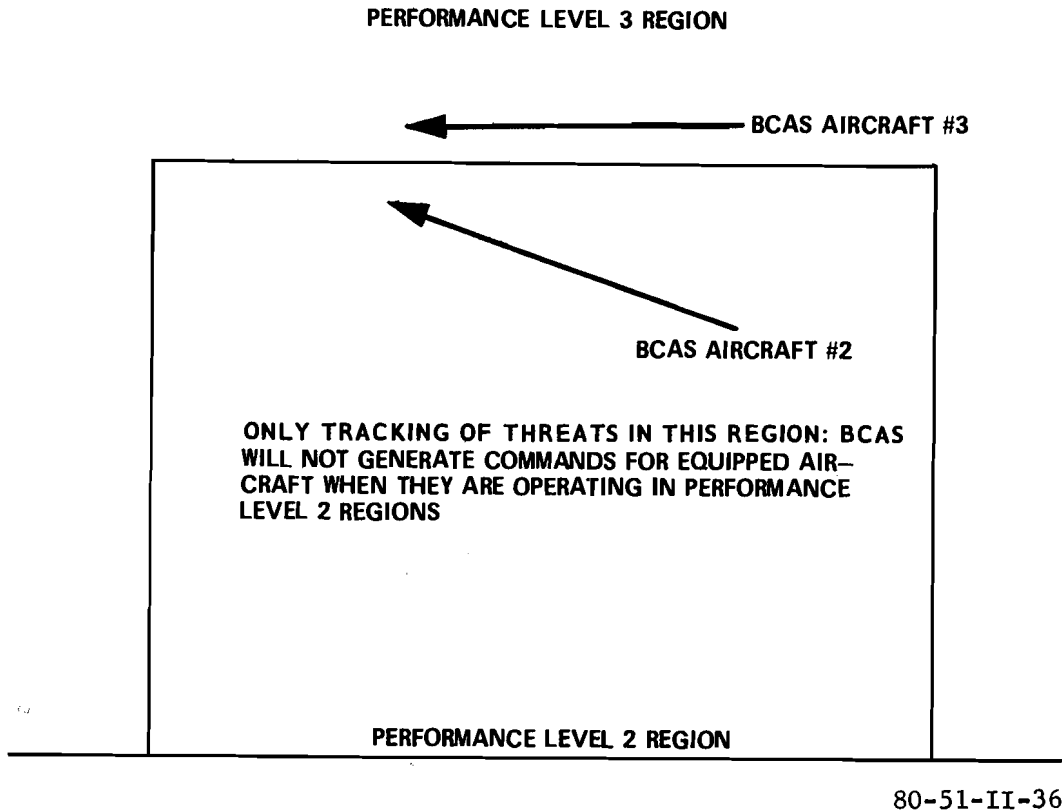

FIGURE 30. CONDITIONS LEADING TO REDUCED PERFORMANCE AGAINST EQUIPPED THREATS IN PERFORMANCE LEVEL 2 REGIONS

COORDINATION LOGIC.

CIR INTERFACE LOGIC PERFORMANCE. When two conflicting aircraft are BCAS equipped, a command coordination procedure takes place between the aircraft. The CIR provides the means by which this coordination takes place. Whenever BCAS selects a new command or drops a command, it must ascertain compatibility with entries in its own CIR and the threat's CIR.

During the analysis of BCAS performance for paired equipped conflicts, the following two logic deficiencies were noted:

1. Creation of a false row in the CIR following the coordination sequence for dropping commands.
2. A hit-miss-hit pattern in DRACT causing a coordination attempt between aircraft with no sense value available for coordination.

Solutions to both problems were found and made a permanent part of the logic. The problems and their solutions are discussed in the next two subsections.

False Threat Generation In CIR. When coordinating the dropping of commands, the subroutine RCV creates an erroneous new entry (row) in the own aircraft's CIR. Upon the generation of a secondary command (within 10 seconds of the last command)

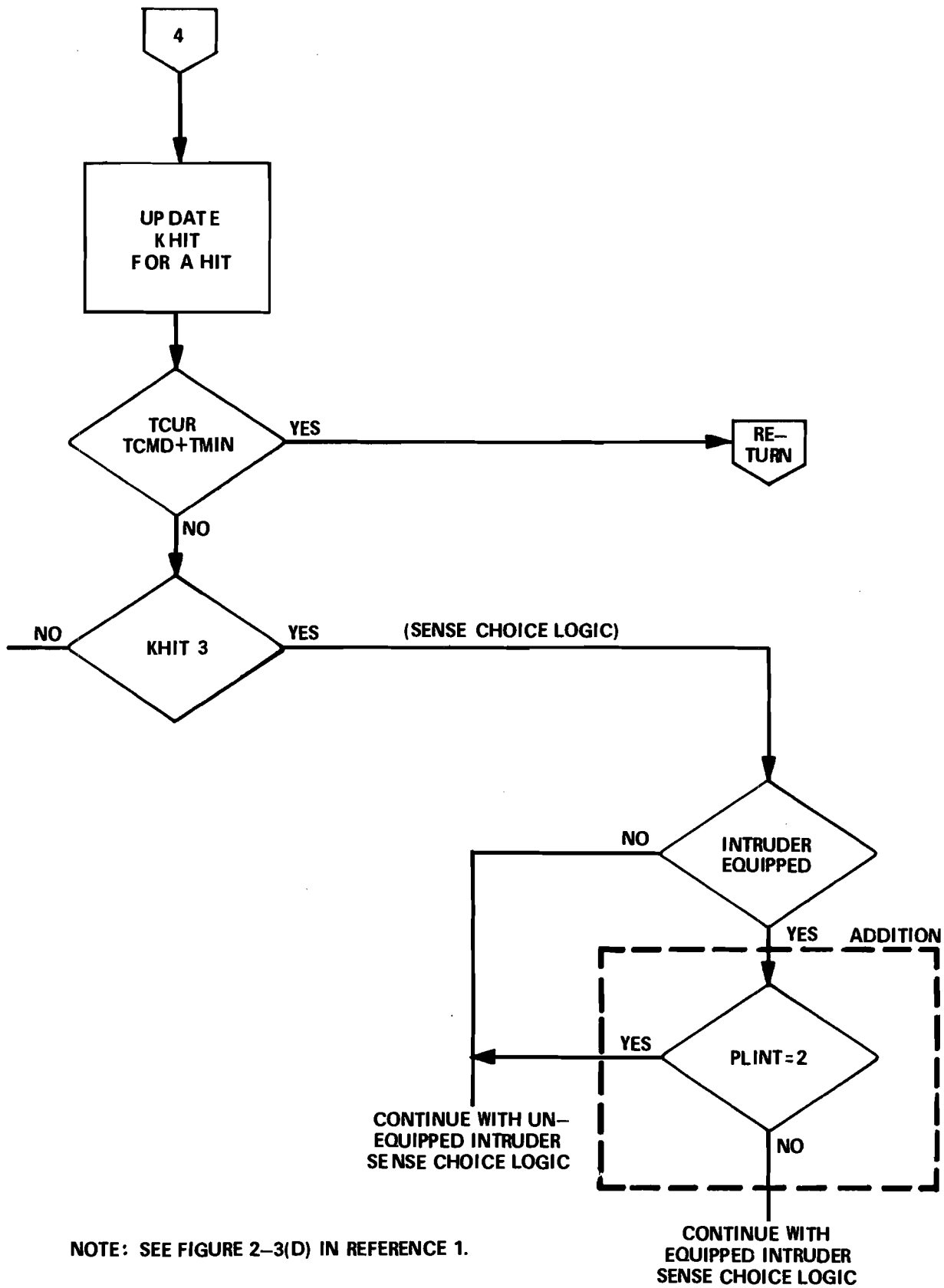

NOTE: SEE FIGURE 2-3(D) IN REFERENCE 1.

80-51-II-37

FIGURE 31. DRACT LOGIC MODIFICATION TO PROPERLY SELECT SENSE FOR PERFORMANCE LEVEL 2 EQUIPPED THREATS

for the same intruder, the CIR is found not to be empty. The erroneous entry can cause the wrong sense to be set for the secondary command. Figure 32 presents the sequence of events which result in the generation of a false row in the CIR. Table 3 recaps the sequence of events of an encounter that results in reduced separation caused by an erroneous row entry in the CIR following a drop command coordination sequence. Own aircraft, UF10, is descending at 4,000 ft/min and is crossing the intruder's level flight path at a 90° angle. With no BCAS interaction, own aircraft will pass 200 feet below the intruder (UF07) at CPA.

A minor change to the RCV subroutine can prevent the erroneous entry of a CIR row during the coordination interrogation for dropping commands. A check of D4, the vertical command presence bit, in the maneuver intent field will solve the problem. Figure 33 shows the recommended modification. After a negative branch from the decision block indicating a CIR row for a given threat was not found, a check of bit 4 of the CMDTRT message is made. If bit 4 is equal to 0, no command is present, and the logic exits without assigning a CIR row.

Improved BCAS performance resulted following the modification to the subroutine RCV. Commands were dropped with no false CIR entries occurring. The command sense did not change with the reinitiation of a command sequence. The planned vertical separation of 200 feet was increased to 510 feet, a significant improvement from the original miss distance of 58 feet.

TABLE 3. SEQUENCE OF EVENTS RESULTING IN SEPARATION LOSS

<u>Logic Cycle</u>	<u>Action</u>
50	Two consecutive hits occurred. The aircraft have penetrated each other's threat volume. TAUV is less than 30 seconds, and a BCAS command is generated. UF10 is directed to limit its descent to less than 2,000 ft/min, and UF07 is directed not to climb.
58-59	Two consecutive misses occurred. As a result of the decrease in the descent rate by UF10, the vertical tau is increased to more than 30 seconds. A drop command coordination sequence follows. An erroneous row is created in UF10's CIR with a descent sense. Aircraft UF10 resumes the 4,000 ft/min descent.
63-64	Two consecutive secondary hits occurred. The return of UF10 to its original rate of descent resulted in the penetration of the TAUV threshold of 30 seconds. Upon entering subroutine COORD, the erroneous CIR entry (row) following the "drop command" sequence is found. The erroneous sense of 1 (descent) is in opposition to the true sense of 0 (climb) in OWNTENT. The resolution results in a descent and limit-climb command for UF10, completely opposite from the initial limit-descent commands. A wrong sense was chosen, resulting in a reversal of command sense. The resulting commands created a near-miss situation.

Aircraft A



Aircraft B



1. Detection and resolution logic directs dropping commands in aircraft A. Subroutine COORD is called.

Transmit coordination containing own ID, own bit, CMDTRT, RCVD.



2. B receives coordination interrogation to "drop command" and B sends his CIR to A.



3. Since OWNTENT = 0, A clears his CIR row for B.

4. Detection and resolution logic directs dropping commands in aircraft B for A. Subroutine COORD is called and B transmits coordination interrogation to drop commands to aircraft A. B clears his CIR since MTENT equals 0.



5. Since CIR is cleared, a row with the threat ID is not found. Assignment of a new CIR row for "new" threat B is made, although the interrogation message was to drop commands (an erroneous entry with a possible false sense is created in A's CIR for aircraft B). If a secondary encounter occurs, there is a 50-50 chance that the sense will be wrong.

FIGURE 32. FALSE THREAT GENERATION IN CONFLICT INDICATOR REGISTER

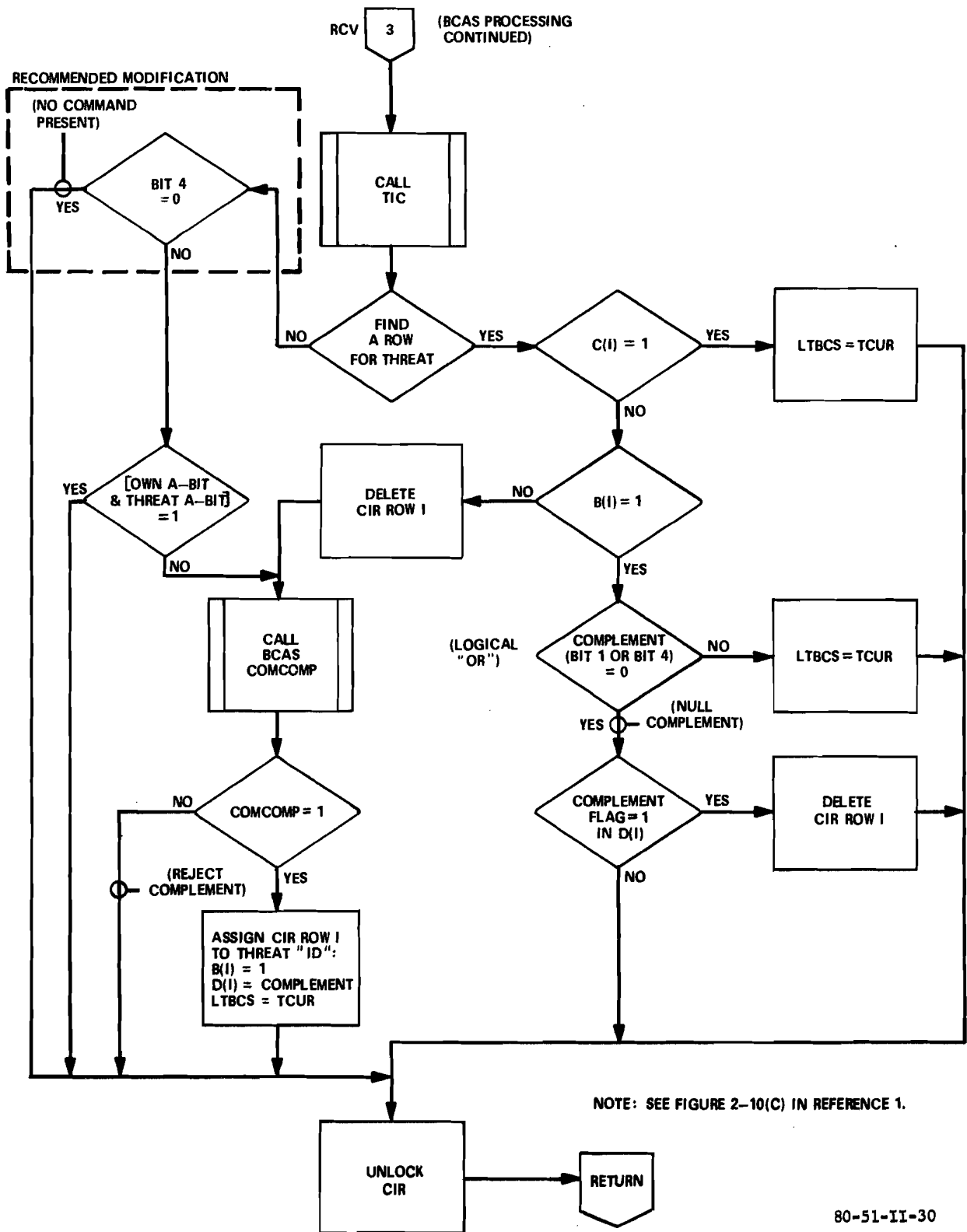

FIGURE 33. RCV MODIFICATION — COMMAND PRESENCE CHECK

Hit-Miss-Hit KHIT Pattern. A problem in the DRACT module in the BCAS logic (reference 1) occurs when the encounter conditions cause an initial hit (KHIT updated for a hit) followed by a miss and then a hit on the third data cycle. Logic in DRACT permits selection command sense on the initial hit only. Sense is not obtained from DRACT after the initial hit. This hit followed by a miss causes the loss of sense resulting in no command.

The algorithm uses a hit counter, KHIT, to identify when the two-out-of-three rule has been satisfied for a particular intruder. Once the rule is satisfied, a command can be presented. On the first hit only a command sense is selected. This sense is supposed to be used until the intruder no longer is a threat. The KHIT pattern for the encounter in question is shown in table 4. The encounter conditions which caused the KHIT pattern in question are shown below. (It should be noted that the loss of the selected sense was independent of the high opposing vertical rates that were used for this encounter.)

	<u>UF010</u>	<u>UF007</u>
Velocity	360 kns	360 kns
Vertical Rate	-4,000 ft/min	4,000 ft/min
BCAS Status	Equipped	Equipped
Crossing Angle	90°	
Vertical Separation	500 feet	
Horizontal Separation	0 feet	

Table 4. KHIT SEQUENCE WHICH PREVENTS COMMAND COORDINATION

<u>TIME*</u>	<u>THREAT DETECTED</u>	<u>KHIT VALUE</u>	<u>SENSE</u>
53	YES	0	----
54	NO	2	CLIMB
55	YES	1	----
56	NO	3	Coordination Attempt with No Sense Value

*Time refers to the time since threat-tracking was initiated.

The initial penetration of threat volume on the 54th data cycle causes the selection of the proper sense, climb (don't descend), and KHIT to be set to 2 for UFO10. Since the two-out-of-three rule for command display has not been satisfied, no command is displayed. Since no command has to be displayed, the command save array, CMDSAV, is undefined. On the next data cycle (Time=55), TAUV >30, and a miss is declared. The logic for updating KHIT for a miss as shown on figure 2-3(b) of reference 1, causes OWNTENT to be equated to CMDSAV which is undefined at this point. Finally, on the 56th data cycle, a hit occurs causing KHIT = 3 and the two-out-of-three rule to be satisfied. As a result, the logic proceeds directly to command generation. Since resolution results in a vertical speed limit command, a 1-second "limit descent to 2,000 ft/min" command is displayed. This occurred because the variable VLIM is stored external to DRACT. Just before exiting DRACT, the logic equates CMDSAV to OWNTENT, but OWNTENT still does not contain a defined sense bit. On subsequent cycles through the logic, sense is never set for the intruder in question. As a result, the sense is neither 0 nor 1, preventing the necessary coordination on subsequent logic cycles with the equipped threat aircraft. This prevented BCAS from generating an increase in vertical separation.

Two possible solutions exist, and both were evaluated. The first solution incorporates the setting of sense in CMDSAV whenever the sense in OWNTENT is set in DRACT. Figure 34 presents the flow chart changes to DRACT that are necessary. The changes were made, and the same encounter conditions were repeated. The changes caused the resulting vertical separation to increase by 313 feet. To handle the hit-miss-hit sense loss problem, a second solution modifies the logic which updates OWNTENT following misses as shown in figure 35. This change was made, independent of the change shown in figure 34. The same encounter conditions were repeated, resulting in the same command sequence and increase in vertical separation that was achieved with the first solution.

IMPROPER DELETION OF CIR ROWS FOLLOWING MISSED BCAS SURVEILLANCE REPORTS. Although this phase of experimentation was dedicated to BCAS equipped threat evaluation, some ATRCBS threats encounters were also analyzed. The purpose was to verify the CIR logic performance for ATRCBS threats. While the CIR logic does not coordinate commands with ATRCBS threats, numerous logic "bookkeeping" procedures were performed with the CIR logic for ATRCBS threats. A problem was detected in deleting CIR rows for ATRCBS aircraft following TDROP (currently 10) consecutive missing BCAS surveillance reports. In TRIACT logic, figure 36, an intruder track can be coasted for up to TDROP seconds. If a command was generated for the intruder in question, the own aircraft would have an active CIR row for that intruder. The only way to eliminate the command is to either reset the CIR D field array with a null OWNTENT vector or delete the row in question. If TDROP consecutive reports were missed, the current TRIACT logic deletes the intruder state vector as shown in block 1 of figure 36. This prevents the OWNTENT vector from being reset to 0 (null vector) since OWNTENT is an element in the intruder state vector which has been deleted.

The current TRIACT logic attempts to identify the CIR row to be deleted by calling TIC the threat identify correlator in block 2. If the intruder is not DABS equipped, the "appropriate" row is found in the CIR by comparing, in the case of Active BCAS, the four element ATRCBS track block data (R, R̂, Z, Ẑ) from each CIR row filled with an ATRCBS threat and the current intruder state vector values

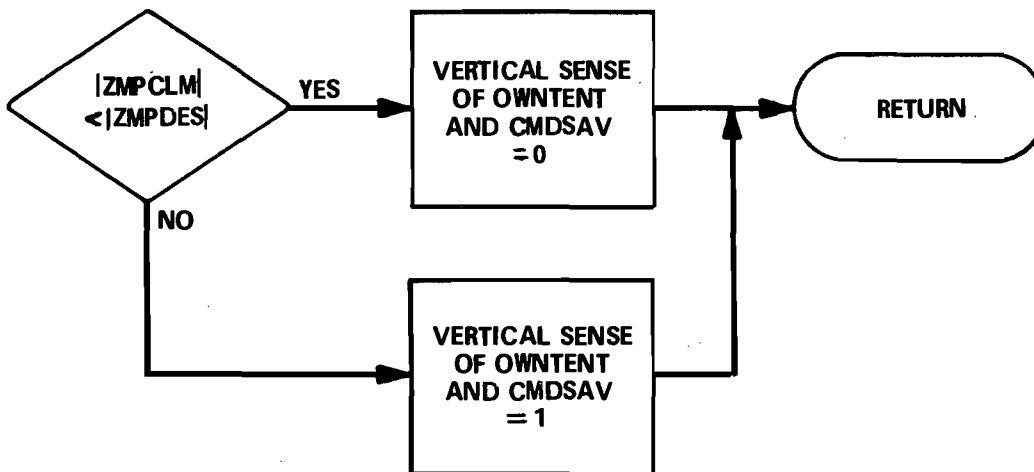
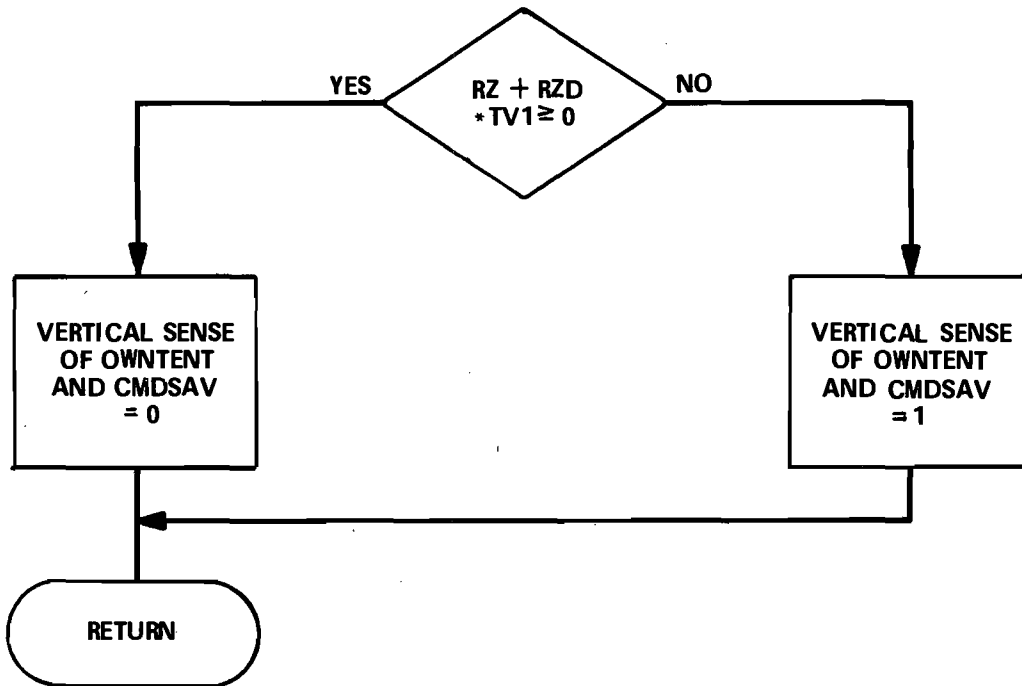

NOTE: SEE FIGURE 2-3(D) IN REFERENCE 1.

80-51-II-32

FIGURE 34. DRACT MODIFICATION — HIT-MISS-HIT PROBLEM (FIRST SOLUTION)

(R, \dot{R} , Z, \dot{Z}). However, the intruder state vector has already been deleted. This prevents TIC from declaring a match and the return from TIC indicates no row was found for the ATRBS threat. As a result, the deletion of CIR row (I) in block 3 does not occur. Without the deletion of the row, the D field array in that row causes DISPLA, the display logic, to continue to generate a command for an intruder for which an intruder track file no longer exists.

A slight TRIACT flow chart change will eliminate the problem of not deleting the CIR row. Figure 37 identifies the changes that should be made. The deletion of the intruder state vector should be delayed until after the call to TIC has been made to identify the CIR row that should be deleted. In the case of ATRBS threats, the intruder state vector would still exist and contain the track block data (R, \dot{R} , Z, \dot{Z}) necessary to identify the CIR row to be deleted. Once the CIR was unlocked, the intruder state vector would then be deleted.

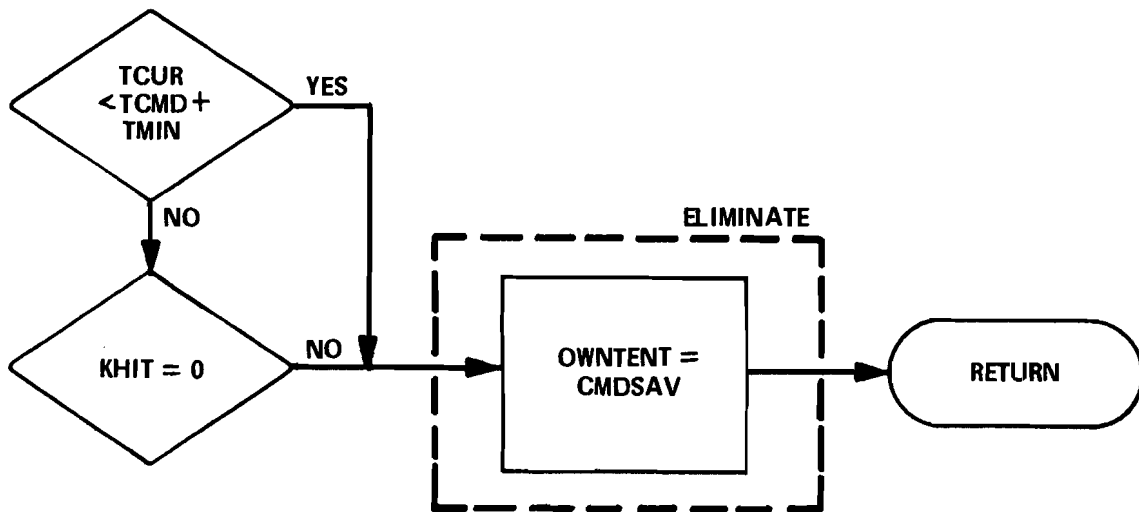

NOTE: SEE FIGURE 2-3(B) IN REFERENCE 1.

80-51-II-33

FIGURE 35. DRACT MODIFICATION — HIT-MISS-HIT PROBLEM (SECOND SOLUTION)

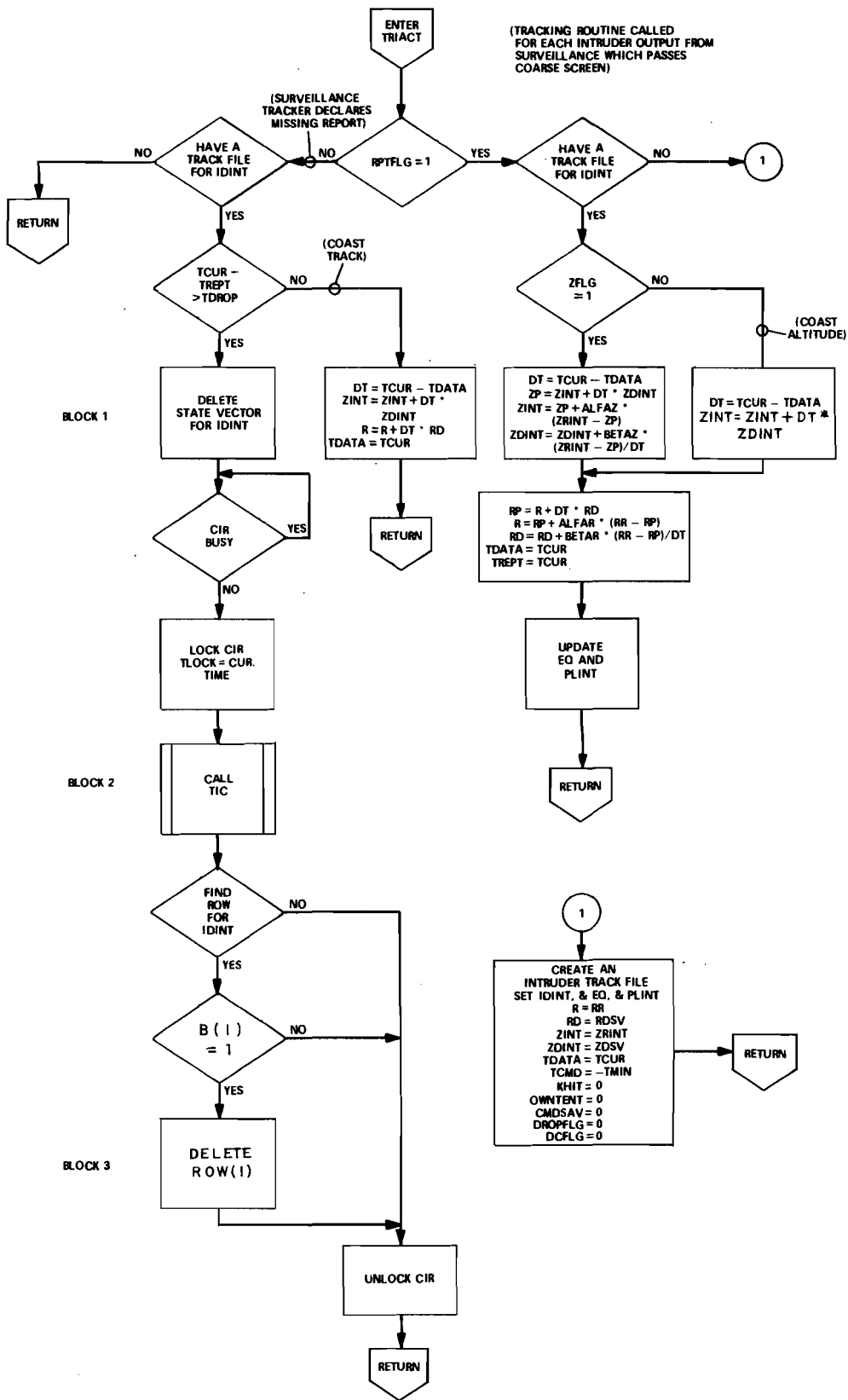

80-51-II-34

FIGURE 36. ORIGINAL TRIACT LOGIC

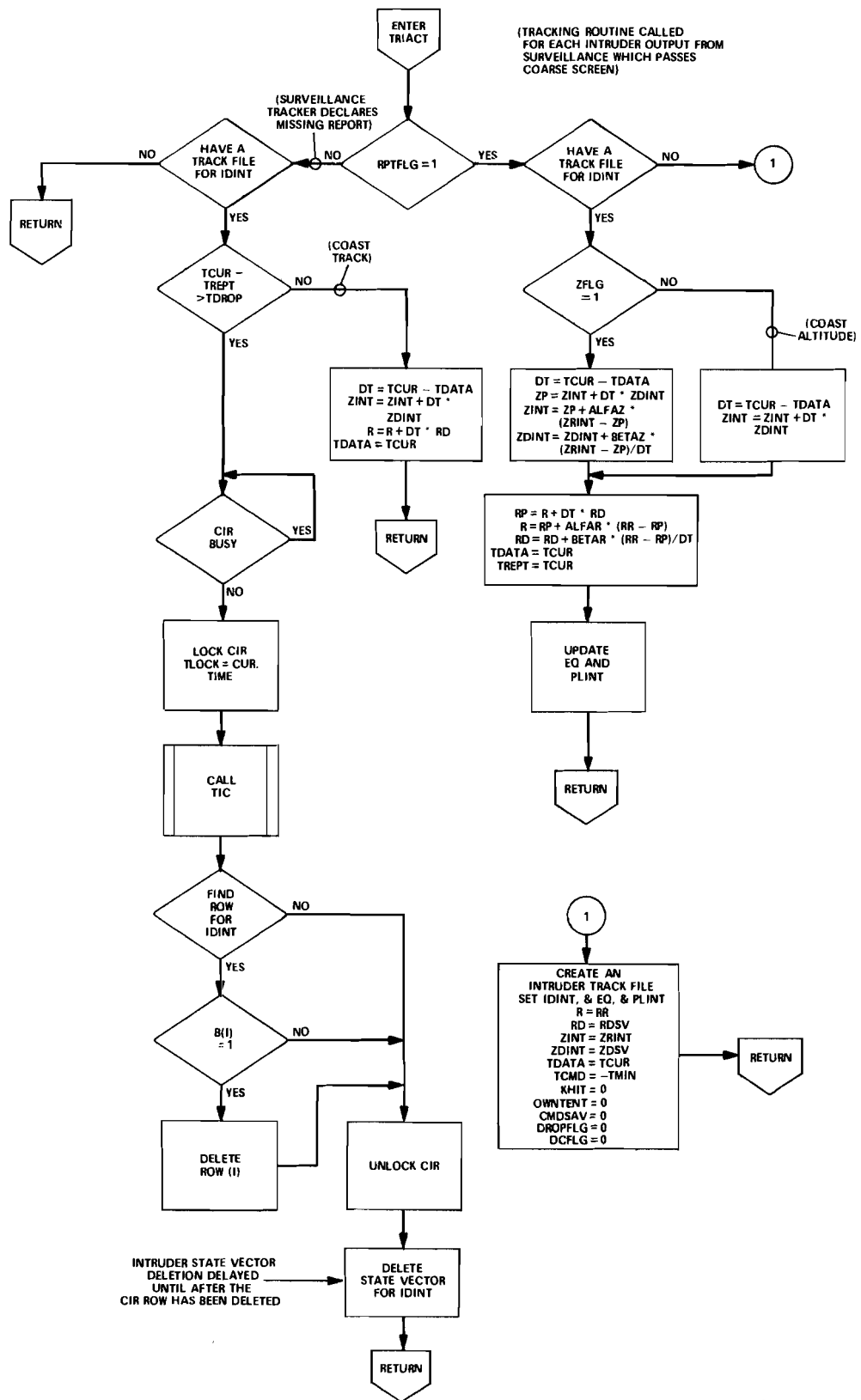

80-51-II-35

FIGURE 37. TRIACT LOGIC MODIFICATION — DELAY INTRUDER STATE VECTOR DELETION

CONCLUSIONS

Extensive testing of the Active Beacon Collision Avoidance System (BCAS) collision avoidance logic has indicated that, generally, consistent and timely BCAS commands occur resulting in adequate collision avoidance performance. Analysis has identified numerous modifications to the logic which results in improved performance.

RESOLUTION LOGIC.

Specific conclusions concerning the resolution logic are:

1. The performance of the resolution logic during paired linear encounters is excellent. The crossing angle (except tail chase $<30^\circ$) has minimal effect on the performance. Although not as much separation was generated for tail chase scenarios, the separation for no-miss conditions still exceeded 300 feet.
2. The tracker lag and oscillations in the tracked vertical rate pose fewer problems during equipped threat encounters than unequipped threat encounters because vertical positions are only projected ahead a maximum of 8 seconds instead of 35 seconds. However, occasional vertical speed limit (VSL) commands can be expected for BCAS aircraft in level flight. The analysis indicates a need for a check on the vertical rate of the BCAS aircraft to inhibit noneffective VSL alarms.
3. The performance of the resolution logic during encounters with equipped intruders maneuvering at low vertical rates is excellent.
4. The performance of the resolution logic during encounters with horizontally maneuvering equipped intruders is good.
5. Lack of vertical miss distance (VMD) filtering for equipped threats causes many alarms which generate excessive vertical separation. A VMD filter similar to the filter used for ATCRBS threats is needed in the equipped threat resolution logic.
6. When a BCAS aircraft descends, the current logic fails to reset the high altitude threat volume parameters to the smaller values associated with low altitude. Only INDEX values should be set in the TROACT logic. The DRACT logic should set all threat volume parameter values to the maximum sensitivity level, based on the INDEX value of the own aircraft and the PLINT value of the equipped threat. The parameter values ZTHR and ALIM should be set, based on the higher altitude of own aircraft or the equipped intruder.
7. When intruders are equipped and radar altimeter information is available, the radar altitude information should be used to inhibit descent commands in close proximity to the ground. Inhibiting descent commands provides protection against commanded descent into the ground without reducing vertical separation performance for equipped threats.

8. The vertical rate tracker can overestimate vertical rates when both own aircraft and the equipped intruder respond to BCAS commands. This overestimate of the vertical divergence rate can result in early command removal. Once the vertical trackers stabilize, complementary BCAS commands reoccur. During vertical flyaway conditions, alarm generation should be based on current vertical separation rather than predicted separation.

9. Treating equipped threats tracked in performance level 2 regions as unequipped threats should result in improved resolution logic performance.

COORDINATION LOGIC.

The BCAS coordination logic was thoroughly analyzed. Review of the BCAS coordination logic performance for equipped threats has led to the following conclusions:

1. Modifications to the coordination logic has eliminated the generation of false Conflict Indicator Register (CIR) rows during the coordination of dropping BCAS commands with equipped threats.

2. A hit-miss-hit threat detection sequence resulted in command coordination attempts without the command sense being selected. Minor changes to the detection and resolution logic has corrected this problem.

3. The reordering of certain logic functions is necessary to delete the proper CIR row following consecutive missed surveillance reports for the threat in question.

REFERENCES

1. Zeitlin, A. D., Active Beacon Collision Avoidance System Collision Avoidance Algorithms, The MITRE Corporation, MTR 79W00110, April 1979.

2. McFarland, A. and Spencer, N., MITRE Letter To ARD-242, W46-0613, January 1980.

3. Adkins, A., Billmann, B., Thomas J., and Windle, J., Active BCAS Collision Avoidance Logic Evaluation: Volume I, Mode C Equipped (ATCRBS) Threat Phase, FAA-RD-80-125-I, June, 1981.

4. Billmann, B., Morgan, T., Strack, R., and Windle, J., Air Traffic Control/Full Beacon Collision Avoidance System Chicago Simulation, FAA-RD-79-16, April 1979.

5. Billmann, B., Morgan, T., Strack, R., and Windle, J., Air Traffic Control/Full Beacon Collision Avoidance System Knoxville Simulation, FAA-RD-79-54, August 1979.

6. Adkins, A., Billmann, B., Strack, R., and Windle, J., Air Traffic Control/Active Beacon Collision Avoidance System Knoxville Simulation, FAA-RD-80-5, May 1980.

7. Berry, T. and Morganstern, B., An Evaluation of Aircraft Separation Assurance Concepts Using Airline Flight Simulators, ARINC Technical Report 1343-01-2058.

APPENDIX A

CHRONOLOGY OF ALGORITHM DEFICIENCIES

<u>DEFICIENCY</u>	<u>MODIFICATION</u>	<u>PAGE</u>
1. Improper threat message handling by the coordination logic causes false rows to be added to the conflict indicator register (CIR) during coordination procedures for dropping commands.	1. Received command threat messages, CMDTRT, are checked for presence of vertical commands prior to establishing a new CIR row. (January 1980)	33
2. Improper event sequencing in the intruder tracking logic prevents proper deletion of CIR rows following TDROP (10) consecutive missing reports.	2. Logic events have been rescheduled to properly delete CIR rows. (January 1980)	39
3. Hit-miss-hit sequences result in incorrect setting of the sense bit. This prevents commands from being properly coordinated.	3. CMDSAV, the previous command array, has been modified. (January 1980)	38
4. When an intruder is Beacon Collision Avoidance System (BCAS) equipped, no filtering of commands based on projected miss distance occurs.	4. A filter which uses projected miss distance information has been added to the threat detection logic for equipped threats. The filter compares the projected range at time of coalitude with DMOD. (January 1980)	10
5. Tracking errors in the vertical rate tracker can result in oscillating vertical speed limits (VSL) alarms for BCAS aircraft in nearly level flight.	5. Logic has been added to reduce the affect of vertical tracker noise on VSL selection. The modification also checks the adequacy of VSL alarms before the command is generated. (January 1980)	29
6. The alpha-beta tracker performs poorly at low vertical rates.	6. The tracking constant, BETAZ, was decreased from 0.15 to 0.10 to limit the effects of tracker noise (August 1979). The value of BETAZ was further reduced to 0.05 (May 1980). Additionally, a variable, ZDLVL, was added to the sense choice logic. This variable causes the unequipped sense choice logic to ignore tracked vertical rate when it is below a threshold value (9.32 feet/per second) (June 1980).	6

7. Equipped threat sense choice logic is used for threats which are tracked in performance level 2 regions. This occurs despite the fact that the threat would not receive BCAS commands.

7. The logic should be modified to use the equipped threat's performance level indicator, PLINT. When PLINT = 2, the command sense selection should be based on the unequipped sense choice logic.

29

8. Some commands may be removed early because the vertical tracker overestimates the vertical divergence rate.

8. The vertical divergence function, $P(-R/\dot{R})$, should be modified to limit early command removal.

8