

**COPY 1**

**Report No. FAA-CT-80-38**

CT

80-38

# **CROSSTALK LEVELS OF SPEECH PLUS DATA IN REMOTE COMMUNICATIONS AIR-GROUND (RCAG)**

**FEDERAL AVIATION ADMINISTRATION**

**AUG 20 1981**

**Albert J. Rehmann**

**TECHNICAL CENTER LIBRARY,  
ATLANTIC CITY, N.J. 08405**



**FINAL REPORT**

**JUNE 1981**

Document is available to the U.S. public through  
the National Technical Information Service,  
Springfield, Virginia 22161.

Prepared for  
**U. S. DEPARTMENT OF TRANSPORTATION  
FEDERAL AVIATION ADMINISTRATION  
TECHNICAL CENTER  
Atlantic City Airport, N.J. 08405**

FAA TECHNICAL CENTER LIBRARY NJ

Federal Avia/Crosstalk levels of speech

21  
82/38



00008160

1. Report No. FAA-CT-80-38		2. Government Accession No.		3. Recipient's Catalog No.	
4. Title and Subtitle  CROSSTALK LEVELS OF SPEECH PLUS DATA IN REMOTE COMMUNICATIONS AIR-GROUND (RCAG)				5. Report Date June 1981	
				6. Performing Organization Code	
7. Author(s)  Albert J. Rehmann				8. Performing Organization Report No.  FAA-CT-80-38	
9. Performing Organization Name and Address Federal Aviation Administration Technical Center Atlantic City Airport, New Jersey 08405				10. Work Unit No. (TRAIS)	
				11. Contract or Grant No. 219-151-200	
12. Sponsoring Agency Name and Address U.S. Department of Transportation Federal Aviation Administration Technical Center Atlantic City Airport, NJ 08405				13. Type of Report and Period Covered  Final August 1979 - May 1980	
				14. Sponsoring Agency Code	
15. Supplementary Notes					
16. Abstract  The Federal Aviation Administration (FAA) is proposing the addition of a digital data channel to the existing telephone lines which connect air route traffic control centers (ARTCC's) with remote communications air-ground (RCAG) sites to economically transfer Remote Monitoring System (RMS) parameters and control data between the ARTCC's and the sites.  FAA Specification FAA-E-2699a establishes the maximum allowable interference level to pilot/controller communications which would be allowed to result from the addition of the data channel. The tests described in this document were designed to verify that the requirements in FAA-E-2699a are sufficient to prevent disturbance to normal air traffic control (ATC) operations. The tests were performed by simulating an existing communications channel using data modems and samples of present-day Voice Frequency Control System (VFCS) equipment. Crosstalk levels of speech and data were measured under actual operating conditions. The test results indicated that the addition of an RMS data channel to existing FAA telephone lines is technically feasible and that the requirement in FAA-E-2699a concerning the data crosstalk in the audio portion of the communication channel is not adequate to prevent disturbance to normal ATC operations. The requirements concerning data crosstalk in the control portion and VFCS crosstalk in the data portion of the channel are sufficient.					
17. Key Words Crosstalk Voice Frequency Control System Voice Frequency Signalling System Remote Monitoring System Modem			18. Distribution Statement Document is available to the U.S. public through the National Technical Information Service, Springfield, Virginia 22161		
19. Security Classif. (of this report) Unclassified		20. Security Classif. (of this page) Unclassified		21. No. of Pages 54	22. Price

# TABLE OF CONTENTS

	Page
INTRODUCTION	1
Objectives	1
Background	1
DISCUSSION	3
Equipment Description	3
Test Configuration	15
Test Procedure (General)	20
System Initial Conditions	24
Test Conduct	24
RESULTS	28
Failure Levels in Modem Equipment	28
VFSS Crosstalk in RMS Modem Equipment	29
RMS Modem Crosstalk in VFSS/VFCS Equipment	30
CONCLUSIONS	31
RECOMMENDATIONS	31
REFERENCES	32
GLOSSARY OF TERMS	34
APPENDICES	
A — Test Results, IM-1307	
B — Test Results, FA-8735	
C — Test Results, CA-1621	
D — Test Results, IM-2076	
E — Test Results, FA-5390	

## LIST OF ILLUSTRATIONS

Figure		Page
1	Proposed Addition of RMS Data Modems	2
2	Laboratory Setup	4
3	Typical RCAG VFSS/VFCS	5
4	FS and AM Sender Operational Diagram	7
5	RMS Modem Operational Diagram	8
6	Spectrum of 110-Baud Mark, Space, and 1:1 RMS Data	9
7	Spectrum of 110-Baud Random RMS Data	10
8	Spectrum of 150-Baud Mark, Space, and 1:1 RMS Data	11
9	Spectrum of 150-Baud Random RMS Data	12
10	RMS Modem Receive Filter Frequency Response (110 Baud)	13
11	RMS Modem Receive Filter Frequency Response (150 Baud)	14
12	Notch Filter Frequency Response	17
13	Bandpass Filter Frequency Response	18
14	Test Setup	19
15	Resistive Matching Networks Schematic Diagram	21
16	Telephone Line Simulator	21
17	Telephone Line Simulator Frequency Response	22
18	Energy and Emotion Distribution in Speech	27

## LIST OF TABLES

Table		Page
1	Specified 1142a Telephone Line Characteristics	23
2	Specified 2002 Telephone Line Characteristics	23

## SCOPE

This report describes the results of laboratory testing to determine the performance of the speech-plus-data technique over existing telephone circuits connecting air route traffic control centers (ARTCC's) and remote communications air-ground (RCAG) sites. To represent the ARTCC-to-site configuration, the tone signalling equipment terminals and modems were interconnected via a telephone line simulator, rather than an actual loop-back Bell Telephone circuit. This point merits a note of caution. The simulated telephone circuit for the ARTCC-to-site path conforms to Federal Aviation Administration (FAA) Specification 1142a for voice-grade lines. The simulated site-to-ARTCC telephone company circuit conforms to Bell System Specification 2002 for voice-grade lines. The 1142a and 2002 specifications, in agreement with the Federal Communications Commission (FCC) tariff No. 260, detail FAA requirements for line loss, noise levels, frequency response, and maximum input signal level limits. They do not, however, address critical parameters

such as impulse noise, in-band intermodulation, or switching effects caused by Bell equipment. The 1142a specification does not limit baseband shift; the 2002 specification does. Furthermore, Bell System publication 43201, which covers Bell specifications for voice-grade lines, imposes the energy density condition that the signal applied to the telephone company lines by the customer shall not, at any time, have power solely in the 2450- to 2750-hertz (Hz) band. Power in this band must be accompanied by at least an equal amount of power in the 800- to 2450-Hz band. The consequence of noncompliance is possible automatic disconnection of the circuit or interference to telephone company network control. This condition applies when the telephone company circuit is routed through a central office.

The tests described in this document were performed using a telephone line simulator designed to provide the specified characteristics of 1142a and 2002 classes of lines. Simulation of all the individual circuits in the field was beyond the scope of this task.

## INTRODUCTION

### OBJECTIVES.

The objectives of this project were to: (1) measure the crosstalk levels in remote communications air-ground (RCAG) Voice Frequency Signalling System (VFSS) equipment filter outputs, (2) to measure the crosstalk levels in the RCAG Remote Monitoring System (RMS) data modem filter outputs, and (3) to validate the requirements for crosstalk levels set forth in Federal Aviation Administration (FAA) Specification FAA-E-2699a, "RCAG Remote Monitoring Subsystem Specification" (reference 1).

This report satisfies the requirements of amendment 2 of task 4B of 9550-0-AAF-501-78-002.

### BACKGROUND.

The FAA is currently involved in an effort to procure an RMS for RCAG sites. Part of the RMS is a modem system which will enable RMS parameter data to be transmitted from the RCAG site to the air route traffic control center (ARTCC) and RMS control data to be transmitted from the ARTCC to the RCAG site. To economically provide RMS data transfer, FAA-E-2699a requires that a modem channel be added to existing telephone lines connecting the ARTCC and RCAG site, thus eliminating the need to use an additional dedicated telephone line for the modem operation. Figure 1 shows the proposed addition of the modems to the existing communications channel. The center frequency of the modem channel was selected to lie between the audio frequency portion and frequency-shift keying (FSK) portion of the telephone company channel used by present-day tone-signalling equipment. The agency specification (FAA-E-2699a) which details the requirements of the RCAG RMS also establishes maximum permissible interference levels to pilot/controller communications and to

the tone-signaling equipment operation, which could result from the addition of RMS data to existing ARTCC site telephone lines. Since sharp cutoff filters are an integral part of both the RMS data modem and tone-signaling equipment, one aim of the testing was to determine if the maximum interference level requirement could be met with existing equipment filtering, which would make external filters unnecessary.

The tests described in this document were, thus, intended to determine if: (1) the requirements (found in FAA-E-2699a) are sufficient to prevent disturbance to normal RCAG operations and (2) the existing VFSS equipment filters were able to meet these requirements.

For convenience, the crosstalk requirements in FAA-E-2699a are reprinted in the following five paragraphs:

"3.13.2.1 Channel loading. The bridging across or insertion of required RMS equipment in the VF communications channel shall not change end-to-end insertion loss or alter the send/receive signal levels associated with operation of the VFCS equipment by more than 2 dB.

"3.13.2.2 Frequency response. Over the range of 300 to 2400 Hz and 2750 to 2860 Hz, the RMS equipment shall not modify the end-to-end frequency response of VFCS equipment by more than 0.5 dB.

"3.13.2.3 Hum and noise. Over the range of 300 to 3000 Hz, the RMS equipment total contribution of additional hum and noise (steady state of impulse) to the end-to-end VF communications channel shall not exceed a level of -65 dBm.

"3.13.2.4 RMS crosstalk. Pilot tones and data signals in the Type II-to-Type I communications channel link shall be not greater than -65 dBm when measured at the Type I equipment external interface (Figure 1) to the VFCS receivers (FAA-E-2431) for the 2400-Hz low pass filter, the AM filters for each of the

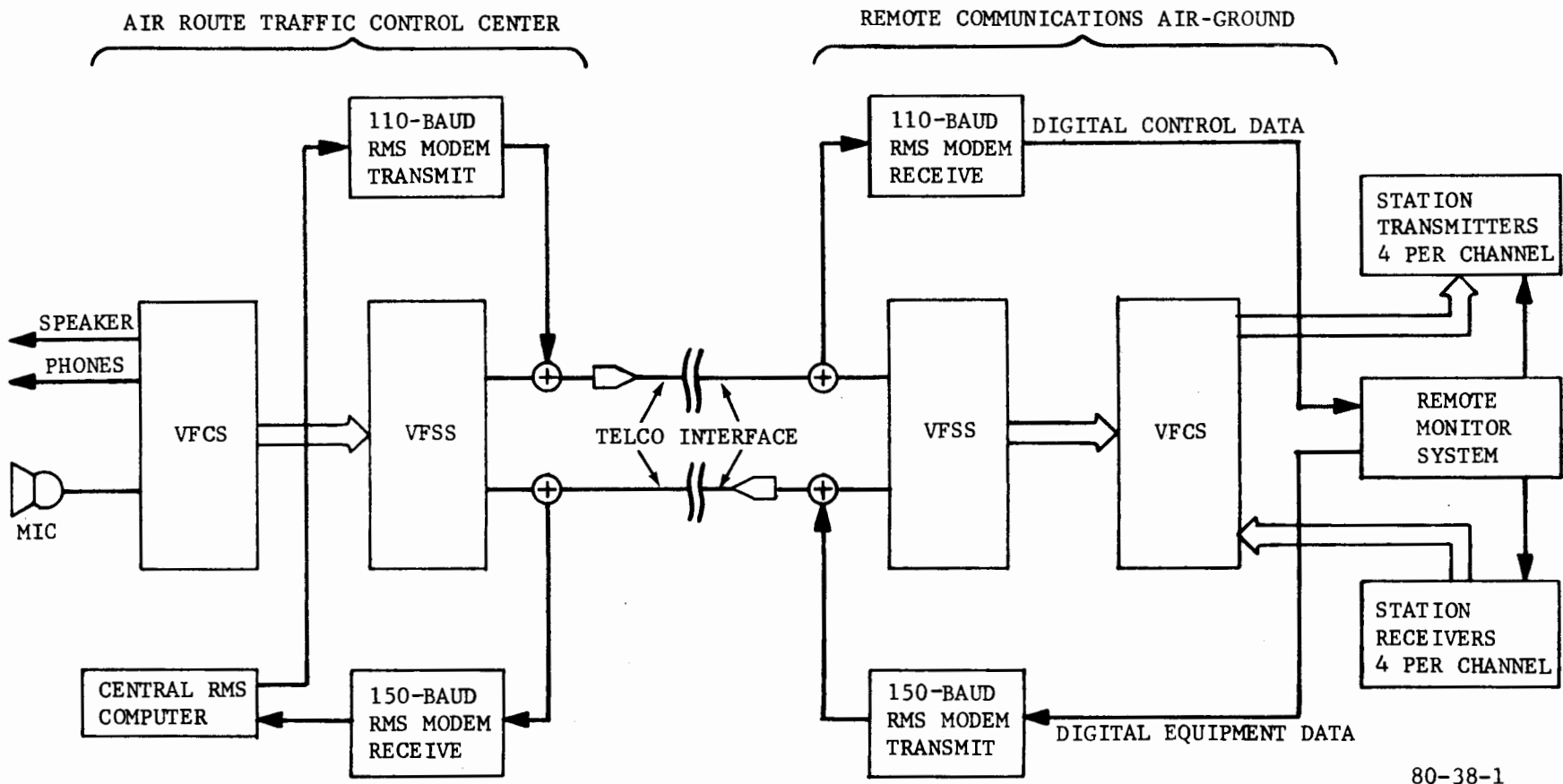

80-38-1

FIGURE 1. PROPOSED ADDITION OF RMS DATA MODEMS

five (5) specified frequencies, and 2805 Hz band pass filter for frequency shift signals. Pilot tones and data signals in the Type I-to-Type II communications channel link shall also be no greater than -65 dBm when measured at the output of the filters in Type II equipment which provides audio from the A/G receivers at the RCAG to equipment at the ARTCC.

"3.13.2.5 VFCS equipment end-to-end delay. Over the range of 590 to 2850 Hz, the contribution of RMS equipment to the delay of end-to-end transmission of AM tone and FSK signaling shall not exceed 5 MS. This delay limit applies only for transmissions from Type II-to-Type I equipment as measured at the VFCS interfaces."

## DISCUSSION

### EQUIPMENT DESCRIPTION.

There are 10 types of Voice Frequency Signalling Systems (VFSS's) presently in use by the FAA. While each of these systems was built to the same specifications, variations in the performance of the equipment filters are known to exist. These variations necessitated the testing of each system. Originally, samples of all 10 of the following systems were to be tested:

<u>TYPE</u>	<u>MANUFACTURER</u>
1. B5	Lynch
2. CA-1621	Radio Frequency Labs (RFL)
3. CA-1708	Benrus Watch Company
4. FA-5390	General Instrument Corporation (GIC)
5. FA-8170	Teledata Electronics
6. FA-8171	Teledata Electronics
7. FA-8187	Orbitronics
8. FA-8735	Telemodem
9. IM-1307	GRM Corporation
10. IM-2076	GRM Corporation

Six VFSS's and one Voice Frequency Control System (VFCS) were actually delivered to the FAA Technical Center. The VFCS used in this project was a GRM model VFCS-6. The delivered VFSS's were:

1. RFL CA-1621
2. GIC FA-5390
3. Orbitronics FA-8187
4. Telemodem FA-8735
5. GRM IM-1307
6. GRM IM-2076

The FA-8187 had several modules missing when it was delivered, and no replacements were available. Therefore, the FA-8187 could not be tested. Each remaining VFSS was installed into equipment racks and interconnected with the VFCS to simulate RCAG tone-channeling equipment operation. Figure 2 is a photograph of the laboratory test setup.

Figure 3 shows the configuration of a typical tone-channeling system. A tone-channeling system is comprised of two subsystems: a VFSS and a VFCS (reference 2). The ARTCC portion of the VFSS is comprised of a filter hybrid unit, five audio mode (AM) senders (each of which generates a different frequency tone when activated), and a frequency-shift (FS) sender. The FS sender generates a 2847.5-Hz tone FSK upshift (FSKU) when deactivated (RCAG transmitters unkeyed), and a 2762.5-Hz tone FSK downshift (FSKD) when activated (RCAG transmitters keyed). The outputs of the AM senders and voice audio are combined and coupled to the telephone line by the filter hybrid unit. The RCAG site portion of the VFSS consists of five AM receivers that provide a relay contact closure (whenever the corresponding AM sender is activated), an FS receiver that provides a contact closure (whenever the FS sender downshifts), and a filter hybrid which provides impedance matching among the AM receivers, the audio line, and the telephone interface. The filter hybrids also contain a sharp cutoff

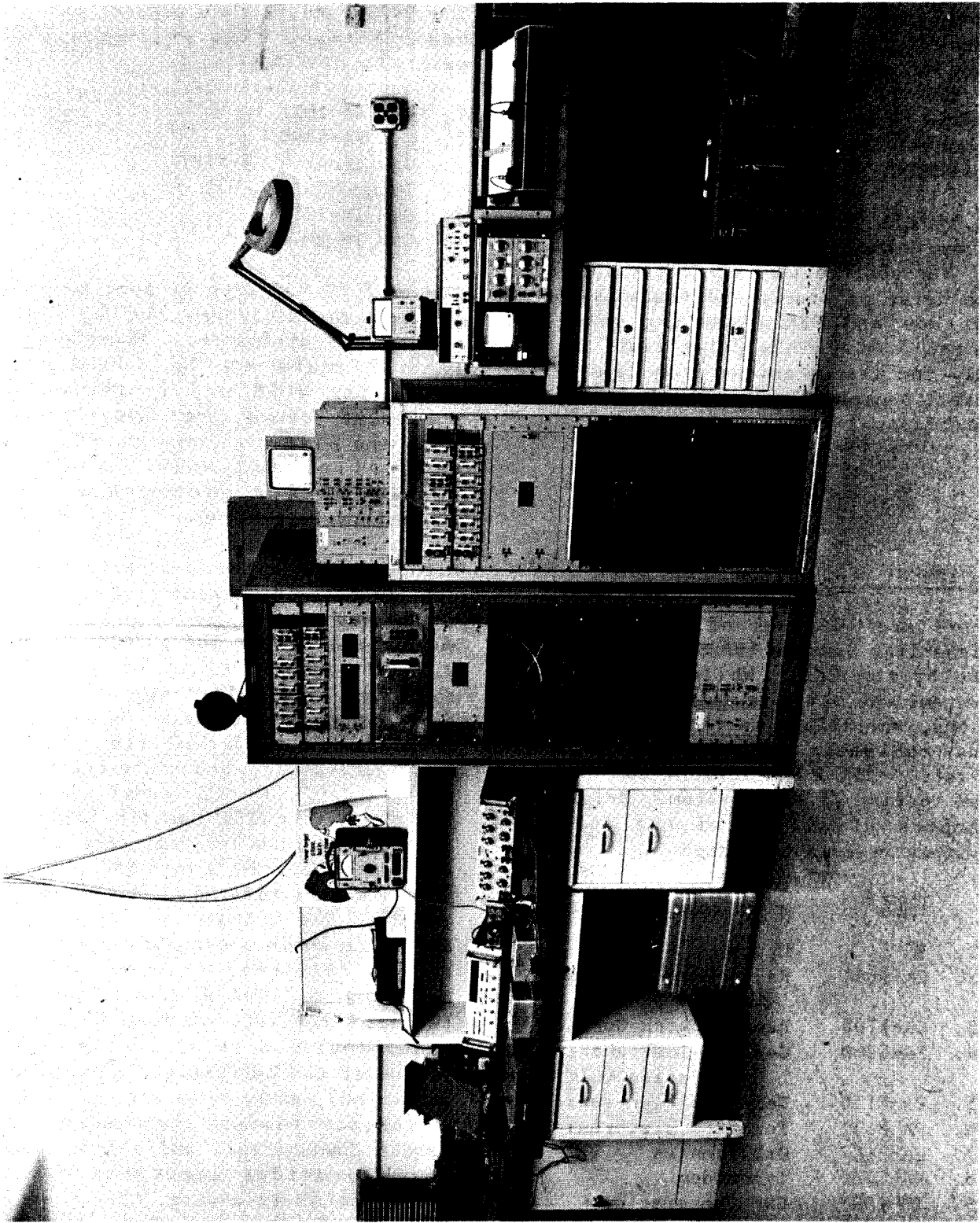

80-38-2

FIGURE 2. LABORATORY SETUP

80-3047

FEDERAL AVIATION ADMINISTRATION  
NATIONAL AVIATION FACILITY EXPERIMENTAL UNIT  
ATLANTA, CITY, MISSISSIPPI

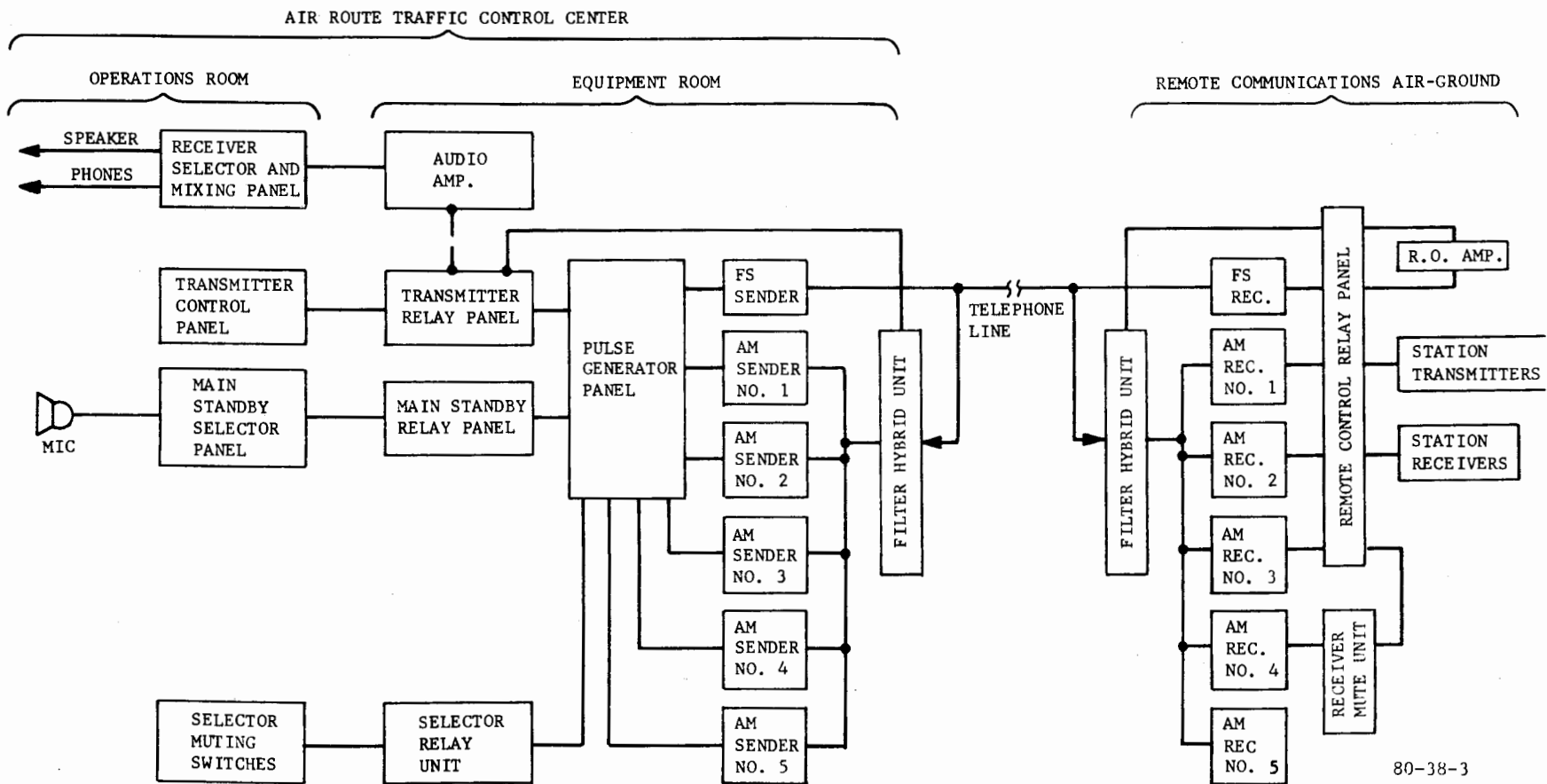

80-38-3

FIGURE 3. TYPICAL RCAG VFSS/VFCS

lowpass filter to remove FS tones from the audio band. The frequencies of the AM senders and receivers are 595, 935, 1275, 1615, and 1955 Hz.

The ARTCC portion of the VFCS is comprised of switching logic that encodes each selected control function into a series of relay contact closures of 60 milliseconds in duration. The contact closures activate the appropriate AM senders for the function selected. The site portion of the VFCS has switching logic that decodes the relay contact closures of the AM and FS receivers and provides the desired control functions. Figure 4 details the tone sender-receiver construction.

Crosstalk in the transmitter audio from RMS pilot tones and data was measured at the output terminals of the remote control relay panel that drive the station transmitters (figure 3). Crosstalk in the AM and FS receive filters from RMS pilot tones and data was measured at the output terminals of the receive filters shown in figure 4.

Figure 5 shows the operation of a typical RMS data modem transmitter and receiver. RMS digital data are converted to tones by FSK modulation. When the data input is a logical 0, the modem outputs a single frequency tone of  $f_0 - 60$  Hz (150 baud) or  $f_0 - 42.5$  Hz (110 baud). When the data input is a logical 1, the modem outputs a tone of  $f_0 + 60$  Hz (150 baud) or  $f_0 + 42.5$  Hz (110 baud). The center frequency of the modem is  $f_0$ . The lower modem frequency is denoted space; the higher is denoted mark. The term "baud" in this case refers to the number of bits transmitted per second (reference 3). For FSK modulation, the data rate transmitted is limited by the maximum transition rate of the tones. As would be expected, the bandwidth required in FSK is directly proportional to the transition rate of the tones. For the ARTCC-to-site path, the transition rate (and bit rate) used was 110 baud,

occupying a spectrum approximately 170 Hz wide centered about  $f_0$ . For the site-to-ARTCC path, the transition rate was 150 baud, occupying a spectrum approximately 240 Hz wide centered at  $f_0$  (reference 4).

Crosstalk in the RMS modem channel resulting from VFCS tones and voice was measured at the output of the modem receive bandpass filter (TP-2) shown in figure 5.

The RMS data modems used were Tele-dynamics Corporation, model 7260B (150 baud) and Commart Corporation model 1105 (110 baud). These modems are available as off-the-shelf components, are typical of a cross section of available modems, and were selected for use in this effort solely because of their availability. The modem operating frequencies are:

	110 Baud (Hz)	150 Baud (Hz)
Center Frequency ( $f_0$ )	2639	2640
Mark Frequency	2681.5	2700
Space Frequency	2596.5	2580

The spectrums of the RMS data modems are shown in figures 6 and 7 (110 baud) and 8 and 9 (150 baud). Frequency response plots of the RMS modem receive filters are shown in figures 10 and 11.

PROBLEMS ENCOUNTERED WITH TONE SIGNALING AND MODEM EQUIPMENT.

During the installation and testing, several flaws in the delivered equipment were discovered and corrected by project personnel.

1. GRM IM-1307.
  - a. The edge connectors on the printed circuit boards (PCB's) in the

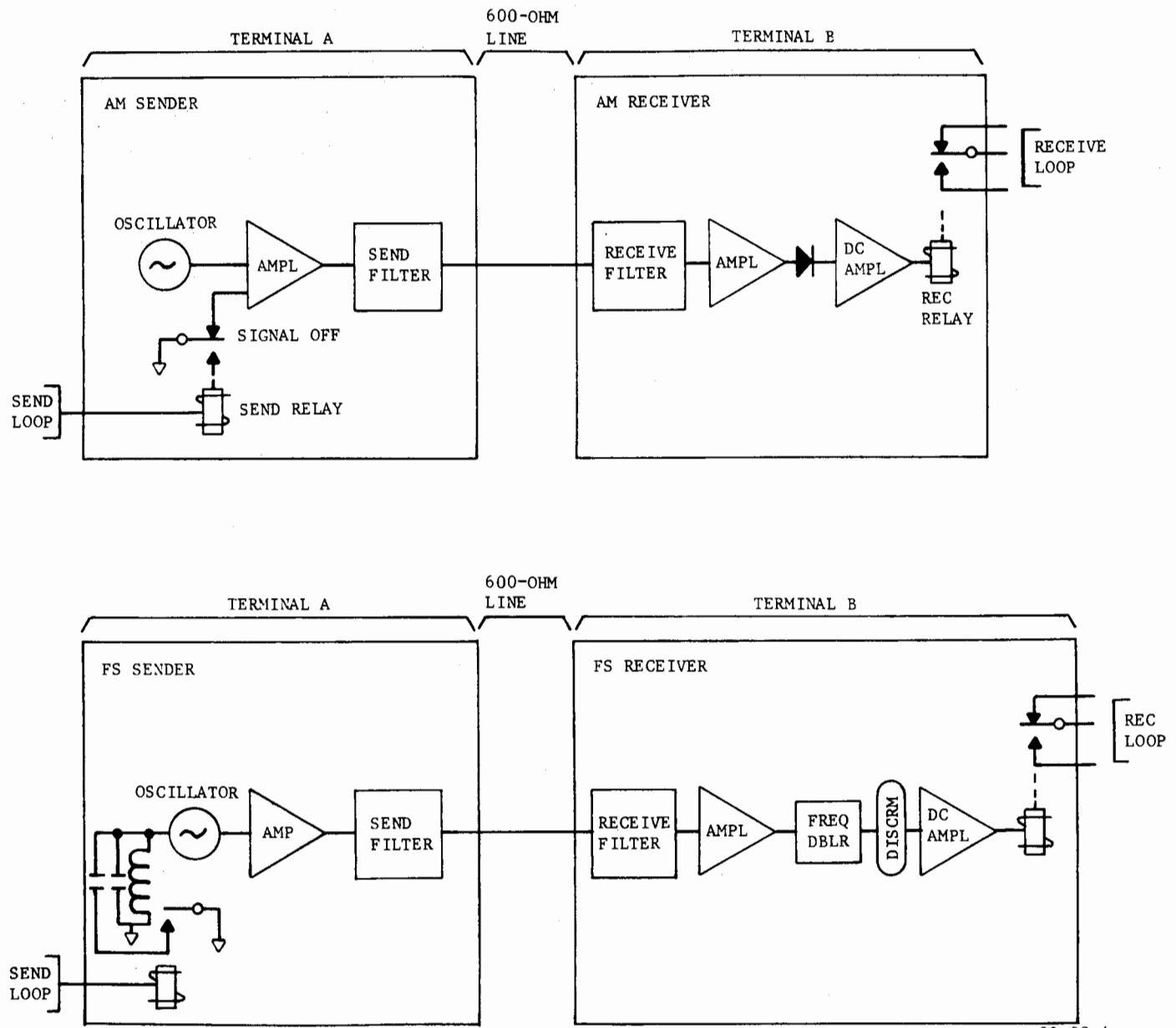

FIGURE 4. FS AND AM SENDER OPERATIONAL DIAGRAM

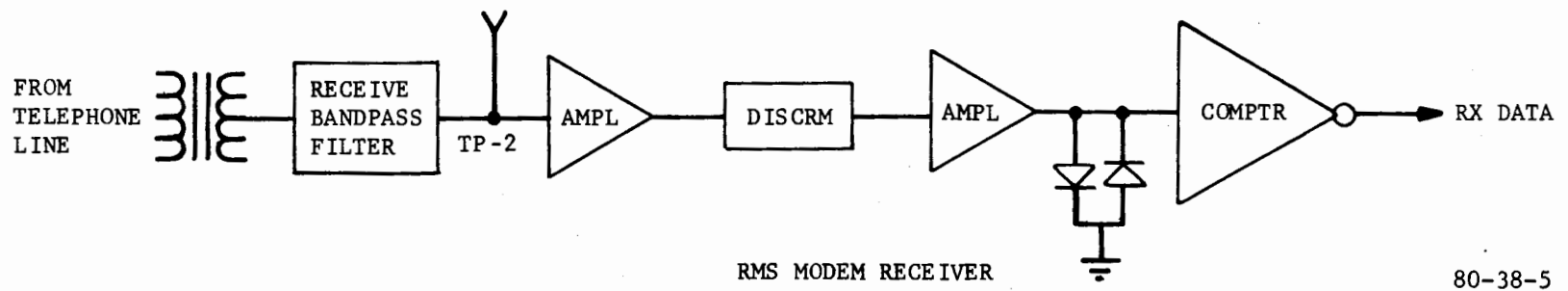
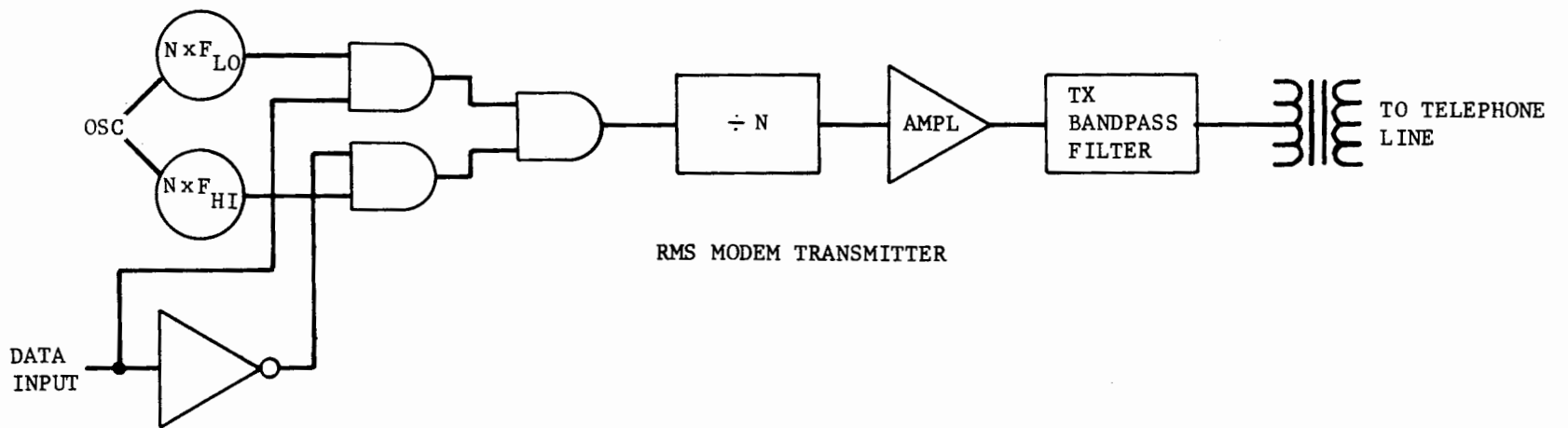

FIGURE 5. RMS MODEM OPERATIONAL DIAGRAM

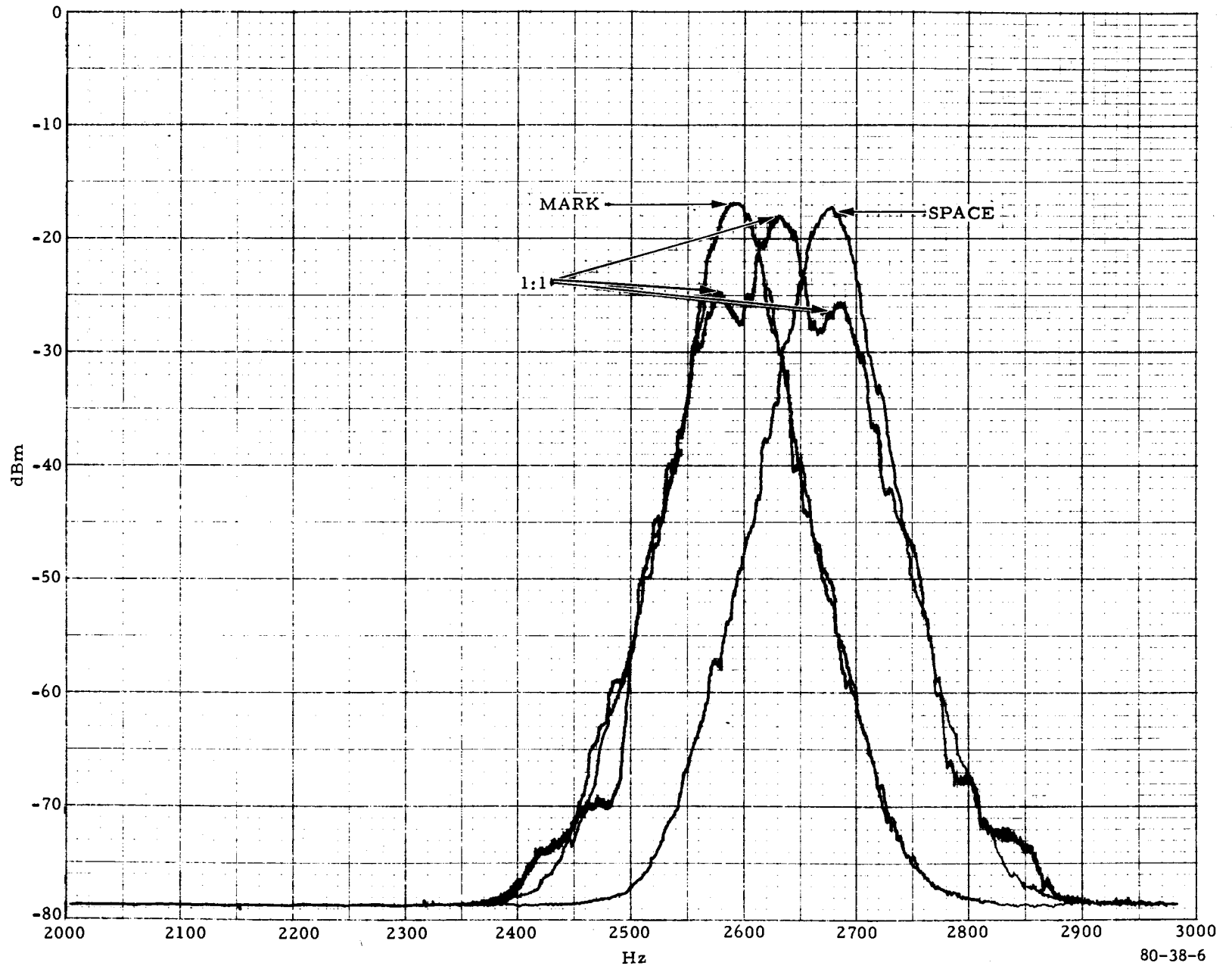

FIGURE 6. SPECTRUM OF 110-BAUD MARK, SPACE, AND 1:1 RMS DATA

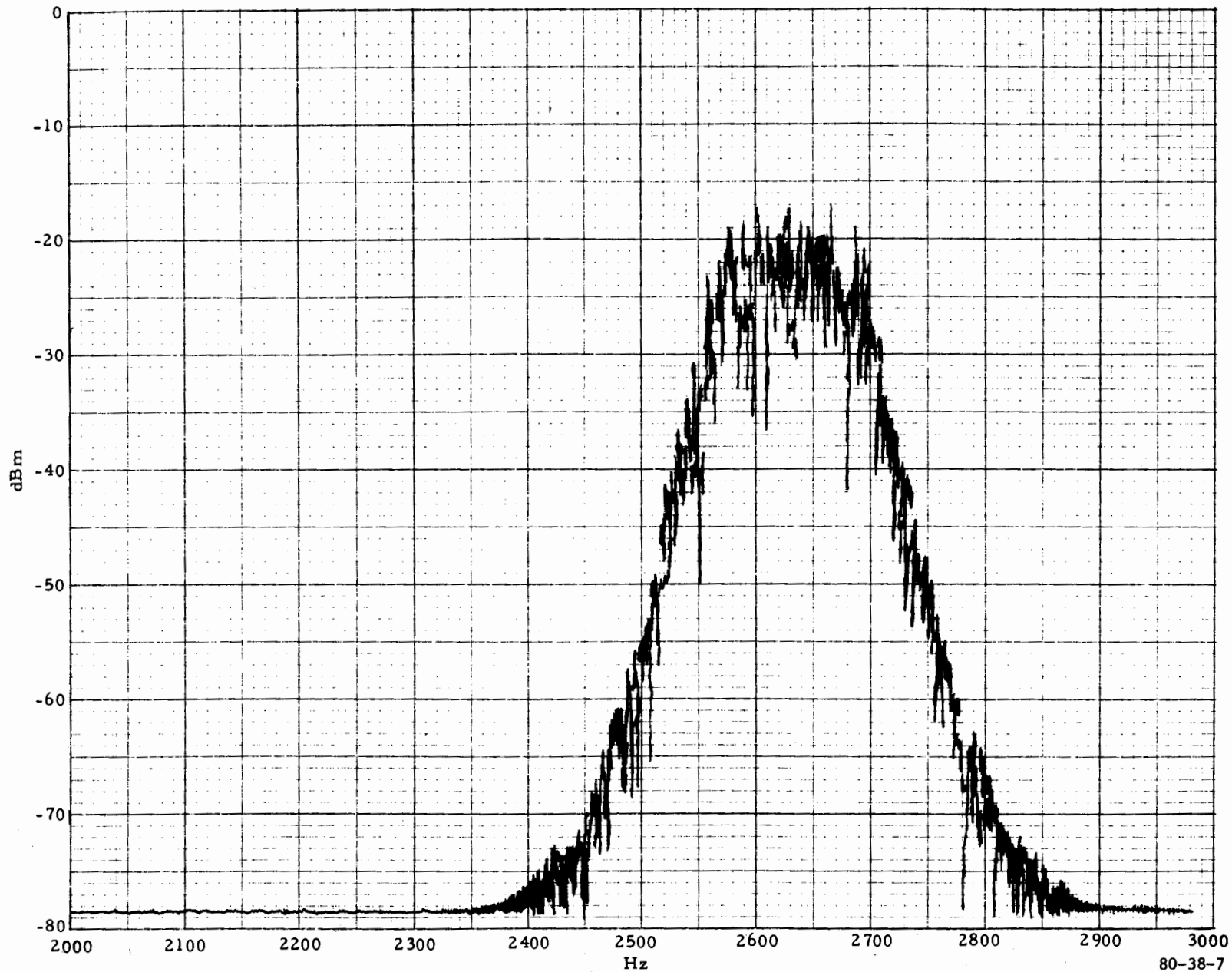

FIGURE 7. SPECTRUM OF 110-BAUD RANDOM RMS DATA

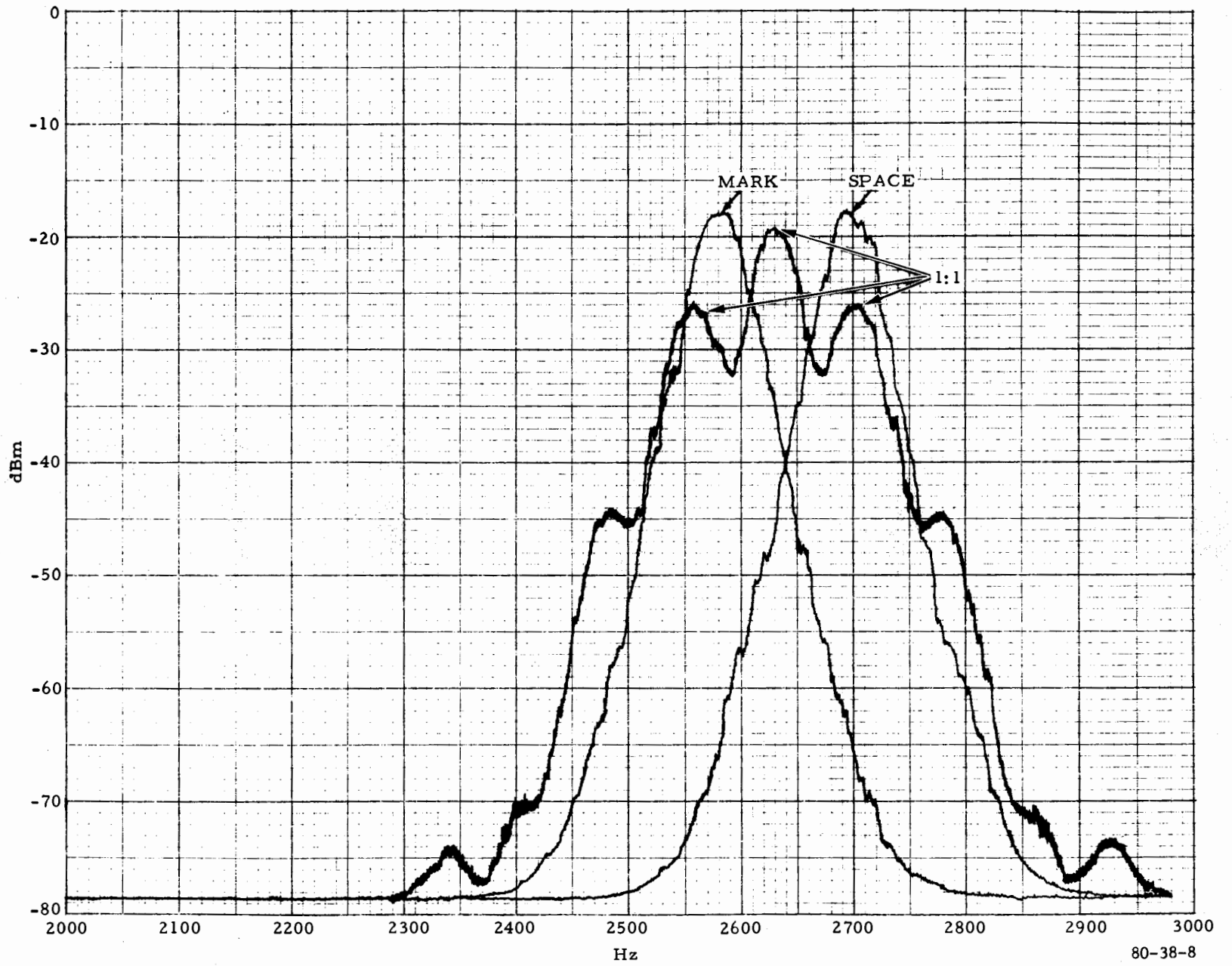

FIGURE 8. SPECTRUM OF 150-BAUD MARK, SPACE, AND 1:1 RMS DATA

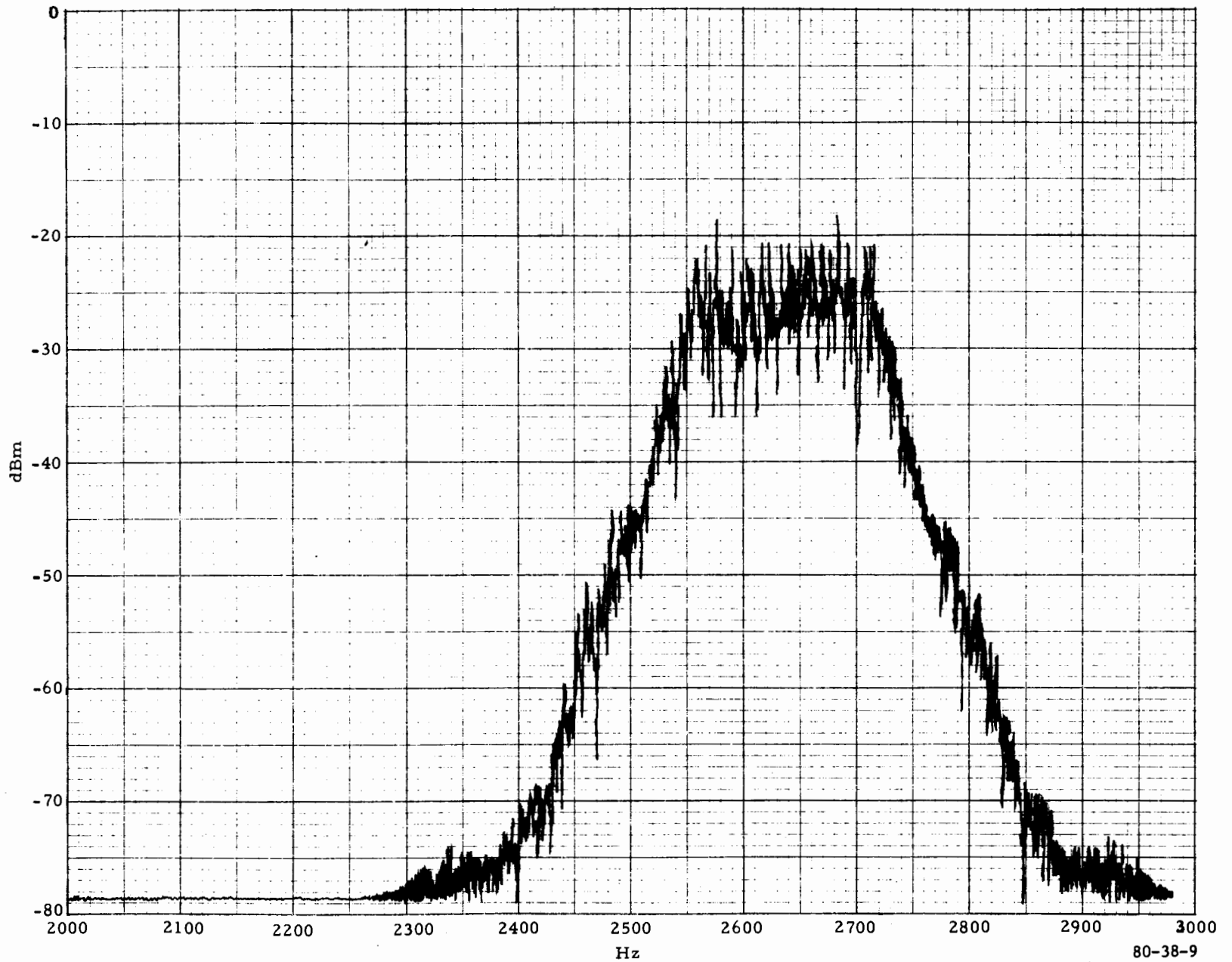

FIGURE 9. SPECTRUM OF 150-BAUD RANDOM RMS DATA

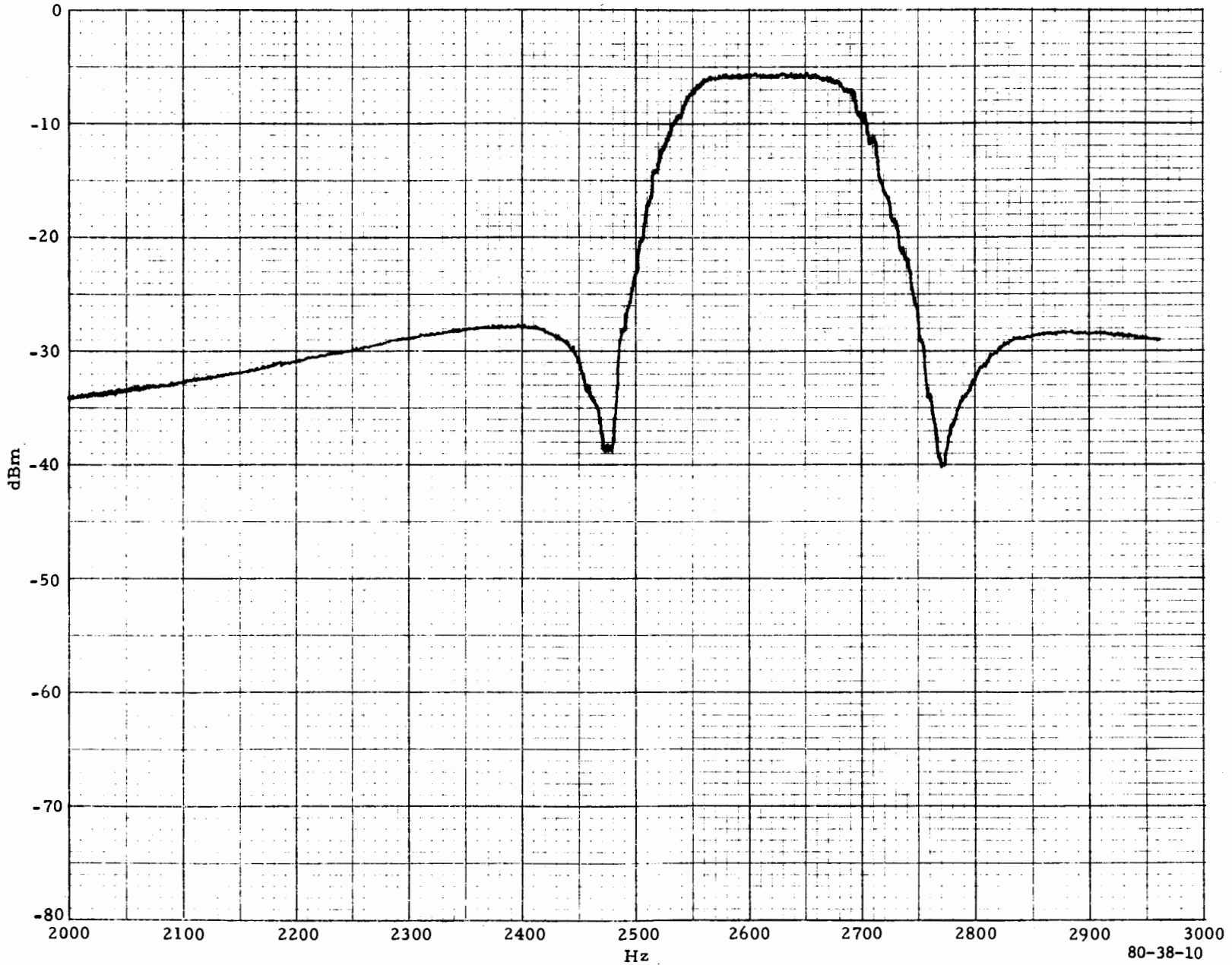

FIGURE 10. RMS MODEM RECEIVE FILTER FREQUENCY RESPONSE (110-BAUD)

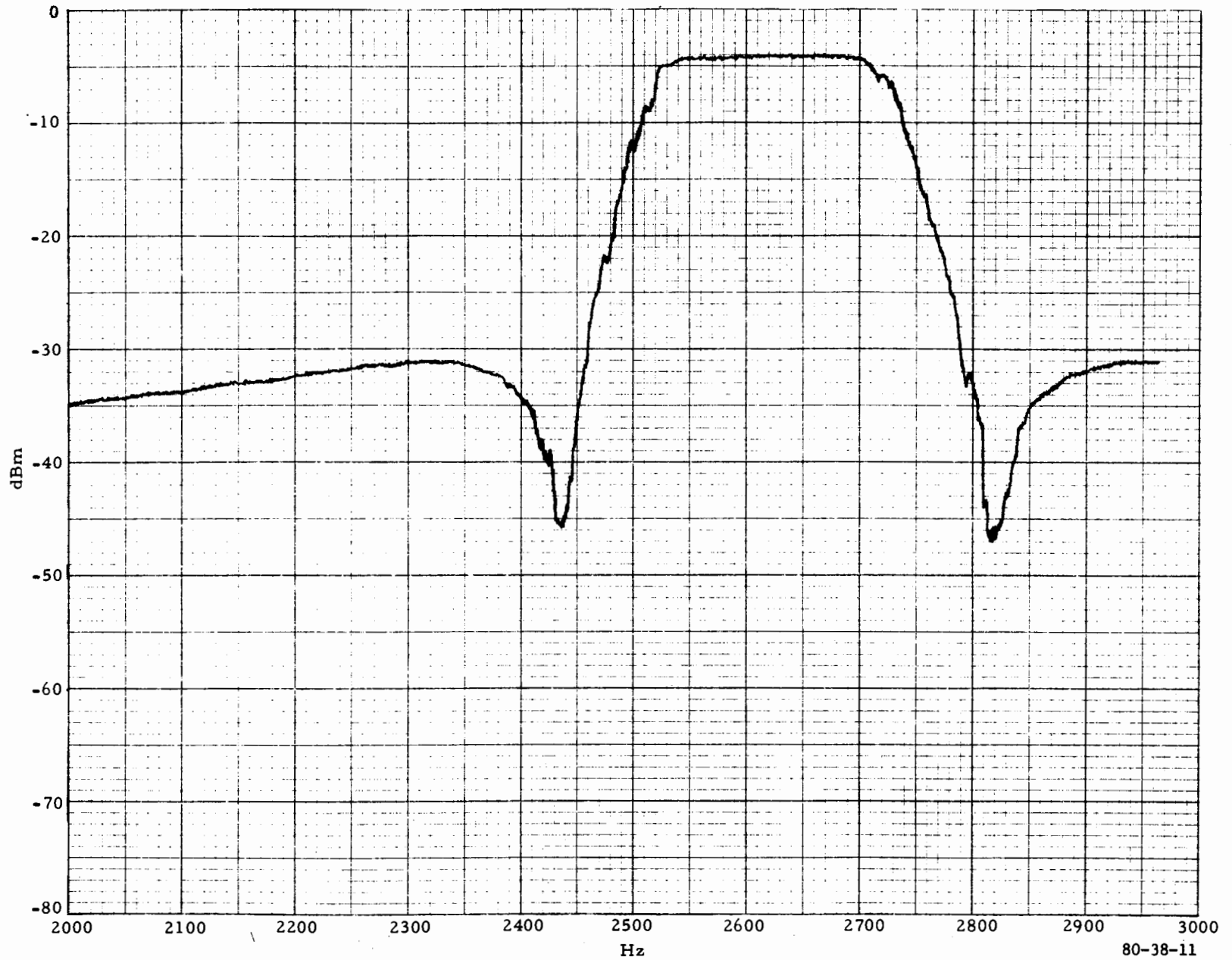

FIGURE 11. RMS MODEM RECEIVE FILTER FREQUENCY RESPONSE (150-BAUD)

935- and the 1955-Hz AM sender modules were not aligned properly; therefore, the senders could not be plugged into the chassis until one side of the PCB was trimmed.

b. Foil paths on the PCB's of several send and receive modules were missing, and the connections were accomplished by wires on the foil side of the board. The added wires were not anchored in any way and were subject to stress when the modules were inserted or removed from the chassis.

c. Two AM receivers, 1275 and 1955 Hz, would not meet the sensitivity requirements set forth in FAA Specification FAA-E-2431, Voice Frequency Signaling System (RCAG). These receivers exhibited a sensitivity threshold of -30 decibels referenced to 1 milliwatt (dBm); the requirement is at least -42 dBm. The problem was corrected by replacing Q6 (2N760) in each receiver with a transistor of higher beta (2N2222).

## 2. Telemodem FA-8735.

a. Two AM receivers, 1275 and 1955 Hz, were inoperative. The problem was corrected by replacing Q6 with a 2N2222 transistor.

## 3. GRM IM-2076.

a. The input/output connectors on the circuit boards of the GRM IM-2076 are formed by the foil paths leading to the edge of the board. FAA Specification FAA-E-2431 (governing the construction of solid-state VFSS/VFCS) requires separate plugs and jacks in this application.

b. Several potentiometers are too sensitive and the exact adjustment difficult to set. One solution was to replace those potentiometers with 10-turn potentiometers of the same value. The sensitive potentiometers are

R-9 (MFS-2880 board), R-5 (LIM-4W board), and R-16 (LIM-4W board).

c. Plugging a carbon microphone into the "orderwire handset" jack or subsequent rapping of the microphone will cause the remote terminal to momentarily lose selected control functions. This problem was greatly alleviated by replacing R-35 (150 ohms, 1/4 watt) with a resistor of higher value (10,000 ohms, 1/4 watt). This resistor was on the LIM-4W board.

## 4. RMS Data Modems.

a. During the testing, a potential problem was noticed in the construction of the RMS data modems. The input and output transformers, which match the modem circuitry to the telephone lines, are physically mounted close to the power transformer. This causes an audible power supply "hum" of sufficient level to affect the crosstalk evaluation to be coupled to the telephone line. The hum had components at 60, 180, and 300 Hz and a total level of -45.3 dBm. The hum was eliminated by using an external direct current (d.c.) supply to power the modem or by moving the line transformers away from the power transformer. It should be noted that for the usual application of these modems this is not a problem. However, because of the stringent crosstalk requirements in this application it is a problem.

## TEST CONFIGURATION.

A simulated ARTCC-RCAG communications channel including VFCS/VFSS equipment, voice communications, and RMS data transfer functions, was constructed using VFCS and VFSS send terminals connected via a telephone line simulator to the receive terminals. The RMS data modems were interfaced to the channel by impedance matching networks at the input and output of the line simulator. RMS data were transmitted over the simulated ARTCC-to-site path at a rate of 110 baud

and over the simulated site-to-ARTCC path at a rate of 150 baud. (In normal RCAG operation, a regulated output amplifier (ROA) is used to compress the audio to the transmitter. The tests described in this document did not include the use of an ROA.)

External filters were installed in the test configuration in accordance with paragraph 3.4.2 of FAA-E-2699a, which calls for external lowpass, bandpass, and highpass filters, or combinations thereof, to be installed at the VFSS-RMS interface to augment existing VFSS filters. These filters were intended to eliminate crosstalk in the voice communications and/or interference to VFCS equipment. The effects of each filter could then be compared to determine which provides greatest reduction of interference. Passive notch and bandpass filters supplied by Genisco Technical, Incorporated, Compton, California, were used. The following filter requirements were derived (reference 5) at the Technical Center and presented to Genisco:

1. Notch.

a. No more than 2 decibels (dB) attenuation from 300 to 2400 Hz.

b. Greater than 30 dB attenuation from 2520 to 2720 Hz.

c. No more than 2 dB attenuation from 2760 to 3000 Hz.

d. Input Impedance — 600 ohms from 300 to 3000 Hz.

e. Output Impedance — 600 ohms from 300 to 3000 Hz.

f. Temperature Range — Industrial (0° to 75° C).

2. Bandpass.

a. Greater than 30 dB attenuation from 300 to 2400 Hz.

b. No more than 3 dB attenuation from 2520 to 2720 Hz.

c. Greater than 30 dB attenuation from 2760 to 3000 Hz.

d. Input Impedance — 600 ohms from 300 to 3000 Hz.

e. Output Impedance — 600 ohms from 300 to 3000 Hz.

f. Temperature Range — Industrial (0° to 75° C).

The physical size of the filters delivered by Genisco was 3 X 7 X 4.7 inches = 98.7 cubic inches. The frequency response curves of the delivered filters are shown in figures 12 and 13.

Figure 14 shows the test setup used in performing the crosstalk evaluation. Test point A is the input to the telephone line simulator. The transmit levels of the modem and tone-signaling equipment are adjusted at this point rather than at the device outputs to compensate for the 9.5 dB loss across the 4-way matching network. Test point B is the output of the phone line simulator. Signals at the output of the phone line are split by the 3-way matching network into two paths. The loss from the input to either output of the 3-way network is 6 dB provided the outputs are terminated in 600 ohms. Test point C is the VFCS receiver audio output while test point D is the VFCS transmitter output. Two other test points are not shown in figure 14; they are the output of the bandpass filter in the RMS data modem receiver and the output of the bandpass filters in the AM and FS receivers. These filters are not preceded by an amplifier in either equipment; their inputs come directly from the telephone interface. For this reason, crosstalk measurements made at these points are not affected by adjustment of the receive gain controls. The 3-way and 4-way matching networks are

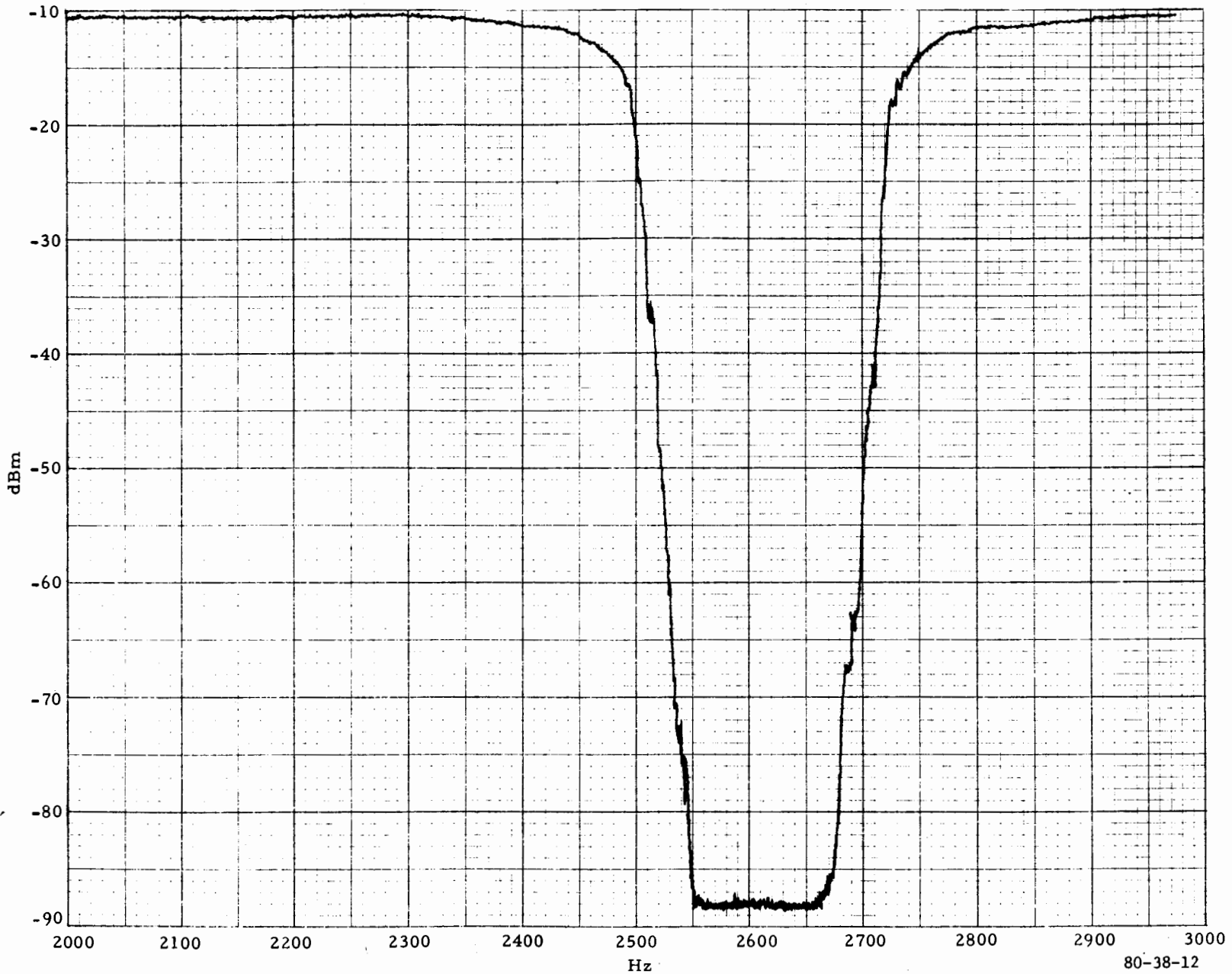

80-38-12

FIGURE 12. NOTCH FILTER FREQUENCY RESPONSE

87

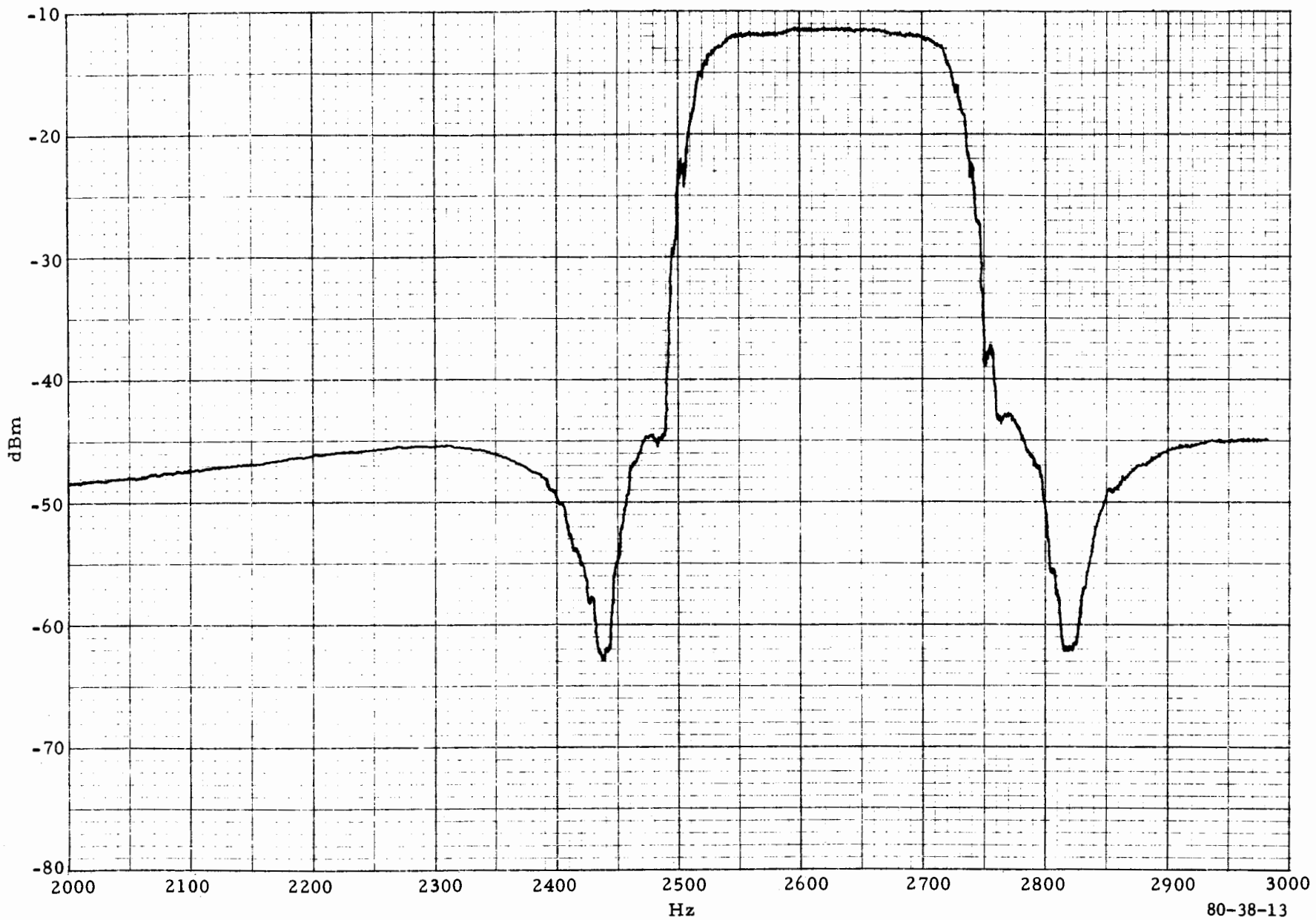

80-38-13

FIGURE 13. BANDPASS FILTER FREQUENCY RESPONSE

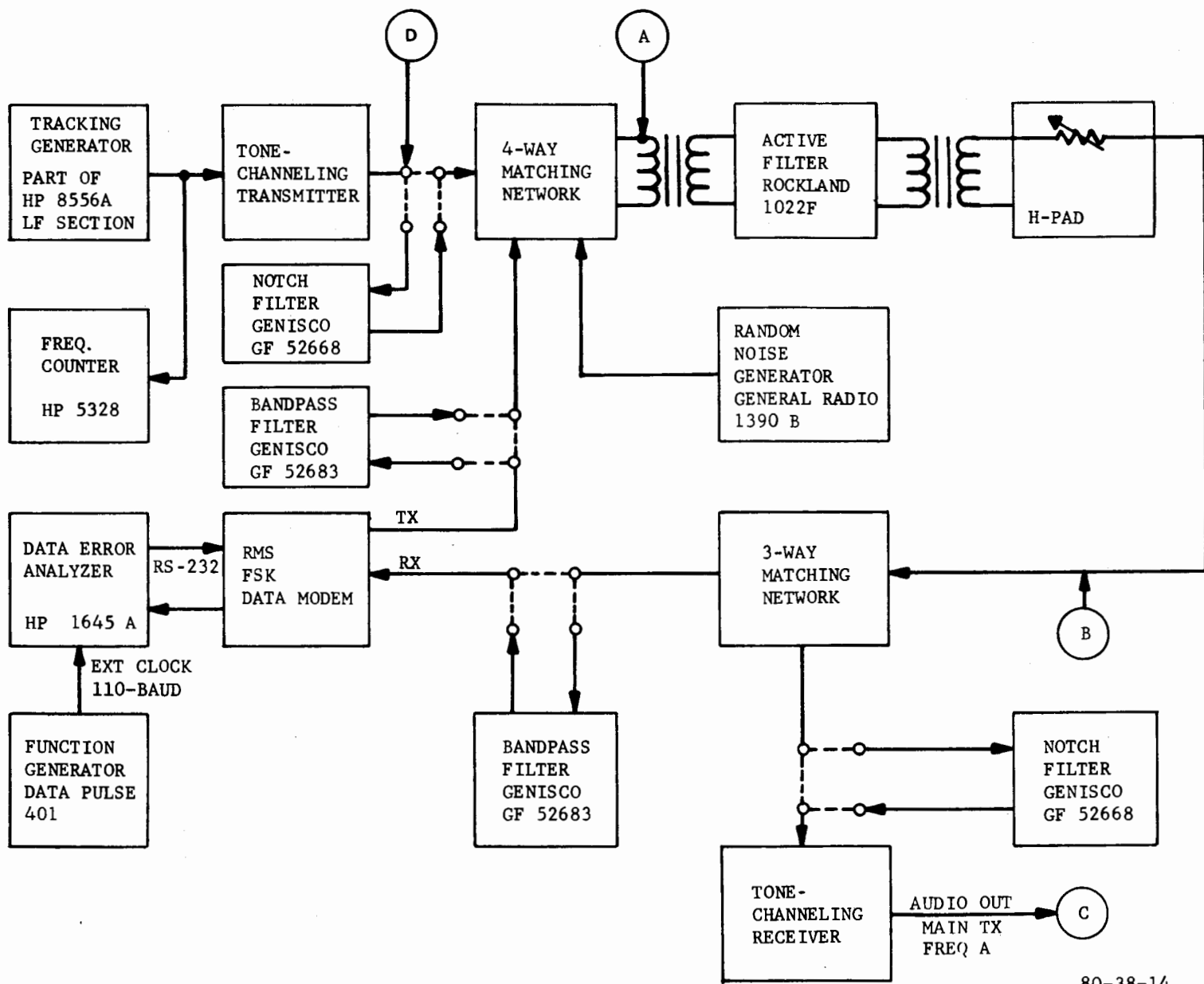

FIGURE 14. TEST SETUP

600-ohm resistive, impedance matching networks and are shown schematically in figure 15.

The Hewlett Packard (HP) 1645 Data Error Analyzer was used to simulate RMS data in four different bit patterns: mark, space, 1:1, and random. Mark or space causes the RMS modem transmitter to continuously output a tone at the mark and space frequencies, respectively. The pattern called 1:1 causes the RMS modem transmitter output to alternate between mark and space. Random mode causes the modem transmitter to output a pseudo-random, mark-space pattern which repeats every 511 bits. For the 110-baud tests, an external clock was injected into the analyzer because it has no internal 110-baud clock. For 150-baud tests, the internal clock was used.

A telephone line simulator was assembled using a two-section active filter to provide rolloff of low and high frequencies and an H-pad to provide loss. The schematic is shown in figure 16. When the simulator was adjusted for 1142a simulation, the simulator controls were adjusted as follows:

1. Low pass = 2250 Hz
2. High pass = 545 Hz and filter gain = 0 dB
3. Response switch set to BW
4. The H-pad was adjusted to provide 9 dB loss at 1000 Hz.

The telephone line simulator frequency response is shown in figure 17. Specified 1142a line characteristics are given in table 1.

When the simulator was adjusted for 2002 simulation, the simulator controls were adjusted as follows:

1. Low pass = 1960 Hz.
2. High pass = 621 Hz and filter gain = 0 dB.

3. Response switch set to BW.

4. The H-pad was adjusted to provide 16 dB loss at 1000 Hz.

Table 2 gives specified characteristics of 2002 lines (reference 6).

The complete summary of test equipment used in these tests is listed below:

1. HP 8556A Spectrum Analyzer low frequency section with HP 141T display section
2. Rockland 1022 Dual Low/High Pass Filter
3. HP-5328A Universal Counter
4. HP-7004A XY Recorder
5. HP-3400A RMS Voltmeter
6. HP-3555B Transmission and Noise Measuring Set
7. Systron Donner 401 Function Generator
8. HP-1645 Data Error Analyzer
9. General Radio Noise Generator
10. Data Precision 245 Digital Voltmeter
11. Impedance Matching Networks

#### TEST PROCEDURE (GENERAL).

The current ARTCC-to-site telephone link is a voice frequency multitone circuit. The two-wire line which forms the ARTCC-to-site path conforms to FAA Specification FAA-S-1142a, while the two-wire line which forms the site-to-ARTCC path is covered by tariff FCC-260 for type 2002 private line circuits. The telephone line simulator can simulate only a two-wire circuit so that only one path could be evaluated at a time. Because the data rates for each path are different and the line

3-WAY COMBINER

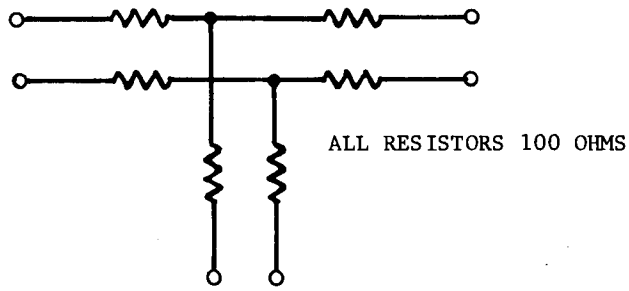

4-WAY COMBINER

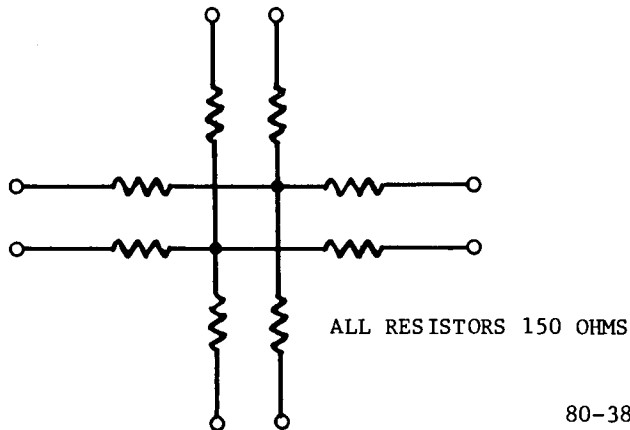

80-38-15

FIGURE 15. RESISTIVE MATCHING NETWORKS SCHEMATIC DIAGRAM

ROCKLAND HI/LO FILTER 1022F

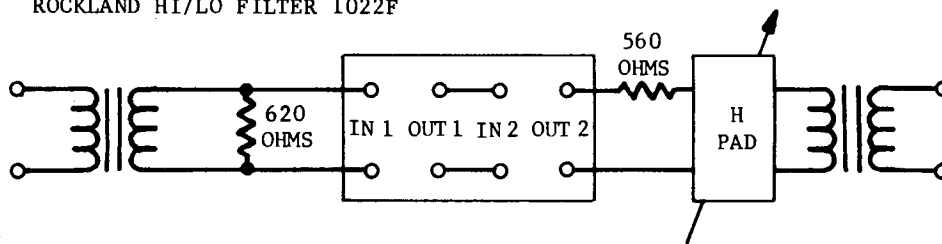

TELEPHONE LINE SIMULATOR

80-38-16

FIGURE 16. TELEPHONE LINE SIMULATOR

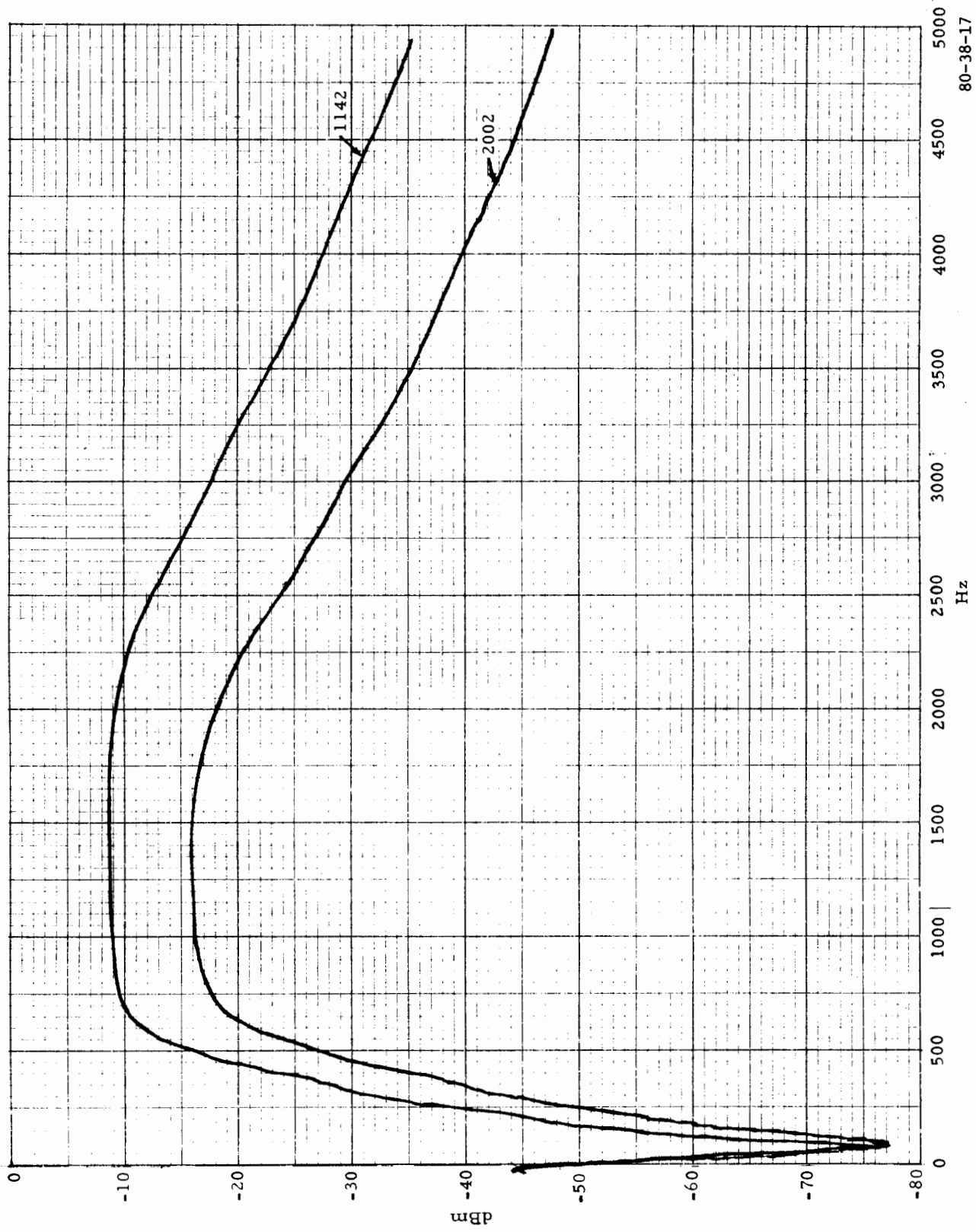

FIGURE 17. TELEPHONE LINE SIMULATOR FREQUENCY RESPONSE

80-38-17

TABLE 1. SPECIFIED 1142a TELEPHONE LINE CHARACTERISTICS

<u>Input (dBm)</u>	<u>Output (nominal) (dBm)</u>	<u>Frequency (Hz)</u>	<u>Loss (dB)</u>
-16	-25	1000	9 (+0, -1)
-16	-31	300	15 (+0, -1)
-16	-28	500	12 (+0, -1)
-16	-30	2500	14 (+0, -1)
-16	-33	2800	17 (+0, -1)
-16	-33	3000	17 (+0, -1)

TABLE 2. SPECIFIED 2002 TELEPHONE LINE CHARACTERISTICS

<u>Input (dBm)</u>	<u>Output (nominal) (dBm)</u>	<u>Frequency (Hz)</u>	<u>Loss (dB)</u>
-16	-32	1000	16 (+3, -1)
-16	-54	300	38 (+0, -3)
-16	-48	500	32 (+0, -2)
-16	-48	2500	32 (+0, -2)
-16	-44	2800	28 (+0, -3)
-16	-44	3000	28 (+0, -3)

simulator is a two-wire device, the crosstalk evaluation was subdivided into several parts:

1. ARTCC-to-Site Path.

a. The line simulator was adjusted for 1142a simulation.

b. The RMS data rate was 110 baud.

c. All VFCS equipment functions were activated.

2. Site-to-ARTCC Path. Normally, only the audio from the site communication receivers is transmitted over this path. Thus, a simulation of this path should include only voice and RMS data. However, this provided an opportunity both to evaluate the performance of a cross section of tone control equipment with the less expensive 2002 lines and to simulate the site-to-ARTCC path by performing this portion of the test as follows:

a. The line simulator was adjusted for 2002 simulation.

b. The RMS data rate was 150 baud.

c. All VFCS equipment functions were activated.

3. Back-to-Back. Back-to-back represents a worst-case condition. It is intended to make more apparent the effects of the external bandpass and notch filters rather than to simulate an existing RCAG configuration.

a. The line simulator was replaced by a jumper.

b. The data rate was 110 baud.

c. All VFCS equipment functions were activated.

Each subdivision described above was further broken down. The crosstalk evaluation was made:

a. With no external filters.

b. With the external notch filter.

c. With the external bandpass filter.

SYSTEM INITIAL CONDITIONS.

The system initial conditions were as follows (figure 14):

1. The AM and FS senders were adjusted for -16 dBm at point A, the input to the telephone line simulator.

2. The AM and FS receiver threshold sensitivities were adjusted for -36 dBm at point B for 1142a line simulation. The threshold was adjusted to -50 dBm for 2002 line simulation.

3. The tracking generator amplitude and frequency were adjusted to provide -8 dBm at 1000 Hz at point A.

4. A frequency counter was connected to the tracking generator output to periodically check the calibration of the spectrum analyzer.

5. The RMS data modem transmitter output was adjusted for -16 dBm at point A.

6. The RMS data modem receiver input sensitivity was adjusted for -36 dBm at point B for 1142a line simulation. The threshold was adjusted to -50 dBm for 2002 line simulation.

TEST CONDUCT.

Performance evaluation of the tone-channeling equipment plus RMS modems was divided into three parts: (1) spectrum analysis, (2) crosstalk measurement, and (3) determination of failure levels. Each will be discussed individually. Data from the first part (spectrum analysis) are contained in a separate data report entitled "Spectrums of Simultaneous Speech, Data and Tone

Control Functions on Federal Aviation Administration (FAA) Telephone Lines," (reference 7). Data from the second and third parts are presented in the appendices which are organized by equipment type:

Appendix A	GRM IM-1307
Appendix B	Telemodem FA-8735
Appendix C	RFL CA-1621
Appendix D	GRM IM-2076
Appendix E	GIC FA-5390

The pages of the appendices are numbered such that the corresponding page number of each appendix contains data from a particular test; e.g., pages A-2 and C-2 contain data for the same test of both the IM-1307 and CA-1621, respectively, thus simplifying comparison of the performance of various VFSS's.

SPECTRUM ANALYSIS. The objective of spectrum analysis was to identify and display all energy present in the band from 300 Hz to 3 kilohertz (kHz) (including steady-state signals, crosstalk, intermodulation products, spurious signals caused by switching, etc.) and to obtain a graphical representation of the characteristics of the VFSS equipment and modems. The description of each spectrum along with the graphs for each VFSS is presented in reference 7.

CROSSTALK MEASUREMENT. The objective of crosstalk measurement was to determine the levels of interference signals observed in spectrum analysis. Test data are tabulated on pages 1 and 2 of the appendices. Crosstalk in the transmitter audio, resulting from only the FS tone sender (RMS data modem off) was measured at point C (figure 14). It was of a sufficiently low level (below -90 dBm) for both FSKU and FSKD that it was not reported on the data sheets. Actual levels of FS crosstalk may be observed on spectrum plot number 11 of each equipment in reference 7.

RMS Modem Crosstalk in VFSS/VFCS Equipment. The level of interference to

the VFSS/VFCS equipment caused by the RMS data was measured in the form of crosstalk in the audio output (audio lowpass filter, point C) and crosstalk at the output of the tone receive filters (FS bandpass filter, figure 4) under the following system conditions:

1. Tracking generator off.
  2. Noise generator output level set for less than -90 dBm (0 decibels reference noise with no weighting (0 dB<sub>rn</sub>)) (reference 8). This setting of the noise generator allows it to remain in the test setup maintaining system impedance without introducing enough noise to affect the measurements.
  3. Crosstalk measurements were made with both 110- and 150-baud RMS data modems.
  4. The test configuration shown in figure 14 was used.
  5. Initial line simulation was per 1142a telephone line characteristics.
  6. Equipment levels were set as described in System Initial Conditions.
- Crosstalk in transmitter audio resulting from the RMS data modem was measured while the modem was operated in each of the following four modes: mark, space, 1:1, and random.

The measurements were made three times:

1. With no external filters.
2. With an external notch filter installed at the input of the tone channeling receiver (The bandpass filter was not used.), and
3. With the external bandpass filter installed at the modem transmitter output (The notch filter was not used.).

Each measurement was made with FSKU and FSKD; the difference in values was not

more than 1 dB. The data reported on pages 1 and 2 of the appendices were collected with FSKD because in normal RCAG operation the FS sender is down-shifted while push-to-talk (PTT) is keyed.

The RMS data modem was then turned off and the tracking generator turned on. The level at point C became the normal transmitter audio receive level. This value was used as the reference level when evaluating relative RMS data interference levels.

Crosstalk at the output of the AM and FS tone receive bandpass filters resulting from the RMS data was measured using the test conditions and procedures described previously, with two exceptions: (1) the FS sender output is adjusted to a minimum while crosstalk measurements are made on the FS receiver, and (2) the tracking generator remains off. There was no observable crosstalk resulting from the RMS data modem or from intermodulation products of FSK tone and RMS data measured at the outputs of the AM receive bandpass filters. For this reason, only the crosstalk at the FS receiver output was recorded on the data sheets. The RMS data modem was then turned off and the FS sender output readjusted for -16 dBm at point A. The level at the FS bandpass filter output became the normal FSK tone receive level. This value was used when investigating the possibility that the RMS data crosstalk would affect system operation.

#### VFSS Crosstalk in RMS Modem Equipment.

The tone-channeling interference in the RMS data modems (appendices, page 2) was measured in the form of crosstalk at the output of the receive bandpass filter in the RMS modem (denoted TP-2 in figure 5), under several system conditions:

1. Tracking generator on, sweeping 0 to 3000 Hz.

2. Noise generator output level set for less than -90 dBm (0 dBrn).

3. Crosstalk measurements were made with both 110- and 150-baud RMS data.

4. The test configuration shown in figure 14 was used.

Crosstalk at TP-2, caused by transmitter audio was measured with the modem transmitter turned off and the FS sender output adjusted to minimum. The crosstalk was measured by monitoring the level at TP-2 while allowing the tracking generator to sweep from 0 to 3000 Hz. The maximum crosstalk level and frequency of occurrence were recorded on the data sheets. This test represents a worst-case condition because normal voice audio will have the energy distribution shown in figure 18 (reference 9). While the average crosstalk energy in the real world due to normal voice will be 12 to 15 dB lower than the values obtained in this test (at frequencies of interest), the peak energy may be 12 dB higher than the average (reference 10). Hence, the levels used in the swept frequency test approximate peak values to guarantee the performance of the RMS modem under worst-case conditions.

Crosstalk caused by the FS and AM senders was measured at TP-2 (figure 5). The FS sender output was readjusted for -16 dBm (point A, figure 14), and the FS sender was switched to provide FSKU and FSKD. The audio and FS tests were run three times:

1. With no external filters,

2. With the bandpass filter in series with the modem receiver line, and

3. With the notch filter in series with the tone-channeling transmit line (figure 14).

The RMS modem transmitter was turned on and the normal receive level of the RMS

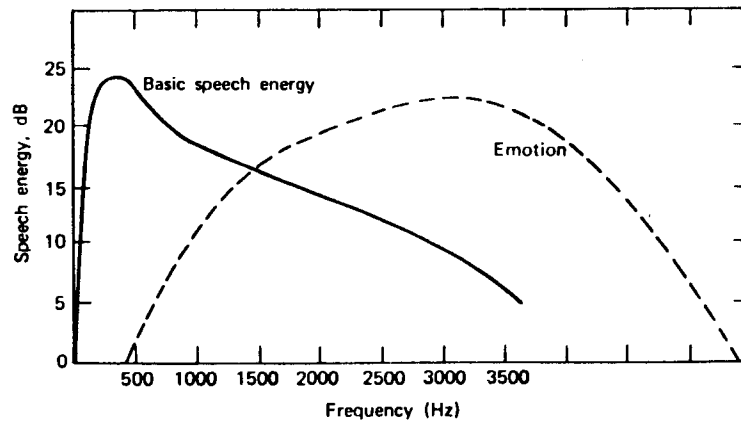

FIGURE 18. ENERGY AND EMOTION DISTRIBUTION IN SPEECH

data was measured at TP-2 with and without the external bandpass filter. The receive level was measured for each of the four bit patterns. Because the notch filter is not in series with the RMS modem, the receive level with the notch filter is the same as the no-filter case and, thus, is not reported on page 2 of the appendices. As before, the comparison of the normal receive level of the signal with the crosstalk level may be used in predicting problems in modem operation.

DETERMINATION OF FAILURE LEVELS. The objective was to determine what RMS data modem transmit level would cause interference to the operation of the VFSS and, conversely, what levels of VFSS crosstalk would interfere with RMS modem operation. This information was necessary to verify the requirements in FAA-E-2699a.

VFSS operational failure is considered to be the point at which the interfering tone causes false transmitter keying with FSKU. Failure with FSKD is considered to be interruption of transmitter keying.

RMS modem operational failure is considered to be a transmission error rate of greater than one error in  $10^5$  bits.

Test results are given on page 3 of the appendices. During these tests, the random noise generator (20-kHz bandwidth) was adjusted to provide a range of -60 to -45 dBm (30 to 45 dBm) at the telephone line simulator output; 45 dBm represents a worst-case signal-to-noise ratio of 10 dB when referenced to receive FS tone levels.

Failure tests of the FS receivers were determined by replacing the modem transmitter output with the tracking generator output at the matching network (figure 14); the tracking generator was adjusted to sweep from 2000 to 3000 Hz at 100 Hz per second. The output amplitude of the tracking generator was increased after each sweep until the operation of tone-channeling equipment was affected. Test conditions were:

1. 1142a telephone characteristics line simulation.

## RESULTS

2. FS transmitter level -16 dBm, point A (figure 14).
3. FS receiver sensitivity -36 dBm (measured at point B).
4. FS receiver gain and bias controls adjusted per FAA Order 6650.4A (reference 11).

This test was performed twice: once as described above, and again with the FS sender output adjusted for a minimum, which would simulate a failure of the FS sender. This would determine the crosstalk level which would cause false station transmitter keying if an FS sender did fail. The highest crosstalk levels before operational failure in both tests were recorded on page 3 of each appendix and are compared with crosstalk levels from the RMS data modem in the Results section.

Failure levels of the RMS data modems were determined by replacing the tone-channeling transmitter output with the tracking generator output at the four-way combiner, reinstalling the RMS modem transmitter at the four-way combiner, and following the procedure described for determining failure levels of the FS receivers. The test conditions were:

1. 1142a telephone characteristics line simulation.
2. Modem transmitter level = -16 dBm, point A.
3. Modem receiver sensitivity (measured at point B) = -36 dBm.
4. The data bit pattern was chosen to be random because this mode was the most susceptible to errors.
5. This test was performed with a noise level of -40 dBm (50 dBrn) measured at point B.

The failure level data for the RMS modems are recorded in Results.

The alignment of the VFSS was a critical factor in the overall performance of the tone control equipment when the RMS modems were added. The sensitivity and noise immunity of the FS receiver are a function of both the receiver gain and bias adjustments. Many combinations of the adjustments enabled the FS receiver to work properly with or without the presence of RMS data. However, when the FS sender output was turned off (simulating an FS sender failure) and the receiver gain and bias adjustments were in a certain range, the crosstalk from the RMS data modem caused sporadic RCAG transmitter keying. To determine if such a situation could exist in properly adjusted VFSS equipment, the gain and bias controls on each FS receiver were adjusted per FAA Order 6650.4A, "Maintenance of Voice/Frequency Signaling System Equipment." The results discussed in the following paragraphs are based on data collected with the VFSS aligned accordingly.

The receiver sensitivity of the RMS data modems used was adequate for operation with a 1142a line, but may not be adequate for 2002 lines. The loss in 2002 lines at 2700 Hz is approximately 26 dB, resulting in an RMS data receive level of -42 dBm at the line simulator output. The 6 dB loss caused by the three-way combiner pad lowers the data level to -48 dBm at the modem receiver input. The manufacturer's specification of the modem receiver sensitivity is -50 dBm. To raise the received signal level, the three-way combiner pad should be replaced with a matching transformer.

### FAILURE LEVELS IN MODEM EQUIPMENT.

The 150-baud RMS data modem used in these tests will operate with a transmission error rate of less than one error in  $10^5$  bits, provided that the level of crosstalk is 6.1 dB below the

level of the RMS data as measured at TP-2 (error threshold = 6.1 dB).

The error threshold of the 110-baud RMS modem used in these tests was 11.1 dB for crosstalk energy in the range 2500 to 2600 Hz. Outside this range, the minimum ratio is 0.6 dB.

#### VFSS CROSSTALK IN RMS MODEM EQUIPMENT.

Of the VFSS's tested, none would cause errors in RMS modem operation resulting from the control portion (AM or FS) of the VFSS. This may be verified by observing graphs 6 through 10 for the equipment of interest shown in reference 7. These spectra show that the level of crosstalk in the modem channel may be measured with the steady-state FSKU or FSKD. Switching noise, intermodulation products, and other spurious energy were demonstrated to be at least 40 dB below the receive level of the RMS data and are negligible (See Failure Levels in Modem Equipment.). (Refer to page 2 of the appendices of the VFSS of interest; for example, for the GRM IM-1307 (appendix A).) For 1142a lines and 110-baud transmission (no external filters) the crosstalk is FSKU = -71.7 dBm, FSKD = -63.8 dBm, and the modem receive level of random RMS data = -39 dBm. This gives a signal-to-crosstalk ratio of 32.7 dB (FSKU) and a ratio of 24.8 dB (FSKD), yielding a worst-case safety margin of 24.8 dB - 11.1 dB = 13.7 dB (The error threshold for the 110-baud modem is 11.1 dB.). Thus, the modem operation will be solid considering only crosstalk from the control portion of the VFSS. A similar analysis may be performed for each VFSS from the data presented in the appendices using the methods in this section.

Crosstalk from the audio portion of several VFSS's can cause errors in the RMS data modems. If the response of the audio lowpass filters of the CA-1621 is compared with the filters of the FA-8735 (graphs 1 through 4 for these equipment

as shown in reference 7), the graphs show that the FA-8735 filter attenuates audio signals in the RMS modem frequency range, but the CA-1621 does not. Pages 2 in appendices B and C show this. As an example, the data for 1142a lines and no filters can be compared:

#### CA-1621

	<u>Audio Crosstalk</u>	<u>Modem Receive Level (Random)</u>
110 baud	-41.2 dBm	-42.0 dBm
150 baud	-40.6 dBm	-41.2 dBm

#### FA-8735

	<u>Audio Crosstalk</u>	<u>Modem Receive Level (Random)</u>
110 baud	-53.7 dBm	-39.5 dBm
150 baud	-51.3 dBm	-38.8 dBm

Thus produced are signal-to-crosstalk ratios (S/C) of:

CA-1621 (110 baud)	S/C = -0.8 dB
(150 baud)	S/C = -0.6 dB
FA-8735 (110 baud)	S/C = 14.2 dB
(150 baud)	S/C = 12.5 dB

The minimum S/C ratios at which the RMS modems operated with the desired error rate were:

150 baud — 6.1 dB  
110 baud — 11.1 dB

Thus, the audio crosstalk from the CA-1621 equipment is too high to guarantee modem operation with less than one error in  $10^5$  bits of transmission.

To confirm the conclusion that a 1 in  $10^5$  RMS data error rate cannot be guaranteed with the CA-1621, the tracking generator was replaced by a tape recorder as the audio source. The tape contained voice audio from a human male reading a magazine article. The average audio level was

adjusted for -16 dBm (averaged over a 3-second interval) at point A. The 110-baud modem had 56 errors in  $10^5$  bits; the performance of the 150-baud modem was similar.

The installation of the external notch filter at the tone-channeling transmitter (point D, figure 14) reduced the crosstalk from the CA-1621 by 19.1 dB (110 baud) and 15.7 dB (150 baud). The reduced crosstalk was measured using the swept tone. The safety margin (worst-case) became 7.2 dB for the 110-baud modem and 9 dB for the 150-baud modem, thus guaranteeing an error rate of less than one in  $10^5$  bits. (This guarantee only considers audio crosstalk interference, not telephone line noise hits or other sources of interference.) When the voice audio test (described previously) was repeated with the notch filter in place, neither the 110- nor the 150-baud RMS modem had any errors in  $10^5$  bits.

#### RMS MODEM CROSSTALK IN VFSS/VFCS EQUIPMENT.

No VFSS's tested showed susceptibility to RMS modem crosstalk. (Refer to page 3, "Failure Levels," of the appendices for the equipment of interest.) For example, the GRM IM-2076 (appendix D) is a combination VFSS/VFCS which does not use the FS/AM operation, described earlier in this report, to provide control functions. Instead, it uses an FSK data modem identical in operation to the 150-baud RMS data modem except that the center frequency is at 2880 Hz. Control functions at the ARTCC terminal are encoded into digital words which are transmitted at 150 baud to the site terminal where the digital word is decoded to provide the selected control functions. This equipment will work with a minimum signal-to-crosstalk ratio of 18 dB measured at the output of the 2880-Hz bandpass filter (page D-3).

The crosstalk from the 150-baud RMS modem using 2002 line simulation was

-62 dBm (RMS data = space (from page D-1)); no external filters were used. The receive level of the 2880-Hz FSK was -23.5 dBm, which resulted in a ratio of 38.5 dB and a safety margin of 38.5 dB - 18 dB = 20.5 dB. As another example, the 110-baud modem crosstalk with 1142a line simulation and no filters may be considered. In the worst-case (RMS data = space), the ratio is 44 dB, and the safety margin is 44 dB - 18 dB = 26 dB.

The effect of crosstalk in the audio portion of the band is a much more difficult problem to analyze because its effects are completely subjective; what one person may consider annoying, another may not even hear. Thus, it is difficult to establish a failure level for the crosstalk. For purposes of this report, such a failure level was evaluated (in dB) under the following conditions:

1. The reference signal was a 1-kHz tone adjusted for -8 dBm at point A.
2. The output of the random noise generator was adjusted for a minimum (since noise tends to mask crosstalk).
3. The VFSS terminals were connected back to back.
4. The VFSS used was GRM IM-1307.

The RMS modem output was attenuated until the crosstalk was inaudible when compared to a comfortable listening level of the 1-kHz tone; this is considered to be a worst-case failure level. The signal-to-crosstalk ratio was found to be 65 dB; that is, the level of the crosstalk must be 65 dB below the 1-kHz receive level when measured at test point C.

Continuing with the analysis of the IM-2076 data, the 1-kHz signal level was adjusted to be -10 dBm at the station transmitter audio input (point C), and the level of the crosstalk was (with no

external filter) -54 dBm, which gave a ratio of 44 dB. This was unacceptable based on the above result. When the external notch filter is installed at the tone-channeling receiver input, the crosstalk from the 110-baud modem drops into the system noise and is inaudible. The notch filter was not able to eliminate the crosstalk produced by the 150-baud modem. However, the crosstalk from 1:1 150-baud RMS data was reduced from -54 dBm to -61 dBm by the notch filter. To be inaudible, the crosstalk should have been below -75 dBm. Suggested notch filter specifications for 150 baud are given in the Recommendations section. A visual representation of this example is given on pages D-12 through D-23 of reference 7.

### CONCLUSIONS

1. The requirement in Federal Aviation Administration (FAA) specification FAA-E-2699a concerning the crosstalk level measured at the voice frequency signalling system (VFSS) and voice frequency control system (VFCS) equipment lowpass filter output is not adequate; but, the requirement for the crosstalk measured at the audio mode (AM) and frequency shift (FS) bandpass filters is adequate to prevent disturbance to normal remote communications air-ground (RCAG) facility operation.
2. The requirements in FAA-E-2699a cannot be met without using external filters. By adding external notch filters, the existing requirements and those recommended in this report can be met.
3. With the Remote Monitoring System (RMS) modems used in these tests, external bandpass filters were not necessary. Therefore, the only external filters necessary for the reduction of crosstalk and interference in the VFSS and RMS modems are notch filters.

4. The different VFSS equipment even though built to the same specification have different filter characteristics.

5. All of the VFSS's tested worked with the simulated 2002-class telephone line.

6. RMS data can be transmitted at either 110 or 150 baud over the existing air route traffic control centers (ARTCC's)-to-site telephone lines without affecting air traffic control (ATC) operation, provided that proper filtering is used.

7. RMS data error rates of less than one error in  $10^5$  bits of transmitted data can be attained, provided proper filtering is used. This transmission error rate concerns only crosstalk interference and noise levels of up to +45 dBm, and not the impulse noise commonly observed on telephone lines.

8. For 2002 lines, impedance matching at the telephone interfaces should be provided by transformers instead of resistive networks; for 1142a lines, a resistive network will suffice.

9. The RMS data modems described in this report are not suitable for this application unless modified because the high level of power supply "hum" at the modem receive terminals is audible in the station transmitter audio.

10. Erratic VFSS operation may result from the addition of RMS data to existing telephone company lines unless the VFSS is aligned in accordance with FAA Order 6650.4A.

### RECOMMENDATIONS

1. Notch filters should be installed at the tone-channeling send terminal output and receive terminal input. These filters should have characteristics of:

a. 150 Baud.

(1) Less than 2 decibel (dB) attenuation from 300 to 2400 hertz (Hz).

(2) Greater than 45 dB attenuation from 2520 to 2680 Hz.

(3) Less than 3 dB attenuation from 2760 to 3000 Hz.

(4) Temperature Range — Industrial (0° to 75° C).

(5) 600-ohm input and output impedance from 300 to 3000 Hz.

b. 110 Baud.

(1) Less than 2 dB attenuation from 300 to 2400 Hz.

(2) Greater than 30 dB attenuation from 2520 to 2720 Hz.

(3) Less than 2 dB attenuation from 2760 to 3000 Hz.

(4) Temperature Range — Industrial (0° to 75° C).

(5) 600-ohm input and output impedance from 300 to 3000 Hz.

2. Remote Monitoring System (RMS) data rates of 150 baud should be used for both the site-to-Air Route Traffic Control Center (ARTCC) path and the ARTCC-to-site path.

3. Paragraph 3.13.2.4 in FAA-E-2699a should be modified to indicate that the level of pilot tones and RMS data (crosstalk) should be at least 65 dB below the level of a 1-kHz test tone (injected into the Voice Frequency Signalling System (VFSS)/Voice Frequency Control and Signalling (VFCS) terminal at the opposite end of the telephone company line) when measured at the audio lowpass filter output. The level of the injected tone is -16 decibels referenced to 1 milliwatt (dBm) measured

at the opposite-end telephone company interface.

4. If the same type of RMS data modems described in this report is used, it should be modified before use for this application.

5. External bandpass filters for the modem channel are not recommended.

6. Remote communications air-ground (RCAG) site VFSS equipment should be realigned in accordance with FAA Order 6650.4A as part of the installation procedure of the remote monitoring system.

#### REFERENCES

1. RCAG Remote Monitoring Subsystem, FAA Specification FAA-E-2699a, July 12, 1979.

2. Voice Frequency Signalling System (RCAG), FAA Specification FAA-E-2431, June 23, 1970.

3. Kohonen, Teuvo, Digital Circuits and Devices, Prentice Hall, 1972.

4. Carlson, B. A., Communications Systems - An Introduction to Signals and Noise in Electrical Communication, McGraw Hill, 1975.

5. Special Functions Databook, National Semiconductor, 1979.

6. Bell System Transmission Engineering Technical Reference, Private Line Interconnection - Voice Applications, Bell System Publication, No. 43201, July 1970.

7. Rehmann, A., Spectrums of Simultaneous Speech, Data, and Tone Control Functions on Federal Aviation Administration (FAA) Telephone Lines, FAA-CT-81-32, to be published fall 1981.

8. Oliver, W., White Noise Loading of Multi-Channel Communications Systems, Marconi Instruments, September 1964.

9. Freeman, R. L., Telecommunications Transmission Handbook, John Wiley and Sons, 1975.

10. ITT Electronics Engineers Handbook, McGraw Hill, 1975 edition.

11. Maintenance of Voice Frequency Signalling System (VFSS) Equipment, FAA Order 6650.4A, September 27, 1978.

## GLOSSARY OF TERMS

1. AM - Audio mode
2. ARTCC - Air route traffic control center
3. ATC - Air traffic control
4. dB - Decibels, reference unspecified
5. dBm - Decibels referenced to 1 milliwatt
6. dBm - Decibels referenced to a -90 dBm level of a 1000-Hz tone
7. d.c. - Direct current
8. FAA - Federal Aviation Administration
9. FCC - Federal Communication Commission
10. FS - Frequency shift
11. FSK - Frequency shift keying
12. FSKD - Frequency shift keyer, down
13. FSKU - Frequency shift keyer, up
14. GIC - General Instrument Corporation
15. Hz - Hertz (denotes frequency)
16. kHz - Kiloherztz
17. PCB - Printed circuit board
18. PTT - Push-to-talk
19. RCAG - Remote Communications Air-Ground
20. RFL - Radio Frequency Laboratories
21. RMS - Remote Monitoring System
22. ROA - Regulated output amplifier
23. S/C - Signal-to-crosstalk ratio
24. VFCS - Voice Frequency Control System
25. VFSS - Voice Frequency Signalling System

APPENDIX A  
TEST RESULTS, IM-1307

TABLE A-1. MODEM INTERFERENCE IN TONE-CHANNELING EQUIPMENT, IM-1307

I-A

		150-BAUD DATA RATE dBm LEVEL MEASURED AT						110-BAUD DATA RATE dBm LEVEL MEASURED AT					
		FS Band- Pass Filter	Audio* Low- Pass Filter	FS Band- Pass Filter	Audio* Low- Pass Filter	FS Band- Pass Filter	Audio* Low- Pass Filter	FS Band- Pass Filter	Audio* Low- Pass Filter	FS Band- Pass Filter	Audio* Low- Pass Filter	FS Band- Pass Filter	Audio* Low- Pass Filter
		1142 Simulated Line		2002 Simulated Line		Back To Back		1142 Simulated Line		2002 Simulated Line		Back To Back	
Crosstalk without filter	Mark	<-90	-62.5	<-90	-71.5	-87.9	-48.5	<-90	-62.5	<-90	-73	-88	-50
	Space	-73	-81	-90.4	-84	-62.6	-69.5	-90.4	-78	<-90	-82	-75	-66.5
	1:1	-70.7	-67.5	-84.4	-75.7	-55.3	-53.5	-86	-67.5	<-90	-77	-69.6	-55
	Random	-71.4	-66	-86.0	-73	-57.3	-51	-87.9	-65	<-90	-73	-72.4	-52
Crosstalk with external notch filter	Mark	<-90	-83.5	<-90	-84	<-90	-78	<-90	-83	<-90	-82.5	<-90	-78.5
	Space	<-90	-83.5	<-90	-84	<-90	-78	<-90	-83	<-90	-82.5	<-90	-81
	1:1	-73.1	-78	-87.9	-83	-57.6	-66.5	-90.4	-83	<-90	-82.5	-77.7	-79
	Random	-77.0	-81	-90.4	-84	-60.9	-70	-93.9	-83	<-90	-82.5	-79.1	-79
Crosstalk with external bandpass filter	Mark	<-90	-61.5	<-90	-72	-90.4	-48	<-90	-63	<-90	-73	-87.9	-50
	Space	-77.7	-79	-93.9	-84	-63	-70	-90.4	-78.5	<-90	-82	-75.4	-67
	1:1	-79.1	-67.5	-93.9	-77	-64.3	-53.5	-90.4	-68	<-90	-77	-76.5	-55
	Random	-80	-66	-93.9	-75	-65	-51	-93.9	-66	<-90	-74	-77.7	-53
FS Rx level without filter	FSK Up	-45.2		-57.7		-29.8		-45.7		-57.3		-29.7	
	FSK Down	-48.8		-61.8		-33.8		-48.3		-50.2		-32.7	
FS Rx level with ext. notch filter	FSK Up	-46.2		-58.3		-30.2		-46.3		-57.9		-30.2	
	FSK Down	54.1		-66.9		-38.4		-53.0		-65.1		-37.4	
Audio Rx w/o filter**			-28		-43		-20		-26.5		-42		-19.5
Audio Rx w/notch filter**			-28		-43		-20		-26.5		-42		-19.5
System Noise***		<-90	-81	<-90	-84	<-90	-80	<-90	-83	<-90	-82.5	<-90	-84

\*\*"Audio lowpass filter" is referred to as point C.  
 \*\*\*"Audio receive" level measured at point C.  
 \*\*\*\*"System noise" under audio lowpass filter column includes FS sender crosstalk.

TABLE A-2. TONE-CHANNELING INTERFERENCE IN MODEM EQUIPMENT, IM-1307

		150-BAUD DATA RATE dBm LEVEL MEASURED AT TP2			110-BAUD DATA RATE dBm LEVEL MEASURED AT TP2		
		1142 Simulated Line	2002 Simulated Line	Back To Back	1142 Simulated Line	2002 Simulated Line	Back To Back
Crosstalk without filter	FSK Up	<-77.8	<-77.8	-71.7	-71.7	<-77.8	-54.3
	FSK Down	-47.6	-59.7	-32	-63.8	-71.7	-46.9
	Audio	-57*	-71.7	-41.4	-53.7***	-71.7	-41.9
Crosstalk with external notch filter	FSK Up	<-77.8	<-77.8	-71.8	-71.7	<-77.8	-53.7
	FSK Down	-51.7	-63.8	-36.12	-68.2	<-77.8	-50.2
	Audio	-57.8*	-71.7	-45.5*	-54.8**	-71.7**	-42.8**
Crosstalk with external band- pass filter	FSK Up	<-77.8	<-77.8	<-77.8	<-77.8	<-77.8	<-77.8
	FSK Down	-71.7	<-77.8	-57.8	<-77.8	<-77.8	<-77.8
	Audio	-57	<-77.8	-41.1	-59.7	<-77.8	-42.6
Modem receive level without filter	Mark	-37.9	-49.5	-25	-38.3	-49.8	-25.2
	Space	-38.9	-52.7	-23.6	-40.7	-55.5	-25.5
	1:1	-38.4	-50.9	-24	-38.8	-51.7	-24.8
	Random	-38.4	-50.9	-24	-39	-51.3	-25.1
Modem receive level with bandpass filter	Mark	-42.8	-54.3	-28.2	-41.9	-53.7	-26.6
	Space	-42.9	-57.8	-26.3	-44.5	-58.7	-26.8
	1:1	-40.9	-53.2	-25.5	-40.5	-54.8	-24.8
	Random	-41.8	-54.9	-26.2	-41.5	-54.2	-25.6
System Noise	<-77.8	<-77.8	<-77.8	<-77.8	<-77.8	<-77.8	<-77.8

1. System noise is equivalent to meter 0.
2. Three-way box not part of telephone company circuit.
3. Audio — 110 baud; 2560 Hz, \*\*2360 Hz, \*\*\*2336 Hz.
4. Audio — 150 baud; 2550 Hz, \*2297 Hz.
5. Modem receive sensitivity = - 44 dBm (in random).

FAILURE LEVELS IM-1307

TEST 1.

1. Conditions:

- a. No external filters,
- b. 1142a line simulation,
- c. Noise level 30-45 dBrn,
- d. FS sender output level = -16 dBm (FSKU),
- e. FS receiver gain and bias controls adjusted per Order 6650.4A,
- f. Signal levels measured at FS receiver bandpass filter (BPF) output.

2. Results:

Interfering signal levels higher than -50.7 dBm (measured at the FS BPF) interrupted PTT when the RCAG transmitters were keyed. The level required to cause false PTT (RCAG transmitters unkeyed) is -46.7 dBm.

The FS receive level (measured at the FS BPF) for FSKD and 1142a lines is -48.5 dBm giving rise to a worst-case signal-to-crosstalk ratio of 2.2 dB.

TEST 2.

1. Conditions:

Same as test 1 except that the FS sender output is turned off to simulate an FS sender failure.

2. Results:

False PTT occurs at an interfering signal level higher than -52 dBm.

**APPENDIX B**  
**TEST RESULTS, FA-8735**

TABLE B-1. MODEM INTERFERENCE IN TONE CHANNELING EQUIPMENT, FA-8735

		150-BAUD DATA RATE dBm LEVEL MEASURED AT						110-BAUD DATA RATE dBm LEVEL MEASURED AT					
		FS Band- Pass Filter	Audio* Low- Pass Filter	FS Band- Pass Filter	Audio* Low- Pass Filter	FS Band- Pass Filter	Audio* Low- Pass Filter	FS Band- Pass Filter	Audio* Low- Pass Filter	FS Band- Pass Filter	Audio* Low- Pass Filter	FS Band- Pass Filter	Audio* Low- Pass Filter
		1142 Simulated Line		2002 Simulated Line		Back To Back		1142 Simulated Line		2002 Simulated Line		Back To Back	
Crosstalk without filter	Mark	<-90	-61.5	<-90	-72	-88	-49	-90.4	-63.5	<-90	-73	-88	-50
	Space	-80.9	-79	-90	-80.5	-65	-68.5	-90.4	-78.5	<-90	-80.5	-79.1	-66
	1:1	-71	-66.5	-82	-75.5	-54.9	-54	-86	-68	<-90	-74	-72	-55
	Random	-73.6	-64	-84.4	-74	-57.6	-51	-87.9	-66	<-90	-75	-75	-53
Crosstalk with external notch filter	Mark	<-90	-82	<-90	-82	<-90	-79	<-90	-82	<-90	-82	<-90	-79.5
	Space	<-90	-82	<-90	-82	-83	-80	<-90	-82	<-90	-82	<-90	-80
	1:1	-73.5	-77.5	-86	-81.5	-57.3	-67	-90	-82	<-90	-82	-80	-79
	Random	-77	-80	-90	-81.5	-60.8	-70	-90	-82	<-90	-82	-80	-79
Crosstalk with external bandpass filter	Mark	<-90	-62	-93.9	-72	-88	-49	<-90	-63.5	<-90	-73.5	-88	-50.5
	Space	-82	-79	-93.9	-81	-65.3	-71	-90	-79	<-90	-82	-80	-66
	1:1	-83	-67	-93.9	-76	-66.4	-54.5	-90	-68.5	<-90	-77.5	-79.2	-55
	Random	-83	-65	-93.9	-74	-66.9	-51	-90	-66	<-90	-76	-80.9	-53
FS Rx level without filter	FSK Up	-45.5		-56.7		-29		-45.3		-56.6		-29.7	
	FSK Down	-47.5		-58.9		-30.9		-46.6		-57.7		-30.9	
FS Rx level with ext. notch filter	FSK Up	-46		-57.4		-29.7		-46		-57.3		-30.3	
	FSK Down	-51.3		-62.8		-34.3		-49.8		-61.5		-34.4	
Audio Rx w/o filter**			-28.5		-42.5		-19		-28		-42.5		-19
Audio Rx w/notch filter**			-28.5		-42.75		-19		-28		-42.5		-19
System Noise***		<-90	-82	<-90	-83	<-90	-81	<-90	-82	<-90	-82	<-90	-80

\*\*"Audio lowpass filter" is referred to as point C.  
 \*\*\*"Audio receive" level measured at point C.  
 \*\*\*"System noise" under audio lowpass filter column includes FS sender crosstalk.

B-1

TABLE B-2. TONE-CHANNELING INTERFERENCE IN MODEM EQUIPMENT, FA-8735

		150-BAUD DATA RATE dBm LEVEL MEASURED AT TP2			110-BAUD DATA RATE dBm LEVEL MEASURED AT TP2		
		1142 Simulated Line	2002 Simulated Line	Back To Back	1142 Simulated Line	2002 Simulated Line	Back To Back
Crosstalk without filter	FSK Up	-77.8	-77.8	-71.8	-71.8	-77.8	-54.3
	FSK Down	-50.54	-62.2	-34	-68.2	-71.8	-52.2
	Audio	-51.3	-71.8	-35.3***	-53.7	-71.8*	-41.4
Crosstalk with external notch filter	FSK Up	-77.8	-77.8	-71.8	-71.8	-77.8	-53.7
	FSK Down	-53.2	-62.2	-36.6	-68.2	-71.8	-53.7
	Audio	-57.8**	-71.8**	-44.9**	-53.7	-71.8	-43.3
Crosstalk with external band- pass filter	FSK Up	-77.8	-77.8	-77.8	-77.8	-77.8	-77.8
	FSK Down	-77.8	-77.8	-63.8	-74.25	-77.8	-77.8
	Audio	-54.8	-77.8†	-38.3***	-56.2*	-71.8*	-77.8†
Modem receive level without filter	Mark	-38	-49.1	-25.2	-38.6	-49.1	-25.4
	Space	-40.3	-54.9	-23.8	-41.1	-56.2	-25.6
	1:1	-38.8	-50.9	-24.3	-39.4	-51.3	-24.9
Modem receive level with bandpass filter	Random	-38.8	-51.3	-24.3	-39.5	-50.9	-25.1
	Mark	-43.5	-54.8	-28	-42.8	-53.2	-25.3
	Space	-44	-58.7	-26.2	-44.1	-59.7	-25.5
System Noise	1:1	-41.4	-54.22	-25.4	-41.5	-54.9	-25
	Random	-42.4	-55.5	-26.2	-42.2	-54.9	-25.1
		-77.8	-77.8	-77.8	-77.8	-77.8	-77.8

NOTES:

1. System noise is equivalent to meter 0.
2. Audio — 110 baud; 2350 Hz, \*2560 Hz, \*\*\*2550 Hz.
3. Audio — 150 baud; 2540 Hz, \*\*2300 Hz, †No observed signal

FAILURE LEVELS FA-8735

TEST 1.

1. Conditions:

- a. No external filters,
- b. 1142a line simulation,
- c. Noise level, 30-45 dBm,
- d. FS sender output level = -16 dBm (FSKU),
- e. FS receiver gain and bias controls adjusted per Order 6650.4A,
- f. Signal levels measured at FS receiver bandpass filter (BPF) output.

2. Results:

Interfering signal levels higher than -54.8 dBm (measured at the FS BPF) interrupted PTT when the RCAG transmitters were keyed.

The FS receive level (measured at the FS BPF) for FSKD and 1142 lines is -46.6 dBm giving rise to a worst-case signal-to-crosstalk ratio of 8.2 dB.

TEST 2.

1. Conditions:

Same as test 1 except that the FS sender output is turned off to simulate an FS sender failure.

2. Results:

False PTT occurs at an interfering signal level higher than -49.3 dBm.

APPENDIX C  
TEST RESULTS, CA-1621

TABLE C-1. MODEM INTERFERENCE IN TONE-CHANNELING EQUIPMENT, CA-1621

		150 BAUD DATA RATE dBm LEVEL MEASURED AT						110 BAUD DATA RATE dBm LEVEL MEASURED AT						
		FS Band- Pass Filter	Audio* Low- Pass Filter	FS Band- Pass Filter	Audio* Low- Pass Filter	FS Band- Pass Filter	Audio* Low- Pass Filter	FS Band- Pass Filter	Audio* Low- Pass Filter	FS Band- Pass Filter	Audio* Low- Pass Filter	FS Band- Pass Filter	Audio* Low- Pass Filter	
		1142 Simulated Line		2002 Simulated Line		Back To Back		1142 Simulated Line		2002 Simulated Line		Back To Back		
Crosstalk without filter	Mark	-90	-50	-80	-61	-77.7	-36	-90	-51.5	-90	-62	-72.9	-37.5	
	Space	-82.6	-87	-90	-89	-66.2	-71	-90	-78	-90	-87.5	-72.7	-63	
	1:1	-73.2	-55	-85.2	-66.5	-53	-41.5	-85.2	-56	-90	-67	-68.2	-42	
	Random	-74.7	-53	-86.7	-65	-59.2	-38	-87.5	-55	-90	-86	-69.7	-40	
Crosstalk with external notch filter	Mark	-90	-87.5	-90	-89	-81	-74.5	-90	-87	-90	-90	-73.7	-67	
	Space	-90	-88	-90	-89	-77.5	-81	-90	-87	-90	-90	-73.7	-70	
	1:1	-76.7	-71.5	-90	-82.5	-62.2	-59	-90	-86	-90	-90	-72.2	-63.5	
	Random	-78.7	-76	-90	-86	-65.2	-63	-90	-86	-90	-90	-72.2	-68	
Crosstalk with external bandpass filter	Mark	-90	-50	-90	-60	-81	-36.5	-90	-51	-90	-61.5	-75.4	-37.5	
	Space	-83.7	-87	-90	-89	-68.2	-72.6	-90	-78	-90	-87	-75.2	-64.5	
	1:1	-80.7	-56	-90	-66	-65.2	-42	-90	-55.5	-90	-66.5	-72.7	-42	
	Random	-81.2	-53	-90	-65	-66.2	-39	-90	-53	-90	-65	-73.2	-40	
FS Rx level without filter	FSK Up	-47.4		-58.7		-29.8		-47.7		-59.2		-29.7		
	FSK Down	-52.7		-63.7†		-35.2		-51.7		-73.2		-33.9		
FS Rx level with ext. notch filter	FSK Up	-48.2		-59.7		-32.7		-40.2		-60.2		-30.4		
	FSK Down	-56.7		-67.7		-41.7		-55.7		-66.9		-37.7		
Audio Rx w/o filter**			-28		-35.5		-19.5		-28		-35		-20.5	
Audio Rx w/notch filter**				-28.5		-35.5		-20.5		-28		-35		-20.5
System Noise***			-90	-88	-90	-89	-81	-81	-90	-87	-90	-90	-81	-81

\*"Audio lowpass filter" is referred to as point C.  
 \*\*"Audio receive" level measured at point C.  
 \*\*\*"System noise" under audio lowpass filter column includes FS sender crosstalk.  
 †FSK TX output is lower.

TABLE C-2. TONE-CHANNELING INTERFERENCE IN MODEM EQUIPMENT, CA-1621

		150-BAUD DATA RATE dBm LEVEL MEASURED AT TP2			110-BAUD DATA RATE dBm LEVEL MEASURED AT TP2		
		1142 Simulated Line	2002 Simulated Line	Back To Back	1142 Simulated Line	2002 Simulated Line	Back To Back
Crosstalk without filter	FSK Up	-77.8	-77.8	-71.7	-71.7	-77.8	-54.2
	FSK Down	-49.1	-62.2	-32.3	-65.7	-71.7	-48.2
	Audio	-40.6	-52.7	-26	-41.2	-53.7	-27.1
Crosstalk with external notch filter	FSK Up	-77.8	-77.8	-71.7	-71.7	-77.8	-77.8
	FSK Down	-52.2	-63.8	-35	-68.2	-74.3	-65.7
	Audio	-59.7	-68.2	-45.7	-56.9	-68.2	-26.7
Crosstalk with external band- pass filter	FSK Up	-77.8	-77.8	-77.8	-77.8	-77.8	-54.2
	FSK Down	-71.7	-77.8	-57.8	-77.8	-77.8	-51.3
	Audio	-42.9	-54.2	-28.4	-43.6	-56.9	-42.6
Modem receive level without filter	Mark	-41.3	-52.6	-26.3	-41.4	-52.6	-26.7
	Space	-40	-55.5	-24.2	-42.2	-56.2	-25.2
	1:1	-41.5	-54.3	-25.6	-42.2	-54.3	-26.1
	Random	-41.2	-48.5	-25.3	-42	-53.7	-26
Modem receive level with bandpass filter	Mark	-44.5	-57.8	-28.8	-43.9	-55.5	-28.4
	Space	-43.8	-62.2	-26.6	-45.3	-62.2	-27.3
	1:1	-43.9	-58.7	-27.2	-43.8	-56.9	-30.9
	Random	-44.2	-57.8	-27.4	-43.9	-56.2	-27.5
System Noise		-77.8	-77.8	-77.8	-77.8	-77.8	-77.8

NOTE:  
System noise is equivalent to meter 0.

FAILURE LEVELS CA-1621

TEST 1.

1. Conditions:

- a. No external filters,
- b. 1142 line simulation,
- c. Noise level 30-45 dBrn,
- d. FS sender output level = -16 dBm,
- e. FS receive gain and bias controls adjusted per Order 6650.4A,
- f. Signal levels measured at FS BPF output.

2. Results:

Interfering signal levels higher than -52.2 dBm (measured at the FS BPF) interrupted PTT when the RCAG transmitters were keyed. The level required to cause false PTT (RCAG transmitters unkeyed) is 10 dB higher.

The FS receive level (measured at the FS BPF) for FSKD and 1142a lines is approximately -52 dBm giving rise to a worst-case signal-to-crosstalk ratio of 0.2 dB.

TEST 2.

1. Conditions:

Same as test 1 except that the FS sender output was turned off simulating an FS sender failure.

2. Results:

False PTT occurs at an interfering signal level higher than -54.3 dBm.

APPENDIX D  
TEST RESULTS, IM-2076

TABLE D-1. MODEM INTERFERENCE IN TONE-CHANNELING EQUIPMENT, IM-2076

		150-BAUD DATA RATE dBm LEVEL MEASURED AT						110-BAUD DATA RATE dBm LEVEL MEASURED AT					
		FS Band- Pass Filter	Audio* Low- Pass Filter	FS Band- Pass Filter	Audio* Low- Pass Filter	FS Band- Pass Filter	Audio* Low- Pass Filter	FS Band- Pass Filter	Audio* Low- Pass Filter	FS Band- Pass Filter	Audio* Low- Pass Filter	FS Band- Pass Filter	Audio* Low- Pass Filter
		1142 Simulated Line		2002 Simulated Line		Back To Back		1142 Simulated Line		2002 Simulated Line		Back To Back	
Crosstalk without filter	Mark	-68.5	-52.5	-80	-55.5	-75	-48	-69	-54	-80	-60	-74.5	-47
	Space	-58	-68.5	-62	-78	-56	-68	-63.5	-68.5	-70	-82	-62	-65
	1:1	-55.5	-54	-66	-58	-53	-50	-65.5	-59	-75	-65	-65	-51.5
	Random	-58	-55	-63	-58	-55	-49	-65	-57	-70	-60	-65	-50
Crosstalk with external notch filter	Mark	-71	-68.5	N.O.†	N.O.	-83	-68	-70	-69	N.O.	N.O.	-82	-67
	Space	-71	-68.5	N.O.	N.O.	-82	-69	-70	-69.5	N.O.	N.O.	-81.5	-68.5
	1:1	-58	-61	-67	-66	-55	-57.5	-70	-68.5	-80	N.O.	-72.5	-67
	Random	-62	-64	-67	-68	-59	-61	-70	-69	-85	N.O.	-75	-67
Crosstalk with external bandpass filter	Mark	-70	-52.5	-80	-57	-75	-48.5	-68.5	-54	-80	-58	-74.5	-48
	Space	-59	-68.5	-62	-80	-56.5	-68	-63	-69	-70	-80	-62	-65.5
	1:1	-63	-57	-68	-60	-61	-52	-67.5	-58.5	-75	-65	-66.5	-53
	Random	-61	-55	-65	-58	-60	-51	-65	-56	-70	-59	-64	-52
FS Rx level without filter	FSK Up	-19		-23.5		-16		-19		-24		-16	
	FSK Down												
FS Rx level with ext. notch filter	FSK Up	-20		-24		-17		-20		-24		-16.5	
	FSK Down												
Audio Rx w/o filter**		-10		-10		-10		-10		-10		-10	
Audio Rx w/notch filter**		-10		-10		-10		-10		-10		-10	
System Noise***		-71	-68.5	-62	-64	-84	-70	-70	-68.5	-60	-65.5	-83	-68.5

\*\*"Audio lowpass filter" is referred to as point C.  
 \*\*\*"Audio receive" level measured at point C.  
 \*\*\*"System noise" under audio lowpass filter column includes FS sender crosstalk.  
 †Not observed.

TABLE D-2. TONE-CHANNELING INTERFERENCE IN MODEM EQUIPMENT, IM-2076

		150-BAUD DATA RATE dBm LEVEL MEASURED AT TP2			110-BAUD DATA RATE dBm LEVEL MEASURED AT TP2		
		1142 Simulated Line	2002 Simulated Line	Back To Back	1142 Simulated Line	2002 Simulated Line	Back To Back
Crosstalk without filter	FSK Up	-69.8	-77.8	-54.3	-70	-77.8	-53.7
	FSK Down						
	Audio	-57.8	-65.7	-43.6	-57	-65.7	-45.5
Crosstalk with external notch filter	FSK Up	-77.8	-77.8	-65.7	-77.8	-77.8	-53.1
	FSK Down						
	Audio	-60.8**	-71.7	-48**	-56.2**	-77.8	-46.2
Crosstalk with external band- pass filter	FSK Up	-77.8	-77.8	-69.8	-77.8	-77.8	-71.2
	FSK Down						
	Audio	-59.7	-65.7	-41.9	-63.8	-71.8	-44.7*
Modem receive level without filter	Mark	-42.5	-52.7	-27.6	-43.1	-51.7	-27.5
	Space	-44.7	-55.5	-27.4	-46.6	-57	-28.3
	1:1	-43.5	-53.2	-27.3	-43.1	-53.2	-27.4
	Random	-43.5	-53.7	-27.5	-43.8	-53.7	-27.6
Modem receive level with bandpass filter	Mark	-45.9	-55.5	-27.9	-45.3	-54.8	-27.7
	Space	-47.4	-56.2	-27.4	-49.2	-57.8	-28.6
	1:1	-46	-54.8	-26.8	-44.3	-55.5	-26.9
	Random	-46.2	-54.8	-27.2	-44.5	-55.5	-27.4
System Noise							
		-77.8	-77.8	-77.8	-77.8	-77.8	-77.8

NOTES:

1. System noise is equivalent to meter 0.
2. Audio — 110 baud; 2400 Hz, \*2450 Hz, \*\*2300 Hz.
3. Audio — 150 baud; 2550.

TEST 1.

1. Conditions:

- a. No external filters,
- b. 1142a line simulation,
- c. Noise level 30-45 dBrn,
- d. FS sender output level = -16 dBm,
- e. Signal levels measured at FS BPF output.

2. Results:

Interference signals higher than -37 dBm interrupted the selected control function and caused the 2076 receive terminal to deselect standby equipment and to disable all PTT commands.

The FS receive level (measured at the FS BPF) is -19 dBm, giving a worst-case signal-to-crosstalk ratio of 18 dB.

Due to the nature of the operation of the IM-2076, false PTT did not occur as a result of interference signals which occurred when the send terminal output was turned off, simulating a failure.

APPENDIX E  
TEST RESULTS, FA-5390

TABLE E-1. MODEM INTERFERENCE IN TONE-CHANNELING EQUIPMENT, CA-5390

		150-BAUD DATA RATE dBm LEVEL MEASURED AT						110-BAUD DATA RATE dBm LEVEL MEASURED AT					
		FS Band- Pass Filter	Audio* Low- Pass Filter	FS Band- Pass Filter	Audio* Low- Pass Filter	FS Band- Pass Filter	Audio* Low- Pass Filter	FS Band- Pass Filter	Audio* Low- Pass Filter	FS Band- Pass Filter	Audio* Low- Pass Filter	FS Band- Pass Filter	Audio* Low- Pass Filter
		1142 Simulated Line		2002 Simulated Line		Back To Back		1142 Simulated Line		2002 Simulated Line		Back To Back	
Crosstalk without filter	Mark	-100	-45	<-100	-59	-96.4	-33	-100	-50	<-100	-60	-99	-34
	Space	-66.2	-77	-76.7	-88	-49.2	-62.5	-86	-70	-96.5	-80	-70.2	-53
	1:1	-60.2	-47.2	-71.2	-60.5	-43.7	-35.5	-74	-50	-83.2	-60.5	-55.9	-34.2
	Random	-62.2	-47.5	-71.2	-60.5	-43.7	-35	-76	-50.5	-84.2	-61	-57.2	-36
Crosstalk with external notch filter	Mark	<-100	-89	<-100	<-90	<-100	-79	-100	<-90	<-90	<-90	<-100	-86.5
	Space	<-100	<-90	<-100	<-90	-94	-84.5	-100	<-90	<-90	<-90	<-100	-89
	1:1	-72.2	-79.2	-82.2	-89.5	-48.7	-72	-81	<-90	-90.2	<-90	-62.7	-82.5
	Random	-72.2	-80.5	-81.2	-91	-50.2	-73	-84	<-90	-93.9	<-90	-67.2	-83
Crosstalk with external bandpass filter	Mark	<-100	-49	<-100	-58.5	-96.5	-33.5	-100	-50	<-100	-59.2	-96.5	-35
	Space	-66.7	-79.5	-77	-89	-50.2	-63	-86.9	-70	-96	-79.7	-70.7	-54
	1:1	-62.2	-50	-73.2	-60	-55.2	-35.5	-79.2	-50	-87.7	-60.5	-61.7	-35
	Random	-63.2	-50	-73.7	-60	-47.2	-36	-77.7	-51.5	-87.2	-60	-60.7	-36
FS Rx level without filter	FSK Up	-48.2		-58.2		-26.7		-48.2		-57.8		-29.2	
	FSK Down	-44.7		-54.4		-24.2		-44		-53.7		-25.7	
FS Rx level with ext. notch filter	FSK Up	-47.5		-57.7		-26.7		-48		-57.7		-29.2	
	FSK Down	-47.2		-57.2		-27.2		-46.7		-56.2		-28.7	
Audio Rx w/o filter**			-36		-41.5		-27		-36		-41		-26.5
Audio Rx w/notch filter**			-36		-41.5		-27		-35.5		-41		-27
System Noise***		-100	<-90	<-100	<-90	-100	<-90	-100	<-90	-100	<-90	-100	<-90

\*\*"Audio lowpass filter" is referred to as point C.  
 \*\*\*"Audio receive" level measured at point C.  
 \*\*\*"System noise" under audio lowpass filter column includes FS sender crosstalk.

TABLE E-2. TONE-CHANNELING INTERFERENCE IN MODEM EQUIPMENT, CA-5390

		150-BAUD DATA RATE dBm LEVEL MEASURED AT TP2			110-BAUD DATA RATE dBm LEVEL MEASURED AT TP2		
		1142 Simulated Line	2002 Simulated Line	Back To Back	1142 Simulated Line	2002 Simulated Line	Back To Back
Crosstalk without filter	FSK Up	-77.8	-77.8	-63.8	-71.7	-77.8	-56.9
	FSK Down	-52.7	-65.7	-31.8	-68.2	-71.7	-50.5
	Audio	-40.7	-51.7	-16.8	-42	-43	-13.6
Crosstalk with external notch filter	FSK Up	-77.8	-77.8	-71.7	-71.7	-74.2	-54.8
	FSK Down	-52.6	-65.7	-34	-68.2	-71.7	-51
	Audio	-60	-68.2	-29.4*	-58	-65.7	-40.7
Crosstalk with external band- pass filter	FSK Up	-77.8	-77.8	-77.8	-77.8	-77.8	-77.8
	FSK Down	-71.7	-77.8	-62.2	-77.8	-77.8	-74.3
	Audio	-43	-53.2	-34.8	-44.2	-44.5	-15
Modem receive level without filter	Mark	-42.8	-59.6	-14	-43	-52.2	-26.1
	Space	-43	-58.7	-24.1	-45.1	-57	-25.8
	1:1	-42.2	-56.2	-25	-42.7	-53.7	-25.3
	Random	-42.5	-57	-25	-43.3	-54.2	-25.7
Modem receive level with bandpass filter	Mark	-46	-60.8	-28.8	-46	-56.9	-28.7
	Space	-45.7	-59.7	-26.9	-47.4	-59.7	-28.3
	1:1	-44	-57.7	-26.8	-44.5	-57.7	-27.1
	Random	-44.9	-59.7	-27.3	-55.5	-57.7	-27.6
System Noise	-77.8	-77.8	-77.8	-77.8	-77.8	-77.8	

\*2750 Hz (over the range 2500 Hz to 2700 Hz <-45 dBm).

NOTES:

1. System noise is equivalent to meter 0.
2. Audio — 150 baud; 2550 Hz.

E-2

FAILURE LEVELS, CA-5390

TEST 1.

1. Conditions:

- a. No external filters,
- b. 1142a line simulation,
- c. Noise level 30-45 dBm,
- d. FS sender output level = -16 dBm,
- e. FS receive gain and bias adjusted per 6650.4A.

2. Results.

Interference signal levels higher than -49.5 dBm (measured at the FS BPF) interrupted PTT when the RCAG transmitters were keyed. The level required to cause false PTT (RCAG transmitters unkeyed) is about 3 dB higher.

The FS receive level (measured at the FS BPF) is approximately -44.7 dBm (FSKD) giving a worst-case signal-to-crosstalk ratio of 4.8 dB.

TEST 2.

1. Conditions:

Same as test 1 except that the FS sender output is turned off to simulate an FS sender failure.

2. Results:

False PTT occurred at an interference signal level higher than -51.2 dBm.