

**EXHAUST EMISSIONS CHARACTERISTICS AND VARIABILITY
FOR PRATT AND WHITNEY JT8D-7A GAS TURBINE
ENGINES SUBJECTED TO MAJOR OVERHAUL AND REPAIR**

**ERIC E. BECKER
GARY FRINGS
WILLIAM C. CAVAGE**



FEDERAL AVIATION ADMINISTRATION

OCT 15 1980

TECHNICAL CENTER LIBRARY
ATLANTIC CITY, N.J. 08405

FINAL REPORT

SEPTEMBER 1980

Document is available to the U.S. public through
the National Technical Information Service,
Springfield, Virginia 22161.

Prepared for
**U. S. DEPARTMENT OF TRANSPORTATION
FEDERAL AVIATION ADMINISTRATION
TECHNICAL CENTER
Atlantic City Airport, New Jersey 08405**

NOTICE

This document is disseminated under the sponsorship of the Department of Transportation in the interest of information exchange. The United States Government assumes no liability for the contents or use thereof.

The United States Government does not endorse products or manufacturers. Trade or manufacturer's names appear herein solely because they are considered essential to the object of this report.

1. Report No. FAA-CT-79-53		2. Government Accession No.		3. Recipient's Catalog No.	
4. Title and Subtitle EXHAUST EMISSIONS CHARACTERISTICS AND VARIABILITY FOR PRATT AND WHITNEY JT8D-7A GAS TURBINE ENGINES SUBJECTED TO MAJOR OVERHAUL AND REPAIR				5. Report Date September 1980	
				6. Performing Organization Code	
7. Author(s) Eric E. Becker, Gary Frings, and William C. Cavage				8. Performing Organization Report No. FAA-CT-79-53	
9. Performing Organization Name and Address Federal Aviation Administration Technical Center Atlantic City Airport, New Jersey 08405				10. Work Unit No. (TRAIS)	
				11. Contract or Grant No. 201-521-100	
12. Sponsoring Agency Name and Address U.S. Department of Transportation Federal Aviation Administration Technical Center Atlantic City Airport, New Jersey 08405				13. Type of Report and Period Covered Final November 78-February 79	
				14. Sponsoring Agency Code	
15. Supplementary Notes					
16. Abstract Seven Pratt and Whitney Aircraft (PWA) JT8D-7A turbofan engines were tested at Kennedy International Airport, New York, to evaluate exhaust emissions characteristics and data variability after overhaul. The measured data show that the engines tested did not meet the Environmental Protection Agency (EPA) emission standards. A comparison of the measured data, obtained from the seven overhauled engines evaluated under this program, with new engine data obtained from PWA show that there is a great deal of similarity between the two sets of data. Differences shown in this report between new engine and overhauled engine data are due to the quantity of the engines sampled; the new engine data represent a larger sample size. Satisfactory data can be measured by using the test procedures, instrumentation, and equipment defined in this report.					
17. Key Words Exhaust Emissions Air Pollution Oxides of Nitrogen Turbine Engines Carbon Monoxide Hydrocarbons			18. Distribution Statement Document is available to the U.S. public through the National Technical Information Service, Springfield, Virginia 22161		
19. Security Classif. (of this report) Unclassified		20. Security Classif. (of this page) Unclassified		21. No. of Pages 50	22. Price

METRIC CONVERSION FACTORS

Approximate Conversions to Metric Measures

Symbol	When You Know	Multiply by	To Find	Symbol
LENGTH				
m	inches	*2.5	centimeters	cm
ft	feet	30	centimeters	cm
yd	yards	0.9	meters	m
mi	miles	1.6	kilometers	km
AREA				
m ²	square inches	6.5	square centimeters	cm ²
ft ²	square feet	0.09	square meters	m ²
yd ²	square yards	0.8	square meters	m ²
mi ²	square miles	2.6	square kilometers	km ²
	acres	0.4	hectares	ha
MASS (weight)				
oz	ounces	28	grams	g
lb	pounds	0.45	kilograms	kg
	short tons (2000 lb)	0.9	tonnes	t
VOLUME				
tsp	teaspoons	5	milliliters	ml
Tbsp	tablespoons	15	milliliters	ml
fl oz	fluid ounces	30	milliliters	ml
c	cups	0.24	liters	l
pt	pints	0.47	liters	l
qt	quarts	0.95	liters	l
gal	gallons	3.8	liters	l
ft ³	cubic feet	0.03	cubic meters	m ³
yd ³	cubic yards	0.76	cubic meters	m ³
TEMPERATURE (exact)				
°F	Fahrenheit temperature	5/9 (after subtracting 32)	Celsius temperature	°C

*1 in = 2.54 (exactly). For other exact conversions and more detailed tables, see NBS Misc. Publ. 286, Units of Weights and Measures, Price \$2.25, SO Catalog No. C13.10.286.

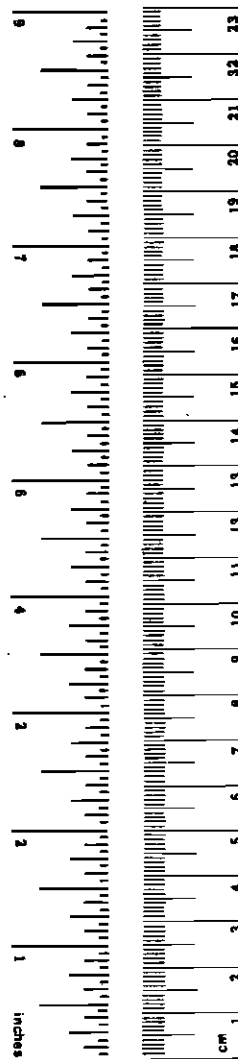

Approximate Conversions from Metric Measures

Symbol	When You Know	Multiply by	To Find	Symbol
LENGTH				
mm	millimeters	0.04	inches	in
cm	centimeters	0.4	inches	in
m	meters	3.3	feet	ft
m	meters	1.1	yards	yd
km	kilometers	0.6	miles	mi
AREA				
cm ²	square centimeters	0.16	square inches	in ²
m ²	square meters	1.2	square yards	yd ²
km ²	square kilometers	0.4	square miles	mi ²
ha	hectares (10,000 m ²)	2.5	acres	
MASS (weight)				
g	grams	0.035	ounces	oz
kg	kilograms	2.2	pounds	lb
t	tonnes (1000 kg)	1.1	short tons	
VOLUME				
ml	milliliters	0.03	fluid ounces	fl oz
l	liters	2.1	pints	pt
l	liters	1.06	quarts	qt
l	liters	0.26	gallons	gal
m ³	cubic meters	35	cubic feet	ft ³
m ³	cubic meters	1.3	cubic yards	yd ³
TEMPERATURE (exact)				
°C	Celsius temperature	9/5 (then add 32)	Fahrenheit temperature	°F

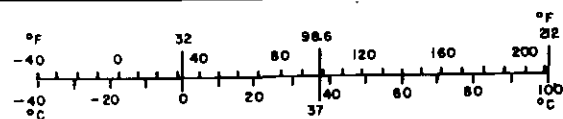

PREFACE

The authors wish to acknowledge the cooperation which was extended them by the management and personnel of Pan American World Airways, JFK International Airport, New York. Their assistance to the FAA personnel during the time period of this work is gratefully appreciated.

TABLE OF CONTENTS

	Page
INTRODUCTION	1
Purpose	1
Background	1
Methodology	1
DISCUSSION	1
Description of Engine	1
Description of Test Procedure	2
Description of Maintenance Procedures	2
Description of Test Cell	2
Test Conditions	2
Description of Emission Sampling Hardware	2
Description of Mobile Emissions Research Facility (MERF)	4
Description of MERF Operation	4
MERF Operational Procedures	5
RESULTS	5
General Comments	5
Results of Baseline Tests (Landing Takeoff Cycle Effects)	7
SUMMARY OF RESULTS	8
CONCLUSIONS	8
REFERENCES	9
APPENDICES	
A - Equations for Calculating Emissions Results	
B - Raw Engine and Emission Data	
C - Fuel Analysis	
D - Detailed Description of MERF	
E - MERF Test Calibration and Operational Procedure	

LIST OF ILLUSTRATIONS

Figure		Page
1	Quartering View of FAA Emission Measurement Probe (Diamond Shaped) Installed on the Exhaust Nozzle of a JT8D-7A Turbofan Engine	10
2	View Looking Forward--Installation of FAA Emission Measurement Probe (Diamond Shaped) Installed on the Exhaust Nozzle of a JT8D-7A Turbofan Engine	11
3	Installed View of FAA Emission Measurement Probe Showing Mounting and Support Details	12
4	The FAA's Mobile Emission Research Facility (MERF) with Tow Vehicle	13
5	Total Emission Characteristics--Carbon Monoxide (CO)--Seven PWA JT8D-7A Engines After Overhaul	14
6	Total Emission Characteristics--Unburned Hydrocarbons (THC)--Seven PWA JT8D-7A Engines After Overhaul	15
7	Total Emission Characteristics--Oxides of Nitrogen (NO _x)--Seven PWA JT8D-7A Engines After Overhaul	16
8	Comparison of JT8D Engine Exhaust Emission Characteristics --New Engine Data Versus Overhauled Engine Data	17
9	Variability in Carbon Monoxide Exhaust Emissions--JT8D-7A Engines	18
10	Variability in Unburned Hydrocarbon Exhaust Emissions--JT8D-7A Engines	19
11	Variability in Oxides of Nitrogen Exhaust Emissions--JT8D-7A Engines	20

LIST OF TABLES

Table		Page
1	Average Corrected Parameters for Seven Engines	3
2	Test Sequence for JT8D-7A Engines	5
3	Summary of Maintenance Performed on Pan Am JT8D-7A Turbofan Engines	6
4	Summary of Ambient Test Conditions	7
5	Average Emission Rate Levels Measured	7

INTRODUCTION

PURPOSE.

The objectives of this investigation were to quantify exhaust emission levels of aircraft turbine engines which had undergone extensive maintenance, determine the variability of these emission levels, and evaluate to what extent these emission levels were affected by various types of maintenance.

BACKGROUND.

In accordance with the Clean Air Act and the Clean Air Amendments of 1970 (reference 1), the Environmental Protection Agency (EPA) in 1973 established aircraft turbine engine emission standards. The Department of Transportation and, specifically the Federal Aviation Administration (FAA), were charged with promulgating regulations enforcing these standards. Changes to these standards (40 CFR, Part 87) (reference 2) have been drafted and are being evaluated, but there remains a requirement to quantify the emission levels of turbine engines throughout their operational life. To meet this requirement, the emission levels of newly manufactured engines have been and still are being investigated. Present data on the effects of "heavy" and "on condition" maintenance on turbine engine emission levels are limited. In order to formulate regulations for control of aircraft exhaust emissions and to establish the requirements for redemonstration of compliance with EPA standards after initial certification, the FAA must have a firm indication of the effects of such maintenance on turbine engine emission levels.

This report provides emission data from Pratt and Whitney (PWA) JT8D engines tested at the Pan American World Airways (Pan Am) facilities located at John F. Kennedy International Airport (JFK), New York. The data herein will further

enhance that data base required by the FAA so that reasonable and appropriate standards and retest requirements can be prepared.

METHODOLOGY.

The turbine engine exhaust constituents which were measured included carbon monoxide (CO), carbon dioxide (CO₂), hydrocarbons (THC), oxides of nitrogen (NO_x), and oxygen (O₂). It was determined that three engine types would be tested: the PWA JT8D-7A, JT9D-7A, and the General Electric CF6-50. These engines were selected on the basis of their high in-use rate, expected long-term service, and availability of new engine emission data. This document will report the JT8D-7A test results.

A contractual effort with Pan Am was initiated wherein they supplied the engine, test cell facilities, support personnel, and necessary engine documentation. The FAA provided the emission measuring equipment and support personnel for its operation. Seven JT8D-7A engine tests were conducted at the main Pan Am maintenance facility located at JFK, Jamaica, New York. These engines were shipped to JFK for normal "on condition" maintenance from Pan Am's Internal German Service Division fleet of B727 aircraft located in Europe.

DISCUSSION

DESCRIPTION OF ENGINE.

The PWA JT8D-7A is an axial flow, front turbofan, two-spool engine rated at 14,000 pounds thrust. A six-stage low-pressure compressor (N₁) is driven by the second-, third-, and fourth-stage turbines, while a seven-stage high-pressure compressor (N₂) is driven by the first-stage turbine. The two-stage fan discharges into a full length annular duct which permits mixing of the

secondary air and primary gas flows in a common exhaust nozzle. The combustion section consists of nine individual can-annular combustion chambers which incorporate individual dual orifice type fuel nozzles (reference 3). Table 1 lists average corrected engine parameters encountered during testing.

All Pan Am JT8D engines are operated to JT8D-1 specifications. The primary difference between the two models is: the -7A is thrust rated to 84° F while the -1 is thrust rated to 59° F. The engines tested included four JT8D-1 models and three JT8D-7 models on the data plates. These engines have been hardware reconfigured to JT8D-7A requirements and specifications.

DESCRIPTION OF TEST PROCEDURE.

Since engine performance acceptance testing and emission sample testing were conducted concurrently, a modified test sequence was adopted which would satisfy both requirements (table 2).

Prior to testing for emissions, the engine was trimmed in accordance with specified PWA/Pan Am trim procedures.

After the engine was trimmed, the power was sequentially increased in steps as shown in table 2. The stabilization times listed in table 2 were required for the engine emissions to achieve equilibrium.

DESCRIPTION OF MAINTENANCE PROCEDURES.

The Pan Am JT8D-7A engines were maintained "on condition." The term "on condition" refers to a general industry wide maintenance practice which dictates an engine is removed from service only on the condition that maintenance is required. This differs from the older policy of removing an engine from service due to the accumulation of time on various rotating components (disc restrictions). "On condition" maintenance also implies doing the

repair or replacement of any other parts found to be faulty during a maintenance tear-down. Table 3 lists the maintenance performed on the engines prior to testing. Note that most of the major components have been replaced. These engines were airlifted to JFK for major maintenance (overhaul) from Germany.

DESCRIPTION OF TEST CELL.

Pan Am's test cell number 1 at JFK was used for all JT8D-7A exhaust emission testing. This is a sea level test cell incorporating inlet and exhaust sound suppression. The only modification to the test cell was the drilling of a 4-inch diameter hole in one wall through which the emission sample line was routed. The engine was mounted on a thrust measuring stand. Engine instrumentation was typical of that required for production engine performance testing. All engine data were manually recorded and processed.

TEST CONDITIONS.

All JT8D-7A engine tests were conducted between November 29, 1978, and February 9, 1979. Table 4 lists the minimum and maximum ambient conditions encountered during testing.

DESCRIPTION OF EMISSION SAMPLING HARDWARE.

The emission sampling probe utilized for JT8D-7A testing is an FAA developed design (reference 4, and figures 1 and 2). Generally, the probe consists of a tube in the shape of a diamond. Each leg of the diamond contains three equally spaced sampling holes of equal diameter. The sampling tube was secured to a backup structure and positioned on the exhaust nozzle rim with four equi-spaced clevis mounting pads. The entire structure was secured to the engine using four tensioning rods between the engine frame and a torsional support ring attached to the clevis

TABLE 1. AVERAGE CORRECTED PARAMETERS FOR SEVEN ENGINES

<u>Power</u>	<u>Thrust Net (lbs)</u>	<u>Fuel Flow (lbs/hr)</u>	<u>Thrust Specific Fuel Consumption (lbs/hr/lb)</u>	<u>N₁ (rpm)</u>	<u>N₂ (rpm)</u>	<u>Exhaust Gas Temp (°C)</u>	<u>Engine Pressure Ratio</u>
Idle Out	1197	998	0.834	2945	7095	374	1.085
Takeoff	13692	8156	0.596	8088	11532	544	1.98
85%	11577	6630	0.573	7558	11144	498	1.78
30%	4429	2499	0.564	5395	9506	349	1.25
Idle	1122	959	.855	2889	7018	373	1.085

pieces (figure 3). Thermal expansion of the exhaust nozzle is taken up by compression springs incorporated with the tensioning rods.

DESCRIPTION OF MOBILE EMISSIONS RESEARCH FACILITY (MERF).

The MERF, a self contained, sound attenuated, environmentally controlled mobile emission measurement laboratory was used for all JT8D turbine engine exhaust emission testing (figure 4). Commercially available power was used in lieu of the on-board generators. Calibration and operating gas cylinders are carried on-board (table D-1). A heated external sample line transports the emission sample from the probe to the MERF. Upon entering the MERF, the emission sample is routed to the analyzers through heated lines. The CO/CO₂ sample is routed through a gas dryer. The CO₂ analyzer is a Beckman model 864 non-dispersive infrared (NDIR) unit calibrated on three ranges at 0-5 percent, 0-3 percent and 0-1 percent full scale. The CO analyzer is a Beckman model 865 NDIR unit calibrated on three ranges at 0-1000 parts per million (ppm) volume, 0-400 ppm and 0-100 ppm full scale. The THC analyzer is a Beckman model 402 flame ionization detector unit calibrated on four ranges at 0-10 ppm, 0-50 ppm, 0-100 ppm and 0-500 ppm propane (C₃H₈). This analyzer has been modified to improve its operation. These modifications are described in detail in reference 5. The NO_x analyzer is a Beckman model 951H_x atmospheric pressure, heated, chemilluminiscent analyzer calibrated on five ranges at 0-10 ppm, 0-25 ppm, 0-100 ppm, 0-250 ppm and 0-1000 ppm full scale. The O₂ analyzer is a Beckman model OM-11 medical unit with a polarographic sensor. The advanced sensor and amplification system combine to make this analyzer an extremely fast responding and highly accurate instrument. It is calibrated up to 20.9 percent oxygen.

The MERF data acquisition system, based on a Hewlett-Packard 9830B calculator, receives the analyzer outputs and converts this information to actual emission concentrations which are printed out after each data point. Communications between the MERF operator and the engine operator's station is provided by a David Clark Company model U3400 utility intercom system.

A more detailed description of the MERF systems may be found in appendix D.

DESCRIPTION OF MERF OPERATION.

A multipoint calibration on each range of the MERF instrumentation is accomplished at least 30 days before testing, and each time major modifications or repairs are performed on the instruments.

A detailed startup, calibration, and operation procedure checklist for the MERF is included (appendix E).

The MERF carries a full complement of working gases including:

- zero gas - 99.999 percent pure nitrogen
- FID fuel - 40 percent hydrogen - 60 percent helium (less than 1 ppm THC)
- FID air - hydrocarbon free (less than 0.1 ppm THC)
- 951 H_x ozonator - 100 percent oxygen

All calibration gases are carried in treated aluminum cylinders. CO/CO₂/C₃H₈/O₂/N₂ are carried as multi-component mixtures in a single cylinder. All calibration gases have a blend tolerance of +0/-5 percent, analytical accuracy of ±1 percent of true value for concentrations greater than 100 ppm and ±2 percent of true value for concentrations less than 100 ppm. Before a new calibration gas is placed into operation it is compared to the existing calibration curves and National Bureau of Standards (NBS),

TABLE 2. TEST SEQUENCE FOR JT8D-7A ENGINES

<u>Mode</u>	<u>Power</u>	<u>Engine Pressure Ratio</u>	<u>%Power</u>	<u>Stabilization Time (min)</u>
1	Idle Out	—	—	20
2	Approach	1.25	30	10
3	Intermediate	1.50	60	5
4	Maximum Cruise	1.65	70	5
5	Maximum Exc. Takeoff	1.79	85	5
6	Takeoff	1.98	100	5
7	Idle In	—	—	20

Standard Reference Material (SRM) gases. All NBS/SRM bottles are less than 1 year old.

MERF OPERATIONAL PROCEDURES.

Prior to the start of actual testing for emissions on the JT8D-7A engine, concern was expressed by the contractor that the installation of the sample probe on the engine exhaust nozzle would create performance shifts. The magnitude of this performance shift was examined by the FAA (reference 4). It was determined that apart from the actual probe size (frontal area exposed to the airstream), the axial downstream probe location was a primary factor affecting the magnitude of the performance shift. The axial probe location, 7 inches downstream of the vertical plane of the nozzle, was chosen prior to testing. It has been shown that this probe location provides a representative emission sample for all species and has a minimal effect on engine performance. Two calibration engine runs were conducted with and without the probe. The performance shift was minimal and acceptable to the contractor. Subsequently, all engine acceptance and

emission sampling runs were conducted concurrently.

The sample probe was attached to the exhaust nozzle before the engine was mounted in the test cell. After mounting, the sample line was connected between the probe and the MERF and allowed to come up to 300°F. The MERF instrumentation was calibrated prior to engine start and again at the conclusion of the test. During all engine starts and shutdowns, the sample line was reverse flushed with nitrogen gas to preclude any fuel from entering the sample train.

RESULTS

GENERAL COMMENTS.

Aircraft gas turbine engine emission tests were conducted to provide the following categories of data:

1. Baseline data for each power mode specified in the Landing Takeoff (LTO) test cycle.

TABLE 3. SUMMARY OF MAINTENANCE PERFORMED ON PAN AM JT8D-7A TURBOFAN ENGINES

<u>Test Order No.</u>	<u>JT8D Engine Serial Number</u>	<u>Plotting Symbol</u>	<u>Date</u>	<u>Low Compressor</u>	<u>High Compressor</u>	<u>Diffuser Case</u>	<u>Fuel Nozzles</u>	<u>Burner Cans</u>	<u>Transition Duct</u>	<u>1st NGV's</u>	<u>High Turbine</u>	<u>Low Turbine</u>	<u>Exhaust Case</u>	<u>Overhaul Standard</u>	<u>Total Operating Hours</u>
				Meet Overhaul	Manual Limits										
1	653571	⊙	11/29/78	x	x	x	x	x	x	x	x	x	Repair	On Cond.	19,058
2	649652	⊠	11/30/78	x	x	x	x	x	x	x	x	x	Repair	On Cond.	20,008
3	654397	⊞	12/12/78	2573 hrs.	2573 hrs.	x	x	x	x	x	x	x	Repair	On Cond.	16,885
4	649609	△	12/15/78	x	x	x	x	x	x	x	x	x	Repair	On Cond.	20,881
5	653394	▲	01/11/79	NO	x	x	x	x	x	x	x	x	Repair	On Cond.	21,762
6	653357	◇	02/06/79	x	NO	NO	NO	NO	NO	NO	x	x	x	On Cond.	20,510
*	653357		01/30/79	NO	x	NO	x	x	x	x	x	No	No	On Cond.	
7	653792	⊡	02/09/79	NO	x	x	x	x	x	x	x	x	Repair	On Cond.	W/A

*This engine failed acceptance for vibration.
xIndicates replaced.

TABLE 4. SUMMARY OF AMBIENT TEST CONDITIONS

	<u>Compressor Inlet Temperature T_{T2}-°F</u>	<u>Compressor Inlet Pressure (P_{T2}-in/Hg)</u>	<u>Dew Point (Grains H₂O/lb_{air})</u>
Minimum	17	29.60	5
Maximum	42	30.56	20

TABLE 5. AVERAGE EMISSION RATE LEVELS MEASURED

	<u>Idle Out (σ₁)</u>	<u>Takeoff (100%) (σ₁)</u>	<u>Climb (85%) (σ₁)</u>	<u>Approach (30%) (σ₁)</u>	<u>Idle In (σ₁)</u>
CO (LB/HR)	30.99 (3.66)	9.74 (2.1)	9.49 (2.5)	19.69 (5.22)	32.25 (2.85)
THC (LB/HR)	8.92 (1.27)	3.17 (0.71)	3.42 (0.76)	3.80 (1.57)	8.80 (1.01)
NO _x (LB/HR)	3.84 (1.29)	156.81 (11.06)	111.03 (11.91)	16.79 (3.97)	3.27 (1.33)

where σ₁ = standard deviation.

2. Maintenance and overhaul data to evaluate the effects of engine reconditioning work on exhaust emission levels.

RESULTS OF BASE LINE TESTS (LTO CYCLE EFFECTS).

Based on an analysis of the factors affecting gas turbine engine emissions (i.e., time in mode, ambient conditions, exhaust fuel/air ratio), it can be shown that the mode conditions having the greatest influence on the gross pollutant levels produced by the combustion process are idle and approach with regard to carbon monoxide (CO) and total hydrocarbons THC while the takeoff and climb modes produce the highest NO_x (table 5).

Figures 5, 6, and 7 present baseline data in bargraph form. These figures compare the total emission characteristics (EPA parameter) of all

the Pan Am JT8D-7A engines tested as a function of the EPA standard in terms of percent of standard. The average emission rate (ER) data that were utilized to develop the "average of seven engines" in figures 5, 6, and 7 are tabulated in summary form in table 5.

The data from the overhauled engines are also compared to new JT8D-9 engine data (reference 6) which were obtained by the FAA from the EPA. The new data were provided to the EPA by PWA. Both the new engine data and the overhauled engine data were measured using JT8D engines. The comparison of the emissions characteristics is shown in figure 8. From the figure it can be seen that the mid-points of the maximum and minimum values for each emission species (i.e., new engine CO mid-point versus overhauled engine CO mid-point) are approximately the same. The data scatter was generally uniform between

the maximum and minimum values. Maximum and minimum values were shown in this figure (in lieu of one standard deviation variability) because the Federal Register states that all engines must meet the standard. It can be seen that the mid-points of all the species exceed the Federal limit. THC exceeds the Federal limit by over 500 percent, CO by over 225 percent, and NO_x by 200 percent. Both sets of bargraphs show an overlapping trend which indicates that the two sets of data are generally similar and exhibit output levels which are in reasonable agreement. The new engine data show a greater spread in the total hydrocarbon pollutant because (1) the PWA engine test data represent a data base measured from a greater number of engines, and (2) THC measurement technology was not as well developed (as it is currently) when the data for the new engines, that were utilized in this report, were collected. The FAA data measured at the Pan Am, New York facility, and using Pan Am overhauled engines represent a data base derived from seven engines.

Figures 9, 10, and 11 provide additional data presentations in terms of Emission Indices (EI). They also illustrate the considerable data scatter at the idle power condition (approximately 7,000 rpm on N₂) for the CO and THC species.

In conclusion, it can be noted that the seven Pan Am JT8D-7A engines tested and evaluated under this project work effort did not meet the EPA engine standard (reference 1). However, the data do show that overhauled engines of the type tested produce emission levels which are similar and comparable to the emission levels of new engines. Spot checks could readily be made at periodic intervals using equipment, instrumentation, and test procedures defined and described in this report. A spot check test of an engine should not take more than 2 to 3 hours (maximum). This would

include the time required to install and remove the test probe and make the necessary hook-up of the probe sample line to the MERF. The test run, itself, should not take more than one to one and a half hours and should follow the basic format of the landing take off (LTO) cycle described herein.

SUMMARY OF RESULTS

1. The seven JT8D-7A aircraft gas turbine engines tested under this project did not meet the EPA standards.
2. The variability of the CO and NO_x emission data produced by the seven JT8D engines under this project is similar to the variability measured by PWA in new production engines. However, the new engine THC variability was significantly greater than the overhauled engines.
3. Satisfactory data can be measured by using the test procedures, instrumentation, and equipment defined by this report.

CONCLUSIONS

The following conclusions are based on the testing accomplished with the Pan Am owned JT8D-7A aircraft gas turbine engines.

1. Data variability in the measurement of aircraft gas turbine engine exhaust emissions between new production and overhauled engines appears to be very similar.
2. If an engine is properly overhauled the emission levels produced by that engine should be at an output level that is comparable to a newly manufactured engine.

REFERENCES

1. Clean Air Amendments of 1970, Public Law 91-604, 91st Congress, H.R. 17255, December 31, 1970.
2. Control of Air Pollution from Aircraft and Aircraft Engines, Federal Register, Volume 38, Number 136, Part II, July 17, 1973.
3. JT8D Commercial Turbofan Engine Installation Handbook, Pratt and Whitney Aircraft, December 1960, Revised September 1971.
4. Slusher, G. R., Emission Sample Probe Investigation of a Mixed Flow JT8D-11 Turbofan Engine, FAA Technical Report FAA-RD-77-175, July 1978.
5. Aircraft Piston Engine Exhaust Emissions Symposium, National Aeronautics and Space Administration Publication NASA CP-2005, September 1976.
6. Letter of Transmittal from Pratt and Whitney Aircraft to Environmental Protection Agency, May 20, 1972, Attachments 1, 2, and 3.

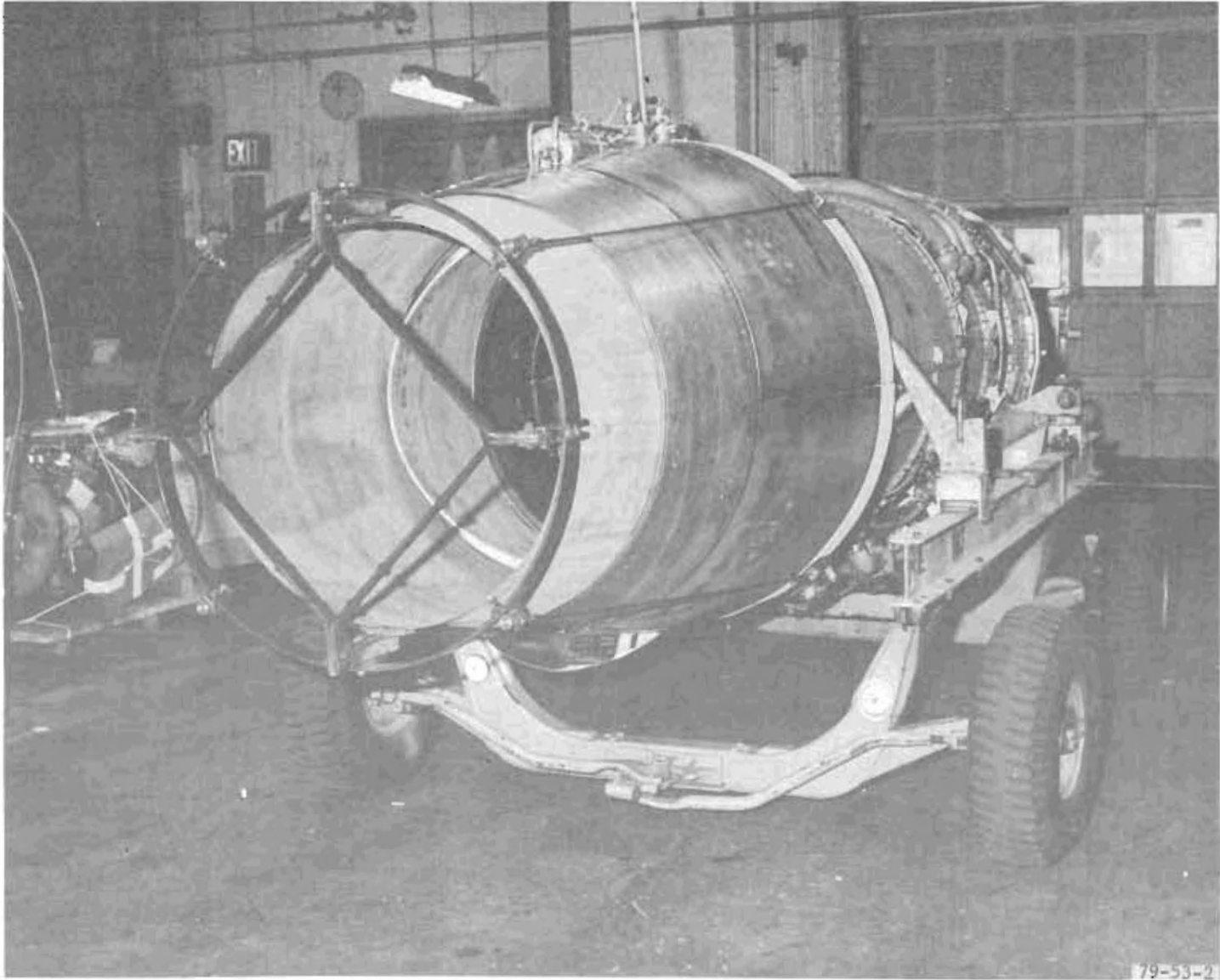

FIGURE 1. QUARTERING VIEW OF FAA EMISSION MEASUREMENT PROBE (DIAMOND SHAPED)
INSTALLED ON THE EXHAUST NOZZLE OF A JT8D-7A TURBOFAN ENGINE

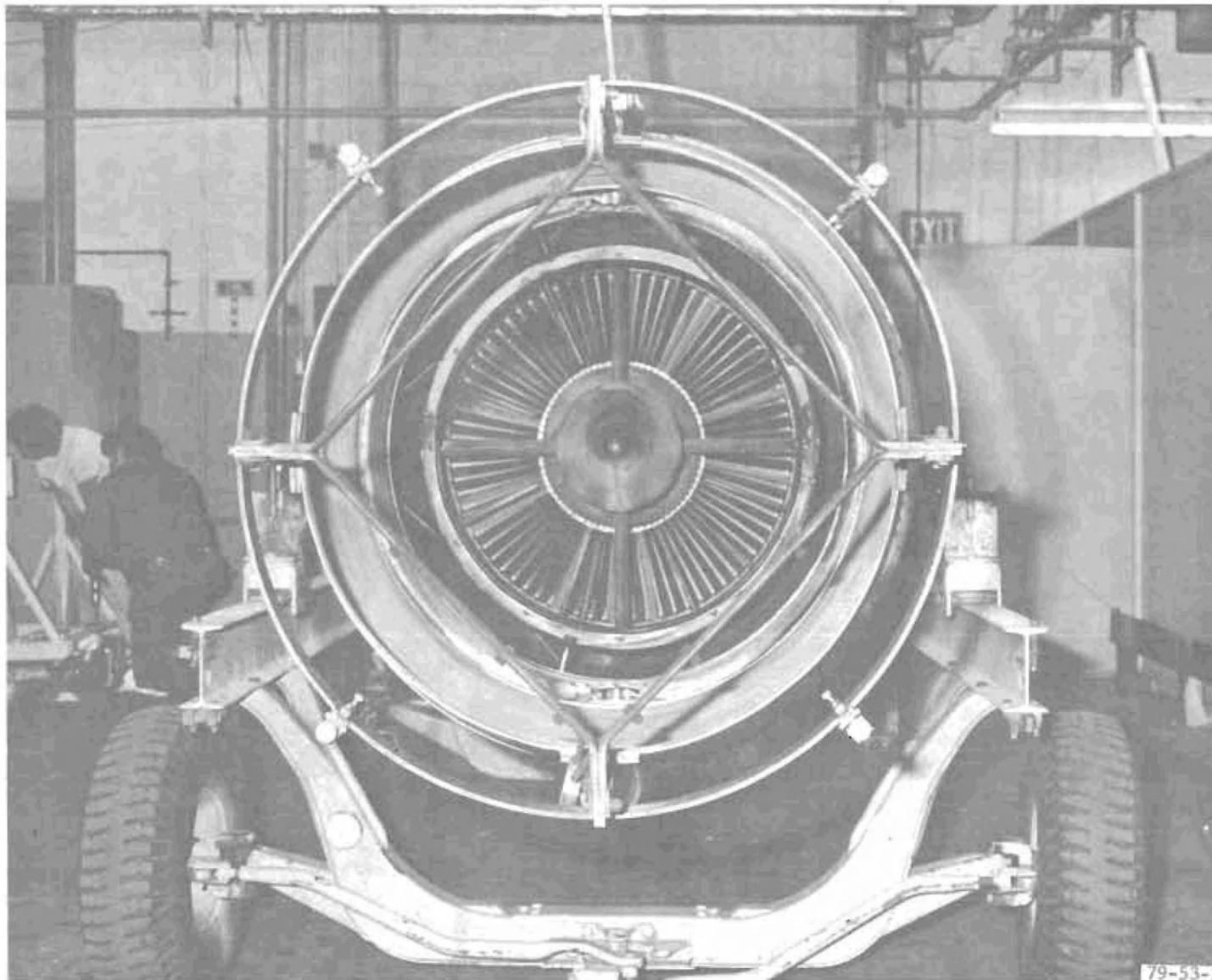

FIGURE 2. VIEW LOOKING FORWARD--INSTALLATION OF FAA EMISSION MEASUREMENT PROBE (DIAMOND SHAPED) INSTALLED ON THE EXHAUST NOZZLE OF A JT8D-7A TURBOFAN ENGINE

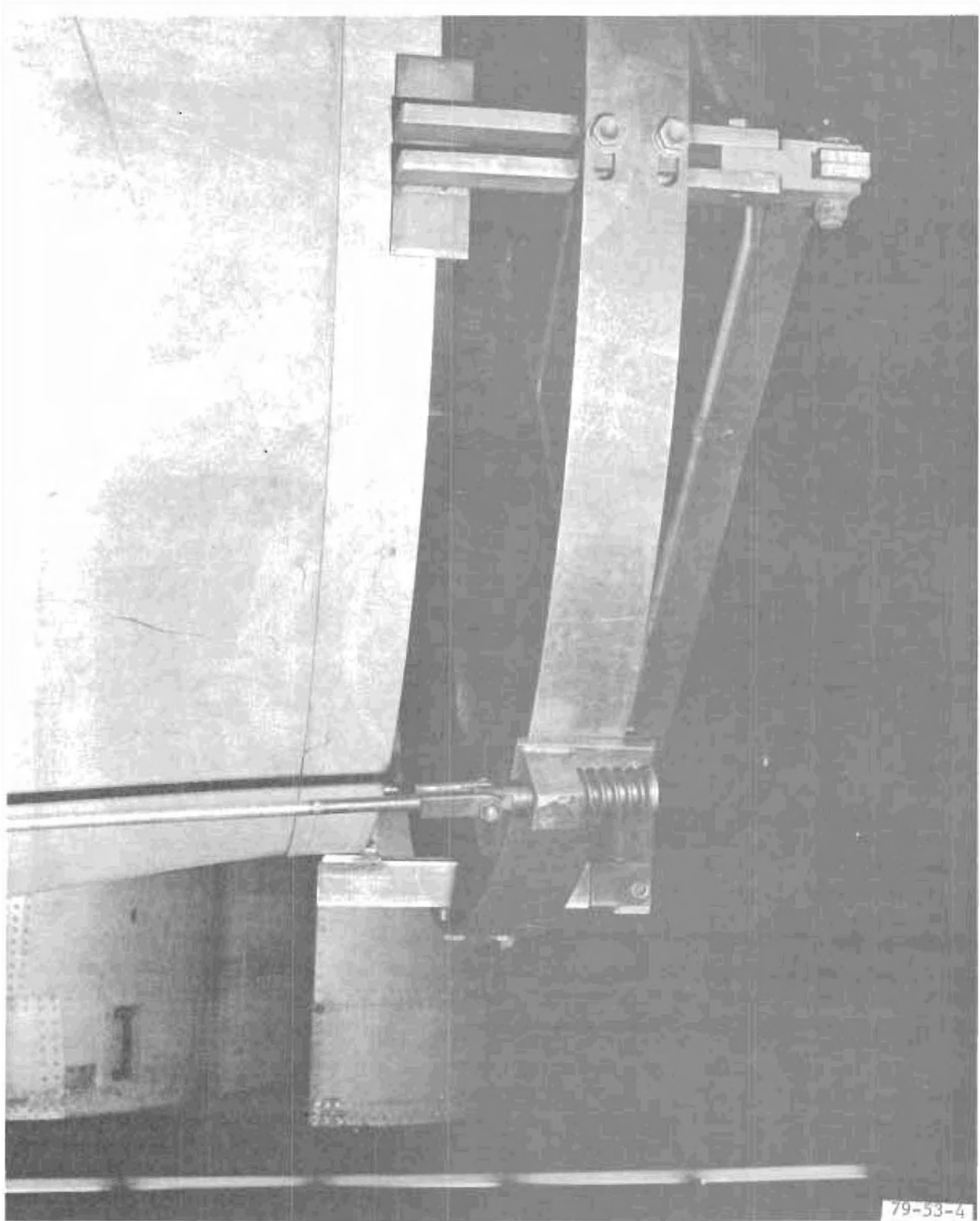

FIGURE 3. INSTALLED VIEW OF FAA EMISSION MEASUREMENT PROBE SHOWING MOUNTING AND SUPPORT DETAILS



FIGURE 4. THE FAA'S MOBILE EMISSION RESEARCH FACILITY (MERF) WITH TOW VEHICLE

NOTES:

1. ENGINE NO. 3 WAS OPERATED WITH A HIGH IDLE SETTING.
2. THE AVERAGE TOTAL TIME PER ENGINE WAS 19,000 HRS.

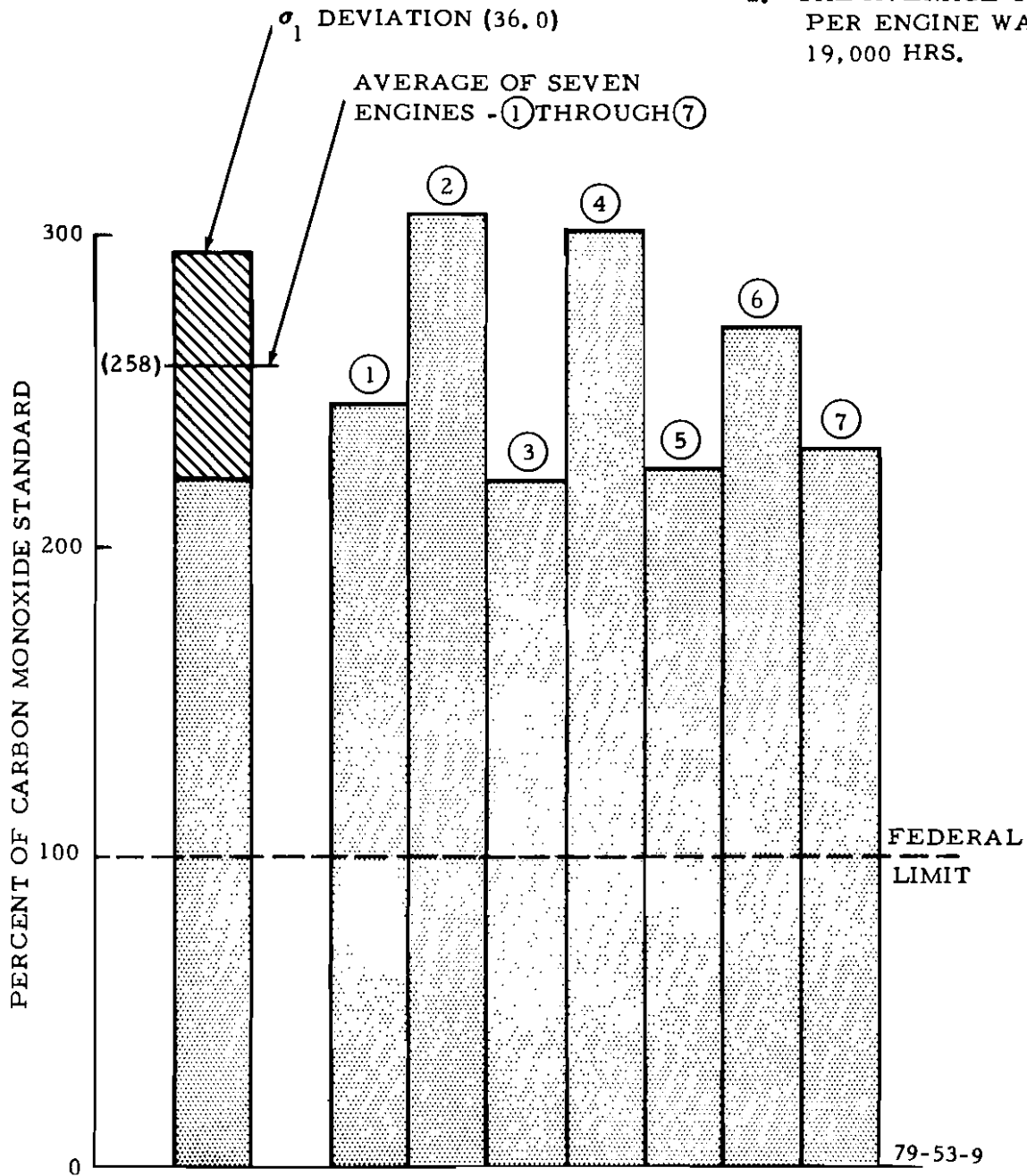

FIGURE 5. TOTAL EMISSION CHARACTERISTICS--CARBON MONOXIDE (CO)--SEVEN PWA JT8D-7A ENGINES AFTER OVERHAUL

NOTES:

1. ENGINE NO. 3 WAS OPERATED WITH A HIGH IDLE SETTING.
2. THE AVERAGE TOTAL TIME PER ENGINE WAS 19,000 HRS.

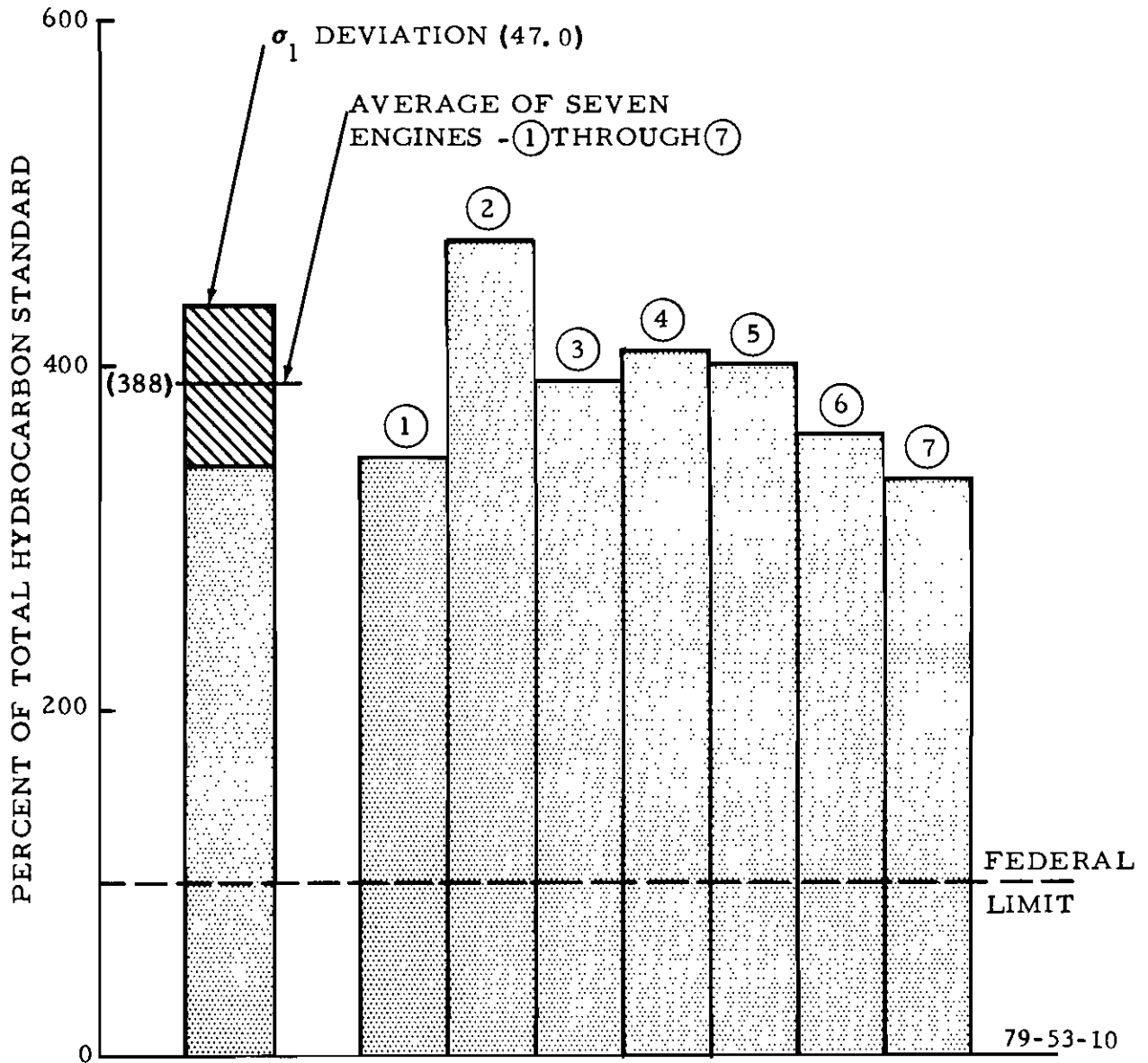

FIGURE 6. TOTAL EMISSION CHARACTERISTICS--UNBURNED HYDROCARBONS (THC)--SEVEN PWA JT8D-7A ENGINES AFTER OVERHAUL

NOTES:

1. ENGINE NO. 3 WAS OPERATED WITH A HIGH IDLE SETTING
2. THE AVERAGE TOTAL TIME PER ENGINE WAS 19,000 HRS.

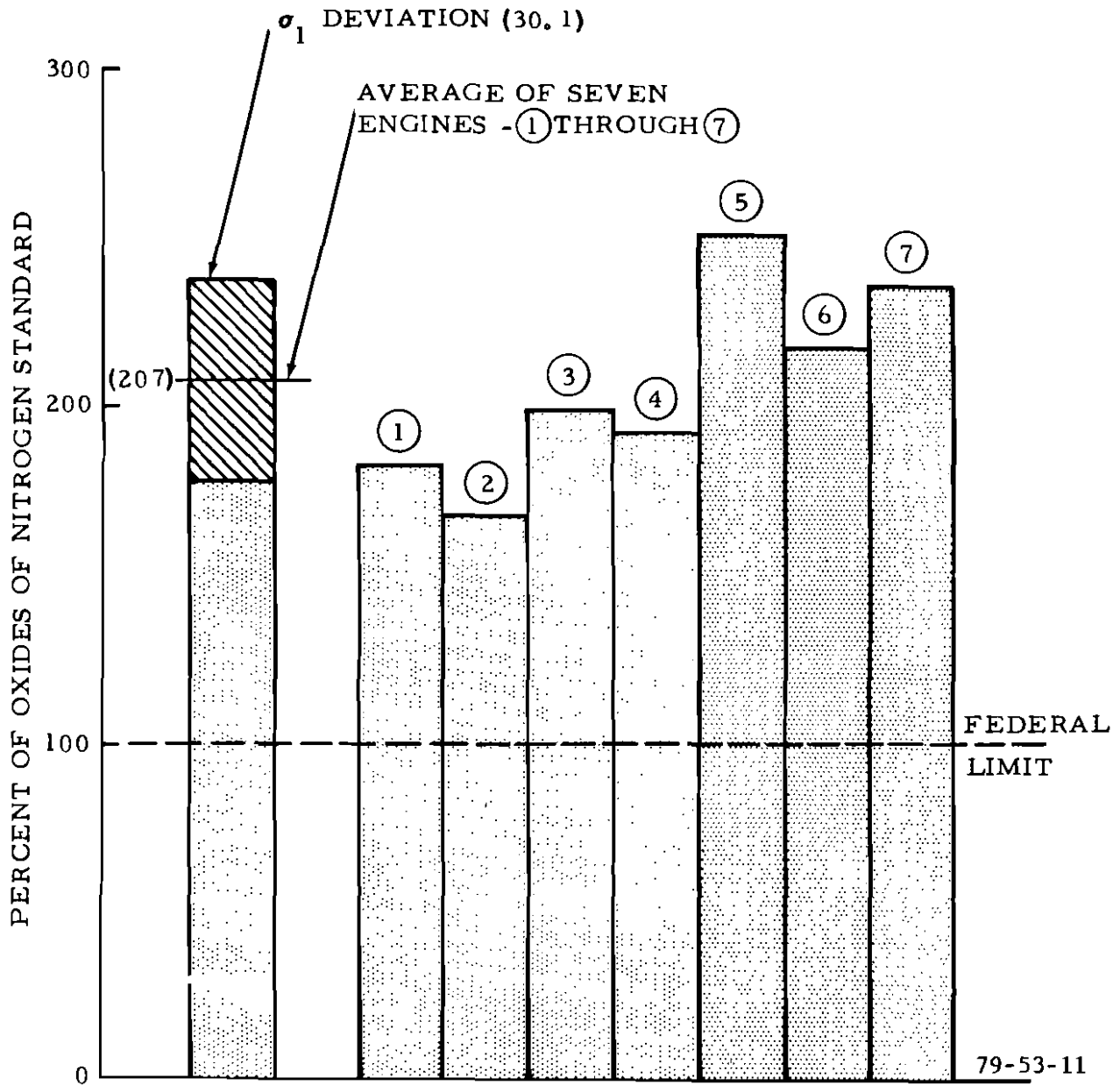

FIGURE 7. TOTAL EMISSION CHARACTERISTICS--OXIDES OF NITROGEN (NO_x)--SEVEN PWA JT8D-7A ENGINES AFTER OVERHAUL

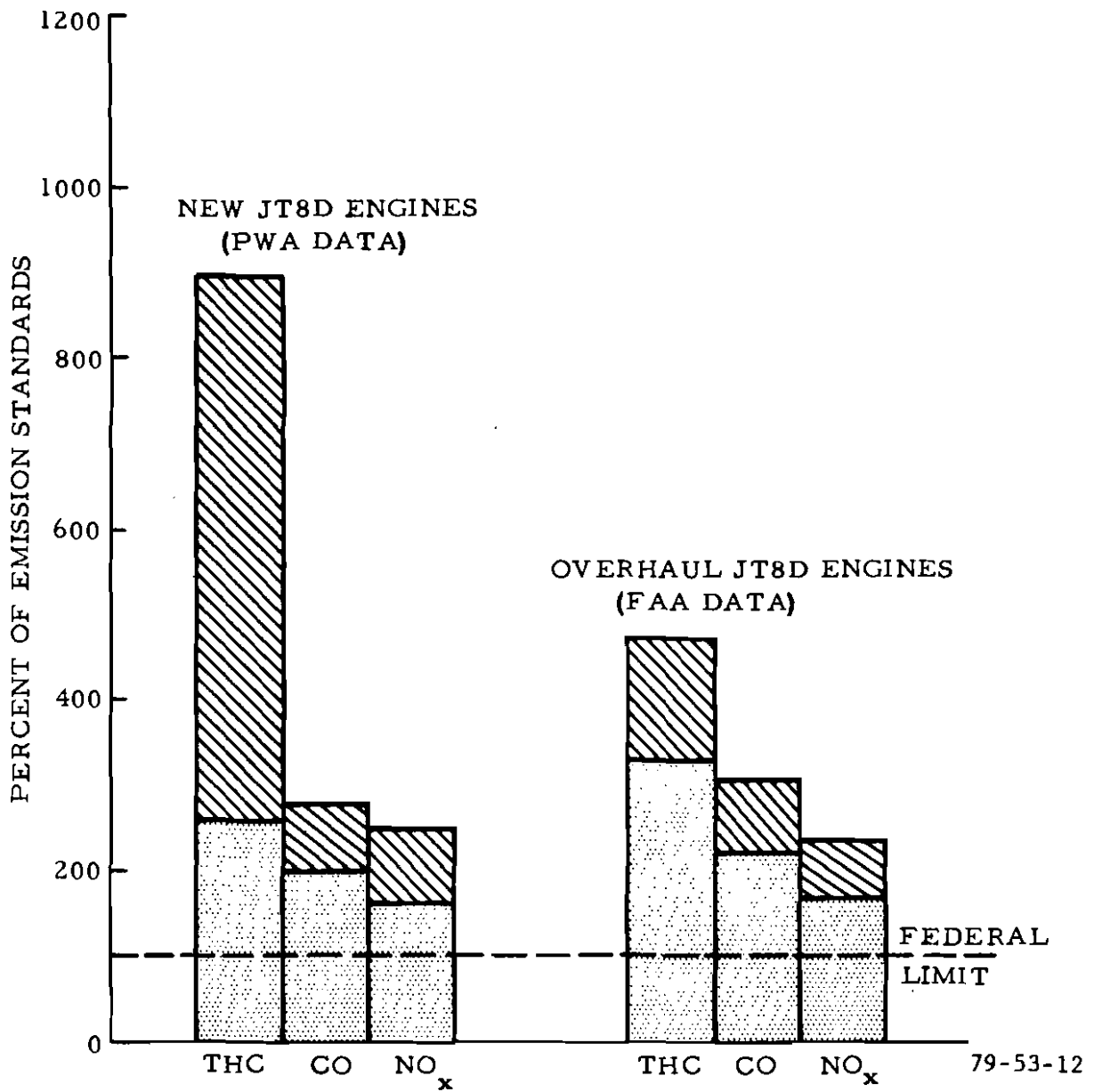

FIGURE 8. COMPARISON OF JT8D ENGINE EXHAUST EMISSION CHARACTERISTICS
 --NEW ENGINE DATA VERSUS OVERHAULED ENGINE DATA

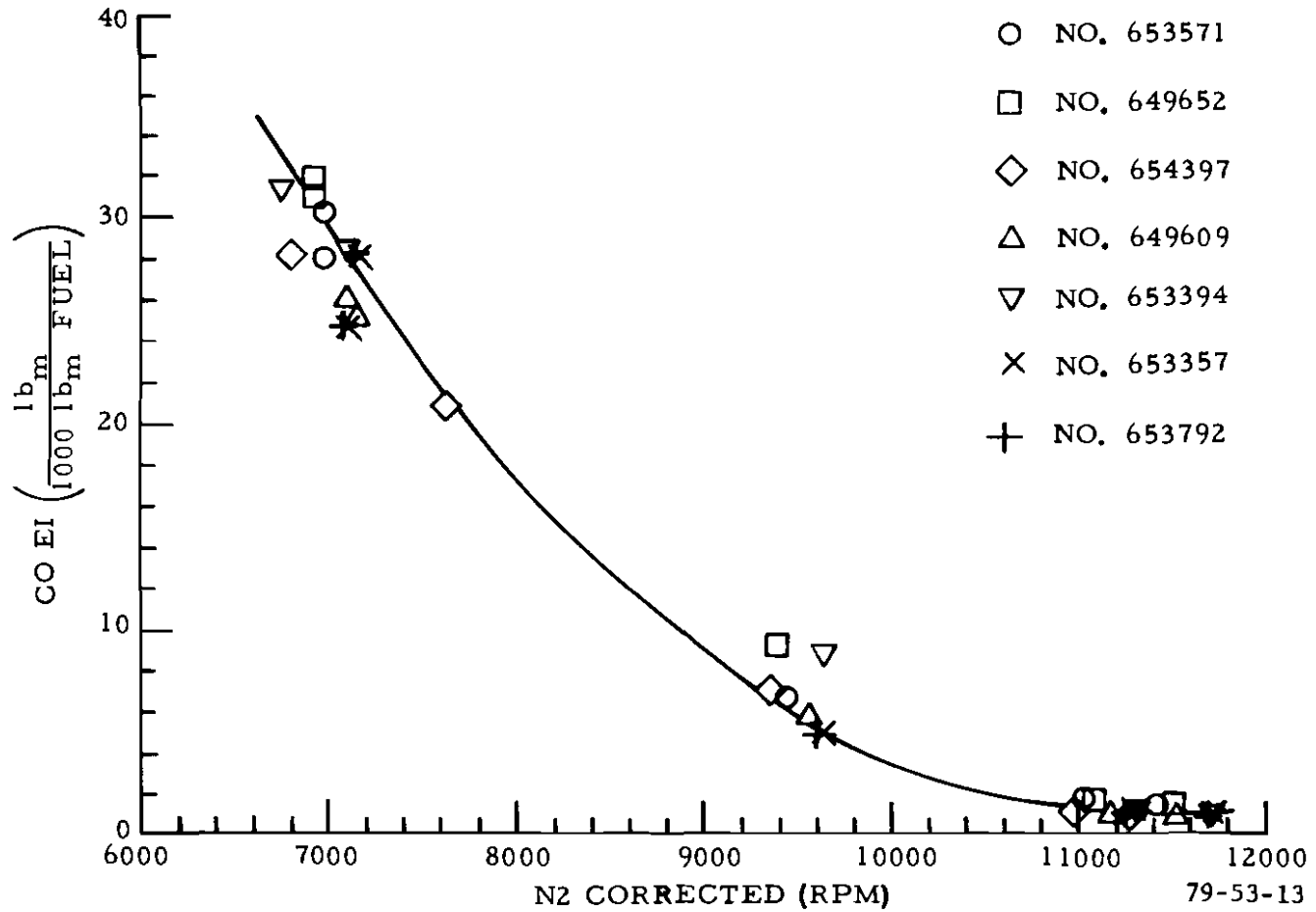

FIGURE 9. VARIABILITY IN CARBON MONOXIDE EXHAUST EMISSIONS--JT8D-7A ENGINES

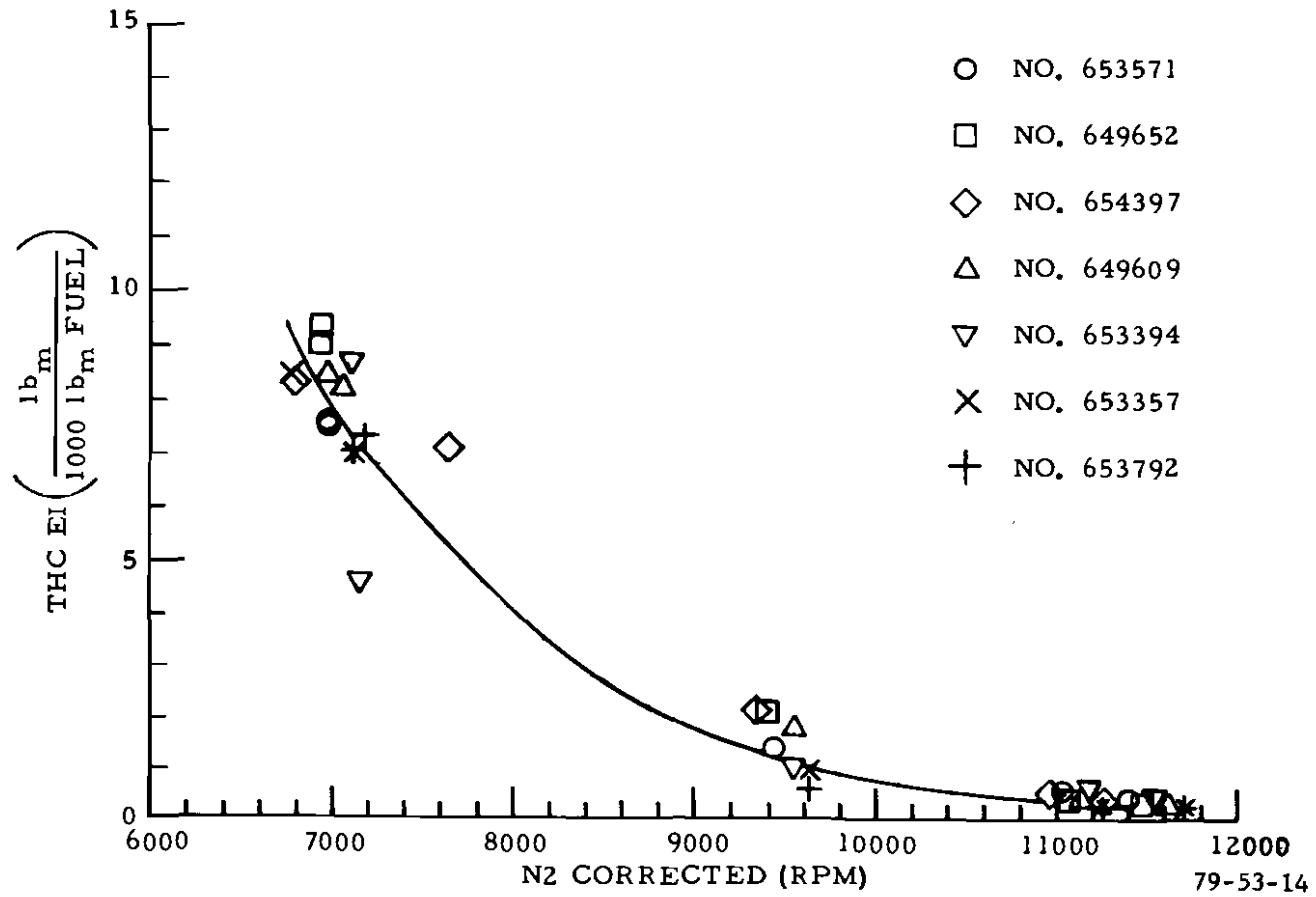

FIGURE 10. VARIABILITY IN UNBURNED HYDROCARBON EXHAUST EMISSIONS--JT8D-7A ENGINES

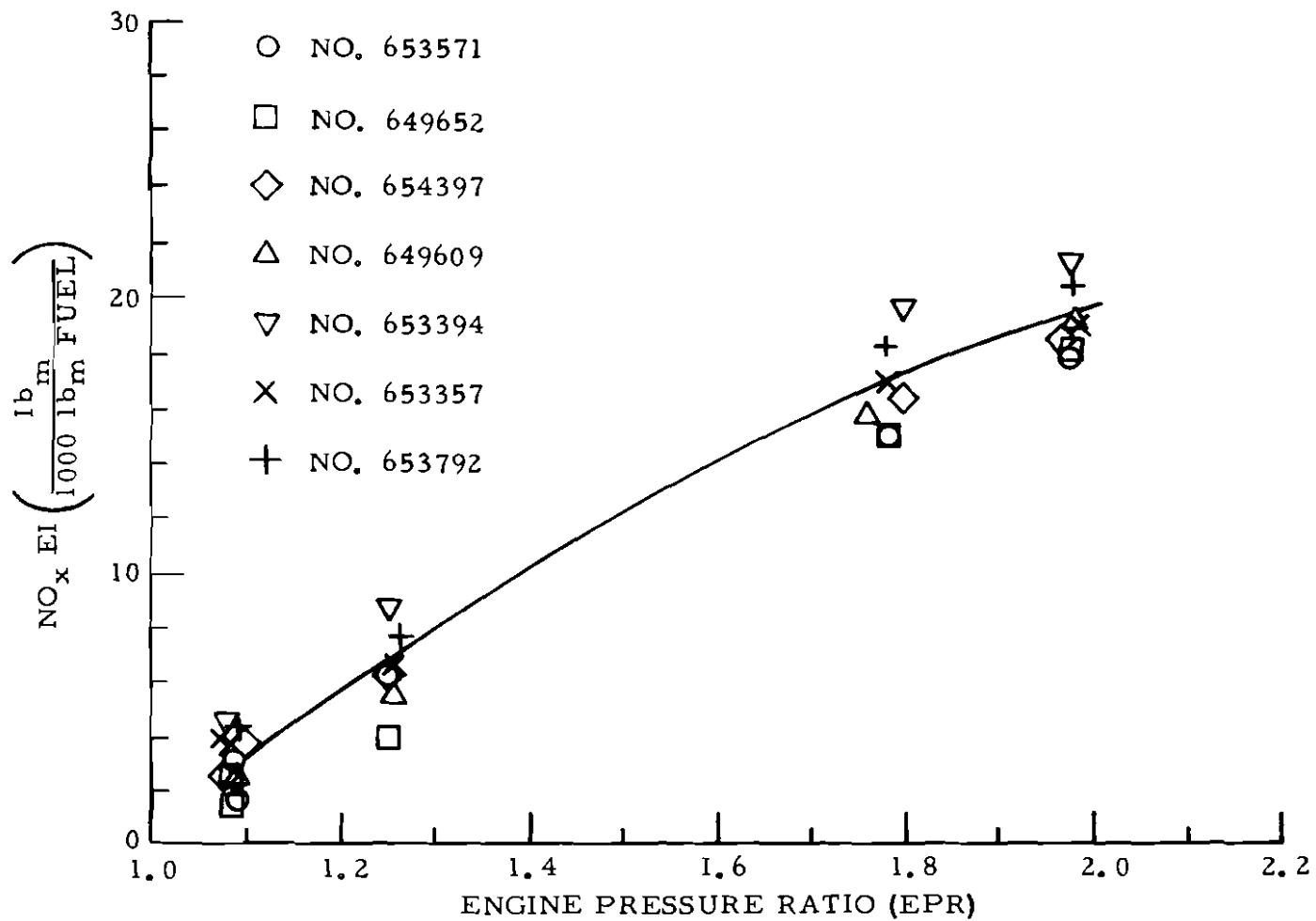

FIGURE 11. VARIABILITY IN OXIDES OF NITROGEN EXHAUST EMISSIONS--JT8D-7A ENGINES

APPENDIX A

EQUATIONS FOR CALCULATING EMISSIONS RESULTS

Equations for Calculating Weight of Emissions: These equations use fuel consumption data and emission concentration values that are expressed on either wet (actual) or dry basis of measurement. However, within any one equation, the bases of measurement must be consistent for all species.

$$ER_{CO} = \frac{M_{CO} \frac{CO}{10^4} F}{(M_C + \alpha M_H) \left(\frac{CO}{10^4} + CO_2 + \frac{C}{10^4} \right)}$$

$$ER_{HC} = \frac{\frac{C}{10^4} F}{\frac{CO}{10^4} + CO_2 + \frac{C}{10^4}}$$

$$ER_{NO_x(\text{as } NO_2)} = \frac{M_{NO_2} \frac{NO_x}{10^4} F}{(M_C + \alpha M_H) \left(\frac{CO}{10^4} + CO_2 + \frac{C}{10^4} \right)}$$

where ER = Emission Rate

APPENDIX B

RAW ENGINE AND EMISSION DATA

TABLE B-1. ESN- 653571

TEST DATE- 11-29-78

MODE		1	2	3	4	5	6	7
<u>POWER</u>		<u>IDLE OUT</u>	<u>APPROACH</u>	<u>INTER-MEDIATE</u>	<u>MAXIMUM CRUISE</u>	<u>MAXIMUM EXCEPT T.O.</u>	<u>TAKE OFF</u>	<u>IDLE IN</u>
EPR		--	1.25	1.51	1.66	1.78	1.98	
Tt ₂	°F	36	35	35	35	35	35	
Pt ₂	in./HgA	30.36	30.35	30.33	30.31	30.30	30.30	
N ₁	RPM	2818	5252	6595	7083	7391	7897	
N ₂	RPM	6834	9213	10163	10550	10775	11134	
W _f	Lbs/Hr	1030	2535	4495	5695	6535	7975	
F _n	Lbs	1011	4230	7860	10026	11328	13443	
EGT	°C	340	328	398	443	469	513	
% CO ₂	(DRY)	0.38	0.37	0.64	0.92	1.18	1.58	0.38
CO	- PPM (DRY)	61.5	15	10	12.6	13	12.6	66.5
THC	- PPM (WET)	34.2	10.66	7.38	7.21	6.23	5.88	33.66
NO _x	- PPM (WET)	2.9	5.58	16.07	28.55	41.15	69.6	1.51

B-1

TABLE B-2. ESN- 649652

TEST DATE- 11-30-78

MODE		1	2	3	4	5	6	7
<u>POWER</u>		<u>IDLE OUT</u>	<u>APPROACH</u>	<u>INTER- MEDIATE</u>	<u>MAXIMUM CRUISE</u>	<u>MAXIMUM EXCEPT T.O.</u>	<u>TAKE OFF</u>	<u>IDLE IN</u>
EPR		1.085	1.25	1.505	1.625	1.78	1.98	
Tt ₂	°F	42	41	41	41	41	41	
Pt ₂	in./HgA	29.95	29.92	29.91	29.91	29.90	29.89	
N ₁	RPM	2857	5273	6619	7097	7456	8006	
N ₂	RPM	6830	9229	10206	10605	10878	11304	
W _F	Lbs/Hr	1145	2580	4525	5640	6600	8155	
F _n	Lbs	993	4107	7734	9624	11091	13224	
EGT	°C	366	346	419	460	490	536	
% CO ₂	(DRY)	0.28	0.25	0.58	0.84	1.12	1.53	0.27
CO	- PPM (DRY)	50	13.2	11.5	11.2	11.4	12	47
THC	- PPM (WET)	28.84	8.87	5.99	5.16	4.59	4.92	26.89
NO _x	- PPM (WET)	1.03	2.51	14.13	26.5	41.25	71.02	1.03

TABLE B-3. ESN- 654397

TEST DATE- 12-12-78

MODE	1	2	3	4	5	6	7
<u>POWER</u>	<u>IDLE OUT</u>	<u>APPROACH</u>	<u>INTER- MEDIATE</u>	<u>MAXIMUM CRUISE</u>	<u>MAXIMUM EXCEPT T.O.</u>	<u>TAKE OFF</u>	<u>IDLE IN</u>
EPR	1.10	1.25	1.50	1.63	1.80	1.97	1.08
Tt ₂ °F	39	38	38	38	38	38	39
Pt ₂ in./HgA	30.29	30.28	30.27	30.25	30.25	30.24	30.31
N ₁ RPM	3313	5244	6558	6976	7430	7849	2708
N ₂ RPM	7489	9157	10076	10395	10740	11036	6681
W _f Lbs/Hr	1360	2605	4585	5595	6880	8140	1090
F _n Lbs	1428	4146	7683	9411	11484	13152	894
EGT °C	365	327	396	428	468	503	365
% CO ₂ (DRY)	0.28	0.25	0.60	0.82	1.17	1.49	0.30
CO - PPM (DRY)	33	10.3	8.2	7.5	8.2	8.2	45.1
THC - PPM (WET)	22.57	9.77	7.91	6.3	5.9	5.78	28.62
NO _x - PPM (WET)	2.63	3.78	14.85	26.1	45.62	69.32	1.92

TABLE B-4. ESN- 649609

TEST DATE- 12-15-78

MODE		1	2	3	4	5	6	7
<u>POWER</u>		<u>IDLE OUT</u>	<u>APPROACH</u>	<u>INTER- MEDIATE</u>	<u>MAXIMUM CRUISE</u>	<u>MAXIMUM EXCEPT T.O.</u>	<u>TAKE OFF</u>	<u>IDLE IN</u>
EPR		1.09	1.255	1.50	1.57	1.76	1.98	1.09
Tt ₂	°F	42.5	42	42	42	42	42	44.0
Pt ₂	in./HgA	29.98	29.96	29.95	29.95	29.94	29.93	29.98
N ₁	RPM	2851	5294	6587	6817	7356	7921	2824
N ₂	RPM	6950	9387	10347	10535	10991	11417	6870
W _f	Lbs/Hr	1120	2590	4520	5030	6510	8210	1060
F _n	Lbs	1000	4194	7653	8556	10970	13314	960
EGT	°C	350	337	403	421	472	522	350
% CO ₂	(DRY)	0.39	0.36	0.72	0.82	1.20	1.62	0.38
% O ₂	(DRY)	20.53	20.53	20.02	19.85	19.33	18.71	20.45
CO	- PPM (DRY)	66.93	21.72	17.17	16.04	14.75	14.31	71.58
THC	- PPM (WET)	34.89	10.24	6.83	5.74	5.22	5.14	34.35
NO _x	- PPM (WET)	2.64	5.09	19.51	25.07	46.72	79.71	2.69

TABLE B-5. ESN- 653394

TEST DATE- 1-11-79

MODE		1	2	3	4	5	6	7
POWER		<u>IDLE OUT</u>	<u>APPROACH</u>	<u>INTER- MEDIATE</u>	<u>MAXIMUM CRUISE</u>	<u>MAXIMUM EXCEPT T.O.</u>	<u>TAKE OFF</u>	<u>IDLE IN</u>
EPR		1.08	1.25	1.50	1.64	1.80	1.98	1.08
Tt ₂	°F	23	23	23	22	22	22	23
Pt ₂	in./HgA	30.45	30.52	30.51	30.50	30.49	30.47	30.54
N ₁	RPM	2874	5273	6519	6922	7347	7821	2841
N ₂	RPM	6900	9224	10113	10433	10772	11108	6862
W _f	Lbs/Hr	1090	2595	4455	5455	6645	8020	1075
F _n	Lbs	1041	4323	7812	9567	11535	13467	996
EGT	°C	318	312	375	406	445	483	316
% CO ₂	(DRY)	0.29	0.30	0.62	0.75	1.09	1.41	0.28
% O ₂	(DRY)	20.7	21.01	20.28	20.27	19.70	18.99	20.71
CO	- PPM (DRY)	44.92	11.53	8.97	7.96	7.67	7.93	44.98
THC	- PPM (WET)	34.35	10.32	7.71	6.46	6.32	6.17	33.74
NO _x	- PPM (WET)	3.05	5.86	18.91	32.79	46.56	71.65	2.83

TABLE B-6. ESN- 653357

TEST DATE- 2-6-79

MODE		1	2	3	4	5	6	7
<u>POWER</u>		<u>IDLE OUT</u>	<u>APPROACH</u>	<u>INTER-MEDIATE</u>	<u>MAXIMUM CRUISE</u>	<u>MAXIMUM EXCEPT T.O.</u>	<u>TAKE OFF</u>	<u>IDLE IN</u>
EPR		1.07	1.255	1.50	1.645	1.78	1.985	1.08
Tt ₂	°F	29	27	26	25	25	25	27
Pt ₂	in./HgA	30.15	30.13	30.11	30.11	30.09	30.08	30.15
N ₁	RPM	2571	5214	6459	6903	7253	7802	2808
N ₂	RPM	6571	9332	10258	10625	10922	11311	6889
W _f	Lbs/Hr	980	2540	4360	5404	6395	7940	1070
F _n	Lbs	875	4320	7620	9570	11166	13335	975
EGT	°C	341	312	373	409	442	488	340
% CO ₂	(DRY)	0.47	0.39	0.75	1.02	1.27	1.64	0.42
% O ₂	(DRY)	20.36	20.47	19.94	19.59	19.19	18.39	20.39
CO	- PPM (DRY)	89.44	22.5	14.47	12.3	11.58	12.07	72.15
THC	- PPM (WET)	52.47	10.56	5.43	4.37	4.00	3.93	38.64
NO _x	- PPM (WET)	4.43	6.02	19.66	32.94	48.33	76.35	3.73

TABLE B-7. ESN- 653792

TEST DATE- 2-9-79

MODE		1	2	3	4	5	6	7
<u>POWER</u>		<u>IDLE OUT</u>	<u>APPROACH</u>	<u>INTER- MEDIATE</u>	<u>MAXIMUM CRUISE</u>	<u>MAXIMUM EXCEPT T.O.</u>	<u>TAKE OFF</u>	<u>IDLE IN</u>
EPR		1.08	1.26	1.50	1.65	1.78	1.98	1.09
Tt ₂	°F	18.0	18.0	17.4	16.7	17.6	16.6	19.4
Pt ₂	in./HgA	30.08	30.07	30.04	30.03	30.02	30.01	30.08
N ₁	RPM	2802	5214	6458	6892	7246	7788	2846
N ₂	RPM	6821	9241	10166	10526	10829	11225	6899
W _f	Lbs/Hr	1090	2555	4385	5390	6380	7875	1080
F _n	Lbs	1008	4260	7632	9438	11085	13215	1014
EGT	°C	331	311	375	408	440	484	324
% CO ₂	(DRY)	0.41	0.35	0.66	0.91	1.19	1.57	0.39
% O ₂	(DRY)	20.34	20.43	20.01	19.58	19.13	18.5	20.5
CO	- PPM (DRY)	64.48	12.33	9.27	12.34	12.3	11.66	69.86
THC	- PPM (WET)	43.19	8.79	5.34	3.85	4.13	3.82	42.88
NO _x	- PPM (WET)	3.76	5.74	17.49	29.68	44.83	73.95	3.68

APPENDIX C

FUEL ANALYSIS

Fourth Quarter 1978

	ETF A (FN 72)		
	<u>Min.</u>	<u>Avg.</u>	<u>Max.</u>
<u>Acidity (mg. KOH/gm)</u>			
Total	0.001	0.003	0.005
Inorganic	--	NIL	--
<u>Appearance</u>			
	CLEAR AND BRIGHT		
Aromatics, Vol. %	17	19	20*
Color, Saybolt	19	26	30
Corrosion - Copper Strip, 2 hr. @ 212° F	--	J-1	--
<u>Distillation</u>			
10% Evaporated, °F	356	372	386
20% Evaporated, °F	375	382	402
50% Evaporated, °F	412	425	436
90% Evaporated, °F	454	474	486
95% Evaporated, °F	466	485	498
Final Boiling Point, °F	488	500	528
Residue, Vol. %	1.0	1.0	1.0
Loss, Vol. %	1.0	1.0	1.0
Flash Point, °F	108	118	124
Freezing Point, °F	(-43)	(-47)	(-53)
Gravity, °API	40.5	42.7	45.0
<u>Gum Content - mg./100ml.</u>			
Accelerated	--	--	--
Existent	0.3	0.5	0.7
<u>Heat of Combustion, Net</u>			
BTU/lb.	18470	18485	18515
BTU/U.S. Gal.	--	--	--
Luminometer Number	45	47	50
Naphthalene Hydrocarbons, Vol. %	--	--	--
Olefins, Vol. %	0.3	0.5	0.9
Pour Point, °F	--	--	--
Smoke Point, mm	--	--	--
<u>Sulphur Content, Wt. %</u>			
Mercaptan	0.001	0.002	0.003
Total	0.10	0.13	0.18
<u>Thermal Stability @ 300/400° F</u>			
Change in Pressure Drop in 5 Hrs., "Hg"	0.3	0.5	1.0
Preheater Deposits	0	0	0
<u>Viscosity, Centistokes (Kinematic)</u>			
@ °F	--	--	--
@ -30° F	8.8	10.7	12.5
<u>Water Interaction</u>			
Ml. Change	0.5	0.5	0.5
Rating of Fuel Interface	1-B	1-B	1-B
W.S.I.M.	92	96	98

FUEL ANALYSIS

First Quarter 1979

Grade & Formula No.	ETF A (FN 72)		
	Min.	Avg.	Max.
<u>Acidity (mg. KOH/gm)</u>			
Total	0.003	0.006	0.011
Inorganic	--	Nil	--
<u>Appearance</u>			
CLEAR AND BRIGHT			
Aromatics, Vol. %	16	18	20*
Color, Saybolt	18	21	28
Corrosion - Copper Strip, 2 hr. @ 212° F	--	J-1	--
<u>Distillation</u>			
10% Evaporated, °F	348	355	369
20% Evaporated, °F	363	369	378
50% Evaporated, °F	412	415	422
90% Evaporated, °F	470	478	488
95% Evaporated, °F	478	490	504
Final Boiling Point, °F	500	512	528
Residue, Vol. %	1.0	1.0	1.0
Loss, Vol. %	1.0	1.0	1.0
Flash Point, °F	108	116	126
Freezing Point, °F	(-42)	(-48)	(-60)
Gravity, °API	40.0	42.0	44.6
<u>Gum Content - mg./100 ml.</u>			
Accelerated	--	--	--
Existent	0.2	0.4	0.8
<u>Heat of Combustion, Net</u>			
BTU/lb.	18465	18480	18510
BTU/U.S. Gal.	--	--	--
Luminometer Number	45	48	53
Naphthalene Hydrocarbons, Vol. %	--	--	--
Olefins, Vol. %	0.2	0.3	0.6
Pour Point, °F	--	--	--
Smoke Point, mm	--	--	--
<u>Sulfur Content, Wt. %</u>			
Mercaptan	0.001	0.002	0.004
Total	0.07	0.13	0.18
<u>Thermal Stability @ 300/400° F</u>			
Change in Pressure Drop in 5 Hrs., "Hg"	0.4	0.5	0.9
Preheater Deposits	0	0	0
<u>Viscosity, Centistokes (Kinematic)</u>			
@ 0° F	--	--	--
@ -30° F	8.65	10.80	12.20
<u>Water Interaction</u>			
Ml. Change	0.5	0.5	0.5
Rating of Fuel Interface	1-B	1-B	1-B
W.S.I.M.	90	94	98

APPENDIX D

DETAILED DESCRIPTION OF MERF

LIST OF ILLUSTRATIONS

APPENDIX D

Figure		Page
D-1	Rear of MERF Panel	D-5
D-2	Gas Analyzers in the MERF Operators Compartment	D-6
D-3	MERF Bottle Compartment —Operating/Reference Gas	D-7
D-4	Part of MERF Data Acquisition System	D-8

DETAILED DESCRIPTION OF MERF.

The MERF trailer is a specially designed, transportable, self-contained environment for emission measuring equipment and personnel. The unit is approximately 8 feet wide, 21 feet long, and 12 feet high. The walls, floors, and ceilings contain high- and low-frequency sound absorbing materials. Access to the operator's area is through two double doorways.

The calibration and operating gas bottle compartment is accessed through two single doors in the front of the trailer. External left and right side generator hatches allow for access to each on-board generator. The air-conditioning unit is mounted on the rear outside wall of the trailer.

Commercially available electrical power is the primary supply for the unit. A secondary electrical supply system consists of two on-board, engine-driven generators which allow for complete remote site operation in areas where commercial power is unavailable. The two engine-driven generator sets include one ONAN four-cylinder, four-cycle, air cooled, 12.5 kilowatt (kW), JC series unit; and one ONAN two-cylinder, four-cycle, air cooled, 7.5 kW, JB series unit. The power requirements are 220 or 208 volts (V), alternating current, single phase, 40 amperes 60 hertz. Internal to external and vice-versa power switching is performed manually. The 7.5 kW generator output feeds six circuits which are used for the analyzers, gas dryer, and switch panel power. The 12.5-kW generator output also feeds six circuits which connect to high amperage devices such as the air conditioner, heated sample lines, and heated enclosures.

The MERF environmental system consists of a Westinghouse, two-ton, "Whispair" model UBO 36 kW air-conditioning package and two Orbit 220 V electrical baseboard heaters. The air-conditioner is thermostatically controlled. The baseboard heating unit in the operator area are rated at 2 kW and also thermostatically controlled. The bottle compartment heater is rated at 1 kW and has an integral thermostat.

The emission sampling systems may be further subdivided into the sample handling train, bottled gases, recorders, analyzers, smoke unit, and exhaust manifold. The sample handling train consists of the external (to the trailer) sample line, internal high temperature electrical resistance heated lines, high-temperature heated enclosure, gas dryer, internal low-temperature electrical resistance heated lines, and the low-temperature heated enclosure (see figure D-1).

The external sample line is a Technical Heater, carbon impregnated teflon, steel braided, double insulated, heated line with abrasion resistant covering. The heating element generates 60 watts (W) per lineal foot at 220 V. A built-in ANSI type J thermocouple controls and monitors the temperature. Either a 50-foot or 80-foot sample line may be used. For attachment to the MERF, the sample line uses two connectors, one for power and one for temperature monitoring and control. A stainless steel straight through quick connect is used for the tube connector.

The internal high-temperature electrical resistance heated lines are constructed using type 304 stainless steel tubing with 0.250-inch outside diameter and 0.028-inch wall thickness. Teflon port connectors are used to insulate the tubing from the nonresistance heated elements of the system. Each line incorporates a thermocouple to monitor and control the wall temperature. A temperature controller operates a variac as the lines are electrically resistance heated. The variac

supplies a separate high-current isolation transformer which outputs approximately 5 V to the tubing. Electrical connections to the tubing are made through standard 316 stainless steel Swagelok unions, elbows, etc., to which a bolt has been silver soldered.

The high-temperature heated enclosure is an insulated box in which a pump, filter, valves, and strip heaters are located. The pump is a Metal Bellows, high temperature, model MB-158 unit. The filter is a one-micron, removable cartridge, non-bypassing type. The sample/room air valve is a four-port ball type with an air operator. The flame ionization detector (FID) sample valve is a two-port normally open solenoid operated valve. Three strip heaters of 250 W each were used to heat the box. A door on the box allows access to the filters and other internal components for inspection or servicing. A type J thermocouple monitors air temperature in the box and also operates a temperature controller for the strip heaters.

The low-temperature electrical resistance heated lines are constructed similar to the high-temperature lines; however, a variac is not used. The low-temperature heated enclosure consists of an insulated box, a Metal Bellows model MB-158 pump, two electrical strip heaters, 1 micron sintered metal type filters, solenoid valves and three fine metering valves. The box has removable top and sides for component servicing and a terminal strip for electrical connections. The fine metering valves are used to adjust the flow to all the analyzers except the Beckman model 402. The three-way solenoid valves are used to select the span gases and the gas dryer (wet or dry) mode. The sample port position of the valves is normally open.

The gas dryer is a Hankison, series E, compressed air dryer, model E-2 GSS. The CO-CO₂ sample may be routed through the dryer before being analyzed. Whether the dryer is selected or not, all bypassed sample flow is dried.

The MERF cylinder compartment contains 10 regulated cylinders for operating the analyzers. Seven cylinders contain reference gases for interpreting instrument response. The other three cylinders contain analyzer operating gases. Three of the reference cylinders contain mixed span gases of carbon monoxide (CO) carbon dioxide (CO₂), propane (C₃H₈), and Nitrogen (N₂) balance. The highest concentration cylinder also contains oxygen (O₂) (table D-1). The three other reference gases are nitric oxide (NO) in various concentrations. Nitrogen is used to zero all analyzers. In the Beckman 402 the flame is sustained by a hydrogen/helium mixture (FID fuel), and hydrocarbon free air (FID air). Oxygen is used for ozone generation in the Beckman 951 Hx. All gases are electrically selected from the switch panel at the operator's station (figure D-2).

Five gas analyzers are mounted on a vibration dampened panel in the operator's area. The analyzers are connected through valves and tubing to the sample handling train, bottled gases, and the exhaust manifold (figure D-3).

The CO₂ analyzer is a Beckman model 864 nondispersive infrared unit. The CO₂ concentration is determined by the differential measurement of the absorption of infrared energy between a reference cell and the sample cell. It is ranged 0-5 percent, 0-3 percent, and 0-1 percent by volume. The CO analyzer is a Beckman model 865 nondispersive infrared unit. This unit is similar to the 864 except that the sample and reference cells are considerably longer, thereby sampling a greater

TABLE D-1. MERF CALIBRATION GASES

<u>Gas Cylinder</u>	Normal Concentration					<u>Balance Gas</u>
	<u>CO (ppm)</u>	<u>CO₂ (%)</u>	<u>C₃H₈ (ppm)</u>	<u>*NO (ppm)</u>	<u>O₂ (%)</u>	
Span 1	100	1	10	25	—	N ₂
Span 2	400	3	50	100	—	N ₂
Span 3	1000	5	500	250	20.9	N ₂

* Three separate cylinders

volume and increasing the sensitivity to much lower concentrations. It is ranged 0-1000 parts per million (ppm), 0-400 ppm, and 0-100 ppm by volume.

The total hydrocarbon (THC) analyzer is a Beckman model 402 FID. The THC concentration is determined by passing a sample through a hydrogen flame in which a complex ionization process charges polarized electrodes proportional to the rate at which carbon atoms enter the burner. For the purposes of this testing, it is ranged 0-10 ppm, 0-50 ppm, 0-100 ppm, and 0-500 ppm propane by volume. The model 402 is modified for linear operation at very high THC concentrations to improve its repeatability. Modifications to this analyzer are described in detail in reference 5. A metering valve was also installed downstream of the filter to control all flow in the analyzer from the front panel. A replacement temperature controller and thermocouple were also installed to decrease its temperature cycling characteristics.

The oxides of nitrogen NO_x are measured by a Beckman model 951 Hx, atmospheric pressure, heated, chemilluminiscent analyzer. The NO concentration is determined by the reaction of nitric oxide and ozone. The light emitted is proportional to the NO concentration. The NO_x can be measured by converting nitrogen dioxide (NO_2) to NO in a thermal converter then routing it to the reaction chamber. The analyzer is ranged 0-10 ppm, 0-25 ppm, 0-100 ppm, 0-250 ppm, and 0-1000 ppm by volume.

The O_2 analyzer is a Beckman model OM-11 with a polarographic sensor. An advanced sensor and amplification system combine to make this analyzer an extremely fast responding and highly accurate instrument. The O_2 concentration is determined by a polarized voltage applied between two electrodes behind a permeable membrane which allows the diffusion of oxygen. This produces a current flow directly proportional to the oxygen partial pressure to which the sensor is exposed. The O_2 pick-up head receives the sample from the outlet of the CO_2 analyzer.

The emission system exhaust manifold provides a slightly lower than atmospheric pressure environment into which is routed the analyzer exhausts and the bypassed sample flow. The manifold routes the flow under the floor into the bottle compartment exhaust fan where dilution and discharge into the air occur.

Three Beckman model 8720-2-03, dual channel, dry stylus strip chart recorders are used to continuously monitor CO , CO_2 , THC, NO_x , and O_2 outputs. The recorders are used only as a visual assurance of stabilized emission levels prior to data acquisition.

The MERF data acquisition system includes a H-P 9830A calculator, 9866A thermal printer, 3495A scanner, 3490A multimeter, 9865A cassette memory, and a 9868A input/output expander. The analyzer outputs, ranges and gas solenoid valve positions are electrically routed to the scanner. The data acquisition program uses this information to compute concentrations, store the data on tape, and output hard copy for each data point taken (figure D-4).

The communications system is a David Clark model U3400 utility intercom system. It consists of an amplifier/power supply, junction boxes, extension cords, belt stations and headsets. Inside the MERF are connections for three belt stations/headsets. An additional connection is reserved for external hookup to the MERF, but with junction boxes and extension cords, one may place as many as 30 headsets on the line at distances of up to 2,000 feet. All headsets attenuate outside noise up to 90 dB and are wired for 600 ohm operation.

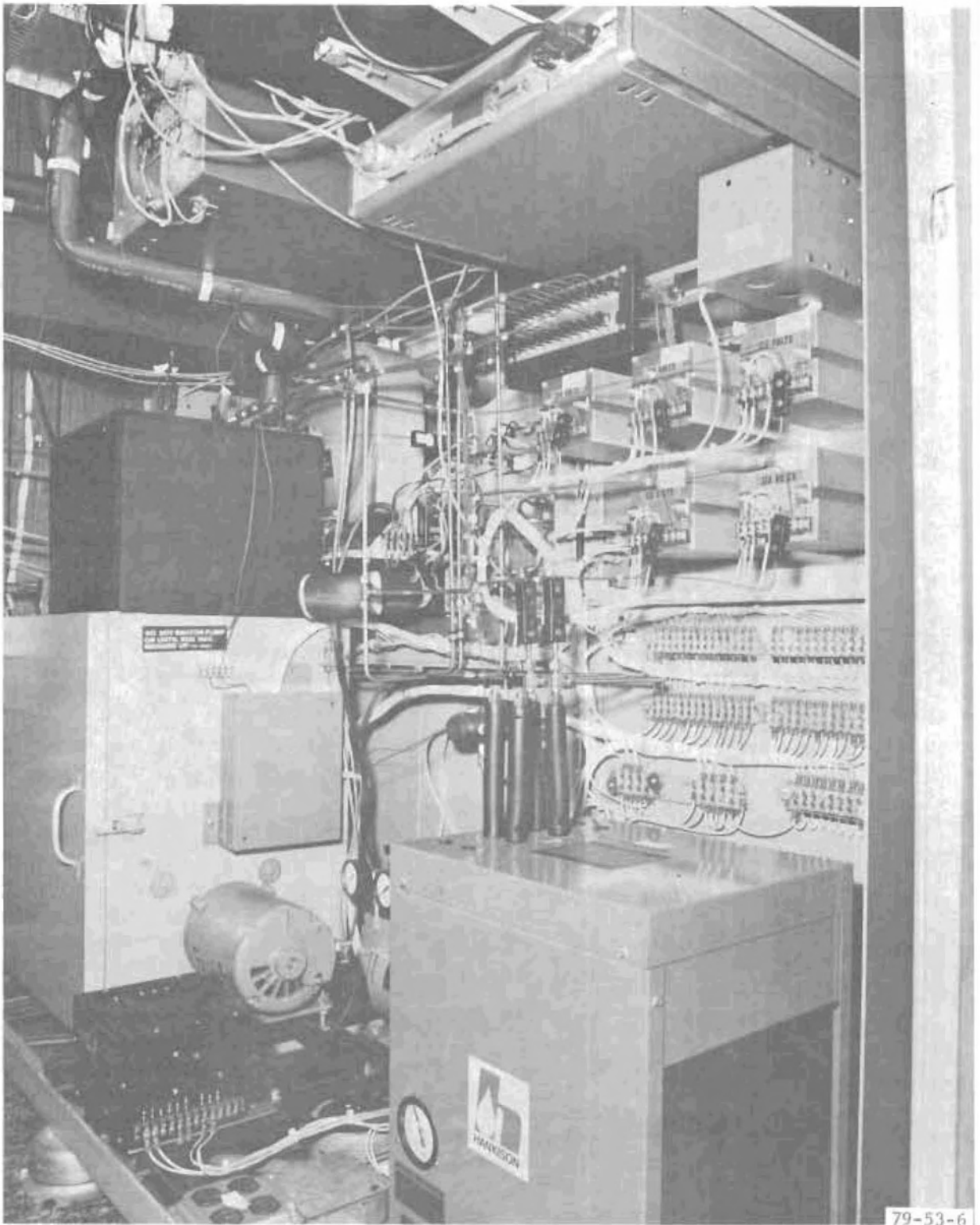

FIGURE D-1. REAR OF MERF PANEL

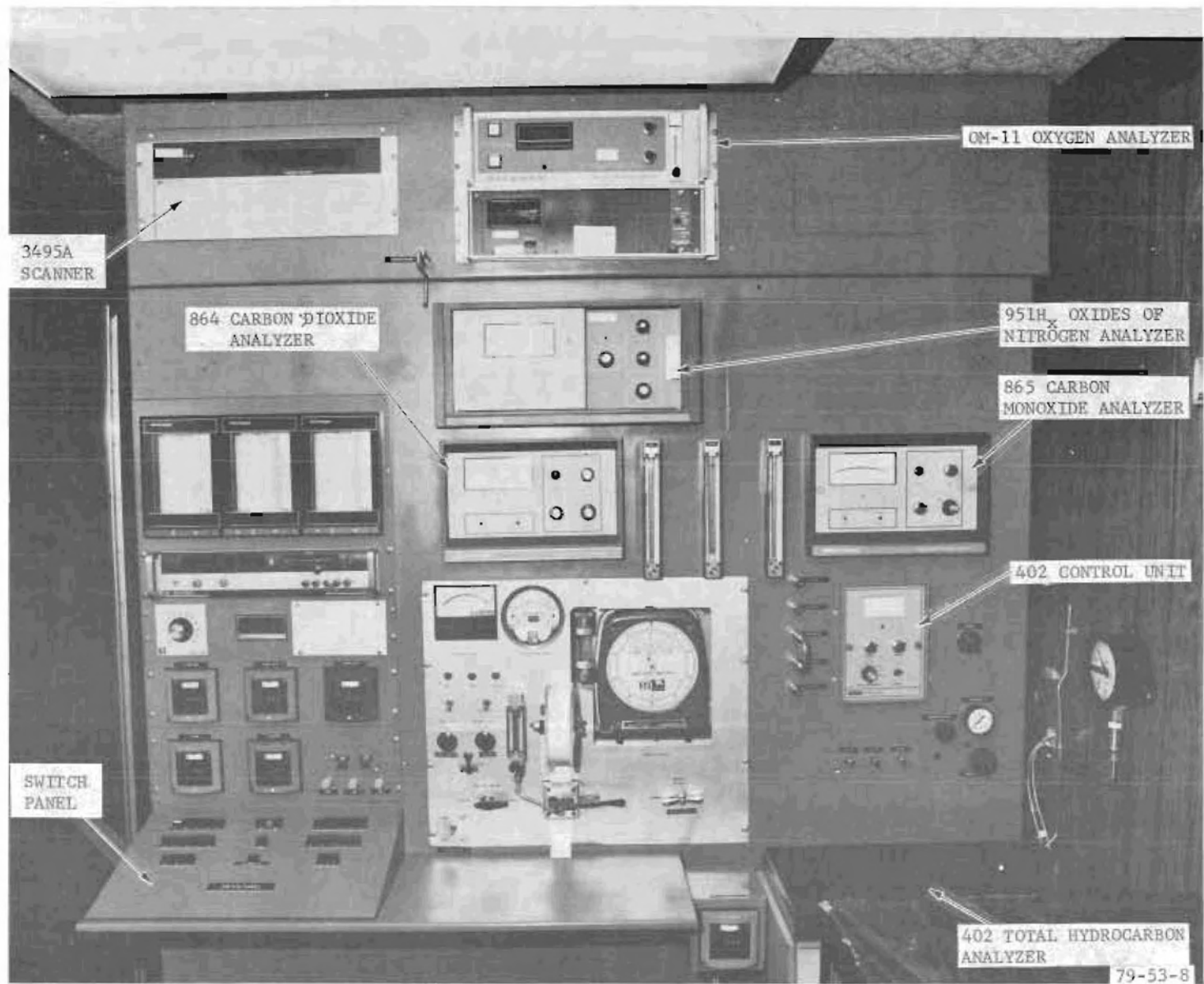

FIGURE D-2. GAS ANALYZERS IN THE MERF OPERATORS COMPARTMENT

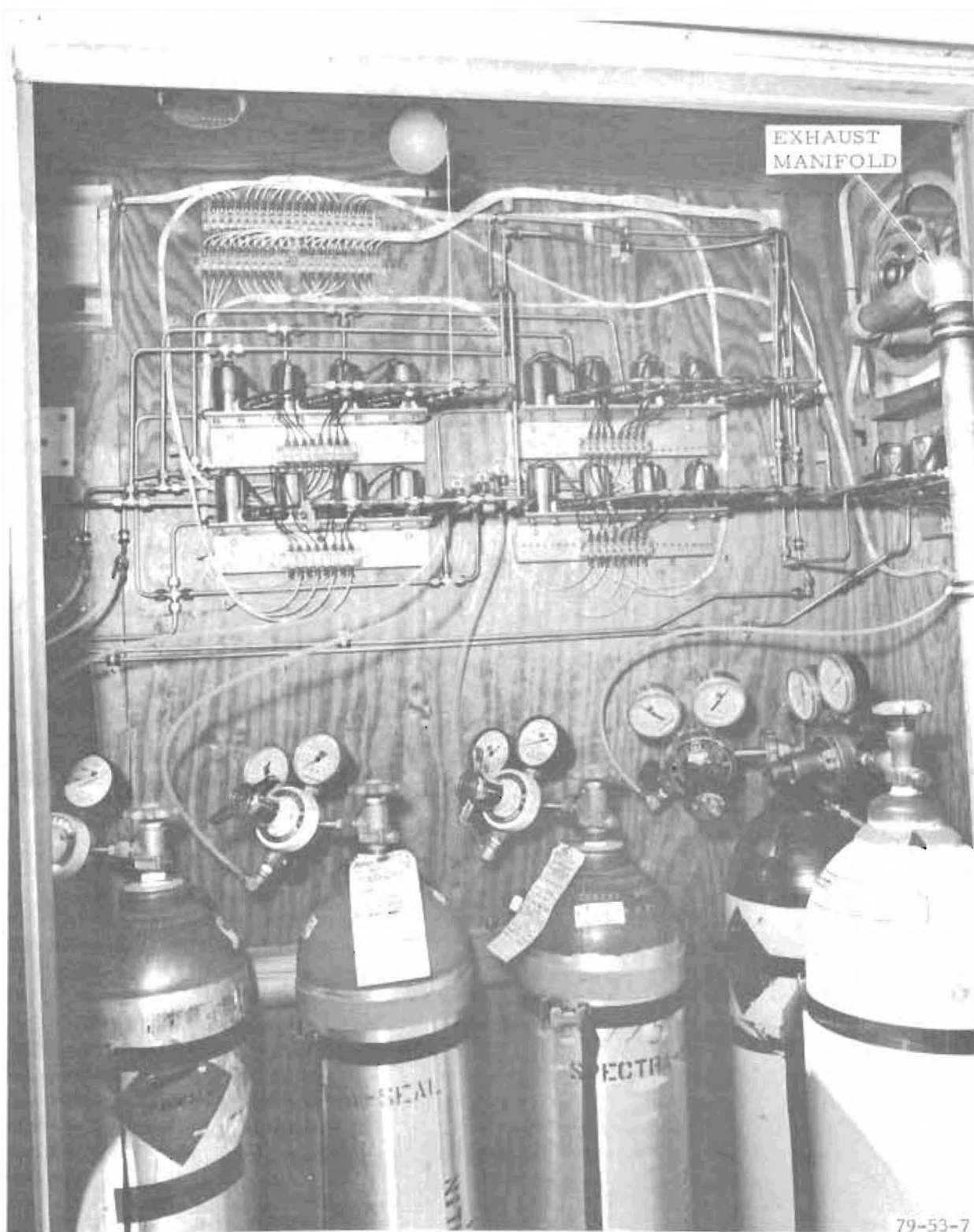
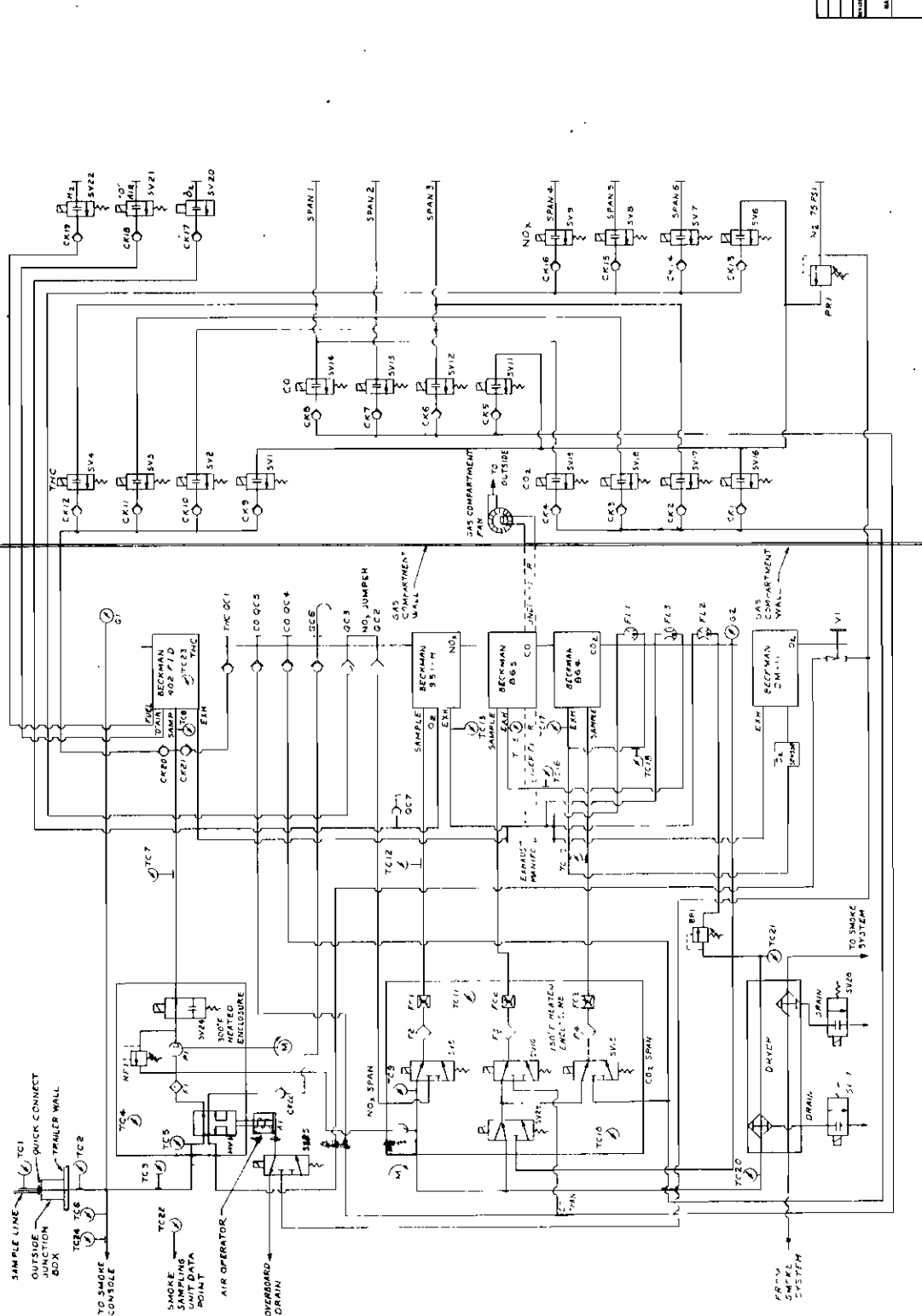

FIGURE D-3. MERF BOTTLE COMPARTMENT--OPERATING/REFERENCE GAS



FIGURE D-4. PART OF MERF DATA ACQUISITION SYSTEM

- A1 = WHITEY AIR OPERATOR P/N MS-115A
- BPI = FAIRCHILD HILLER BACK PRESSURE REGULATOR
- CK1 THRU CK12 = NUORO CHECK VALVE P/N SS-4C-1
MODEL NUMBER 108P
- CK13 THRU CK22 = NUORO CHECK VALVE P/N SS-4C-10
- FL1 = FILTER LOCALITY MADE
- FL2, FL3 = NUORO FILTER P/N SS-ATF-2
- FL4, FL5 = NUORO FINE METRICAL VALVE
- FL6 = MATHESON ROTOMETER P/N 7640T
- FL7 = MATHESON ROTOMETER P/N 7600
- FL8 = MATHESON ROTOMETER P/N 7640T
- GI = SOLIFONT COMPOUND PRESSURE GAUGE
- W/ STAINLESS STEEL 1/2" B1, CO. 1/2" B1, 10 PA.
- G2 = FAIRCHILD PRESSURE GAUGE 0-15 MAX P/N W/SP-1
- MV1 = WHITEY 4 WAY BALL VALVE P/N SS-437FE
- (SOLE W/ BALL GALLED TO 1/2" B1)
- P1 = METAL BELLOWS P/N N18-158 PT PUMP
- P2 = METAL BELLOWS P/N MF-158 PUMP
- SV1 THRU SV14 = SKINNER SOLENOID VALVE, N.C.
- P/N V54DAE125
- SV15 = SKINNER SOLENOID VALVE, 3-WAY, P/N V54DAE125
- SV16 THRU SV21 = SKINNER SOLENOID VALVE, N.C.
- P/N V54DAE125
- SV22 = SKINNER SOLENOID VALVE, 3-WAY, P/N V54DAE125
- SV23 = SKINNER SOLENOID VALVE, 1-WAY, P/N V54DAE125
- SV24 = SKINNER SOLENOID VALVE, N.C., P/N V54DAE125
- SV25 = SKINNER SOLENOID VALVE, 3-WAY, P/N V54DAE125
- SV26 = SKINNER SOLENOID VALVE, N.C., P/N V54DAE125
- SV27 = SKINNER SOLENOID VALVE, 3-WAY, P/N V54DAE125
- SV28 = SKINNER SOLENOID VALVE, 1-WAY, P/N V54DAE125
- SV29 = SKINNER SOLENOID VALVE, 3-WAY, P/N V54DAE125
- SV30 = SKINNER SOLENOID VALVE, 1-WAY, P/N V54DAE125
- SV31 = SKINNER SOLENOID VALVE, 3-WAY, P/N V54DAE125
- SV32 = SKINNER SOLENOID VALVE, 1-WAY, P/N V54DAE125
- SV33 = SKINNER SOLENOID VALVE, 1-WAY, P/N V54DAE125
- SV34 = SKINNER SOLENOID VALVE, N.C., P/N V54DAE125
- SV35 = SKINNER SOLENOID VALVE, 3-WAY, P/N V54DAE125
- SV36 = SKINNER SOLENOID VALVE, 1-WAY, P/N V54DAE125
- SV37 = SKINNER SOLENOID VALVE, 3-WAY, P/N V54DAE125
- SV38 = SKINNER SOLENOID VALVE, 1-WAY, P/N V54DAE125
- SV39 = SKINNER SOLENOID VALVE, 3-WAY, P/N V54DAE125
- SV40 = SKINNER SOLENOID VALVE, 1-WAY, P/N V54DAE125
- SV41 = SKINNER SOLENOID VALVE, 3-WAY, P/N V54DAE125
- SV42 = SKINNER SOLENOID VALVE, 1-WAY, P/N V54DAE125
- SV43 = SKINNER SOLENOID VALVE, 3-WAY, P/N V54DAE125
- SV44 = SKINNER SOLENOID VALVE, 1-WAY, P/N V54DAE125
- SV45 = SKINNER SOLENOID VALVE, 3-WAY, P/N V54DAE125
- SV46 = SKINNER SOLENOID VALVE, 1-WAY, P/N V54DAE125
- SV47 = SKINNER SOLENOID VALVE, 3-WAY, P/N V54DAE125
- SV48 = SKINNER SOLENOID VALVE, 1-WAY, P/N V54DAE125
- SV49 = SKINNER SOLENOID VALVE, 3-WAY, P/N V54DAE125
- SV50 = SKINNER SOLENOID VALVE, 1-WAY, P/N V54DAE125
- SV51 = SKINNER SOLENOID VALVE, 3-WAY, P/N V54DAE125
- SV52 = SKINNER SOLENOID VALVE, 1-WAY, P/N V54DAE125
- SV53 = SKINNER SOLENOID VALVE, 3-WAY, P/N V54DAE125
- SV54 = SKINNER SOLENOID VALVE, 1-WAY, P/N V54DAE125
- SV55 = SKINNER SOLENOID VALVE, 3-WAY, P/N V54DAE125
- SV56 = SKINNER SOLENOID VALVE, 1-WAY, P/N V54DAE125
- SV57 = SKINNER SOLENOID VALVE, 3-WAY, P/N V54DAE125
- SV58 = SKINNER SOLENOID VALVE, 1-WAY, P/N V54DAE125
- SV59 = SKINNER SOLENOID VALVE, 3-WAY, P/N V54DAE125
- SV60 = SKINNER SOLENOID VALVE, 1-WAY, P/N V54DAE125
- SV61 = SKINNER SOLENOID VALVE, 3-WAY, P/N V54DAE125
- SV62 = SKINNER SOLENOID VALVE, 1-WAY, P/N V54DAE125
- SV63 = SKINNER SOLENOID VALVE, 3-WAY, P/N V54DAE125
- SV64 = SKINNER SOLENOID VALVE, 1-WAY, P/N V54DAE125
- SV65 = SKINNER SOLENOID VALVE, 3-WAY, P/N V54DAE125
- SV66 = SKINNER SOLENOID VALVE, 1-WAY, P/N V54DAE125
- SV67 = SKINNER SOLENOID VALVE, 3-WAY, P/N V54DAE125
- SV68 = SKINNER SOLENOID VALVE, 1-WAY, P/N V54DAE125
- SV69 = SKINNER SOLENOID VALVE, 3-WAY, P/N V54DAE125
- SV70 = SKINNER SOLENOID VALVE, 1-WAY, P/N V54DAE125
- SV71 = SKINNER SOLENOID VALVE, 3-WAY, P/N V54DAE125
- SV72 = SKINNER SOLENOID VALVE, 1-WAY, P/N V54DAE125
- SV73 = SKINNER SOLENOID VALVE, 3-WAY, P/N V54DAE125
- SV74 = SKINNER SOLENOID VALVE, 1-WAY, P/N V54DAE125
- SV75 = SKINNER SOLENOID VALVE, 3-WAY, P/N V54DAE125
- SV76 = SKINNER SOLENOID VALVE, 1-WAY, P/N V54DAE125
- SV77 = SKINNER SOLENOID VALVE, 3-WAY, P/N V54DAE125
- SV78 = SKINNER SOLENOID VALVE, 1-WAY, P/N V54DAE125
- SV79 = SKINNER SOLENOID VALVE, 3-WAY, P/N V54DAE125
- SV80 = SKINNER SOLENOID VALVE, 1-WAY, P/N V54DAE125
- SV81 = SKINNER SOLENOID VALVE, 3-WAY, P/N V54DAE125
- SV82 = SKINNER SOLENOID VALVE, 1-WAY, P/N V54DAE125
- SV83 = SKINNER SOLENOID VALVE, 3-WAY, P/N V54DAE125
- SV84 = SKINNER SOLENOID VALVE, 1-WAY, P/N V54DAE125
- SV85 = SKINNER SOLENOID VALVE, 3-WAY, P/N V54DAE125
- SV86 = SKINNER SOLENOID VALVE, 1-WAY, P/N V54DAE125
- SV87 = SKINNER SOLENOID VALVE, 3-WAY, P/N V54DAE125
- SV88 = SKINNER SOLENOID VALVE, 1-WAY, P/N V54DAE125
- SV89 = SKINNER SOLENOID VALVE, 3-WAY, P/N V54DAE125
- SV90 = SKINNER SOLENOID VALVE, 1-WAY, P/N V54DAE125
- SV91 = SKINNER SOLENOID VALVE, 3-WAY, P/N V54DAE125
- SV92 = SKINNER SOLENOID VALVE, 1-WAY, P/N V54DAE125
- SV93 = SKINNER SOLENOID VALVE, 3-WAY, P/N V54DAE125
- SV94 = SKINNER SOLENOID VALVE, 1-WAY, P/N V54DAE125
- SV95 = SKINNER SOLENOID VALVE, 3-WAY, P/N V54DAE125
- SV96 = SKINNER SOLENOID VALVE, 1-WAY, P/N V54DAE125
- SV97 = SKINNER SOLENOID VALVE, 3-WAY, P/N V54DAE125
- SV98 = SKINNER SOLENOID VALVE, 1-WAY, P/N V54DAE125
- SV99 = SKINNER SOLENOID VALVE, 3-WAY, P/N V54DAE125
- SV100 = SKINNER SOLENOID VALVE, 1-WAY, P/N V54DAE125



FEDERAL AVIATION ADMINISTRATION		QUANTITY	DATE
NATIONAL AVIATION FACILITIES EXPERIMENTAL CENTER			
MOBILE EMISSION RESEARCH FACILITY			
EMISSION SYSTEM PLENUM DIAGRAM			
REVISED BY	ANA-4-D	DATE	12-2-75
APPROVED BY		DATE	1-1-77
PROJECT NO.		WORK ORDER NO.	XC-2379

APPENDIX E

MERF TEST CALIBRATION AND OPERATIONAL PROCEDURE

1. Connect sample line
2. Change FID filter
3. Turn on heater control circuit breaker
4. Turn on FID heat controller
5. Turn on data acquisition system power
6. Turn on all gas bottles
7. Turn on cylinder room fan
8. Log bottle pressure (at end of test)
Note: Change gas bottles at 200 psi, enter change on "MERF calibration data" tape.
9. Verify heater controls are set properly
 - High temperature lines - 300°F
 - High temperature box - 300°F
 - Sample line - 320°F
 - Low temperature lines - 150°F
 - Low temperature box - 150°F
 - FID oven - 300° F
10. Set Sensotec pressure selector to "TEST", set indicator balance and span
11. Set pressure selector to FID
12. Switch Panel:
 - A. Turn on dryer
 - B. Select wet or dry
 - C. Open drain for 3 seconds
 - D. Turn on ozone
 - E. Select purge/room air
13. Data Acquisition System Startup
 - A. Insert "MERF Operation Programs" into primary tape drive
 - B. Insert "MERF Calibration Data" into No. 3 tape drive
 - C. Key in "Load 2 Execute", then "Run Execute"
 - D. Follow instructions to "Input Rdg. I.D."
14. Switch Panel:
 - A. Turn on fuel and air to FID

15. 951 H_x Analyzer:
 - A. Turn on ozonator
 - B. Select span
16. 402 Analyzer:
 - A. Select "override"
 - B. Set fuel and air pressure to "start"
 - C. Depress ignitor; hold until flame-out indicator goes off
 - D. Select "normal"
 - E. Do not increase air pressure at this time
17. 864 Analyzer:
 - A. Select "tune"
 - B. Verify correct oscillator tuning of 40
18. 865 Analyzer:
 - A. Select "tune"
 - B. Verify correct analyzer tuning of 40
19. Turn on chopper motor switch
20. 402 Analyzer:
 - A. Increase fuel and air pressure to normal settings
21. OM-11 Analyzer:
 - A. Depress "operate"
22. Perform leak check
 - A. Open dryer drain for 3 seconds
23. Shut off pumps
24. Analyzer standardization:
 - A. Determine next calibration number by checking previous day's data in log book or "TLIST" zero/span check tape
 - B. Key calibration I.D. number
 - C. Select zero gas to all analyzers
 - D. Select most sensitive ranges used
 - E. Adjust flows and pressures
 - F. Use calculator keys to set zero
 - G. Select least sensitive ranges
 - H. Select HI span to all analyzers
 - I. Adjust flows and pressures
 - J. Use calculator keys to set span
 - K. Select zero gas
 - L. Select most sensitive ranges used
 - M. Recheck zero settings

- N. Record zero data (continue program)
- O. Select least sensitive range
- P. Record data
- Q. Select HI span
- R. Stabilize
- S. Record data
- T. Select MID span
- U. Stabilize
- V. Record data
- W. Select MID range
- X. Stabilize
- Y. Record data
- Z. Select LO span
- AA. Stabilize
- BB. Record data
- CC. Select LO range
- DD. Stabilize
- EE. Record data
- FF. Select room air/probe purge
- GG. Stabilize
- HH. Record data

25. Prior to engine start:

- A. Pumps off
- B. Select probe purge/room air
- C. Turn on nitrogen gas purge and adjust to 5 psi

26. After engine start:

- A. Turn off purge
- B. Pump on
- C. Select proper range for engine power (response greater than 40 percent full-scale on all analyzers, if possible)
- D. Select sample
- E. Verify correct flows and pressures
- F. Verify proper system operation
- G. Check temperatures
- H. Select room air

27. Sampling:

- A. Select sample 1 minute before end of engine stabilization period
- B. Select proper ranges for engine power
- C. Key in proper "Reading I.D."
- D. Verify correct analyzer flow and pressure
- E. Verify correct 402 analyzer auxiliary range setting
- F. Verify correct 951 H_x analyzer mode
- G. Verify data acquisition system is flashing "STAND BY"
- H. At test engineer's signal select sample on data acquisition system for 1 minute

- I. Switch off data acquisition
- J. Allow time for data to store on tapes
- K. Select room air

28. Analyzer Restandardization:

(At least once per test sequence or every 30 minutes, whichever is sooner, all analyzers must be restandardized.)

- A. Key in next calibration I.D. number
- B. Select zero gas to all analyzers
- C. Select most sensitive range used
- D. Adjust flows and pressures
- E. Record data
- F. If any data is greater than 2 percent off of target, use keys to reset zero
- G. Key in next calibration I.D. number
- H. Record adjusted data
- I. Select least sensitive range
- J. Select HI span gas
- K. Adjust flows and pressures
- L. Record data
- M. If any data is greater than 2 percent off of target, use keys to reset span
- N. Key in calibration I.D. number
- O. Record adjusted data
- P. Set up for sampling (see step 27)