



**pennsylvania**

DEPARTMENT OF TRANSPORTATION

# LWD & DCP Testing for Pavement Foundation and Subbase

FINAL REPORT

Date: November 1, 2024

By Mansour Solaimanian  
Xiaogang Guo  
Darya Shahidi Masouleh  
Scott Milander  
Behnam Jahangiri Koohbanani

The Pennsylvania State University



COMMONWEALTH OF PENNSYLVANIA  
DEPARTMENT OF TRANSPORTATION

CONTRACT # 512101  
WORK ORDER # PSU 02

<b>1. Report No.</b> FHWA-PA-2024-008-PSU WO 02	<b>2. Government Accession No.</b>	<b>3. Recipient's Catalog No.</b>	
<b>4. Title and Subtitle</b> LWD & DCP Testing for Pavement Foundation and Subbase		<b>5. Report Date</b> November 1, 2024	<b>6. Performing Organization Code</b>
<b>7. Author(s)</b> Mansour Solaimanian, Xiaogang Guo, Darya Shahidi Masouleh, Scott Milander, Behnam Jahangiri Koohbanani		<b>8. Performing Organization Report No.</b> LTI 2025-08	
<b>9. Performing Organization Name and Address</b> The Thomas D. Larson Pennsylvania Transportation Institute The Pennsylvania State University 201 Transportation Research Building University Park, PA 16802		<b>10. Work Unit No. (TRAIS)</b>	<b>11. Contract or Grant No.</b> 512101
<b>12. Sponsoring Agency Name and Address</b> The Pennsylvania Department of Transportation Bureau of Planning and Research Commonwealth Keystone Building 400 North Street, 6 <sup>th</sup> Floor Harrisburg, PA 17120-0064		<b>13. Type of Report and Period Covered</b> Final Report 7/20/2022 – 11/1/2024	
<b>15. Supplementary Notes</b> Dennis Neff and Beverly Miller of PennDOT served as the project technical advisors. Heather Sorce served as the project contract manager.		<b>14. Sponsoring Agency Code</b>	
<b>16. Abstract</b> This research effort was undertaken to establish test methods, limits, and protocols to implement lightweight deflectometer (LWD) and dynamic cone penetrometer (DCP) testing and acceptance criteria for Pennsylvania's subgrade soil and unbound pavement layers. Historically, density-based criteria have been predominantly used to assess the subgrade/base compaction quality. This study sought to assess the viability of LWD and DCP as tools for quality control/assurance in the compaction of highway subbase and base materials in Pennsylvania. Five different types of soils, covering a wide range of gradations, were selected for the laboratory study. The study included small-scale laboratory testing and progressed to large-scale laboratory testing in a test pit and subsequently field testing. The optimum moisture content was determined in the laboratory for each soil. Laboratory LWD testing was conducted on all soils at different moisture contents and compaction levels. The LWD/DCP research in the test pit and in the field was limited to two of the soils. The general conclusion from this study was that LWD and DCP are useful tools and PennDOT can benefit from including them in its subgrade/base compaction quality control specifications. The lab LWD deflections were significantly lower than those obtained in the field and in the test pit due to the effect of the strong floor, an important finding to consider when developing threshold values. The results of the study were used to develop a set of recommendations for PennDOT toward the use of LWD/DCP for field quality control of compacting subgrade, subbase, and base layers. The recommended threshold values are based on this study and subject to validation and/or adjustment as further information and data become available from LWD/DCP testing in actual field conditions.			
<b>17. Key Words</b> Subgrade, subbase, base, soil, aggregate, Lightweight Deflectometer, LWD, Dynamic Cone Penetrometer, DCP, compaction, optimum moisture content		<b>18. Distribution Statement</b> No restrictions. This document is available from the National Technical Information Service, Springfield, VA 22161	
<b>19. Security Classif. (of this report)</b> Unclassified	<b>20. Security Classif. (of this page)</b> Unclassified	<b>21. No. of Pages</b> 206	<b>22. Price</b> \$230,635.35

# **LWD & DCP Testing for Pavement Foundation and Subbase**

**Final Report**

**Prepared by**

**Mansour Solaimanian**

**Xiaogang Guo**

**Darya Shahidi Masouleh**

**Scott Milander**

**Behnam Jahangiri Koohbanani**

**Larson Transportation Institute  
The Pennsylvania State University**

**November 1, 2024**

# Table of Contents

Acknowledgements.....	xviii
Disclaimer.....	xviii
CHAPTER 1 .....	1
Introduction.....	1
Background.....	1
Objective and Scope of Work.....	1
REPORT ORGANIZATION.....	2
CHAPTER 2 .....	4
Review of Literature .....	4
Approach in Literature Review.....	4
Literature Review.....	4
Common Tests Performed on Subgrade and Base Materials.....	5
In-situ Density-based Devices .....	6
Nuclear Moisture and Density Gauge.....	6
Sand-Cone Test .....	7
Stiffness/Modulus-based Devices.....	9
Light Weight Deflectometer (LWD) .....	9
LWD Test Procedures.....	10
Dynamic Cone Penetrometer (DCP).....	10
DCP Test Procedures:.....	10
Additional Stiffness/Modulus-based Devices.....	11
Briaud Compaction Device (BCD).....	11
Clegg Hammer (CH).....	12
Soil Stiffness Gauge (SSG) .....	12
Soil Modulus Tests .....	12

Small-Scale Laboratory Test.....	12
Resilient Modulus (Triaxial Test).....	13
LWD on the Soil Compacted in the Proctor Mold.....	13
Large-Scale Laboratory Test.....	14
Previous Studies.....	14
Effect of Moisture Content on the LWD and DCP Test Results .....	22
Effect of Sublayers on the LWD and DCP Test Results .....	26
Effect of Sample Size on the LWD and DCP Test Results .....	27
States Practices.....	29
Pennsylvania Department of Transportation (PennDOT).....	29
Minnesota Department of Transportation (MnDOT) .....	30
Indiana Department of Transportation (INDOT).....	31
Florida Department of Transportation (FDOT) .....	32
Nebraska Department of Transportation (NDOT).....	32
United Kingdom (UK) .....	33
Analysis of the recommendations and criteria for DCP and LWD in the current specifications and research reports .....	33
Pennsylvania Department of Transportation (PennDOT).....	36
Minnesota Department of Transportation (MnDOT) .....	36
Indiana Department of Transportation (INDOT).....	36
Florida Department of Transportation (FDOT) .....	36
Nebraska Department of Transportation (NDOT).....	36
United Kingdom (UK) .....	37
Other Publications.....	37
Survey on Recommended Standards for LWD/DCP Usage by State Highway Agencies .....	37

Minnesota Department of Transportation (MnDOT) .....	37
Indiana Dot Standard Specifications.....	40
Standardizing Light Weight Deflectometer Modulus Measurements for Compaction Quality Assurance (Report, Maryland Department of Transportation) .....	44
Others listed in the Scope of Work and Tasks .....	44
Recommended Standards for LWD/DCP Usage from Other Agencies .....	45
Final Report Performance-Based Quality Assurance/Quality Control (QA/QC) Acceptance Procedures for In-Place Soil Testing Phase 3 (FDOT).....	45
Nebraska Department of Roads NDR Standard Test Method T 2835.....	46
United Kingdom (UK) .....	48
The Oklahoma Department of Transportation (ODOT).....	48
Other publications .....	48
Quality Control/Assurance on Base Course and Embankment with the Dynamic Cone Penetrometer-Louisiana Transportation Research Center .....	48
Draft Technical Note – Guidance on Use of Light Weight Falling Deflectometers (LWDs) to be Accepted as an Alternative Method for Verification of Earthworks Compaction Requirements –June2021. National Asset Centre of Excellence (Australia) .....	50
Using the Dynamic Cone Penetrometer (DCP) and Light Weight Deflectometer (LWD) For Construction Quality Assurance .....	50
Maximum Allowable Deflection by Light Weight Deflectometer and Its Calibration and Verification (Joint transportation research program, Indiana Department of Transportation and Purdue University) .....	50
Summary .....	54
CHAPTER 3 .....	57
Experimental Program .....	57
Background.....	57

Selection of Experiment Factors .....	57
Scope of Work FOR Testing.....	60
Conduct Volumetric and Stiffness Tests.....	60
Collection, organization, and analysis of data .....	60
Laboratory Proctor Mold .....	61
Test Pit .....	61
Field Testing .....	62
Materials.....	62
PennDOT 2A .....	63
PennDOT 2RC .....	63
PennDOT OGS .....	64
AASHTO A-4.....	65
AASHTO A-6.....	66
Equipment.....	68
Proctor Mold and Hammer .....	68
Vibratory Roller Compactor .....	68
Plate Compactor.....	69
Nuclear Density Gauge.....	70
Light Weight Deflectometer (LWD) .....	70
Dynamic Cone Penetrometer (DCP).....	71
Moisture Gauge.....	72
Execution of the Experimental Plan .....	73
Investigating the Effect of Moisture Content.....	73
Investigating the Effect of Compaction Level .....	73
LWD Testing of Proctor Mold Specimens .....	74

Setting up the Specimens for LWD Test .....	74
LWD Testing .....	75
LWD Response Data.....	76
Testing at the Pit .....	78
Selection of Materials .....	80
Preparation of the Pit and the Soil Samples for Testing .....	80
Testing with LWD and DCP at the Pit.....	83
Data Collection from Field Projects .....	84
Materials .....	85
2A material.....	86
A-6 material .....	87
Summary .....	88
CHAPTER 4 .....	90
Data Analysis and Interpretation .....	90
Data from Small-Scale Laboratory Tests.....	92
Optimum Moisture Content (OMC) .....	92
Impact of Modified Proctor Compaction on OMC.....	94
Effect of Moisture Content/Density on LWD Response .....	95
Study Parameters (Soil Type, Moisture Content, and Compaction Level).....	95
LWD Response Parameters .....	96
LWD Test Results: Moisture Content Effect.....	100
LWD Test Results: Compaction Energy Effect.....	102
Effect of Change in Moisture Content on LWD Response at a Single Density .....	110
Sensitivity of LWD response to the LWD test parameters.....	111
Rest period between weight drops .....	111

Effect of weight drop sequence on calculated modulus and deflection.....	112
Effect of the Underlying Support.....	118
Experimental Results .....	118
Computational Results .....	120
Repeatability of the LWD test using the Proctor mold.....	123
Data from Large-Scale Laboratory Tests.....	125
Variation in Soil Moisture Content in the Test Pit .....	125
LWD Response Data.....	127
Existing Subgrade .....	127
Placement, Compaction, and Testing 2RC Material (Plate Compacted).....	128
Placement, Compaction and Testing 2RC Material (Roller Compactor) .....	131
LWD Test Results.....	131
DCP Test Results.....	133
Density Test Results .....	135
Placement, Compaction, and Testing 2A Material .....	138
LWD Test Results.....	138
DCP Test Results.....	140
Density Test Results .....	142
Data from the Field Tests.....	146
Testing 2A Material .....	146
Testing A-6 Material.....	154
LWD Test Results.....	154
DCP Test Results .....	155
Density Test Results .....	157
Moisture Content .....	158
Relation between DCP and LWD Results .....	159

LWD Deflection: Comparison of Results between Tests of Various Scales.....	161
Comparison of Modulus Estimated from CBR (Calculated via DPI) and Modulus from LWD Test.....	163
Summary.....	166
CHAPTER 5 .....	167
Summary, Conclusions, Recommendations .....	167
Summary.....	167
Conclusions.....	168
Recommendations for future work .....	171
References.....	173

## List of Figures

Figure 1. Nuclear moisture-density gauge operation modes (PTM No. 402, 2020).....	7
Figure 2. Schematic of the sand cone apparatus (Geotechnical Engineering Bureau, 2015). .....	8
Figure 3. Process of the sand-filling for (a) dry and (b) wet ground holes (Park et al., 2021). .....	8
Figure 4. Dynamic Cone Penetrometer (DCP) (Mohammadi et al., 2008). .....	11
Figure 5. The schematic of the load in the Triaxial test.....	13
Figure 6. Schematic of LWD testing on mold. ....	14
Figure 7. Comparison between modulus obtained from field and Proctor mold test using Zorn, Dynatest, and Olson LWDs (Schwartz et al., 2017). .....	16
Figure 8. Observed modulus vs. CBR ratio and DPI index (Makwana & Kumar, 2019). .....	16
Figure 9. Predicted from CBR and DCP test vs. observed modulus (Makwana & Kumar, 2019). .....	17
Figure 10. The relationship between stiffness and (a) degree of compaction from the sand cone and (b) CBR (Kongkitkul et al., 2014). .....	18
Figure 11. LWD modulus versus relative compaction of the base layer of a low-volume road (Hariprasad et al., 2019).....	18
Figure 12. Modulus of the subgrade soil obtained from FWD vs. PFWD (George, 2006).....	20
Figure 13. The obtained MC from Ohaus MB45 moisture analyzer vs. oven dry method (Schwartz et al., 2017). .....	24
Figure 14. The correlation between moisture content obtained from (a) Ohaus MB45 moisture analyzer vs. nuclear gauge and (b) Decagon vs. nuclear gauge (Schwartz et al., 2017). .....	24
Figure 15. Effect of moisture (degree of saturation) on soil stiffness modulus in a laboratory setup (NOVA = Northern Virginia) (Hossain & Apeagyei, 2010). .....	25
Figure 16. LWD test results in Wooden Box for ASTM #57 aggregate material (Vibratory Plate Compaction) (Mondal et al., 2022).....	27
Figure 17. LWD testing on a 2-layered system (Schwartz et al., 2017). .....	27
Figure 18. Schematic representation of three different mold configurations (Mondal et al., 2022) .....	28

Figure 19. INDOT recommended test locations in the field for LWD (InDOT ITM No.514-20, 2020). .....	41
Figure 20. INDOT recommended test locations in the field for DCP (InDOT ITM No.514-20, 2020). .....	43
Figure 21. Flow chart showing key steps for assessment/derivation of equivalent acceptance thresholds for LWD use (in lieu of traditional (density) testing minimum thresholds included in MRTS04-General Earthworks) (Lee & Lacey, 2021) .....	50
Figure 22. Hierarchy of sample preparation and testing.....	59
Figure 23: 2RC (left) and 2A (right) stockpiles at CITEL utilized in this study.....	63
Figure 24. Resultant OGS blend after mixing 50% of #57, 35% of #8, and 15% of #10.....	64
Figure 25. OGS material utilized in this study. ....	65
Figure 26. A-4 soil utilized in this study.....	66
Figure 27. A-6 soil utilized in this study.....	67
Figure 28. Gradation chart for OGS, 2A, 2RC, A-4 and A-6 materials. ....	68
Figure 29. A roller compactor was used in this study.....	69
Figure 30: The vibratory plate compactor used in this study.....	69
Figure 31 Nuclear Moisture-Density Gauge used in this study.....	70
Figure 32: The LWD used in this study.....	71
Figure 33. The DCP used in this study. ....	72
Figure 34. A Compacted Soil Specimen with fine sand applied to the surface.....	75
Figure 35. LWD in the compacted soil in the Proctor mold. ....	76
Figure 36. Soil compacted in the Proctor mold: (a) before the LWD test, (b) after the LWD test. ....	76
Figure 37. Responses of the LWD device: (a) good quality response, (b) poor quality response.....	77
Figure 38. Dimensions of the soil after placement and compaction in the test pit. ....	80
Figure 39. The existing soil after removal of the topsoil and before placement of the soil to be tested (anchors were also removed). ....	81
Figure 40. Soil prepared for placement in the test pit before testing.....	81
Figure 41. Uniform blending water and aggregate inside the mixer. ....	82
Figure 42. The Layered system of soil placement employed in the test pit.....	82
Figure 43. Using a vibratory roller for compaction of the soil inside the pit .....	83

Figure 44. Side by Side aggregates prepared in the test pit showing LWD/DCP test locations. .	84
Figure 45. Determination of three spots 3 ft apart longitudinally at: (a) 2A and (b) A6 materials. .....	86
Figure 46. LWD and DCP testing at the job site. ....	87
Figure 47. Sand cone test on the (a) 2A, and (b) A6 materials.....	88
Figure 48. Variation of dry density with moisture content for different soils. ....	93
Figure 49. Comparison of standard and modified compaction in terms of density and OMC. ....	95
Figure 50. Measured and calibrated Poisson’s ratio with the degree of saturation for 18 different soils (Thota, Cao, and Vahedifard, 2021). ....	99
Figure 51. Dry density and the soil LWD modulus as a function of moisture content for soil A-6. .....	100
Figure 52. Dry density and LWD modulus as a function of moisture content for soil A-4. ....	101
Figure 53. Dry density and LWD modulus as a function of moisture content for soil 2RC. ....	101
Figure 54. Dry density and LWD modulus as a function of moisture content for soil 2A.....	102
Figure 55. Dry density and LWD modulus as a function of moisture content for soil OGS.....	102
Figure 56. Dry density and LWD modulus as a function of compaction level, soil A-6 at optimum moisture content.....	103
Figure 57. Effect of compaction on dry density at dry side of optimum moisture content. ....	104
Figure 58. Effect of compaction on dry density at optimum moisture content. ....	105
Figure 59. Effect of compaction on dry density at wet side of optimum moisture content.....	105
Figure 60. Effect of compaction on the soil LWD modulus at dry side of optimum moisture content.....	106
Figure 61. Effect of compaction on the soil LWD modulus at optimum moisture content.....	107
Figure 62. Effect of compaction on the soil LWD modulus at wet side of optimum moisture content.....	107
Figure 63. Effect of moisture content on the soil LWD modulus at low compaction level. ....	108
Figure 64. Effect of moisture content on the soil LWD modulus at standard compaction level. .....	109
Figure 65. Effect of moisture content on the soil LWD modulus at high compaction level. ...	109
Figure 66. The modulus of the 2RC soil tested at different times and moisture contents. ....	111
Figure 67. Calculated modulus as a function of the drops at three times. ....	112

Figure 68. The response modulus of the A-6 soil as a function of the drops at 6% MC.....	113
Figure 69. The response modulus of the A-6 soil as a function of the drops at 8% MC.....	113
Figure 70. The response modulus of the A-6 soil as a function of the drops at 15% MC.....	114
Figure 71. The response modulus of the A-6 soil as a function of the drops at 20% MC.....	114
Figure 72. The response modulus of the OGS soil as a function of the drops at 2% MC.....	115
Figure 73. The response modulus of the OGS soil as a function of the drops at 3% MC.....	115
Figure 74. The response modulus of the OGS soil as a function of the drops at 5.5% MC.....	116
Figure 75. The response modulus of the OGS soil as a function of the drops at 9% MC.....	116
Figure 76. The deviation of modulus value of the A-6 soil as a function of the drops at 15% MC. .....	117
Figure 77. The deviation of modulus value of the OGS soil as a function of the drops at 3% MC. .....	117
Figure 78. LWD deflection average response for the first three drops and the last three drops.	118
Figure 79. Soil dry density on different support layers. ....	120
Figure 80. Average LWD tested moduli on different support layers. ....	120
Figure 81. Calculated Deflection on different support layers.....	122
Figure 82. Average deflection of Proctor mold samples for 2RC aggregate.....	123
Figure 83. Average deflection of Proctor mold samples for 2A aggregate. ....	124
Figure 84. Comparison of moisture content using different measurement methods for 2A.....	126
Figure 85. Comparison of moisture content using different measurement methods for 2RC. ...	127
Figure 86. The LWD testing modulus of the existing soil and compacted soil.....	128
Figure 87. LWD modulus of the existing soil and the 2RC soil.....	129
Figure 88. LWD modulus of the 2RC soil with different MCs. ....	130
Figure 89. LWD modulus of the top layer at different compaction levels (plate compacted). ..	130
Figure 90. LWD modulus of the top layer at different compaction levels (roller compacted)...	132
Figure 91. Comparing Proctor mold results and pit results for the 2RC soil modulus.....	132
Figure 92. Accumulated penetration for 2RC material across different compaction and moisture levels in the Test Pit.....	134
Figure 93. Penetration index for 2RC material across different compaction and moisture levels in the Test Pit. ....	134

Figure 94. Dry Density from the nuclear gauge as a function of number of passes at 5.6% moisture content.....	135
Figure 95. Dry Density from the nuclear gauge as a function of number of passes at 7.5% moisture content.....	136
Figure 96. Dry Density from the nuclear gauge as a function of number of passes at 8.2% moisture content.....	136
Figure 97. Dry Density of 2RC material at various compaction and moisture levels measured with a Nuclear Gauge.....	137
Figure 98. Dry Density of 2RC material at various moisture contents.....	138
Figure 99 . Modulus of 2A material at different compaction and moisture levels in the Test Pit. ....	139
Figure 100. The number of roller passes to maximum modulus as a function of moisture content .....	140
Figure 101. Accumulated penetration of 2A material at various moisture contents tested in the Pit. ....	141
Figure 102. Penetration index of 2A material at various moisture contents tested in the Pit. ....	141
Figure 103. Dry Density from the nuclear gauge as a function of number of passes at 5.9% moisture content.....	142
Figure 104. Dry Density from the nuclear gauge as a function of number of passes at 6.8% moisture content.....	143
Figure 105. Dry Density from the nuclear gauge as a function of number of passes at 8.8% moisture content.....	143
Figure 106. Dry Density of 2A material at various compaction and moisture levels measured with a Nuclear Gauge.....	144
Figure 107. Dry Density of 2A Material at various moisture contents.....	145
Figure 108. Impact of compaction level on the modulus of 2A material in section A. ....	147
Figure 109. Impact of compaction level on the modulus of 2A material in section B. ....	148
Figure 110. Impact of compaction level on the modulus of 2A material in section C. ....	149
Figure 111. Dry Density measurements of 2A material in Section A using a Nuclear Density Gauge. ....	150

Figure 112. Dry Density measurements of 2A material in Section C using a Nuclear Density Gauge.....	151
Figure 113. Accumulated Penetration at different compaction levels in Section A.....	152
Figure 114. Penetration index for 2A material at different compaction levels in Section A.....	152
Figure 115. Accumulated Penetration for 2A material across different compaction in Section B .....	153
Figure 116. Penetration index for A-6 material across different compaction and levels in Section B.....	153
Figure 117. Impact of compaction level on the modulus of A-6 material in Section A.....	155
Figure 118. Accumulated Penetration for A-6 material at different compaction levels in Section A. ....	156
Figure 119. Penetration index for A-6 material at different compaction levels in Section A. ...	156
Figure 120. Dry Density measurements at various points on Section A in the field for A-6 material using a Nuclear Gauge.....	158
Figure 121. Correlation between LWD modulus and DCP for A-6 material as tested in the field. ....	160
Figure 122. Correlation between LWD modulus and DCP for 2A material as tested in the field. ....	160
Figure 123. Replotting the E-DCP data after removing a single point of highest penetration. ..	161
Figure 124. LWD Deflections comparison between laboratory tests, pit tests, and field tests. .	162

## List of Tables

Table 1. Various Hammers’ mass and height for Clegg Hammer test (Mooney et al., 2008).....	12
Table 2. The correlation between LWD and different devices (Duddu and Chennarapu, 2022).	21
Table 3. Guidance on typical variations of surface modulus results (Edwards and Fleming, 2009). .....	22
Table 4. Spatial variability of soil stiffness modulus (Hossain and Apeagyei, 2010).....	22
Table 5. PennDOT compaction moisture and density requirements (PTM No. 402, 2020).....	30
Table 6. MnDOT compaction requirements (MnDOT, 2020).....	31
Table 7. DCP/DPI criteria.....	34
Table 8. LWD modula/deflection criteria. ....	35
Table 9. Soil types and correlating Nebraska Group Indices (Schwartz et al., 2017). ....	36
Table 10. MnDOT maximum seat and DPI requirement for the base layer (MnDOT, 2020).....	38
Table 11. LWD minimum elastic moduli for granular, clay and clay loam, and base (MnDOT, 2016). ....	39
Table 12. LWD calibration area dimensions (MnDOT, 2016).....	40
Table 13. INDOT LWD allowable average deflection and maximum deflection for chemically modified soils and aggregate over chemically modified soils (InDOT, 2022).....	40
Table 14. INDOT LWD requirements for aggregate over untreated Soils: Where proof rolling can be performed (InDOT, 2022).....	40
Table 15. INDOT LWD requirements for aggregate over untreated soils: Where proof rolling cannot be performed (InDOT, 2022). ....	41
Table 16. INDOT DCP requirements for different soil classifications (InDOT, 2022). ....	42
Table 17. DCP target values from Phase II test pit data (Glagola et al., 2015).....	46
Table 18. LWD target values from Phase II test pit data (Glagola et al., 2015).....	46
Table 19. NDOR max allowable LWD deflection values for different NGI (Schwartz et al., 2017). .....	47
Table 20. Target pavement foundation surface modulus by the UK (Highway Agency, 2006). .	48
Table 21. Acceptable DCPI criteria for layer types (Ferguson & Gautreau, 2021).....	49
Table 22. Blow count criteria per layer type (Ferguson & Gautreau, 2021). ....	49

Table 23 Adjusted target deflections for compaction of No. 53 aggregate in small areas (Zhao et al., 2018). .....	51
Table 24. Recommended MADs for No. 53 aggregates on chemically modified soil subgrade (Zhao et al., 2018). .....	52
Table 25. Recommended MADs for No. 53 aggregates on compacted soil subgrade (Zhao et al., 2018). .....	53
Table 26. Potential factors in research and their corresponding levels.....	58
Table 27. Prioritization and expectation of results .....	60
Table 28. Material testing for this research .....	62
Table 29. Moisture content for dry, optimum, and wet conditions across various soils examined in this study. ....	73
Table 30. Soil compaction levels: Low, Regular, and High, differentiated by drop counts and hammer weights. ....	74
Table 31. Schedule of site preparation and testing. ....	79
Table 32. Material testing protocols. ....	79
Table 33. Data from study on optimum moisture content based on AASHTO T 99. ....	93
Table 34. Effect of Poisson’s Ratio on the Formulas to Calculate Modulus.....	97
Table 35. Change in Moisture Content with Time. ....	110
Table 36. Comparison of moisture content using different measurement methods. ....	126
Table 37. Nuclear gauge dry density of A-6 material at different compaction levels (15-cm depth). .....	157
Table 38. Field-measured Nuclear Gauge moisture content as a function of number of roller passes for Soil A-6, measured at the depth of 15 cm (6 in). ....	159
Table 39. DPI-estimated resilient modulus (Mr) versus the LWD measured modulus.....	165

## Acknowledgements

The authors greatly appreciate the financial support for this research project that was provided by the Pennsylvania Department of Transportation and the Federal Highway Administration. Mr. Dennis Neff and Ms. Beverly Miller from PennDOT acted as the project technical advisors and Ms. Heather Sorce from PennDOT oversaw the execution of the project as the contract administrator. The support and their guidance was necessary for the success of the project and is sincerely appreciated. Thanks are also extended to Mr. Jason Tyler of PennDOT for coordinating with the research team for testing at the SR 3014 project, as well as to HRI, Inc. construction personnel at the job site for working with the research team in conducting the required field tests. We are also grateful to 3N Consulting, Inc. for procuring samples and conducting the required nuclear gauge moisture and density tests. Finally, we extend our appreciation to the staff of the Larson Transportation Institute at Penn State for their support.

## Disclaimer

The contents of this report reflect the views of the authors, who are responsible for the facts and the accuracy of the data presented herein. The contents do not necessarily reflect the official views or policies of the Federal Highway Administration or the Commonwealth of Pennsylvania at the time of publication. This report does not constitute a standard, specification, or regulation.

# CHAPTER 1

## Introduction

### **BACKGROUND**

Several factors contribute to the quality of subgrade, subbase, and base material to serve as an acceptable foundation for the superstructure or upper pavement layers of roadways. For a specified material, the most important factor affecting the quality of the prepared subgrade or base is its density. The highest level of density must be achieved through adequate compaction so that a strong foundation is provided, resisting excessive deformation or shear failure when subject to repeated loading. Good quality compaction of the subgrade and base provides the needed stability and strength of the foundation before upper layers are built.

Various testing techniques are available to ensure that adequate compaction has taken place, and the required density has been achieved in the field. Examples include the sand-cone test and the rubber balloon test. ASTM standards are available for these tests. The measured in-place density is compared with the maximum dry density of the soil, as established in the laboratory according to established test standards. However, these tests have limitations, including the time it takes to conduct the test, and the results are not available quickly. An alternative is to use a nuclear gauge as a faster technique for determination of the in-place density, even though the nuclear gauge has its own shortcomings. Sometimes, non-movement is used to decide completion of the compaction process, i.e., through visual inspection and ensuring no further movement of the compacted soil under the roller. Some state highway agencies have considered the use of devices such as Dynamic Cone Penetrometer (DCP) or Light Weight Deflectometer (LWD) to assess the quality of compaction and as an indirect way of ensuring that the required density is achieved. This research project was sponsored by PennDOT to investigate DCP and LWD for possible use with the projects constructed in the Commonwealth of Pennsylvania.

### **OBJECTIVE AND SCOPE OF WORK**

PennDOT has sponsored this research project to evaluate the use of LWD and DCP for quality control and quality assurance of subgrade and unbound pavement layers. The objective of this

research project was to establish test methods, limits, and protocols to implement LWD and DCP testing and acceptance criteria for Pennsylvania's subgrade soil and unbound pavement layers. This research provided an assessment of the mechanical and volumetric properties of subgrade soils and unbonded materials at different moisture and compaction levels using LWD and DCP.

The work conducted under this research, as well as the work by other state highway agencies, has been used as the base for establishing test limits. Specifically, the documents and guidance developed by the Minnesota Department of Transportation (MnDOT) and the Indiana Department of Transportation (INDOT) have been used as part of the knowledge base for this purpose. MnDOT has been a pioneer in using LWD and DCP for such applications.

The work included four major parts: (1) literature review, (2) development and execution of a testing plan, (3) analysis and interpretation of the data, and (4) development of the test protocols and establishing test limits. The review of literature was focused on the past and present research and guidance regarding the use of LWD and DCP for the evaluation of quality of the subgrade and unbound pavement layers in terms of compaction. This review was used as the basis to develop an experimental program, which was shared and discussed with PennDOT. The plan included three stages of testing to evaluate LWD and DCP: small-scale laboratory tests, large-scale laboratory tests, and field testing. The proposed experimental plan was geared toward evaluating LWD and DCP capability in quality assurance (QA) /quality control (QC) of the base, subbase, and subgrade layers in a pavement structure. The plan was executed after approval by PennDOT and was the most time-consuming part of the research. Five types of soils were tested in the small-scale lab work; two of the five were tested in the large-scale lab work, and two of the five were also tested in the field work. Only one of the five soils was common to all three stages of the work. The materials obtained for this work were characterized for gradation and, if necessary, for consistency limits. The plan also included determination of the optimum moisture content and preparation of laboratory specimens at three different moisture content levels and three different compaction levels. A massive amount of data was collected during the course of the research. The data were analyzed and the results interpreted and used to develop the test limits.

## **REPORT ORGANIZATION**

This report is organized into five chapters, with the intent to present the research activities and findings in an organized sequence. Chapter 2 is allocated to the findings from the literature review.

The experimental program of the research is covered in Chapter 3. The collected data and corresponding analysis are presented in Chapter 4. These two chapters form the largest portion of the research and required the longest time to execute. They cover details of the testing program and extensive work conducted on collection, analysis, and interpretation of data. Finally, a summary, conclusions, and general recommendations are presented in Chapter 5. The work resulted in the development of recommendations for the use of LWD/DCP for field applications. These recommendations are included in this report as an appendix.

## CHAPTER 2

# Review of Literature

### **APPROACH IN LITERATURE REVIEW**

The literature review was conducted to collect relevant information and data from previous research and practical efforts to achieve this project's objectives. With the project goal in mind, it was essential to investigate past work on topics related to assessing compaction quality for unbound pavement layers. To this end, several relevant reports and papers were reviewed, and this chapter presents a summary of the implemented methods, findings, and recommendations in the following sections.

- Standard practices to evaluate soil compaction quality
- The importance of modulus in the design and evaluation of soils
- Test methods that result in modulus measurements
- Requirements set by different state DOTs on LWD and DCP test results

### **LITERATURE REVIEW**

Construction of new pavements or rehabilitation of old distressed pavements most often requires extensive construction materials. As pavements comprise an expensive part of transportation infrastructure, the quality of these materials and how they are constructed become extremely important. A typical pavement includes several layers of compacted materials on top of the compacted natural soil subgrade. These layers are referred to as the subbase, base, and one or more layers of asphalt or concrete. An acceptable pavement structure must resist distresses, be durable, provide satisfactory ride quality, and be constructed based on the local area's traffic requirements and climatic conditions.

Regardless of the surface layer of the pavement, asphalt, or concrete, the quality of the underlying layers significantly impacts the overall quality of the pavement system. A high-quality subbase and base provide a strong road that is more durable to withstand traffic-induced and temperature-induced stresses in the pavement. The subbase and base layers distribute the imposed

traffic loads so that the subgrade will be exposed to lower stress levels. It should be mentioned that subgrade should be treated as a vital pavement element, and its function is to provide consistent support to the foundation structure and stability of the pavement.

Knowing the underlying materials' engineering properties is one of the most critical steps to having a better-quality road. The response of the subgrade soil and unbound subbase/base materials to loading is complex because these materials, even after compaction, tend to be inhomogeneous and isotropic. Most often, reasonable assumptions are made to make pavement structure analysis and design possible due to this complexity in material behavior. The main properties considered in the design of the pavement unbound layers include density, moisture content, shear strength, and modulus. Among these properties, density is the most common parameter measured in the field to assess the quality of the placed and compacted material. Various techniques are available to make density measurements, the most common technique being the use of a nuclear density gauge. In recent decades, several state highway agencies have investigated other engineering properties of the compacted subgrade or the compacted unbound pavement layers to ensure the acceptable quality of the constructed material. Examples include determining the layer stiffness using a Dynamic Cone Penetrometer and Light Weight Deflectometer. Minnesota is among the states seeking such techniques to replace density measurements and has adopted LWD in its provisional specifications.

### **Common Tests Performed on Subgrade and Base Materials**

Conducting QA/QC in road construction is critical to the project's success and delivering a high-quality product. An essential part of this QA/QC process regards the quality of the compacted subgrade and base materials. To ensure that these materials are compacted to satisfactory levels, they must be tested according to accepted standards, and the results must be compared with the criteria established in the specifications. Most of the current testing protocols for this purpose focus on determining the moisture content and density of the compacted material, as these two factors are well known to be heavily interrelated with a significant impact on the material stability and durability. Examples of common nondestructive devices used to determine in-situ density and moisture content include nuclear moisture density gauges (NDG) and electromagnetic sensors or electrical density gauges (EDG). In addition to utilizing density-based devices, there has been significant progress in using stiffness/modulus-based devices, as will be discussed in this chapter.

### *In-situ Density-based Devices*

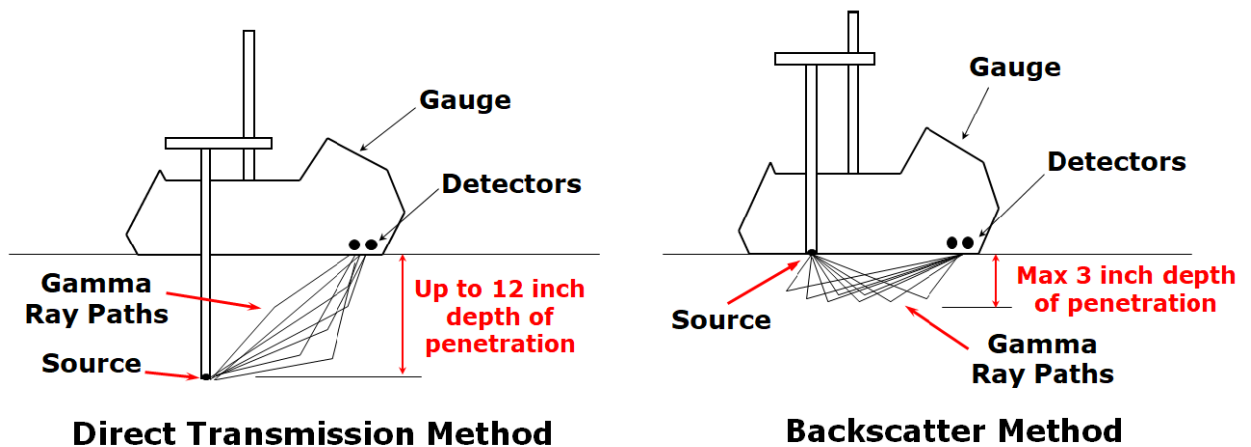
Using density testing methods is a common practice to perform QA/QC on the compaction quality of the pavement unbound layers. It was mentioned previously that some of the common methods of measuring the density of the layers beneath the pavement surface include the Sand Cone Test (SCT), Core Cutter Test (CCT), Rubber Balloon Test (RBT), Nuclear Density Gauge (NDG), Moisture Density Indicator (MDI), Electrical Density Gauge (EDG), and Soil Density Gauge (SDG) (Davich et al., 2006).

### *Nuclear Moisture and Density Gauge*

The Nuclear Moisture Density device (or Nuclear Gauge) is specifically designed to measure the moisture and density of soils, aggregates, cement, and lime-treated materials and to measure the density of asphalt concrete. It offers inspectors and contractors a quick method of obtaining in-place density and moisture content. Gamma rays are emitted from the source and interact with electrons in the pavement material through absorption, Compton scattering, and the photoelectric effect. A detector (situated in the gauge opposite side of the handle) counts gamma rays that reach it from the source. Pavement and subgrade density is then correlated to the number of gamma rays received by the detector. Nuclear density gauges are typically operated in one of two modes, each using a different correlation to determine pavement and subgrade density (PTM No. 402, 2020).

- **Direct transmission:** The retractable rod is lowered into the mat through a pre-drilled hole (Figure 1). The hole can be formed by pounding a steel rod with a similar diameter to the gauge's retractable rod. The source emits gamma rays, which then interact with electrons in the material and lose energy and/or are redirected (scattered). Gamma rays that lose sufficient energy or are scattered away from the detector are not counted. The denser the material, the higher the probability of interaction and the lower the detector count. Therefore, the detector count is inversely proportional to the material density. A calibration factor is used to relate gamma count to actual density.

- **Backscatter:** The retractable rod is lowered even with the detector but still within the instrument (Figure 1). The source emits gamma rays, which then interact with electrons in the material and lose energy and/or are redirected (scattered). Gamma rays that are spread toward the detector are counted. The denser the pavement, the higher the probability that a gamma ray will be redirected toward the sensor. Therefore, the detector count is proportional to density. A calibration factor is used to relate gamma count to actual density.



**Figure 1. Nuclear moisture-density gauge operation modes (PTM No. 402, 2020).**

A nuclear moisture gauge uses a neutron source. The source emits high energy, “fast” neutrons, colliding with various nuclei in the material. Due to momentum conservation, those neutrons that collide with hydrogen nuclei slow down much more quickly than those that collide with other, larger nuclei. The gauge detector counts only thermal (low energy) or “slow” neutrons, making the detector count proportional to the number of hydrogen atoms in the subgrade. Since water contains many hydrogen atoms (H<sub>2</sub>O), the detector count is proportional to moisture content. A calibration factor relates thermal neutron count to actual moisture content.

### Sand-Cone Test

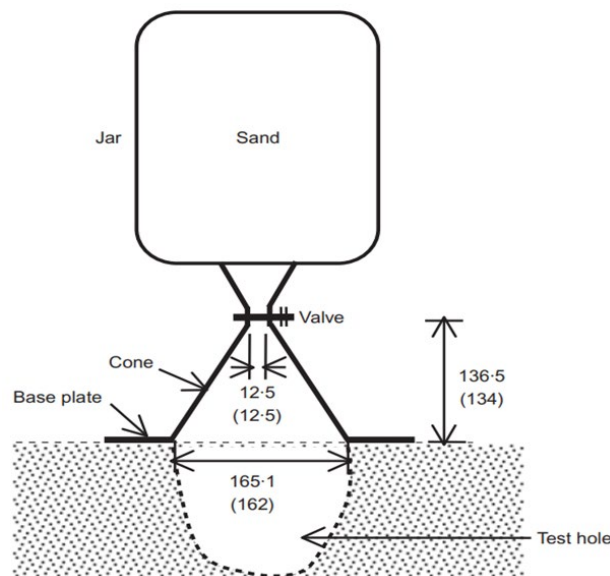
The sand cone test (SCT) is used to determine the water content and density of the compacted soil during the fabrication of the structural backfill, road fill, and earth embankment according to ASTM D 1556. To perform the SCT, the selected area must be clean without loose surface materials. The surface must be level, and the plate must be seated in the designated area. Using the plate’s opening, the operator digs the hole with a height of roughly 150 mm. The volume of the hole is around 2,832 cm<sup>3</sup>. The volume of the hole must never be less than 1,700 cm<sup>3</sup>. After digging the hole, all materials should be quickly removed and weighed. In the next step, the prepared sand should be filled in the hole using a sand cone test apparatus. The sand should appropriately fill the hole. The weight of the sand filled in the hole is calculated after measuring the weight of the remaining sand in the sand cone apparatus. The volume of the hole is either calculated using the weight of the sand and the sand calibration factor (Equation 1) or by using a volumeter. In the final step, the compacted soil’s in-situ

density is obtained by dividing the weight of the removed soil by the hole volume (Geotechnical Engineering Bureau, 2015). Figure 2 shows the schematic of the sand cone apparatus.

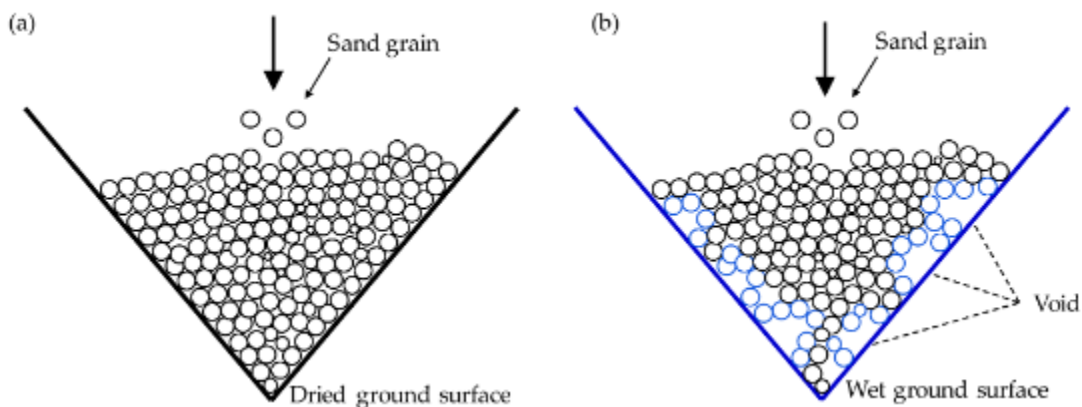
$$V = \frac{M_1}{\rho_{d(sand)}} \quad \text{Eq. (1)}$$

where  $V$  is the volume of the excavated hole,  $\rho_{d(sand)}$  the dry density of the sand, and  $M_1$  the mass of the dry sand.

It should be noted that this test is highly affected by the wetness of the filling sand and holes, which reduces the test reliability. Figure 3 shows the schematic formation of the voids in the holes (Park et al., 2021). Moreover, the test is unsuitable for highly plastic, saturated, and organic soils due to their lower resistance to deformation during the excavation (ASTM D 1556).



**Figure 2. Schematic of the sand cone apparatus (Geotechnical Engineering Bureau, 2015).**



**Figure 3. Process of the sand-filling for (a) dry and (b) wet ground holes (Park et al., 2021).**

There are advantages to using density methods, such as being simple in theory, relatively easy to conduct, and providing a measure of density, which is well established to correlate with the quality of the compacted material. However, there are also disadvantages such as being time-consuming in some cases (for example, the sand cone test), requiring special certification due to radiation exposure (for example, the nuclear gauges), being sometimes imprecise, and finally being difficult to perform on large-sized aggregates. Also, density may not be a reliable indicator of future performance compared to stress-based parameters such as stiffness and strength. Because of the disadvantages, the nondestructive tests based on the modulus/stiffness have gained attention to replace the moisture and density tests.

### *Stiffness/Modulus-based Devices*

The stiffness/modulus and nondestructive test devices include the Briaud Compaction Device (BCD), Clegg Hammer (CH), Dynamic Cone Penetrometer (DCP), Soil Stiffness Gauge (SSG), and deflectometer devices such as Dropping Weight Deflectometer (DWD), Heavyweight Deflectometer (HWD), Falling Weight Deflectometer (FWD), Rolling Weight Deflectometer (RWD), and Light Weight Deflectometer (LWD). These deflectometers measure the compacted geomaterials' deformation and calculate the layer's modulus. Nowadays, LWD is more functional for evaluating the quality of any compacted geomaterials because of its portability and rapid measurement of the soil's shear strength and stiffness in the field. Over the past three decades, several researchers and agencies have investigated using LWD devices for the lower pavement layers' quality control or quality assurance.

### Light Weight Deflectometer (LWD)

The LWD is a simplified version of FWD and offers a portable device to determine the modulus of subgrade and subbase materials. The LWD's results provide the opportunity for a better understanding of the underlayer properties, long-term performance, and the connection between long-term pavement performance and pavement design. The components of the LWD device consist of a falling weight, a load plate, a deflection sensor, a load cell, and a data processing and storage system. Various manufacturers produce LWD devices, including Zorn, Keros, Dynatest, Prima, Loadman, ELE, TFT, Olson, Humboldt, and CSM (Schwartz et al., 2017). Parameters such as the diameter of the loading plate, plate rigidity, plate contact stress, loading rate, buffer type, location, and

deformation transducer influence the LWD's measurement of the compacted geomaterials. The LWD is developed to simulate a truck with 10 tons of axle weight moving at a speed of 80 km/hr. Therefore, the pressure of 0.1 MN/m<sup>2</sup> is applied to the soil with a loading time of 18 ms (Jardine et al., 2004).

### LWD Test Procedures

To conduct the LWD test, the device is set up on a test site or in a laboratory. Then, the weight is dropped from a standard height, guided down along a rod, until it hits a buffer made of either rubber pads or steel springs. As the spring-dashpot unit is attached to the plate sitting on the ground, the impact force of the weight is carried to the plate and then to the ground, causing deflection. Normally a total of six drops are applied, of which the first three drops are seating drops, and the last three are data-collecting drops. A velocity sensor (or an accelerometer) records the speed or acceleration of the plate's downward movement (Kessler, 2009). Then the modulus is calculated for the field application using the Boussinesq equation (Schwartz et al., 2021):

$$E = \frac{2k_s(1 - \nu^2)}{Ar_0} \quad \text{Eq. (2)}$$

where  $\nu$  = Poisson's ratio (assumed),  $r_0$  = plate radius,  $A$  = stress distribution factor (assumed),  $k_s$  = soil stiffness =  $F/\delta$  as calculated by the LWD device,  $F$  = LWD peak applied load (measured or assumed), and  $\delta$  = LWD measured peak deflection.

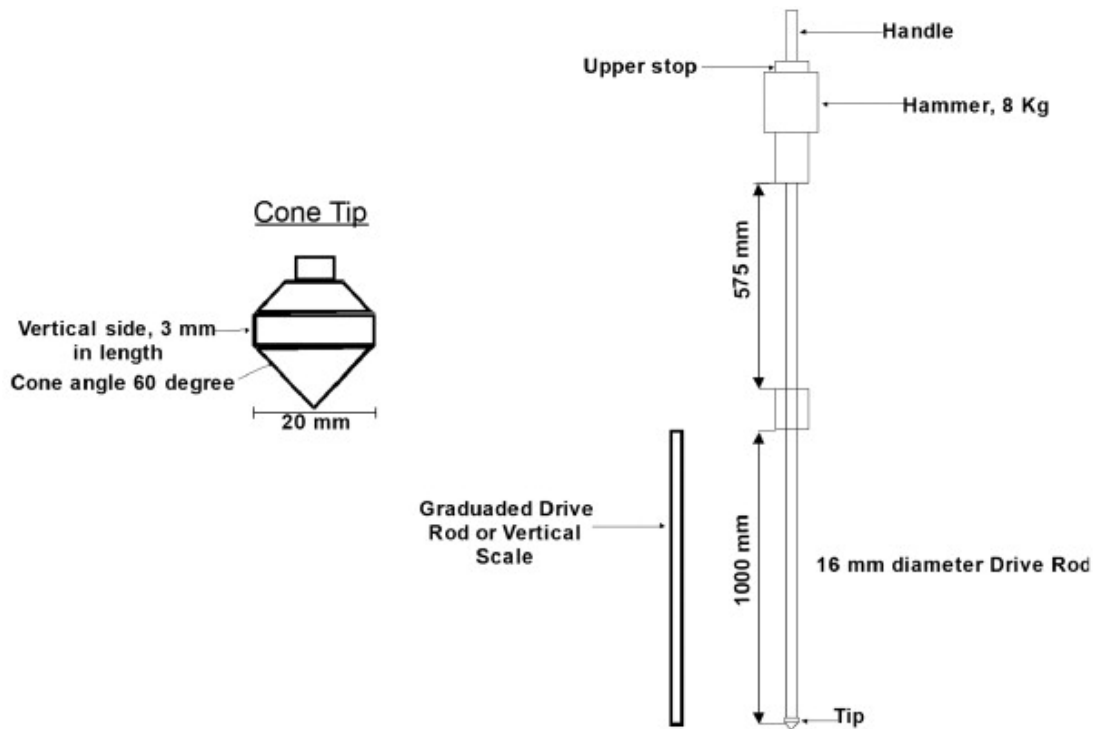
### Dynamic Cone Penetrometer (DCP)

The Dynamic Cone Penetrometer is a more advanced version of a hand cone penetrometer. The DCP is an affordable, portable, and effective tool to rapidly determine in-situ soil strength and geomaterial engineering properties. When the cone drives into the subgrade, subbase, or base, the device's penetration into the soil is measured after each hammer blow. The material's resistance to penetration is an indication of the material's stiffness. One of the test outputs is the DCP Penetration Index (PI), defined as the penetration depth divided by the number of drops (Morian et al., 2012; Sawangsurriya & Edil, 2005).

### DCP Test Procedures:

This device consists of a steel rod with a 60-degree, standard-diameter steel rod, hardened council tip, and an 8-kg hammer that drops from a standard height of 575 mm from the top of the rod above

the anvil. The penetration of the rod is measured and recorded after each drop. The test result can be correlated to CBR or other stiffness-based devices to assess the strength of the compacted geomaterial of the road layer. Figure 4 shows a schematic of the DCP.



**Figure 4. Dynamic Cone Penetrometer (DCP) (Mohammadi et al., 2008).**

### Additional Stiffness/Modulus-based Devices

#### Briaud Compaction Device (BCD)

The Briaud compaction process is a simple, nondestructive testing method used to measure compacted soil modulus and test soil compaction in several minutes. The compacted soil is subjected to a small repeatable load applied to the plate via the rigid rod (Weidinger & Ge, 2009). The main objective of this test is to establish a modulus versus moisture content graph, similar to the relationship between density and moisture content developed from the compaction of the soil in the Proctor mold (Li, 2004).

### Clegg Hammer (CH)

Clegg Hammer or Clegg Impact Soil Tester is a device with a standard weight or hammer that drops from a standard height of 457 mm (18 inches) according to ASTM D 5874. Hammer masses vary for different device applications (see Table 1.). The significant parts of this device are a flat-ended cylindrical hammer and a tube through which the weight is dropped. The measurement section of the device is an accelerometer attached to the top of the hammer to measure deceleration after contact with soil. The device records a Clegg Impact Value (CIV), and the peak deceleration value calculated for different conditions (Mooney et al., 2008).

**Table 1. Various Hammers' mass and height for Clegg Hammer test (Mooney et al., 2008).**

Hammer Mass (kg)	Hammer Diameter (mm)	Recommended Applications
0.5	50	Soft turf, sand, golf greens
2.25	50	Natural or synthetic turf (athletic fields)
4.5	50	Foundations, pre-constructed soils, bell holes, trench reinstatement
10	130	Roadbeds, flexible pavement, trench, aggregate
20	130	Foundations, reinstatement, bell holes

### Soil Stiffness Gauge (SSG)

The Soil Stiffness Gauge (SSG), also known as GeoGauge, is used to assess the stiffness of unbound materials. It is a useful device to determine construction anomalies. It can identify and aid in reducing variation in layers' properties by measuring stiffness. Consequently, it is possible to take corrective actions during construction to ensure that the best quality base and subgrade are achieved despite differences in the materials.

### **Soil Modulus Tests**

Soil modulus tests can be done in the laboratory or in the field using LWD and other devices. Laboratory compaction tests help look at soil deformation and behavior at different loads and conditions. On the other hand, the soil modulus test in the field or large test pits gives a more accurate measurement of the soil as-constructed modulus.

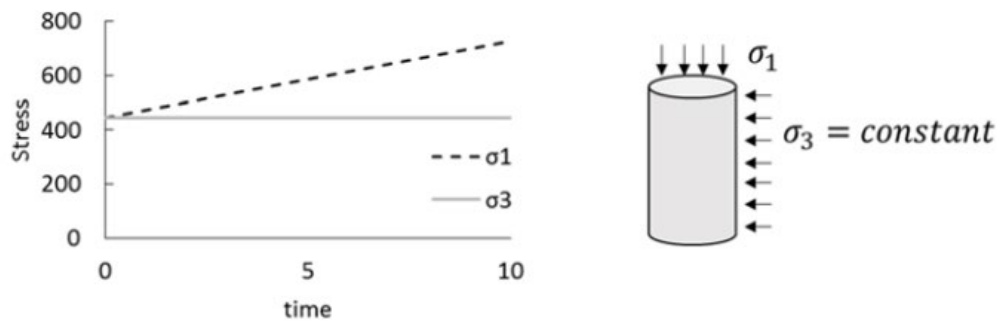
### Small-Scale Laboratory Test

Small-scale laboratory tests for determining the soil modulus include triaxial tests and LWD tests on the soil compacted in the Proctor mold. It is not expected that the triaxial test and LWD on the

cylindrical specimens will deliver similar results. This is the case because of several factors such as assuming a value for Poisson’s ratio, different stress paths in the two tests, and different levels of resilience against deflection.

Resilient Modulus (Triaxial Test)

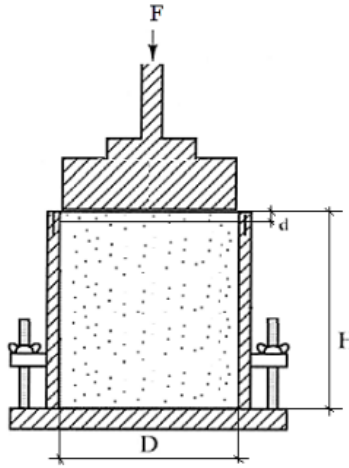
The Triaxial test is a method to determine the shear strength of soil, cohesion, and dilatancy stress. The resilient modulus of unbound material is assessed in the laboratory based on the AASHTO T 307. In these tests, a cylindrical soil specimen is sealed and confined using a rubber membrane to prevent the confining fluid from entering the specimen. In this test, a constant stress is applied ( $\sigma_3$ ) from all directions to the sample. Also, axial stress, known as deviator stress and equal to  $\sigma_d$ , is applied vertically. This stress configuration results in a minor principal stress in the lateral direction ( $\sigma_3$ ) and a major principal stress in the vertical direction ( $\sigma_1$ ). Figure 5 shows the stress-time relation and stress applied to the specimen in this test.



**Figure 5. The schematic of the load in the Triaxial test.**

LWD on the Soil Compacted in the Proctor Mold

This method is for compaction quality control of unbound geomaterial using the LWD test of soil and aggregates inside the Proctor mold. The goal is to find the target field modulus at the determined moisture content. A total of six drops are applied to the soils inside the mold, and the first three drops are excluded from calculations. The maximum peak stiffness, impact load, and deformation are averaged for the last three drops and are used in the analysis. Figure 6 shows the schematic of LWD testing on the Proctor compacted soil. The modulus is calculated based on Equation 3.



**Figure 6. Schematic of LWD testing on mold.**

The modulus of the soil is as follows:

$$E = \left(1 - \frac{2\nu^2}{1 - \nu}\right) \frac{4H}{\pi D^2} k \quad \text{Eq. (3)}$$

where  $D$  = diameter of the mold,  $H$  = Height of the mold,  $k$  = soil stiffness, and  $\nu$  = Poisson's ratio.

### Large-Scale Laboratory Test

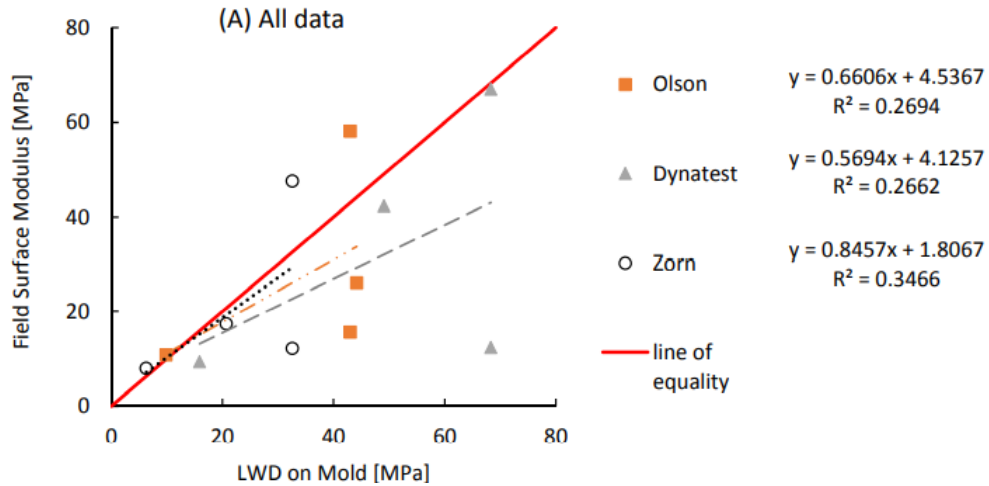
One way to evaluate the properties of compacted soil on a large scale in the laboratory is through the use of large test pits. Test pits mainly help assess the soil's modulus by simulating the field conditions. The use of test pits also effectively evaluates the tests' repeatability or the devices' variability. The unbonded materials are compacted under controlled conditions to evaluate the modulus. The results obtained from the test pits using stiffness-based devices such as LWD can be used to compare the correlation between field and lab modulus and investigate LWD responses to test layer thickness (Schwartz et al., 2017).

### **Previous Studies**

Comprehensive research was conducted to evaluate the compaction of subbase and base by Schwartz et al. (2017). Three types of soils were used in that study: cohesive high-plasticity clay (HPC) subgrade soil, non-cohesive silty sand subgrade soil, and a well-graded aggregate base. Two non-nuclear techniques for measuring moisture content, including a gravimetric moisture analyzer and a volumetric water content sensor, were assessed. The correlation between these two devices was strong, with the coefficient of determination equal to 94.5%. Experimental tests were performed in

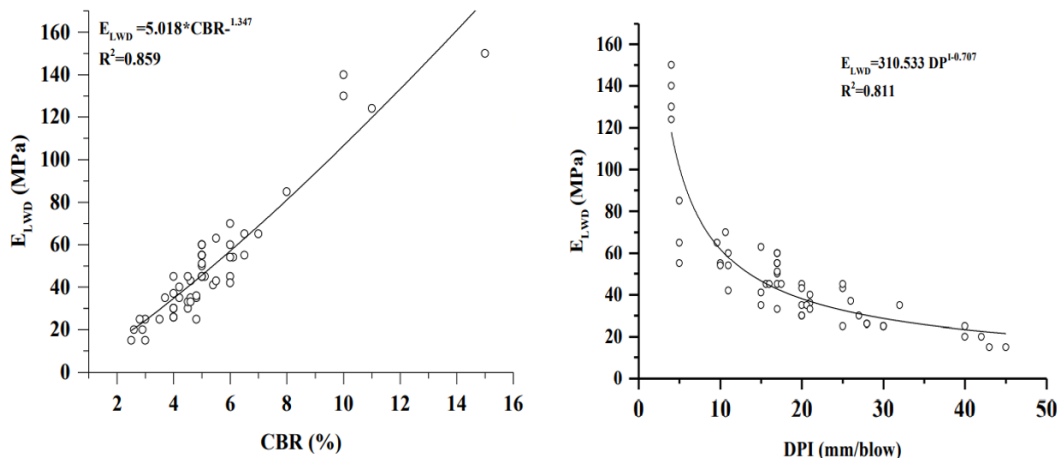
the laboratory to evaluate the characteristics of the soils. Densities were determined at different moisture contents to establish the moisture-density relationship, and triaxial compression tests were conducted to find the soil's resilient modulus. Three LWDs (Olson's LWD-1, Dynatest 3031 LWD, and Zorn ZFG 3000 LWD) were used to obtain the range of commercially available LWD modulus of the soils. The mentioned soils with the different combinations of the base and subbase layer were compacted in the pits into one or two layers with different densities, moisture contents, and thicknesses. Moreover, the static load using a plate was applied to the soils in the same pits. The deflection was measured based on the various loads applied to the soils.

The study's results showed a strong correlation between the predicted modulus from static load and the modulus obtained from LWDs. The correlation of the determination between the results of these two tests was 97.7%, 94.8%, and 78% for Zorn, Olson, and Dynatest, respectively. LWDs were also utilized to obtain the modulus of the various soils using Proctor molds. There was a relatively strong correlation between results obtained from multiple LWDs. However, the LWD results from the test pits and LWD results from the Proctor mold did not correlate strongly. The developed regression line and their coefficient of determination ( $R^2$ ) are shown in Figure 7. A strong correlation was observed between the triaxial compression test and LWD results on the Proctor-mold-compacted soils. The correlations of the determination between resilient modulus from the triaxial compression test and modulus from Zorn, Olson, and Dynatest were 79%, 73%, and 89%, respectively. Finally, the research results were used to develop two modulus-based standards for quality assurance of the base and subbase soils in AASHTO format. These two proposed standards include Laboratory Determination of Target Modulus Using Light Weight Deflectometer (LWD) Drops on Compacted Proctor Mold and Compaction Quality Control Using Light Weight Deflectometer (LWD).



**Figure 7. Comparison between modulus obtained from field and Proctor mold test using Zorn, Dynatest, and Olson LWDs (Schwartz et al., 2017).**

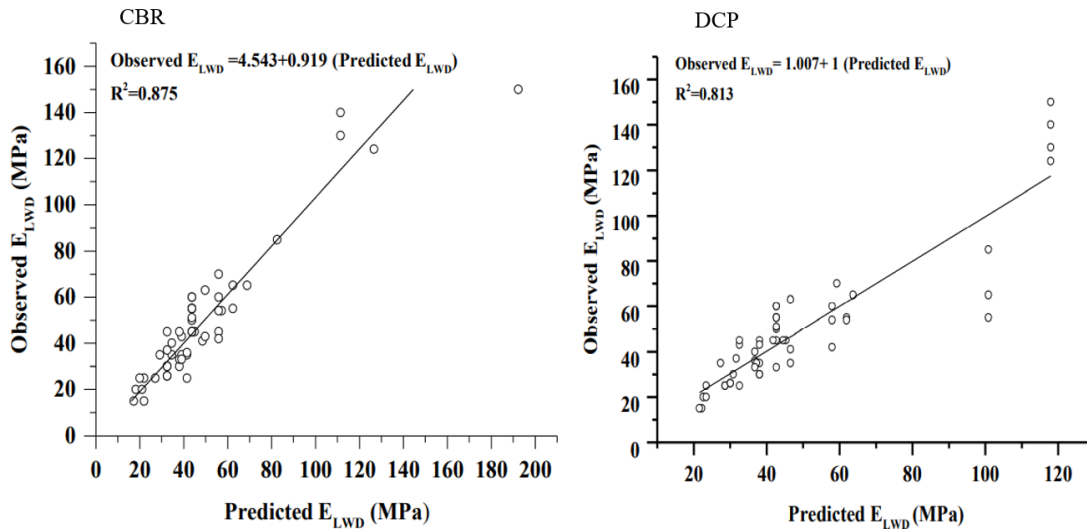
Makwana and Kumar (2019) conducted a study to find the correlation between LWD as a response variable, and DCP and CBR as explanatory variables for subgrade soils separately. Based on the results, a strong correlation with a coefficient of determination ( $R^2$ ) of 0.86 was observed between LWD and CBR test results. Furthermore, the relation between LWD and DCP test results was developed with an  $R^2=0.81$ . Figure 8 shows the relationship between the observed modulus vs. CBR ratio and DPI index, respectively.



**Figure 8. Observed modulus vs. CBR ratio and DPI index (Makwana & Kumar, 2019).**

In the next step, a linear regression model was developed to compare the predicted and observed modulus; the results are provided in Figure 9. As was evident in the graphs, there was a

strong correlation between predicted and observed modulus. The correlation of determination between the observed modulus as a response variable and the predicted modulus as an explanatory variable obtained from CBR and DCP models were 0.875 and 0.813, respectively, which showed a strong relationship between these variables. In other words, 87.5% and 81.3% variation in observed modulus could be explained by predicted modulus for CBR and DCP.

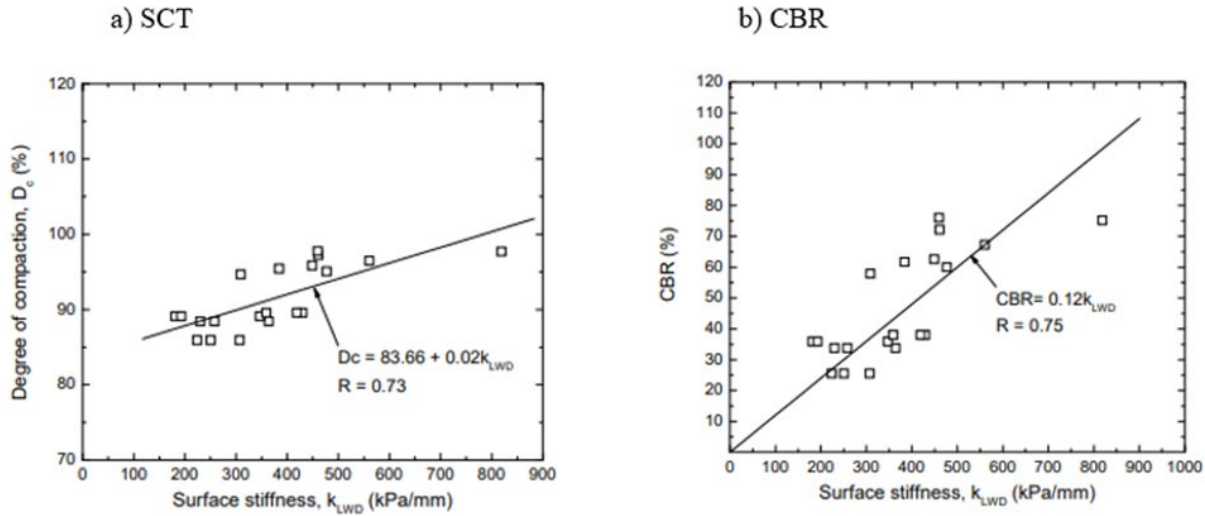


**Figure 9. Predicted from CBR and DCP test vs. observed modulus (Makwana & Kumar, 2019).**

The results showed that with decreasing fines or increasing moisture content, the suction decreased. An opposite trend with fines content and the same direction in variation in moisture content was captured. Therefore, neither of the two first models indicated satisfactory results. In the third model, the impact of different friction coefficients was used to represent the variability in lubrication between coarse particles because of fine aggregates. Based on the results, average penetration from DCP and peak deflection from LWD tests increased by decreasing the friction. This result was in agreement with trends observed in the estimated values. Therefore, the friction-based model was the best model used in the study.

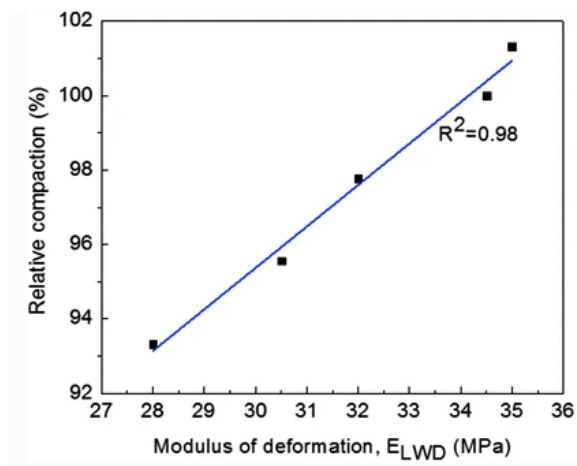
A research study was performed by Kongkitkul et al. (2014) to obtain the correlation between LWD stiffness and degree of compaction. This study used sand cone and CBR tests to determine the compaction and density levels. On the other hand, LWD was used to measure the stiffness modulus of the soil. A test pit was used to simulate the compacted soil in the field. Figure 10 shows the correlation between stiffness modulus and the degree of compaction. Figure 10a shows a relatively

good correlation between the degree of compaction and stiffness modulus. Similarly, Figure 10b shows a relatively good correlation between CBR and stiffness, with an  $R^2$  of 0.75.



**Figure 10. The relationship between stiffness and (a) degree of compaction from the sand cone and (b) CBR (Kongkitkul et al., 2014).**

Hariprasad et al. (2019) investigated the relationship between the compaction degree obtained from the sand cone test and LWD modulus for low-volume roads (Figure 11). Increasing the degree of compaction leads to an increase in the modulus. Accordingly, a robust correlation was observed between these parameters with an  $R^2$  of 0.98. The authors suggested developing a similar correlation between modulus from LWD and density obtained from SCT for any pavement layer, including base and subbase, as well as compacted embankments.

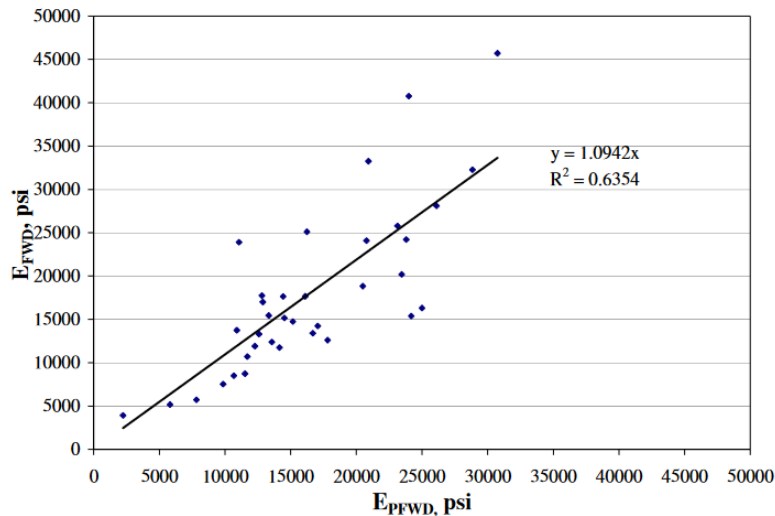


**Figure 11. LWD modulus versus relative compaction of the base layer of a low-volume road (Hariprasad et al., 2019).**

George (2006) conducted a study to evaluate the possibility of using the portable FWD known as PRIMA 100 for in-situ subgrade evaluation. In this study, 13 sections reflecting the subgrade soils across the State of Missouri were selected. For these test sections, FWD and Portable FWD (PFWD) were utilized to obtain the soil's modulus, and a nuclear gauge was used to determine the in-situ density and unit weight. Furthermore, samples were collected from the selected areas, and triaxial tests (AAHTO T 307) were conducted. A correlation was established between the modulus obtained from FWD and PFWD (Figure 12). Further, George investigated the correlation between the ratio of the modulus obtained from portable FWD to the modulus obtained from the resilient modulus test in the laboratory and the ratio of the plasticity index to the amount of soil passing through the sieve #200. The results showed a negative correlation (-0.73) between these two values (see Equation 4).

$$\frac{E_{PFWD}}{M_{R95}} = -2.30 + 3.860 D_{\left(\frac{f}{95}\right)} - 0.31M_{\left(\frac{f}{o}\right)} - 0.635 \frac{PI}{P_{200}} \quad \text{Eq. (4)}$$

where  $\frac{E_{PFWD}}{M_{R95}}$ =ratio of measured PFWD elastic modulus to laboratory-determined resilient modulus at 95% compaction,  $D_{\left(\frac{f}{95}\right)}$ =ratio of field unit weight to unit weight at 95% compaction,  $M_{\left(\frac{f}{o}\right)}$ =ratio of field moisture to optimum moisture, and  $\frac{PI}{P_{200}}$ = ratio of plasticity index (%) to passing sieve size #200 (%). George observed that coarse-grained soils, with a low PI/P<sub>200</sub> ratio, have a relatively large in-situ modulus in comparison to the resilient modulus. The higher in-situ modulus was attributed to the superior confinement offered by the surrounding soil.



**Figure 12. Modulus of the subgrade soil obtained from FWD vs. PFWD (George, 2006).**

A partial correlation was found between the results of these two tests, implying some level of relationship, albeit not strong. On average, the modulus from the FWD test was almost 9 percent higher than that from the PFWD test. The higher mass of the FWD can be responsible for the higher modulus. Based on the studies conducted by Fleming et al. (2000) and Philips (2005), the ratio of moduli was 1.03 and 1.23, respectively. Furthermore, in the study by Fleming and Frost (2002), an increase in the mass of the bearing plate from 15 to 25 kg increased the movement's endurance, resulting in a lower deflection and, therefore, a lower modulus. Shafiee et al. (2013) used LWD and FWD to characterize the subgrade soil's modulus. A study was performed to evaluate the relation between FWD and LWD results in the outer wheel path of a pavement. The results showed that the modulus obtained from FWD is 1.16 times higher than the ones obtained from the LWD test. The differences between the equipment weight and the loading rate were recognized as a source of variability in these two tests. The authors believe performing FWD on the subgrade soil is problematic because it is sensitive to various variables along the road. Also, the researchers found that special care is needed where the topography is variable and at the transition zone between fill and cut sections.

Researchers have developed relationships between the results from LWD and those from other devices because LWD is a rapid and easy test. Some of the proposed formulas for this purpose are provided in Table 2. These relations are between LWD as an explanatory variable and one of the unconfined compressive strength, density, or California bearing ratio as a response variable. As we

can see, the coefficient of determination is roughly high for all models (more than 80%), which shows a strong correlation between these variables.

**Table 2. The correlation between LWD and different devices (Duddu and Chennarapu, 2022).**

Materials	Regression/ Empirical Correlations	Coefficient of Determination
Sandy soil	$CBR_{(us)} = 0.0009 E_{LWD}^2 - 0.064 E_{LWD} + 6.904$	0.807
	$CBR_{(US)} = 0.0001 E_{LWD}^2 - 0.0015 E_{LWD} + 1.184$	0.805
	$\gamma_d = 1 \times 10^{-5} E_{LWD}^2 + 0.002 E_{LWD} + 1.098$	0.77
Lime stabilized subgrade soil	$UCS = 4.9 E_{LWD}$	0.99
	$CBR = 0.15 E - LWD$	0.93
Lateritic subgrade	$CBR = -2.754 + 0.2867 E_{LWD}$	0.90
Soil classification	$E_{V1} = 0.91 E_{LWD-P3} - 1.81$	0.84
GC, GC, GW, GP, SP, CL-ML, CL	$E_{V2} = 25.25 e^{0.006 E_{LWD-P3}}$	0.90
Cohesive soils	$E_{V1} = 0.833 \times E_{LWD-Z3}$	-
Non-cohesive soils	$E_{V1} = 150 \ln [180 / (180 - E_{LWD-Z3})]$ or $E_{V1} = 1.25 \times E_{LWD-Z3} - 12.5$ ( $E_{LWD-Z3}$ ranging between 10 and 90 MPa)	-
Crushed limestone	$CBR = -14 + 0.66 E_{LWD}$	0.83
Sandy soils	$E_{V2} = (600 - 300) / (300 - E_{LWD-Z3})$	-

$E_{LWD}$ =deformation modulus measured by LWD;  $CBR_{(us)}$ =unsoaked California bearing ratio;  $UCS$ =unconfined compressive strength;  $CBR(s)$ =soaked California bearing ratio;  $E_{V1}$ =static modulus of the layer.

The coefficient of variation (COV) for different soils as a variability expression has been presented in a study by Edwards and Fleming (2009). Table 3 shows the data obtained from that study on the COV of the cohesive subgrade clay soils, granular capping materials, granular subbase mixtures, and bound subbase mixtures. The bound subbase mixtures and cohesive subgrade clay soils have the lowest and highest COV, respectively. Per the authors' recommendations, three drops are usually used for setting the plate on the surface of the soil layers to ensure good surface contact. However, plate contact on stiffer-bound material is not always improved by increasing the number of drops. The targeted load should be selected to ensure the plate is bedded into the material, and the load should not exceed the test load. The test repeatability needs to increase for the LWD device to

be reliably used as a QC/QA tool. To achieve this, a well-trained operator should carry out the test consistently and cautiously. Further, incorporating a thin sand layer on the testing spot provides a level surface that distributes the impact pressure more uniformly (Matthew and John, 2007).

**Table 3. Guidance on typical variations of surface modulus results (Edwards and Fleming, 2009).**

Material type and layer in pavement	Range of coefficient of variation (COV)
Cohesive subgrade clay soils	25 to 60%
Granular capping materials	10 to 40%
Granular subbase mixtures	5 to 20%
Bound subbase mixtures	5 to 30%*

\* a larger COV may be expected for testing stiffer materials, dependent on the Working Range of the equipment and Test Protocol adopted.

Hossain and Apeageyi (2010) employed three devices to measure the in-place stiffness of the soils in seven different projects across Virginia. In this study, the authors used LWD, DCP, and GeoGauge (Geo) devices to measure the stiffness of the soils. Table 4 shows a very high degree of spatial variability (COVs ranging from 8 to 77%) was observed in the measured stiffness moduli. The COV values varied from 13 to 68% for the DCP-measured modulus, 8 to 42% for the GeoGauge modulus, and 22 to 77% for the LWD modulus. Pointing to the differences in moisture content as one of the sources for high variabilities, Hossain and Apeageyi (2010) raised concern over using such devices for construction QC/QA.

**Table 4. Spatial variability of soil stiffness modulus (Hossain and Apeageyi, 2010).**

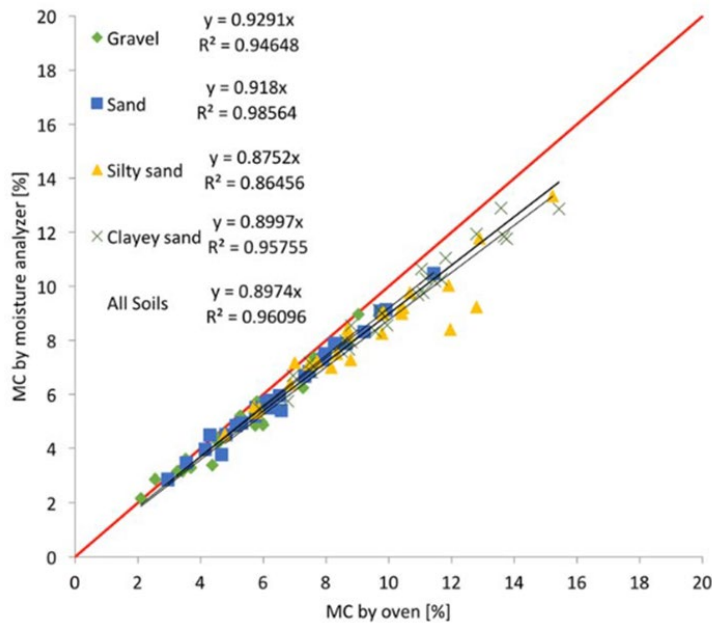
Project	No. of Locations Tested	Mean (ksi)			Coefficient of Variation (%)			Layer Tested
		Geo	LWD	DCP	Geo	LWD	DCP	
Route 3	20	23	24	-	14	42	-	Subgrade
Route 644	6	24	19	17	30	43	44	
Route 743	11	9	6	6	40	34	32	
Route 15	5	28	31	76	8	32	35	Base
Route 782	6	43	92	209	21	77	68	Gravel Road
Route 785	6	29	12	47	42	63	73	
Route 797	5	51	81	209	18	22	13	

### Effect of Moisture Content on the LWD and DCP Test Results

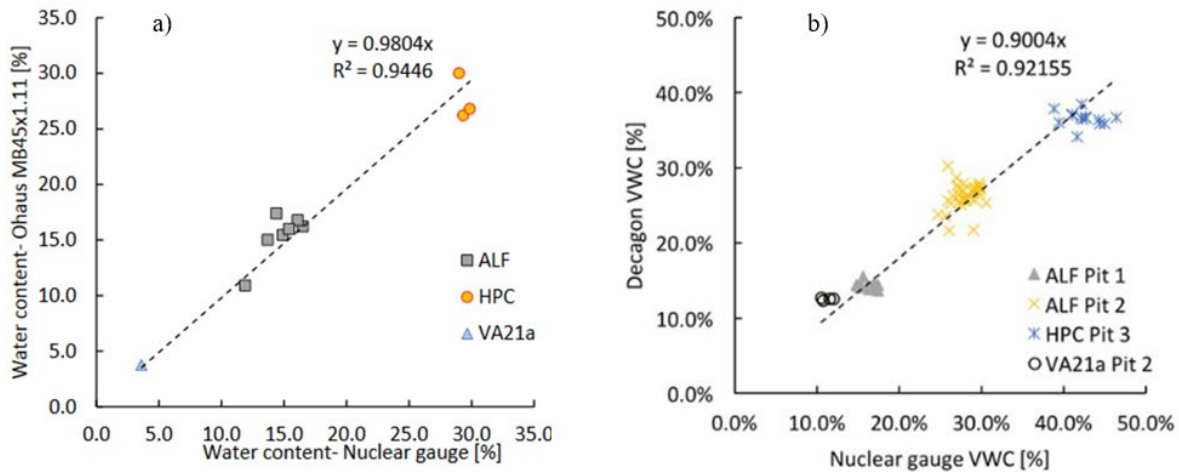
Moisture content (MC) is one of the most critical parameters affecting the soil's behavior. The MC should be measured during and after compaction to ensure it is in an acceptable range. To this end,

various devices can be used. The most common way to measure MC is using the nuclear density gauge. There are also different non-nuclear devices for measuring the MC, such as road-bed water content meter (such as DOT600), Moisture+Density Indicator (M+DI) device, Electrical Density Gauge (EDG), Speedy Moisture Tester (SMT), and Soil Density Gauge (SDG). The results of the study by Sotelo et al. (2014) showed that the bias in measuring the MC increased by increasing the moisture content. This study concluded that SMT and DOT600 were the best and the worst, respectively. It is worth mentioning that there are safety concerns over the SMT, since the reagent used is considered a hazardous product (Tirado et al., 2018). Sotelo et al. (2014) also used three different devices, including a Time Domain Reflectometer (TDR), the SMT, and the SDG, to measure the moisture content of the soil. By comparing the results from these devices, the authors concluded that SMT and TDR were in an acceptable range and were comparable to the results obtained from the oven-dry method. The SDG was highly soil-dependent compared to the two other devices.

Schwartz et al. (2017) used three different devices to examine the MC of the soils. These three devices included a decagon ruggedized GS-1 volumetric water content sensor, an Ohaus MB45 moisture analyzer, and nuclear moisture/density gauge. Figure 13 shows the correlation between MC measured for various soils using the Ohaus MB45 moisture analyzer and MC obtained from the oven-dry method. There was a robust correlation between these two parameters in all soils. Figure 14 indicates the correlation between MC obtained from the Ohaus MB45 moisture analyzer and MC obtained from the nuclear gauge. Although the number of samples was limited, good correlation was found for all types of soils used in the test pit.



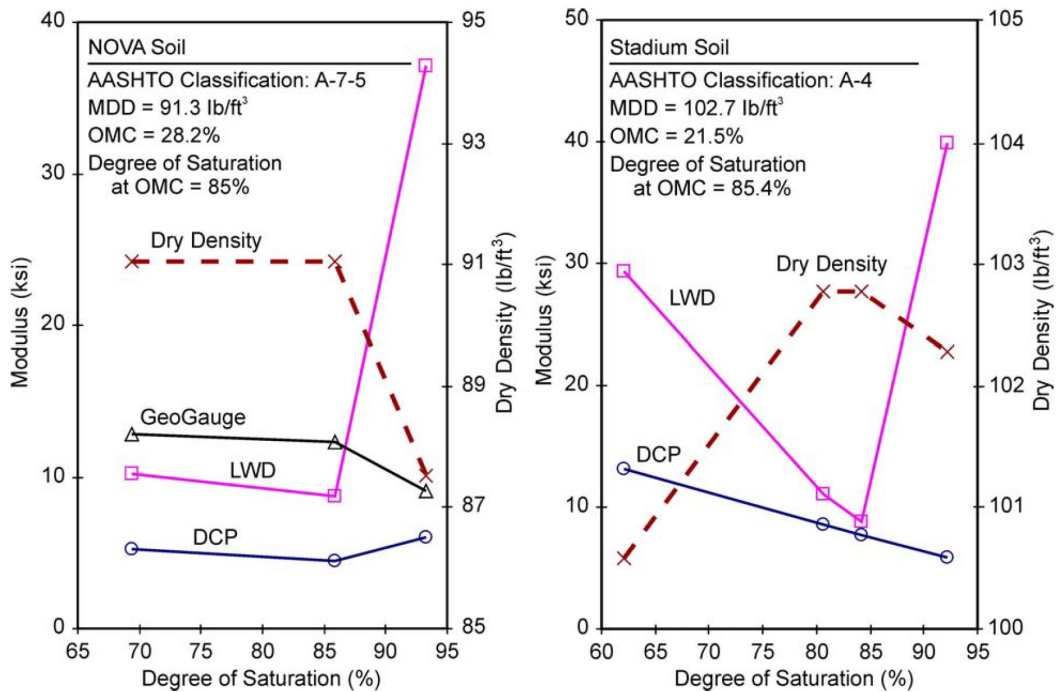
**Figure 13. The obtained MC from Ohaus MB45 moisture analyzer vs. oven dry method (Schwartz et al., 2017).**



**Figure 14. The correlation between moisture content obtained from (a) Ohaus MB45 moisture analyzer vs. nuclear gauge and (b) Decagon vs. nuclear gauge (Schwartz et al., 2017).**

Hossain and Apeageyi (2010) investigated the effect of moisture on stiffness modulus obtained from LWD testing on base aggregates, gravel road surfaces, and subgrades in Virginia. The results did not show any clear trend in the LWD test results (Figure 15). On the other hand, there was a good correlation between DCP and moisture content. The authors reported that the moisture content

significantly impacts the results of the LWD and DCP. As the effect of moisture on the LWD modulus measurements did not follow a consistent trend, the author suggested conducting further investigation to establish this effect.



**Figure 15. Effect of moisture (degree of saturation) on soil stiffness modulus in a laboratory setup (NOVA = Northern Virginia) (Hossain & Apeageyi, 2010).**

Danielle et al. (2014) quantified the effect of moisture in DCP and LWD tests. They developed a mechanistic model for the dry aggregate base to enhance its applicability to more tests and materials utilized in Minnesota. In this research, the discrete element method (DEM) was used to simulate the impact of moisture and fine aggregate on DCP and LWD tests for the granular mixture. The results obtained from different numerical models were subsequently compared with the actual test results. The first model was based on the liquid bridge theory. This model obtained a higher deflection peak by increasing the moisture content. However, the model could not accurately simulate the fine aggregate’s presence. The experimental work was the base of the second numerical model. Davich et al. (2006) conducted a research study to validate Minnesota’s LWD and DCP moisture specification for granular materials. It was found that the DCP specification provided suitable criteria regarding the compaction quality of the soils. However, some suggestions were proposed by the authors to improve the test. Firstly, the number of DCP drops should not be limited to three, and the test should continue until the cone passes through the subbase lift of interest. MnDOT also has a limitation on

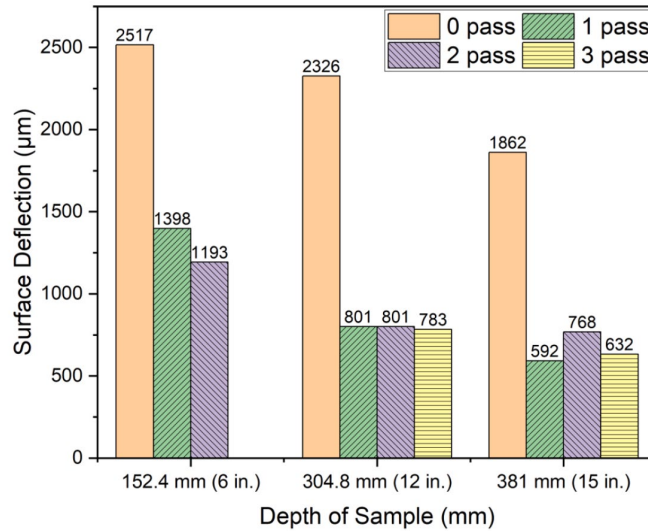
the test layer requiring that the layer being tested be thicker than a “minimum test layer” that varies based on grading number (sum of percentages passing the seven most common sieves divided by one hundred). Secondly, there was no goal to use the seating requirement for the subbase layer, and it should not be included in the specification. Thirdly, the moisture content of the soil should not be higher than 10%. It was suggested to use three moisture content levels: less than 5%, 5% to 7.5 %, and 7.5% to 10%. The authors also reported that LWD yielded at least the same accuracy as DCP, and it needed less effort from the inspector. The authors also recommended that the LWD specification include three seating drops and three data drops at each new height.

Effect of Sublayers on the LWD and DCP Test Results

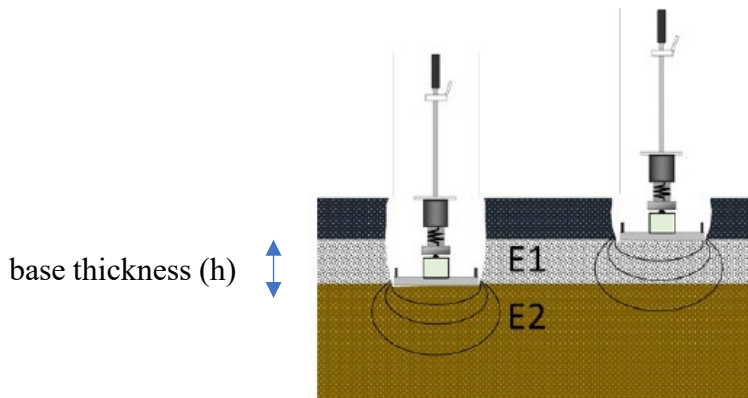
In the LWD test, the zone of influence extends to 1 and 1.5 times the plate diameter below the test level (Edwards and Fleming, 2009). Therefore, a smaller plate size for thin unbound layers can help avoid capturing the sublayer effects on the surface layer moduli. Mondal et al. (2022) used a wooden box (1.2m\*1.2m\*1.2m) to compact the #57 aggregate material with three different layers, namely 152.4 mm, 304.8 mm, and 381 mm (6, 12, and 15 in) through a vibratory plate compactor. Once each layer was placed, LWD tests were carried out after 0, 1, and 2 passes of the vibratory plate compactor. Figure 16 shows that the deflection measured on the second and third lifts (especially after zero passes) was lower than the first, indicating the importance of the sublayer compaction level. Mentioning that the total surface deflection under the LWD plate was the accumulated deformations in the base and subgrade layers, Schwartz et al. (2017) attempted to adjust the target modulus for the finite-thickness base layer using Equation 5.

$$E_{target-adj} = 1/ \left\{ \frac{1}{E_2 \left[ \sqrt{1 + \left( \frac{h}{d} \sqrt{\frac{E_1}{E_2}} \right)^2} \right]} + \frac{\left[ \sqrt{1 - \left( 1 + \left( \frac{h}{d} \right)^2} \right) \right]}{E_1} \right\} \quad \text{Eq. (5)}$$

Where  $E_{target-adj}$  = adjusted target modulus for the base material,  $E_2$  = modulus of the subgrade measured before the base placement,  $E_1$  = target modulus for the base material,  $h$  = base layer thickness, and  $d$  = LWD plate radius used during field testing (Figure 17).



**Figure 16. LWD test results in Wooden Box for ASTM #57 aggregate material (Vibratory Plate Compaction) (Mondal et al., 2022).**

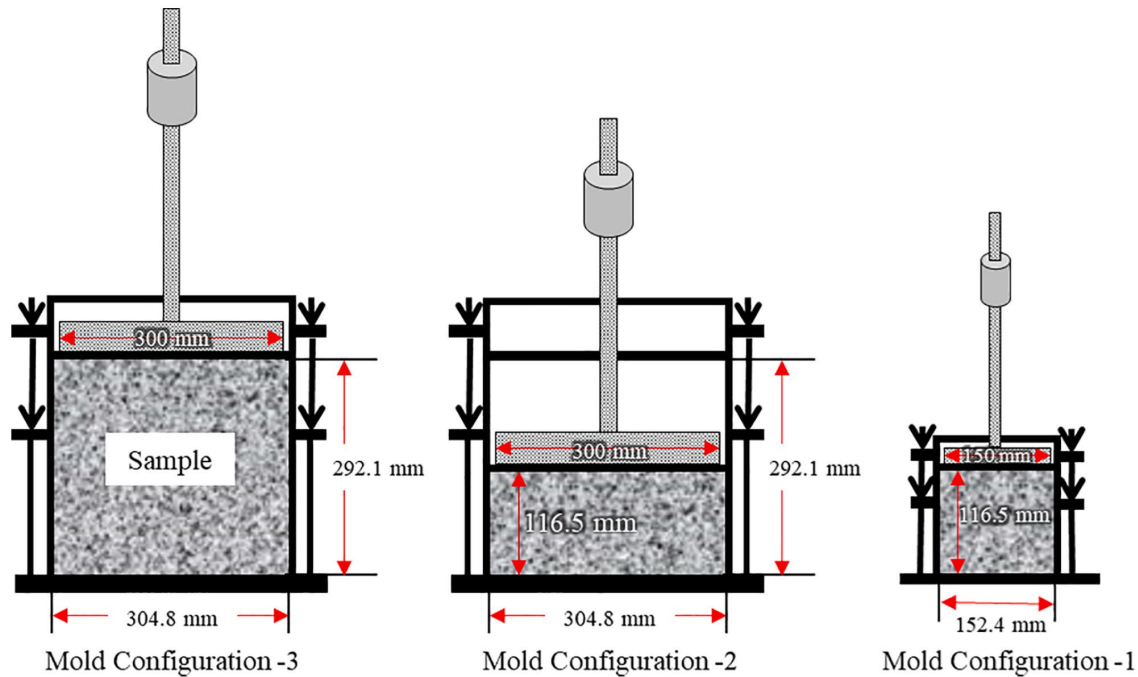


**Figure 17. LWD testing on a 2-layered system (Schwartz et al., 2017).**

Effect of Sample Size on the LWD and DCP Test Results

In 2018, researchers at Purdue University in Indiana pointed out the drawbacks of the sand cone and nuclear gauge tests (Zhao et al., 2018). In addition, after running the LWD tests on compacted soil samples within the Proctor mold, they noticed that the lubrication of the mold’s wall significantly affected the deflection measurements. This observation encouraged them to conduct the experiments in a test pit. The modeling results indicated that a 90×90×90 cm (3×3×3 ft) pit provided sufficient space and satisfactory analysis accuracy. The complementary field testing and the historical data led to recommendations related to the number of tests and the thresholds defined on the deflections for different types of soils. Mondal et al. (2022) explained the challenges associated with testing the open-graded materials using the conventional Proctor mold. Due to the larger aggregate sizes used in

AASHTO #4 and #57, the 152-mm (6-in) diameter molds could not provide enough room for laboratory compaction. In addition, in the field, a vibratory roller was typically used to compact the coarse-grained materials, which the Proctor hammer might not fully represent. The authors fabricated a custom mold with 305-mm (12-in) diameter and 292-mm (11.5-in) height to address these issues (Figure 18).



**Figure 18. Schematic representation of three different mold configurations (Mondal et al., 2022)**

Three compaction methods, including drop-hammer, vibratory, and impact, and using LWD mass, jackhammer, and vibratory plate, respectively, were implemented. Studying the deflection and stress states recorded by the LWD device on AASHTO #4 in 305-mm (12-in) molds revealed that the compacted samples became stable after nine drops of weight. Therefore, the number of seating drops on the open-graded soils was set to nine. The LWD and density measurements after different cycles of jackhammer compaction indicated that applying only 5 seconds of vibration is enough to reach the highest achievable compaction level. It is important to note that the same experiment on the 152-mm (6-in) molds resulted in increased surface deflection, as the compaction energy led to the destabilization of the soil due to the small mold and large aggregate sizes. This observation was the case for the 305-mm (12-in) diameter mold and 116.5-mm (4.6-in) height samples. Compacted

samples using a vibratory shake table after 5 and 10 seconds showed a higher deflection rate in Mold Configuration 3 than in Mold Configuration 2 for both #4 and #57 aggregates.

## **STATES PRACTICES**

Every state highway agency has specifications to ensure that the subgrade and subbase/base material have been adequately compacted and meet the minimum required density before the upper pavement layers are placed. While there are many similarities in the specifications developed by various states to ensure adequate density has been achieved for subgrade and various pavement layers, there are also differences. This section is allocated to reviewing the specifications and protocols followed by multiple state highway agencies, especially those that have already implemented or are moving toward the development of the LWD and DCP specs for quality control of compaction.

### **Pennsylvania Department of Transportation (PennDOT)**

PennDOT calls for specific compaction levels for different materials used in pavement layers. The requirements are set for the maximum thickness of the compacted layers and the compaction equipment based on the material type. For example, Table 5 presents the moisture and compaction requirements for two material categories, “Soil” and “Granular, Type 1,” commonly used within pavement structures as subgrade and base layers, respectively. These requirements are based on in-situ testing using a nuclear gauge according to PTM 402. It is worth mentioning that the top 90 cm (3 ft) of the compacted layers must have a higher compaction level (or higher shear resistance), as it experiences higher stress levels induced by traffic load. Also, the moisture-density (M-D) relation needs to be established in the laboratory before field compaction to calculate the maximum dry density and the optimum moisture content. PennDOT uses PTM No. 106, which is adopted from AASHTO T-99 test method to determine the M-D curves. Then, the field density and moisture content are measured using a nuclear gauge according to PTM No. 402.

**Table 5. PennDOT compaction moisture and density requirements (PTM No. 402, 2020).**

Material	Location	Density	Moisture	Test Method
Soil	Top 3 ft of fill	100% of Maximum Dry Density	Between Minus 3% of Optimum and Optimum	PTM No. 402 using Direct Transmission Method
	Below 3 ft depth	97% of Maximum Dry Density		
Granular, Type 1	Top 3 ft of fill	100% of Maximum Dry Density	+/- 2% of Optimum	PTM No. 402 using Direct Transmission Method*
	Below 3 ft depth	97% of Maximum Dry Density		

\*The representative may allow the backscatter method if the material is too coarse to conduct the direct transmission method effectively.

### Minnesota Department of Transportation (MnDOT)

To implement new technologies and testing methods in road construction, MnDOT evaluated both DCP and LWD tests in 2006. Although density-related tests have been frequently used in Minnesota to control the quality of construction, the outputs of the DCP and LWD tests were found to correlate better to the mechanical properties such as the modulus and shear resistance of the compacted soils. The direct insight into the mechanical performance of the compacted lifts offered by these tests could facilitate the design and QC/QA processes. In addition, the higher confidence level and repeatability provided by these tests resulted in less time allocated to in-situ testing and increased safety of the operators (Geotechnical Section MnDOT, 2017). Table 6 presents the compaction requirements specified by MnDOT (MnDOT Spec, 2020). These requirements vary based on the material type and the depth of the lift and include density, LWD, and DCP testing. According to Minnesota standard specifications for construction, the DCP test is performed according to ASTM D6951 with some revisions. It is worth mentioning that MnDOT sets criteria on the maximum allowable seat, maximum allowable DPI obtained from the DCP test, and minimum elastic modulus from LWD testing based on grading numbers (GNs). The GN is calculated using the sieving data and according to Equation 6.

$$GN (\%passing) = \frac{25mm + 19mm + 9.5mm + 4.75mm + 2mm + 425\mu m + 75\mu m}{100} \quad \text{Eq. (6)}$$

**Table 6. MnDOT compaction requirements (MnDOT, 2020).**

<b>Material Type</b>	<b>Location</b>	<b>Required Compaction *</b>
Materials meeting the requirement of 3149.2B, “Granular and select Granular Material”	All depth and locations	100% specified density, Quality Compaction, Penetration index, and LWD
Materials meeting the requirement of 3149.2B, “Granular and select Granular Material”	>3 ft below Grading Grade of Road Core, trails, or sidewalks	95% specified density, and LWD when the engineer performs a correlation test between 95% specified density, and an LWD.
Materials meeting the requirement of 3149.2B, “Granular and select Granular Material”	≤ 3 ft below Grading Grade of Road Core, trails, or sidewalks	100% specified density, Quality Compaction, and LWD
All material	All depth within an excavation trench and backfill of structures, 2451, “Structure Excavations and Backfills”	100% specified density, Quality Compaction, and LWD
* See 2106.3G.1, “Specified Density,” 2106.3G.2, “Quality Compaction,” 2106.3G.3, “Penetration Index,” and 2106.3G.4, Light Weight Deflectometer (LWD) Method” for compaction requirements.		

**Indiana Department of Transportation (INDOT)**

The LWD and DCP requirements presented in this section are obtained from the standard specifications of Indiana DOT published in 2020. INDOT calls for 10 LWD tests on the test section with 68.6 m (225 ft) length at the approximate locations. The 10 measured deflections are averaged. If the difference between the average LWD test values obtained from 4 and 5 roller applications is greater than 0.02 mm, an additional roller application in the vibratory mode shall be made. Proof rolling is perceived as a cost-effective assessment of the unbound layers and subgrade compaction quality and offers evidence of the mass response of the soil layers to vehicle-type loads. The method can potentially reveal subgrade drainage issues (Dunston et al., 2018). According to INDOT standard specification of 2022, Section 203.26, proof rolling (also termed test rolling) is performed using a dump truck weighing at least 15 tons with a minimum tire pressure of 90 psi. This proof rolling is conducted for original ground or embankment construction. For subgrade preparation, proof rolling is performed using a dump truck weighing at least 33 tons. In both cases, the operating speed of the proof rolling truck shall not exceed 3.2 kph (2 mph). Deflections or rutting above 12.5 mm (0.5 in) require remediation of the surface as directed. Deflection or rutting above 75 mm (3.0 in) requires

corrective remediation measures, and the Department's Geotechnical Engineering Division will be contacted. Once proof rolling is completed, the LWD test is carried out on subgrade and subsequent unbound layers to meet maximum target values. Deflection requirements for LWD and DCP depend on the type of materials and conditions. For chemically modified soils or the aggregate layers, LWD requirements vary, while for base layers with AASHTO #53 aggregates, deflections are influenced by thickness and the use of proof rolling.

### **Florida Department of Transportation (FDOT)**

In 2015, Glagola et al. developed a QA/QC specification for the Florida Department of Transportation using LWD and DCP testing. Their study provided two methods to determine the LWD and DCP target values. As the first method, the criteria used to evaluate the compaction level includes the optimum moisture content and material type. The second method involved direct measurement in a test strip. The unbound layer is constructed using the contractor's material and roller compactor in the test strip. Then, LWD deflection measurements are conducted after four passes of the roller in vibratory mode. An additional pass is made, and another round of 10 LWD deflection measurements is taken. If the difference between average deflections is less than 0.02 mm, the LWD average deflection values after the fifth pass would be the maximum target deflection. Otherwise, this procedure should continue until the average difference is less than 0.02 mm.

### **Nebraska Department of Transportation (NDOT)**

Following "No building is better than its foundation," The NDOT construction manual (2019 edition) encourages inspectors to conduct the LWD according to NDOT T2835 Light Weight Deflection (LWD) specification. The Deflection Target Value (DTV) is the deflection value of each soil determined by using a test strip or from correlation with the Nebraska Group Index for an individual soil. According to Schwartz et al., 2017, before 2017, the Nebraska Department of Roads (NDOR) defined the maximum allowable LWD deflection values depending on the unbound material location (under concrete or asphalt pavement and for the top 3 ft or below 3 ft under the pavement). In case a specific soil does not fit into the specific categories they provided in the specification, three LWD tests are conducted after each roller pass until the average deflection for three consecutive passes does not change more than 10% with any additional pass.

## **United Kingdom (UK)**

UK specifications proposed target LWD modulus values for four foundation classes according to the long-term in-service surface modulus values. The Surface Modulus value defines the four Foundation Classes at the top of the foundation level used for design purposes: Class I - 50 MPa, Class II - 100 MPa, Class III - 200 MPa, and Class 4 - 400 MPa. The target mean and minimum modulus values for construction quality control are specified for these four foundation classes. The moving mean of five consecutive in-situ foundation surface modulus measurements must equal or exceed the target mean foundation surface modulus. All individual in-situ foundation surface modulus measurements must equal or exceed the target minimum foundation surface modulus.

## **ANALYSIS OF THE RECOMMENDATIONS AND CRITERIA FOR DCP AND LWD IN THE CURRENT SPECIFICATIONS AND RESEARCH REPORTS**

To develop and determine the criteria for utilizing DCP and LWD in the field practice for the Commonwealth of Pennsylvania, the specifications and reports from other states and institutions are reviewed and analyzed in this section. The reviewed documents include those discussed previously in this chapter.

This section starts with a summary of the introduced documents with a short description of their major results. Afterwards, according to the same order, the specifications and reports are analyzed, focusing on the criteria and recommendation for use of DCP and LWD in road construction, and the process of deciding the values, and the rationale behind them. Twenty-four publications and documents were reviewed. Their criteria for DPC/DPI and LWD can be simplified into two tables, as shown in Table 7 and Table 8.

**Table 7. DCP/DPI criteria.**

State	Parameter	Aggregate Gradation Type			
		Coarsest	Coarser	Finer	Finest
MnDOT	GN (Grading Number) *	3	4	5	6
	Maximum DPI (in/blow) (Moisture Content 5-8%)	0.5	0.7	0.8	0.9
INDOT	Textual Classification	Granular soils	Sandy soils (Max. Dry Density ≥121 pcf)	Silty soils (Max. Dry Density 115-120 pcf)	Clay soils (Max. Dry Density ≤114 pcf)
	Acceptable Minimum DCP (Number of blows for 12 in. penetration), 95% compaction (*Optimum)	6-16	12-15	9-11	12-16*
	Additional Info (Number of blows)	9-19 (For 100% compaction)	N/A	N/A	6-8 (Number of blows for 6 in. penetration, 95% compaction)
FDOT	Classification*	A-2-4	A-3	Limerock base	Stabilized subgrade
	DCP target values (Number of blows for 12 in. penetration), 95% compaction (Optimum)	35	26	53	28
	DCP target values (Number of blows for 12 in. penetration), 95% compaction (Below Optimum)	44	34	54	21
Louisiana Transportation Research Center	Classification	Base Course	Interlayer	Subgrade	Clay/Silty Embankment
	Minimum Blow for 12 in. penetration	30	19	19	12

$$*GN(\% \text{ passing}) = \frac{25\text{mm}+19\text{mm}+9.5\text{mm}+4.75\text{mm}+2.00\text{mm}+425\mu\text{m}+75\mu\text{m}}{100}$$

\*Optimum stands for Optimum Moisture Content Range.

\* 12-16 is converted values based on “6-8 (For 6 in, 95% compaction)”.

\*A-1, A-2, A-3 are based on the AASHTO Soil Classification System.

**Table 8. LWD modulus/deflection criteria.**

State	Parameter	Coarsest	Coarser	Finer	Finest	Others
MnDOT	Material type	Base or Reclamation	Granular	Clay and Clay Loam	N/A	N/A
	Minimum Elastic Modulus (MPa)	50	40	20	N/A	N/A
INDOT	Material type	Cement Modified soil	Aggregate over Cement Modified soil	Lime Modified soil	Aggregate over Lime Modified soil	Aggregate over Untreated Soils (6 in Thick Coarse Aggregate No. 53)
	Allowable Average Deflection (mm) (Single Test)	0.30	0.30	0.27	0.27	0.51
	Allowable Single Test Deflection (mm)	0.35	0.35	0.31	0.31	0.57
FDOT	Classification	A-2-4	A-3	Stabilized subgrade	N/A	Limerock base
	Target Single Test Deflection (mm)(Optimum)	0.45	0.43	0.55	N/A	0.26
	Target Single Test Deflection (mm) (below Optimum)	0.34	0.40	0.39	N/A	0.23
NDOT	NGI*(Nebraska Group Index)	-2 to 1 (Gravel/Fine Sand)	2 to 7 (Sandy silt)	8 to 14 (Loess/Till)	15 to 21 (Till/Shale)	N/A
	Concrete Upper 3'	0.5-1	1-2	1.5-3	3-6	N/A
	Concrete Below 3'	0.5-1.5	1.5-3	3-5	5-9	N/A
	Asphalt Upper 3'	0.5	0.5-1	0.75-2	2-5	N/A
	Asphalt Below 3'	0.5-1.5	1.5-3	3-5	5-9	N/A

**Table 9. Soil types and correlating Nebraska Group Indices (Schwartz et al., 2017).**

Soil Type	NGI
Gravel	-4 to -2
Fine Sand	-1 to 1
Sandy Silt	2 to 7
Loess	8 to 12
Loess/ Till	13 to 14
Till	15 to 21
Shale	22 to 24

Major results from review of state specifications are summarized as follows:

*Pennsylvania Department of Transportation (PennDOT)*

Current PennDOT Publication 408, 2020 Edition, Change #4, Sections 206, 208, 210, and 350, do not mention the criteria on LWD and DCP.

*Minnesota Department of Transportation (MnDOT)*

MnDOT has criteria on LWD and DCP based on calibration and regression equations developed under their study, *Advancement of Grading & Base Material Testing*, and specification, Minnesota DOT Grading & Base Manual Section 5-692.256 Light Weight Deflectometer – LWD Procedure & Target Value Determination.

*Indiana Department of Transportation (INDOT)*

INDOT sets Allowable Average Deflection and Maximum Deflection at a Single Test Location to control QC/QA for LWD determined by the lowest average of 10 LWD test values from a test section. DCP value is obtained from the test section procedure and the average number of blows for 12-in. penetration should indicate 95% compaction.

*Florida Department of Transportation (FDOT)*

FDOT developed a QA/QC specification using LWD and DCP testing based on MnDOT and INDOT’s criteria.

*Nebraska Department of Transportation (NDOT)*

NDOT provides two methods to determine LWD target value: (1) based on resilient modulus correlations to Nebraska group index (NGI), and (2) direct measurement from a test strip or calibration area.

### United Kingdom (UK)

UK specifications propose that properly calibrated LWD can be used in lieu of FWD to perform the surface modulus testing (according to target pavement foundation surface modulus values).

### Other Publications

There are other publications that have explored methods for establishing standards for DCP and LWD, but they have not established any set criteria.

### **Survey on Recommended Standards for LWD/DCP Usage by State Highway Agencies**

The specifications, literature, and reports discussed previously in this chapter were reviewed according to the order of the list. An analysis was conducted for these publications one by one. Regarding DCP and LWD, the requirements, recommended indicators, and practical steps were summarized.

### Minnesota Department of Transportation (MnDOT)

This specification is based on the report titled *Validation of DCP and LWD Moisture Specifications for Granular Materials 2006-20* (Davich et al., 2006). It provides Special Provision for DCP. It suggests the Special Provision should only be applied to select granular borrow materials at moisture contents of 1% to 2% below their optimum moisture content. MnDOT Standard Specifications for Construction 2020 Volume II - Division II Table 2211.3-3 provides the requirements and Maximum Allowable DPI for DCP, as shown in Table 10.

**Table 10. MnDOT maximum seat and DPI requirement for the base layer (MnDOT, 2020).**

Grading Number *	Moisture Content [%] ‡	Maximum Allowable SEAT [mm]	Maximum Allowable DPI [mm/blow]	Test Layer [inches] †
3.1 – 3.5	< 5.0	40	10	4 – 6
	5.0 – 8.0	40	12	
	>8.0	40	16	
3.6 - 4.0	< 5.0	40	10	4 – 6
	5.0 – 8.0	45	15	
	>8.0	55	19	
4.1 – 4.5	< 5.0	50	13	5 – 6
	5.0 – 8.0	60	17	
	>8.0	70	21	
4.6 – 5.0	< 5.0	65	15	6 – 12
	5.0 – 8.0	75	19	
	>8.0	85	23	
5.1 – 5.5	< 5.0	85	17	7 -12
	5.0 – 8.0	95	21	
	>8.0	105	25	
5.6 – 6.0	< 5.0	100	19	8 - 12
	5.0 – 8.0	115	24	
	>8.0	125	28	

\*As Determined by Form G&B-204

‡ percent of dry weight.

† If the Layer to be placed is thinner than the Test layer, use 2211.3D.2.b, “Quality Compaction Method.”

Note: When recycled bituminous content is  $\geq 50$  percent, compact to achieve a penetration index value of 10 millimeters and seating value of 40 millimeters, as determined by Form G&B-205.

Note that a moisture test is not required if the material meets the toughest requirement for the Grading Number.

According to the report titled *Advancement of Grading & Base Material Testing* March 30, 2004, the DPI Threshold is developed based on the assumption of “quality compaction” regarding each of the data points. The engineer in charge evaluated a level of “quality compaction” at each test location. Notes were made in the field about each test section and those that received “quality compaction” ratings were considered passing DCP test locations. A failing “quality compaction” score equated to a failing DCP test. Using this approach, 51 data points were used in developing the regression equations.

The final equations for DPI and SEAT are shown in Equations 7 and 8. SEAT (Seating Penetration) is a measure used to evaluate the initial penetration of a material under a specific load. The SEAT value is determined from the penetration resulting from the first two drops of a Dynamic Cone Penetrometer (DCP).

$$\text{DPI(mm/blow)} = 4.76 \times \text{GN} + 1.68 \times \text{MC} - 14.4 \quad \text{Eq. (7)}$$

$$\text{SEAT(mm)} = 36.8 \times \text{GN} + 4.12 \times \text{MC} - 124 \quad \text{Eq. (8)}$$

GN stands for Grading Number, which is expressed by the following equation:

$$\text{GN(\% passing)} = \frac{25\text{mm}+19\text{mm}+9.5\text{mm}+4.75\text{mm}+2.00\text{m}+425\mu\text{m}+75\mu\text{m}}{100} \quad \text{Eq. (9)}$$

The penetration acceptance table was created by breaking the continuous variables GN and MC (Moisture Content) into small ranges. To be conservative, the upper limit of each range was used to calculate the maximum penetration values.

LWD response is expected to meet requirements of LWD Minimum Elastic Moduli as specified in Minnesota DOT Grading & Base Manual Section 5-692.256 Light Weight Deflectometer – LWD Procedure & Target Value Determination (see Table 11).

**Table 11. LWD minimum elastic moduli for granular, clay and clay loam, and base (MnDOT, 2016).**

MnDOT Specification	Material Type	Minimum Elastic Modulus [MPa]
2106	Granular	40
2106	Clay and Clay Loam	20
2211 or 2215	Base or Reclamation	50

LWD-TV (target value) is calculated by “Deflection Test Measurement.” The average deflection is measured from the fourth, fifth, and sixth drop in the testing sequence. The first, second and third drops in the testing sequence are seating drops. The LWD target value is determined using a calibration area for a given soil type or source.

The LWD-TV is determined using a Calibration Area as discussed below:

1. Calibration Area Requirements: Construct the Calibration area to determine the LWD-TV for each type or source of materials.
2. Construct a new Calibration Area when: a. There is a new source, or an observable variation in material properties or a Proctor is required; b. the moisture content of the material varies more than 2 percent of the calibration area moisture content; or c. as determined by the Engineer.
3. Calibration Area Dimensions, see Table 12.

**Table 12. LWD calibration area dimensions (MnDOT, 2016).**

Embankment	Length	Width (ft)	Fill Thickness
Roadbed Embankment Soil, reclamation, and Base	≥50 ft	Equal to the excavated embankment width	Equal to the planned layer thickness for base reclamation & 12 inch minimum for embankment
Miscellaneous trench, culvert, or other tapered construction	≥10 ft	Equal to the excavated embankment width	Equal to the planned layer thickness for base reclamation & 12 inch minimum for embankment

Compact the entire lift to achieve the LWD-TV per Table 11. If quality compaction is not achieved while meeting the minimum elastic modulus, raise the minimum elastic modulus. The Engineer may also use both the target value method and the predetermined target method to determine target values.

Indiana Dot Standard Specifications

The Indiana DOT Specifications 2022, Section 203.24 Method of Making Strength, Stiffness and Density Tests, specifies the standard values for LWD for different types of soil, as shown in Table 13, Table 14, and Table 15.

**Table 13. INDOT LWD allowable average deflection and maximum deflection for chemically modified soils and aggregate over chemically modified soils (INDOT, 2022).**

Material Type	Maximum Allowable Average Deflection (mm)	Maximum Deflection at a Single Test Location (mm)
Lime Modified Soil	≤ 0.30	0.35
Cement Modified Soil	≤ 0.27	0.31
Aggregate over Lime Modified Soil	≤ 0.30	0.35
Aggregate over Cement Modified Soil	≤ 0.27	0.31

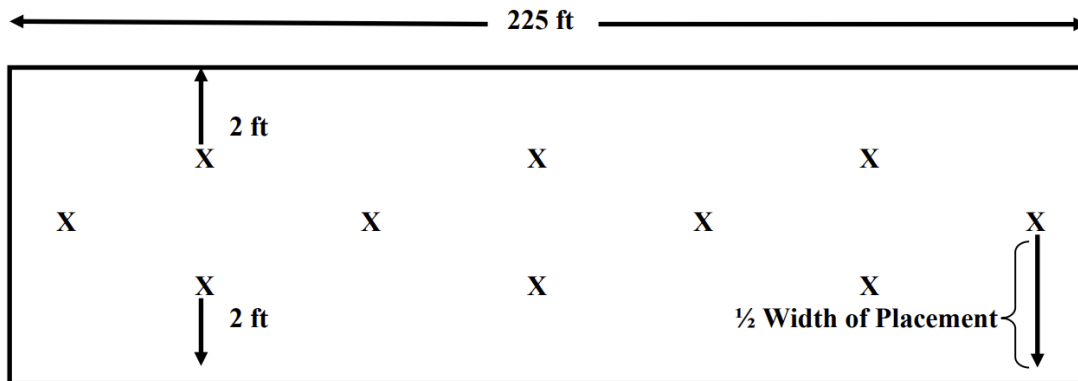
**Table 14. INDOT LWD requirements for aggregate over untreated Soils: Where proof rolling can be performed (INDOT, 2022).**

Material Thickness	Allowable Average Deflection (mm)	Maximum Deflection at a Single Test Location (mm)
6 in. Thick Coarse Aggregate No. 53	≤ 0.51	0.57*
12 in. Thick Coarse Aggregate No. 53	≤ 0.34	0.40**
18 in. Thick Coarse Aggregate No. 53	≤ 0.31	0.35**
* When deflection exceeds this value, the area shall be recompacted or undercut as directed. The failed area will be delineated prior to excavation. Deflection will be measured based on the top 6 in. thick coarse aggregate No. 53 material placed for undercut. ** The Contractor shall recompact the coarse aggregate No. 53 in accordance with 301.06.		

**Table 15. INDOT LWD requirements for aggregate over untreated soils: Where proof rolling cannot be performed (INDOT, 2022).**

Material Thickness	Allowable Average Deflection (mm)	Maximum Deflection at a Single Test Location (mm)
6 in. Thick Coarse Aggregate No. 53	≤ 0.60	0.65*
12 in. Thick Coarse Aggregate No. 53	≤ 0.47	0.52**
18 in. Thick Coarse Aggregate No. 53	≤ 0.44	0.49**
* When deflection exceeds this value, the area shall be recompacted or undercut as directed. The failed area will be delineated prior to excavation. Deflection will be measured based on the top 6 in. thick coarse aggregate No 53 material placed for undercut. ** The Contractor shall recompact the coarse aggregate No. 53 in accordance with 301.06.		
Note: The Engineer will perform the moisture test on in-situ soils prior to placement of coarse aggregate. If the result of the moisture test is >13%, the Engineer will contact the Geotechnical Section.		

The LWD allowable deflection is decided by the method in INDOT Spec **ITM 514**. The allowable deflection will be determined from a test section or will be specified, as shown in Figure 19. Test sections shall be constructed in accordance with ITM 514 in the presence of a representative of the Geotechnical Engineering Division for other materials not included in the Tables to determine the maximum allowable deflection.



**Figure 19. INDOT recommended test locations in the field for LWD (INDOT ITM No.514-20, 2020).**

The steps are conducted as follows:

1. Initial Compaction:

Compact the test section with a vibratory roller, applying it four times (one pass over the entire section counts as one application). Do not stop or turn within the section.

2. LWD Testing:

Conduct 10 LWD (Light Weight Deflectometer) tests at marked locations. Average the results of these 10 tests.

3. Additional Compaction and Testing:

Apply one more roller pass in vibratory mode. Conduct 10 LWD tests at the same locations and average the results. If the difference between the average results of 4 and 5 applications is  $\leq 0.02$  mm, compaction is complete. If the difference is  $> 0.02$  mm, apply another roller pass and repeat the testing. Continue this process until the difference between averages of consecutive tests is  $\leq 0.02$  mm.

4. Final Requirement:

The maximum allowable deflection is the lowest average of the 10 LWD test values. Follow proof rolling procedures as per 203.26.

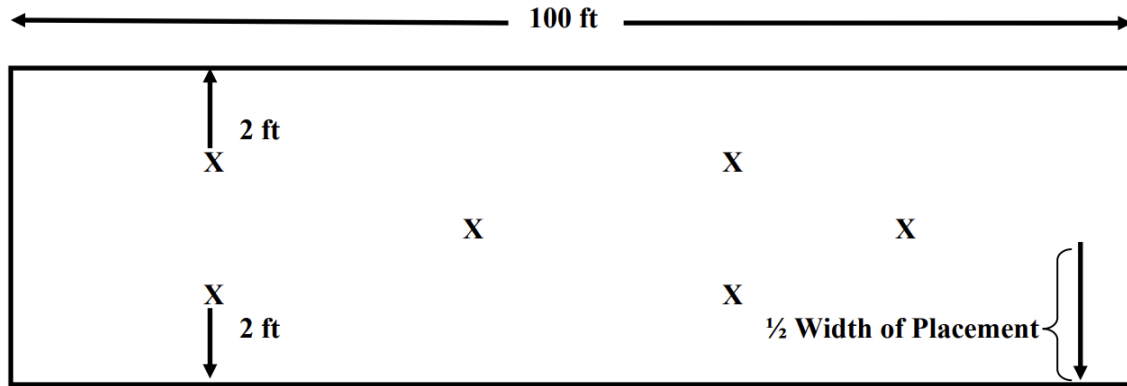
Similarly, INDOT has also provided standard values for DCP to be used for quality control during construction, as shown in Table 16.

**Table 16. INDOT DCP requirements for different soil classifications (InDOT, 2022).**

Textural Classification	Maximum Dry Density (pcf)	Optimum Moisture Content Range (%)	Acceptable Minimum DCP value for 6 in. for 95% compaction	Acceptable Minimum DCP value for 12 in. for 95% compaction	Acceptable Minimum DCP value for 12 in. for 100% compaction
<b>CLAY SOILS</b>					
Clay	< 105	19 - 24	6		*
Clay	105 - 110	16 - 18	7		*
Clay	111 - 114	14 - 15	8		*
<b>SILTY SOILS</b>					
Silty	115 - 116	13 - 14		9	*
Silty	117 - 120			11	*
<b>SANDY SOILS</b>					
Sandy	121 - 125	8 - 12		12	*
Sandy	> 125			15	*
<b>GRANULAR SOILS - STRUCTURE BACKFILL and A-1, A-2, A-3 SOILS</b>					
No. 30				6	9
No. 4				7	10
1/2 in.				11	14
1 in.				16	19
Note: *Test section required in accordance with ITM 513.					

Unless otherwise specified, all material directed to be compacted in accordance with 203.23 shall meet the acceptable minimum DCP value for 95% compaction. Subgrade shall meet the acceptable minimum DCP value for 100% compaction when required. They are following the requirements of *Indiana Department of Transportation Standard Specifications 2022* 203.23.

The Acceptable Minimum DCP value is decided by test sections. And the test sections follow the requirements of **ITM 514**, as shown in Figure 20.



**Figure 20. INDOT recommended test locations in the field for DCP (InDOT ITM No.514-20, 2020).**

The entire test procedure is conducted as follows:

1. Placement and Compaction:

Place material in two successive 6-inch lifts as per 203.23. Compact the section with a required roller, applying it four times. Do not stop or turn within the test section.

2. Sand Cone Test:

After rolling, perform three sand cone tests according to AASHTO T 191. If material has more than 35% passing #200 sieve, test the top 6 inches. If material has less than 35% passing #200 sieve, test 6 inches below the surface. Space the test locations uniformly throughout the section. Calculate the average density from the three tests. Compare this average density to the maximum dry density of the soil. If the average is 95% of the maximum dry density, the compaction is complete.

3. DCP Test:

Mark the test section as described in Figure 20. Conduct 10 DCP (Dynamic Cone Penetrometer) tests at specified locations. Discard blow counts greater than 10 or less than 6 for each 6 or 12 inches and select a new random test location to ensure 10 DCP tests are obtained.

#### 4. Average the blow counts:

For clay soils: top 6 inches. For silty, sandy, and granular soils: 12 inches. If the average blow counts indicate 95% compaction, the test section procedure is complete.

#### Standardizing Light Weight Deflectometer Modulus Measurements for Compaction Quality Assurance (Report, Maryland Department of Transportation)

To find the threshold, material with passing and failing compaction are graphed versus  $E_{\text{field}}/E_{\text{target}}$  for each LWD by MDOT. Only subgrade soils or base materials for which  $E_{\text{target}}$  has been corrected for the influence of the foundation layer should be used to define the minimum acceptable  $E_{\text{field}}$  to  $E_{\text{target}}$  ratio.

For the Zorn LWD, a field to target modulus ratio of 1 is the threshold to separate the under-compacted sites from the well-compacted soils. This ratio is about 0.5 for Dynatest LWD and 0.8 for Olson LWD.

It is recommended that each state implement a local calibration procedure to find the lower specification limit (LSL) for  $E_{\text{field}}/E_{\text{target}}$  for their local materials. The following steps shall be taken:

- (1) Determine the  $E_{\text{target}}$  by performing LWD on mold test in the laboratory.
- (2) Measure  $E_{\text{field}}$  after a few passes of the compactor and before achieving MDD (i.e., under-compacted condition).
- (3) Measure  $E_{\text{field}}$  after achieving MDD (i.e., well-compacted condition).
- (4) Calculate the  $E_{\text{field}}/E_{\text{target}}$  for both passing and failing conditions.
- (5) Find the threshold which separates the field to target ratio for passing and failing condition.

#### Others listed in the Scope of Work and Tasks

##### **Quantifying Moisture Effects in DCP and LWD Tests Using Unsaturated Mechanics**

A numerical model was developed, capable of simulating the effects of moisture content and fine particle content on LWD and DCP test results.

##### **Validation of DCP and LWD Moisture Specifications for Granular Materials**

The study developed a specification and procedure for DCP testing and investigated the effects of various factors on DCP test results and the relationship between DCP and LWD.

##### **Ensuring Construction Quality Assurance with Light-Weight Deflectometers**

Introduce the implementation of LWDs in construction.

##### **Portable FWD (Prima 100) for In-Situ Subgrade Evaluation**

Using Prima 100, Portable Falling Weight Deflectometer comparing to FWD, a correction equation with density ratio and moisture assessing the importance of field moisture and field unit weight on  $E_{PFWD}$ .

### **Use of DCP and LWD for QC/QA on Subgrade and Aggregate Base**

DCP and LWD PROCEDURES were discussed in this study based on MnDOT.

### **Evaluation of Light Weight Deflectometer (LWD) for Characterization of Subgrade Soil Modulus**

A linear correlation was established between the backcalculated subgrade resilient modulus ( $M_r$ ) from LWD and FWD tests.

### **Investigation of the DCP and SSG as Alternative Methods to Determine Subgrade Stability**

A simple linear semi logarithmic relationship is observed between SSG stiffness and DPI.

### **Developing Standards and Specifications for Full Depth Pavement Reclamation**

DCP and LWD were used to perform In-Situ Testing in the protocol of Full-Depth Pavement Reclamation.

### **Correlative Study of LWD, DCP and CBR for sub-grade**

DPI vs CBR, DPI vs  $E_{LWD}$ , and CBR vs  $E_{LWD}$  were investigated, and Equations were developed.

### **Recommended Standards for LWD/DCP Usage from Other Agencies**

#### *Final Report Performance-Based Quality Assurance/Quality Control (QA/QC) Acceptance Procedures for In-Place Soil Testing Phase 3 (FDOT)*

This approach has employed both Mn/DOT and INDOT methods to develop the data tables of target values for devices such as the DCP and LWD. Target values and their ranges based on the 95% confidence intervals were generated for the DCP and LWD from the Phase II test pit data. These values are provided in Table 17 and Table 18.

**Table 17. DCP target values from Phase II test pit data (Glagola et al., 2015).**

Phase II Test Pit Data	Below Optimum (95% Confidence Interval)				At Optimum (95% Confidence Interval)				
	DCP Target Values	< Opt. Target	< Opt. Lower CI	< Opt. Upper CI	Moisture (%)	at Opt. Target	at Opt. Lower CI	at Opt. Upper CI	Moisture (%)
<b>A-2-4 low fines</b>									
DCP depth/blow (mm)	6.99	6.57	7.41	5.67~6.8	8.83	8.29	9.38	8.2~10.0	
in./blow	0.275	0.259	0.292	5.6~6.8	0.348	0.326	0.369	8.3~10.0	
blows/6 in.	22	23	21	17	17	18	16		
blows/12 in.	44	46	41		35	37	33		
<b>A-3</b>									
DCP depth/blow (mm)	8.91	8.11	9.71	4.4~4.9	11.63	10.9	12.35	8.2~10.5	
in./blow	0.351	0.319	0.382	4.4~4.9	0.458	0.429	0.486	8.2~10.5	
blows/6 in.	17	19	16		13	14	12		
blows/12 in.	34	38	31		26	28	25		
<b>Limerock base</b>									
DCP depth/blow (mm)	5.63	4.91	6.35	10.0~10.7	5.74	4.68	6.8	11.8~13.7	
in./blow	0.222	0.193	0.25	10.0~10.7	0.226	0.184	0.268	11.8~13.7	
blows/6 in.	27	31	24		27	33	22		
blows/12 in.	54	62	48		53	65	45		
<b>Stabilized subgrade</b>									
DCP depth/blow (mm)	14.73	12.63	16.83	7.1~8.7	10.95	9.66	12.24	8.2~10.1	
in./blow	0.58	0.497	0.663	7.1~8.7	0.431	0.38	0.482	8.2~10.1	
blows/6 in.	10	12	9		14	16	12		
blows/12 in.	21	24	18		28	32	25		

**Table 18. LWD target values from Phase II test pit data (Glagola et al., 2015).**

LWD-1 deflection (mm)	Target	Lower CI	Upper CI	Moisture (%)	Target	Lower CI	Upper CI	Moisture (%)
A-2-4 low fines	0.34	0.31	0.38	5.6~6.8	0.45	0.42	0.48	8.3~10.0
A-3	0.40	0.37	0.43	4.4~4.9	0.43	0.40	0.46	8.2~10.5
Lime rock base	0.23	0.19	0.28	10.0~10.7	0.26	0.23	0.29	11.8~13.7
Stabilized subgrade	0.39	0.33	0.44	7.1~8.7	0.55	0.46	0.65	8.2~10.1

*Nebraska Department of Roads NDR Standard Test Method T 2835*

According to Nebraska DOT Quick reference Guide titled *Light Weight Deflectometer (LWD) Field Testing*, Two methods of LWD target value determination are provided: (1) based on resilient

modulus correlations to Nebraska group index (NGI), and (2) direct measurement from a test strip or calibration area.

In the first method, the specification requires the moisture content to be within the specification limit, then the LWD target deflection should pass the values in the Table 19, depending on the unbound material location (under concrete or asphalt pavement, and for the top 3 ft or below 3 ft under the pavement).

When deflection data for a specific soil type are not available, a 61-m (200-ft) test strip must be compacted in two 200-mm (8-in) lifts. Moisture content testing is required to confirm it is within the acceptable limits. Three LWD tests are conducted after each pass of the roller until the average deflection for three consecutive passes does not change significantly with any additional pass (less than 10% change). This final deflection value becomes the LWD target value. The field LWD deflections after compaction must not surpass 1.1 times the LWD target value.

**Table 19. NDOR max allowable LWD deflection values for different NGI (Schwartz et al., 2017).**

Nebraska Group Index	Concrete Upper 3'	Concrete Below 3'	Asphalt Upper 3'	Asphalt Below 3'
	Max Deflection (mm)	Max Deflection (mm)	Max Deflection (mm)	Max Deflection (mm)
-2	0.5	0.5	0.5	0.5
-1	0.5	0.5	0.5	0.5
0	0.5	0.5	0.5	0.5
1	1	1.5	0.5	1.5
2	1	1.5	0.5	1.5
3	2	3	1	3
4	2	3	1	3
5	2	3	1	3
6	2	3	1	3
7	1.5	3	0.75	3
8	1.5	3	0.75	3
9	1.5	3	0.75	3
10	2	4	1	4
11	2	4	1	4
12	2	4	1	4
13	2	4	1	4
14	3	5	2	5
15	3	5	2	5
16	3	5	2	5
17	4	6	3	6
18	4	6	3	6
19	5	8	4	8
20	5	8	4	8

United Kingdom (UK)

The UK Highways Agency (2006) specifies target pavement foundation surface modulus values based on four foundation classes, as shown in Table 20. The Surface Modulus testing, required by the specification, must be carried out using a Dynamic Plate Test device, which has been properly calibrated to the manufacturer’s specification; this includes the FWD as well as the LWD.

**Table 20. Target pavement foundation surface modulus by the UK (Highway Agency, 2006).**

Long-Term In-Service Modulus (MPa)		Class I	Class II	Class III	Class IV	
		≥50	≥100	≥200	≥400	
Target Mean Modulus (MPa)	Unbound	40	80	...	...	
	Bound	Fast Curing	50	100	300	600
		Slow Curing	40	80	150	300
Target Minimum Modulus (MPa)	Unbound	25	50	...	...	
	Bound	Fast Curing	25	50	150	300
		Slow Curing	25	50	75	150

The Oklahoma Department of Transportation (ODOT)

It does not appear to have specific information about LWD and DCP.

**Other publications**

Quality Control/Assurance on Base Course and Embankment with the Dynamic Cone Penetrometer-Louisiana Transportation Research Center

This is a research report that aims to supplement the Louisiana Department of Transportation and Development (LaDOTD) TR 645 specification by attempting to determine possible DCP acceptance criteria for embankment, subgrade, and base course layers. To this end, data from multiple roadway layer types is used in relation to INDOT and MnDOT’s already established DCP acceptance procedures. The specification, however, has not yet been implemented. Results are shown in Table 21.

**Table 21. Acceptable DCPI criteria for layer types (Ferguson & Gautreau, 2021).**

DCPI Analysis			
Layer Type	Material Properties	Acceptable DCPI	
		Top 6-in	Full Layer
Clay/Silty Embankment	MDD < 105; OMC 19-24%	< 25 mm/blow	< 25 mm/blow
	MDD >105; OMC 8-18%	< 22 mm/blow	< 25 mm/blow
Subgrade	Lime Treated	< 19 mm/blow	< 16 mm/blow
	Cement Treated		
	Untreated		
Interlayer (< 6-in)	Class II Stone	< 10 mm/blow	NA
Base Course	Recycled PCC	< 19 mm/blow	< 16 mm/blow
	Class II Stone	< 10 mm/blow	<10 mm/blow

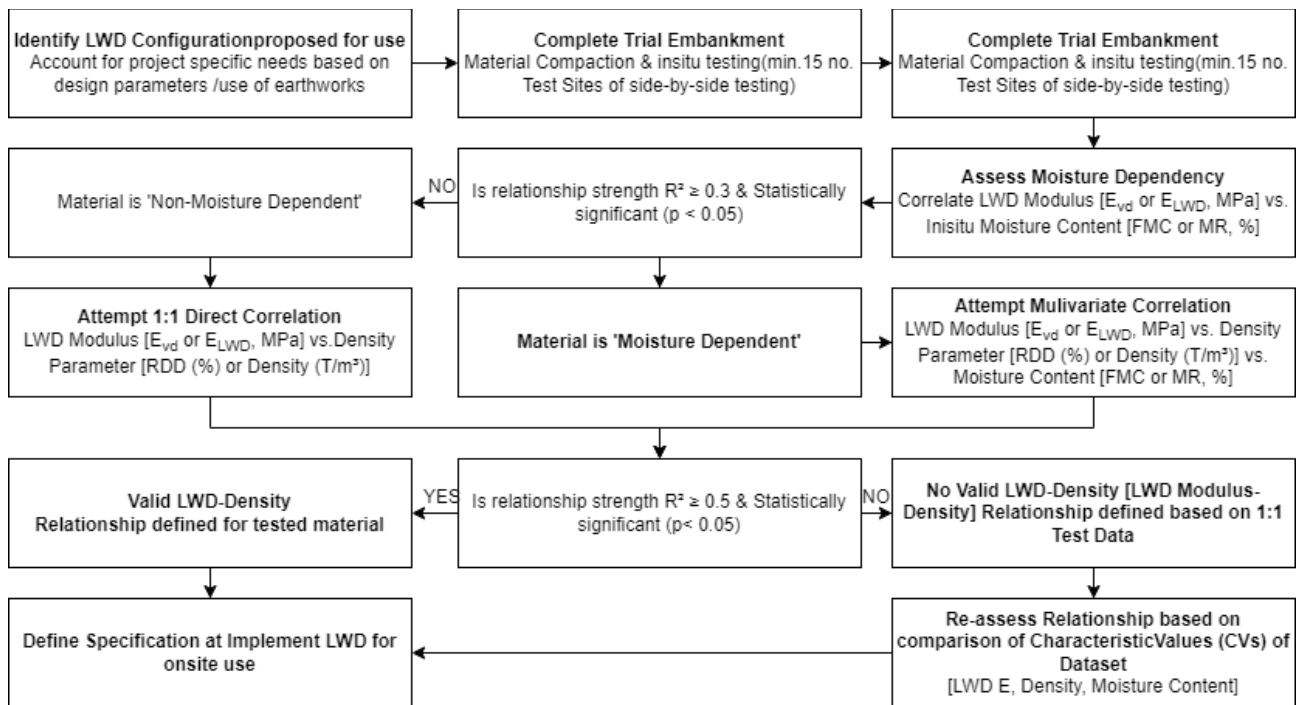
Table 22 is an additional acceptance benchmark that can be utilized based on minimum blow counts for a given layer thickness.

**Table 22. Blow count criteria per layer type (Ferguson & Gautreau, 2021).**

Blow Count Analysis		
Layer Type	Layer Depth, inches	Minimum Blow Count
Clay/Silty Embankment	6	7
	8	8
	10	10
	12	12
Subgrade	6	8
	8	11
	10	15
	12	19
Interlayer (Stone)	2	6
	4	10
Base Course	6	8
	8	11
	10	15
	12	19
Base Course (Stone)	6	15
	8	20
	10	25
	12	30

Draft Technical Note – Guidance on Use of Light Weight Falling Deflectometers (LWDs) to be Accepted as an Alternative Method for Verification of Earthworks Compaction Requirements – June 2021. National Asset Centre of Excellence (Australia)

This report provides: (1) on-site testing methods; (2) key parameters; (3) establishment of single-variable and multi-variable regression analyses; (4) determination of Acceptance Threshold Values applicable to the  $E_{LWD}$  or  $E_{vd}$  parameter through LWD-density-moisture content relationships (see Figure 21).



**Figure 21. Flow chart showing key steps for assessment/derivation of equivalent acceptance thresholds for LWD use (in lieu of traditional (density) testing minimum thresholds included in MRTS04-General Earthworks) (Lee & Lacey, 2021)**

Using the Dynamic Cone Penetrometer (DCP) and Light Weight Deflectometer (LWD) For Construction Quality Assurance

This report supports Minnesota DOT Grading & Base Manual Section 5-692.256 Light Weight Deflectometer – LWD Procedure & Target Value Determination

Maximum Allowable Deflection by Light Weight Deflectometer and Its Calibration and Verification (Joint transportation research program, Indiana Department of Transportation and Purdue University)

This report suggests that the maximum allowable deflections recommended by this study should be further fine-tuned to take into account the field practice and experience in statewide roadway

construction (see Table 23). Backcalculation of modulus from deflection of the compacted aggregate in the mold or in-situ is influenced by several factors. For aggregate compaction, the LWD deflection varies significantly with the moisture content. It is recommended that the LWD test for compaction QA should be conducted within 2 hours after compaction. An in-situ moisture content test is necessary to implement QA for compaction with LWD.

Presented in Table 24 and Table 25 are the possible MADs (maximum allowable deflections) derived from the values in Table 23 without considering the effect of inverted layer system. MADs for the moisture contents of  $w_0+1\%$ ,  $w_0+2\%$ , and  $w_0+3\%$  were determined by multiplying the corresponding MADs at the optimum moisture content ( $w_0$ ) by a factor of 1.02, 1.03, and 1.05, respectively. These three factors were derived from the laboratory tests performed on the aggregate samples compacted at a moisture content of  $w_0+1\%$ ,  $w_0+2\%$ , and  $w_0+3\%$ , respectively.

**Table 23 Adjusted target deflections for compaction of No. 53 aggregate in small areas (Zhao et al., 2018).**

Aggregate Layer Thickness (in.)	Subgrade Modulus (psi)	Adjusted Target Deflection (mm)								
		$w_0-4\%$	$w_0-3\%$	$w_0-2\%$	$w_0-1\%$	$w_0^*$	$w_0+1\%$	$w_0+2\%$	$w_0+3\%$	$w_0-4\%$
6	725	1.035	1.125	1.246	1.402	1.584	1.615	1.631	1.663	
	1450	0.783	0.849	0.938	1.053	1.183	1.207	1.219	1.243	
	4000	0.510	0.551	0.622	0.708	0.806	0.823	0.831	0.847	
	6000	0.426	0.464	0.512	0.586	0.689	0.703	0.710	0.724	
	9000	0.323	0.355	0.403	0.464	0.551	0.562	0.568	0.579	
	12700	0.259	0.285	0.323	0.386	0.472	0.482	0.486	0.496	
	14100	0.242	0.267	0.321	0.366	0.451	0.460	0.465	0.474	
12	725	0.626	0.687	0.769	0.878	1.013	1.033	1.043	1.063	
	1450	0.479	0.528	0.597	0.691	0.806	0.823	0.831	0.847	
	4000	0.345	0.388	0.454	0.550	0.677	0.691	0.697	0.711	
	6000	0.318	0.364	0.429	0.533	0.688	0.702	0.709	0.722	
	9000	0.261	0.303	0.365	0.462	0.611	0.623	0.630	0.642	
	12700	0.224	0.262	0.323	0.417	0.564	0.575	0.581	0.592	
	14100	0.215	0.253	0.312	0.406	0.551	0.562	0.568	0.579	
18	725	0.359	0.418	0.500	0.610	0.733	0.748	0.755	0.770	
	1450	0.301	0.350	0.423	0.538	0.692	0.706	0.712	0.726	
	4000	0.244	0.288	0.360	0.468	0.627	0.640	0.646	0.658	
	6000	0.231	0.277	0.346	0.464	0.634	0.647	0.653	0.666	
	9000	0.204	0.249	0.317	0.427	0.595	0.607	0.613	0.625	
	12700	0.188	0.229	0.296	0.404	0.570	0.581	0.587	0.598	
	14100	0.183	0.224	0.290	0.399	0.565	0.576	0.582	0.593	

\* $w_0$  = optimum moisture content.

**Table 24. Recommended MADs for No. 53 aggregates on chemically modified soil subgrade (Zhao et al., 2018).**

No. 53 Thickness Chemically Modified Subgrade*		No. 53 Moisture Content ( $w_0$ : optimum moisture content)							
		$w_0-4\%$	$w_0-3\%$	$w_0-2\%$	$w_0-1\%$	$w_0$	$w_0+1\%$	$w_0+2\%$	$w_0+3\%$
(1) Large Compactor Accessible Areas									
6"	Lime Treated	0.212	0.234	0.266	0.316	0.387	0.395	0.399	0.406
	Cement Treated	0.198	0.219	0.263	0.3	0.37	0.377	0.381	0.389
12"	Lime Treated	0.184	0.215	0.265	0.316	0.387	0.395	0.399	0.406
	Cement Treated	0.176	0.207	0.256	0.300	0.370	0.377	0.381	0.389
18"	Lime Treated	0.154	0.188	0.243	0.316	0.387	0.395	0.399	0.406
	Cement Treated	0.150	0.184	0.238	0.300	0.370	0.377	0.381	0.389
(2) Small Areas Using Small Compactors									
6"	Lime Treated	0.259	0.285	0.325	0.386	0.472	0.482	0.486	0.496
	Cement Treated	0.242	0.267	0.321	0.366	0.451	0.460	0.465	0.474
12"	Lime Treated	0.224	0.262	0.323	0.386	0.472	0.482	0.486	0.496
	Cement Treated	0.215	0.253	0.312	0.366	0.451	0.460	0.465	0.474
18"	Lime Treated	0.188	0.229	0.296	0.386	0.472	0.482	0.486	0.496
	Cement Treated	0.183	0.224	0.290	0.366	0.451	0.460	0.465	0.474

\*The chemical soil modification chemical should refer to as Item 301.09 of INDOT Standard Specifications, 2018.

**Table 25. Recommended MADs for No. 53 aggregates on compacted soil subgrade (Zhao et al., 2018).**

No. 53 Thickness	Subgrade		No. 53 Moisture Content (w0: optimum moisture content)								
	Soil type	DCP	w0-4%	w0-3%	w0-2%	w0-1%	w0	w0+1%	w0+2%	w0+3%	
<b>(a) Large Compactor Accessible Areas</b>											
6"	Clay	6	0.368	0.399	0.443	0.504	0.583	0.595	0.600	0.612	
		7	0.340	0.370	0.411	0.473	0.554	0.565	0.571	0.582	
		8	0.307	0.335	0.373	0.432	0.510	0.520	0.525	0.536	
	Silt	9	0.284	0.311	0.348	0.404	0.480	0.490	0.494	0.504	
		11	0.245	0.269	0.303	0.357	0.430	0.439	0.443	0.452	
	Sandy	12	0.233	0.256	0.289	0.342	0.414	0.422	0.426	0.434	
		15	0.199	0.220	0.251	0.301	0.372	0.379	0.383	0.391	
	Backfill	#30	6	0.368	0.399	0.443	0.504	0.583	0.595	0.600	0.612
		#4	7	0.340	0.370	0.411	0.473	0.554	0.565	0.571	0.582
		½"	11	0.245	0.269	0.303	0.357	0.430	0.439	0.443	0.452
		1"	16	0.191	0.212	0.243	0.292	0.362	0.369	0.373	0.380
	12"	Clay	6	0.267	0.303	0.358	0.443	0.558	0.569	0.575	0.586
			7	0.255	0.291	0.347	0.431	0.557	0.568	0.574	0.585
			8	0.237	0.272	0.325	0.408	0.532	0.543	0.548	0.559
		Silt	9	0.224	0.259	0.311	0.392	0.515	0.525	0.530	0.541
			11	0.203	0.235	0.286	0.357	0.430	0.439	0.443	0.452
Sandy		12	0.196	0.228	0.278	0.342	0.414	0.422	0.426	0.434	
		15	0.177	0.208	0.251	0.301	0.372	0.379	0.383	0.391	
Backfill		#30	6	0.267	0.303	0.358	0.443	0.558	0.569	0.575	0.586
		#4	7	0.255	0.291	0.347	0.431	0.557	0.568	0.574	0.585
		½"	11	0.203	0.235	0.286	0.357	0.430	0.439	0.443	0.452
		1"	16	0.173	0.203	0.243	0.292	0.362	0.369	0.373	0.380
18"		Clay	6	0.192	0.230	0.288	0.380	0.515	0.525	0.530	0.541
			7	0.187	0.224	0.282	0.377	0.514	0.524	0.529	0.540
			8	0.179	0.216	0.272	0.364	0.503	0.513	0.518	0.528
		Silt	9	0.172	0.210	0.265	0.356	0.493	0.503	0.508	0.518
			11	0.163	0.198	0.254	0.357	0.430	0.439	0.443	0.452
	Sandy	12	0.160	0.195	0.250	0.342	0.414	0.422	0.426	0.434	
		15	0.150	0.185	0.251	0.301	0.372	0.379	0.383	0.391	
	Backfill	#30	6	0.192	0.230	0.288	0.380	0.515	0.525	0.530	0.541
		#4	7	0.187	0.224	0.282	0.377	0.514	0.524	0.529	0.540
		½"	11	0.203	0.235	0.286	0.357	0.430	0.439	0.443	0.452
		1"	16	0.148	0.183	0.243	0.292	0.362	0.369	0.373	0.380

(Table 25 Continued)

(b) Small Areas Using Small Compactors											
6"	Clay		6	0.449	0.487	0.540	0.615	0.711	0.726	0.732	0.747
			7	0.415	0.451	0.501	0.577	0.676	0.689	0.697	0.710
			8	0.375	0.409	0.455	0.527	0.622	0.634	0.641	0.654
	Silt		9	0.346	0.379	0.425	0.493	0.586	0.598	0.603	0.615
			11	0.299	0.328	0.370	0.436	0.525	0.536	0.540	0.551
	Sandy		12	0.284	0.312	0.353	0.417	0.505	0.515	0.520	0.529
			15	0.243	0.268	0.306	0.367	0.454	0.462	0.467	0.477
	Backfill	#30	6	0.449	0.487	0.540	0.615	0.711	0.726	0.732	0.747
		#4	7	0.415	0.451	0.501	0.577	0.676	0.689	0.697	0.710
		½"	11	0.299	0.328	0.370	0.436	0.525	0.536	0.540	0.551
		1"	16	0.233	0.259	0.296	0.356	0.442	0.450	0.455	0.464
	12"	Clay		6	0.326	0.370	0.437	0.540	0.681	0.694	0.702
			7	0.311	0.355	0.423	0.526	0.680	0.693	0.700	0.714
			8	0.289	0.332	0.397	0.498	0.649	0.662	0.669	0.682
Silt			9	0.273	0.316	0.379	0.478	0.628	0.641	0.647	0.660
			11	0.248	0.287	0.349	0.436	0.525	0.536	0.540	0.551
Sandy			12	0.239	0.278	0.339	0.417	0.505	0.515	0.520	0.529
			15	0.216	0.254	0.306	0.367	0.454	0.462	0.467	0.477
Backfill		#30	6	0.326	0.370	0.437	0.540	0.681	0.694	0.702	0.715
		#4	7	0.311	0.355	0.423	0.526	0.680	0.693	0.700	0.714
		½"	11	0.248	0.287	0.349	0.436	0.525	0.536	0.540	0.551
		1"	16	0.211	0.248	0.296	0.356	0.442	0.450	0.455	0.464
18"		Clay		6	0.234	0.281	0.351	0.464	0.628	0.641	0.647
			7	0.228	0.273	0.344	0.460	0.627	0.640	0.646	0.658
			8	0.218	0.264	0.332	0.444	0.614	0.626	0.632	0.644
	Silt		9	0.210	0.256	0.323	0.434	0.601	0.613	0.620	0.632
			11	0.199	0.242	0.310	0.436	0.525	0.536	0.540	0.551
	Sandy		12	0.195	0.237	0.304	0.417	0.505	0.515	0.520	0.529
			15	0.183	0.226	0.306	0.367	0.454	0.462	0.467	0.477
	Backfill	#30	6	0.234	0.281	0.351	0.464	0.628	0.641	0.647	0.660
		#4	7	0.228	0.273	0.344	0.460	0.627	0.640	0.646	0.658
		½"	11	0.248	0.287	0.349	0.436	0.525	0.536	0.540	0.551
		1"	16	0.181	0.223	0.296	0.356	0.442	0.450	0.455	0.464

## SUMMARY

The unsaturated and unbonded geomaterials are used as subbase and base layers in many roads across the United States. Currently, most states have various dry density requirements in their specification for different unbonded layers (base, subbase, subgrade). Quality control/assurance of in-situ compaction using the nuclear density gauge is common in many states and has been around for many years. Using nuclear density gauge for field density measurement is relatively quick but calibration of the gauge against direct measurement of density is necessary for reliable measurements. Furthermore, density does not fully reflect the engineering properties of the soils and cannot be used as a direct input for structural design.

In order to close this gap, extensive research has been conducted worldwide to implement stiffness-based tests for quality assurance of the unbonded layers of road structures. These tests have shown the potential to better assess the engineering properties of the geomaterials. Some states, such

as Minnesota and Indiana, have developed specifications for using stiffness-based related tests for QA purposes. Some other states are either considering or conducting research studies to implement these tests. These standards are primarily based on the specifications and research results of MnDOT and INDOT.

The current chapter covered some of the most critical tests used to measure the underlying properties of the soils in the road structure. Nuclear gauge and sand cone tests were introduced as density-based tests. In addition, some of the stiffness-based tests, such as Briaud Compaction Device, Clegg Hammer, and Soil Stiffness GeoGauge, were briefly discussed. Testing with LWD and DCP was introduced and discussed in detail as a stiffness-based test. These two pieces of equipment were the focus of this PennDOT experimental research.

This chapter also covered several studies on the correlation between various engineering properties of unbonded materials with either LWD or DCP test results. A relatively strong correlation was observed between the modulus obtained from LWD and the outcome of the other tests. The main approach involves constructing models based on soil type and moisture content or using test sections to calibrate maximum or minimum limits based on the actual compaction of the soil. However, these methods cannot encompass all possible scenarios. Therefore, it is essential to calibrate different types of soils during field work. For commonly used soils, a certain threshold can be set based on data and empirical verification, thereby reducing the need for the extra work of calibration.

Upon completion of this literature review, the research team was left with the following questions to be addressed before developing guidelines for practical implementation.

- Can LWD and DCP effectively measure the compaction quality of the soils in PA?
- Do these tests distinguish different types of soils used in PA as base and subgrade?
- How well do the DCP, LWD, and density correlate?
- How repeatable are the results from LWD and DCP testing? What are the practical solutions to improve repeatability (decrease the COV)?
- What is the effect of sample size on the LWD and DCP test outputs? Does Proctor compaction in the mold correlate with field compaction?
- What is the proper LWD test output for QA/QC purposes? Are deflection measurements enough, or must the soil modulus be reported?

- Is using one geophone enough when using the LWD test? What are the benefits and/or applications of the additional two geophones?
- What are the effects of moisture content on the DCP and LWD test outputs? At what moisture level does the test need to be conducted?
- To ensure compaction quality, what would be the minimum requirements for selected output from the tests?

Some of these questions were answered through the research presented in this report. This research investigated different types of commonly used soil types in PA. Applying different compaction levels, moisture contents, and specimen sizes and conducting various LWD and DCP tests provided the research team and PennDOT with a dataset that can be effectively analyzed to address the questions above. Also, running the tests at the field level enabled the researchers at Penn State to develop recommendations for compaction quality based on LWD/DCP that PennDOT may consider for inclusion in specifications or implementation during the QC/QA process.

## CHAPTER 3

# Experimental Program

### **BACKGROUND**

The experimental plan was focused on evaluating LWD and DCP capability in QA/QC of the base, subbase, and subgrade layers in a pavement structure. The two testing methods yield parameters related to the stiffness of the soil and are meant to replace or complement the nuclear density gauge (NDG) test. More specifically, the modulus obtained from the LWD testing represents a fundamental engineering property of interest and is a direct input into the pavement design protocols. The work included an extensive laboratory study using LWD in testing various soils at different moisture content and compaction levels in a laboratory Proctor mold. This work was accompanied by applying both LWD and DCP in a large-scale laboratory setting in a test pit as well as a field test section. Once the research team investigated the efficiency and practicality of the test outputs, the thresholds were established to ensure that adequate structural capacity of the subgrade and the unbound layers had been achieved through the compaction effort. The results and findings from this research are expected to assist PennDOT in developing QA/QC specifications for the roadbed unbound layers construction.

### **SELECTION OF EXPERIMENT FACTORS**

Given the outcomes of the previous studies discussed in Task 1, five factors were considered in developing the testing plan: material type and gradation, moisture content, compaction level, and the test specimen dimensions, and support conditions. The treatment levels in Table 26 were used for each primary factor.

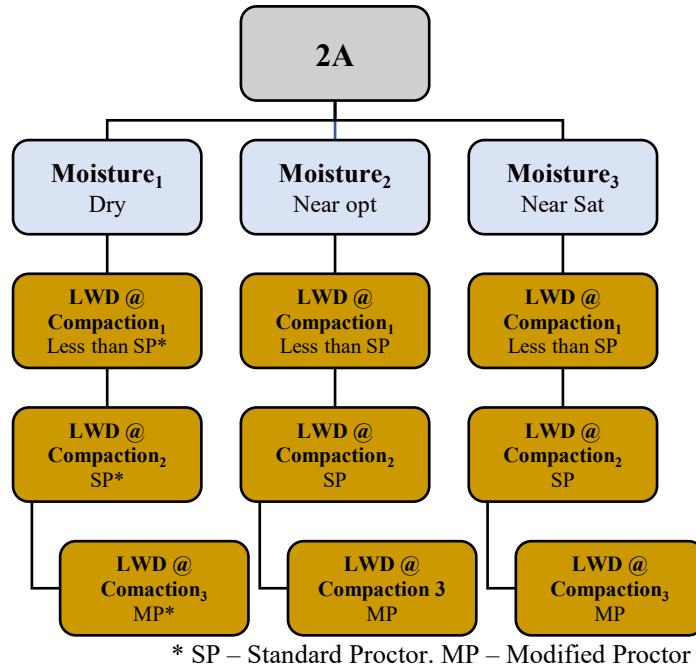
**Table 26. Potential factors in research and their corresponding levels**

<b>Factor</b>	<b>Levels</b>
Material type and gradation	5: 2A, 2RC, OGS, AASHTO A-4, AASHTO A-6
Moisture content	3: Dry side of optimum, near or at optimum, and wet side of optimum
Compaction level	3: Standard Proctor, modified Proctor, and low-density compaction
Specimen dimensions	3: 152.4 mm (6-inch) diameter (Proctor mold), 203.2 mm (8-inch) diameter, 177.8 cm(L)* 101.6 cm (W)* 45.7 cm (H)(70"*40"*18"), placed in a testing pit
Support type	3: Stiff, intermediate, and soft

It should be noted that the effects of material type and gradation were combined. In other words, the five types of materials selected for the study were not only different in composition but also in gradation and particle size distribution. For example, the 2A, 2RC, and OGS (Open-Graded Subbase) were on the coarse side of gradation, while AASHTO A-4 and A-6 soils were on the fine side. Ideally, an additional factor could have been added to this matrix, to cover the effect of gradation changes within the same aggregate. For example, one could investigate how the change of gradation within OGS could affect the results. However, such an investigation was not included in the study, as the work already included an extensive effort considering the budget and time constraints.

As depicted in Figure 22, for each material type selected (in this case, one of the 2A gradations), there were nine distinct testing conditions due to the planned variations in moisture content and compaction level. A similar hierarchy was considered for each material type/gradation combination, as presented in the example of Figure 22. It should be noted that the experiment became extensive when all factors were included in a full-factorial design. Using all the factors and corresponding levels of Table 26, even without replicates, yielded 90 individual specimens ( $5*3*3*2=90$ ). Given the size of the test pit at the Penn State Civil Infrastructure Testing and Evaluation Laboratories (CITEL), roughly two tons of material was required to create a test section for a single material at a single moisture content. Testing all five materials in the pit at three different moisture contents would have required fifteen test sections. Creating each test section in the pit was a time consuming process requiring significant manpower. Therefore, testing in the pit was limited to two materials. However, testing with the Proctor mold was expanded to all five materials as presented in Figure 22. The two factors that could not be compromised were the material type and the moisture

content. For all five material types, three moisture content levels were applied. This process yielded 15 specimens for each compaction level.



**Figure 22. Hierarchy of sample preparation and testing**

There is vast variability in the types of soils located within PA. Further, for soils within a given classification (such as AASHTO A-6), the strength behavior is expected to be quite variable. This variability makes studying these materials within this research project likely inconclusive to the desired outcome. That outcome is a definitive and narrow target range of resilient modulus values for a given general classification of soil or aggregate. The priority of this work was the study and understanding of the processed aggregate subbase types (2A, 2RC, and OGS). Processed aggregates are more predictable and consistent than natural soils. Therefore, less emphasis was placed on fine-grained soil types for the reasons listed below, and work in the test pit was limited to two of the subbase materials.

- The potentially large number of tests required if all types are tested (OGS, 2A, 2RC, A-4, and A-6)
- The uncertainty or impracticality of obtaining the desired quantity and quality of natural soil samples/sites.
- The variability of natural soils

Through coordination with the project technical advisor, it was possible to establish a site where test strips could be tested to validate the proposed target ranges from this research. Table 27 outlines the three methods, and their prioritization proposed to determine acceptable modulus for each material type in construction specification criteria.

**Table 27. Prioritization and expectation of results**

<b>Material Type</b>	<b>LWD and DCP Expected Ranges and Targets, Minimum based on Material Class</b>	<b>LWD and DCP Optimal Targets based on Test-Strip</b>	<b>LWD and DCP Targets based on physical and/or behavioral properties (gradation, PI, etc.)</b>
OGS	Primary goal	Primary goal	Secondary goal
2A	Primary goal	Primary goal	Secondary goal
2RC	Primary goal	Primary goal	Secondary goal
A4	Secondary goal	Primary goal	Primary goal
A6	Secondary goal	Primary goal	Primary goal

## **SCOPE OF WORK FOR TESTING**

### **Conduct Volumetric and Stiffness Tests**

Compacted specimens were prepared and subjected to the testing protocol presented in Table 28. The activities for this experimental plan are sequenced as follows.

- Procure and store materials (a continuous process)
- Set up LWD for data collection and analysis
- Establish gradation of received materials
- Establish moisture-density relationships and optimum moisture content
- Conduct LWD and DCP testing with Proctor compacted specimens
- Place and compact materials in the test pit. One material at a time was placed at three different moisture contents.
- Conduct LWD, DCP, moisture determination, and density determination for the material placed in the test pit
- Organize and analyze collected data (a continuous process)

### **Collection, organization, and analysis of data**

The testing associated with the experimental plan was expected to generate the required data to achieve the goals of this research project. The data were stored in an Excel database as the data were collected. The data included the types of materials used, their gradations, moisture content levels,

compaction levels, DCP results, LWD results, Proctor compaction test results, and density results. The data were analyzed to determine optimum moisture content, the moisture-density relations, and any relationships that could be developed between densities and LWD response parameters (deflection and modulus), between densities and DCP responses (penetration depth and rate), and between DCP and LWD.

### **Laboratory Proctor Mold**

Conditions presented in Figure 22 were applied to all five materials in the 15.2 cm (6-inch) diameter Proctor mold, yielding 45 specimens. For two of these materials (2A and 2RC), three replicates were used to investigate the test variability at optimum moisture content and at standard compaction level. Due to the scope and extensive experimental work, only one gradation for each material type was considered. One of the objectives of this research was to evaluate the correlation between the soils' density and stiffness-related properties. Since moisture plays an essential role in the stiffness of unbound materials, the moisture content needed to be monitored. For the Proctor mold testing, the Penn State team followed the AASHTO T 265 and AASHTO T 180 (or T 99) specifications to measure the density and moisture levels, respectively.

Conducting LWD tests with Proctor mold specimens, as outlined in Figure 22, formed the heart of this research study. However, the Proctor mold LWD testing for some soils also included testing at multiple compaction levels beyond just the three levels. The study also included testing with 20.3 cm (8-inch) mold size to evaluate the mold size effect, testing at different time durations between the hammer drop to evaluate the effect of rest period, and testing the same specimen at different times to evaluate the drying effect at the same dry density level.

### **Test Pit**

The test pit was used for two of the aggregates with high priority (2A and 2RC). For each of these two aggregates, three different moisture contents were used, and at each moisture content, the material was placed in three 15.2 cm (6-inch) thick layers. Testing with LWD and DCP was conducted for each layer. For the final (top) layer testing was conducted at various levels of compaction. Testing in the pit also included the determination of density, moisture content, stiffness, and modulus using the LWD and DCP. Density and moisture content of the soil in the test pit measured according to ASTM D6938 using a nuclear moisture density gauge. To correlate density measurements, sand code

tests were performed at the test pit according to ASTM D1556. Also, in addition to the oven-dry method to validate the moisture content, real-time measurements were conducted using moisture sensors. Table 28 summarizes the experiments conducted for this research project.

**Table 28. Material testing for this research**

<b>Experiment</b>	<b>Standard</b>	<b>Response</b>
Moisture content	AASHTO T 265	Moisture content
Moisture-density relations	AASHTO T 180 and T 99, Methods B and D	Optimum moisture content and maximum dry density
LWD	ASTM E2583	Deflection and modulus
DCP	ASTM D6951	Deflection, DPI
In-Place density and water content using a nuclear gauge	ASTM D6938	Moisture content and density of the aggregates at the test pit
In-place density	ASTM D1556	Verification of density measures at the test pit

### **Field Testing**

Field testing was limited to one site and covered two materials: 2A base material and A-6 subgrade material. The site was visited twice and tested with both LWD and DCP under different roller passes. The material density was measured using both the nuclear density gauge and the sand cone test. Samples were taken and tested in the lab to determine the moisture content.

## **MATERIALS**

The soils/aggregates for this research project were selected in collaboration with the PennDOT project technical liaison. The idea was to include materials that are typically encountered as subgrade in highway construction projects in Pennsylvania as well as materials that are typically used as subbase or base material of the road structure. As a result, two of the soils selected were classified as AASHTO A-4 and A-6 coming from subgrade of two PA construction projects. The other three were PennDOT classified aggregates 2A, 2RC, and OGS. OGS (Open-Graded Subbase) is an intermediate layer between pavements layers and subbase 2A, designed for better drainage and reduced fines pumping, though it requires careful blending to meet gradation standards. The research also included AASHTO soils A-4 and A-6, with A-4 being silt-dominated and low in plasticity, while A-6, richer in clay, exhibits higher plasticity and volume change potential. Materials were collected from various quarries and construction sites to conduct performance evaluations.

## **PennDOT 2A**

2A is designed as a subbase/base material before placement of the asphalt or Portland cement concrete. It is also used as road fill or pipe bedding. Municipalities may use 2A as a surfacing aggregate. This aggregate type has a top size of 2" and can act as either an open or well-graded aggregate based on the fine content (material passing #200 sieve), which is allowed to vary from 0–10%. For this research, 20 tons of 2A material was collected from the Hanson Oak Hall quarry, an approved PennDOT source as identified in Bulletin 14 (HAP14B14 Plant 71712). The material was stockpiled at Penn State's CITEL on 10/6/2022 (Figure 23).



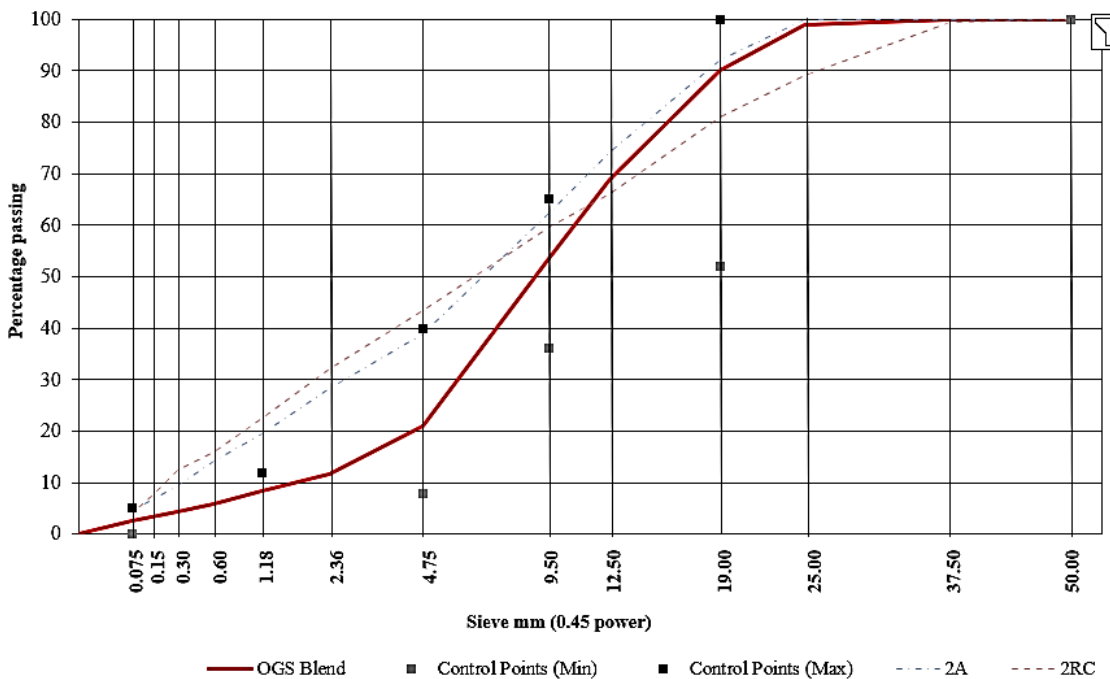
***Figure 23: 2RC (left) and 2A (right) stockpiles at CITEL utilized in this study.***

## **PennDOT 2RC**

With a top size of 2" and few other restrictions, 2RC typically has a considerably higher clay content compared with 2A aggregate and may contain soil and organic components. Because it is easy to make, it is usually a cost-effective option for use in lieu of 2A for pipe bedding or road fill. Similar to 2A, 20 tons of 2RC material was procured and stockpiled at the Penn State CITEL on 11/14/2022 (Figure 23).

## PennDOT OGS

PennDOT uses an open-graded subbase (OGS) as an inter-layer between rigid pavements and 2A aggregate. OGS was developed to provide an aggregate layer under pavements that is well-drained, does not “pump” fines, and is capable of supporting pavement loads. The OGS gradation is in between the gradations of the high-permeability aggregate and 2A aggregate. OGS has a greater tendency to segregate during handling and placing operations than denser-graded subbase. As a result, the number of quarries across PA that produce OGS is limited. Hence, an average gradation was considered for OGS in the research, roughly in the middle of upper and lower bands of OGS gradation. Two aggregate sources were used to blend the aggregates in the laboratory in the proper proportions to achieve this average OGS gradation. As one of the viable options, 50% of AASHTO #57, 35% of #8, and 15% of #10 were blended together to meet the OGS gradation requirements (Figure 24). Hence, the OGS for this research was produced in-house, using the aggregate sources available at Penn State’s Northeast Center of Excellence for Pavement Technology (NECEPT) laboratories (Figure 25).



**Figure 24. Resultant OGS blend after mixing 50% of #57, 35% of #8, and 15% of #10.**



**Figure 25. OGS material utilized in this study.**

#### **AASHTO A-4**

With at least 36% retained on the #200 sieve, a maximum liquid limit of 40, and a maximum plasticity index of 10, the A-4 soil is composed mainly of silt, with only moderate to small amounts of coarse material and only small amounts of clay. The soil type A-4 can vary texturally from sandy loams to silt to clay loams. In collaboration with 3N Consulting Services, 2 tons of AASHTO A-4 soil was collected from a job site of Interstate Highway 80 (I-80) and stockpiled at Penn State CITEL on 6/6/2023 (Figure 26).



**Figure 26. A-4 soil utilized in this study.**

### **AASHTO A-6**

Based on AASHTO classification, the difference between A-4 and A-6 is the plasticity index (PI), such that A-6's PI should be greater than 10. The typical material of this group is plastic clay soil, 75% or more of which usually passes the #200 sieve. The group includes mixtures of fine clayey soil and up to 64% of sand and gravel retained on the #200 sieve. Materials of this group usually have high volume change between wet and dry states. This soil type has low stability at high moisture content but is stable otherwise. Depending on the quality of A-6 in terms of the fine content and PI as well as the pavement structure and traffic, the soil may need replacement or stabilization to be used as subgrade. For this research, approximately 2 tons of the subgrade soil in SR 3014 (Atherton Street, State College, PA) was collected and stockpiled at CITEL on 7/19/2023 (Figure 27).



***Figure 27. A-6 soil utilized in this study.***

Figure 28 shows the gradation chart for all of the materials used in this study. One can see that the OGS exhibited the coarsest gradation followed by 2A and 2RC aggregates, respectively. The AASHTO A-4 and A-6 are on the fine side of gradation, with the A-6 demonstrating a fine gradation with over 85% of material passing #200 sieve.

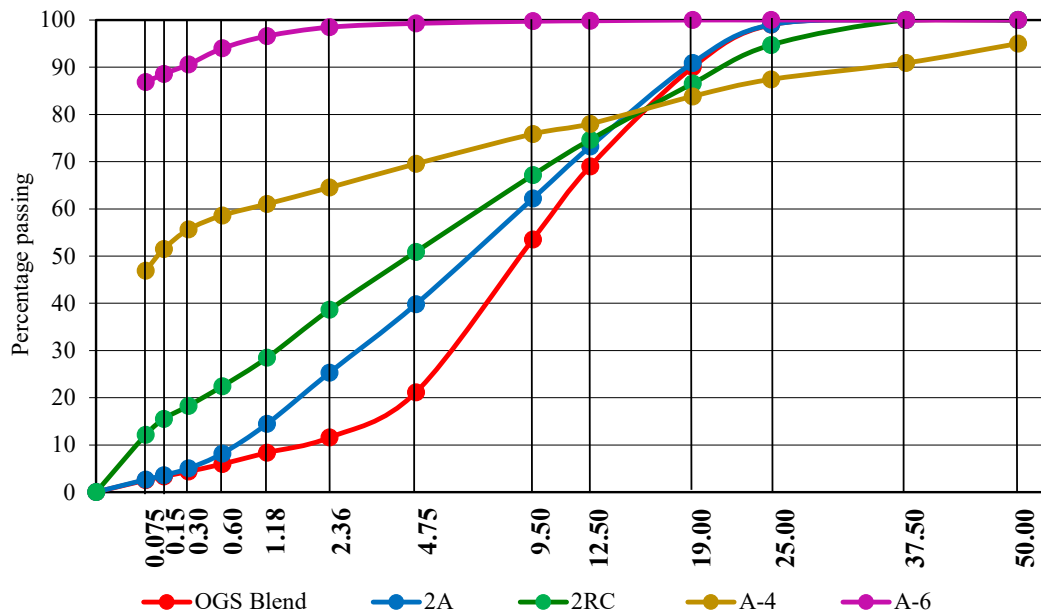


Figure 28. Gradation chart for OGS, 2A, 2RC, A-4 and A-6 materials.

## EQUIPMENT

### Proctor Mold and Hammer

The main test specimens were prepared in a cylindrical Proctor mold and compacted according to either AASHTO T 99 (standard) or T 180 (modified but in 3 layers), depending on the application. In both protocols, Methods B and D were considered. These two methods include the use of a 15.2 cm (6-inch)-diameter mold, with the difference that Method B is applied to soils passing the No. 4 sieve (4.75 mm), while Method D is for material passing the 19.0 mm sieve (¾-inch). The moisture contents of soils and aggregates were determined according to AASHTO T 265 or AASHTO T 255.

### Vibratory Roller Compactor

The single drum SX-170H Ingersoll Rand walk-behind roller (Figure 29) was used to compact the surface aggregates within the test pit. The roller compactor provides 8.9 kN (2,000 lb.) of centrifugal force, resulting in a 229-mm (9-in.) compaction depth. Although the roller compactor was

used primarily for compaction of the last layer, the vibratory plate compactor was used for the first and second layers.



**Figure 29. A roller compactor was used in this study.**

### **Plate Compactor**

The plate compactor was utilized to compact the first two layers in the pit test. The BX Series from Ingersoll-Rand (Figure 30), featuring single-direction compaction, is well-suited for compacting granular soils, crushed aggregates, and hot-mix asphalt at various open job sites, irrespective of their size. For this project, the plate compactor was specifically used to compact 2RC and 2A materials.



**Figure 30: The vibratory plate compactor used in this study.**

## **Nuclear Density Gauge**

The density of the compacted soil in the pit was measured using a nuclear density gauge (Troxler Model 3440, Figure 31). Nuclear gauge measurements were taken at a minimum of three random spots on each specimen at various passes of the roller compactor. Before measuring the density value on the testing specimens, the gauges were calibrated and validated.



***Figure 31 Nuclear Moisture-Density Gauge used in this study.***

## **Light Weight Deflectometer (LWD)**

Dynatest LWD Model 3032 (Figure 32) is a portable dynamic plate loading device designed for compaction quality assurance and determination of the modulus of unbound or partially bound materials. Dynatest LWD is intended to determine the “surface modulus” (often termed stiffness), a response of the underlying structure, in terms of a transient deflection, to the dynamic stress applied through a circular bearing plate. The device uses 10 kg (22 lb.) standard weight or optional 5 kg (11 lb.), 15 kg (33 lb.), or 20 kg (44 lb.), and the drop weight setup can apply up to 14.7 kN (3,300 lb.) impact force. The 300-mm (11.8-in) and 150-mm (9-in) loading plates were available depending on the specimen size. The data were collected using a tablet connected to the LWD device via Bluetooth. As noticed in Figure 32, in case of a soft or weak material, the LWD base plate leaves a footprint after the impact of the dropping weight. It is conceivable that the effect of this impact may go beyond

just leaving a footprint and may induce some minor soil displacement or surface compaction. However, the impression made on the surface of the soil through this impact was negligible and did not influence the measured response. The research team investigated the effect of this displacement during the analysis phase of this research. The frequent practice with LWD testing is to conduct six weight drops, disregard the first three drops, and use the average of the last three drops as an indicator of the material response. However, to study the effect of soil displacement (if any) during the test, the response measured from initial drops was considered and compared with the response from the second set of three drops.



**Figure 32: The LWD used in this study.**

### **Dynamic Cone Penetrometer (DCP)**

The Dual Mass Dynamic Cone Penetrometer (DCP) by Salem Tool Company (Figure 33) consists of a steel extension shaft assembly with a 60-degree hardened steel cone tip attached to one end, which is driven into the pavement or subgrade through a sliding dual mass hammer. The diameter of the base of the cone is 20 mm (0.79 in). The DCP is driven into the soil by dropping either the 8-kg or 4.6-kg sliding hammer from a height of 575 mm (22.6 in). The 8-kg hammer is converted to 4.6 kg by removing the hexagonal set screw and the outer steel sleeve from the dual mass hammer. The 4.6-

kg hammer is more suitable for use and yields better test results in weaker soils having a CBR of 10% or less.

The depth of cone penetration is measured at selected penetration or hammer drop intervals, and the soil's shear strength is reported in terms of the penetration index. The average penetration per hammer blow of the 4.6-kg hammer must be multiplied by 2 to obtain the DCP index value. The DCP is designed to penetrate soils to a depth of 1 m ( $\approx$  3.3 ft). The recorder is responsible for recording the number of hammer blows between measurements and measuring and recording the penetration after each set of hammer blows. The penetration measurements are recorded to the nearest millimeter.



**Figure 33.** *The DCP used in this study.*

### **Moisture Gauge**

Volumetric water content (VWC) type sensors are frequently used to measure a soil's moisture level. VWC is the volume of liquid water per volume of soil. It is usually expressed as a percentage. For example, 10% VWC means 100 mL of water per cubic meter of soil (or 0.1 cubic inches of water per cubic inch of soil). The TEROS-10 sensor, which is designed for installation in mineral soils and various types of growing media and other proposed materials, was utilized in this research to measure

the soil moisture content during the pit test. Concurrently, the ZL6 data logger from Meter Group was employed to collect data throughout the duration of the experiment in the pit test.

## EXECUTION OF THE EXPERIMENTAL PLAN

### Investigating the Effect of Moisture Content

According to the relevant literature, the moisture content is one of the main factors influencing soil modulus. Minnesota and Indiana DOTs identify the maximum allowable deflection and DPI (DCP Penetration Index) obtained from the DCP test as a function of moisture content. In addition, these states considered the moisture content when developing specifications for use of LWD for subbase evaluation. For the current research, the optimum moisture content was first determined using established AASHTO protocols. Afterwards, the Proctor specimens were fabricated at three moisture levels (dry of optimum, near-optimum, and wet of optimum) to perform the LWD tests. Similarly, these three moisture levels were applied in the soils tested in the large-scale test pit for testing with LWD and DCP. Table 29 presents the moisture contents established for various soils in this study. Testing at these three moisture levels was essential and an integral part of this research. In addition, it was found necessary during the course of the research to determine how LWD response varies as the moisture content of the soil is reduced at the same density level. Therefore, another factor that was investigated was the effect of moisture loss after compaction on the modulus. In this test, a sample of soil after compaction was dried in an oven and then tested with LWD. The results were compared with the results from testing a similar sample of soil created at the same density but tested in moist condition.

**Table 29. Moisture content for dry, optimum, and wet conditions across various soils examined in this study.**

Soil	Dry Condition	Optimum Condition	Wet Condition
2A	5%	8%	10%
2RC	6%	9%	10%
OGS	2%	3.5%	5%
A-4	6%	8.5%	10%
A-6	10%	15%	20%

### Investigating the Effect of Compaction Level

There are two AASHTO test standards in producing Proctor mold soils specimens for determination of optimum moisture content in the laboratory: T 99 (standard protocol) and T 180 (modified

protocol). AASHTO T 180 produces approximately four times more compactive effort compared with T 99. For this research, three (and in some cases four) scenarios were generated to study the effect of compaction energy on the LWD response. The study not only included compaction according to T 99 and T 180 but also compaction to a different number of hammer drops in the standard process. For example, a low-density compaction level was achieved through the standard Proctor method (AASHTO T 99) with fewer hammer blows at each sublayer (Table 30). In addition, one change was made to the AASHTO T 180 procedure, and that was compacting the soil in three layers rather than five layers as specified in the AASHTO protocol. The reason for this change was to eliminate any problems associated with compacting larger-size aggregates in thin layers inside the mold. Table 30 indicates the main compaction levels followed in this research. The approach taken in selecting moisture contents and compaction levels closely followed the original proposed plan. Hence, each material type was subjected to nine distinct testing conditions in the Proctor mold to cover the required matrix of testing for evaluating the effect of water content and compaction levels.

**Table 30. Soil compaction levels: Low, Regular, and High, differentiated by drop counts and hammer weights.**

Low Compaction	Regular Compaction	High Compaction
28 Drops, 2.5kg (5.5-lb) Hammer, 3 Layers	56 Drops, 2.5kg (5.5-lb) Hammer, 3 Layers	56 Drops, 4.5kg (10-lb) Hammer, 3 Layers

To control the compaction level in the test pit, the number of passes by the roller (either in static or vibratory mode) was recorded before each LWD and DCP measurement. A plate compactor was used to compact the bottom layers, while a roller compactor was used to compact the top layer of soils in the test pit.

## LWD Testing of Proctor Mold Specimens

### Setting up the Specimens for LWD Test

The soil, prepared at the specified moisture content, was placed into a Proctor mold, and compacted in three distinct layers, with each layer receiving a specific number of hammer drops tailored to the desired compaction level. The height of the prepared specimen for testing was 116 mm (4.5 in) with a diameter of 152 mm (6 in). The number of drops and the weight of the hammer varied depending on the required compaction levels, as outlined in Table 30. After compaction, the surface of the

sample was sometimes uneven, complicating the LWD testing process. To address this issue, very fine sand (passing 0.15 mm or #100 sieve) was used to smooth out the surface irregularities. Figure 34 shows a soil sample compacted in the mold and the sand applied to the surface to level and smoothen the surface.



**Figure 34. A Compacted Soil Specimen with fine sand applied to the surface.**

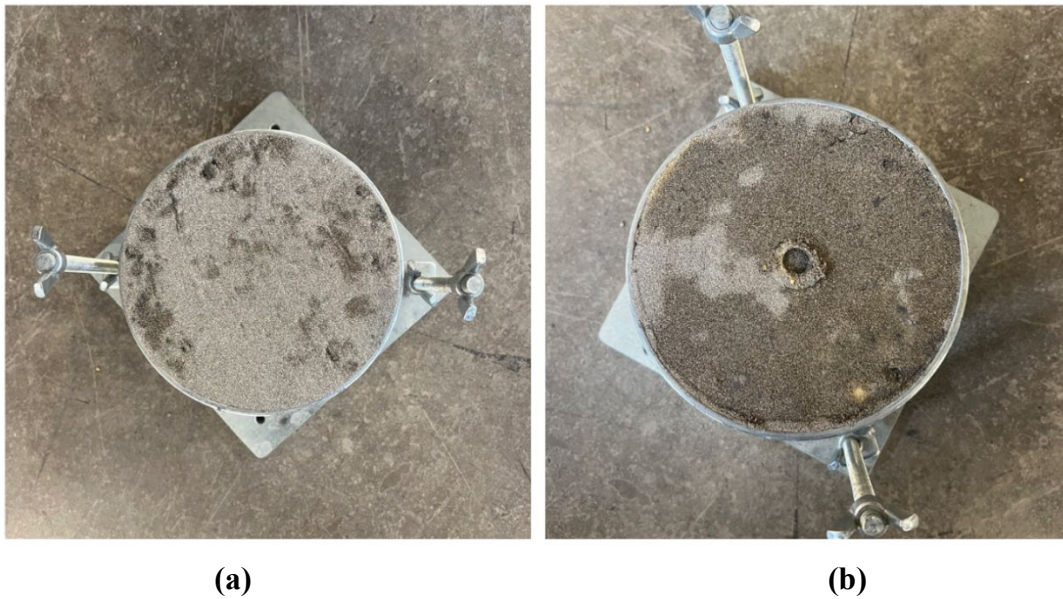
#### LWD Testing

Once preparation of the specimen was completed at a specified moisture level and compaction level, the specimen was subjected to testing with LWD. A uniform test procedure was conducted for all samples. The LWD device was carefully positioned on the top of the Proctor mold and aligned at the center before starting the test (Figure 35). After making the surface smooth and placing the LWD on the soil, care was taken to ensure that the LWD plate did not touch the edges of the Proctor mold and was completely sitting on the soil surface. Six impact drops were then applied to the sample, with the first three drops used for stabilization and not used in computations. The modulus of the soil tested in the Proctor mold was reported based on the average of the last three drops.

Figure 36 depicts the soil compacted in the Proctor mold before and after the LWD test, with sand used to smooth the surface.



**Figure 35. LWD in the compacted soil in the Proctor mold.**



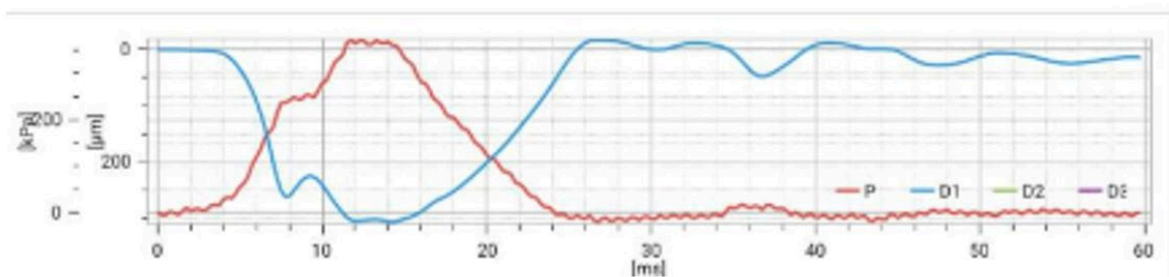
**Figure 36. Soil compacted in the Proctor mold: (a) before the LWD test, (b) after the LWD test.**

#### LWD Response Data

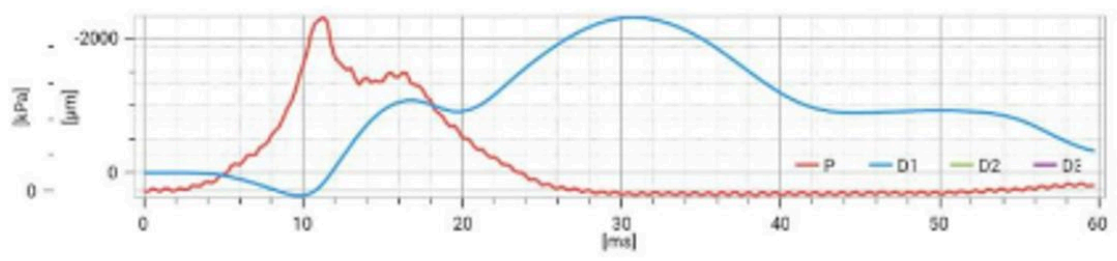
Figure 37 displays the results of the LWD tests, illustrating both a high-quality and a poor-quality response, respectively. In the graph, the red line indicates the force (load) applied to the soil, while the blue line presents the response to the load in the form of deflection. In Figure 37a, the optimal

response is evident as the maximum deflection aligns with the peak force, and as the force approaches zero the deflection stabilizes near zero. Conversely, Figure 37b shows a suboptimal response, where the deflection follows an unsteady and erratic behavior after the force diminishes to almost zero. This variable deflection response may indicate that the results may not accurately reflect the soil's characteristics.

a)



b)



**Figure 37. Responses of the LWD device: (a) good quality response, (b) poor quality response.**

The theory of elasticity was applied to calculate the modulus of the compacted soil with lateral constraint movement imposed by the rigid mold (Equation 3). To this end, assumptions were made that (a) soil is an elastic material, (b) the deformation occurred in the soil material only and not in the underlying stiff floor, and (c) the dynamic impact load can be converted into an equivalent static load.

$$E = \left(1 - \frac{2\nu^2}{1 - \nu}\right) \frac{4H}{\pi D^2} k \quad \text{Eq. (3)}$$

where  $\nu$ =poison's ratio,  $H$ =height of the mold,  $D$ =the diameter of the plate or mold, and  $k$  = soil stiffness = $F/\delta$  as calculated by LWD device. Based on ASTM E2583, six LWD drops were carried out and the average modulus of the last three drops was obtained.

## **Testing at the Pit**

The research included testing at a larger scale beyond testing the soils in the Proctor mold. This scale of testing was needed to get the condition of the compacted soil closer to the field condition. For this reason, the test pit located at the Penn State CITEEL was used by the research team for compaction of larger quantity of materials. Preparation of materials in the pit and testing required an extensive amount of work and labor. A coordinated teamwork was pursued to ensure successful completion of the required testing at the pit. The work started in mid-June 2023 and the last testing was completed in mid-October. Details of the testing schedule and testing protocols are presented in Table 31 and Table 32, respectively.

**Table 31. Schedule of site preparation and testing.**

Soil	Activity	Date	Moisture Contents	Tests
2RC	Removal of the top 25.4 cm (10 inches) of old soil	6/14/2023	----	This was a trial practice
	Placement of two layers of soil	6/26/2023	----	LWD
2RC	Removal of the top 45.7 cm (18 inches) of old soil	8/2/2023 & 8/3/2023	----	----
	Placement of the first two layers	8/8/2023	8.7% (Opt), and 9.5% (Wet)	LWD and DCP
	Placement of the top layer	8/9/2023	7.7% (Opt) And 8.2% (Wet)	LWD, DCP, Nuclear Density, and Sand Cone, Moisture content sensors
	Removal of the top 15.2 cm (6 inches)	09/05/2023	----	----
	Placement of the top 15.2 cm (6 inches)	9/12/2023	----	LWD and DCP
2RC and 2A	Removal of the top 45.7 cm (18 inches) of old soil	10/9/2023	----	----
	Placement of the first two layers	10/16/2023	6.0% (2RC) and 5.0% (2A)	LWD and DCP
	Placement of the top layer	10/17/2023	6.0% (2RC) and 5.0% (2A)	LWD, DCP, Nuclear Density, Sand Cone, Moisture content sensors
2A	Removal of the top 45.7 cm (18 inches) of old soil	03/9/2024	----	----
	Placement of the first two layers	03/20/2024	7.8 (Opt), and 9.9% (Wet)	LWD and DCP
	Placement of the top layer	03/21/2024	7.5% (Opt), and 9% (Wet)	LWD, DCP, Nuclear Density, Sand Cone, Moisture content sensors

**Table 32. Material testing protocols.**

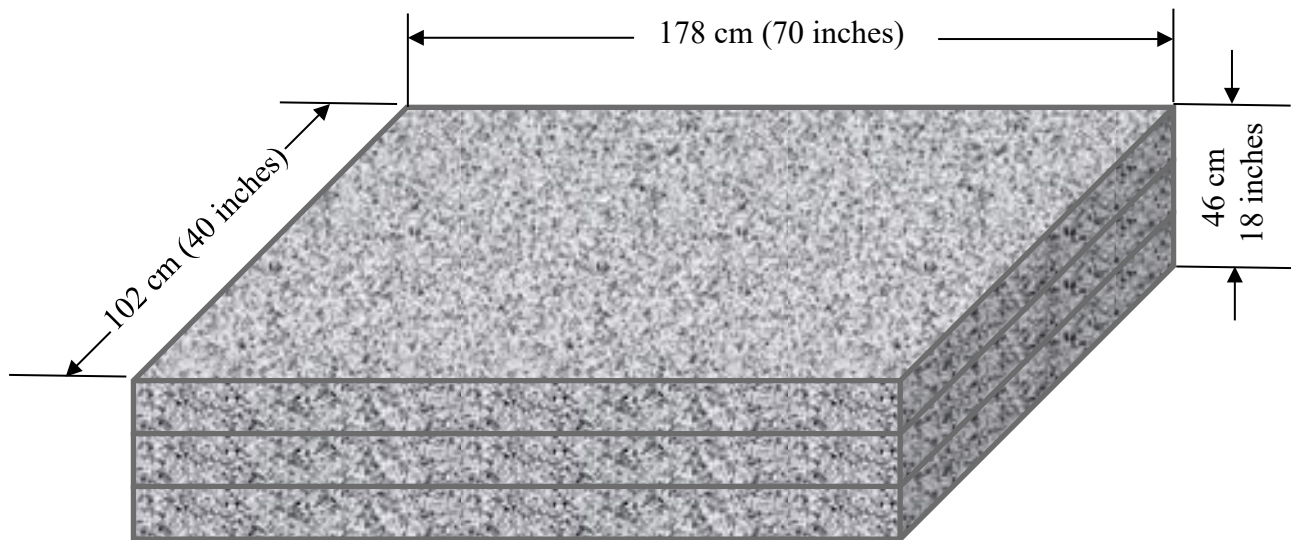
Experiment	Standard	Response
Moisture content	AASHTO T 265	Moisture content
Moisture-density relations	AASHTO T 180 and T 99, Methods B and D	Optimum moisture content and maximum dry density
LWD	ASTM E2583	Deflection and modulus
DCP	ASTM D6951	Deflection, DPI
In-Place density and water content using a nuclear gauge	ASTM D6938	Moisture content and density of the aggregates at the test pit
In-place density	ASTM D1556	Soil density at the test pit

### Selection of Materials

The original plan was designed to include three materials: 2A, 2RC, and OGS. However, during the research it was found that investigating additional parameters using the Proctor mold was required, and it was decided to exclude OGS from testing at the pit in favor of expanding the Proctor mold study. This decision was communicated and approved by PennDOT's technical advisor of the project. Hence, testing at the pit was limited to two sources: 2RC and 2A aggregates. Testing these two aggregates was completed following the schedule shown in Table 31.

### Preparation of the Pit and the Soil Samples for Testing

To prepare the soil samples and conduct the LWD and DCP tests, the pit was divided into two parallel long sections. Each soil section was dimensioned in a way to be small enough to make the work feasible due to the need of transporting a large enough quantity of the material to allow compaction of the soil through a rolling operation. Approximate dimensions of the soil as placed in the pit are presented in Figure 38. The 45.7 cm (18 inches) thickness was placed in three layers, each approximately 15.2 cm (6 inches) thick.



**Figure 38. Dimensions of the soil after placement and compaction in the test pit.**

Before placement of the soil, the existing soil was removed to a depth of 45.7 to 50.8 cm (18 to 20 inches) to prepare the platform for placing the soil to be tested. After removal of the topsoil, a layer of compacted soil, at least 106.7 cm (42 inches) thick, was left in place (Figure 39).



**Figure 39. The existing soil after removal of the topsoil and before placement of the soil to be tested (anchors were also removed).**

A few days before testing, the materials to be tested (either 2RC or 2A) were brought inside the building to control their moisture content and to prepare them for placing into the pit (Figure 40). Samples were taken to determine the existing moisture content and decide the amount of water needed to be added to achieve the target moisture content. On the test date, the soil was brought to the target moisture content and uniformly blended inside a rotary mixer (Figure 41).

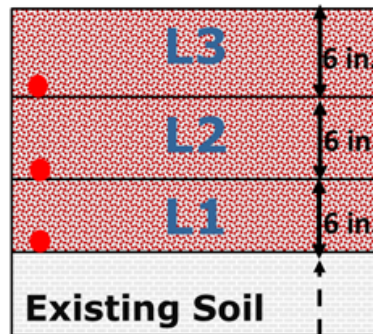


**Figure 40. Soil prepared for placement in the test pit before testing.**



**Figure 41. Uniform blending water and aggregate inside the mixer.**

The material was compacted in three 15.2 cm (6 inches) layers at three different moisture contents (Figure 42). Compaction was achieved using a vibratory plate compactor for the first two layers and a roller compactor for the third layer (Figure 43).



**Figure 42. The Layered system of soil placement employed in the test pit.**



**Figure 43. Using a vibratory roller for compaction of the soil inside the pit**

#### Testing with LWD and DCP at the Pit

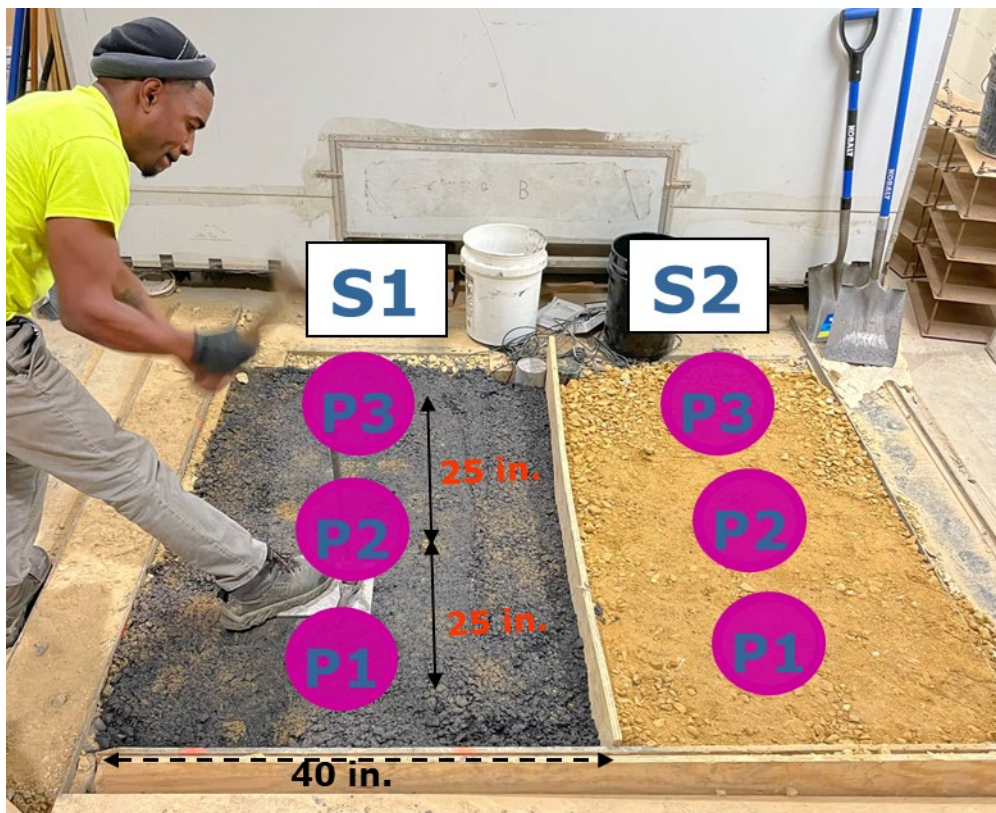
After preparation and compaction of each of the two bottom layers, LWD and DCP tests were conducted on the soil quickly. Once the final layer at the top was constructed, testing included not only LWD and DCP but also nuclear density and sand cone density tests. LWD and DCP tests on the top layer were performed following 2, 4, 8, and 12 roller passes. A moisture gauge was employed to monitor the soil moisture content in all three layers for each test section. A sensor of the moisture content measuring device was installed in each layer, tracking the moisture levels from the time of compaction until twenty-four hours post-compaction. Density was measured using a nuclear density gauge according to ASTM D6938 as well as sand cone test according to ASTM D1556.

To systematically record data, a labeling system was implemented to include the test section, the layer, and the location of testing. For example, ‘S1L2P3’ denotes Section 1, Layer 2, Point 3. This coding facilitates precise mapping of test results to specific locations within the test pits, enabling detailed analysis of how soil properties vary across the depth and with different compaction efforts. Figure 44 shows the measurement locations for the two soil sections prepared side by side. From the figure one can see what is meant by “section” and “point.” It can also be inferred that for testing with LWD, testing was repeated three times for each layer, resulting in repeating the test 18 times when

both sections are considered. To this, one should add the data collected from the two geophones extended beyond the center point under LWD. It is easy to see that an extensive amount of data was calculated during each of the experiments conducted in the pit. The data were processed, and the compacted soil modulus was calculated using the Boussinesq equation (Equation 4).

$$E = \frac{2k_s(1-\nu^2)}{Ar_0} \quad \text{Eq. (4)}$$

where  $k_s = \left| \frac{F_{peak}}{\omega_{peak}} \right|$  calculated by the LWD device,  $A$  is the stress distribution factor,  $\nu$  is the Poisson's ratio, and  $r_0$  is the plate radius.



**Figure 44. Side by Side aggregates prepared in the test pit showing LWD/DCP test locations.**

### Data Collection from Field Projects

Originally, two field projects were identified by the PennDOT project technical advisor to be investigated during the course of this research: SR 3014 (Atherton Street) and I-80. The former was successfully included in the testing program while the latter was finally dropped from the work due to delays in construction, with the latest estimated schedule showing the work planned for July 2024.

It was decided that testing so late in the project may jeopardize other parts of the work and jeopardize timely delivery of the research outcome.

The field work for SR 3014 included testing of 2A and AASHTO A-6 materials at the construction job site. The A-6 material was tested on 7/19/2023 and 7/31/2023 but the A-6 material was tested only on 7/19/2023, as the subgrade was fully covered by 7/31/2023 when the next opportunity for testing was presented to the research team. The materials tested were already subjected to some level of compaction before arrival and evaluation by the research team. Both the Light Weight Deflectometer and Dynamic Cone Penetrometer were employed at the site. These tests were performed on samples that had undergone varying degrees of compaction by a steel wheel roller compactor. This approach provided insights into how the compaction process influenced the properties of these materials. Furthermore, two sand cone tests were executed at the final compacted area to attain a comprehensive understanding of the soil density in addition to density measurements by a nuclear gauge. Moreover, at the conclusion of the study, three samples of moisture content were collected from the three tested spots.

### Materials

The work was focused on conducting LWD and DCP for two distinct soil materials, 2A and A-6. The methodology involved selecting three different locations for each type of soil, spaced 3 ft apart longitudinally, and tested by LWD. Then, DCP tests were conducted at three parallel locations, equidistant by 3 ft (Figure 45). At each of these locations, the tests were performed at various levels of compaction. Nuclear density readings were recorded at the LWD test locations using the surface method, i.e., with the gauge seated flat on the surface when taking the readings. In addition, nuclear density readings were also taken at depth using penetration of a 15.2 cm (6 inches) probe at three spots at the vicinity of the spots where LWD measurements took place. The same steps were repeated three more times after various levels of compaction. The compaction was done by HRI Inc., using a Caterpillar CS56B vibratory roller. One pass was counted as the roller completing either a forward pass over the spot or a backward movement. Finally, after the initial testing was complete, two sand cone tests were conducted at the final compact area. At the conclusion of this work, three moisture content samples were obtained at the three tested spots, and each sample was securely double bagged for preservation of moisture and accuracy of moisture content determination. The samples were taken back to the NECEPT laboratories where moisture content was measured.



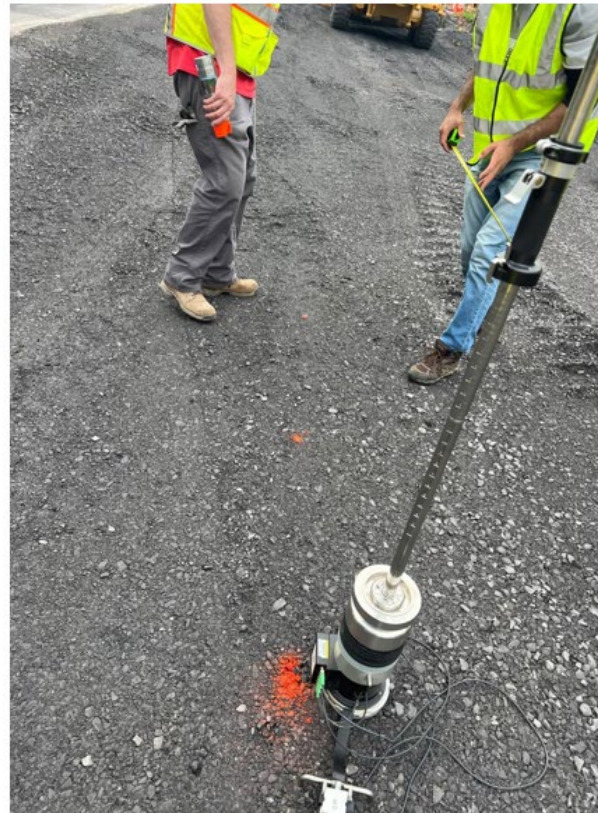
**Figure 45. Determination of three spots 3 ft apart longitudinally at: (a) 2A and (b) A6 materials.**

#### 2A material

The 2A material, with a thickness of around 20.3 to 25.4 (8 to 10 inches), had already been sealed off, and according to the information received from the foreman at the jobsite it had probably received 4 roller passes. Following this, LWD and DCP tests were conducted at three different spots with varying compaction levels, including uncompacted soil and soil compacted after 2, 4, and 6 passes of a compactor roller on the 2A materials (Figure 46). Sand cone tests were completed as the last set of tests (Figure 47).



(a)



(b)

**Figure 46. LWD and DCP testing at the job site.**

A-6 material

LWD, DCP, and nuclear density tests were conducted at three different spots with varying compaction levels. This process included uncompacted soil and a sequence of four compactor roller passes - two forward and two backward. Notably, the roller was set to vibration mode for the initial and final passes. Following this, an additional compaction phase was initiated involving one forward and one backward pass, both executed with the vibratory function enabled. This rigorous compaction process set the stage for the subsequent LWD and DCP tests.



(a)



(b)

**Figure 47. Sand cone test on the (a) 2A, and (b) A6 materials.**

## SUMMARY

This chapter provided a detailed overview of how to establish criteria that could be considered by PennDOT to develop recommendations for use of LWD and DCP for quality control or acceptance of subbase/base materials. The research was planned with a structured testing matrix that considered various factors such as material type and gradation, moisture content, and compaction level. Laboratory and field testing of five different soil types was completed, primarily utilizing LWD and DCP tests under both controlled laboratory settings and direct field investigations to generate and analyze significant data.

In the initial phases of the project, extensive preparations were made, including the identification and sourcing of suitable materials such as PennDOT 2A, 2RC, and OGS aggregates, along with AASHTO A-4 and A-6 soils. These materials were delivered to the Penn State laboratories where they were processed for determination of gradation, moisture content, and consistency limits where applicable. The open-graded subbase material was an exception to the list of aggregates in

terms of preparation and processing. As no source could be identified for obtaining this aggregate, materials from different sources were blended to yield the required gradation for OGS. Various pieces of equipment were utilized in the course of research, including nuclear density gauge, moisture gauge, Proctor mold, sand cone device, water/soil rotary blender, plate compactor, and roller compactor. The equipment necessary for the research was arranged and made operational, and staff involved in data collection were trained and conducted practice runs to ensure accuracy and reliability in test results.

The study included laboratory testing at three scales: 15.2 cm (6 inches)cylindrical Proctor mold, 20.3 cm (8-inch) cylindrical mold, and a test pit accommodating soil samples 1.78 m (70 inches) long, 1.02 m (40 inches) wide, and 0.46 m (18 inches) deep. The main laboratory testing component of the study involved creating Proctor mold samples with varying moisture contents and compaction levels. These samples underwent LWD testing to assess the effect of moisture contents and compaction levels on the response. The response was captured as deflection under the LWD dynamic load. Testing at the test pit comprised two aggregate types (2A and 2RC) and included LWD, DCP, nuclear density, and sand cone tests.

Field investigations complemented the laboratory tests, with visits to an actual road construction site where the subgrade and base materials were tested under varying compaction levels using the same suite of tests employed in the lab. This approach allowed the research team to observe the performance of materials in situ, providing valuable insights into their behavior under practical application conditions.

A massive amount of data was generated as a result of this work. This data was processed and analyzed, and the result of analysis are provided in the following chapter.

## CHAPTER 4

# Data Analysis and Interpretation

There were several types of laboratory and field data collected for this research and the methods and types of the collected data were extensively discussed in Chapter 3. The reader is encouraged to see the details of data collection in the previous chapter. This chapter is solely allocated to the analysis and discussion of the collected data. All data have been organized in a series of Excel™ databases that accompany this report.

The sequence of the data, as discussed in this chapter, is presented below.

- **Data from Small-scale Laboratory Tests**

- Gradation and characteristics of the materials
- Optimum moisture content from standard Proctor test
- Comparison of OMC between standard and modified Proctor compaction
- Sensitivity of LWD response to material and compaction parameters
  - moisture content
  - density
  - compaction energy
  - effect of moisture content on LWD response at a single density level
- Sensitivity of LWD response to the LWD test parameters
  - rest period between weight drops
  - weight drop sequence
- Effect of underlying support stiffness
- Repeatability of the test

- **Data from Large-scale Laboratory Tests**

- Density
  - Sand Cone Test
  - Nuclear Gauge Density Test
- Moisture content

- Conventional method (oven drying)
- In-situ moisture gauge
- LWD response data
  - at different compaction levels
  - at different moisture contents
- DCP response data
  - at different compaction levels
  - at different moisture contents
- **Data from Field Measurements**
  - Density
    - Sand Cone Test
    - Nuclear Gauge Density Test
  - Moisture content
    - LWD response data at different compaction levels
    - DCP response data at different compaction levels

## DATA FROM SMALL-SCALE LABORATORY TESTS

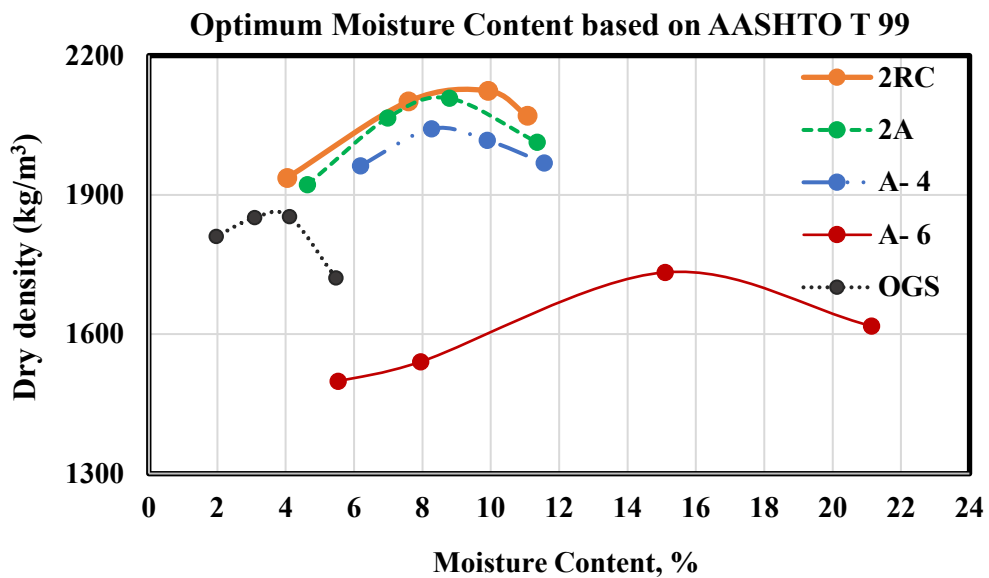
### Optimum Moisture Content (OMC)

The optimum moisture content (OMC) is the soil moisture content at which the highest dry density (or unit weight) is achieved under a specified level of compaction energy. The laboratory standard tests followed for this purpose include AASHTO T 99 and T 180. The former, commonly referred to as “standard Proctor,” uses a lower energy of compaction (drop of a 2.5kg (5.5-lb) hammer for a distance of 30.5 cm (12 inches)) compared with the latter, commonly referred to as “modified Proctor” (drop of a 4.5kg (10-lb) hammer from a height of 45.7 cm (18 inches)). The AASHTO T 99 standard requires compaction in 3 layers with 56 blows per layer for the 15.2 cm (6-inch) mold, while T 180 requires compaction in 5 layers with 56 blows per layer. One can see that the modified Proctor method delivers significantly higher compaction energy compared with the standard Proctor method. In this research, AASHTO T 99 was applied to all soils, while T 180 was used in some cases to study the effect of compaction. It must also be noted that due to the limited height of the specimen, in both standard and modified tests, the soil was compacted in three layers. This indicates a deviation from AASHTO T 180, where the compaction is stated to take place in five layers. A summary of results from the OMC study is presented in Table 33 and Figure 48.

For each soil type, the optimum moisture content (OMC) reported in Table 33 is obtained from the moisture content–dry density curve. This curve was established using one Proctor-compacted specimen at each moisture content, giving a total of 4 specimens.

**Table 33. Data from study on optimum moisture content based on AASHTO T 99.**

Soil Type	Moisture Content		Dry density kg/m <sup>3</sup>	OMC %
	Target %	Measured %		
A-6	6.0	5.5	1498.5	15.0
	8.0	8.0	1540.7	
	15.0	15.1	1733.1	
	20.0	21.1	1617.4	
A-4	6.0	6.2	1962.4	8.5
	8.0	8.3	2042.1	
	10.0	9.9	2017.4	
	12.0	11.6	1968.6	
2RC	4.0	4.0	1936.5	9.5
	8.0	7.6	2101.2	
	10.0	9.9	2123.9	
	12.0	11.1	2069.9	
2A	4.0	4.6	1921.8	8.0
	6.0	7.0	2065.7	
	8.0	8.8	2107.7	
	10.0	11.4	2013.1	
OGS	6.0	5.5	1721.4	3.5
	4.0	4.1	1853.3	
	3.0	3.1	1850.9	
	2.0	2.0	1810.3	



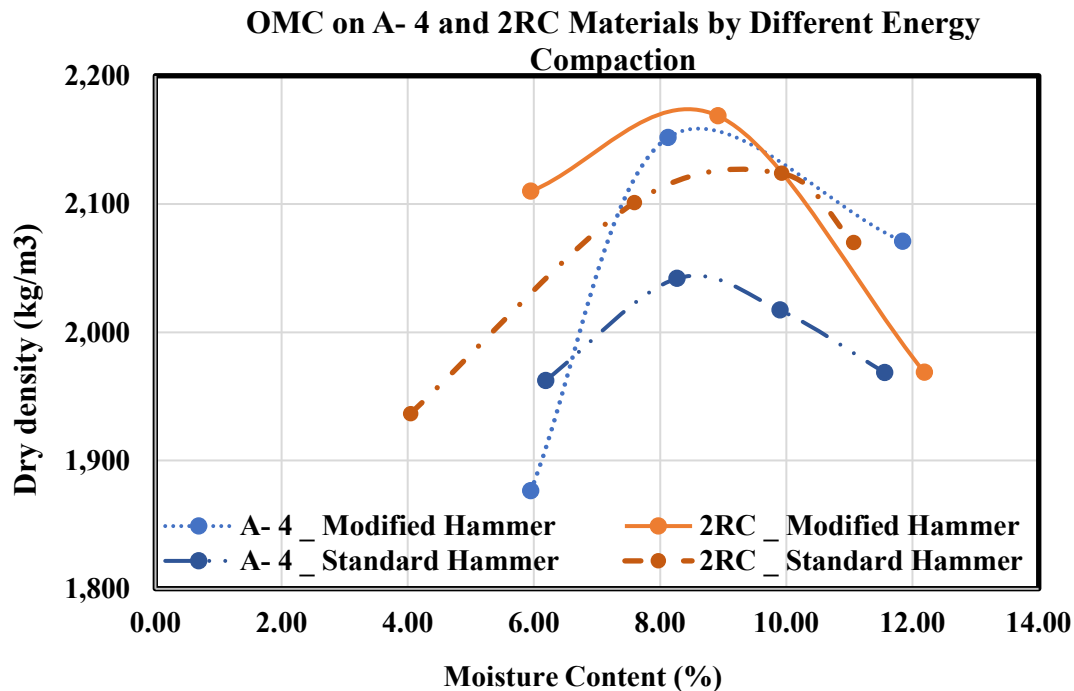
**Figure 48. Variation of dry density with moisture content for different soils.**

The graph in Figure 48 presents the characteristics profile of compaction curves, where the dry density peaks at the OMC for each material. The observed peak densities vary among the materials, indicating that different soils have unique moisture–density relationships. One can see that the finer materials have a higher OMC compared with coarser materials, as expected. Soil A-6, the finest of all studied here, has the highest OMC, while soil OGS, the coarsest of all, has the lowest OMC. The optimum moisture content varies in the range of 3.5% to 15%, depending on the soil type.

### **Impact of Modified Proctor Compaction on OMC**

It is generally the case that heavier soil compaction achieved in AASHTO T 180 yields a higher density and a lower optimum moisture content (OMC) compared with AASHTO T 99. Two of the soils used in the research, namely AASHTO A-4 and 2RC, were selected for investigating this matter. AASHTO A-4 was selected because it is considered a fine-sized material with a considerable amount of material passing the #200 sieve (roughly 48 percent). Material 2RC was selected to represent a coarser material but still with some amount of material passing the #200 sieve (roughly 12%). These two materials were subjected to modified compaction at different water contents. It should be noted that in both standard and modified compaction the same number of drops and the same number of soil layers were used, with the only difference being the hammer weight and the drop height.

Results are presented in Figure 49 in terms of dry density versus moisture content. It can be seen that the dry density is higher in the tests employing the modified hammer and a moisture content in the vicinity of OMC. For 2RC, the modified hammer significantly alters the optimum moisture content, with a difference of at least one percent. However, for A-4, the difference in optimum moisture content derived from compaction with standard and modified hammer is minimal and can be considered negligible.



**Figure 49. Comparison of standard and modified compaction in terms of density and OMC.**

### Effect of Moisture Content/Density on LWD Response

#### Study Parameters (Soil Type, Moisture Content, and Compaction Level)

It is well established that the quality of soil compaction is significantly affected by the moisture content of the soil. Ideally, the subgrade soil or the unbound subbase/base material is compacted at or near the optimum moisture content (OMC) to achieve the highest density possible. The rolling pattern is typically determined in a way to deliver the highest in-situ density without over-compaction. A significant portion of the laboratory work for this research was focused on evaluating the impact of the compaction level and moisture content on the LWD response. LWD measurements were conducted for at least three moisture contents and three compaction levels for all five soils. This testing matrix delivered 45 individual tests to include all materials and all moisture/compaction conditions. The moisture contents were used as dry of optimum, optimum, and wet of optimum. The compaction levels were lighter compaction energy compared with the standard Proctor compaction, standard compaction, and heavier compaction energy than standard Proctor compaction (modified compaction). For some of the soils, other moisture contents and compaction levels were also included in the study.

### LWD Response Parameters

It is important to understand the difference in the LWD response when used in the laboratory with the Proctor mold compared with its application in the field. The kinetic energy of the dropping weight generates a pulse load, and duration of this pulse is influenced by the induced energy and the material characteristics. The response is captured in terms of velocity, recorded by the device geophones, and converted to deflection under the LWD plate. This deflection is used to calculate the stiffness (elastic modulus of the soil). Throughout this report, the response is either reported in terms of deflection or modulus. Whether deflection or modulus should be used as criteria for quality control of compaction is an agency's choice. It will be easier to establish the criteria based on deflection, as it is a direct response from the LWD device and more tangible. It is the authors' recommendation to use deflection as the criterion for this purpose. However, conversion of deflection to modulus is a simple calculation, and it makes sense to also report the modulus, as it is an important engineering property of the material and an indicator of the level of stiffness of the tested material.

The confinement of the soil by mold plays a significant role in the response. The level of confinement of the soil in the laboratory Proctor mold is very different from the level of confinement observed in the field. This difference in test conditions is the reason for using different equations to calculate the soil modulus from deflection data. These equations were discussed previously and are presented here again.

$$E = \left(1 - \frac{2\nu^2}{1 - \nu}\right) \frac{4H}{\pi D^2} k \quad \text{Eq. (10) for Proctor mold}$$

$$E = \frac{2k_s(1 - \nu^2)}{Ar_0} \quad \text{Eq. (11) for field condition}$$

The reader is referred to the previous chapter for definition of the terms. It may not be directly clear from the preceding equations that the impact of Poisson's ratio ( $\nu$ ) is much more significant in the Proctor mold compared to the field conditions. Table 34 is presented to convey the importance of this point. One can see that, for example, the change of the Poisson's ratio from 0.15 to 0.40 in the case of the Proctor mold changes the modulus calculation multiplier from 0.978 to 0.467, which implies a 50% reduction in the value of calculated modulus. For the field condition, the same change in  $\nu$  results in only 14% reduction in the calculated modulus.

**Table 34. Effect of Poisson's Ratio on the Formulas to Calculate Modulus.**

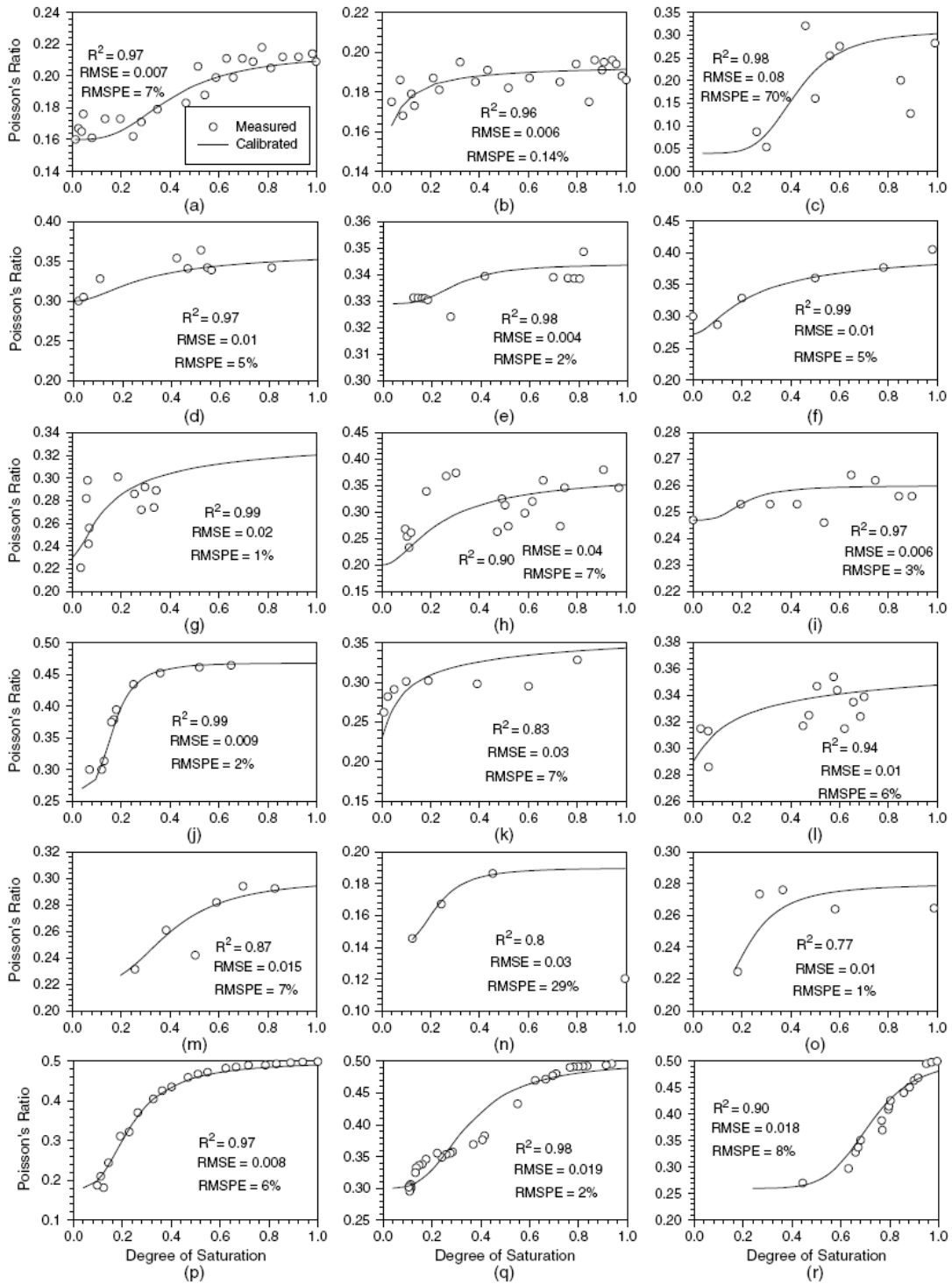
$\nu$	Multiplier in EQ. 10 $1 - \frac{2\nu^2}{1 - \nu}$	Multiplier in EQ. 11 $1 - \nu^2$
0.05	0.995	0.998
0.10	0.978	0.990
0.15	0.947	0.978
0.20	0.900	0.960
0.25	0.833	0.938
0.30	0.743	0.910
0.35	0.623	0.878
0.40	0.467	0.840
0.45	0.264	0.798
0.50	0.000	0.750

One can see that using a reasonable value for the Poisson's ratio is very important in calculating the soil modulus based on the LWD deflection from the laboratory test. The Poisson's ratio for a given soil is heavily dependent on the moisture content and degree of saturation. As the moisture content goes higher, the Poisson's ratio goes higher due to inclusion of the water incompressibility. Figure 50, for example, shows how the Poisson's ratio changes for different soils. The figure is directly obtained from the paper published by Thota et al. (2021). The eighteen soils presented in this figure cover a very wide range of clay, silt, and sandy soils when classified according to the Unified Soil Classification System. One can see that the drier side of some soils yields a Poisson's ratio as low as 0.1, or for some soils near saturation close to 0.5.

The importance of this matter in the current research is that testing is conducted at different moisture contents, and hence different degrees of saturation for the same soil. There is potentially the chance of a change in the Poisson's ratio as a result of this moisture content change. If such is the case, it may not be reasonable to use the same Poisson's ratio for all modulus calculations, regardless of the moisture content. This may not have a significant impact for field applications, but it was shown that it could have a considerable effect on the computations from laboratory test results.

Another matter of importance in comparing the lab testing and field testing with LWD is related to the underlying support and the depth of influence of the LWD impact weight. These two will be discussed more extensively later in this report, but one must be aware of the significance of the foundation stiffness on the response. In the case of Proctor mold, when testing the material to a

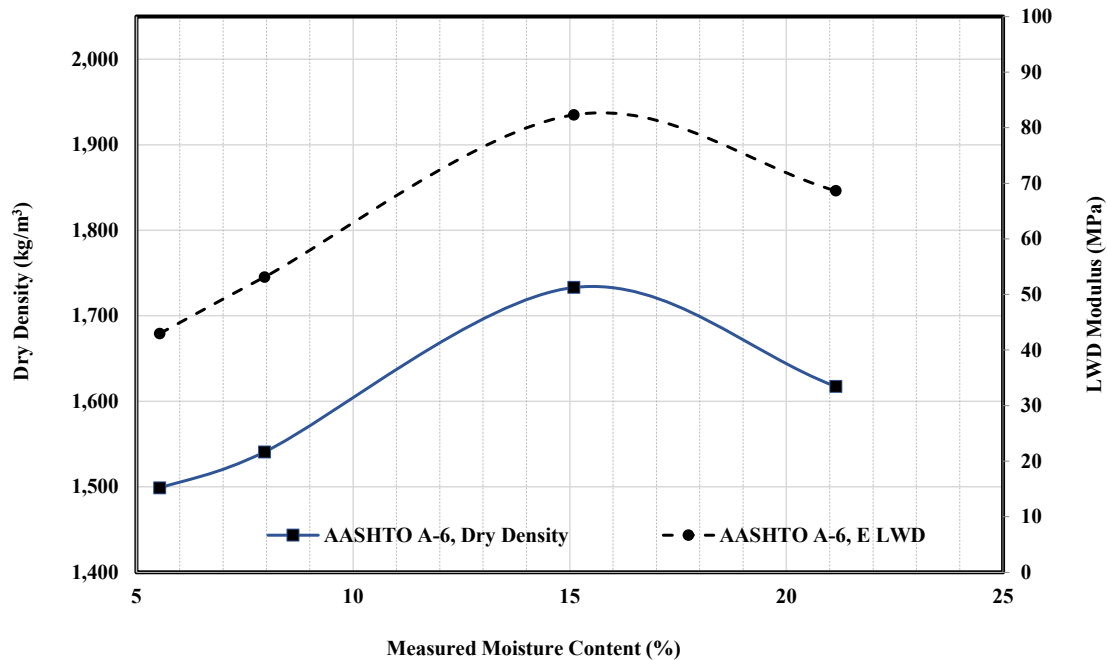
thickness of only 12.7 cm (5 inches), one must expect a significant effect from the support floor, which is often made of concrete, since the depth of influence well exceeds the thickness of the tested soil. Hence, the measurement is not truly an indication of the tested material property, rather influenced by the stiffness of the material it is residing on. Under these conditions, multi-layered analysis is needed, but that is not easy to do with the Proctor mold.



**Figure 50. Measured and calibrated Poisson's ratio with the degree of saturation for 18 different soils (Thota, Cao, and Vahedifard, 2021).**

### LWD Test Results: Moisture Content Effect

The deflection data and modulus data are presented in a series of graphs in Figure 51, Figure 52, Figure 53, Figure 54, and Figure 55. The change in dry density as a function of moisture content is also presented in these graphs. For three of the soils (A-6, 2A, and OGS), the density and modulus appear to follow similar trends, and the highest modulus is almost obtained at the highest dry density. For soil A-4, the modulus keeps decreasing with increase in the moisture content regardless of how the density changes as a function of moisture content. This behavior is completely different from that of the other four soils. The response for the 2RC soil is somewhere between the behavior observed for the A-4 soil and the other three soils. For 2RC, the modulus increases as the moisture content increases close to the optimum but at the dry side of the optimum, and then shows a drastic drop with further increase in the moisture content.



**Figure 51. Dry density and the soil LWD modulus as a function of moisture content for soil A-6.**

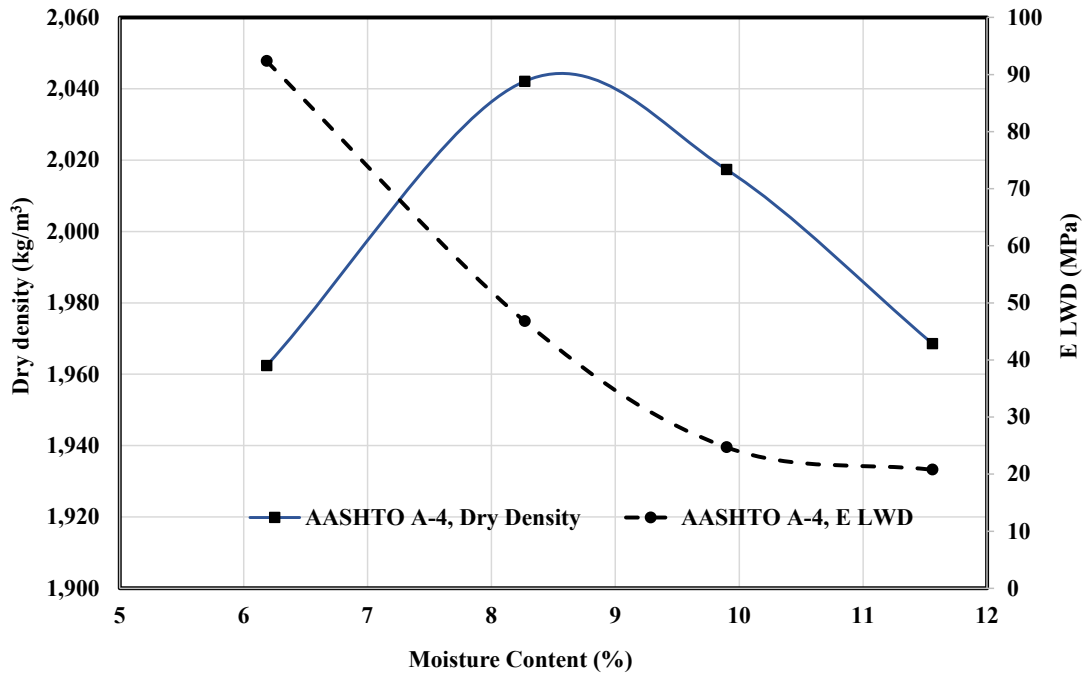


Figure 52. Dry density and LWD modulus as a function of moisture content for soil A-4.

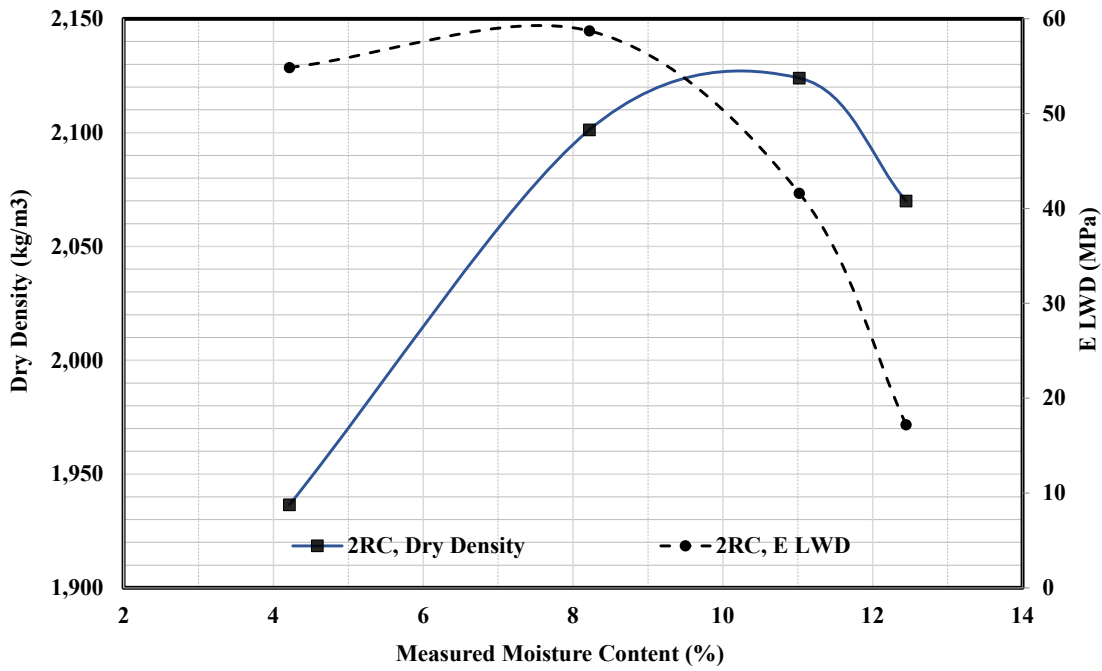


Figure 53. Dry density and LWD modulus as a function of moisture content for soil 2RC.

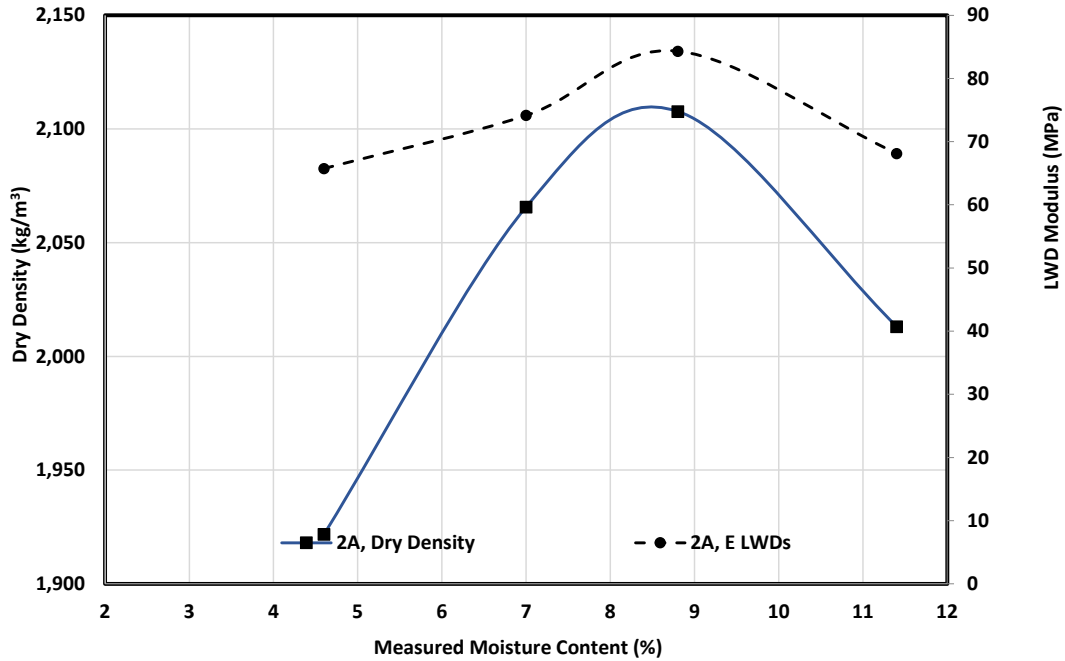


Figure 54. Dry density and LWD modulus as a function of moisture content for soil 2A.

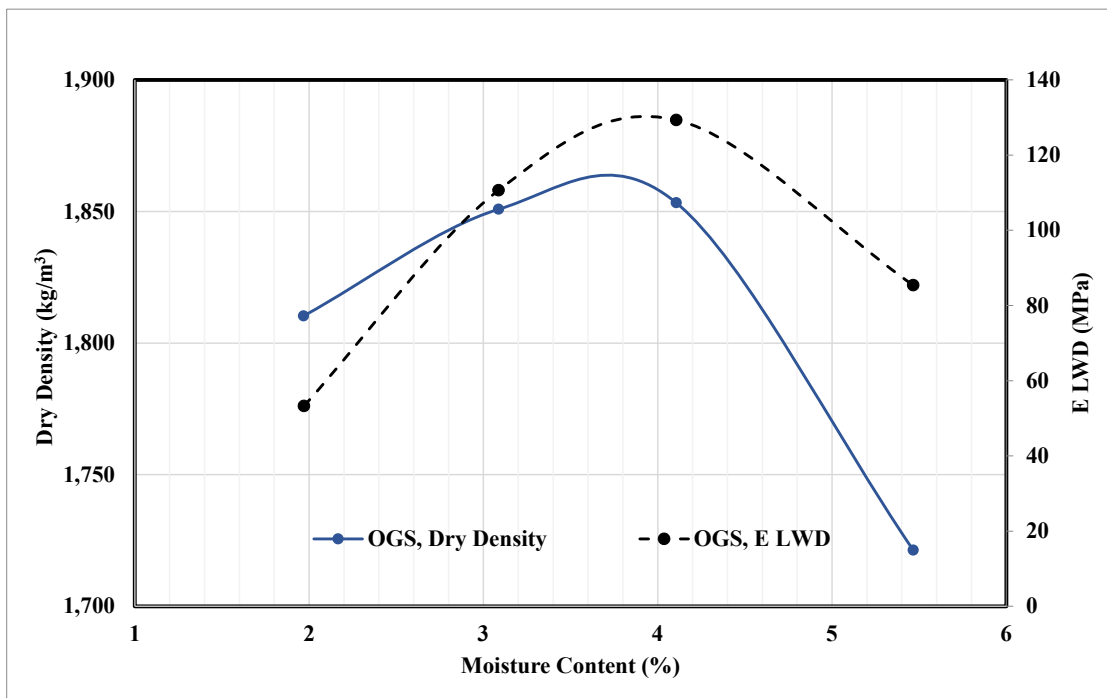


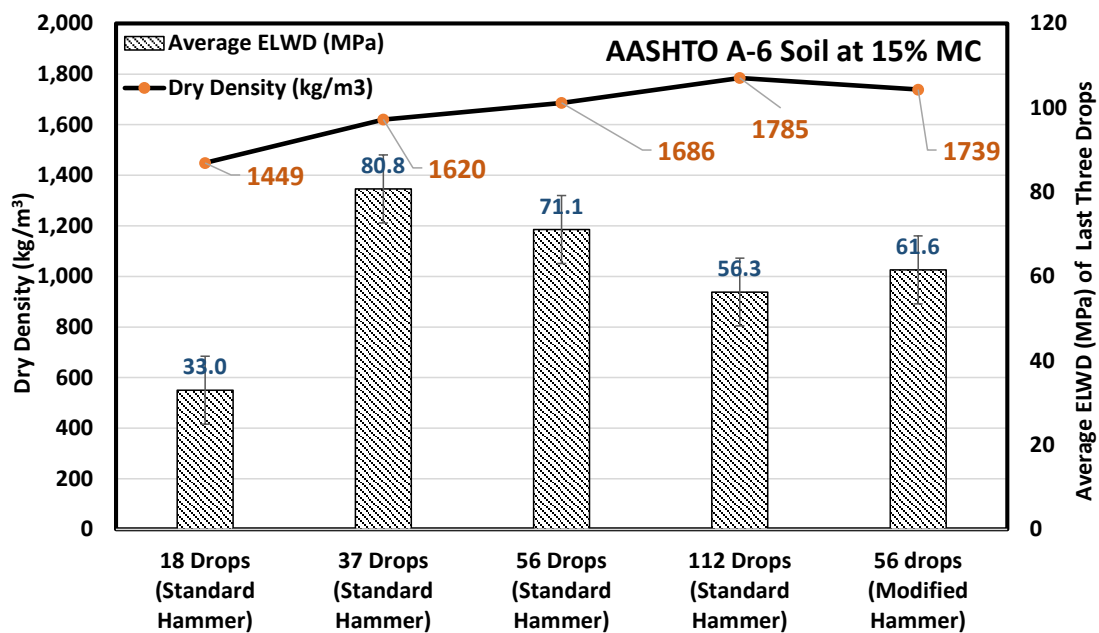
Figure 55. Dry density and LWD modulus as a function of moisture content for soil OGS.

LWD Test Results: Compaction Energy Effect

It was mentioned that a major part of this work was focused on investigating the soil response to LWD in the Proctor mold at a combination of conditions covering different moisture contents and

compaction levels. The results of this study are presented and discussed in this section. Throughout this document and corresponding tables and figures, the reader may encounter the term “LWD modulus” or “ELWD.” These terms are used to refer to the soil modulus obtained from the LWD device and are used in this way as a matter of brevity. Modulus is always referring to the modulus of the tested soil, unless noted otherwise.

In the first experiment, soil A-6 was compacted at five different compaction levels at the optimum moisture content, and the LWD response was measured. Results are presented in Figure 56. One can see a significant increase of modulus to 37 drops and a slight decrease afterwards at standard compaction. Beyond the standard compaction, it appears that over-compaction is taking place, resulting in considerable drop in the modulus. Further investigation is required to determine why the deflection is increased and modulus decreased while the density keeps increasing beyond the 37 hammer drops.

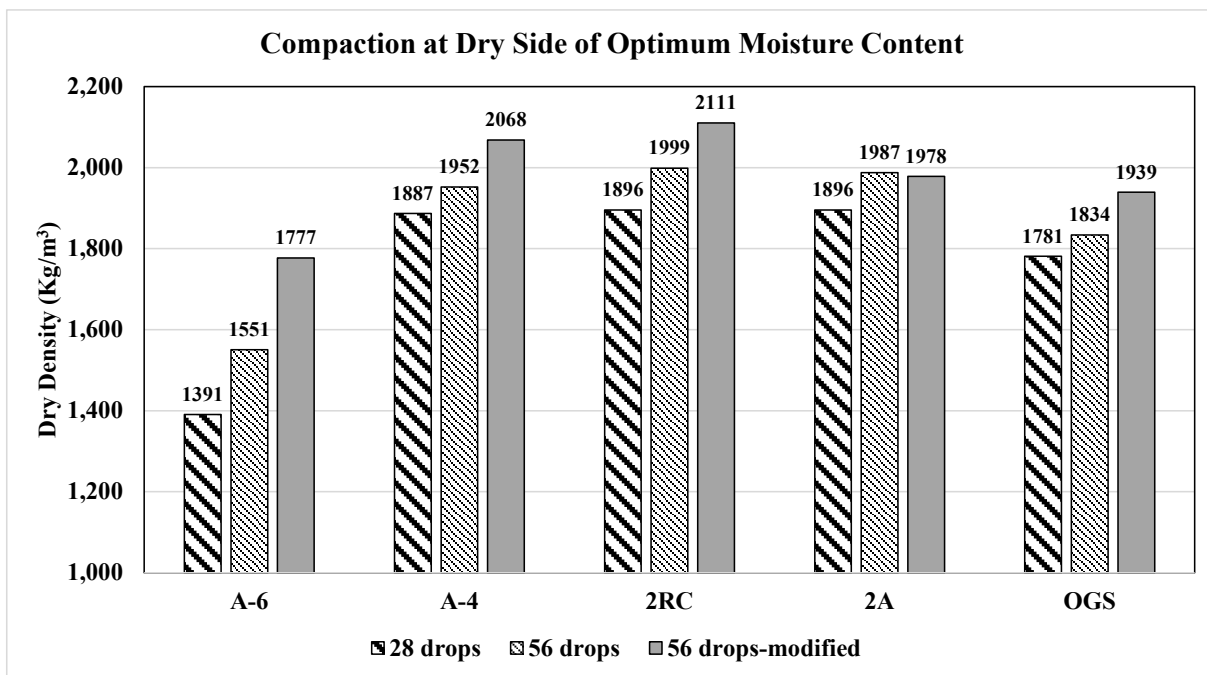


**Figure 56. Dry density and LWD modulus as a function of compaction level, soil A-6 at optimum moisture content.**

The effect of compaction level on the soil dry density and the LWD response in the Proctor mold and at different moisture contents is presented in a series of graphs (Figure 57 through Figure 62). The first three graphs present the density data and the last three show the modulus data. The data

are presented in the sequence of dry of optimum, optimum, and wet of optimum in terms of the moisture content. The soils in each graph are shown from the finest to the coarsest gradation, moving from left to right.

There are several important findings from the density data. As the soil becomes finer, the increase in density as a result of the increase in compaction level becomes more significant. For example, the A-6 soil tends to be more giving to the compaction increase compared to the 2A soil at the dry side and at optimum moisture contents (Figure 57 and Figure 58). However, as the moisture content increases to the wet side of optimum, the effect of compaction is less pronounced for all soils (Figure 59). Another observation is that, at the wet side of optimum, for A-6, 2RC, and 2A soils, changing the compaction level from the standard level to the modified level does not result in an increase in density. There is, however, some increase observed for the A-4 and OGS soils.



**Figure 57. Effect of compaction on dry density at dry side of optimum moisture content.**

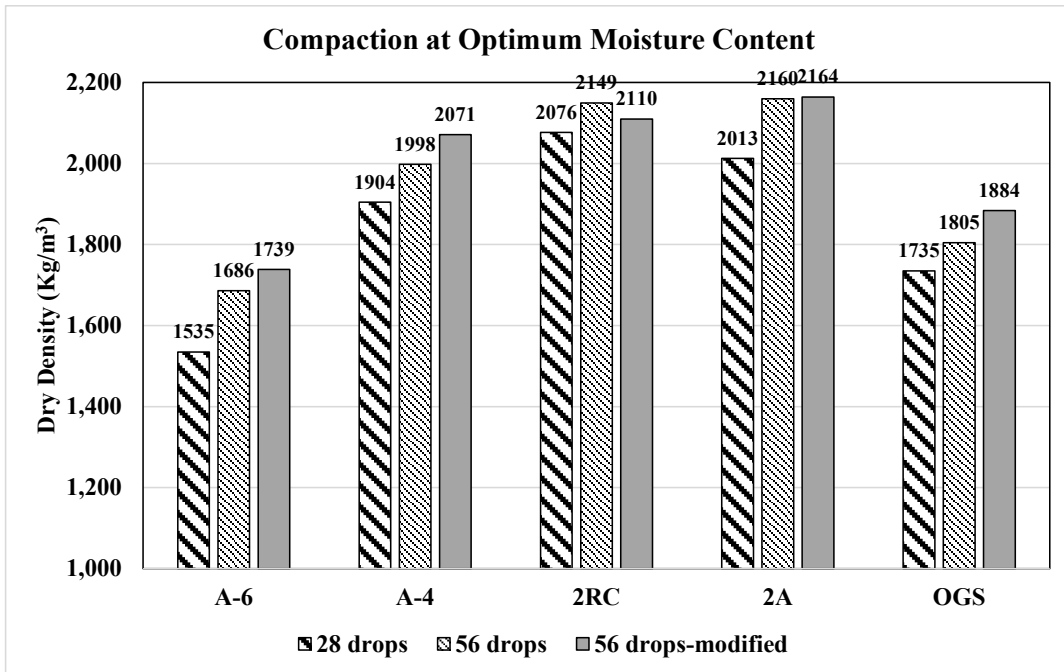


Figure 58. Effect of compaction on dry density at optimum moisture content.

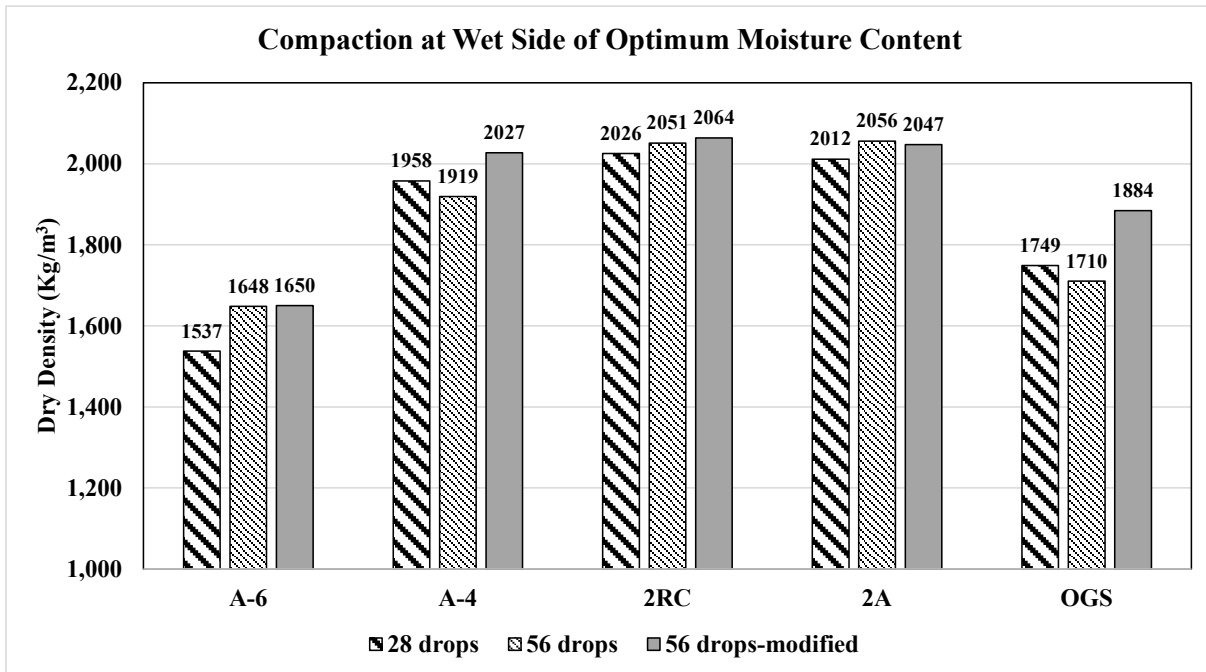
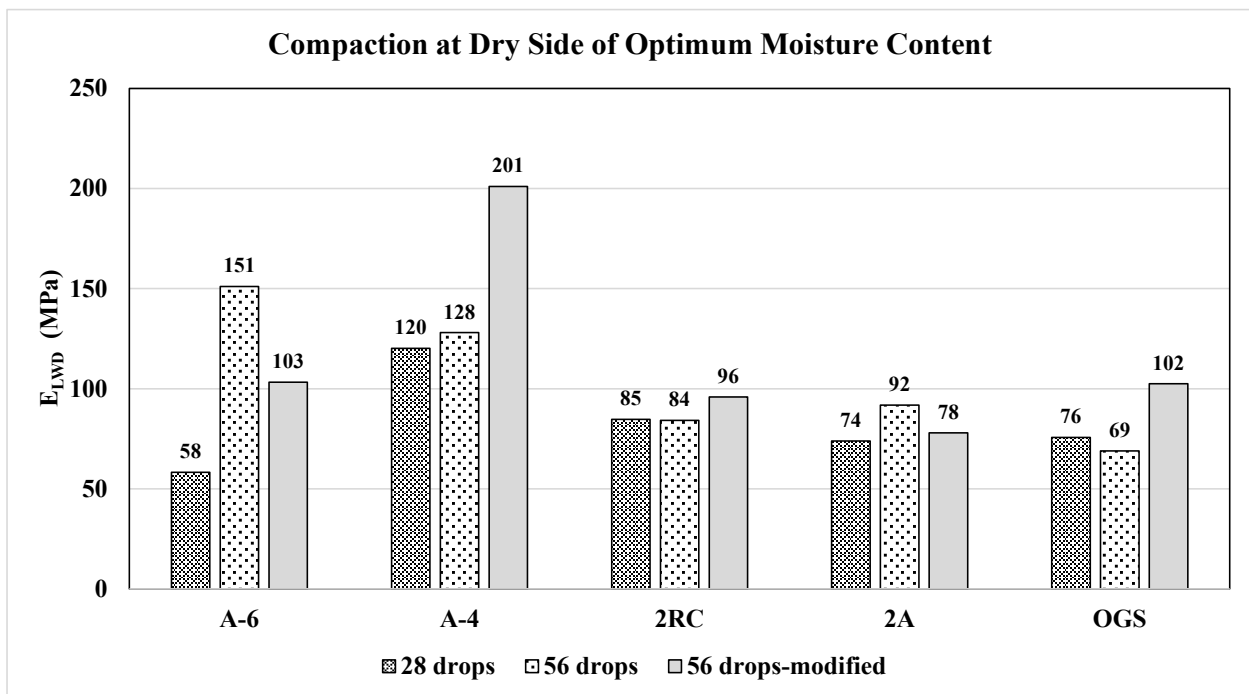


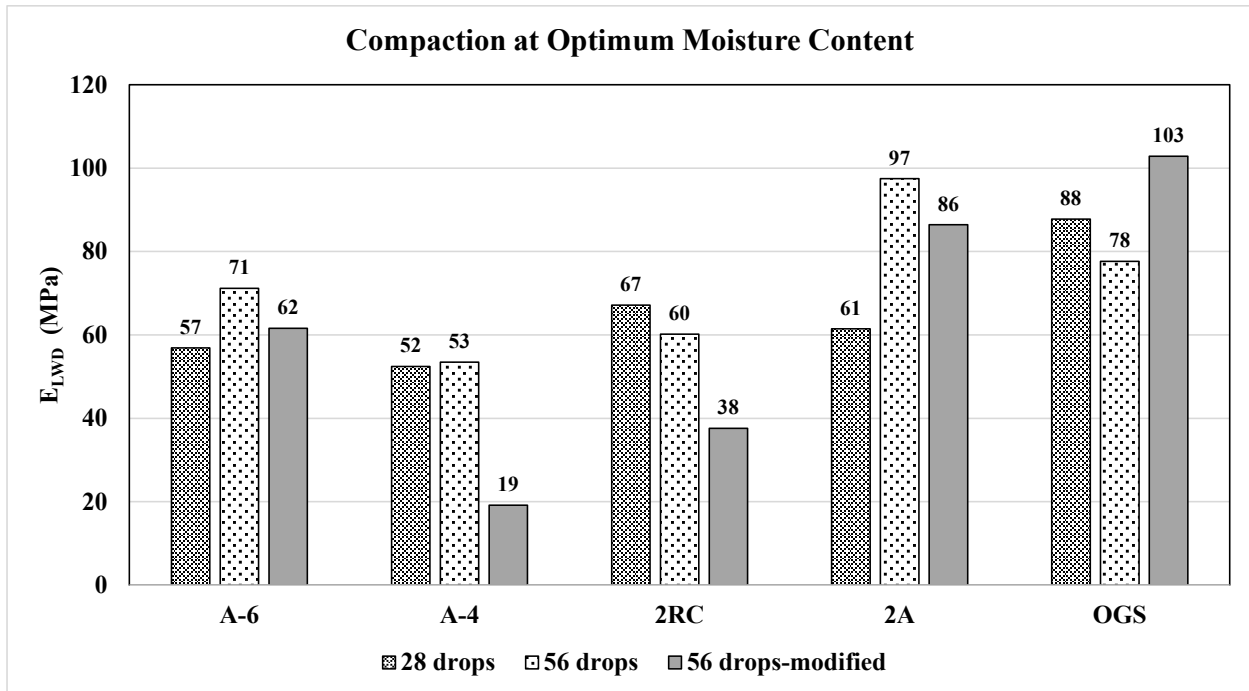
Figure 59. Effect of compaction on dry density at wet side of optimum moisture content.

The trend observed in the change of dry density as a function of compaction level is not followed in the LWD modulus or deflection data (Figure 60, Figure 61, Figure 62). For example, one

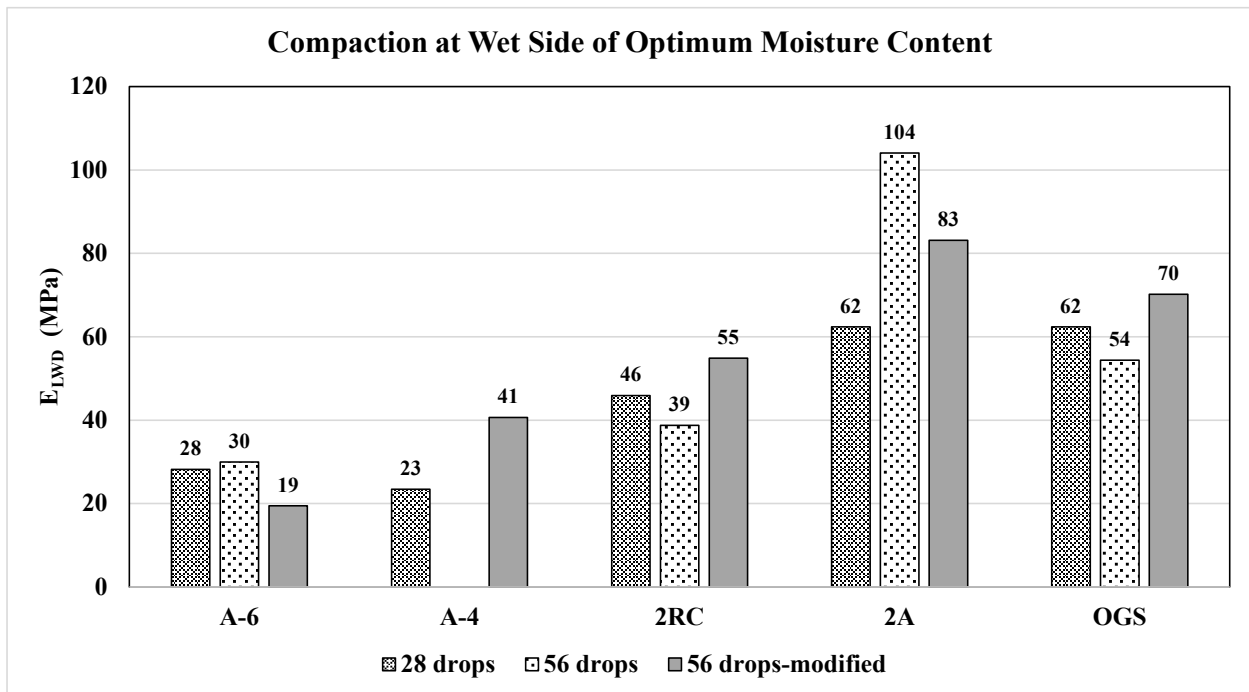
can see that, at the dry side of the optimum, the A-6 soil yields the highest modulus at the optimum moisture content, whereas the highest density was achieved at the level of modified compaction. Similar conclusions can be drawn at optimum and wet of optimum moisture contents. In general, the findings revealed that under dry conditions, all compaction levels resulted in the lowest deflection, indicating the highest modulus. Both low and standard compaction levels produced nearly similar moduli. Note should be made that for the A-6 soil, the value of 57 MPa for modulus at 28 drops and at optimum moisture content is driven from interpolation between 18 and 37 drops, as presented previously. Other data points in the figures are the result of direct measurement.



**Figure 60. Effect of compaction on the soil LWD modulus at dry side of optimum moisture content.**

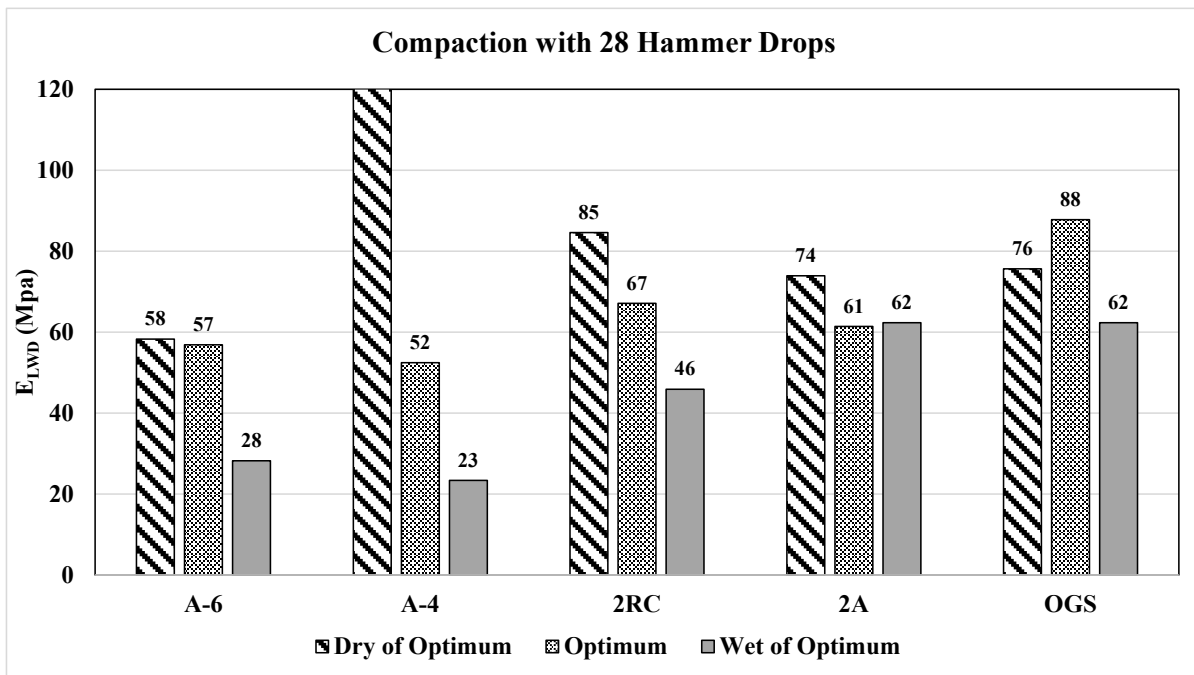


**Figure 61. Effect of compaction on the soil LWD modulus at optimum moisture content.**



**Figure 62. Effect of compaction on the soil LWD modulus at wet side of optimum moisture content.**

Plots in Figures 63, 64, and 65 are provided for better understanding the importance of the moisture content impact on the LWD response in the Proctor mold. It can be seen that as the soil is drier, the modulus is higher regardless of the fact that lower density is achieved at drier conditions. This is an extremely important observation in terms of interpreting the LWD data and using those data to assess the compaction quality. These results show that moisture content significantly impacts the results, and one cannot use the LWD response data from the Proctor mold directly to decide on the quality of the pavement without properly considering the effect of the moisture.



**Figure 63. Effect of moisture content on the soil LWD modulus at low compaction level.**

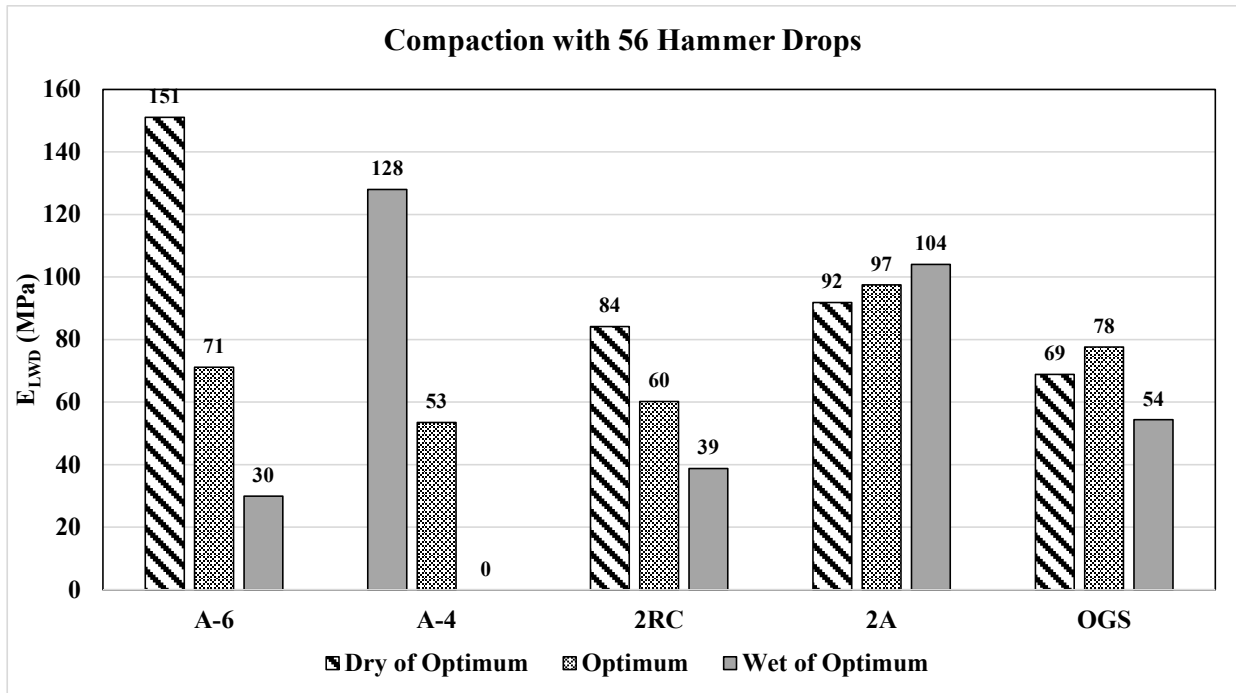


Figure 64. Effect of moisture content on the soil LWD modulus at standard compaction level.

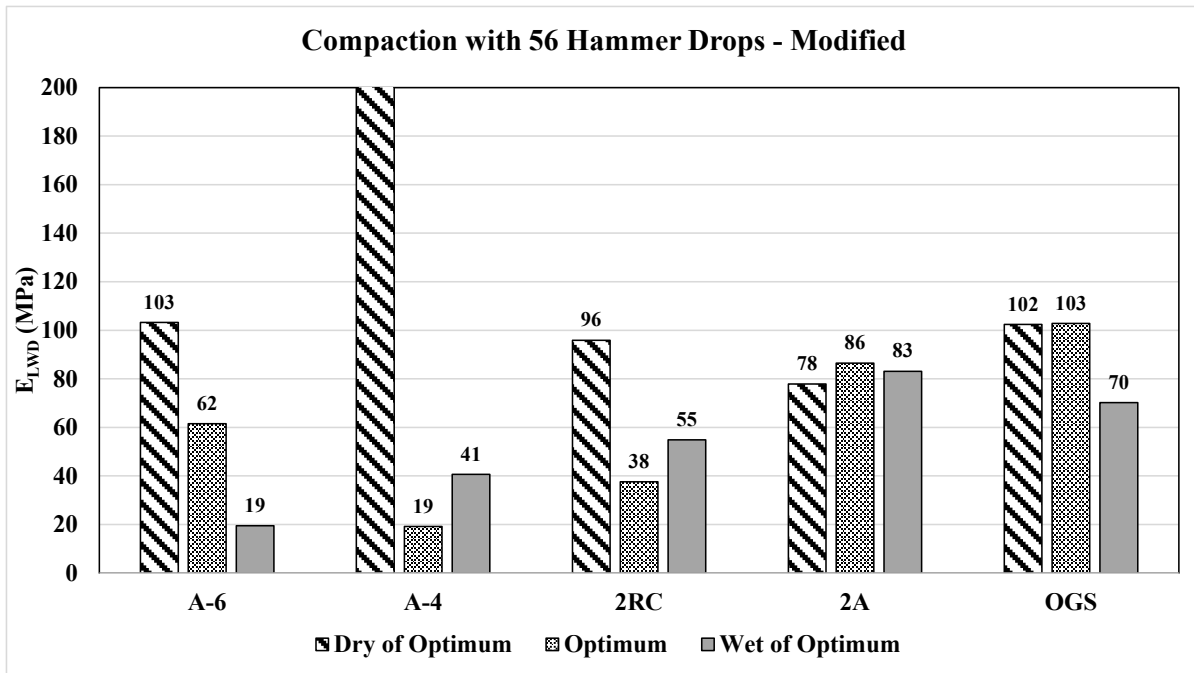


Figure 65. Effect of moisture content on the soil LWD modulus at high compaction level.

### **Effect of Change in Moisture Content on LWD Response at a Single Density**

Previously, it was shown how the LWD response varies when the soil is compacted at different moisture contents and when tested at the moist condition. It was discussed that the LWD response is affected not only by the soil density but also by the moisture content. One should realize that the relation between LWD data and dry density data presented previously is convoluted because of the moisture effect. The density–water content interaction makes the case complicated with respect to data interpretation. This observation makes it important to find a way of separating the impact of density from that of moisture content on the stiffness measurement response.

One way of doing this is through compacting the soil at OMC and testing the same sample at different times, allowing reduction of the moisture through a drying process. To be able to do such an experiment, two replicate samples were compacted at OMC using the standard compaction. One sample was maintained for testing while the second sample was used at different time intervals for determination of the moisture content. Table 35 shows the times of testing and the moisture content for each case.

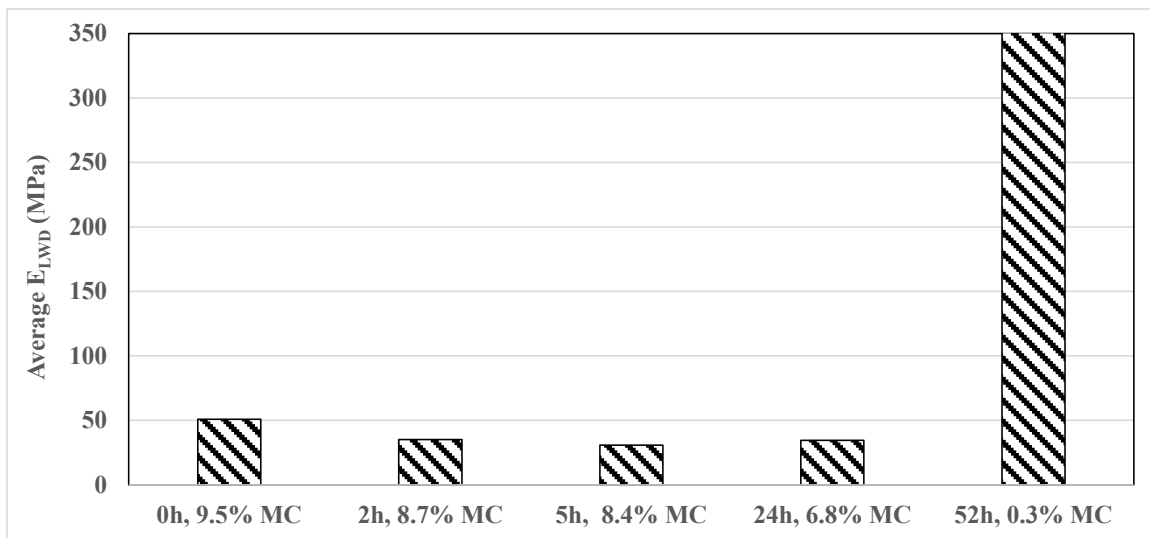
**Table 35. Change in Moisture Content with Time.**

<b>Time from preparation (hours)</b>	<b>Condition</b>	<b>Moisture Content (%)</b>
0	Wet at Optimum Moisture	9.5
2	Air Dried	8.7
5	Air Dried	8.4
24	Air Dried	6.8
52	Oven-dried overnight	0.3

The 2RC samples were compacted in a Proctor mold at approximately 9% moisture content, which was the targeted moisture content. For sample A, the LWD test was conducted immediately after compaction. For sample B, the soil was collected to obtain the initial moisture content immediately after compaction. Sample B was used to monitor moisture content throughout the test. After two hours, the LWD test was conducted again on sample A. At the same time, approximately one centimeter of soil was stripped from the top surface of sample B and discarded. Afterwards, a small portion of the remaining soil was collected for determination of moisture content. The process of LWD testing and taking moisture content samples was repeated three more times at time intervals shown in Table 35. At the completion of the last measurement at the 24-hr time period, the sample was placed in the oven and maintained there overnight. After 52 hours from the start of the test, the

LWD test was conducted again on the cooled oven-dried sample without removing it from the mold. Obviously, the moisture content gradually reduced over time. Initially at 9.5%, after oven drying the moisture content was extensively reduced, getting to only 0.3%.

Figure 66 shows the average modulus obtained from the last three drops of the LWD test at different drying times. The results indicate that the modulus right after compaction was around 50 MPa. There was some drop in the modulus as time passed. There is no clear explanation for this observation except perhaps the drop in the water content with time is accompanied by the moisture working on the fine soil and weakening it. Once the specimen was dried in the oven, the modulus increased significantly, as expected. It is well known that the fine dry soil is significantly stiffer and stronger than the wet soil.



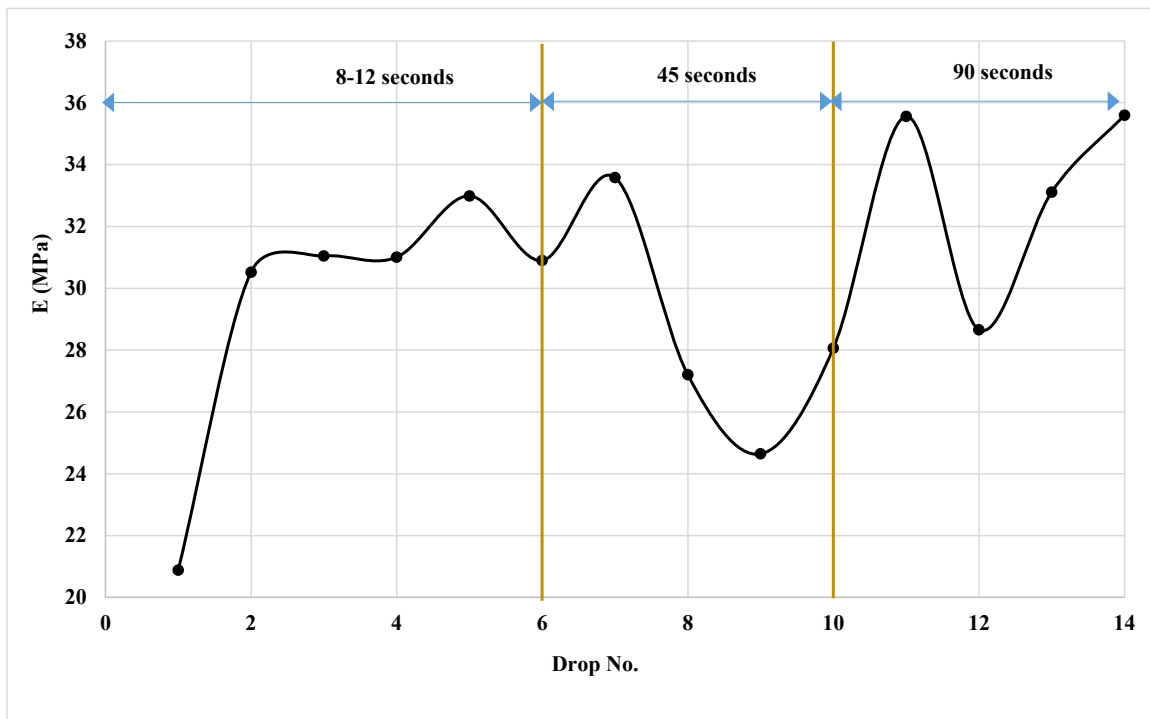
**Figure 66. The modulus of the 2RC soil tested at different times and moisture contents.**

### Sensitivity of LWD response to the LWD test parameters

#### Rest period between weight drops

In a typical LWD test, the weight is dropped six times, and the response is measured for each drop. In the testing conducted under this research, the time interval between two consecutive drops varied between 8 and 12 seconds. It is expected and assumed that this time interval is applicable to any operator of the device. However, one could intentionally wait longer between the weight drops, for example, to allow further stabilization of the soil before the next drop is applied.

It was decided to investigate how the response would be affected if this time interval is increased. The study was conducted on the 2RC material. Three time intervals were selected: typical (8 to 12 seconds), 45 seconds, and 90 seconds. The first six drops under normal process were followed by four drops after a 45-second wait and four drops after a 90-second wait. Hence, the response was recorded for 14 consecutive drops. The calculated modulus for each drop is presented as a function of the drops in Figure 67. The average modulus of the last three drops for these time intervals were 31.6, 26.6, and 32.5 MPa, respectively. Through a single-factor statistical analysis and including all 14 drops, it was found that there was no statistical difference between the three groups.

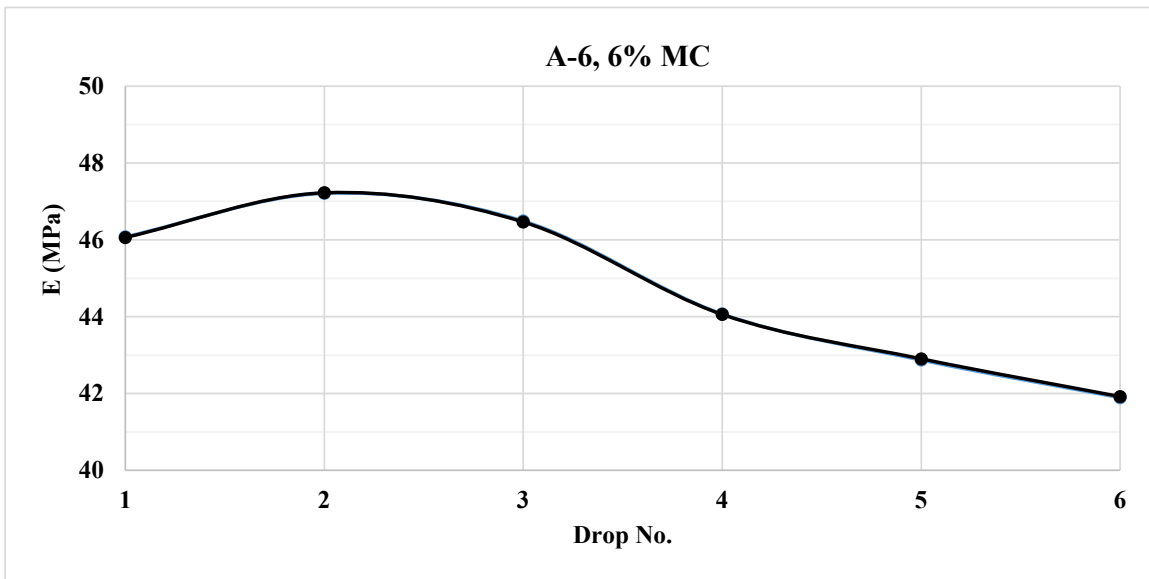


**Figure 67. Calculated modulus as a function of the drops at three times.**

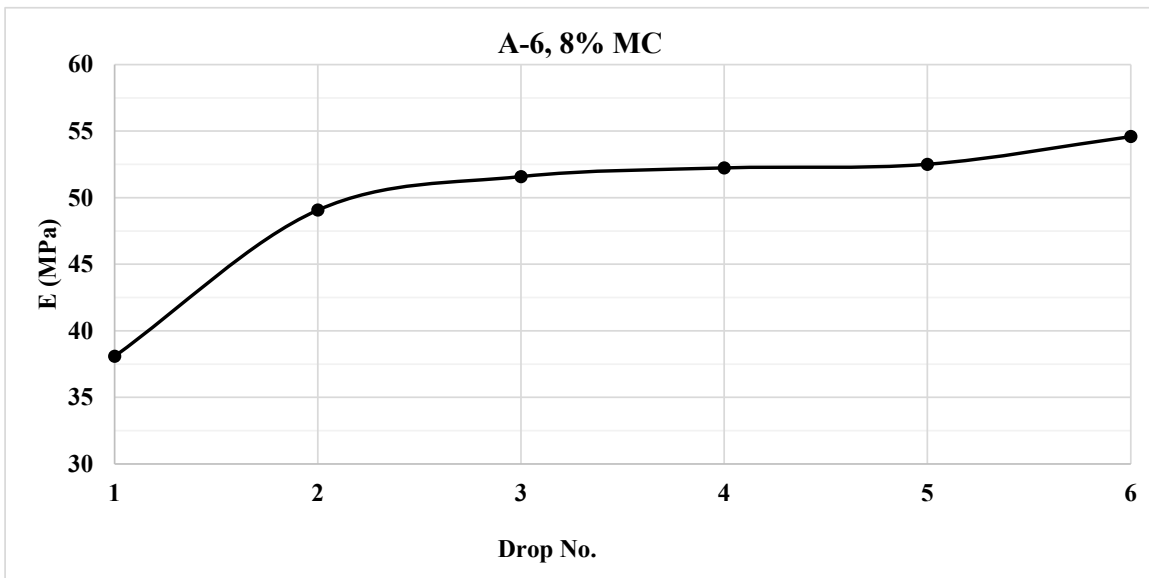
Effect of weight drop sequence on calculated modulus and deflection

The common practice is to apply six weight drops and use the average of the last three drops as the soil response to the LWD test. The first three drops are discarded to exclude any potential response that could be unreliable due to material not stabilized or seated well. It is presumed that the initial drops will assist with stabilizing the conditions for subsequent weight drops. A valid question, however, is how the response changes between the drops and how the response values compare between the average of the first three drops and the last three drops. Results of this investigation, at

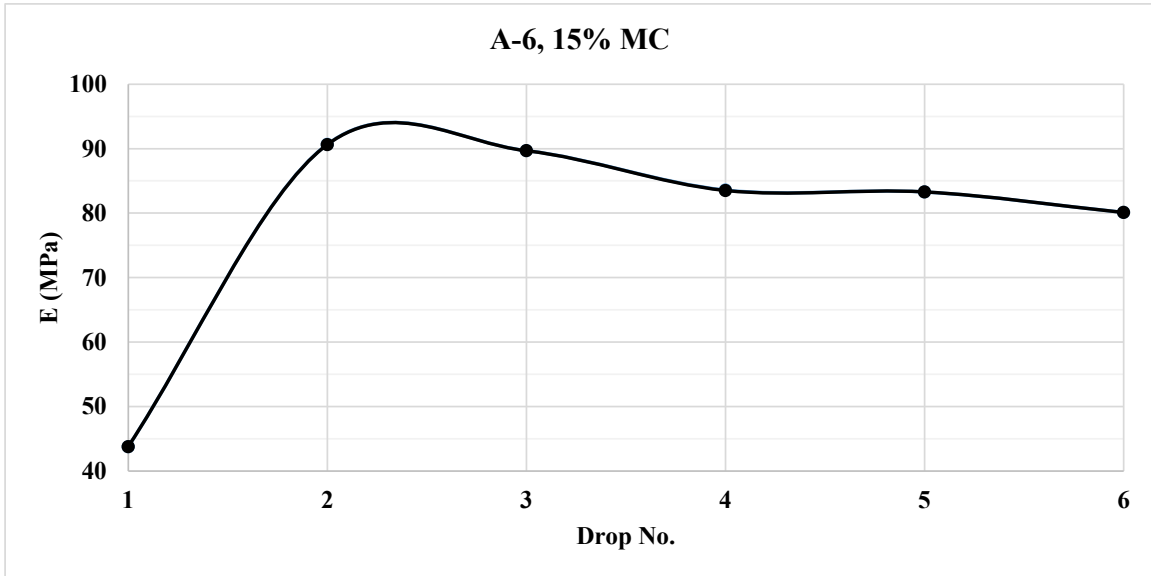
various moisture contents, are presented in Figure 68 through Figure 75 for two of the soils: A-6 and OGS. Similar trends are observed for the other materials researched in this project.



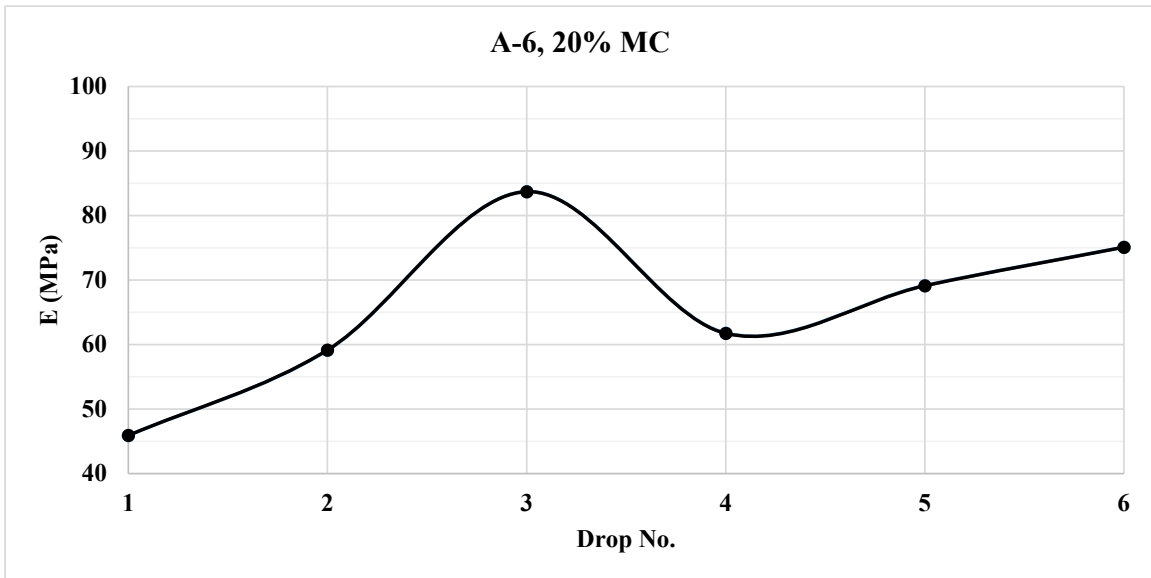
**Figure 68.** The response modulus of the A-6 soil as a function of the drops at 6% MC.



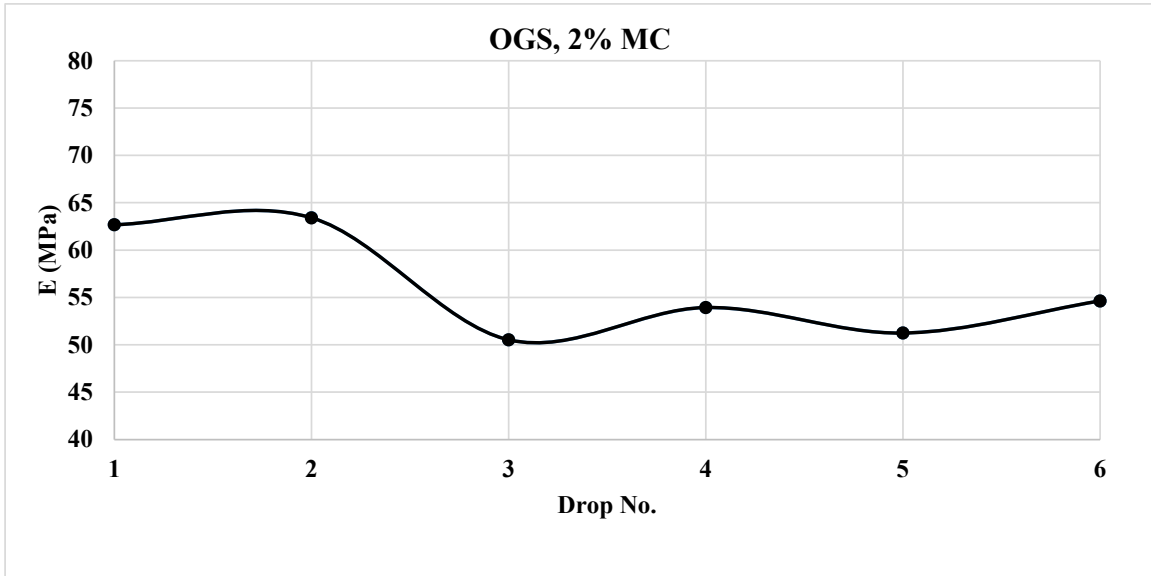
**Figure 69.** The response modulus of the A-6 soil as a function of the drops at 8% MC.



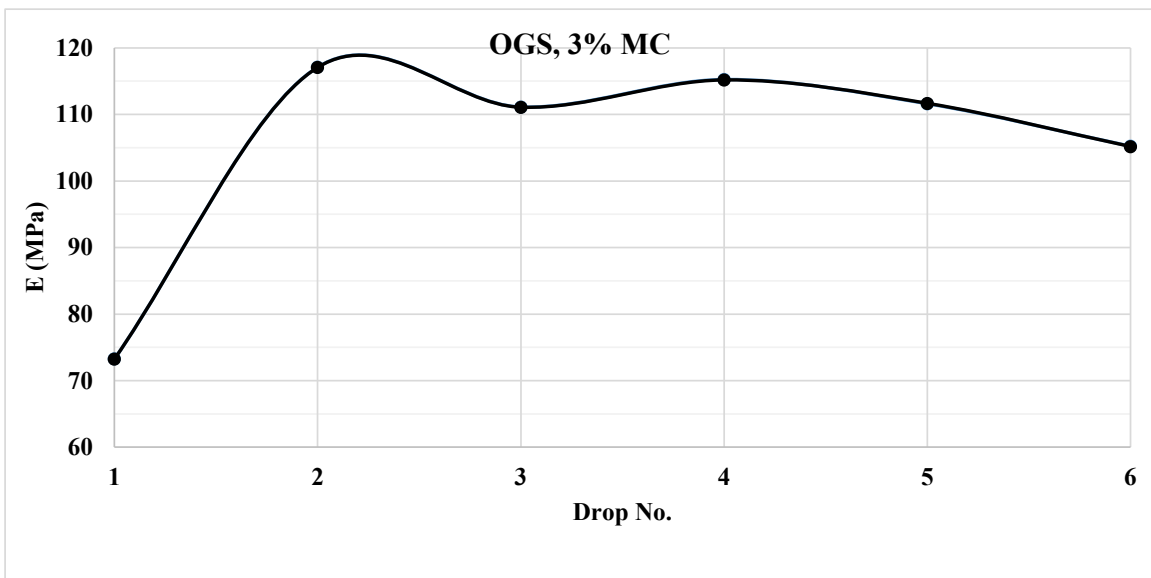
**Figure 70.** The response modulus of the A-6 soil as a function of the drops at 15% MC.



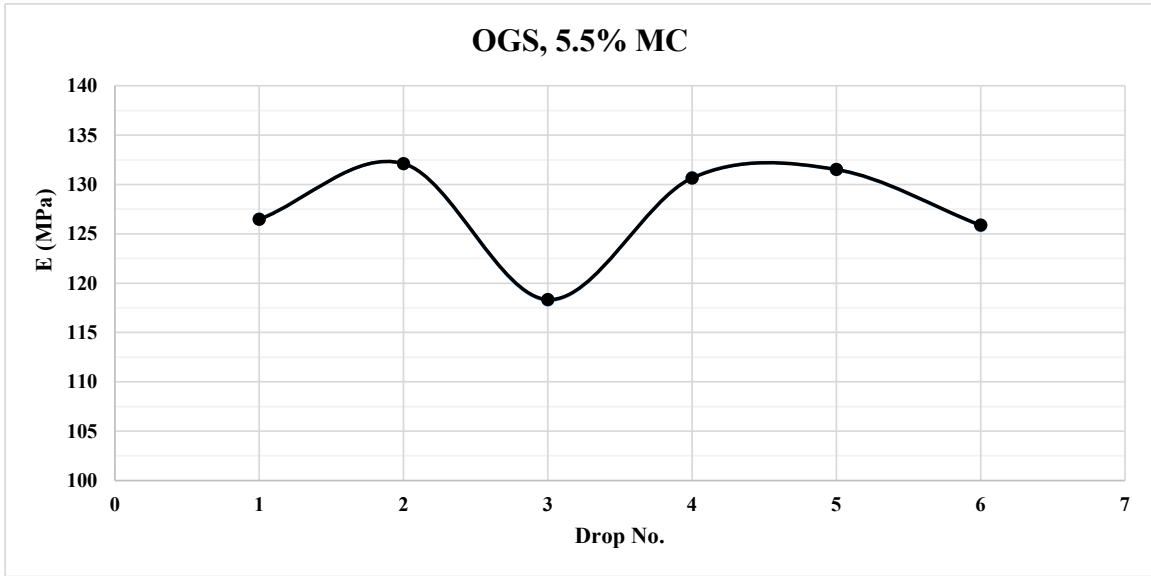
**Figure 71.** The response modulus of the A-6 soil as a function of the drops at 20% MC.



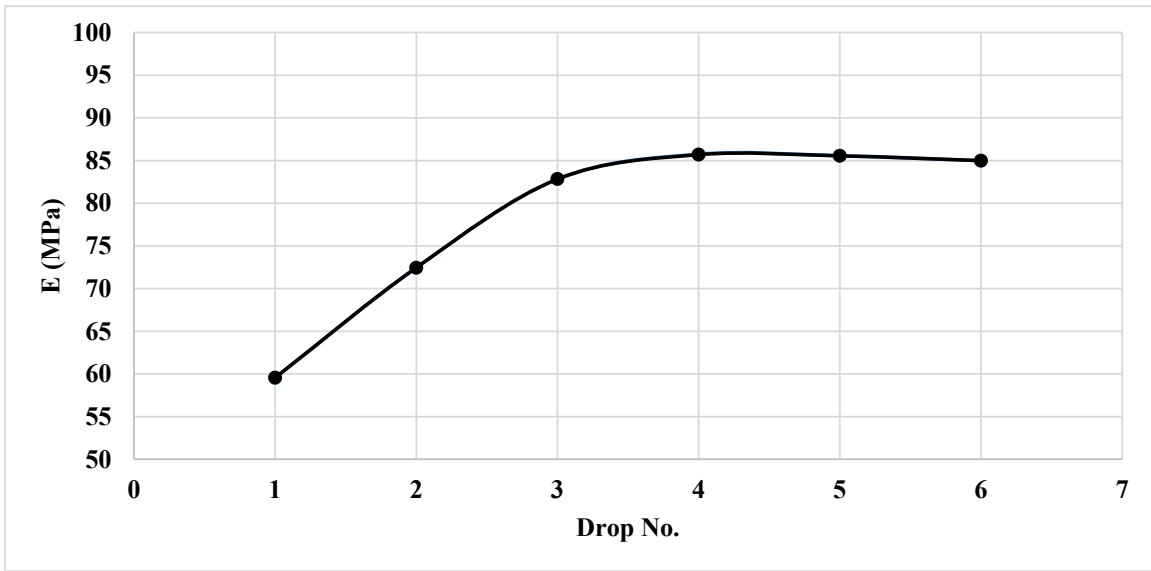
**Figure 72.** The response modulus of the OGS soil as a function of the drops at 2% MC.



**Figure 73.** The response modulus of the OGS soil as a function of the drops at 3% MC.



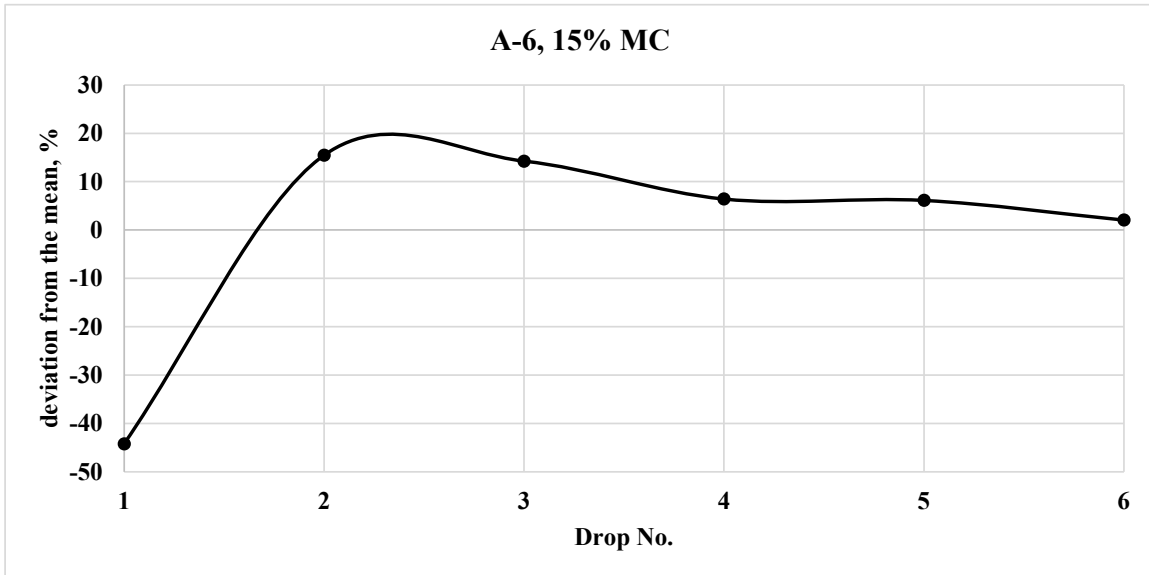
**Figure 74.** The response modulus of the OGS soil as a function of the drops at 5.5% MC.



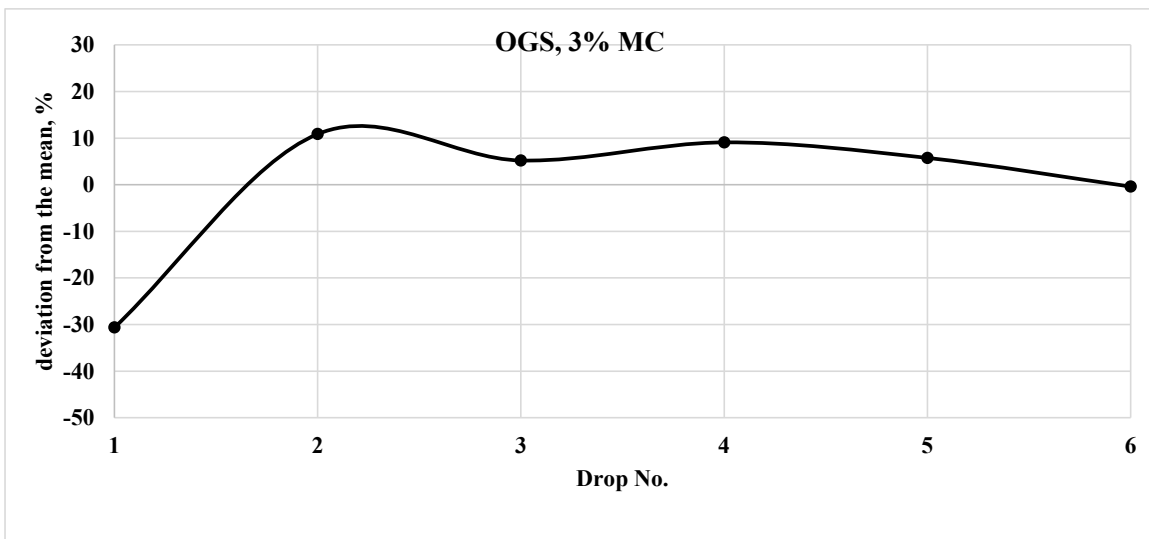
**Figure 75.** The response modulus of the OGS soil as a function of the drops at 9% MC.

One can see that, in general, the last three drops have a considerably lower variation compared to the first three drops, with the only exception being soil A-6 at 6% moisture content. This fact is better depicted through normalizing the difference between each drop response and the overall average. For example, for the A-6 soil at 6% MC, the overall mean modulus for all six drops is 44.8 MPa. The first drop yields a value of 46.1 MPa; the deviation of this value from the mean, as a percent

of the mean, is 2.9%. Through this process, it can clearly be seen that the data variability for the last three drops is by far smaller than that observed for the first three drops. Two examples are presented in Figure 76 and Figure 77.



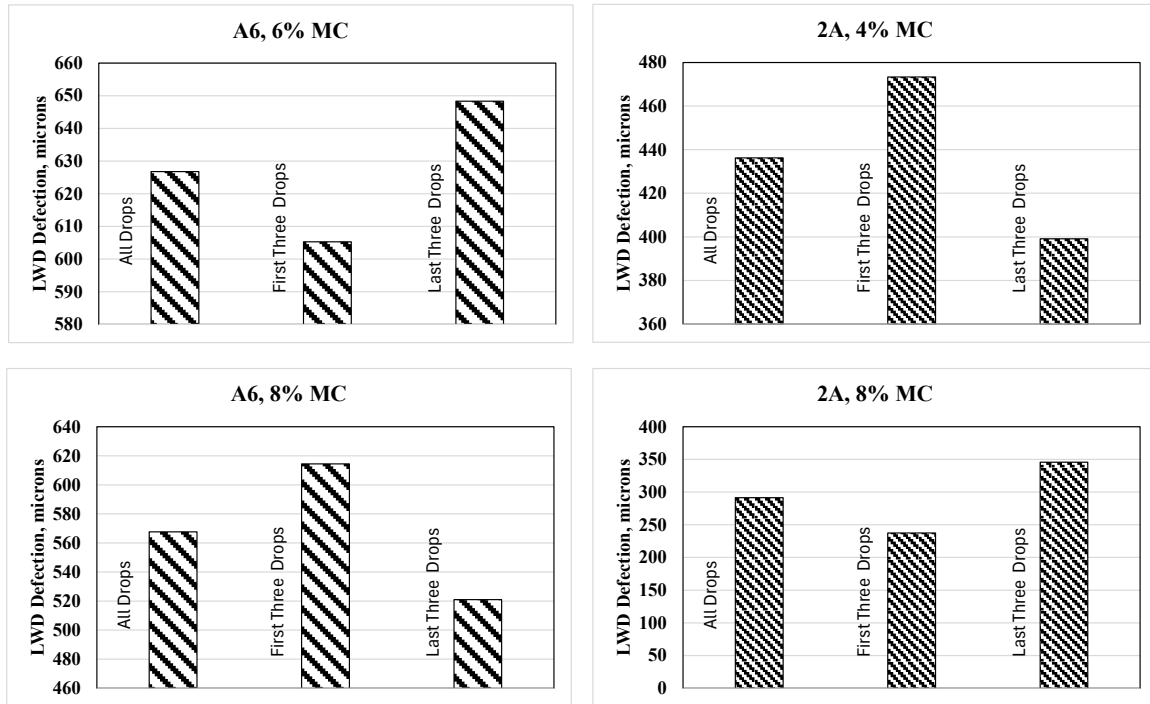
**Figure 76.** The deviation of modulus value of the A-6 soil as a function of the drops at 15% MC.



**Figure 77.** The deviation of modulus value of the OGS soil as a function of the drops at 3% MC.

Lastly, the question that remains is how the average response from the first three drops compares with that of the last three drops. To answer this question, several examples are presented in

the form of bar charts (Figure 78). It can be seen that no clear pattern is observed, as in some cases the former is larger than the latter and sometimes the opposite trend is observed. However, as data variability is higher for the first three drops (as shown previously), including the first three drops in the average would decrease the overall stability of the data.



**Figure 78. LWD deflection average response for the first three drops and the last three drops.**

## Effect of the Underlying Support

### Experimental Results

There are two major factors influencing the LWD response when the test is conducted on a specific soil. One is the thickness of the layer to be tested and the other is the stiffness of the layer underlying the test soil. Regarding the former, as the surface soil layer becomes thicker, the influence of the underlying layer is reduced. The depth of influence of LWD is considered to be in the range of 1.5 to 2 times the LWD plate diameter. As the plate diameter used is 150 mm ( $\approx$  6 inches), the depth affected by the impact weight will be roughly in the range of 225 to 300 mm. The height of the material tested in the Proctor mold is almost 115 mm, and the mold is sitting on a concrete floor. Considering the depth of influence, it is expected that the response will be influenced by the concrete floor. Regarding the latter (impact of the stiffness of the underlying support), the expectation is that a stiffer support provides a more suitable foundation and lowers the surface deflection under the LWD weight impact.

To investigate the effect of the underlying support material, a mold was obtained with a diameter of 200 mm and a height of almost 213 mm. This mold is deeper and wider than the typical Proctor mold. The bottom portion of the mold was used to prepare different types of support conditions, and the top portion was used to compact the test soil. The support thickness was selected at roughly 100 mm to accommodate a thickness of roughly 113 mm for the topsoil, i.e., a height of material close to what was used in the experiment with the standard 150-mm Proctor mold. Two types of wood support, basswood, and birch, as well as a steel support were used for this investigation. Once the support was in place, the test soil was poured into the mold in three layers and compacted using a modified Proctor hammer, with 112 drops for each layer. After compaction, the LWD test was conducted.

The engineering properties of the support layers were not directly determined through this research. Rather, reference was made to the existing literature to draw the required properties. Basswood is softer than birch and provides a weaker support. Basswood has a modulus of elasticity in the proximity of 10,000 MPa ( $\approx 1.5 \times 10^6$  psi) at 12% moisture level, while birchwood's modulus is around 15,000 MPa ( $\approx 2.2 \times 10^6$  psi). Both are much softer than steel, which has a modulus of elasticity of 200,000 MPa ( $29 \times 10^6$  psi). The effect of the support stiffness on density is clearly seen in Figure 79. It can be seen that the soil on a stiffer support can be compacted better and delivers higher density compared to the soil on a softer support. However, this logical observation on density did not manifest itself in the LWD response. The LWD test results are presented in Figure 80. The reader is referred to a preceding discussion on the impact of density/moisture content, where it was shown that for some of the materials including 2RC, it appears that there is the effect of the moisture delivering a lower modulus at a higher moisture content, even if the density is increased. Here, the situation is not exactly as discussed previously, as the moisture content is the same for all three support conditions. However, the moisture is there, and it does impact the LWD response, and it is possible that it results in higher deflection when density is higher. This is an observation for which a definite clear answer is not yet available and that requires further investigation.

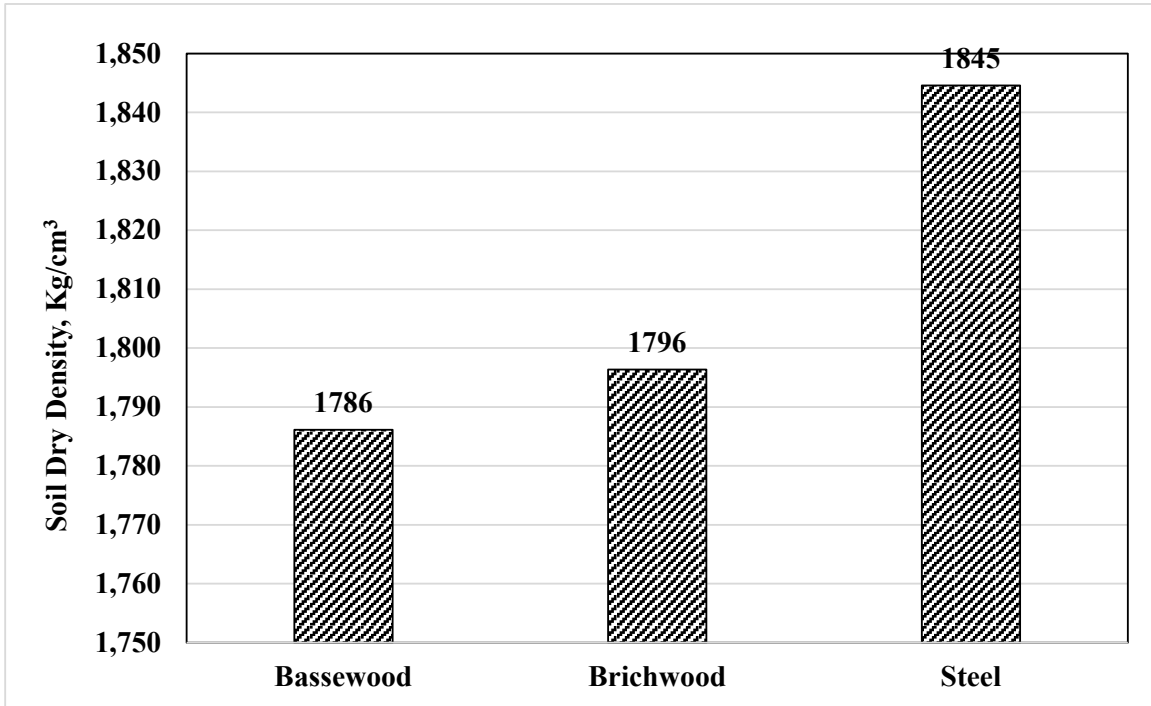


Figure 79. Soil dry density on different support layers.

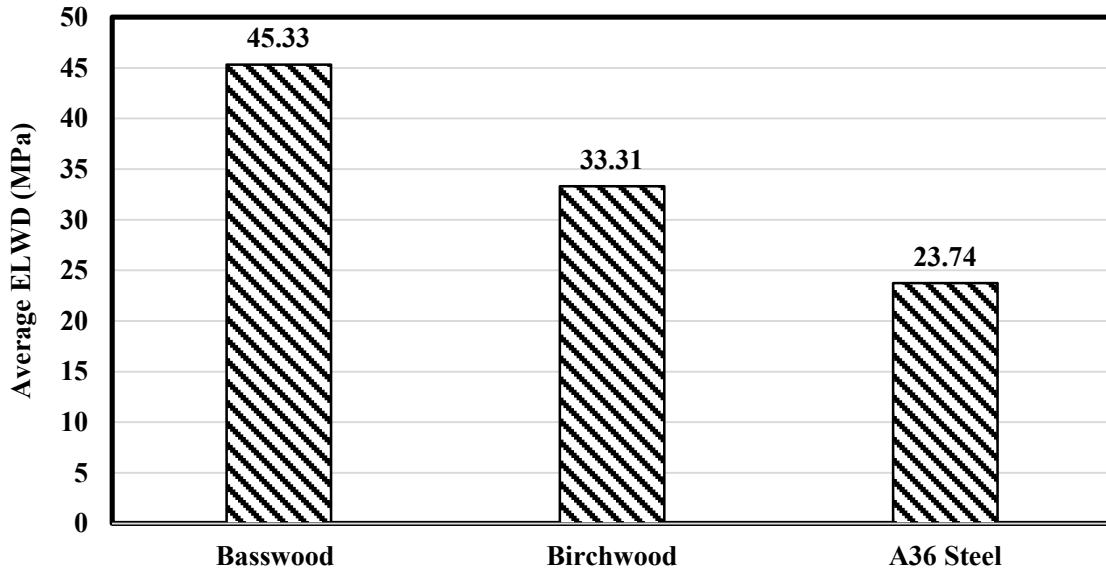


Figure 80. Average LWD tested moduli on different support layers.

Computational Results

For better understanding of the support effect on deflection in the Proctor mold, modified Boussinesq formula was used to calculate the deflections of different support layer combinations. A homogenous

elastic multilayered system was assumed. To account for the finite thickness  $h$  of the upper layer in a multi-layer system, the deflection  $\delta$  can be calculated using the following formula:

$$w(r) = \frac{(1-\nu^2) \cdot P \cdot h}{E \cdot \pi \cdot r} \quad \text{Eq. (12)}$$

Where:

$r$  is the radial distance from the center of the load.

$P$  is the applied concentrated load.

$E$  is the elastic modulus of the material.

$\nu$  is the Poisson's ratio of the material.

$h$  is the thickness of the soil layer.

The deflection due to a uniformly distributed load was calculated by breaking it down into many small, concentrated loads and integrating the effect of each small load. This provides the total deflection under a uniformly distributed load using the following formula:

$$\delta_1 = \frac{2(1-\nu_1^2)P}{\pi E_1} \int_0^\infty \left( \frac{1}{r} \left( 1 - \exp \left( -\frac{2hr}{a^2} \right) \right) \right) dr \quad \text{Eq. (13)}$$

where:

$a$  is the radius of the uniformly distributed load.

$x$  is the integration variable, representing the radial distance from the load center to  $a$ .

The calculation results are shown in Figure 81. Deflections were calculated for five different combinations of soil layers, including: a granular soil layer on a concrete support layer, a single soil layer, a granular soil layer on a soil support layer, double granular soil layers on a soil support layer, and a soil layer with double granular soil layers on a soil support layer. Here are the parameters:

Granular Soil Parameters:

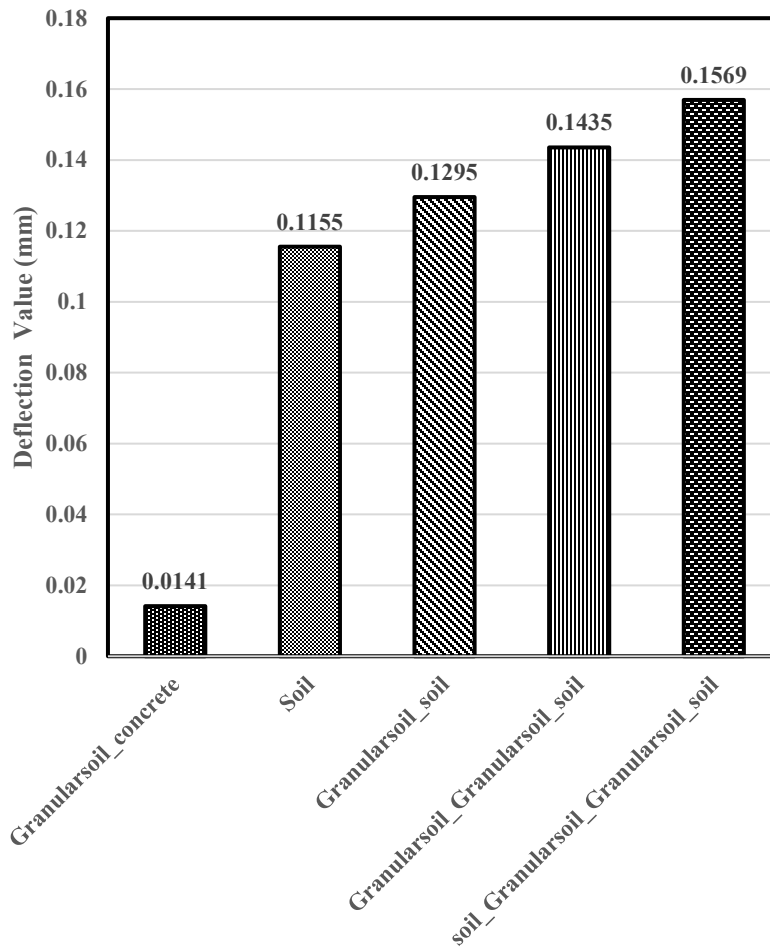
- Layer Thickness: 0.116 m
- Elastic Modulus ( $E_{\text{soil1}}$ ): 30 MPa
- Poisson's Ratio: 0.35

Concrete Layer Parameters:

- Elastic Modulus: 30 GPa
- Poisson's Ratio: 0.2

Fine Soil Layer Parameters:

- Thickness: 0.45 m
- Elastic Modulus: 30 MPa
- Poisson's Ratio: 0.40

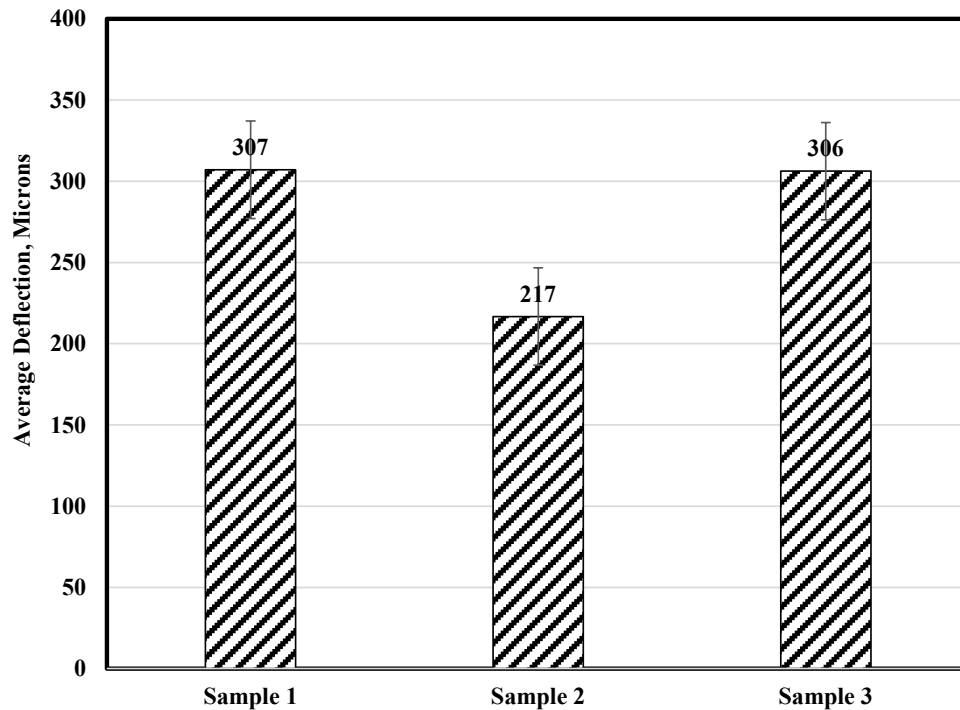


**Figure 81. Calculated Deflection on different support layers.**

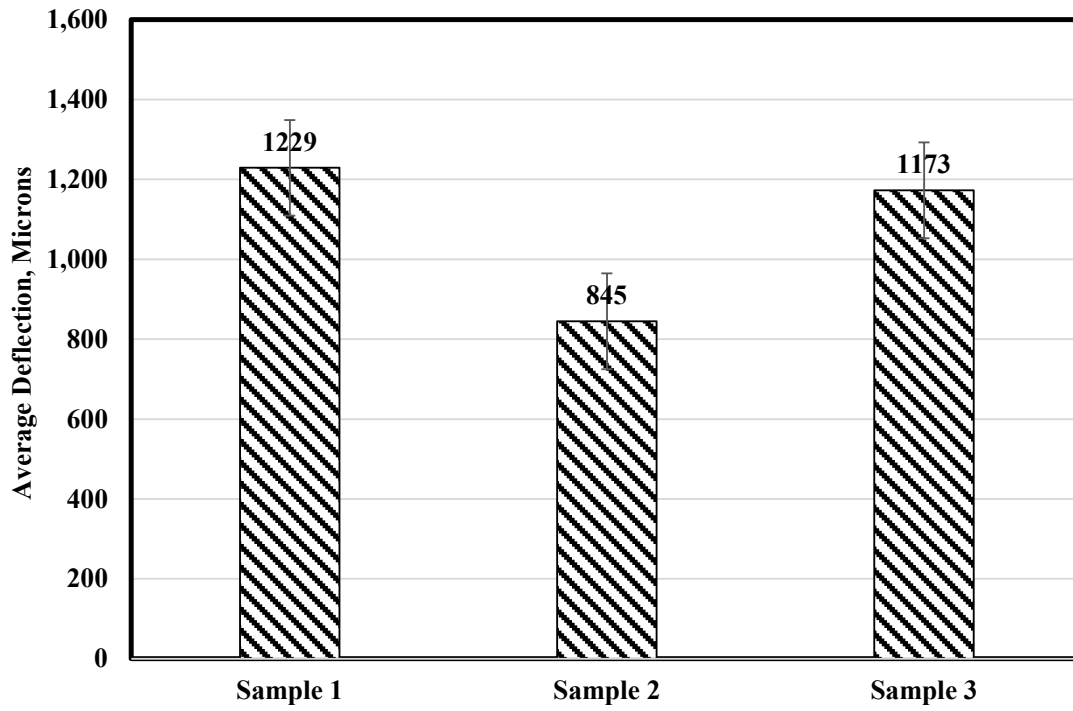
It can be seen that different support layers produce significant differences. For instance, the results for granular soil on concrete and on soil are 0.014 and 0.115 mm (14 and 115 microns), respectively, showing a difference of nearly 8 times. For instance, in the case of 2A-8%MC, the average of the last three drops in field testing was 504 microns, compared to 82 microns in the laboratory—roughly a sixfold difference. The consistency with the computed results is observed.

Repeatability of the LWD test using the Proctor mold

An important factor in any standard test protocol regards the test repeatability. At this point, there is a precision statement on the test repeatability stated in AASHTO T 99 and T 180, but there is no precision statement regarding the LWD response when used with the Proctor mold with either of these two standards. To establish the precision of a test method, standard protocols such as ASTM E691 must be followed, and that is beyond the scope of this research. However, a limited study was undertaken to determine the variability in LWD response when used with the Proctor mold. As such, three replicates were made for 2RC and 2A aggregates and the results of LWD testing, in terms of deflection, are presented in Figure 82 and Figure 83. One can see that for both cases, while two of the replicates produced very close results, one replicate produced a significantly different output. The difference is also statistically significant based on one-factor analysis of variance. Several factors play a role in causing such variability. The inherent variability in the materials, the variability of the material in terms of distribution in the mold, the insufficient accuracy of the compaction process, and the variability associated with the LWD test itself, all contribute to the outcome. This finding must be considered when interpreting the test results.



**Figure 82. Average deflection of Proctor mold samples for 2RC aggregate.**



*Figure 83. Average deflection of Proctor mold samples for 2A aggregate.*

## **DATA FROM LARGE-SCALE LABORATORY TESTS**

Details of the setup for the large-scale laboratory test were discussed previously. In brief, materials 2RC and 2A were selected for the study. Each was prepared and compacted at three moisture contents, bracketing the optimum moisture content to the extent possible. For each soil, material was placed and compacted in three layers. LWD and DCP tests were conducted at three spots for each prepared test section and for each layer of the test section. The data collected from this experiment are discussed in this section.

### **Variation in Soil Moisture Content in the Test Pit**

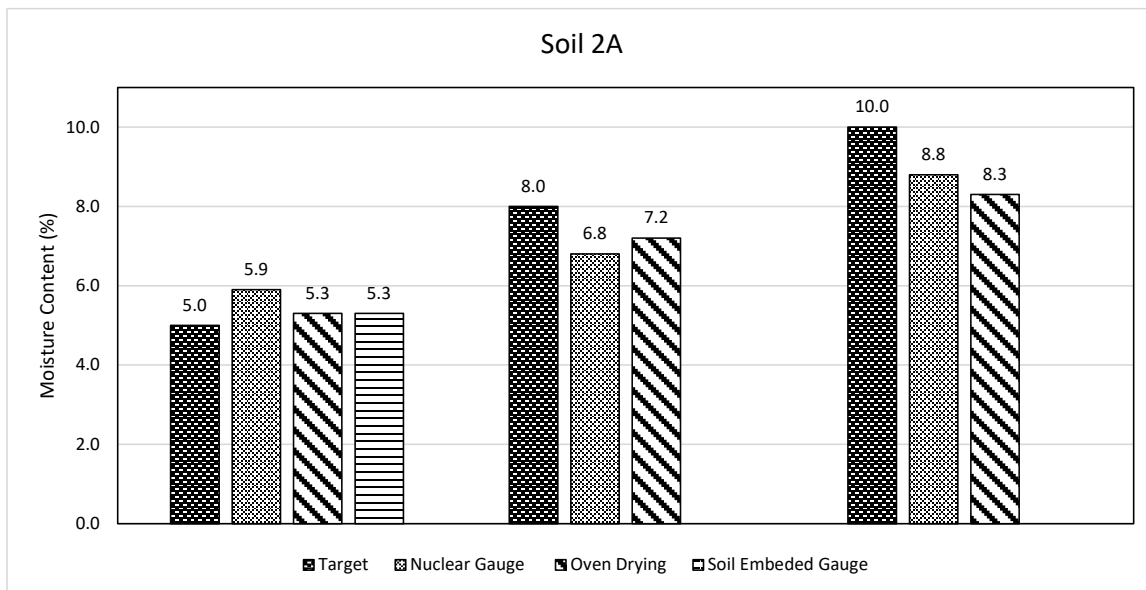
The plan for testing the soils 2RC and 2A in the pit was to include the moisture content at three levels to the extent possible: dry side of optimum, optimum, and wet side of optimum. Because of the water loss during the placement, compaction, and testing of the moist soil in the pit, it was expected that the final moisture content would deviate from the target moisture content. The actual water content was measured through three different methods: from the nuclear gauge, from the moisture gauges embedded in the soil, and through the traditional technique of oven drying the soil sample obtained at the pit.

The results are presented in Table 36, Figure 84, and Figure 85. It can be seen that regardless of the method used, the measured moisture content is generally lower than the target moisture content. This water loss is caused by several factors, including evaporation during the steps of the experimental process (such as mixing and placement). The exception is the low moisture content of 2A material, for which the measured values are higher than the target value. This increase could be the result of using a higher moisture content to begin with.

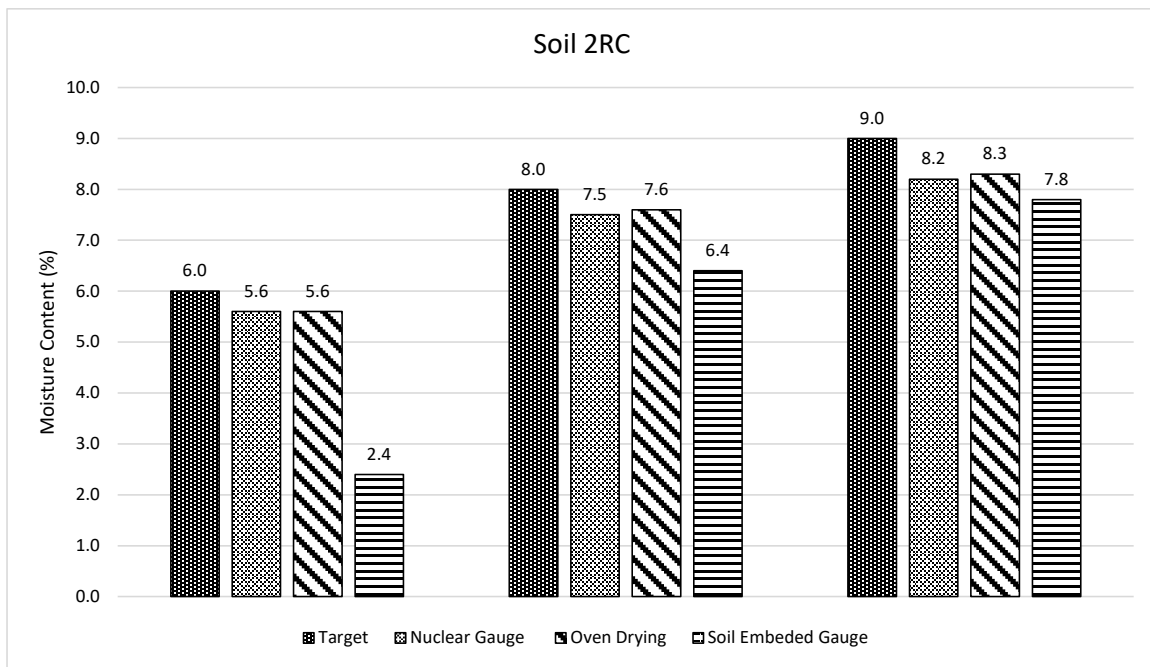
In general, the three methods provide comparable results with the exception of the embedded gauge for 2RC soil, where clearly the measured value of 2.4% is an outlier. It is not clear what may have caused such a low measurement. One possible explanation could be poor installation of the moisture gauge in the test pit, or non-uniformity of the soil moisture content at the vicinity of the gauge.

**Table 36. Comparison of moisture content using different measurement methods.**

Soil	Nuclear Tested Moisture Content (%)	Gauge Moisture Content (%)	Sand Tested Moisture Content (%)	Cone Moisture Content (%)	Moisture Gauge Tested Moisture Content (%)	Target moisture content (%)
2A	5.9		5.3		5.3	5.0
	6.8		7.2		N/A	8.0
	8.8		8.3		N/A	10.0
2RC	5.6		5.6		2.4	6.0
	7.5		7.6		6.4	8.0
	8.2		8.3		7.8	9.0



**Figure 84. Comparison of moisture content using different measurement methods for 2A**

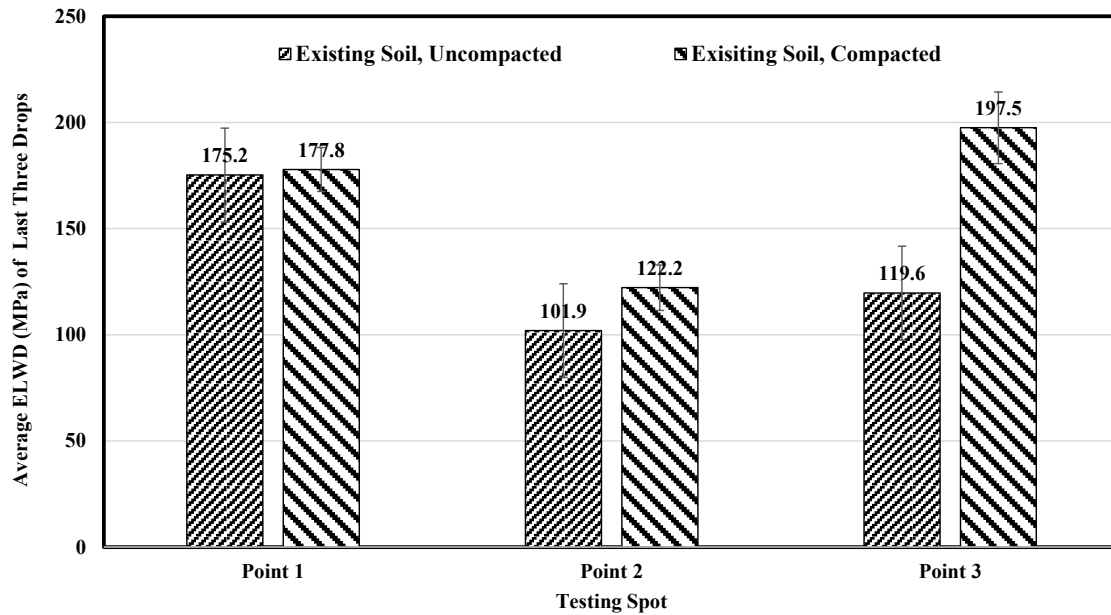


**Figure 85. Comparison of moisture content using different measurement methods for 2RC.**

## LWD Response Data

### Existing Subgrade

It is important to discuss the stiffness of the existing subgrade before discussing the results from testing of the candidate soils, as the response of the test soil is affected by the stiffness of the subgrade. The existing subgrade is a fine-sized material that has been classified as silt with sand (ML) based on Unified Soil classification (USCS) and A-4(4) based on the AASHTO M 145 specification (Tang, 2011). The soil has been densified through time, delivering a very hard layer. The soil modulus based on the LWD test is in the range of 102 to 175 MPa before compaction and in the range of 122 to 197 MPa after compaction with a plate compactor. The results are obtained assuming a Poisson's ratio of 0.35 (see Figure 86).



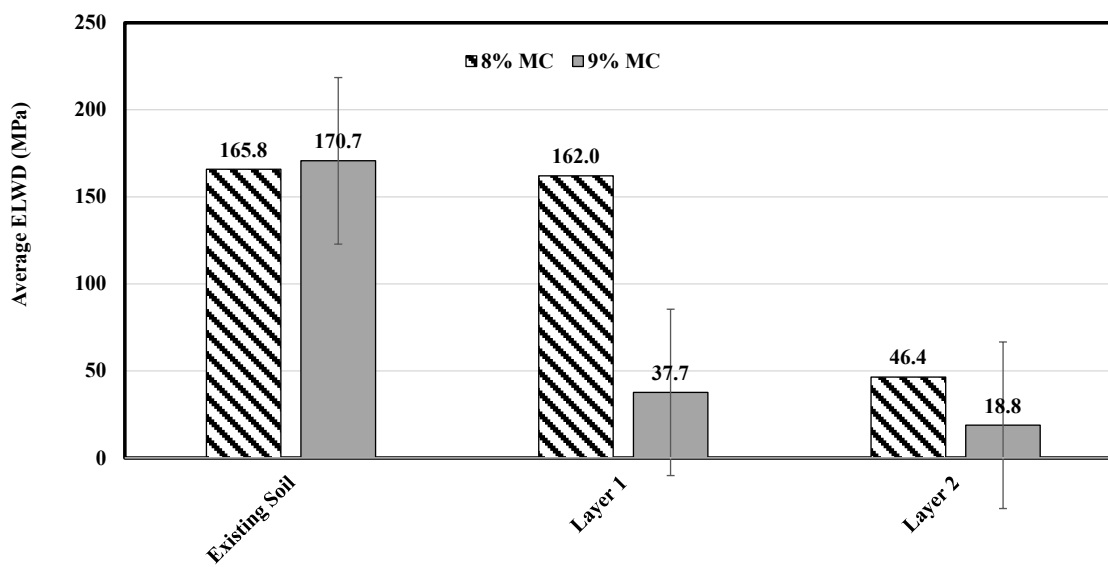
**Figure 86. The LWD testing modulus of the existing soil and compacted soil.**

Placement, Compaction, and Testing 2RC Material (Plate Compacted)

The 2RC material was placed, compacted, and tested at three moisture contents of 6%, 8%, and 9% on different dates. The experiment with 8% and 9% moisture content was repeated twice. In the first attempt, compaction of the soil was achieved using the plate compactor. In the subsequent attempt, compaction was done with the roller compactor. The 45.7 cm (18-inch) thick soil was placed in three 15.2 cm (6-inch) layers. LWD and DCP tests were conducted on each layer.

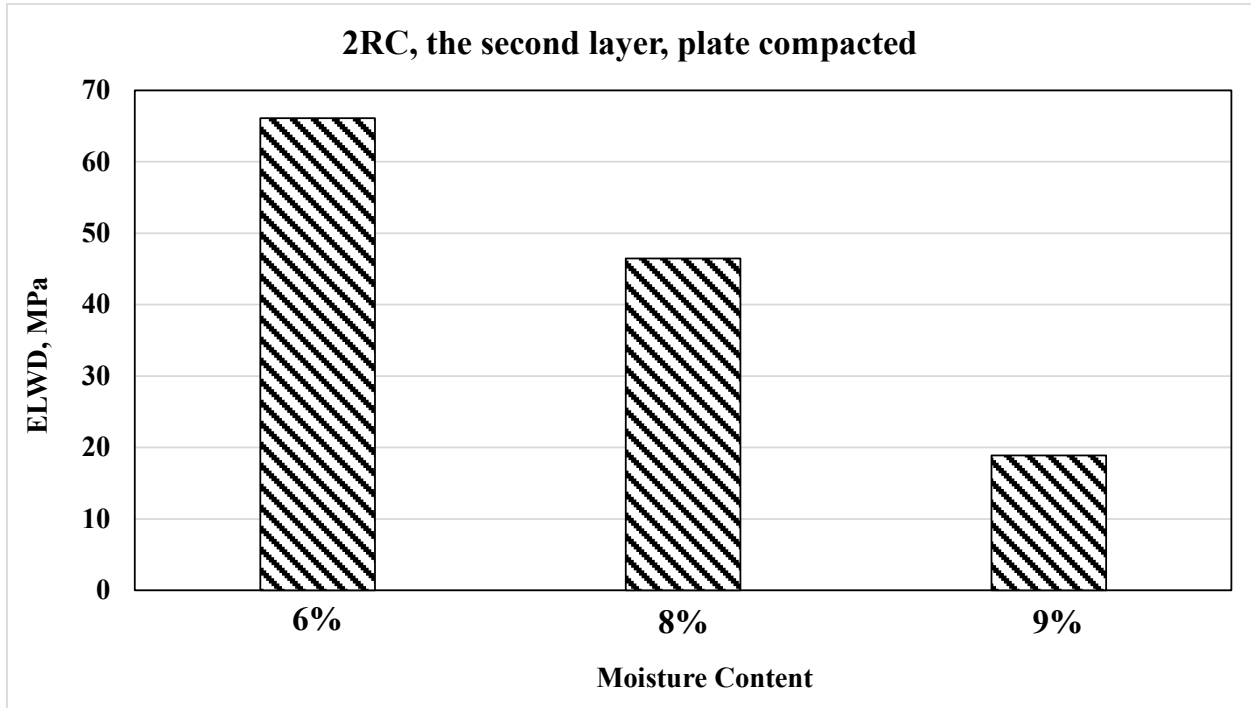
Results for the first attempt (compaction with a plate compactor) clearly indicate the impact of the hard existing subgrade. One can see from Figure 87 that the first layer delivers a significantly higher modulus compared with the second layer. The LWD response for the first layer is heavily affected by the hard ground. In fact, the recorded modulus for the first 15.2 cm (6-inch) compacted layer, as presented in the figure, is not truly representative of this layer’s modulus; rather, it is representative of the combined modulus from both the existing ground and the first compacted layer. As the surface of the soil to be tested gets further away from the hard existing soil, the influence is reduced.

### 2RC, Plate Compaction of All Layers



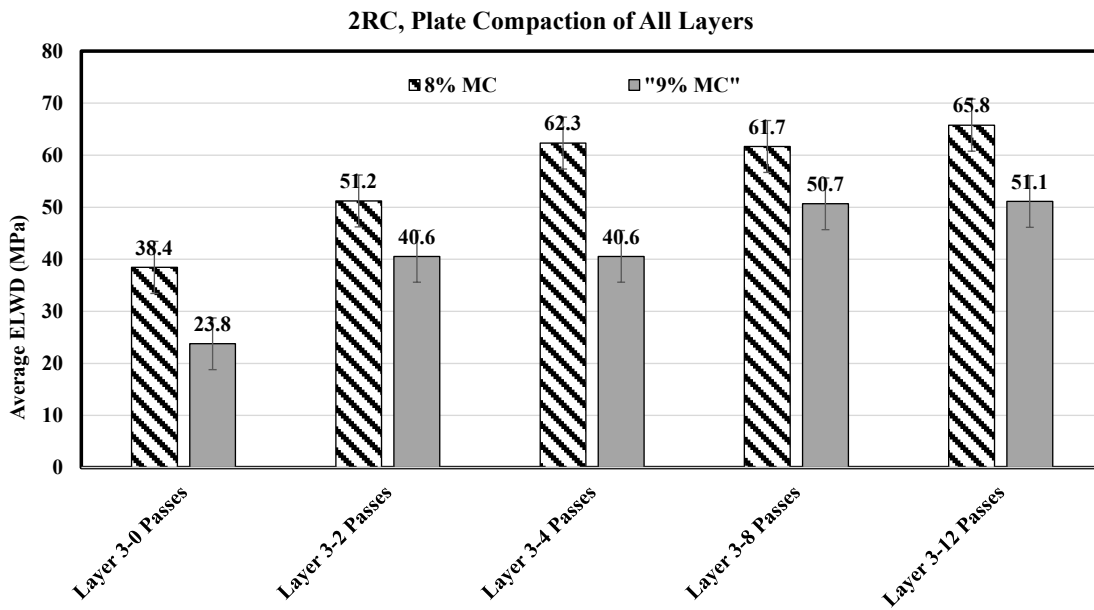
**Figure 87. LWD modulus of the existing soil and the 2RC soil.**

It is also worth exploring the impact of the moisture content on the modulus of the second layer after compaction with the plate compactor (see Figure 88). The first layer is not discussed here because of the impact of the existing soil. For the second layer, one can see that as the moisture content increases, the modulus consistently decreases.



**Figure 88. LWD modulus of the 2RC soil with different MCs.**

Finally, Figure 89 shows how more densification of the third layer, as a result of more compaction with the plate compactor, increases the material stiffness. This trend is observed for both moisture contents.



**Figure 89. LWD modulus of the top layer at different compaction levels (plate compacted).**

## Placement, Compaction and Testing 2RC Material (Roller Compactor)

### LWD Test Results

Data for the 2RC material when compacted under the plate compactor were previously discussed for both 8% and 9% moisture content. For the 2RC material, a second experiment was conducted using the roller compactor for the top layer for both of these moisture contents. The top 15.2 cm (6-inch) layer was removed from the previous experiment and was replaced with a new layer that was compacted using the roller compactor. The final experiment for the 2RC material included compaction at the dry side of the optimum moisture content (6%).

The response as a function of the passes for the top 15.2 cm (6-inch) layer is presented in Figure 90. Increase in the modulus is generally observed for all moisture contents as the number of roller passes increases. The highest modulus is achieved for the 9% moisture content and at both 4 and 8 passes. Recall that the optimum moisture content using standard Proctor compaction was established at 9.5% moisture. For this experiment, a 9% moisture content was targeted as the highest amount to be used for this experiment, as higher contents appeared too wet for the pit construction. The actual moisture content as measured at the end of the experiment was about 8.3% compared to the target content of 9%. The other two moisture contents were targeted at 6 and 8 percent, but by the end of the experiment the actual measured values were 5.6 and 7.5 percent. Therefore, one can see that as the moisture content increases, it takes a smaller number of passes to achieve the highest modulus at that specific moisture content. For example, the two lower moisture contents delivered the highest value maximum number of passes (i.e., 12 passes), whereas the highest moisture content delivered the highest modulus after 4 passes.

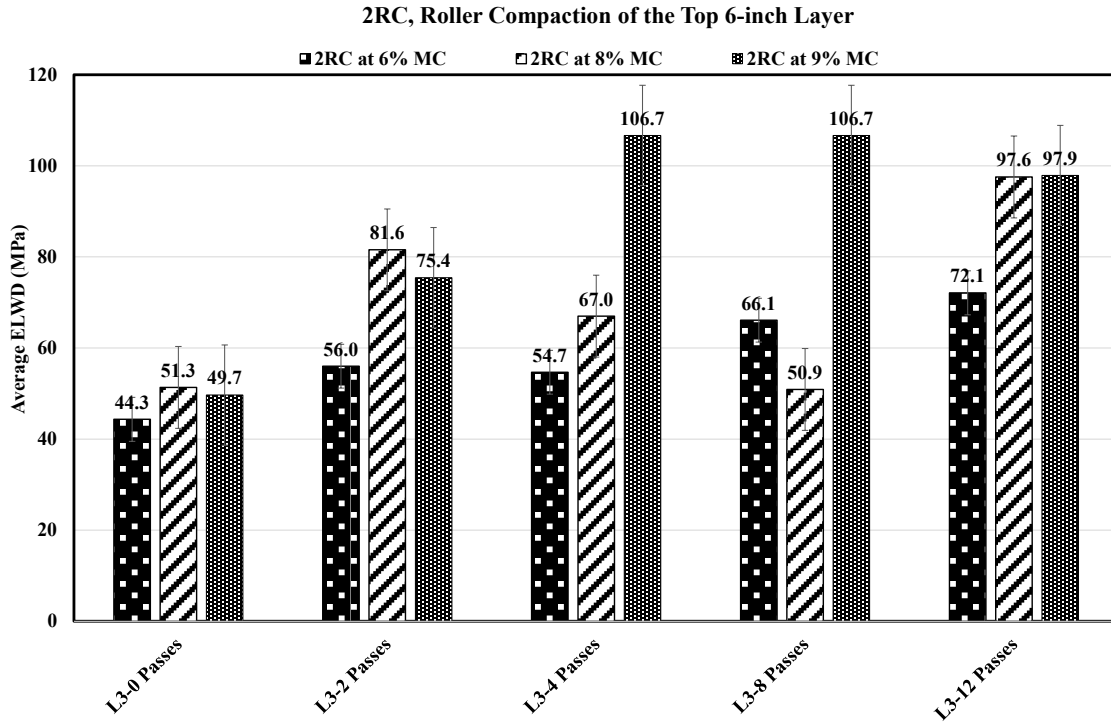


Figure 90. LWD modulus of the top layer at different compaction levels (roller compacted).

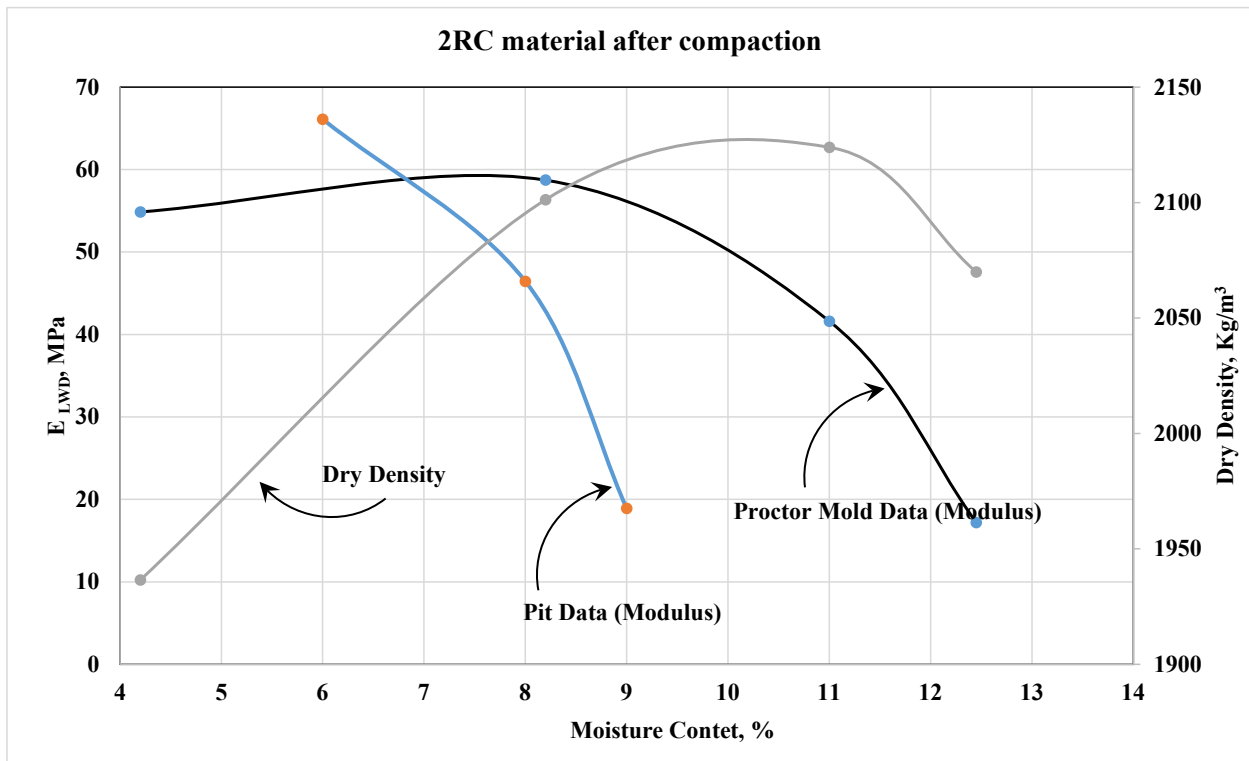
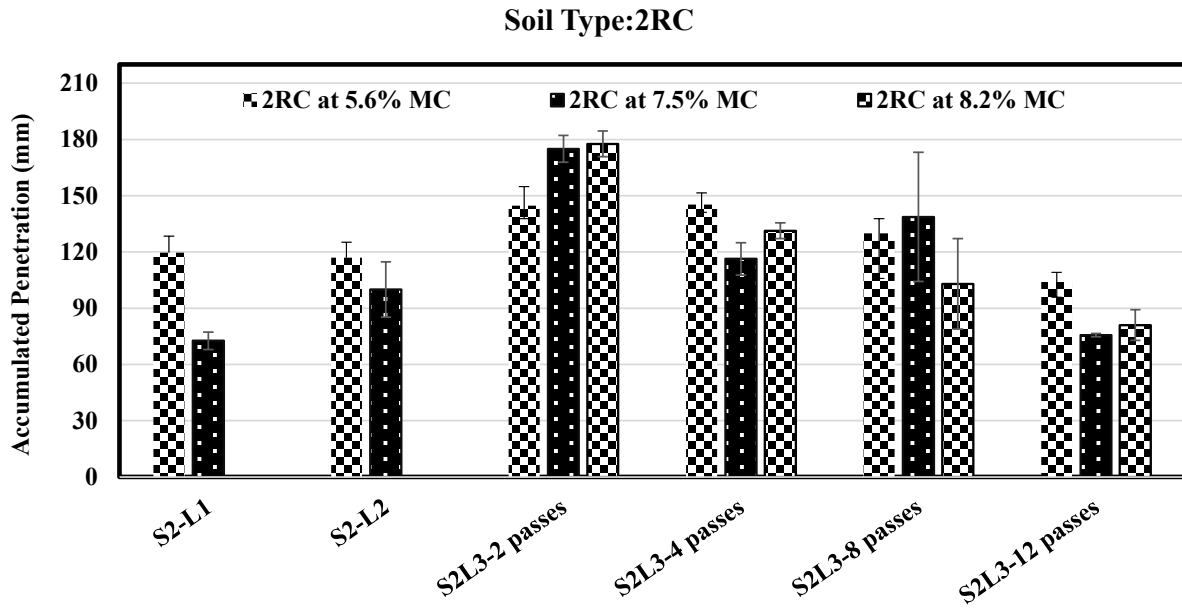


Figure 91. Comparing Proctor mold results and pit results for the 2RC soil modulus.

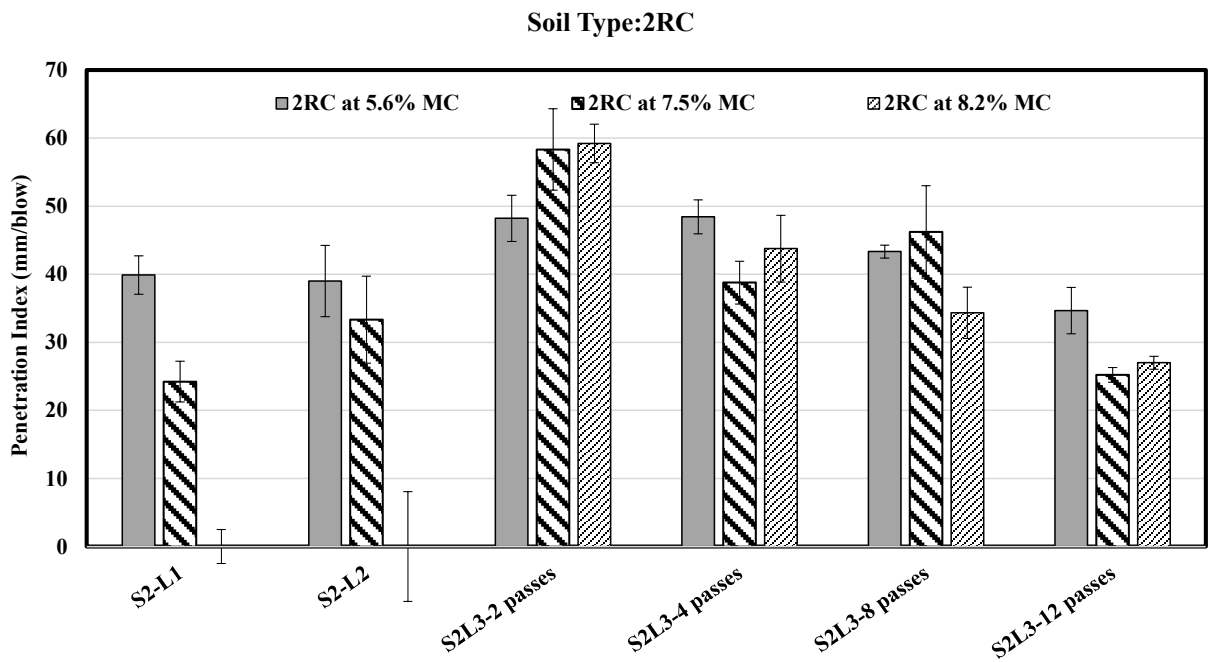
Figure 91 presents a comparison of modulus for 2RC material as obtained in Proctor mold and the test pit. In general, one can see a similar trend, as in both cases there is an increase of modulus with an increase of moisture content. However, it can be seen that the pit delivers a significantly lower modulus at the same moisture content except when the soil is well into the dry side, with moisture content under 7 percent.

#### DCP Test Results

The Dynamic Cone Penetrometer (DCP) test was conducted on various sections of the 2RC soils, with Figure 92 and Figure 93 presenting the outcomes in terms of accumulated penetration for the 2RC material derived from the DCP test. The results detail the accumulated penetration in millimeters over six consecutive drops. The focus of this graph is on the third layer compacted with the roller compactor. DCP measurements were taken at a different number of roller passes for this layer. The most significant conclusion from the results is that, as expected, the soil becomes stiffer as the number of passes increases at the same moisture content. This is evident from the graph, as the accumulated penetration is decreased with an increase in the roller passes. For example, at 7.5% moisture content, the accumulated penetration is 175 mm, whereas after 12 passes it is only 76 mm. This reduction is most likely the result of increased density as the number of passes increases. The density results are presented later. It is important to notice that the penetration is affected not only by the soil density but also by the moisture content. It is expected that higher density and lower moisture content result in a stiffer soil and hence lower penetration. For example, consider the DCP results at 2 roller passes. One can see that accumulated penetration increases when the moisture content goes from 5.6% to 7.5%. The dry density also decreases as a result of this moisture content increase. Therefore, both density and moisture are contributing to reducing the stiffness of the soil, as reflected in the DCP result. However, some of the data show strange behavior. For example, consider the DCP results at four roller passes for all three moisture contents. It can be seen that the penetration is reduced as the moisture content is reduced. The increase in moisture content also shows a reduction in density. It is expected that higher moisture content and lower density result in higher penetration, but that is not what is observed at 4 roller passes. This is hard to explain. There is obviously an inherent variability in the soil, and it is inhomogeneous and anisotropic, and it might have played a role in the observed behavior.



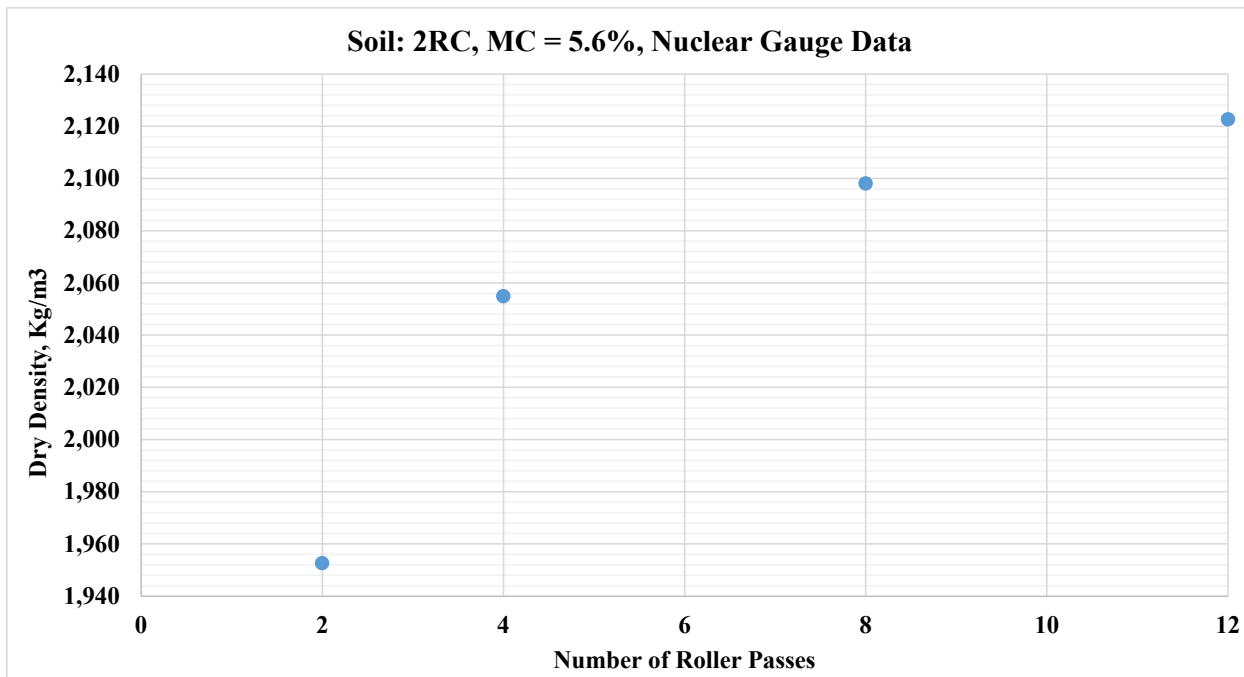
**Figure 92. Accumulated penetration for 2RC material across different compaction and moisture levels in the Test Pit.**



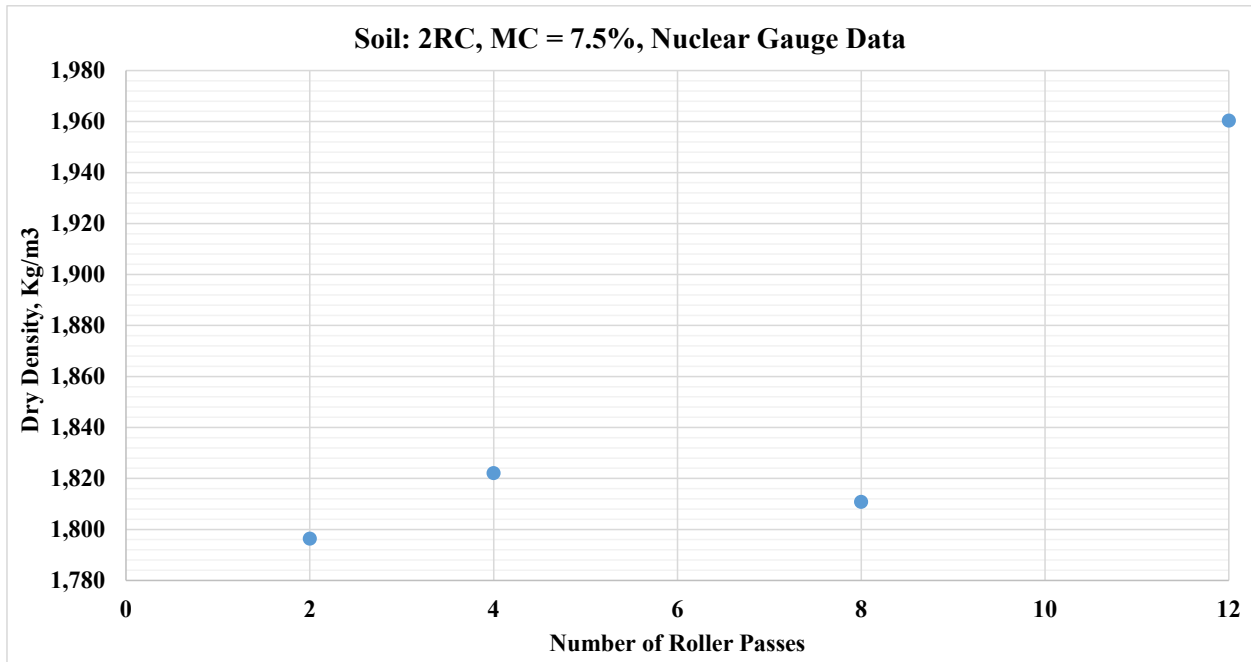
**Figure 93. Penetration index for 2RC material across different compaction and moisture levels in the Test Pit.**

### Density Test Results

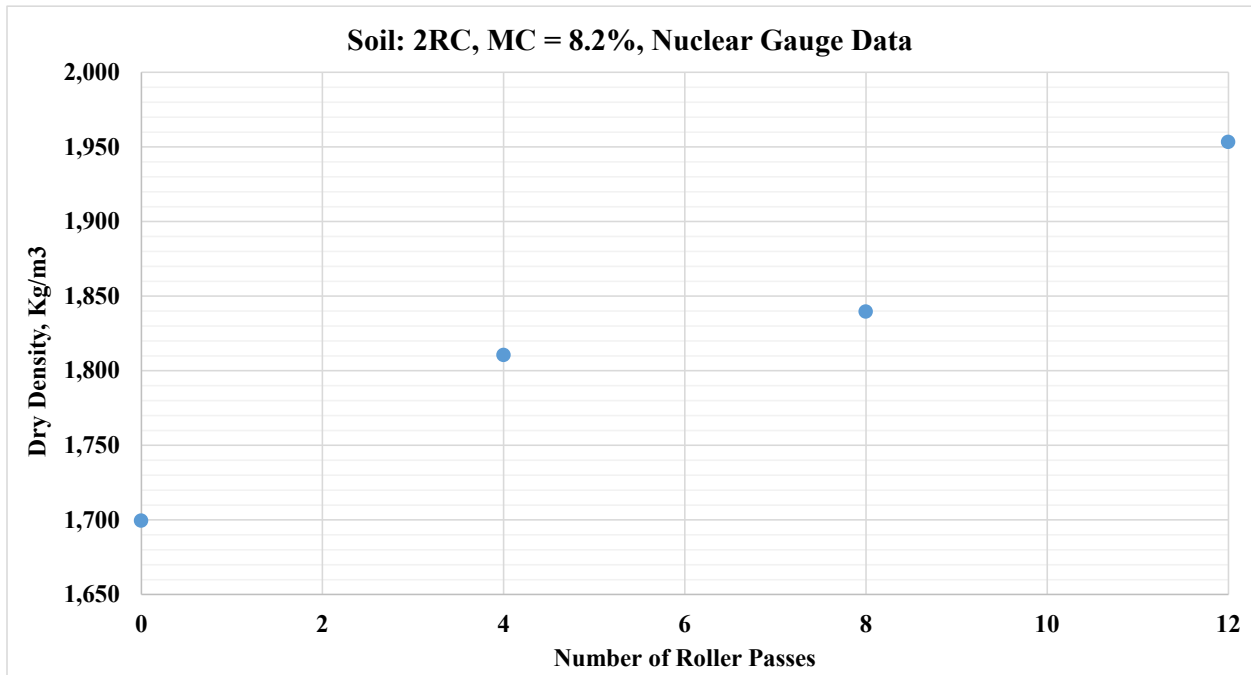
It was mentioned that while increased density results in higher stiffness of the material, one cannot ignore the effect of the moisture content and material variability. Density results presented below indicate that in general a high level of compaction is achieved as the number of roller passes is increased but a strong correlation was not found between the dry density and the penetration index (DPI) from this project. The graphs in Figure 94, Figure 95, and Figure 96 indicate that for all three moisture contents the density increases as a result of increase in the compaction level.



**Figure 94. Dry Density from the nuclear gauge as a function of number of passes at 5.6% moisture content.**

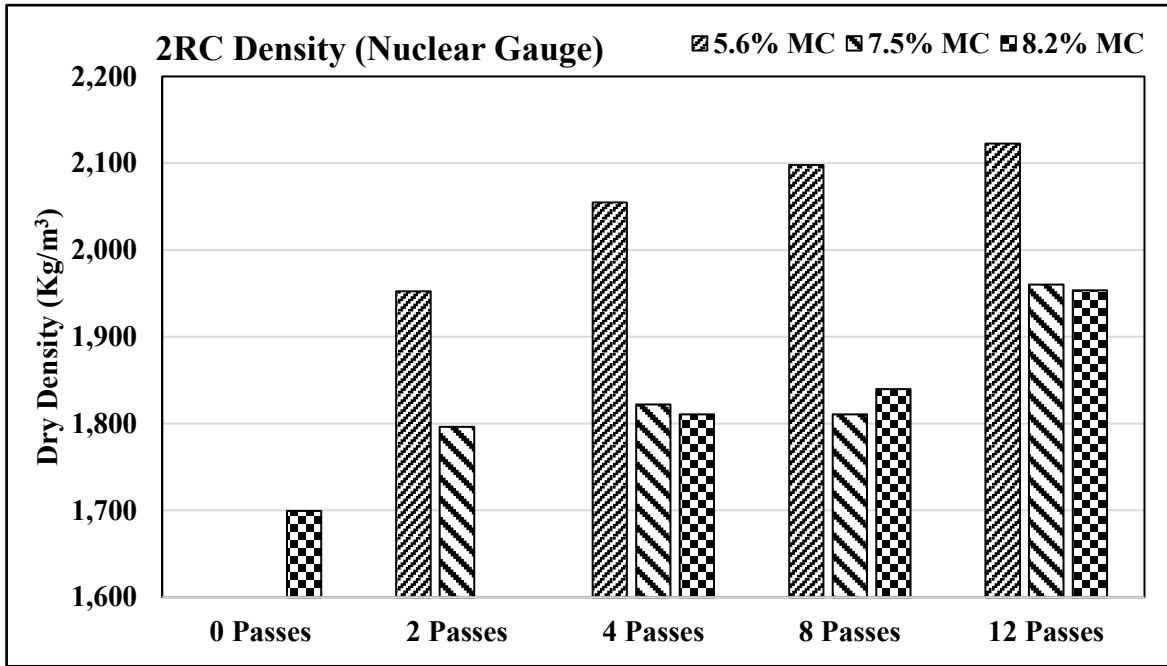


**Figure 95. Dry Density from the nuclear gauge as a function of number of passes at 7.5% moisture content.**



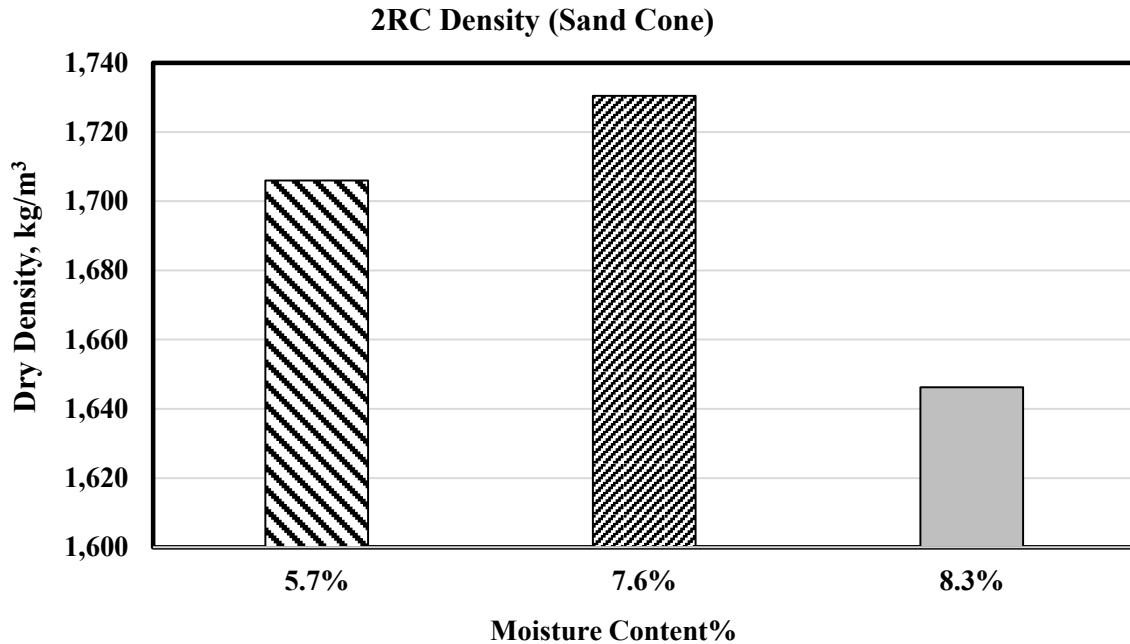
**Figure 96. Dry Density from the nuclear gauge as a function of number of passes at 8.2% moisture content.**

Figure 97 presents summary results for densities obtained from the nuclear gauge density tests. Notably, these tests were exclusively performed on the third layer, following two, four, eight, and twelve compaction passes. As discussed previously, with limited exceptions, the data indicate that an increase in the number of passes generally leads to a rise in dry density.



**Figure 97. Dry Density of 2RC material at various compaction and moisture levels measured with a Nuclear Gauge**

Additionally, the sand cone test was performed to ascertain the soil’s dry density after 12 compaction passes (Figure 98). The findings indicated that the specimen with 7.6% moisture content achieved the highest dry density. This was succeeded by the specimen with 5.7% moisture content, and the specimen with 8.3% moisture content had the lowest dry density among the tested samples. One can also see that the densities obtained from the sand cone test are lower than those obtained from the nuclear gauge discussed previously. It can also be seen that the highest dry density from the sand cone test is reported for the 7.6% moisture content, whereas the nuclear gauge gives the soil with 5.7% moisture content the highest density.



**Figure 98. Dry Density of 2RC material at various moisture contents**

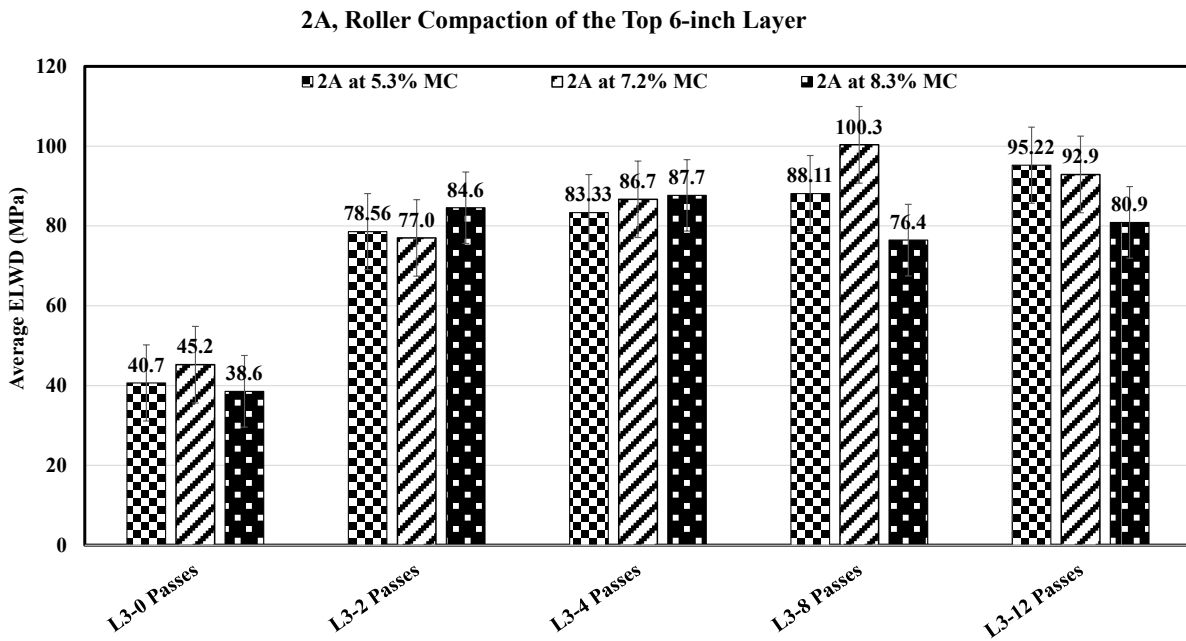
Placement, Compaction, and Testing 2A Material

LWD Test Results

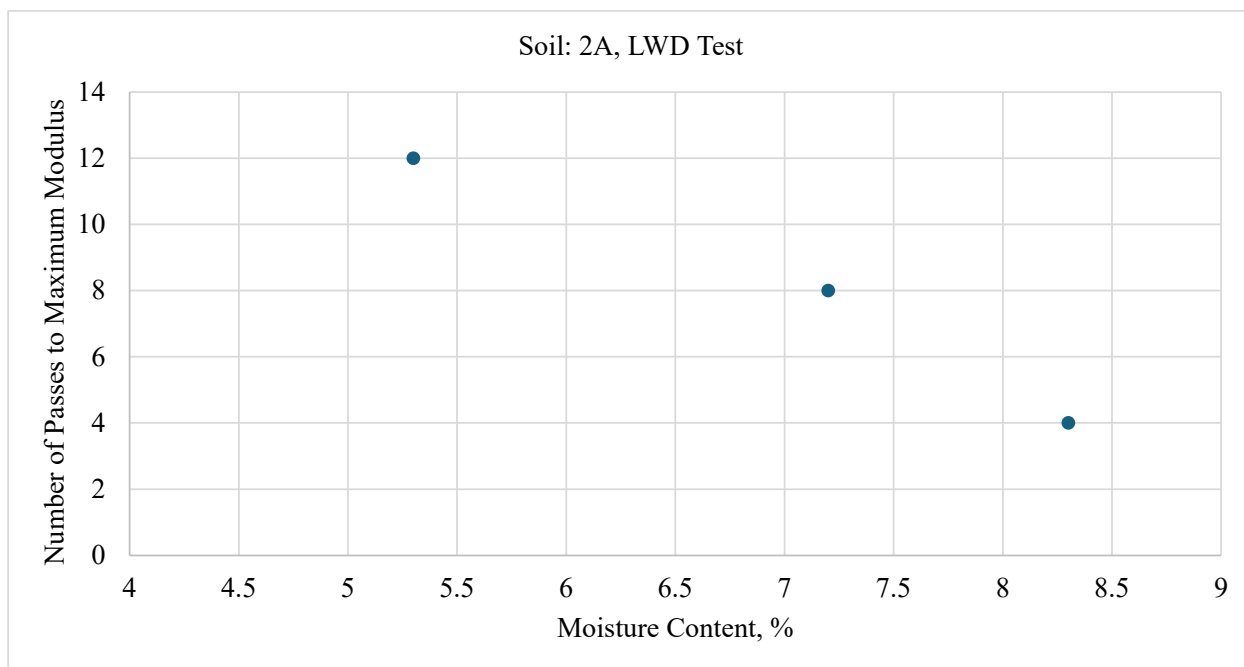
Figure 99 displays the modulus results for the test pit containing 2A material, tested at three different target moisture contents: 5%, 8%, and 10%. Actual moisture content was higher for the case representing the dry side of optimum (5.3% versus 5.0%) and lower for the other two (7.2% versus 8% and 8.3% versus 10%). Part of the significant loss in the moisture content for the two cases at optimum and wet of optimum may be attributed to water evaporation and the time it took between preparation, compaction, and testing of the material.

Figure 99 only presents the data for the third layer. The initial soil exhibited a modulus range between 120 to 145 MPa, though it was marked by significant variability. The LWD test, conducted on the first layer, revealed that the section with 5% moisture content exhibited the highest modulus, while the section with 10% moisture content had the lowest. Similar to the 2RC sections, the plate compactor was utilized for compacting both the first and second layers. In the second layer, the sample with 8% moisture content demonstrated the highest modulus, contrasting with the first layer, where the section with 8% moisture content showed the medium modulus.

The third layer was compacted using the roller compactor. The LWD/DCP tests were conducted after the layer was placed and after 2, 4, 8, and 12 passes. As evidenced by the data presented in Figure 99, the highest modulus is achieved at optimum moisture content after 8 roller passes. An interesting observation is that compaction at the dry side of optimum resulted in an increase of modulus through the end of the compaction process (i.e., up to 12 passes), and the modulus for this condition is close to the maximum modulus obtained at the optimum water content at 8 passes. However, the highest modulus for the optimum is achieved at 8 passes and that for the wet side of optimum at 4 passes (Figure 100). The conclusion is that as the water content is increased, fewer roller passes yields the highest modulus for that moisture content and further compaction will not necessarily produce a higher stiffness.



**Figure 99 . Modulus of 2A material at different compaction and moisture levels in the Test Pit.**



**Figure 100. The number of roller passes to maximum modulus as a function of moisture content**

#### DCP Test Results

Figure 101 and Figure 102 display the accumulated penetration from the DCP test and the penetration index (DPI) for the 2A material for different layers. The first observation is that the first and second layers show the lowest penetration. This was expected, as these layers were compacted on the existing hard soil. For the third layer, irrespective of the moisture content, one can see that in general the penetration is reduced as the number of passes is increased. Increasing the number of roller passes from two to four, then from four to eight, and finally from eight to twelve, revealed a consistent trend of decreasing accumulated penetration for all samples. An interesting observation is that at the end of compaction, the soil with the lowest moisture content has the least penetration (i.e., the highest stiffness) and the soil with the highest moisture content has the largest penetration. One should realize that the stiffness of a specific soil is affected by both the density and moisture content.

Soil Type: 2A

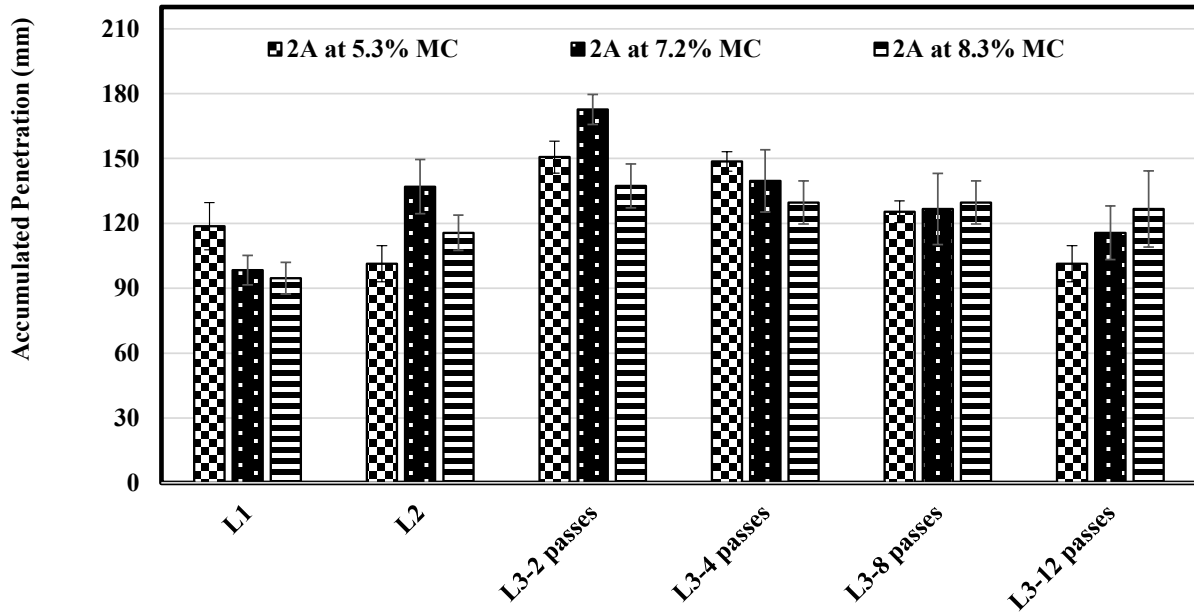


Figure 101. Accumulated penetration of 2A material at various moisture contents tested in the Pit.

Soil type: 2A

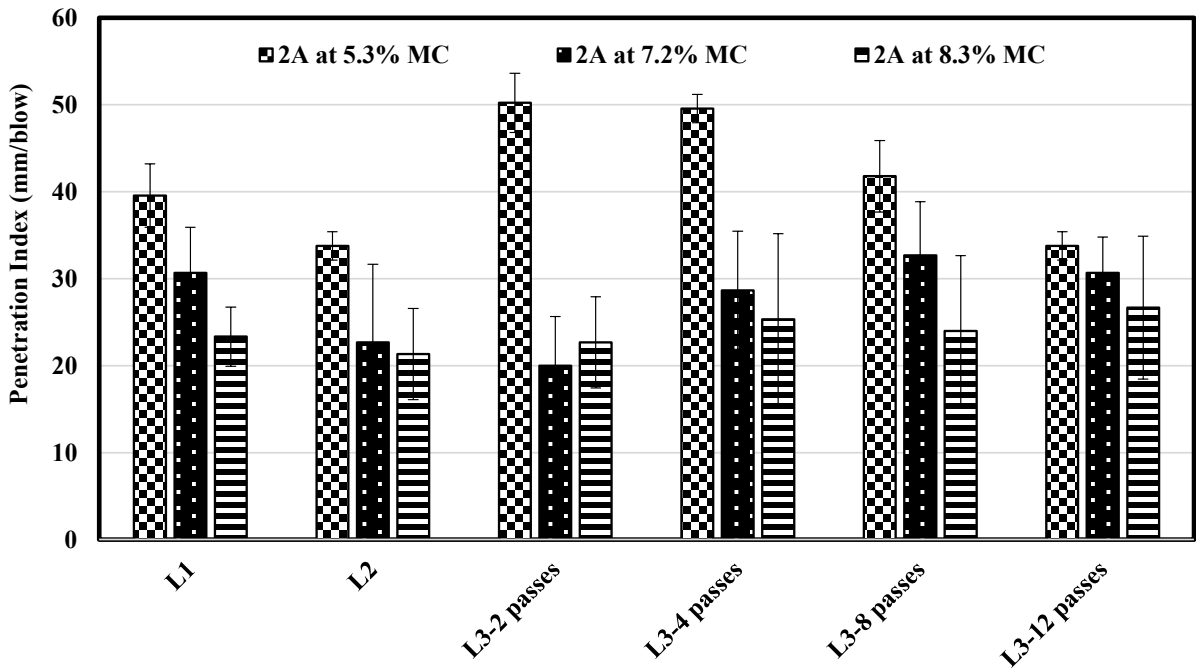
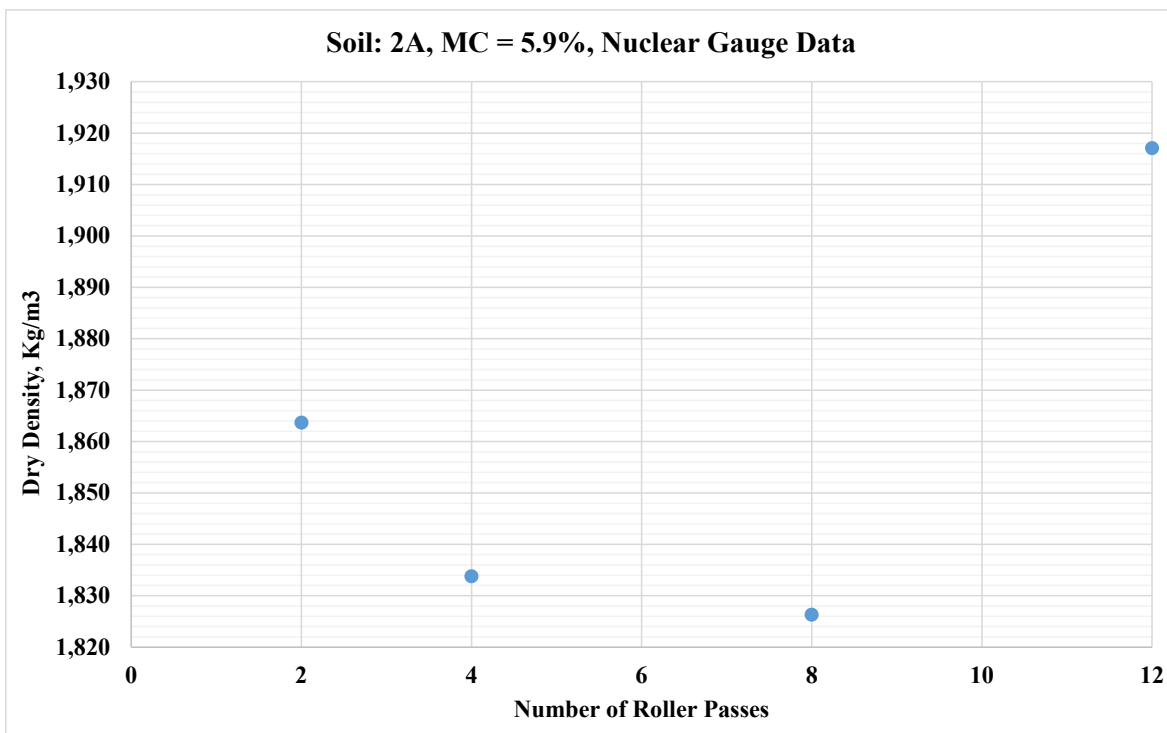


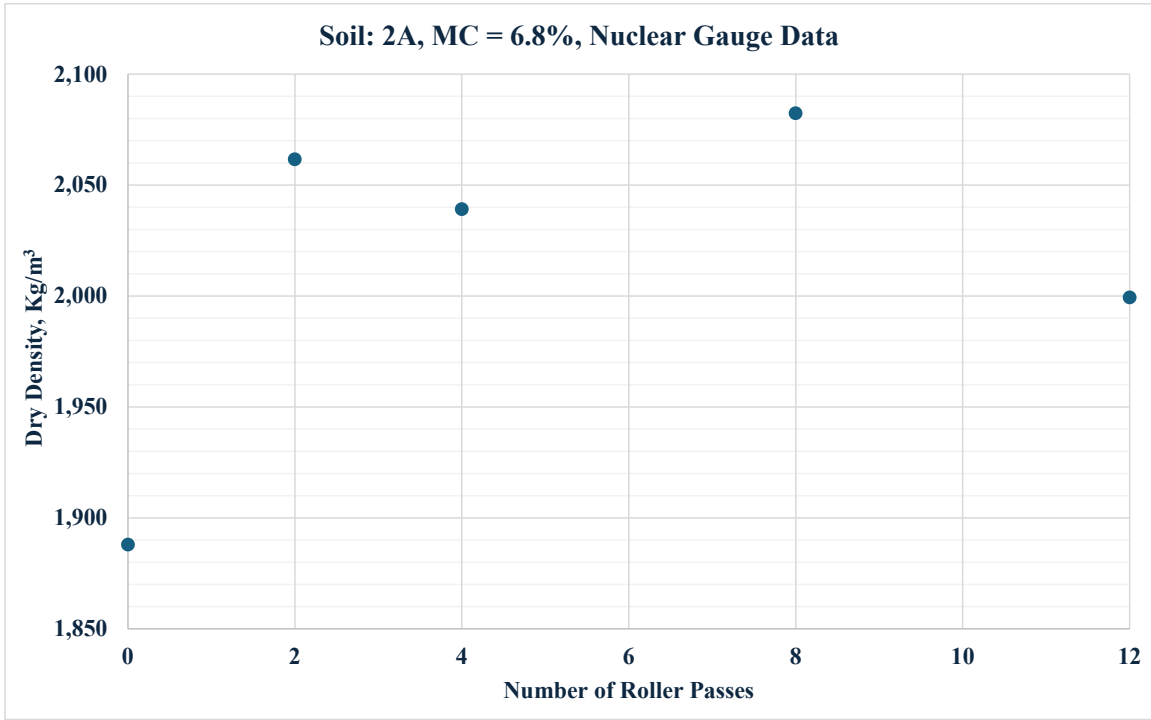
Figure 102. Penetration index of 2A material at various moisture contents tested in the Pit.

### Density Test Results

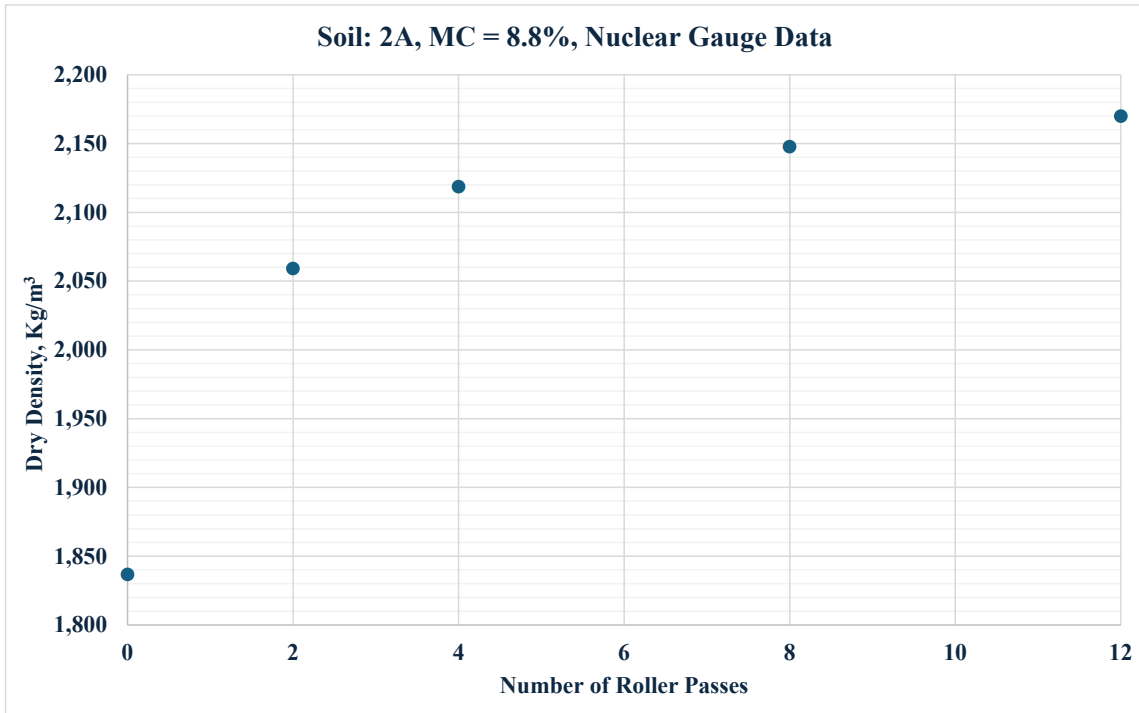
The dry density obtained from the nuclear gauge does not follow a strong correlation as a function of number of passes, as observed for the 2RC material (Figure 103, Figure 104). The exception is the highest moisture content, for which the density is consistently increasing with the increase in the roller passes (Figure 105). Relative comparison of densities among moisture contents can be seen in Figure 106. One can see that at 4, 8, and 12 roller passes, there is an increase in the dry density as the moisture content increases from 5.9% to 8.8%. Recall that the optimum moisture content for 2A was established around 8%.



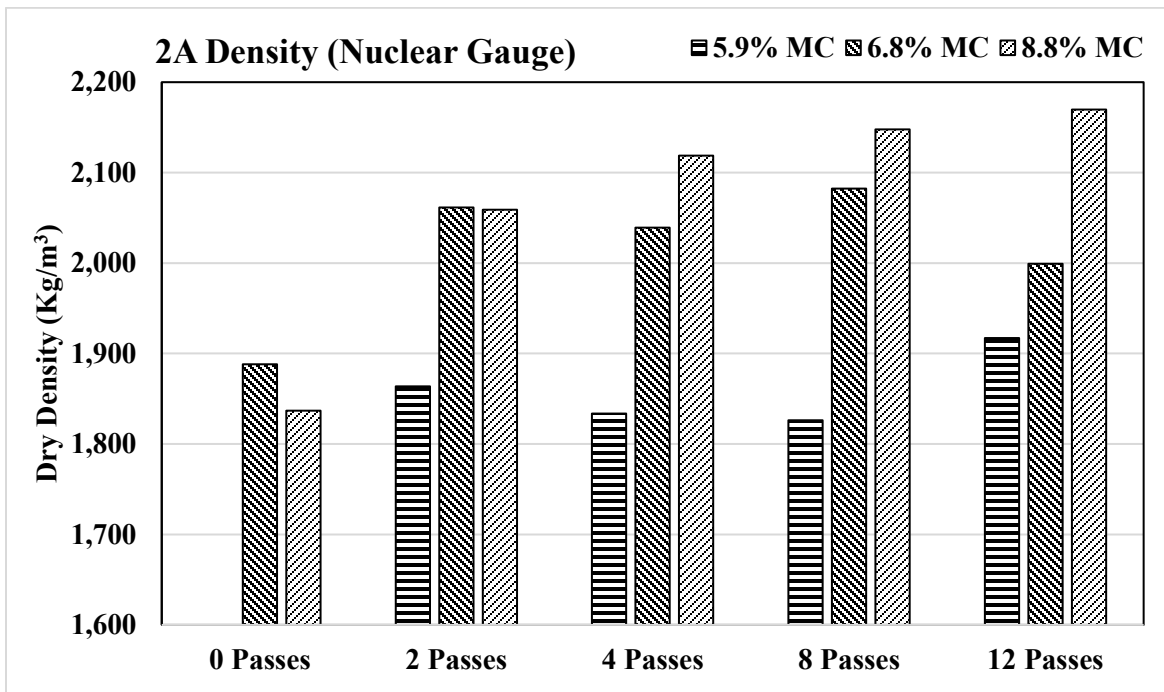
**Figure 103. Dry Density from the nuclear gauge as a function of number of passes at 5.9% moisture content.**



**Figure 104. Dry Density from the nuclear gauge as a function of number of passes at 6.8% moisture content.**

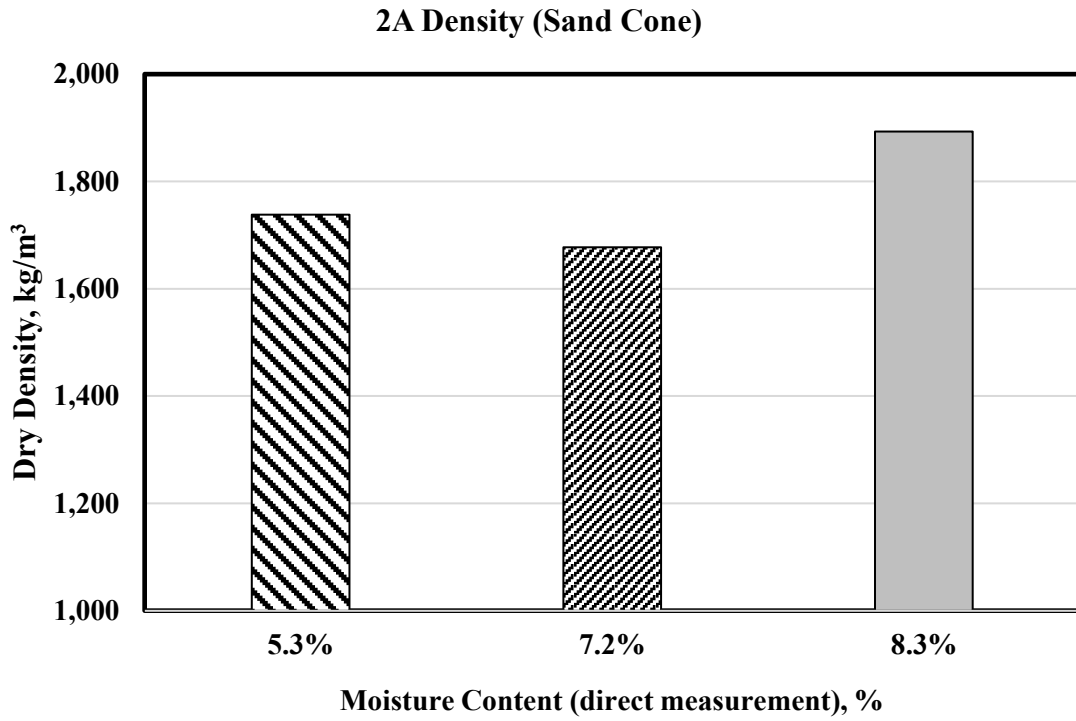


**Figure 105. Dry Density from the nuclear gauge as a function of number of passes at 8.8% moisture content.**



**Figure 106. Dry Density of 2A material at various compaction and moisture levels measured with a Nuclear Gauge.**

Figure 107 displays the dry density results of 2A material from the sand cone test at different moisture contents and as tested in the pit. For each case, the sand cone test was conducted after completion of all 12 passes. The moisture contents are from direct laboratory measurement after completion of the test. These density values are smaller than what was previously reported for the nuclear gauge results. However, once can see that again the highest density is achieved for the highest moisture content, which is close to the optimum moisture content.



**Figure 107. Dry Density of 2A Material at various moisture contents.**

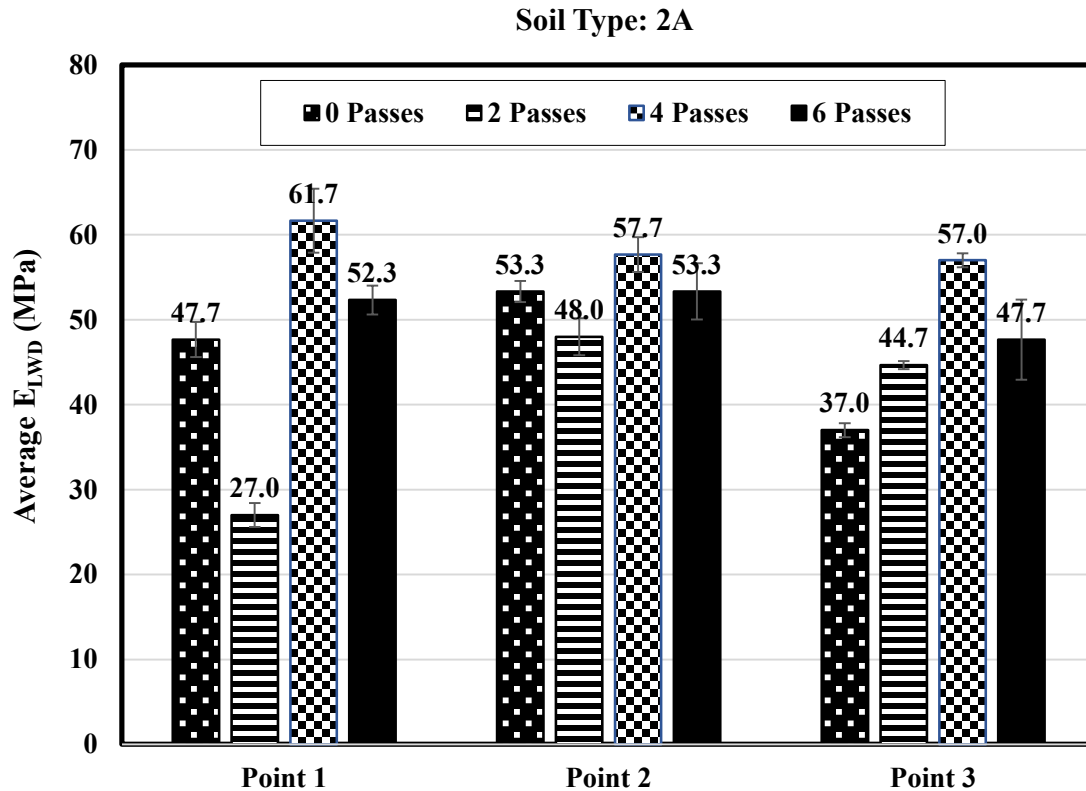
## **DATA FROM THE FIELD TESTS**

The third phase of this research project was related to LWD/DCP data collection in the field. Details of the field condition and location were discussed previously. Two materials were tested for this purpose: 2A and AASHTO A-6. The 2A material formed the base for placement of the asphalt binder and wearing courses. The A-6 material was the existing subgrade, which was covered by one layer of Class 4 Type C geotextile, followed by 30.5 cm (12 inches) of AASHTO #1, one layer of Class 4 Type A geotextile, and finally 20.3 cm (8-inch) of 2A subbase material.

The flexibility of the research team for this data collection was limited, as the team had to follow the conditions of the site as existed at the time of testing. In addition to LWD and DCP testing, the sand cone and nuclear gauge density tests were conducted at the site for determination of the material density. The results from testing the 2A material at three different sections and the A-6 material in one section are presented in this part of the report.

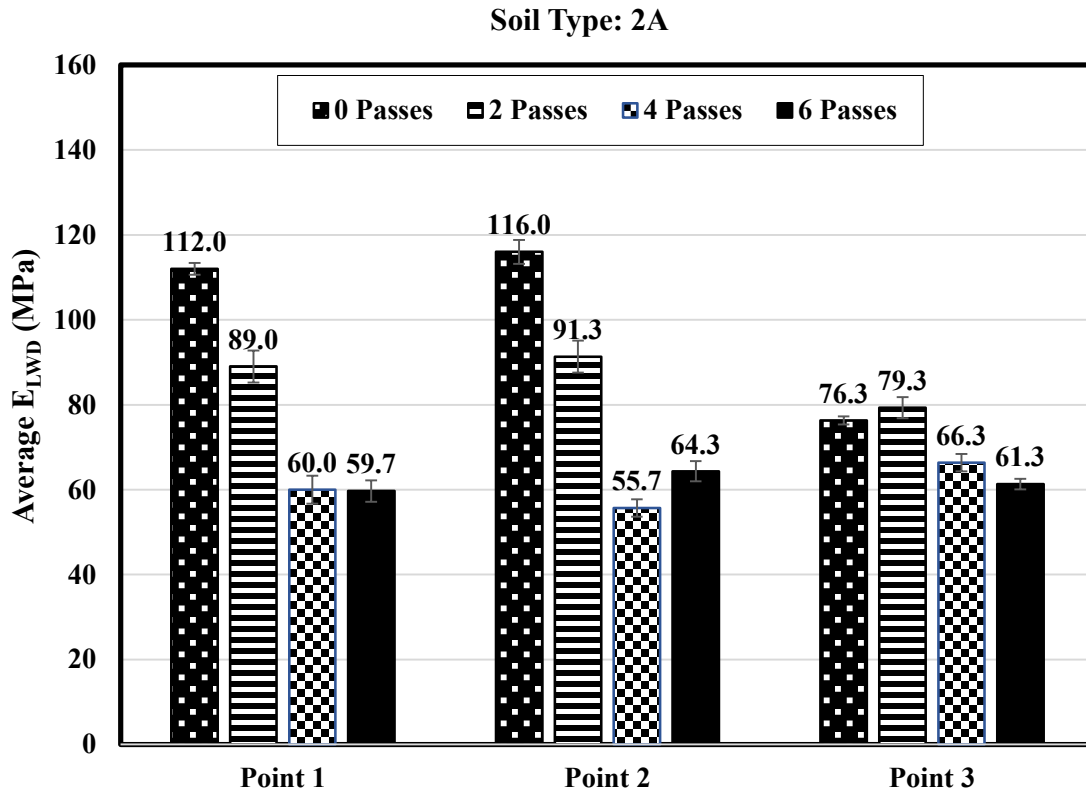
### **Testing 2A Material**

The 2A material, used as the base for placement of the asphalt layers, was already compacted, and had received several passes of heavy rollers before the research team made their measurements at the site. The tests were carried out across three distinct sections before and after additional compaction. The selected sections for testing were spaced almost 90 cm (3 ft) apart in the longitudinal direction. Figure 108 illustrates the modulus as a function of the roller passes for the first section (Section A) of testing at three different points. One pass is defined as either the forward rolling or backward rolling of the roller. At the first point, the modulus decreased after two additional passes, then significantly increased after another two passes, and decreased again after two more passes. At the second point, the modulus slightly decreased after the first two passes, increased after the next two passes, and decreased again after reaching a total of six passes. Notably, for this second point, the modulus after six passes was identical to that before any passes were applied. For the third point, the modulus increased with the initial increase from zero to two passes, continued to increase from two to four passes, but decreased when the number of passes went from four to six. In general, one may conclude that for this soil having 4 roller passes provided the best outcome in terms of material stiffness.



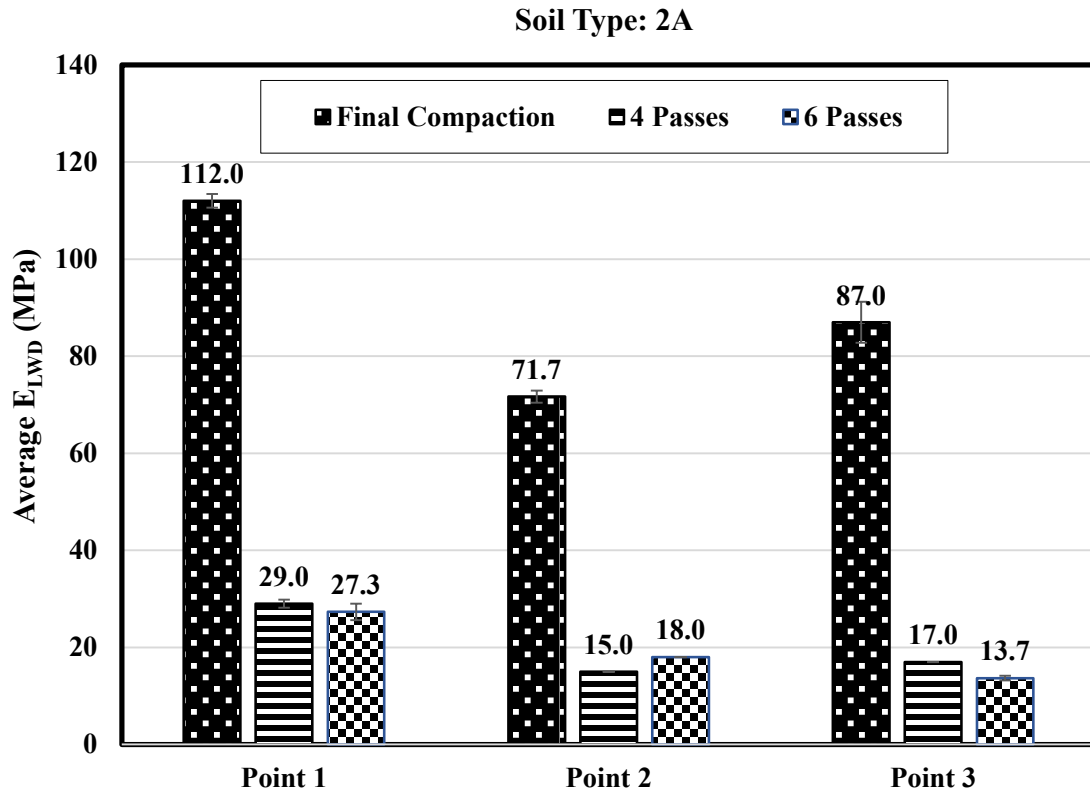
**Figure 108. Impact of compaction level on the modulus of 2A material in section A.**

This test was replicated in a second section, where the observed results varied (Figure 109). At the first point within this section, the modulus decreased with an increase from zero to two passes and continued to decrease from two to four passes. From four to six passes, the modulus remained nearly unchanged. In contrast, at the second point, the modulus also fell upon applying two passes and experienced a significant decrease when the number of passes was increased to four. However, an increase in the number of passes from four to six resulted in a slight increase in the modulus. At the third point, the modulus received a slight increase with the application of two passes, then decreased from two to four passes, with this decreasing trend continuing from four to six passes. Notably, despite some exceptions, the general observation across the second section was that increasing the number of passes tended to decrease the modulus of the soil. The most logical explanation for this observation is that since the material was already compacted, additional compaction induced for this research may have been excessive, resulting in over-compaction and density decrease.



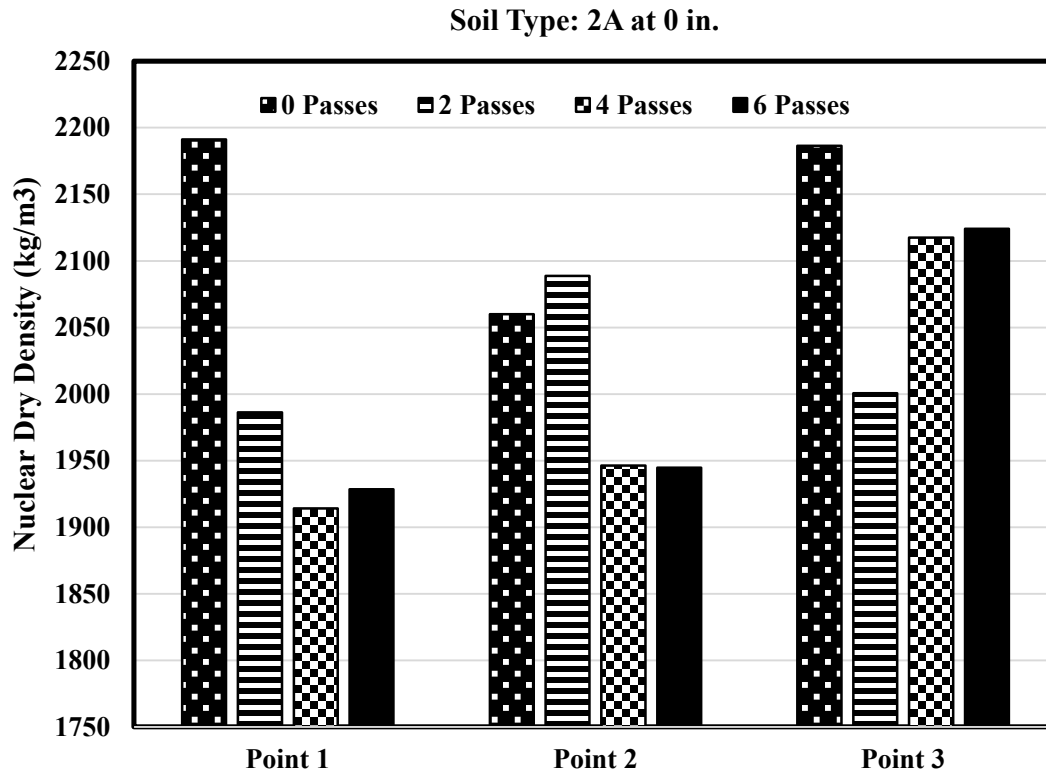
**Figure 109. Impact of compaction level on the modulus of 2A material in section B.**

Figure 110 displays the modulus of 2A soil measured at three distinct points within the third section. The initial tests were conducted on the soil that had already been compacted. Subsequently, four and six additional passes were executed, and the modulus was measured after each set of passes. The results indicated a significant decrease in the modulus across all three points as the number of passes increased. Again, this could be the result of material getting overcompacted through the additional compaction, and possibly disturbing the soil structure.



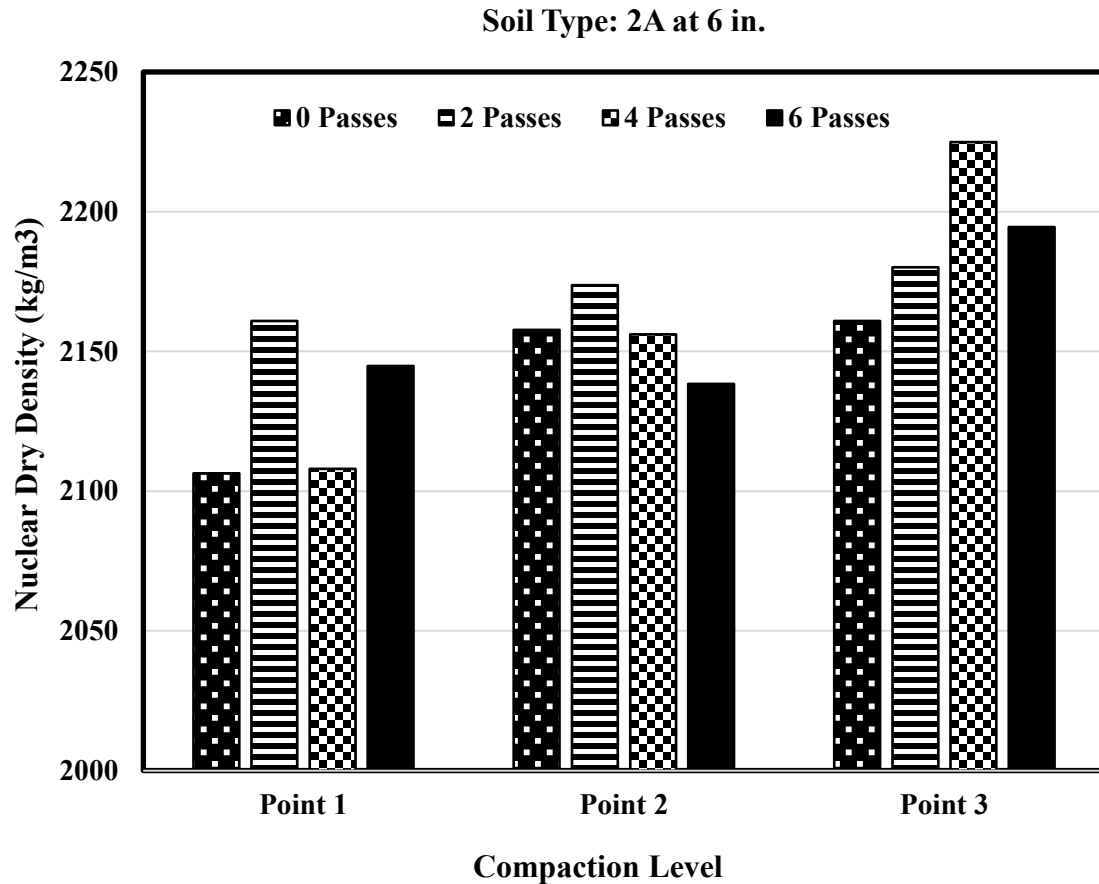
**Figure 110. Impact of compaction level on the modulus of 2A material in section C.**

The nuclear gauge density test, conducted in section A of the 2A material, is detailed in Figure 111. The graph reveals an unexpected relationship between the number of compaction passes and the dry density. Remarkably, at Point 1, an increase in the number of passes led to a reduction in density, possibly due to the reason explained previously regarding over-compaction. At Point 2, the trend similarly indicated a decline in dry density with more passes. At Point 3, an initial decrease in dry density was observed as the number of passes increased from zero to two; however, further increases in the number of passes resulted in a rise in dry density.



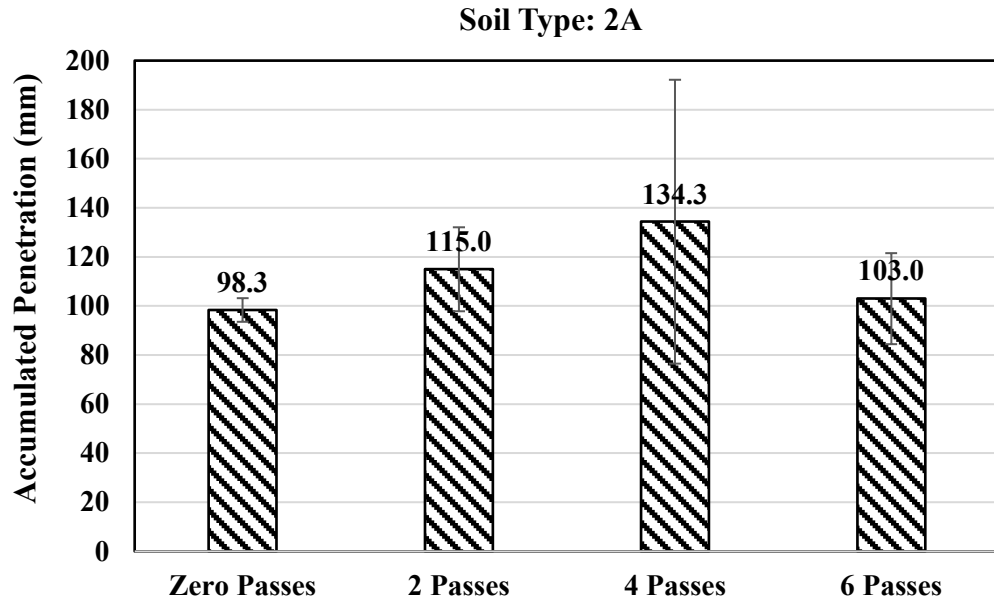
**Figure 111. Dry Density measurements of 2A material in Section A using a Nuclear Density Gauge.**

Figure 112 presents the outcomes of the nuclear gauge density test conducted on Section C of the 2A material. Although the results do not exhibit a definitive trend overall, certain observations can be made. At point 3, there is a discernible increase in dry density from zero to four passes, followed by a decrease from four to six passes. At point 2, an initial increase in dry density is noted from zero to two passes, which then diminishes from two to six passes. Regarding point 1, a fluctuating pattern is observed: the dry density initially increases from zero to two passes, decreases from two to four passes, and then increases again from four to six passes.

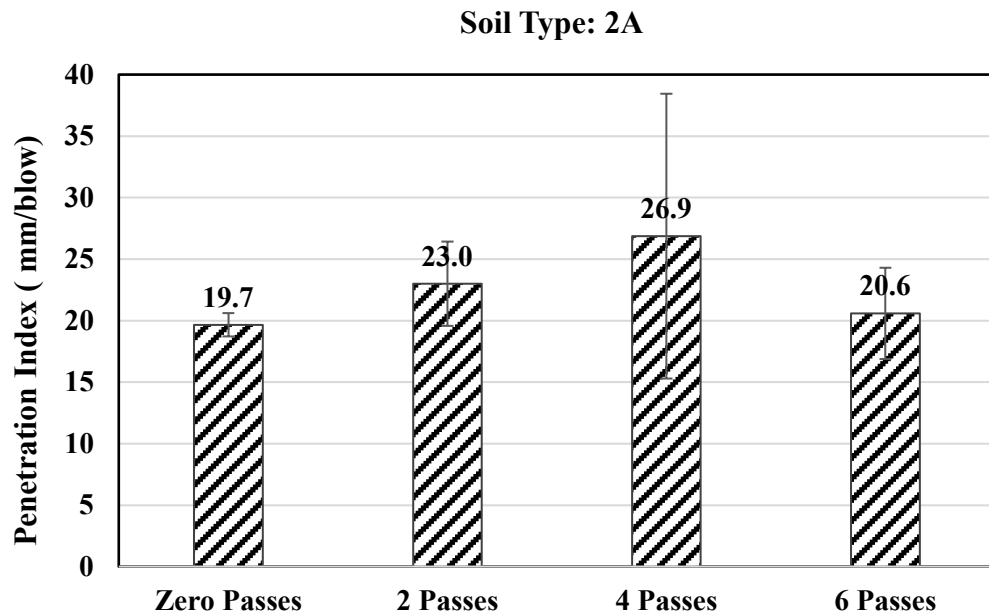


**Figure 112. Dry Density measurements of 2A material in Section C using a Nuclear Density Gauge.**

The Dynamic Cone Penetrometer (DCP) test was performed on 2A material in two distinct sections, namely section A and section C. The findings for section A are depicted in Figure 113 and Figure 114. Figure 113 presents accumulated penetration after applying 10 blows for a different number of passes. The figure indicates that the accumulated penetration initially increased from 98.3 to 128 mm and then to 134.3 mm as the number of passes escalated from zero to two and then from two to four, respectively. However, upon reaching six passes, the accumulated penetration decreased to 103 mm. Penetration index in Figure 114, reported in millimeters per blow, is simply calculated by dividing the accumulated penetration by the number of blows multiplied by 2. The multiplier “2” is used to convert the index to the standard index that is for a hammer weight of 8 kg. This conversion is needed if the DPI is to be used for calculation of California bearing ratio (CBR) or the soil resilient modulus (Mr).



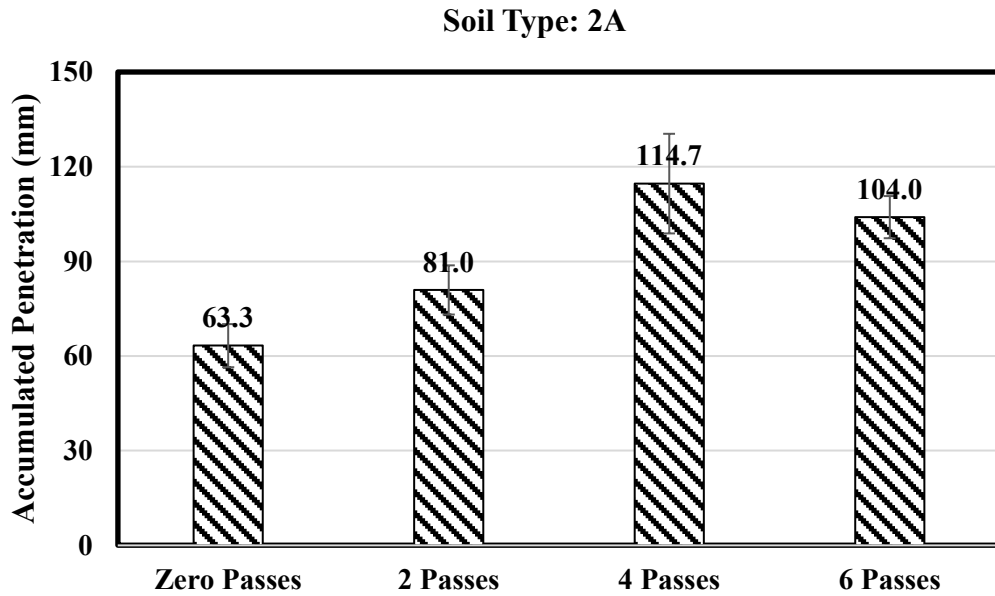
**Figure 113. Accumulated Penetration at different compaction levels in Section A.**



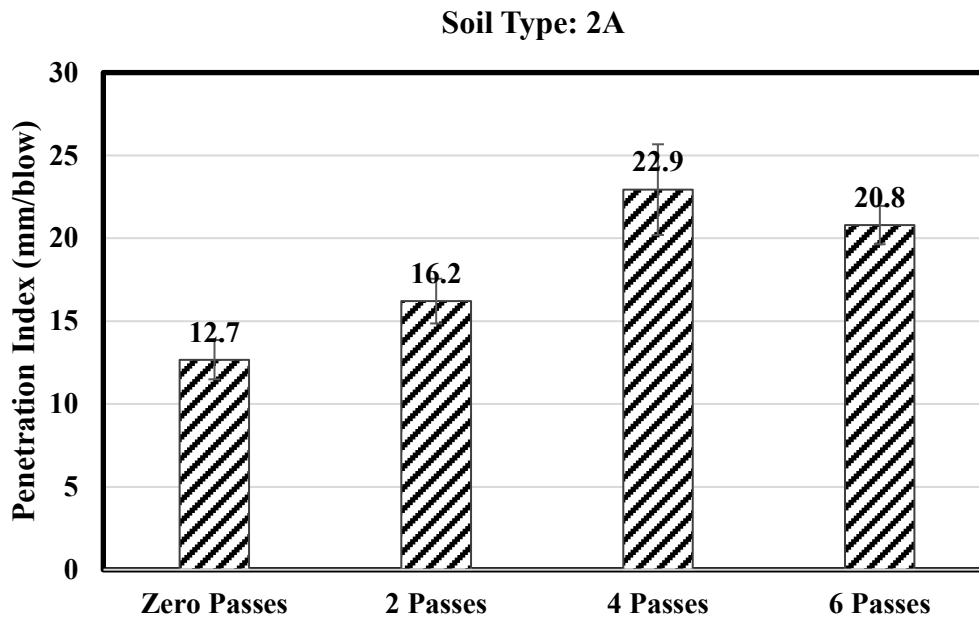
**Figure 114. Penetration index for 2A material at different compaction levels in Section A.**

The analysis extended to Section B, with outcomes depicted in Figure 115 and Figure 116. These figures demonstrate an increase in the penetration and the corresponding index as the number of passes increases from zero to four. Afterwards, a decrease is observed. This behavior is extremely

similar to what was observed for Section A, except the penetration values are lower than those observed for Section A, except the values after six passes, for which both sections deliver similar results.



*Figure 115. Accumulated Penetration for 2A material across different compaction in Section B*



*Figure 116. Penetration index for A-6 material across different compaction and levels in Section B.*

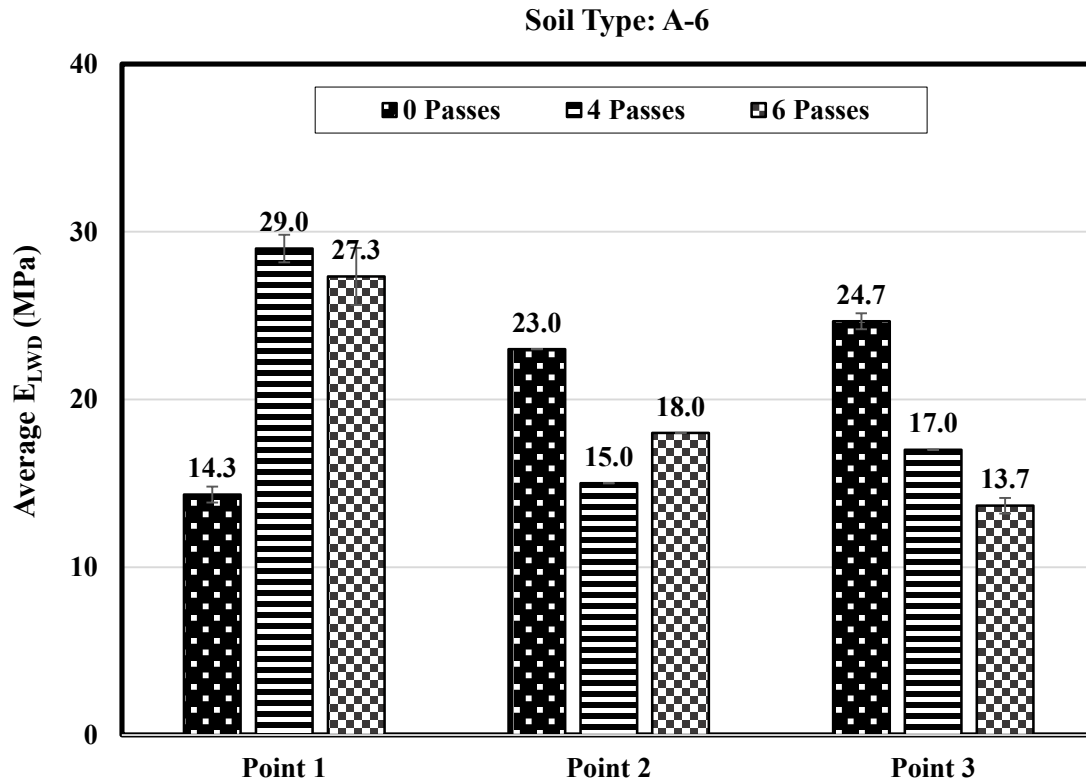
## Testing A-6 Material

LWD and DCP tests were conducted at three different points with varying compaction levels. It must be noted that the subgrade area selected for testing was exposed because of removal of the old pavement and the base material. This subgrade had already been considerably compacted in the past as a result of the original compaction as well through decades of service under traffic.

The LWD/DCP testing was conducted at the existing grade before and after additional compaction conducted at the request of the research team. A sequence of four and six additional compactor roller passes—two or three forward rolling and two or three backward rolling—were applied to the subgrade. Notably, the roller was set to vibration mode for the initial and final passes. Inclusion of vibration was an oversight and not intentional, as it is best to do static compaction for such a fine-grained soil. Following this, an additional compaction phase was initiated, involving one forward and one backward pass, both executed with the vibratory function enabled. This rigorous compaction process set the stage for the subsequent LWD and DCP tests.

### *LWD Test Results*

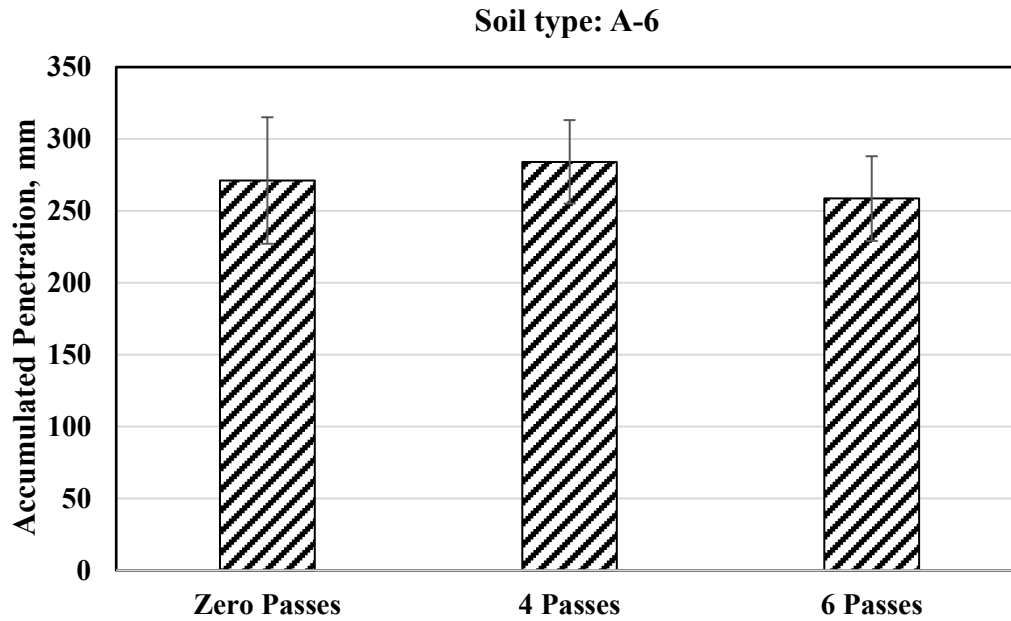
Figure 117 illustrates the modulus results for the A-6 material, tested at three different points. The graph reveals distinct responses to compaction passes at each point. At the first point, the modulus demonstrates an increase from 14.3 to 29 MPa with the initial four passes. However, upon increasing the number of passes from 4 to 6, there is a slight decrease in the modulus. At the second point, the modulus shows a decrease from 23 to 15 MPa after four passes. An additional two passes result in a slight increase in the modulus by 3 MPa. For the third point, the trend shows a consistent decrease in the modulus with an increasing number of passes. Specifically, after four passes, the modulus drops from 24.7 to 17 MPa. Upon reaching six passes, the modulus decreases further, indicating a trend where the response to compaction varies across different points within the A-6 material. Several factors may have played a role here requiring explanation. The nuclear density test results for the A-6 soil are presented later in this section (Table 37 and Figure 120). Those results indicate an increase in the dry density with the increase in the number of passes. Therefore, the increase in density due to increased passes, while moisture content is not changing, does not correlate well with the observed modulus trend. It is not clear, but one possible explanation is disturbance of the material structure even though higher density is achieved.



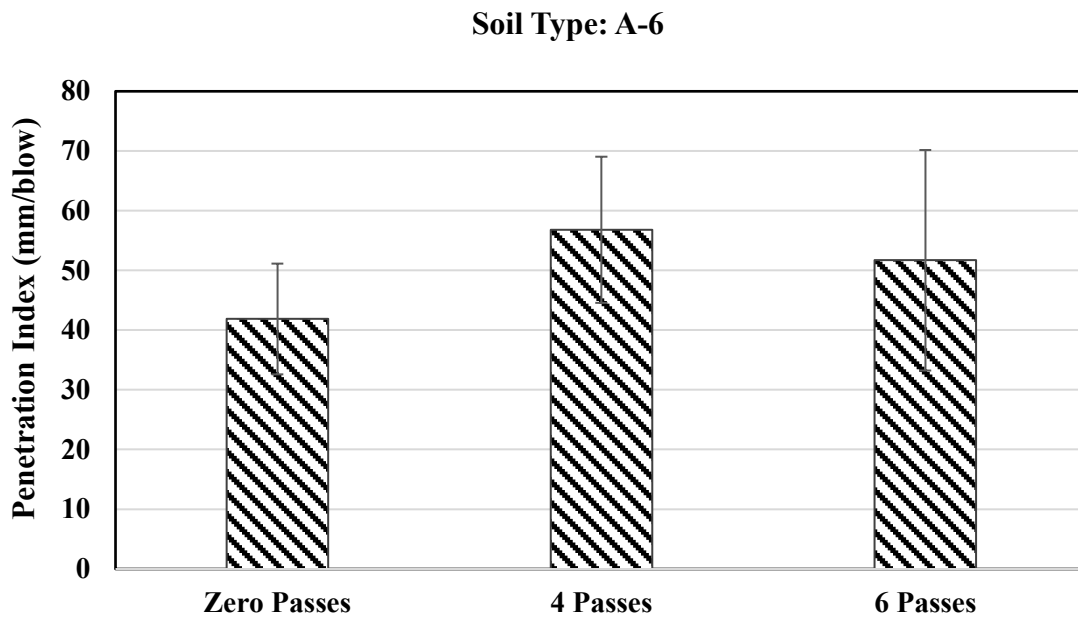
**Figure 117. Impact of compaction level on the modulus of A-6 material in Section A.**

DCP Test Results

The DCP Test was performed on A-6 material, with the outcomes illustrated in Figure 118. The results are presented as the average value of measurements at two spots. This figure indicates that the accumulated penetration rises as the number of passes increases from zero to four, then diminishes with the increase in passes from four to six. A similar pattern is observed for the penetration index presented in Figure 119.



*Figure 118. Accumulated Penetration for A-6 material at different compaction levels in Section A.*



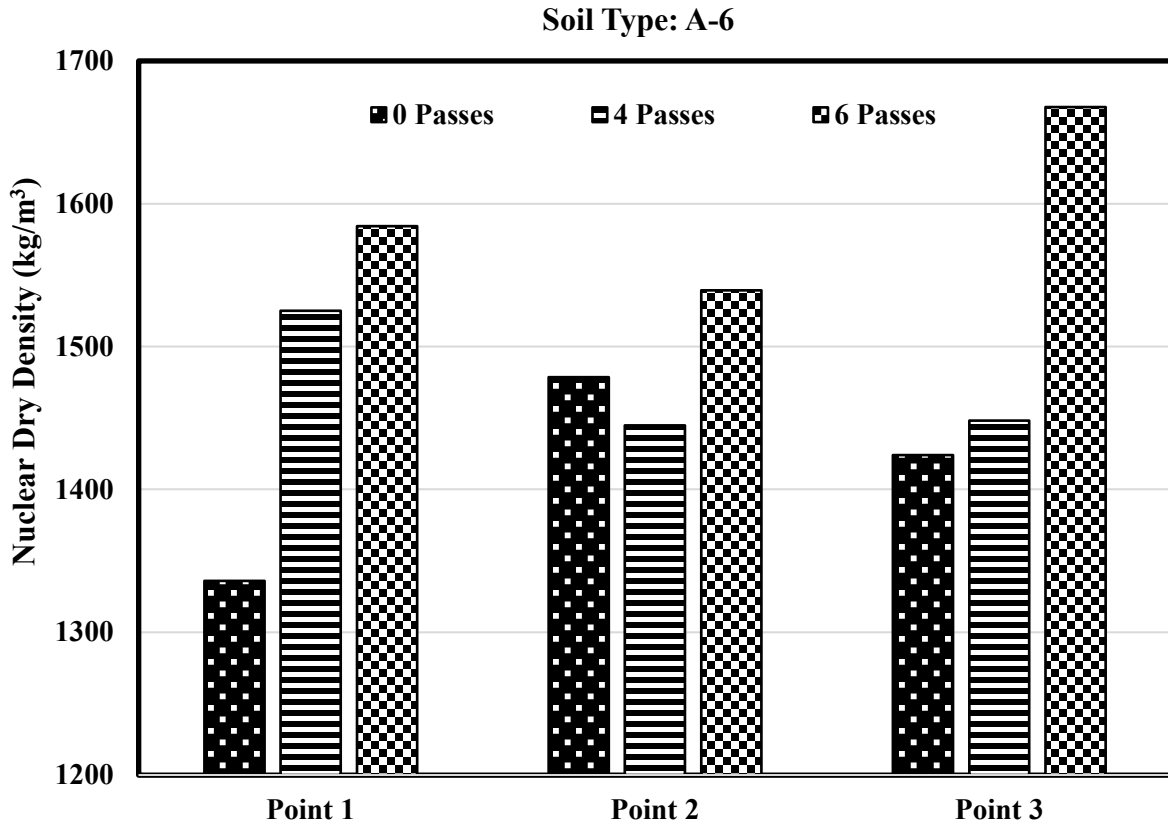
*Figure 119. Penetration index for A-6 material at different compaction levels in Section A.*

### Density Test Results

The nuclear gauge density test results for the A-6 subgrade soil are presented in Table 37 and Figure 120. The measurement was conducted at a depth of 150 mm (6 inches) from the surface. At zero passes, the average density was recorded at 1,412.8 kg/m<sup>3</sup>, with a standard deviation (STD) of 58.7 and a coefficient of variation (COV) of 4.2%. With 4 passes, the average density increased to 1,472.6 kg/m<sup>3</sup>, accompanied by a reduction in both STD to 37.0 and COV to 2.5%. Further compaction at 6 passes yielded a more significant increase in average density to 1597.0 kg/m<sup>3</sup>, with an intermediate STD of 53.1 and COV of 3.3% (Table 37). The data illustrate a clear relationship between the number of passes and the compaction of the material, with density increasing as the number of passes grows. The variation in density also appears to be more controlled at higher passes, potentially indicating an optimal compaction point for this particular layer in A-6. Further investigations may provide insights into how to utilize this relationship for construction or engineering applications.

**Table 37. Nuclear gauge dry density of A-6 material at different compaction levels (15-cm depth).**

<b>Nuclear Gauge Density (6-in depth) (kg/m<sup>3</sup>)</b>						
<b>Number of passes</b>	<b>Point #1</b>	<b>Point #2</b>	<b>Point #3</b>	<b>Average</b>	<b>STD</b>	<b>COV</b>
0	1335.9	1478.5	1424.0	1412.8	58.7	4.2
4	1524.9	1444.8	1448.0	1472.6	37.0	2.5
6	1584.2	1539.3	1667.5	1597.0	53.1	3.3



**Figure 120. Dry Density measurements at various points on Section A in the field for A-6 material using a Nuclear Gauge.**

Moisture Content

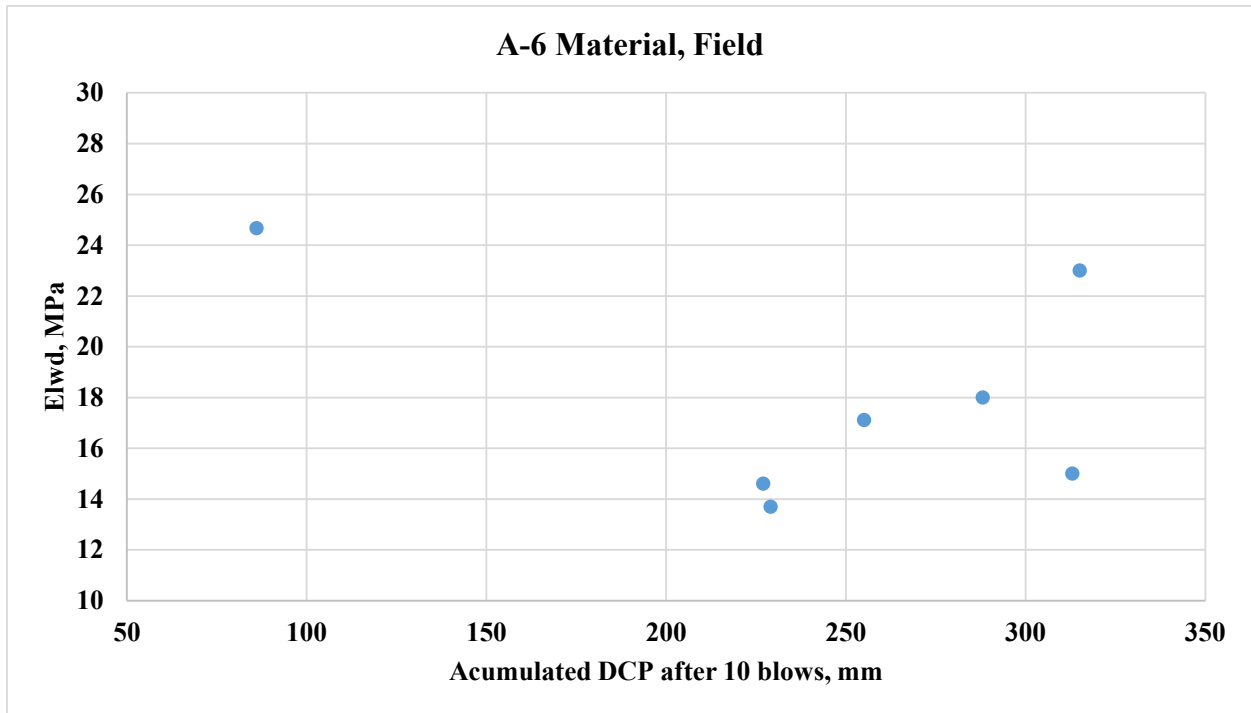
The moisture content in the A-6 soil, as measured through the nuclear gauge, demonstrated some variation at different points. For example, the lowest moisture content was found to be 16.1% at point 3 and when no passes were applied. The highest moisture content was 24% for point 2 after 6 passes. However, on average, all three points show a moisture content in the range of 19.6% to 20.9% when all data are considered (Table 38).

**Table 38. Field-measured Nuclear Gauge moisture content as a function of number of roller passes for Soil A-6, measured at the depth of 15 cm (6 in).**

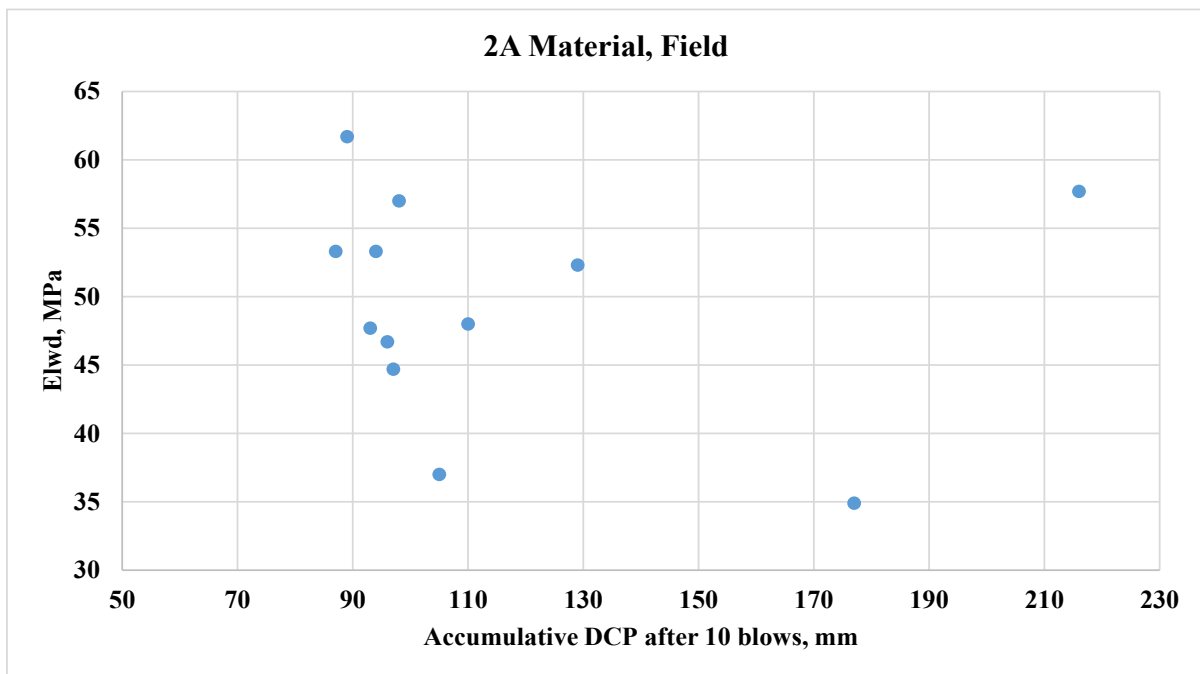
Nuclear Gauge Moisture Content (6-in depth)						
Number of passes	Point #1	Point #2	Point #3	Average	STD	COV
0	21.0	21.7	16.1	19.6	2.5	12.7
4	19.2	23.3	20.3	20.9	1.7	8.3
6	19.4	24.0	18.9	20.8	2.3	11.1

### **RELATION BETWEEN DCP AND LWD RESULTS**

For the case of testing at the pit and in the field, both LWD and DCP results are available. In general, one expects an inversion correlation between these two parameters, i.e., as the penetration increases at the same number of blows, the modulus decreases. However, no correlation was found for either A-6 or 2A materials as tested in the field, as shown in Figure 121 and Figure 122. In these figures, total penetration is repeated after 10 blows of DCP hammer. For the A-6 material, one can tell that the stiffest soil condition as represented by the DCP penetration also delivers the highest modulus. However, all the other data points are clustered between 225 and 315 mm DCP penetration. For the 2A material, if the point representing 216 mm of penetration is treated as an outlier and removed, and the data are replotted, Figure 123 is obtained. This graph shows a general pattern of decreased modulus with increased penetration. The data points in this graph follow the expected trend to some extent.



**Figure 121. Correlation between LWD modulus and DCP for A-6 material as tested in the field.**



**Figure 122. Correlation between LWD modulus and DCP for 2A material as tested in the field.**

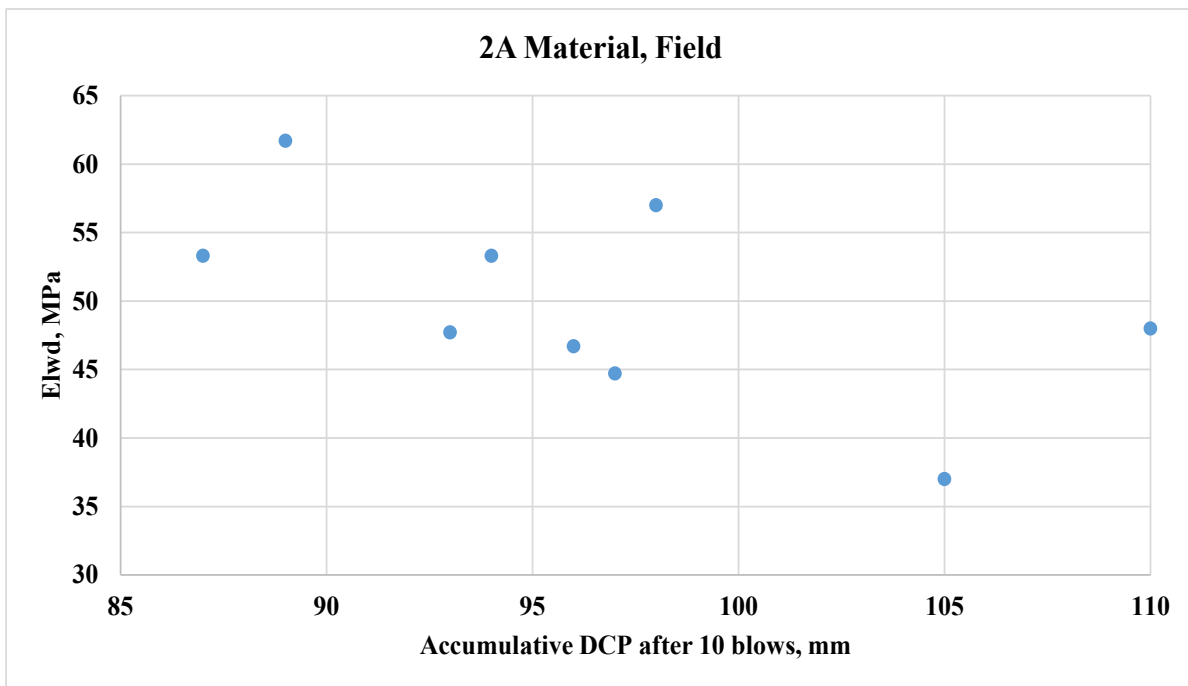
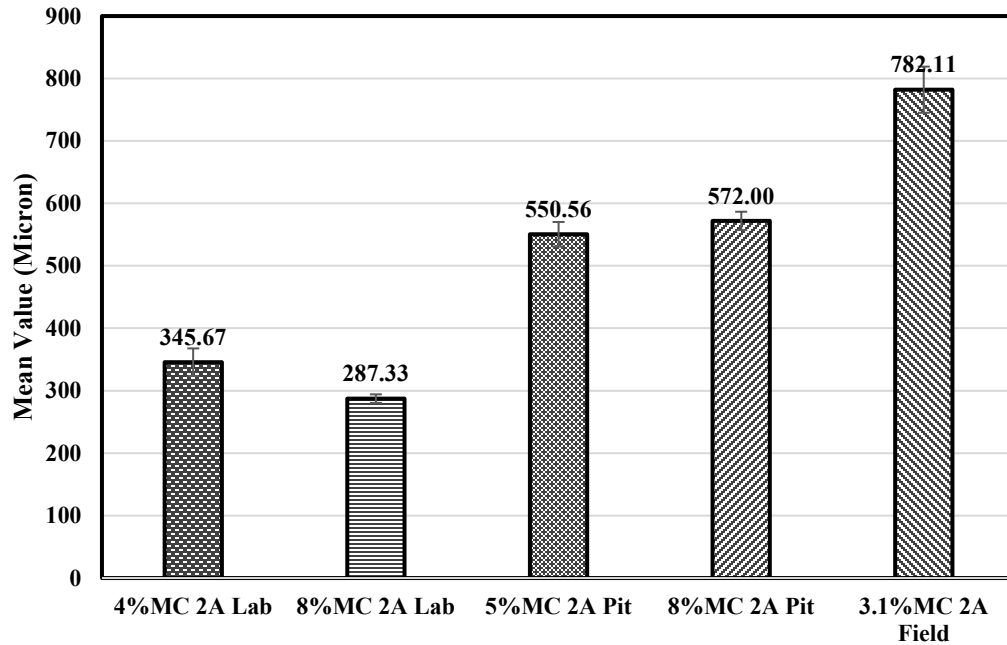


Figure 123. Replotting the E-DCP data after removing a single point of highest penetration.

## LWD DEFLECTION: COMPARISON OF RESULTS BETWEEN TESTS OF VARIOUS SCALES

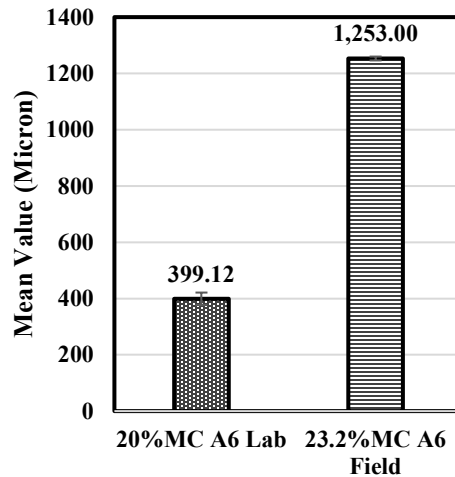
Detailed test results from three different test conditions were presented in preceding sections. These conditions included small-scale testing using the Proctor mold, large-scale testing in a test pit, and field testing. Since the field conditions are completely different from laboratory test conditions, it is important to determine how the test results compare. To compare the differences in LWD deflections between laboratory tests, pit tests, and field tests, results were selected under maximum compaction conditions with almost similar moisture content for the same soil. Despite the availability of numerous laboratory and pit test data (including LWD test data), the field data are confined to only 2A and A-6 soils. Consequently, only these two types of soil were compared. Laboratory LWD data selected for this comparison included 8% and 4% moisture content for 2A, and 20% MC for A6. For pit test LWD data, results were chosen from 5% and 8% MC for the top layer of section 1 after 4 roller passes (S1-L3-4) for the 2A material. This condition of the 2A material was selected, as it showed optimal compaction and aligned with laboratory conditions. For field data, 2A and A-6 were selected with 4 passes and at moisture contents of 3.1% and 23.2%, respectively, for comparison with the 4% MC for 2A and 20% MC for A6 from the laboratory tests. The results are shown in Figure 124.

### Deflection



a. 2A

### Deflection



b. A-6

**Figure 124. LWD Deflections comparison between laboratory tests, pit tests, and field tests.**

In this figure the “lab” refers to testing with the Proctor mold. It can be observed that, regardless of whether the soil is coarser grained such as 2A or highly finer grained such as A-6, the

LWD deflections under the Proctor mold are considerably smaller than those obtained in the field. For 2A soil, one can see that the deflection in the pit is between those obtained for the Proctor mold and the field. This indicates that the support provided by the underlying layer in the laboratory plays a significant role in reducing deflection values. When using the pit for LWD testing, an increase in the thickness of the supporting layer results in increased deflections. At 8% MC, the pit deflection results are approximately twice as high as the deflection in the Proctor mold. The field data shows even greater discrepancies. The deflections for 2A at 3.1% moisture are significantly higher than the 5% MC pit test results and 4% MC Proctor mold results. For the A-6 soil, the field deflection is more than three times higher than the deflection in the Proctor mold. This suggests that the impact of support stiffness on deflection measurement is much more pronounced for fine-grained soils compared to granular soils.

These differences are primarily due to variations in the underlying support. As demonstrated previously by the calculated deflections, different support layers significantly impact both theoretical and actual measured deflections. Additionally, changes in moisture content in the underlying layers and the instability of soil moisture content during field compaction can affect test results. One can see the difficulty in establishing a direct relationship between the small-scale Proctor mold testing and field testing results considering the unpredictability in performance. It will be challenging to calibrate laboratory-measured deflections to match field soil layer deflections,

## **COMPARISON OF MODULUS ESTIMATED FROM CBR (CALCULATED VIA DPI) AND MODULUS FROM LWD TEST**

The LWD deflection and modulus data are investigated in this research for the purpose of field compaction quality control. It may be useful to use this modulus for design purposes. To this end, an investigation was conducted to determine how the LWD modulus compared with the resilient modulus ( $M_r$ ) of the tested material. As no direct measurement of the resilient modulus was conducted for the materials tested in this work,  $M_r$  values were estimated from the DCP penetration index (DPI). First, using the penetration index (mm/blow), an estimate was made of the California bearing ratio of the soil. Knowing that  $M_r$  correlates with CBR with a ratio between 1,300 and 1,500, the CBR values were multiplied by the average value of 1,400 to obtain  $M_r$  in psi, and then converted to MPa units for comparison with the LWD modulus.

As discussed before, the dynamic cone penetration test was conducted at different moisture contents and compaction levels. For the work presented in this section, only the lowest DPI for each soil was selected (representing the stiffest condition) regardless of the moisture content or the number of passes. The selected DPI was matched with the corresponding LWD modulus. Data from both the field and the pit tests were included for this comparison. That covered three of the soils: A6, 2RC, and 2A. The following equations, established from past work (Webster, Grau, and Williams 1992), were used to calculate the CBR (and hence the estimated resilient modulus) and compare it with the modulus obtained from LWD tests. In these equations, PR is the DCP penetration rate in mm per blow, the same as DPI discussed throughout this report.

$$CBR = 292 / PR^{1.12} \quad \text{Eq. (14)}$$

This equation is used for all soils except for CL soils with CBR below 10% as well as CH soils. For these soils, Equations 15 and 16 are recommended by the US Army Corps of Engineers (Webster, Brown, and Porter 1994).

$$\text{Cl soils: } CBR < 10: CBR = 1/(0.017019 * PR)^2 \quad \text{Eq. (15)}$$

$$\text{CH soils: } CBR = 1/(0.002871 * PR) \quad \text{Eq. (16)}$$

The A-6 used in this research is classified as a clayey soil (CL) with a Plasticity Index (PI) of 11. Therefore, Equation 2 was used to determine the CBR for this soil. For all the other soils, Equation 1 was applied. The results are presented in Table 39. Considering the soil variability and the difference among LWD and Mr testing, the results presented in Table 39 are reasonably close. One can see that for the A-6 soil, the estimated Mr and measured LWD are the lowest among all the values presented in the table. There were only two of the soils that were used in the pit testing: 2RC and 2A. The estimated resilient modulus is higher for the 2A material compared with the 2RC material, whereas the LWD modulus shows the opposite. In spite of this discrepancy, one can attest that the data between these two moduli compare relatively well.

**Table 39. DPI-estimated resilient modulus ( $M_r$ ) versus the LWD measured modulus.**

<b>Soil</b>	<b>Location</b>	<b>Max DPC Index (mm/blow)</b>	<b>Estimated CBR(%)</b>	<b>Estimated Modulus (psi)</b>	<b>Converted Modulus (MPa)</b>	<b>LWD Modulus (MPa)</b>
A6	Field	51.7	1.3	1808	12.5	19.7
2RC	Pit	25.2	7.9	11,040	76.1	97.6
2A	Field Section A	20.6	9.9	13,850	95.5	51.1
2A	Field Section B	18.2	11.4	15,911	109.7	86.6
2A	Pit	22.7	8.9	12,444	85.8	84.6

## SUMMARY

The primary goal of this research was to evaluate the use of Light Weight Deflectometer (LWD) and Dynamic Cone Penetrometer (DCP) in verifying the compaction quality of highway materials used in subbase and base courses. Historically, density-based criteria have been predominantly used to assess the subgrade/base compaction quality. This study sought to assess the viability of LWD and DCP as tools for quality control/assurance in the compaction of highway sub-base and base materials in Pennsylvania.

Five different aggregates were selected for examination in this study: 2A, 2RC, A-4, A-6, and OGS (open-graded stone). Various tests, including LWD and DCP, were performed on these materials to investigate their compaction quality. Additionally, the study included analysis to determine how moisture content and compaction levels influence the modulus of elasticity. Testing was conducted at three different levels in terms of scale of testing: small-scale laboratory testing, large-scale laboratory testing, and full-scale field testing. The work began with small-scale laboratory tests on all five materials to determine their optimum moisture content using the Proctor mold test. Following this, LWD modulus test was conducted on samples at their optimum moisture content.

The study progressed to large-scale laboratory testing in a test pit, focusing on evaluating compaction at a larger scale compared to testing in the Proctor mold. The construction of a layered soil system within the pit presented substantial challenges, and due to limited resources, only two materials, 2A and 2RC, were selected for compaction and subsequent testing. These materials were evaluated at three distinct moisture content levels to examine the effects of moisture and compaction energy on the soil behavior. LWD and DCP tests were performed on the compacted soils to assess their condition, specifically aiming to determine the impact of compaction energy and moisture content. This was achieved by compacting the first and second layers using a plate compactor and the third layer with a roller compactor, with varying number of passes to simulate different compaction energies. The results from LWD and DCP tests on the compacted first and second layers, as well as after two, four, eight, and twelve passes on the third layer, were instrumental in understanding how compaction energy influences the overall quality of soil compaction.

Field tests constituted the final category of testing. LWD and DCP were used on-site to test 2A and A-6 material, on SR 3014, College Township, Centre County, PA. For A-6, one section was tested, while for 2A, three sections were evaluated. Tests were conducted after 0, 4, and 6 passes to assess the effect of compaction energy on the compaction quality of each section.

## CHAPTER 5

# Summary, Conclusions, Recommendations

### SUMMARY

A PennDOT-sponsored research effort was undertaken to establish test methods, limits, and protocols to implement Lightweight Deflectometer (LWD) and Dynamic Cone Penetrometer (DCP) testing and acceptance criteria for Pennsylvania's subgrade soil and unbound pavement layers. Historically, density-based criteria have been predominantly used to assess the subgrade/base compaction quality. This study sought to assess the viability of LWD and DCP as tools for quality control/assurance in the compaction of highway sub-base and base materials in Pennsylvania.

The project began in July 2022 and was completed in October 2024. As part of this work, a literature review was conducted to determine which state highway agencies use these devices for their compaction quality control. It was found that the Minnesota and Indiana Departments of Transportation have implemented these devices in their specifications in some form. Their work was used as the base for conducting this research.

Five different types of soils, covering a wide range of gradations, were selected for the laboratory study. The materials were PennDOT 2A, PennDOT 2RC, PennDOT OGS (Open-Graded Stone), AASHTO A-4, and AASHTO A-6. Testing was conducted at three different levels in terms of scale of testing: small-scale laboratory testing, large-scale laboratory testing (using a test pit), and full-scale field testing.

The study began with small-scale laboratory testing and progressed to large-scale laboratory testing in a test pit and subsequently field testing. The small-scale laboratory testing encompassed all five soils and was the most extensive portion of the research. For each soil, optimum moisture content was determined in the laboratory using pertinent AASHTO standards. Soils were subjected to testing with LWD at three different moisture contents and three different compaction levels. Attempts were made to choose the moisture contents in a way to bracket the optimum moisture content.

The construction of a 3-layered soil system within the test pit presented substantial challenges, and due to limited resources and time, only two materials, 2A and 2RC, were selected for compaction and subsequent testing in the test pit. These materials were evaluated using LWD/DCP at three

distinct moisture content levels and different numbers of roller passes to examine the effects of moisture and compaction energy on the soil behavior. This was achieved by compacting the first and second layers using a plate compactor and the third layer with a roller compactor, with varying number of passes to simulate different compaction energies. The results from LWD and DCP tests on the first and second compacted layers, as well as after two, four, eight, and twelve passes on the third layer, were instrumental in understanding how compaction energy influences the overall quality of soil compaction.

Field tests constituted the final category of testing. LWD and DCP were used on-site to test 2A and A-6 material, on SR 3014, College Township, Centre County, PA. For A-6, one section was tested, while for 2A, three sections were evaluated. Tests were conducted after 0, 4, and 6 passes to assess the effect of compaction energy on the compaction quality of each section.

An extensive amount of data was collected through both the laboratory and field work. Data were analyzed and conclusions were drawn. Analysis included determination of how moisture content and compaction levels influence the LWD deflection and the soil modulus of elasticity. The results of the work were used to develop a set of recommendations for PennDOT regarding the usage of these devices and corresponding threshold values to control the quality of the compacted subgrade or base in the field. The recommended threshold values are presented in the appendix to this report and are based on this study and subject to validation and/or adjustment as further information and data becomes available from LWD/DCP testing in actual field conditions.

## **CONCLUSIONS**

The general conclusion from this study was that LWD and DCP are useful tools and PennDOT could benefit from including them in its subgrade/base compaction quality control specifications. Specific conclusions were drawn, as presented in the following sections.

The Proctor mold test was employed to identify the optimum moisture content (OMC) for all five soils. The OMC was found to be 9% for 2RC, 8% for 2A, 8.5% for A-4, 15% for A-6, and 3.5% for OGS. Additionally, the Proctor mold test was also carried out with a modified hammer for 2RC and A-4 material. The findings demonstrated that the modified hammer decreased the optimum moisture content for 2RC by about 1% in comparison to the standard hammer.

The results from the Proctor mold test demonstrated that the soil behavior significantly varies with the soil type. Coarse aggregates, for example, respond differently to increases in moisture levels

or compaction energy compared to soils with a high content of fine aggregates. Specifically, aggregates like 2RC, A-4, and A-6, which are rich in fine materials, exhibited a higher modulus at lower moisture levels or in drier conditions than those with a significant amount of coarse aggregate. Additionally, there was a noticeable decrease in the modulus of these soils as the moisture content increased.

The laboratory work with the Proctor mold included LWD testing at various moisture contents. Conducting LWD tests with a 15.2 cm (6-inch) Proctor mold requires careful attention and is challenging, as there is a chance of the device hitting the mold edge. The most important finding from this laboratory experiment was that correlation could not be developed consistently for all soils between the dry density and LWD deflection (or modulus) when tested at different moisture contents. This may be the result of the effect of the moisture content on deflection values masking the density effect on deflection when tested in the Proctor mold. In soils with a high content of fine aggregates, a lack of correlation between dry density and modulus was observed. For instance, samples with lower moisture content showed a significantly high modulus, despite having the lowest density compared to samples with higher moisture. Moreover, in cases where the soil contained a high amount of fine aggregate, an increase in compaction energy generally led to higher density.

A highly important conclusion is that the laboratory-scale LWD deflection values are significantly influenced by the high stiffness of the strong floor (typically concrete) where the mold containing the compacted soil is residing. This effect is substantial and cannot be ignored. A compacted soil at the same moisture content, the same density, and the same thickness would deliver a significantly higher deflection when tested in actual field conditions.

Despite lower deflection values in the laboratory, it was concluded that the laboratory-produced LWD data are useful and could be used as reference to establish the field expected deflection values. The procedure for this transition of LWD deflection values was developed as part of this research study and is explained in the set of recommendations presented as the appendix to this report.

The laboratory work also included the use of different levels of compaction energy, and it was generally found that higher compaction produced lower deflection values unless the energy of compaction became excessive, resulting in over-compaction and increased deflection. For example, for PennDOT 2A material at the optimum moisture content, as the compaction increased from 19 drops of standard hammer to 37 drops and subsequently to 56 drops, the dry density continued

increasing and the LWD deflection continued decreasing, delivering the expected trend. However, further compaction using 112 hammer drops resulted in decrease of density and increase of deflection. In brief, with the 2A material, the highest modulus and density were achieved using standard compaction levels. An increase in compaction level did not result in an increase in density, highlighting the unique response of coarse aggregates to compaction efforts.

The large-scale laboratory work with a test pit made it possible to simulate the field conditions to a better extent and also made it possible to utilize both the LWD and DCP devices. The soils (PennDOT 2A and 2RC materials) were placed in three 15.2 cm (6-inch) layers. Again, the effect of underlying support on the response was evident from the test results. The first layer sitting on the top of a very hard existing soil delivered the lowest deflection compared with the other two layers built on the top of the first layer. The conclusion was the effect of the underlying support on the measured LWD deflection response becomes more pronounced as the soil layer of interest for testing becomes thinner or gets closer to the supporting layer.

The work with the test pit also indicated that the number of roller passes to obtain the lowest level of deflection is driven by the soil moisture content. It was generally found that as the moisture content increased, a lower number of roller passes was required to obtain the lowest deflection (i.e., the highest modulus). The 2RC sample, evaluated in the pit test, showed that a rise in compaction energy typically resulted in a higher modulus, though there were some exceptions across different moisture content levels. Likewise, the DCP test revealed that with an increase in the number of passes, or as compaction energy was intensified, the penetration index decreased for all moisture content levels. The pit test for the 2A aggregate suggested that a higher number of passes typically resulted in decreased deflection (increased modulus) for the last layer, with a few exceptions noted. On the other hand, the DCP test outcomes indicated that an increase in the number of passes led to minimal or no change, or at most a slight increase, in the penetration index, consistent across various moisture content levels.

There were moisture content measuring gauges installed in the test pit. These sensors collect the volumetric moisture content at a selected sampling rate and data are recorded in a datalogger. It was concluded from using these gauges that they can be reliably used to capture the soil moisture content. The gauges can be used either temporarily during placement and compaction or used in place for long-term monitoring of the moisture. A simple conversion is applied to transit from volumetric

water content as measured by the in-situ gauge to gravimetric water content, which is obtained from conventional over-drying.

The field work was limited to two soils (A-6 and 2A). Both LWD and DCP were utilized. For the subgrade A-6 material, no clear trend was found between the LWD/DCP response, and the number of roller passes, possibly because the soil was already compacted and densified under existing layers and vehicle traffic. For the 2A material, it was generally found that 4 passes of the roller delivered the lowest deflection (highest modulus). However, the DCP results did not follow the same trend.

## **RECOMMENDATIONS FOR FUTURE WORK**

This study included five different soils tested with a single LWD device. The study was focused on generating data for PennDOT toward the use of LWD/DCP for compaction quality control. Based on the conducted research, several areas are recommended for further study to complement the work presented in this report and enhance the reliability of the thresholds and established criteria for compaction quality control.

There is a need to do more extensive laboratory work with the materials compacted in cylindrical molds. While all five soils for this research were tested with LWD in a 15.2 cm (6-inch) Proctor mold, testing with a larger diameter mold (20.3 cm (8-inch) mold) was limited to the 2RC material. Testing LWD with larger-sized molds may provide more reliable results compared with using the LWD 148-mm ( $\approx 6$  inches) plate because of better stability in testing and leaving a margin between the edge of the LWD plate and the edge of the mold. Albeit, using a larger mold requires more soil and more effort in preparing a compacted specimen.

This study was also limited to a specific gradation within each soil type. It is recommended to include variation in gradation within each soil type to study the effect of particle size distribution on the soil deflection and modulus under LWD testing.

For this research, only two soils were tested in the large-scale laboratory study using the test pit. This part of the experiment required a considerable amount of work and extensive manpower but provided invaluable information as needed to develop the required criteria. It is highly recommended that more soil types be tested through such an experiment to provide data for increasing the reliability of recommended thresholds. If possible, the dimensions of the test pit could also be extended to allow more room for compaction using the steel-wheel rollers.

Additionally, experimenting with a composite layer system for materials in the subbase and base layers is suggested. For instance, using A-6 material as the underlying layer in the test pit, topped with 2A material as the base layer, could help in exploring the interaction between the layers and the effect of the layer composition on the LWD test response. The test pit configuration could also be utilized to study the effect of geocomposite interlayers on the soil stiffness using LWD and DCP.

Finally, this study was limited to conducting LWD/DCP for one single field project. While attempts were made to include a second field project, the time of construction of such project did not align well with the time of this research and was not included in the work. It is important to include LWD/DCP testing with two or more field projects, as the test results in the field are ultimately the most important data to consider in deciding the quality of the compacted subgrade and base materials.

# References

- AASHTO. (2003). *Standard Method of Test for Determining the Resilient Modulus of Soils and Aggregate Materials*.
- Agency, H. (2006). *Design Guidance for Road Pavement Foundations (Draft HD25)*. Stationery Office London.
- ASTM. (2007). Standard Test Method for Density and Unit Weight of Soil in Place by the Sand-Cone Method. In *D1556-07; American Society for Testing and Materials: West Conshohocken, PA*.  
<https://www.astm.org/d1556-07.html>
- ASTM. (2016). *Standard Test Methods for Determination of the Impact Value (IV) of a Soil*.  
<https://www.astm.org/d5874-16.html>
- BS. (1990). Methods of Test for Soils for Civil Engineering Purposes. In-Situ Tests; British Standards Institution: Milton Keynes, UK. In *ASTM*.
- Charles Schwartz, Xiong Zhang, Nayyar Siddiki, & Andrew Dawson. (2021, September 29). *Ensuring Construction Quality Assurance with Light Weight Deflectometers | National Academies*. TRB Webinar-Transportation Research Board.
- Danielle Tan, Kimberly Hill, & Lev Khazanovich. (2014). Quantifying Moisture Effects in DCP and LWD Tests Using Unsaturated Mechanics - Google Search. In *Minnesota Department of Transportation*.  
<https://www.lrrb.org/pdf/201413.pdf>
- Davich, P., Camargo, F., Larsen, B., Roberson, R., & Siekmeier, J. (2006). Validation of DCP and LWD Moisture Specifications for Granular Materials. *Minnesota Department of Transportation*.
- Edwards, P., & Fleming, P. (2009). LWD Good Practice Guide. *PFG Pavement Foundation Group*.
- Ferguson, N., & Gautreau, G. (2021). *Quality Control/Assurance on Base Course and Embankment With the Dynamic Cone Penetrometer*. Louisiana Transportation Research Center.
- Fleming, & Frost. (2002). In-Situ Assessment of Stiffness Modulus for Highway Foundation During Construction. *Loughborough University, Loughborough, UK*.
- Fleming, P. R., Rogers, C., & Frost, M. (2000). A Comparison of Devices for Measuring Stiffness In-Situ. *Proc. of the 5th Int. Symp. on Unbound Aggregates in Roads (UNBAR 5), Edited by Dawson, A., Balkema, Pp. 193-200*.

- George, K. P. (2006). Portable FWD (Prima 100) for in-situ subgrade evaluation. *Mississippi Department of Transportation*. <https://doi.org/10.21949/1503647>
- Geotechnical Engineering Bureau. (2015). *Test Method for Earthwork Compaction Control by Sand Cone or Volumeter Apparatus* .
- Geotechnical Section, M. (2017). *MnDOT Grading and Base Manual*.
- Glagola, C., Rilko, W., Agdas, D., Avila, L., Zheng, X., & Patel, J. (2015). *Performance-based quality assurance/quality control (QA/QC) acceptance procedures for in-place soil testing phase 3*. Florida. Dept. of Transportation.
- Hariprasad, C., Umashankar, B., & Garala, T. K. (2019). Lightweight deflectometer for compaction quality control. *Lecture Notes in Civil Engineering*, 16, 35–42. [https://doi.org/10.1007/978-981-13-0899-4\\_5](https://doi.org/10.1007/978-981-13-0899-4_5)
- Hossain, M. S., & Apeageyi, A. K. (2010). *Evaluation of the lightweight deflectometer for in-situ determination of pavement layer moduli*. Virginia Transportation Research Council.
- Jardine, R. J., Potts, D. M., Higgins, K. G., Brandl, H., & Adam, D. (2004). Load plate test with the light falling weight device. In *Advances in geotechnical engineering: The Skempton conference: Proceedings of a three day conference on advances in geotechnical engineering, organised by the Institution of Civil Engineers and held at the Royal Geographical Society, London, UK, on 29–31 March 2004 (Vol. 39)*.
- Kessler, K. (2009). Use of DCP (Dynamic Cone Penetrometer) and LWD (Light Weight Deflectometer) for QC/QA on Subgrade and Aggregate Base. *Geotechnical Special Publications 193*. [https://doi.org/10.1061/issno\(352\)9](https://doi.org/10.1061/issno(352)9)
- Kongkitkul, W., Saisawang, T., Thitithavoranan, P., Kaewluan, P., & Posribink, T. (2014). Correlations between the Surface Stiffness Evaluated by Light-Weight Deflectometer and Degree of Compaction. *Tunneling and Underground Construction.*, 65–75. <https://doi.org/10.1061/9780784413449.007>
- Li, Y. (2004). Use of a BCD for compaction control. *Ph.D. Thesis, Dept. of Civil Engineering, Texas A&M University* .
- Lee, J., & Lacey, D. (2021). *Best practice in compaction quality assurance for pavement and subgrade materials: 2020–21 Year 5*.
- Makwana, AE. P., & kumar, Dr. R. (2019). Correlative Study of LWD, DCP and CBR for sub-grade. *International Journal of Engineering Trends and Technology*, 67(9), 89–98. <https://doi.org/10.14445/22315381/IJETT-V67I9P215>

- Matthew, W., & John, P. (n.d.). *A review of the lightweight deflectometer (LWD) for routine insitu assessment of pavement material stiffness.*
- Michael A. Mooney, Christopher S. Nocks, Kristi L. Selden, Geoffrey T. Bee, & Christopher T. Senseney. (2008). *Improving Quality Assurance of MSE Wall and Bridge Approach Earthwork Compaction .*
- MnDOT Spec. (2020). *MnDOT Standard Specifications for Construction.*
- Mohammadi, S. D., Nikoudel, M. R., Rahimi, H., & Khamehchiyan, M. (2008). Application of the Dynamic Cone Penetrometer (DCP) for determination of the engineering parameters of sandy soils. *Engineering Geology*, 3–4(101), 195–203. <https://doi.org/10.1016/J.ENGGE0.2008.05.006>
- Mondal, R., Fazle Rabbi, M., Smith, D., & Mishra, D. (2022). Compaction studies on open-graded aggregates using portable impulse plate load test devices. *Construction and Building Materials*, 327. <https://doi.org/10.1016/j.conbuildmat.2022.126876>
- Morian, D. A., Solaimanian, M., Scheetz, B., Jahangirnejad, S., & Quality Engineering Solutions, Inc. (2012). Developing standards and specifications for full depth pavement reclamation. *Pennsylvania Department of Transportation*. <https://doi.org/10.21949/1503647>
- Oman, M. (2004). Advancement of grading & base material testing. *Office of Materials, Minnesota Department of Transportation, Minnesota*, 30p.
- Park, S. S., Ogunjinmi, P. D., Lee, H. il, Woo, S. W., & Lee, D. E. (2021). Effect of Wetting Conditions on the In Situ Density of Soil Using the Sand-Cone Method. *Applied Sciences 2021, Vol. 11, Page 718, 11(2)*, 718. <https://doi.org/10.3390/APP11020718>
- Philips, L. D. (2005). Field Evaluation of Rapid Airfield Assessment Technologies. *ERDC/GSL TR-05-11, U.S. Army Corps of Engineers, ERDC, Vicksburg, MS, .*
- PTM No. 402. (n.d.). *Commonwealth of Pennsylvania DEPARTMENT OF TRANSPORTATION Publication 408/2020 SPECIFICATIONS.*
- Sawangsurriya, A., & Edil, T. (2005). Investigation of DCP and SSG as alternative methods to determine subgrade stability. *Wisconsin Highway Research Program*. <https://minds.wisconsin.edu/handle/1793/53963>
- Schwartz, C. W., Zahra Afsharikia, & Sadaf Khosravifar. (2017). Standardizing Lightweight Deflectometer Modulus Measurements for Compaction Quality Assurance. *Administration, Maryland. State Highway*. <https://doi.org/10.21949/1503647>

- Shafiee, M., Nassiri, S., & Bayat, A. (2013). Evaluation of Light Weight Deflectometer (LWD) for Characterization of Subgrade Soil Modulus (Poster). *Conference and Exhibition of the Transportation Association of Canada*.
- Sidhu Ramulu Duddu, & Hariprasad Chennarapu. (2022). Quality control of compaction with lightweight deflectometer (LWD) device: a state-of-art. *International Journal of Geo-Engineering*.
- Sotelo, M. J., Mazari, M., Garibay, J., & Nazarian, S. (2014). Variability of Moisture Content Measurement Devices on Subgrade Soils. *Geo-Congress 2014 Technical Papers*.  
<https://doi.org/10.1061/9780784413272>
- Thota, S. K., Coa, T. D., and Vahedifard, F. “Poisson’s Ratio Characteristic Curve of Unsaturated Soils.” *Journal of Geotechnical and Geoenvironmental Engineering*, vol. 147, no. 1, Jan. 2021,  
[https://doi.org/10.1061/\(asce\)gt.1943-5606.0002424](https://doi.org/10.1061/(asce)gt.1943-5606.0002424).
- Tirado, C., Fathi, A., Rocha, S., Mazari, M., & Nazarian, S. (2018). *Deflection-based field testing for quality management of earthwork*. Texas Department of Transportation. Research and Technology Implementation
- Webster, S.L., Grau, R.H. Williams, T.P., (May 1992), “Description and Application of Dual mass Dynamic Cone Penetrometer”, Report GL-92-3, Department of the Army, Washington D.C., Pg. 19
- Webster, S.L., Brown, R. W., Porter, J.R. (April 1994), “Force Projection Site Evaluation Using the Electric Core Protection (ECP) and the Dynamic Cone Penetrometer (DCP)”, Technical Report No. GL-94-17, Air Force Civil Engineering Support Agency, U.S. Air Force, Tyndall Air Force Base, Florida
- Weidinger, D. M., & Ge, L. (2009). Laboratory Evaluation of the Briaud Compaction Device. *Journal of Geotechnical and Geoenvironmental Engineering*, 135(10), 1543–1546.  
[https://doi.org/10.1061/\(ASCE\)GT.1943-5606.0000111](https://doi.org/10.1061/(ASCE)GT.1943-5606.0000111)
- Zhao, G. , Yao, Y. , Li, S. , & Jiang, Y. (2018). Maximum Allowable Deflection by Light Weight Deflectometer and Its Calibration and Verification (No. FHWA/IN/JTRP-2018/21). *Purdue University. Joint Transportation Research Program*.

# APPENDIX

## USE OF LIGHTWEIGHT DEFLECTOMETER AND DYNAMIC CONE PENETROMETER FOR QUALITY CONTROL OF SUBGRADE, SUBBASE, AND BASE COMPACTION

### Objective of this Document

The objective of this document is to provide guidance on the use of the Lightweight Deflectometer (LWD) and Dynamic Cone Penetrometer (DCP) in deciding the quality of compacted subgrade soil as well as subbase or base aggregate in Pennsylvania construction projects. It is intended for use by PennDOT, construction contractors, consultants, and those involved with the design and construction of underlying pavement or infrastructure layers.

### Scope

The content presented in this document includes two parts: (1) relevant terminology, references, and background information related to the use of LWD and DCP for compaction quality control, and (2) field application of the devices (LWD, DCP, and moisture sensors) and the corresponding criteria.

### Terminology

- **Density:** mass per unit volume of a material, reported in  $\text{lb/ft}^3$ ,  $\text{kg/m}^3$ , or  $\text{g/cm}^3$
- **Gravimetric Moisture Content (GMC):** the weight of the water in a soil mass reported as a percent of the weight of dry soil; the term “Moisture Content” by default refers to GMC
- **Gravimetric Water Content (GWC):** the same as GMC. Water content by default refers to GMC
- **Volumetric Moisture Content (VMC):** the volume of the water in a soil mass reported as a percent of the total volume of the wet soil
- **Volumetric Water Content (VWC):** the same as VMC
- **Optimum Moisture Content (OMC):** the gravimetric water content giving the highest dry density of a soil mass for a given compaction standard in a laboratory test
- **Moisture Sensor:** a sensor embedded in the soil to measure the soil volumetric water content
- **Datalogger:** the device connected to the moisture sensor for collecting volumetric moisture content at a specified data collection frequency

- **LWD:** *Lightweight Deflectometer, a device used to capture soil stiffness related properties through a drop weight and geophone and/or accelerometer sensors*
- **DCP:** *Dynamic Cone Penetrometer, a device used to capture soil stiffness and strength related properties through the use of a penetrating cone under drop impact of a hammer with a known weight (either 8 kg or 4.6 kg)*
- **Deflection:** *the soil surface deflection under LWD*
- **Modulus:** *a soil engineering property representing soil stiffness; calculated using stress and strain developed within the soil*
- **DPI:** *Dynamic Cone Penetration Index, an index defined as the ratio of total penetration over the number of blows reported as mm/blow or inches/blow*

## Reference Documents

- **AASHTO T 99:** Standard Method of Test for Moisture-Density Relations of Soils Using a 2.5-kg (5.5-lb) Rammer and a 305-mm (12-in.) Drop
- **AASHTO T 180:** Standard Method of Test for Moisture-Density Relations of Soils Using a 4.54-kg (10-lb) Rammer and a 457-mm (18-in.) Drop
- **AASHTO M 145:** Classification of Soils and Soil-Aggregate Mixtures for Highway Construction Purposes
- **AASHTO T 265:** Standard Method of Test for Laboratory Determination of Moisture Content of Soils
- **AASHTO T 310:** Standard Method of Test for In-Place Density and Moisture Content of Soil and Soil-Aggregate by Nuclear Methods (Shallow Depth)
- **ASTM E2583:** Standard Test Method for Measuring Deflections with a Lightweight Deflectometer
- **ASTM D1556:** Standard Test Method for Density and Unit Weight of Soil in Place by Sand-Cone Method
- **ASTM D2167:** Standard Test Method for Density and Unit Weight of Soil in Place by the Rubber Ballon Method
- **ASTM D6938:** Standard Test Method for In-Place Density and Water Content of Soil and Soil-Aggregate by Nuclear Methods (Shallow Depth)
- **ASTM D698:** Standard Test Methods for Laboratory Compaction Characteristics of Soil Using Standard Effort (12,400 ft-lbf/ft<sup>3</sup> (600 kN-m/m<sup>3</sup>))
- **ASTM 7759:** Standard Guide for Nuclear Surface Moisture and Density Gauge Calibration1
- **PennDOT Spec 408/206:** Placement and Compaction of Embankment and Fill
- **PennDOT Spec 408/210:** Subgrade

## Principles of LWD and DCP Operations and Corresponding Criteria

This section outlines the fundamental principles governing the use of the Light Weight Deflectometer and Dynamic Cone Penetrometer in field testing. The operational principles of LWD and DCP are

based on experimental data and research findings, developed in alignment with the existing guidelines and standards from other states.

1. The LWD applies a dynamic load to the soil surface and measures the resulting deflection, providing an assessment of soil stiffness. The data gathered from LWD tests are essential for determining the elastic modulus of subgrades, which is a critical factor in pavement designs.
2. The DCP drives a cone into the soil with a standard hammer, and the depth of penetration per blow is recorded. This provides a rapid assessment of soil strength and compaction, typically correlating with California bearing ratio (CBR) values.
3. The recommended criteria for LWD and DCP operations are generally determined based on the laboratory and field data and validated through test strip testing. A tiered approach can be used in deciding the governing criteria depending on the size and scale of the project. For smaller projects, the previously recommended values can be applied according to the soil type. For larger projects, some level of laboratory and/or field measurements will be needed.
4. The criteria for these operations are based on soil classification, ensuring that the methods and standards can be applied effectively for different soil types.
5. Calibration of both LWD and DCP should follow standardized methods to ensure accuracy and consistency.
6. The establishment of a test strip is critical for verifying the chosen LWD and DCP criteria. A well-prepared test strip allows for the evaluation of soil performance under controlled conditions.
7. The test strip should be representative of the materials to be used in the actual project.
8. For both the test strip and the actual routine application, the locations for LWD testing, DCP testing, and installation of the moisture sensors must be representative of the full range of conditions expected on-site, including varying soil types, moisture levels, and compaction areas.

These principles serve as a foundation for establishing recommended criteria, calibration methods, test strips process, and the installation of moisture sensors.

## **Establishing Criteria for Field Application of LWD/DCP**

### *A Review of State of Practice*

Assessing the quality of compaction for subgrade and subbase/base layers varies among different state highway agencies. Some make a decision based on non-movement of the compacted soil, a process that relies solely on the experience of the operator of the compaction equipment and the judgement of the inspector-in-charge or the representative as stated in Section 206 of PennDOT Construction Specification 408. The idea is to continue compaction until no displacement of the

material is observed under the roller and no shoving or shearing of the material to the sides or to the back and front of the compaction equipment is observed.

Some other states require a quantitative measure of density (and therefore, adequacy of compaction) through a nuclear gauge (ASTM D6938), the sand cone test (ASTM D1556), or the rubber balloon method (ASTM D2167). Note should be made that both D1556 and D2167 were withdrawn from ASTM standards of testing in 2024. Each of these procedures has its own advantages and limitations, and they are not the subject of this document for detailed coverage. One major limitation with measuring density using sand cone or rubber balloon methods is that the test is conducted after completion of compaction. Therefore, monitoring compaction level through the process of rolling is not possible. Furthermore, the density test results are not immediately available because of the time it takes to dry the soil, even though rapid drying techniques have been developed. In the case of the nuclear gauge, calibration of the gauge and establishing correlation between the gauge results and another direct measurement technique of density (such as the sand cone test) is highly recommended.

A few states have investigated the use of more advanced techniques such as the lightweight deflectometer and dynamic cone penetrometer. There have also been research efforts in using Ground Penetrating Radar (GRP) for estimating the density and water content of some subgrade soils. The advantage of LWD is that it provides a measure of soil engineering property (modulus) through a rapid process. The idea is to use surface deflection, or the soil modulus measured by LWD, to decide the quality of compaction, an indirect way of ensuring that the required density is achieved. A similar statement could be made regarding the use of DCP, except that the response from DCP is the total penetration of the cone into the soil under a set number of blows. Total penetration is used to determine the dynamic cone penetration index (DPI) and is reported in average penetration for one blow. In any case, proper and reliable use of the LWD/DCP for quality control of compaction in the field requires understanding the soil type and construction requirements such as the optimum moisture content (OMC), thickness of various layers built over the subgrade, and the target compaction level for each layer.

### Use of the Nuclear Gauge

Calibration of the nuclear gauge is essential for reliable density and moisture measurements. Both ASTM D7759 and D6938 address the gauge calibration. The process involves conducting standard counts on a reference standard block. Field calibration uses representative site materials, and actual density and moisture content are determined through comparison with other methods (such as the sand cone method). These materials are measured using a nuclear density gauge at different densities, and a relationship curve between the instrument readings and the actual density is established. The gauge is then used to ensure 95% of the laboratory Proctor maximum dry density (or any other percentages as specified) is achieved in the field.

### Challenge with Determination of Optimum Moisture Content

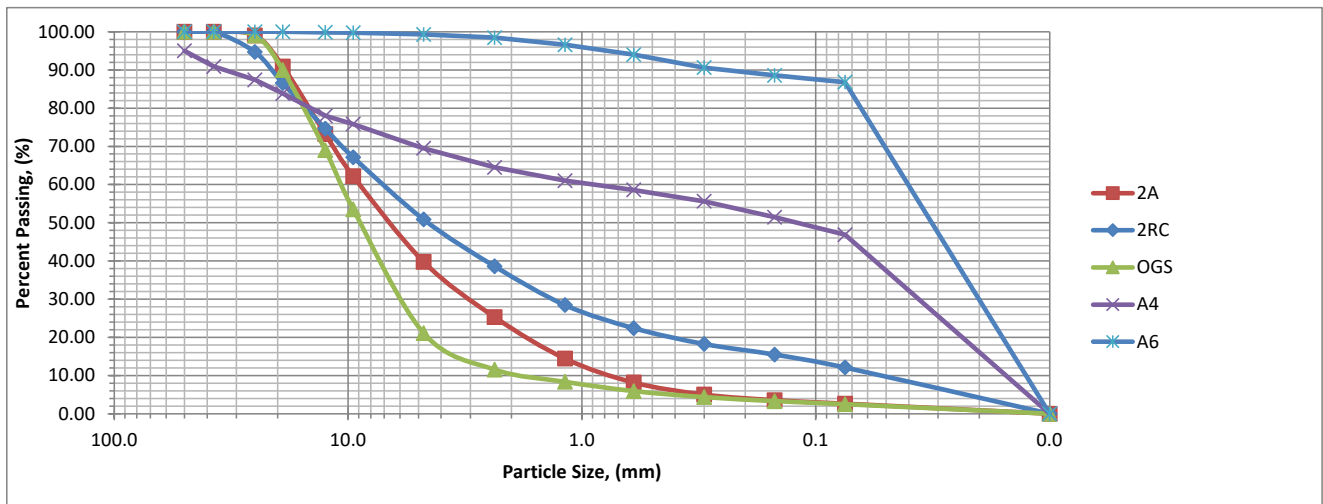
Certain soils, such as those with a large proportion of coarse particles, may not yield accurate results using the standard Proctor test for determination of optimum moisture content. For soil mixtures with 30% or less retained on the 19.0 mm (3/4 in.) sieve, the modified Proctor test (ASTM D1557 and AASHTO T 180), which applies higher compaction energy, can be used. This test utilizes a heavier 10-lb (4.54-kg) hammer dropped from a greater height of 18 inches (457 mm), delivering approximately 4.5 times more compaction energy than the standard Proctor test. Both AASHTO T 99 (standard Proctor) and T 180 (modified Proctor) allow use of 4-inch and 6-inch molds. For large size materials, using the 6-inch mold is utilized, as it allows the soil specimen weight increase to around 13 lb (5.9 kg) compared to 5 lb (2.3 kg) for 4-inch molds. In any case, for use of LWD with the Proctor compacted soil, the mold diameter must be at least 6 inches, and the use of the 4-inch mold is not feasible.

Alternatively, when the Proctor mold cannot be used to establish the OMC using standard or modified protocols, field test sections or non-movement methods using actual construction equipment for compaction can be employed. For example, AASHTO T 310 outlines the use of nuclear methods to measure in-place density and moisture content of soil and soil-aggregate mixtures. These methods enable direct measurement of dry density and moisture content, aiding in the determination of the OMC.

## Soil Classification and the Impact of Soil Type on Results

### Soil Classification Based on PennDOT and AASHTO Standards

Proper determination of the soil type based on established standards such as AASHTO and the Unified Soil Classification System is crucial for reliable interpretation of the results from the Light Weight Deflectometer and Dynamic Cone Penetrometer. In general, the soil type and properties influence the selection of testing methods, the deflection values from LWD, the penetration values from DCP, and the interpretation of results. Use standard tests to determine particle size distribution (gradation) and soil consistency limits (liquid limit, plastic limit, plasticity index, etc.) if needed. Based on these data, categorize the soil using AASHTO soil classification systems and/or PennDOT standards, as required based on PennDOT specifications. The AASHTO standards are widely applied across the country and have high authority and applicability, while the PennDOT specifications can supplement the AASHTO classifications in specific cases, especially concerning the classification of coarse aggregates. These classifications will guide the appropriate testing protocols, parameter settings, and acceptance criteria. An example of gradations for different types of soils is shown in Figure A-1. The figure shows significant difference among the particle size distribution, especially the fine material passing the #200 (0.075 mm) sieve.



The Impact of Soil Type on LWD Test Values.

Different soil types exhibit varying responses in LWD and DCP tests. For example, loose sandy soils tend to show greater displacement and lower penetration resistance than dense clayey soils. Proper classification ensures the selection of appropriate testing standards and parameter settings. As an example, deflection data from LWD are presented in Table A-1 for five soil types examined in the research study used as the base to develop the recommendations included in this document. The LWD deflection data are generated from testing the soil compacted in the laboratory according to ASTM D698 or AASHTO T 99 in a Proctor mold and at optimum moisture content.

**Table A-1 LWD Deflection Values Measured on Proctor Mold Samples at Optimum Moisture Content.**

Soil Type	OMC, (%)	Average Deflection, Last 3 Drops, (micron)
AASHTO A-6	15.0	397
AASHTO A-4	8.5	515
PennDOT 2RC	9.0	533
PennDOT 2A	8.0	242
PennDOT OGS	3.5	367

**Understanding the Relationship Between Dry Density, Moisture Content, Modulus, and LWD Deflection Response**

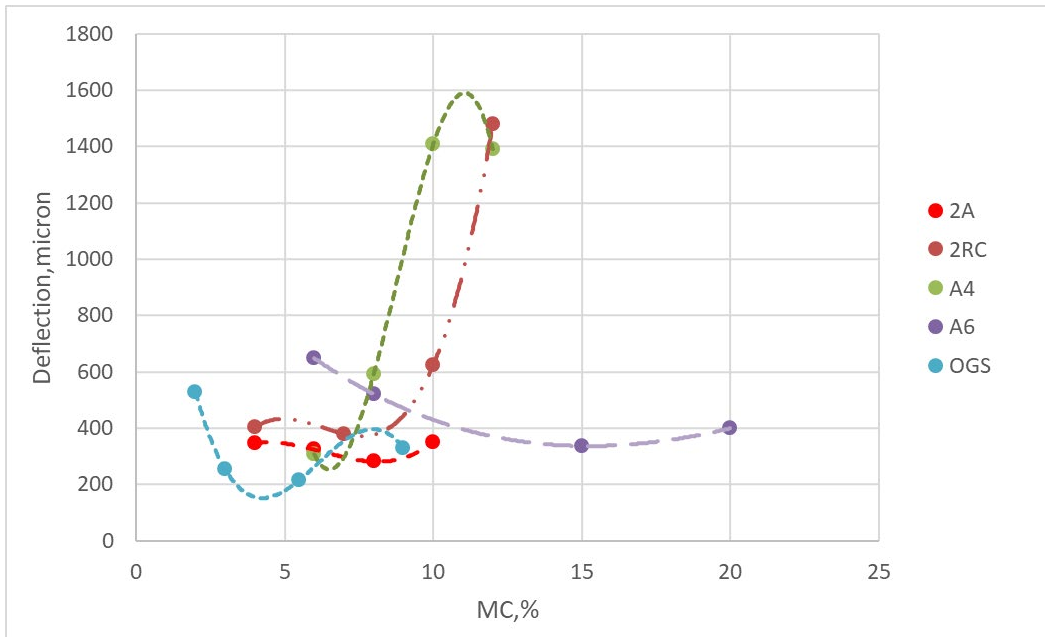
The Impact of Moisture Content on LWD Test Values.

LWD tests are highly sensitive to variations in moisture content. Understanding the impact of moisture content on LWD test values is vital for interpreting test results and making informed decisions regarding soil compaction and stability. An example for the impact of moisture content on soil LWD results is shown in Table A-2 and Figure A-2. A large variation in response is observed in deflection values, not only with respect to the effect of moisture content but also with respect to the soil type. One can see that the deflection response in coarser materials such as 2A and OGS, which have very low fine content, is not so sensitive to moisture content, and that is different from the response of materials with higher fine content such as 2RC and A-4. For 2RC and A-4, a clear trend between the moisture content and deflection is observed. For these two materials, deflection continues to increase as the material's moisture content is increased. For extremely fine soils such as A-6, the effect of moisture level is more complex, showing a decreasing trend but a small variation in

deflection results. The A-6 response does not fit any of the trends shown for other materials. This is possibly due to the high clay content of the A-6 soil, how the clay interacts with the moisture within the soil, and how pore pressure buildup takes place under the load impact and its effect on the deflection response.

**Table A-2 LWD Deflection Values Measured on Proctor Mold Samples at Different Moisture Contents**

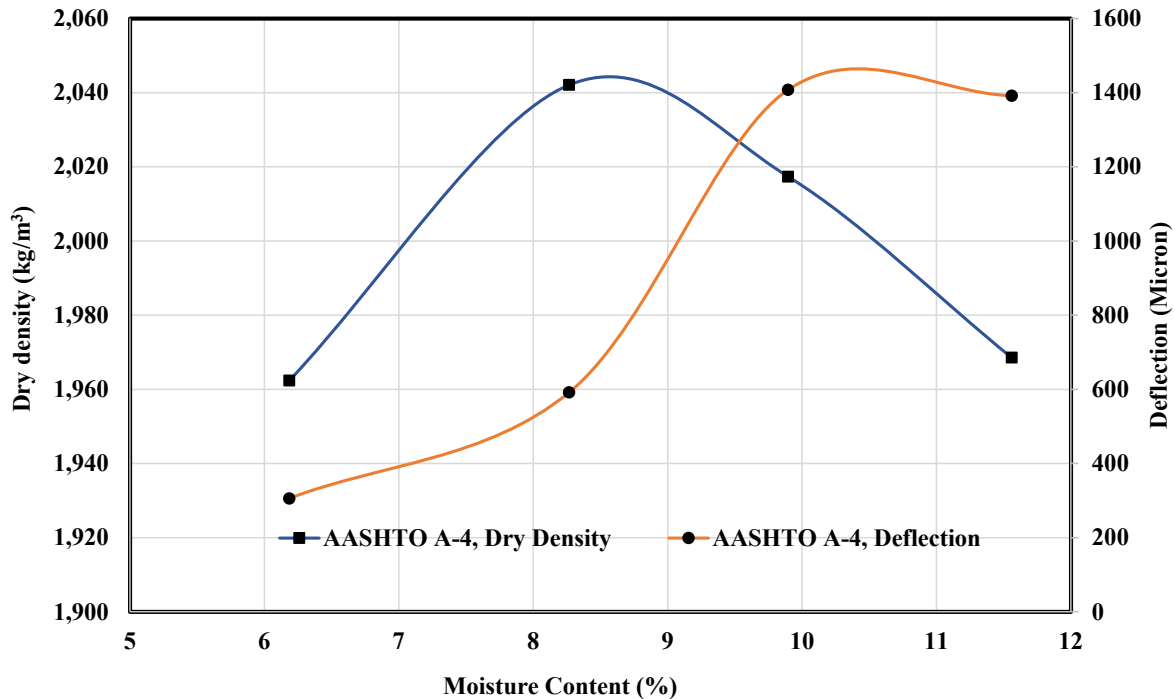
<b>Soil Type</b>	<b>MC, (%)</b>	<b>Average Deflection, Last 3 Drops, <math>\mu\text{m}</math> (micron)</b>
2RC	4.0	402
	7.0	380
	10.0	624
	12.0	1,478
2A	4.0	346
	6.0	324
	8.0	281
	10.0	351
A-4	6.0	306
	8.0	592
	10.0	1,408
	12.0	1,392
A-6	6.0	648
	8.0	521
	15.0	337
	20.0	399
OGS	2.0	528
	3.0	253
	5.5	216
	9.0	329



**Figure A-2 LWD Deflection Values Measured on Proctor Mold Samples at Different Moisture Contents**

Modulus versus Density

Deflection response from LWD is a function of the soil stiffness (modulus). For a given soil type with a specific gradation, the modulus itself is affected by the soil density and the moisture content. In general, higher density and lower moisture content will provide the soil with both higher strength and higher stiffness. Moisture content plays a major role in the LWD deflection response, especially for fine soils. Because of this significant effect, establishing a reliable correlation between the LWD deflection (or modulus) and the soil dry density will be difficult if not impossible, as has been shown by experimental research. For example, LWD testing of A-4 soil compacted in a proctor mold showed that as the moisture content increased from the dry range to the optimum, the deflection continued increasing. At optimum moisture content, the soil had the maximum dry density but the highest LWD deflection. Under dry conditions, as the soil density increases, the stiffness of the soil increases. Such an increase will result in a low deflection response from LWD. However, when the soil becomes wetter, even though the dry density may be at its maximum, the stiffness is reduced, as reflected in the LWD response, showing high deflection. This indicates that for this soil, the effect of moisture content in reducing the soil stiffness dominated the increase in stiffness caused by increase in dry density. Figure A-3 shows this concept.



**Figure A-3 Dry Density and LWD Deflection Measured on Proctor Mold Samples as a Function of Moisture Content for Soil A-4.**

### Calibration of LWD

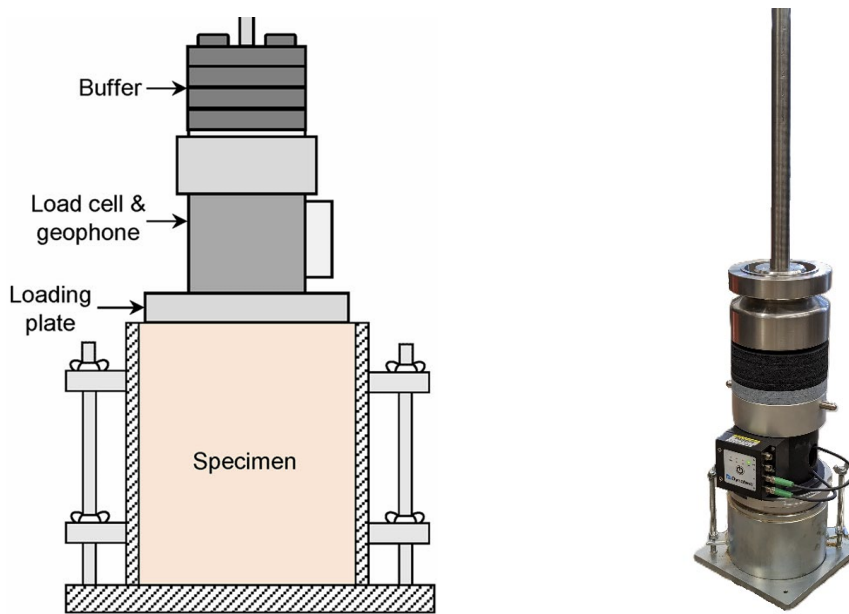
Calibration of LWD is an important step to ensure that reliable data can be generated during the quality control operation. As there may be differences among equipment made by different manufacturers, the calibrating protocol established by the manufacturer of the equipment in use must be followed. The manufacturer’s recommendation must be considered in connection with the calibration procedure described in Section 7 of ASTM E2583. This ASTM standard test method covers using LWD for deflection measurements.

### Method for Determining Acceptance Criteria

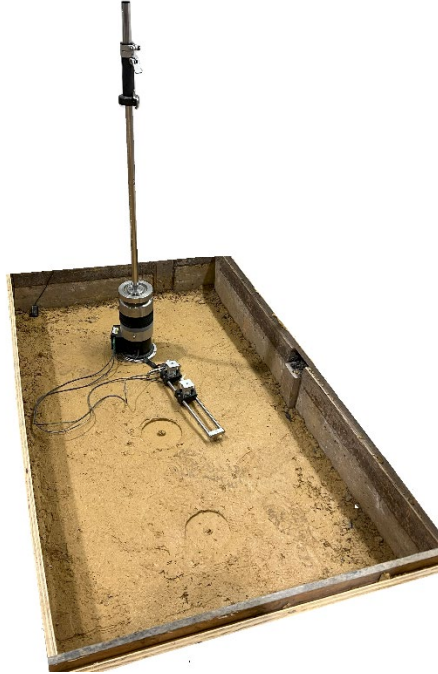
The LWD deflection response is heavily affected by the stiffness of the underlying layers. For example, if LWD is conducted on a soil in a laboratory Proctor mold, sitting on a concrete floor in the laboratory, the deflection values are significantly lower than those obtained for the same soil in the field. Even in the field application, the response of the tested surface depends on the thickness and stiffness of the underlying layers. As the underlying layers become stiffer and thicker compared to the surface layer, the deflection is decreased. The depth of influence of the impact from LWD is

estimated to be between 1.5 and 2 times the LWD plate diameter. For example, for a 6-inch-diameter plate, the influence can be as deep as 12 inches under the plate. Therefore, if a soil layer to be tested is thinner than 6 inches, one should expect the impact of the type and properties of the underlying layer.

A research experiment was conducted to establish a correlation between the proctor lab results and field results. Three conditions were considered in the order of decreasing effect of the underlying layer: lab Proctor test (perform LWD on the material in the Proctor mold), lab pit test (LWD was performed on the test pit with 12\*6.8\*4.5 ft (length\*width\*height). An 18-inch thickness of soils was placed in three layers, each approximately 6 inches thick, and field test performed on site samples that had undergone varying degrees of compaction by a steel wheel roller compactor. LWD testing was conducted for these three conditions. Criteria were developed based on the varying performance of LWD tests conducted in this laboratory (see Figure A-4), pit (see Figure A-5), and field experiments.



**Figure A-4 Schematic and Test Setup of LWD Testing on Proctor Mold**



**Figure A-5 Setup of LWD Testing in a Pit (the extended arm indicates additional geophones if needed).**

In the tests conducted under laboratory and pit conditions, parameters such as moisture content and compaction can be tightly controlled and the support layer typically exhibits high strength and stiffness. For these controlled cases, the LWD and DCP values for deflection and penetration are highly conservative and lower than that in the field. These lab values, when applied to field scenarios, may set overly stringent standards, making them unsuitable for accurate quality control in construction conditions. The relationship between laboratory and pit test results can be used to determine the typical values, while the relationship between laboratory and field test results can be used to establish the maximum values. The typical deflection values from the lab and pit results can serve as reference values, and the maximum deflection values from the lab and field test results can be used for quality control. Therefore, an appropriate correction factor,  $k_1$  and  $k_2$ , can be established based on the current research findings:

$$k_1 \times Value_{lab} \approx Value_{pit} \leq Value_{field} = k_2 \times Value_{lab} \quad (1)$$

For LWD, the relationships were compared between test results conducted in laboratory, pit, and field experiments for two soils: 2A and A-6. By analyzing the performance of these typical materials in the three testing scenarios, the following were observed:

### **1. Correction factor $k_1$ for typical LWD deflection value**

The establishment of correction factor  $k_1$  is based on comparing laboratory data with pit experiment data. For the 2A material, the lab LWD test result at a nominal moisture content of 8% (the actual moisture content of 8.1%) and regular compaction level was 242  $\mu\text{m}$ , while the pit test value was 572  $\mu\text{m}$  (the actual moisture content of 8.3% and measured in the top layer of the 2A placed in three layers in the pit, after 4 passes with highest LWD modulus). The resulting ratio of deflections between these two scenarios was 2.36 times, i.e., the pit delivered 2.36 times higher deflection compared to the Proctor mold.

For 2RC, with a moisture content of 9% (the actual moisture content of 9.3%), the highest LWD modulus (lowest deflection) was achieved after 12 passes, with an average deflection of 962  $\mu\text{m}$  for the last three drops in the pit test, compared to a laboratory result of 533  $\mu\text{m}$  (the actual moisture content of 8.9% with a regular compaction level), resulting in a ratio of 1.80. Considering both soils, using an average factor of 2 as a correction factor ( $k_1$ ) is appropriate for guiding typical field performance parameters. Based on observations and the representativeness of the two soils, the correction factor has a certain general applicability. When using this factor, it is convenient to use data obtained from the laboratory to infer the results of the pit experiments. According to MnDOT and INDOT specifications, the pit test results can be considered suitable reference values to represent the minimum deflection that may be targeted in the field.

### **2. Correction factor $k_2$ for allowable maximum LWD deflection value**

The establishment of correction factor  $k_2$  is based on comparing laboratory data with field data. For the 2A material, as mentioned above, the lab LWD deflection was 242  $\mu\text{m}$  (microns), while the corresponding field value was 782  $\mu\text{m}$ . For the A-6 material, at optimum moisture content, the laboratory LWD deflection was 397  $\mu\text{m}$ , while the field measurement was 1,253  $\mu\text{m}$ . In both cases, the field values were more than three times the lab values.

Considering the research-generated data, correction factor  $k_2$  for the maximum allowable LWD deflection in the field operations can be set to 3. Similarly, this value has general applicability. By using this value, it is convenient to use the data obtained from the laboratory to infer the possible results of field tests, which can serve as the allowable maximum value and the control value for field operations.

### **3. Correction factors for DCP test results**

The DCP test values can be established through a process similar to that for LWD, as presented previously. The criteria apply to the Dynamic Cone Penetration Index, as reported in mm/blow. The recommended maximum allowable DPI for field application was determined based on the DCP test results as employed in the test pit and the field.

#### *Recommended Criteria for the Allowable Maximum LWD Deflection Values for Typical Soil Types*

Review and incorporate standards from other states to provide additional context and benchmarks for the recommended values. This comparison will help align the recommendations with established practices and enhance their applicability. Use empirical data and experience to determine appropriate correction factors to account for variability and uncertainties in the testing process.

#### *Recommended Criteria for the Allowable Maximum LWD Deflection Values at Different Moisture Contents*

Based on the current research, typical values refer to the maximum possible values of field LWD testing under optimal moisture content and compaction conditions. These values are derived by applying a conversion factor to the laboratory test results. The corresponding dynamic modulus is calculated using the typical deflection values at the original selected points, assuming identical conditions for all other factors, as shown in Table A-3. These points are the original measurement points for LWD in the investigation. That is, the stresses at that time were considered, resulting in a more accurate dynamic modulus. Poisson's ratio is assumed to be constant with a value of 0.35 at the corresponding moisture content. At the moisture content of 8.9%, Proctor mold laboratory testing of 2RC yielded a deflection of 533  $\mu\text{m}$ , which is significantly higher than the 380  $\mu\text{m}$  observed at the moisture content of 8.2%. Similarly, for OGS, the Proctor mold laboratory test at 3.4% moisture content yielded 367  $\mu\text{m}$ , which is considerably higher than the 216  $\mu\text{m}$  measured at 4.1% moisture content. To ensure conservatism in the standards, the deflection values of 380  $\mu\text{m}$  and 216  $\mu\text{m}$  were adopted as the representative values for 2RC and OGS, respectively.

**Table A-3 Typical Field Deflection Values Derived from Lab/Field LWD Testing for Several Soils**

Soil Type	Typical Deflection ( $\mu\text{m}$ )	Corresponding Dynamic Modulus (MPa)
A-6	794	35
A-4	1,030	27
2RC	760	30
2A	484	48
OGS	432	65

Using the methods described earlier, standard deflection values can be established for various soil types and moisture conditions. Table A-4 presents the recommended maximum LWD deflection values for different soil types. Field LWD criteria can be calculated using the conversion factor  $k_2$  for specific soils. The corresponding allowable minimum dynamic modulus values are calculated using the typical deflection values at the original selected points. These points are the original measurement points for LWD in the investigation. Comparing Penn State research results with standards from agencies such as INDOT and MnDOT, it could be stated that the Thick Coarse Aggregate No. 53 studied by INDOT is a coarse-grained material, and its allowable average deflection is comparable to requirements for 2A and OGS in the PennDOT/Penn State research study. MnDOT specifies a modulus requirement of 40 MPa for Granular materials and 20 MPa for Clay and Clay Loam, which aligns with the recommended values presented in Table A-4. For A-3 soil, the median values of A-4 and A-2 soils were used.

**Table A-4 Field LWD Criteria for Different Soils**

Soil Types	Allowable Maximum Deflection ( $\mu\text{m}$ )	Allowable Minimum Dynamic Modulus (MPa)
A-6	$\leq 1,191$	23
A-4	$\leq 1,545$	18
A-3	$\leq 1,342$	19
A-2	$\leq 1,140$	20
A-1	$\leq 726$	38

Consider the classifications in Pub 408 Section 206 and AASHTO; both categorize Granular Material differently. Therefore, the subbase materials can be classified as Granular Material Type 1 (the portion classified differently by AASHTO compared to Pub 408 Section 206), Granular Material

Type 2 (the portion defined by Pub 408 Section 206), and soil. According to this classification, the corresponding LWD requirements for different soils can be obtained, as shown in Table A-5. The criteria for fine soils were selected from the larger deflection values and corresponding dynamic moduli of A-4 and A-6. The criteria for Granular Material Type 2 were selected from the larger deflection values and corresponding moduli of A-1 and A-2 materials. The criteria for Granular Material Type 1 were selected from the deflection values and corresponding moduli of A-3 material.

**Table A-5 Field LWD Requirements Based on Modified Soil Classification**

<b>Soil Type</b>	<b>Allowable Maximum Deflection (<math>\mu\text{m}</math>)</b>	<b>Allowable Minimum Dynamic Modulus (MPa)</b>
Soil	$\leq 1,545$	18
Granular Material Type 1	$\leq 1,342$	19
Granular Material Type 2	$\leq 1,140$	20

The criteria in Table A-4 and Table A-5 should be used to evaluate soil compaction at optimum moisture content in the field. If the measured LWD deflection value exceeds the recommended maximum, it indicates that the soil may be under-compacted, and further adjustments or additional roller passes may be needed. Always consider environmental factors and soil variability when applying the criteria. The recommended values serve as a guideline, and field conditions may require adjustments based on practical observations and experience.

*Recommended Criteria for the Allowable Maximum DPI Values for Typical Soil Types*

Recommended maximum DPI values are shown in Table A-6 using the DPI values obtained from Penn State research in the pit and field tests for DCP. For the A-6 material, the DPI value was selected from the field test after 6 passes; for the 2RC material, the test value was selected from the pit test after 12 passes; and for the 2A material, the test value was selected from the field test after 6 passes.

**Table A-6 Typical Field DPI Values for Tested Soils**

<b>Soil Type</b>	<b>Typical DPI (mm/blow)</b>	<b>Estimated Modulus (MPa)</b>
A-6	≤ 49.8	13
2RC	≤ 25.2	76
2A	≤ 20.8	94

According to the requirements set by MnDOT and INDOT, MnDOT's specifications are quite stringent. For coarse aggregates, a maximum value of 12.7 mm/blow is permitted, while for fine aggregates, the allowable maximum value is 22.9 mm/blow. In contrast, INDOT requires a range of 19.1 to 50.8 mm/blow for granular soils. This range significantly exceeds the results obtained from Penn State research. However, it includes a variety of materials such as structure backfill and A-1, A-2, and A-3 soils. Therefore, their specifications are consistent with the results in Table A-6. DCP testing is unaffected by the underlying support layer, so pit and field test results can be directly used as standard values.

For these three typical materials, A-6, 2RC, and 2A, the second-lowest performance values were selected as the maximum limit. For A-6, the slightly lower value after 4 passes was 56.8 mm/blow; for 2RC, the slightly lower value after 4 passes was 38.8 mm/blow; and for 2A, the slightly lower value after 4 passes was 22.9 mm/blow. By comparing these values to their respective optimal numbers, the average difference was calculated to be 1.26 times. Therefore, a correction factor of 1.26 can be used to calculate the maximum allowable value.

Combined with the extreme value limits adopted by INDOT and MnDOT, DPI requirements for different soils are recommended as shown in Table A-7.

**Table A-7 Field DPI Requirements for Different Soils**

<b>Soil Type</b>	<b>Allowable Maximum DPI For a Single Test (mm/blow)</b>
A-6	$\leq 60$
A-4	$\leq 50$
A-3	$\leq 40$
A-2	$\leq 30$
A-1	$\leq 25$

Similarly, if the Modified Soil Classification, as presented in Table A-5, is adopted (i.e., Soil, Granular Material Type 1, and Granular Material Type 2), then the selection principles outlined in Table A-5 are followed for DPI requirements as well. Revision is proposed to PennDOT 408 Specification Section 206, redefining Granular Materials as containing less than 35% fines, rather than the current threshold of less than 20%. Therefore, the allowable maximum DPI values according to the Modified Soil Classification are shown in Table A-8.

**Table A-8 Field DPI Requirements Based on Modified Soil Classification**

<b>Soil Type</b>	<b>Allowable Maximum DPI For a Single Test (mm/blow)</b>
Soil	$\leq 60$
Granular Material Type 1	$\leq 40$
Granular Material Type 2	$\leq 30$

An example is using LWD and DCP to test an actual field section to control the soil compaction quality of that segment. Assume that the deflection and DPI yielded average values of 500  $\mu\text{m}$  and 30 mm/blow, respectively, with the variance falling within an acceptable range. Based on the soil type, the corresponding allowable values can be found in Table A-4 and Table A-7. If the material is classified as A-1, the allowable maximum field deflection is 726  $\mu\text{m}$ , the allowable minimum modulus is 48 MPa, and the allowable maximum DPI is 25 mm/blow. Comparing these standard values, the tested deflection of 500  $\mu\text{m}$  is less than the required value of 726  $\mu\text{m}$  for the compacted

soil, which meets the requirements. However, the tested DPI of 30 mm/blow is greater than the required value of 25 mm/blow, indicating insufficient compaction. If both the DPI and deflection meet the standards, it can be concluded that the quality is acceptable.

*Scope and Limitations of the Criteria for Maximum Deflection and DPI Values*

The criteria for maximum LWD deflection and DPI values are designed to guide the assessment of soil compaction quality to a range of soil types, as identified in Table A-3 and Table A-4. The criteria may not fully account for all environmental factors that can impact LWD measurements. Soil properties can vary significantly within a given soil type. The criteria provide general guidelines, but local variations in soil composition, texture, and structure may affect deflection values and performance.

Users should be prepared to make field adjustments for LWD and DCP testing, and compaction conditions based on real-time conditions and observations. Field adjustments could include additional compaction, adjusting field moisture, removing and replacing under-performing materials, and adding geosynthetics. The criteria should be used as a guideline, with flexibility for practical application and local considerations.

**Techniques of Using LWD Response for Compaction Quality Control**

The information provided previously indicates how the complex reaction between the soil density and moisture content affects the LWD deflection response. Detailed information was also provided on how the LWD deflection response data is used to establish practical criteria. Considering the complexity of the matter and the preceding information provided in setting values, three approaches, as presented in Table A-9, are recommended for controlling the quality of compaction based on LWD deflection data. When encountering special soil types, types of soil not mentioned in this specification, or other special circumstances, a test strip can be used to determine the maximum allowable values for LWD and DCP.

**Table A-9 Methods of LWD Use for Compaction Quality Control**

<b>Approach</b>	<b>Description</b>	<b>Type of Projects</b>	<b>Based on Length of Subgrade Construction (ft)</b>	<b>Based on Traffic Level (ESALs)<sup>(1)</sup>, millions</b>
I	Pre-established Criteria	Small-Scale	Less than 1,000 ft	≤0.3
II	Lab Proctor Based Criteria	Medium-Scale	1,000–3,000 ft	≤3
III	Field Conducted Test Strip	Large-Scale	Greater than 3,000 ft	>3

<sup>(1)</sup> Equivalent Single Axle Load.

The definition of project scale in this document is relative, and the decision of what approach to be used is at the discretion of the state highway agency. As the approach moves to the next higher level, the data become more reliable, but more extensive work is involved in the process.

Approach I: Using Pre-established Values

Use the criteria presented in Table A-4, depending on the soil type and following information provided previously regarding the values of this table.

Approach II: Using LWD Deflection Criteria Using Laboratory Proctor Mold

It is possible to determine the deflection values of a compacted soil at a specified moisture content and use those values to establish the field maximum allowable deflection. The following process shows how this objective can be achieved:

1. Using a Proctor mold, establish the optimum moisture content for the soil according to either AASHTO Standard Method T 99 or T 180. Follow PennDOT requirements in establishing the optimum moisture content.
2. Once the moisture content is established, prepare three Proctor-compacted specimens at 0.5% dry of optimum moisture content.
3. Test the three specimens prepared in Step 2 using LWD according to ASTM E2583.
4. Record the deflection under six repeated load drops of LWD. Use the average deflection for the last three drops.

5. Find the average deflection for three specimens.
6. Use the average deflection from Step 5 and the appropriate multiplication factor to find the corresponding field deflection.
7. A value of 3 can be used for the multiplication factor  $k_2$  to convert the lab deflection data to the field deflection data, as per the method presented in Table A-4. Alternatively, it can be determined independently based on the results from test strip testing.

### Approach III: Test Strip and Site Preparation

#### Situations Requiring a Test Strip

Test strips provide a more direct and effective approach for determining the required values for LWD and DCP tests. The objective of using the test strip is to simulate the field materials and compaction process as closely as possible. The compaction process can then be monitored through assessment of changes in LWD/DCP response after each pass of the rollers. The following scenarios typically require the use of test strips:

1. when there is a need for more precise results and enhanced control; for example, large-sized projects.
2. when the typical soil types listed in Table A-4 are not used.
3. when materials are changed, and further calibration is needed to achieve the required compaction level.

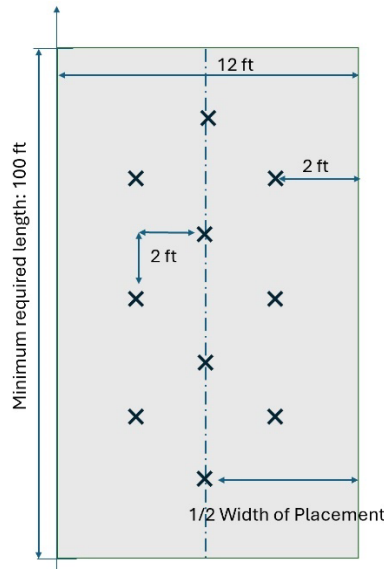
#### Selection of materials

When selecting soil for the test strip, it is essential to choose material that is representative of the soils to be used in the actual construction project. This involves considering various factors, including soil type, texture, and moisture content. The selected soil should reflect the conditions expected in the field, including variations in particle size distribution and plasticity. It is also important to ensure that the soil meets project specifications and standards.

#### Site preparation

Proper site preparation ensures that the test strip accurately reflects the project conditions. The test strip site can be prepared as shown in Figure A-6. The test strip should be long and wide enough to

allow proper rolling and conducting measurements at an adequate number of test spots. A minimum length of 100 ft and a minimum width of 12 ft is recommended. Clean and remove vegetation, debris, and other obstructions from the site to create a smooth, level surface for placement and compaction of material. The underlying materials should also meet the compaction requirements.



**Figure A-6 Test Strip Site Preparation (perform a minimum of 10 tests)**

### Testing process and documentation

1. **Material Placement:** For subbase/base material, the material should be placed in successive lifts of 6 inches (after compaction) or as specified by the project guidelines. Spread each lift evenly and ensure uniform thickness. Select test points within the test strip that represent different areas of the compaction zone. Ensure that the locations cover a range of conditions and center areas. Spread the test points in both longitudinal and transverse directions, as shown in Figure A-6, and mark the points.
2. **Initial Compaction:** Compact the section with a vibratory roller for granular materials and a static roller for soils, applying two passes. One pass consists of covering the entire section once. Do not stop or turn the roller within the test section to maintain consistency.
3. **LWD/DCP Tests:** Perform LWD (or DCP) tests at marked locations (at least 10 points) within the test strip, with a minimum of 10 test locations. For each test location, conduct six drops and use the average of the last three drops as the result for LWD. Test locations on LWD and DCP test strips should be evenly distributed across the entire test area, with random point selection, and a minimum spacing of 2 ft between points. Follow standard testing procedures for measuring LWD deflection or DCP index. Ensure that equipment is calibrated and functioning correctly.
4. Record the values and average the results of these 10 test locations to establish a baseline.

5. After application of two additional passes (3<sup>rd</sup> and 4<sup>th</sup> passes), start reconducting LWD/DCP tests and make measurements of response at the same locations.
6. Continue monitoring the surface condition by conducting additional passes (5<sup>th</sup> and beyond, if necessary) and adjust the roller speed or pass count if needed to prevent over-compaction or surface damage.
7. The maximum allowable deflection (or DPI) for the test section is determined by the lowest average deflection value obtained from the 10 LWD (or DCP) tests after the final compaction.
8. If more than one lift is used, LWD/DCP tests are conducted on each lift separately.

The preceding steps are applicable to construction of subbase/base type material. In the case of subgrade material, application of lifts or use of vibratory mode roller for highly fine materials can be excluded.

#### Criteria for determining valid and invalid points

Valid test points are the points where the LWD deflection values fall within the expected range and meet the criteria for compaction and performance. The control values for LWD and DCP assessments can be determined based on either:

1. the minimum average values measured after achieving the optimal number of compaction passes.
2. the average values correspond to 95% compaction, following guidelines from agencies such as INDOT and MnDOT.

These control values serve as the benchmark for assessing whether the test strip meets the project's compaction standards and can be applied to the larger construction area.

#### Conditions for re-testing

Re-test LWD or DCP if initial results indicate that the test strip does not meet performance criteria or if there are significant deviations from expected values.

After initial compaction, perform 10 LWD tests at marked locations within the test strip and record the deflection values and average the results of these 10 tests to establish a baseline deflection. Apply one additional pass with the roller in either vibratory or static mode as required by specifications. Repeat the LWD testing at the same 10 locations and average the deflection values again.

If the difference between the average deflection values after the fourth and fifth roller passes is  $\leq 0.02$  mm (20  $\mu\text{m}$ ), the compaction is considered complete. If the difference is greater than 0.02 mm, apply another roller pass and conduct the LWD tests again. Continue this process until the difference between the averages of consecutive tests is  $\leq 0.02$  mm.

#### Density Verification through Sand Cone Test (or Troxler Density Gauge)

After completion of compaction and final LWD measurements in the test strip, perform a minimum of five sand cone tests (considering alternatives like Troxler density gauge for faster results) to measure soil density according to AASHTO T 191. The minimum of five locations selected for density measurement should be spread throughout the test strip and be at the vicinity of LWD/DCP test points.

Calculate the average density from the five tests. Compare the average density with the maximum dry density obtained from previous laboratory tests (e.g., Proctor test). Percent compaction can be determined and correlated with the deflection value obtained from the LWD test. It is typically required that the average density be at least 95% of the Proctor maximum dry density.

#### **Measuring Moisture Content in the Field**

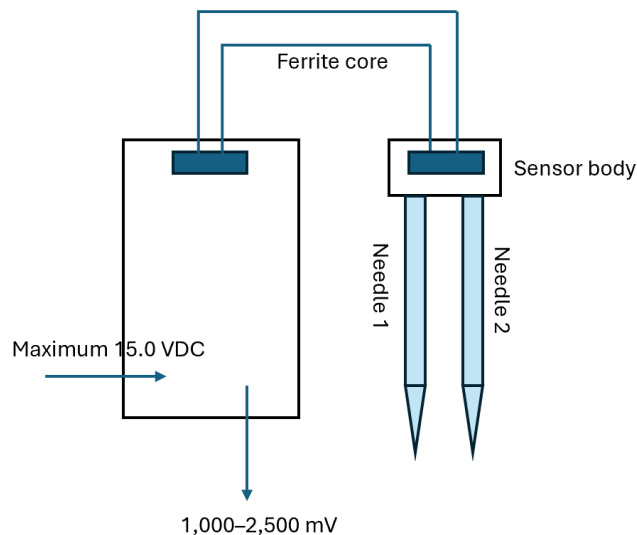
Mixing and compacting the soil, whether it is the subgrade soil or the base material, at the properly established moisture content is essential for quality compaction and achieving the highest density possible. The most accurate technique for determination of the soil water content is taking a properly sized wet sample and drying it in the oven (AASHTO T 265). This is a time-consuming process, and the results are not quickly available during the time of construction. There are devices that could be used during construction to monitor the moisture content, including nuclear and non-nuclear devices as well as time-domain reflectometers (TDR). When LWD and DCP are used for compaction quality control, embedded moisture sensors could be installed to continuously monitor the moisture content. These embedded sensors produce the volumetric water content (VWC) at a set frequency of data collection established in a datalogger. The results are converted to the gravimetric water content (GWC) through specific gravity of the compacted soil.

### Equipment

Soil moisture gauges, also known as soil moisture meters, are specialized instruments designed to measure the volumetric water content in porous materials such as soil. These devices utilize embedded moisture sensors that employ electromagnetic techniques, such as capacitance, time-domain reflectometry, or electrical resistance, to measure the dielectric properties of soil and calculate water content. Consisting of a sensor probe inserted into the soil and a data acquisition system, these instruments provide accurate and continuous moisture measurements. The embedded sensors use sophisticated sensing technologies to detect and quantify moisture levels, allowing for quick and precise readings. Soil moisture gauges are widely used in soil science research, environmental monitoring, and civil engineering. By providing crucial data for informed decision-making about soil saturation quality and environmental conditions, these instruments contribute significantly to improved QA/QC processes across multiple fields.

Based on Figure A-7, the Soil Moisture Gauge consists of several key components:

- Sensor body: This is the main part of the instrument, containing the measurement circuitry and other critical components.
- Needles: Needle 1 and Needle 2 are inserted into the soil for measurements.
- Ferrite core: The ferrite core is used to suppress electromagnetic interference and as part of the circuit.
- Power input: The maximum operating voltage for the instrument is 5.0 volts DC.
- Signal output: The instrument's output signal range is between 1,000 and 2,500 mV.



**Figure A-7 Schematic Diagram of a Soil Moisture Gauge**

### Installation of Moisture Gauge

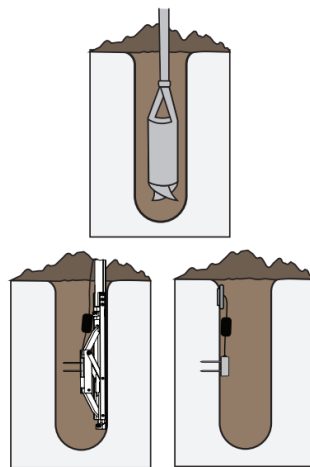
To install a moisture gauge correctly and ensure reliable data collection, it is important to follow a systematic approach that considers both the environmental conditions and the technical requirements of the device.

### Preparation

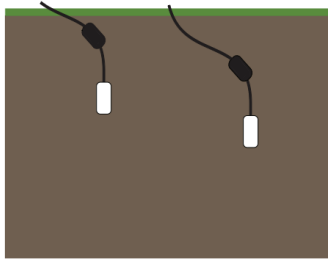
- Gather all necessary tools such as an auger or shovel, protective conduit for cables, and a data logger with its mounting components, and verify that all equipment is functioning properly before installation, as shown in Figure A-8, Figure A-9, and Figure A-10.
- Pre-calibrate the sensor to ensure accurate readings.
- Perform a system check to ensure the sensor and data logger are working properly.
- Plug the sensor into the data logger and confirm that its readings fall within expected ranges. For example, using a verification clip, the readings should be around 0.35 to 0.42 m<sup>3</sup>/m<sup>3</sup>.
- Test the sensor in air and water to ensure proper functionality. It is critical to verify the equipment in a controlled environment to avoid issues during field installation.

The two common methods are drilling (borehole) or trenching. Each method has its advantages and disadvantages:

- Borehole Installation: Minimal soil disturbance and used for deeper installations.
- Trench Installation: Ideal for shallow depths but causes more surface disruption.



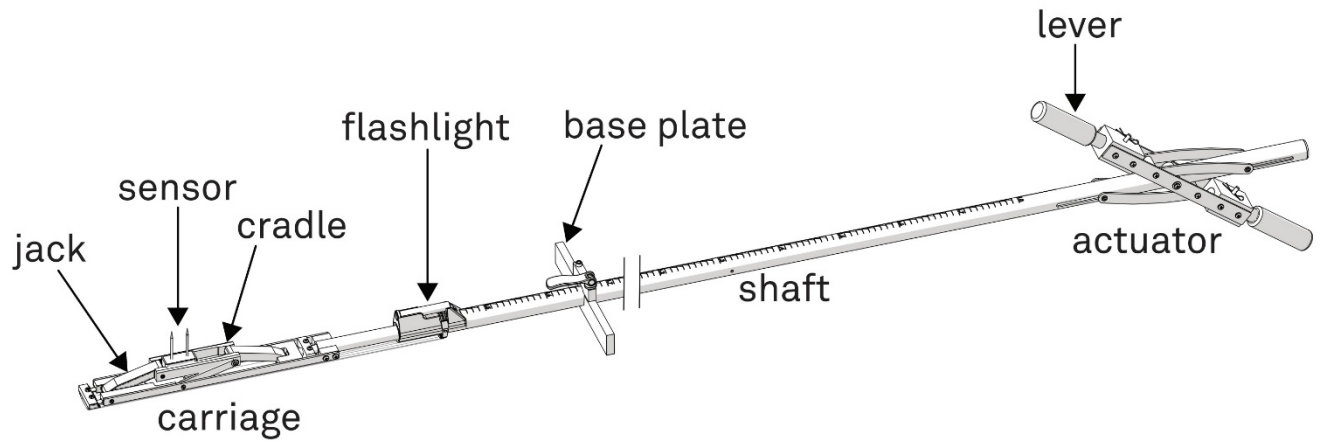
**Figure A-8 Borehole**



**Figure A-9 Trench**

### Installation Steps

- Dig or drill a hole based on the chosen method (drilling or trenching) to the desired depth. A 10-cm (4-in) borehole is augured vertically at the measurement location. Sensors should ideally be installed at depths less than 40 cm, while specialized tools are required for installations deeper than 50 cm.
  - NOTE: For moisture readings taken immediately after layer placement and compaction, the moisture content may not vary much within the depth, and the moisture measurement may be limited to the top and bottom of the soil and the average used as the soil moisture content. At the discretion of the inspector, a single measurement of the moisture content close to the surface may also be deemed adequate. However, if a time delay or other conditions introduce uncertainty regarding moisture variation with depth, it is recommended to excavate a test hole and make at least three measurements at different depths to ensure accurate measurements.
- Be cautious to avoid obstacles such as large rocks, roots, or metal objects that could interfere with sensor functionality or data accuracy. The hole should be the correct depth based on the type of sensor and installation method.
- Place the sensor carefully, ensuring full contact with the soil to avoid air gaps around the sensor probes, as these can lead to inaccurate readings. Vertical installation often provides a more integrated soil moisture profile, though horizontal installation may be preferred for specific depth measurements. Avoid bending the sensor's probes, especially in rocky soil, where careful handling is essential.
- Protect cables from environmental damage by external sources like rodents or weather by covering them with protective tubing and securing them properly. Connect the sensor to the data logger and verify that readings are within the expected range.
- If necessary, backfill the hole with soil, packing it down to restore the original bulk density, avoiding disturbing the sensor or hitting any delicate components during this process.
- After installation, verify that all connections are secure and that the data logger is receiving accurate readings. It is important to document the installation details, including sensor location, depth, and soil type.
- Regular maintenance and inspection are necessary to ensure the sensor continues to perform correctly. Recalibration may be required if the sensor readings begin to deviate from normal levels.



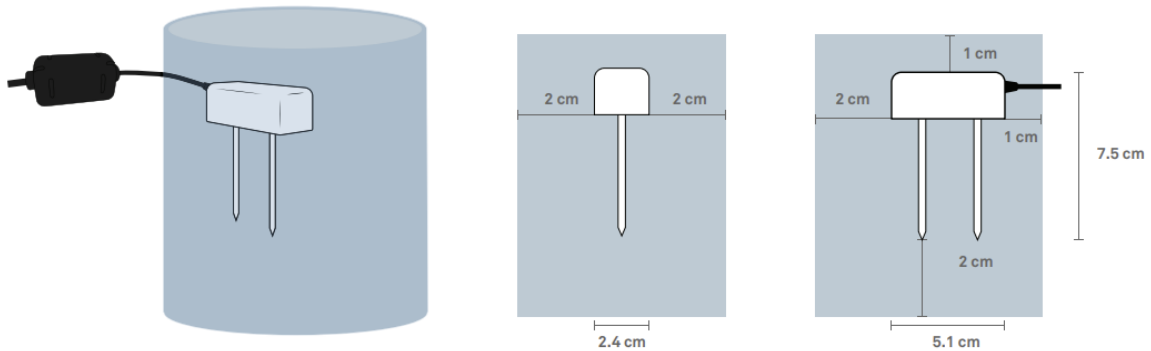
**Figure A-10 Mounted Sensors and Data Logger**

Moisture Gauge Sensor is shown in Figure A-11.



**Figure A-11 Moisture Gauge Sensor**

The testing protocol is shown in Figure A-12.



**Figure A-12 An example of Testing Protocol**

### Calibration Method for the Moisture Gauge

The calibration of a moisture gauge is essential to ensure accurate and reliable measurements of soil moisture content. Calibration involves adjusting the sensor readings to match known reference values, allowing the sensor to accurately reflect the actual volumetric water content (VWC) of the soil.

Moisture gauges measure the VWC in soil, represented by  $\Theta$  (in  $\text{m}^3/\text{m}^3$ ). The raw sensor output, known as *RAW*, is recorded by a meter or third-party data logger.

Moisture gauges are not sensitive to variation in soil texture and electromagnetic conductivity (EC) because they run at a high measurement frequency. This robustness allows for a default calibration equation to yield reasonable absolute accuracy, typically within  $\pm 0.03 \text{ m}^3/\text{m}^3$  for most mineral soils with EC values up to 8 dS/m. However, for enhanced measurement accuracy, particularly in soils with unusual properties, users are encouraged to perform soil-specific calibrations. Generally, a single calibration equation suffices for most mineral soil types with EC values ranging from 0 to 8 dS/m.

VWC ( $\Theta$ ) can be determined using Equation 2:

$$\Theta(\text{m}^3/\text{m}^3) = 1.895 \times 10^{-10} \times \text{RAW}^3 - 1.222 \times 10^{-6} \times \text{RAW}^2 + 2.855 \times 10^{-3} \times \text{RAW} - 2.154 \quad (2)$$

### Example Data

A data table containing 10 recorded entries is presented. Each entry is characterized by the following fields, as shown in Table A-10.

- Timestamp refers to the time at which the record was made.
- Volumetric Water Content ( $\text{m}^3/\text{m}^3$ ) indicates the volumetric water content that is reported for each sample.
- Dry Density ( $\text{g}/\text{cm}^3$ ) represents the dry density, which is obtained through soil testing.
- Gravimetric Water Content (or simply water content, MC) is calculated using the Volumetric Water Content and Dry Density. To perform this conversion, Equation 3 is used.

$$\text{MC} = \text{Volumetric Water Content} \times (1/\text{Dry Specific Gravity}) \quad (3)$$

**Table A-10 Example Data**

<b>Task</b>	<b>Records: 10</b>	<b>Port 1 (Section 1)</b>		
No.	Timestamp	Volumetric Water Content (m <sup>3</sup> /m <sup>3</sup> )	Dry Density of the Soil (g/cm <sup>3</sup> )	MC (%)
1	45147.566	0.115	1.907	6.0
2	45147.569	0.114	1.907	6.0
3	45147.573	0.115	1.907	6.0
4	45147.576	0.115	1.907	6.0
5	45147.580	0.113	1.907	6.0
6	45147.583	0.114	1.907	6.0
7	45147.587	0.114	1.907	6.0
8	45147.590	0.114	1.907	6.0
9	45147.594	0.115	1.907	6.0
10	45147.597	0.113	1.907	6.0

For instance, in the first entry, the Volumetric Water Content is recorded as 0.115 m<sup>3</sup>/m<sup>3</sup>, and the Dry Density of soil is 1.907 g/cm<sup>3</sup>. Applying the conversion, one finds the gravimetric water content to be 6.0%, as shown below.

$$MC = 0.115 \times \left( \frac{1}{1.907} \right) \approx 0.06 = 6.0\%$$

Excellent uniformity of data is noticeable in this table. The range in Volumetric Water Content is between 0.113 and 0.115 m<sup>3</sup>/m<sup>3</sup>, indicating a very small variability.

### **Summary**

This document highlights the critical role of the Lightweight Deflectometer and Dynamic Cone Penetrometer in evaluating the quality of compacted subgrade soil and subbase/base aggregate layers in Pennsylvania's construction projects. It provides essential guidance for practitioners in ensuring effective compaction quality control. The two deciding parameters are the surface deflection from LWD and the dynamic penetration index (DPI) from DCP testing. Three techniques are introduced

depending on the significance of the project, with increasing complexity of the process for higher-level techniques. Maximum limits for deflection or DPI are established either from values that have already been set, depending on the soil type, or found from testing the materials in the laboratory Proctor mold or a test strip in the field. The proctor mold technique is only applicable to LWD. The deflection values obtained from the Proctor mold testing are converted to field values to be the thresholds for compaction quality control. This conversion is conducted through using established multiplication factors depending on the soil type.