

TECHNICAL REPORT DOCUMENTATION PAGE

1. Report No. TX -99/7-4936-2	2. Government Accession No.	3. Recipient's Catalog No.	
4. Title and Subtitle Test Method Tex-899-B Radio-Frequency Interference (RFI) Testing: Trost Draft		5. Report Date February 2001	
		6. Performing Organization Code TechMRT	
7. Author(s) Thomas F. Trost		8. Performing Organization Report No. 4936-2	
9. Performing Organization Name and Address Texas Tech University Department of Civil Engineering Box 41023 Lubbock, Texas 79409-1023		10. Work Unit No. (TRAIS)	
		11. Contract or Grant No. Project 7-4936	
12. Sponsoring Agency Name and Address Texas Department of Transportation Research and Technology P. O. Box 5080 Austin, TX 78763-5080		13. Type of Report and Period Cover Trost Draft	
		14. Sponsoring Agency Code	
15. Supplementary Notes Study conducted in cooperation with the Texas Department of Transportation. Research Project Title: "Test Method Tex-899-B Radio-Frequency Interference (RFI) Testing: Trost Draft"			
16. Abstract 17. This test method assures the compatibility of Texas Department of Transportation (TxDOT) fleet vehicles and VHF FM radio equipment operating in the frequency ranges of 30 to 50 MHz and 150 to 174 MHz. It is intended to identify 90% or more of RFI ingress and egress problems.			
17. Key Words radio interference, noise interference, vehicle generated interference		18. Distribution Statement No restrictions. This document is available to the public through the National Technical Information Service, Springfield, Virginia 22161	
19. Security Classif. (of this report) Unclassified	20. Security Classif. (of this page) Unclassified	21. No. of Pages 170	22. Price

Form DOT F 1700.7 (8-72)

This page replaces an intentionally blank page in the original.

-- CTR Library Digitization Team

Test Method Tex-899-B Radio-Frequency
Interference (RFI) Testing: Trost Draft

by

Thomas F. Trost
Department of Electrical Engineering
Texas Tech University
Lubbock, Texas

Project Number: 7-4936
Research Report Number: 4936-2

conducted for:

Texas Department of Transportation

by the

Texas Tech University
Center for Multidisciplinary Research in Transportation
Box 41023
Lubbock, TX 79409-1023

February, 2001

This page replaces an intentionally blank page in the original.

-- CTR Library Digitization Team

IMPLEMENTATION STATEMENT

Included among the results of the present study is a newly expanded version of the TxDOT Tex-899-B radio-interference test. This version includes several improvements to the original, which serve to make a good test even better. It is recommended that a test document based on this expanded version be included in TxDOT procurement specifications for new motor vehicles.

Time will be required to judge the effectiveness of the expanded test in reducing the incidence of interference problems in new vehicles. At some point, consultation with the vehicle manufacturers to discuss the progress in this regard would seem advisable.

The survey indicates that some other states suffer radio-interference problems similar to those of TxDOT. The test document mentioned above should be sent to these states, so they can benefit from TxDOT's experience. It may also be a good idea to arrange some type of forum with these states, e.g. a special session at a national meeting, to facilitate continued exchange of information on vehicle-generated radio interference.

Prepared in cooperation with the Texas Department of Transportation and the U.S. Department of Transportation, Federal Highway Administration.

AUTHOR'S DISCLAIMER

The contents of this report reflect the views of the authors who are responsible for the facts and the accuracy of the data presented herein. The contents do not necessarily reflect the official view of policies of the Department of Transportation or the Federal Highway Administration. This report does not constitute a standard, specification, or regulation.

PATENT DISCLAIMER

There was no invention or discovery conceived or first actually reduced to practice in the course of or under this contract, including any art, method, process, machine, manufacture, design or composition of matter, or any new useful improvement thereof, or any variety of plant which is or may be patentable under the patent laws of the United States of America or any foreign country.

ENGINEERING DISCLAIMER

Not intended for construction, bidding, or permit purposes.

TRADE NAMES AND MANUFACTURERS' NAMES

The United States Government and the State of Texas do not endorse products or manufacturers. Trade or manufacturers' names appear herein solely because they are considered essential to the object of this report.

SI* (MODERN METRIC) CONVERSION FACTORS

APPROXIMATE CONVERSIONS TO SI UNITS

APPROXIMATE CONVERSIONS FROM SI UNITS

Symbol	When You Know	Multiply By	To Find	Symbol	Symbol	When You Know	Multiply By	To Find	Symbol
LENGTH					LENGTH				
in	inches	25.4	millimeters	mm	mm	millimeters	0.039	inches	in
ft	feet	0.305	meters	m	m	meters	3.28	feet	ft
yd	yards	0.914	meters	m	m	meters	1.09	yards	yd
mi	miles	1.61	kilometers	km	km	kilometers	0.621	miles	mi
AREA					AREA				
in ²	square inches	645.2	square millimeters	mm ²	mm ²	square millimeters	0.0016	square inches	in ²
ft ²	square feet	0.093	square meters	m ²	m ²	square meters	10.764	square feet	ft ²
yd ²	square yards	0.836	square meters	m ²	m ²	square meters	1.195	square yards	yd ²
ac	acres	0.405	hectares	ha	ha	hectares	2.47	acres	ac
mi ²	square miles	2.59	square kilometers	km ²	km ²	square kilometers	0.386	square miles	mi ²
VOLUME					VOLUME				
fl oz	fluid ounces	29.57	milliliters	mL	mL	milliliters	0.034	fluid ounces	fl oz
gal	gallons	3.785	liters	L	L	liters	0.264	gallons	gal
ft ³	cubic feet	0.028	cubic meters	m ³	m ³	cubic meters	35.71	cubic feet	ft ³
yd ³	cubic yards	0.765	cubic meters	m ³	m ³	cubic meters	1.307	cubic yards	yd ³
NOTE: Volumes greater than 1000 l shall be shown in m ³ .									
MASS					MASS				
oz	ounces	28.35	grams	g	g	grams	0.035	ounces	oz
lb	pounds	0.454	kilograms	kg	kg	kilograms	2.202	pounds	lb
T	short tons (2000 lb)	0.907	megagrams (or "metric ton")	Mg (or "t")	Mg (or "t")	megagrams (or "metric ton")	1.103	short tons (2000 lb)	T
TEMPERATURE (exact)					TEMPERATURE (exact)				
°F	Fahrenheit temperature	5(F-32)/9 or (F-32)/1.8	Celcius temperature	°C	°C	Celcius temperature	1.8C + 32	Fahrenheit temperature	°F
ILLUMINATION					ILLUMINATION				
fc	foot-candles	10.76	lux	lx	lx	lux	0.0929	foot-candles	fc
fl	foot-Lamberts	3.426	candela/m ²	cd/m ²	cd/m ²	candela/m ²	0.2919	foot-Lamberts	fl
FORCE and PRESSURE or STRESS					FORCE and PRESSURE or STRESS				
lbf	poundforce	4.45	newtons	N	N	newtons	0.225	poundforce	lbf
lbf/in ²	poundforce per square inch	6.89	kilopascals	kPa	kPa	kilopascals	0.145	poundforce per square inch	lbf/in ²

* SI is the symbol for the International System of Units. Appropriate

(Revised September 1993)

Test Method Tex-899-B (Trost Draft)

RADIO-FREQUENCY INTERFERENCE (RFI) TESTING

February 2001

This test method assures the compatibility of Texas Department of Transportation (TxDOT) fleet vehicles and VHF FM radio equipment operating in the frequency ranges of 30 to 50 MHz and 150 to 174 MHz. It is intended to identify 90 % or more of RFI ingress and egress problems.

Contents

I. DEFINITIONS	2
II. EQUIPMENT	2
III. FACILITIES	3
IV. SAFETY NOTES	3
V. INGRESS COMPATIBILITY	
A. Antenna Qualification	4
B. Ingress Compliance Test for Vehicle	5
C. Vehicle Ingress Qualification	5
VI. EGRESS COMPATIBILITY	
A. Antenna Qualification	6
B. Radio Receiver Qualification	6
C. SINAD Test Options	7
D. Site Qualification	
1. Measurements	8
2. Effective Sensitivity Calculation	9
E. Egress Compliance Test for Vehicle	10
F. Site Qualification—Faster Method	11
G. Egress Compliance Test for Vehicle—Faster Method	12
H. Vehicle Egress Qualification	12

VII. EGRESS COMPATIBILITY– <i>ALTERNATE METHOD</i>	
A. Antenna Qualification	13
B. Egress Compliance Test for Vehicle, Using Modified SAE Test	13
C. Vehicle Egress Qualification	13
VIII. VEHICLE QUALIFICATION FOR ACCEPTANCE	13

I. DEFINITIONS

Ingress (vehicle electromagnetic susceptibility): Any action, reaction, indication, or failure to perform or comply by vehicle equipment and/or accessory items caused by the activation of the VHF FM radio transmitter in any mode of operation

Egress (vehicle electromagnetic emission): Any mode of operation, action, reaction or indication by the vehicle equipment and/or accessory equipment which degrades the VHF FM radio receiver effective sensitivity

II. EQUIPMENT

The following instrumentation is required if sections V and VI are to be carried out. However if section VII is substituted for section VI, then items 3, 4, 5, and 6 are omitted and an EMI receiver or spectrum analyzer, as specified in SAE J551/4 and CISPR 16-1, is required instead. (SAE J551/4: “Test Limits and Methods of Measurement of Radio Disturbance Characteristics of Vehicles and Devices, Broadband and Narrowband, 150 kHz to 1000 MHz,” Society of Automotive Engineers, Warrendale PA, USA, May 2000. CISPR 16-1: “Specification for radio disturbance and immunity measuring apparatus and methods, Part 1: Radio disturbance and immunity measuring apparatus,” International Special Committee on Radio Interference, International Electrotechnical Commission (IEC), Geneva, Switzerland, 1999 [available from American National Standards Institute (ANSI), New York NY, USA].)

1. 100-W VHF FM communications radio (transceiver) capable of operating on all frequencies of interest, such as Motorola *MaraTrac*, with noise blanker switched on. TxDOT low-band VHF channels lie at 47.02, 47.04, 47.06, 47.08, 47.10, 47.12, 47.14, 47.16, 47.18, 47.20, 47.22, 47.24, 47.26, 47.34 MHz.

2. 12-V DC power supply or 12-V battery for radio

3. FM signal generator

4. Signal-to-noise-and-distortion (SINAD) meter, as specified in “Land Mobile FM or PM Communications Equipment Measurement and Performance Standards,” ANSI TIA/EIA-603-1992, Telecommunications Industry Association, Washington DC, USA, February 1993, Section 1.5.1

5. Audio load for radio

6. RF matched three-port coupler with one low-attenuation path, such as a directional coupler with less than 1.2 VSWR, less than 0.5 dB attenuation, about 20 dB or higher coupling, and greater than 20 dB directivity and all parameters essentially constant over the range of test frequencies

7. RF low-power coaxial load
8. Whip antenna with magnetic mount for frequencies of interest
9. Coaxial cable (RG-58 or similar) of sufficient length to reach from the vehicle under test to the test instrumentation. See Figure 1. If the test results are found to be sensitive to the position of the cable or the instrumentation, a suitable external RF choke should be employed. Such a choke could consist of several ferrite beads on the cable or of a 6 ft by 6 ft (1.8 m by 1.8 m) sheet of hardware cloth, laid flat on the test area floor with the coaxial cable making one complete loop approximately four feet in diameter under it
10. RF directional watt meter for radio

III. FACILITIES

1. Free of high ambient RF noise (for egress test)
2. Providing for rotation of vehicle wheels, such as, for example, by raising the vehicle off the floor (for ingress test)
3. Free of large nearby metal objects, except possibly the floor, unless they are covered with RF-absorbing material (for both tests)

IV. SAFETY NOTES

Safety must never be compromised during tests. Hazards exist due to moving vehicle parts, exposed electrical wires, and electromagnetic radiation. Strict compliance with accepted work practices must be observed at all times. Sudden actions may result when the radio transmitter is activated. Stay clear of vehicle and antenna. One person should operate the vehicle, and another the radio.

V. INGRESS COMPATIBILITY

A. Antenna Qualification

Step	Action
1	Locate vehicle at a suitable test site. (See FACILITIES.)
2	Assemble test setup as shown in Figure 1. Solid arrows in figure show signal path.
3	Verify engine is switched off.
4	Provide for rotation of vehicle wheels.
5	Place magnetic-mount antenna in center of vehicle roof. *
6	Key microphone on radio.
7	Record forward RF power to the antenna.
8	Record reflected RF power from the antenna.
9	Adjust length of antenna, if needed, and repeat steps 6 through 8 until forward power is $100\text{ W} \pm 10\text{ W}$ and reflected power is less than 10 % of forward power on all TxDOT channels of interest.

* On some vehicles the roof may be obstructed so that an alternate antenna location, consistent with good radio communications, is required.

The antenna is qualified when the reflected power is less than 10 % of the forward power on all TxDOT channels of interest.

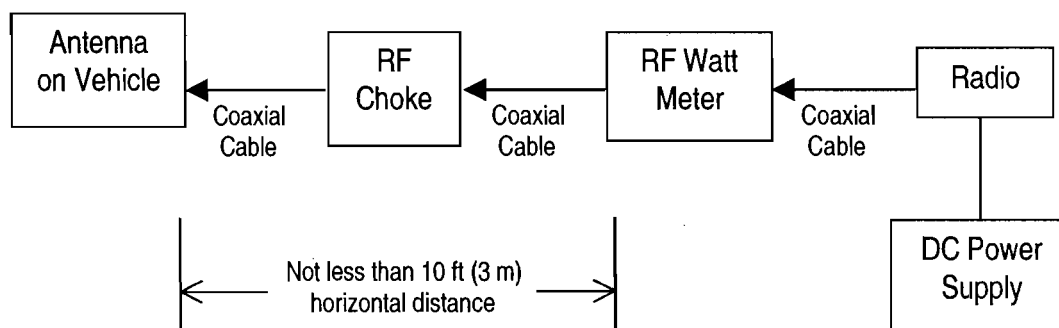

Figure 1. Setup for Antenna Qualification and Ingress Compliance Test

B. Ingress Compliance Test for Vehicle

Step	Action
1	Setup same as in Figure 1. Start vehicle engine.
2	Put vehicle in gear and rotate tires at a moderate speed.
3	Activate one vehicle system or accessory. Be certain to check the braking operation.
4	Activate the radio transmitter for approximately five seconds.
5	Record results as one of the following: 1. No adverse reaction. 2. Reaction resulting in safety hazard. 3. Reaction resulting in a nuisance operation.
6	Repeat steps 3 through 5 until all vehicle systems and accessories are activated.
7	Repeat vehicle qualification for all radio channels to be used.
8	Stop wheels of vehicle and turn off engine.

C. Vehicle Ingress Qualification

The vehicle under test passes the ingress compliance test when no reactions occur which result in a safety hazard or a nuisance operation.

VI. EGRESS COMPATIBILITY

A. Antenna Qualification

The antenna qualification procedure described above in INGRESS COMPATIBILITY serves also to qualify the antenna for egress compatibility testing.

An alternative to this procedure is to use an RF network analyzer instead of the radio and power meter to measure the reflected power and insure that it is less than 10 % of the incident power at the frequencies of interest.

B. Radio Receiver Qualification

Step	Action
1	Assemble test setup as shown in Figure 2.
2	Generate a standard signal (on-channel FM with 1.0 kHz sinewave tone at ± 3.3 kHz deviation) on first test frequency.
3	Vary signal amplitude to establish 12 dB SINAD.
4	Record signal amplitude, that is, receiver basic sensitivity, in dB μ V.
5	Increase signal 6 dB above that in step 4.
6	Increase peak deviation until SINAD is degraded to 12 dB.
7	Record receiver modulation acceptance (bandwidth).
8	Repeat steps 2 through 7 at all remaining test frequencies. (See NOTE 1 below.)

NOTE 1: Test frequencies should include TxDOT channel frequencies plus additional nearby frequencies, in order to detect possible vehicle emissions that, over the course of time, could drift onto TxDOT channels. For the TxDOT frequency band from 47.020 MHz to 47.340 MHz, 61 test frequencies, spaced 10 kHz apart, are required as follows: 46.880, 46.890, 46.900, 46.910, 46.920, 46.930, . . . , 47.430, 47.440, 47.450, 47.460, 47.470, 47.480 MHz.

The receiver is qualified for vehicle acceptance testing if the following conditions hold at all test frequencies:

1. The receiver basic sensitivity value is less than -8 dB μ V (0.4 μ V) for 12 dB SINAD.
2. The receiver bandwidth is a minimum of ± 6.5 kHz and a maximum of ± 8.0 kHz.

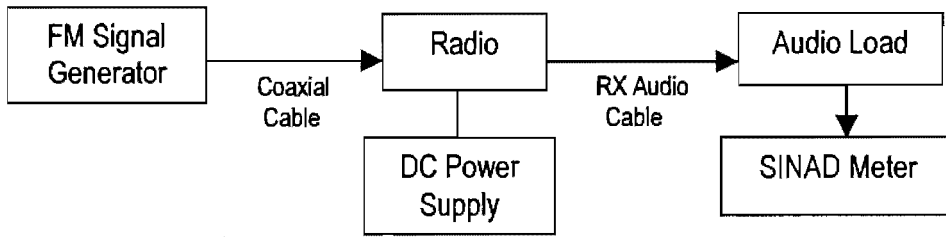

Figure 2. Setup for Receiver Qualification

C. SINAD Test Options

To complete sections D and E below, a large number of SINAD measurements is required because of a multiplicity of frequencies and vehicle conditions. According to the steps shown, in each measurement one adjusts the FM signal generator to give a 12-dB SINAD reading and then records the signal generator amplitude. From this amplitude one calculates the receiver effective sensitivity. After completing the measurements for Site Qualification, one checks to see if all of the receiver effective sensitivity values lie below the $-6 \text{ dB}\mu\text{V}$ limit; and after completing the measurements for Egress Compliance, one similarly checks to see if all of the receiver effective sensitivity values lie below the $0 \text{ dB}\mu\text{V}$ limit.

The process of adjusting the signal generator for 12 dB SINAD on each measurement is time consuming, but it gives one the effective sensitivity and thus allows one to know the dB difference between the effective sensitivity and the limit. If one does not care about the value of this difference but only whether the limit is exceeded and if furthermore the performance of the RF coupler does not vary over the test frequencies, one can save time by employing an alternate measurement procedure that does not require the adjustment for 12 dB. This faster measurement procedure is given in sections F and G as an alternative to the procedure in sections D and E.

At this point one should proceed with the testing by carrying out either sections F, G, and H or sections D, E, and H.

D. Site Qualification

1. Measurements

Step	Action
1	Locate vehicle at a suitable test site. (See FACILITIES.)
2	Assemble test setup as shown in Figure 3. Low-attenuation path of coupler is between radio and antenna or load.
3	Verify that magnetic-mount antenna is located in center of vehicle roof.
4	Disconnect the vehicle battery cable.
5	Terminate the RF line into the RF load.
6	Generate a standard signal (on-channel FM with a 1 kHz sinewave tone at ± 3.3 kHz deviation) on first test frequency.
7	Increase the signal generator RF output level until a 12 dB SINAD indication is achieved.
8	Record signal amplitude, that is, sensitivity into RF load, in $\text{dB}\mu\text{V}$.
9	Disconnect load and connect antenna.
10	Increase signal generator RF output level until a 12 dB SINAD indication is achieved.
11	Record sensitivity into antenna in $\text{dB}\mu\text{V}$.
12	Compute and record the effective sensitivity, using steps in Table (Effective Sensitivity Calculation) below.
13	Repeat steps 5 through 12 at all remaining test frequencies. (See NOTE 1 under <u>Radio Receiver Qualification</u> above.)

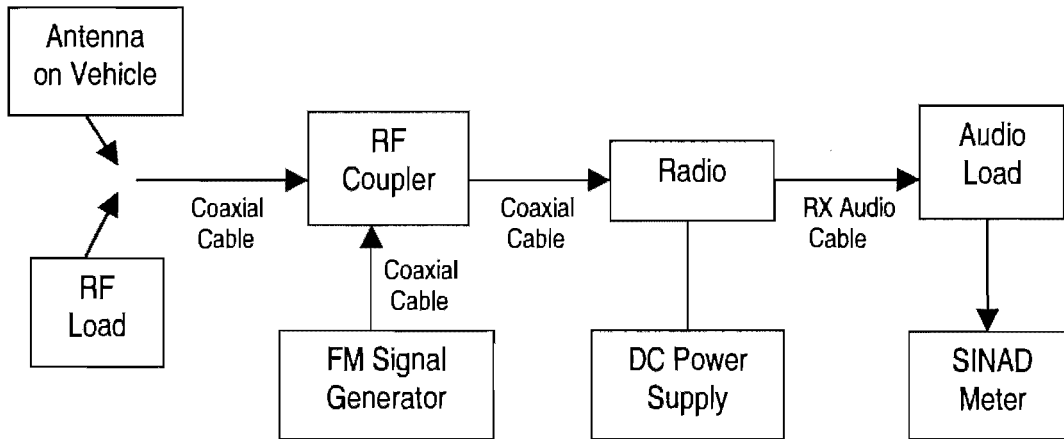

Figure 3. Setup for Site Qualification and Egress Compliance Test

2. Effective Sensitivity Calculation

Step	Action
1	Subtract sensitivity into load from sensitivity into antenna.
2	Record this difference.
3	Add this difference to the receiver basic sensitivity in $\text{dB}\mu\text{V}$.
4	Record the receiver effective sensitivity in $\text{dB}\mu\text{V}$.

The site is qualified if the receiver effective sensitivity value is less than $-6 \text{ dB}\mu\text{V}$ ($0.5 \mu\text{V}$) at all test frequencies.

E. Egress Compliance Test for Vehicle

Step	Action
1	Setup same as Figure 3, with antenna connected. Reconnect the vehicle battery cable.
2	No vehicle systems are activated. Increase the signal generator RF output level until a 12 dB SINAD indication is achieved.
3	Record the signal generator RF output level.
4	Activate one vehicle system or accessory.
5	Increase the signal generator output level until a 12 dB SINAD indication is achieved.
6	Record the signal generator RF output level.
7	Repeat Steps 4 through 6 until all vehicle systems and accessories are activated.
8	Compute and record the effective sensitivity as in Table (Effective Sensitivity Calculation) above.
9	Repeat steps 2 through 8 at all remaining test frequencies. (See NOTE 1 under <u>Radio Receiver Qualification</u> above.)
10	Turn off engine.

F. Site Qualification—Faster Method

Step	Action
1	Locate vehicle at a suitable test site. (See FACILITIES.)
2	Assemble test setup as shown in Figure 3. Low-attenuation path of coupler is between radio and antenna or load.
3	Verify that magnetic-mount antenna is located in center of vehicle roof.
4	Disconnect the vehicle battery cable.
5	Terminate the RF line into the RF load.
6	Generate a standard signal (on-channel FM with a 1 kHz sinewave tone at ± 3.3 kHz deviation) on first test frequency.
7	Increase the signal generator RF output level until a 12 dB SINAD indication is achieved.
8	Record signal amplitude in $\text{dB}\mu\text{V}$.
9	Subtract from this value the value in step 4 of <u>Radio Receiver Qualification</u> and then add $-6 \text{ dB}\mu\text{V}$.
10	Set signal generator RF output level to this value.
11	Disconnect load and connect antenna.
12	If SINAD meter reading is less than 12 dB, the site exceeds the limit; if greater than 12 dB, the site does not exceed the limit. Record result.
13	Repeat step 12 at all remaining test frequencies. (See NOTE 1 under <u>Radio Receiver Qualification</u> above.)

The site is qualified if the SINAD meter reading is greater than 12 dB at all test frequencies.

G. Egress Compliance Test for Vehicle—Faster Method

Step	Action
1	Setup same as Figure 3, with antenna connected. Reconnect the vehicle battery cable.
2	Increase the signal generator RF output level by 6 dB from the value set in step 10 in <u>Site Qualification—Faster Method</u> above.
3	No vehicle systems are activated. If SINAD meter reading is less than 12 dB, the vehicle exceeds the limit; if greater than 12 dB, the vehicle does not exceed the limit. Record result.
4	Activate one vehicle system or accessory.
5	If SINAD meter reading is less than 12 dB, the vehicle exceeds the limit; if greater than 12 dB, the vehicle does not exceed the limit. Record result.
6	Repeat Steps 4 and 5 until all vehicle systems and accessories are activated.
7	Repeat steps 3 through 6 at all remaining test frequencies. (See NOTE 1 under <u>Radio Receiver Qualification</u> above.)
8	Turn off engine.

H. Vehicle Egress Qualification

The vehicle under test passes the egress compliance test when the effective sensitivity value does not exceed $0 \text{ dB}\mu\text{V}$ ($1.0 \mu\text{V}$)— or in the faster method when the SINAD meter reading is greater than 12 dB— for all modes of operation, which includes engine off, engine on, (from idle to partial throttle), and all vehicle systems or any combination thereof.

VII. EGRESS COMPATIBILITY– ALTERNATE METHOD

A. Antenna Qualification

The antenna qualification procedure described above in INGRESS COMPATIBILITY serves also to qualify the antenna for egress compatibility testing.

An alternative to this procedure is to use an RF network analyzer instead of the radio and power meter to measure the reflected power and insure that it is less than 10 % of the incident power at the frequencies of interest.

B. Egress Compliance Test for Vehicle, Using Modified SAE Test

An alternative to the SINAD test specified above in section VI is a modified version of the test described in SAE Standard J551/4. See EQUIPMENT. This is not a SINAD test but rather an RF noise emissions test. The FM signal generator, RF coupler, SINAD meter, and audio load are not required. Instead an EMI receiver or spectrum analyzer, as specified in J551/4 and CISPR 16-1, is used. The J551/4 procedure should be followed with the following modifications:

1. The flow chart in FIGURE 1 and the limits in TABLE 5 of J551/4 are not used.
2. The limit of noise emissions from vehicle electronic modules = -3 dB μ V measured with an EMI receiver or spectrum analyzer with 9 kHz bandwidth connected to the antenna on the vehicle. Module emissions can be measured with the ignition key switched on but engine and all DC motors off. DC motors include those used in fuel pump, HVAC fan, windshield wipers, radiator fan, and electric windows.
3. The limit of noise emissions from vehicle DC motors = 40 dB μ V measured with an EMI receiver or spectrum analyzer with 120 kHz bandwidth connected to the antenna on the vehicle. DC-motor emissions should be measured with all DC motors running (only driver's electric window).
4. Since according to J551/4 the ambient noise emission levels must be at least 6 dB below the vehicle limits and in view of the modified vehicle limits specified in 2 and 3 above, the ambient limits are -9 dB μ V and 34 dB μ V, respectively.

Emissions should be measured at each TxDOT channel frequency of interest plus additional nearby frequencies as mentioned in NOTE 1 in Radio Receiver Qualification. For the TxDOT frequency band from 47.020 MHz to 47.340 MHz, the range 46.980 MHz to 47.380 MHz must be scanned. Peak detection is to be used, with a measurement time of two seconds at each frequency.

C. Vehicle Egress Qualification

The vehicle under test passes the egress compliance test when it meets these limits at all test frequencies.

VIII. VEHICLE QUALIFICATION FOR ACCEPTANCE

The vehicle passes the Tex-899-B test and is qualified for acceptance if it qualifies for Ingress (section V-C) and it qualifies for Egress (section VI-H or section VII-C).