

**TECHNICAL REPORT STANDARD TITLE PAGE**

<p>1. Report No. <b>TX-01 4188-3</b></p>	<p>2. Government Accession No.</p>	<p>3. Recipient's Catalog No.</p>	
<p>4. Title and Subtitle <b>A Study of Expediting Construction of Rigid Pavements in Urban Areas by Using Alternative Pavement Sections</b></p>		<p>5. Report Date <b>August 2003</b></p>	
<p>7. Author(s) <b>O. Melchor-Lucero, J. Weissmann, Y. Wanyan, and S. Nazarian</b></p>		<p>6. Performing Organization Code</p> <p>8. Performing Organization Report No. <b>Research Report 4188-3</b></p>	
<p>9. Performing Organization Name and Address <b>Center for Highway Materials Research The University of Texas at El Paso El Paso, Texas 79968-0516</b></p>		<p>10. Work Unit No.</p>	<p>11. Contract or Grant No. <b>Study No. 0-4188</b></p>
<p>12. Sponsoring Agency Name and Address <b>Texas Department of Transportation P.O. Box 5051 Austin, Texas 78763</b></p>		<p>13. Type of Report and Period Covered <b>Interim Report Sept. 1, 2001 --Aug 31, 2002</b></p>	
<p>14. Sponsoring Agency Code</p>			
<p>15. Supplementary Notes <b>Research Performed in Cooperation with TxDOT</b></p>			
<p>16. Abstract <b>Since most urban roads experience high traffic volumes, there is a high motivation for highway agencies to open a newly constructed highway to traffic as soon as possible. To carry the heavy traffic on these roads, several layers of high-quality or heavily stabilized materials are normally placed during construction. For TxDOT, this usually consists of one or more layers of stabilized subgrade and base, a layer of ACP to act as a bond breaker, and a PCC slab. The large number of layers may be cost-effective from the standpoint of agency costs; however, the number of steps involved in the construction increases construction times, increasing user costs borne by the motoring public. As demonstrated by this project, it may be possible to minimize the number of layers and shorten construction time without compromising the performance of the pavement. This may increase the construction cost, but, considering the user costs, the expedited pavement cross sections are more economical alternatives.</b></p>			
<p>17. Key Words <b>PCC Pavements, Expedited Construction, Users Cost, Opening to Traffic</b></p>		<p>18. Distribution Statement <b>No restrictions. This document is available to the public through the National Technical Information Service, 5285 Port Royal Road, Springfield, Virginia 22161</b></p>	
<p>19. Security Classif. (of this report) <b>Unclassified</b></p>	<p>20. Security Classif. (of this page) <b>Unclassified</b></p>	<p>21. No. of Pages <b>152</b></p>	<p>22. Price</p>

# **A Study of Expediting Construction of Rigid Pavements in Urban Areas by Using Alternative Pavement Sections**

**by**

**Octavio Melchor-Lucero, M.S.C.E., E.I.T.**

**José Weissmann, Ph.D., P.E.**

**Yaqi Wanyan, B.S.C.E.**

**and**

**Soheil Nazarian, Ph.D., P.E.**

**Research Project 0-4188**

**Development of Methods and Materials to Accelerate Construction and Opening of PCC Pavements**

**Conducted for  
Texas Department of Transportation**

**The Center for Highway Materials Research  
The University of Texas at El Paso  
El Paso, TX 79968-0516  
Research Report 4188-3  
August 2003**

The contents of this report reflect the view of the authors, who are responsible for the facts and the accuracy of the data presented herein. The contents do not necessarily reflect the official views or policies of the Texas Department of Transportation or the Federal Highway Administration. This report does not constitute a standard, specification, or regulation.

**NOT INTENDED FOR CONSTRUCTION, BIDDING,  
OR PERMIT PURPOSES**

Octavio Melchor-Lucero, M.S.C.E., E.I.T.  
José Weissmann, Ph.D., P.E. (79815)  
Yaqi Wanyan, B.S.C.E.  
Soheil Nazarian, Ph.D., P.E. (69263)

## **Acknowledgements**

The authors acknowledge James Hunt of TxDOT for his ever-present support. We also acknowledge Charles Gaskin, Al Aramoon, Andrew Wimsatt, Susan Chu, David Hearnberger, Magdy Mikhail, Tomas Saenz, David Stauder, Richard Williammee, Ronnie Van Pelt, and Mark Schluter for providing us with information on current pavement construction practices.

This page replaces an intentionally blank page in the original.

-- CTR Library Digitization Team

## **Implementation Statement**

In this project, procedures and guidelines for expediting the construction of PCC roads were evaluated from the standpoint of structural feasibility and cost effectiveness in terms of agency and user costs. In close cooperation with the five districts that construct the majority of PCC in Texas, a catalog of cross-sections that are feasible for climatic condition, subgrade type, traffic volume of each district are proposed. The proposed cross-sections need to be evaluated from the standpoint of pavement performance, constructability and the compression of construction schedules and consequent reduction of user costs through the implementation of pilot test-sections where these parameters would be carefully monitored.

This page replaces an intentionally blank page in the original.

-- CTR Library Digitization Team

# Table of Contents

Chapter 1.....	1
Introduction.....	1
Previous Work.....	2
Modified Work Plan.....	3
Scope of Report.....	4
Chapter 2.....	7
Alternate Rigid Pavement Sections To Accelerate Construction.....	7
Traditional Pavement Sections.....	7
Selection Process.....	7
Alternate Pavement Cross-Sections.....	14
Alternate Rigid Pavement Cross-Sections Based on Local District Practices.....	18
Alternate Rigid Pavement Cross-Sections with Geosynthetics.....	23
Summary of Rigid Pavement Cross-Sections: Traditional and Alternate.....	25
Chapter 3.....	35
Construction Time and Agency Cost for Rigid Pavements.....	35
Construction Schedules.....	35
Estimating Total Project Duration and Cost.....	36
Assessment of Alternate Cross-Sections for Expediting Construction.....	38
Summary of Relative Construction Time and Agency Cost for Alternate Rigid Pavement Cross-Sections.....	40
Chapter 4.....	51
User Costs Associated with Rigid Pavement Construction.....	51
Introduction.....	52
Components of Road User Costs at Workzones.....	52
Modeling Work Zone User Costs.....	57
Manual Modeling of Work Zone Road User Costs.....	59
Added Capacity Projects Using a “Before versus After” Comparison and Rehabilitation projects Using a “Construction versus After Comparison”.....	61
Chapter 5.....	65
Full Cost Comparison.....	65
District Surveys.....	65
Calculation of Full-Cost Ratios.....	67
Summary of Rigid Pavement Cross-Sections: Traditional and Alternate with Full-Cost Ratios.....	68
Chapter 6.....	81
Summary and Conclusions.....	81
Summary.....	81
Final Remarks.....	82

<b>References .....</b>	<b>83</b>
<b>Appendix A: Traditional Rigid Pavement Sections.....</b>	<b>A1</b>
<b>Appendix B: Determining Potential Vertical Rise .....</b>	<b>B1</b>
<b>Appendix C: Construction Time Analysis Summary .....</b>	<b>C1</b>
<b>Appendix D: Agency Cost Analysis Summary .....</b>	<b>D1</b>

# List of Figures

Figure 2.1. Typical Interface Layer Conditions Used in ISLAB2000 ..... 8

Figure 2.2 Typical Slab Setup in ISLAB2000 ..... 9

Figure 2.3 Stress Contours at Bottom of PCC Slab for ISLAB2000 for Different Loading Regimes. .... 11

Figure 2.4 Stress Contours at Bottom of PCC Slab for ISLAB2000 for Different Moduli of Subgrade Reactions (k)..... 12

Figure 2.5 Slab Deflection Profile under Single Axle Loading for Different Moduli of Subgrade Reactions (k). .... 13

Figure 2.6 Search Algorithm to Determine Alternate Cross-Sections..... 14

Figure 2.7 Tensile Stress vs. Asphalt Thickness for Different Loading Regimes for Typical Slab over HMAC Cross-Sections Placed on a Soft Subgrade. .... 16

Figure 2.8 Tensile Stress vs. HMAC Thickness for Different Moduli of Subgrade Reaction (k) and Different Loading Regimes for a Typical Slab over HMAC Cross-Section..... 17

Figure 2.9 Tensile Stress vs. PCC Slab Thickness for Different Moduli of Subgrade Reaction (k) and Different Loading Regimes for a Typical Full-Depth Slab Cross-Section. .... 17

Figure 2.10 Alternate Rigid Cross-Sections: PVR Compliant under Dry Soil Conditions. .... 21

Figure 2.11 Alternate Rigid Cross-Sections: PVR Compliant under Soil with Average Moisture Conditions. .... 21

Figure 2.12 Alternate Rigid Cross-Sections with Layer of Select Material to Meet PVR Limit. 22

Figure 3.1 Construction Activities Setup and Time-Scale Diagram for Construction Time Analysis. .... 39

Figure 4.1 Work Zone User Cost Components. .... 53

This page replaces an intentionally blank page in the original.

-- CTR Library Digitization Team

## List of Tables

Table 2.1 Layer properties used in ISLAB2000.....	9
Table 2.2 Local Geotechnical Soil Properties Used for PVR Analysis.....	19
Table 2.3 Potential Vertical Rise (PVR) for Natural Subgrade in Dallas District (Dry Soil Conditions) (1 in. = 25.4 mm).....	20
Table 2.4 Minimum Pavement Structure Load to Reduce PVR to Minimum in Dallas District, (Dry Soil Conditions) (1 in. = 25.4 mm).....	20
Table 2.5 Advantages/Disadvantages of Current Construction Practices.....	23
Table 2.6 Alternate Rigid Cross-Sections: Dallas District.....	25
Table 2.7 Alternate Rigid Cross-Sections: Fort Worth District.....	31
Table 2.8 Alternate Rigid Cross-Sections: Houston District.....	32
Table 2.9 Alternate Rigid Cross-Sections: Beaumont District.....	33
Table 2.10 Alternate Rigid Cross-Sections: El Paso District.....	34
Table 3.1 Daily Production Rates for Common Highway Construction Activities: Survey Findings.....	37
Table 3.2 Relative Time and Cost: Dallas District.....	40
Table 3.3 Relative Time and Cost: Fort Worth District.....	46
Table 3.4 Relative Time and Cost: Houston District.....	47
Table 3.5 Relative Time and Cost: Beaumont District.....	48
Table 3.6 Relative Time and Cost: El Paso District.....	49
Table 4.1 Accident reduction attributed to wider lanes.....	56
Table 4.2 Estimates for different accident type costs.....	56
Table 4.3 Summary of VOT Values for Selected States.....	57
Table 4.4 Categories of Candidate Projects for Application of RUC (Daniels <i>et. al.</i> 1999).....	60
Table 4.5 Example of RUC Tables for Added-Capacity Projects (Daniels <i>et. al.</i> 1999).....	62
Table 4.6 Example of RUC Tables for Rehabilitation Projects (Daniels <i>et. al.</i> 1999).....	63
Table 5.1 Calculation of RUC for Freeway and Arterials.....	67
Table 5.2 Sample Full-Cost Ratio Calculation for Alternate Rigid Cross-Section.....	68
Table 5.3 Full-Cost Ratios for Alternate Rigid Cross-Sections: Dallas District.....	69
Table 5.4 Full-Cost Ratios for Alternate Rigid Cross-Sections: Fort Worth District.....	75
Table 5.5 Full-Cost Ratios for Alternate Rigid Cross-Sections: Houston District.....	76

Table 5.6 Full-Cost Ratios for Alternate Rigid Cross-Sections: Beaumont District.....	77
Table 5.7 Full-Cost Ratios for Alternate Rigid Cross-Sections: El Paso District.....	78
Table A.1 Selected Traditional Pavement Sections: Dallas District .....	A3
Table A.2 Selected Traditional Pavement Sections: Fort Worth District .....	A8
Table A.3 Selected Traditional Pavement Sections: Houston District .....	A10
Table A.4 Selected Traditional Pavement Sections: Beaumont District .....	A11
Table A.5 Selected Traditional Pavement Sections: El Paso District.....	A12

# Chapter 1

## Introduction

Several TxDOT districts throughout the state rely almost solely on Portland cement concrete pavements (PCCP), especially continuously reinforced concrete pavements (CRCP), for heavily traveled metropolitan highways and the urban and suburban sections of the interstate system. The goal of most urban projects is to provide smooth and maintenance-free roads to the public with a minimal closure time. Timely opening of the roads to traffic during construction and lane additions is also extremely important.

Highway agencies tend to build pavement sections with several layers of high quality or heavily stabilized materials to withstand the forecasted design traffic. For TxDOT, this usually consists of one or more layers of stabilized subgrade and base, a layer of ACP to act as a bond breaker, and a PCC slab. The large number of layers may be cost-effective from the standpoint of initial costs; however, the number of steps involved increase the construction period, increasing user costs borne by the motoring public, and also in some instances increasing the sensitivity of construction schedules to weather conditions, adding to their overall variability.

TxDOT has not devised a structured procedure to select an appropriate pavement section for a given project. Beg *et al.* (1999) studied a series of parameters that a pavement engineer should account for when selecting a pavement section. Beg *et al.* summarized the results from a survey performed in Texas, nationwide and in some Canadian provinces. The factors that affect the selection process range from soil characteristics, pavement types, pavement performance factors, the lowest life cycle cost, as well as a series of subjective factors. Among the subjective factors are historical construction practices, highway classification, traffic volume, material availability, weather, and drainage and user costs.

The American Association of State Highway and Transportation Officials (AASHTO) provide guidelines for pavement type selection. The 1993 AASHTO design guide suggests the use of engineering procedures and economic analyses as the primary items. The guideline cautions that the structural designs and economic analyses alone are not enough to select a pavement section. The decision-making process requires the consideration of more factors. As the process becomes

more complex, the engineering experience and judgment of pavement managers and designers become more necessary and crucial in the selection process of optimized pavement cross-sections.

Past research has focused on construction or rehabilitation processes to expedite the opening of road sections and urban intersections to traffic in new construction, expansion and rehabilitation or replacement situations. Cole and Voight (1996) and Secmen et al. (1996) have shared their experiences with materials and construction, or have provided guidelines to facilitate the overall planning and execution to expedite the construction process.

## **Previous Work**

Since urban areas throughout Texas, such as Dallas, Houston and Beaumont districts, are rapidly growing and experiencing increasing levels of traffic, maintenance and rehabilitation are required at many locations. Originally, the goal of this project was to combine readily available inter-district experience in the development of an expert system that would suggest pre-design pavement sections, ranked according to construction time or cost. The expert system would have preserved current pavement design procedures, the expertise of the construction engineers, and user cost estimation, to select pavement sections that would optimize and expedite their construction and reduce opening times to traffic.

To develop such an expert system, the research team approached the problem by investigating several alternatives to develop a framework under which realistic design and construction processes could be used for determining cross-sections for faster construction in urban areas, and possibly rural areas as well. First, an exhaustive search for documented and undocumented expertise in expediting highway construction was carried out. More than 40 papers and technical reports were identified. The paper topics ranged from PCC construction materials and material selection, to selection, design, construction and performance of concrete overlays, to criteria for opening to traffic, to expedited construction/reconstruction scheduling and sequencing. The literature survey also resulted in 34 papers on expert system (ES) applications to pavements and civil engineering in general. Appendix A of Melchor-Lucero et al. (2001) summarizes the most relevant information of that literature search.

The second step taken towards the development of the expert system consisted of distributing more than 150 questionnaires, among district pavement engineers, contractors, material suppliers, and members of the Transportation Research Board (TRB) Committee A2F01 that deals with the PCC Pavement Construction. About 25 responses were received. The respondents around the nation and the state, including the five districts that place 90% of the concrete pavement in Texas, addressed the relevant issues in accelerated pavement construction. The researchers also interviewed the staff of the TxDOT Dallas District office. The outcome of the meeting was that the most critical bottleneck to early opening to traffic is the efficient management of traffic operations, for both pavement and bridge construction.

As reflected in Melchor-Lucero et al. (2001), the development of a useful expert system did not seem to be feasible, due to the scarce response from practitioners, and the futile attempts to acquire useful expertise from documented sources. In consultation with the Project Management

Committee (PMC), the development of the expert system was abandoned. After several attempts to acquire useful expertise from documented sources and a series of surveys among district pavement engineers, contractors, material suppliers and national experts, the development of the expert system did not prove feasible because of regional preferences that are ingrained through generations of habitual design practices.

## **Modified Work Plan**

To still address the objectives of the project, a custom-made district-by-district approach was adopted. A sensitivity study on a number of design and construction parameters related to rigid pavements was carried out to identify the pavement layers that may not significantly contribute to the long-term performance of a rigid pavement. These layers could then be eliminated and supplanted by either improving the strength parameters of underlying layers, or thickening and strengthening the overlaying ones.

A second survey was forwarded among districts in Texas to collect “traditional” rigid pavement sections used. Thirteen districts replied to the survey. These districts build six typical pavement sections. Further classifications depend on number of layers in the section and type of layer beneath the PCC slab. For a detailed summary on the traditional rigid pavement sections constructed in Texas, the reader is referred to Report 4188-1 (Melchor-Lucero et al., 2001).

TXDOT’s rigid pavement design is based on the AASHTO 1986 Design Equations, and the statewide federally mandated guidelines as reflected in TxDOT (2001). The sensitivity study showed that the thickness of the PCC slab is not very sensitive to the type and number of layers underneath it. Therefore, any number of pavement sections with the same slab thickness will provide sufficient capacity to carry the design traffic. Consequently, the determination of alternative pavement sections that can expedite the construction of highways from the design standpoint was not feasible. A nationwide attempt to obtain quantitative information yielded no additional information.

A careful evaluation of programs PaveSpec (PaveSpec, 2002), HiperPav (Transtec, 2002) and PCase (PCase, 2002) with respect to identify relevant construction parameters, only yielded a few standard lift specifications. Therefore, due to insufficient construction information, the sensitivity study on the most relevant construction parameters was not feasible.

The next step consisted of identifying the activities that significantly impacted the duration of construction in Texas. Using TxDOT’s guidelines to determine contract time (TxDOT, 1993), and TxDOT’s standard specifications for highway construction (TxDOT, 1995), hypothetical construction schedules using the Critical Path Method (CPM) approach were developed. The treatment and stabilization phases were assessed as the main bottlenecks in traditional construction. This observation was confirmed by a number of District Construction Engineers.

Two prototype alternative pavement structures, with their corresponding construction period, and associated cost estimates were proposed. In the proposed sections, the layers treated with asphalt concrete or full-depth concrete were used instead of lime or cement treated layers. These sections

showed noticeable improvements in time compression, but with higher construction costs as a tradeoff.

A library of alternate pavement sections that would be as structurally sound as the traditional ones, while compressing the construction schedules was then developed. Different alternatives were proposed for Dallas, Fort Worth, Houston, Beaumont and El Paso districts.

The new cross-sections would be determined under the following assumptions:

1. alternate pavement sections would be a function of geographic location, soil characteristics, level of traffic, highway type, among others;
2. alternate pavement sections may differ from those chosen by the districts based on their current practices; for example, slabs may not rest on treated base layers. Also some of the recommendations would be different from those advocated by the Federal Highway Administration (FHWA), in which case, the proposed sections would structurally perform equally or better than the FHWA compliant sections;
3. one set of alternate pavement structures would consist of sections that replace current layers of treated base, with full-depth asphalt concrete, or full-depth PCC concrete, except that the number and thickness of the underlying layers would be reduced, until the minimal structural stress level is achieved;
4. another set of alternate pavement structures would consist of cross-sections that meet current district practices, and/or include layers of materials suggested by the corresponding district offices, based on their experience. These pavement sections should also maintain the minimal performance level specified by each district.

The alternate sections would be determined based on structural evaluation, using mechanistic approaches under different levels of subgrade condition, and levels of traffic loading. Simplified construction times and initial investment costs would be determined for both traditional and alternate pavement structures, using standard estimation tools such as RSMMeans construction indices for comparison purposes. The user costs, for different types of construction, would be combined with the agency costs in a full cost analysis to aid in the selection of the proposed sections.

## **Scope of Report**

The contents of this report describe the determination of alternate rigid pavement structures, and compare their construction time and total cost to traditional practices in various TxDOT districts.

Chapter 2 describes the different alternate rigid cross-sections determined based on the assumptions made for the modification.

Chapter 3 discusses the preparation of simplified construction schedules, and cost estimates for traditional and alternative pavement sections. A comparison is presented from both time and cost standpoints.

Chapter 4 presents discussion of the methods for estimating user costs at work zones is presented. A manual process is recommended for estimating user costs to be used in Chapter 5 to calculate full-cost ratios.

Chapter 5 A summary of a survey of TxDOT District strategies for establishing and managing work zones is presented. Using the construction schedules estimated in Chapter 3 and the user cost estimate discussion presented in Chapter 4, simplified manual procedures for estimating user costs are applied to the traditional and alternate rigid pavement cross sections. Schedule and agency cost estimates discussed in Chapter 3 are combined with the user cost estimates to calculate full cost ratios between the alternate and traditional cross sections.

Chapter 6 summarizes the work accomplished in the second and last year of the project, to accelerate rigid pavement construction through alternate cross-sections.

Five appendices contain summary tables of traditional pavement designs and corresponding alternate rigid pavement designs, as well as their estimated construction times and costs and calculation of full cost ratios between alternate and traditional cross sections.

*This page left blank intentionally*

## **Chapter 2**

# **Alternate Rigid Pavement Sections To Accelerate Construction**

This chapter describes the approach towards the determination of several sets of alternate pavement sections for traditional rigid pavement cross-sections around the State. A brief description of the structural analysis approach, and software used to arrive at the alternate sections that meet the minimal structural criteria are contained in this chapter. In addition, other alternative sections that account for local design and construction practices are presented.

### **Traditional Pavement Sections**

Appendix E of Report 4188-1 (Melchor-Lucero et al. 2001), summarizes the TxDOT traditional rigid pavement sections. The focus was on the top five districts that build approximately 90% of the rigid pavements statewide (i.e., Dallas, Houston, Fort Worth, El Paso and Beaumont). These districts provided a pool of twenty-five traditional pavement sections as graphically depicted in Appendix A. Thirteen sections correspond to Dallas district alone. Dallas classifies its highway facilities into three categories a) Highest Volume Highway, b) Arterial, Frontage and Collector, and c) City/Local Streets. Sections are classified based on this criterion.

### **Selection Process**

A criterion is required to select the structurally-sound alternate rigid pavement cross-sections. The tensile stresses at the bottom of the PCC slab of the traditional sections were used for this purpose. In other words, an alternate cross-section was considered acceptable as long as the tensile stress at the bottom of the slab of that section would not exceed the tensile stress calculated for the traditional section.

To perform the desired pavement layer analysis, KenPave (KenSlab module) (Huang, 1993), Illi-Slab2 (Tabatabaie and Barenberg, 1980), and ISLAB2000 (Khazanovich *et al.* 2000) were

investigated. ISLAB2000, which is a FE analysis program, was specifically selected because of its ability to consider multiple-layer subgrade (Ioannides and Khazanovich, 1998).

The software allows for different layer interface conditions (e.g. fully bonded, fully unbonded, and intermediate). Figure 2.1 depicts the layer interface conditions used in this research. A simplified friction model for analyzing the interaction of a concrete pavement with the layers beneath the slab is implemented in ISLAB2000 (Khazanovich and Gotlif 2002). The model (a.k.a. as Totski model) allows partial shear transfer between layers to prevent the separation between layers. The latest mechanistic-empirical design methodologies and guidelines (AASHTO, 2002) require an “unbonded” layer interface condition for all layers resting on top of the subgrade. Since current construction practices do not account for procedures that ensure full bondage between layers, the “bonded” condition is never considered, regardless of the layer system. ISLAB2000 requires that for any layer interface defined as “unbonded”, the immediate layer interface beneath it must be analyzed with the Totski model.

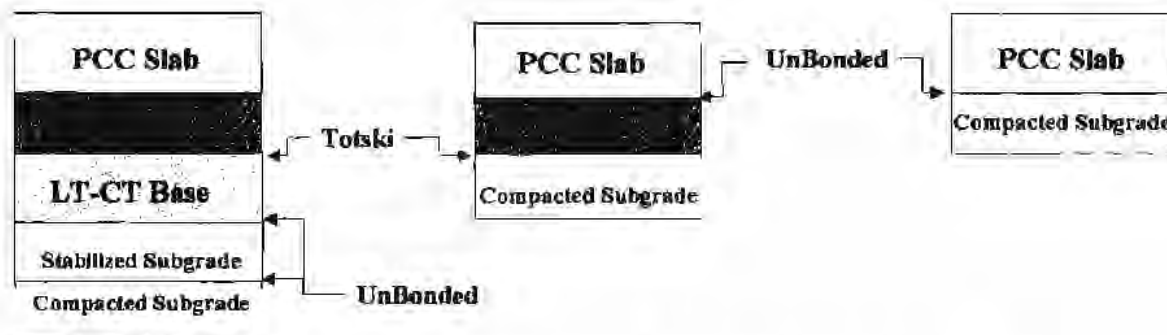

**Figure 2.1. Typical Interface Layer Conditions Used in ISLAB2000**

In the development of the finite element mesh, a typical CRCP slab was considered to be 12 ft. wide by 28 ft. (3.7 m. by 8.5 m). The transverse joints were eliminated by modeling the longitudinal steel reinforcement as continuous through the joint. The FE mesh consisted of (1 ft by 1 ft (0.3 m by 0.3 m) elements as shown in Figure 2.2. Table 2.1 summarizes the pavement layer properties assumed in the analyses. Values are based on local geotechnical data and/or researchers' experience. All layers are assumed to be uniform in thickness and orthotropic, resting on a Winkler foundation.

Two loading conditions were considered for the structural analysis conducted:

1. A standard 18 kip. (80 kN) distributed over four wheel footprints, representing lighter and lower traffic volumes, and
2. A standard 36 kip. (160 kN) dual-tandem load distributed over two-four wheel axles 4 ft (1.2 m.) apart, representing heavier and higher traffic volumes.

The loads are placed at the edge of the slab, aligned with the longitudinal center of the slab. Each tire exerts a pressure of 100 psi (700 kPa). This research study did not contemplate temperature loading because of its general nature.

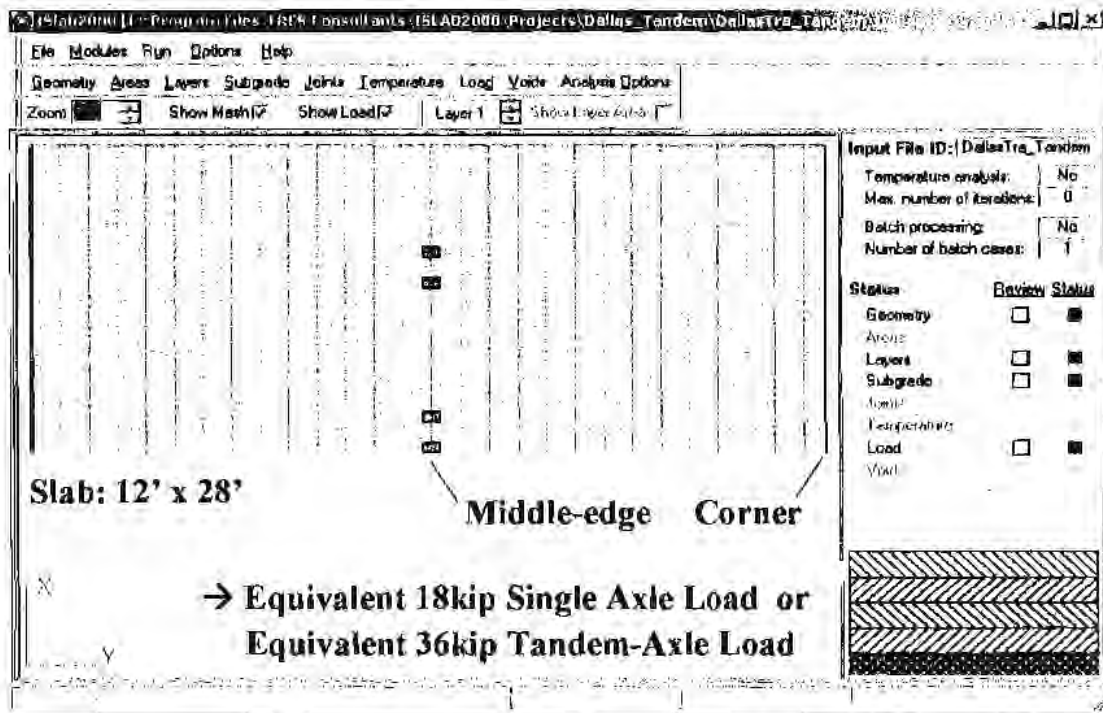

Figure 2.2 Typical Slab Setup in ISLAB2000

Table 2.1 Layer properties used in ISLAB2000.

Layer (1)	Poisson Ratio (2)	Modulus (ksi) (3)	Modulus (MPa) (4)	Unit Weight (pcf) (6)	Unit Weight (kN/m <sup>3</sup> ) (7)
Concrete slab	0.18	4'000	2.758x10 <sup>4</sup>	150	23.614
Bond breaker (asphalt)	0.35	500	3.4475x10 <sup>3</sup>	145	22.8
Hot Mix Asphalt Concrete	0.35	500	3.4475x10 <sup>3</sup>	145	22.8
Cement Treated Base	0.35	1'000	6.895x10 <sup>3</sup>	147	23.072
Lime Treated Base	0.45	50	3.4475x10 <sup>2</sup>	136	21.443
Select Material (Crushed aggregate)	0.35	72.5	5.000x10 <sup>2</sup>	135	21.305
Compacted subgrade	0.45	20	1.379x10 <sup>2</sup>	124	19.543

To account for the various types of subgrade soils and conditions throughout the aforementioned districts (e.g. from the highly compressible clays in Dallas-Fort Worth, to the clayey sands in El Paso), two values of modulus of subgrade reaction (k) were considered. An average modulus of

subgrade reaction of 350 pci ( $95 \text{ MN/m}^3$ ) was considered for the “stiff” subgrade and 150 pci ( $40 \text{ MN/m}^3$ ) for the “soft” one. In cases where bedrock is shallow, a modulus of subgrade reaction of 500 pci ( $13.5 \text{ MN/m}^3$ ) is considered.

The output from ISLAB2000 consists of a text file that includes the input information, and a detailed description of the pavement response at each node of the FE mesh. ISLAB2000 also provides a postprocessor module that graphically displays the interpreted results. Typical pavement layer responses that ISLAB2000 displays include contour plots of stresses in X ( $\sigma_{xx}$ ), Y ( $\sigma_{yy}$ ), and principal directions ( $\sigma_1$  and  $\sigma_2$ ) at the top or bottom of each layer, as well as deflection profiles.

A case study was carried out to compare patterns in pavement response that ISLAB computes when subjected to different loading conditions and levels of subgrade stiffness. The tradition Fort Worth cross-section with a 12 in. (305 mm) slab, 4 in. (100 mm) of HMAC, and 18 in. (457 mm) of lime-stabilized subgrade (see Appendix A) was selected for this case study.

Figure 2.3 depicts stress contour plots at the bottom of the first layer (PCC slab) when the cross-section is resting on a softer subgrade. The left-hand stress contours correspond to the single axle loading, while the right-hand ones correspond to the dual-tandem axle loading. Each contour plot has an associated contour color reference bar, showing the entire stress range developed at the interface. Positive stress values correspond to tensile stresses, while negative values correspond to compressive stresses. As expected, the contour plots in the two directions (X and Y) are different, as well as for each loading condition. The dual-tandem axle loading results in higher stresses in both the X and Y directions when compared to the single axle loading. The maximum tensile stresses are approximately 4% higher in both directions, and the maximum compressive stress is about 50% and 65% greater in the X and Y directions, respectively.

Figure 2.4 illustrates the stress contour plots at the bottom of the PCC slab, in X and Y directions, when the cross-section is loaded with a single-axle load. The right-hand contours correspond to the stiffer subgrade condition, while the left-hand ones correspond to the softer subgrade condition. For the softer subgrade, the maximum tensile stresses in the X and Y directions are about 1% and 15% higher than for the stiffer soil condition, respectively. Conversely, for the stiffer subgrade condition, the maximum compressive stresses are about 7% and 26% higher in the X and Y directions than for the softer subgrade.

Figure 2.5 shows the slab deflection profiles when the pavement structure is loaded under the single axle load. As expected, the deflections are larger for the softer subgrade condition.

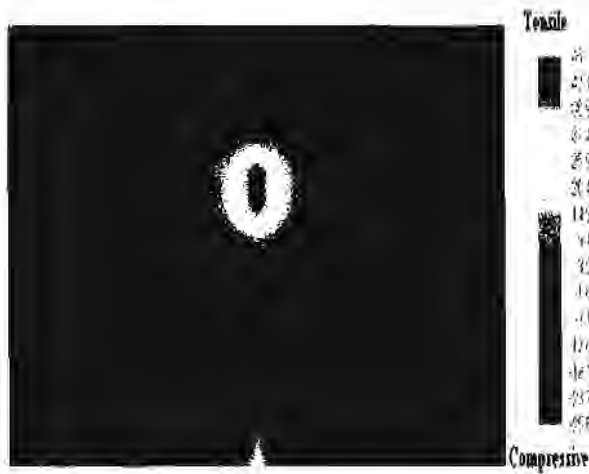

a)  $\sigma_{xx}$  for Single Axle Load

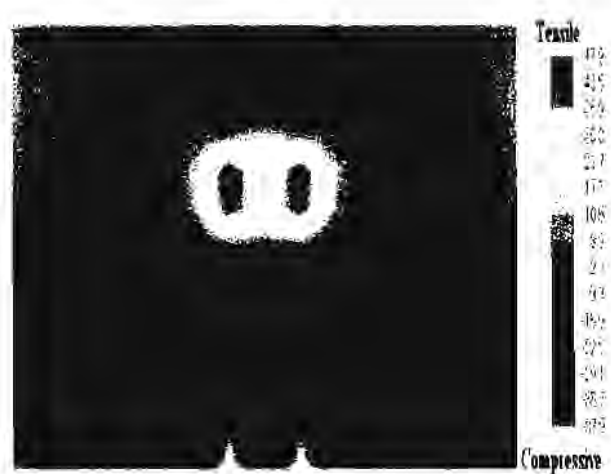

b)  $\sigma_{xx}$  for Dual Tandem Axle Load

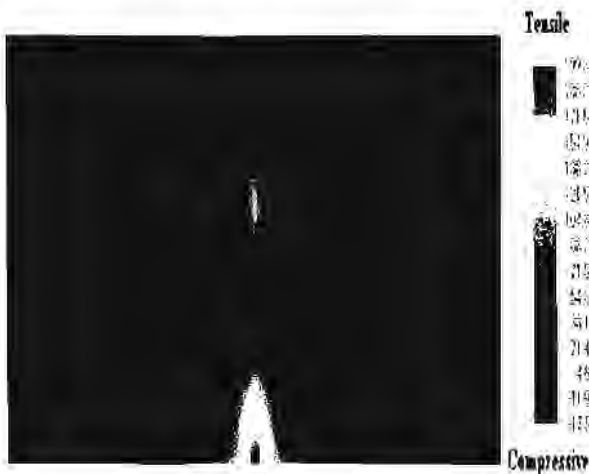

c)  $\sigma_{yy}$  for Single Axle Load

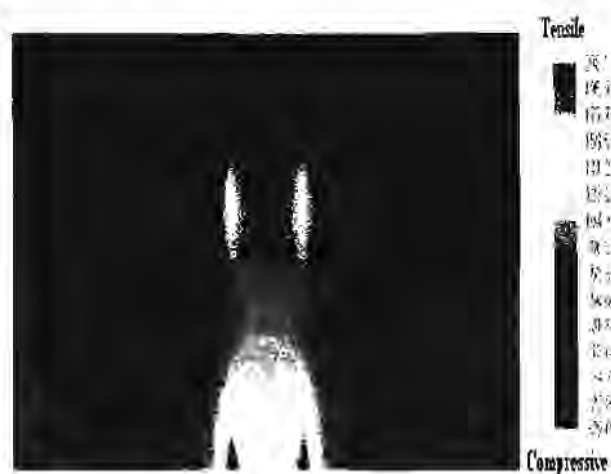

d)  $\sigma_{yy}$  for Dual Tandem Axle Load

**Figure 2.3 Stress Contours at Bottom of PCC Slab for ISLAB2000 for Different Loading Regimes.**

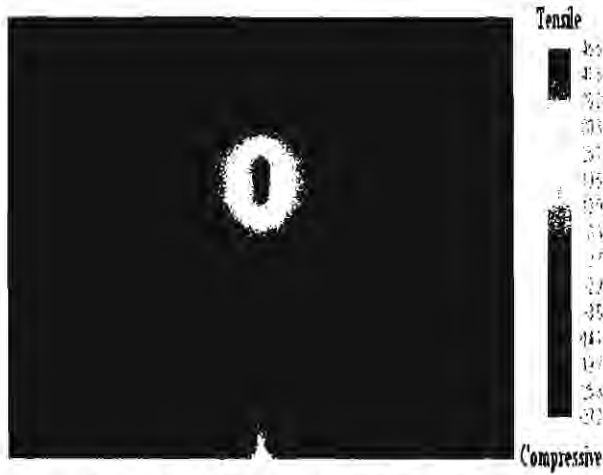

a)  $\sigma_{xx}$  for  $k=350$  pci ( $95 \text{ MN/m}^3$ )

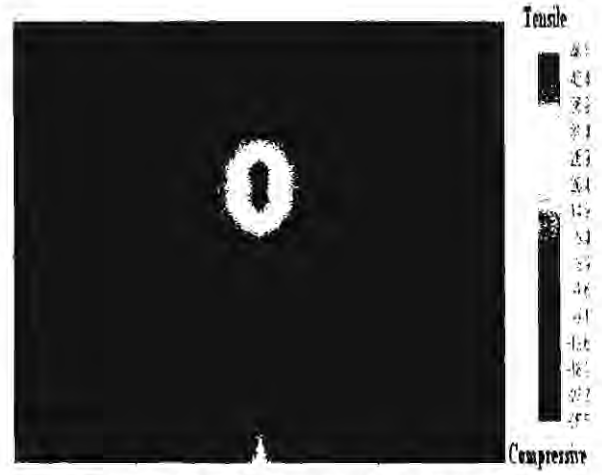

b)  $\sigma_{xx}$  for  $k=150$  pci ( $40 \text{ MN/m}^3$ )

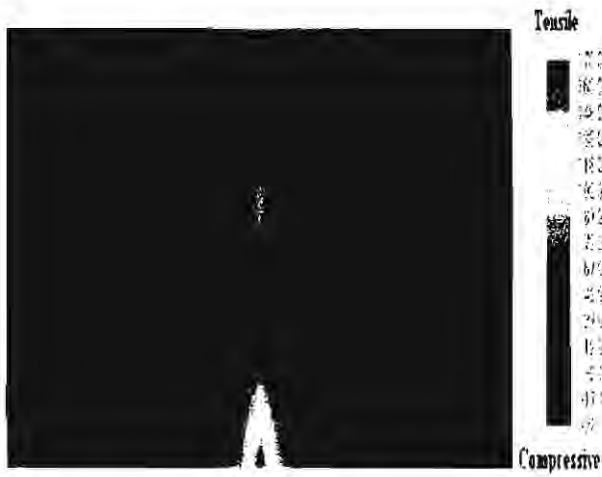

c)  $\sigma_{yy}$  for  $k=350$  pci ( $95 \text{ MN/m}^3$ )

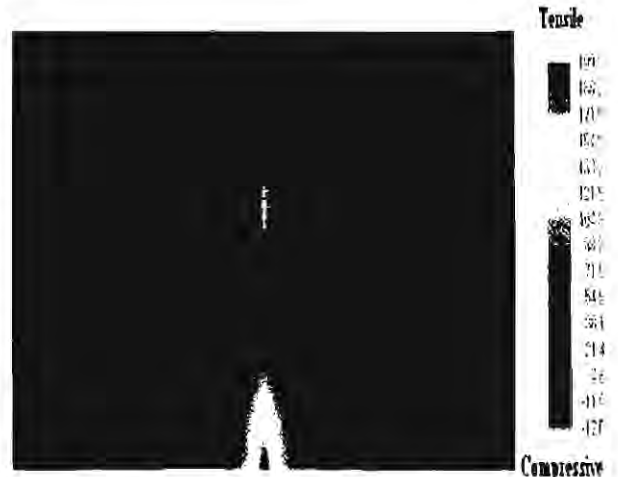

d)  $\sigma_{yy}$  for  $k=150$  pci ( $40 \text{ MN/m}^3$ )

**Figure 2.4 Stress Contours at Bottom of PCC Slab for ISLAB2000 for Different Moduli of Subgrade Reactions ( $k$ ).**

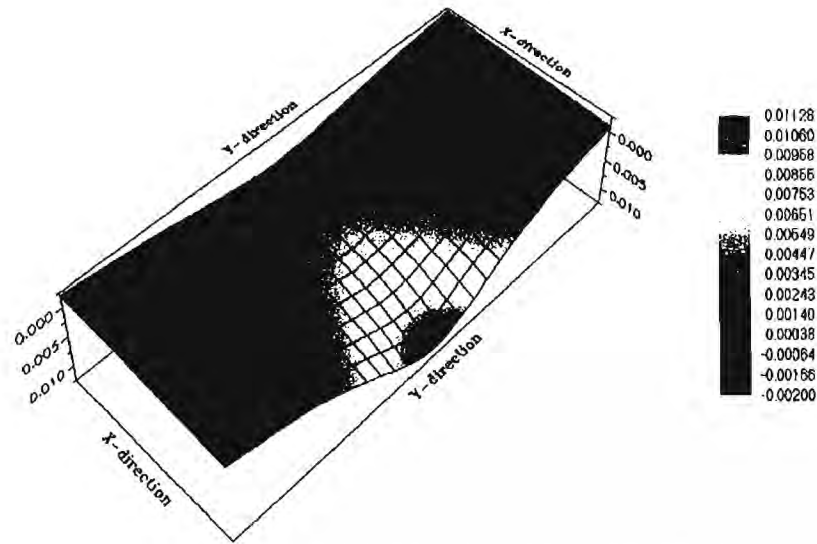

a) Stiffer Subgrade Condition  $k = 350 \text{ pci}$  ( $95 \text{ MN/m}^3$ )

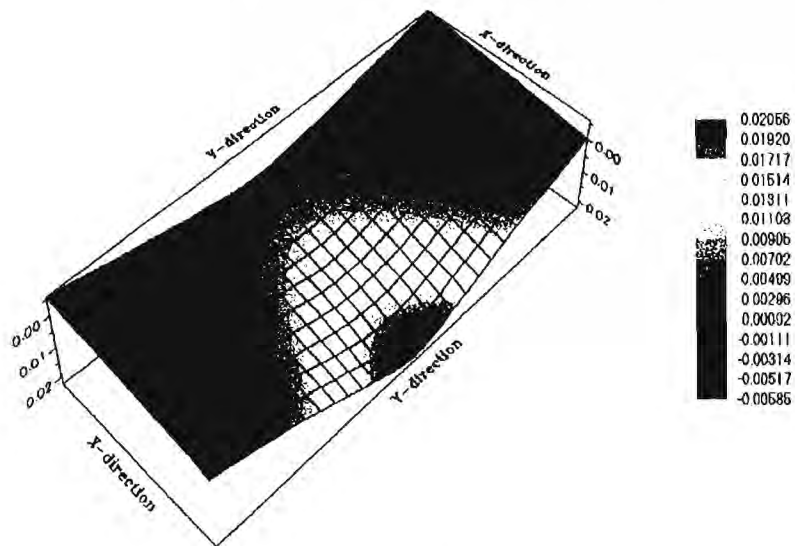

b) Softer Subgrade Condition  $k = 150 \text{ pci}$  ( $41 \text{ MN/m}^3$ )

**Figure 2.5 Slab Deflection Profile under Single Axle Loading for Different Moduli of Subgrade Reactions ( $k$ ).**

## Alternate Pavement Cross-Sections

The first set of alternate pavement structures consist of cross-sections that replace current layers of treated base, with hot mix asphalt concrete (HMAC), or are removed from the section and replaced with an optimized full-depth PCC slab placed directly on the compacted native soil. Figure 2.6 depicts the systematic search approach for this set of alternate sections.

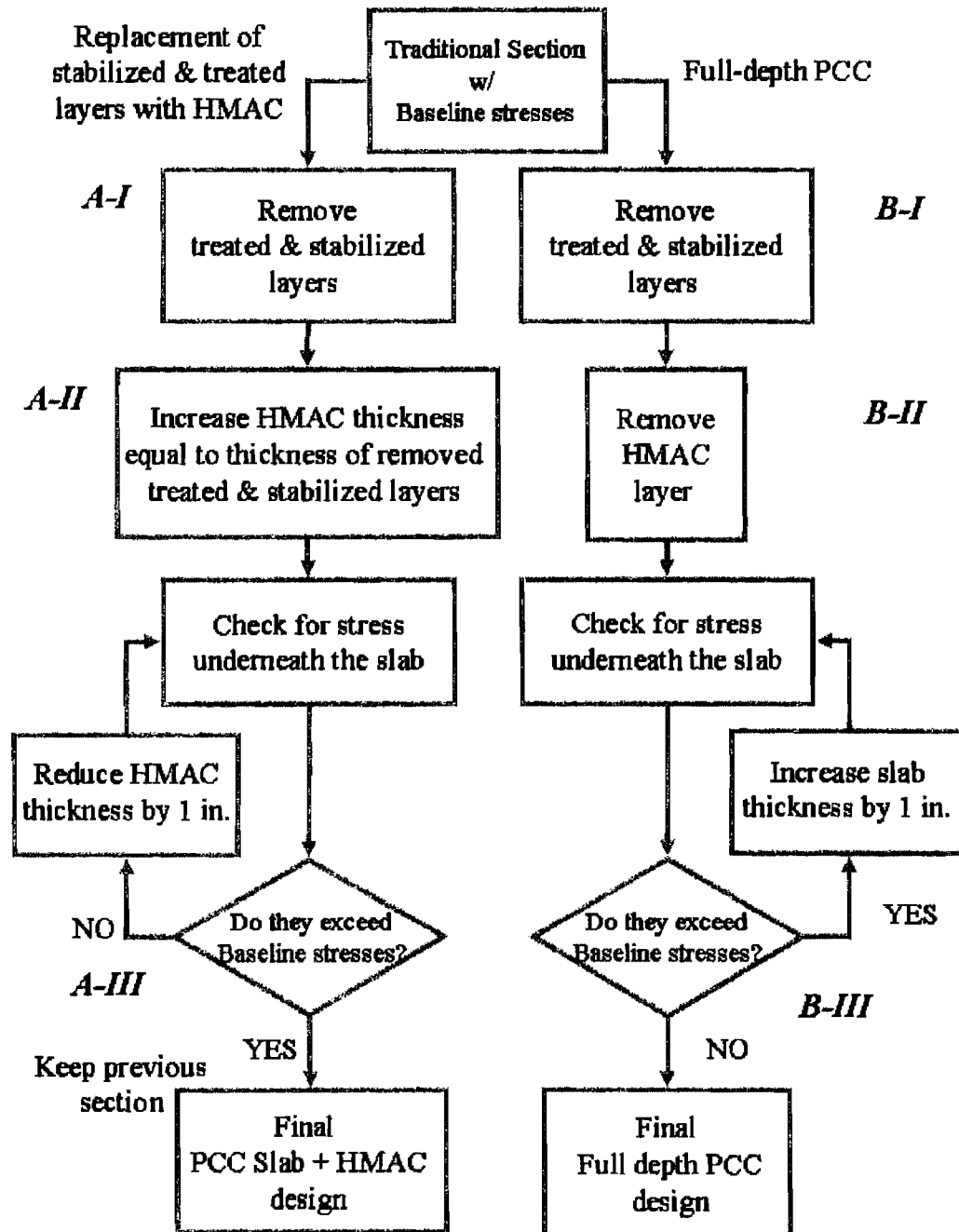

Figure 2.6 Search Algorithm to Determine Alternate Cross-Sections

First, the baseline stresses at the bottom of the PCC slab in each traditional cross-section was determined. Algorithms A and B were then followed. Algorithm A serves to determine a section consisting of a slab over an HMAC in the following manner:

- A-I: Remove the layers of treated and/or stabilized material.
- A-II: Replace those layers with hot mix asphalt concrete while maintaining the original PCC slab thickness. The thickness of the HMAC layer should approximately match the combined thickness of the layers being substituted.
- A-III: Compare the critical stresses for the alternate cross-section with the baseline stresses. If the stresses do not exceed the baseline stresses, maintain the previous slab thickness, and reduce the HMAC layer thickness (e.g. by 1 in., 25 mm, intervals), until the stresses exceed the baseline stresses. When this occurs, the previous section constitutes an alternate section

Alternate algorithm B, serves to determine a section consisting of only a full-depth PCC slab by following the steps itemized below.

- B-I: Remove the layers of treated and/or stabilized material from the section.
- B-II: Remove the HMAC layer from the section. The new cross-section consists of a full-depth PCC slab with slab thickness maintained.
- B-III: Compare the critical stresses for the alternate cross-section with the baseline stresses. If the stresses exceed the baseline stresses, increase the slab thickness (e.g. by 1 in., 25 mm, intervals) until stresses are lower than baseline stresses. When this occurs, the current full-depth slab cross-section constitutes an alternate section.

The final alternate cross-sections, which meet the minimal structural criterion, have reduced the total section depth compared to the traditional cross-section; thus, it is expected that their construction time may be less than for traditional sections.

A cross-section from Dallas district was chosen as a test section, to compare the final alternate cross-sections determined with the aforementioned search criteria, under different loading and subgrade stiffness combinations.

Figure 2.7 illustrates the variation in structural performance, expressed in terms of the ratio of tensile stresses of the alternate sections over the stresses of the traditional section when different HMAC layer thickness substitutes the 18 in. (457 mm) layer of lime-stabilized base material. For sections with the same slab thickness, as the asphalt thickness decreases, the tensile stress ratios increase. When comparing different sections with the same asphalt thickness (e.g. 6 vs. 4 in., 152 vs. 102 mm) the sections with a thicker slab exhibit smaller tensile stress ratios. In addition, the trends for both single tandem and dual tandem loading conditions are very similar, even though the actual stresses are different between dual-tandem and single axle loading.

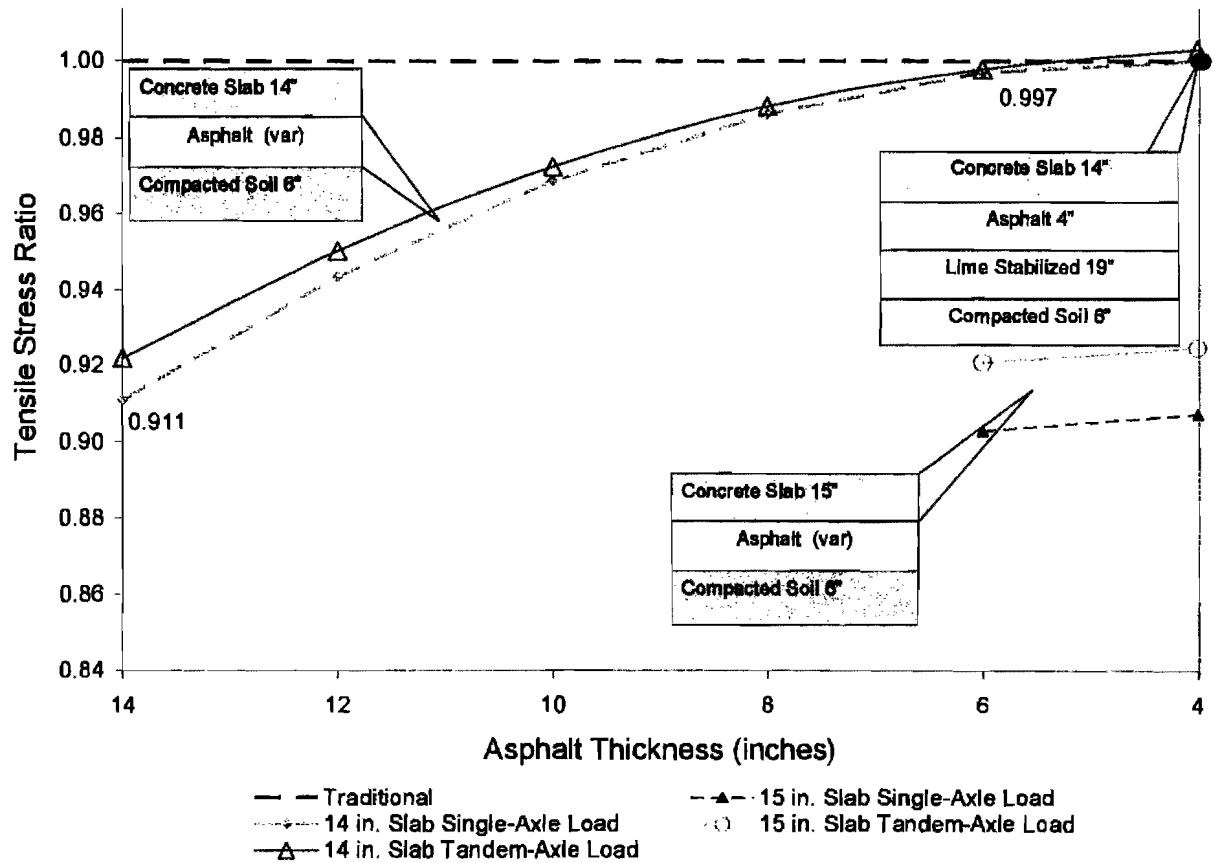

**Figure 2.7 Tensile Stress vs. Asphalt Thickness for Different Loading Regimes for Typical Slab over HMAC Cross-Sections Placed on a Soft Subgrade.**

Figure 2.8 depicts the variations in tensile stress ratio as a function of AC layer thickness when the slab thickness is fixed. The observed trends are similar to the ones in Figure 2.7. The stress ratios vary only slightly under different loading conditions. As the HMAC thickness increases the impact of the stiffness of the subgrade on the stress ratios becomes even less significant.

A similar exercise was conducted for the full-depth PCC slab. Figure 2.9 illustrates that for the same load case, e.g. dual-tandem axles, the curves for different levels of subgrade stiffness are almost identical. However, for thick slabs, the tensile stress ratios converge to a value of 0.62. Further investigation considered comparing the maximum principal compressive stresses of each cross-section for each load-soil stiffness combination. These aforementioned stresses for all load-soil stiffness combinations also converge at the same section, which resulted in a final alternate full-depth PCC slab of 18 in. (457 mm).

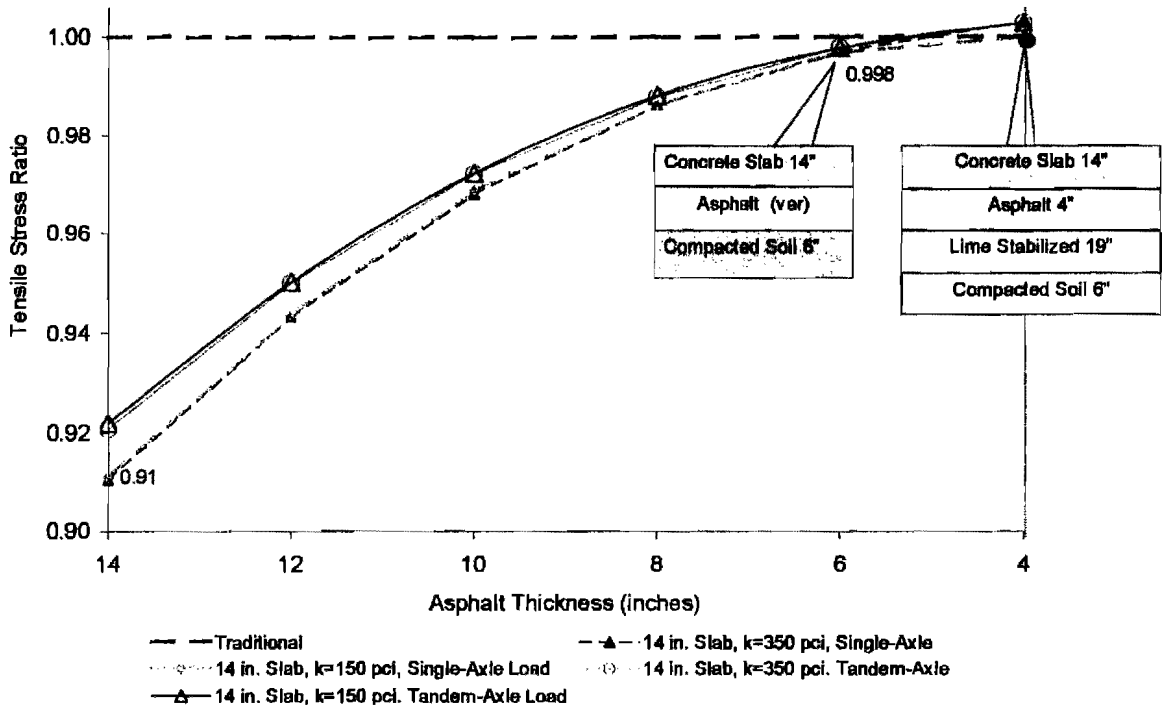

**Figure 2.8 Tensile Stress vs. HMAC Thickness for Different Moduli of Subgrade Reaction (k) and Different Loading Regimes for a Typical Slab over HMAC Cross-Section.**

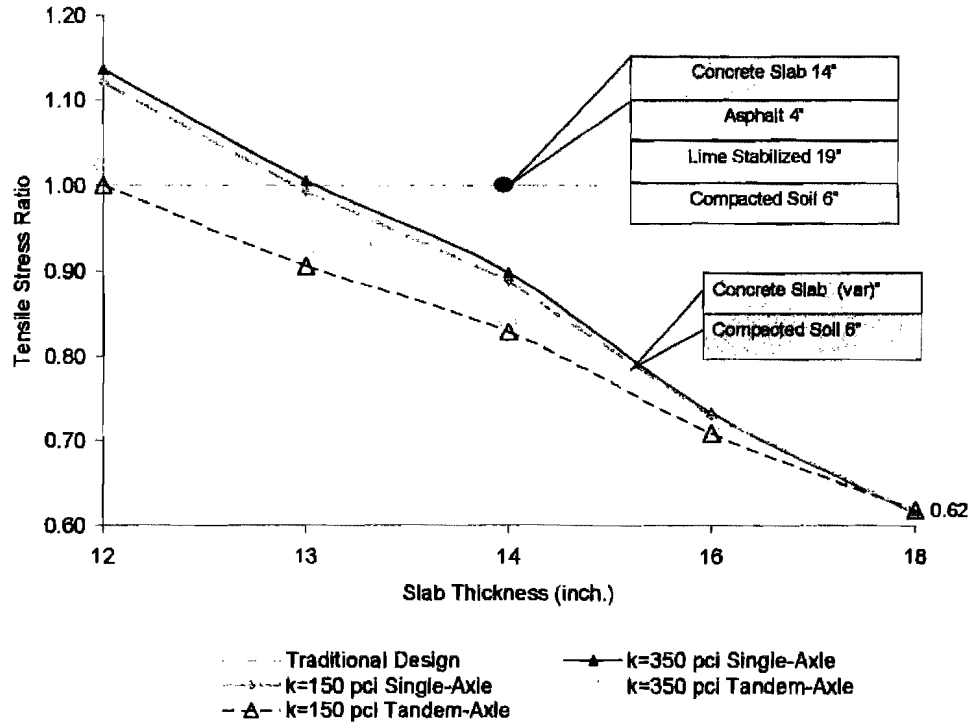

**Figure 2.9 Tensile Stress vs. PCC Slab Thickness for Different Moduli of Subgrade Reaction (k) and Different Loading Regimes for a Typical Full-Depth Slab Cross-Section.**

## **Alternate Rigid Pavement Cross-Sections Based on Local District Practices**

The selected alternate sections that comply with the minimal structural criteria were presented to the Project Management Committee (PMC) and the district staff for review and feedback. The PMC requested that the potential for vertical rise (PVR) check be carried out on both alternate sections (e.g. Slab over HMAC and full-depth slab) under the assumption that all alternate sections rest on clayey soil.

TxDOT districts follow the Tex-124-E testing procedure (TxDOT, 2002) to determine the potential vertical rise in soil strata. A copy of the procedure is included in Appendix B. Each district provided the following typical geotechnical data used in the PVR check, including:

- the number of layers or total depth usually checked, and
- for each layer
  - a. the liquid limit
  - b. actual moisture content
  - c. plasticity index
  - d. percent material passing No. 40 sieve
- PVR limiting criteria.

Table 2.2 summarizes the soil properties provided by the districts and/or assumed based on experience, as well as suggested limits and computed PVR for the natural subgrade.

A typical PVR analysis is depicted in Table 2.3. This analysis corresponds to the Dallas natural subgrade without any pavement structure surcharge, assuming 'dry' layer conditions, which are the most critical since the PVR reaches its highest value. Alternate cross-sections that meet the PVR limit criteria of 1 in. (25 mm) are a function of their pavement load. Therefore, the minimum pavement load that reduces the PVR to the limit was obtained

Table 2.4 the analysis for the minimum pavement load per unit area, required to reduce the PVR from 3 in. (75 mm) to 1 in. (25 mm) in Dallas. The minimum load obtained is 5 psi (35 kPa). Therefore, the weight of any alternate structure should exert at least 5 psi (35 kPa) to ensure that the PVR will be equal or less to 1 in. (25 mm).

**Table 2.2 Local Geotechnical Soil Properties Used for PVR Analysis.**

District	Depth of analysis (ft) (m)	Liquid limit LL (%)	Moisture (%)	Dry/ Avg./ Wet	% Passing No. 40 mesh	Plasticity index (%)	PVR limit (in.) (mm.)	Natural subgrade PVR (in) (mm)
Dallas	6 (1.83)	65	N/A	Dry	95-100	42	1 (25.4)	3 (76.2)
			N/A	Avg.				2 (50.8)
Fort Worth	6 (1.83)	50	N/A	Dry	90	40	*1 (25.4)	1.9 (48.3)
			N/A	Avg.				1.29 (32.8)
			Usually soil is sampled 20 ft. (6.1 Mt.) below the proposed grade or until refusal due to limestone.					(0 - 70)
Houston	0 - 2 (0 - 0.61)	63	N/A	Dry	100	45	1 (25.4)	3 (76.2)
	2 - 6 (0.61 - 1.83)	52	N/A		100	30		
Houston does not conduct soil investigations. Supplied summaries with top layer soil data for different geographic regions within the district. NO PVR limit is observed.								
Beaumont	6 (1.83)	49	N/A	Dry- Avg.	100	30	N/A	1.1 (27.9)
Average values determined from several PVR studies previously conducted								
El Paso	0 - 1 (0 - 0.30)	47	N/A	Dry	100	30	N/A	0.6 (15.2)
	1 - 3 (0 - 0.91)	53			100	37		
	3 - 5 (0.91 - 1.52)	44			100	44		
Test is required whenever clay is suspected to be encountered. Reported results vary between 0.25 and 1.0 inches (6.3 - 25.4 mm) in the active zone								

**Table 2.3 Potential Vertical Rise (PVR) for Natural Subgrade in Dallas District (Dry Soil Conditions).  
(1 in. = 25.4 mm).**

Pavement load		0.000		psi													
1	2	3	4	5	6	7	8	9	10	11	12	13	14	15	16	17	
Depth	Avg. Load ~0.072337963 pci	124.416 pcf ~125 pcf	LL	Dry (0.2LL + 9)	Wet (0.47LL + 2)	% moisture	Dry- Avg.-Wet	-No.40	PI	% vol swell	% FREE swell	PVR top	PVR bottom	Diff	MODIF -No.40	MODIF density	PVR per layer
IN	0.083333333 PSI	144 pcf		swell potential	capillar absorption					figure 1-30	swell under no load	figure 1-28	figure 1-28			125 / actual	INCHES
0-24	2	1	65	22	28		Dry	100	42	6.214 12.5	9.244 15.975	0	1.2	1.2	1	1	1.2
24-48	2									6.214 12.5	9.244 15.975	1.2	2.3	1.1	1	1	1.1
48-72	2	3	65	22	28		Dry	100	42	6.214 12.5	9.244 15.975	2.3	3	0.7	1	1	0.7
	5	5	65	22	28					-2.9 2.6	-0.5 2.6	0	0	0	1	1	0
<b>Total PVR =</b>																<b>3</b>	

**Table 2.4 Minimum Pavement Structure Load to Reduce PVR to Minimum in Dallas District, (Dry Soil Conditions).  
(1 in. = 25.4 mm).**

Pavement load		5.000		psi													
1	2	3	4	5	6	7	8	9	10	11	12	13	14	15	16	17	
Depth	Avg. Load ~0.072337963 pci	124.416 pcf ~125 pcf	LL	Dry (0.2LL + 9)	Wet (0.47LL + 2)	% moisture	Dry- Avg.-Wet	-No.40	PI	% vol swell	% FREE swell	PVR top	PVR bottom	Diff	MODIF -No.40	MODIF density	PVR per layer
IN	0.083333333 PSI	144 pcf		swell potential	capillar absorption					figure 1-30	swell under no load	figure 1-28	figure 1-28			125 / actual	INCHES
0-24	2									6.214 12.5	9.244 15.975	3	3.2	0.2	1	1	0.2
24-48	2	6	65	22	28			100	42	6.214 12.5	9.244 15.975	3.2	3.7	0.5	1	1	0.5
48-72	2	8	65	22	28			100	42	6.214 12.5	9.244 15.975	3.7	4	0.3	1	1	0.3
	5	10	65	22	28					-2.9 2.6	-0.5 2.6	0	0	0	1	1	0
<b>Total PVR =</b>																<b>1</b>	

The second set of alternate pavement structures consist of cross-sections that replace current layers of treated base, with HMAC, or full-depth PCC slab, with adjusted layer thickness to provide enough pavement load per unit area to reduce the PVR to the minimum practiced by the districts. Figure 2.10 shows the alternate sections for the aforementioned traditional section in Dallas. These sections, however, are obviously not practical for construction.

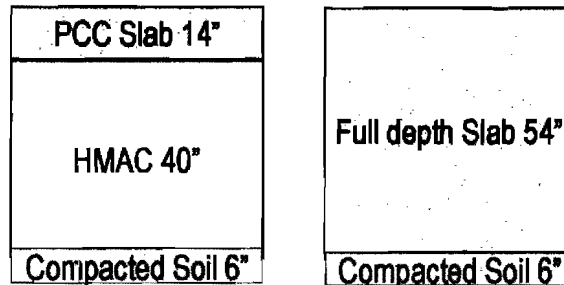

**Figure 2.10 Alternate Rigid Cross-Sections: PVR Compliant under Dry Soil Conditions.**

It should be noted that the pavement structure load of the traditional cross-section resulted in about 3.5 psi. (24 kPa), which is approximately 30% less than the required pressure. Therefore, the PVR associated with the traditional cross-section is obviously greater than 1 in. (25 mm.). Therefore, the PVR analysis was conducted in a manner that would provide a PVR that was equivalent to the traditional cross section. Similar analyses were conducted for all five districts. The final section of this chapter presents the alternate sections that comply with local PVR criteria.

Additional PVR analysis was conducted on the above section, assuming the average moisture conditions in the subgrade. The resulting PVR in the natural soil was about 2 in. (50 mm). The load per unit area required to reduce the PVR to 1 in. (25 mm) is obviously less than for dry conditions, and is about 2.8 psi (19 kPa). Figure 2.11 depicts the required alternate sections which are thinner than the ones for ‘dry’ conditions.

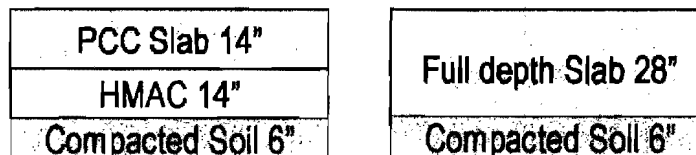

**Figure 2.11 Alternate Rigid Cross-Sections: PVR Compliant under Soil with Average Moisture Conditions.**

The modified alternate sections determined in the previous section reduce the potential for vertical rise (PVR) according to district practices, and comply with the minimal structural criteria as well. However, some of those sections may not be practical to build or even economically feasible. To overcome these issues, and yet provide the required weight to reduce the PVR, another set of alternate sections is proposed. These sections consist of the alternate Slab over HMAC cross-sections that meet the minimal structural criteria, with additional layers of alternative materials that are easier and faster to build.

One option is to add a layer of select material (e.g. crushed stone or fill material) with sufficient thickness, underneath the pavement structure. The stresses underneath the PCC slab of these sections were lower than for the Slab over HMAC section itself. Figure 2.12 depicts the alternate cross-sections with select material for the traditional section under study that comply with Dallas' PVR limit. When the pavement is resting on a dry clayey soil, 36 in. (900 mm) of select material are required, in addition to the 14 in. (350 mm) slab, and 6 in. (150 mm) of HMAC. However, when the pavement is resting on soil with an average moisture condition, only 10 in. (250 mm) of select material are required to reduce the PVR to 1 in. (25 mm).

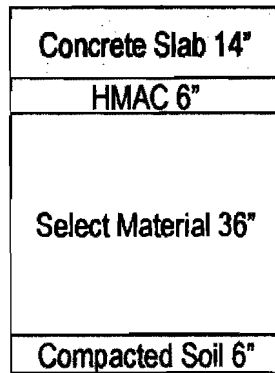

a) Dry Soil

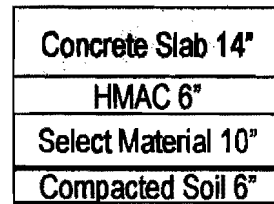

b) Soil with Average Moisture Condition.

**Figure 2.12 Alternate Rigid Cross-Sections with Layer of Select Material to Meet PVR Limit**

Similar alternate cross-sections with a layer of select material were obtained for the remaining traditional sections in Dallas district. The PVR is less of a concern for Fort Worth, Beaumont and El Paso, according to the local geotechnical data provided and summarized in Table 2.2. It is not a common practice for Houston district to use select material, nevertheless a couple of alternate sections are proposed. A summary of alternate sections with a layer of select material is included at the end of this chapter.

## Alternate Rigid Pavement Cross-Sections with Geosynthetics

Water infiltration from precipitation is a major concern during and after the construction of a roadway. The detrimental effects that water has on the pavement structure include base erosion, freeze-thaw weakening of subgrade soils, and differential heaving over swelling soils, among others. To minimize the infiltration of surface water during the various construction stages of a pavement, a good drainage layer or the presence of a moisture-resistant layer is required. The use of lime or cement treated soils or select materials is one way to minimize this problem.

Table 2.5 briefly summarizes some of the advantages and disadvantages of the traditional practices, as well as of the proposed alternate construction processes, from the moisture infiltration standpoint

**Table 2.5 Advantages/Disadvantages of Current Construction Practices.**

<b>Practice</b>	<b>Advantages</b>	<b>Disadvantages</b>
Lime stabilization	Reduces swelling, and provides resistance to the damaging effects of moisture, among other improvements to important engineering properties in soils.	Delays construction due to lengthy mixing and curing periods.
Cement treatment	Greatly reduces permeability; are typically used to improve subgrade soils or to amend local aggregates for use as base in lieu of more costly transported aggregates. Highly durable and resistant to leaching over the long term.	Delays construction due to lengthy mixing and curing periods.
Select material	Used for drainage purposes To satisfy filter requirements, it may be necessary to use several different aggregates, one placed adjacent to the other.	Difficult to construct without contamination.

In addition to the above methods and materials, geosynthetics can be used for filtration purposes. To find other alternate expedited cross-sections, the use of geogrids/geosynthetics as alternative material to layers of treated/stabilized material was explored.

A geogrid also performs as a structural load-bearing element. To perform as such, the geogrid must possess several important attributes, including: load transfer mechanism; working load capacity (both dynamic and sustained load capacity); structural integrity when subjected to deforming forces; and durability and resistance to degradation. After conducting a literature search on geogrids, and requesting feedback from a major geogrid contractor nationwide, the following information was gathered:

Perkins (2001) focused on providing analytical methods to determine the benefit of the reinforcement. The outcome consisted of a set of equations that relate geogrid benefit to pavement design parameters that were implemented into software. Since the model is based on a narrow range of parameters, Perkins states that judgment and experience are required for the selection of other design values.

Ling and Liu (2001) describe the performance of geosynthetic-reinforced asphalt pavement under various loading conditions. The results show that the grid increased the stiffness and bearing capacity of the asphalt pavement; but these benefits were not quantified.

Hsieh and Wu (2001) measured the installation damage to a geogrid. The results showed that the tensile strength retained for geogrids placed within different subgrade types (clayey-gravel to well-graded crushed stone gravel) is between 57% and 95% of the single-rib tensile strength tests.

Appea and Al-Qadi (2000) focused on monitoring the performance and structural condition of flexible pavements stabilized with geogrids and geotextiles. The results confirm the effectiveness of using the woven geotextile as a separator in a pavement system built over weak subgrade to protect against fine intrusion into the aggregate layer, while geogrid provides partial protection.

The research team contacted Tensar Corp. via phone and email (Archer, 2002) to request feedback and specific geogrid properties, required for modeling in ISLAB, and for cost and time analysis. The most relevant information provide by the contractor was a paper by Perkins (1999). Perkins studied the improvement of the modulus of subgrade reaction using Tensar geogrids. The paper concludes that an improved modulus of subgrade reaction of 46% and 92% is achieved when using one layer of Tensar reinforcement with 6 in. (150 mm) and 12 in. (300 mm) of aggregate base. This information is insufficient to be incorporated in the ISLAB analysis.

Tensar (1988) illustrates the procedure to determine the thickness of select material above the grid based on the California bearing ratio (CBR). At this time, this information could not be correlated to required properties.

The research team also reviewed Tensar's SpectraPave2 software (Tensar, 2002) for subgrade improvement and base reinforcement. This software was developed to support analysis and design of flexible pavements. Information on productivity rates for placing geogrids to accelerate pavement construction, and reduction on swelling of clayey soils was requested. That information was not currently available in a conclusive manner.

The use of geogrids has benefits in pavement construction by strengthening weak subgrades vs. traditional treatments/stabilization practices, and as drainage mechanism. However, no quantifiable data is available at the time to model a reinforced rigid cross-section in ISLAB, nor to compare cost and construction time savings with traditional and other alternative construction.

# Summary of Rigid Pavement Cross-Sections: Traditional and Alternate

Table 2.6 Alternate Rigid Cross-Sections: Dallas District.

Roadway Classification	Traditional		Slab over HMAC	Full-depth PCC	Slab over HMAC over Select Fill
<b>Highest Vol. Highway</b> (IH-35-E / 190T Mainlanes NB / SB Entrance Ramp / NB Exit Ramp)		Min. structural criteria met	Concrete Slab 14" HMAC 6" Compacted Soil 6"	Concrete Slab 18" Compacted Soil 6"	
	CRCP 14" HMAC (Type B) 4" Lime Stab. SG (6 %) 19" Compacted Soil 6"	2" PVR limited to 1" Layers w/Avg. moisture	Concrete Slab 14" HMAC 14" Compacted Soil 6"	Concrete Slab 28" Compacted Soil 6" (May NOT Be Practical)	Concrete Slab 14" HMAC 6" Select Material 10" Compacted Soil 6"
		3" PVR limited to 1" "Dry" layers: Critical	Concrete Slab 14" HMAC 40" Compacted Soil 6" (NOT Practical)	Concrete Slab 54" Compacted Soil 6" (NOT Practical)	Concrete Slab 14" HMAC 6" Select Material 36" Compacted Soil 6"

**Table 2.6 Alternate Rigid Cross-Sections: Dallas District...cont.**

<b>Roadway Classification</b>	<b>Traditional</b>		<b>Slab over HMAC</b>	<b>Full-depth PCC</b>	<b>Slab over HMAC over Select Fill</b>
<b>Highest Vol. Highway</b> (IH-35-E / 190T Mainlanes EB, WB)	CRCP 13" HMAC (Type B) 6" Lime Stab. SG (6 %) 18" Compacted Soil 6"	Min. structural criteria met	Concrete Slab 13" HMAC 8" Compacted Soil 6"	Concrete Slab 16" Compacted Soil 6"	
	CRCP 13" HMAC (Type A) 3" HMAC (Type D) 3" Lime Stab. SG (4%) 10" Select Fill Mat. (PI < 20) 18"(sand) – 21"(clay)		3" PVR limited to 1" "Dry" layers: Critical	Concrete Slab 13" HMAC 42" Compacted Soil 6" (NOT Practical)	Concrete Slab 54" Compacted Soil 6" (NOT Practical)
<b>Highest Vol. Highway</b> (US 75 Mainlane SB)	CRCP 13" HMAC (Type A) 3" HMAC (Type D) 7" Compacted Soil 18" Rock	Min. structural criteria met	--	Concrete Slab 16" Compacted Soil 6"	

**Table 2.6 Alternate Rigid Cross-Sections: Dallas District...cont.**

Roadway Classification	Traditional	Min. structural criteria met	Slab+HMAC	Full-depth PCC	+ Select Fill Material PI<= 20
<b>Highest Vol. Highway</b> (IH-30 Sta. 665 / Mainlane widening)	Concrete Slab 15" HMAC (600 / 660 # / SY) 6" Embankment Type C Lime Stab. SG (4%) 18" Compacted Soil "		3" PVR limited to 1" "Dry" layers: Critical	Concrete Slab 15" HMAC 6" Compacted Soil 6"	Concrete Slab 20" Compacted Soil 6"
(IH-30 Sta. 593)	Concrete Slab 15" HMAC (1320 # / SY) 12" Embankment Type C Lime Stab. SG (4%) 12" Compacted Soil "	Min. structural criteria met		Concrete Slab 15" HMAC 12" Compacted Soil 6"	Concrete Slab 20" Compacted Soil 6"
			3" PVR limited to 1" "Dry" layers: Critical	Concrete Slab 15" HMAC 40" Compacted Soil 6" (NOT Practical)	Concrete Slab 54" Compacted Soil 6" (NOT Practical)

**Table 2.6 Alternate Rigid Cross-Sections: Dallas District...cont.**

Roadway Classification	Traditional	Slab over HMAC	Full-depth PCC	Slab over HMAC over Select Fill
<b>Arterial, Frontage &amp; Collector Roads</b>  (IH-30 Frontage Rd. / Bobtown Rd.)	CPCD 10" HMAC (880 / 800 # / SY) 8" Compacted Soil 18"	--  Concrete Slab 10" HMAC 46" Compacted Soil 6" (NOT Practical)	Concrete Slab 14" Compacted Soil 6"  Concrete Slab 54" Compacted Soil 6" (NOT Practical)	Slab 10" HMAC 8" Sel. Mat. 40" Com Soil 6"

3" PVR limited to 1" ,Mfn. structural  
 "Dry" layers: Critical criteria met

**Table 2.6 Alternate Rigid Cross-Sections: Dallas District...cont.**

<b>Roadway Classification</b>	<b>Traditional</b>		<b>Slab over HMAC</b>	<b>Full-depth PCC</b>	<b>Slab over HMAC over Select Fill</b>
<b>Arterial, Frontage &amp; Collector Roads</b>  Scenic Dr.	CPCD CL K 8"	Min. structural criteria met	--	Concrete Slab 14" Compacted Soil 6"	
	HMAC 14" Compacted Soil 6"				
<b>City/Local Streets</b>  Heritage / Harborside	Compacted Soil 6"	3" PVR limited to 1" "Dry" layers: Critical	Concrete Slab 8" HMAC 48" Compacted Soil 6" (NOT Practical)	Concrete Slab 54" Compacted Soil 6" (NOT Practical)	Slab 8" HMAC 14" Sel. Mat. 36" Comp Soil 6"
<b>Arterial, Frontage &amp; Collector Roads</b>  Lakeshore Dr.	CPCD CL K 8" HMAC 8" Compacted Soil 6"	Min. structural criteria met	--	Concrete Slab 10" Compacted Soil 6"	
<b>City/Local Streets</b>  2 <sup>nd</sup> . St.	CPCD 8" HMAC 4" Compacted Soil 6"	3" PVR limited to 1" "Dry" layers: Critical	Concrete Slab 8" HMAC 48" Compacted Soil 6" (NOT Practical)	Concrete Slab 54" Compacted Soil 6" (NOT Practical)	Slab 8" HMAC 8" Sel. Mat. 42" Comp Soil 6"

**Table 2.6 Alternate Rigid Cross-Sections: Dallas District...cont.**

<b>Roadway Classification</b>	<b>Traditional</b>	<b>Slab over HMAC</b>	<b>Full-depth PCC</b>	<b>Slab over HMAC over Select Fill</b>
<b>Arterial, Frontage &amp; Collector Roads</b>  (IH-35-E / 190T Frontage Rds.)	Concrete Slab 8" HMAC 6" Lime Stab. SG (6%) 8" Compacted Soil 6"	Min. structural criteria met	Concrete Slab 8" HMAC 8" Compacted Soil 6"	Concrete Slab 9" Compacted Soil 6"
	(SH 66 Mainlane)		CPCD 8" HMAC 4" Lime Stab. SG (7%) 22" Compacted Soil 6" 0.25 Gal. / SY	Concrete Slab 8" HMAC 48" Compacted Soil 6"
SH 66 Embank Washington St. Rusk St.	Concrete Slab 8" HMAC 4" Lime Stab. SG (7%) 8" Compacted Soil 6" 0.25 Gal. / SY	3" PVR limited to 1" "Dry" layers: Critical	(NOT Practical)	(NOT Practical)
				Slab 8" HMAC 8" Sel. Mat. 42" Comp Soil 6"

**Table 2.7 Alternate Rigid Cross-Sections: Fort Worth District.**

Highway type	Traditional	PVR Not critical	Slab over HMAC	Full-depth PCC	Slab over HMAC over Select Fill											
IH / US / SH 360/ FM / High Vol. Urban	<table border="1"> <tr><td>Concrete Slab 13"</td></tr> <tr><td>HMAC 4"</td></tr> <tr><td>Lime Stab. SG 18"</td></tr> </table> <table border="1"> <tr><td>Concrete Slab 13"</td></tr> <tr><td>HMAC 4"</td></tr> <tr><td>Lime Stab. SG 8"</td></tr> </table>	Concrete Slab 13"	HMAC 4"	Lime Stab. SG 18"	Concrete Slab 13"	HMAC 4"	Lime Stab. SG 8"		<table border="1"> <tr><td>Concrete Slab 13"</td></tr> <tr><td>HMAC 6"</td></tr> <tr><td>Compacted Soil 6"</td></tr> </table>	Concrete Slab 13"	HMAC 6"	Compacted Soil 6"	<table border="1"> <tr><td>Concrete Slab 16"</td></tr> <tr><td>Compacted Soil 6"</td></tr> </table>	Concrete Slab 16"	Compacted Soil 6"	
Concrete Slab 13"																
HMAC 4"																
Lime Stab. SG 18"																
Concrete Slab 13"																
HMAC 4"																
Lime Stab. SG 8"																
Concrete Slab 13"																
HMAC 6"																
Compacted Soil 6"																
Concrete Slab 16"																
Compacted Soil 6"																
IH / US / SH / FM / High Vol. Urban	<table border="1"> <tr><td>Concrete Slab 12"</td></tr> <tr><td>HMAC 4"</td></tr> <tr><td>Lime Stab. SG 18"</td></tr> </table> <table border="1"> <tr><td>Concrete Slab 12"</td></tr> <tr><td>HMAC 4"</td></tr> <tr><td>Lime Stab. SG 8"</td></tr> </table>	Concrete Slab 12"	HMAC 4"	Lime Stab. SG 18"	Concrete Slab 12"	HMAC 4"	Lime Stab. SG 8"		<table border="1"> <tr><td>Concrete Slab 12"</td></tr> <tr><td>HMAC 6"</td></tr> <tr><td>Compacted Soil 6"</td></tr> </table>	Concrete Slab 12"	HMAC 6"	Compacted Soil 6"	<table border="1"> <tr><td>Concrete Slab 15"</td></tr> <tr><td>Compacted Soil 6"</td></tr> </table>	Concrete Slab 15"	Compacted Soil 6"	
Concrete Slab 12"																
HMAC 4"																
Lime Stab. SG 18"																
Concrete Slab 12"																
HMAC 4"																
Lime Stab. SG 8"																
Concrete Slab 12"																
HMAC 6"																
Compacted Soil 6"																
Concrete Slab 15"																
Compacted Soil 6"																
US / SH / FM	<table border="1"> <tr><td>Concrete Slab 8"</td></tr> <tr><td>HMAC 4"</td></tr> <tr><td>Lime Stab. SG 18"</td></tr> </table> <table border="1"> <tr><td>Concrete Slab 8"</td></tr> <tr><td>HMAC 4"</td></tr> <tr><td>Lime Stab. SG 8"</td></tr> </table>	Concrete Slab 8"	HMAC 4"	Lime Stab. SG 18"	Concrete Slab 8"	HMAC 4"	Lime Stab. SG 8"		<table border="1"> <tr><td>Concrete Slab 8"</td></tr> <tr><td>HMAC 6"</td></tr> <tr><td>Compacted Soil 6"</td></tr> </table>	Concrete Slab 8"	HMAC 6"	Compacted Soil 6"	<table border="1"> <tr><td>Concrete Slab 9"</td></tr> <tr><td>Compacted Soil 6"</td></tr> </table>	Concrete Slab 9"	Compacted Soil 6"	
Concrete Slab 8"																
HMAC 4"																
Lime Stab. SG 18"																
Concrete Slab 8"																
HMAC 4"																
Lime Stab. SG 8"																
Concrete Slab 8"																
HMAC 6"																
Compacted Soil 6"																
Concrete Slab 9"																
Compacted Soil 6"																

**Table 2.8 Alternate Rigid Cross-Sections: Houston District.**

Highway type	Traditional	Slab over HMAC	Full-depth PCC	Slab over HMAC over Select Fill														
SH / FM	<table border="1"> <tr><td>Concrete Slab 13"</td></tr> <tr><td><del>Base 11"</del></td></tr> <tr><td>Cement Treated 6"</td></tr> <tr><td>Lime Stab. SG 6"</td></tr> <tr><td>Compacted Soil 6"</td></tr> </table>	Concrete Slab 13"	<del>Base 11"</del>	Cement Treated 6"	Lime Stab. SG 6"	Compacted Soil 6"	<table border="1"> <tr><td>Concrete Slab 13"</td></tr> <tr><td>HMAC 6"</td></tr> <tr><td>Compacted Soil 6"</td></tr> </table>	Concrete Slab 13"	HMAC 6"	Compacted Soil 6"	<table border="1"> <tr><td>Concrete Slab 16"</td></tr> <tr><td>Compacted Soil 6"</td></tr> </table>	Concrete Slab 16"	Compacted Soil 6"	<table border="1"> <tr><td>Slab 13"</td></tr> <tr><td>HMAC 6"</td></tr> <tr><td>Sel. Mat. 8"</td></tr> <tr><td>Comp Soil 6"</td></tr> </table>	Slab 13"	HMAC 6"	Sel. Mat. 8"	Comp Soil 6"
	Concrete Slab 13"																	
<del>Base 11"</del>																		
Cement Treated 6"																		
Lime Stab. SG 6"																		
Compacted Soil 6"																		
Concrete Slab 13"																		
HMAC 6"																		
Compacted Soil 6"																		
Concrete Slab 16"																		
Compacted Soil 6"																		
Slab 13"																		
HMAC 6"																		
Sel. Mat. 8"																		
Comp Soil 6"																		
Min. structural criteria met	2.45" PVR limited to 1" "Dry" layers: Critical	<table border="1"> <tr><td>Concrete Slab 13"</td></tr> <tr><td>HMAC 13"</td></tr> <tr><td>Compacted Soil 6"</td></tr> </table> <p>(May NOT Be Practical)</p>	Concrete Slab 13"	HMAC 13"	Compacted Soil 6"	<table border="1"> <tr><td>Concrete Slab 26"</td></tr> <tr><td>Compacted Soil 6"</td></tr> </table> <p>(May NOT Be Practical)</p>	Concrete Slab 26"	Compacted Soil 6"										
Concrete Slab 13"																		
HMAC 13"																		
Compacted Soil 6"																		
Concrete Slab 26"																		
Compacted Soil 6"																		
FR	<table border="1"> <tr><td>Concrete Slab 10"</td></tr> <tr><td><del>Base 11"</del></td></tr> <tr><td>Cement Treated 6"</td></tr> <tr><td>Lime Stab. SG 6"</td></tr> <tr><td>Compacted Soil 6"</td></tr> </table>	Concrete Slab 10"	<del>Base 11"</del>	Cement Treated 6"	Lime Stab. SG 6"	Compacted Soil 6"	<table border="1"> <tr><td>Concrete Slab 10"</td></tr> <tr><td>HMAC 6"</td></tr> <tr><td>Compacted Soil 6"</td></tr> </table>	Concrete Slab 10"	HMAC 6"	Compacted Soil 6"	<table border="1"> <tr><td>Concrete Slab 12"</td></tr> <tr><td>Compacted Soil 6"</td></tr> </table>	Concrete Slab 12"	Compacted Soil 6"	<table border="1"> <tr><td>Slab 10"</td></tr> <tr><td>HMAC 6"</td></tr> <tr><td>Sel. Mat. 12"</td></tr> <tr><td>Comp Soil 6"</td></tr> </table>	Slab 10"	HMAC 6"	Sel. Mat. 12"	Comp Soil 6"
	Concrete Slab 10"																	
<del>Base 11"</del>																		
Cement Treated 6"																		
Lime Stab. SG 6"																		
Compacted Soil 6"																		
Concrete Slab 10"																		
HMAC 6"																		
Compacted Soil 6"																		
Concrete Slab 12"																		
Compacted Soil 6"																		
Slab 10"																		
HMAC 6"																		
Sel. Mat. 12"																		
Comp Soil 6"																		
Min. structural criteria met	2.45" PVR limited to 1" "Dry" layers: Critical	<table border="1"> <tr><td>Concrete Slab 10"</td></tr> <tr><td>HMAC 16"</td></tr> <tr><td>Compacted Soil 6"</td></tr> </table> <p>(May NOT Be Practical)</p>	Concrete Slab 10"	HMAC 16"	Compacted Soil 6"	<table border="1"> <tr><td>Concrete Slab 26"</td></tr> <tr><td>Compacted Soil 6"</td></tr> </table> <p>(May NOT Be Practical)</p>	Concrete Slab 26"	Compacted Soil 6"										
Concrete Slab 10"																		
HMAC 16"																		
Compacted Soil 6"																		
Concrete Slab 26"																		
Compacted Soil 6"																		

**Table 2.9 Alternate Rigid Cross-Sections: Beaumont District.**

<b>Highway type</b>	<b>Traditional</b>		<b>Slab over HMAC</b>	<b>Full-depth PCC</b>	<b>Slab over HMAC over Select Fill</b>										
IH US 96/ SH 105/ FM High Vol Rds	<table border="1"> <tr><td>Concrete Slab 12"</td></tr> <tr><td><del>Concrete Slab 12"</del></td></tr> <tr><td>Cement Treated 6"</td></tr> <tr><td>Lime Stab. SG 6"</td></tr> <tr><td>Compacted Soil 6"</td></tr> </table>	Concrete Slab 12"	<del>Concrete Slab 12"</del>	Cement Treated 6"	Lime Stab. SG 6"	Compacted Soil 6"	PVR NOT critical	<table border="1"> <tr><td>Concrete Slab 12"</td></tr> <tr><td>HMAC 6"</td></tr> <tr><td>Compacted Soil 6"</td></tr> </table>	Concrete Slab 12"	HMAC 6"	Compacted Soil 6"	<table border="1"> <tr><td>Concrete Slab 14"</td></tr> <tr><td>Compacted Soil 6"</td></tr> </table>	Concrete Slab 14"	Compacted Soil 6"	
Concrete Slab 12"															
<del>Concrete Slab 12"</del>															
Cement Treated 6"															
Lime Stab. SG 6"															
Compacted Soil 6"															
Concrete Slab 12"															
HMAC 6"															
Compacted Soil 6"															
Concrete Slab 14"															
Compacted Soil 6"															

**Table 2.10 Alternate Rigid Cross-Sections: El Paso District.**

Highway type	Traditional	critical	Slab over HMAC	Full-depth PCC	Slab over HMAC over Select Fill					
IH 10	<table border="1"> <tr><td>Concrete Slab 14"</td></tr> <tr><td>HMAC 4"</td></tr> <tr><td>Compacted Soil 6"</td></tr> </table>	Concrete Slab 14"	HMAC 4"	Compacted Soil 6"	critical	--	<table border="1"> <tr><td>Concrete Slab 18"</td></tr> <tr><td>Compacted Soil 6"</td></tr> </table>	Concrete Slab 18"	Compacted Soil 6"	
Concrete Slab 14"										
HMAC 4"										
Compacted Soil 6"										
Concrete Slab 18"										
Compacted Soil 6"										
IH 10	<table border="1"> <tr><td>Concrete Slab 12"</td></tr> <tr><td>HMAC 4"</td></tr> <tr><td>Compacted Soil 6"</td></tr> </table>	Concrete Slab 12"	HMAC 4"	Compacted Soil 6"	NOT	--	<table border="1"> <tr><td>Concrete Slab 14"</td></tr> <tr><td>Compacted Soil 6"</td></tr> </table>	Concrete Slab 14"	Compacted Soil 6"	
Concrete Slab 12"										
HMAC 4"										
Compacted Soil 6"										
Concrete Slab 14"										
Compacted Soil 6"										
IH 10	<table border="1"> <tr><td>Concrete Slab 10"</td></tr> <tr><td>HMAC 4"</td></tr> <tr><td>Compacted Soil 6"</td></tr> </table>	Concrete Slab 10"	HMAC 4"	Compacted Soil 6"	PVR	--	<table border="1"> <tr><td>Concrete Slab 11"</td></tr> <tr><td>Compacted Soil 6"</td></tr> </table>	Concrete Slab 11"	Compacted Soil 6"	
Concrete Slab 10"										
HMAC 4"										
Compacted Soil 6"										
Concrete Slab 11"										
Compacted Soil 6"										

## **Chapter 3**

### **Construction Time and Agency Cost for Rigid Pavements**

The approach followed to determine several sets of expedited pavement sections for several districts around the State was described in Chapter 2. In this chapter, the procedure and assumptions made to estimate the total construction time, and the agency costs are discussed. A simple time-cost comparison between alternate sections and traditional ones is also presented to assess the feasibility of expediting highway construction.

#### **Construction Schedules**

Construction schedules for traditional pavements, as well as alternate structures, were developed using the critical path method (CPM) technique. To simplify the schedules, a number of assumptions, similar to the ones reported in Chapter 4 of report 4188-1 (Melchor-Lucero et al. 2001) were made. These assumptions include:

- The length of the project is 1 mile (1600 m) with four 12-ft- (3.7-m-) wide lanes.
- Construction activities are planned based on the assumption that a new highway is being constructed.
- The primary sources for determining the number and sequence of construction activities were TxDOT's guidelines to determine contract time (TxDOT, 1993), and TxDOT's standard specifications for highway construction (TxDOT, 1995). However, these documents neither provide a detailed description of the construction crews and equipment associated to each activity, nor provide guidelines in terms of layer thickness considered for preparation of base layers and wearing courses.
- Construction schedules start with the preparation and compaction of subgrade as the first activity, and end with the pouring of the PCC slab. The placement of structural reinforcement in the slab is not considered due to the general nature of the project.
- For practical purposes, some activities such as the removal of the underground utilities, the installation of drainage and manhole, the construction of bridges or culverts, among others are not considered in the construction scheduling.
- For each activity, normal or ideal set of working conditions are considered. The impact of the

climatic condition per se on the duration of an activity is not considered.

## **Estimating Total Project Duration and Cost**

After breaking the project down into activities and determining the sequence of work, the duration and extent of each individual activity are estimated. The daily production rate-based (DPR) (Pierce 1988) method is used for determining the duration of each activity.

To provide the most accurate results possible, several potential sources of daily production rates were investigated. The five TxDOT districts were surveyed to obtain feedback on their historical DPRs first. Partial information gathered from the districts is summarized in Table 3.1. Traditionally, the districts do not keep historical records of productivity rates, while construction companies possibly do. Efforts were then made to obtain preliminary information from an ongoing TxDOT research project that is attempting to establish state-wide productivity rates. However the relevant information was not available at the time that our analysis was carried out.

TxDOT's Contract Time Guidelines (TxDOT, 1993) was studied next. That guideline contains daily and base production rates for standard work items. Three different levels of production rates are presented, as well as adjustment factors that reflect the impact of the different conditions under which the construction is carried out (e.g. urban, rural, light traffic conditions, bad soil conditions, etc.). However, these tables do not provide details as to the type of construction equipment considered, or layer thickness assumed for base preparation or wearing courses. Relevant information gathered from this document is also summarized in Table 3.1.

Other published materials such as Harber (1988) and Pierce (1998) were then reviewed in search of real-time productivity rates. Most information provided by this source was not considered useful for highway construction in Texas.

Finally, the RSMeans nationwide Heavy Construction Cost Data (RSMeans, 2001) were inspected and eventually selected as the only source for productivity rates and cost data to estimate the proposed construction schedules. RSMeans offers a differentiation of productivity rates by lift thickness, as well as a breakdown of the total activity cost, into four cost components (bare materials, bare labor, bare equipment, and overhead and profit). Construction activities in RSMeans are identified by an "Activity Number", a "General Description", "Productivity Units", "Crew Code" among other descriptors. The selection criteria consisted of selecting the activity or combination of activities with a general description that closely matched the one under consideration.

After calculating the times for the individual activities, a time-scale diagram was developed to determine the order in which the activities are performed, and the duration of the entire project. The primary goal was to compress the work schedules as much as feasibly possible to expedite the construction of the one-mile highways, by minimizing starting and finishing lags.

**Table 3.1 Daily Production Rates for Common Highway Construction Activities: Survey Findings.**

	<b>HOUSTON (Accelerated)</b>	<b>HOUSTON</b>	<b>FORT WORTH</b>	<b>FORT WORTH</b>	<b>TxDOT</b>
	3 - 8 hr. shift 7 days / week		Project No. STP 2001	Project No. C 8665-2-1	Administrative Circular No. 17-93
<b>Roadway excavation</b>		3000 sy./day/crew			
<b>Lime stabilized subgrade</b>	1500 LF/Day (3 day cure)	3000 sy./day/crew	2600 sy./day/crew	3000 sy./day/crew	2000 - 4000 - 6000 sy./day
<b>Cement stabilized subgrade</b>	1400 LF/Day (3 day cure)	3000 sy./day/crew			1500 - 3000 - 4500 sy./day
<b>HMAC base or HMAC surface</b>					500 - 1200 - 2000 Ton/day
<b>Asphalt surface treatment (1 course)</b>					30,000 - 50,000 - 70,000 sy./day
<b>ACP Base</b>		1500 sy./day/crew			
<b>ACP Pavement</b>	1800 Ton/Day	5000 sy./day/crew	4" - 1000 Ton/day	4" - 1500 Ton/day	
	13"	800 sy./day/crew			
	12"	900 sy./day/crew			1000 - 3000 - 5000 sy./day
<b>CRCP Slab</b>	2000 LF/Shift/Run (14 day cure)	1200 sy./day/crew	2000 cy/day	3000 - 4000 sy./day	(rebar & curing)
	9"				
	6"	1800 sy./day/crew			
<b>Bad weather</b>	15 days				

Starting times and finishing times for each activity were identified and established, considering the maximum number of construction crews per activity per day that would avoid crowded or interfering crew setups. Eight-hour days are assumed

Figure 3.1 illustrates a typical time analysis and corresponding time-scale diagram for the construction of the traditional pavement section. The construction of the lime-stabilized soil layer is performed in two phases. The first layer is 12 in. (0.30 m) thick; while the second layer is only 7 in. (0.18 m) thick. The same crew performs the activity; however, the productivity rates are slightly different. In addition, the following activity to each stabilized layer is delayed seven days to account for the curing period specified (TxDOT 1995). The reader is also referred to Appendix H of report 4188-1 (Melchor-Lucero et al. 2001) to inspect the composition of each crew used in the analysis. Activity costs as well as total project costs are automatically calculated.

Similar exercises were performed for each traditional and alternate cross-section of all five districts. Appendix C summarizes construction time analyses and Appendix D summarizes agency cost analyses.

### **Assessment of Alternate Cross-Sections for Expediting Construction**

To quantify the reduction in construction time when the expedited cross-sections was used, the ratio between the time required to finish the expedited cross-section and the traditional cross-section was determined. Whenever the ratio is less than unity, the construction of the alternate cross-section is faster than the traditional one. Similarly, the ratio of the cost associated with the expedited cross-section and the traditional cross-section was used to determine the cost saving/increase associated with the proposed cross-sections.

Tables 3.2 thru 3.6 graphically present the construction time and cost ratios for each alternative, relative to their corresponding traditional sections. The format in which the information is presented is consistent with Tables 2.6 thru 2.10

<b>CRCP 14"</b>
<b>HMAC (Type B) 4"</b>
<b>Lime Stab. SG (6 %) 19"</b>
<b>Compacted Soil 6"</b>

Thickness	Qty	Description	Crew	No. of Crews	Daily Output	Units	Duration	Start Time	Finish Time
14	28,160.00	Conc pavement, w/fl,fnsh&curing,fx form,12' pass,unreinforced,14"T w/ continuous welded steel reinforcement over 10' wide	B26	2	1,600	S.Y.	8.80	16.00	24.80
4	28,160.00	Base course, bituminous concrete, 4" thick	B25	2	4,550	S.Y.	3.09	15.00	18.09
12	28,160.00	Soil stabilization, hydrated lime, for base, 2% mix by weight, 12" D	B74	2	1,550	S.Y.	9.08	8.00	17.08
7	28,160.00	Soil stbin, w/scarifying & cmpct, hydrated lime,base,2% by weight,7"D	B74	2	1,800	S.Y.	7.82	1.00	8.82
6	4,693.33	Compaction, riding, vibrating roller, 12" lifts, 4 passes	B10Y	1	2,600	C.Y.	1.81	0.00	1.81
							<i>Project</i>	<i>Duration</i>	24.80

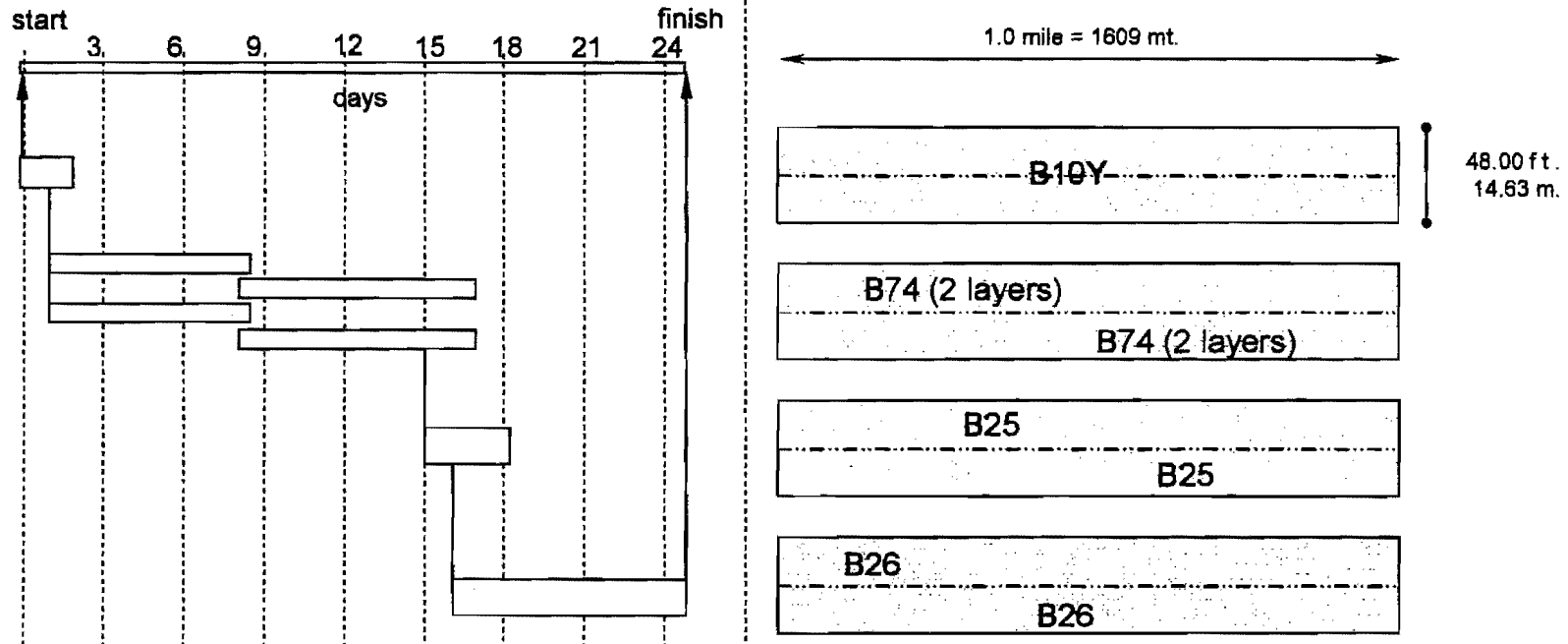

**Figure 3.1 Construction Activities Setup and Time-Scale Diagram for Construction Time Analysis.**

# Summary of Relative Construction Time and Agency Cost for Alternate Rigid Pavement Cross-Sections

Table 3.2 Relative Time and Cost: Dallas District.

Roadway Classification	Traditional	Slab over HMAC	Full-depth PCC	Slab over HMAC over Select Fill
<b>Highest Vol. Highway</b> (IH-35-E / 190T Mainlanes NB / SB Entrance Ramp / NB Exit Ramp)	CRCP 14" HMAC (Type B) 4" Lime Stab. SG (8 %) 19" Compacted Soil 6"	Min. structural criteria met 		
		2" PVR limited to 1" Layers w/Avg. moisture 	 (May NOT Be Practical)	
		3" PVR limited to 1" "Dry" layers: Critical (NOT Practical)	(NOT Practical)	(NOT Practical)
Construction Time <input type="checkbox"/> Agency Cost <input type="checkbox"/>				

**Table 3.2 Relative Time and Cost: Dallas District...cont.**

Roadway Classification	Traditional	Slab over HMAC	Full-depth PCC	Slab over HMAC over Select Fill
<b>Highest Vol. Highway</b> (IH-35-E / 190T Mainlanes EB, WB)  (US 75 Mainlanes NB, SB)	CRCP 13" HMAC (Type B) 6" Lime Stab. SG (6 %) 18" Compacted Soil 6"	Min. structural criteria met  	 	
	CRCP 13" HMAC (Type A) 3" HMAC (Type D) 3" Lime Stab. SG (4%) 10" Select Fill Mat. (Pl<=20) 18"(sand) - 21"(clay)	3" PVR limited to 1" "Dry" layers: Critical (NOT Practical)	(NOT Practical)	 
<b>Highest Vol. Highway</b> (US 75 Mainlane SB)	CRCP 13" HMAC (Type A) 3" HMAC (Type D) 7" Compacted Soil 18" Rock	Min. structural criteria met --		

Construction Time  Agency Cost

**Table 3.2 Relative Time and Cost: Dallas District...cont.**

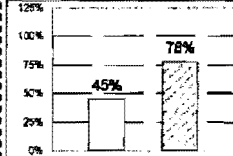
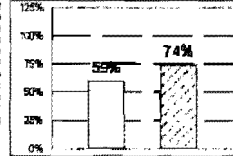
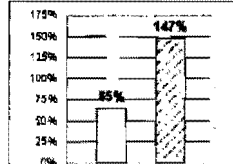
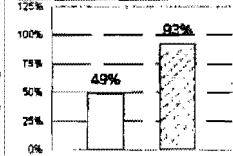
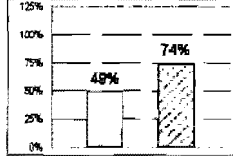
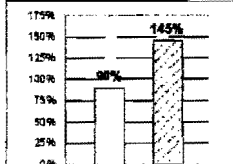
Roadway Classification	Traditional	Slab over HMAC	Full-depth PCC	Slab over HMAC over Select Fill
<b>Highest Vol. Highway</b> (IH-30 Sta. 666 / Maindane widening)	Concrete Slab 15" HMAC (600 / 600 # / SY) 6" Embankment Type C Lime Stab. SG (4%) 18" Compacted Soil 6"	Min. structural criteria met 		
	(NOT Practical)	(NOT Practical)		
(IH-30 Sta. 593 )	Concrete Slab 15" HMAC (1320 # / SY) 12" Embankment Type C Lime Stab. SG (4%) 12" Compacted Soil 18"	Min. structural criteria met 		
	(NOT Practical)	(NOT Practical)		

Construction Time  Agency Cost

**Table 3.2 Relative Time and Cost: Dallas District...cont.**

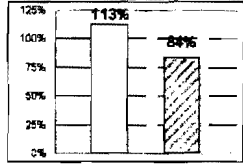
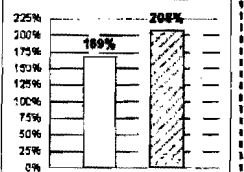
Roadway Classification	Traditional	Slab over HMAC	Full-depth PCC	Slab over HMAC over Select Fill
<p><b>Arterial, Frontage &amp; Collector Roads</b></p> <p>(IH-30 Frontage Rd. / Bobtown Rd.)</p>	<p>CPCD 10"</p> <p>HMAC (680 / 800 # / SY) 8"</p> <p>Compacted Soil 18"</p>	<p>Min. structural criteria met</p> <p>3" PVR limited to 1" "Dry" layers: Critical</p> <p>--</p> <p>(NOT Practical)</p>	 <p>(NOT Practical)</p>	
<p>Construction Time <input type="checkbox"/> Agency Cost <input type="checkbox"/></p>				

**Table 3.2 Relative Time and Cost: Dallas District...cont.**

Roadway Classification	Traditional		Slab over HMAC	Full-depth PCC	Slab over HMAC over Select Fill
<b>Arterial, Frontage &amp; Collector Roads</b> Scenic Dr.	CPCD CL K 8"	Min. structural criteria met 3" PVR limited to 1" "Dry" layers: Critical	--		
	HMAC 14"				
<b>City/Local Streets</b> Heritage / Harborside	Compacted Soil 6"		(NOT Practical)	(NOT Practical)	
<b>Arterial, Frontage &amp; Collector Roads</b> Lakeshore Dr.	CPCD CL K 8"	Min. structural criteria met	--		
	HMAC 8"				
<b>City/Local Streets</b> 2 <sup>nd</sup> . St.	Compacted Soil 8"				
	CPCD 8"	3" PVR limited to 1" "Dry" layers: Critical	(NOT Practical)	(NOT Practical)	
HMAC 4"					
	Compacted Soil 6"				



Construction Time  Agency Cost

**Table 3.2 Relative Time and Cost: Dallas District...cont.**

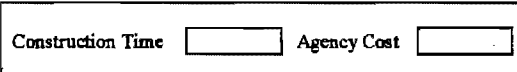
Roadway Classification	Traditional	Slab over HMAC	Full-depth PCC	Slab over HMAC over Select Fill		
<b>Arterial, Frontage &amp; Collector Roads</b>  (IH-35-E / 190T Frontage Rds.)	Concrete Slab 8" HMAC 6"					
	Lime Stab. SG (6%) 8" Compacted Soil 6"					
	CPCD 8" HMAC 4" Lime Stab. SG (7%) 22" Compacted Soil 6" 0.25 Gal. / SY					
(SH 66 Mainlane)	Concrete Slab 8" HMAC 4"	Min. structural criteria met	(NOT Practical)	(NOT Practical)		
	Lime Stab. SG (7%) 6" Compacted Soil 6" 0.25 Gal. / SY					
	Concrete Slab 8" HMAC 4"					
Lime Stab. SG (7%) 6" Compacted Soil 6" 0.25 Gal. / SY						
SH 66 Embank Washington St. Rusk St.	3" PVR limited to 1" "Dry" layers: Critical				(NOT Practical)	(NOT Practical)

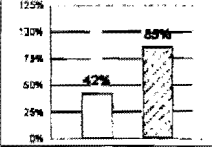
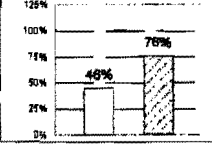
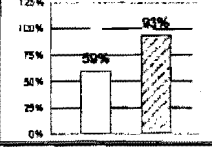

**Table 3.3 Relative Time and Cost: Fort Worth District.**

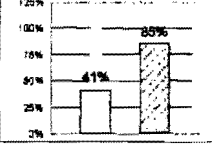
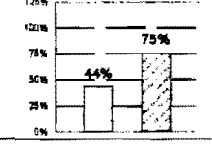
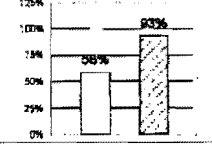
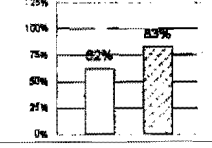
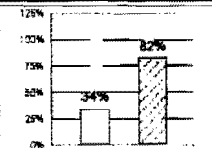
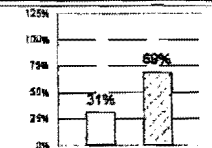
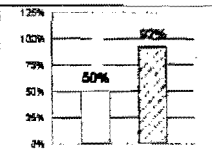
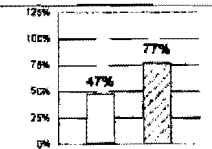
Highway type	Traditional		Slab+HMAC	Full-depth PCC
IH / US / SH 360/ FM / High Vol. Urban	Concrete Slab 13" HMAC 4" Lime Stab. SG 18"	PVR Not critical		
	Concrete Slab 13" HMAC 4" Lime Stab. SG 8"			
IH / US / SH / FM / High Vol. Urban	Concrete Slab 12" HMAC 4" Lime Stab. SG 18"	PVR Not critical		
	Concrete Slab 12" HMAC 4" Lime Stab. SG 8"			
US / SH / FM	Concrete Slab 8" HMAC 4" Lime Stab. SG 18"	PVR Not critical		
	Concrete Slab 8" HMAC 4" Lime Stab. SG 8"			

Construction Time  Agency Cost

**Table 3.4 Relative Time and Cost: Houston District.**

Highway type	Traditional	Slab over HMAC	Full-depth PCC	Slab over HMAC over Select Fill	
SH / FM	<div style="border: 1px solid black; padding: 2px; text-align: center;"> <b>Concrete Slab 13"</b>  <hr/> <b>Cement Treated 6"</b>  <b>Lime Stab. SG 6"</b>  <b>Compacted Soil 6"</b> </div>	Min. structural criteria met			
			2.45" PVR limited to 1" "Dry" layers: Critical	<p>(May NOT Be Practical)</p>	<p>(May NOT Be Practical)</p>
FR	<div style="border: 1px solid black; padding: 2px; text-align: center;"> <b>Concrete Slab 10"</b>  <hr/> <b>Cement Treated 6"</b>  <b>Lime Stab. SG 6"</b>  <b>Compacted Soil 6"</b> </div>	Min. structural criteria met			
			2.45" PVR limited to 1" "Dry" layers: Critical	<p>(May NOT Be Practical)</p>	<p>(May NOT Be Practical)</p>

Construction Time  Agency Cost

**Table 3.5 Relative Time and Cost: Beaumont District.**

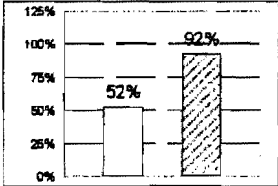
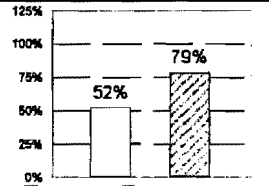
Highway type	Traditional	Slab+HMAC	Full-depth PCC				
IH US 96/ SH 105/ FM High Vol Rds	<table border="1"> <tr><td>Concrete Slab 12"</td></tr> <tr><td>Cement Treated 6"</td></tr> <tr><td>Lime Stab. SG 6"</td></tr> <tr><td>Compacted Soil 6"</td></tr> </table>	Concrete Slab 12"	Cement Treated 6"	Lime Stab. SG 6"	Compacted Soil 6"	PVR NOT critical 	
Concrete Slab 12"							
Cement Treated 6"							
Lime Stab. SG 6"							
Compacted Soil 6"							
<table border="1"> <tr> <td>Construction Time</td> <td><input type="checkbox"/></td> <td>Agency Cost</td> <td><input type="checkbox"/></td> </tr> </table>				Construction Time	<input type="checkbox"/>	Agency Cost	<input type="checkbox"/>
Construction Time	<input type="checkbox"/>	Agency Cost	<input type="checkbox"/>				

**Table 3.6 Relative Time and Cost: El Paso District.**

Highway type	Traditional		Slab+HMAC	Full-depth PCC									
IH 10	<table border="1"> <tr><td>Concrete Slab 14"</td></tr> <tr><td>HMAC 4"</td></tr> <tr><td>Compacted Soil 6"</td></tr> </table>	Concrete Slab 14"	HMAC 4"	Compacted Soil 6"	critical	--	<table border="1"> <tr><th>Category</th><th>Value</th></tr> <tr><td>Construction Time</td><td>118%</td></tr> <tr><td>Agency Cost</td><td>98%</td></tr> </table>	Category	Value	Construction Time	118%	Agency Cost	98%
Concrete Slab 14"													
HMAC 4"													
Compacted Soil 6"													
Category	Value												
Construction Time	118%												
Agency Cost	98%												
IH 10	<table border="1"> <tr><td>Concrete Slab 12"</td></tr> <tr><td>HMAC 4"</td></tr> <tr><td>Compacted Soil 6"</td></tr> </table>	Concrete Slab 12"	HMAC 4"	Compacted Soil 6"	NOT	--	<table border="1"> <tr><th>Category</th><th>Value</th></tr> <tr><td>Construction Time</td><td>100%</td></tr> <tr><td>Agency Cost</td><td>91%</td></tr> </table>	Category	Value	Construction Time	100%	Agency Cost	91%
Concrete Slab 12"													
HMAC 4"													
Compacted Soil 6"													
Category	Value												
Construction Time	100%												
Agency Cost	91%												
IH 10	<table border="1"> <tr><td>Concrete Slab 10"</td></tr> <tr><td>HMAC 4"</td></tr> <tr><td>Compacted Soil 6"</td></tr> </table>	Concrete Slab 10"	HMAC 4"	Compacted Soil 6"	PVR	--	<table border="1"> <tr><th>Category</th><th>Value</th></tr> <tr><td>Construction Time</td><td>94%</td></tr> <tr><td>Agency Cost</td><td>87%</td></tr> </table>	Category	Value	Construction Time	94%	Agency Cost	87%
Concrete Slab 10"													
HMAC 4"													
Compacted Soil 6"													
Category	Value												
Construction Time	94%												
Agency Cost	87%												

Construction Time	<span style="display: inline-block; width: 20px; height: 10px; border: 1px solid black;"></span>	Agency Cost	<span style="display: inline-block; width: 20px; height: 10px; border: 1px solid black;"></span>
-------------------	--	-------------	--

The following conclusions are drawn from the tables.

*Dallas District*

For “Highest Volume” highways, full depth slab alternates or alternates with slabs over HMAC expedite construction up to 46%, except for the sections with a 14-in. (355-mm) thick slab where they cost more than the traditional. For the “Arterial, Collector Roads” category, all alternates for traditional sections with 8-in. (205-mm) slabs over stabilized material can save construction time. For traditional sections consisting of slab over HMAC, all alternates take more time to build. None of the City/Local Streets alternates can expedite construction and only two of them can save some money.

Under all categories, alternate sections with select material always cost more than their corresponding traditional sections, due to the fact that their overall depth is determined to reduce the subgrade’ PVR to allowable limits.

*Fort Worth District*

Both alternative types expedite construction at about the same ratio. However, the full-depth slab alternative is at least 10% less expensive than the slab over the HMAC alternative.

*Houston District*

All alternatives reduce construction time between 40 and 50%. Whenever a high PVR is expected, the alternatives built with layers of select material, would be a better option to consider building, since the other two options are not practical.

*Beaumont District*

Alternate sections can be built in about half the time of the traditional. Cost savings on the order of 10% to 20 % are observed

*El Paso District*

Generally speaking, the alternate sections for El Paso offer little or no time saving advantages compared to traditional practice. Construction times vary depending on the total depth of the traditional section. The deeper the traditional section, the closer the construction time for the expedited cross-section is to the traditional one. For example, the alternate section corresponding to the traditional section with a 14 in. (356 mm) slab, takes almost 20% longer to build, while the one with a 10 in. (254 mm) slab is 6% faster.

## **Chapter 4**

### **User Costs Associated with Rigid Pavement Construction**

This chapter provides an extensive background discussion on several aspects related to estimation of user costs associated with pavement construction and rehabilitation. The following sections are included in this chapter:

1. **Components of road user costs at work zones:** In this section the different cost components of road user costs such as time delays, accidents and Vehicle Operating Costs (VOCs) are discussed. This is an optional section and the reader may choose to skip it.
2. **Modeling workzone user costs.** In this section the different modeling approaches to estimating road user costs at work zones are discussed, with an emphasis on available computerized tools. This is also an optional section that the reader may choose to skip.
3. **Manual modeling of work zone road user costs.** This section discusses the methodology used to quantify the user costs employed in the full-cost ratio calculations for alternate rigid cross-sections reported in Chapter 5. It is strongly recommended that the reader goes through this section in order to understand the calculations reported in Chapter 5.

The optional reading recommendations in items one and two above are supported by the fact that even with the availability of computerized tools discussed in the modeling section of this chapter, the estimation of RUCs is a complex and data intensive activity, subjected to several assumptions by the analyst. However, items one and two above provide a good summary of cost components and modeling techniques, which serve as relevant background information for understanding the manual technique discussed in this chapter. Based on the information summarized in the sections for items one and two above, it is recommended that the economical comparison of traditional versus expedited concrete pavement cross-sections reported in Chapter 5 uses a simplified method for estimating road user costs. This manual technique is summarized in the manual modeling of work zone road user costs section.

## **Introduction**

When activities are undertaken on highway pavements remaining in use, a system of traffic controls and protective barriers is instituted to ensure worker safety. Traffic management in work zones is influenced by type of infrastructure, environment, traffic characteristics, duration and type of work and available sight distance. Work zone configurations require a balance between contractor efficiency and traffic speeds and safety. When vehicle flows are light, impacts on speed (and to a lesser degree safety) may be slight. But as demand increases, such impacts rise substantially and rapidly. Modeling these impacts must therefore incorporate the impact a work zone has on speed, and how changes in speed translate into estimates of user costs.

Through the work zone, drivers face posted speeds which are calculated based on lane width and other physical characteristics and are also determined by a reduction of capacity due to a reduction on the number of available lanes or narrowing of existing lanes. These reduced speed zones remain in effect until the work zone terminates. In the termination zone, two elements occur in terms of velocity. Drivers, while remaining alert, will first accelerate to the new desired speed, which when attained, will become the final speed produced by the work zone.

Speed patterns are important because they relate directly to vehicle operating costs and to loss of time and hence, delay costs. Also, speed changes, particularly those that result in idling, produce higher levels of emissions. Finally, the transitional zone, particularly related to the non-recovery area before the work zone, is typically one where higher accident rates are recorded as vehicles merge into the constrained flows through the work zone.

Current work zone modeling in general and certainly that specifically related to policy-making, such as the one involved in this research project, cannot address all these speed-flow elements. The work zone models generally assume a constant deceleration and acceleration and a constant speed through the work zone. In this respect, they may be somewhat conservative in nature and underestimate the true speed profile of vehicles.

## **Components of Road User Costs at Work zones**

The speed changes mentioned in the previous section manifest themselves in additional costs which are measured in a variety of ways. These groups, categorized under the general label of user costs, comprise four elements for purposes of work zone evaluation. The first group is related to delay or travel time costs. Here, reduced speeds and speed cycle changes lengthen the trip time which means that time is lost in making the journey compared with that expended on the same route without the work zone. Such time elements are typically aggregated and then converted to monetary values by dollar rates for work and social values. The second group is vehicle operating costs. These are the traditional elements of vehicle operation, which result in costs which are met by the vehicle owner. These comprise fuel consumption, tire wear, vehicle maintenance, vehicle depreciation and spare parts. Again, speed changes and queuing alter the consumption of these items, particularly those related to fuel. The next group of costs relate to speed change cycling, which again work their way through certain operating costs and emissions and other tailpipe pollutants. The final group of user costs are those associated with accidents

which are generally higher at work zones for reasons given in the previous section. Again, these are costs that would not ordinarily be generated by a regular trip, but are a result of imposing a work zone on traffic, so they need to be part of the total user costs evaluated in a full systems approach to work zone impacts. Figure 4.1 summarizes the different user cost components.

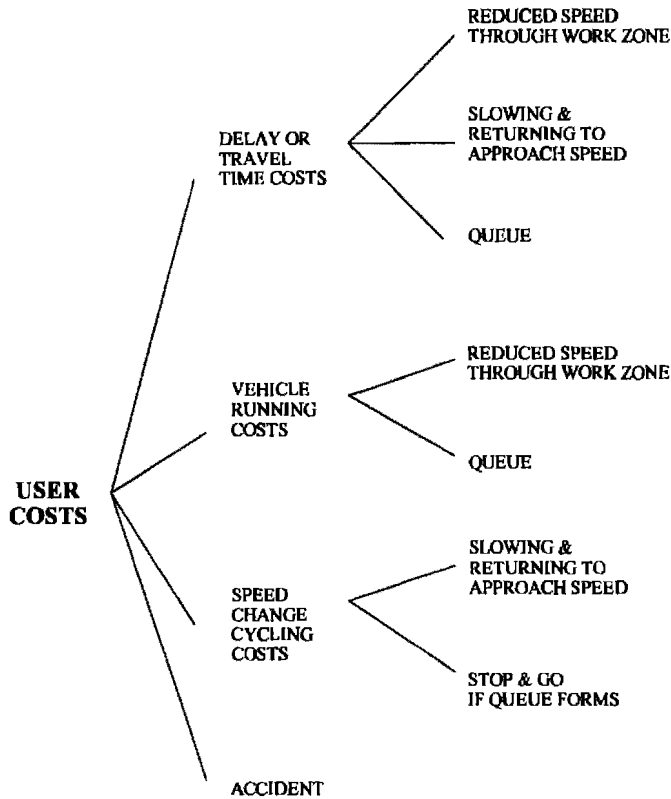

**Figure 4.1 Work Zone User Cost Components.**

Using a simplified formulation, Road User Costs (RUC) include Vehicle Operating Costs (VOC), Total Delay Costs (TDC), and Total Accident Costs at the work zone (TAC).

Therefore,

$$RUC = VOC + TDC + TAC$$

As long as the work zone capacity exceeds vehicle demand on the facility, user costs are normally manageable and represent more of an inconvenience than a serious cost to the traveling public. Unfortunately, this is not usually the case for work zones established for the rehabilitation or capacity addition for concrete pavements. Concrete pavements, due to their higher initial cost, long term performance and reduced maintenance, are the pavements of choice for high volume traffic applications.

When vehicle demand on the facility exceeds work zone capacity, the facility operates under forced flow conditions, and additional user costs must be considered, such as queue delay, and rerouting costs. Different vehicle classes have different operating characteristics and associated

operating costs, as a result, user cost are usually analyzed for at least three broad vehicle classes: passenger vehicle, single-unit trucks, and combination trucks.

### **Vehicle operating costs**

Vehicle Operating Costs (VOCs) components includes cost of fuel, tires, engine oil, maintenance, and depreciation. These can be increased by congestion and speed variations that occur at work zones. Appropriate unit cost values for the operating characteristics of the work zone are multiplied by the number of vehicles affected in each vehicle class to estimate the total VOCs.

For many years, highway engineers have been concerned with the relationships between highway design, condition and road user costs and indeed such research has been conducted for over 100 years. Vehicle operating costs first received attention in North America shortly after the first World War, when Agg (1923) studied the performance of a small test fleet fitted with flow meters and chart distance recorders. By 1935, researchers (Agg and Carter, 1928) (particularly those at Iowa State College Engineering Station) had reported on the effect of geometry operating costs, on truck operations in Iowa (Winfrey, 1993), on tractive resistance and road surface (Paustian, 1934), and on tire skidding characteristics, surface types and safety (Moyer, 1934).

Despite the considerable efforts devoted to collecting US and European vehicle operating cost information, by 1965 only fuel consumption could be predicted with sufficient accuracy and most of the information available was not well suited for use outside North America. Accordingly, in 1969 the World Bank initiated a program of research to develop models relevant to conditions in developing countries with which to examine the trade-offs between initial construction costs, future maintenance expenditures and road user costs for alternative highway design and maintenance strategies. This resulted in two separate approaches being developed for user cost data.

In the United States, work continued along orthodox, traditional lines. In 1981, an updated version of the Federal Highway Administration Vehicle Operating Cost and Pavement Type Manual was published (Zaniewski *et. al.* 1981), revising the earlier version based on Winfrey (Winfrey, 1969) and Claffey's work on fuel consumption (Claffey, 1971). Winfrey and Claffey summarized their results in tables that reported operating costs for a range of vehicle types at constant speeds, and over speed cycles. Zaniewski (Zaniewski *et. al.* 1981) conducted a series of fuel experiments on paved roads using a test fleet of four cars, a pickup and three trucks. He also modeled tire wear using procedures developed by Della Moretta (Della Moretta and Sullivan, 1976) for use in the Forest Service model. The latter model was of interest because it simulated vehicle travel along a route requiring a relatively detailed route description together with extensive information on vehicle characteristics. It contains constraints on vehicle performance derived from physical principals and assumptions concerning what drivers will do when faced with different combinations of highway characteristics. Times for acceleration, braking or coasting are determined and the associated speeds, travel times, forces and energy requirements are calculated. These energy requirements are converted to instantaneous fuel consumption and tire wear with other operating cost components to give predictions of total vehicle costs.

In terms of usable cost equations in the United States, those wishing to determine work zone effects have tended to rely on the models developed by Zaniewski (Zaniewski *et. al.* 1981) in the early 1980s. The items required for the VOC elements of a highway model are:

- Fuel and oil consumption,
- Tire consumption,
- Maintenance and repair costs, and
- Depreciation

The extent to which a work zone model measures all these elements depends on whether one takes a system-wide or project level view. If one is analyzing a large network in which a work zone is to be placed, and which will be affected by the impact that the work zone has on the flows passing on that particular part of the system, it is likely that all items could and should be modeled to the extent possible. For a site-specific work zone, it is more difficult to model the elements of tires and maintenance and repair costs since the major determinant of the model will not be changes in pavement condition (roughness), but rather changes in speed flow through the entire influence area of the work zone. In this instance, one would expect to emphasize the fuel and depreciation elements of vehicle operating costs.

#### **Accident costs**

Total Accident Costs (TAC) component generally reflects three different subcomponents: fatal accidents, non-fatal injury accidents, and accidents involving property damage only. Some states also include a multiplier factor to account for accident costs for unreported property damage in damage-only accidents. Therefore the accident cost can be expressed as:

$$TAC = FA + NFA + (PDO)x$$

Where,

FA = fatal accident costs

NFA = non-fatal accident costs

PDO = property damage only accident costs

x = adjustment factor for unreported PDO accidents

Several roadway factors and conditions influence the rates and categories of accidents. The Organization for Economic Cooperation and Development (OECD, 1999), produced a study which enumerated the most influencing factors and ranked them in order of importance. The factor that most affects the accident rate the most is the width of the traffic lanes. The OECD study reports the decrease in accidents when lanes are widened from nine feet to 10, 11, 12, and 13 feet. The results are given in Table 4.1. Table 4.1 shows, for example, that a twelve foot wide lane is reported having a 32 percent reduction in the amount of accidents related to width.

**Table 4.1 Accident reduction attributed to wider lanes**

<b>Lane Width (ft)</b>	<b>% Reduction from 9' lanes</b>
10	12
11	23
12	32
13	40

Accident costs are difficult to determine because they are influenced by the methodology adopted and the location (urban/rural) and country where the study was undertaken. Table 4.2 (Urban Institute, 1991) shows the results of one study that attempted to quantify the costs of accidents of differing severity.

**Table 4.2 Estimates for different accident type costs**

<b>Injury Type</b>	<b>Cost in \$ 1988 prices</b>
Fatal Injury	1,744,000
Incapacitating Injury	134,000
Non-incapacitating Injury	23,000
Possible Injury	10,000
Property Damage	960
Unreported	250

### **Total Delay Costs**

Total Delay Costs (TDC) are calculated by estimating a Value of Time (VOT) and multiplying this value by the delays caused by congestion, queues and detours for each of the vehicle classes considered in the analysis.

VOT is basically a function of an hourly wage rate, most often multiplied by an average ridership component that can be expressed by:

$$\text{VOT} = f(\text{AWR})(\text{occupancy})$$

Where,

AWR = average wage rate

AR = average ridership

A recent survey (Daniels *et. al.* 1999) summarized unit costs for VOT in different states around the nation. These values are summarized in Table 4.3.

**Table 4.3 Summary of VOT Values for Selected States**

State	Value of time Autos	Value of Time Trucks
North Carolina	\$8.70	—
New York	9.00	21.14
Florida	11.12	22.36
Georgia	11.65	—
TEXAS	11.97	21.87
Virginia	11.97	21.87
California	12.10	30.00
Pennsylvania	12.21	24.18
Washington	12.51	50.00
Ohio	12.60	26.40

Basic steps to be followed in calculating work zone user costs are to:

1. Obtain traffic demands for the construction period,
2. Identify workzone layout and phases,
3. Quantify traffic affected by each phase,
4. Calculate reduced speed delay,
5. Select and assign VOC cost rates,
6. Select and assign VOT delay cost rates,
7. Assign affected traffic to vehicle classes,
8. Estimate Accident counts,
9. Calculate VOC and TDC components by vehicle class, and
10. Add all the User Cost components (VOC, TDC, and TAC) to get the cost associated with the workzone.

Several approaches are available to estimate the behavior of traffic through work zones, providing support for the calculation and are summarized in the next section.

### **Modeling Work Zone User Costs**

The modeling process predicts an output as a function of specified inputs, using mechanisms that can vary between a simple equation to a complex simulation process. The important issues for work zone modeling is the type of the system being considered, traffic flow characteristics, available analytical relationships, and their incorporation into the model structure. For work zones, outputs could include speed projections, operating speed, distance headway distributions, and/or density levels.

Traffic stream models can often be used for uninterrupted flow situations, where demands do not exceed capacities. For interrupted oversaturated flow situations, more complex techniques such

as queuing analysis, and simulation modeling appear to offer more accuracy in modeling the situation.

Furthermore, the analysis may be microscopic where individual vehicles are considered in the analysis, or macroscopic where groups of vehicles (platoons) are used. The former may be selected for moderate-sized systems where the traffic passing the system is relatively small and there is the need to study the behavior of individual vehicles in the system. The latter may be selected for higher-density, larger-scale systems in which a study of the groups of vehicles is sufficient, rather than individual vehicles.

When demand exceeds capacity for a period of time or arrival time headway is less than the service time at a specific location, a queue is formed. The queue may be a moving queue or stopped queue. Essentially, excess vehicles are stopped upstream of the bottleneck or service area, and their departure is delayed to a later time period. Queuing analysis can be deterministic or stochastic process. When the arrival distribution and/or the service time is probabilistic, it is referred to as a stochastic analysis.

Computer based traffic engineering tools can be grouped in two ways, first as analysis/optimization and second as simulation. The former is typically based on empirical relationships, while the latter incorporates physical relationships to model the behavior of traffic flows. More complex models, particularly macroscopic approaches, utilize simulation to resolve many of the data problems that are not adequately addressed by current empirical work.

There is a comprehensive manual procedure for work zone evaluation adopted in the US (TRB 1985), which sets out a stage-by-stage process to permit the selection of the most appropriate traffic control strategy for a particular maintenance task. Some of the assessment elements are also available as routines on micro-computers. For example, estimations may be made of the additional user costs (time and vehicle operation) associated with lane closures using QUEWZ (Queue and User cost Evaluation at Work Zones) (Memmott and Dudek, 1984). An indication of the impact of traffic disruption due to maintenance projects may be obtained from another routine called CAHOP (Computer-Assisted Reconstruction -- Highway Operations and Planning) (Leonard and Recker, 1986). This program provides a method of testing alternative maintenance management schemes by reviewing changes in journey time and travel on the surrounding network.

The main economic appraisal procedures widely used in the United Kingdom are embodied in two Department of Transport computer programs, COBA9 (DE, 1990) and QUADRO2 (DE, 1982). The former program is concerned with identification, evaluation and comparison of costs and benefits of new road schemes over a given period of time. The second program provides a method of economic assessment of road maintenance. The program models a simple network consisting of a main route, containing the work zone, and a representative route around the works. The program is run with and without the works present, and evaluations are made for the differences in time and vehicle operating costs incurred by all traffic on the network, together with accidents costs. An additional model calculates the time costs associated with breakdowns and accidents which occur in the work zone. Output available from the model includes information on the speed, queue, and diversionary behavior of traffic in each hour of a typical

week during the maintenance season, plus cost summaries by vehicle type and category. In Germany, while no generally applicable framework has been introduced to assess safety and traffic management aspects at work zones, many of the individual evaluation elements have been determined (OECD, 1989).

A considerable number of analytical and computer techniques and models are available to maintenance personnel to aid in decision making and scheduling of work zone lane closures on the arterial. The main drawback to almost all these techniques is that, in the final analysis, an arterial is divided into several segments and each is analyzed individually - with no relation to the other. For example, in a typical analysis of a work zone in an arterial, the arterial is divided into three sections: (a) the intersections, (b) the strip between the intersections, but not including the lane closure, and (c) the work zone, including the lane closure. While several comprehensive computers programs, such as QUEWZ and FREECON (Rouphal, 1991) had been developed to analyze work zones on freeways, few models have been developed to analyze the arterial system with the work zone as an overall comprehensive unit. One of them, the micro computer WZATA (Work Zone Analysis Tool for the Arterial) (Joseph, 1987) permits the analysis and evaluation of a system consisting of a lane closure between two signalized intersections. This program consists of two parts: a semi-simulation model to represent and analyze flow between the intersections, and a macroscopic model to represent traffic characteristics at the downstream direction.

More recently, the tool that researchers have been using for the development of Road User Costs (RUC) values is MicroBENCOST, a planning-level economic analysis tool developed by the Texas Transportation Institute (TTI) under NCHRP Project 7-12 (NCHRP, 1993 and MacFarland et.al, 1993). The MicroBENCOST (MBC) program is designed for economic analysis of a variety of highway improvements. It uses standard methodologies for traffic allocation and speed/delay calculations. From an economic standpoint, the advantage of the program is that the calculation of user costs is included in the computations. For example, the program takes into account the vehicle mix (including trucks) and the impact of vehicle speeds when it assigns delay costs. The program calculates user costs for a 24-hour period, 365 days per year.

## **Manual Modeling of Work Zone Road User Costs**

It is evident from the discussion in the previous sections of this chapter, that even with the availability of computerized tools such as QUEWZ and MicroBENCOST, the estimation of RUCs is a complex and data intensive activity, subjected to several assumptions by the analyst. For the simplified economical comparison of traditional versus expedited concrete pavement cross-sections developed in the previous chapters, a simplified method for estimating RUCs is required.

A recent TTI report, "Techniques for Manually Estimating Road User Costs associated with Construction Projects" (Daniels *et. al.* 1999), from now on referred to in this text as the TTI report, developed simplified manual procedures to estimate road user costs for different situations such as rehabilitation and added capacity projects, that encompass a series of tables developed using the MicroBENCOST program. This simplified manual procedure was selected

by the researchers in this project to estimate the RUC values needed to compare the expedited and traditional concrete pavement cross-sections, addressing agency and road user costs in a full-cost evaluation.

Table 4.4 (Daniels *et. al.* 1999) summarizes the general categories of projects and the suggested analysis technique for estimating RUC. Project types and attributes are divided into four broad categories based on the differences in analysis approach and technique. Categories of projects are either classified as urban, rural, or a combination of both. Category I and II projects involve detailed analysis with freeway analysis models such as CORSIM for the controlled access facilities, and with signal timing and simulation models such as PASSER, for the interrupted flow facilities such as urban arterials. Cases I and II projects are beyond the scope of the full-cost analysis planned for this research project and are applicable for projects that deserve detailed analysis for the establishment of incentives and disincentives for contractors. This report will concentrate on the application of the techniques described in categories III and IV, which can be solved by the manual techniques and tables described in reference 4.0.

**Table 4.4 Categories of Candidate Projects for Application of RUC  
(Daniels *et. al.* 1999)**

Category	Description of Projects	Setting	General Analysis Approach	Technique
I	<b>High Impact Urban Freeway Construction or Rehabilitation</b> <ul style="list-style-type: none"> <li>• Severe capacity reduction during construction</li> <li>• Phase completion time critical</li> <li>• Interaction with other freeway or arterial projects</li> </ul>	Urban	Phase-by-Phase or Before vs. After	FREQ, CORSIM, or HCS models
II	<b>Urban Arterial Roadways</b> <ul style="list-style-type: none"> <li>• Signalized intersections</li> <li>• Diamond interchanges</li> </ul>	Urban	Before vs. After	PASSER models
III	<b>Other Added Capacity Projects</b> <ul style="list-style-type: none"> <li>• Highway widening projects not classified as I or II above (rural highways, suburban arterials, urban freeways)</li> <li>• New facility construction</li> </ul>	Urban or Rural	Before vs. After	Manual Technique
IV	<b>Rehabilitation and other Non-Capacity-Added Projects</b> <ul style="list-style-type: none"> <li>• Paving projects (no capacity increase)</li> <li>• Bridge replacements</li> <li>• Detour routing</li> </ul>	Urban or Rural	During Construction vs. After	Manual Technique

Two different approaches are recommended by the TTI report: a “before versus after” approach for added capacity projects, and a “during construction versus after” approach for rehabilitation projects. However, it is the opinion of the authors of this report that the “before versus after” approach for added capacity projects needs to be corrected to incorporate work zone costs during construction of the additional lanes, an issue that is not addressed by the TTI report, and will be discussed in the numerical examples presented in the next section.

### **Added Capacity Projects Using a “Before versus After” Comparison and Rehabilitation projects Using a “Construction versus After Comparison”.**

To drive a given length of roadway, motorists will experience costs: the value of the motorists’ time to travel that section, the expenses to operate the vehicle over that section, and, in the aggregate, accident cost for the roadway section based on a rate of accident type per vehicle-miles of travel. The absolute difference between the total motorist costs in the “before” condition and “after” condition is the total daily excess cost, which is the value to be used to compare different construction alternatives such as traditional and expedited concrete pavement sections.

In addition to these “Before versus After” costs, costs during the construction phase, as induced by the work zone establishment to build the additional capacity, need to be considered in the analysis. This is where the approach proposed by this research project diverges from the approach described by the TTI report.

Several tables are included in the TTI report to support the estimation of user costs for different traffic volumes, vehicle mixes and work zone layouts. Tables 4.5 and 4.6 present an example of the application of these tables to estimate the before versus after added capacity project user costs per mile for upgrading a rural interstate from four lanes to six lanes. This assumes the work zone layout for the project will involve the narrowing of the existing lanes to accommodate the work zone for adding the additional lanes. The Average Daily Traffic (ADT) for this project is assumed to be 90,000 vehicles per day with 15% of trucks in the mix.

The user costs are comprised by two components, one for the loss of use of the upgraded six lane facility, calculated in Table 4.5, and the other comprised by the delays and accidents caused by the lane narrowing for establishing the work zone for implementing this added capacity project, calculated in Table 4.6. The calculations summarized in Table 4.6 for the work zone impacts are not considered in the TTI report, but obviously are an important component of the road user costs and should not be neglected in the calculations. For this specific project, each day of delay in the project will cost \$32,150/day/mile, which is the addition of the loss of added capacity costs, \$16,500/day/mile with the work zone costs of \$15,650/day/mile.

If we were to compare two alternatives for construction of these two additional lanes (one in each direction), for traditional and expedited concrete pavement sections, the \$32,150/day/mile in user costs would need to be incorporated in the cost comparisons in combination with the agency costs and schedule reduction estimates discussed in Chapter 3 of this report. This analysis will be summarized in Chapter 5 of this report, where Full-Cost ratios are calculated for the alternate cross sections.

**Table 4.5 Example of RUC Tables for Added-Capacity Projects  
(Daniels et. al. 1999)**

Four-Lane Rural Interstate Added Capacity (in \$/day per mile)					Six-Lane Rural Interstate Added Capacity (in \$/day per mile)				
ADT	5% trucks	10% trucks	15% trucks	25% trucks	ADT	5% trucks	10% trucks	15% trucks	25% trucks
70,000	27,300	28,200	29,000	29,800	70,000	21,500	22,100	22,800	23,400
72,500	29,100	30,000	30,900	31,800	72,500	22,300	23,000	23,700	24,400
75,000	30,900	31,900	32,800	33,800	75,000	23,200	23,900	24,600	25,300
77,500	32,900	33,900	35,000	36,000	77,500	24,100	24,800	25,600	26,300
80,000	35,100	36,200	37,300	38,300	80,000	25,000	25,800	26,500	27,300
82,500	37,300	38,500	39,600	40,800	82,500	26,000	26,800	27,600	28,400
85,000	39,600	40,800	42,000	43,300	85,000	26,900	27,800	28,600	29,400
87,500	42,000	43,300	44,600	45,900	87,500	27,900	28,800	29,600	30,500
90,000	44,500	45,800	47,200	48,600	90,000	28,900	29,800	30,700	31,600
92,500	47,100	48,500	50,000	51,400	92,500	30,000	30,900	31,800	32,800
95,000	49,800	51,300	52,800	54,400	95,000	31,100	32,000	33,000	33,900
97,500	52,600	54,200	55,800	57,400	97,500	32,200	33,200	34,200	35,200
100,000	55,300	57,000	58,700	60,400	100,000	33,400	34,400	35,500	36,500
102,500	58,100	59,900	61,700	63,500	102,500	34,600	35,700	36,800	37,800
105,000	61,000	62,900	64,700	66,600	105,000	35,900	37,000	38,100	39,200
107,500	63,900	65,800	67,800	69,800	107,500	37,300	38,400	39,600	40,700
110,000	66,800	68,900	70,900	73,000	110,000	38,600	39,800	41,000	42,200
112,500	69,800	72,000	74,100	76,300	112,500	40,000	41,300	42,500	43,800
115,000	73,000	75,200	77,500	79,700	115,000	41,400	42,700	44,000	45,200

**Example problem:** A proposed project involves the upgrade of one mile of a four-lane rural interstate to a six-lane rural interstate. The proposed project will have an average daily traffic (ADT) volume of 90,000 vehicles per day and 10% trucks.  
**Existing condition:** Road user costs are \$47,200/day  
**Proposed condition:** Road user costs are \$30,700/day  
**Difference** \$16,500/day  
**Costs of motorist delay for each day the project is delayed:** \$16,500 per day per mile

**Table 4.6 Example of RUC Tables for Rehabilitation Projects  
(Daniels et. al 1999)**

One Lane Closed in One Direction		All Lanes Open with Reduced Capacity	
ADT	Road User Costs	ADT	Road User Costs
10,000	0	10,000	0
15,000	0	15,000	0
20,000	100	20,000	0
25,000	100	25,000	0
30,000	300	30,000	100
35,000	900	35,000	100
40,000	1,900	40,000	100
45,000	1,700	45,000	200
50,000	5,200	50,000	300
55,000	7,500	55,000	400
60,000	9,800	60,000	1,200
65,000	12,300	65,000	2,200
70,000	14,600	70,000	3,000
75,000	17,200	75,000	4,000
80,000	19,100	80,000	4,400
85,000	21,600	85,000	6,400
90,000	23,700	90,000	7,600
95,000	25,600	95,000	9,400
100,000	27,800	100,000	12,000
105,000	29,100	105,000	13,900
110,000	30,200	110,000	15,500
115,000	31,400	115,000	17,100
120,000	31,800	120,000	18,200
125,000	31,900	125,000	18,800
130,000	31,800	130,000	18,700
135,000	31,800	135,000	18,800

Example problem: Four-lane rural interstate with an ADT of 90,000 and 15% truck volume, a one-mile rehabilitation project is proposed that will involve a work zone with all lanes open with reduced capacity 50% of the time and one lane closed in one direction 50% of the time. Road user cost from the table are the average of \$23,700/day/mile for the lane closed with \$7,600/day/mile for the lane narrowing, or \$15,650/day/mile.

*This page left blank intentionally*

## **Chapter 5**

### **Full Cost Comparison**

#### **District Surveys**

The project staff e-mailed a survey to the District pavement engineers regarding several aspects of work zones in controlled access highways. Three of the major urban TxDOT Districts, Houston, Dallas and Forth Worth, were surveyed to establish their work zone strategies, traffic volumes and composition. The survey results were then used for estimating user costs for the traditional and alternate rigid pavement cross sections. The results of the survey follow:

#### **Survey Questions and Answers:**

1) What are the most common projects involving PCC pavements on controlled access highways in your District ?

Examples: New construction, lane additions, reconstruction.

HOUSTON: The most common type is reconstruction.

DALLAS : We have a fairly equal amount of all types.

FORT WORTH: Probably 90% or more of the PCC pavements constructed are new construction or reconstruction projects, with reconstruction probability being the greatest volume.

2) What are the most common configurations used at work zones for controlled access facilities such as urban freeways and rural interstates?

Examples of configurations are: one lane closed in one direction or all lanes open with reduced capacity due to narrowing or a combination of these.

HOUSTON: The most common configuration is lane closure.

DALLAS: Our district has a combination of all of these.

FORT WORTH: The choice of traffic control plan configuration is very project-specific and phase-specific, it depends on many factors, including traffic volume, design/operating speed, available space, contractor access, public access to abutting property abutting property, and other factors. Usually a combination of configurations may be in place at any given time.

3) Is it possible to assign specific strategies as a function of the original number of lanes in the facility and the type of project?

Examples: lane addition projects on four lane divided facilities are implemented by closing one lane in one direction. Reconstruction projects on six lane divided facilities are implemented by narrowing the existing lanes.

HOUSTON: For IH 610 west by the Galleria (very heavy traffic), we did lane closure + narrowed lanes. We either do lane closures or lane closures + narrowed lanes.

DALLAS : Strategies vary, but they follow lane closure guidelines established by the District.

FORT WORTH: It is difficult to assign any specific strategy as a function of number of lanes and type of facility. Existing lane widths, curbs versus shoulders, shoulder material, and other factors must be considered, such as staging of drainage facilities, intersecting streets etc.

4) What is the minimum average and maximum ADT for these work zones?

HOUSTON: Minimum ADT on major freeways is 100,000. The average ADT on major freeways is 150,000. The maximum ADT on their major freeways is 300,000.

DALLAS : generally 100,000 to 300,000 ADT on their controlled access roadways.

FORT WORTH: for Tarrant County controlled-access facilities, the estimated range of ADT is from 60,000 to 150,000.

5) What is the average percentage of trucks?

HOUSTON: The average percentage is between 10-15%, we have a few locations like I-10 east where there are several chemical plants, the percentage of trucks is greater than 20%.

DALLAS: No answer.

FORT WORTH: Truck percentage generally run in the 8-10% range.

Discussion of the survey results

As it may be inferred from the survey results, it is very difficult to establish set strategies for work zones in controlled access facilities. However, it may be concluded from the survey that

the traffic volumes involved are from the order of 150,000 vehicles per day and the percentage of trucks in the 10% to 15% range. Lane closure, or a combination of lane closure and lane narrowing, is involved in the establishment of work zones. Reconstruction and new construction are the most common types of activities.

### Calculation of Full-Cost Ratios

Using the results from the District survey and the manual procedures discussed in Chapter 4, the research team calculated the user costs considering the values summarized in Table 5.1. Table 5.1 summarizes the calculation of the user costs for two cases: Controlled access facilities for added capacity projects from four lanes to six lanes, and Urban arterials and frontage roads with interrupted traffic flows, also for added capacity projects from four lanes to six lanes. Calculations were based in the manual procedure and tables described in reference (4.0). A detailed example of the calculations is presented in Chapter 4, Tables 4.5 and 4.6. For the full cost comparison presented later in this chapter, user costs were estimated according to Table 5.1 as being \$70,500/day/mile for the cross sections in controlled access facilities and \$45,400/day/mile for the cross sections in interrupted flow facilities such as arterials and frontage roads.

**Table 5.1 Calculation of RUC for Freeway and Arterials**

<b>Freeway</b>			
ADT during operation is 135,000 15% trucks freeway flow			
Capacity addition from 4 lanes to 6 lanes			
Rehabilitation costs are the average of lane narrowing and lane closing, 50% time for each			
	Before	After	
Added Capacity	101,300	56,100	45,200
	Lane Closure	Lane Narrowing	
Rehabilitation	31,800	18,800	25,300
		<b>User Costs \$/day/mile</b>	<b>70,500</b>
<b>Arterial or Frontage Road</b>			
ADT during operation is 100,000 5% trucks arterial flow			
Capacity addition from 4 lanes to 6 lanes			
Rehabilitation costs are the average of lane narrowing and lane closing, 50% time for each			
	Before	After	
Added Capacity	82,400	52,800	29,600
	Lane Closure	Lane Narrowing	
Rehabilitation	18,000	13,600	15,800
		<b>User Costs \$/day/mile</b>	<b>45,400</b>

Full-cost ratios are calculated using the following formulation:

$$\text{Full-Cost Ratio} = \frac{\text{Full-Cost Alternate Section}}{\text{Full-Cost Traditional Section}}$$

Where:

- Full-cost for the Alternate Section is the sum of the construction costs for the alternate section with the multiplication of the duration in days for the alternate section by the estimate of the user costs. Both the cost of construction and duration were calculated in Chapter 3, user costs are calculated in this chapter.
- Full-cost for the Traditional Section is the sum of the construction costs for the traditional sections with the multiplication of the duration in days for the traditional section by the estimate of the user costs. Both cost of construction and duration were calculated in Chapter 3, user costs are calculated in this chapter.

Table 5.2 presents a detailed calculation of the Full-Cost ratio for one of the alternate cross sections in the Dallas District. The user cost calculations assume the cost per mile per day calculated in Table 5.1 for the controlled access facilities multiplied by the duration in days estimated in Chapter 3 and also summarized in Table 5.2. The Full-Cost ratio in the comparison as summarized in Table 5.2 is 66%, meaning that by selecting the alternate cross section, instead of using the traditional cross section, a Full-Cost reduction of 34% could be achieved.

**Table 5.2 Sample Full-Cost Ratio Calculation for Alternate Rigid Cross-Section.**

Traditional Cross Section Highest Volume Highway Dallas District						
<i>Layers</i>	<i>Thickness</i>	<i>Construction cost</i>	<i>Duration</i>	<i>User Costs</i>	<i>Full Costs</i>	<i>Full Cost Ratio</i>
slab	14	\$1,112,320.00	24.80			
		\$112,076.80				
HMAC	4	\$208,384.00	18.09			
Lime Stabilized Soil	12	\$229,504.00	17.08			
	7	\$216,832.00	8.82			
Compacted Soil	6	\$1,314.13	1.81			
Subgrade	infinite	\$1,880,430.93	24.80	\$1,748,400	\$3,628,831	

Alternate Cross Section Highest Volume Highway Dallas District						
<i>Layers</i>	<i>Thickness</i>	<i>Construction cost</i>	<i>Duration</i>	<i>User Costs</i>	<i>Full Costs</i>	<i>Full Cost Ratio</i>
slab	14	\$1,112,320.00	10.80			
		\$112,076.80				
HMAC	6	\$394,240.00	5.69			
Compacted Soil	6	\$1,314.13	1.81			
Subgrade	infinite	\$1,619,950.93	10.80	\$761,400	\$2,381,351	66%

### Summary of Rigid Pavement Cross-Sections: Traditional and Alternate with Full-Cost Ratios

Tables 5.3 through 5.7 summarize the Full-Cost ratios for the Alternate Rigid Cross-Sections for the Dallas, Fort Worth, Houston, Beaumont and El Paso Districts.

**Table 5.3 Full-Cost Ratios for Alternate Rigid Cross-Sections: Dallas District.**

Roadway Classification	Traditional	Slab over HMAC	Full-depth PCC	Slab over HMAC over Select Fill									
<b>Highest Vol. Highway</b>	<table border="1"> <tr><td>CRCP 14"</td></tr> <tr><td>HMAC (Type B) 4"</td></tr> <tr><td>Lime Stab. SG (6 %) 19"</td></tr> <tr><td>Compacted Soil 6"</td></tr> </table>	CRCP 14"	HMAC (Type B) 4"	Lime Stab. SG (6 %) 19"	Compacted Soil 6"	<table border="1"> <tr><td>Concrete Slab 14"</td></tr> <tr><td>HMAC 6"</td></tr> <tr><td>Compacted Soil 6"</td></tr> </table>	Concrete Slab 14"	HMAC 6"	Compacted Soil 6"	<table border="1"> <tr><td>Concrete Slab 18"</td></tr> <tr><td>Compacted Soil 6"</td></tr> </table>	Concrete Slab 18"	Compacted Soil 6"	
CRCP 14"													
HMAC (Type B) 4"													
Lime Stab. SG (6 %) 19"													
Compacted Soil 6"													
Concrete Slab 14"													
HMAC 6"													
Compacted Soil 6"													
Concrete Slab 18"													
Compacted Soil 6"													
(IH-35-E / 190T Mainlanes NB / SB Entrance Ramp / NB Exit Ramp)		<table border="1"> <tr><td>Concrete Slab 14"</td></tr> <tr><td>HMAC 14"</td></tr> <tr><td>Compacted Soil 6"</td></tr> </table>	Concrete Slab 14"	HMAC 14"	Compacted Soil 6"	<table border="1"> <tr><td>Concrete Slab 28"</td></tr> <tr><td>Compacted Soil 6"</td></tr> </table>	Concrete Slab 28"	Compacted Soil 6"	<table border="1"> <tr><td>Concrete Slab 14"</td></tr> <tr><td>HMAC 6"</td></tr> <tr><td>Select Material 10"</td></tr> <tr><td>Compacted Soil 6"</td></tr> </table>	Concrete Slab 14"	HMAC 6"	Select Material 10"	Compacted Soil 6"
Concrete Slab 14"													
HMAC 14"													
Compacted Soil 6"													
Concrete Slab 28"													
Compacted Soil 6"													
Concrete Slab 14"													
HMAC 6"													
Select Material 10"													
Compacted Soil 6"													
		<b>Ratio=66%</b>	<b>Ratio=61%</b>										
		<b>Ratio=74%</b>	(May NOT Be Practical)	<b>Ratio=76%</b>									
		<table border="1"> <tr><td>Concrete Slab 14"</td></tr> <tr><td>HMAC 40"</td></tr> <tr><td>Compacted Soil 6"</td></tr> </table>	Concrete Slab 14"	HMAC 40"	Compacted Soil 6"	<table border="1"> <tr><td>Concrete Slab 54"</td></tr> <tr><td>Compacted Soil 6"</td></tr> </table>	Concrete Slab 54"	Compacted Soil 6"	<table border="1"> <tr><td>Concrete Slab 14"</td></tr> <tr><td>HMAC 6"</td></tr> <tr><td>Select Material 36"</td></tr> <tr><td>Compacted Soil 6"</td></tr> </table>	Concrete Slab 14"	HMAC 6"	Select Material 36"	Compacted Soil 6"
Concrete Slab 14"													
HMAC 40"													
Compacted Soil 6"													
Concrete Slab 54"													
Compacted Soil 6"													
Concrete Slab 14"													
HMAC 6"													
Select Material 36"													
Compacted Soil 6"													
		(NOT Practical)	(NOT Practical)	<b>Ratio=110%</b>									

**Table 5.3 Full-Cost Ratios for Alternate Rigid Cross-Sections: Dallas District...cont.**

Roadway Classification	Traditional		Slab over HMAC	Full-depth PCC	Slab over HMAC over Select Fill
<b>Highest Vol. Highway</b> (IH-35-E / 190T Mainlanes EB, WB)	CRCP 13" HMAC (Type B) 6" Lime Stab. SG (6%) 18" Compacted Soil 6"	Min. structural criteria met	Concrete Slab 13" HMAC 8" Compacted Soil 6" <b>Ratio=63%</b>	Concrete Slab 16" Compacted Soil 6" <b>Ratio=57%</b>	
	CRCP 13" HMAC (Type A) 3" HMAC (Type D) 3" Lime Stab. SG (4%) 10" Select Fill Mat. (Pl<=20) 18"(sand) - 21"(clay)		3" PVR limited to 1" "Dry" layers: Critical	Concrete Slab 13" HMAC 42" Compacted Soil 6" (NOT Practical)	Concrete Slab 54" Compacted Soil 6" (NOT Practical)
<b>Highest Vol. Highway</b> (US 75 Mainlane SB)	CRCP 13" HMAC (Type A) 3" HMAC (Type D) 7" Compacted Soil 18" Rock	Min. structural criteria met	--	Concrete Slab 16" Compacted Soil 6" <b>Ratio=83%</b>	

**Table 5.3 Full-Cost Ratios for Alternate Rigid Cross-Sections: Dallas District...cont.**

<b>Roadway Classification</b>	<b>Traditional</b>	<b>Slab over HMAC</b>	<b>Full-depth PCC</b>	<b>Slab over HMAC over Select Fill</b>
<b>Highest Vol. Highway</b>  (IH-30 Sta. 666 / Mainlane widening)	Concrete Slab 15" HMAC (600 / 860 # / SY) 6" Embankment Type C Lime Stab. SG (4%) 18" Compacted Soil 18"	Min. structural criteria met Concrete Slab 15" HMAC 6" Compacted Soil 6" <b>Ratio=62%</b>	Concrete Slab 20" Compacted Soil 6" <b>Ratio=67%</b>	
		3" PVR limited to 1" "Dry" layers: Critical Concrete Slab 15" HMAC 40" Compacted Soil 6" (NOT Practical)	Concrete Slab 54" Compacted Soil 6" (NOT Practical)	Slab 15" HMAC 6" Sel. Mat. 36" Comp Soil 6" <b>Ratio=109%</b>
(IH-30 Sta. 593 )	Concrete Slab 15" HMAC (1320 # / SY) 12" Embankment Type C Lime Stab. SG (4%) 12" Compacted Soil 6"	Min. structural criteria met Concrete Slab 15" HMAC 12" Compacted Soil 6" <b>Ratio=71%</b>	Concrete Slab 20" Compacted Soil 6" <b>Ratio=66%</b>	
		3" PVR limited to 1" "Dry" layers: Critical Concrete Slab 15" HMAC 40" Compacted Soil 6" (NOT Practical)	Concrete Slab 54" Compacted Soil 6" (NOT Practical)	Slab 15" HMAC 12" Sel. Mat. 30" Comp Soil 6" <b>Ratio=110%</b>

**Table 5.3 Full-Cost Ratios for Alternate Rigid Cross-Sections: Dallas District...cont.**

Roadway Classification	Traditional	Slab over HMAC	Full-depth PCC	Slab over HMAC over Select Fill
<b>Arterial, Frontage &amp; Collector Roads</b>  (IH-30 Frontage Rd. / Bobtown Rd.)	CPCD 10" HMAC (880 / 800 # / SY) 8" Compacted Soil 18"	--	Concrete Slab 14" Compacted Soil 6" <b>Ratio=90%</b>	Slab 10" HMAC 8" Sel. Mat. 40" Com Soil 6"

**Table 5.3 Full-Cost Ratios for Alternate Rigid Cross-Sections: Dallas District...cont.**

Roadway Classification	Traditional		Slab over HMAC	Full-depth PCC	Slab over HMAC over Select Fill
<b>Arterial, Frontage &amp; Collector Roads</b>  Scenic Dr.	CPCD CL K 8"	Min. structural criteria met	--	Concrete Slab 14" Compacted Soil 6" <b>Ratio=86%</b>	
	HMAC 14"				Slab 8" HMAC 14" Sel. Mat. 36" Comp Soil 6" <b>Ratio=184%</b>
<b>City/Local Streets</b>  Heritage / Harborside	Compacted Soil 6"	3" PVR limited to 1" "Dry" layers: Critical	Concrete Slab 8" HMAC 48" Compacted Soil 6" (NOT Practical)	Concrete Slab 54" Compacted Soil 6" (NOT Practical)	
<b>Arterial, Frontage &amp; Collector Roads</b>  Lakeshore Dr.	CPCD CL K 8"	Min. structural criteria met	--	Concrete Slab 10" Compacted Soil 6" <b>Ratio=88%</b>	
	HMAC 8"				
<b>City/Local Streets</b>  2 <sup>nd</sup> . St.	Compacted Soil 6"	3" PVR limited to 1" "Dry" layers: Critical	Concrete Slab 8" HMAC 48" Compacted Soil 6" (NOT Practical)	Concrete Slab 54" Compacted Soil 6" (NOT Practical)	Slab 8" HMAC 8" Sel. Mat. 42" Comp Soil 6" <b>Ratio=249%</b>

**Table 5.3 Full-Cost Ratios for Alternate Rigid Cross-Sections: Dallas District...cont.**

<b>Roadway Classification</b>	<b>Traditional</b>	<b>Slab over HMAC</b>	<b>Full-depth PCC</b>	<b>Slab over HMAC over Select Fill</b>
<b>Arterial, Frontage &amp; Collector Roads</b>  (IH-35-E / 190T Frontage Rds.)	Concrete Slab 8" HMAC 6" Lime Stab. SG (6%) 8" Compacted Soil 6"	Min. structural criteria met	Concrete Slab 8" HMAC 8" Compacted Soil 6"	
	CPCD 8" HMAC 4" Lime Stab. SG (7%) 22" Compacted Soil 6" 0.25 Gal. / SY		Concrete Slab 9" Compacted Soil 6"	
(SH 66 Mainlane)	Concrete Slab 8" HMAC 4" Lime Stab. SG (7%) 6" Compacted Soil 6" 0.25 Gal. / SY	3" PVR limited to 1" "Dry" layers: Critical	Concrete Slab 8" HMAC 48" Compacted Soil 6"	Concrete Slab 54" Compacted Soil 6"
SH 66 Embank Washington St. Rusk Sr.	Concrete Slab 8" HMAC 4" Lime Stab. SG (7%) 6" Compacted Soil 6" 0.25 Gal. / SY		(NOT Practical)	
			Ratio=77%	Ratio=61%
				Slab 8" HMAC 8" Sel. Mat. 42" Comp Soil 6"
				Ratio=139%

**Table 5.4 Full-Cost Ratios for Alternate Rigid Cross-Sections: Fort Worth District.**

Highway type	Traditional		Slab over HMAC	Full-depth PCC	Slab over HMAC over Select Fill															
IH / US / SH 360/ FM / High Vol. Urban	<table border="1"> <tr><td>Concrete Slab 13"</td></tr> <tr><td>HMAC 4"</td></tr> <tr><td>Lime Stab. SG 18"</td></tr> <tr><td> </td></tr> <tr><td>Concrete Slab 13"</td></tr> <tr><td>HMAC 4"</td></tr> <tr><td>Lime Stab. SG 8"</td></tr> </table>	Concrete Slab 13"	HMAC 4"	Lime Stab. SG 18"		Concrete Slab 13"	HMAC 4"	Lime Stab. SG 8"	PVR Not critical	<table border="1"> <tr><td>Concrete Slab 13"</td></tr> <tr><td>HMAC 6"</td></tr> <tr><td>Compacted Soil 6"</td></tr> </table> <p><b>Ratio=64%</b></p> <table border="1"> <tr><td>Concrete Slab 13"</td></tr> <tr><td>HMAC 6"</td></tr> <tr><td>Compacted Soil 6"</td></tr> </table> <p><b>Ratio=79%</b></p>	Concrete Slab 13"	HMAC 6"	Compacted Soil 6"	Concrete Slab 13"	HMAC 6"	Compacted Soil 6"	<p><b>Ratio=61%</b></p> <table border="1"> <tr><td>Concrete Slab 16"</td></tr> <tr><td>Compacted Soil 6"</td></tr> </table> <p><b>Ratio=75%</b></p>	Concrete Slab 16"	Compacted Soil 6"	
Concrete Slab 13"																				
HMAC 4"																				
Lime Stab. SG 18"																				
Concrete Slab 13"																				
HMAC 4"																				
Lime Stab. SG 8"																				
Concrete Slab 13"																				
HMAC 6"																				
Compacted Soil 6"																				
Concrete Slab 13"																				
HMAC 6"																				
Compacted Soil 6"																				
Concrete Slab 16"																				
Compacted Soil 6"																				
IH / US / SH / FM / High Vol. Urban	<table border="1"> <tr><td>Concrete Slab 12"</td></tr> <tr><td>HMAC 4"</td></tr> <tr><td>Lime Stab. SG 18"</td></tr> <tr><td> </td></tr> <tr><td>Concrete Slab 12"</td></tr> <tr><td>HMAC 4"</td></tr> <tr><td>Lime Stab. SG 8"</td></tr> </table>	Concrete Slab 12"	HMAC 4"	Lime Stab. SG 18"		Concrete Slab 12"	HMAC 4"	Lime Stab. SG 8"	PVR Not critical	<table border="1"> <tr><td>Concrete Slab 12"</td></tr> <tr><td>HMAC 6"</td></tr> <tr><td>Compacted Soil 6"</td></tr> </table> <p><b>Ratio=63%</b></p> <table border="1"> <tr><td>Concrete Slab 12"</td></tr> <tr><td>HMAC 6"</td></tr> <tr><td>Compacted Soil 6"</td></tr> </table> <p><b>Ratio=78%</b></p>	Concrete Slab 12"	HMAC 6"	Compacted Soil 6"	Concrete Slab 12"	HMAC 6"	Compacted Soil 6"	<p><b>Ratio=60%</b></p> <table border="1"> <tr><td>Concrete Slab 15"</td></tr> <tr><td>Compacted Soil 6"</td></tr> </table> <p><b>Ratio=74%</b></p>	Concrete Slab 15"	Compacted Soil 6"	
Concrete Slab 12"																				
HMAC 4"																				
Lime Stab. SG 18"																				
Concrete Slab 12"																				
HMAC 4"																				
Lime Stab. SG 8"																				
Concrete Slab 12"																				
HMAC 6"																				
Compacted Soil 6"																				
Concrete Slab 12"																				
HMAC 6"																				
Compacted Soil 6"																				
Concrete Slab 15"																				
Compacted Soil 6"																				
US / SH / FM	<table border="1"> <tr><td>Concrete Slab 8"</td></tr> <tr><td>HMAC 4"</td></tr> <tr><td>Lime Stab. SG 18"</td></tr> <tr><td> </td></tr> <tr><td>Concrete Slab 8"</td></tr> <tr><td>HMAC 4"</td></tr> <tr><td>Lime Stab. SG 8"</td></tr> </table>	Concrete Slab 8"	HMAC 4"	Lime Stab. SG 18"		Concrete Slab 8"	HMAC 4"	Lime Stab. SG 8"	PVR Not critical	<table border="1"> <tr><td>Concrete Slab 8"</td></tr> <tr><td>HMAC 6"</td></tr> <tr><td>Compacted Soil 6"</td></tr> </table> <p><b>Ratio=63%</b></p> <table border="1"> <tr><td>Concrete Slab 8"</td></tr> <tr><td>HMAC 6"</td></tr> <tr><td>Compacted Soil 6"</td></tr> </table> <p><b>Ratio=78%</b></p>	Concrete Slab 8"	HMAC 6"	Compacted Soil 6"	Concrete Slab 8"	HMAC 6"	Compacted Soil 6"	<p><b>Ratio=54%</b></p> <table border="1"> <tr><td>Concrete Slab 9"</td></tr> <tr><td>Compacted Soil 6"</td></tr> </table> <p><b>Ratio=67%</b></p>	Concrete Slab 9"	Compacted Soil 6"	
Concrete Slab 8"																				
HMAC 4"																				
Lime Stab. SG 18"																				
Concrete Slab 8"																				
HMAC 4"																				
Lime Stab. SG 8"																				
Concrete Slab 8"																				
HMAC 6"																				
Compacted Soil 6"																				
Concrete Slab 8"																				
HMAC 6"																				
Compacted Soil 6"																				
Concrete Slab 9"																				
Compacted Soil 6"																				

**Table 5.5 Full-Cost Ratios for Alternate Rigid Cross-Sections: Houston District.**

Highway type	Traditional		Slab over HMAC	Full-depth PCC	Slab over HMAC over Select Fill
SH / FM	Concrete Slab 13" Bond Breaker 1" Cement Treated 6" Lime Stab. SG 6" Compacted Soil 6"	Min. structural criteria met	Concrete Slab 13" HMAC 6" Compacted Soil 6" <b>Ratio=72%</b>	Concrete Slab 16" Compacted Soil 6" <b>Ratio=69%</b>	
			(May NOT Be Practical)	(May NOT Be Practical)	Slab 13" HMAC 6"
		2.45" PVR limited to 1" "Dry" layers: Critical	Concrete Slab 13" HMAC 13" Compacted Soil 6" <b>Ratio=86%</b>	Concrete Slab 26" Compacted Soil 6"	Sel. Mat. 8" Comp Soil 6" <b>Ratio=78%</b>
FR	Concrete Slab 10" Bond Breaker 1" Cement Treated 6" Lime Stab. SG 6" Compacted Soil 6"	Min. structural criteria met	Concrete Slab 10" HMAC 6" Compacted Soil 6" <b>Ratio=74%</b>	Concrete Slab 12" Compacted Soil 6" <b>Ratio=65%</b>	
			(May NOT Be Practical)	(May NOT Be Practical)	Slab 10" HMAC 6"
		2.45" PVR limited to 1" "Dry" layers: Critical	Concrete Slab 10" HMAC 16" Compacted Soil 6" <b>Ratio=96%</b>	Concrete Slab 26" Compacted Soil 6"	Sel. Mat. 12" Comp Soil 6" <b>Ratio=96%</b>

**Table 5.6 Full-Cost Ratios for Alternate Rigid Cross-Sections: Beaumont District.**

Highway type	Traditional	PVR NOT critical	Slab over HMAC	Full-depth PCC	Slab over HMAC over Select Fill										
IH US 96/ SH 105/ FM High Vol Rds	<table border="1"> <tr><td>Concrete Slab 12"</td></tr> <tr><td>Soil 6"</td></tr> <tr><td>Cement Treated 6"</td></tr> <tr><td>Lime Stab. SG 6"</td></tr> <tr><td>Compacted Soil 6"</td></tr> </table>	Concrete Slab 12"	Soil 6"	Cement Treated 6"	Lime Stab. SG 6"	Compacted Soil 6"		<table border="1"> <tr><td>Concrete Slab 12"</td></tr> <tr><td>HMAC 6"</td></tr> <tr><td>Compacted Soil 6"</td></tr> </table> Ratio=74%	Concrete Slab 12"	HMAC 6"	Compacted Soil 6"	<table border="1"> <tr><td>Concrete Slab 14"</td></tr> <tr><td>Compacted Soil 6"</td></tr> </table> Ratio=66%	Concrete Slab 14"	Compacted Soil 6"	
Concrete Slab 12"															
Soil 6"															
Cement Treated 6"															
Lime Stab. SG 6"															
Compacted Soil 6"															
Concrete Slab 12"															
HMAC 6"															
Compacted Soil 6"															
Concrete Slab 14"															
Compacted Soil 6"															

**Table 5.7 Full-Cost Ratios for Alternate Rigid Cross-Sections: El Paso District.**

Highway type	Traditional	critical	Slab over HMAC	Full-depth PCC	Slab over HMAC over Select Fill					
IH 10	<table border="1"> <tr><td>Concrete Slab 14"</td></tr> <tr><td>HMAC 4"</td></tr> <tr><td>Compacted Soil 6"</td></tr> </table>	Concrete Slab 14"	HMAC 4"	Compacted Soil 6"	critical	--	<table border="1"> <tr><td>Concrete Slab 18"</td></tr> <tr><td>Compacted Soil 6"</td></tr> </table> <b>Ratio=105%</b>	Concrete Slab 18"	Compacted Soil 6"	
Concrete Slab 14"										
HMAC 4"										
Compacted Soil 6"										
Concrete Slab 18"										
Compacted Soil 6"										
IH 10	<table border="1"> <tr><td>Concrete Slab 12"</td></tr> <tr><td>HMAC 4"</td></tr> <tr><td>Compacted Soil 6"</td></tr> </table>	Concrete Slab 12"	HMAC 4"	Compacted Soil 6"	NOT	--	<table border="1"> <tr><td>Concrete Slab 14"</td></tr> <tr><td>Compacted Soil 6"</td></tr> </table> <b>Ratio=94%</b>	Concrete Slab 14"	Compacted Soil 6"	
Concrete Slab 12"										
HMAC 4"										
Compacted Soil 6"										
Concrete Slab 14"										
Compacted Soil 6"										
IH 10	<table border="1"> <tr><td>Concrete Slab 10"</td></tr> <tr><td>HMAC 4"</td></tr> <tr><td>Compacted Soil 6"</td></tr> </table>	Concrete Slab 10"	HMAC 4"	Compacted Soil 6"	PVR	--	<table border="1"> <tr><td>Concrete Slab 11"</td></tr> <tr><td>Compacted Soil 6"</td></tr> </table> <b>Ratio=89%</b>	Concrete Slab 11"	Compacted Soil 6"	
Concrete Slab 10"										
HMAC 4"										
Compacted Soil 6"										
Concrete Slab 11"										
Compacted Soil 6"										

The following conclusions are drawn from the tables.

#### *Dallas District*

For “Highest Volume” highways, full depth slab alternates, or alternates with slabs over HMAC reduce Full-Costs from 38% to 26%. For the “Arterial, Collector Roads” category, all alternates for traditional sections using 8-in. (205-mm) slabs over stabilized material can reduce the Full-Costs by a maximum of 39% for the 9 inch slab over compacted soil and for a minimum reduction of 10% for the 14 inch slab over compacted soil. For traditional sections consisting of slab over HMAC, the only reduction in Full-Costs is for the 8 inch slab over 8 inch HMAC at 23%.

Under all categories, alternate sections with select material always imply in an increase of the Full-Cost ratios due to the fact that their overall depth is determined to reduce the subgrade’ PVR to allowable limits.

#### *Fort Worth District*

A reduction across the board for the Full-Cost ratios is observed for the Fort Worth District. Reductions in the full costs-ratio range from 40% for the 15 inch slab over compacted soil to 21% for the 13 inch slab over HMAC.

#### *Houston District*

All alternatives reduce Full-Costs from 14% to 35%, when we do not consider the slab over HMAC and select fill alternative, which does not seem to be feasible economically. However, whenever a high PVR is expected, the alternatives built with layers of select material, would be a better option, since the other two options are not practical.

#### *Beaumont District*

Alternate sections can be built in about half the time of the traditional. This fact, combined with the Agency and User costs leads to Full-Cost reductions from 34% to 26%.

#### *El Paso District*

Generally speaking, the alternate sections for the El Paso District offer little or no Full-Cost savings when compared to traditional cross-sections. The 11 inch concrete slab over compacted soil shows a reduction of 11% in Full-Costs.

*This page left blank intentionally*

## **Chapter 6**

### **Summary and Conclusions**

#### **Summary**

This report describes the research effort made to determine alternate rigid cross-sections that could optimize the duration of construction of urban and rural highways in various TxDOT Districts. It seems that based on the research, that the rationale behind the current traditional construction processes for the number and nature of supporting layers is supported by local experience at the Districts and Federal regulatory mandates. The procedures for optimizing the duration of the construction of PCC roads were theoretically evaluated from the standpoint of equivalent stress-state under the PCC slab, and compressibility of construction schedules. Optimized alternate layer layouts to substitute the traditional construction processes were evaluated based on construction costs, duration, user costs and ultimately by combining all the cost components in a Full-Cost analysis procedure. Three major categories of alternate cross-sections are proposed as an alternative for each traditional TxDOT District practice.

Chapter 1 provides a brief overview of the initial efforts during the first year of the project, to develop an expert system for expediting rigid pavement construction. A brief discussion on the sensitivity of the various design and construction parameters is addressed.

Chapter 2 describes the systematic approach followed and adopted criteria to determine the alternate cross-sections for five major districts in TxDOT. The use of alternate materials within a cross-section, such as select material and geogrids are briefly addressed. The Chapter summarizes the final alternate cross-sections, grouped in three categories, 1) alternate sections based on PCC slab and HMAC; 2) full-depth PCC slabs; and 3) PCC slab and HMAC sections with layers of select material.

Chapter 3 addresses simplified construction schedules to estimate construction time and agency costs for both traditional and alternate pavement structures. After performing a statewide survey for productivity rates, RSM means nationwide construction indices were selected. Construction time ratios between the two cross-sections are used as criteria to roughly assess whether an alternate rigid cross-sections is faster to build than its corresponding traditional section.

Chapter 4 summarized a survey of methods to evaluate User Costs associated with the establishment of work-zones to implement highway construction. It recommends a manual procedure for evaluating user-costs that is implemented in the calculation of Full-Costs in Chapter 5.

Full-Cost ratios between traditional and alternate cross-sections are calculated in Chapter 5 and used to examine the economic feasibility of alternate cross-sections. A survey of selected TxDOT District work-zone implementation practices and traffic volumes and composition is also included in Chapter 5.

Appendix A graphically summarizes all the rigid pavement cross-section traditionally built in Dallas, Fort Worth, Houston, Beaumont and El Paso. Appendix B contains the current procedure followed by TxDOT, to estimate the potential vertical rise of clayey soils. Appendix C summarizes the construction schedule analysis and Appendix D summarizes cost analysis.

## **Final Remarks**

In general, the alternate sections show noticeable improvements in time reduction as well as cost. The Full-Cost analysis also shows a benefit in overall costs reductions for the alternate cross sections. However, it is strongly recommended that the performance of these alternate cross-sections be field evaluated from the standpoint of pavement performance and constructability, through the implementation of pilot test-sections where these parameters would be carefully monitored.

Contrary to the initial belief that the proposed alternate cross sections would cost more to build than the traditional cross sections, the cost analysis for the agency costs showed that in general the alternate cross sections are cheaper to build than the traditional cross sections, with additional savings accruing in the user costs.

## References

- Agg, T.R. (1923), "The Economics of Highway Grades", *Iowa Engineering Experiment Station Bulletin 65*, Iowa State College, Ames, Iowa, 1923.
- Agg, T.R., and H.S. Carter (1928), "Operating Cost Statistics of Automobiles and Trucks", *Iowa Engineering Experiment Station Bulletin 91*, Iowa State College, Ames, Iowa, 1928.
- American Association of State Highway and Transportation Officials (AASHTO), (1986). *Guide for Design of Pavement Structures 1986*, Washington D.C.
- American Association of State Highway and Transportation Officials (AASHTO), (1993). *Guide for Design of Pavement Structures 1993*, Washington D.C.
- American Association of State Highway and Transportation Officials (AASHTO), (2002). *Guide for Design of Pavement Structures 2000*, Washington D.C.
- Appea, A. K. and Al-Qadi, I.L. (2000). "Assessment of Falling Weight Deflectometer Data for Stabilized Flexible Pavements", *Transportation Research Record No. 1709*, 2000, pp. 19-25.
- Archer, S. (2002). Phone and email correspondence with Stephen Archer, Tensar Earth Technologies, Southwest Region, July 2002.
- Beg, M.A., Zhang, Z. and Hudson, W. R. "Pavement Type Selection and Its Current Practices in North American Highway Agencies" *Transportation Research Board 78<sup>th</sup> Annual Meeting 1999*, Paper 00702, Washington D.C., Transportation Research Board, January 1999.
- Claffey, P.J. (1971), "Running Cost of Motor Vehicles as Affected by Road Design and Traffic", *National Co-operative Highway Research Program, Report 111*, Highway Research Board, Washington, D.C., 1971.
- Cole, L.W. and Voigt, G.F. (1996). "Fast-Track Concrete Paving—Overview of Key Components." *Materials for the New Millennium Fourth Materials Engineering Conference: Washington D.C., November 10-14*, 446-455.
- Daniels G., D. R. Ellis, and W. R. Stockton (1999), *Techniques for Manually Estimating Road User Costs Associated with Construction Projects*, Texas Transportation Institute, December 1999.
- Della Moretta, L. And E. C. Sullivan (1976), "US Forest Service Vehicle Operating Cost Model", *Lessening Energy Waste in the Road-Tire-Vehicle Driver System Workshop Proceedings*, US Forest Service and University of California, Claremont, CA., 1976.

- Department of the Environment (1990), Cost Benefit Analysis Program - COBA9, Ministry of Transportation, London, 1990.
- Department of the Environment (1982), Queues and Relays at Roadworks - QUADROZ, Ministry of Transportation, London 1982.
- Harber, Michael A. (1988). "Survey of Productivity Rates Used for Highway Construction." Report presented to the Graduate Committee of the Department of Civil Engineering in Partial Fulfillment of the Requirements for the Degree of Master of Engineering. University of Florida. Summer 1988. Reproduced by NTIS, Publication No. ADA197405, Springfield VA 22161.
- Huang, Y. H. (1993). "Pavement Analysis and Design", Prentice Hall, Englewood Cliffs, New Jersey 07632, 1993.
- Hsieh, C. W. and Wu, J.H. "Installation Survivability of Flexible Geogrids in Various Pavement Subgrade Materials", *Transportation Research Record No. 1772*, 2001, pp. 190-196.
- Ioannides, A.M., and L. Khazanovich, (1998). "General Formulation for Multi-Layered Pavement Systems." *Journal of Transportation Engineering*, American Society of Civil Engineers, ASCE, Vol. 124, No. 1, January/February 1998, pp.82-90.
- Joseph, C.T. (1987), Model for the Analysis of Work Zones in Arterials, Master's Thesis, Arizona State University, Tempe, 1987
- Khazanovich, L., and Gotlif, A. (2002). "ISLAB2000 Simplified Friction Model." Submitted for publication at the Transportation Research Board Annual Meeting 2002. Washington, D.C.
- Khazanovich, L., H.T. Yu, S. Rao, K. Galasova, E. Shats, and R. Jones, (2000). "ISLAB2000 —Finite Element Analysis Program for Rigid and Composite Pavements. *User's Guide*." ERES Consultants, Champaign, IL.
- Leonard, J. D., and W. W. Recker (1986), "CARHOP: An Environment for Computer Assisted Reconstruction — Highway Operations and Planning," University of California, Irvine, 1986.
- Ling, H. I. and Liu, Z. "Performance of Geosynthetic-Reinforced Asphalt Pavements" *Journal of Geotechnical and Geoenvironmental Engineering*, American Society of Civil Engineers, ASCE, Vol. 127, No. 2, February 2001, pp.177-184.
- MacFarland, William F. et al. (1993), MicroBENCOST User's Manual – Version 1.0. Prepared for the National Cooperative Highway Research Program, Project 7-12. Texas Transportation Institute. October 1993.

- Melchor-Lucero, O., Wanyan, Y., Nazarian, S., and Weissmann, J. (2001). "Methods to Expedite Construction of PCC Pavements: An Overview." *Research Rep. No. 0-4188*, to be published. Center for Highway Materials Research, University of Texas at El Paso, El Paso, TX., 142 pp.
- Memmott, J. L., and C. L. Dudek (1984), "Queue and User Cost Evaluation of Work Zones," *Transportation Research Record 979*, TRB, Washington, D.C., 1984.
- Microcomputer Evaluation of Highway User Benefits (1993), Final Report for National Cooperative Highway Research Program, Project 7-12. Texas Transportation Institute. October 1993.
- Moyer, R.A. (1934), "Skidding Characteristics of Automobile Tires on Roadway Surfaces and Their Relation to Highway Safety", *Iowa Engineering Experiment Station Bulletin 120*, Iowa State College, Ames, Iowa, 1934.
- Organization for Economic Cooperation and Development (OECD),(1999), "Behavioral Adaptations to Changes in the Road Transport System", Paris, 1990.
- Organization for Economic Co-operation and Development (OECD), (1989), Traffic Management and Safety at Work Zones, OECD Scientific Expert Group, Paris, 1989.
- Paustian, R.G. (1934), "Tractive Resistance as Related to Roadway Surface and Motor Vehicle Operation", *Iowa Engineering Experiment Station Bulletin 119*, Iowa State College, Ames, Iowa, 1934
- PavSpec (2002), Performance Related Specifications for PCC Pavements, software download site <http://www.tfrc.gov/pavement/pccp/pavespec/pavespec.htm>, (August 2002).
- PCASE, (2002), Pavement-Transportation Computer Assisted Structural Engineering software download site. <http://www.pcase.com/>, (August 2002).
- Perkins, S.W. (1999). "Use of Tensar Geogrid for Improvement of the Modulus of Subgrade Reaction: Final Report", Prepared for Tensar Technologies, Inc., December 1999. 12 pp.
- Perkins, S.W. (2001). "Mechanistic-Empirical Modeling and Design Model Development of Geosynthetic Reinforced Flexible Pavements: Final Report", *FHWA/MT-01-002/99160-1A, Final Report*, October 2001, 170 pp.
- Pierce, David, R. Jr. (1998). "Project Scheduling and Management for Construction.", Second Edition. RSMMeans CMD Group, Construction Publishers and Consultants, Kingston MA 02364.

- Roupal, N.M. (1991), A Model of Traffic Flow at Freeway Lane Closures, Ph. D. Dissertation, Ohio State University, Columbus, 1991.
- RSMMeans (2001), *Means Heavy Construction Cost Data* (2001). CostWorks 2001 compact disk.
- Secmen S., Schwartz, J.J., Anderson, S.D., and Zollinger, D.G. (1996). "Accelerated Construction Methodology for Concrete Pavements at Urban Intersections." *Research Rep. No. 1454-1F*, Texas Transportation Institute, Texas A&M University, College Station Texas, 204 pp.
- Tabatabaie, A.M. and E.J. Barenberg. (1980). "Structural Analysis of Concrete Pavement Systems", *Journal of Transportation Engineering*, American Society of Civil Engineers, ASCE, Vol. 106, No. 5, 1980, pp.493-506.
- Tensar (2002). SpectraPave2 software download site.  
[http://www.tensarcorp.com/systems/content\\_software\\_spectra.htm](http://www.tensarcorp.com/systems/content_software_spectra.htm), August 2002.
- Tensar (1988). "Design Guidelines for Subgrade Improvement under Dynamic Loading with Tensar<sup>®</sup> Geogrids", Technical Note: BR5, January 1988.
- Texas Department of Transportation (TxDOT), (1993). "Determination of Contract Time." *Administrative Circular No. 17-93*.
- Texas Department of Transportation (TxDOT), (1995). "Standard Specifications for Construction and Maintenance of Highways, Streets and Bridges." March 1, 1995.
- Texas Department of Transportation (TxDOT), (2001). *Pavement Design Manual, Chapter 3, Rigid Pavement Design*. <http://manuals.dot.state.tx.us/dynaweb>, (March, 2001).
- Texas Department of Transportation (TxDOT), (2002). *Manual of Testing Procedures, Chapter 1, Section 23. Tex-124-E, Determining Potential Vertical Rise*. <http://manuals.dot.state.tx.us/dynaweb>, (August, 2002).
- Transportation Research Board (1985), "Highway Capacity Manual," *Special Report 209*, TRB, Washington, D.C., 1985.
- TransTec (2002), Hi Performance Paving software download site.  
<http://www.hiperpav.com/default.asp>, (August 2002).
- Urban Institute (1991), "The Costs of Highway Crashes", Final Report, Washington, D.C., 1991.
- Winfrey, R. (1969), *Economic Analysis for Highways*, International Textbook Co., Scranton, PA., 1969.

- Winfrey, R. (1933), "Statistics of Motor Truck Operation in Iowa", *Iowa Engineering Experiment Station Bulletin 14*, Iowa State College, Ames, Iowa, 1933.
- Zaniewski, J.P., B.C. Butler Jr., G. Cunningham, G.E. Elkins, M. Paggi, and R. Machemehl (1981), *Vehicle Operating Costs, Fuel Consumption, and Pavement Type and Condition Factors*, Federal Highway Administration-RD80, Washington, D.C., 1981.

## **Appendix A: Traditional Rigid Pavement Sections**

*This page left blank intentionally*

**Table A.1 Selected Traditional Pavement Sections: Dallas District**

<b>Roadway Classification</b>	<b>Cross-Section</b>	<b>Road example</b>				
<b>Highest Volume Highway</b>	<table border="1"> <tr><td><b>CRCP 14"</b></td></tr> <tr><td><b>HMAC (Type B) 4"</b></td></tr> <tr><td><b>Lime Stab. SG (6 %) 19"</b></td></tr> <tr><td><b>Compacted Soil 6"</b></td></tr> </table>	<b>CRCP 14"</b>	<b>HMAC (Type B) 4"</b>	<b>Lime Stab. SG (6 %) 19"</b>	<b>Compacted Soil 6"</b>	<p><b>IH-35-E / 190 T Mainlanes NB / SB Entrance Ramp NB Exit Ramp</b></p>
	<b>CRCP 14"</b>					
	<b>HMAC (Type B) 4"</b>					
<b>Lime Stab. SG (6 %) 19"</b>						
<b>Compacted Soil 6"</b>						
<table border="1"> <tr><td><b>CRCP 13"</b></td></tr> <tr><td><b>HMAC (Type B) 6"</b></td></tr> <tr><td><b>Lime Stab. SG (6 %) 18"</b></td></tr> <tr><td><b>Compacted Soil 6"</b></td></tr> </table>	<b>CRCP 13"</b>	<b>HMAC (Type B) 6"</b>	<b>Lime Stab. SG (6 %) 18"</b>	<b>Compacted Soil 6"</b>	<p><b>IH-35-E / 190 T Mainlanes EB / WB</b></p>	
<b>CRCP 13"</b>						
<b>HMAC (Type B) 6"</b>						
<b>Lime Stab. SG (6 %) 18"</b>						
<b>Compacted Soil 6"</b>						
<table border="1"> <tr><td><b>CRCP 13"</b></td></tr> <tr><td><b>HMAC (Type A) 3"</b></td></tr> <tr><td><b>HMAC (Type D) 3"</b></td></tr> <tr><td><b>Lime Stab. SG (4%) 10"</b></td></tr> <tr><td><b>Select Fill Mat. (PI&lt;=20) 18"(sand) – 21"(clay)</b></td></tr> </table>	<b>CRCP 13"</b>	<b>HMAC (Type A) 3"</b>	<b>HMAC (Type D) 3"</b>	<b>Lime Stab. SG (4%) 10"</b>	<b>Select Fill Mat. (PI&lt;=20) 18"(sand) – 21"(clay)</b>	<p><b>US 75 Mainlanes NB / SB</b></p>
<b>CRCP 13"</b>						
<b>HMAC (Type A) 3"</b>						
<b>HMAC (Type D) 3"</b>						
<b>Lime Stab. SG (4%) 10"</b>						
<b>Select Fill Mat. (PI&lt;=20) 18"(sand) – 21"(clay)</b>						

**Table A.1 Selected Traditional Pavement Sections: Dallas District...cont**

<b>Roadway Classification</b>	<b>Cross-Section</b>	<b>Road example</b>
<b>Highest Volume Highway</b>	<b>Concrete Slab 15"</b>	<b>IH-30 Sta. 666 / Mainlane widening</b>
	<b>HMAC (600 / 660 # / SY) 6"</b>	
	<b>Embankment Type C Lime Stab. SG (4%) 18"</b>	
	<b>Compacted Soil 6"</b>	
	<b>Concrete Slab 15"</b>	<b>IH-30 Sta. 593</b>
	<b>HMAC (1320 # / SY) 12"</b>	
	<b>Embankment Type C Lime Stab. SG (4%) 12"</b>	
	<b>Compacted Soil 18"</b>	

**Table A.1 Selected Traditional Pavement Sections: Dallas District...cont**

<b>Roadway Classification</b>	<b>Cross-Section</b>	<b>Road example</b>
<p><b>Highest Volume Highway</b></p>	<p><b>CRCP 13"</b></p>	<p><b>US 75 Mainlane SB</b></p>
	<p><b>HMAC (Type A) 3" HMAC (Type D) 7"</b></p>	
	<p><b>Compacted Soil 18"</b></p>	
	<p><b>Rock</b></p>	
<p><b>Arterial, Frontage Collector Roads</b></p>	<p><b>CPCD 10"</b></p>	<p><b>IH-30 Frontage Rd. / Bobtown Rd.</b></p>
<p><b>HMAC (280 / 600 # / SY) 8"</b></p>		
<p><b>Compacted Soil 18"</b></p>		

**Table A.1 Selected Traditional Pavement Sections: Dallas District...cont**

<b>Roadway Classification</b>	<b>Cross-Section</b>	<b>Road example</b>				
<b>Arterial, Frontage &amp; Collector Roads</b>	<table border="1"> <tr><td><b>Concrete Slab 8"</b></td></tr> <tr><td><b>HMAC 6"</b></td></tr> <tr><td><b>Lime Stab. SG (6%) 8"</b></td></tr> <tr><td><b>Compacted Soil 6"</b></td></tr> </table>	<b>Concrete Slab 8"</b>	<b>HMAC 6"</b>	<b>Lime Stab. SG (6%) 8"</b>	<b>Compacted Soil 6"</b>	<b>IH-35-E / 190 T Frontage Roads</b>
	<b>Concrete Slab 8"</b>					
	<b>HMAC 6"</b>					
<b>Lime Stab. SG (6%) 8"</b>						
<b>Compacted Soil 6"</b>						
<table border="1"> <tr><td><b>CPCD 8"</b></td></tr> <tr><td><b>HMAC 4"</b></td></tr> <tr><td><b>Lime Stab. SG (7%) 22"</b></td></tr> <tr><td><b>Compacted Soil 6"</b> 0.25 Gal. / SY</td></tr> </table>	<b>CPCD 8"</b>	<b>HMAC 4"</b>	<b>Lime Stab. SG (7%) 22"</b>	<b>Compacted Soil 6"</b> 0.25 Gal. / SY	<b>SH 66 Mainlane</b>	
<b>CPCD 8"</b>						
<b>HMAC 4"</b>						
<b>Lime Stab. SG (7%) 22"</b>						
<b>Compacted Soil 6"</b> 0.25 Gal. / SY						
<table border="1"> <tr><td><b>Concrete Slab 8"</b></td></tr> <tr><td><b>HMAC 4"</b></td></tr> <tr><td><b>Lime Stab. SG (7%) 6"</b></td></tr> <tr><td><b>Compacted Soil 6"</b> 0.25 Gal. / SY</td></tr> </table>	<b>Concrete Slab 8"</b>	<b>HMAC 4"</b>	<b>Lime Stab. SG (7%) 6"</b>	<b>Compacted Soil 6"</b> 0.25 Gal. / SY	<b>SH 66 Embank Washington St. Rusk St.</b>	
<b>Concrete Slab 8"</b>						
<b>HMAC 4"</b>						
<b>Lime Stab. SG (7%) 6"</b>						
<b>Compacted Soil 6"</b> 0.25 Gal. / SY						

**Table A.1 Selected Traditional Pavement Sections: Dallas District...cont**

<b>Roadway Classification</b>	<b>Cross-Section</b>	<b>Road example</b>			
	<table border="1"> <tr> <td data-bbox="684 399 1062 456"><b>CPCD CL K 8"</b></td> </tr> <tr> <td data-bbox="684 456 1062 561"><b>HMAC 14"</b></td> </tr> <tr> <td data-bbox="684 561 1062 626"><b>Compacted Soil 6"</b></td> </tr> </table>	<b>CPCD CL K 8"</b>	<b>HMAC 14"</b>	<b>Compacted Soil 6"</b>	<p data-bbox="1367 431 1514 464"><b>Scenic Dr.</b></p> <hr data-bbox="1335 496 1545 505"/> <p data-bbox="1356 545 1524 610"><b>Heritage/ Harborside</b></p>
<b>CPCD CL K 8"</b>					
<b>HMAC 14"</b>					
<b>Compacted Soil 6"</b>					
<p data-bbox="306 708 590 773"><b>Arterial, Frontage &amp; Collector Roads</b></p> <hr data-bbox="380 805 516 813"/> <p data-bbox="327 854 579 886"><b>City/Local Streets</b></p>	<table border="1"> <tr> <td data-bbox="684 708 1062 764"><b>CPCD CL K 8"</b></td> </tr> <tr> <td data-bbox="684 764 1062 829"><b>HMAC 8"</b></td> </tr> <tr> <td data-bbox="684 829 1062 902"><b>Compacted Soil 6"</b></td> </tr> </table>	<b>CPCD CL K 8"</b>	<b>HMAC 8"</b>	<b>Compacted Soil 6"</b>	<p data-bbox="1335 870 1545 902"><b>Lakeshore Dr.</b></p> <hr data-bbox="1335 935 1545 943"/>
<b>CPCD CL K 8"</b>					
<b>HMAC 8"</b>					
<b>Compacted Soil 6"</b>					
	<table border="1"> <tr> <td data-bbox="684 959 1062 1016"><b>CPCD 8"</b></td> </tr> <tr> <td data-bbox="684 1016 1062 1081"><b>HMAC 4"</b></td> </tr> <tr> <td data-bbox="684 1081 1062 1154"><b>Compacted Soil 6"</b></td> </tr> </table>	<b>CPCD 8"</b>	<b>HMAC 4"</b>	<b>Compacted Soil 6"</b>	<p data-bbox="1388 976 1493 1008"><b>2<sup>nd</sup>. St.</b></p>
<b>CPCD 8"</b>					
<b>HMAC 4"</b>					
<b>Compacted Soil 6"</b>					

**Table A.2 Selected Traditional Pavement Sections: Fort Worth District**

<b>Highway Type</b>	<b>Cross-Section</b>	<b>Road example</b>			
<p style="text-align: center;"> <b>IH /</b>  <b>US /</b>  <b>SH /</b>  <b>FM /</b>  <b>High Vol. Urban</b> </p>	<table border="1" style="width: 100%; text-align: center;"> <tr><td><b>Concrete Slab 13"</b></td></tr> <tr><td><b>HMAC 4"</b></td></tr> <tr><td><b>Lime Stab. SG 18"</b></td></tr> </table>	<b>Concrete Slab 13"</b>	<b>HMAC 4"</b>	<b>Lime Stab. SG 18"</b>	<p><b>SH 360</b></p>
	<b>Concrete Slab 13"</b>				
	<b>HMAC 4"</b>				
	<b>Lime Stab. SG 18"</b>				
<table border="1" style="width: 100%; text-align: center;"> <tr><td><b>Concrete Slab 13"</b></td></tr> <tr><td><b>HMAC 4"</b></td></tr> <tr><td><b>Lime Stab. SG 8"</b></td></tr> </table>	<b>Concrete Slab 13"</b>	<b>HMAC 4"</b>	<b>Lime Stab. SG 8"</b>		
<b>Concrete Slab 13"</b>					
<b>HMAC 4"</b>					
<b>Lime Stab. SG 8"</b>					
<table border="1" style="width: 100%; text-align: center;"> <tr><td><b>Concrete Slab 12"</b></td></tr> <tr><td><b>HMAC 4"</b></td></tr> <tr><td><b>Lime Stab. SG 18"</b></td></tr> </table>	<b>Concrete Slab 12"</b>	<b>HMAC 4"</b>	<b>Lime Stab. SG 18"</b>		
<b>Concrete Slab 12"</b>					
<b>HMAC 4"</b>					
<b>Lime Stab. SG 18"</b>					
<table border="1" style="width: 100%; text-align: center;"> <tr><td><b>Concrete Slab 12"</b></td></tr> <tr><td><b>HMAC 4"</b></td></tr> <tr><td><b>Lime Stab. SG 8"</b></td></tr> </table>	<b>Concrete Slab 12"</b>	<b>HMAC 4"</b>	<b>Lime Stab. SG 8"</b>		
<b>Concrete Slab 12"</b>					
<b>HMAC 4"</b>					
<b>Lime Stab. SG 8"</b>					

**Table A.2 Selected Traditional Pavement Sections: Fort Worth District...cont**

<b>Roadway Classification</b>	<b>Cross-Section</b>	<b>Road example</b>			
<p style="text-align: center;">US/ SH/ FM</p>	<table border="1" style="width: 100%; text-align: center;"> <tr> <td>Concrete Slab 8"</td> </tr> <tr> <td>HMAC 4"</td> </tr> <tr> <td>Lime Stab. SG 18"</td> </tr> </table>	Concrete Slab 8"	HMAC 4"	Lime Stab. SG 18"	
	Concrete Slab 8"				
HMAC 4"					
Lime Stab. SG 18"					
<table border="1" style="width: 100%; text-align: center;"> <tr> <td>Concrete Slab 8"</td> </tr> <tr> <td>HMAC 4"</td> </tr> <tr> <td>Lime Stab. SG 8"</td> </tr> </table>	Concrete Slab 8"	HMAC 4"	Lime Stab. SG 8"		
Concrete Slab 8"					
HMAC 4"					
Lime Stab. SG 8"					

**Table A.3 Selected Traditional Pavement Sections: Houston District**

<b>Roadway Classification</b>	<b>Cross-Section</b>	<b>Road example</b>					
SH/ FM	<table border="1" style="width: 100%; text-align: center;"> <tr><td>Concrete Slab 13"</td></tr> <tr><td>Base 6"</td></tr> <tr><td>Cement Treated 6"</td></tr> <tr><td>Lime Stab. SG 6"</td></tr> <tr><td>Compacted Soil 6"</td></tr> </table>	Concrete Slab 13"	Base 6"	Cement Treated 6"	Lime Stab. SG 6"	Compacted Soil 6"	
Concrete Slab 13"							
Base 6"							
Cement Treated 6"							
Lime Stab. SG 6"							
Compacted Soil 6"							
FR	<table border="1" style="width: 100%; text-align: center;"> <tr><td>Concrete Slab 10"</td></tr> <tr><td>Base 6"</td></tr> <tr><td>Cement Treated 6"</td></tr> <tr><td>Lime Stab. SG 6"</td></tr> <tr><td>Compacted Soil 6"</td></tr> </table>	Concrete Slab 10"	Base 6"	Cement Treated 6"	Lime Stab. SG 6"	Compacted Soil 6"	
Concrete Slab 10"							
Base 6"							
Cement Treated 6"							
Lime Stab. SG 6"							
Compacted Soil 6"							

**Table A.4 Selected Traditional Pavement Sections: Beaumont District**

<b>Roadway Classification</b>	<b>Cross-Section</b>	<b>Road example</b>					
<p style="text-align: center;">SH/ US/ High Vol. Roads</p>	<table border="1" style="margin-left: auto; margin-right: auto;"> <tr> <td style="text-align: center;">Concrete Slab 12"</td> </tr> <tr> <td style="background-color: #cccccc;"> </td> </tr> <tr> <td style="text-align: center;">Cement Treated 6"</td> </tr> <tr> <td style="text-align: center;">Lime Stab. SG 6"</td> </tr> <tr> <td style="text-align: center;">Compacted Soil 6"</td> </tr> </table>	Concrete Slab 12"		Cement Treated 6"	Lime Stab. SG 6"	Compacted Soil 6"	<p>US 96 from Call to Buna, RM418 to RM428/ SH 105 @ FM2518, RM725/ SH 105 @ FM146, RM739/ SH 105 @ FM770, RM751/</p>
Concrete Slab 12"							
Cement Treated 6"							
Lime Stab. SG 6"							
Compacted Soil 6"							

**Table A.5 Selected Traditional Pavement Sections: El Paso District**

<b>Roadway Classification</b>	<b>Cross-Section</b>	<b>Road example</b>			
<b>IH</b>	<table border="1" style="margin: auto;"> <tr><td style="text-align: center;">Concrete Slab 14"</td></tr> <tr><td style="text-align: center;">HMAC 4"</td></tr> <tr><td style="text-align: center;">Compacted Soil 6"</td></tr> </table>	Concrete Slab 14"	HMAC 4"	Compacted Soil 6"	<b>IH 10</b>
	Concrete Slab 14"				
	HMAC 4"				
Compacted Soil 6"					
<table border="1" style="margin: auto;"> <tr><td style="text-align: center;">Concrete Slab 12"</td></tr> <tr><td style="text-align: center;">HMAC 4"</td></tr> <tr><td style="text-align: center;">Compacted Soil 6"</td></tr> </table>	Concrete Slab 12"	HMAC 4"	Compacted Soil 6"		
Concrete Slab 12"					
HMAC 4"					
Compacted Soil 6"					
<table border="1" style="margin: auto;"> <tr><td style="text-align: center;">Concrete Slab 10"</td></tr> <tr><td style="text-align: center;">HMAC 4"</td></tr> <tr><td style="text-align: center;">Compacted Soil 6"</td></tr> </table>	Concrete Slab 10"	HMAC 4"	Compacted Soil 6"		
Concrete Slab 10"					
HMAC 4"					
Compacted Soil 6"					

## **Appendix B: Determining Potential Vertical Rise**

*This page left blank intentionally*

•

## Section 23. Tex-124-E, Determining Potential Vertical Rise

### Overview

This procedure determines the potential vertical rise (PVR) in soil strata, such as may be encountered in the placement of a roadway, bridge, or building foundation.

### Definitions

The following terms and definitions are referenced in this test method:

- ◆ potential vertical rise - Potential Vertical Rise is expressed in millimeters (inches), is the latent or potential ability of a soil material to swell, at a given density, moisture, and loading condition, when exposed to capillary or surface water, and thereby increase the elevation of its upper surface, along with anything resting on it.
- ◆ liquid limit - A liquid limit (LL) is the moisture content expressed as a percentage of the weight of oven-dried soil, at which soil changes from a plastic to a liquid state. It is the moisture content of a soil at which two halves of a soil part, separated by a groove of standard dimension (1 cm deep) will join at the length of 1/2 inch under impact of 25 blows using the Mechanical Liquid Limit Device, and Test Method "Tex-104-E, Determining Liquid Limits of Soils." The percent of moisture in a soil sample where a decrease in moisture changes from a viscous or liquid state to a plastic state.
- ◆ plasticity index - Plasticity index is a test conducted on soil samples as set out in Test Method "Tex-106-E, Calculating the Plasticity Index of Soils." The plasticity index is a range of moisture in which a soil remains in a plastic state while passing from a semisolid state to liquid state. Numerical difference between Liquid Limit and Plastic Limit of a soil ( $PI = LL - PL$ ) using Test Method "Tex-106-E, Calculating the Plasticity Index of Soils."
- ◆ overburden - The overburden is the soil above the layer or layers being investigated. Example: A clay layer covered with 3.1 m (10 ft.) of sand would have 3.1 m (10 ft.) of overburden on it.
- ◆ layer - Layer is a horizontal soil structure of uniform or nearly uniform material. When the material changes due to moisture, density, or composition, a new layer is considered to have been created.
- ◆ loading - Loading is the load (vertical pressure) per unit area in kPa (lb/ft<sup>2</sup>) from both the structure and overburden of each layer of soil involved.
- ◆ moisture preservation - Moisture preservation is the use of "Blanket Sections" with wide shoulders consisting of granular materials, stabilized soils, or where asphalt membranes are applied for this purpose.

### Apparatus

The following apparatus is required:

- ◆ apparatus as listed in test methods:
  - 'Part I, Preparing Samples for Soil Constants and Particle Size Analysis' of "Tex-101-E, Preparing Soil and Flexible Base Materials for Testing"
  - "Tex-103-E, Determining Moisture Content in Soil Materials"
  - "Tex-104-E, Determining Liquid Limit of Soils"

- "Tex-105-E, Determining Plastic Limit of Soils"
- ◆ supply of paraffin, small cutting knives, etc.
- ◆ sampling device, core-drilling rig equipped to take disturbed or undisturbed core samples of the material in place.

NOTE: Undisturbed cores are not absolutely necessary if an approximation of the wet density is known.

### **Sampling**

Perform exploration and sampling according to the Design Division's *Foundation Exploration and Design Manual* except that greater emphasis must be placed on sampling of top strata layering to a depth of 4.5 m (15 ft.) in most cases, and as much as 6.0 m (20 ft.) when very highly expansive clays are encountered.

- ◆ In some instances, the presence of rock, gravel, or sand substrata will eliminate the necessity for drilling a large number of deep exploration holes.
- ◆ Thicknesses of soil layers, especially clay layers, existing below the proposed structure should be determined.
- ◆ In the case of massive clay layers, the maximum depth to investigate will depend on the position and amount of load proposed and the expansive characteristics of the clay.
- ◆ Secure cores or cuttings to represent these layers as shown in the 'Drilling Log.'
- ◆ In sampling, all holes should be logged and moisture contents determined.

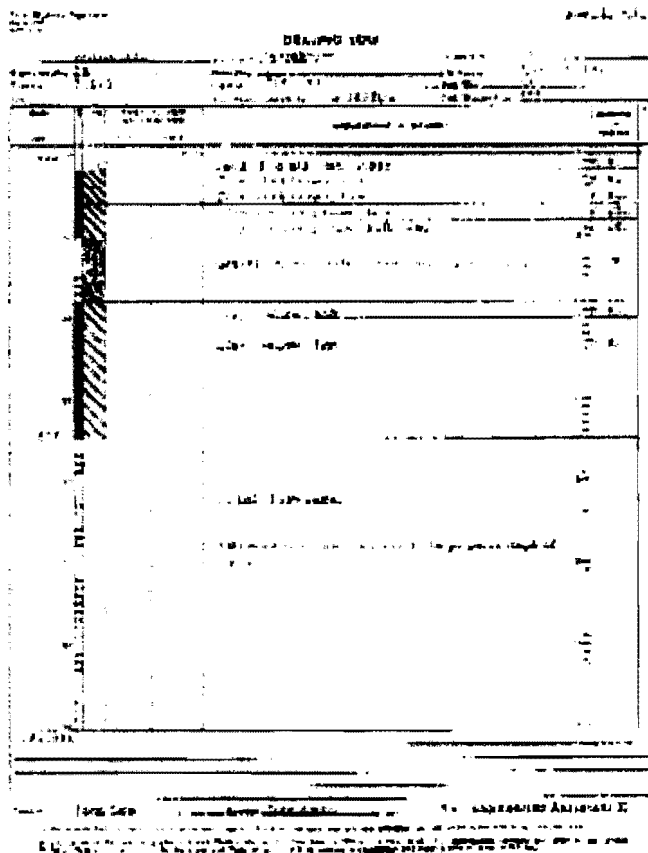

Figure 1 -27. Drilling Log.

### Procedure

The following steps are necessary to determine potential vertical rise.

- ◆ If only cuttings were taken during sampling, determine the moisture content of each layer according to Test Method "Tex-103-E, Determining Moisture Content in Soil Materials."
  - If core samples were paraffined for moisture preservation, use those samples in this procedure.
  - For core sampling, select cores representative of each swelling layer.
- Trim cores into right circular cylinders using knives or other convenient hand tools.
- Measure the height,  $h$ , and diameter,  $D$ , and calculate the volume of the core in cubic meters (cubic feet).
- Determine the mass of the wet core to the nearest 0.5 g.

- Calculate the wet density by dividing the wet mass by the volume of the core and record to the nearest  $0.02 \text{ kg/m}^3$  ( $0.001 \text{ lb./ft.}^3$ ).

NOTE: If only cuttings are taken during sampling, use a wet density of  $2002.5 \text{ kg/m}^3$  ( $125 \text{ lb./ft.}^3$ ), which is usually a reasonable value. Other accepted methods for determining density of cores, such as set forth by paraffin coatings in Test Method "Tex-207-F, Determining Density of Compacted Bituminous Mixtures," may be used, if desired.

- ◆ From representative portions of the cuttings or cores, determine the Liquid Limit (LL), Plasticity Index (PI), and percent soil binder in the soil layers according to test methods:
  - "Tex-104-E, Determining Liquid Limit of Soils"
  - "Tex-105-E, Determining Plastic Limit of Soils"
  - 'Part I, Preparing Samples for Soil Constants and Particle Size Analysis' of "Tex-101-E, Preparing Soil and Flexible Base Materials for Testing," respectively.
- Record the test results.
- ◆ In calculating the PVR, it is convenient or preferable to use 0.6 m (2 ft.) elements or layers, provided the moisture contents and the log of the hole will permit.
  - The use of 0.6 m (2 ft.) layers and the assumption of  $2002.5 \text{ kg/m}^3$  ( $125 \text{ lb./ft.}^3$ ) wet density, which is usually a reasonable wet density, makes the tabulation simpler.
  - The modification caused by using  $2002.5 \text{ kg/m}^3$  ( $125 \text{ lb./ft.}^3$ ) rather than  $2307 \text{ kg/m}^3$  ( $144 \text{ lb./ft.}^3$ ), for 22.6 kPa/m (1 psi/ft.), has already been incorporated into the curves on 'Relation of Load to Potential Vertical Rise (No. 1),' and 'Relation of Load to Potential Vertical Rise (No. 2),'
  - Where wet densities vary from  $2002.5 \text{ kg/m}^3$  ( $125 \text{ lb./ft.}^3$ ), and greater accuracy is desired, a modification factor should be applied to that layer equivalent to  $2002.5 \text{ kg/m}^3$  ( $125 \text{ pcf}$ ) divided by the actual wet density.

NOTE: In the 0.6 m (2 ft.) layer at the surface, the "average" load in the layer is 6.9 kPa (1 psi); likewise, in the 0.6 to 1.2 m (2 to 4 ft.) layer, the load is 13.8 kPa (2 psi) for the top 0.6 m (2 ft.) plus one half of the 0.6 to 1.2 m (2 to 4 ft.) layer or 20.7 kPa (3 psi) total. Therefore, the average load in any 0.6 m (2 ft.) layer is the average depth of the layer (subject to the correction factor as described above).

- ◆ Beginning with the logging data for the top layer at the surface of the ground, start compilation of the 'Example Calculation.'
  - Determine average load in each layer (column 2).
  - Record the liquid limit for each layer (column 3).
- ◆ The value of  $0.2 \text{ LL} + 9$ , in the 'Example Calculation,' represents the "dry" condition from which little shrinkage is experienced, but where volumetric swell potential is greatest.
  - It is the minimum moisture content swelling clays usually dry to.
  - Record this value in column 4.
- ◆ The "wet" condition ( $0.47 \text{ LL} + 2$ ), in the 'Example Calculation,' corresponds to the maximum capillary absorption by laboratory tests on specimens molded at optimum moisture and surcharged with 6.9 kPa (1 psi) load.

- This is also analogous to moisture contents found beneath old pavements or other lightweight structures.
- This is the "optimum" condition.
- Record this value in column 5.
- ◆ Determine whether the layers are "wet," "dry," or "average" by comparing actual moisture content with "dry" (column 4) and "wet" (column 5) values.
  - The layer is considered "average" if the moisture content is closer to the average of the "wet" and "dry" conditions.
  - The percent moisture values from the samples are recorded in column 6.
- ◆ Examine the test record forms and enter the percent soil binder (% minus 425  $\mu\text{m}$  [No. 40] material) and the P.I. of the layers in column 8 and 9, respectively.
- ◆ Locate the P.I. of the first soil layer on the abscissa in 'Interrelationship of P.I. and Volume Change.'
  - Move upward to the appropriate swell line (dry, average or wet) and read the percent volumetric change on the ordinate.
  - This percent volumetric change is for 6.9 kPa (1 psi) surcharge.
  - Record this as "% Vol. Swell" in column 10.
- ◆ The PVR vs. Load Curves in 'Relation of Load to Potential Vertical Rise (No. 1).' and 'Relation of Load to Potential Vertical Rise (No. 2).' are for free swelling clays under no load and are based on a wet density of soil of 2002.5 kg/m<sup>3</sup> (125 lb./ft.<sup>3</sup>).
  - In order to use these curves, the swelling determined from 'Interrelationship of P.I. and Volume Change' needs to be converted to the swelling under no load by % Free Swell = (% Vol. Swell @ 6.895 kPa) (1.07) + 2.6.
  - Record as "% Free Swell" in column 11.
- ◆ Determine the PVRs from 'Relation of Load to Potential Vertical Rise (No. 1)' or 'Relation of Load to Potential Vertical Rise (No. 2).' as follows:
  - In the first layer, 0 - 0.6 m (0 - 2 ft.), read the ordinate (PVR) at 6.9 kPa (1 psi) load and the corresponding percent free swell curve and record on 'Example Calculation' as "Bottom of Layer."
  - From the same curve, read the PVR at the "Top of Layer" with corresponding load, zero in the case of this layer. Record on 'Example Calculation' as "Top of Layer."
  - The difference in the two readings is the PVR in the first layer. Record this in column 14.
  - The PVR value in column 14 is modified when % minus 425  $\mu\text{m}$  (No. 40) (column 8) is greater than or equal to 25 %.
  - The correction factor is equal to the % minus 425  $\mu\text{m}$  (No. 40) material divided by 100.
  - Correction factors for density are obtained as described in Step 4 and recorded in column 16.
  - Multiply the difference in PVR (column 14) by the two correction factors (column 15 & 16) and record the results in column 17.
- ◆ Next, take the second layer and determine the percent volumetric swell by modifying the value determined from 'Interrelationship of P.I. and Volume Change.'
  - On this percent volumetric swell curve, or a sketched in penciled curve where the line is not actually on 'Relation of Load Potential Vertical Rise (No. 1)' or 'Relation

of Load Potential Vertical Rise (No. 2)' read the PVR on the ordinate corresponding to 20.7 kPa (3 psi) (bottom of layer) and record on the 'Example Calculation' table. Read the ordinate corresponding to 6.9 kPa (1 psi) (top of layer) from the same curve and record.

- The difference in the two readings is the swelling in the second layer, subject to any density or soil binder minus 425  $\mu\text{m}$  (No.40) modifications.
- ◆ Continue determining PVR in each layer until each swelling layer has been loaded out as determined by the curves on 'Relation of Load to Potential Vertical Rise (No. 1)' and 'Relation of Load to Potential Vertical Rise (No. 2)' leveling out horizontally and indicated by no difference when PVR is read from that curve.
  - Actually, the swell is negligible or zero anywhere beyond the end of any given curve as shown on these two figures.
  - Thicker layers may be used in this calculation where they consist of uniform soil having similar P.I. and moisture contents.
- ◆ Check each layer for modifications for density factor and soil binder.
- ◆ Add the PVR in all layers to obtain the total PVR for the site.

NOTE: The 'Example Calculation' table has been calculated for no loading due to the structure. When loads due to the structures are known, then simply add it in "Average Load, kPa (psi)" and increase each figure in the column by the amount of structure load, but note that the swell will be reduced because of increased loading.

Example Calculations																
Depth m (ft.)	Avg. Load kPa (psi)	LL	Dry .2 LL +9	Wet .47 LL +2	% Moist ure	Dry Avg Wet	% - 425 □m (- No. 40)	PI	% Vol Swell	% Free Swell	PVR, mm (in.) Top of Layer	PVR, mm (in.) Bottom of Layer	Diff. mm (in.)	Mod. - 425 □m(- No. 40) Factor	Mod. Density Factor*	PVR in Layer mm (in.)
0-0.6 (0 - 2)	6.9 (1)	21			3.1	Dry	100	4	0.0	0	0.00 (0.00)	0.00 (0.00)	0.00 (0.00)	1.00	1.00	0.00 (0.00)
0.6-1.2 (2 - 4)	20.7 (3)	60	21.0	30.2	39.7	Wet	100	38	5.5	8.5	10.41 (0.41)	22.35 (0.88)	11.94 (0.47)	1.00	1.00	11.94 (0.47)
1.2-1.8 (4 - 6)	34.5 (5)	60	21.0	30.2	20.9	Dry	100	38	11.0	14.5	39.37 (1.55)	55.88 (2.20)	16.51 (0.65)	1.00	1.00	16.51 (0.65)
1.8-2.4 (6 - 8)	48.3 (7)	75	24.0	37.3	24.4	Dry	100	45	13.5	17.0	71.37 (2.81)	86.61 (3.41)	15.24 (0.60)**	1.00	1.00	15.24 (0.60)
2.4-3.0 (8 - 10)	62.1 (9)	75	24.0	37.3	36.5	Wet	100	45	7.0	10.0	42.93 (1.69)	46.99 (1.85)	4.06 (0.16)	1.00	1.00	4.06 (0.16)
3.0-3.7 (10-12)	75.8 (11)	65	22.0	32.6	8.5	Wet	15	40			n/a+	n/a+	n/a+	0.00	1.00	0.00 (0.00)
3.7-4.3 (12-14)	89.6 (13)	65	22.0	32.6	8.5	Wet	15	40			n/a+	n/a+	n/a+	0.00	1.00	0.00 (0.00)
4.3-4.9 (14-16)	103.5 (15)	65	22.0	32.6	8.5	Wet	15	40			n/a+	n/a+	n/a+	0.00	1.00	0.00 (0.00)
4.9-5.5 (16-18)	117.2 (17)	65	22.0	32.6	8.5	Wet	15	40			n/a+	n/a+	n/a+	0.00	1.00	0.00 (0.00)
5.5-6.1 (18-20)	131.0 (19)	85	26.0	42.0	41.5	Wet	100	60	10.2	13.5	89.92 (3.54)	91.95 (3.62)	2.03 (0.08)	1.00	1.00	2.03 (0.08)

6.1-6.7 (20-22)	144.8 (21)	80	25.0	39.6	33.9	Avg	100	54	12.6	16.0	123.95 (4.88)	127.00 (5.00)	3.05 (0.12)	1.00	1.00	3.05 (0.12)
6.7-7.3 (22-24)	158.6 (23)	80	25.0	39.6	33.9	Avg	100	54	12.6	16.0	127.00 (5.00)	129.79 (5.11)	2.79 (0.11)	1.00	1.00	2.79 (0.11)
7.3-7.9 (24-26)	172.5 (25)	80	25.0	39.6	33.9	Avg	100	54	12.6	16.0	129.79 (5.11)	132.08 (5.20)	2.29 (0.09)	1.00	1.00	2.29 (0.09)
7.9-8.5 (26-28)	186.3 (27)	80	25.0	39.6	33.9	Avg	100	54	12.6	16.0	132.08 (5.20)	133.86 (5.27)	1.78 (0.07)	1.00	1.00	1.78 (0.07)
8.5-9.1 (28-30)	200.0 (29)	80	25.0	39.6	33.9	Avg	100	54	12.6	16.0	133.86 (5.27)	135.38 (5.33)	1.52 (0.06)	1.00	1.00	1.52 (0.06)
9.1-9.8 (30-32)	213.7 (31)	80	25.0	39.6	33.9	Avg	100	54	12.6	16.0	135.38 (5.33)	135.64 (5.34)	0.25 (0.01)	1.00	1.00	0.25 (0.01)
												Total PVR = 61.47 mm (2.42 in.)				
6.1-9.8 (**20-32)	131.0- 213.7 (19-31)	80	25.0	39.6	33.9	Avg	100	54	12.6	16.0	123.95 (4.88)	135.64 (5.34)	11.68 (0.46)	1.00	1.00	11.68 (0.46)
* 2002.5 kPa wet density assumed for all layers. When greater accuracy is desired, use 2002.5 (or 125) + actual wet density of soil in kPa (pcf) as the modifier.																
** NOTE: Since the 3.7 m (12 ft.) layer from 6.1-9.8 m (20-32 ft.) is uniform, the PVR may be determined in one reading by using the "top of layer" as 131.0 kPa (19 psi) (as in 0.6 m [2 ft.] layers) and reading the "bottom of layer at 213.7 kPa (31 psi) load as in 9.1-9.8 m (30-32 ft.) layer. Readings of 123.95 mm (4.88 in.) and 135.64 mm (5.34 in.) respectively, or a difference of 11.68 mm (0.46 in.), will be obtained which is a summation of increments (difference) as shown above for the bottom 3.7 m (12 ft.). When layers of expansive clays of less than 0.6 m (2 ft.) exist, it is preferable to enter the abscissa on the proper swell curve at 4 and 4.6 respectively, and use the difference in the respective ordinate readings as the unmodified swell in the 0.18 m (0.6 ft.) thick layer.																
*** See example in 'Relation of Load to Potential Vertical Rise (#1).																
+ n/a = less than 25% minus 425 µm (No. 40) material.																

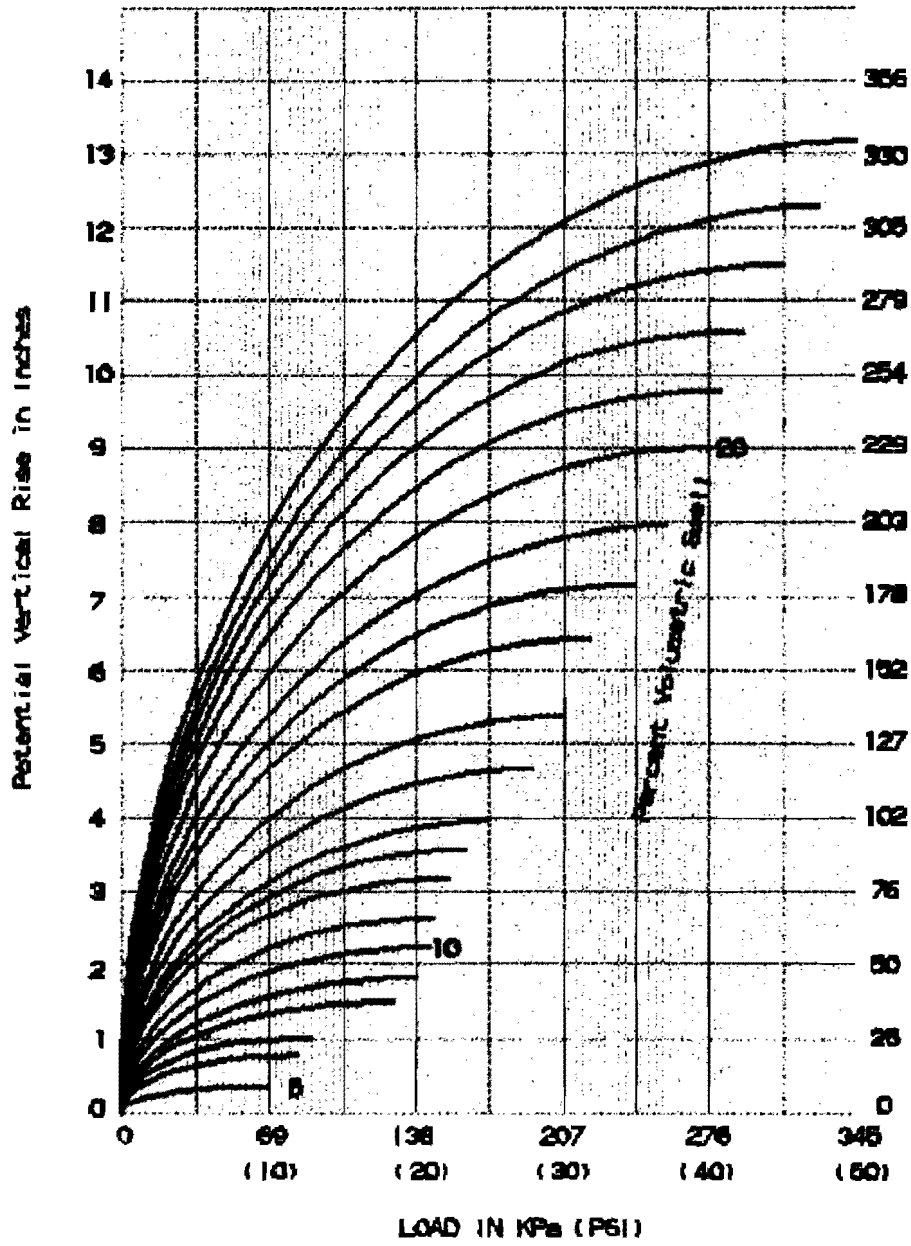

Figure 1 -28. Relation of Load to Potential Vertical Rise (No. 1).

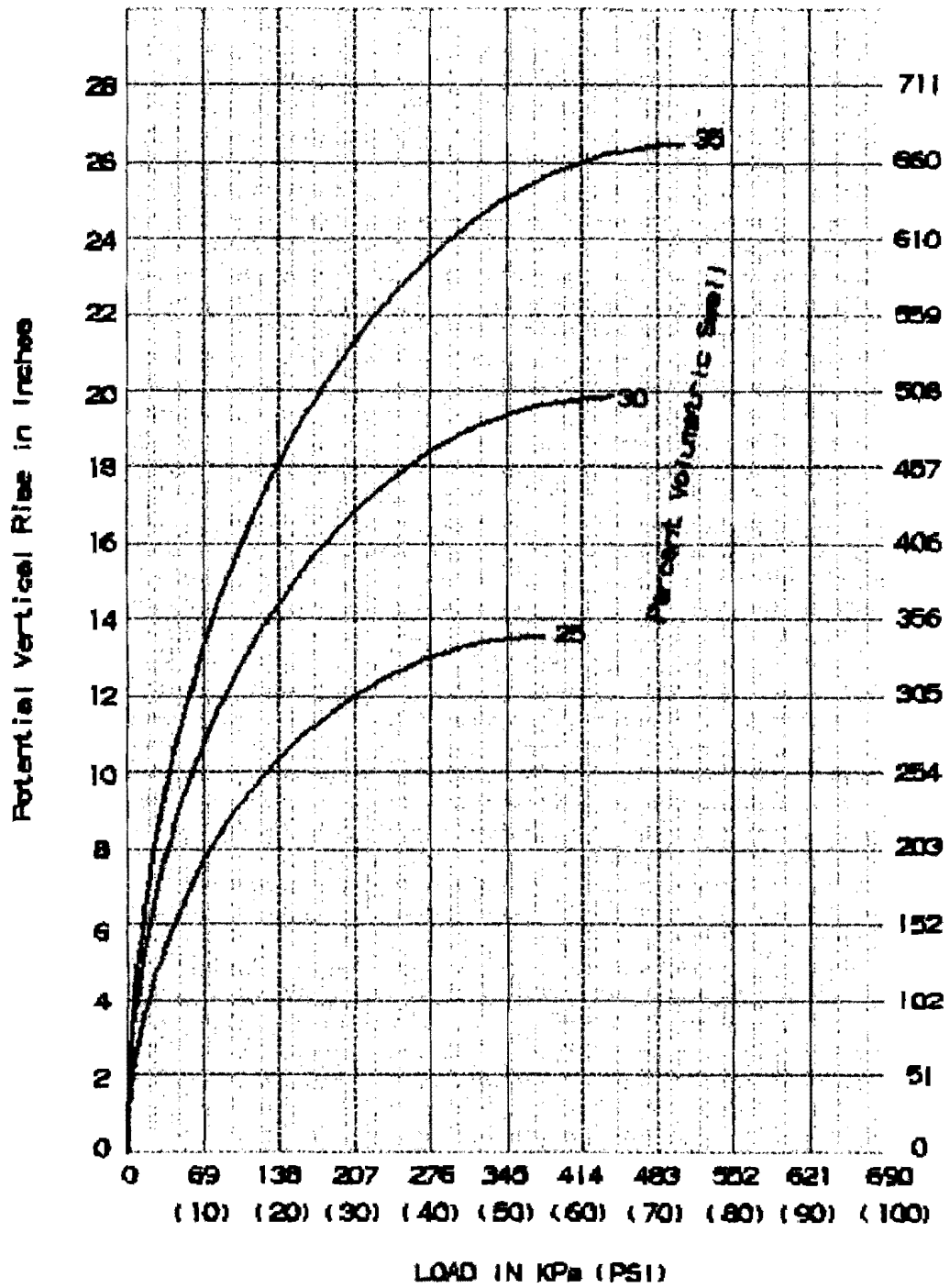

Figure 1 -29. Relation of Load to Potential Vertical Rise (No. 2).

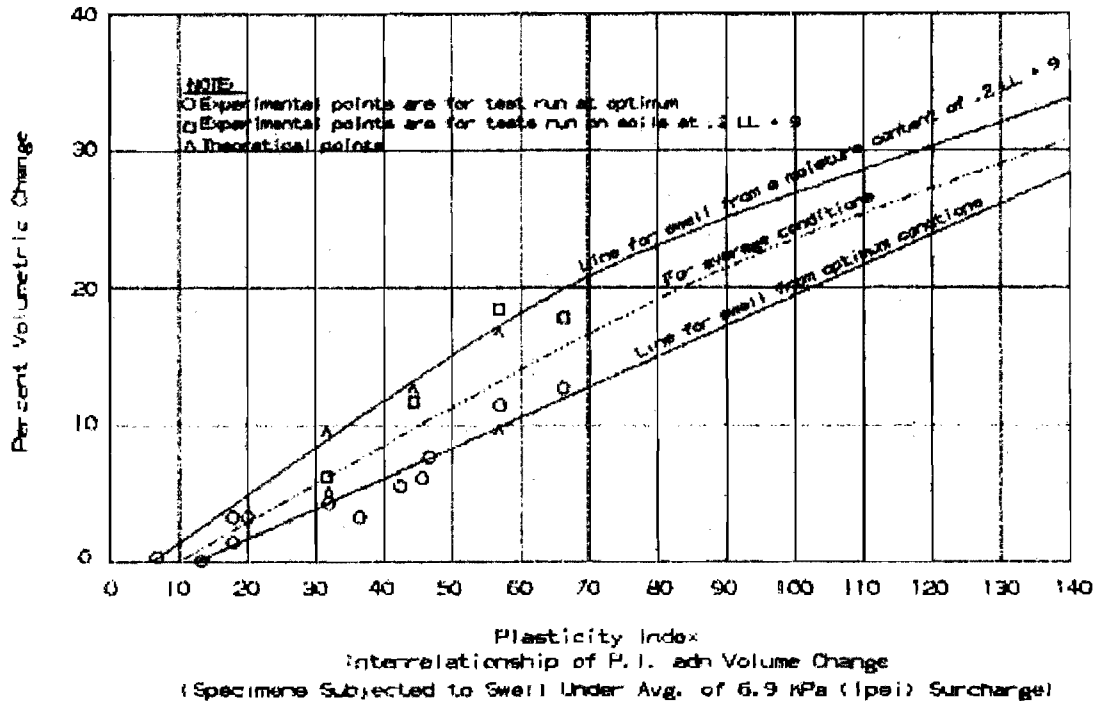

Figure 1 -30. Interrelationship of P.I. and Volume Change.

### Test Report

To report the test results, submit a copy of the 'Example Calculation,' with appropriate job and site identifications.

### Notes

- ◆ Often, during design, it is necessary to estimate PVR without knowing moisture contents anticipated at time of construction. In cases of this kind, the design and planning of the job should influence the choice of line on 'Interrelationship of P.I. and Volume Change' to be selected for use.
  - If the project exists in an arid to semiarid climate and the plans and specifications do not provide for moisture-density control nor preservation of moisture, use the line for  $0.2 LL + 9$ .
  - If the plans and specifications require moisture-density control and moisture preservation, use the average line.
  - In the high rainfall areas, use the average line where moisture preservation is provided for, but if moisture-density control and moisture preservation are provided for, use the lower line ( $0.47 LL + 2$ ) on 'Interrelationship of P.I. and Volume Change.'
- ◆ The determination of PVR in deep cut sections or deep side hill cuts presents a special case of this test method.
  - In the case of these two conditions, the material is surcharged in such a manner that the movement from swell is mostly in one direction
  - in some high rainfall areas could be greater than that obtained by use of these procedures.
- ◆ When layers of expansive clays of less than 0.6 m (2 ft.) exist, (Example: 1.2 to 1.4 m [4 to 4.6 ft.]) it is preferable to enter the abscissa of the proper swell curve at 1.2 and

1.4 m (4 and 4.6 ft.), respectively; and use the difference in the respective ordinate readings as the unmodified swell in the 0.2 m (0.6 ft.) thick layer.

- ◆ At optimum conditions the following relationships are valid from 'Interrelationship of P.I. and Volume Change':
  - Percent Volumetric swell at 6.9 kPa (1 psi) surcharge =  $0.217 (PI) - 2.9$ .
  - Percent free swell =  $0.232 (PI) - 0.5$ .
- ◆ For average conditions up to Plasticity Indexes of about 60, the following relationships are valid from 'Interrelationship of P.I. and Volume Change':
  - Percent Volumetric swell at 6.9 kPa (1 psi) surcharge =  $0.294 (P.I.) - 2.9$ .
  - Percent free swell =  $0.314 (P.I.) - 0.5$ .
- ◆ 'Relation of Load to the Volume Change of Swelling Clay Soil' giving Family Member Curves, will be useful in determining equivalent swell, such as where a cut is made through a swelling clay hillside.
  - For example, assume that in cutting through a clayey hillside, a soil representing 41.4 kPa (6 psi) load is removed.
  - The 54 P.I. Soil is found to have a moisture content near 0.2 LL + 9 (dry condition).
  - The percent volumetric swell, at 1 psi surcharge, from 'Interrelationship of P.I. and Volume Change,' (top curve) is 16%.
  - On 'Relation of Load to the Volume Change of Swelling Clay Soil,' plot the point, 6.9 kPa (1 psi) abscissa and 16% volumetric swell. This point is on, or slightly below, the 20% swell member curve.
  - Now add 41.4 kPa (6 psi) by moving parallel to the abscissa to the point 48.3 kPa (7 psi) abscissa and 16% volumetric swell. This point is on or about the 29.5% family member curve.
  - If necessary, sketch in this curve in pencil similar to the 30% curve and follow this curve upwards to where it crosses the 6.9 kPa (1 psi) load and then read 23.7% volumetric swell on the ordinate.
  - Using the formula, the % free swell (no load) =  $1.07 (23.7) + 2.6 = 28.0\%$ .
  - Conversely, if we load the 28% volumetric swell curve with 7 psi load, then the ordinate is 15.5% swell which compares to the original 16%.

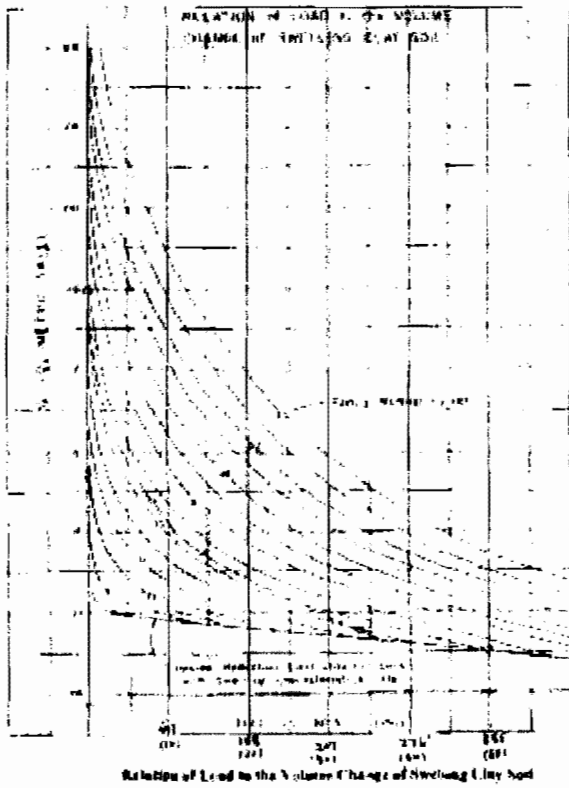

Figure 1-31. Relation of Load to the Volume Change of Swelling Clay Soil.



*This page left blank intentionally*

## **Appendix C: Construction Time Analysis Summary**

*This page left blank intentionally*

## **Appendix D: Agency Cost Analysis Summary**

*This page left blank intentionally*