

1. Report No. FHWA/TX-85/ +333-1F		2. Government Accession No.		3. Recipient's Catalog No.	
4. Title and Subtitle Small Car Interactions With Roadside Barriers Volume 1 -- Engineering Evaluation				5. Report Date January 1985	
				6. Performing Organization Code	
7. Author(s) Donald L. Woods				8. Performing Organization Report No. Research Report 333-1F	
9. Performing Organization Name and Address Texas Transportation Institute The Texas A&M University System College Station, Texas 77843				10. Work Unit No.	
				11. Contract or Grant No. Study No. 2-18-84-333	
12. Sponsoring Agency Name and Address Texas State Department of Highways and Public Transportation; Transportation Planning Division P. O. Box 5051 Austin, Texas 78763				13. Type of Report and Period Covered Final - September 1984 January 1985	
				14. Sponsoring Agency Code	
15. Supplementary Notes Research was performed in cooperation with DOT, FHWA. Research Study Title: Small Car Interactions With Highway Barriers.					
16. Abstract A detailed statistical analysis of Texas roadside barrier accidents in comparison with another state which uses the nationally accepted guard fence standard was conducted. Snagging on the unblocked out system used in Texas was not an obvious problem based on this data set, although vehicles under 2500 pounds in curb weight did have a 9 percent greater probability of rollover. The w-beam barrier redirects about 65 percent of the impacting vehicles and the expected increased severity with decreasing vehicle curb weight upon impact with a concrete safety shape could not be tested due to the very small number of concrete safety shape impacts in the Texas data set.					
17. Key Words Statistical analysis, accidents, roadside barriers.			18. Distribution Statement No restrictions. This document is available to the public through the National Technical Information Service, 5285 Port Royal Road, Springfield, Virginia 22161.		
19. Security Classif. (of this report) Unclassified		20. Security Classif. (of this page) Unclassified		21. No. of Pages 27	22. Price

SMALL CAR INTERACTIONS WITH ROADSIDE BARRIERS
VOLUME 1 -- ENGINEERING EVALUATION

By

Donald L. Woods
Research Engineer

Research Report 333-1F
Research Study Number 2-18-84-333
Small Car Interactions With Highway Barriers

Sponsored by

Texas State Department of Highways and Public Transportation
In cooperation with
U. S. Department of Transportation, Federal Highway Administration

SEPTEMBER
~~January~~ 1985

TEXAS TRANSPORTATION INSTITUTE
The Texas A&M University System
College Station, Texas

PREFACE

The accepted "wisdom" of roadside barrier design is the blocked out w-beam on strong posts (8x8 inch wooden or 6 pound per foot steel I-beam posts). The Texas barrier design, an unblocked out w-beam on a 7-inch round wooden post, was thought to have the potential for post snagging especially for smaller cars (i.e., those under 2500 pounds in vehicle curb weight). The Texas barrier design is stiffer than the typical weak post system in common use and weaker than the commonly accepted strong post blocked out w-beam barrier. The general consensus seems to be that the unblocked out Texas barrier is more nearly similar to the strong post system than the weak post concept. So strong was this impression that the Texas w-beam barrier was not included as an operational barrier in the 1977 AASHTO publication "A Guide For Selecting, Designing And Locating Traffic Barriers." This general impression combined with pressure from the Federal Government to adopt a blocked out design led to some concern that the increasing numbers of small cars in the traffic stream might experience a severity above and beyond that expected by the difference of weight alone upon impact with a w-beam barrier. This concern led to several problem statements which were ultimately expanded to include the concrete safety shape as well as the w-beam barrier. The concrete safety shape has been identified as having a higher percentage of rollover accidents with smaller, lighter, narrower wheel track modern vehicles.

Every effort was made from the beginning of the project to insure absolute objectivity in the data collection and analysis processes. The sample size was large enough to insure a minimum risk of an unreliable conclusion being reached. In addition, data from another state which uses the strong post blocked out system as a standard were obtained. Direct

comparison of the data from Texas barrier accidents and those from another state should reveal the more severe nature of barrier accidents with the Texas unblocked out system as compared to the blocked out strong post system of the other state, if indeed a greater severity does exist.

ABSTRACT

SMALL CAR INTERACTIONS WITH ROADSIDE BARRIERS

VOLUME 2 - - STATISTICAL EVALUATION

A detailed statistical analysis of Texas roadside barrier accidents in comparison with another state which uses the nationally accepted guard fence standard was conducted. Snagging on the unblocked out system used in Texas was not an obvious problem based on this data set, although vehicles under 2500 pounds in curb weight did have a 9 percent greater probability of rollover. The w-beam barrier redirects about 65 percent of the impacting vehicles and the expected increased severity with decreasing vehicle curb weight upon impact with a concrete safety shape could not be tested due to the very small number of concrete safety shape impacts in the Texas data set.

DISCLAIMER

The contents of this report reflect the views of the author, who is responsible for the accuracy of the material presented herein. The contents do not necessarily reflect the official views or policy of the Texas State Department of Highways and Public Transportation or the Federal Highway Administration. This report does not constitute a standard, specification, or regulation.

ACKNOWLEDGEMENTS

This work was sponsored by the Texas State Department of Highways and Public Transportation under Project 333. Special appreciation for assistance in achieving the project goals is expressed to the following persons:

Mr. Harold Cooner, SDHPT File D-8, for his support, concern, and guidance in the project.

Mr. C. P. Damon, Federal Highway Administration, for his suggestions on the conduct of this research.

Mr. Terry Palmer and Mr. Edwin Smith, SDHPT File D-18TS, who served as the Departmental Representatives on this project.

Mrs. Delores Grote, Department of Public Safety, who arranged for the data collection which made the analysis possible.

Dr. Bill Hunter, University of North Carolina, for his assistance in this project.

TABLE OF CONTENTS

PREFACE i

ABSTRACT iii

ACKNOWLEDGEMENTS iv

1.0 INTRODUCTION 1

2.0 SUMMARY OF STATISTICAL FINDINGS FROM VOLUME 2 2

3.0 ENGINEERING EVALUATION 4

4.0 RECOMMENDATIONS 11

5.0 APPENDIX 12

1.0 INTRODUCTION

This project was undertaken to determine if the increasing frequency of smaller cars in the traffic stream had an increased severity over larger cars upon impact with a w-beam barrier or a concrete safety shape. Supplemental areas of concern were the influence of terrain on barrier performance and, to the degree it was possible to do so, the performance of the various end treatments for w-beam barriers.

This report is Volume 1, Engineering Evaluation, and is based on the statistical findings reported in Volume 2, Statistical Analysis. The primary reason for dividing the research findings was the realization that the engineering user has little interest in the detailed statistical analysis, while the policy makers and research personnel are vitally interested in the statistical details. Volume 2 includes the statistical justification for Volume 1 with a listing of the statistical findings from that report. This same listing is presented in 2.0 below as the beginning point of the engineering evaluation of the statistical findings. Section 3.0 of this report discusses the ramifications of the statistical finding and section 4.0 is a summary of the recommendations from the study.

2.0 SUMMARY OF STATISTICAL FINDINGS FROM VOLUME 2

2.1 Guard Fence and Guardpost Accident Severity

The probability of injury in guard fence and guardpost accidents are significantly related to vehicle curb weight for all injury groupings except the severe injury plus fatal (A+K) group. The B thru K and the C thru K codes pooled show significant vehicle curb weight relationships to injury probability at the alpha level of 0.05 (See Section 4.2.2 of Volume 2).

2.2 Guard Fence Accidents Only Severity

Using only the guard fence accidents, the analysis of 4.3.3 revealed the same severity relationship to curb weight as for the combined guard fence and guardpost accident file. This finding suggests that the probability of injury in guardpost accidents is related to vehicle curb weight in the same manner as guard fence accidents (See Section 4.3.3 of Volume 2).

2.3 Vehicle Curb Weight Severity Changes

Vehicles with a curb weight under 2500 pounds had a significantly higher frequency of B severity injury accidents and a significantly lower frequency of PDO accidents for the guard fence accident population (See Section 4.3.3 of Volume 2).

2.4 Comparison of Texas W-Beam Barrier Accident Severity With Another State

There is no significant difference in the proportion of severe w-beam barrier accidents between Texas and another state for light or heavier vehicles. There was also no significant difference in the proportion of severe accidents between light and heavier vehicles within each state (See Section 4.5.3 of Volume 2).

There was a significant difference in PDO accident frequencies between light and heavy vehicles in both states. There was a significantly greater

proportion of PDO accidents for heavy vehicles than light vehicles. There was also a significant difference between the states in the proportion of PDO accidents for heavy vehicles, Texas having significantly fewer reported PDO accidents among heavy vehicles than the other state. There was no significant difference for light vehicle PDO accidents between the states.

2.5 Location of Barrier Hits - Median Barriers and Roadside Barriers

End hits with median barriers on roadside barriers, either metal or concrete, were too few to allow statistical testing of end impact severity (See Sections 4.5.5 and 4.5.6 of Volume 2).

2.6 Redirection Probability vs. Vehicle Curb Weight

Redirection of the vehicle for heavy vehicles (over 2,500 pounds curb weight) and light vehicles (under 2,500 pounds curb weight) upon impact with a w-beam barrier is not significantly different with about 65 percent of the impacts resulting in redirection for both curb weight classes (See Section 4.3.1 of Volume 2).

2.7 Accident Severity After Redirection

The lighter vehicles (less than or equal to 2500 pounds curb weight) which are redirected by a w-beam barrier had a significantly greater proportion of injury accidents than redirected heavier vehicles (See Table 4.3.6 of Volume 2).

There was no significant difference in the proportion of injury accidents between lighter and heavier vehicles for those vehicles which were not redirected (See Table 4.3.7 in Volume 2).

2.8 Rollover Probability vs. Vehicle Curb Weight

There was a significant relationship between the probability of rollover and vehicle curb weight. The proportion of light vehicles rolling over was 8.8 percentage points greater than the proportion of heavy vehicles that rolled over.

3.0 ENGINEERING EVALUATION

3.1 Discussion of Findings -- Texas Barrier Accidents and those from Another State.

3.1.1 Median Barrier (Metal Beam and Concrete) Accident Severity

Two basic tests of median barrier accident severity were conducted:

- (1) Severity frequency for heavy (>2500 pounds) and light (<2500 pounds) vehicles for each state, and
- (2) Comparison of accident severity between states.

The statistical evaluation of the median barrier accidents (combined metal beam and concrete) population found no significant difference in median barrier accident severity between heavy and light vehicles in either state as well as no significant differences between the Texas median barriers and similar barriers in another state. This finding was consistent when the serious injury plus fatal (A plus K) injuries were pooled and when all injury accidents were pooled. Figure 3.6 is a bar chart of accident severity upon impact with a median barrier (concrete or metal).

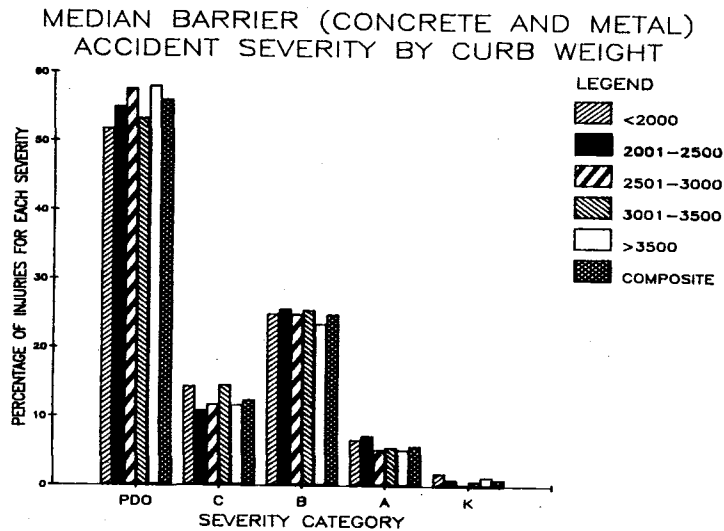

Figure 3.1

3.1.2 Guard Fence and Guardpost Accident Severity

The severity of accidents with the Texas w-beam barrier is significantly related to the vehicle curb weight at the alpha level of 0.01. Interestingly, the serious injury (A code) and fatal (K code) combined show no significant trends with vehicle curb weight. Individual cell analysis revealed that PDO accidents were significantly lower for lighter vehicles than the heavier ones and the moderate injuries (B code) were significantly higher. The effect of vehicle curb weight is then essentially a reduction in the PDO accidents and an increase in moderate injury (code B) accidents. Figure 3.7 illustrates the trends for the five curb weight categories used in this study.

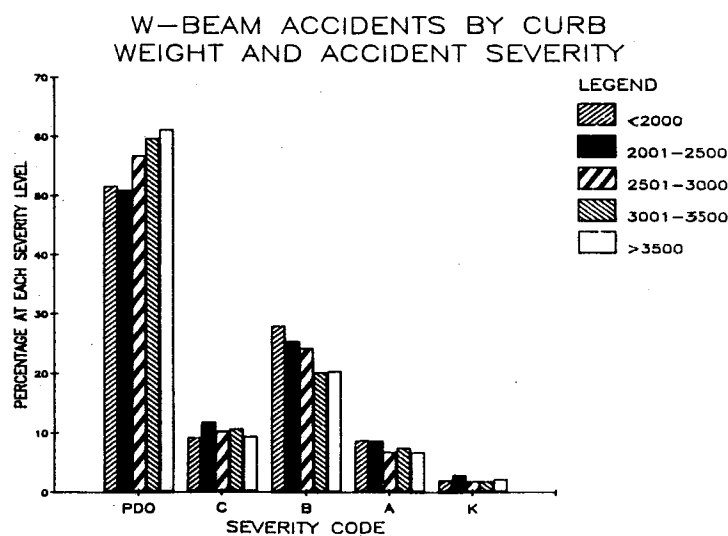

Figure 3.2

The population of w-beam barrier accidents was estimated by using the sample frequency of w-beam barrier accidents to total guard fence and guardpost accidents. This ratio was multiplied by the cell frequency of guard fence and guardpost accidents. The resulting w-beam guard fence accident data were then statistically analyzed. The findings indicate no meaningful differences in accident severity in the total guard fence and

guardpost population and the estimated guard fence population. This indicates that guardpost accidents are, for practical purposes, equally severe as guard fence accidents when struck by an errant vehicle. This comparison is presented in Figure 3.3.

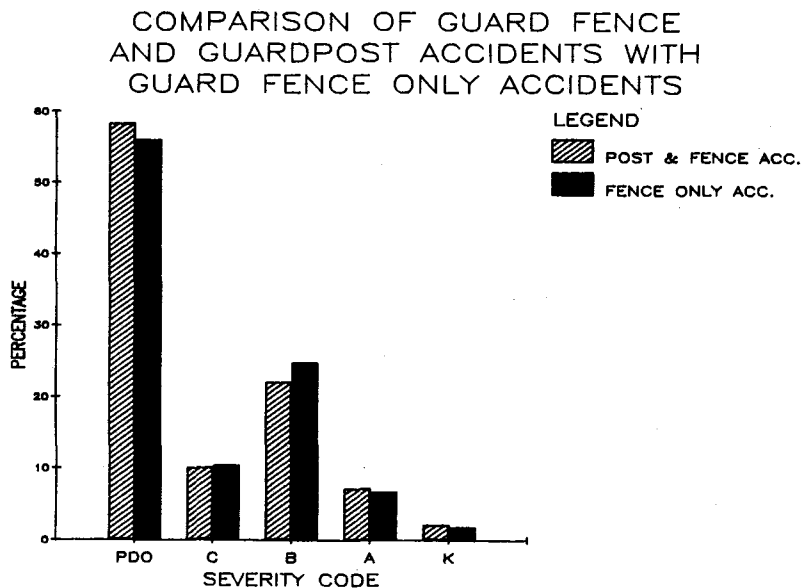

Figure 3.3

Since guardposts are intended primarily for delineation, the use of the post is questionable in this application. It is recommended that the standard use of guardposts be discontinued in favor of a less hazardous delineation system. Figure 3.4 is the logistic regression curve to estimate the injury probability for the Texas sample post and rail accidents.

The trends in the two years for which data were collected (i.e., 1981 and 1982) were examined to determine if a significant difference might exist between the annual data sets. All three years yield the same trend relationships and these relationships are not significantly different from the composite of all three year's data. The graphical presentation of this comparison is presented in Figure 3.5.

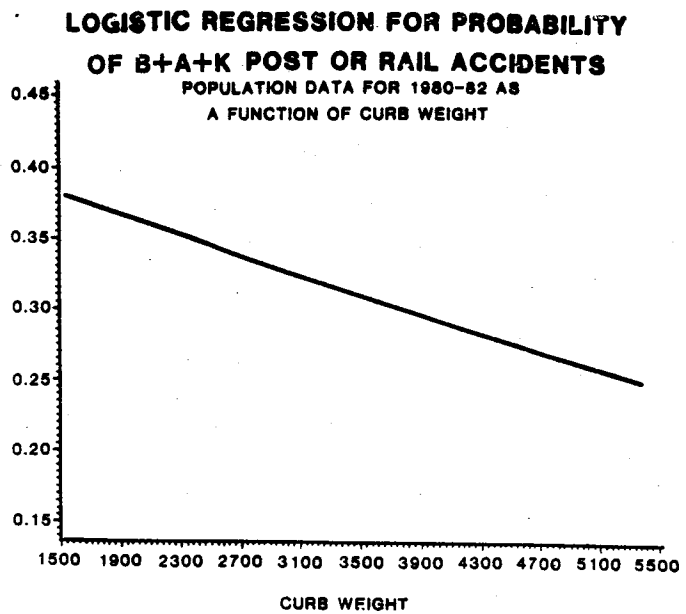

Figure 3.4

LOGISTIC REGRESSION FOR PROBABILITY OF POST OR RAIL ACCIDENTS

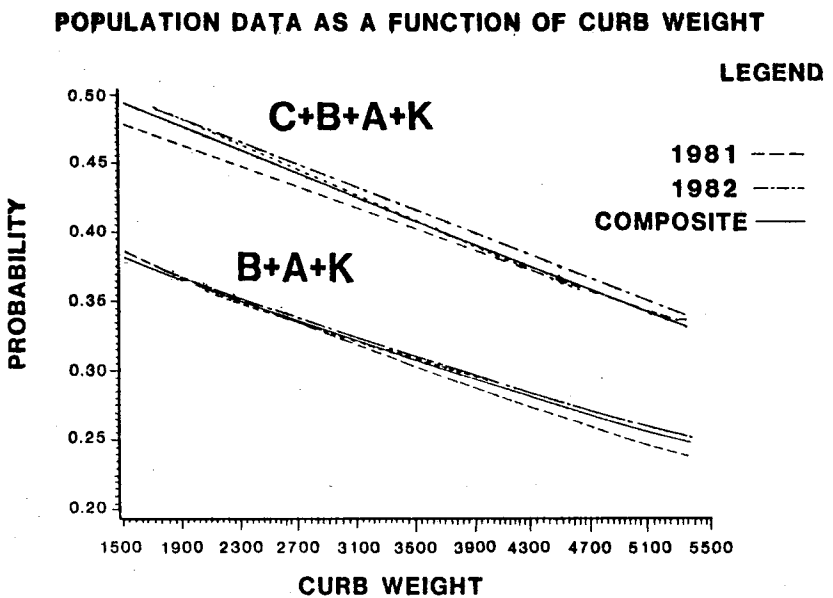

Figure 3.5

3.1.4 End Hits With Concrete Median Barriers

The end of the concrete safety shape represents a substantial object and has the potential for high severity collisions. An attempt to statistically test the severity between Texas and another state was unsuccessful as there were too few reported concrete shape end hits in the Texas data to allow statistical evaluation.

3.1.5 Redirection Capability Of The Texas W-Beam Barrier For Heavy And Light Cars

Another indicator of post snagging on the part of smaller cars would be a reduction in percentage of vehicles being redirected by the Texas w-beam barrier. The hypothesis was an increased frequency of post snagging and rollover for vehicles below 2500 pounds in curb weight. Table 3.2 contains the frequency and percentage data by the heavy and light vehicle groups.

Table 3.2

REDIRECTION AND OTHER POST IMPACT ACTIONS FOR FACE IMPACTS
WITH A W-BEAM ROADSIDE BARRIER
HEAVY (>2500 POUNDS) AND LIGHT (<2500 POUNDS)

WEIGHT CLASSIFICATION	REDIRECTED		OTHER	
	FREQ.	%	FREQ.	%
Equal To Or Less Than 2500 #	80	62	50	38
Greater Than 2500 #	281	67	133	33
Total	361		183	

While Table 3.2 does indicate a lower percentage of lighter vehicles being redirected (62% vs. 67%), the frequencies or percentages are not significantly different. Figure 3.6 graphically presents the findings of the redirection study.

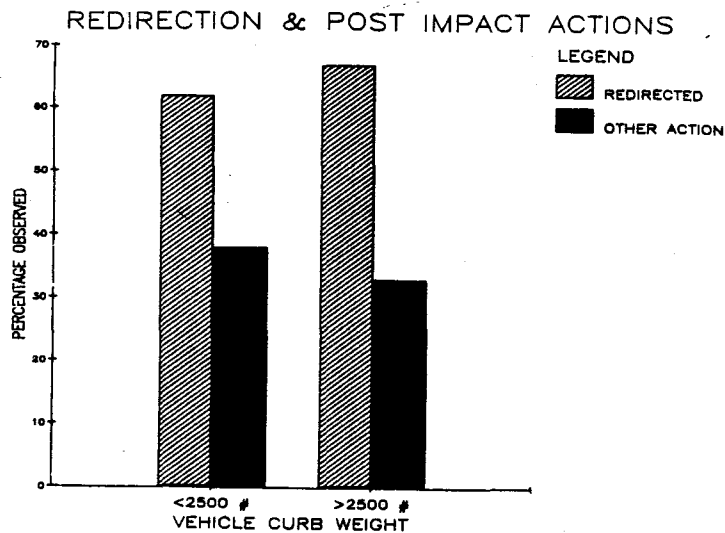

Figure 3.6

3.2.6 Accident Severity After Redirection

Redirection of the errant vehicle by the barrier does not necessarily reduce the severity of the event. The Texas sample data revealed that lighter vehicles (i.e., those under 2500 pounds) which are redirected by a w-beam barrier have a significantly greater accident severity than their heavier counterparts over 2500 pounds in curb weight. This difference, while being statistically significant, is not dramatically different and can be logically associated with the difference in vehicle curb weight. Figure 3.7 illustrates this relationship.

COMPARISON OF ACCIDENT SEVERITY LEVEL BY VEHICLE CURB WEIGHT

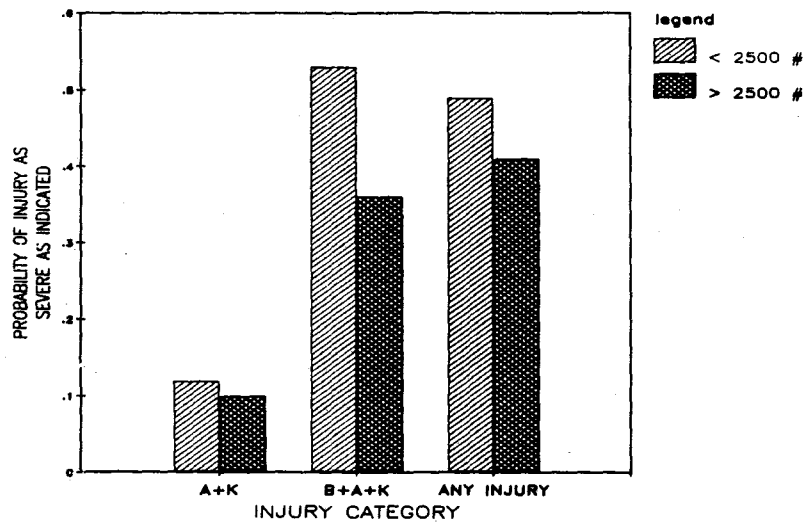

Figure 3.7

4.0 RECOMMENDATIONS

A detailed analysis of the Texas roadside guard fence performance in comparison with another state which uses the blocked, out strong post w-beam barrier revealed no truly significant trends which justify any recommendations for changes in present Texas barrier design standards. This finding is supported by the theoretical analysis of the expected decelerations of large and small vehicles presented in Appendix A. Smaller cars are involved in more severe barrier accidents but in no greater proportion than would be expected for the difference in weight. Some of the findings do justify suggestions for possible Departmental action:

1. The unexpectedly high severity of guardpost accidents suggests that their use should be discontinued and a more crashworthy delineation system be used in lieu of the guardpost.

2. ^{Texas} Guard fence accident severity combined with the fact that ~~one-third~~ ^{high} ~~number of~~ ~~of all reported incidents with the w-beam barrier result in the vehicles~~ going ~~over~~ ^{behind} the barrier and the lack of significant difference in the severity of the accident for redirected and nonredirected ^{under 2500 pounds} vehicles, suggests the need to minimize the amount of barrier used on all new designs and on redesign of older roadways. They also tend to indicate the desirability of removing unneeded barriers that are in place. ^{curb weight}

5.0 APPENDIX A

5.1 Guardrail Post Reaction on Cohesionless and Cohesive Soils

The purpose of this section was to compute the deceleration a car undergoes when it strikes a guardrail post. The first step was determining the maximum force that could be applied to a given post. Using the results from Broms (1964 a,b) on the general distribution of lateral earth pressures on piles, two analyses were made for cohesive and cohesionless soils. The soil characteristics used were based on the ones shown in the Texas Transportation Institute (TTI) Research Report 343-1 (pp. 117,122). A 7-inch diameter post embedded 38 inches in the ground was used in both analyses. The assumption was made that the guardrail post would behave like a short free-headed post (no plastic hinge would form). The guardrail was bolted to the post and it was assumed to tear out at a force of 13,700 lbs. Then using the equations $\text{Force} = \text{Mass} \times \text{Acceleration}$ and $\text{Weight} = \text{Mass} \times \text{Gravity}$, the deceleration of vehicles of different weights was found.

5.1.1 Cohesionless Soils

To compute the maximum force a post embedded in this type of soil could resist some information about the properties of the soil was required. These properties were the angle of internal friction and the unit weight of the soil. The angle of internal friction used in this problem was 50 degrees and the unit weight was 119 pcf. The general distribution of the lateral earth pressures used were the same as those given by Broms (1964a), shown in Figure 5.1. The area of the triangle is the resultant earth pressure, in this case 7,882 lbs. The magnitude and location of the forces that were applied to the guardrail post are shown in Figure 5.2. A summation of forces in the horizontal direction resulted in a maximum force the post could resist of 21,582 lbs.

POST PRESSURE DISTRIBUTION

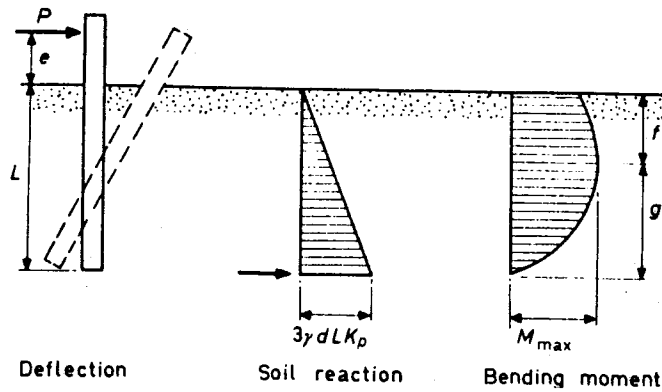

Figure 5.1

The deceleration a car undergoes was found using the equations $F = M \times A$ and $WT = M \times G$. These equations were solved for different car weights; in this case, a 2250 lb car was used. By solving these equations the deceleration was found to be 308.86 ft/sec^2 or 9.59 g's.

LOCATION OF FORCES FOR GUARD FENCE POST COHESIONLESS SOILS

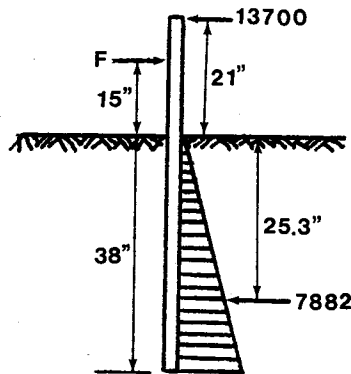

Figure 5.2

The deceleration was found for different car weights. To show how it changes, a graph was plotted and is shown in Figure 5.3.

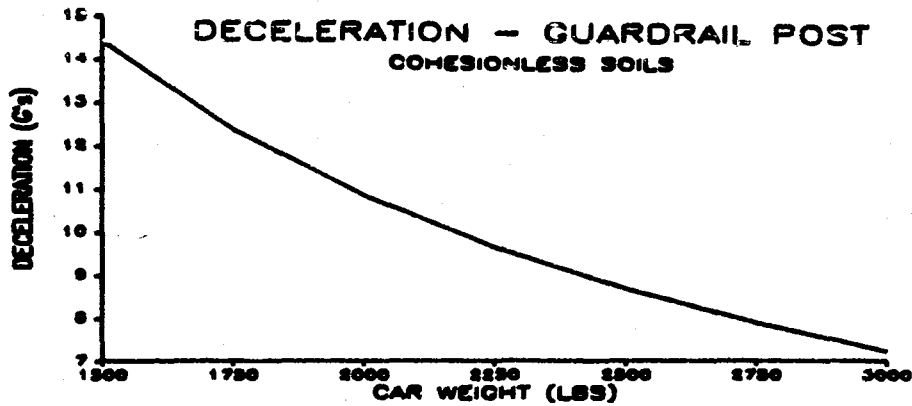

Figure 5.3

Resultant earth pressure:

$$\begin{aligned}
 K_p &= (1 + \sin 0) / (1 - \sin 0) \\
 &= (1 + \sin 50) / (1 - \sin 50) \\
 &= 7.54
 \end{aligned}$$

$$\begin{aligned}
 P &= (\text{base} \times \text{height}) / 2 \\
 &= 0.5 \times ((3 \times 119 \times (38/12) \times (7/12) \times 7.54) \times (38/12)) \\
 &= 7,883 \text{ lbs}
 \end{aligned}$$

Summation of horizontal forces:

$$-13,700 \text{ lbs} - 7,882 \text{ lbs} + F = 0$$

$$F = 21,582 \text{ lbs}$$

=====

Computing the deceleration:

$$M = 2,250 \text{ lbs} / (32.2 \text{ ft/sec}^2)$$

$$A = F / M$$

$$A = 21,582 \text{ lbs} / (2,250 \text{ lbs} / 32.2 \text{ ft/sec}^2)$$

$$A = 308.86 \text{ ft/sec}^2 \text{ or } 9.59 \text{ g's}$$

=====

5.1.2 Cohesive Soils

Cohesive soils have a different distribution of lateral earth pressures than cohesionless soil. The distribution of lateral earth pressures used were the same as those given by Broms (1964b) shown in Figure 5.4.

FORCE AND MOMENT DISTRIBUTION FOR GUARDPOST IN COHESIVE SOILS

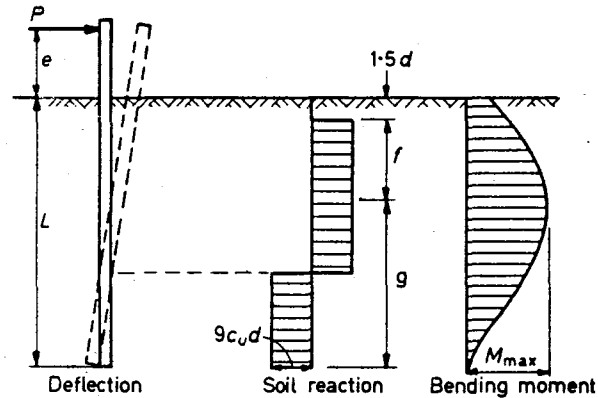

Figure 5.4

To compute the maximum resisting force, the only soil characteristic required was the soil shear strength; in this case, 2000 psf was used. First, the depth to the center of rotation of the post was found. This was done using the procedure shown in the TTI research report 343-1 (pp. 80). The procedure is a trial and error approximation of the depth to the center of rotation. A depth is assumed and the moment about the point of application of the force is computed. If the moment is non-zero, a new depth to the center of rotation is assumed. The procedure is repeated until the moment is within tolerance limits. In this case, the depth to the center of rotation was about 26.5 inches. Second, the area of both rectangles was calculated. The magnitude and location of the forces applied to the guardrail post embedded in cohesive soils are shown in Figure 5.5. A summation of

horizontal forces resulted in a maximum lateral load of 17,637 lbs. Finally, the deceleration was found in the same manner as for cohesive soils. For the 2250 lb car used in this problem, the deceleration was 7.84 g's.

FORCE LOCATION FOR GUARD FENCE POST IN
COHESIONLESS SOILS

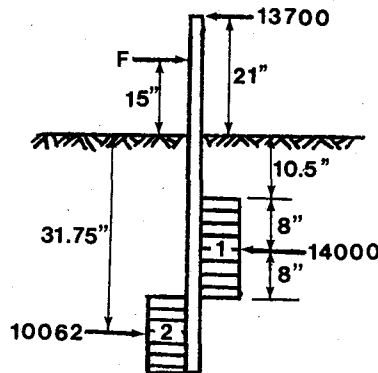

Figure 5.5

Finding the depth to the center of rotation by trial and error solution:

First trial 26 inches

Area of rectangle 1:

$$A_1 = 9 \times 2,000 \times 7/12 \times (26 - (1.5 \times 7))/12$$

$$= 13,562.5$$

Area of rectangle 2:

$$A_2 = 9 \times 2,000 \times 7/12 \times (38 - 26)/12$$

$$= 10,500$$

Summation of moments:

$$10,600 \times (26 + 15 + 12/2) = 13,563 \times (15 + 10 + 15.5/2)$$

$$493,500 = 450,953$$

Second trial at 27 inches from the surface

Area of rectangle 1:

$$A1 = 9 \times 2,000 \times 7/12 \times (27 - 10.5)/12$$

$$= 14,437.5$$

Area of rectangle 2:

$$A2 = 9 \times 2,000 \times 7/12 \times (38 - 27)/12$$

$$= 9,625$$

Summation of moments:

$$9,625 \times (27 + 15 + 11/2) = 14,438 \times (15 + 10.5 + 16.5/2)$$

$$457,188 = 487,265$$

Since from the summation of moments the center of rotation was found to be between 26 inches and 27 inches, 26.5 inches was used in this problem.

Resultant earth pressures:

$$\text{Rectangle 1} = 9 \times 2,000 \times 7/12 \times 16/12$$

$$= 14,000 \text{ lbs}$$

$$\text{Rectangle 2} = 9 \times 2,000 \times 7/12 \times 11.5/2$$

$$= 10,063 \text{ lbs}$$

Summation of horizontal forces:

$$-13,700 \text{ lbs} - 14,000 \text{ lbs} + 10,063 \text{ lbs} - F = 0$$

$$F = 17,637 \text{ lbs}$$

$$=====$$

Computing the deceleration:

$$M = 2,250 \text{ lbs} / 32.2 \text{ ft/sec}^2$$

$$A = F / M$$

$$A = 17,637 \text{ lbs} / (2,250 \text{ lbs} / 32.2 \text{ ft/sec}^2)$$

$$A = 252.4 \text{ ft/sec}^2 \text{ or } 7.84 \text{ g's}$$

$$=====$$

The deceleration changes for different car weights; to show this, a graph was plotted. The graph is shown in Figure 5.6.

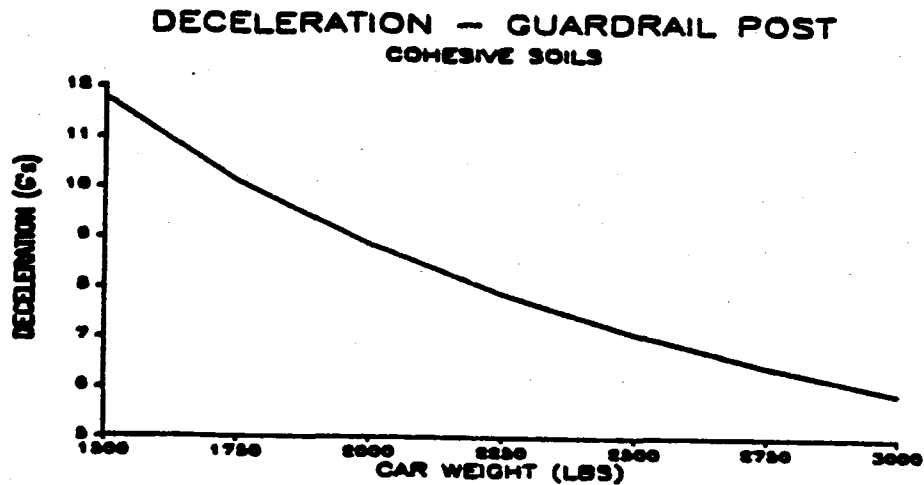

Figure 5.6

5.2 Post Reaction on Cohesionless and Cohesive Soils

The purpose of this section was to compute the deceleration a car undergoes when it strikes a post. This was basically the same problem as with the guardrail post except the post was not bolted. The same type of posts (7-inch in diameter and embedded 38 inches) was used. Also the soil properties were the same (cohesive soil: shear strength of 2,000 psf, and cohesionless soil: angle of internal friction of 50 degrees and unit weight of 119 pcf) soil conditions were used as with the guardrail posts. This was done so that the soil reactions computed for the guardrail posts embedded in cohesive and cohesionless soils could be used. Since the posts were not bolted, the summation of horizontal forces and the deceleration changed.

5.2.1 Cohesionless Soils

The resultant earth pressure for cohesionless soils was computed for the guardrail posts to be 7,882 lbs. A summation of horizontal forces

resulted in a maximum force the post could resist of 7,882 lbs. For the 2250 pound car used in this problem, the deceleration was found to be 3.5 g's.

Summation of horizontal forces:

$$-7,882 \text{ lbs} + F = 0$$

$$F = 7,882 \text{ lbs}$$

=====

Computing the deceleration:

$$M = 2,250 \text{ lbs} / (32.2 \text{ ft/sec}^2)$$

$$A = F / M$$

$$A = 7,882 \text{ lbs} / (2,250 \text{ lbs} / 32.2 \text{ ft/sec}^2)$$

$$A = 117.7 \text{ ft/sec}^2 \text{ or } 3.5 \text{ g's}$$

=====

The deceleration can be solved for different car weights. To show how it changes, a graph was plotted and is shown in Figure 5.7.

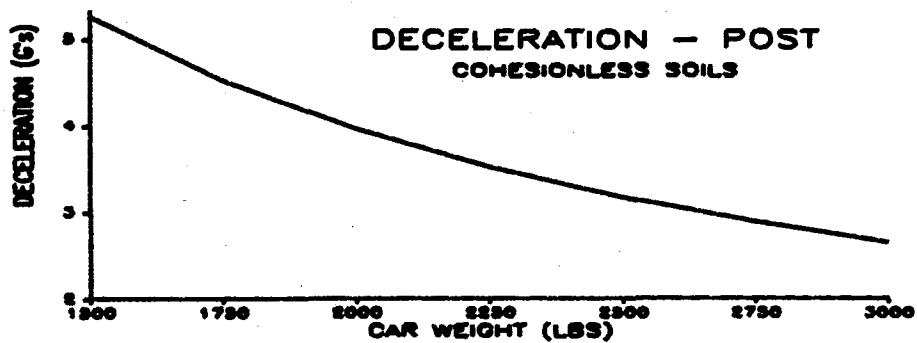

Figure 5.7

5.2.2 Cohesive Soils

The resultant earth pressures for cohesive soils computed for the guardrail post were 14,000 lbs for rectangle 1 and 10,062 lbs for rectangle 2. A summation of forces in the horizontal direction resulted in a maximum force the post could resist of 3,938 lbs.

Summation of horizontal forces:

$$-14,000 \text{ lbs} + 10,062 \text{ lbs} + F = 0$$

$$F = 3,938 \text{ lbs}$$

=====

Computing the deceleration:

$$A = 2,250 \text{ lbs} / (32.2 \text{ ft/sec}^2)$$

$$A = F / M$$

$$A = 56.36 \text{ ft/sec}^2 \text{ or } 1.75 \text{ g's}$$

=====

The deceleration can be solved for different car weights. To show how it changes with different car weights a graph was plotted and is shown in Figure 5.8.

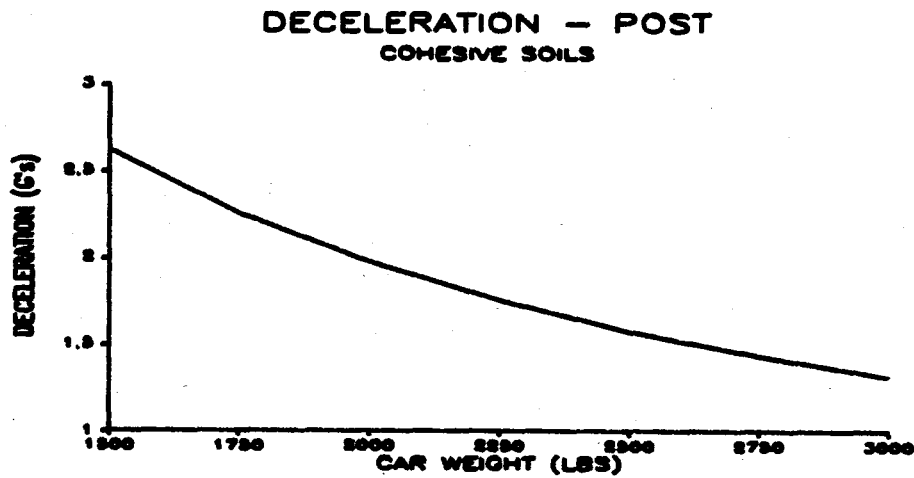

Figure 5.8

1. Report No. FHWA/TX-85/ +333-1F		2. Government Accession No.		3. Recipient's Catalog No.	
4. Title and Subtitle Small Car Interactions With Roadside Barriers Volume 2 -- Statistical Evaluation				5. Report Date January 1985	
				6. Performing Organization Code	
7. Author(s) Olga Pendleton, Mark Von Tress and Donald L. Woods				8. Performing Organization Report No. Research Report 333-1F	
9. Performing Organization Name and Address Texas Transportation Institute The Texas A&M University System College Station, Texas 77843				10. Work Unit No.	
				11. Contract or Grant No. Study No. 2-18-84-333	
12. Sponsoring Agency Name and Address Texas State Department of Highways and Public Transportation; Transportation Planning Division P. O. Box 5051 Austin, Texas 78763				13. Type of Report and Period Covered Final - September 1984 January 1985	
				14. Sponsoring Agency Code	
15. Supplementary Notes Research performed in cooperation with DOT, FHWA. Research Study Title: Small Car Interactions with Highway Barriers.					
16. Abstract <p>A detailed statistical analysis of Texas roadside barrier accidents in comparison with another state which uses the nationally accepted guard fence standard was conducted. The object of the statistical evaluation of accident data was to identify any deficiencies in the Texas guard fence design for small cars.</p> <p>No practical difference in the performance of the the Texas guard fence when compared with the national standard design of another state were found. Snagging on the unblocked out system used in Texas was not an obvious problem, based on the data set. The w-beam barrier redirects about 60 percent of the impacting vehicles.</p>					
17. Key Words Roadside barrier accidents, W-beam barrier.			18. Distribution Statement No restrictions. This document is available to the public through the National Technical Information Service, 5285 Port Royal Road, Springfield, Virginia 22161.		
19. Security Classif. (of this report) Unclassified		20. Security Classif. (of this page) Unclassified		21. No. of Pages 42	22. Price

SMALL CAR INTERACTIONS WITH ROADSIDE BARRIERS
VOLUME 2 -- STATISTICAL EVALUATION

By

Olga Pendleton
Research Statistician

Mark Von Tress
Research Assistant

and

Donald L. Woods
Research Engineer

Research Report 333-1F
Research Study Number 2-18-84-333
Small Car Interactions With Highway Barriers

Sponsored by

Texas State Department of Highways and Public Transportation
In cooperation with
U. S. Department of Transportation, Federal Highway Administration

January 1985

TEXAS TRANSPORTATION INSTITUTE
The Texas A&M University System
College Station, Texas

PREFACE

The accepted "wisdom" of roadside barrier design is the blocked out w-beam on strong posts (8x8 inch wooden or 6 pound per foot steel I-beam posts). The Texas barrier design, an unblocked out w-beam on a 7 inch diameter round wooden post, was thought to have the potential for post snagging especially with smaller cars (i.e., those under 2500 pounds in curb weight). The Texas barrier design is stiffer than the weak post systems used in other states and weaker than the strong post system which is the national standard. The general consensus seemed to be that the unblocked out Texas design was more similar to the strong post system than the weak post system. So strong was this opinion, that the Texas barrier was excluded as an operational system in the 1977 publication by AASHTO " A Guide For Selecting, Designing, And Locating Traffic Barriers". This general impression, combined with increasing pressure from the Federal Government to adopt a blocked barrier standard, led to several concerns as to the adequacy of the Texas design. This was especially true for smaller modern cars. Several problem statements were combined into a single proposal which included w-beam and concrete safety shape roadside barriers which resulted in this project.

Every effort was made from the beginning of the project to insure absolute objectivity in the data collection and analysis processes. The sample sizes were large enough to insure a minimum risk of reaching an unreliable conclusion. In addition, data from another state which used the national standard w-beam barrier were obtained. Direct comparison of the two data sets should reveal any deficiencies in the Texas Barrier design, if indeed any such deficiencies do exist.

ABSTRACT

SMALL CAR INTERSECTIONS WITH ROADSIDE BARRIERS

VOLUME 2 - - STATISTICAL EVALUATION

A detailed statistical analysis of Texas roadside barrier accidents in comparison with another state which uses the nationally accepted guard fence standard was conducted. The object of the statistical evaluation of accident data was to identify any deficiencies in the Texas guard fence design for small cars.

No practical difference in the performance of the the Texas guard fence when compared with the national standard design of another state were found. Snagging on the unblocked out system used in Texas was not an obvious problem, based on the data set. The w-beam barrier redirects about 60 percent of the impacting vehicles.

DISCLAIMER

The contents of this report reflect the views of the authors, who are responsible for the accuracy of the material presented herein. The contents do not necessarily reflect the official views or policy of the Texas State Department Of Highways And Public Transportation or the Federal Highway Administration. This report does not constitute a standard, specification, or regulation.

ACKNOWLEDGEMENTS

This work was sponsored by the Texas State Department of Highways and Public Transportation under Project 333. Special appreciation for assistance in achieving the project goals is expressed to the following persons:

Mr. Harold Cooner, SDHPT File D-8, for his support, concern and guidance in this project.

Mr. C. P. Damon, Federal Highway Administration, for his suggestions on the conduct of this research.

Mr. Terry Palmer and Mr. Edwin Smith, SDHPT File D-18TS, who served as the Departmental contact persons on this project.

Mrs. Delores Grote, Department Of Public Safety, who arranged for the data collection which made the analysis possible.

Dr. Bill Hunter, University Of North Carolina, for his assistance in this project.

TABLE OF CONTENTS

	Preface.....	i
	Abstract.....	ii
	Disclaimer.....	ii
	Acknowledgements.....	ii
	Table Of Contents.....	iii
	List Of Tables.....	iv
	List Of Figures.....	vi
1.0	INTRODUCTION.....	1
2.0	EXPERIMENTAL DESIGN.....	1
2.1	The Basic Data Files.....	1
2.2	Sampling Strategy.....	2
2.2.1	Problem With The Texas Accident File.....	3
3.0	RESEARCH METHODOLOGY.....	4
3.1	The Basic Comparisons.....	4
4.0	TEXAS AND OTHER STATE BARRIER ACCIDENT COMPARISON.....	6
4.1	Introduction	6
4.2	Sampling And Estimation Procedure.....	8
4.2.1	Down Weighting Population Values Based On Sample Data.....	8
4.2.2	Severity Analysis Of Accidents Based On 80-82 Texas Population	11
4.2.2.1	Guardpost And Guard Fence Accidents.....	11
4.2.2.2	Median Barrier Accidents.....	18
4.3	W-Beam Barriers.....	18
4.3.1	Vehicle Action Analysis (metal guard fence accidents only)....	18
4.3.2	Location Of Barrier Impacts Analysis (metal guard fence accidents only).....	23
4.3.3	Severity Analysis (metal guard fence accidents only).....	24
4.4	Concrete Median Barrier Analysis.....	25
4.5	Comparison With Another State.....	26
4.5.1	All Median Barrier Accidents.....	26
4.5.2	Concrete Median Barrier Accidents.....	27
4.5.3	All Roadside Barriers.....	27
4.5.4	Metal Roadside Guard Fence Only Accidents.....	28
4.5.5	Location Of Barrier Impacts - Median Barriers.....	29
4.5.6	Location Of Barrier Impacts - Roadside Guard Fence.....	31
5.0	SUMMARY OF STATISTICAL FINDINGS.....	33
5.1	Guardrail And Guardpost Accident Severity.....	33
5.2	Guardrail Accidents Only Severity.....	33
5.3	Vehicle Curb Weight Accident Severity Changes.....	33
5.4	Comparison Of Texas W-Beam Accident Severity With Another State.....	33
5.5	Location Of Barrier Hits - Median Barriers And Roadside Barriers.....	33
5.6	Redirection Probability vs. Vehicle Curb Weight.....	33
5.7	Accident Severity After Redirection.....	34
5.8	Rollover Probability vs. Vehicle Curb Weight.....	34
6.0	SUMMARY OF BASIC COMPARISONS FINDINGS.....	35

LIST OF TABLES

TABLE NO.	TITLE	PAGE
4.2.1	Proportion Structure In The Population Table Of Curb Weight By Severity For Guardpost Or Guardrail Accidents.....	9
4.2.2	Median Barrier Accident Frequency Data From Texas 1980 Thru 1982 By Vehicle Curb Weight And Accident Severity.....	9
4.2.3	Estimated Proportion Of Guardrail Accidents Based On Sample.....	10
4.2.4	Estimated Rail Only Accidents Based On Sample.....	10
4.2.5	Estimated Proportion Of Concrete Median Barrier Accidents.....	10
4.2.6	Estimated Frequency Of Concrete Median Barrier Accidents.....	11
4.2.7	Proportion Of Guardpost And Guardrail Accidents By Severity Classification.....	11
4.2.8	Logistic Regression Of Guardpost And Guard Fence Injury Probability.....	15
4.2.9	Median Barrier Accident Severity By Vehicle Weight.....	18
4.3.1	Probability Of Vehicle Action After W-Beam Rail Accident.....	19
4.3.2	Texas Sample Data Accident Frequencies Of Vehicle Action By Curb Weight - W-Beam Barriers.....	19
4.3.3	Logistic Regression Results For Vehicle Action.....	19
4.3.4	Redirection vs. Vehicle Curb Weight.....	22
4.3.5	Redirection Only.....	22
4.3.6	Not Redirected.....	23
4.3.7	Probability Of Impacting Vehicle Hitting The Face (Middle) And The End Or Back Of The Rail.....	23
4.3.8	Table Of Accident Frequency By Location Of The Barrier For W-Beam Rail.....	24
4.3.9	Statistical Comparison Of Metal Beam Guard Fence Accident Severity.....	24
4.3.10	Contribution To Chi-Square From Each Cell.....	24
4.4.1	Probability Of Vehicle Action Given An Impact With A Concrete Median Barrier.....	25
4.4.2	Frequency Of Various Vehicle Actions On Impact With A Concrete Median Barrier.....	26

4.5.1	Median Barrier Accidents 1982 Texas vs. Another State.....	26
4.5.2	Concrete Median Barrier Accidents For Texas And Another State 1982.....	27
4.5.3	Roadside Barrier Accidents 1982 Texas vs. Another State.....	27
4.5.4	Roadside Barrier (A + K) Accident Proportion For 1982 Texas And Another State.....	28
4.5.5	Metal Roadside Barrier Accidents (face and end hits) For The Other State.....	28
4.5.6	Estimated Proportion Of Metal Guard Fence Accidents In Texas (weights).....	29
4.5.7	Estimated Frequency Of Metal Roadside Barrier Accidents In Texas	29
4.5.8	End Hits For Other State Median Barrier.....	29
4.5.9	Texas Concrete Barrier End Hits.....	30
4.5.10	Face Hits For Other State Median Barrier.....	30
4.5.11	Face And End Hit Frequencies Of Roadside Barrier From Another State.....	31
4.5.12	Estimated Texas Metal Beam Guard Fence Accident Frequencies For Face And End Hits.....	31
4.5.13	Proportion Of A + K Injuries For Texas And Other State Metal Beam Guard Fence Accidents - Face And End Hits.....	32

LIST OF FIGURES

FIGURE NO.	TITLE	PAGE
4.1	Data Flow Diagram Post Or Rail Accidents.....	6
4.2	Data Flow Diagram Median Barrier Accidents.....	7
4.3	Frequency Of Accident Level PDO.....	12
4.4	Frequency Of Accident Level C.....	12
4.5	Frequency Of Accident Level B.....	13
4.6	Frequency Of Accident Level A.....	13
4.7	Frequency Of Accident Level K.....	14
4.8	Logistic Regression For Probability Of C + B + A + K Post Or Rail Accident.....	16
4.9	Logistic Regression For Probability Of B + A + K Post Or Rail Accident.....	17
4.10	Logistic Regression For Probability Of Going Over The Barrier Or Rolling Over.....	20
4.11	Logistic Regression For Probability Of Rollover.....	21
4.12	Vehicle Curb Weight vs. Probability Of Injury Redirected Or Not Redirected.....	23

1.0 INTRODUCTION

1.1 Purpose of Volume 2

A detailed statistical analysis of the Barrier accident data may be of limited interest to the engineering professional. It is very important to support the engineering interpretation of the statistical findings. For this reason, the final report has been divided into two reports: Volume 1 is entitled "Small Car Interactions with Roadside Barriers -- Engineering Evaluation" and Volume 2, "Small Car Interactions with Roadside Barriers -- Statistical Analysis." Volume 1 accepts the findings of the statistical analysis included in Volume 2 and attempts to provide reasonable engineering interpretation and recommendations to overcome any deficiencies identified in the Texas barrier designs. Volume 2 contains the detailed data and statistical analysis to support the findings used as the beginning point for the engineering analysis and recommendations presented in Volume 1.

The purpose of Volume 2 is to provide the detailed statistical analysis of the three basic data sets and to arrive at findings that can be supported by the data with reasonable engineering certainty.

2.0 EXPERIMENTAL DESIGN

2.1 The Basic Data Files

Three basic data sets were utilized in this study. These are:

1. Texas Barrier and Guardpost Accident Population for 1980, 1981, and 1982.
2. Another State's Barrier Accident Population Data for 1982.
3. A Statistically designed Subsample of the Texas Barrier and Guardpost Accidents (Sample Data).

Throughout the text, the names underlined above are used to refer to the data set being considered.

2.2 Sampling Strategy

The primary data sets 1 and 2 are the complete data files for the time period indicated. Data Set number one, the Texas Barrier and Guard Post accident file, is not coded so as to allow automated separation of barrier or guard post incidents and end hits and face-of-the-barrier hits could not be distinguished. Thus, direct comparison of the Texas Barrier and Guard Post accident file with the more detailed data of the other state was not possible with regard to the subgroupings of location of the barrier hit or separation of guard post and barrier.

To overcome this deficiency of the Texas Accident coding system, a sampling scheme was devised which would reflect, on a quasi-random basis, the distribution of vehicle curb weights observed in the complete accident file. The sampling concept involved four steps:

1. Determine the frequency of vehicles impacting a barrier or guard post in the Texas 1980, 1981, and 1982 files by vehicle curbweight and severity.
2. Randomly select accidents in a manner that would insure that the same percentage exists in each vehicle weight group and severity category as in the original Texas Barrier Accident Population file.
3. Pull the hard copy of the accident report and subclassify each accident according to the barrier type and location of impact.
4. Expand the sample data to estimate the population data and compare these results with the data obtained from the other state.

Theoretically, the frequencies resulting from this procedure would be unbiased estimates of the population of accidents in each category and thus could be directly compared to the more detailed barrier data obtained from another state. However, this sampling procedure had to be modified due to the sample size economical limitations and the low frequency of fatal accidents in the data set. Within the economic scope of the project, a limited number of hard copies could be pulled representing less than 14 percent of the population. A truly random sample could have resulted in extremely low numbers of fatal and severe injury accidents.

To overcome this deficiency, all fatal barrier related accidents were included in the sample. Two replicate samples were extracted from the computerized Department of Public Safety (DPS) data file. These samples contained a distribution of vehicle curb weights matching the barrier accident population data and all fatal barrier accidents.

2.2.1 Problem with the Texas Accident File

The original concept of the data reduction was to have DPS personnel extract the needed information from the microfilm file, thus eliminating the need for expensive hardcopy. Coding procedures were devised and the DPS staff trained in using the procedures. Since the data derived for Sample One resulted in too small a population, Sample Two was submitted for data coding. After both sets of sample data had been received, they both included the fatal barrier related accidents. In removing the fatal accidents from Sample Two during the data set merging process, a direct comparison of the accuracy of the coding procedures was possible. The results were very discouraging. Radical differences were uncovered in the coding of the same incident. As an example, an incident was coded as a "hit barrier face and redirected" accident in Sample One and a "hit back of barrier" accident in Sample Two. It was apparent that the data set prepared by the DPS personnel from the original accident reports were not adequate for the evaluation process.

The DPS was asked to print a hardcopy of every barrier accident in both samples. This resulted in a \$3,000 additional cost and about a 3-month delay in the project analysis process. Each hardcopy accident was reviewed by two project team members and the coding process was repeated in its entirety. In addition to guard post accidents, certain other accidents were eliminated for the following reasons:

1. The impact angle was more than 45° (i.e., head on hit).
2. The vehicle was spinning out of control on impact.
3. The barrier impact was a secondary impact rather than the primary event.
4. The necessary data were not available on the accident form.

In the resulting data set, the Texas Sample Set, the frequency of barrier face impacts and barrier end impacts in each vehicle curb weight classification and for each accident severity code was determined. The resulting frequencies for the Texas Sample Set of vehicle curbweight by severity did not reflect the Texas Barrier Accident Population file after this data screening procedure. The bias was in the direction of more fatal and severe small car accidents being included in the sample than was evident in the population. A down weighting procedure was used to adjust the population severity curbweight frequencies by the barrier location and guard post or barrier ratios based on the sample. This procedure yielded estimated frequencies which could be compared to the more detailed data available from the other state preserving the severity-curbweight distribution of the Texas Population. More detail on this down weighting procedure is presented in 4.2.

3.0 RESEARCH METHODOLOGY

3.1 The Basic Comparisons

The research methodology involved a fundamental study of six basic questions:

1. Is the accident severity with the Concrete Safety Shape the same in Texas as for the other state? Any difference noted here would suggest a difference in coding of the accidents as the shape used by Texas and the other state are identical.

H_0 : There is no significant difference in the proportions of Concrete Safety Shape Barrier Accidents by severity in Texas and another state.

2. Is the w-beam accident severity by vehicle curb weight class the same for Texas Barrier accidents as compared to another state?

H_0 : There is no significant difference in the accident severity level proportions of w-beam barrier accidents between Texas and another state.

3. Is there a difference in the w-beam barrier end impact between Texas and another state? Texas has a combination of twisted and buried end treatments and standup ends, and the other state had a combination of Breakaway cable Terminal end treatments and standup ends.

H_0 : There is no significant difference in the proportion of w-beam barrier end accidents by severity between Texas and another state.

4. Is there a significant difference in accident severity or barrier performance between front wheel drive vehicles and rear wheel drive vehicles?

H_0 : There is no significant difference in the proportion of accidents by severity or barrier performance between vehicles with front wheel drive and those with rear wheel drive.

5. What are the significant terrain and barrier design features on w-beam barrier performance?

H_0 : None of the terrain, slope in front of the barrier, curb present, etc., and/or barrier design features, block out and steel or wooden, etc., contribute significantly to predicting the performance of the barrier.

6. What is the relationship between the lateral distance from the edge of the traffic lane to the barrier and the angle of impact with the barrier?

H_0 : There is no relationship between the lateral distance from the edge of the traffic lane to the barrier and the angle of impact with the barrier.

The null hypotheses have been formulated such that they will be rejected when they are true, constituting a Type I error, alpha, 10 percent of the time. The term "highly significant" will refer to testing H_0 at an alpha level of .05.

The data are both continuous and categorical and thus a variety of test statistics were used in the analysis. Each is presented when it is used in the report.

4.0 TEXAS AND OTHER STATE BARRIER ACCIDENTY COMPARISON

4.1 Introduction

The data obtained from the Department of Public Safety as previously described were processed as illustrated in Figure 4.1 and 4.2. In general, the sample data were used to adjust the cell frequencies of the population data in order to make them directly comparable to the data obtained from another state, as described in Section 4.2. The analysis presented in the remaining sections contains justification for the findings presented in Section 6.0 of this report and in Section 2.0 of Volume 1.

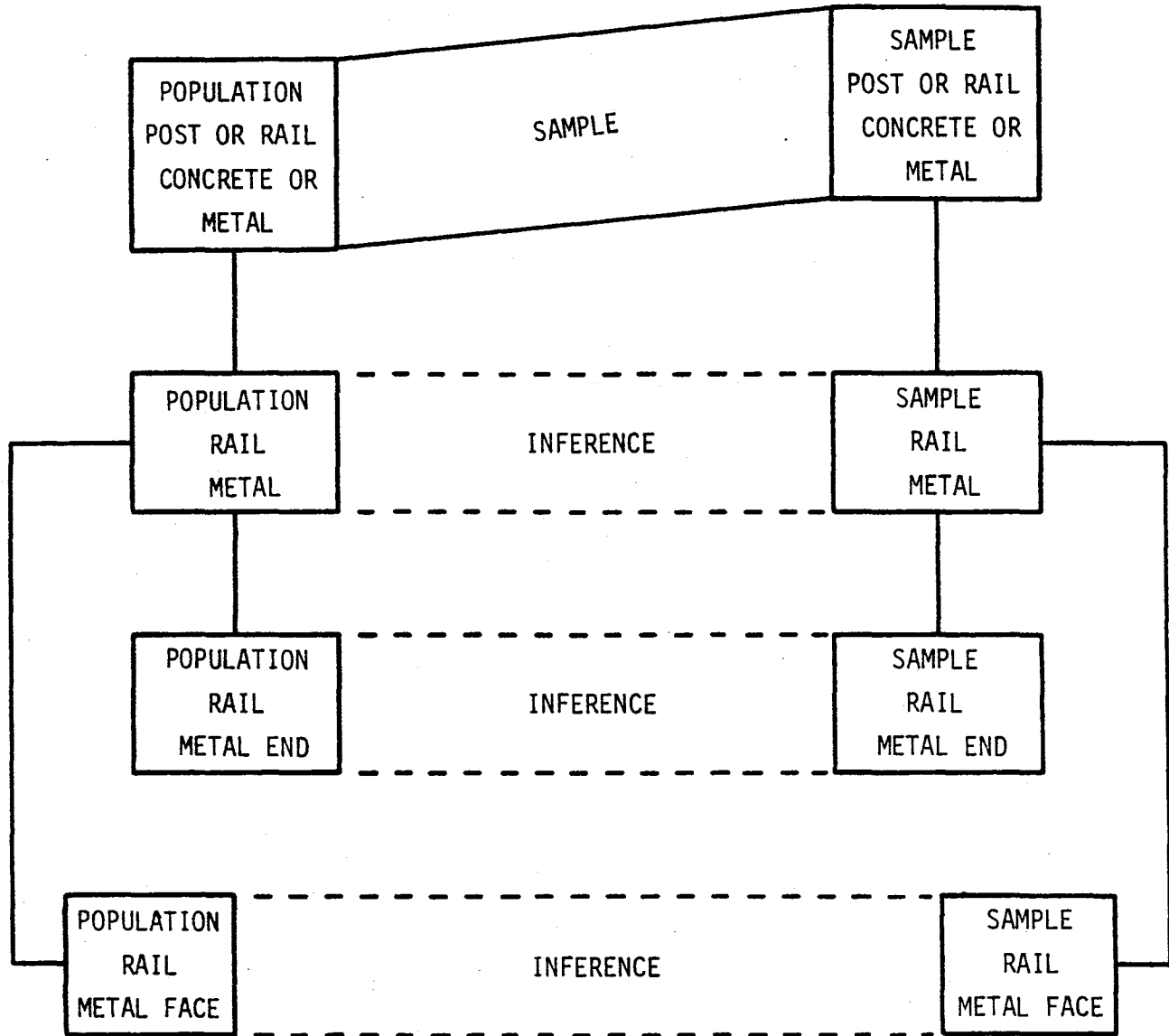

FIGURE 4.1 DATA FLOW DIAGRAM POST OR RAIL ACCIDENTS

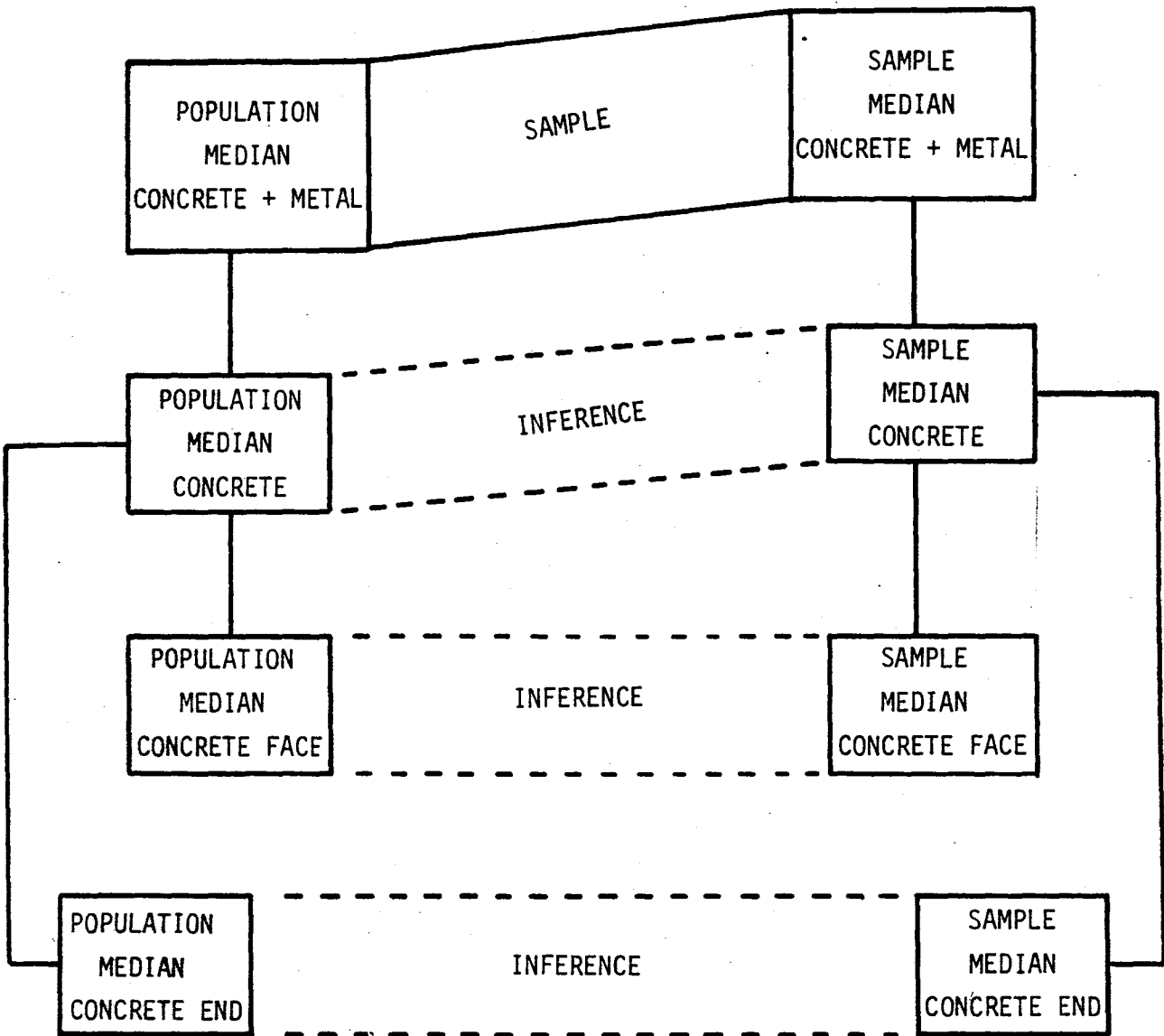

FIGURE 4.2 DATA FLOW DIAGRAM - MEDIAN BARRIER ACCIDENTS

4.2 Sampling and Estimation Procedure

The computerized Texas Accident Data File maintained by TTI contained the entire population of interest for this study, i.e. all post or rail and median barrier accidents in the State of Texas occurring between January 1, 1980 through December 31, 1982. However, this data file did not contain the specific information required to identify an accident as a guard post or rail, face or end hit, concrete or metal median barrier, etc. Vehicle action upon impact was also not available. This information had to be obtained manually from the Department of Public Safety. Since it was not practically feasible to obtain this information on the entire population, a quasi-random sample was drawn.

One of the potential dangers of sampling is that the sample may yield biased estimates of certain critical population variables. In this study, it is important that the conditional distributions of accidents in a particular curb weight class and severity level not be distorted by the sample. Generally, the population values are not known and the researcher hopes that by randomly selecting the sample, bias will not be a problem. In this study a truly random sample was not feasible, as will be discussed, but we have the advantage of knowing the population frequency distribution of accidents by curb weight class and severity level. These values which represent true parameters, not estimates, are shown in Tables 4.2.1 and 4.2.2 for Texas guard post or rail and median barrier accidents. Similarly, these distributions are known for the other state and will be presented later.

A truly random sample in this study could have resulted in poor representation of the rare accident severities such as fatalities. Since fatal and severe accidents constitute such a small proportion of the population (2.15 and 7.3 percent for fatalities and "A" injury accidents for guardpost and rail and 1.03 and 5.77 per cent for median barriers, respectively) a truly random sample (1048/8201) of only 13 per cent of guard post and rail accidents, for example, could conceivably exclude higher severity levels. Since these levels were felt to be extremely important to the conclusions of this study, the sample was drawn in such a manner that these more severe accidents were forced into the selection. This naturally resulted in a bias towards the more severe accident end of the distribution, which does not reflect reality. However, since the true distributions are known, the sample information can be used with the population distribution information as will be described.

4.2.1 Downweighting Population Values Based on Sample Data

Table 4.2.3 lists the proportion of rail accidents which occurred for each severity-curb weight classification based on the sample of 1059 containing both guard post and rail accidents.

Table 4.2.1 PROPORTION STRUCTURE IN THE POPULATION TABLE OF CURBWEIGHT BY SEVERITY FOR GUARDPOST OR GUARD FENCE ACCIDENTS

FREQUENCY PERCENT ROW PCT COL PCT	PDO	C	B	A	K	TOTAL
< 2001	195	35	106	33	8	377
	2.38	0.43	1.29	0.40	0.10	4.60
	51.72	9.28	28.12	8.75	2.12	
	4.08	4.20	5.86	5.51	4.55	
2001-2499	550	128	275	94	32	1079
	6.71	1.56	3.35	1.15	0.39	13.16
	50.97	11.86	25.49	8.71	2.97	
	11.50	15.35	15.21	15.69	18.18	
2500-2999	723	131	310	86	24	1274
	8.82	1.60	3.78	1.05	0.29	15.53
	56.75	10.28	24.33	6.75	1.88	
	15.11	15.71	17.15	14.36	13.64	
3000-3499	1259	225	428	158	39	2109
	15.35	2.74	5.22	1.93	0.48	25.72
	59.70	10.67	20.29	7.49	1.85	
	26.32	26.98	23.67	26.38	22.16	
> 3499	2057	315	689	228	73	3362
	25.08	3.84	8.40	2.78	0.89	41.00
	61.18	9.37	20.49	6.78	2.17	
	43.00	37.77	38.11	38.06	41.48	
TOTAL	4784	834	1808	599	176	8201
	58.33	10.17	22.05	7.30	2.15	100.00

Table 4.2.2 MEDIAN BARRIER ACCIDENT FREQUENCY DATA FROM TEXAS 1980 THRU 82 BY VEHICLE CURB WEIGHT AND ACCIDENT SEVERITY

FREQUENCY EXPECTED CELL CH12 PERCENT ROW PCT COL PCT	PDO	C	B	A	K	TOTAL
< 2000	54	15	26	7	2	104
	58.3	13.0	25.7	6.0	1.1	
	0.3	0.3	0.0	0.2	0.8	
	2.78	0.77	1.34	0.38	0.10	5.38
	51.82	14.42	25.00	6.73	1.92	
4.96	6.20	5.43	6.25	10.00		
2001-2499	187	33	78	22	3	303
	189.9	37.8	74.7	17.5	3.1	
	0.0	0.6	0.1	1.2	0.0	
	8.60	1.70	4.02	1.13	0.15	15.60
	55.12	10.68	25.74	7.26	0.99	
15.34	13.64	16.28	19.64	15.00		
2500-2999	206	42	88	19	1	357
	200.2	44.5	88.1	20.8	3.7	
	0.2	0.1	0.0	0.1	1.9	
	10.61	2.18	4.58	0.98	0.05	18.38
	57.70	11.76	24.93	5.32	0.28	
18.92	17.36	18.58	16.96	5.00		
3000-3499	256	70	122	27	4	479
	268.6	59.7	118.1	27.8	4.9	
	0.6	1.8	0.1	0.0	0.2	
	13.18	3.60	6.28	1.39	0.21	24.67
	53.44	14.61	25.47	5.64	0.84	
23.51	28.93	25.47	24.11	20.00		
> 3499	406	82	164	37	10	689
	392.0	87.1	172.4	40.3	7.2	
	0.5	0.3	0.4	0.3	1.1	
	20.91	4.22	8.44	1.91	0.51	35.99
	58.08	11.73	23.46	5.29	1.43	
37.28	33.88	34.24	33.04	50.00		
TOTAL	1089	242	479	112	20	1842
	58.08	12.48	24.67	5.77	1.03	100.00

Table 4.2.3 Estimated Proportion Of Guard Fence Accidents Based On Sample

Curb Weight Group	PDO	C	B	A	K
<2000	.45	.44	.72	.56	.50
2000-2499	.67	.78	.80	.67	.63
2500-2999	.53	.67	.65	.61	.61
3000-3499	.58	.48	.73	.56	.50
>3500	.63	.71	.67	.55	.56

Multiplication of the population accident frequencies of Table 4.2.1 by these proportions provide an estimate of the rail only accident frequencies in the population. These are shown in Table 4.2.4.

Table 4.2.4 Estimated Fence Only Accidents For Texas 80-82

Curb Weight Group	PDO	C	B	A	K	TOTAL
<2000	88	16	76	19	4	203
2000-2499	369	100	220	63	20	772
2500-2999	383	88	202	53	14	740
3000-3499	730	108	312	88	20	1258
>3500	1296	224	462	126	41	2149
Total	2866	536	1272	349	99	5122

Similarly, based on the sample of 597 median barrier accidents, the following proportions of concrete median barrier injury severities were estimated. (Due to the small frequencies of concrete median barrier accidents, the Table was collapsed into two weight groups.)

Table 4.2.5 Estimated Proportion Of Concrete Median Barrier Accidents

Curb Weight Group	PDO	C	B	A	K
Equal To Or Less Than 2500 #	.176	.160	.206	.286	0
Greater Than 2500 #	.165	.157	.283	.290	.188

Downweighting the population frequencies of Table 4.2.2 which are known to contain both concrete and metal median barrier accidents, we obtain the following estimates of concrete median barrier accident frequencies:

Table 4.2.6 Estimated Frequency Of Concrete Barrier Accidents

Weight	PDO	C	B	A	K
Equal To Or Less Than 2500 #	1.4	.8	1.9	2.3	0
Greater Than 2500 #	8	2.2	9.1	3.2	.6

These downweighted frequencies of the population values were the basic unit of analysis used throughout this study. When additional characteristics were estimated from the sample such as vehicle action or location of the impact, a second weight was applied by down weighting the values of Tables 4.2.4 and 4.2.6, respectively.

4.2.2 Severity Analysis of Accidents Based on 80-82 Texas Population

Since the known population values are available on accident severity by curb weight class for the entire population of interest here, i.e. guardpost and guard rail accidents in Texas for 80-82, no weighted estimation based on the sample is necessary. Technically, it could be argued that no statistical testing of hypothesis is necessary if the population is known. However, if it is of interest to ask whether there is a significant relationship between vehicle curb weight and severity level for potential inference on a general basis, then statistical inference is justified. This is the basic premise on which this section is based. The results of applying a test of independence (or equality of proportions) to the values of Table 4.2.1 collapsed for curb weights of equal to or less than 2500 and greater than 2500 pounds follows:

4.2.2.1 Guardpost And Guard Fence Accidents

There was a significant difference in the probability of an injury accident for lighter vehicles involved in a guard post or guard fence accident than for heavier vehicles. This relationship was true for the groupings of C or greater and B or greater severities, but not for the (A + K) grouping (Table 4.2.7).

Table 4.2.7 Proportion Of Guard Post And Guard Rail Accidents By Severity Classification Vehicle Curb Weight vs. Probability Of Severity

Comparison	Equal Or <2500 #	(Frequency)	>2500 #	(Frequency)	p - value
A + K	0.11	(167)	0.09	(608)	0.15
B + A + K	0.38	(548)	0.30	(2035)	0.01
C + B + A + K	0.49	(711)	0.40	(2706)	0.002

There was a significant increase in the probability of a (B + A + K) accident in the light vehicles of 8 percent over the same severity accident in the larger vehicle. This increase was 9 percent for any injury involved accident. Histograms representing these distributions are shown in Figures 4.3-4.7.

PROJECT 2333
 ACCIDENT FREQUENCIES DATA FROM TEXAS
 YEAR-1980-82 COMBINED STATE-TEXAS OBJECT STRUCK-RAIL ACCIDENT SEVERITY LEVEL-PBB
 FREQUENCY BAR CHART

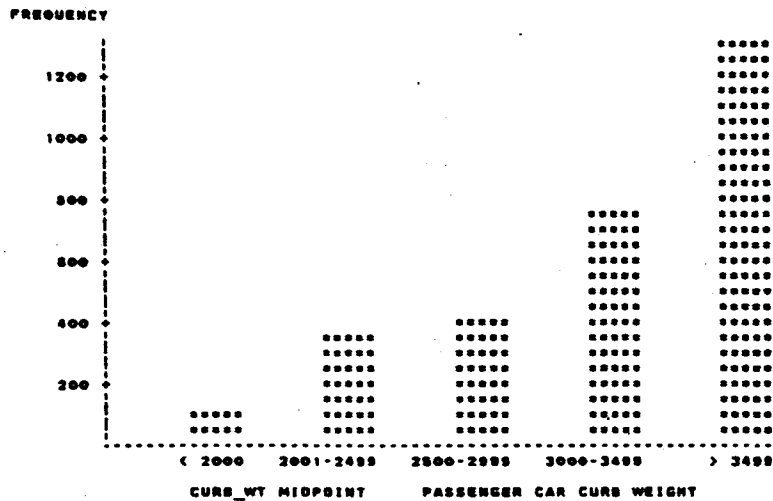

FIGURE 4.3 FREQUENCY OF ACCIDENT LEVEL PDO

PROJECT 2333
 ACCIDENT FREQUENCIES DATA FROM TEXAS
 YEAR-1980-82 COMBINED STATE-TEXAS OBJECT STRUCK-RAIL ACCIDENT SEVERITY LEVEL-C
 FREQUENCY BAR CHART

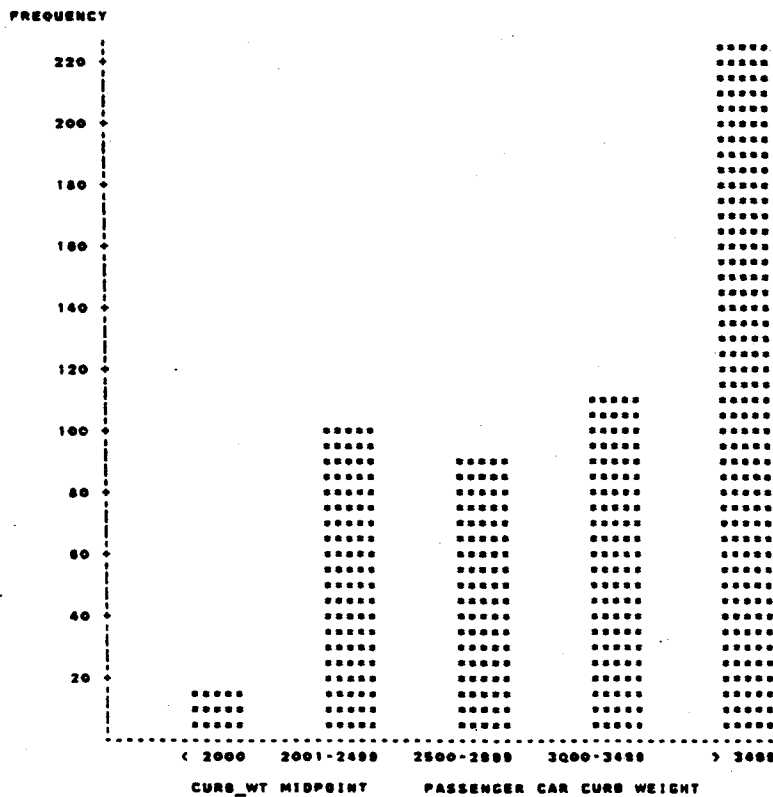

FIGURE 4.4 FREQUENCY OF ACCIDENT LEVEL C

PROJECT 2333
 ACCIDENT FREQUENCIES DATA FROM TEXAS
 YEAR:1980-82 COMBINED STATE:TEXAS OBJECT STRUCK:RAIL ACCIDENT SEVERITY LEVEL:B
 FREQUENCY BAR CHART

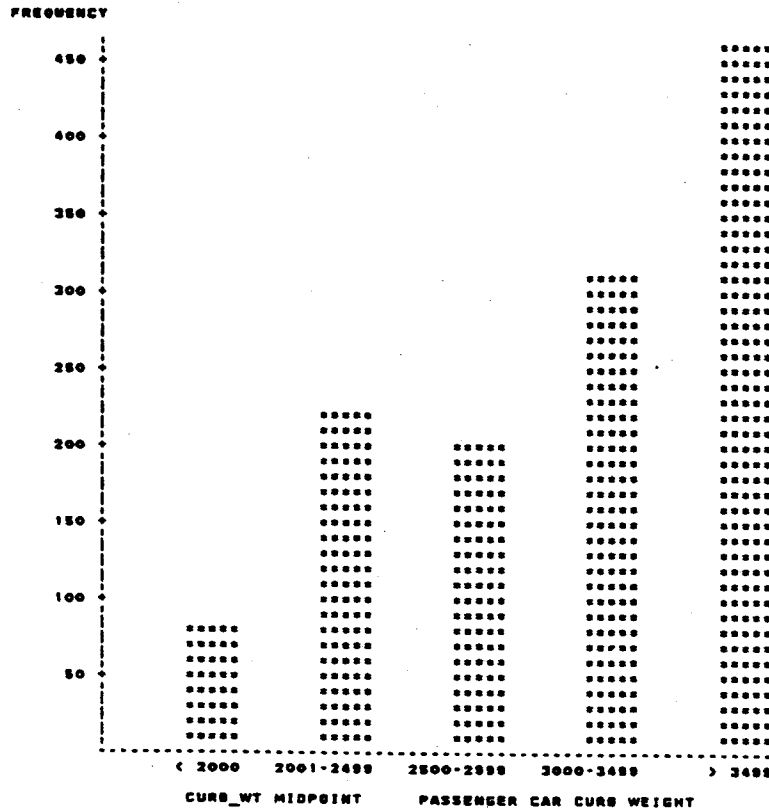

FIGURE 4.5 FREQUENCY OF ACCIDENT LEVEL B

PROJECT 2333
 ACCIDENT FREQUENCIES DATA FROM TEXAS
 YEAR:1980-82 COMBINED STATE:TEXAS OBJECT STRUCK:RAIL ACCIDENT SEVERITY LEVEL:A
 FREQUENCY BAR CHART

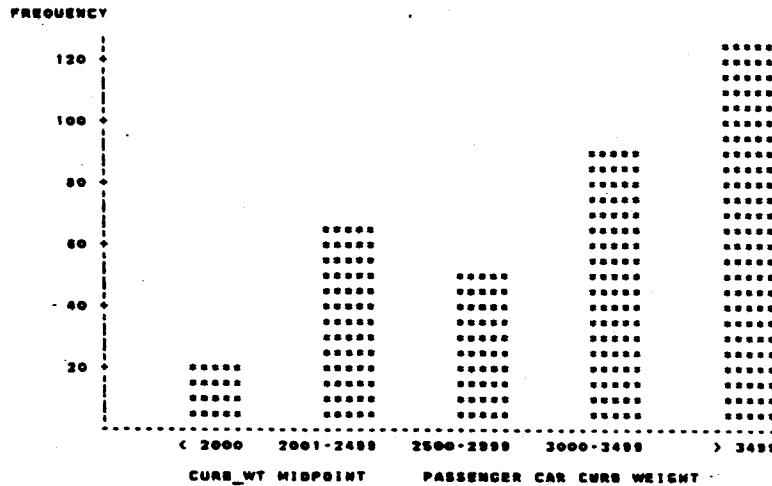

FIGURE 4.6 FREQUENCY OF ACCIDENT LEVEL A

PROJECT 2333
 ACCIDENT FREQUENCIES DATA FROM TEXAS
 YEAR:1980-82 COMBINED STATE:TEXAS OBJECT STRUCK:RAIL ACCIDENT SEVERITY LEVEL:K
 FREQUENCY BAR CHART

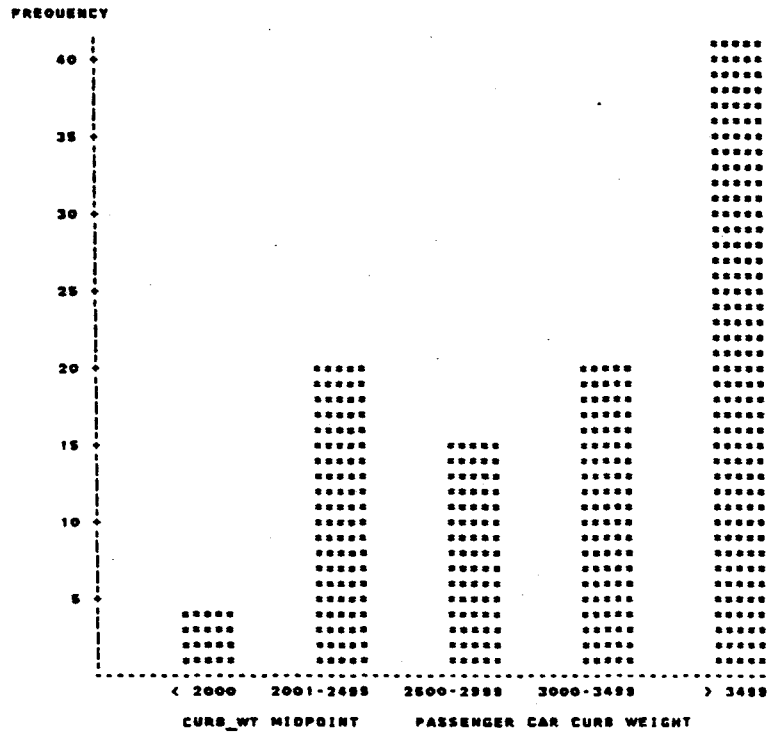

FIGURE 4.7 FREQUENCY OF ACCIDENT LEVEL K

Since vehicle curb weight is a continuous variable, another method of analysis is available which does not require the arbitrary partitioning of curb weight into less than or equal to 2500 pounds and greater than 2500 pounds. This method is logistic regression analysis and the dependent variable of interest is a function of the probability of some discrete event. An inherent assumption in this model is that the probability of injury changes monotonically with vehicle curb weight. In this example, the event of interest is the occurrence of an accident at a particular level of severity, e.g. the probability of an A or K accident as a function of vehicle curb weight. The results of this modelling, i.e., the model parameters, goodness-of-fit statistics, and plots are listed in Table 4.2.8 and Figures 4.8 and 4.9.

Table 4.2.8
Logistic Regression Of Guard Post And Guard Fence Injury Probability

$$\text{Model: } \ln \left(\frac{p_i}{1 - p_i} \right) = a_0 + a_1 (\text{curb weight})$$

p_i	a_0	a_1	p - value	R Sq.
C + B + A + K	0.243	-0.00028	<0.0001	0.495
B + A + K	-0.239	-0.00016	<0.0001	0.484

Predicted Values and Confidence Limits (95% level)
for C + B + A + K Injury

Curb Weight	P	Lower	Upper
1500-1599	0.494	0.467	0.522
1700-1799	0.485	0.460	0.510
1900-1999	0.454	0.467	0.498
2100-2199	0.447	0.466	0.485
2300-2399	0.441	0.459	0.464
2700-2799	0.427	0.440	0.453
2900-2999	0.420	0.432	0.444
3100-3199	0.413	0.424	0.435
3300-3399	0.403	0.413	0.424
3500-3599	0.394	0.405	0.417
3700-3799	0.385	0.398	0.410
3900-3999	0.374	0.388	0.402
4100-4199	0.368	0.383	0.399
4300-4399	0.355	0.373	0.390
5200-5299	0.310	0.322	0.360

LOGISTIC REGRESSION FOR PROBABILITY OF C+B+A+K POST OR RAIL ACCIDENTS

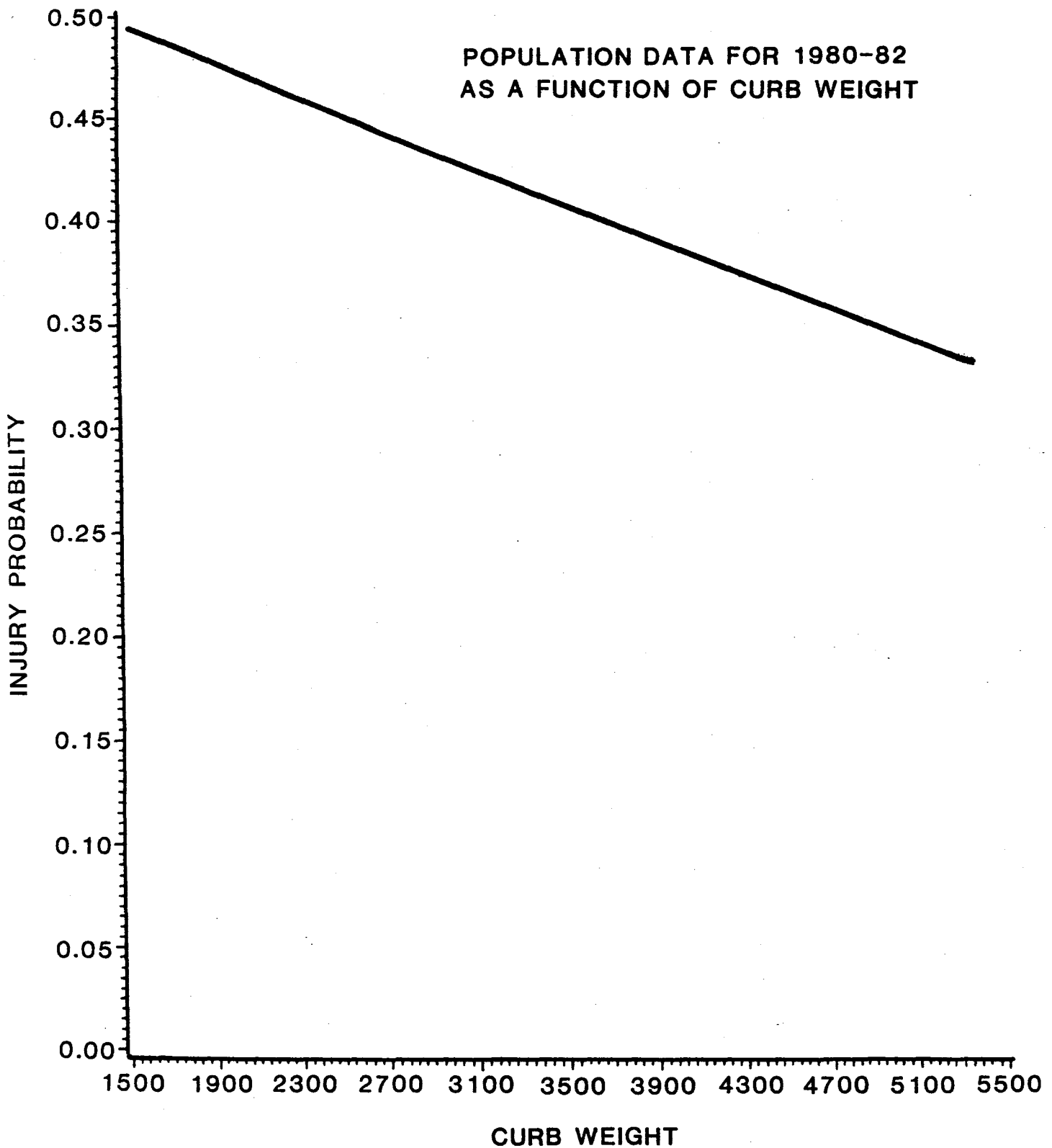

FIGURE 4.8

LOGISTIC REGRESSION FOR PROBABILITY OF B+A+K POST OR RAIL ACCIDENTS

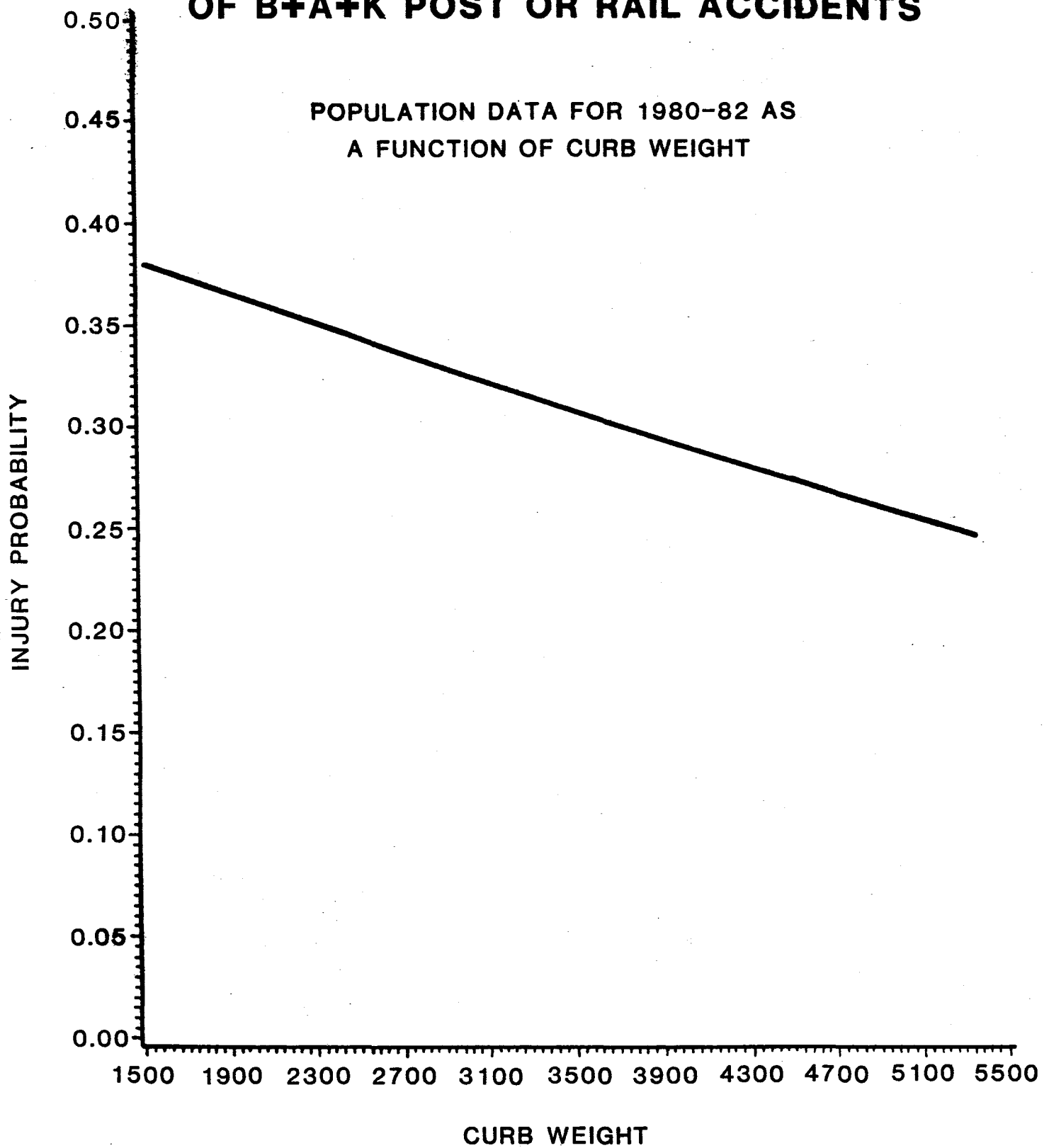

FIGURE 4.9

The results of this analysis agree with the Chi-Square test results of Table 4.2.7 indicating that there is a significant relationship between severity levels (C + B + A + K) and (B + A + K) and vehicle curb weight. The relationship is inversely related; i.e. as vehicle curb weight increases the probability of serious injury decreases. This is reflected in the negative value of the coefficient "a₁" of Table 4.2.8 (negative slope). When "C" level accidents are included, the probability of injury decreases faster than for (B + A + K) alone accidents. A listing of predicted injury probabilities for various curb weight classes is listed in Table 4.2.8. That is, for vehicle weights of 1500 - 1599 pounds, the probability of an injury accident is 0.494 whereas for vehicles of the 5200 - 5299 pound class, the probability is reduced to 0.310. The R Squared values were moderate, (0.495 and 0.484) and the model was based on a total sample size of 8201 vehicles of Table 4.2.1.

4.2.2.2 Median Barrier Accidents

The accident frequencies of Table 4.2.2 include both concrete and metal median barriers. Accident severity analysis of these data collapsed into curb weight classes of equal to or less than 2500 pounds or greater than 2500 pounds found that there was no significant difference in the probability of being involved in a serious injury or fatal (A + K) accident between lighter cars and heavier cars given that the accident involved a median barrier. This conclusion held true for the following comparisons:

Table 4.2.9 Median Barrier Accident Severity By Vehicle Weight

Comparison	Proportion (Frequency)		p-value
	Equal Or <2500 #	>2500 #	
A + K	0.08 (34)	0.05 (78)	0.18
B + A + K	0.34 (138)	0.36 (453)	0.77

The overall Chi Square test for independence at all severity levels and five curb weight classifications was also non-significant, implying that the relative severity frequencies were independent of the curb weight classification. Logistic regression analysis yielded slopes which were likewise not significantly different from zero.

4.3 W-Beam Barriers

4.3.1 Vehicle Action Analysis (metal beam guard rail face hit accidents only).

1. All Actions.

Light cars had a significantly higher probability of rolling over as compared to other vehicle actions than did heavier cars (given that a rail accident occurred). Table 4.3.1 illustrates this fact.

Table 4.3.1 Probability Of Vehicle Action After A W-Beam Rail Accident

Vehicle Weight	Roll Over (Frequency)	Other Actions (Frequency)
Equal To Or Less Than 2500 #	0.14 (18)	0.86 (112)
Greater Than 2500 #	0.05 (21)	0.95 (398)

The probability of a light vehicle rolling, given that the vehicle was involved in a w-beam rail accident, is 9 percent greater than a heavier car. None of the other vehicle actions were significantly different between light and heavy vehicles. The frequency of various post impact actions are presented below in Table 4.3.2

Table 4.3.2 Texas Sample Data Accident Frequencies Of Vehicle Action By Curb Weight For W-Beam Barriers

Vehicle Weight	Over Barrier	Rolled Over	Redirected	Broken Barrier	Spin Out
Equal To Or Less Than 2500 #	13 (10.0%)	18 (13.8%)	80 (61.6%)	6 (4.6%)	13 (10.0%)
Greater Than 2500 #	47 (11.2%)	21 (5.0%)	281 (67.1%)	37 (8.8%)	33 (7.9%)

Logistic regression analysis of these data for the probability of going through or over the barrier are provided in Table 4.3.3 and Figure 4.10. Figure 4.11 contains a plot of the probability of rollover only.

Table 4.3.3 Logistic Regression Results For Vehicle Action

$$\text{MODEL: } \ln \left(\frac{p_i}{1-p_i} \right) = a_0 + a_1 (\text{Curb Weight})$$

	a_0	a_1	χ^2	p	R^2	n
Over Or Rollover	-.9259	-.00018	1.91	0.17	0.071	549
Rollover Only	-.9260	-.00054	6.88	.0087	0.227	549

The logistic regression results concurred with the Chi-Square results on the two-category partitioning of vehicle curb weight. That is, there was a significant relationship between the probability of a vehicle rolling over the barrier and curb weight. The negative sign on the coefficient a_1 indicates that the the probability of rollover decreases as vehicle curb weight increases. The R^2 values were not very large (0.513 and 0.587) and were based on a large sample size of 549. Of these 549 accidents, only 39 vehicles rolled over and 99 vehicles either rolled over or went over the barrier. There was no significant relationship between curb weight and the probability of rollover or going over the barrier when these two vehicle actions were combined, however.

LOGISTIC REGRESSION FOR PROBABILITY OF GOING OVER THE BARRIER OR ROLLING OVER

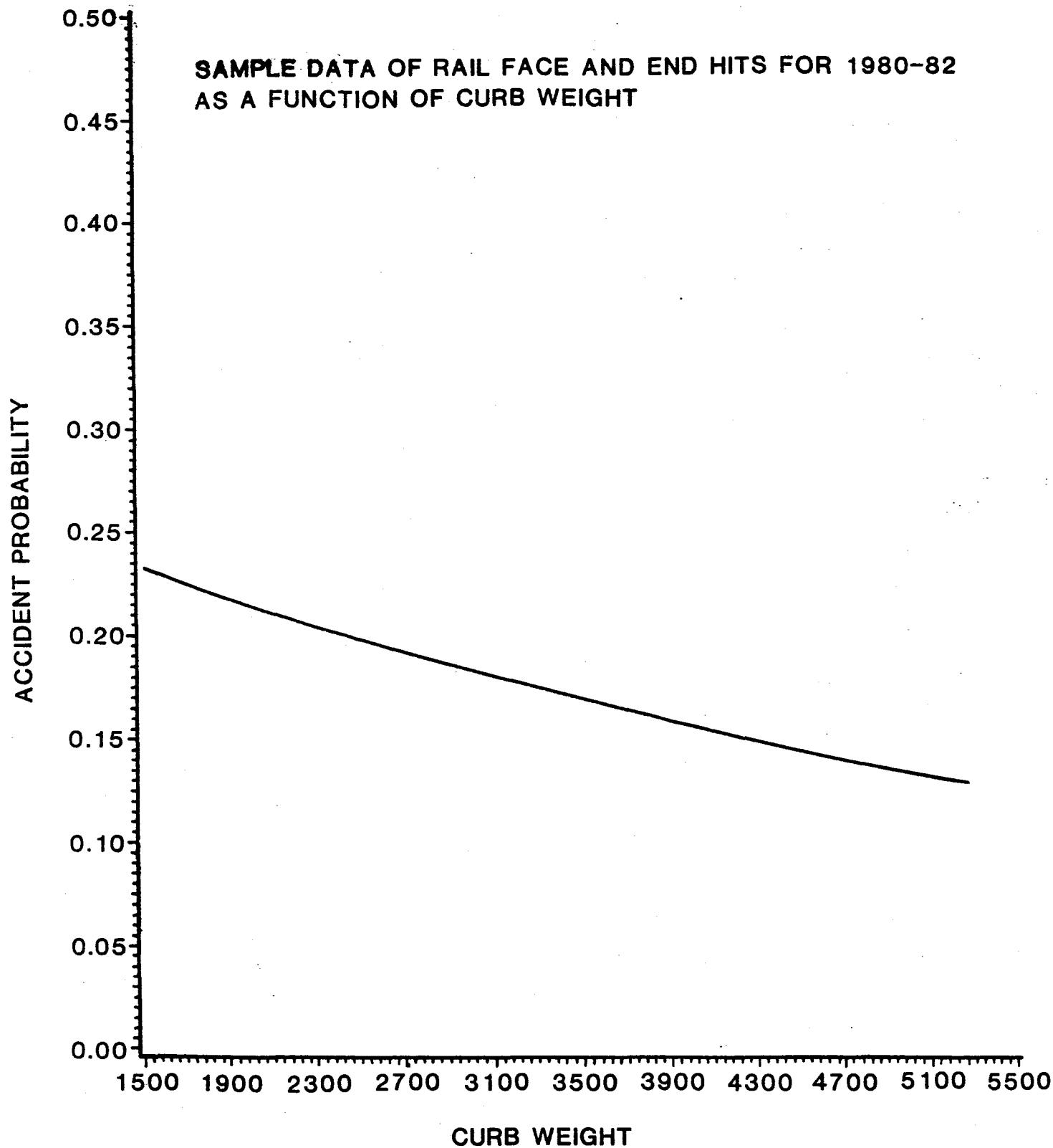

FIGURE 4.10

LOGISTIC REGRESSION FOR PROBABILITY OF ROLLOVER

SAMPLE DATA OF RAIL FACE AND END HITS FOR 1980-82
AS A FUNCTION OF CURB WEIGHT

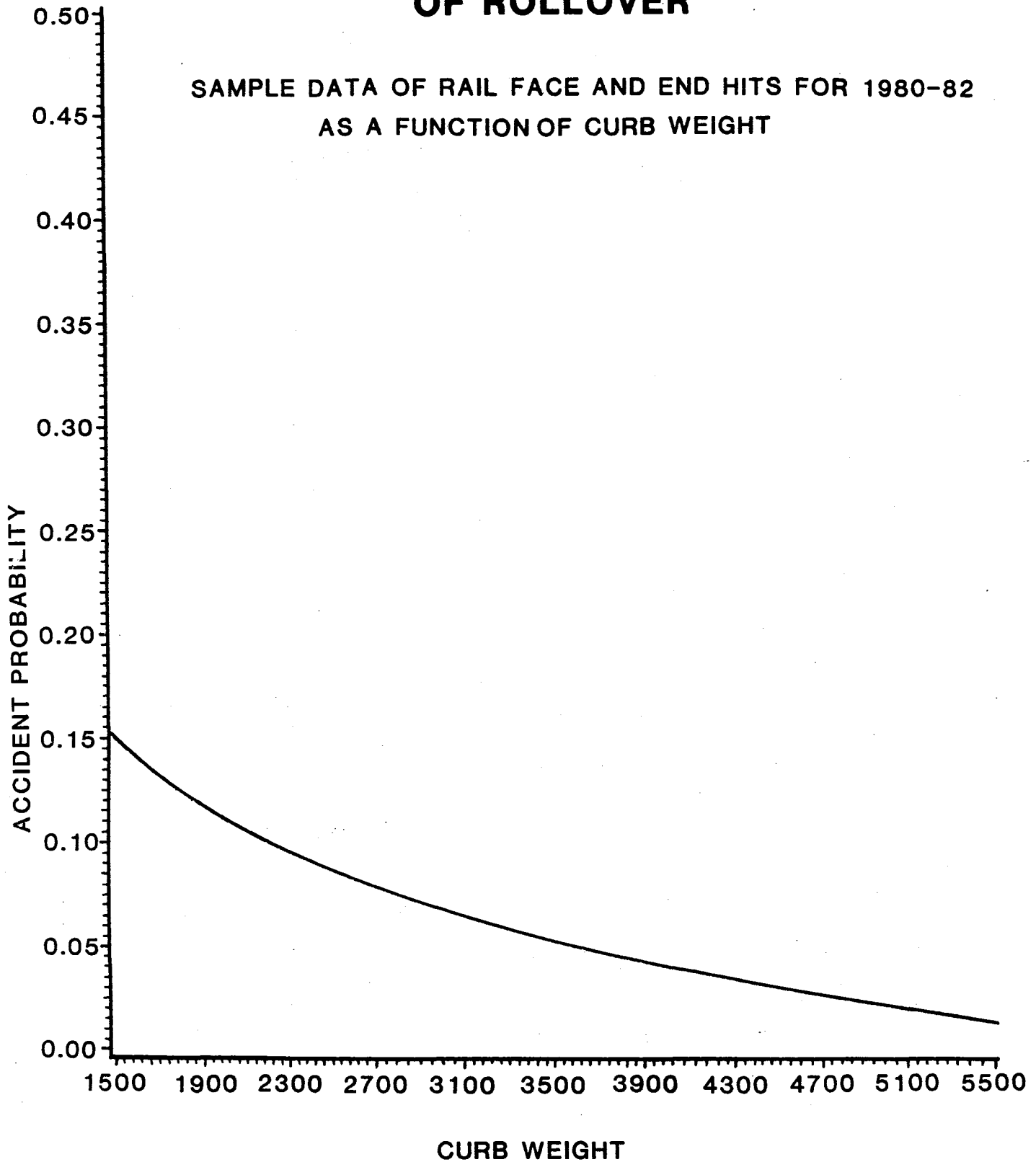

FIGURE 4.11

2. Redirected

This analysis was done for the metal beam rail Texas accidents face hits only from 1980 through 1982 sample. Concrete median barrier accidents were not represented in sufficient frequency to examine vehicle actions.

The following is the table of frequencies and proportions of these accidents:

Table 4.3.4 Redirection vs. Vehicle Curb Weight (face hits only)

	Redirected (Frequency)	Other (Frequency)	Total
Equal To Or Less Than 2500 #	0.62 (80)	0.38 (50)	(130)
Greater Than 2500 #	0.67 (281)	0.33 (138)	(419)
Total	(361)	(188)	(549)

$$\chi^2 = 1.34 \quad p = 0.24 \quad \text{NS}$$

There was no significant relationship between redirection proportion and curb weight. However, when these frequencies were separated by PDO only and greater than PDO, the proportion of injury accidents was significantly higher in small cars that were redirected than in larger cars that were redirected.

Table 4.3.5 Injury vs. PDO - Redirected Only

	Injury (Frequency)	PDO Only (Frequency)	Total
Equal To Or Less Than 2500 #	0.65 (52)	0.35 (28)	(80)
Greater Than 2500 #	0.40 (113)	0.60 (168)	(281)
Total	(165)	(196)	(361)

$$\chi^2 = 15.4 \quad p < 0.0001 \quad **$$

There was a 25 percent increase in the probability of an injury in a light vehicle given that the vehicle was redirected. Table 4.3.9 however, indicates that the probability of vehicle redirection is the same for heavy and light vehicles. Thus, light vehicles are no more likely to be redirected than heavier vehicles; however when redirection does occur, occupants of lighter vehicles have a greater chance of being injured.

For those vehicles which were not redirected, there was no significant difference in the injury severity as defined by injury of PDO only (See Table 4.3.6).

Table 4.3.6 Injury vs. PDO - Not Redirected

	Injured (Frequency)	PDO Only (Frequency)	Total
Equal To Or Less Than 2500 #	0.72 (36)	0.28 (14)	(50)
Greater Than 2500 #	0.65 (90)	0.35 (48)	(138)
Total	(126)	(62)	(188)

$\chi^2 = 0.764$ $p = 0.382$ NS

The following Figure approximately reflects these results:

Figure 4.12 Vehicle Curb Weight vs. Probability Of Injury Redirected or Not Redirected

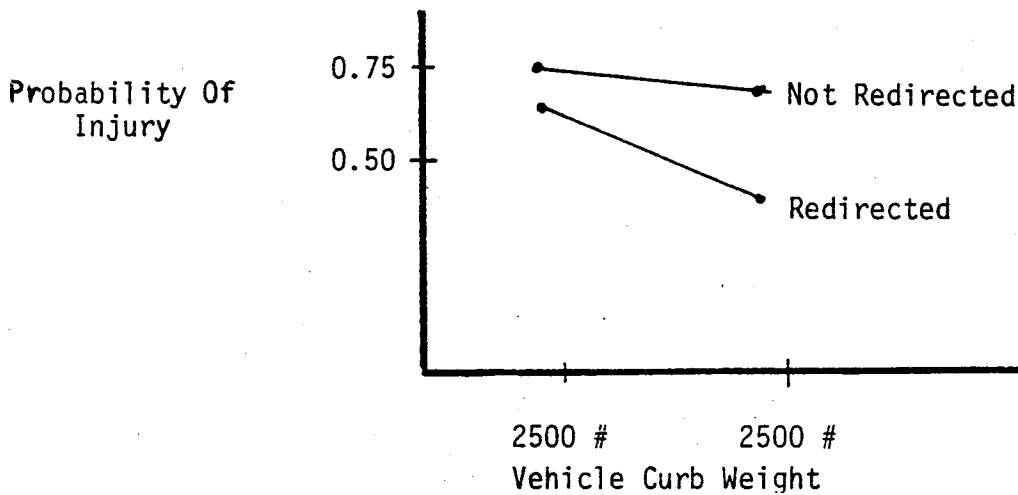

4.3.2 Location Of Barrier Impacts Analysis (metal beam guard fence only)

There is no significant difference in the proportion of light vehicles that hit the face of the barrier as compared to heavier vehicles for w-beam accidents. No analysis could be done on the median barrier accidents since the frequency of non-face hits was very small. Table 4.3.7 presents these proportions and Table 4.3.8 presents the frequencies.

Table 4.3.7 Probability Of Impacting Vehicle Hitting The Face (Middle) And The End Or Back Of The Rail

Vehicle Weight	Hit Middle	Hit End Or Back
Equal To Or Less Than 2500 #	0.87	0.13
Greater Than 2500 #	0.85	0.15

Table 4.3.8 Accident Frequency By Location
On The Barrier For W-Beam Barriers

Vehicle Weight	Hit End	Hit Back	Hit Middle (i.e., face)
Equal To Or Less Than 2500 #	19	0	130
Greater Than 2500 #	68	5	419
Total	87	5	549

4.3.3 Severity Analysis (Metal Guard Fence Accidents Only)

The downweighted population values of Table 4.2.4 were analyzed to determine the relationship between vehicle curb weight and accident severity for metal beam guard fence accidents only.

The statistical analysis for the comparisons of the differences in probability of a serious injury, moderate injury, and any injury between light and heavy vehicles is listed below:

Table 4.3.9 Statistical Comparison Of Metal Beam
Guard Fence Accident Severity

Descriptor	Comparison	Equal To Or		p-value	Statistical Significance
		<2500 #	>2500 #		
Serious Injury	A + K	0.11	0.08	0.15	NS
Moderate Injury Thru Fatality	B + A + K	0.41	0.32	<0.001	**
Any Injury	C + B + A + K	0.53	0.42	<0.001	**

The probability of a (B + A + K) accident is 11 percent greater for lighter vehicles and the probability of an injury related accident is 9 percent greater.

An interesting observation can be made for the PDO and B accident severity levels from the individual cell contributions to the overall Chi-Square. The cells contributing a substantial portion to the overall Chi-Square and their deviations from their expected value are listed below:

Table 4.3.10 Contribution To Chi-Square From Each Cell

		Cell Deviation	Chi- Square	Percent Contribution
Equal To Or Less Than 2500 #	PDO Only	-87.9	14.2	35 %
Greater Than 2500 #	PDO Only	+87.9	3.2	8 %
Equal To Or Less Than 2500 #	B Only	+54.4	12.2	30 %
Greater Than 2500 #	B Only	-54.4	2.9	7 %

Note the reversal in signs in the deviations from expected for PDO's and B accidents. There were fewer PDO's and more B severities for lighter cars and more PDO's and fewer B severities for heavier cars than were expected if there were no relationship between curb weight and accident severity. Further, this deviation was so large in the lighter vehicles that the cell Chi-Square for PDO and B alone account for 65 percent of the overall Chi-Square statistic.

The conclusions of this analysis were identical to the analysis on the population data which included guardposts (4.2.3). This could be an indication that the relationship between severity and curb weight is basically the same for guardposts and w-beam guard fence. Based on the sample, approximately 62 percent of all accidents labeled guardpost or rail in the population are actually rail accidents. If guardpost accidents did not have the same severity experience with regard to curb weight, the conclusions reached based on the analysis of this section and 4.2.3 would, in all likelihood, disagree.

4.4 Concrete Median Barrier Analysis

Although a sample of 597 total barrier accidents was drawn, there were only 145 accidents involving concrete median barriers. When these were categorized by severity level, vehicle action, or location of barrier impact, frequencies were generally too small to be analyzed statistically. The following section presents summary statistics of these accidents and analyses when possible. The conclusions of these analyses should be interpreted cautiously as they are based on very limited data.

Statistical analysis of the concrete median barrier accident data revealed no significant differences in vehicle actions across all weight groups. However, the data were very sparse, that is, many cells had extremely low frequencies.

Table 4.4.1 Probability Of Vehicle Action Given An Impact
With A Concrete Median Barrier

Vehicle Curb Weight	Proportion Rollover	Proportion Other Actions
Equal To Or Less Than 2500 #	0.13	0.87
Greater than 2500 #	0.06	0.94

For documentation, the frequency of various actions in the Texas sample are presented in Table 4.4.2.

Table 4.4.2 Frequency Of Various Actions On Impact
With A Concrete Median Barrier

Vehicle Curb Weight	Rolled Over Barrier	Rolled Over	Redirected	Broke Barrier	Spin Out
Equal To Or Less Than 2500 #	0% (0)	13.3% (4)	80% (24)	0% (0)	6.7% (2)
Greater Than 2500 #	1% (1)	5.7% (6)	86.8% (92)	1% (1)	5.7% (6)

The frequencies of concrete median barrier accidents by face or end hits were too low and are reported in Section 4.5.

4.5 Comparison With Another State

Since the comparison of interest with the other state focuses on a comparison of severity and curb weight frequency distributions, the downweighting estimation scheme is employed whenever the Texas sample must be used to make inference to the population. Information was available on the entire population for the other state with regard to severity and curb weight distribution for metal beam and concrete barriers and by face or end hits. The Texas population frequencies could only be used directly in comparing all median barrier accidents (metal and concrete) for end and face hits combined. For all other comparisons, Texas population frequencies were downweighted by the proportions for that characteristic (i.e. rail only face hits) for a given severity-curb weight category as estimated from the sample. This analysis was based on 1982 data from both states.

4.5.1 All Median Barrier Accidents

Table 4.5.1 lists the median barrier accidents (concrete and metal) for the other state and Texas. There was no significant difference in the proportion of median barrier accidents involving lighter cars in Texas (0.23) compared to the other state (0.26).

Table 4.5.1 Median Barrier Accidents 1982
Texas vs. Another State

OTHER STATE	A + K	B + C	PDO	Total
Equal To Or Less Than 2500 #	0.10 (6)	0.31 (19)	0.59 (36)	0.26 (61)
Greater Than 2500 #	0.10 (18)	0.33 (56)	0.57 (98)	0.74 (172)
Total	(24)	(75)	(134)	(233)
TEXAS				
Equal To Or Less Than 2500 #	0.08 (18)	0.35 (76)	0.57 (126)	0.23 (220)
Greater Than 2500 #	0.06 (43)	0.38 (288)	0.56 (424)	0.77 (755)
Total	(61)	(364)	(550)	(975)

When accidents were grouped by PDO versus other severities, there were no significant differences in the proportion of accidents between lighter and heavier vehicles for either state. This was also true if accidents were grouped by severe injury (A + K) versus other injury severities (testing at the 0.01 level required for multiple hypothesis testing).

4.5.2 Concrete Median Barrier Accidents Only

Table 4.5.2 lists the population data for the other state for concrete median barrier accidents and the estimates for the Texas data based on the sample described in Section 4.2 and listed in Table 4.2.6.

Table 4.5.2 Concrete Median Barrier Accidents For Texas
And Another State - 1982

	Vehicle Weight	A + K	C + B	PDO	Total
OTHER STATE	Equal To Or Less Than 2500 #	1	9	22	32
	Greater Than 2500 #	3	27	40	70
TEXAS	Equal To Or Less Than 2500 #	2.3	1.4	2.7	6.4
	Greater Than 2500 #	3.8	3.8	14.1	21.7

Sample frequencies were too small to allow for any statistical testing of differences. The Texas estimates were based on too small a sample to provide a realistic estimate of the distribution of concrete median barrier accidents and no statistical comparison was made on the Texas concrete median barrier accident frequency.

4.5.3 All Roadside Barriers

Table 4.5.3 lists the roadside barrier accident frequencies (concrete and metal, face and end hits) for the other state and Texas.

Table 4.5.3 Roadside Barrier Accidents 1982
Texas and Another State

OTHER STATE	A + K (Freq.)	B + C (Freq.)	PDO (Freq.)	Total
Equal To Or Less Than 2500 #	0.13 (26)	0.41 (82)	0.46 (94)	0.34 (202)
Greater Than 2500 #	0.08 (32)	0.28 (109)	0.64 (255)	0.66 (396)
Total	(58)	(191)	(349)	(598)
TEXAS				
Equal To Or Less Than 2500 #	0.12 (59)	0.37 (181)	0.51 (181)	0.22 (489)
Greater Than 2500 #	0.10 (175)	0.31 (558)	0.59 (1051)	0.78 (1784)
Total	(234)	(739)	(1232)	(2273)

There was a significant difference ($p = 0.001$) in the proportion of small car accidents between these two states, Texas having 12 percent fewer roadside barrier accidents involving vehicles weighting less than 2500 pounds. Table 4.5.4 lists the proportion of accidents in Texas and the other state for both vehicle weight groups by severity. There was no significant difference among these proportions for A + K or PDO only accidents (tested at the 0.01 level of significance required for multiple hypothesis testing).

Table 4.5.4 Roadside Barrier Accident Proportions For 1982

	Texas		Other State	
	A + K	PDO	A + K	PDO
Equal To Or Less Than 2500 #	0.12	0.51	0.13	0.46
Greater Than 2500 #	0.10	0.59	0.08	0.64

The only statistically significant difference occurred when comparing the light and heavy vehicle accident proportions within each state. Both in Texas and the other state, there were significantly fewer PDO accidents for lighter vehicles than for the heavy vehicles: eight percent fewer in Texas and 18 percent fewer in the other state. There was no significant difference in the A + K accident proportions between light and heavy vehicles although in Texas there was a 2 percent increase in the proportion of A + K accidents in the light vehicles and in the other state a 5 percent increase.

4.5.4 Metal Roadside Guard Fence Only Accidents

The entire population of metal roadside barrier accidents for 1982 for the other state were known and are listed in Table 4.5.5

Table 4.5.5 Metal Roadside Barrier Accidents
(face and end hits) For The Other State

	A + K (Freq.)	B + C (Freq.)	PDO (Freq.)	Total
Equal To Or Less Than 2500 #	0.12 (23)	0.42 (78)	0.46 (86)	(187)
Greater Than 2500 #	0.08 (31)	0.28 (103)	0.64 (237)	(371)
Total	(54)	(181)	(323)	(558)

Note that due to relative infrequency of concrete roadside barrier accidents in the other state, Table 4.5.5 has essentially the same frequency as Table 4.5.3.

In order to compare Texas metal beam roadside barriers and those for another state, the population values in Table 4.5.3 had to be downweighted by the proportion of metal guard fence accidents estimated in the sample. The downweighting proportions and resulting frequencies are reflected in the tables below:

Table 4.5.6 Estimated Proportions Of Metal Guard Fence Accidents In Texas (weights)

Vehicle Weight Group	K	A	B	C	PDO
Equal To Or Less Than 2500 #	0.61	0.64	0.68	0.73	0.63
Greater Than 2500 #	0.62	0.61	0.67	0.56	0.55

Table 4.5.7 Estimated Frequency Of Metal Roadside Barrier Accidents In Texas

Vehicle Weight Group	A + K	B + C	PDO	Total
Equal To Or Less Than 2500 #	37(0.12)	125(0.39)	157(0.49)	319(0.24)
Greater Than 2500 #	107(0.10)	353(0.34)	578(0.56)	1038(0.76)
Totals	144	478	735	1357

Since the estimated proportion of metal roadside guard fence accidents collapsed according to light and heavy vehicles (based on the sample data of Table 4.2.3) were essentially constant (Table 4.5.6), there was little change in the proportions in Table 4.5.7 from the population frequencies of Table 4.5.3 of all roadside guard fence accidents. Thus the conclusions drawn regarding differences in the proportion of A + K accidents between states for heavier and lighter vehicles and within states between heavier and lighter vehicles were the same for roadside metal barrier, metal and concrete, guardpost or guard fence; that is, there is no statistically significant differences at the alpha = 0.01 level of confidence required for multiple hypothesis testing for A + K severity accidents. There was still a significant difference in the proportion of lighter vehicle accidents between Texas and the other state, with Texas having 10 percent fewer light vehicle metal beam roadside guard fence accidents than the other state. When PDO accidents were compared to the more severe accidents, significant differences occurred when heavy vehicle accident proportions were compared both between and within states. Texas had significantly fewer heavy vehicle PDO accidents (0.56) than the other state (0.64). Light vehicle PDO accident proportions were not significantly different between states.

4.5.5 Location Of Barrier Impacts - Median Barriers

Metal beam median barrier end hits appeared to be more severe than concrete median barrier end hits for each state. Table 4.5.8 depicts the severity of end hits with each barrier type:

Table 4.5.8 End Hit With Other State's Median Barrier

Barrier Type	Vehicle Weight Group	PDO	C + B	A + K	Notes
Metal	Equal To Or Less Than 2500 #	3	3	3	one
	Greater Than 2500 #	17	9	7	fatality
Concrete	Equal To Or Less Than 2500 #	8	2	0	no
	Greater Than 2500 #	12	6	1	fatalities

Texas median barrier end hits were very rare in the data file. For example, Table 4.5.9 contains all the end hits for 1982 and the associated severity:

Table 4.5.9 Texas Concrete Barrier End Hits

Vehicle Weight Group	PDO	C	B	A	K
Equal To Or Less Than 2500 #	0	0	1	0	0
Greater Than 2500 #	1	0	1	1	0

If these are downweighted by the sample estimates to include only concrete median barrier end hits, the result would become zeroes in every cell (i.e. based on the sample, one would conclude none of the above four accidents involved a concrete median barrier).

If this fact is assumed, then it appears that the state has more median barrier end hits, both on concrete and metal barriers, than does Texas. This cannot be tested statistically due to the small cell frequencies. Given the number of data elements rejected in the sample, this could be an artifact of the reporting practice.

Table 4.5.10 lists face hits for concrete and metal beam median barriers for the other state.

Table 4.5.10 Face Hits For Other State Median Barriers

METAL BEAM	PDO	C	B	A	K	Total
Equal To Or Less Than 2500 #	11	3	6	1	0	21
Greater Than 2500 #	42	12	13	7	1	75
Total	53	15	19	8	1	96
CONCRETE	PDO	C	B	A	K	Total
Equal To Or Less Than 2500 #	14	3	2	1	1	21
Greater Than 2500 #	29	7	11	2	0	49
Total	43	10	13	3	1	70

Since accident frequencies were extremely low, the only severity comparison which could be made on these data was PDO vs. the more severe accidents. There were no significant differences in the proportion of PDO accidents between light and heavy vehicles for either metal or concrete barriers for the other state. Due to the low frequencies, care must be exercised in extrapolating this finding.

Texas estimated frequencies were too low to allow statistical comparison of concrete median barrier face hit accidents, as evidenced in Table 4.5.6. The other state's frequencies were too low for statistical comparison on metal beam barrier face hit only accidents.

4.5.6 Location Of Barrier Impacts - Roadside Guard Fence

Table 4.5.11 lists the face and end impacts on metal beam and concrete barriers for the other state.

Table 4.5.11 Face And End Hit Frequencies
Of Roadside Barriers For Another State

Barrier Type And Impact Location	A + K	B + C	PDO

Face Hits			
Metal Beam Barrier			
Equal To Or Less Than 2500 #	17	64	72
Greater Than 2500 #	22	69	187
Concrete Barrier			
Equal To Or Less Than 2500 #	3	4	8
Greater Than 2500 #	1	6	18

End Hits			
Metal Beam Barrier			
Equal To Or Less Than 2500 #	6	14	14
Greater Than 2500 #	9	34	50
Concrete Barrier			
Equal To Or Less Than 2500 #	0	2	3
Greater Than 2500 #	0	1	4

The relative frequency of concrete roadside barrier accidents for the other state prevented statistical comparisons from being made. Table 4.5.12 lists the estimated frequencies of metal beam barrier accidents in Texas by face or end hit as reflected in the sample.

Table 4.5.12 Estimated Texas Metal Beam Guard Fence Accident Frequencies
For Face And End Hits

Location Of Hit and Weight Group	A + K	B + C	PDO

Face Hits			
Equal To Or Less Than 2500 #	31	113	150
Greater Than 2500 #	87	307	509
End Hits			
Equal To Or Less Than 2500 #	6	12	7
Greater Than 2500 #	20	46	69

Table 4.5.13 lists the proportion of A + K and PDO accidents for both states for metal beam guard fence accidents by face or end hit.

Table 4.5.13 Proportion Of A + K And PDO Injuries For Texas
And The Other State - Face And End Hits

Location Of Hit And Weight Group	Proportion Of Accidents			
	Texas		Other State	
	A + K	PDO	A + K	PDO

Face Hits				
Equal To Or Less Than 2500 #	0.11	0.51	0.11	0.47
Greater Than 2500 #	0.09	0.56	0.08	0.67
End Hits				
Equal To Or Less Than 2500 #	0.22	0.28	0.18	0.41
Greater Than 2500 #	0.15	0.51	0.10	0.54

There was no significant difference in the proportion of A + K face hit accidents for lighter and heavier cars within each state or between states. While the proportion of A + K severities was greater for end hit accidents, sample sizes available in the accident files of the two states were insufficient for statistical comparison.

When PDO accidents were compared to more severe accidents, most of the conclusions of Section 4.5.4, i.e., metal roadside guard fence accidents for face or end hits were again confirmed. The only exception was that there was no significant difference in the proportion of PDO accidents between light and heavy vehicles for the Texas sample when the end hits were excluded. There was still a significant difference in the proportion of PDO accidents among heavy vehicles between the states, Texas having 11 percent fewer reported PDO accidents among heavier vehicles.

Thus, the conclusion drawn regarding differences in the proportion of A + K or PDO accidents between states for light and heavy vehicles and within states between lighter and heavier vehicles were essentially the same for metal beam roadside barriers as for all roadside barriers, metal beam and concrete, guardpost and guard fence, etc.

There was still a significant difference in the proportion of light vehicle accidents between Texas and the other state, Texas having 10 percent fewer light vehicle metal beam roadside guard fence accidents than did the other state when face hits were analyzed separately.

5.0 SUMMARY OF STATISTICAL FINDINGS

5.1 Guard Fence and Guardpost Accident Severity

The probability of injury in guard fence and guardpost accidents are significantly related to vehicle curb weight for all injury groupings except the severe injury plus fatal (A+K) group. The B thru K and the C thru K codes pooled show significant vehicle curb weight relationships to injury probability at the alpha level of 0.05 (See Section 4.2.2).

5.2 Guard Fence Accidents Only Severity

Using only the guard fence accidents, the analysis of 4.3.3 revealed the same severity relationship to curb weight as for the combined guard fence and guardpost accident file. This finding suggests that the probability of injury in guardpost accidents is related to vehicle curb weight in the same manner as guard fence accidents (See Section 4.3.3).

5.3 Vehicle Curb Weight Severity Changes

Vehicles with a curb weight under 2500 pounds had a significantly higher frequency of B severity injury accidents and a significantly lower frequency of PDO accidents for the guard Fence accident population (See Section 4.3.3).

5.4 Comparison of Texas W-Beam Barrier Accident Severity With Another State

There is no significant difference in the proportion of severe w-beam barrier accidents between Texas and another state for light or heavier vehicles. There was also no significant difference in the proportion of severe accidents between light and heavier vehicles within each state (See Section 4.5.3).

There was a significant difference in PDO accident frequencies between light and heavy vehicles in both states. There was a significantly greater proportion of PDO accidents for heavy vehicles than light vehicles. There was also a significant difference between the states in the proportion of PDO accidents for heavy vehicles, Texas having significantly fewer reported PDO accidents among heavy vehicles than the other state. There was no significant difference for light vehicle PDO accidents between the states.

5.5 Location of Barrier Hits - Median Barriers and Roadside Barriers

End hits with median barriers on roadside barriers, either metal or concrete, were too few to allow statistical testing of end impact severity (See Sections 4.5.5 and 4.5.6).

5.6 Redirection Probability vs. Vehicle Curb Weight

Redirection of the vehicle for heavy vehicles (over 2,500 pounds curb weight) and light vehicles (under 2,500 pounds curb weight) upon impact with a w-beam barrier is not significantly different with about 60 percent of the impacts resulting in redirection for both curb weight classes (See Section 4.3.1).

5.7 Accident Severity After Redirection

The lighter vehicles (less than or equal to 2500 pounds curb weight) which are redirected by a w-beam barrier had a significantly greater proportion of injury accidents than redirected heavier vehicles (See Table 4.3.6).

There was no significant difference in the proportion of injury accidents between lighter and heavier vehicles for those vehicles which were not redirected (See Table 4.3.7).

5.8 Rollover Probability vs. Vehicle Curb Weight

There was a significant relationship between the probability of rollover and vehicle curb weight. The proportion of light vehicles rolling over was 8.8 percentage points greater than the proportion of heavy vehicles that rolled over.

6.0 SUMMARY OF BASIC COMPARISONS FINDINGS

- 6.1 H_0 : There is no significant difference in the proportion of concrete safety shape accident by severity in Texas and another state.

Result: Concrete roadside and median barrier reported accidents were too few to allow statistical testing of the severity between states. Table 4.5.1. has very little data but does indicate no practical difference.

- 6.2 H_0 : There is no significant difference in the accident severity level proportions of w-beam barrier accidents between Texas and another state.

Result: Table 4.5.3 indicates no practical difference in severity proportions. Both states have a significantly greater severity with smaller cars (2500 pounds and under) as compared with those 2500 pounds (see Section 4.5).

- 6.3 H_0 : There is no significant difference in the proportion of w-beam barrier end accidents by severity between Texas and another state.

Result: End hits in the other state were too few to permit statistical comparison. The Texas sample revealed very few end hits.

- 6.4 H_0 : There is no significant difference in the proportion of accidents by severity of barrier performance between vehicles with front wheel drive and those with rear wheel drive.

Result: Observed frequencies of front wheel drive vehicles were too small to allow testing of this hypothesis.

- 6.5 H_0 : None of the terrain, slope in front of the barrier, design features, block out and steel or wooden posts, etc., contribute significantly to predicting the performance of the barrier.

Result: The Texas data file made terrain effects testing impossible. Attempts were made to evaluate terrain effects from a sample of national barriers accident experience. Questions about the suitability of the data, after the analysis was completed, resulted in these findings being discarded.

- 6.6 H_0 : There is no relationship between lateral distance from the traffic lane to the barrier and the angle of impact with the barrier.

Result: The national roadside barrier file was analyzed only to discover after the fact that "Impact Angle" as reported in the that file was the line-of-action of the vehicle C.G. at the instant of impact. Since this definition is essentially meaningless to those interested in the design of safe roadside barriers, the results were discarded.