

# **U.S. Rail Equipment Crashworthiness Standards**

David C. Tyrell  
Volpe National Transportation Systems Center  
U.S. Department of Transportation

## **1. ABSTRACT**

In 1999 the U.S. Department of Transportation's Federal Railroad Administration (FRA) issued new regulations and the American Public Transportation Association (APTA) issued new standards for rail passenger equipment crashworthiness. These new regulations and standards include conventional strength-based requirements for equipment used below 200 kph (125 mph), crash-energy management for equipment used above 200 kph (125 mph), and dynamic sled testing of occupant seats.

## **2. INTRODUCTION**

In the United States there has been substantial activity in the last ten years to develop and refine crashworthiness standards for both passenger trains and freight locomotives. Much of the activity in developing and refining crashworthiness standards has come about because of interest in high-speed passenger rail, increased rail traffic, the application of equipment built to specifications different from U.S. practice, and because accidents continue to happen. (See a companion paper for a detailed discussion of rail passenger accidents in the U.S. (1).) Amtrak has recently introduced the high-speed Acela trainset for service from Boston to New York to Washington, with speeds up to 241 kph (150 mph). The Maryland Area Rail Commuter Service has recently introduced commuter service at speeds up to 200 kph (125 mph). Commuter rail service has recently been started in Seattle, Washington. The Massachusetts Bay Transportation Authority (MBTA) recently reopened the Old Colony line from Boston to the south shore. The state of Washington has purchased Talgo trainsets originally developed for service in Spain. Increased traffic, which can increase the likelihood of the occurrence of train collisions, increased equipment speed, which can increase the severity of train collisions, and the application of equipment developed for operating environments which include smaller and lighter freight equipment than the equipment used in the U.S. have raised concerns about the crashworthiness of rail equipment.

Fatalities and injuries occur as a result of train collisions and derailments. The crashworthiness features of the train are intended to provide protection to the passengers and crew in the event of a collision or derailment. Crashworthiness standards are intended to assure that the rail equipment includes features that provide at least a minimum level of protection for the occupants.

Crashworthiness standards can be described as either design standards or performance standards. Design standards prescribe requirements that are not necessarily directly related to the conditions expected in a collision. For example, current industry standards for interior equipment require that the attachment be able to support a longitudinal static load equal to eight times the weight of the equipment. The load supported by an attachment during a collision is dynamic, and is related to the stiffness of the attachment as well as the deceleration time-history. Compliance with design standards can generally be evaluated using classical closed-form structural analysis techniques or non-destructive testing. Performance standards attempt to prescribe desired performance under conditions closely related to the conditions expected in a collision. For example, current rail passenger industry standards require that human injury criteria remain within survivable levels when an interior seating arrangement with test dummies is decelerated with a pulse representative of the occupant volume deceleration expected in an in-line train to train collision. Demonstration of compliance with performance standards generally requires detailed computer simulation or destructive testing. The principal advantages of performance standards are that they require fewer assumptions on the design approaches or details of the equipment and that required performance is more closely related to the desired performance under collision conditions.

Computers and computer-aided engineering tools allow accurate simulation of rail equipment crashworthiness, and have minimized the need for relatively expensive destructive tests. Such tools have also increased the utility of those destructive tests, by allowing extrapolation of the test results to a wide range of conditions. By being relatively inexpensive and accurate, these tools have allowed adoption of crashworthiness performance standards for rail equipment. Activities to develop and refine crashworthiness standards for rail equipment have resulted in new performance standards, as well as in refinement of existing design standards.

## **2.1 Background**

Organizations in the U.S. that participate in the development of rail equipment crashworthiness regulations, standards, and recommended practices include the federal government, industry organizations, labor unions, and passenger organizations. The FRA represents the federal government, along with the National Transportation Safety Board (NTSB). The Association of American Railroads (AAR) represents the interests of the freight railroad operators, while the American Public Transportation Association (APTA) represents the interests of the passenger railroad operators. The Brotherhood of Locomotive Engineers, the Brotherhood of Railway Carmen, the United Transportation Union, and the Transportation Workers Union of America, labor unions that represent operators and train crewmembers, participate. Other organizations that also participate include the Railway Progress Institute, an organization representing the equipment manufacturers, the American Association of State Highway and Transportation Officials, and the National Association of Railroad Passengers.

The FRA regulates the rail industry in order to assure safe operation. The FRA has jurisdiction over freight, inter-city passenger, and commuter passenger operations on the general system of railroad transportation. (The Federal Transit Administration has the safety

oversight of rapid transit operations in urban areas.) The regulations promulgated by the FRA have the force of law, and include crashworthiness regulations for freight and passenger rail equipment. The FRA regulates all aspects of railroad safety, including operations, track, and equipment. Equipment safety includes brake performance, vehicle trackworthiness, and other aspects as well as crashworthiness.

In the rail freight industry, the AAR publishes a manual of standards and recommended practices (2), and in the rail passenger industry, the APTA publishes a manual (3); both manuals address equipment crashworthiness. These standards and recommended practices principally address safety, but they also address other aspects of railroad operation, such as interchange. In general, the industry standards and recommended practices are intended to compliment the federal regulations, to provide an even greater level of safety. Compliance with industry standards is voluntary, however, it is believed that compliance with them is nearly universal.

## **2.2 Recent Standards Development**

In recent years, the FRA, APTA and AAR have led efforts to develop crashworthiness regulations, standards and recommended practices. On May 12, 1999, the FRA published passenger equipment safety standards in the Federal Register (4). In December 1999, APTA published its manual of standards and recommended practices (3). Currently, the FRA is working with the AAR and APTA to develop recommendations for crashworthiness requirements for both freight and passenger locomotives (5, 6). (These organizations have also been active in other areas of railroad safety. For example, the FRA is currently working with the industry to develop standards for the safe implementation of positive train control. The FRA regulations and APTA Manual cover other aspects of rail passenger equipment safety, such as fire safety, in addition to crashworthiness.)

The Locomotive Crashworthiness Working Group of the Railway Safety Advisory Committee (RSAC) is developing these locomotive crashworthiness recommendations. The FRA organized the RSAC in 1996 with the purpose of developing recommended solutions to safety issues for the rail industry. The RSAC is a government/industry committee that includes all segments of the rail community – the railroads, the suppliers, and the unions. The Locomotive Crashworthiness Working Group was formed in 1998 and is currently developing recommendations on locomotive crashworthiness. The Working Group is currently considering alternative means of specifying crashworthiness: with design loads and with descriptions of performance under impact conditions. The Working Group has not yet finalized its recommendations. These recommendations will address both passenger and freight locomotives.

In 1998, APTA organized the Passenger Rail Equipment Safety Standards (PRESS) Committee to develop its manual of standards and recommended practices. This group included participants from the railroads, the unions, and the rail equipment suppliers. This committee includes four subcommittees: the Electrical Subcommittee, the Passenger Systems Subcommittee, the Mechanical Subcommittee, and the Construction/Structural Subcommittee. The Construction/Structural Subcommittee is responsible for developing crashworthiness standards and recommended practices. The APTA/PRESS Manual of Standards and Recommended Practices was first published in July 1999 (3). The construction/structural standards were revised and consolidated on January 11, 2000 (7). The committee continues to meet yearly, and the Construction/Structural Subcommittee continues to meet quarterly.

On June 7, 1995, with a mandate from Congress (8), the FRA convened a working group to draft passenger equipment regulations. This group included participants from the railroads, the unions, the rail equipment suppliers, as well as the NTSB. An advanced notice of proposed rulemaking (ANPRM) was published in the Federal Register on June 17, 1996 (9). This ANPRM articulated the areas that the FRA intended to address in its final rule. These issues included fire safety, emergency egress, brake performance, and equipment crashworthiness. A notice of proposed rulemaking was published on March 19, 1997 (10). This notice included a draft of the final rule. The final rule was published on May 12, 1999 (4).

In 1994 the FRA worked with Amtrak to develop the safety-related specifications for Amtrak's high-speed trainset, including the crashworthiness specifications. These crashworthiness specifications included performance requirements for energy absorbing crush zones in the locomotives and coach cars. This specification later became the basis for the crashworthiness regulations that apply to passenger equipment used at speeds greater than 125 mph, issued on May 12 1999 (4).

### **2.3 Role of Research in Developing Crashworthiness Standards**

In the late 1980's high-speed passenger train service, with train speeds up to 320 kph (200 mph), was proposed (and subsequently cancelled) for Texas on a triangular route with San Antonio, Houston, and Dallas/Fort Worth at the corners. In the early 1990's Amtrak demonstrated the German ICE and Swedish X200 in the Northeast Corridor. In 1989, in response to growing interest in high-speed passenger rail, the Federal Railroad Administration initiated a program of research into the safety aspects of high-speed passenger train systems. Collision safety – the balancing of collision avoidance measures of the system with the crashworthiness features of the train – was part of this program of research. One of the first results of this research was a risk-based approach for assessing collision safety (11). This approach was used in the development of the crashworthiness specifications for Amtrak's high-speed trainset, which is now in service in the Northeast Corridor. Additional studies of alternative crashworthiness approaches and occupant protection measures were also carried out to support the development of the high-speed trainset crashworthiness specifications (12, 13, 14).

The scope of the crashworthiness research was later broadened to include inter-city and commuter rail passenger trains operated at speeds less than 200 kph (125 mph). In 1996, a Rail Equipment Crashworthiness Symposium was held at the Volpe Center, with sessions on collision risk, structural crashworthiness, and occupant protection. Researchers from England and France made presentations, as did researchers from the U.S. (15). This Symposium was held to support the development of the FRA passenger equipment safety standards. A number of other studies on occupant protection (16) and structural crashworthiness (17) were also carried out in support of this rulemaking effort.

The results of the FRA's research on rail equipment crashworthiness were made available to APTA for development of its Manual of Standards and Recommended Practices, by allowing ex officio representation of the FRA and Volpe Center on APTA Passenger Rail Equipment Safety Standard (PRESS) Construction/Structural Subcommittee and by conducting several studies requested by APTA. These studies include cost/benefit analysis of alternative

structural crashworthiness strategies and sled tests of commuter rail passenger seats. (Reports are being prepared on these studies, but have not yet been published.)

As part of this research simulation models of locomotive collisions were developed and exercised. The results of that effort provided technical information for a report to Congress on locomotive cab safety and working conditions (18), published in 1996. The information developed for the report to Congress, as well as the results of efforts conducted specifically to support the RSAC Locomotive Crashworthiness Working Group (5, 19, 20), have been used by the Working Group to draft recommendations (6).

Research studies on passenger equipment crashworthiness are being carried out to develop the base of information required for the next phase of rulemaking. Ongoing research into rail equipment crashworthiness ranges from field investigations of the causes of occupant injury and fatality in train accidents, to full-scale testing of existing and modified designs under conditions intended to approximate accident conditions (21, 22, 23, 24, 25, 26), to investigations of the fundamental mechanics of structural crush.

### **3. OVERVIEW OF PASSENGER EQUIPMENT REGULATIONS AND STANDARDS**

This section includes an overview of current federal passenger equipment regulations and industry standards and recommended practices for passenger rail equipment crashworthiness, with discussions on selected regulations, standards and recommended practices. For application of the regulations, standards, and recommended practices, careful review of the actual regulations, standards, and recommended practices is advised. It is within the purview of the FRA Office of Safety Assurance and Compliance to resolve any issues related to the application of federal regulations, and the responsibility of APTA Member Services Department to resolve any issued related to the APTA standards and recommended practices.

#### **3.1 Design Standards**

Design standards typically call for a particular structure to support a specified static load either without permanent deformation or without failure. Compliance with design standards can be generally accomplished through structural analysis techniques such as elastic beam analysis, elastic buckling analysis, and limit-load analysis. Geometrically complex structures, which are difficult to analyze with classical analysis techniques, may require non-destructive tests in order to demonstrate compliance. Elastic finite-element analysis techniques may also be used to demonstrate compliance.

The principal design standard for rail equipment crashworthiness is the federal static end strength regulation, 49 Code of Federal Regulations (CFR) § 238.203 (4). A passenger rail car structure must be able to support a longitudinal static compressive load of 3.56 MN (800 kips) applied at the buff stops without permanent deformation. Figure 1 schematically illustrates the application of such a load to a single-level passenger coach car. This design standard is intended to assure a least a minimum strength of the occupied volume of the car. Compliance with this regulation is typically demonstrated by a non-destructive test or by a linear-elastic finite-element analysis. For passenger equipment without crush-zones, the APTA Standard SS-C&S-034-99 adds a requirements for an end-compression load of 2.22 MN (500 kips) applied at the extreme ends of the car, vertically centered on the underframe (7). Since the buff load is not applied at the extreme ends of the car, but instead about 1.8 m (six feet)

inboard at the buff stops, it is possible to design a car with end structures which crush in a controlled fashion and meet the static end strength requirement.

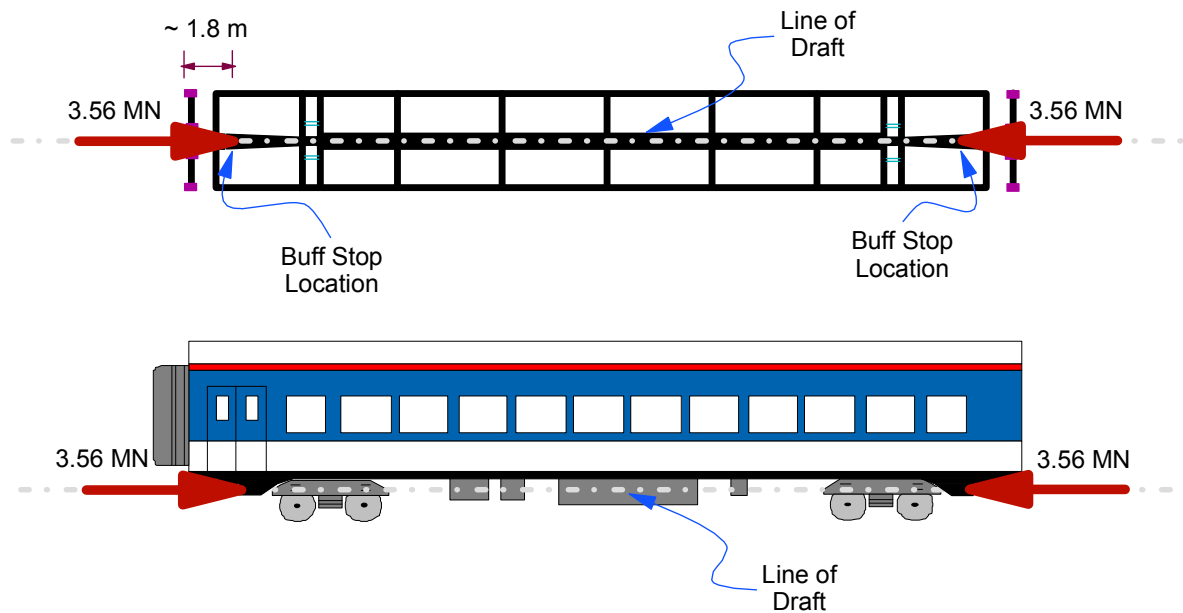

**Figure 1. Schematic drawing of static end strength load applied to a single-level passenger coach car.**

The static end strength requirement is based on longstanding practice, and originated in specifications for U.S. Railway Postal Office (RPO) cars (27, 28) in the 1940's. Numbers of earlier RPO cars, which were built to lower static end strength requirements, were crushed in train collisions. These cars were placed in freight trains, often with many trailing freight cars, with postal workers on board sorting the mail to be left at the various train stops. During a collision substantial compressive loads would be applied to such cars. For cars not built to the 800 kip static end strength requirement, the results could be catastrophic, with structural collapse of the cars and many postal workers killed (27). The introduction of cars that met the 800 kip static end strength requirement effectively eliminated this type of complete structural collapse.

In addition to the static end strength requirement, there are also federal regulations and industry standards for the strength of the end structure, the strength of the truck attachment, the strength of interior equipment attachment, the strength of exterior equipment attachment, and the strength of the anti-climber arrangement. These structural crashworthiness requirements all implicitly rely on the main structure strength prescribed by the static end strength requirement. The FRA regulations and APTA standards both require that a static load be supported by the corresponding structure either without permanent deformation or failure. Generally, the APTA standards specify a greater number of loads to the structure than the corresponding FRA requirements.

Figure 2 shows a schematic of the federal collision post load regulation, 49 CFR § 238.211, for the cab ends of locomotives, cab cars, and self-powered multiple-unit cars. Collision posts at the lead end of such equipment must be able to support a 2.22 MN (500 kip) longitudinal force at the top of the underframe, and a 890 kN (200 kip) longitudinal force 762 mm (30 inches) above the top of the underframe, without failure (4). Compliance with this regulation

is typically demonstrated with closed-form limit-load analysis, assuming that the post is fixed at the base and pinned at the roof. The APTA standard also requires that the post be able to support these loads when oriented 15 degrees from the longitudinal, as well as a 167 kN (60 kip) load at any height, oriented within 15 degrees of longitudinal.

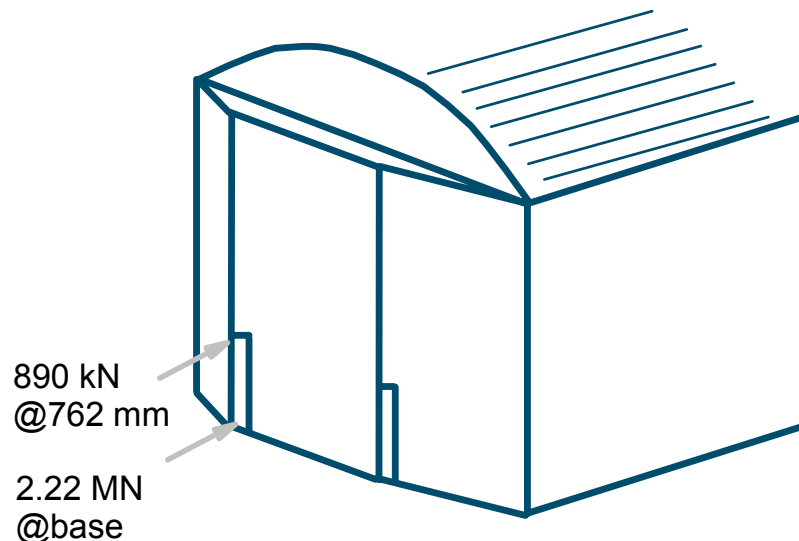

**Figure 2. Schematic drawing of collision post loads for cab ends of locomotives, cab cars, multiple-unit cars.**

### 3.2 Performance Standards

Demonstration of compliance with performance standards generally requires either detailed numerical simulation or destructive testing. Evaluation techniques – both numerical simulation and destructive testing techniques – are available for evaluating car crush under prescribed conditions, behavior of the entire train during a collision, and the response of occupants inside the train. These evaluation techniques are illustrated in Figure 3. The principal objectives of the car crush evaluation are to determine the load required to crush the car (i.e., the force/crush characteristic) and the mode of crush, i.e., the changing geometry of the structure as it crushes. The principal objectives of the train collision dynamics evaluation are to determine the distribution of the crush among the cars in the train, and to determine the trajectories of the cars during the collision, including the decelerations of the occupied areas. The principal objective of the evaluation of the occupant response is to determine if the forces and decelerations imparted to the occupants remain within survivable levels.

Car crush can be analyzed using closed-form limit-load analysis for relatively simple geometries and loading conditions; more complex geometries and loading conditions require detailed elastic-plastic large-deformation finite element analysis (6, 19). Car crush can be destructively tested either in full-scale or subscale using substructure components as test specimens (29), or entire cars (21). If subscale or substructure testing is done, analyses can be used to extend the test results to full-scale or the entire structure. Figure 3 shows a detailed finite element analysis of a passenger car impacting a fixed barrier. The principal results of the car crush evaluation – the force crush characteristic and the mode of crush -- are used to develop the train collision dynamics analysis.

Train collision dynamics can be analyzed using lump-mass parameter models, with non-linear force characteristics developed from crush analysis of the cars (14, 18, 20, 26). Such models

may be one-dimensional, planar, or three-dimensional, depending upon the details of the equipment and collision condition being analyzed. Analyses based on conservation of momenta and conservation of energy can also provide useful information on the trajectories and crush of the equipment during a collision. Full-scale (24, 26) and subscale (30) tests can also be made of collision dynamics. Figure 3 shows a three-dimensional lumped-parameter model of a passenger train impacting a fixed barrier. The barrier has been removed from the figure to show the behavior of the train. Results of train collision dynamics evaluations include loss of occupant volume, which can be used to estimate the number of fatalities. Results also include decelerations of the occupant volumes, which is used in test and analysis of occupant dynamics.

Occupant dynamics can be evaluated using lumped-parameter models, with non-linear characteristics to represent the behavior of human joints under impact conditions (16). A relatively simple one-dimensional model can also be used to evaluate the potential for head injury due to impact with a compliant surface (18). Dynamic sled tests of interior configurations, with instrumented test dummies to measure the forces and decelerations that would be imparted to occupants can also be used to evaluate occupant dynamics (13). Interior configurations with test dummies can also be used as part of full-scale tests of rail cars and trains (22, 25). Figure 3 shows a photograph from a sled test of rows of commuter passenger seats. Results of occupant dynamics evaluations include the forces and decelerations that would be experienced by occupants under the conditions analyzed or tested. The likelihood of injury and fatality can be estimated from the forces and decelerations experienced by the occupants (16, 18).

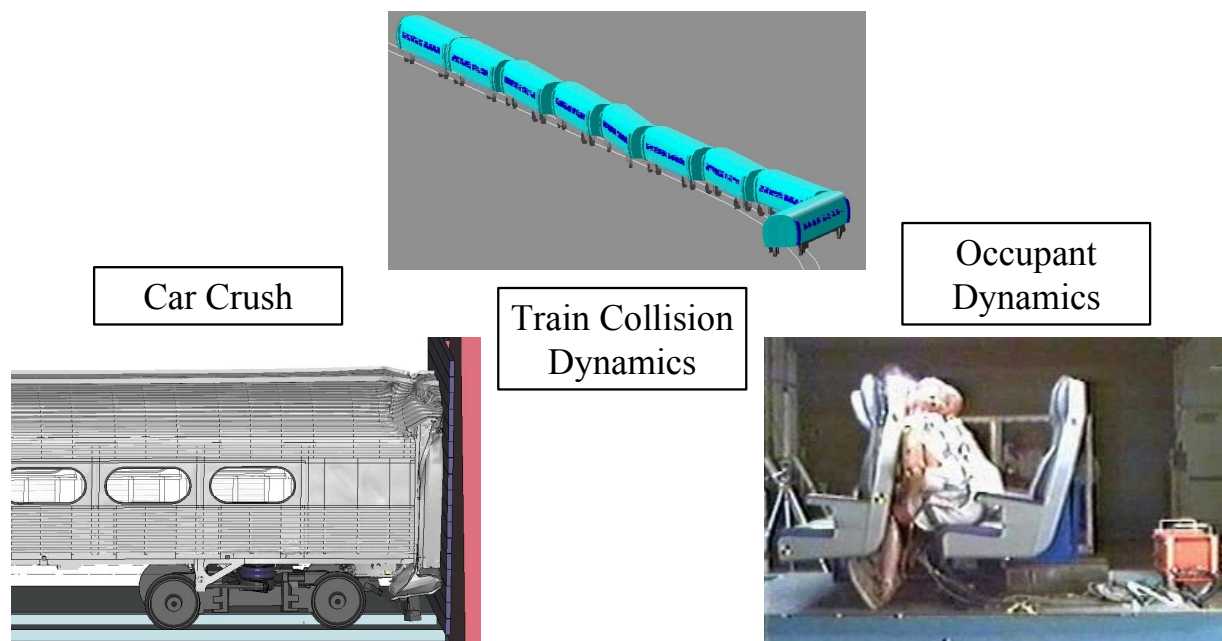

**Figure 3. Illustration of evaluation techniques for demonstrating compliance with performance requirements.**

For passenger equipment operated at speeds below 200 kph (125 mph), performance standards include 49CFR § 238.201 Scope/alternative compliance, 49CFR §238.203 Static end strength (grandfathering), and 49 CFR § 238.211 (c) Collision Posts (exemption for articulated equipment), and 49CFR§ 238.233 Interior fittings and surfaces (4). The first three regulations



only apply to equipment that does not comply with one or more of the design regulations. Alternative compliance allows for exception to all of the design regulations except buff strength, if an equivalent level of safety to equipment compliant with the design regulations can be shown. Grandfathering allows equipment that is not compliant with the 3.56 MN (800 kip) static end strength requirement to remain in service, if it was in operation when the rule became effective and if it can be shown that such service “is in the public interest and consistent with railroad safety.” Articulated equipment may be exempted from the collision post design requirements if it can be shown “that the articulated connection is capable of preventing disengagement and telescoping to the same extent as equipment satisfying the anti-climbing and collision post” design requirements. The APTA recommended practices SS-C&S-034-99 Section 7.0 Analysis and SS-C&S-034-99 Section 8.0 Tests (7) provide guidance on approaches that may be used to show compliance with the performance requirements. The regulation for interior fittings and surfaces apply to essentially all passenger equipment operated at speeds less than 200 kph (125 mph). This regulation requires that the seats remain attached when an interior seating arrangement with test dummies is decelerated with a prescribed crash pulse. The APTA standard SS-C&S-016-99, Standard for Seating in Commuter Rail Cars, adds requirements that the human injury criteria for such a situation remain within survivable levels (3).

For passenger equipment operated at speeds greater than 200 kph (125 mph), performance standards include 49CFR § 238.403 Crash energy management, and 49 CFR § 238.435 Interior fittings and surfaces (4). These regulations apply to all equipment operated above 200 kph (125 mph). The crash energy management regulation requires, where practical, that the unoccupied sections of the train be designed to collapse in a controlled fashion. The train must be capable of absorbing 13 MJ of energy, with the leading end of the locomotive capable of absorbing 5 MJ, the trailing end of the locomotive capable of absorbing 3 MJ, and the leading end of the first passenger car behind the locomotive capable of absorbing 5 MJ. The deceleration of the passenger cars must not exceed 8 G’s for a 48 kph (30 mph) head-on collision with an identical train, when the crash pulse is filtered with a 50 Hz low-pass filter. The crash energy management regulation is illustrated schematically in Figure 4. The APTA PRESS Manual includes SS-C&S-034-99 Section 6.0 Crash Energy Management Recommended Practice (7). This recommended practice does not prescribe crashworthiness performance, but rather outlines a general approach for developing crash energy management equipment.

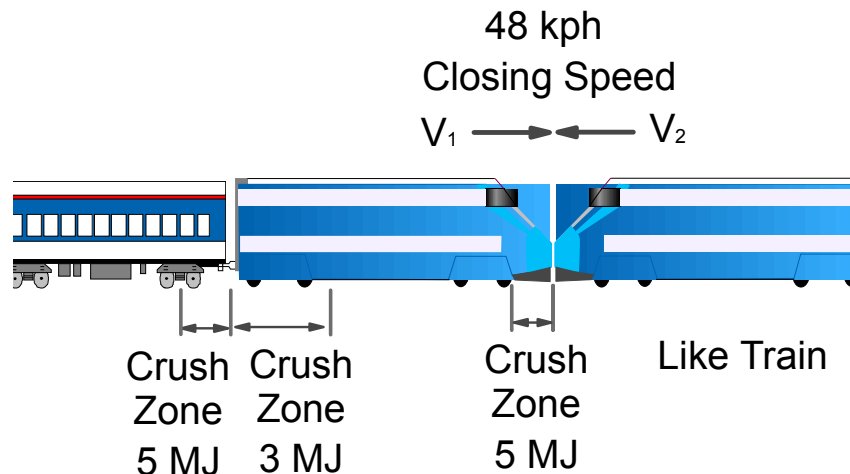

**Figure 4. Schematic illustration of crash energy management requirements for high-speed passenger trains.**

#### **4. SUMMARY**

Specifications for crashworthiness can be either design standards or performance standards. Design standards prescribe requirements under some intermediate condition, not necessarily directly related to the conditions expected in a collision, while performance standards attempt to prescribe desired performance under conditions closely related to the conditions expected in a collision. Compliance with design standards can be verified with relatively simple closed-form calculations or non-destructive tests. Compliance with performance standards typically requires detailed numerical simulation, destructive tests or some combination. The principal advantages of performance requirements is that they require fewer assumptions on the design approaches or details of the equipment and that required performance is more closely related to the desired performance under collision conditions.

Modern computers and computer-aided engineering tools allow accurate simulation of rail equipment crashworthiness, and have minimized the need for relatively expensive destructive tests. Passenger equipment regulations and industry standards have recently been introduced; these regulations, standards, and recommended practices contain performance requirements as well as enhancements to previously existing design requirements. The RSAC Locomotive Crashworthiness Working Group is currently considering alternative means of specifying crashworthiness, including specifying equipment performance under prescribed impact conditions. Specifying crashworthiness with performance under impact conditions is also likely to be considered in the next phase of passenger equipment rulemaking by the FRA.

#### **5. ACKNOWLEDGEMENTS**

The author would like to thank Dr. Tom Tsai, Program Manager, and Ms. Claire Orth, Division Chief, Equipment and Operating Practices Research Division, Office of Research and Development, Federal Railroad Administration, for their support. The author would also like to thank Mr. Grady Cothen, Deputy Associate Administrator for Safety Standards and Program Development, Federal Railroad Administration, for his efforts to coordinate the regulations and standards development with the crashworthiness research. Finally, the author would like to thank Ms. Kristine Severson, Senior Engineer, Volpe Center, Mr. Eloy Martinez, Senior Engineer, Volpe Center, and Professor A. Benjamin Perlman, Tufts University, for reviewing this paper.

#### **6. REFERENCES**

1. Tyrell, D., "Rail Passenger Equipment Accidents and the Evaluation of Crashworthiness Strategies", Institute of Mechanical Engineers, May 2001.
2. Association of American Railroads, Technical Services Division, Mechanical Section - Manual of Standards and Recommended Practices, "Locomotive Crashworthiness Requirements, Standard S-580," Adopted: 1989, Revised, 1994.
3. American Public Transportation Association, Member Services Department, Manual of Standards and Recommended Practices for Passenger Rail Equipment, Issue of July 1, 1999.

4. U.S. Department of Transportation, Federal Railroad Administration, "49 CFR Part 216 et al., Passenger Equipment Safety Standards; Final Rule," Federal Register, May 12, 1999.
5. Tyrell, D., Severson, K., Marquis, B., Martinez, E., Mayville, R., Rancatore, R., Stringfellow, R., Hammand, R., Perlman, A.B., 1999, "Locomotive Crashworthiness Design Modifications Study," Proceedings of the 1999 IEEE/ASME Joint Railroad Conference, April 13-15, 1999, IEEE Catalog Number 99CH36340, ASME RTD Volume 16.
6. Martinez, E., Tyrell, D., "Alternative Analyses of Locomotive Structural Designs for Crashworthiness," presented at the 2000 International Mechanical Engineering Congress and Exposition, November 6, 2000, Orlando, Florida.
7. American Public Transportation Association, Member Services Department, APTA SS-C&S-034-99 Standard for the Design and Construction of Passenger Railroad Rolling Stock, Authorized January 11, 2000.
8. 49 United States Code 20133, Swift Rail Development Act, November 2, 1994.
9. U.S. Department of Transportation, Federal Railroad Administration, "49 CFR Parts 223, 229, 232, and 238 Passenger Equipment Safety Standards; Proposed Rule," Federal Register, June 17, 1996
10. U.S. Department of Transportation, Federal Railroad Administration, "49 CFR Part 216 et al., Passenger Equipment Safety Standards; Proposed Rule," Federal Register, September 23, 1997.
11. Bing, A., 1993, "Collision Avoidance and Accident Survivability, Volume 4: Proposed Specifications" DOT/FRA/ORD-93-02.IV, FRA, U.S. Department of Transportation.
12. Tyrell, D.C., A Rubin, editors, 1998, "Proceedings of the Symposium on Rail Vehicle Crashworthiness, June 1996", U.S. Department of Transportation, DOT/FRA/ORD-97/08.
13. Tyrell, D., Severson, K.J., "Crashworthiness Testing of Amtrak's Traditional Coach Seat", U.S. Department of Transportation, DOT/FRA/ORD-96/08, October 1996.
14. Tyrell, D.C., Severson, K.J., Mayville, R.A., Stringfellow, R.G., Berry, S., Perlman, A.B., 1997, "Evaluation of Cab Car Crashworthiness Design Modifications," Proceedings of the 1997 IEEE/ ASME Joint Railroad Conference, IEEE Catalog Number 97CH36047.
15. Federal Railroad Administration, "Locomotive Crashworthiness and Cab Working Conditions Report to Congress", Office of Safety Assurance and Compliance, 1996.
16. Tyrell, D.C., Severson, K.J., Marquis, B.J., 1995, "Analysis of Occupant Protection Strategies in Train Collisions," ASME International Mechanical Engineering Congress and Exposition, AMD-Vol. 210, BED-Vol. 30, pp. 539-557.
17. Tyrell, D.C., Severson, K.J., Marquis, B.J., 1995, "Train Crashworthiness Design for Occupant Survivability," ASME International Mechanical Engineering Congress and Exposition, AMD-Vol. 210, BED-Vol. 30, pp. 59-74.
18. Tyrell, D.C., Severson, K.J., Marquis, B.J., 1998, "Crashworthiness of Passenger Trains", U.S. Department of Transportation, DOT/FRA/ORD-97/10.

19. Tyrell, D.C., Martinez, E.E., Wierzbicki, T., "Crashworthiness Studies of Locomotive Wide Nose Short Hood Designs," Crashworthiness, Occupant Protection and Biomechanics in Transportation Systems, American Society of Mechanical Engineers, AMD Vol. 237/BED Vol. 45, 1999.
20. Tyrell, D., Severson, K., Marquis, B., Perlman, A.B., "Simulation of an Oblique Collision of a Locomotive and an Intermodal Container," Crashworthiness, Occupant Protection and Biomechanics in Transportation Systems, American Society of Mechanical Engineers, AMD Vol. 237/BED Vol. 45, 1999.
21. Tyrell, D., Severson, K., Perlman, A.B., March, 2000, "Single Passenger Rail Car Impact Test Volume I: Overview and Selected Results," U.S. Department of Transportation, DOT/FRA/ORD-00/02.1.
22. VanIngen-Dunn, C., March 2000, "Single Passenger Rail Car Impact Test Volume II: Summary of Occupant Protection Program," U.S. Department of Transportation, DOT/FRA/ORD-00/02.2.
23. Tyrell, D., Severson, K., Perlman, A.B., Brickle, B., VanIngen-Dunn, C., "Rail Passenger Equipment Crashworthiness Testing Requirements and Implementation," presented at the 2000 International Mechanical Engineering Congress and Exposition, November 6, 2000, Orlando, Florida.
24. Severson, K., Tyrell, D., Perlman, A.B., "Rail Passenger Equipment Collision Tests: Analysis of Structural Measurements," presented at the 2000 International Mechanical Engineering Congress and Exposition, November 6, 2000, Orlando, Florida.
25. Tyrell, D., Zolock, J., VanIngen-Dunn, C., "Rail Passenger Equipment Collision Tests: Analysis of Occupant Protection Measurements," presented at the 2000 International Mechanical Engineering Congress and Exposition, November 6, 2000, Orlando, Florida.
26. Severson, K., "Development of Collision Dynamics Models to Estimate the Results of Full-scale Rail Vehicle Impact Tests," Tufts University Master's Thesis, November 2000.
27. White, J.H., Jr., "The American Railroad Passenger Car," The Johns Hopkins University Press, 1978.
28. Woodbury, C.A., 3<sup>rd</sup>, "North American Passenger Equipment Crashworthiness: Past, Present, and Future," in "Rail Vehicle Crashworthiness Symposium," DOT/FRA/ORD-97/08, 1998.
29. Mayville, R.A., Hammond, R.P., Johnson, K.N., 1999, "Static and Dynamic Crush Testing and Analysis of a Rail Vehicle Corner Structural Element," Proceedings of the 8th ASME Symposium on Crashworthiness, Occupant Protection and Biomechanics in Transportation November 14-19, 1999; Nashville, Tennessee.
30. Holmes, B.S. and J.D. Colton, "Application of Scale Modeling Techniques to Crashworthiness Research," Kenneth J. Saczalski, et al. Editors, Aircraft Crashworthiness, Charlottesville, VA: University Press of Virginia, 1975.