

TECHNICAL REPORT STANDARD TITLE PAGE

1. Report No. FHWA/TX-92/1219-1F		2. Government Accession No.		3. Recipient's Catalog No.	
4. Title and Subtitle Two Post Drivable Sign Supports				5. Report Date November 1991	
				6. Performing Organization Code	
7. Author(s) James R. Morgan and D. Lance Bullard, Jr.				8. Performing Organization Report No. Report 1219-1F	
9. Performing Organization Name and Address Texas Transportation Institute The Texas A&M University System College Station, Texas 77843-3135				10. Work Unit No.	
				11. Contract or Grant No. Study No. 2-5-91-1219	
12. Sponsoring Agency Name and Address Texas Department of Transportation P.O. Box 5051 Austin, Texas 78763				13. Type of Report and Period Covered Final - September 1990- August 1991	
				14. Sponsoring Agency Code	
15. Supplementary Notes Research performed in cooperation of the U.S. Department of Transportation and Federal Highway Administration. Research Study Title: Two Post Driveable Sign Supports					
16. Abstract  <p>Small sign supports and installations represent a major and ongoing investment by the Texas Department of Transportation. The development of a generic system could result in substantial savings without sacrificing safety. To this end, during the period of 10/21/1987 - 8/31/1989, the Texas Department of Transportation and the Texas Transportation Institute conducted research project 2-18-88-1122. A single post system was developed and tested as a part of the project. In addition, a driveable anchor was developed and tested for tubular sign supports. The anchor successfully met all current federal impact performance criteria for single post installations in either strong or weak soils (NCHRP Report 230 classification S1 and S2, respectively). Also, the anchor installation proved to be fully reusable following impact by a test vehicle. The anchor is easily driven and was designed to minimize field maintenance problems (such as leaning posts). While this anchor system has received good reviews, the two-post version with current 2-3/8 inch diameter steel tube sign posts fails to meet federal impact performance criteria for low impact speeds.</p> <p>The concept of developing a successful generic dual post sign support system was extended under this study. Successful development and implementation of such a system would permit the vast majority of all small sign installations to be treated as a single system. This will result in substantial savings in acquisition, replacement and inventory costs.</p>					
17. Key Words sign supports, driveable, safety			18. Distribution Statement No restrictions. This document is available to the public through the National Technical Information Service. 5285 Port Royal Road Springfield, Virginia 22161		
19. Security Classif. (of this report) Unclassified		20. Security Classif. (of this page) Unclassified		21. No. of Pages 96	
				22. Price	



---

**TWO POST DRIVABLE SIGN SUPPORTS**

Study No. 2-5-91-1219

Prepared by:  
James R. Morgan  
D. Lance Bullard, Jr.

Prepared for:  
Texas Department of Transportation  
Austin, Texas

---

TEXAS TRANSPORTATION INSTITUTE  
TEXAS A&M UNIVERSITY SYSTEM  
COLLEGE STATION, TEXAS 77843

August 1991



# METRIC (SI\*) CONVERSION FACTORS

## APPROXIMATE CONVERSIONS TO SI UNITS

Symbol	When You Know	Multiply By	To Find	Symbol
<b>LENGTH</b>				
in	inches	2.54	centimetres	cm
ft	feet	0.3048	metres	m
yd	yards	0.914	metres	m
mi	miles	1.61	kilometres	km

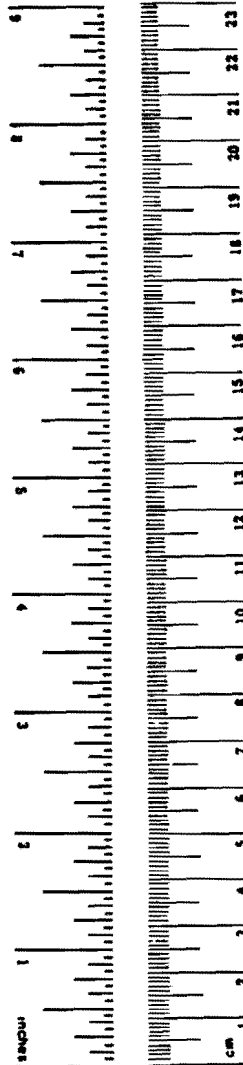

<b>AREA</b>				
in <sup>2</sup>	square inches	645.2	centimetres squared	cm <sup>2</sup>
ft <sup>2</sup>	square feet	0.0929	metres squared	m <sup>2</sup>
yd <sup>2</sup>	square yards	0.836	metres squared	m <sup>2</sup>
mi <sup>2</sup>	square miles	2.59	kilometres squared	km <sup>2</sup>
ac	acres	0.395	hectares	ha

<b>MASS (weight)</b>				
oz	ounces	28.35	grams	g
lb	pounds	0.454	kilograms	kg
T	short tons (2000 lb)	0.907	megagrams	Mg

<b>VOLUME</b>				
fl oz	fluid ounces	29.57	millilitres	mL
gal	gallons	3.785	litres	L
ft <sup>3</sup>	cubic feet	0.0328	metres cubed	m <sup>3</sup>
yd <sup>3</sup>	cubic yards	0.0765	metres cubed	m <sup>3</sup>

NOTE: Volumes greater than 1000 L shall be shown in m<sup>3</sup>.

## TEMPERATURE (exact)

°F	Fahrenheit temperature	5/9 (after subtracting 32)	Celsius temperature	°C
----	------------------------	----------------------------	---------------------	----

## APPROXIMATE CONVERSIONS TO SI UNITS

Symbol	When You Know	Multiply By	To Find	Symbol
<b>LENGTH</b>				
mm	millimetres	0.039	inches	in
m	metres	3.28	feet	ft
m	metres	1.09	yards	yd
km	kilometres	0.621	miles	mi

<b>AREA</b>				
mm <sup>2</sup>	millimetres squared	0.0016	square inches	in <sup>2</sup>
m <sup>2</sup>	metres squared	10.764	square feet	ft <sup>2</sup>
km <sup>2</sup>	kilometres squared	0.39	square miles	mi <sup>2</sup>
ha	hectares (10 000 m <sup>2</sup> )	2.53	acres	ac

<b>MASS (weight)</b>				
g	grams	0.0353	ounces	oz
kg	kilograms	2.205	pounds	lb
Mg	megagrams (1 000 kg)	1.103	short tons	T

<b>VOLUME</b>				
mL	millilitres	0.034	fluid ounces	fl oz
L	litres	0.264	gallons	gal
m <sup>3</sup>	metres cubed	35.315	cubic feet	ft <sup>3</sup>
m <sup>3</sup>	metres cubed	1.308	cubic yards	yd <sup>3</sup>

## TEMPERATURE (exact)

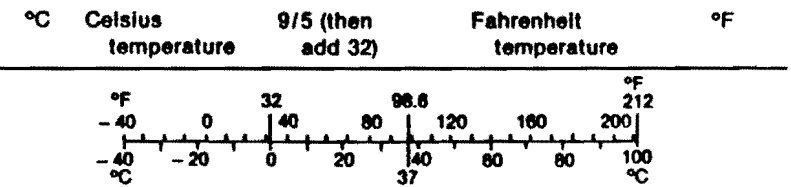

These factors conform to the requirement of FHWA Order 5190.1A.

\* SI is the symbol for the International System of Measurements



## **DISCLAIMER**

This document is disseminated under the sponsorship of the Texas Department of Transportation in the interest of information exchange. The Texas Department of Transportation assumes no liability for its contents or use thereof. The contents of this report reflect the views of the authors who are solely responsible for the opinions, findings, and conclusions presented herein. The report does not necessarily reflect the official views or policies of the Texas Department of Transportation. This report does not constitute a standard, specification, or regulation.

The Texas Department of Transportation does not endorse products or manufacturers. Trade or manufacturers' names may appear herein only because they are considered essential to the object of this document.





## PREFACE

Small sign supports and installations represent a major and ongoing investment by the Texas Department of Transportation. The development of a generic system could result in substantial savings without sacrificing safety. To this end, during the period of 10/21/1987 - 8/31/1989, the Texas Department of Transportation and the Texas Transportation Institute conducted research project 2-18-88-1122. A single post system was developed and tested as a part of the project. In addition, a driveable anchor was developed and tested for tubular sign supports. The anchor successfully met all current federal impact performance criteria for single post installations in either strong or weak soils (NCHRP Report 230 classification S1 and S2, respectively). Also, the anchor installation proved to be fully reusable following impact by a test vehicle. The anchor is easily driven and was designed to minimize field maintenance problems (such as leaning posts). While this anchor system has received good reviews, the two-post version with current 2-3/8 inch diameter steel tube sign posts fails to meet federal impact performance criteria for low impact speeds.

The concept of developing a successful generic dual post sign support system was extended under this study. Successful development and implementation of such a system would permit the vast majority of all small sign installations to be treated as a single system. This will result in substantial savings in acquisition, replacement and inventory costs.



## TABLE OF CONTENTS

Disclaimer	ii
Preface	iii
Table of Contents	iv
List of Tables	v
List of Figures	vi
Introduction & Study Approach	1
Static Load Tests	2
Pendulum Tests	3
Full-Scale Crash Tests	12
Description of Test Installation	12
Description of Crash Test Procedures	13
Data Analysis Procedures	13
Crash Test Results	14
Test 1219-1	14
Test 1219-2	15
Tests 1219-3&4	16
Test 1219-5	17
Test 1219-6	18
Conclusions	70
Appendix A - Static load tests: force-displacement curves	71
Appendix B - Tensile coupons: load-strain curves	83



**LIST OF TABLES**

<u>Table</u>	<u>Title</u>	<u>Page</u>
1.	Performance Evaluation Summary - Pendulum Tests . . . . .	4



## LIST OF FIGURES

<u>Figure</u>	<u>Title</u>	<u>Page</u>
1.	Pendulum longitudinal accelerometer trace (1219-P1) . . . . .	5
2.	Pendulum longitudinal accelerometer trace (1219-P2) . . . . .	6
3.	Pendulum longitudinal accelerometer trace (1219-P3) . . . . .	7
4.	Pendulum longitudinal accelerometer trace (1219-P4) . . . . .	8
5.	Pendulum longitudinal accelerometer trace (1219-P5) . . . . .	9
6.	Pendulum longitudinal accelerometer trace (1219-P6) . . . . .	10
7.	Pendulum longitudinal accelerometer trace (1219-P7) . . . . .	11
8.	1122 Generic anchor system . . . . .	20
9.	Vehicle before test 1219-1 . . . . .	22
10.	Sign installation before test 1219-1 . . . . .	23
11.	Vehicle/sign geometrics (test 1219-1) . . . . .	24
12.	Test vehicle properties (1219-1 & 2) . . . . .	25
13.	Sequential photographs of test 1219-1 . . . . .	26
14.	Sign installation after test 1219-1 . . . . .	27
15.	Vehicle after test 1219-1 . . . . .	28
16.	Summary of results for test 1219-1 . . . . .	29
17.	Vehicle angular displacement for test 1219-1 . . . . .	30
18.	Longitudinal accelerometer trace (1219-1) . . . . .	31
19.	Lateral accelerometer trace (1219-1) . . . . .	32
20.	Vertical accelerometer trace (1219-1) . . . . .	33
21.	Vehicle before test 1219-2 . . . . .	34
22.	Sign installation before test 1219-2 . . . . .	35
23.	Sequential photographs of test 1219-2 . . . . .	36
24.	Sign installation after test 1219-2 . . . . .	38
25.	Vehicle after test 1219-2 . . . . .	39
26.	Summary of results for test 1219-2 . . . . .	40
27.	Vehicle angular displacement for test 1219-2 . . . . .	41
28.	Longitudinal accelerometer trace (1219-2) . . . . .	42

**LIST OF FIGURES (continued)**

<u>Figure</u>	<u>Title</u>	<u>Page</u>
29.	Lateral accelerometer trace (1219-2) . . . . .	43
30.	Vertical accelerometer trace (1219-2) . . . . .	44
31.	Vehicle before test 1219-5 . . . . .	45
32.	Sign installation before test 1219-5 . . . . .	46
33.	Vehicle/sign geometrics (test 1219-5) . . . . .	47
34.	Test vehicle properties (1219-5) . . . . .	48
35.	Sequential photographs of test 1219-5 . . . . .	49
36.	Sign installation after test 1219-5 . . . . .	51
37.	Vehicle after test 1219-5 . . . . .	52
38.	Summary of results for test 1219-5 . . . . .	53
39.	Vehicle angular displacement for test 1219-5 . . . . .	54
40.	Longitudinal accelerometer trace (1219-5) . . . . .	55
41.	Lateral accelerometer trace (1219-5) . . . . .	56
42.	Vertical accelerometer trace (1219-5) . . . . .	57
43.	Vehicle before test 1219-6 . . . . .	58
44.	Sign installation before test 1219-6 . . . . .	59
45.	Vehicle/sign geometrics (test 1219-6) . . . . .	60
46.	Test vehicle properties (1219-6) . . . . .	61
47.	Sequential photographs of test 1219-6 . . . . .	62
48.	Sign installation after test 1219-6 . . . . .	64
49.	Vehicle after test 1219-6 . . . . .	65
50.	Summary of results for test 1219-6 . . . . .	66
51.	Vehicle angular displacement for test 1219-6 . . . . .	67
52.	Longitudinal accelerometer trace (1219-6) . . . . .	68
53.	Lateral accelerometer trace (1219-6) . . . . .	69



## INTRODUCTION & STUDY APPROACH

The Texas Department of Transportation (TxDOT) contracted with the Texas Transportation Institution (TTI) to develop, crash test, and evaluate the performance of a generic two post driveable sign support system. The scope of this project included an examination of suitability of the generic driveable sign support anchor developed under a previous project (#1122), the adaptability of this anchor to different post materials and the crash testing of generic dual post sign systems.

The primary objective of the study was to determine if a generic driveable dual post sign support system can satisfy safety impact criteria. The following two modifications were made to the current steel post system in an effort to meet the project objectives:

1. Increase the diameter of the sign support to 3 inches (thereby decreasing required wall thickness of the steel sign post and allowing easier collapsing of the tube during impact), and
2. study alternative [to the set screw used in the 1122 design] attachment details between the post and the anchor (possibly allowing easier pullout of the sign post from the anchor under impact conditions while still providing vandal resistance).

Increasing the sign post diameter to 3 in and altering the attachment mechanism also allows for wider availability of alternative materials such as aluminum or fiber reinforced plastic with adequate bending capacity to support wind loads. These substitutions may afford superior impact performance but also should increase competition thereby reducing overall cost of the system.

In addition, static and pendulum tests were performed during the development phase of this project to 1) study the pull out characteristics of the various post-to-anchor attachment systems, 2) verify wind load performance and 3) to study the performance of the modified breakaway systems under low speed impacts.

The final phase of this project was full-scale vehicle crash testing. The crash tests performed allowed for assessment of the actual safety performance of the appurtenance in both strong and weak soils (NCHRP Report 230 classification S1 and S2, respectively).

## STATIC LOAD TESTS

Static load tests were conducted using a small sign support test apparatus developed at TTI. Each static load test was conducted on a single support that was securely held vertical and fixed against rotation while applying a horizontal concentrated load at a distance of 9 ft (2.7 m) above the theoretical ground surface. Loading was perpendicular to the plane of the post and applied continuously by means of a actuated hydraulic cylinder. The applied load was measured using a load cell, also mounted 9 ft (2.7 m) above the ground surface. In addition, sign post angle of rotation was measured near the theoretical ground surface. The effective load and angle of rotation were electronically recorded. Loading of the post specimen continued until a buckling failure occurred. The maximum load recorded prior to failure defined the capacity of the support. Load versus displacement graphs for each configuration tested are shown in Appendix A. For the purposes of this study, acceptable supports were those which provide at least as much static bending capacity as the 2-3/8 in steel Poz-Loc system currently used by TxDOT. The following supports and configurations were found to be acceptable:

Poz-Loc (0.095 in x 2-3/8 in steel tube)

HwyCom (0.25 in x 3 in FRP tube)

0.065 in x 3 in 1026 Steel Tube - with or w/o champher

0.065 in x 3 in 1026 Steel Tube - with or w/o styrene sleeve

## PENDULUM TESTS

TTI has an outdoor gravitational pendulum facility located on the Texas A&M Riverside Campus. The facility was equipped with a rigid nosed 2,250 pound pendulum and NCHRP Report 230 S-1 soil (strong) for conducting the developmental tests. Although, actual full-scale crash testing requires use of an 1,800 pound vehicle, the pendulum facility provides insight into the low speed impact performance of a system and an economical method of comparing the performance of candidate systems.

A low impedance, piezoelectric accelerometer was mounted on the rear of the pendulum to measure acceleration in the longitudinal direction. Provision was made for transmission of calibration signals before and after the test, and a accurate time reference signal was simultaneously recorded with the data. A contact switch on the pendulum was actuated just prior to impact by a wooden dowel to indicate the elapsed time over a known distance to provide a measurement of impact velocity. The initial contact also produced an "event" mark on the data record to establish the exact instant of impact. The electronic signals from the accelerometer and contact switch were telemetered to a base station for recording on magnetic tape and for display on a real-time strip chart.

A total of seven pendulum tests were conducted during the developmental effort. A performance evaluation summary of the pendulum tests is shown in Table 1. In addition, longitudinal accelerometer traces are shown in Figures 1 through 7. Tests were conducted by inserting the sign post into the modified generic anchor (with 6 inch insertion for all but test P3 which used a 12 inch insertion and a 2-1/2 in x 6 in pipe sleeve between the anchor and the post). It should be noted that in all pendulum tests, except P5 and P6, the sign post pulled out of the anchor. Comparison of the results shown clearly indicate that pullout of the sign post from the anchor is required for satisfactory impact performance.

Table 1. Performance Evaluation Summary - Pendulum Tests

<u>Test No.</u>	<u>Installation Description</u>	<u>Occ. Contact Velocity</u>	<u>Change in Vehicle Velocity</u>
1219-P1	0.065" x 3.0" 1026 Steel Tube secured w/8-18 x 3/4 Type AB Slotted Hex Head Tapping Screw, Steel.	N/A	4.02 f.p.s.
1219-P2	HWYCOM 3" Fiberglass Sign Support	N/A	1.28 f.p.s.
1219-P3	POZ-LOC 2-3/8" Steel Tube Sign Support	N/A	2.96 f.p.s.
4 1219-P4	0.065" x 3.0" 1026 Steel Tube secured w/8-18 x 3/4 Type AB Slotted Hex Head Tapping Screw, Steel. 0.030" White Styrene Sleeve inside anchor.	4.66 f.p.s.	4.62 f.p.s.
1219-P5	0.065" x 3.0" 1026 Steel Tube secured w/12-14 x 3/4 Type AB Slotted Hex Head Tapping Screw, Steel.	13.89 f.p.s.	14.42 f.p.s.
1219-P6	0.065" x 3.0" 1026 Steel Tube secured w/10-16 x 3/4 Type AB Slotted Hex Head Tapping Screw, Steel.	14.35 f.p.s.	16.19 f.p.s.
1219-P7	0.065" x 3.0" 1026 Steel Tube - unsecured	N/A	1.23 f.p.s.

# PENDELUM TEST 1219-1

## Class 180 Filter

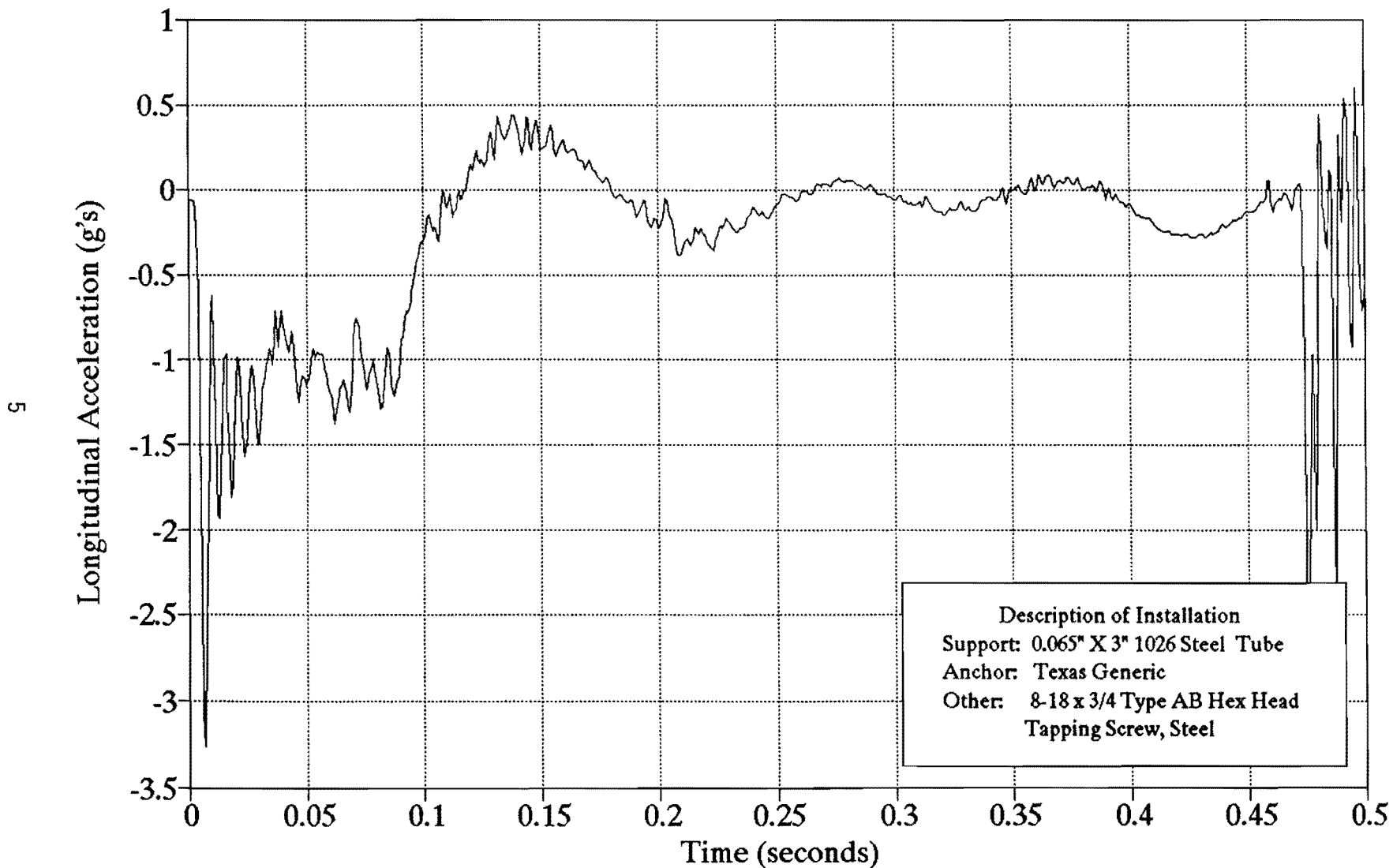

Figure 1. Pendulum longitudinal accelerometer trace (1219-P1).

# PENDELUM TEST 1219-2

## Class 180 Filter

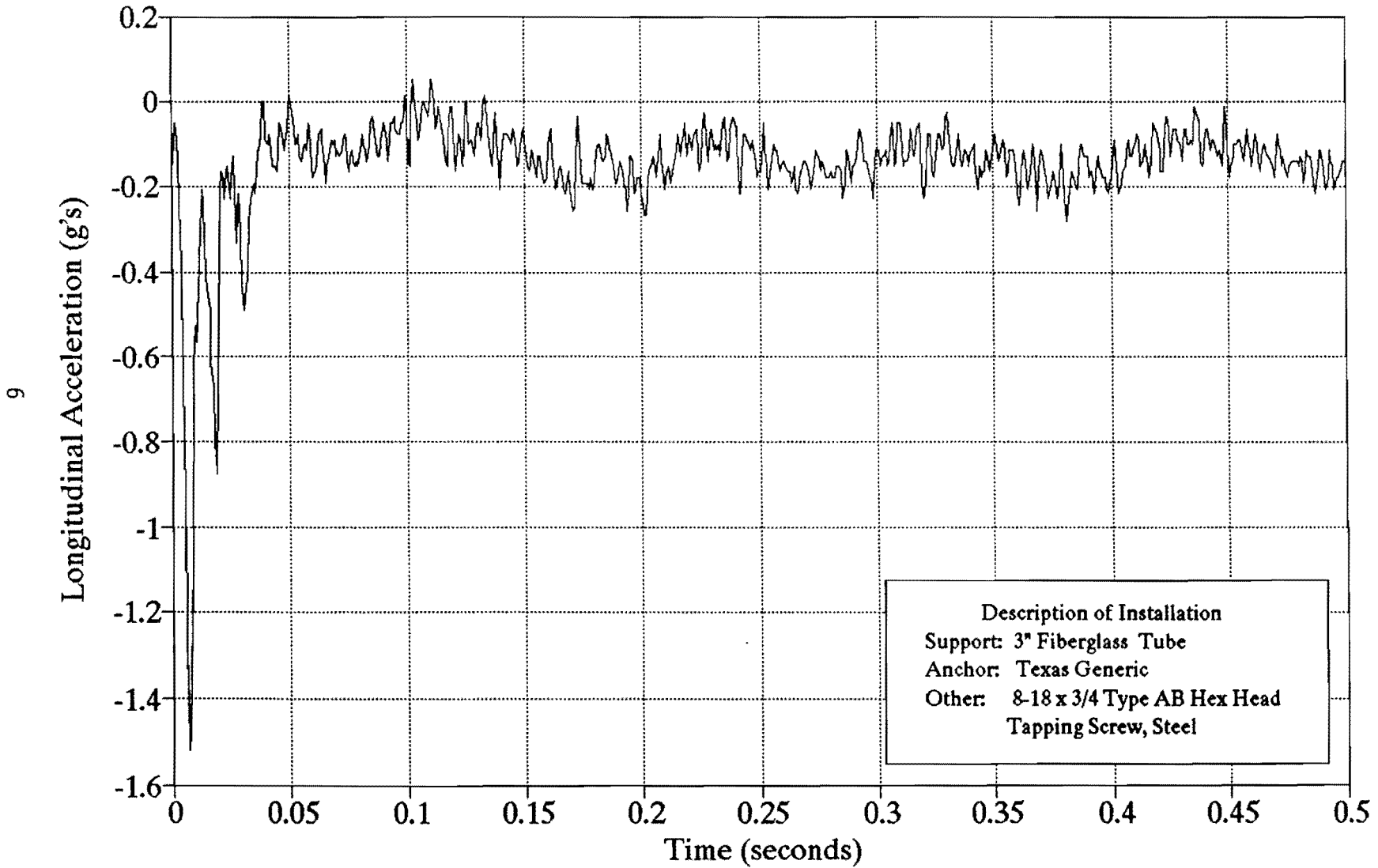

Figure 2. Pendulum longitudinal accelerometer trace (1219-P2).

# PENDELUM TEST 1219-3

## Class 180 Filter

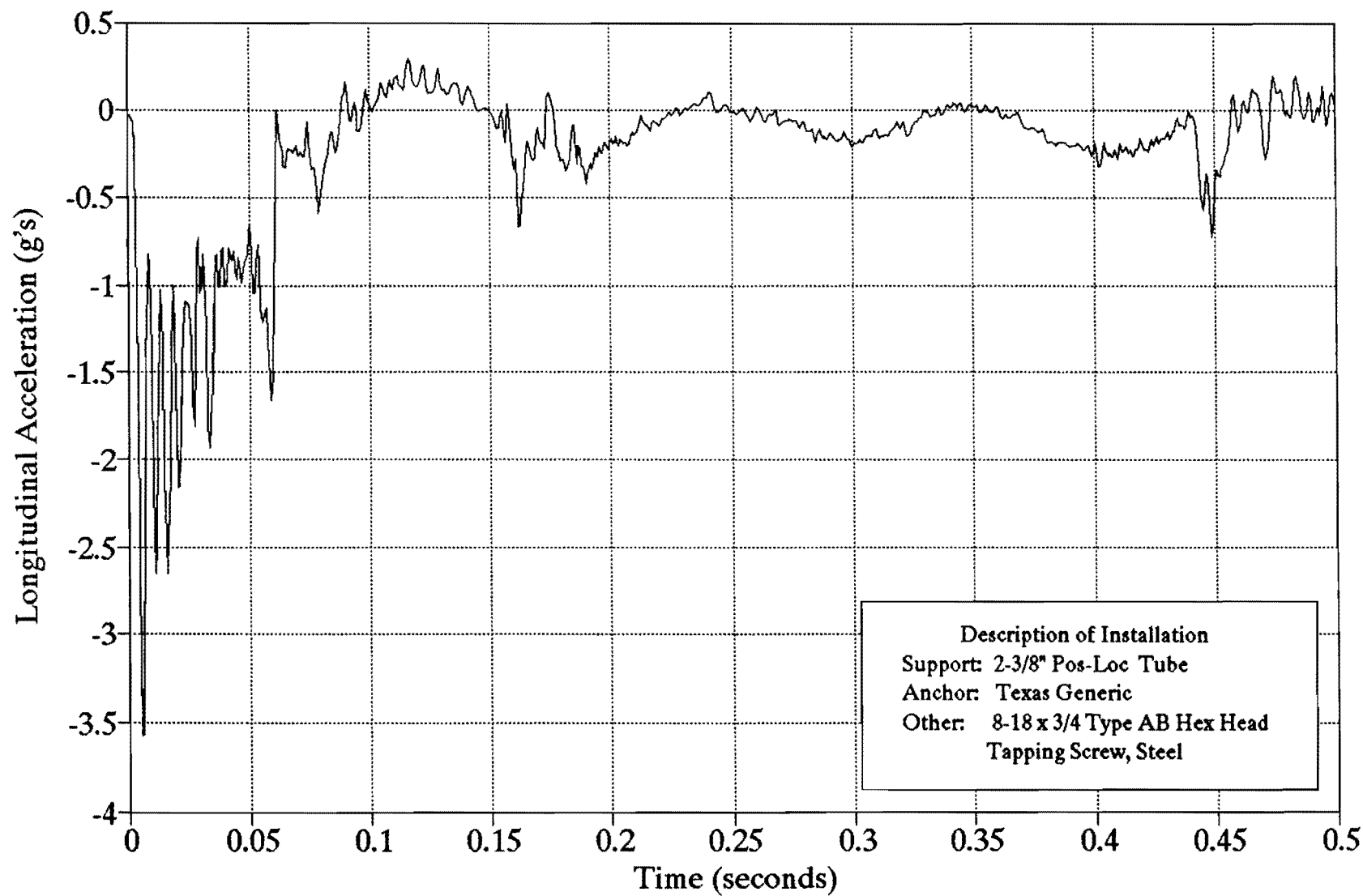

Figure 3. Pendulum longitudinal accelerometer trace (1219-P3).

# PENDELUM TEST 1219-4

## Class 180 Filter

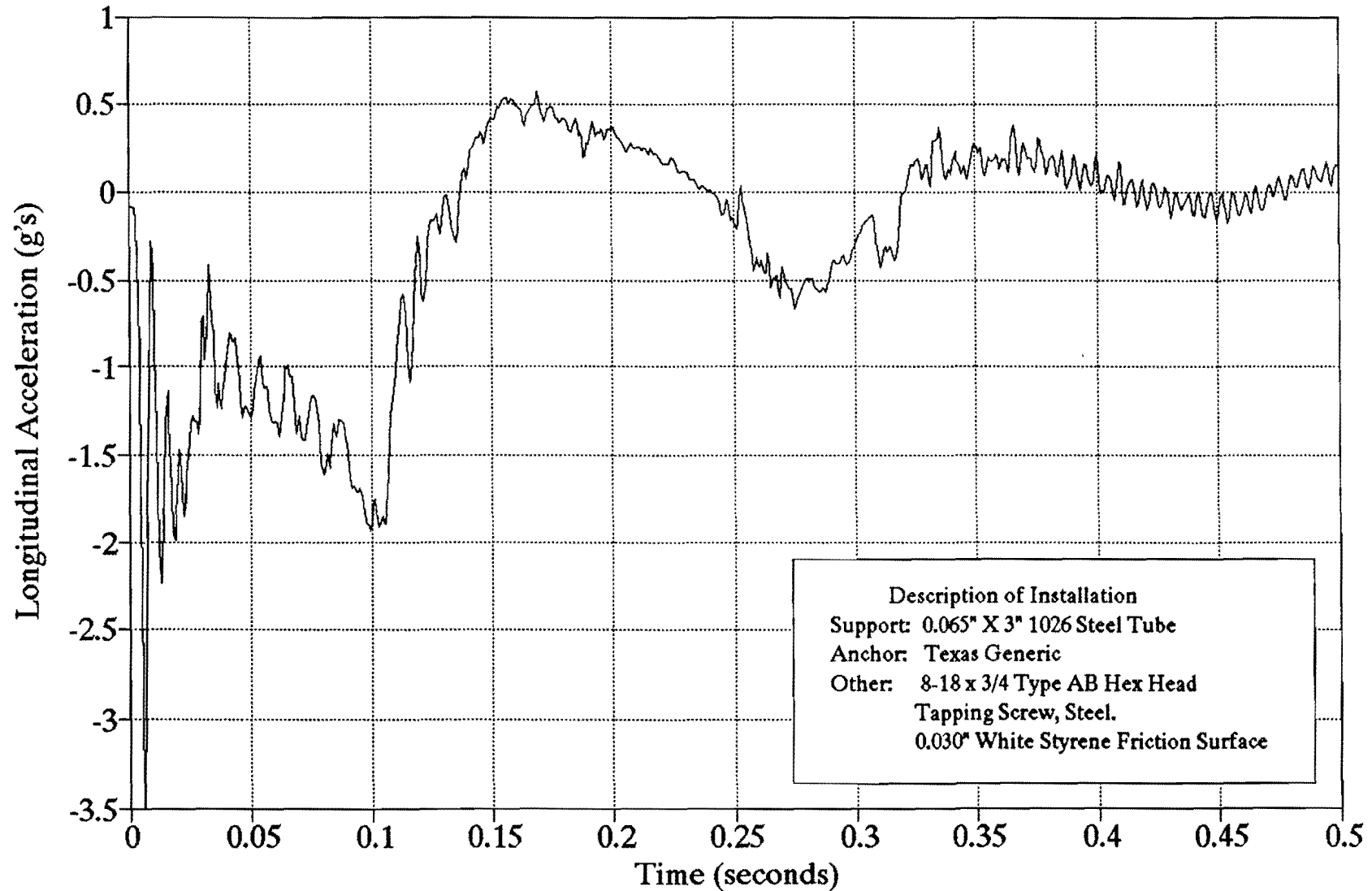

Figure 4. Pendulum longitudinal accelerometer trace (1219-P4).



# PENDELUM TEST 1219-5

## Class 180 Filter

6

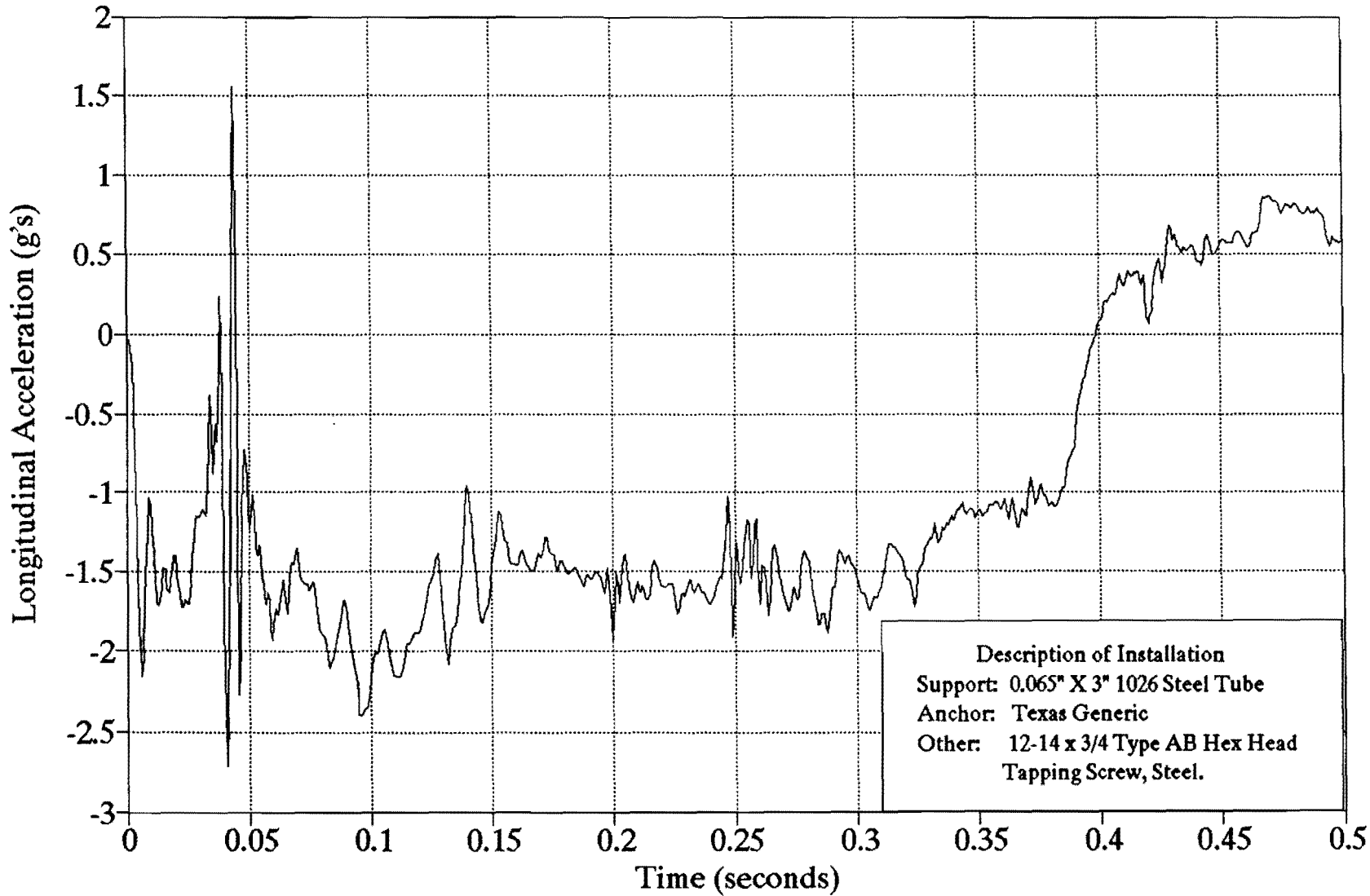

Figure 5. Pendulum longitudinal accelerometer trace (1219-P5).

# PENDELUM TEST 1219-6

## Class 180 Filter

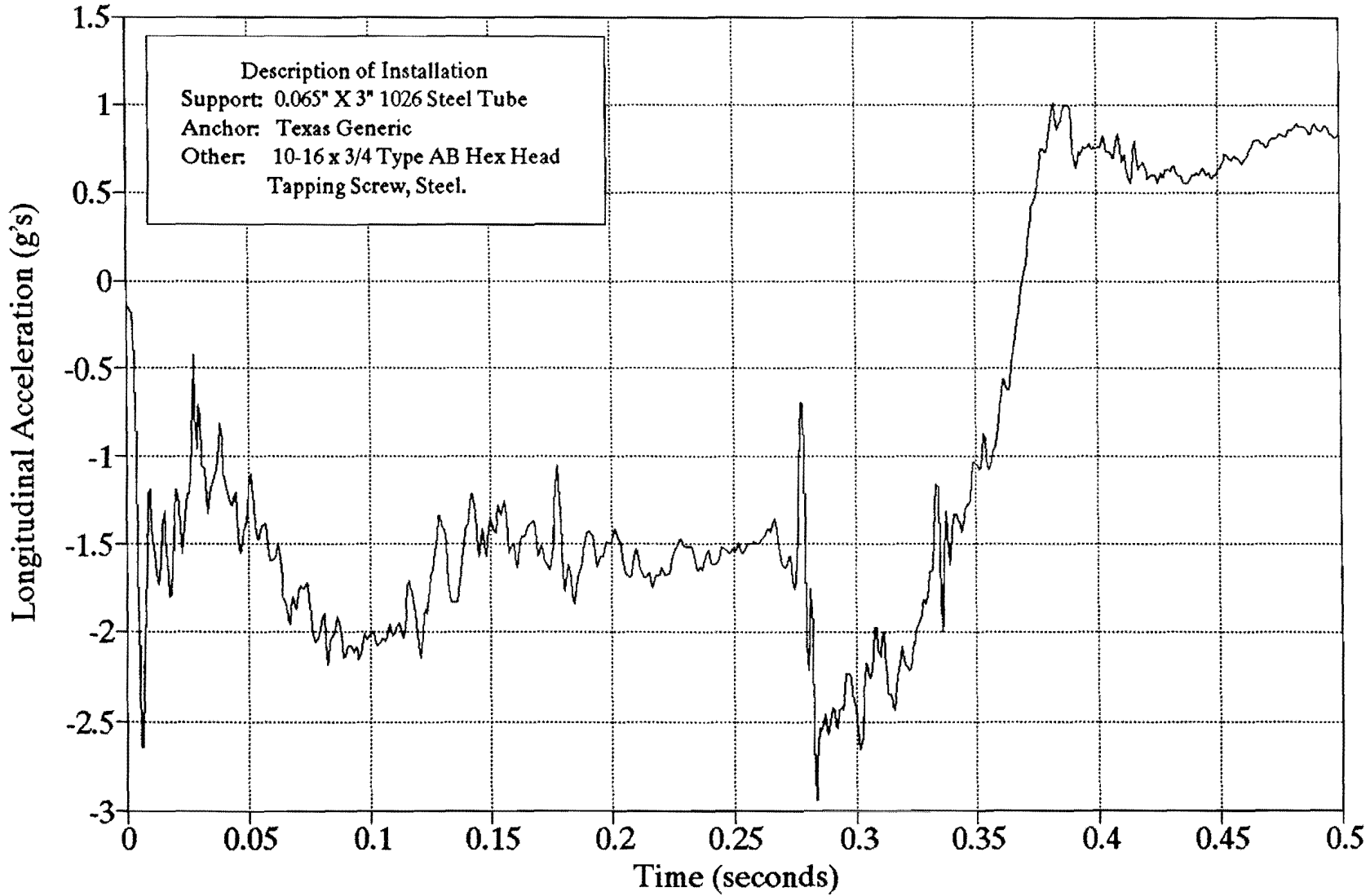

Figure 6. Pendulum longitudinal accelerometer trace (1219-P6).

# PENDELUM TEST 1219-7

## Class 180 Filter

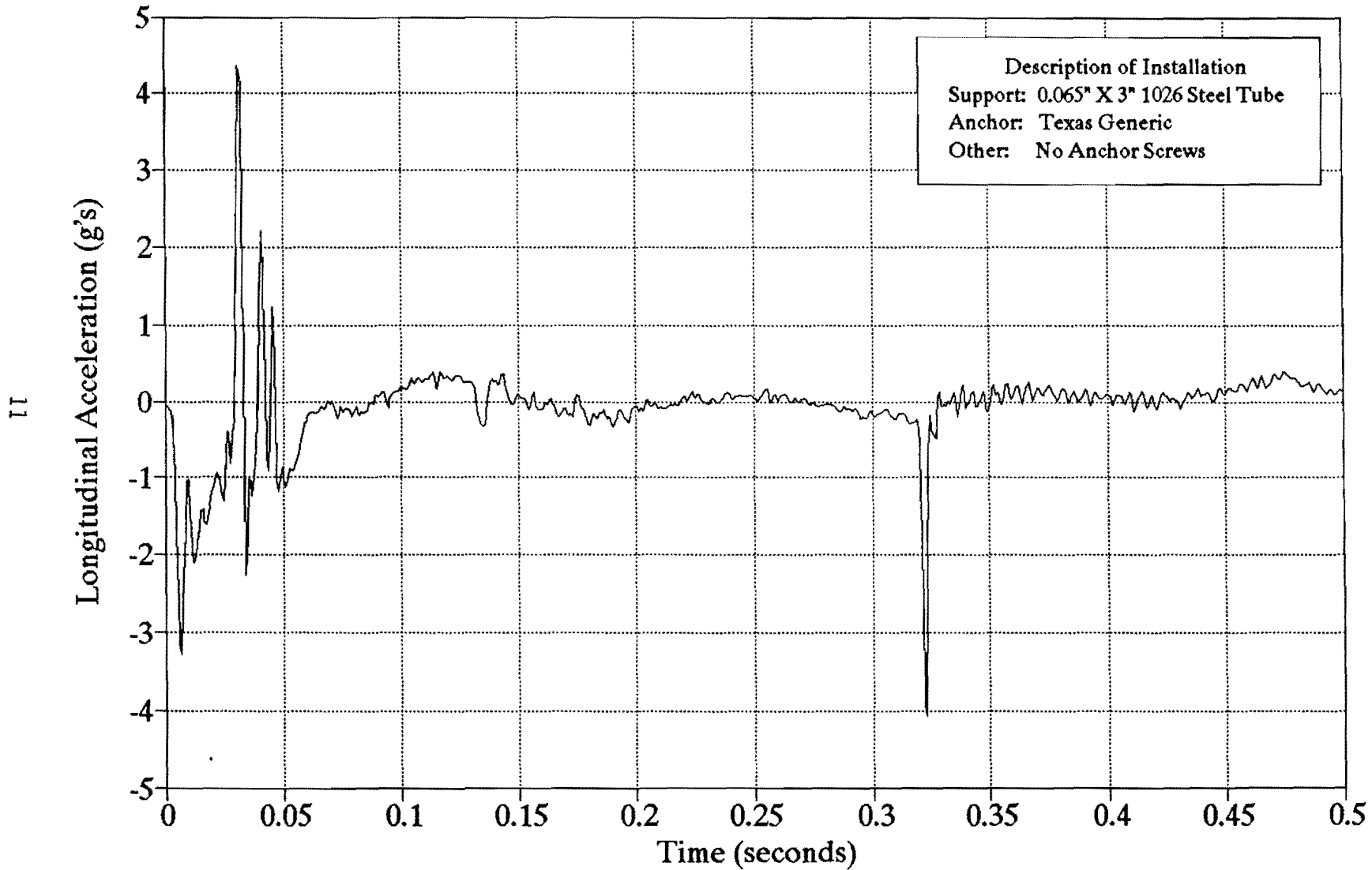

Figure 7. Pendulum longitudinal accelerometer trace (1219-P7).



## FULL-SCALE CRASH TESTS

The objective of these tests were to determine the impact characteristics of dual-support sign installations when attached to Texas Generic Sign Anchors and placed in NCHRP Report 230 "strong soil". These tests were conducted using an 1,800 lb vehicle travelling at 20 and 60.0 mi/h. Standards established in AASHTO "Standard Specifications for Structural Supports for Highway Signs, Luminaires, and Traffic Signals" and NCHRP Report 230 were used for analyses and evaluation of these tests.

### DESCRIPTION OF TEST INSTALLATION

The sign installations used in the full-scale crash tests consisted of a 5/8 in X 4 ft X 7 ft-3 in plywood sign blank mounted to two - 0.065 in x 3 in x 138 in 1026 DOM steel tube supports. Each support was placed into a Texas Generic Sign Anchor driven into either NCHRP Report 230 S-1 or S-2 (strong and weak, respectively) soil. The bottom of sign mounting height was 7 ft-0 in.

The Texas Generic Driveable Sign Anchor was developed at Texas Transportation Institute (TTI) in cooperation with the Texas Department of Transportation (TxDOT) under a previously conducted research project (Study No. 2-18-88-1122). Details of the 1122 anchor system are shown in Figure 8. The body of the 1122 anchor is constructed from 2 in schedule 40 steel pipe, 22 in. in length. Attached to the top of the 2 in pipe, by welding, is a 2-1/2 in x 6 in schedule 40 section of pipe. The 2-1/2 in pipe is used as the sign support anchoring sleeve. The 1122 anchor was modified for this project by shortening the bottom 2 in section to 16 in and adding a 3 in x 6 in schedule 40 section of pipe to the top to serve as the anchoring sleeve for a 3 in diameter sign post. This modification allows the anchor to accept either a 3 in post (with a 6 in insertion) or a 2-3/8 in post (with a 12 in insertion). The anchor is designed to be manually driven into the ground and cross anchored using three - #6 (3/4 in diameter x 36 in), grade 60 steel, concrete reinforcing bars. The cross anchors are guided and attached through 3/4 in X 4 in steel tubes welded to the outer circumference of the 2-1/2 in pipe at 120 degree intervals using 3/16 in scalloped steel plates. In addition, the steel cross anchor tubes are rotated 30 degrees off of the anchors vertical axis. The overall length of the anchor assembly is 28 in.

The sign posts are placed six inches into the 3 in pipe sleeve and in tests 1219-1,2 & 5 are secured by means of two 8-18 x 3/4 Type AB slotted hex head steel tapping screws per post. In test 1219-6 the sign post is placed six inches into the 3 in pipe sleeve but is unsecured.

## DESCRIPTION OF CRASH TEST PROCEDURES

The crash test procedures were in accordance with guidelines presented in NCHRP Report 230. The test vehicle was instrumented with three rate transducers to measure roll, pitch, and yaw rates and a triaxial accelerometer near the vehicle center of gravity to measure acceleration levels.

The electronic signals from the accelerometers and transducers were telemetered to a base station for recording on magnetic tape and for display on a real-time strip chart. Provision was made for transmission of calibration signals before and after the test, and accurate time reference signal was simultaneously recorded with the data. Contact switches on the bumper were actuated just prior to impact by wooden dowels to indicate the elapsed time over a known distance to provide a measurement of impact velocity. The initial contact also produced an "event" mark on the data record to establish the exact instant of impact.

In accordance with NCHRP Report 230, an unrestrained, uninstrumented special purpose 50th percentile anthropomorphic test dummy was positioned in the front seat of the test vehicle. This dummy was used to evaluate typical unsymmetrical vehicle mass distribution and its effect on vehicle stability during impact.

Photographic coverage of the tests included two high-speed cameras, one perpendicular to the sign installation and the other located downstream 45 degrees from the point of impact. The films from these cameras were used to observe phenomena occurring during collision and to obtain time-event, displacement and angular data. A 3/4-inch video-camera and 35 mm still cameras were also used for documentary purposes.

## DATA ANALYSIS PROCEDURES

The analog data from the accelerometers and transducers were digitized, using a microcomputer, for analysis and evaluation of performance. The digitized data were then

analyzed using two computer programs: DIGITIZE and PLOTANGLE. Brief descriptions on the functions of these two computer programs are provided as follows.

The DIGITIZE program uses digitized data from vehicle-mounted linear accelerometers to compute occupant/compartments impact velocities, time of occupant/compartments impact after vehicle impact, and the highest 0.010-second average ridedown acceleration. The DIGITIZE program also calculates vehicle impact velocity and the change in vehicle velocity at the end of a given impulse period. In addition, maximum average accelerations over 0.050-second intervals in each of three directions are computed. Acceleration versus time curves for the longitudinal, lateral, and vertical directions are then plotted from the digitized data of the vehicle-mounted linear accelerometers using commercially available software (Quattro Pro 3.0).

The PLOTANGLE program uses the digitized data from the yaw, pitch, and roll rate transducers to compute angular displacement in degrees at approximately 0.001-second intervals and then instructs a plotter to draw a reproducible plot: yaw, pitch, and roll versus time. These displacements are in reference to the vehicle-fixed coordinate system with the initial position and orientation of the vehicle-fixed coordinate system being that which existed at initial impact.

## CRASH TEST RESULTS

### Test 1219-1

A 1986 Chevrolet Sprint (shown in Figure 9) impacted the sign installation (Figures 10 and 11) at 19.9 miles per hour (32.0 km/h) using a cable reverse tow and guidance system. Test inertia mass of the vehicle was 1,800 lb (817 kg) and its gross static mass was 1,970 lb (894 kg). The height from roadway surface to the lower edge of the vehicle bumper was 15.8 inches (40.0 cm) and 21.0 inches (53.3 cm) to the top of the bumper. Other dimensions and information on the vehicle are given in Figure 12.

The vehicle was free wheeling and unrestrained just prior to impact. The point of impact was the centerline of the sign installation with the centerline of the vehicle. Upon impact, the sign supports began to yield at bumper height and ground level. By

approximately 1.816 seconds, the vehicle had come to rest 15 ft (4.6 m) from point of impact and atop the sign installation. Sequential photographs of the test are shown in Figure 13.

The installation yielded by pulling the left anchor from the ground and shearing the anchor/support attachment screws from the right anchor, allowing disengagement of the support from the anchor. In addition, the right anchor was pushed rearward and the sign support tubes bent (Figure 14). The vehicle sustained only minor damage to the bumper and right front fender as shown in Figure 15.

A summary of the test results and other information pertinent to this test are given in Figure 16. The maximum 0.050 second average acceleration experienced by the vehicle was -2.5 g in the longitudinal direction and 1.0 g in the lateral direction. Vehicle angular displacements are plotted in Figure 17 and vehicle accelerometer traces are displayed in Figures 18 through 20. Occupant impact velocity was 14.1 ft/s (4.3 m/s) and occupant ridedown acceleration was -0.6 g in the longitudinal direction. Change in vehicle velocity was 10.1 mi/h (16.3 km/h) and change in momentum was 828 lb-s.

In summary, the sign installation yielded to the vehicle. The vehicle sustained very minor damage and did not present undue hazard to other traffic. There was minimum deformation and no penetration into the occupant compartment. Occupant risk factors were within the limits specified in NCHRP Report 230. This sign installation in "weak soil" is acceptable according to the evaluation criteria recommended in NCHRP Report 230 and the 1985 AASHTO Standards.

#### Test 1219-2

The same 1986 Chevrolet Sprint (shown in Figure 21) used in the 20 mile per hour crash test was used for the 60 mile per hour test. The vehicle impacted the sign installation (Figure 22) at 64.6 miles per hour (103.9- km/hr) using a cable reverse tow and guidance system.

The vehicle was free wheeling and unrestrained just prior to impact. The point of impact was the centerline of the sign installation with the centerline of the vehicle. Upon impact, the sign supports began to buckle at bumper height. By approximately 0.053 second,



the supports had separated from the ground anchors. As the vehicle passed through the installation, the sign blank slapped the roof of the vehicle at 0.103 second. The vehicle lost contact with the installation at 0.171 second, the brakes were applied, and the vehicle came to rest approximately 300.0 ft (91.5 m) from point of impact. The sign installation came to rest 60.0 ft (18.3 m) from its originally installed position. Sequential photographs of the test are shown in Figure 23.

The installation yielded by shearing the anchor/support attachment screws and pulling the supports from the ground anchors. The anchors were pushed rearward and the sign support tubes bent (Figure 24). The vehicle sustained only minor damage to the bumper, hood and roof. In addition, the windshield was broken at the right-top-corner due to contact with the sign support. Post-test photographs of the vehicle are shown in Figure 25.

A summary of the test results and other information pertinent to this test are given in Figure 26. The maximum 0.050 second average acceleration experienced by the vehicle was -3.2 g in the longitudinal direction and 1.4 g in the lateral direction. Vehicle angular displacements are plotted in Figure 27 and vehicle accelerometer traces are displayed in Figures 28 through 30. Occupant impact velocities and ridedown accelerations were not applicable to this test. Change in vehicle velocity was 1.5 mi/h (2.5 km/h) and change in momentum was 126 lb-s.

In summary, the sign installation yielded to the vehicle. The vehicle sustained minor damage and did not present undue hazard to other traffic. There was minimal deformation and penetration into the occupant compartment. Occupant risk factors were within the limits specified in NCHRP Report 230. This sign installation in "weak soil" is acceptable according to the evaluation criteria recommended in NCHRP Report 230 and the 1985 AASHTO Standards.

#### Tests 1219-3&4

Technical difficulties encountered during testing rendered the data obtained in tests 1219-3 and 1219-4 unusable for the purposes of this project. Following equipment repair and other adjustments, these tests were rerun as tests 1219-5 and 1219-6.

### Test 1219-5

A 1987 Chevrolet Sprint (shown in Figure 31) impacted the sign installation (Figure 32 and 33) at 21.0 miles per hour (33.7 km/h) using a cable reverse tow and guidance system. Test inertia mass of the vehicle was 1,800 lb (817 kg) and its gross static mass was 1,965 lb (892 kg). The height from roadway surface to the lower edge of the vehicle bumper was 15.0 inches (38.1 cm) and 19.3 inches (48.9 cm) to the top of the bumper. Other dimensions and information on the vehicle are given in Figure 34.

The vehicle was free wheeling and unrestrained just prior to impact. The point of impact was the centerline of the sign installation with the centerline of the vehicle. Upon impact, the sign supports began to yield at bumper height and ground level. By approximately 0.209 seconds forward motion of the vehicle was arrested. Simultaneous to vehicle motion arrest, the rear wheels of the vehicle lost contact with the roadway and the dummy contacted the windshield. The vehicle came to rest at the point of impact. Sequential photographs of the test are shown in Figure 35.

The installation did not allow the vehicle to pass safely through . The support tubes yielded, but remained attached to the ground anchors. The sign installation came to rest at the point of impact on the roadway (Figure 36). The vehicle sustained damage to the bumper, grill, hood and windshield as shown in Figure 37.

A summary of the test results and other information pertinent to this test are given in Figure 38. The maximum 0.050 second average acceleration experienced by the vehicle was -5.4 g in the longitudinal direction and -1.8 g in the lateral direction. Vehicle angular displacements are plotted in Figure 39 and vehicle accelerometer traces are displayed in Figures 40 through 42. Occupant impact velocity was 23.3 ft/s (7.1 m/s) and occupant ridedown acceleration was -4.3 g in the longitudinal direction. Change in vehicle velocity was 21.0 mi/h (33.7 km/h) and change in momentum was 1722 lb-s.

In summary, the sign installation failed to yield to the vehicle. The vehicle sustained minor damage and did not present undue hazard to other traffic. There was no deformation or penetration into the occupant compartment. However, Occupant impact velocity in the longitudinal direction (23.3 ft/s) was above the recommended limit of 15 ft/s as specified in

NCHRP 230. This sign installation in "strong soil" is not acceptable according to the evaluation criteria recommended in NCHRP Report 230 and the AASHTO Standards.

#### Test 1219-6

A 1986 Yugo (shown in Figure 43) impacted the sign installation (Figures 44 and 45) at 19.8 miles per hour (31.9 km/h) using a cable reverse tow and guidance system. Test inertia mass of the vehicle was 1,800 lb (817 kg) and its gross static mass was 1,965 lb (892 kg). The height from roadway surface to the lower edge of the vehicle bumper was 13.0 inches (33.0 cm) and 18.3 inches (46.4 cm) to the top of the bumper. Other dimensions and information on the vehicle are given in Figure 46.

The vehicle was free wheeling and unrestrained just prior to impact. The point of impact was the centerline of the sign installation with the centerline of the vehicle. Upon impact, the sign supports began to yield at bumper height and ground level. By approximately 0.208 seconds forward motion of the vehicle was arrested. Simultaneous to vehicle motion arrest, the rear wheels of the vehicle lost contact with the roadway and the dummy contacted the windshield. The vehicle came to rest at the point of impact. Sequential photographs of the test are shown in Figure 47.

The installation did not allow the vehicle to pass safely through . The support tubes yielded, but remained attached to the ground anchors. The sign installation came to rest at the point of impact on the roadway (Figure 48). The vehicle sustained damage to the bumper, grill, hood and right front strut shown in Figure 49.

A summary of the test results and other information pertinent to this test are given in Figure 50. The maximum 0.050 second average acceleration experienced by the vehicle was -4.6 g in the longitudinal direction and 1.1 g in the lateral direction. Vehicle angular displacements are plotted in Figure 51 and vehicle accelerometer traces are displayed in Figures 52 through 54. Occupant impact velocity was 22.3 ft/s (6.8 m/s) and occupant ridedown acceleration was -5.4 g in the longitudinal direction. Change in vehicle velocity was 19.8 mi/h (31.9 km/h) and change in momentum was 1623 lb-s.

In summary, the sign installation failed to yield to the vehicle. The vehicle sustained minor damage and did not present undue hazard to other traffic. There was no deformation

or penetration into the occupant compartment. However, Occupant impact velocity in the longitudinal direction (22.3 ft/s) was above the recommended limit of 15 ft/s as specified in NCHRP 230. This sign installation in "strong soil" is not acceptable according to the evaluation criteria recommended in NCHRP Report 230 and the AASHTO Standards.

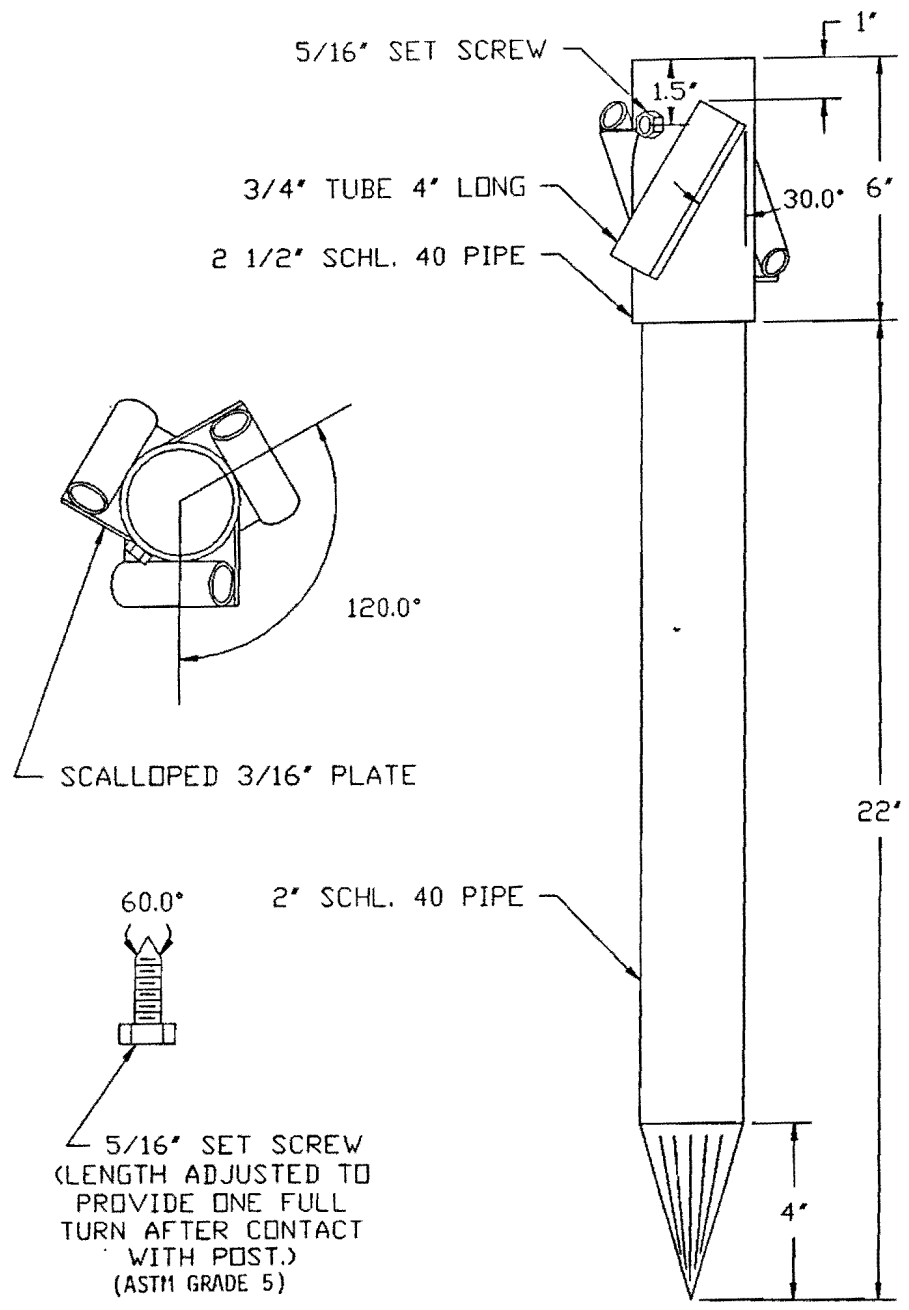

Figure 8. 1122 Generic anchor system

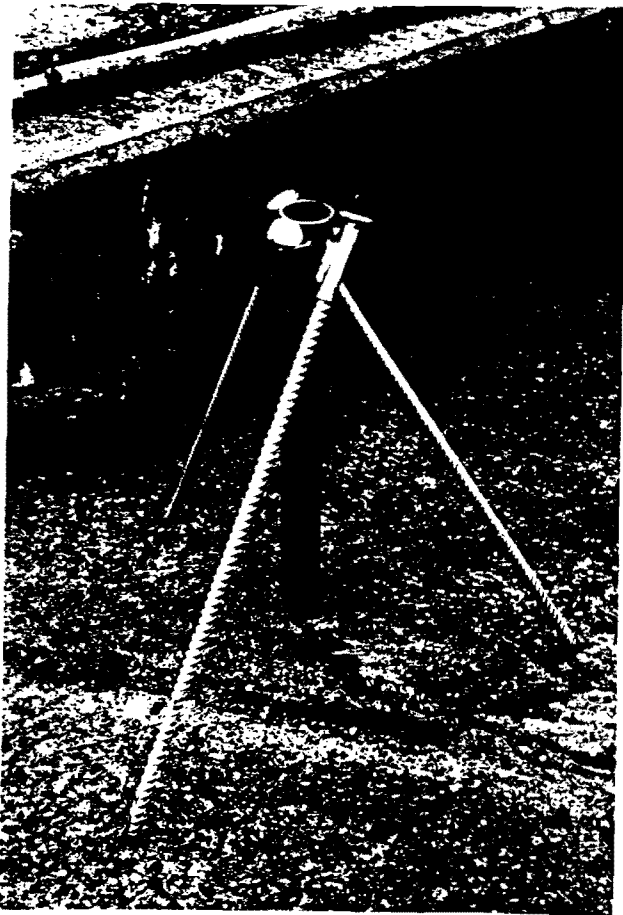
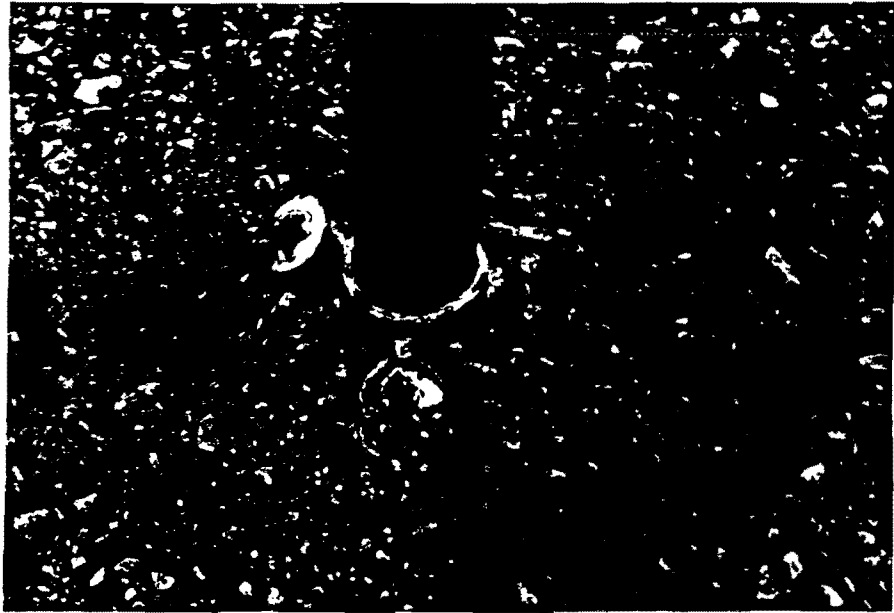

Figure 8. 1122 Generic anchor system (continued)



Figure 9. Vehicle before test 1219-1.

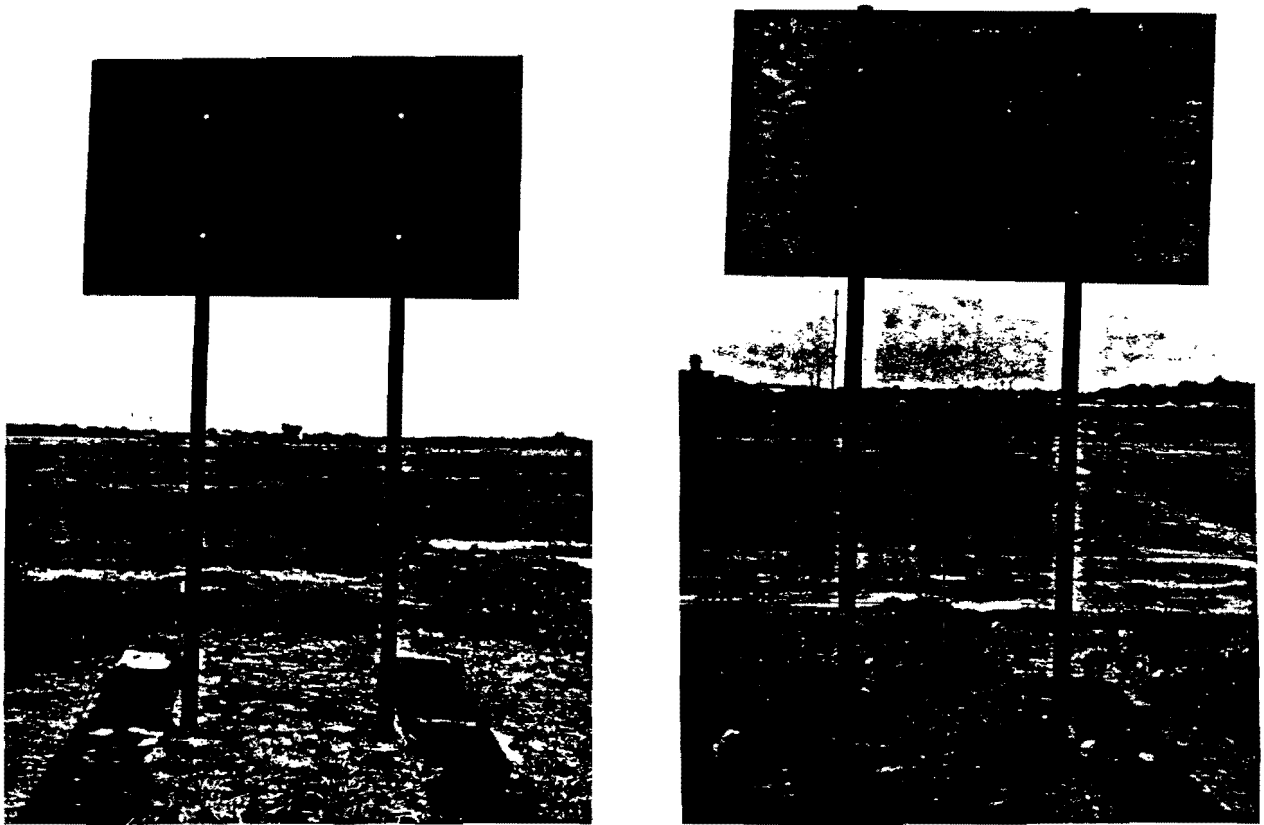

Figure 10. Sign installation before test 1219-1.



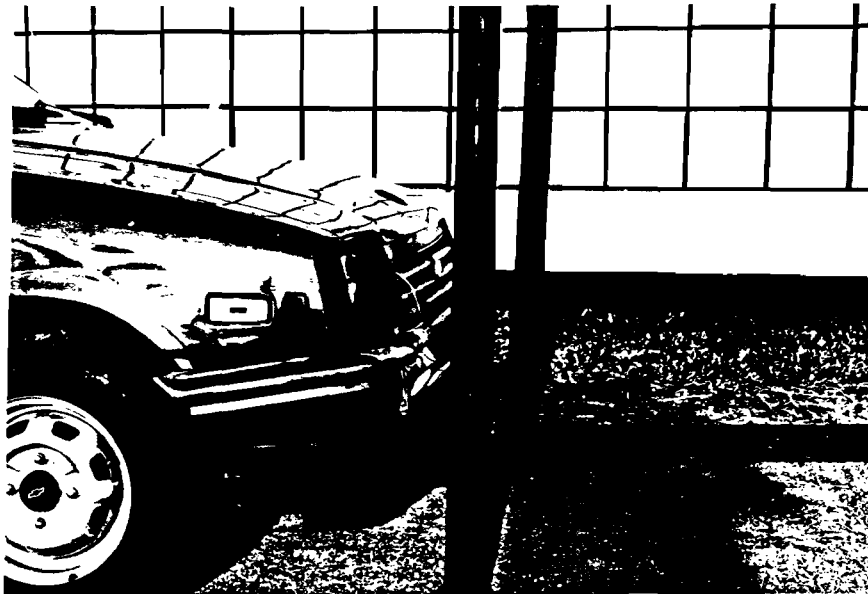
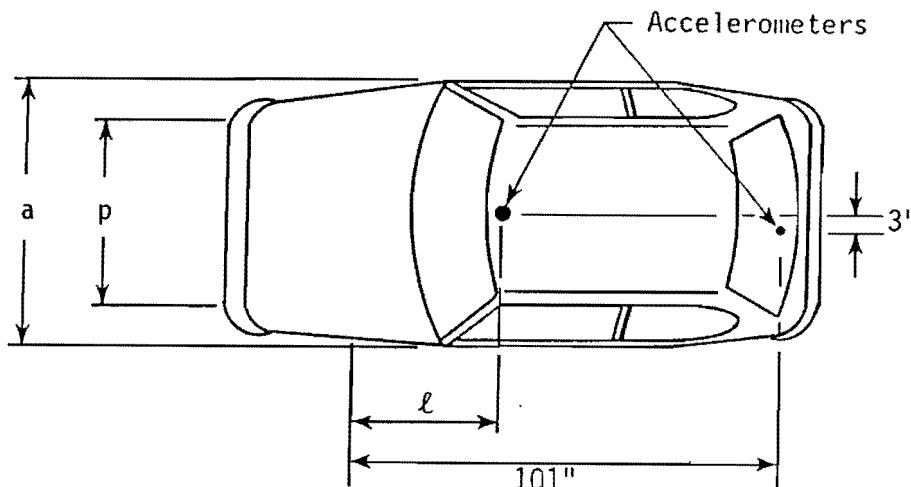

Figure 11. Vehicle/sign geometrics (test 1219-1).

Date: 08/22/91 Test No.: 1219-1 and 2 VIN: JG1MR0857GK725285

Make: Chevrolet Model: Sprint Year: 1986 Odometer: 15521

Tire Size: P145 80 R12 Ply Rating: \_\_\_\_\_ Bias Ply:  Belted:  Radial:



Tire Condition: good   
 fair   
 badly worn   
 Height of rear accelerometer 29 1/2"

Vehicle Geometry - inches

a	<u>59 3/4"</u>	b	<u>24 1/2"</u>
c	<u>88 1/2"</u>	d*	<u>52 1/2"</u>
e	<u>25 1/2"</u>	f	<u>138 1/2"</u>
g	_____	h	<u>35.3"</u>
i	<u>----</u>	j	<u>29"</u>
k	<u>14 3/4"</u>	l	<u>42 1/2"</u>
m	<u>21"</u>	n	<u>4"</u>
o	<u>15 3/4"</u>	p	<u>52"</u>
r	<u>20 1/2"</u>	s	<u>13"</u>

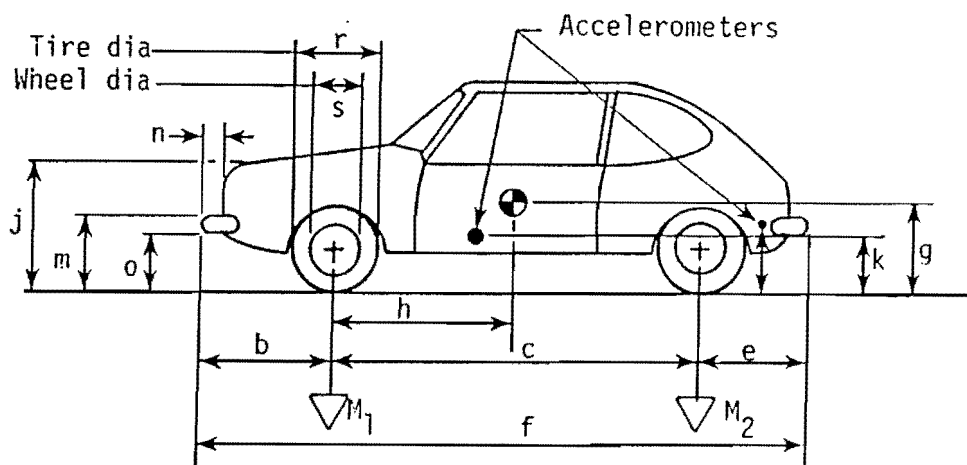

Engine Type: 3 cyl  
 Engine CID: 1.0 ltr.  
 Transmission Type: \_\_\_\_\_

~~XXXXXX~~ or Manual  
 FWD or ~~XXXX~~ or ~~XXXX~~  
 Body Type: 3 door

Steering Column Collapse Mechanism:  
 Behind wheel units  
 Convoluted tube  
 Cylindrical mesh units  
 Embedded ball  
 NOT collapsible  
 Other energy absorption  
 Unknown

Brakes:  
 Front: disc  drum \_\_\_\_\_  
 Rear: disc \_\_\_\_\_ drum

4-wheel weight for c.g. det. lf 582 rf 500 lr 365 rr 353

Mass - pounds	Curb	Test Inertial	Gross Static
M <sub>1</sub>	<u>477/931/454</u>	<u>1082</u>	<u>1165</u>
M <sub>2</sub>	<u>283/568/285</u>	<u>718</u>	<u>805</u>
M <sub>T</sub>	<u>1499</u>	<u>1800</u>	<u>1970</u>

Note any damage to vehicle prior to test:  
 ---  
 \_\_\_\_\_  
 \_\_\_\_\_

\*d = overall height of vehicle

Figure 12. Test vehicle properties (1219-1 & 2).

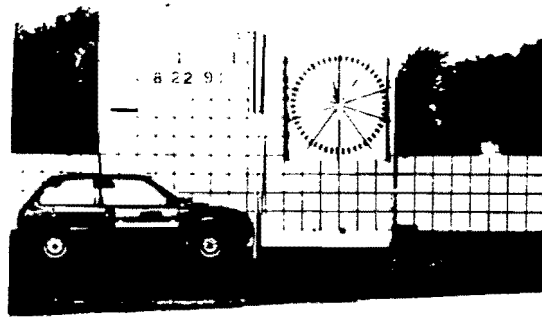

0.000 s

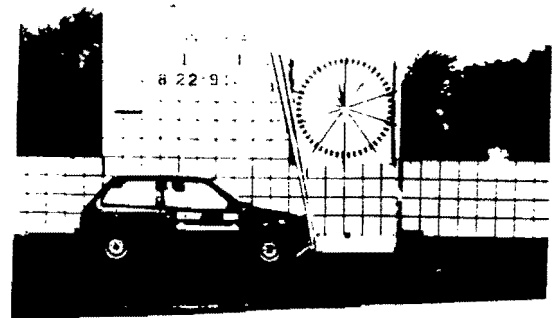

0.108 s

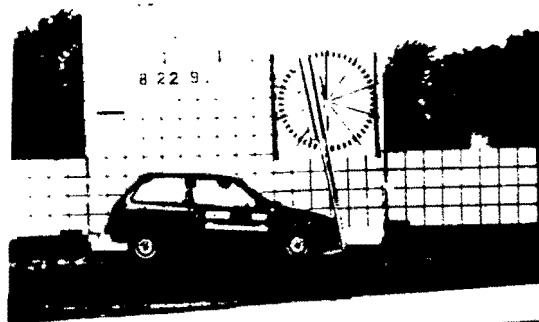

0.216 s

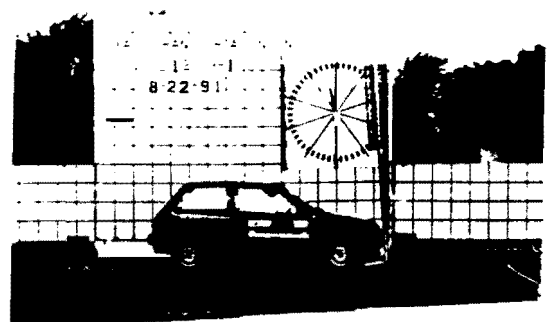

0.325 s

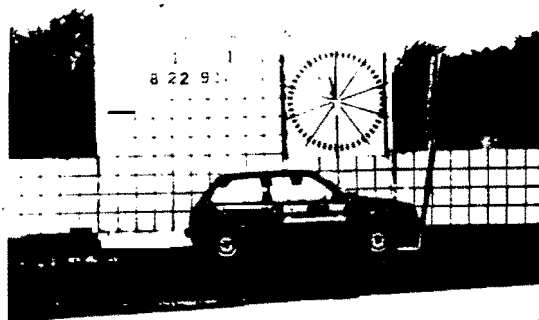

0.433 s

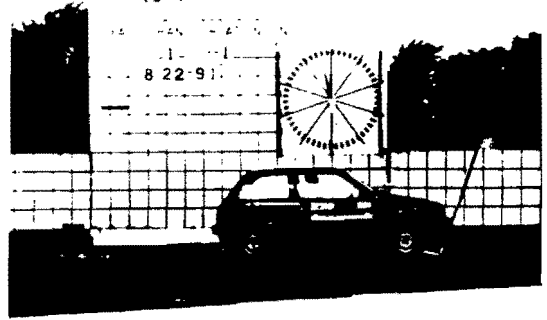

0.541 s

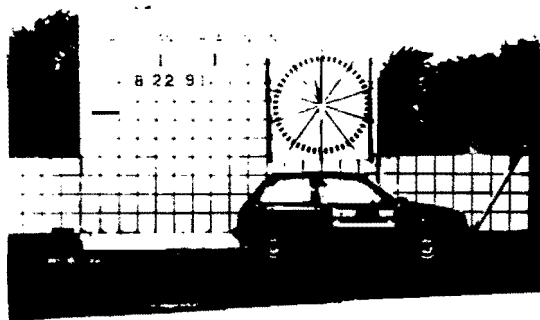

0.649 s

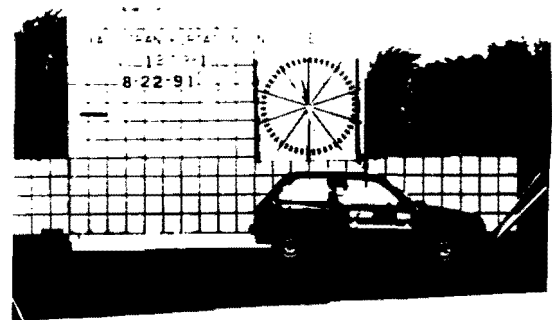

0.757 s

Figure 13. Sequential photographs of test 1219-1.

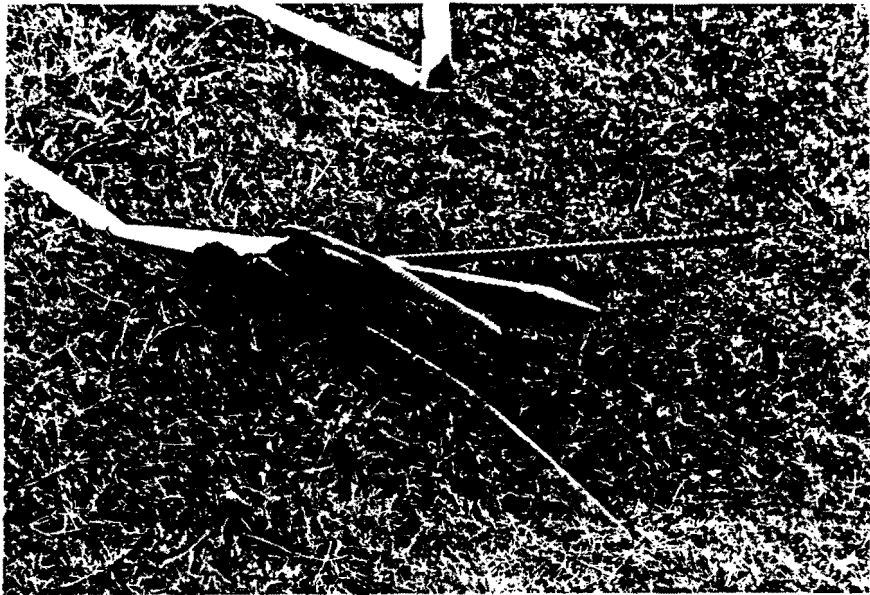
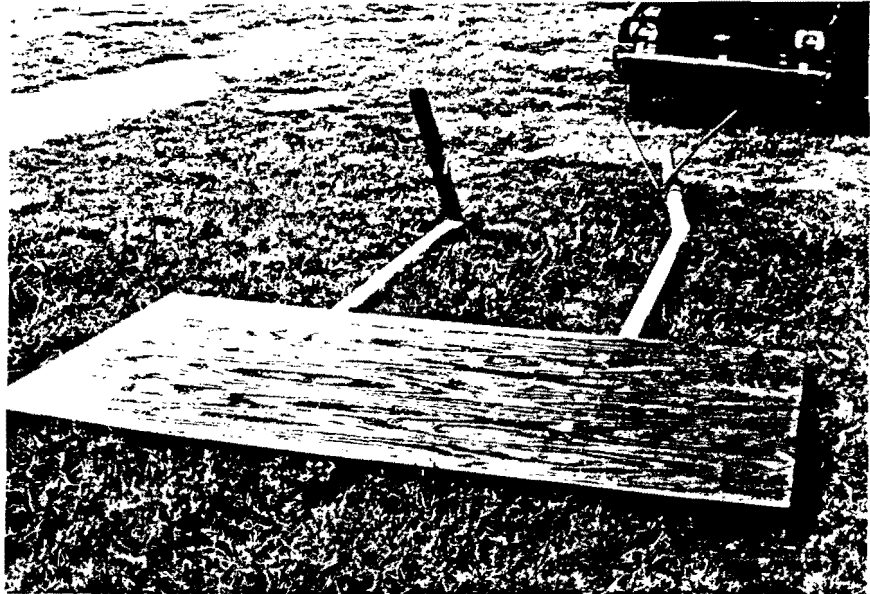

Figure 14. Sign installation after test 1219-1.

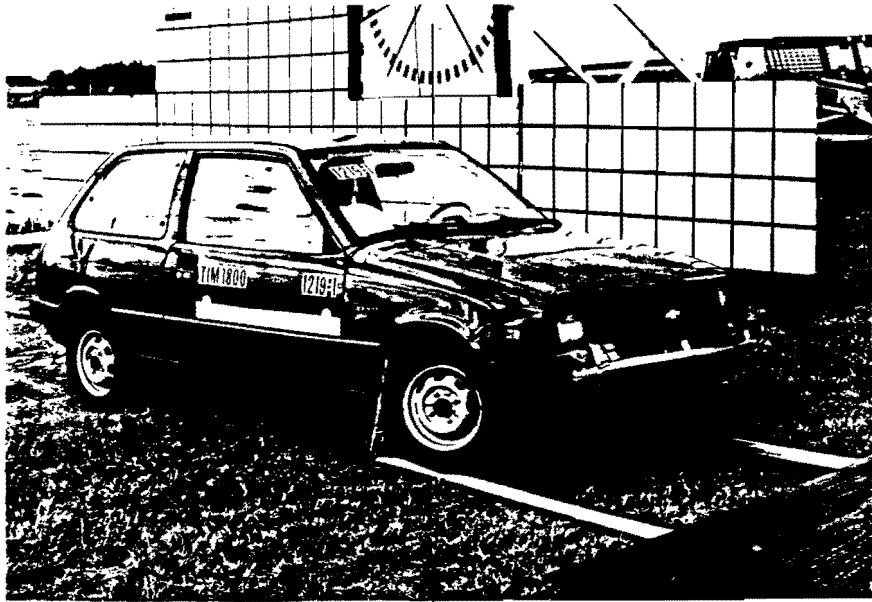
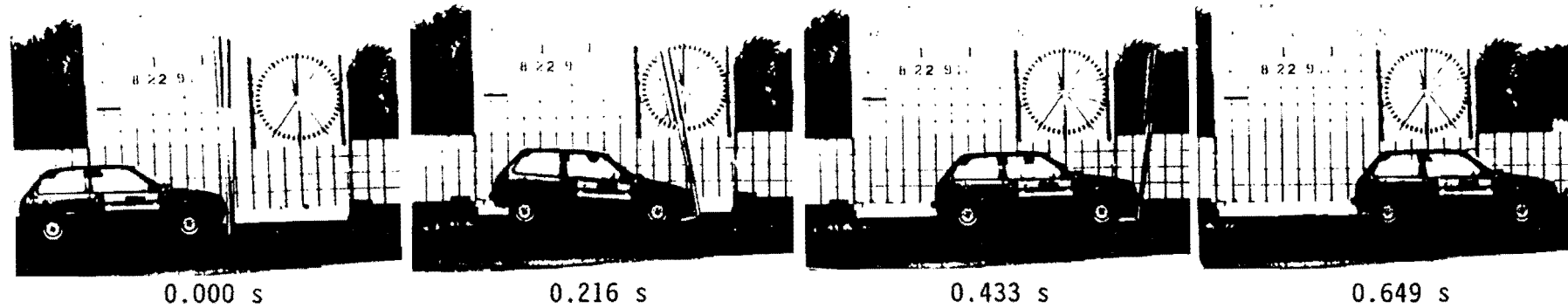

Figure 15. Vehicle after test 1219-1.



Test No. . . . . 1219-1  
 Date . . . . . 08/22/91  
 Test Article . . . . . Texas Generic  
                     Sign Anchor Installation  
 Support. . . . . 0.065 in x 3 in  
                     1026 round steel tube  
 Embedment. . . . . 28 in driven  
                     (NCHRP S-2 soil)  
 Vehicle. . . . . 1986 Chevrolet Sprint  
 Vehicle Weight  
   Test Inertia . . . . . 1,800 lb (817 kg)  
   Gross Static . . . . . 1,970 lb (894 kg)  
 Vehicle Damage Classification  
   TAD . . . . . 12FD-1  
   SAE . . . . . 12FDEW1

Impact Speed. . . . . 19.9 mi/h (32.0 km/h)  
 Change in Velocity. . . . . 10.1 mi/h (16.3 km/h)  
 Change in Momentum. . . . . 828.0 lb-s  
 Vehicle Accelerations  
   Max. (0.050-sec Avg)  
   Longitudinal. . . . . -2.5 g  
   Lateral . . . . . 1.0 g  
 Occupant Impact Velocity  
   Longitudinal. . . . . 14.1 ft/s (4.3 m/s)  
   Lateral . . . . . N/A  
 Occupant Ridedown Accelerations  
   Longitudinal. . . . . -0.6 g  
   Lateral . . . . . No Contact

Figure 16. Summary of results for test 1219-1.

○ 1219-1 r  
 △ 1219-1 p  
 ◇ 1219-1 y

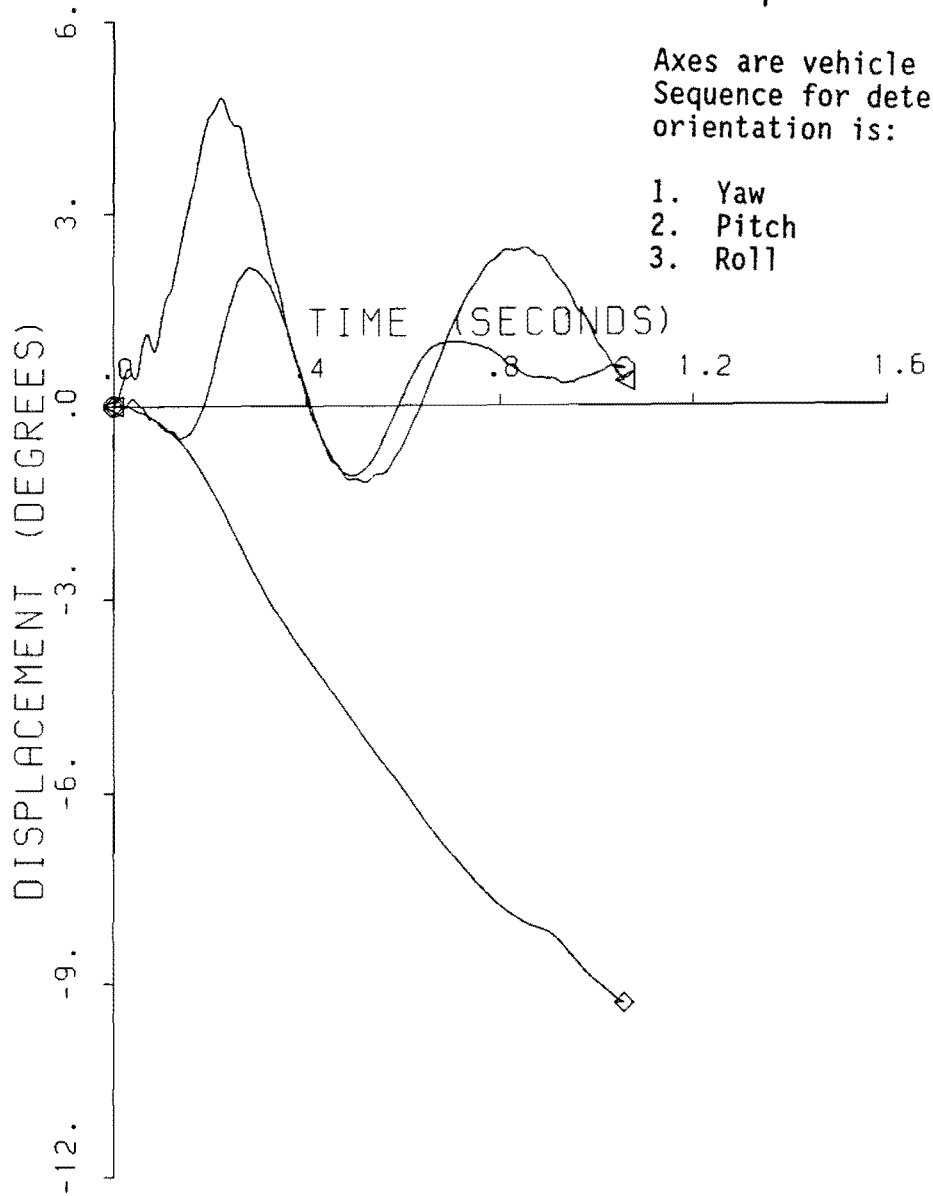
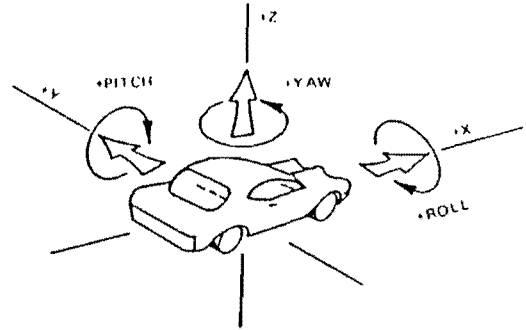

Figure 17. Vehicle angular displacement for test 1219-1.

# CRASH TEST 1219-1

## Class 180 Filter

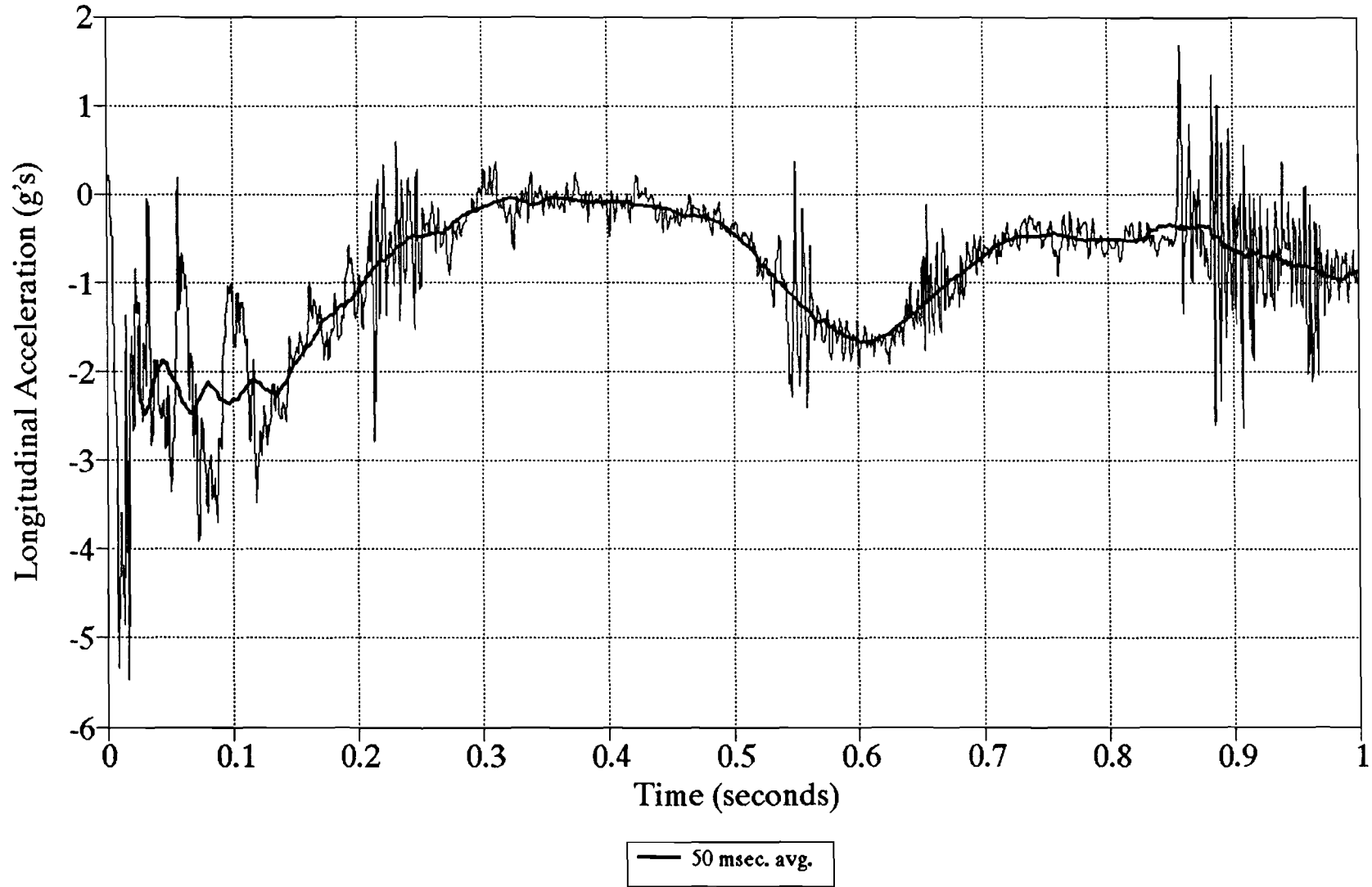

Figure 18. Longitudinal accelerometer trace (1219-1).



CRASH TEST 1219-1  
Class 180 Filter

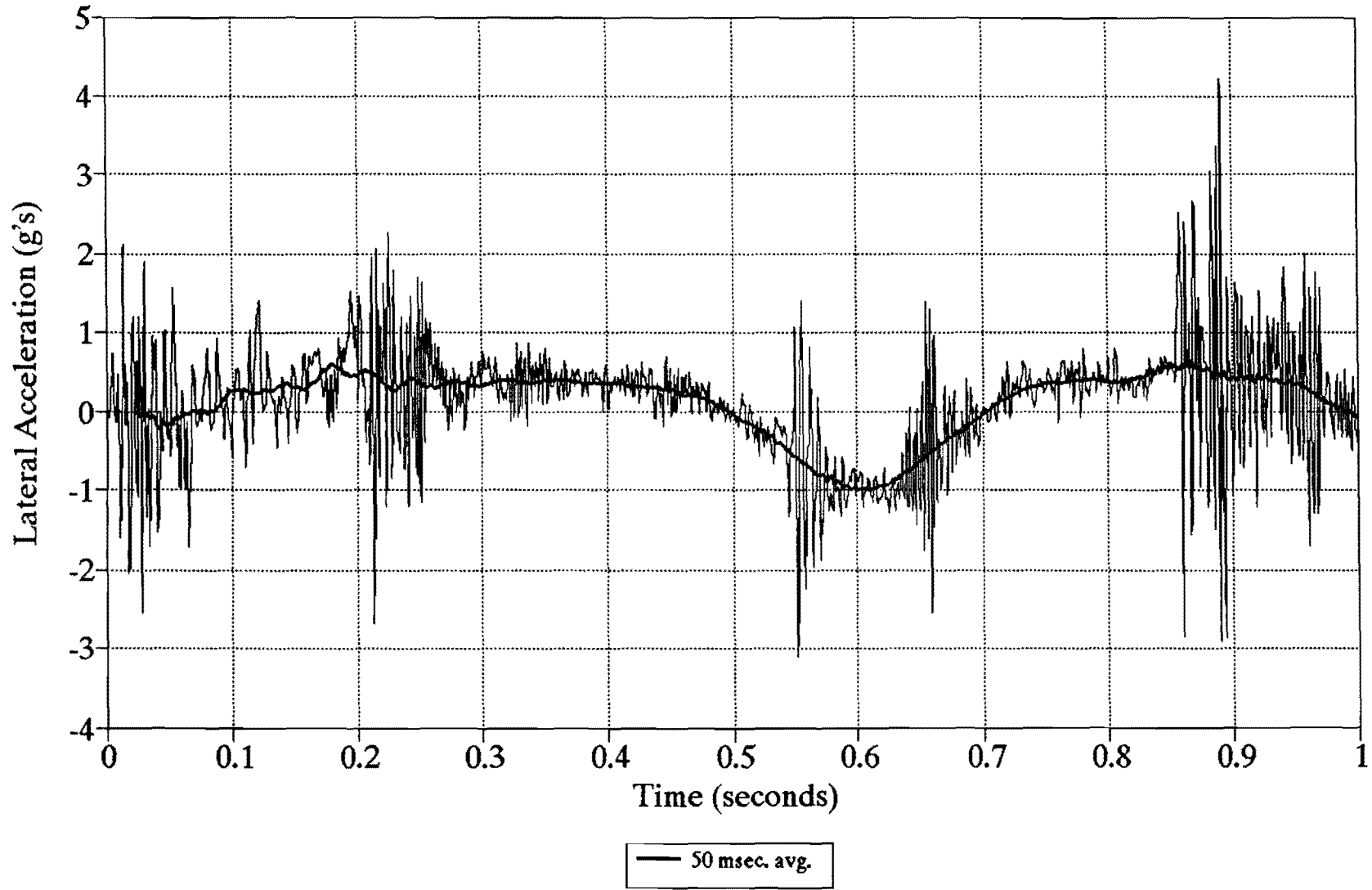

Figure 19. Lateral accelerometer trace (1219-1).

# CRASH TEST 1219-1

## Class 180 Filter

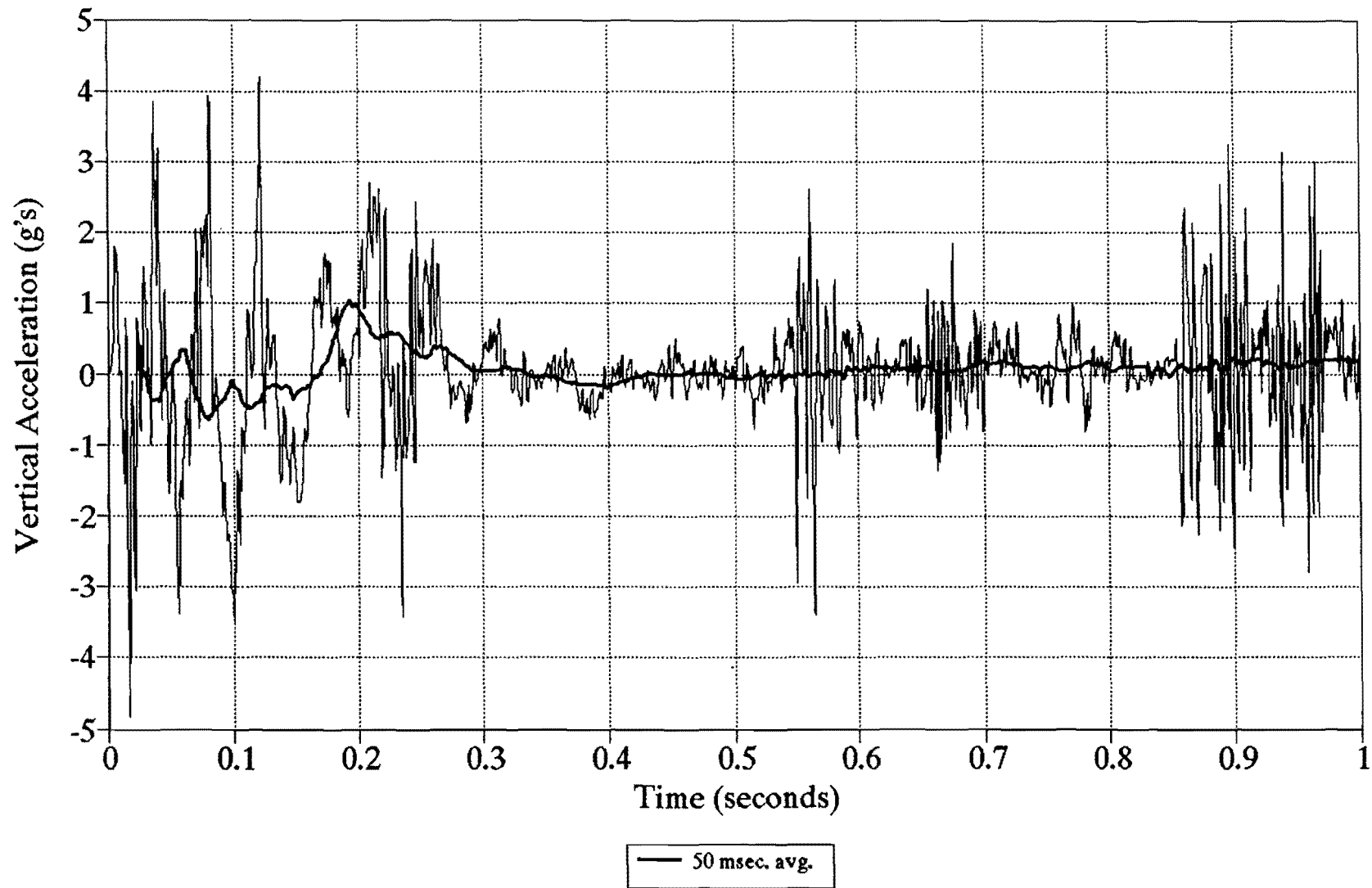

Figure 20. Vertical accelerometer trace (1219-1).

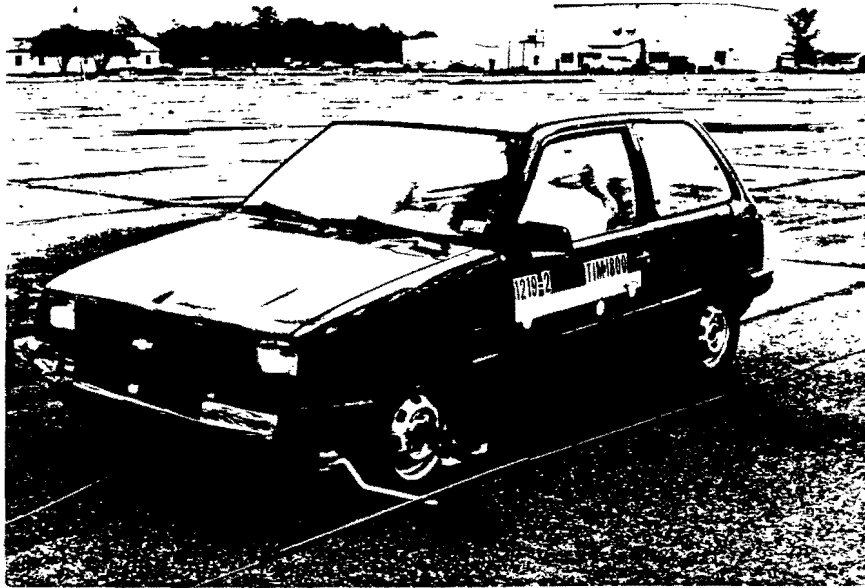

Figure 21. Vehicle before test 1219-2.

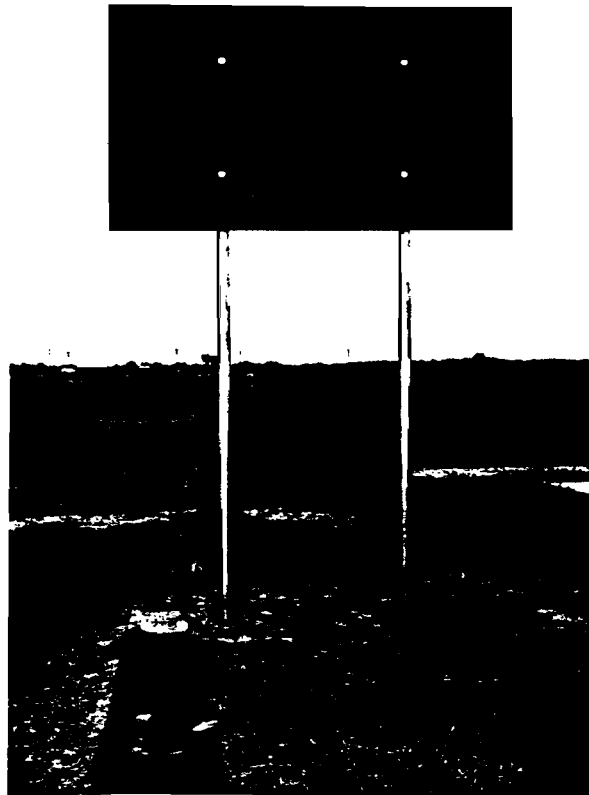
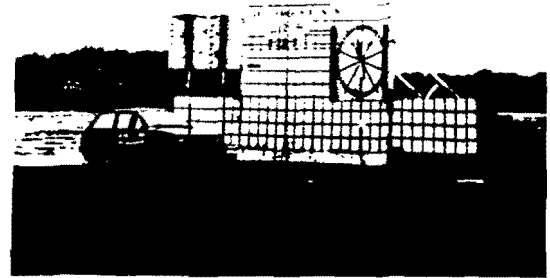
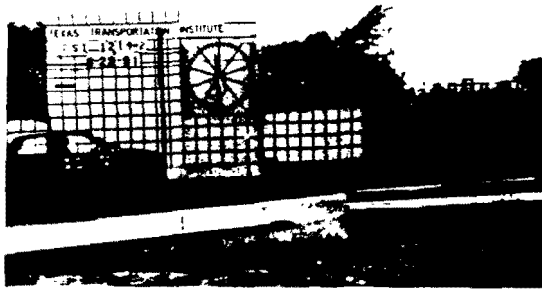
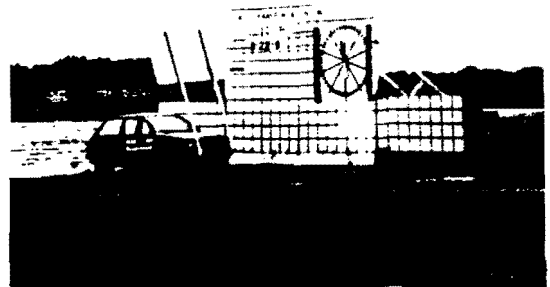
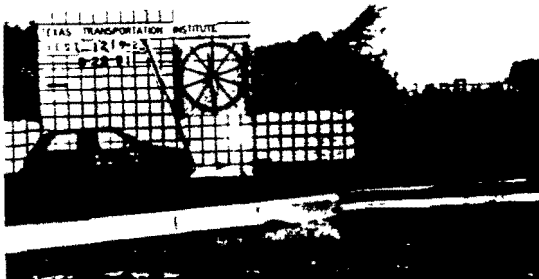

Figure 22. Sign installation before test 1219-2.



0.000 s



0.028 s

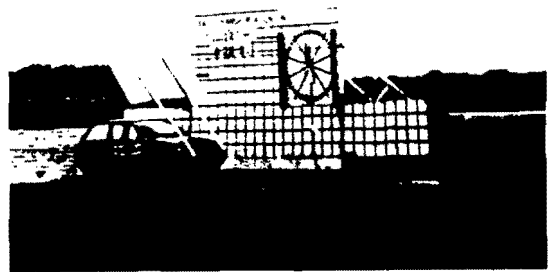
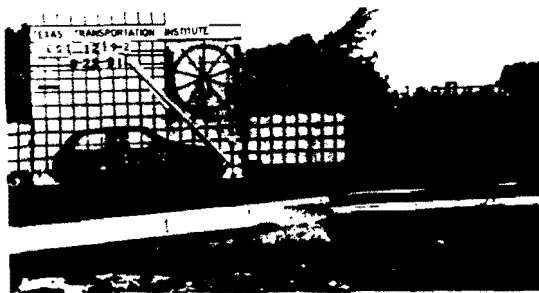

0.055 s

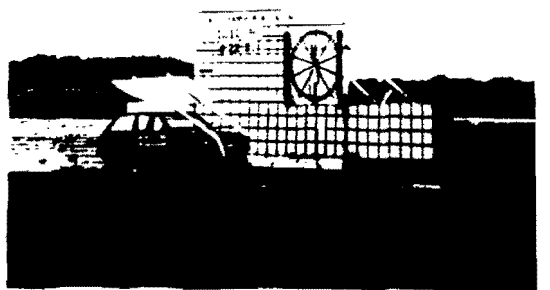
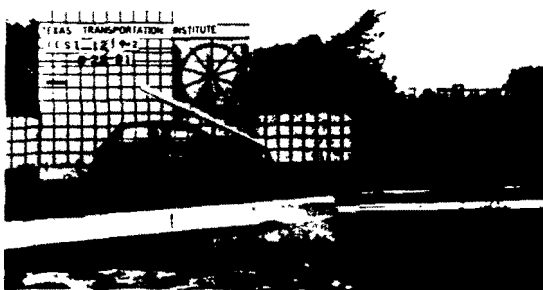

0.083 s

Figure 23. Sequential photographs of test 1219-2.

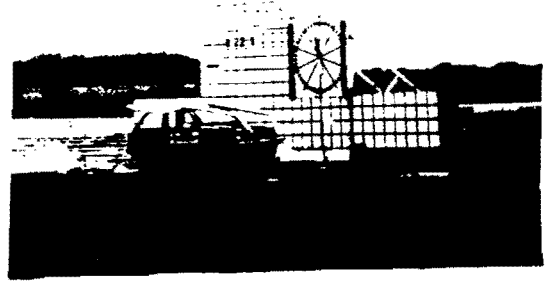
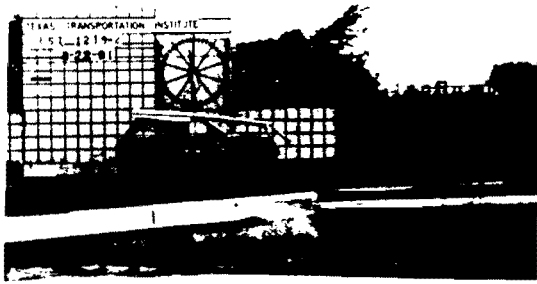

0.111 s

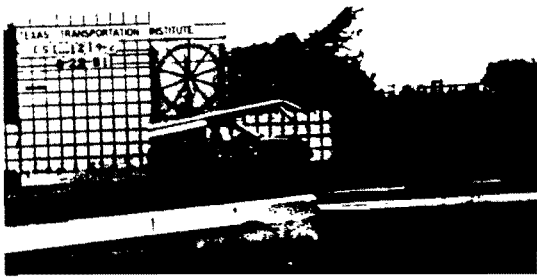

0.139 s

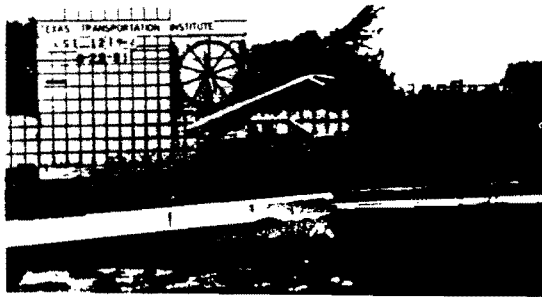

0.166 s

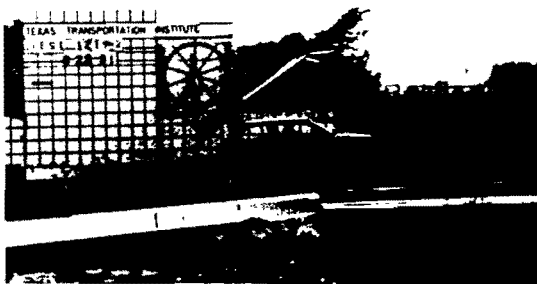

0.194 s

Figure 23. Sequential photographs of test 1219-2 (continued).

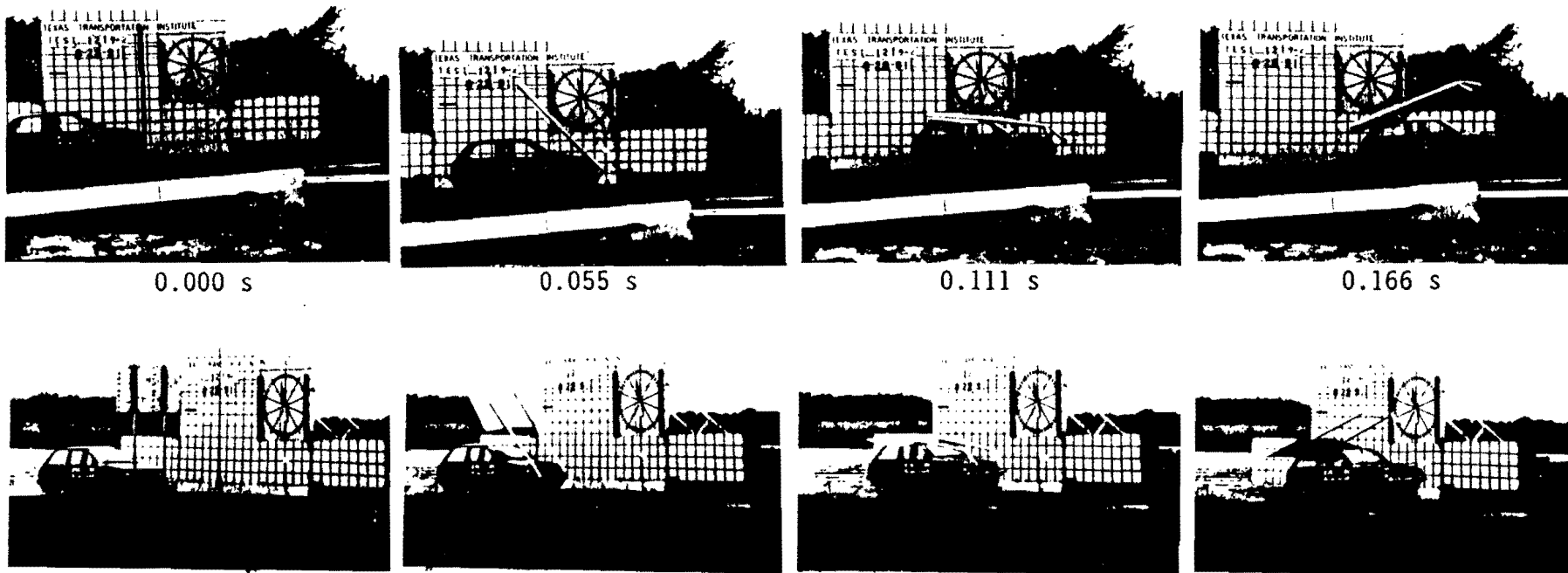

Figure 24. Sign installation after test 1219-2.



Figure 25. Vehicle after test 1219-2.





Test No. . . . . 1219-2  
 Date . . . . . 08/22/91  
 Test Article . . . . . Texas Generic  
                     Sign Anchor Installation  
 Support. . . . . 0.065 in x 3 in  
                     1026 round steel tube  
 Embedment. . . . . 28 in driven  
                     (NCHRP S-2 soil)  
 Vehicle. . . . . 1986 Chevrolet Sprint  
 Vehicle Weight  
   Test Inertia . . . . . 1,800 lb (817 kg)  
   Gross Static . . . . . 1,970 lb (894 kg)  
 Vehicle Damage Classification  
   TAD . . . . . 12FD-2  
   SAE . . . . . 12FDAW1

Impact Speed. . . . . 64.6 mi/h (103.9 km/h)  
 Change in Velocity. . . . . 1.5 mi/h ( 2.5 km/h)  
 Change in Momentum. . . . . 126.0 lb-s  
 Vehicle Accelerations  
   Max. (0.050-sec Avg)  
   Longitudinal. . . . . -3.2 g  
   Lateral . . . . . 1.4 g  
 Occupant Impact Velocity  
   Longitudinal. . . . . N/A  
   Lateral . . . . . N/A  
 Occupant Ridedown Accelerations  
   Longitudinal. . . . . No Contact  
   Lateral . . . . . No Contact

Figure 26. Summary of results for test 1219-2.

- ⊖ 1219-2 r
- △ 1219-2 p
- ◇ 1219-2 y

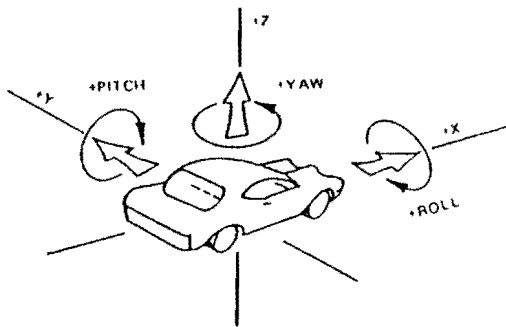

Axes are vehicle fixed.  
Sequence for determining orientation is:

1. Yaw
2. Pitch
3. Roll

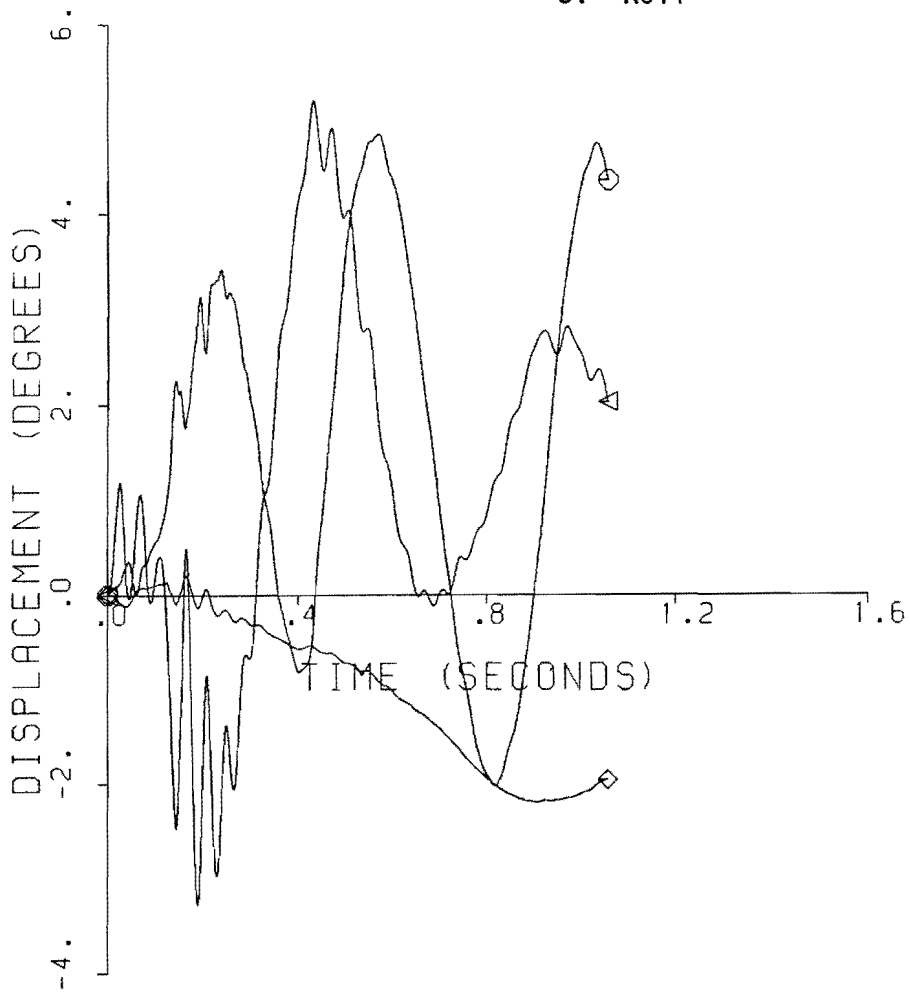

Figure 27. Vehicle angular displacement for test 1219-2.

# CRASH TEST 1219-2

## Class 180 Filter

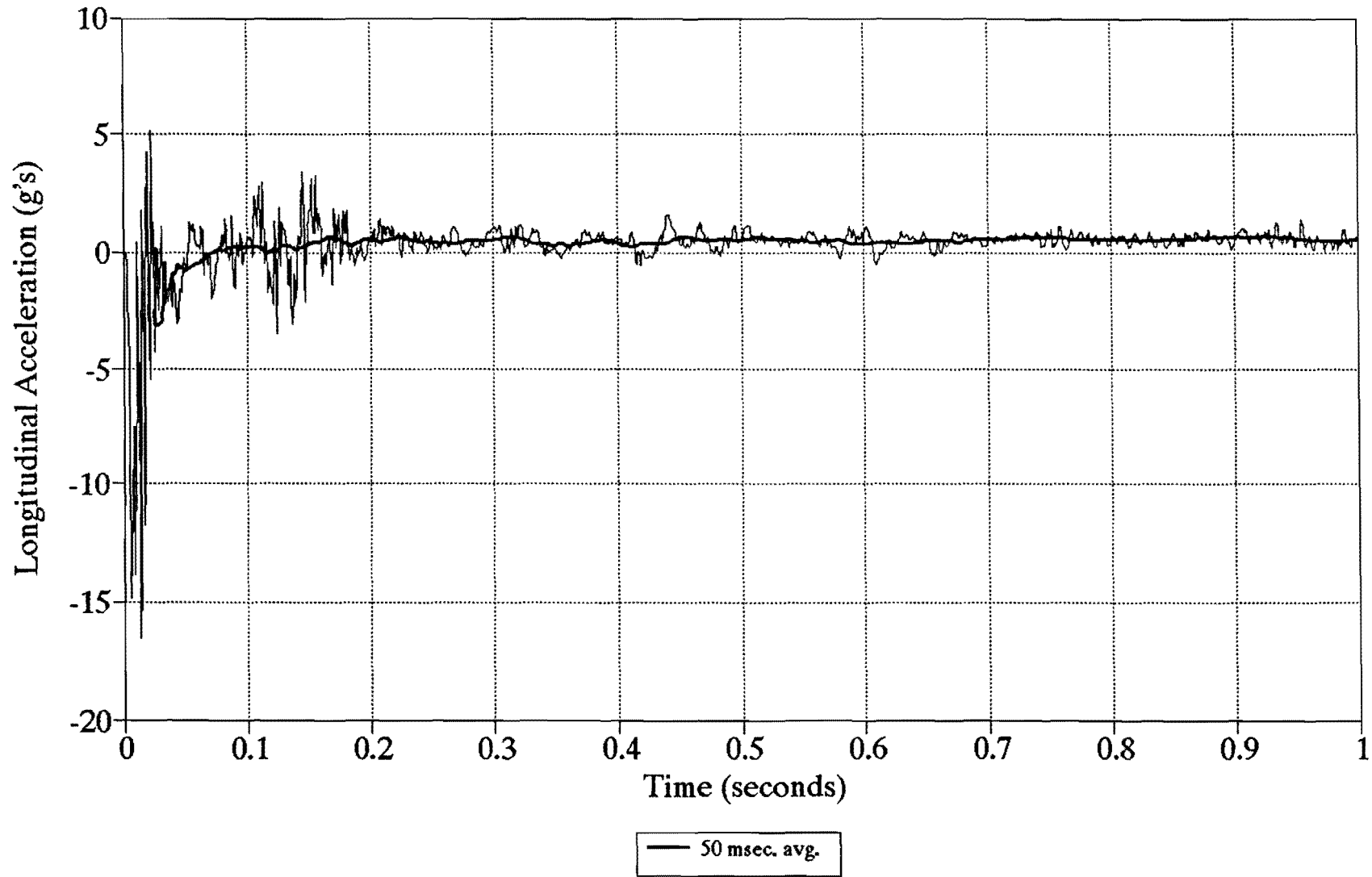

Figure 28. Longitudinal accelerometer trace (1219-2).

CRASH TEST 1219-2  
Class 180 Filter

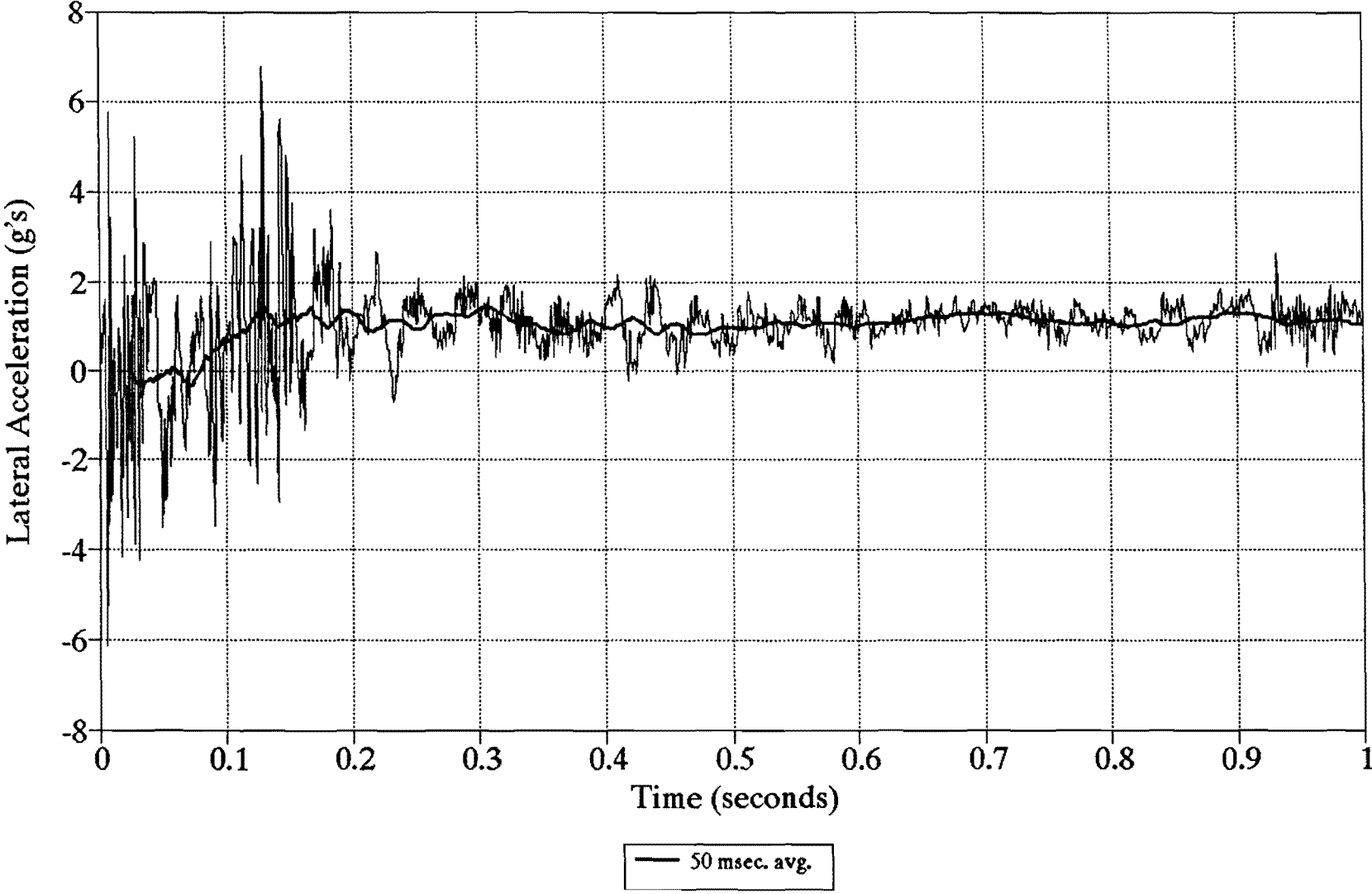

Figure 29. Lateral accelerometer trace (1219-2).

# CRASH TEST 1219-2

## Class 180 Filter

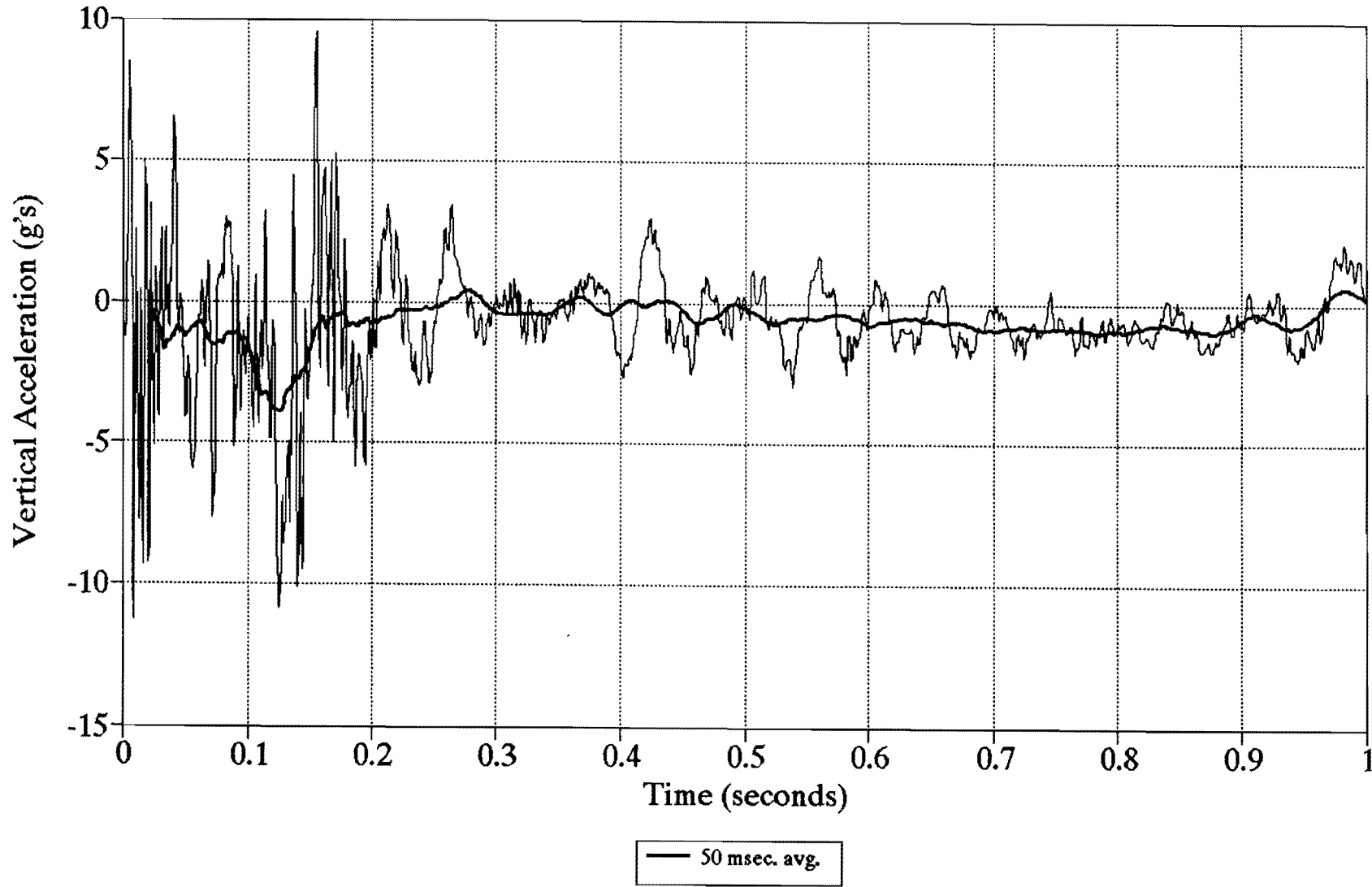

Figure 30. Vertical accelerometer trace (1219-2).



Figure 31. Vehicle before test 1219-5.

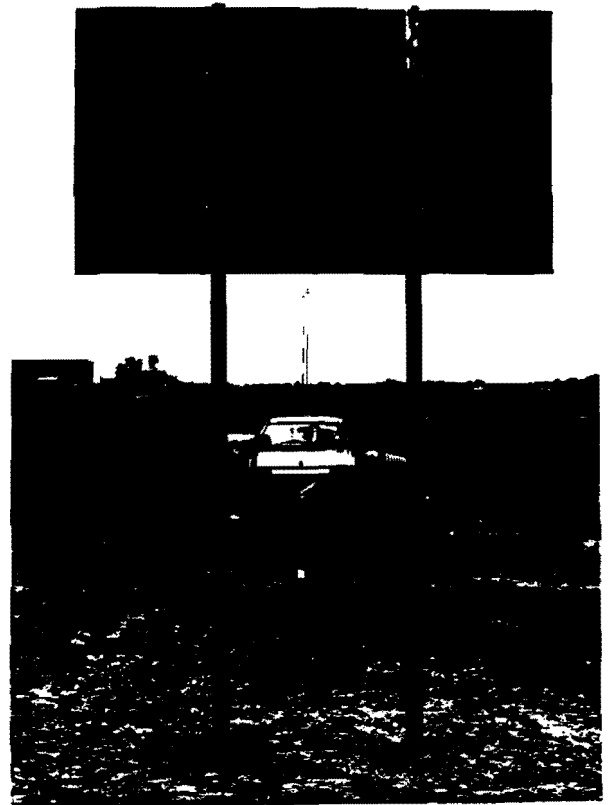
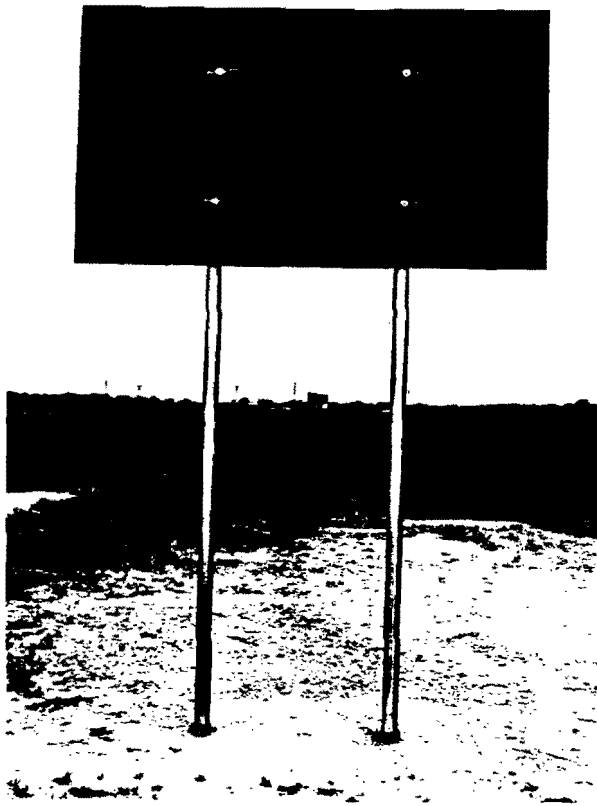

Figure 32. Sign installation before test 1219-5.



Figure 33. Vehicle/sign geometrics before test 1219-5.



Date: 08/27/91 Test No.: 1219-5 VIN: JG1M5215XHK742416

Make: Sprint Model: ER Year: 1987 Odometer: 14605

Tire Size: 155 R12 Ply Rating: \_\_\_\_\_ Bias Ply: \_\_\_\_\_ Belted: \_\_\_\_\_ Radial: X

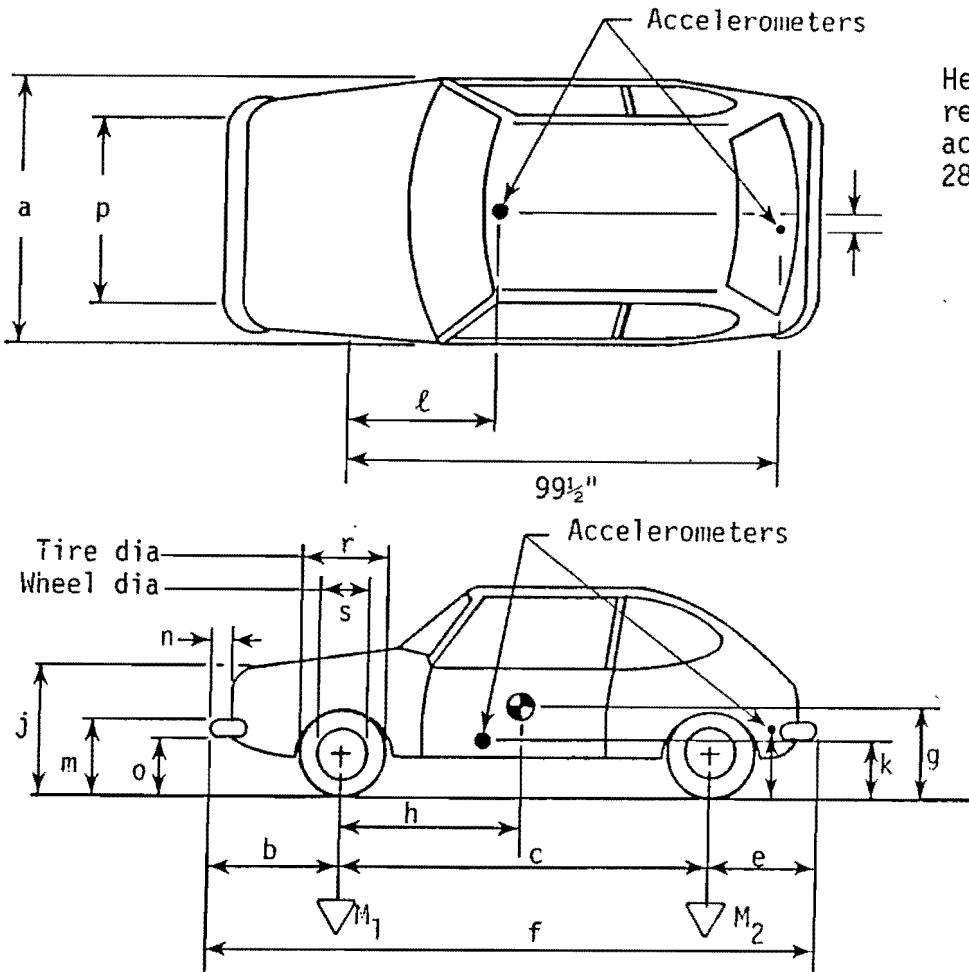

Tire Condition: good \_\_\_\_\_  
 fair X  
 badly worn \_\_\_\_\_  
 Height of rear accelerometer 28"

Vehicle Geometry - inches

a	<u>61"</u>	b	<u>28 1/2"</u>
c	<u>88 1/2"</u>	d*	<u>52 1/4"</u>
e	<u>26"</u>	f	<u>143"</u>
g	_____	h	<u>34.7</u>
i	<u>----</u>	j	<u>28 1/4"</u>
k	<u>13 3/4"</u>	l	<u>41 1/2"</u>
m	<u>19 1/4"</u>	n	<u>6 1/2"</u>
o	<u>15"</u>	p	<u>52 3/4"</u>
r	<u>21 1/2"</u>	s	<u>13 1/4"</u>

Engine Type: 3 cyl  
 Engine CID: 1.0 litre  
 Transmission Type:

~~Automatic~~ or Manual  
 FWD or ~~RWD~~ or ~~AWD~~

Body Type: 3 door

Steering Column Collapse Mechanism:

- Behind wheel units
- Convoluted tube
- Cylindrical mesh units
- Embedded ball
- NOT collapsible
- Other energy absorption
- Unknown

Brakes:

Front: disc X drum \_\_\_\_\_  
 Rear: disc \_\_\_\_\_ drum X

4-wheel weight for c.g. det. lf 542 rf 553 lr 350 rr 355

Mass - pounds	Curb	Test Inertial	Gross Static
M <sub>1</sub>	<u>480/932/452</u>	<u>1095</u>	<u>604/1166/562</u>
M <sub>2</sub>	<u>292/573/281</u>	<u>705</u>	<u>418/799/381</u>
M <sub>T</sub>	<u>1305</u>	<u>1800</u>	<u>1965</u>

Note any damage to vehicle prior to test:

Minor ding in right rear fender.

\*d = overall height of vehicle

Figure 34. Test vehicle properties (1219-5).

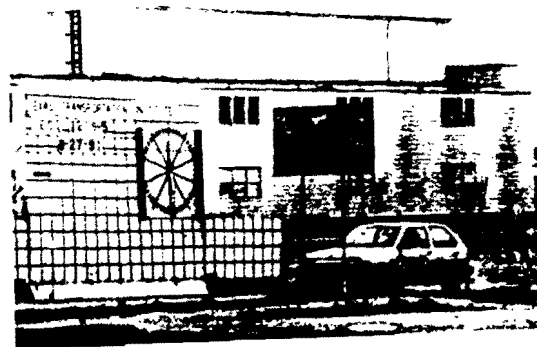
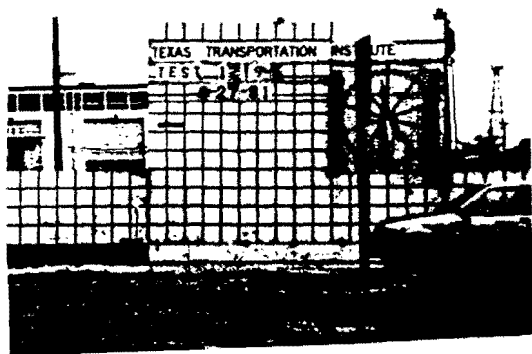

0.000 s

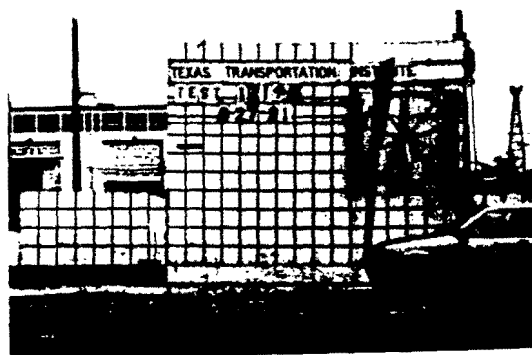

0.035 s

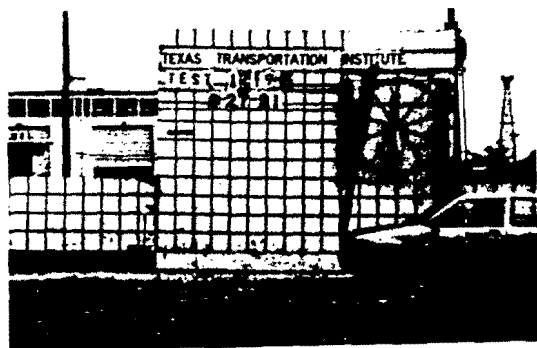

0.070 s

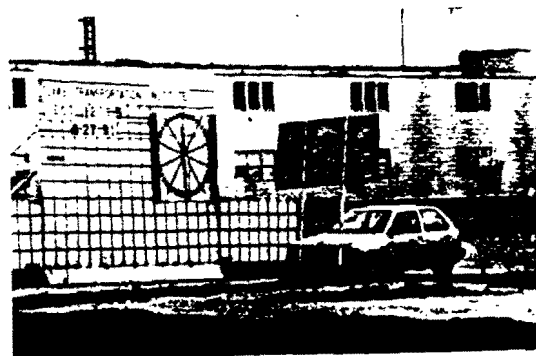
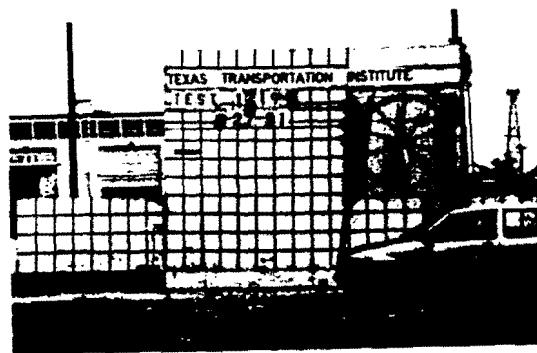

0.105 s

Figure 35. Sequential photographs of test 1219-5.

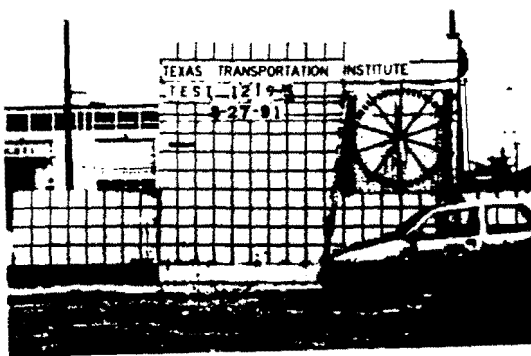

0.140 s

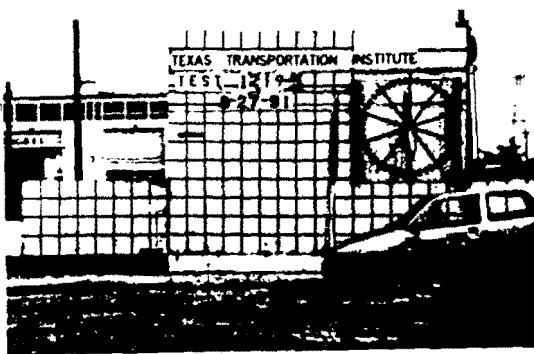

0.175 s

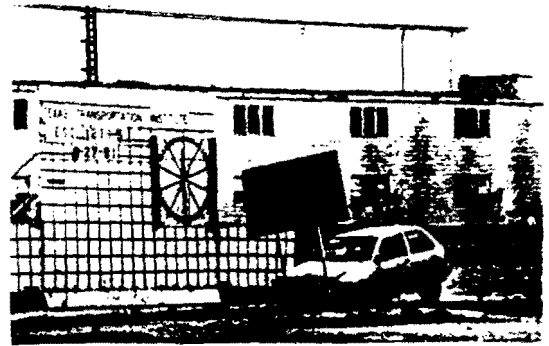
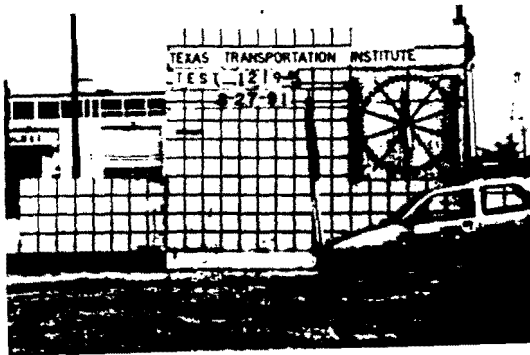

0.210 s

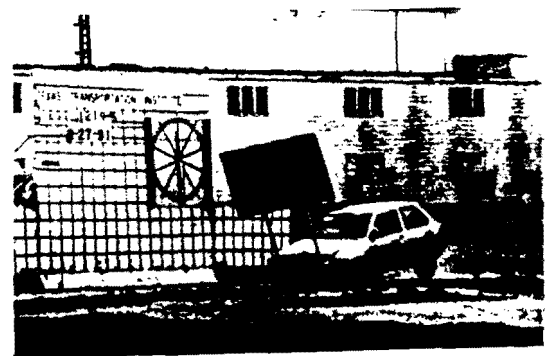
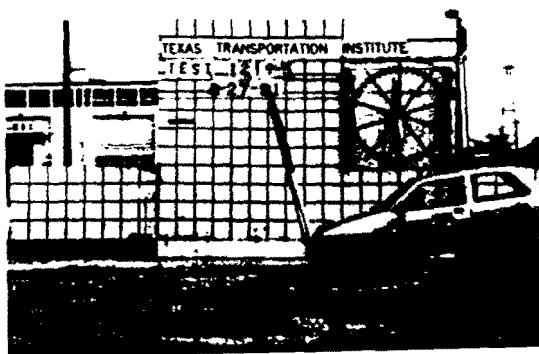

0.245 s

Figure 35. Sequential photographs of test 1219-5 (continued).

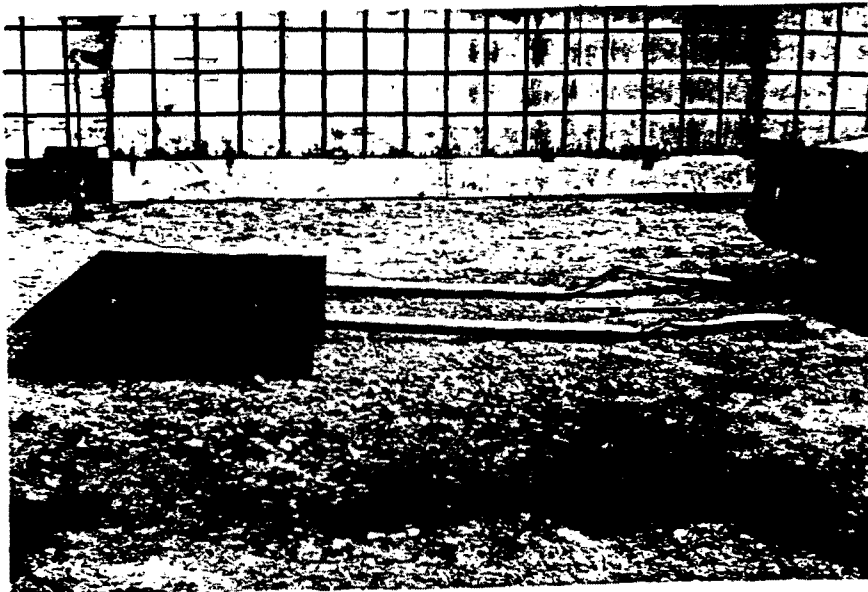
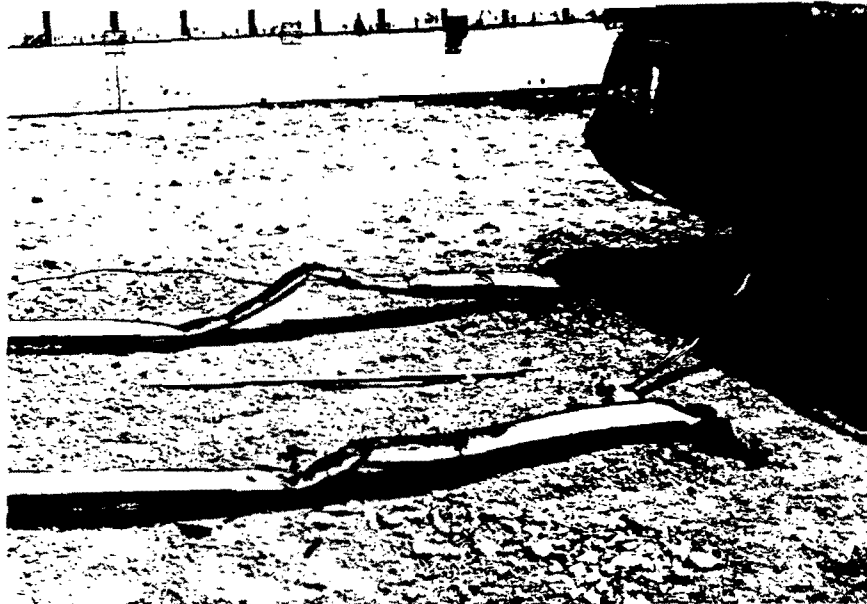

Figure 36. Sign installation after test 1219-5.

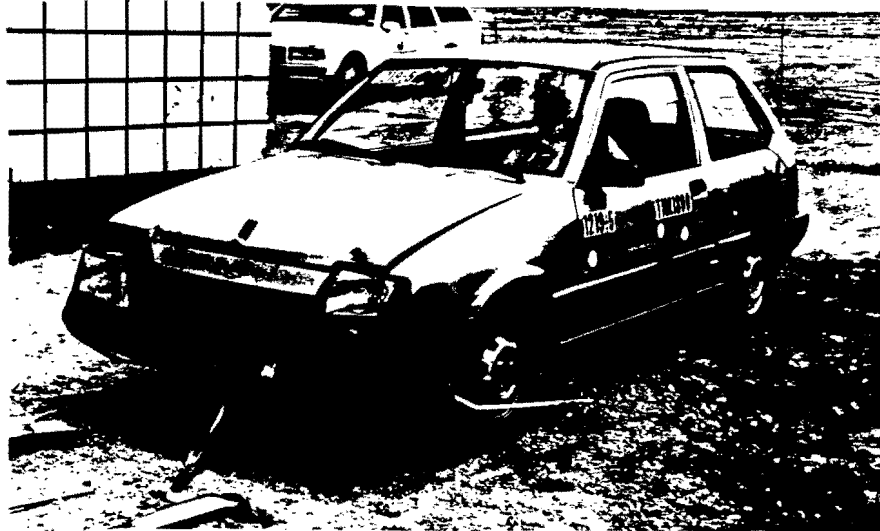
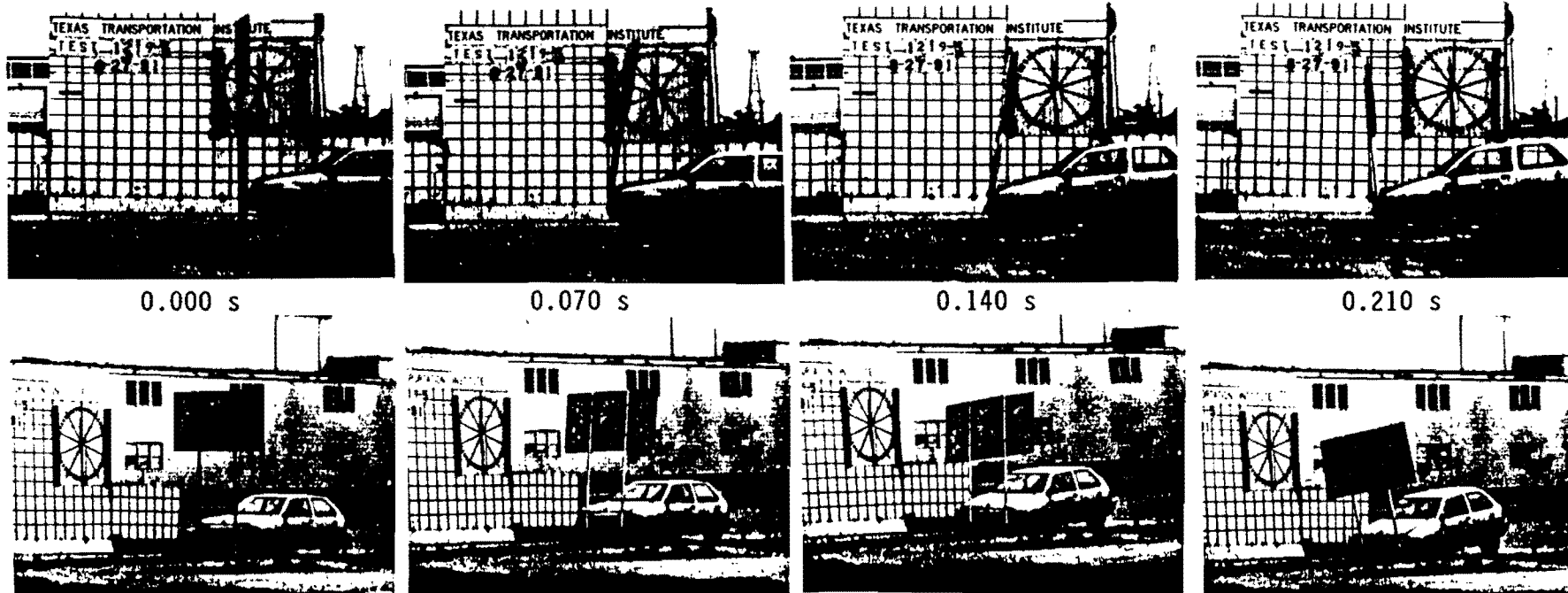

Figure 37. Vehicle after test 1219-5.



Test No. . . . . 1219-5  
 Date . . . . . 08/27/91  
 Test Article . . . . . Texas Generic  
                     Sign Anchor Installation  
 Support. . . . . 0.065 in x 3 in  
                     1026 round steel tube  
 Embedment. . . . . 28 in driven  
                     (NCHRP S-1 soil)  
 Vehicle. . . . . 1987 Chevrolet Sprint  
 Vehicle Weight  
   Test Inertia . . . . . 1,800 lb (817 kg)  
   Gross Static . . . . . 1,965 lb (892 kg)  
 Vehicle Damage Classification  
   TAD . . . . . 12FD-2  
   SAE . . . . . 12FDEW1

Impact Speed. . . . . 21.0 mi/h (33.7 km/h)  
 Change in Velocity. . . . . 21.0 mi/h (33.7 km/h)  
 Change in Momentum. . . . . 1722 lb-s  
 Vehicle Accelerations  
   Max. (0.050-sec Avg)  
   Longitudinal. . . . . -5.4 g  
   Lateral . . . . . -1.8 g  
 Occupant Impact Velocity  
   Longitudinal. . . . . 23.3 ft/s (7.1 m/s)  
   Lateral . . . . . N/A  
 Occupant Ridedown Accelerations  
   Longitudinal. . . . . -4.3 g  
   Lateral . . . . . No Contact

Figure 38. Summary of results for test 1219-5.

- 1219-5 r
- △ 1219-5 p
- ◇ 1219-5 y

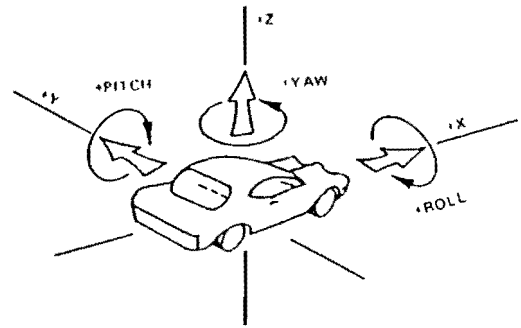

Axes are vehicle fixed.  
Sequence for determining orientation is:

1. Yaw
2. Pitch
3. Roll

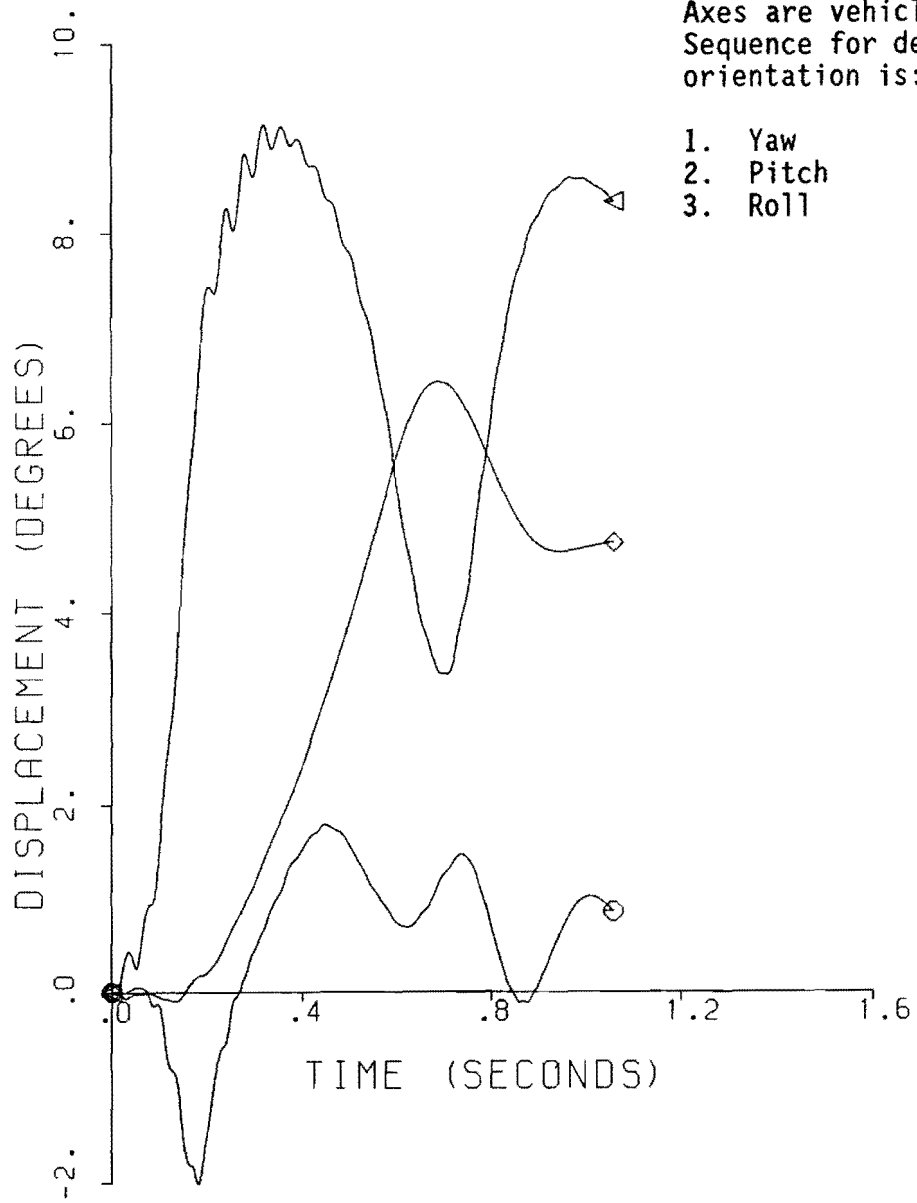

Figure 39. Vehicle angular displacement for test 1219-5.

CRASH TEST 1219-5  
Class 180 Filter

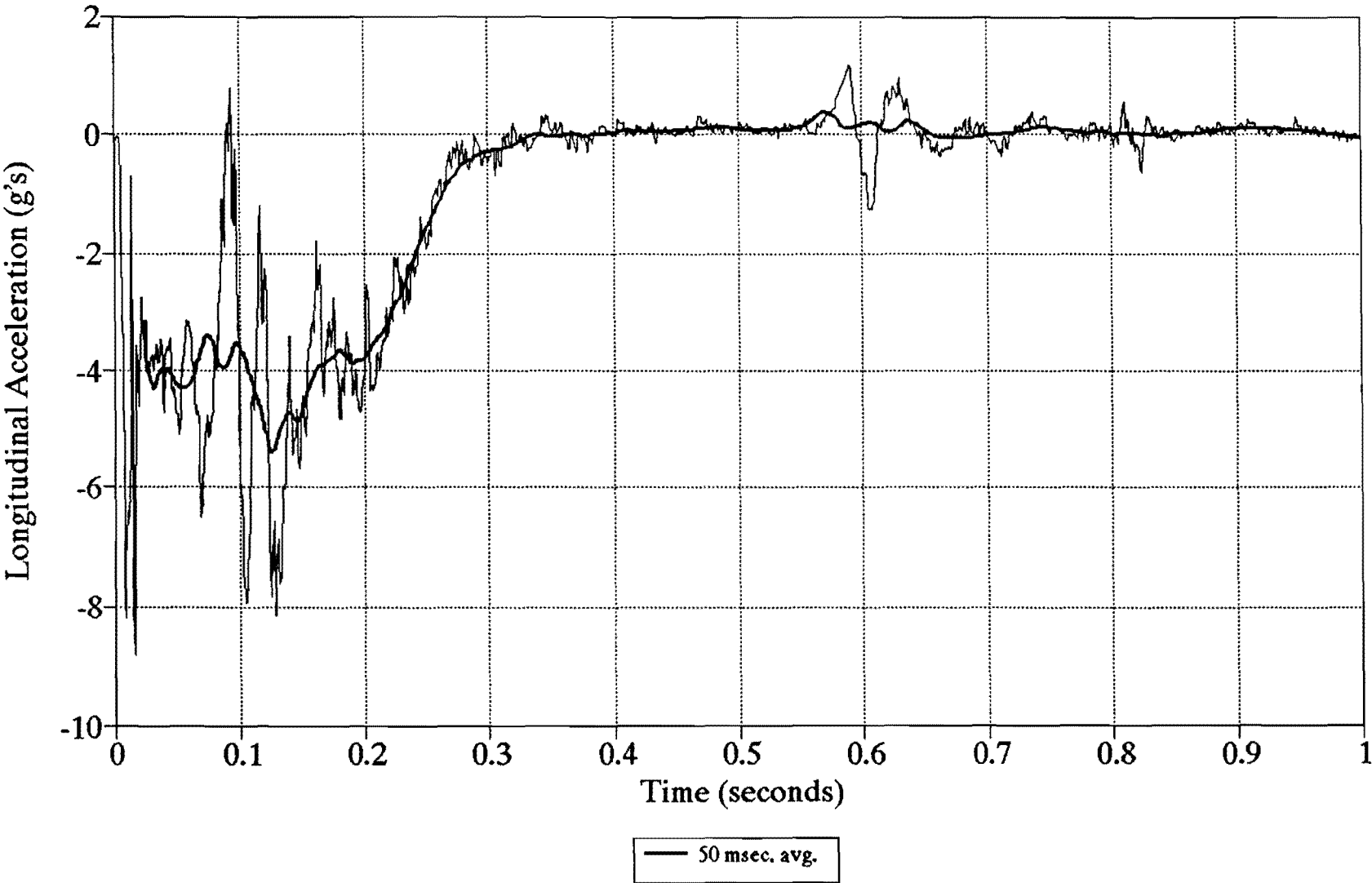

Figure 40. Longitudinal accelerometer trace (1219-5).



# CRASH TEST 1219-5

## Class 180 Filter

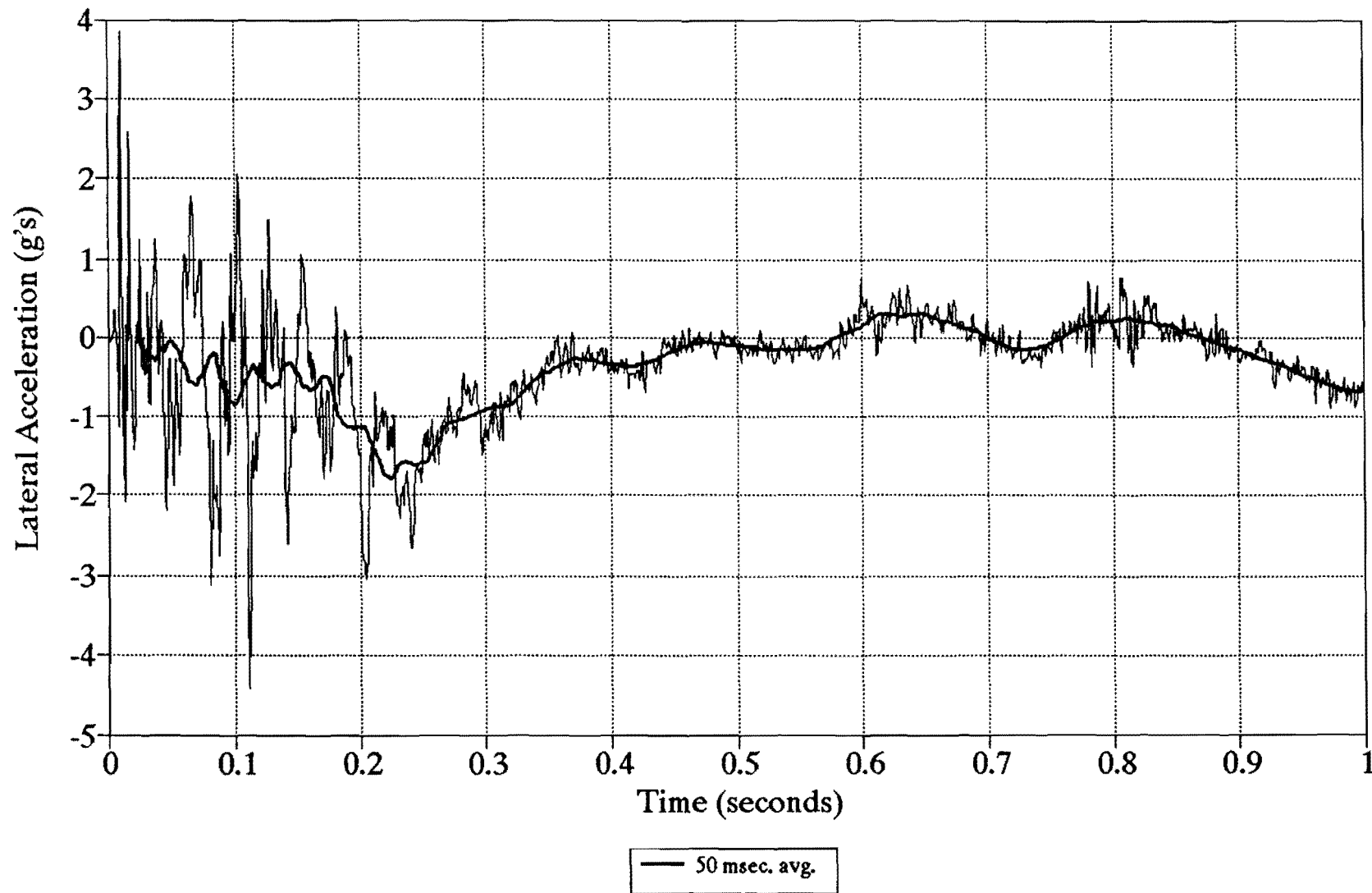

Figure 41. Lateral accelerometer trace (1219-5).

# CRASH TEST 1219-5

## Class 180 Filter

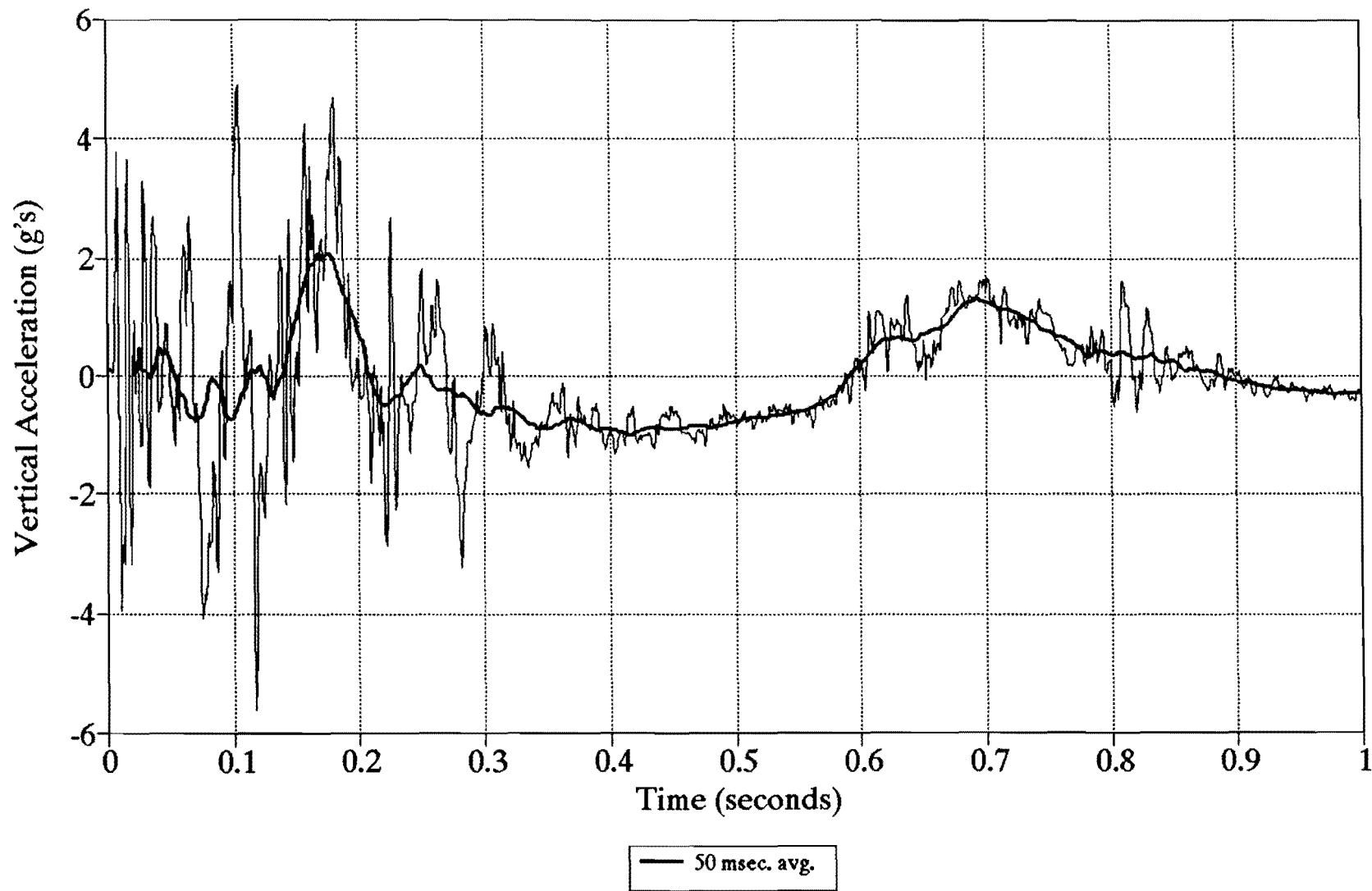

Figure 42. Vertical accelerometer trace (1219-5).

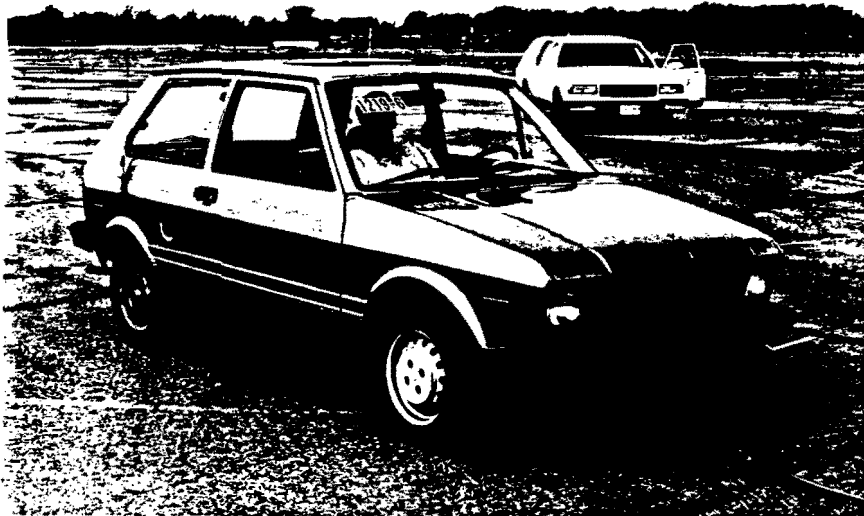

Figure 43. Vehicle before test 1219-6.

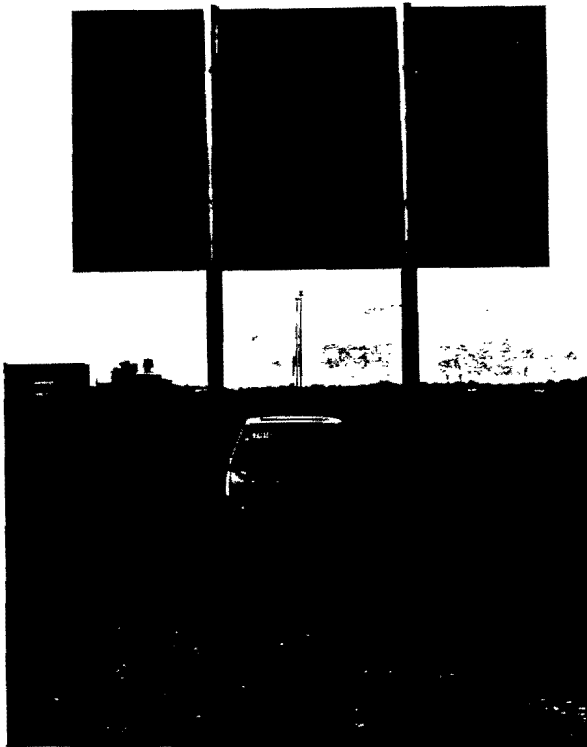
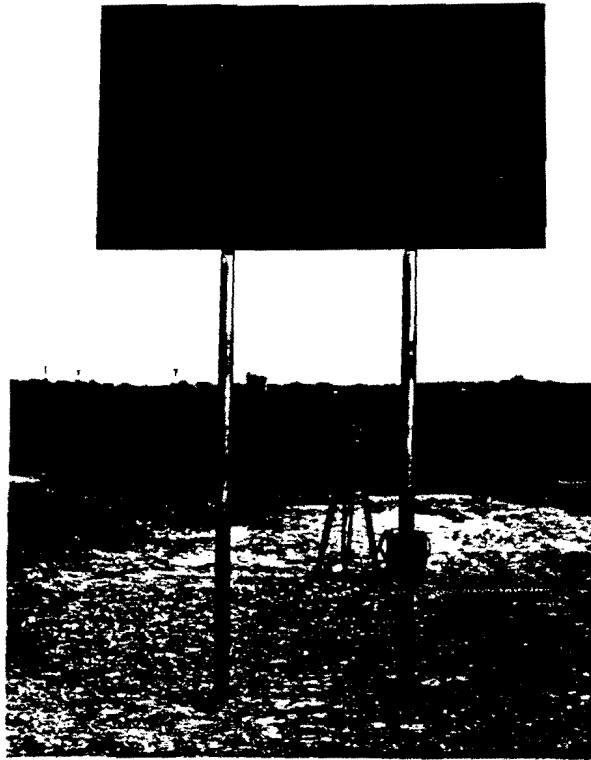

Figure 44. Sign installation before test 1219-6.

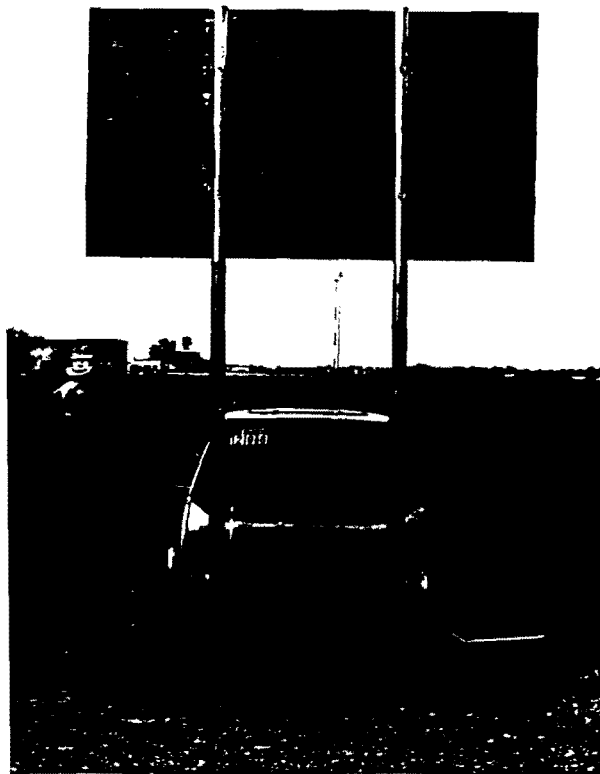
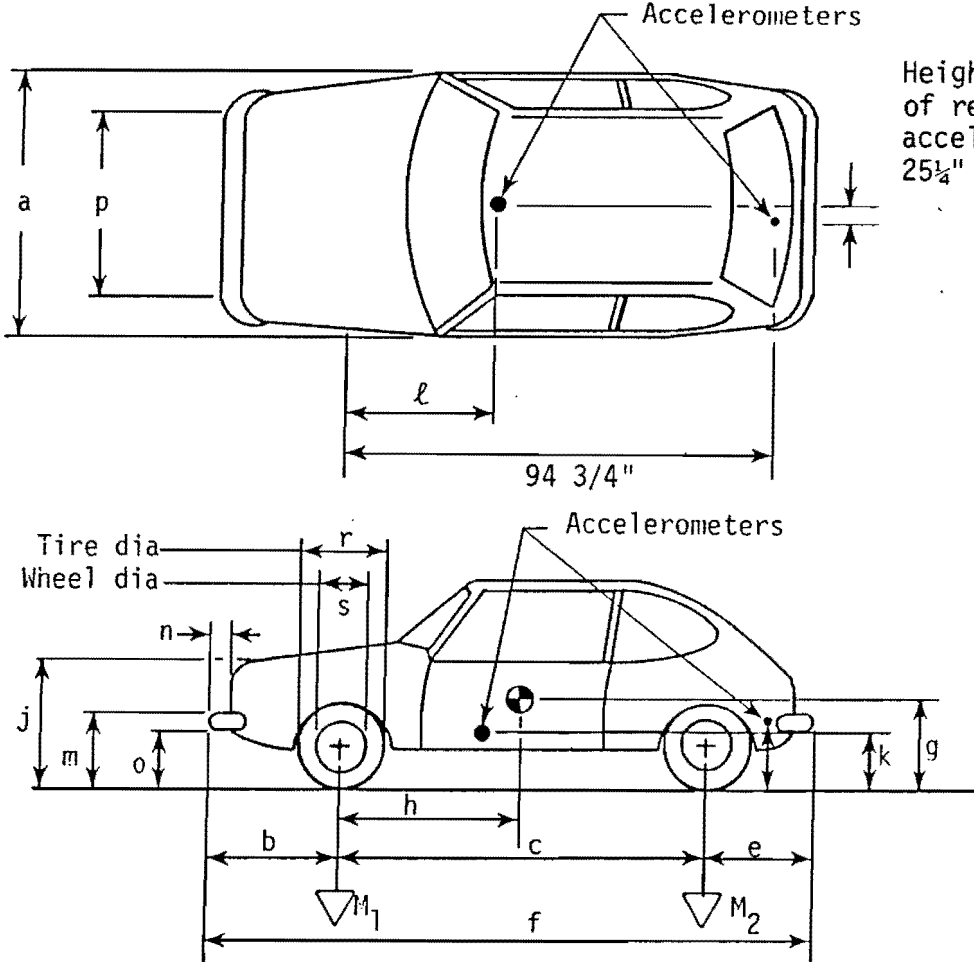

Figure 45. Vehicle/sign geometrics (test 1219-6).

Date: 08/29/91 Test No.: 1219-6 VIN: VX1BA1218GK303982

Make: Yugo Model: GV Year: 1986 Odometer: 12343

Tire Size: 145 SR 13 Ply Rating: \_\_\_\_\_ Bias Ply: \_\_\_\_\_ Belted: \_\_\_\_\_ Radial: x



Accelerometers  
Tire Condition: good \_\_\_\_\_  
fair X  
badly worn \_\_\_\_\_  
Height of rear accelerometer 25 1/4"

Vehicle Geometry - inches

a	<u>60 1/2"</u>	b	<u>28"</u>
c	<u>85 3/4"</u>	d*	<u>55 3/4"</u>
e	<u>23"</u>	f	<u>135 3/4"</u>
g	_____	h	<u>30.7"</u>
i	<u>----</u>	j	<u>27 1/2"</u>
k	<u>15 1/4"</u>	l	<u>32"</u>
m	<u>18 1/2"</u>	n	<u>2 1/2"</u>
o	<u>13"</u>	p	<u>53 1/2"</u>
r	<u>22 1/2"</u>	s	<u>14 1/4"</u>

Engine Type: 4 cyl  
Engine CID: 68.12  
Transmission Type:

~~Automatic~~ or Manual  
FWD or ~~RWD~~ or ~~AWD~~  
Body Type: 3 door

Steering Column Collapse Mechanism:  
 Behind wheel units  
 Convoluted tube  
 Cylindrical mesh units  
 Embedded ball  
 NOT collapsible  
 Other energy absorption  
 Unknown

Brakes:  
Front: disc X drum \_\_\_\_\_  
Rear: disc \_\_\_\_\_ drum x

4-wheel weight for c.g. det. lf 590 rf 558 lr 316 rr 336

Mass - pounds	Curb	Test Inertial	Gross Static
M <sub>1</sub>	<u>606/1199/593</u>	<u>1148</u>	<u>657/1221/564</u>
M <sub>2</sub>	<u>305/638/333</u>	<u>652</u>	<u>382/744/362</u>
M <sub>T</sub>	<u>1837</u>	<u>1800</u>	<u>1965</u>

Note any damage to vehicle prior to test:  
 ---  
 \_\_\_\_\_  
 \_\_\_\_\_

\*d = overall height of vehicle

Figure 46. Test vehicle properties (1219-6).

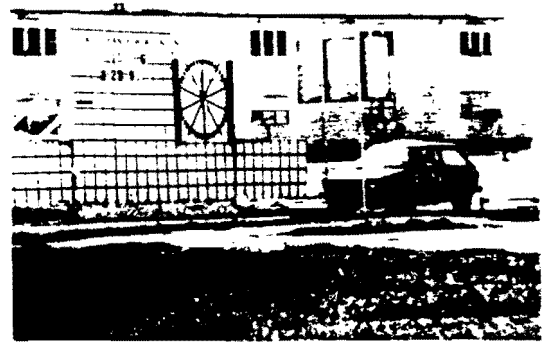
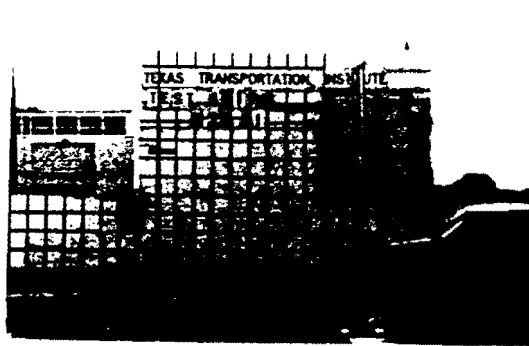

0.000 s

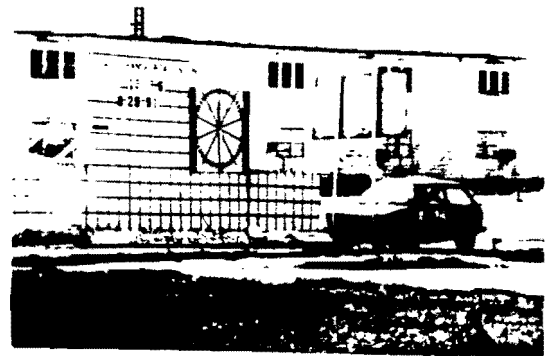

0.035 s

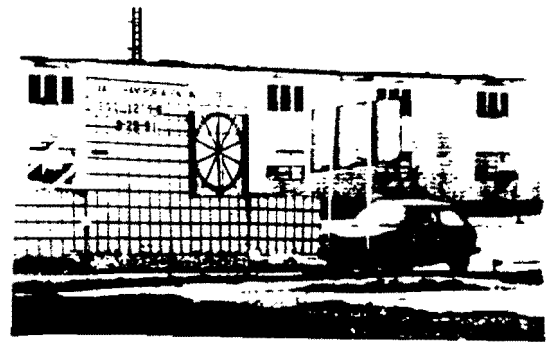
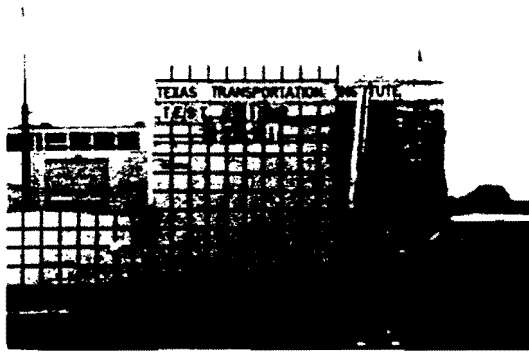

0.070 s

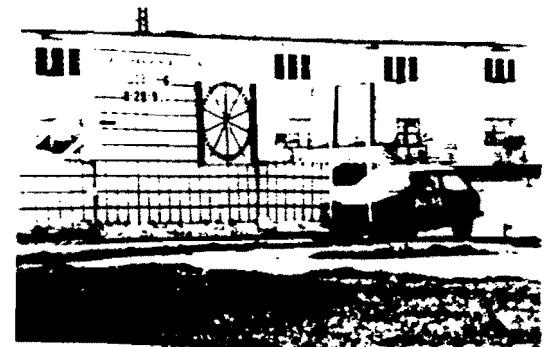

0.105 s

Figure 47. Sequential photographs of test 1219-6.

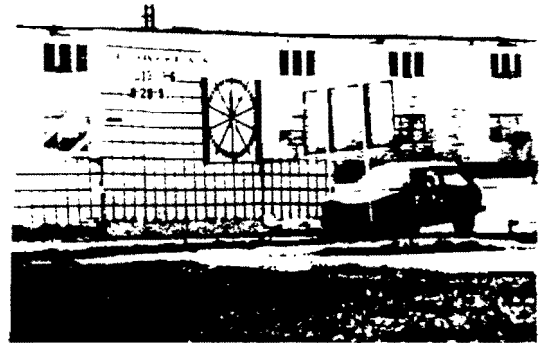
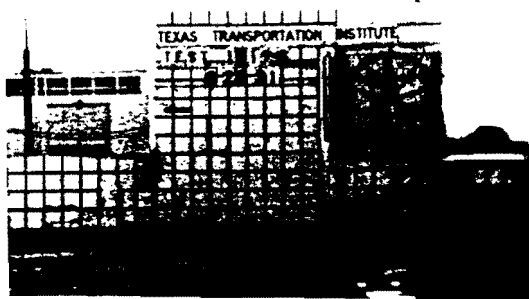

0.140 s

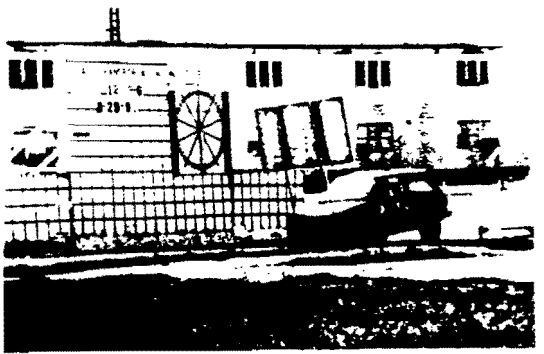
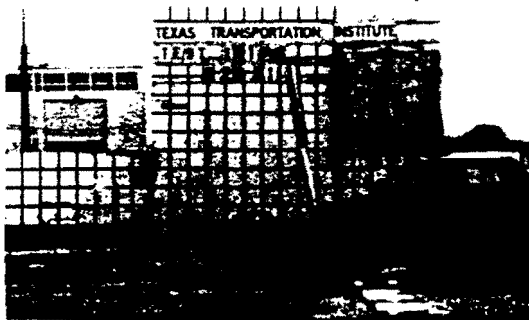

0.176 s

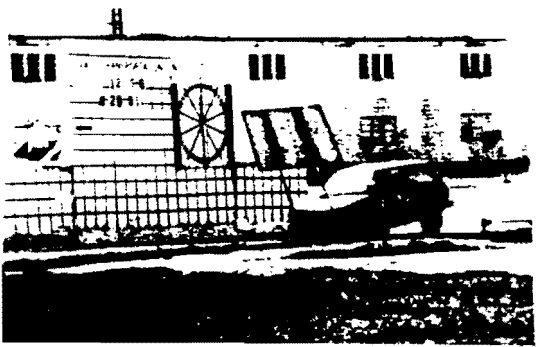
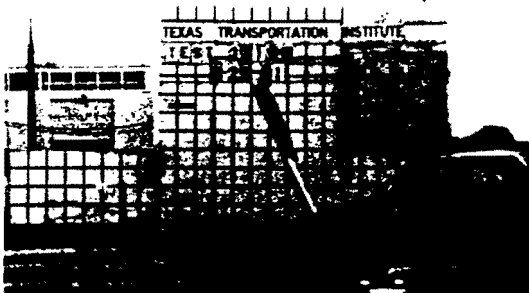

0.211 s

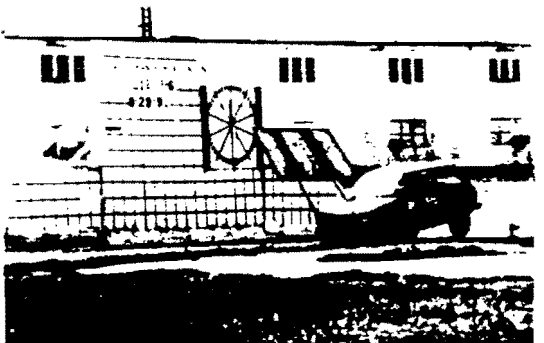
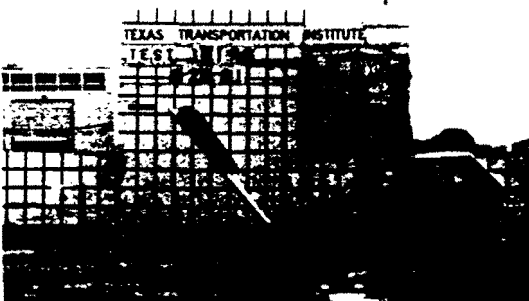

0.246 s

Figure 47. Sequential photographs of test 1219-6 (continued).



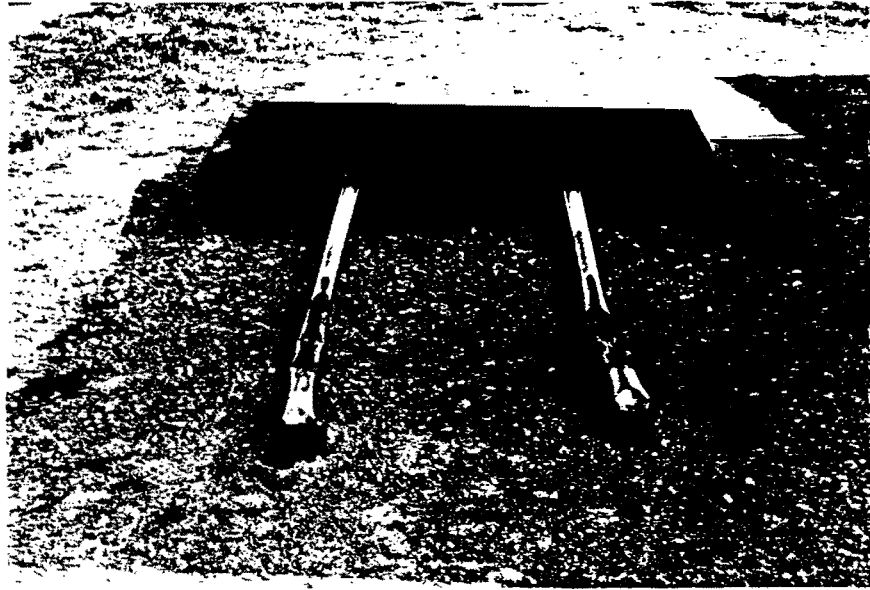

Figure 48. Sign installation after test 1219-6.

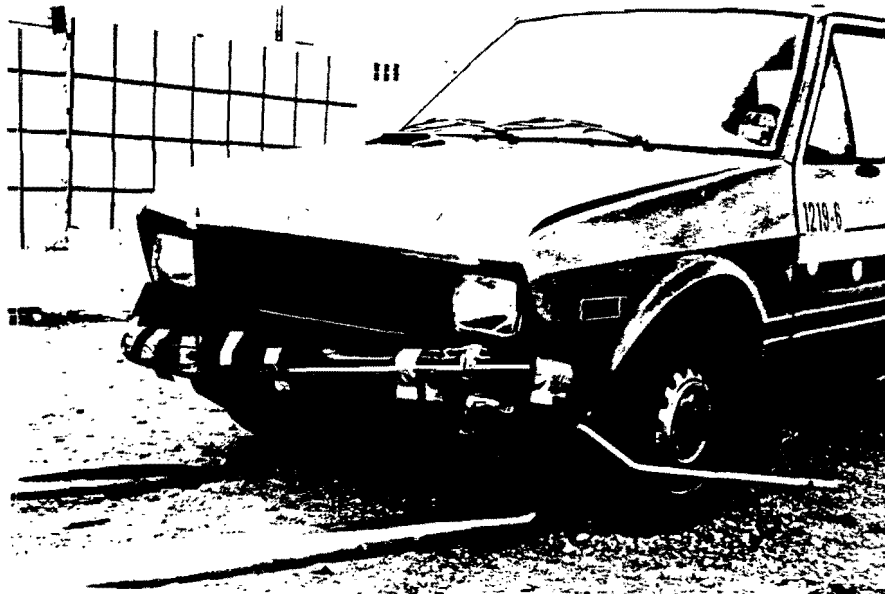
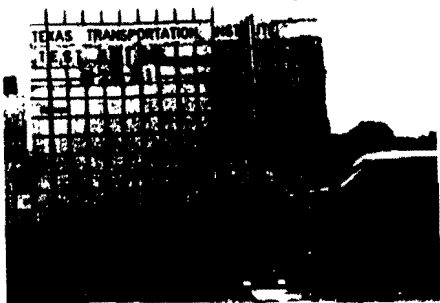
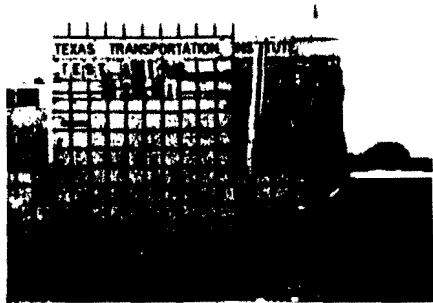

Figure 49. Vehicle after test 1219-6.



0.000 s



0.070 s



0.140 s

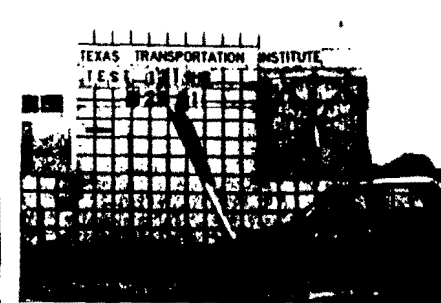

0.211 s

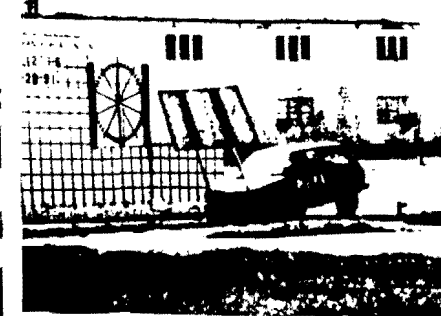
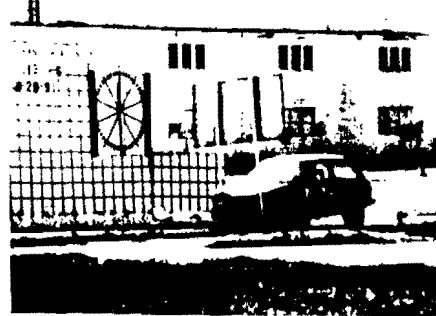

Test No. . . . . 1219-6  
 Date . . . . . 08/29/91  
 Test Article . . . . . Texas Generic  
                     Sign Anchor Installation  
 Support. . . . . 0.065 in x 3 in  
                     1026 round steel tube  
 Embedment. . . . . 28 in driven  
                     (NCHRP S-1 soil)  
 Vehicle. . . . . 1986 Yugo GV  
 Vehicle Weight  
   Test Inertia . . . . . 1,800 lb (817 kg)  
   Gross Static . . . . . 1,965 lb (892 kg)  
 Vehicle Damage Classification  
   TAD . . . . . 12FD-2  
   SAE . . . . . 12FDEW1

Impact Speed. . . . . 19.8 mi/h (31.9 km/h)  
 Change in Velocity. . . . . 19.8 mi/h (31.9 km/h)  
 Change in Momentum. . . . . 1623 lb-s  
 Vehicle Accelerations  
   Max. (0.050-sec Avg)  
   Longitudinal. . . . . -4.6 g  
   Lateral . . . . . 1.1 g  
 Occupant Impact Velocity  
   Longitudinal. . . . . 22.3 ft/s (6.8 m/s)  
   Lateral . . . . . N/A  
 Occupant Ridedown Accelerations  
   Longitudinal. . . . . -5.4 g  
   Lateral . . . . . No Contact

Figure 50. Summary of results for test 1219-6.

- ⊙ 1219-6 r
- △ 1219-6 p
- ◇ 1219-6 y

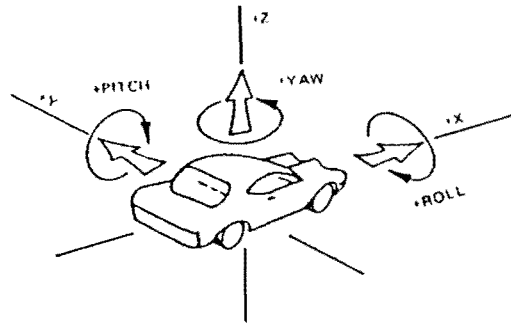

Axes are vehicle fixed.  
Sequence for determining orientation is:

1. Yaw
2. Pitch
3. Roll

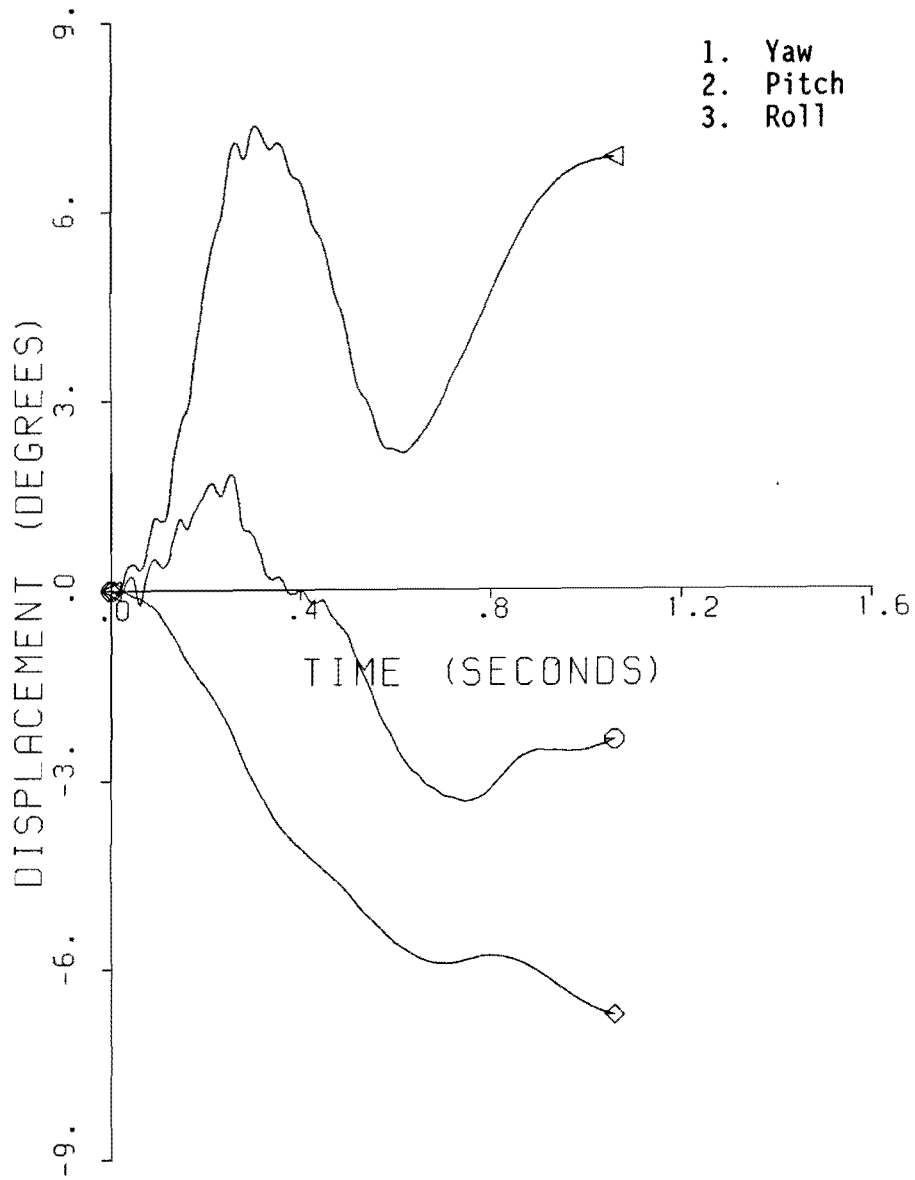

Figure 51. Vehicle angular displacement for test 1219-6.

# CRASH TEST 1219-6

## Class 180 Filter

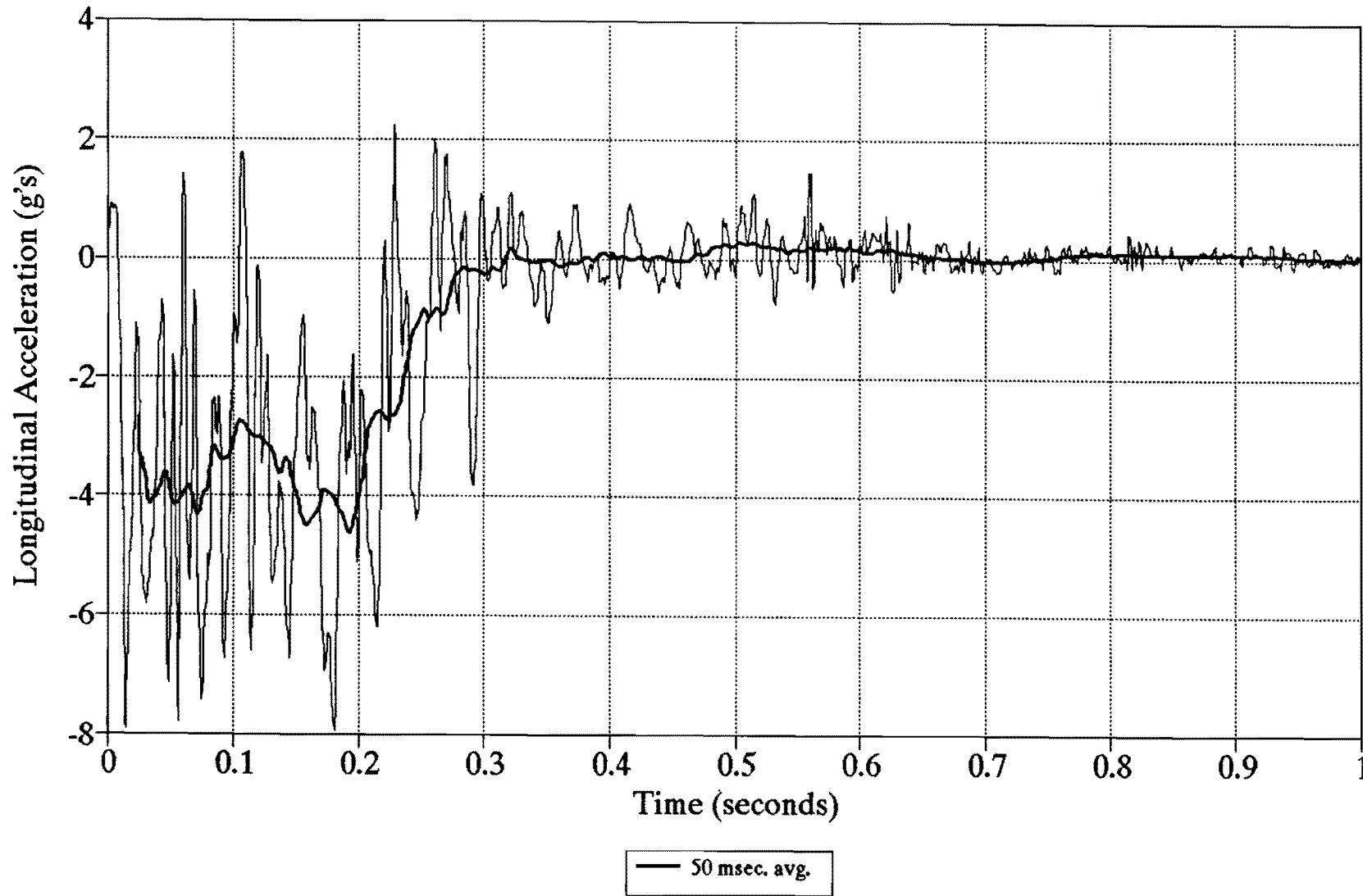

Figure 52. Longitudinal accelerometer trace (1219-6).

CRASH TEST 1219-6  
Class 180 Filter

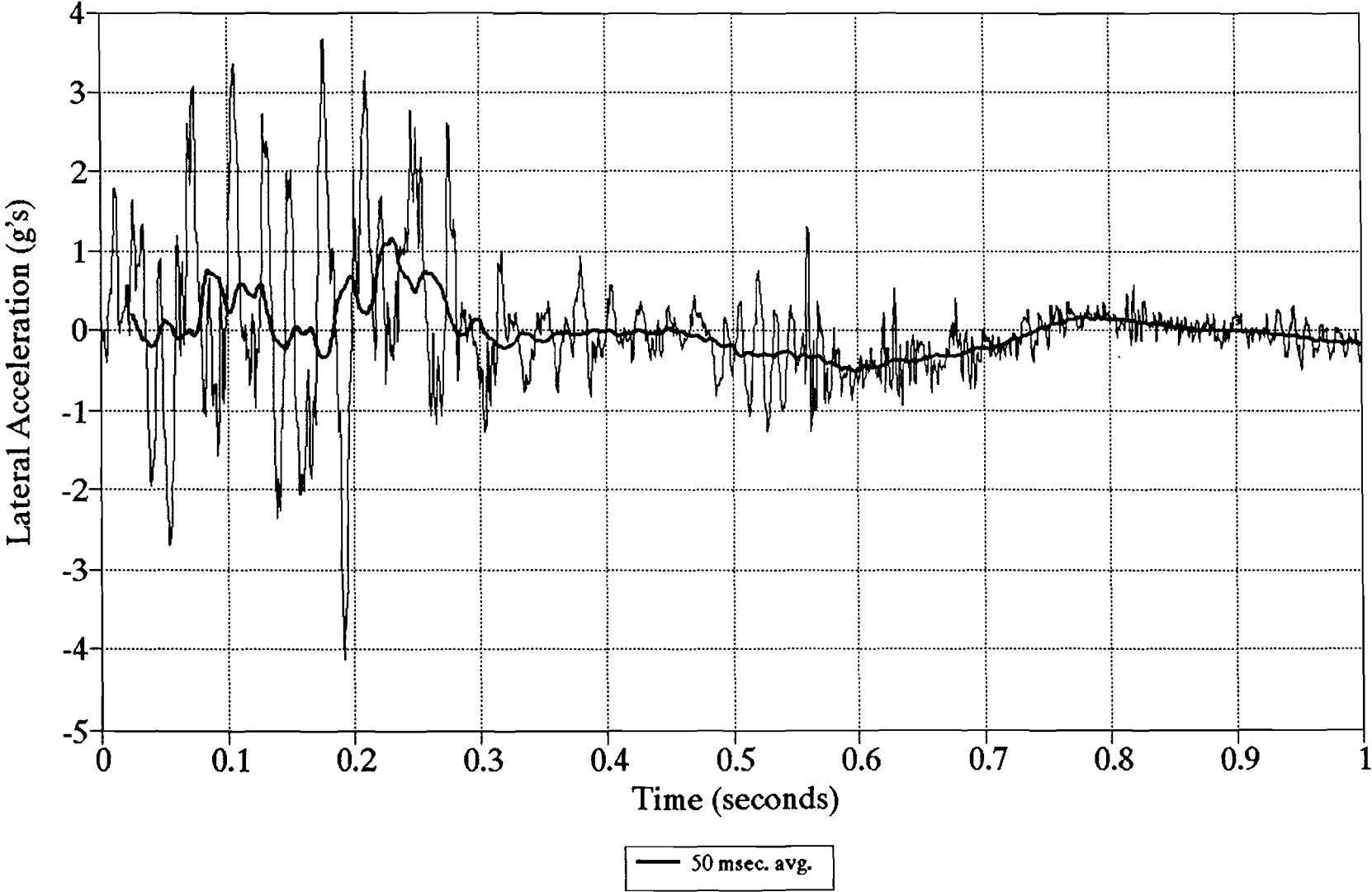

Figure 53. Lateral accelerometer trace (1219-6).

## CONCLUSIONS

The installation was found to be acceptable for application in weak soil (NCHRP 230 classification S2) -- tests 1219-1 & 2. However, the current steel post system fails to meet federal impact performance criteria for low speed impacts for two post installations in strong soil (NCHRP 230 classification S1) -- tests 1219-5 & 6.

Modifications in anchor design or attachment details and/or other sign post materials (such as fiberglass or aluminum) may provide a satisfactory solution for multiple post systems. However, from the results of tests 1219-6 (in which no screws were used to secure the sign post to the anchor), it does not look like minor changes will cause a two steel post system to work in strong soil.

The primary difference seems to be the enhanced ability of the anchor system to pull-out under impact loading in weak soil, whereas the post collapses around the anchor and the anchor is unable to pull-out in strong soil. An anchor to post connection with a combined pull-out and shear failure mechanism would appear to be a solution to the two soil problem. In a stiff soil (S1) there would be enough resistance to activate a slip base. In a softer soil (S2), where a slip base could not function, the anchor pull-out would soften the impact and allow the system to satisfy impact criteria.





**APPENDIX A**

**STATIC LOAD TESTS**

**FORCE-DISPLACEMENT CURVES**



# PROJECT 1219 STATIC LOAD TEST POZ-LOC SYSTEM

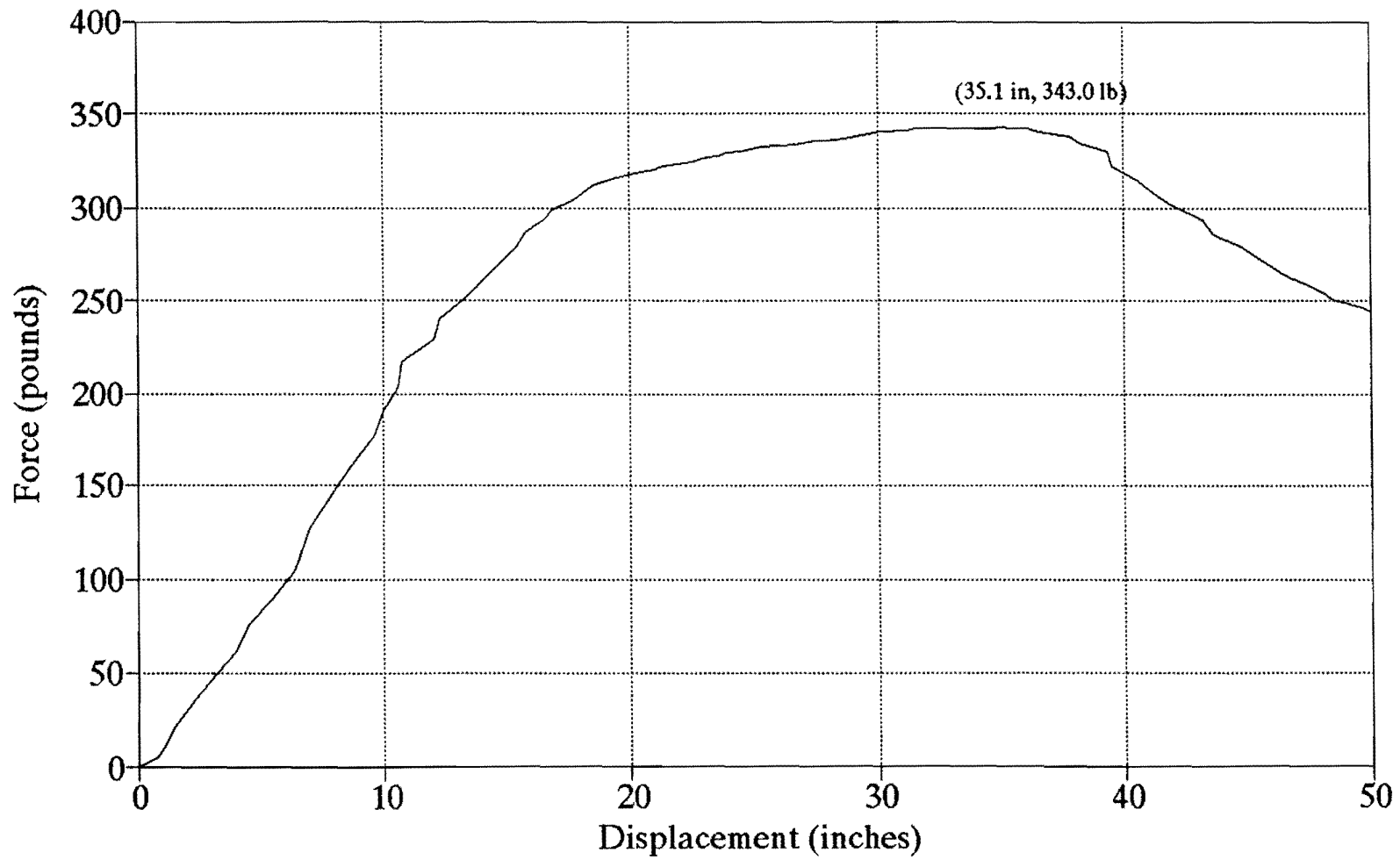

# PROJECT 1219 STATIC LOAD TEST HWYCOM SYSTEM

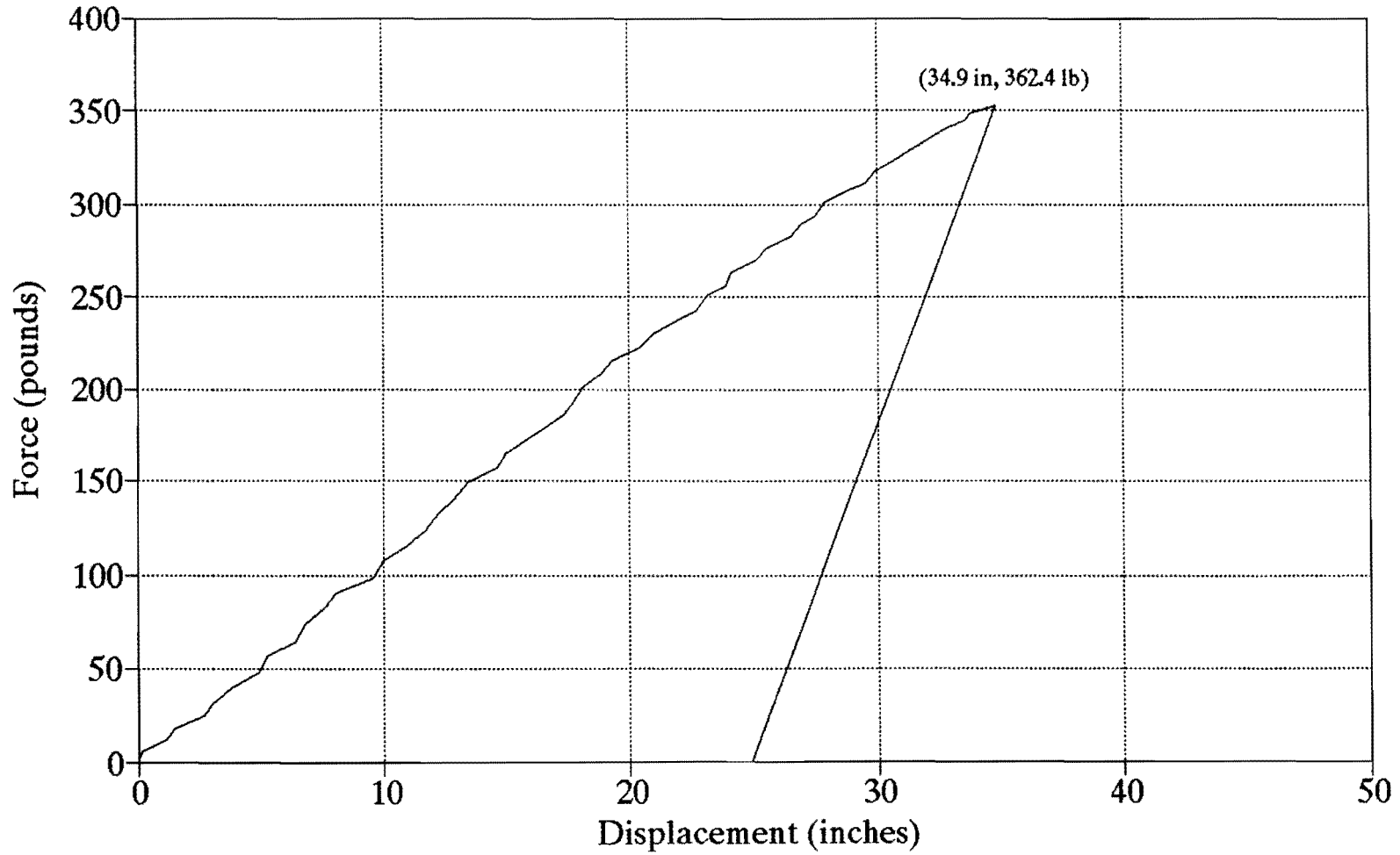

PROJECT 1219 STATIC LOAD TEST  
STEEL TUBE W/ GENERIC ANCHOR (6" DEPTH)  
0.065" x 3.0" 1026 ROUND STEEL TUBE

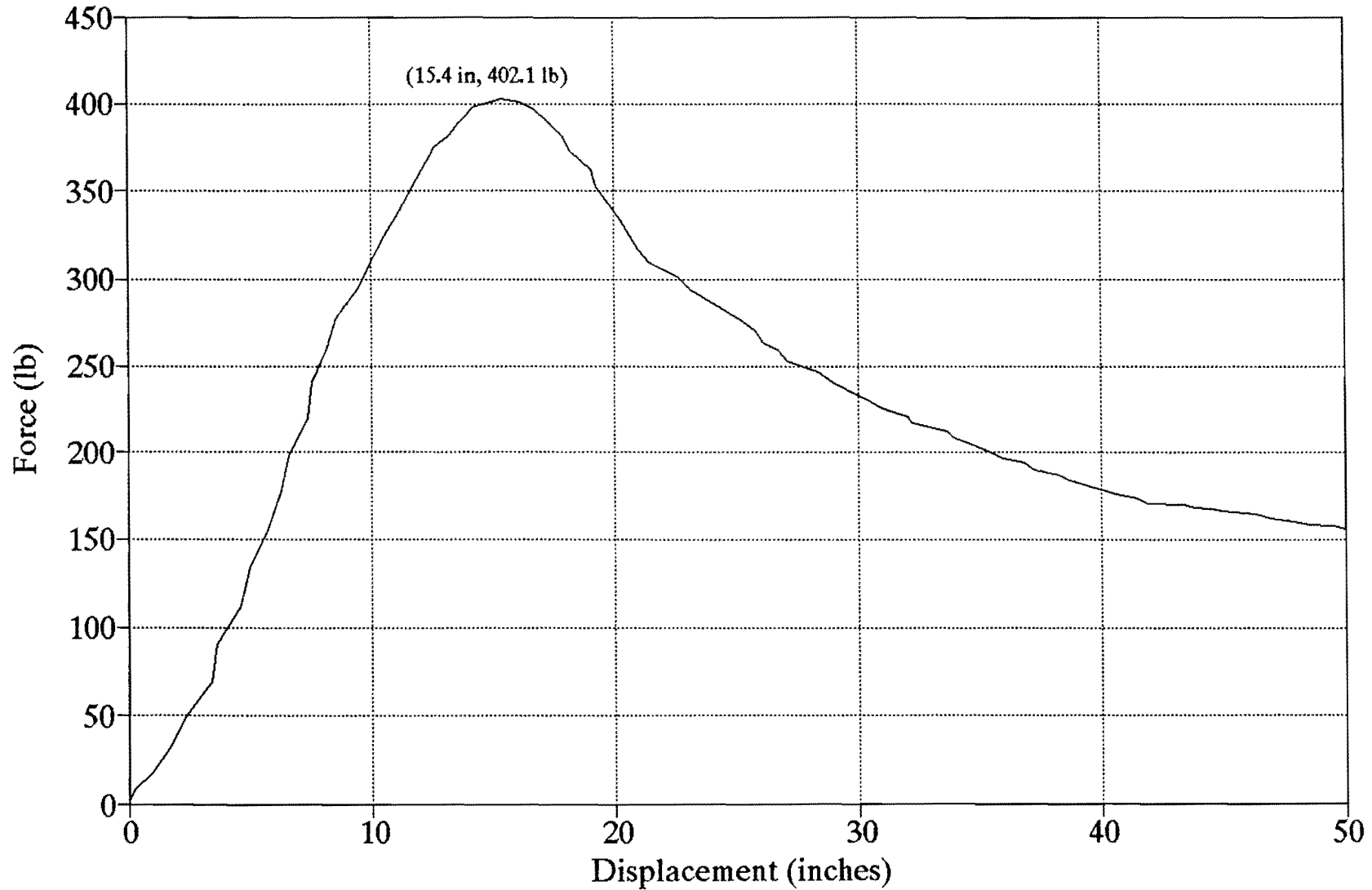

**PROJECT 1219 STATIC LOAD TEST  
STEEL TUBE W/ GENERIC ANCHOR (6" DEPTH)**

**0.065" x 3.0" 1026 ROUND STEEL TUBE  
W/O CHAMFER ON ANCHOR**

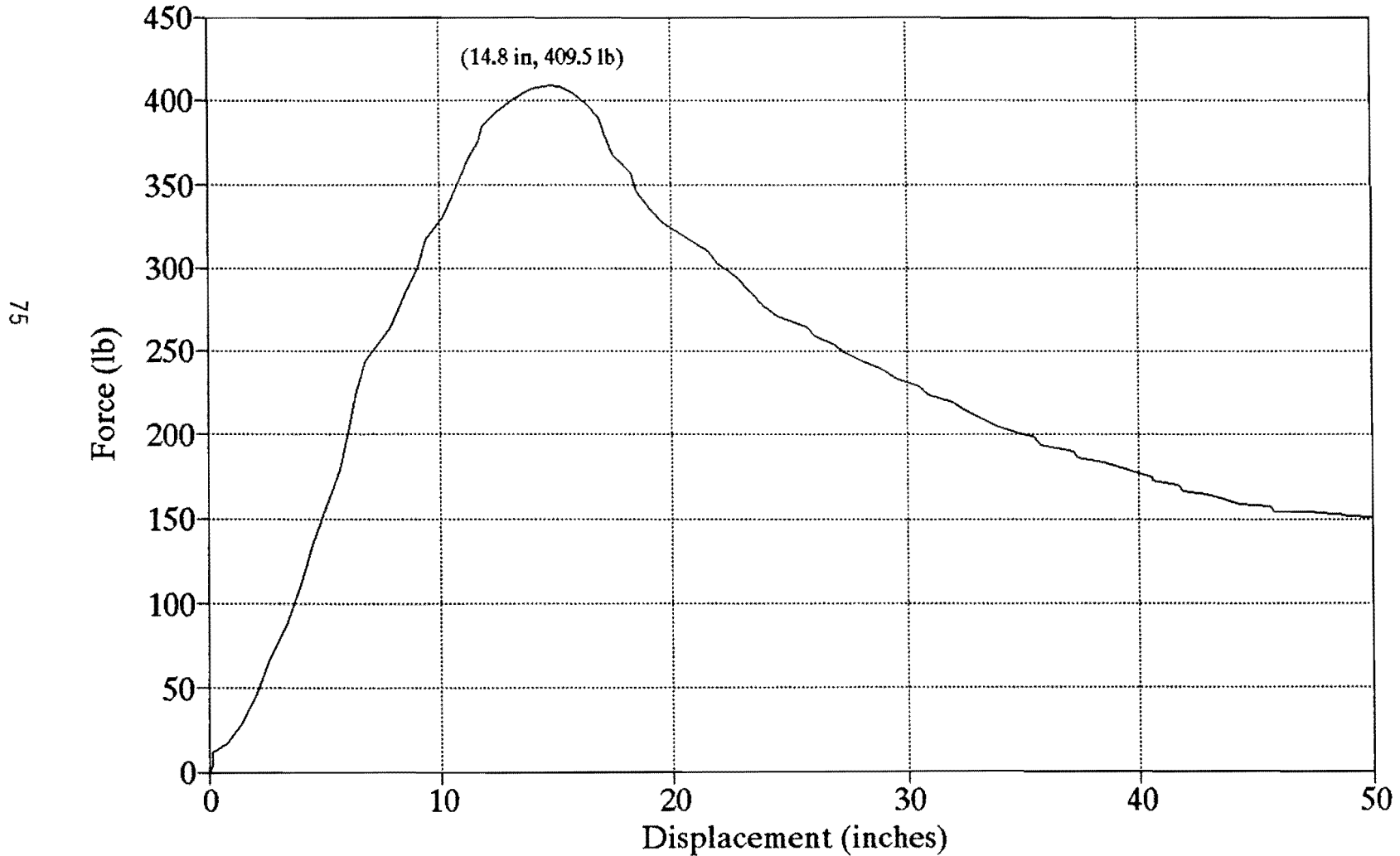

PROJECT 1219 STATIC LOAD TEST  
STEEL TUBE W/GENERIC ANCHOR (6" DEPTH)  
0.065" x 3.0" 1026 ROUND STEEL TUBE  
W/0.030" WHITE STYRENE SLEEVE

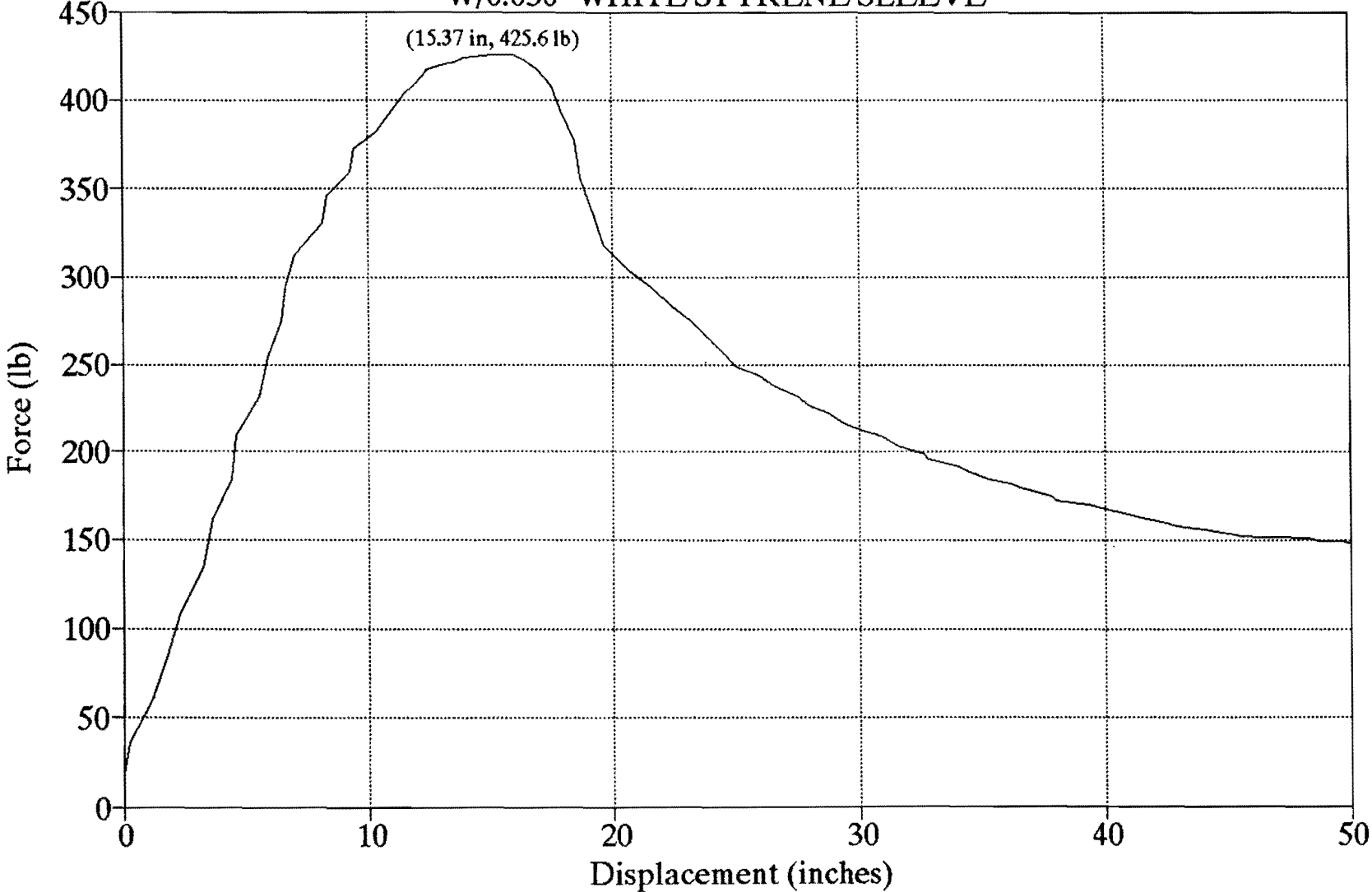

**PROJECT 1219 STATIC LOAD TEST**  
**STEEL TUBE W/ GENERIC ANCHOR (2" DEPTH)**  
**0.049" x 3.0" 1010 ROUND STEEL TUBE**

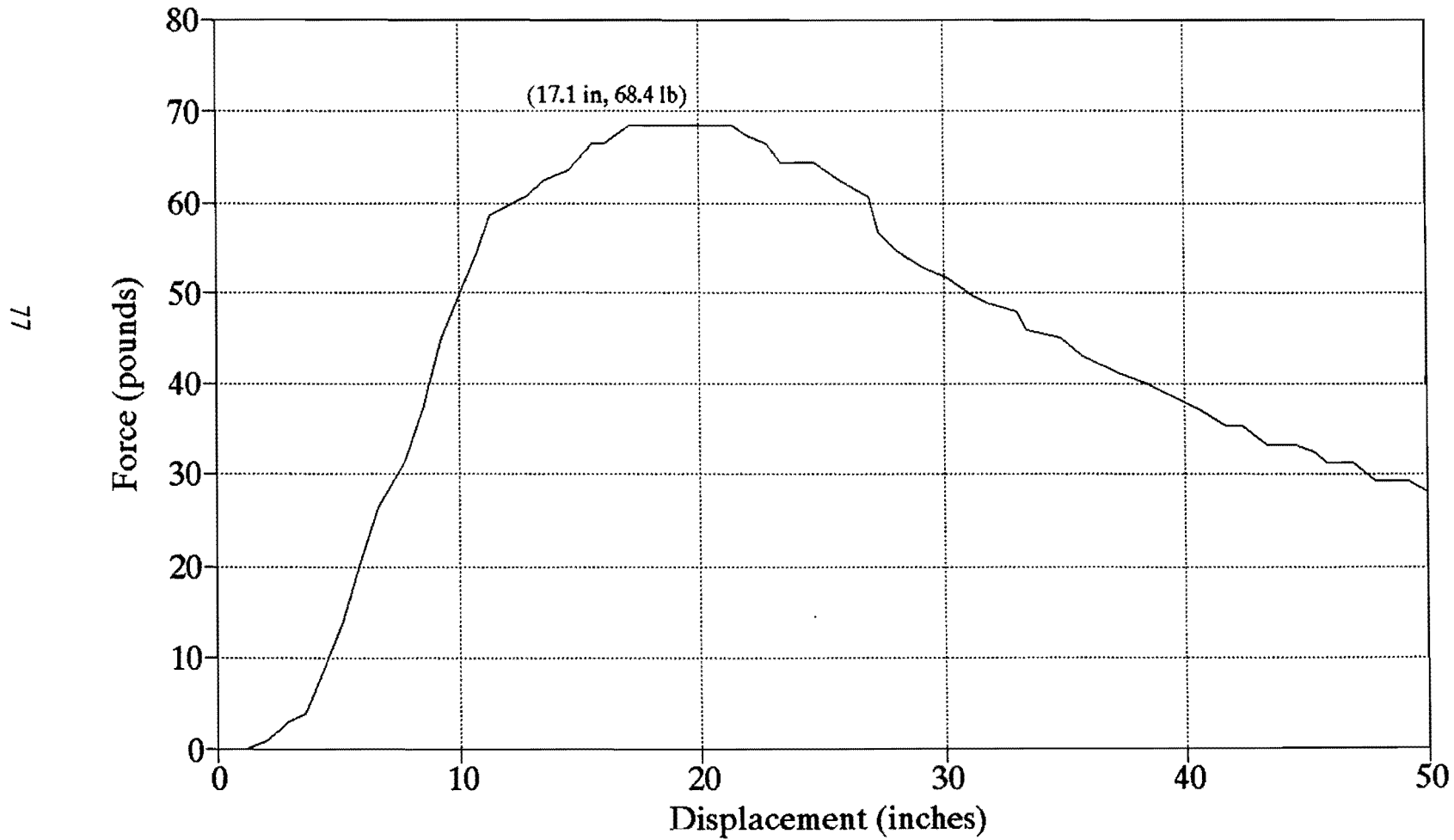



**PROJECT 1219 STATIC LOAD TEST**  
**STEEL TUBE W/ GENERIC ANCHOR (4" DEPTH)**  
**0.049" x 3.0" 1010 ROUND STEEL TUBE**

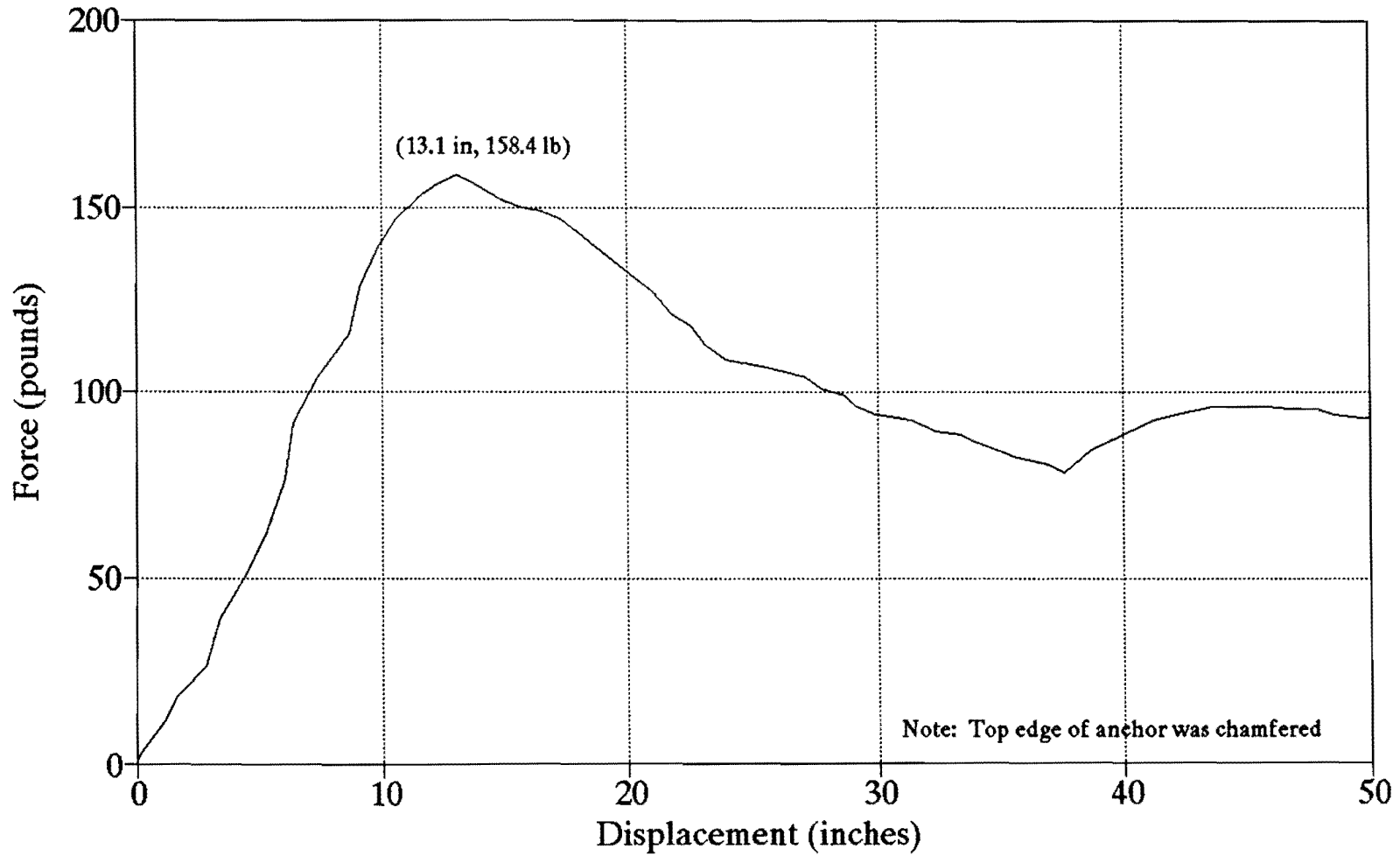

PROJECT 1219 STATIC LOAD TEST  
STEEL TUBE W/ GENERIC ANCHOR (4" DEPTH)  
0.049" x 3.0" 1010 ROUND STEEL TUBE

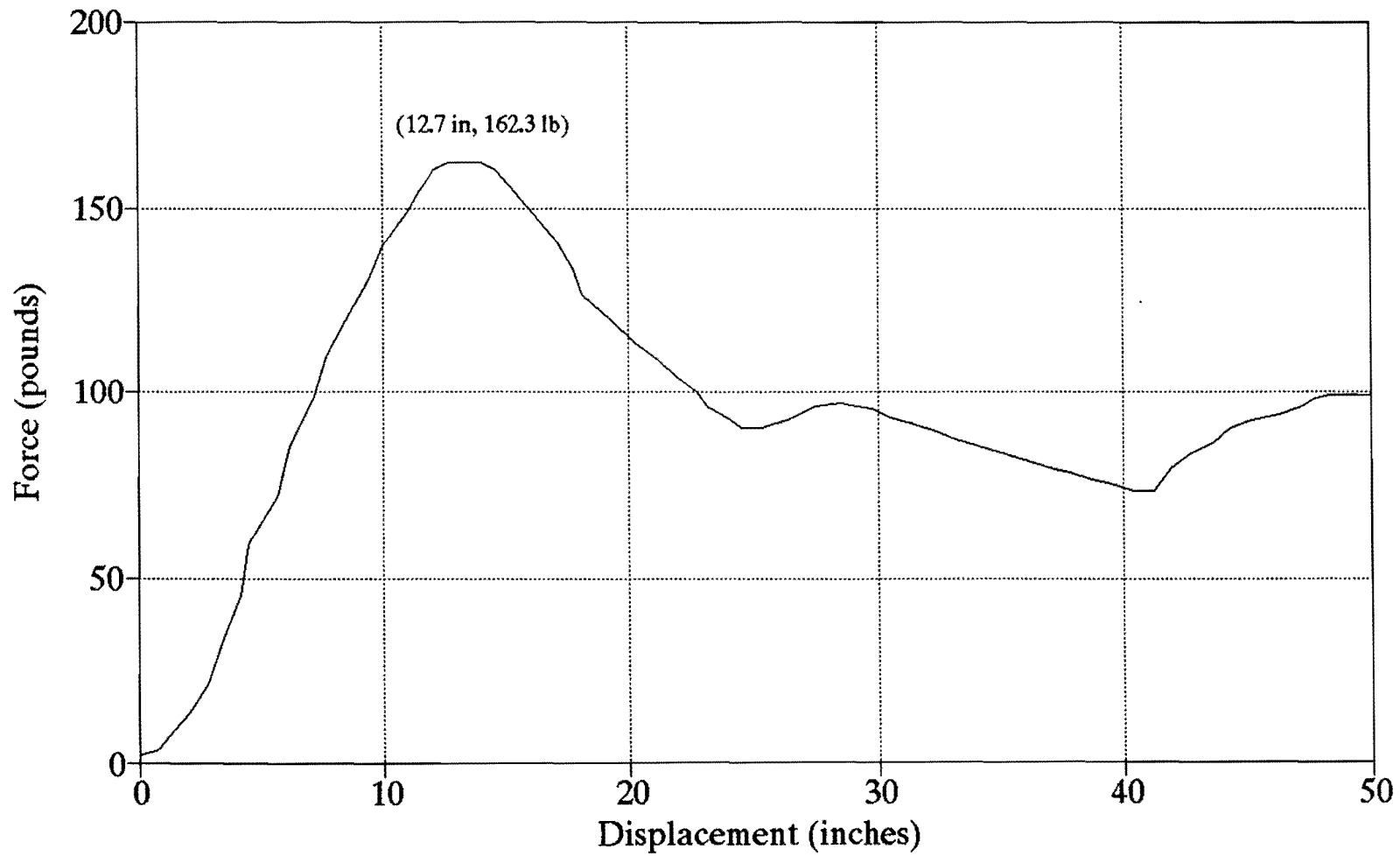

**PROJECT 1219 STATIC LOAD TEST**  
**STEEL TUBE W/ GENERIC ANCHOR (6" DEPTH)**  
**0.049" x 3.0" 1010 ROUND STEEL TUBE**

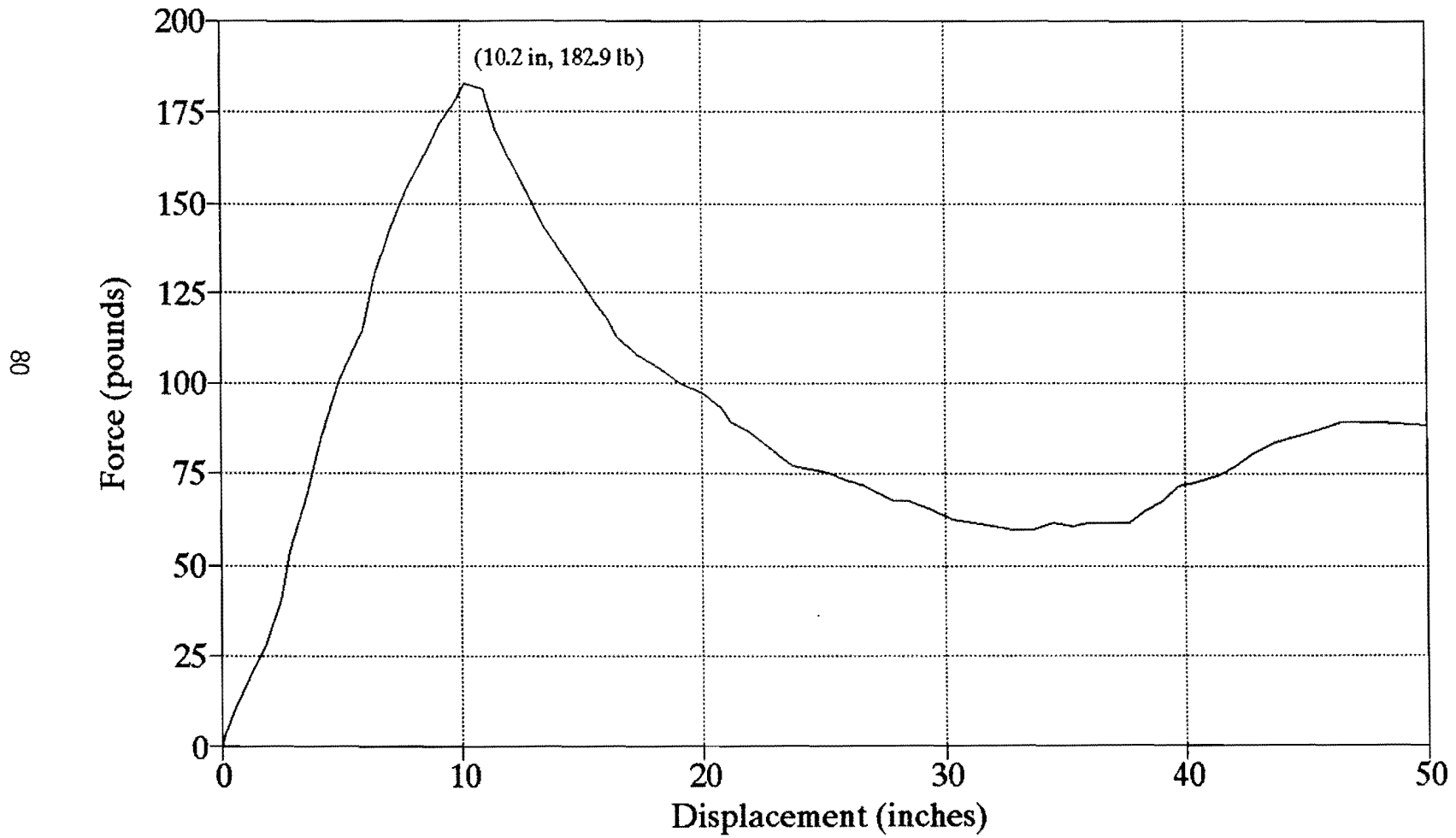

# PROJECT 1219 STATIC LOAD TEST HWYCOM POST W/GENERIC ANCHOR (6" DEPTH)

18

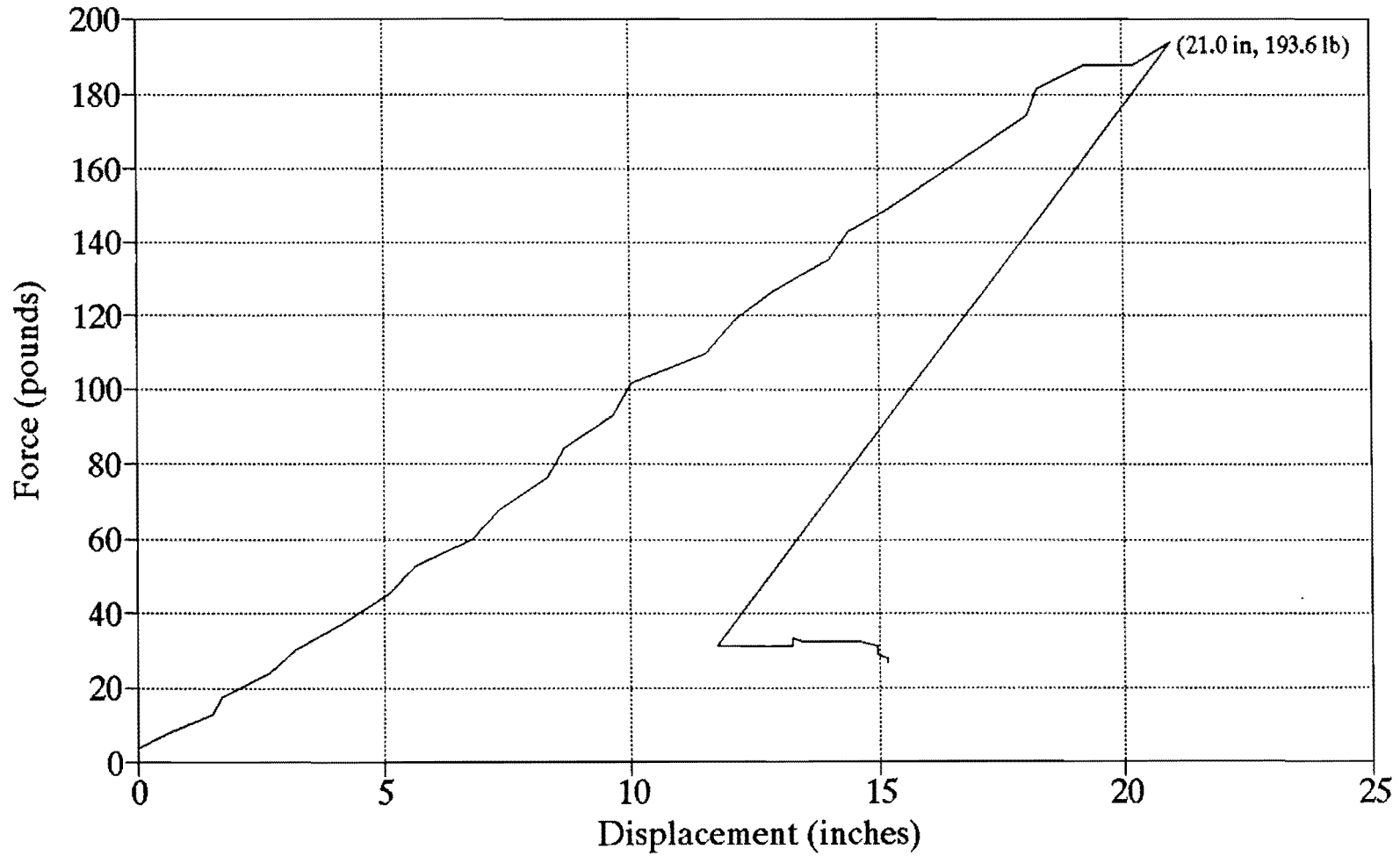

# PROJECT 1219 STATIC LOAD TEST HWYCOM POST W/GENERIC ANCHOR (6" DEPTH)

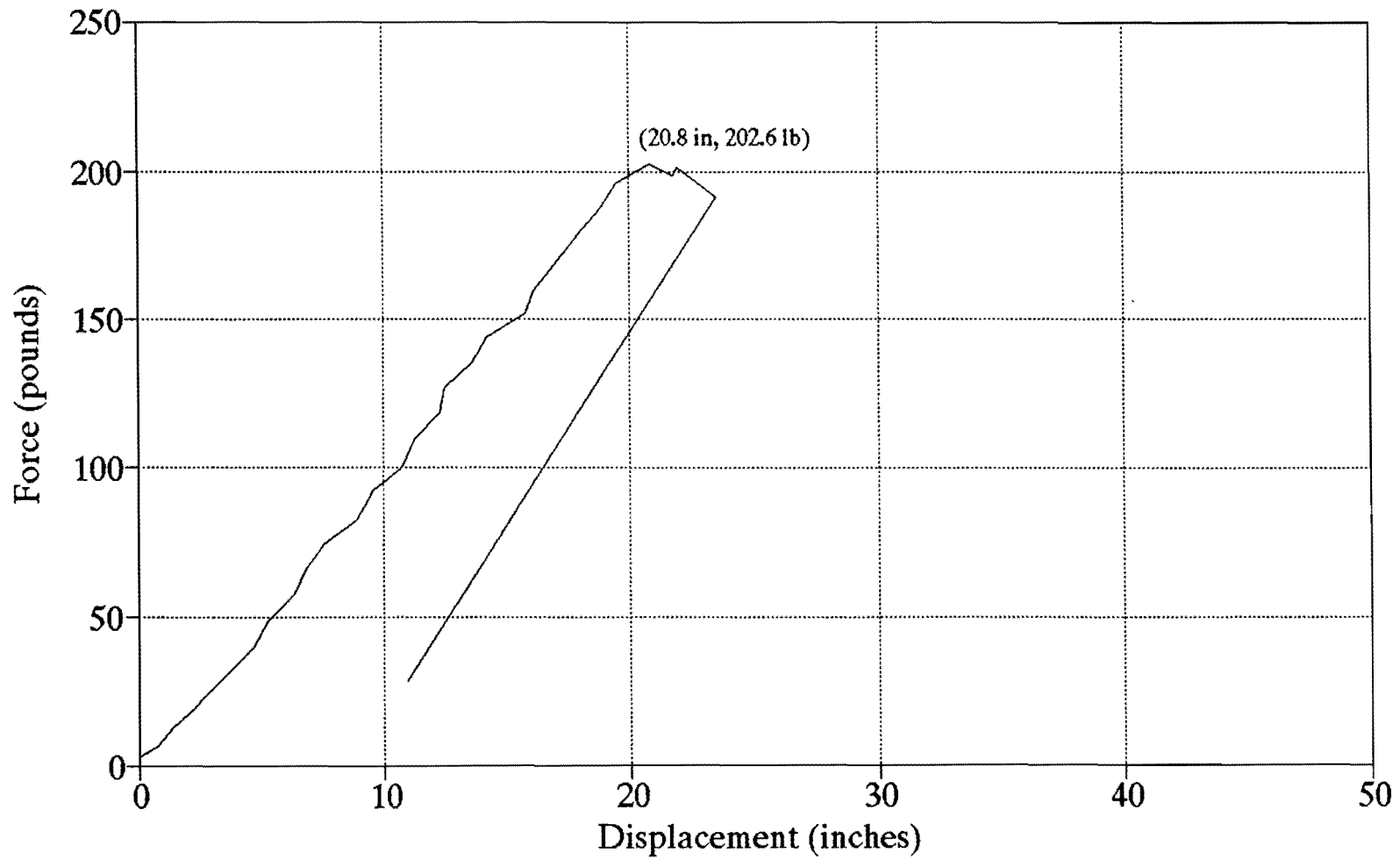



**APPENDIX B**

**TENSILE COUPON**

**LOAD-STRAIN CURVES**





TENSILE COUPON TEST 1219-1A  
0.085" x 3.0" 1026 DOM Steel Tube

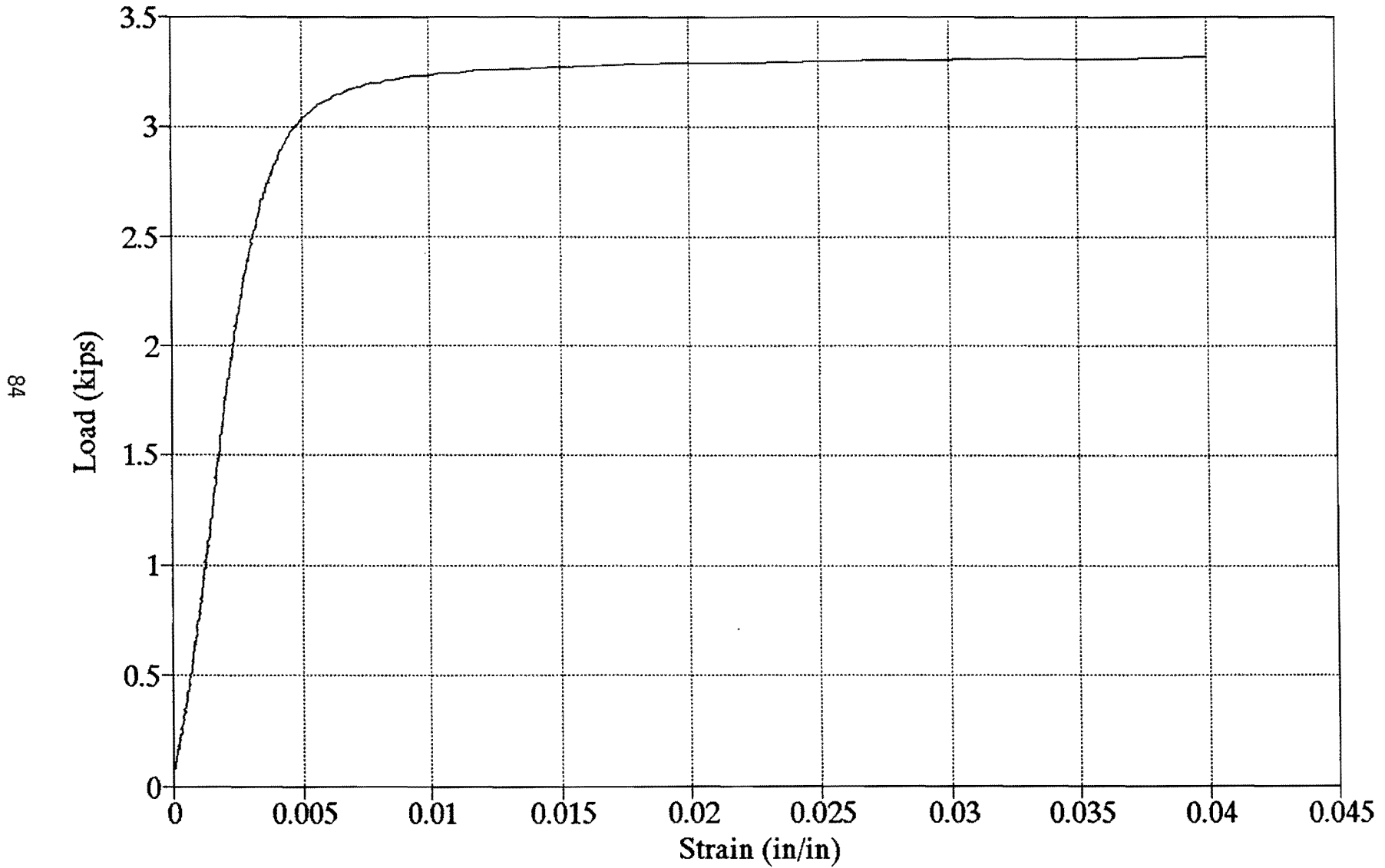

TENSILE COUPON TEST 1219-1B  
0.085" x 3.0" 1026 DOM Steel Tube

85

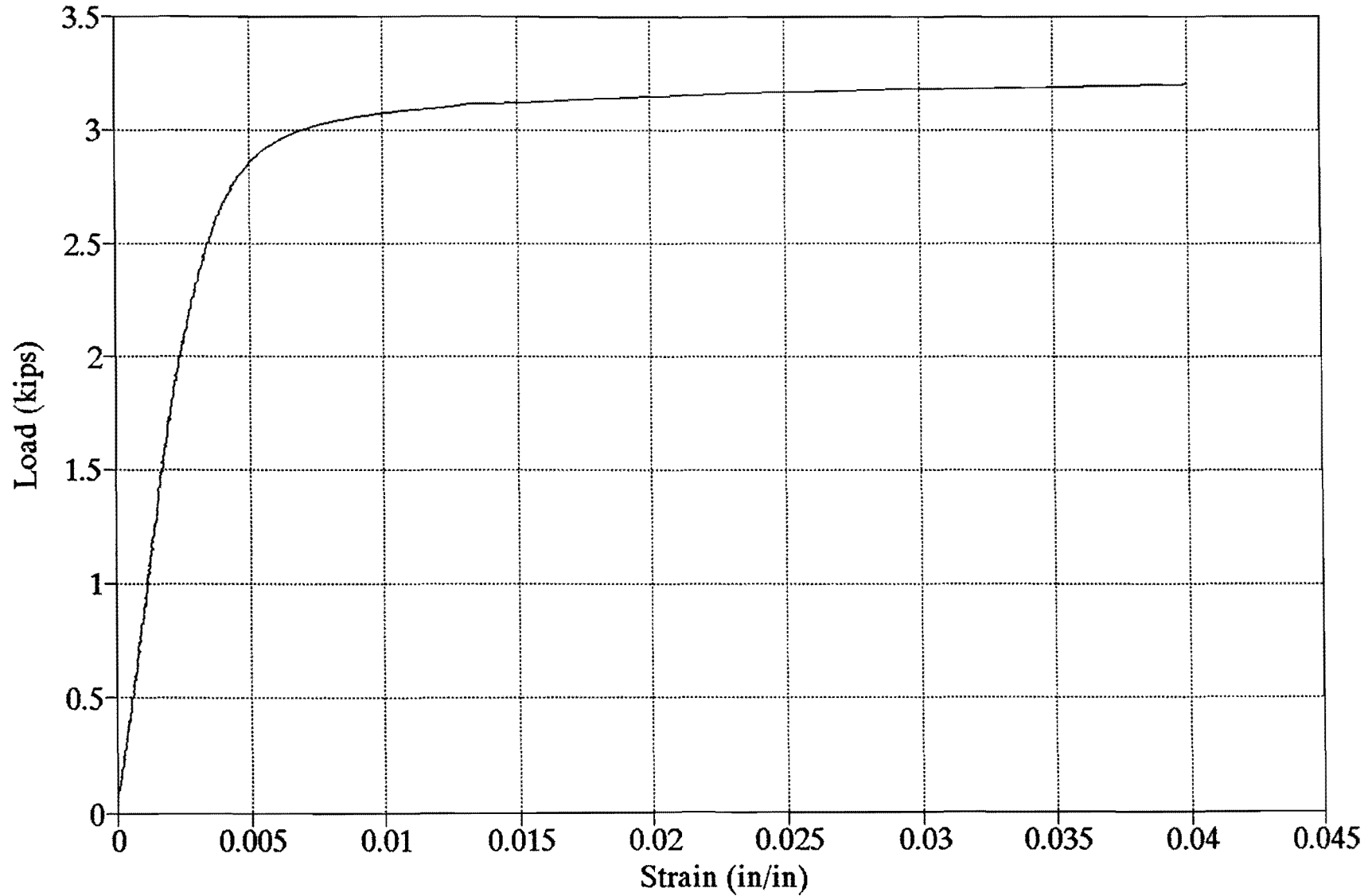

TENSILE COUPON TEST 1219-2A  
0.065" x 3.0" 1026 DOM Steel Tube

98

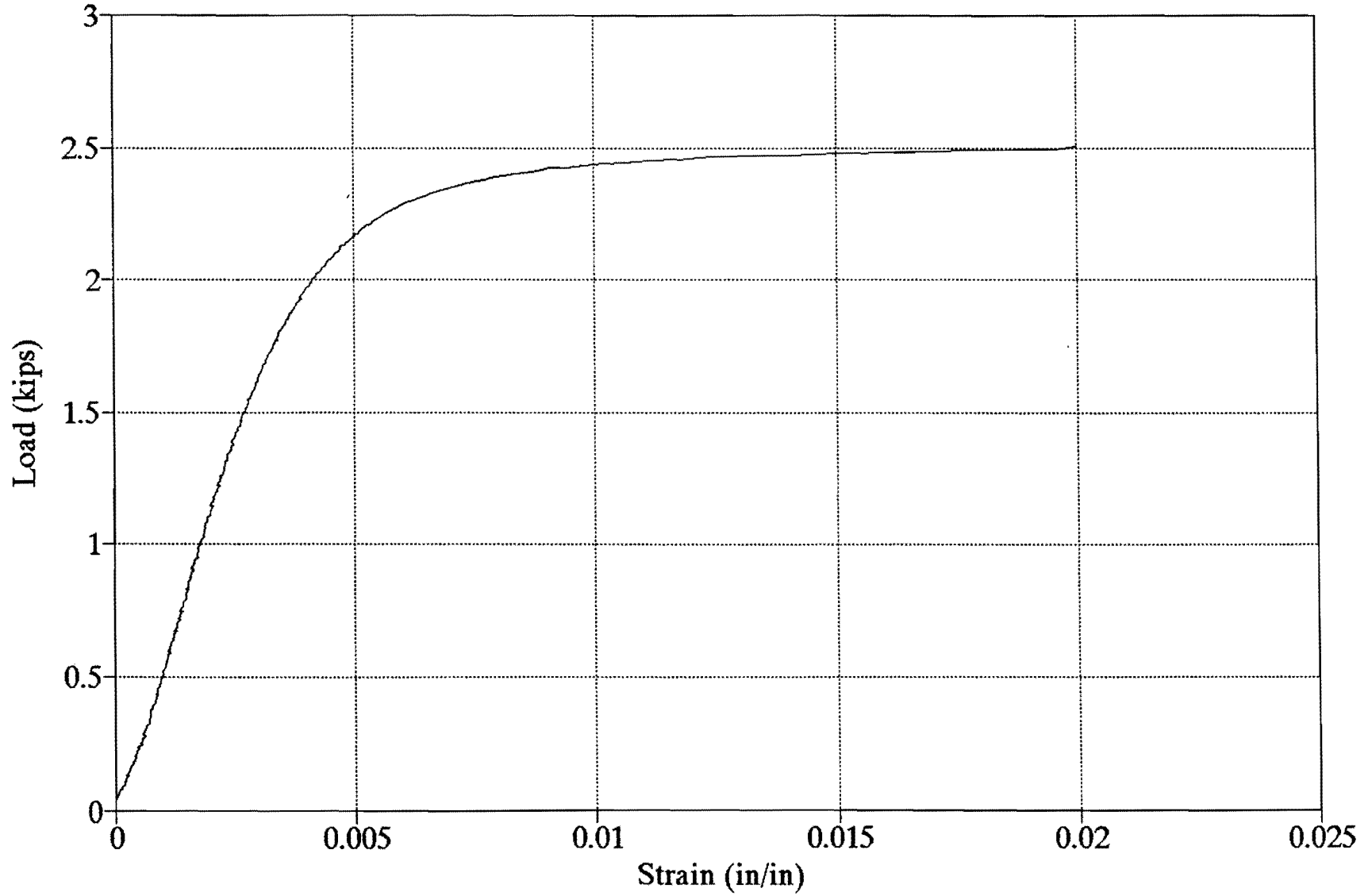

TENSILE COUPON TEST 1219-2B  
0.065" x 3.0" 1026 DOM Steel Tube

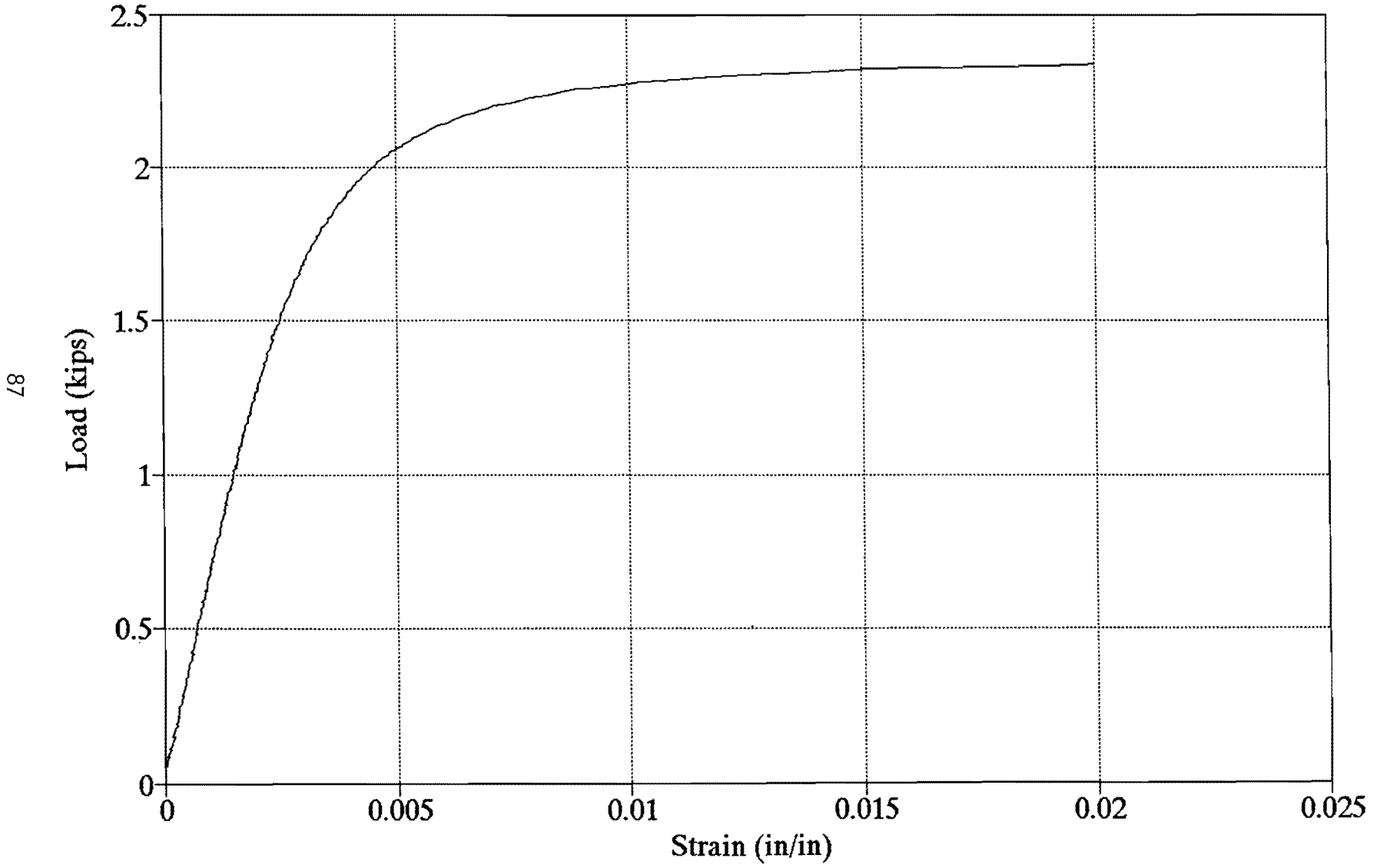

TENSILE COUPON TEST 1219-3A  
0.049" x 3.0" 1018 Steel Tube

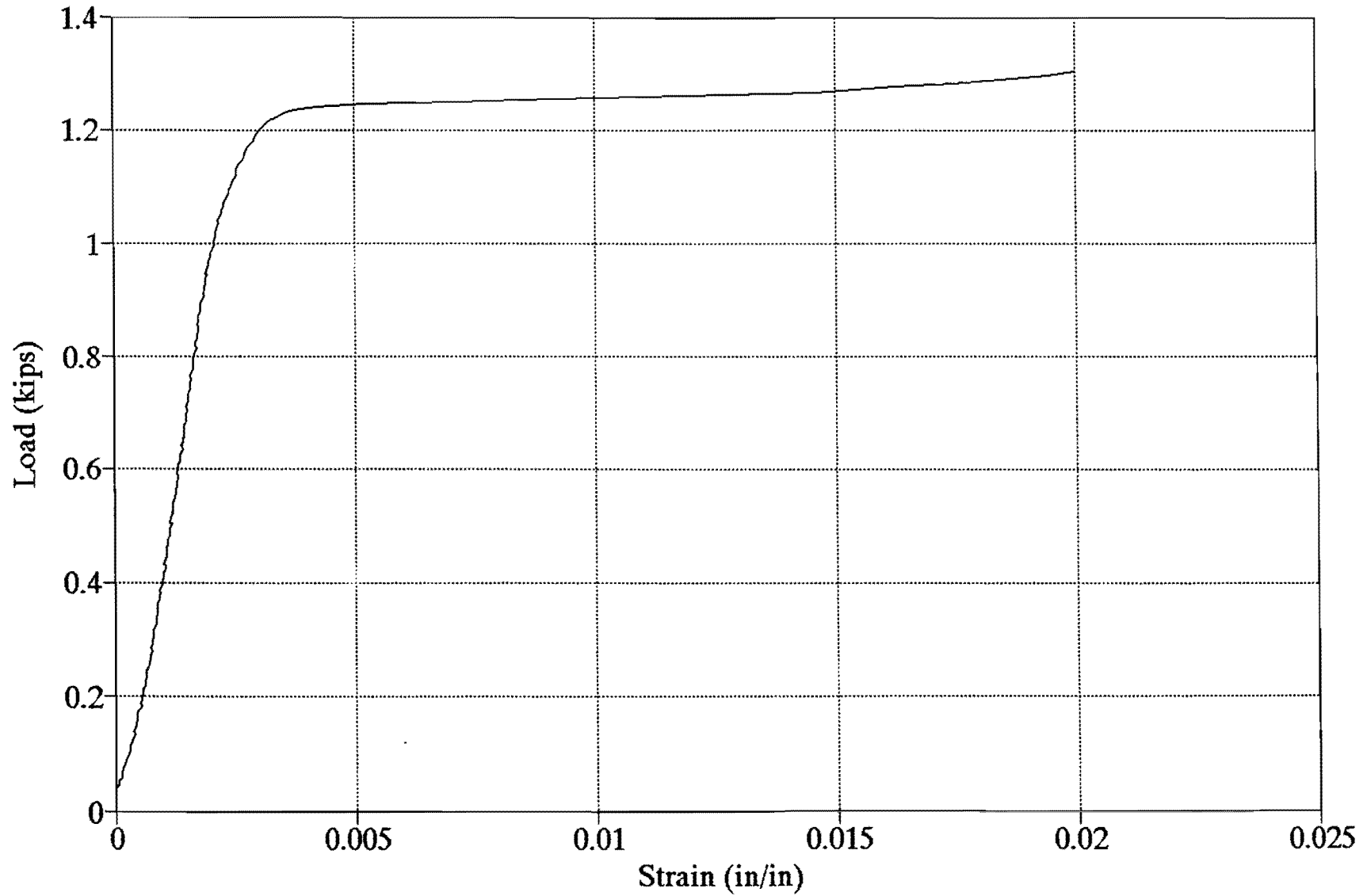

TENSILE COUPON TEST 1219-3B  
0.049" x 3.0" 1018 Steel Tube

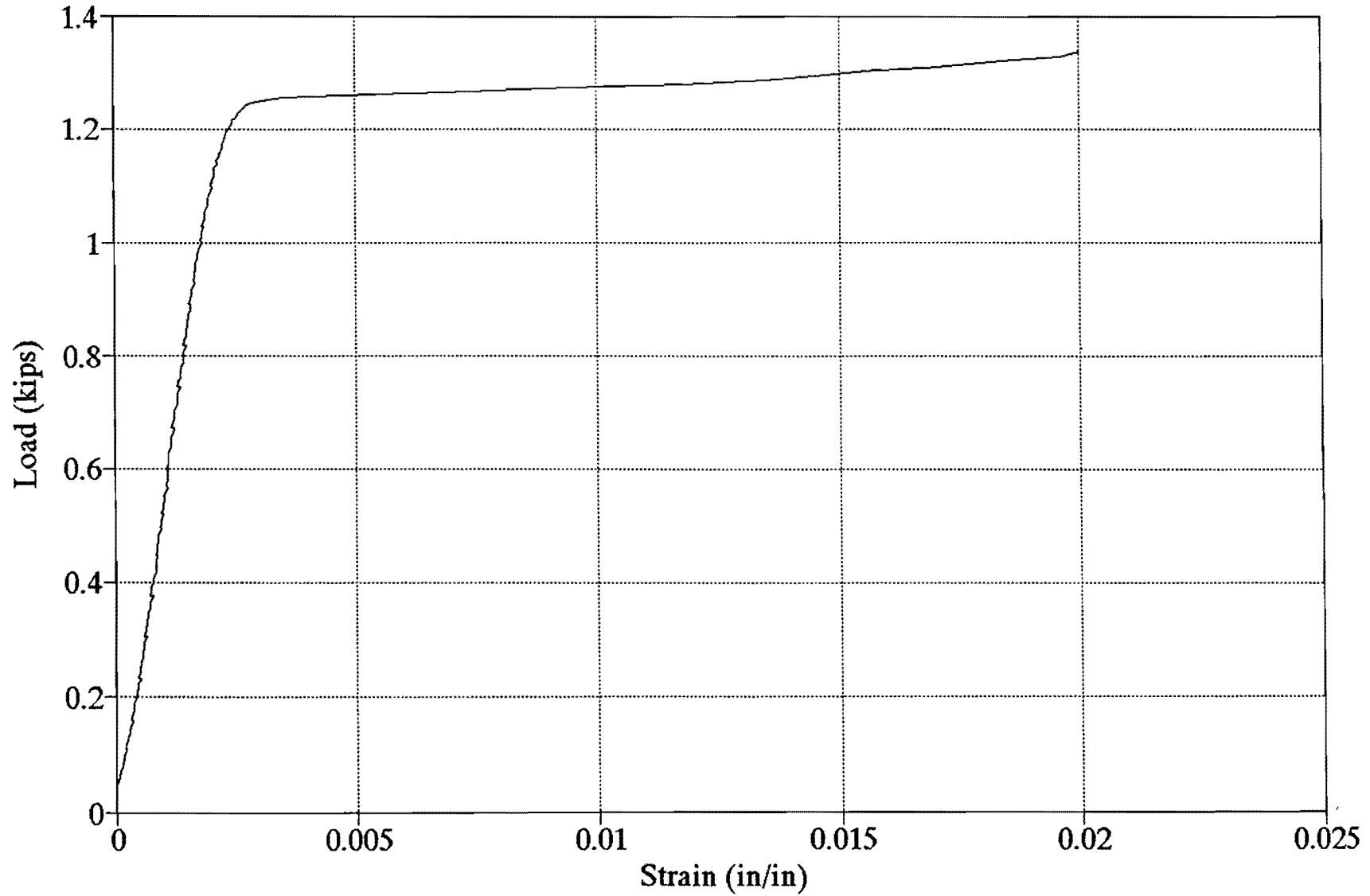

TENSILE COUPON TEST 1219-4A  
0.065" x 3.0" 1018 Steel Tube

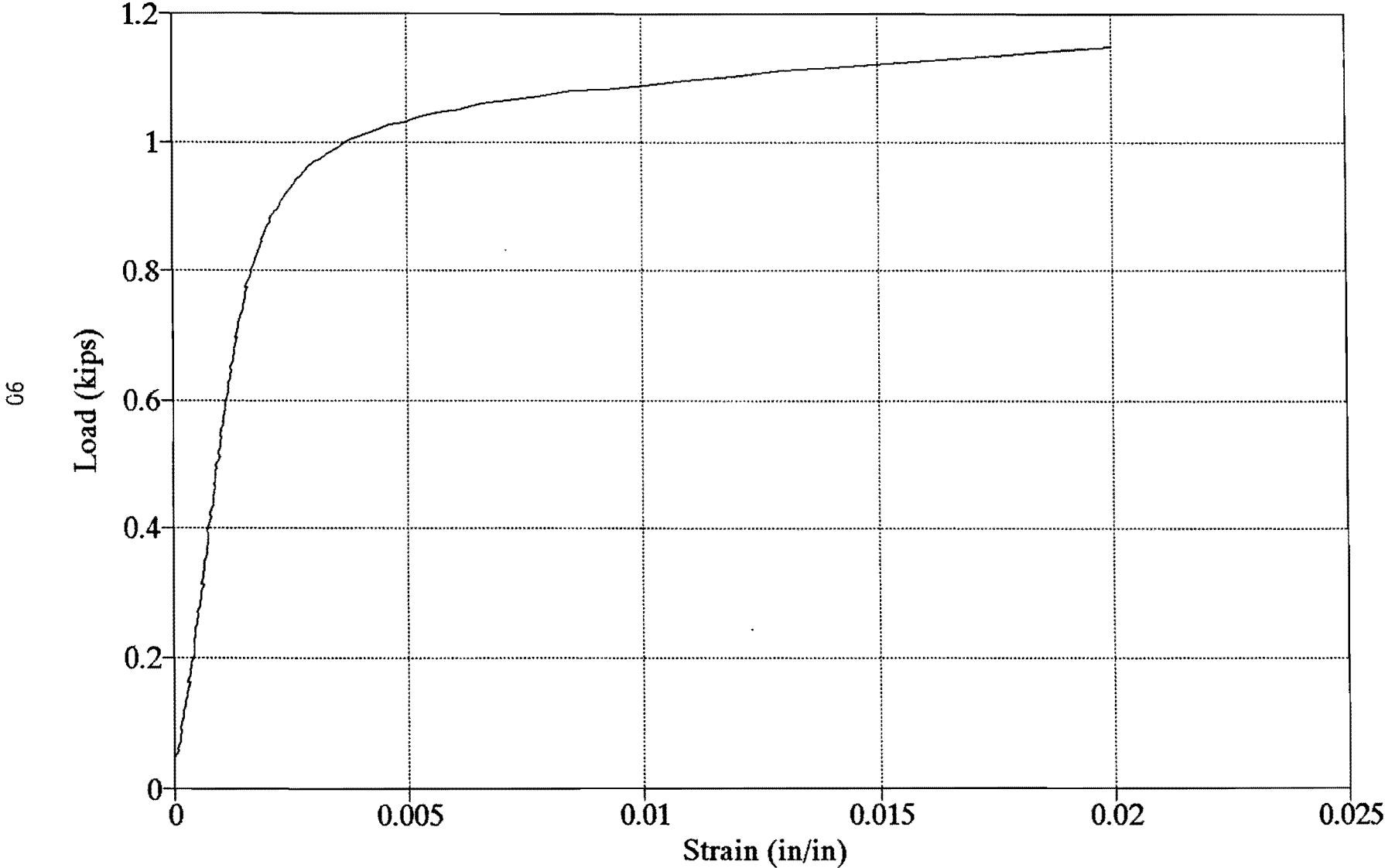

TENSILE COUPON TEST 1219-4B  
0.065" x 3.0" 1018 Steel Tube

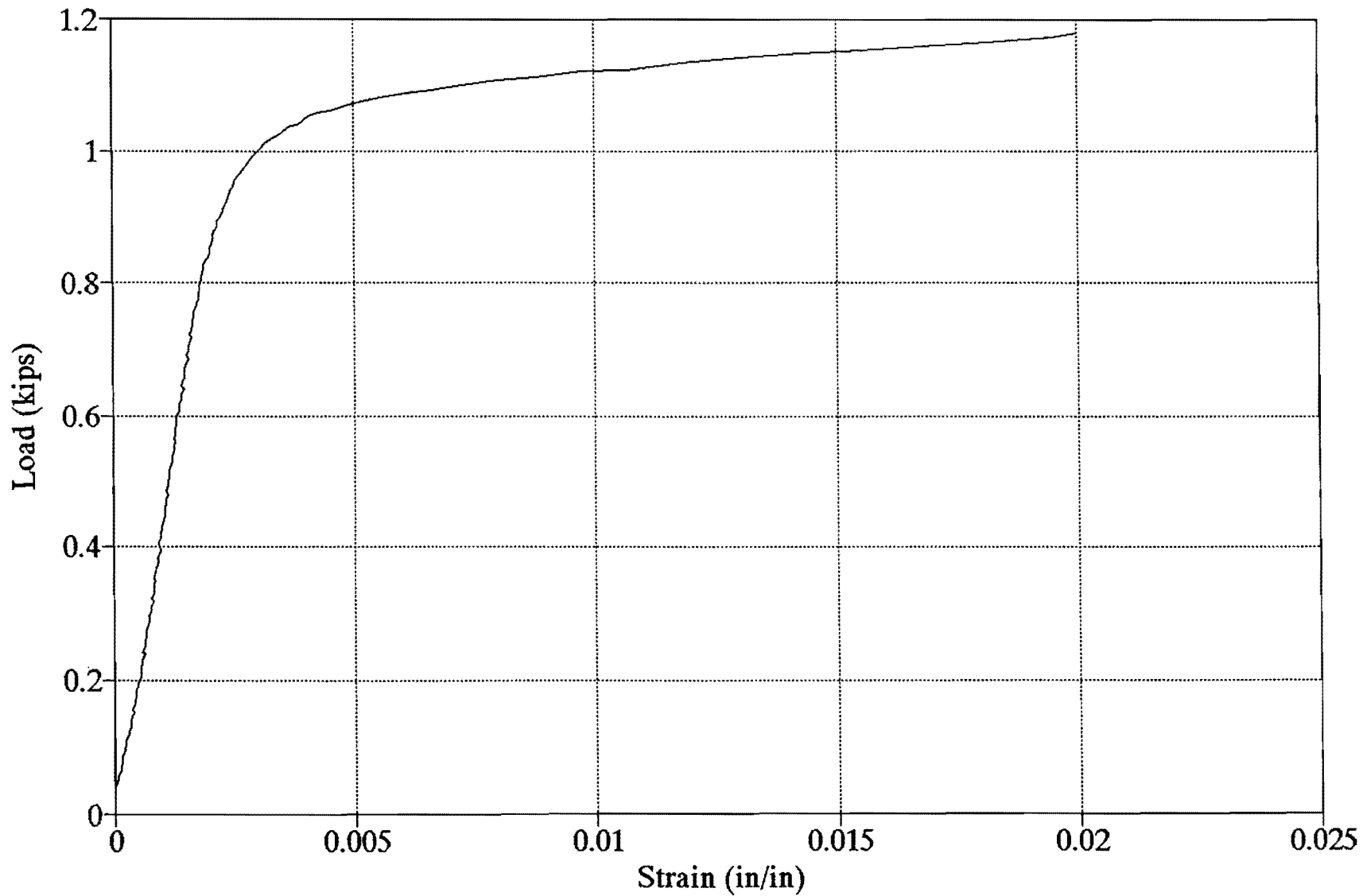



TENSILE COUPON TEST 1219-5A  
0.095" x 3.0" 1026 DOM Steel Tube

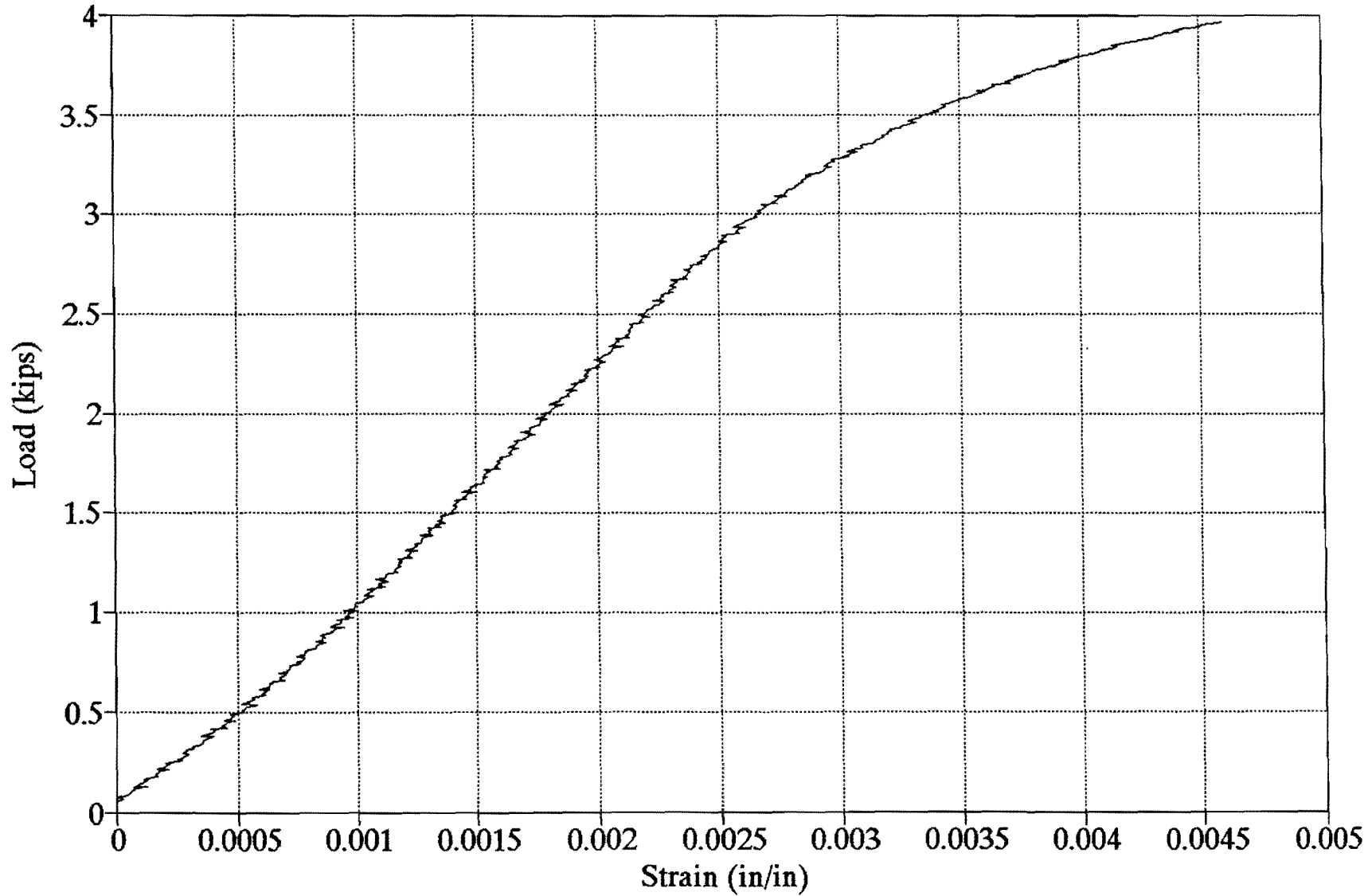

TENSILE COUPON TEST 1219-5B  
0.095" x 3.0" 1026 DOM Steel Tube

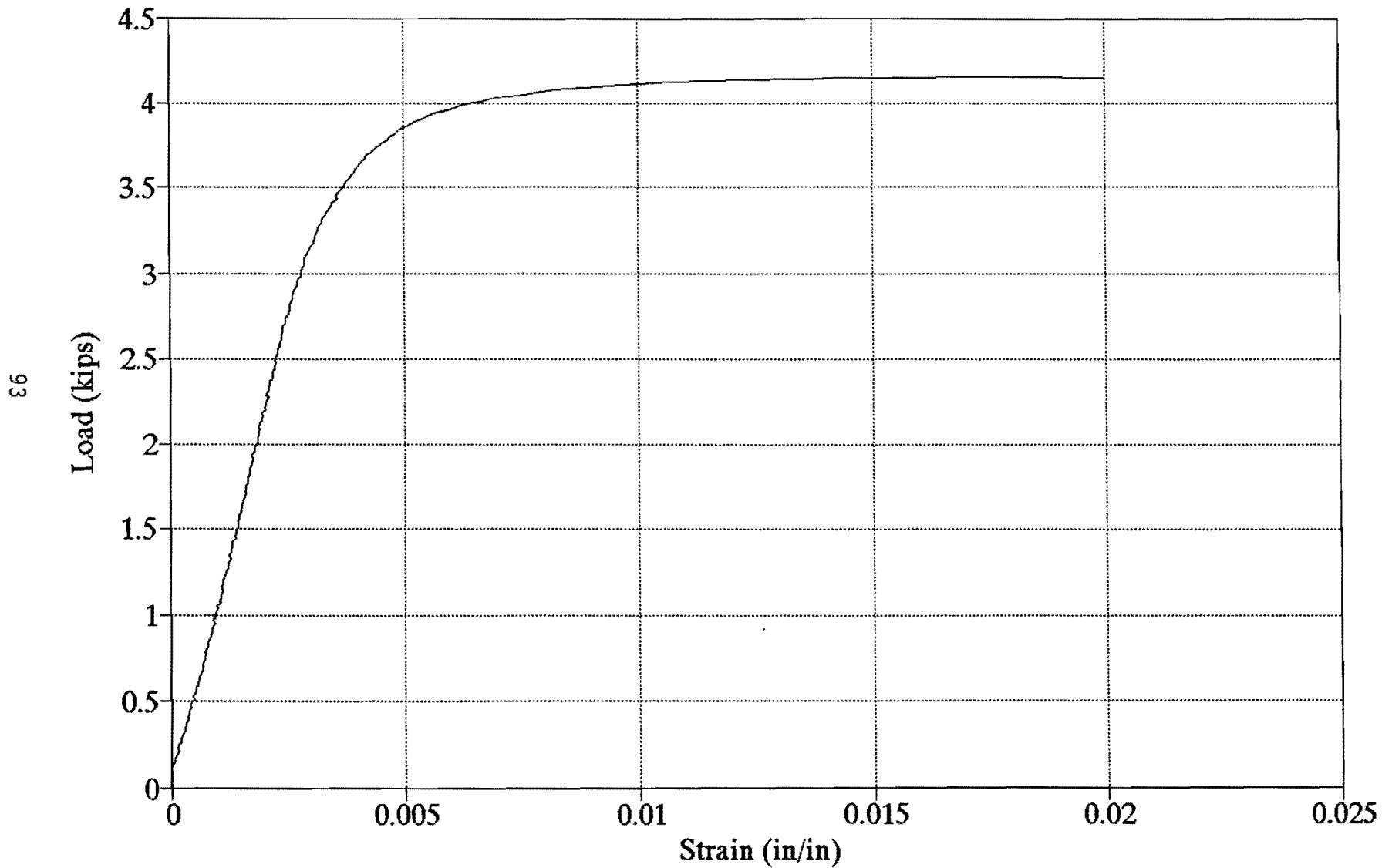

TENSILE COUPON TEST 1219-6A  
0.065" x 3.0" 1018 Steel Tube

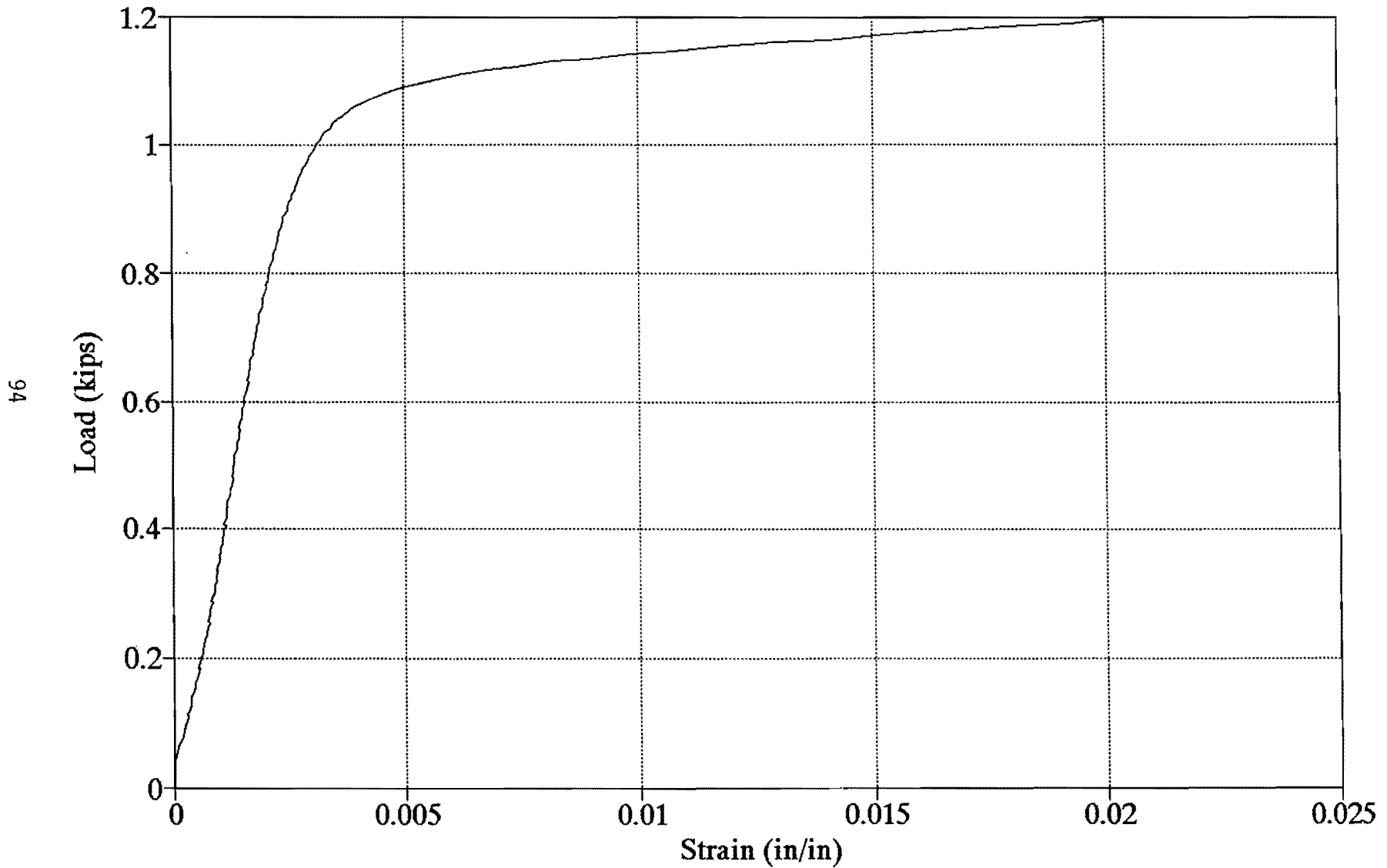

TENSILE COUPON TEST 1219-6B  
0.065" x 3.0" 1018 Steel Tube

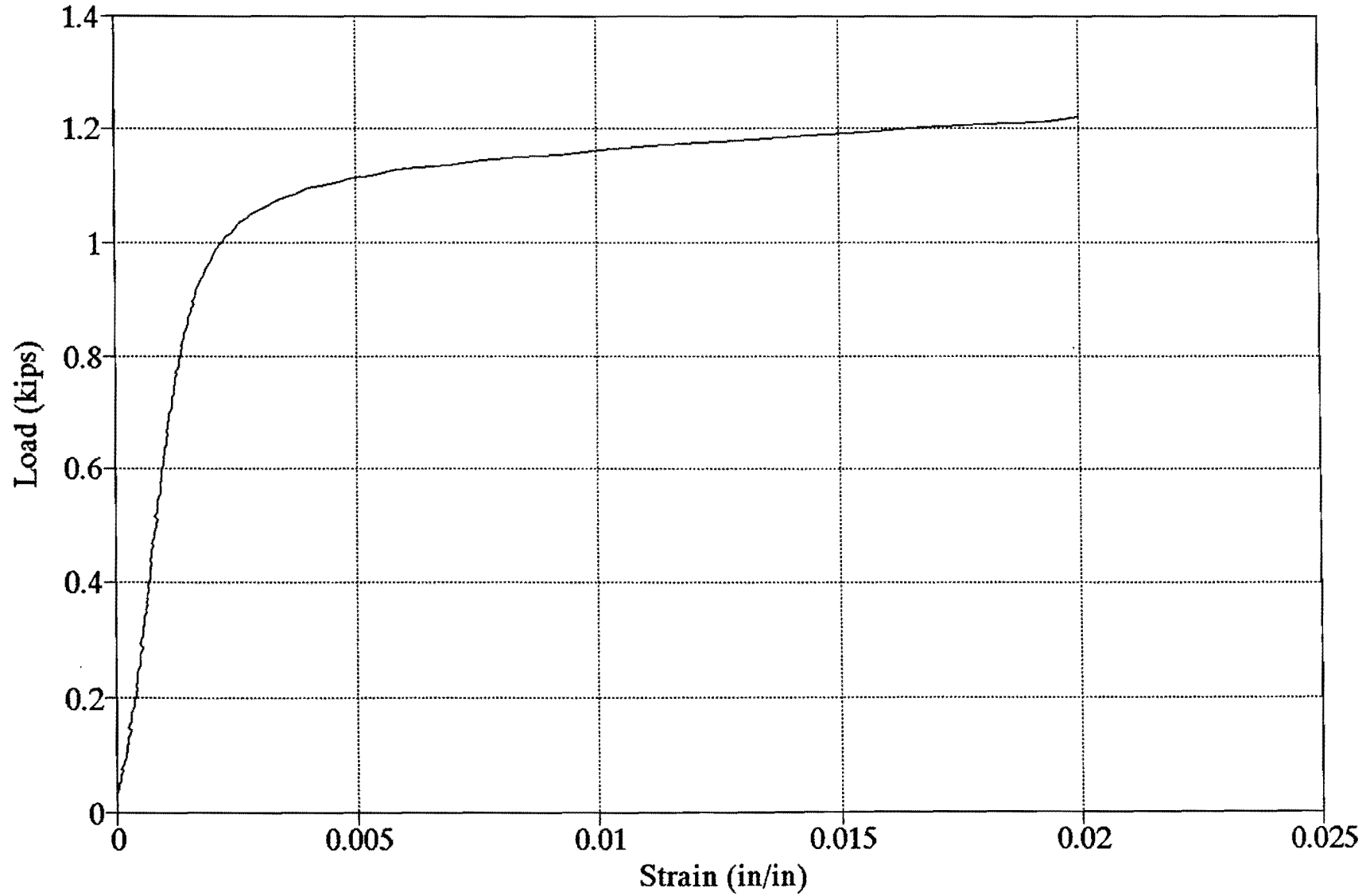

TENSILE COUPON TEST 1219-1X  
0.065" x 3.0" 1026 DOM Steel Tube

96

