

Test Report No. 440863-03-1



**MASH TEST 4-12 EVALUATION OF A LUMINAIRE POLE BEHIND
SINGLE SLOPE TRAFFIC RAIL**

COOPERATIVE RESEARCH PROGRAM

Texas Department of Transportation

<https://tti.tamu.edu/documents/0-7086.pdf>

TEXAS A&M TRANSPORTATION INSTITUTE PROVING GROUND

Roadside Safety & Physical Security

Texas A&M University System RELLIS Campus

Building 7091

1254 Avenue A

Bryan, TX 77807



ACCREDITED

ISO 17025 Laboratory

Testing Certificate # 2821.01

1. Report No.	2. Government Accession No.	3. Recipient's Catalog No.	
4. Title and Subtitle MASH Testing of Luminaire Pole behind Single Slope Traffic Rail		5. Report Date Published: November 2024	6. Performing Organization Code
		8. Performing Organization Report No. TRNo 440863-03-1	
7. Author(s) Roger Bligh, Ph.D., PE, and Brianna Bastin		10. Work Unit No. (TRAIS)	
9. Performing Organization Name and Address Texas A&M Transportation Institute Proving Ground 3135 TAMU College Station, Texas 77843-3135		11. Contract or Grant No. Project 0-7086	
		13. Type of Report and Period Covered Technical Report: 2023-06-22–August 2023	
12. Sponsoring Agency Name and Address Texas Department of Transportation Research and Technology Implementation Office 125 E. 11th Street Austin, Texas 78701-2483		14. Sponsoring Agency Code	
		15. Supplementary Notes Name of Contacting Representative: Taya Retterer, P.E., Bridge Division	
16. Abstract <p>The purpose of the test reported herein was to assess the performance of a luminaire pole mounted behind a single slope traffic rail according to the safety-performance evaluation guidelines included in the second edition of the American Association of State Highway and Transportation Officials <i>Manual for Assessing Safety Hardware (MASH)</i> (1). The crash test was performed in accordance with <i>MASH</i> Test 4-12, which includes a 10000S vehicle weighing 22,000 lb impacting the longitudinal barrier upstream of the luminaire pole while traveling at a nominal speed of 56 mi/h and nominal angle of 15 degrees.</p> <p>This report provides details of the Luminaire Pole behind Single Slope Traffic Rail, the crash test and results, and the performance assessment of the Luminaire Pole behind Single Slope Traffic Rail for <i>MASH</i> Test 4-12 evaluation criteria.</p> <p>The Luminaire Pole behind Single Slope Traffic Rail met the performance criteria for <i>MASH</i> Test 4-12.</p>			
17. Key Words Longitudinal barrier, bridge rail, crash testing, MASH, luminaire pole, box truck, SUT		18. Distribution Statement No restrictions. This document is available to the public through NTIS: National Technical Information Service Alexandria, Virginia https://www.ntis.gov	
19. Security Classification. (of this report) Unclassified	20. Security Classification. (of this page) Unclassified	21. No. of Pages 78	22. Price

Form DOT F 1700.7 (8-72) Reproduction of completed page authorized.

MASH Testing of a Luminaire Pole behind Single Slope Traffic Rail

by
Roger Bligh, Ph.D., PE
Senior Research Engineer
Texas A&M Transportation Institute

and

Brianna Bastin
Research Assistant
Texas A&M Transportation Institute

TRNo 440863-01
Contract No.: 0-7086

Sponsored by the
Texas Department of Transportation
and the
Federal Highway Administration

Published: November 2024

TEXAS A&M TRANSPORTATION INSTITUTE
College Station, Texas 77843-3135

DISCLAIMER

This research was sponsored by the Texas Department of Transportation (TxDOT) and the Federal Highway Administration (FHWA). The contents of this report reflect the views of the authors, who are responsible for the facts and the accuracy of the data presented herein. The contents do not necessarily reflect the official view or policies of FHWA or TxDOT. This report does not constitute a standard, specification, or regulation.

TTI PROVING GROUND DISCLAIMER

The results of the crash testing reported herein apply only to the article tested.

REPORT AUTHORIZATION



Bill L. Griffith, Research Specialist
Quality Manager



William J. L. Schroeder., Research
Engineering Associate



Matthew N. Robinson, Research
Specialist
Test Facility Manager & Technical
Manager



Roger Bligh, Ph.D., PE Senior
Research Engineer

ACKNOWLEDGMENTS

This project was sponsored by TxDOT and FHWA. The authors thank the project managers, Wade Odell and Darrin Jensen, for their support. The authors also acknowledge the significant guidance and feedback provided by Taya Retterer, Bridge Division, throughout the project.

TABLE OF CONTENTS

	Page
List of Figures	viii
List of Tables	ix
Chapter 1. Introduction	1
Chapter 2. System Details	3
2.1. Test Article and Installation Details	3
2.2. Design Modifications during Test	3
2.3. Material Specifications	8
Chapter 3. Test Requirements and Evaluation Criteria	9
3.1. Crash Test Conditions	9
3.2. Evaluation Criteria.....	10
Chapter 4. Test Conditions	11
4.1. Test Facility	11
4.2. Vehicle Tow and Guidance System	11
4.3. Data Acquisition Systems	11
4.3.1. Vehicle Instrumentation and Data Processing	11
4.3.2. Anthropomorphic Dummy Instrumentation.....	12
4.3.3. Photographic Instrumentation Data Processing	13
Chapter 5. MASH Test 4-12 (Crash Test 440863-03-1)	15
5.1. Test Designation and Actual Impact Conditions.....	15
5.2. Weather Conditions	17
5.3. Test Vehicle	17
5.4. Test Description	19
5.5. Damage to Test Installation	19
5.6. Damage to Test Vehicle.....	20
5.7. Occupant Risk Factors.....	23
5.8. Test Summary.....	24
Chapter 6. Summary and Conclusions	27
6.1. Assessment of Test Results.....	27
6.2. Conclusions	27
Chapter 7. Implementation	29
References	31
Appendix A. Details of Luminaire Pole behind Single Slope Traffic Rail	33
Appendix B. Supporting Certification Documents	41
Appendix C. MASH Test 4-12 (Crash Test 440863-03-1)	57
C.1. Vehicle Properties and Information	58
C.2. Sequential Photographs.....	60
C.3. Vehicle Angular Displacements	63
C.4. Vehicle Accelerations.....	64

LIST OF FIGURES

	Page
Figure 2.1. Details of Luminaire Pole behind Single Slope Traffic Rail.....	4
Figure 2.2. Impact Angle on Traffic Side of Luminaire Pole behind Single Slope Traffic Rail Prior to Testing.....	5
Figure 2.3. Field Side of Luminaire Pole behind Single Slope Traffic Rail Prior to Testing.	5
Figure 2.4. Base of the Luminaire Pole behind Single Slope Traffic Rail Prior to Testing.	6
Figure 2.5. In-line View of the Luminaire Pole behind Single Slope Traffic Rail Prior to Testing.	6
Figure 2.6. Overall View of the Luminaire Pole behind Single Slope Traffic Rail at Impact Prior to Testing.	7
Figure 2.7. Field Side of the Luminaire Pole behind Single Slope Traffic Rail Prior to Testing.	7
Figure 3.1. Target CIP for <i>MASH</i> Test 4-12 Test on Luminaire Pole behind Single Slope Traffic Rail.....	9
Figure 5.1. Luminaire Pole behind Single Slope Traffic Rail/Test Vehicle Geometrics for Test 440863-03-1.....	16
Figure 5.2. Luminaire Pole behind Single Slope Traffic Rail/Test Vehicle Impact Location 440863-03-1.	16
Figure 5.3. Impact Side of Test Vehicle before Test 440863-03-1.	17
Figure 5.4. Opposite Impact Side of Test Vehicle before Test 440863-03-1.....	18
Figure 5.5. Perpendicular View of Luminaire Pole behind Single Slope Traffic Rail at Impact Location after Test 440863-03-1.	20
Figure 5.6. Traffic Side View of the Damage to the Base of the Luminaire Pole after Test 440863-03-1.....	20
Figure 5.7. Impact Side of Test Vehicle after Test 440863-03-1.	21
Figure 5.8. Rear Impact Side of Test Vehicle after Test 440863-03-1.	21
Figure 5.9. Overall Interior of Test Vehicle after Test 440863-03-1.....	22
Figure 5.10. Interior of Test Vehicle on Impact Side after Test 440863-03-1.	22
Figure 5.11. Summary of Results for <i>MASH</i> Test 4-12 on Luminaire Pole behind Single Slope Traffic Rail.....	25
Figure C.3. Vehicle Parameters for Test 440863-03-1.....	59
Figure C.4. Sequential Photographs for Test 440863-03-1 (Overhead Views).	60
Figure C.5. Sequential Photographs for Test 440863-03-1 (Frontal Views).	61
Figure C.6. Sequential Photographs for Test 440863-03-1 (Rear Views).	62
Figure C.7. Vehicle Angular Displacements for Test 440863-03-1.....	63
Figure C.8. Vehicle Longitudinal Accelerometer Trace for Test 440863-03-1 (Accelerometer Located at Center of Gravity).	64
Figure C.9. Vehicle Lateral Accelerometer Trace for Test 440863-03-1 (Accelerometer Located at Center of Gravity).	64
Figure C.10. Vehicle Vertical Accelerometer Trace for Test 440863-03-1 (Accelerometer Located at Center of Gravity).	65

LIST OF TABLES

	Page
Table 2.1. Concrete Strength.	8
Table 3.1. Test Conditions and Evaluation Criteria Specified for <i>MASH</i> Test 4-12 Longitudinal Barrier.	9
Table 3.2. Evaluation Criteria Required for <i>MASH</i> Testing.	10
Table 5.1. Impact Conditions for <i>MASH</i> TEST 4-12, Crash Test 440863-03-1.	15
Table 5.2. Exit Parameters for <i>MASH</i> TEST 4-12, Crash Test 440863-03-1.	15
Table 5.3. Weather Conditions 440863-03-1.....	17
Table 5.4. Vehicle Measurements 440863-03-1.....	18
Table 5.5. Events during Test 440863-03-1.	19
Table 5.6. Deflection and Working Width of the Luminaire Pole behind Single Slope Traffic Rail for Test 440863-03-1.....	19
Table 5.7. Occupant Compartment Deformation 440863-03-1.....	23
Table 5.8. Exterior Vehicle Damage 440863-03-1.	23
Table 5.9. Occupant Risk Factors for Test 440863-03-1.....	24
Table 6.1. Assessment Summary for <i>MASH</i> Test 4-12 Test on Luminaire Pole behind Single Slope Traffic Rail.	27

SI* (MODERN METRIC) CONVERSION FACTORS

APPROXIMATE CONVERSIONS TO SI UNITS

Symbol	When You Know	Multiply By	To Find	Symbol
LENGTH				
in	inches	25.4	millimeters	mm
ft	feet	0.305	meters	m
yd	yards	0.914	meters	m
mi	miles	1.61	kilometers	km
AREA				
in ²	square inches	645.2	square millimeters	mm ²
ft ²	square feet	0.093	square meters	m ²
yd ²	square yards	0.836	square meters	m ²
ac	acres	0.405	hectares	ha
mi ²	square miles	2.59	square kilometers	km ²
VOLUME				
fl oz	fluid ounces	29.57	milliliters	mL
gal	gallons	3.785	liters	L
ft ³	cubic feet	0.028	cubic meters	m ³
yd ³	cubic yards	0.765	cubic meters	m ³
NOTE: volumes greater than 1000L shall be shown in m ³				
MASS				
oz	ounces	28.35	grams	g
lb	pounds	0.454	kilograms	kg
T	short tons (2000 lb)	0.907	megagrams (or metric ton")	Mg (or "t")
TEMPERATURE (exact degrees)				
°F	Fahrenheit	5(F-32)/9 or (F-32)/1.8	Celsius	°C
FORCE and PRESSURE or STRESS				
lbf	poundforce	4.45	newtons	N
lbf/in ²	poundforce per square inch	6.89	kilopascals	kPa

APPROXIMATE CONVERSIONS FROM SI UNITS

Symbol	When You Know	Multiply By	To Find	Symbol
LENGTH				
mm	millimeters	0.039	inches	in
m	meters	3.28	feet	ft
m	meters	1.09	yards	yd
km	kilometers	0.621	miles	mi
AREA				
mm ²	square millimeters	0.0016	square inches	in ²
m ²	square meters	10.764	square feet	ft ²
m ²	square meters	1.195	square yards	yd ²
ha	hectares	2.47	acres	ac
km ²	Square kilometers	0.386	square miles	mi ²
VOLUME				
mL	milliliters	0.034	fluid ounces	oz
L	liters	0.264	gallons	gal
m ³	cubic meters	35.314	cubic feet	ft ³
m ³	cubic meters	1.307	cubic yards	yd ³
MASS				
g	grams	0.035	ounces	oz
kg	kilograms	2.202	pounds	lb
Mg (or "t")	megagrams (or "metric ton")	1.103	short tons (2000lb)	T
TEMPERATURE (exact degrees)				
°C	Celsius	1.8C+32	Fahrenheit	°F
FORCE and PRESSURE or STRESS				
N	newtons	0.225	poundforce	lbf
kPa	kilopascals	0.145	poundforce per square inch	lb/in ²

*SI is the symbol for the International System of Units

Chapter 1. INTRODUCTION

Luminaire poles provide illumination of the roadway for motorists. When traversing a bridge structure, the luminaire poles are sometimes mounted to a deck extension behind the bridge rail. This makes access to the anchor bolts and electrical hand holes challenging, which can complicate installation, maintenance, and repair.

Another option for structure-mounted luminaire poles is to construct a mounting block on the field side of the bridge rail and mount the luminaire to the top of the block behind the bridge rail. Such a detail improves access for installation, maintenance, and repair, and avoids the need for deck extensions.

In addition to being designed for service loads such as wind, structure-mounted luminaire poles should also be designed for vehicular impact to avoid a large pole from separating from the structure and becoming a hazard to motorists on or below the structure. Additionally, the offset of the pole should be sufficient to avoid significant contact and intrusion into the occupant compartment of the impacting vehicle(s).

Criteria for testing and evaluating roadside safety features are contained in the American Association of State Highway and Transportation Officials (AASHTO) *Manual for Assessing Safety Hardware (MASH)*, Second Edition (1). *MASH* describes different test levels of longitudinal barriers such as bridge rails. Bridge rail systems implemented on high-speed facilities are typically Test Level 3 (TL-3) or higher. The higher test levels incorporate various sizes of commercial trucks in addition to the baseline passenger vehicles that comprise TL-3. Bridge rails are commonly designed for Test Level 4 (TL-4), which includes evaluation with a 22,000-lb single unit truck. TL-4 bridge rails may be used based on the percentage of trucks on the facility or other criteria established by the user agency.

The objective of this research is to test and evaluate the impact performance of a luminaire pole anchored to a concrete mounting block integrally constructed behind a single slope traffic rail (SSTR) in accordance with *MASH* TL-4. The critical test for evaluating the strength of the pole and its anchorage, as well as the potential for excessive vehicle intrusion associated with vehicle-pole contact, is *MASH* Test 4-12. This report provides details of *MASH* Test 4-12 performed on a luminaire pole mounted behind a single slope traffic rail and an assessment of *MASH* compliance of the luminaire pole mounting details.

Chapter 2. SYSTEM DETAILS

2.1. TEST ARTICLE AND INSTALLATION DETAILS

The test installation was 130 feet long and consisted of a 36-inch-tall SSTR anchored to an 8-inch thick, 40-inch-wide cantilevered concrete deck. A 21-inch-wide, 21-inch-deep, and 36-inch-tall concrete block was monolithically poured onto the back of the barrier at a distance of 45 feet from the upstream end. A 50-foot-tall steel luminaire pole with a single 12-foot steel mast arm and LED luminaire was mounted onto the top of this concrete block behind the bridge rail. The barrier, deck, and luminaire mounting block were all reinforced with grade 60 rebar. Figure 2.1 presents overall information on the Luminaire Pole behind Single Slope Traffic Rail, and

Figure 2.2 through Figure 2.7 provide photographs of the test installation. Appendix A provides further details on the Luminaire Pole behind Single Slope Traffic Rail. Drawings were provided by the Texas A&M Transportation Institute (TTI) Proving Ground based on details provided by the Texas Department of Transportation (TxDOT), and construction was performed by MBC Management and supervised by TTI Proving Ground personnel.

2.2. DESIGN MODIFICATIONS DURING TEST

No modifications were made to the installation during the testing phase.

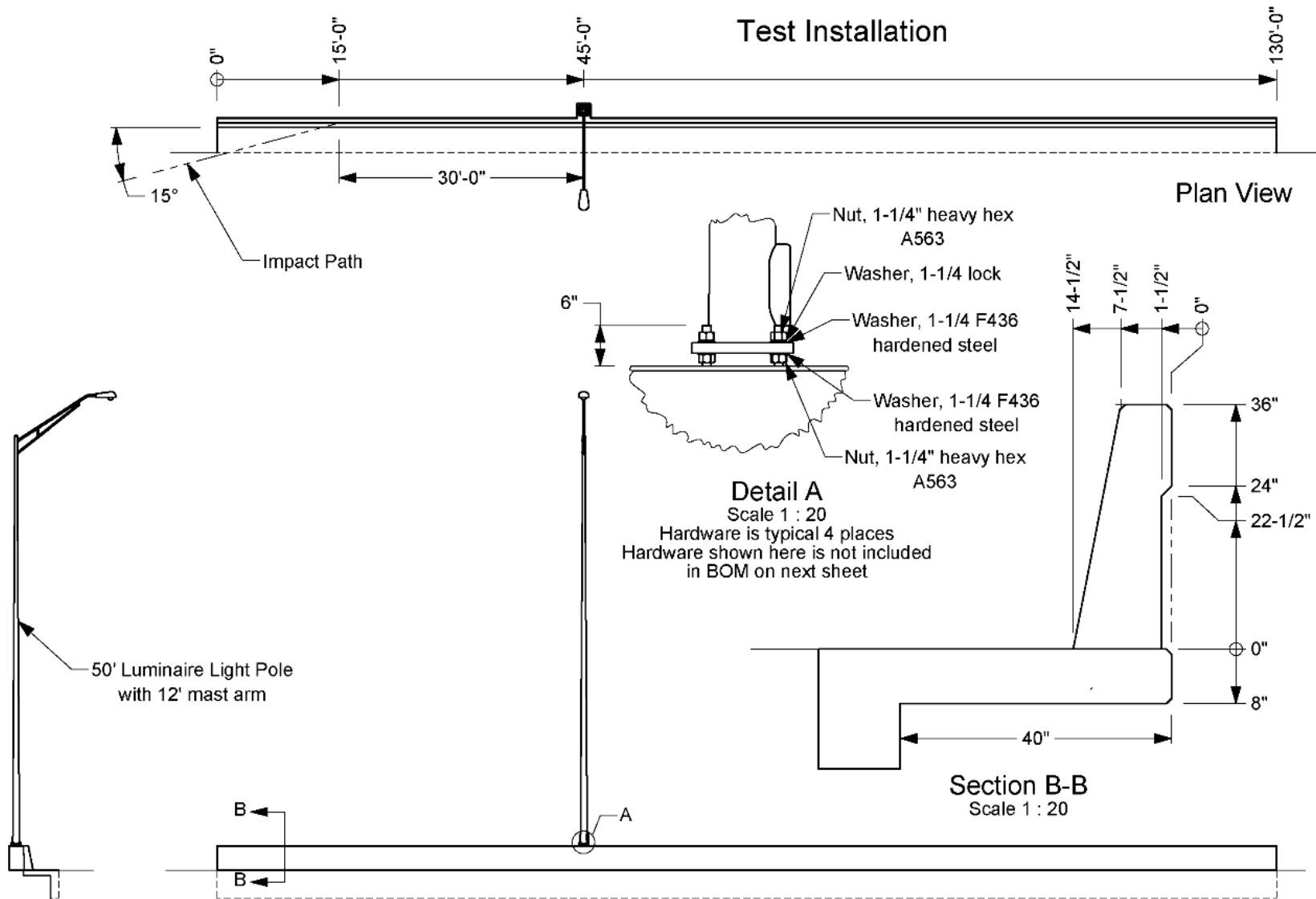

Figure 2.1. Details of Luminaire Pole behind Single Slope Traffic Rail.



Figure 2.2. Impact Angle on Traffic Side of Luminaire Pole behind Single Slope Traffic Rail Prior to Testing.



Figure 2.3. Field Side of Luminaire Pole behind Single Slope Traffic Rail Prior to Testing.



Figure 2.4. Base of the Luminaire Pole behind Single Slope Traffic Rail Prior to Testing.



Figure 2.5. In-line View of the Luminaire Pole behind Single Slope Traffic Rail Prior to Testing.



Figure 2.6. Overall View of the Luminaire Pole behind Single Slope Traffic Rail at Impact Prior to Testing.



Figure 2.7. Field Side of the Luminaire Pole behind Single Slope Traffic Rail Prior to Testing.

2.3. MATERIAL SPECIFICATIONS

Appendix B provides material certification documents for the materials used to install/construct the Luminaire Pole behind Single Slope Traffic Rail. Table 2.1 shows the average compressive strength of the concrete used in the test installation on the day of the test (2023-06-22).

Table 2.1. Concrete Strength.

Location	Design Strength (psi)	Avg. Strength (psi)	Age (days)	Detailed Location
Wall	4000	4447	17	Downstream 100 feet of the wall.
Deck	4000	4297	17	Downstream 100 feet of the deck.
Deck and Wall	4000	3953	17	Remainder of deck and wall.
Barrier and Mounting Block	3600	3363	7	A complete 40-foot section of the barrier was poured starting at the upstream end of the barrier, then 50 percent of the barrier was poured over the next 70 feet. This section included the mounting block.
Barrier and Mounting Block	3600	3667	7	The remaining half of the 70-foot section of barrier from the previous pour, including the mounting block, and 100 percent of the last 20 feet of the barrier on the downstream end.

Chapter 3. TEST REQUIREMENTS AND EVALUATION CRITERIA

3.1. CRASH TEST CONDITIONS

Table 3.1 shows the test conditions and evaluation criteria for *MASH* Test 4-12 for longitudinal barriers. The target critical impact point (CIP) for the test was determined through film analysis of a previous *MASH* Test 4-12 into a 36-inch-tall SSTR (2). The distance from the luminaire pole was selected to maximize interaction with the single unit truck. Figure 3.1 shows the target CIP for *MASH* Test 4-12 test on the Luminaire Pole behind Single Slope Traffic Rail.

Table 3.1. Test Conditions and Evaluation Criteria Specified for *MASH* Test 4-12 Longitudinal Barrier.

Test Designation	Test Vehicle	Impact Speed	Impact Angle	Evaluation Criteria
4-12	10000S	56 mi/h	15°	A, D, G

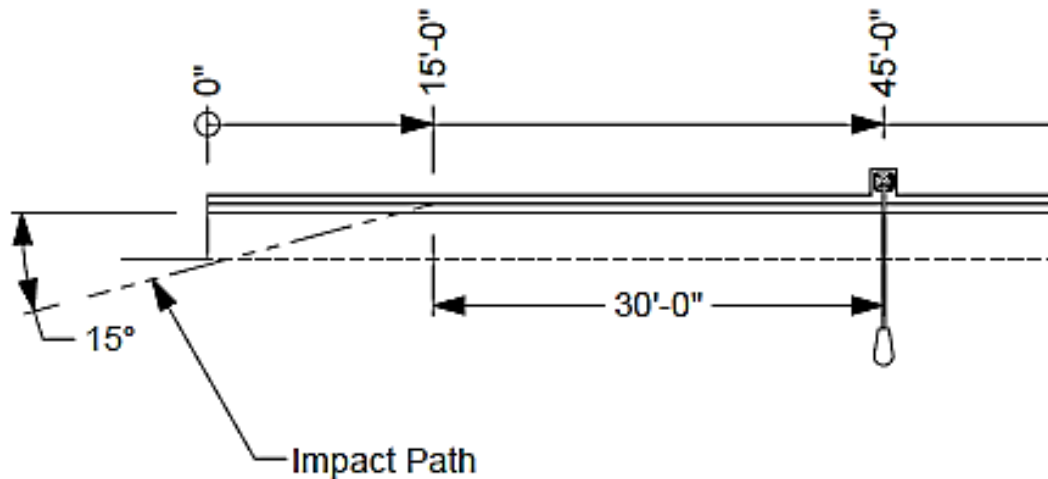

Figure 3.1. Target CIP for *MASH* Test 4-12 Test on Luminaire Pole behind Single Slope Traffic Rail.

The *MASH* TL-4 test matrix also recommends performing Test 4-10 with the 1100C passenger car and Test 4-11 with the 2270P pickup truck. However, based on the acceptable impact performance of a single-slope barrier of similar profile in previous testing with both design passenger vehicles, these tests were not considered necessary (3, 4). Based on the vehicle working width observed in these tests, neither vehicle would interact with the luminaire pole based on the height of the bridge rail and the offset of the pole assembly from the field side edge of the barrier.*

* The opinions/interpretations identified/expressed in this section of the report are outside the scope of TTI Proving Ground's A2LA Accreditation.

The crash test and data analysis procedures were in accordance with guidelines presented in *MASH*. Chapter 4 presents brief descriptions of these procedures.

3.2. EVALUATION CRITERIA

The appropriate safety evaluation criteria from Tables 2.2 and 5.1 of *MASH* were used to evaluate the crash test reported herein. Table 3.1 lists the test conditions and evaluation criteria required for *MASH* Test 4-12, and Table 3.2 provides detailed information on the evaluation criteria.

Table 3.2. Evaluation Criteria Required for *MASH* Testing.

Evaluation Factors	Evaluation Criteria
A.	Test article should contain and redirect the vehicle or bring the vehicle to a controlled stop; the vehicle should not penetrate, underide, or override the installation although controlled lateral deflection of the test article is acceptable.
D.	Detached elements, fragments, or other debris from the test article should not penetrate or show potential for penetrating the occupant compartment, or present undue hazard to other traffic, pedestrians, or personnel in a work zone. Deformations of, or intrusions into, the occupant compartment should not exceed limits set forth in Section 5.2.2 and Appendix E of <i>MASH</i> .
G.	It is preferable, although not essential, that the vehicle remain upright during and after the collision.

Chapter 4. TEST CONDITIONS

4.1. TEST FACILITY

The full-scale crash test reported herein was performed at the TTI Proving Ground, an International Standards Organization (ISO)/International Electrotechnical Commission 17025-accredited laboratory with American Association for Laboratory Accreditation (A2LA) Mechanical Testing Certificate 2821.01. The full-scale crash test was performed according to TTI Proving Ground quality procedures, as well as *MASH* guidelines and standards.

The test facilities of the TTI Proving Ground are located on the Texas A&M RELLIS Campus, which consists of a 2000-acre complex of research and training facilities situated 10 mi northwest of the flagship campus of Texas A&M University. The site, formerly a United States Army Air Corps base, has large expanses of concrete runways and parking aprons well suited for experimental research and testing in the areas of vehicle performance and handling, vehicle-roadway interaction, highway pavement durability and efficacy, and roadside safety hardware and perimeter protective device evaluation. The site selected for construction and testing of the Luminaire Pole behind Single Slope Traffic Rail was along the edge of an out-of-service apron. The apron consists of an unreinforced jointed-concrete pavement in 12.5-ft x 15-ft blocks nominally 6 inches deep. The aprons were built in 1942, and the joints have some displacement but are otherwise flat and level.

4.2. VEHICLE TOW AND GUIDANCE SYSTEM

The 10000S vehicle was towed into the test installation using a steel cable guidance and reverse tow system. A steel cable for guiding the test vehicle was tensioned along the path, anchored at each end, and threaded through an attachment to the front wheel of the test vehicle. An additional steel cable was connected to the test vehicle, passed around a pulley near the impact point and around a pulley on the tow vehicle, and then anchored to the ground such that the tow vehicle moved away from the test site. A 2:1 speed ratio between the test and tow vehicle existed with this system. Just prior to impact with the installation, the test vehicle was released and ran unrestrained into the test installation. The vehicle remained freewheeling (i.e., no steering or braking inputs) until it cleared the immediate area of the test site.

4.3. DATA ACQUISITION SYSTEMS

4.3.1. Vehicle Instrumentation and Data Processing

The test vehicle was instrumented with a self-contained onboard data acquisition system. The signal conditioning and acquisition system is a multi-channel data acquisition system (DAS) produced by Diversified Technical Systems Inc. The accelerometers, which measure the x, y, and z axis of vehicle acceleration, are strain gauge type with linear millivolt output proportional to acceleration. Angular rate sensors,

measuring vehicle roll, pitch, and yaw rates, are ultra-small, solid-state units designed for crash test service. The data acquisition hardware and software conform to the latest SAE J211, Instrumentation for Impact Test. Each of the channels is capable of providing precision amplification, scaling, and filtering based on transducer specifications and calibrations. During the test, data are recorded from each channel at a rate of 10,000 samples per second with a resolution of one part in 65,536. Once data are recorded, internal batteries back these up inside the unit in case the primary battery cable is severed. Initial contact of the pressure switch on the vehicle bumper provides a time zero mark and initiates the recording process. After each test, the data are downloaded from the DAS unit onto a laptop computer at the test site. The Test Risk Assessment Program (TRAP) software then processes the raw data to produce detailed reports of the test results.

Each DAS is returned to the factory annually for complete recalibration and to ensure that all instrumentation used in the vehicle conforms to the specifications outlined by SAE J211. All accelerometers are calibrated annually by means of an ENDEVCO® 2901 precision primary vibration standard. This standard and its support instruments are checked annually and receive a National Institute of Standards Technology (NIST) traceable calibration. The rate transducers used in the data acquisition system receive calibration via a Genisco Rate-of-Turn table. The subsystems of each data channel are also evaluated annually, using instruments with current NIST traceability, and the results are factored into the accuracy of the total data channel per SAE J211. Calibrations and evaluations are also made anytime data are suspect. Acceleration data are measured with an expanded uncertainty of ± 1.7 percent at a confidence factor of 95 percent ($k = 2$).

TRAP uses the DAS-captured data to compute the occupant/compartiment impact velocities, time of occupant/compartiment impact after vehicle impact, and highest 10-ms average ridedown acceleration. TRAP calculates change in vehicle velocity at the end of a given impulse period. In addition, maximum average accelerations over 50-ms intervals in each of the three directions are computed. For reporting purposes, the data from the vehicle-mounted accelerometers are filtered with an SAE Class 180-Hz low-pass digital filter, and acceleration versus time curves for the longitudinal, lateral, and vertical directions are plotted using TRAP.

TRAP uses the data from the yaw, pitch, and roll rate transducers to compute angular displacement in degrees at 0.0001-s intervals, and then plots yaw, pitch, and roll versus time. These displacements are in reference to the vehicle-fixed coordinate system, with the initial position and orientation being initial impact. Rate of rotation data is measured with an expanded uncertainty of ± 0.7 percent at a confidence factor of 95 percent ($k = 2$).

4.3.2. Anthropomorphic Dummy Instrumentation

MASH does not recommend or require use of a dummy in the 10000S vehicle, and no dummy was placed in the vehicle for this test.

4.3.3. Photographic Instrumentation Data Processing

Photographic coverage of the test included three digital high-speed cameras:

- One located overhead with a field of view perpendicular to the ground and directly over the impact point.
- One placed upstream from the installation at an angle to have a field of view of the interaction of the rear of the vehicle with the installation.
- One placed with a field of view parallel to and aligned with the installation at the downstream end.

A flashbulb on the impacting vehicle was activated by a pressure-sensitive tape switch to indicate the instant of contact with the Luminaire Pole behind Single Slope Traffic Rail. The flashbulb was visible from each camera. The video files from these digital high-speed cameras were analyzed to observe phenomena occurring during the collision and to obtain time-event, displacement, and angular data. A digital camera recorded and documented conditions of each test vehicle and the installation before and after the test.

Chapter 5. MASH TEST 4-12 (CRASH TEST 440863-03-1)

5.1. TEST DESIGNATION AND ACTUAL IMPACT CONDITIONS

See Table 5.1 for details on *MASH* impact conditions for this test and Table 5.2 for the exit parameters. Figure 5.1 and Figure 5.2 depict the target impact setup.

Table 5.1. Impact Conditions for *MASH* TEST 4-12, Crash Test 440863-03-1.

Test Parameter	Specification	Tolerance	Measured
Impact Speed (mi/h)	56	± 2.5 mi/h	54.4
Impact Angle (deg)	15	± 1.5°	15.0
Impact Severity (kip-ft)	106	≥ 106 kip-ft	146.5
Impact Location	30 ft upstream from centerline of luminaire, on top traffic side edge of barrier	± 1 ft	29 ft 5.2 inches upstream from centerline of luminaire pole

Table 5.2. Exit Parameters for *MASH* TEST 4-12, Crash Test 440863-03-1.

Exit Parameter	Measured
Speed (mi/h)	Not measurable, vehicle exited the installation out of frame of the overhead camera
Trajectory (deg)	Along the barrier
Heading (deg)	Along the barrier
Brakes applied post impact (s)	2.1
Vehicle at rest position	269 ft downstream of impact point 3 ft to the traffic side 0° downstream
Comments:	Vehicle remained upright and stable. The box of the single unit truck snagged the luminaire pole, causing the box to deform significantly and pull off the truck frame.



Figure 5.1. Luminaire Pole behind Single Slope Traffic Rail/Test Vehicle Geometrics for Test 440863-03-1.



Figure 5.2. Luminaire Pole behind Single Slope Traffic Rail/Test Vehicle Impact Location 440863-03-1.

5.2. WEATHER CONDITIONS

Table 5.3 provides the weather conditions for 440863-03-1.

Table 5.3. Weather Conditions 440863-03-1.

Date of Test	2023-06-22
Wind Speed (mi/h)	3.3
Wind Direction (deg)	67
Temperature (°F)	87
Relative Humidity (%)	70
Vehicle Traveling (deg)	185

5.3. TEST VEHICLE

Figure 5.3 and Figure 5.4 show the 2011 International 4300 used for the crash test. Table 5.4 shows key vehicle measurements. Figure C.1 in Appendix C.1 gives additional dimensions and information on the vehicle.



Figure 5.3. Impact Side of Test Vehicle before Test 440863-03-1.



Figure 5.4. Opposite Impact Side of Test Vehicle before Test 440863-03-1.

Table 5.4. Vehicle Measurements 440863-03-1.

Test Parameter	<i>MASH</i>	Allowed Tolerance	Measured
Dummy (if applicable) ^a (lb)	165	N/A	N/A
Curb Weight (lb)	13200	± 2200 lb	13030
Test Inertial Weight (lb)	22046	± 660 lb	22110
Wheelbase (inches)	240	≤ 240 inches	204.7
Overall Length (inches)	394	≤ 394 inches	331.7
Cargo Bed Height (inches) ⁱ	49	± 2 inches	50.5
CG of Ballast above Ground ^e (inches)	63	± 2 inches	63.0

Note: N/A = not applicable; CG = center of gravity.

^a If a dummy is used, the gross static vehicle mass should be increased by the mass of the dummy.

ⁱ Without ballast.

^e See section 4.2.1.2 in *MASH* 2016 for recommended ballasting procedures.

5.4. TEST DESCRIPTION

Table 5.5 lists events that occurred during Test 440863-03-1. Figures C.4, C.5, and C.6 in Appendix C.2 present sequential photographs during the test.

Table 5.5. Events during Test 440863-03-1.

Time (s)	Events
0.0000	Vehicle tire impacted the installation
0.0180	Flash bulb was activated due to the bumper's contact with the installation
0.0490	Vehicle began to redirect
0.1680	Box of the vehicle began to lean towards the field side
0.2930	Vehicle parallel with installation
0.4420	Impact side top of door frame of test vehicle impacted the pole
0.4840	Box of the vehicle impacted the pole
0.4890	Luminaire pole began to deflect downstream
1.3350	Vehicle exited the installation

5.5. DAMAGE TO TEST INSTALLATION

The concrete traffic barrier had a 7-ft gouge beginning near the impact point. The luminaire light pole was leaning 14 degrees downstream from vertical.

Table 5.6 describes the deflection and working width of the Luminaire Pole behind Single Slope Traffic Rail. Figure 5.5 and Figure 5.6 show the damage to the Luminaire Pole behind Single Slope Traffic Rail.

Table 5.6. Deflection and Working Width of the Luminaire Pole behind Single Slope Traffic Rail for Test 440863-03-1.

Test Parameter	Measured
Permanent Deflection/Location	0 inches
Dynamic Deflection	0 inches
Working Width ^a and Height	57.9 inches, at a height of 123.2 inches, at the back left corner of the box at impact with the luminaire pole

^a Per *MASH*, "The working width is the maximum dynamic lateral position of any major part of the system or vehicle. These measurements are all relative to the pre-impact traffic face of the test article." In other words, working width is the total barrier width plus the maximum dynamic intrusion of any portion of the barrier or test vehicle past the field side edge of the barrier.



Figure 5.5. Perpendicular View of Luminaire Pole behind Single Slope Traffic Rail at Impact Location after Test 440863-03-1.



Figure 5.6. Traffic Side View of the Damage to the Base of the Luminaire Pole after Test 440863-03-1.

5.6. DAMAGE TO TEST VEHICLE

Figure 5.7 and Figure 5.8 show the damage sustained by the vehicle. Figure 5.9 and Figure 5.10 show the interior of the test vehicle. Table 5.7 and Table 5.8 provide details on the occupant compartment deformation and exterior vehicle damage.

Figures C.2 and C.3 in Appendix C.1 provide exterior crush and occupant compartment measurements.



Figure 5.7. Impact Side of Test Vehicle after Test 440863-03-1.



Figure 5.8. Rear Impact Side of Test Vehicle after Test 440863-03-1.



Figure 5.9. Overall Interior of Test Vehicle after Test 440863-03-1.



Figure 5.10. Interior of Test Vehicle on Impact Side after Test 440863-03-1.

Table 5.7. Occupant Compartment Deformation 440863-03-1.

Test Parameter	Specification	Measured
Roof	≤ 4.0 inches	0.0 inches
Windshield	≤ 3.0 inches	0.0 inches
A and B Pillars	≤ 5.0 overall/≤ 3.0 inches lateral	0.0 inches
Foot Well/Toe Pan	≤ 9.0 inches	0.0 inches
Floor Pan/Transmission Tunnel	≤12.0 inches	7.0 inches
Side Front Panel	≤12.0 inches	0.0 inches
Front Door (above Seat)	≤ 9.0 inches	0.0 inches
Front Door (below Seat)	≤12.0 inches	0.0 inches

Table 5.8. Exterior Vehicle Damage 440863-03-1.

Side Windows	Side windows remained intact.
Maximum Exterior Deformation	14 inches in the left fender.
VDS	11LFQ7.
CDC	01FLWH3.
Fuel Tank Damage	None.
Description of Damage to Vehicle:	The left front bumper, grill, left front headlight, left fender, left front wheel, left front tire, left side mirror, left door, top left side, top of box, steps, air tanks, and the left rear outer tire and wheel were damaged. There was a 3-inch-wide × 4-inch-long × 1-inch-deep dent on the top of the door frame on impact side. The top and sides of the box were pulled off. The floorpan had a 2-ft-long and 7-inch-high separation at a seam. The seam separation in the floor pan of the vehicle was not caused by intrusion of the test article, but due to the flexing of the vehicle during the crash.

5.7. OCCUPANT RISK FACTORS

Data from the accelerometers were digitized for evaluation of occupant risk for information purposes, and the results are shown in Table 5.9. Figure C.7 in Appendix C.3 shows the vehicle angular displacements, and Figures C.8 through C.10 in Appendix C.4 show acceleration versus time traces.

Table 5.9. Occupant Risk Factors for Test 440863-03-1.

Test Parameter	Measured	Time
OIV, Longitudinal (ft/s)	6.4	0.1850 seconds on the left side of interior
OIV, Lateral (ft/s)	10.5	0.1850 seconds on the left side of interior
Ridedown, Longitudinal (g)	4.5	0.4733–0.4833 seconds
Ridedown, Lateral (g)	5.5	0.2929–0.3029 seconds
THIV (m/s)	3.9	0.1785 seconds on left side of interior
ASI	0.5	0.1010–0.1510 seconds
50-ms MA Longitudinal (g)	-1.8	0.0651–0.1151 seconds
50-ms MA Lateral (g)	4.2	0.0819–0.1319 seconds
50-ms MA Vertical (g)	-3.2	1.1993–1.2493 seconds
Roll (deg)	33.0	0.6644 seconds
Pitch (deg)	7.2	0.7783 seconds
Yaw (deg)	17.9	0.5607 seconds

^a Values in italics are the preferred *MASH* values.

5.8. TEST SUMMARY

Figure 5.11 summarizes the results of *MASH* Test 440863-03-1.





	Test Agency		Texas A&M Transportation Institute (TTI)					
	Test Standard/Test No.		MASH 2016, Test 4-12					
	TTI Project No.		440863-03-1					
	Test Date		2023-06-22					
TEST ARTICLE								
Type		Longitudinal Barrier						
Name		Luminaire Pole behind Single Slope Traffic Rail						
[Length Spec]		130 ft						
Key Materials		Steel luminaire pole, reinforced concrete bridge rail, mounting block, and deck						
	Soil Type and Condition		Concrete, damp					
	TEST VEHICLE							
	Type/Designation		10000S					
	Year, Make and Model		2011 International 4300					
Curb (lb)		13030						
Inertial Weight (lb)		22110						
IMPACT CONDITIONS								
Impact Speed (mi/h)		54.4						
Impact Angle (deg)		15.0						
Impact Location		The bumper impacted 29 ft 5.2 inches upstream from centerline of the luminaire pole.						
Impact Severity (kip-ft)		146.5						
EXIT CONDITIONS								
Exit Speed (mi/h)		Not measurable, out of frame						
Trajectory/Heading Angle (deg)		Along barrier						
Stopping Distance		269 ft downstream 3 ft to the traffic side						
	TEST ARTICLE DEFLECTIONS							
	Barrier Dynamic (inches)		0					
	Barrier Permanent (inches)		0					
	Working Width / Height (inches)		57.86 / 123.18					
VEHICLE DAMAGE								
VDS		11LFQ7						
CDC		01FLWH3						
Max. Ext. Deformation (inches)		14						
Max Occupant Compartment Deformation		7 on left front side of floor pan, in location of seam separation						
OCCUPANT RISK VALUES								
Long. OIV (ft/s)	6.4	Long. Ridedown (g)	4.5	Max 50-ms Long. (g)	-1.8	Max Roll (deg)	33.0	
Lat. OIV (ft/s)	10.5	Lat. Ridedown (g)	5.5	Max 50-ms Lat. (g)	4.2	Max Pitch (deg)	7.2	
THIV (m/s)	3.9	ASI	0.5	Max 50-ms Vert. (g)	-3.2	Max Yaw (deg)	17.9	
								

Figure 5.11. Summary of Results for MASH Test 4-12 on Luminaire Pole behind Single Slope Traffic Rail.

Chapter 6. SUMMARY AND CONCLUSIONS

6.1. ASSESSMENT OF TEST RESULTS

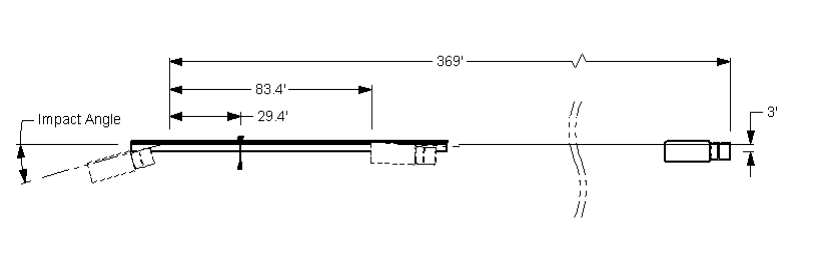
The crash test reported herein was performed in accordance with *MASH* Test 4-12.

6.2. CONCLUSIONS

Table 6.1 shows that the Luminaire Pole behind Single Slope Traffic Rail met the performance criteria for *MASH* Test 4-12 Longitudinal Barrier.

Table 6.1. Assessment Summary for *MASH* Test 4-12 Test on Luminaire Pole behind Single Slope Traffic Rail.

Evaluation Criteria	Description	Test 440863-03-1
A	Test article should contain and redirect the vehicle or bring the vehicle to a controlled stop; the vehicle should not penetrate, underide, or override the installation although controlled lateral deflection of the test article is acceptable.	S
D	Detached elements, fragments, or other debris from the test article should not penetrate or show potential for penetrating the occupant compartment, or present undue hazard to other traffic, pedestrians, or personnel in a work zone. Deformations of, or intrusions into, the occupant compartment should not exceed limits set forth in Section 5.2.2 and Appendix E of <i>MASH</i> .	S
G	It is preferable, although not essential, that the vehicle remain upright during and after the collision.	S
Overall	Evaluation result	Pass

Note: S = Satisfactory.

Chapter 7. IMPLEMENTATION*

Based on the results of the crash testing reported herein, the mounting of luminaire poles onto a concrete mounting block poured monolithically behind a 36-inch-tall SSTR is considered suitable for implementation as a *MASH* TL-4 system. The *MASH* matrix for TL-4 longitudinal barriers consists of three tests: Test 4-10, 4-11, and 4-12. *MASH* Test 4-12 was performed under this project and successfully met all *MASH* evaluation criteria.

MASH also recommends performing Test 4-10 with the 1100C passenger car and Test 4-11 with the 2270P pickup truck. However, based on the acceptable impact performance of a single-slope barrier of similar profile in previous testing with both design passenger vehicles, these tests were not considered necessary (3, 4). The 1100C passenger car would not interact with the luminaire pole behind the 36-inch-tall barrier. In Test No. 420020-3, the maximum extension of the 2270P pickup truck beyond the field side edge of the single slope barrier was 2.5 inches, which corresponded to the side mirror (4). In the system tested herein, the edge of the luminaire pole baseplate has an offset of 3 inches from the field side edge of the SSTR, and the base of the luminaire pole has an additional 2.25 inches of offset beyond the baseplate. Therefore, the 2270P pickup truck would have no contact with the luminaire pole assembly.

Statewide implementation of this barrier and luminaire pole combination can be achieved by TxDOT's Bridge Division through development of a standard detail sheet. The details provided in Appendix A can be used for this purpose.

*The opinions/interpretations identified/expressed in this section of the report are outside the scope of TTI Proving Ground's A2LA Accreditation.

REFERENCES

1. AASHTO. *Manual for Assessing Safety Hardware*, Second Edition. American Association of State Highway and Transportation Officials, Washington, DC, 2016.
2. N.M. Sheikh, R.P. Bligh, W.L. Menges. Determination of Minimum Height and Lateral Design Load for MASH Test Level 4 Bridge Rails. Research Report 9-1002-5, Texas Transportation Institute, College Station, TX, December 2011.
3. FHWA Safety Roadway Departure Eligibility Letter B-338, May 26, 2020. (<https://highways.dot.gov/sites/fhwa.dot.gov/files/2022-08/b338.pdf>)
4. W.F. Williams, R.P. Bligh, W.L. Menges. MASH Test 3-11 of the TxDOT Single Slope Bridge Rail (Type SSTR) on Pan-Formed Bridge Deck. Research Report 9-1002-3, Texas Transportation Institute, College Station, TX, March 2011.

**APPENDIX A. DETAILS OF LUMINAIRE POLE BEHIND SINGLE
SLOPE TRAFFIC RAIL**

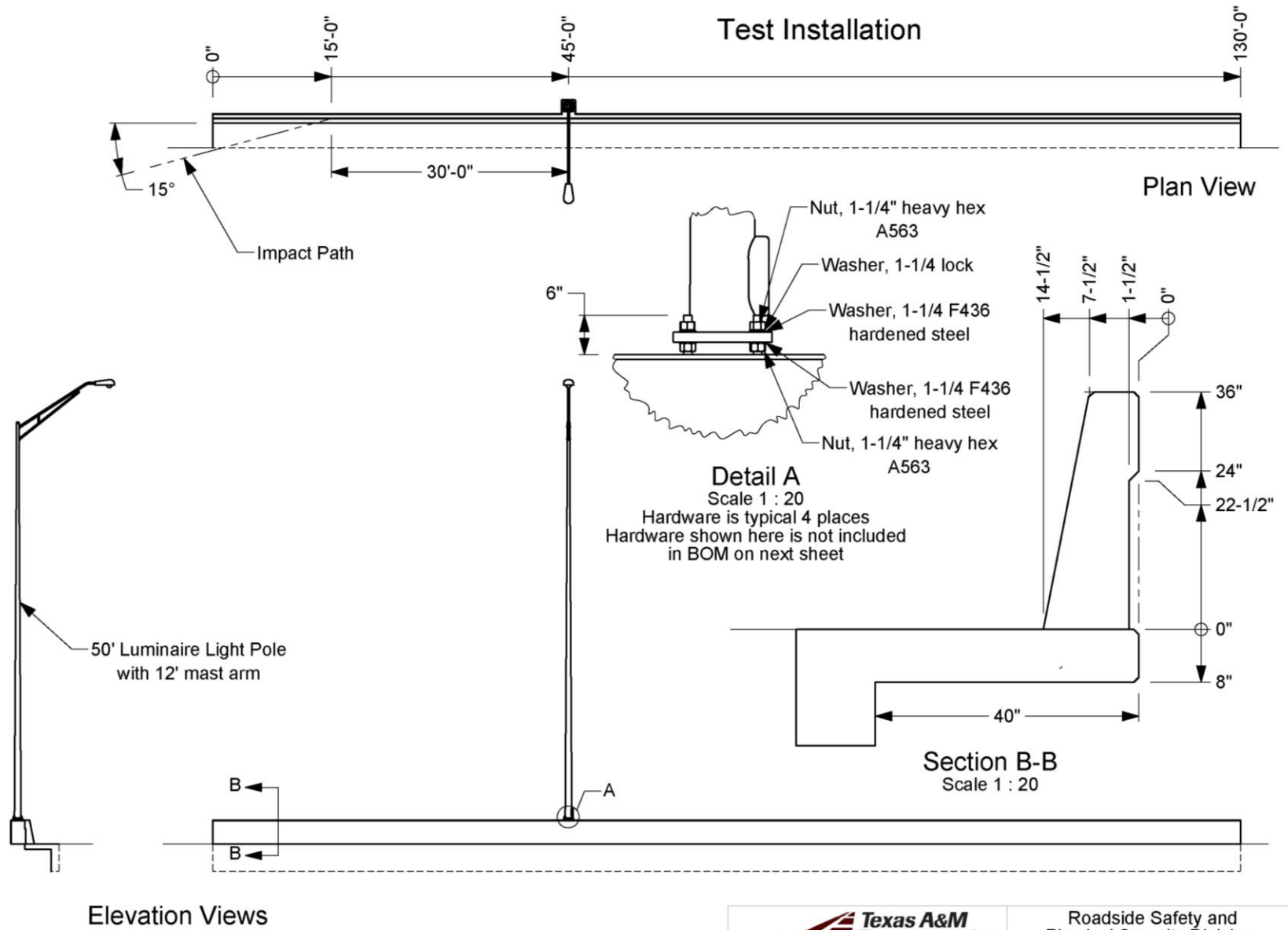

	Roadside Safety and Physical Security Division - Proving Ground	
	Project #440863-01-3 Single Slope with Luminaire	2023-05-11
Drawn by GES	Scale 1:200	Sheet 1 of 6 Test Installation

Concrete Details

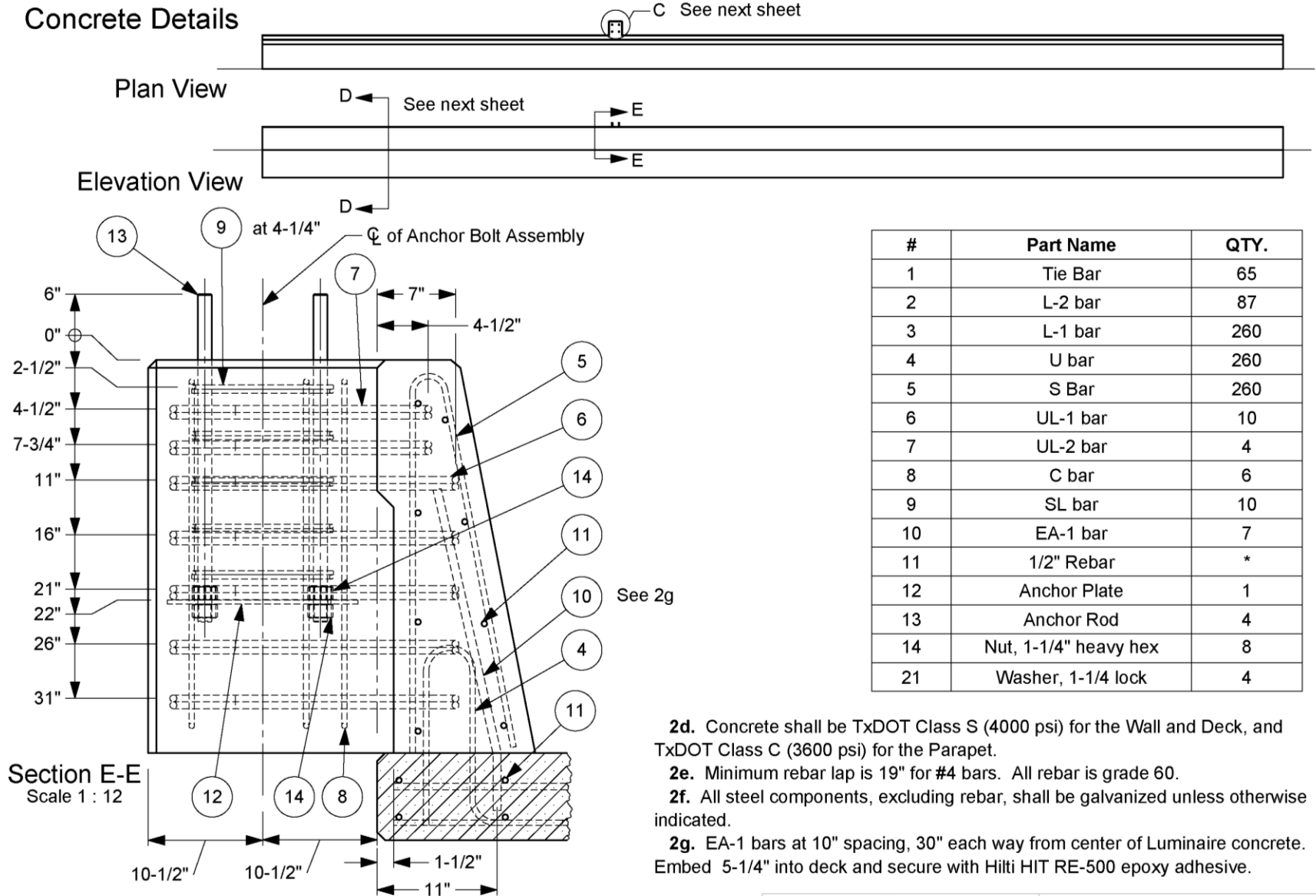

#	Part Name	QTY.
1	Tie Bar	65
2	L-2 bar	87
3	L-1 bar	260
4	U bar	260
5	S Bar	260
6	UL-1 bar	10
7	UL-2 bar	4
8	C bar	6
9	SL bar	10
10	EA-1 bar	7
11	1/2" Rebar	*
12	Anchor Plate	1
13	Anchor Rod	4
14	Nut, 1-1/4" heavy hex	8
21	Washer, 1-1/4 lock	4

- 2a. UL- and SL Bars are in pairs. Alternate laps on SL bars.
- 2b. Chamfer concrete edges 1" (3/4" each way) where shown.
- 2c. All rebar dimensions are to center of bar unless otherwise indicated by "cvr" (cover).

2d. Concrete shall be TxDOT Class S (4000 psi) for the Wall and Deck, and TxDOT Class C (3600 psi) for the Parapet.

2e. Minimum rebar lap is 19" for #4 bars. All rebar is grade 60.

2f. All steel components, excluding rebar, shall be galvanized unless otherwise indicated.

2g. EA-1 bars at 10" spacing, 30" each way from center of Luminaire concrete. Embed 5-1/4" into deck and secure with Hilti HIT RE-500 epoxy adhesive.



Roadside Safety and Physical Security Division - Proving Ground

Project #440863-01-3 Single Slope with Luminaire

2023-05-11

Drawn by GES

Scale 1:200

Sheet 2 of 6 Concrete Details

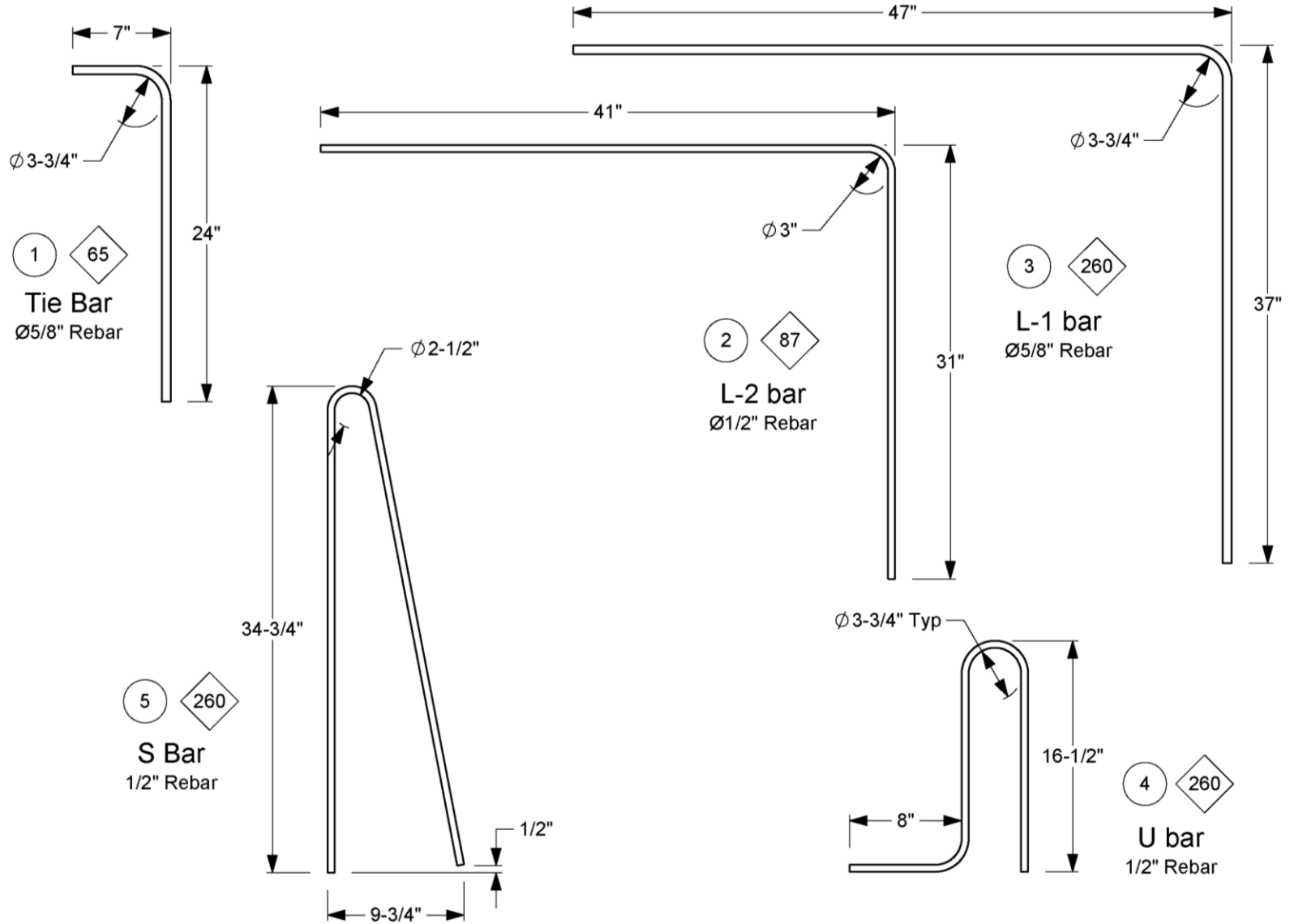

4a. Numeral in circle indicates BOM number.
 Numeral in diamond indicates quantity needed.

	Roadside Safety and Physical Security Division - Proving Ground	
	Project #440863-01-3 Single Slope with Luminaire	2023-05-11
Drawn by GES	Scale 1:10	Sheet 4 of 6 Rebar Details-1

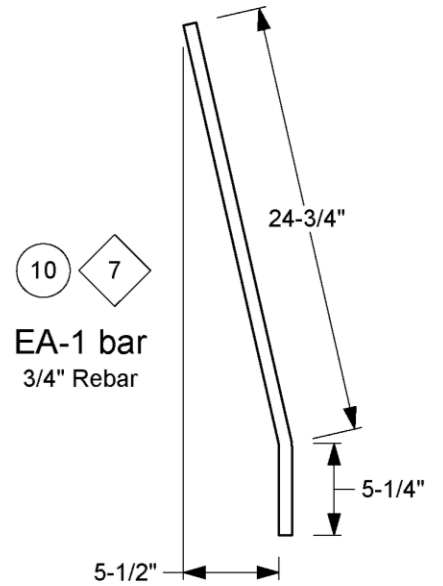
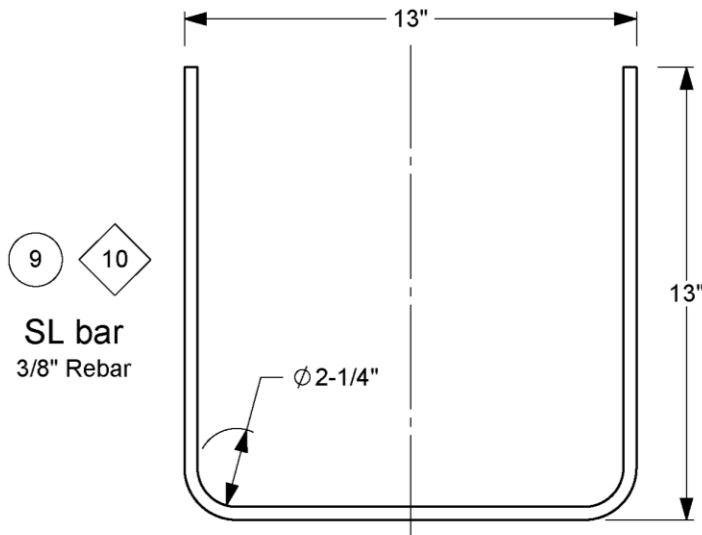
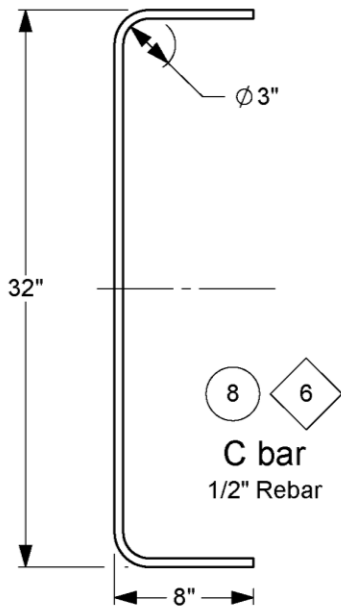
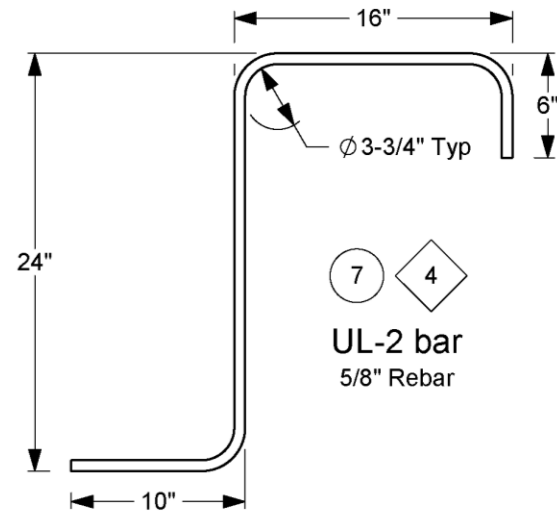
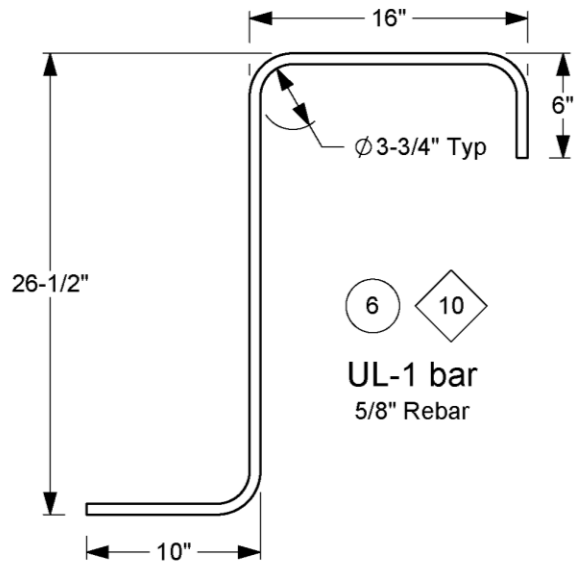

5a. Numeral in circle indicates BOM number.
Numeral in diamond indicates quantity needed.

		Roadside Safety and Physical Security Division - Proving Ground
Project #440863-01-3 Single Slope with Luminaire		2023-05-11
Drawn by GES	Scale 1:10	Sheet 5 of 6 Rebar Details-2

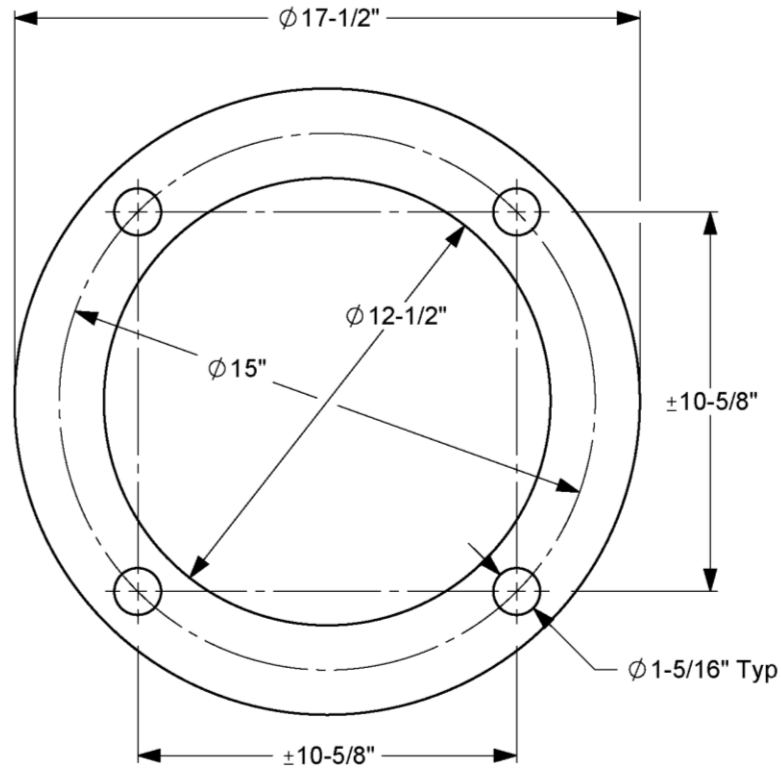

12

Anchor Plate
ASTM A36 3/8" Plate
Galvanizing not required for this part



Roadside Safety and
Physical Security Division -
Proving Ground

Project #440863-01-3 Single Slope with Luminaire		2023-05-11
Drawn by GES	Scale 1:5	Sheet 6 of 6 Anchor Plate

APPENDIX B. SUPPORTING CERTIFICATION DOCUMENTS

QUALITY CERTIFICATE

INV. NO.:	SF225	QUANTITY:	21600						
P.O. NO.:	O-209141	TEST DATE:	2022/4/10						
S/C NO.:		ON BOARD:	2022/6/20						
PART NO.:	DHWGA12500	SIZE:	1-1/4						
LOT NO.:	HJ41246224	DESCRIPTION:	Hardened Washer F436 HDG						
PRODUCTION DATE:									
Size:									
Material and Mechanical properties: ANSI / ASME B18.18-2011									
1. Chemical Composition Of Material (%)									
STEEL GRADE/ HEAT NO:	DIA.(mm)	C	Si	Mn	P	S	Cr	Ni	Cu
1045 STEEL/20011404		0.43	0.19	0.55	0.032	0.028	0.24	0.28	0.21
2. Dimension									
INSPECTION ITEM	SPECIFICATION			RESULT					
	MIN.	MAX.	1	2					
Inside Dia (mm)	34.75	35.69	34.86	35.28					
Outside Dia (mm)	76.02	76.96	76.43	76.77					
Thickness (mm)	3.45	4.88	3.64	4.25					
HARDNESS	38	45	38	43					
Coating Thickness (um)	50	-	60	68					
Hydrogn Embrittlement Test	48hrs	OK							
APPEARANCE	VISUAL	OK							
Manufacturer name	HJ TECH INDUSTRY LIMITED								

INSPECTED BY ANDY

CERTIFIED BY Cherry



440863-3

**Certified Material Test Report to ISO16228 F3.1 (EN 10204-2004 3.1)
FOR ASME SA194/ ASTM A194-16 GRADE 2H HVY HEX NUTS**

FACTORY: NINGBO HAIJIN HARDWARE CO.,LTD. DATE: JUN.11.2018
 ADDRESS: XIJINGTANG.LUOTUO NINGBO ZHEJIANG 315205 CHINA COUNTRY OF ORIGIN: CHINA
 MFG LOT NUMBER: 5138400004
 CUSTOMER: BRIGHTON-BEST INTERNATIONAL (TAIWAN) INC PO NUMBER: MILL
 QNTY SHIPPED: 10.800MPCS PART NO: 313390
 SAMPLE SIZE : ACC. TO ASME B18.18.1-11 MANUFACTURER DATE: 2018/5/29
 SIZE & DESCRIPTION 1.1/4-7+0.024"(HDG)
 FINISH: H.T.HOT DIP GAL PER ASTM A153-09/ASTM F2329-13

STEEL PROPERTIES: TEST FACILITY: S
 STEEL GRADE: 45# SIZE: 36mm HEAT NO: 2-97352

CHEMISTRY COMPOSITION:

CHEMIST	C %	Mn %	P %	S %	Si %	Cr %	Ni %	Cu %	Mo %	OTHERS
SPE:	MIN	MAX	MAX	MAX	MAX					
	0.40	1.00	0.04	0.05	0.40					
TEST:	0.43	0.57	0.019	0.006	0.21					

DIMENSIONAL INSPECTIONS SPECIFICATION: ASME /ANSI B18.2.2-2015 TEST FACILITY: M

CHARACTERISTICS	TEST METHOD	SPECIFIED	ACTUAL RESULT	ACC.	REJ.
*****	*****	*****	*****	*****	*****
APPEARANCE	ASTM F812-12		PASSED	100	0
WIDTH A/F	1.938"-2.000"		1.950"-1.995"	32	0
WIDTH A/C	2.209"-2.309"		2.217"-2.284"	32	0
THREAD	ASME B1.1-03		PASSED	8	0
HEIGHT	1.187"-1.251"		1.195"-1.236"	32	0
MARK	2HZN LM		PASSED	100	0
HDG THICKNISS	ASTM A153-09/ASTM F2329-13 min:43um		55UM-78UM	20	0

MECHANICAL PROPERTIES: TO 1-1/2" in SPECIFICATION: ASTM/ASME A194/SA194-16 TEST FACILITY: M

CHARACTERISTICS	TEST METHOD	SPECIFIED	ACTUAL RESULT	ACC.	REJ.
*****	*****	*****	*****	*****	*****
HARDNESS	ASTM E18-12	24-35HRC	HRC29-30	5	0
PROOF LOAD	ASTM F606-11	MIN169575LBF	169575LBF	5	0
HARDNESS AFTER 24H AT 540°C	ASTM A194	MIN 89 HRB	HRB 92-94	5	0
TEMPERING TEMPERATURE	Min455°C		PASSED(520°C)		
MACROETCH	ASTM E381-12	S1/R1/C1-S4/R4/C4	S2/R2/C2	5	0

PARTS ARE MANUFACTURED AND TESTED IN ACCORDANCE WITH ASTM/ASME A194/SA194-16

PARTS MEET ASME SECTION II PART A

ALL TESTS IN ACCORDANCE WITH THE METHODS PRESCRIBED SPECIFICATION. WE CERTIFY THAT THIS DATA IS A TRUE REPRESENTATION OF INFORMATION PROVIDED BY THE MATERIAL SUPPLIER AND OUR TESTING LABORATORY.

All parts meet the requirements of FQA and records of compliance are on file.

Maker's ISO#00109Q211593R0M/3302



HANGZHOU SPRING WASHER CO.,LTD
QUALITY TEST CERTIFICATE OF SPRING LOCK WASHER

Standard: ASME B 18.21.1-2009 Contract No.: _____
 Order No.: PO U95683 Invoice No.: 22SHD142

Chemical Composition (%)	C	Si	Mn	P	S	Cr	Ni	Cu
	0.66	0.19	0.58	0.01	0.01	0.01	0.01	0.03
Material Type.	65#	Heat No.	J931002805		TEST FACILITY:S			
Specification	REGULAR HELICAL LOCK WASHER 1 1/4" HDG							
Quantity	3.6 M				COUNTRY OF ORIGIN:CHINA			
Lot No.	22040439							
Part No.	350010							
Testing Item	Ac/n	Norm(mm)	Result(mm)	Reject	Norm	Result	Reject	
Inside Diameter	2/100	32.02-32.91	32.29-32.89	0				
Outside Diameter	1/32	Max52.51	Max51.28	0				
Width	1/32	Min9.22	Min9.23	0				
Thickness	1/32	8.02-8.72	8.33-8.46	0				
Height								
Section								
Surface Defects	2/100	None	None	0				
Hardness	0/8	HRC38-46	HRC38-40	0				
Springing								
Toughness	0/8	Qualified	Qualified	0				
Zinc Coating	0/8	Min53um	Min59.4um	0				
TEST FACILITY:M								
Zinc Coating Standard of: ASTM F2329M-2015.								
Customer Name: _____								
General: The spring lock washers are conformed with the standard of ASME B 18.21.1-2009. QUALIFIED.								
THE REPORT IS ISSUED ACCORDING TO ISO16228 F3.1(EN10204 3.1)								

Inspector: Shiweiqing

Quality Inspection

Date: 2022.06.08

TEXCRETE
Ready-mix Concrete Company

TEXCRETE

129418

REMIT PAYMENT TO:
P.O. BOX 138
KURTEN, TX 77862

5222 Sandy Point RD.
Bryan, Tx 77807

17534 SH 6 South
College Station, TX 77845

18935 Circle Lake Dr.
Pinehurst, TX 77362

BCS DISPATCH - 979-316-2906
PINEHURST DISPATCH - 936-232-5815
OFFICE - 979-985-3636

HWY 6N. LT TEXAS AVE (886), LT 2818, RT HWY
47. LT INTO RELLIS CAMPUS. STAY ON THE MAIN
RD ALL THE WAY TO THE GATE
MBC MANAGEMENT
RELLIS - TTI WAREHOUSE, BRYAN TX

TIME	FORMULA	LOAD SIZE	YARD ORDERED	YARD	DRIVER/TRUCK	PLANT TRANSACTION#
9:23	TDCLC3600	10.00	17.00			111 15
DATE	PROJECT	LOAD#	YARDS DEL.	BATCH#	WATER TRIM	TICKET NUMBER
5/15/23	SINGLES	10.00	10.00	PLT 02		5.00 in 80543

QUANTITY	CODE	DESCRIPTION	UNIT PRICE	EXTENDED PRICE
10.00	yd	TDCLC3600		CLASS C 3600
1.00	ea	FUEL		Fuel Charge

Thank you for your business
Tax
Prev. AMT
Ticket Total

LEFT PLANT	ARRIVED JOB	START UNLOADING	SLUMP	CONCRETE TEMP.	AIR TEMP
933	1010				
FINISH UNLOADING	LEFT JOB	ARRIVED AT PLANT	ON SITE TESTING		
			TESTING LAB:	TERRACON GESSNER CME	OTHER
TESTED			AIR	CYLINDERS	
<input type="checkbox"/> YES <input type="checkbox"/> NO					

ADDITIONAL CHARGE 1 _____
ADDITIONAL CHARGE 2 _____
GRAND TOTAL

WARNING
IRRITATING TO THE SKIN AND EYES
Contains Portland Cement, Wear Rubber Boots and Gloves. PROLONGED CONTACT MAY CAUSE BURNS. Avoid Contact With Eyes and Prolonged Contact with Skin. In Case of Contact with Skin or Eyes, Rinse Thoroughly With Water. If Irritation Persists, Get Medical Attention **KEEP CHILDREN AWAY.**
CONCRETE is a PERISHABLE COMMODITY and BECOMES THE PROPERTY of the PURCHASER UPON LEAVING the PLANT. ANY CHANGES or CANCELLATION of ORIGINAL INSTRUCTIONS MUST be TELEPHONED to the OFFICE BEFORE LOADING Starts. The undersigned promises to pay all costs, including reasonable attorney's fees, incurred in collecting any sums owed.
All accounts not paid within 30 days of delivery will bear interest at the rate of 18% per annum. Not Responsible For Reactive Aggregate or Color Quality. No Claim Allowed Unless Made at Time Material is Delivered.
A \$25.00 Service Charge and Loss of the Cash Discounted will be Collected on all Returned Checks. Demerage charge after 50 min. will be \$100.00/day.

PROPERTY DAMAGE RELEASE
(TO BE SIGNED IF DELIVERY TO BE MADE INSIDE CURB LINE)
Dear Customer - The driver of this truck in presenting this RELEASE to you for your signature is of the opinion that the size and weight of this truck may possibly cause damage to the premises and/or adjacent property if he places the material in the load where you desire it. It is our wish to help you in every way that we can, but in order to do this the driver is requesting that you sign this RELEASE relieving him and this supplier from any responsibility from damage that may occur to the premises and/or adjacent property, buildings, sidewalks, driveways, curbs, etc. by the delivery of this material and that you also agree to help him remove mud from the wheels of this vehicle so that he will not use the public streets. Further as additional consideration, the undersigned agrees to indemnify and hold harmless the driver of this truck and this supplier for any and all damage to the premises and/or adjacent property which may be caused by anyone to have arisen out of delivery of this order SIGNED.

Excessive Water is Detrimental to Concrete Performance.
H₂O Added by Request/Authorized By: _____
GAL X
WEIGHMASTER
Surcharge for credit cards
NOTICE: MY SIGNATURE BELOW INDICATES THAT I HAVE READ THE HEALTH WARNING NOTICE AND SUPPLIER WILL NOT BE RESPONSIBLE FOR ANY DAMAGE CAUSED WHEN DELIVERING INSIDE CURB LINE.
LOAD RECEIVED BY _____

129418

TEXCRETE
Ready-mix Concrete Company

REMIT PAYMENT TO:
P.O. BOX 138
KURTEN, TX 77862

5222 Sandy Point RD.
Bryan, Tx 77807

17534 SH 6 South
College Station, TX 77845

18935 Circle Lake Dr.
Pinehurst, TX 77362

129419

BCS DISPATCH - 979-316-2906
PINEHURST DISPATCH - 936-232-6815
OFFICE - 979-985-3636

MBC MANAGEMENT
BELLIS - TTI WAREHOUSE, BRYAN TX RD ALL THE WAY TO THE GATE

HWY 6N.LT TEXAS AVE (836).LT 2818.PT HWY
47.LT INTO BELLIS CAMPUS.STAY ON THE MAIN

TIME	FORMULA	LOAD SIZE	YARD ORDERED	YD#	DRIVER/TRUCK	PLANT TRANSACTION#
9:41	TDCLC3600	7.00	17.00			116 16
DATE	PROJECT	LOAD#	YARDS DEL.	BATCH#	WATER TRIM	TICKET NUMBER
5/15/23	SINGLES	7.00	17.00	PLT 02		5.00 in 80544

QUANTITY	CODE	DESCRIPTION	UNIT PRICE	EXTENDED PRICE
7.00 vd	TDCLC3600	CLASS C 3600		
1.00 ea	FUEL	Fuel Charge		

Thank you for your business

LEFT PLANT	ARRIVED JOB	START UNLOADING	SLUMP	CONCRETE TEMP.	AIR TEMP.
4521024					
FINISH UNLOADING	LEFT JOB	ARRIVED AT PLANT	ON SITE TESTING		
			TESTING LAB:	TERRACON GESSNER CME	OTHER
TESTED			AIR	CYLINDERS	
<input type="checkbox"/> YES <input type="checkbox"/> NO					

Tax
Prev. amt
Ticket Total
ADDITIONAL CHARGE 1
ADDITIONAL CHARGE 2
GRAND TOTAL

WARNING
IRRITATING TO THE SKIN AND EYES
Contains Portland Cement, Wear Rubber Boots and Gloves. PROLONGED CONTACT MAY CAUSE BURNS. Avoid Contact With Eyes and Prolonged Contact with Skin. In Case of Contact with Skin or Eyes, Rinse Thoroughly With Water. If Irritation Persists, Get Medical Attention. **KEEP CHILDREN AWAY.**

CONCRETE is a PERISHABLE COMMODITY and BECOMES THE PROPERTY OF THE PURCHASER UPON LEAVING THE PLANT. ANY CHANGES or CANCELLATION of ORIGINAL INSTRUCTIONS MUST be TELEPHONED to the OFFICE BEFORE LOADING starts. The undersigned promises to pay all costs, including reasonable attorney's fees, incurred in collecting any sums owed.
All accounts not paid within 30 days of delivery will bear interest at the rate of 18% per annum. Not Responsible For Reactive Aggregate or Color Quality. No Claim Allowed Unless Made at Time Material is Delivered.
A \$25.00 Service Charge and Loss of the Cash Discounted will be Collected on all Returned Checks. Demerage charge after 90 min. will be \$100.00/hr.

PROPERTY DAMAGE RELEASE
(TO BE SIGNED IF DELIVERY TO BE MADE INSIDE CURB LINE)
Dear Customer - The driver of this truck in presenting this RELEASE to you for your signature is of the opinion that the size and weight of this truck may possibly cause damage to the premises and/or adjacent property if he places the material in this load where you desire it. It is our wish to help you in every way that we can, but in order to do this the driver is requesting that you sign this RELEASE relieving him and this supplier from any responsibility from damage that may occur to the premises and or adjacent property, buildings, sidewalks, driveways, curbs, etc. by the delivery of this material and that you also agree to help him remove mud from the wheels of his vehicle so that he will not litter the public streets. Further as additional consideration, the undersigned agrees to indemnify and hold harmless the driver of this truck and this supplier for any and all damage to the premises and/or adjacent property which may be caused by anyone to have arisen out of delivery of this order SIGNED.

Excessive Water is Detrimental to Concrete Performance.
H₂O Added by Request/Authorized By:

GAL X
WEIGHMASTER

Surcharge for credit cards

NOTICE: MY SIGNATURE BELOW INDICATES THAT I HAVE READ THE HEALTH WARNING NOTICE AND SUPPLIER WILL NOT BE RESPONSIBLE FOR ANY DAMAGE CAUSED WHEN DELIVERING INSIDE CURB LINE.

LOAD RECEIVED BY

X _____ X _____

129419

CONCRETE COMPRESSIVE STRENGTH TEST REPORT

Report Number: A1171057.0273
Service Date: 05/15/23
Report Date: 05/25/23
Task: PO# 440863-3

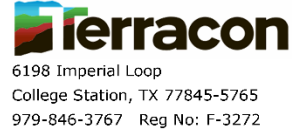

Client

Texas Transportation Institute
Attn: Bill Griffith
TTI Business Office
3135 TAMU
College Station, TX 77843-3135

Project

Riverside Campus
Riverside Campus
Bryan, TX
Project Number: A1171057

Material Information

Specified Strength: 3,600 psi @ 28 days

Mix ID: TDCLC3600

Supplier: Texcrete

Batch Time: 0923

Truck No.: 111

Plant:

Ticket No.: 80543

Sample Information

Sample Date: 05/15/23 **Sample Time:** 1021

Sampled By: Daniel Calvo

Weather Conditions: Sunny

Accumulative Yards: 10.00/17.0 **Batch Size (cy):** 10

Placement Method: Direct Discharge

Water Added Before (gal): 5

Water Added After (gal): 0

Sample Location: Luminaire Bridge Deck 20' North of South end

Placement Location: Luminaire Bridge Deck

Sample Description: 6-inch diameter cylinders

Field Test Data

Test	Result	Specification
Slump (in):	7 1/2	
Air Content (%):	0.8	
Concrete Temp. (F):	95	
Ambient Temp. (F):	78	
Plastic Unit Wt. (pcf):	147.2	
Yield (Cu. Yds.):		

Laboratory Test Data

Set No.	Spec ID	Cyl. Cond.	Avg Diam. (in)	Area (sq in)	Date Received	Date Tested	Age at Test (days)	Max Load (lbs)	Comp Strength (psi)	Frac Type	Tested By
1	A	Good	6.01	28.37		05/22/23	7	93,380	3,290	3	TJT
1	B	Good	6.01	28.37		05/22/23	7	97,430	3,430	2	TJT
1	C	Good	6.01	28.37		05/22/23	7	95,680	3,370	2	TJT
								Average (7 days)	3,370		
1	D						Hold				

Initial Cure: Cure Blanket

Final Cure: Field Cured

Comments: Note: Reported air content does not include Aggregate Correction Factor (ACF).

Samples Made By: Terracon

Services: Obtain samples of fresh concrete at the placement locations (ASTM C 172), perform required field tests and cast, cure, and test compressive strength samples (ASTM C 31, C 39, C 1231).

Terracon Rep.: Daniel Calvo

Start/Stop: 0830-1245

Reported To:

Contractor: MBC Management

Report Distribution:

(1) Texas Transportation Institute, Bill Griffith (1) Texas Transportation Institute, Adam Mayer

Test Methods: ASTM C 31, ASTM C143, ASTM C231, ASTM C1064

The tests were performed in general accordance with applicable ASTM, AASHTO, or DOT test methods. This report is exclusively for the use of the client indicated above and shall not be reproduced except in full without the written consent of our company. Test results transmitted herein are only applicable to the actual samples tested at the location(s) referenced and are not necessarily indicative of the properties of other apparently similar or identical materials.

CONCRETE COMPRESSIVE STRENGTH TEST REPORT

Report Number: A1171057.0273
Service Date: 05/15/23
Report Date: 05/25/23
Task: PO# 440863-3

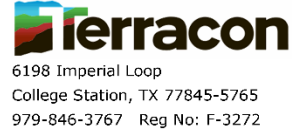

Client

Texas Transportation Institute
 Attn: Bill Griffith
 TTI Business Office
 3135 TAMU
 College Station, TX 77843-3135

Project

Riverside Campus
 Riverside Campus
 Bryan, TX
 Project Number: A1171057

Material Information

Specified Strength: 3,600 psi @ 28 days

Mix ID: TDCLC3600
Supplier: Texcrete
Batch Time: 0941 **Plant:**
Truck No.: 116 **Ticket No.:** 80544

Sample Information

Sample Date: 05/15/23 **Sample Time:** 1055
Sampled By: Daniel Calvo
Weather Conditions: Sunny
Accumulative Yards: 17.00/17.0 **Batch Size (cy):** 7
Placement Method: Direct Discharge
Water Added Before (gal): 10
Water Added After (gal): 0
Sample Location: Luminaire Bridge Deck 15' South of North end
Placement Location: Luminaire Bridge Deck
Sample Description: 6-inch diameter cylinders

Field Test Data

Test	Result	Specification
Slump (in):	5 1/4	
Air Content (%):	0.9	
Concrete Temp. (F):	95	
Ambient Temp. (F):	80	
Plastic Unit Wt. (pcf):	147.5	
Yield (Cu. Yds.):		

Laboratory Test Data

Set No.	Spec ID	Cyl. Cond.	Avg Diam. (in)	Area (sq in)	Date Received	Date Tested	Age at Test (days)	Max Load (lbs)	Comp Strength (psi)	Frac Type	Tested By
2	A	Good	6.01	28.37		05/22/23	7	101,700	3,580	3	TJT
2	B	Good	6.01	28.37		05/22/23	7	101,730	3,590	2	TJT
2	C	Good	6.01	28.37		05/22/23	7	108,790	3,830	2	TJT
								Average (7 days)	3,670		
2	D						Hold				

Initial Cure: Cure Blanket **Final Cure:** Field Cured

Comments: Note: Reported air content does not include Aggregate Correction Factor (ACF).

Samples Made By: Terracon

Services: Obtain samples of fresh concrete at the placement locations (ASTM C 172), perform required field tests and cast, cure, and test compressive strength samples (ASTM C 31, C 39, C 1231).

Terracon Rep.: Daniel Calvo

Start/Stop: 0830-1245

Reported To:

Contractor: MBC Management

Report Distribution:

(1) Texas Transportation Institute, Bill Griffith (1) Texas Transportation Institute, Adam Mayer

Reviewed By:

Alexander Durigan, P.E.
 Project Manager

Test Methods: ASTM C 31, ASTM C143, ASTM C231, ASTM C1064

The tests were performed in general accordance with applicable ASTM, AASHTO, or DOT test methods. This report is exclusively for the use of the client indicated above and shall not be reproduced except in full without the written consent of our company. Test results transmitted herein are only applicable to the actual samples tested at the location(s) referenced and are not necessarily indicative of the properties of other apparently similar or identical materials.

TEXCRETE
Real with Concrete Technology

REMIT PAYMENT TO:
 P.O. BOX 138
 KURTEN, TX 77862

5222 Sandy Point RD.
 Bryan, Tx 77807

17534 SH 6 South
 College Station, TX 77845

18935 Circle Lake Dr.
 Pinehurst, TX 77362

154876

BCS DISPATCH - 979-316-2906
 PINEHURST DISPATCH - 936-232-5815
 OFFICE - 979-985-3636

MBC MANAGEMENT
 RELLIS - TTI WAREHOUSE, BRYAN TX

RT 2818, RT HWY 21, LT SILVER HILL, RT
 AT "T", RT HWY 47, LT INTO RELLIS' CAMPUS
 STAY STRAIGHT THE MAINDRIVE TO THE GATE

TIME	FORMULA	LOAD SIZE	YARD ORDERED	DRIVER/TRUCK	PLANT TRANSACTION#
9:29	TDCLS4000	10.00	28.00 PD#	THOMAS TRAVIS	78884
DATE	LOAD#	YARDS DEL.	BATCH#	WATER TRIM	TICKET NUMBER
5/5/23	PROJECT SINGLES	10.00	10.00	5.00 in	77078
QUANTITY	CODE	DESCRIPTION	UNIT PRICE	EXTENDED PRICE	

10.00 yd TDCLS4000 CLASS S 4000 PSI
 1.00 ea FUEL Fuel Charge

Thank you for your business

LEFT PLANT	ARRIVED JOB	START UNLOADING	SLUMP	CONCRETE TEMP.	AIR TEMP
940	955	10:00			
FINISH UNLOADING	LEFT JOB	ARRIVED AT PLANT	ON SITE TESTING		
			TESTING LAB:	TERRACON GESSNER CME	OTHER
	TESTED		AIR	CYLINDERS	
	<input type="checkbox"/> YES	<input type="checkbox"/> NO			

Tax
 Prev. AMT
 Ticket Total

ADDITIONAL CHARGE 1 _____
 ADDITIONAL CHARGE 2 _____
GRAND TOTAL _____

WARNING
IRRITATING TO THE SKIN AND EYES
 Contains Portland Cement. Wear Rubber Boots and Gloves. PROLONGED CONTACT MAY CAUSE BURNS. Avoid Contact With Eyes and Prolonged Contact with Skin. In Case of Contact with Skin or Eyes, Rinse Thoroughly With Water. If Irritation Persists, Get Medical Attention. **KEEP CHILDREN AWAY.**

CONCRETE is a PERISHABLE COMMODITY and BECOMES THE PROPERTY of the PURCHASER UPON LEAVING the PLANT. ANY CHANGES or CANCELLATION of ORIGINAL INSTRUCTIONS MUST be TELEPHONED to the OFFICE BEFORE LOADING starts. The undersigned promises to pay all costs, including reasonable attorney's fees, incurred in collecting any sums owed.

All accounts not paid within 30 days of delivery will bear interest at the rate of 18% per annum. Not Responsible For Reactive Aggregate or Color Quality. No Claim Allowed Unless Made at Time Material is Delivered. A \$25.00 Service Charge and Loss of the Cash Discounted will be Collected on all Returned Checks. Demerage charge after 90 min. will be \$100.00/hr.

PROPERTY DAMAGE RELEASE
 (TO BE SIGNED IF DELIVERY TO BE MADE INSIDE CURB LINE)
 Dear Customer - The driver of this truck in presenting this RELEASE to you for your signature is of the opinion that the size and weight of this truck may possibly cause damage to the premises and/or adjacent property if he places the material in this load where you desire it. It is our wish to help you in every way that we can, but in order to do this the driver is requesting that you sign this RELEASE relieving him and this supplier from any responsibility from damage that may occur to the premises and/or adjacent property buildings, sidewalks, driveways, curbs, etc. by the delivery of this material and that you also agree to help him remove the mud from the wheels of his vehicle so that he will not litter the public streets. Further as additional consideration, the undersigned agrees to indemnify and hold harmless the driver of this truck and this supplier for any and all damage to the premises and/or adjacent property which may be claimed by anyone to have arisen out of delivery of this order SIGNED:

Excessive Water is Detrimental to Concrete Performance.
 H₂O Added by Request/Authorized By:

GAL X
 WEIGHMASTER

Surcharge for credit cards

NOTICE: MY SIGNATURE BELOW INDICATES THAT I HAVE READ THE HEALTH WARNING NOTICE AND SUPPLIER WILL NOT BE RESPONSIBLE FOR ANY DAMAGE CAUSED WHEN DELIVERING INSIDE CURB LINE.

LOAD RECEIVED BY _____

154876

TEXCRETE
Reliable Concrete Company

REMIT PAYMENT TO:
 P.O. BOX 138
 KURTEN, TX 77862

TEXCRETE

154879

5222 Sandy Point RD.
 Bryan, Tx 77807

17534 SH 6 South
 College Station, TX 77845

18935 Circle Lake Dr.
 Pinehurst, TX 77362

BCS DISPATCH - 979-316-2906
 PINEHURST DISPATCH - 936-232-5815
 OFFICE - 979-985-3636

MBC MANAGEMENT
 RELLIS - TTI WAREHOUSE, BRYAN TX

RT 2818, RT HWY 21, LT SILVER HILL, RT
 AT "T", RT HWY 47, LT INTO RELLIS CAMPUS
 STAY STRAIGHT THE MAINDRIVE TO THE GATE

TIME	FORMULA	LOAD SIZE	YARD ORDERED		DRIVER/TRUCK		PLANT TRANSACTION#
10:04	TDCLS4000	10.00	28.00	PO#	CROSS,	DWANTE8	78887
DATE	PROJECT	LOAD#	YARDS DEL.	BATCH#	WATER TRIM	SLUMP	TICKET NUMBER
5/5/23	SINGLES	10.00	20.00			5.00 in	77081

QUANTITY	CODE	DESCRIPTION	UNIT PRICE	EXTENDED PRICE
10.00 yd	TDCLS4000	CLASS S 4000 PSI		
1.00 ea	FUEL	Fuel Charge		

Thank you for your business

LEFT PLANT	ARRIVED JOB	START UNLOADING	SLUMP	CONCRETE TEMP	AIR TEMP
10:20	10:35	10:40			
FINISH UNLOADING	LEFT JOB	ARRIVED AT PLANT	ON SITE TESTING		
			TESTING LAB:	TERRACON GESSNER CME	OTHER
		TESTED	AIR	CYLINDERS	
		<input type="checkbox"/> YES <input type="checkbox"/> NO			

Tax
 Prev. AMT
 Ticket Total

ADDITIONAL CHARGE 1 _____
 ADDITIONAL CHARGE 2 _____
GRAND TOTAL

WARNING
IRRITATING TO THE SKIN AND EYES
 Contains Portland Cement, Wear Rubber Boots and Gloves. PROLONGED CONTACT MAY CAUSE BURNS. Avoid Contact With Eyes and Prolonged Contact with Skin. In Case of Contact with Skin or Eyes, Rinse Thoroughly With Water. If Irritation Persists, Get Medical Attention KEEP CHILDREN AWAY.
 CONCRETE is a PERISHABLE COMMODITY and BECOMES THE PROPERTY OF THE PURCHASER UPON LEAVING THE PLANT. ANY CHANGES or CANCELLATION of ORIGINAL INSTRUCTIONS MUST be TELEPHONED to the OFFICE BEFORE LOADING starts. The undersigned promises to pay all costs, including reasonable attorney's fees, incurred in collecting any sums owed.
 All accounts not paid within 30 days of delivery will bear interest at the rate of 18% per annum. Not Responsible For Reactive Aggregate or Color Quality. No Claim Allowed Unless Made at Time Material is Delivered.
 A \$25.00 Service Charge and Loss of the Cash Discounted will be Collected on all Returned Checks. Demerage charge after 90 min. will be \$100.00/hr.

PROPERTY DAMAGE RELEASE
 (TO BE SIGNED IF DELIVERY TO BE MADE INSIDE CURB LINE)
 Dear Customer - The driver of this truck in presenting this RELEASE to you for your signature is of the opinion that the size and weight of this truck may possibly cause damage to the premises and/or adjacent property if he places the material in this load where you desire it. It is our wish to help you in every way that we can, but in order to do this the driver is requesting that you sign this RELEASE relieving him and this supplier from any responsibility from damage that may occur to the premises and/or adjacent property, buildings, sidewalks, driveways, curbs, etc. by the delivery of this material and that you also agree to help him remove mud from the wheels of his vehicle so that he will not litter the public streets. Further as additional consideration, the undersigned agrees to indemnify and hold harmless the driver of this truck and this supplier for any and all damage to the premises and/or adjacent property which may be claimed by anyone to have arisen out of delivery of this order SIGNED.

Excessive Water is Detrimental to Concrete Performance.
 H₂O Added by Request/Authorized By: _____
 GAL X
 WEIGHMASTER

Surcharge for credit cards

NOTICE: MY SIGNATURE BELOW INDICATES THAT I HAVE READ THE HEALTH WARNING NOTICE AND SUPPLIER WILL NOT BE RESPONSIBLE FOR ANY DAMAGE CAUSED WHEN DELIVERING INSIDE CURB LINE.

LOAD RECEIVED BY _____

154879

TEXCRETE
Redi-mix Concrete Company

REMIT PAYMENT TO:
P.O. BOX 138
KURTEN, TX 77862

5222 Sandy Point RD.
Bryan, Tx 77807

17534 SH 6 South
College Station, TX 77845

18935 Circle Lake Dr.
Pinehurst, TX 77362

154882

BCS DISPATCH - 979-316-2906
PINEHURST DISPATCH - 936-232-5815
OFFICE - 979-985-3636

MBC MANAGEMENT
RELLIS - TTI WAREHOUSE, BRYAN TX
RT 2818, RT HWY 21, LT SILVER HILL, RT
AT "T", RT HWY 47, LT INTO RELLIS CAMPUS
STAY STRAIGHT THE MAINDRIVE TO THE GATE

TIME	FORMULA	LOAD SIZE	YARD ORDERED	DRIVER/TRUCK	PLANT TRANSACTION#
10:21	TDCLS4000	8.00	28.00	BURNS, CHRISTO	78891
DATE	PROJECT	LOAD#	YARDS DEL.	BATCH#	TICKET NUMBER
5/5/23	SINGLES	8.00	28.00		77085
QUANTITY	CODE	DESCRIPTION	UNIT PRICE	EXTENDED PRICE	

8.00 yd TDCLS4000 CLASS 5 4000 PSI
1.00 ea FUEL Fuel Charge

Thank you for your business

LEFT PLANT	ARRIVED JOB	START UNLOADING	SLUMP	CONCRETE TEMP.	AIR TEMP
1030	1050	1059			
FINISH UNLOADING	LEFT JOB	ARRIVED AT PLANT	ON SITE TESTING		
			TERRACON		
			TESTING LAB: GESSNER		
			CME	OTHER	
			TESTED	AIR	CYLINDERS
			<input type="checkbox"/> YES <input type="checkbox"/> NO		

Tax
Prev. AMT
Ticket Total

ADDITIONAL CHARGE 1 _____
ADDITIONAL CHARGE 2 _____
GRAND TOTAL

WARNING
IRRITATING TO THE SKIN AND EYES
Contains Portland Cement. Wear Rubber Boots and Gloves. PROLONGED CONTACT MAY CAUSE BURNS. Avoid Contact With Eyes and Prolonged Contact with Skin. In Case of Contact with Skin or Eyes, Rinse Thoroughly With Water. If Irritation Persists, Get Medical Attention. KEEP CHILDREN AWAY.
CONCRETE is a PERISHABLE COMMODITY and BECOMES THE PROPERTY OF THE PURCHASER UPON LEAVING THE PLANT. ANY CHANGES or CANCELLATION of orders. The undersigned promises to pay all costs, including reasonable attorney's fees.
All accounts not paid within 30 days of delivery will bear interest at the rate of 18% per annum. Not Responsible For Reactive Aggregate or Color Quality. No Claim Allowed Unless A \$25.00 Service Charge and Loss of the Cash Discounted will be Collected on all Returned Checks. Demerage charge after 90 min. will be \$100.00/hr.

PROPERTY DAMAGE RELEASE
(TO BE SIGNED IF DELIVERY TO BE MADE INSIDE CURB LINE)
Dear Customer - The driver of this truck in presenting this RELEASE to you for your signature is of the opinion that the size and weight of this truck may possibly cause damage to the premises, and/or adjacent property if he places the material in this load where you desire it. It is our wish to help you in every way that we can, but in order to do this the driver is requesting that you sign this RELEASE relieving him and this supplier from any responsibility from damage that may occur to the premises and/or adjacent property, buildings, sidewalks, driveways, curbs, etc. by the delivery of this material and that you also agree to help him remove this material from the premises and hold harmless the driver of this truck and this supplier for any and all damage to the premises, and/or adjacent property, which may be claimed by anyone to have arisen out of delivery of this order.
X _____

Excessive Water is Detrimental to Concrete Performance.
H₂O Added by Request/Authorized By:

SJ GAL X
WEIGHMASTER

Surcharge for credit cards

NOTICE: MY SIGNATURE BELOW INDICATES THAT I HAVE READ THE HEALTH WARNING NOTICE AND SUPPLIER WILL NOT BE RESPONSIBLE FOR ANY DAMAGE CAUSED WHEN DELIVERING INSIDE CURB LINE.

LOAD RECEIVED BY
X _____

154882

CONCRETE COMPRESSIVE STRENGTH TEST REPORT

Report Number: A1171057.0272
Service Date: 05/05/23
Report Date: 05/25/23 Revision 1 - 17-day results
Task: PO# 440863-3

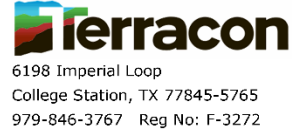

Client
Texas Transportation Institute
Attn: Bill Griffith
TTI Business Office
3135 TAMU
College Station, TX 77843-3135

Project
Riverside Campus
Riverside Campus
Bryan, TX
Project Number: A1171057

Material Information
Specified Strength: 4,000 psi @ 28 days
Mix ID: TDCLS4000
Supplier: Texcrete
Batch Time: 1004 **Plant:**
Truck No.: DWANTE8 **Ticket No.:** 77081

Sample Information
Sample Date: 05/05/23 **Sample Time:** 1046
Sampled By: Justin Maass
Weather Conditions: Clear, light wind
Accumulative Yards: 20/30 **Batch Size (cy):** 10
Placement Method: Direct Discharge
Water Added Before (gal): 0
Water Added After (gal): 0
Sample Location: Middle of wall
Placement Location: Bridge wall deck
Sample Description: 6-inch diameter cylinders

Field Test Data

Test	Result	Specification
Slump (in):	6	
Air Content (%):	2.0	
Concrete Temp. (F):	84	
Ambient Temp. (F):	75	
Plastic Unit Wt. (pcf):	147.7	
Yield (Cu. Yds.):		

Laboratory Test Data

Set No.	Spec ID	Cyl. Cond.	Avg Diam. (in)	Area (sq in)	Date Received	Date Tested	Age at Test (days)	Max Load (lbs)	Comp Strength (psi)	Frac Type	Tested By
2	A	Good	6.01	28.37		05/22/23	17 F	124,390	4,380	2	TJT
2	B	Good	6.01	28.37		05/22/23	17 F	120,780	4,260	2	TJT
2	C	Good	6.01	28.37		05/22/23	17 F	120,460	4,250	2	TJT
2	D						Hold				

Initial Cure: Outside Plastic Lids **Final Cure:** Field Cured

Comments: F = Field Cured
Note: Reported air content does not include Aggregate Correction Factor (ACF).

Samples Made By: Terracon

Services: Obtain samples of fresh concrete at the placement locations (ASTM C 172), perform required field tests and cast, cure, and test compressive strength samples (ASTM C 31, C 39, C 1231).

Terracon Rep.: Justin Maass **Start/Stop:**
Reported To: Bill w/ TTI
Contractor: MDC

Report Distribution:
(1) Texas Transportation Institute, Bill Griffith (1) Texas Transportation Institute, Adam Mayer

Test Methods: ASTM C 31, ASTM C143, ASTM C231, ASTM C1064

The tests were performed in general accordance with applicable ASTM, AASHTO, or DOT test methods. This report is exclusively for the use of the client indicated above and shall not be reproduced except in full without the written consent of our company. Test results transmitted herein are only applicable to the actual samples tested at the location(s) referenced and are not necessarily indicative of the properties of other apparently similar or identical materials.

CONCRETE COMPRESSIVE STRENGTH TEST REPORT

Report Number: A1171057.0272
Service Date: 05/05/23
Report Date: 05/25/23 Revision 1 - 17-day results
Task: PO# 440863-3

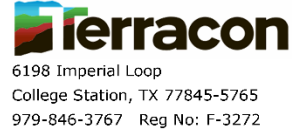

Client

Texas Transportation Institute
Attn: Bill Griffith
TTI Business Office
3135 TAMU
College Station, TX 77843-3135

Project

Riverside Campus
Riverside Campus
Bryan, TX
Project Number: A1171057

Material Information

Specified Strength: 4,000 psi @ 28 days

Mix ID: TDCLS4000

Supplier: Texcrete

Batch Time:

Plant:

Truck No.: TEAVI3

Ticket No.: 77078

Sample Information

Sample Date: 05/05/23 **Sample Time:** 1010

Sampled By: Justin Maass

Weather Conditions: Clear, light wind

Accumulative Yards: 10/30 **Batch Size (cy):** 10

Placement Method: Direct Discharge

Water Added Before (gal): 0

Water Added After (gal): 0

Sample Location: East end

Placement Location: Bridge wall deck

Sample Description: 6-inch diameter cylinders

Field Test Data

Test	Result	Specification
Slump (in):	5 1/2	
Air Content (%):	2.2	
Concrete Temp. (F):	85	
Ambient Temp. (F):	76	
Plastic Unit Wt. (pcf):	148.0	
Yield (Cu. Yds.):		

Laboratory Test Data

Set No.	Spec ID	Cyl. Cond.	Avg Diam. (in)	Area (sq in)	Date Received	Date Tested	Age at Test (days)	Max Load (lbs)	Comp Strength (psi)	Frac Type	Tested By
1	A	Good	6.00	28.27		05/12/23	7 F	102,700	3,630	2	TJT
1	B	Good	6.01	28.37		05/22/23	17 F	130,610	4,600	2	TJT
1	C	Good	6.01	28.37		05/22/23	17 F	127,730	4,500	2	TJT
1	D	Good	6.01	28.37		05/22/23	17 F	120,400	4,240	3	TJT

Initial Cure: Outside Plastic Lids

Final Cure: Field Cured

Comments: F = Field Cured

Note: Reported air content does not include Aggregate Correction Factor (ACF).

Samples Made By: Terracon

Services: Obtain samples of fresh concrete at the placement locations (ASTM C 172), perform required field tests and cast, cure, and test compressive strength samples (ASTM C 31, C 39, C 1231).

Terracon Rep.: Justin Maass

Start/Stop:

Reported To: Bill w/ TTI

Contractor: MDC

Report Distribution:

(1) Texas Transportation Institute, Bill Griffith (1) Texas Transportation Institute, Adam Mayer

Test Methods: ASTM C 31, ASTM C143, ASTM C231, ASTM C1064

The tests were performed in general accordance with applicable ASTM, AASHTO, or DOT test methods. This report is exclusively for the use of the client indicated above and shall not be reproduced except in full without the written consent of our company. Test results transmitted herein are only applicable to the actual samples tested at the location(s) referenced and are not necessarily indicative of the properties of other apparently similar or identical materials.

CONCRETE COMPRESSIVE STRENGTH TEST REPORT

Report Number: A1171057.0272
Service Date: 05/05/23
Report Date: 05/25/23 Revision 1 - 17-day results
Task: PO# 440863-3

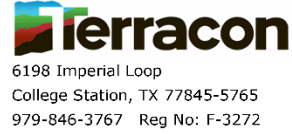

Client
Texas Transportation Institute
Attn: Bill Griffith
TTI Business Office
3135 TAMU
College Station, TX 77843-3135

Project
Riverside Campus
Riverside Campus
Bryan, TX
Project Number: A1171057

Material Information
Specified Strength: 4,000 psi @ 28 days
Mix ID: TDCLS4000
Supplier: Texcrete
Batch Time: 1021 **Plant:**
Truck No.: CHEISTO1 **Ticket No.:** 77085

Sample Information
Sample Date: 05/05/23 **Sample Time:** 1100
Sampled By: Justin Maass
Weather Conditions: Clear, light wind
Accumulative Yards: Cloudy, lig **Batch Size (cy):** 10
Placement Method: Direct Discharge
Water Added Before (gal): 0
Water Added After (gal): 0
Sample Location: West end of wall
Placement Location: Bridge wall deck
Sample Description: 6-inch diameter cylinders

Field Test Data

Test	Result	Specification
Slump (in):	6 3/4	
Air Content (%):	1.5	
Concrete Temp. (F):	84	
Ambient Temp. (F):	75	
Plastic Unit Wt. (pcf):	146.8	
Yield (Cu. Yds.):		

Laboratory Test Data

Set No.	Spec ID	Cyl. Cond.	Avg Diam. (in)	Area (sq in)	Date Received	Date Tested	Age at Test (days)	Max Load (lbs)	Comp Strength (psi)	Frac Type	Tested By
3	A	Good	6.01	28.37		05/22/23	17 F	113,600	4,000	2	TJT
3	B	Good	6.01	28.37		05/22/23	17 F	112,140	3,950	2	TJT
3	C	Good	6.01	28.37		05/22/23	17 F	110,790	3,910	2	TJT
3	D						Hold				

Initial Cure: Outside Plastic Lids **Final Cure:** Field Cured
Comments: F = Field Cured
Note: Reported air content does not include Aggregate Correction Factor (ACF).

Samples Made By: Terracon
Services: Obtain samples of fresh concrete at the placement locations (ASTM C 172), perform required field tests and cast, cure, and test compressive strength samples (ASTM C 31, C 39, C 1231).

Terracon Rep.: Justin Maass
Reported To: Bill w/ TTI
Contractor: MDC

Start/Stop:

Report Distribution:
(1) Texas Transportation Institute, Bill Griffith (1) Texas Transportation Institute, Adam Mayer

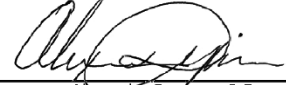
Reviewed By: 
Alexander Durigan, P.E.
Project Manager

Test Methods: ASTM C 31, ASTM C143, ASTM C231, ASTM C1064
The tests were performed in general accordance with applicable ASTM, AASHTO, or DOT test methods. This report is exclusively for the use of the client indicated above and shall not be reproduced except in full without the written consent of our company. Test results transmitted herein are only applicable to the actual samples tested at the location(s) referenced and are not necessarily indicative of the properties of other apparently similar or identical materials.

APPENDIX C. *MASH* TEST 4-12 (CRASH TEST 440863-03-1)

C.1. VEHICLE PROPERTIES AND INFORMATION

Date: 2023-06-22 Test No.: 440863-03-1 VIN No.: 1HTMMAAN8BH318185
 Year: 2011 Make: INTERNATIONAL Model: 4300
 Odometer: 224951 Tire Size Front: 275/80R22.5 Tire Size Rear: 275/80R22.5

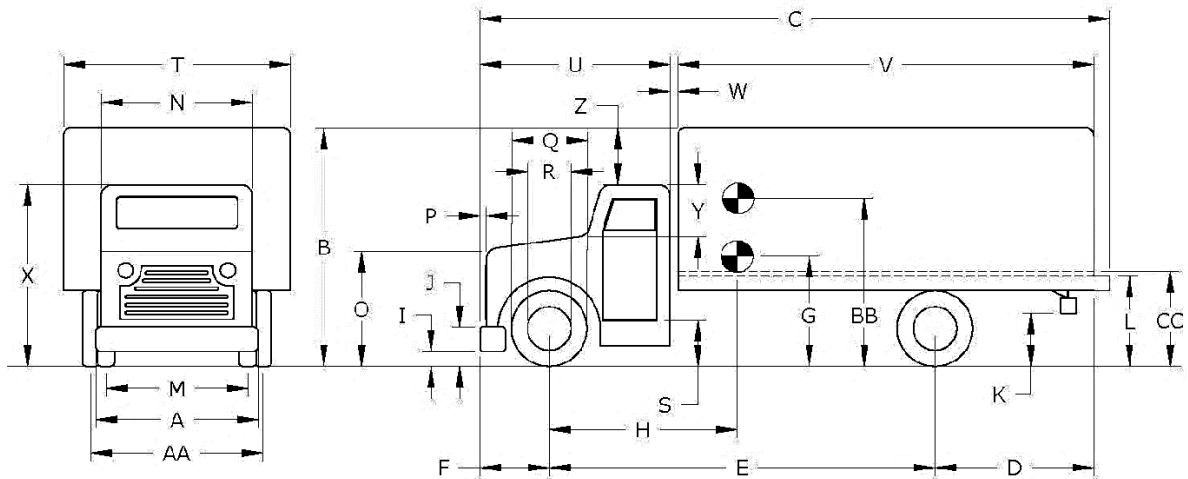

Vehicle Geometry:		<input checked="" type="checkbox"/> inches	or	<input type="checkbox"/> mm		
A	Front Bumper Width:	<u>92.50</u>		K	Rear Bumper Bottom:	<u>0.00</u>
B	Overall Height:	<u>134.50</u>		L	Rear Frame Top:	<u>37.50</u>
C	Overall Length:	<u>331.72</u>		M	Front Track Width:	<u>79.50</u>
D	Rear Overhang:	<u>89.00</u>		N	Roof Width:	<u>76.00</u>
E	Wheel Base:	<u>204.72</u>		O	Hood Height:	<u>60.00</u>
F	Front Overhang:	<u>38.00</u>		P	Bumper Extension:	<u>1.50</u>
G	C.G. Height:	<u>-</u>		Q	Front Tire Width:	<u>40.00</u>
H	C.G. Horizontal Dist. w/Ballast:	<u>129.72</u>		R	Front Wheel Width:	<u>22.50</u>
I	Front Bumper Bottom:	<u>17.25</u>		S	Bottom Door Height:	<u>37.50</u>
J	Front Bumper Top:	<u>34.50</u>		T	Overall Width:	<u>96.50</u>
				U	Cab Length:	<u>107.00</u>
				V	Trailer/Box Length:	<u>225.00</u>
				W	Gap Width:	<u>2.25</u>
				X	Overall Front Height:	<u>97.75</u>
				Y	Roof-Hood Distance:	<u>30.50</u>
				Z	Roof-Box Height Difference:	<u>36.75</u>
				AA	Rear Track Width:	<u>74.00</u>
				BB	Ballast Center of Mass:	<u>63.00</u>
				CC	Cargo Bed Height:	<u>50.50</u>
Allowable Range: C = 394 inches max.; E = 240 inches max.; CC = 49 ±2 inches; BB = 63 ±2 inches above ground;						
	Wheel Center Height Front	<u>19.00</u>			Wheel Well Clearance (Front)	<u>9.00</u>
	Wheel Center Height Rear	<u>20.00</u>			Wheel Well Clearance (Rear)	<u>7.00</u>
					Bottom Frame Height (Front)	<u>26.00</u>
					Bottom Frame Height (Rear)	<u>27.00</u>

Figure C.1. Vehicle Properties for Test 440863-03-1

Date: 2023-06-22 Test No.: 440863-03-1 VIN No.: 1HTMMAAN8BH318185
 Year: 2011 Make: INTERNATIONAL Model: 4300

WEIGHTS (<input checked="" type="checkbox"/> lb or <input type="checkbox"/> kg)	CURB	TEST INERTIAL
$W_{front\ axle}$	<u>6870</u>	<u>8100</u>
$W_{rear\ axle}$	<u>6160</u>	<u>14010</u>
W_{TOTAL}	<u>13030</u>	<u>22110</u>

Allowable Range for CURB = 13,200 ±2200 lb | Allowable Range for TIM = 22,046 ±660 lb

Ballast: 9080 (lb or kg) (as-needed)
 (See MASH Section 4.2.1.2 for recommended ballasting)

Mass Distribution
 (lb or kg): LF: 4070 RF: 4030 LR: 6990 RR: 7020

Engine Type: DT
 Engine Size: 466

Accelerometer Locations (inches or mm)

Transmission Type:
 Auto or Manual
 FWD RWD 4WD

	x ¹	y	z ²
Front:	<u>0.00</u>	<u>0.00</u>	<u>0.00</u>
Center:	<u>129.00</u>	<u>0.00</u>	<u>50.00</u>
Rear:	<u>241.22</u>	<u>0.00</u>	<u>50.00</u>

Describe any damage to the vehicle prior to test: _____

Other notes to include ballast type, dimensions, mass, location, center of mass, and method of attachment:

TWO BLOCKS 30W X 30H X 60L
CENTERED IN MIDDLE OF BED
TIED DOWN WITH FOUR 3/8 CABLES PER BLOCK
63 INCHES FROM GROUND TO CENTER OF BLOCK

Performed by: RK Date: 2023-06-22

¹ Referenced to the front axle
² Above ground

Figure C.3. Vehicle Parameters for Test 440863-03-1.

C.2. SEQUENTIAL PHOTOGRAPHS



(a) 0.000 s

(b) 0.100 s



(c) 0.200 s

(d) 0.300 s



(e) 0.400 s

(f) 0.500 s



(g) 0.600 s

(h) 0.700 s

Figure C.4. Sequential Photographs for Test 440863-03-1 (Overhead Views).



(a) 0.000 s

(b) 0.100 s



(c) 0.200 s

(d) 0.300 s



(e) 0.400 s

(f) 0.500 s



(g) 0.600 s

(h) 0.700 s

Figure C.5. Sequential Photographs for Test 440863-03-1 (Frontal Views).



(a) 0.000 s

(b) 0.100 s



(c) 0.200 s

(d) 0.300 s



(e) 0.400 s

(f) 0.500 s



(g) 0.600 s

(h) 0.700 s

Figure C.6. Sequential Photographs for Test 440863-03-1 (Rear Views).

C.3. VEHICLE ANGULAR DISPLACEMENTS

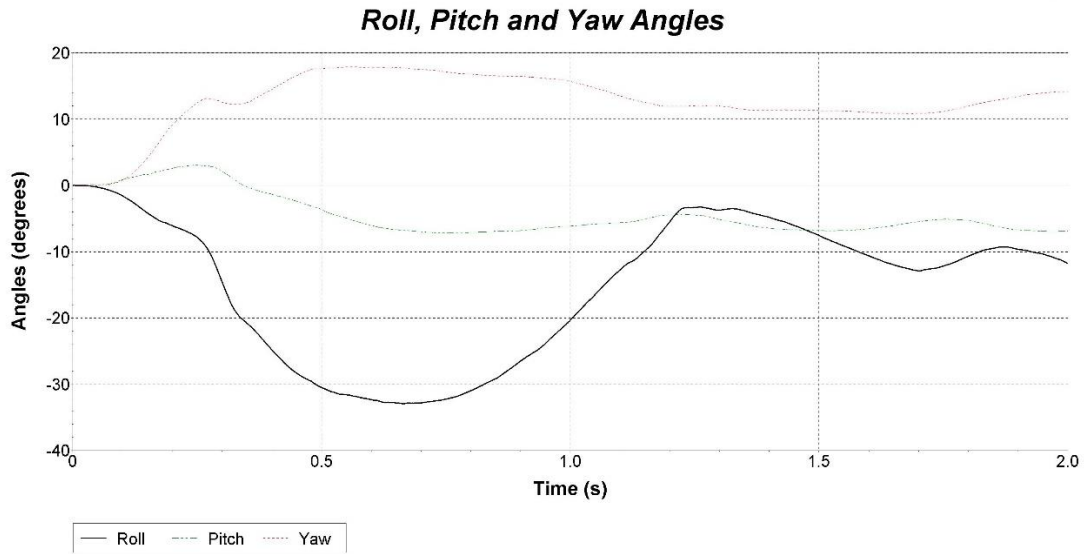

Axes are vehicle-fixed.
Sequence for determining orientation:

1. Yaw.
2. Pitch.
3. Roll.

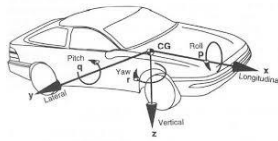

Test Number: 440863-03-1
 Test Standard Test Number: *MASH* Test 4-12
 Test Article: Luminaire Pole behind Single Slope Traffic Rail
 Test Vehicle: 2011 International 4300
 Inertial Mass: 22110 lbs
 Gross Mass: 22110 lbs
 Impact Speed: 54.4 mi/h
 Impact Angle: 15.0°

Figure C.7. Vehicle Angular Displacements for Test 440863-03-1.

C.4. VEHICLE ACCELERATIONS

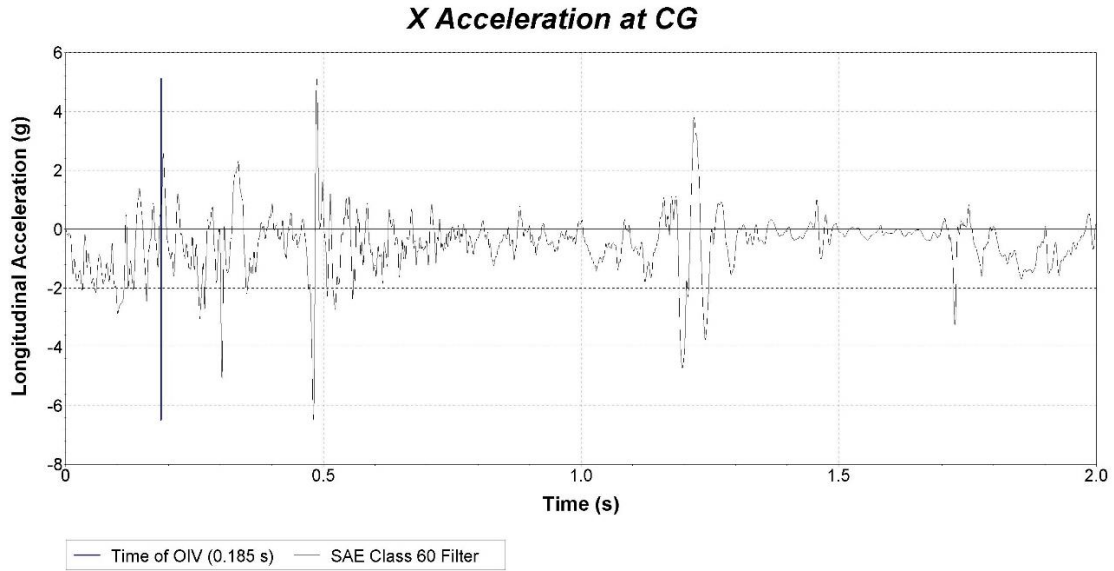

Figure C.8. Vehicle Longitudinal Accelerometer Trace for Test 440863-03-1 (Accelerometer Located at Center of Gravity).

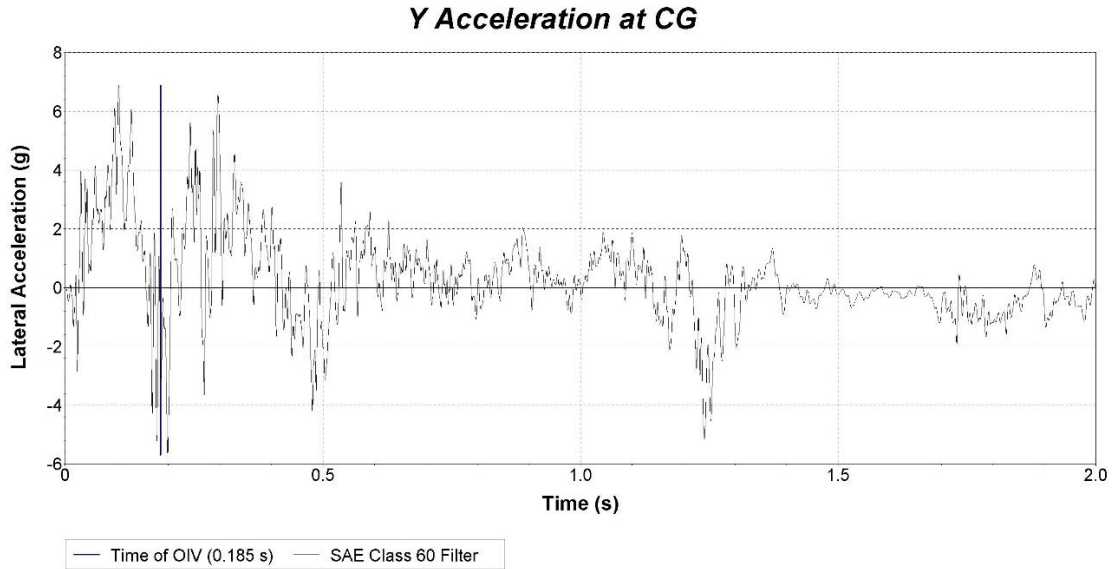

Figure C.9. Vehicle Lateral Accelerometer Trace for Test 440863-03-1 (Accelerometer Located at Center of Gravity).

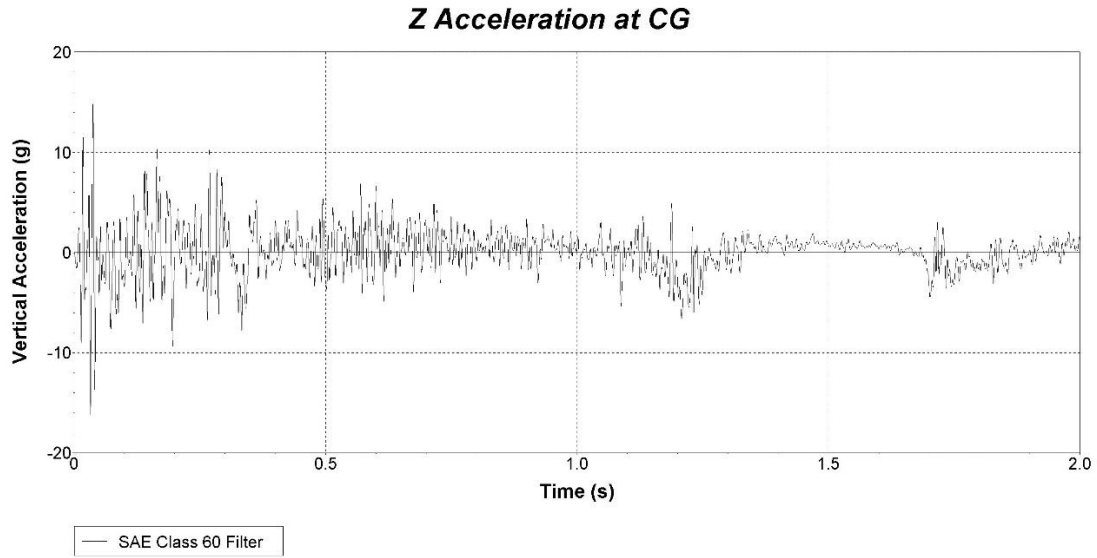

Figure C.10. Vehicle Vertical Accelerometer Trace for Test 440863-03-1 (Accelerometer Located at Center of Gravity).

