

## TECHNICAL REPORT STANDARD PAGE

---

- |   |  |
|---|--|
| 1. Title and Subtitle<br><b>Skew Detection System Replacement on Vertical Lift Bridges (Phase 2)</b>  | 5. Report No.<br><b>FHWA/LA.24/703</b>   |
| 2. Author(s)<br>Gareth Rees, P.E.   | 6. Report Date<br>November 2024  |
| 3. Performing Organization Name and Address<br>Wiss, Janney, Elstner Associates, Inc. (WJE)<br>800 Hyde Park<br>Doylestown, PA 18902            | 7. Performing Organization Code<br>LTRC Project Number: 22-2ST<br>SIO Number: DOTLT1000428 |
| 4. Sponsoring Agency Name and Address<br>Louisiana Department of Transportation and Development<br>P.O. Box 94245<br>Baton Rouge, LA 70804-9245 | 8. Type of Report and Period Covered<br>Final Report<br>February 2022 – August 2024        |
|   | 9. No. of Pages<br>60  |

10. Supplementary Notes

Conducted in cooperation with the U.S. Department of Transportation, Federal Highway Administration.

11. Distribution Statement

Unrestricted. This document is available through the National Technical Information Service, Springfield, VA 21161.

12. Key Words

Skew detection system; skew control; vertical lift; movable bridges; programmable logic controller (PLC); SMART relays; encoders; inclinometers; lasers; differential Selsyn system

13. Abstract

A potential vulnerability of a tower drive vertical lift bridge is a failure to maintain level operation over the length or width of its movable span; this is known as longitudinal or transverse skew, respectively. When either of these conditions occurs, they can cause the movable span to jam in its guides; without adequate protection, this can lead to a catastrophic bridge failure. Vertical lift tower drive skew indication and monitoring has historically used a differential synchro (i.e., differential Selsyn) system. However, this technology is now considered obsolete, and replacements are difficult to obtain. A study was commissioned to evaluate alternatives to the differential Selsyn system. These alternatives were selected based on several criteria, including their availability, ease of maintenance and replacement, and minimization of the use of advanced electronic equipment. This report summarizes Phase 2 of the study. In this phase, several alternative skew detection methods were field-tested and evaluated. Based on the results of this evaluation, an alternative to the differential Selsyn system was selected to provide the required skew monitoring, indication, and operating system protection. The considered alternative

systems included the use of direct skew measurement using an inclinometer and indirect skew measurement using encoders. To minimize maintenance and mean-time-to-repair, as well as limit dependency on PLC systems, consideration for the deployment of these alternative methods included the use of SMART relays with self-diagnostics that can be replaced easily in the event of a malfunction.

## **Project Review Committee**

Each research project will have an advisory committee appointed by the LTRC Director. The Project Review Committee is responsible for assisting the LTRC Administrator or Manager in the development of acceptable research problem statements, requests for proposals, review of research proposals, oversight of approved research projects, and implementation of findings.

LTRC appreciates the dedication of the following Project Review Committee Members in guiding this research study to fruition.

### ***LTRC Administrator/Manager***

Walid Alaywan, Ph.D., P.E.  
Senior Structures Research Engineer

### ***Members***

Fallon Faber, P.E., DOTD Bridge Design  
Matt Peneguy, P.E., DOTD Bridge Design  
Kian Yap, P.E., DOTD Bridge Design  
Jeffrey Hastings, P.E., DOTD Bridge Design  
Christopher LeBourgeois, P.E., DOTD Bridge Design  
Jason Michiels, P.E., DOTD Bridge Maintenance  
Corey Mayeux, P.E., LTRC  
Paul Fossier, P.E., FHWA

### ***Directorate Implementation Sponsor***

Chad Winchester, P.E.  
DOTD Chief Engineer

# **Skew Detection System Replacement on Vertical Lift Bridges (Phase 2)**

By  
Gareth Rees, P.E.

Wiss, Janney, Elstner Associates, Inc.  
800 Hyde Park  
Doylestown, PA 18902

LTRC Project No. 22-2ST  
SIO No. DOTLT1000428

conducted for  
Louisiana Department of Transportation and Development  
Louisiana Transportation Research Center

The contents of this report reflect the views of the author/principal investigator, who is responsible for the facts and the accuracy of the data presented herein.

The contents do not necessarily reflect the views or policies of the Louisiana Department of Transportation and Development, the Federal Highway Administration, or the Louisiana Transportation Research Center. This report does not constitute a standard, specification, or regulation.

November 2024

## **Abstract**

A potential vulnerability of a tower drive vertical lift bridge is a failure to maintain level operation over the length or width of its moving span; this is known as longitudinal or transverse skew, respectively. When either of these conditions occurs, they can cause the movable span to jam in its guides; without adequate protection, this can lead to a catastrophic bridge failure. Vertical lift tower drive skew indication and monitoring has historically used a differential synchro (i.e., differential Selsyn) system. However, this technology is now considered obsolete, and replacements are difficult to obtain. A study was commissioned to evaluate alternatives to the differential Selsyn system. These alternatives were selected based on several criteria, including their availability, ease of maintenance and replacement, and minimization of the use of advanced electronic equipment. This report summarizes Phase 2 of the study. In this phase, several alternative skew detection methods were field-tested and evaluated. Based on the results of this evaluation, an alternative to the differential Selsyn system was selected to provide the required skew monitoring, indication, and operating system protection. The considered alternative systems included the use of direct skew measurement using an inclinometer and indirect skew measurement using encoders. To minimize maintenance and mean-time-to-repair, as well as limit dependency on PLC systems, consideration for the deployment of these alternative methods included the use of SMART relays with self-diagnostics that can be replaced easily in the event of a malfunction.

## **Acknowledgments**

The author wishes to thank the Louisiana Department of Transportation and Development (DOTD) for providing the resources necessary for this project and the Louisiana Transportation Research Center (LTRC) for the funding of this study. For the Phase 1 investigation [1], a significant portion of the work relied on feedback from owners and control systems vendors regarding installation trends and the effectiveness of installed skew control systems. As part of the current work, the systems vendor subcontractor (Panatrol Automation and Controls) and the installation contractor (Walter J. Barnes Electric Co., Inc.) were both essential in the installation and testing associated with the alternatives. The author is grateful to all who have participated in this work.

## **Implementation Statement**

Phase 2 of this study focused on implementation, centering on the installation, field-testing, and evaluation of alternative skew detection methods for use on tower drive vertical lift bridges. The goal of this phase was to assess the installation, performance, accuracy, reliability, and maintainability of alternative skew control systems and the selection of the preferred alternative(s) based on this evaluation. The results are intended to be utilized in the design of future skew control systems for tower drive vertical lift bridges, including the installation of new systems and the retrofitting of existing systems.

# Table of Contents

Technical Report Standard Page .....	1
Project Review Committee .....	3
LTRC Administrator/Manager .....	3
Members .....	3
Directorate Implementation Sponsor .....	3
Skew Detection System Replacement on Vertical Lift Bridges (Phase 2).....	4
Abstract .....	5
Acknowledgments.....	6
Implementation Statement .....	7
Table of Contents .....	8
List of Tables.....	9
List of Figures .....	10
Introduction.....	11
Literature Review.....	13
Objective .....	14
Scope.....	15
Methodology .....	16
Understanding.....	16
Alternative Systems Considered .....	17
Approach.....	17
Design and Installation .....	17
Testing and Commissioning of Systems .....	33
Evaluation Criteria .....	41
Discussion of Results .....	42
Conclusions.....	56
Recommendations.....	57
Acronyms, Abbreviations, and Symbols.....	58
References.....	59
Appendix.....	60



## List of Tables

Table 1. Encoder specifications, installation, and calibration details .....	20
Table 2. Initial procured laser specifications and calibration details .....	23
Table 3. Final procured laser specifications and calibration details .....	23
Table 4. Inclinometer specifications and calibration details .....	24
Table 5. Summary of software used for installed skew monitoring system .....	31
Table 6. Summary of site visits .....	33
Table 7. Skew device evaluation table .....	55

## List of Figures

Figure 1. Tower drive vertical lift bridge schematic, bridge in skewed position.....	11
Figure 2. Northwest absolute encoder installation.....	19
Figure 3. Southwest encoder final installation with cover.....	19
Figure 4. Excerpt from drawings showing laser with extension beam.....	21
Figure 5. Laser installation photos at tower.....	21
Figure 6. Laser installation photos at lift span target.....	22
Figure 7. Inclinometers in a common enclosure.....	24
Figure 8. Tower-to-tower antenna, north tower.....	26
Figure 9. Span to north tower wireless installation.....	26
Figure 10. Aerial cables.....	27
Figure 11. Operator’s main SMART relay HMI and skew enclosure.....	29
Figure 12. North tower skew enclosure.....	29
Figure 13. Operator’s house skew enclosure.....	30
Figure 14. Initial laser distance measurements (1/11/24).....	35
Figure 15. Laser measurements following replacement at NE and SW corners of the lift span (5/9/24).....	36
Figure 16. Typical laser beam extension installation.....	37
Figure 17. Cable reel used in attempted Power Line Communication.....	40
Figure 18. Final skew data, full cycle (7/28/24).....	43
Figure 19. Final skew data, opening cycle (7/28/24).....	44
Figure 20. Final skew data, closing cycle (7/28/24).....	46
Figure 21. Final skew data, seating (7/28/24).....	47
Figure 22. Final skew data, full cycle (7/29/24).....	48
Figure 23. Final skew data, opening cycle (7/29/24).....	49
Figure 24. Final skew data, closing cycle (7/29/24).....	49
Figure 25. Final skew data, full cycle (8/3/24).....	50
Figure 26. Final skew data, opening cycle (8/3/24).....	51
Figure 27. Final skew data, closing cycle (8/3/24).....	51
Figure 28. Final skew data, full cycle (8/4/24).....	52
Figure 29. Final skew data, opening cycle (8/4/24).....	53
Figure 30. Final skew data, closing cycle (8/4/24).....	53

# Introduction

The Louisiana Department of Transportation and Development (DOTD) and Louisiana Transportation Research Center (LTRC) identified a potential vulnerability in the operation of tower drive vertical lift movable bridges. This vulnerability relates to the critical control function of maintaining the movable span level during operation. A lack or malfunction of this control function could cause the span to become tilted during an operation, which is known as span skew. Span skew can happen over the span's length or width; this is known as longitudinal and transverse skew, respectively. See Figure 1 for a depiction of longitudinal skew. When span skew occurs, it can cause the movable span to jam in its guides, and without adequate protection, this can result in damage to the bridge structure and machinery.

**Figure 1. Tower drive vertical lift bridge schematic, bridge in skewed position**

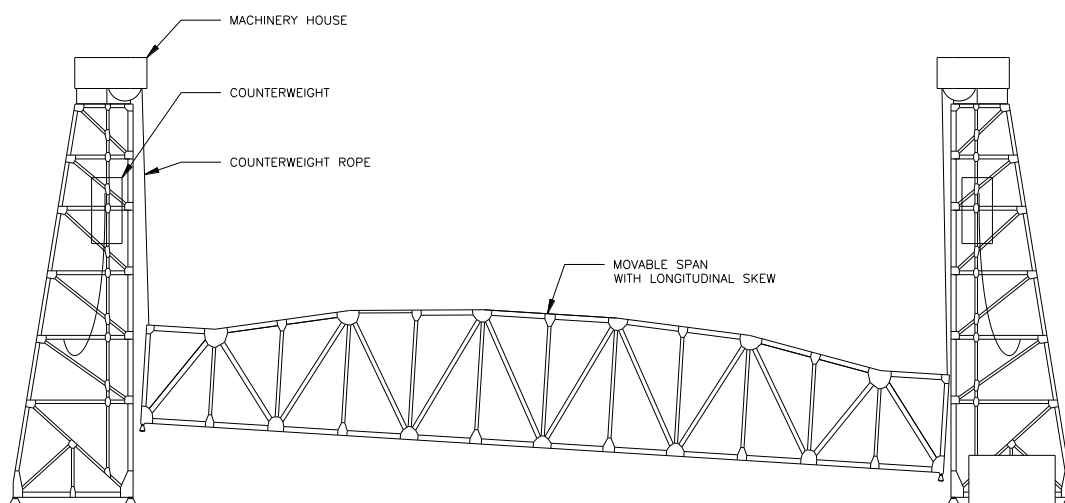

Bridge control systems were historically designed to detect these skew conditions using a control technology called a differential synchro, commonly known as a differential Selsyn system. Although this technology has been effective for many years in monitoring and controlling skew, it is now considered obsolete. Differential Selsyn technology has been overtaken by modern electronic instruments, which require the use of microprocessor-based programmable logic controllers (PLC). The maintenance and troubleshooting of these modern PLC based systems demand a different skill set from maintenance personnel.

To address this vulnerability, LTRC solicited the assistance of Wiss, Janney, Elstner Associates, Inc. (WJE) to investigate and evaluate possible solutions that, if possible, do not require the application of advanced technology methods. WJE was retained to perform

a study consisting of two phases. Phase 1 of the study included a review of alternatives for skew control, monitoring, and indication for tower drive vertical lift bridges. These alternatives were based on the effective management of skew and aimed to minimize, as much as possible, the use of advanced electronic equipment.

The findings of this review were presented in a 2020 report [1]. In this report, a list of potential alternative systems for skew control was developed and presented to DOTD and LTRC. These solutions were selected based on several criteria, including the minimization of maintenance, the reduction of mean-time-to-repair, and the limitation of dependence on highly complex PLC systems. In place of a PLC, SMART relays were used; these relays contain control and detection monitoring logic, which is able to be used with the selected alternatives. The selected SMART relays are readily available, provide self-diagnostics, are able to be remotely monitored, and can easily be replaced as needed by DOTD personnel without specialized electronic or control system knowledge.

This report summarizes Phase 2 of the study, which included the creation of a pilot program to apply the proposed skew measurement systems on a bridge selected by DOTD. The selected bridge is the Ellender Ferry Vertical Lift Bridge, a tower drive vertical lift bridge located over the Intracoastal Waterway in Calcasieu Parish, Louisiana.

## Literature Review

A literature review has not been included in Phase 2 of the study; instead, it can be found in the Phase 1 report [1]. This review included available documents, books, conference publications, and design specifications. Unfortunately, it yielded little guidance on skew control systems for tower drive vertical lift bridges. It did, however, yield useful information on devices and systems which could be adopted for use as part of a skew control system.

The Phase 1 literature review also included a survey of bridge owners, maintenance personnel, and control system vendors to determine current industry practices of skew control for tower drive vertical lift bridges. The review made clear that the industry is moving to replace the long-utilized Selsyn systems in favor of encoders, resolvers, inclinometers, and other devices. While these systems were often deployed using programmable logic controllers (PLCs), the preference for conventional relay logic does not preclude the use of inclinometers and encoders to provide skew control and indication. SMART relays have sufficient computing capabilities, while also being relatively inexpensive and easily replaceable.

## **Objective**

The objectives of Phase 2 of this study were to develop documents for the installation and testing of potential replacements for the differential Selsyn system skew control which meet DOTD criteria and provide a report evaluating these alternatives. The evaluated technologies were chosen based on the findings of Phase 1 of this study and were deployed at the Ellender Ferry Vertical Lift Bridge located over the Intracoastal Waterway in Calcasieu Parish, Louisiana.

## Scope

The scope of Phase 2 of this study was to develop documents for the installation and testing of potential replacements for the differential Selsyn system skew control, analyze the performance of selected skew control systems, and determine the preferred system for future use on new and existing DOTD bridges. These steps included:

- Analysis of the Ellender Ferry Bridge's existing control system, electrical installation, and bridge structure to determine the design approach and installation efforts required.
- Development of mechanical and electrical design for the installation of the selected skew technologies on the Ellender Ferry Bridge.
- Installation of the skew systems, including a data transmission network and remote access to monitor and capture system data.
- Calibration and testing of the installation, including providing support and troubleshooting following installation.
- Analysis of the test results to determine the effectiveness of the skew technologies.
- Selection of a preferred system and additional recommendations as an aid in the design of future systems.
- Production of a report summarizing Phase 2 results.

## **Methodology**

The goal of Phase 2 of this study was to develop implementation documents and evaluate recommended alternative systems based on the findings of Phase 1, ultimately providing DOTD with a reliable alternative to the department's existing skew monitoring systems.

The selected technologies must meet DOTD criteria and be readily applicable for use as part of movable bridge design and replacement projects in the future.

The bridge selected by DOTD for the application of new skew technology was the Ellender Ferry Vertical Lift Bridge, a tower drive vertical lift bridge located over the Intracoastal Waterway in Calcasieu Parish, Louisiana.

## **Understanding**

The methodology was based on an understanding of the need to monitor, detect, and control tower drive vertical lift span skew. It was essential that the evaluation include a review of how selected technologies would function, be monitored, and be applied to control the bridge operating system.

The study was initiated because the historical method of skew monitoring and control, known as the differential Selsyn system, is obsolete and no longer widely available. This has created a vulnerability in the reliability and operational maintainability of DOTD's tower drive vertical lift bridges.

As a replacement for this historical system, several alternative means for skew monitoring and control have been successfully deployed at many bridges throughout the country. These alternatives have primarily involved the use of control systems that utilize programmable logic controllers (PLCs). However, these PLC based systems conflict with DOTD's preference for control systems with reliable, relay-based low technology systems.

This study's objective was to recommend and apply an accurate and reliable alternative form of skew monitoring and control that satisfies the DOTD requirement to utilize a low technology system with readily available replacement parts requiring limited maintenance.



## **Alternative Systems Considered**

Alternative forms of skew monitoring and control were identified for further evaluation in Phase 1 of the study. Direct lift span skew indication is based on the physical measurements of lift span elevation relative to the piers, towers, or physical measurements of lift span tilt. Indirect lift span skew indication is based on rotational measurements of the drive machinery in each tower. This study included both types of devices, including indirect skew measurement through encoders and direct skew measurement through lasers and inclinometers. The means of data collection and forms of communication were also evaluated.

## **Approach**

Based on information and analysis from Phase 1, as well as the developed criteria, a pilot program was introduced to assess the selected skew monitoring systems. The program included the design, procurement, installation, testing, and evaluation of the selected systems on the Ellender Ferry Bridge. This approach allowed the selected technologies to be evaluated against the developed criteria under real operating conditions.

## **Design and Installation**

The initial design of the systems to be deployed on the Ellender Ferry Bridge was based on a review of the existing bridge systems, including a review of provided drawings and field inspection. WJE personnel were on site on 7/3/22 to review existing conditions and determine the final scope of the design documents.

The completed design documents are provided in Appendix A. Two subcontractors were engaged for procurement, systems design, and field installation. Panatrol Automation and Controls (Panatrol) oversaw the procurement of key components and system network design, while field installation of the equipment was performed by the Walter J. Barnes Electric Co., Inc. (WJBE).

The selected devices and design were based on the Phase 1 report, WJE's experience on other lift bridges, and the following design criteria:

- Adjustable longitudinal skew between 1 and 5 feet, measured at each end of the movable span. The skew measurement must be repeatable within +/- 6 inches.

- Components were utilized that have a history of reliable service in similar applications.
- Systems and technologies were selected to operate using conventional 120V and were designed to be resistant to power surges and lightning strikes.
- Systems were selected that can be easily maintained and adjusted by maintenance personnel without advanced electronic control or instrumentation knowledge and experience.
- All of the components utilized consisted of heavy-duty construction and were rated for severe or marine duty applications, as applicable.
- All of the system components selected were readily available within two weeks and could be obtained from multiple manufacturers.
- Not all components were mounted in areas protected from the weather (i.e., bridge towers and lift span). These exposed components required enclosures that are corrosion resistant and rated IP66 or better for such environmental conditions.

### **Selected Skew Measurement Devices**

Two different forms of measurement are employed to provide skew indication: direct and indirect. Direct skew indication is based on the physical measurements of the lift span elevation relative to the piers, towers, or physical measurements of lift span tilt. Indirect lift span skew indication is based on the rotational measurements of the drive machinery in each tower. Both approaches were evaluated in this study; the evaluated devices are summarized below.

**Encoders.** Encoders provide an indirect form of skew measurement. An encoder is a sensor that converts rotational motion into digital electrical pulses. Absolute encoders were selected, as recommended in the Phase 1 report. Two absolute encoders were used to provide a measurement of the absolute angular position difference of the counterweight sheave trunnion shafts in both towers, thereby providing an indirect measurement of longitudinal skew.

Encoders manufactured by Avtron (Model: AV6A) were selected due to the manufacturer's global reputation, as well as WJE's and Paratrol's personal experience with them. The selected encoders were required to meet the accuracy, resolution, and environmental standards established in the design criteria detailed above.

The encoders installed at the Ellender Ferry Bridge utilized existing sheave trunnion stub shaft extensions that extended past the inboard trunnion bearing housings. The encoders

were installed at the northwest and southwest sheave trunnions. Both installations included a cover to protect the components from environmental elements; see Figures 2 and 3.

**Figure 2. Northwest absolute encoder installation**



(a) Encoder installation at NW sheave trunnion

(b) Close up of encoder at NW sheave trunnion

**Figure 3. Southwest encoder final installation with cover**



The encoders featured a native network connection utilizing TCP/Modbus wired and wireless communication protocol and SMART relays for data conversion, transmission, and computation. The south encoder data was transmitted to the south tower SMART relay and converted from rotational angular position to bridge height in feet, then re-transmitted to the main SMART relay in the operator’s house via wireless and wired communications. The north encoder data was transmitted directly to the main SMART relay in the operator’s house via Ethernet cabling and converted from rotational angular position to bridge height in feet. The main SMART relay then provided a differential measurement of bridge height

from each encoder as a measure of the bridge moving span longitudinal skew for indication, monitoring, and control.

The installed encoder model, its specifications, and critical installation and calibration details are summarized in Table 1. A cut sheet for the provided encoders is included in Appendix B.

**Table 1. Encoder specifications, installation, and calibration details**

Item	Description / Value
Manufacturer	Avtron
Model	AV6A
Output	Network- TCP/Modbus
Counters per turn	4096 (12 bits)
Max turns	4096 (12 bits)
Pulses per revolution (PPR)	8192 (13 bits)
Shaft size	10 mm
Sheave diameter (rope pitch)	10.5 ft.
Resolution (device)	$360^\circ/8192 = 0.0439^\circ$
Resolution (bridge height)	0.047 in. (calculated)

**Lasers.** Lasers provide direct skew measurement. Four laser distance sensors were used to provide measurements of the position of the lift span relative to the towers, and utilizing the differential between these measurements, to provide a direct measurement of both longitudinal and transverse skew.

Laser distance measurement devices were not recommended after analyzing the results from Phase 1 due to their relatively high costs and limited track record in the movable bridge industry. However, because this phase was designed to evaluate potential skew replacement systems, lasers were selected to determine if they should be considered for skew control on tower-driven vertical lift bridges. With this goal in view, two laser models and manufacturers were selected.

Each sensor was mounted on an extension beam that was secured to the tower structure; see Figure 4. The lasers were directed downward to project the laser beams onto retro-reflective aluminum target plates mounted on top of the lift girders on the lift span.

**Figure 4. Excerpt from drawings showing laser with extension beam**

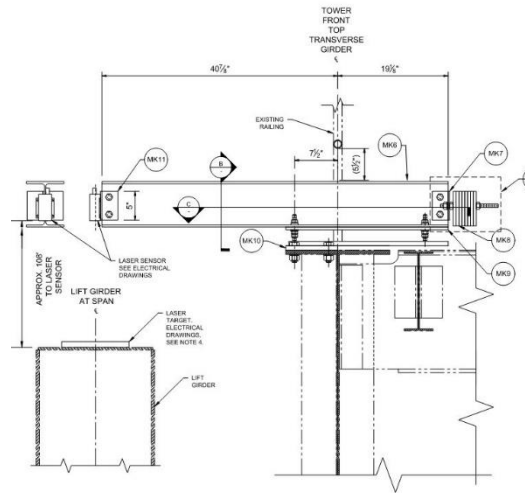

The lasers were procured with NEMA 4X enclosures to provide protection from the harsh environmental conditions to which they were exposed. Additional custom non-metallic enclosures were provided to reduce heat from sunlight exposure. To optimize performance, the lasers also included a dust tube to reduce any interference produced by sunlight and debris; see Figure 5.

**Figure 5. Laser installation photos at tower**



(a) View of NEMA 4X laser located within one of the non-metallic enclosures, prior to installation



(b) Final laser installation at NW location

The retro-reflective aluminum target plates installed at the lift span were designed by the manufacturer of the laser to provide a defined target for laser measurement. Their finish and color were selected to improve the reflected signal strength of the laser. The size of the

target plates (24 in. x 24 in.) was selected to ensure engagement of the laser beam with the target due to shifts from lift span movement and vibrations during operation; see Figure 6.

**Figure 6. Laser installation photos at lift span target**



(a) North lift span laser target plates



(b) Close up of NE lift span laser target plate

The initial laser device selected was the Dimetix Model DAE-10-50. These lasers were installed at all four corners of the lift span. The south tower lasers were directly connected to the south tower SMART relay. The south tower SMART relay converted the analog outputs from the south tower lasers and transmitted digital lift height data to the operator's house main SMART relay via wireless and wired communication methods. The north tower lasers utilized a SMART rail I/O module to convert the analog outputs from the north tower lasers and transmit digital lift height data to the operator's house main SMART relay. The main SMART relay in the operator's house compared the laser height data input and provided a differential measurement of the lift span height of each laser set (i.e., the north and south sides of the lift span). This provided a measure of skew that could be used for skew indication. However, during the initial testing, it was determined that the selected lasers did not provide reliable and accurate data for skew measurement.

Following an investigation into alternative lasers, two new lasers (Acuity Model AS2100) were procured and installed at the northeast and southwest corners of the lift span. The original lasers remained at the other two corners of the lift span but were not evaluated further. The results are discussed in detail later in this report.

The characteristics of both selected lasers are summarized in Tables 2 and 3. A cut sheet for each of the lasers are included in Appendix B.

**Table 2. Initial procured laser specifications and calibration details**

<b>Item</b>	<b>Description / Value</b>
Manufacturer	Dimetix
Model	DAE-10-50
Range	2 in. to 164 ft. (natural target), 131 ft. to 164 ft. (orange reflective foil)
Application accuracy	1.36 in. (calculation from distance / model accuracy)
Accuracy	0.039 in.
Repeatability	0.012 in.
Analog resolution	0.322 in. (calculation for 12-bit DAC)
Operating temperature	14°F to 140°F

**Table 3. Final procured laser specifications and calibration details**

<b>Item</b>	<b>Description / Value</b>
Manufacturer	Acuity
Model	AS2100
Range	20 in. to 1640 ft.
Application accuracy	1.36 in. (calculation from distance / model accuracy)
Accuracy	0.039 in.
Repeatability	0.012 in.
Analog resolution	0.322 in. (calculation for 12-bit DAC)
Operating temperature	14°F to 122°F

**Inclinometers.** Inclinometers provide a direct form of skew measurement. Two redundant inclinometers were installed on the lift span, with each one capable of providing a measurement of skew in both the longitudinal and transverse direction. The inclinometers were installed in a single enclosure located at the mid-span on the east side of the lift span. This enclosure was accessible from a catwalk that provides access to the bridge navigation lights; see Figure 7.

The inclinometers selected were the Rieker Model H6V. As with the encoders described above, these specified inclinometers have a proven track record within the movable bridge industry of providing reliable and accurate angular measurements.

The inclinometers were connected to a SMART relay in the inclinometer enclosure on the lift span. The SMART relay converted the inclinometer angular data to bridge skew in inches. The inclinometer data was transmitted wirelessly to the north tower via two omnidirectional antennae. The inclinometer skew data was re-transmitted from the north tower back to the main SMART relay in the operator’s house via network switches and cables.

**Figure 7. Inclinometers in a common enclosure**

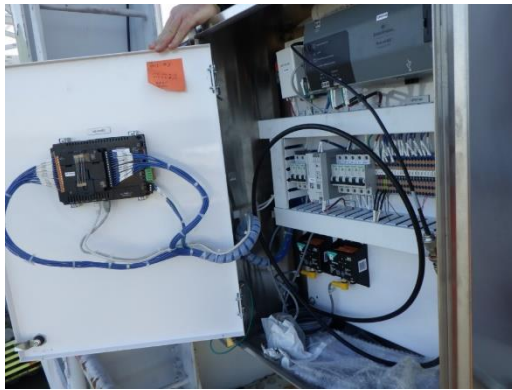

(a) View within inclinometer enclosure mid-span



(b) Close up of inclinometers

The specifications and calibration details of the installed inclinometer model are summarized in Table 4. A cut sheet for the selected inclinometers is included in Appendix B.

**Table 4. Inclinometer specifications and calibration details**

Item	Description / Value
Manufacturer	Rieker
Model	H6V
Output	4 - 20 mA
Accuracy (unit)	0.05°
Application accuracy	3.14 in. (calculation based on span length)
Resolution	< 0.005°



Item	Description / Value
Range setting	-1° to 1°

**Data Transmission Methods**

It is critical to provide an alternative to the differential Selsyn system of skew monitoring that can reliably communicate and accurately transmit data. As part of this evaluation, researchers investigated several communication alternatives that meet the criteria of simplicity, reliability, and transmission effectiveness. Additionally, the team selected communication methods that could be integrated into the existing Ellender Ferry Bridge control system.

Three different technologies were selected and tested: wireless, Single-Pair High-Speed Digital Subscriber Line (SHDSL), and Power Line Communication.

**Wireless Communications**

Wireless communications were selected because they do not require extensive cabling. Additionally, they are suitable for integrating digital data transfers in existing systems. However, wireless communications can be unstable and are significantly impacted by environmental RF (i.e., radio frequency) noise and shadowing. Two sets of wireless units were utilized and configured into the overall skew network to distribute data. One set established tower-to-tower wireless communication, and the other provided wireless communication between the lift span and the north tower.

**Tower-to-Tower Communications.** A pair of NanoBeam AC Gen 2 (Model: NBE-5AC-Gen2) units were installed for wireless communication between the two towers; see Figure 8. This wireless link was used to transmit the south tower laser and encoder data to the north tower. The NanoBeam unit directs RF energy in a tighter bandwidth than most other antennae. While a smaller bandwidth requires a more precise alignment, it improves noise immunity. Additionally, the NanoBeam features a multi-radio architecture that includes a dedicated radio and CPU to analyze the full 5GHz spectrum and provide RF analytics. This allows the end user to diagnose issues and auto-configures the units to block or spatially filter any RF noise encountered.

**Figure 8. Tower-to-tower antenna, north tower**



**Lift span to north tower communications.** A pair of wireless local area network (WLAN) access points (Model: FL WLAN 1011) and associated omni-directional antennae (Model: RAD-ISM-2459-ANT-FOOD-6-0-N) manufactured by Phoenix Contract were procured; see Figure 9. The wireless access points provided the communication path for the inclinometer data from the moving span to the north tower. The antennae selected were multiband with a gain of 8 dBi. Additionally, each antenna was equipped with an inline surge suppression device to mitigate damage caused by nearby lightning strikes.

**Figure 9. Span to north tower wireless installation**

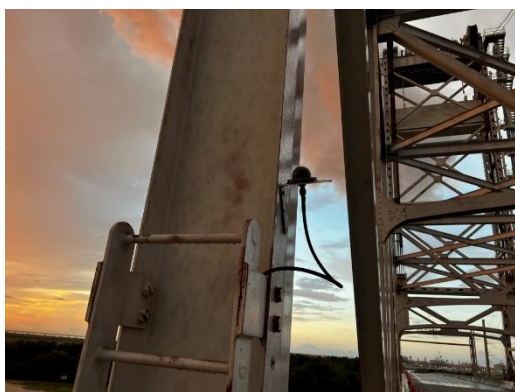

(a) Inclinometer wireless antenna located mid-span



(b) Inclinometer wireless antenna at north tower

## SHDSL Modem Units

SHDSL is a data communications technology that enables faster data transmission over copper twisted pairs and provides symmetrical transmit and receive data rates. This technology was selected since it provides adequate bandwidth for this application and can be integrated into existing systems with spare conductors.

The SHDSL units are Ethernet Extenders (Model: TC Extenders 2001 ETH-2S) manufactured by Phoenix Contact. A SHDSL modem unit was installed in each tower to transmit network data tower-to-tower via existing spare conductors in the bridge aerial cables; see Figure 10.

**Figure 10. Aerial cables**



## Power Line Communication

Power line communications carry data on a conductor that is used simultaneously for electric power distribution. This system was selected for further evaluation because it could be used with the existing bridge electrical distribution infrastructure where spare conductors were not available. The selected power line communication methods provide the bandwidth necessary for this application and have a simple installation process with minimal maintenance.

A pair of Netgear Powerline 1000 modules were installed to transmit inclinometer output data through a 120V power feed cable. An existing power feed cable, running from the operator's house to the lift span via a cable reel, was utilized for this purpose. Issues arose

during the installation process due to a cable reel failure; see the Testing and Commissioning of Systems section of the report for further details.

One power line communication module was installed inside the inclinometer enclosure located on the lift span, and the other module was installed in the main skew enclosure in the operator's house.

## **Communications Network**

The designed system network consisted of the integration of the multiple communication methods described above. It created a local area network (LAN) and wireless local area network (WLAN). The LAN/WLAN incorporated a secure link via the cellular system and the internet to enable remote access to the skew system for data capture and adjustment.

## **Communications Network Support Equipment**

**SMART Relays.** SMART relays were used to provide the intelligence to allow data collection, calculation, and analysis. These relays were HMI-based and manufactured by Horner. The total system included three installed units. The main 10-inch HMT unit (Model: HE-EXV1E0) was located in the operator's house skew enclosure; see Figure 11. The other two 7-inch HMT units (Model: HE-XW1E2) were located in the south tower skew enclosure and inclinometer skew enclosure, respectively. The HMIs were configured to display raw data, bridge skew, network health parameters, equipment and skew alarms/faults, and more. Not only were the HMIs beneficial for the operator, but also for electricians and engineers to troubleshoot any alarms/faults.

**SMART Rail I/O (Input/Output).** The system had two SMART Rail I/O units. The SMART Rail I/O modules were used as extensions to increase the I/O capacity of SMART relays as well as increase the distance of connectivity for south input devices. The SMART Rail I/O consisted of a base module and support for up to eight I/O extension modules.

A SMART Rail I/O unit was in the north tower skew enclosure and consisted of an Ethernet base module (Model: HE599ETX200) and an analog input extension module (Model: HE599ADC170). This I/O unit was used to transmit north laser data via a network switch to the main SMART relay in the skew enclosure in the operator's house; see Figure 12. The second SMART Rail I/O unit was in the operator's house skew enclosure and consisted of a CsCAN base module (Model: HE599CNX100) with a digital input module (Model: HE599DIQ512) and an analog input and output module (Model: HE599MIX116); see Figure 13. This I/O unit provided a data trigger input into the main SMART relay unit and allows for future expansion into the existing bridge control system for skew control.

**Figure 11. Operator’s main SMART relay HMI and skew enclosure**



**Figure 12. North tower skew enclosure**

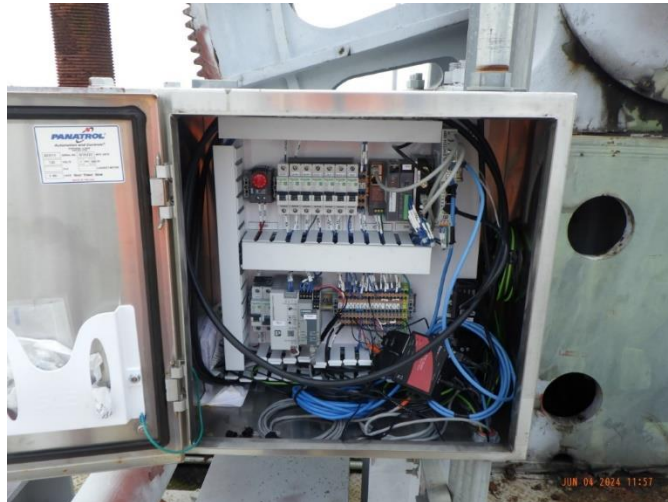

**Network Switches.** Network switches were used throughout the skew monitoring data communication network to expand the network and connect all devices. The operator’s house skew enclosure, north tower skew enclosure, and south tower skew enclosure all had a singular network switch. The switches were managed 8-port switches manufactured by Phoenix Contact.

**M-Guard.** M-Guard is a secure means of accessing the installed system from a remote location. The unit has a built-in VPN and can only be tunneled through with private credentials. Remote access was a key design feature that allowed for data capture, monitoring, and adjustments remotely from WJE’s office in Doylestown, PA, and the systems vendor’s office in Chicago. These units are commonly used in the movable bridge

industry. Further security can be provided by disconnecting the unit until needed and having maintenance staff reconnect it to allow for secure remote access.

**Remote Desktop and Hotspot.** A cellular hotspot device and a laptop were installed near the skew monitoring enclosure in the operator's house. The hotspot device was used for both M-Guard (Panatrol access) and Remote Desktop (WJE VPN access) for remote monitoring, device adjustments, and data acquisition.

**Figure 13. Operator's house skew enclosure**

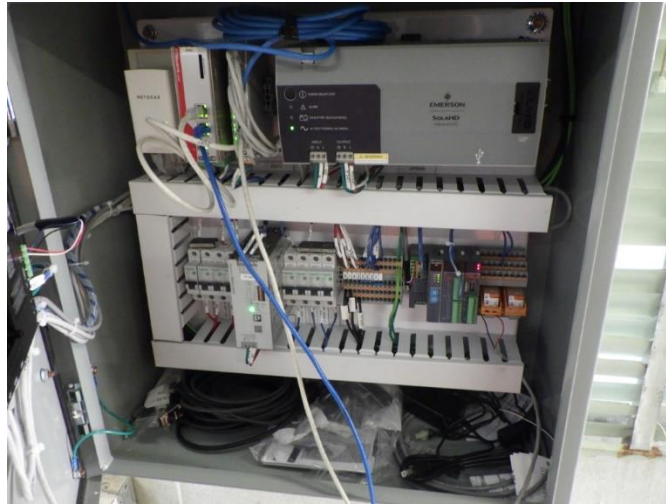

**Media Converters.** A pair of Ethernet-to-serial-media converters were installed, one in each tower skew enclosure, to interface with the lasers. The equipment was manufactured by Antaira (Model: Devolinx STE-520C). These units were selected because they allow two serial communications connections.

### **Power and Control Equipment**

**Uninterruptible Power Supply (UPS).** Two UPSs were installed to ensure that the skew system remained energized during a power outage. One UPS was located in the operator's house skew enclosure and provided backup power for all devices located in this enclosure, the north tower skew enclosure, and south tower skew enclosure. The other UPS was located in the inclinometer skew enclosure and provided backup power for all devices in that enclosure. Both UPSs were manufactured by Sola (Model: SDU850B).

**Circuit Breakers.** Square D circuit breakers were provided to protect each of the installed devices in each skew enclosure.

**Surge Suppressors.** Surge suppressors were provided to reduce the likelihood of damage from voltage surges and lightning strikes.

**Relays.** Relays were installed to interface with the existing control system. These relays were used to trigger the main SMART relay in the operator’s house and record skew data each time the bridge was in operation.

**Terminal Blocks.** Phoenix Contact terminal blocks were installed in each enclosure to organize field wiring and connect devices in accordance with Panatrol’s drawings.

**Cables/Conductors.** Existing bridge conductors, both active and spare, were incorporated into the skew system installation. Ethernet cables (CAT 6 unshielded, CAT 6 shielded, CAT 5 unshielded) and Belden cable (4 wire, shielded) were used for systems communications.

**Enclosures.** Four skew system enclosures were installed at the bridge. The main skew enclosure, a NEMA 4 rated enclosure, was in the operator’s house. This rating was selected to provide added protection; see Figure 11. The other three skew enclosures were located outdoors and thus exposed to harsh environmental conditions. These outdoor enclosures were stainless steel NEMA 4X rated enclosures; see Figures 7 and 12. All skew enclosures and associated panels were manufactured by Saginaw Control & Engineering and wired by Panatrol. In addition, a non-metallic enclosure was installed over the encoders and lasers to provide further environmental hardening.

## Software

Table 5 includes a summary of significant software used as part of the installation.

**Table 5. Summary of software used for installed skew monitoring system**

Name	Description
Distance Sensor Utility	Laser configuration software
Laser Terminal Program	Additional laser configuration software with terminal interface
Filezilla	Open-source FTP client and server; facilitates data collection and transfer to local PC
C-Scape	SMART relay (Horner) programming software
UIISP	Configuration, upgrade, and monitoring of tower-to-tower wireless system

Name	Description
Splashtop	PC remote access and control software utilized by WJE
Remote PC	PC remote access and control software utilized by Panatrol

### **Data Recording and Saving**

The main SMART relay utilized the communication network described above to collect data from all of the new skew devices and calculate and display it in real time. However, due to the memory limitations of the SMART relay device, data recording was limited and thus designed to record only during bridge operation. The skew data recording and data capture was triggered by a relay tied to the bridge control power “ON” switch located in the bridge control console. Recording stopped when the bridge control power switch was turned “OFF” following a bridge operating cycle. This ensured that all skew data was recorded and captured prior to bridge movement, during bridge operation, and for a short time following the completion of the bridge operating cycle. The outputs from the main SMART relay were saved in eight separate Comma-Separated-Values (CSV) files as follows:

1. Laser distance measurements from the southwest laser, converted from analog to digital format within the south tower SMART relay device and transmitted to the main SMART relay for data capture.
2. Laser distance measurements from the northeast laser, converted from analog to digital format by north tower SMART rail I/O unit and transmitted to the main SMART relay for data capture.
3. Bridge height measurement from the south encoder, calculated within the south SMART relay device and transmitted to the main SMART relay for data capture.
4. Bridge height measurement from the north encoder, calculated within the main SMART relay device.
5. Longitudinal skew measurements from one of the inclinometers located on the lift span, calculated within the lift span SMART relay device and transmitted to the main SMART relay for data capture.
6. Transverse skew measurements from one of the inclinometers located on the lift span, calculated within the lift span SMART relay device and transmitted to the main SMART relay for data capture.
7. Longitudinal skew based on the two lasers’ distance measurement, calculated within the main SMART relay device.



8. Longitudinal skew based on the two encoders' bridge height measurement, calculated within the main SMART relay device.

The captured data was stored on a removable 32GB micro-SD card, which was inserted into the main SMART relay device. The files were accessed through a software called FileZilla. FileZilla interfaced with the main SMART relay and facilitated file transfer between the SMART relay and the field laptop. Files could be accessed remotely by utilizing a remote PC access software such as Splashtop or Remote PC. Splashtop allows a user to run the FileZilla application remotely to extract data from the main SMART relay. Once data is downloaded to the field laptop, Splashtop can facilitate data transfer from the field laptop to the office laptop.

### **Testing and Commissioning of Systems**

WJE collaborated with the systems vendor and electrical subcontractor to complete the installation and test the installed systems. The data captured from each device was reviewed for signal quality and accuracy. Notes on the installation, including performance and installation challenges, are summarized below. Once installation challenges were addressed and accurate data was captured, the skew devices were calibrated. See Table 6 for a summary of site visits during Phase 2.

**Table 6. Summary of site visits**

<b>Dates</b>	<b>Event</b>	<b>Description</b>
07/13/22 – 07/15/22	Site Visit 1	WJE performed a scoping inspection to form the basis for a design package implementing the results from Phase 1 of the study.
12/06/23 – 12/08/23	Site Visit 2	WJE performed a visual inspection of the ongoing field installation.
01/09/24 – 01/12/24	Site Visit 3	WJE performed an inspection of the final field installation and attempted to calibrate all skew devices with Panatrol.
02/12/24 – 02/16/24	Office Testing	WJE performed a bench test of the new demo lasers and compared results with data collected from the originally installed lasers.
05/09/24 – 05/12/24	Site Visit 4	WJE and WJBE installed new lasers and targets. Additionally, both encoders were rewired. All skew devices were calibrated.

Dates	Event	Description
05/13/24 – 05/24/24	Remote Data Collection/Analysis	DOTD performed multiple bridge operations under varying environmental conditions. WJE remotely collected and analyzed all the data from all three skew systems.
06/03/24 – 06/04/24	Site Visit 5	WJE and DOTD personnel performed a walkthrough of the new skew system installation. WJE performed additional network tests to investigate the ongoing network faults.
07/09/24 – 07/12/24	Site Visit 6	WJE performed the installation of tower-to-tower wireless devices, and additional troubleshooting of network devices.

### **Laser Device Application**

**Laser Installation.** Alignment of the lasers with the lift span targets was a minor challenge. Due to visibility issues, nighttime work was required to align the units. Retro-reflective targets were added to increase reflected laser beam signal strength.

**Laser Device Issues.** The initial laser specified was the Dimetix model DAE-10-50 and was installed at all four tower laser locations. Measured output from these lasers was found to be unreliable and inaccurate during the initial testing phase (see Site Visit 3). As a result, poor quality data was noted through a significant portion of the bridge operation, and this data proved to be unusable; see Figure 14.

**Figure 14. Initial laser distance measurements (1/11/24)**

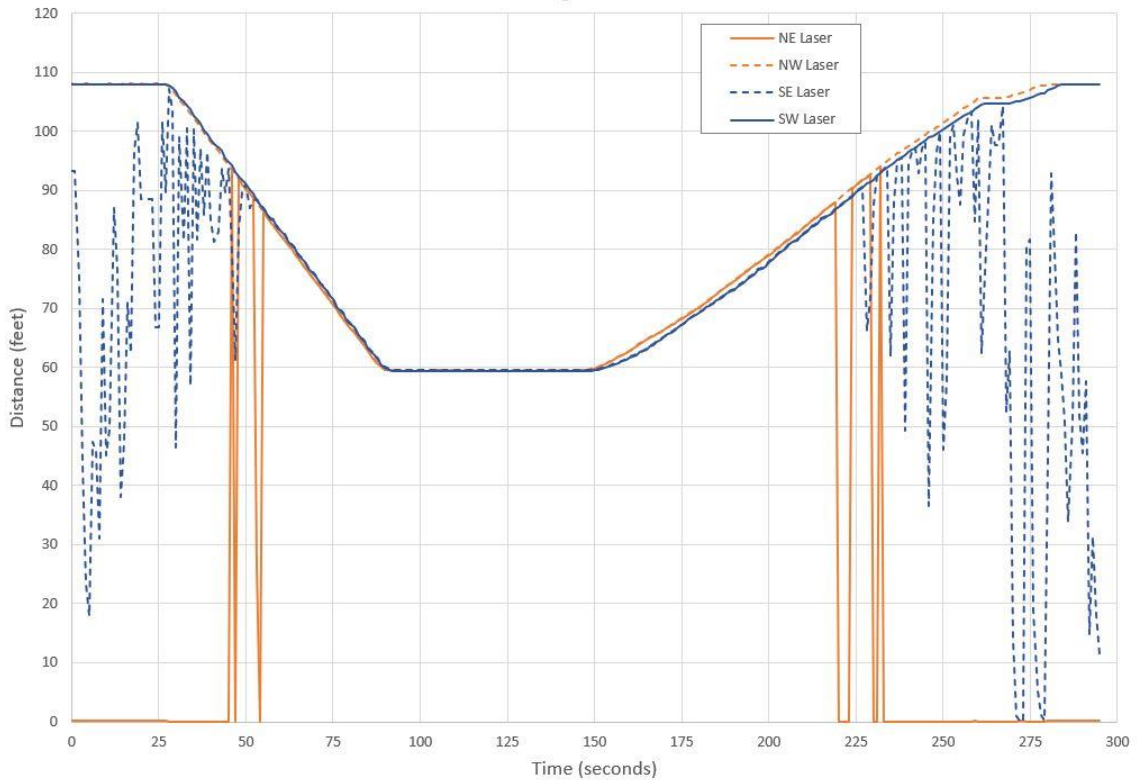

Following an investigation and further research, a replacement laser unit (Acuity Model AS2100) was identified. Given the issues with the initial laser, these replacement lasers, which had enhanced hardware specifications, were thoroughly reviewed in a laboratory setting prior to their installation at the bridge (see Office Testing). Once the lasers were vetted in the laboratory setting, they were installed at the northeast and southwest locations under WJE’s supervision (see Site Visit 4). The new lasers were incorporated into the recordings, while the remaining two original laser installations were discarded. A recording of the laser data following the replacement of the northeast and southwest lasers is shown in Figure 15. Note that inaccurate measurement issues continued at the northwest and southeast locations, where the original lasers remained active. These are indicated with orange arrows in the figure. Even with the change, data communication issues remained. Note the apparent inaccuracies indicated with blue arrows in Figure 15. The southwest laser data issue was determined to be due to a communications fault involving the SHDSL modules. This was corrected during Site Visit 6, as summarized in Table 6. The northeast laser data issue was determined to be related to the SMART rail I/O unit installed in the north tower skew enclosure. While extensive troubleshooting efforts took place during Site Visits 5 and 6, this issue was not corrected and remained apparent in the final data captured.

**Figure 15. Laser measurements following replacement at NE and SW corners of the lift span (5/9/24)**

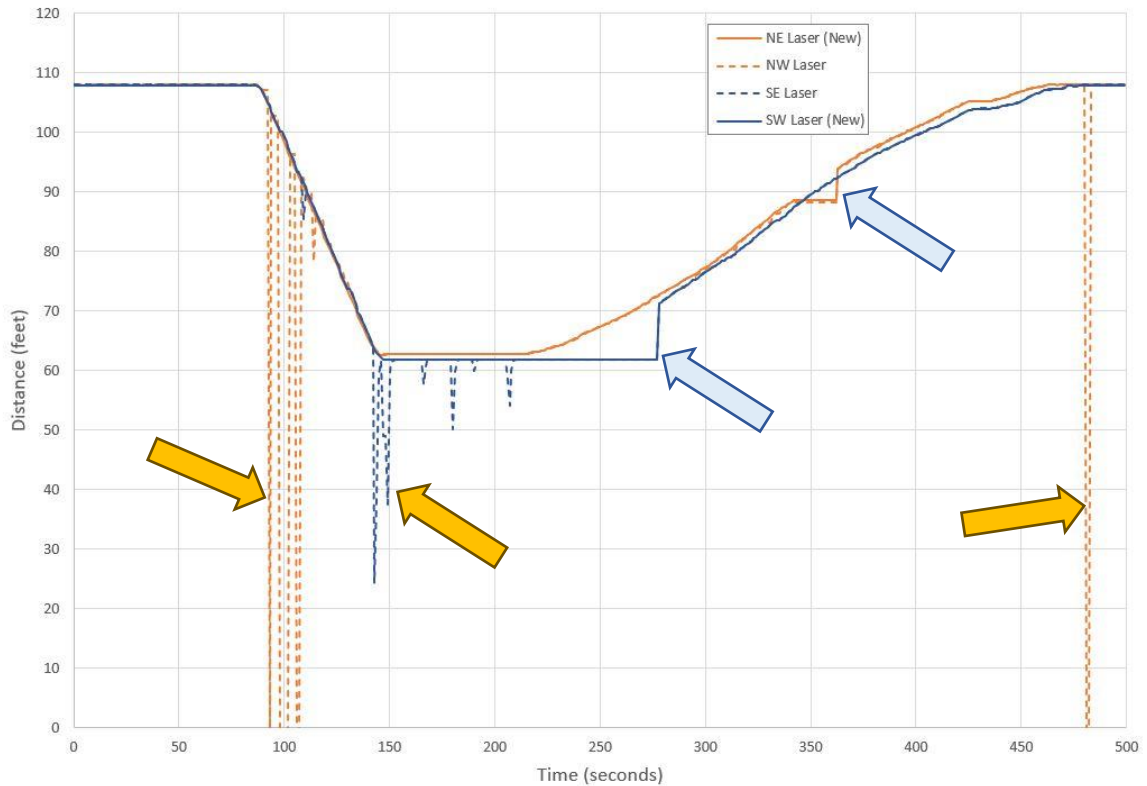

**Laser Field Installation Modifications.** The location of the laser installations, which was necessary to satisfy operating requirements, subjected them to harsh environmental exposure, including direct sunlight. While the laser assembly was protected by the NEMA 4X enclosure provided by the manufacturer, enhancements were made to their installation in close coordination with the device manufacturer. These enhancements included the installation of non-metallic enclosures to shield the lasers from sunlight, dust, and debris; this was done at all four laser locations. The enclosure was also updated to provide dust shield tubes that surround the output of the lasers; see Figure 5. These modifications took place during Site Visit 4.

**Laser Configuration Adjustments.** In the initial design, configuration adjustments required access to the lasers for a direct connection between the lasers and a laptop. These adjustments were cumbersome because they required pulling back the extension beams to which they were mounted, then realigning them following the desired changes; see Figure 16. To address this issue, the design was updated to add serial media converters in each tower that allowed remote interfacing with the lasers. The installation of these devices occurred during Site Visit 4.

**Figure 16. Typical laser beam extension installation**



**Laser Target Adjustments.** To improve laser signal capture, targets specifically designed by the manufacturer were installed. The targets were comprised of retro-reflective orange layers on top of the aluminum targets; see Figure 6.

### **Encoder Application**

**Encoder Installation Issues.** During preliminary testing of the encoder installation, it was found that the south tower encoder had failed and needed to be replaced (see Site Visit 3). The lead time for the replacement and ongoing deck replacement work caused a delay of approximately six weeks. The replacement occurred during Site Visit 4 and was performed by WJBE.

**Encoder Wiring Issues.** The original installation included a 4-wire shielded cable between the encoders and the tower skew enclosures. Data quality was improved by the replacement of these cables with Ethernet CAT 6 cables, using two of four twisted pairs unshielded. The replacement occurred during Site Visit 4 and was performed by WJBE.

### **Laser and Encoder Calibration**

Once all installation issues for lasers and encoders were addressed, the devices were calibrated to provide an accurate reading of the lift span's position. This involved zeroing the encoders while the bridge was seated and setting the laser distance range to improve resolution. After collecting and analyzing data, the outputs of the encoders and lasers were found to be within +/- 2 inches of each other throughout a bridge operation.

## **Inclinometer Application**

**Ease of Installation.** The installation and configuration of the inclinometers at mid-span was relatively simple. The cabinets were installed to set the inclinometers to an approximately level position in both their longitudinal and transverse directions.

**Inclinometer Calibration.** After installation, the inclinometers were calibrated or zeroed while the bridge was seated (see Site Visit 3). The inclinometer data captured during the testing was accurate and repeatable, providing a true picture of lift span skew.

## **General Installation Quality Issues**

During the installation and commissioning process, several data quality issues were investigated. In some cases, the quality of wiring splices, including Ethernet splices, and excessive lengths of communication cabling were determined to be contributors to poor quality transmitted data. These installation deficiencies were corrected to the extent possible during the installation and commissioning process (see Site Visits 3 and 4).

## **Signal Transmission by SHDSL Modules through the Aerial Cables**

Signal transmission from the south tower to the north tower through the aerial cables proved unsuccessful. The design utilized unshielded and untwisted spare conductors in the existing aerial cables. These signal transmission issues were not unexpected and were attributed to electro-magnetic interference (EMI). EMI is often an issue when transmitting control signals through unshielded and untwisted conductors. Adjacent power conductors can also significantly increase EMI on control signals, as seen in the aerial cables. Due to the unsuccessful south tower encoder data transmission through the aerial cables, a wireless system was installed to provide the required networking link between each tower (see Site Visit 6). Although transmission through the aerial cables was not successful, this remains a viable alternative for new installations as appropriate shielded, twist-pair conductors or fiber optic cables can be used in the application.

## **Signal Transmission by Wireless Communication (Tower-to-Tower)**

Due to the unsuccessful south tower encoder data transmission through the aerial cables, a wireless system was installed, using a directional antenna on each tower. The antennae were aligned during the installation and configured for point-to-point transmission using the configuration application to create a dedicated signal link. This installation took place during Site Visit 6.

### **Signal Transmission by Wireless Communication (Tower-to-Span)**

Per the design, the inclinometer data was transmitted through a wireless network. Each wireless antenna produced a radiation pattern through which the signal propagates spatially. It is common for radiation patterns to include dead spots where the signal is low. Additionally, physical structures such as truss members can interfere with wireless signals by creating dead spots. The installation consisted of two omni-directional antennae, with one mounted on the lift span and the other mounted at a higher elevation on top of the north tower. During the initial installation, the wireless connection was made when the bridge was seated, but connection was lost during bridge operation. It is likely that the antenna on the lift span encountered dead spots during span movement, which caused loss in data transmission. The lift span antenna was repositioned to successfully resolve this issue during Site Visit 6; see Figure 9 for a picture of the final antenna mounting. Although the use of the omni-directional antennae proved successful, it was still considered deficient due to the dead spots and inconsistent transmission results. On reflection and analysis of the captured data, directional antennae may prove to be more suitable for this application. Phoenix Contact manufactures directional antennae with less gain but larger beam widths. This application requires antennae with large beam elevation angles since each antenna is placed at different heights during bridge operation. Future consideration should be given to replacing the omni-directional antennae with directional antennae.

### **Signal Transmission by Power Line through Cable Reel**

Per the design, the inclinometer data was also transmitted using Power Line Communication over the navigation light feeder conductors, which traveled through a bridge cable reel. Initial attempts at achieving communication through the Power Line Communication scheme were unsuccessful, and it was considered possible that the poor condition of the cable reel was a factor (see Site Visit 3). The installation was reviewed again by others following the replacement of the cable reel; see Figure 17. Communication through the cable reel remained unsuccessful even after the new cable reel installation (see Site Visit 5). It is unclear if the issue was due to interference with other devices, the length of the cables, or something else.

**Figure 17. Cable reel used in attempted Power Line Communication**



### **SMART Relay Sampling Rate and Network Limitations**

**Data Sampling Rate.** The Horner HMI-based SMART relays were a key element in the installed skew system because they provided for the collection and analysis of the data and were able to be integrated into a relay-based movable bridge control system. After an extensive review of the data provided by the unit, and multiple attempts at reconfiguring the system, it became apparent that the effective recording frequency of the system is limited to 1 to 10 Hz, depending on the device location. This sampling and capture rate was lower than desired for a data acquisition application on the Ellender Ferry Bridge operating at a conventional speed. It was determined that the total scan rate (i.e., SMART relay + network scan rate) should be approximately 100 Hz to provide the desired results.

**Data Logging Issues from Network Faults.** Additionally, multiple network faults were noted during bridge operation, caused by data transmission failures. When this occurred, the last recorded value was stored for the duration of the fault. These areas of the recordings are indicated by a flatline on the charts. The blue arrows in Figure 15 provide examples of this type of failure in recordings of the raw data for the lasers. Following these faults, the real-time measured data returned and was logged. This change is indicated by large spikes on the charts of the recorded data; see Figures 18 through 30.

The limited recording frequency and the network faults seen in this application do not preclude the use of a similar arrangement in a full application with the appropriate modifications. For this application, the installed system was adequate to analyze the performance of the selected skew devices against the evaluation criteria. In the recordings included in this report, the impact is most apparent during higher speed operation (i.e.,



opening) of the movable span and with calculated skew results in which two different devices are compared (i.e., laser and encoder skew calculations).

## **Evaluation Criteria**

Evaluation criteria were established to provide a true assessment of each system and sub-system against a common base. The developed criteria included all elements required to provide a fully functional system. The criteria included:

1. **System and System Component Availability:** Availability of the proposed system and components. Manufactured in North America and available from several manufacturers.
2. **System Simplicity:** Effect of the number of component parts, system reliability, time-to-repair, and expertise required to repair.
3. **Setup and Calibration:** Degree of difficulty and special requirements setting up and calibrating the systems.
4. **Maintainability:** Amount and frequency of maintenance required for the systems.
5. **System Accuracy and Repeatability:** Accuracy of the system to monitor skew over the complete operating cycle of the bridge.
6. **System Drift:** Ability of the system to maintain its accuracy following multiple bridge operations, including the effect of rope slippage.
7. **Environmental Resilience:** Ability of the system to perform under varying environmental conditions such as sunlight, temperature, and humidity.
8. **Degree of Electromagnetic Interference (EMI) Immunity:** System susceptibility and effects of EMI generated by external sources.
9. **Cost:** Total costs associated with procuring and installing all equipment associated with each system.

## Discussion of Results

The goal of the testing in this phase of the study was to assess the performance of each of the selected alternatives. To ensure that accurate and comparable results were obtained for analysis, the testing was set up to simultaneously capture data from each of selected systems during the operation of the bridge.

Despite some remaining sampling and quality issues, the data captured was of sufficient quality to provide an evaluation following the testing and commissioning process. The system and devices were evaluated based on skew data captured via the main SMART relay for multiple bridge operations. Results are provided in Figures 18 through 30.

In these charts, the output of the inclinometer after calibration provided a direct measurement of skew. The laser skew measurements provided are the northeast laser measurement minus the southwest laser measurement. Similarly, the encoder skew measurements are based on the calculated bridge travel determined by sheave trunnion rotation at the north installation minus the calculated travel at the south installation. For all calculations, a positive value was shown if the south side of the lift span was higher than the north side.

Figure 18 depicts all skew data recorded by the main SMART relay during a typical full bridge operation. The report presents four operations, each of which exhibited very similar bridge operating characteristics. Each bridge operation can be divided into three separate phases: opening, holding when open, and closing. These phases are depicted on all full cycle bridge operation figures (see Figures 18, 22, 25, and 28) with text and arrows. Additionally, bridge height (i.e., near encoder data) is graphed using a red line to emphasize lift span speed and skew results in relation to bridge position. The three phases during a bridge operation are summarized below.

**Opening Phase.** During this phase, the motors were energized, and the lift span was quickly raised to an open position. The lift span moved at approximately 8 inches per second during this phase.

**Holding at Open.** During this phase, the lift span was held open to allow the marine vessel to pass. The lift span was held open with brakes and did not move at this time. Additionally, the full open position varied between each bridge operation because the operators did not rely on a full open indication. Bridge operators have a general bridge height target, which provides the required amount of clearance necessary for the vessels operating in the channel.

**Closing Phase.** During this phase, the bridge was drifted down. As a result, the lift span moved at varying speeds, with an average speed of less than 1 inch per second. As the lift span approached the seated position, the bridge operator significantly reduced the speed and controlled the lift span by feathering the drive motor brakes. This was done to seat the lift span in a controlled manner and prevent structural impact when seating.

The unique and unsymmetrical bridge operating characteristics were significant in stress-testing the three skew systems under varying operating conditions. The results captured from the three skew systems under these varying operating conditions are discussed below.

**Figure 18. Final skew data, full cycle (7/28/24)**

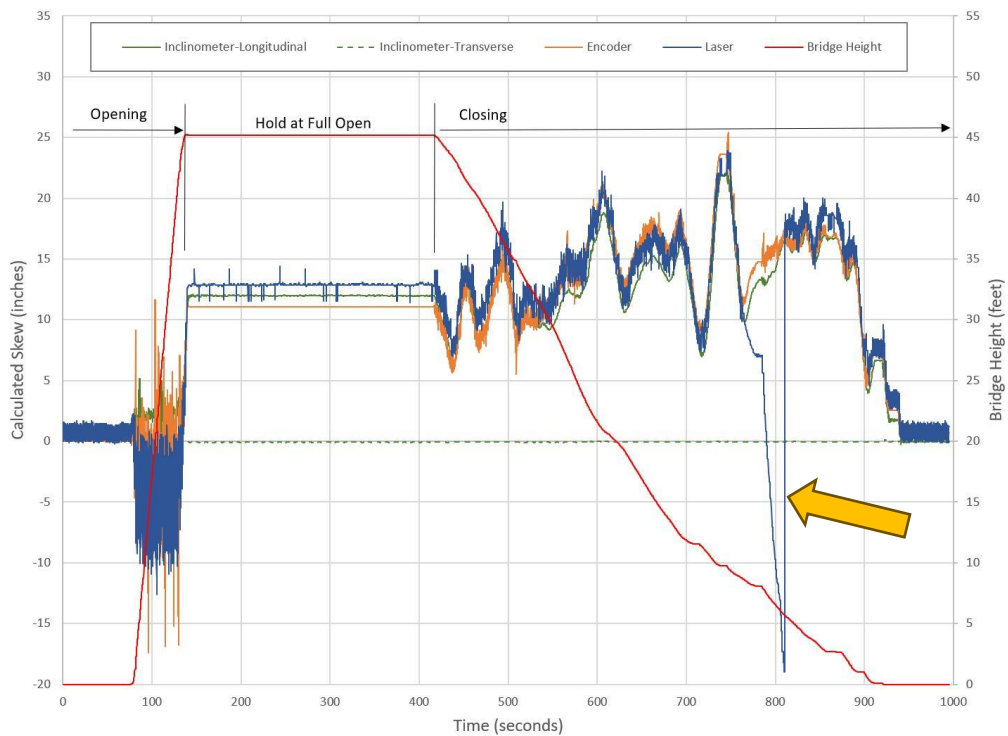

**Figure 18 Commentary**

The lift span opening time was much less than the closing time. This is due to the way the bridge was operated; it was powered to raise the lift span but unpowered when closing, allowing the span to drift down. The lift span was controlled during closing by feathering the drive motor brakes. Drifting was instituted to reduce or eliminate excessive skew when closing the bridge. The skew characteristics when closing the lift span demonstrate the uncontrolled nature of this operating procedure.

Note the spike in laser skew during the closing cycle, indicated by the arrow. This was caused by a communication fault with the north tower SMART rail I/O, as discussed above in the laser device application section. The north laser signal loss caused an error in the calculated skew. This shortcoming was not resolved and remained evident throughout the final testing.

The transverse skew, as measured by the inclinometer, was stable. This was consistent across all runs.

During the opening cycle, the recorded data was extremely crowded and thus deemed unusable in its present form. For a clearer picture, as well as an explanation for the crowded nature of the bridge opening portion of the chart, see Figure 19 and its commentary.

**Figure 19. Final skew data, opening cycle (7/28/24)**

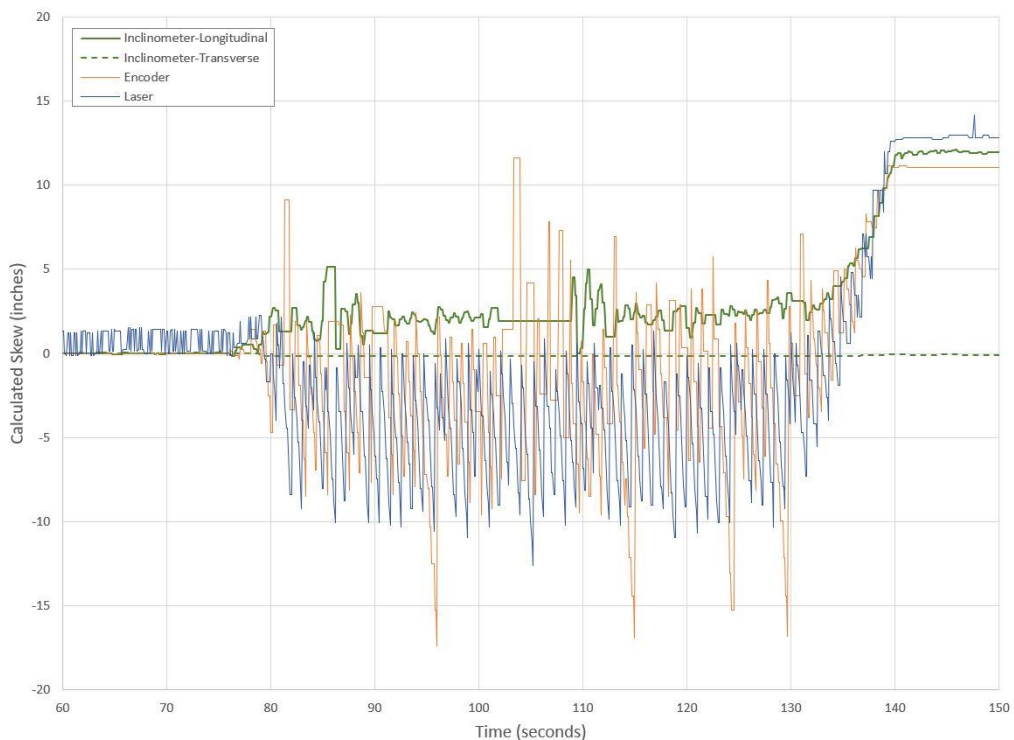

### Figure 19 Commentary

To clearly see the recorded data over the bridge opening cycle, the time scale has been expanded to indicate the results from all three alternative skew systems.

The inclinometer appeared to provide a relatively stable indication of longitudinal skew during the opening cycle, while skew data from both the encoders and lasers appeared as unstable high amplitude oscillatory recordings that were unusable as a measure of lift span skew. Based on a close review of the skew data in the bridge opening portion of the recording, it is apparent that the data quality is suspect. This is attributed to the system sampling frequency, which is now considered inadequate for a detailed analysis of skew at these lift span speeds. The issue is apparent in the laser and encoder skew calculations, as these require comparisons and calculations to be performed between two devices. The limitation in sampling frequency appears to be due to a combination of limitations of the SMART relay units to capture, process, and re-transmit data, as well as other network elements acting as a buffer. This deficiency is considered a flaw in the configured use of the selected SMART relay as part of a recommended differential Selsyn system replacement.

It is apparent that the skew increased significantly, to approximately 12 inches, near the full open position. Bridge operators for the Ellender Ferry Bridge manually stopped the bridge before reaching the intended full open position. Since this bridge was manually operated via drum controllers, a slight difference in time shifting the drum controller handles back to “OFF” would result in each end of the lift in a different position, i.e. longitudinal skew.

At the full open position, the longitudinal skew from the inclinometer, encoder, and laser stabilize all within 2 inches of each other. This is demonstrated on the right side of Figure 19 and in Figure 18 when it is held at the full open position. While skew data during the opening phase for the lasers and encoders were severely impacted due to the system sampling rate, this was not an issue when the span was stationary. The system sampling rate induced an error which is relative to the speed of the lift span. As a result, the induced error was removed as the lift span came to a stop, which is seen by the stability of the recordings at stopped positions; see Figures 18 and 19.

**Figure 20. Final skew data, closing cycle (7/28/24)**

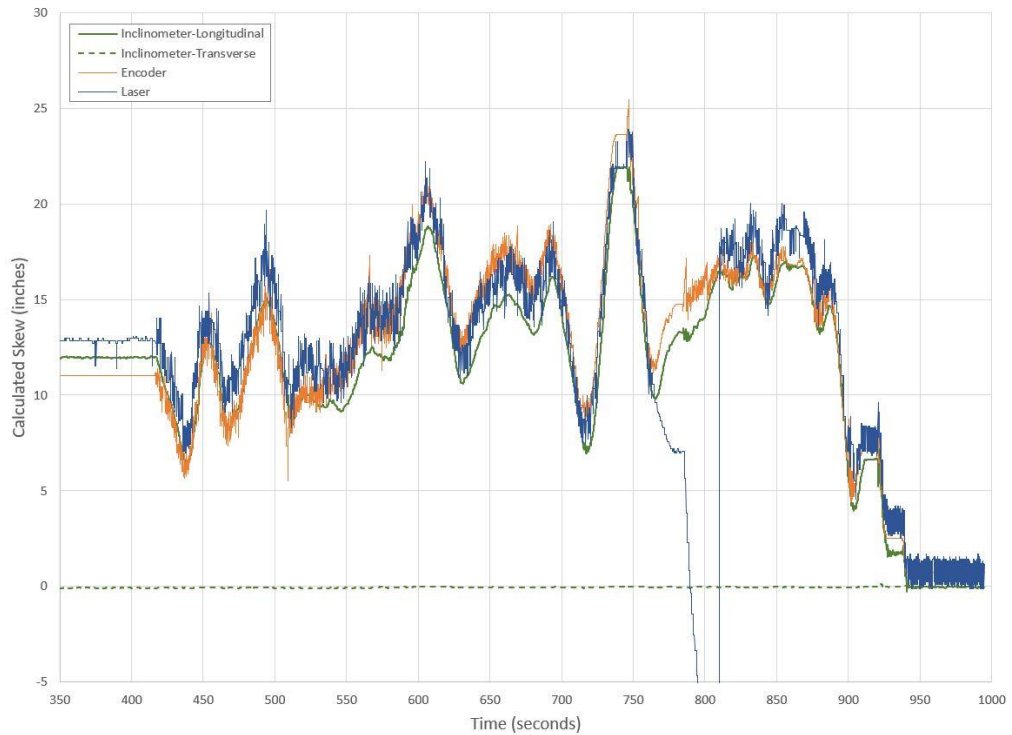

**Figure 20 Commentary**

At full open, the difference in calculated longitudinal skew from the different measurements was within 2 inches. Apart from the lost laser signal, this overall approximate range remained consistent through the closing cycle, though with minor changes in relative readings, which were considered insignificant.

**Figure 21. Final skew data, seating (7/28/24)**

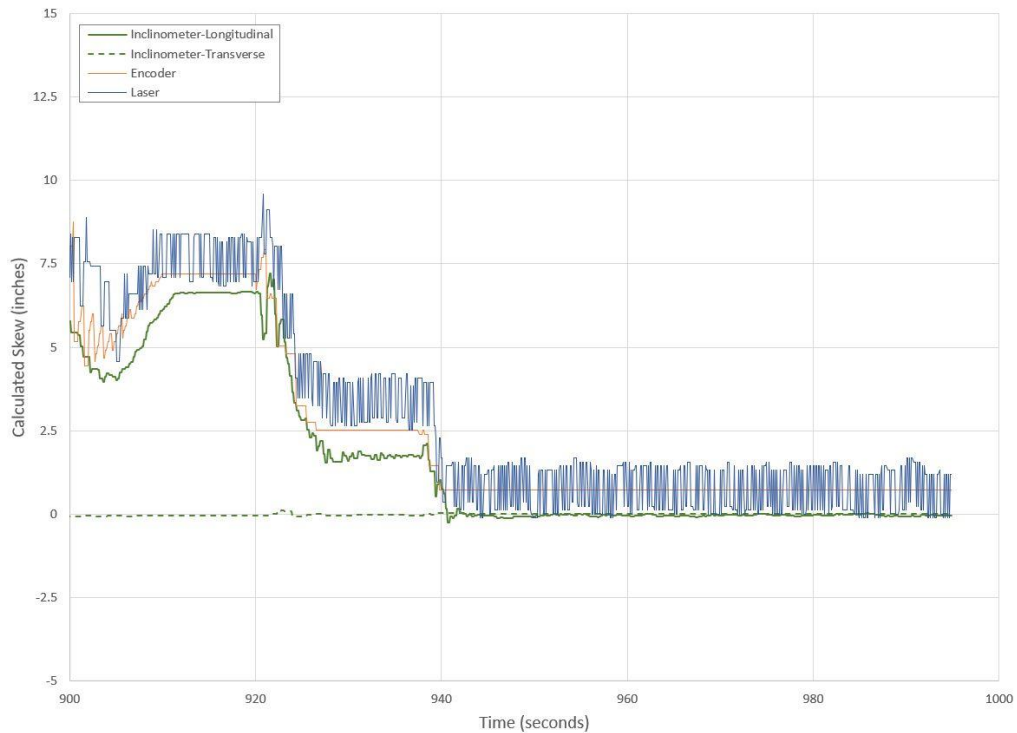

**Figure 21 Commentary**

The inclinometer skew signal returned to zero, while both the laser and encoder measurements ended up near 1 inch, indicating that the south end was estimated to be higher than the north end by approximately 1 inch. Possible contributors to the issue were seating differences (i.e., the bridge was not positively seated by the motors), counterweight rope slippage at the counterweight sheaves, or changes to the laser target alignment due to the movement of the lift span in the guide systems. These are not significant issues and would not impede the full integration of a skew control system. Additionally, it should be noted that in the conventional control system design of a tower drive vertical lift bridge, skew control is normally disabled to seat the bridge.

**Figure 22. Final skew data, full cycle (7/29/24)**

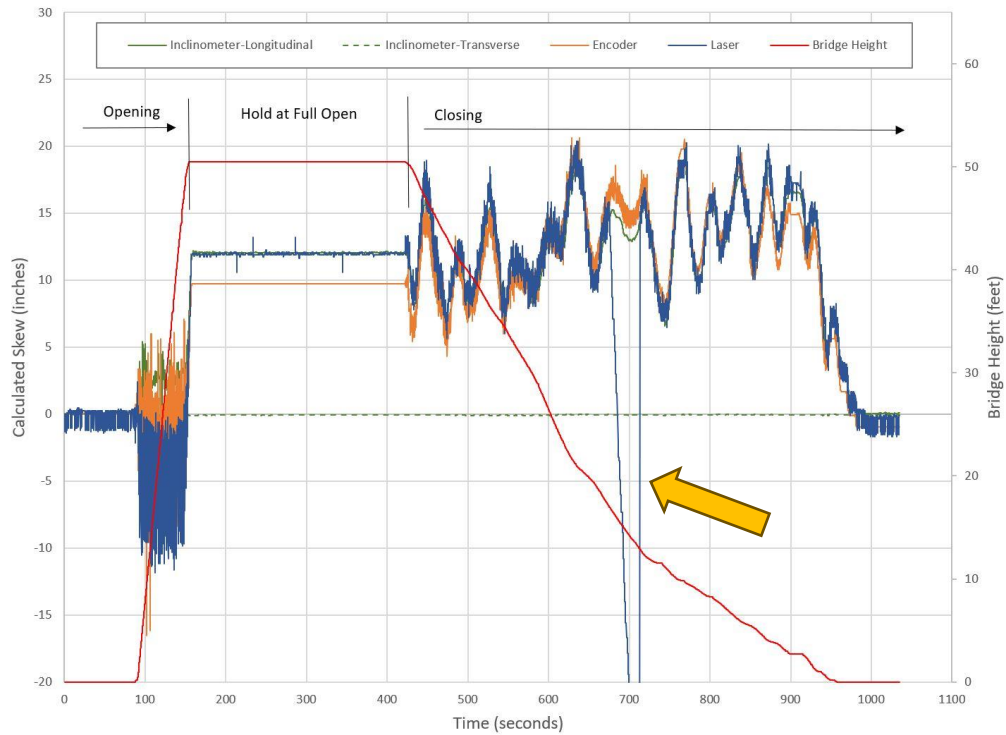
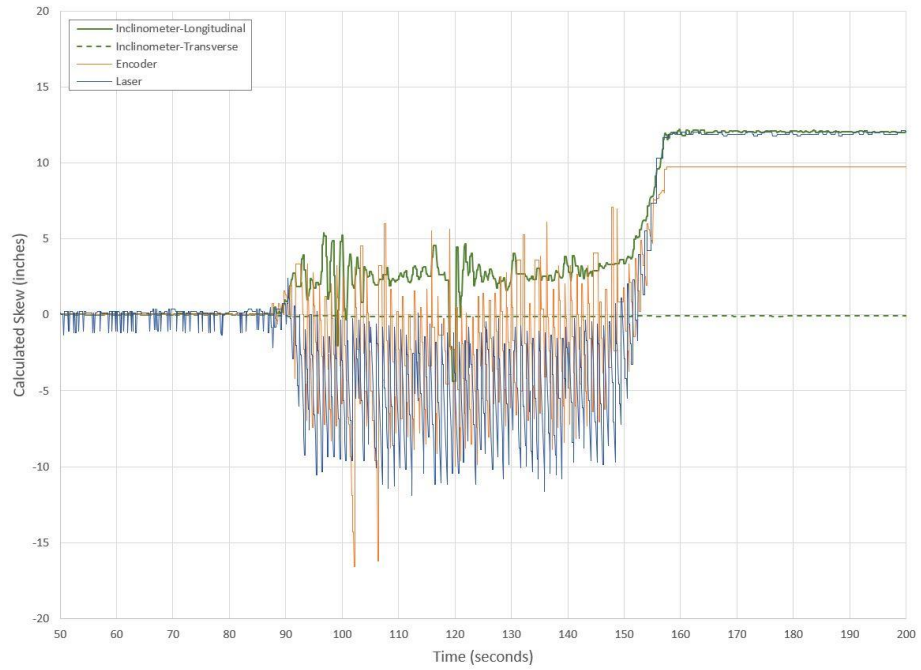

**Figure 22 Commentary**

The characteristics of this recording are similar to the 7/28/24 recording presented in the preceding figures. Note again an error in the laser skew calculation, indicated by the arrow.



**Figure 23. Final skew data, opening cycle (7/29/24)**



**Figure 24. Final skew data, closing cycle (7/29/24)**

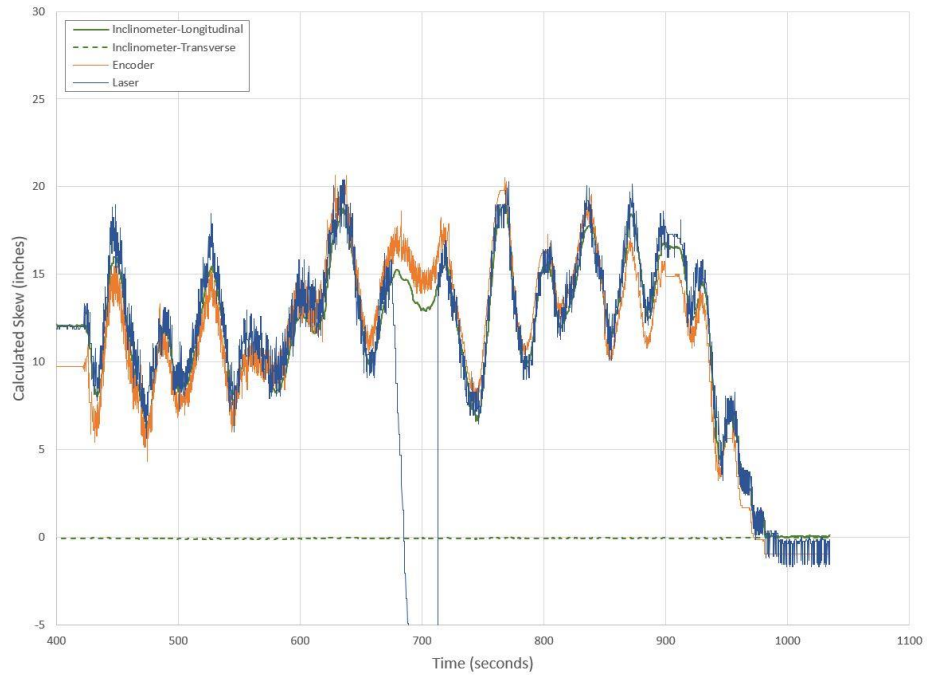

## Figures 23 and 24 Commentary

The characteristics of the recordings are consistent with the 7/28/24 recording, including an issue with the data quality at the lasers.

Figure 25. Final skew data, full cycle (8/3/24)

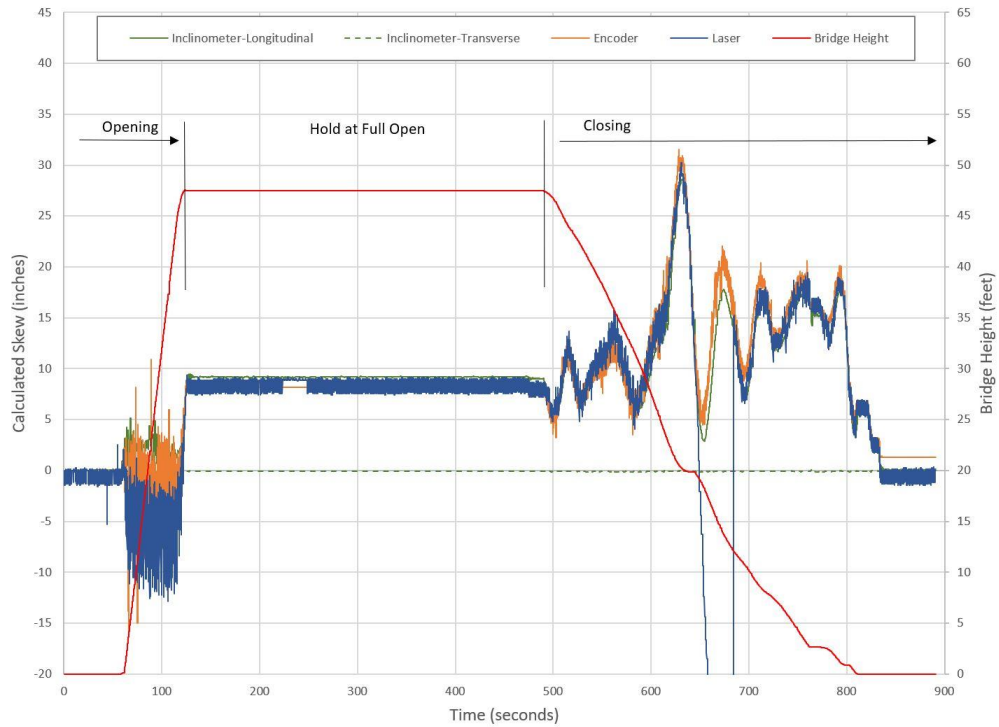

## Figure 25 Commentary

The 8/3/24 run included many of the same characteristics of the previous runs, though it is notable that the calculated skew when closing the bridge was almost 50% greater than that of previous runs.

**Figure 26. Final skew data, opening cycle (8/3/24)**

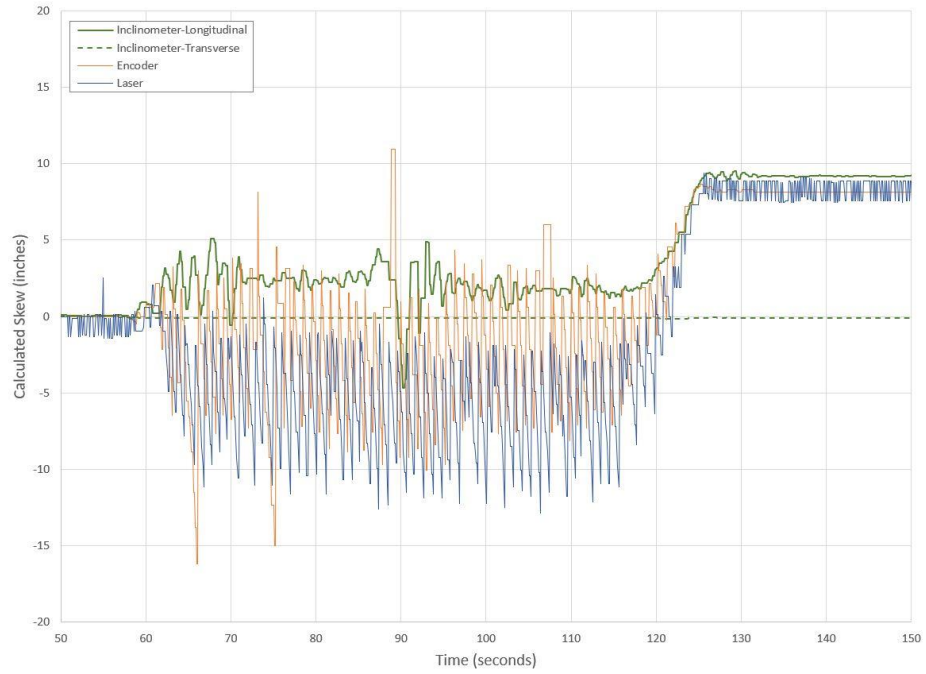

**Figure 27. Final skew data, closing cycle (8/3/24)**

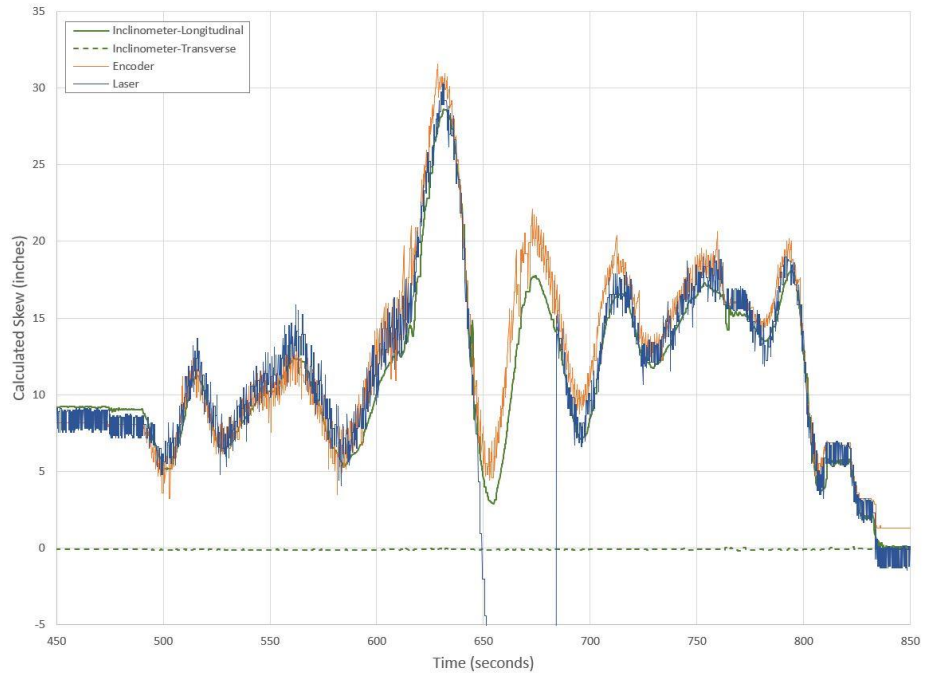

## Figures 26 and 27 Commentary

The duration of the closing cycle was significantly less than some of the other runs, reflecting the variability in the manual, drift down form of the lift span lowering operation.

Figure 28. Final skew data, full cycle (8/4/24)

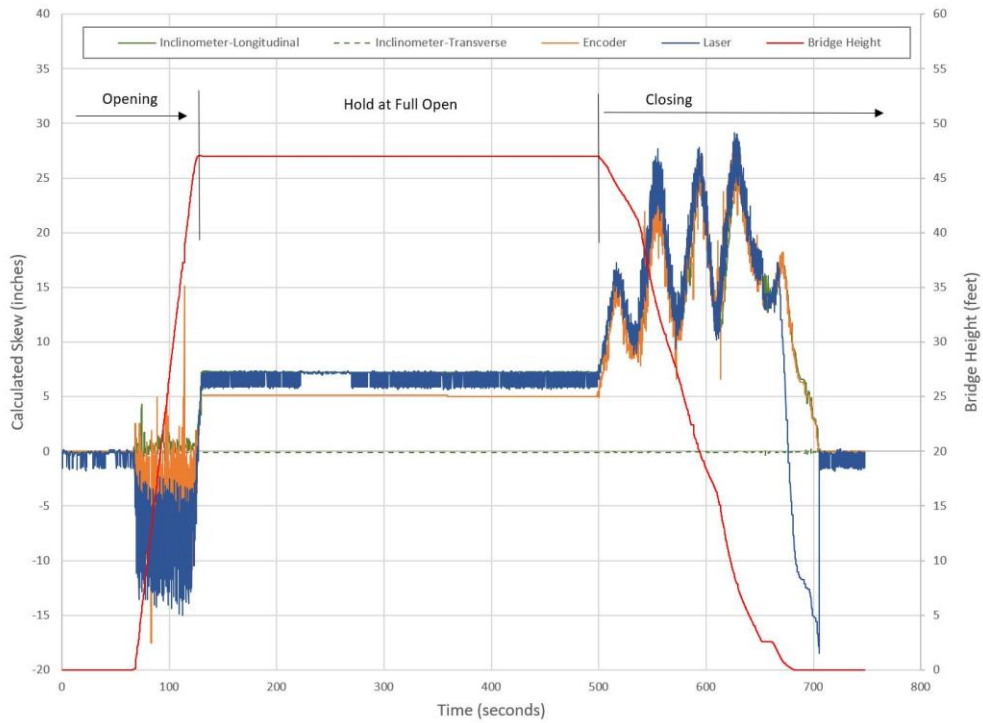

**Figure 29. Final skew data, opening cycle (8/4/24)**

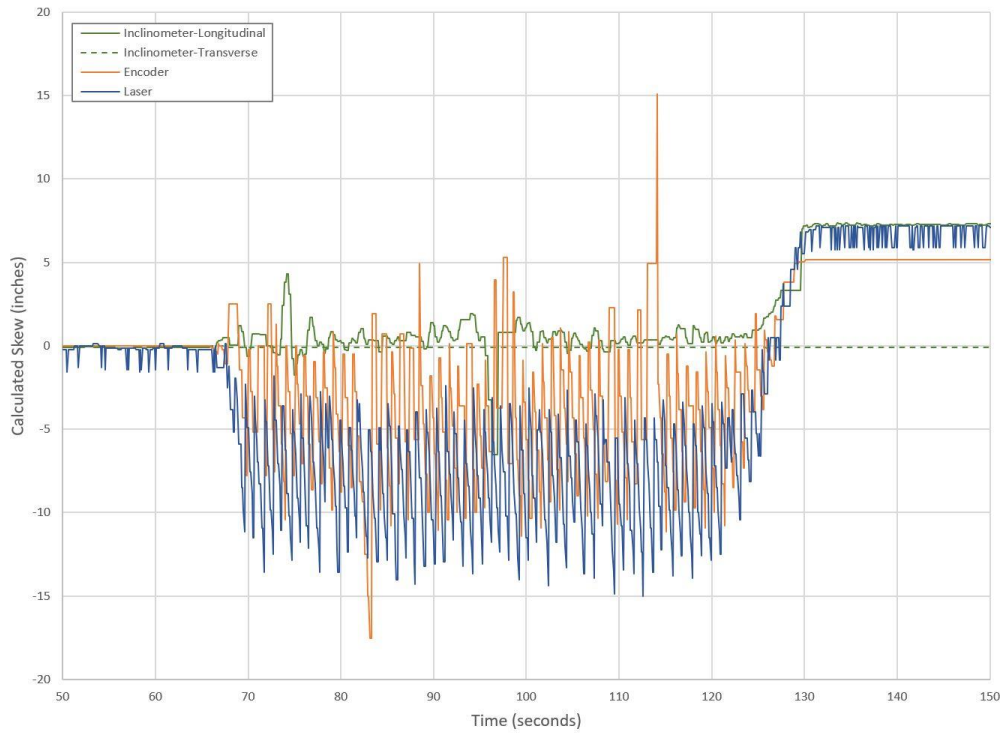

**Figure 30. Final skew data, closing cycle (8/4/24)**

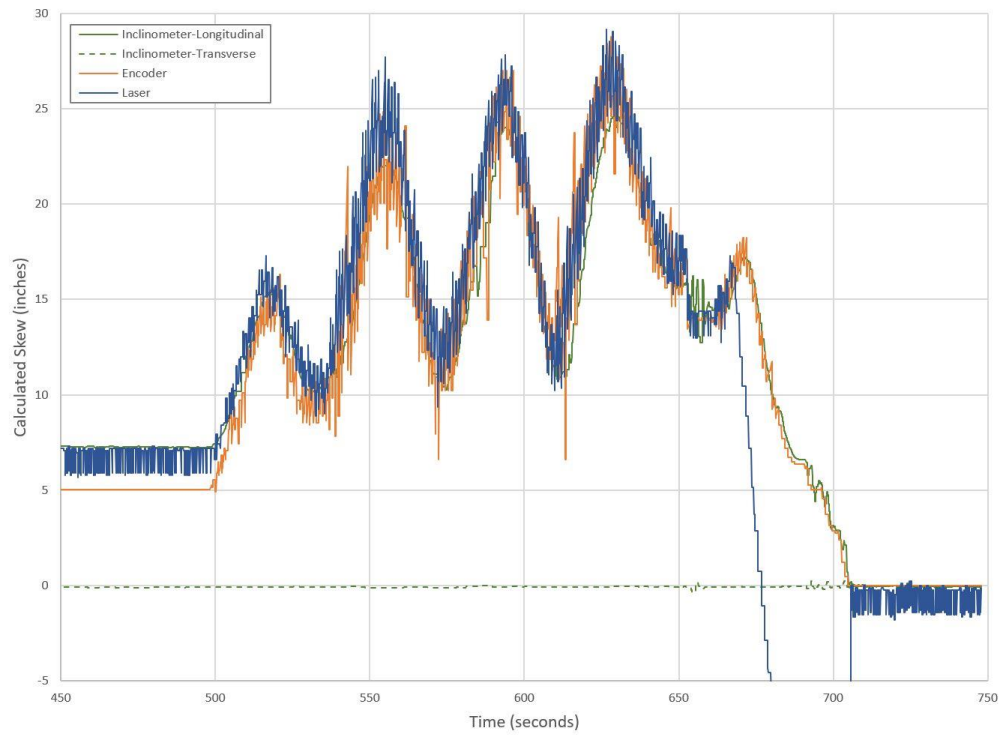

### **Figures 28 through 30 Commentary**

The calculated skew characteristics during this run were similar to previous runs, though a higher skew was noted for this run.

### **Final Thoughts**

The sampling limitations and network fault issues must be addressed for an application to be fully integrated into a movable bridge control and operator feedback system. A successful application would include selected SMART relays, network application, and wiring details that would ensure a high sampling frequency (100 Hz) and ensure data transmission integrity.

Although an existing operational differential Selsyn system is not available for comparison purposes, it is clear from the recordings that the selected alternative devices provide reliable skew position indication and that refinements could be utilized as a replacement to the differential Selsyn system. The evaluation of the skew devices against the criteria is summarized below in Table 7.

**Table 7. Skew device evaluation table**

<b>Criteria</b>	<b>Encoders</b>	<b>Lasers</b>	<b>Inclinometer</b>	<b>Notes</b>
System / Component Availability	7	6	9	All devices readily available, but lead times vary from 2 weeks for inclinometers to as long as 9 weeks for encoders.
System Simplicity	8	6	6	Encoders require coupling to machinery. Inclinometers have to be installed on the lift span and require a communications link between the lift span and the bridge fixed structure.  Lasers require a target mounted on the lift span structure with positioning complications.
Ease of Setup and Calibration	9	7	9	Lasers are challenging for initial alignment and calibration.
Ease of Maintenance	9	6	9	Encoders require no maintenance. Inclinometers require minor periodic adjustments.  Laser targets require regular cleaning and maintenance, between 6 and 12 months.
System Accuracy / Repeatability	8	9	10	Indirect encoder measurements should be zeroed before runs.
System Drift	10	10	10	No apparent drift issues.
Environmental Resilience	10	5	8	Lasers susceptible to degradation to target.
Cost	8	4	7	Lower rating = higher cost of system.
Total	69	53	68	

Criteria Rank from 1 (lowest rating) to 10 (highest rating)

Based on the results of the table above, it can be seen that the encoder and inclinometer alternatives are ranked equally, ahead of the laser alternative.

## Conclusions

The objectives of Phase 2 of this study were to develop documents for the installation and testing of potential replacements for the differential Selsyn system skew control which meet DOTD criteria and provide a report evaluating these alternatives. The evaluated technologies were chosen based on the findings of Phase 1 of this study and were deployed at the Ellender Ferry Vertical Lift Bridge located over the Intracoastal Waterway in Calcasieu Parish, Louisiana. This bridge lacked an operational skew monitoring system that could be used for comparative purposes as part of the study.

Sampling limitations and network shortcomings led to an incomplete evaluation of the selected alternative forms of skew monitoring.

Data communication, network selection, and installation are critical to the success of modern skew indication systems. This is especially true when retrofitting existing movable bridges and utilizing their existing wiring infrastructure, as in the case of the Ellender Ferry Bridge. For hardwired signals, shielded-twisted pair lines or fiber optic cables are essential for data transmission, as evidenced by the failure of data transmission using Power Line Communication for the inclinometer and the use of the existing aerial cable (i.e., south tower encoder signals, with SHDSL modems). Where suitable conductors are not available, consideration should be given to installing manufacturers' recommended cables. However, this study has demonstrated that wireless transmission can at times be a successful substitute for hard wiring.

To achieve a reliable and accurate form of skew indication, it is important that the selected SMART relays, network application, and wiring provide a high sampling frequency (100 Hz) and data transmission integrity.

Despite the limitations of the data recordings, it is clear from this study that the selected alternative systems provide reliable skew position indication and are viable alternatives to the differential Selsyn system.

As shown in Table 7, all three devices provide suitable skew measurements. However, the encoder and inclinometer both offer clear advantages, including ease of setup, maintenance, simplicity, and environmental resilience. It is concluded that all three considered alternative skew systems can be reliably used to monitor, alarm, and control skew conditions.



## Recommendations

Based on the issues uncovered during this phase of the study, it is recommended that the installed systems be investigated further and reconfigured to meet the defined design criteria in Phase 3 of the study, as described below:

1. Provide a redundant system that utilizes absolute encoders for indirect skew measurement and an inclinometer for direct skew measurement.
2. The SMART relay selection and network design must ensure sufficient sampling frequency and successful data transmission. This will include an in-depth analysis of the existing Horner SMART relays to either reconfigure or replace them with a more appropriate relay.
3. Proper cabling must be used for communications signal transmission. Data transmission through Power Line Communication is likely not a suitable method for movable bridges. Data transmission through shielded, twisted-pair conductors or fiber optic cable and transceivers are preferred.
4. Where cabling is not available, wireless transmission of data signals should be considered. When specifying wireless systems, carefully select antenna style and antennae with large beam widths, which allow for easier alignments. Additionally, ensure proper orientation during installation to ensure antenna waves radiate in the correct direction.
5. As part of future work, it is recommended that the installed skew monitoring system be integrated into the existing the Ellender Ferry Bridge control system and used to indicate bridge skew status, alarming and tripping the bridge if a skew condition occurs during bridge operation.
6. During the installation of the systems at the bridge, oversight is strongly recommended to ensure proper installation practices are followed and that installation issues do not impact data transmission.

## Acronyms, Abbreviations, and Symbols

<b>Term</b>	<b>Description</b>
DOTD	Louisiana Department of Transportation and Development
EMI	Electromagnetic interference
HMI	Human-machine-interface
I/O	Input/output
LAN	Local area network
LTRC	Louisiana Transportation Research Center
NEMA	National Electrical Manufacturers Association
PC	Personal computer
PLC	Programmable logic controller
PPR	Pulses per revolution
RF	Radio frequency
SHDSL	Single-pair, high speed digital subscriber line
UPS	Uninterruptible power supply
VPN	Virtual private network
WLAN	Wireless local-area network

## References

- [1] G. Rees, “Skew Detection System Replacement on Vertical Lift Bridges”, LTRC FHWA/LA.17/643, 2020.

# Appendix

Appendix A Skew Installation Design Documents

Appendix B Skew Measurement Device Cut Sheets