



MID-AMERICA TRANSPORTATION CENTER

Report # MATC-UNO: 111-4

Final Report

WBS: 25-1121-0005-111-4



Real-Time Emergency Communication System for HAZMAT Incidents (REaCH) - Phase III-VI

Ann Fruhling, PhD, MBA

Professor and Director
School of Interdisciplinary Informatics
University of Nebraska at Omaha

Aaron Yoder, PhD

Associate Professor
College of Public Health
University of Nebraska Medical Center

Sharon Medcalf, PhD

Associate Professor
College of Public Health
University of Nebraska Medical Center

Chandran Achutan, PhD

Associate Professor
College of Public Health
University of Nebraska Medical Center

Dario Gherzi, PhD

Associate Professor
School of Interdisciplinary Informatics
University of Nebraska at Omaha



2023

A Cooperative Research Project sponsored by
U.S. Department of Transportation- Office of the Assistant
Secretary for Research and Technology

The contents of this report reflect the views of the authors, who are responsible for the facts and the accuracy of the information presented herein. This document is disseminated in the interest of information exchange. The report is funded, partially or entirely, by a grant from the U.S. Department of Transportation's University Transportation Centers Program. However, the U.S. Government assumes no liability for the contents or use thereof.

MATC

Real-Time Emergency Communication System for HAZMAT Incidents (REaCH) – Phase III-VI

Ann Fruhling, PhD, MBA (2018-2023)
Professor and Director
School of Interdisciplinary Informatics
University of Nebraska at Omaha

Aaron Yoder, PhD (2018-2023)
Associate Professor
College of Public Health
University of Nebraska Medical Center

Sharon Medcalf, PhD (2018-2020)
Associate Professor
College of Public Health
University of Nebraska Medical Center

Chandran Achutan, PhD (2019-2020)
Associate Professor
College of Public Health
University of Nebraska Medical Center

Dario Ghersi, PhD, MD (2020-2023)
Associate Professor
School of Interdisciplinary Informatics
University of Nebraska at Omaha

Final Report on Research Sponsored by

Mid-America Transportation Center

University of Nebraska–Lincoln

June 2023

TECHNICAL REPORT DOCUMENTATION PAGE

1. Report No. 25-1121-0005-111-4	2. Government Accession No.	3. Recipient's Catalog No.	
4. Title and Subtitle Real-Time Emergency Communication System for HAZMAT Incidents (REaCH) – Phase III-VI		5. Report Date June 2023	
		6. Performing Organization Code	
7. Author(s) Ann Fruhling, https://orcid.org/0000-0001-9481-3069 Chandran Achutan, https://orcid.org/0000-0003-1512-0868 Sharon Medcalf, https://orcid.org/0000-0002-1230-7996 Aaron Yoder, https://orcid.org/0000-0003-4195-7469 Dario Ghersi, https://orcid.org/0000-0002-0630-0843		8. Performing Organization Report No. 25-1121-0005-111-4	
9. Performing Organization Name and Address University of Nebraska – Omaha EAB 203 6001 Dodge Street Omaha, NE 68182-0210; University of Nebraska Medical Center 984355 Nebraska Medical Center Omaha, NE 68198-4355		10. Work Unit No.	
		11. Contract or Grant No. 69A3551747107	
12. Sponsoring Agency Name and Address Mid-America Transportation Center 2200 Vine St. PO Box 830851 Lincoln, NE 68583-0851		13. Type of Report and Period Covered Final Report (2018-2023)	
		14. Sponsoring Agency Code MATC TRB RiP No. 91994-91	
15. Supplementary Notes			
16. Abstract The goal of the REaCH (Real Time Emergency Communication System for HAZMAT Incidents) project was to develop a real-time interactive dashboard and application that captures and displays first responders' health data and environmental exposure information to an incident commander during a transportation HAZMAT (Hazardous Materials) incident or a fire call. The REaCH application monitors individual health parameters and alerts incident commanders if individuals need to be removed from the scene due to their health status being compromised. The REaCH application is a real-time communication network that utilizes the latest Internet of Things (IoT) technologies to integrate multiple IoT sensors that capture human and environmental data. The application includes real-time health data monitoring of first responders and transportation workers through wearable devices. This report presents the activities during the six-year project.			
17. Key Words HAZMAT; Intelligent Transportation System (ITS) technologies; hazardous materials; statewide technology system; Real-Time Emergency Communication System. IoT, First Responders, biosensors		18. Distribution Statement No restrictions.	
19. Security Classif. (of this report) Unclassified	20. Security Classif. (of this page) Unclassified	21. No. of Pages 143	22. Price

Table of Contents

Disclaimer	viii
Abstract	ix
Chapter 1 Introduction	1
1.1 Organization of the Report.....	1
1.2 Background	1
1.3 Project Description.....	3
1.4 Year 1 (2018-19) Activities	7
1.5 Year 2 (2019-20) Activities	7
1.6 Year 3 (2020-21) Activities	8
1.7 Year 4 (2021-22) Activities	9
1.8 Year 5 (2022-23) Activities	10
1.9 Year 6 (2023) Activities.....	11
Chapter 2 Literature Review	13
2.1 Sensor Technologies	13
2.1.1 Wearable Technology/Wearable Devices.....	13
2.1.2 Health Monitoring Sensors	15
2.1.3 Environmental Monitoring Sensors	15
2.2 Environmental Scan	16
Chapter 3 Research Approach and Methods.....	17
3.1 Focus Groups	17
3.1.1 Omaha Fire Department Special Operations	17
3.1.2 HAZMAT Haulers Interviews	20
3.2 Integrated Sensor Dashboard Design.....	21
3.3 Surveys.....	22
3.3.1 First Responders’ Wearable Technology Survey	22
3.3.2 Professional Drivers Wearable Technology Survey	26
Chapter 4 Other Notable Activities.....	29
4.1 Year 1 (2018-19).....	29
4.2 Year 2 (2019-20).....	30
4.3 Year 3 (2020-21).....	31
4.4 Year 4 (2021-22).....	32
4.5 Year 5 (2022-23).....	33
4.6 Year 6 (2023)	35
Chapter 5 IT System Development Artifacts.....	37
5.1 REaCH IT System Requirements Documentation.....	38
5.2 REaCH System User Interface Prototype	38
5.3 REaCH Technical Development Documentation	38
5.4 REaCH Database Schema Diagram.....	39
5.5 REaCH Application Screenshots	39
Chapter 6 Future Work	40
References	42
Acknowledgements.....	44
Appendix A Sample User Diagram and User Scenarios	45

Appendix B Agile Methods Flowchart	48
Appendix C Surveys	49
C.1 First responder survey	49
C.2 Professional driver survey	54
Appendix D Posters	61
Appendix E REaCH System Architecture Documentation	68
Appendix F REaCH System User Interface Prototype Documentation	102
Appendix G REaCH Technical Development Documentation	113
G.1 Document Scope	114
G.2 Steps to Install and Create a PostgreSQL Database.....	114
G.3 Install Git Bash and Pycharm from the below link	126
G.4 Steps to Clone and Run the app in your Local Machine.....	126
G.5 Steps to connect PostgreSQL Database to PgAdmin4.....	131
G.6 Definitions of Packages used at requirements.txt for Building the App.....	131
Appendix H REaCH Database Schema Diagram	132
Appendix I REaCH Application Screenshots	133
Appendix J Table of major products.....	140
Appendix K Table of students	143

List of Figures

Figure 3.1 Responder Safety Themes and Concerns	20
Figure F.1 Dashboard Page.....	102
Figure F.2 People’s Page	103
Figure F.3 Team’s Page.....	105
Figure F.4 Device Page.....	107
Figure F.5 Device-Assignment Page	109
Figure F.6 Threshold Page.....	110
Figure F.7 Site-Administration Page	112
Figure G.1 PostgreSQL Database Download Versions	114
Figure G.2 Screenshot of PostgreSQL bin and lib paths in the Edit environment variable settings.	115
Figure G.3 PostgreSQL Setup Screen.....	116
Figure G.4 Stack Builder 4.2.0 Setup Screen	120
Figure G.5 Screenshot of pgAdmin	123
Figure G.6 Creating a Database in pgAdmin.....	124
Figure G.7 Entering the Database Name	125
Figure G.8 Terminal showing ‘(env)’ prefix before project folder path	128
Figure I.1 Snapshot of Home page showcasing the event and crews' panel.....	133
Figure I.2 Snapshot of Dashboard page showcasing the weather information.....	133
Figure I.3 Snapshot of Admin Home page showcasing the statistics of crews, devices, and events	134
Figure I.4 Snapshot of People page	134
Figure I.5 Snapshot of Crews page.....	135
Figure I.6 Snapshot of Devices page	136
Figure I.7 Snapshot of Sensors page.....	136
Figure I.8 Snapshot of Thresholds page	137
Figure I.9 Snapshot of Roles page.....	138
Figure I.10 Snapshot of Event page.....	138
Figure I.11 Snapshot of Person detailed page showing individual data	139

List of Tables

Table 3.1 Station 33 – HAZMAT Focus Group for Needs Assessment 19

Table 3.2 The frequency of response to question “If someone were to monitor your HEALTH while working in the field, who would you prefer?” 24

Table 3.3 The frequency response to question “If someone were to monitor your ENVIRONMENT while working in the field, who would you prefer?” 26

List of Abbreviations

Mid-America Transportation Center (MATC)
Nebraska Transportation Center (NTC)
Personal protective equipment (PPE)
Internet of things (IoT)
Real-Time Emergency Communication System for HAZMAT (REaCH)
Hazardous materials (HAZMAT)
Pipeline and Hazardous Materials Safety Administration (PHMSA)
Office of Hazardous Materials Safety (OHMS)
National Fire Protection Association (NFPA)
First responder (FR)
Omaha Fire Department (OFD)

Disclaimer

The contents of this report reflect the views of the authors, who are responsible for the facts and the accuracy of the information presented herein. This document is disseminated in the interest of information exchange. The report is funded, partially or entirely, by a grant from the U.S. Department of Transportation's University Transportation Centers Program. However, the U.S. Government assumes no liability for the contents or use thereof.

Abstract

The goal of the REaCH (Real Time Emergency Communication System for HAZMAT Incidents) project was to develop a real-time interactive dashboard and application that captures and displays first responders' health data and environmental exposure information to an incident commander during a transportation HAZMAT (Hazardous Materials) incident or a fire call. The REaCH application monitors individual health parameters and alerts incident commanders if individuals need to be removed from the scene due to their health status being compromised. The REaCH application is a real-time communication network that utilizes the latest Internet of Things (IoT) technologies to integrate multiple IoT sensors that capture human and environmental data. The application includes real-time health data monitoring of first responders and transportation workers through wearable devices. This report presents the activities during the six-year project.

Chapter 1 Introduction

1.1 Organization of the Report

In this document we report on the overall activities for the REaCH - Real-Time Emergency Communication System for HAZMAT Incidents project. This report begins with background on the HAZMAT transportation domain in the context of this project. Next, we describe the project goals. In Chapter 1 we also present research conducted in the first year including 1) interviews with Nebraska transportation professionals, first responders, and key stakeholders, 2) focus group findings, 3) a review of current biosensor and wearable technologies, and 4) requirements for an integrated sensor dashboard design. Subsequently, we report on the activities and research conducted for years 2 through 6.

In Chapter 2 we begin with a literature review, followed by a discussion on the research approach and development methods used in this project. The results from our studies are discussed in Chapter 3. Other notable project activities are highlighted in Chapter 4. Chapter 5 presents the details related to the IT development outputs and lastly, in Chapter 6 we discuss our future work directions.

1.2 Background

According to the U.S. DOT Pipeline and Hazardous Materials Safety Administration (PHMSA), Office of Hazardous Materials Safety (OHMS), hazardous materials traffic in the U.S. now exceeds 800,000 shipments per day (Lasisi, 2012) and results in more than 3.1 billion tons of hazardous materials annually (OHMS Research and Special Programs Administration). Approximately 300 million shipments of hazardous materials are transported annually within the United States. Out of these, 94% of the HAZMAT shipments are moved by trucks (Lasisi, 2012). Between 2007 and 2016, there were 144,002 HAZMAT incidents on US highways, with damage

totaling nearly \$600M (Office of the Federal Register National Archives and Records Administration, 2011). The top two incident types in the past three years involved flammable-combustible liquids and corrosive materials.

The sensitivity and risks of HAZMAT shipment transportation requires a collaborative framework with technology that enables reliable and cost-effective means to communicate and exchange data during incidents. Today, individual companies track and monitor the status of their trucks and drivers using a range of Intelligent Transportation Systems in the Internet of Vehicles.

Transporting hazardous materials safely, establishing requirements for real-time emergency response information, and monitoring human exposure from hazardous material incidents are national concerns. These concerns are documented in the Fixing America's Surface Transportation Act, or "FAST Act" President Obama signed into law on December 4, 2015.

Past research reports from transportation companies divulge the lack of real-time monitoring of their drivers transporting hazardous materials. In some cases, the status of hazardous materials is not being measured, and thus potential risks are difficult to identify and are not reported to drivers in a timely manner. Should a hazardous material incident occur, the condition of the drivers' and first responders' exposure must be monitored closely. This could be made possible via wearable devices that have sensory technology.

A recent study reported that it was difficult for an "Emergency Response Coordination Center" to obtain basic information (e.g., name, nature, and quality of the hazardous materials, etc.) and real-time information (e.g., the location of an accident, the severity level of an accident, etc.) of vehicles, drivers, and hazardous materials during transportation (Ma et al., 2014). In the

first year of our study we conducted focus groups to further assess the current situation in Nebraska.

During such HAZMAT emergencies, first responders are the first to reach the incident site. A first responder is an individual who would immediately be present at the scene during a HAZMAT emergency. They include the fire department, police department, emergency medical services and the department of environmental quality. Over the last few years, there has been an increase in the number of deaths of first responders mainly due to cardiac arrest, heat stroke, stress, lack of oxygen in the blood, and inhalation of hazardous chemicals. National Fire Protection Association (NFPA) statistics reveal the following: there were more than 60,000 firefighter injuries in 2021 and 25% of injuries were caused by physical stress and overexertion (National Fire Protection Association, 2022b).

1.3 Project Description

The goal of the REaCH (Real Time Emergency Communication System for HAZMAT Incidents) project was to develop a real-time interactive dashboard that captures and displays first responders' health data and environmental exposure information to an incident commander during a transportation HAZMAT (Hazardous Materials) incident or a fire call (US DOT Region VII Grant). The REaCH application monitors individual health parameters and helps Incident Commanders evaluate if individuals need to be removed from the scene due to a compromised health status. The REaCH application utilizes the latest Internet of Things (IoT) technologies integrating multiple IoT sensors that capture human and environmental data, using a real-time communication network.

During a HAZMAT incident, first responders such as firefighters are the first to reach the incident site. In doing so they often put their lives at risk (Horan et al., 2021). According to the

2022 National Fire Protection Association report (National Fire Protection Association, 2022a), there have been 60-70 on-duty firefighter deaths over the past 3 years. Sudden cardiac death accounted for about 40% of the on-duty fatalities. First responders are often asked to perform physically and physiologically demanding tasks over a prolonged period of time. If not allowed adequate rest and recovery, first responders may develop fatigue and exhaustion due to physical stressors (Corrigan et al., 2021). These stressors may cause the first responder to develop health problems, such as cardiovascular and pulmonary issues, and heat exhaustion. Health monitoring is a crucial IoT capability because it offers a way to remotely monitor people's health data and environment conditions, providing a more complete picture of their health status (Alrizq et al., 2021). Better remote monitoring is made possible by integrating wearable IoT devices and sensors since they can help identify human health parameters that require medical attention.

The REaCH system is currently at an MVP (Minimum Viable Product) stage. We have successfully completed controlled laboratory testing. The next phase is to increase the wireless network bandwidth, integrate sensors that are more compatible or easier to connect to the system, and conduct field tests of the system in collaboration with rural volunteer fire departments. Our project was guided by requirements gathered from a focus group consisting of special operation HAZMAT first responders employed by a large metropolitan fire department in Nebraska (Medcalf et al., 2021).

The REaCH application utilizes the latest IoT technology that integrates multiple smart sensors which capture environmental and human health data (Fruhling et al., 2023). The REaCH system integrates the Kestrel DROP wireless sensor (Kestrel D3) to collect environmental data to monitor the Ambient Heat Index and the Polar H10 to collect heart rate from the sensors placed inside the First Responder's PPE suit. The sensors employ a Bluetooth Low Energy

communication protocol which is a low-power wireless communication technology. The REaCH system must be able to establish connectivity and reliably stream live, accurate data from the sensor smoothly. We have been able to successfully demonstrate this in a laboratory setting.

The REaCH research team considered several key software, hardware, usability, design, and system requirements in developing the MVP. These included the design of an intuitive dashboard that displays complex data for each member of a crew (Appendix F), the physical durability of the wearable devices, the length of the sensors' battery life, connectivity capabilities using only Wi-Fi, understanding the complexity of the data streaming process, the physical location of the wearable device on the first responder, algorithms to support real-time data analytics of the sensor data, a user interface that minimizes cognitive load of the incident commander while monitoring the data, and optimal visualization of health data trends for each first responder.

Key features of REaCH are:

- Assigns devices and sensors to each first responder.
- Displays real-time health data of first responders and ambient person temperature inside a PPE suit.
- Connects to a weather API that displays local weather and time information on the dashboard.
- Monitors first responders' health and environmental data during an on-going event.
- Captures, stores, and displays individual first responders' details and trending health and temperature data.

- Assigns customized health values for each first responder. The customized health values e.g., thresholds, determine if an alert needs to be signaled to the incident commander and help determine the current health risk level.
- Alerts the incident commander when the first responder's health data crosses the limit of the critical values.
- Displays situational awareness of the entire crew while responding to an event including the time each responder is active and in recovery modes (Fruhling et al., 2023).

We successfully completed multiple sensor integration and dashboard usability tests in a controlled laboratory environment. The system was designed to easily incorporate new sensors and we are currently looking at sensor options for blood pressure, oxygen, and respiratory levels.

The project team followed an agile information system development methodology (Appendix B) for both the hardware implementation and software development processes. For the first phase of our project, we conducted several systems-requirements-gathering activities including a literature review on the background of the transportation hazardous material industry, interviews with key stakeholders, a focus group with first responders, a review of current sensor technology and prepared a research study on best practices for human health parameter data visualizations on the dashboard. In the second year, we focused on defining the technical REACH system Information Technology requirements for the new dashboard. In the remaining years of the project we completed user interface designs, software development, device and sensor integration, unit testing, usability testing, and simulated laboratory system testing. The end result is a working high-fidelity viable product.

1.4 Year 1 (2018-19) Activities

- Defined the REaCH system requirements. Examples of output artifacts are presented in Appendix A.
- Interviewed HAZMAT carriers, NE Transportation stakeholders, various units of first responders at Omaha Fire Department.
- Conducted a focus group workshop with HAZMAT first responders.
- Met with local hazardous material response teams to identify health monitoring and exposure data needed over a multi-year period for multiple response scenarios.
- Conducted a broad review of the current state of wearables for HAZMAT protection, Internet of Vehicles (IoV) technologies, Intelligent Transportation Systems, and technology used in the field. Two project team members attended the International HAZMAT and Firefighters conference to learn about the latest technology.
- Received IRB approval to conduct interviews, a focus group workshop with stakeholders, and to survey OFD firefighters on their use and attitudes toward health monitoring wearables.

1.5 Year 2 (2019-20) Activities

- Attended and presented at the National Transportation Research Board Annual Meeting, January 2019.
- Met with leaders of the Nebraska Trucking Association.
- Evaluated Internet of Things COTS (commercial-off-the-shelf) sensors and customizable biosensor and environment sensors quality, accuracy, viability, ruggedness, and reliability. Identified the products we plan to field test.

- Continued to identify new and existing wearable and sensory components/features for development and integration into REaCH design.
- Completed several REaCH system requirements artifacts (see Appendix E).
- Developed and validated REaCH acceptance testing scenarios (e.g. software and hardware requirements).
- Developed a low fidelity integrated user interface and technology platform prototype (REaCH) and prepared usability studies intended to get feedback from first responders (see Appendix E).
- Completed an Environmental Scan of transportation hazmat incidents types.
- Researched predictive measures for biomarkers to aid in the coding requirements for the threshold processes.
- Wrote report on the focus group results from year 1 and began preparing manuscript.

1.6 Year 3 (2020-21) Activities

- Updated user interface designs and conducted various human computer interaction research studies (e.g. usability, cognitive walkthroughs, etc.). One of the studies was Vikas Suhu's master thesis.
- Completed coding the functionality to create, update, and delete people, crews (teams), thresholds, devices, and device assignments on the REaCH system.
- Completed Technology Transfer, Invention Notification application.
- Evaluated wearable devices.
 - Kestrel Drop; Nielsen-Kellerman; Boothwyn, PA
 - S-patch; Wellysis; Seoul, Korea

- Biobeat; Biobeat Technologies Ltd.; Petach-Tikva, Israel
- Met wearable vendors and discussed NDAs.
 - Mor Hershkovitz; Biobeat Technologies Ltd.
 - Young Juhn; Wellysis Corp.
 - Joe Racosky; Nielsen-Kellerman
- Finalized the NDA with Nielsen-Kellerman and received the communication protocol from them. We will be able to communicate with the Kestrel DROP device from the command line and read temperature, heat stress, etc. over the Bluetooth protocol, without having to rely on the phone app.
- Awarded planning grant: internal College of Public Health grant; PI, Achutan, C., Co-PIs, Medcalf, S., Yoder, A, Fruhling, A, Lynden, E.; Integrating wearable sensors in firefighter suits to prevent heat-related illnesses, \$25K.

1.7 Year 4 (2021-22) Activities

- Completed coding of dashboard main page for the simulated laboratory test to test heat index sensor, this includes alert notification.
- Completed coding and constructing technology (hardware and software) to capture real-time heat index data from sensor, send to REaCH database, and display on dashboard.
- Completed laboratory experiment transmitting real-time data to dashboard; Omaha Fire Fighter Stan Scheer attended lab experiment and provided feedback.
- Reviewed laboratory experiment results and identified potential problems that needed to be addressed and discussed plan for the next phase of development.

- Completed writing an in-depth test plan for the REaCH Application including test scenarios, test plan and test data, and inserting data analytics approaches to visualize health trends.
- Completed study of appropriate thresholds values and entered values into test system and completed threshold validation code as needed for the REaCH system.
- Researched POLAR SDK to capture heart rate and ECG data.
- Started surveying the literature to identify computational approaches for analyzing and labeling ECG or other heart monitoring data.
- Connected the Polar H10 device to a Linux operating system and succeeded in extracting real-time heart rate and ECG data.
- Identified from the literature viable Machine Learning approaches to characterize the R-R variability (i.e., the variability in the distance between R waves in the ECG signal) as a possible indicator of cardiovascular issues.
- Brainstormed data visualization designs for individual health trend analyses.
- Completed professional driver behavior and health monitoring attitudes survey and conducted study on first responders' perception of wearable technology.
- Updated developer workstations with latest version of software and continued to keep documentation up to date, started working on expanding the data dictionary.
- Completed moving project artifacts and documents from Box to MS Office 365.

1.8 Year 5 (2022-23) Activities

- Conducted single and multiple sensor integration tests using Polar H10 and Kestrel Drop sensors.

- Brainstormed and designed the First Responder page for REaCH dashboard. This page presents detailed and trending data for individual responders.
- Conducted a survey on Truck Drivers' perceptions of wearable technology.
- Updated developer workstations with latest version of development software.
- Researched Polar SDK to capture heart rate and ECG data.
- Expanded REaCH data dictionary and continued to keep REaCH technical documentation up to date.
- Prepared research study design on analyzing professional drivers' perceptions of wearable technology and attitudes towards being monitored.
- Deployed several user interface enhancements for the REaCH application.

1.9 Year 6 (2023) Activities

- Enhanced the REaCH system by adding a new admin page displaying high level overview of devices (assigned, active), on-site and off-site crews, and details of the on-going event.
- Developed a new functionality: individual crew member detail page displaying a graphical chart of the heart rate and heat index trends using Chart.js.
- Developed and tested an event page as a new functionality.
- Enhanced existing active crew logic and refined the user interface; changed the health icons/color schema and included appropriate threshold flashing colors.
- Updated the Heroku database with the latest changes and conducted tests for the new pages.

- Developed scripts and videos to simulate and demonstrate key functionalities of the dashboard.
- Completed technical software updates with a Java 15 version update, Heroku database subscription renewal, Raspberry PI backup and code refactoring, etc.
- Prepared final report of the REaCH project.

A list of all presentations, conference proceedings and publications are presented

Appendix J.

Chapter 2 Literature Review

2.1 Sensor Technologies

In our project we leveraged Internet of Things (IoT) technologies that support human and environmental data capture and transmission through sensors. There are many wearable IoT sensor technologies available that could be utilized in our project. In year 1 we conducted a broad review of the current state of technology. Below we present our findings.

2.1.1 Wearable Technology/Wearable Devices

Wearable Technology/Wearable Devices refers to all electronic technologies that can be incorporated into clothing, accessories, or computing devices that can be comfortably worn on the body. A special feature of wearable devices is that they can provide real time information to their users, and some monitor the users' health.

With the latest developments in technology, the Internet of Things (IoT) has paved the way for monitoring healthcare through the evolution of wearable devices built using wearable sensors. The increasing need for self-health monitoring and preventive medicine has given rise to the development of numerous wearable devices, which can be used to monitor health parameters such as body core temperature, heart rate, blood pressure, blood oxygen level, hydration level, etc. in various areas. Wearable systems range from microsensors integrated efficiently and effectively into textile materials such as exoskeletons, computerized watches, earplugs, hand gloves, and bracelets to computerized eye glasses such as the Google glass.

Personal Protection Equipment (PPE) are specialized clothing designed for first responders. PPE provides protection from serious injuries and illnesses resulting from contact with chemical, radiological, physical, electrical, and other hazards. Wearing PPE often puts a first responder at considerable risk of developing heat stress. This can result in health effects

ranging from heat fatigue to serious illnesses such as heat stroke and cardiac failure which may cause death. Heat stress is caused by a number of interacting factors, including environmental conditions, clothing, workload, and the individual characteristics of the worker.

First responders are often subjected to working in extreme environmental conditions. The Personal Protection Equipment, Self-Contained Breathing Apparatus and the remaining set of safety gear acts as an extra load on their body, especially under strenuous conditions where the temperature can be extremely dry or extremely wet. One of the main challenges of PPE is the inability to eliminate heat through radiation, convection (transfer of heat through mass motion) and evaporation. The PPE is impermeable in nature which is good from a chemical resistant point of view, but it also prevents the elimination of heat, which results in the lack of heat loss while wearing PPE.

The first responder wearing the PPE produces his or her own body heat in addition to the temperature conditions outside the PPE. The suit also impedes the wearer's ability to balance the heat production and heat dissipation. This results in the degradation of the effectiveness of the individual i.e. as their core body temperature increases ($TC > 37^{\circ}\text{C}$), their cardiac output i.e. their heart rate increases.

Temperature and humidity affect the thermal balance of the human body via skin and the respiratory system. If there is no scope of evaporation inside the PPE, then the heat dissipated from the first responders' bodies will have no way out, resulting in dryness of skin and other harmful and fatal conditions. Thus, it is extremely important to monitor the temperature and humidity inside and outside the protection suit of the first responder when subjected to strenuous conditions. Monitoring these parameters can be achieved through biosensors, which are

unobtrusive, durable, can be easily worn, and can be used as an intervention during crisis emergency responses.

The following section gives an overview of the different health monitoring sensors and their functionalities. Biosensor options were explored using specific criteria: how it monitors, compatible application, what it monitors, location on the body, connectivity, FDA/OSHA approval status, batter/battery life, and price.

2.1.2 Health Monitoring Sensors

Twelve health monitoring sensors were reviewed and considered for potential use. These included devices such as watches, straps around chest or wrist, wired sensors, and skin patches. One of the main limiting factors for device selection was availability for purchase on the open market. Several devices were not available for purchase. Additionally, high cost was another consideration in selecting a health monitoring sensor. The Polar H10 was selected for heart rate monitoring as it was minimally disruptive and could be worn underneath clothes as a chest strap. The accuracy of heart rate data was more reliable, being proximal on the body rather than distal. The price was lower compared to other sensors that monitored heart rate. The Polar H10 monitors heart rate via chest strap. It can connect to two Bluetooth devices simultaneously or with an ANT+ and a Bluetooth device simultaneously. The battery life is about 400 hours (about 16 days) with BLE connectivity. The H10 was selected based on its affordable price (\$89.95) and body placement.

2.1.3 Environmental Monitoring Sensors

There were five environmental sensors reviewed and considered for potential use. Device types included glasses, watches, and clip-ons. The Kestrel Meters were significantly lower in cost compared to the other devices. The battery life was significantly longer (6 months to 1 year)

compared to other devices. The Kestrel Meters were unobstructive as they could be clipped-on to the person, for example, on a belt loop. Additionally, they could connect with Bluetooth. Overall, the Kestrel Drop was selected as it could log several environmental data including temperature, relative humidity, heat stress index, dew point temperature, and station pressure. The device was durable, designed for fires, and was affordable in cost at \$129.00.

2.2 Environmental Scan

In year 2, a master's student completed an independent study to explore existing literature on firefighters and their occupational exposures that could be harmful to their health. In particular, he focused on special operations firefighter units commonly known as HAZMAT firefighter units. These HAZMAT firefighter units are a specially trained group that control and clean up different forms of hazardous material spills, leaks, and explosions. Additionally, collecting information on the transportation of hazardous materials was necessary to fully comprehend the potential for a hazardous material event to occur. He presented the literature review to the team. Another student researched literature on the scientific predictive measures for human biomarkers, specifically: heart rate, blood pressure, oxygen pulse, respiration rate, blood oxygen saturation levels, and recovery time. This information was used in the design and analysis for the human thresholds algorithms in the REaCH system. Student reports are available upon request.

Chapter 3 Research Approach and Methods

The team employed several research approaches and methods, including gathering requirements and performing data analyses to understand the needs of the stakeholders in the HAZMAT response field. We conducted interviews and a focus group workshop, and surveyed literature on biosensors, HAZMAT, and first responder health concerns. We met with subject matter expert (SMES) in Omaha and around the world at the FDIC International Conference in Detroit.

Our project began with defining the REaCH system requirements. Our goal was to move from conceptual technology ideas and visions to building, testing, and evaluating working prototypes in the field with end users. We followed best practices in an iterative development approach known as Agile Development. A flowchart of the Agile Development approach is shown in Appendix B.

We employed the IT Industry Standards Unified Modeling Techniques (Booch et al., 1998) as part of our analysis efforts. For example, we utilized use case diagrams and user scenarios as our modeling tools. A sample use case diagram and examples of user scenarios are shown in Appendix A. In year 2, we refined these artifacts (Appendix E).

3.1 Focus Groups

3.1.1 Omaha Fire Department Special Operations

UNMC Institutional Review Board (IRB) approval was obtained to conduct a systematic process for data collection in a focus group format. Participants were recruited from the Omaha Fire Department Station 33 HAZMAT team with the goal to elicit a consensus on their personal and health concerns while responding to HAZMAT incidents to better delineate the results of this project. The following represents the procedures for the focus group data collection and the

results. After introductions, Dr. Fruhling (PI) provided an overview of the project; Dr. Medcalf then facilitated the session. First, the participants were given a half sheet of paper and asked to list items in response to the following question: When you are responding to a HAZMAT event, what are the things that you worry about? The participants were asked to list at least ten items. Then each item was transferred to its own Post-it note and participants were asked to place their top 4-5 items on the table. Following questions of clarity on the items on the table, participants were asked to group notes that were similar. This process was repeated until all notes were on the table and clustered into groups. Participants were then asked to assign a name or theme to each cluster.

The cluster with the most notes (items) was chosen and each note was placed in a row at the top of the table. Participants were asked to begin to create additional Post-it notes that represented “solutions” to any or all the notes (items) on the table. Participants were instructed to think of solutions that were not limited by time, technology or availability of funding. Solution Post-it notes were placed in a column below each original item derived from the cluster that generated the most concerns. Table 1 below represents the clusters of concerns that participants considered when they respond to a HAZMAT event. Thematic areas included: Responder Safety; Training; Risk Assessment; Incident Command; Personal Protective Equipment; Weather and Location; Communication; Hazard/Product Identification; Public Safety and Post Incident Review. Each item under “concerns” represents an individual note placed by all participants.

Table 3.1 Station 33 – HAZMAT Focus Group for Needs Assessment

Themes	Concerns	Notes
Responder Safety	Safety of responders	Life safety
	Fire fighter accountability	Respondent exposure
	Potential external hazards	Long-term health effects
	Adequate staffing	Education/awareness of political level
	Exit strategy if things go bad	Taking home to family Incident stabilization/ property conservation
Training	Sufficient training	Previous incident experience
	Proper equipment/tools	
Risk Assessment	Secondary explosions	Bioterrorism
Incident Command	Availability of subject matter expert	Will proper procedures be followed by incident commander?
PPE	Adequate PPE/ Proper/correct PPE	Extra resources
	Can't see	Maintenance and equipment
Weather and Location	Exact location of spill/leak; topography	Weather conditions
Communication	Communication to the community	Communication before we get to the scene
	Communication among responders (own unit) and interagency	Information collection and dissemination
Hazard/Product Identification	Stop problem/ mitigation/stabilization/ isolation	How big is the spill/leak
	Equipment needed for ID/Mitigation	Accurately identify hazard/product
	Accurate information	Mixed products
	Building layout/incident layout	Data gathering
	Is the equipment working?	How/what will HAZMAT change?
Public Safety	Evacuate vs shelter	Where can HAZMAT go?
	Property conservation	Notify and evacuate potential victims
	How many have been exposed/potential victims?	Safety of citizens/public
Post Incident Review	Interagency results and findings	Lessons learned
	What to do differently next time	What worked/what didn't

The diagram below (Figure 1) represents the brainstormed solutions to the items of concern clustered under the thematic area entitled: Responder Safety. White boxes indicate the original concerns from the notes generated by participants. The blue boxes represent the solutions that participants wrote to address the concerns.

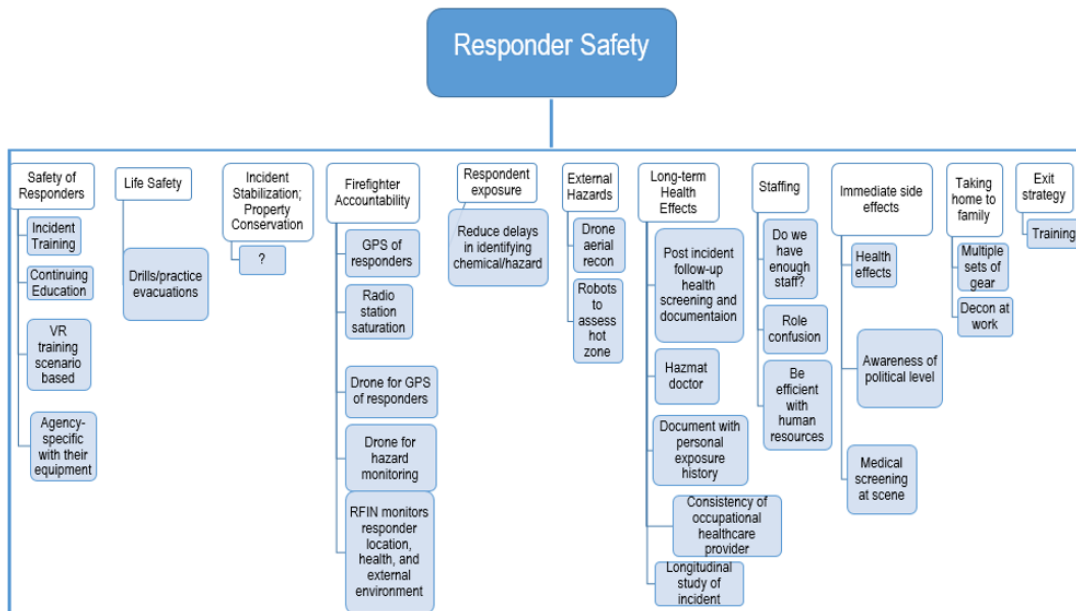

Figure 3.1 Responder Safety Themes and Concerns

3.1.2 HAZMAT Haulers Interviews

In June 2018, Drs. Ann Fruhling and Chandran Achutan met with the CEO of a trucking company in Omaha. The purpose of the meeting was to understand the health and safety concerns of the trucking industry. The company employs between 130 and 140 truckers. They work 14 hours a day, driving up to 11 hours a day. They are allowed to work 70 hours over 8 days before they have to take 34 hours of rest. This company transports gases such as nitrogen,

oxygen, argon, carbon dioxide, hydrogen, helium, hydrogen chloride, ethylene, and carbon monoxide. Potential health and safety hazards include asphyxiation in confined spaces. When the professional drivers are in refineries, they wear oxygen and hydrogen sulfide monitors. Instead of being washed (changing chemicals) trailers are purged. Sometimes there are fuel spills and oil leaks; truckers usually have PPE on hand. The trucks have satellite devices which monitor speed, truck performance, and sudden stops and starts. Cameras that face inwards and outwards capture driver behavior.

The CEO raised the following health and safety concerns:

- Unknown chemicals at the destination,
- Physical security of truckers from guns,
- Counter terrorism threat as trucks cross country land borders, and
- Lack of places to park the trailer at night.

The CEO offered to allow truckers to participate in a focus group with our research team. The project team met with Lincoln-Lancaster County Health Department Senior Environmental Health Specialist, Ron Eriksen, faculty in the UNO Emergency Management program, and faculty in the UNO Biomechanics program that have expertise in health biosensor research. The team also had numerous interviews with the Omaha Fire Department leadership, firefighters, and special operations unit members.

3.2 Integrated Sensor Dashboard Design

A first responder (FR) is an individual who arrives first at a hazardous material incident site and takes the initiative to minimize the risk to public health and property. The FRs are often firefighters. Information collected during the interviews and focus groups above revealed that

FRs may experience severe health related issues due to physical exertion, psychological stress, and extreme working conditions. These issues range from thermoregulatory exhaustion and acute dehydration to fatal cardiac arrest, cancer and suicides. Research shows that 39% of FR fatalities are due to heart failure and 61% due to other reasons like trauma, burns, etc. (Perroni et al., 2014).

To ensure FRs' safety, the incident commander (IC) monitors critical information about FRs and the incident site. The IC's decision regarding FRs' safe evacuation or withdrawal from the site is dependent on the collected information. The most critical parameters for an IC to monitor during emergencies are FRs' heart rate, core body temperature, available oxygen percentage, and environmental air quality.

As part of our goal for this project, was to develop a Dashboard prototype, a smaller study was conducted by a graduate student focusing on the most usable display formats to visualize FR critical health and environmental data.

3.3 Surveys

3.3.1 First Responders' Wearable Technology Survey

The First Responders' Wearable Technology Survey was designed to gain more insight into first responders' use of technology and identify methods that further our understanding of monitoring exposure to hazardous environments. This information helped identify the feasibility of first responders using wearable technology for monitoring real-time diagnostics and health data during environmental incidents. All the information collected was kept confidential and personal identifying information (email, etc.) was separated from responses to ensure that no individual could be identified.

In the second year, the First Responders' Wearable Technology Survey was sent to a Special Operations Unit of the Omaha Fire Department (n=20). In the second phase of distribution, the entire Omaha Fire Department (n=500) was surveyed.

The survey consisted of six open-ended questions, three dichotomous questions, three multiple-choice, and four multiple response questions for a total of 16 questions. The survey intended to gain firefighters' perspectives on 1) the idea of and confidence using wearable technology, 2) which physiological and environmental indicators should be monitored, and 3) who should be responsible for monitoring the health and environment while in the field. Prior to being administered, the survey was approved by the Institutional Review Board (IRB) (IRB # 691-17-EX) of the University of Nebraska Medical Center. The survey was distributed to all the Omaha Fire Department stations and then subsequently to all firefighters. The survey could be completed via mobile devices or personal computers using Microsoft Forms. The survey is in Appendix C.

Out of the 645 first responders in the Omaha Fire Department, there were 115 (17%) responses with a mean age of 42 ± 7.2 . Out of the 115, 112 stated whether they were part of the special operations group. There were 78 (70%) who were not part of the special operations group, and 34 (30%) who were part of the special operations group.

Among the 113 responses to the question of whether they have ever used wearable technology (i.e., Fitbit, Smartwatch), 53 (47%) selected yes, and 60 (53%) selected no. Amongst the 53 respondents who selected yes, 31 (58%) of the respondents selected that they were currently using wearable technology. Also, 16 of 31 (52%) said they were extremely confident in their ability to operate wearable technology, 11 of 31 (35%) were very confident, 4 of 31 (13%) were somewhat confident, and 0 of 31 for both not so confident, and not at all confident.

Seventy (70) out of 111 (63%) respondents preferred to have their health indicators monitored by both the Safety and Environmental Management System (SEMS) operator and themselves while working in the field. Twenty-eight (28) (25%) preferred to monitor themselves only, 9 (8%) preferred to have the SEMS operator be solely responsible, and 2 (2%) selected to have neither monitor or listed another preference referred to in Table 2. In answer to which health indicators respondents perceived as important for monitoring, 98.2% indicated heart rate, 93.8% indicated blood pressure, 89.2% indicated core body temperature, 67.6% indicated skin temperature, and 87.3% indicated hydration level monitoring while in the field.

Additionally, 49.1% selected stability, 51.8% selected falls, and 87.5% selected their breathing rate for monitoring. Sixty-four percent (64.9%) preferred breathing depth, 91.1% chose blood oxygen levels, 86.1% chose respiration carbon dioxide (CO2) levels, 86.6% selected cortisol levels, and 71.8% selected skin resistance (Stress and Hydration) levels to be monitored while working in the field.

Table 3.2 The frequency of response to question “If someone were to monitor your HEALTH while working in the field, who would you prefer?”

Responses	N
A paramedic dedicated to monitor during the entire incident	1
Designated paramedic or rehab officer. SEMS Operator has other responsibilities and is not always a medic.	1
My SEMS Operator	9
My SEMS Operator and myself	70
Myself	28
Neither, I prefer not to have my health monitored	2

Seventy-one (71) out of 111 (64%) respondents preferred to have environmental indicators monitored by both the SEMS operator and themselves, 18 (16%) preferred only the SEMS operator to monitor the environment, 16 (14%) chose solely themselves to monitor, 4 (4%) selected another option, and 2 (2%) preferred neither, referred to in Table 3.3. When choosing what to monitor in the environment, 59.8% chose PH, 95.5% chose O₂, 100% selected CO, 99.1% selected H₂S, 96.5% chose combustible gas, 78.8% selected ammonia, 88.5% chose particulates, 87.4% selected CO₂, 71.2% selected Biological Proteins, and 82.9% chose Radiation.

Additionally, 97.3% selected lower exposure limit (LEL), 90.2% chose temperature inside the suit, and 82.9% chose the temperature outside the suit to be monitored. 70% selected humidity inside the suit, 69.1% chose humidity outside the suit, and 53.6% chose noise levels inside the suit to be monitored. 53.2% selected noise levels outside the suit, 98.2% chose hydrogen cyanide (HCN), 83.9% indicated volatile organic compounds (VOCs), and 78.6% selected polyhalogenated compounds (PHCs) to be monitored while working in the field.

Table 3.3 The frequency response to question “If someone were to monitor your ENVIRONMENT while working in the field, who would you prefer?”

Responses	N
A paramedic captain	1
Assistant Safety Officer	1
Battalion Chief	1
My SEMS Operator	18
My SEMS Operator and myself	71
Myself	16
Neither, I prefer not to have my environment monitored	2
Somebody assigned by the incident commander	1

There were three open-ended questions regarding why respondents do not use wearable technology, whether there are any additional types of health indicators that should be monitored, and whether there are any other types of environmental hazards that should be monitored. Regarding wearable technology, sixteen respondents commented that current wearable devices are too expensive, and sixteen respondents said there is no need for them to wear them. Five respondents would prefer blood glucose levels to be added as a physiological indicator. One respondent indicated that radon levels should be monitored in all stations, and one commented that wind direction and speed should be added as an environmental indicator to be monitored.

3.3.2 Professional Drivers Wearable Technology Survey

The purpose of this study was to survey professional drivers on their perceptions of wearable devices and to explore whether they would accept wearable technology that monitors their health and the surrounding environment. This project analyzed qualitative focus group data

and quantitative survey data from professional drivers. Before the survey was dispersed, three experts in the field reviewed the survey to ensure the questions were straightforward, and the terminology was correct for those in the trucking industry. These included a HAZMAT expert from local state patrol, a Safety Manager for a HAZMAT trucking company, and a Commercial Driver's License (CDL) Truck Driver Instructor.

A similar survey was sent to first responders regarding their perception of wearable technology. The first responder study was completed at a local fire department with no inclusion or exclusion criteria for the study. This survey contained similar questions to the previous, in addition to asking whether the first responders worked in special operations (Grothe et al., 2022). During the professional driver survey, the drivers were asked similar questions on demographics and perception of wearable technology. Each respondent was also asked if they haul hazardous material. The survey also included questions regarding the types of health information that professional drivers would like to have monitored such as heart rate, blood pressure, core body temperature, skin temperature, hydration level, stability, falls, breathing rate, breathing depth, blood oxygen levels, etc. Oxygen, carbon monoxide, flammable gases, non-flammable gases, carbon dioxide, infectious substances, radiation, poison, explosives, temperature, humidity, noise, pressure, and air quality were evaluated in the survey for environmental information.

The survey responses were collected electronically through Microsoft Forms, sent via email. The survey is presented in Appendix C.

Survey results showed that 67% of respondents hauled hazardous materials. 187 or 86% of respondents selected "yes" to using wearable technology. Comments from the 14% that did not use wearable technology cited usefulness, interest, and understanding how to use the technology as reasons for not using the technology. A majority of the respondents were either

extremely confident (52%) or very confident (29%) on their ability to operate wearable technology. The top three health indicators rated as important by the respondents that said “yes” to monitoring health were postural stability (85%), heart rate (81%), and hydration level (73%). The top three environmental indicators rated as important by respondents that said “yes” to monitoring environment were oxygen, temperatures, and flammable gases. These results supported the idea that professional drivers would potentially support the use of technology to monitor their health. There was no insight into costs, but multiple respondents commented usefulness as a problem.

Chapter 4 Other Notable Activities

4.1 Year 1 (2018-19)

Two graduate students presented their literature research and research project at the annual UNO Student Research Fair. Vikas Sahu's poster presentation, "Visualize to Realize: Improving Safety of First Responders" received the third place award, Meritorious Graduate Poster/Demonstration, out of 150 student presentations (Sahu). Graduate student, Chaitra Venkatesan, had a poster presentation called "Testing Environmental Sensors to Reduce Health Ailments among First Responders." The posters are presented in Appendix D. Drs. Sharon Medcalf, Aaron Yoder, Chandran Achutan, Matt Hale, and Ann Fruhling presented the focus group needs assessment results to the Engine 33 Special Operations Unit in the Omaha Fire Department.

Graduate Student Vikas Sahu and Dr. Ann Fruhling presented and published a paper in the proceedings of the Americas Conference for Information Systems (Sahu & Fruhling, 2018a; Sahu, 2018b). Graduate student Chaitra Venkatesan, Dr. Sharon Medcalf and Dr. Ann Fruhling presented and published a paper in the proceedings of the Americas Conference for Information Systems (Venkatesan et al., 2018a; Venkatesan et al., 2018b).

As a direct result of the partnership developed between our research team and the Omaha Fire Department, we submitted a research grant titled "Preventing heat-related illnesses in firefighters through integrated sensors" to the Department of Homeland Security (Achutan, PI; Fruhling, Co-PI). The grant had the following specific aims: 1) assess participants' work practices, work equipment, and comfort with technology; 2) design a novel, user-friendly way to integrate temperature, relative humidity, and heart rate sensors in firefighter suits; and 3) evaluate the efficacy of the integrated technology in Personal Protective Equipment (PPE) to

mitigate heat-related illnesses. The grant was not funded and we continued to look for other opportunities.

4.2 Year 2 (2019-20)

Two students graduated in May, 2019. They were able to utilize the experience working on this research when looking for jobs. Brian Collett was offered and accepted a position at Valmont, as documented on the College of Information Science and Technology's website. Another student, Suzy Fendrick, was offered an information technology internship at a National Long-Haul company. Graduate Assistant, Vika Suhu, completed his thesis titled "A Comparative Study on Visualization Design Preferences to Monitor First Responders' Health" (Sahu, 2019) and was offered a UX position at Mutual of Omaha. Graduate Assistant Jacob Grothe was offered a position as an Epidemiologist at the Pottawattamie County Health Department. Khatri wrote the following note: "Thank you Dr. Fruhling for all your help, support and guidance. It's been a great learning experience for me. I really have learned a lot from REaCH and Nebraska Watershed Project. You always gave us the freedom to learn and implement, that really helped me to grow. Good news is 'I got a full-time job as a Backend Software Developer' at TSG (The Strawhecker Group) in Omaha."

Drs. Medcalf, S., Yoder, A., and Fruhling, A. attended the Transportation Research Board (TRB) 99th Annual Meeting in January, 2020. They presented a poster titled "Requirements Gathering through Focus Groups for A Real-Time Emergency Communication System for Hazmat Incidents (Reach)". The research area was new to many attendees, introducing them to transportation worker and first responder health and environment safety monitoring perceptions and interests.

Students involved in the project have learned numerous skills in system and software development processes and procedures and about the transportation industry and safety. They shared their knowledge at the UNO Student Creative Activities and Research Fair. Student Suzy Fendrick presented a poster titled “Design for Safety: Decreasing First Responder Health Risk through Real-Time Bio-Sensor Alerts” and student Naveena Akula presented a poster titled “Lessons Learned from Designing a Health Monitoring System to Improve First Responders Safety User Interface” at the UNO 2019 and 2020 Student Research Fairs (Fendrick and Fruhling, 2019; Akula, et al., 2020).

Dr. Fruhling and Dr. Medcalf participated in the University of Nebraska-Lincoln Transportation Centers External Review from June 17-20, 2019.

Tyler Scherr served as the Project Monitor. He is a Ph.D. Licensing Associate at UNeMed Corporation, located at 986099 Nebraska Medical Center, Omaha, NE 68198. He can be reached by office phone at 402-559-2140 or email at tyler.scherr@unmc.edu.

A paper titled “Designing a Real-time Integrated First Responder Health and Environmental Monitoring Dashboard” was accepted at the DESRIST Design Science Research in Information Systems 2020 conference held in December, 2020.

4.3 Year 3 (2020-21)

On March 12, 2020 students working in the lab were asked to begin working remotely due to the COVID-19 pandemic. Likewise, some of the faculty on the project were asked to work remotely by the University, if possible. One faculty member was pulled from the project to support the Medical Center’s preparation and response to COVID-19 and to care for patients.

The estimated impact to the project reduced productivity to around 80% until

August, 2020. Students had many distractions; although, they all attended every meeting. As the Associate Director in the Center for Emergency Preparedness at UNMC, co-PI Dr. Medcalf was unavailable for meetings due to her job assignments being re-allocated to front-line support for COVID-19 at UNMC. Dr. Sharon Medcalf, reported, “I think I can safely say that the COVID-19 response has derailed me completely from the project.”

Further, there was tremendous impact on our student productivity at a time when seasoned students on the project graduated and we needed to find replacements who could work remotely and learn quickly. The transfer of knowledge was very challenging, but four new graduate assistants were able to start in Fall 2020 to keep the project on schedule. One of them is enrolled in the College of Public Health.

Dr. Fruhling agreed to be a thesis advisor for Jason Ellicott, Data Scientist III at Hunt Transport, Inc. He will work on data analytics for the health and environmental parameters’ alerts for REaCH using wearable sensor data.

4.4 Year 4 (2021-22)

During March, 2021, the team participated in the UNO Student Creativity and Research Fair and presented a poster titled “Wireless Sensor Integration into System’s Network for Real-time Data Streaming: Lessons Learned” with authors Ng, R., Rogers, J., Yachamaneni, K., Baysa, K., Li, D., Suwondo, T., Yoder, A., Ghersi, D., Fruhling, A.

The team worked on two manuscripts:

1. Grothe, J., Blake, A., Yoder, A., Achutan, C., Medcalf, S., Fruhling., A., “Exploring First Responders’ Use and Perceptions on Continuous Health and Environmental Monitoring,

target International Journal of Environmental Research and Public Health. (Grothe et al., 2023).

2. Sharon Medcalf, PhD, Matthew L. Hale, PhD, Chandran Achutan, PhD, CIH1, Aaron M. Yoder, PhD, Stanley W. Shearer, FF/EMT-P, Ann Fruhling, PhD, “Requirements Gathering Through Focus Groups for a Real-Time Emergency Communication System for Hazmat Incidents (REaCH)”, submitted to Journal of Public Health Issues and Practices. (Medcalf et al., 2021).

In the last quarter of 2021, Dr. Fruhling hired two graduate students to replace three students who received internships and permanent employment.

4.5 Year 5 (2022-23)

In Spring 2022, Dr. Fruhling onboarded one additional graduate student: Soundarya Jonnalagadda. Two students graduated in May, 2022. Justin Fay (Graduate) and Troy Suwondo (MPH). In the Fall of 2022, Dr. Fruhling onboarded Environmental Health, Occupational Health, & Toxicology doctoral student, Sarah Tucker and Cybersecurity undergraduate student, Luke Irwin. Luke was a computer science sophomore and spent time learning the REaCH development environment. Sarah is a Public health doctoral student who researched rural fire departments hazmat challenges and response to agricultural emergencies due to transporting hazardous materials.

Dr. Ann Fruhling and graduate student Elizabeth Reisher submitted “Assessing Decision Makers’ Cognitive Load for a First Responder Health Monitoring System” for the SAIS 2022 Conference. Soundarya Jonnalagadda researched new information focusing on the HAZMAT Incidents that occurred during transportation in Nebraska and the most pressing health concerns of first responders when they are involved in a hazmat spill. She found a very helpful dataset that

documents incidents and presented it to the team at a weekly meeting. She also completed the REaCH website, available at <https://afruhling.github.io/Reach.html>.

In September, 2022 the team was invited to attend the MākuSafe users conference in Iowa. We met with Makusafe.com leadership including Mr. Brett Burkhart. MākuSafe is an award-winning Safety, Data & Analytics solution aimed at improving worker health, safety, and productivity while reducing incidents and mitigating workplace hazards and risk exposures. MākuSafe gathers real-time environmental motion and near-miss data from connected devices, including their proprietary *wearable armband* technology. Attending this conference provided validation of our current UI setup and we learned about their technology and data analytics monitoring their manufacturing workforce.

Troy Suwondo (MPH student) and Dr. Aaron Yoder developed a survey to collect feedback from professional drivers on their potential use of wearable technology to monitor their environment and health. The survey was validated by experts from law enforcement and the trucking industry across the United States. The survey was implemented through Facebook Ads and email lists at trucking companies. The results of this survey were presented in Troy's MPH Capstone Presentation.

The team started writing a manuscript comparing health behavior monitoring attitudes between first responders and professional drivers; both groups of individuals could potentially be involved in a HAZMAT transportation incident. The manuscript is currently under review.

Matthew Thiele (student worker) and Dr. Dario Ghersi prototyped a computational approach to analyze data obtained from the Polar H10 device. The data contains both heart rate information and RR intervals (i.e., the time between two successive R-waves in the QRS complex of the electrocardiogram). RR intervals can be used to compute heart rate variability

(HRV), a measure that is associated with overall cardiovascular health. In order to prototype their code, Dr. Ghersi and Matthew Thiele are working with a publicly available dataset of RR intervals obtained from PhysioNet (<https://physionet.org/content/?topic=rr+interval>). The dataset contains RR intervals obtained over a 24 hour period for 54 healthy subjects and 29 patients with congestive heart failure. The dataset will allow us to determine how well HRV can discriminate between healthy individuals and patients with heart failure. Furthermore, the data will also be useful to benchmark the dashboard and for demonstration purposes. Matthew Thiele completed his Honor's Thesis with advisor Dr. Ghersi titled "A Machine Learning Approach for Predicting Patient Mortality with Heart Rate Variability Statistics" that built on some of the research he did for this project.

With the assistance of PhD student Sarah Tucker, Dr. Fruhling prepared and submitted a proposal to the Central States Center for Agricultural Safety and Health (CS-CASH) Pilot/Feasibility Projects Program. In December, 2022 another paper titled "Applying the Trajectories Conceptual Framework: A case study of an IoT health data monitoring application" was submitted and accepted to the HCII 2023 Conference authored by Elizabeth Reisher, Soundarya Jonnalagadda, and Dr. Fruhling. The conference in Denmark July, 2023 wherein Dr. Fruhling presented.

4.6 Year 6 (2023)

In Spring 2023, four students participated in the UNO Student Research Fair. Soundarya Jonnalagadda (Graduate student from UNO) and Sarah Tucker (PhD Student from UNMC) presented their work via poster presentation. The poster, titled "Does profession matter toward perception of Wearable Technology for Health Monitoring in the field?", outlined the exploratory study comparing and evaluating the perceptions of

first responders (FR) and professional truck drivers (PTD) on wearable technology and attitudes toward real-time health monitoring.

Elizabeth Reisher and Soundarya Jonnalagadda presented their research work via an oral presentation titled “Applying the Trajectories Conceptual Framework: A case study of an IoT health data monitoring application” at the UNO fair. In this study students examined the design and development of a dashboard utilizing Trajectories Conceptual Framework (TCF) and Action Research (AR). The aim of this research was to analyze if TCF can guide the development of a dashboard from research to industry.

Another undergraduate student, Matthew Thiele, presented his research on “Heart Rate Variability and Patient Mortality”. This work aimed to establish the efficacy of HRV statistic-based machine learning algorithms in predicting patient mortality in a diverse critical care environment and illuminate future challenges and considerations in implementing such statistics into prediction models.

Sarah edited the manuscript “Exploring First Responders’ Use and Perceptions on Continuous Health and Environmental Monitoring”, which was recently published in the *International Journal of Environmental Research and Public Health* by Grothe, J., Tucker, S., Blake, A., Achutan, C., Medcalf, S., Suwondo, T., Fruhling, A., and Yoder, A. M. in 2023.

In May 2023, Dr. Fruhling and Soundarya Jonnalagadda demonstrated the REaCH application at the 8th ACM/IEEE Conference on Internet of Things Design and Implementation in San Antonio, Texas.

Chapter 5 IT System Development Artifacts

In this chapter we present the activities, artifacts, and products produced during the system development phases of REaCH. Year 1 is presented in the background section of Chapter 1.

In year 2, we continued working on REaCH Requirements and Design Documentation and completed several UML diagramming artifacts: use cases, sequence diagrams, component diagrams, and security elements. We continued the design of the threshold user interface with the logic of entering thresholds and comparing first responder health biomarkers to thresholds. We completed building a low fidelity REaCH system prototype using Protoshare wireframe software. Five graduate students contributed to this phase of the project: Jackson Urrutia, Naveena Akula, Anusha Manda, Hitesh Khatri, and Jacob Grothe.

We completed a research study design including prototypes for three scenarios. We scheduled a comprehensive user interface evaluation with Stan Shearer OFD and others (Incident Commanders and Medics) on April 6, 2020 via Zoom. Stan Shearer became ill with COVID-19, and he had to postpone his involvement. This study was completed in year 3.

In year 3, the project team continued to develop the REaCH system from a low-fidelity prototype to a high-fidelity prototype. Further, we continued the IT (information technology) development of the REaCH Application including test scenarios, test plan and test data, and integrating data analytics approaches to visualize health trends. We rescheduled the comprehensive user interface evaluation with Stan Shearer OFD and others (Incident Commanders and Medics).

In year 4, we completed most of the software coding and constructing technology to capture heat index data real-time from devices and sensors placed on humans and transmitting data to the REaCH database to be displayed on a dashboard in real time. The team successfully completed several simulated laboratory experiments demonstrating various scenarios in real-time to dashboard. Omaha Fire Fighter Stan Scheer attended lab experiment.

In year 5, the team conducted lab experiments with multiple devices and sensors connected to the REaCH system. These system tests went as planned. Data transmission was correct, reliable and timely. These successful lab experiments are the foundation for future field tests. ECG data was correctly captured and displayed. The user interface format was updated, and several new pages were designed.

In year 6, the team completed the development and testing of an event page and admin and individual detail pages. There were several technical updates such as Java version upgrade (version 15) and backups for the Heroku database and Raspberry Pi. The team worked on streamlining/automating the device connection process by using the MAC address, implemented Python scripts on the Pi to get devices connected and posting data. Lastly, the team created a simulation script to demonstrate the capabilities of the dashboard.

5.1 REaCH IT System Requirements Documentation

The REaCH IT System Requirements Documentation can be found in Appendix E.

5.2 REaCH System User Interface Prototype

The REaCH System User Interface Prototype Documentation can be found in Appendix F.

5.3 REaCH Technical Development Documentation

The REaCH Technical Development Documentation can be found in Appendix G.

5.4 REaCH Database Schema Diagram

The REaCH Database Schema Diagram can be found in Appendix H.

5.5 REaCH Application Screenshots

The REaCH Application Screenshots can be found in Appendix I.

Chapter 6 Future Work

The REaCH System is poised to be translated to a production ready IoT solution for small to large fire departments. Dr. Fruhling submitted a proposal as part of the UNO NSF ART submission. The aims of the project are 1) Develop, test and implement a production-ready Rural Fire Department First Responder Health & Environmental Data Monitoring System, 2) Create an IT Start-up business that contributes to rural economic development, and 3) License/Patent REaCH System Software. The anticipated impact and outcomes for this future work are:

- An IT application: a real-time interactive dashboard that captures and displays first responders' health data and environmental exposure information that can be used to monitor an individual's situation and send alerts when there are concerns.
- Improve safety of VFF and FR from using the Health & Environmental Data Monitoring Systems for Rural Fire Departments.
- Increase Nebraska economic and workforce development in rural communities by developing a skilled workforce and increasing accessibility to technology usage learning opportunities.
- Contribute to the scientific community on innovative uses of Internet of Things sensor by improving effectiveness and optimization and gaining a better understanding of health monitoring using wearable sensor technologies.
- Develop long-term and sustainable health monitoring of volunteer firefighters and first responders to improve their health and wellness.
- Integration of technology to change safety culture of the workforce.

If the UNO NSF ART grant is awarded, we plan to do the following. In the first year we plan to enhance the REaCH system; integrate sensors that are more compatible or easier to connect to the system; design, test, and implement wireless network; test and evaluate attaching the sensors to various parts of the body under PPE; and write proposals to get the VFD state to match funding for hardware and software needs. We also plan to upgrade devices and sensors as needed due to new software and hardware versions and integrate security protocols and encryption to meet HIPAA regulations. In the second year we plan to conduct beta tests with rural Volunteer Fire Departments during controlled burning training and real events. At the same time, we will develop a business plan for a start-up, establish a partnership to support technical 24/7 support, roll out the REaCH system into production, test the REaCH system during actual fires and other emergencies, and prepare marketing and promotion material to announce the launch of the system.

References

- Alrizq, M., Solangi, A.S., Alghamdi, A., Nizamani, M.A., Memon, M.A. & Hamdi, M. (2021). An Architecture Supporting Intelligent Mobile Healthcare Using Human- Computer Interaction HCI Principles. *Computer Systems Science & Engineering*, 40(2), 557–569. <https://doi.org/10.32604/csse.2022.018800>
- Booch, G., Rumbaugh, J., and Jacobson, I. (1998). The Unified Modeling Language User Guide. <http://www.icst.pku.edu.cn/course/uml/reference/the-unified-modeling-language-user-guide.9780201571684.997.pdf>
- Corrigan, S. L., Roberts, S., Warmington, S., Drain, J., & Main, L. C. (2021). Monitoring stress and allostatic load in first responders and tactical operators using heart rate variability: a systematic review. *BMC Public Health*, 21(1). <https://doi.org/10.1186/s12889-021-11595-x>
- Fruhling, A., Yoder, A. & Jonnalagadda, S. (2023). An IoT Dashboard Monitoring First Responders' Health and Environmental Data during HAZMAT Emergencies. IEEE/ACM Eighth International Conference on Internet-of-Things Design and Implementation (IoTDI), San Antonio, TX.
- Grothe, J., Tucker, S., Blake, A., Achutan, C., Medcalf, S., Suwondo, T., Fruhling, A. & Yoder, A. M. (2023). Exploring First Responders' Use and Perceptions on Continuous Health and Environmental Monitoring. *International journal of environmental research and public health*, 20(6), 4787. <https://doi.org/10.3390/ijerph20064787>
- Horan, K. A., Marks, M., Ruiz, J., Bowers, C. & Cunningham, A. (2021). Here for My Peer: The Future of First Responder Mental Health. *International journal of environmental research and public health*, 18(21), 11097.
- Kestrel D3- Wireless sensor. <https://kestrelmeters.com/products/kestrel-drop-d3-ballistics>
- Lasisi, A., Bai, L., & Sun, Z. (2012). An Empirical Study on Risk Mitigation in Transporting Hazardous Material. Industrial and Systems Engineering Research Conference
- Ma, Q., Wang, C., Lu, J., and Jiang, C. (2014). Development of an Integrated Emergency Management System for Hazardous Materials Transport: Improve the Transportation Safety and Enhance the Efficiency of Emergency Response. IEEE 17th International Conference on Intelligent Transportation Systems (ITSC)
- Medcalf, S., Hale, M. L., Achutan, C., Yoder, A., Fruhling, A. & Shearer, S. Requirements Gathering through Focus Groups for a Real-Time Emergency Communication System for Hazmat Incidents (REaCH). *Journal of Public Health Issues and Practices*, 5(2), 188. <https://doi.org/10.33790/jphip1100188>
- NFPA (National Fire Protection Association) (2022a). *Firefighter Fatalities in the US in 2021*. <https://www.nfpa.org/News-and-Research/Data-research-and-tools/Emergency-Responders/Firefighter-fatalities-in-the-United-States>

NFPA (National Fire Protection Association) (2022b). *United States Firefighter Injuries in 2021*. <https://www.nfpa.org/-/media/Files/News-and-Research/Fire-statistics-and-reports/Emergency-responders/osffinjuries.pdf>

Office of the Federal Register National Archives and Records Administration, October 2011, Code of Federal Regulations Title 49 (Transportation)

Perroni, F., Guidetti, L., Cignitti, L., & Baldari, C. (2014). Psychophysiological Responses of Firefighters to Emergencies: A Review. *The Open Sports Sciences Journal*, 7(1), 8-15. <https://doi.org/10.2174/1875399x01407010008>

Polar H10 - Heart Rate Sensor. <https://www.polar.com/us-en/sensors/h10-heart-rate-sensor>

Sahu, Vikas. “Visualize to Realize: Improving Safety of First Responders”, poster presentation at University of Nebraska at Omaha Student Research and Creative Activity Fair, March 2, 2018. <https://digitalcommons.unomaha.edu/srcaf/2018/schedule/177/>

US Department of Transportation Region VII: UTC 25-1121-0005-110, sub-award from UNL UTC MATC. (2016-2023). [Grant]

Acknowledgements

The REaCH team would like to thank Mr. John Rogers, Dr. George Grispos, and Dr. Matthew Hale for their technical expertise and consultations.

Appendix A Sample User Diagram and User Scenarios

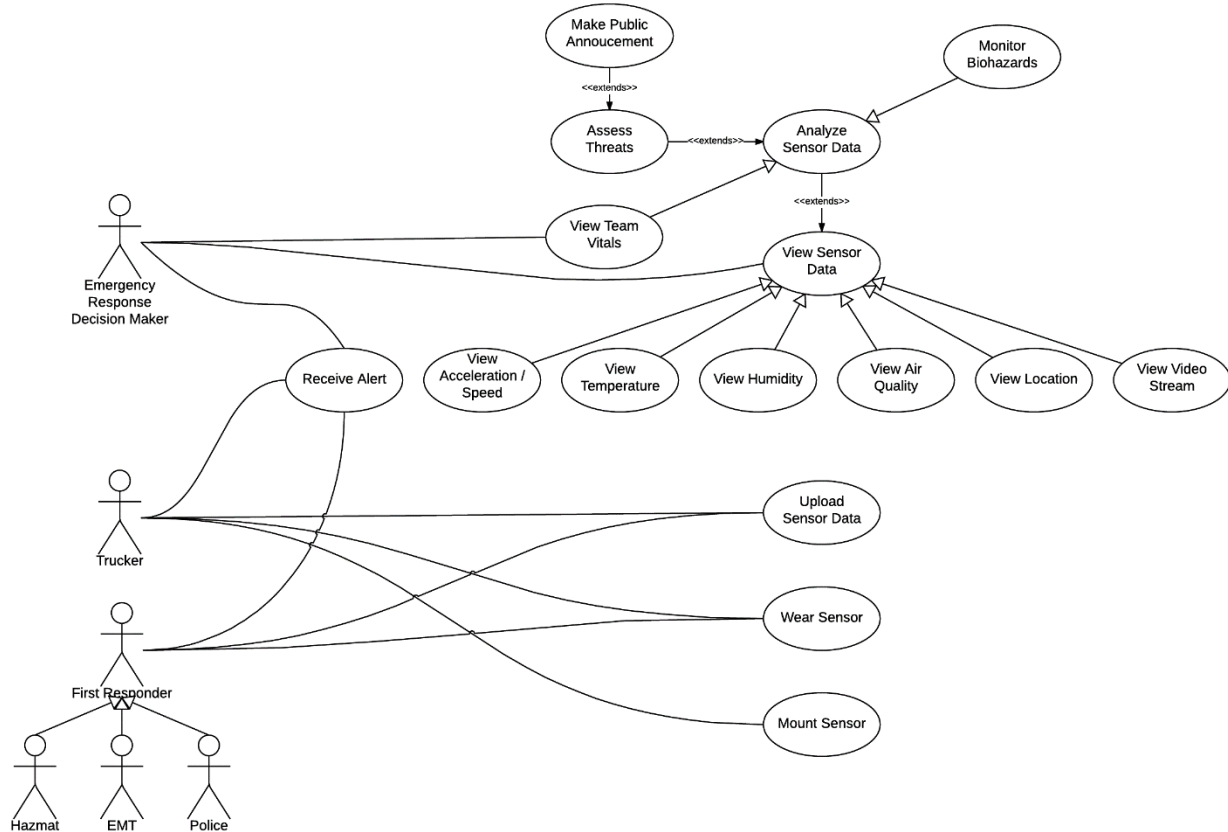

Backlog

1. As a researcher, I must know when the device is powered on and off, so that I know that I can record my participant's data.
2. As a researcher, I need to know that the dashboard is displaying sensor data, so I know that device is transmitting data and the dashboard is receiving data.
3. As a researcher, I need to be notified about a transmission error with the sensor, so I know that I can troubleshoot (this needs to be further defined).
4. As a HAZMAT captain, I want to read data from smart devices, so that I can more accurately identify hazards.
5. As a HAZMAT captain, I want to read data from smart devices, so that I can more rapidly identify hazards.
6. As a HAZMAT tech, I want to monitor the health of individuals on my team, so that I can extricate them from dangerous situations.

7. As a HAZMAT tech, I want to keep track of my team, so that I can strategically deploy resources.
8. As a HAZMAT captain, I want to communicate with corporate entities, so that I can more rapidly identify hazards.
9. As a HAZMAT first responder, I want to receive alerts if my vitals are at abnormal levels, so that I can avoid the area to maintain my health and safety.
10. As a HAZMAT first responder, I want to be able to identify hazards quickly, so that I can better adapt to and mitigate the situation.
11. As a researcher, I want to be able to jump to a particular date/time in the dataset, so I can quickly go to a particular section of data.
12. As a researcher, I want to be able to customize the dashboard, so I can select, view and organize specific datasets.
13. As a researcher, I want to be able to see the information in moveable panes, so that I can focus on just the information I want.
14. As a designer/researcher, I want the information to be color blind accessible, so that a wider range of people are able to effectively use the interface.
15. As a researcher, I want to see data organized by participant, group, or other attributes, so that I can compare the data and do analyses.
16. As a researcher I need to login to the dashboard so that the data is protected.
17. As a researcher I need to be able to select which function I want to do (e.g. view data, connect sensors, etc.).
18. As a researcher I need to be able select the sensor(s) I want to connect for transmission so that data is being captured.
19. As a sensor I need to have day and time included in the transmitted data so that the researcher can group the data and a particular participant can be identified.
20. As a researcher I need to be able to assign a sensor to a participant so that I have the association of a participant.
21. As a researcher I need be able to add an event as a marker on the current data so I can go back and do further analysis.
22. As a researcher I need to have the EPOCH data converted to the local time zone since it is collected in GMT time so that the time and data matches the local time zone.
23. As a HAZMAT first responder, I want to read data from smart devices, so that I can more accurately identify hazards.
24. As a HAZMAT captain, I want to keep track of my team, so that I can strategically deploy resources.
25. As a HAZMAT captain, I want to keep track of my team, so that I can help them avoid hazards.
26. As a HAZMAT captain, I want to monitor the health of individuals of on my team, so that I can track longitudinal health and safety.

27. As a HAZMAT first responder, I want to be able to identify hazards accurately, so that I can better adapt to and mitigate the situation.
28. As a HAZMAT captain, I want to monitor the health of individuals on my team, so that I can extricate them from dangerous situations.
29. As a HAZMAT captain, I want to identify hazards quickly, so that I can strategically deploy and initiate the correct resources to mitigate them.
30. As a HAZMAT first responder, I want to read data from smart devices, so that I can more rapidly identify hazards.
31. As a HAZMAT captain, I want to keep track of my team, so that I can help them if they are in distress.
32. As a HAZMAT first responder, I want to keep track of my teammates, so that I can help them if they are in distress.
33. As an admin, I want to be able to assign a sensor to a user during the setup process, so that I know where their data is coming from.
34. As a HAZMAT tech, I want to keep track of my team, so that I can help them avoid hazards.
35. As a HAZMAT tech, I want to keep track of my team, so that I can help them if they are in distress.

Appendix B Agile Methods Flowchart

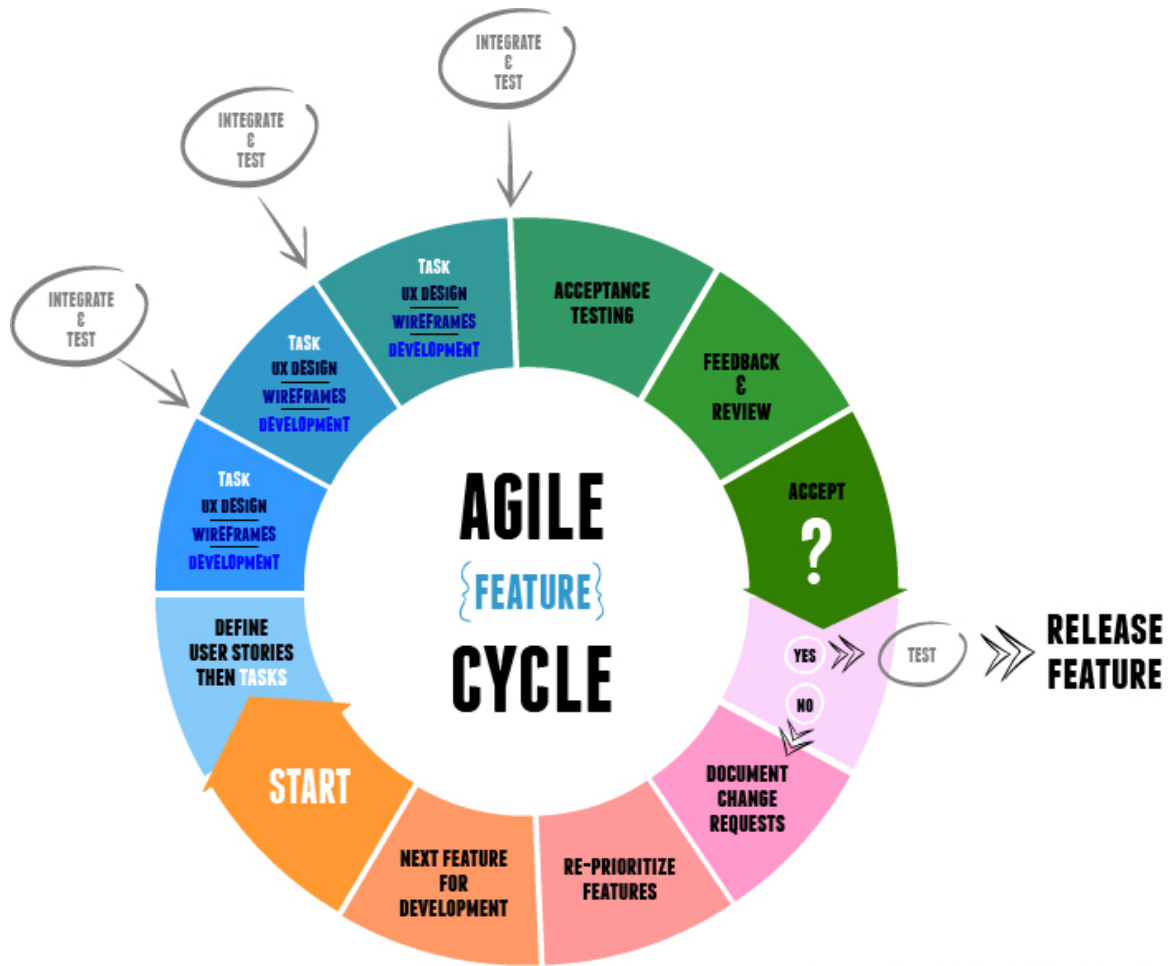

Agile development utilizes a *feature* centric approach that guides the definition and realization of *user stories*. User stories are, as the name implies, short descriptions of the kinds of activities a user is involved in relation to the software. User stories are structured and define the type of *user involved*, the *action* they want to take, and the *goal(s)* of the action as they relate to the user. This structure forms the basis of a software requirement that is implemented as a feature. Feature development is not monolithic, so as user stories are defined, their realization (or achievement) is decomposed into a set of synchronous or asynchronous tasks. Once the tasks are completed, they produce code artifacts that are then integrated together, tested, reviewed, and either accepted or not. If a feature is accepted, then development proceeds onward to the next user story. If not, new tasks are created to realize the story, the story is changed given lessons learned, or the development team re-focuses on other important features needed for the final product. Ultimately, when the core user stories related to a feature are realized, the feature can be released. Often feature releases are grouped together into a new overall product version.

Appendix C Surveys

C.1 First responder survey

2

Are you part of Special Operations?

- Yes
- No

3

What year were you born? (YYYY)

Please enter a number less than or equal to 2000

4

Have you ever used wearable technology (Fitbit, Smart Watch, etc.)?

- Yes
- No

5

Do you currently use wearable technology?

- Yes
- No

6

Why don't you use wearable technology?

Enter your answer

7

How confident are you in your ability to operate wearable technology?

- Extremely confident
- Very confident
- Somewhat confident
- Not so confident
- Not at all confident

8

If someone were to monitor your HEALTH while working in the field, who would you prefer?

- Myself
- My SIMS Operator
- My SIMS Operator and myself
- Neither, I prefer not to have my health monitored
- Other

9

In your opinion, what types of HEALTH information would be useful to monitor for first responder safety when working in the field.

	Yes	No	Don't Know
Heart Rate	<input type="radio"/>	<input type="radio"/>	<input type="radio"/>
Blood Pressure	<input type="radio"/>	<input type="radio"/>	<input type="radio"/>
Core Body Temperature	<input type="radio"/>	<input type="radio"/>	<input type="radio"/>
Skin Temperature	<input type="radio"/>	<input type="radio"/>	<input type="radio"/>
Hydration Level	<input type="radio"/>	<input type="radio"/>	<input type="radio"/>

10

In your opinion, what types of HEALTH information would be useful to monitor for first responder safety when working in the field.

	Yes	No	Don't Know
Stability	<input type="radio"/>	<input type="radio"/>	<input type="radio"/>
Falls	<input type="radio"/>	<input type="radio"/>	<input type="radio"/>
Breathing Rate	<input type="radio"/>	<input type="radio"/>	<input type="radio"/>
Breathing Depth	<input type="radio"/>	<input type="radio"/>	<input type="radio"/>
Blood Oxygen Levels	<input type="radio"/>	<input type="radio"/>	<input type="radio"/>
Respiration CO2 Levels	<input type="radio"/>	<input type="radio"/>	<input type="radio"/>
Cortisol Levels (Stress)	<input type="radio"/>	<input type="radio"/>	<input type="radio"/>
Skin Resistance (Stress and Hydration)	<input type="radio"/>	<input type="radio"/>	<input type="radio"/>

11

In your opinion, are there any additional types of HEALTH information that would be useful to monitor for first responder safety. If so, please list below.

Enter your answer

12

If someone were to monitor your ENVIRONMENT while working in the field, who would you prefer?

- Myself
- My SIMS Operator
- My SIMS Operator and myself
- Neither, I prefer not to have my environment monitored
- Other

13

In your opinion, what types of ENVIRONMENTAL information would be useful to monitor for first responder safety.

	Yes	No	Don't Know
PH	<input type="radio"/>	<input type="radio"/>	<input type="radio"/>
Oxygen	<input type="radio"/>	<input type="radio"/>	<input type="radio"/>
Carbon Monoxide	<input type="radio"/>	<input type="radio"/>	<input type="radio"/>
Hydrogen Sulfide	<input type="radio"/>	<input type="radio"/>	<input type="radio"/>
Combustible Gases	<input type="radio"/>	<input type="radio"/>	<input type="radio"/>
Ammonia	<input type="radio"/>	<input type="radio"/>	<input type="radio"/>
Particulates	<input type="radio"/>	<input type="radio"/>	<input type="radio"/>
Carbon Dioxide	<input type="radio"/>	<input type="radio"/>	<input type="radio"/>
Biological Proteins	<input type="radio"/>	<input type="radio"/>	<input type="radio"/>
Radiation	<input type="radio"/>	<input type="radio"/>	<input type="radio"/>

14

In your opinion, what types of ENVIRONMENTAL information would be useful to monitor for first responder safety.

	Yes	No	Don't Know
LEL - Lower Explosive Limit	<input type="radio"/>	<input type="radio"/>	<input type="radio"/>
Temp (inside suit)	<input type="radio"/>	<input type="radio"/>	<input type="radio"/>
Temp (outside suit)	<input type="radio"/>	<input type="radio"/>	<input type="radio"/>
Humidity (inside suit)	<input type="radio"/>	<input type="radio"/>	<input type="radio"/>
Humidity (outside suit)	<input type="radio"/>	<input type="radio"/>	<input type="radio"/>
Noise - Sound Level (inside suit)	<input type="radio"/>	<input type="radio"/>	<input type="radio"/>
Noise - Sound Level (outside suit)	<input type="radio"/>	<input type="radio"/>	<input type="radio"/>
Hydrogen Cyanide	<input type="radio"/>	<input type="radio"/>	<input type="radio"/>
VOCs - Volatile Organic Compounds	<input type="radio"/>	<input type="radio"/>	<input type="radio"/>
PHCs - Polyhalogenated Compounds	<input type="radio"/>	<input type="radio"/>	<input type="radio"/>

15

In your opinion, are there any additional types of ENVIRONMENTAL i
be useful to monitor for first responder safety. If so, please list below

Enter your answer

16

Questions, Comments, and/or Concerns?

Enter your answer

C.2 Professional driver survey

2

What is the zip code of the company you currently work for?

The value must be a number

3

What year were you born? (YYYY) *

Please enter a number less than or equal to 2000

4

Do you ever haul any hazardous materials? *

Enter your answer

5

If yes, what are your greatest concerns when hauling hazardous materials? *

Enter your answer

6

Have you ever used wearable technology (Fitbit, Smart Watch, etc.)? *

Enter your answer

7

Do you currently use wearable technology? *

Enter your answer

8

If not, why do you not use wearable technology? *

Enter your answer

9

How confident are you in your ability to operate wearable technology? *

- Extremely confident
- Very confident
- Somewhat confident
- Not so confident
- Not at all confident

10

If someone were to monitor your HEALTH while working in the field, who would you prefer? *

- Myself
- Safety Officer
- Safety Officer and myself
- Dispatcher
- Dispatcher and myself
- I prefer not to have my health monitored
- Other

11

In your opinion, what types of HEALTH information would be useful to monitor for your or your coworkers' safety when working in the field. *

	Yes	No	Don't Know
Heart Rate	<input type="radio"/>	<input type="radio"/>	<input type="radio"/>
Blood Pressure	<input type="radio"/>	<input type="radio"/>	<input type="radio"/>
Core Body Temperature	<input type="radio"/>	<input type="radio"/>	<input type="radio"/>
Skin Temperature	<input type="radio"/>	<input type="radio"/>	<input type="radio"/>
Hydration Level	<input type="radio"/>	<input type="radio"/>	<input type="radio"/>

12

In your opinion, what types of HEALTH information would be useful to monitor for you or your coworkers' safety when working in the field.

	Yes	No	Don't Know
Stability	<input type="radio"/>	<input type="radio"/>	<input type="radio"/>
Falls	<input type="radio"/>	<input type="radio"/>	<input type="radio"/>
Breathing Rate	<input type="radio"/>	<input type="radio"/>	<input type="radio"/>
Breathing Depth	<input type="radio"/>	<input type="radio"/>	<input type="radio"/>
Blood Oxygen Levels	<input type="radio"/>	<input type="radio"/>	<input type="radio"/>
Respiration CO2 Levels	<input type="radio"/>	<input type="radio"/>	<input type="radio"/>
Cortisol Levels (Stress)	<input type="radio"/>	<input type="radio"/>	<input type="radio"/>
Skin Resistance (Stress and Hydration)	<input type="radio"/>	<input type="radio"/>	<input type="radio"/>

13

In your opinion, are there any additional types of HEALTH information that would be useful to monitor for you and your coworkers' safety. If so, please list below. *

Enter your answer

14

If someone were to monitor your ENVIRONMENT while working in the field, who would you prefer? *

- Myself
- Safety Officer
- Safety Officer and myself
- Dispatcher
- Dispatcher and myself
- I prefer not to have my environment monitored
- Other

In your opinion, what types of ENVIRONMENTAL information would be useful to monitor you or your coworkers' safety. *

	Yes	No	Don't Know
Oxygen	<input type="radio"/>	<input type="radio"/>	<input type="radio"/>
Carbon Monoxide	<input type="radio"/>	<input type="radio"/>	<input type="radio"/>
Flammable gases	<input type="radio"/>	<input type="radio"/>	<input type="radio"/>
Non-flammable gases	<input type="radio"/>	<input type="radio"/>	<input type="radio"/>
Carbon Dioxide	<input type="radio"/>	<input type="radio"/>	<input type="radio"/>
Infectious substances	<input type="radio"/>	<input type="radio"/>	<input type="radio"/>
Radiation	<input type="radio"/>	<input type="radio"/>	<input type="radio"/>
Poison	<input type="radio"/>	<input type="radio"/>	<input type="radio"/>
Explosives	<input type="radio"/>	<input type="radio"/>	<input type="radio"/>

16

In your opinion, what types of ENVIRONMENTAL information would be useful to monitor for you or your coworkers' safety.

	Yes	No	Don't Know
Temperature	<input type="radio"/>	<input type="radio"/>	<input type="radio"/>
Humidity	<input type="radio"/>	<input type="radio"/>	<input type="radio"/>
Noise - Sound Level	<input type="radio"/>	<input type="radio"/>	<input type="radio"/>
Pressure	<input type="radio"/>	<input type="radio"/>	<input type="radio"/>
Air quality	<input type="radio"/>	<input type="radio"/>	<input type="radio"/>

17

In your opinion, are there any additional types of ENVIRONMENTAL information that would be useful to monitor for you or your coworkers' safety. If so, please list below. *

Enter your answer

18

Questions, Comments, and/or Concerns? *

Enter your answer

Appendix D Posters



Visualize to Realize: Improving Safety of First Responders

Vikas Sahu, Ann L. Fruhling, PhD

Introduction

- The goal of this study is to improve the safety of first responders during an emergency hazardous material (hazmat) incident.
- A first responder (FR) is an individual who arrives first during a hazmat incident and takes the initiative to act in order to minimize the risk to public health and property from such incidents. Often first responders are firefighters.
- The reports of National Fire Protection Association recorded a national average of more than 30,000 firefighter injuries between 2010-16 (National Fire Protection Association, 2017).
- According to the US Fire Administration, an average fatality of 120 firefighters were recorded between 2010-16 throughout the nation. In 2017, a total number of 81 fatalities were recorded. (FEMA, Department of Homeland Security, 2017).
- In order to ensure FRs' safety, the IC at the incident command and control center monitors critical information about first responders and local environment.
- In the state of Nebraska, the IC uses a dated system with two displays with different information to gather the required information and monitor the scenario. The user interface of these displays often have slow response times. (Shearer & Bernard, 2017).

Purpose of Research

The purpose of this experimental study is to develop and evaluate the usability of a new dashboard integrating critical information about first responders' health and safety for an incident commander to monitor and make decisions. At this stage, the dashboard will be generally defined as a visualization tool that will help to reduce cognitive load for the incident commander during emergency situations and improve decision making capability regarding safety of first responders.

Problems

- Data integration problems** – The critical data about FRs and incident environment are displayed on **two different screens** because each system has its own user interface, which makes it difficult to make effective decision during emergencies.
- Current technology is dated** – The user interface works on a Windows XP platform with limited processing capabilities that gets updated in a time interval of 45 seconds. This implies that the data available to IC about FRs is often not available until after 20 steps have been taken and thus potential exposure to hazardous materials may have already occurred before the FR is aware.
- Incident commander experiences cognitive overload** – There is a constant exchange of critical data between FRs and IC during emergencies. The visualization of so much data on separate displays leads to cognitive overload for IC.
- System user interface usability issues** – The dated user interfaces for the current systems have several problems such as: not well organized, do not match the emergency management work, poor navigation, etc.

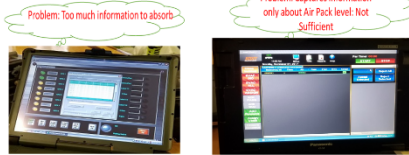

Prototype Design Sketch

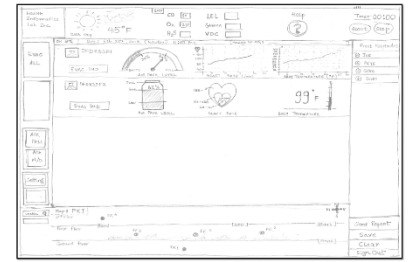

Current Work Flow



Research Question

What are the most critical dashboard display design features that will optimize the performance and decision making of an incident commander during a hazmat response situation?

Research Design

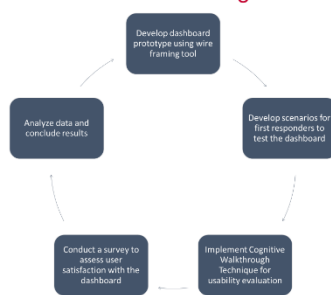

Projected Contributions from this Research

- Several contributions from this study are anticipated such as:
 - Integrated user-interface of dashboard will reduce the cognitive load of Incident Commander (IC) during emergencies.
 - Visualization of critical data (for FRs and incident environment) on a single screen will allow IC to make efficient decision for first responders.
 - Integration of critical data into a single screen will improve the usability of the dashboard.
- Overall, we hope the new dashboard will help in improving the safety of first responders during hazardous incident responses.

Future Work

- The future work for this study includes the following steps:
 - Transformation of final screen sketches into dashboard prototype using a suitable wire framing software package.
 - Usability evaluation of the dashboard prototype in a simulated scenario-based test environment using Cognitive Walkthrough Technique. Cognitive Walkthrough-based information is used to determine the ease with which a new user will learn to interact with a computer-based information system.

This research is being conducted in collaboration with the **Special Operations Team**, Omaha Fire Department, who are responsible to contain hazmat incidents in the Omaha Metropolitan Area.

Acknowledgement

Funding for this research is supported through a US Department of Transportation, University Transportation Center (UTC) Competition 2016 award.

References

- National Fire Protection Association. (2017, June). Firefighter activities, injuries, and deaths. Retrieved from National Fire Protection Association: <https://www.nfpa.org/News-and-Research/Fire-statistics-and-reports/Fire-statistics/The-fire-service/Fatalities-and-injuries/Firefighter-activities-injuries-and-deaths>
- Shearer, S., & Bernard, W. (2017, Nov 10). Safety and Information Technology Division. (A. Fruhling, & V. Sahu, Interviewers)

Other Contributor Logos Go Here



Design for Safety: Decreasing First Responder Health Risks Through Real-Time Bio-Sensor Alerts

Suzy Fendrick, Ann Fruhling PhD
College of Information Science & Technology, University of Nebraska at Omaha, Omaha, NE 68182

Introduction

The focus of this research project is using the Design Thinking process to create an informative dashboard for first responders. Design Thinking involves empathizing with the user, defining the problems to be solved, ideation, creating prototypes, and testing. This iterative process focuses on the user, resulting in the most effective product possible. The dashboard will display real-time biosensor data from sensors in the first responders' uniforms. This project is part of a larger project with the goal of vastly improving the safety of first responders during emergency hazardous material incidents. This project is funded by U.S. Department of Transportation.

Design Thinking Process

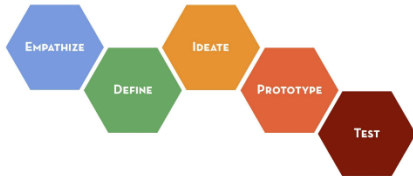

Figure 1

The Design Thinking Process is an iterative process for creative problem solving, as displayed in Figure 1.^(1,2)

- **Empathize:** getting to know who the user is, learning and researching their needs.
- **Define:** begin analysis of research and define a problem statement. The problem statement is written from the perspective of the user, not yourself or the company.
- **Ideate:** brainstorming, coming up with as many solutions to the problem as possible.
- **Prototype:** narrow down the best possible solution for the problem and defining how it will work.
- **Test:** see how the potential user will interact with the product created, identifies problems in the design, and what needs to be altered.

Benefits of the Design Thinking Process

- Usability problems found early
- Takes less time, improvements are made early
- Saves money, improvements are made when work is cheap to produce

Empathize and Define

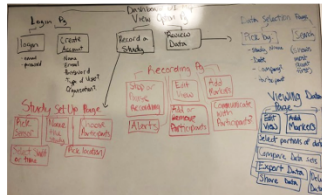

Figure 2

The first step of the process is Empathize. This involved researching current first responder technology, emergency response dashboards and iconography, and communication with local firefighters. After researching, the Define process began. Displayed here in Figure 2 is a map of all the potential web pages needed for the dashboard. The needs of the user need to be defined before designing.

Ideate and Low-Fidelity Prototype

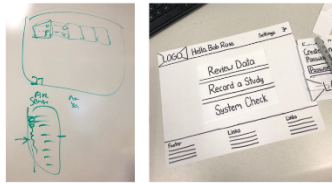

Figure 3

Figure 4

After defining the problem and the user's needs, the ideation process can begin. Ideate involved making simple designs on a whiteboard as displayed in Figure 3. Many ideas were sketched on the whiteboard before moving to Prototype phase displayed in Figure 4. These paper prototypes are low-fidelity and the first step in the prototyping process. They underwent critiques with the HazMat team to alter the design until it was solidified. After making paper prototypes, the next step was creating high-fidelity prototypes and prepare for testing.

High-Fidelity Prototype

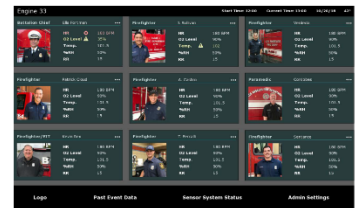

Figure 5

After creating low-fidelity paper prototypes, high fidelity prototypes were created, as seen in Figure 5. They were made on the computer to seem more real and are easier to test on the user. Preparation for the Test phase has begun. So far, these high fidelity mock-ups have been tested out in once with the firefighter leads.

Next Steps and Assessment

The next steps in this research would be:

- Completing all design work and mockups
- Completing all development work of the actual website
- Testing all work with real users

An assessment of the effectiveness of the Design Thinking Process would be the conclusion of this project. This would validate if the system met the user's needs.

References and Acknowledgements

I would like to acknowledge the U.S. Department of Transportation, Region VII Grant: UTC 25-1121-0005-110 for funding my research.

1. Design Thinking Process [Digital image]. (n.d.). Retrieved February 21, 2019, from <http://longevy3.stanford.edu/designchallenge/design-thinking-process/>
2. Dam, R., & Slang, T. (2019, February). 5 Stages in the Design Thinking Process. Retrieved February 21, 2019, from <https://www.interaction-design.org/literature/article/5-stages-in-the-design-thinking-process>

Lessons Learned from Designing a Health Monitoring System to Improve First Responders Safety User Interface

N. Akula¹, J. Urrutia¹, H. Khatri¹, M. Anusha¹, J. Grothe², S. Medcalf², A. Yoder², D. Ghersi¹, C. Achuthan², A. Fruhling¹
 University of Nebraska at Omaha¹, University of Nebraska Medical Center²

Introduction

Every day, first responders put their own lives at risk to help individuals, families, and communities. They experience many safety and health hazards on the frontline that can lead to injuries, chronic illnesses, and even death. Chronic illnesses include cancer, heart diseases, and behavioral health issues that often cause first responders life expectancy to be significantly shortened.

According to the National Fire Protection Association, there were 64 on-duty firefighter deaths in 2018. Sudden cardiac death accounted for about 40% of the on-duty fatalities. During 2017, there were an estimated 44,530 documented exposures to hazardous conditions (e.g. chemicals, fumes, radioactive materials) and 15,430 collisions involving fire department emergency vehicles responding to or returning from incidents.

To help minimize the health impact of first responders, the overarching goal of the University of Nebraska at Omaha - Mid America Transportation Center - Department of Transportation (UNO MATC DOT) research project is to build a health and environment monitoring system that can be used during a hazardous material exposure. The system aims to improve first responders' safety by integrating bio and environmental sensor data and employing decision support technology to send alerts when a first responders' health is at risk. Sensors are useful to monitor the activities and track the individual's health vitals such as heart rate, heat index, respiratory rate, blood oxygen saturation levels, and blood pressure. Through the monitoring of health vitals, an incident commander or medic can take immediate action to remove a first responder from the front-line to minimize long-term health issues when their vitals reach certain thresholds. This poster presents the lessons learned while participating in the design of the user interface and analyzing what technology to use for development.

The primary goal of the REaCH System dashboard is to build a health and environment monitoring system for improving the first responder's safety during an HAZMAT (hazardous material) incidents.

Overview of REaCH System

In the REaCH System, mainly we have concentrated on hazmat first responders health and safety. First responders need a tablet- or smartphone-based dashboard showing the status of sensors worn by first responders or sensors connected to the equipment they use. Multiple technological solutions (sensors) exist in both the public safety and consumer markets today to monitor the health of first responders and to monitor their activities and equipment. The primary goal of this research is to track the individual's health vitals. Since, health data are useful to get insights about the individual's vitals. Below are the health vitals which we considered in this design

- Heart rate(HR),
- Ambient Heat Index (HI)
- Respiratory Rate (RR)
- Blood Oxygen Saturation Levels (SPO2)
- Blood Pressure (BP)

Research Question

What are the best user interface practices to design an emergency health monitoring system for first responders?

REaCH System Design

Below are the few important displays in the health monitoring system which gives the information about the first responder health vitals and which team are they in use. Also, the threshold value ranges for all different health vitals.



Figure 1- The main dashboard contains the information of the first responders who are in the HAZMAT event, and their health vitals (HR, BP, RR, SPO2).

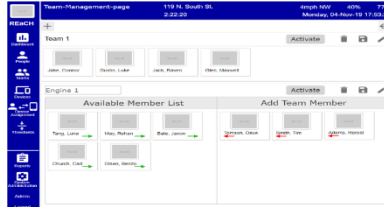

Figure 2- Teams Page- Assigning first responders to specific teams



Figure 3- Thresholds page- Collecting all the health vitals (HR,RR,BP,SPO2) ranges and assigning a grade to each health vital parameter.

Lessons Learned

While designing this REaCH System we focused more several important design practices:

- **Concentrate on User Experience**- We discussed the process when the users open the REaCH system dashboard they need to easily understand how to navigate from one page to another. For example, on the dashboard side bar we have placed different buttons which links to each respective page. Also, the names on the buttons are easily understandable by the user.
- **Common design elements throughout the application**- We have placed all the tables, buttons, icons, logo consistently in the application. So that users has a good feel for the consistency and knows what to expect.
- **Some elements take precedence over others**- Another important design feature is when it comes to visuals and the human eye, A few elements proliferate over others (bigger sizes, bright colors, etc.), depending on how "noticeable" they are. For example, we have used the orange color to indicate that the first responder is in danger and red color for indicating which health indicator is causing or putting the first responder in danger.
- **Consistent design** - The user interface should consist of a minimum number of actions when user performing tasks. For example, if we want to delete the team, the user just clicks delete icon in the team page.
- **Consistent communication** - Every interaction with your user is communicated. For an application to be successful, it must speak to the user and keep them informed on what is happening. And, as with everything else, the way the system communicates should be consistent. For this project we had routine communication with real first responders and employed their feedback into the design.

Future Work

The future work for this prototype is developing the application which requires the following frameworks:

- Building the front end using Angular framework and styling with Angular Material
- Developing the backend using with Django REST API and Django framework
- Connecting the backend with PostgreSQL.
- Integrating front end and backend.
- Deploying and host the application on the HEROKU server.

This research is being conducted in collaboration with the Special Operations Team, Omaha Fire Department, who are responsible to contain hazmat incidents in the Omaha Metropolitan Area and UNL Nebraska Transportation Center.

Acknowledgement

Funding for this research is supported through a US Department of Transportation award number (25-1121-0005-1110)

References

- Firefighter Fatalities in the United States
<https://www.cflpa.org/news-and-research/Data-research-and-tools/Emergency-Responders/Firefighter-fatalities-in-the-United-States>
 Context 007
<https://www.safetyprotocols.challenge.org/context/context-007/>



Does profession matter toward perception of Wearable Technology for Health Monitoring in the field?

College of Information Science & Technology, School of Interdisciplinary Informatics¹
College of Public Health, Department of Environmental, Agricultural and Occupational Health²

CONTRIBUTORS:

- Soundarya Jonnalagadda, B.Tech¹
- Sarah Tucker, MS²
- Cheryl Beseler, PhD²
- Aaron Yoder, PhD²
- Ann Fruhling, PhD²

Introduction

Hazardous materials (HAZMAT) pose risk to health and safety of professionals involved with emergency response and transportation. Wearable technology is a tool to assist with monitoring the health of professionals involved in HAZMAT events. The REACH (Real-Time Emergency Communication System for HAZMAT incidents) application was created for real-time monitoring of the two occupational groups through wearable devices to capture health indicators and environmental exposures.

Objective

The aim of our exploratory study was to compare and evaluate the perceptions of first responders (FR) and professional truck drivers (PTD) on wearable technology and attitudes toward real-time health monitoring.

Research Questions

1. Do first responders and professional drivers differ in their history of using wearable technology?
2. Do the two professions differ in their views of who should monitor their health data collected using wearable technology?
3. Do the two professions differ in acceptance of monitoring different health indicators?
4. Are there patterns in the acceptance of monitoring specific health indicators in the sample of the two professions?
5. What factors such as a history of using wearable technology, exposure to HAZMAT, or views on who should monitor health data explain any patterns identified in the acceptance of measuring health indicators?
6. What are the barriers of use for these professions using wearable technology?

Methods

- A 16-question self-administered survey for both first responders and professional truck drivers.
- There were 113 and 219 respondents used for analysis for first responders and professional truck drivers, respectively. The final sample with completed data was N=261.
- Statistical approach included bivariate analysis, latent class analysis, logistic regression analysis, and path analysis for the variables of interest.

Data Analysis/Results

Professional drivers were more likely to have a history of wearable technology use compared to first responders (OR=10.1; CI 4.42,22.9), reported greater exposure to HAZMAT (OR=4.32; CI 2.24-8.32), and were more willing to have their health data monitored by someone other than themselves (OR=9.27; CI 3.67, 23.4).

Multinomial regression model with three classes revealed that occupation was not significant predictor of class preference for high or low acceptance of monitoring specific health indicators.

Figure 1. Estimated probability of class inclusion for 13 possible health parameters

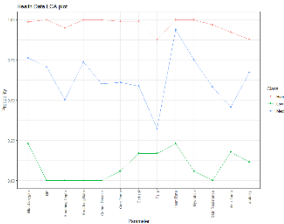

Figure 2: The path analysis shows that being a professional driver mediates the relationship between hazmat and preferring that others monitor personal health data. The chi-square statistics was not significant (p=0.68), the CFI and TLI were 1.00, and RMSEA was 0.



Table 1. Characteristics of first responders (n=112) and professional drivers (n=159) and their preferences for monitoring health parameters using wearable technology grouped by statistically significant differences at p<0.05

Variable	FR n (%)	PTD n (%)	Chi-square (p)
Ever used wearable technology			
Yes	46 (45.1)	147 (89.9)	67.0
No	56 (54.9)	16 (10.1)	(0.02)
Exposed to hazardous materials at work			
Yes	31 (30.7)	117 (75.0)	49.3
No	70 (69.3)	39 (25.0)	(<0.0001)
Preferred person to monitor health data			
No one	7 (7.0)	3 (1.9)	
Myself	25 (25.0)	34 (21.4)	
Someone else	10 (10.0)	67 (42.1)	32.2
Myself and someone else	63 (63.0)	56 (35.2)	(<0.0001)

Table 2. First responders (n=112) and professional drivers (n=159) preferences for monitoring health parameters using wearable technology grouped by statistically significant differences at p<0.05

Variable	FR n (%)	PTD n (%)	Chi-square (p)
Heart rate			
Yes	100 (98.0)	140 (88.1)	8.38
No	12 (1.0)	39 (11.9)	(0.004)
Blood Pressure			
Yes	95 (93.1)	110 (69.2)	21.2
No	7 (6.9)	49 (30.8)	(<0.0001)
Core Body Temperature			
Yes	91 (89.2)	103 (63.5)	21.1
No	11 (10.8)	58 (36.5)	(<0.0001)
Stability			
Yes	48 (47.1)	141 (88.7)	53.9
No	54 (52.9)	18 (11.3)	(<0.0001)
Blood oxygen levels			
Yes	93 (91.2)	122 (76.7)	8.93
No	9 (8.8)	37 (23.3)	(0.003)
Respiration CO2 levels			
Yes	87 (85.3)	104 (65.4)	12.5
No	15 (14.7)	55 (34.6)	(0.0004)
Cortisol Levels (stress)			
Yes	88 (86.3)	103 (64.3)	11.6
No	14 (13.7)	56 (35.2)	(0.0001)

Key Findings

1. Professional drivers were more likely to have a history of wearable technology use. (Table 1)
2. Professional drivers were more willing to have someone other than themselves monitor their health data
3. There were significant differences between first responders and professional drivers' acceptance of monitoring certain health indicators (Table 2)
4. Characteristics of professional truck drivers including age, exposure to HAZMAT, and wearable technology use were considered with class inclusion for those that with strong acceptability for health monitoring (Figure 1)
5. Acceptance of someone else monitoring health data was a strong predictor for using wearable technology among the professional truck driver group (Table 1)
6. Barriers for both occupations were lack of interest. Barriers among first responders were durability and cost while among professional drivers were lack of owning wearable devices.

Conclusion

This study successfully compared the two occupational groups using the six research questions via strong statistical models, which provided plausible effect on the direction of variables that impacted perceptions of health monitoring between the two groups. This is important for further investigation of additional factors that might influence attitudes toward wearable technology application for monitoring of health and safety of workers in dangerous occupations involving HAZMAT.

Acknowledgements

Funding provided by the US DOT award number 69A355174107. We would like to express our gratitude to Dr. Sharon Medical, UNMC; Chandran Achuthan, PhD, UNMC; Danilo Ghersi, MD, PhD, UNMC; graduate students - Jacob Grothe and Troy Sawwado for their support of this project. IRB # 691-17-EX.



Can we improve the health & safety of rural first responders during agricultural emergency events by integrating wearable technology?

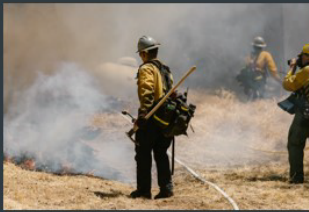

Sarah Tucker¹, Aaron Yoder¹, & Ann Fruhling²

¹ College of Public Health, Department of Environmental, Agricultural and Occupational Health, UNMC
² College of Information Science & Technology, School of Interdisciplinary Informatics, UNO
 Funding provided by US DOT, Mid-America Transportation Center grant number 69A355174107

Pathway to Enhance First Responder Safety During Agricultural Emergencies

REaCH dashboard monitoring crews at an emergency event

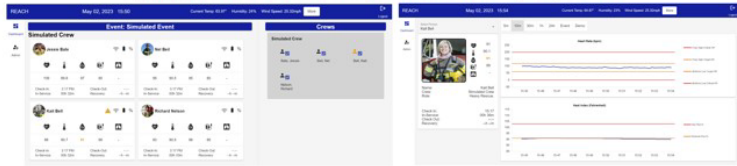

Translating from prototype to rural community

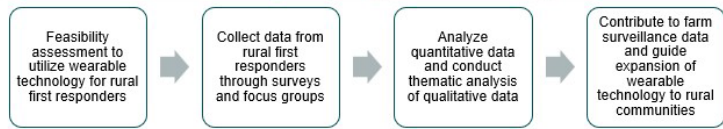

REaCH system development process

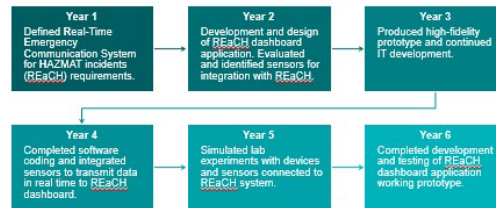

Appendix E REaCH System Architecture Documentation

VERSIONING.....	36
RELEASES.....	36
DEPLOYMENT INFORMATION.....	36
DEPLOYABLE FILES	36
CONFIGURATION.....	37
STATIC CONTENT	37
DEPLOYMENT PROCESS.....	37

DOCUMENT SCOPE

This document captures all the design architectures used to build Reach system. The purpose of the document is to help understand Visual representation of the system.

REVISION HISTORY

Rev. #	Date	Author	Description of Changes
0.1	04/06/2020	Anusha Manda	Added Sequence diagrams, Use case diagrams
0.2	04/13/2020	Anusha Manda	Added data dictionary and component diagrams
0.3	04/18/2020	Anusha Manda	Added Frameworks and patterns
0.4	04/19/2020	Anusha Manda	Added Deployment details
0.5	04/20/2020	Anusha Manda	Added security considerations and component diagrams for device page and person page
0.6	04/21/2020	Anusha Manda	Added Component diagrams of team's page device assignment and sequence diagrams of threshold page
0.7	04/21/2020	Anusha Manda	Added infrastructure diagram and device diagram

APPROVER REVIEW

Rev. #	Date	Component	Approved by
0.1	03/10/2020	Sequence diagram for Login	Dr. Ann Fruhling, John Rodgers
0.2	03/13/2020	Device diagram	Dr. Ann Fruhling, John Rodgers
0.3	03/26/2020	Sequence diagram for Threshold page	Dr. Ann Fruhling, John Rodgers
0.4	03/31/2020	Sequence diagram for Device page and person page.	Dr. Ann Fruhling, John Rodgers
0.5	03/31/2020	UML Use case diagram	Dr. Ann Fruhling, John Rodgers
0.6	04/08/2020	Component diagram for device page, validation	Dr. Ann Fruhling, John Rodgers
0.7	04/14/2020	Component diagram for Threshold's page and person page	Dr. Ann Fruhling, John Rodgers
0.8	04/22/2020	Component diagram for Team's page and	Dr. Ann Fruhling, John Rodgers

		Device assignment page	

SECURITY CONSIDERATIONS

Authentication Must be able to be accomplished without network access due to connectivity issues

- Usenames and Passwords
- Done using Django Authentication
- Session tokens handled with JWT Tokens

Future Considerations

- Authentication for the local network
- Devices may connect directly to the system

AUTHORIZATION

- Administrators

Can manipulate the system including some data such as user accounts and teams.

- Base Level Users

Users can view some data

SENSITIVE DATA HANDLING

- Data being handled may be considered PHI and may be considered sensitive
- Encryption in-transit with Unsigned Certificates
- SSL V3/TLS 1.3
- Future Considerations
- Encrypt data at rest? ie. Encrypting database data

INPUT VALIDATION/OUTPUT ENCODING

- Client/Server-side Validation
 - Password validation mainly server-side

Future Considerations

- Data is being input from devices

FILE UPLOAD

- Image files are going to be uploaded
- File upload security will be handled through trusted backend uploads

LOGGING

Logging information captured by the application includes the following elements

- IP Address
- User ID
- Date & Time
- Compliance/Security Related Action

ASSUMPTIONS

- System Account Activity
 - a. Users Creation
 - b. Logins
 - c. Data Manipulation
 - d. Logging Using Django Built In Logging

INFRASTRUCTURE DIAGRAM

A technology infrastructure diagram provides a high-level graphical view of the physical architecture required to support the application architecture.

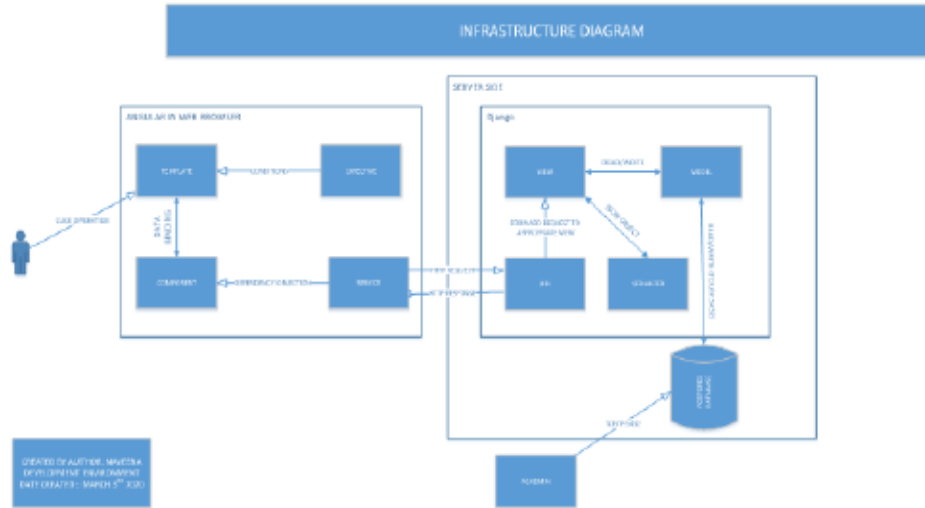

This diagram template uses the Tool, Visio which can be found at <https://www.microsoft.com/en-us/microsoft-365/visio/flowchart-software>

DEVICE DIAGRAM

This diagram gives an overview of how the system could be setup in the future. The components of this diagram are webservers, Wireless Radios within a truck or fixed, computers connected to the internet, tablet devices, shortwave wireless radios, health monitoring devices, and people.

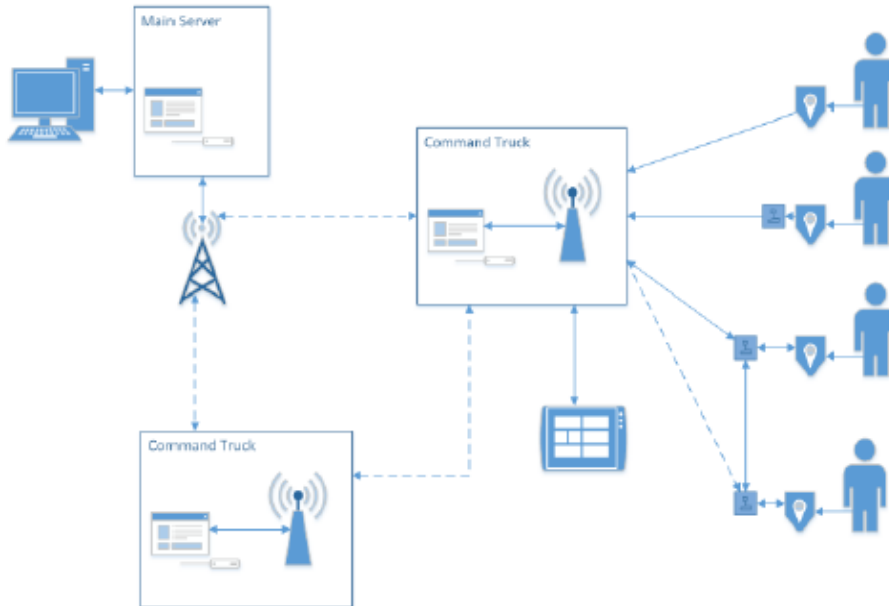

This diagram template uses the Tool, Visio which can be found at <https://www.microsoft.com/en-us/microsoft-365/visio/flowchart-software>

Starting from the computer, this computer is any computer or tablet or phone that is connected to the internet such that it can connect to the main server and retrieve the served web page. The Main Server is a fixed webserver that is always connected to the internet and acts as a source of data that other webservers can retrieve data from, or as a source of truth that can resolve conflicts. The Main Server can be connected to the Command Trucks through a WAN wireless system that may be transient, thus making it necessary that the Command Truck webservers need to be self-contained. The Command Trucks have wireless radios that can connect back to the Main Server as well as peer between each other.

On the right starting from the top are the different methods that Health Monitoring Devices can connect and send data back to the Command Truck:

First is a device that can connect directly to the Command Truck to send data.

Next is a device that connects to a shortwave radio and uses that network to send data to the Command Truck.

The next two are devices that connect to shortwave radios where one of the radios is unable to connect to the Command Truck and needs to mesh with another short-wave radio to send data back to the Command Truck.

COMPONENT MODELS

The following component models illustrate a static view, of the encapsulated software functions including services, batch processes, or modules illustrating their points of interaction. Textual descriptions follow the diagram.

COMPONENT DIAGRAM FOR VALIDATION

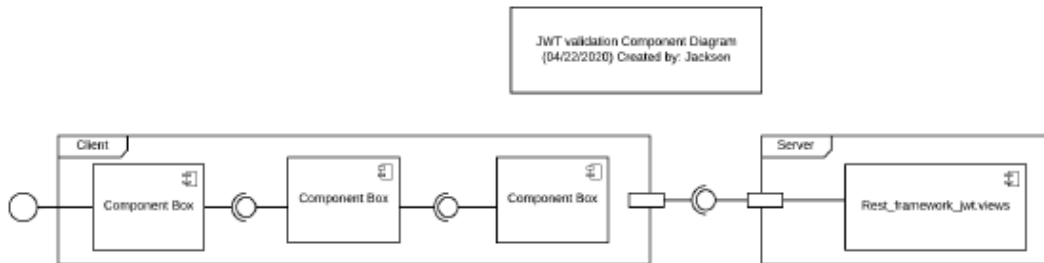

This Component diagram template is done by tool LUCID CHART, available at <https://www.lucidchart.com/users/login>:

COMPONENT DIAGRAM FOR PERSON PAGE

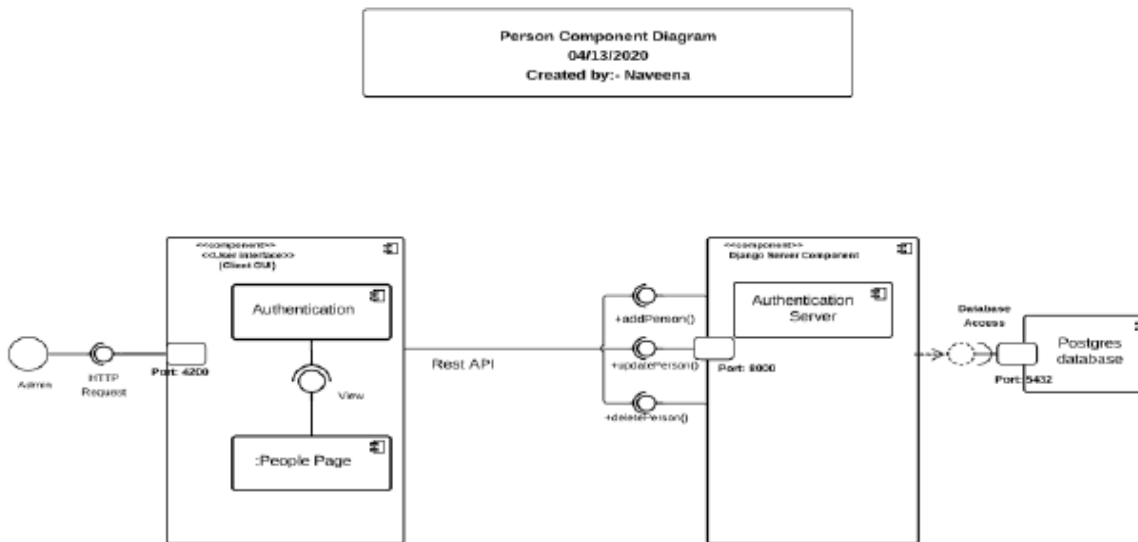

This Component diagram template is done by tool LUCID CHART, available at <https://www.lucidchart.com/users/login>:

COMPONENT DIAGRAM FOR DEVICE PAGE

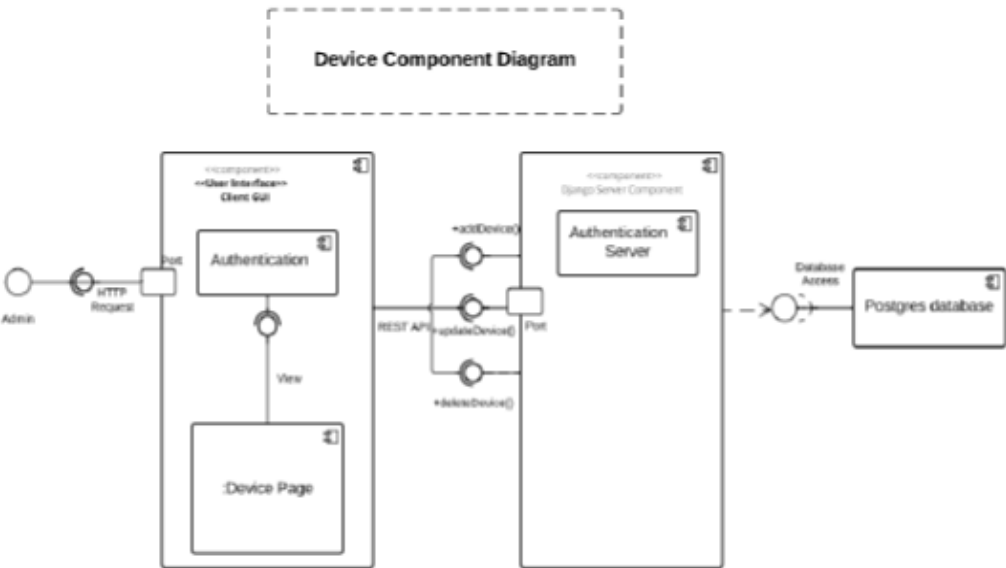

This Component diagram template is done by tool LUCID CHART, available at <https://www.lucidchart.com/users/login>:

COMPONENT DIAGRAM FOR TEAMS PAGE

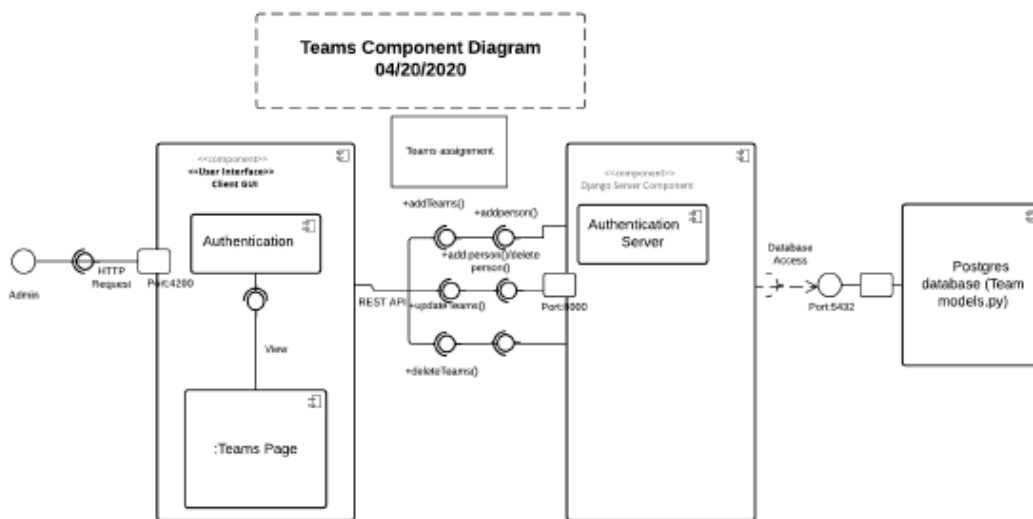

This Component diagram template is done by tool LUCID CHART, available at <https://www.lucidchart.com/users/login>:

COMPONENT DIAGRAM FOR THRESHOLD PAGE

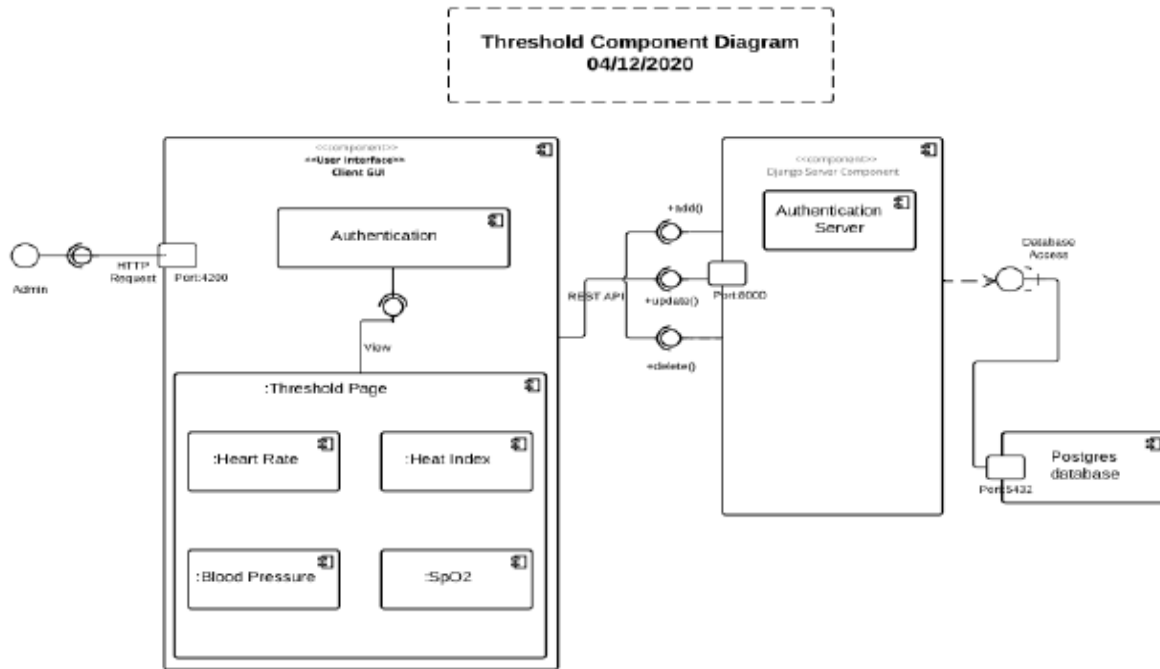

This Component diagram template is done by tool LUCID CHART, available at <https://www.lucidchart.com/users/login>:

COMPONENT DIAGRAM FOR DEVICE ASSIGNMENT PAGE

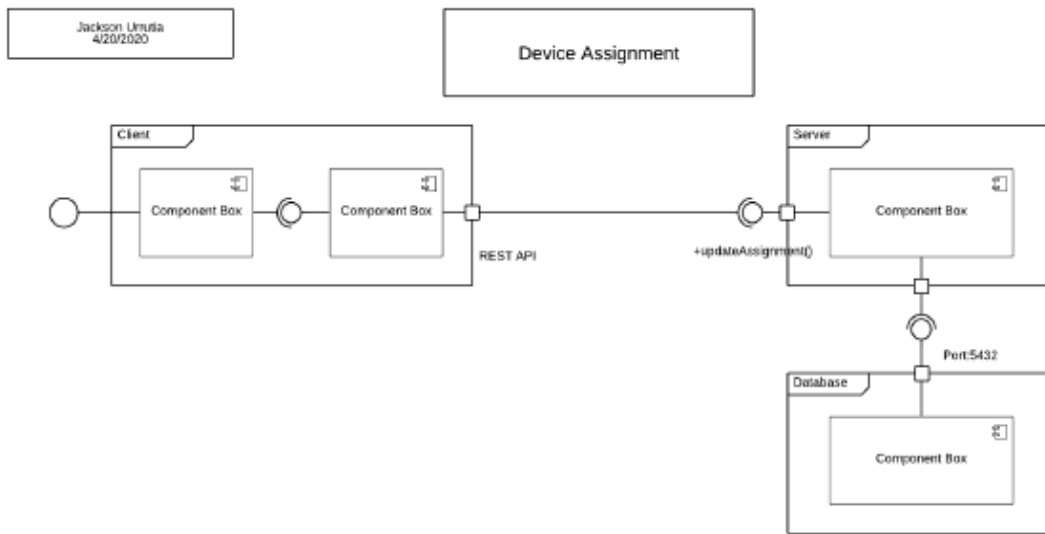

This diagram template uses the Tool, VISIO which can be found at <https://www.microsoft.com/en-us/microsoft-365/blog/2017/03/01/visio-online-anywhere-anytime-access-to-your-diagrams/>

SEQUENCE DIAGRAMS

The following are UML Sequence Diagrams are interaction diagrams that detail how operations are carried out. They capture the interaction between objects in the context of a collaboration. Sequence Diagrams are time focus and they show the order of the interaction visually by using the vertical axis of the diagram to represent time what messages are sent and when

SEQUENCE DIAGRAM

Sequence diagrams are created for each functionality in the reach system in order to get better understanding on the flow between the objects. Diagrams bellow illustrates the sequence diagrams for login, device page, Peoples page, Threshold page

SEQUENCE DIAGRAM FOR LOGIN

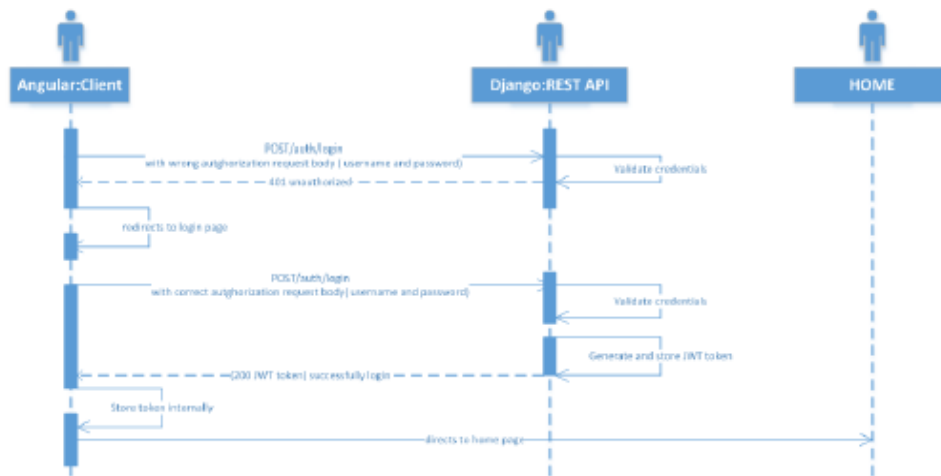

This diagram template uses the Tool, VISIO which can be found at <https://www.microsoft.com/en-us/microsoft-365/blog/2017/03/01/visio-online-anywhere-anytime-access-to-your-diagrams/>

SEQUENCE DIAGRAM FOR DEVICE PAGE

Add device

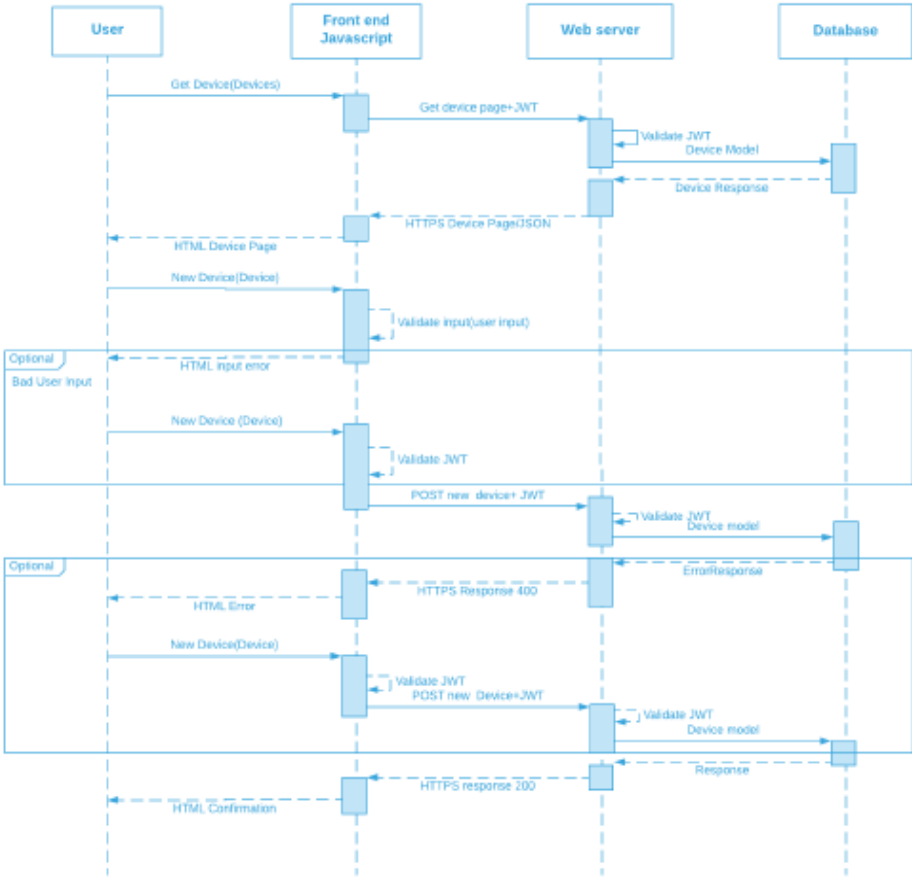

This diagram template uses the Tool, LUCID chart which can be found at <https://www.lucidchart.com/users/login>

Edit Device

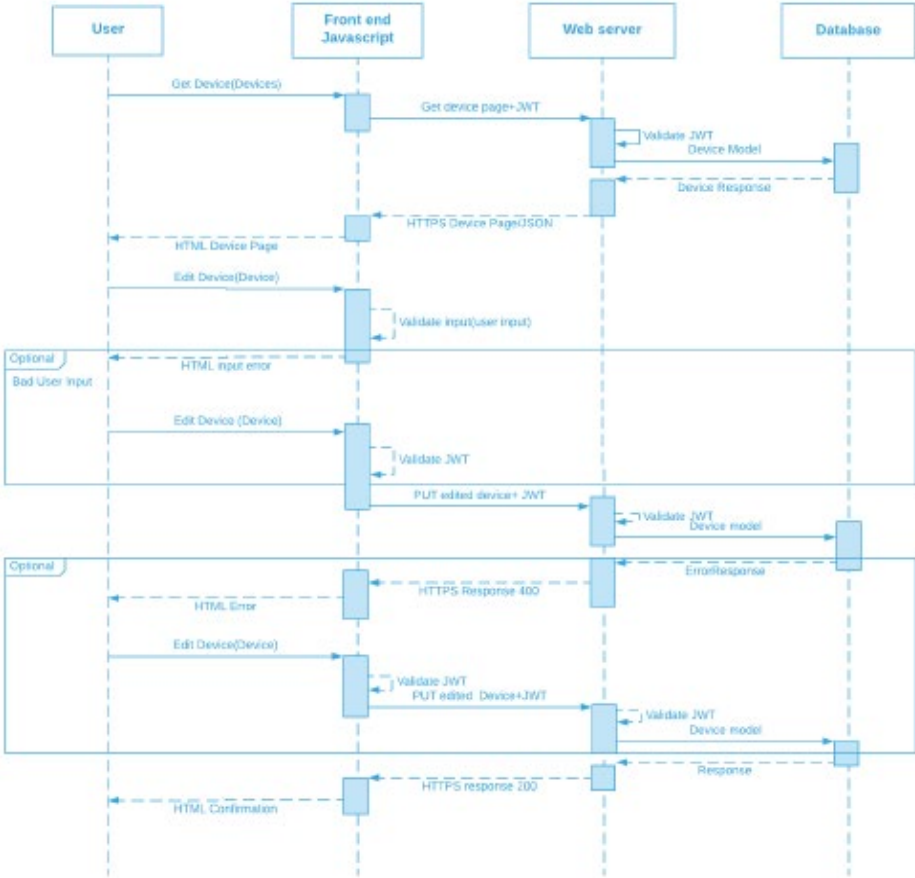

This diagram template uses the Tool, LUCID chart which can be found at <https://www.lucidchart.com/users/login>

Delete device

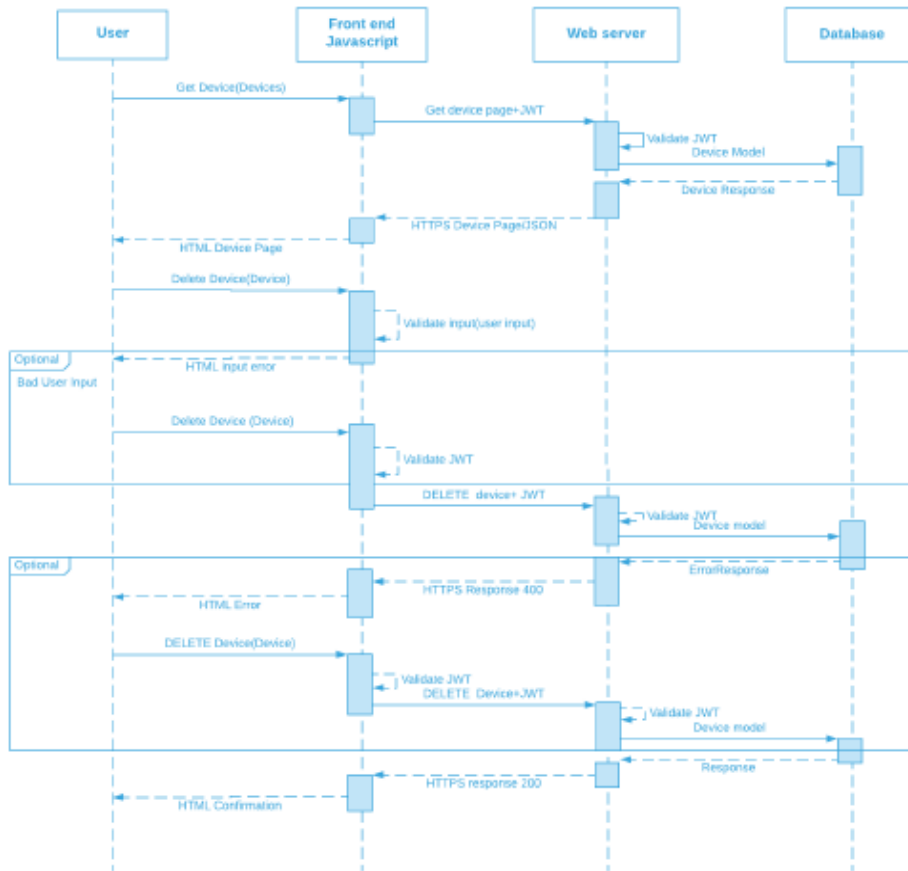

]

This diagram template uses the Tool, LUCID chart which can be found at <https://www.lucidchart.com/users/login>

SEQUENCE DIAGRAM FOR PERSON PAGE

Add people

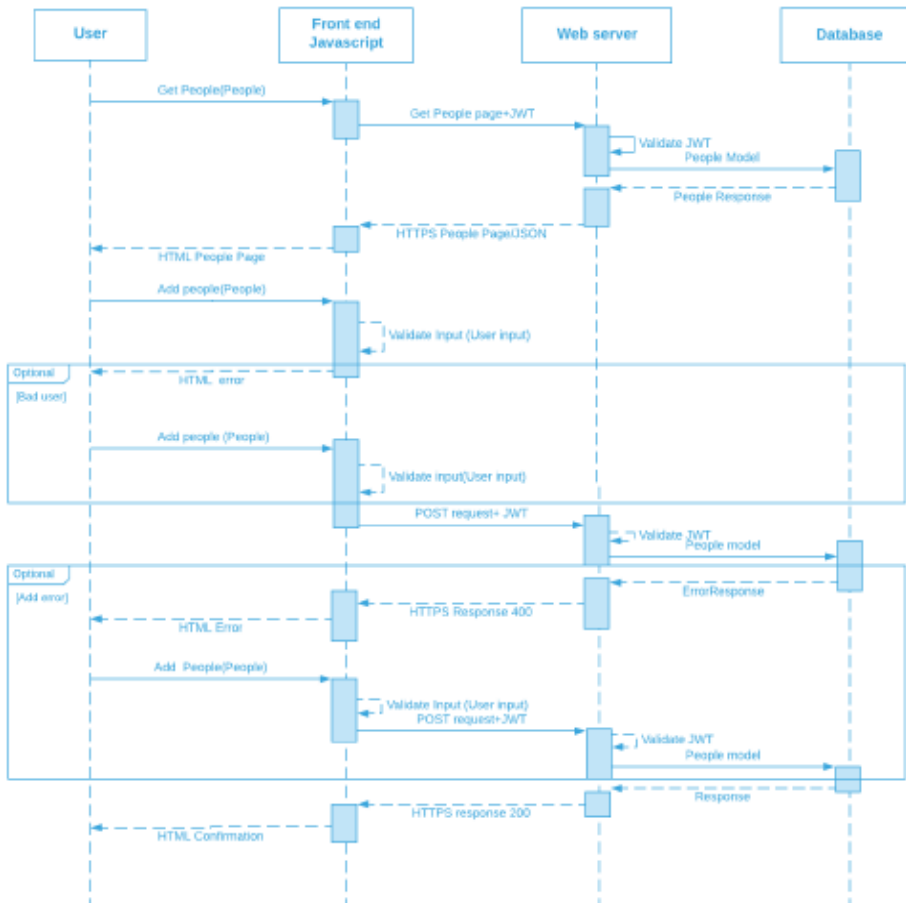

This diagram template uses the Tool, LUCID chart which can be found at <https://www.lucidchart.com/users/login>

Edit people

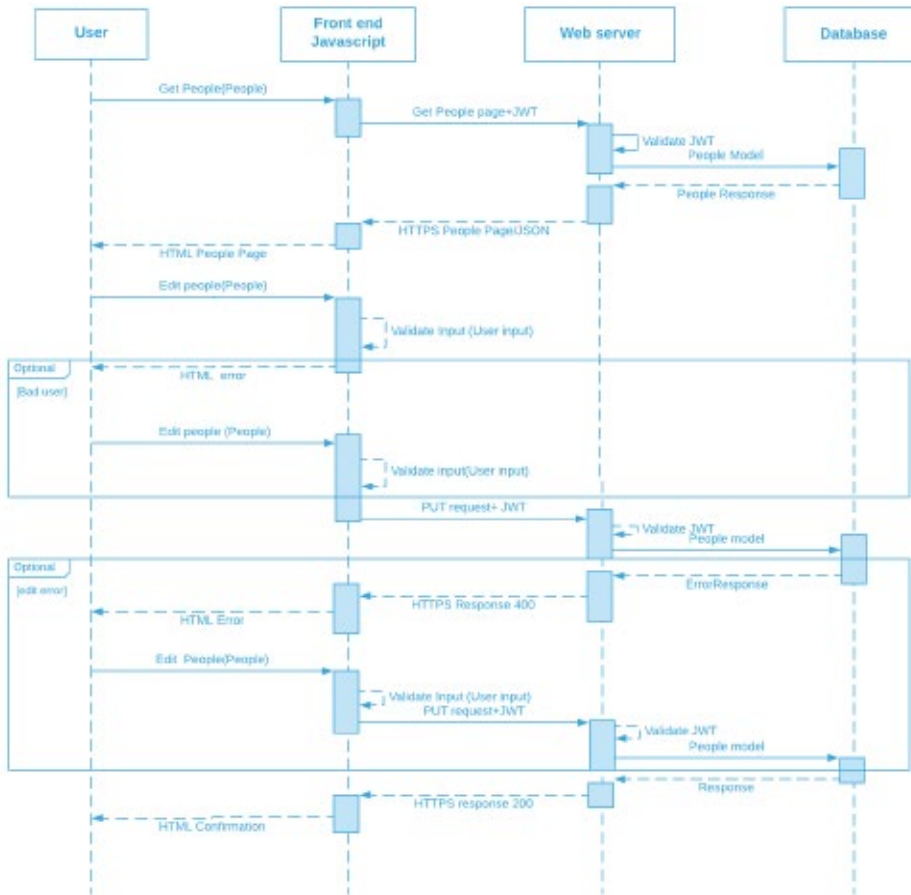

This diagram template uses the Tool, LUCID chart which can be found at <https://www.lucidchart.com/users/login>

Delete people

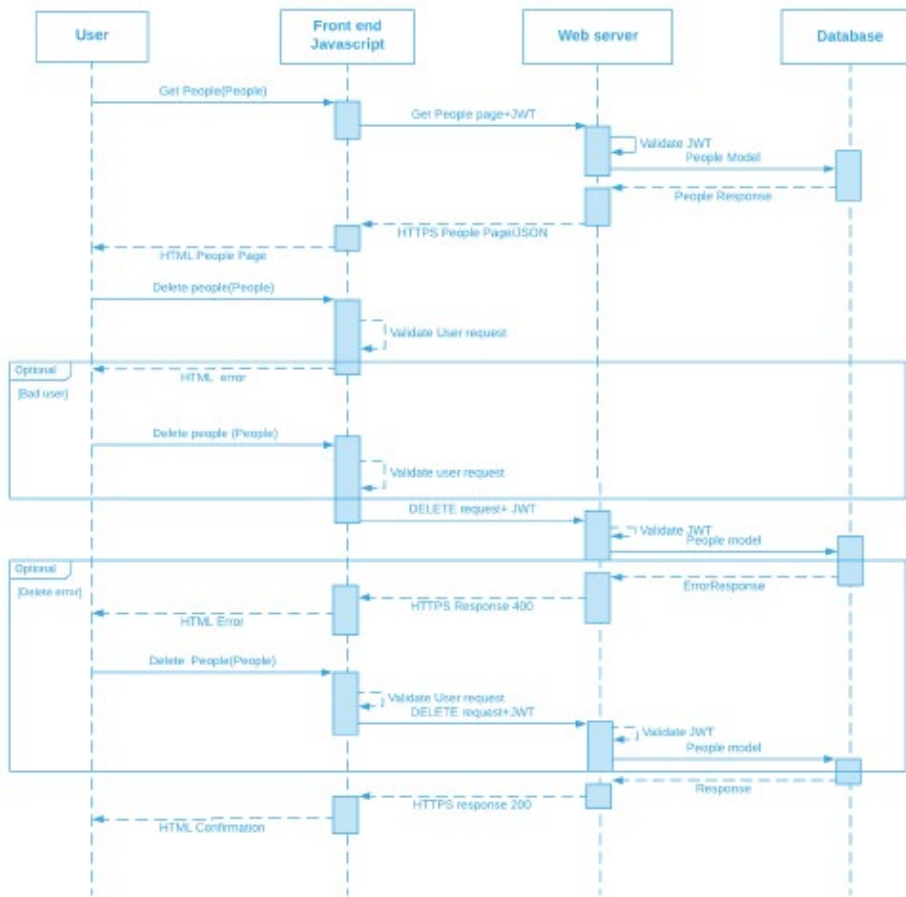

This diagram template uses the Tool, LUCID chart which can be found at <https://www.lucidchart.com/users/login>

SEQUENCE DIAGRAM FOR THRESHOLD PAGE

Add Threshold

Jackson Urrutia
3/24/2020

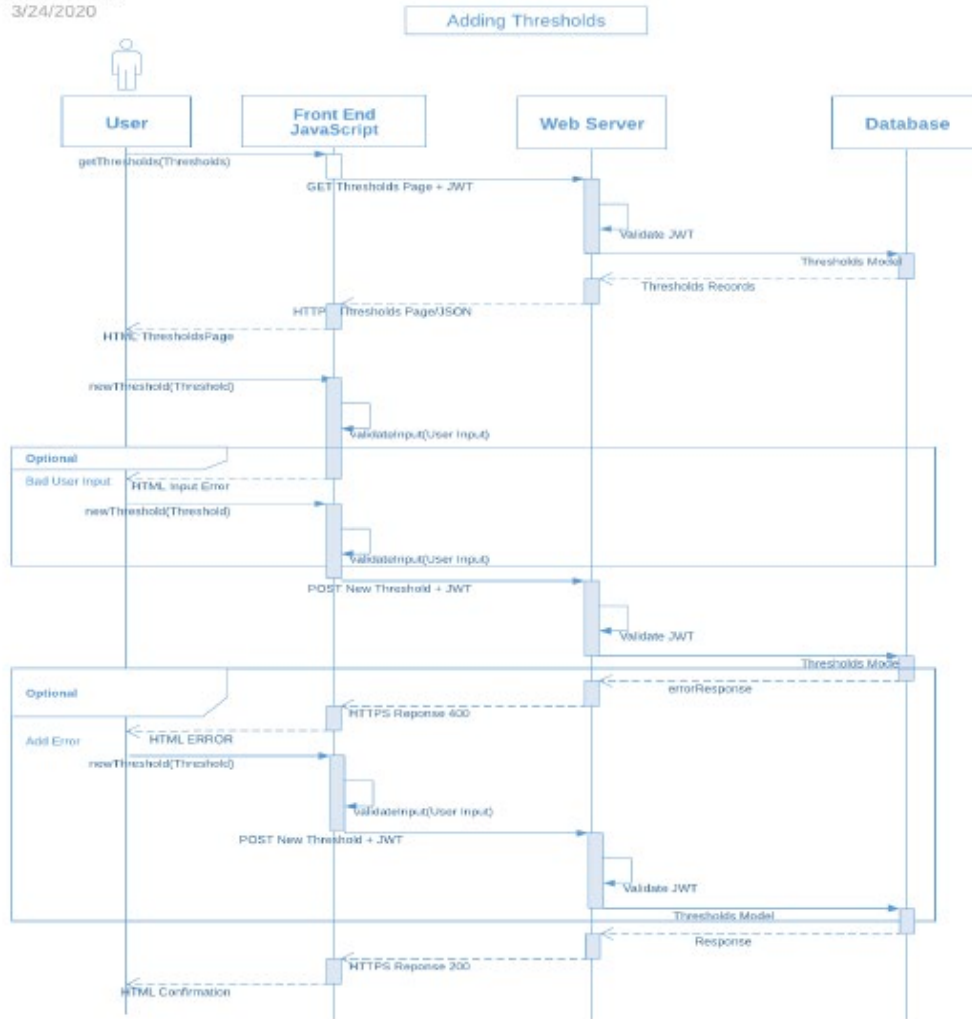

This diagram template uses the Tool, Visio which can be found at <https://www.microsoft.com/en-us/microsoft-365/visio/flowchart-software>

Update Threshold

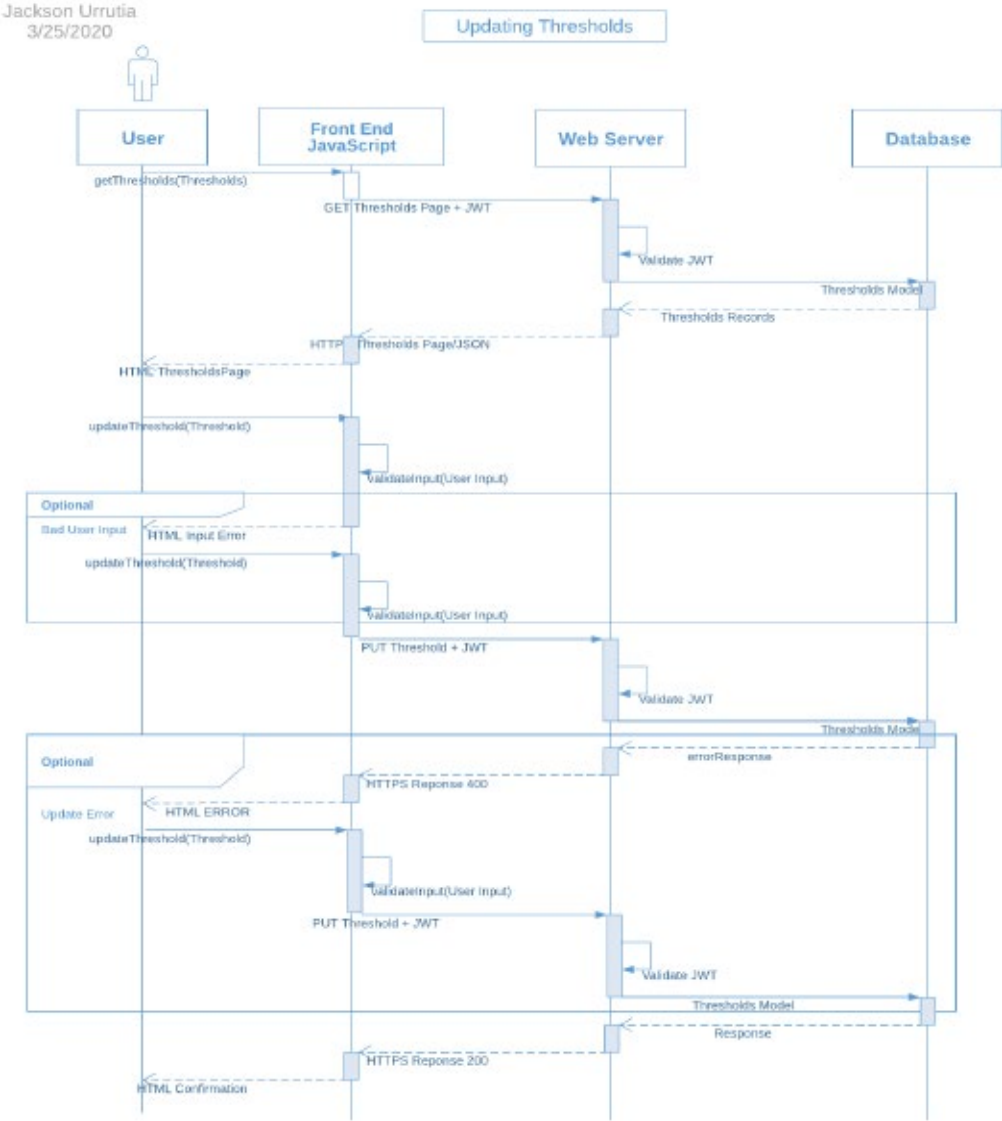

This diagram template uses the Tool, Visio which can be found at <https://www.microsoft.com/en-us/microsoft-365/visio/flowchart-software>

Delete Threshold

Jackson Urrutia
3/25/2020

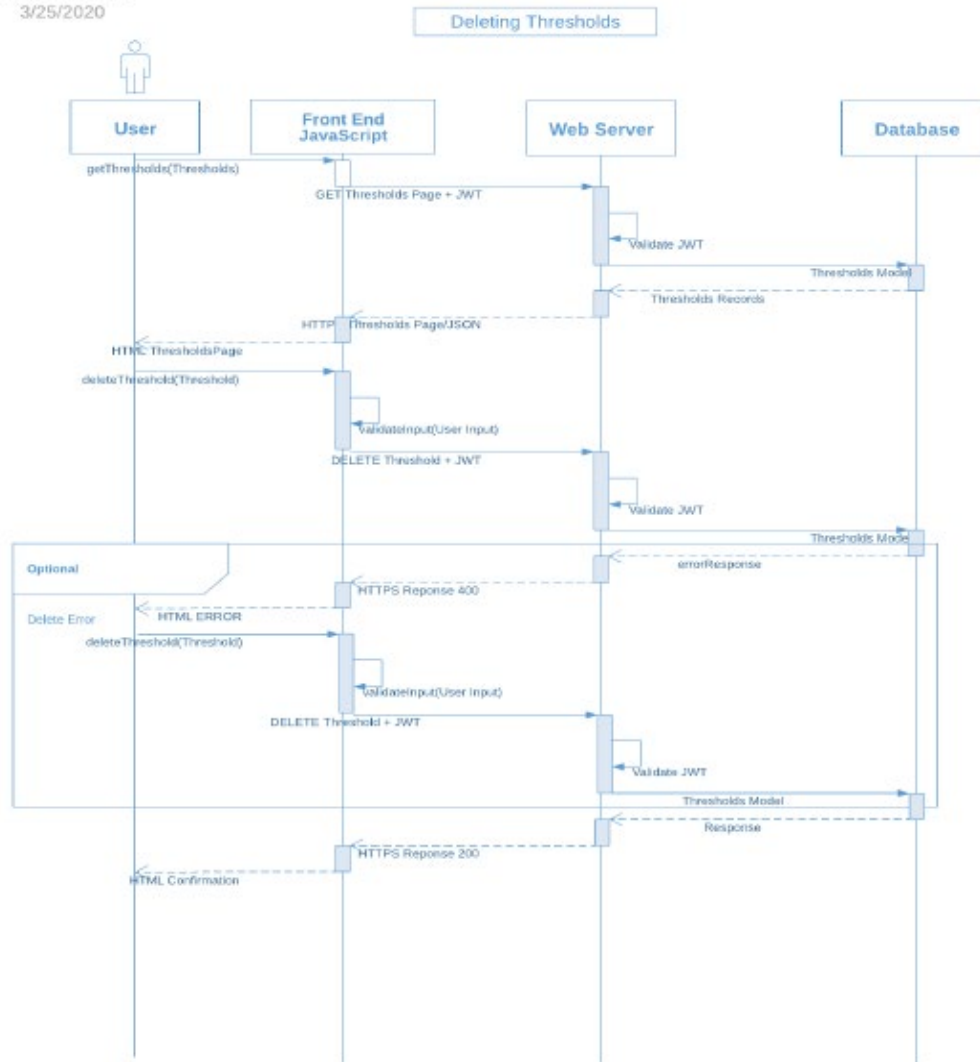

This diagram template uses the Tool, Visio which can be found at <https://www.microsoft.com/en-us/microsoft-365/visio/flowchart-software>

ENTITY RELATIONSHIP DIAGRAM

This entity relationship diagram (ERD) illustrates the database entities that make up the solution and their relationships to each other. Detailed descriptions of the required tables and their respective columns may be found after the diagram.

ENTITY RELATIONSHIP DIAGRAM

ER diagram explains the tables which are created in the database and how they are communicating with each other. In reach system, there is table created for each functionality i.e., device, people, threshold, sensor, team.

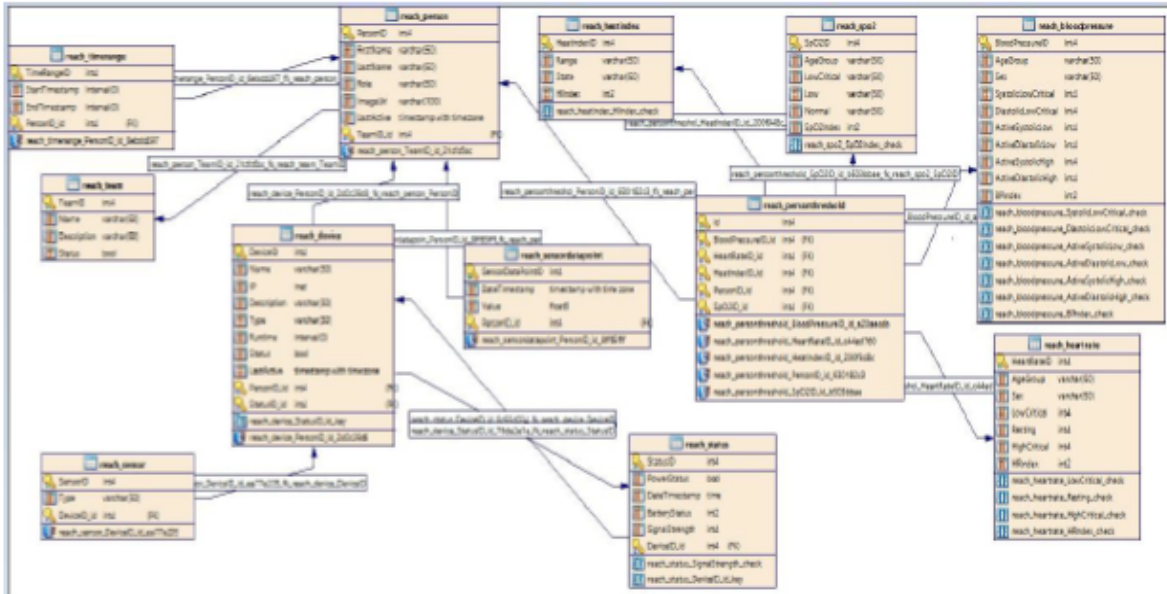

This diagram template uses the Tool, LUCID chart which can be found at <https://www.lucidchart.com/users/login>

SCREENSHOTS OF PROTOTYPE

DASHBOARD PAGE

Dashboard 119 N. South St. 4mph NW 40% 77°F
2:22:20 Monday, 04-Nov-19

Truck 1

Name	HR	BP	Heat	Index	O2	Resp
Tomson, Dave	60	140/90	89	99	40	
Smith, Tim	60	140/90	89	99	40	
Adams, Harold	60	140/90	89	99	40	
Olsen, Benito	60	140/90	89	99	40	

Active

Truck 1
Tomson, Dave Smith, Tim Adams, Harold Olsen, Benito

Engine 1
Bell, Neil Church, Carl Churchill, Jaxx Wickens, Rajan Bate, Jaxon May, Rohan Tang, Luna

Medic 1
Tomson, Dave Smith, Tim Adams, Harold Olsen, Benito

Rescue 1
Tomson, Dave Smith, Tim Adams, Harold Olsen, Benito

REACH Dashboard People Devices Device Management Thresholds Reports Administration Admin Logout

Dashboard 119 N. South St. 4mph NW 40% 77°F
2:22:20 Monday, 04-Nov-19

Engine 1

Name	HR	Heat	Index	O2	Resp
Bell, Neil	60	10	77	40	
Church, Carl	60	10	99	40	
Churchill, Jaxx	60	10	99	40	
Wickens, Rajan	60	10	99	40	
Bate, Jaxon	60	10	99	40	
May, Rohan	60	10	99	40	
Tang, Luna	60	10	99	40	

Active

Truck 1
Tomson, Dave Smith, Tim Adams, Harold Olsen, Benito

Engine 1
Bell, Neil Church, Carl Churchill, Jaxx Wickens, Rajan Bate, Jaxon May, Rohan Tang, Luna

Medic 1
Tomson, Dave Smith, Tim Adams, Harold Olsen, Benito

Rescue 1
Tomson, Dave Smith, Tim Adams, Harold Olsen, Benito

REACH Dashboard People Devices Device Management Thresholds Reports Administration Admin Logout

PEOPLE'S PAGE

Special-Operation-People-page 119 N. South St. 4mph NW 40% 77°C
2:22:20 Monday, 04-Nov-19

REaCH

Dashboard

People

Teams

Devices

Device Assignments

Thresholds

Reports

Advanced Search

Admin

Logout

Photo	First Name	Last Name	Team Name	Role	Last Active	Elapsed Time	Threshold Values					Actions			
							HR	HR	SP	SR	SpO2				
	Ramon	Dave	Stalk 1	FM	10-18-2019 18:30:02	00:08:00 Hours	0	0	0	1	0				
	Shay	Tim	Stalk 1	TL	10-18-2019 18:30:02	00:10:28 Hours	N/A								
	Adam	Herold	Engine 1	TL	10-18-2019 18:30:02	04:15:16 Hours	N/A								
	Chris	Berke	Stalk 2	FR	10-18-2019 18:30:02	01:48:19 Hours	2	2	0	1	0				
	Charles	Carl	Engine 1	FR	10-18-2019 18:30:02	05:20:06 Hours	0	0	4	1	0				

Special-Operation-People-page 119 N. South St. 4mph NW 40% 77°C
2:22:20 Monday, 04-Nov-19

REaCH

Dashboard

People

Teams

Devices

Device Assignments

Thresholds

Reports

Advanced Search

Admin

Logout

Photo	First Name	Last Name	Team Name	Role	Last Active	Elapsed Time	Threshold Values					Actions			
							HR	HR	SP	SR	SpO2				
	Ramon	Dave	Stalk 1	FM	10-18-2019 18:30:02	00:08:00 Hours	0	0	0	1	0				
	Shay	Tim	Stalk 1	TL	10-18-2019 18:30:02	00:10:28 Hours	N/A								
	Adam	Herold	Engine 1	TL	10-18-2019 18:30:02	04:15:16 Hours	N/A								
	Chris	Berke	Stalk 2	FR	10-18-2019 18:30:02	01:48:12 Hours	0	0	0	1	0				
	Charles	Carl	Engine 1	FR	10-18-2019 18:30:02	05:20:06 Hours	0	0	4	1	0				
	Shay	Tim	Last Name	Device	10-18-2019 18:30:02	00:00:00 Hours	0	0	0	0	0				

Special-Operation-People-page 119 N. South St. 4mph NW 40% 77°C
2:22:20 Monday, 04-Nov-19

REACH

Dashboard

People

Teams

Devices

Device Assignments

Thresholds

Reports

System Dashboard

Admin

Logout

Photo	First Name	Last Name	Team Name	Role	Last Active	Elapsed Time	Threshold Values					Actions			
							HR	SB	BP	SR	SpO2				
	Timothy	Conk	Truck 1	FD	10-19-2019 10:00:02	00:00:00 hours	2	0	0	1	0				
	Smith	Tan	Station 1	TL	10-19-2019 10:00:02	02:18:25 hours									
	Adam	Harold	Engine 1	TL	10-19-2019 10:00:02	04:10:15 hours									
	Oliver	Bernd	Truck 2	FD	10-19-2019 10:00:02	01:40:12 hours	2	2	2	1	0				
	Chuck	Carl	Engine 1	FD	10-19-2019 10:00:02	05:20:06 hours	0	0	4	1	0				
	Atstock	John	Engine 1	FD	10-19-2019 10:00:02	01:01:08 hours	2	2	1	0	4				

Special-Operation-People-page 119 N. South St. 4mph NW 40% 77°C
2:22:20 Monday, 04-Nov-19

REACH

Dashboard

People

Teams

Devices

Device Assignments

Thresholds

Reports

System Dashboard

Admin

Logout

Photo	First Name	Last Name	Team Name	Role	Last Active	Elapsed Time	Threshold Values					Actions			
							HR	SB	BP	SR	SpO2				
	Timothy	Conk	Truck 1	FD	10-19-2019 10:00:02	00:00:00 hours	2	0	0	1	0				
	Smith	Tan	Station 1	TL	10-19-2019 10:00:02	02:18:25 hours									
	Adam	Harold	Engine 1	TL	10-19-2019 10:00:02	04:10:15 hours									
	Oliver	Bernd	Truck 2	FD	10-19-2019 10:00:02	01:40:12 hours	2	2	2	1	0				
	Chuck	Carl	Engine 1	FD	10-19-2019 10:00:02	05:20:06 hours	0	0	4	1	0				
	Atstock	John	Engine 1	FD	10-19-2019 10:00:02	01:01:08 hours	2	2	1	0	4				

Special-Operation-People-page 119 N. South St. 4mph NW 40% 77°C
2:22:20 Monday, 04-Nov-19

REaCH

Dashboard

People

Teams

Devices

Control Assignments

Threats

Reports

System Administration

Admin

Logout

Photo	First Name	Last Name	Team Name	Role	Last Active	Elapsed Time	Threshold Values					Actions			
							HR	IB	BP	FR	Sy00				
	Ramon	Barb	Truck 1	PO	10-19-2019 19:00:02	03:30:00 hours	0	0	0	1	4				
	Geir	Den	Truck 1	TL	10-19-2019 19:00:02	02:10:25 hours	N/A								
	Adam	Harold	Engine 1	TL	10-19-2019 19:00:02	04:15:15 hours	N/A								
	Olsen	Berde	Truck 2	FR	10-19-2019 19:00:02	01:45:12 hours	2	2	0	1	7				
	Chuck	Carl	Engine 1	FR	10-19-2019 19:00:02	06:30:06 hours	0	0	4	1	0				
	Wesley	Jade	Engine 1	FR	10-19-2019 19:00:02	01:45:06 hours	2	2	1	0	4				

Remove Person X

Are you sure, you want to remove the person?

TEAM'S PAGE

Team-Management-page 119 N. South St. 4mph NW 40% 77°C
2:22:20 Monday, 04-Nov-19

REaCH

Dashboard

People

Teams

Devices

Control Assignments

Threats

Reports

System Administration

Admin

Logout

Truck 1 Activate

Jake, Connor

Dustin, Luke

Jack, Raven

Glen, Maxwell

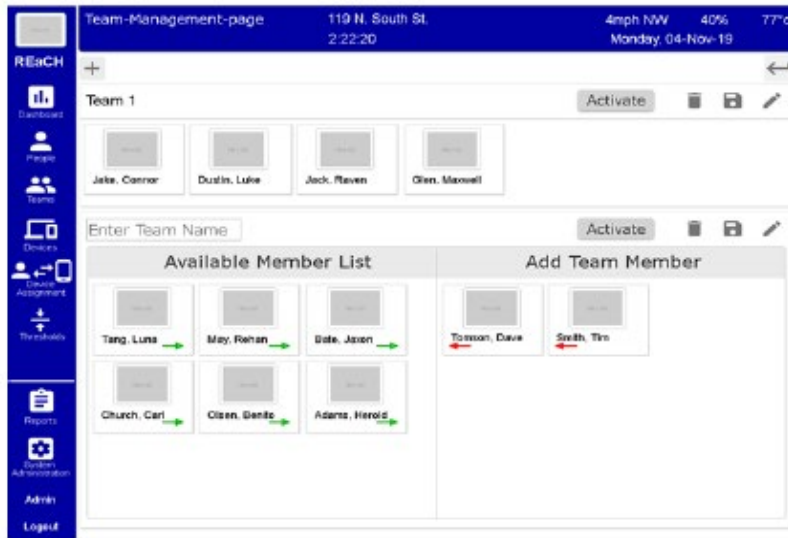
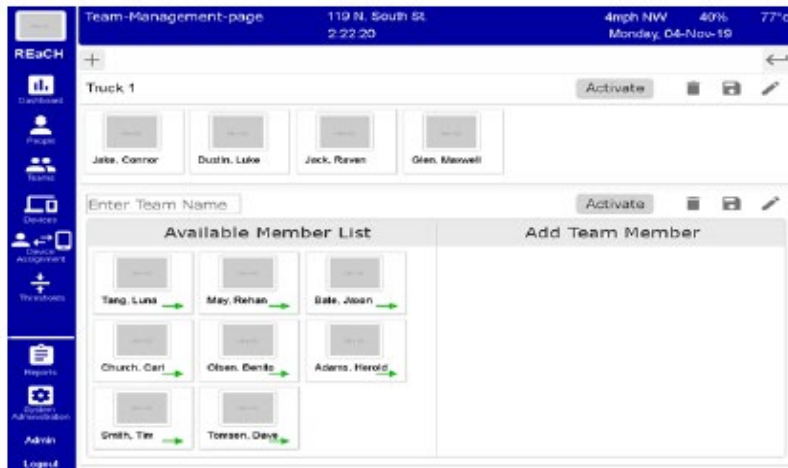

Team-Management-page 119 N. South St. 4mph NW 40% 77°C
2:22:20 Monday, 04-Nov-19

REaCH

Dashboard

Trucks

Devices

Device Assignment

Thresholds

Reports

System Administration

Admin

Logout

Truck 1 Activate

Jake, Center Dustin, Luke Jack, Raven Glen, Maxwell

Engine 1 Activate

Torson, Dave Smith, Tim

DEVICE PAGE

Device-Management-page 119 N. South St. 4mph NW 40% 77°C
2:22:20 Monday, 04-Nov-19

REaCH

Dashboard

Trucks

Devices

Device Assignment

Thresholds

Reports

System Administration

Admin

Logout

Device ID	Device IP	Device Description	Device Type	Status	Actions
954143254	11.23.21.25	Measuring temperature and humidity	Type 1	📶 100%	✎ 🗑️ 📄 📊
754632146	231.25.64.23	Measuring heart rate	Type 1	📶 60%	✎ 🗑️ 📄 📊

Device-Management-page 119 N. South St. 4mph NW 40% 77°c
2:22:20 Monday, 04-Nov-19

Device ID	Device IP	Device Description	Device Type	Status	Actions
954143254	11.23.21.25	Measuring temperature and humidity	Type 1	100%	
754832146	231.25.04.23	Measuring heart rate	Type 1	50%	
954143254	11.12.13.14	Measuring heat index	General	100%	

Device-Management-page 119 N. South St. 4mph NW 40% 77°c
2:22:20 Monday, 04-Nov-19

Device ID	Device IP	Device Description	Device Type	Status	Actions
954143254	11.23.21.25	Measuring temperature and humidity	Type 1	100%	
754832146	231.25.04.23	Measuring heart rate	Type 1	50%	
954143254	11.12.13.14	Measuring heat index	General	100%	
754832146	21.22.23.24	Measuring humidity	Type 2	50%	

Remove Device

Are you sure you want to remove the device ?

DEVICE -ASSIGNMENT PAGE

Device-Assignment-page 119 N. South St. 4mph NW 40% 77°c
2:22:20 Monday, 04-Nov-19

REaCH

Unassigned Assigned All

Photo	First Name	Last Name	Assigned Device ID	Device Description
	Neil	Ball	Device 1	
	Carl	Crutch	Device 1	

Dashboard
People
Teams
Devices
Device Assignment
Threats
Reports
System Administration
Admin
Logout

Device-Assignment-page 119 N. South St. 4mph NW 40% 77°c
2:22:20 Monday, 04-Nov-19

REaCH

Unassigned Assigned All

Photo	First Name	Last Name	Assigned Device ID	Device Description
	Don	Sanzar	Device 1	Sensor: Temp, Humidity, Gyro
	Ronald	Smith	Device 1	Sensor: Temp, Humidity, Gyro

Dashboard
People
Teams
Devices
Device Assignment
Threats
Reports
System Administration
Admin
Logout

Device-Assignment-page 119 N. South St. 4mph NW 40% 77°C
2:22:20 Monday, 04-Nov-19

Unassigned Assigned **All**

Photo	First Name	Last Name	Assigned Device ID	Device Description
	Neil	Dee	Device 1	
	Carl	Crutch	Device 1	
	Dan	Swarc	Device 1	Servotag: Temp, Humidity, Oxy
	David	Smith	Device 1	Servotag: Temp, Humidity, Oxy

THRESHOLD PAGE

Threshold-page 119 N. South St. 4mph NW 40% 77°C
2:22:20 Monday, 04-Nov-19

+

Age Group	Sex	Blood Pressure		Oxygen (SpO2)		Grade	Actions
		Low Critical (O2)	Resting (O2)	High Critical (O2)	Resting (O2)		
15-20	Male	53	62	93	93		
	Female	56	67	93	93		
30-39	Male	55	64	94	94		
	Female	56	67	94	94		
40-49	Male	55	65	94	94		
	Female	56	67	94	94		
50-59	Male	55	64	94	94		
	Female	56	65	94	94		
60-69	Male	54	63	94	94		
	Female	55	65	94	94		
70-79	Male	52	61	93	93		

Threshold-page 119 N. South St 4mph NW 40% 77°c
2:22:20 Monday, 04-Nov-19

REaCH

Heart Rate Heat Index Blood Pressure Oxygen (SpO2)

Heart Rate (b/min)	Heat Index Status	Blood Pressure Grade	Oxygen (SpO2) Actions
80 - 90	Caution	1	✎ 🗑️ 📄
91 - 103	Extreme Caution	2	✎ 🗑️ 📄
104 - 134	Danger	3	✎ 🗑️ 📄
135 - 160	Extreme Danger	4	✎ 🗑️ 📄

Dashboard People Groups Devices Device Assignments Thresholds Reports System Administration Admin Logout

Threshold-page 119 N. South St 4mph NW 40% 77°c
2:22:20 Monday, 04-Nov-19

REaCH

Heart Rate Heat Index Blood Pressure Oxygen (SpO2)

Heart Rate	Heat Index	Blood Pressure	Oxygen (SpO2)	Grade	Actions
Age Group	Low Critical	Low	Normal		
10-73	0 - 90%	91 - 94%	95 - 100%	1	✎ 🗑️ 📄

Dashboard People Groups Devices Device Assignments Thresholds Reports System Administration Admin Logout

SITE-ADMINISTRATION PAGE

Site-Administration-page 119 N. South St. 77°C 22m20s Monday, 04-Nov-19 17:53:27 UTC

Health Status		User Accounts		Notifications	
Degraded	Normal	Logged In Users	User Accounts	Pending	
1	30	3	250	10/21/2019	Tim Taylor account "ttaylor" creation request
People		Teams		10/21/2019	Harold Adams added to the system
In Service	Out of Service	Active Teams	Inactive Teams	10/21/2019	Tim Smith added to the system
2	29	2	1	10/21/2019	Dave Tompison added to the system
Devices		Status Alerts		10/21/2019	
Assigned	Unassigned	Status Alert	Status Normal	Jones created team Team 2	
31	2	1	30		
System Performance				Historical	
Connections	Network	Disk Usage		10/21/2019	Jones modified Team 1 members
36	50mbps	150Gb/2tb		10/21/2019	Jones created team Team 1
System Alerts		System notifications			
Communication Failure		Connection Ended			
Unexpected Shutdown		Disk Usage at 10%			
		New Connection			
		System Booted			

Admin
Logout

Site Administration / Users 119 N. South St. 77°C 22m20s Monday, 04-Nov-19 17:53:27 UTC

Users				Admin, Admin	
Username	Team	Email	Search	Username:	Admin
admin	Admin, Admin	admin@gmail.com		Name:	Admin,Admin
DTompson	Tompson,Dave	dave@bmsafl.com		Email:	Admin@gmail.com
Harold	Adams, Harold	harold@gmail.com		Password:	*****
Jones	Jones, Jin	jing@gmail.com		Last Login:	Monday, 04-Nov-19 16:53:27 UTC
TSmith	Smith, Tim	tsmith@gmail.com			
TTaylor	Taylor, Tim	tt@gmail.com			

Admin
Logout

INFORMATION FLOWS

These information flow diagrams illustrate the flow of information across the system.

[An information flow is a less formal diagram that may take on whatever form is appropriate to effectively and clearly communicate the flow of information across a system. When a solution includes a significant data flow and/or ETL implementation, this section should be included to illustrate the high-level flow of information between major components listed above in the "Component Models" section. It should always include service endpoints, messaging functions, and file I/O.]

FRAMEWORKS AND PATTERNS

The following frameworks and patterns will be used by this project.

Angular8: Angular is a platform and framework for building single-page client applications using HTML and TypeScript. Angular is written in TypeScript. It implements core and optional functionality as a set of TypeScript libraries that you import into your apps.

To get start with angular and for more details on installation and creating working environment please visit <https://angular.io/start>

Python-Django Framework: Django is a high-level Python web framework that enables rapid development of secure and maintainable websites. Built by experienced developers, Django takes care of much of the hassle of web development, so you can focus on writing your app without needing to reinvent the wheel. It is free and open source, has a thriving and active community, great documentation, and many options for free and paid-for support. Currently we are using Django 3.0

For detail steps on installation visit <https://docs.djangoproject.com/en/3.0/topics/install/>

PostgreSQL: Postgres is a powerful, open source object-relational database system. PostgreSQL features transactions with Atomicity, Consistency, Isolation, Durability (ACID) properties, automatically updatable views, materialized views, triggers, foreign keys, and stored procedures. It is designed to handle a range of workloads, from single machines to data warehouses or Web services with many concurrent users. It is the default database for macOS Server and is also available for Linux, FreeBSD, OpenBSD, and Windows. Currently we are using Postgres version 12.2 for both Mac and windows.

Installation and use of PostgreSQL can be done by referring to development environment documentation which can be found under <https://unomaha.app.box.com/file/631407180911>

Postgres can be downloaded from <https://www.enterprisedb.com/downloads/postgres-postgresql-downloads>

PROCESS MODELS

This project requires the use of one or more non-standard software development processes as described here.

VERSIONING

RELEASES

DEPLOYMENT INFORMATION

The project will generate deployable artifacts. The following provides details about those artifacts and any additional processes that they require.

DEPLOYABLE FILES

Heroku: Heroku is a container-based cloud Platform as a Service (PaaS). Developers use Heroku to deploy, manage, and scale modern apps. Our platform is elegant, flexible, and easy to use, offering developers the simplest path to getting their apps to market.

Files required while deploying to Heroku can be accessed through <https://unomaha.app.box.com/folder/108100783476>

To get started with Heroku please visit

https://signup.heroku.com/t/platform?c=70130000001xDpdAAE&qclid=EAlalQobChMlzp7Jhu366AIVkvwjBx3zXw1jEAAYA_SAAEqJ8YPD_BwE

To install Heroku toolbelt (Heroku CLI) please visit <https://devcenter.heroku.com/articles/heroku-cli>

CONFIGURATION

STATIC CONTENT

DEPLOYMENT PROCESS

There are multiple process in which we can deploy code to Heroku. Always make sure to make a copy of the folder, which ensures you have a backup if something goes wrong while deploying.

Push your code to GitHub by creating a branch of your name in Reach repository, which is available at <https://github.com/uno-public-health-informatics-lab/REACH>

Information regarding deploying code through Github can be found in <https://github.com/uno-public-health-informatics-lab/REACH>

Reach application is deployed in Heroku and can be accessed through <http://hazmat-reach-cat.herokuapp.com/>

Appendix F REaCH System User Interface Prototype Documentation

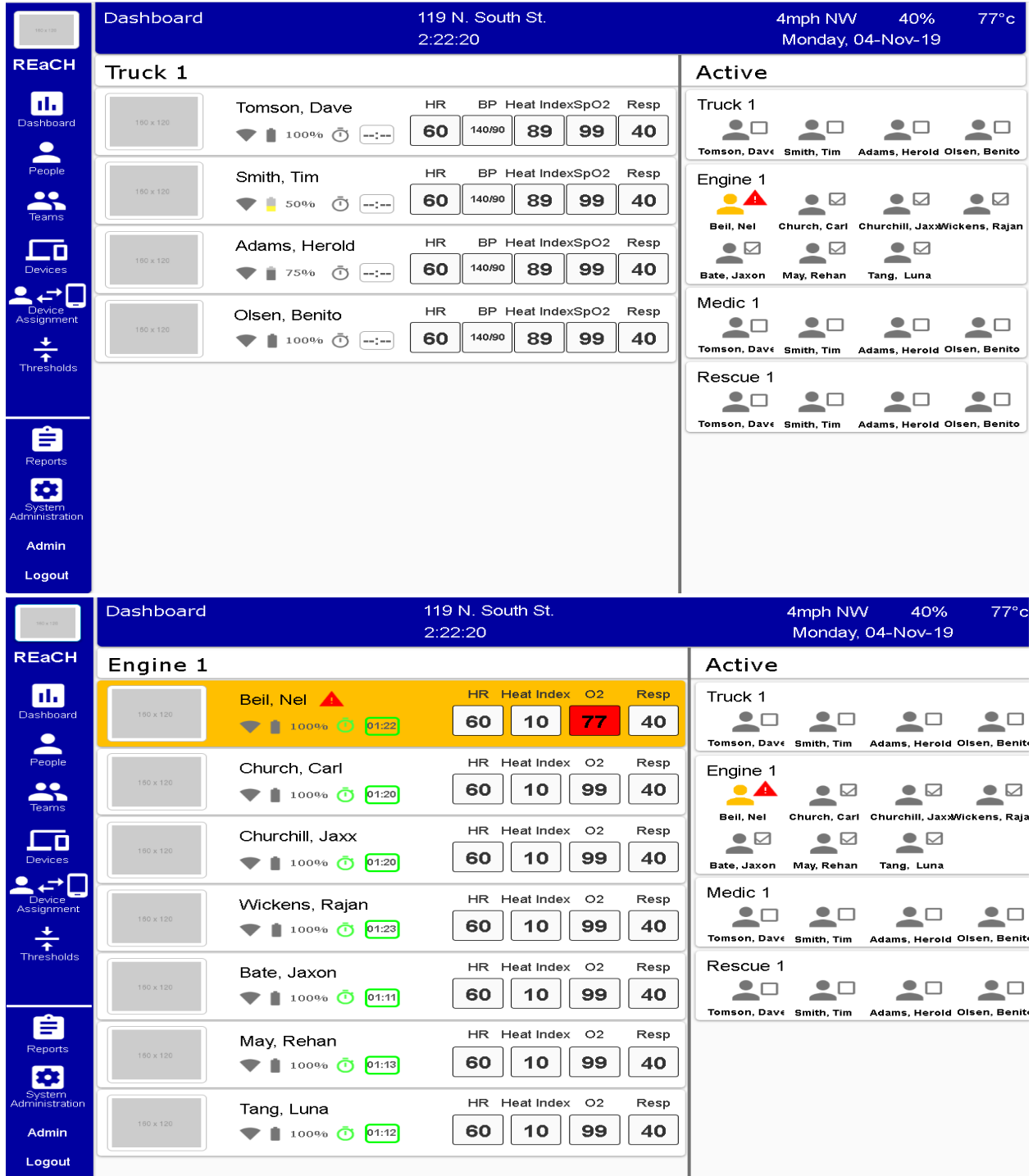

Figure F.1 Dashboard Page

Special-Operation-People-page 119 N. South St. 4mph NW 40% 77°C
2:22:20 Monday, 04-Nov-19

REaCH

- Dashboard
- People
- Teams
- Devices
- Device Assignment
- Thresholds
- Reports
- System Administration
- Admin
- Logout

Photo	*First Name	*Last Name	Team Name	*Role	Last Active	Elapsed Time	Threshold Values					Actions			
							HR	HI	BP	RR	SpO2				
	Tomson	Dave	Truck 1	FR	10-18-2019 10:00:02	03:05:00 hours	2	2	2	1	5				
	Smith	Tim	Station 2	TL	10-18-2019 10:00:02	02:10:25 hours	N/A								
	Adam	Herald	Engine 1	TL	10-18-2019 10:00:02	04:15:15 hours	N/A								
	Olsen	Benito	Truck 2	FR	10-18-2019 10:00:02	01:45:12 hours	2	2	3	1	3				
	Church	Carl	Engine 2	FR	10-18-2019 10:00:02	05:20:06 hours	3	3	4	1	5				

Special-Operation-People-page 119 N. South St. 4mph NW 40% 77°C
2:22:20 Monday, 04-Nov-19

REaCH

- Dashboard
- People
- Teams
- Devices
- Device Assignment
- Thresholds
- Reports
- System Administration
- Admin
- Logout

Photo	*First Name	*Last Name	Team Name	*Role	Last Active	Elapsed Time	Threshold Values					Actions			
							HR	HI	BP	RR	SpO2				
	Tomson	Dave	Truck 1	FR	10-18-2019 10:00:02	03:05:00 hours	2	2	2	1	5				
	Smith	Tim	Station 2	TL	10-18-2019 10:00:02	02:10:25 hours	N/A								
	Adam	Herald	Engine 1	TL	10-18-2019 10:00:02	04:15:15 hours	N/A								
	Olsen	Benito	Truck 2	FR	10-18-2019 10:00:02	01:45:12 hours	2	2	3	1	3				
	Church	Carl	Engine 2	FR	10-18-2019 10:00:02	05:20:06 hours	3	3	4	1	5				
upload image	First Name	Last Name	Choose	Choose	mm-dd-yyyy 00:00:00	00:00:00 hours	0	0	0	0	0				

Figure F.2 People's Page

Special-Operation-People-page 119 N. South St. 4mph NW 40% 77°C
2:22:20 Monday, 04-Nov-19

REaCH

Dashboard

People

Teams

Devices

Device Assignment

Thresholds

Reports

System Administration

Admin

Logout

Photo	*First Name	*Last Name	Team Name	*Role	Last Active	Elapsed Time	Threshold Values					Actions			
							HR	HI	BP	RR	SpO2				
	Tomson	Dave	Truck 1	FR	10-18-2019 10:00:02	03:05:00 hours	2	2	2	1	5				
	Smith	Tim	Station 2	TL	10-18-2019 10:00:02	02:10:25 hours	N/A								
	Adam	Herald	Engine 1	TL	10-18-2019 10:00:02	04:15:15 hours	N/A								
	Olsen	Benito	Truck 2	FR	10-18-2019 10:00:02	01:45:12 hours	2	2	3	1	3				
	Church	Carl	Engine 2	FR	10-18-2019 10:00:02	05:20:06 hours	3	3	4	1	5				
upload image	Nelson	Jade	Engine 2	FR	10-18-2019 10:00:02	01:45:45 hours	2	2	1	3	4				

Special-Operation-People-page 119 N. South St. 4mph NW 40% 77°C
2:22:20 Monday, 04-Nov-19

REaCH

Dashboard

People

Teams

Devices

Device Assignment

Thresholds

Reports

System Administration

Admin

Logout

Photo	*First Name	*Last Name	Team Name	*Role	Last Active	Elapsed Time	Threshold Values					Actions			
							HR	HI	BP	RR	SpO2				
	Tomson	Dave	Truck 1	FR	10-18-2019 10:00:02	03:05:00 hours	2	2	2	1	5				
	Smith	Tim	Station 2	TL	10-18-2019 10:00:02	02:10:25 hours	N/A								
	Adam	Herald	Engine 1	TL	10-18-2019 10:00:02	04:15:15 hours	N/A								
	Olsen	Benito	Truck 2	FR	10-18-2019 10:00:02	01:45:12 hours	2	2	3	1	3				
	Church	Carl	Engine 2	FR	10-18-2019 10:00:02	05:20:06 hours	3	3	4	1	5				
upload image	Nelson	Jade	Engine	FR	10-18-2019 10:00:02	01:45:45 hours	2	2	1	3	4				

Figure F.2 cont. People's Page

Special-Operation-People-page 119 N. South St. 4mph NW 40% 77°C
2:22:20 Monday, 04-Nov-19

REaCH

- Dashboard
- People
- Teams
- Devices
- Device Assignment
- Thresholds
- Reports
- System Administration
- Admin
- Logout

Photo	*First Name	*Last Name	Team Name	*Role	Last Active	Elapsed Time	Threshold Values					Actions			
							HR	HI	BP	RR	SpO2				
	Tomson	Dave	Truck 1	FR	10-18-2019 10:00:02	03:05:00 hours	2	2	2	1	5				
	Smith	Tim	Station 2	TL	10-18-2019 10:00:02	02:10:25 hours	N/A								
	Adam	Herald	Engine 1	TL	10-18-2019 10:00:02	04:15:15 hours	N/A								
	Olsen	Benito	Truck 2	FR	10-18-2019 10:00:02	01:45:12 hours	2	2	3	1	3				
	Church	Carl	Engine 2	FR	10-18-2019 10:00:02	05:20:06 hours	3	3	4	1	5				
upload image	Nelson	Jade	Engine 2	FR	10-18-2019 10:00:02	01:45:45 hours	2	2	1	3	4				

Remove Person ✕

Are you sure, you want to remove the person?

Figure F.2 cont. People's Page

Team-Management-page 119 N. South St. 4mph NW 40% 77°C
2:22:20 Monday, 04-Nov-19

REaCH

- Dashboard
- People
- Teams
- Devices
- Device Assignment
- Thresholds
- Reports
- System Administration
- Admin
- Logout

Truck 1 Activate

Jake, Connor

Dustin, Luke

Jack, Raven



Glen, Maxwell





Figure F.3 Team's Page



Team-Management-page 119 N. South St. 4mph NW 40% 77°c
2:22:20 Monday, 04-Nov-19









REaCH

- Dashboard
- People
- Teams
- Devices
- Device Assignment
- Thresholds
- Reports
- System Administration
- Admin
- Logout

Truck 1 Activate   

 Jake, Connor	 Dustin, Luke	 Jack, Raven	 Glen, Maxwell
---	---	--	--



Enter Team Name Activate   





Available Member List			Add Team Member
 Tang, Luna →	 May, Rehan →	 Bate, Jaxon →	
 Church, Carl →	 Olsen, Benito →	 Adams, Herold →	
 Smith, Tim →	 Tomson, Dave →		

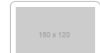

Team-Management-page 119 N. South St. 4mph NW 40% 77°c
2:22:20 Monday, 04-Nov-19

REaCH

- Dashboard
- People
- Teams
- Devices
- Device Assignment
- Thresholds
- Reports
- System Administration
- Admin
- Logout

Team 1 Activate   

 Jake, Connor	 Dustin, Luke	 Jack, Raven	 Glen, Maxwell
---	---	--	--

Enter Team Name Activate   











Available Member List			Add Team Member	
 Tang, Luna →	 May, Rehan →	 Bate, Jaxon →	 Tomson, Dave ←	
 Church, Carl →	 Olsen, Benito →	 Adams, Herold →		 Smith, Tim ←

Figure F.3 cont. Team's Page



Team-Management-page 119 N. South St. 4mph NW 40% 77°C
2:22:20 Monday, 04-Nov-19

REaCH

- Dashboard
- People
- Teams
- Devices
- Device Assignment
- Thresholds
- Reports
- System Administration
- Admin
- Logout

Truck 1 Activate   

Jake, Connor Dustin, Luke Jack, Raven Glen, Maxwell

Engine 1 Activate   

Tomson, Dave Smith, Tim

Figure F.3 cont. Team's Page

Device-Management-page 119 N. South St. 4mph NW 40% 77°C
2:22:20 Monday, 04-Nov-19

REaCH

- Dashboard
- People
- Teams
- Devices
- Device Assignment
- Thresholds
- Reports
- System Administration
- Admin
- Logout

Device ID	Device IP	Device Description	Device Type	Status	Actions
954143254	11.23.21.25	Measuring temperature and humidity	Type 1	  100%	   
754832146	231.25.64.23	Measuring heart rate	Type 1	  50%	   

Figure F.4 Device Page

Device-Management-page 119 N. South St. 4mph NW 40% 77°C
2:22:20 Monday, 04-Nov-19

REaCH

- Dashboard
- People
- Teams
- Devices
- Device Assignment
- Thresholds
- Reports
- System Administration
- Admin
- Logout

Device ID	Device IP	Device Description	Device Type	Status	Actions
954143254	11.23.21.25	Measuring temperature and humidity	Type 1	100%	[Edit] [Delete] [Refresh] [Chart]
754832146	231.25.64.23	Measuring heart rate	Type 1	50%	[Edit] [Delete] [Refresh] [Chart]
954143254	11.12.13.14	Measuring Heat Index	General	100%	[Edit] [Delete] [Refresh] [Chart]

Device-Management-page 119 N. South St. 4mph NW 40% 77°C
2:22:20 Monday, 04-Nov-19

REaCH

- Dashboard
- People
- Teams
- Devices
- Device Assignment
- Thresholds
- Reports
- System Administration
- Admin
- Logout

Device ID	Device IP	Device Description	Device Type	Status	Actions
954143254	11.23.21.25	Measuring temperature and humidity	Type 1	100%	[Edit] [Delete] [Refresh] [Chart]
754832146	231.25.64.23	Measuring heart rate	Type 1	50%	[Edit] [Delete] [Refresh] [Chart]
954143254	11.12.13.14	Measuring Heat Index	General	100%	[Edit] [Delete] [Refresh] [Chart]
754832146	21.22.23.24	Measuring humidity	Type 2	50%	[Edit] [Delete] [Refresh] [Chart]

Remove Device ✕

Are you sure, you want to remove the device ?

Figure F.4 cont. Device Page

REaCH

Device-Assignment-page 119 N. South St. 4mph NW 40% 77°c
2:22:20 Monday, 04-Nov-19

Unassigned Assigned All

Photo	First Name	Last Name	Assigned Device ID	Device Description
	Nel	Bell	Device 1	
	Carl	Church	Device 1	

Dashboard
People
Teams
Devices
Device Assignment
Thresholds
Reports
System Administration
Admin
Logout

REaCH

Device-Assignment-page 119 N. South St. 4mph NW 40% 77°c
2:22:20 Monday, 04-Nov-19

Unassigned Assigned All

Photo	First Name	Last Name	Assigned Device ID	Device Description
	Dan	Salazar	Device 1	Sensortag: Temp, Humidity, Gyro
	Ronald	Smith	Device 1	Sensortag: Temp, Humidity, Gyro

Dashboard
People
Teams
Devices
Device Assignment
Thresholds
Reports
System Administration
Admin
Logout

Figure F.5 Device-Assignment Page

REaCH Dashboard

Device-Assignment-page 119 N. South St. 4mph NW 40% 77°c
2:22:20 Monday, 04-Nov-19

Unassigned Assigned All

Photo	First Name	Last Name	Assigned Device ID	Device Description
	Nel	Bell	Device 1	
	Carl	Church	Device 1	
	Dan	Salazar	Device 1	Sensortag: Temp, Humidity, Gyro
	Ronald	Smith	Device 1	Sensortag: Temp, Humidity, Gyro

Reports System Administration Admin Logout

Figure F.5 cont. Device-Assignment Page

REaCH Dashboard

Threshold-page 119 N. South St. 4mph NW 40% 77°c
2:22:20 Monday, 04-Nov-19

+

Heart Rate	Heat Index	Blood Pressure	Oxygen (SpO2)			
Age Group	Sex	Low Critical (Q1)	Resting (Q2)	High Critical (Q3)	Grade	Actions
18-29	Male	53	62	169		
	Female	56	67	169		
30-39	Male	55	64	161		
	Female	56	67	161		
40-49	Male	55	65	154		
	Female	56	67	154		
50-59	Male	55	64	147		
	Female	56	66	147		
60-69	Male	54	63	140		
	Female	55	65	140		
70-79	Male	52	61	133		

















Reports System Administration Admin Logout

Figure F.6 Threshold Page

Threshold-page 119 N. South St. 4mph NW 40% 77°c
2:22:20 Monday, 04-Nov-19

REaCH +

Heart Rate Heat Index Blood Pressure Oxygen (SpO2)

Heat Index (inside suit)	Status	Grade	Actions
80 - 90	Caution	1	   
91 - 103	Extreme Caution	2	   
104 - 124	Danger	3	   
125 - 160	Extreme Danger	4	   

Dashboard People Teams Devices Device Assignment Threshholds Reports System Administration Admin Logout

Threshold-page 119 N. South St. 4mph NW 40% 77°c
2:22:20 Monday, 04-Nov-19

REaCH +

Heart Rate Heat Index Blood Pressure Oxygen (SpO2)

Age Group	Low Critical	Low	Normal	Grade	Actions
18-79	0 - 90%	91 - 94%	95 - 100%	1	   

Dashboard People Teams Devices Device Assignment Threshholds Reports System Administration Admin Logout

Figure F.6 cont. Threshold Page

Site-Administration-page 119 N. South St. 77°C 22m20s Monday, 04-Nov-19 17:53:27 UTC

Health Status		User Accounts		Notifications		
Danger!	Normal	Logged In Users	User Accounts	Pending		
1	30	3	250	10/21/2019	Tim Talor account "ttalor" creation request	
People		Teams		10/21/2019	Herod Adams added to the system	
In Service	Out of Service	Active Teams	Inactive Teams	10/21/2019	Tim Smith added to the system	
2	29	2	1	10/21/2019	Dave Tompson added to the system	
Devices		Status Alert		10/21/2019	JJones created team Team 2	
Assigned	Unassigned	Status Alert	Status Normal	Historical		
31	2	1	30	10/21/2019	JJones modified Team 1 members	
System Performance			10/21/2019			JJones created team Team 1
Connections	Network	Disk Usage				
36	50mbps	350gb/2tb				
System Alerts		System notifications				
Communication Failure Unexpected Shutdown		Connection Ended Disk Usage at 10% New Connection System Booted				

REaCH Dashboard People Teams Devices Device Assignment Thresholds Reports System Administration Admin Logout

Site Administration / Users 119 N. South St. 77°C 22m20s Monday, 04-Nov-19 17:53:27 UTC

Users			Admin, Admin
Username	Name	Email	Username: Admin
Admin	Admin, Admin	Admin@email.com	Name: Admin,Admin
DTompson	Tompson,Dave	dave@email.com	Email: Admin@email.com
HAdams	Adams, Herod	herod@email.com	Password: *****
JJones	Jones, Jin	jin@email.com	Last Login: Monday, 04-Nov-19 16:53:27 UTC
TSmith	Smith, Tim	tsmith@email.com	
TTalor	Talor, Tim	tt@email.com	

REaCH Dashboard People Teams Devices Device Assignment Thresholds Reports System Administration Admin Logout

Figure F.7 Site-Administration Page

Appendix G REaCH Technical Development Documentation

Table of Contents

G.1 Document Scope	114
G.2 Steps to Install and Create a PostgreSQL Database.....	114
G.3 Install Git Bash and Pycharm from the below link.....	126
G.4 Steps to Clone and Run the app in your Local Machine.....	126
G.5 Steps to connect PostgreSQL Database to PgAdmin4.....	131
G.6 Definitions of Packages used at requirements.txt for Building the App.....	131

G.1 Document Scope

The Scope of this document is to guide the developer to run the hazmat application in their local system. This document will illustrate the steps to install Postgres Database which we are going to use in our app. It covers the commands required to run the app in a local system.

After completing the document, the user will be able to successfully run the app.

G.2 Steps to Install and Create a PostgreSQL Database

Go to <https://www.enterprisedb.com/downloads/postgres-postgresql-downloads> to download the PostgreSQL for your system.

The version should be 10.11.

PostgreSQL Database Download

PostgreSQL Version	Linux x86-64	Linux x86-32	Mac OS X	Windows x86-64	Windows x86-32
12.1	N/A	N/A	Download	Download	N/A
11.6	N/A	N/A	Download	Download	N/A
10.11	Download	Download	Download	Download	Download
9.6.16	Download	Download	Download	Download	Download
9.5.20	Download	Download	Download	Download	Download
9.4.25	Download	Download	Download	Download	Download
9.3.25 (Not Supported)	Download	Download	Download	Download	Download

Please Note: EDB no longer provides Linux installers for PostgreSQL 11 and later versions, and users are encouraged to use the [platform-native packages](#). Version 10.x and below will be supported until their [end of life](#). For more information, please see this blog post on [Platform Native EDB Packages for Linux Users](#).

[PostgreSQL 12.0 Installation Guide](#)

[PostgreSQL 12.0 Language Pack Guide](#)

Note: For Mac you don't have to set the environment variable. But for windows, you will have to set the environment variable. So Please remember the path where you are installing your PostgreSQL.

Figure G.1 PostgreSQL Database Download Versions

Below is a screenshot showing two file paths. After installing PostgreSQL, the environment variable should be added.

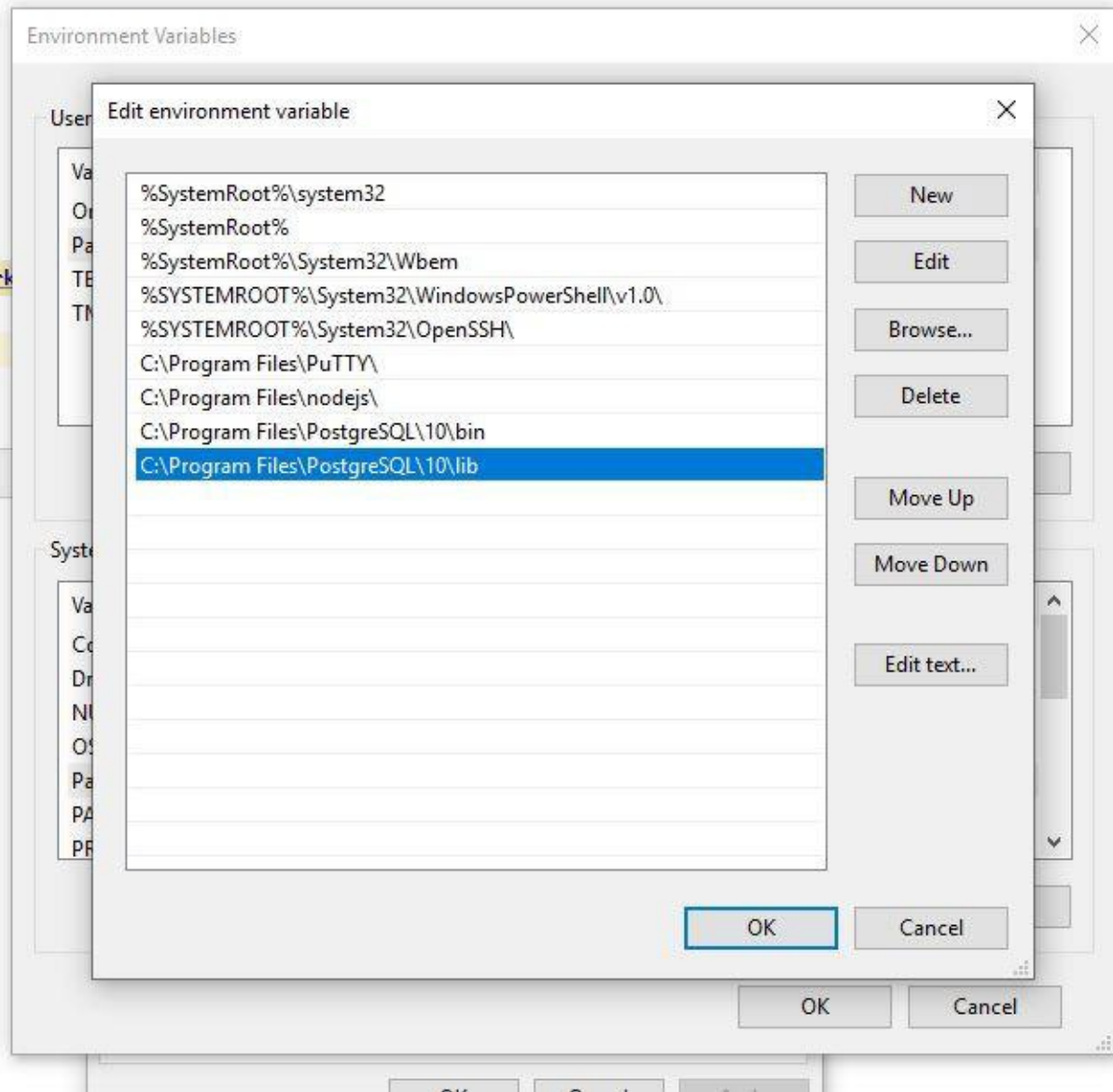

Figure G.2 Screenshot of PostgreSQL bin and lib paths in the Edit environment variable settings.

Things to Remember:

- Remember the name and password of your database.

- Download the version 10.11 (you can download the updated version as well)
- Keep everything default.
- Keep the port number 5432

Follow the steps shown in images to install PostgreSQL 10.

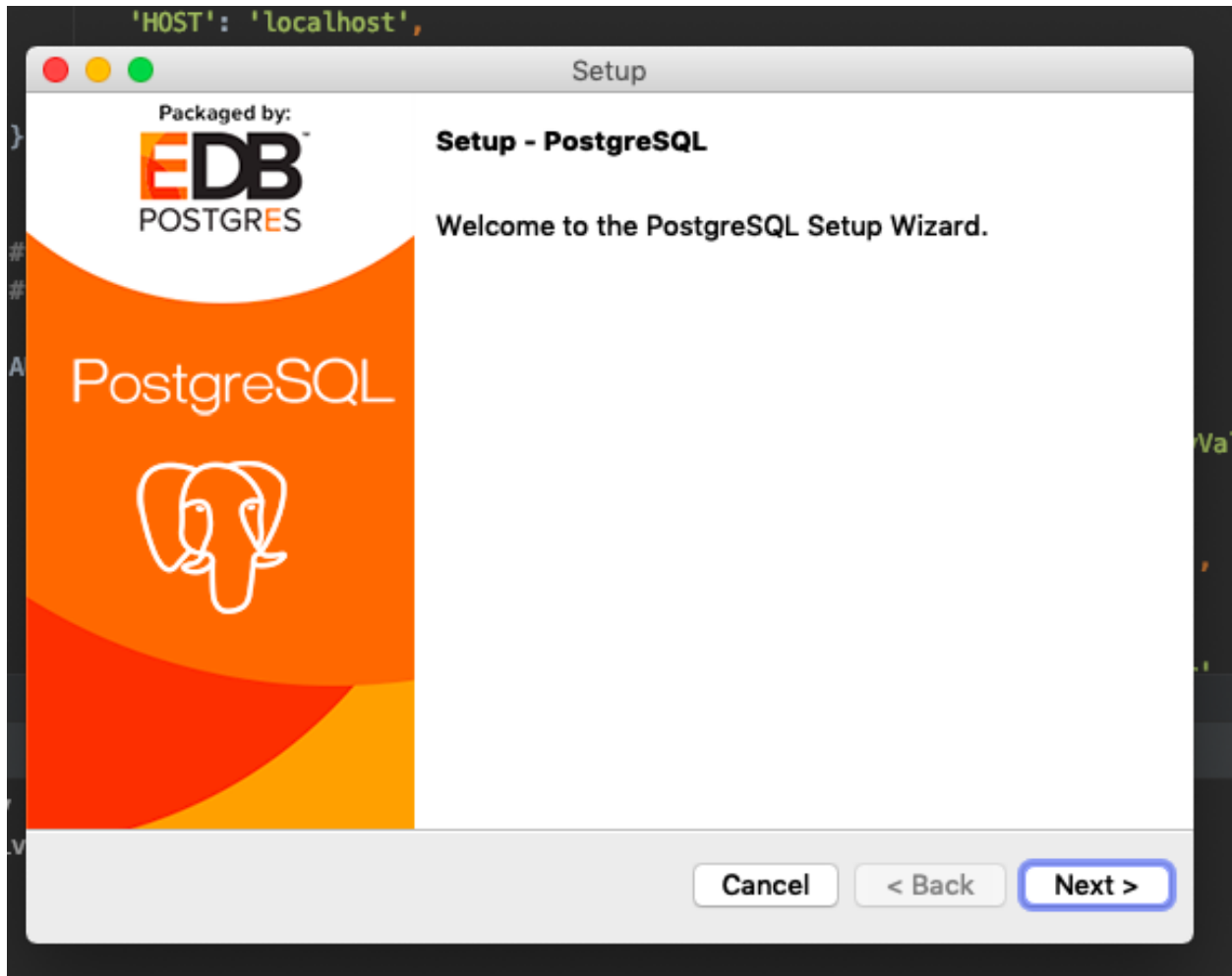

Figure G.3 PostgreSQL Setup Screen

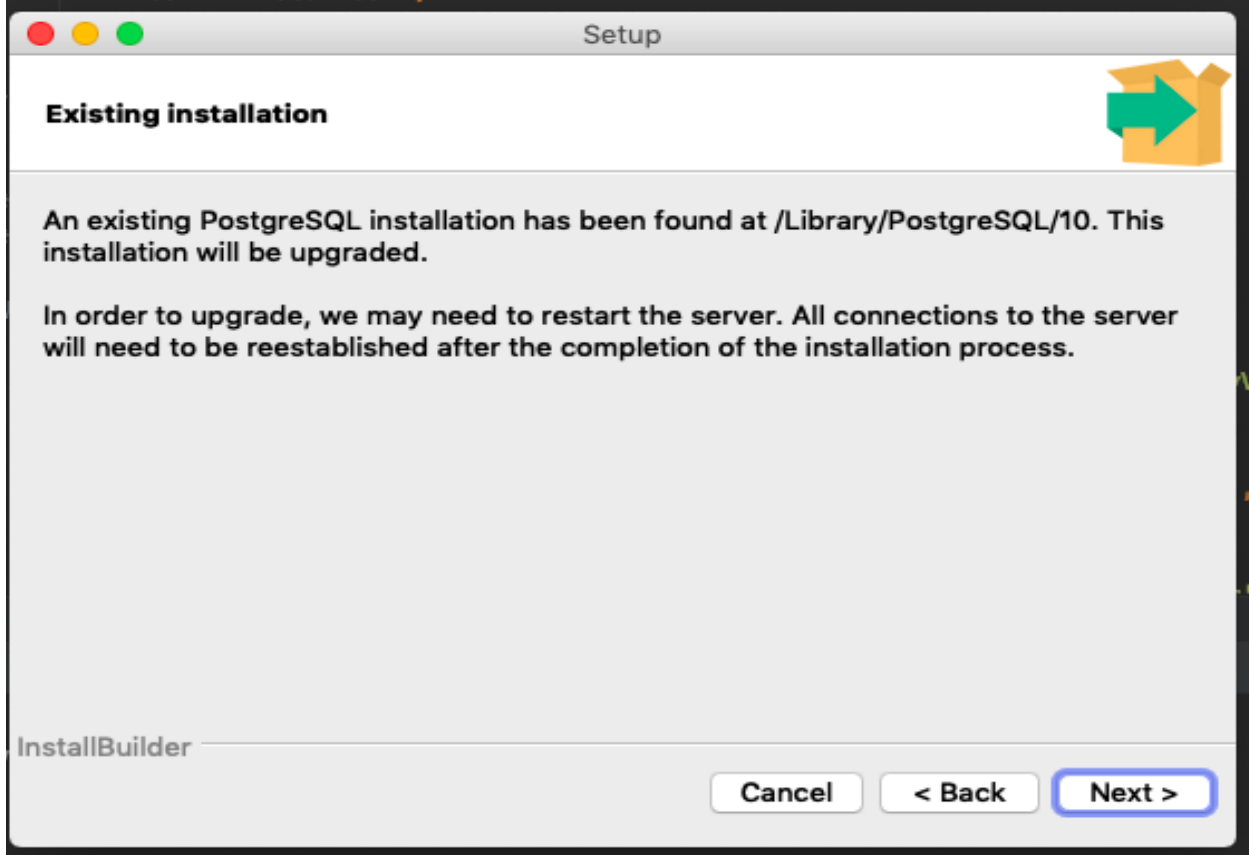
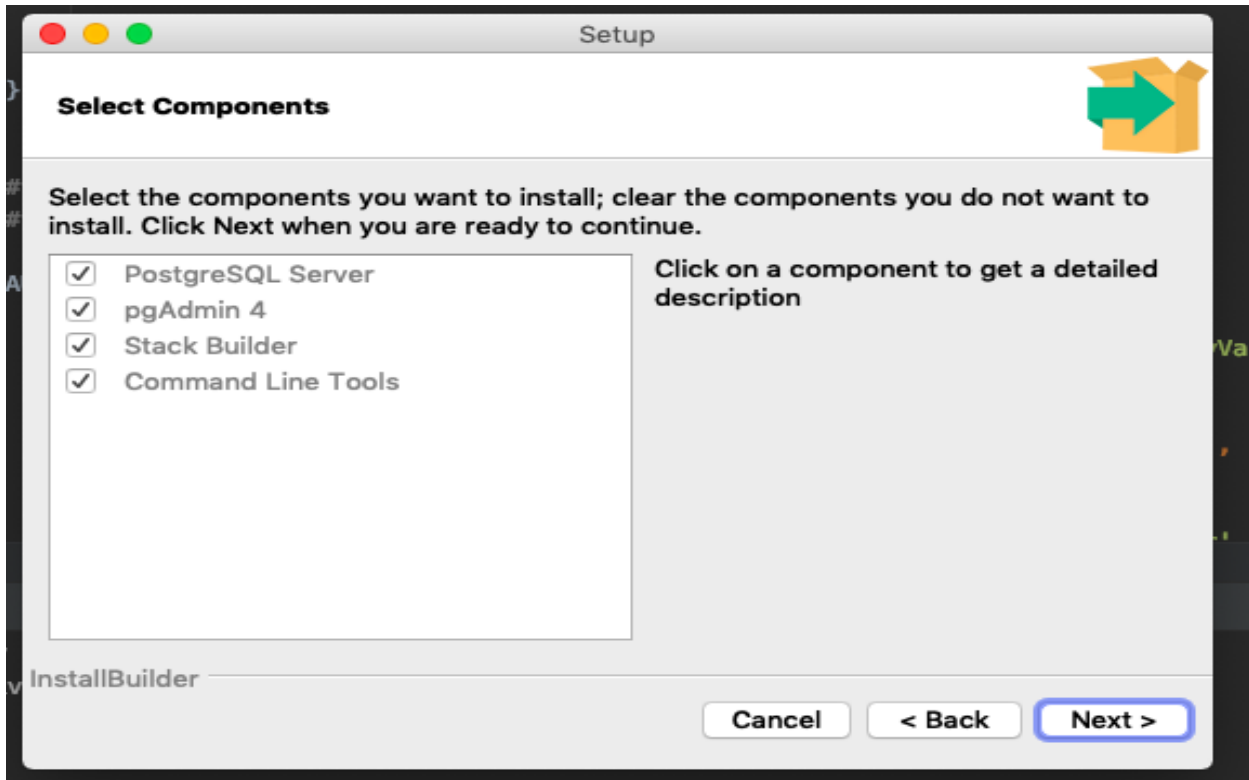

Figure G.3 cont. PostgreSQL Setup Screen

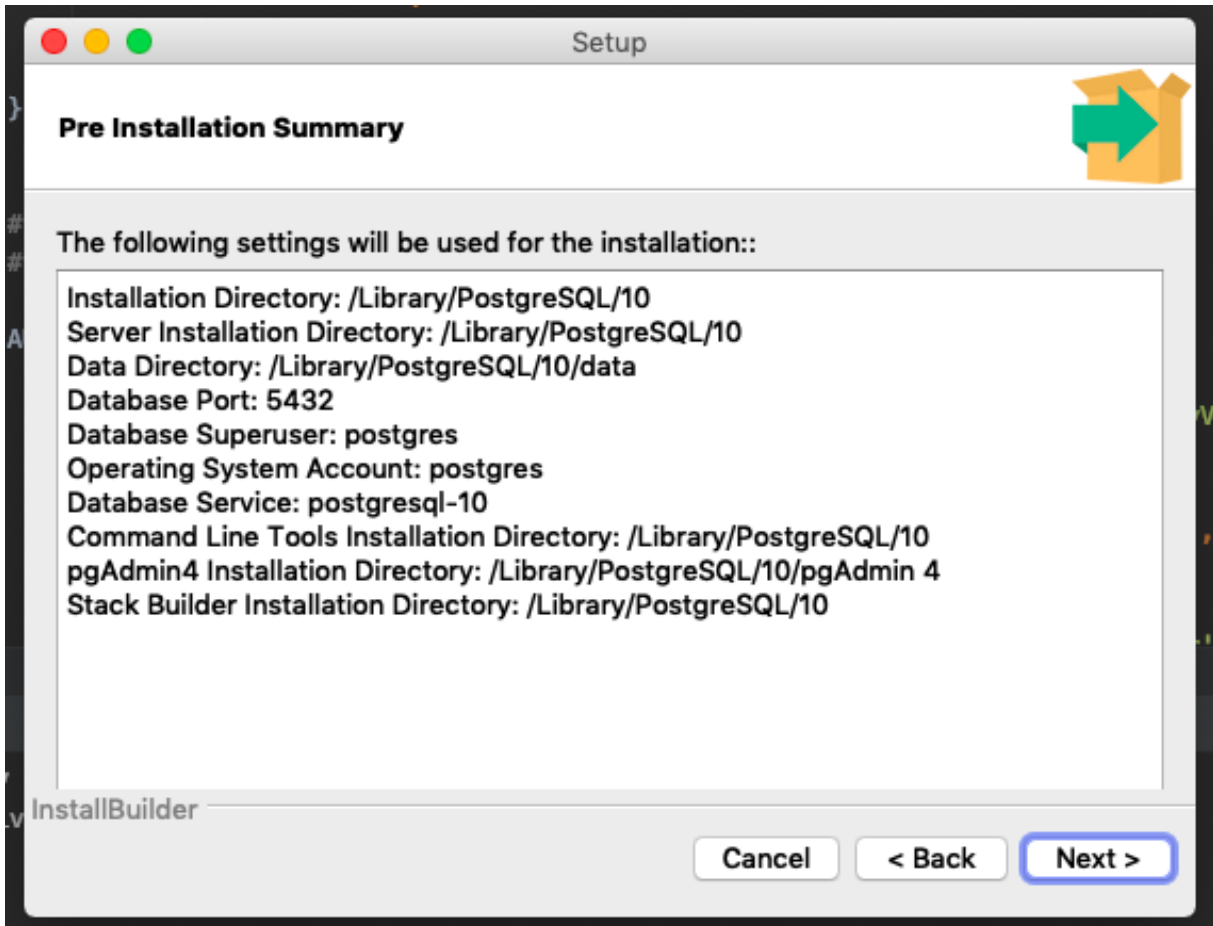
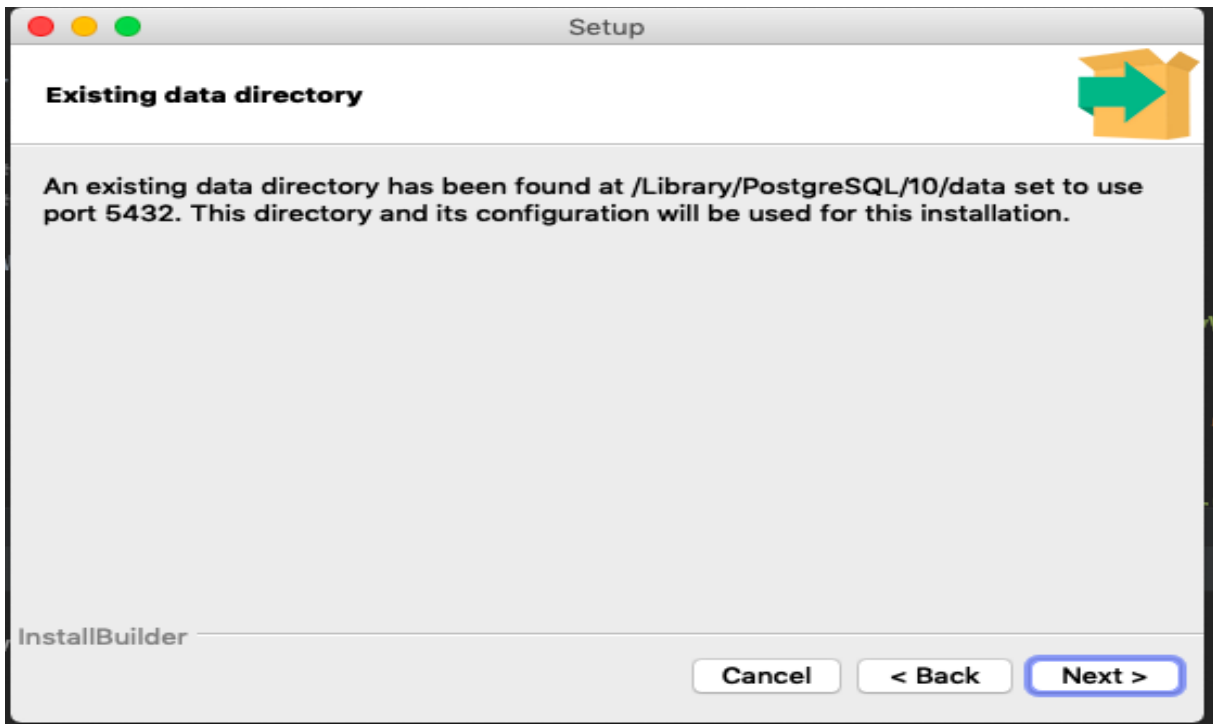

Figure G.3 cont. PostgreSQL Setup Screen

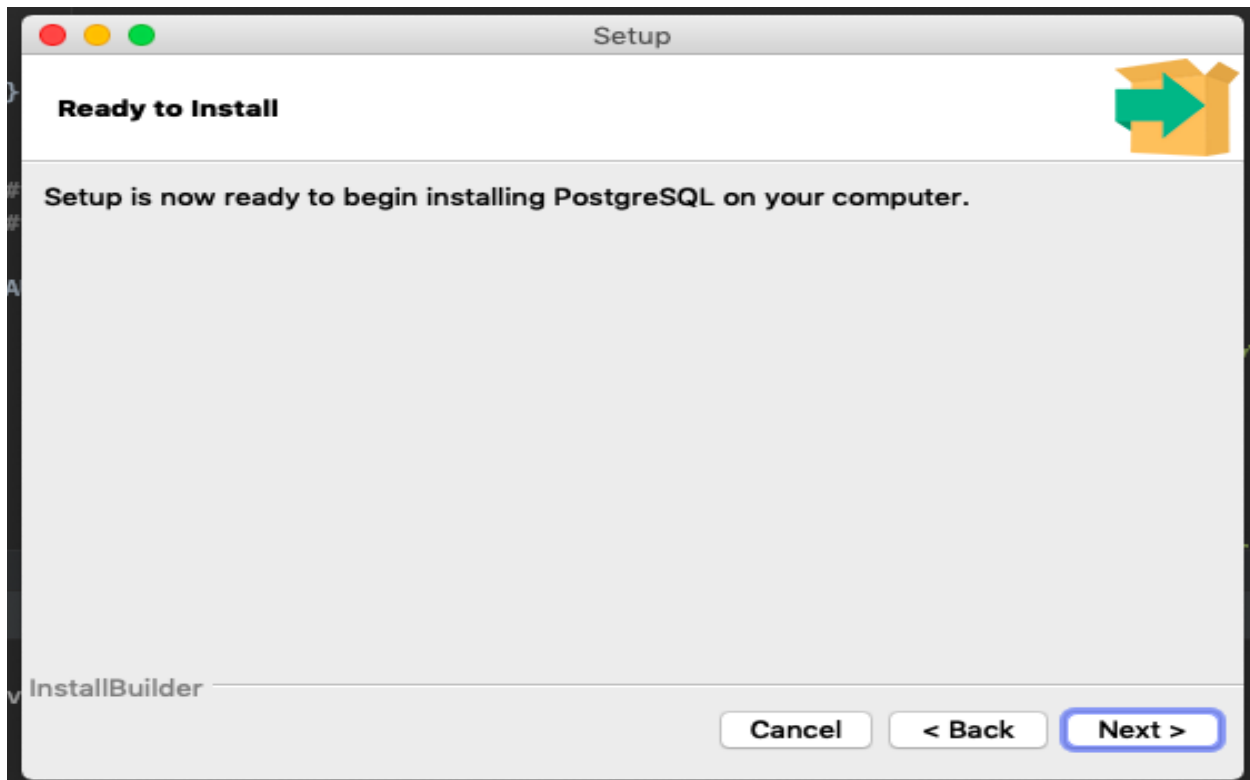

Figure G.3 cont. PostgreSQL Setup Screen

Now launch Stack Builder. Select “PostgreSQL 10...” from the list.

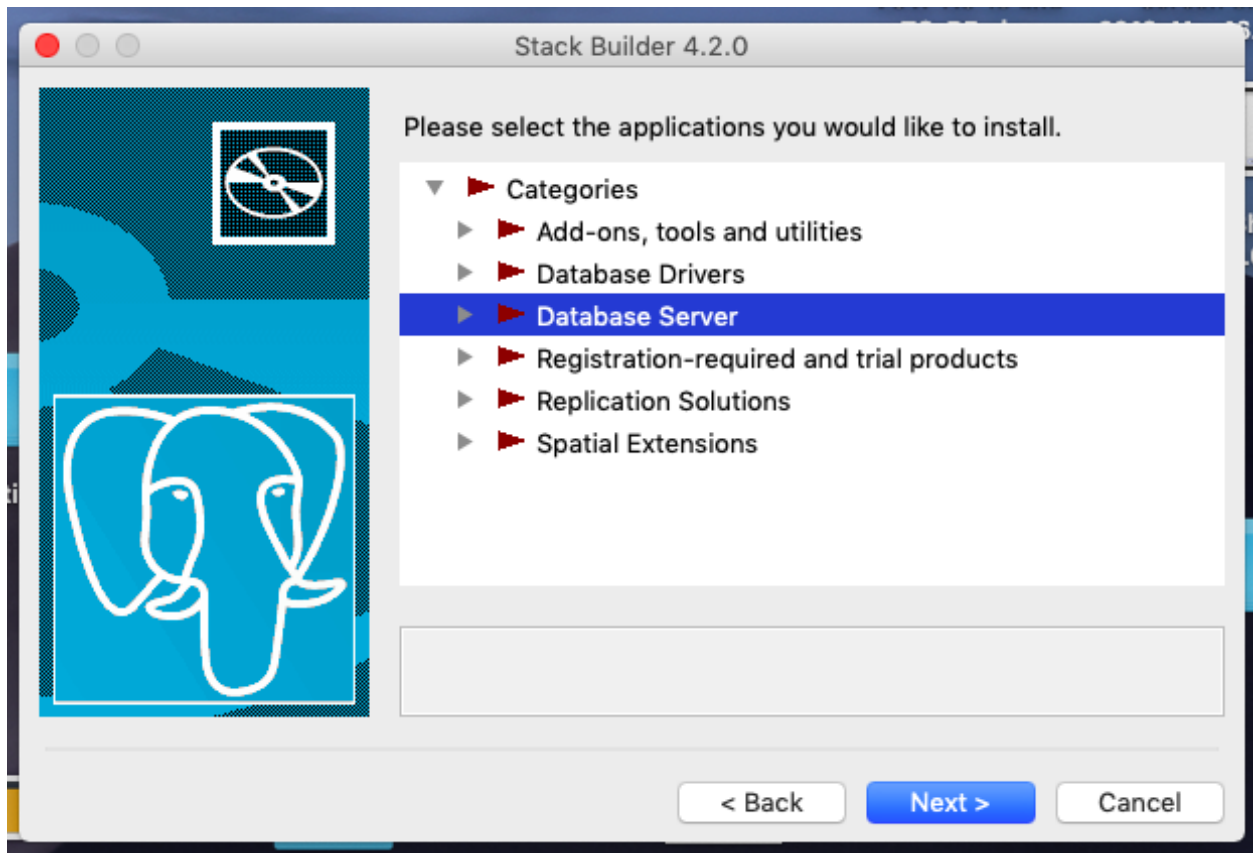

Figure G.4 Stack Builder 4.2.0 Setup Screen

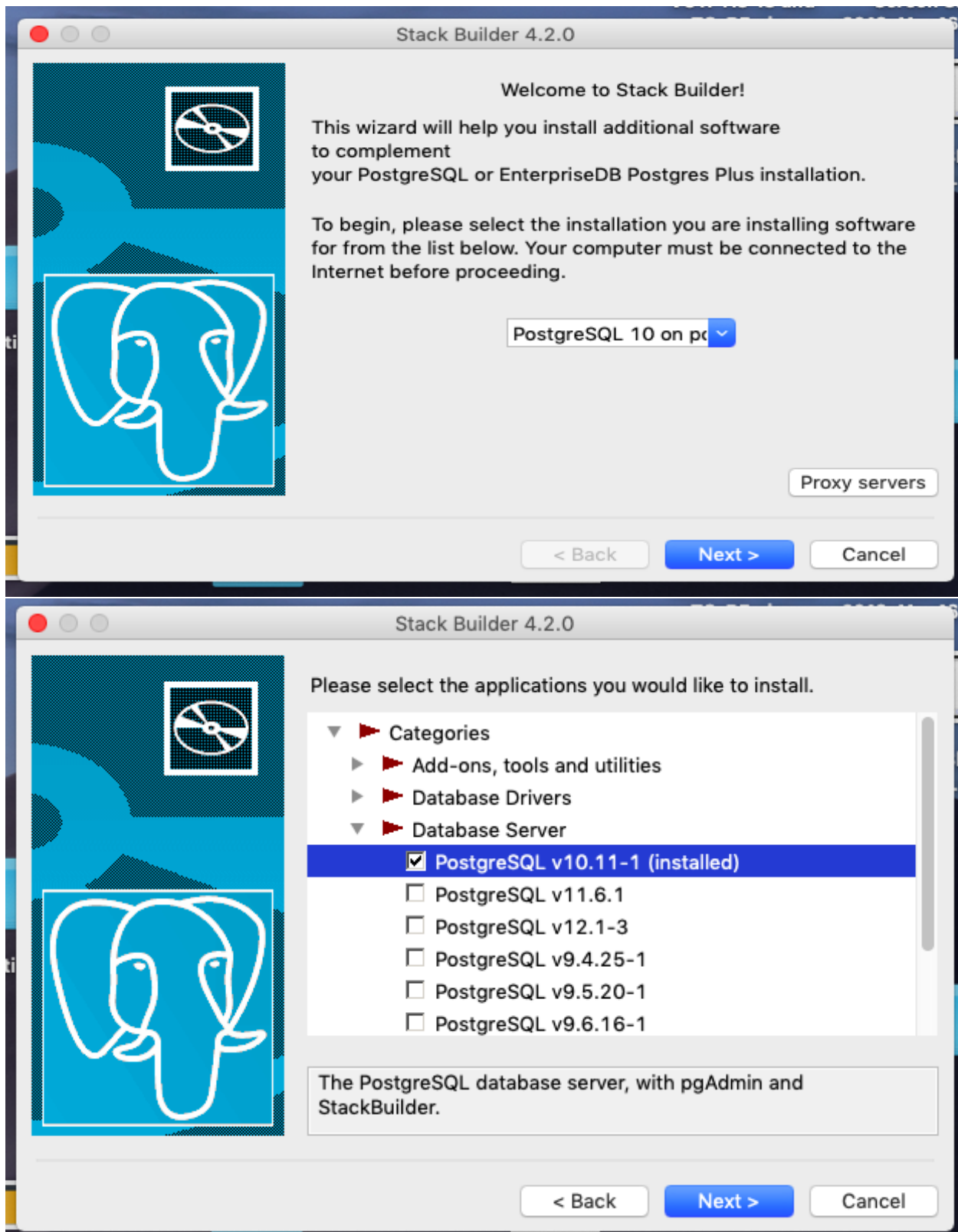

Figure G.4 cont. Stack Builder 4.2.0 Setup Screen

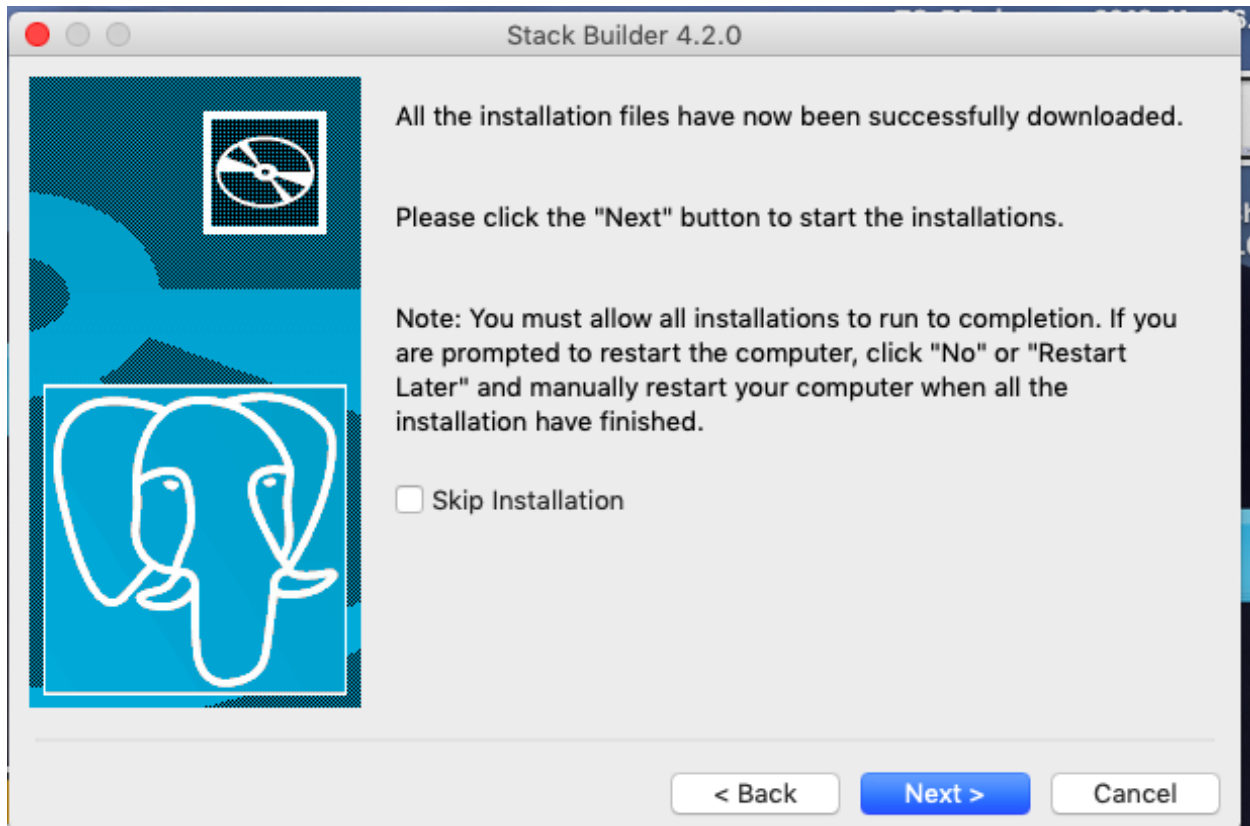

Figure G.4 cont. Stack Builder 4.2.0 Setup Screen

This will install pgAdmin4. Launch pgAdmin4 from your system and Enter your system master password here.

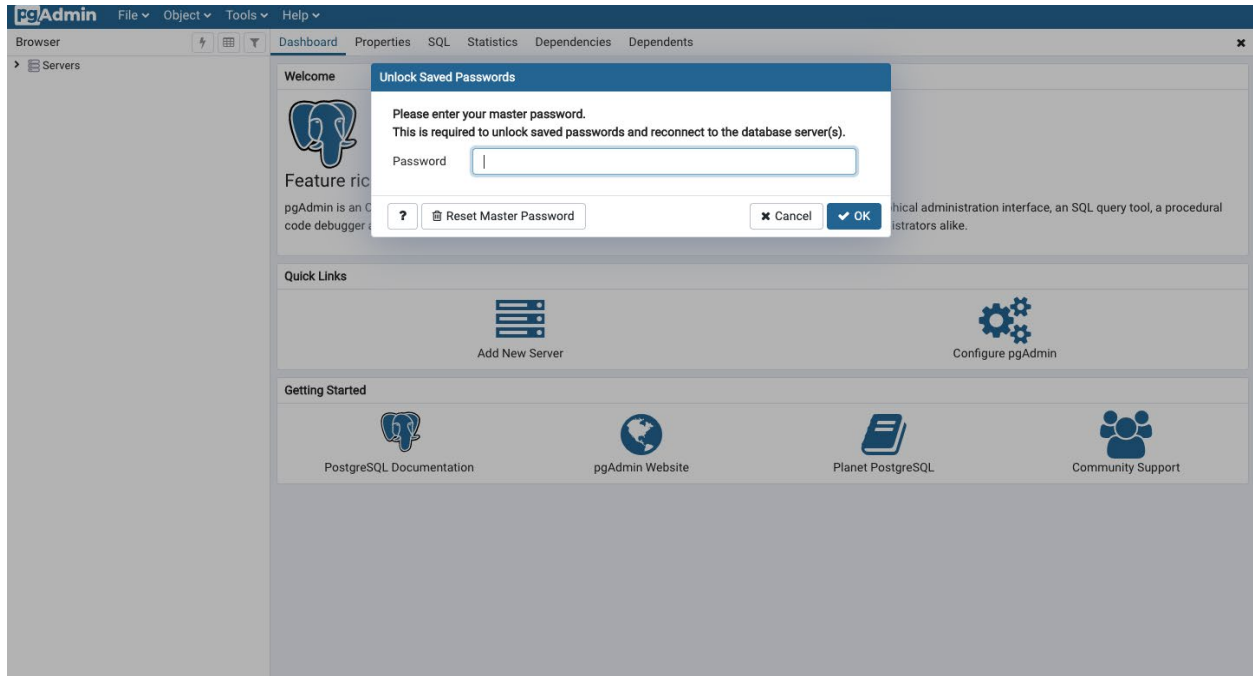

Figure G.5 Screenshot of pgAdmin

Click on “Server”, then right click on “PostgreSQL”. Click on “Create new Database”.

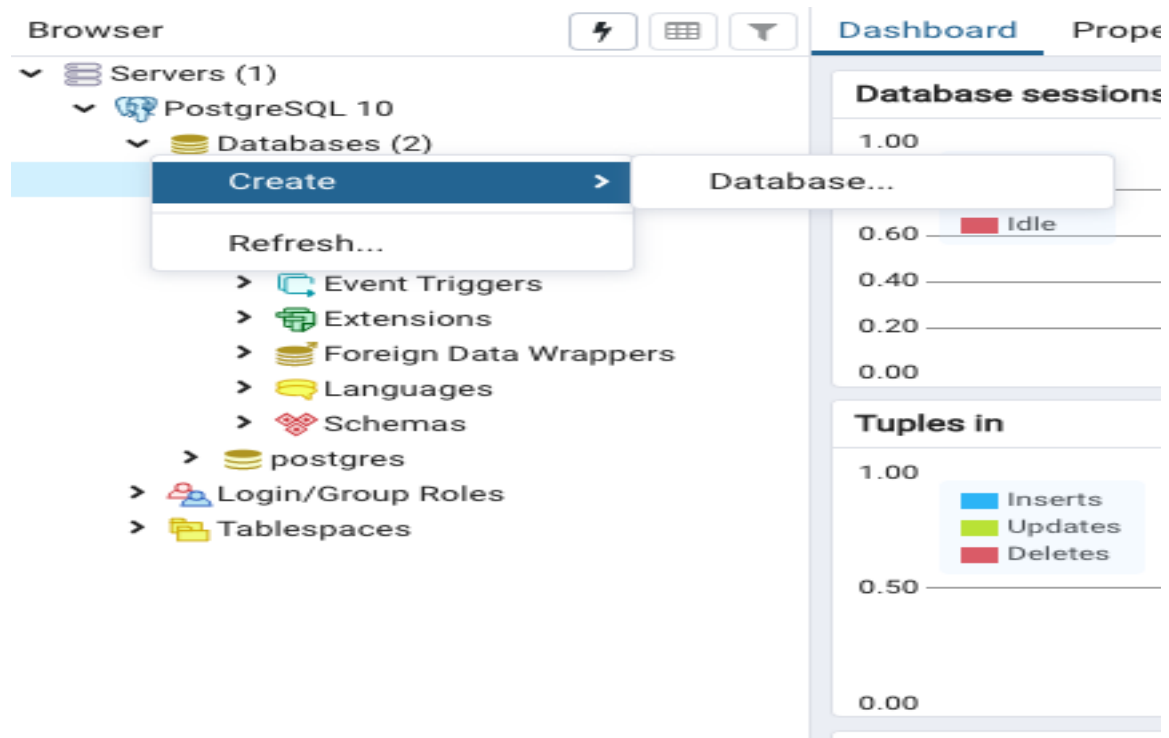

Figure G.6 Creating a Database in pgAdmin

Give a name to the database. Remember the name because you have to use it in your settings.py.

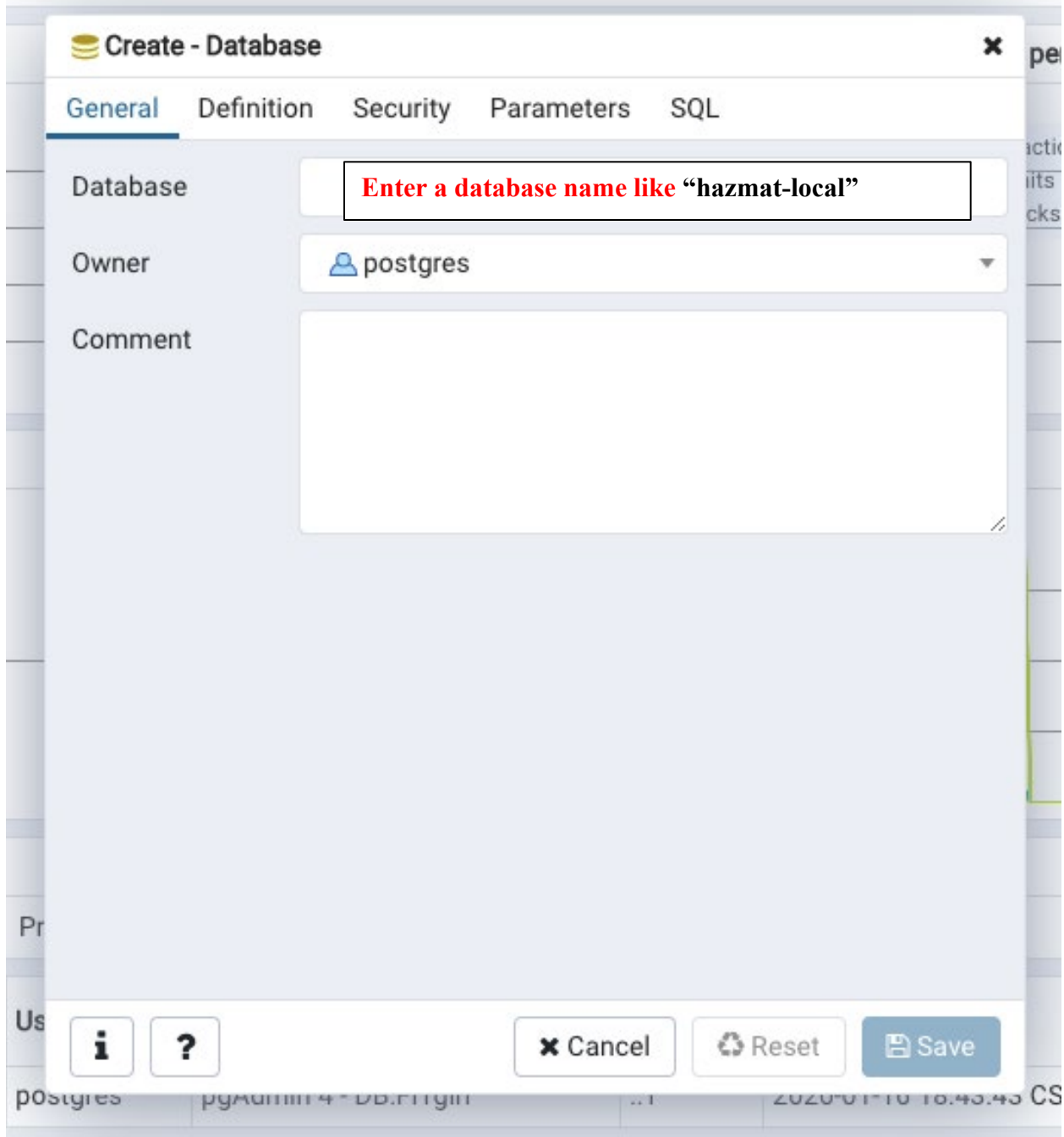

Figure G.7 Entering the Database Name

Hit “Save” after entering the name of the database.

G.3 Install Git Bash and Pycharm from the below link

GitBash is a terminal that we use to write git commands and Pycharm is an IDE which we use for writing code.

- **GitBash Download Link:** <https://git-scm.com/downloads>.
- **Pycharm Download Link:** <https://www.jetbrains.com/pycharm/download/#section=mac>.
- **Python Download Link (Version 3.8.3):** <https://www.python.org/downloads/>.
- **Django Download & Installation Guide (Widows):** <https://docs.djangoproject.com/en/3.0/howto/windows/#:~:text=To%20install%20Python%20on%20your,then%20click%20%E2%80%9CInstall%20Now%E2%80%9D>.

G.4 Steps to Clone and Run the app in your Local Machine

Assumption

The next steps assume access to the REaCH Git Repository and PyCharm is installed. This section contains technical information for running the complete app in your local system. We are also assuming that you have created a PostgreSQL database for your local. [Click here](#) or go to step 2 to create PostgreSQL database.

Step 1

Login to your git repository and go to “uno-public-health-informatics-lab/REACH repository”.

Open the terminal/Git Bash (to download Git Bash [Click here](#)) in your System and go to the desired path where you want to keep the folder of the project.

The development branch should be checked out from the GitHub to further develop the project.

Example: git clone -b development <https://github.com/uno-public-health-informatics-lab/REACH.git>

Clone the folder from GitHub using

```
git clone "url of the repository"
```

Or Download the folder on your PC

Once the project folder is cloned or downloaded in your System.

Open the downloaded project folder using Pycharm or Visual Code

Step 2

Now we need to create a virtual environment to run the app.

We need to follow step 2, step 3 and step 4 for this.

Install Virtual Environment

On macOS and Linux:

```
python3 -m pip install --user virtualenv
```

On Windows:

```
py -m pip install --user virtualenv
```

Step 3

Create a Virtual Environment

On macOS and Linux:

```
python3 -m venv env
```

On Windows:

```
py -m venv env
```

Step 4

Activate your Virtual Environment

On macOS and Linux:

```
source env/bin/activate
```

On Windows:

```
.\env\Scripts\activate
```

Now you have your virtual environment activated. This you can confirm by seeing an '(env)' prefix before your project folder path.

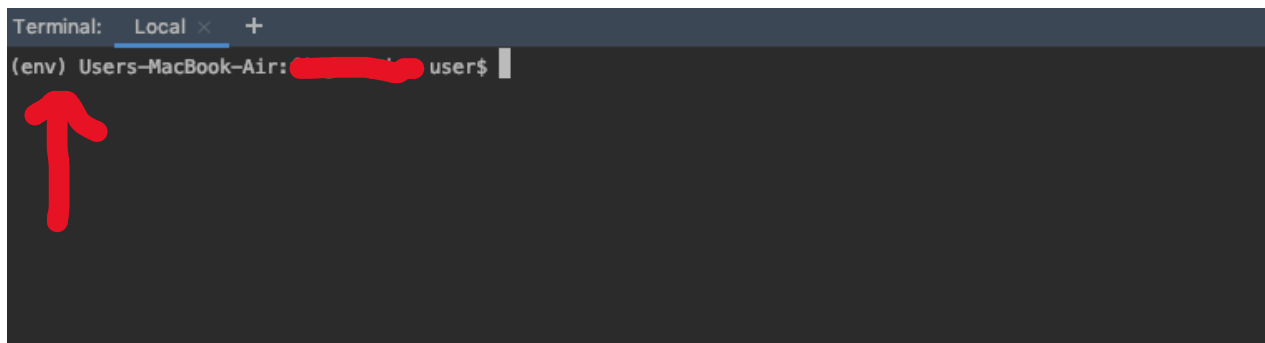

Figure G.8 Terminal showing '(env)' prefix before project folder path

Step 5

From PyCharm click on hazmat settings.py.

Note that after cloning the code from Github, you always need to change the Database credentials to local database credentials and while pushing it back to github, again you have to change the database credential to heroku postgres credentials. So, it will be better if you keep a copy of both settings.py handy and replace the settings.py as required.

Step 6

Inside settings.py change the database name and password with your local Postgres SQL database name and password. Keep the rest same as shown in picture below.

Note that when you are working in your local keep the Host as localhost and User as postgres as shown below.

```
## ## Local Setting
DATABASES = {
    'default': {
        'ENGINE': 'django.db.backends.postgresql',
        'NAME': 'Enter you local postgres database name',
        'USER': 'postgres',
        'PASSWORD': 'Enter your local postgres database password',
        'HOST': 'localhost',
        'PORT': '5432',
    }
}
# Password validation
# https://docs.djangoproject.com/en/2.0/ref/settings/#auth-password-validators
AUTH_PASSWORD_VALIDATORS = [
    {
        'NAME': 'django.contrib.auth.password_validation.UserAttributeSimilarityValidator',
    },
    {
        'NAME': 'django.contrib.auth.password_validation.MinimumLengthValidator',
    },
    {
        'NAME': 'django.contrib.auth.password_validation.CommonPasswordValidator',
    },
    {
        'NAME': 'django.contrib.auth.password_validation.NumericPasswordValidator',
    },
]
```

Step 7

Now we need to install some dependency and packages that is required to build and run the app.

Install All requirements

```
pip install -r requirements.txt
```

This command will install all the packages mentioned in requirements.txt file of your project.

Step 8

To create Schema, Tables and rules of the Database Table for our app, we will use following two commands.

Generate database from the code using

```
python manage.py makemigrations
```

```
python manage.py migrate
```

Step 9

Navigate to the Hazmat-client location in the terminal and run the command “npm install” to download the package and its dependencies and run “ng build” for compiling the application.

Step 10

Navigate back to the reach app in the terminal. Now we need to create a superuser/admin login id and password to login. Below command will create Username and password for admin account.

Create Superuser

```
python manage.py createsuperuser
```

Step 11

Now we are ready to run the app in our local server 127.0.0.1:8000. Below command will run the app in local server.

```
Run localserver
```

```
python manage.py runserver
```

G.5 Steps to connect PostgreSQL Database to PgAdmin4

This section assumes that you have PgAdmin4 install in your system. This section will guide a developer to connect PostgreSQL Database to PgAdmin4. [Click here](#) to see the steps.

G.6 Definitions of Packages used at requirements.txt for Building the App

- Django-Rest-Framework: <https://pypi.org/project/djangorestframework/>
- Beautifulsoup4: <https://pypi.org/project/beautifulsoup4/>
- Dj-Database-url: <https://pypi.org/project/dj-database-url/>
- Django-Bootstrap4: <https://pypi.org/project/django-bootstrap4/>
- Django-Crispy-Forms: <https://pypi.org/project/django-crispy-forms/>
- Psycopg2: <https://pypi.org/project/psycopg2/>
- Whitenoise: <https://pypi.org/project/whitenoise/>

Appendix H REaCH Database Schema Diagram

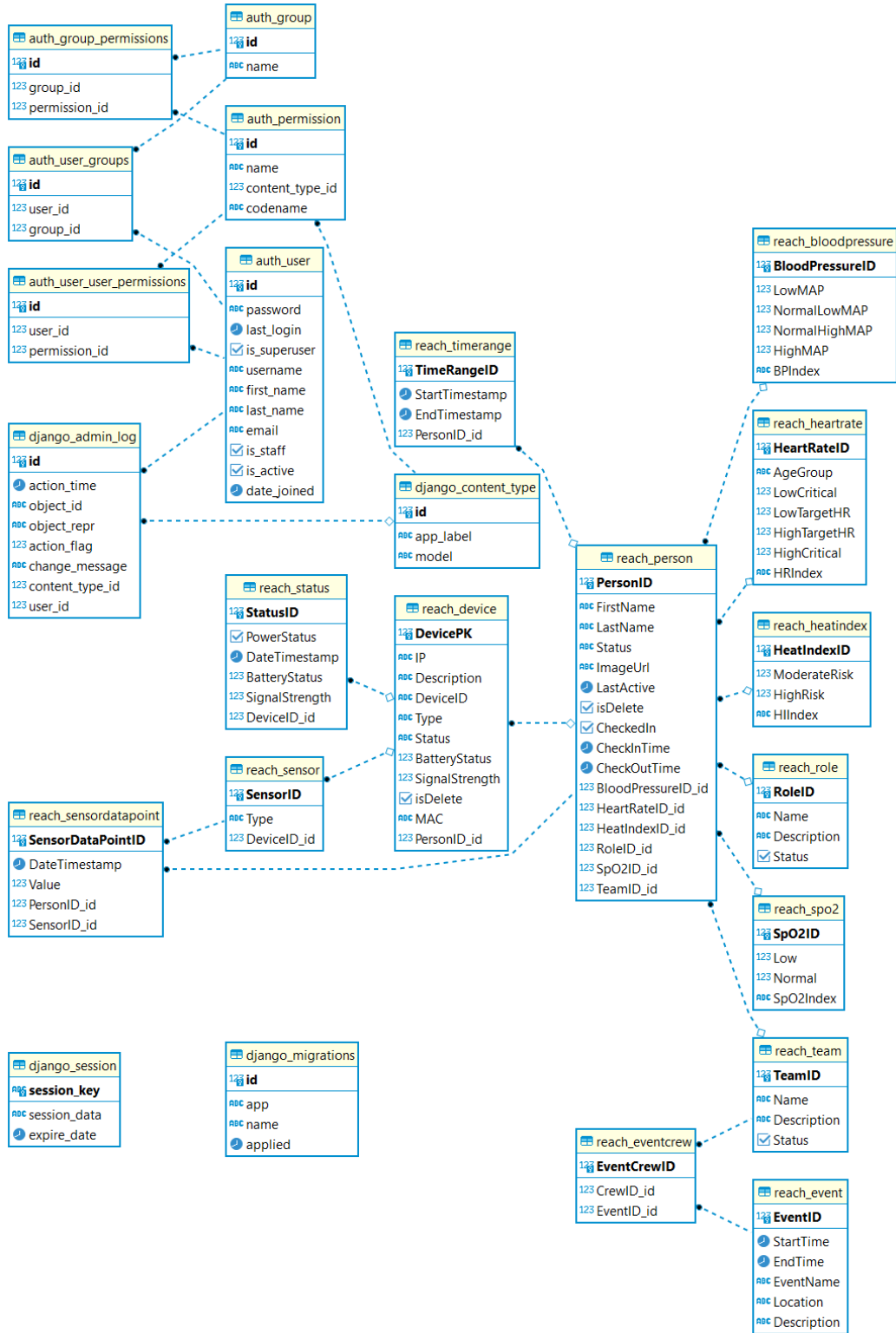

Appendix I REaCH Application Screenshots

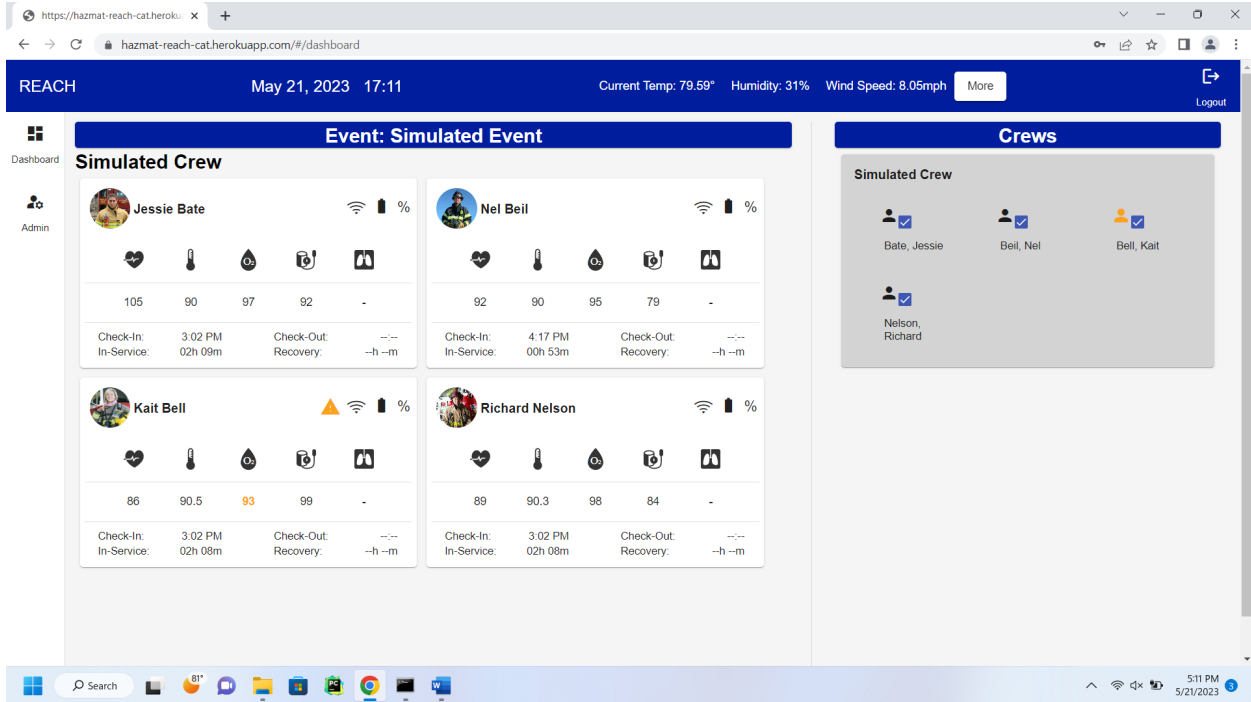

Figure I.1 Snapshot of Home page showcasing the event and crews' panel

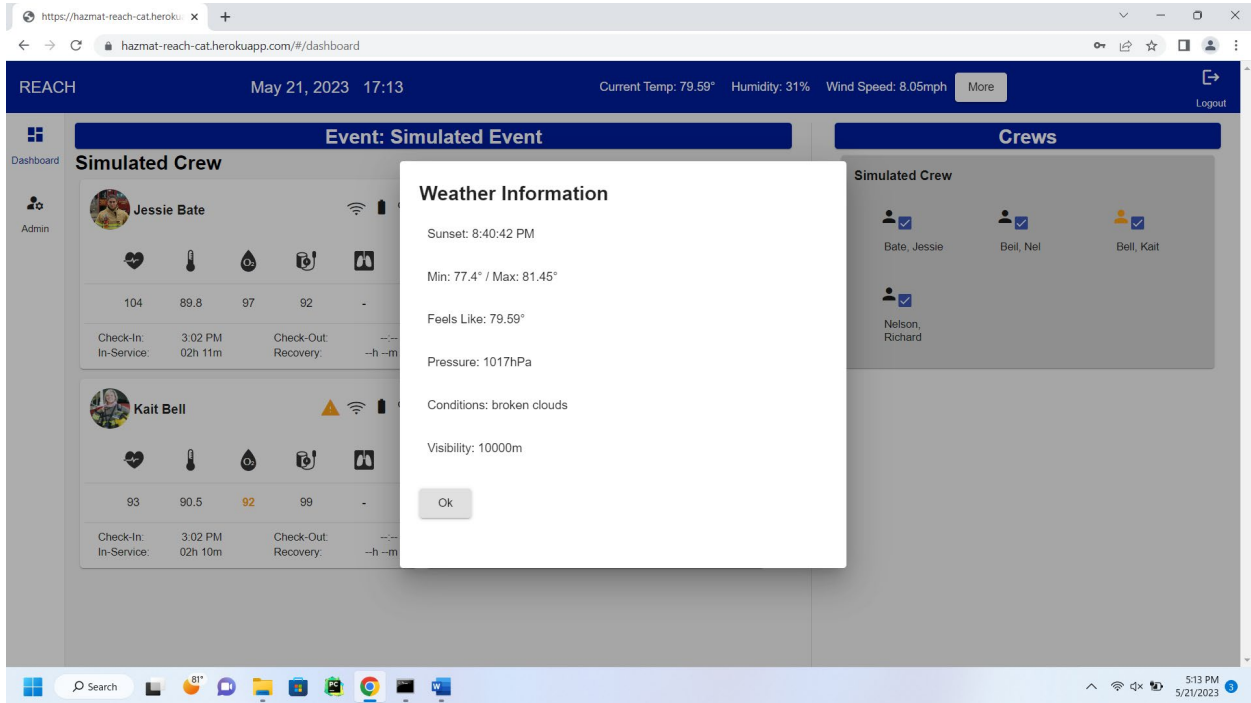

Figure I.2 Snapshot of Dashboard page showcasing the weather information

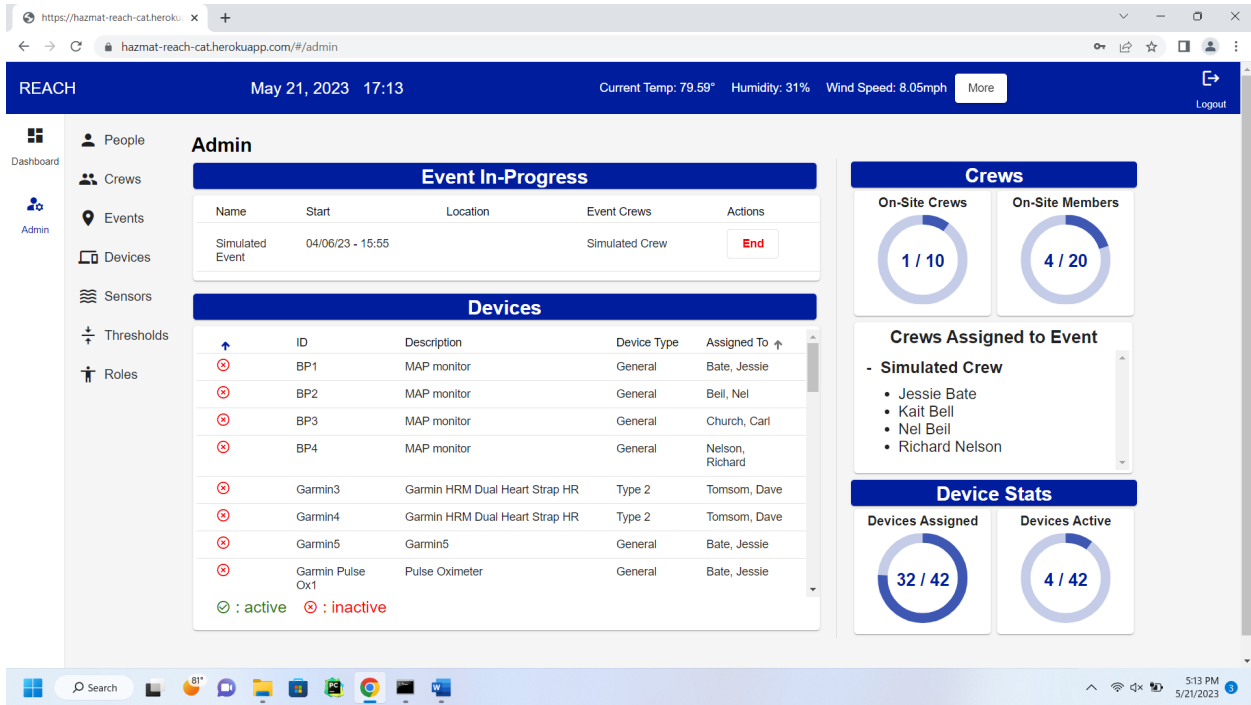

Figure I.3 Snapshot of Admin Home page showcasing the statistics of crews, devices, and events

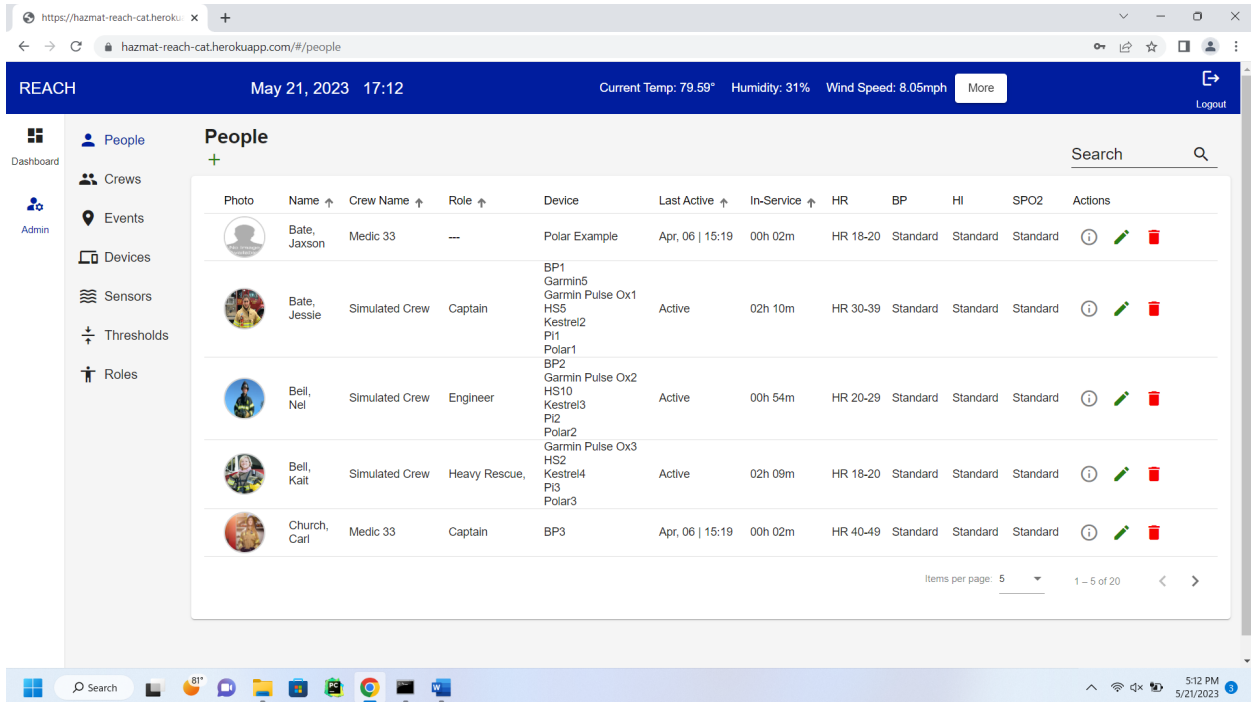

Figure I.4 Snapshot of People page

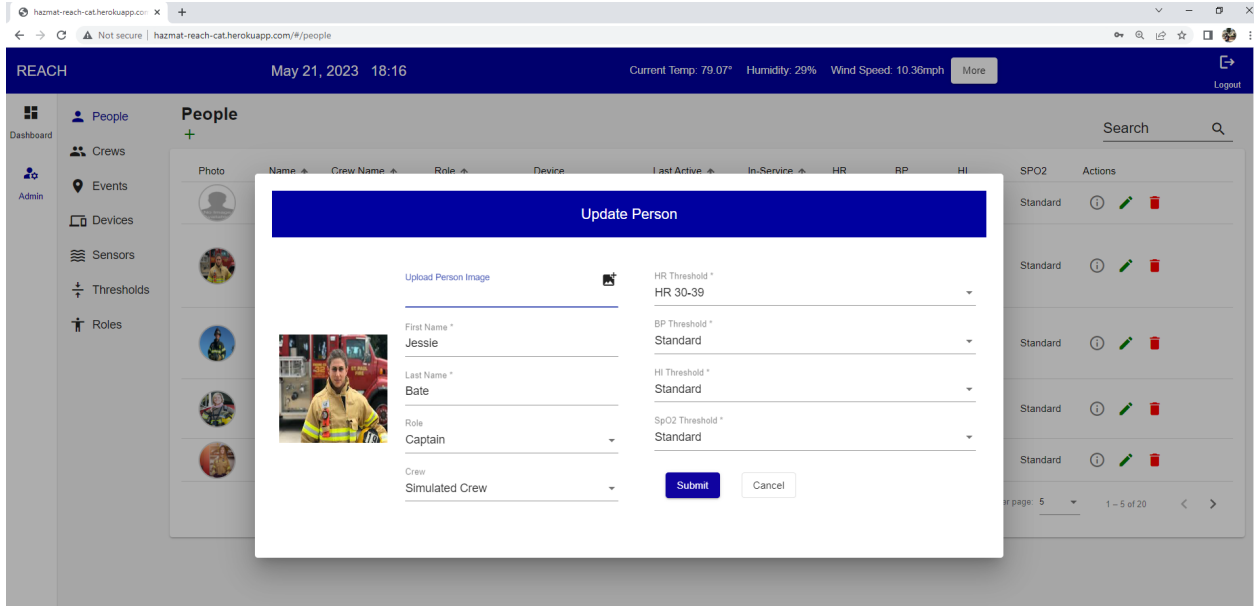

Figure I.4 cont. Snapshot of People page

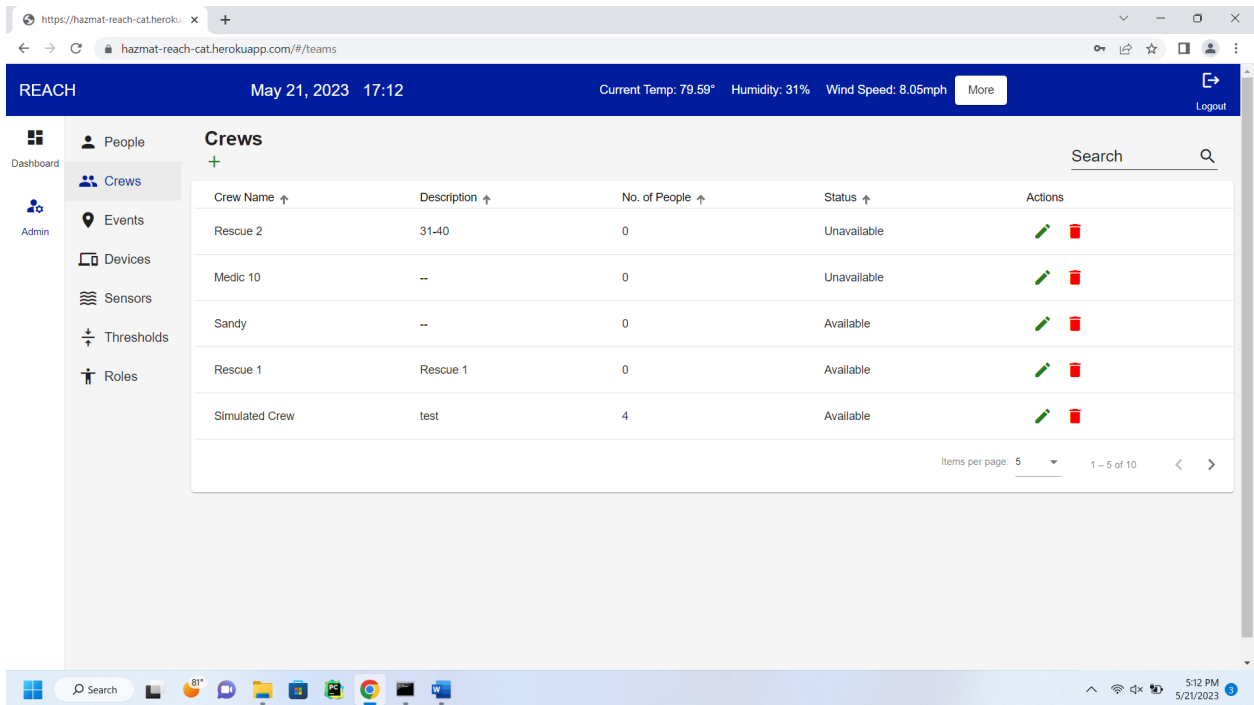

Figure I.5 Snapshot of Crews page

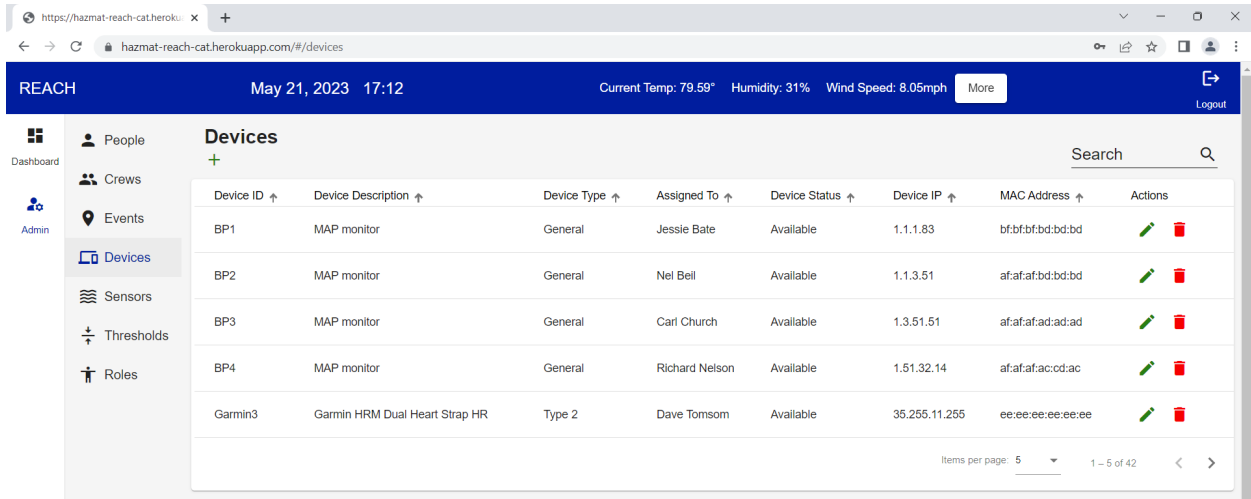

Figure I.6 Snapshot of Devices page

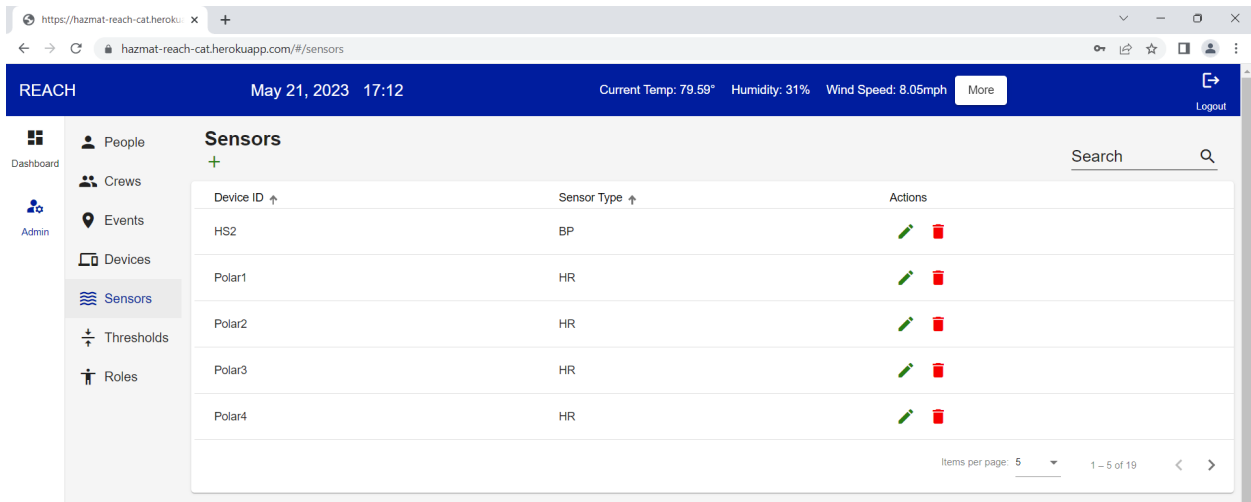

Figure I.7 Snapshot of Sensors page

REACH May 21, 2023 18:20 Current Temp: 79.07° Humidity: 29% Wind Speed: 10.36mph More Logout

Dashboard Admin

People Crews Events Devices Sensors **Thresholds** Roles

Thresholds

Heart Rate Heat Index Blood Pressure (Mean Arterial Pressure MAP) Oxygen (SpO2)

HR Index ↑	Age Group ↑	Low Critical ↑	Low Target Heart Rate ↑	High Target Heart Rate ↓	High Critical ↑	Actions
HeartRate Example	20-29	40	50	140	180	
HR 18-20	18-20	1	60	120	200	
HR 20-29	20-29	60	70	140	200	
HR 30-39	30-39	60	95	133	190	
HR 40-49	40-49	60	90	126	180	

Items per page: 5 1 - 5 of 8

REACH May 21, 2023 18:22 Current Temp: 79.07° Humidity: 29% Wind Speed: 10.36mph More Logout

Dashboard Admin

People Crews Events Devices Sensors **Thresholds** Roles

Thresholds

Heart Rate Heat Index Blood Pressure (Mean Arterial Pressure MAP) Oxygen (SpO2)

Heat Index ↑	Moderate Risk ↑	High Risk ↑	Actions
HeatIndex Example	100	120	
Standard	91	103	

Items per page: 5 1 - 2 of 2

REACH May 21, 2023 18:22 Current Temp: 79.07° Humidity: 29% Wind Speed: 10.36mph More Logout

Dashboard Admin

People Crews Events Devices Sensors **Thresholds** Roles

Thresholds

Heart Rate Heat Index Blood Pressure (Mean Arterial Pressure MAP) Oxygen (SpO2)

MAP Index ↑	Critical Low MAP ↑	Low MAP ↑	High MAP ↑	Critical High MAP ↑	Actions
BloodPressure Example	60	70	100	110	
Standard	61	70	100	110	

[Learn more about MAP](#)

Items per page: 5 1 - 2 of 2

REACH May 21, 2023 18:23 Current Temp: 79.07° Humidity: 29% Wind Speed: 10.36mph More Logout

Dashboard Admin

People Crews Events Devices Sensors **Thresholds** Roles

Thresholds

Heart Rate Heat Index Blood Pressure (Mean Arterial Pressure MAP) Oxygen (SpO2)

SpO2 Index ↑	Low SpO2 (%) ↑	Normal SpO2 (%) ↑	Actions
SpO2 Example	100	110	
Standard	90	95	

Items per page: 5 1 - 2 of 2

Figure I.8 Snapshot of Thresholds page

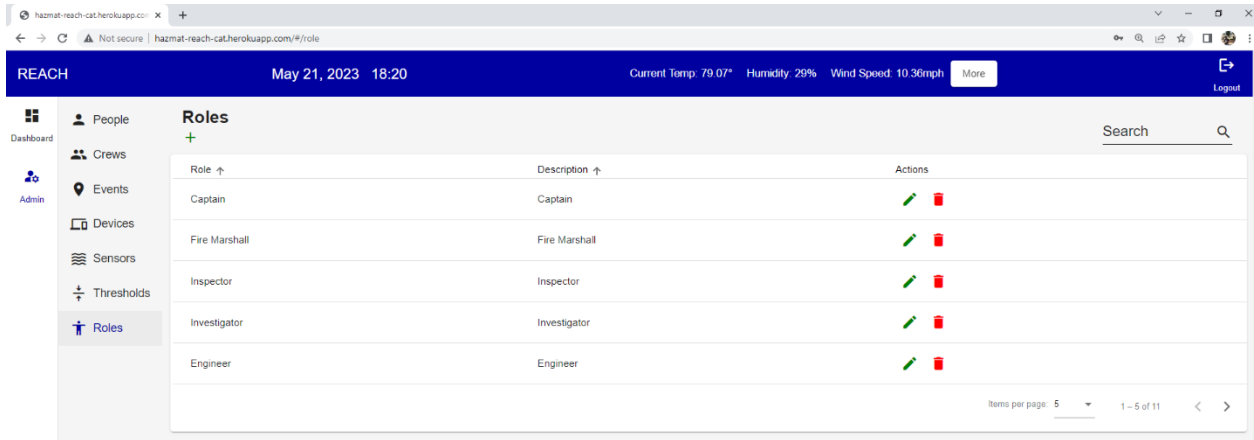

Figure I.9 Snapshot of Roles page

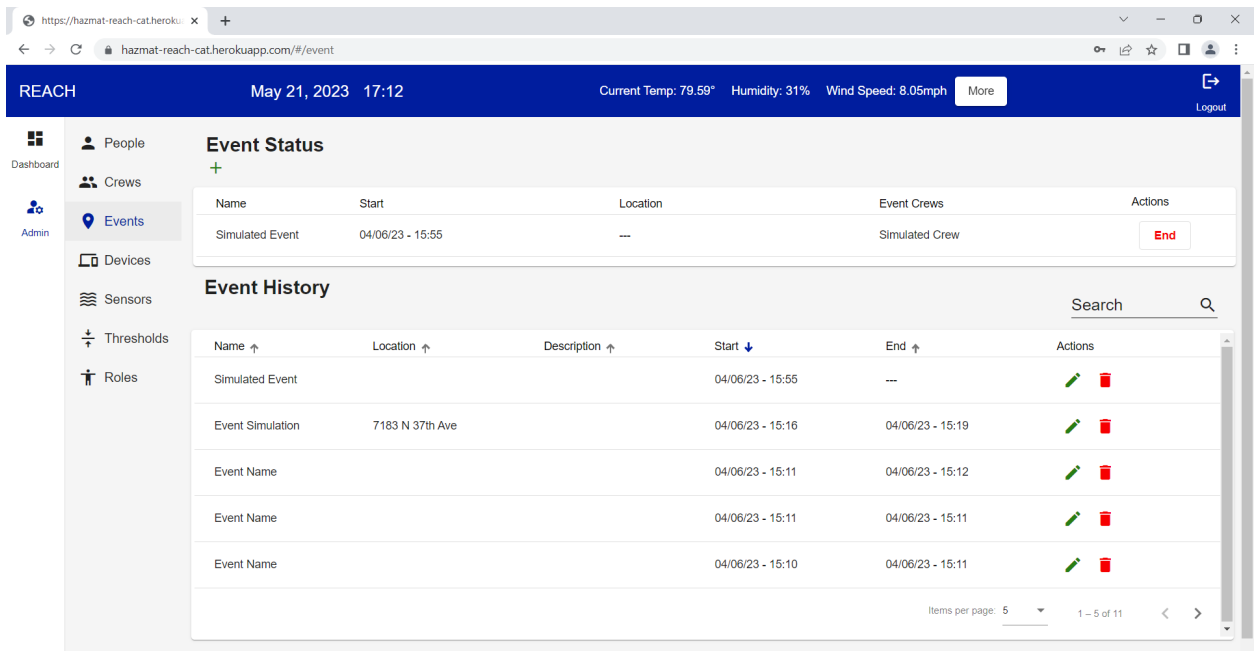

Figure I.10 Snapshot of Event page

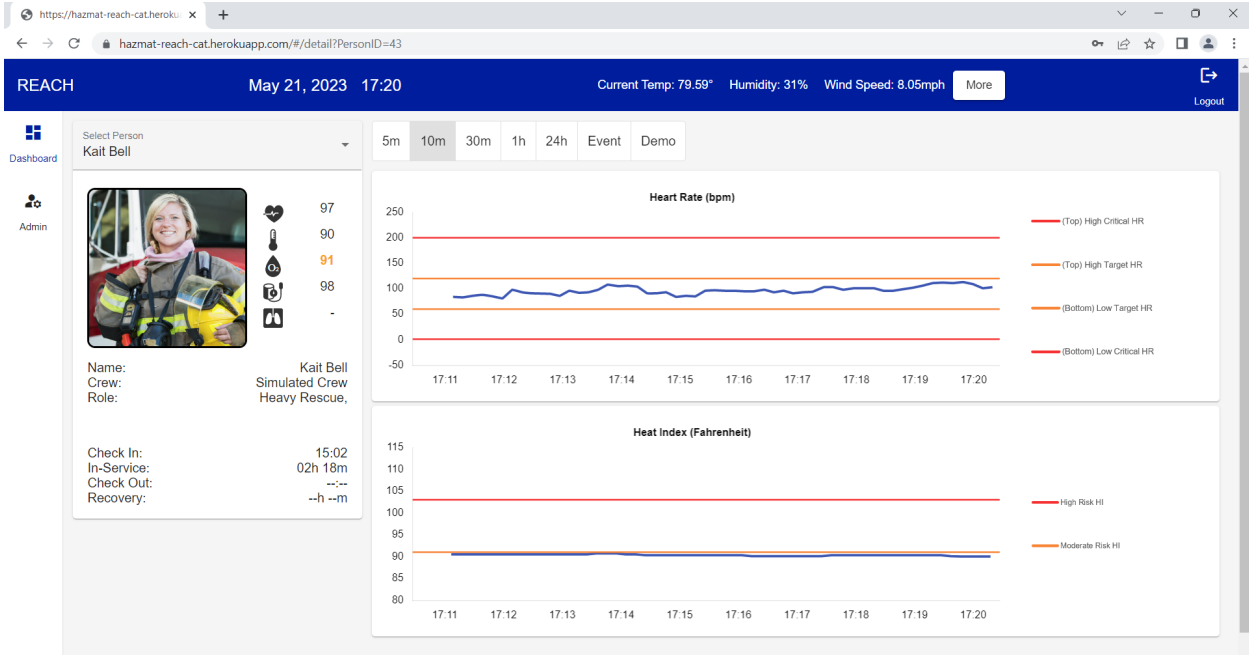

Figure I.11 Snapshot of Person detailed page showing individual data

Appendix J Table of major products

Product	Authors	Date	Title	Location
Poster presentation	Venkatesan, C., Hale, M., Fruhling, A.	Mar-18	Testing Environmental Sensors to Reduce Health Ailments among First Responders	UNO Annual Student Activity and Research Fair
Conference proceedings	Vikas, S.; Fruhling, A.	Aug-18	Improving Decision-Making for Incident Commanders by Analyzing Visualizations for First Responder's Vital Information	Technology Research, Education, and Opinion (TREO) Talk, Americas Conference for Information Systems, New Orleans, LA, USA
Conference proceedings	Venkatesan, C., Medcalf, S., Fruhling, A.	Aug-18	Assessing Wearable Technology's Role to Reduce HAZMAT Health Risks	Technology Research, Education, and Opinion (TREO) Talk, Americas Conference for Information Systems, New Orleans, LA, USA
Conference presentation	Vikas, S.	Aug-18	Improving Decision-Making for Incident Commanders by Analyzing Visualizations for First Responder's Vital Information	Technology Research, Education, and Opinion (TREO) Talk, Americas Conference for Information Systems, New Orleans, LA, USA
Conference presentation	Venkatesan, C.	Aug-18	Assessing Wearable Technology's Role to Reduce HAZMAT Health Risks,	Technology Research, Education, and Opinion (TREO) Talk, Americas Conference for Information Systems, New Orleans, LA, USA
Presentation	Medcalf, S., Yoder, A., Achutan, C., Hale, M., Fruhling, A.	2018	Engine 33 Special Operations: Needs Assessment Presentation	Omaha, NE
Poster presentation	Fendrick, S. & Fruhling, A.	Mar-19	Design for Safety: Decreasing First Responder Health Risks Through Real-Time Bio-Sensor Alerts	UNO Annual Student Activity and Research Fair
Thesis	Vikas, S.	May-19	A Comparison Study on Visualization Design Preferences to Monitor First Responders' Health	UNO program?
Poster presentation	Medcalf, S., Hale, ML., Achutan, C., Yoder, A., Shearer, S., Fruhling, A.	Jan-20	Requirements Gathering through Focus Groups for A Real-Time Emergency Communication System for Hazmat Incidents (Reach)	Transportation Research Board (TRB) 99th Annual Meeting, Washington DC, USA
Poster presentation	Akula, N., Urrutia, J., Khatri, H., Anusha, M., Grothe J., Medcalf, S., Yoder, A., Ghersi, D., Achuthan, C., Fruhling, A.	Mar-20	Lessons Learned from Designing a Health Monitoring System to Improve First Responders Safety User Interface	UNO Annual Student Activity and Research Fair

Conference proceedings	Fruhling, A., Hall, M., Medcalf, S., Yoder, A.	Dec-20	Designing a Real-time Integrated First Responder Health and Environmental Monitoring Dashboard	15th International Conference on Design Science Research Systems and Technology (DESRIST), Virtual from University of Agder, Kristiansand, Norway
Conference presentation	Fruhling, A.	Dec-20	Designing a Real-time Integrated First Responder Health and Environmental Monitoring Dashboard	15th International Conference on Design Science Research Systems and Technology (DESRIST), Virtual from University of Agder, Kristiansand, Norway
Poster presentation	Ng, R., Rogers, J., Yachamaneni, K., Baysa, K., Li, D., Suwondo, T., Yoder, A., Ghersi, D., Fruhling A.	Mar-21	Wireless Sensor Integration into System's Network for Real-time Data Streaming: Lessons Learned	UNO Annual Student Activity and Research Fair
Journal publication	Medcalf, S., Hale, M. L., Achutan, C., Yoder, A. M., Fruhling, A., & Shearer, S. W	Nov-21	Requirements Gathering Through Focus Groups for a Real Time Emergency Communication System for HAZMAT Incidents (REACH)	J Pub Health Issue Pract, 5(2), 188
Extended abstract presentation	Fruhling, A. L., Reisher, E.	Mar-22	Assessing Decision Makers' Cognitive Load for a First Responder Health Monitoring System,	Southern Association for Information System (SAIS) 2022 Conference, Myrtle Beach, SC, USA
Thesis	Thiele, M.	Dec-22	A Machine Learning Approach for Predicting Patient Mortality with Heart Rate Variability Statistics	UNO program?
Journal publication	Grothe J, Tucker S, Blake A, Achutan C, Medcalf S, Suwondo T, Fruhling A, Yoder A.	Mar-23	Exploring First Responders' Use and Perceptions on Continuous Health and Environmental Monitoring.	IJERPH, 20(6):4787
Poster presentation	Jonnalagadda, S., Tucker, S.	Mar-23	Does profession matter toward perception of Wearable Technology for Health Monitoring in the field?	UNO Annual Student Activity and Research Fair
Oral presentation	Reisher, E. and Jonnalagadda, S.	Mar-23	Applying the Trajectories Conceptual Framework: A case study of an IoT health data monitoring application	UNO Annual Student Activity and Research Fair
Poster presentation	Thiele, M.	Mar-23	Heart Rate Variability and Patient Mortality	UNO Annual Student Activity and Research Fair
Poster presentation	Tucker, S.	Apr-23	Does profession matter toward perception of Wearable Technology for Health Monitoring in the field?	UNMC Student Research Conference

Conference poster and demo	Fruhling, A. L., Yoder, A. M., & Jonnalagadda, S	May-23	An IoT Dashboard Monitoring First Responders' Health and Environmental Data during HAZMAT Emergencies	IEEE/ACM Eighth International Conference on Internet-of-Things Design and Implementation (IoTDI). May 9-12, 2023, San Antonio, TX, USA
Poster presentation	Tucker, S. Yoder, A., & Fruhling A.	Jun-23	Pathway to Enhance First Responder Safety During Agricultural Emergencies	International Society for Agricultural Health & Safety Annual Conference 2023, Tampa, FL, USA
Journal publication (under review)	Tucker, S., Jonnalagadda, S., Beseler, C., Yoder, A., & Fruhling, A.	Jun-23	Exploring wearable technology use and importance of health monitoring in the hazardous occupations of first responders and professional drivers	Under review Journal of Occupational Health
Poster presentation	Tucker, S. Yoder, A., & Fruhling A.	Jul-23	Pathway to Enhance First Responder Safety During Agricultural Emergencies	American Society of Agricultural & Biological Engineers Annual International Meeting 2023, Omaha, NE, USA
Conference Paper & Presentation	Reisher, E., Jonnalagadda, S. Fruhling, A.	Jul-23	Applying the Trajectories Conceptual Framework: A case study of an IoT health data monitoring application	25th International Conference on Human-Computer Interaction (HCI), Copenhagen, Denmark

Appendix K Table of students

Name	Years Active	Current Status
Hitesh Khatri	2018-2019	Graduated UNO MS 2019 backend software developer at TSG (The Stawhecker Group)
Vineeth Ramasahayam	2018-2019	Graduate UNO MS MIS 2019 FT position at NHHS
Ramakanth Venkata	2018-2019	Graduated UNO MS MIS 2019
Vikas Suhu	2018-2019	Graduated UNO MS MIS 2020 with thesis and FT employment at Mutual of Omaha
Chaitra Venkatesan	2018-2019	Graduated UNO MS 2019 Business Analyst at Bank of the West
Brian Collett	2018-2019	Graduated UNO BS 2019 and accepted position at Valmont
Suzy Fendrick	2018-2019	Graduated UNO BS 2019 accepted an IT internship at Werner
Naveena Akula	2019-2020	Graduated UNO MS MIS 2020
Jackson Urrutia	2020-2021	Graduated UNO MS CS 2021
Anusha Manda	2019-2020	Graduated UNO MS MIS 2020
Ru Ng	2021-2022	Graduated UNO MS CS 2023
Krishna Yachamaneni	2020-2021	Graduated UNO MS MIS 2021 – FT employment offered Valmont
Kaitlyn Baysa	2021	Graduated UNO BS ITIN when on to pursue BS MIS 2021
Dawai Li	2020-2021	Graduated UNO MS MIS 2021 FT employment at Mutual of Omaha
Jacob Grothe	2019-2020	Graduated UNMC MPH 2019 and accepted a position as epidemiologist at Pottawattamie County Health Department
Justin Fay	2021-2022	Graduated UNO MS 2022 Government position
Troy Suwondo	2020-2022	Graduated MPH 2022 and continuing his education in the MD program at UNMC
Soundarya Jonnalagadda	2022-2023	Will graduate UNO MS Summer 2023, Business Analyst International Bank
Sarah Tucker	2022-2023	Second year PhD student at UNMC
Luke Irwin	2022-2023	Junior in the UG Cybersecurity at UNO
Matthew Thiele	2022-2023	Graduated UNO BS 2022 – continuing in UNO MS BMI program
Elizabeth Reisher	2022-2023	Will graduate UNO MS BMI 2023 – FT employment at UNMC – Great Plains IDeA CTR