

000100

WYLE LABORATORIES REPORT WCR 73-5

# Assessment of Noise Environments Around Railroad Operations

**Prepared for:**

Southern Pacific Transportation Company

Union Pacific Railroad

The Atchison, Topeka & Santa Fe Railway Company

The Association of American Railroads

**July, 1973**

WYLE LABORATORIES RESEARCH STAFF

REPORT WCR 73-5

ASSESSMENT OF NOISE ENVIRONMENTS  
AROUND RAILROAD OPERATIONS

Prepared By:

Jack W. Swing

and

Donald B. Pies

Wyle Laboratories  
128 Maryland Street  
El Segundo, California

For:

Southern Pacific Transportation Company

Union Pacific Railroad

The Atchison, Topeka & Santa Fe Railway Company

The Association of American Railroads

Under Contract No. 0300-94-07991

July 1973

## ACKNOWLEDGMENTS

Wyle Laboratories would like to express its gratitude to the following groups and individuals who graciously gave their full cooperation to the various phases of the program:

Mr. Paul Garin, Mr. Robert Byrne and Mr. Bryan Shewmake  
of the Southern Pacific Transportation Company,

Mr. D. J. Inman, Mr. J. R. Merritt and Mr. R. L. Dixon  
of The Atchison, Topeka and Santa Fe Railway Company,

Mr. P. L. Stageman and Mr. W. F. Cocking of the  
Union Pacific Railroad,

Dr. William Harris of the Association of American Railroads,

Mr. Robert Torassa, Mr. Robert McKee and Mr. David Long  
of the Pacific Fruit Express Company, and

The many employees of the Southern Pacific, Santa Fe and  
Union Pacific Railroads throughout the Southern California  
region who were extremely courteous in allowing the Wyle  
measurement crews free access to their facilities.

Acknowledgments are also due to those members of the Research Staff at Wyle Laboratories who assisted in the various phases of the program. They include: Dr. Ben Sharp, Frank Chien, Charles Grotke, Ron Brown, Fancher Murray and Patrick Glenn. Special consideration is given to Mr. Louis C. Sutherland for his technical guidance to this program.

## TABLE OF CONTENTS

		<u>Page</u>
1.0	INTRODUCTION . . . . .	1-1
2.0	SUMMARY . . . . .	2-1
2.1	Introduction . . . . .	2-1
2.2	Line Operations . . . . .	2-2
2.3	Yard Operations . . . . .	2-5
2.4	Conclusions . . . . .	2-11
3.0	RAILROAD LINE OPERATIONS . . . . .	3-1
3.1	Introduction . . . . .	3-1
3.2	Characteristics of Noise Emitted by Railroad Line Operations . . . . .	3-2
	3.2.1 Diesel Locomotive Noise . . . . .	3-2
	3.2.2 Freight Car Generated Noise . . . . .	3-6
3.3	Development of a Community Noise Rating for Railroad Line Operations . . . . .	3-13
	3.3.1 Requirements of the Rating Technique . . . . .	3-13
	3.3.2 Single Event Noise Exposure Level (SENEL) . . . . .	3-13
	3.3.3 Community Noise Equivalent Level (CNEL) . . . . .	3-17
3.4	Computational Procedure for CNEL Determination . . . . .	3-24
3.5	Example Application of CNEL Rating Technique for Line Operations . . . . .	3-34
3.6	Locomotive Horns and Crossing Bells . . . . .	3-38
4.0	RAILROAD YARD OPERATIONS . . . . .	4-1
4.1	Introduction . . . . .	4-1
4.2	Discussion of Classification Operations in a Railroad Yard . . . . .	4-3
4.3	The Nature of Noise Emitted by Railroad Yard Operations . . . . .	4-8

## TABLE OF CONTENTS (Continued)

		<u>Page</u>
4.3.1	Road Locomotives and Switcher . . . . .	4-9
4.3.2	Car Impacts . . . . .	4-14
4.3.3	Retarders . . . . .	4-17
4.3.4	Loudspeakers and Public Address Systems . . . . .	4-19
4.3.5	Engine Load Tests . . . . .	4-21
4.3.6	Locomotive Service Racks . . . . .	4-22
4.3.7	Mechanical Refrigerator Cars . . . . .	4-23
4.4	Potential Techniques for Estimation of Noise Emitted by Railroad Yard Operations . . . . .	4-30
4.5	Quantification of the Noise Emitted by Railroad Yard Operations . . . . .	4-36
4.5.1	Definition of Predominant Noise Centers . . . . .	4-36
4.5.2	Evaluation of Noise from Specific Sources . . . . .	4-45
4.6	Calculation Procedure for $L_{dn}$ Noise Contours of Railroad Yard Operations . . . . .	4-51
4.7	Example Application of $L_{dn}$ Noise Contours Around Railroad Yard Operations . . . . .	4-63

### REFERENCES

### BIBLIOGRAPHY

APPENDIX A	APPLICATION OF COMPOSITE A-WEIGHTED NOISE LEVELS TO ESTIMATION OF COMMUNITY RESPONSE
APPENDIX B	FIELD MEASUREMENT LOCATIONS FOR LINE AND YARD OPERATIONS
APPENDIX C	COMPUTERIZED MODEL OF LINE OPERATIONS (TRAIN PASSBYS)
APPENDIX D	SOUND PROPAGATION OF NOISE EMITTED BY RAILROAD OPERATIONS

## TABLE OF CONTENTS (Continued)

APPENDIX E	MULTIPLE ACOUSTIC SOURCE MODEL FOR IDLING LOCOMOTIVES AND MECHANICAL REFRIGERATOR CARS
APPENDIX F	THREE-DIMENSIONAL SOUND PROPAGATION FROM DIESEL - ELECTRIC LOCOMOTIVES
APPENDIX G	A STATISTICAL SURVEY OF NOISE LEVELS GENERATED BY RAILROAD YARD OPERATIONS
APPENDIX H	SUGGESTED TECHNIQUES FOR SOUND LEVEL MEASUREMENTS OF RAILROAD OPERATIONS
APPENDIX I	THEORETICAL CORRELATION OF REQUIRED HORSEPOWER TO SPEED/GRADE CONDITIONS
APPENDIX J	WORKSHEETS

## LIST OF TABLES

<u>Table Number</u>	<u>Title</u>	<u>Page</u>
2-1	Variables Affecting Freight Car Wheel/Rail Noise Emission	2-3
2-2	Typical Mean-Maximum Noise Levels Produced by Railroad Yard Operations	2-7
2-3	Percentage of Time Spent at Specified Throttle Setting for Typical Road and Switcher Locomotive	2-9
3.2-1	Summary of Statistical Parameters Describing A-Weighted Diesel-Electric Locomotive Noise Output Under Varying Grade Conditions	3-4
3.2-2	Variables Affecting Freight Car Wheel/Rail Noise Emission	3-8
3.3-1	Comparison of Predicted SENEls for Train Passbys with Measured Values	3-18
3.4-1	Decibel Addition Table	3-31
3.6-1	Noise Levels of Horn Represented in Figure 3.6-2	3-81
4.3-1	Percentage of Time Spent at Specified Throttle Setting for Typical Road and Switcher Locomotive	4-12
4.3-2	Noise Levels Emitted by Idling Locomotives	4-14
4.3-3	Typical Noise Levels Emitted by Mechanical Refrigerator Cars	4-26
4.6-1	$L_{dn}$ Corrections for Master and Group Retarders	4-56

## LIST OF FIGURES

<u>Figure Number</u>	<u>Title</u>	<u>Page</u>
2-1	Typical A-Weighted Time History of a Train Pass-by (Measured at 100 Feet from Track, 32 mph at +0.6 percent grade, Tehachapi Summit).	2-12
2-2	Noise Levels of Locomotive Traveling at Level Grade (+ 0.75% grade) Measured at 100 Feet Distance to Track.	2-13
2-3	Illustration of Grade Dependence of Mean A-Weighted Noise Levels Produced by Locomotives.	2-14
2-4	A-Weighted Pass-By Time Histories of Freight Trains Illustrating the Velocity Dependence of Car-Generated Noise Levels.	2-15
2-5	Comparison of Synthesized Triangle-Rectangle Time History and Actual Curve.	2-16
2-6	Comparison of A) 100 Foot and B) 1000 Foot A-Weighted Time Histories of Train Pass-by.	2-17
2-7	Example Application of Line Operations Methodology Illustrating Variation of CNEL Contour Values.	2-18
2-8	A-Weighted Time History of Flat Yard Switching Cycle.	2-19
2-9	Frequency Spectrum of Idling Switcher Locomotive.	2-20
2-10	Frequency Spectrum of Noise Emitted from Master Retarder.	2-21
3.2-1	Idealized Time History of Train Passby Illustrating Locomotive and Freight Car Components.	3-40
3.2-2	Typical A-Weighted Time History of a Train Pass-By.	3-41
3.2-3	Noise Levels of Locomotive Traveling at Level Grade.	3-42



LIST OF FIGURES (continued)

<u>Figure Number</u>	<u>Title</u>	<u>Page</u>
3.2-4	Noise Level of Locomotives Traveling Upgrade.	3-43
3.2-5	Distribution of Observed Locomotive Noise Levels for Level Grade Operation.	3-44
3.2-6	Distribution of Observed Locomotive Noise Levels for 2.2% Upgrade Operation.	3-45
3.2-7	Illustration of Grade Dependence of Mean A-Weighted Noise Levels Produced by Locomotives.	3-46
3.2-8	Time History of Train Passby Under Severe Downgrade Conditions.	3-47
3.2-9	Spectrum of Noise Emitted by a Diesel-Electric Locomotive Operating Over Level Grade.	3-48
3.2-10	Spectrum of Noise Emitted by a Diesel-Electric Locomotive Under Maximum Power Conditions.	3-49
3.2-11	Spectrum of Noise Emitted by a Diesel-Electric Locomotive Operating Over Severe Downgrade.	3-50
3.2-12	Decrease in A-Weighted Locomotive Noise Levels with Distance.	3-51
3.2-13	Measurements of Freight Car Noise Levels Over Welded and Jointed Track.	3-52
3.2-14	A-Weighted Pass-By Time Histories of Freight Trains Illustrating the Velocity Dependence of Car-Generated Noise Levels.	3-53
3.2-15	Comparison of Car Noise Frequency Spectra at Speeds of 58 and 24 Miles Per Hour.	3-54
3.2-16	Comparison of A-Weighted Time Histories for Train Passage Over a Switching Frog and the Same Train Passing Over a Smooth Segment.	3-55

LIST OF FIGURES (continued)

<u>Figure Number</u>	<u>Title</u>	<u>Page</u>
3.2-17	Comparative Frequency Spectra of Noise Levels Emitted by a Frog Crossover vs. Smooth Track.	3-56
3.2-18	Illustrations of Wheel Screech Generated by Freight Cars Negotiating Tight Radius Bends.	3-57
3.2-19	Frequency Spectra of Wheel Screech Produced by Operations Through 574 and 765 Foot Radius Bends.	3-58
3.2-20	A-Weighted Time History of Train Pass-by.	3-59
3.2-21	Decrease in A-Weighted Freight Car-Generated Noise Levels with Distance from Track.	3-60
3.2-22	Comparison of A) 100 Foot and B) 1000 Foot A-Weighted Time Histories of Train Pass-by.	3-61
3.2-23	Comparison of 100 Foot and 1000 Foot A-Weighted Time Histories of Train Pass-by.	3-62
3.2-24	Illustration of the Relative Effects of an Elevated Right of Way.	3-63
3.2-25	Effect of Depressed Right-of-Way.	3-64
3.3-1	Comparison of Synthesized Triangle-Rectangle Time History and Actual Curve	3-65
3.3-2	A-Weighted Time Histories of Train Passby.	3-66
3.3-3	A-Weighted Time Histories of Train Passby.	3-67
3.4-1	CNEL Worksheet for Line Operations.	3-68
3.4-2	Noise Level of Freight Cars.	3-69
3.4-3	Logarithmic Duration Term of Train Pass-By.	3-69

LIST OF FIGURES (continued)

<u>Figure Number</u>	<u>Title</u>	<u>Page</u>
3.4-4	Attenuation Correction to be Subtracted from Engine and Car SENEL Values.	3-70
3.4-5	Attenuation of Car Sound Level Due to Shielding Barrier .	3-71
3.4-6	Engine SENEL Contribution.	3-72
3.4-7	Attenuation of Locomotive Sound Level Due to a Shielding Barrier.	3-73
3.4-8	Equivalent Operations Worksheet for Use in CNEL Calculations.	3-74
3.4-9	Graphical Method for Determination of CNEL.	3-75
3.4-10	Form for Determination of CNEL Contour Locations.	3-76
3.5-1	Example Application of CNEL Rating Technique for Line Operations.	3-77
3.5-2	Equivalent Operations Worksheet for Use in CNEL Calculations.	3-78
3.5-3	Example Application of Line Operations Methodology Illustrating Variation of CNEL Contour Values.	3-79
3.6-1	A-Weighted Time History of Train Pass-By Illustrating Warning Bell at Crossing.	3-80
3.6-2	Directionality of Locomotive Horn Noise.	3-81
3.6-3	Noise Level of Locomotive Horn Versus Distance.	3-81
3.6-4	Frequency Spectrum of a Locomotive Horn.	3-82

## LIST OF FIGURES (continued)

<u>Figure Number</u>	<u>Title</u>	<u>Page</u>
3.6-5	Distribution of A-Weighted Levels Emitted from Crossing Bells.	3-83
4.2-1	Basic Classification Yard Layout.	4-72
4.3-1	A-Weighted Time History of Switcher Movements .	4-73
4.3-2	Frequency Spectra of Switcher Pulling a Cut of Cars at Low Speed.	4-74
4.3-3	Frequency Spectra of Switcher Accelerating With Cut of Cars.	4-75
4.3-4	Frequency Spectra of Switcher Accelerating.	4-76
4.3-5	Distribution of Noise Levels Emitted by Passing Switchers.	4-77
4.3-6	A-Weighted Time History of Flat Yard Switching Cycle.	4-78
4.3-7	Frequency Spectra of Idling Road Engine.	4-79
4.3-8	Frequency Spectrum of Idling Switcher Locomotive.	4-80
4.3-9	Combined Air Absorption and Excess Ground Attenuation of Noise Emitted from Various Sources in a Yard.	4-81
4.3-10	Distribution of Noise Levels Emitted by Idling Locomotives .	4-82
4.3-11	Comparison of Data from Five Idling Road Engines and Predicted Values.	4-83
4.3-12	Group of Idling Road Engines.	4-84
4.3-13	Distribution of A-Weighted Levels Emitted from Impacts.	4-85

## LIST OF FIGURES (continued)

<u>Figure Number</u>	<u>Title</u>	<u>Page</u>
4.3-14	A-Weighted Time Histories of Impacts in Flat Yard.	4-86
4.3-15	Frequency Spectra of Noise Emitted from Coupling Impact.	4-87
4.3-16	Frequency Spectra of Noise Emitted from Chain Reaction Impact.	4-88
4.3-17	Typical Retarder Hump Yard.	4-89
4.3-18	Frequency Spectrum of Noise Emitted from Master Retarder.	4-90
4.3-19	Frequency Spectra of Noise Emitted from Inert Retarder.	4-91
4.3-20	A-Weighted Time History of Noise Emitted from Master Retarder.	4-92
4.3-21	Distribution of A-Weighted Noise Levels Emitted from Master Retarders.	4-93
4.3-22	Distribution of Noise Levels Emitted from Inert Retarders.	4-94
4.2-23	Public Address Speaker Directivity.	4-95
4.3-24	2500 HP Diesel Electric Locomotive Under Load Test.	4-96
4.3-25	Spectral Content of Noise Emitted by 2500 HP Locomotive Under Load Test.	4-97
4.3-26	Typical Layout of Mechanical Refrigerator Car Engine/Compressor System.	4-98
4.3-27	Investigation of Mechanical Refrigerator Car Noise Directionality Pattern.	4-99

LIST OF FIGURES (continued)

<u>Figure Number</u>	<u>Title</u>	<u>Page</u>
4.3-28	1/3 Octave Band Frequency Spectra of Noise Emitted by Operation of Mechanical Refrigerator Cars.	4-100
4.3-29	Mechanical Refrigerator Unit Powered by 220 V Auxiliary Electric Power.	4-101
4.3-31	Attenuation Correction for an Entire Train of Mechanical Refrigerator Cars.	4-102
4.5-1	Push Engine Noise Center Location in a Receiving Yard.	4-39
4.5-2	Concentrated Switching Noise Center Along a Switching Lead.	4-39
4.5-3	Effective Noise Center of a Large Number of Tracks with Distributed Random Switching.	4-40
4.5-4	Effective Noise Center Among Master and Group Retarders.	4-41
4.5-5	Two Effective Noise Centers for Inert Retarders.	4-43
4.5-6	Effective Noise Centers for Various Combinations of Idling Road Engines.	4-44
4.6-1	Effective Number of Cars Through Hump Yard Per Day.	4-103
4.6-2	$L_{dn}$ of Hump Yard Push Engine.	4-104
4.6-3	Effective Percentage of Time a Switcher is Used in a Concentrated Area of Switching.	4-105
4.6-4	$L_{dn}$ for an Area of Concentrated Switching.	4-106
4.6-5	$L_{dn}$ for Master and Group Retarder.	4-107

## LIST OF FIGURES (continued)

<u>Figure Number</u>	<u>Title</u>	<u>Page</u>
4.6-6	$L_{dn}$ for Inert Retarders.	4-108
4.6-7	Logarithmic Effective Fraction of Time Usage for a Line of Noise Sources.	4-109
4.6-8	$L_{dn}$ for Line of Idling Road Engines.	4-110
4.6-9	$L_{dn}$ for Line of Idling Switchers .	4-111
4.6-10	$L_{dn}$ for Line of Mechanical Refrigeration Cars.	4-112
4.6-11	Determination of Weighting Factor for Number of Load Test Occurrences During the 24-Hour Time Period.	4-113
4.6-12	$L_{dn}$ for Load Test as a Function of Distance to the Noise Center.	4-114
4.6-13	Techniques for Composite $L_{dn}$ Contour Construction.	4-115
4.6-14	$L_{dn}$ Worksheet for Yard Operations.	4-116
4.7-1	Example Yard Layout.	4-117
4.7-2	$L_{dn}$ Worksheet for Yard Operations Example	4-118

## 1.0 INTRODUCTION

The history of America is closely tied to the development of the railroad industry. Millions of people have grown up to its familiar sights and sounds. Many people fondly remember magnificent steam engines puffing their way over the width and breadth of this land. The railroads are indeed considered by many as a treasured piece of Americana. As such, many of the minor inconveniences caused by their operation have been tolerated with minimal concerted action instituted on the part of individuals or governmental bodies. However, the railroads have acknowledged the need for a reduction in noise pollution and, through funding of this study effort, have accepted their responsibility in achievement of this goal.

In recognition of the need for assessment of the noise emitted by railroad operations, this report has been prepared under sponsorship of Southern Pacific Transportation Company, Union Pacific Railroad, Atcheson, Topeka and Santa Fe Railway Company, and Association of American Railroads. The report is intended to provide substantial background data to aid Federal rule making efforts on railroad noise and to satisfy the requirements for "noise elements" in the State of California Code Number 65302 (Senate Bill 691). The specific requirements of this bill are as follows:

(g) A noise element in quantitative, numerical terms, showing contours of present and projected noise levels associated with all existing and proposed major transportation elements. These include but are not limited to the following:

- (1) Highways and freeways,
- (2) Ground rapid transit systems,
- (3) Ground facilities associated with all airports operating under a permit from the State Department of Aeronautics.



These noise contours may be expressed in any standard acoustical scale which includes both the magnitude of noise and frequency of its occurrence. The recommended scale is sound level A, as measured with A-weighting network of a standard sound level meter, with corrections added for the time duration per event and the total number of events per 24-hour period.

Noise contours shall be shown in minimum increments of five decibels and shall be continued down to 65 dB(A). For regions involving hospitals, rest homes, long-term medical or mental care, or outdoor recreational areas, the contours shall be continued down to 45 dB(A).

Conclusions regarding appropriate site or route selection alternatives or noise impact upon compatible land uses shall be included in the general plan.

The state, local, or private agency responsible for the construction or maintenance of such transportation facilities shall provide to the local agency producing the general plan, a statement of the present and projected noise levels of the facility, and any information which was used in the development of such levels.

Additionally, the information contained herein is expected to be of value to all parties concerned in assessing rational guidelines concerning noise emission of railroad operations. The specific goals of the work and effort performed are summarized below.

#### I Yard Operations

The following operations will be analyzed and considered for their contribution to the external noise environment around three railroad yards, each of different volume of operations and one for each railroad company engaged in this project (Southern Pacific, Union Pacific, and A. T. S. F.).

- A. Engine load tests
- B. Hump yard operations including car impact and retarder noise
- C. Flat yard operations
- D. Idling switch engines including round house operations
- E. Horns, whistles, bells, alarms in yard
- F. In yard shop operations
- G. Mechanical refrigeration cars
- H. Other miscellaneous yard operations deemed significant in terms of contribution to the local noise environment

## II Line Operations

Line operations will include all noises associated outside of the yard with railroad trains including crossings and warning devices. For each grade configuration, a minimum of three train types will be studied as well as operations at various speed settings.

- A. Operations at grade - will include variations in noise output levels due to up and down grade conditions as well as wheel-rail noises produced by cornering and braking. Network crossovers will also be considered.
- B. Operations below grade (depressed right of way).
- C. Operations above grade (elevated right of way).
- D. Railroad crossings.
  - 1. Warning devices at crossing gates - bells, alarms, horns.
  - 2. Locomotive/train noise at crossings.
- E. Three dimensional locomotive noise propagation characteristics (both field measurement and analytical studies will be conducted to determine the extent and relative magnitude of this factor).

The organization of this presentation is divided into two broad categories: Section 3.0, which discusses Line Operations, and Section 4.0, which considers Railroad Yards. A summary of the findings is presented in Section 2.0. Additional analytical detail is contained in the Appendices.

Intentionally Left Blank

## 2.0 SUMMARY

### 2.1 Introduction

The railroad industry has moved to supplement the current knowledge in the areas of prediction of noise emitted by railroad operations in anticipation of Federal and State regulations concerning the environment. This report is largely directed at satisfaction of the "noise elements" portion of the State of California Code Number 65302 and to provide useful background data to aid the Federal Government in its efforts towards proposed rule making. The California Code requires that the agency responsible for the construction or maintenance of the railroads provide data on the present and projected noise levels of their system and any information used to develop such levels. The noise levels or contours may be expressed in any standard acoustical scale which includes both the magnitude of noise and frequency of occurrence. Further, it is recommended that A-weighted noise levels be used with corrections added for the time duration per event and the total number of events per 24-hour period. Finally, it is required that the noise contours be shown in minimum increments of 5 decibels down to 65 dB(A), with continuance down to 45 dB(A) in special situations.

In satisfaction of the "noise elements" requirement, this report incorporates A-weighted noise measurements of both line and yard operations, and weights their duration in terms of total integrated sound energy for each event or combined series of events. Additionally, a methodology has been presented for application to line and yard operations which allows inclusion of weighting factors for time of day of the noise event and numbers of events during defined time periods.

The broad topic of noise emitted by railroad operations has been divided into two general categories: line operations and yard operations.

## 2.2 Line Operations

Line operations is a term applied to movements of locomotives and freight cars over main line and local branch main line tracks. The typical characteristics of the noise emitted by these operations are shown in Figure 2-1 to be comprised of individual contributions of the diesel-electric locomotive and the freight cars.

For the locomotives measured, the noise emitted by the engine component was apparently independent of train velocity as illustrated in Figure 2-2. However, further investigation, summarized in Figure 2-3, indicates a dependence of the noise output of locomotives on track grade conditions. As indicated, the mean A-weighted noise output of the engines increases slightly under upgrade operations, but decreases rapidly when descending grade. The leveling off of noise levels as grade conditions approach  $-2$  to  $-2\frac{1}{2}$  percent (downhill) is a result of increased noise output emanating from the cooling fans of the dynamic braking system.

Car noise, attributed to wheel/rail interaction, proved to be highly speed dependent, increasing approximately 6 dB for each doubling of train velocity. This velocity dependence is shown in Figure 2-4, which presents noise level time histories during train passbys at speeds of 21 and 52 mph. A number of other variables, primarily relating to physical track or wheel condition, were also found to significantly influence wheel/rail generated noise. These factors are summarized in Table 2-1. Generally, these factors tended to increase the noise level generated by cars, but did not significantly alter the shape of the frequency spectrum and hence otherwise influence the "character" of the noise. An exception to this generalization is the occurrence of wheel "screech" on short radius turns. This screech, as the term implies, is primarily a high frequency (2500 to 5000 Hz) sound of short duration and occurs on a random basis.

Table 2-1  
Variables Affecting Freight Car  
Wheel/Rail Noise Emission

Variable	Increase in A-Weighted Noise Level*	Comments
1. Jointed Rails (vs. Welded)	4 to 8 dB(A)	Generally no correction for main line tracks; assign higher value to low speed classified track
2. Presence of Grade Crossings and Frogs	6 to 8 dB(A)	
3. Wheel Irregularities - Flat Spots or Built-up Tread	to 15 dB(A)	
4. Passage Over Bridgework a. Light Steel Structure b. Heavy Steel Structure c. Concrete Structure	to 30 dB(A) to 15 dB(A) 0 to 12 dB(A)	Use lower range of corrections for heavier structures
5. Short Radius Curves a. Less than 600 Ft. Radius b. 600 to 900 Ft. Radius	15 to 25 dB(A) 5 to 15 dB(A)	Random occurrence of wheel squeal

\* These factors are assumed to act individually. When in combinations of two or more, the net increase will not be equal to the sum of each component, but most likely the largest individual factor.

To facilitate estimation of noise levels from train operations, it was necessary to develop a method of synthesizing their noise signatures. The basic synthesis model is shown in Figure 2-5. The approach utilized consisted of a triangle and rectangle representation of the locomotive and car components of the noise time history. The synthesis model yielded a duration-corrected measure of the noise from a single event (called the Single Event Noise Exposure Level, SENEL) which agreed with measured values determined from actual passbys within  $\pm 3$  dB. These synthesized SENEL values must be corrected for their decrease in magnitude with distance and the increased effective duration of the event as the observer moves further away from the track. This behavior is illustrated in Figure 2-6.

The final step in development of the model of railroad line operations involved summation of all the individual SENELs produced by a defined number of operations over a segment of line and weighting their effective noise levels (to permit construction of noise contours to the surrounding community) according to their time of occurrence during the 24-hour day (i.e., a nighttime occurrence was deemed equivalent to 10 daytime events in terms of relative annoyance). A stepwise procedure for these calculations has been developed and is included in the report with a detailed worksheet. The final result of these event summations and weighting for time of occurrence allows the generation of noise contours in the Community Noise Equivalent Level (CNEL) noise scale or the very similar day-night average noise level ( $L_{dn}$ ). Either of these composite noise scales satisfies the requirements of the California Code by providing an integrated measure of A-weighted noise levels which accounts for the number of events occurring and the time of day they occur.

Due to the number of variables involved, it is impractical to offer a generalized statement on values of the composite (CNEL or  $L_{dn}$ ) noise contour produced by all types of line operations. However, an example of the change in typical CNEL contour values with increasing distance away from the track is illustrated

in Figure 2-7. This example is based upon actual operations over a segment of two-way (east-west) track at 2.2 percent upgrade in the east direction. The traffic mix was divided into east-west designations with average speeds of 35 and 28 miles per hour assumed respectively. Typical lengths of train operations were defined as 3600 feet for eastbound and 2700 feet for westbound. The number of daily freight train operations used were 22 eastbound and 24 westbound. For this example, the indicated values of CNEL assumed flat surrounding ground without any attenuation for barriers or nearby buildings.

### 2.3 Yard Operations

A variety of operations may be associated with activity in a yard or terminal complex including, primarily, the classification of cars and the general maintenance of cars and locomotives. The noise environment around a railroad yard is a composite of these events. The methodology developed in this report for assessment of the noise emitted from these operations assumes that the major noise production emanates from "noise centers" distributed logically throughout the yard. These "noise centers" are distinct regions where specific operations are concentrated and it is assumed that the noise produced by these activities dominates the overall noise "picture" of the yard operation. (This assumption has been verified experimentally in the course of this study.) The controlling noise centers of a typical railroad classification yard have been defined as follows:

1. Hump engine operations.
2. Concentrated switcher locomotive operations at the main leads of the arrival, classification and departure yards.
3. Master, group and individual track (or tangent-point) car retarders.
4. Inert retarders.



5. Idling road and switcher locomotives located in engine pooling areas, shop facilities, engine service racks or ready (departure) tracks.
6. Mechanical refrigerator cars - either in specified regions throughout the yard complex or spotted throughout the surrounding community.
7. Diesel locomotive load test facilities.

A concise technique is presented in the report for definition and location of the applicable dominant noise centers in a given yard layout, be it either a humping operation, flat-yard or combination of both.

The method of yard noise assessment developed is based upon the A-weighted measure of discrete noise sources. Through field measurements at the major Southern California classification yard operations, mean-maximum noise levels (arithmetic mean plus one standard deviation) have been assigned specific operations. These values and the dominant noise producing operations are summarized in Table 2-2. The noise emitted by public address systems and car coupling impacts is included for reference in that these sources may be distinguishable; however, their cumulative noise effect was secondary to the other items listed.

Because a major part of activity in most yards consists of classification operations, a main source of noise from these operations stems from the movements of switcher locomotives. Figure 2-8 illustrates the character of the noise of a typical "switching-cycle." This type of behavior is quite dominant in flat yard arrangements due to the "rev-shove-stop" procedure followed in switching out a cut (or group) of cars. This procedure is also utilized to a lesser extent in hump yards where greater emphasis in humping operations is given to a steady push of cars over the crest of the hump.

Table 2-2

Typical Mean-Maximum Noise Levels Produced by Railroad Yard Operations	
Significant Yard Noise Producing Operations	Noise Level at 100 ft, dB(A)
1. Switcher engine movements a. Steady Pull Through Yard b. Classification Start-Stop Cycle	76-80 80
2. Idling Locomotives a. Road Engine* b. Switch Engine*	71 65
3. Car Impacts a. Single or multiple cars into parked cars - coupling b. Chain reaction impacts - start-up or stopping of a line of cars	91 91
4. Car Retarders a. Master b. Group retarders or individual track retarders c. Inert or pull-out retarders	110 110 95
5. Loudspeakers and PA Systems (at 0 degrees)	90-95
6. Auxiliary Service Operations Performed in Yards a. Engine load tests (at No. 8 Throttle)* b. Locomotive Service Racks c. Operation of stationary mechanical refrigeration car * - Engine-Generator Side - Condenser Side	92 (as in 2a)  64-74** 59-68**

\* one only

\*\* at 50 feet

As indicated in Table 2-3, most engine operations in yards are at low throttle settings (except for stationary engine load tests which are run at full power settings). Clearly, idling is the dominant operational mode for all locomotive types within yard facilities. The classification of areas involving concentrations of idling locomotives as dominant noise centers results not from the magnitude of the noise levels produced (typically 71 dB(A) at 100 feet), but rather as a result of the constant nature of the intrusive noise (service racks, ready tracks, etc., will typically maintain a relatively constant volume of activity over the 24-hour period), and the relative location of these services out of the main activity flow, which usually results in their placement in the close proximity to the yard boundary. Furthermore, since idling locomotives are usually found clustered in groups, the combined noise level emitted by such congregations may exceed that of a single engine by 10 to 15 dB.

An additional factor associated with the noise emitted by idling locomotives, and all low throttle engine movements in general, is the predominance of low frequency content in the spectrum of noise emitted as illustrated in Figure 2-9. These low frequency components, which correspond to firing frequency, are not rapidly attenuated by low barriers (other cars, for example) or atmospheric absorption of sound, and hence may be audible at large distances from a yard.

The operation of mechanical refrigerator cars may also contribute to the overall noise levels of yard operations. These cars may be spotted at designated locations within the yard complex or on sidings near residential communities. Here again, as in the case of idling locomotives, the significance of these units in the overall yard noise picture results primarily from their placement and the constant nature of their operation. Additionally, as they are normally spotted in groups, their cumulative noise emission will exceed that of a single unit.

Table 2-3

Percentage of Time Spent at Specified Throttle Setting for  
Typical Road and Switcher Locomotive\*

Throttle Setting	Locomotive Description	
	Switcher Engines	Avg. All Road Power
8	0	30
7	0	3
6	1	3
5	1	3
4	2	3
3	4	3
2	5	3
1	10	3
Idle	77	41
Dynamic Brake	0	8

\* Reference 1

In contrast to the predominant low frequency output of diesel engines, car retarders produce high frequency sounds in the range of 2000 to 3150 Hz at relatively high noise levels as shown in Table 2-2. Measurements of retarder screech at 100 feet from master and group retarders indicated mean noise levels of the order of 100 dB(A). A spectra illustrating the typical frequency content of a screeching car retarder is shown in Figure 2-10. The occurrence of retarder screech is somewhat random and is influenced by many variables including the weight and speed of the car and the presence of lubricant on the retarder shoes. To facilitate development of the yard noise model, a nominal percentage of the cars passing through any given master, group or track retarder which emit high noise level screech has been assumed to be 25 percent. However, the step-wise procedure for estimation of yard noise emission allows for this factor to be increased or decreased depending upon the observed performance of the particular retarder system under investigation. Inert retarder screech has been assumed to occur 100 percent of the time due to the nature of their construction and lack of sensitivity to most factors affecting master retarder screech.

In compilation of the composite yard noise model, the mean-maximum A-weighted noise levels emitted by the aforementioned dominant sources were combined with observed typical noise event durations to yield time integrated measures of the noise (single event noise exposure level or SENEL) emitted from the various "noise centers". For switcher locomotive operations, it was assumed that their total noise emission followed the typical "switcher-cycle" presented in Table 2-3, i.e., at idle 77 percent of the time (hence 65 dB(A) at 100 feet) and low throttle settings the remaining 23 percent (nominally 85 dB(A) at 100 feet). For assessment of the total sound energy emitted by idling road locomotives and mechanical refrigerator cars, an average number was assigned to particular areas of the yard over daytime and nighttime time periods, thus yielding constant noise output from these sources. In cases where load test

operations are conducted, their typical day/night operations schedule was considered along with an assumed average duration of 30 minutes.

The analysis method then combines these events to yield cumulative yard noise exposure contours expressed in terms of the day-night average noise level,  $L_{dn}$ . This community noise rating scale is essentially identical to the CNEL technique advocated for assessment of line operations with the only difference being the elimination of a separate evening time period (7 pm - 10 pm) and including these hours into the daytime period. This simplification was deemed more compatible with the record keeping procedures of most railroads which tend to classify yard activity levels by work shifts.

#### 2.4 Conclusions

The noise emitted by railroad operations may be suitably synthesized and incorporated into analytical procedures for determination of its composite effect on the noise environment in surrounding communities. The techniques developed in this report are in accord with the recommendations of California State Code Number 65302 and yield a defined methodology to assist in development of noise contours of railroad operations.

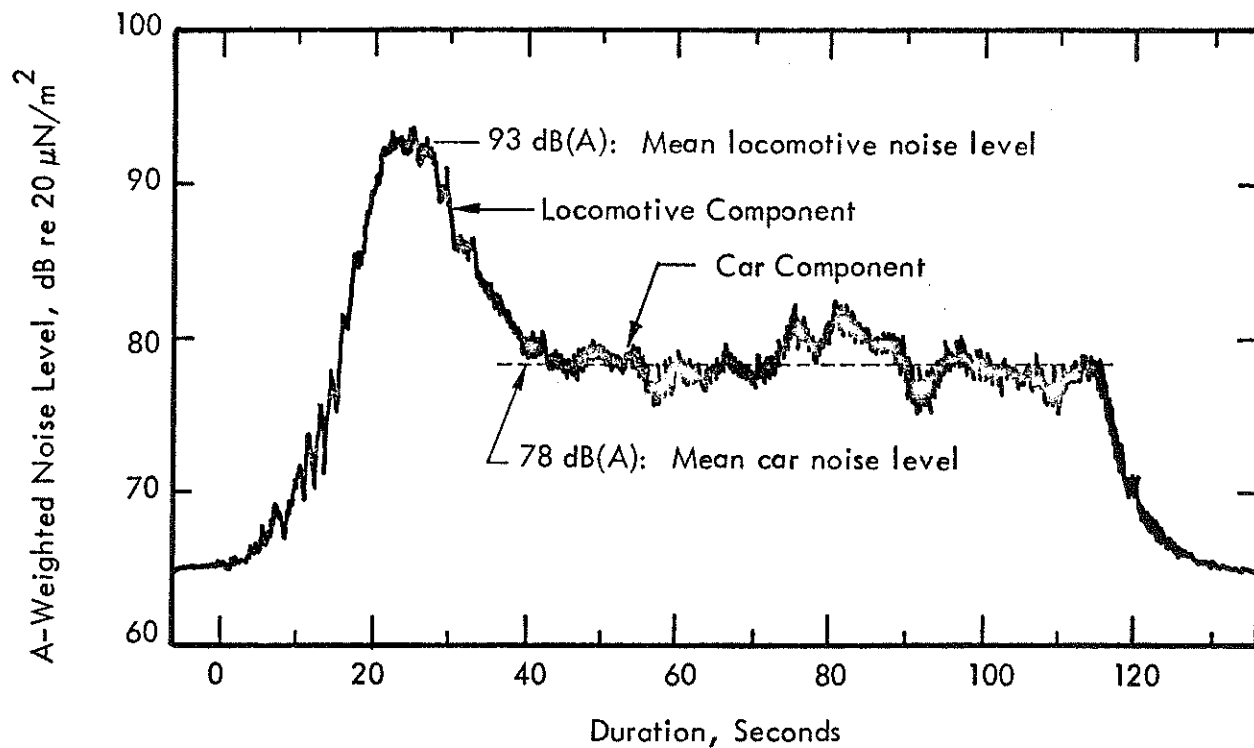


Figure 2-1. Typical A-Weighted Time History of a Train Pass-By (Measured at 100 Feet From Track, 32 mph at +0.6 percent grade, Tehachapi Summit).

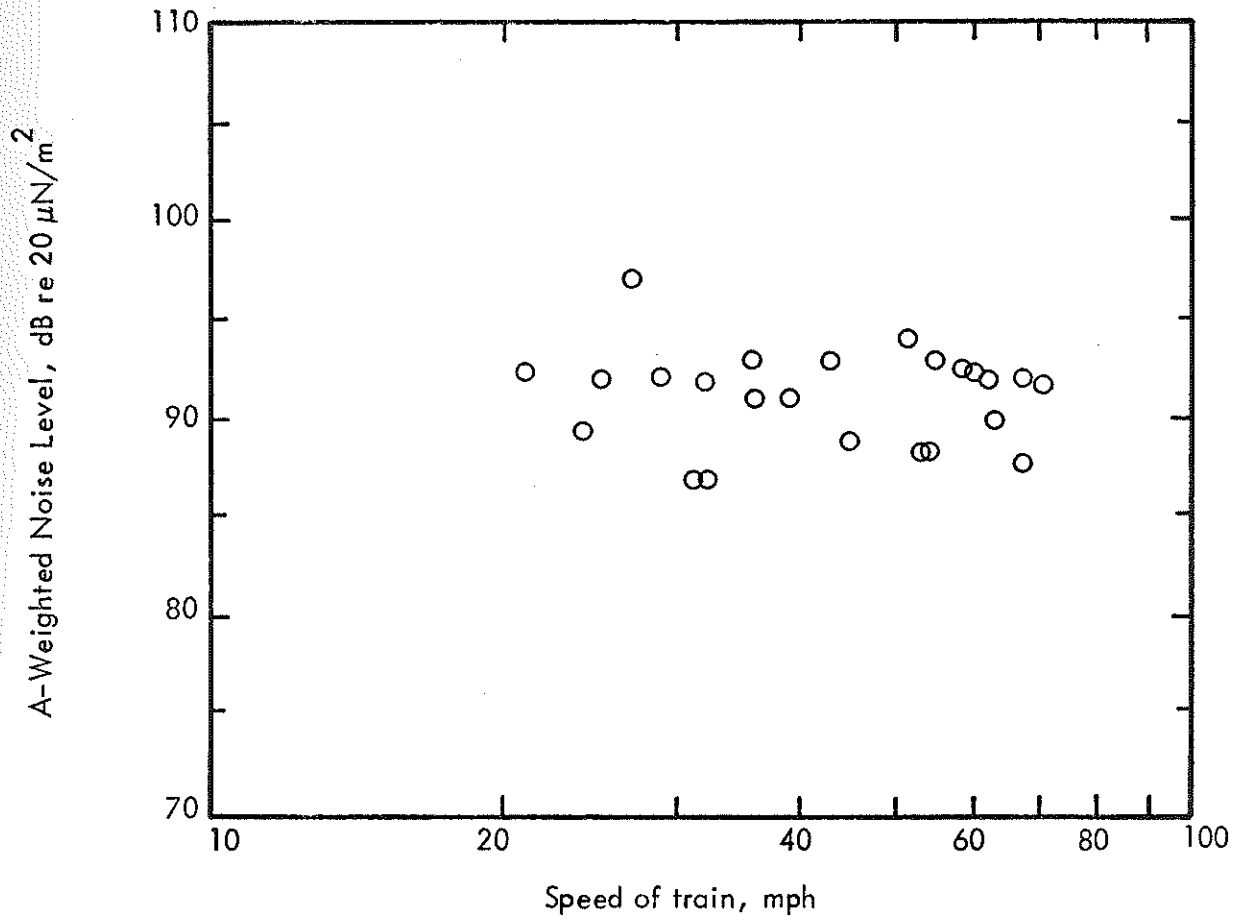


Figure 2-2. Noise Levels of Locomotive Traveling at Level Grade ( $\pm 0.75\%$  grade) Measured at 100 Feet Distance to Track.



A-Weighted Locomotive Noise Output in dB,  
re  $20 \mu\text{N}/\text{m}^2$  Relative to Mean Level Produced at 0% Grade

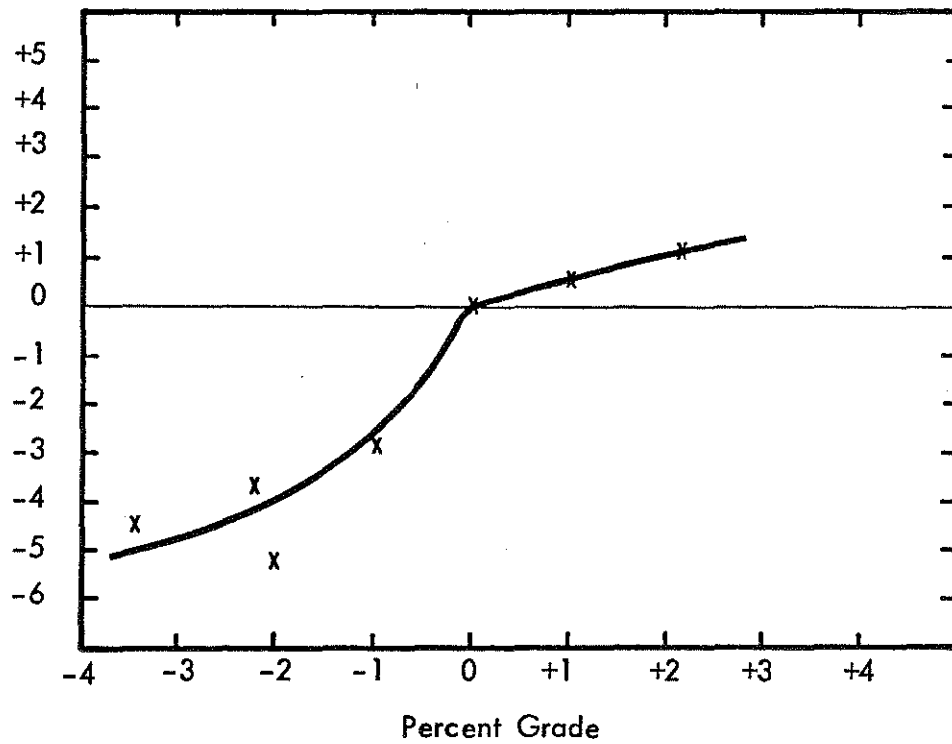
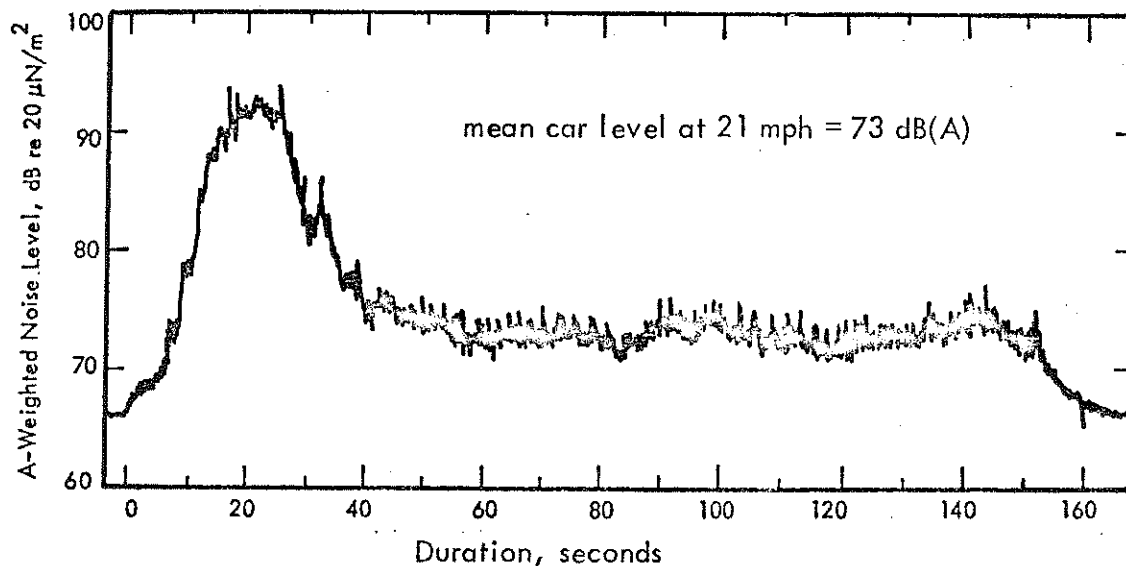
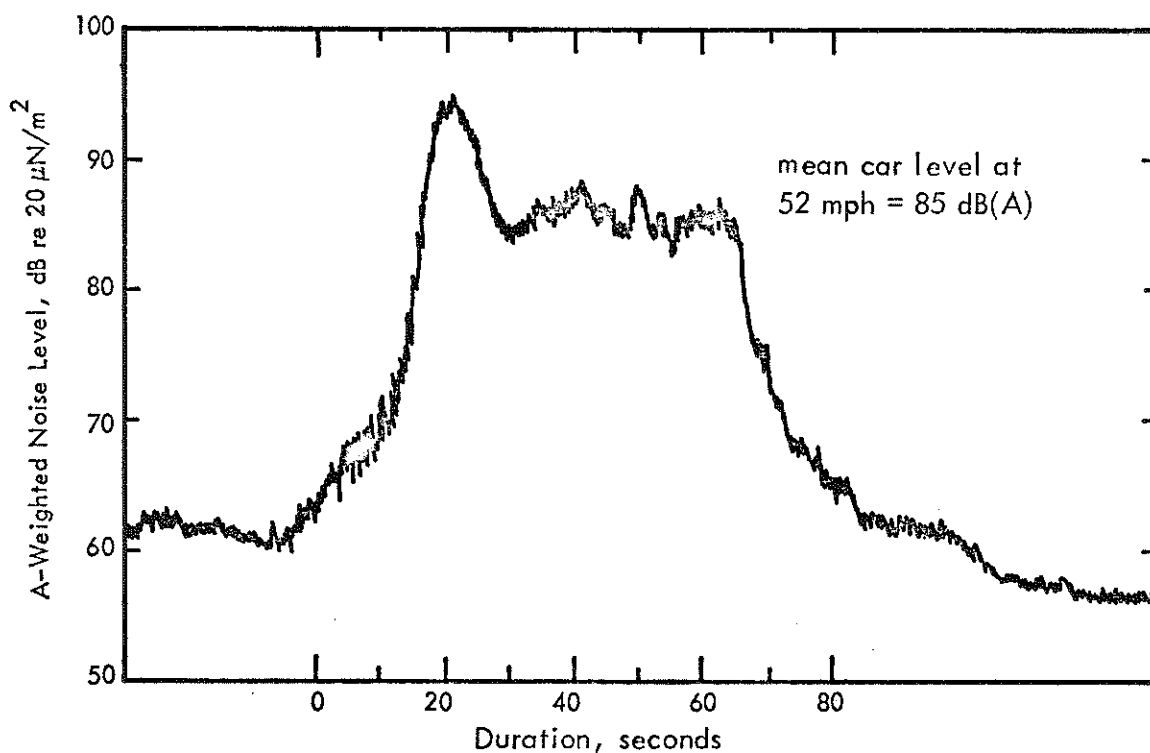


Figure 2-3. . Illustration of Grade Dependence of Mean A-Weighted Noise Levels Produced by Locomotives.



A. Pass-by at 21 mph, Hesperia (0% grade)



B. Pass-by at 52 mph, Tehachapi Summit (+0.6% grade)

Figure 2-4. A-Weighted Pass-By Time Histories of Freight Trains at 21 and 52 mph Over Similar Track Conditions Illustrating the Velocity Dependence of Car-Generated Noise Levels. (measurements at 100 feet to tracks)

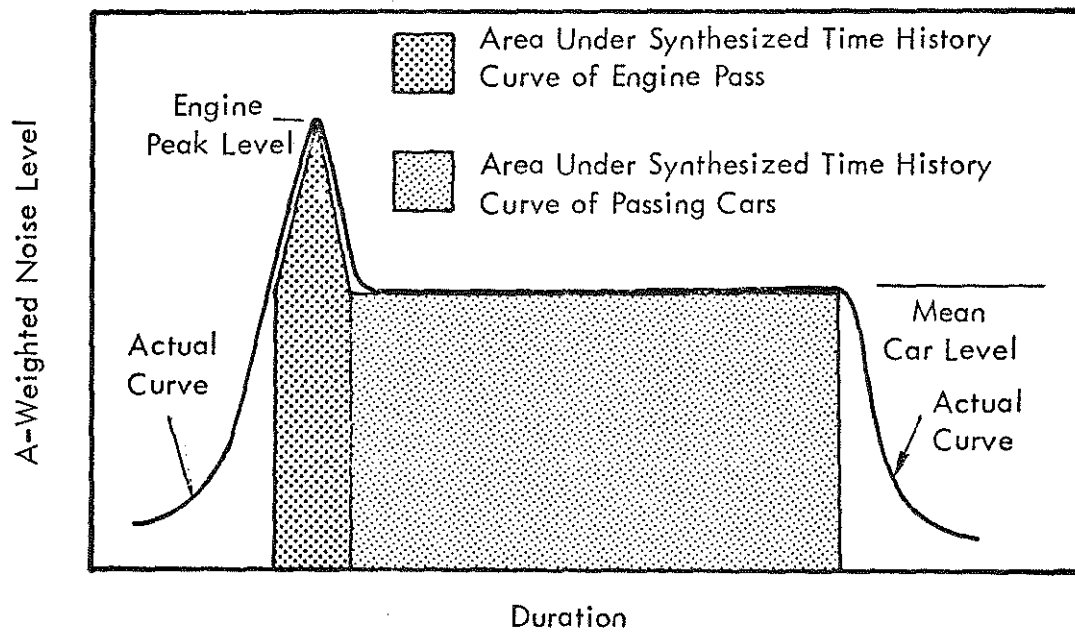


Figure 2-5. . Comparison of Synthesized Triangle-Rectangle Time History and Actual Curve

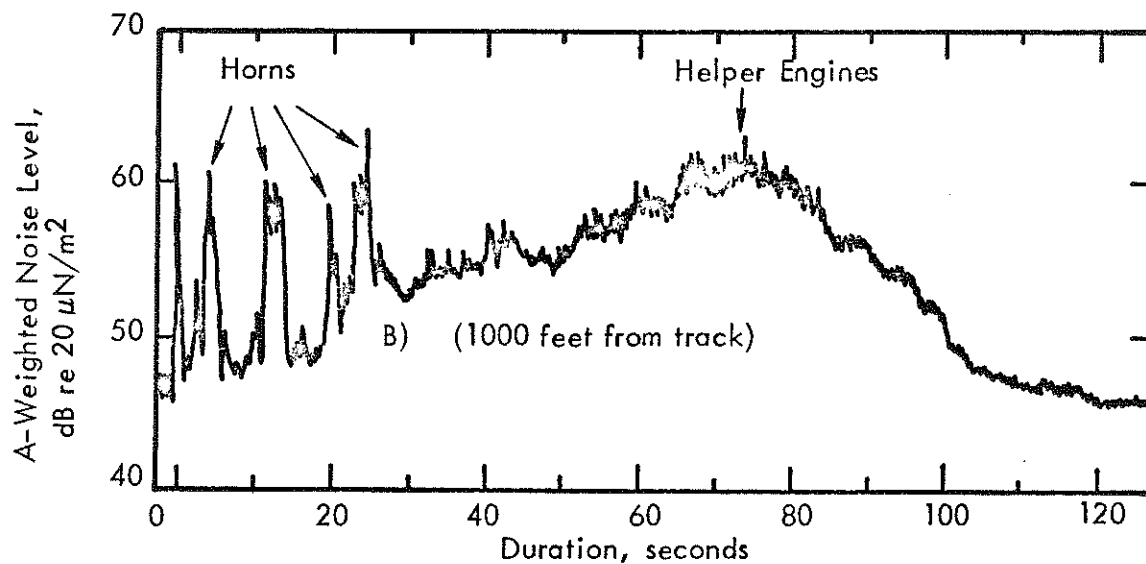
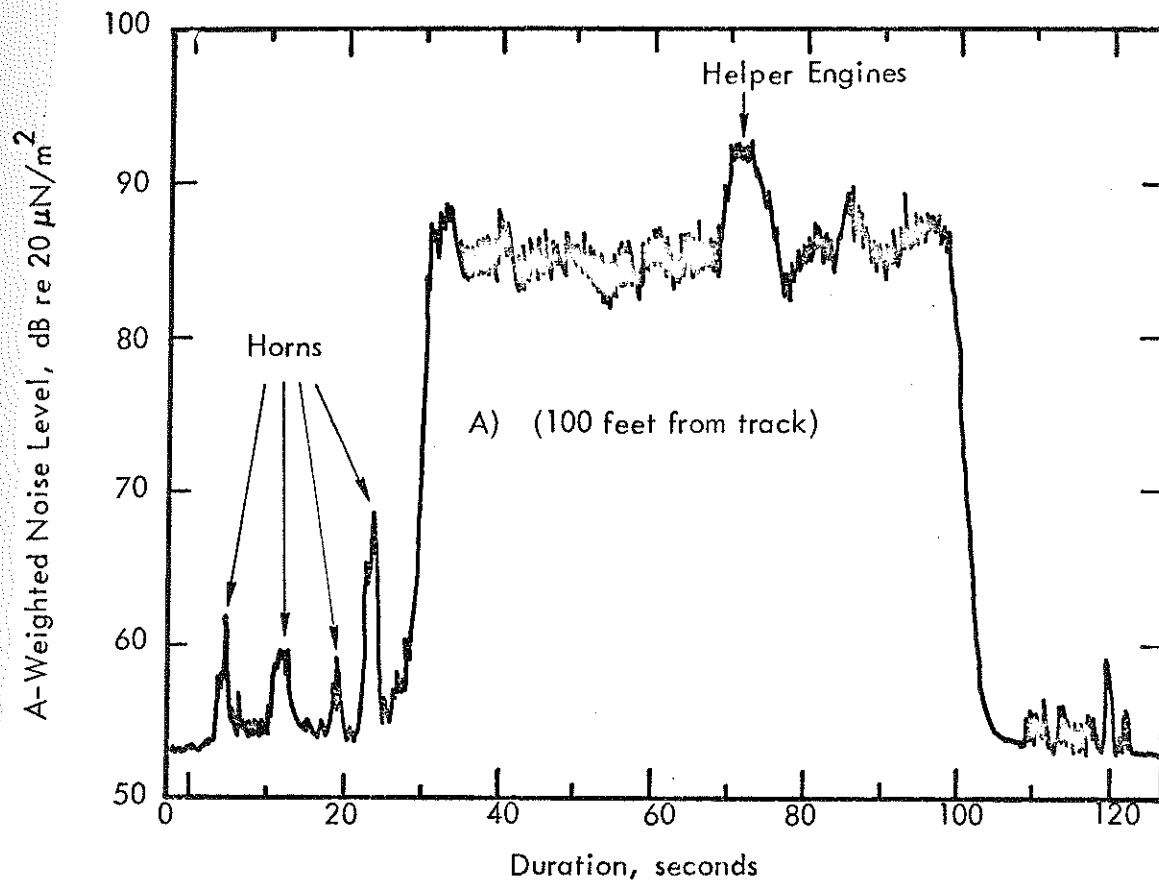


Figure 2-6. . Comparison of A) 100 Foot and B) 1000 Foot A-Weighted Time Histories of Train Pass-by at Location Between Lancaster and Rosamond, California (67 mph at 0% grade).

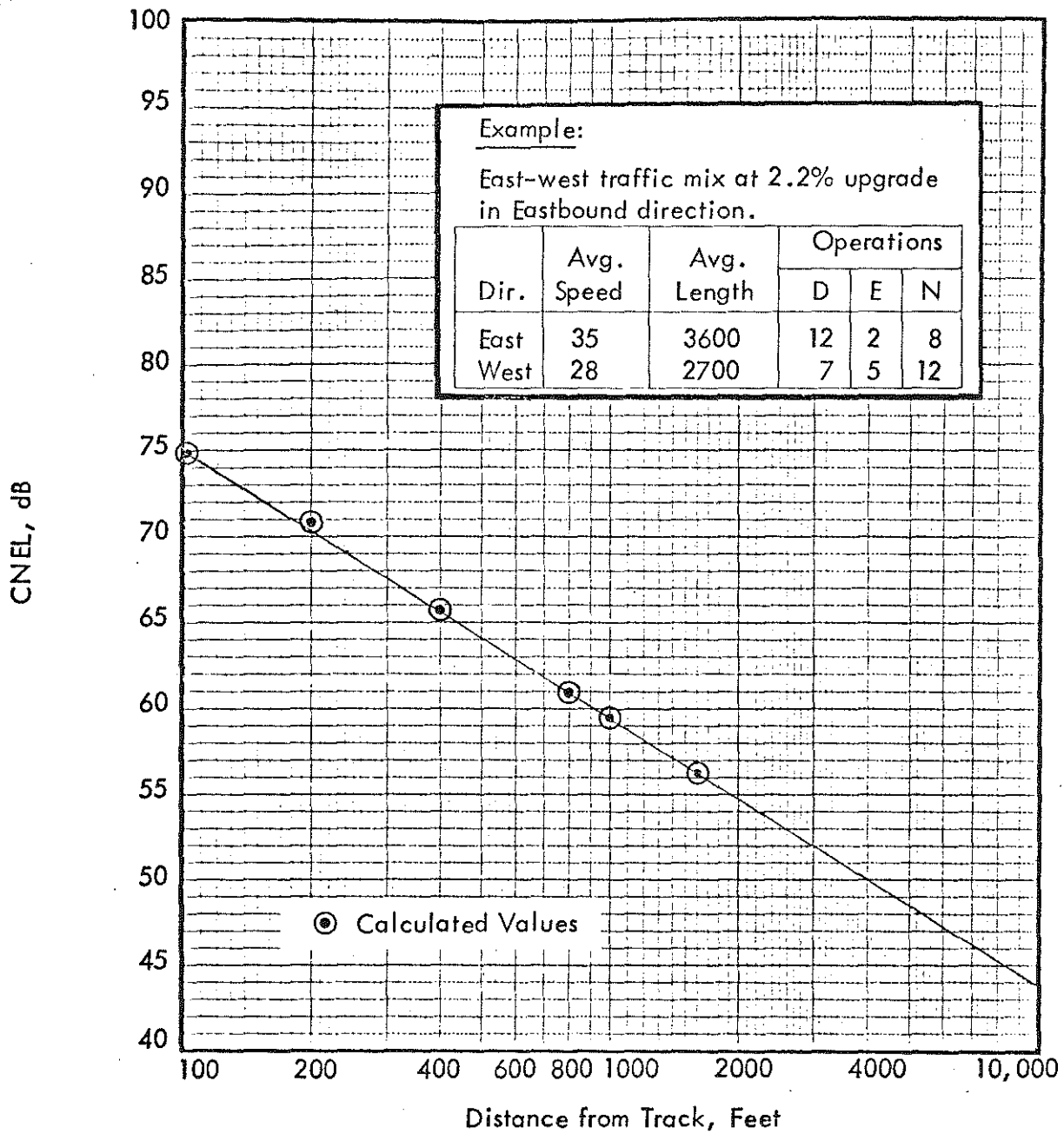


Figure 2-7. Example Application of Line Operations Methodology Illustrating Variation of CNEL Contour Values With Distance Away from the Tracks.

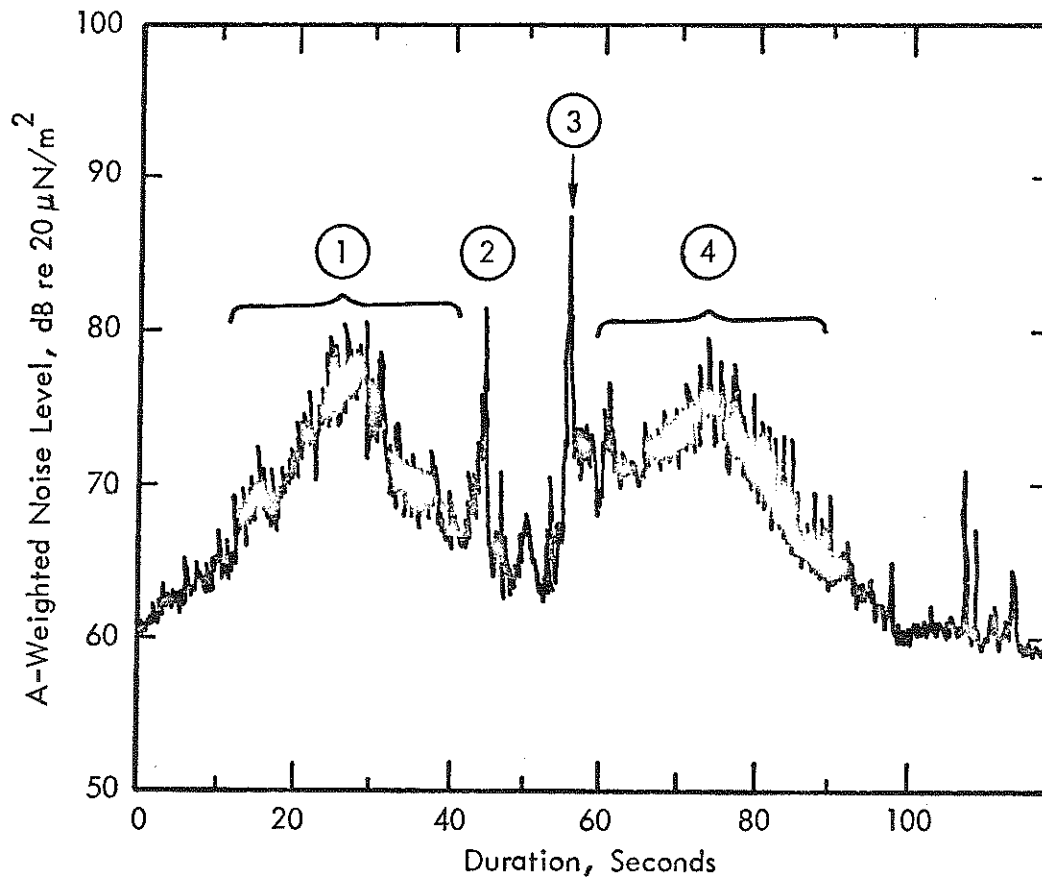


Figure 2-8. A-Weighted Time History of Flat Yard Switching Cycle: (1) Switcher Approaches with Cut of Cars, (2) Chain Reaction Impact Occurs When Switcher Suddenly Stops to Release Car Being Classified, (3) Released Car Couples with Stationary Cut in Classification Tracks, and (4) Switcher Moves Away (Measurements taken 25 feet from switching track).

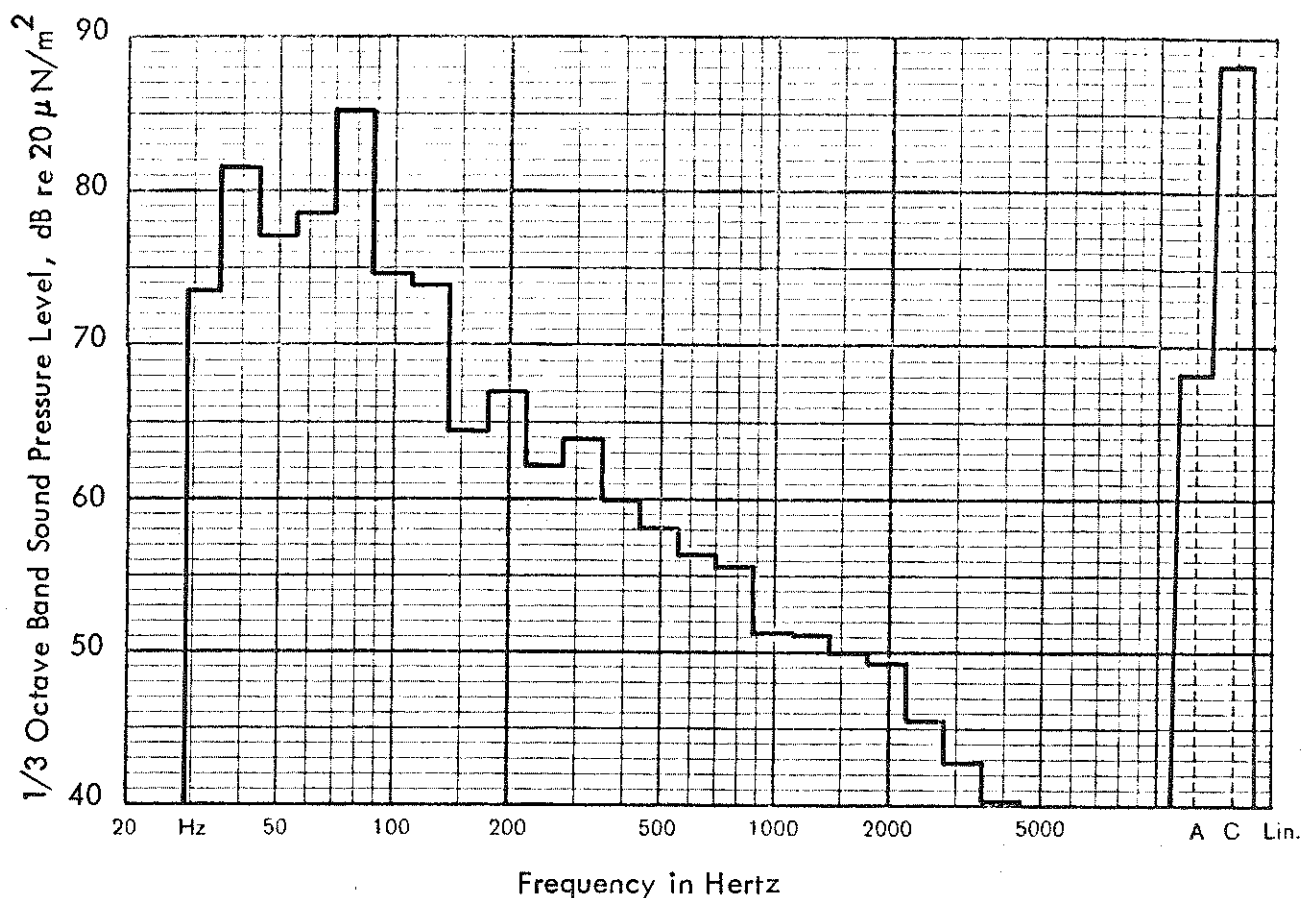


Figure 2-9. . Frequency Spectrum of Idling Switcher Locomotive  
 (Measurements Taken at 50 Feet from Track)

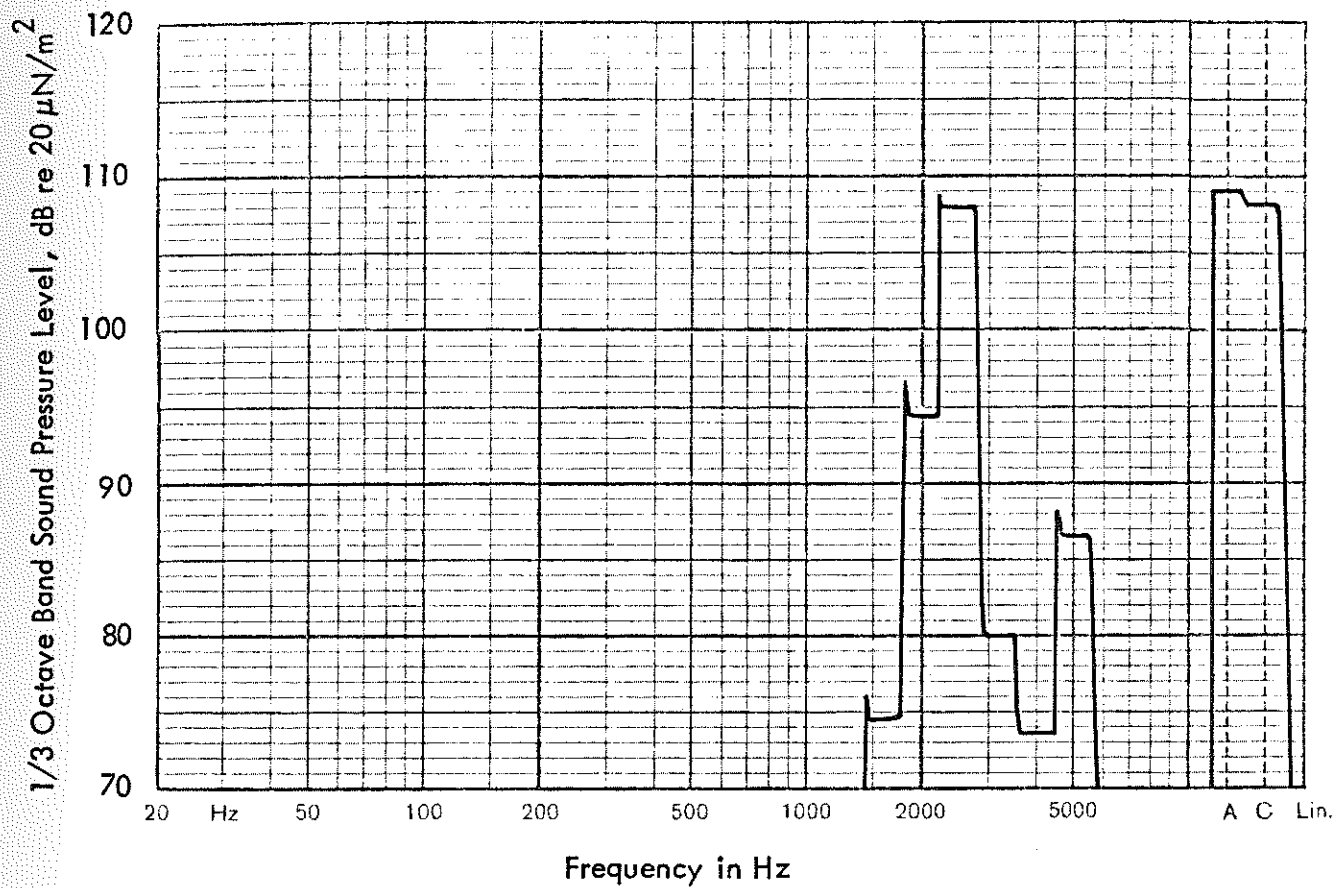


Figure 2-10. Frequency Spectrum of Noise Emitted from Master Retarder (Measurements Taken 100 feet from Retarder). Spectrum is Similar for Group Retarders



Intentionally Left Blank

## 3.0 RAILROAD LINE OPERATIONS

### 3.1 Introduction

Line operations is the term applied principally to operation of freight trains over main line track and local branch main lines. Only operations involving diesel-electric locomotives (which comprise 99% of the engine fleet) and freight cars will be treated. Track inspection and repair or maintenance, including emergency machinery, are considered outside of the scope of this discussion. Furthermore, all operations which occur on spur or set-off tracks which are stationary in nature, i.e., idling road engines and mechanical refrigeration cars, will be treated in Section 4.0, Railroad Yard Operations.

The discussion of line operations considers the two major contributions responsible for noise generation: the road power (diesel-electric locomotives in combination) and the car-generated noise levels (wheel/rail interaction). The method of presentation of field measurements will be presented in the form of A-weighted pass-by time histories at a specified standard reference distance perpendicular to the centerline of the track (generally 100 feet). Where appropriate, these time histories are supplemented by 1/3 octave band frequency spectra of significant events.

In addition, the noise emitted by safety warning devices, in particular locomotive horns and crossing bells, will receive some consideration, although it is intended that these factors will be omitted from inclusion in the community noise contours of railroad operations.

## 3.2

### Characteristics of Noise Emitted by Railroad Line Operations

Noise emitted by freight trains depends not only upon the operational mode of the train but its physical makeup and the properties of the track and local terrain. As illustrated in Figure 3.2-1, the train pass-by may be ideally described as the combination of two distinct elements: noise emitted by locomotives and noise emitted by the freight cars.

Figure 3.2-2 illustrates an actual freight train pass-by measured at a distance of 100 feet at 32 mph. At this distance and speed, the individual contributions of the engine and cars are clearly discernible. To achieve the program goals, it was necessary to analyze both the locomotive and the freight car elements of this pass-by time history, and develop a suitable method of synthesizing train time histories given a number of basic parameters.

### 3.2.1

#### Diesel Locomotive Noise

While the general consensus of available literature on train noise is that noise emitted by diesel locomotives is a function of engine throttle setting, this factor, in itself, is difficult to evaluate. See Reference 2.

As discussed in Appendix I, the amount of road power a particular train may be equipped with does not necessarily correlate with the theoretical power required to maintain a specified velocity and grade condition. Based upon numerous observations over a wide variety of operational conditions, it is concluded that the A-weighted noise output of the diesel-electric locomotive varies little with velocity over most normal operational ranges. This fact is illustrated in Figure 3.2-3 which presents the maximum A-weighted noise level emitted by the locomotive vs. velocity operating on track between 0.75 percent up and down grade. To further illustrate the lack of dependence upon train velocity, Figure 3.2-4 has been included

which shows locomotive noise output vs. velocity for various upgrade conditions.

Rather than attempt to correlate engine noise output with velocity, it has been determined that locomotive noise output correlates well with level, ascending or descending grade conditions.

For the purpose of this report, level grade is defined as  $\pm 0.75\%$  grade. It has been observed that the variation in noise output relative to these limits is negligible. Ascending grade is defined as a grade of greater than plus 0.75 percent in the direction of travel. Descending grade is defined as a grade of greater than minus 0.75 percent in the direction of travel.

Figures 3.2-5 and 3.2-6 illustrate histograms of locomotive noise data collected under grade conditions of level and 2.2% upgrade, respectively. A summary of the mean A-weighted noise levels produced by diesel-electric locomotives operating under a variety of grade conditions ranging from -3.4% to +2.2% is included in Table 3.2-1. While it is recognized that the sample size for some of the grade conditions is small, the trends illustrated are considered valid. Figure 3.2-7 is a graphic illustration of the observed grade dependence of the locomotive noise output. It should be noted that under steep downgrade conditions (greater than 2-1/2 - 3%), there is a pronounced leveling-off of noise level which is due to application of dynamic braking systems. An A-weighted time history of a train undergoing extreme downgrade conditions (3.4% downgrade) is presented in Figure 3.2-8.

Representative 1/3 octave bandwidth frequency spectra of locomotives under conditions of varying grade are presented in Figures 3.2-9 through 3.2-11. It may be observed that under conditions of steep grade ascent which require maximum locomotive power output, the low frequency content

of the spectrum is accentuated. This performance reflects the relative contribution of the exhaust noise component to the overall noise levels produced by the locomotive. In general, due to their characteristic low speeds of revolution, the noise emission is dominated by low frequency components which follow the engine firing frequency. (Diesel-electric locomotives typically are run at "notch 8" maximum throttle setting 24 to 30% of the time. Maximum engine speeds for the most common varieties of locomotives range from 800 to 1100 rpm.)

Table 3.2-1

Summary of Statistical Parameters Describing A-Weighted Diesel-Electric Locomotive Noise Output Under Varying Grade Conditions

% Grade	Arithmetic Mean, dB	Standard Deviation, dB	Number of Data Points
1% up	92.8	1.1	4
2% up	91.0	0	1
2.2% up	93.3	1.65	9
1% down	88.3	2.62	3
2% down	86.0	3.27	3
2.2% down	87.5	1.5	4
3.4% down	86.8	0.62	3
Level	91.2	2.37	24

For a 16 cylinder, 3000 HP, 2 cycle diesel with a maximum rated engine speed of 900 rpm, this results in a fundamental firing frequency of 240 Hz. As may be observed in Figures 3.2-9 and 3.2-10, the predominant low frequency content is centered nearly one octave below this fundamental firing frequency in the 125 Hz octave band. This occurrence results from the basic design of the engine crankshaft. To achieve the balance of engine firing forces, cylinders are arranged in pairs such that two will always fire simultaneously. Hence, the "effective" fundamental engine frequency will be half to one octave below that of the firing frequency. For a more extensive treatment of the relative contributions of the major subsource elements of a diesel engine (casing noise, inlet noise, fan, etc.) to the overall noise levels produced at various operating conditions, the reader is referred to References 2 and 3.

For the preceding discussion, noise levels of locomotives were measured at a standard reference distance of 100 feet perpendicular to the centerline of the track. To assess locomotive noise in the surrounding community, it is necessary to consider the attenuation of these noise levels with increasing distance away from the railroad tracks.

By considering the pass-by of a locomotive as a distinct single event, and considering its noise emission to be reasonably non-directional (a reasonable assumption due to the dominance of the exhaust component in the spectra and the placement of the exhaust outlet atop the locomotive, generally midway along its length), the noise attenuation with distance due to spherical spreading (Reference Appendix D) could be assumed equal to that of an acoustic point noise source or 6 dB per each doubling of the distance away from the source. The dominance of low frequency content in the engine spectra implies that excess sound attenuation due to atmospheric

and ground absorption will not play a major role in further reduction of these levels. Nonetheless, these factors have been considered for a typical A-weighted noise spectra over level grade. The result is an additional attenuation of 6 dB at 1000 feet for assumed reference conditions of 60°F and 50% relative humidity. The theoretical spreading loss (6 dB/doubling) is shown in combination with this excess attenuation in Figure 3.2-12 along with several field data points taken at distances out to 1000 feet. The theoretical curve, fitted through the mean value of 91 dB(A) at 100 feet (reference Table 3.2-1), yields a conservative estimate of predicted levels at 1000 feet which is approximately 5 dB above the mean of the data at this point. Considering the variability of the data and the many other factors not considered which may affect sound propagation, such as bending of the sound rays by wind and temperature gradients, this slight conservatism is considered reasonable.

### 3.2.2 Freight Car Generated Noise

In contrast to engine-generated noise, the contribution of the freight car generated noise to a train passby time history indicates a definite dependence upon train velocity. As illustrated in Figure 3.2-13, the noise emitted by the wheel/rail interaction of freight cars over welded track and jointed main line track increases by approximately 6 dB for every doubling of the velocity. This relationship may be expressed by the empirical formula, fitted to the data points of Figure 3.2-13, as:

$$NL_{\text{car}} = 50 + 20 \text{ Log}_{10} V, \text{ dB(A)} \quad (3-1)$$

where

V = Speed of train in miles per hour.

The increased noise output due to wheel/rail interaction with increasing train speed is illustrated in Figure 3.2-14, which presents time histories of

two train passbys over similar track and terrain at speeds of 21 and 52 miles per hour. A comparison of the frequency spectra of car-generated noise levels at high and low speed (Figure 3.2-15) shows relatively similar frequency content. The spectral makeup of wheel/rail noise may generally be described as reasonably flat out to 2500 Hz in some cases and then rolling off at a rate of 5 to 6 dB per octave.

There are several factors which may significantly influence the wheel/rail noise emission of freight cars. Of primary consideration are:

- (1) Physical track description - welded or jointed
- (2) Presence of grade crossings or frogs
- (3) Radius of track curvature
- (4) Passage over bridge work and nature of bridge work
- (5) Wheel and track irregularities

The generalized effects of these variables on wheel/rail generated noise levels are summarized in Table 3.2-2.

#### 3.2.2.1 Welded and Jointed Track

The majority of the literature on train noise indicates car noise levels produced by trains operating over jointed track to exceed levels produced over welded track by up to 8 dB (Reference 3). A low speed classified line will yield higher noise levels as predicted in the literature. However, based on measurements of noise from main line operations in the Southern California region, noises emitted by wheel/rail interaction over welded and jointed track at specific speeds are of the same magnitude. The observance is illustrated in Figure 3.2-13. Hence, the empirical equation developed to express A-weighted wheel/rail noise levels as a function of train velocity (Equation 3-1) is based upon data from operations over both welded and jointed main line track. The correction factor for jointed



Table 3.2-2

Variables Affecting Freight Car  
Wheel/Rail Noise Emission

Variable	Increase in A-Weighted Noise Level*	Comments
1. Jointed Rails (vs. Welded)	4 to 8 dB(A)	Generally no correction for main line tracks; assign higher value to low speed classified track
2. Presence of Grade Crossings and Frogs	6 to 8 dB(A)	
3. Wheel Irregularities - Flat Spots or Built-up Tread	to 15 dB(A)	
4. Passage Over Bridgework a. Light Steel Structure b. Heavy Steel Structure c. Concrete Structure	to 30 dB(A) to 15 dB(A) 0 to 12 dB(A)	Use lower range of corrections for heavier structures
5. Short Radius Curves a. Less than 600 Ft. Radius b. 600 to 900 Ft. Radius	15 to 25 dB(A) 5 to 15 dB(A)	Random occurrence of wheel squeal

\* These factors are assumed to act individually. When in combinations of two or more, the net increase will not be equal to the sum of each component, but most likely the largest individual factor.

track (Item 1 in Table 3.2-2) should only be applied to branch line tracks and segments of line where large or uneven rail joints are observed to exist.

#### 3.2.2.2 Frogs and Crossings

The presence of switching frogs and grade crossings along a line of track may create a localized condition. Figure 3.2-16 presents two time histories of train passbys over adjacent sections of track and illustrates measurements of the noise emitted by passage over a frog as compared with those over smooth track 950 feet downstream. The nominal increase in noise levels was observed to be 6 to 8 dB. Comparative frequency spectra are presented in Figure 3.2-17, which more fully illustrates the character of the noise emitted by a frog crossover. The spectral content in both cases, shown in Figure 3.2-17, is observed to be of a similar nature to that produced by wheel/rail noise over smooth track except that it occurs at higher amplitudes. A tendency for some dominance in the 400 to 500 Hz  $1/3$  octave frequency bands is also noted.

#### 3.2.2.3 Track Curvature

The radius of track curvature, when negotiating a main line curve, has also been observed to have an effect on freight car generated wheel noise levels. The net effect of a tight radius curve is the generation of wheel screech which may exceed the nominal car noise levels by 15 to 25 dB. Time histories are presented in Figure 3.2-18 of trains negotiating short radius turns (574 and 765 foot radius) to illustrate the nature of wheel screech occurrence. The generation of wheel screech is apparently due to a stick-slip mechanism in combination with other factors such as small amplitude vibration caused by wheel and rail irregularities and "micro-impacts" resulting from these irregularities (Reference 3). Figure 3-2-19

presents the frequency spectra of screech occurrences at the two aforementioned radius curves. As may be observed, the spectra exhibits the tonal content of the screech occurring in 1/3 octave bands from 2500 Hz to 3150 Hz.

#### 3.2.3.4 Passage Over Bridge Work

An additional factor which may have an effect on wheel/rail noise generation is passage over bridge work. While this program did not include field measurements of such occurrences, this factor is treated in some detail in the available literature (Reference 2). It has been reported that passage over light steel bridge work without ballast may increase levels in specific octave bands by as much as 27 to 30 dB over those produced over normal graded roadbed. Passage over heavy steel bridges may reduce this effect to approximately 15 dB over normal ballasted track (Reference 2). Concrete bridge work may yield increased levels up to 14 dB. Conversion of octave band correction levels for the aforementioned types of bridge work listed in Reference 3 to effective A-weighted values yielded the factors shown in Table 3.2-2.

#### 3.2.2.5 Wheel and Track Irregularities

An additional factor which will be considered which may have an effect upon wheel/rail generated noise levels is that of wheel and rail roughness and irregularities such as flat spots and builtup tread. A flat wheel may produce increased car noise levels of the order of 10 to 15 dB. The effect of a flat wheel is illustrated in Figure 3.2-20. During the field measurement portion of this program, the observed occurrence of flat wheels was rather random. Due to the random and unpredictable nature of their occurrence, noisy wheels are not considered in the formulation of the line model in Section 3.3.

In considering the attenuation of car-generated noise levels with increasing distance from the track, the point source approximation utilized for locomotive analysis is no longer valid. The noise level does not follow the inverse square law prediction of loss due to spherical spreading (i.e., 6 dB decrease for each doubling of distance away from the source). Rather, a more appropriate representation of the noise generated by a moving line of freight cars is that of a line of uncorrelated noise sources of equal strength. Since the train of cars is of finite length, it may be expected that the noise level will fall off at a rate of 3 dB per doubling of distance (as expected for an acoustic line source) out to a distance approximately equal to the train length divided by  $\pi$ . At this point, the line gradually transcends to an effective point noise source and neglecting any propagation losses, a fall-off of 6 dB per doubling of distance is predicted.

Considering the spectral content of typical car-generated noise, additional attenuation resulting from air absorption and excess ground attenuation at assumed reference conditions of 60° F and 50 percent relative humidity results in an additional loss of 8 to 9 dB at 1000 feet distance. The theoretical sound attenuation resulting from the combined effect of these factors is plotted against actual field measurements of car-generated noise in Figure 3.2-21. A transition point between line and point source dominance has been chosen as 300 feet for the train samples represented in this figure. The agreement between the data and general trend in the theoretical model is quite reasonable. Figures 3.2-22 and 3.2-23 are actual time histories taken at distances of 100 and 1000 feet which further illustrate the attenuation of train noise as the observer moves away from the line of operations.

Two additional factors which were evaluated for their effect on train noise were the presence of elevated or depressed train right-of-ways.

The treatment of elevated passings has been limited to situations representative of line routings in and around rural inhabited areas. Hence, the relative elevation of the track above the adjacent ground level is limited to approximately 60 feet. Field measurements of such situations were conducted at three locations (Appendix B). The results, as illustrated in Figure 3.2-24, indicate that the A-weighted noise levels produced by trains passing over elevated right-of-ways (to 60 feet relative elevation) are not significantly different (from those at zero elevation at comparable speeds).

Depressed right-of-ways, or cuts, have been discussed to some extent in the literature (Reference 5). Embleton has suggested that for a typical cut, involving side wall slopes of generally  $45^{\circ}$  (unless through rock, where steeper slopes may exist), that the sound attenuation effect may be similar to that of a barrier of comparable effective height between the noise source and the observer. As discussed in Appendix D, the effectiveness of a barrier is frequency-dependent. Thus, due to the different characteristics of the frequency spectra of diesel-electric locomotives and car noise, the barrier attenuation will be different for these two elements. In addition, the effectiveness of a barrier or cut in reducing noise levels is dependent upon its relative height above the source of the noise. Clearly, for wheel/rail generated car noise, the source is quite low to the ground; hence, even a slight cut (or low barrier) will be moderately effective. On the other hand, locomotive noise is largely dominated by the low frequency exhaust component and, by virtue of the placement of the exhaust outlet some 15 feet above the ground, the relative height of a given barrier is severely reduced. The results of

field measurements which verify and serve to illustrate these factors are presented in Figure 3.2-25. Hence, it is concluded that the treatment of cuts as barriers as discussed in Appendix D is a reasonable approach.

### 3.3 Development of a Community Noise Rating for Railroad Line Operations

#### 3.3.1 Requirements of the Rating Technique

In Section 3.2, the characteristics of the noise emitted by line operations have been discussed primarily in terms of maximum A-weighted noise levels. The California Code No. 65302 recommends not only that A-weighted levels be used to describe the magnitude of the noise but that, in addition, corrections be added to reflect the duration of each event and the total number of occurrences per 24-hour period. Hence, it is necessary to introduce the concept of duration-corrected intrusive noise events. This concept is developed in the following section.

#### 3.3.2 Single Event Noise Exposure Level (SENEL)

The most appropriate noise level-duration rating scale was felt to be one that is proportional to the sound energy of a train passby. Noise exposure level is a general term now used to define the time-integrated measure of a noise time history. For a single event such as a train passby, the quantity Single Event Noise Exposure Level (SENEL) has been developed. The SENEL is a logarithmic measure of the time integrated energy of a single event. The formal definition of SENEL is given by the following expression on the next page:

$$\text{SENEL} = 10 \log \left[ \frac{1}{P_{\text{ref}}^2} \int_{t_1}^{t_2} p^2(t) dt \right] \quad (3-2)$$

where

- $P(t)$  = Acoustic Pressure (Time Dependent)
- $P_{\text{ref}}$  =  $20 \mu\text{N/m}^2$  (Standard Reference Pressure)
- $t_2, t_1$  = Limits on time interval of event studied.  
(For practical measurements, these times can be taken as the times for which the level is within about 10 dB of its maximum value.)

For practical applications, this expression can be replaced by

$$\text{SENEL} = \text{NL}_{\text{max}} + 10 \log_{10} t_{\text{ea}}, \text{ dB} \quad (3-3)$$

where

- $\text{NL}_{\text{max}}$  = maximum noise level as observed on the  
A scale of a standard sound level meter,

and

- $t_{\text{ea}}$  = effective time duration of the noise level  
(on A scale) in seconds. It is approximately  
1/2 of the 10 dB down duration, which is the  
duration for which the noise level is within  
10 dB of  $\text{NL}_{\text{max}}$ .

As mentioned in Section 3.2, a train passby time history is comprised of two basic components: the engine contribution and the car contribution. From Equation (3-2) it is seen that an expression is required for the acoustic pressure at any instant of time during a passby. Since the maximum noise levels and durations of the engine and car portions of the train are independent of each other, due to their differing dependence on grade and velocity, it was deemed appropriate to model the SENEL for engines and cars separately and then combine the two for a total SENEL of the train passby. In order to make the acoustic pressure equations more readily integrable, the time history representations were synthesized by describing the A-weighted noise level versus duration curve for an engine as a triangle (at noise levels greater than the maximum level of the cars), and the cars as a rectangle. Figure 3.3-1 compares a representative and a modeled time history.

Although the actual duration may be slightly longer than that predicted in Figure 3.3-1, the model was considered reliable at distances close to the track (say, 100 feet). At such distances, the train noise levels increase rapidly as the train approaches and decrease rapidly as the train passes by. The noise levels increase more gradually during a train approach and durations increase as the microphone distance to the track increases. This duration effect is illustrated by Figures 3.3-2 and 3.3-3, where noise level time histories are presented at distances varying from 100 to 900 feet.

To avoid mathematical complexity at this point, it is sufficient to point out that for engine noise, the duration correction term in Equation (3-3) increases at the rate of 3 dB per doubling of distance from the train while for distances close to a long train, the duration correction for car noise is constant. The net effect is that for both engine noise and for car noise close to the train, the duration-corrected level or SENEL decreases ideally



at the rate of 3 dB per doubling of distance. In addition to the decrease in SENEL with increased distance from the track being controlled by spreading loss of sound and increased perceived duration, additional attenuation results from air absorption and excess ground attenuation. These two additional attenuation contributions are dependent upon the spectral content of the noise, temperature and relative humidity.

Finally, one further attenuation correction is required for SENEL values where a barrier such as a hill or side of a cut is present.

Further details on propagation and attenuation of train noise levels with distance are given in Appendix D. The preceding has provided the essential concepts for SENEL calculations which are utilized in Section 3.4.

The overall SENEL of the train is calculated by the logarithmic addition of  $SENEL_{Engine}$  and  $SENEL_{Car}$  as described in Equation (3-4).

$$SENEL_{Train} = 10 \log_{10} \left[ 10 \left( \frac{SENEL_{Engine}}{10} \right) + 10 \left( \frac{SENEL_{Car}}{10} \right) \right] \text{ dB} \quad (3-4)$$

A systematic SENEL calculation procedure is presented in Section 3.4 with further refinements for rail joints, wheel screech on curves, presence of bridgework, switching frogs and helper engines.

The accuracy of the above described synthesis technique is illustrated in Table 3.3-1 which presents SENEL values calculated from actual passby time histories compared to those resulting from this method. The overall accuracy is relatively good ( $\pm 3$  dB) except at distances of 700 feet or greater.

### 3.3.3

#### Community Noise Equivalent Level (CNEL)

The final factors which must be considered in the development of a suitable community noise contouring technique are the frequency of occurrence of the intrusive noise events and the time of their occurrence during the 24-hour day.

The appropriate rating scale for analysis of railroad line operations is the Community Noise Equivalent Level (CNEL) rating technique currently used by the California State Department of Aeronautics for assessment of aircraft noise around the state's major airports. The CNEL scale is based upon A-weighted time integrated measures of discrete single events (SENELs) and weights their effective impact upon human activity by their time of occurrence. This technique divides the 24-hour day into three time zones, as listed on page 3-21.

Table 3.3-1

Comparison of Predicted SENELs for Train Passbys with Measured Values					
Train Length ft	Speed mph	Grade Condition	Distance from Track ft	SENEL Predicted dB	SENEL Measured dB
3827	28	Up	100	103.9	103.3
3300	24	Down	100	99.1	97.5
4484	32	Down	100	100.6	101.0
3450	43	Level	100	102.7	104.1
3800	51	Level	100	102.8	105.5
3916	32	Level	100	102.9	104.3
3400	28	Level	100	102.9	100.1
4000	39	Level	100	103.0	102.5
4131	32	Level	100	103.1	103.1
1440	40	Up	100	102.4	104.0
3700	27	Up	100	103.9	106.3
2900	53	Level	100	102.1	101.0
5100	16	Down	100	100.0	103.0
2434	71	Level	100	101.5	104.1
4042	60	Level	100	102.8	106.8
4729	63	Level	100	103.3	106.8
5709	67	Level	100	103.9	104.6
3200	49	Up	100	103.2	104.8
4600	58	Down	100	101.7	105.9
5900	55	Down	100	102.3	104.1
2300	56	Up	100	102.6	104.0
5642	52	Up	100	104.2	104.1
5926	56	Up	100	104.5	102.8
1700	56	Down	100	97.7	98.2

Table 3.3-1 (Continued)

Train Length ft	Speed mph	Grade Condition	Distance from Track ft	SENEL Predicted dB	SENEL Measured dB
6448	36	Level	100	104.0	105.2
1052	25	Level	100	102.1	100.6
4679	29	Level	100	103.8	102.3
4488	36	Level	100	103.1	101.4
4100	19	Down	100	99.5	101.5
4700	20	Up	100	104.4	106.1
*5507	11	Up	100	107.5	110.2
3200	27	Down	100	99.2	102.0
5400	28	Down	114	98.4	100.1
2900	26	Down	114	99.1	99.1
4100	28	Down	114	100.0	99.8
4000	24	Up	100	104.2	106.0
4100	25	Level	100	103.2	101.5
4700	45	Level	114	103.3	101.7
3700	53	Level	114	102.8	100.9
4100	21	Level	100	103.2	104.4
4000	58	Level	114	103.0	105.9
5100	27	Level	100	103.4	106.3
3400	55	Level	114	103.1	102.3
4600	58	Down	300	93.9	100.8
5900	55	Down	300	94.6	98.7
5926	56	Up	300	97.5	98.2
2300	56	Up	300	96.0	98.9
1700	56	Down	300	90.1	89.2
5642	52	Up	300	97.3	96.9

Table 3.3-1 (Continued)

Train Length ft	Speed mph	Grade Condition	Distance from Track ft	SENEL Predicted dB	SENEL Measured dB
3200	49	Up	300	96.6	99.4
4600	58	Down	500	89.5	93.5
5900	55	Down	500	90.2	90.0
5926	56	Up	500	93.9	94.0
2300	56	Up	500	92.6	92.3
3800	51	Level	600	89.7	94.2
4600	58	Down	700	86.4	86.2
5900	55	Down	700	87.2	80.1
5926	56	Up	700	91.4	83.3
2300	56	Up	700	90.4	76.1
1700	56	Down	700	82.8	77.9
5642	52	Up	700	91.3	84.3
1700	56	Down	900	80.7	74.8
5642	52	Up	900	89.6	82.5
2434	71	Level	1000	84.2	70.4
4042	60	Level	1000	85.4	75.8
4729	63	Level	1000	85.7	78.5
5709	67	Level	1000	86.1	76.7
4225	60	Level	1000	85.8	72.8
**3400	25	Down	160	88.4	89.4

\*Includes upgrade helper engine correction

\*\*Train passes through cut illustrated in Figure 3.2-25 (barrier taken as 15 feet high, 60 feet from track)

Day	7:00 AM - 7:00 PM
Evening	7:00 PM - 10:00 PM
Night	10:00 PM - 7:00 AM

The number of operations in each of the three time periods - day, evening, night - are termed, respectively:  $N_D$ ,  $N_E$ ,  $N_N$ . The effective or equivalent number of operations,  $(N)$ , is calculated by the following expression:

$$N = N_D + 3N_E + 10 N_N \quad (3-5)$$

Thus, as defined in Equation (3-5), the CNEL technique essentially weights the degree of annoyance created by operations in the evening period as being three times as significant as the same operation during the day and, similarly, nighttime occurrences as being 10 times as significant as the same operations during the day.

The composite CNEL value resulting from  $N$  railroad line operations may be predicted by the following formula:

$$CNEL = \overline{SENEL} = 10 \log N - 49.4 \quad (3-6)$$

where

$\overline{SENEL}$  = the average SENEL (Single Event Noise Exposure Level) for a particular type of single event.

The constant -49.4 is equal to  $10 \log (3600 \times 24)$ , which normalizes the integrated noise exposure to one second.

For computing day - night average level ( $L_{dn}$ ), the equivalent number of operations ( $N$ ) is computed by  $N = N_D + N_E + 10 N_N$  instead of by Equation 3-5.  $L_{dn}$  is then found from Equation 3-6 substituting  $L_{dn}$  for CNEL.

To apply the CNEL rating technique to a segment of railroad line, one must first develop certain information which may be used to describe a typical traffic mix operating over the line in question. As has been discussed in Section 3.2, up or downgrade operation plays a significant role in the noise generated by locomotives; hence, a first step in mix description is the breakout of traffic traveling in either direction over the line. Even in the situation where a level ( $\pm 0.75$  percent grade) segment of track is being analyzed, this directional distinction is a useful tool in development of a suitable mix.

To provide the required traffic mix data, it will be necessary to obtain a reasonably accurate measure of what may be considered normal activity over an entire 24-hour day, and in so doing, define the operations of a "typical day". Cyclical behavior throughout a normal week should be weighted so as to select a typical day for operations data which would represent the mean level of activity throughout the week. In addition, if there are significant variations in line activity with the various seasons of the year (say, for example, particularly high usage during harvest months in a primarily agricultural zone and relatively low level of activity during other times of the year), the total number of daily operations should ideally consist of the total activity for the year divided by 365. (If desired, the daily activity for a peak traffic period might be used to define the "worst case" environment.)

The next order of significance in mix formulation is the assignment of representative train speeds on both directions over the segment in question and, further, selection of typical train lengths over these routes.

It becomes immediately apparent that on any segment of line with a significant volume of operations, this task could get extremely complicated. To a first approximation, the average length in train in either direction should be selected as the arithmetic mean of the actual operations considered over a typical day.\* Furthermore, it is suggested that the permissible speed over the segment of tract in question, as defined in the various railroad company's time tables, be conditionally used for computational purposes. Clearly, a predominance of heavy or light freight traffic will influence this average speed, as will the presence of up or downgrade conditions. Therefore, a more appropriate specification of average or typical speed in either direction should be left to the discretion of the railroad official with a working knowledge of actual operations over this segment. Wherever possible, it would be highly desirable to achieve further refinement by further subdivision of the mix into, say, two or three length/speed categories for the traffic in both directions.

Hence, the worksheet for CNEL calculations included herein has space for three classifications in each direction of travel; however, the extent of the coverage in this presentation will be limited to one generalized mix in each direction.

Now, given the basic traffic mix data in terms of numbers of operations of trains of an average length,  $L$ , at selected velocity,  $V$ , one may proceed with the calculation of representative CNEL values for each train type category.

---

\* A computerized analysis of operations comprising a typical day's traffic mix could be used to refine this value.



## 3.4

Computational Procedure for CNEL Determination

For each train type category, we wish to calculate the composite SENEL at certain predefined distances due to summation of the individual contributions of the locomotives and the cars. The column numbers of the CNEL work sheet, Figure 3.4-1, are keyed to the following itemized steps required to obtain the SENEL values at these distances. Two additional spaces are provided for consideration of other specific distances from the track which may be of special interest.

The information required for each train type category is:

1. Typical train speed; V (mph)
2. Typical train length; L (feet)
3. Grade condition in either direction (percent up or down)
4. Distance from the track of any shielding barrier (wall, hill, depressed right-of-way, etc.) and the relative height of the barrier above the track. (As has been discussed previously, a depressed right-of-way or cut will be treated the same as a barrier, while an elevated right-of-way of nominal elevation [ less than 50 feet ] has been shown to have little influence on noise levels measured at distances greater than about 200 feet from the tracks.)

The stepwise procedure for CNEL calculation follows:

Step 1 Determine duration of train pass-by,  $t$ , in seconds, for each train type category.

Given: L; typical train length in feet

V; typical velocity in mph

$$t = 0.68 \times \frac{L \text{ (feet)}}{V \text{ (mph)}}, \text{ seconds}$$

Enter this value(s) in Column 1.

Step 2 Determine C2 duration term.

Given:  $t$  in seconds as found in Step 1.

C2 may be calculated via the expression:

$C2 = 10 \log_{10} t$ , or may be determined graphically in Figure 3.4-3 as follows:

Enter at value corresponding to  $t$  on horizontal scale and read down until intersect with diagonal line.

Read C2 on vertical scale directly left of intersection.

Enter this value(s) in Column 2.

Step 3 Determine C1, Typical A-Weighted Sound Pressure Level of Freight Cars at 100 feet.

Given:  $V$ ; speed of train for each type category.

Enter horizontal scale of Figure 3.4-2 at velocity corresponding to  $V$  and read up until intersect with diagonal line. Read C1 on vertical scale directly left of intersection.

Enter this value(s) in Column 3.

Step 4 Determine distance attenuation factor,  $\alpha$ , for car-generated noise.

$\alpha$  represents the decrease in SENEL as the observer moves away from the track along a line perpendicular to the track.

The combined influence of spreading loss, air and ground absorption, and increased duration of the event at the observers position are considered.

Given: Distances from track of 200, 400 and 800 feet plus two optional distances as specified by the investigator.

Determine  $\alpha$  for each distance by entering Figure 3.4-4 at the value along the horizontal axis corresponding to the desired distance and read up until an intersect is achieved with the appropriate curve. Read the value of  $\alpha$  on the vertical scale directly left of the intersection.

Record the values of  $\alpha$  at each of the distances specified under each train type category in Column 4.

Step 5 Determine attenuation due to barrier shielding,  $\alpha_{bc}$ , IF APPLICABLE.

Given: The relative height of barrier above track and the distance of track from barrier (consider this distance corresponding to highest point of barrier).

Figure 3.4-5 provides an approximate barrier attenuation factor for distances greater than 200 feet from the track. (To assess barrier effectiveness at closer distances, the more rigorous procedure outlined in Appendix D, Reference 6, must be followed.)

Enter Figure 3.4-5 at the value along the horizontal axis which corresponds to the relative height of the barrier above the tracks. Read up until intersect is achieved with curve corresponding to approximate distance of barrier to tracks. Read the value of  $\alpha_{bc}$  on the vertical scale directly left of the intersection. The value of  $\alpha_{bc}$

so obtained is assumed to hold at all distances greater than 200 feet from the track (a practical maximum barrier attenuation of 24 dB is assumed).

Enter the value of  $\alpha_{bc}$  so obtained in all spaces provided in Column 5.

Step 6 Determine C3, car noise adjustment factor.

From the table below, select the appropriate car noise adjustment factor corresponding to the physical characteristics of the track segment under investigation and enter it in Column 6 (in the cases of crossings, frogs and bridgework, these factors are assumed influential only at discrete locations; for tight radius bends, the factor is assumed to apply over the curved portion of the track).

TRACK CHARACTERISTIC	C3
1. Mainline welded or jointed track	0
2. Low speed classified jointed track	8
3. Presence of switching frogs or grade crossing	8
4. Tight radius curve	
a. radius less than 600 feet	8 *
b. radius 600 to 900 feet	2 *
c. radius greater than 900 feet	0
5. Presence of bridgework	
a. light steel trestle	20
b. heavy steel trestle	10
c. concrete structure	0

\* Interpolate between values for additional refinement.

Note: In case of simultaneous occurrence of these factors, the single largest correction is to be applied.

Step 7 Calculate SENEL of cars alone at distances specified.

For each train type category at distances of 100, 200, 400, 800 feet and the two optional distance specifications, the car contribution to the total SENEL is found as follows:

$$\text{SENEL}_{\text{car}} = C1 + C2 + C3 - \alpha - \alpha_{bc}$$

Enter the calculated values in Column 7.

Step 8 Determine C4, Locomotive SENEL contribution at 100 foot reference distance from track.

Given: V; typical train speed in mph for each train type category under consideration.

Utilize the appropriate curve from Figure 3.4-6.

<u>Grade Condition</u>	<u>Curve Number</u>
Level (within $\pm 0.75\%$ )	a
Upgrade (greater than $+0.75\%$ )	b
Downgrade (greater than $-0.75\%$ )	c

Determine C4 by entering the figure appropriate for each train type category at the value along the horizontal axis corresponding to the typical velocity, V. Read up to intersect with curve. Read C4 ( $\text{SENEL}_{\text{engine}}$ ) on vertical scale directly left of intersection.

Enter values of C4 so determined in Column 8.

Step 9 Determine distance attenuation factor  $\alpha$  for engine-generated noise levels.

At distances 200, 400, 800 feet and two optional distances, utilize Figure 3.4-4 and the identical procedure described in Step 4.

Record the values of  $\alpha$  so determined in Column 9.

Step 10 Determine attenuation due to barrier shielding,  $\alpha_{bc}$  IF APPLICABLE

Utilize the information and procedures described in Step 5 in conjunction with Figure 3.4-7 with the exception that the relative height of the barrier is now measured with respect to the locomotive exhaust outlet (assumed to be 15 feet).

Record the value of  $\alpha_{bc}$  so determined in all spaces provided in Column 10.

Step 11 Determine C5, correction for presence of helper engines on upgrade.

For each specific train type category, if typical train has helper engines and is traveling upgrade,  $C5 = 3$ .

For all level or downgrade operations,  $C5 = 0$ .

Enter values of C5 in Column 11.

Step 12 Calculate SENEL of locomotives alone at distances specified.

For each train type category at distances of 100, 200, 400 and 800 feet and the two optional distance specifications, the locomotive contribution to the total SENEL is found as follows:

$$\text{SENEL}_{\text{engine}} = C4 + C5 - \alpha - \alpha_{bc}$$

Enter the calculated values in Column 12.

Step 13 Determine total SENEL of train by logarithmic summation of engine and car contributions.

For each train type category and at each distance specified, the  $SENEL_{train}$  may be calculated by the summation of the locomotive and car components listed in Columns 12 and 7, respectively.

The Decibel Addition Table (Table 3.4-1) is required for this operation:

- (a) Determine the difference between the two values to be added and find the value nearest this under the heading termed "Difference".
- (b) Read the value adjacent to this under the heading termed "Increment".
- (c) The  $SENEL_{train}$ , in dB, is now equal to the larger of the two values being summed plus the increment determined in step (b).

The  $SENEL_{train}$  values so determined should be recorded in Column 13.

Step 14 Resolution of traffic mix for each train category type into equivalent number of daily operations.

The equivalent number of daily operations has been described by Equation (3-6) as

$$N = N_d + 3 N_e + 10 N_n$$

Table 3.4-1  
Decibel Addition Table

Difference ( $\Delta$ )	Increment (Inc.)	Difference ( $\Delta$ )	Increment (Inc.)
0	3.00	5.00	1.19
.20	2.91	5.50	1.08
.40	2.81	6.00	.97
.60	2.72	6.50	.88
.80	2.63	7.00	.79
1.00	2.54	7.50	.71
1.20	2.45	8.00	.64
1.40	2.37	8.50	.57
1.60	2.28	9.00	.51
1.80	2.20	9.50	.46
2.00	2.12	10.00	.41
2.20	2.05	11.00	.33
2.40	1.97	12.00	.27
2.60	1.90	13.00	.21
2.80	1.83	14.00	.17
3.00	1.76	15.00	.14
3.50	1.60	20.00	.04
4.00	1.46		
4.50	1.32		

Instructions for Usage:

Determine the difference ( $\Delta$ ) between each set of two levels to be added. Add the corresponding increment (Inc.) to the larger of the two levels.

Example 1. 79 }  $\Delta = 2$  dB; Inc = 2.12; Sum = 81 + 2.12 = 83.1 dB  
81 }

Example 2. 62 }  $\Delta = 2$ , Inc = 2.12  
64 } Sum = 66.1  
67 }  $\Delta = .88$ , Inc = 2.6  
69 } Sum = 69.6  
 $\Delta = .6$   
Inc = 2.72  
Sum = 72.3

Total: 72.3 dB



The number of operations for each type category in each time period, as determined for the "typical day's" operations should be inserted in the spaces provided in Figure 3.4- 8. Equivalent Operations Worksheet, and then worked through. The resulting N's for each type category (1 through 6) should then be logged in Column 14.

Step 15 Determine CNEL contributions of each train type category as per Equation (3-7) at each distance specified.

$$\text{CNEL} = \overline{\text{SENEL}} + 10 \log_{10} N - 49.4 \quad (3-7)$$

Given an average SENEL and its corresponding number of equivalent operations, N, the above formula may be utilized to calculate CNEL or one may utilize Figure 3.4- 9 for a graphical solution. Insert these values in Column 15.

Step 16 Determination of total CNEL for traffic mix containing up to  
through six train type categories at distances specified.

Step 21 The Decibel Addition Table (Table 3.4-1) will again be utilized for summation of up to six contributing CNEL components at each distance specified.

The procedure is as follows:

1. Arrange the 2-6 numbers to be added in a column.
2. Take the difference of the first two numbers and find the value nearest this amount under the heading "Difference".
3. Read directly left under the column entitled "Increment" and add this value to the larger of the first two values.

4. Now compare this new value with the third value in the column, take the difference, and again find the value nearest this amount under the heading "Difference".
5. Proceed on down the column in a like manner.
6. The resultant value is to be inserted under the appropriate distance in Columns 16 through 21.

(An example of this procedure is illustrated in Figure 3.4-1).

Step 22 Graphical method for determination of distance from track to specific CNEL contours.

Procedure:

1. Plot the CNEL values listed in Columns 16 through 21 at the distances specified in each column on semi-logarithmic graph paper as illustrated in Figure 3.4-10.
2. Draw a best-fit curve through the 4 to 6 points so plotted.
3. The desired CNEL contour may now be located by entering the curve at the value on the vertical axis which corresponds to the contour of interest.

Draw a straight line across the graph paper until it intersects the "best-fit" curve. Read the distance to this contour on the horizontal axis directly below the point of intersection.

A discussion of community response as might be related to noise from railroad operations expressed in terms of CNEL is presented in Appendix J.

An example utilizing this technique follows in Section 3.5.

### 3.5 Example Application of CNEL Rating Technique for Line Operations

It is desired to know the CNEL contour locations at a given section of track. Grade conditions at this location are +2.2% upgrade to the east and -2.2% to the west. The typical speed of eastbound trains is 35 mph and westbound trains typically travel at 28 mph. The mean length of eastbound trains is known to be 3600 feet and the mean length of westbound trains is 2760 feet. The eastbound day-evening-night spread is: 7:00 am - 7:00 pm, 12 trains; 7:00 pm - 10:00 pm, 2 trains; 10:00 pm - 7:00 am, 8 trains. The westbound day-evening-night spread is: 7:00 am - 7:00 pm, 7 trains; 7:00 pm - 10:00 pm, 5 trains; 10:00 pm - 7:00 am, 12 trains. At this location, no barriers are present, the rail is welded, no bridgework, no frogs or grade crossings, and no helper engines are used.

For this example, calculations for eastbound trains are listed in Category 1 and westbound trains in Category 2. (Values listed on Figure 3.5-1.)

Step	Category 1 (eastbound)	Category 2 (westbound)
1	Calculate Pass-by Duration, $t = 0.68 \times \frac{L \text{ (feet)}}{V \text{ (mph)}}$  $t = 0.68 \times \frac{3600}{35} = 70 \text{ seconds}$	$t = 0.68 \times \frac{2760}{28} = 67 \text{ seconds}$
2	Determine C2 (logarithmic duration term) from Figure 3.4-3. For $t = 70$ seconds $C2 = 18.5 \text{ dB}$	For $t = 67$ seconds $C2 = 18.0 \text{ dB}$
3	Determine Car SPL at 100' from Figure 3.4-2. For speed = 35 mph $C1 = 80 \text{ dB}$	For speed = 28 mph $C1 = 78.5 \text{ dB}$

Step	Category 1 (eastbound)	Category 2 (westbound)
4	Determine attenuation correction for car noise from Figure 3.4-4.	
	Distance (ft.)	$\alpha$ (dB)
	100	0
	200	4
	400	10
	800	16.5
Optional	1000	18.5
	1600	22.5

Category 2 values same as Category 1

5 No barriers present:

$$\alpha_{bc} = 0$$

$$\alpha_{bc} = 0$$

6 For welded rail, no bridgework, no frogs or grade crossings and no helper engines:

$$C3 = 0$$

$$C3 = 0$$

7 Calculate SENEL of Car Contribution.

$$SENEL_{car} = C1 + C2 + C3 - \alpha - \alpha_{bc}$$

Distance (ft.)	SENEL <sub>car</sub> (dB)	Distance (ft.)	SENEL <sub>car</sub> (dB)
100	80+18.5+0-0-0=98.5	100	78.5+18+0-0-0=96.5
200	80+18.5+0-4-0=94.5	200	78.5+18+0-4-0=92.5
400	80+18.5+0-10-0=88.5	400	78.5+18+0-10-0=86.5
800	80+18.5+0-16.5-0=82	800	78.5+18+0-16.5-0=80
1000	80+18.5+0-18.5-0=80	1000	78.5+18+0-18.5-0=78
1600	80+18.5+0-22.5-0=76	1600	78.5+18+0-22.5-0=74

8 Determine locomotive SENEL at 100' using curves b and c from Figure 3.4-6.

For speed = 35 mph, upgrade  
(Figure 3.4-6 in progress)

$$C4 = 102 \text{ dB}$$

For speed = 28 mph, downgrade  
(Figure 3.4-6 in progress)

$$C4 = 95 \text{ dB}$$



Step	Category 1 (eastbound)	Category 2 (westbound)
14	Equivalent number of daily operations: see Figure 3.4- 8.	
15	Determine CNEL contribution from Figure 3.4- 9.	
	For N = 98	For N = 142
	Distance (ft.)	Distance (ft.)
	SENEL	SENEL
	CNEL	CNEL
	100	100
	200	200
	400	400
	800	800
	1000	1000
	1600	1600
	103.6	98.82
	99.96	94.82
	95.47	89.27
	90.64	83.27
	89.51	81.54
	86.41	77.54
	73	70.5
	69	66.5
	64.5	60
	60	54.5
	58.5	53
	55.5	48

Combine east-west mix using logarithmic addition

	Distance (ft.)	CNEL
16	100	75
17	200	71
18	400	66
19	800	61
20	1000	60
21	1600	56

### 3.6 Locomotive Horns and Crossing Bells

Locomotive horns and grade crossing safety warning devices (typically warning bells) have not been included for consideration in the composite noise contours produced by railroad line operations. It is felt that regulation and control of the noise emitted by said devices, at the present time, constitutes a hazard to safety. However, a brief discussion of the noise emitted by these devices has been included for reference.

The two types of safety warning devices commonly used at grade crossings are horns attached to the locomotives and bells at the crossing. It is normal practice for a locomotive to sound its horn (usually three times) as a crossing is approached. The distance from the crossing to where the horn is sounded varies between trains, thus, a receiver along the track will not always experience the same noise level from warning horns.

Crossing bells are activated when the train is at a prescribed distance upstream from the crossing and stop immediately after the train has passed.

A typical time history of the noise levels at a grade crossing (for observer 100 feet from the track) is given in Figure 3.6-1. In this figure, the crossing bells appear well in advance of the train passage and the first horn blast is sounded roughly ten seconds before the locomotive passes.

Locomotive horns by virtue of their design are somewhat directional sources of noise as illustrated by Figure 3.6-2 in which the nominal noise level of 95 dB(A) is roughly 5 dB greater in front of the horn than to the side measured at a radius of 300 feet (Reference 7). The attenuation of noise from these horns with distance is illustrated by the curve in Figure 3.6-3. A typical frequency spectrum of a distant locomotive horn is given in Figure 3.6-4.

Crossing bell noise levels vary between different crossings and a statistical distribution of observed noise levels for several crossings is presented in Figure 3.6-5. Using the observed mean-maximum noise level (mean + 1σ) of 71 dB(A) as the reference level at 100 feet, the crossing bell noise level at any distance is predicted by

$$NL_{\text{bell}} = 71 - 20 \log \left( \frac{\text{DISTANCE (feet)}}{100 \text{ feet}} \right), \text{ dB(A)}$$

This formulation does not include air and ground attenuation but should predict conservative noise levels.



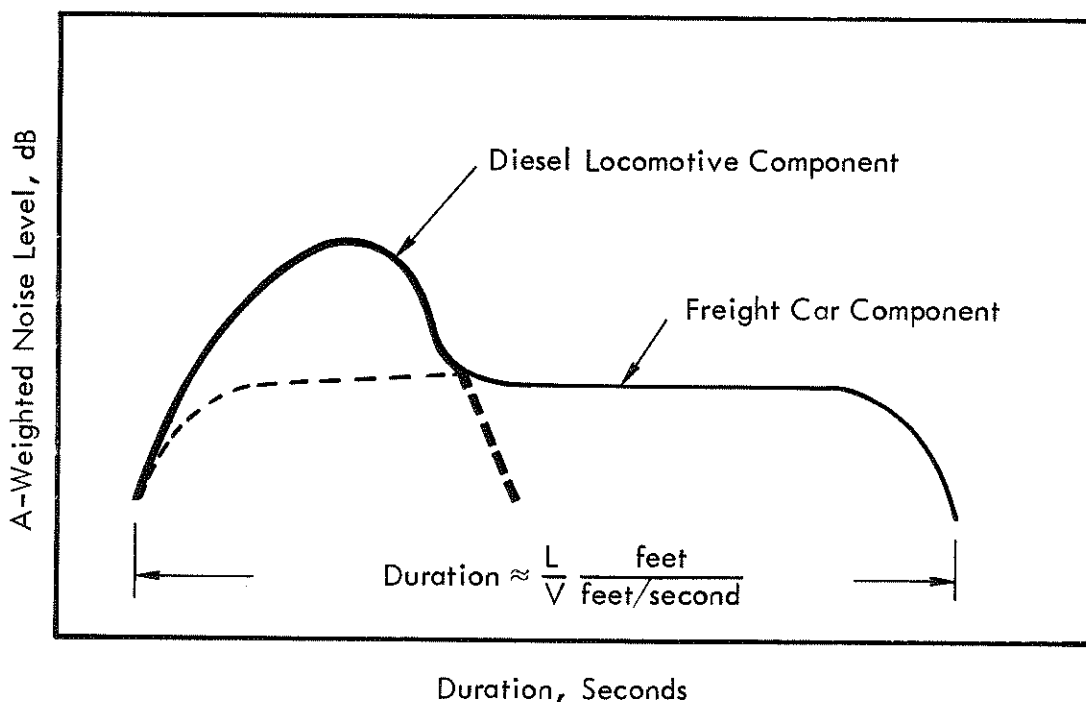


Figure 3.2-1. Idealized Time History of Train Passby Illustrating Locomotive and Freight Car Components

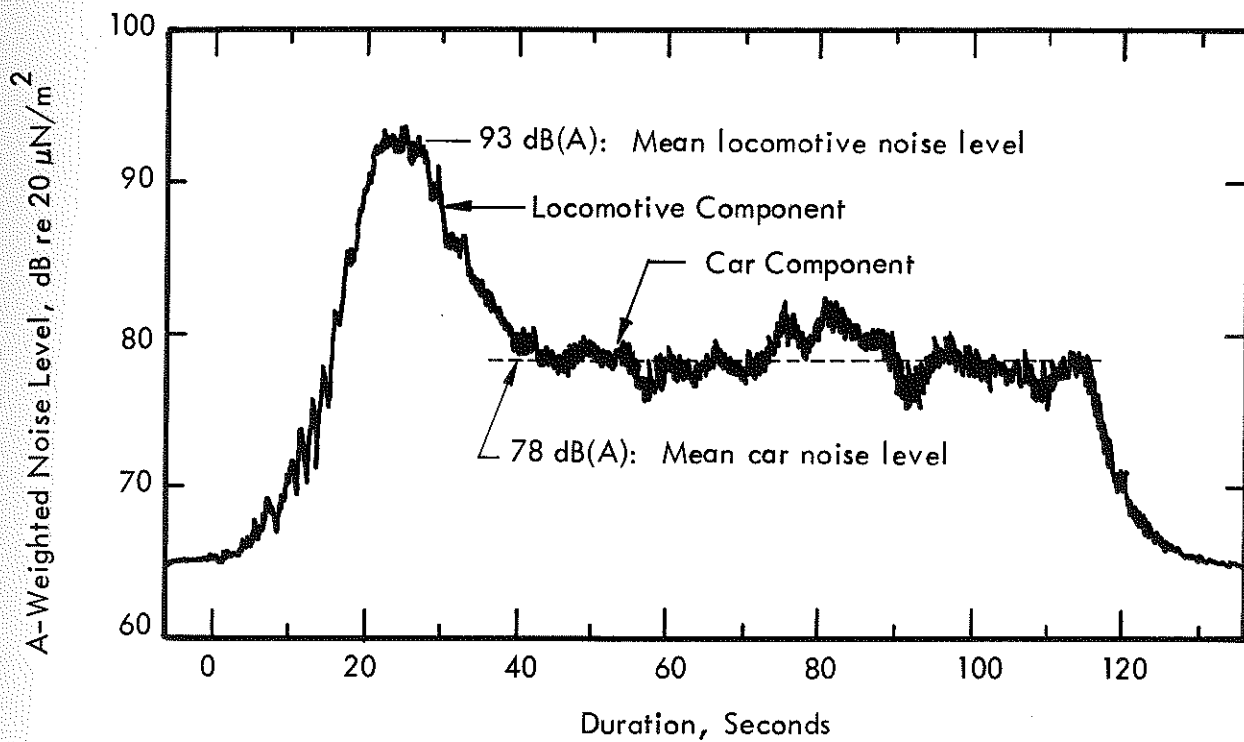


Figure 3.2-2. Typical A-Weighted Time History of a Train Pass-By (Measured at 100 Feet From Track, 32 mph at +0.6 percent grade, Tehachapi Summit).

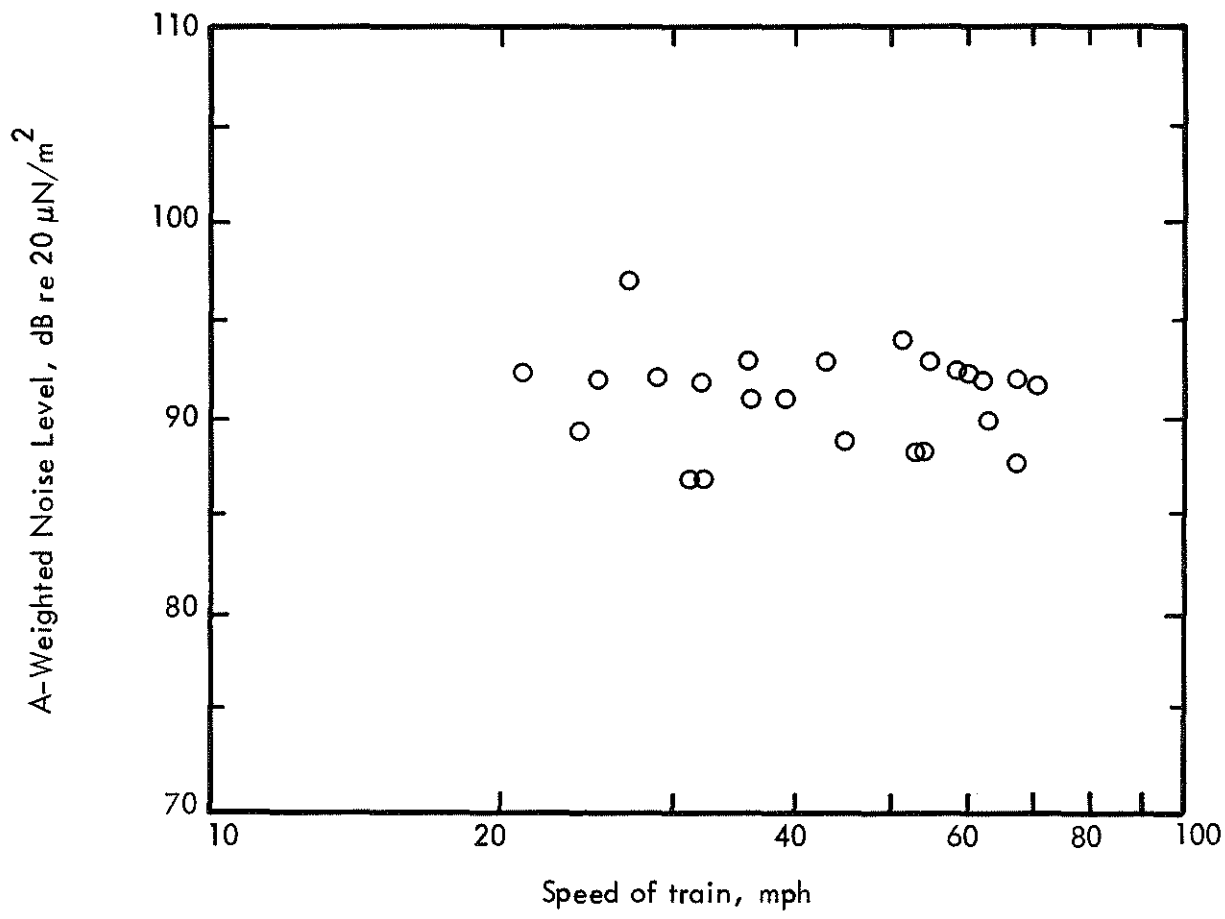


Figure 3.2-3. Noise Levels of Locomotive Traveling at Level Grade ( $\pm 0.75\%$  grade) Measured at 100 Feet Distance to Track.

A-Weighted Noise Level, dB re 20  $\mu$ N/m<sup>2</sup>

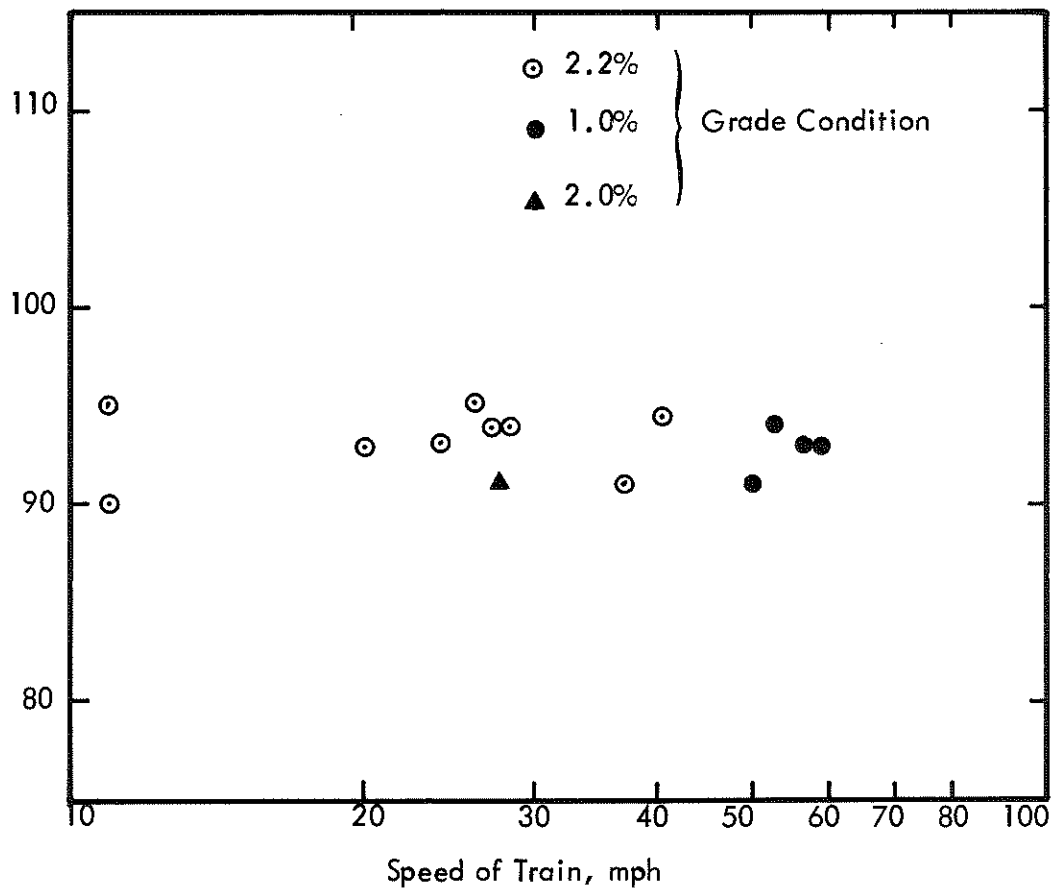


Figure 3.2-4 . Noise Level of Locomotives Traveling Upgrade (greater than +0.75% grade) Measured at 100 Feet Distance to Track.

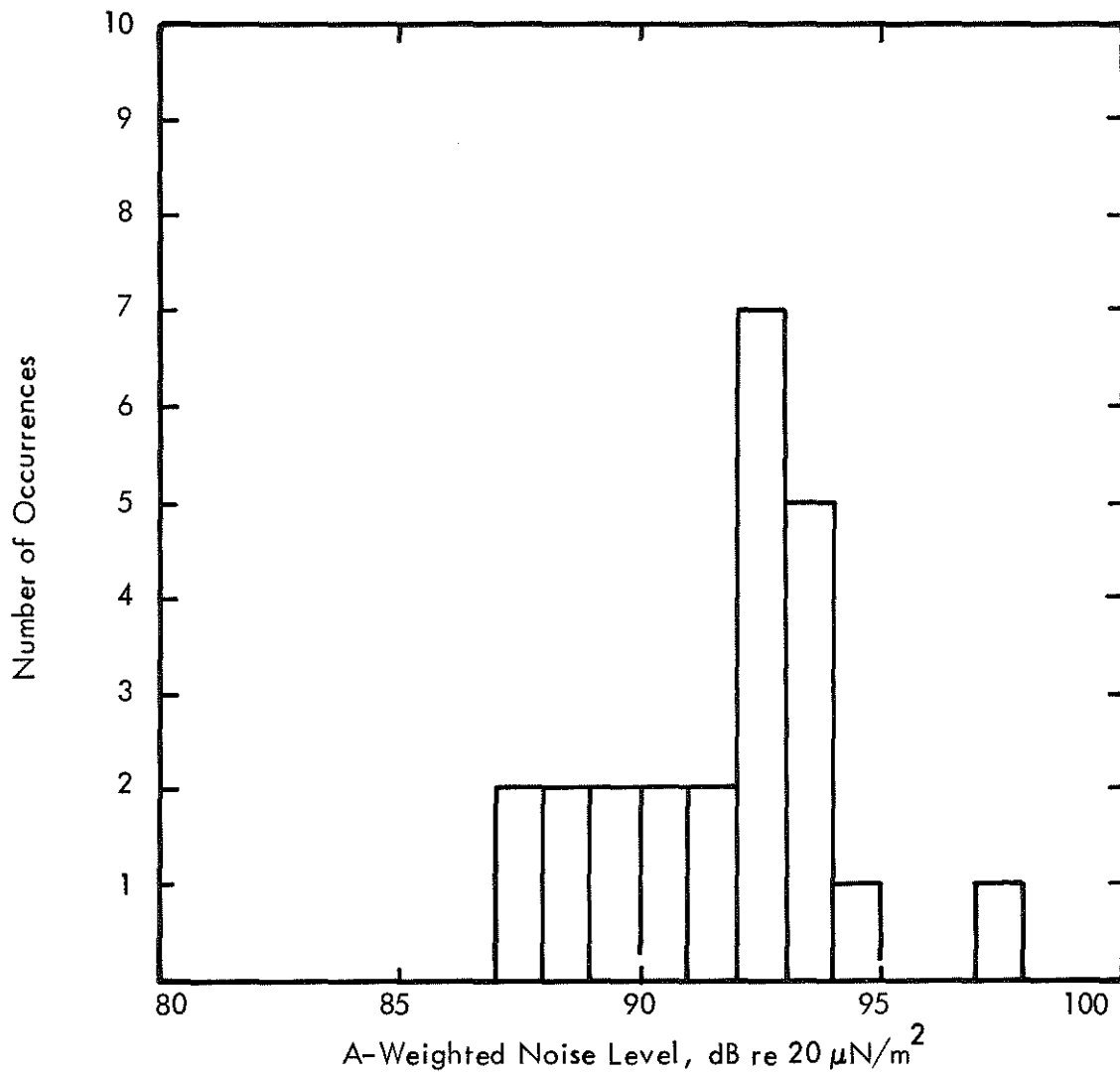


Figure 3.2-5. Distribution of Observed Locomotive Noise Levels for Level Grade ( $\pm 0.75\%$  grade) Operation. Measurements Are of Locomotives at All Speeds at Distance of 100 Feet to Track.

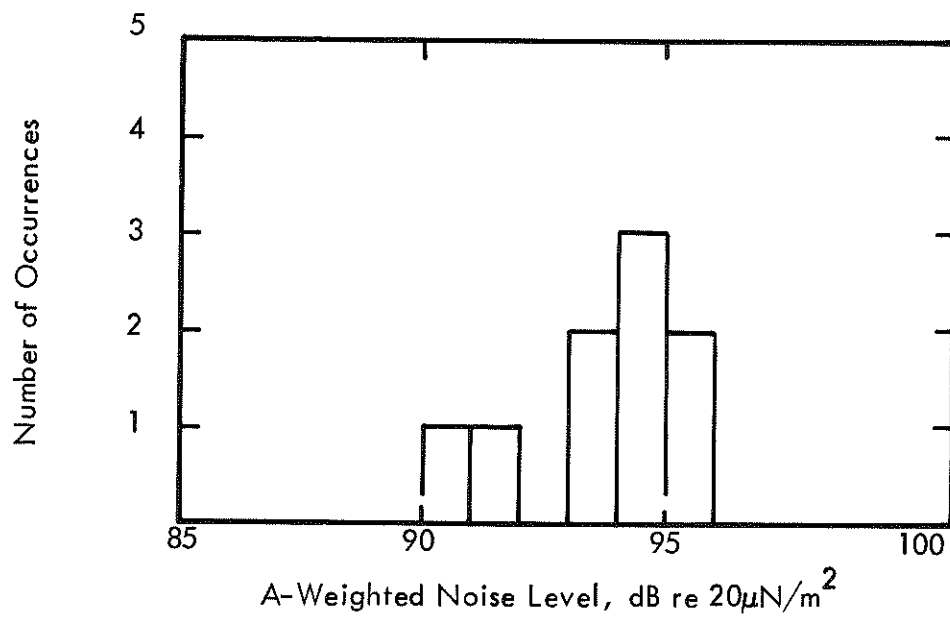


Figure 3.2-6. Distribution of Observed Locomotive Noise Levels for 2.2% Upgrade Operation. Measurements are of All Speeds at Distance of 100 Feet to Track.

A-Weighted Locomotive Noise Output in dB,  
re  $20 \mu\text{N}/\text{m}^2$  Relative to Mean Level Produced at 0% Grade

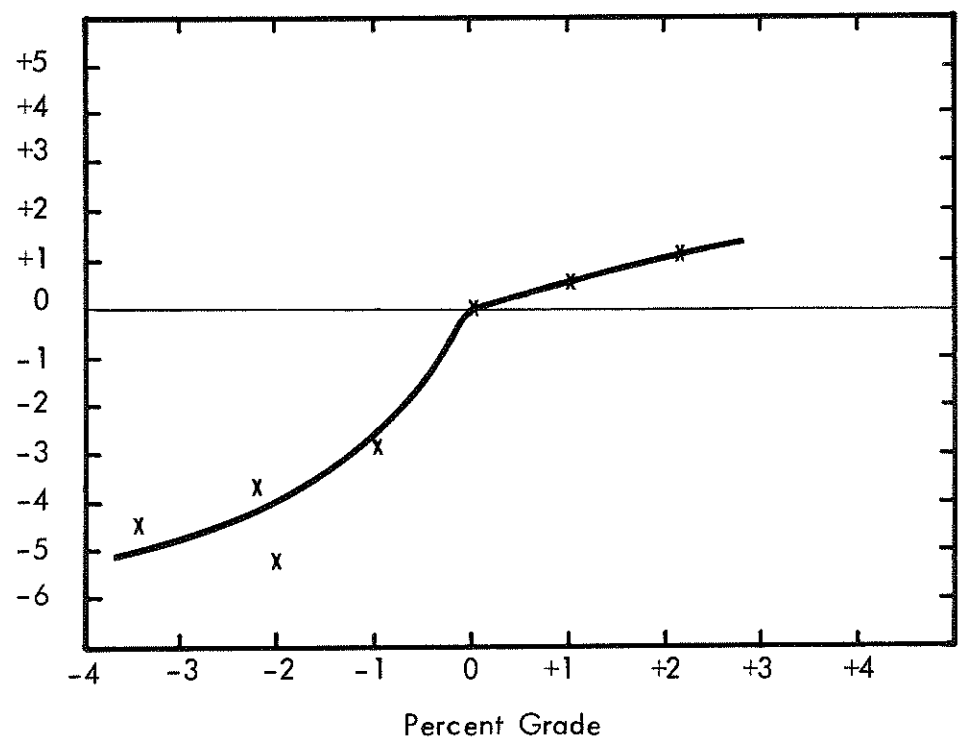


Figure 3.2-7. Illustration of Grade Dependence of Mean A-Weighted Noise Levels Produced by Locomotives.

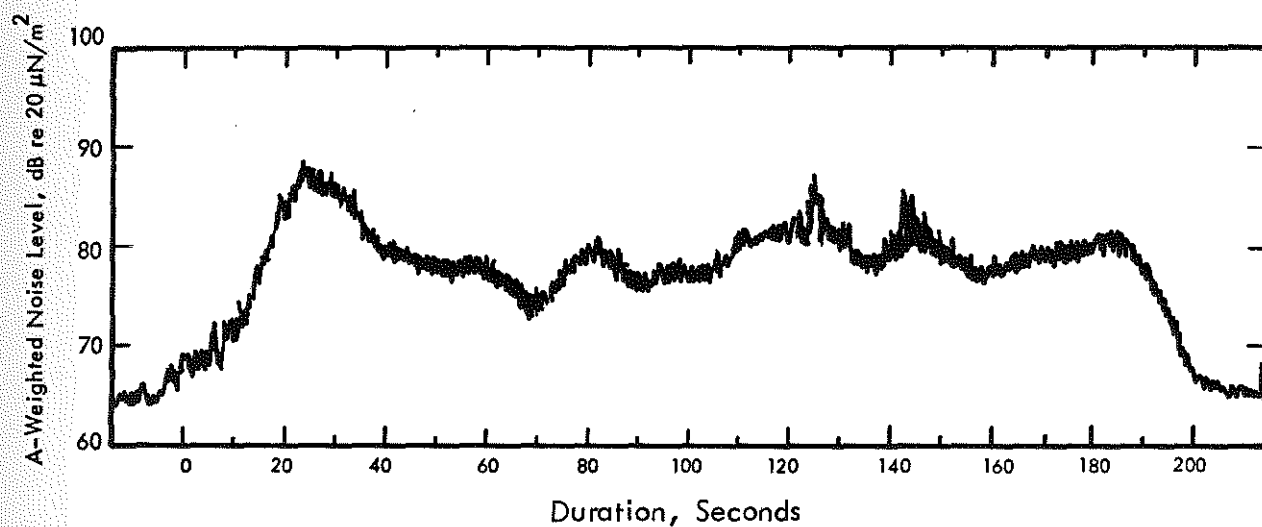


Figure 3.2-8. Time History of Train Passby Under Severe Downgrade Conditions (-3.4 Percent Grade) with Dynamic Brake System in Operation. (Measured at 100-foot Distance to Track and at 19 mph)



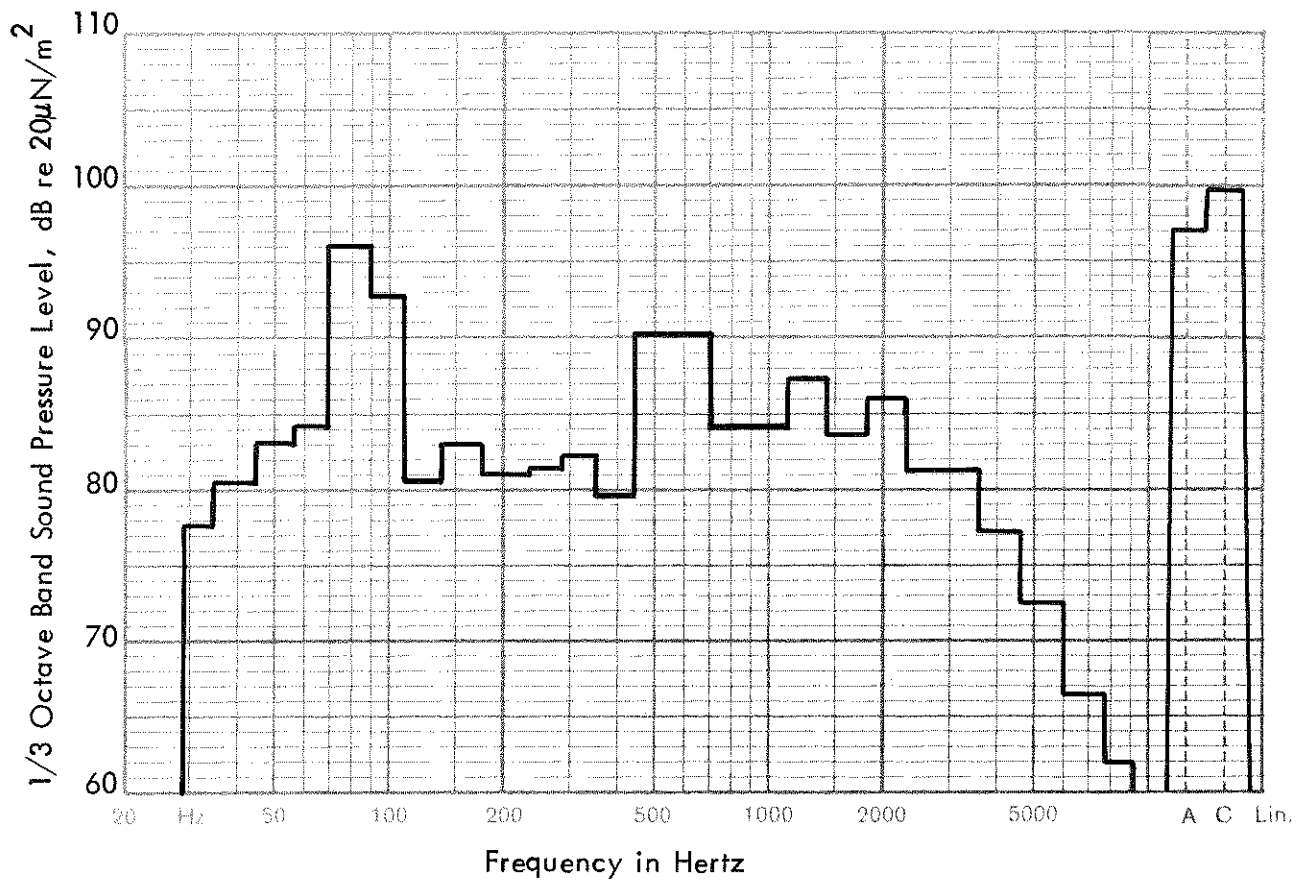


Figure 3.2-9. Spectrum of Noise Emitted by a Diesel-Electric Locomotive Operating Over Level Grade (0% Grade at 58 mph, Measurements at 50 Feet).

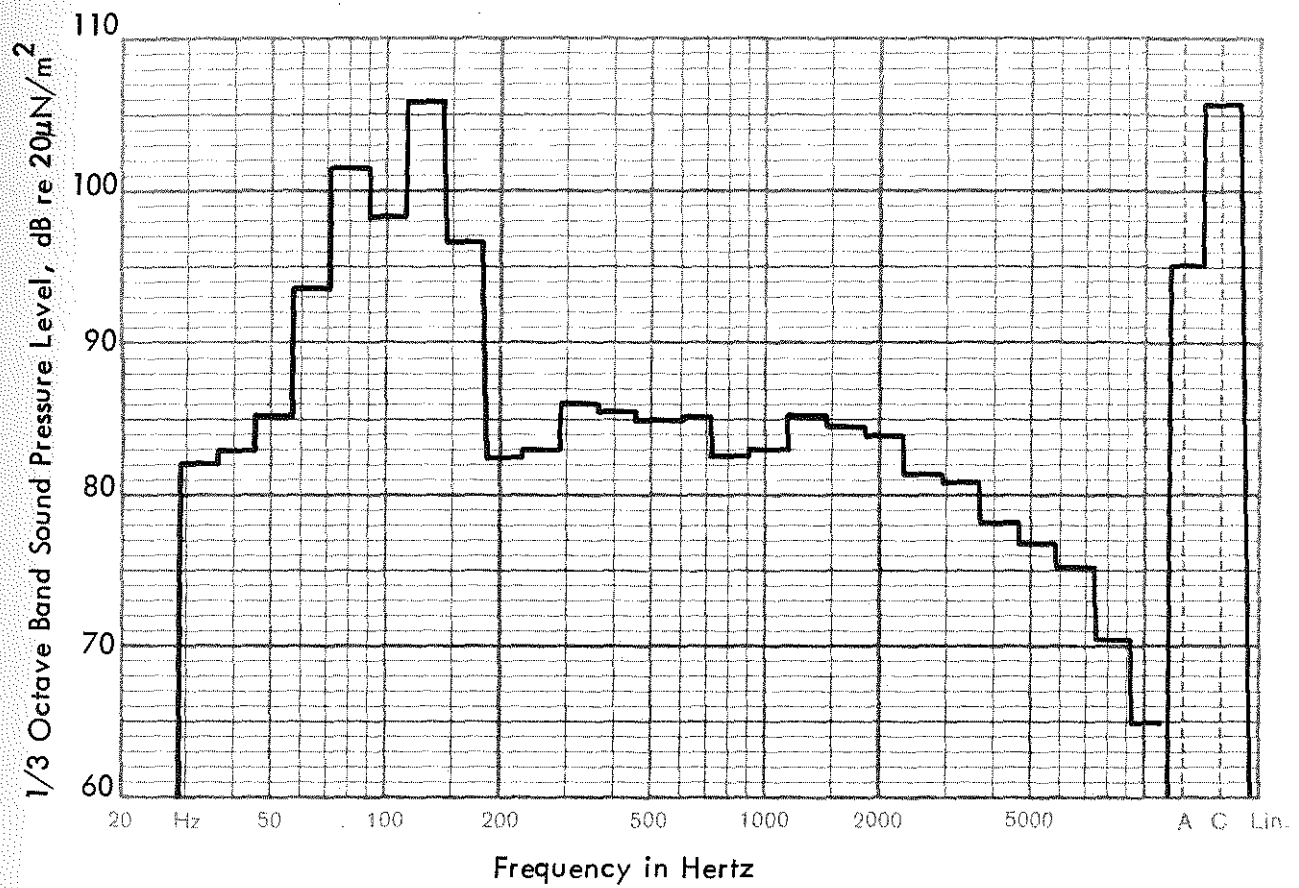


Figure 3.2-10. Spectrum of Noise Emitted by a Diesel-Electric Locomotive Under Maximum Power Conditions (Ascending 2.2% Grade at 20 mph, Measurements at 50 Feet).

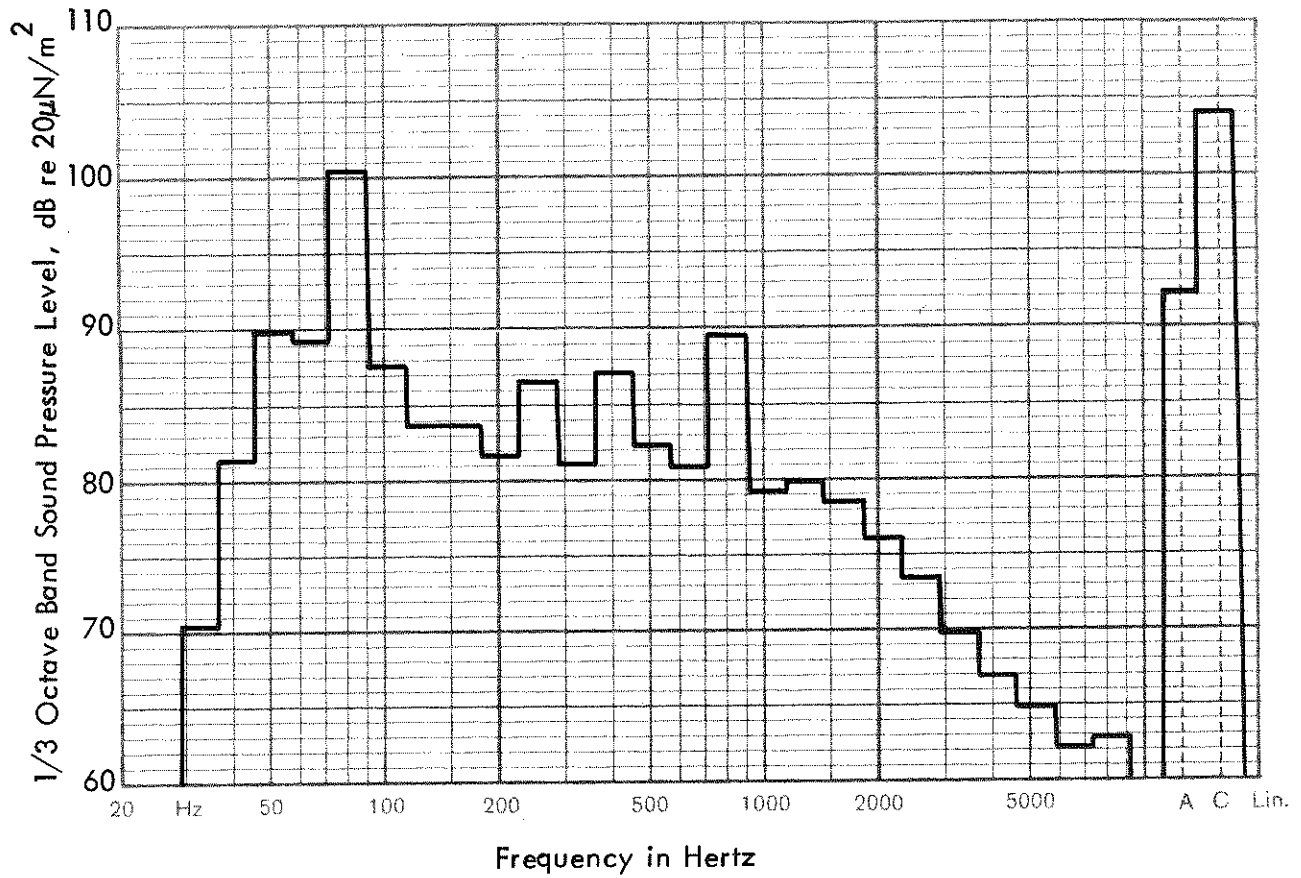


Figure 3.2-11. Spectrum of Noise Emitted by a Diesel-Electric Locomotive Operating Over Severe Downgrade with Dynamic Braking (-3.4% Grade at 19 mph, Measurements at 50 Feet).



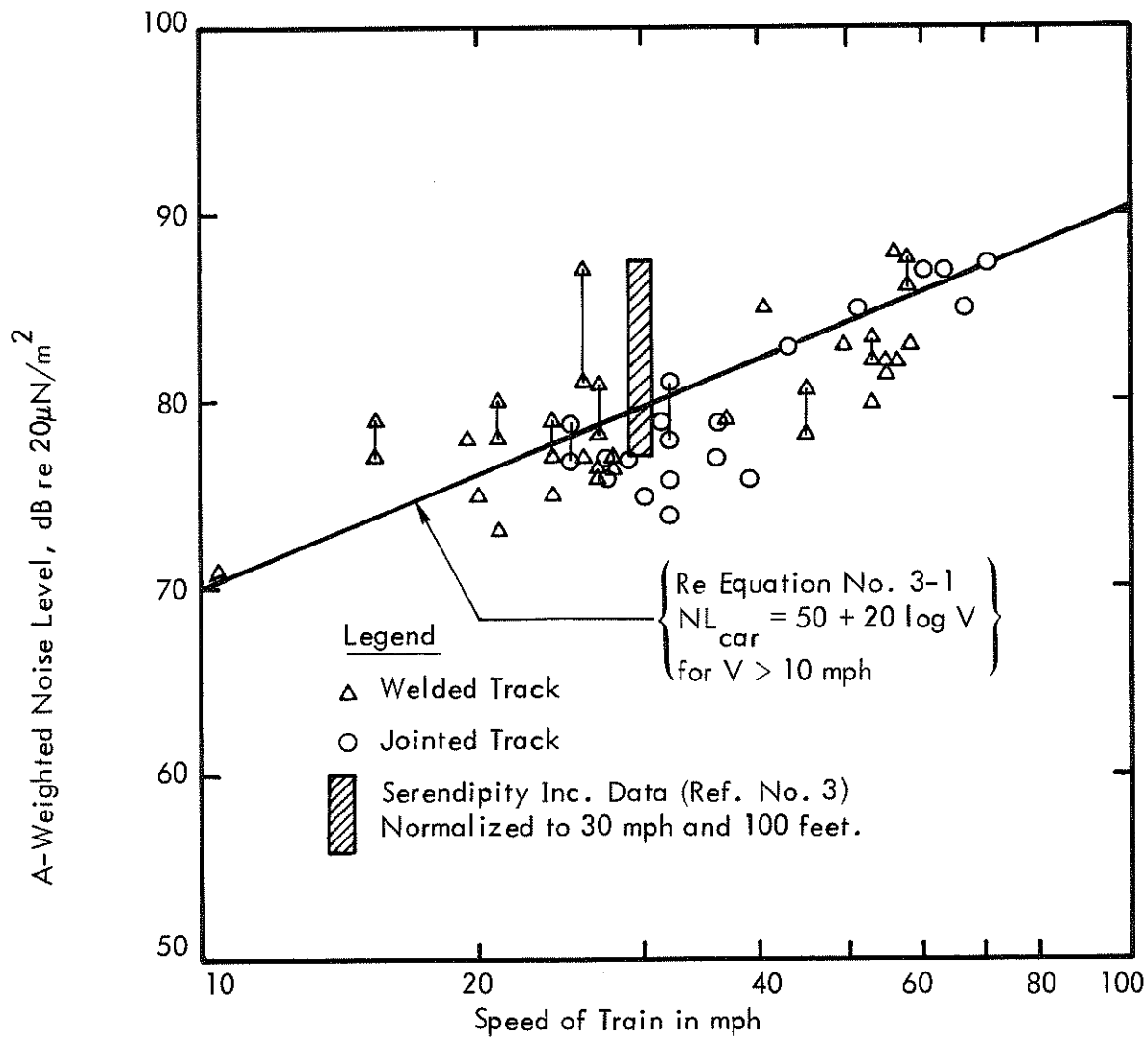
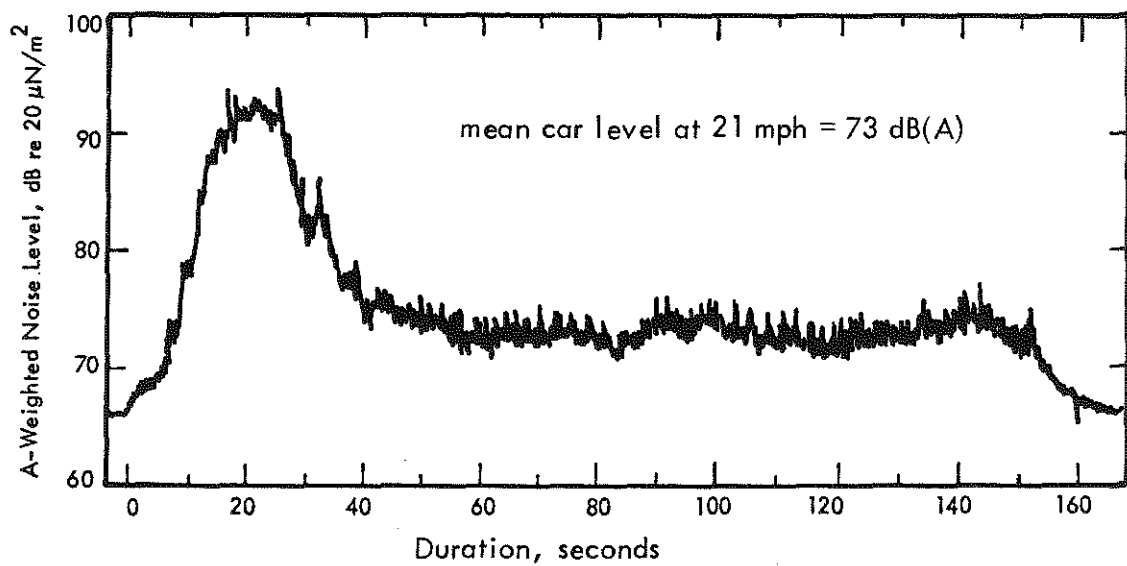
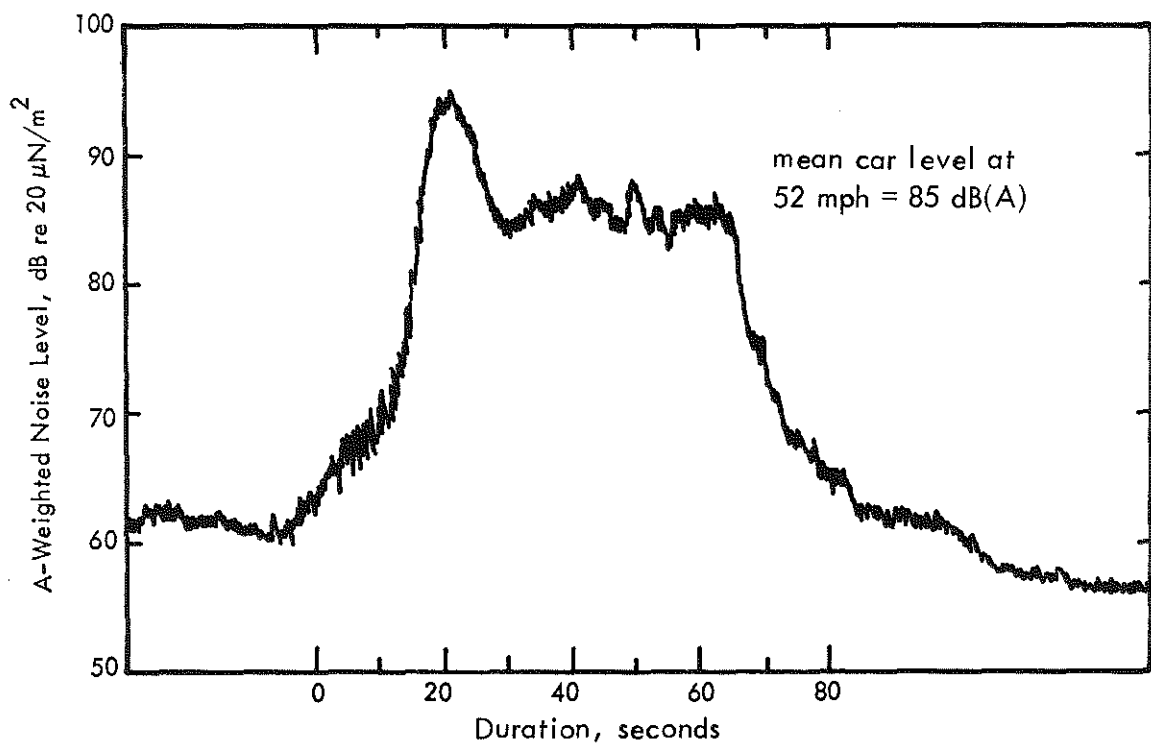


Figure 3.2-13. Measurements of Freight Car Noise Levels Over Welded and Jointed Track at 100 Feet Distance to Track.



A. Pass-by at 21 mph, Hesperia (0% grade)



B. Pass-by at 52 mph, Tehachapi Summit (+0.6% grade)

Figure 3.2-14. A-Weighted Pass-By Time Histories of Freight Trains at 21 and 52 mph Over Similar Track Conditions Illustrating the Velocity Dependence of Car-Generated Noise Levels. (measurements at 100 feet to tracks)

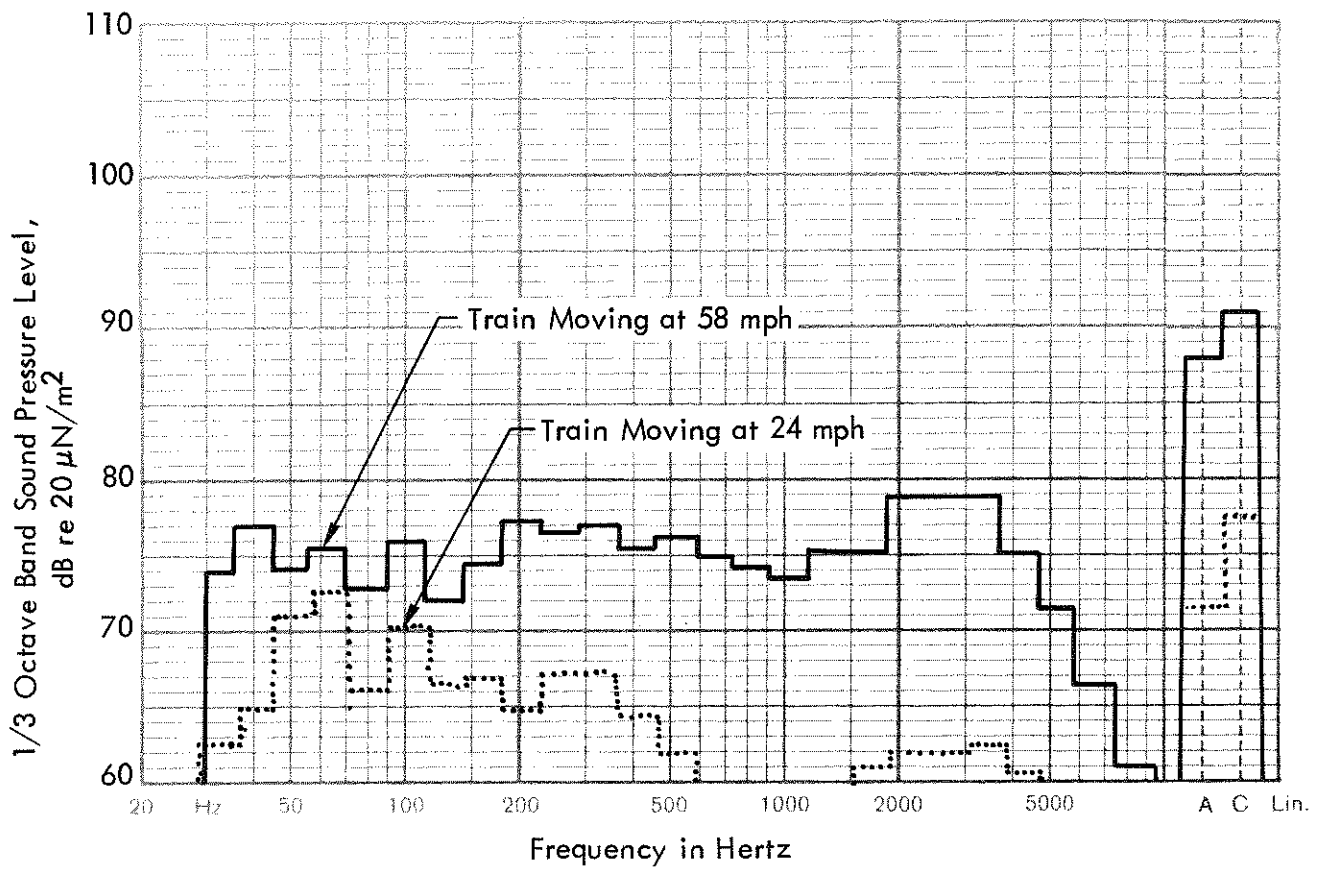


Figure 3.2-15. Comparison of Car Noise Frequency Spectra at Speeds of 58 and 24 Miles Per Hour (Measurements at 100 Foot Distance to Track)

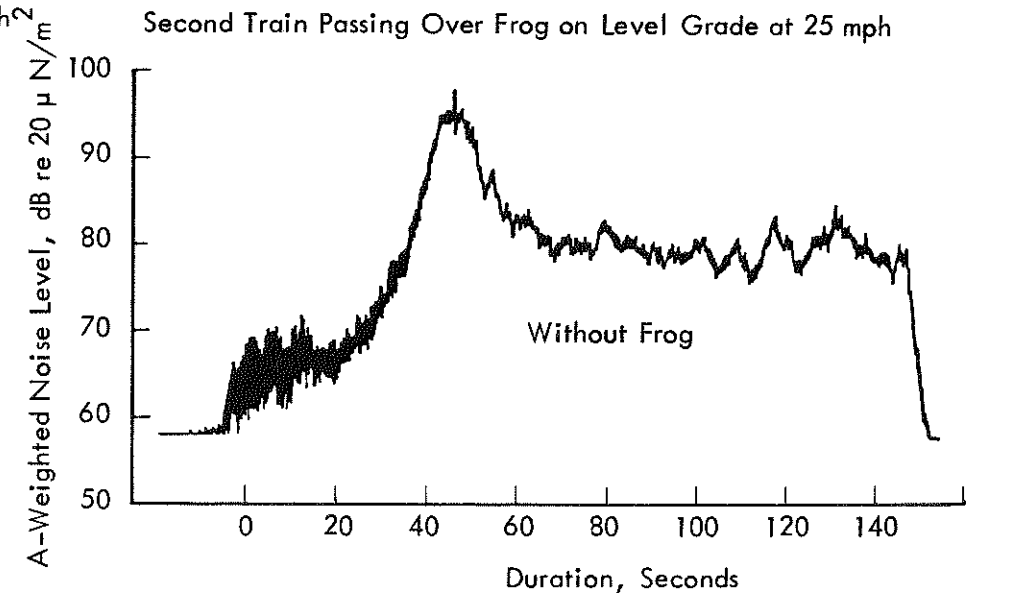
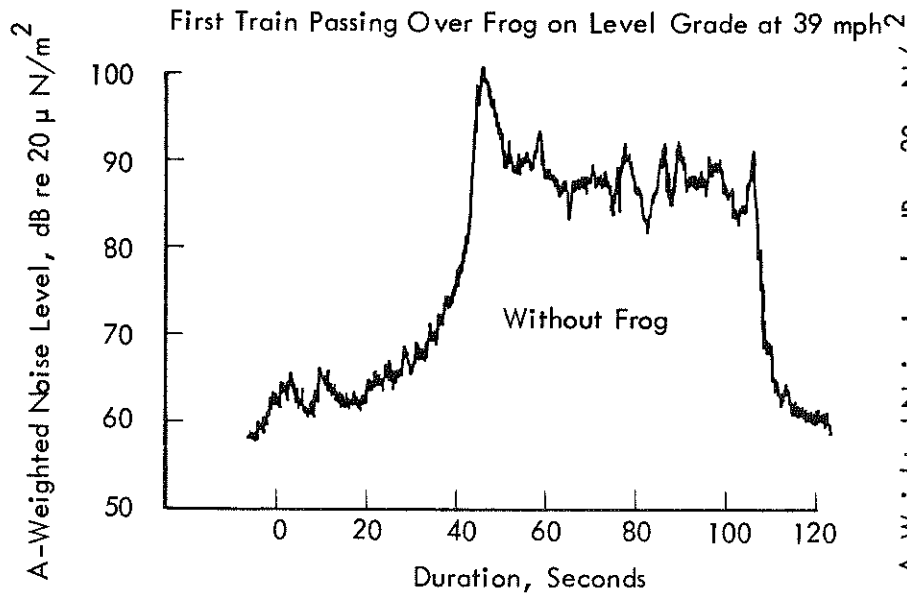
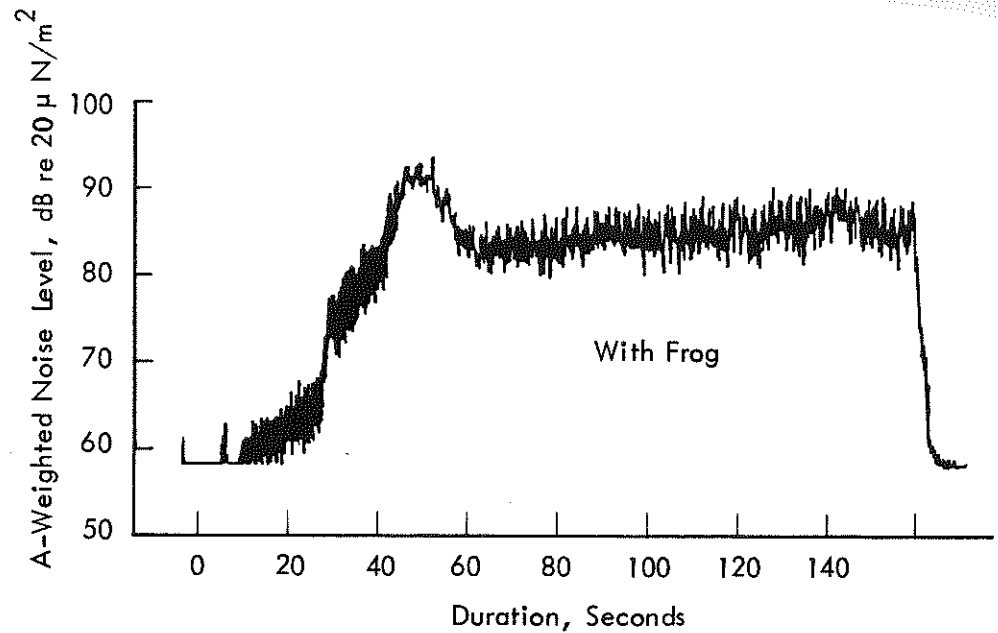
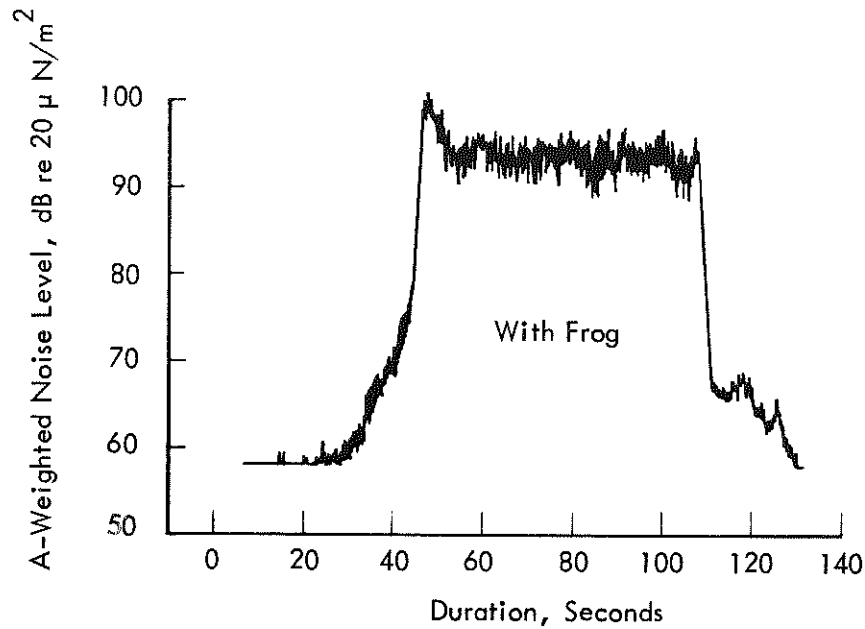


Figure 3.2-16. Comparison of A-Weighted Time Histories for Train Passage Over a Switching Frog and the Same Train Passing Over a Smooth Segment of Track 950 feet from the Frog (measurements taken 100 feet from Track).



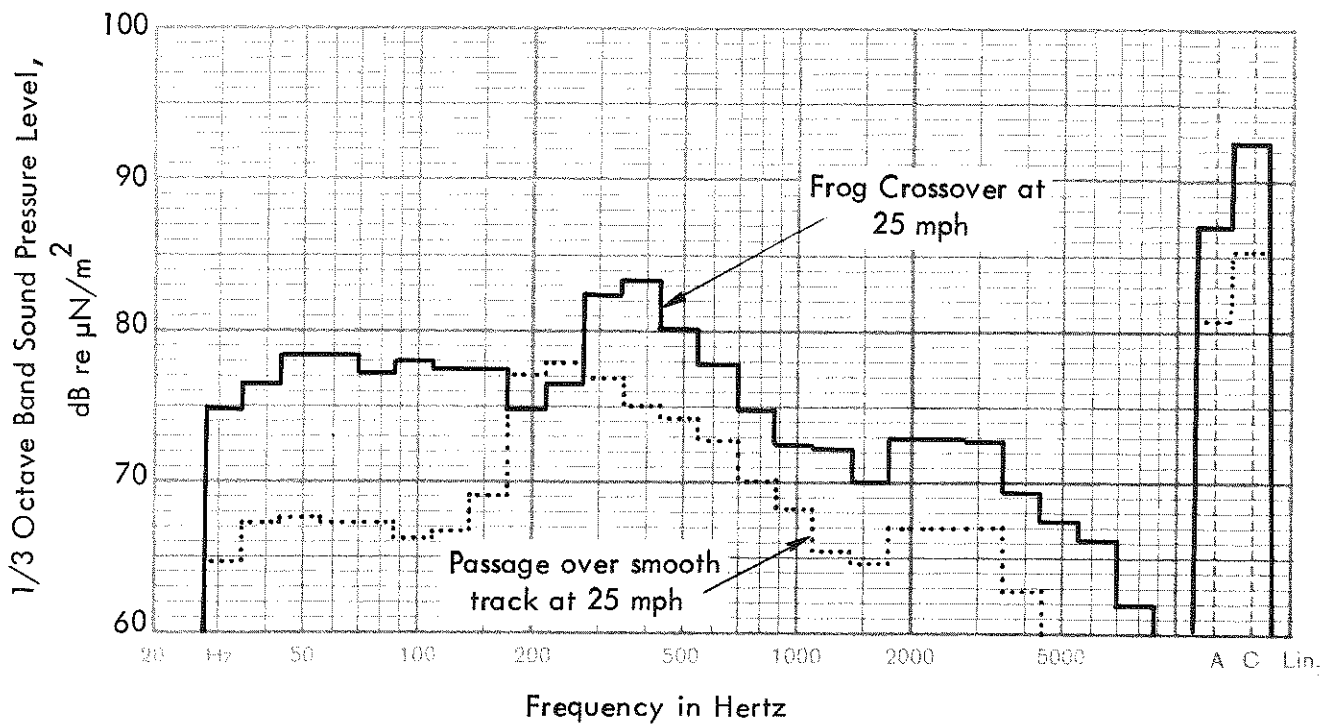
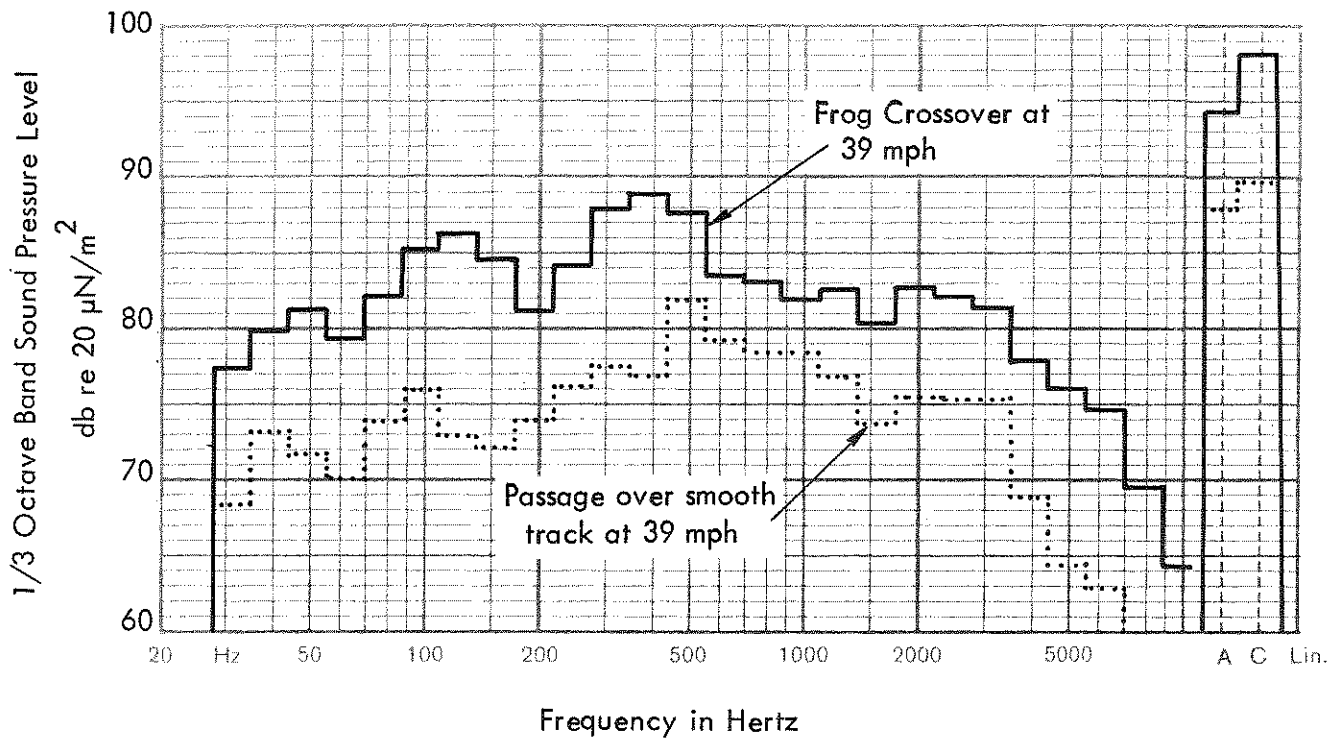
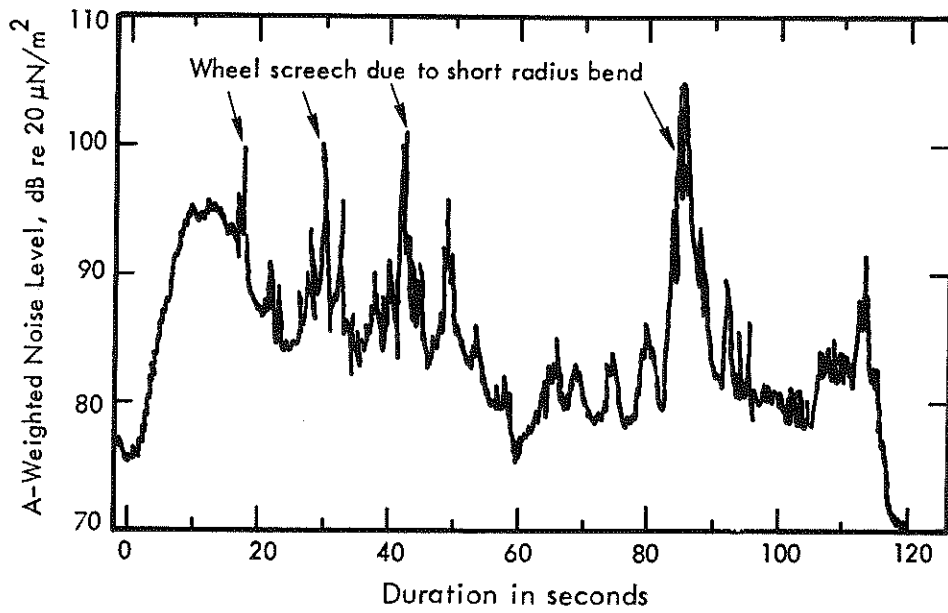
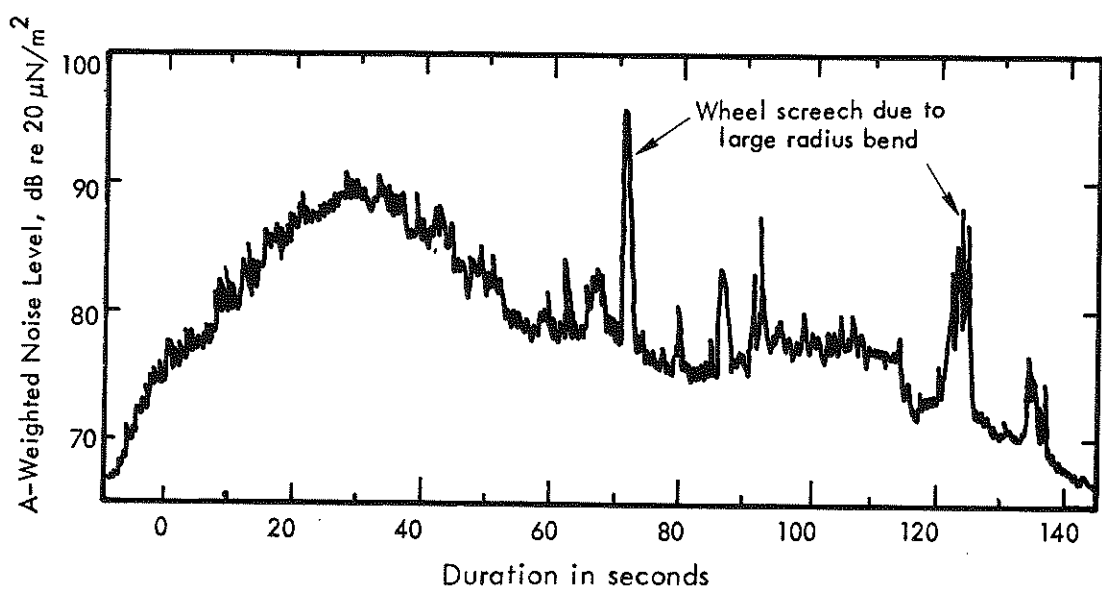


Figure 3-2-17. Comparative Frequency Spectra of Noise Levels Emitted By a Frog Crossover vs. Smooth Track (Measurements at 50 feet).

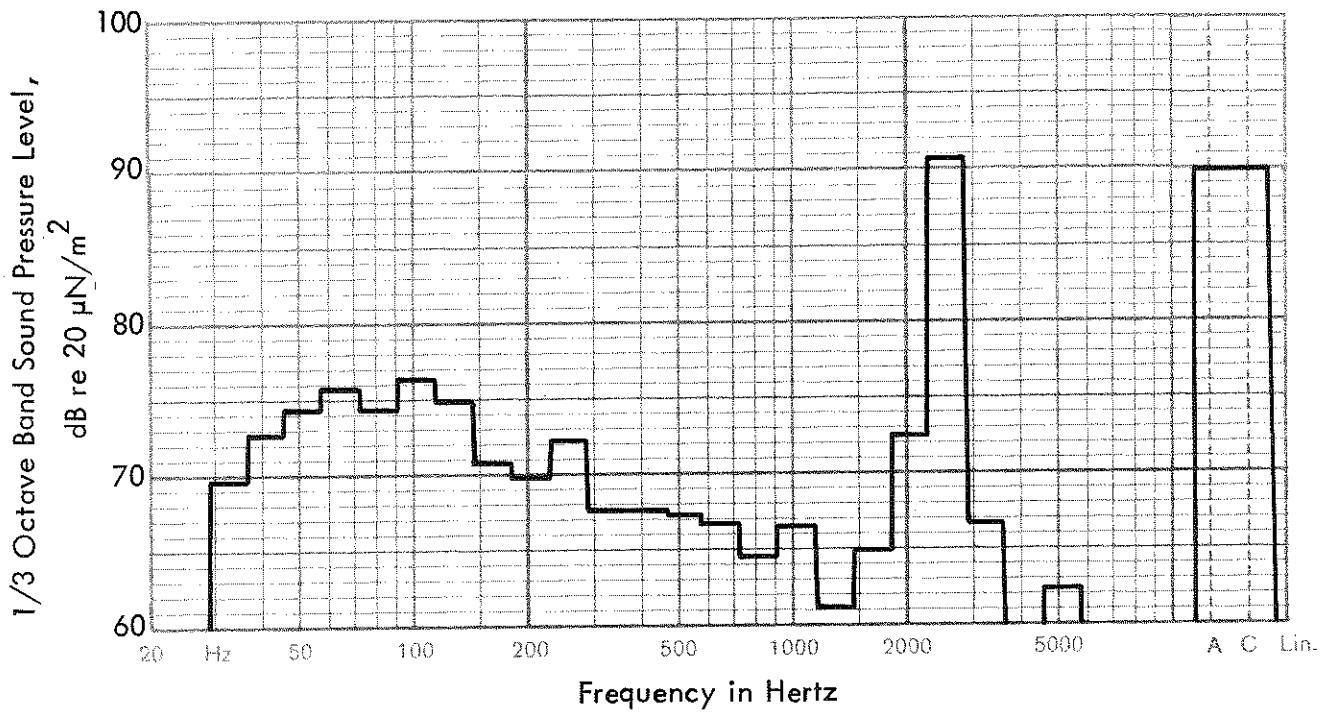


A. 574 Foot Radius Bend. Measurements at 100 Feet, 26 mph (2.2% Ascent Grade)

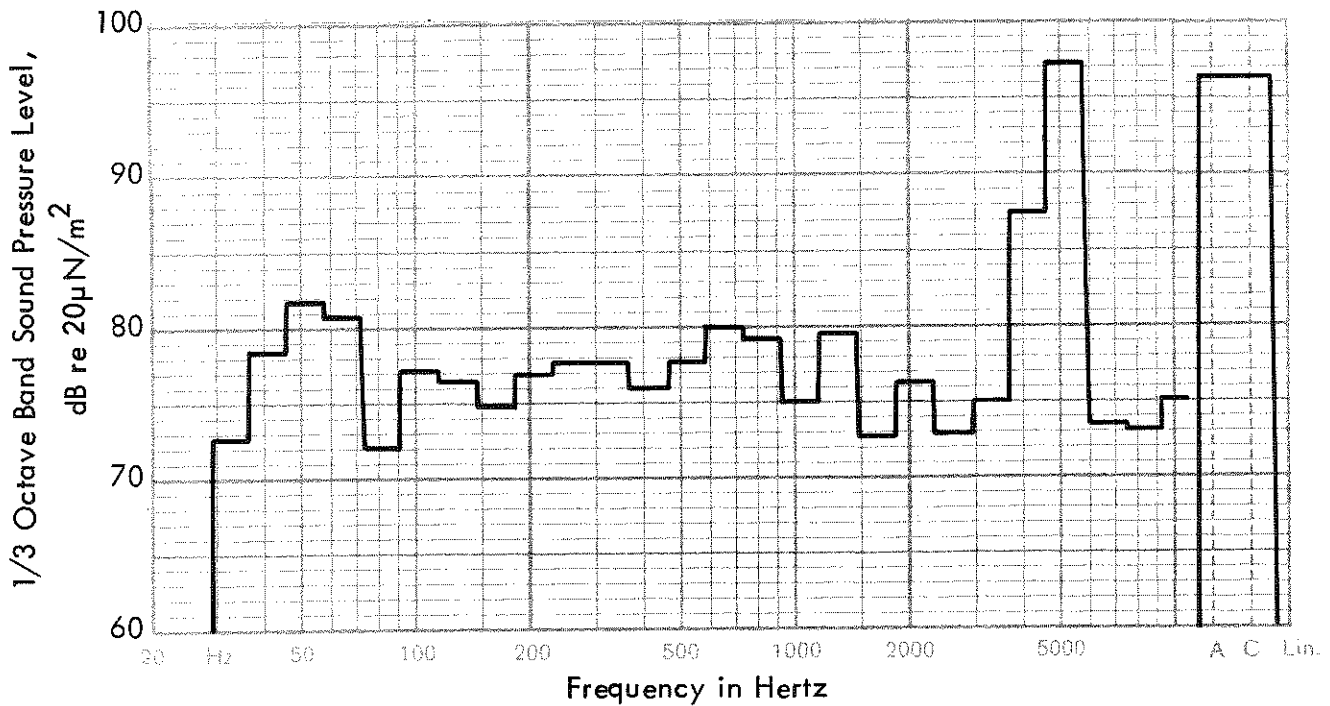


B. 765 Foot Radius Bend. Measurements at 250 Feet, 27 mph (3.0% Ascent Grade)

Figure 3.2-18. Illustrations of Wheel Screech Generated by Freight Cars Negotiating Tight Radius Bends.



A. 765 Foot Radius Bend at 27 mph (measurements at 250 feet, 3% Ascent Grade)



B. 574 Foot Radius Bend at 26 mph (measurements at 50 feet, 2.2% Ascent Grade)

Figure 3.2 - 19. Frequency Spectra of Wheel Screech Produced by Operations Through 574 and 765 Foot Radius Bends.

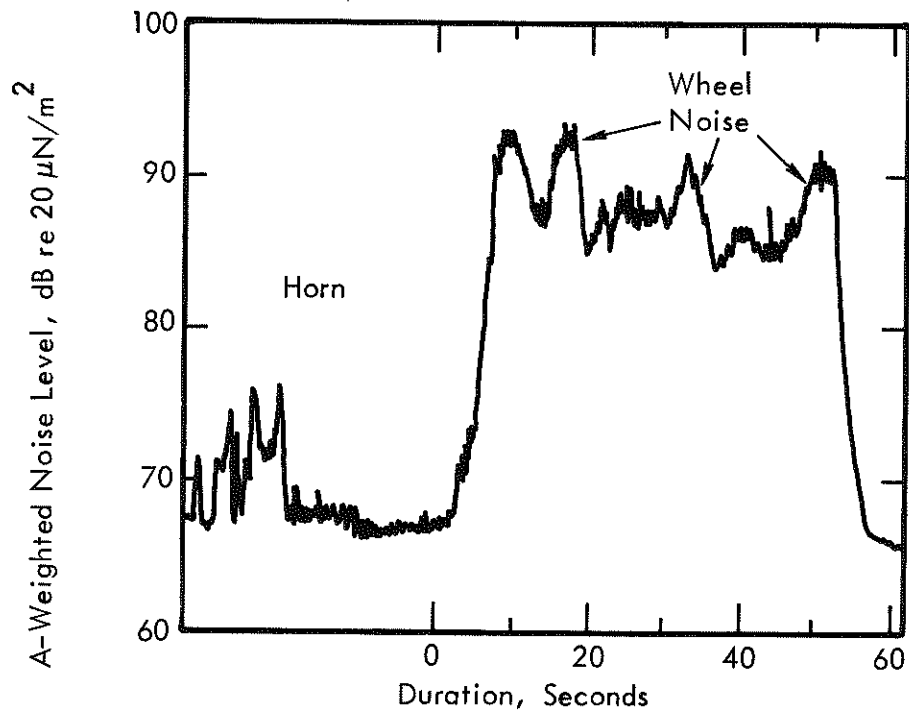


Figure 3.2-20. A-Weighted Time History of Train Pass-by at Hesperia, California Illustrating Excessive Wheel Noise (measured at 114 feet from track, 58 mph at 0% grade).

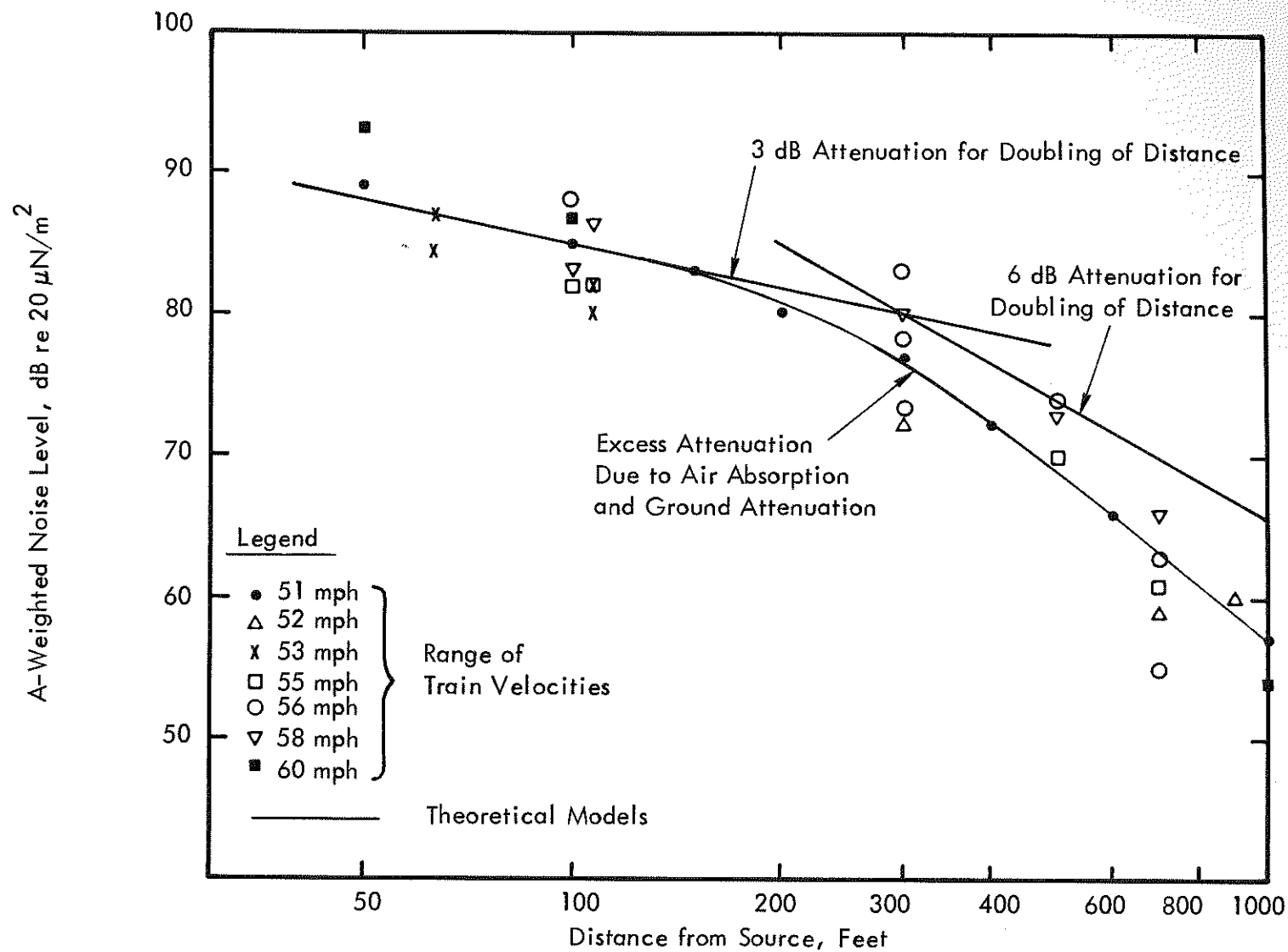


Figure 3.2-21. Decrease in A-Weighted Freight Car-Generated Noise Levels With Distance from Track.

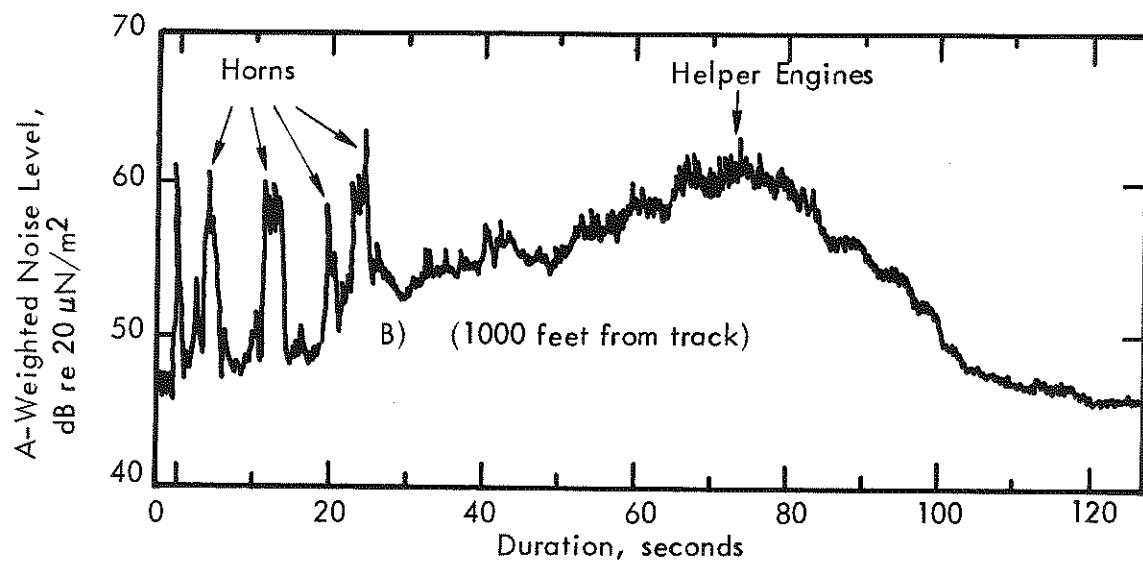
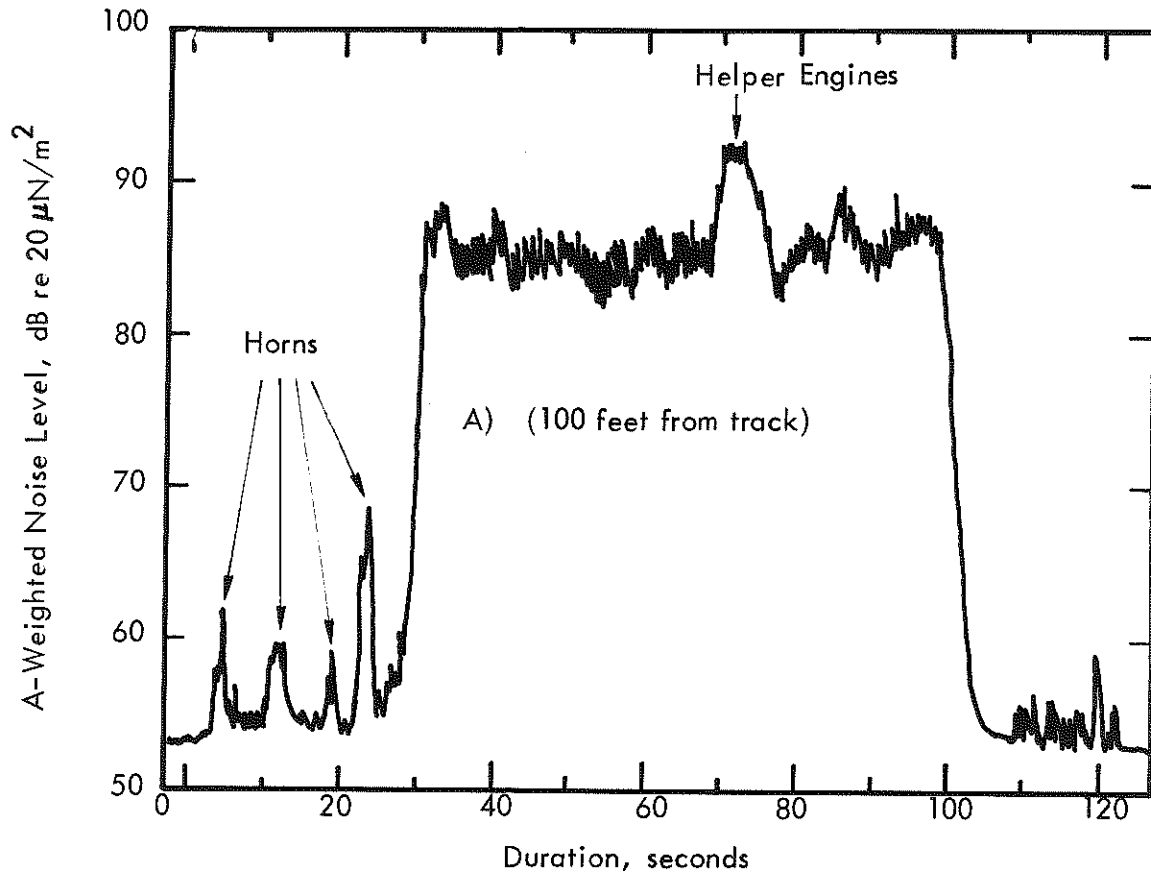


Figure 3.2-22. Comparison of A) 100 Foot and B) 1000 Foot A-Weighted Time Histories of Train Pass-by at Location Between Lancaster and Rosamond, California (67 mph at 0% grade).

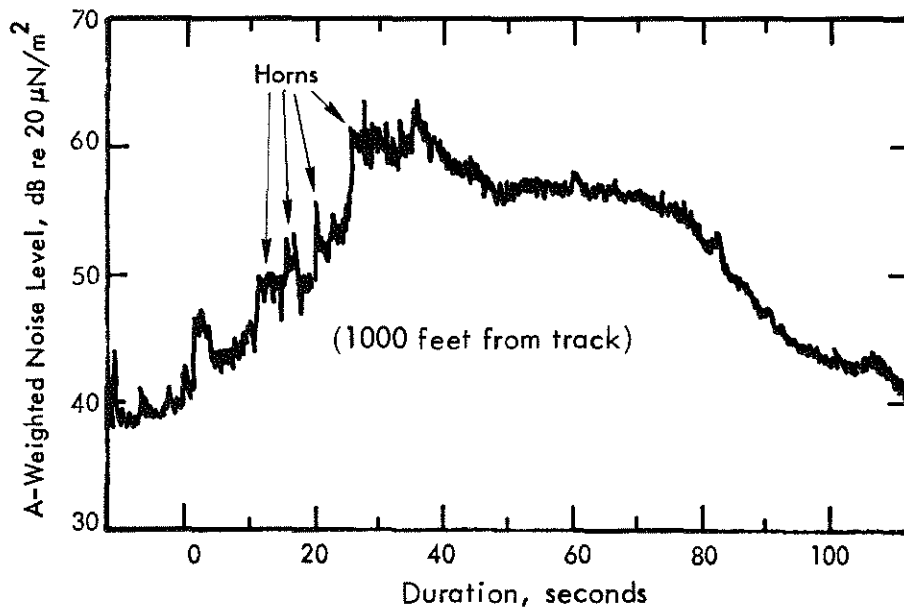
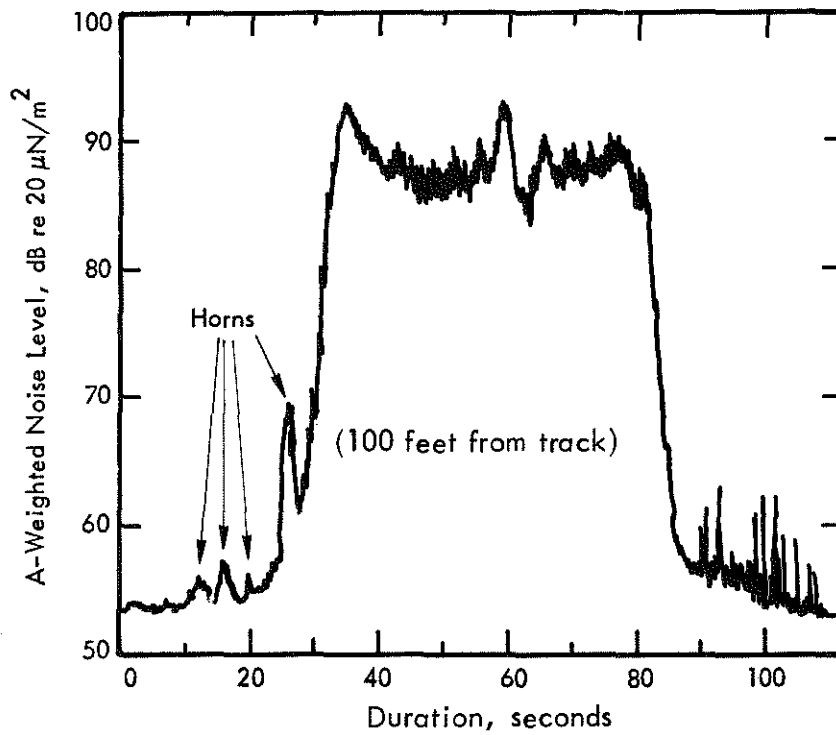
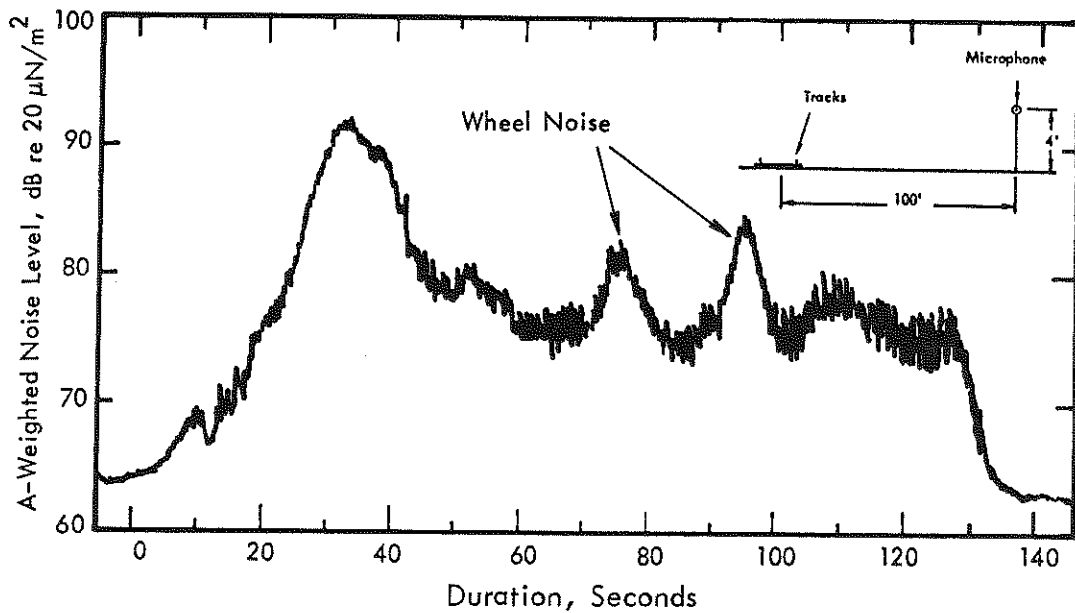
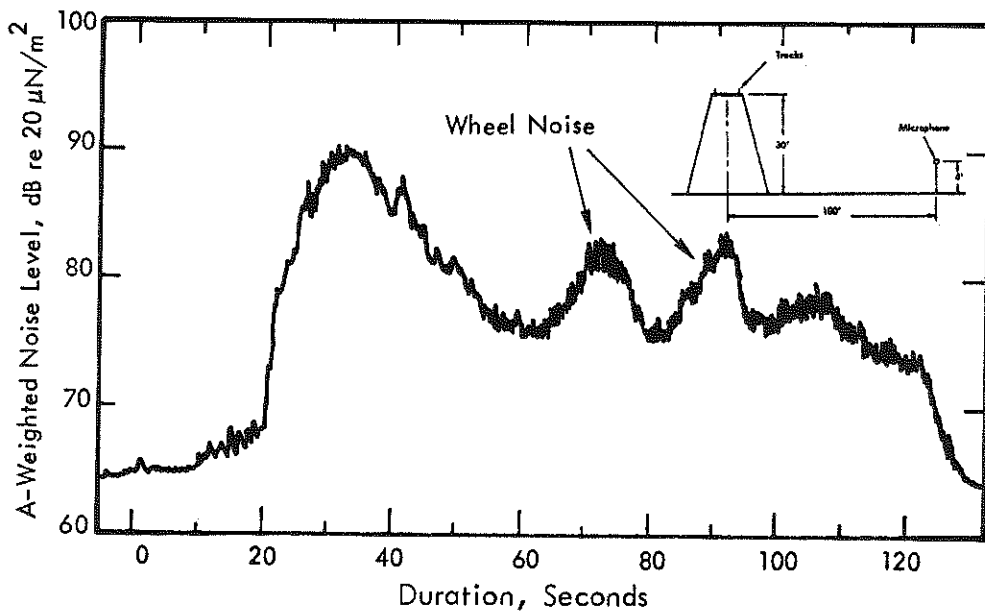


Figure 3.2-23. Comparison of 100 Foot and 1000 Foot A-Weighted Time Histories of Train Pass-by at Location Between Lancaster and Rosamond, California (60 mph at 0% grade).



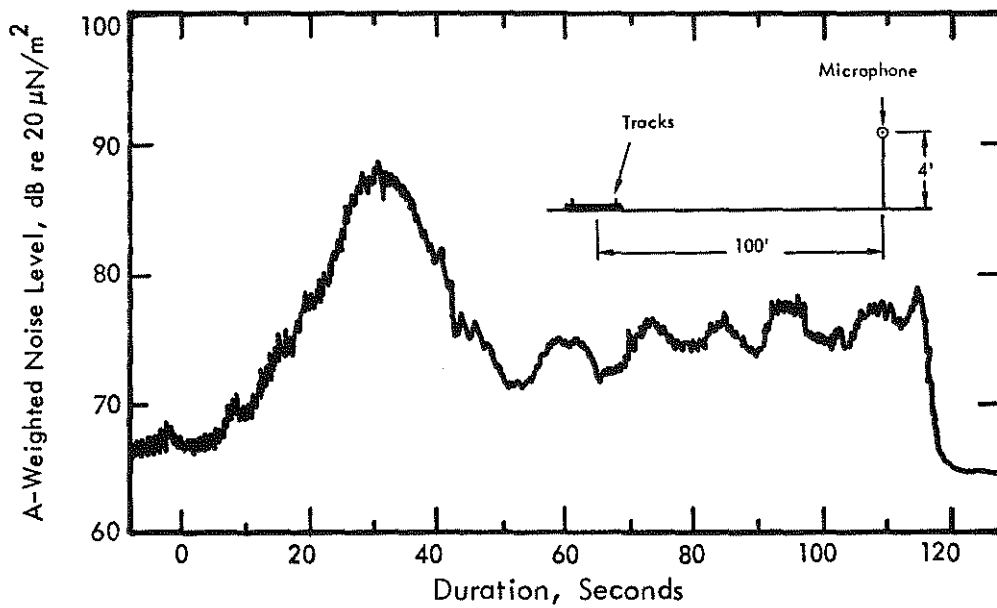
A) Passby at Level Grade. (Humphreys, California, + 2 Percent Grade at 28 mph, Measured at 100 Feet)



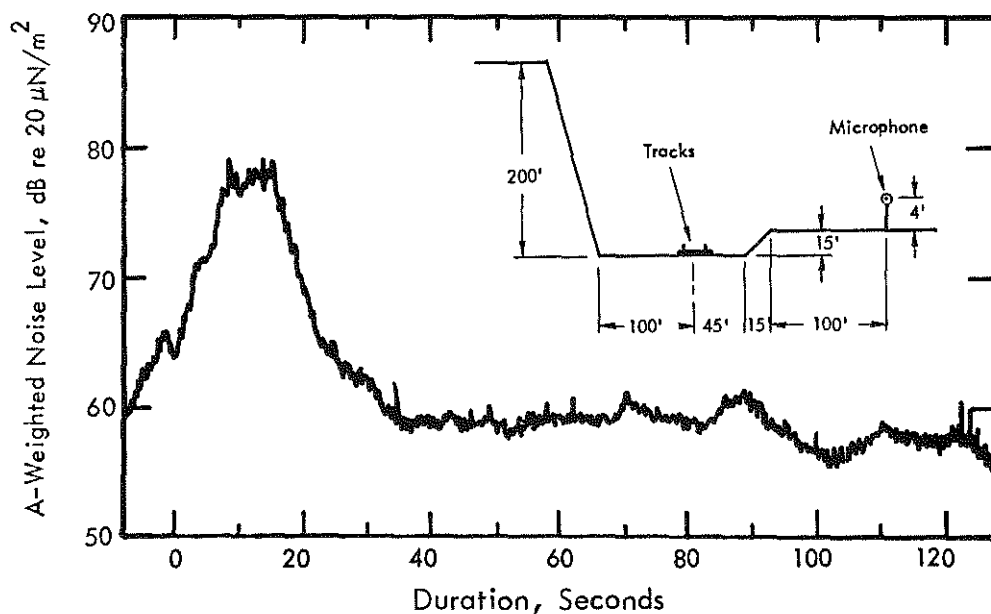
B) Passby at Elevated Position on Hill. (Two miles East of Humphreys, +1 Percent Grade at 33 mph, Measured at 100 Feet)

Figure 3.2-24. Illustration of the Relative Effects of an Elevated Right of Way on the Noise Emitted by a Train Passby





A) A-weighted Time History at Level Grade. (Tehachapi Summit, -0.6 Percent Grade at 27 mph, Measured at 100 Feet.)



B) A-weighted Time History for Train Traversal Through Depressed Right-of-Way (5 Miles East of Tehachapi Summit, -2 Percent Grade at 24 mph, Measured at 160 Feet.)

Figure 3.2-25. Effect of Depressed Right-of-Way (Cutting) on Noise Emitted by a Train Passby.

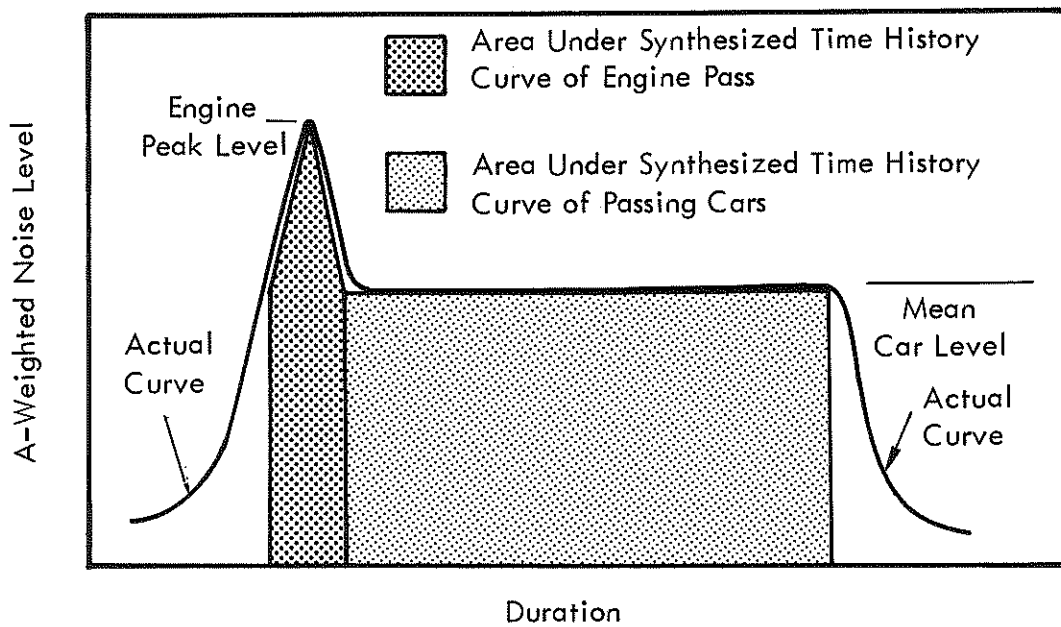


Figure 3.3-1. Comparison of Synthesized Triangle-Rectangle Time History and Actual Curve

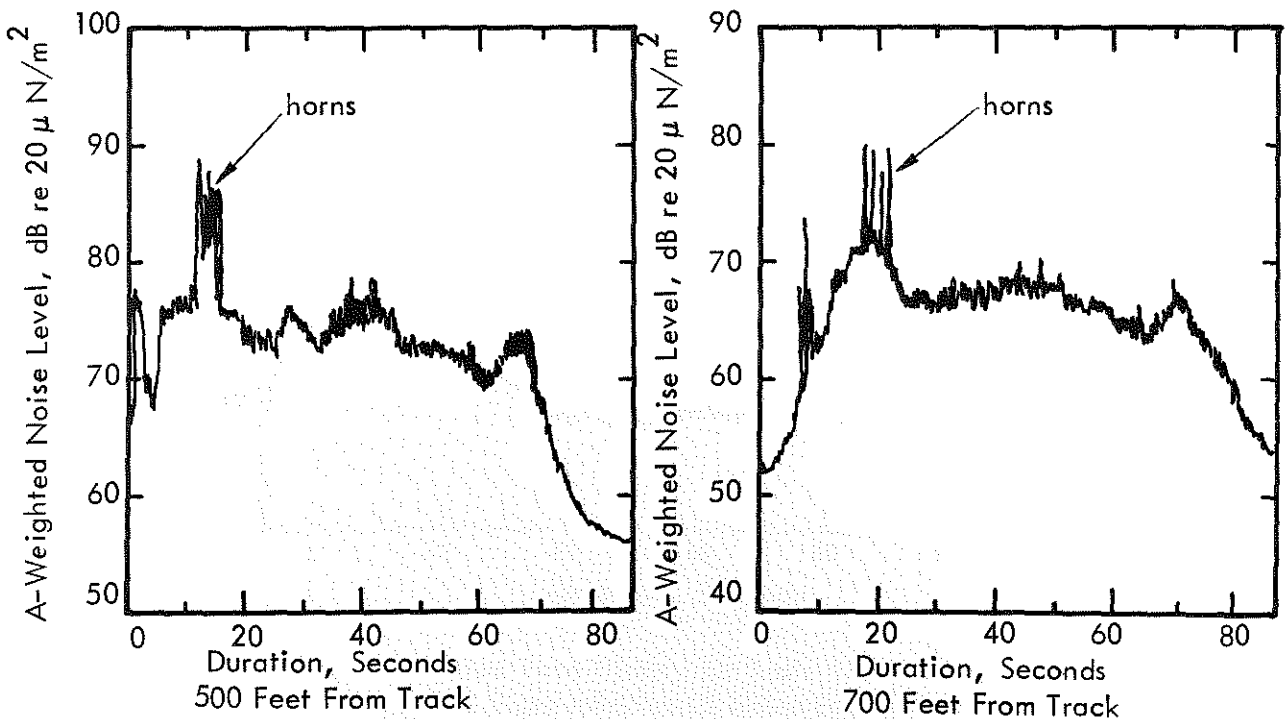
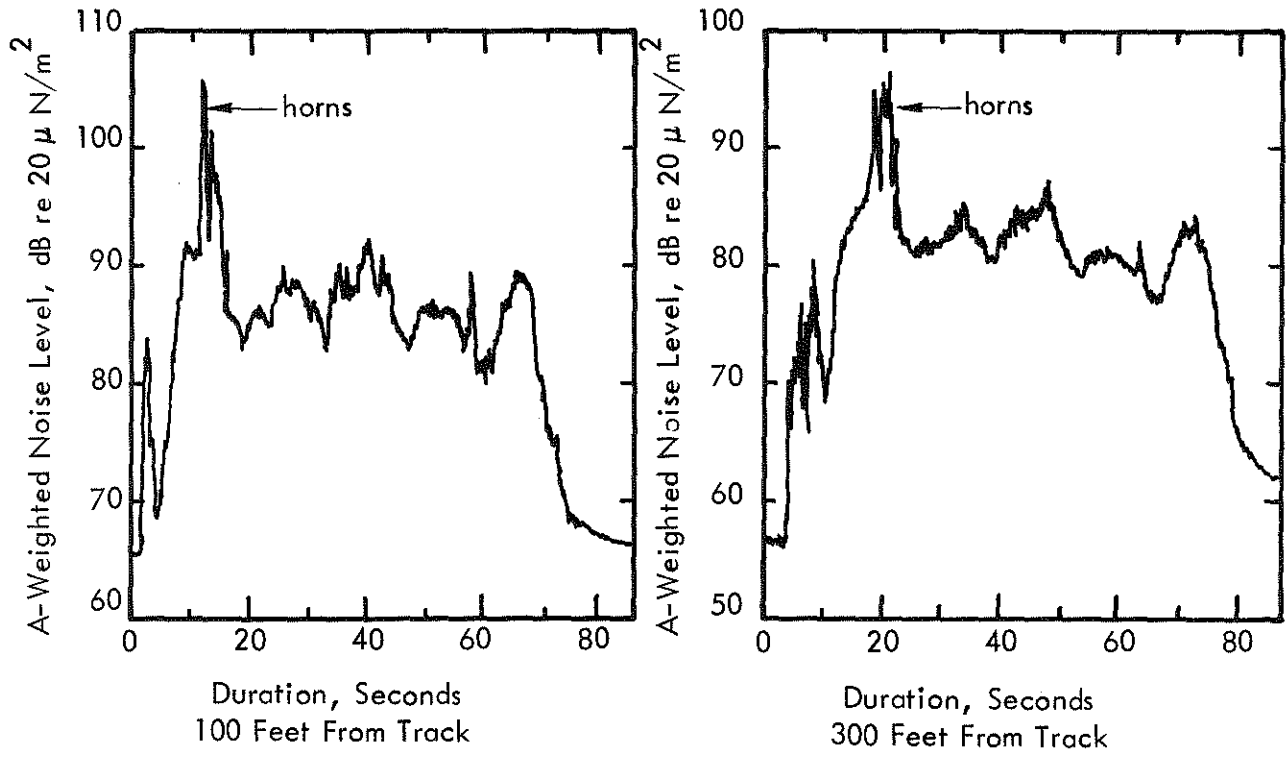


Figure 3.3-2. A-Weighted Time Histories of Train Passby at Intersection of Imperial Highway and Riverside Freeway Illustrating Effect of Different Observer Distances from Track (58 mph, -1% Grade).

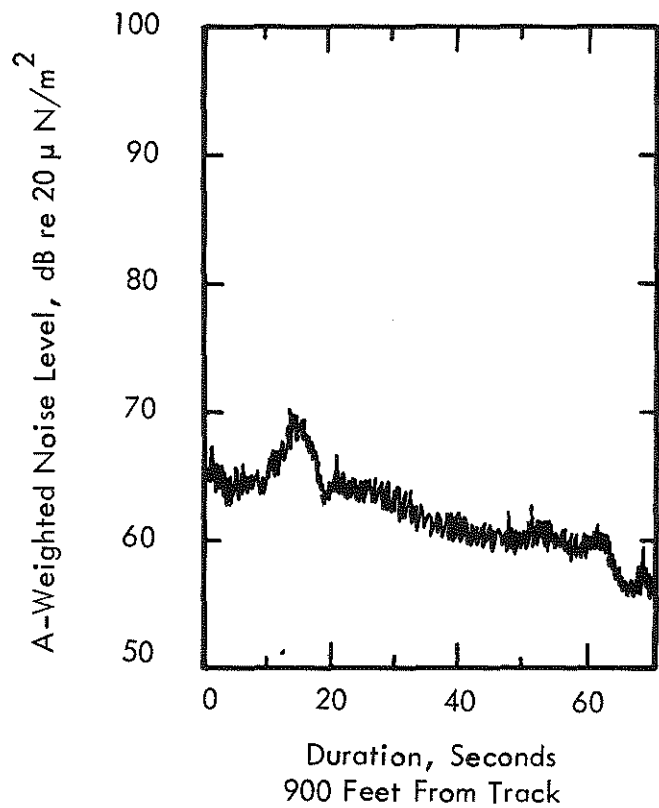
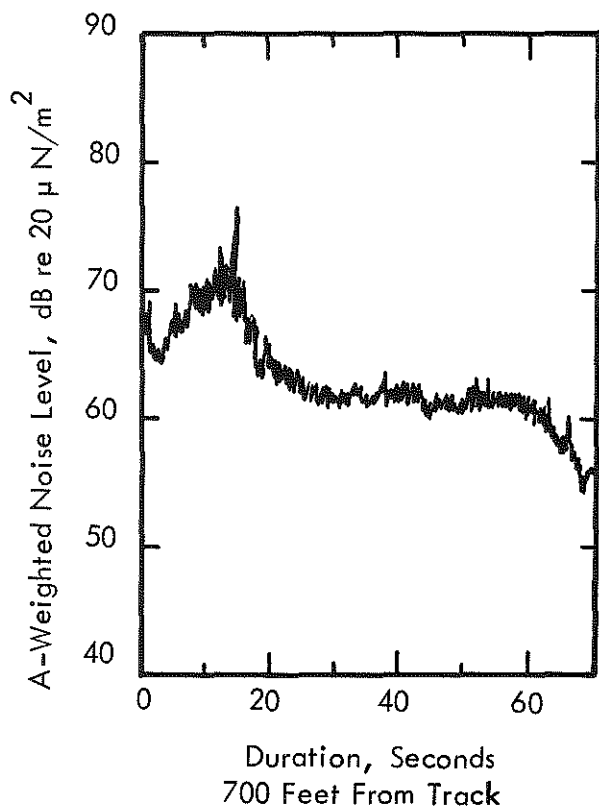
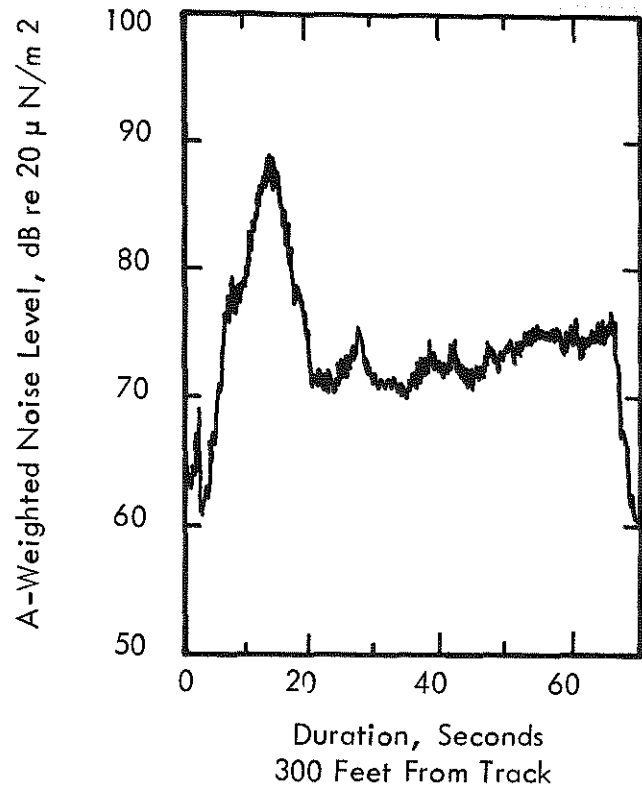
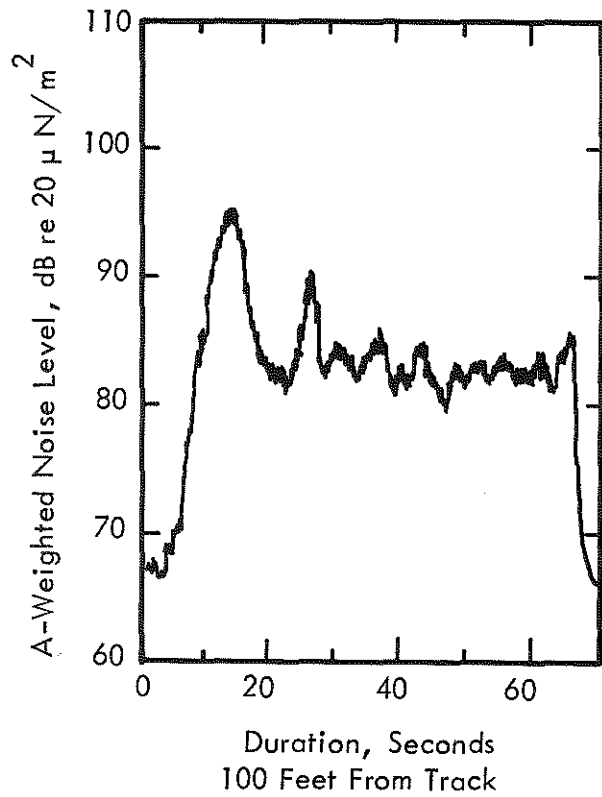


Figure 3.3 -3. A-Weighted Time Histories of Train Passby at Intersection of Imperial Highway and Riverside Freeway Illustrating Effect of Different Observer Distances from Track (52 mph, +1% Grade).



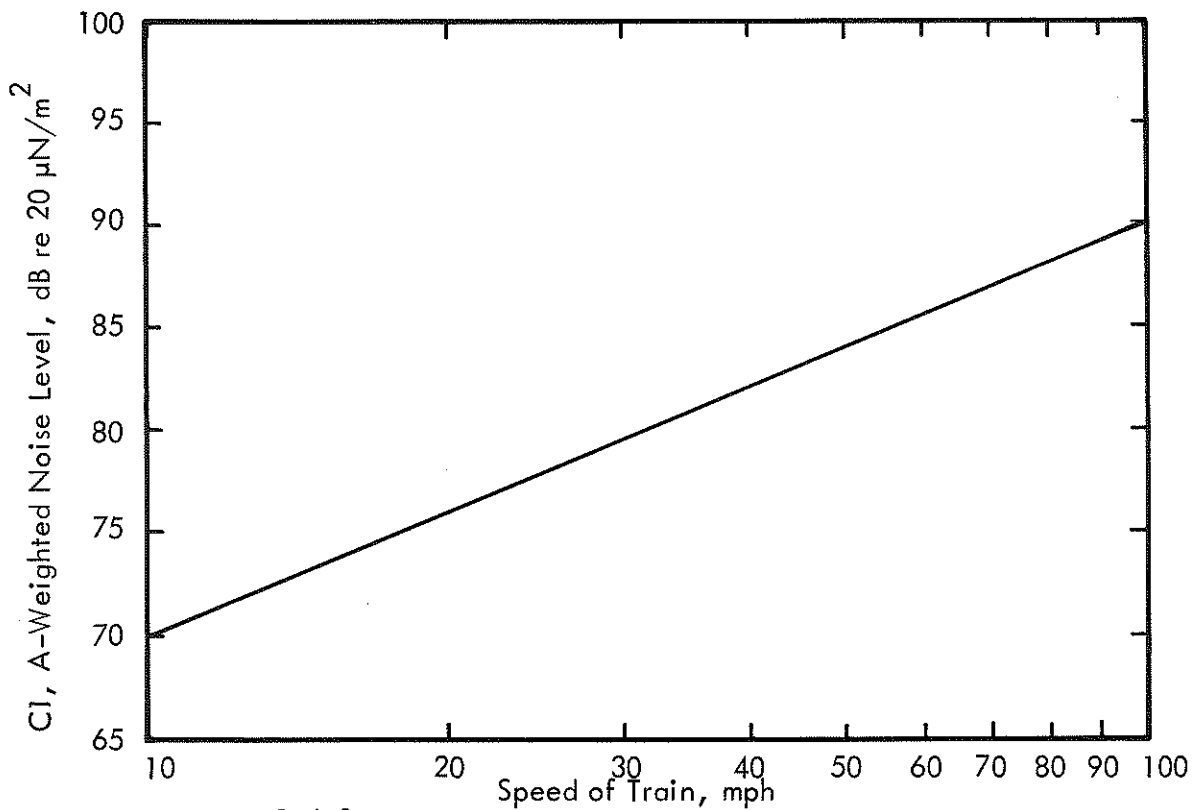


Figure 3.4-2. Noise Level of Freight Cars at 100 Feet From the Track

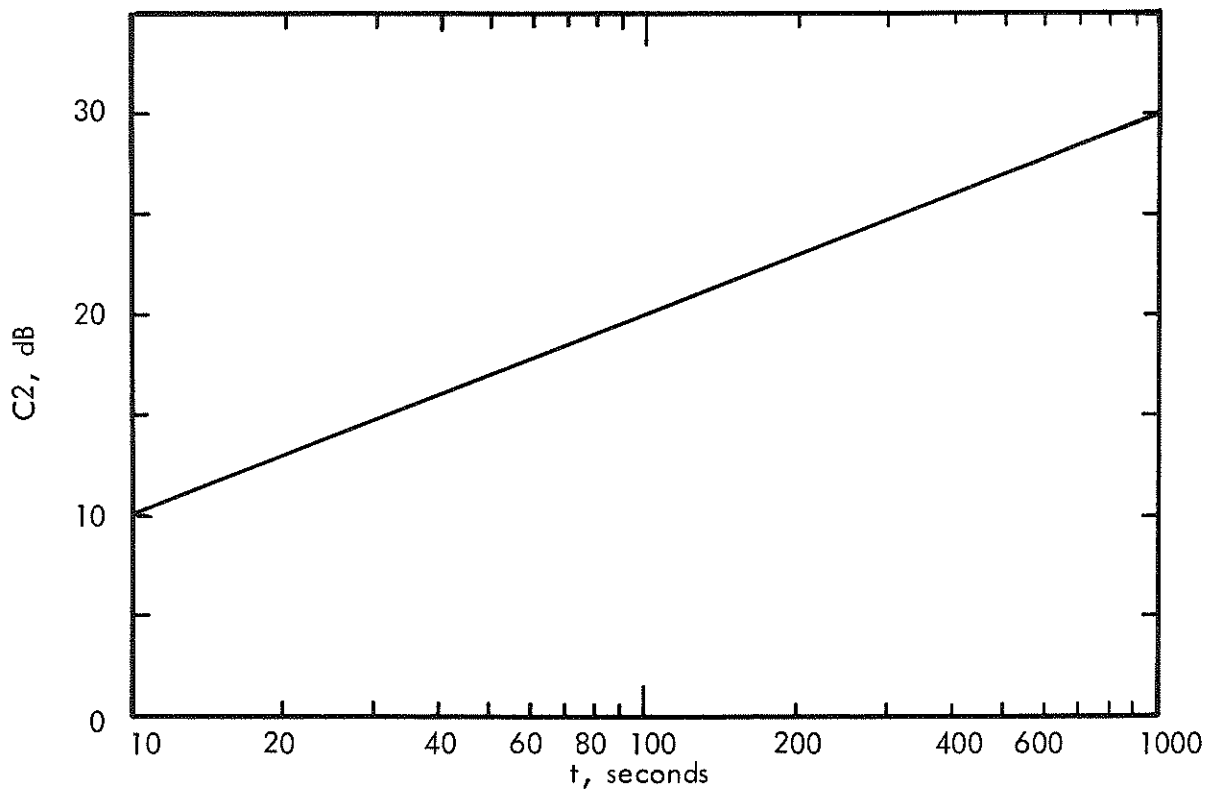


Figure 3.4-3. Logarithmic Duration Term of Train Pass-By at 100 Feet From the Track

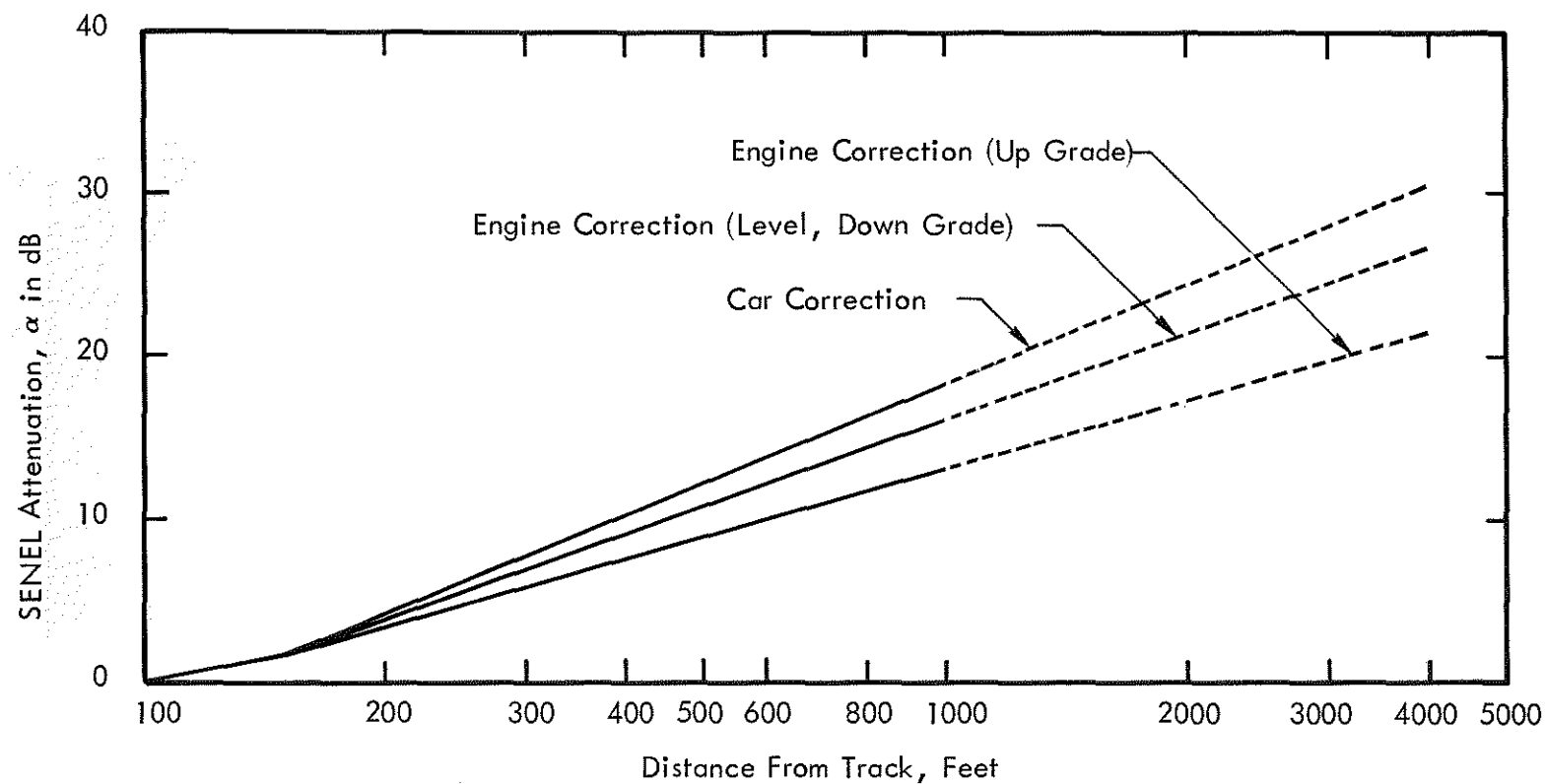


Figure 3.4-4. Attenuation Correction to be Subtracted from Engine and Car SENEL Values at 100 Feet for Observer Distances Greater Than 100 Feet. These correction factors account for attenuation due to spreading of sound waves, increased duration of noise as observer moves away from the source, air absorption (at 60°F, 50 percent Relative Humidity), and excess ground attenuation.

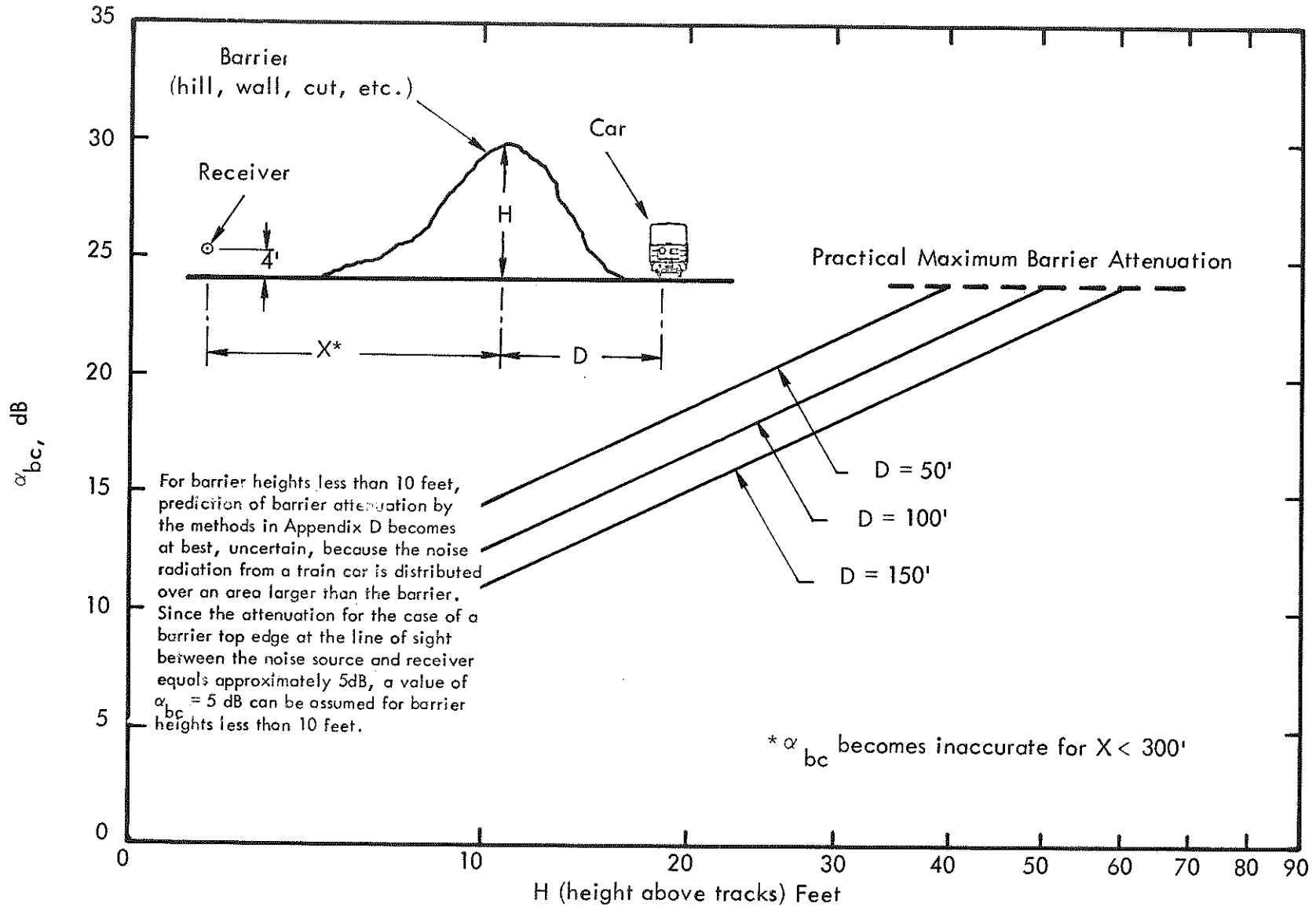


Figure 3.4-5. Attenuation of Car Sound Level Due to Shielding Barrier



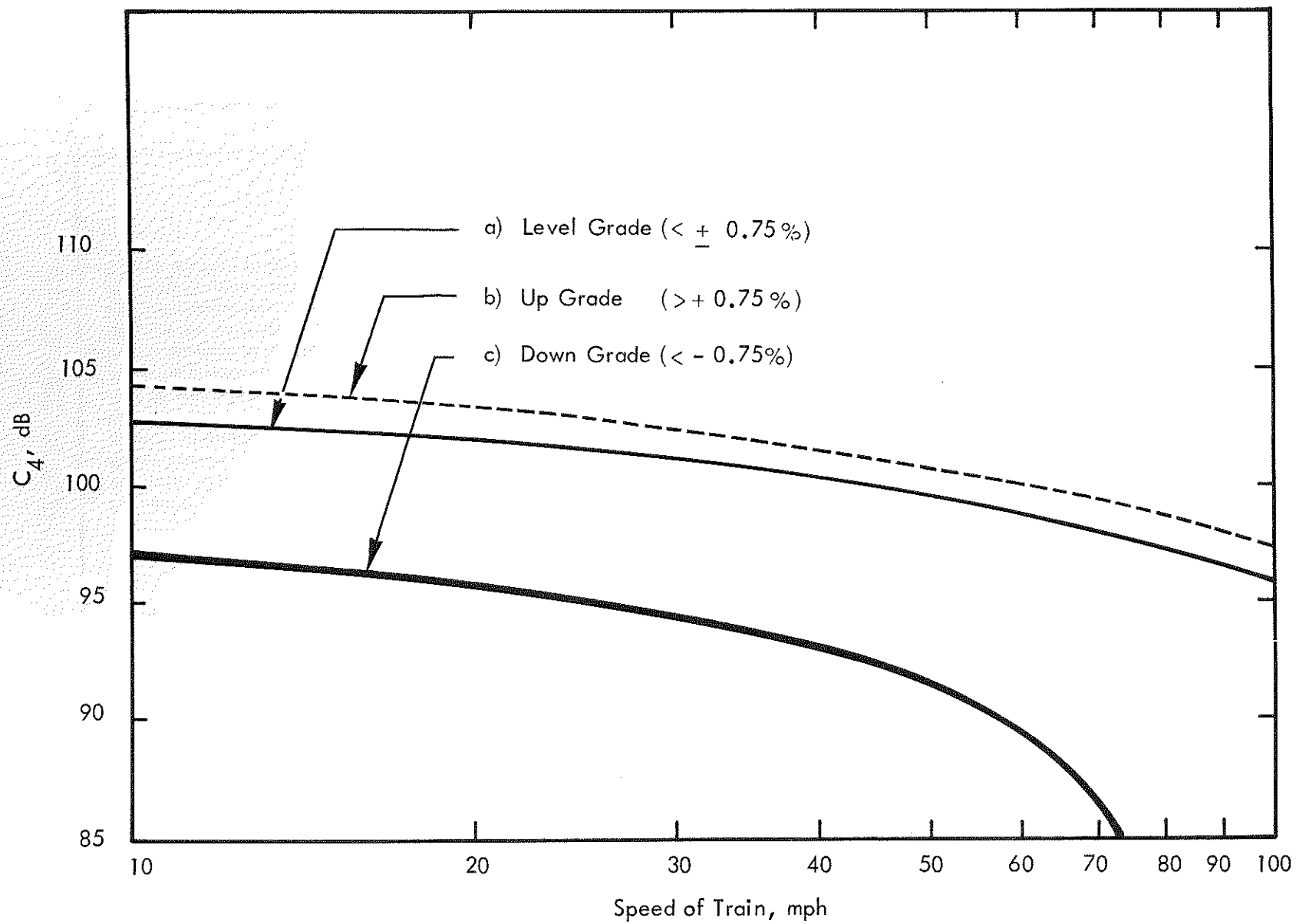


Figure 3.4-6. Engine SENEL Contribution at 100 Feet From The Track For A Train Traveling at The Grade Condition Indicated.

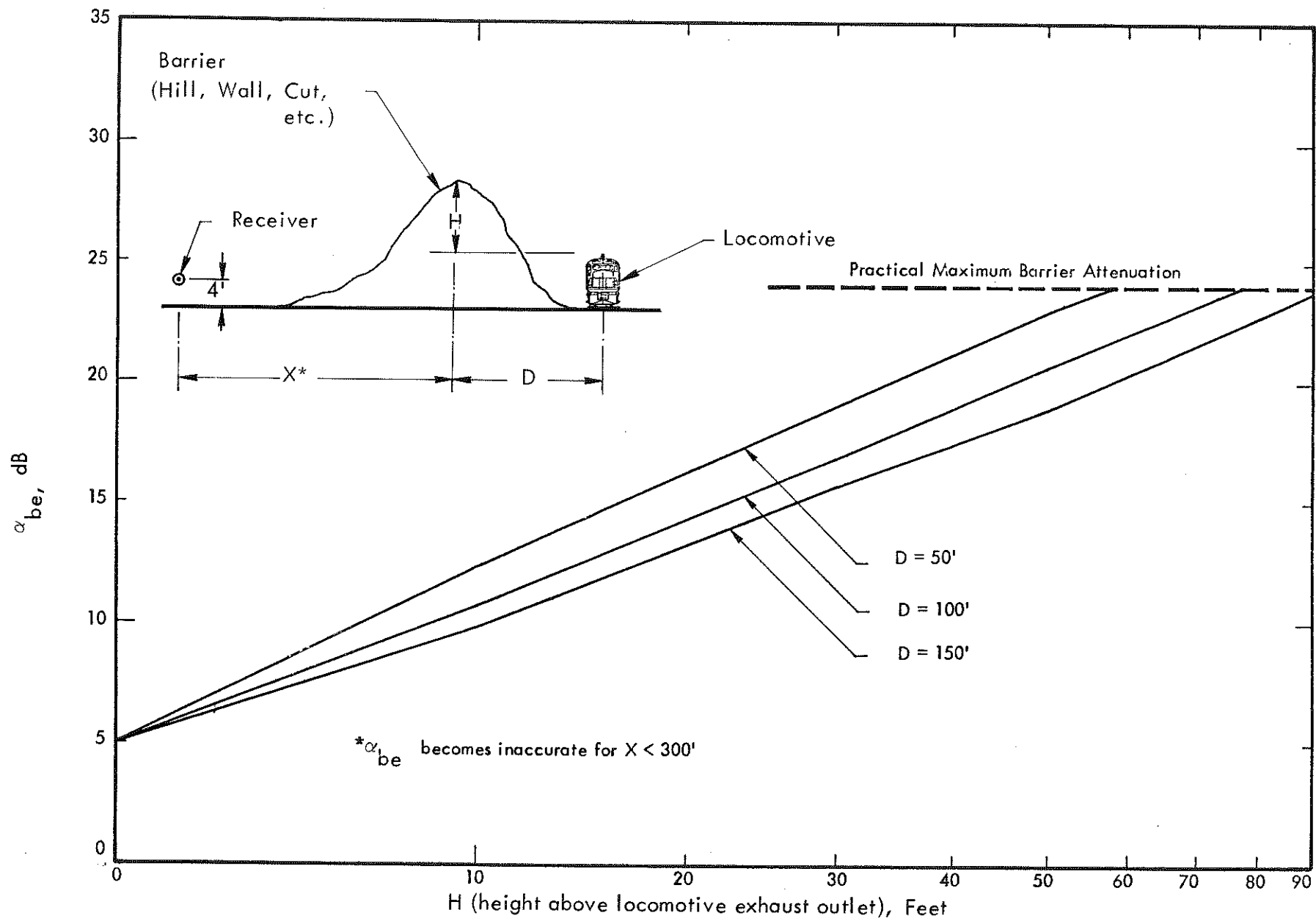


Figure 3.4-7. Attenuation of Locomotive Sound Level Due to a Shielding Barrier

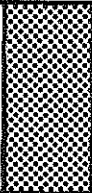
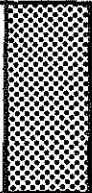
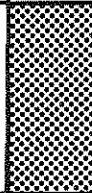
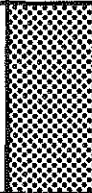
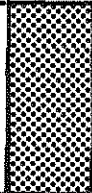
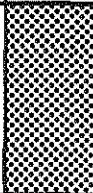
Time Period	Train Category Identification					
	1	2	3	4	5	6
(7:00am-7:00pm) $N_D$						
(7:00pm-10:00pm) $N_E^*$	_____ x 3 = _____	_____ x 3 = _____	_____ x 3 = _____	_____ x 3 = _____	_____ x 3 = _____	_____ x 3 = _____
(10:00pm-7:00am) $N_N$	_____ x 10 = _____	_____ x 10 = _____	_____ x 10 = _____	_____ x 10 = _____	_____ x 10 = _____	_____ x 10 = _____
$N$						

Figure 3.4-8. Equivalent Operations Worksheet for Use in CNEL Calculations

\* For computing day-night average noise level ( $L_{dn}$ ), use unity weighting factor (instead of 3) during evening period.

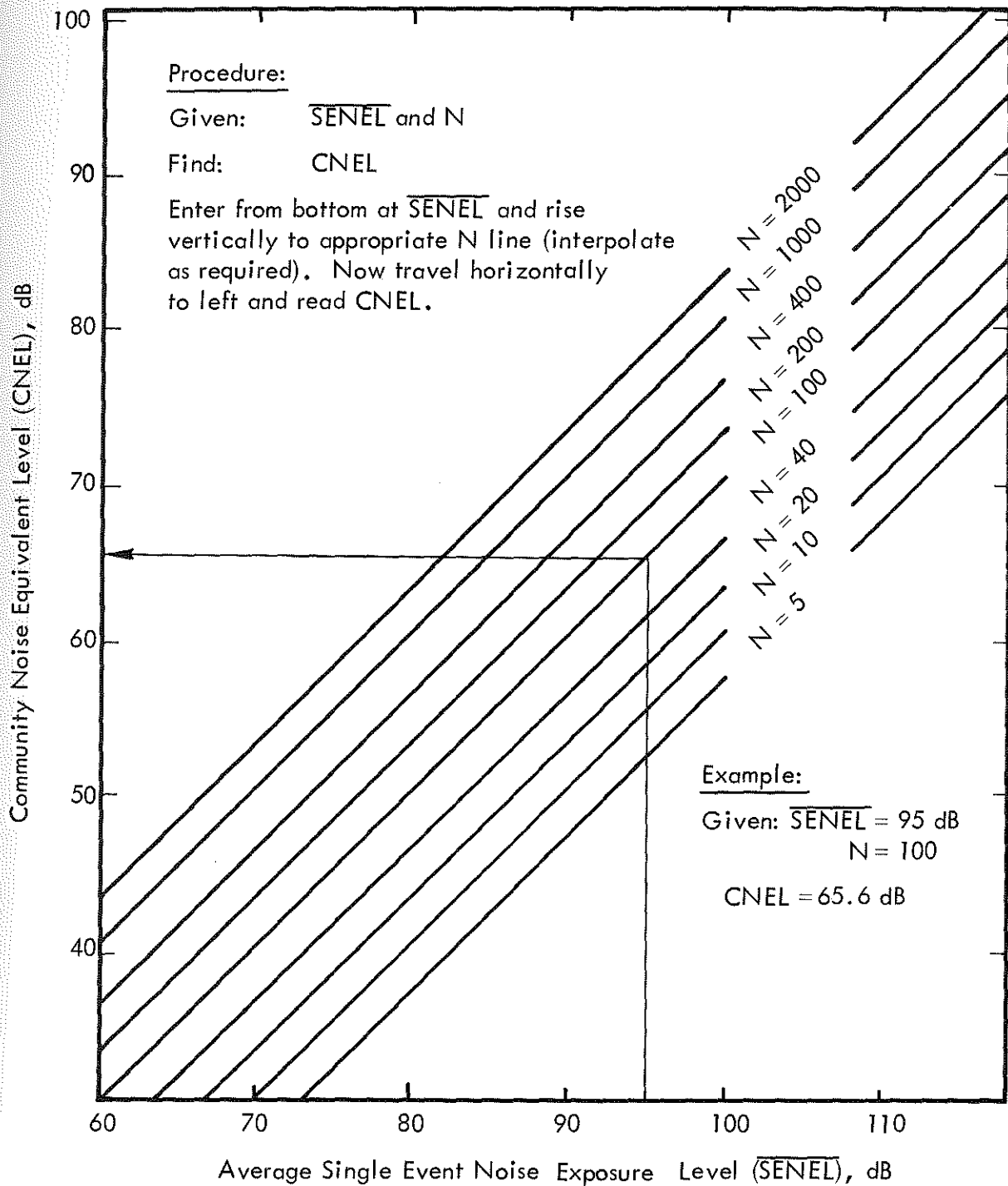


Figure 3.4-9. Graphical Method for Determination of CNEL Given  $\overline{\text{SENEL}}$  and Equivalent Number of Operations; N.

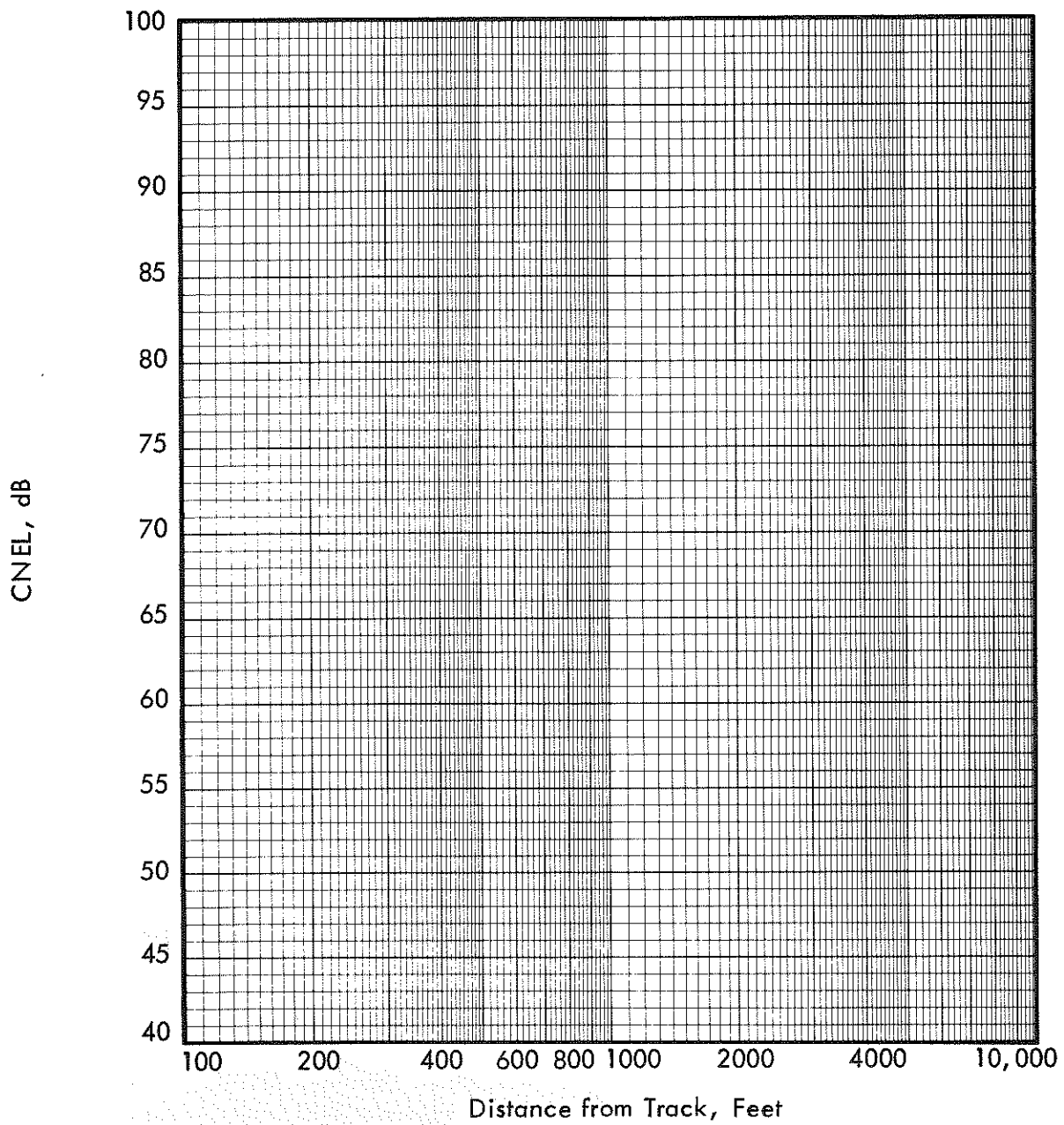


Figure 3.4-10. Form for Determination of CNEL Contour Locations via Graphical Interpolation.

CNEL WORKSHEET FOR LINE OPERATIONS																										
Train Category Identification	L, feet (train length)	V, mph (train speed)	% grade	Barrier (if existing)	Distance to track, feet	(1) Pass-by Duration, sec $t = L/V$	(2) $C_1$ $(10 \log_{10} t)$	(3) Car SPL at 100', dB $C_2$	(4) Car - distance attenuation $\sigma$	(5) $\sigma_{bc}$ Car barrier correction	(6) Car Noise Adjustment: $C_3$	(7) SENEL (cars), dB $C_1 + C_2 + C_3 - \sigma - \sigma_{bc}$	(8) Loco. SENEL at 100', $C_4$ , dB	(9) Loco. distance attenuation $\sigma$	(10) $\sigma_{be}$ Loco. Barrier correction	(11) Helper engine adjustment, $C_5$	(12) SENEL (loco.), dB $C_4 + C_5 - \sigma - \sigma_{be}$	(13) SENEL (Train) dB	(14) N equiv. no. of daily operations	(15) CNEL contribution	COMPOSITE CNEL AT DISTANCE INDICATED					
																					(16) 100'	(17) 200'	(18) 400'	(19) 800'	(20) (20)	(21) (21)
1					100'																					
					200'																					
					400'																					
					800'																					
2					100'																					
					200'																					
					400'																					
					800'																					
3					100'																					
					200'																					
					400'																					
					800'																					
4					100'																					
					200'																					
					400'																					
					800'																					
5					100'																					
					200'																					
					400'																					
					800'																					
6					100'																					
					200'																					
					400'																					
					800'																					

Figure 3.5-1. Example Application of CNEL Rating Technique for Line Operations.

Time Period	Train Category Identification					
	1 <i>EAST BOUND</i>	2 <i>WEST BOUND</i>	3	4	5	6
(7:00am-7:00pm) $N_D$	12	7				
(7:00pm-10:00pm) $N_E$	$\frac{2}{=} \times 3$ = 6	$\frac{5}{=} \times 3$ = 15	$\frac{\quad}{=} \times 3$ =	$\frac{\quad}{=} \times 3$ =	$\frac{\quad}{=} \times 3$ =	$\frac{\quad}{=} \times 3$ =
(10:00pm-7:00am) $N_N$	$\frac{8}{=} \times 10$ = 80	$\frac{12}{=} \times 10$ = 120	$\frac{\quad}{=} \times 10$ =	$\frac{\quad}{=} \times 10$ =	$\frac{\quad}{=} \times 10$ =	$\frac{\quad}{=} \times 10$ =
$N$	98	142				

Figure 3.5-2. Equivalent Operations Worksheet for Use in CNEL Calculations

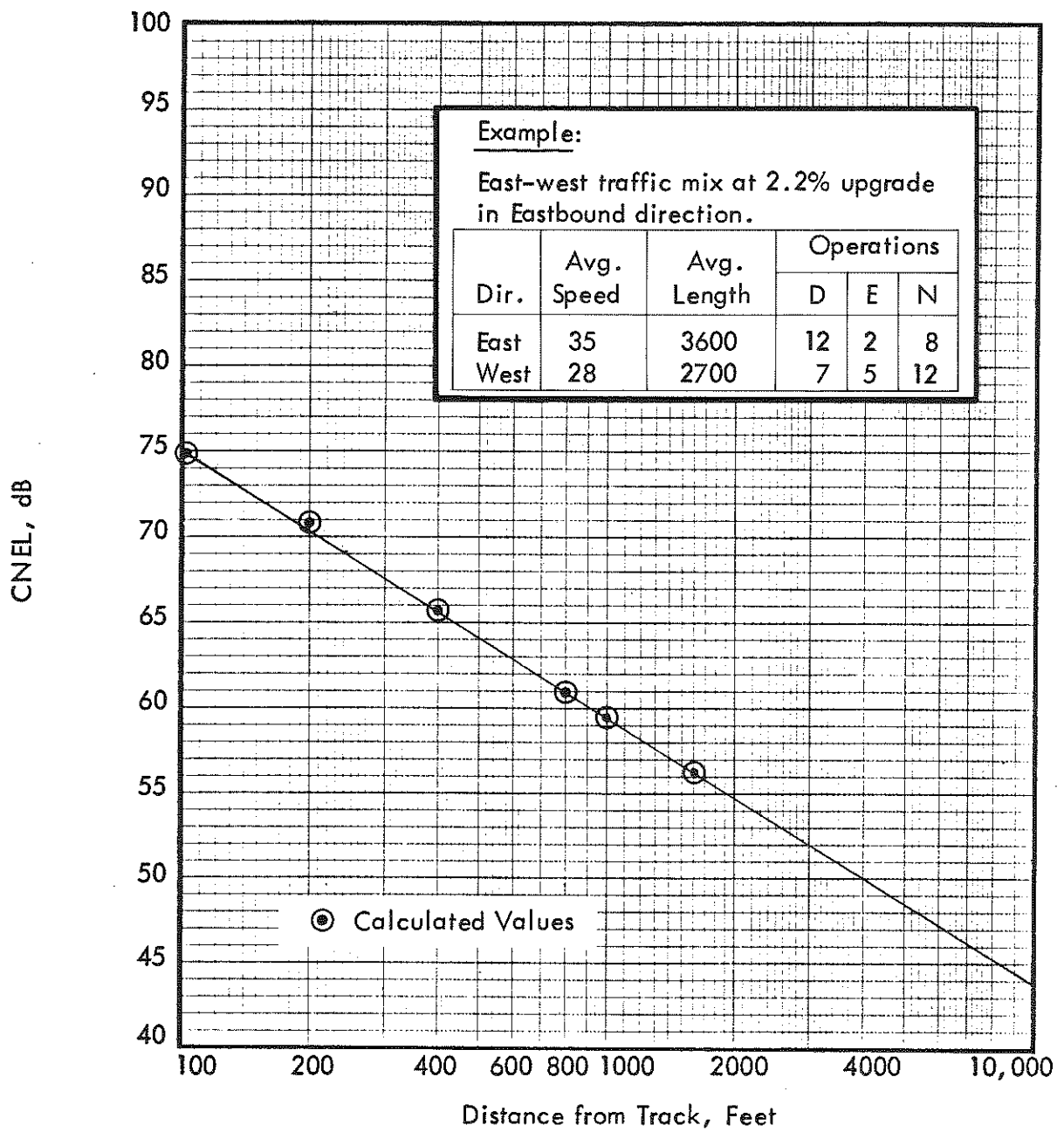


Figure 3.5-3. Example Application of Line Operations Methodology Illustrating Variation of CNEL Contour Values With Distance Away from the Tracks.



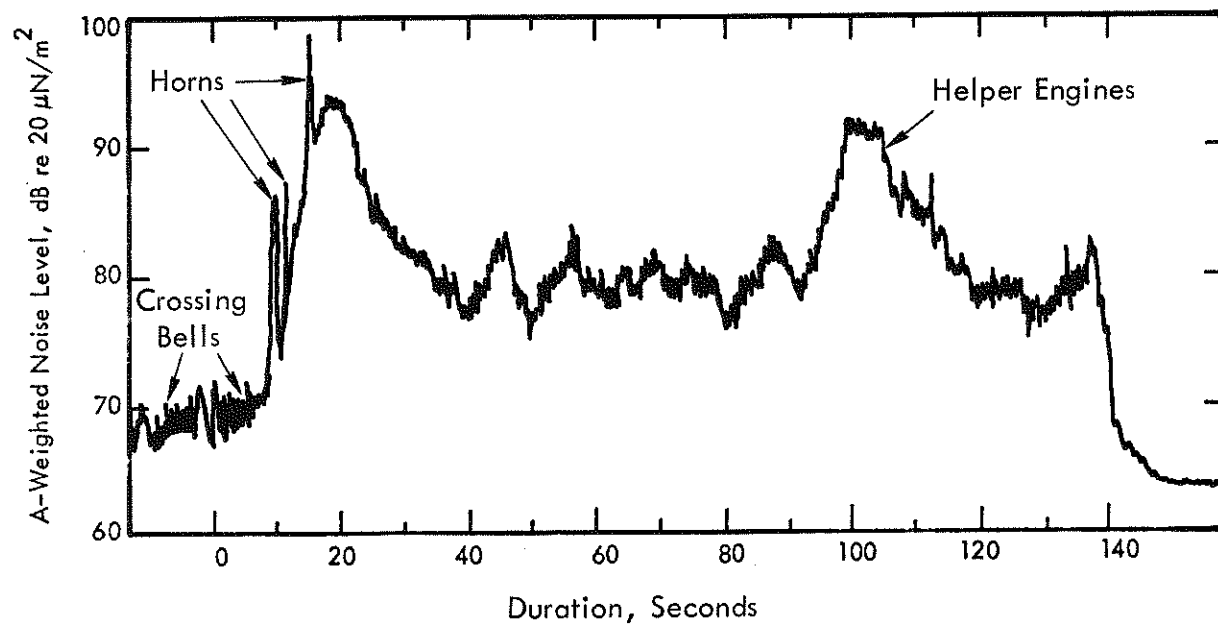


Figure 3.6-1 A-Weighted Time History of Train Pass-By at Edison, California Illustrating Warning Bells at Crossing and Horns from Locomotive (Measured at 100 Ft. from Track, 36 mph at +0.7 percent grade)

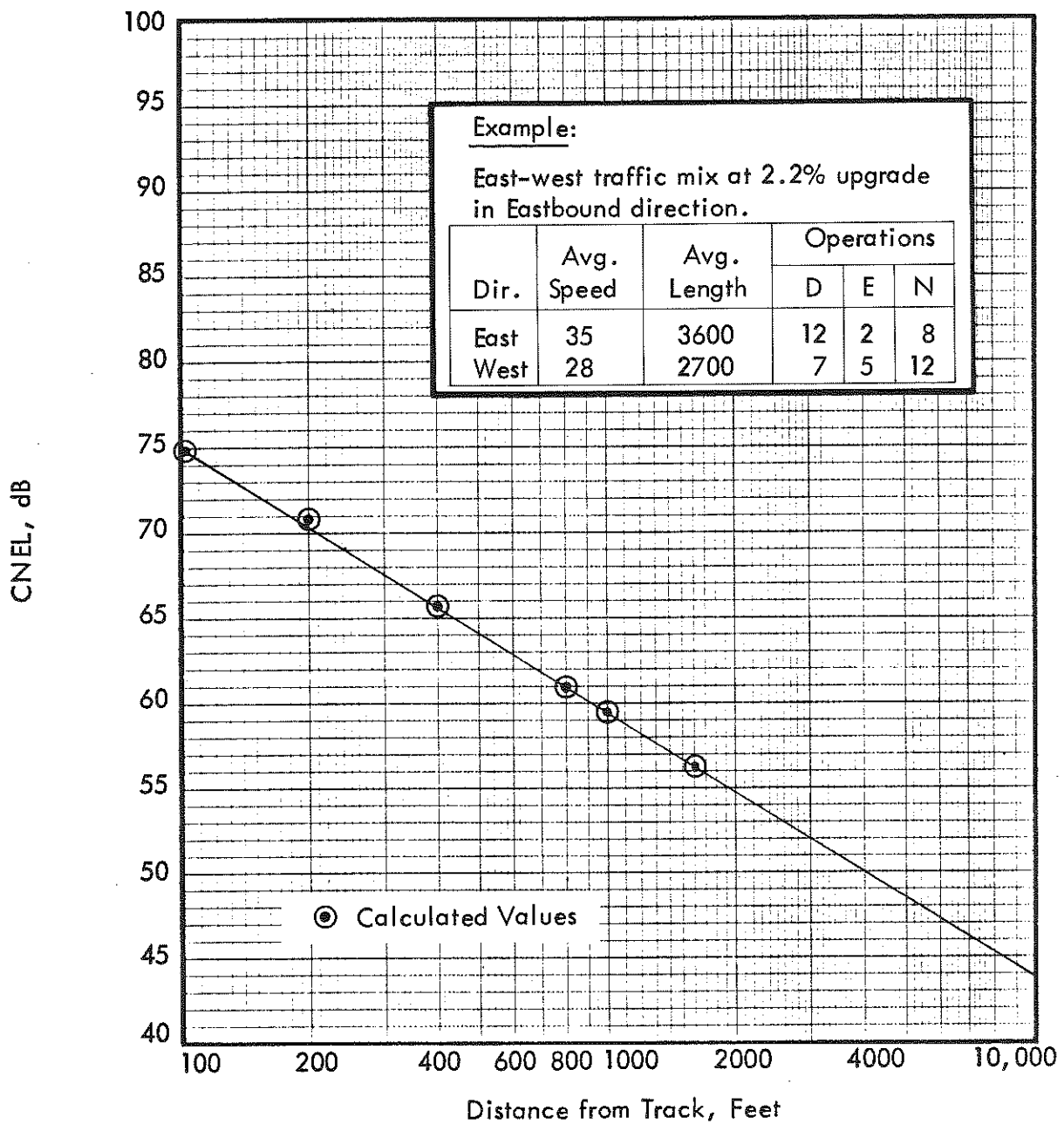


Figure 3.5-3. Example Application of Line Operations Methodology Illustrating Variation of CNEL Contour Values With Distance Away from the Tracks.

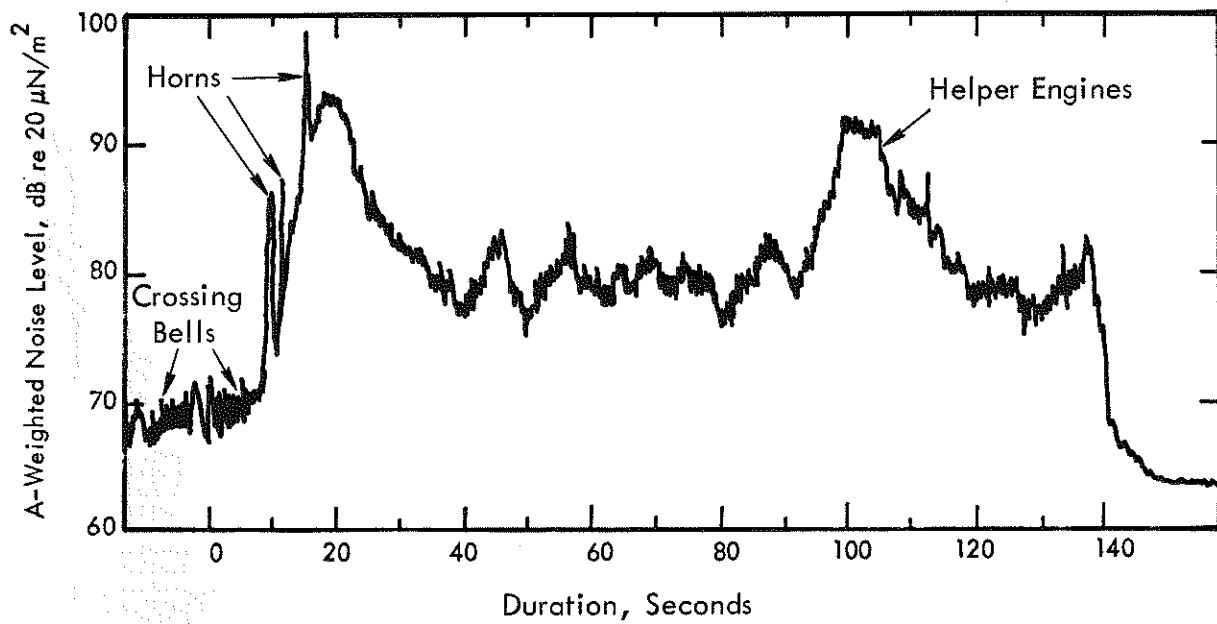


Figure 3.6-1 A-Weighted Time History of Train Pass-By at Edison, California Illustrating Warning Bells at Crossing and Horns from Locomotive (Measured at 100 Ft. from Track, 36 mph at +0.7 percent grade)

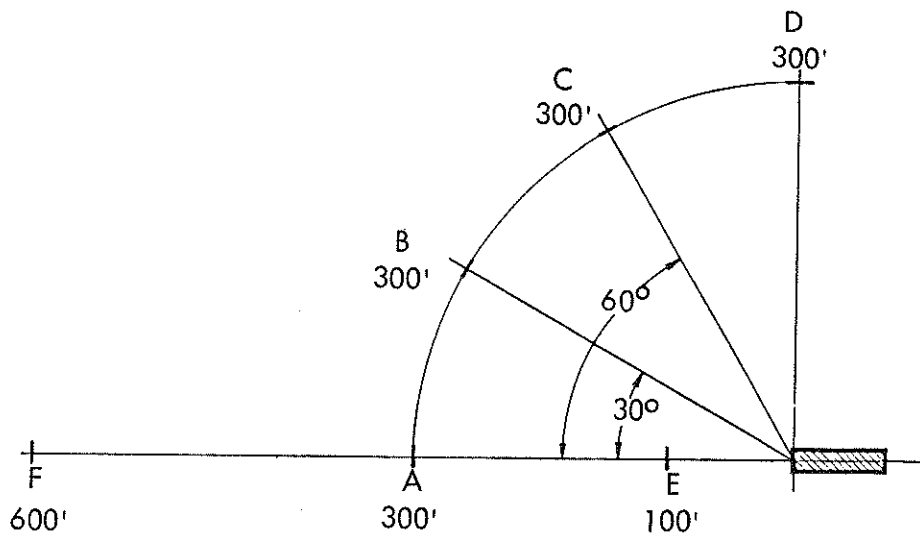


Figure 3.6-2. Directionality of Locomotive Horn Noise

Location	A	B	B	D	E	F
Distance	300'	300'	300'	300'	100'	600'
Angle	0	30	60	90	0	0
Range of C-Weighted Noise Level dB re $20 \mu \text{N/m}^2$	$94^{+6}_{-4}$	$94^{+3}_{-6}$	$91^{+6}_{-5}$	$89^{+5}_{-7}$	$105^{+5}_{-4}$	$87^{+5}_{-6}$

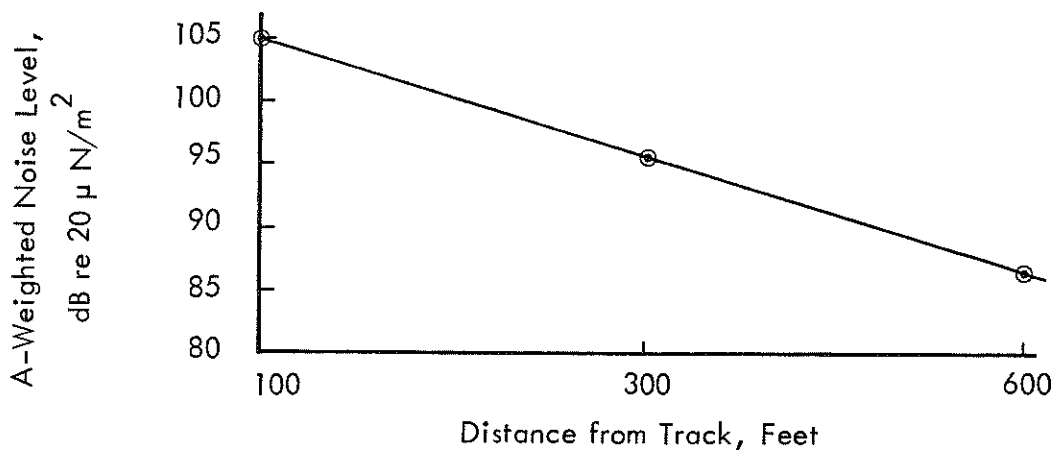


Figure 3.6-3. Noise Level of Locomotive Horn Versus Distance

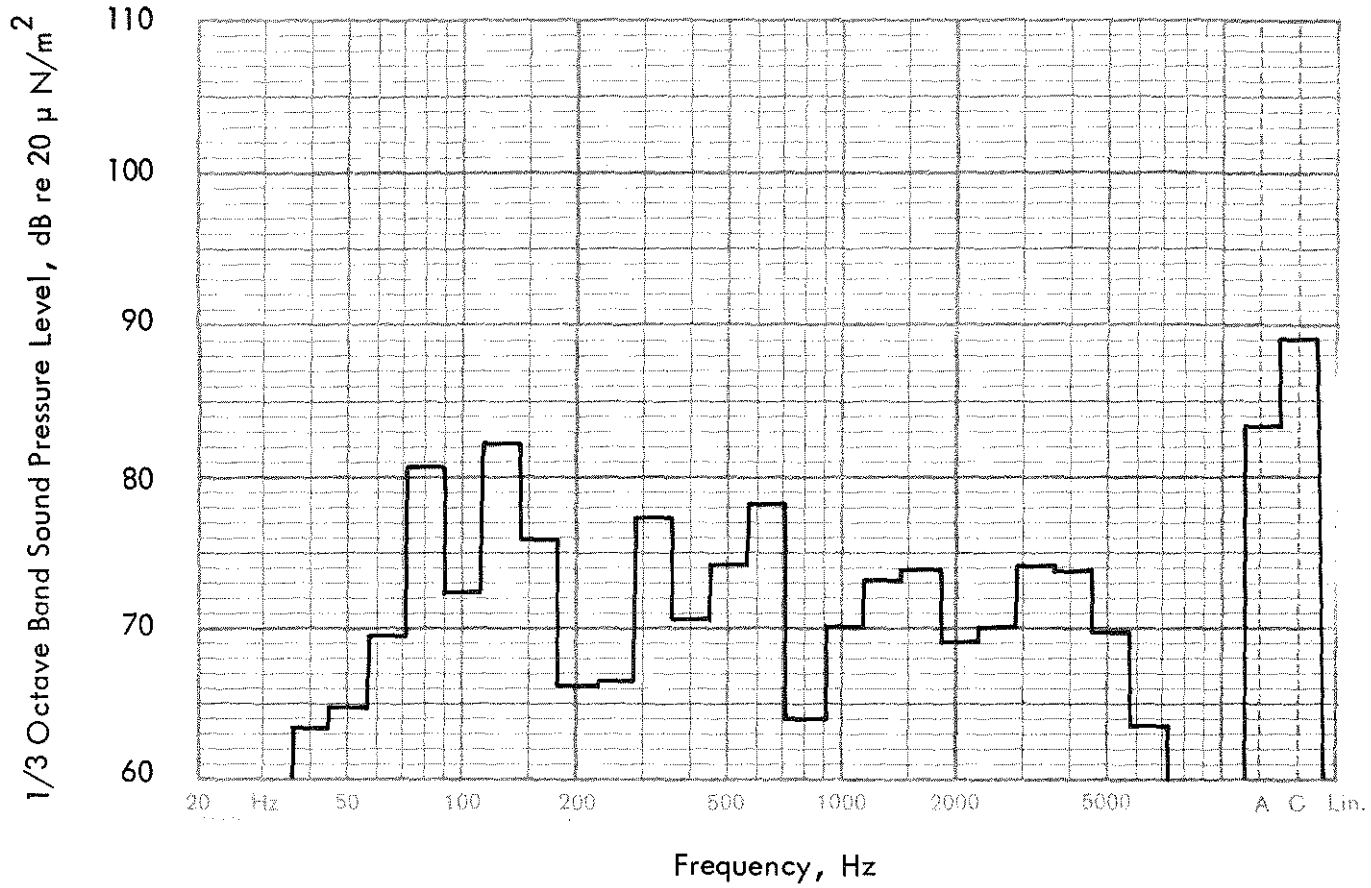


Figure 3.6-4 Frequency Spectrum of a Locomotive Horn (Measurement Distance Unknown).

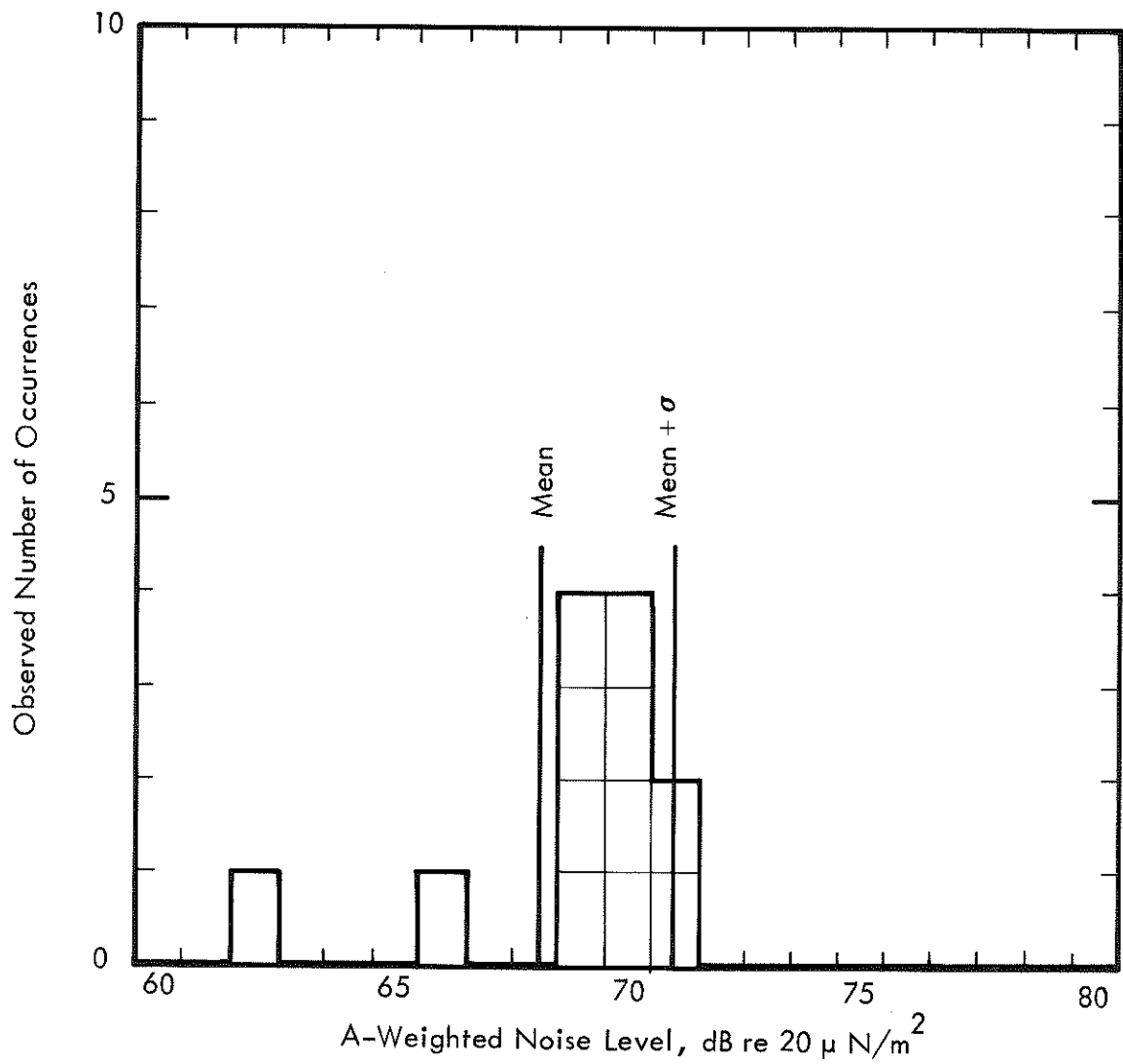


Figure 3.6-5 Distribution of A-Weighted Levels Emitted from Crossing Bells (Measurements Taken at 100 Feet).

Intentionally Left Blank

## 4.0 RAILROAD YARD OPERATIONS

### 4.1 Introduction

Only operations conducted within the confines of yard property boundaries will be considered for railroad yard operations. The majority of yard operations considered will be associated with the classification of freight cars in the yard complex and services related to performance testing and routine maintenance of locomotives. Additionally, noise emitted by stationary idling road engines and mechanical refrigeration cars will be treated. These operations may occur outside the yard boundary on sidings and spur tracks located throughout the surrounding community.

Discussion of this topic will consider first the physical operation of a classification yard and define those specific elements of the operation which are considered to influence the composite noise impact of the facility. These contributing elements will then be individually analyzed and the characteristics of the noise emitted by each presented. The noise levels emitted by individual yard operations will be expressed in terms of A-weighted sound pressure level. Since the spread of noise levels from these individual operations may easily encompass a band of 10 to 15 dB variation, the philosophy has been adopted to select representative levels from the upper limits of the data for projection into the community. These levels will be termed the "mean-maximum" quantities as determined by the statistical mean of the observed data plus one standard deviation.



Alternate methods for description of the composite yard noise environment are considered. The statistical measures of community noise, the  $L_{10}$ ,  $L_{50}$ , and  $L_{90}$  levels, represent the percentage of time a particular noise level is exceeded, i.e., 10 percent, 50 percent, and 90 percent, respectively. A yard synthesis model will then be developed from one of these potential methods and an example of application will be illustrated.

In order to establish a methodology for the estimation of noise levels emitted from operation of a railroad classification yard, one must begin by first defining the functions performed in the various areas of a yard. Clearly, for a given volume of activity in a yard (which may be defined in terms of total number of cars classified in a specified time period), there will be specific operations of equipment and facilities associated with this operation. For purposes of this discussion, railroad yards will be categorized into two general classifications: hump (or retarder) yards, and flat yards (although in actual practice, many yards contain both flat and hump yard switching areas and some have combinations of both, i. e., a mild downgrade sans retarders).

We wish to first analyze the operation of a classification yard (either flat or hump) by the following hypothetical discussion which considers the "classification cycle" for an incoming train which arrives, say, from the East at a West Coast yard for classification into local units for distribution, local trains, interchanges, etc.

As the incoming train approaches the yard from the East, it leaves the main line tracks at the easternmost end of the yard (designated C yard in Figure 4.2-1) and proceeds through the yard on what would typically be a set of tracks near the main line (generally an extension off the main line or storage track area) and stops (when its cars are completely contained on this track or multiple tracks depending upon train length) at the western end of the yard (A yard). At this point the road power is disconnected from the cars and, usually, the locomotive is driven to a local service facility for minor service (sanding, washing, oil inspection, refueling, etc.).

Locomotives are kept idling continuously except for major maintenance and following service may be sent to special engine set-off tracks or an engine spur. Similarly, a switcher crew will uncouple the caboose and transfer it to a separate caboose track. The train, now less road power and caboose, will be transferred to the switching tracks either when ready for classification or, under busy operations, it may be necessary to clear the set-off tracks for additional incoming units. Under optimum conditions, the cars would be moved off the set-off tracks only when ready to be humped or switched-out.

Depending upon the particular yard car capacity and operating procedures, the units to be reclassified will be in cuts ranging from the entire train length (to 100 cars or more) or in cuts of only 5 to 10 cars each.

Once on the switching tracks, the switcher engines (working singly or coupled together) begin to manipulate the cuts of cars to form new compositions down in the classification tracks (C yard) area. In a hump yard operation, the switchers push the cut of cars over the hump where, at the crest of the hump, the cars are usually released either singly or in multiple car cuts down the hump if bound for the same destination, through the master retarder, and switched out into any one of a number of classification tracks. Once through the master retarder, the cars may pass through one to two additional group retarders or individual track retarders which adjust their velocity ideally to achieve an impact just sufficient to attain coupling at a defined distance down the track.

The humping operation is generally the most efficient operation in terms of switcher engine utilization. Standard practice is to push as long a cut as is feasible (sometimes the entire train) at a constant rate (2 to 4 mph) over the hump. Depending upon the hump yard master, this entire cut may sometimes be classified in one continuous push by the switchers.

Flat yard switching, on the other hand, requires the switcher crew to follow a repetitive rev-shove-stop cycle on a given cut of cars. The switcher engineer will receive a "kick" sign from the crew. At this time, he revs up his engine and accelerates the cut of cars up to 4 to 5 mph. At the appropriate time, he brakes to a stop and the end cars are released down the track through the appropriate switches onto the classification tracks. This rev-shove-stop cycle is repeated until all the cars in the cut are classified.

Occasionally, in either operation, one or several cars are accidentally switched onto the wrong track and coupled into the wrong train. When this occurs, the switcher must travel down into the classification yard to retrieve the errant cars and reclassify them.

As the cars are switched out, they are directed onto different classification tracks depending upon their destination or when they are expected to be moved again. Those cars which are classified during the day and night shifts are termed the day and night spreads, respectively. Often in the classification of cars during a particular shift, some cars come up which are designated for trains which will not be formed until the next shift. Hence, for example, during operations on the day shift, the classification tracks will be filled with the day spread, and any cars that belong to the night spread will be diverted onto separate "sluff" tracks. At shift change, or when the yard is cleared of the day spread, these sluff tracks will be cleared and, in the case of a hump yard, these cuts of cars will be pulled back over the hump and then reclassified along with the normal night spread. Here again, the following day spread cars will now go to the sluff tracks, etc.

A particular spread will consist of units in several different categories. Of the units in this assembly, a number will be destined to go to local trains for further diversion throughout a broad area. These cars are either left in the classification tracks until road power and cabooses are added and they are pulled out as complete units (where they are pulled through an inert set of retarders at the far end of the classification tracks in a hump yard) or they are transferred by the trim engines which operate at the far end of the classification tracks from the master retarder over to the pick-up tracks where they await inclusion into another train passing through the yard.

Cars bound for industries in the near vicinity are generally transferred onto "local" tracks in the yard and then shuttled back and forth to the adjacent industries on demand. These shuttle operations are generally performed by the switcher crews and "local" trains. Still other cars may be classified onto "interchange" tracks where they await transfer to another railroad company's lines.

One particular deviation to the aforementioned full "classification cycle" is the occasional case where road engine switching is permitted. A particular example of this may occur when an incoming train consists of cars bound for just two or three destinations. In this case, the road engine crew would simply set-off the cuts of cars on two or three different pick-up tracks to await direct pick-up by subsequent trains.

In addition to the classification cycles in railroad yards just described, some peripheral activity goes on at a fairly regular basis. Classification yards typically utilize loudspeaker systems to give directions to yard crews from the tower. Also, at shift changes, the switcher crews generally return their engines to a switcher service area where they are serviced and usually sit at idle for 30 minutes to an hour every 8 to 12 hours. Additionally, the switcher crews will park their engines at idle at random locations in the A, B, and C yard regions at their break times.

The following conclusions may be drawn from the preceding discussion:

- A. In a given classification yard (flat or hump), certain reasonably well-defined types of operations occur in defined regions of the yard.
- B. For a particular classification yard, it would appear to be extremely difficult to assign a specific "classification cycle" (as discussed above) which is representative of all trains passing through that yard due to the extreme variability involved in incoming and outgoing train compositions.

At this point in the discussion, we may state that a classification (hump or flat) yard will always consist of at least the basic elements as illustrated in Figure 4.2-1. Yards may vary considerably in size and number of tracks (and hence number of switcher crews operating) and additionally may have any or all of the related service areas on the yard property: engine shops, car shops, load test facilities, engine service racks, etc.

Prior to actual formulation of a model of railroad yard operations, it is useful to discuss the nature of the noise emitted by each yard operation and consider how these levels may be affected by the activity volume of the yard.

4.3

The Nature of Noise Emitted by Railroad Yard Operations

Based on the discussion in Section 4.2 concerning classification cycles in a railroad yard, the significant noise producing operations and the operational modes of the equipment involved can now be itemized.

1. Locomotives - Road and Switcher
  - a. Switcher engine operations including road engines pulling trains through yard
    - uniform pull or shove
    - braking
    - acceleration
  - b. Idling road and switcher engines (singly or in groups of up to 25 or more)
2. Car Impacts
  - a. Single or multiple cars into standing cars - coupling
  - b. Chain reaction (slack action) impacts - start-up or stopping of a line of cars
3. Car Retarders
  - a. Master retarder
  - b. Group retarders or individual track retarders
  - c. Inert or pull-out retarders
4. Loudspeakers and PA Systems
5. Auxiliary Service Operations Performed in Yards
  - a. Engine load tests
  - b. Locomotive service racks and shop facilities
  - c. Operation of stationary mechanical refrigeration cars

The approach to yard noise prediction is to assign these various operations and services to specific regions of the railroad yard, and hence, using them as building blocks, create a total noise model of a railroad yard operation. By allowing variable placement of the building blocks, the model is adaptable to any particular yard under consideration.

Prior to formulation of the noise model, a brief discussion is in order of the nature of the noise emitted from the major types of yard equipment under their various operational modes.

#### 4.3.1 Road Locomotives and Switchers

The operation of diesel-electric locomotives represents a major source of noise emitted from yards. Both road engines and switcher engines are operated within the yard property. The operations treated involving road power will be limited to idling locomotives on engine spur tracks and sidings and in engine service facilities. Those operations involving road engines pulling cars within the yard property will be lumped together with switcher engine movements. These operations will be treated apart from those complete trains which bypass the yard on the main line and do not stop. Bypass operations are technically considered as a part of the line operations and are covered in Section 3.2.

##### 4.3.1.1 Switcher Movements Throughout the Yard

As a train departs from the main line on the main line extension, destined for the set-off tracks or storage track area, their speed is reduced considerably, generally down to 5 to 10 mph. At these low speeds, as illustrated by the time history of switcher movements in Figure 4.3-1, car noise will be at minimum levels except for occasional crossings or stop and start impacts. Hence, it is reasonable to consider only the noise emitted by the



slow running locomotives in these cases. The engines, depending upon design, will generally run at a number 1 - 2 throttle setting (275 to 400 rpm) which produces a noise dominated by low frequency content. The low frequency predominance (fundamental engine firing frequency less than 100 Hz) is illustrated in the spectral plot in Figure 4.3-2. Based upon a number of observations, average noise levels in the range of 76 to 80 dB(A) at 100 feet are emitted by switcher operations of this nature involving steady pulling at low speeds.

The majority of observed switcher operations involved short acceleration and braking cycles required to transfer cuts (or groups) of cars throughout various regions of the yard. Spectra illustrating both events are presented in Figures 4.3-3 and 4.3-4. As observed, the exhaust component dominates the lower end of the spectrum while brake application squeal is quite evident in the 5000 and 6300 Hz 1/3 octave frequency bands. A histogram of maximum switcher-generated A-weighted noise levels observed for a number of acceleration passbys is presented in Figure 4.3-5. The mean A-weighted noise level noted for these operations is shown to be approximately 80 dB(A). For purposes of predicting anticipated community exposure from these operations, it is recommended that the mean value plus one standard deviation (approximately 85 dB(A)) be utilized in subsequent model construction. The time histories of a number of these typical switcher movement cycles are illustrated in Figure 4.3-6.

While switcher operations involved in actual car classification are of a somewhat different nature in hump vs. flat yard switching situations (the hump operations being more of a steady push while flat switching involves considerably more start-stop cyclic behavior), it may be assumed that the noise output of switchers in either situation will be similar.

As for idling locomotives (to be discussed in the following section), the majority of noise emitted by switcher movements is heavily influenced by the exhaust component and, due to the placement of the exhaust outlet some 15 or so feet above the ground, does not benefit much from the acoustic barrier shielding effects of nearby cars and other locomotives.

Based upon the discussions of Section 4.2, it is apparent that switch engine movements may affect the noise emitted from any portion of the yard. However, the concentration of switcher activity throughout the yard will vary considerably. The highest density of switcher operations occur towards the central portion of the yard or that region which contains the hump or central classification switches. The remainder of switch engine activity is more or less randomly distributed over the extreme ends of the yard complex, reflecting the operations performed by the trim engines. As presented in Table 4.3-1, the major percentage of switcher running time is spent at idle (77%) with the remainder concentrated at throttle settings 1 (10%) and 2 (5%).

#### 4.3.1.2 Noise Levels from Idling Road Engines and Switchers

Common practice in railroad yards is to leave road engines and switchers idling while not in use. These engines are left running because diesels can become difficult to start when cold, and starting a cold engine can cause excess wear due to low oil pressure and seal leaks. Additionally, cold starts generally produce excessive smoke emission which the railroads seek to avoid. Idling road engines are usually found in congregations in the vicinity of the sand towers, fuel depot, wash racks, and diesel service facility. Idling switchers are also found in the same locations as idling road engines, although switchers are more frequently left idling in a pooling area when not switching cars. Generally, all switchers in

Table 4.3-1  
 Percentage of Time Spent at Specified Throttle Setting for  
 Typical Road and Switcher Locomotive\*

Throttle Setting	Locomotive Description	
	Switcher Engines	Avg. All Road Power
8	0	30
7	0	3
6	1	3
5	1	3
4	2	3
3	4	3
2	5	3
1	10	3
Idle	77	41
Dynamic Brake	0	8

\* Reference 1

a yard are pooled at one location between work shifts. As supported by Table 4.3-1, the occurrence of a diesel engine idling in a yard is very significant (41% to 59% of the time for road engines and 70% to 77% of the time for switchers).

Noise generation by idling locomotives is attributed to several sources; of these are the exhaust outlet, cooling fans and mechanical radiation from side panels. Standard idling rpm for road engines and switchers varies between 275 rpm and 450 rpm, depending on the model of locomotive. Observation of the frequency spectra of idling road engines and switchers, in Figure 4.3-7 and 4.3-8, respectively, show similar shapes at low frequencies due to the influence of the exhaust component although road engines appear to generate more noise in the higher frequency bands. Since high frequencies attenuate more rapidly with increased distance, due to air absorption, than low frequencies, the overall noise level of road engines drops more quickly than switcher levels as the observer moves away from either when idling.

Data were collected from a number of idling road diesels and switchers at various distances in order to arrive at an appropriate reference noise level. Since idling engines are usually only found in clusters, most data had to be acquired from a line of several idling engines. With the aid of the computer model described in Appendix E, the equivalent reference noise level for a single idling engine could then be determined. Histograms of the equivalent reference noise level values for idling road engines and switchers at 100 feet are presented in Figure 4.3-10. The mean and mean-maximum (mean plus one standard deviation) values so obtained are summarized in the table on the next page.

Table 4.3-2  
Noise Levels Emitted by Idling Locomotives

Locomotive Type	Mean	Mean-Maximum
Road Engine	68	71
Switcher Engine	64	65

As indicated, the noise output of idling road engines is approximately 4 to 6 dB(A) above that emitted by switchers. The computer model treats idling engines as uncorrelated point noise sources and calculates the combined noise levels for a line of any number of engines. Application of this technique is fully discussed in Appendix E. Actual data from a line of five idling diesels is compared with that predicted by this method in Figure 4.3-11 minus corrections for air absorption and excess ground attenuation values derived from Figure 4.3-9. Figure 4.3-12 illustrates an actual configuration of idling engines observed at a major yard facility. The calculated value of 77dB(A) compares favorably with that value actually measured of 79.5 dB(A).

#### 4.3.2 Car Impacts

Car impacts constitute one of the more randomly distributed sources of noise in a railroad yard. Car impacts fall under two classifications: those resulting from coupling of two cars, and the other occurring when the slack in the coupler assembly of a line of cars is suddenly taken out or in. The impact from coupling of two cars is the predominant type of impact in a hump yard; however, when a car being humped couples with a cut of stationary cars, a chain reaction of impacts often occurs. These chain reaction impacts usually have a considerably lower noise level than the level of the impact from the car being humped because much

energy is absorbed in rolling friction and in the coupler cushions as the impacts propagate down the cut of cars. On the other hand, when a cut of connected cars is switched into one classification track, both coupling type impact and chain reaction type impact are significant. An improvement in hump yard operation that reduces wear and tear on cars and reduces the impact noise due to coupling is obtained with the implementation of an automated retarder system. This system applies a computer calculated amount of retardation at each retarder stage to allow the cars to couple with a low impact.

Flat yard switching impacts are much more significant than hump yard impacts because of the back-and-forth action by the switcher shoving cars down classification tracks during the typical "rev-shove-stop" cycle. The impacts from moving cars coupling with stationary cars is of the same nature as those occurring in hump yards. In addition to the coupling impacts and the chain reaction type impacts, the removal of slack between cars in the start and stop operation of switchers can cause higher levels of noise over longer durations than a simple car to car coupling impact. These start and stop induced slack action type impacts may be controlled by the switcher operator's ability to accelerate and stop smoothly, but even with experienced operators, the occurrence of such impacts is quite frequent.

The nature of impact noise is attributed to the impulse seen in the couplers as the knuckles meet which transmits vibration into the body of the car. Noise is radiated from the walls of the car in the same manner as sound is emitted from the sides of a square tin can when struck by a sudden blow. For modeling purposes, it was necessary to treat the decrease with distance of impact noise as originating from a point source for observer distances greater than the length of the car. Although two categories of impact

events (two cars coupling and chain reaction) have been defined, the actual noise generation from a car should be the same for either case since the only requirement for impact noise is a shock between two knuckles. On the other hand, the level of noise will vary from impact to impact as a function of relative speed between cars, type of cars, type of couple (cushioned or non-cushioned), weight of cars, size and weight of load, and possibly spring rate of the car's suspension. Since the parameters involved in impact noise at a point in a yard vary randomly with time, it was considered impractical to predict impact levels based on information such as type of car, weight of car, etc., but rather take an approach to lump all impact levels together, and use the mean-maximum noise levels as a basis for estimates.

Figure 4.3-13 displays many impact level data points taken during typical classification operations at Santa Fe's Hobart flat yard and from the hump and flat yards at the Union Pacific yard in the City of Commerce. Data scatter are mainly attributed to lack of knowledge of the precise distance to the point of impact and the numerous parameters which affect the noise level of a particular impact. The distance defined in this figure is the perpendicular distance from the observer to the track upon which the impact occurred. Obviously, impacts occurring to the left or right of the microphone will be at greater distances than that indicated in Figure 4.3-13. Hence, the distribution of these data points is considered representative of the maximum levels from impacts under normal operations. However, the mean-maximum level (mean plus one standard deviation) shown of 91 dB(A) should be used for noise projections.

Time histories of impacts recorded at the Union Pacific flat yard are illustrated in Figure 4.3-14. Typical impacts last about one second, although the duration varies for chain reaction impacts. Frequency spectrum data is given in Figures 4.3-15 and 4.3-16 for the cases of two cars

coupling and a chain reaction impact. Analysis of the frequency spectra indicated rather broadband content out to around 2500 Hz with a rolloff at higher frequencies. A more detailed analysis would be required to assign contributions at particular frequencies to the components generating the sound. Such detail was not felt warranted for this investigation due to the generalized treatment of A-weighted noise levels resulting from all types of impacts.

#### 4.3.3 Retarders

A characteristic noise associated with hump yards is the high frequency sound occasionally emitted by car retarders. These retarders are categorized as master, group, and individual track inert retarders. A car being classified in a hump yard will first pass through the master retarder located a short distance past the crest of the hump. The retardation setting of the shoes is controlled by the operator, depending on velocity and weight of the car. In the special computer-controlled hump yards, retardation is calculated depending on car weight, number of axles, frontal area, car rollability, car standing time in yard, route, distance from retarder to coupling point, temperature, wind velocity and direction, and moisture. After a car has passed the master retarder, it goes through one or more switches and then makes a pass through a group retarder. In some yards, the cars pass through additional switches and a second group retarder. The retardation for the group retarders is determined by the same procedure as used for the master retarder. Master, group, and track retarders are usually of identical construction and operated by pneumatic or hydraulic cylinders, and are placed on one or both rails. Since hump yards have a slight grade, inert retarders are required to hold a classified cut of cars from rolling out the bottom of the hump yard. Inert retarders are either the constant retardation spring-type or of the self-energizing weight sensitivity controlled category. A typical hump yard retarder layout is depicted in Figure 4.3-17.



The mechanism for the generation of retarder screech is not well defined analytically, but is known to be of a stick-slip nature between wheels and the steel retarder shoes (Reference 8 ). Attempts to quiet retarders have met with partial success through the application of lubricant to the shoes or usage of somewhat ductile iron shoes in place of the standard heat-treated cast steel (Reference 8 ). These two methods have shortcomings in that the lubricant decreases retarder efficiency and the softer shoes wear out quite rapidly.

While a multitude of variables may affect the noise output of retarders, occurrence appears to be primarily dependent on speed of the car, its weight, and amount of retardation applied to control its velocity. Maximum sound pressure levels appear to be the same for both master and group retarders, although inert retarders are nominally about 15 dB(A) lower. Not all cars passing through the master and group retarders emit a screech. The rate of screech occurrence appears quite random. Inert retarders screech for two situations: (1) when a cut of cars is being pulled out of the classification tracks, and (2) when a car, being humped, collides with a stationary cut of cars, thus forcing the end car to move slightly in the inert retarder. For these two cases, only the former is significant. The duration of master and group retarder screech usually varies from one to five seconds and may yield noise levels which exceed 110 dB(A) at 100 feet. The duration of screech is considerably longer for inert compared to master or group retarders and the noise produced can exceed 100 dB(A) at 25 feet. Only directionality in the horizontal plane was investigated in this report. The spreading of sound appears to be quite uniform except in the direction of small angles between the observer and track where levels can drop 6 to 10 dB(A). Typical sound pressure level time history and frequency spectrum data are presented in Figures 4.3-18,

4.3-19, and 4.3-20. Master, group and inert retarder frequency spectrums are generally dominated by content in the 2500 Hz frequency band. The observed directional spreading of sound and shape of the frequency spectrum are consistent with the findings of Kendall (Reference 8 ). Kendall also looked at the case of spreading sound in the vertical plane where it was found that the sound level decreased rapidly for increasing height above the ground.

Since the variables which affect the level of retarder noise such as speed and weight of car can vary considerably throughout the classification of a cut of cars, it was appropriate to use sound levels typical of the maximum observed for many cases of screeching retarders. This was accomplished by plotting many data points of retarder noise levels normalized to 100 feet and determining the mean and mean-maximum noise levels of the distribution. The histograms for these studies are presented in Figures 4.3-21 and 4.3-22. The resultant mean-maximum noise levels so determined for master, group and inert retarders were 109 dB(A) and 94 dB(A) respectively at 100 feet distance.

The data used for development of these numbers were taken at Southern Pacific's Taylor Yard in Glendale, California and the Union Pacific Yard in City of Commerce, California.

#### 4.3.4 Loudspeakers and Public Address Systems

Public address loudspeakers, such as found in railroad yards, are designed according to characteristics such as power output, frequency response, and directivity to suit specific applications. In addition, emphasis is placed on ruggedness and adequate response in the mid-audio range. Public address speakers, typical of those utilized in a railroad yard, will reproduce speech with sufficient fidelity to maintain a high degree of intelligibility. Directionality of the speaker, or array of speakers, is selected to restrict the area of sound coverage.

Directivity of the loudspeaker is related to its effective cross-sectional dimensions; for instance, a larger diameter horn opening will be more directional at a given frequency than a small diameter horn. The directivity pattern may be used to predict the approximate sound level at a given distance surrounding the loudspeaker. Figure 4.3-23 illustrates the directivity of a typical PA loudspeaker at a distance of 10 feet for a speech spectrum input. This will generally represent the directivity at greater distances as well, but consideration must be given to the effects of reflections and other acoustic field distortions. When a speaker of this type is installed at a given location, the directivity may be affected by ground reflections, reflections from nearby structures, wind, air temperature gradients, and other minor effects. The totality of these effects can make gross changes in the SPL at distances far from the loudspeaker. These variations are generally not severe enough to adversely affect speech intelligibility.

The speech level at distances greater than 10 feet may be estimated based on "square law" spreading losses. That is, the level is 6 dB less for each doubling of the distance from the source. This would mean that a typical level at 100 feet would be approximately 90 dB(A) on the principal axis of the speaker. At other angles, the level would normally be less and may be approximately by using the directivity information. However, it is important to remember the variability of the sound level due to other factors may be greater than the variations produced by distance or angle from the source.

Generally, to meet nominal speech intelligibility requirements in yards, PA system levels of the order of 90 to 95 dB(A) at 100 feet must be generated. A second general requirement of such systems is that their levels produced be of the order of 10 dB greater than the noise environment in which they operate. This requirement is expected to yield values along the railroad property boundary in the range of 74 dB(A).

Actual measurements along the boundaries of yards yielded observed levels emanating from PA systems in the range of 70 to 75 dB(A); however, the distances to the noise sources were not determined.

#### 4.3.5 Engine Load Tests

When diesel-electric locomotives undergo a major engine service or repair, they are generally subjected to a series of static performance tests and functional inspections. These include tests of engine performance under load. By the nature of their traction motor propulsion system, locomotives can be essentially dynamometer tested at all throttle settings including full power by routing the electrical power generated into resistor banks termed "load boxes" adjacent to the test site.

Diesel-electric road engines are generally equipped with an onboard resistor bank and accompanying cooling fans as part of their dynamic braking system and hence have the capacity for some self-loading testing at the lower throttle settings. This mode of load test is usually conducted in the service rack facility, while the full power runs are made at load test installations, usually in the vicinity of the engine shop area.

The time required for a locomotive to complete load testing varies, but may last up to 60 minutes or more with at least 50 percent of this time spent at Number 8 throttle setting.

Load test facilities, like most railroad yard operations, are operated on a 24-hour per day basis with load tests being conducted any time during the day or night, as required. Analysis of load testing operations was primarily conducted at the Southern Pacific's Trolor Yard facility in Glendale, California. In addition to measurement of noise levels at a reference distance (50 feet) perpendicular to the track, some limited directionality investigations were conducted. Due to the close proximity of other

locomotives awaiting load testing and adjacent buildings, the directionality tests were necessarily conducted under less than ideal conditions. The net conclusion drawn from this effort was that the highest levels measured in any direction for the engines under load test should be the value projected into the surrounding community for noise contour generation.

The results of one such investigation are presented in Figure 4.3-24. The slightly reduced noise levels measured at 135° are probably due to shielding effects of the load box itself. The maximum value presented in this figure of 92 dB(A) is recommended as a mean typical value for load test operations for community noise impact analysis. The frequency content of the noise emitted by a 2500 hp locomotive under test at the Numbers 6, 7, and 8 (Full Power) throttle settings is presented in Figure 4.3-25. As indicated, the predominant frequency content falls in the lower frequency bands which correspond to the fundamental output of engine firing frequency.

#### 4.3.6 Locomotive Service Racks

As discussed in Section 4.2, most locomotives which come into a yard are serviced either locally or in the near proximity. This servicing is primarily a routine maintenance inspection at which time the locomotives are washed, sanded, fueled, and have their lube oil analyzed. Other minor underbody inspections and lubrications may also be performed. The nature of these operations are such that they make only minor contributions to the overall yard noise. The main source of noise emitted by engine service racks, and engine shops in general, may be attributed to the running of the engines themselves. As stated in Section 4.3.1, the engines are not shut down during routine operations. Thus, for the most part, the noise environment

of service racks is created by the cluster of idling locomotives present in the facility at any given time. Occasionally, during these routine inspections, the locomotives are self-loaded at the lower throttle settings for cursory performance checks. The duration of these self-loading tests is generally of such a short period that the mean noise level created by the idling engines will not be significantly affected.

A large service facility is able to handle 20 to 24 units simultaneously. An average time required for a locomotive to undergo service at Taylor Yard has been reported to be in the range of one and one-half to two hours. The total number of engines services in a facility of this size will normally range from 110 to 160 units per day (Reference 9).

Estimation of the noise emitted by operations of this nature should be treated in the same manner as used for combinations of idling locomotives, as discussed in Section 4.3.1.2 and Appendix F. Using this procedure yields an estimated value of 74 dB(A) at 300 feet for the Taylor Yard facility operating at full capacity.

#### 4.3.7 Mechanical Refrigerator Cars

Over the past few years, the railroad industry has been gradually changing over from block ice-cooled perishable transport cars to closed system diesel engine driven mechanical refrigerator units. It is estimated that there are presently 26,000 of these units in operation in the United States. The largest single operator of these units is the Pacific Fruit Express Company of San Francisco. PFE's mechanical refrigerator car fleet numbers approximately 13,000, the majority of which are equipped with GM model 2-71 engines. There are approximately 170 GM model 2-53 engines still in the fleet but are expected to be retired and replaced by the model 2-71 in 1973.

While awaiting transit, refrigerator units are kept running continuously at one of two throttle settings, depending upon cargo and external heat load. For the most predominant varieties of refrigerator units, these engine speeds are generally in the range of 800 rpm for the low throttle setting and 1200 rpm for the high throttle setting. Some older units were run at 1800 rpm, but these have been largely replaced by the lower speed units.

A typical layout of the mechanical refrigerator unit is as illustrated in Figure 4.3-26. As cars of this general description are deemed most predominant, only this type are covered here. Field measurements of the noise emitted by mechanical refrigerator units were conducted at locations deemed representative of typical situations. These locations are itemized as follows:

- (1) Local spur track at fruit packing house - adjacent to residential housing development.
- (2) Shop facility - car repair yard.
- (3) Central facility in classification yard.
- (4) Tracks adjacent to yard boundary.

It was observed that noise levels which emanate from the engine side of the car (engine radiator side) generally exceed those levels out of the condenser side by 5 to 6 dB(A). The amount of noise emitted on either side of the unit may vary somewhat depending upon the capacity of the refrigeration unit (which depends on car size and amount of cooling required) and the model of manufacturer of the compressor unit itself.

Table 4.3-3 lists noise values considered typical of mechanical refrigerator units, based upon the selected field measurements carried out in this study. In the instances where units were measured in the yard and service facilities, it was not possible to obtain unobstructed measurements at 50-foot distance from the cars. For these cars, indicated by asterisks in Table 4.3-3, near

field measurements were made in the vicinity of the radiator grill opening on the engine side and the grill covering the condenser coils on the condenser side. The mean A-weighted near field noise levels over the entire areas of the grill openings were combined with the areas of the grills (in square feet) to yield a measure of the acoustic intensity of these grill openings. Noise levels were then extrapolated to larger distances, assuming an idealized piston model for the noise source and an empirical directionality pattern (Reference 10). The results obtained by this technique were verified by both measurements of the near field and at 50 feet on one model at the low throttle setting. The calculated and measured values were in agreement within 1.5 dB.

The directionality of the noise emitted from mechanical refrigerator car operation was also studied. Since the exhaust exit is located atop the car, its contribution to the overall noise levels is rather nondirectional in a horizontal plane. However, engine grills are essentially rectangular openings in a flat plane, which would tend to suggest the possibility of a fairly directional noise emission pattern. The noise levels of several cars were measured over 45-degree increments of a 50-foot radius emanating from both engine and condenser grill openings, as illustrated in Figure 4.3-27. These measurements indicated that, over angles ranging from  $\pm 45^\circ$  to the line perpendicular to the track, the noise levels typically varied by less than 1 dB. At those positions near the track ( $90^\circ$  off the perpendicular), the levels were generally down by 3 to 6 dB due to shielding effects of the measured car itself or the next car coupled to the measured car at the engine end. When a second car was not present at the engine end, levels adjacent to the track were usually similar to the perpendicular measurements. Since this program is concerned primarily with community noise, the levels occurring along a line parallel to the tracks can be neglected and consideration given only to those levels in a direction  $\pm 45^\circ$  from the perpendicular to the track.



Table 4.3-3

Typical Noise Levels Emitted by Mechanical Refrigerator Cars			
Model: Engine/ Compressor	Operating Mode	A-Weighted Noise Level in dB (re $20 \mu \text{N/m}^2$ ) at 50 ft.	
		Engine Side	Condenser Side
2-71/ Trane	Low Throttle: 800 rpm High Throttle: 1200 rpm	69.5 76.5	66 * 70.5*
2-71/ Carrier	Low Throttle: 800 rpm High Throttle: 1200 rpm	— 75.5*	65 (66.5*) 71
2-71/ Carrier	Diesel off - motor compressor driven by 220V auxiliary electrical power- High Setting	61*	64 (63*)
3-71/ Trane	High Throttle: 1200 rpm	80*	73.5*
3-53/ Trane	High Throttle: 1200 rpm	80.5*	71.5*

\* Calculated via near field measurement procedure and analytical technique.

Figure 4.3-28 presents one-third octave band frequency spectra at 50-foot distance (perpendicular to the track) for both the engine and condenser side of a typical refrigerator unit at the high and low throttle settings. As indicated, low frequency dominance of the spectra to the diesel engine is apparent on either side of the car. Typically, the high throttle setting, when measured on either side of the car produces noise levels from 7 to 8 dB higher than the low setting.

To compare noise from diesel versus electrical drive of the units, Figure 4.3-29 presents a spectrum of the noise emitted on the condenser side when the refrigeration unit is run by auxiliary 220 V electric power. It appears that use of auxiliary electrical power under standby conditions may be a potential method for achieving noise reductions of the order of 5 to 6 dB in critical localities.

Regions which yield large amounts of agricultural produce normally see a high volume of mechanical refrigerator car movements. It is a common practice to compose entire trains (typically on the order of 100 cars) solely of mechanical refrigerator cars.

Section 3.2 describes the speed dependent nature of the wheel/rail noise emitted by freight cars. At 22 mph, the noise level emitted by wheel/rail interaction is of approximately equal magnitude to that emitted by a line of mechanical refrigeration units. The noise produced by the refrigeration units may be assumed relatively constant, hence below 10 mph it will dominate the noise level of the train passby while above this speed, the wheel rail noise will assume increasing dominance up to approximately 50 mph where the refrigeration unit contribution is no longer significant. Thus, the noise produced by a moving mechanical refrigerator car train may be categorized into the following three classifications depending on speed:

- (1) Less than 10 mph, the cars are traveling at a low enough speed that the noise from the refrigerator compartment completely masks the wheel noise;
- (2) 10 to 50 mph, neither the refrigerator compartment noise nor the wheel noise dominates, hence, the overall noise level is a composite of the two noise sources.
- (3) Greater than 50 mph, the car is traveling at a great enough speed that the wheel noise completely masks the refrigerator compartment noise.

Hence, for line operations of a train composed entirely of mechanical refrigerator cars, a refinement of the CNEL contour procedures presented in Section 3.4 can be made by the following method.

#### Modified Refrigerator Car Train Procedure

In place of C1 (A-weighted Noise Level of the Passing Cars) from Figure 3.4-2, use the new value of C1 from Figure 4.3-30 for a train composed solely of mechanical refrigerator cars.

- (A) For speeds less than 10 mph, C1 was calculated as 77 dB(A) at 100 feet by Equation E-4 (Re: Appendix E - for the condition of a line of 100 mechanical refrigerator cars using a reference noise level for one car equal 70 dB(A) at 100 feet. Calculations were made for various length lines of mechanical refrigerator cars and it was observed that the noise level remained unchanged for lines with more than 50 cars, and the noise level equal 77 dB(A) at 100 feet became conservative for a train with less than 50 cars).
- (B) For train speeds between 10 and 50 mph, C1 on Figure 4.3-30 was determined by the decibel addition of the mechanical refrigerator car noise and wheel noise components.

(C) For train speeds greater than 50 mph, wheel/rail noise dominates and CI for this speed range (calculated by Equation 3-1) is also found on Figure 4.3-30.

A second refinement to the CNEL contour procedure in Section 3.4 is to use the value of  $\alpha$  (distance attenuation factor) from Figure 4.3-31 for a train composed entirely of mechanical refrigerator cars traveling less than 50 mph in place of the value given in Figure 3.4-4. For speeds equal to or greater than 50 mph,  $\alpha$  may be determined from Figure 3.4-4. Other than the new values of CI and  $\alpha$  from Figures 4.3-30 and 4.3-31, the CNEL calculation for an entire train of mechanical refrigerator cars remains the same as in Section 3.4.

#### 4.4 Potential Techniques for Estimation of Noise Emitted by Railroad Yard Operations

In the previous sections the activity cycles which occur during classification operations and the nature of the noise associated with the various operations involved in these cycles have been discussed. What must now be considered is a simple, reliable, and reasonably accurate methodology for assessment of the impact to the surrounding community resulting from the cumulative noise emission of the operations involved. A study of this problem, which involved investigations of the major yard operations in and around the Los Angeles area, produced four potential techniques for consideration.

The potential options for noise assessment of yard operations are as follows:

1. Statistical measure of lumped events at specified key locations in a railroad yard complex (centralized hub of activity concept). Hence, measurement of  $L_{10}$ ,  $L_{50}$ ,  $L_{90}$  (where  $L_x$  is the A-weighted noise level exceeded "x" percent of the time) levels could then be extrapolated to the yard boundary. For this method to be successful, the  $L_{10}$ ,  $L_{50}$ ,  $L_{90}$  levels would correlate to the volume of activity within the yard.
2. Statistical measure of yard activity at key locations along the yard boundary. Again, as in 1, the levels would theoretically correlate to activity volume.
3. Noise contours based solely upon the A-weighted noise level emitted by individual operations, independent of duration or frequency of occurrence.
4. CNEL,  $L_{dn}$ , or other A-weighted duration-corrected noise contours around yard operations based upon predictable SENELs of yard operations and incorporating corrections for time of day and frequency of occurrence.

The relative merits of these techniques and the problems associated with their implementation are discussed as follows:

The first method considered was based on a centralized hub of activity concept. The base for this concept is a statistical measure of yard activity at specific centers within the yard. The statistical quantities so determined ( $L_{10}$ ,  $L_{50}$  and  $L_{90}$  levels), either through discrete sampling throughout the 24-hour day or continuous 24-hour recording of data, would then theoretically be weighted to reflect the number of cars handled for each specified time period. The key to this technique would be the ability to identify three or four main centers of activity at which measurements could be made at standard reference locations and that these measurements would then theoretically reflect the level of activity of the yard.

In an effort to more fully evaluate this technique, studies were conducted at three yards with the intent of obtaining statistical measures of the main activity centers in these yards (Appendix G). The immediate problems which arose were first, defining, and then, determining the location of "main" activity centers. Clearly, in a hump yard, the region around the master and group retarders may be considered a primary activity center; however, location of all other "main" centers become more difficult. Switcher engine movement may encompass the entire length of a yard and over this entire length, car impacts are likely to occur. Additionally, the entire classification track area is subject to impact noise on a more or less randomly distributed basis. Also, the fact that a given number of cars may have a widely varied number of operations associated with them in their

classification cycle makes it very difficult to assign a quantitative activity volume index to the various statistical quantities measured. A further difficulty encountered with this approach stems from the observation that, while all classification yards may indeed have similar components and perform identical operations, yards are generally laid out in totally individual arrangements. This means that selection of a standardized reference location for measurement becomes highly impractical. It must be concluded that although some areas of a yard, specifically the hump area, produce higher activity levels than others, by and large, the activity of a yard operation is too spread out and randomly distributed to allow the "hub of activity" concept to be a practical or workable consideration.

The next method which received consideration was also based upon a statistical measure of yard activity, but the measurement stations were positioned along the yard boundary in hopes of alleviating the problems associated with definition of principal activity centers. A six-point boundary measurement survey was conducted at Taylor Yard, Glendale, California, to evaluate the potential usefulness of this technique. The results of this survey and the measurement locations are presented in Appendix G. In general, the 10-minute sample times utilized for this survey were of insufficient duration for accurate measurement of the yard activities, indicating that due to the random nature of most yard operations, 24-hour continuous recordings would most likely be required. Additionally, since the volume of activity within most yards goes through a high and low cycle throughout the week, it would appear that, as a minimum, the highest and lowest volume days would each have to be monitored for 24 hours.

Unfortunately, some of the same problems that plagued the "centralized activity hub" concept were again apparent here. One of the foremost problems, which is common to all techniques, is that the amount of yard activity which may be associated with classification of a given number of cars may vary quite markedly. Hence, it again becomes extremely difficult to relate the measured  $L_{10}$ ,  $L_{50}$ , and  $L_{90}$  levels to a well-defined number of cars classified. A further difficulty which may arise in attempting to obtain the measured statistical values is that of generally high ambient noise levels in the vicinity of most railroad yards. As may be observed in the data taken at Taylor Yard, both the  $L_{90}$  and  $L_{50}$  levels are controlled by the ambient, a problem not only in this effort, but a potential problem facing any regulatory officials attempting to evaluate these levels. Perhaps the most severe restriction on this method is the fact that at the yard boundary, certain activities which will naturally occur in the near proximity to the measurement stations will tend to obscure the overall picture. For example, an idling locomotive or a passing switch engine may completely mask the impact and retarder outputs emanating from the center of the yard. Furthermore, measurements at the property boundary may be lower in some cases due to barrier shielding of cars, etc., which are much less effective barriers to sounds perceived at distances farther into the surrounding community. The only solution to the aforementioned problems is, in itself, unrealizable. Ideally, one would measure levels at, say, 500 feet from the boundary and hence minimize localized disturbances and misleading barrier attenuation effects. Unfortunately, measurements at a 500 foot distance are usually impractical due to the ambient noise levels and generally industrialized land use of adjacent properties. A further limitation of the boundary assessment approach is the physical size and layout of a typical yard. Far too many measurement stations would be required to adequately assess noise levels emanating from the vast expanse of tracks, sometimes extending over a two to three mile area.



The third method considered would be a relatively straightforward, conservative approach which would simply create outer noise envelopes around the yard operations at various predicted mean-maximum A-weighted noise levels which would, in essence, represent the maximum potential impact of yard operations. This technique would consider noise produced by individual or closely related events and assign a sphere of influence in terms of individual noise contours around each event which may be applied like building blocks over that portion of the yard where it might logically occur. A composite A-weighted noise contour of the entire operation would then be created by connecting the outermost extensions of the individual contours. Through use of the building block type of approach, this method could be easily tailored to any given yard configuration. Furthermore, this concept is based upon easily measured quantities (in dB(A)) which, by virtue of the mean-maximum philosophy, would be largely independent of the variables which affect noise output of individual operations.

The primary drawback to this approach is that it does not totally satisfy the requirements of the State Code 65302 in that duration of individual events are not considered nor are frequency of occurrence nor time of day.

The final method considered and the one deemed most appropriate for noise assessment of railroad yard operations draws from the previous three approaches in an effort to create the most usable and workable technique without undue complexity. This technique utilizes mean-maximum A-weighted noise levels of generalized events in combination with observed typical durations to create estimates of Single Event Noise Exposure Levels (SENELs) for individual yard operations. Centralized locations in the yard are then assigned particular activities or series of activities. The noise emitted by these events is then assumed to emanate from these central positions. A detailed study has been performed to analyze the record keeping practices of the railroads of their yard operations in an effort to provide sufficient information regarding levels

of activities and volumes of operations in various yards. It appears that sufficient information is available to yield adequate data for at least a first approximation of frequency and time of occurrence for events and mean durations of these occurrences.

The final output of this approach is in the form of A-weighted, duration-corrected noise contours which additionally account for number of operations and time of occurrence during the 24-hour day. The rating scale utilized for this presentation will be the day-night level:  $L_{dn}$ . The resulting composite noise levels will be nearly identical to corresponding values that would have been obtained using the CNEL scale.

The construction of  $L_{dn}$  noise contours and a stepwise procedure for application of this technique are presented in the following sections.

#### 4.5 Quantification of the Noise Emitted by Railroad Yard Operations

As discussed in Section 3.3.1, the California Code No. 65302 recommends not only that A-weighted levels be used to describe the magnitude of the noise but that, in addition, corrections be added to reflect the duration of each event and the total number of occurrences per 24-hour period. The Single Event Noise Exposure Level (SENEL), as discussed in Section 3.3.2, is again utilized to account for maximum level and duration of noise events. A rating scale similar to that used for line operations, termed the  $L_{dn}$ , was selected for overall description of yard noise emission.  $L_{dn}$  is essentially the same as the previously used CNEL, however, it is simplified slightly by the elimination of special weighting for the evening time period.  $L_{dn}$  can be defined as

$$L_{dn} = \overline{\text{SENEL}} + 10 \log (N_d + 10 N_n) - 49.4, \text{ dB} \quad (4-1)$$

where

$\overline{\text{SENEL}}$  is the average SENEL (as defined in Equations 3-2 and 3-3) of a particular event.

$N_d$  = number of daytime occurrences, where day is defined as 7 am to 10 pm. (Note: The evening time period as used in CNEL is simply lumped into the day category.)

$N_n$  = number of nighttime events, where night is defined as 10 pm to 7 am.

The multiplication of  $N_n$  by a factor of ten weights occurrences at night as ten times as significant as those during the day.

##### 4.5.1 Definition of Predominant Noise Centers

Section 4.2 discusses in detail the many operations in classification yards. These yards can vary from relatively small switching areas to large facilities which include hump yard classification, flat yard switching, road engine and switcher servicing and repair, car servicing and repair, mechanical refrigerator

car servicing and discrete areas for train arrival, make-up and departure. The placement of these operations throughout the yard property is different from yard to yard and no general description of a yard's composition and layout can be made. On the other hand, the majority of operations within individual categories throughout the yard are reasonably well defined and may be assumed to occur in centralized areas termed "noise centers". We wish to deal primarily with noise centers located in the following major segments of a railroad yard:

- (a) Arrival Tracks (Receiving Yard)
- (b) Classification Tracks
- (c) Departure Tracks (Departure Yard)
- (d) Engine Service Areas
- (e) Repair Shop Facilities (Primarily Engine Load Test Operations)

In a receiving yard, one area may be dominated by switch engine noise resulting from caboose removal while another area may typically have heavier activity as the road power is cut from the train and transferred to the engine service area. Additionally, cuts of cars are often pushed directly from a receiving track, over the hump yard crest, thus distributing the noise of the hump engine over the entire length of this track.

Dominant noise areas in hump yard classification operations can be broken down into screeching master and group retarders at one end, car impacts distributed over all the tracks and inert retarder screeches distributed at the bottom of the hump yard. Flat yard classification typically is marked with concentrated switcher noise along switching leads and impacts distributed throughout the flat yard. In addition, this flat yard activity may be proportioned with a higher percentage of the switching at the leads at one end of the flat yard than at the other.

Departure yard noise emission may include heavy switcher and car impact noise along a switching lead as trains are made-up, distributed light switcher activity throughout the departure tracks, and high level road engine noise at the departure end as a train accelerates out of the yard. In some yards, train arrival, flat yard car classification, train make-up and train departure may intermingle over the tracks in a central portion of the yard and the function of a particular track at any time will depend primarily on its availability.

Idling road engines and switchers can be found in various locations throughout the yard and their specific locations are usually assigned to areas such as engine receiving and ready tracks, service racks, fueling and sanding depot and switcher pooling areas. It is also common to find groupings of mechanical refrigeration cars and these are normally parked on designated tracks throughout the yard.

In order to predict the total noise emitted from any yard, noise centers must be defined based on prior knowledge of the yard's activity. Given these noise centers and typical activity levels, first approximation noise projections can be made into surrounding areas. The specific noise centers applicable to this study have been identified as follows:

- 1) The length of the track an engine must travel to push a cut of cars over the crest of the hump.

This length will vary depending on the length of the cut being classified but an average length of track typically traveled should be assigned. In the case of a receiving yard where several tracks are used throughout the day to hump a cut of cars, a central location between these tracks should be used. For instance, say the cuts in the receiving yard in Figure 4.5-1 are to be classified, a noise center of hump engine activity should be defined by a centerline down the receiving tracks.

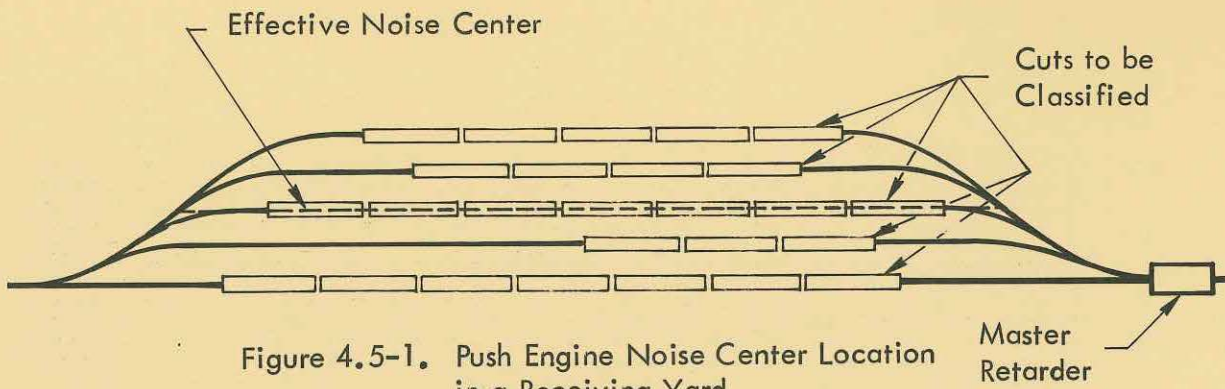


Figure 4.5-1. Push Engine Noise Center Location in a Receiving Yard

2) Concentrated areas of flat yard switching.

Noise centers for switchers undergoing the "rev-shove-stop" cycle can be assigned to a point along switching leads half way between the first and last switching track that takes off the lead as illustrated in Figure 4.5-2.

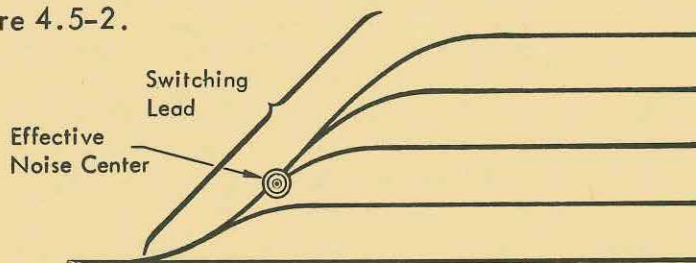


Figure 4.5-2. Concentrated Switching Noise Center Along a Switching Lead

3) Concentrated areas of chain reaction impacts due to the "rev-shove-stop" cycle along switching leads will have a noise center defined by the effective noise center in Figure 4.5-2.

4) Distributed switcher movement over a large area of tracks.

Where a switcher does random switching such as pulling single cars out of set-off tracks or train make-up trim, a noise center can be established along a centerline down the area of random switching as in Figure 4.5-3.

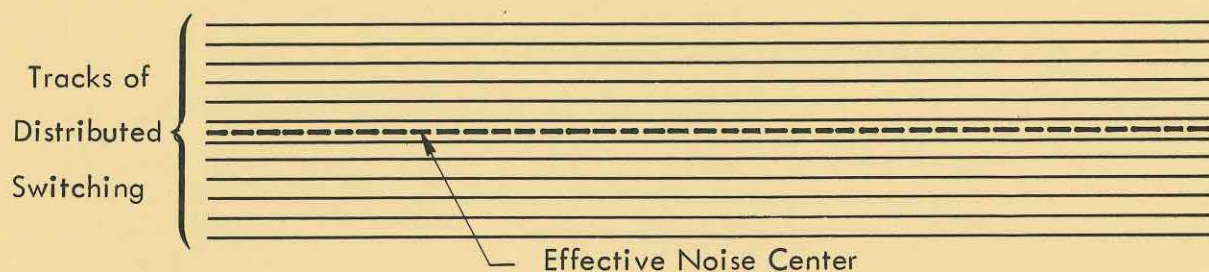


Figure 4.5-3. Effective Noise Center of a Large Number of Tracks with Distributed Random Switching

- 5) Distributed impacts over a large area of tracks.

For the case of randomly distributed impacts that occur in hump yards and areas of random switching, a noise center can be defined by a central line through the area similar to that in Figure 4.5-3.

- 6) Noise emitted by the master and group retarders.

Retarder noise may emanate from a combination of master and several group or individual track retarders. Ideally, one noise center can be used for all these retarders and this noise center should be placed at the overall geometric mean location of the retarders. This geometric mean location is found by the following process. Using a layout of the master and group retarders shown in Figure 4.5-4, draw a vertical line through the master retarder.

Since each car has the option of traveling one of several routes and must pass through any number of retarders per route, the geometric mean location of the retarders for each possible route must first be found. This position for each route is at a distance from the vertical line through the master retarder equal the sum of the individual distances between each retarder along a particular route and the vertical line divided by the number of retarders a

car will pass on the route. The overall geometric mean distance to the right of the master retarder is taken as the average distance of the individual geometric means for each of these routes. The overall geometric mean position in the vertical direction is calculated by the identical method as was in the horizontal direction and a convenient reference line may be placed through the retarder furthest down on the page. The vertical and horizontal reference lines and the overall geometric mean location for a set of master and group retarders is illustrated in Figure 4.5-4.

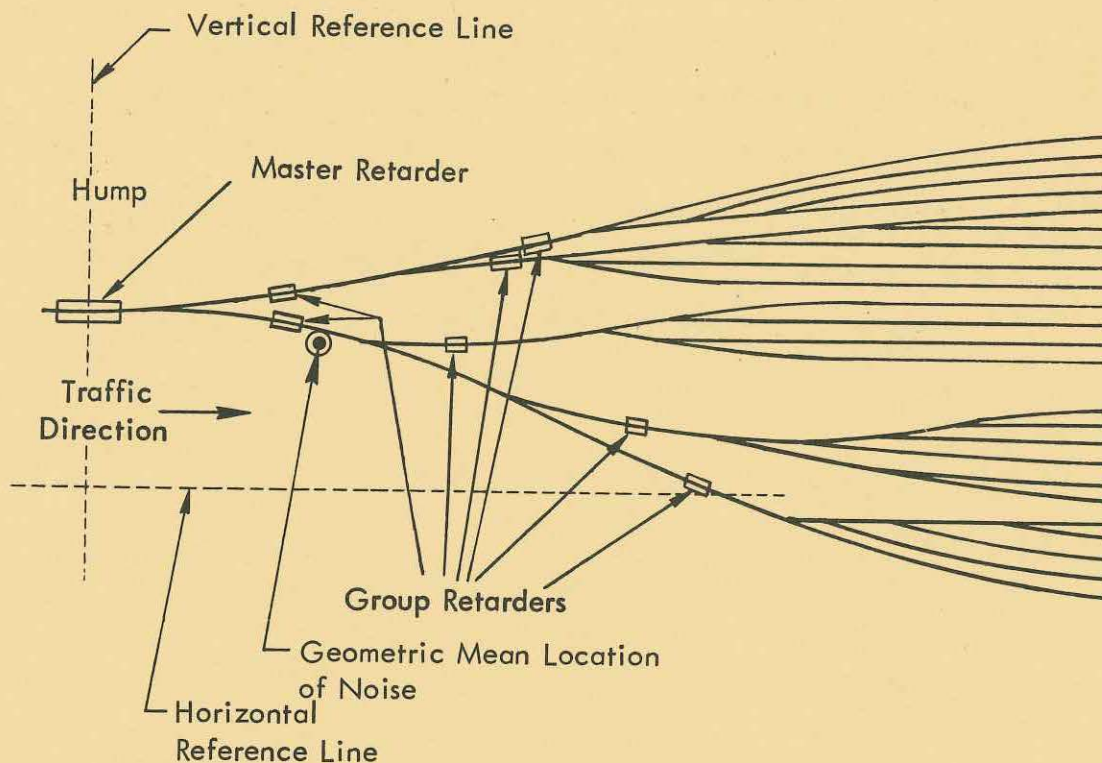


Figure 4.5-4. Effective Noise Center Among Master and Group Retarders



7) Noise emitted by inert retarders.

These retarders are usually spread over a much broader area of the hump yard than master and group retarders and it was deemed appropriate that noise centers should be assigned two locations.

Inert retarders are usually distributed in a non-symmetric fashion and some judgment is required to break the inert retarders into two groups. The geometric mean location for each of these two groups is found by the following process. Using a layout of the retarders, draw a vertical line through the retarder to the left most of the group and a horizontal line through the retarder nearest the bottom of the layout. The geometric mean to the right of the vertical line is equated by the sum of the individual horizontal distances between the vertical line and each retarder divided by the total number of retarders in the group. Again, the geometric mean above the horizontal line is given by the sum of the individual vertical distances between the horizontal line and each retarder divided by the total number of retarders. Figure 4.5-5 illustrates the position of the geometric mean for each of the two groups.

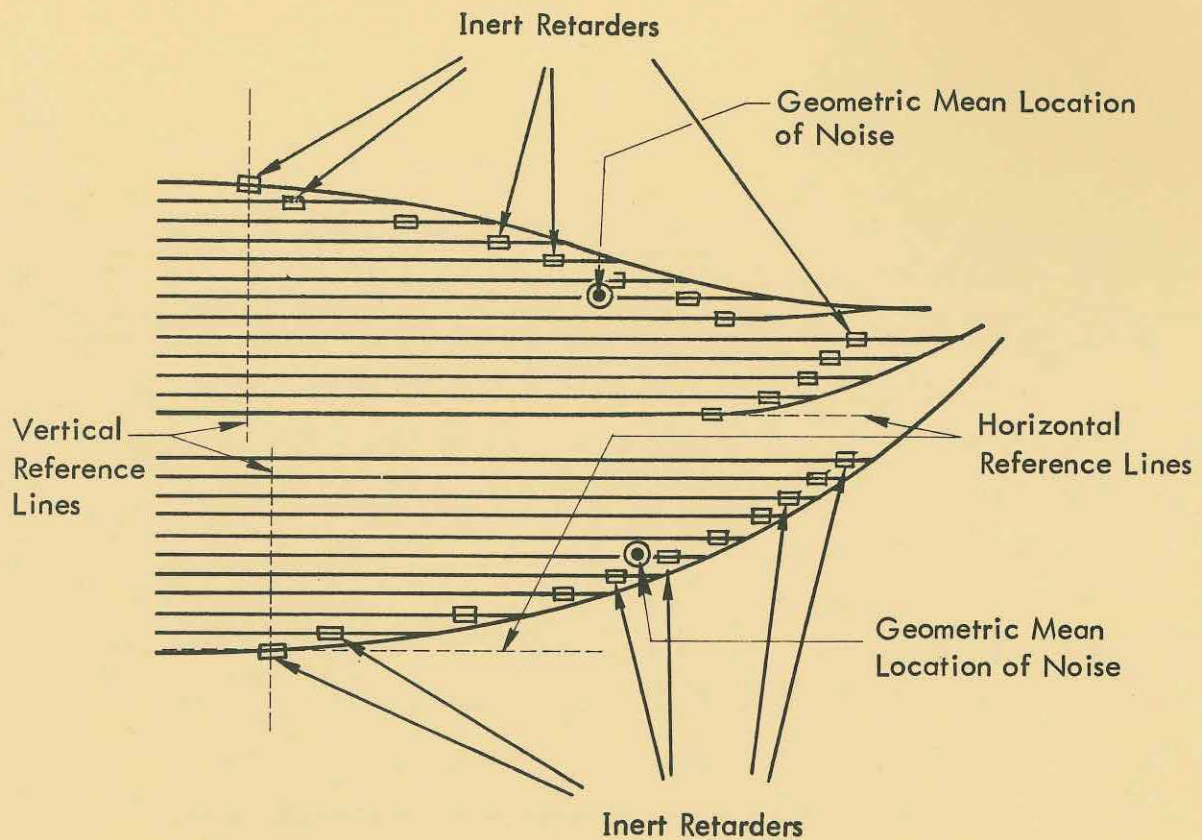


Figure 4.5-5. Two Effective Noise Centers for Inert Retarders

- 8) Multiple or single lines of idling engines positioned in designated areas throughout the yard.

These sources of noise are handled by placing a line along the centerline of an idling engine area as shown by the dotted lines in Figure 4.5-6. Since several groups of idling engines commonly exist throughout a yard (such as the service racks, ready tracks, etc.), it is best to break the noise centers into several groups.

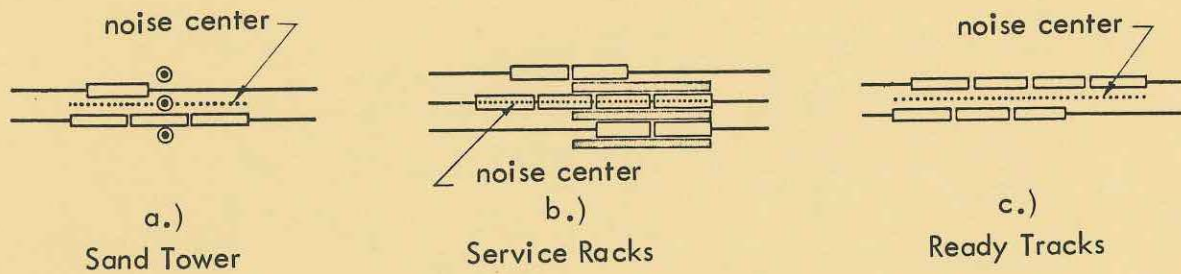


Figure 4.5-6. Effective Noise Centers (Dotted Lines) for Various Combinations of Idling Road Engines

9) Multiple or single lines of parked mechanical refrigeration cars.

Effective noise centers for mechanical refrigeration cars can be determined in the same fashion as required for lines of idling engines.

#### 4.5.2 Evaluation of Noise from Specific Sources

Quantitative estimation procedures for the noise emitted from the various "noise centers" discussed in Section 4.5.1 are presented as follows. These formulations are based upon either SENEL values,  $L_{dn}$  of a single source or noise level in dB(A); all at a standard reference distance of 100 feet.  $L_{dn}$  values at a desired distance may then be calculated by inserting this distance in these equations and selecting air and ground attenuation values ( $\alpha_{ag}$ ) at that distance from Figure 4.3-9.

##### 1) Hump engine.

It is assumed that, on an average, each cut pushed over the hump will contain 50 cars and that each time a cut is humped, two passes of the hump engine will be required (one pass for the engine to move down the tracks into position to make its push, and another while making its push). The general expression for the day-night contribution of the hump engine is:

$$L_{dn} = \overline{\text{SENEL}}_{p.e.} + 10 \log \left( \frac{2 \times N_2}{50} \right) - 49.4 - 10 \log \left( \frac{\text{Distance}}{100'} \right) - \alpha_{ag}, \text{ dB} \quad (4-2)$$

where

$\overline{\text{SENEL}}_{p.e.}$  = Average SENEL of a single pass of a switcher at 100' moving approximately 4 mph = 95 dB.

$N_2$  = Effective number of cars handled. For this case,  $N_2$  is equal to number of cars humped during the day (7 a.m. to 10 p.m.) plus ten times the number humped at night (10 p.m. to 7 a.m.).

$\alpha_{ag}$  = Air and Ground Attenuation from Figure 4.3-9.

49.4 = Normalization factor for one day of operation.

Equation (4-2) is simplified as:

$$L_{dn} = 31.6 + 10 \log N_2 - 10 \log \left( \frac{\text{Distance}}{100'} \right) - \alpha_{ag}, \text{ dB} \quad (4-3)$$

2) Concentrated switcher activity.

Whereas the  $L_{dn}$  for the hump engine was based on a discrete number of point source passes, concentrated switching may be effectively assumed similar to a stationary noise source emanating from a point (this implies a 3 dB drop in SENEL per doubling of distance away from the push engine and a 6 dB drop per doubling of distance for concentrated switching). The  $L_{dn}$  for concentrated switching is expressed by:

$$L_{dn} = 79 + 10 \log N_1 - 20 \log \left( \frac{\text{Distance}}{100'} \right) - \alpha_{ag}, \text{ dB} \quad (4-4)$$

where

$79 = L_{dn}$  of concentrated switching at 100' assuming switcher operates at low throttle for no more than 23 percent of the time (85 dBA at 100'), idle throttle 77 percent of the time (65 dBA at 100'), and 3 hours/day of the idle time taken out due to switcher being moved to pooling area at shift change. Percentage use factors are based on Table 4.3-1.

$N_1 =$  Effective fraction of time a switcher is used in this location equal to  $\frac{1}{24}$  (hours used between 7 am and 10 pm + 10 times the number of hours used between 10 pm and 7 am).

3) Master and group retarder noise.

The  $L_{dn}$  associated with retarder screech is given by:

$$L_{dn} = \overline{\text{SENEL}}_{\text{m.g. ret.}} + 10 \log (S\% \times N_2) - 49.4 - 20 \log \left( \frac{\text{Distance}}{100'} \right) - \alpha_{ag}, \text{ dB} \quad (4-5)$$

where

$\overline{\text{SENEL}}_{\text{m.g. ret.}}$  = Average SENEL of a master or group retarder

at 100' = 107 dB. This is based upon a mean-maximum noise level of 110 dB(A) and an average effective  $t_{10}$  duration of 1 second.

S% = The percentage of cars through the retarder which screech. 25% has been selected as a conservative first estimate; however, a methodology is presented in Section 4.6 which allows for readjustment of this factor for improved retarder systems.

$N_2$  = The same value of  $N_2$  as calculated for the hump engine  $L_{\text{dn}}$ .

49.4 = Normalization factor for one day of operation.

#### 4) Inert retarder screeches.

Since inert retarder noise was broken into two noise centers, the  $L_{\text{dn}}$  calculation for each noise center will apply for one-half the cars leaving the hump yard per day. The evaluation is given by:

$$L_{\text{dn}} = \overline{\text{SENEL}}_{\text{in. ret.}} + 10 \log \left( \frac{N_2}{2} \right) - 49.4 - 20 \log \left( \frac{\text{Distance}}{100'} \right) - \alpha_{\text{ag}}, \text{ dB} \quad (4-6)$$

where

$\overline{\text{SENEL}}_{\text{in. ret.}}$  = Average SENEL of an inert retarder at 100' = 95 dB.

Based upon a mean-maximum noise level of 95 dB(A) and average  $t_{10}$  duration of 2 seconds:

$N_2$  = Effective number of cars handled. For this case,  $N_2$  is equal the number of cars leaving hump yard between 7 am and 10 pm plus 10 times the number leaving between 10 pm and 7 am.

Because inert retarders have constant retardation, it is assumed 100 percent of the car passes have screeches. If the inert retarder system is equipped with positive release devices, this factor may be neglected.

5) Line of idling road engines, switchers, and mechanical refrigeration cars.

The  $L_{dn}$  for these cases is equal to the A-weighted noise level of the line plus corrections for day-night weightings. Evaluation of these A-weighted noise levels can be made by the equations in Appendix E depending on the number of sources and distance to the line of sources. The  $L_{dn}$  for a line of engines or mechanical refrigeration cars may be expressed by:

$$L_{dn} = NL + N_3 + 10 \log (\text{number of rows}) - \alpha_{ag}, \text{ dB} \quad (4-7)$$

where

NL= A-weighted noise level of a line of stationary noise sources which depends on level of single source, distance from line, spacing of sources and number of sources (ref. Appendix E).

$N_3 = 10 \log (1/24 \times (\text{number of hours idling in this location between 7 am and 10 pm} + 10 \text{ times the number of hours idling between 10 pm and 7 am}))$ .

6) Load Test

The  $L_{dn}$  for load test is based on a mean-maximum A-weighted noise level of 86 dBA at 100' and it is assumed that each test takes one-half hour. The  $L_{dn}$  is equated by:

$$L_{dn} = \overline{SENE}_{1t} + 10 \log N_5 - 20 \log \left( \frac{\text{Distance}}{100'} \right) - 49.4 - \alpha_{ag}, \text{ dB} \quad (4-8)$$

where

$\overline{\text{SENEL}}_{1t}$  = Average SENEL of a one-half hour load test =  
115.5 at 100 feet.

$N_5$  = Effective number of occurrences = number of tests  
per day + 10 times the number of tests per night.

49.4 = Normalization factor.

To assess the relative magnitudes of the various noise sources, detailed  $L_{dn}$  contours were calculated for a large California yard. Information describing the volume of cars classified and amount of switching activity throughout the yard was made available by the railroad line's main operating department (Reference 11). The yard chosen possessed noise centers which could be easily defined and also the yard's volume was high enough that somewhat of an upper bound limit on the  $L_{dn}$  values could be determined. Some discretion was used to assign distribution of car impacts and the percentage of active switcher time (the time a switcher is not at idle) in particular areas of the yard. One important assumption was that switchers were active 23 percent of the time based on Reference 1. Of the remaining 77 percent, 3 hours per day were assigned to idling in a switcher pooling area between work shifts and the rest was assumed idling time in the vicinity of the active switching area. The one exception was for hump engines where the active time was based on whatever time was required to hump the total number of cars through the classification yard assuming each cut averaged 50 cars. Uniform hourly activity was also assumed over the 24-hour day.

An  $L_{dn}$  of 65 dB at 100 feet was set as the upper limit on noise sources which could be counted as negligible. Of the noise centers investigated, the following sources had  $L_{dn}$  values greater than 65 dB at 100 feet:



- 1) Hump engine.
- 2) Concentrated switching
- 3) Concentrated area of car impacts
- 4) Master and group retarder noise
- 5) Inert retarder noise
- 6) Multiple or single lines of idling engines
- 7) Multiple or single lines of parked mechanical refrigeration cars
- 8) Diesel load test

It was also observed that the levels from concentrated switching were considerably higher than concentrated areas of car impacts and since these two sources of noise occur at coincident locations, it was felt valid to drop  $L_{dn}$  calculations for the latter.

Noise sources having  $L_{dn}$  values less than 65 dB at 100 feet were:

- 1) Distributed switcher movement over a large area of track
- 2) Distributed car impacts over a large area of track
- 3) Industrial spotting
- 4) Train arrivals and departures (other than trains that bypass the yard without stopping)

Noise contours for trains moving through the yard should be calculated by the procedure in Section 3.3.3 for speeds greater than 10 mph and can be disregarded at lower speeds. It is noted that elimination of distributed and concentrated car impacts and distributed switching greatly reduces the analytical complexity due to the difficulty in estimating the numbers of these occurrences.

#### 4.6 Calculation Procedure for $L_{dn}$ Noise Contours of Railroad Yard Operations

---

A multi-step procedure is presented herein to facilitate the calculation of yard  $L_{dn}$  noise contours. The  $L_{dn}$  equations applying to the various noise centers in Section 4.5.2 were evaluated for a large number of cases and generalized plots have been developed in order to reduce the need for future hand computations. Section 4.7 presents an example based on a fictitious yard which may aid in understanding application of this procedure. A scale map of the particular yard being studied is a required tool in assigning noise centers and drawing overall composite yard noise contours. Also, it is considered essential that a person having first hand experience with the particular yard under consideration be responsible for definition of noise centers and description of yard activity levels. In practice, the 65 and 80 dB  $L_{dn}$  contours are of primary interest, hence the stepwise procedure that follows is oriented towards determination of the position of these two contours; however, the identical steps may be followed to achieve other desired value contours.

The following procedure is designed to be general enough to encompass the broad variety of classification yards encountered in this study. The treatment is set up such that while a given type of activity may occur in several locations throughout the yard (for example, concentrated switch engine activity), the methodology for contour generation is only considered once.

The steps in the procedure and railroad yard operations associated with them are outlined as follows:

- Steps 1-5: Hump engine operations associated with hump yard classification.
- Steps 6-9: Concentrated switch engine activities - applicable to flat and hump yard operations.
- Steps 10-17: Noise emitted by master, group (or track) and inert retarders.

Steps 18-22: Idling diesel locomotives in shop, service or ready track regions.

Steps 23-27: Mechanical refrigeration cars (auxiliary electric driven compressors not considered).

Steps 28-31: Diesel engine load test operations.

Step 32: Methodology for combining individual noise contours to produce overall composite  $L_{dn}$  65 and 80 dB yard noise contours.

The yard noise evaluation worksheet (Figure 4.6-14) should be utilized to aid in this procedure.

Steps 1-5: Hump engine operations associated with hump yard classification.

Step 1 Define the hump engine noise center as described in Section 4.5.1-1. Locate this noise center on scale map of yard layout.

Step 2 Define the amount of hump yard classification activity.

$N_H$  = Typical number of cars passing over hump per 24-hour period.

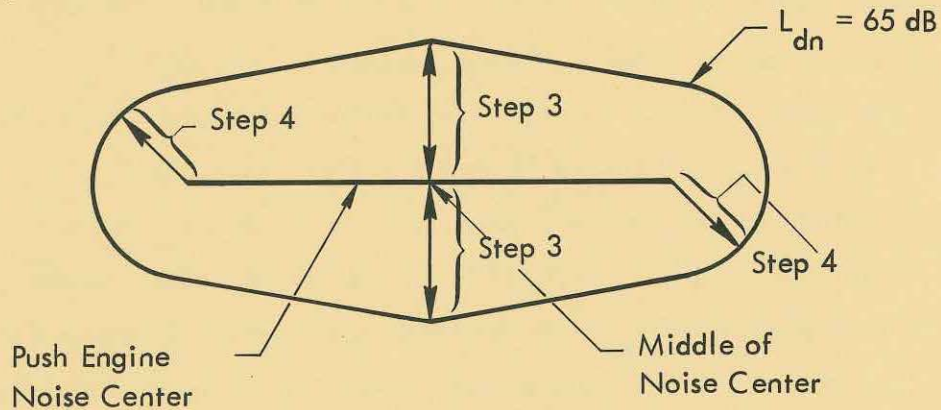
$f_d$  = Fraction of the total number of cars humped per 24-hour period which are humped between 7am and 10 pm.

Enter the horizontal scale in Figure 4.6-1 at the value corresponding to  $N_H$  and move vertically up until the line corresponding to the value of  $f_d$  just defined is reached. Then move horizontally to the vertical scale and read a value for  $N_2$ . Note that value of  $N_2$  should be multiplied by  $10^4$ . Enter these values on the worksheet.

Step 3 Determine distance to central noise contour positions for hump engine at the midpoint of the noise center. Enter  $L_{dn} = 65$  dB on the vertical scale in Figure 4.6-2 and move horizontally until the line for the value of  $N_2$  found in Step 2 is reached. Then move vertically down and read the distance to the contour on the horizontal scale. It is noted that there are no realistic values of  $N_2$  corresponding to  $L_{dn} = 80$  dB ( $\geq 100$  feet) so it can be assumed this contour acts at the noise center. It can also be assumed that the  $L_{dn} = 65$  dB contour acts along the noise center for low values of  $N_2$  such that the distance being sought is less than 100 feet. On the yard layout, draw the position of the  $L_{dn} = 65$  dB contour at the middle point of hump engine noise center using the distance found in this step and enter this distance on the worksheet.

Step 4 Determine  $L_{dn} = 65$  dB noise contour position at the two ends of the hump engine noise center. Since an observer at either extremity of the noise center only sees one-half the activity that occurs at the middle of the noise center, the  $L_{dn}$  is 3 dB less at the two ends than the middle. Thus, the position of the 65 dB contour for the two ends may be found in the same manner as was the contour in Step 3 except that a value of  $L_{dn} = 68$  dB on the vertical scale should be used. With this new distance, half circles can be drawn at the two ends of the noise center. This end distance should also be entered on the worksheet.

Step 5 Complete the hump engine noise contour by connecting these points as shown in the following illustration.



$L_{dn} = 65$  dB Noise Contour Around Hump Yard Push Engine

#### Steps 6-9: Concentrated Switch Engine Activities

Step 6 Define the noise center for areas of concentrated switching by the method described in Section 4.5.1-2. There may be several such areas and separate calculations should be made for each individual noise center. Locate these noise centers on yard layout.

Step 7 Describe amount of switcher activity at each noise center. Define  $H_d$  = number of hours a switcher is in the area of concentrated switching between 7 am and 10 pm. Enter  $H_d$  in worksheet.

Define  $H_n$  = number of hours a switcher is in the area of concentrated switching between 10 pm and 7 am. Enter  $H_n$  in worksheet.

Enter  $H_d$  on the horizontal scale in Figure 4.6-3 and move vertically up until the line corresponding to  $H_n$  is reached. Then move horizontally to the vertical scale and read  $N_1$ . Enter  $N_1$  in worksheet. Repeat this procedure for each zone of concentrated switcher activity.

Step 8 Determine distance to  $L_{dn} = 65$  and 80 dB contours for concentrated switching. Enter  $L_{dn} = 65$  dB on vertical scale in Figure 4.6-4 and move horizontally until the line corresponding to  $N_1$  evaluated in Step 7 is found. Then move vertically down and read the distance to the 65 dB contour. Enter distance in worksheet.

Repeat for the  $L_{dn} = 80$  dB contour and enter this distance in worksheet. Repeat this procedure for each zone as in Step 7.

Step 9 Draw circles on the yard layout around the concentrated switcher noise centers with radii equal the distances determined in Step 8 for the 65 dB and 80 dB noise contours, respectively.

Steps 10-17: Noise emitted by master, group (or track) and inert retarders.

Step 10 Define the noise center for master and group retarders as described in Section 4.5.1-6. Locate this noise center on yard layout.

Step 11 Define amount of hump yard classification activity. This step is identical to Step 2 and the same values of  $N_H$ ,  $f_d$  and  $N_2$  are to be used.

Enter  $N_H$ ,  $f_d$  and  $N_2$  on the worksheet.

Step 12 Determine distance to the  $L_{dn} = 65$  and 80 dB contours for master and group retarders. Although it was assumed that 25 percent of the cars passing through retarders screech, a correction to the  $L_{dn}$  can be found in Table 4.6-1 for the case of a retarder that is known statistically to screech differently than 25 percent of the time. Also, a correction is found in Table 4.6-1 which accounts for the number of retarders each car must pass through. The total correction is given by the sum of the two corrections just mentioned. For example, say, a yard's retarders are known to screech 50 percent of the time and that each car must pass through one master and two group retarders. The

corrections are +3 dB for 50 percent screech and +5 dB for the three retarders. Thus, the total  $L_{dn}$  adjustment is  $3 + 5 = 8$  dB. Enter  $L_{dn} = (65 - \text{total correction})$  on vertical scale in Figure 4.6-5 and move horizontally until the line corresponding to  $N_2$  defined in Step 11 is reached. Then move vertically down and read the distance on the horizontal line to the 65 dB noise contour. Enter this distance in worksheet. Repeat this procedure to determine distance to the 80 dB contour (again entering the vertical scale at a value =  $80 - \text{total corrections}$ ) and enter the distance to the  $L_{dn} = 80$  dB contour on the worksheet.

**Step 13** Draw two circles on the yard layout around the noise center of the master and group retarders with radii equal the distances determined in Step 12 for the  $L_{dn} = 65$  and 80 dB noise contours, respectively.

Table 4.6-1

$L_{dn}$  Corrections for Master and Group Retarders

Percent of Cars Screeching in Retarders	Number of Retarders Each Car Must Pass Through	$L_{dn}$ Correction
100	4	+6
75	3	+5
50	2	+3
25	1	+0
20	-	-1
15	-	-2
10	-	-4
5	-	-7

Step 14 Define the two noise centers for the inert retarders as outlined in Section 4.5.1-7. Locate these noise centers on the yard layout.

Step 15 Describe activity leaving the hump yard.

$N_H$  = number of cars leaving hump yard per 24-hour period. Enter  $N_H$  in worksheet.

$f_d$  = fraction of the total number of cars leaving hump yard which depart between 7 am and 10 pm. Enter  $f_d$  in worksheet.

Enter  $N_H$  on the horizontal scale in Figure 4.6-1 and move vertically up until the line corresponding to the value of  $f_d$  just defined is reached. Then move horizontally to the vertical scale and read the value for  $N_2$ . Enter  $N_2$  in worksheet.

Step 16 Determine distances to the  $L_{dn} = 65$  and 80 dB contours for each of the two inert retarder noise centers.

Enter  $L_{dn} = 65$  dB on the vertical scale in Figure 4.6-6 and move horizontally until the line corresponding to  $N_2$  defined in Step 15 is reached. Then move vertically down and read the distance to the  $L_{dn} = 65$  dB contour. Enter this distance in worksheet.

Repeat for the  $L_{dn} = 80$  dB contour and enter this distance in worksheet.

Step 17 For each of the two inert retarder noise centers, draw circles on the yard layout around these centers with radii equal to the distances as determined in Step 16 for the 65 dB and 80 dB noise contours.

Steps 18-22: Idling diesel locomotives in shop, service or ready track regions.

Step 18 Define noise centers as described in Section 4.5.1-8 for idling road engines and switchers and locate on yard layout.



Step 19 Describe activity in each particular location over a 24-hour period for idling road engines and switchers.

$H_d$  = number of hours the noise source is at this location between 7 am and 10 pm. Enter  $H_d$  in worksheet.

$H_n$  = number of hours the noise source is at this location between 10 pm and 7 am. Enter  $H_n$  in worksheet.

Enter  $H_d$  in horizontal scale of Figure 4.6-7 and move vertically up until the line corresponding to  $H_n$  from above is reached. Then move horizontally to read  $N_3$  from vertical scale. Enter  $N_3$  on worksheet.

Step 20 Define  $N_4$ .

$N_4 = 10 \log$  (the number of rows of idling engines). This value may be calculated or selected from the following table.

<u><math>N_4</math></u>	<u>Number of Rows</u>
0	1
3	2
5	3
6	4
7	5
8	6

Enter  $N_4$  on the worksheet.

Step 21 Determine distance to the  $L_{dn} = 65$  and 80 dB contours for idling engines.

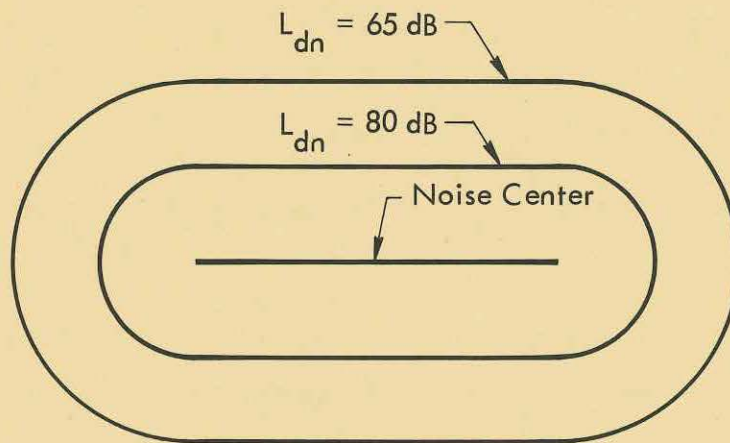
First, determine the adjusted contour value. The adjusted 65 and 80 dB contour values are found by subtracting  $N_3$  and  $N_4$  (given in Steps 19 and 20) from both 65 and 80. Enter these adjusted values on the worksheet.

Second, enter the adjusted contour values in the vertical scale in Figure 4.6-8 for idling road engines/Figure 4.6-9 for idling switchers and move horizontally until the curved line corresponding

to the typical number of engines found in each row is reached. Then move vertically down and read distances to the desired contour on the horizontal scale. Enter these distances on the worksheet.

Step 22 Construct the  $L_{dn} = 65$  and  $80$  dB contours on yard layout map for each idling engine noise center.

At the two ends of each noise center, draw half circles with radii equal the  $65$  and  $80$  dB contour distances given in Step 21. Connect the half circles with straight lines parallel to the noise center as illustrated by the following figure.



$L_{dn} = 65$  and  $80$  dB Noise Contours Around Line of Noise Sources

#### Construction of $L_{dn}$ Contours Around Idling Locomotives

#### Steps 23-27: Mechanical Refrigerator Cars

Step 23 Locate the noise center for each group of mechanical refrigeration cars by the procedure in Section 4.5.1-9.

Step 24 Describe mechanical refrigeration car activity in each location over a 24-hour period.

$H_d$  = number of hours the noise source is at this location between 7 am and 10 pm. Enter  $H_d$  on worksheet.

$H_n$  = number of hours the noise source is at this location between 10 pm and 7 am. Enter  $H_n$  on worksheet.

Enter  $H_d$  in horizontal scale of Figure 4.6-7 and move vertically up until the line corresponding to  $H_n$  is reached. Then move horizontally to read  $N_3$  on the vertical scale. Enter  $N_3$  on worksheet.

Step 25 Define  $N_4$  for mechanical refrigeration cars by the identical procedure as used for idling engines in Step 20 using table as shown. Enter new value of  $N_4$  in worksheet.

Step 26 Determine distance to  $L_{dn} = 65$  and 80 dB contours for mechanical refrigeration cars.

This procedure is similar to Step 21 for idling engines except it is known that the engine-generator side of a mechanical refrigeration car is 5 dB(A) higher in noise level than the condenser side. For the sake of conservatism and simplicity in the calculations, the noise level will be assumed that of the engine-generator side.

As in Step 21, the adjusted 65 and 80 dB contour values must be found. These adjusted contour values are evaluated by subtracting  $N_3$  and  $N_4$  (given in Steps 24 and 25) from both 65 and 80. Enter the adjusted values on worksheet.

Next, enter the adjusted contour values in the vertical scale in Figure 4.6-10 and move horizontally until the line corresponding to the typical number of mechanical refrigeration cars found in each row is reached. Then, move vertically down and read both distances

on the horizontal scale. These distances are the positions of the  $L_{dn} = 65$  and  $80$  dB contours. Enter these contour distances in worksheet.

Step 27 Construct  $L_{dn} = 65$  and  $80$  dB contours on the yard layout for the mechanical refrigeration car noise center. The procedure as outlined in Step 22 should be followed except that the new contour radii as determined in Step 26 will be used.

Step 28 Define the load test noise center as the geometric mean position of the load test boxes and locate this position on yard map.

Step 29 Determine the correction factor used to weight the  $L_{dn}$  for number of load test throughout the 24-hour period. Let  
 $NT_d$  = the number of tests conducted during daytime (7 am to 10 pm).  
 $NT_n$  = the number of tests conducted during nighttime (10 pm to 7 am).

The weighting factor,  $NT$ , is defined as

$NT = 10 \log_{10} (NT_d + 10 \times NT_n)$ . This factor may be calculated or found by entering the horizontal scale of Figure 4.6-11 at the value equal to  $NT_d + 10 \times NT_n$  and moving vertically until the line is reached.  $NT$  may then be read on the vertical scale directly across. Enter  $NT$  on the worksheet.

Step 30 Determine distance to the  $L_{dn} = 65$  and  $80$  dB contours for load test operations. First, find the adjusted contour values. The adjusted 65 and 80 dB contour values are found by subtracting the weighting factor determined in Step 29 from both 65 and 80.

Second, enter the adjusted contour values on the vertical scale in Figure 4.6-12 and move horizontally until the curve is reached. Then, move vertically down and read the two distances. These distances determine the location of the 65 and 80 dB noise contours.

Step 31 Draw the 65 and 80 dB noise contours on the yard layout. These contours will be circles around the load test noise center with radii equal the distances found in Step 30.

Step 32 Combine the  $L_{dn}$  contours for individual noise centers into composite noise contours.

The methods for creating overall noise contours given individual  $L_{dn}$  contours for point and line sources are illustrated in Figure 4.6 -13.

For combination of two or more adjacent point source contours, simply connect them by lines drawn tangent to adjacent circles as shown in Figure 4.6 -13A.

For combination of point (circle) and line source contours as shown in Figure 4.6 -13B, a line is drawn tangent to the circle and intersects the line source contour at a point such that equal legs are formed between the point of intersection of the line and point source contours (A) and the tangent point (B) and between (A) and the intersect with the line source contour (C); hence,  $AC = AB$  as illustrated.

#### 4.7 Example Application of $L_{dn}$ Noise Contours Around Railroad Yard Operations

---

A hypothetical railroad yard layout was defined to illustrate application of the  $L_{dn}$  noise contour technique presented in Section 4.6. It was assumed that each of the eight major noise sources described in Section 4.5.2 occurred at least once at some location in the yard. Activity levels in this yard were assigned such that they would present a realistic picture of typical operations for a high volume yard. A simplified schematic drawing of the yard is given in Figure 4.7 - 1 identifying the five basic operational areas: receiving yard, hump yard classification area, departure yard, flat yard classification area, and engine service area. The noise produced by operation of this yard has been defined in terms of thirteen noise centers which have been defined by the methods illustrated in Section 4.5.1 and are shown on Figure 4.7 - 1. These noise centers and the corresponding definition of their activity are discussed as follows:

1. Hump Engine Operations - A single switching locomotive is used to push cuts of cars over the crest of the hump from the receiving yard. It is assumed there are 3000 cars humped per 24 hour day and this activity is uniformly distributed over each hour of the day and night.
2. Trim Locomotive in Receiving Yard - Single switcher operation concentrated at the west end of the receiving yard is assumed over the entire 24 hour day except for 3 hours per day spent in the switcher pooling area. The concentrated activity at this location is distributed throughout the day as 13 hours of switcher presence between 7 AM and 10 PM and 8 hours between 10 PM and 7 AM.
3. Concentrated Flat Yard Switching - West End - A switcher locomotive operates at the west end of the flat yard over the same hours of the day as the switcher at noise center number 2.

4. Concentrated Flat Yard Switching - East End - A switcher operates at the east end of the flat yard and it is known that this switcher is used less than half the time of the switcher at the west end. Distribution of hours the switcher locomotive is present at this location is set at 6 hours between 7 AM and 10 PM and 3 hours between 10 PM and 7 AM.
5. Trim Switcher Locomotives in Departure Yard - West End - Operations of two switchers are concentrated at the west end of the departure yard during the day assembling trains and operate lightly at night. It is assumed that each switcher is used at this location for 13 hours of the time between 7 AM and 10 PM and only 3 hours per switcher between 10 PM and 7 AM.
6. Trim Locomotive in Departure Yard - East End - One switcher operates at the east end of the departure yard the same hours of the day as a single switcher described in 5. above.
7. Master and Group Retarders - Each car classified in the hump yard must pass through the master retarder and two group retarders. It is assumed that for the master and group retarders used in this yard that only one out of every ten cars (10 percent) passing through the retarder produces high level screech. As discussed for noise center number 1, 3000 cars are humped per 24 hour day and the activity is distributed evenly over each hour in the 24 hour period.
8. Inert Retarders - Inert retarder noise is subdivided into two noise centers at the east end of the hump yard shown in Figure 4.7 -1. It is assumed the majority of the trains are assembled during the daytime hours and of the 3000 cars humped per 24 hour day, 75 percent of these cars leave the hump yard (implying they are pulled through the retarders) between 7 AM and 10 PM.

9. Locomotive Service Facility - The diesel service tracks are assumed to have one row of six idling road locomotives all hours of the day and night.
10. Switcher Locomotive Pooling Area - The switcher pooling area is known to have one row of 10 switchers for a two hour total duration between 7 AM and 10 PM and one hour between 10 PM and 7 AM.
11. Mechanical Refrigerator cars - On the average, a row of 15 mechanical refrigeration cars is assumed to stand on the southernmost departure track throughout the 24 hour day.
12. Engine Load Test Facility (Load Box) - The load box facility averages one load test between 7 AM and 10 PM and one load test between 10 PM and 7 AM.
13. Engine Ready Tracks - The ready tracks for the engine service are assumed to have an average usage of three rows of six idling road engines per row at all hours of the day and night.

The  $L_{dn}$  noise contour locations for the above described noise centers must now be determined. Step numbers correspond to the numbers in Section 4.6 and noise center numbers are those defined previously in this section. An example worksheet is also included to provide reference documentation of the yard's activity and noise contour locations.

<u>Step Number</u>	<u>Noise Center Number</u>	<u>Calculation</u>
2	1	$N_H = 3000$ cars humped /24 hour day. $f_d = 0.625$ (no variation between daytime and nighttime hump yard activity). $N_2 = 13,000$ cars (Figure 4.6 -1)



<u>Step Number</u>	<u>Noise Center Number</u>	<u>Calculation</u>
3	1	From Figure 4.6 -2, the $L_{dn} = 65$ dB contour is 500 feet from the middle of the hump engine noise center.
4	1	Using the adjusted contour value of 68 dB and Figure 4.6 -2, the $L_{dn} = 65$ dB contour at the two ends of the noise center is located at a radius of 300 feet.
7	2	$H_d = 13$ hours $H_n = 8$ hours $N_1 = 3.9$ from Figure 4.6 -3
8	2	From Figure 4.6 -4, $L_{dn} = 65$ dB contour radius equals 800 feet and $L_{dn} = 80$ dB contour radius equals 170 feet.
7	3	$H_d = 13$ hours $H_n = 8$ hours $N_1 = 3.9$ from Figure 4.6 -3
8	3	From Figure 4.6 -4, $L_{dn} = 65$ dB contour radius equals 800 feet and $L_{dn} = 80$ dB contour radius equals 170 feet.
7	4	$H_d = 6$ hours $H_n = 3$ hours $N_1 = 1.5$ from Figure 4.6 -3

<u>Step Number</u>	<u>Noise Center Number</u>	<u>Calculation</u>
8	4	From Figure 4.6 -4, $L_{dn} = 65$ dB contour radius equals 500 feet and $L_{dn} = 80$ dB contour radius equals 100 feet.
7	5	$H_d = 13$ hours $H_n = 3$ hours $N_1 = 1.8$ from Figure 4.6 -3
8	5	Since two switchers operate at noise center number 5, the composite 65 and 80 dB contour must be located. The Decibel Addition Table 3.4-1 may be used for multiple sources at the same location. The "Difference" for equal strength sources = 0 and the "Increment" is = 3.0 dB; thus the composite 65 and 80 dB contours coincide with the adjusted contour values = 65 - Increment and 80 - Increment respectively. Using an adjusted 65 dB contour value of $65-3 = 62$ dB in Figure 4.6 -4, the $L_{dn} = 65$ dB contour is found at a radius of 750 feet. Using an adjusted 80 dB contour value of $80-3 = 77$ dB in Figure 4.6 -4, the $L_{dn} = 80$ dB contour is found at a radius of 170 feet.

<u>Step Number</u>	<u>Noise Center Number</u>	<u>Calculation</u>
7	6	$H_d = 13$ hours $H_n = 3$ hours $N_1 = 1.8$ from Figure 4.6 -3
8	6	From Figure 4.6 -4, $L_{dn} = 65$ dB contour radius equals 550 feet and $L_{dn} = 80$ dB contour radius equals 110 feet.
11	7	$N_H = 3000$ cars humped /24 hour day. $f_d = 0.625$ (assume no variation between daytime and nighttime hump yard activity). $N_2 = 13,000$ cars (Figure 4.6 -1)
12	7	<p>Given that 10 percent of the cars passing through the retarders emit screech, a correction of -4 dB from Table 4.6 -1 is indicated.</p> <p>Since each car must pass through 3 retarders, this yields an additional correction of +5 dB; thus, the total correction to the <math>L_{dn}</math> is <math>+5 -4 = +1</math> dB. Using an adjusted 65 dB contour value of <math>65 -1 = 64</math> dB in Figure 4.6 -5, the <math>L_{dn} = 65</math> dB contour is found at a radius of 800 feet. Using an adjusted 80 dB contour value of <math>80 -1 = 79</math> dB in Figure 4.6 -5, the <math>L_{dn} = 80</math> dB contour is found at a radius of 350 feet.</p>

<u>Step Number</u>	<u>Noise Center Number</u>	<u>Calculation</u>
15	8	$N_H = 3000$ cars leaving hump yard per 24 hour day. $f_d = 0.75$ $N_2 = 10,000$ cars from Figure 4.6 -1.
16	8	From Figure 4.6 -6, $L_{dn} = 65$ dB contour radius equals 380 feet and $L_{dn} = 80$ dB contour radius equals 120 feet.
19	9	$H_d = 15$ hours $H_n = 9$ hours $N_3 = 6.4$ from Figure 4.6 -7
20	9	$N_4 = 0$ for 1 row of idling locomotives.
21	9	Using an adjusted 65 dB contour value of $65 - 6.4 = 58.6$ dB in Figure 4.6 -8, the $L_{dn} = 65$ dB contour is found at a distance of 600 feet.  Using an adjusted 80 dB contour value of $80 - 6.4 = 73.6$ dB in Figure 4.6 -8, the $L_{dn} = 80$ dB contour is found at a distance of 140 feet.
19	10	$H_d = 2$ hours $H_n = 1$ hour $N_3 = -3$ from Figure 4.6 -7
20	10	$N_4 = 0$ for 1 row

<u>Step Number</u>	<u>Noise Center Number</u>	<u>Calculation</u>
21	10	<p>Using an adjusted 65 dB contour value of <math>65 - (-3) = 68</math> dB in Figure 4.6 -9, the <math>L_{dn} = 65</math> dB contour is found at a distance of 190 feet.</p> <p>Using an adjusted 80 dB contour value of <math>80 - (-3) = 83</math> dB in Figure 4.6 -9, the <math>L_{dn} = 80</math> dB contour is not shown and may be neglected.</p>
24	11	<p><math>H_d = 15</math> hours  <math>H_n = 9</math> hours  <math>N_3 = 6.4</math> from Figure 4.6 -7</p>
25	11	<p><math>N_4 = 0</math> for 1 row of mechanical refrigerator cars.</p>
26	11	<p>Using an adjusted 65 dB contour value of <math>65 - 6.4 = 58.6</math> dB in Figure 4.6 -10, the <math>L_{dn} = 65</math> dB contour is found at a distance of 800 feet.</p> <p>Using an adjusted 80 dB contour value of <math>80 - 6.4 = 73.6</math> dB in Figure 4.6 -10, the <math>L_{dn} = 80</math> dB contour is found at a distance of 160 feet.</p>
29	12	<p><math>NT_d = 1</math>  <math>NT_n = 1</math>  <math>NT = 10.5</math> from Figure 4.6 -11</p>

<u>Step Number</u>	<u>Noise Center Number</u>	<u>Calculation</u>
30	12	Using an adjusted 65 dB contour value of $65 - 10.5 = 54.5$ dB in Figure 4.6 -12, the $L_{dn} = 65$ dB contour is found at a radius of 400 feet. Using an adjusted 80 dB contour value of $80 - 10.5 = 69.5$ dB in Figure 4.6 -12, the $L_{dn} = 80$ dB contour is found at a radius of 100 feet.
19	13	$H_d = 15$ hours $H_n = 9$ hours $N_3 = 6.4$ from Figure 4.6 -7
20	13	$N_4 = 5$ for 3 rows of idling locomotives
21	13	Using an adjusted 65 dB contour value of $65 - 6.4 - 5 = 53.6$ dB in Figure 4.6 -8, the $L_{dn} = 65$ dB contour is found at a distance of 900 feet.
21	13	Using an adjusted 80 dB contour value of $80 - 6.4 - 5 = 68.6$ dB in Figure 4.6 -8, the $L_{dn} = 80$ dB contour is found at a distance of 250 feet.

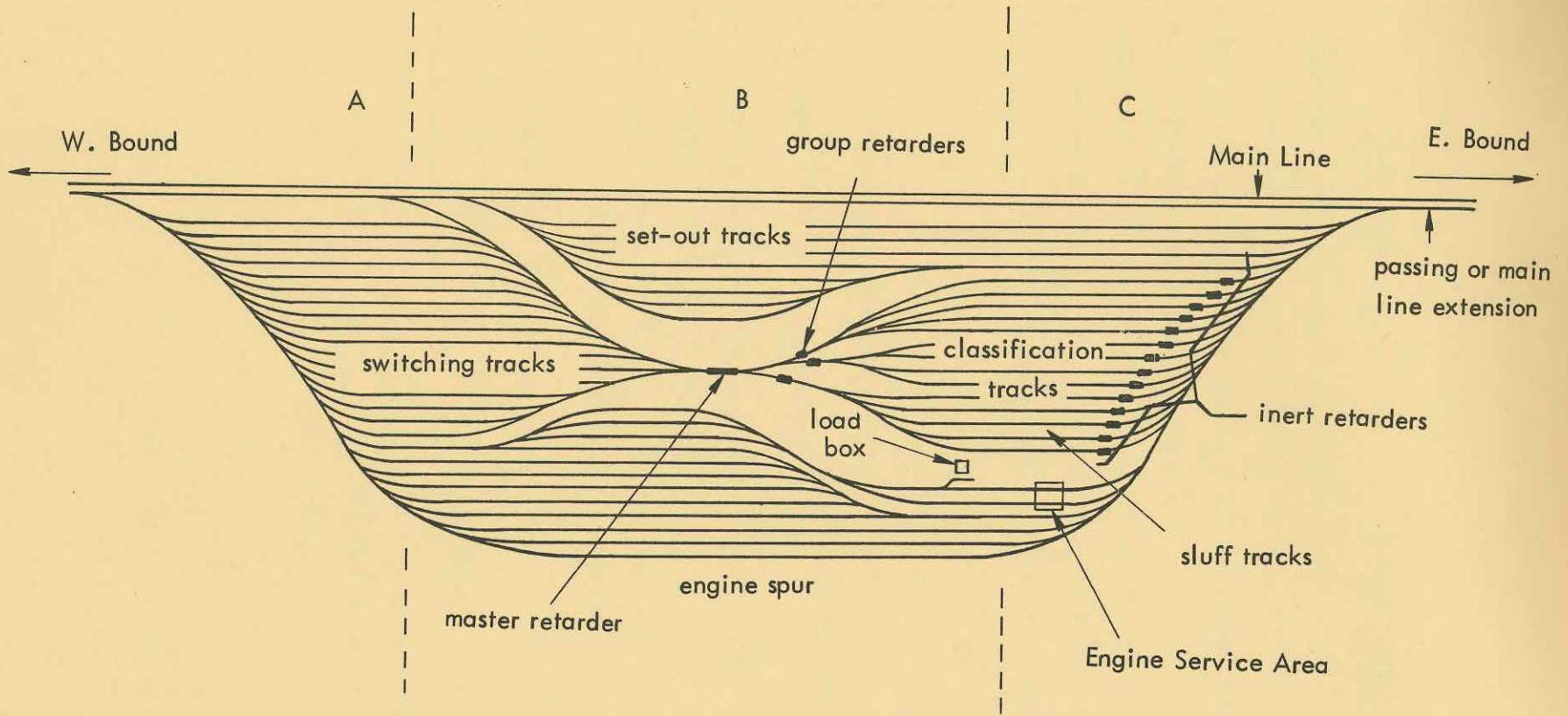


Figure 4.2-1. Basic Classification Yard Layout.

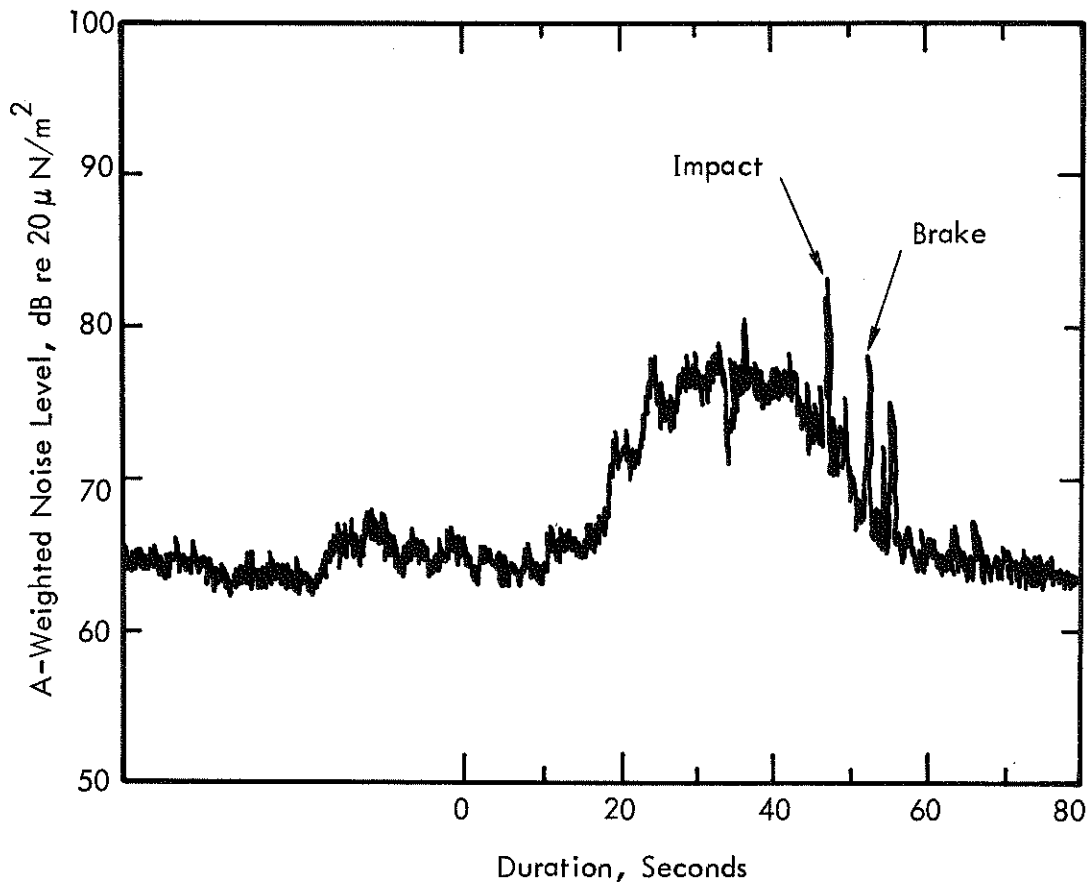


Figure 4.3-1. A-Weighted Time History of Switcher Movements During Typical Classification Operations (Measurements Taken at 100 Feet from Track).



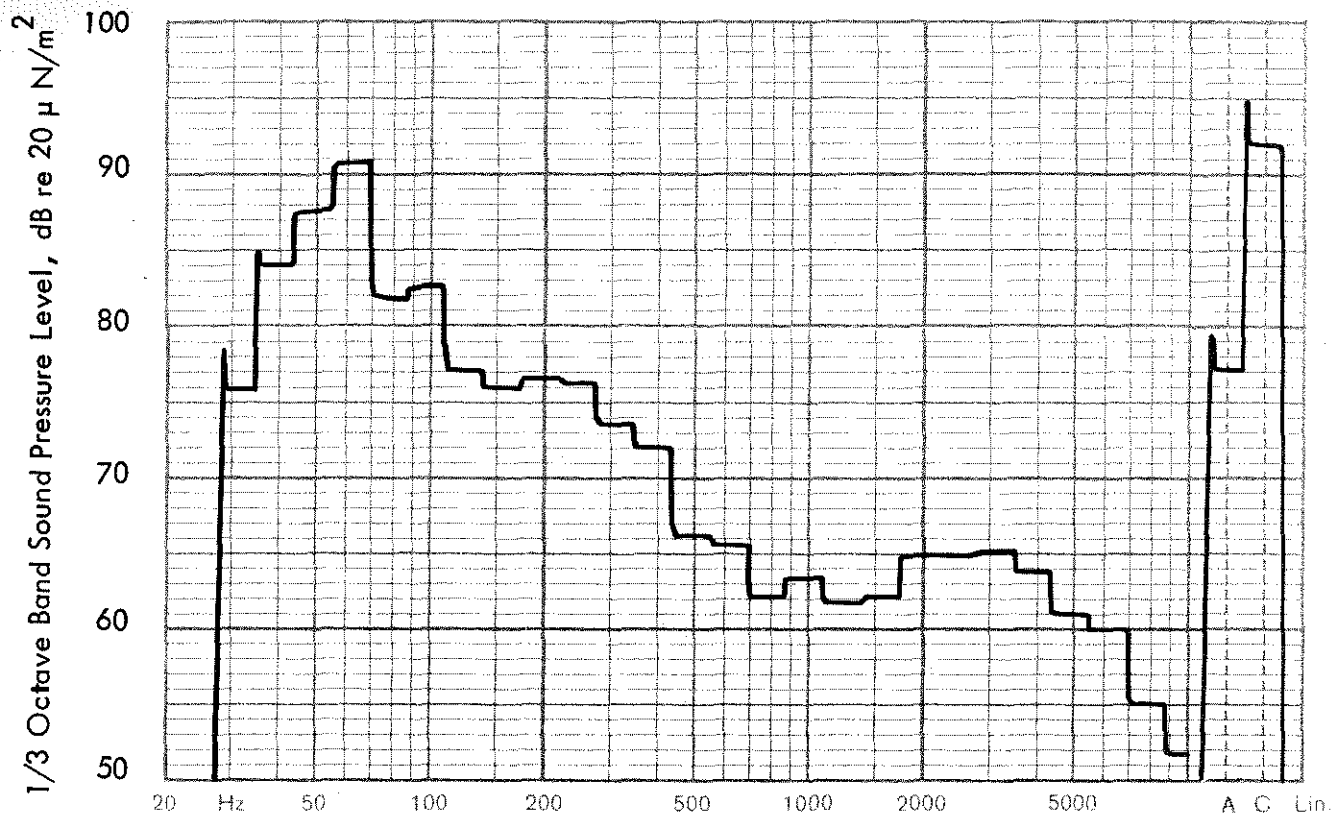


Figure 4.3 -2. Frequency Spectra of Switcher Pulling a Cut of Cars at Low Speed (measurements taken at 90 feet from track).

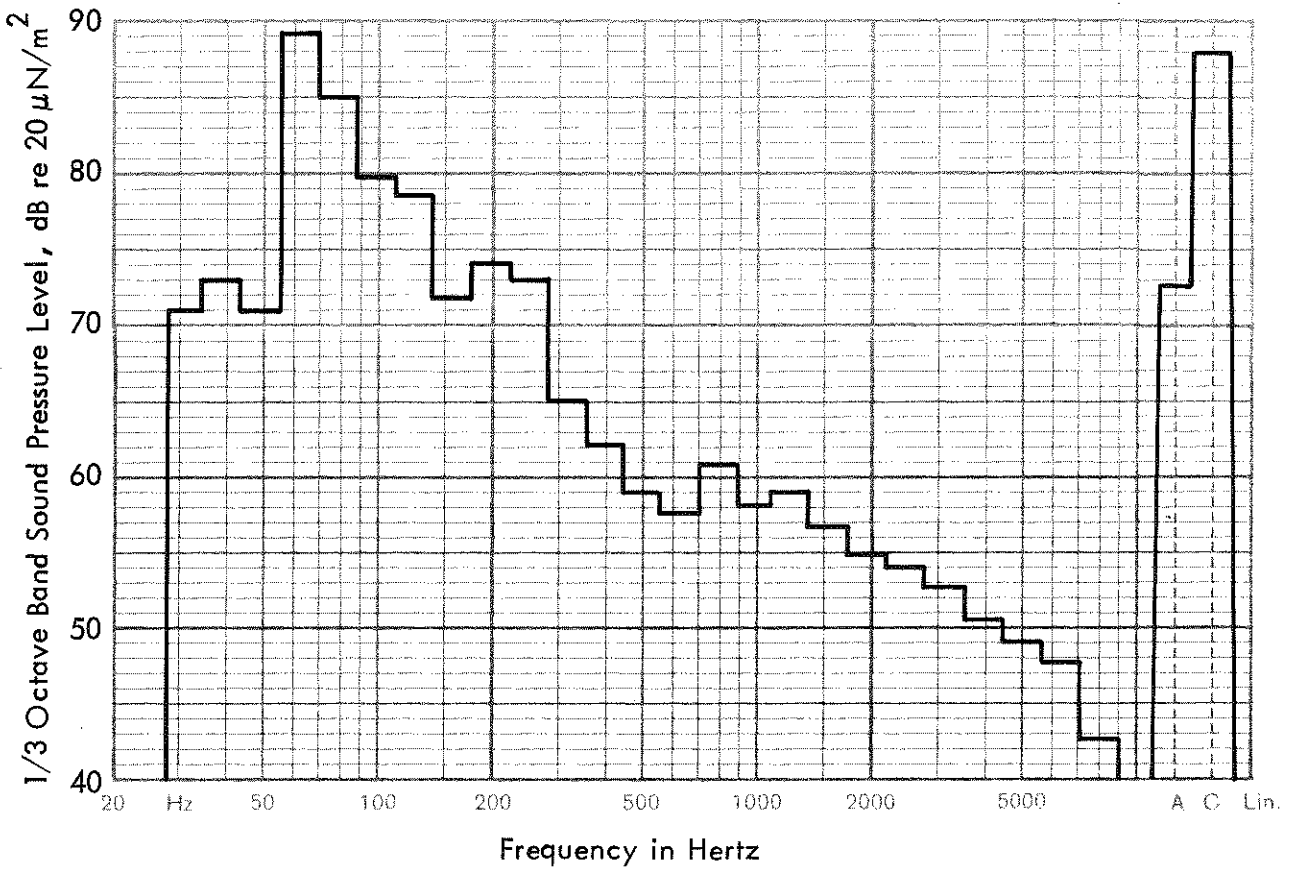


Figure 4.3-3. Frequency Spectra of Switcher Accelerating With Cut of Cars (measurements taken at 100 feet from track).

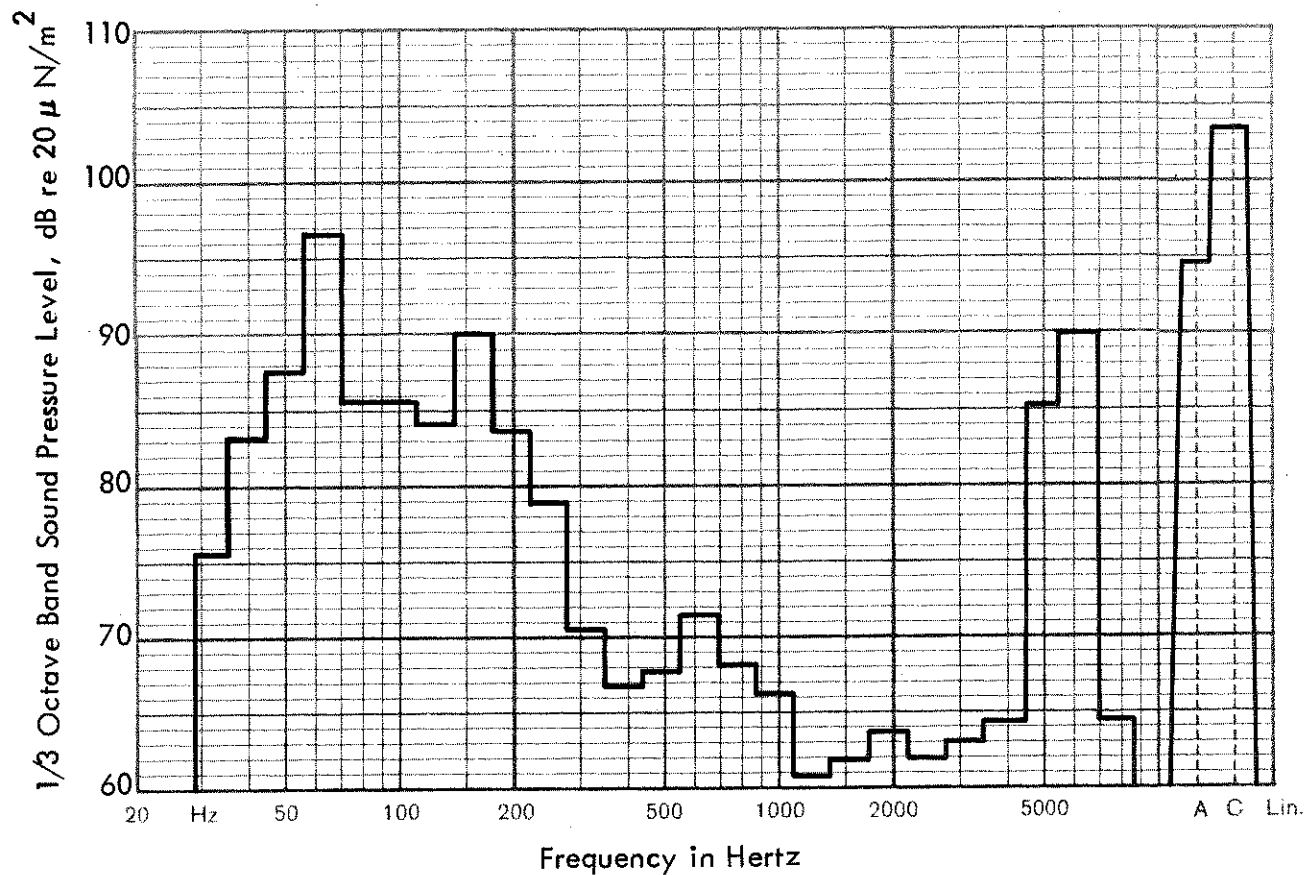


Figure 4.3-4. Frequency Spectra of Switcher Accelerating (Measurements Taken at 100 Feet from Track). The 5000 Hertz and 6300 Hertz One-Third Octave Bands were Excited by Squealing Brakes.

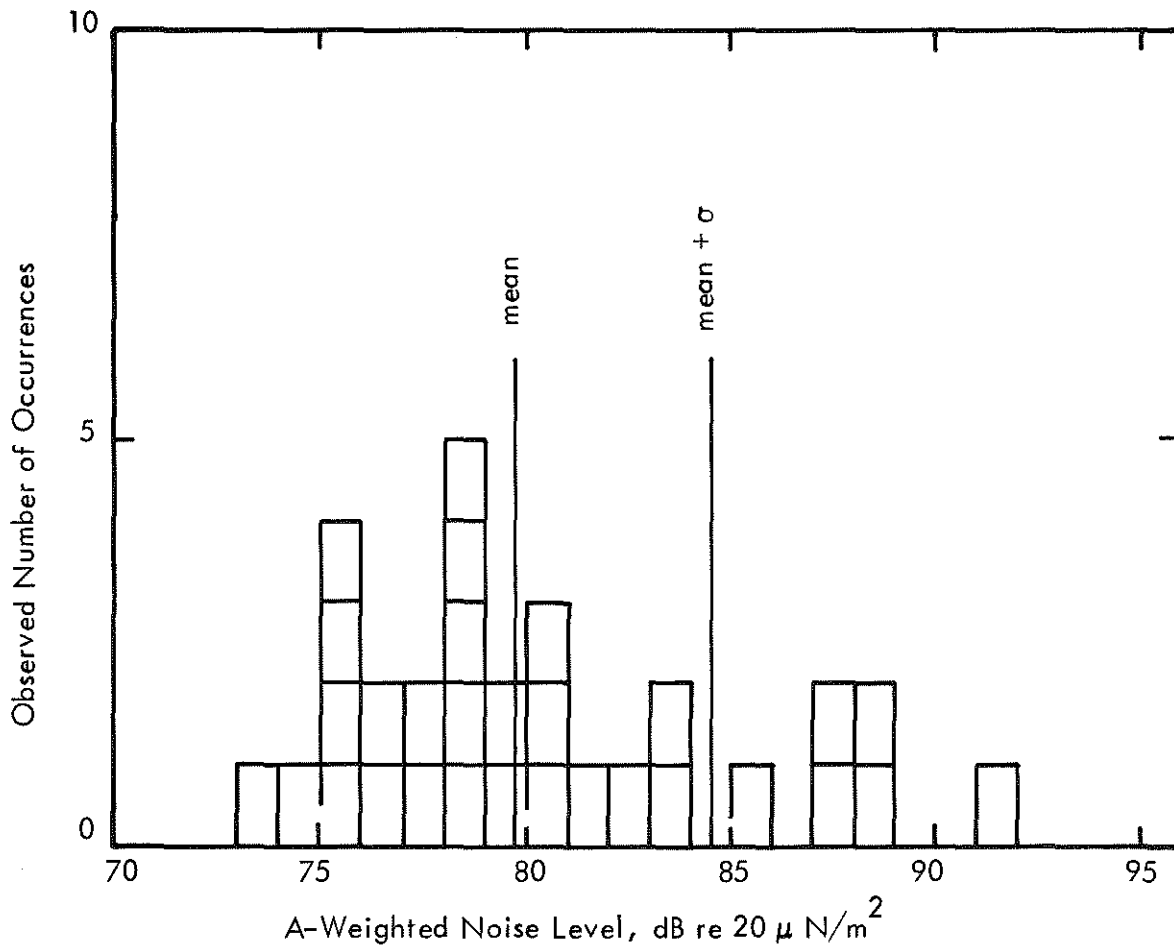


Figure 4.3-5. Distribution of Noise Levels Emitted by Passing Switchers (measurements taken at 100 feet for track).

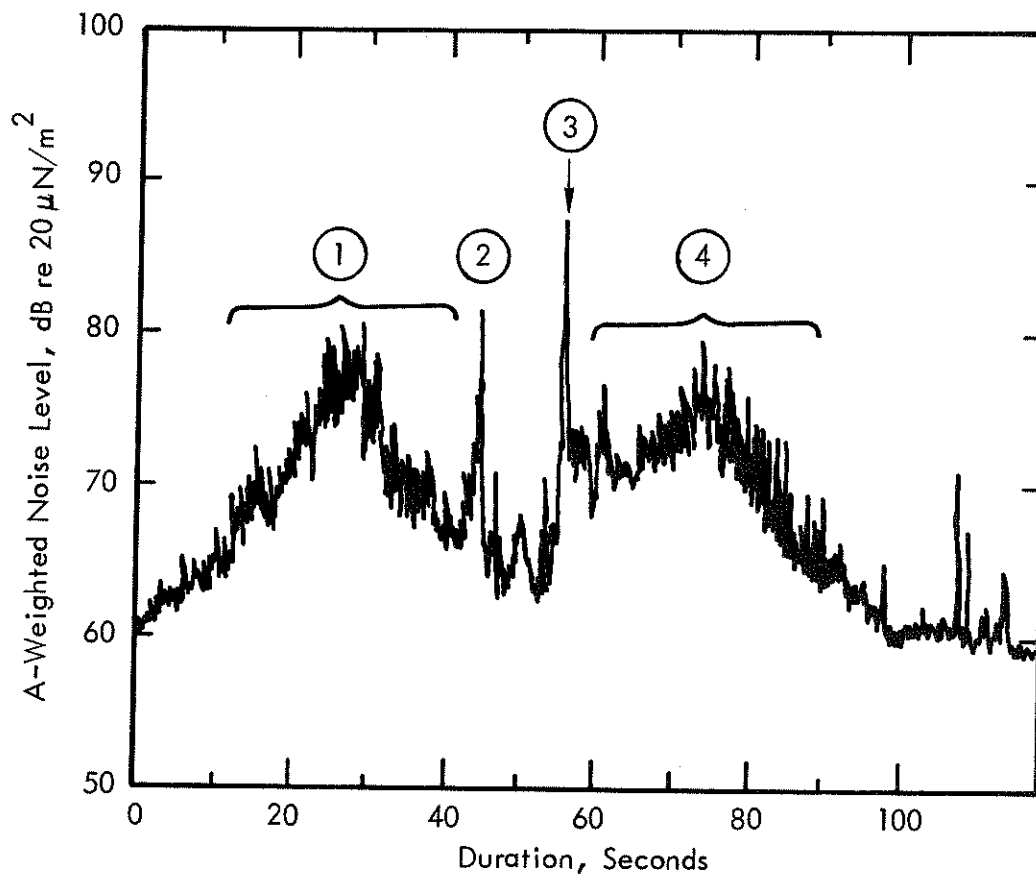


Figure 4.3-6 A-Weighted Time History of Flat Yard Switching Cycle: (1) Switcher Approaches with Cut of Cars, (2) Chain Reaction Impact Occurs When Switcher Suddenly Stops to Release Car Being Classified, (3) Released Car Couples with Stationary Cut in Classification Tracks, and (4) Switcher Moves Away (Measurements taken 25 feet from switching track).

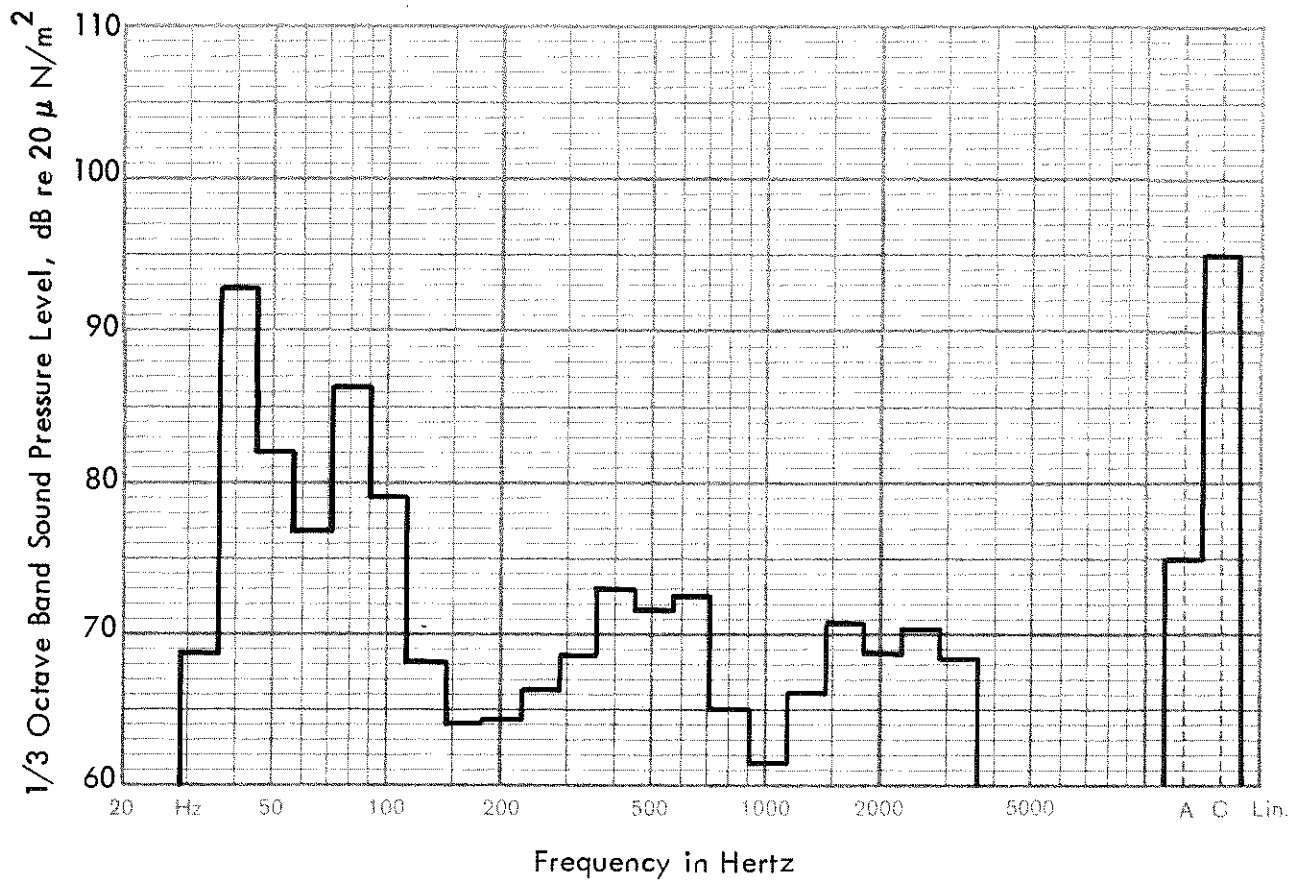


Figure 4.3-7. Frequency Spectra of Idling Road Engine  
(Measurements Taken 50 Feet from Track)

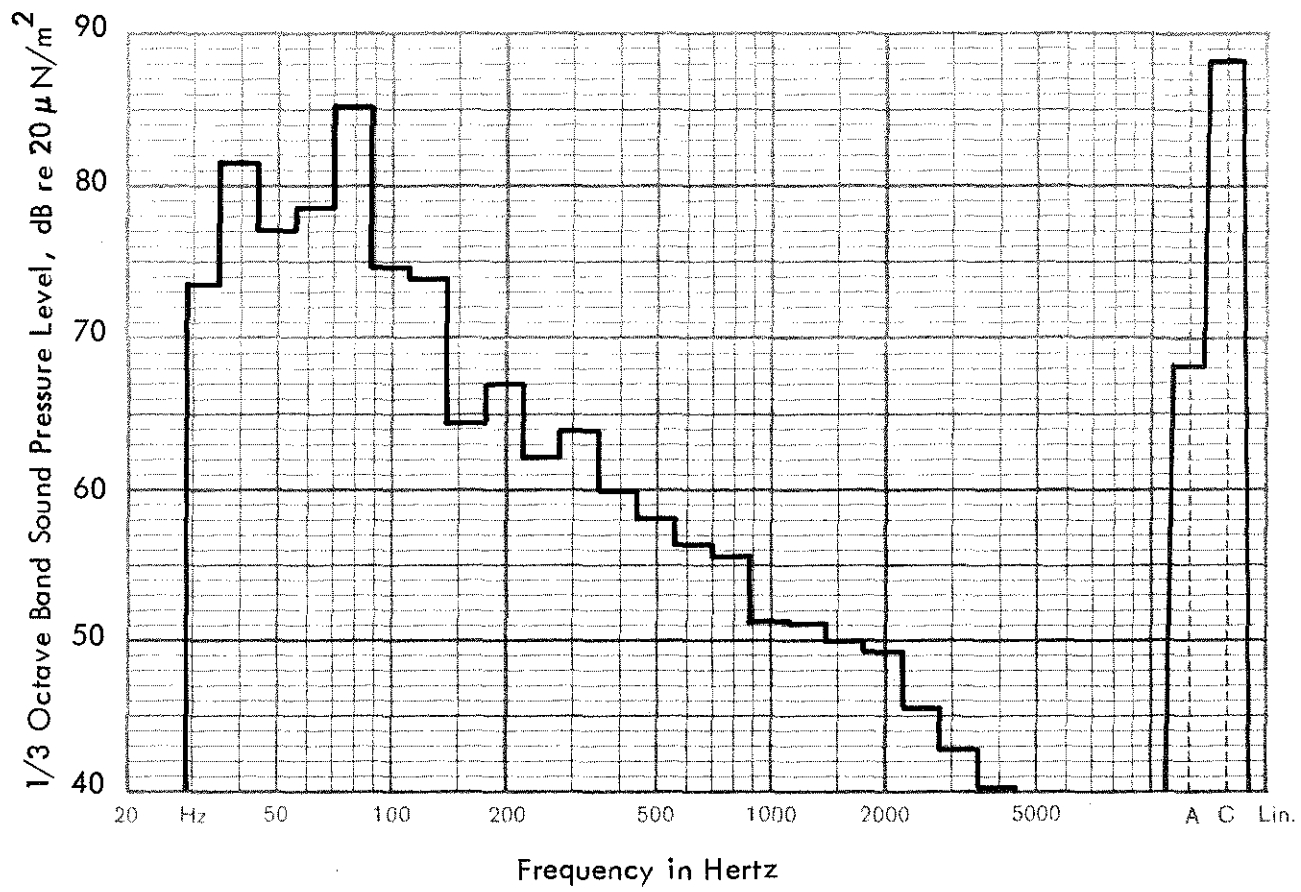


Figure 4.3-8. Frequency Spectrum of Idling Switcher Locomotive  
(Measurements Taken at 50 Feet from Track)

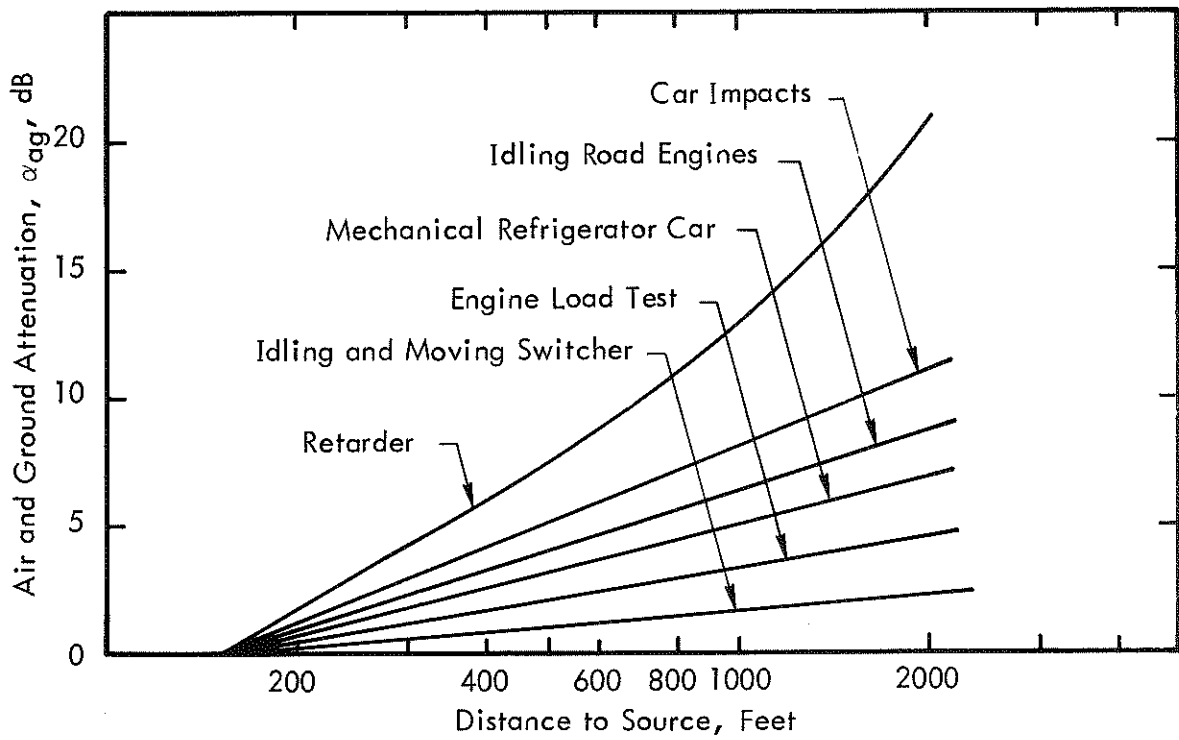


Figure 4.3-9. Combined Air Absorption and Excess Ground Attenuation of Noise Emitted from Various Sources in a Yard (at Standard Reference Conditions: 60°F and 50 Percent Relative Humidity).



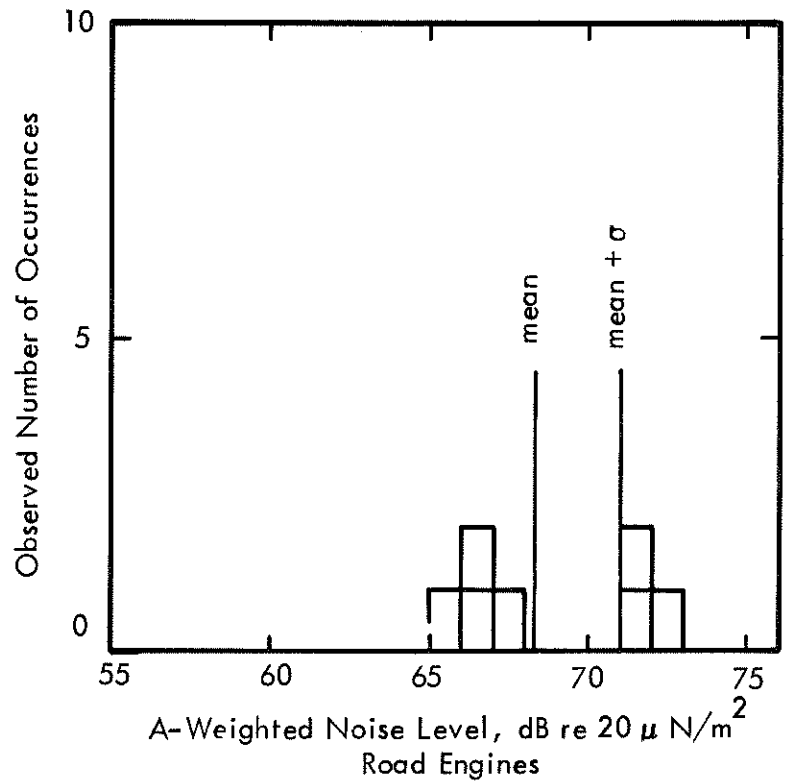
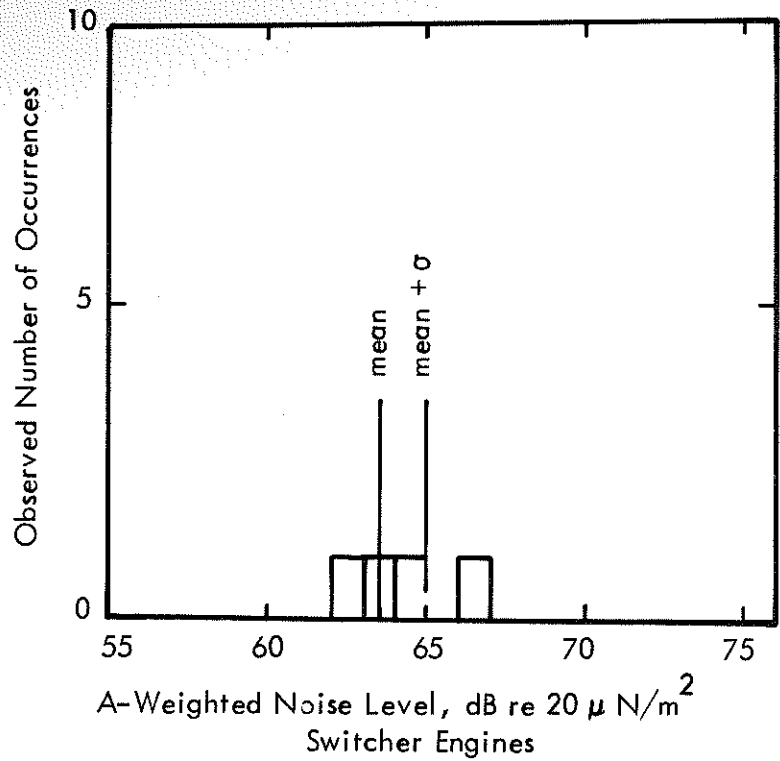


Figure 4.3-10. Distribution of Noise Levels Emitted by Idling Locomotives at 100 feet from Locomotive.

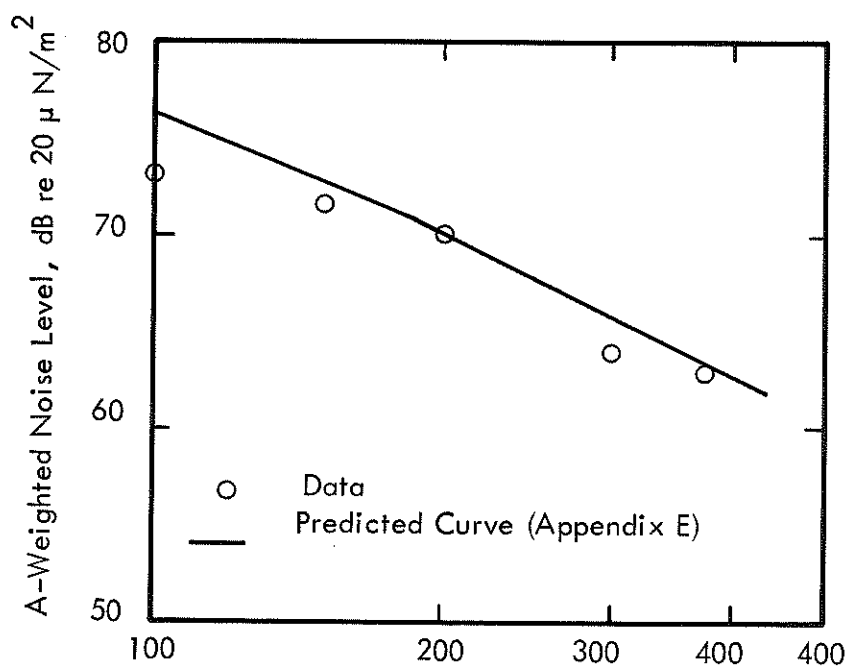


Figure 4.3 -11. Comparison of Data from Five Idling Road Engines and Predicted Values.

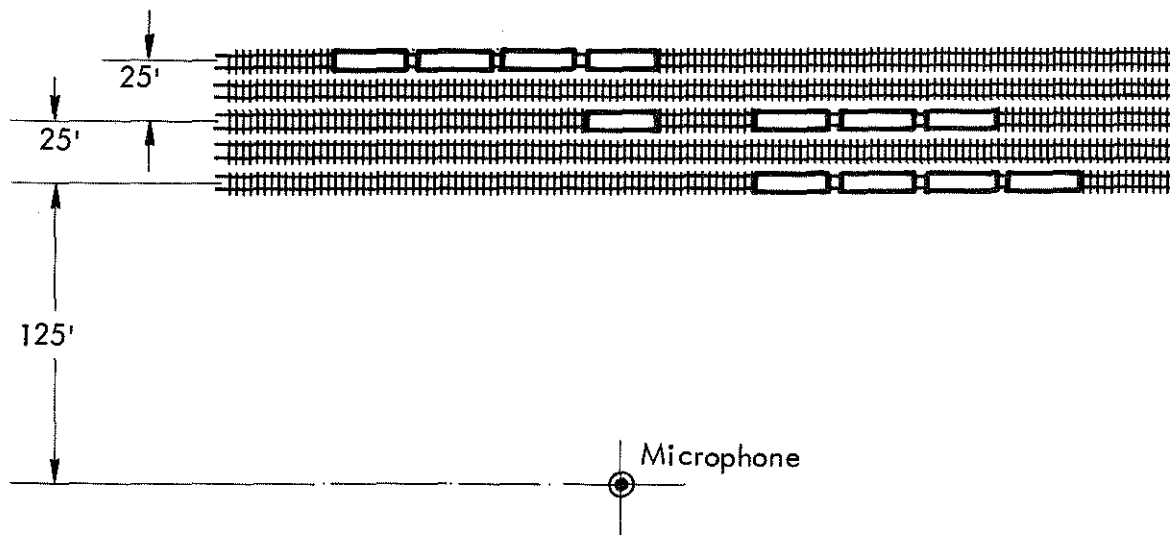


Figure 4.3 -12

Group of Idling Road Engines Near Engine Service Facility at Taylor Yard.

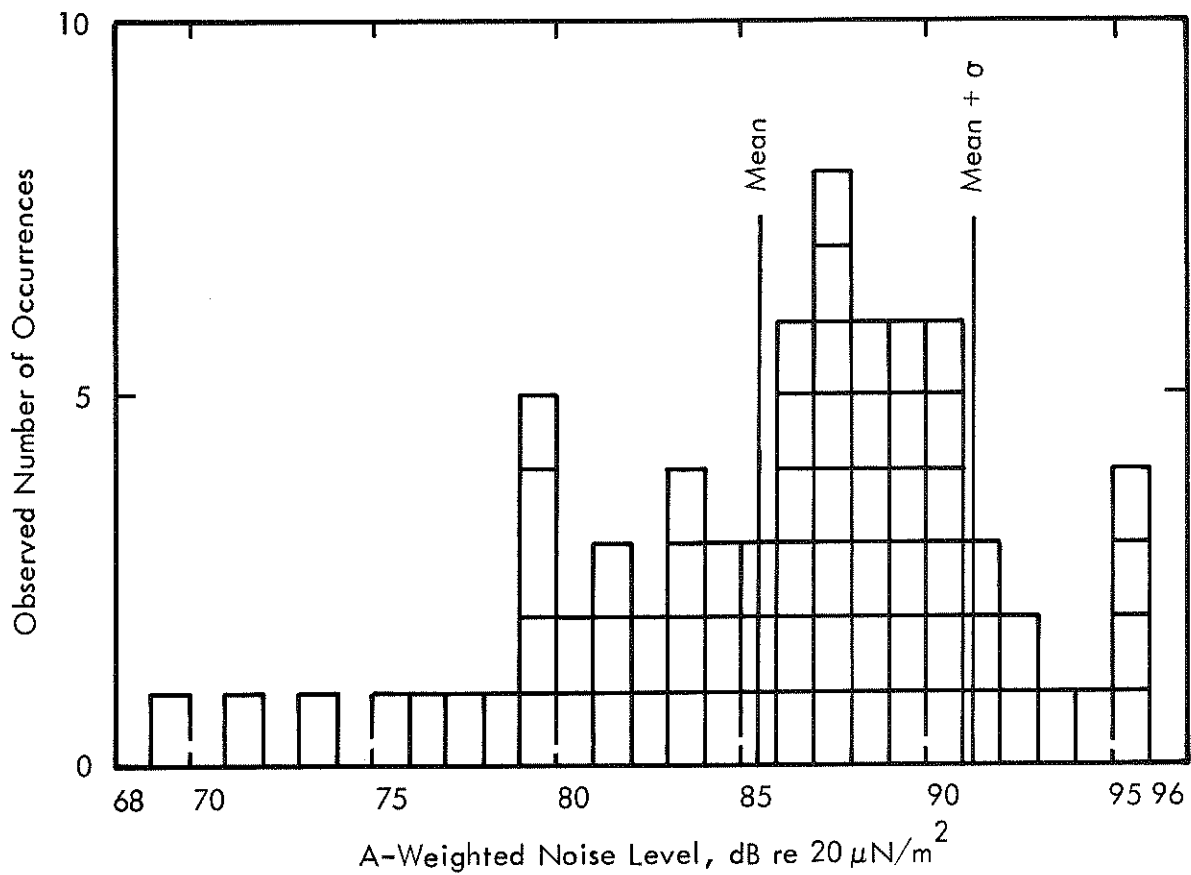


Figure 4.3-13. Distribution of A-Weighted Levels Emitted from Impacts (Measurements Taken at 100 Feet)

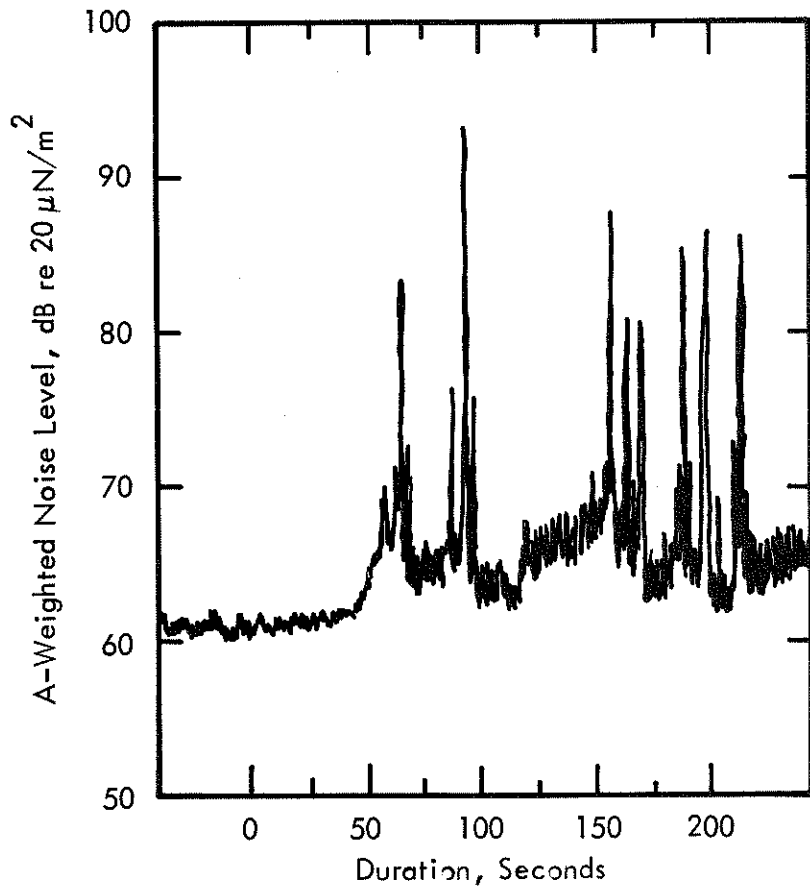


Figure 4.3-14. A-Weighted Time Histories of Impacts in Flat Yard (Measurement Taken 80 Feet from Switching Track).

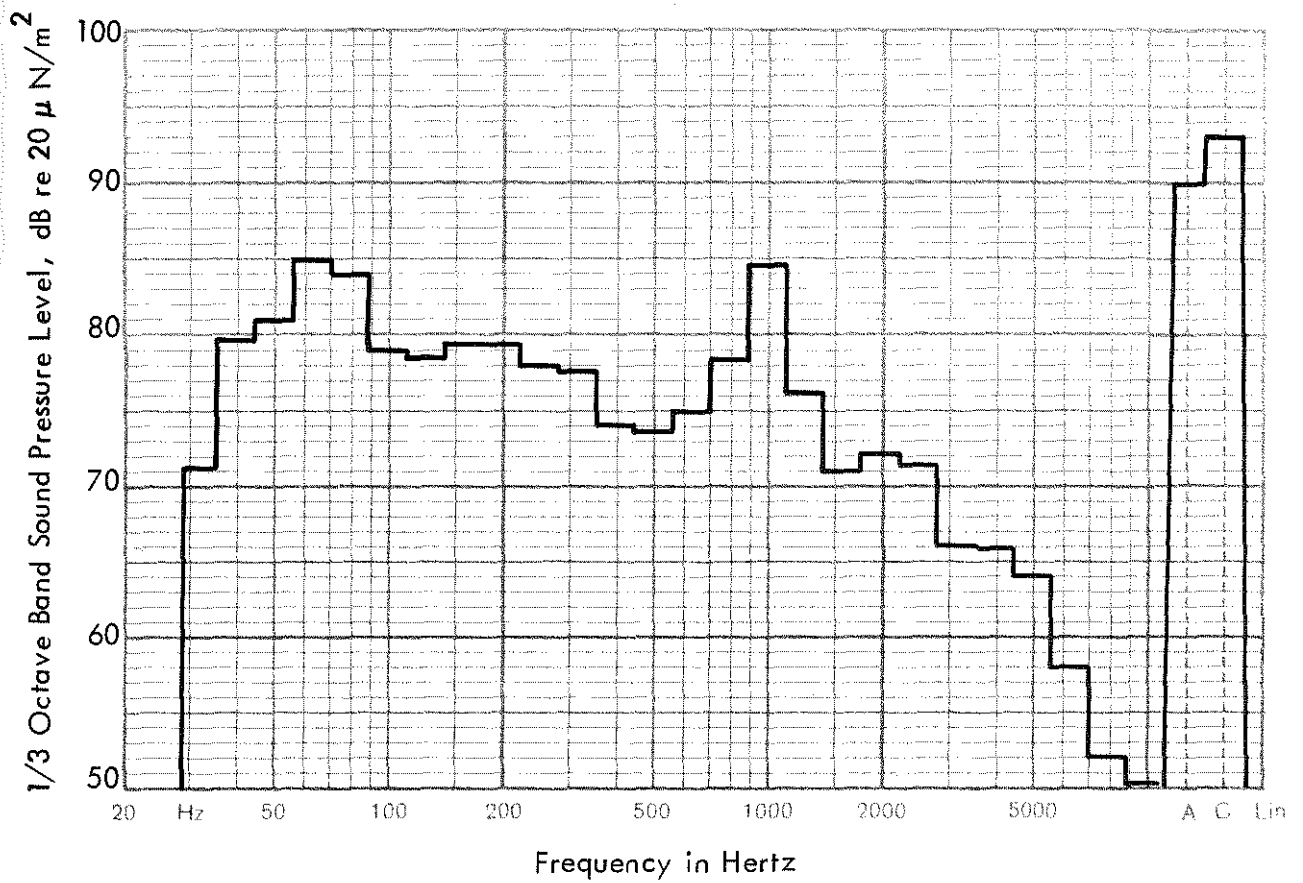


Figure 4.3-15. Frequency Spectra of Noise Emitted from Coupling Impact (Measurements 100 Feet from Track)

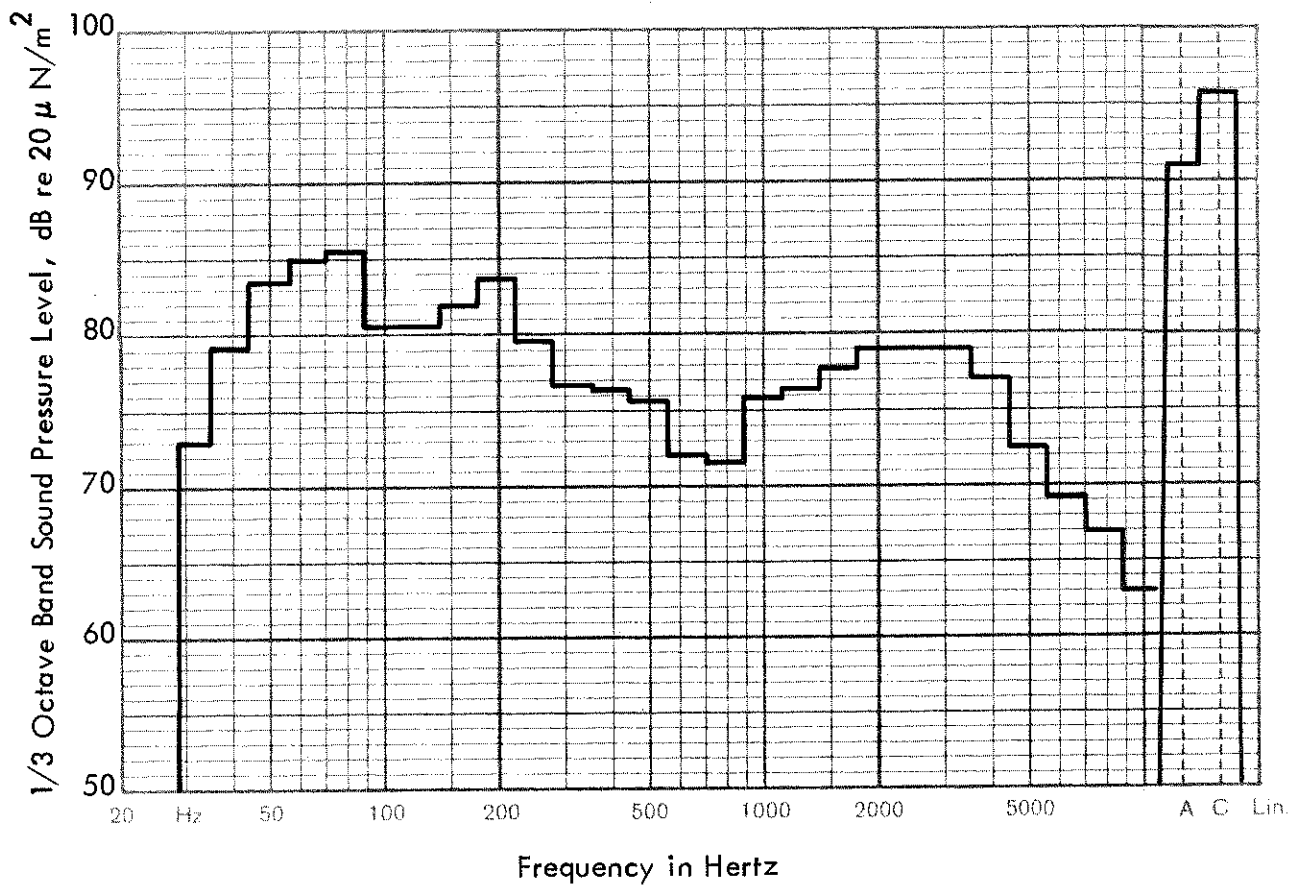


Figure 4.3-16. Frequency Spectra of Noise Emitted from Chain Reaction Impact (Measurements Taken 100 Feet from Track)

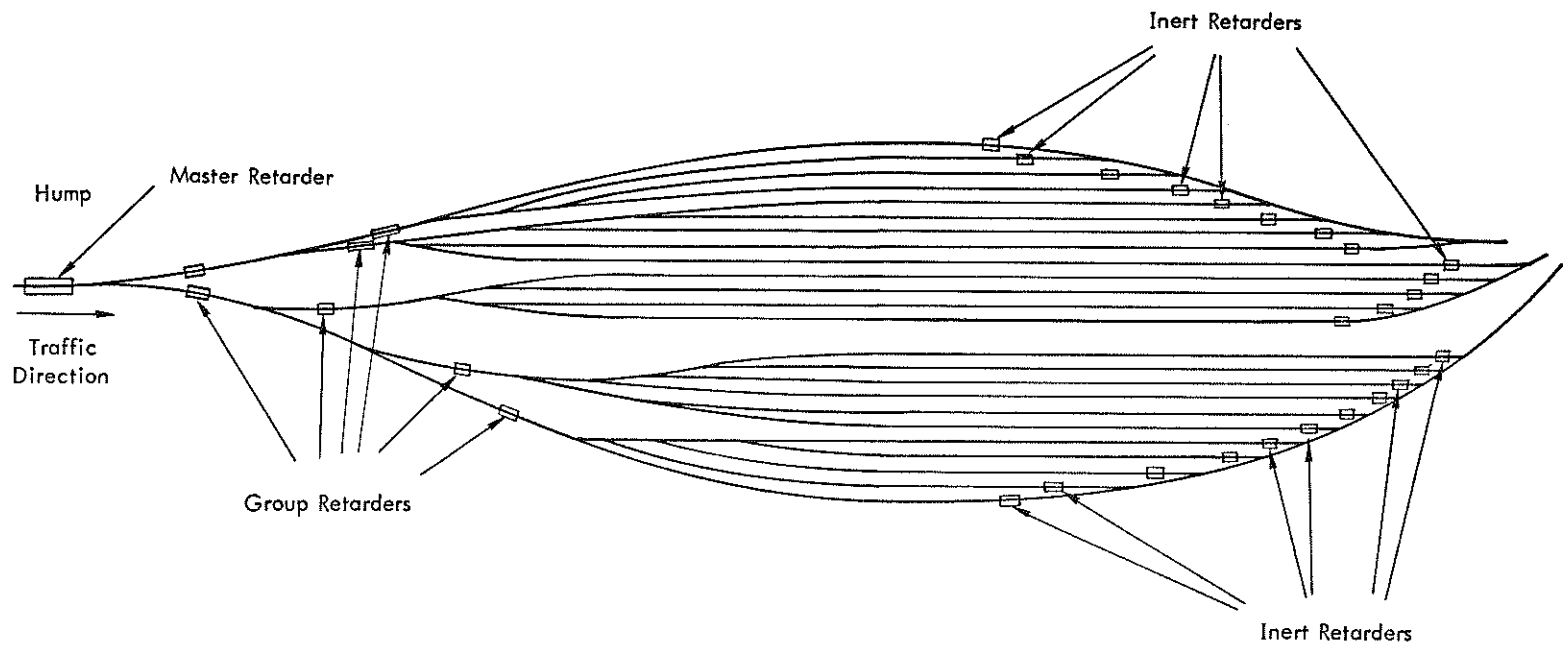


Figure 4.3-17. Typical Retarder Hump Yard



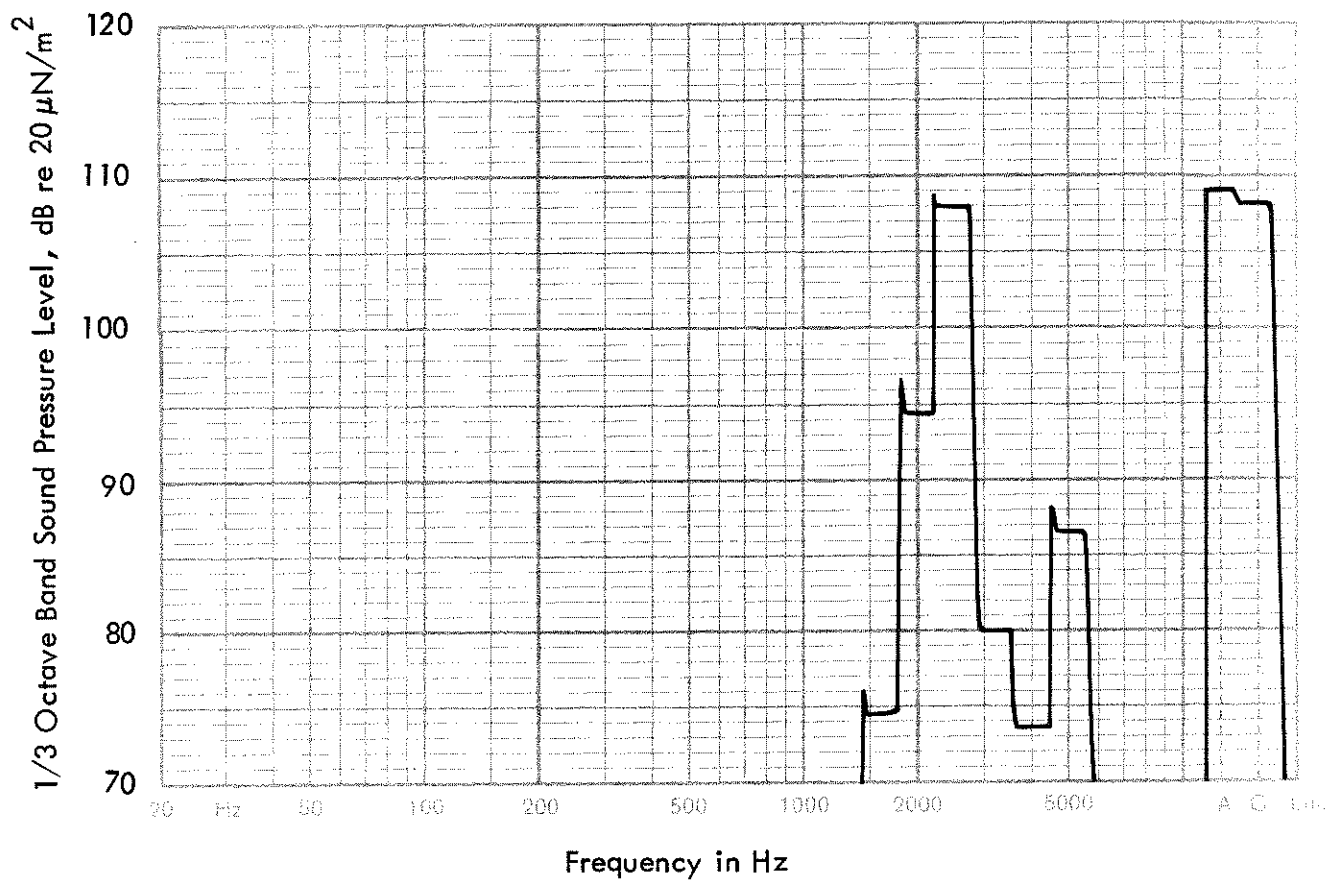


Figure 4.3-18. Frequency Spectrum of Noise Emitted from Master Retarder (Measurements Taken 100 feet from Retarder). Spectrum is Similar for Group Retarders

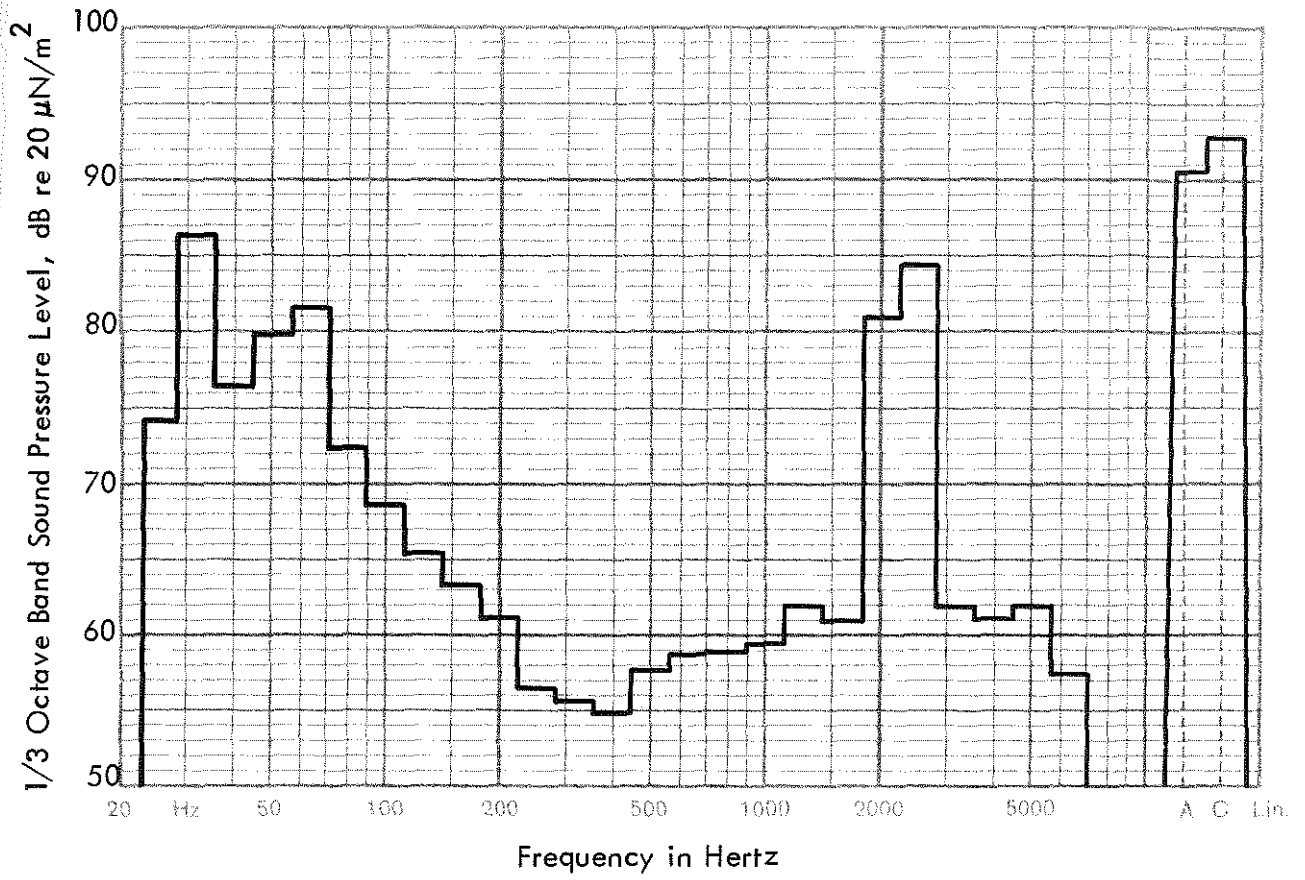


Figure 4.3-19. Frequency Spectra of Noise Emitted from Inert Retarder  
(Measurements Taken 100 Feet from Track)

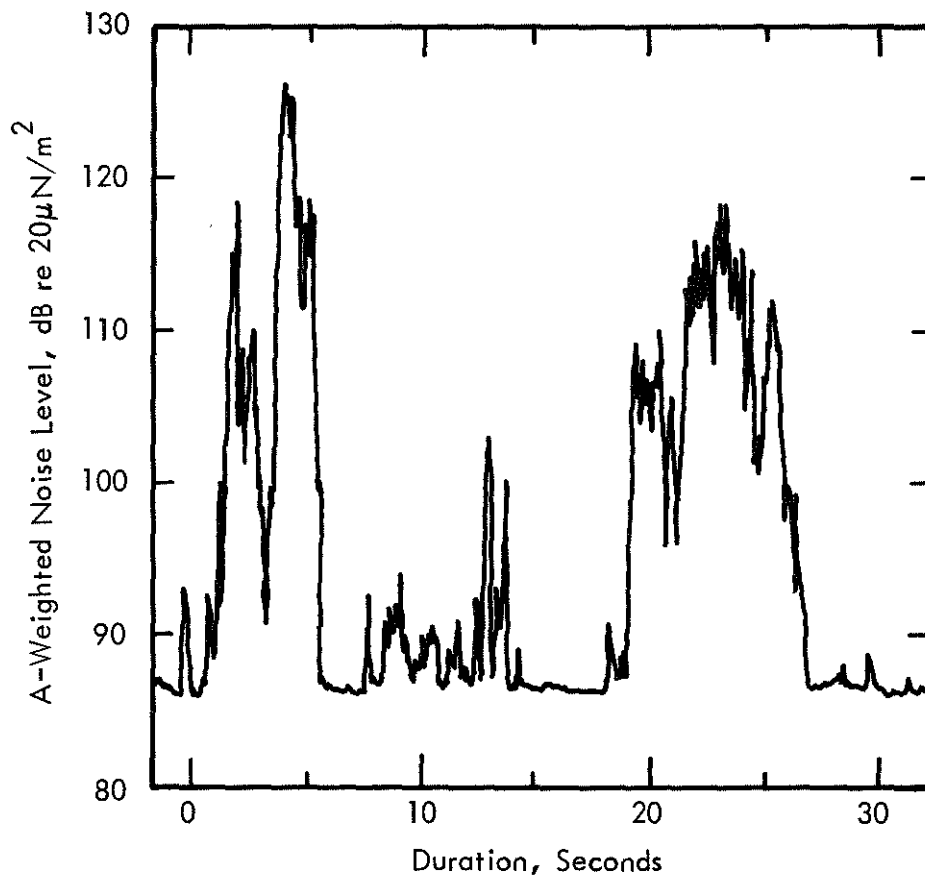


Figure 4.3-20. A-Weighted Time History of Noise Emitted from Master Retarder (Measurements Taken at 25 Feet from Retarder)

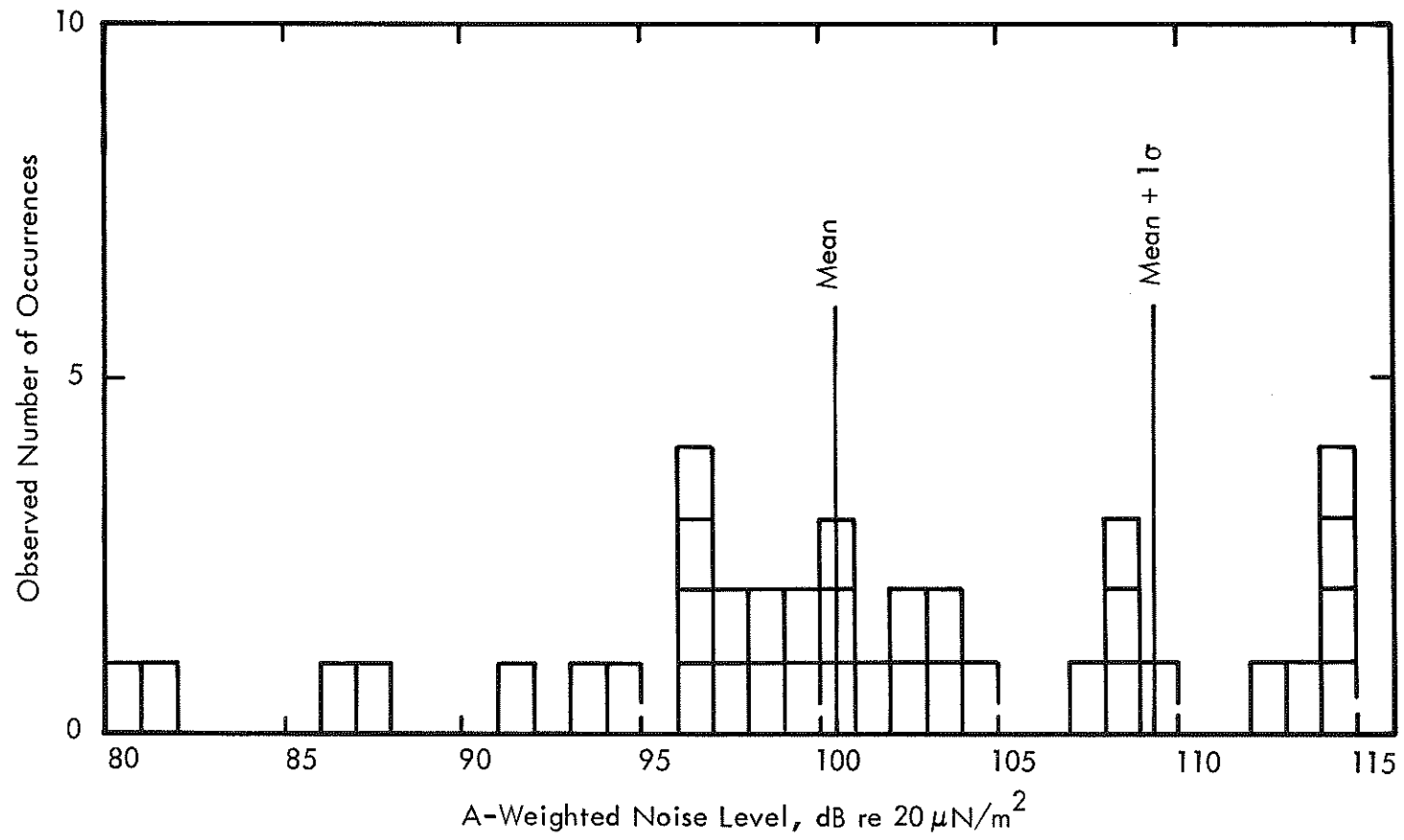


Figure 4.3-21. Distribution of A-Weighted Noise Levels Emitted from Master Retarders (Measured 100 Feet from the Retarder).

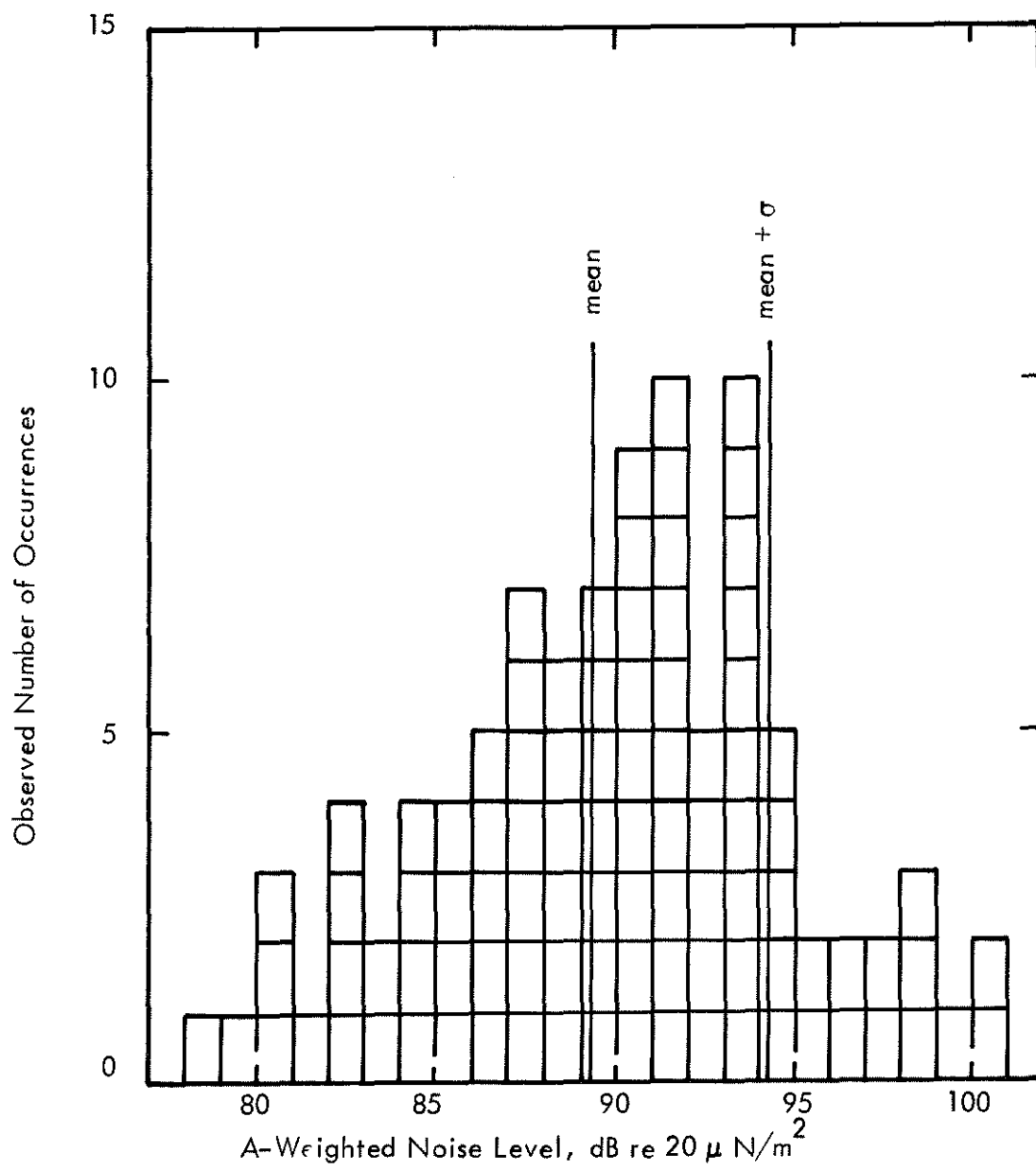


Figure 4.3-22. Distribution of Noise Levels Emitted from Inert Retarders (measurements taken 100 feet from retarder).

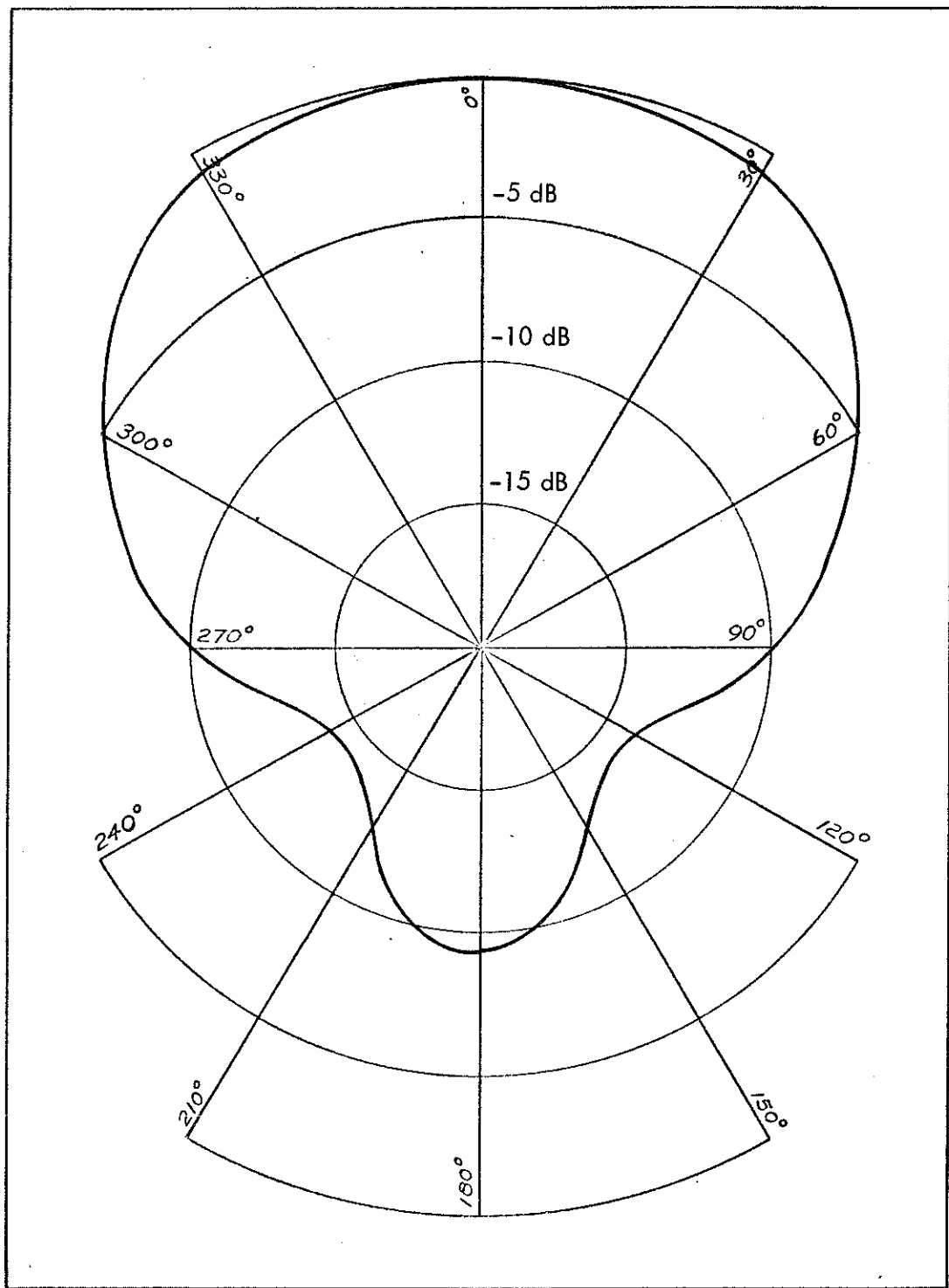


Figure 4.3 -23. Public Address Speaker Directivity. Directivity pattern at 10 Feet Distance with Speech Spectrum Input. Noise Level = 110 dB re  $20 \mu \text{N/m}^2$  for 10 Watt Input.

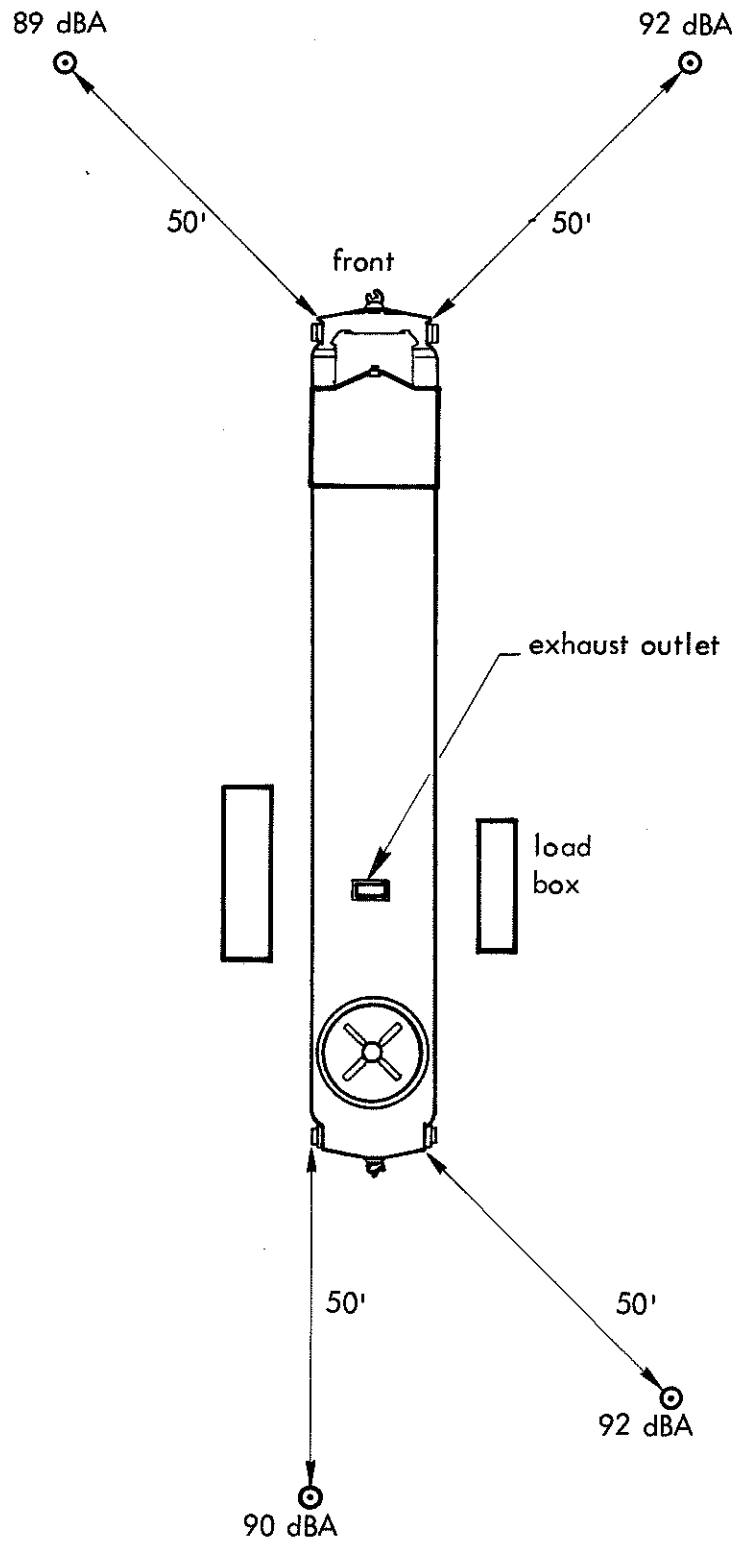


Figure 4.3 -24 2500 HP Diesel Electric Locomotive Under Load Test at Number 8 Throttle Setting. Analysis of Sound Directionality.

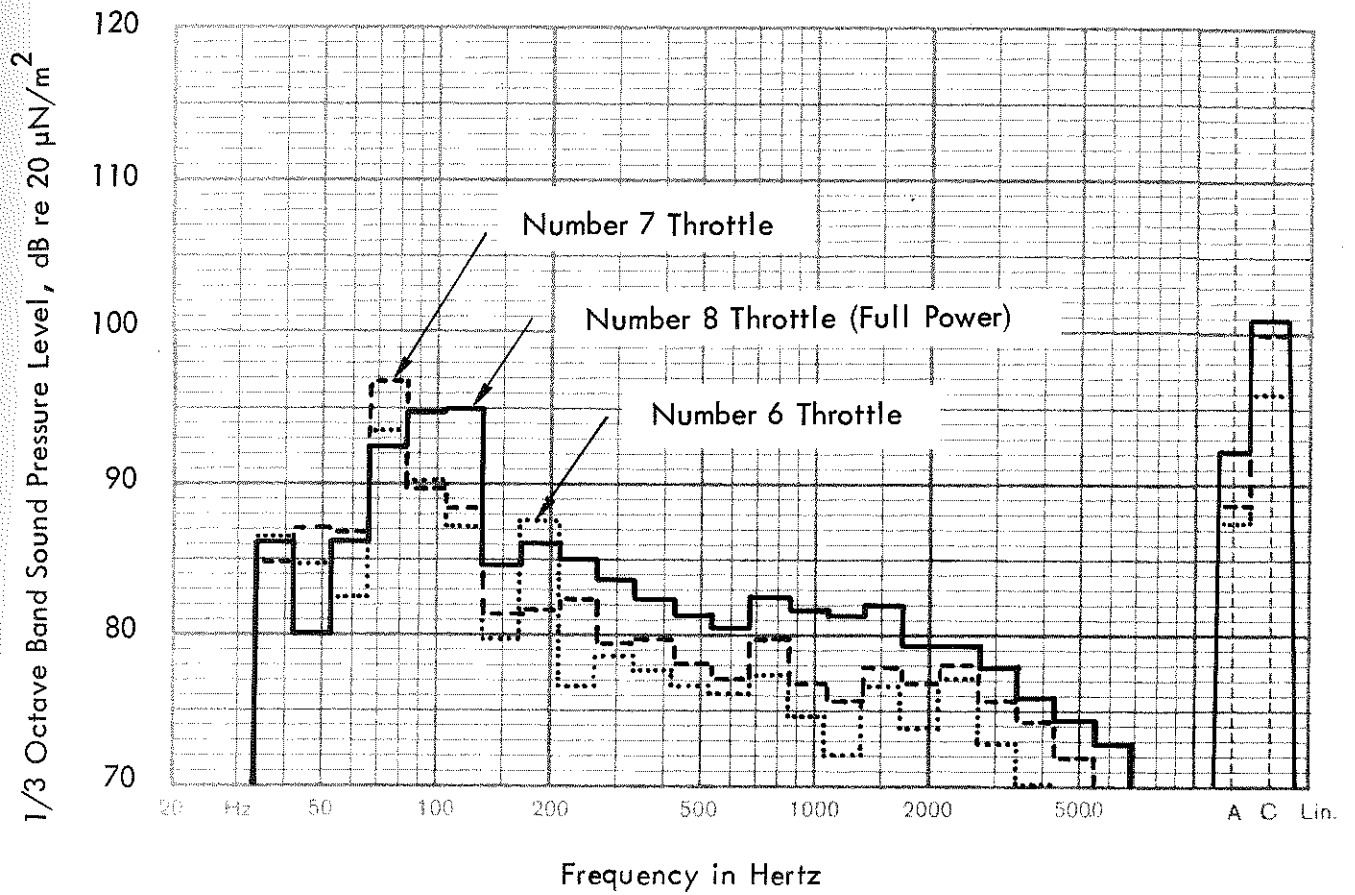


Figure 4.3-25. Spectral Content of Noise Emitted by 2500 HP Locomotive Under Load Test at Throttle Settings 6, 7 and 8. (Measurements at 50 Feet)



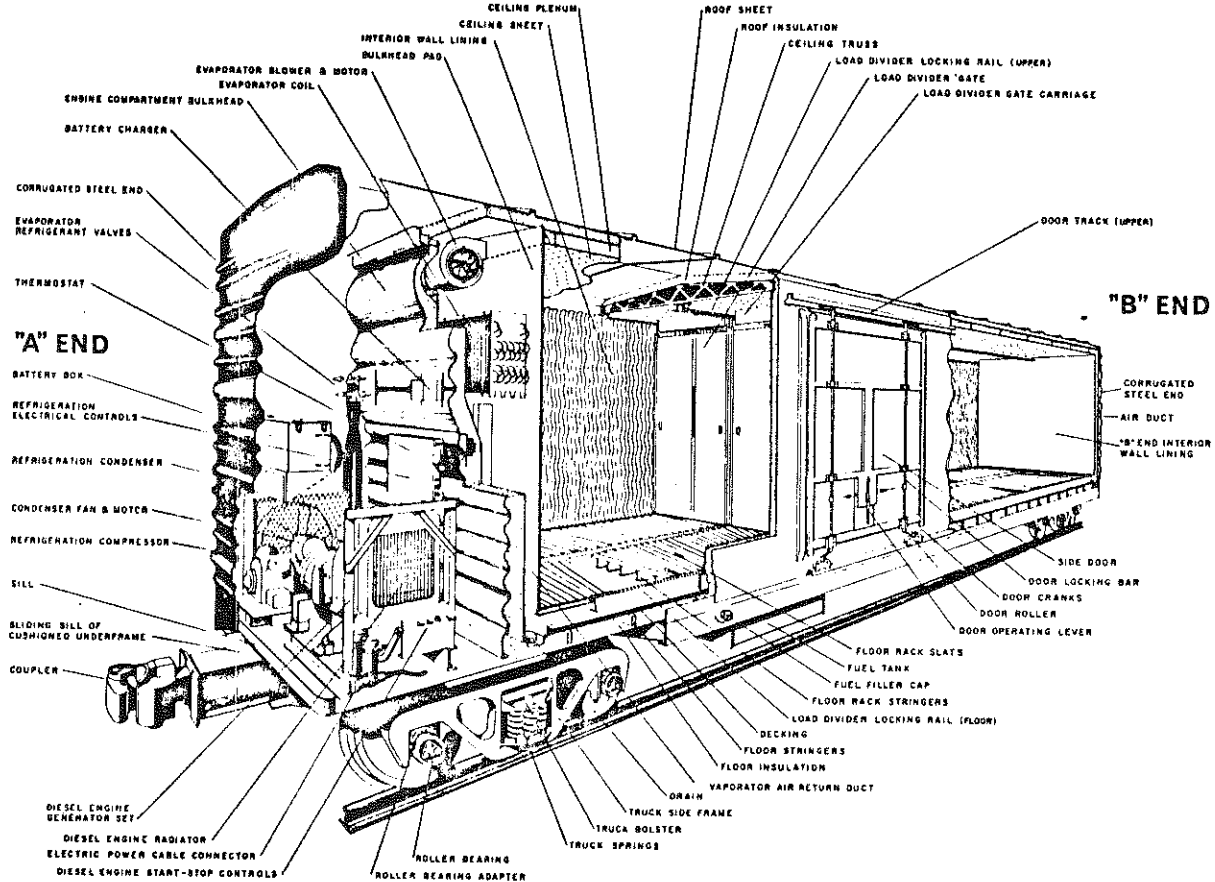


Figure 4.3-26. Typical Layout of Mechanical Refrigerator Car Engine/Compressor System.

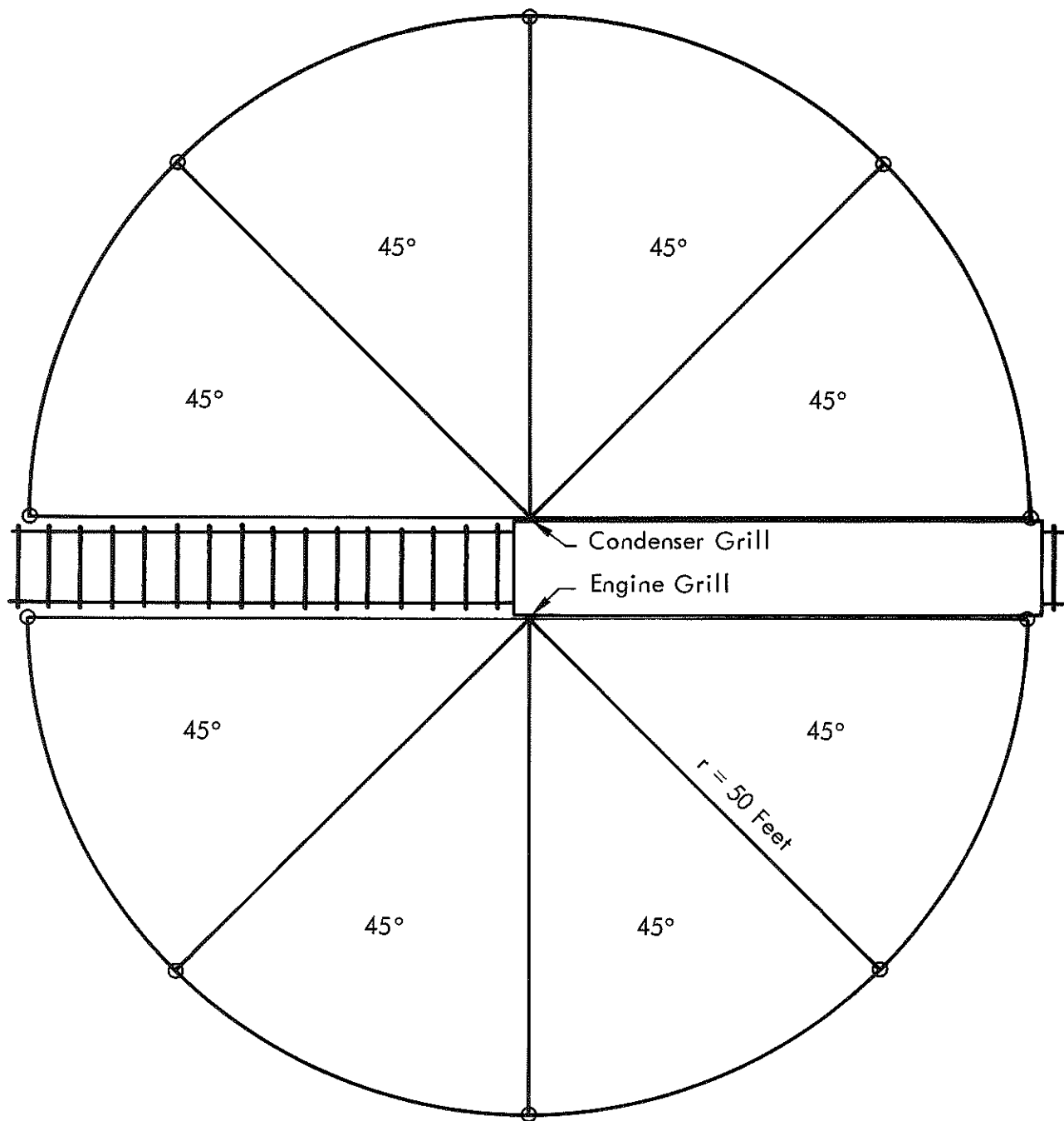


Figure 4.3-27. Investigation of Mechanical Refrigerator Car Noise Directionality Pattern

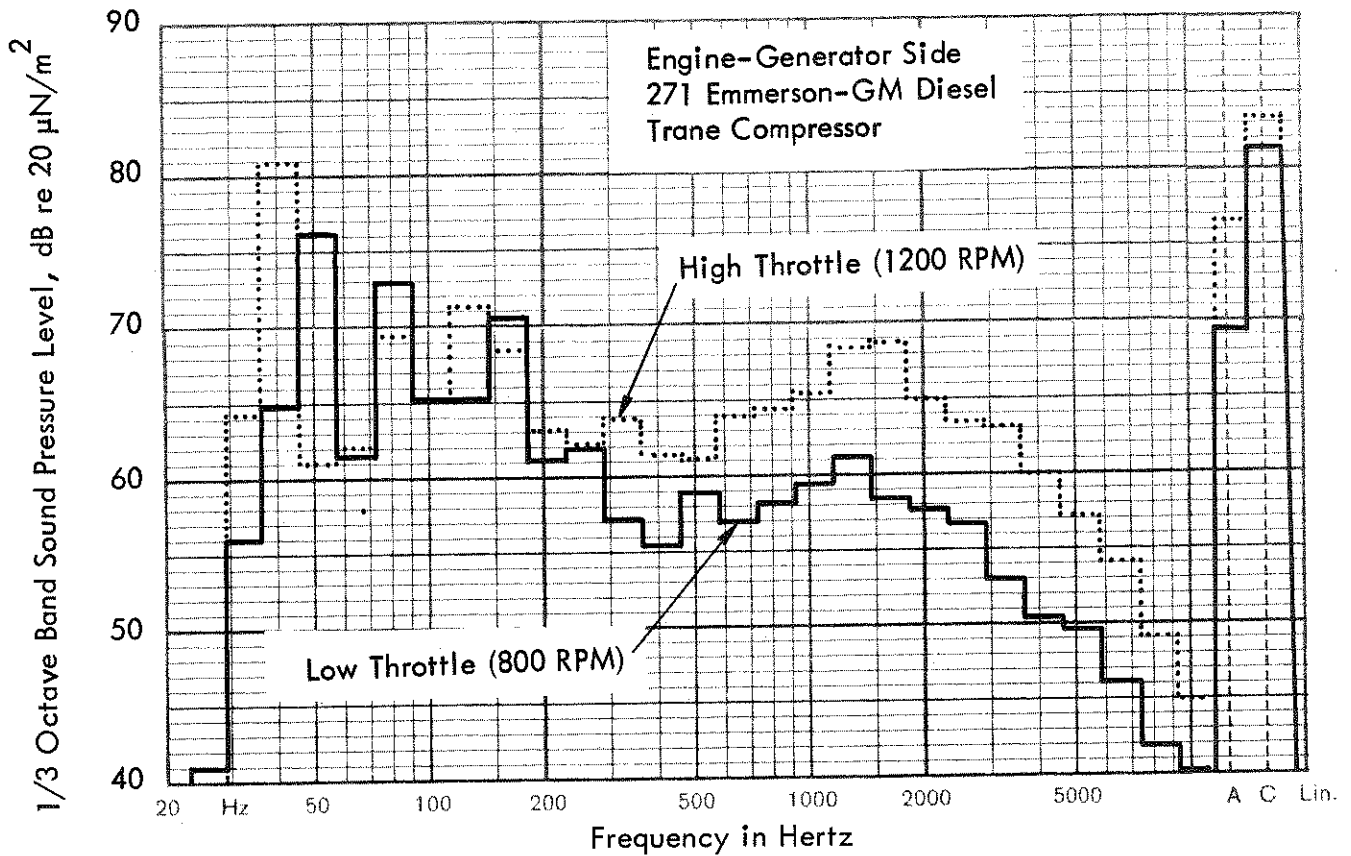
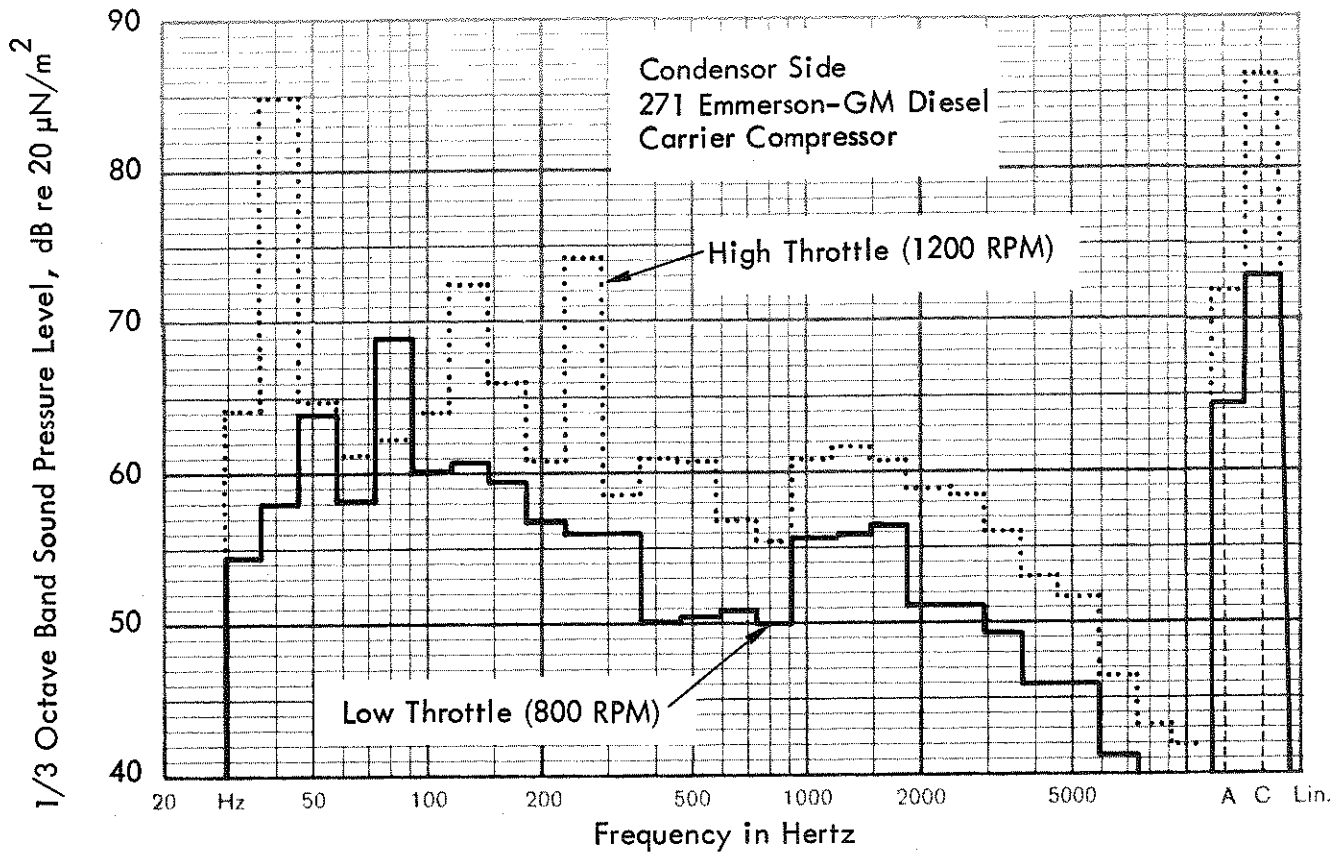


Figure 4.3-28. 1/3 Octave Band Frequency Spectra of Noise Emitted by Operation of Mechanical Refrigerator Cars Measured at 50 Feet From Track.

1/3 Octave Band Sound Pressure Level, dB re 20  $\mu\text{N}/\text{m}^2$

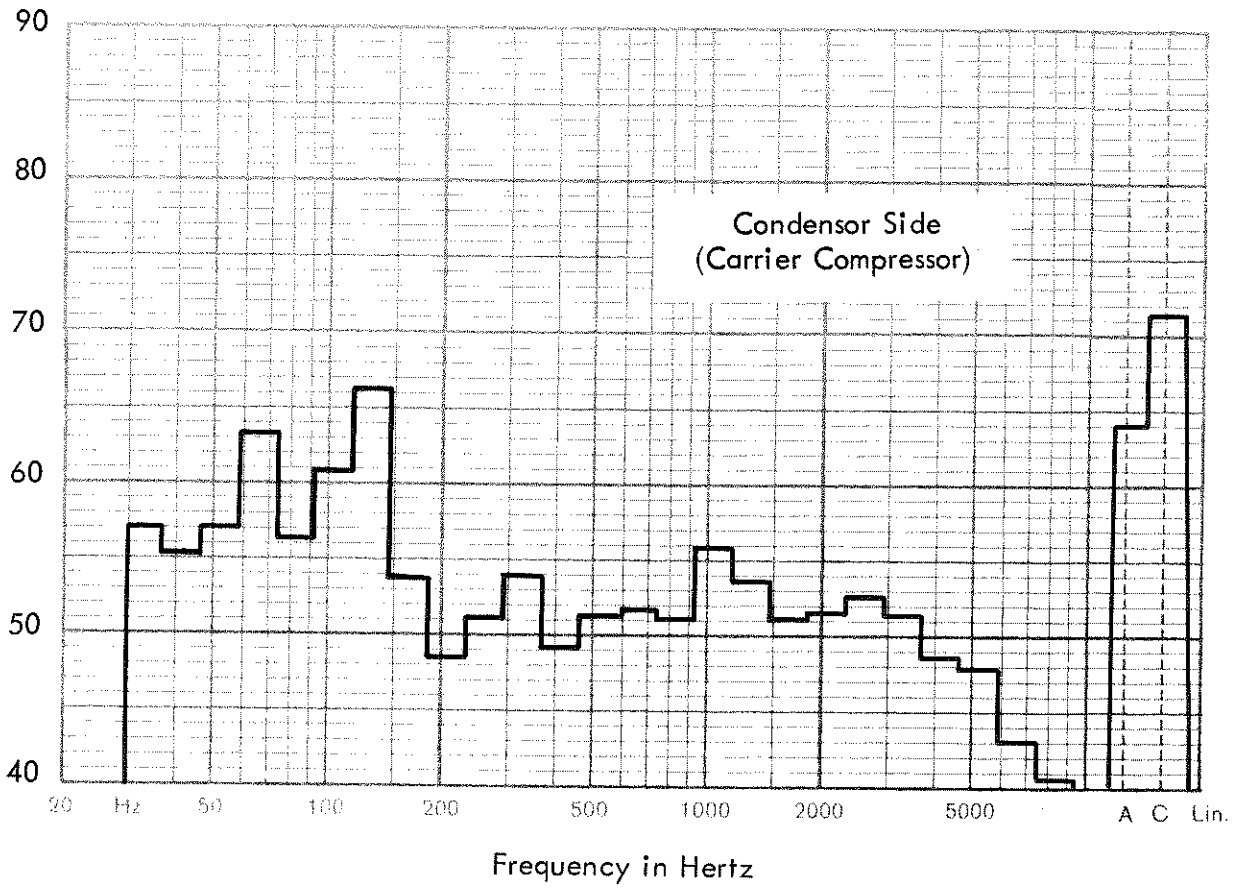


Figure 4.3-29. Mechanical Refrigerator Unit Powered by 220 V Auxiliary Electric Power. (Measurements at 50 Feet)

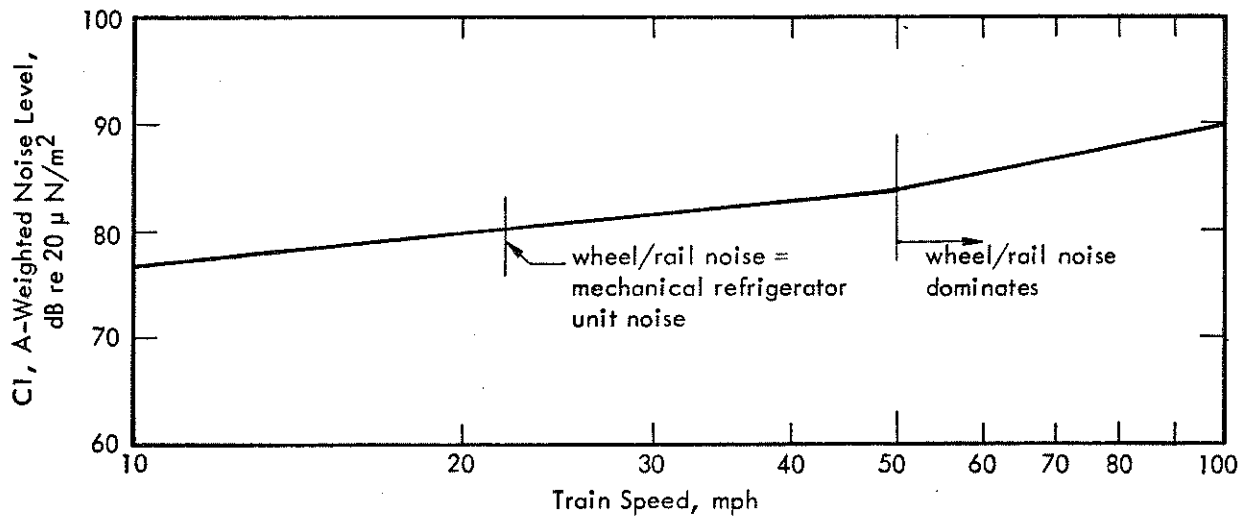


Figure 4.3-30. Noise Level of a Line of 100 Moving Mechanical Refrigerator Cars for Observer 100 Feet from the Track.

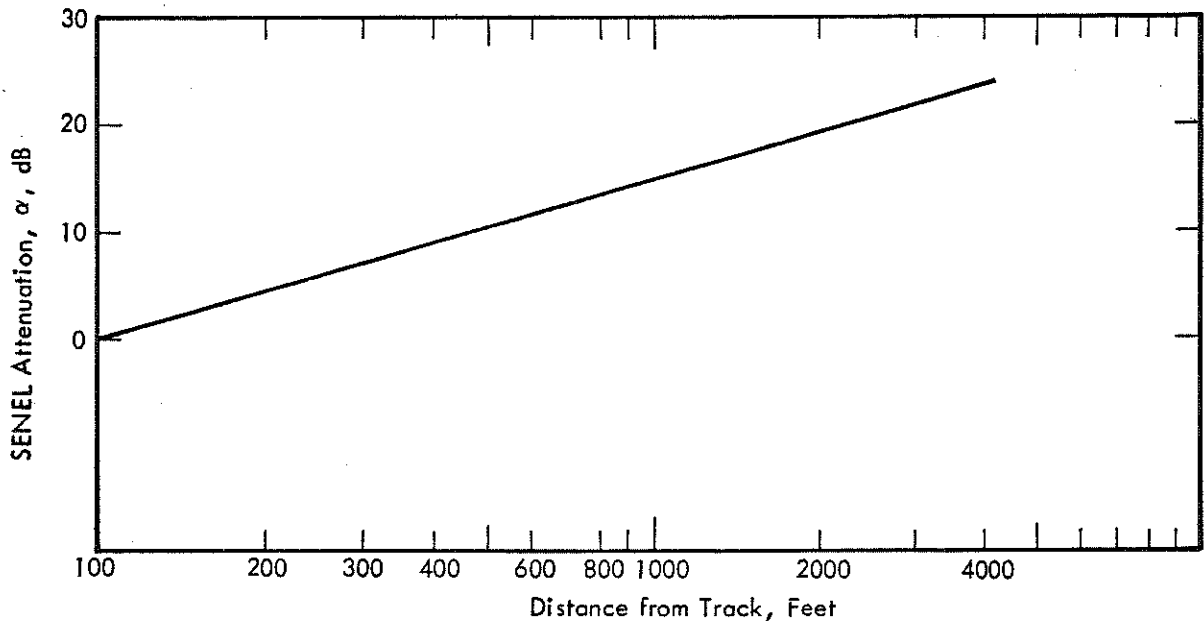


Figure 4.3-31. Attenuation Correction to be Subtracted from the Car SENEL at 100 Feet for an Entire Train of Mechanical Refrigerator Cars for Train Speeds Less Than 50 mph. (Use Figure 3.4-4 for Train Speeds Greater than 50 mph). These Correction Factors Account for Attenuation Due to Spreading of Sound Waves, Increased Duration of Noise As Observer Moves Away from the Source, Air Absorption (at 60°F, 50 Percent Relative Humidity), and Excess Ground Attenuation.

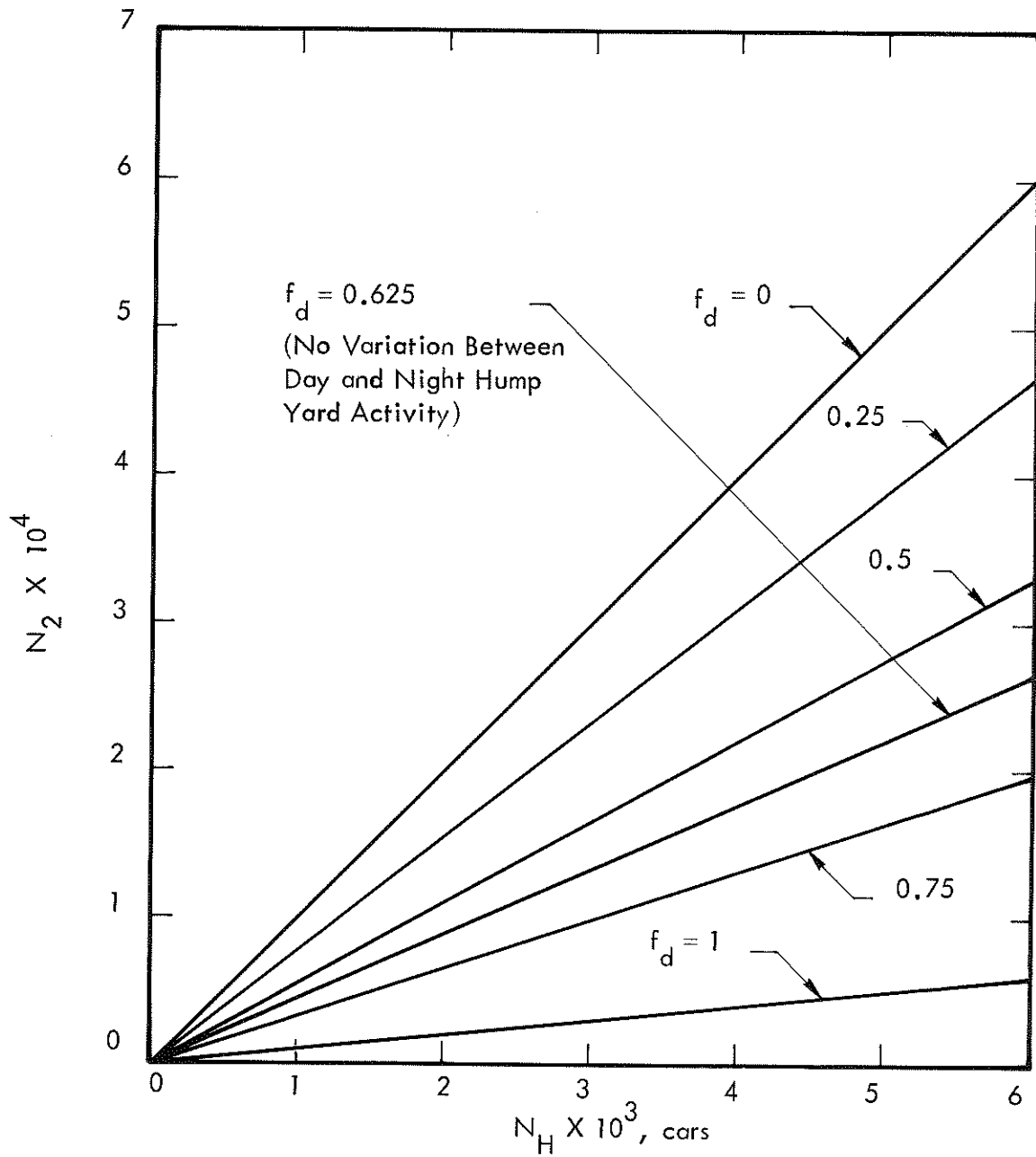


Figure 4.6-1. Effective Number of Cars Through Hump Yard Per Day.  $N_H$  is Equal Actual Number of Cars Through Hump Yard Per 24-Hour Day and  $f_d$  is the Fraction of the Total Through Hump Yard Per Day Which Move Between 7:00 a.m. and 10:00 p.m.

4-104

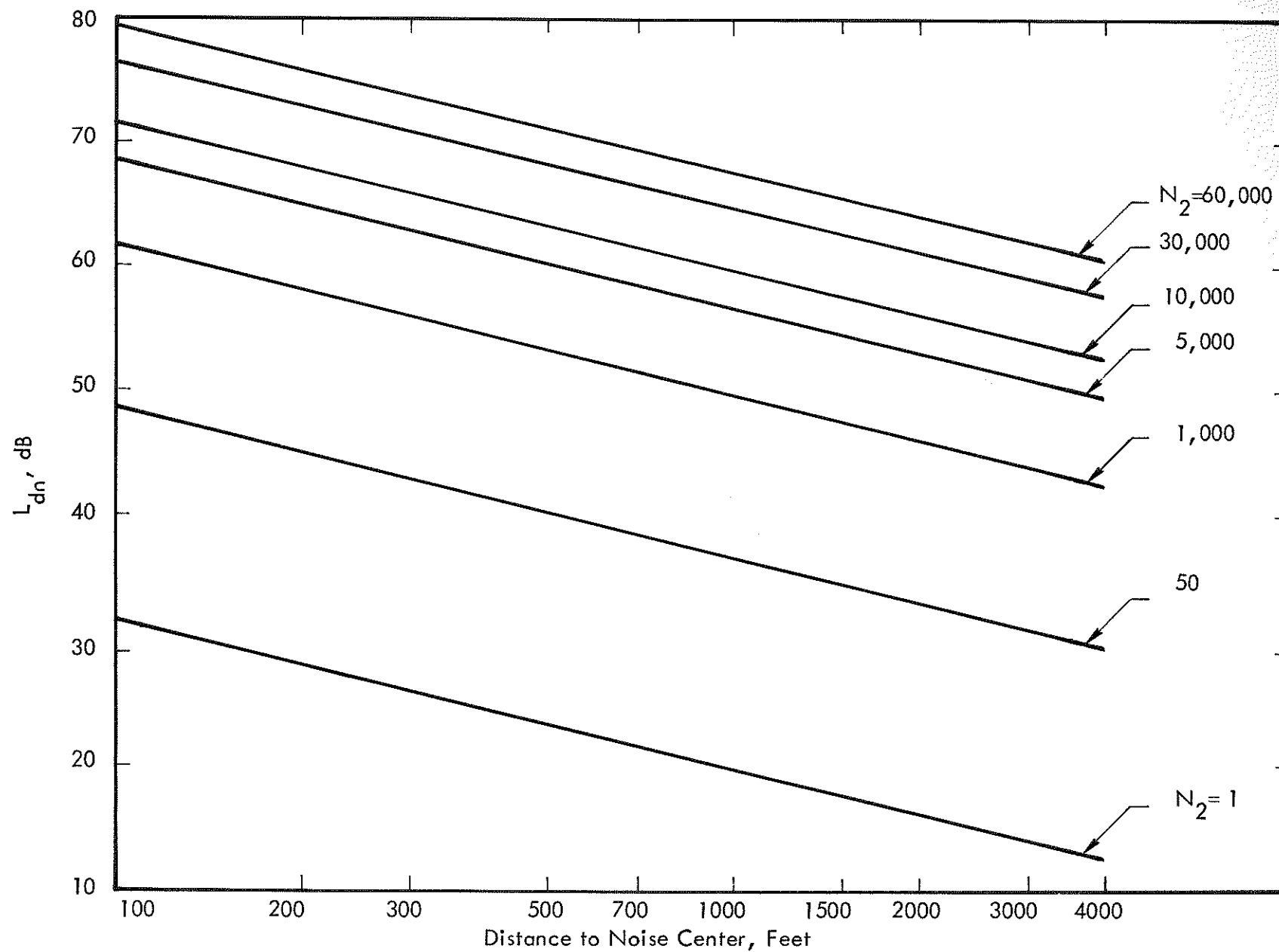


Figure 4.6-2.  $L_{dn}$  of Hump Yard Push Engine as a Function of Distance to the Noise Center and Effective Number of Cars Humped. This Figure Corresponds to Steps 3 and 4.

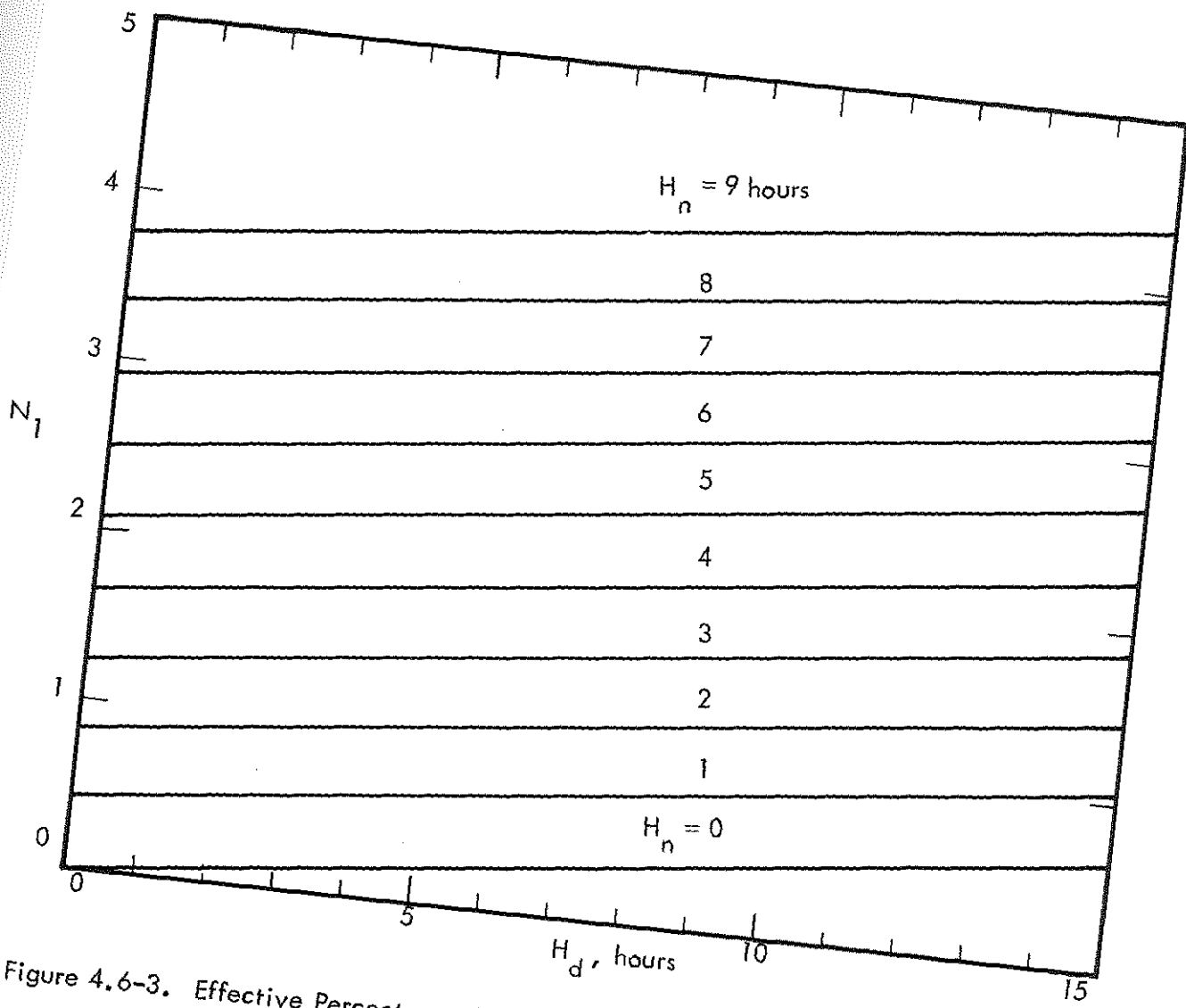


Figure 4.6-3. Effective Percentage of Time a Switcher is Used in a Concentrated Area of Switching.  $H_d$  is Equal the Number of Hours a Switcher is Used Between 7:00 a.m. and 10:00 p.m. and  $H_n$  is Equal the Number of Hours of Switcher Usage Between 10:00 p.m. and 7:00 a.m.



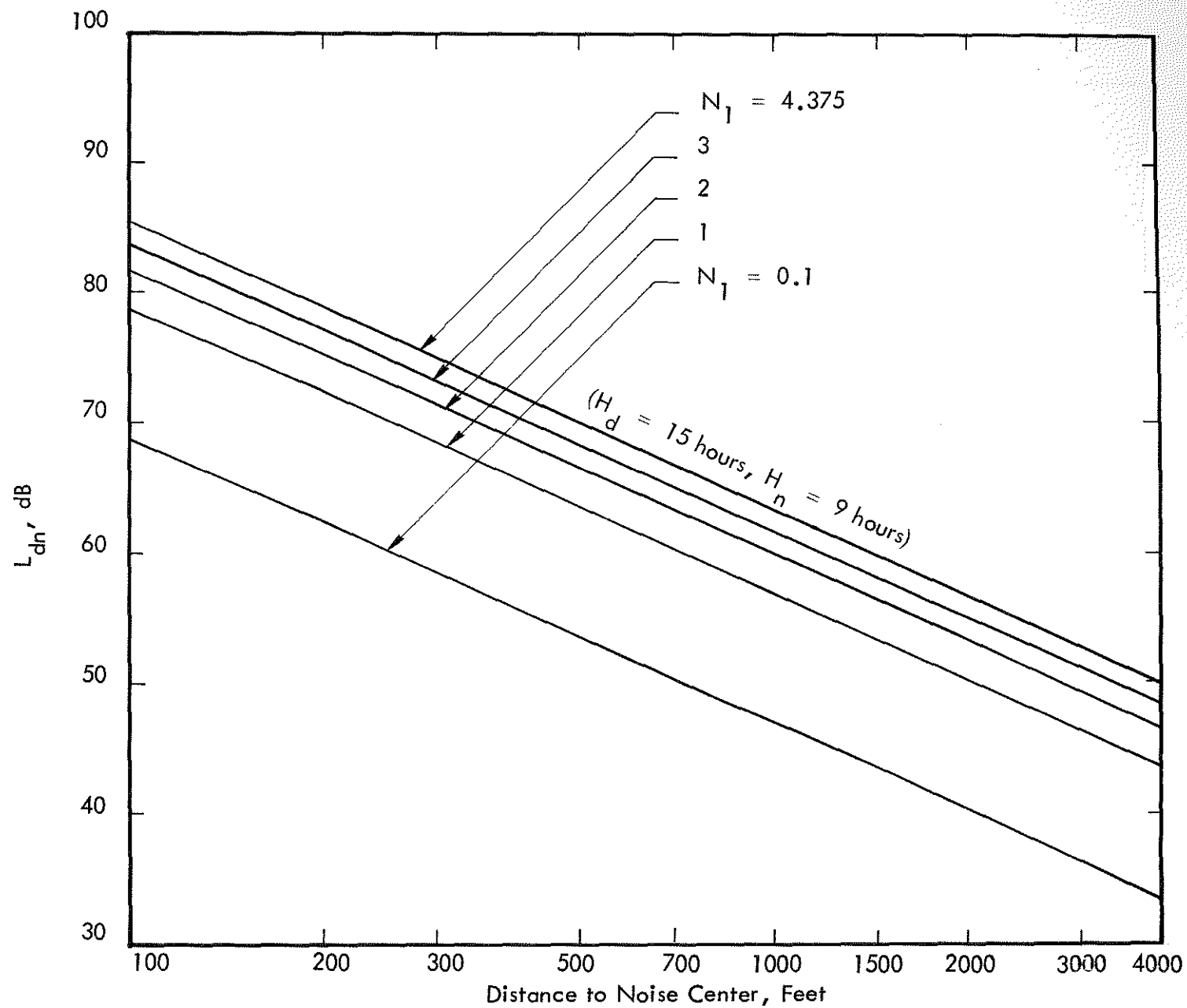


Figure 4.6-4.  $L_{dn}$  for an Area of Concentrated Switching as a Function of Distance to the Noise Center and Effective Percentage Time in Use at a Location. This Figure Corresponds to Step 8.

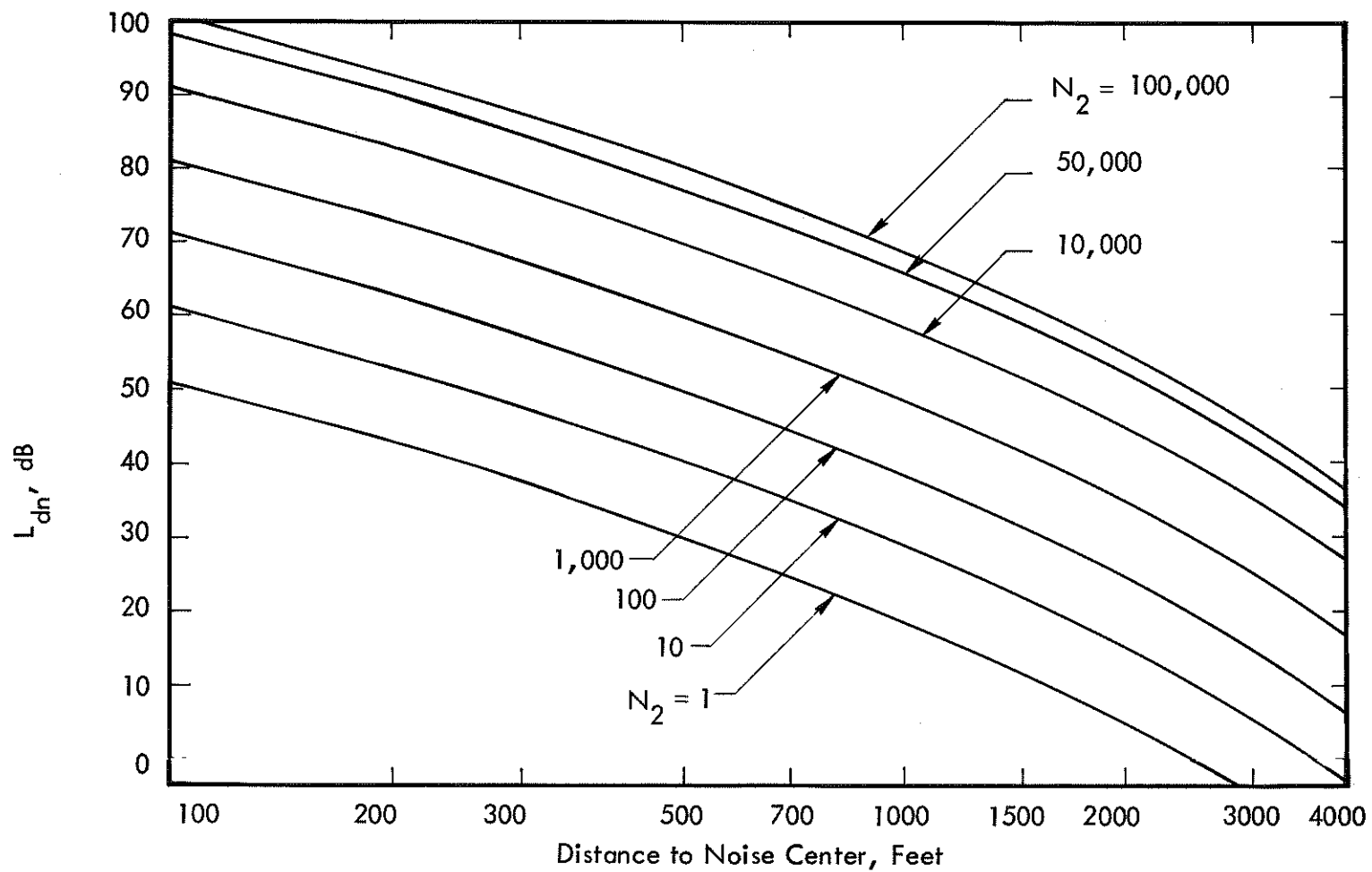


Figure 4.6-5.  $L_{dn}$  for Master and Group Retarder as a Function of Distance to the Noise Center and Effective Number of Cars Humped.

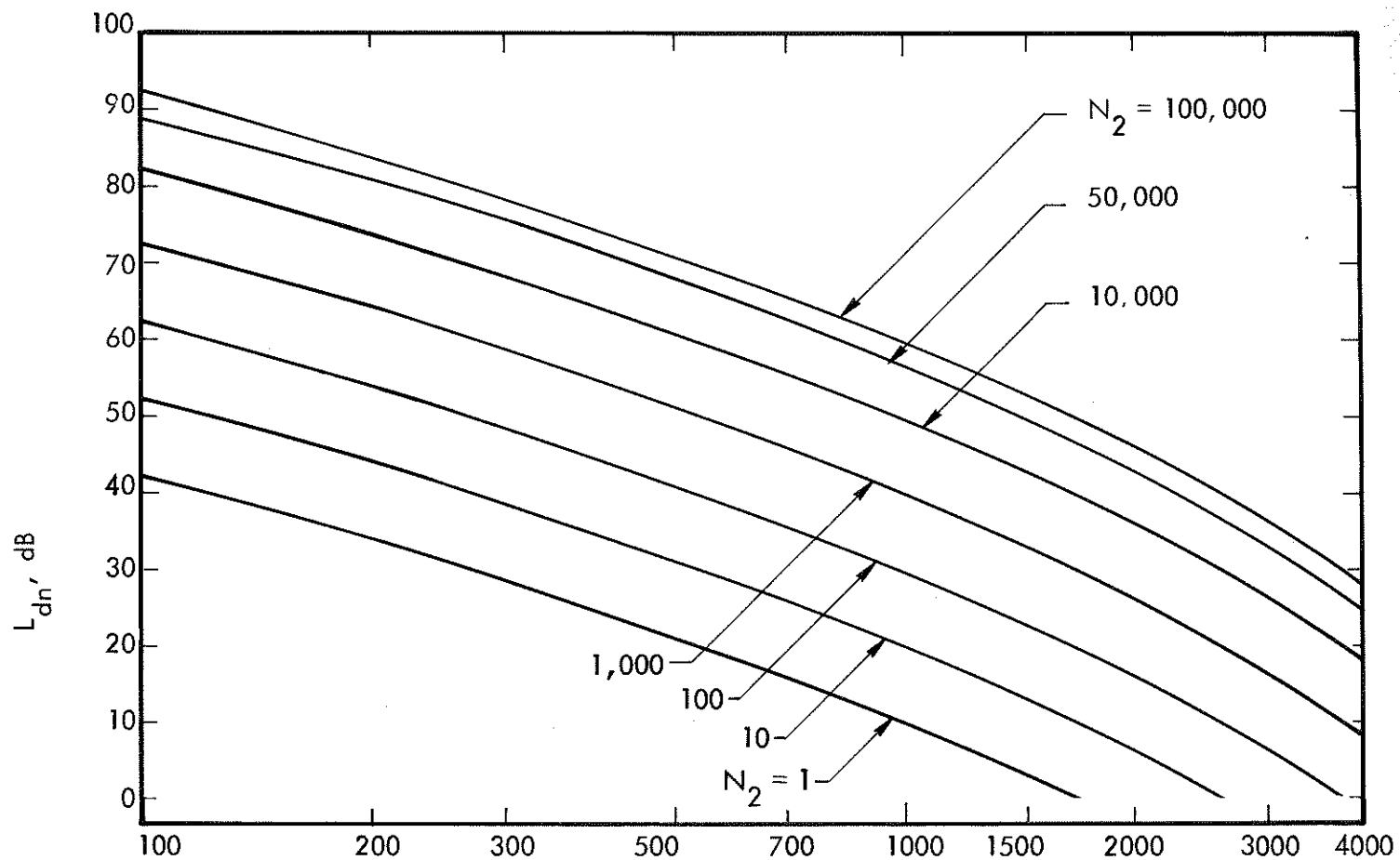


Figure 4.6-6  $L_{dn}$  for Inert Retarders as a Function of Distance to the Noise Center and Effective Number of Cars Leaving Hump Yard. This Figure Corresponds to Step 16.

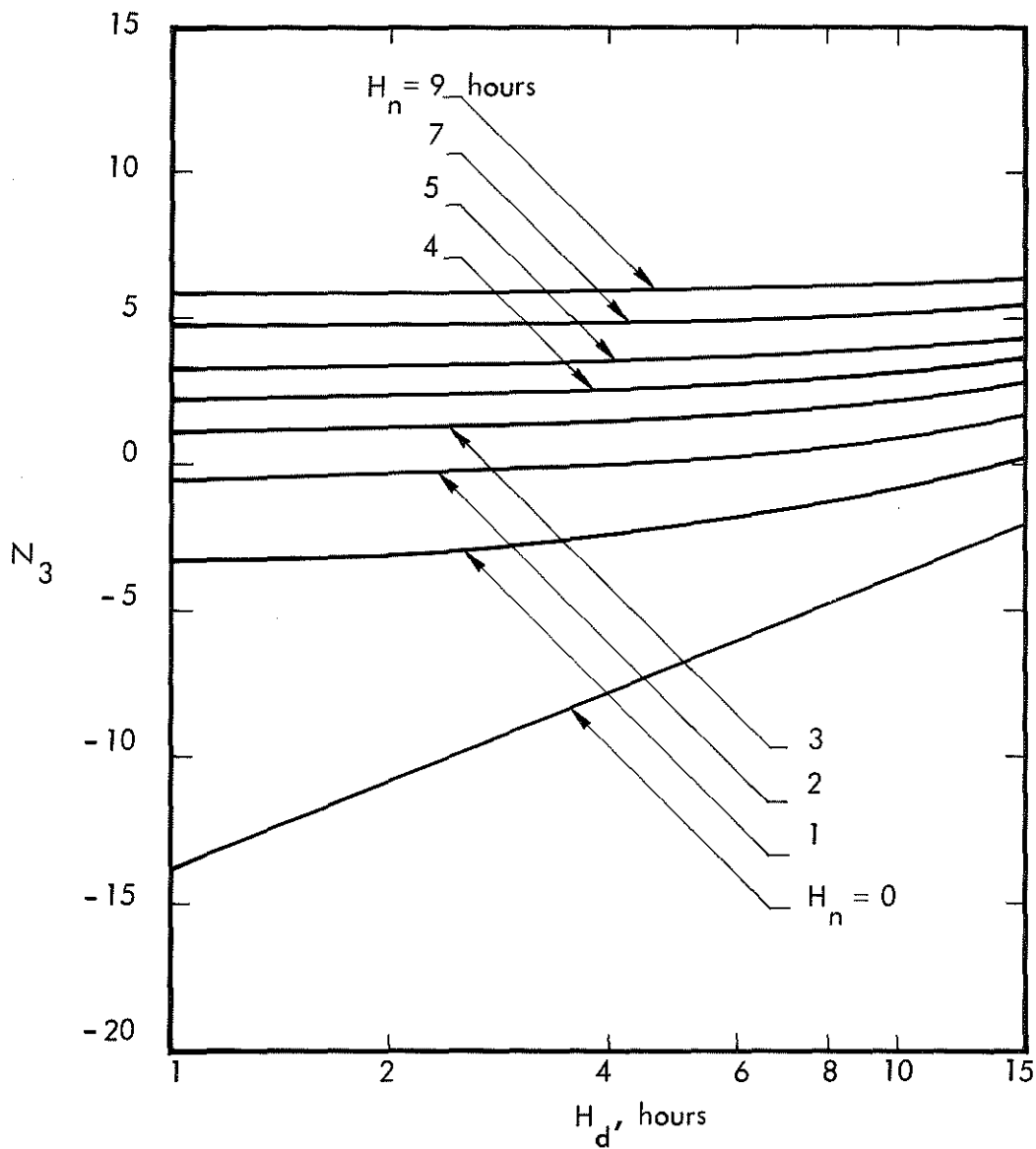


Figure 4.6-7. Logarithmic Effective Fraction of Time Usage for a Line of Noise Sources.  $H_d$  is Equal the Number of Hours the Noise Source Remains at this Location Between 7:00 a.m. and 10:00 p.m. and  $H_n$  is Equal the Number of Hours the Noise Source Remains at this Location Between 10:00 p.m. and 7:00 a.m.

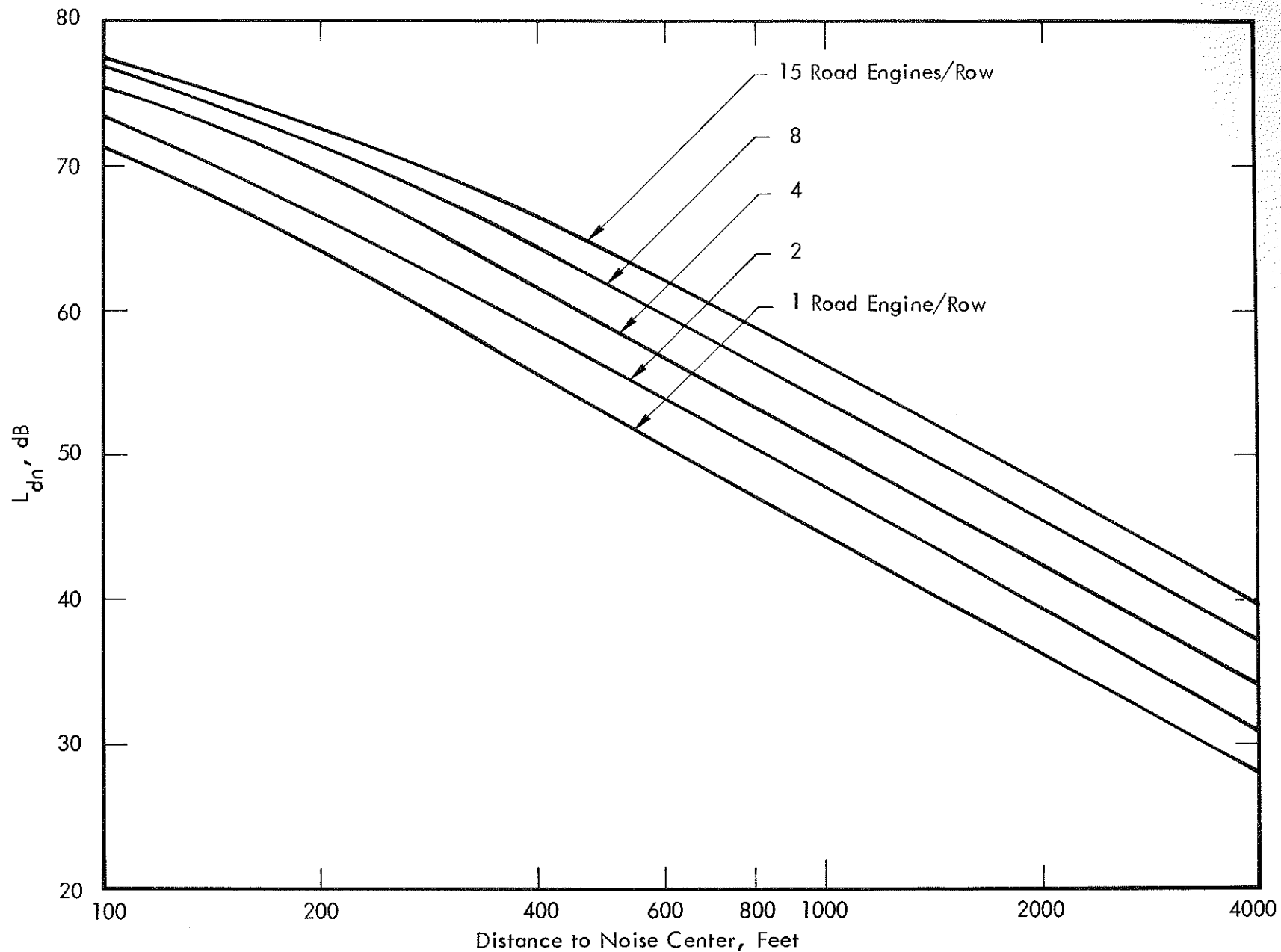


Figure 4.6-8.  $L_{dn}$  for Line of Idling Road Engines as a Function of Number of Idling Engines Per Row and Distance to the Noise Center. The  $L_{dn}$  to be used is the adjusted Contour Value Described in Step 21.

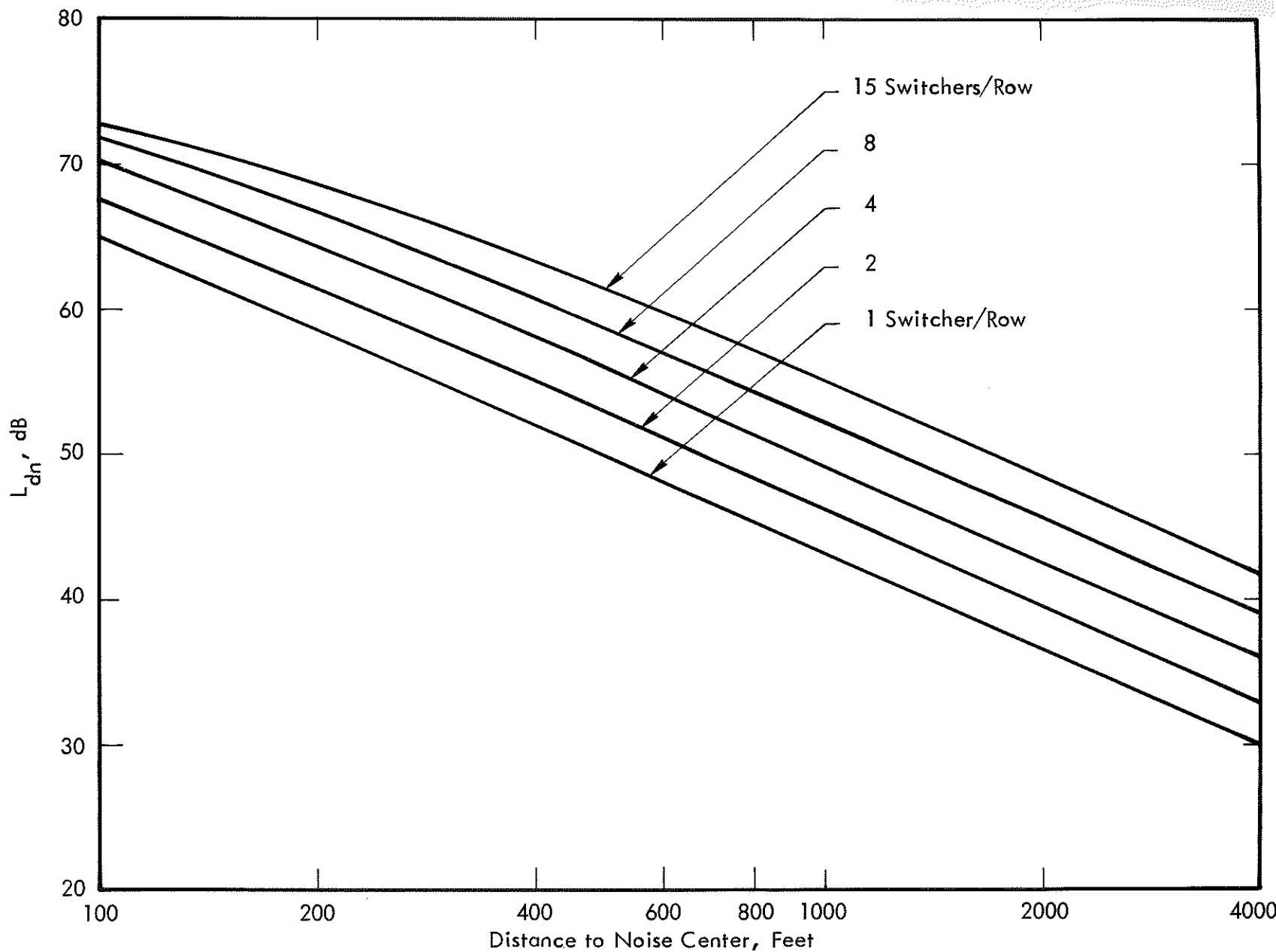


Figure 4.6-9.  $L_{dn}$  for Line of Idling Switchers as a Function of Number of Idling Engines Per Row and Distance to the Noise Center. The  $L_{dn}$  to be Used is the Adjusted Contour Value Described in Step 21.

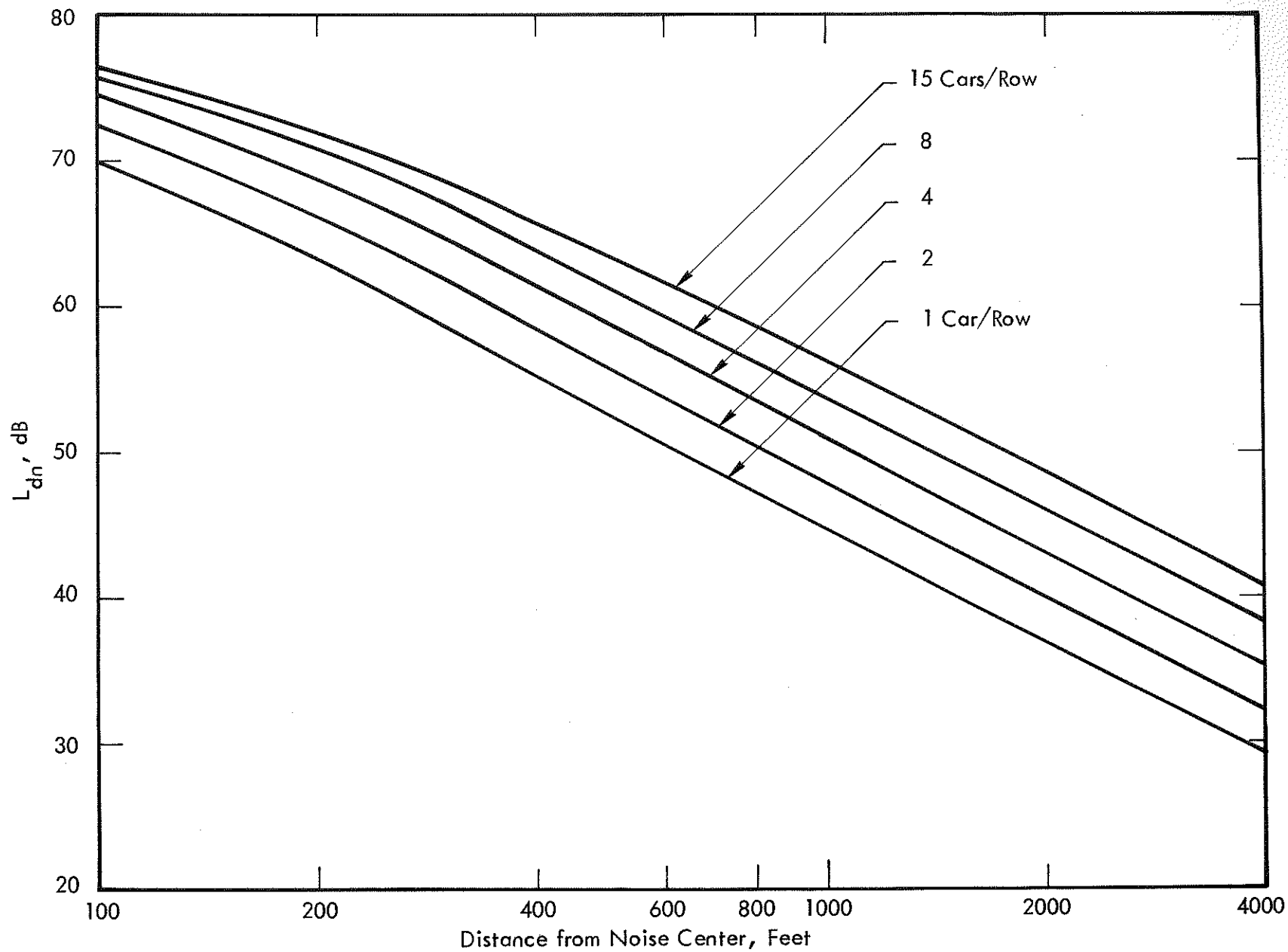


Figure 4.6-10.  $L_{dn}$  for Line of Mechanical Refrigeration Cars (Engine-Generator Side) as a Function of Number of Cars Per Row and Distance to the Noise Center. The  $L_{dn}$  to be Used is the Adjusted Contour Value Described in Step 26.

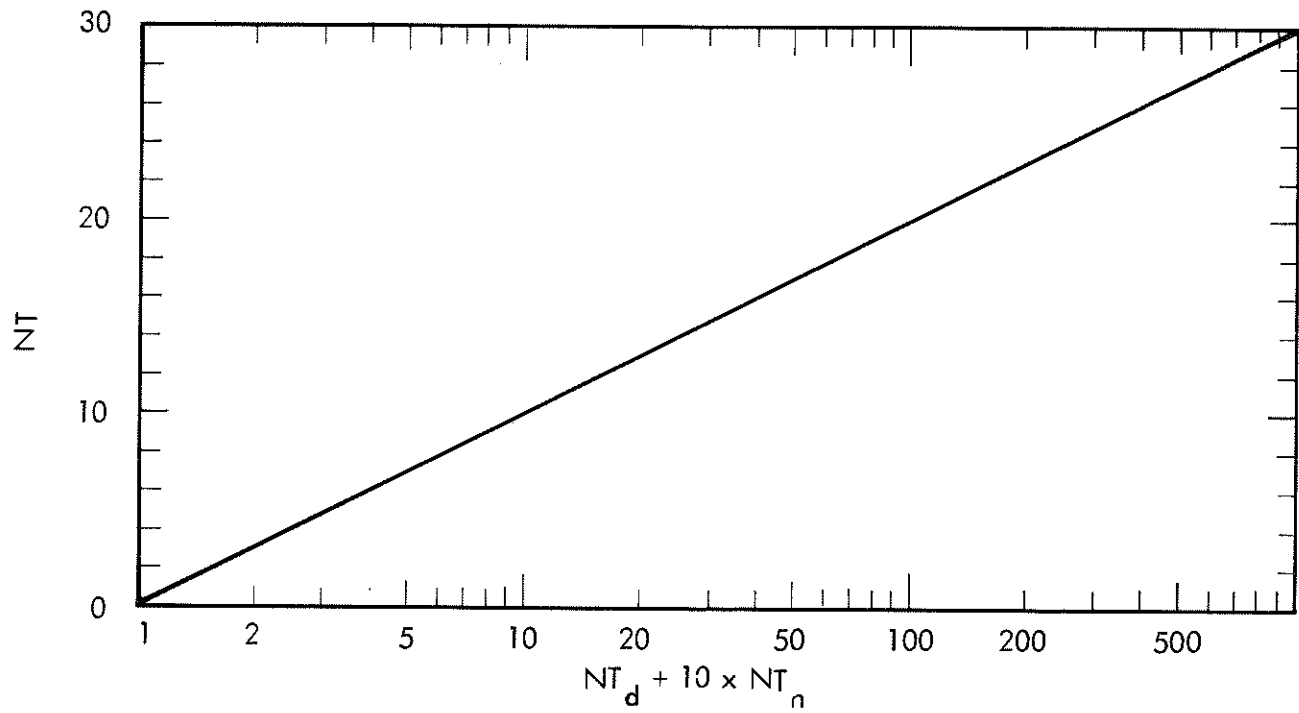


Figure 4.6-11. Determination of Weighting Factor for Number of Load Test Occurrences During the 24-Hour Time Period



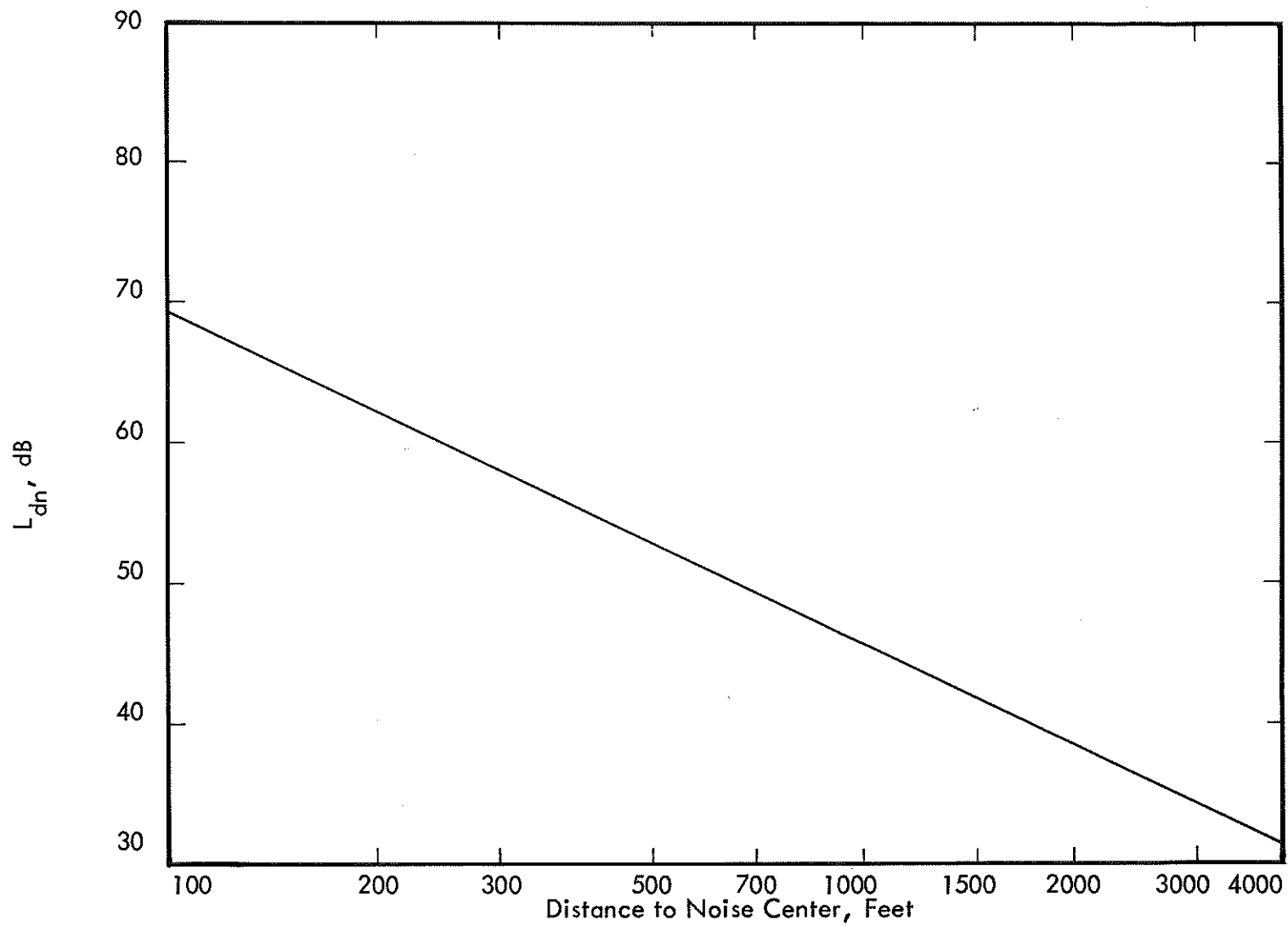
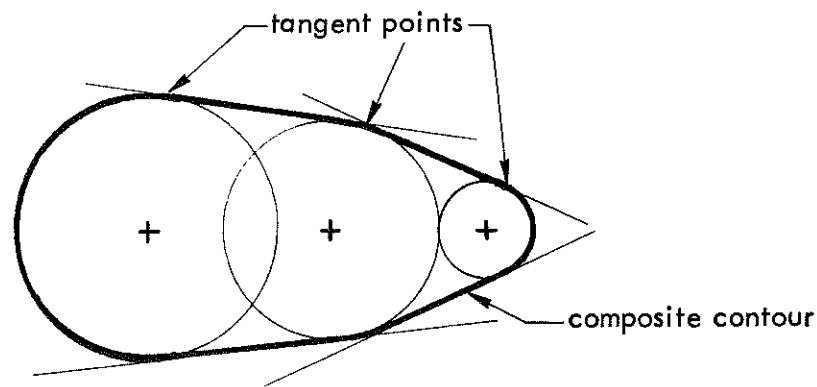
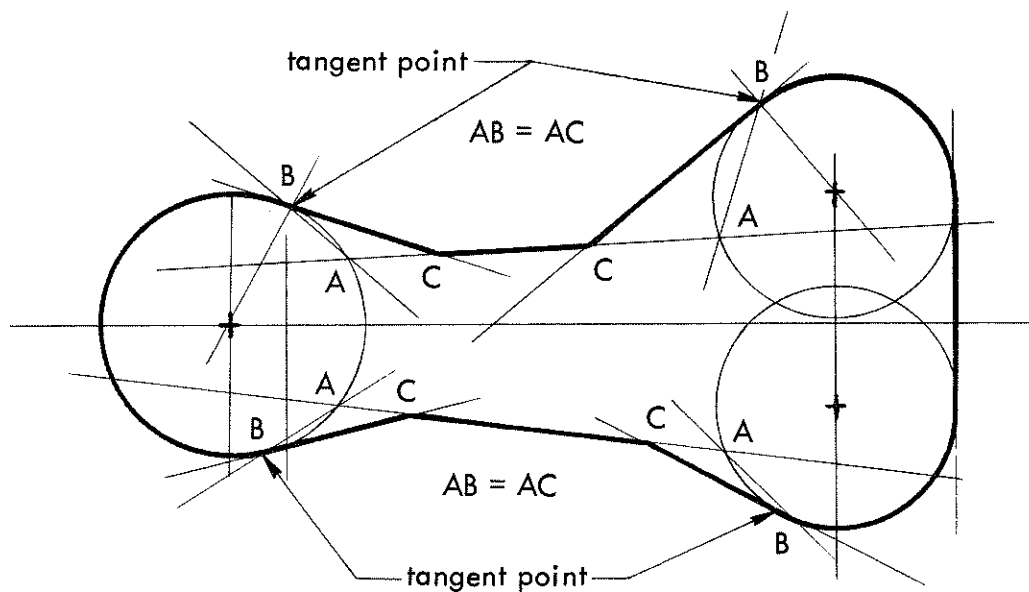


Figure 4.6-12.  $L_{dn}$  for Load Test as a Function of Distance to the Noise Center.  
The  $L_{dn}$  used is the Adjusted Contour Value Described in Step 30.



A. Simplified "Tangent-Point" Construction of Overall Contour for Combination of Point Source Contours.



B. Simplified "Tangent-Point" Equal Leg Construction Technique for Composite Contour Construction for Combination of Point Source and Line Source Contours.

Figure 4.6-13. Techniques for Composite  $L_{dn}$  Contour Construction.

# $L_{dn}$ WORKSHEET FOR YARD OPERATIONS

NOISE CENTER	$N_H$	$f_d$	$N_2$	Distance to Contour at Mid-Point of Noise Center				Distance to Contour at End of Noise Center							
Hump Engine				65 dB	80 dB	___ dB	___ dB	65 dB	80 dB	___ dB	___ dB				
Concentrated Switching	$H_d$	$H_n$	$N_1$					Distance to Noise Contour							
1															
2															
3															
4															
5															
6															
Master and Group Retarder	$N_H$	$f_d$	$N_2$	S% Correction	Number of Retarders Correction	$L_{dn}$ Adjustment	Value of Adjusted Contour								
							65 dB	80 dB	___ dB	___ dB					
Inert Retarder	$N_H$	$f_d$	$N_2$												
Idling Locomotives and/or Mechanical Refrigeration Cars	$H_d$	$H_n$	$N_3$	$N_4$			$L_{dn}$ Adjustment	Value of Adjusted Contour							
							65 dB	80 dB	___ dB	___ dB					
1															
2															
3															
4															
5															
6															
Load Test	$NT_d$	$NT_n$	NT												

Figure 4.7-1.  $L_{dn}$  Worksheet for Yard Operations

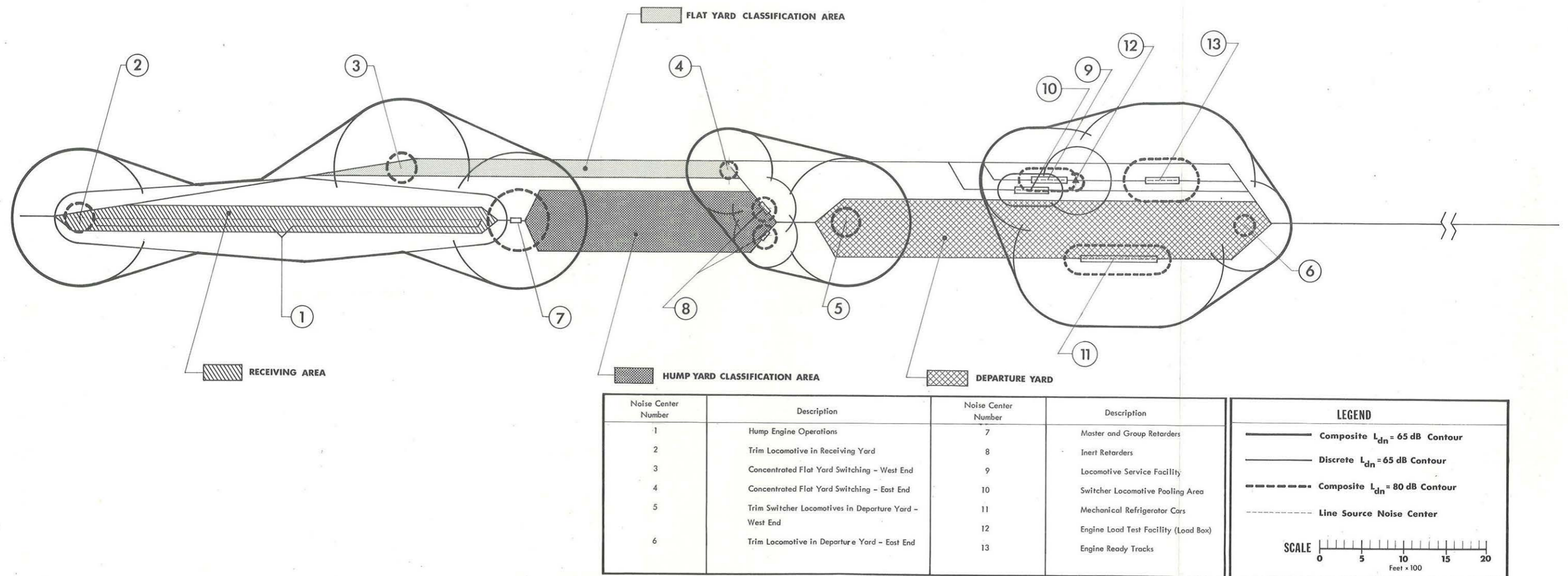


Figure 4.7-1. Illustration of  $L_{dn}$  Noise Contours Around Railroad Classification Yard Operations.

# L<sub>dn</sub> WORKSHEET FOR YARD OPERATIONS

NOISE CENTER	N <sub>H</sub>	f <sub>d</sub>	N <sub>2</sub>	Distance to Contour at Mid-Point of Noise Center				Distance to Contour at End of Noise Center							
				65 dB	80 dB	___ dB	___ dB	65 dB	80 dB	___ dB	___ dB				
Hump Engine															
Noise Center #1	3000	0.625	13,000	500'	-			300'	-						
Concentrated Switching	H <sub>d</sub>	H <sub>n</sub>	N <sub>1</sub>					Distance to Noise Contour							
								65 dB	80 dB	___ dB	___ dB				
1 Noise Center #2	13	8	3.9					800'	170'						
2 Noise Center #3	13	8	3.9					800'	170'						
3 Noise Center #4	6	3	1.5					500'	100'						
4 Noise Center #5	13	3	1.8					750'	170'						
5 Noise Center #6	13	3	1.8					550'	110'						
6															
Master and Group Retarder	N <sub>H</sub>	f <sub>d</sub>	N <sub>2</sub>	5% Correction	Number of Retarders Correction	L <sub>dn</sub> Adjustment	Value of Adjusted Contour								
							65 dB	80 dB	___ dB	___ dB					
Noise Center #7	3000	0.625	13,000	10 -4	3 +5	+1	64	79			800'	350'			
Inert Retarder	N <sub>H</sub>	f <sub>d</sub>	N <sub>2</sub>												
Noise Center #8	3000	0.75	10,000											380'	120'
Idling Locomotives and/or Mechanical Refrigeration Cars	H <sub>d</sub>	H <sub>n</sub>	N <sub>3</sub>	N <sub>4</sub>					L <sub>dn</sub> Adjustment	Value of Adjusted Contour					
									65 dB	80 dB	___ dB	___ dB			
1 Noise Center #9	15	9	+6.4	0					+6.4	58.6	73.6		600'	140'	
2 Noise Center #10	2	1	-3.0	0					-3.0	68.0	83.0		190'	-	
3 Noise Center #11	15	9	+6.4	0					+6.4	58.6	73.6		800'	160'	
4 Noise Center #13	15	9	+6.4	5					+11.4	53.6	68.6		900'	250'	
5															
6															
Load Test	NT <sub>d</sub>	NT <sub>n</sub>	NT												
Noise Center #12	1	1	10.5					10.5	54.5	69.5			400'	100'	

4-119

Figure 4.7-2

## REFERENCES

1. Hare and Springer, Exhaust Emissions from Uncontrolled Vehicles and Related Equipment Using Internal Combustion Engines, Final Report, Part I, prepared by Southwest Research Institute for Environmental Protection Agency, Contract No. EHS 70-108, October 1972.
2. Bender, E.K. and Ely, R., "Evaluation of Railroad Environmental Noise," Technical Report prepared for Washington Metropolitan Area Transit Authority by Bolt, Beranek and Newman, Inc., April 1969.
3. A Study of the Magnitude of Transportation Noise Generation and Potential Abatement, U.S. Department of Transportation, Technical Report No. OST-ONA-71-1, November 1970.
4. Transportation Noise and Noise From Equipment Powered by Internal Combustion Engines, prepared by Wyle Laboratories for the U.S. Environmental Protection Agency, Report No. NTID300.13, December 1971.
5. Embleton, T.F.W. and Thiessen, G.J., "Train Noises and Use of Adjacent Land," Sound: Its Uses and Control, January/February 1962.
6. Rathe, E.J., "Note on Two Common Problems of Sound Propagation," Journal of Sound and Vibration, Volume 10, No. 3, November 1969.
7. "The Visibility and Audibility of Trains Approaching Rail-Highway Grade Crossings," FRA-RP-71-1, Federal Railroad Administration, May 1971.
8. Kendall, H.C., "Noise Studies in Retarder Yards," Railway Systems Control, Vol. 2, No. 7, 1971.
9. Private Conversation with Southern Pacific Railroad Officials at Taylor Yard, June 22, 1973.
10. "The Sound Pressure of a Uniform Finite, Plane Source," Journal of Sound and Vibration, Vol. 13, No. 4, December 1970.
11. Private Conversation with Personnel in Southern Pacific Railroad's Operations Department in San Francisco, July 18, 1973.
12. Community Noise, prepared by Wyle Laboratories for the U. S. Environmental Protection Agency, NTID300.3, December 1971.

## REFERENCES (Continued)

13. "Standard Values of Atmospheric Absorption as a Function of Temperature and Humidity for Use in Evaluating Aircraft Flyover Noise," Technical Report No. ARP 866, Society of Automotive Engineers, Inc., August 1964.
14. Beranek, L.L., "Noise and Vibration Control," McGraw-Hill Book Co., Inc. 1971.
15. Mark's Standard Handbook for Mechanical Engineers, 7th Ed 1967, McGraw-Hill, Inc., New York, Section 11, pp. 24 - 44.

## BIBLIOGRAPHY

1. Bender, E. K., *Effects of Wheel and Rail Roughness on Ground Vibrations*, " Technical Report prepared for Washington Metropolitan Area Transit Authority by Bolt Beranek and Newman, Inc., April 1969.
2. Jack, W.A., "Noise in Rail Transportation," Handbook of Noise Control, Chapter 32, 1957.
3. Kirschner, F., "Control of Railroad Wheel Screech Noise," Sixth International Congress on Acoustics, Tokyo, Japan, August 1968.
4. Lyon, R.H., "Propagation of Environmental Noise," Science, Volume 179, March 1973.
5. Paterson, W.H. and Northwood, T.D., "Noise Control in Toronto's New Subway," Noise Control, September 1956.
6. Car and Locomotive Cyclopedia, Simmons-Boardman Publishing, 1970.
7. Manual for Highway Noise Prediction (Appendix B), Department of Transportation, Report No. DOT-TSC-FHWA-72-1, March 1972.
8. Manual for Highway Noise Prediction, Department of Transportation, Report No. DOT-TSC-FHWA-72-1, March 1972.
9. User's Manual for the Prediction of Road Traffic Noise Computer Program, U.S. Department of Transportation, Report No. DOT-TSC-315-1, May 1972.



## APPENDIX A

### APPLICATION OF COMPOSITE A-WEIGHTED NOISE LEVELS TO ESTIMATION OF COMMUNITY RESPONSE

The noise environments computed by methods outlined in this report are specified in terms of a composite or time-averaged measure of noise levels. This composite scale accounts for the magnitude of a noise, its duration, number of occurrences and time of day it occurs. This appendix will illustrate how this composite physical measure of the noise environment, when normalized by additional empirical factors to account for community sensitivity to noise, can be used to estimate community response to outdoor noise environments.

The magnitude of the noise is defined with the use of the A-weighted noise scale. As illustrated in Figure A-1, this weighting represents a modification to the frequency response of a noise measurement system which attempts to account, approximately, for the relative frequency response of the human ear. That is, an A-weighted noise level includes a deemphasis of low frequency content of a sound in a manner similar to the way the human ear deemphasizes low frequencies.

As outlined in Section 3.3, the CNEL or  $L_{dn}$  composite noise scales combine this magnitude estimate of a noise with factors which account for the duration of a single event, and the number of events per day. In addition, noises occurring during evening hours from 7:00 p.m. to 10:00 p.m. (for the CNEL scale only) and at night from 10:00 p.m. to 7:00 a.m. (for both CNEL and  $L_{dn}$  scales) are weighted by a factor of 3 and 10 respectively.

However, it was established in the 1950's, during early studies of community noise problems, that an improved predictor of community response to noise is obtained by accounting for additional subjective factors. A current summary of this technique of predicting community response is presented in Reference 12.

Table A-1, adopted from Reference 12, summarizes the nature and magnitude of these additional subjective correction factors. They fall into four groups.

Table A-1

Corrections to be Added to the Nominal Community Noise Equivalent Level (CNEL) or Day-Night Average Level ( $L_{dn}$ ) to Obtain Normalized CNEL or  $L_{dn}$  Values\*

Type of Correction	Description	Amount of Correction to Be Added to Nominal CNEL or $L_{dn}$ in dB
Seasonal Correction	Summer (or year-round operation).	0
	Winter only (or windows always closed).	-5
Correction for Out-door Residual Noise	Quiet suburban or rural community (remote from large cities and from industrial activity and trucking).	+10
	Normal suburban community (not located near industrial activity).	+5
	Urban residential community (not immediately adjacent to heavily traveled roads and industrial areas).	0
	Noisy urban residential community (near relatively busy roads or industrial areas).	-5
	Very noisy urban residential community.	-10
Correction for Previous Exposure and Community Attitudes	No prior experience with the intruding noise	+5
	Community has had some previous exposure to intruding noise but little effort is being made to control the noise. This correction may also be applied in a situation where the community has not been exposed to the noise previously, but the people are aware that bona fide efforts are being made to control the noise.	0
	Community has had considerable previous exposure to the intruding noise and the noise maker's relations with the community are good.	-5
	Community aware that operation causing noise is very necessary and it will not continue indefinitely. This correction can be applied for an operation of limited duration and under emergency circumstances.	-10
Pure Tone or Impulse	No pure tone or impulsive character.	0
	Pure tone or impulsive character present.	

\*Adopted, with applications for  $L_{dn}$ , from Reference 12.

- Seasonal Correction. (i.e., noise exposure during the winter only is usually less noticeable due to the tendency for people to keep their windows shut.)
- Residual Noise Level. (The most important correction of all which attempts to account for the apparent increased response of people to intruding sounds when the normal residual or ambient noise level in the community is low.)
- Previous Exposure or Attitude Corrections. (A correction to account for a tendency of communities to be less sensitive to noises they are used to and to noises which they are positively involved with or for which they feel reasonable noise abatement steps are being made.)
- Pure Tone or Impulse Correction. (A correction to account for the more disturbing quality of a sudden noise or one which contains distinct pure tones.)

As outlined in detail in Reference 12, when these corrections were carefully applied to 55 observed cases of community noise exposure and corresponding response, the correlation between various levels of noise and community response illustrated in Figure A-2 was obtained. The composite noise scale is in terms of CNEL. However, it has been found that in most cases, the numerical value of  $L_{dn}$  would be nearly identical. It is worth noting that the 55 cases used for constructing this figure cover a wide variety of fixed and moving sources of noise, including one case of railroad car vibrator noise.

While there is a substantial spread in the "curve" illustrated in Figure A-2 (about  $\pm 5$  dB), the trend is unmistakable and has proven to be sufficiently reliable, in recent applications, to demonstrate the utility of using such a normalized composite noise scale for predicting the approximate degree of response by a community to an intruding noise.

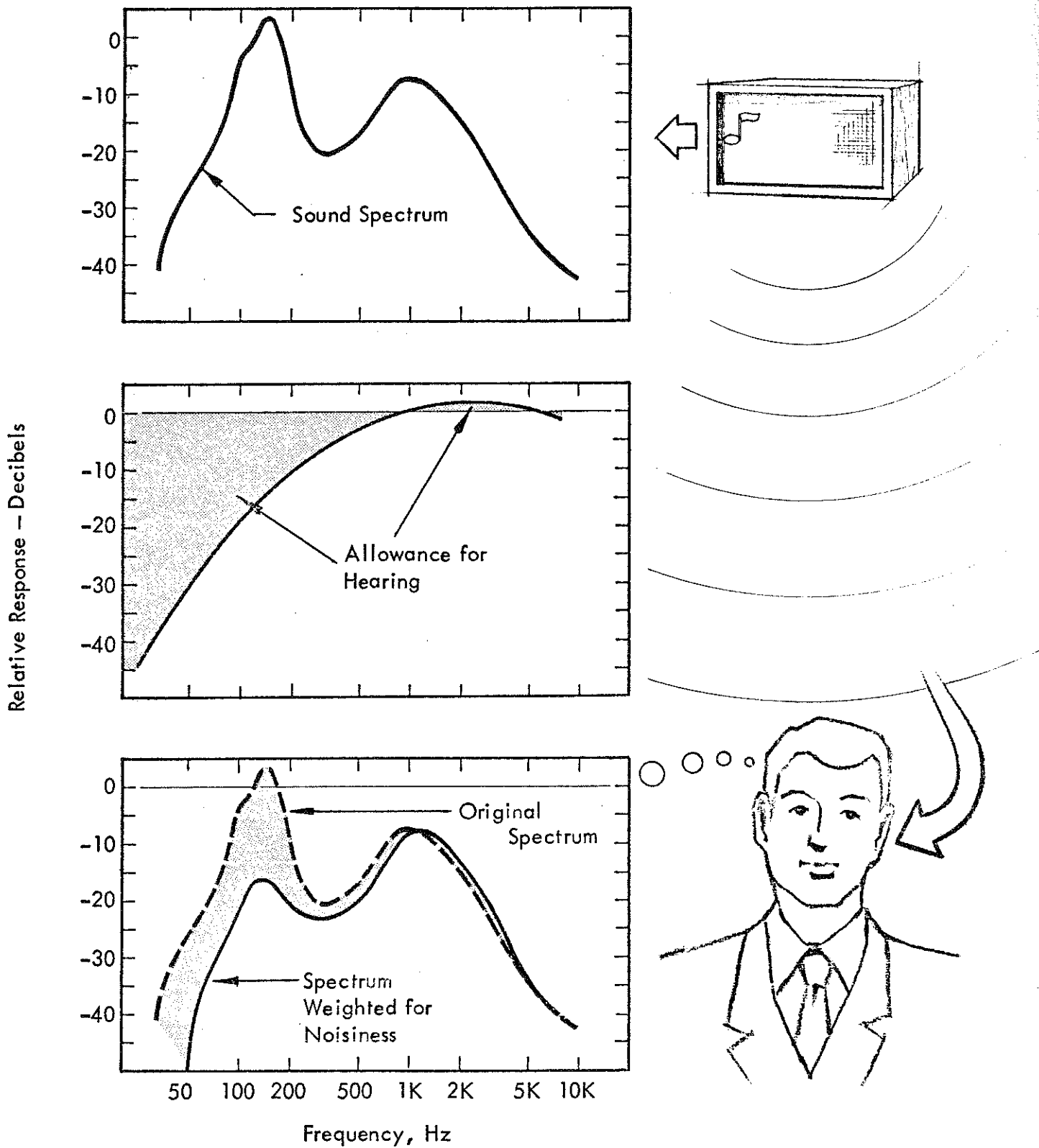


Figure A-1. Weighting the Measured Spectrum to Account for the Frequency Response of the Human Ear

Community Reaction

Vigorous community action

Several threats of legal action, or strong appeals to local officials to stop noise

Widespread complaints or single threat of legal action

Sporadic complaints

No reaction, although noise is generally noticeable

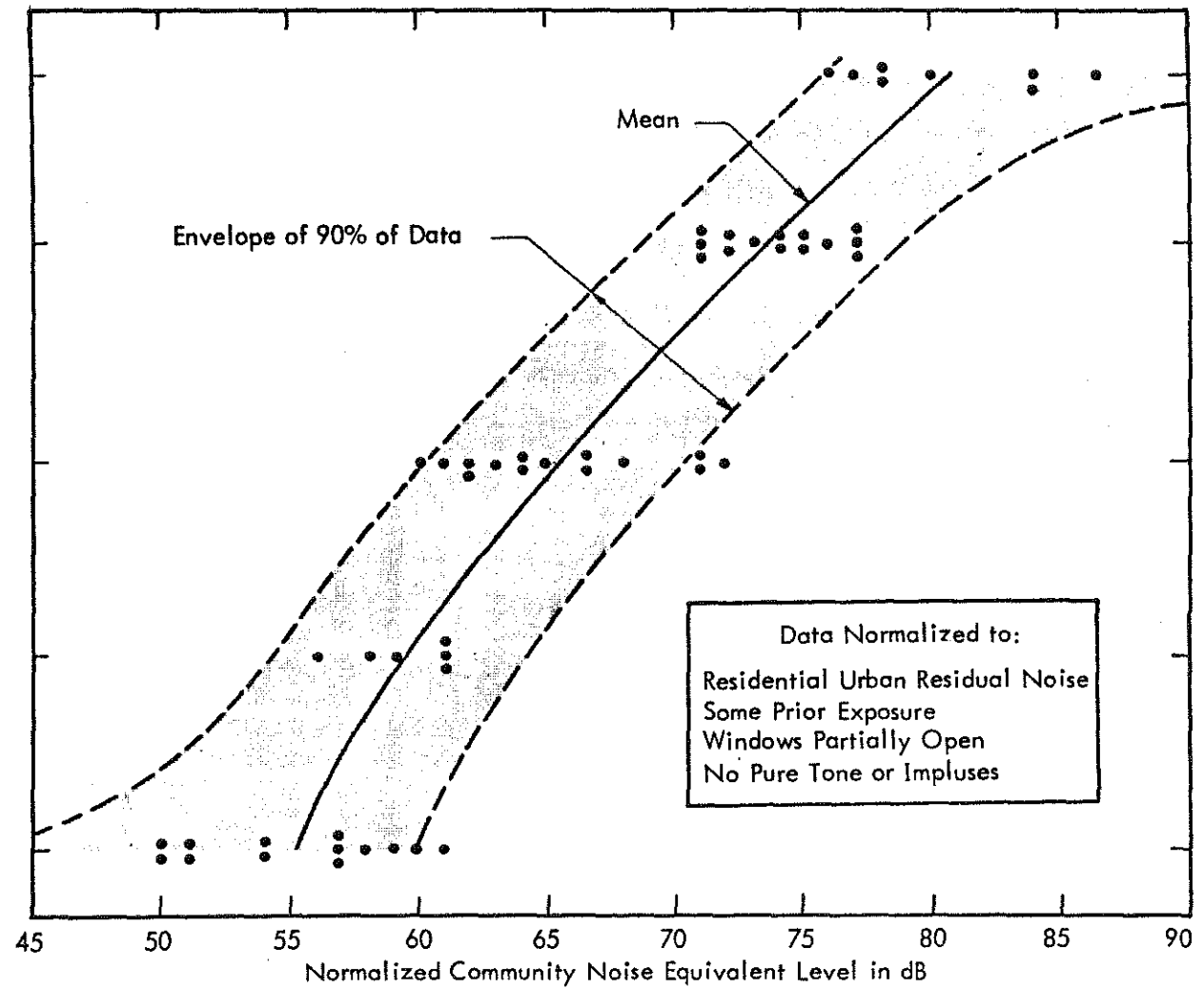


Figure A-2. Community Reaction to Intrusive Noises of Many Types as a Function of the Normalized Community Noise Equivalent Level

APPENDIX B  
FIELD MEASUREMENT LOCATIONS OF NOISE EMITTED  
BY YARD AND LINE OPERATIONS

I. Yard Operations

A. Taylor Yard – Glendale (SP)

1. Load Test – 50' measurements and near field
2. Hump Yard – master retarder noise level close up and afar, retarder directionality, inert retarders, car impacts afar
3. Seven site boundary sampling program
4. Idling engine levels in service area
5. Moving train through yard
6. Mechanical refrigeration car noise

B. Hobart Yard – E. Los Angeles (ATSF)

1. Idling engines
2. Flat yard switching impacts

C. U.P. Yard – E. Los Angeles

1. Idling engine levels in service area and flat yard
2. Flat yard switching (impacts, switcher accelerations, brakes)
3. Hump yard – retarder noise levels close up and afar  
– impact noise level close up and afar
4. Mechanical refrigeration car noise

D. Delores Yard (SP) – flat yard boundary measurements

E. Mechanical Refrigeration Cars

1. Villa Park Orchards – Orange County (adjacent to residential property).
2. City of Industry Car Repair Yards (SP)

3. ATSF Car Repair Facility – San Bernardino
4. Taylor Yard – Glendale (SP) (Yard Boundary)
5. U.P. Yard – Commerce (data taken from moving train at yard boundary near residential property)

## II. Line Operations

### A. Open Terrain – At Grade

1. Cajon Pass Region – San Bernardino County
  - a. 2.2 percent up and down grade (UP, SP, ATSF) at Devore
  - b. 2.2 percent up grade (short and large radius turn) at Cleghorn Road near Devore
  - c. 3.4 percent down grade at Cajon Pass, Highway 138 exit (maximum dynamic brake noise).
  - d. 0.0 percent grade at Hesperia.
2. Bakersfield to Palmdale Region
  - a. 2.0 percent up and down grade at Humphreys
  - b. 0.0 percent grade between Rosamond and Lancaster
  - c. 0.6 percent up and down grade (constant speed and accelerations) at Tehachapi Summit
  - d. 0.7 percent up and down grade at Edison.
3. Near Los Angeles
  - a. 1.0 percent up and down grade at junction of Imperial Highway and Riverside Freeway

### B. Elevated Right-of-way

1. 2 miles east of Humphreys  
(30' elevation)

2. Caliente (337 mile marker)  
(50' to 60' elevation)
3. Caliente (334 mile marker)  
(25' elevation cut into hill)

C. Depressed Right-of-Way

1. 5 miles east of Tehachapi Summit  
(15' depression with reflecting hillside at far  
side of depression)
2. Caliente (337 mile marker)  
(20' to 30' cut in hill shielding train)

D. Crossings and Switching Frogs

1. Bealville – crossing
2. Edison – crossing
3. Bakersfield – crossing (at intersection with medium auto traffic)
4. Caliente (334 mile marker) – Switching Frog
5. Near junction of Imperial Highway and Riverside Freeway –  
Switching Frog



APPENDIX C  
COMPUTER MODELED TIME HISTORIES

A mathematical prediction of the noise level at any instant during a train passing is difficult to obtain by summing the noise generated by a series of discrete sources distributed over the entire train. Since this investigation was primarily concerned with observer distances greater than the dimensions of a diesel locomotive, the noise level generated by the locomotive could be lumped into one composite level by assuming the sound was generated at a point in the center of the locomotive. A similar argument holds for modeling the noise level of individual passing freight cars, although a line of connected cars generates sound in the same fashion as a line of connected point sources. As the observer moves away from the track, the line of connected point sources approximates a line of continually distributed sound. Therefore, it was felt valid to model the train sound pressure level as the combination of a spherically radiating point source and a cylindrically radiating line source for the engine and cars, respectively.

A schematic of the train model is shown in Figure C-1.

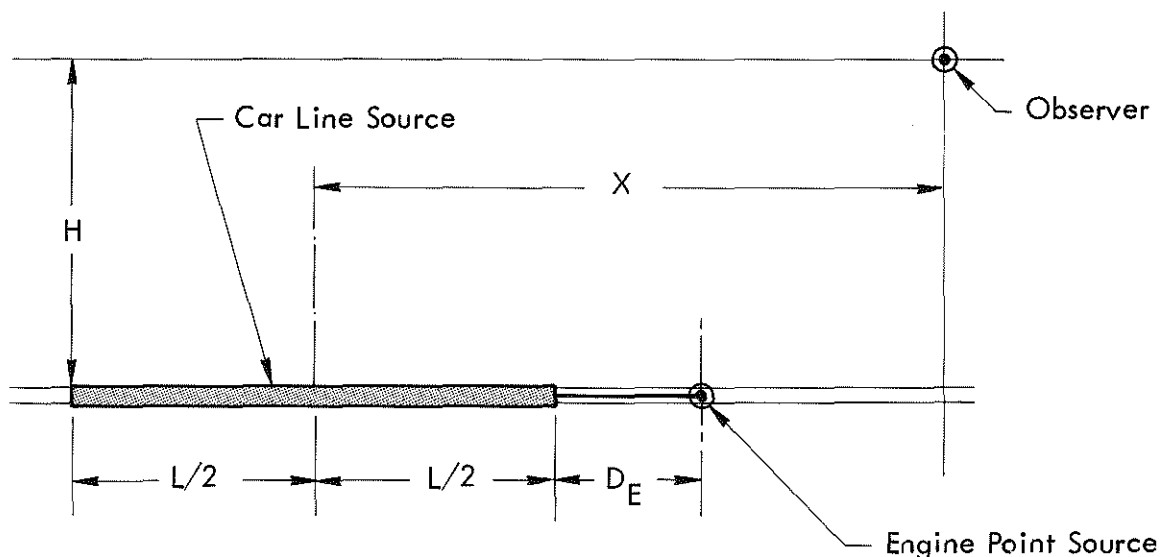


Figure C-1. Schematic of Train Model

where

H = Distance from observer to track, feet

X = Distance from observer to center of car portion of train, feet

DE = Distance from first car to effective engine noise center, feet

L = Length of car portion of train, feet

The noise level for the contribution of the cars is given by Equation (C-1) and the engine's noise level is given by Equation (C-2).

$$NL_{Car} = NL_{rc} + 10 \log_{10} \left( \frac{\theta_1 + \theta_2}{H/L} \right) - 10 \log_{10} \left( \frac{\theta_{r1} + \theta_{r2}}{H_r/L} \right) \quad (C-1)$$

$$NL_{Eng} = NL_{re} + 10 \log_{10} \left( \frac{R_r^2}{H^2 + \left( X - \frac{L}{2} - DE \right)^2} \right) \quad (C-2)$$

where

$NL_{Car}$  = Noise level of cars at arbitrary X and H

$NL_{rc}$  = Noise level of cars passing observer at reference distance  $H_r$  and  $X = 0$

$NL_{Eng}$  = Noise level of engine at arbitrary X and H

$NL_{re}$  = Noise level of engine passing observer at reference distance  $R_r$ .

$$\theta_1 = \tan^{-1} \left( \frac{1/2 - X/L}{H/L} \right)$$

$$\theta_2 = \tan^{-1} \left( \frac{1/2 + X/L}{H/L} \right)$$

$$\theta_{r1} = \theta_1 \text{ at } H = H_r \text{ and } X = 0$$

$$\theta_{r2} = \theta_2 \text{ at } H = H_r \text{ and } X = 0$$

Derivation of Equations (C-1) and (C-2) can be found by the methods in Reference 3.

The composite level of the car and engine contributions is given by:

$$NL_{Total} = 10 \log_{10} \left[ 10^{(NL_{Car}/10)} + 10^{(NL_{Eng}/10)} \right] \text{ dB} \quad (C-3)$$

Thus, Equation (C-3) enables the prediction of the noise level at any desired position (at least fifty feet from the track) and any desired instant during a train pass provided previous reference values  $NL_{rc}$  and  $NL_{re}$  are known.

Ideally,  $NL_{rc}$  and  $NL_{re}$  will be constant at the measured reference distances for all operating conditions. As discussed in Sections 3.2.1 and 3.2.2, car reference levels are speed dependent and engine reference levels are dependent on grade conditions. The reference distance was chosen as 100 feet where car reference A-weighted noise levels and engine reference A-weighted noise levels are given by Equations (C-4) and (C-5), respectively, where V is the speed of the train in mph.

$$NL_{rc} = 20 \log_{10} V + 50 \text{ dB} \quad (C-4)$$

$$NL_{re} = \begin{cases} 86.4 \text{ dB} & \text{(downgrade)} \\ 92.4 \text{ dB} & \text{(level grade)} \\ 93.5 \text{ dB} & \text{(upgrade)} \end{cases} \quad (C-5)$$

where

V = Train speed in miles per hour.

Attenuation of sound for distances moving away from the track is discussed in Appendix D. Equations (C-1) and (C-2) account for spreading losses of sound, and the combination of air absorption and ground attenuation may be found in Equations (C-6) and (C-7) for distances greater than 150 feet from the track (assuming air absorption and ground attenuation equal zero for distances less than 150 feet).

$$Atten_{Car} = 10.7 \log_{10} H - 23.2 \text{ dB (attenuation of car noise at distance H in feet)} \quad (C-6)$$

$$\text{Atten}_{\text{Eng}} = \left\{ \begin{array}{l} 7.5 \log_{10} H - 16.5 \text{ dB for level or downgrade} \\ 3.8 \log_{10} H - 8 \text{ dB for upgrade} \end{array} \right\} \begin{array}{l} \text{(attenuation of} \\ \text{engine noise at} \\ \text{distance H in feet)} \end{array} \quad (\text{C-7})$$

Comparison of the predicted values from the preceding model and actual time histories generally shows good agreement at distances out to 500 feet, and for greater distances, predicted values tend to become conservative. Figure C-1 is a typical comparison of predicted and actual time history. As observed from this figure, the predicted levels fore and aft of the train are higher than actual levels; this effect is attributed to more sound being radiated perpendicular to the track than in line with the track. Although this nonuniformity of sound radiation in front and to the rear of the train is a shortcoming of the point source – line source model, the effect is not felt important because we are only concerned with directions perpendicular to the track.

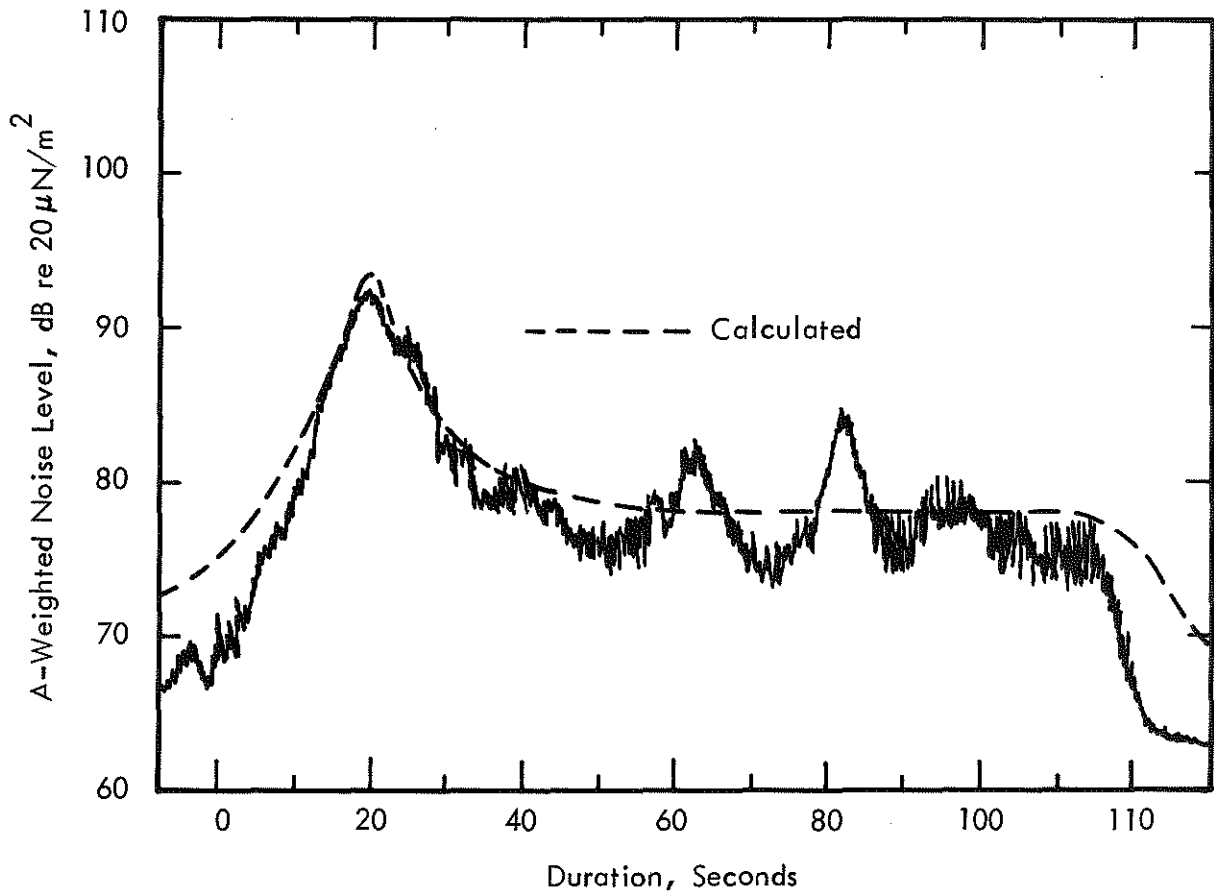


Figure C-1. Comparison Between Actual A-Weighted Time History and Computer Prediction. Train Moving Climbing +2 Percent Grade at 28 mph, 100 Feet from Track.

## APPENDIX D

### SOUND PROPAGATION OF NOISE EMITTED BY RAILROAD OPERATIONS

#### ATTENUATION OF SOUND

The primary mechanisms for natural attenuation of sound emitted from railroad operations are geometric spreading losses of sound, air absorption, ground attenuation and barrier shielding. These four classifications are discussed individually in the following sections.

#### GEOMETRIC SPREADING LOSSES

Geometric spreading losses result from an expansion of the wave front as the sound travels from the source and this increased surface area through which the sound must pass reduces the acoustic intensity. Each unit area encloses less acoustic intensity as the distance traveled increases. Spreading loss of sound is not dependent on frequency, and for distances far from a noise source (classified as a point source) the geometric spreading gives a 6 dB loss per doubling of distance. This decrease is generally termed spreading loss or inverse square loss. The noise level at any distance from a point source is given by Equation D-1 for a known level at a reference distance from the point source.

$$NL_p = NL_r - 20 \log_{10} \left( \frac{X}{X_r} \right) \quad (D-1)$$

where,

$NL_p, NL_r$  = calculated level and reference level, dB

$X, X_r$  = observer distance and reference distance, feet

A line source may be considered a line of many, closely spaced, uncorrelated point noise sources and since each point source is adjacent to other sources,

the strength of the sound is reinforced and a 3 dB loss per doubling of distance is observed. The noise level at any distance from a line source is given by Equation D-2 for a known level at a reference distance from the line source.

$$NL_{In} = NL_r - 10 \log_{10} \left( \frac{X}{X_r} \right) \quad (D-2)$$

where,

$NL_{In}, NL_r$  = calculated level and reference level, dB

$X, X_r$  = observer distance and reference distance, feet

#### AIR ABSORPTION

Air absorption losses result from vibrational relaxation of air molecules, viscosity of the air (converting acoustic energy into heat), and heat conduction. These losses depend on frequency, temperature, and relative humidity. Air absorption loss values may be determined from Reference 13. The air absorption loss for the 2500 Hz 1/3 octave band are given in Figure D-1. This band was found to be adequate for predicting the absorption losses for retarder noise. Tabulated values of air absorption at 60°F and 50 percent relative humidity which were used in this investigation are shown in Figure D-2.

#### EXCESS GROUND ATTENUATION

In addition to geometric spreading and air absorption attenuation, ground attenuation is important. Such attenuation is also dependent on frequency and shows a higher attenuation at high frequencies. Values of excess ground attenuation may be determined from Equation D-3 if the frequency and distance to source are known (Reference 14 ).

$$A_g = \begin{cases} 10 \log_{10} \left( \frac{fR}{4 \times 10^5} \right) & \text{for } fR \geq 4 \times 10^5 \\ 0 & \text{for } fR < 4 \times 10^5 \end{cases} \quad (\text{D-3})$$

where,

$A_g$  = excess ground attenuation, dB

$f$  = frequency, Hz

$R$  = distance from observer to source, feet.

### BARRIER ATTENUATION

For train passes through cuts and behind hills, barrier corrections should be used. Implementing the methods from Reference 6, barrier attenuation values can be evaluated by the following general procedure.

First calculate the Fresnel number  $N$  by Equation D-4.

$$N = 2 \delta \left( \frac{f}{C} \right) \quad (\text{D-4})$$

where,

$\delta = A + B - a - b$  in Feet (see Figure D-3)

$C = 1130 \frac{\text{ft}}{\text{sec}}$

$f$  = frequency, Hz

Using Figure D-3 and  $N$  from Equation D-4, look up the attenuation ( $\alpha$ ).

It may be noted that the case for the top of the barrier in the line of sight between observer and source gives a 5 dB attenuation. As mentioned in Reference 6, the maximum barrier attenuation observed in practice is 24 dB. Although hills and cuts along railroad lines do not necessarily have uniform heights and can only be considered an approximation to the barrier in Figure D-3 (a), it is felt the method should give at least approximate barrier attenuation values.



Calculation of the total attenuation is achieved by first calculating the air absorption, excess ground attenuation and barrier attenuation for each 1/3 octave band. A new frequency spectrum is derived by subtracting the attenuation values at each 1/3 octave band frequency from the original frequency band values. A new overall noise level can then be calculated from this spectrum and geometric spreading losses can be subtracted from the new overall noise level to give the noise level that includes the four types of attenuation.

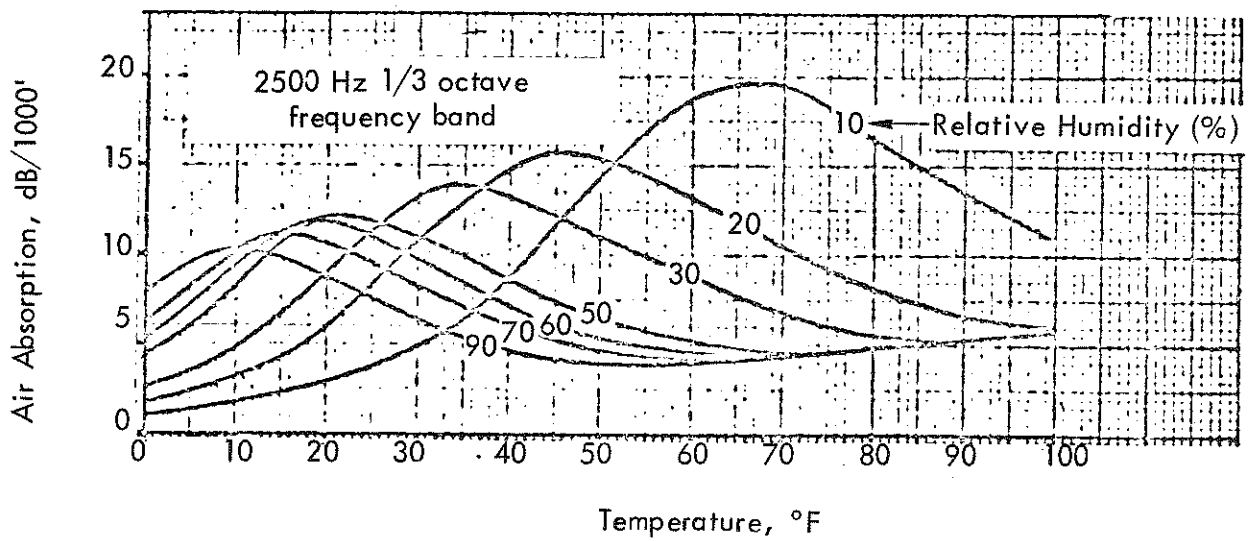
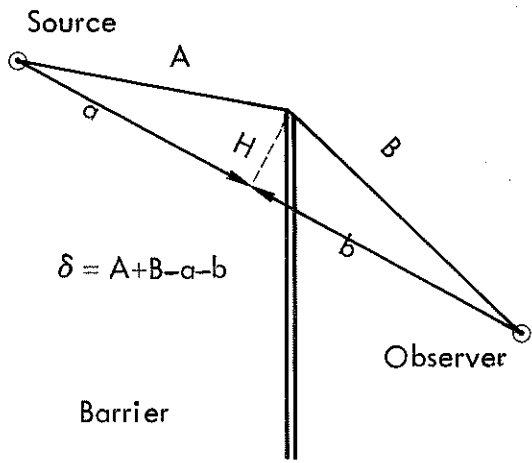


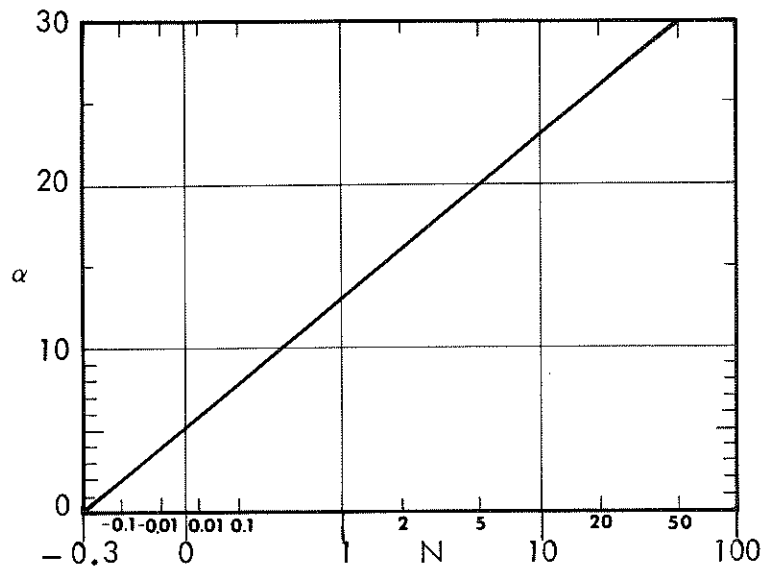
Figure D-1. Air Absorption for the 2500 Hz 1/3 Octave Band

1/3 Octave Band, Hz	40	50	63	80	100	125	160	200	250	315	400	500	630	800	1000	1200	1600	2000	2500	3150	4000	5000	6300	8000
Air Absorption, dB/1000 Ft.	0	0	0	0	0	0	0	0.5	0.5	0.5	1	1	1	1	2	2	3	3.5	5	7.5	10.5	13	18	25

Figure D-2. Air Absorption Losses at 60°F and 50 Percent Relative Humidity



a.) Barrier Position



b.) Barrier Attenuation

Figure D-3.

## APPENDIX E

### MULTIPLE ACOUSTIC SOURCE MODEL FOR IDLING LOCOMOTIVES OR MECHANICAL REFRIGERATOR CARS

An acoustic model of a line of idling locomotives or mechanical refrigerator cars may be described as a line of point sources at an arbitrary distance from an observer. In order to predict the acoustic level at the observer's position, an analysis is made of the noise level produced by an arbitrary number of either locomotives or mechanical refrigerator cars. Figure E-1 depicts the line of engines or refrigerator cars used to derive the multiple source noise equation.

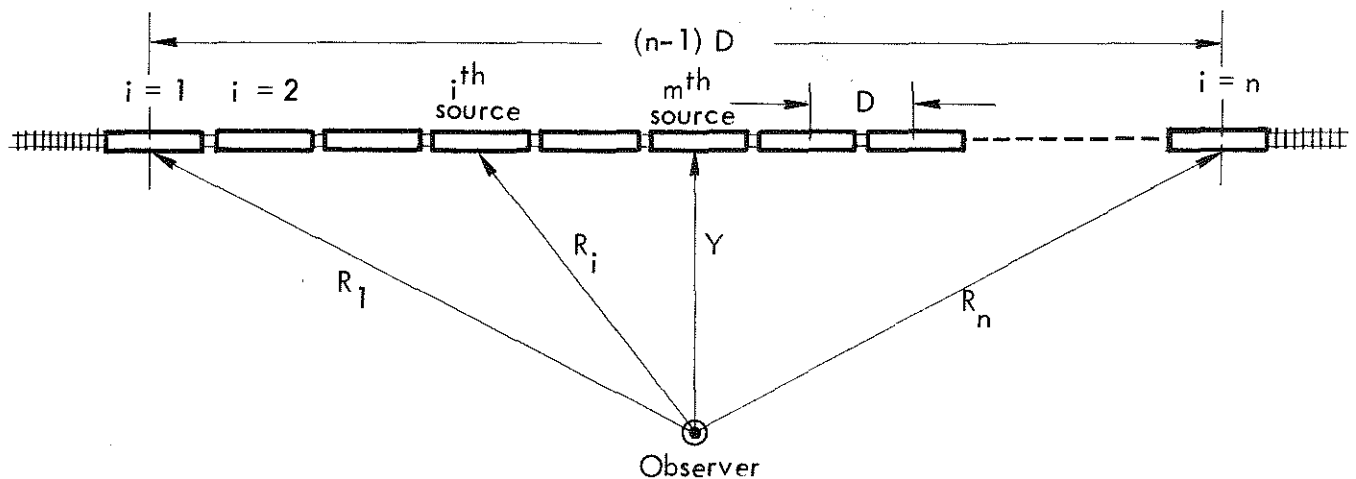


Figure E - 1 Line Comprised of  $n$  Noise Sources

The noise level at the observer's position, a distance  $Y$  from the track, is comprised of the noise received from each of  $n$  sources, a distance  $R_i$  from the observer. The sources are separated by a distance  $D$  and the  $i = m$ th source is directly adjacent to the observer. The acoustic pressure due to the  $i$ th source is

$$P_i^2 = P_r^2 \left( \frac{R_r^2}{R_i^2} \right) \quad (\text{E-1})$$

where

$P_r$  is the reference acoustic pressure of a single noise source measured at a reference distance  $R_r$

The distance to each source may be expressed as:

$$R_i^2 = Y^2 + (i - m)^2 D^2 \quad (\text{E-2})$$

And since the noise level is

$$NL_i = 10 \log_{10} \left( \frac{P_i^2}{P_{ref}^2} \right) \quad (\text{E-3})$$

where

$$P_{ref} = 20 \mu \text{ N/m}^2$$

Then the noise level at the observer position due to  $n$  sources is

$$NL_{total} = NL_r + 10 \log \left( R_r^2 \sum_{i=1}^n \frac{1}{Y^2 + (i - m)^2 D^2} \right) \quad (\text{E-4})$$

where

$NL$  is the A-weighted noise level in dB

When more than a few sources are considered, equation E -4 becomes cumbersome for hand calculations so a generalized computer program was devised. This program, listed in Table E - 1, was written in Super Fortran for use with a Tymshare computer system. Program inputs required are the reference noise level for a single source, the source's reference distance, the distance between noise sources, and the relative position of the observer with respect to the line of noise sources. A printout for a case of 1 to 15 road diesel locomotives at observer distances of 50 to 8000 feet is shown in Table E - 2. Abbreviations used in the program listing and the printout are defined as follows:

SPLR = Reference A-weighted noise level of a single source, dB.

DISR = Reference distance to a single source, feet.

LTH = Distance between centers of the noise sources, feet.

FRAC = Fraction of the distance down the line of noise sources where the observer is located (for example, FRAC = 0.5 places the observer at the middle of the line).

M = The index on the noise source in direct line with the observer (see Figure E - 1)

N = Number of noise sources in the line.

The data for 1 to 15 sources from the printout are plotted in Figure E - 2. The computation neglects the effects of air absorption and ground attenuation which are discussed in Appendix D. Typical data for lines of switchers and mechanical refrigeration cars are shown in Figures E - 3 and E - 4. Experimental measurements were made and compared with the calculated data. Good agreement was obtained and the results are presented in Figure 4.3 -11.

The case for an observer adjacent to the end noise source, rather than the central source, was investigated. Variations in the noise level between these two locations were less than 1.5 dB for a line of 1 to 15 sources. This variation was deemed insufficient to warrant more rigorous calculations, hence, to estimate the noise from lines of idling locomotives or mechanical refrigeration cars, a single tabulation with the observer adjacent to the line center will approximate the noise level for observer positions along the entire line of noise sources.

Table E-1  
Tymshare Computer Program

```

.8
1 REAL LTH
2 DIMENSION Y(10),SPL(10)
3 Y(1)=50
4 Y(2)=100
5 Y(3)=200
6 Y(4)=400
7 Y(5)=800
8 Y(6)=1000
9 Y(7)=2000
10 Y(8)=4000
11 Y(9)=8000
12 ACCEPT "READ SPLR,DISR,LTH,FRAC",SPLR,DISR,LTH,FRAC
13.5 WRITE(1,10) (Y(I),I=1,9)
14.6 10 FORMAT(" M N",9F6.0)
15 DO 50 N=1,30
16 XN=N
17 M=XN*FRAC+0.51
18.5 IF(M.EQ.0)M=1
19 XN=M
20 DO 75 J=1,9
21 SUM=0
22 DO 100 I=1,M
23 XI=I
24.5 100 SUM=SUM+1./Y(CJ)**2+((XI-XN)*LTH)**2)
25 X=(DISR**2)*SUM
26 SPL(J)=SPLR+10.*ALOG10(X)
27 WRITE(1,15)M,N,(SPL(I),I=1,9)
28.5 15 FORMAT(2I5,9F6.1)
29 STOP
30 END

```



Table E-2

Computer Printout of A-Weighted Noise Levels  
for a Line of 1 to 15 Road Diesel Locomotives

READ	SFLR	DISR	LTH	FRRC	71	100	200	400	800	1000	2000	4000	8000
M	N	50.	100.	200.	400.	800.	1000.	2000.	4000.	8000.			
1	1	77.0	71.0	65.0	59.0	52.9	51.0	45.0	39.0	32.9			
1	2	78.5	73.4	67.8	61.9	55.9	54.0	46.0	42.0	35.9			
2	3	79.8	74.9	69.5	63.7	57.7	55.6	49.7	43.7	37.7			
2	4	80.0	75.6	70.5	64.8	58.8	57.0	51.0	45.0	39.0			
3	5	80.3	76.2	71.3	65.8	59.9	58.0	52.0	45.9	39.9			
3	6	80.4	76.5	71.8	66.5	60.6	58.7	52.7	46.7	40.7			
4	7	80.6	76.8	72.3	67.1	61.3	59.4	53.4	47.4	41.4			
4	8	80.6	76.9	72.6	67.5	61.8	59.9	54.0	48.0	42.0			
5	9	80.7	77.1	72.9	67.9	62.3	60.4	54.5	48.5	42.5			
5	10	80.8	77.2	73.1	68.3	62.7	60.9	54.9	49.0	42.9			
6	11	80.8	77.3	73.3	68.6	63.1	61.3	55.4	49.4	43.3			
6	12	80.8	77.4	73.5	68.9	63.5	61.6	55.7	49.7	43.7			
7	13	80.9	77.4	73.6	69.1	63.8	61.9	56.1	50.1	44.1			
7	14	80.9	77.5	73.7	69.3	64.0	62.2	56.4	50.4	44.4			
8	15	80.9	77.5	73.8	69.5	64.3	62.5	56.7	50.7	44.7			

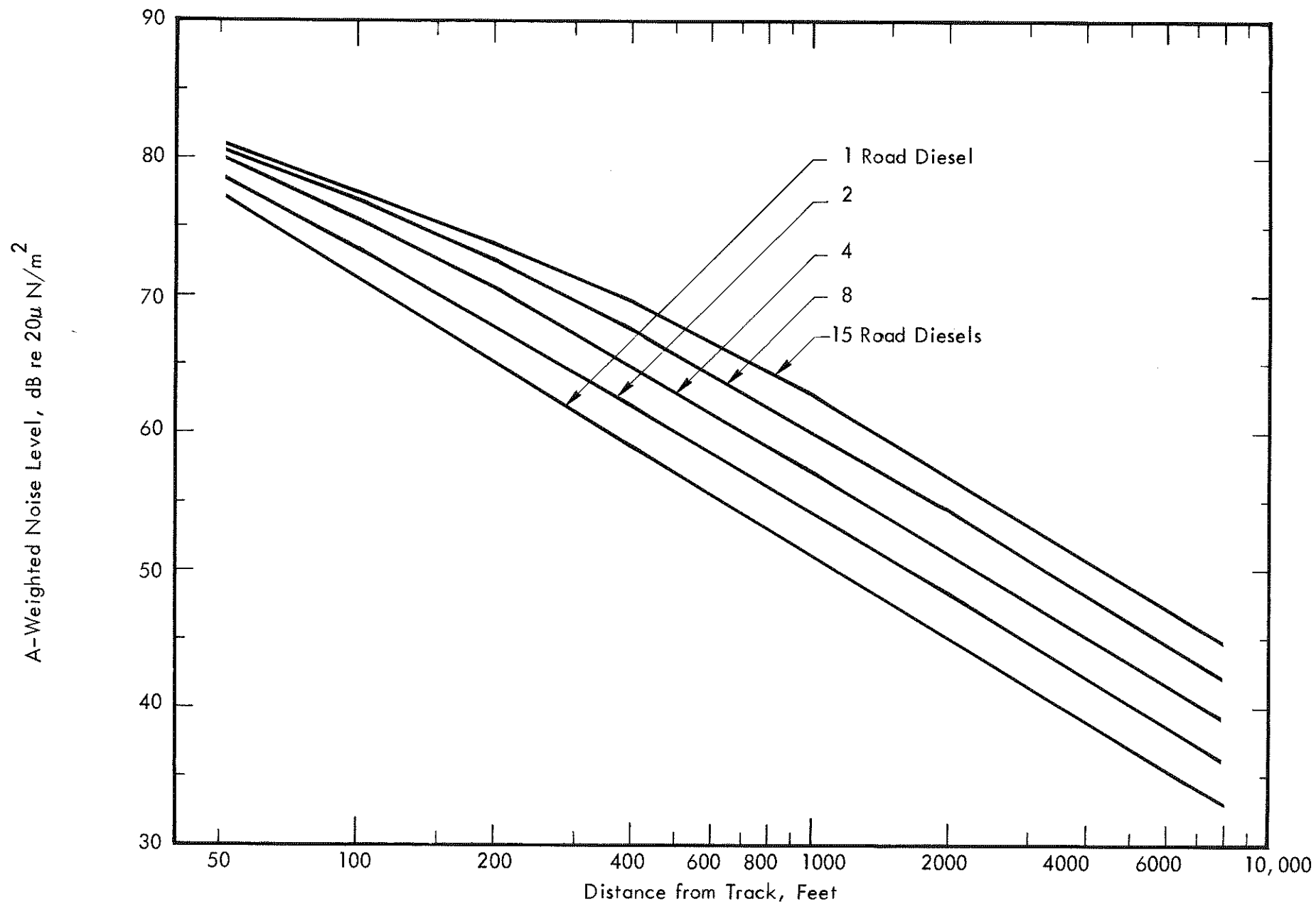


Figure E-2. A-Weighted Noise Level of Idling Road Diesels Less Air Absorption and Excess Ground Attenuation For Observer Centered with Line of Road Diesels

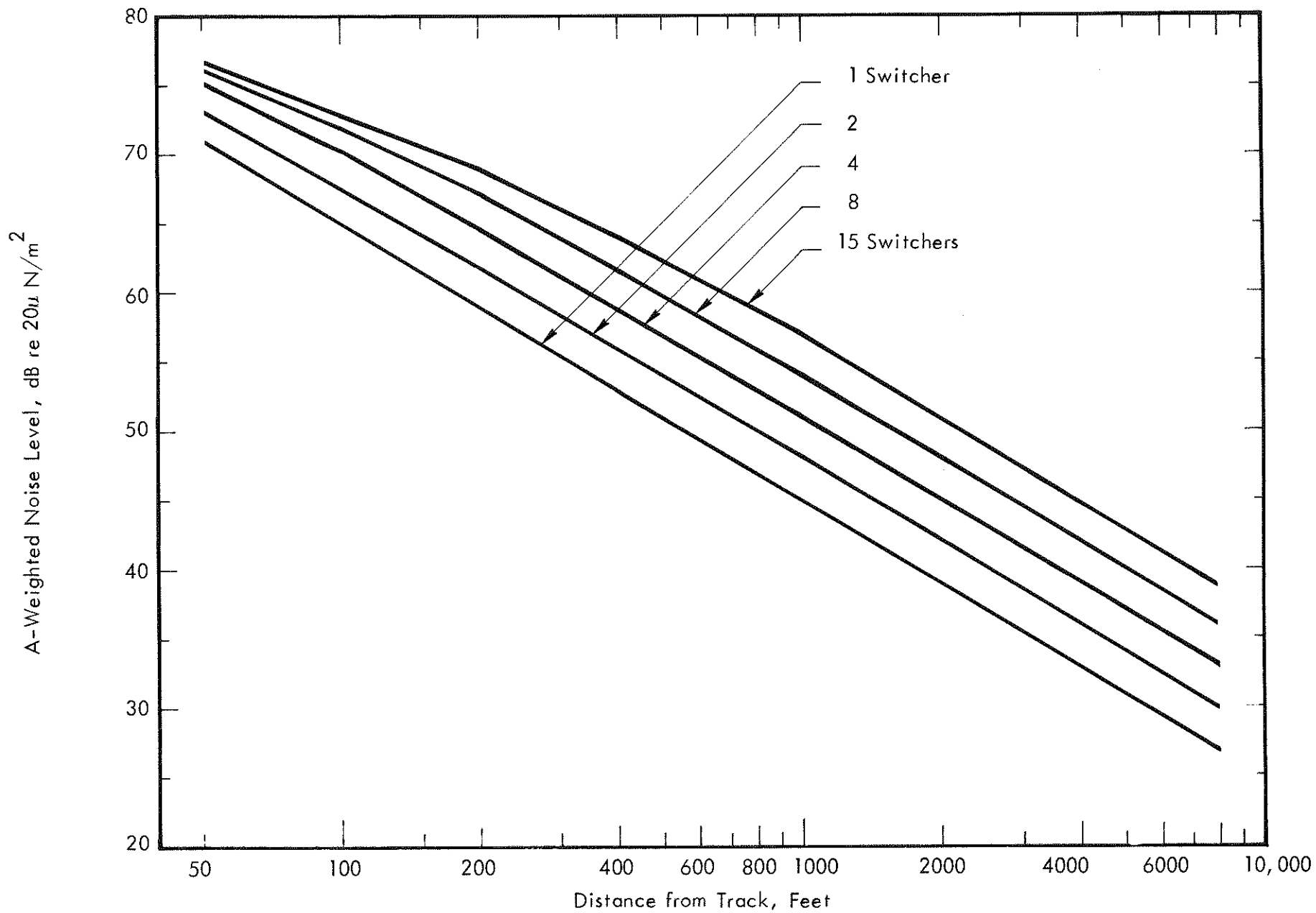


Figure E-3. A-Weighted Noise Level of Idling Switchers Less Air Absorption and Excess Ground Attenuation For Observer Centered with Line of Switchers

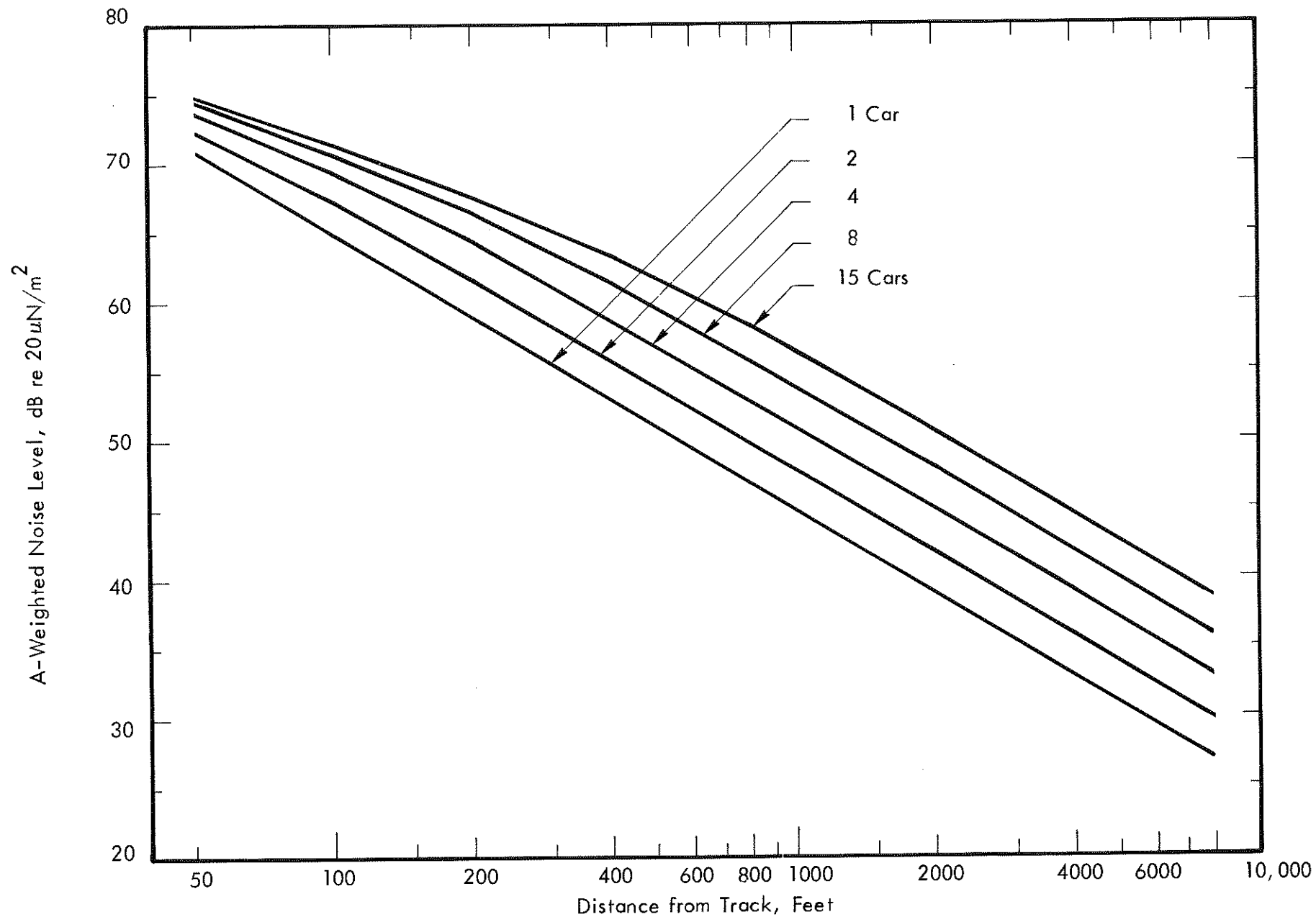


Figure E-4. A-Weighted Noise Level of Mechanical Refrigeration Cars Less Air Absorption and Excess Ground Attenuation (Condenser Side, High Throttle [1200 rpm]) for Observer Centered with Line of Cars

## APPENDIX F

### THREE - DIMENSIONAL SOUND PROPAGATION FROM DIESEL - ELECTRIC LOCOMOTIVES

Measurements were made in the space surrounding a diesel - electric locomotive to determine the directionality of the radiated noise. A model EMD DD40 645 E locomotive (Union Pacific locomotive number 6911) with only one of the two engines running was used as the noise source. This engine was a 16 cylinder, two cycle, turbocharged diesel rated at 3000 HP through the wheels. These measurements were taken at 900 rpm (throttle 8) and the energy was dissipated through a resistor grid. For the purposes of determining the directionality, it was assumed the locomotive resembled a line source radiating noise uniformly along a line through its center.

Microphone positions were chosen at locations approximately 50 feet from the locomotive's perimeter. These positions were chosen so each represented a constant sectional surface area surrounding the locomotive. An extension mast, mounted on an instrumented van allowed placement of the microphone at positions 50 feet above and around the locomotive.

The broadband noise was recorded at each of 22 locations. Analysis of the tape was performed to obtain the 1/3 octave and A-weighted noise level at each position. Variations in noise level were between 84 dBA and 102 dBA while variations in the 1/3 octave level at 120 Hz, which was a predominant frequency, were between 88 and 105 dB SPL. Distribution of the noise around the locomotive was relatively smooth with the highest energy radiated upward from the area around the engine compartment and exhaust.

To obtain a plot of the directivity, a determination was made of the position at which the noise level would be 95 dBA. This computation was made assuming square law attenuation, even though the measurements were likely made within the near field of the source. Atmospheric absorption and ground attenuation were neglected in the computation.

Figure F -1 is a perspective view of the locomotive with contours drawn to indicate the position at which the computed noise level was 95 dBA. The ground level contour is quite smooth and the contour at the 18 foot elevation indicates a higher noise level radiated to the sides. The contours parallel to the tracks show noise level is higher toward the rear of the locomotive. From this analysis, it was concluded that noise levels above the engine were about 3 to 5 dB greater than noise levels to the side of the engine at the same radii from the engine in both the vertical and horizontal directions.

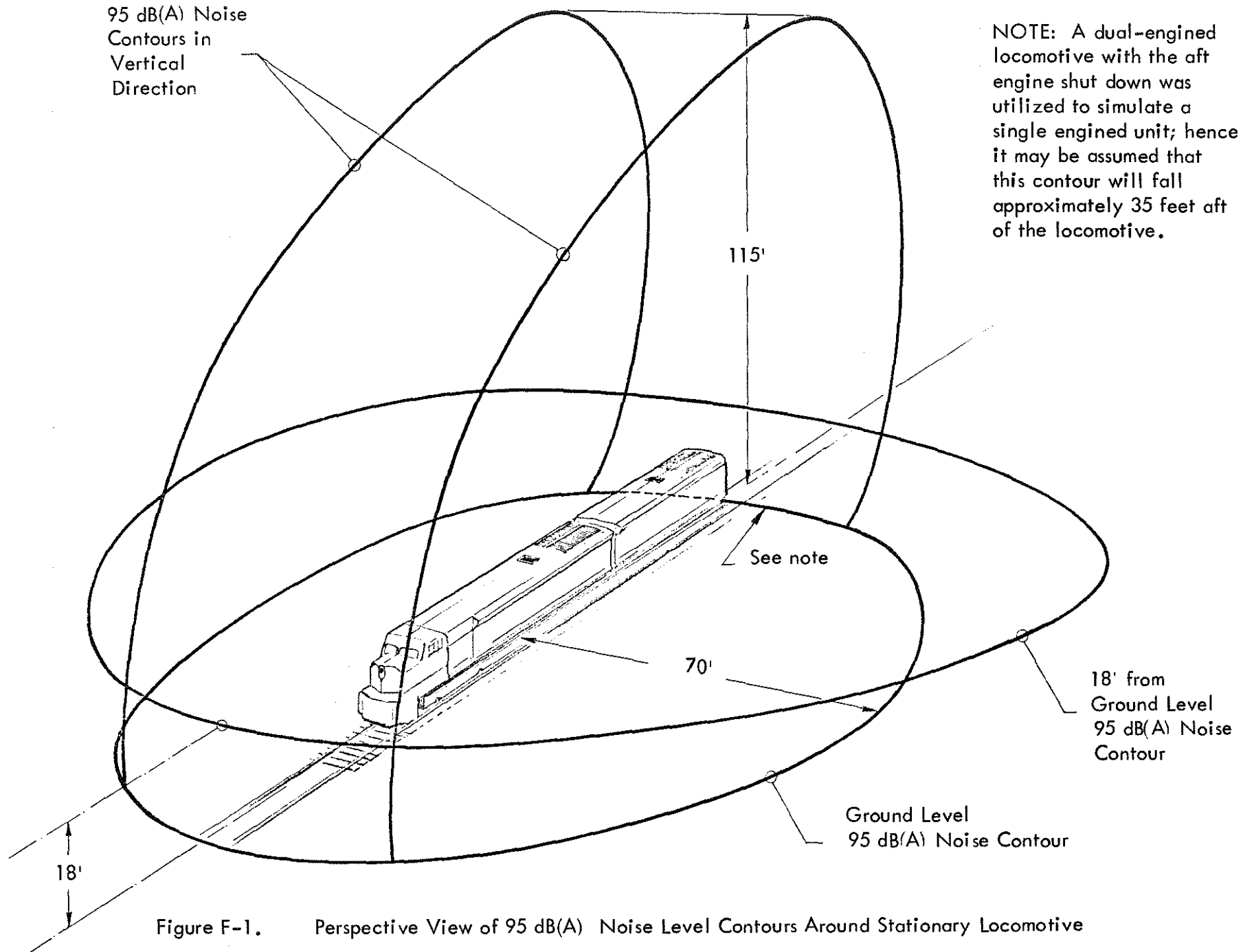


Figure F-1. Perspective View of 95 dB(A) Noise Level Contours Around Stationary Locomotive

## APPENDIX G

### A STATISTICAL STUDY OF NOISE LEVELS GENERATED BY RAILROAD YARD OPERATIONS

Two of the proposed methods of estimating the noise of railroad yard operations involved correlation of statistical measures of the cumulative noise emitted by specific operations or from specific regions of the yard to the volume of activity occurring in the region. In order to investigate the feasibility of such an analysis, a number of field investigations were conducted as outlined below:

- A. Union Pacific Yard (East Los Angeles)
  - A -1. Flat Yard Classification
  - A -2. Hump Yard Classification
  
- B. Dolores Yard (Carson, California)
  - B -1. Flat Yard Classification
  - B -2. Miscellaneous Flat Yard Activity
  
- C. Taylor Yard (Glendale, California)
  - C -1. Property Boundary Noise Near Diesel Shops
  - C -2. Property Boundary Noise Near Sand and Fuel Towers
  - C -3. Noise Received by the Community Near Locomotive Facility
  - C -4. Centralized Noise Near Hump Yard
  - C -5. Noise Received by the Community Near Hump Yard
  - C -6. Property Boundary Noise Along Heavily Traveled Road

The results of these studies, other than aiding in identification of the major noise elements within the yard complex, proved to be somewhat inconclusive.



The objective of the studies was to assess the techniques of describing yard noise emission through statistical measurement of noise levels at centralized hubs of activity within the yard and at discrete locations along the yard boundary opposite major activity centers. The major problems which plagued these techniques (as discussed in detail in Section 4.4 of the text) are summarized below.

I "Centralized-Hub" Concept

1. Statistical noise values did not correlate with observed classification activity.
2. Standardization of measurement position was not feasible due to individuality of yard layouts.
3. Noise measurements at defined activity centers are easily obscured by miscellaneous events occurring in the near proximity - many yards have multiple operations occurring simultaneously in a given "high volume" region.
4. Data sampling durations would necessarily be too lengthy to make this a simple and workable approach.

II Boundary Measurements

1. Required data sampling time durations would prove this technique impractical for wide application.
2. Presence of extraneous yard equipment (switchers, road engines, mechanical refrigerator cars, etc.) obscures data - additionally, localized sound barrier effects due to parked cars, etc., are not effective at further distances out in the community.
3. The number of yard boundary measurement sites required to adequately assess total noise emission from the yard is too large for this plan to be feasible.
4. Yard noise measurements along the yard boundary are often obscured by the typically high ambient noise levels normally found in adjacent industrialized neighborhoods.

A description of the activity at the various measurement sites and the observed statistical noise levels follow. The legend for the statistical noise level scale is given in Figure G -1.

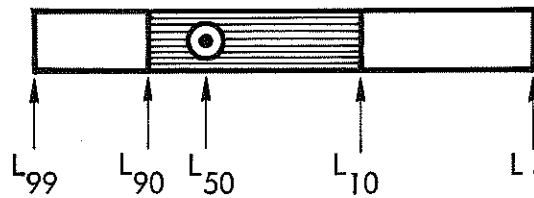
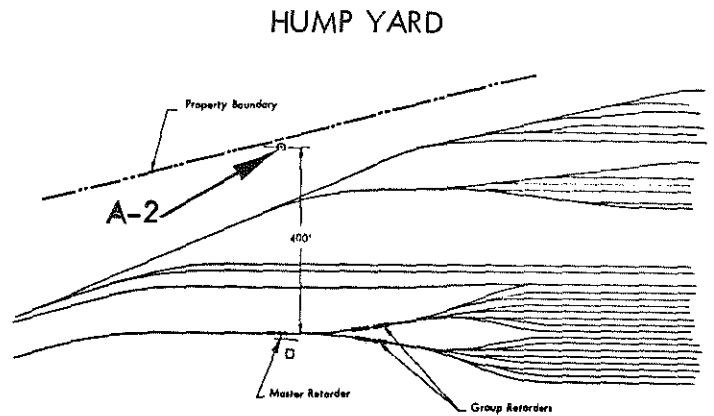
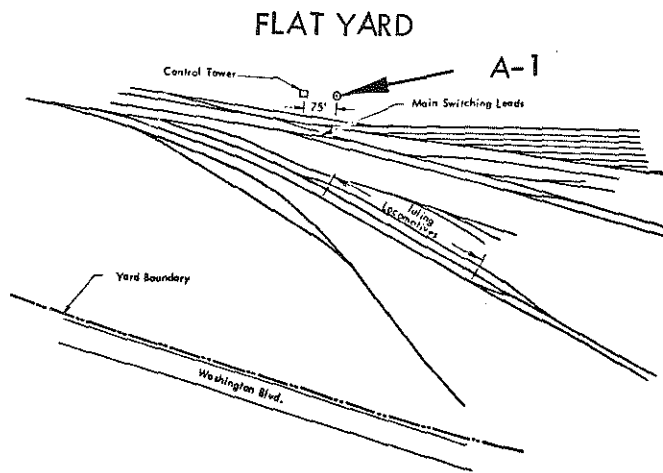


Figure G -1. Legend for Statistical Noise Levels

$L_x$  is defined as the A-weighted noise level which is exceeded X percent of the time. For example,  $L_{10} = 85$  dB implies that the A-weighted noise level equal 85 dB is exceeded 10 percent of the time.

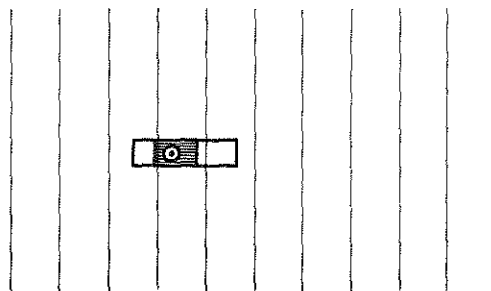
A. Union Pacific Yard (East Los Angeles)



Measurement Site

A -1 on 5-17-73 at 10 PM. Flat yard classification area along main switching leads. Microphone was 75 feet from control tower.

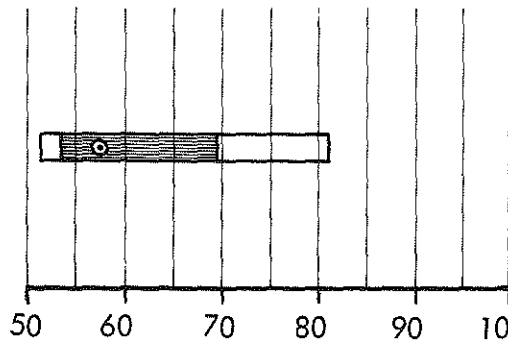
Statistical Noise Level Distribution



Comments

30 cars classified. Constant background noise from a line of idling locomotives.

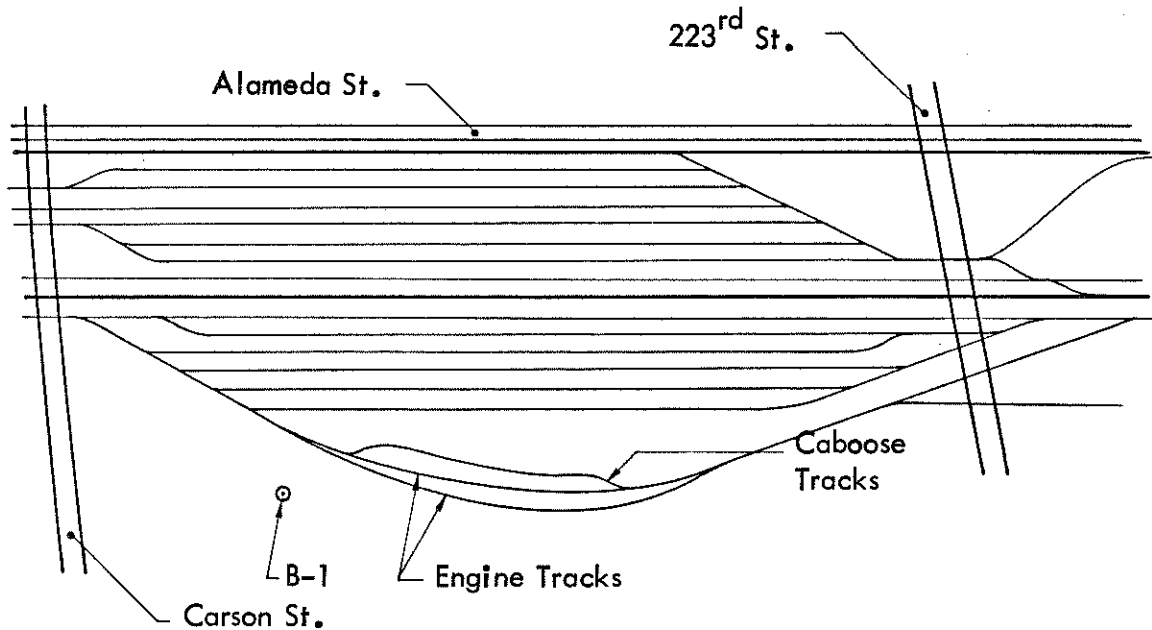
A -2 on 5-17-73 at 11:30 PM. Hump yard classification area. Microphone was at yard boundary 400 feet from master retarder.



25 cars classified. Some switcher activity between microphone and retarder.

A-Weighted Noise Level, dB re  $20 \mu \text{N/m}^2$

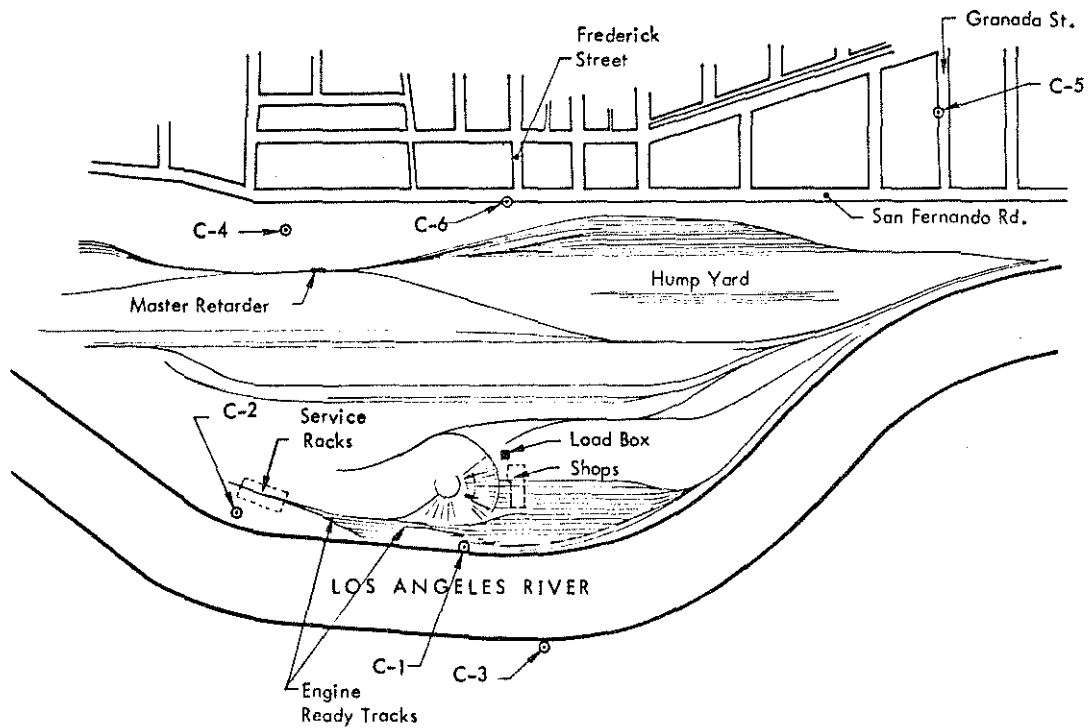
B. Dolores Yard (Carson, California)



Measurement Site	Statistical Noise Level Distribution	Comments
B-1 on 5-15-73 at 12:10 AM. Flat yard classification area. Microphone was positioned near yard boundary.		18 cars classified. Ambient noise level was con- trolled by local industry.
B-1 on 5-15-73 at 1 AM. Flat yard classification area. Microphone was positioned near yard boundary.		No definite clas- sification. Mis- cellaneous switch- ing movement and car couplings. Ambient noise level was controlled by local industry.

A-Weighted Noise Level, dB re 20  $\mu$  N/m<sup>2</sup>

C. Taylor Yard (Glendale, California)



<u>Measurement Site</u>	<u>Statistical Noise Level Distribution</u>	<u>Comments</u>
C -1 on 2-26-73 at 11 AM. Property boundary near diesel shops.		Load box was not in operation. Numerous idling road engines predominated the observed noise.
C -1 on 2-26-73 at 1:51 PM. Property boundary near diesel shops. Microphone was 400 feet from load box.		Load box was in operation. Numerous idling road engines contributed to the observed noise.

A-Weighted Noise Level, dB re 20  $\mu$  N/m<sup>2</sup>

Measurement Site	Statistical Noise Level Distribution	Comments
C -2 on 2-26-73 at 11:30 AM. Property boundary near service racks.		Numerous idling road engines pre- dominated the ob- served noise.
C -2 on 2-26-73 at 1:10 PM. Prop- erty boundary near service racks.		Numerous idling road engines pre- dominated the ob- served noise.
C -3 on 2-26-73 at 12:13 PM. Microphone was lo- cated in residential area near diesel shops (end of Forney Street at the Los Angeles river).		The noise levels were primarily con- trolled by steam being released from a locomotive and a number of idling road engines.
C -4 on 2-26-73 at 2:30 PM. Micro- phone was located on a walk bridge over set-off tracks 325 feet from the master retarder.		The noise emanated from retarders, a train moving slowly through the yard and traffic on a nearby road.
C -5 on 2-28-73 at 5:45 PM. Micro- phone was located in residential area near the hump yard (2627 Granada Street).		The predominate noise sources were automobiles, retarders and a train horn.
C -6 on 2-28-73 at 6:10 PM. Micro- phone was located at the property boundary near the hump yard (corner of San Fernando Road and Frederick Street).		The statistical noise levels were controlled by traffic on San Fer- nando Road. Noise from the yard emanated from retarders, car to car impacts, train horns and a passing passenger train.

50 60 70 80 90 100  
A-Weighted Noise Level, dB re 20  $\mu$  N/m<sup>2</sup>

## APPENDIX H

### RECOMMENDED PRACTICES FOR SOUND LEVEL MEASUREMENTS OF RAILROAD OPERATIONS

Prepared by Wyle Laboratories Research Staff  
El Segundo, California

The following specific comments pertain to the attached sample data sheet. The paragraph designations correspond to those in the data sheet.

- C. Weather Information: Weather parameters are listed in their approximate order of importance.

Wind Speed and Direction: Measurements should not be conducted in winds greater than 5 - 10 mph. Direction of the wind relative to the direction of sound propagation from the source to the microphone is very important. In any wind, the best conditions are for sound propagation at 90° to the wind.

Relative Humidity: Optional, but should be noted for measurements at distances greater than about 200 feet from the noise source.

Weather Conditions: A descriptive commentary is sought; i.e., cloudy, clear, raining, overcast, foggy, etc.

- D. Instrumentation: Electronic equipment used for sound level measurements should be certified by the manufacturer to be in accordance with ANSI 1.4 and should be periodically calibrated.

It is considered good engineering practice to note on any acoustic data sheet model numbers, specific serial numbers, and calibration dates of the equipment utilized, otherwise the validity of the data obtained may be legally questionable.

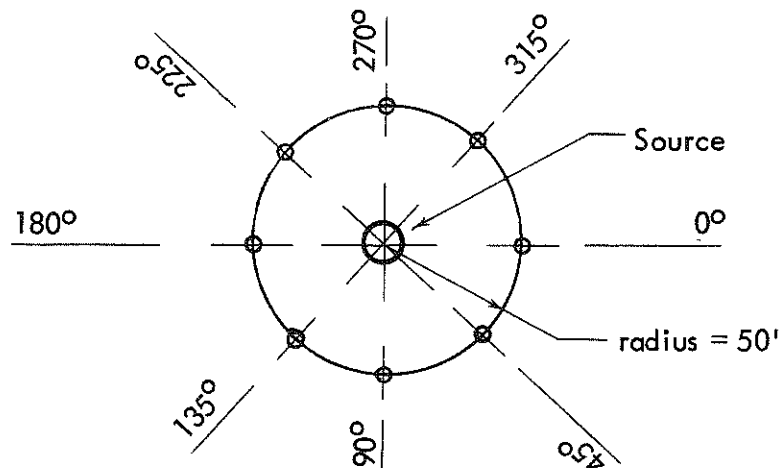
Even under conditions of no wind, gusts of wind will cause problems. A wind screen should be used over the microphone for all outdoor measurements.

- E. Measurement Site Description: The following guidelines are offered in selection of a proper measurement site:

- a. Suggested measurement distance: 50 feet (additional distances are encouraged to check sound propagation characteristics).
- b. Suggested measurement height (microphone to ground) - 4 feet.
- c. The sound level meter should be held as far as possible from the measurement engineer, preferably on a tripod.
- d. Level terrain between source and measurement position is recommended.
- e. Minimal ground cover between source and measurement location - preferably pavement, hard soil or short grass.

- f. The area around the measurement position should be relatively clear of any large reflecting objects (hills, walls, buildings, parked cars, large rocks, etc.) for a radius of at least 50 feet.
- g. Preferred measurement position for all operations which occur on the railroad tracks is on a line radiating outward from the center of the source perpendicular to the tracks.

For measurement of stationary noise sources, determination of the directional characteristics is generally desirable. Such information may be obtained at measurement points as indicated in the sketch below:



If the source is reasonably symmetrical about any axis, 1/2 the measurement positions may be eliminated. As an initial measure of directionality, 90° increments will suffice. If the investigator is so motivated, data at 45° increments will contribute significantly to a definition of the source noise characteristic.

F. Noise Source Description: In general, a reasonably precise description of the noise source should be reported. Such a description should consist of a minimum of the following information:

1. Manufacturer
2. Model
3. Physical description (function, size, HP output, etc)
4. Operational mode (RPM, speed, etc)
5. Manufacturers specifications of the device
6. Approximate age of device.

When dealing with trains in particular, the following variables should be reported (in detail if possible):

1. speed
2. length, number of cars, tonnage, full or empty, type cargo
3. Engine type(s), horse power, throttle setting



4. % grade of track
5. curvature of track (radius)
6. track type/road bed type
7. presence of booster engines, position in train.

G. Test Data - Suggested technique for acquisition of railroad noise information.

1. Stationary or Constant Noise Sources

Record maximum observed dB(A) and dB(C) noise levels (these maxima are to be the time-averaged maximum levels, as observed for a period of 5-10 seconds - sound level meter on slow response).

If SLM is equipped with an octave band filter set - record also the time-averaged maximum levels in each octave band (63 Hz - 8000 Hz) (Slow response).

2. Ambient Noise Levels (A-weighted)

The ambient noise may best be identified by a human listener. This is the residual noise level existing while no identifiable noise source is radiating (unless it is a constant source that cannot or should not be shut down). It is the lowest level reached by the meter when the identifiable sources are gone.

Determination of the ambient is best accomplished by measurements over, say, a 30-45 second period, every 5-10 seconds (slow response). One seeks in each 5-10 second measurement period to select the lowest average noise level not directly attributable to specific sources. The ambient for the site may then be reported as the average of this series of individual estimates.

3. Single Event Noise Levels.

For single event occurrences of medium to long duration (for example - train pass-bys) the graphical recording procedure demonstrated on page 2a of the Data Summary Record should be incorporated (this method to be followed if tape recording and analysis equipment is not available).

The recommended method involves generation of a discontinuous time history of the intrusive noise from the time that the particular source under consideration becomes discernable over the ambient until it has passed and again becomes indistinguishable.

The noise level data should be recorded every 5-10 seconds, with each recording representing either the average observed value over that time period (for relatively constant noises, i.e., pass-by of freight cars once engine has passed) or the maximum level at the end of each time period (for increasing or decreasing noise levels).

A theoretical example using this procedure is illustrated on sheet 2a. All recordings should be of A scale data on slow meter response.

(It should be noted that this type of data presentation is particularly useful in that it may easily be integrated to yield a SENEL value for the particular event.)

This time history data should be obtained over a time period sufficiently long so that the noise level rises above and falls below a level approximately 10 dB below the maximum.

RAILROAD NOISE DATA SUMMARY RECORD

A. DATE: \_\_\_\_\_  
 B. LOCATION: \_\_\_\_\_  
 C. WEATHER INFORMATION:  
 Temp. (°F): \_\_\_\_\_  
 Rel. Humidity (%): \_\_\_\_\_  
 Wind Speed/Dir: \_\_\_\_\_  
 Weather Conditions: \_\_\_\_\_  
 \_\_\_\_\_

D. INSTRUMENTATION:  

Instrument	Model	Serial No.	Cal. Date
Sound Level Meter	_____	_____	_____
Microphone Calibrator	_____	_____	_____
Tape Recorder	_____	_____	_____
_____	_____	_____	_____
_____	_____	_____	_____

E. MEASUREMENT SITE DESCRIPTION:  
 (Include Sketch)  
 Measurement Distance: \_\_\_\_\_  
 Height off Ground: \_\_\_\_\_  
 Ground Cover: \_\_\_\_\_  
 \_\_\_\_\_

F. NOISE SOURCE DESCRIPTION:  
 \_\_\_\_\_  
 \_\_\_\_\_  
 \_\_\_\_\_

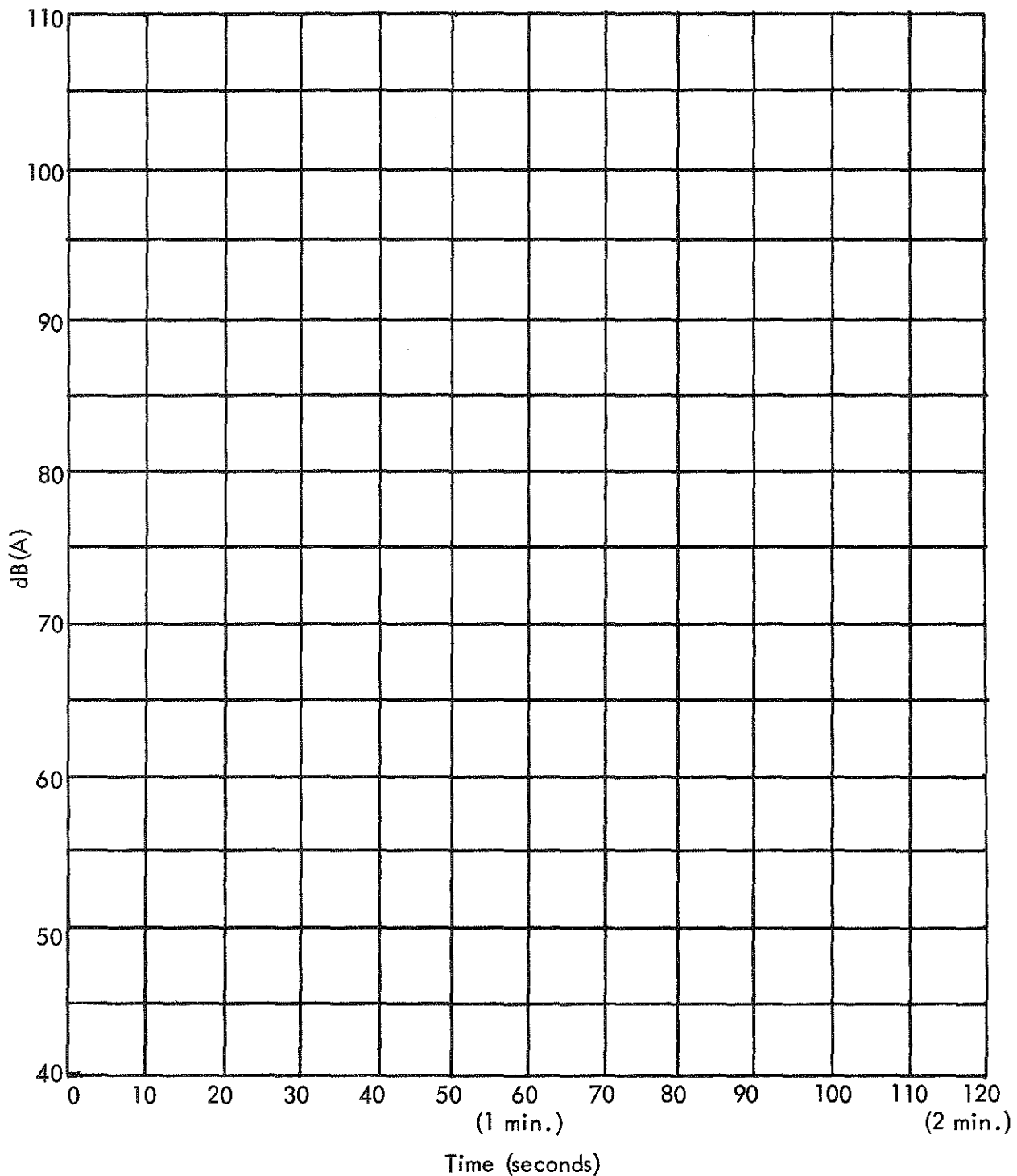
G. TEST DATA: (For Stationary or Constant Noise Sources – For Moving Sources, Use Page 2)

Test Point	dB(A)	dB(C)	Center Frequency - Hertz							
			63	125	250	500	1000	2000	4000	8000
Ambient										

COMMENTS:  
 \_\_\_\_\_  
 \_\_\_\_\_  
 MEASUREMENT PERSONNEL:  
 \_\_\_\_\_

G. TEST DATA - (Continued)

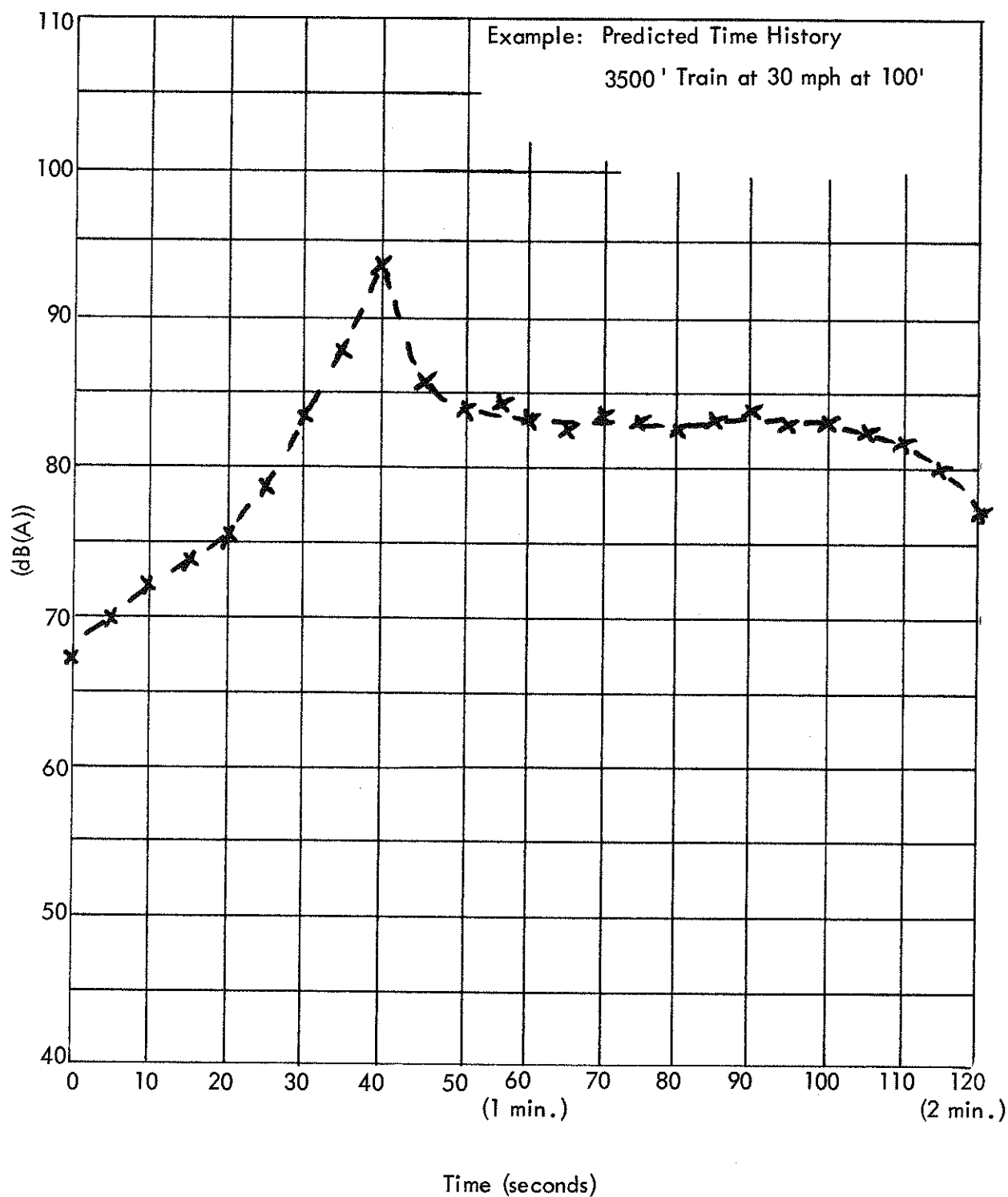
Graphical Method of Presentation of Single Event Occurrences -



RAILROAD NOISE DATA SUMMARY

G. TEST DATA - (Continued)

Graphical Method of Presentation of Single Event Occurrences -



## APPENDIX I

### THEORETICAL CORRELATION OF REQUIRED ENGINE HORSEPOWER TO SPEED/GRADE CONDITIONS

In the early formulation of the mathematical model for synthesis of railroad line operations, an effort was made to assess the variables which affect the noise output of the diesel locomotive. Clearly, the total acoustic power emitted by the locomotives will be proportional to the power output of the engines.

Efforts to correlate the predicted power required for a particular track segment, given the parameters - speed, tonnage and percent grade - were observed; however, because extra road power may be added to a train for negotiation of severe grade conditions which is not needed on level terrain, the net result is that the calculated power required to achieve given velocity over defined conditions will generally not agree with the total engine horsepower on the train at any given time. It was initially thought that the noise level emitted by the locomotives might be correlated to the total road power on the train; however, this concept was dropped in favor of correlation to grade conditions as discussed in Section 3.2 of the text.

The formulation utilized for estimation of the theoretically required horsepower is outlined below. (Reference 15 )

The theoretical horsepower required for given conditions of grade ascent, velocity and total train tonnage may be expressed as

$$HP = \frac{VR}{550}, \text{ horsepower} \quad (I-1)$$

where

V = Velocity, ft/sec

R = Resistance in lbs

550 = Conversion factor from  $\frac{\text{ft} - \text{lbs}}{\text{sec}}$  to HP

evaluation of the Resistance term initially utilized the modified Davis formula (Reference 15).

$$\begin{aligned} \text{Locomotive: } R_L &= 1.3 + (29/w) + .03V + (0.002AV^2/wn) & (I-2) \\ \text{Cars} &: R_C = 1.3 + (29/w) + .03V + (0.00034AV^2/wn) & (I-3) \end{aligned}$$

where

$R_{L,c}$  = Resistance, lb per ton

w = Average weight per axle, tons

V = Speed, mph

n = Total number of axles

A = Project frontal cross sectional area, ft<sup>2</sup>

To simplify the calculation procedure, a formulation was developed which lumped the rolling resistance factors into a single constant which was assumed = 10 lbs/ton.

Additionally, the air drag resistance was considered of secondary order of magnitude and neglected. (This assumption was verified for the locomotive case considering an assumed drag coefficient of 0.45, speed of 60 mph and projected frontal area of 160 feet<sup>2</sup>. The air drag component for this case equaled 655 lbs). Furthermore, a grade resistance was assumed = 20 lbs/ton per percent ascent grade (valid for the small angles involved).

Hence, the modified formulation may be expressed as

$$R = \text{No. tons} \left( \frac{20 \text{ lb}}{\text{Ton}/\% \text{ grade}} (\% \text{ grade}) + 10 \frac{\text{lbs}}{\text{tons}} \right) \quad (\text{I-4})$$

Table I-1 is included to illustrate some sample calculations involving this formulation to show the inclusive nature of correlation studies between predicted horsepower and noise level emitted by the locomotives.

Table I - 1  
Comparison of Actual and Theoretical  
Horsepower Calculations

Train Identification	Actual Total Horsepower H. P.	Maximum Engine Noise Level, dB(A) at 100 feet	Tonnage	Grade	Speed MPH	Theoretical Horsepower
1. ATSF #5942	10, 800	95	970	2.2	40	5, 587
2. SP #8720	9, 900	95	5340	2.2	11	8, 458
3. ATSF #5519	13, 800	93	3690	2.2	20	10, 627
4. ATSF #5631	14, 400	94	2670	2.2	27	10, 380



APPENDIX J  
FULL SIZE WORKSHEETS

This appendix includes the noise contour worksheets to be used for future calculations. The CNEL Worksheets for Line Operations supplement Section 3.4 and the  $L_{dn}$  Worksheet for Yard Operations supplement Section 4.6.



# L<sub>dn</sub> WORKSHEET FOR YARD OPERATIONS

NOISE CENTER	N <sub>H</sub>	f <sub>d</sub>	N <sub>2</sub>	Distance to Contour at Mid-Point of Noise Center				Distance to Contour at End of Noise Center					
Hump Engine				65 dB	80 dB	___ dB	___ dB	65 dB	80 dB	___ dB	___ dB		

Concentrated Switching	H <sub>d</sub>	H <sub>n</sub>	N <sub>1</sub>					Distance to Noise Contour					
1													
2													
3													
4													
5													
6													

Master and Group Retarder	N <sub>H</sub>	f <sub>d</sub>	N <sub>2</sub>	5% Correction	Number of Retarders Correction	L <sub>dn</sub> Adjustment	Value of Adjusted Contour						
							65 dB	80 dB	___ dB	___ dB			

Inert Retarder	N <sub>H</sub>	f <sub>d</sub>	N <sub>2</sub>								

Idling Locomotives and/or Mechanical Refrigeration Cars	H <sub>d</sub>	H <sub>n</sub>	N <sub>3</sub>	N <sub>4</sub>		L <sub>dn</sub> Adjustment	Value of Adjusted Contour						
							65 dB	80 dB	___ dB	___ dB			
1													
2													
3													
4													
5													
6													

Load Test	N <sub>Td</sub>	N <sub>Tn</sub>	N <sub>T</sub>										