

35-km/h Broadside Crash Test of a 1994 Chevrolet C2500 and the FOIL300K Rigid Pole: FOIL Test Number 97S016

Publication No.: FHWA-RD-98-081

November 1998

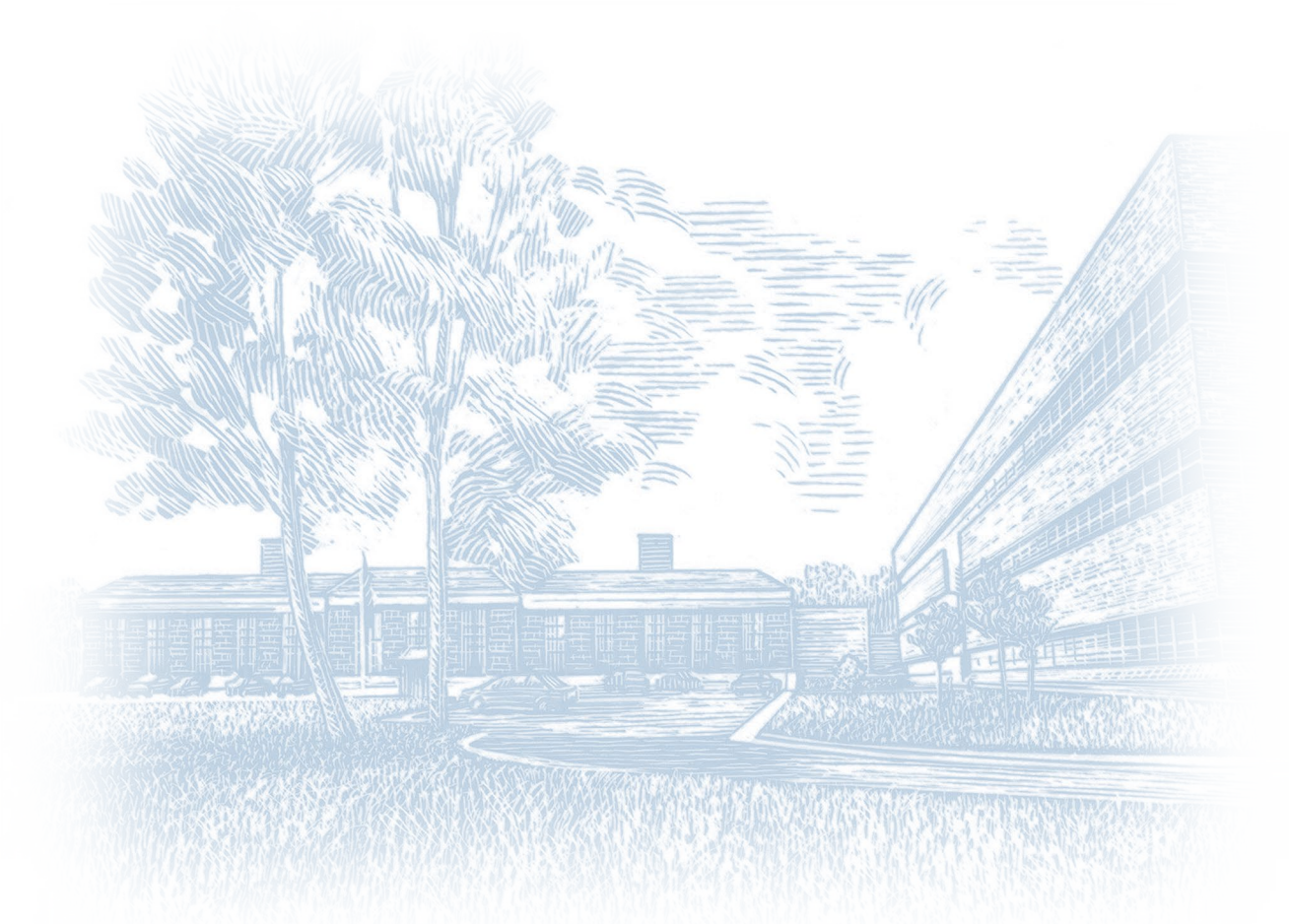

U.S. Department of Transportation
Federal Highway Administration

Federal Highway Administration
Turner-Fairbank Highway Research Center
6300 Georgetown Pike, McLean, VA 22101

The original format of this document was an active HTML page(s). The Federal Highway Administration converted the HTML page(s) into an Adobe® Acrobat® PDF file to preserve and support reuse of the information it contained.

The intellectual content of this PDF is an authentic capture of the original HTML file. Hyperlinks and other functions of the HTML webpage may have been lost, and this version of the content may not fully work with screen reading software.

35-km/h Broadside Crash Test of a 1994 Chevrolet C2500 and the FOIL 300K Rigid Pole: FOIL Test Number 97S016

PUBLICATION NO. FHWA-RD-98-081

NOVEMBER 1998

| | |
|--|-----|
|  FOREWARD | i |
|  NOTICE | i |
|  SI CONVERSION FACTORS | iii |
|  LIST OF FIGURES | iv |
|  LIST OF TABLES | vi |
|  INTRODUCTION | 1 |
|  SCOPE | 1 |
|  TEST MATRIX | 2 |
|  TEST VEHICLE | 2 |
|  INSTRUMENTED DUMMY | 7 |
|  RIGID POLE | 11 |
|  INSTRUMENTATION | 13 |
| Onboard data acquisition system (ODAS) | 13 |
| Tape recorder-umbilical cable | 13 |
|  HIGH-SPEED PHOTOGRAPHY | 17 |
|  DATA ANALYSIS | 20 |
| ODAS system | 20 |
| Umbilical cable | 20 |
| High-speed film | 20 |
|  RESULTS | 21 |
| Vehicle response | 22 |
| Occupant response | 26 |
| Rigid Pole | 27 |
|  CONCLUSIONS AND OBSERVATIONS | 28 |
|  APPENDIX A. DATA PLOTS FROM VEHICLE ACCELEROMETERS | 30 |
|  APPENDIX B. DATA PLOTS FROM INSTRUMENTED SIDH3 | 50 |
|  APPENDIX C. TEST PHOTOGRAPHS | 66 |
|  APPENDIX D. DATA PLOTS FROM RIGID POLE LOAD CELLS | 73 |
|  REFERENCES | 81 |



U.S. Department of Transportation
Federal Highway Administration

Research and Development
Turner-Fairbank Highway Research Center
6300 Georgetown Pike
McLean, VA 22101-2296

FOREWORD

This report documents the test procedures followed and the test results from one broadside crash test between a Chevrolet C2500 pickup truck and a FOIL 300K rigid pole. The Federal Highway Administration (FHWA) has invested many resources in the development of finite element models (FEM) of passenger vehicles, pickup trucks, and roadside safety hardware. Computer simulations using these FEM's of collisions between the vehicles and roadside safety hardware are used to investigate the behavior of and improve the safety performance of roadside safety hardware. An essential step for developing the FEM is to validate the models by comparing data from simulation output with data collected from full-scale vehicle crash tests with roadside safety hardware. The FHWA's Federal Outdoor Impact Laboratory (FOIL) was used to conduct this rigid pole test to provide side-impact crush characteristics of the Chevrolet C2500 pickup.

This report (FHWA-RD-98-081) contains test data, photographs taken with high-speed film, and a summary of the test results. The target test speed for this test was 35 km/h.

This report will be of interest to all State departments of transportation; FHWA headquarters; region and division personnel; and highway safety researchers interested in the crashworthiness of roadside safety hardware.

A. George Ostensen, Director
Office of Safety and Traffic
Operations Research and Development

NOTICE

This document is disseminated under the sponsorship of the Department of Transportation in the interest of information exchange. The United States Government assumes no liability for its contents or use thereof. This report does not constitute a standard, specification, or regulation.

The United States Government does not endorse products or manufacturers. Trade and manufacturers' names appear in this report only because they are considered essential to the object of the document.



| | | | |
|--|--|--|-----------|
| 1. Report No. FHWA-RD-98-081 | 2. Government Accession No. | 3. Recipient's Catalog No. | |
| 4. Title and Subtitle 35-KM/H BROADSIDE CRASH TEST OF A 1994 CHEVROLET C2500 AND THE FOIL 300K RIGID POLE: FOIL TEST NUMBER 97S016 | | 5. Report Date | |
| | | 6. Performing Organization Code | |
| 7. Author(s) Christopher M. Brown | | 8. Performing Organization Report No. | |
| 9. Performing Organization Name and Address MiTech Incorporated 8484 Georgia Avenue, Suite 950 Silver Spring, MD 20910 | | 10. Work Unit No. (TRAIS) 3A5F3142 | |
| | | 11. Contract or Grant No. DTFH61-94-C-00008 | |
| 12. Sponsoring Agency Name and Address Office of Safety and Traffic Operations R&D Federal Highway Administration 6300 Georgetown Pike McLean, VA 22101-2296 | | 13. Type of Report and Period Covered Test Report, October 1997 | |
| | | 14. Sponsoring Agency Code | |
| 15. Supplementary Notes Contracting Officer's Technical Representative (COTR)- Richard King, HSR-20 | | | |
| 16. Abstract <p>This report contains the test procedures followed and test results from a broadside crash test between a Chevrolet C2500 pickup truck and the FOIL instrumented 300K rigid pole. The crash test will provide simulation engineers with data that will aid in the development and validation of a finite element side-impact model of a 2,000-kg pickup truck. The test was conducted at the Federal Highway Administration (FHWA) Federal Outdoor Impact Laboratory (FOIL) located at the Turner-Fairbank Highway Research Center (TFHRC) in Mclean, Virginia. The National Highway Traffic Safety Administration (NHTSA) supplied a calibrated SIDH3 dummy for the test. The target test speed for the test was 35km/h and the target test weight, including the SIDH3 dummy, was 2,080 kg. Previous crash tests using similar impact conditions between a Chevrolet C2500 pickup truck and Valmont Industries slip away lighting standard produced lower head injury values. The results from the broadside crash tests with a slip away lighting standard can be found in the reports <i>35-km/h Broadside Crash Test of a 1994 Chevrolet C2500 and a Valmont Industries Slip Away Lighting Standard: FOIL Test Number 97S012</i> and <i>50-km/h Broadside Crash Test of a 1994 Chevrolet C2500 and a Valmont Industries Slip Away Lighting Standard: FOIL Test Number 972015</i>.</p> | | | |
| 17. Key Words Chevrolet, C2500 pickup, FOIL, rigid pole, broadside, HIC, FEM | | 18. Distribution Statement No restrictions. This document is available to the public through the National Technical Information Service, Springfield, VA 22161. | |
| 19. Security Classif. (of this report) Unclassified | 20. Security Classif. (of this page) Unclassified | 21. No. of Pages 86 | 22. Price |



SI* (MODERN METRIC CONVERSION FACTORS)

| APPROXIMATE CONVERSIONS TO SI UNITS | | | | |
|--|----------------------------|--------------------------------|--------------------------------|-------------------|
| Symbol | When You Know | Multiply By | To Find | Symbol |
| LENGTH | | | | |
| in | inches | 25.4 | millimeters | mm |
| ft | feet | 0.305 | meters | m |
| yd | yards | 0.914 | meters | m |
| mi | miles | 1.61 | kilometers | km |
| AREA | | | | |
| in ² | square inches | 645.2 | square millimeters | mm ² |
| ft ² | square feet | 0.093 | square meters | m ² |
| yd ² | square yards | 0.836 | square meters | m ² |
| ac | acres | 0.405 | hectares | ha |
| mi ² | square miles | 2.59 | square kilometers | km ² |
| VOLUME | | | | |
| fl oz | fluid ounces | 29.57 | milliliters | mL |
| gal | gallons | 3.785 | liters | L |
| ft ³ | cubic feet | 0.028 | cubic meters | m ³ |
| yd ³ | cubic yards | 0.765 | cubic meters | m ³ |
| NOTE: Volumes greater than 1000 L shall be shown in m ³ | | | | |
| MASS | | | | |
| oz | ounces | 28.35 | grams | g |
| lb | pounds | 0.454 | kilograms | kg |
| T | short tons (2000lb) | 0.907 | megagrams (or "metric ton") | MG (or "t") |
| TEMPERATURE (exact) | | | | |
| °F | farenheit temperature | $5(F-32)/9$ or $(F-32)/1.8$ | Celcius temperature | °C |
| ILLUMINATION | | | | |
| fc | foot-candles | 10.76 | lux | lx |
| fl | foot-Lamberts | 3.426 | candela/m ² | cd/m ² |
| FORCE and PRESSURE or STRESS | | | | |
| lbf | pundforce | 4.45 | newtons | N |
| lbf/in ² | poundforce per square inch | 6.89 | kilopascals | kPa |

| APPROXIMATE CONVERSIONS FROM SI UNITS | | | | |
|---------------------------------------|--------------------------------|-------------|----------------------------|---------------------|
| Symbol | When You Know | Multiply By | To Find | Symbol |
| LENGTH | | | | |
| mm | millimeters | 0.039 | inches | in |
| m | meters | 3.28 | feet | ft |
| m | meters | 1.09 | yards | yd |
| km | kilometers | 0.621 | miles | mi |
| AREA | | | | |
| mm ² | square millimeters | 0.0016 | square inches | in ² |
| m ² | square meters | 10.764 | square feet | ft ² |
| m ² | square meters | 1.195 | square yards | yd ² |
| ha | hecteaes | 2.47 | acres | ac |
| km ² | square kilometers | 0.386 | square miles | mi ² |
| VOLUME | | | | |
| mL | milliliters | 0.034 | fluid ounces | fl oz |
| L | liters | 0.264 | gallons | gal |
| m ³ | cubic meters | 35.71 | cubic feet | ft ³ |
| m ³ | cubic meters | 1.307 | cubic yards | yd ³ |
| MASS | | | | |
| g | grams | 0.035 | ounces | oz |
| kg | kilograms | 2.202 | pounds | lb |
| Mg (or "t") | megagrams (or "metric ton") | 1.103 | short tons (2000lb) | T |
| TEMPERATURE (exact) | | | | |
| °C | Celcius temperature | $1.8C + 32$ | Fahrenheit temperature | °F |
| ILLUMINATION | | | | |
| lx | lux | 0.0929 | foot-candles | fc |
| cd/m ² | candela/m ² | 0.2919 | footLamberts | fl |
| FORCE and PRESSURE or STRESS | | | | |
| N | newtons | 0.225 | poundforce | lbf |
| kPa | kilopascals | 0.145 | poundforce per square inch | lbf/in ² |

LIST OF FIGURES

| <u>Figure</u> | <u>Page</u> |
|--|--------------------|
| 1. Vehicle physical parameters in mm | 6 |
| 2. HYBRID III neck and head assembly on SIDH3 #28 | 8 |
| 3. SIDH3 longitudinal clearance and position measurements | 9 |
| 4. SIDH3 lateral clearance and position measurements | 10 |
| 5. Sketch of FOIL instrumented 300K rigid pole | 12 |
| 6. Test setup and camera locations | 19 |
| 7. Vehicle profile measurements, test 97S016 | 25 |
| 8. Acceleration vs. time, c.g. X-axis primary, test 97S016 | 30 |
| 9. Acceleration vs. time, c.g. Y-axis primary, test 97S016 | 31 |
| 10. Acceleration vs. time, c.g. Y-axis redundant, test 97S016 | 32 |
| 11. Acceleration vs. time, c.g. Z-axis primary, test 97S016 | 33 |
| 12. Acceleration vs. time, driver seat, test 97S016 | 34 |
| 13. Acceleration vs. time, passenger floor sill, test 97S016 | 35 |
| 14. Acceleration vs. time, passenger roof rail, test 97S016 | 36 |
| 15. Acceleration vs. time, driver interior door-beam, test 97S016 | 37 |
| 16. Acceleration vs. time, longitudinal frame member, test 97S016 | 38 |
| 17. Acceleration vs. time, transmission cross member, test 97S016 | 39 |
| 18. Acceleration vs. time, front bed cross member, test 97S016 | 40 |
| 19. Acceleration vs. time, middle bed cross member, test 97S016 | 41 |
| 20. Acceleration vs. time, rear bed cross member, test 97S016 | 42 |
| 21. Acceleration vs. time, engine X-axis, test 97S016 | 43 |
| 22. Acceleration vs. time, engine Y-axis, test 97S016 | 44 |
| 23. Acceleration vs. time, rear bumper X-axis, test 97S016 | 45 |
| 24. Acceleration vs. time, rear bumper Y-axis, test 97S016 | 46 |
| 25. Pitch rate and angle vs. time, test 97S016 | 47 |
| 26. Roll rate and angle vs. time, test 97S016 | 48 |
| 27. Yaw rate and angle vs. time, test 97S016 | 49 |
| 28. Acceleration vs. time, head X-axis, test 97S016 | 50 |
| 29. Acceleration vs. time, head Y-axis, test 97S016 | 51 |
| 30. Acceleration vs. time, head Z-axis, test 97S016 | 52 |
| 31. Force vs. time, neck X-axis, test 97S016 | 53 |
| 32. Force vs. time, neck Y-axis, test 97S016 | 54 |
| 33. Force vs. time, neck Z-axis, test 97S016 | 55 |
| 34. Moment vs. time, neck X-axis, test 97S016 | 56 |
| 35. Moment vs. time, neck Y-axis, test 97S016 | 57 |
| 36. Moment vs. time, neck Z-axis, test 97S016 | 58 |
| 37. Acceleration vs. time, upper rib primary, test 97S016 | 59 |
| 38. Acceleration vs. time, upper rib redundant, test 97S016 | 60 |
| 39. Acceleration vs. time, lower rib primary, test 97S016 | 61 |
| 40. Acceleration vs. time, lower rib redundant, test 97S016 | 62 |
| 41. Acceleration vs. time, spine T12 primary, test 97S016 | 63 |
| 42. Acceleration vs. time, spine T12 redundant, test 97S016 | 64 |
| 43. Acceleration vs. time, pelvis, test 97S016 | 65 |
| 44. Test photographs during impact, test 97S016 | 66 |
| 45. Pre-test photographs, test 97S016 | 68 |
| 46. Post-test photographs, test 97S016 | 70 |
| 47. Rigid pole, force vs. time, bottom face lower load cell, test 97S016 | 73 |
| 48. Rigid pole, force vs. time, bottom face lower upper cell, test 97S016 | 74 |
| 49. Rigid pole, force vs. time, lower-middle face lower load cell, test 97S016 | 75 |
| 50. Rigid pole, force vs. time, lower-middle face upper load cell, test 97S016 | 76 |
| 51. Rigid pole, force vs. time, upper-middle face lower load cell, test 97S016 | 77 |
| 52. Rigid pole, force vs. time, upper-middle face upper load cell, test 97S016 | 78 |
| 53. Rigid pole, force vs. time, upper face lower load cell, test 97S016 | 79 |
| 54. Rigid pole, force vs. time, upper face upper load cell, test 97S016 | 80 |

LIST OF FIGURES

| <u>Table</u> | <u>Page</u> |
|---|--------------------|
| 1. Test matrix | 2 |
| 2. Vehicle description and statistics | 4 |
| 3. SIDH3 chalk colors | 11 |
| 4. Summary of instrumentation and channel assignments | 14 |
| 5. Vehicle sensor location | 16 |
| 6. Camera configuration and placement | 17 |
| 7. Summary of test conditions and results | 21 |
| 8. Vehicle sensor peak accelerations | 23 |
| 9. Summary of SIDH3 data | 27 |
| 10. Summary of rigid pole data | 28 |



INTRODUCTION

The Federal Highway Administration (FHWA) has invested many resources in the development of finite element models (FEM) of passenger vehicles, pickup trucks, and roadside safety hardware. Computer simulations using these FEM's of collisions between the vehicles and roadside safety hardware are used to investigate the behavior of and improve the safety performance of roadside safety hardware. An essential step for developing the FEM is to validate the models by comparing data from simulation output with data collected from full-scale vehicle crash tests with roadside safety hardware. The FHWA's Federal Outdoor Impact Laboratory (FOIL) was used to conduct several crash tests to provide simulation engineers with data for the FEM validation process. The test vehicles used for the crash tests were 1994 Chevrolet C2500 pickup trucks. The C2500 pickup truck tests were broadside collisions between the pickup trucks and a narrow object. The narrow fixed object in these tests was either the FOIL's instrumented rigid pole or a Valmont Industries three-bolt Slip Away lighting standard. The rigid pole tests were conducted to provide side-impact crush characteristics of the Chevrolet C2500 to support validation of the truck FEM. The lighting standard tests were conducted to provide data in support of validation of a simulated collision between the pickup truck and a common roadside safety device. This test report outlines the laboratory test procedures, test setup, and results from one of the broadside crash tests.

SCOPE

This report documents the test procedures followed and test results from one broadside crash test between a Chevrolet C2500 pickup truck and the FOIL instrumented 300K rigid pole. Many of the test procedures followed (dummy positioning and vehicle preparation) are outlined in the Federal Motor Vehicle Safety Standard (FMVSS) 214.⁽¹⁾ The test was conducted at the FHWA's FOIL facility located at the Turner-Fairbank Highway Research Center (TFHRC) in McLean, Virginia. The crash test will provide simulation engineers with data that will aid in the development and validation of a finite element side-impact model of a 2,000-kg pickup truck. The target test speed for the test and target vehicle inertial weight of the Chevrolet C2500 were 35 km/h and 2,000 kg, respectively. The target test weight, including one anthropometric dummy, was 2,080 kg. The dummy used was a calibrated SIDH3 dummy supplied by the National Highway Traffic Safety Administration (NHTSA). A SIDH3 dummy is a combination of a Hybrid III dummy used for frontal crash testing and a side-impact dummy (SID) used for side-impact testing. In addition, the NHTSA supplied an OSCAR to determine the three-dimensional location of a dummy's hip point (H-point). This information was used the morning of the test to place the dummy in the proper



position. The dummy, pickup truck, and rigid pole were instrumented with various transducers to record pertinent test data.

TEST MATRIX

One broadside crash test was conducted in support of the FHWA's computer simulation program. The vehicle used was a 1994 Chevrolet C2500 pickup truck. The pickup truck was oriented on the FOIL runway perpendicular to the runway centerline (broadside-impact). The FOIL 300K rigid pole was erected on the FOIL runway foundation base plate in the impact zone. A SIDH3 dummy was placed in the driver seat in accordance with FMVSS 214. The 300K rigid pole was aligned with a point on the driver door just forward of the SIDH3's head so as not to allow contact between the SIDH3's head and the pole. This point was later determined to be 1,320 mm rearward of the pickup truck's front axle or 102 mm forward of the pickup truck's longitudinal center of gravity (c.g.). Table 1 outlines the test matrix followed for the broadside crash test.

| Table 1. Test matrix. | | | | | |
|-----------------------|------------------------------|-----------------------------|---------------|-----------------|------------------------|
| Test No. | Test Vehicle | Vehicle weight | Vehicle speed | Test article | Impact location |
| 97S016 | Chevrolet C2500 pickup truck | 2000 kg, w/SIDH3 2080 kg | 35 km/h | 300K rigid pole | Forward of SIDH3 head. |

TEST VEHICLE

The test vehicle used was a 1994 Chevrolet C2500 pickup truck. The pickup truck was equipped with standard equipment and options. Prior to the test, the truck was drained of all fluids and the curb weight, sill attitudes, and the vehicle's physical parameters were measured. A NHTSA-supplied OSCAR was used to determine the three-dimensional coordinate of the SIDH3's H-point relative to the driver door-striker. The measurement was recorded and was used the day of the test to position the dummy in the driver seat just before the test. The test vehicle was loaded with instrumentation, guidance system components, a high-speed camera, and ballast (if needed) to attain the proper test weight. The target test weight (not including the SIDH3) for the pickup truck was 2,000 kg (SIDH3 weighed 80 kg). The test vehicle was reweighed; the new sill attitudes, lateral and longitudinal c.g., and pertinent physical parameters were measured and recorded. The fuel tank was empty during the test.



No components were removed from the engine compartment during vehicle preparations. The truck was not equipped with a driver side air bag.

Included in the final test configuration were the two side-impact carriages. The main monorail carriage was bolted to the test vehicle 200 mm forward of the vehicle's longitudinal c.g. The rear outrigger carriage was bolted 2,770 mm rearward of the monorail carriage centerline (a point within the truck bed rearward of the rear axle). The side-impact carriages were constructed from aluminum and remained fastened to the vehicle throughout the test, although the main monorail carriage was fastened to the truck using long, small-diameter bolts, which allowed the carriage to swing away from impact in the event the carriage made contact with a substantial structure.

The FOIL broadside test setup procedures require that the test vehicle's tires are off the ground while the test vehicle rests on the side-impact monorail. Due to the truck's ground clearance and the truck suspension system, the tires remained in contact with the ground after typical guidance system installation procedures. Therefore, the suspension system at each wheel was tied to the vehicle frame using 5-mm wire rope and cable clamps. The amount necessary to raise the tires was minimal and the suspension system retained the majority of its range of motion. Applying an oscillating load to the front and rear of the truck (while on the ground) demonstrated that the truck suspension's range of motion was not hindered. Once the truck was placed on the side-impact rails, the sill attitudes were adjusted to within 0.5° of the final sill attitudes measured while the truck was on the ground.

Target tape and circular targets were placed on the test vehicle in accordance with FMVSS 214. The 25-mm yellow and black target tape was placed along the struck side of the vehicle at five elevations. The elevations included the lower door sill, the mid-door height, occupant H-point height, top-door sill, and roof sill. The target tape was used to measure pretest and post- test side profile measurements to determine vehicle damage or crush. The FOIL used a 2.5-m-long by 1.4-m-high peg board placed along the driver (left) side of the vehicle to measure the vehicle profile. The board's position was referenced from two points directly across from the impact location on the right side of the vehicle. This was done to ensure that the reference location would not be severely damaged. The two points were chosen directly across from impact because the least amount of bowing occurs directly across from impact. It was necessary to position the board in the same position relative to the vehicle after the crash test to obtain accurate crush measurements. The pretest and post-test profile measurements are shown in figure 7 later in this report.



Table 2 lists the pickup truck's optional equipment and physical parameters. Figure 1 is a sketch of the C2500 pickup truck with its physical dimensions.

| Table 2. Vehicle description and statistics | |
|---|----------------------|
| Vehicle make | Chevrolet |
| Vehicle model | 1994 C2500 pickup |
| Vehicle identification number (VIN) | 1GCFC24H3RE239250 |
| Engine | 5.0 L, 8 cylinder |
| Transmission | Automatic |
| Drive chain | Rear wheel drive |
| Wheel base | 3,353 mm |
| Wheel track | 1,607 mm |
| Fuel capacity | No fuel used |
| Tested capacity of stoddard solvent | N/A |
| Seat type | Bench |
| Position of front seat for test | Center |
| Seat back angle | Fixed 18.0E in front |
| Steering wheel adjustment for test | Fixed |

| OPTIONS | | | | | |
|--------------|------------------|--------------|------------------|--------------|-------------------|
| x | Air conditioning | | Traction control | x | Clock |
| | Tinted glass | | All wheel drive | | Roof rack |
| x | Power steering | | Cruise control | | Console |
| | Power windows | | Rear defroster | | Driver air bag |
| | Power door locks | | Sun roof/T-top | | Passenger air bag |
| | Power seat(s) | x | Tachometer | x | Front disc brakes |
| x | Power brakes | | Tilt steering | | Rear disc brakes |
| x | Anti-lock brakes | x | AM/FM radio | | Other |
| WEIGHTS (kg) | | DELIVERED | | TEST MODE | |
| Left front | | 543 | | 602 | |
| Right front | | 513 | | 590 | |
| Left rear | | 382 | | 444 | |
| Right rear | | 406 | | 440 | |
| TOTAL | | 1,844 | | 2,076 | |



| Table 2. Vehicle description and statistics (continued). | | |
|--|------------------|------------------|
| ATTITUDE (mm) | DELIVERED | TEST MODE |
| Left front | 822 | 830 |
| Right front | 838 | 829 |
| Left rear | 891 | 899 |
| Right rear | 902 | 902 |
| | | |
| ATTITUDE (degrees) | DELIVERED | TEST MODE |
| Driver | pitch down 2 | pitch up 1.5 |
| Passenger | pitch up 1.5 | pitch down 1.2 |
| Front | roll down 0.1 | roll up 0.2 |
| Rear | 0 | roll up 0.2 |
| | | |
| C.g. (mm) measurements | DELIVERED | TEST MODE |
| Behind front axle | 1,433 | 1,428 |
| Lateral | 801 | 797 |



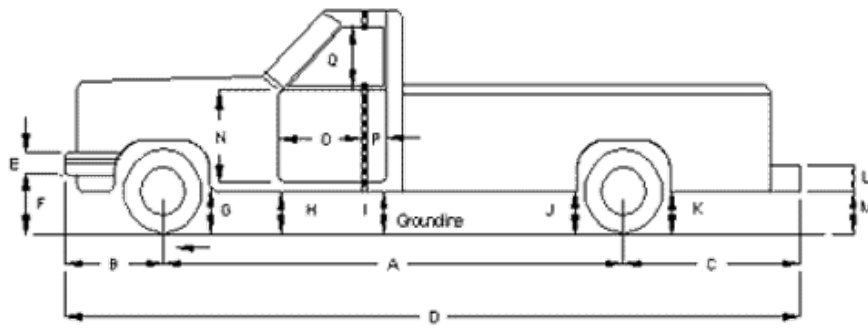

| | PRE-TEST | POST-TEST | -CHANGE |
|----|-----------|-----------|---------|
| A | 3,353 | 3,100 | -253 |
| B | 838 | 1,050 | 212 |
| C | 1,295 | 1,295 | 0 |
| D | 5,487 | 5,445 | -42 |
| E | 202 | 202 | 0 |
| F* | 386 / 388 | 437 | 49 |
| G* | 350 / 350 | 367 | 17 |
| H* | 350 / 350 | 346 | -4 |
| I* | 389 / 390 | 332 | -58 |
| J* | 425 / 415 | 400 | -15 |
| K* | 488 / 490 | 549 | 59 |
| L | 183 | 183 | 0 |
| M* | 565 / 566 | 670 | 104 |
| N | 762 | 762 | 0 |
| O | 762 | 515 | -247 |
| P | 470 | 180 | -290 |
| Q | 525 | 500 | -25 |

* These measurements were taken in the "as delivered" and in the "as tested" configuration, respectively.

Figure 1. Vehicle physical parameters in mm.



INSTRUMENTED DUMMY

One SIDH3, serial number 28, was placed in the driver seat. The SIDH3 was supplied by the NHTSA and was calibrated by a NHTSA-approved dummy calibration facility before shipment to the FOIL. The SIDH3 is a combination of the standard SID torso with the neck and head replaced with a Hybrid III dummy's neck and head. The neck bracket was removed from the SID and replaced with the neck bracket from a Hybrid III. This provided the necessary bolt pattern and alignment for a Hybrid III neck and head assembly. It was noted that the dummy's head had a slight twist about the neck. This may have been a result of the attachment between the neck and head or between the neck and head assembly and the dummy's torso. Figure 2 is a sketch of the modifications made to the SID. The dummy was shipped with the necessary hardware for assembly. Tools at the FOIL were used to assemble the SIDH3. Clothing consisting of white thermal underwear was purchased and placed on the dummy, along with a pair of brown hard leather shoes. Eighteen extension cables were supplied with the SIDH3. The extensions allowed for installation of connectors necessary for attachment to the FOIL data acquisition system without removing the standard dummy connectors. The transducers within the dummy were of the half bridge type and therefore completion resistors were soldered into the connectors at the data acquisition system interface.

The morning of the test, the SIDH3 was positioned in the driver seat in accordance with FMVSS 214. The data acquired from the OSCAR was used to place the dummy H-point at the correct location. The driver seat was set in the center position with the seat back at 18.0° from the vertical. Using FMVSS 214 as a guide and alignment tools supplied by the NHTSA, the SIDH3's feet, legs, thighs, pelvis, torso, and head were positioned just before test. While the dummy was positioned in the test vehicle, a tent was used to prevent direct sunlight from striking the dummy. The dummy is best used in a specific temperature range of 20.5° C to 22.2° C. Temperature measurements, using a thermocouple positioned near the dummy's head, were taken in 15-min intervals during the hour prior to the test. Pertinent SIDH3-to-interior longitudinal and lateral clearance measurements are shown in figure 3 and figure 4. The SIDH3 was belted in the driver seat using the pickup truck's seatbelt restraining system. Several different color chalks, listed in table 3, were put on the side surfaces of the dummy to determine the contact points between the dummy and the vehicle's interior.



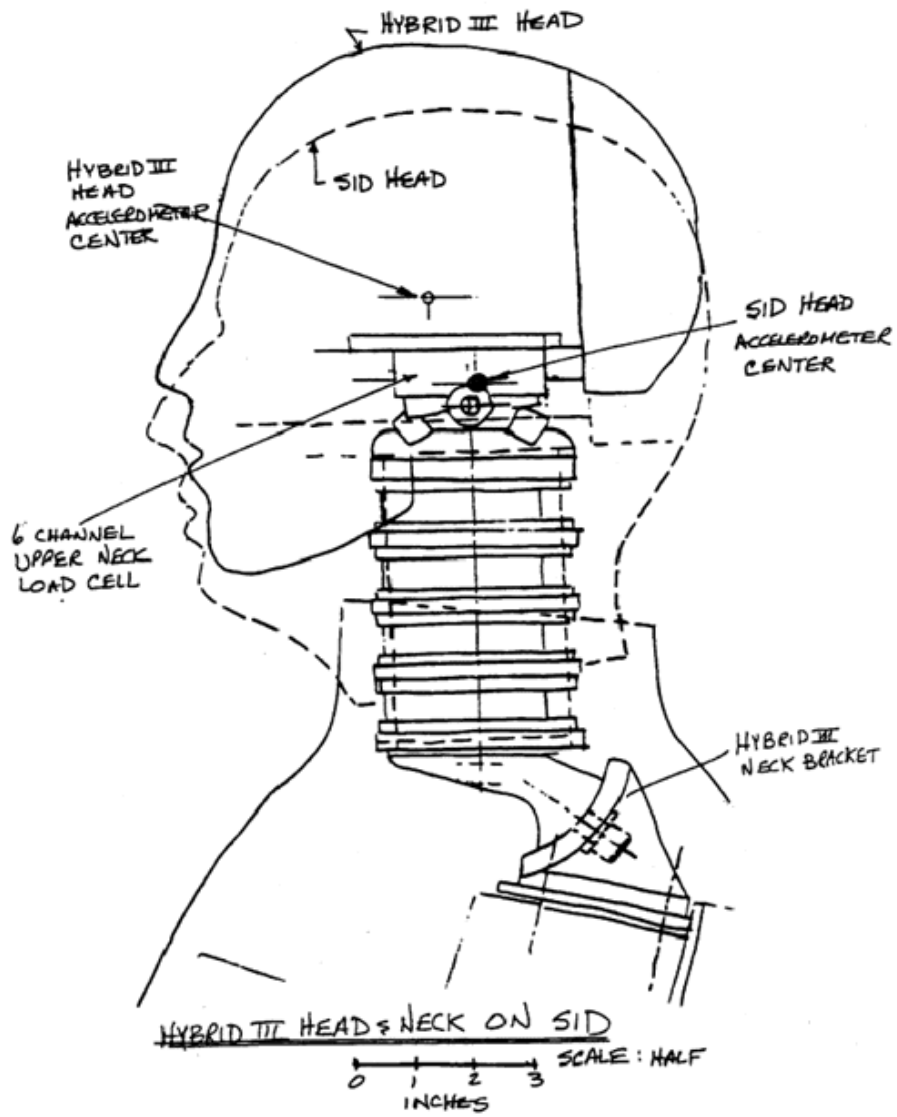
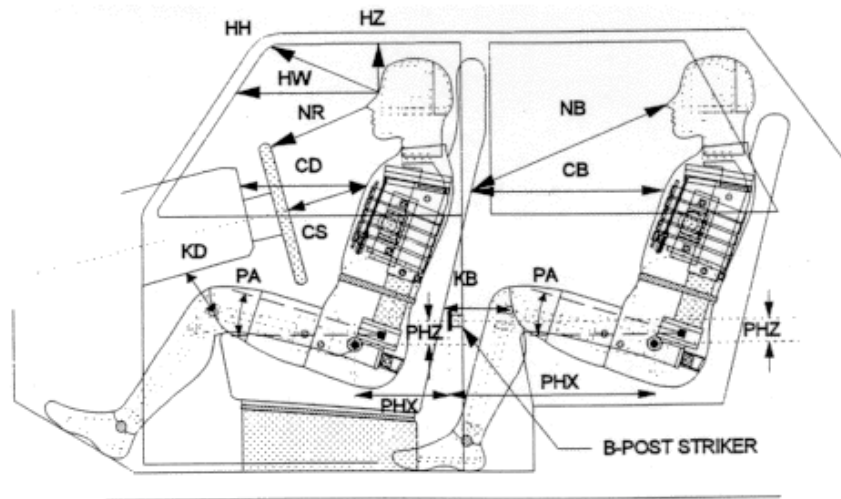

Figure 2. HYBRID III neck and head assembly on SIDH3 #28





LEFT SIDE VIEW

NOTE: 2-DOOR VEHICLE SHOWN.
 REAR DUMMY PHX & PHZ
 MEASUREMENTS FOR A 4-DOOR
 VEHICLE WOULD USE THE C-POST
 STRIKER AS A REFERENCE POINT

| MEASUREMENT (mm) | DRIVER SIDH3 ID# 28 |
|------------------|---------------------|
| HH | 480 |
| HW | 693 |
| HZ | 194 |
| NR | 398 |
| CD | 561 |
| CS | 249 |
| KDL(KDA°) | 175(16.5°) |
| KDR(KDA°) | 177(16.7°) |
| PA° | 15° |
| PHX | 324 |
| PHZ | 7 |
| PHY | 267 |

Figure 3. SIDH3 longitudinal clearance and position measurements.



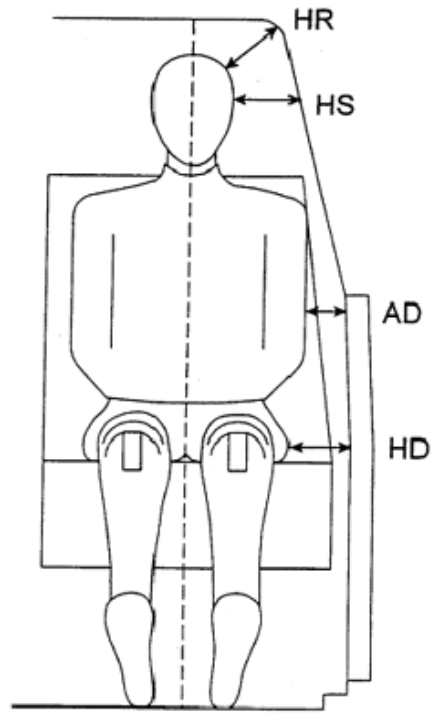

| MEASUREMENT (mm) | DRIVER SIDH3 ID# 28 |
|------------------|---------------------|
| HR | 280 |
| HS | 609 |
| AD | 171 |
| HD | 245 |

Figure 4. SIDH3 lateral clearance and position measurements.



| Table 3. SIDH3 chalk colors | |
|-----------------------------|--------|
| DUMMY PART | COLOR |
| Face | Blue |
| Top of head | Green |
| Left side of head | Yellow |
| Back of head | red |
| Left hip | Yellow |
| Left shoulder | Violet |

The SIDH3 instrumentation recorded during the test was as follows:

| | Number of Channels |
|---|--------------------|
| Head triaxial accelerometer (A_x, A_y, A_z) | 3 |
| Neck 3-axis force load cell (F_x, F_y, F_z) | 3 |
| Neck 3-axis neck moment load cell (M_x, M_y, M_z) | 3 |
| No completion resistors required | |
| Upper and Lower Rib and redundant (A_y) | 4 |
| T12 and redundant (A_y) | 2 |
| Pelvis (A_y) | 1 |
| TOTAL SIDH3 channels | 16 |

Data from the SIDH3 dummy were recorded by the FOIL ODAS III data acquisition system from DSP Technologies. The sample rate was factory set at 12,500 Hz with an analog prefilter with a cutoff frequency of 4000 Hz.

RIGID POLE

The FOIL instrumented 300K rigid pole was designed to measure vehicle frontal and side crush characteristics. The rigid pole was set up in the side-impact configuration. The rigid pole side-impact configuration consisted of four solid half-circle steel impact faces mounted to two load cells via two high-strength connecting rods per face (eight load cells total). The diameter of the pole impact faces was 255 mm. The load cells measured the forces exerted on the pole at each location. This provided insight into what structures on the vehicle produced the significant loads. The 300K rigid pole was mounted in line with the target impact location, forward of SIDH3's head.

A spike (e.g., sharpened welding rod) was affixed to one impact face to verify the impact location by physically puncturing the vehicle body. Figure 5 is a sketch of the FOIL 300K rigid pole (side-impact configuration).



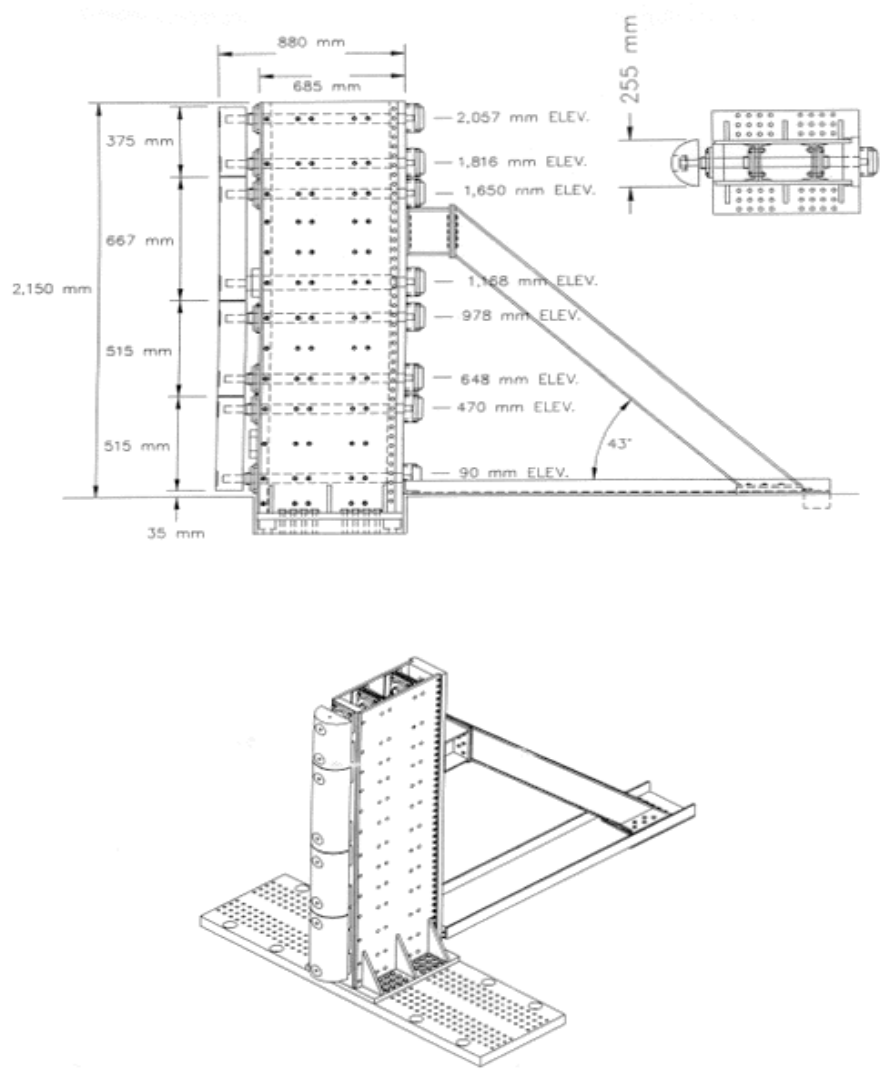

Figure 5. Sketch of FOIL instrumented 300K rigid pole.

INSTRUMENTATION

A monorail speed trap, transducers attached to the pickup truck and SIDH3, and rigid pole load cells were used to collect data during the broadside crash test. The output from the transducers, load cells, and speed trap were recorded via two data acquisition systems, the ODAS III onboard system and an umbilical cable/FM tape recorder system. Table 4 summarizes the channel assignments for each data system.

Onboard data acquisition system (ODAS)

The ODAS III system collected 35 channels of data. The data were from accelerometers, a triaxial rate transducer, and 16 SIDH3 channels. The output from the sensors was prefiltered, digitally sampled, and digitally stored within the ODAS III units mounted directly to the test vehicle outside the occupant compartment in the truck bed. The ODAS III units are factory set with a 4,000 Hz analog prefilter and a digital sampling rate of 12,500 Hz.

Tape recorder-umbilical

The FOIL umbilical cable system utilizes a 90-m cable between the vehicle transducers, rigid pole load cells, or other sensors, and a rack of 10 signal conditioning amplifiers. The output from the amplifiers was recorded on 25-mm magnetic tape via a Honeywell 5600E FM tape recorder. After the test, the tape is played back through anti-aliasing filters, then input to a data translation analog-to-digital converter. The sample rate was set to 5,000 Hz. The tape recorded signals from 12 transducers. The system recorded outputs from one c.g. accelerometer, one displacement transducer, eight rigid pole load cells, the monorail speed trap, and an impact contact switch to electronically mark first contact between the vehicle and the pole. The speed trap signals and the impact contact switch were not conditioned before being recorded.

The speed trap consisted of a single microswitch mounted to the monorail 4.2 m from the pole. The wheels from the main side-impact carriage trip the switch as the vehicle passes over the speed trap. The distance between the two main carriage wheels was 965 mm.



Table 4. Summary of instrumentation and channel assignments

| ODAS III onboard data system | | | |
|------------------------------|-----------------|------------|------------------------------|
| Reference & Channel | Transducer | Max. range | Data description |
| 1 | Accelerometer | 2000 g's | Head, X-axis |
| 2 | Accelerometer | 2000 g's | Head, Y-axis |
| 3 | Accelerometer | 2000 g's | Head, Z-axis |
| 4 | Accelerometer | 2000 g's | Upper rib, Y-axis (P) |
| 5 | Accelerometer | 2000 g's | Upper rib, Y-axis (R) |
| 6 | Accelerometer | 2000 g's | Lower rib, Y-axis (P) |
| 7 | Accelerometer | 2000 g's | Lower rib, Y-axis (R) |
| 8 | Accelerometer | 2000 g's | Lower spine, Y-axis, T12 (P) |
| 9 | Accelerometer | 2000 g's | Lower spine, Y-axis, T12 (R) |
| 10 | Accelerometer | 2000 g's | Pelvis, Y-axis |
| 11 | Load cell | 9000 N | Neck force, X-axis |
| 12 | Load cell | 9000 N | Neck force, Y-axis |
| 13 | Load cell | 9000 N | Neck force, Z-axis |
| 14 | Load cell | 282 N·m | Neck moment, X moment |
| 15 | Load cell | 282 N·m | Neck moment, Y moment |
| 16 | Accelerometer | 100 g's | Z-axis, c.g. data |
| 17 | Accelerometer | 100 g's | Y-axis, c.g. data |
| 18 | Rate transducer | 500 deg/s | Pitch rate, c.g. |
| 19 | Rate transducer | 500 deg/s | Roll rate, c.g. |
| 20 | Rate transducer | 500 deg/s | Yaw rate, c.g. |
| 21 | Accelerometer | 2000 g's | X-axis, engine block |
| 22 | Accelerometer | 2000 g's | Y-axis, engine block |
| 23 | Accelerometer | 2000 g's | Driver seat track |
| 24 | Load cell | 340 N·m | Neck moment, Z moment |
| 25 | Accelerometer | 2000 g's | Right side lower sill |
| 26 | Accelerometer | 2000 g's | Right side roof rail |

| Table 4. Summary of instrumentation and channels (continued). | | | |
|---|-------------------------|-----------|---|
| 27 | Accelerometer | 2000 g's | Driver door-beam |
| 28 | Accelerometer | 2000 g's | Longitudinal frame member |
| 29 | Accelerometer | 2000 g's | Transmission cross member/mount |
| 30 | Accelerometer | 2000 g's | Truck bed cross member #1 |
| 31 | Accelerometer | 2000 g's | Truck bed cross member #2 |
| 32 | Accelerometer | 2000 g's | Truck bed cross member #3 |
| 33 | Accelerometer | 2000 g's | Rear bumper, X-axis |
| 34 | Accelerometer | 2000 g's | Rear bumper, Y-axis |
| 35 | Accelerometer | 100 g's | X-axis, c.g. data |
| Umbilical cable, tape recorder system. | | | |
| 1 | Accelerometer | 100 g's | c.g., Y-axis |
| 2 | Displacement transducer | 1,905 g's | Span between left and right door interior |
| 3 | Load cell | 111,000 N | Pole force, Y-axis |
| 4 | Load cell | 222,000 N | Pole force, Y-axis |
| 5 | Load cell | 222,000 N | Pole force, Y-axis |
| 6 | Load cell | 222,000 N | Pole force, Y-axis |
| 7 | Load cell | 222,000 N | Pole force, Y-axis |
| 8 | Load cell | 222,000 N | Pole force, Y-axis |
| 9 | Load cell | 222,000 N | Pole force, Y-axis |
| 10 | Load cell | 222,000 N | Pole force, Y-axis |
| 11 | Contact switch | 1.5 Volts | Time of impact, T0 |
| 12 | Micro switch | 1.5 Volts | Monorail speed trap |
| 13 | Generator | 1.5 Volts | 1 kHz reference signal |

The shaded entries in table 4 represent SIDH3 data channels. The displacement transducer malfunctioned during test preparation and was omitted before the test.



Table 5 contains the three-dimensional location of each vehicle sensor. The origin for these measurements was the right front wheel hub. The hub was 370 mm above ground.

| Table 5. Vehicle sensor location. | | |
|---|--|--------------------------|
| Sensor | Data | Location (X,Y,Z) (mm) |
| Six c.g. accelerometers | $(A_{x1}, A_{y1}, A_{z1}, A_{x2}, A_{y2}, A_{z2})$ | (-965,840,290) |
| Angular rate sensor at c.g. | (pitch, roll, yaw rate) | (-965,840,290) |
| Top of engine | (A_x, A_y) | (30,900,515) |
| Seat under SIDH3 | (A_y) | (-1550,1525,265) |
| Right side door sill across from impact | (A_y) | (-1310,25,100) |
| Right side roof rail across from impact | (A_y) | (-1310,185,1345) |
| Driver door-beam | (A_y) | (-1310,1815,455) |
| Longitudinal frame under driver at impact point | (A_y) | (-1310,1450,-20) |
| Transmission mount cross member | (A_y) | (-870,855,-65) |
| Lateral cross member #1 under truck bed | (A_y) | (-1980,840,190) |
| Lateral cross member #2 under truck bed | (A_y) | (-2705,800,260) |
| Lateral cross member #3 under truck bed | (A_y) | (-3990,865,310) |
| Rear bumper | (A_x, A_y) | (-4545,900,220) |

The coordinate system used for the sensor location measurements and transducer polarity was as follows:

- X-axis - Front to rear of vehicle, longitudinal centerline.
Positive direction toward the front end.
- Y-axis - Laterally door to door.
Positive direction toward driver door.
- Z-axis - Floor to roof.
Positive upward out of roof.



HIGH-SPEED PHOTOGRAPHY

A total of nine high-speed cameras were used to record the side-impact collision. All high-speed cameras were loaded with Kodak color daylight film 2253. The cameras operated at 500 frames/s and were positioned for best viewing of the contact between the Chevrolet C2500 and the rigid pole. Three 35-mm still cameras and one 16-mm real-time telecine camera were used to document the pre- and post-crash environment. Table 6 lists the position and lens used for each camera. The camera numbers in table 6 are shown in figure 6. The interior of the driver door was painted flat white for better onboard camera image quality.

Table 6. Camera configuration and placement.

| Camera Number | Type | Film Speed (frames/s) | Lens (mm) | Location |
|---------------|-----------------------|-----------------------|-----------|--------------------------------|
| 1 | LOCAM II | 500 | 100 | 90° to impact right side |
| 2 | LOCAM II | 500 | 75 | 90° to impact right side |
| 3 | PHOTEC | 500 | 45 | 90° to impact right side |
| 4 | LOCAM II | 500 | 50 | 45° right side |
| 5 | LOCAM II | 500 | 25 | 180° mounted behind rigid pole |
| 6 | LOCAM II | 500 | 50 | 45° left side oblique |
| 7 | LOCAM II | 500 | 75 | 45° left side oblique |
| 8 | LOCAM II | 500 | 12.5 | overhead, over pole |
| 9 | LOCAM II | 500 | 5.7 | onboard in passenger window |
| 10 | Bolex | 24 | zoom | documentary |
| 11 | Canon A-1 (prints) | still | zoom | documentary |
| 12 | Canon A-1 (slides) | still | zoom | documentary |

Black and yellow circular targets and 25-mm-wide black and yellow target tape were placed on the Chevrolet pickup truck for film data collection purposes. Circular targets and target tape were placed on the vehicle for certain vehicle measurements and for film analysis. The 25-mm tape was placed on the driver side of the vehicle at five levels or elevations referenced from the ground. The levels included:



- LEVEL 1 -- Axle centerline or lower door sill top height
- LEVEL 2 -- Occupant H-point height
- LEVEL 3 -- Mid-door height
- LEVEL 4 -- Window sill height
- LEVEL 5 -- Top of window height on roof rail

In addition, target tape was placed vertically on the driver side of the vehicle coincident with the pole impact location. Target tape was also placed on top of the vehicle in the following locations:

- Along the longitudinal centerline for the full length of the vehicle, excluding windows.
- Laterally across the roof perpendicular to the centerline tape and coincident with the pole impact location.

Target tape was placed laterally on the front and rear bumpers in the YZ plane. Black and yellow circular targets 100 mm in diameter were placed at various locations on the test vehicle for film data collection purposes. The targets were placed as follows:

- Driver door to denote the vehicle's longitudinal c.g.
- Driver door to denote the dummy H-point.
- The roof to denote the vehicle's longitudinal and later c.g. location.
- Two targets on the roof aligned with the vehicle's longitudinal centerline 610 mm apart centered on the impact line.
- Two targets aligned with the impact line 610 mm apart centered on the vehicle's longitudinal centerline.
- Two targets on the hood aligned with the vehicle's longitudinal centerline 610 mm apart.
- Two targets placed on the front and back side of two vertical sheet metal stanchions affixed to the rear half of the roof, centered on the longitudinal centerline and 610 mm apart.
- Two targets on the front and rear bumper (YZ plane) 610 mm apart centered on the longitudinal centerline.
- Targets were placed in 610-mm increments along the bottom of the truck bed for the length of the bed.

Figure 6 presents a side view of the test vehicle showing the target tape locations. Figure 6 also contains an overhead sketch of the facility depicting the setup of the vehicle, pole, test track, and the location of each high-speed camera. Positioned in each camera's view was at least one strobe light. The lights flashed when the vehicle struck the pole. This synchronized the film with the electronic data.



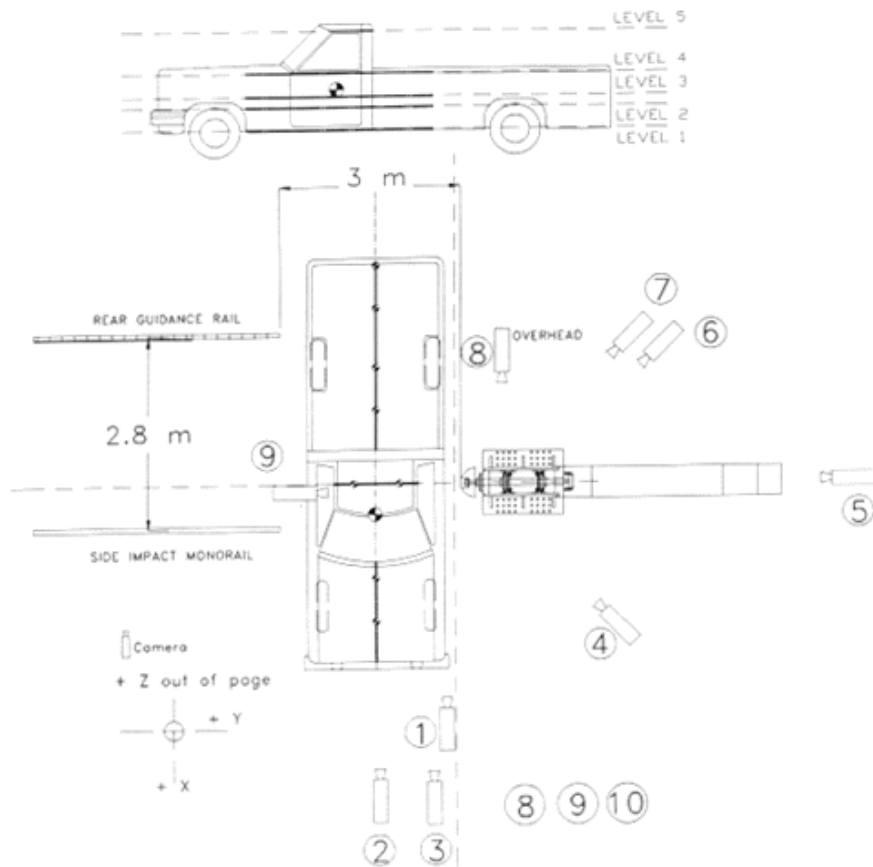

Figure 6. Test setup and camera locations.



DATA ANALYSIS

Two data acquisition systems, the ODAS system and the umbilical cable system, along with high-speed cameras, were used to record the data during the side-impact crash test.

ODAS system. The data from the ODAS system included 16 channels of SIDH3 data, 16 localized accelerometer channels, and three rate transducer channels. The data were filtered and digitally stored within the ODAS unit during the test. The filter was factory set at 4,000 Hz. The ADC sampling rate was factory set at 12,500 Hz. After the test, the data were down-loaded to a portable computer for analysis. The data were converted to the ASCII format, zero-bias removed, and digitally filtered at either 1,650 Hz (Society of Automotive Engineers (SAE) class 1000) for SIDH3 data, or at 300 Hz (SAE class 180) for vehicle data. Rib, spine, and pelvic data were filtered a second time using a NHTSA-supplied FIR100 filter. The class-1000 data were input into a spreadsheet for plotting. The resultant head acceleration was calculated via a spreadsheet containing the data from the triaxial accelerometer inside the SIDH3's head. The resultant data file was fed into a head injury criteria (HIC) algorithm to compute the HIC value for the crash test. The pelvic injury criteria were determined from the pelvic acceleration data. The pelvic acceleration was filtered using the FIR100 filter and the peak was located. The thoracic trauma index (TTI) was calculated from the FIR100 filtered rib and spine (T12) data. The following formula was used to compute the TTI:

$$TTI = [\text{Maximum}(4 \text{ rib channels}) + \text{Maximum}(\text{spine})] \times 2$$

Umbilical cable. Data collected via the umbilical cable tape recorder system was played back through an analog filter set at 1,000 Hz. The signal was then input to a data translation ADC. The data included one accelerometer channel (located at the c.g.), eight rigid pole load cell channels, an impact switch, and a monorail speed trap signal. The sample rate was set to

5,000 Hz. The digital data were converted to the ASCII format, zero-bias removed, and digitally filtered to 300 Hz (SAE class 180). The filtered data were input into a spreadsheet for plotting. Using techniques outlined in the National Cooperative Highway Research Program Report Number 350 (NCHRP Report 350)⁽²⁾ the lateral occupant impact velocity (OIV) was computed.

Two square wave pulses from the lone monorail microswitch were recorded on analog tape during the crash test. The time between pulses was determined and the speed was calculated by dividing the wheel spacing (965 mm) by the time between micro-switch pulses.

High-speed film. The high-speed 16-mm film was analyzed via an NAC 160-F film motion analysis system in conjunction with a desktop personal computer. The overhead and one 90°-camera were used to acquire pertinent test data. The analyzer reduced the



test film frame by frame to Cartesian coordinates, which were input into a spreadsheet for analysis. Using the coordinate data and the known time between frames (operating speed of the cameras), a displacement-time history was produced. Differentiation of the displacement-time history produced the initial vehicle speed. Data measurements included initial vehicle impact speed, roll angle, yaw angle, and pitch angle.

RESULTS

The Chevrolet C2500 pickup truck was placed on the FOIL side-impact monorail with its longitudinal centerline perpendicular to the runway centerline, ensuring alignment of the target impact point with the rigid pole. The morning of the test, the dummy was positioned in the driver seat using the

H-point data and FMVSS 214. The dummy was restrained using the vehicle shoulder-lap belt restraining system. Just prior to testing, the following was noted: the emergency brake was released (not engaged), the head rests were positioned in the highest adjustment, the windows were down, the transmission was placed in neutral, the battery was disconnected, and the key was placed in the "on" position. The Chevrolet C2500 passed over the monorail speed trap, which measured a speed of 38.3 km/h. Due to the frictional forces between the truck tires and the wet pavement, the vehicle speed was reduced to 36.5 km/h at impact and the truck leaned or rolled toward the pole at 3.9°. The initial yaw angle was 87°. Table 7 summarizes the test conditions and selected results.

| Table 7. Summary of test conditions and results. | |
|--|--|
| FOIL test number | 97S016 |
| Date of test | October 22, 1997 |
| Test vehicle | 1994 Chevrolet C2500 2-door pickup truck |
| Weight: C2500 Truck | 1,996 kg |
| SIDH3 | 80 kg |
| Total | 2,076 kg |
| Test article | FOIL 300K instrumented rigid pole |
| Temperature inside vehicle | 25° C |
| Impact speed: 16-mm film | 36.5 km/h |
| Impact point (mm) | 100 forward of vehicle c.g. |
| Initial roll angle | 3.8° |
| Initial yaw angle | 87° |



| Table 7. Summary of test conditions and results (continued). | |
|--|-----------|
| Total rigid pole load observed (load cells) | 247,300 N |
| Traffic accident data (TAD) | 9-LP-7 |
| Vehicle damage index (VDI) | 09LPAN5 |
| Lateral occupant impact velocity | 7.3 m/s |
| Lateral ridedown acceleration | 8.5 g's |
| Head injury criteria | |
| Limit | 1000 g's |
| Observed | 952 g's |
| Start time | 0.0429 s |
| Stop time | 0.0608 s |
| Interval time | 0.0179 s |
| Thoracic trauma data | |
| Limit (2-door) | 90 g's |
| Peak rib acceleration (FIR100) | 59.1 g's |
| T12 spine (FIR100) | 77.7 g's |
| Thoracic trauma index (TTI) | 68.4 g's |
| Pelvic injury | 112.5 g's |

Vehicle response. A sharpened rod attached to the rigid pole punctured the vehicle on the vertical target tape, denoting the intended impact location. The door cross section collapsed 0.008 s after contact with the rigid pole. The door was pushed inward and struck the SIDH3's lower torso and pelvic region. After 0.030 s, the B-pillar was drawn forward toward the rigid pole, making contact with the rear portion of the SIDH3's head. The rigid pole made contact and bent the truck's longitudinal frame rail at approximately 0.033 s (from the acceleration trace). The pole continued to penetrate the occupant compartment, causing the dashboard and bench seat to buckle. The bench seat was forced into the passenger door, causing the door to bulge outward. The door remained latched throughout the test. The truck bed and front end continued to wrap around the pole until approximately 0.200 s. Double integration of the c.g. accelerometer yielded a maximum deflection of 800 mm. This may be exaggerated due to the extreme buckling of the floor pan. The maximum static deflection was 562 mm. The intrusion was limited by the 170-mm-wide transmission mount cross member. The C-shape frame deflected back until the breadth of the deflection included the transmission mount cross member. The center of the



transmission mount was 350 mm forward of the impact location. When contact was made with the transmission mount, the transmission housing fractured, releasing transmission fluid onto the runway. As the C-shape frame rail deflected, one leg of the C-shape ripped a hole in the fuel tank located on the left side of the vehicle and inboard of the frame rail. The static intrusion into the occupant compartment was calculated by measuring the interior distance between the doors before and after the test. The static intrusion was 500 mm.

Damage to the pickup truck was extensive. The driver door caved, the B-pillar was drawn inward, the windshield shattered, the dash and bench seat buckled, the left frame rail bent, and the fuel tank was punctured. The two doors remained latched during the test. The peak c.g. acceleration recorded was 17.1 g's (334,600 N) and occurred 0.0724 s after impact. Table 8 lists the positive and negative peak accelerations from each vehicle accelerometer.

| Table 8. Vehicle sensor peak accelerations. | | |
|---|------------------------|------------------------|
| Sensor | Maximum positive (g's) | Maximum negative (g's) |
| C.g. accelerometer A_x , primary | 9.9 | -10.7 |
| C.g. accelerometer A_y , primary | 1.9 | -17.1 |
| C.g. accelerometer A_z , primary | 15.3 | -12.7 |
| C.g. accelerometer A_y , redundant | 2.0 | -15.9 |
| Engine block, A_x | 3.6 | -12.6 |
| Engine block, A_y | 2.1 | -11.6 |
| Driver seat, A_y | 34.3 | -62.7 |
| Right lower sill, A_y | 35.6 | -28.7 |
| Right roof rail, A_y | 6.0 | -21.1 |
| Driver door-beam, A_y | No data | -685.5 |
| Longitudinal frame member, A_y | 187.6 | -263.6 |
| Transmission mount, A_y | 41.7 | -75.5 |
| Bed cross member #1, A_y | 39.3 | -31.7 |
| Bed cross member #2 A_y | 4.3 | -29.0 |
| Bed cross member #3 A_y | 6.5 | -21.1 |
| Rear bumper, A_x | 18.7 | -20.2 |
| Rear bumper, A_y | 14.6 | -18.9 |



After the test a damage profile of the vehicle was produced. Figure 7 depicts the driver side profile measurements before and after the test. The measurements were made using a reference line parallel to the driver side of the vehicle. The parallel line was drawn a certain distance from and perpendicular to a line formed by the passenger side sill across from the impact location. This ensured that the same reference plane was used after the test to measure the post-test measurements. The measurements were made in 75-mm and 150-mm increments forward and aft of the impact point. After the test, measurements were taken at the same points forward and aft, rather than measuring at the same increments. From the figure, the maximum static deflection recorded was 562 mm at mid-door height along the vertical impact target tape.

Data plots from the transducers mounted to the test vehicle are presented in appendix A. Photographs taken from high-speed film and photographs of the pre- and post-test environment are presented in appendix C.



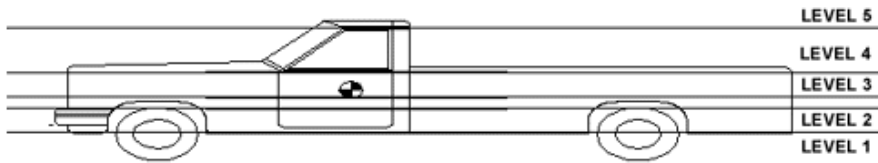

| | | | Distance from impact point (mm). | | | | | | | | | | | | | | | | |
|-------------------------------------|--------|-------|----------------------------------|------|------|------|------|------|------|------|------|------|------|-----|-----|-----|-----|-----|--|
| LEVEL | HEIGHT | | -762 | -610 | -457 | -381 | -305 | -229 | -152 | -76 | 0 | 76 | 152 | 229 | 305 | 381 | 457 | 533 | |
| 1 | 438 | PRE | 590 | 582 | 580 | 580 | 578 | 578 | 575 | 575 | 570 | 568 | 568 | 565 | 565 | 565 | 565 | 564 | |
| | 381 | POST | 511 | 591 | 695 | 756 | 825 | 881 | 963 | 1024 | 1054 | 1051 | 998 | 932 | 845 | 795 | 717 | 660 | |
| | | CRUSH | -79 | 9 | 115 | 176 | 247 | 303 | 388 | 449 | 484 | 483 | 430 | 367 | 280 | 230 | 152 | 96 | |
| 2 | 876 | PRE | 530 | 522 | 520 | 520 | 520 | 520 | 521 | 521 | 521 | 520 | 520 | 520 | 520 | 520 | 521 | 520 | |
| | 835 | POST | 481 | 598 | 725 | 790 | 851 | 912 | 978 | 1045 | 1078 | 1068 | 1011 | 945 | 868 | 792 | 714 | 629 | |
| | | CRUSH | -49 | 76 | 205 | 270 | 331 | 392 | 457 | 524 | 557 | 548 | 491 | 425 | 348 | 272 | 193 | 109 | |
| 3 | 775 | PRE | 527 | 519 | 517 | 517 | 517 | 517 | 518 | 518 | 518 | 517 | 517 | 517 | 517 | 517 | 518 | 517 | |
| | 734 | POST | 483 | 599 | 732 | 790 | 855 | 909 | 985 | 1044 | 1080 | 1065 | 1012 | 942 | 865 | 792 | 724 | 635 | |
| | | CRUSH | -44 | 80 | 215 | 273 | 338 | 392 | 467 | 526 | 562 | 548 | 495 | 425 | 348 | 275 | 206 | 118 | |
| 4 | 1162 | PRE | 570 | 566 | 567 | 565 | 564 | 563 | 560 | 561 | 560 | 560 | 560 | 561 | 560 | 561 | 561 | 561 | |
| | 1084 | POST | 483 | 609 | 725 | 787 | 848 | 925 | 981 | 1041 | 1074 | 1057 | 1006 | 948 | 863 | 792 | 709 | 651 | |
| | | CRUSH | -87 | 43 | 158 | 222 | 284 | 362 | 421 | 480 | 514 | 497 | 446 | 387 | 303 | 231 | 148 | 90 | |
| 5 | 1683 | PRE | | | | | | 765 | 765 | 765 | 763 | 762 | 762 | 760 | 760 | 762 | 762 | | |
| | 1653 | POST | | | | | | 991 | 1048 | 1098 | 1115 | 1093 | 1043 | 971 | 903 | 841 | 820 | | |
| | | CRUSH | 0 | 0 | 0 | 0 | 0 | 226 | 283 | 333 | 352 | 331 | 281 | 211 | 143 | 79 | 58 | 0 | |
| All units of measurement are in mm. | | | | | | | | | | | | | | | | | | | |

Figure 7. Vehicle profile measurements, test 907S016.



Occupant response. The SIDH3 remained upright during the vehicle propulsion stage. The vehicle exited the side-impact monorail and began to slide sideways along the wet concrete runway. The drop off the monorail, coupled with the frictional forces between the tires and the wet runway, slowed the vehicle and induced a vehicle roll angle of 3.9° at impact. The roll angle and vehicle deceleration caused the SIDH3 to lean toward the driver door and make slight contact. The pole intruded into the occupant compartment forward of the dummy's head and in line with the dummy's pelvic region. Contact between the door and the dummy's lower torso and pelvis occurred approximately 0.020 s after impact. The dummy torso was wedged between the seat and intruding door, the head continued toward the door and window and contacted the B-pillar before protruding through the open window (0.032 s). The femur and shoulder area made contact with the intruding door as anticipated. While the dummy's head was outside the window, the truck continued to wrap around the rigid pole. The B-pillar was drawn toward the pole and struck the rear of the dummy's head, forcing the head into the side of the rigid pole (0.058 s). The head was pinched between the B-pillar and rigid pole for approximately 0.050 s. While the head was pinched and stationary, the torso continued to bounce and recoil from the pole, bending and twisting the neck. The dummy rose up and leaned out the window enough that the left shoulder made contact with the rigid pole.

Inspection of the pole and vehicle interior revealed red, green, yellow, blue, and purple chalk on various surfaces, confirming contact from specific dummy parts. Blue chalk from the dummy's face was found on the side of the rigid pole and red chalk from the rear surface of the head was found on the

B-pillar, confirming the pinching action between the B-pillar and the rigid pole. Red chalk was also found on the interior surface of the B-pillar, along with some green chalk. These colors indicate contact between the rear and side surface of the dummy's head and the B-pillar, before the head exited the window. The purple chalk (shoulder/torso region) was found on the pole and the interior door panel. Yellow from the thigh was found along the interior door panel and arm rest. The SIDH3 remained upright in the driver seat after the test. The dummy remained wedged between the collapsed door and bench seat. As shown in table 8, the HIC (952 g's), TTI (68 g's), and pelvic injury (112 g's) values are below the current side-impact safety performance standards specified in FMVSS 214.

Using the techniques outlined in NCHRP Report 350, the lateral OIV was calculated. The lateral OIV is based on vehicle c.g. lateral acceleration data. The computed lateral OIV was 7.3 m/s.



| Table 9. Summary of SIDH3 data. | | |
|--|------------------------|------------------------|
| Recorded Data | Maximum positive (g's) | Maximum negative (g's) |
| Head X-axis acceleration | 210.5 | -73.9 |
| Head Y-axis acceleration | 35.8 | -84.2 |
| Head Z-axis acceleration | 23.8 | -44.2 |
| X-axis neck force load cell(N) | 466.6 | -496.6 |
| Y-axis neck force load cell(N) | 941.5 | -168.0 |
| Z-axis neck force load cell(N) | 897.9 | -1,384.8 |
| X-axis neck moment load cell (1000 mm·N) | 7.9 | -116.0 |
| Y-axis neck moment load cell (1000 mm·N) | 27.0 | -56.3 |
| Z-axis neck moment load cell (1000 mm·N) | 5.3 | -24.2 |
| Left upper rib acceleration(P) | 5.7 | -45.7 |
| Left upper rib acceleration(R) | 6.3 | -44.4 |
| Left lower rib acceleration(P) | 9.1 | -59.1 |
| Left lower rib acceleration(R) | 10.4 | -55.5 |
| Spine T12 Y acceleration (P) | 15.3 | -71.6 |
| Spine T12 Y acceleration (R) | 17.5 | -77.7 |
| Pelvis Y acceleration | 17.1 | -112.5 |
| Shaded values from output of FIR100 filter, other values class 1000. | | |

Data plots from the SIDH3 transducers are presented in appendix B. All data plots are of class 1000 data.

Rigid pole. The load cells measured eight separate forces on the rigid pole. The total load from summing the eight load cells was 247,300 N. The significant loads were contributed by the roof-rail, floor-sill, and middle-point of the driver door. The peak loads from the roof-rail, mid-door, and lower sill were 26,000 N, 67,300 N, and 184,600 N, respectively. Using torque equations, the height of the resultant load was determined to be 570 mm. This corresponds to a point 120 mm above the lower sill height (level 1). The resultant load is shifted toward the lower sill because the truck frame (which hangs below level 1) contributes 75 percent of the peak force (184,600 N of 247,300N). Table 10 summarizes the load cell data. Data plots from the rigid pole load cells are presented in appendix D.



| Table 10. Summary of rigid pole data. | | |
|---------------------------------------|---------------------|-----------|
| Load cell / height (mm) | Peak force (1000 N) | Time (ms) |
| Top face | -10.4 | 54.8 |
| Upper load cell/ 2,057 | -2.6 | 70.0 |
| Lower load cell/ 1,816 | -9.5 | 54.6 |
| Middle-upper face | -23.9 | 53.6 |
| Upper load cell / 1,650 | -19.7 | 58.6 |
| Lower load cell / 1,168 | -8.6 | 53.8 |
| Middle-lower face | -67.3 | 41.8 |
| Upper load cell / 978 | -30.7 | 41.6 |
| Lower load cell / 648 | -36.7 | 42.0 |
| Bottom face | -184.6 | 51.8 |
| Upper load cell / 470 | -68.0 | 54.2 |
| Lower load cell / 90 | -120.3 | 51.8 |
| Total, rigid pole | -247.3 | 51.8 |

CONCLUSIONS AND OBSERVATIONS

Visual inspection of the Chevrolet C2500 and pole after the collision produced immediate conclusions. The door latches remained latched throughout the test. The vehicle deformation was greater than 305 mm—the distance to the truck's frame—which was deep enough to cause significant bending of the truck frame rail and to fracture the transmission housing. Chalk marks on various vehicle components and the rigid pole confirmed both expected and unexpected dummy contact. The chalk signified contact between the dummy's head and the side of the rigid pole, which was not anticipated. Previous crash tests using similar impact conditions between a Chevrolet C2500 pickup truck and a Valmont Industries slip away lighting standard produced lower head injury values. The breakaway performance of the light pole prevented any contact between the light pole and the SIDH3's head. The results from the broadside crash tests with a slip away lighting standard can be found in the reports *35 km/h Broadside Crash Test of a 1994 Chevrolet C2500 and a Valmont Industries Slip away Lighting Standard: FOIL Test Number 97S012⁽³⁾* and *50 km/h Broadside Crash Test of a 1994 Chevrolet C2500 and a Valmont Industries Slip Away Lighting Standard: FOIL Test Number 97S015⁽⁴⁾*. The head acceleration data from test 97S016 revealed a



high longitudinal (X-axis) peak acceleration compared with the light pole tests. The peak X-axis head acceleration was produced from the B-pillar forcing the head into the rigid pole. The peak X-axis acceleration contributed to a higher HIC (952 g's) than recorded during test with the break away light pole. Because the pole was not intended to break away, the pickup truck deformed around the pole much farther and longer than during the break away light pole tests. The extensive wrap around the rigid pole and prolonged head protrusion led to the eventual direct contact between the head and the rigid pole.

The crush profile, electronic data, and high-speed film will aid computer simulation engineers in developing and validating side-impact FEM's of pickup trucks.



APPENDIX A. DATA PLOTS FROM VEHICLE ACCELEROMETERS

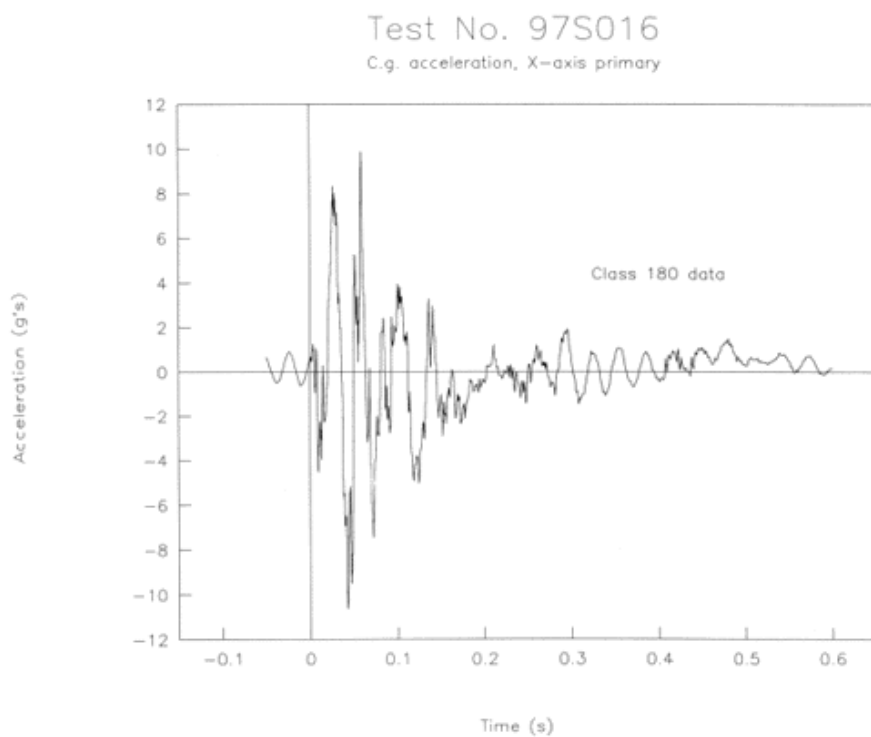

Figure 8. Acceleration vs. time, c.g. X-axis primary, test 97S016



Test No. 97S016

C.g. acceleration, Y-axis primary

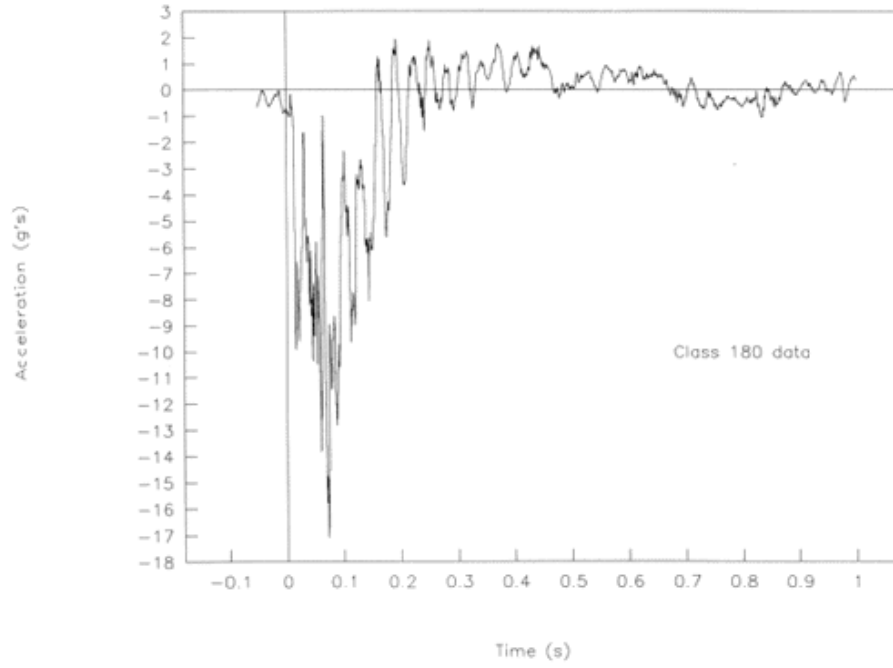

Figure 9. Acceleration vs. time, c.g. Y-axis primary, test 97S016.



Test No. 97S016

C.g. acceleration, Y-axis redundant

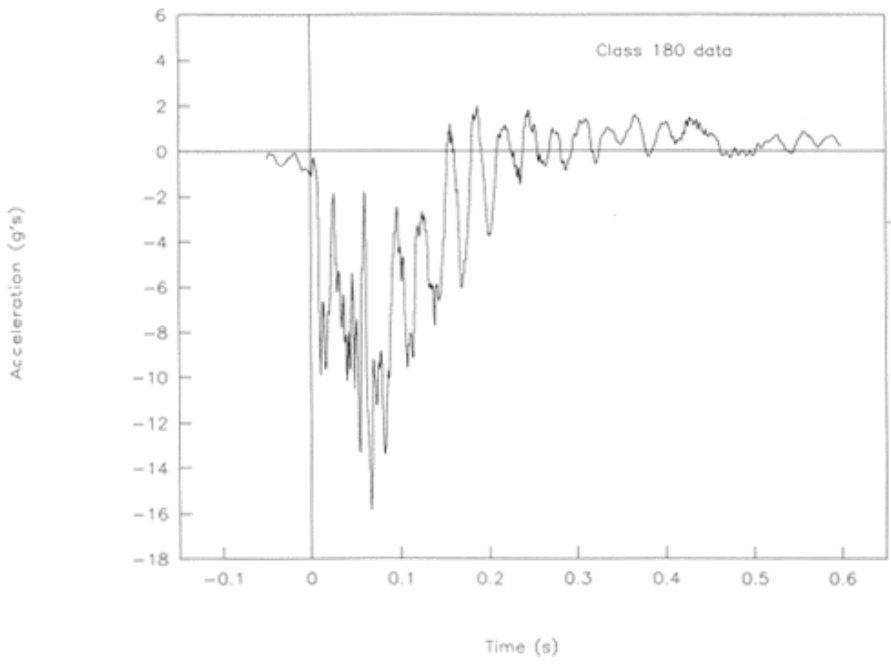

Figure 10. Acceleration vs. time, c.g. Y-axis redundant, test 97S016.



Test No. 97S016

C.g. acceleration, Z-axis primary

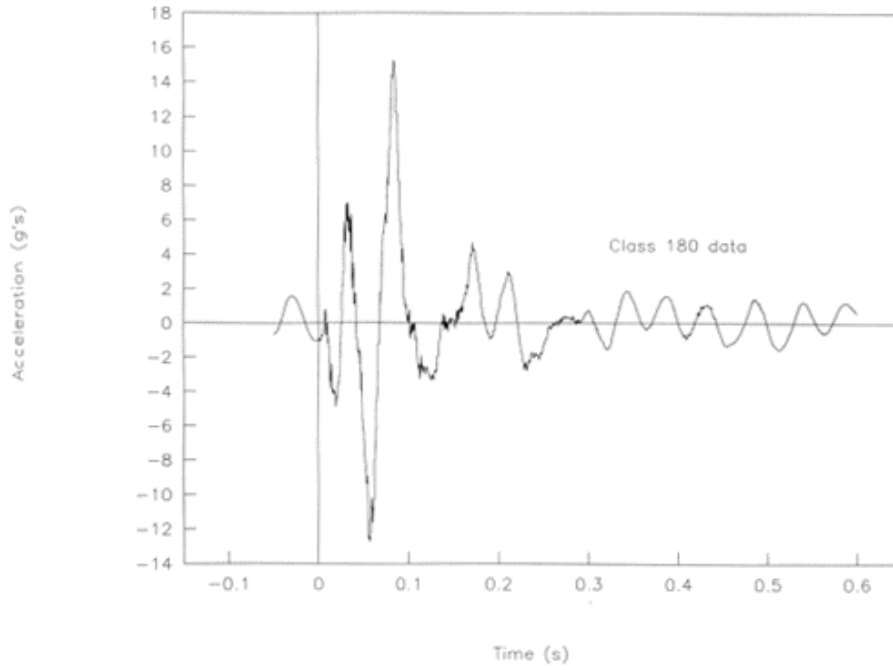

Figure 11. Acceleration vs. time, c.g. Z-axis primary, test 97S016.



Test No. 97S016

Driver seat acceleration

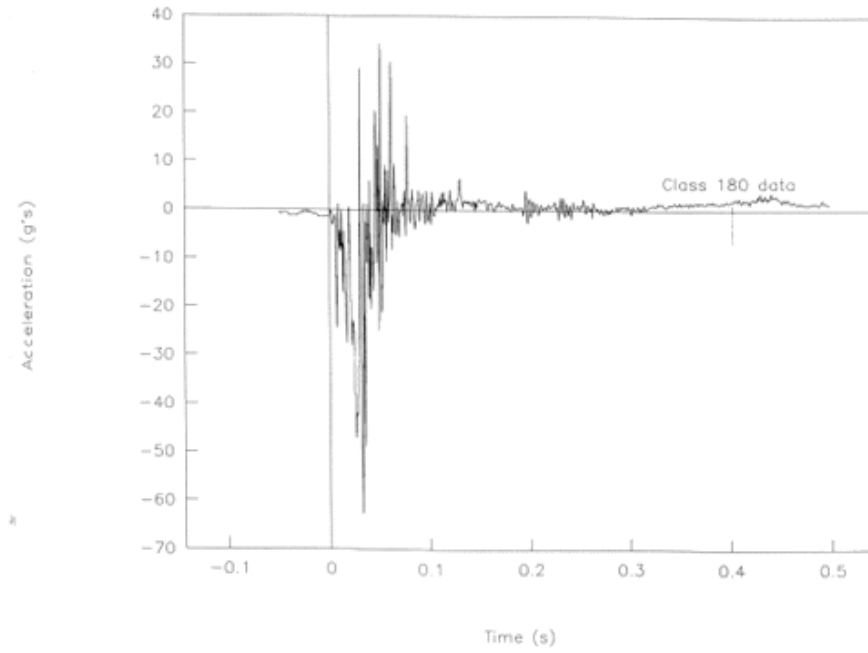

Figure 12. Acceleration vs time, driver seat, test 97S016.



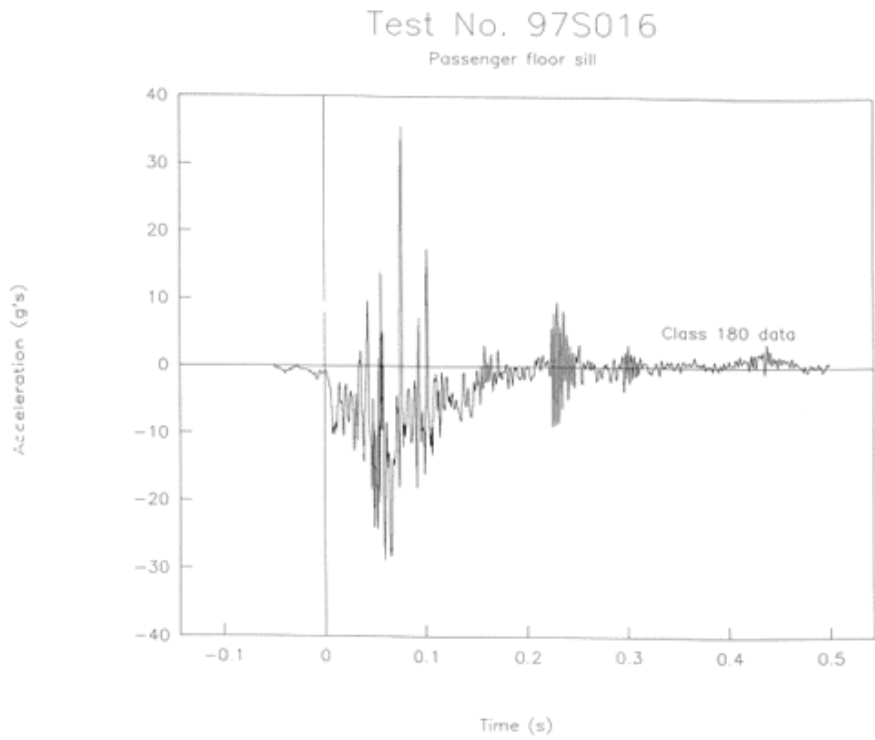

Figure 13. Acceleration vs time, passenger floor sill, test 97S016.



Test No. 97S016

Passenger roof rail

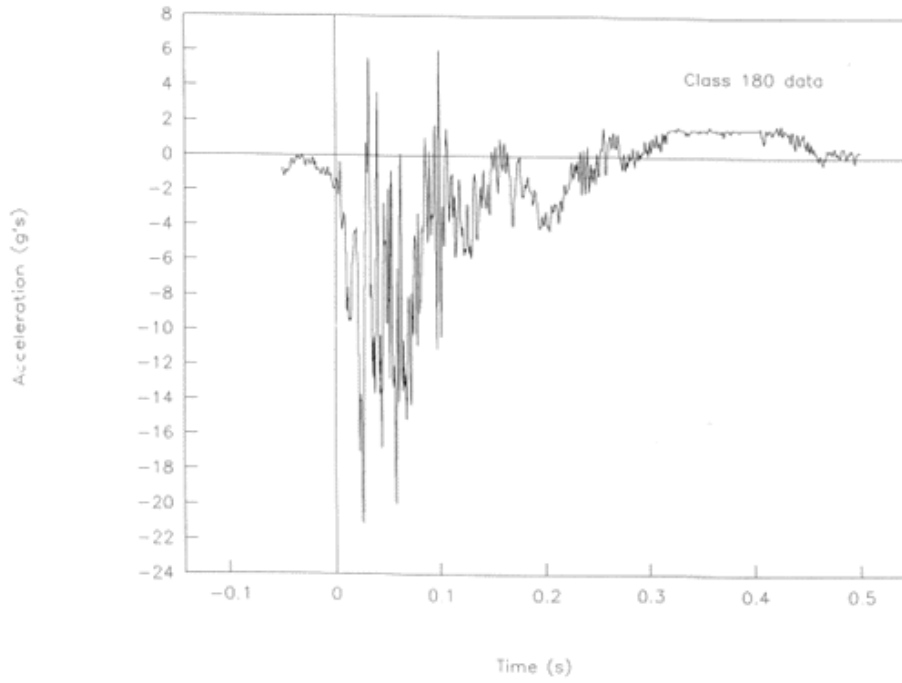

Figure 14. Acceleration vs time, passenger floor rail, test 97S016.



Test No. 97S016

Driver interior door beam

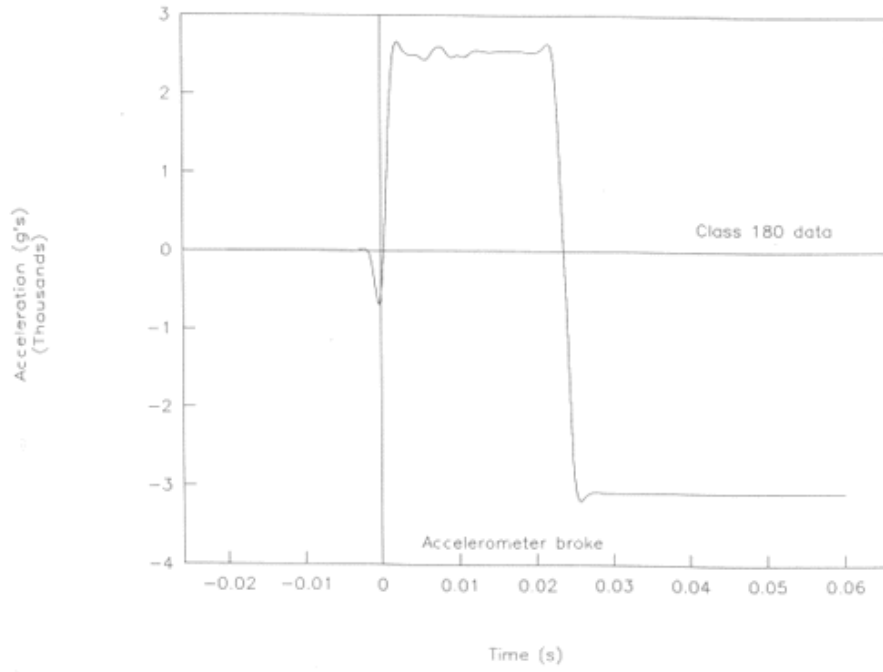

Figure 15. Acceleration vs time, driver interior door beam, test 97S016.



Test No. 97S016

Longitudinal frame member

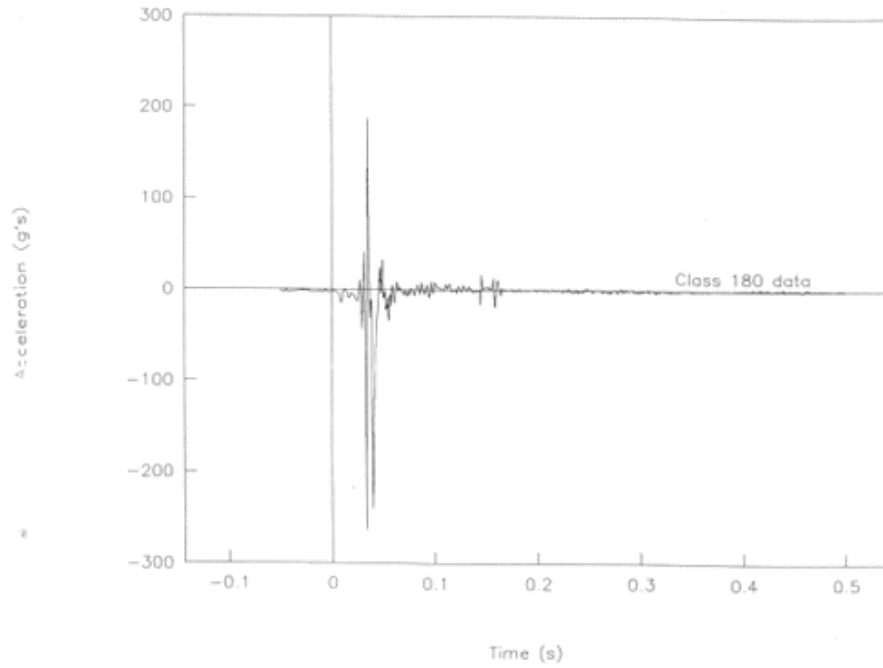

Figure 16. Acceleration vs. time, longitudinal frame member, test 97S016.



Test No. 97S016

Transmission cross member

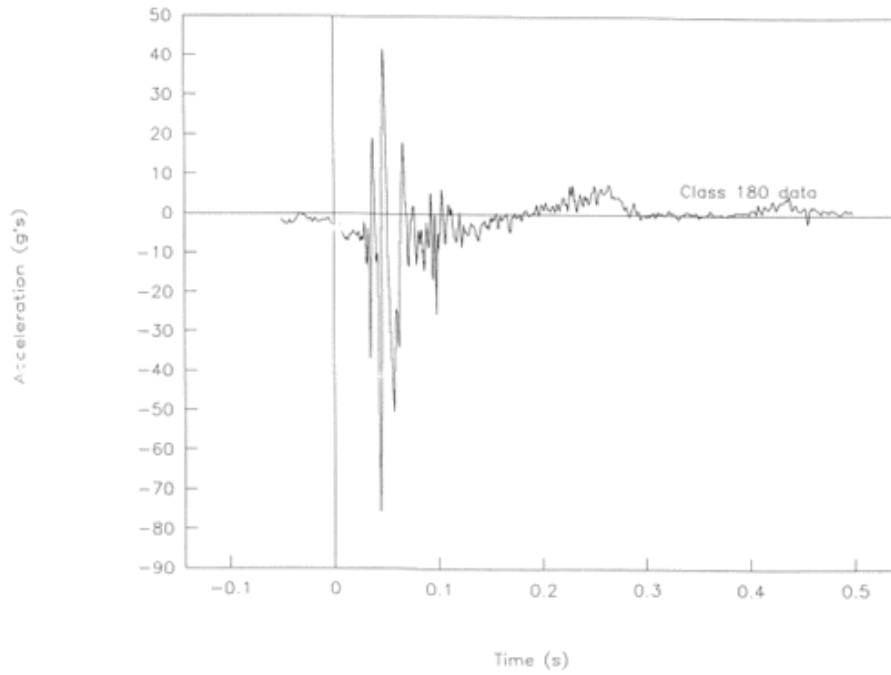

Figure 17. Acceleration vs time, transmission cross member, test 97S016.



Test No. 97S016

Front bed cross member

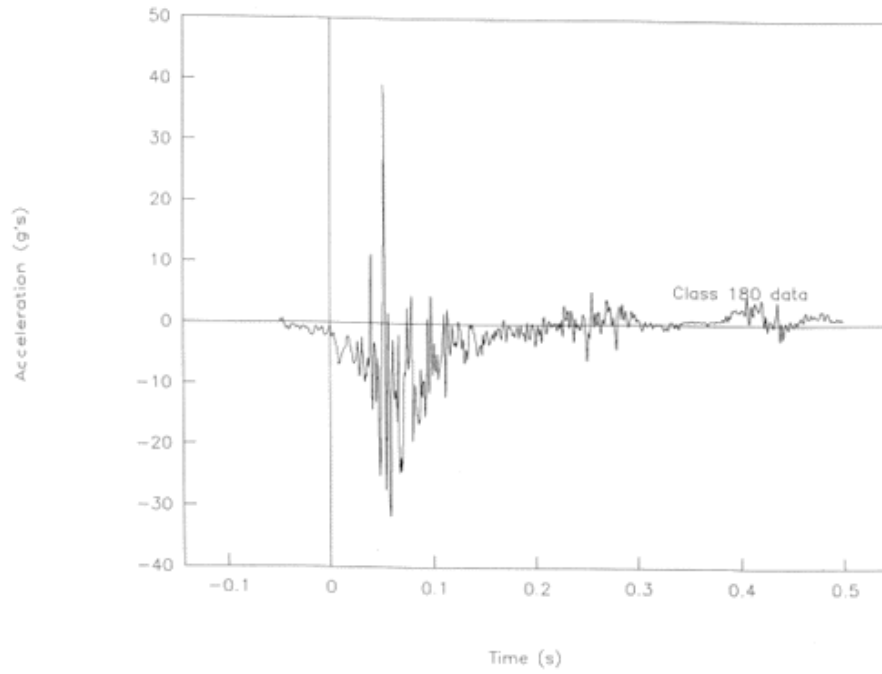

Figure 18. Acceleration vs time, front bed cross member, test 97S016.



Test No. 97S016

Middle bed cross member

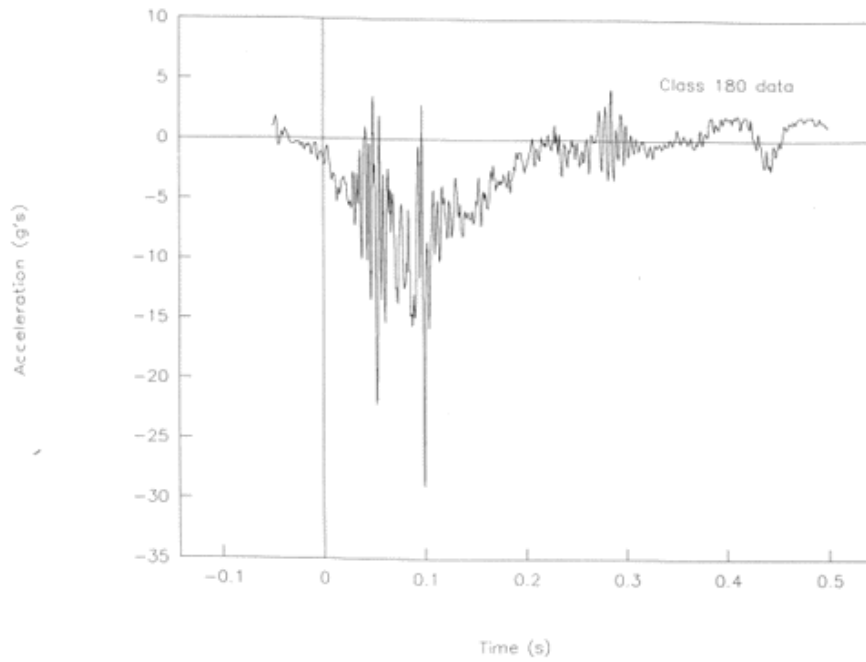

Figure 19. Acceleration vs time, middle bed cross member, test 97S016.



Test No. 97S016

Rear bed cross member

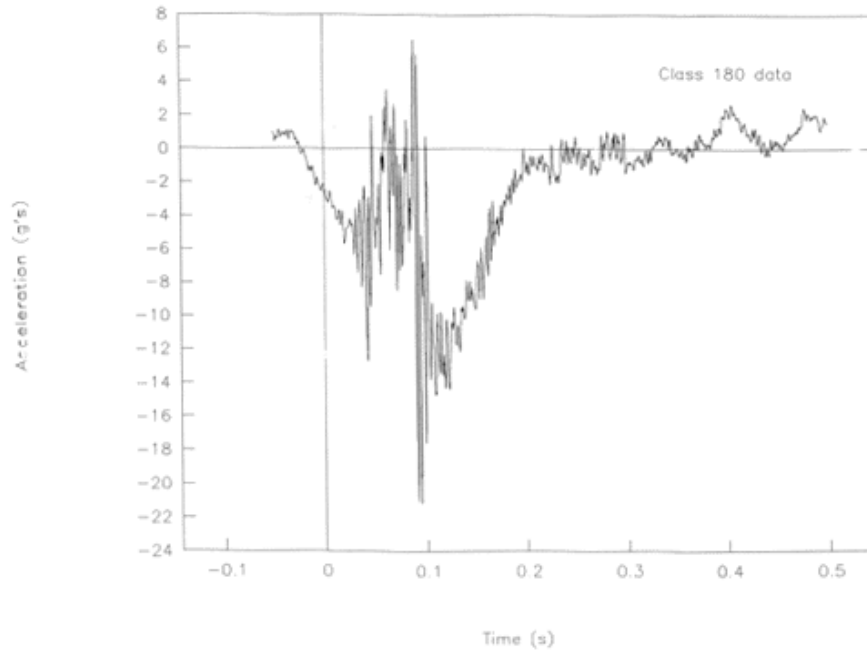

Figure 20. Acceleration vs time, rear bed cross member, test 97S016.



Test No. 97S016

Engine acceleration, X-axis

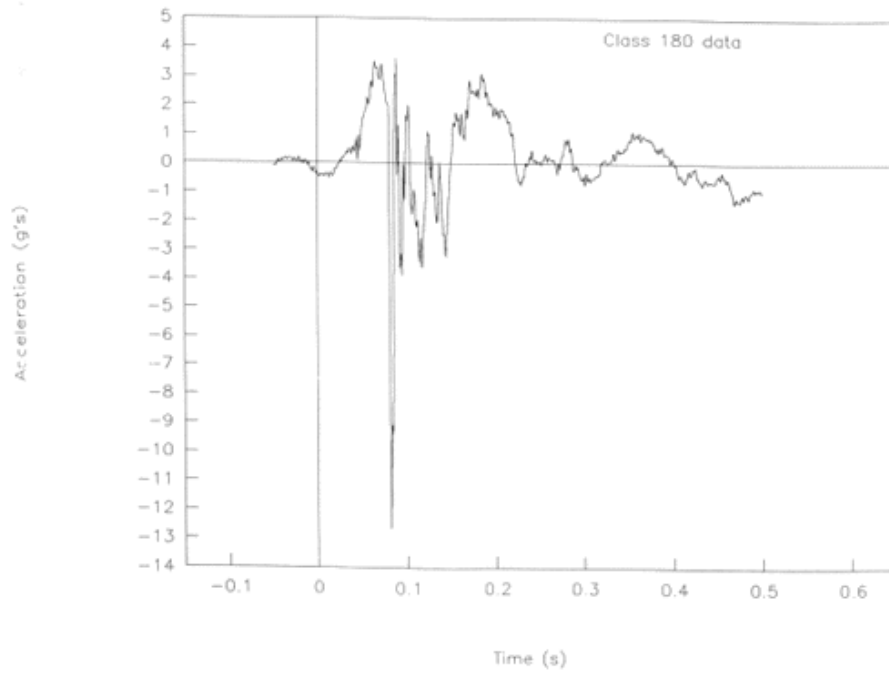

Figure 21. Acceleration vs time, engine X-axis, test 97S016.



Test No. 97S016

Engine acceleration, Y-axis

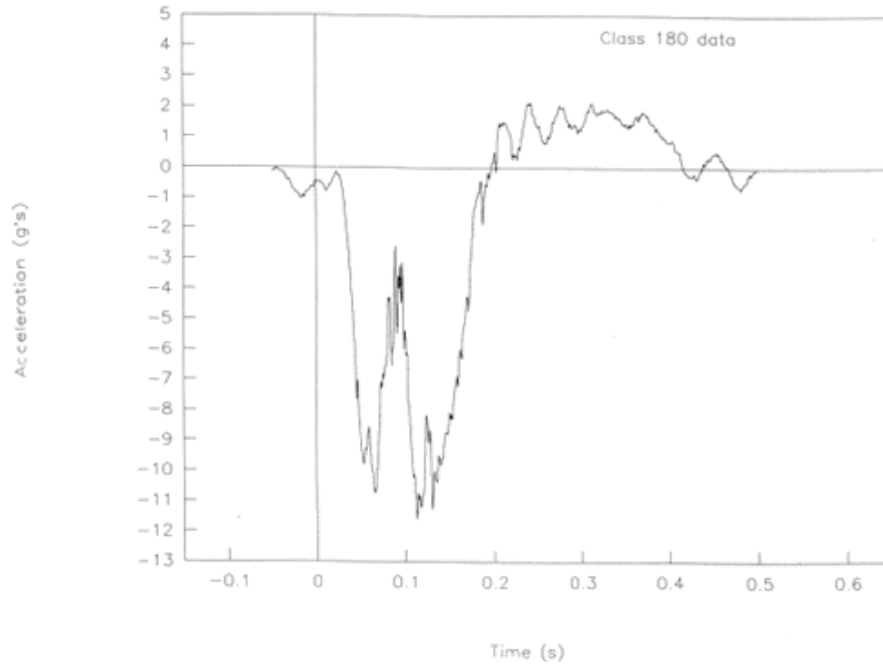

Figure 22. Acceleration vs time, engine Y-axis, test 97S016.



Test No. 97S016

Rear bumper, X-axis

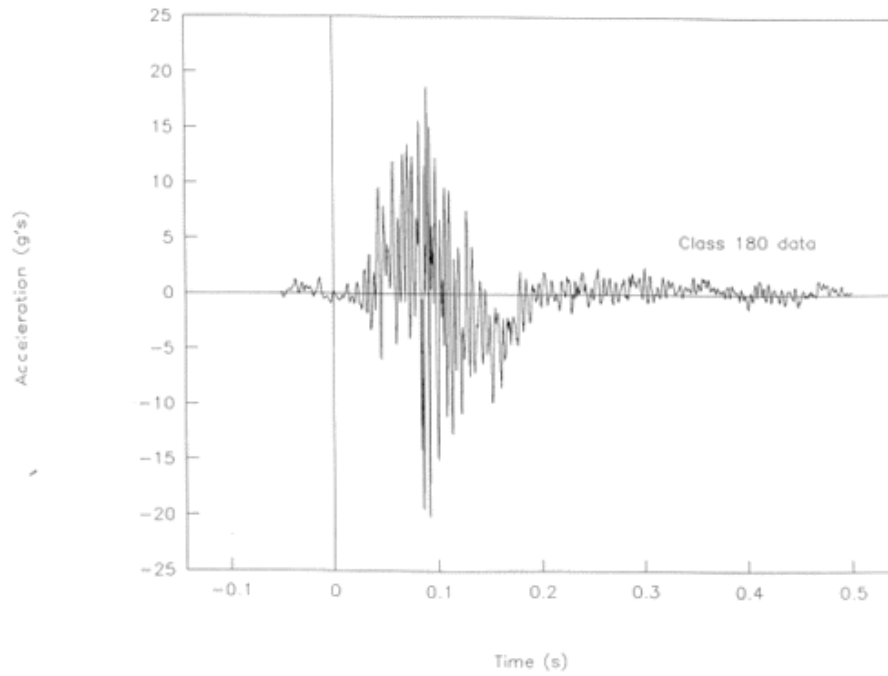

Figure 23. Acceleration vs time, rear bumper X-axis, test 97S016.



Test No. 97S016

Rear bumper, Y-axis

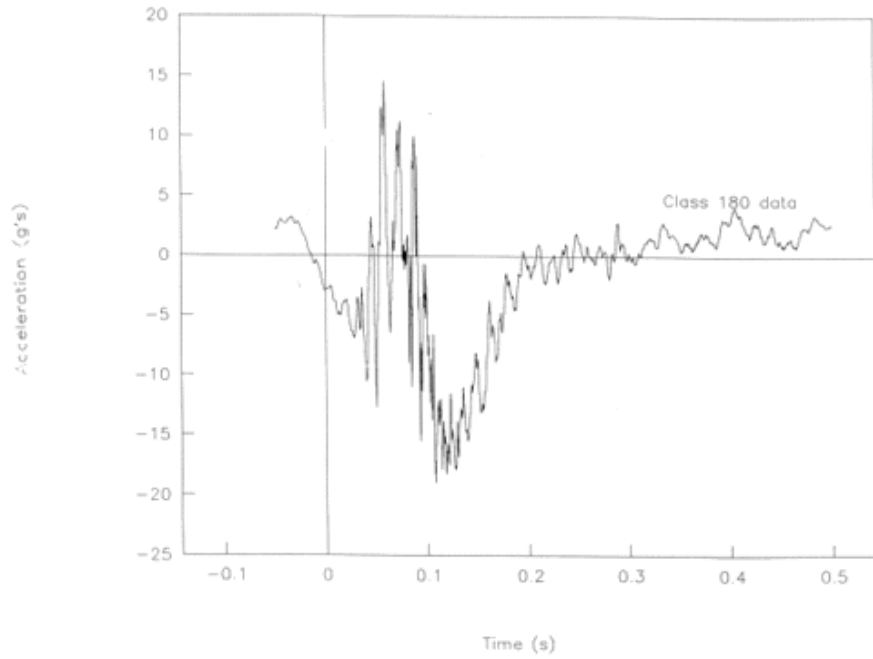

Figure 24. Acceleration vs time, rear bumper Y-axis, test 97S016.



Test No.97S016
Pitch rate and angle vs. time

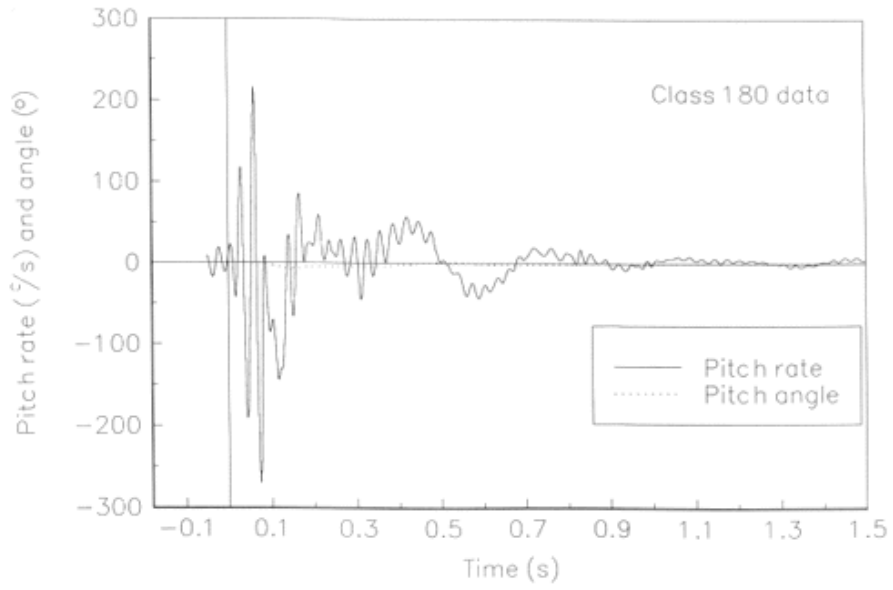

Figure 25. Pitch rate and angle vs. time, test 97S016.



Test No.97S016
Roll rate and angle vs. time

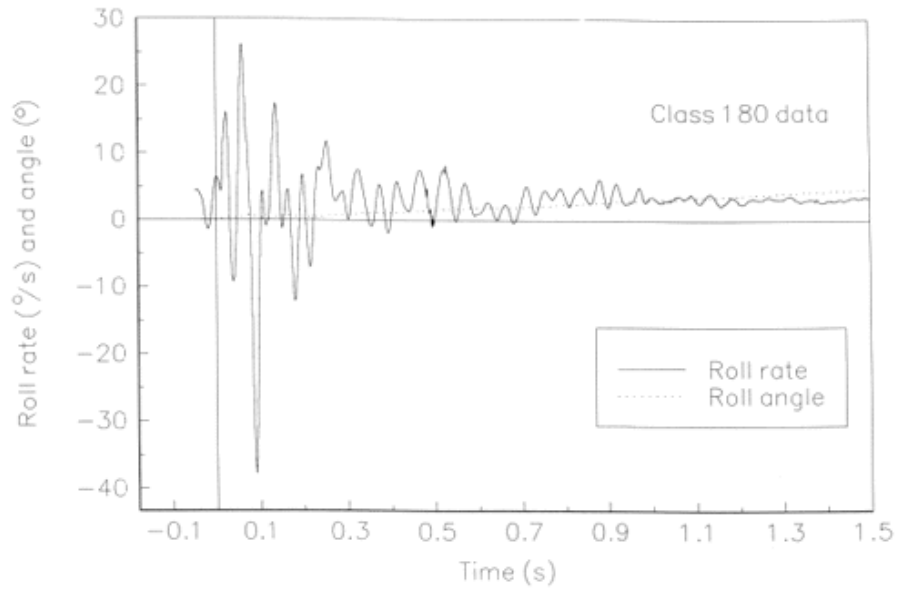

Figure 26. Roll rate and angle vs. time, test 97S016.



Test No.97S016
Yaw rate and angle vs. time

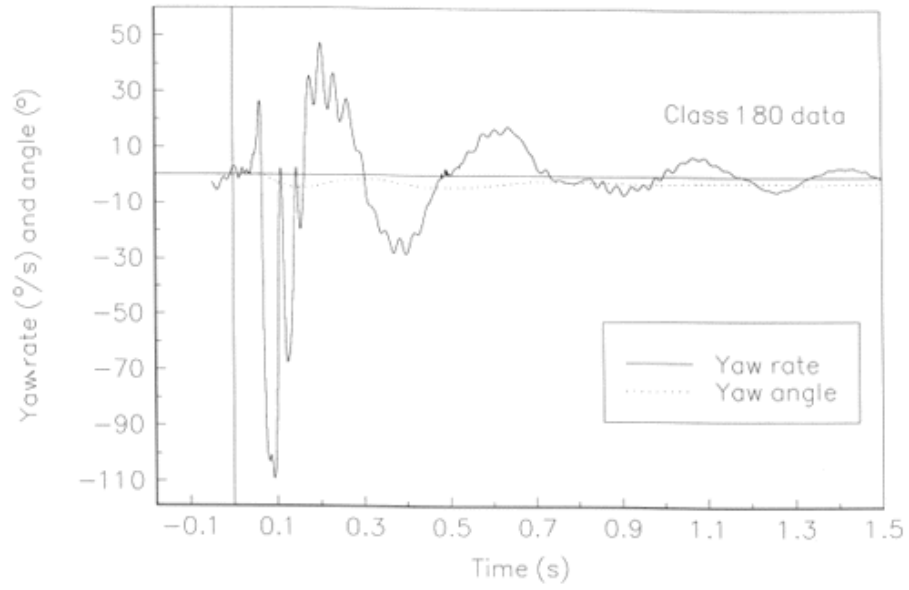

Figure 27. Yaw rate and angle vs. time, test 97S016.



Test No. 97S016

Head acceleration, X-axis

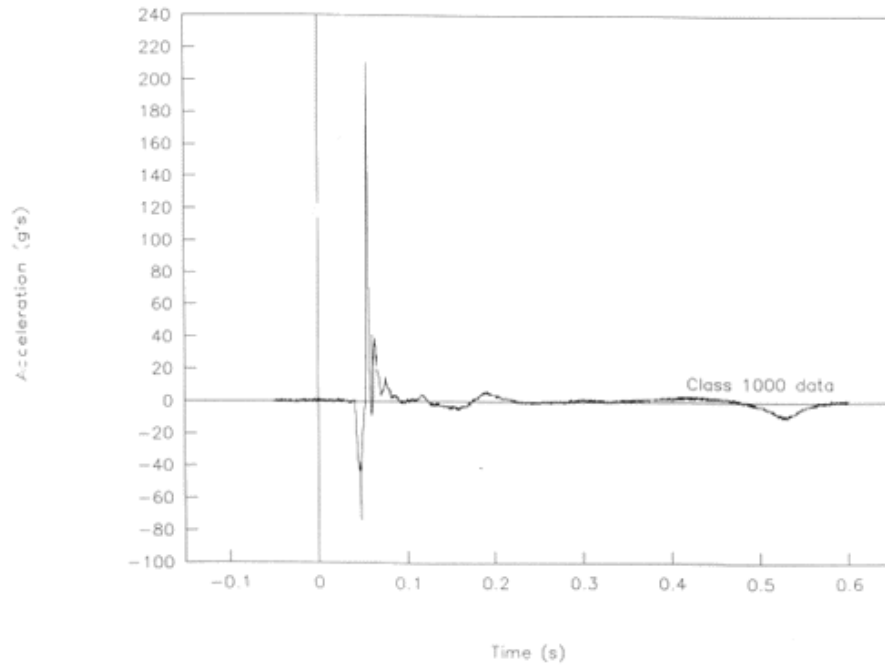

Figure 28. Acceleration vs. time, head X-axis, test 97S016.



Test No. 97S016

Head acceleration, Y-axis

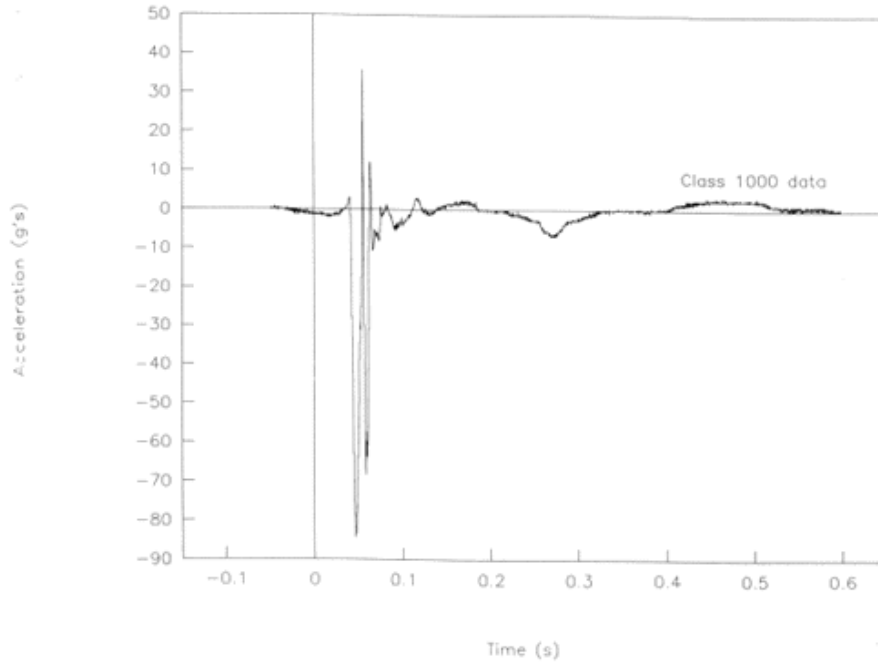

Figure 29. Acceleration vs time, head Y-axis, test 97S016.



Test No. 97S016

Head acceleration, Z-axis

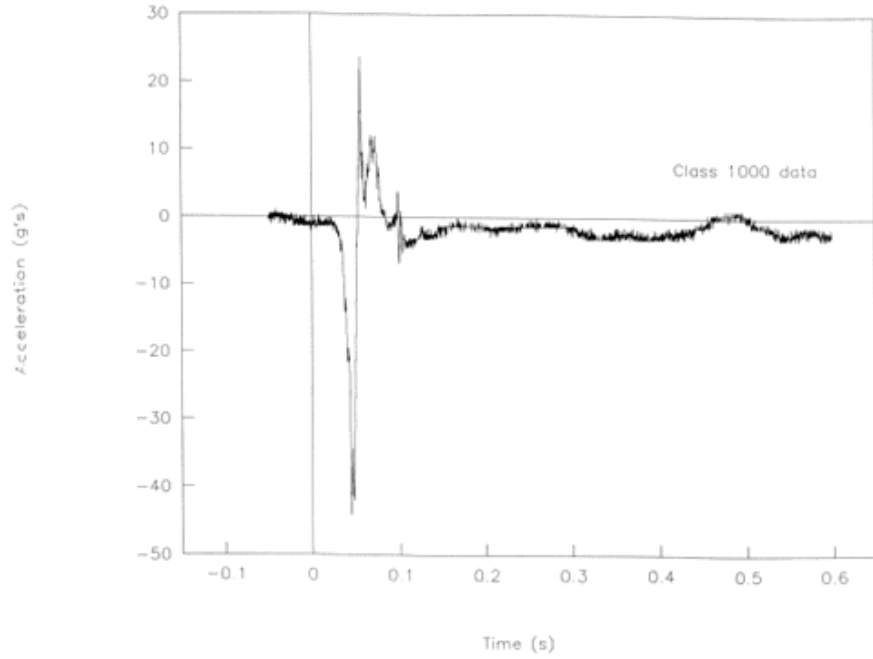

Figure 30. Acceleration vs. time, head Z-axis, test 97S016.



Test No. 97S016
Neck force, X-axis

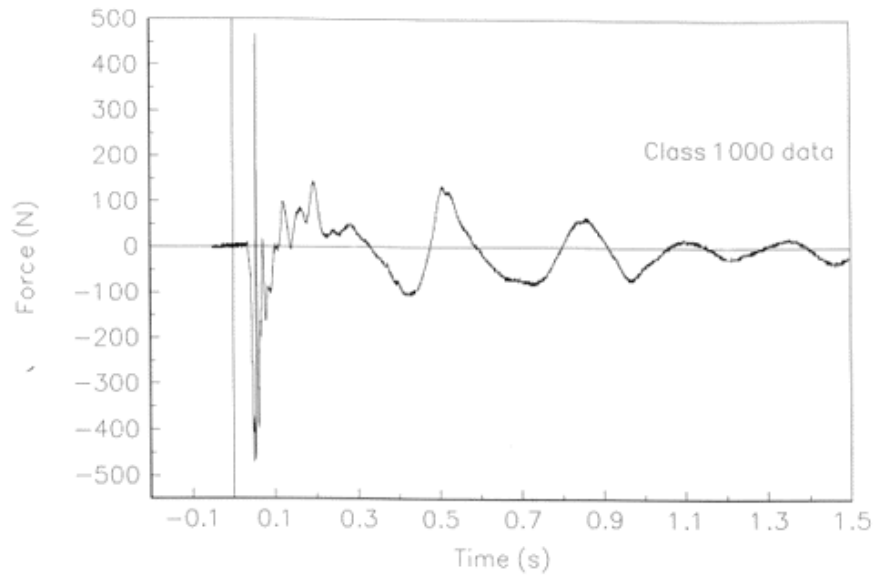

Figure 31. Force vs. time, neck X-axis, test 97S016.



Test No. 97S016
Neck force, Y-axis

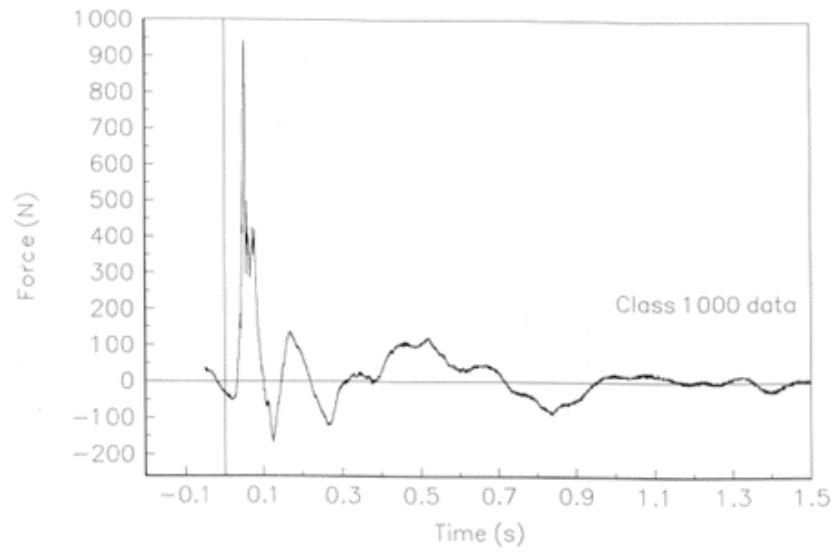

Figure 32. Force vs. time, neck Y-axis, test 97S016.



Test No. 97S016
Neck force, Z-axis

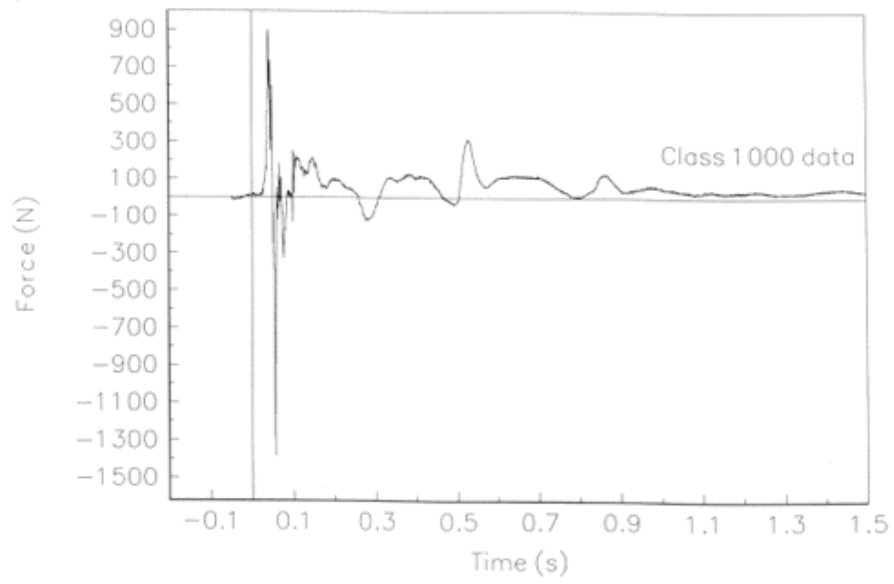

Figure 33. Force vs. time, neck Z-axis, test 97S016.



Test No. 97S016
Neck Moment, X-axis

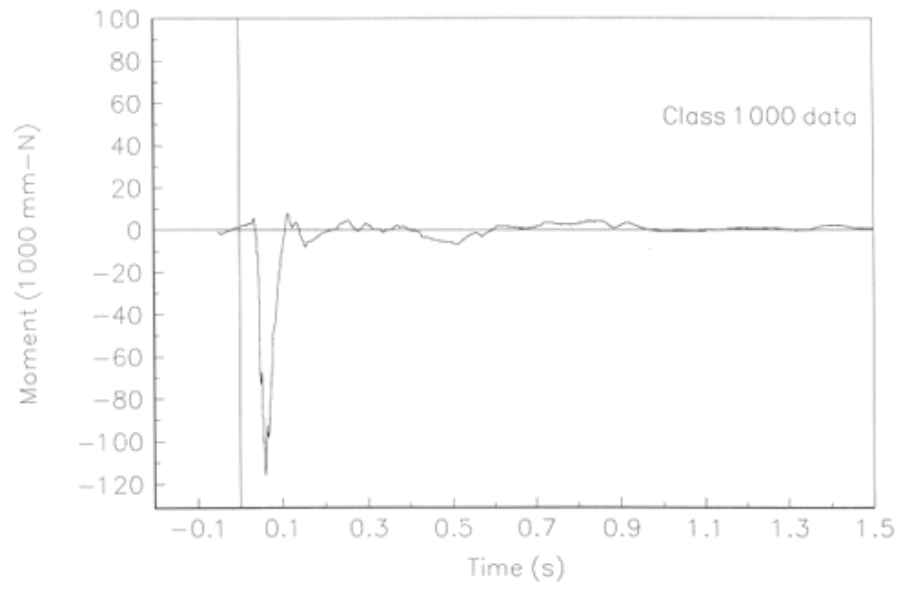

Figure 34. Moment vs. time, neck X-axis, test 97S016.



Test No. 97S016
Neck Moment, Y-axis

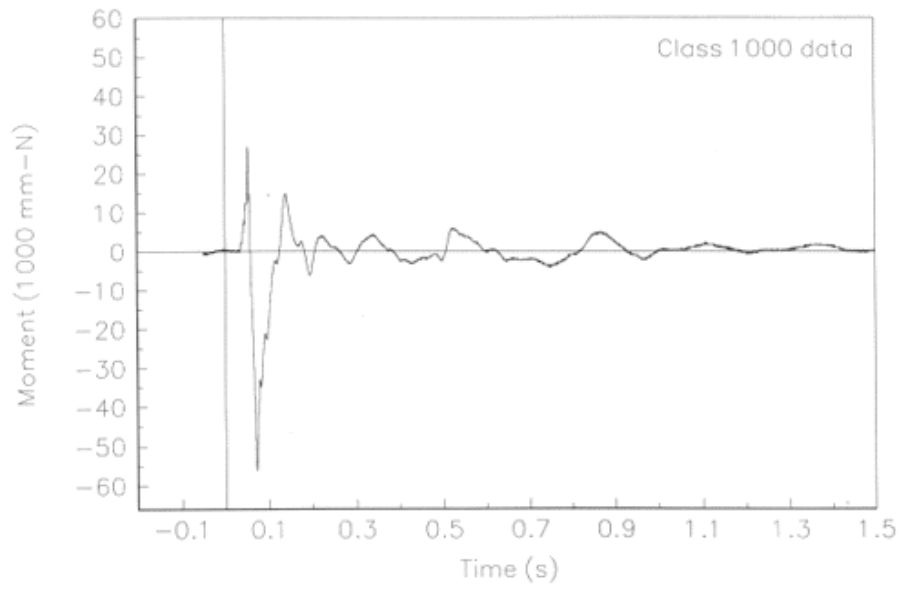

Figure 35. Moment vs. time, neck Y-axis, test 97S016.



Test No. 97S016
Neck Moment, Z-axis

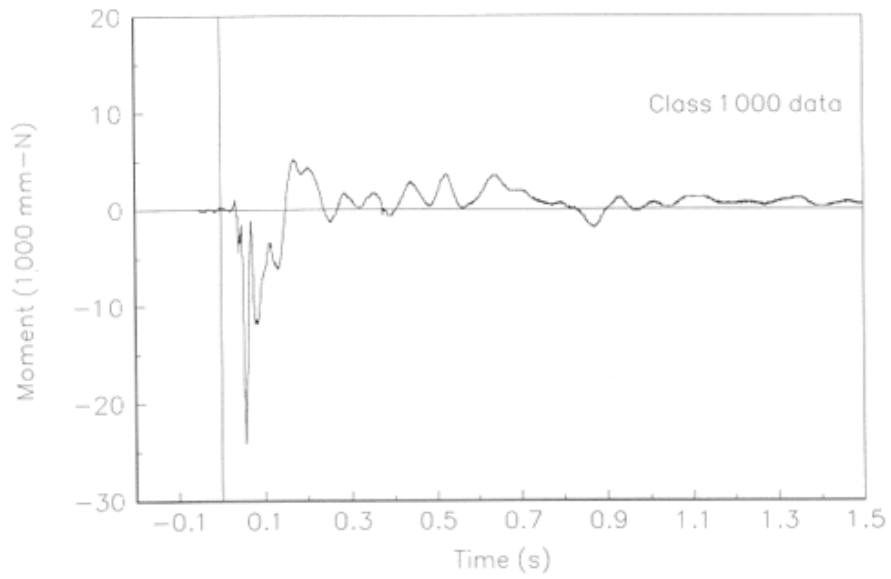

Figure 36. Moment vs. time, neck Z-axis, test 97S016.



Test No. 97S016

Upper rib acceleration, primary

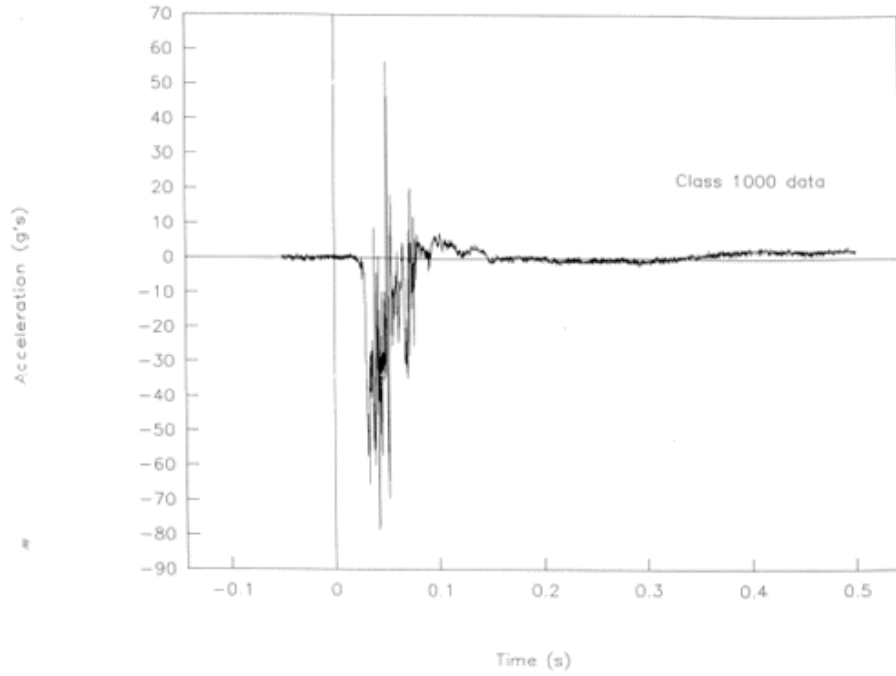

Figure 37. Acceleration vs. time, upper rib primary, test 97S016.



Test No. 97S016

Upper rib acceleration, redundant

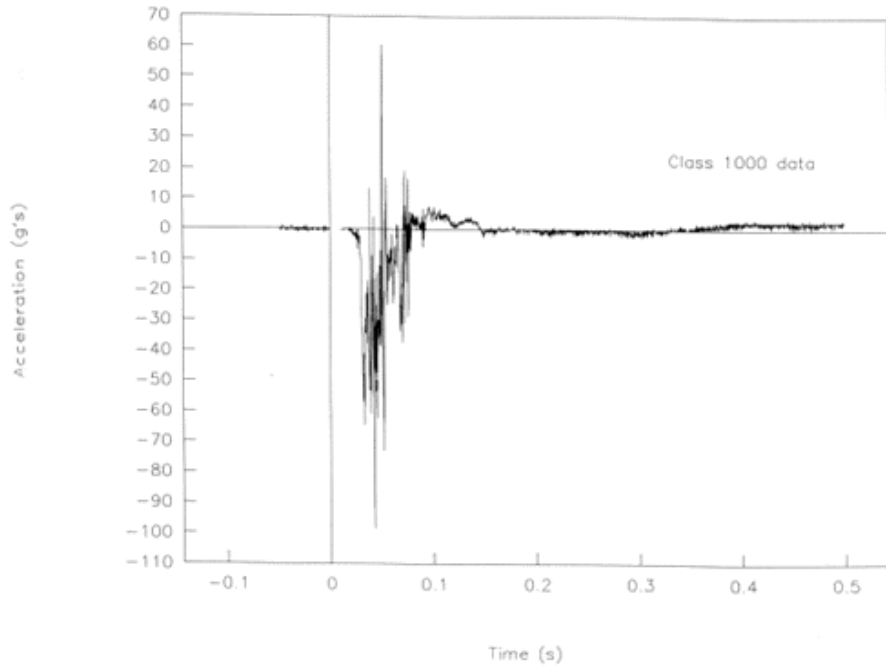

Figure 38. Acceleration vs. time, upper rib redundant, test 97S016.



Test No. 97S016

Lower rib acceleration, primary

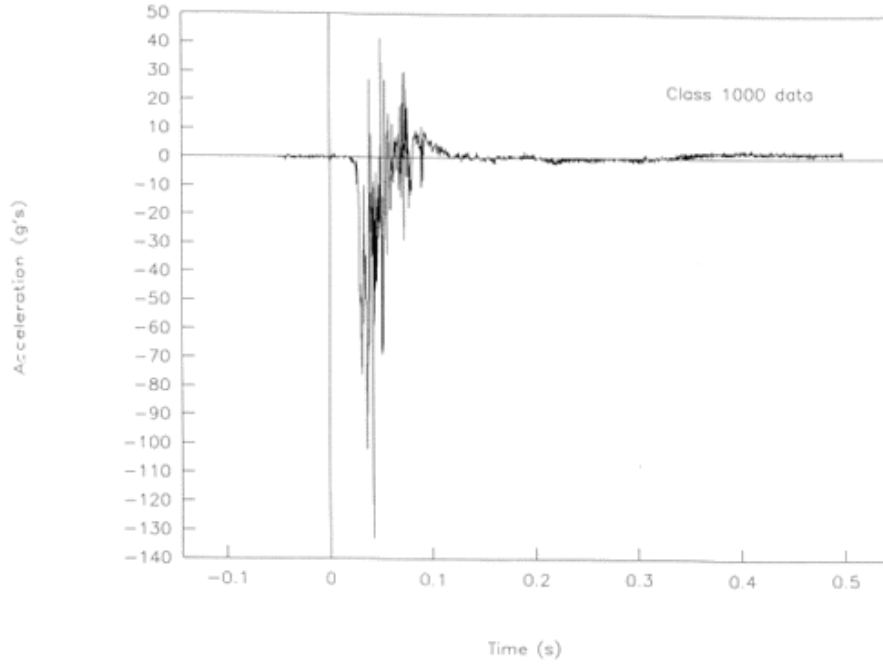

Figure 39. Acceleration vs. time, lower rib primary, test 97S016.



Test No. 97S016

Lower rib acceleration, redundant

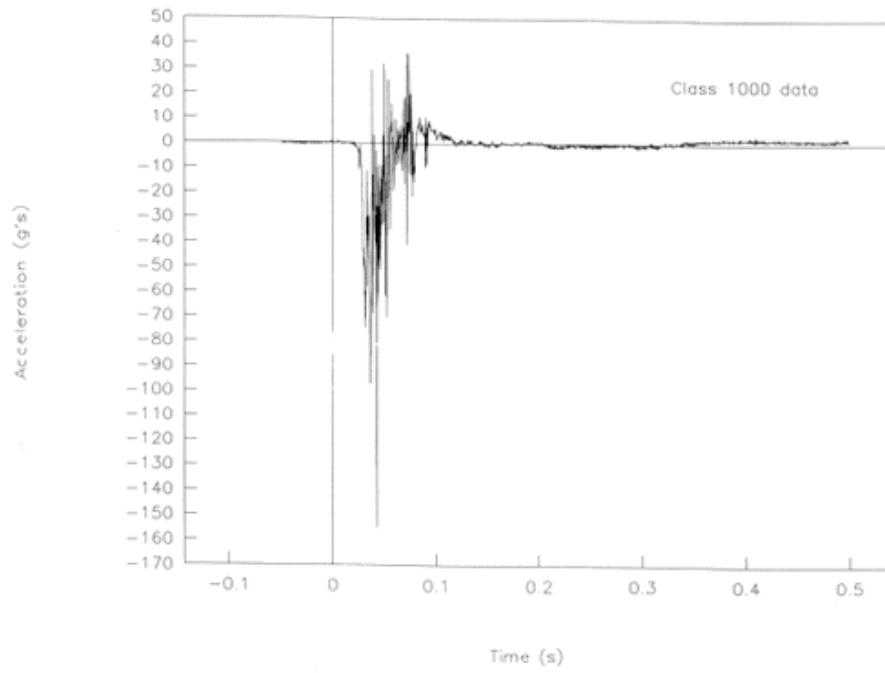

Figure 40. Acceleration vs. time, lower rib redundant, test 97S016.



Test No. 97S012

Upper rib acceleration, redundant

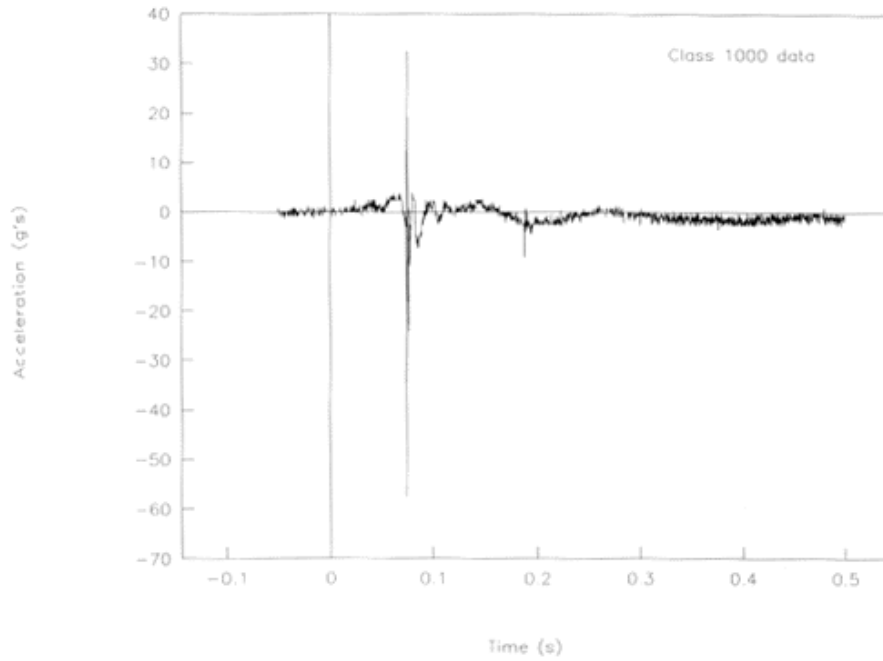

Figure 41. Acceleration vs. time, spline T12 primary, test 97S016.



Test No. 97S016

Spine (T12) acceleration, redundant

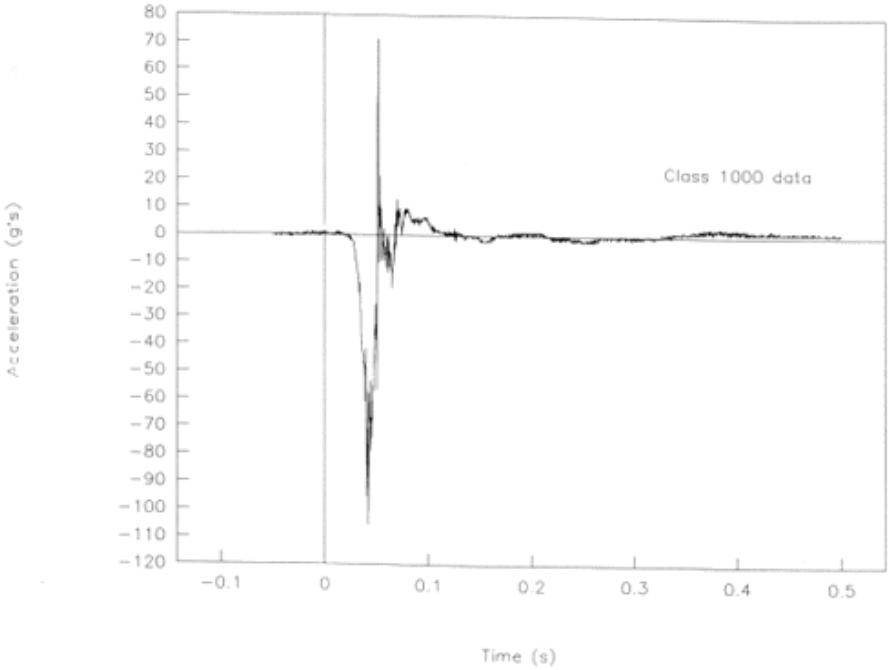

Figure 42. Acceleration vs. time, spline T12 redundant, test 97S016.



Test No. 97S016

Pelvis acceleration

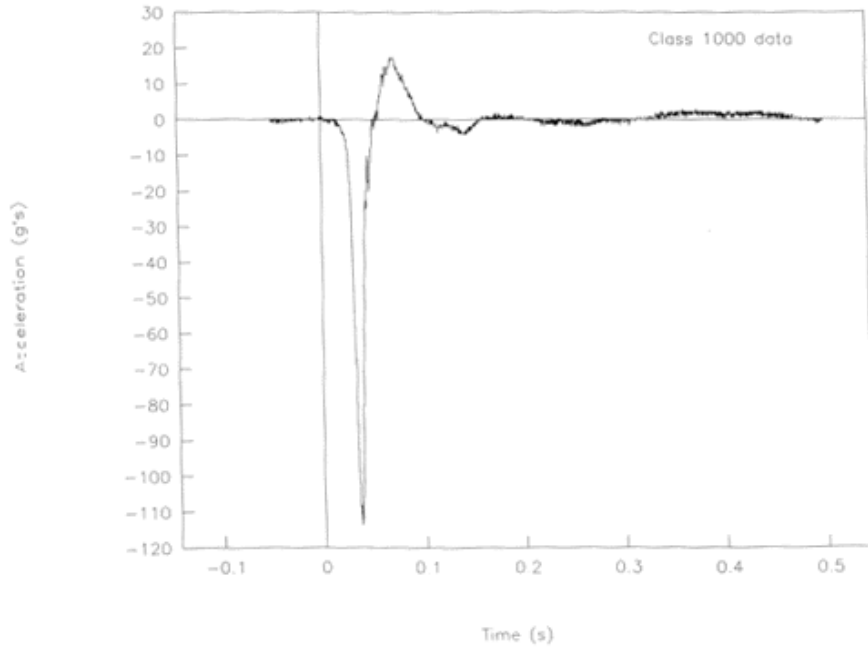

Figure 43. Acceleration vs. time, pelvis, test 97S016.



APPENDIX C. TEST PHOTOGRAPHS

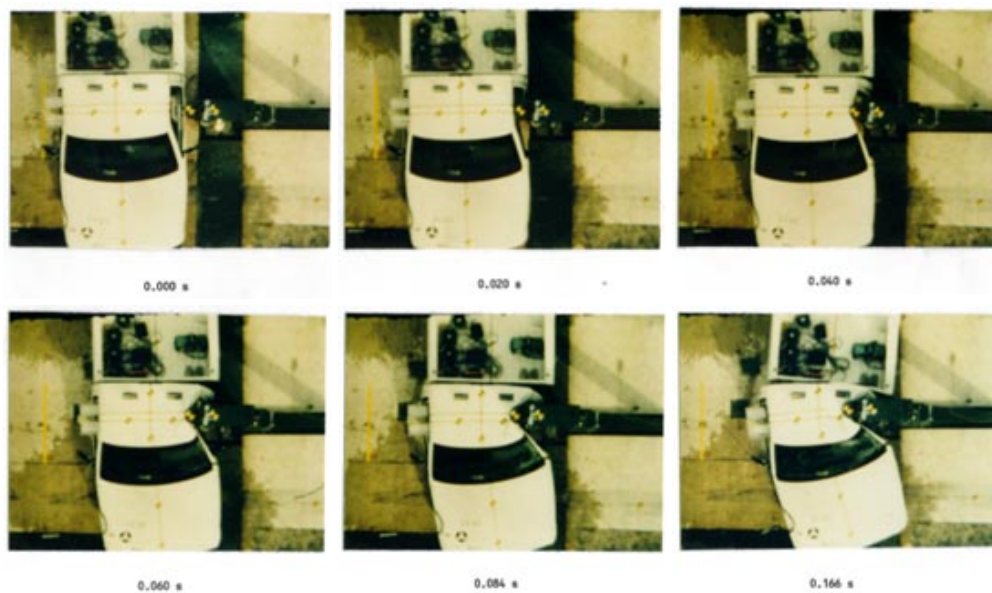

Figure 44. Test photographs during impact, test 97S016.





Figure 44. Test photographs during impact, test 97S016 (continued).





Figure 45. Pretest photographs, test 97S016.





Figure 45. Pretest photographs, test 97S016 (continued).





Figure 46. Post-test photographs, test 97S016.





Figure 46. Post-test photographs, test 97S016 (continued).



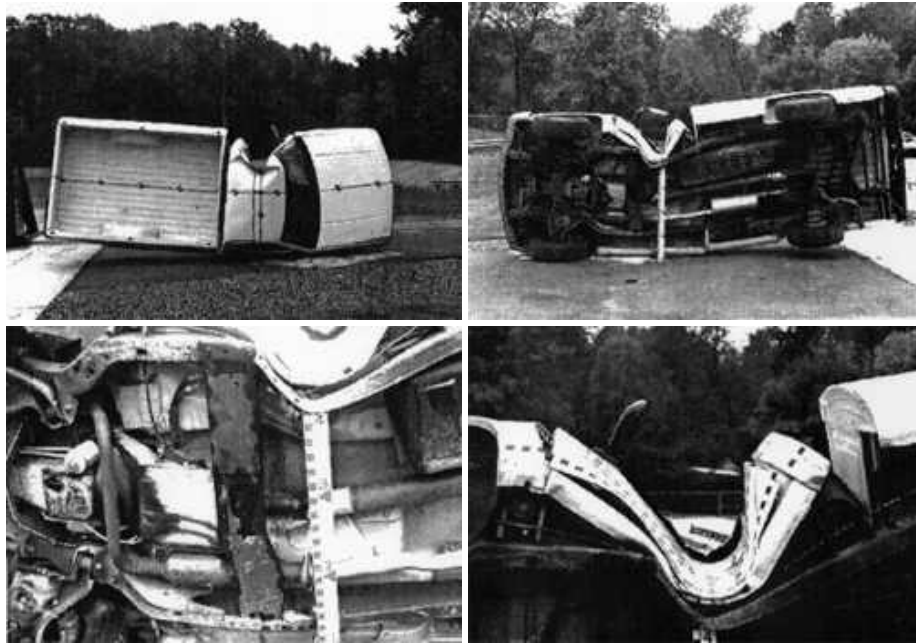

Figure 46. Post-test photographs, test 97S016 (continued).



APPENDIX D. DATA PLOTS FROM RIGID POLE LOAD CELLS

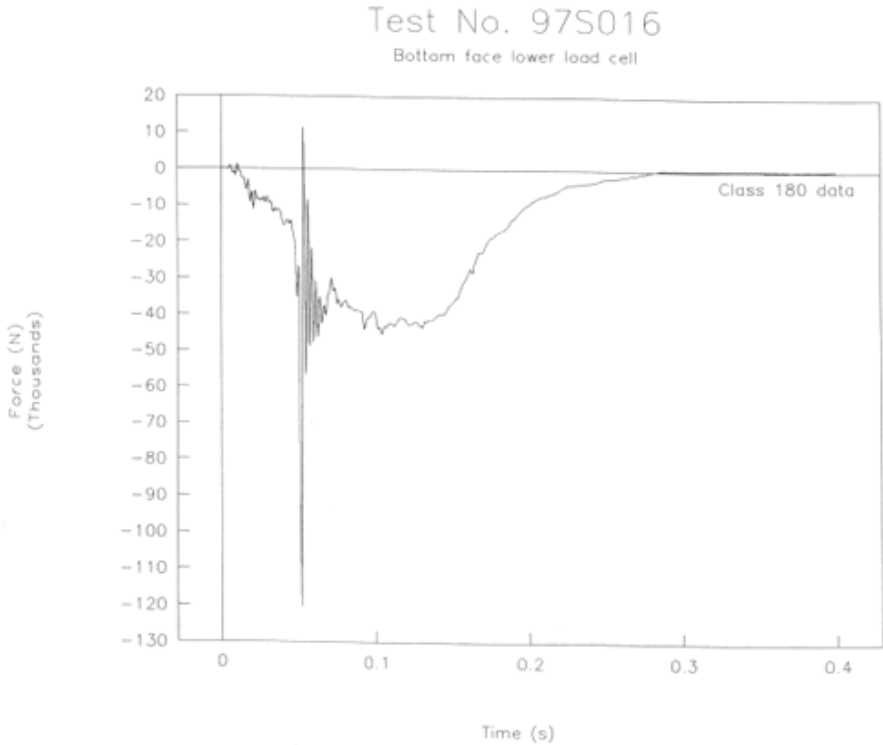

Figure 47. Rigid pole, force vs. time, bottom face lower load cell, test 97S016.



Test No. 97S016

Bottom face upper load cell

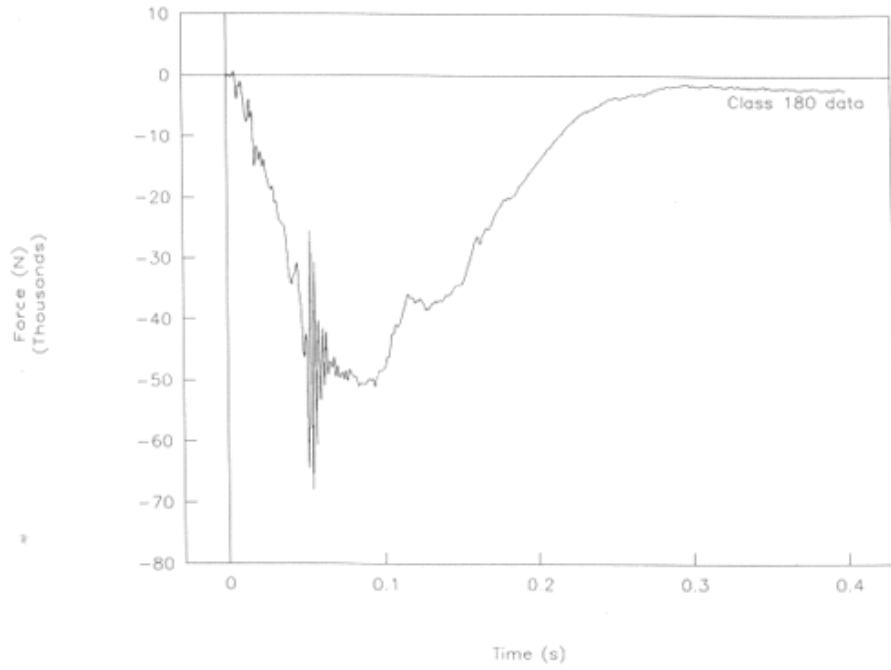

Figure 48. Rigid pole, force vs. time, bottom face upper load cell. test 97S016.



Test No. 97S016

Lower-middle face lower load cell

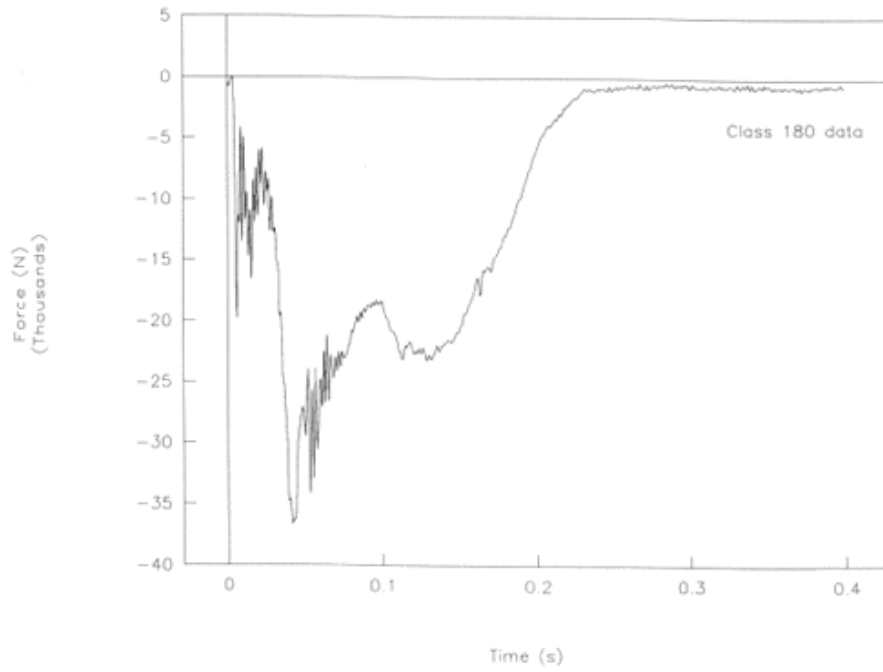

Figure 49. Rigid pole, force vs. time, lower-middle face lower load cell, test 97S016.



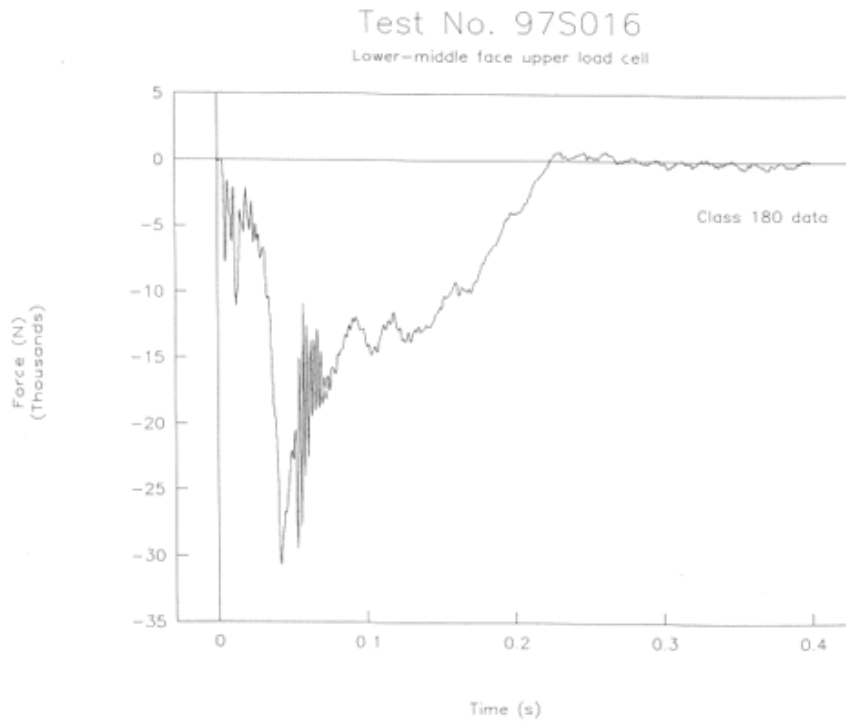

Figure 50. Rigid pole, force vs. time, lower-middle face upper load cell, test 97S016.



Test No. 97S016

Upper-middle face lower load cell

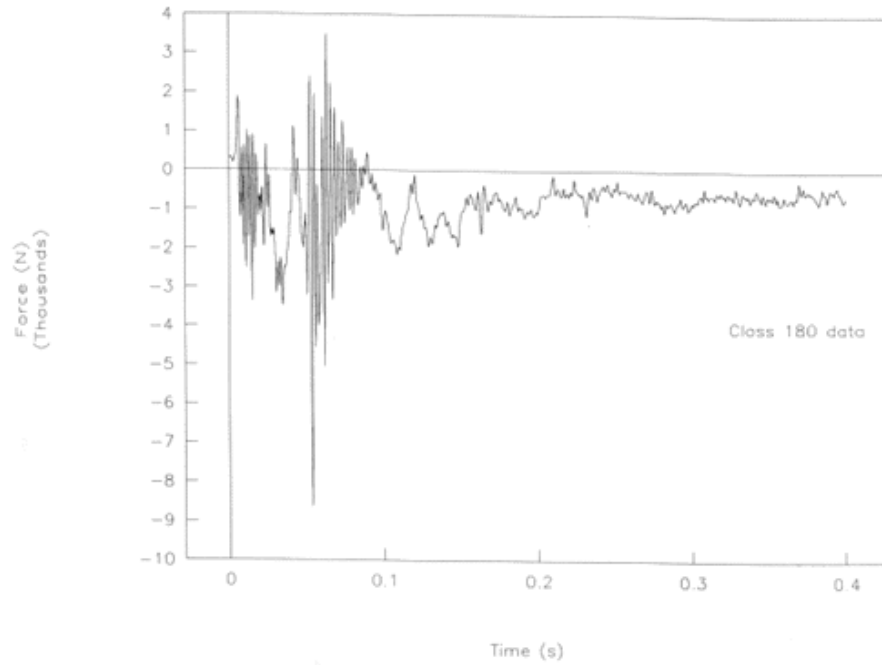

Figure 51. Rigid pole, force vs. time, upper-middle face lower load cell, test 97S016.



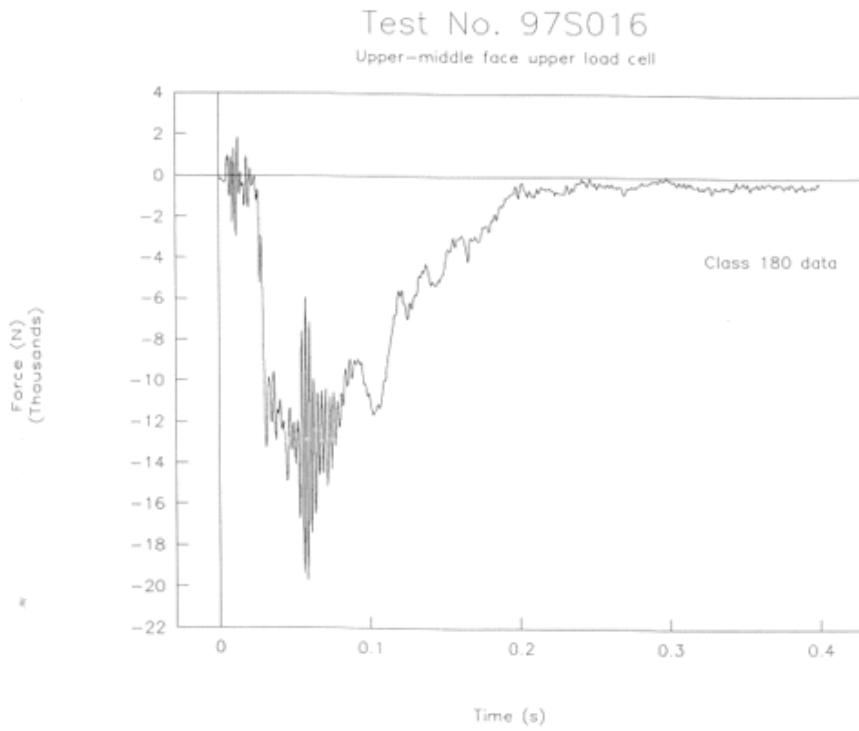

Figure 52. Rigid pole, force vs. time, upper-middle face upper load cell, test 97S016.



Test No. 97S016

Upper face lower load cell

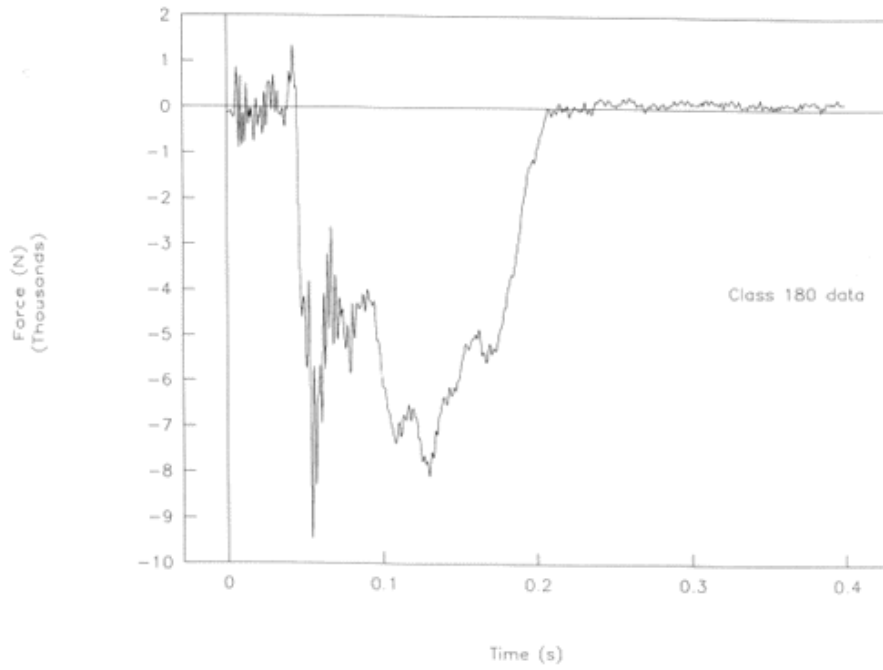

Figure 53. Rigid Pole, force vs. time, upper face lower load cell, test 97S016.



Test No. 97S016

Upper face upper load cell

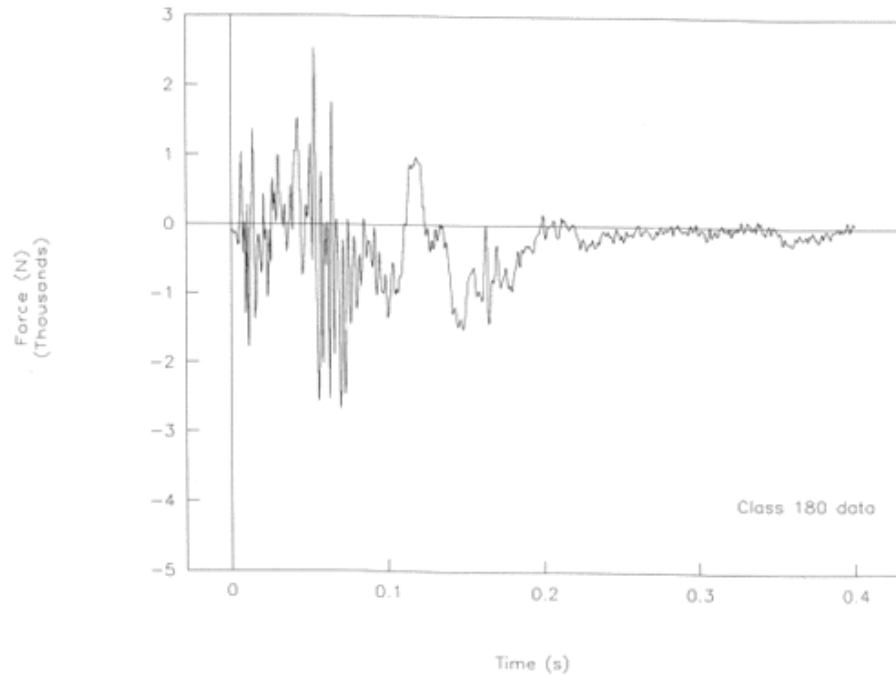

Figure 54. Rigid pole, force vs. time, upper face upper load cell, test 97S016.



REFERENCES

Number

1. NHTSA. *Laboratory Test Procedure for Federal Motor Vehicle Safety Standard 214*, National Highway Traffic Safety Administration, Washington, DC, May 1992.
2. Ross, H. E., Jr., Sickling, D. L., Zimmer, R. A. and Michie, J. D., *Recommended Procedures for the Safety Performance Evaluation of Highway Features*, NCHRP Report 350, National Cooperative Highway Research Program, Transportation Research Board, Washington, DC, 1993.
3. Brown, Christopher M., *35 km/h Broadside Crash Test of a 1995 Chevrolet C2500 and a Valmont Industries Slip Away Lighting Standard: FOIL Test Number 97S012*, Report No. FHWA-RD-98-032, Federal Highway Administration, McLean, VA, September 1997.
4. Brown, Christopher M., *50 km/h Broadside Crash Test of a 1995 Chevrolet C2500 and a Valmont Industries Slip Away Lighting Standard: FOIL Test Number 97S015*, Report No. FHWA-RD-98-054, Federal Highway Administration, McLean, VA, October 1997.

