

PB86-182128

Hydraulic Design of Improved Inlets for  
Culverts Using Programmable Calculators,  
Hewlett-Packard (HP-65)

(U.S.) Federal Highway Administration  
Washington, DC

Oct 80

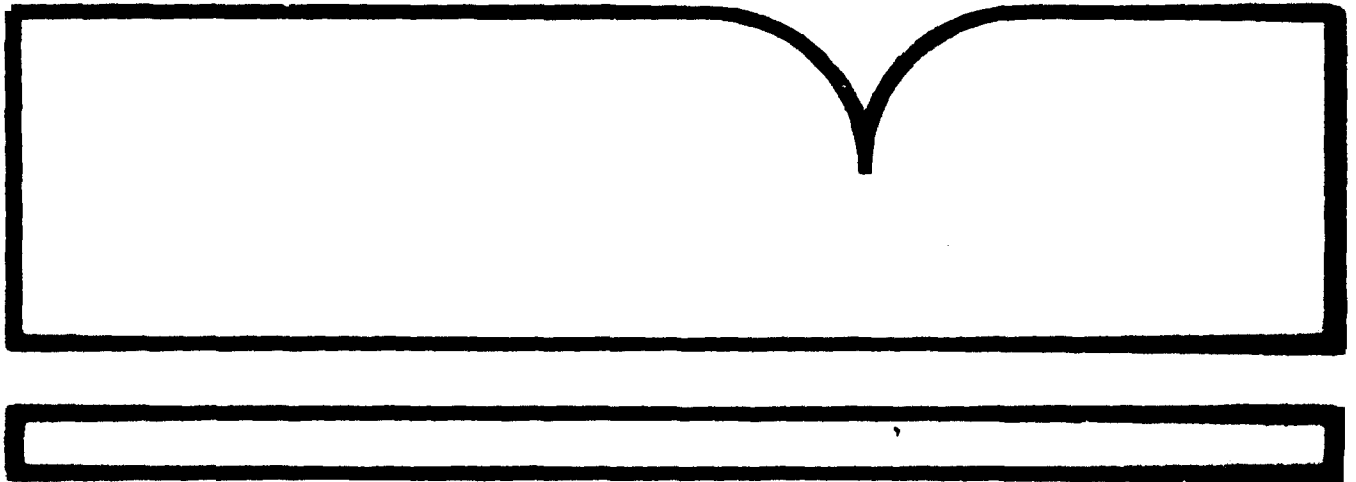

U.S. Department of Commerce  
National Technical Information Service  
NTIS

Technical Report Documentation Page

1. Report No. FHWA-EPD-86-117		2. Government Accession No.		3. Recipient's Catalog No.	
4. Title and Subtitle Hydraulic Design of Improved Inlets for Culverts Using Programmable Calculators, Calculator Design Series (CDS) No. 2				5. Report Date October 1980	
				6. Performing Organization Code	
7. Author(s) P. Wlaschin and P. L. Thompson				8. Performing Organization Report No.	
9. Performing Organization Name and Address Office of Engineering, HNG-31 Federal Highway Administration 400 7th Street, SW. Washington, D.C. 20590				10. Work Unit No. (TRIS)	
				11. Contract or Grant No.	
12. Sponsoring Agency Name and Address				13. Type of Report and Period Covered	
				14. Sponsoring Agency Code	
15. Supplementary Notes					
16. Abstract <p>This manual provides programmable design procedures for both box and pipe culverts with either conventional or improved inlets, for the Hewlett Packard, HP-65 calculator.</p> <p>The same terminology and algorithms used in "The Design of Improved Inlets for Culverts" (HEC No. 13) are used in these programs.</p> <p>Each program listed in the manual is accompanied by an explanation and an illustration of its use.</p>					
17. Key Words Culvert, Improved Inlets, Inlet Control, Outlet Control, HP-65			18. Distribution Statement No restrictions. This document is available to the public through the National Technical Information Service, Springfield, Virginia 22161.		
19. Security Classif. (of this report) Unclassified		20. Security Classif. (of this page) Unclassified		21. No. of Pages 157	22. Price

TABLE OF CONTENTS

Introduction . . . . .	1
Program Limitations . . . . .	111
List of Symbols . . . . .	vi
Program Outline: Box Culverts . . . . .	ix
Program Outline: Pipe Culverts . . . . .	x
Programs . . . . .	1
Appendix . . . . .	133
References . . . . .	147

## INTRODUCTION

The programable calculator as a culvert designing tool offers many desirable features. Compared with the hand method, the calculator is more accurate, less time consuming, and eliminates all the searching through charts and nomographs. In one quarter of the time it takes to design one culvert by hand, the designer could use the calculator to design the culvert, checking four or five different sizes to find the best one, while also evaluating several inlet configurations including both side- and slope-tapered inlets.

In an office where it is not feasible to use a computer for culvert design, the programable calculator becomes a desirable alternative. The accuracy remains the same, and the calculator method offers a segment by segment design approach. This method allows the culvert design parameters to be changed as the design is proceeding along.

The procedure herein covers both box and circular pipe culverts and follows the culvert design methods presented in "Hydraulic Design of Improved Inlets for Culverts," Hydraulic Engineering Circular No. 13 (HEC 13), dated August 1972. The programs begin with the computation of tailwater, proceed through the design of the culvert barrel, and conclude with the design of the culvert inlet most applicable to the site. The programs produce detailed inlet dimensions, performance curve data, and the outlet velocity.

Since the procedure is subdivided into a series of programs, the designer may enter the sequence at any point, provided the necessary input data is available, and obtain the desired design results.

These box and pipe culvert programs have been written for use on the Hewlett Packard - 65 calculator. It is expected that with the equations, examples, and program listings, a designer will be able to write similar programs for any other calculator he may have available.

Terminology used in this publication assumes that the designer is familiar with HEC 13 and understands the principles and design philosophy expressed therein.

This document was written by Mr. Patrick Wlaschin and edited by Mr. Philip L. Thompson.

### PROGRAM LIMITATIONS

When computing headwater depths,  $H_f$  and  $H_t$ , the upper and lower limits for these values are  $4.5 D$  and  $0.5 D$ . These limits indicate the range over which research was performed on these culverts. Because polynomial best-fit equations are used to produce the chart values from HFC #13, values outside these limits can be obtained. Since the programs do not check for these conditions, it is left to the designer.

When designing either a side-tapered or slope-tapered inlet, the number of barrels,  $N$ , is limited to two. For multiple barrels, each barrel should be designed individually.

In programs for circular pipes where  $d_n/D$  is greater than  $0.89$ , the program assumes the pipe to be flowing full in calculating the outlet velocity.

In calculating the "H" value in the outlet control performance programs, it is assumed that the culvert is flowing full.

In the design of slope-tapered inlets, the FALL slope,  $S_f$ , must range between a  $2:1$  and a  $3:1$  ratio.

In any of the programs which use FALL, this value is limited to a range of  $\frac{1}{2}D$  to  $1\frac{1}{2}D$  for slope-tapered inlets.

For side-tapered inlets the value of side taper,  $ST$ , must be between  $4:1$  and  $6:1$ .

The value of  $L_3$  must be greater than or equal to  $\frac{1}{2}B$ . This value has been set so that control will occur at the throat section

rather than at the bend section.

In addition to the design limitations given previously for box culverts with slope-tapered inlets, the following criteria apply to slope-tapered and rectangular side-tapered inlets for pipe culverts:

The rectangular throat of the inlet must be a square section with sides equal to the diameter of the pipe culvert.

The transition from the square throat section to the circular throat section must be no shorter than half the culvert diameter. If excessive lengths are used, the frictional losses within this section of the culvert should be considered in the design.

The design of multiple barrels for circular culverts using slope-tapered improved inlets can be performed the same as for box culverts except that the center wall must be flared in order to provide adequate space between the pipes for proper compaction of the backfill. The amount of flare required will depend on the size of the pipes and the construction techniques used. No more than two barrels may feed from the same inlet structure using the design methods of these programs.

An alternative would be to design a series of individual circular culverts with slope-tapered inlets. This permits the use of an unlimited number of barrels and the design programs are applicable.

The wingwall flare angles used in side-tapered inlets are limited from  $15^{\circ}$  to  $26^{\circ}$  with the top edge beveled, and from  $26^{\circ}$  to  $90^{\circ}$  with or without bevels.

The socket entrance used in these programs refers to the ball and spigot type of pipe.

All the dimensions used in these programs are in English units. The programs require all of their inputs to be in this type of format.

The use of slopes equal to a value of zero will produce incorrect results.

These programs do not check for errors in input values.

Several of the equations given in the equation section of a program may not be the exact formula used in the program. This is due to the size limitations of the HP-65 calculator. It was determined that these small differences did not significantly change the final results.

Generally the order of program execution is from Label A, through Labels B, C, and D. The user should refrain from performing calculations between using these labels.

For the most part, these limitations are repeated in the discussions with the programs.

LIST OF SYMBOLS

<u>Symbol</u>	<u>Units</u>	<u>Description</u>
A	sq.ft.	Area, generally the cross-sectional area of flow
a	ft.	Bevel dimension used for circular pipe culverts
ADJ.L	ft.	Adjusted length of a culvert, after its original length has been altered by the addition of an improved inlet.
ADJ.S		Adjusted slope of a culvert, after its original slope has been lowered by the use of FALL
Alpha		Velocity distribution factor used with pipe culverts, 1.04 for concrete, 1.12 for corrugated metal
AHW EL.	ft.	Allowable headwater elevation at the culvert entrance
B	ft.	Width of the box culvert barrel or the diameter of a pipe culvert
b	ft.	Bevel dimension used for circular pipe culverts
B <sub>f</sub>	ft.	Width of the face section of an improved inlet
BW	ft.	Base width of a rectangular or trapezoidal channel section
c	ft.	Bevel dimension used for circular pipe culverts
CW	ft.	Width of the weir crest
D	ft.	Height of a box culvert or the diameter of a pipe culvert
d	ft.	Bevel dimension used for circular pipe culverts
d <sub>c</sub>	ft.	Critical depth of flow
d <sub>n</sub>	ft.	Normal depth of flow
d <sub>2</sub> , d <sub>3</sub> , d <sub>4</sub>	ft.	Variable depths of flow



<u>Symbol</u>	<u>Units</u>	<u>Description</u>
$H$	ft.	Height of side-tapered pipe culvert face section, excluding bevel dimension
EL.FACE	ft.	Invert elevation of the face section of a culvert
EL.FD	ft.	Catch point elevation of the fill slope at the downstream end of the cross section
EL.FU	ft.	Catch point elevation of the fill slope at the upstream end of the cross section
EL.IN	ft.	Invert elevation of the culvert before any improved inlet adjustments
EL.OUT	ft.	Invert elevation of the culvert outlet
EL.THR	ft.	Invert elevation of the culvert throat section
FALL	ft.	Distance between the culvert inlet and the control section. Measured in a downward direction
$g$	ft./sec <sup>2</sup>	Acceleration of gravity; 32.2
$H$	ft.	Head or energy required to pass a given quantity of water through a culvert flowing in outlet control
$H_c$	ft.	The depth of pool, or head, above the weir crest
$H_e$	ft.	Head loss at a culvert due to the entrance configuration
$H_f$	ft.	Depth of pool, or head, above the face section invert
$H_t$	ft.	Depth of pool, or head, above the throat section invert
$H_v$	ft.	Head due to velocity
HW EL.	ft.	Headwater elevation at the entrance to a culvert
$k_e$		Entrance energy loss coefficient
$L$	ft.	The length of the culvert, measured along the barrel

<u>Symbol</u>	<u>Units</u>	<u>Description</u>
$L_1, L_2, L_3, L_4$	ft.	Dimensions relating to the improved inlet as shown in sketches of the different inlet types
N		Number of culvert barrels
n		Manning roughness coefficient
Q	cfs.	The volume rate of flow
R	ft.	Hydraulic radius
r	ft.	Variable parameter equal to the absolute value of the difference between the flow depth in a pipe culvert and the radius
S	ft./ft.	Slope of the culvert barrel
$S_{FD}$	ft./ft.	Downstream fill slope
$S_{FU}$	ft./ft.	Upstream fill slope
$S_f$	ft./ft.	Slope of FALL for slope tapered inlets, (ratio of horizontal to vertical) See design sketches
$S_o$	ft./ft.	Slope of the natural channel
ST	ft./ft.	Sidewall taper
TW	ft.	Tailwater depth at the culvert outlet
V	fps.	Mean velocity of flow
WA	degree	Wingwall taper angle
WP	ft.	Wetted perimeter
WT	ft./ft.	Wingwall taper
X		Variable parameter used to simplify calculations
Y,y		Variable parameter used to simplify calculations
$Y_a, Y_b$	ft.	Parameters used to indicate the equations of various slope lines
Z		Variable parameter used to simplify calculations
$Z_1, Z_2$	ft./ft	Side slopes of a channel section

## PROGRAM OUTLINE

	<u>Program #</u>
A. Box Culverts	
1. Tailwater Calculations	1
2. Culvert Length	2
3. Culvert Size	3
4. Outlet Control: Performance Curve	3
5. Outlet Control: Outlet Velocity	4
6. Inlet Control: Performance Curve	
a. Square Edge with Headwalls	5
b. Square Edge with Wingwalls	6
c. Bevel Edge with Headwalls	7
d. Bevel Edge with Wingwalls	8
1) Slope and Length Adjustments	9
2) Crest Evaluation	10
e. Tapered Throat Sections	11
1) Side Tapered: Square Edges	12
2) Side Tapered: Bevel Edges	13
a) Slope and Length Adjustments	14, 15
b) Crest Evaluation	10
3) Slope Tapered: Vertical Face	16
4) Slope Tapered: Mitered Face	17
a) Slope and Length Adjustments	18, 19
b) Face Dimensions	20, 21
c) Crest Evaluation	22
7. Inlet Control: Outlet Velocity	23, 24

PROGRAM OUTLINE

	<u>Program #</u>
<b>B. Pipe Culverts</b>	
1. Tailwater Calculations	1
2. Culvert Length	2
3. Critical Depth	25
4. Culvert Size	26
5. Outlet Control: Performance Curve	26
6. Outlet Control: Outlet Velocity	27
7. Inlet Control: Performance Curve	
a. Thin-edge Projecting Inlet	28
b. Standard End Section	29
c. Bevel Edges	30
d. Square Edges in Headwall	31
e. Projecting Socket Edge	32
f. Socket Edge in Headwall	33
1) Slope and Length Adjustments	9
2) Crest Evaluation	10
g. Tapered Inlet: Smooth Throat	34
h. Tapered Inlet: Rough Throat	35
1) Side Tapered: Projecting	36
2) Side Tapered: Square Edges	37
3) Side Tapered: Bevel Edges	38
a) Slope and Length Adjustments	14, 15
b) Crest Evaluation	10
4) Slope Tapered: Vertical Face	16
5) Slope Tapered: Mitered Face	17
a) Slope and Length Adjustments	18, 19
b) Face Dimensions	20, 21
c) Crest Evaluation	22
8. Inlet Control: Outlet Velocity	39, 40

**CULVERT PROGRAMS**

## PROGRAM #1 - NORMAL DEPTH

In calculating the performance of a culvert, the tailwater depth is required. This tailwater depth is used in determining the water surface elevation at the outlet of the culvert. One method of estimating this depth is to set it equal to the normal depth of the flow in the channel.

Program #1 calculates the normal depth of water flowing in a natural channel. For the program to operate, the channel cross-section is assumed to be prismatic in shape. Depending upon the inputs, a triangular, rectangular, or trapezoidal section may be evaluated. These various shapes are dimensioned as follows:

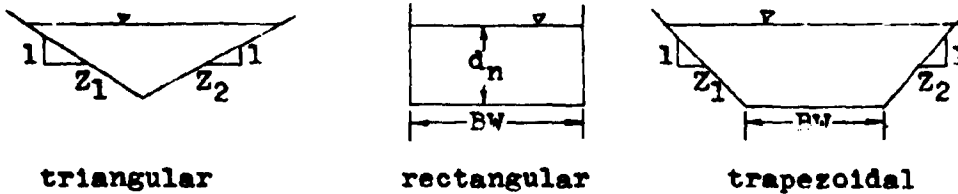

## EQUATIONS

$$Q = 1.486(AR^{.67}S_0^{.5})/n$$

$$A = d_n(BW + d_n(Z_1 + Z_2)/2)$$

$$WP = BW + d_n((Z_1^2 + 1) \cdot 5 + (Z_2^2 + 1) \cdot 5)$$

$$R = A/WP$$

$$V = Q/A$$

REMARKS

For the program to operate properly, the base width (BW) and the stream roughness value (n), must be stored together as a sum in register #2. To avoid the mixing of data, the base width (BW), must be an integer.

The channel depth ( $d_n$ ) must be calculated using Label A before the channel velocity ( $V_o$ ) can be determined.

STEP	INSTRUCTION	INPUTS	KEYS	DISPLAY
1	Load program			
2	Input register values	Q	STO 1	Q
		BW	ENTER	BW
		n	+ STO 2	BW+n
		$S_o$	STO 3	$S_o$
		$Z_1$	STO 4	$Z_1$
		$Z_2$	STO 5	$Z_2$
3	Calculate normal depth		A	$d_n$
4	Calculate channel velocity		F	$V_o$
5	For a change in any of the channel properties go to step #2 and change only the necessary data.			

EXAMPLE #1

Find the normal depth for a trapezoidal channel with a base width of 6 feet and side slopes of 2:1 and 3:1. The channel slope is 0.048 and the roughness value is 0.045. The estimated flowrate is 650 c.f.s.

<u>KEYSTROKES</u>	<u>DISPLAY</u>
650 STO 1 . . . . .	650.00
6 ENTER .045 + STO 2 . .	6.05
.048 STO 3 . . . . .	0.05
2 STO 4 . . . . .	2.00
3 STO 5 . . . . .	3.00
A . . . . .	3.61 ft. normal depth
B . . . . .	11.97 fps. channel velocity

EXAMPLE #2

Evaluate the previous example for a triangular cross-section.  
The base width (BW) is set to zero.

<u>KEYSTROKES</u>	<u>DISPLAY</u>
.045 STO 2 . . . . .	0.05
A . . . . .	4.64 ft.
B . . . . .	12.05 fps.

LISTING - PROGRAM #1

```

LEL A 1 STO 6 STO 8 LEL 1 RCL 4 RCL 5 + RCL 6 x 2
+ RCL 2 f INT + RCL 6 x RCL 4 ENTER x 1 + f  $\sqrt{x}$ 
RCL 5 ENTER x 1 + f  $\sqrt{x}$  + RCL 6 x RCL 2 f INT + +
2 ENTER 3 + g  $y^x$  x RCL 3 f  $\sqrt{x}$  x 1 . 4 8 6 x
RCL 2  $r^{-1}$  INT + RCL 1 - 0 g  $x \geq y$  g  $x = y$  RCL 6 RTN RCL 7
g  $x \geq y$  STO 7 - g  $x = y$  RCL 6 RTN RCL 7 RCL 8 x g  $x \geq y$  +
STO 8 STO - 6 GTO 1 LEL B g R↑ RCL 1 g  $x \geq y$  + RTN
(95 STEPS)

```



PROGRAM #2 - CULVERT LENGTH, INLET AND OUTLET ELEVATIONS

This program uses the site characteristics to determine the culvert length for a given barrel height. The inlet and outlet elevations for the culvert are also calculated by this program.

Both box and pipe culverts can be evaluated by this program.

The necessary input data are indicated in the diagram below:

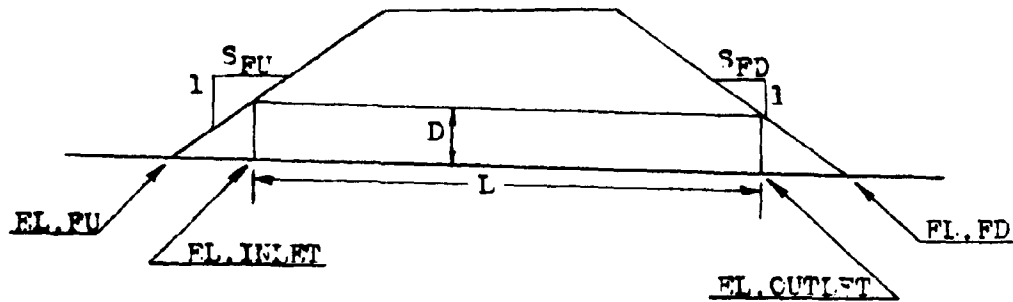

Roadway Cross section

EQUATIONS

$$L = (EL.INLET - EL.OUTLET)(S_o^2 + 1)^{.5} / S_o$$

$$EL.INLET = EL.FU - (DS_o S_{FU} (S_o^2 + 1)^{.5} / (1 + S_o S_{FU}))$$

$$EL.OUTLET = EL.FD + (DS_o S_{FD} (S_o^2 + 1)^{.5} / (1 - S_o S_{FD}))$$

The derivations of these equations are found in the appendix.

REMARKS

The length of the culvert (L) is measured along the barrel and is not a horizontal dimension.

REMARKS (cont.)

The ends of the culvert are assumed to be vertical.

<u>STEP</u>	<u>INSTRUCTIONS</u>	<u>INPUTS</u>	<u>KEYS</u>	<u>DISPLAY</u>
1	Load program			
2	Input register values	D	STO 2	D
		S <sub>o</sub>	STO 3	S <sub>o</sub>
		S <sub>FD</sub>	STO 5	S <sub>FD</sub>
		S <sub>FU</sub>	STO 6	S <sub>FU</sub>
		EL.FU	STO 8	EL.FU
		EL.FD	STO 9	EL.FD
3	Calculate the culvert length		A	L
4	Calculate inlet elevation		B	EL.IN
5	Calculate outlet elevation		C	EL.OUT
6	For a change in any of the register values go to step #2 and change only the necessary data.			

EXAMPLE #1

Find the length of a 9x5 box culvert on a 4% slope. Both the upstream and the downstream fill slopes are on a 3:1 ratio. The elevation of the catch point on the upstream fill is 100 feet. The catch point elevation for the downstream slope is 90 feet.

<u>KEYSTROKES</u>	<u>DISPLAY</u>
5 STO 2 . . . . .	5.00

<u>KEYSTROKES</u>	<u>DISPLAY</u>
.04 STO 3 . . . . .	0.04
3 STO 5 . . . . .	3.00
STO 6 . . . . .	3.00
100 STO 8 . . . . .	100.00
90 STO 9 . . . . .	90.00
A . . . . .	219.71 ft. LENGTH
B . . . . .	99.46 ft. EL.INLET
C . . . . .	90.68 ft. EL.OUTLET

EXAMPLE #2

It was later decided to use a 66 inch pipe culvert at this location instead of the 9x5 box culvert. Find the length and the inlet and outlet invert elevations for this situation.

<u>KEYSTROKES</u>	<u>DISPLAY</u>
66 ENTER 12 + STO 2 . .	5.50
A . . . . .	216.66 ft. LENGTH
B . . . . .	99.41 ft. EL.INLET
C . . . . .	90.75 ft. EL.OUTLET

LISTING - PROGRAM #2

```

LEL A B C - RCL 3 + RCL 3 ENTER x 1 + f  $\sqrt{x}$  x
STO 7 RTN LBL B RCL 3 ENTER x 3 + f  $\sqrt{x}$  RCL 2 x
RCL 3 x RCL 6 x RCL 3 RCL 6 x 1 + CHS + RCL 8 +
RTN LBL C RCL 3 ENTER x 1 + f  $\sqrt{x}$  RCL 2 x RCL 3
x RCL 5 x RCL 3 RCL 5 CHS x 1 + + RCL 9 + STO 4
RTN (68 STEPS)

```

PROGRAM #3 - BOX CULVERT, SIZE AND OUTLET CONTROL PERFORMANCE

This program has two functions. First, it can be used to select the appropriate box culvert size. Second, once this box size has been selected, the program will evaluate its performance for various flowrates. The outlet control performance curve can be made by plotting these flowrates versus the generated headwater elevations (HW EL.).

In determining the best box culvert size, the designer must first select a trial height (D) and width (B). For these two values the program computes the water surface elevation of the headwater pool at the culvert inlet. A visual comparison of this value to the allowable headwater elevation (AHW EL.) is made and the designer adjusts the height (D) and width (F) accordingly.

Once the box size has been determined, various flowrate values can be placed into the program to obtain the performance curves.

The following diagram indicates the location of the energy losses associated with culvert flow.

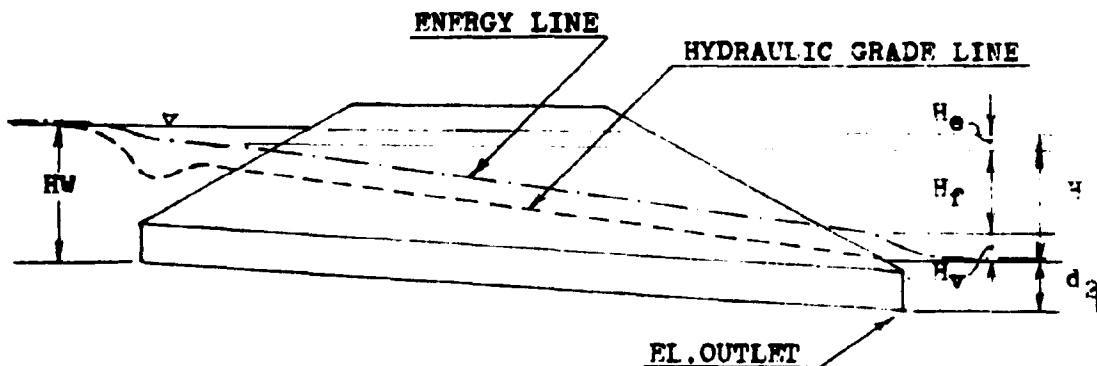

### EQUATIONS

$$H_e = k_e v^2 / 2g$$

$$H_f = 29n^2 LV^2 / 2gR^{1.33}$$

$$H_v = v^2 / 2g$$

$$\begin{aligned} H &= H_e + H_f + H_v \\ &= (1 + k_e + 29n^2 L / (EL / 2(F+D))^{1.33}) (Q / DEN)^2 / 2g \end{aligned}$$

$$d_2 = (d_c + D) / 2 \text{ or the Tailwater depth, whichever is largest}$$

$$HW \text{ EL.} = H + d_2 + EL. \text{OUTLET}$$

$$d_c = 0.315(Q/PN)^{.67}$$

### REMARKS

The critical depth ( $d_c$ ) cannot be greater than the height of the box (D). The program includes a test for this situation.

Since the water at the inlet is considered to be a pool, the velocity at this point is assumed to be approximately zero. This allows the hydraulic grade line to be equated to the energy line.

For the program to operate properly, the number of barrels (N) and the barrel roughness value (n), must be stored together as a sum in register #8. The limitations of the assumptions made also require that the number of barrels (N) be limited to a value of 1 or 2.

Label A (HW EL.) must be executed before Label D ( $d_2$ ).

<u>STEP</u>	<u>INSTRUCTIONS</u>	<u>INPUTS</u>	<u>KEYS</u>	<u>DISPLAY</u>
1	Load program			
2	Input register values	Q	STO 1	Q
		D	STO 2	D
		B	STO 3	B
		EL.OUT	STO 4	EL.OUT
		$k_e$	STO 5	$k_e$
		TW	STO 6	TW
		L	STO 7	L
		N	ENTER	N
		n	+ STO 8	N+n
3	Calculate headwater elevation		A	HW EL.
4	Calculate critical depth		B	$d_c$
5	Calculate total head loss		C	H
6	Calculate depth of water at outlet		D	$d_2$
7	To evaluate another box size, reenter another height and/or width and go to step #3. *			
8	To obtain outlet control performance curve coordinates, input various flowrates and calculate the corresponding headwater elevations. **			
	* If the length and the elevation of the outlet of the culvert change with the depth, they must also be reentered.			
	** If the tailwater depth changes, it must be reentered.			

EXAMPLE #1

For a flowrate of 400 cfs., and an entrance loss coefficient of 0.5, find an appropriate box culvert size. The tailwater depth for this flowrate is 2 feet. From the site conditions, it has been determined that for a 5 foot box height, a 255.00 foot barrel is required. The outlet elevation for this box would be 99.70 feet. If a 6 foot box height is selected the length would change to 250.00 feet with an outlet elevation of 100.00 feet. The culvert is to be constructed of concrete with a roughness factor of 0.012. The allowable headwater elevation is set at 130.00 feet.

<u>KEYSTROKES</u>	<u>DISPLAY</u>
400 STO 1 . . . . .	400.00
.5 STO 5 . . . . .	0.50
2 STO 6 . . . . .	2.00
1 ENTER .012 + STO 8 . .	1.01

Try a 5x5 box.

5 STO 2 . . . . .	5.00
STO 3 . . . . .	5.00
255 STO 7 . . . . .	255.00
99.7 STO 4 . . . . .	99.70
A . . . . .	113.81 ft. HW EL.

HW EL. is lower than AHW EL. Try 4x5 box.

4 STO 3 . . . . .	3.00
A . . . . .	119.76 ft. HW EL.

HW EL. is closer to the AHW EL. Try 3x5 box.

KEYSTROKES

DISPLAY

3 STO 3 . . . . . 3.00

A . . . . . 134.08 ft. HW EL.

HW EL. exceeds the AHW EL. The 4x5 box will work.

Try a 4x6 box.

6 STO 2 . . . . . 6.00

4 STO 3 . . . . . 4.00

250 STO 7 . . . . . 250.00

100 STO 4 . . . . . 100.00

A . . . . . 116.00 ft. HW EL.

HW EL. is less than the AHW EL. Try a 3x6 box.

3 STO 3 . . . . . 3.00

A . . . . . 125.51 ft. HW EL.

HW EL. is close to the AHW EL. Try 2x6 box.

2 STO 3 . . . . . 2.00

A . . . . . 158.31 ft. HW EL.

HW EL. exceeds the AHW EL.

Use either a 4x5 or a 3x6 box culvert.

EXAMPLE #2

Evaluate the performance curve in outlet control for the 3x6 box culvert designed above. Plot four points on the curve corresponding to the 0.6Q, 0.8Q, Q, and 1.2Q.

KEYSTROKES

DISPLAY

400 ENTER .6 x STO 1 . . 240.00

6 STO 2 . . . . . 6.00



<u>KEYSTROKES</u>	<u>DISPLAY</u>
3 STO 3 . . . . .	3.00
100 STO 4 . . . . .	100.00
.5 STO 5 . . . . .	0.50
2 STO 6 . . . . .	2.00
250 STO 7 . . . . .	250.00
1 ENTER .012 + STO 8 . .	1.01
A . . . . .	112.95 ft. HW EL. ● .6Q
400 Enter .8 x STO 1 . .	320.00
A . . . . .	118.48 ft. HW EL. ● .8Q
400 ENTER 1.2 x STO 1 .	480.00
A . . . . .	134.09 ft. HW EL. ● 1.2Q
400 STO 1 . . . . .	400.00
A . . . . .	125.51 ft. HW FL.
B . . . . .	8.22 ft. $d_0$
C . . . . .	19.51 ft. H
D . . . . .	6.00 ft. $d_2$

LISTING - PROGRAM #3

```

LBL A B RCL 2 g xsy RCL 2 g NOP + 2 + RCL 6 g xsy
g xzy g NOP STO 9 C RCL 4 + RCL 9 + RTN LBL P RCL 1
RCL 3 + RCL 8 f INT + 2 ENTER 3 + g yx . 3 1 5 x
RTN LBL C 2 9 RCL 8 f-1 INT ENTER x x RCL 7 x RCL 3
RCL 2 x RCL 3 RCL 2 + 2 x + 4 ENTER 3 + g yx +
RCL 5 + 1 + RCL 1 RCL 3 + RCL 2 + RCL 8 f INT +
ENTER x 6 4 . 4 + x RTN LBL D RCL 9 RTN (99 STEPS)

```

Plot of the performance of a 3x6 box culvert operating in outlet control.

Plotting Coordinates

Q	240.00	320.00	400.00	480.00
HW EL.	112.95	118.48	125.51	134.09

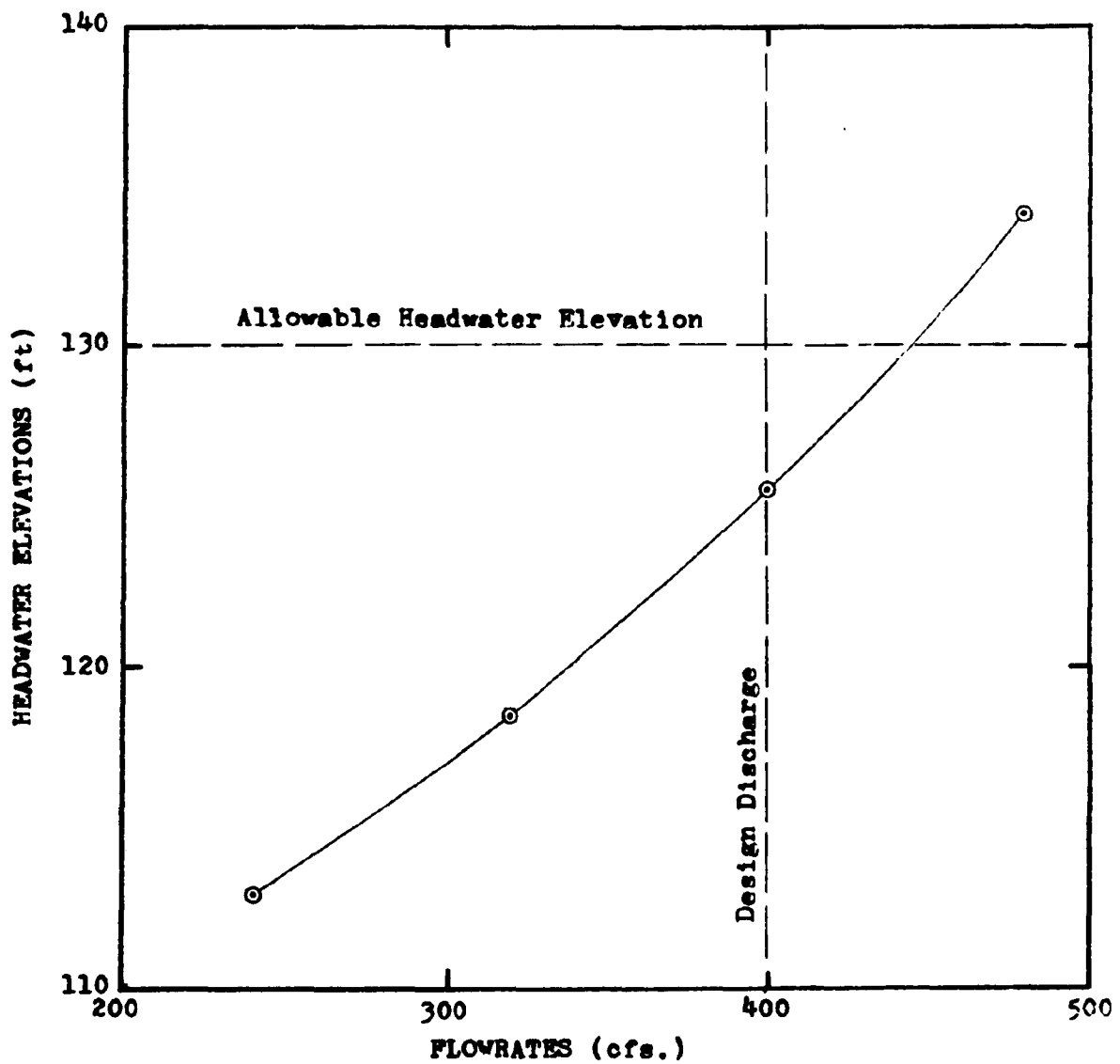

PROGRAM #4 - BOX CULVERT; OUTLET CONTROL OUTLET VELOCITY

This program determines the outlet velocity of a box culvert operating in outlet control.

The formula incorporated in this program is simply  $V = Q/A$ . The depth of flow used in the computation of the cross-sectional area is equal to the critical depth or the tailwater depth, whichever is larger. However, if this depth is found to be greater than the height of the box culvert, then the box culvert height is used as the depth of flow.

EQUATIONS

$$V = Q/A = Q/(Bnd_3)$$

$$d_3 = d_c \text{ or } TW, \text{ whichever is larger, not to exceed } D$$

$$d_c = 0.315(Q/BN)^{.67}$$

REMARKS

The outlet velocity, Label A, must be calculated before the depth of flow value, Label C, can be displayed.

<u>STEP</u>	<u>INSTRUCTIONS</u>	<u>INPUT</u>	<u>KEYS</u>	<u>DISPLAY</u>
1	Load program			
2	Input register values	Q	STO 1	Q
		D	STO 2	D
		B	STO 3	B
		TW	STO 6	TW
		N	STO 8	N

<u>STEP</u>	<u>INSTRUCTIONS</u>	<u>INPUT</u>	<u>KEYS</u>	<u>DISPLAY</u>
3	Calculate outlet velocity		A	V
4	Calculate critical depth		B	$d_c$
5	Calculate depth of flow		C	$d_3$
6	For a change in any of the culvert properties go to step #2 and change only the necessary data.			

EXAMPLE #1

What is the outlet velocity of a 9x5 box culvert at a flowrate of 600 cfs.? The tailwater depth is 4.5 feet.

<u>KEYSTROKES</u>	<u>DISPLAY</u>
600 STO 1 . . . . .	600.00
5 STO 2 . . . . .	5.00
9 STO 3 . . . . .	9.00
4.5 STO 6 . . . . .	4.50
1 STO 8 . . . . .	1.00
A . . . . .	13.33 fps. V
B . . . . .	5.18 ft. $d_c$
C . . . . .	5.00 ft. $d_3$

EXAMPLE #2

What velocity values could be expected for the box culvert in the above example at discharges of 400, 500, and 800 cfs.?

KEYSTROKES

DISPLAY

With the previous problem still stored in the calculator.

400	STO 1 . . . . .	400.00
A	. . . . .	9.88 fps. V
500	STO 1 . . . . .	500.00
A	. . . . .	12.11 fps. V
800	STO 1 . . . . .	800.00
A	. . . . .	17.78 fps. V

LISTING - PROGRAM #4

```
LPL A P RCL 6 g x>y GTO 1 g x>y RCL 2 g x>y g x>y  
g NOP GTO 2 LBL 1 RCL 2 g x>y g x>y g NOP LPL 2  
STO 9 RCL 3 x RCL 8 f INT x RCL 1 g x>y + RTN  
LBL B RCL 1 RCL 3 + RCL 8 f INT + 2 ENTER 3 +  
g yx . 3 1 5 x RTN LPL C RCL 9 RTN (60 STEPS)
```

PROGRAMS #5-8 BOX CULVERT; INLET CONTROL PERFORMANCE

Program #5: Square Edged Inlet with Headwalls

Program #6: Square Edged Inlet with 30°-75° Wingwalls

Program #7: 1:1 Bevel Edged Inlet with Headwalls

Program #8: 1:1 Bevel Edged Inlet with 45° Wingwalls or  
1½:1 Bevel Edged Inlet with 18°-33.7° Wingwalls

These programs evaluate the hydraulic performance for the above inlet configurations. Although the shape of the inlet faces differ dramatically, the analysis formulas are very similar. For this reason, these programs are grouped together. A further detailed explanation of the geometry of these inlets is depicted in the diagrams below:

Program #5

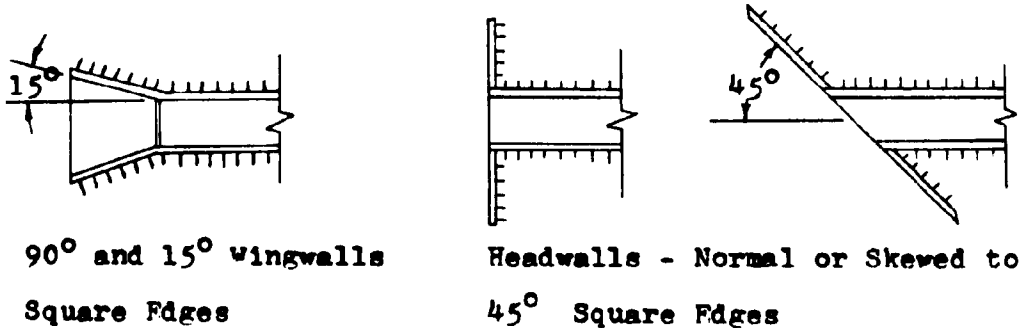

Program #6

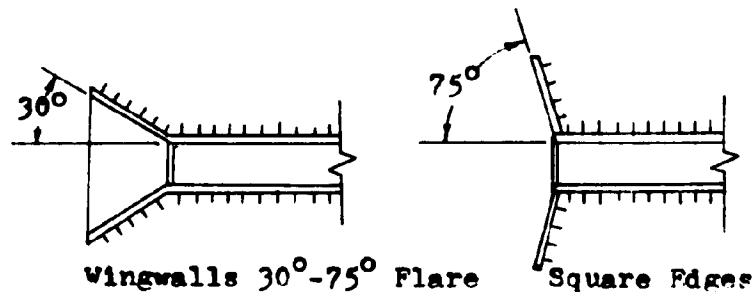

Program #7

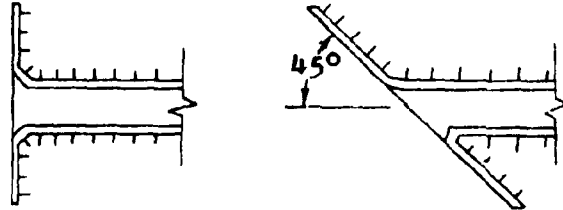

Headwalls - Normal to  $45^\circ$  Skew, 1:1 Bevel Edged,  
Variable Bevel on Acute Angle of Skewed Headwall

Program #8

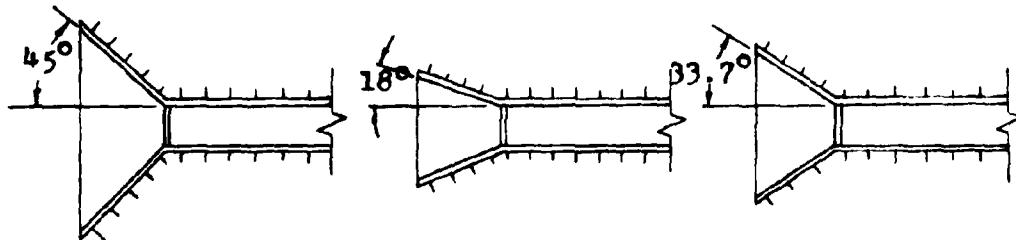

$45^\circ$  Wingwall Flare

1:1 Beveled Top Edge

$18^\circ$  to  $33.7^\circ$  Wingwall Flare

$1\frac{1}{2}$ :1 Beveled Top Edge

For each particular inlet, the program calculates the height of the water at the face of the culvert ( $H_f$ ). This value is then added to the culvert inlet invert elevation ( $H_f + \text{EL.IN}$ ). If this sum is less than the allowable headwater elevation (AHW EL.), then the inlet elevation becomes the elevation of the face (EL.FACE). However, if the sum of the height of the water at the face of the culvert and the elevation of the inlet exceeds the allowable headwater elevation, the difference between this sum and the allowable headwater elevation is subtracted from the inlet invert elevation. This new elevation

is now called the elevation of the face (EL.FACE). For the culvert to operate properly, the inlet invert must be reset to this elevation. The drop in elevation of the inlet invert is called the FALL. The diagrams below graphically show this occurrence. It should be noted that as the inlet invert elevation drops, the culvert barrel rotates about the outlet invert.

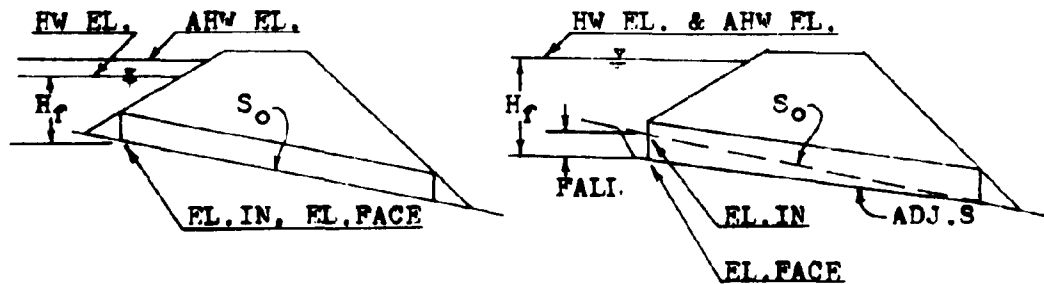

No FALL Required

$$EL.IN + H_f < AHW EL.$$

FALL Required

$$EL.IN + H_f \geq AHW EL.$$

As indicated in the diagrams, when the calculated headwater elevation is above the allowable headwater elevation, the headwater elevation is set equal to the allowable and the difference is taken up by the FALL.

Generally speaking, the invert elevation of the culvert can always be thought of as the elevation of the face (EL.FACE). The original elevation of the culvert inlet invert before considering the affects of inlet control and FALL, can be taken as the elevation of the inlet (EL.INLET).

Once the culvert has been sized for the design flowrate conditions, the same program can be used to evaluate the



performance of the culvert for other flowrate values. In this manner a performance curve for the culvert operating in inlet control can be drawn.

### EQUATIONS

$$\begin{aligned} \text{EL.FACE} &= \text{AHW EL.} - H_f && \text{(With FALL)} \\ &= \text{EL.INLET} && \text{(Without FALL)} \end{aligned}$$

$$\text{HW EL.} = \text{EL.FACE} + H_f$$

$$\text{FALL} = \text{EL.FACE} - \text{EL.INLET}$$

Note: The FALL is measured in a downward direction and therefore is always a positive value.

$$X = Q / (\text{PND})^{1.5}$$

### Program #5

$$\begin{aligned} H_f &= D(0.122117 + 0.505435X - 0.108560X^2 + 0.0207809X^3 \\ &\quad - 0.00136757X^4 + 0.00003456X^5) \end{aligned}$$

### Program #6

$$\begin{aligned} H_f &= D(0.0724927 + 0.507087X - 0.117474X^2 + 0.0221702X^3 \\ &\quad - 0.00148958X^4 + 0.0000380X^5) \end{aligned}$$

### Program #7

$$\begin{aligned} H_f &= D(0.1566086 + 0.3989353X - 0.0640392X^2 + 0.01120135X^3 \\ &\quad - 0.0006449X^4 + 0.000014566X^5) \end{aligned}$$

Program #8

$$H_f = D(0.0895633 + 0.4412465X - 0.0743498X^2 + 0.01273183X^3 - 0.0007588X^4 + 0.00001774X^5)$$

REMARKS

In evaluating these inlets, the box size must be determined before the culvert performance values can be generated. Once the box culvert has been sized and the elevation of the face (EL.FACE) established using the design flowrate, the program can then be used for performance evaluations. In calculating the performance curve values, the elevation of the face (EL.FACE) must remain a constant. To insure that this value does remain a constant, Label A on the calculator should not be used during the performance curve evaluation.

These programs have been written with the input values stored in the same registers for each program. This allows the designer to store the input data once and evaluate all four inlet configurations by just loading the individual program cards.

Whenever applicable, a bevel edged inlet is recommended for use in lieu of a square edged inlet. The large increase in hydraulic performance gained by using the bevel edged inlet, greatly outweighs the small additional cost.

To insure the proper operation of these inlets, the FALL value is limited to a minimum value of  $\frac{1}{4}D$  and a maximum value of  $1\frac{1}{4}D$ . If the minimum value is exceeded, i.e., FALL = 0.2D,

one of three alternatives may be considered. First, since the FALL is so small, the culvert will operate as though no FALL is present. Therefore, in this case, the culvert should be designed with no FALL present. Second, the box size could be reduced for the same inlet configuration. This would increase the amount of FALL produced. And third, the same box size can be used only with another inlet design. If the maximum value for FALL,  $1\frac{1}{2}D$ , is exceeded, either a larger box size or a more efficient inlet is required.

Polynomial best-fit equations are used to determine the headwater depths for these inlets. Since these equations are an approximation for the curves in HEC #13, they are subject to the same limitations. Therefore, the headwater depth ( $H_f$ ) is limited to a maximum of  $4\frac{1}{2}D$  and a minimum of  $\frac{1}{2}D$ . To avoid the possibility of culvert failure due to buoyancy forces, it is recommended that  $H_f$  be limited to a value around  $2D$ .

For the programs to operate properly, the width of the box culvert (B) and the number of barrels (N), must be stored together as a product in register #3.

<u>STEP</u>	<u>INSTRUCTIONS</u>	<u>INPUT</u>	<u>KEYS</u>	<u>DISPLAY</u>
1	Load program			
2	Input register values	Q	STO 1	Q
		D	STO 2	D
		B	ENTER	P
		N	x STO 3	PxN

<u>STEP</u>	<u>INSTRUCTIONS</u>	<u>INPUT</u>	<u>KEYS</u>	<u>DISPLAY</u>
2	Input register values	EL.IN AHW EL.	STO 5 STO 6	EL.IN APW EL.
3	Calculate the	EL.FACF	A	EL.FACF
4	Calculate the	headwater elev.	B	HW EL.
5	Calculate the	FALL	C	FALL
6	Calculate the	headwater depth	D	H <sub>f</sub>
7	To evaluate the same inlet with different design criteria, go to step #2.			
8	To evaluate another inlet, load the desired program card and go to step #3.			
9	To obtain the performance curve coordinates, input the selected flowrates in register #1 and press Label P to obtain the headwater elev.  Note: Label A must not be used during the performance curve evaluation.			

### EXAMPLE #1

For a 10-year discharge of 600 cfs., an allowable headwater elevation of 113.00 feet, and an inlet elevation of 98.00 feet, determine an appropriate box culvert size. The site characteristics indicate a box height of 5 feet should be used. A headwall configuration with a 30° skew should be employed.

Load program #5

<u>KEYSTROKES</u>	<u>DISPLAY</u>
600 STO 1 . . . . .	600.00
5 STO 2 . . . . .	5.00
98 STO 5 . . . . .	98.00
113 STO 6 . . . . .	113.00

Try a 5 foot width. And a single barrel.

5 STO 3 . . . . .	5.00
A . . . . .	85.45 ft. EL.FACE
C . . . . .	12.55 ft. FALL

The allowable FALL is  $1\frac{1}{2}D$  or 7.5 ft. Try larger width.

6 STO 3 . . . . .	6.00
A . . . . .	92.73 ft. EL.FACE
C . . . . .	5.27 ft. FALL

The FALL value is between  $\frac{1}{2}D$  and  $1\frac{1}{2}D$ . Check the  $H_f$ .

D . . . . .	20.27 ft. $H_f$
-------------	-----------------

$H_f$  is below the maximum value of  $4\frac{1}{2}D$ .

This 6x5 square edged box culvert may be used if anchored securely.

For the same site, design a beveled inlet.

Load program #7

<u>KEYSTROKES</u>	<u>DISPLAY</u>
5 STO 3 . . . . .	5.00
A . . . . .	90.86 ft. EL.FACE

KEYSTROKES

DISPLAY

C . . . . . 7.14 ft. FALL

The FALL is in the acceptable range.

D . . . . . 22.14 ft.  $H_f$

The headwater depth is in the acceptable range.

A 5x5 bevel edged box culvert may be used.

Other alternatives

6 STO 3 . . . . . 6.00

A . . . . . 96.38 ft. EL.FACE

C . . . . . 1.62 ft. FALL = .32D

D . . . . . 16.62 ft.  $H_f = 3.32D$

7 STO 3 . . . . . 7.00

A . . . . . 98.00 ft. EL.FACE = EL.IN

C . . . . . 0.00 ft. FALL

B . . . . . 111.28 ft. HW EL.

D . . . . . 13.28 ft.  $H_f = 2.7D$

A 6x5 bevel edged inlet with 1.62 ft. of FALL, or a 7x5 bevel edged inlet box culvert with no FALL.

EXAMPLE #2

For the conditions in Example #1, using the 5x5 bevel edged box culvert, calculate the performance curve coordinates.

Load program #7

<u>KEYSTROKES</u>	<u>DISPLAY</u>
600 STO 1 . . . . .	600.00
5 STO 2 . . . . .	5.00
5 STO 3 . . . . .	5.00      N = 1
98 STO 5 . . . . .	98.00
113 STO 6 . . . . .	113.00
A . . . . .	90.86 ft. EL.FACF
F . . . . .	113.00 ft. HW EL.
400 STO 1 . . . . .	400.00
F . . . . .	102.96 ft. HW EL. @ Q = 400cfs.
500 STO 1 . . . . .	500.00
F . . . . .	107.48 ft. HW EL.
700 STO 1 . . . . .	700.00
F . . . . .	119.53 ft. HW EL.

Note: In the above calculations, Label A was only pressed while the design flowrate (600 cfs.) was in register #1. While other flowrates are being used for performance curve evaluations, Label A should not be pressed.

**EXAMPLE #3**

For a design flowrate of 1000 cfs., an inlet elevation of 437.50 feet and an allowable headwater elevation of 442.20 feet, design an appropriate box culvert. The stream requires 45° wingwalls. The bottom width of the stream measures 15 feet across and therefore a twin 7-foot wide box culvert is

chosen. Site conditions require that the culvert be placed on the stream bed. No FALL can be employed.

Note: When no FALL is specified for a design, a short-cut method of analysis is possible. The inlet elevation is stored in register #8 instead of register #5. Also instead of the allowable headwater elevation, a very large number is stored in register #6. By visually comparing the calculated headwater elevations with the allowable value, a box culvert design can be quickly obtained.

Load program #6

<u>KEYSTROKES</u>	<u>DISPLAY</u>
1000 STO 1 . . . . .	1000.00
5 STO 2 . . . . .	5.00 Trial height
7 ENTER 2 x STO 3 . .	14.00
437.5 STO 8 . . . . .	437.50
10000 STO 6 . . . . .	10000.00 Any number >> ALLOW EL.
B . . . . .	448.61 ft. HW EL.

This HW EL. exceeds the ALLOW EL. Try a 6 foot height.

6 STO 2 . . . . .	6.00
B . . . . .	446.98 ft. HW EL.

This HW EL. is within the allowable. A twin 7x6 square top edged box culvert would work.

Try a bevel edged inlet.

Load program #8.



KEYSTROKES

DISPLAY

Note: The width still equals 6 feet from the previous problem.

B . . . . . 446.89 ft. HW EL.

This HW EL. is satisfactory. Try a smaller height.

5 STO 2 . . . . . 5.00

B . . . . . 448.09 ft. HW EL.

This HW EL. is within the allowable. Therefore, a twin 7x5 box culvert with a beveled top edge could be used.

LISTING - PROGRAM #5

```

LBL A D RCL 6 RCL 5 - g xSy g xzy g NOP RCL 6 g xzy
- STO 8 RTN LBL B D RCL 8 + RTN LBL C RCL 5 RCL 8
- RTN LBL D RCL 1 RCL 3 + RCL 2 ENTER f  $\sqrt{x}$  x +
ENTER ENTER ENTER 3 4 . 5 6 x 1 3 6 7 . 5 7
- x 2 0 7 8 0 . 9 + x 1 0 8 5 6 0 - x 5
0 5 4 3 5 + x 1 2 2 1 1 7 + 6 f-1 LOG ÷
RCL 2 x RTN (94 STEPS)

```

LISTING - PROGRAM #6

```

LBL A D RCL 6 RCL 5 - g xSy g xzy g NOP RCL 6 g xzy
- STO 8 RTN LBL B D RCL 8 + RTN LBL C RCL 5 RCL 8
- RTN LBL D RCL 1 RCL 3 + RCL 2 ENTER f  $\sqrt{x}$  x +
ENTER ENTER ENTER 3 8 0 x 1 4 8 9 5 . 8 - x
2 2 1 7 0 2 + x 1 1 7 4 7 4 0 - x 5 0 7 0
8 7 0 + x 7 2 4 9 2 7 + 7 f-1 LOG + RCL 2 x
RTN (93 STEPS)

```

LISTING - PROGRAM #7

```
LEL A D RCL 6 RCL 5 - g xSy g xzy g NOP RCL 6 g xzy
- STO 8 RTN LEL B D RCL 8 + RTN LBL C RCL 5 RCL 8
- RTN LBL D RCL 1 RCL 3 + RCL 2 ENTER f  $\sqrt{x}$  x +
ENTER ENTER ENTER 1 4 5 . 6 6 x 6 4 4 9 - x 1
1 2 0 1 3 . 5 + x 6 4 0 3 9 2 - x 3 9 8 9
3 5 3 + x 1 5 6 6 0 8 6 + 7 r-1 LOG + RCL 2
x RTN (95 STEPS)
```

LISTING - PROGRAM #8

```
LEL A D RCL 6 RCL 5 - g xSy g xzy g NOP RCL 6 g xzy
- STO 8 RTN LEL B D RCL 8 + RTN LBL C RCL 5 RCL 8
- RTN LBL D RCL 1 RCL 3 + RCL 2 ENTER f  $\sqrt{x}$  x +
ENTER ENTER ENTER 1 7 7 . 4 x 7 5 8 8 - x 1
2 7 3 1 8 . 3 + x 7 4 3 4 9 8 - x 4 4 1
2 4 6 5 + x 8 9 5 6 3 3 + 7 r-1 LOG + RCL 2
x RTN (93 STEPS)
```

Plot of the performance of a 5x5 bevel edged box culvert operating in inlet control.

Data taken from Example #2.

Plotting Coordinates

Q	400.00	500.00	600.00	700.00
HW EL.	102.96	107.48	113.00	119.53

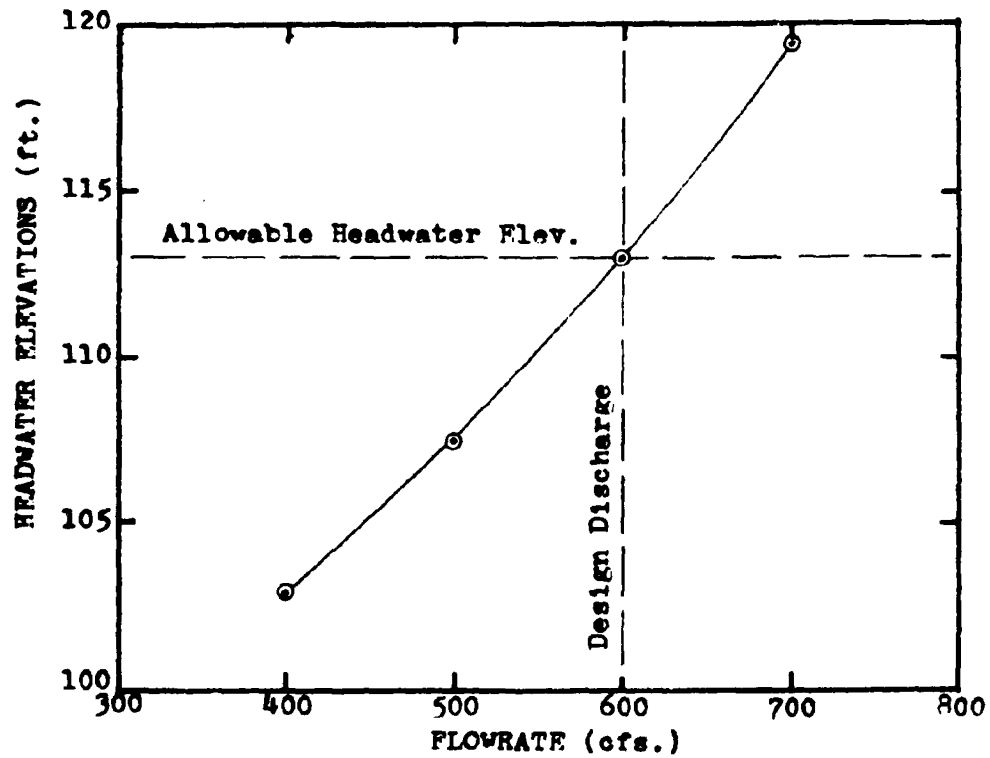

## PROGRAM #9 - INLET CONTROL; SLOPE AND LENGTH ADJUSTMENTS

Once a culvert has been designed for inlet control with FALL, an adjustment must be made to the slope and the length of the culvert. The need for an adjustment in the slope of the culvert results from the lowering of the elevation of the culvert inlet while keeping the elevation of the outlet a constant. Since the culvert pivots about the outlet invert, the culvert slope decreases. Since the height of the culvert (D) remains constant, the lowering of the inlet forces the culvert to be lengthened to again intersect the fill slope.

Both box and pipe culverts can be evaluated by this program.

The existing streambed and original culvert are altered to allow for inlet control with FALL. The diagram below depicts the changes.

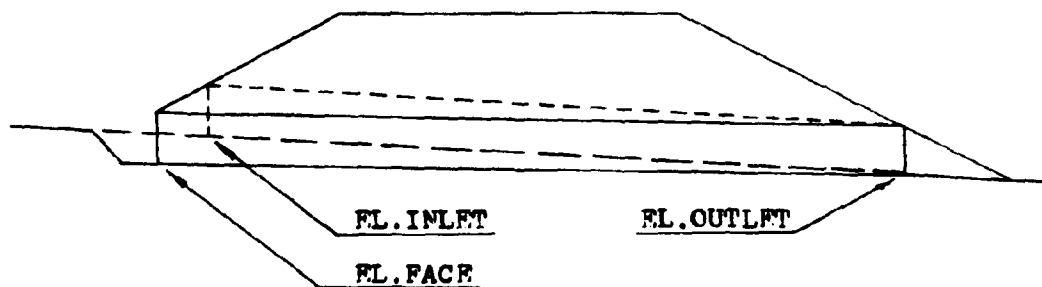

### EQUATIONS

$$ADJ.S = (LS_o - FALL(S_o^2 + 1) \cdot 5) / (L + yS_{FU}(S_o^2 + 1) \cdot 5)$$

### EQUATIONS

$$y = FALL + D((S_0^2 + 1) \cdot 5 - (ADJ.S^2 + 1) \cdot 5)$$

The equations for ADJ.S and y are solved by trial and error.

$$ADJ.L = ((LS_0 / (S_0^2 + 1) \cdot 5) - FALL) / (((ADJ.S)^2 + 1) \cdot 5 / ADJ.S)$$

The derivations of these equations are found in the appendix.

### REMARKS

Since this program does not use the width of the culvert in any of its equations, the program can be applied to multiple barrel applications.

Both the original culvert length (L) and the adjusted culvert length (ADJ.L) are measured along the barrel. They are not horizontal measurements.

In the design of the streambed in front of the entrance to the culvert, the adjusted slope (ADJ.S) should be extended a minimum distance of  $\frac{1}{2}D$ . The transition slope which connects the stream slope ( $S_0$ ) to the adjusted culvert slope (ADJ.S) should be established between a 2:1 and a 3:1 ratio. This transition slope is referred to as the FALL slope ( $S_f$ ). The performance of this weir construction is evaluated in another program.

The adjusted slope value (ADJ.S), Label A, must be determined before the adjusted length (ADJ.L), Label B, can be calculated. No intermediate calculations should be performed between these calculations.

<u>STEP</u>	<u>INSTRUCTIONS</u>	<u>INPUT</u>	<u>KEYS</u>	<u>DISPLAY</u>
1	Load program			
2	Input register values	D	STO 2	D
		S <sub>o</sub>	STO 4	S <sub>o</sub>
		FALL	STO 5	FALL
		S <sub>FU</sub>	STO 6	S <sub>FU</sub>
		L	STO 7	L
3	Calculate adjusted slope		A	ADJ.S
4	Calculate adjusted length		B	ADJ.L
5	For a change in any of the culvert properties, go to step #2 and change only the necessary data.			

EXAMPLE #1

A 6-foot pipe culvert has been designed for inlet control with a FALL of 6.52 feet. The normal channel slope is 5%, and the upstream fill slope is a 3:1 ratio. Early investigations showed that a 349.61 foot culvert should have worked if laid in the streambed. Find the adjusted slope and length of the culvert for the new design conditions.

<u>KEYSTROKES</u>	<u>DISPLAY</u>
6 STO 2 . . . . .	6.00
.05 STO 4 . . . . .	0.05
6.52 STO 5 . . . . .	6.52
3 STO 6 . . . . .	3.00

<u>KEYSTROKES</u>	<u>DISPLAY</u>
349.61 STO 7 . . . . .	349.61
A . . . . .	0.029664 ADJ.S
B . . . . .	368.91 ft. ADJ.I

EXAMPLE #2

For a 3x5 box culvert on a 4% slope with 1½ foot of FALL, find the adjusted slope and length. The fill slope is 3:1 and the inlet elevation is 250.00 feet.

<u>KEYSTROKES</u>	<u>DISPLAY</u>
5 STO 2 . . . . .	5.00
.04 STO 4 . . . . .	0.04
1.5 STO 5 . . . . .	1.50
3 STO 6 . . . . .	3.00
250 STO 7 . . . . .	250.00
A . . . . .	0.033393 ADJ.S
B . . . . .	254.45 ft. ADJ.I

LISTING - PROGRAM #9

```

LEL A 1 STO 8 LPL 1 RCL 7 RCL 4 x RCL 4 F RCL 5
x - RCL 4 F RCL 1 x RCL 6 x RCL 7 + + ENTER F RCL 2
CHS x RCL 5 + RCL 4 F RCL 2 x + RCL 1 - 0 R x y
g x=y GTO 2 RCL 3 g x y STO 3 - R x=y GTO 2 RCL 3
RCL 8 x g x y + STO 8 STO - 1 GTO 1 LPL F F R x y
+ RCL 7 RCL 4 x RCL 4 F + RCL 5 - x DSP . 2 RTN
LEL E ENTER x 1 + f √x RTN LPL 2 R R R DSP .
6 RTN (95 STEPS)

```

PROGRAM #10 - CREST CONTROL EVALUATION

If not properly designed, the transition section between the streambed and the culvert entrance could adversely affect the operation of the culvert. To insure that the culvert operates in the proper manner, this program computes the required inlet dimensions.

This program is designed to evaluate the crest control dimensions for both box and pipe culverts operating under inlet control and side-tapered throat control.

The diagrams below indicate the dimensions determined by the program.

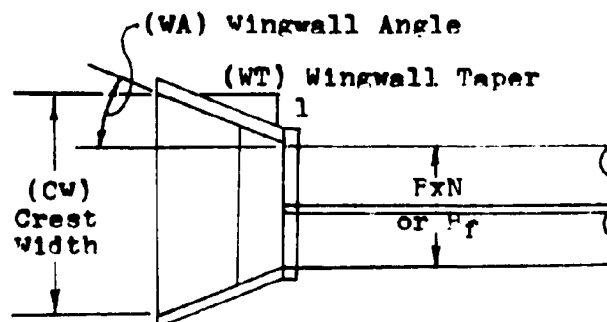
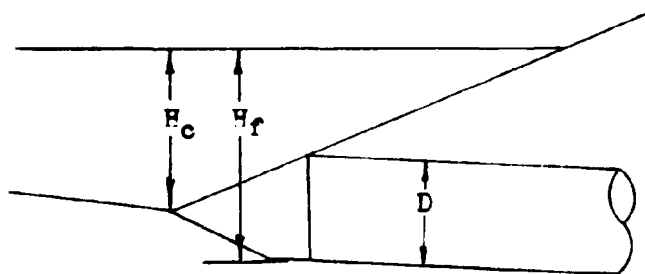



### EQUATIONS

$$H_c = \text{HW EL.} - \text{EL. OUTLET} - \frac{S_o(S_f - \text{ADJ. } S)(\frac{1}{2}D + \text{ADJ. } L)}{(S_f - S_o)\sqrt{\text{ADJ. } S^2 + 1}}$$

$$CW = Q / (2H_c)^{1.5}$$

$$WT = (L_o - L / \sqrt{\text{ADJ. } S^2 + 1}) / ((CW - B \times N) / 2)$$

$$WA = 90 - \arctan(WT)$$

The derivations of these equations are found in the appendix.

### REMARKS

As mentioned before, this program may be used with either conventional or side-tapered inlet designs. For conventional inlets, the culvert width (B) and the number of barrels (N) are stored together as a product in register #3. When this program is used for side-tapered inlets, the face width (B<sub>f</sub>) is stored in register #3 instead of the product BxN.

This program is written in such a manner that the labels must be pressed in an ascending order.

<u>STEP</u>	<u>INSTRUCTIONS</u>	<u>INPUT</u>	<u>KEYS</u>	<u>DISPLAY</u>
1	Load program			
2	Input register values	Q	STO 1	Q
		D	STO 2	D
		B	ENTER	B
		N	x STO 3	BxN
		S <sub>o</sub>	STO 4	S <sub>o</sub>

STEP	INSTRUCTIONS	INPUT	KEYS	DISPLAY
2	Input register values	HW EL.	ENTER	HW EL.
		EL.OUT	- STO 5	HW EL.-EL.OUT
		$S_f$	STO 6	$S_f$
		ADJ.L	STO 7	ADJ.L
		ADJ.S	STO 8	ADJ.S
3	Calculate crest height		A	$H_c$
4	Calculate crest width		B	CW
5	Calculate wingwall taper		C	WT
6	Calculate wingwall angle		D	WA
7	For a change in any of these culvert properties, go to step #2 and reenter ADJ.S and the desired item.			

EXAMPLE #1

What is the recommended wingwall taper to insure inlet control for a flowrate of 850 cfs. through a twin 9x5 box culvert? The channel slope is 0.042 with an adjusted slope of 0.01. The culvert was originally 197 feet long but due to the applied FALL, it has been lengthened to 223 feet. The fill slopes of the roadway cross-section are 2:1 ratios. The outlet elevation is 473.00 feet and the headwater elevation at the face is 488.00 feet. The FALL slope is set at a 2:1 ratio.

<u>KEYSTROKES</u>	<u>DISPLAY</u>
850 STO 1 . . . . .	850.00

<u>KEYSTROKES</u>	<u>DISPLAY</u>
5 STO 2 . . . . .	5.00
9 ENTER 2 x STO 3 . . .	18.00
.042 STO 4 . . . . .	0.04
488 ENTER 473 - STO 5 .	15.00
2 STO 6 . . . . .	2.00
223 STO 7 . . . . .	223.00
.01 STO 8 . . . . .	0.01
A . . . . .	5.37 ft. H <sub>c</sub>
P . . . . .	24.12 ft. CW
C . . . . .	2.02 WT
D . . . . .	26.32° WA

Note: Labels A thru D must be used ascendingly for proper crest evaluation.

EXAMPLE #2

A 3-foot diameter pipe culvert with a side-tapered inlet is to be used under a city street. The outlet invert elevation is 115.32 feet and the headwater elevation is 121.85 feet. The side-tapered inlet section has a 4½ foot opening. The culvert is to be laid on a 1% slope where as the stream slope is 3½%. The total length of the culvert is 64 feet. The FALL slope has been chosen at a 3:1 ratio. A design flowrate of 210 cfs. is expected. Evaluate this culvert and determine the necessary dimensions to insure inlet control.

<u>KEYSTROKES</u>	<u>DISPLAY</u>
210 STO 1 . . . . .	210.00
3 STO 2 . . . . .	3.00
4.5 STO 3 . . . . .	4.50
.035 STO 4 . . . . .	0.04
121.85 ENTER 115.32 - STO 5	6.53
3 STO 6 . . . . .	3.00
64 STO 7 . . . . .	64.00 *
.01 STO 8 . . . . .	0.01
A . . . . .	4.22 ft. H <sub>c</sub>
B . . . . .	8.57 ft. CW
C . . . . .	1.01 WT
D . . . . .	44.76° WA

\* Note: When the side-tapered inlet is evaluated with this program, the value stored in register #7 is the total length of the culvert. The total length is comprised of the adjusted length (ADJ.L) and the length of the side-tapered section (L<sub>1</sub>).

LISTING- PROGRAM #10

```

LBL A 0 STO 9 RCL 7 F + STO 9 RCL 2 2 + E + +
RCL 6 RCL 8 - x RCL 6 RCL 4 - + STO - 9 RCL 4 CHS
x RCL 5 + RTN LBL B RCL 1 g x2y 2 r ENTER f √x x
+ RTN LBL C RCL 3 - 2 + RCL 9 CHS + g 1/x 0 g x2y
g x2y g NOP RTN LBL D f-1 TAN 9 0 g x2y - RTN LBL
E RCL 8 ENTER x 1 + f √x RTN (81 ST&PS)

```

PROGRAM #11 - BOX CULVERT, THROAT CONTROL, TAPERED INLET

Besides improving the face configuration of an inlet, designing a new throat section will also increase a culverts performance.

This program evaluates the performance of a culvert operating in throat control. The formulas from this program can be applied to two different inlet shapes; side tapered and slope tapered. Like the improved inlet programs, throat inlet programs often can use FALL to increase the flow capacity of the culvert. The following diagrams describe the throat control inlets.

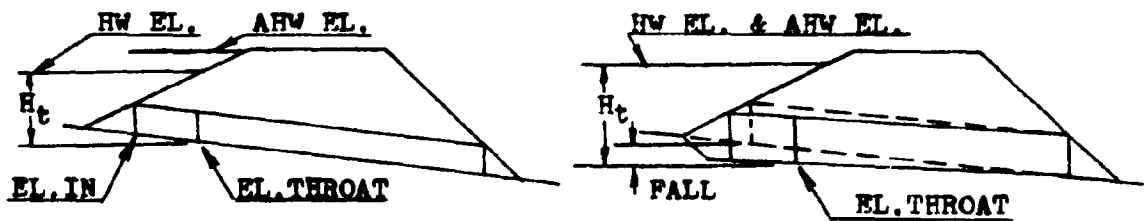

ELEVATION VIEW



PLAN VIEW

SIDE-TAPERED INLET  
NO FALL, AHW EL. > HW EL.

SIDE-TAPERED INLET  
WITH FALL, AHW EL. ≤ HW EL.

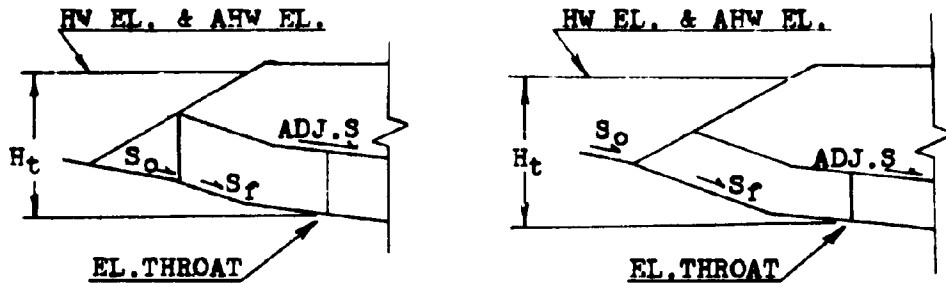

ELEVATION VIEW



PLAN VIEW

SLOPE-TAPERED INLET  
VERTICAL FACE

SLOPE-TAPERED INLET  
MITERED FACE

EQUATIONS

$$\begin{aligned} \text{EL. THROAT} &= \text{AHW EL.} - H_t \quad (\text{With FALL}) \\ &= \text{EL. INLET} \quad (\text{Without FALL}) \end{aligned}$$

$$\text{HW EL.} = \text{EL. THROAT} + H_t$$

$$\text{FALL} = \text{EL. INLET} - \text{EL. THROAT}$$

$$H_t = D(0.1295033 + 0.3789445X - 0.0437778X^2 + 0.00426329X^3 - 0.000106358X^4)$$

$$X = Q / (NBD^{1.5})$$

REMARKS

Label A is used during the culvert size determination part of

the program. Once a culvert size has been selected, it is put into the calculator and Label A evaluates the appropriate throat elevation for the design flowrate. When using other flowrates during the performance curve evaluation, Label A must not be used.

Since the input registers have the same identity as the ones used for the inlet control programs (5-8), these programs can be run in succession. If all the inlet control programs exceed their maximum limit of FALL ( $1\frac{1}{2}D$ ), the designer can immediately load this program and proceed with the culvert design without restoring any of the design values.

Due to the size limitations of this calculator, a small error results in the computation of the FALL. The program assumes that the elevation of the inlet and the elevation of the throat are equal before determining the value of the headwater elevation. This equality is false and a small difference, equal to the channel slope times the vertical distance between the inlet and the throat section ( $S_0 \times L_1$ ), exists. This  $L_1$  distance is an unknown in this program. It is determined by program #12. By understanding this error, a correction, if necessary, can be made.

The limits placed on the FALL value earlier, still apply. A minimum value of  $\frac{1}{2}D$  and a maximum value of  $1\frac{1}{2}D$ . If the upper limit is exceeded, a larger culvert size should be tried. If the minimum value is exceeded, the presence of FALL will not increase the capacity of the culvert.

A polynomial best-fit equation is used to determine the headwater depths for these inlets. Since the equation is an approximation for the curves in HEC #13, it is subject to the same restrictions. The headwater depth ( $H_t$ ) is limited to  $4\frac{1}{2}D$  and not less than  $\frac{1}{2}D$ . It is recommended that the value of  $H_t$  be kept around a value of  $2D$ .

For the program to operate properly, the culvert width ( $B$ ) and the number of barrels ( $N$ ) are stored together as a product in register #3.

The number of barrels ( $N$ ) is limited to a value of 1 or 2.

<u>STEP</u>	<u>INSTRUCTIONS</u>	<u>INPUT</u>	<u>KEYS</u>	<u>DISPLAY</u>
1	Load program			
2	Input register values	Q	STO 1	Q
		D	STO 2	D
		B	Enter	B
		N	x STO 3	BxN
		EL.IN	STO 5	EL.IN
		AHW EL.	STO 6	AHW EL.
3	Calculate throat elevation		A	EL.THR
4	Calculate headwater elevation		B	HW EL.
5	Calculate the FALL		C	FALL
6	Calculate headwater depth		D	$H_t$
7	For a change in any of these culvert properties, go to step #2 and change only the necessary items.			



<u>STEP</u>	<u>INSTRUCTIONS</u>	<u>INPUT</u>	<u>KEYS</u>	<u>DISPLAY</u>
-------------	---------------------	--------------	-------------	----------------

- |   |   |  |  |  |
|---|---|--|--|--|
| 8 | To obtain the performance curve coordinates, input the selected flowrates in register #1 and press Label F to obtain the headwater elevations.<br>Note: Label A must not be used during the performance curve evaluation. |  |  |  |
| 9 | To evaluate another inlet, load the required program card and go to step #3.  |  |  |  |

EXAMPLE #1

Evaluate the throat control performance of a 3x3 box culvert with a flowrate of 150 cfs. The inlet elevation is 120 feet and the allowable headwater elevation is 124 feet.

<u>KEYSTROKES</u>	<u>DISPLAY</u>	
150 STO 1 . . . . .	150.00	
3 STO 2 . . . . .	3.00	
STO 3 . . . . .	3.00	
120 STO 5 . . . . .	120.00	
124 STO 6 . . . . .	124.00	
A . . . . .	116.17 ft.	EL.THROAT
E . . . . .	124.00 ft.	HW EL.
C . . . . .	3.83 ft.	FALL
D . . . . .	7.83 ft.	H <sub>t</sub>

The culvert size is satisfactory since both the FALL and the headwater depth are within their allowable ranges.

A range of flowrates around the design value, are used to obtain the performance curve coordinates.

<u>KEYSTROKES</u>	<u>DISPLAY</u>
90 STO 1 . . . . .	90.00
B . . . . .	120.85 ft. HW EL. @ 0.6Q
120 STO 1 . . . . .	120.00
B . . . . .	122.24 ft. HW EL. @ 0.8Q
180 STO 1 . . . . .	180.00
B . . . . .	126.20 ft. HW EL. @ 1.2Q

LISTING - PROGRAM #11

```

LBL A D RCL 6 RCL 5 -  $\pi$  xSy  $\pi$  x $\pi$ y  $\pi$  NOP RCL 6  $\pi$  x $\pi$ y
- STO 8 RTN LBL B D RCL 8 + RTN LBL C RCL 5 RCL 8
- RTN LBL D RCL 1 RCL 3 + RCL 2 ENTER  $\sqrt{x}$  x +
ENTER ENTER ENTER 1 0 6 3 . 5 8 CHS x 4 2 6 3
2 . 9 + x 4 3 7 7 7 8 - x 3 7 8 9 4 4 5 +
x 1 2 9 5 0 3 3 + 7  $r^{-1}$  LOG + RCL 2 x RTN
(90 STEPS)

```

Plot of the performance curve of a 3x3 box culvert operating in throat control.

Data taken from Example #1.

Plotting Coordinates

Q	90.00	120.00	150.00	180.00
HW FL.	120.85	122.24	124.00	126.20

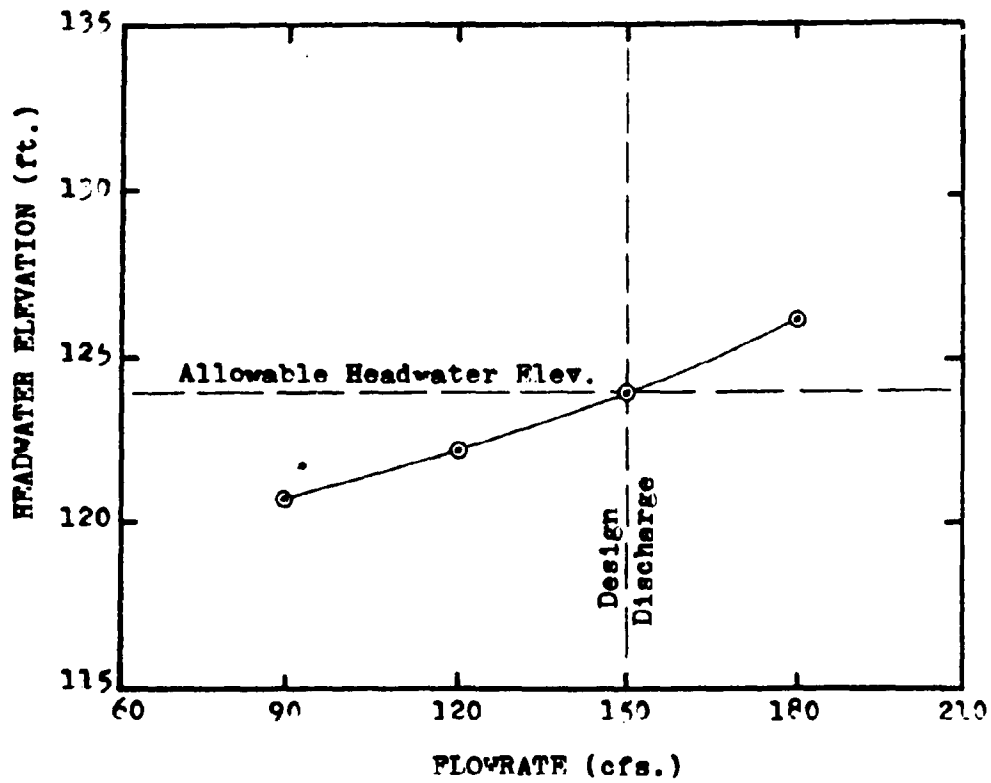

PROGRAMS #12 & #13 - BOX CULVERTS; FACE DIMENSIONS

SIDE-TAPERED INLET WITH SQUARE EDGES

SIDE-TAPERED INLET WITH PEVELED EDGES

These programs continue with the design of a culvert operating in throat control. For a side-tapered entrance, these programs compute the face width ( $E_f$ ) and the horizontal distance between the entrance and the throat control section ( $L_1$ ).

Program #12 deals with square edged inlets. Inlets with wingwall flare angles from  $15^\circ$  to  $26^\circ$  with a top beveled edge, or inlets with wingwall flare angles from  $26^\circ$  to  $90^\circ$  with all edges squared. These inlets can be seen graphically below.

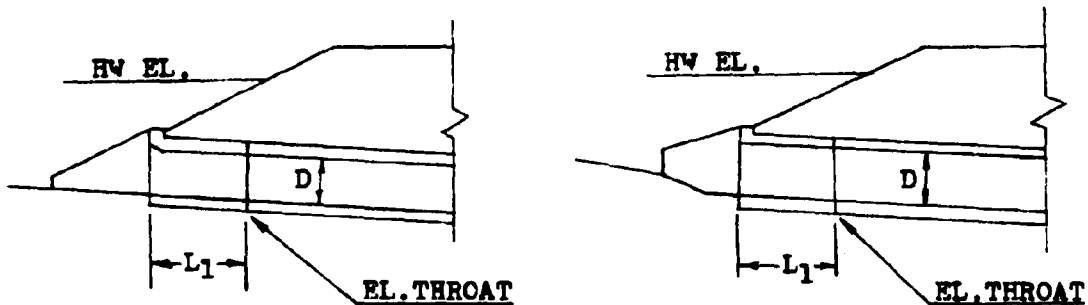

ELEVATION VIEW

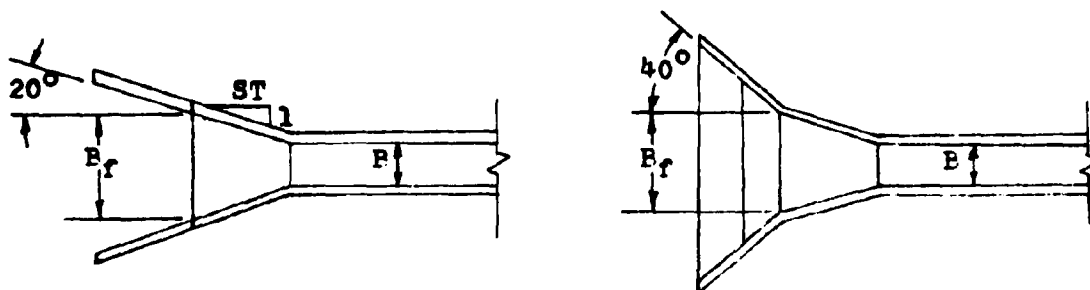

PLAN VIEW

$15^\circ$  to  $26^\circ$  wingwall Flare  
Top Edge Peveled - No FALL

$26^\circ$  to  $90^\circ$  wingwall Flare  
All Edges Square - With FALL

The bevel edged program, #13, pertains to inlets with wing-wall flare angles of  $26^\circ$  to  $45^\circ$  with top edges beveled, and to inlets with wingwall flare angles of  $45^\circ$  to  $90^\circ$  with both top and side edges beveled. For further details, refer to the diagrams below.

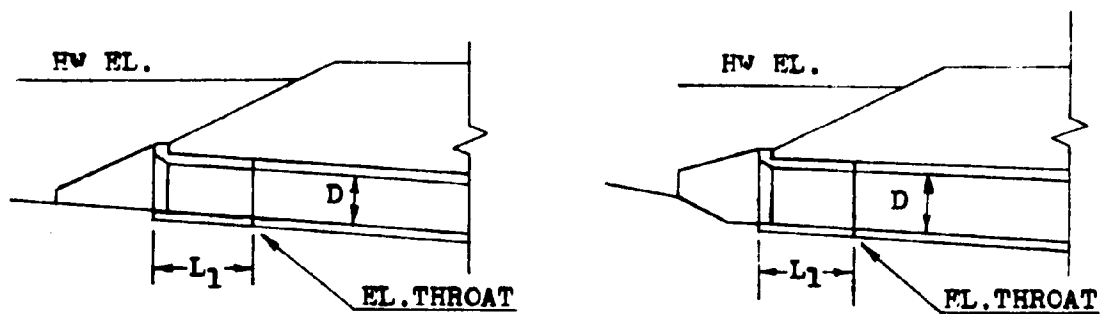

ELEVATION VIEW

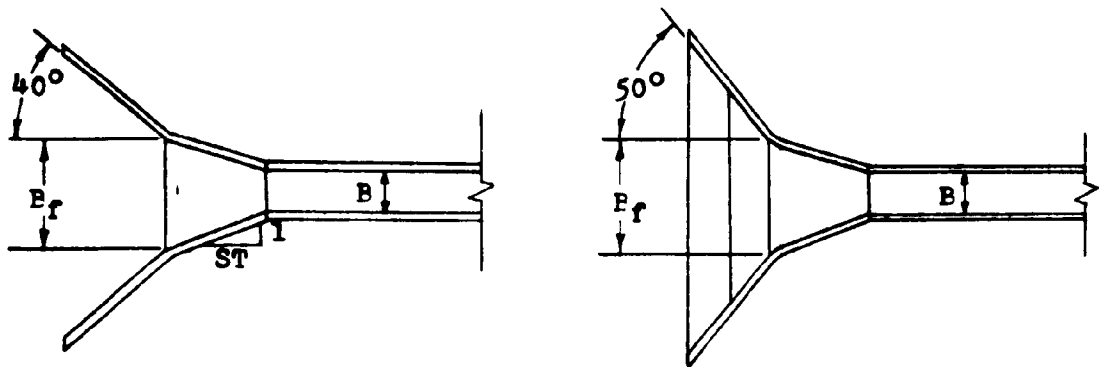

PLAN VIEW

$26^\circ$  to  $45^\circ$  wingwall Flare

$45^\circ$  to  $90^\circ$  wingwall Flare

Top Edge Beveled - No FALL

Top and Sides Beveled - FALL

The determination of  $E_f$  and  $L_1$  is a lengthy computation which exceeds the capacity of the HP-65 calculator. An extra program card is needed to complete these calculations. Programs #12 and #13 compute  $E_f$  and  $L_1$  but one of the inputs for these

calculations, the adjusted slope, is not determined until program #14. Correspondingly, program #14 needs the  $L_1$  value of programs #12 and #13, to complete its evaluation of ADJ.S.

The method used to solve this dilemma is to alternately use either programs #12 and #14 or programs #13 and #14, several times until the values of  $P_f$ ,  $L_1$ , and ADJ.S stabilize. This stabilization of values usually only takes two or three cycles.

For the initial calculation of  $P_f$  and  $L_1$ , the adjusted slope value is approximated by using the channel slope or a number slightly smaller.

Where prefabricated inlet sections are available,  $P_f$  and  $L_1$  have usually been set by the manufacturing company. These values are normally fixed at  $1\frac{1}{2}$  times the culvert depth. If this type of design is desired, the given values of  $P_f$  and  $L_1$  can be used in lieu of programs #12 and #13. The value of  $L_1$  can be directly used in program #14.

#### EQUATIONS

$$L_1 = ((P_f - E_x N) / 2) ST$$

$$H_f = HW \text{ EL.} - FL. \text{ THROAT} - L_1 (ADJ.S) = H_t - L_1 (ADJ.S)$$

$$X = H_f / D$$

Program #12

$$P_f = Q / (D^{1.5} (-1.219 + 4.3X - 0.6153X^2 + 0.0273X^3 + 0.0027X^4))$$

EQUATIONS (cont)

Program #13

$$B_f = Q / (D^{1.5} (-1.13607 + 3.69853X + 0.12128X^2 - 0.205339X^3 + 0.0256923X^4))$$

REMARKS

The product of the culvert width (B) and the number of barrels (N) is stored in register #3.

The number of culvert barrels (N), should be limited to a value of one or two.

As mentioned before, for the initial value of the adjusted slope (ADJ.S), the original channel slope (S<sub>0</sub>) should be used as an approximation. This value is stored in register #4.

The sidewall taper (ST) chosen for the culvert inlet is limited to a value between a 4:1 and a 6:1 ratio. Values less than 4:1 are unacceptable and will not operate as side-tapered inlets. Values greater than 6:1 will perform better than the design will indicate. Therefore with this larger value, the design will be conservative.

The value for L<sub>1</sub> determined by these programs is a horizontal measurement. As compared with L or ADJ.L which are measured along the culvert barrel.

<u>STEP</u>	<u>INSTRUCTIONS</u>	<u>INPUT</u>	<u>KEYS</u>	<u>DISPLAY</u>
1	Load program			

STEP	INSTRUCTIONS	INPUT	KEYS	DISPLAY
2	Input register values  Initially use $S_0$	Q	STO 1	Q
		D	STO 2	D
		B	ENTER	B
		N	x STO 3	BxN
		ADJ.S	STO 4	ADJ.S
		H <sub>t</sub>	STO 5	H <sub>t</sub>
		ST	STO 6	ST
3	Calculate the face width		A	B <sub>f</sub>
4	Calculate the inlet length		B	L <sub>1</sub>
5	Run program #14			
6	Repeat steps #2, #3, #4, and #5 until the values of B <sub>f</sub> and L <sub>1</sub> stabilize.			

EXAMPLE #1

In designing a 7x6 box culvert for a  $Q_{50}$  of 1000 cfs., the throat elevation was determined to be 181.75 feet. The headwater elevation was 205 feet. If a 4:1 side taper is chosen, what is the face width and the length of the side-tapered inlet? The natural channel slope is 5%, and the inlet is to have square edges. The headwater depth at the throat section is 23.25 feet.

Load program #12

<u>KEYSTROKES</u>	<u>DISPLAY</u>
1000 STO 1 . . . . .	1000.00
6 STO 2 . . . . .	6.00



<u>KEYSTROKES</u>	<u>DISPLAY</u>
7 STO 3 . . . . .	7.00
.05 STO 4 . . . . .	0.05
23.25 STO 5 . . . . .	23.25
4 STO 6 . . . . .	4.00
A . . . . .	8.12 ft. B <sub>f</sub>
B . . . . .	2.25 ft. L <sub>1</sub>

Using L<sub>1</sub> in program #14, ADJ.S is calculated to be 0.029816

1000 STO 1 . . . . .	1000.00
6 STO 2 . . . . .	6.00
7 STO 3 . . . . .	7.00
.029816 STO 4 . . . . .	0.03
23.25 STO 5 . . . . .	23.25
4 STO 6 . . . . .	4.00
A . . . . .	8.11 ft. B <sub>f</sub>
B . . . . .	2.23 ft. L <sub>1</sub>

From program #14, the ADJ.S = 0.029814

1000 STO 1 . . . . .	1000.00
6 STO 2 . . . . .	6.00
7 STO 3 . . . . .	7.00
.029814 STO 4 . . . . .	0.03
23.25 STO 5 . . . . .	23.25
4 STO 6 . . . . .	4.00
A . . . . .	8.11 ft. B <sub>f</sub>
B . . . . .	2.23 ft. L <sub>1</sub>

$B_f$  and  $L_1$  stabilized after two trials.

EXAMPLE #2

Design the same inlet only using the bevel edged program.

Load program #13

<u>KWYSTROKES</u>	<u>DISPLAY</u>
1000 STO 1 . . . . .	1000.00
6 STO 2 . . . . .	6.00
7 STO 3 . . . . .	7.00
.029814 STO 4 . . . . .	0.03
23.25 STO 5 . . . . .	23.25
4 STO 6 . . . . .	4.00
A . . . . .	7.68 ft. $B_f$
B . . . . .	1.36 ft. $L_1$

From program #14, the ADJ.S = 0.029734

1000 STO 1 . . . . .	1000.00
6 STO 2 . . . . .	6.00
7 STO 3 . . . . .	7.00
.029734 STO 4 . . . . .	0.03
23.25 STO 5 . . . . .	23.25
4 STO 6 . . . . .	4.00
A . . . . .	7.68 ft. $B_f$
B . . . . .	1.36 ft. $L_1$

As in the previous example, the values of  $B_f$  and  $L_1$  stabilized rapidly.

LISTING - PROGRAM #12

```
LPL A 1 LPL 1 CHS RCL 5 + RCL 2 + ENTER ENTER ENTER
. 0 0 2 7 x . 0 2 7 3 + x . 6 1 5 3 - x 4
. 3 + x 1 . 2 1 9 - RCL 1  $\times x \div y$  + RCL 2 ENTER f
 $\sqrt{x}$  x + 3  $r^{-1}$  LOG x f INT 3  $r^{-1}$  LOG + RCL 9  $\times x \div y$ 
 $\times x = y$  GTO 2 RCL 3 - 2 + RCL 6 x STO 8 RCL 4 x GTO 1
LPL B RCL 8 RTN LBL 2 DSP . 2 RCL 3  $\times x \div y$   $\times x \div y$ 
RTN 0 STO 8 RCL 3 RTN (97 STEPS)
```

LISTING - PROGRAM #13

```
LPL A 1 LPL 1 CHS RCL 5 + RCL 2 ÷ ENTER ENTER ENTER
. 0 2 5 6 9 x . 2 0 5 3 - x . 1 2 1 3 + x
3 . 6 9 9 + x 1 . 1 3 6 - RCL 1  $\times x \div y$  + RCL 2
ENTER f  $\sqrt{x}$  x + 3  $r^{-1}$  LOG x f INT 3  $r^{-1}$  LOG + RCL
9  $\times x \div y$   $\times x = y$  GTO 2 RCL 3 - 2 + RCL 6 x STO 8 RCL 4
x GTO 1 LPL B RCL 8 RTN LBL 2 DSP . 2 RCL 3  $\times x \div y$ 
 $\times x \div y$  RTN 0 STO 8 RCL 3 RTN (100 STEPS)
```

#### PROGRAM #14 - SLOPE ADJUSTMENT FOR SIDE-TAPERED INLETS

This program calculates the adjusted slope of a culvert which has been designed with a side-tapered inlet with FALL. A complex equation results from solving the geometry of the culvert rotation. The calculator solves this equation by a trial and error method.

As mentioned in other programs, the computation of the adjusted slope (ADJ.S) requires the length of the side-tapered inlet. The small size of the HP-65's program storage, requires that this length be determined in other programs. For box culverts the side-tapered inlet length ( $L_1$ ) is determined by programs #12 or #13. For pipe culverts, this length is calculated by programs #36, #37, or #38. By alternately using the values of ADJ.S and  $L_1$ , the correct values can be found.

The value of  $L_1$  to be used in this program, must be a horizontal measurement. If a prefabricated inlet section is used, care must be taken to not use the manufactures inlet length. This length must be adjusted by setting the inlet on the channel slope and figuring the in-place horizontal length.

#### EQUATIONS

$$0 = (FALL + D(S_0^2 + 1) \cdot 5 - D(ADJ.S^2 + 1) \cdot 5 - ADJ.S L_1) (S_{FU} (S_0^2 + 1) \cdot 5 ADJ.S) \\ - S_0 L + FALL (S_0^2 + 1) \cdot 5 - L_1 ADJ.S (S_0^2 + 1) \cdot 5 + L ADJ.S$$

ADJ.S is solved by a trial and error method.

The derivation of this equation is found in the appendix.

<u>STEP</u>	<u>INSTRUCTIONS</u>	<u>INPUT</u>	<u>KEYS</u>	<u>DISPLAY</u>
1	Load program			
2	Input register values	D	STO 2	D
		$S_o$	STO 4	$S_o$
		FALL	STO 5	FALL
		$S_{FU}$	STO 6	$S_{FU}$
		L	STO 7	L
		$L_1$	STO 8	$L_1$
3	Calculate adjusted slope		A	ADJ.S
4	For a change in any of these properties after the program has been, the culvert height (D) must be restored along with the desired value to be changed.			
5	If necessary, reuse program #12, #13, #36, #37, or #38.			
6	Repeat steps #2, #3 and #5 until $B_f$ , $L_1$ , and ADJ.S stabilize.			

EXAMPLE #1

Find the adjusted slope for a side-tapered, 7x6 box culvert with 6.25 feet of FALL. The culvert is 325 feet long with an upstream fill slope of 2:1. The channel slope is 5% and the initial value of the horizontal inlet length is 2.25 feet.

KEYSTROKES

DISPLAY

6 STO 2 . . . . . 6.00

<u>KRSTROKFS</u>	<u>DISPLAY</u>
.05 STO 4 . . . . .	0.05
6.25 STO 5 . . . . .	6.25
2 STO 6 . . . . .	2.00
325 STO 7 . . . . .	325.00
2.25 STO 8 . . . . .	2.25
A . . . . .	0.029816 ADJ.S

Using this value of ADJ.S in program #12,  $I_1 = 2.23$  ft.

6 STO 2 . . . . .	6.00
.05 STO 4 . . . . .	0.05
6.25 STO 5 . . . . .	6.25
2 STO 6 . . . . .	2.00
325 STO 7 . . . . .	325.00
2.23 STO 8 . . . . .	2.23
A . . . . .	0.029814 ADJ.S

LISTING - PROGRAM #14

```

LEI A RCL 2 1 STO 1 STO 3 DSP . 6 LFL 1 g R+ RCL 4
E RCL 3 E - x RCL 5 + RCL 3 RCL 8 x - RCL 4 F
RCL 6 x x RCL 3 x RCL 4 RCL 7 x - RCL 4 F RCL 5
x + RCL 4 F RCL 3 x RCL 8 x - RCL 7 RCL 3 x +
0 g x=y g x=y RCL 3 RTN RCL 1 g x=y STO 1 - x=y
RCL 3 RTN x R+ g x=y RCL 1 RCL 2 x g x=y + 6 f-1
LOG x f INT 6 f-1 LOG + STO 2 STO + 3 STO 1 LFL
F ENTER x 1 + f  $\sqrt{x}$  RTN (95 STEPS)

```

### PROGRAM #15 - LENGTH ADJUSTMENT, SIDE-TAPERED INLETS

When a culvert is improved with a side-tapered inlet, the length of the culvert barrel is affected. If the new inlet is designed with FALL, the barrel length will increase due to the rotation of the culvert. It will also be shortened by the addition of the inlet section. If no FALL is applied, the original culvert length will be shortened by the length of the inlet. Program #15 computes these changes and corrects the culvert length accordingly.

With the change in culvert length, the elevation of the face of the improved inlet may also be affected. This calculation is also handled by program #15.

### EQUATIONS

$$ADJ.L = (S_0 L / (S_0^2 + 1)^{.5} - FALL) ((ADJ.S^2 + 1)^{.5} / ADJ.S) - L_1 (ADJ.S^2 + 1)^{.5}$$

$$EL.FACE = EL.THROAT + L_1 ADJ.S$$

The derivations for these equations can be found in the appendix.

### REMARKS

The length of the inlet ( $L_1$ ) to be used by this program must be a horizontal distance.

The adjusted length, on the other hand, is measured along the culvert barrel. As mentioned in the paragraph above, the adjusted length does not include the length of the improved inlet.

This program can be used with either box or pipe culverts.

STEP	INSTRUCTIONS	INPUT	KEYS	DISPLAY
1	Load program			
2	Input register values	FL.THR	STO 1	FL.THROAT
		ADJ.S	STO 3	ADJ.S
		S <sub>o</sub>	STO 4	S <sub>o</sub>
		FALL	STO 5	FALL
		L	STO 7	L
		L <sub>1</sub>	STO 8	L <sub>1</sub>
3	Calculate adjusted length		A	ADJ.L
4	Calculate face elevation		B	EL.FACE
5	For a change in any of these channel variables, go to step #2 and change the necessary data.			

EXAMPLE #1

Determine the adjusted length and the face invert elevation for a box culvert with the following conditions. The culvert slope has been adjusted from 3.2% to 1.79%. The required channel FALL is 4.23 feet and the horizontal length of the inlet is 9.8 feet. The elevation of the throat is 346.78 feet and the original culvert length is 352 feet.

<u>KEYSTROKES</u>	<u>DISPLAY</u>
346.78 STO 1 . . . . .	346.78
.0179 STO 3 . . . . .	0.02
.032 STO 4 . . . . .	0.03



<u>KEYSTROKES</u>	<u>DISPLAY</u>
4.23 STO 5 . . . . .	4.23
352 STO 7 . . . . .	352.00
9.8 STO 8 . . . . .	9.80
A . . . . .	382.90 ft. ADJ.L
B . . . . .	346.96 ft. EL.FACE

EXAMPLE #2

A larger side-tapered culvert is to be used in the previous example. This new size eliminates the FALL. Determine the adjusted length and the face elevation. Since there is no FALL, the adjusted slope value should be set equal to the original channel slope.

<u>KEYSTROKES</u>	<u>DISPLAY</u>
0 STO 5 . . . . .	0.00
RCL 4 STO 3 . . . . .	0.03
A . . . . .	342.19 ft. ADJ.L
B . . . . .	347.09 ft. EL.FACE

LISTING - PROGRAM #15

```

LBL A RCL 7 RCL 4 x RCL 4 F + RCL 5 - RCL 3 F x
RCL 3 + RCL 3 F RCL 8 x - DSP . 2 RTN LBL B RCL 1
RCL 3 RCL 8 x + RTN LBL F ENTER x 1 + f  $\sqrt{x}$  RTN
(41 STEPS)

```

PROGRAMS #16 & #17 - SLOPF ADJUSTMENTS

SLOPE-TAPERED INLET WITH VERTICAL FACE

SLOPE-TAPERED INLET WITH MITERED FACE

When an improved inlet incorporates FALL in the design, the culvert slope is altered and must be recalculated. Program #16 analyzes the inlet geometry and determines the adjusted slope for a slope-tapered, vertical face inlet. Program #17 solves for the adjusted slope of a slope-tapered, mitered face inlet. The diagrams below show the difference between these two inlet configurations.

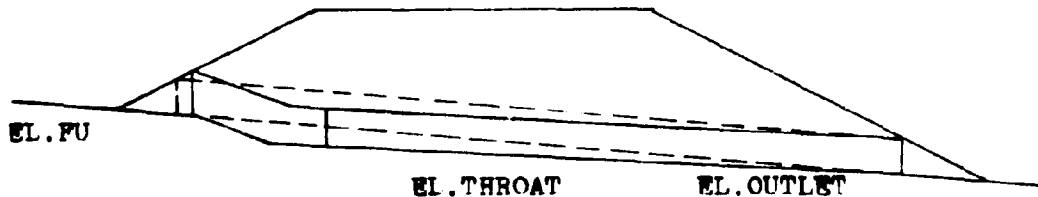

SLOPE-TAPERED, VERTICAL FACE INLET

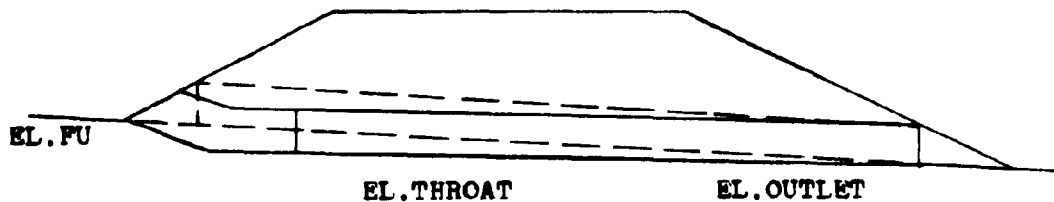

SLOPE-TAPERED, MITERED FACE INLET

These programs can be used with either box or pipe culverts.

## EQUATIONS

### PROGRAM #16

$$0 = \text{EL.FU} + (D(S_f^2 + 1) \cdot 5(S_{FU} + S_f)) / ((S_{FU}S_o + 1)(S_f^2)) + L_3/S_f \\ + (\text{EL.OUT} - \text{EL.FU}) / (S_o S_f) + (\text{EL.THR} - \text{EL.OUT}) / (S_f \text{ADJ.S}) \\ - L_3 \text{ADJ.S} - D(\text{ADJ.S}^2 + 1) \cdot 5 - \text{EL.THROAT}$$

### PROGRAM #17

$$0 = \text{EL.FU} + (D(S_f^2 + 1) \cdot 5/S_f) + L_3/S_f + (\text{EL.OUT} - \text{EL.FU}) / (S_o S_f) \\ + (\text{EL.THR} - \text{EL.OUT}) / (S_f \text{ADJ.S}) - L_3 \text{ADJ.S} - D(\text{ADJ.S}^2 + 1) \cdot 5 \\ - \text{EL.THROAT}$$

These two equations are solved by a trial and error method.

Their derivations can be found in the appendix.

## REMARKS

The value of  $L_3$  is not calculated but is usually set equal to one-half the culvert width ( $B/2$ ). Values slightly larger than  $B/2$  may be used, but smaller values are not recommended.

In operating these programs, the values stored in registers #4, #6, #7, #8, and #9 are removed during the calculations of the adjusted slope. If the particular program is to be immediately reused, these register values must first be restored.

<u>STEP</u>	<u>INSTRUCTIONS</u>	<u>INPUT</u>	<u>KEYS</u>	<u>DISPLAY</u>
1	Load program			
2	Input register values	D	STO 2	D
		$L_3$	STO 3	$L_3$

STPP	INSTRUCTIONS	INPUT	KEYS	DISPLAY
2	Input register values	$S_o$	STO 4	$S_o$
		WL.OUT	STO 5	WL.OUT
		$S_{FU}$	STO 6	$S_{FU}$
		WL.FU	STO 7	WL.FU
		$S_f$	STO 8	$S_f$
		EL.THR	STO 9	EL.THR
3	Calculate adjusted slope		A	ADJ.S
4	To change any of the channel variables go to step #2, reenter that value plus $S_o$ , $S_{FU}$ , WL.FU, $S_f$ , and WL.THR.			

#### EXAMPLE #1

Determine the adjusted slope for a slope-tapered, vertical face inlet with the following site conditions. The culvert is a 5x4 box, with an outlet elevation of 102.00 feet, a throat elevation of 118.50 feet, and a channel slope of 5%. The upstream fill slope is on a 3:1 ratio and intersects the streambed at elevation 125.00 feet. The face slope has been set at a 3:1 ratio.

#### Load Program #16

<u>KEYSTROKES</u>	<u>DISPLAY</u>
4 STO 2 . . . . .	4.00
5 ENTER 2 + STO 3 . . .	2.50

<u>KEYSTROKES</u>	<u>DISPLAY</u>
.05 STO 4 . . . . .	0.05
102 STO 5 . . . . .	102.00
3 STO 6 . . . . .	3.00
125 STO 7 . . . . .	125.00
3 STO 8 . . . . .	3.00
118.5 STO 9 . . . . .	118.50
A . . . . .	0.038524 ADJ.S

EXAMPLE #2

Evaluate the same site conditions for a mitered face, 60-inch pipe culvert.

Load Program #17

<u>KEYSTROKES</u>	<u>DISPLAY</u>
60 ENTER 12 + STO 2 . .	5.00
2 + STO 3 . . . . .	2.50
.05 STO 4 . . . . .	0.05
102 STO 5 . . . . .	102.00
3 STO 6 . . . . .	3.00
STO 8 . . . . .	3.00
125 STO 7 . . . . .	125.00
118.5 STO 9 . . . . .	118.50
A . . . . .	0.037716 ADJ.S

LISTING - PROGRAM #16

```
LBL A RCL 2 RCL 8 ENTER x 1 + f  $\sqrt{x}$  x RCL 8 RCL 6
RCL 4 x 1 + x + RCL 6 RCL 8 + RCL 8 + x RCL 7 +
RCL 9 - RCL 3 RCL 8 + + RCL 5 RCL 7 - RCL 8 + RCL 4
STO 7 STO 1 STO 6 + + STO 4 RCL 9 RCL 5 - RCL 8 +
STO 8 DSP . 6 LBL 1 RCL 2 RCL 1 ENTER x 1 + f  $\sqrt{x}$ 
x RCL 3 RCL 1 x + RCL 8 RCL 1 + - RCL 4 - 0  $x \geq y$ 
 $x = y$  RCL 1 RTN RCL 7  $x \geq y$  STO 7 -  $x = y$  RCL 1 RTN
RCL 7 RCL 6 x  $x \geq y$  + STO 6 STO + 1 GTO 1 (100 STEPS)
```

LISTING - PROGRAM #17

```
LBL A RCL 2 RCL 8 ENTER x 1 + f  $\sqrt{x}$  x RCL 8 + RCL 9
+ RCL 9 - RCL 3 RCL 8 + + RCL 5 RCL 7 - RCL 8 +
RCL 4 STO 7 STO 1 STO 6 + + STO 4 RCL 9 RCL 5 - RCL 8
+ STO 8 DSP . 6 LBL 1 RCL 2 RCL 1 ENTER x 1 + f  $\sqrt{x}$ 
x RCL 3 RCL 1 x + RCL 8 RCL 1 + - RCL 4 - 0  $x \geq y$ 
 $x = y$  RCL 1 RTN RCL 7  $x \geq y$  STO 7 -  $x = y$  RCL 1 RTN
RCL 7 RCL 6 x  $x \geq y$  + STO 6 STO + 1 GTO 1 (88 STEPS)
```

PROGRAMS #18 & #19 - INLET DIMENSIONS

SLOPE-TAPERED INLET WITH VERTICAL FACE

SLOPE-TAPERED INLET WITH MITERED FACE

In order to complete the design of the slope-tapered inlet, several inlet dimensions are required. Programs #18 and #19 calculate these values for the vertical face inlet and the mitered face inlet respectively.

Since the slope of the original culvert has been lowered, the original culvert length will be affected. The programs determine a new adjusted culvert length. The invert elevation of the face of the culvert is also determined by these programs. Two critical inlet lengths are also solved by these programs. The location of these values can be seen in the diagrams below.

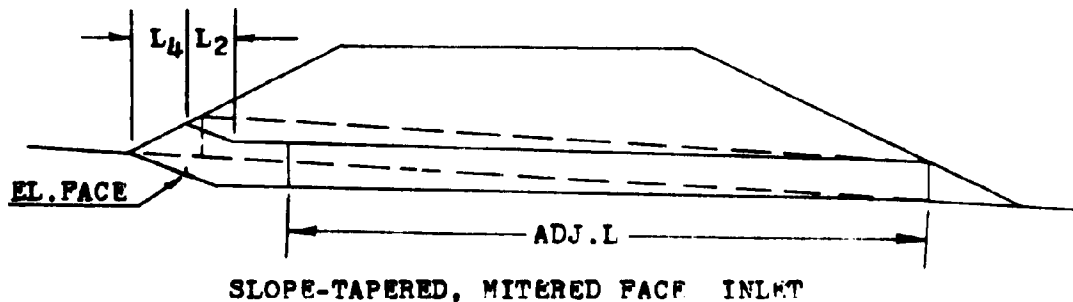
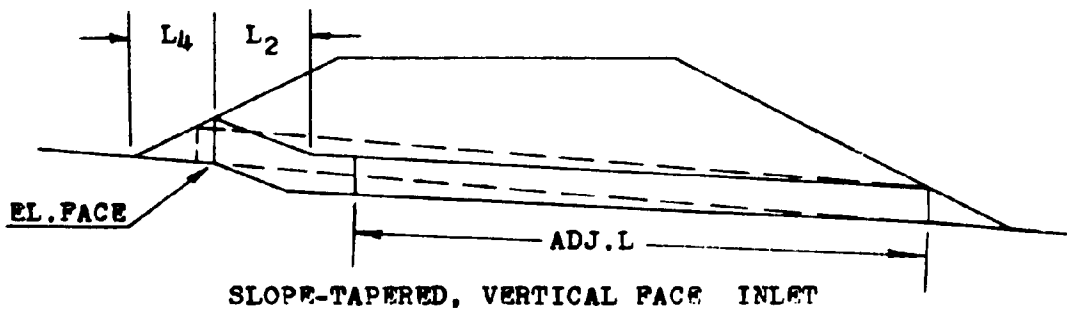

These programs can be applied to either box or pipe culvert situations.

It should be noted that even though the face elevation is calculated by program #19, for the mitered face inlet, there is no break in the culvert slope to mark this elevation.

### EQUATIONS

#### PROGRAM #18

$$\begin{aligned} \text{EL.FACE} &= \text{EL.FU} - L_4 S_o \\ L_4 &= S_{FU} D (S_f^2 + 1)^{.5} / (S_f (S_o S_{FU} + 1)) \end{aligned}$$

#### PROGRAM #19

$$\begin{aligned} \text{EL.FACE} &= \text{EL.FU} - L_4 / S_f \\ L_4 &= S_{FU} D (S_f^2 + 1)^{.5} / (S_{FU} + S_f) \end{aligned}$$

#### BOTH

$$\begin{aligned} L_2 &= (\text{EL.FU} - \text{EL.OUT}) / S_o - L_4 - L_3 - (\text{EL.THR} - \text{EL.OUT}) / \text{ADJ.S} \\ \text{ADJ.L} &= (\text{EL.THR} - \text{EL.OUT}) (\text{ADJ.S}^2 + 1)^{.5} / \text{ADJ.S} \end{aligned}$$

The derivations of these equations can be found in the appendix.

### REMARKS

The adjusted length value (ADJ.L) is measured along the culvert and does not include the length of the improved inlet.

<u>STEP</u>	<u>INSTRUCTIONS</u>	<u>INPUT</u>	<u>KEYS</u>	<u>DISPLAY</u>
-------------	---------------------	--------------	-------------	----------------

1	Load program			
---	--------------	--	--	--



STEP	INSTRUCTIONS	INPUT	KEYS	DISPLAY
2	Input register values	ADJ.S	STO 1	ADJ.S
		D	STO 2	D
		$L_3$	STO 3	$L_3$
		$S_o$	STO 4	$\epsilon_o$
		EL.OUT	STO 5	EL.OUT
		$S_{FU}$	STO 6	$S_{FU}$
		EL.FU	STO 7	EL.FU
		$S_f$	STO 8	$S_f$
		EL.THR	STO 9	EL.THR
3	Calculate face elevation		A	WL.FACE
	Calculate $L_4$		P	$L_4$
	Calculate $L_2$		C	$L_2$
	Calculate adjusted length		D	ADJ.L
4	For a change in any of these values go to step #2 and reenter only the necessary value.			

#### EXAMPLE #1

Determine the inlet dimensions for a vertical face , slope-tapered culvert with the following characteristics. Original channel slope is 6.2% and after the improved inlet evaluation, the slope has been adjusted to 4.42%. The culvert is a 5x4 box, with an upstream fill slope of 3:1 and an inlet face slope of 2:1. The throat elevation is 117.00 feet, the outlet elevation is 105.40 feet, and the upstream fill catch-point elevation is 124.10 feet.

KEYSTROKES

DISPLAY

.0442 STO 1 . . . . . 0.04  
4 STO 2 . . . . . 4.00  
5 ENTER 2 + STO 3 . . . . . 2.50  
.062 STO 4 . . . . . 0.06  
105.4 STO 5 . . . . . 105.40  
3 STO 6 . . . . . 3.00  
124.1 STO 7 . . . . . 124.10  
2 STO 8 . . . . . 2.00  
117 STO 9 . . . . . 117.00

Load Program #18

A . . . . . 123.40 ft. EL.FACE  
B . . . . . 11.31 ft. L<sub>4</sub>  
C . . . . . 25.36 ft. L<sub>2</sub>  
D . . . . . 262.70 ft. ADJ.L

EXAMPLE 42

Evaluate the same site conditions for the mitered face inlet.

Load Program #19

A . . . . . 121.42 ft. EL.FACE  
B . . . . . 5.37 ft. L<sub>4</sub>  
C . . . . . 31.30 ft. L<sub>2</sub>  
D . . . . . 262.70 ft. ADJ.L

LISTING - PROGRAM #18

LBL A DSP . 2 B RCL 4 x RCL 7 g x $\rightarrow$ y - RTN LBL P  
RCL 2 RCL 8 ENTER x 1 + f  $\sqrt{x}$  x RCL 8 + RCL 4 RCL 6  
g 1/x + + RTN LBL C RCL 7 RCL 5 - RCL 4 + B -  
RCL 3 - RCL 9 RCL 5 - RCL 1 + - RTN LBL D RCL 9  
RCL 5 - RCL 1 ENTER x 1 + f  $\sqrt{x}$  x RCL 1 + RTN  
(69 STEPS)

LISTING - PROGRAM #19

LBL A DSP . 2 B RCL 8 + RCL 7 g x $\rightarrow$ y - RTN LBL B  
RCL 2 RCL 6 x RCL 8 ENTER x 1 + f  $\sqrt{x}$  x RCL 6 RCL 8  
+ + RTN LBL C RCL 7 RCL 5 - RCL 4 + B - RCL 3 -  
RCL 9 RCL 5 - RCL 1 + - RTN LBL D RCL 9 RCL 5 -  
RCL 1 ENTER x 1 + f  $\sqrt{x}$  x RCL 1 + RTN (66 STEPS)

PROGRAMS #20 & #21 - FACE DIMENSIONS

SLOPE-TAPERED INLET WITH SQUARE EDGES

SLOPE-TAPERED INLET WITH BEVELED EDGES

These programs continue with the design of a culvert operating in throat control. For a slope-tapered inlet, these programs compute the face width of the improved inlet ( $B_f$ ), and the taper of the inlet's sidewall ( $ST$ ).

Program #20 deals with square edged inlets. Inlets in this category have wingwall flare angles from  $15^\circ$  to  $26^\circ$  with a top beveled edge, or inlets with wingwall flare angles from  $26^\circ$  to  $90^\circ$  with all squared edges. These inlets can be seen graphically below.

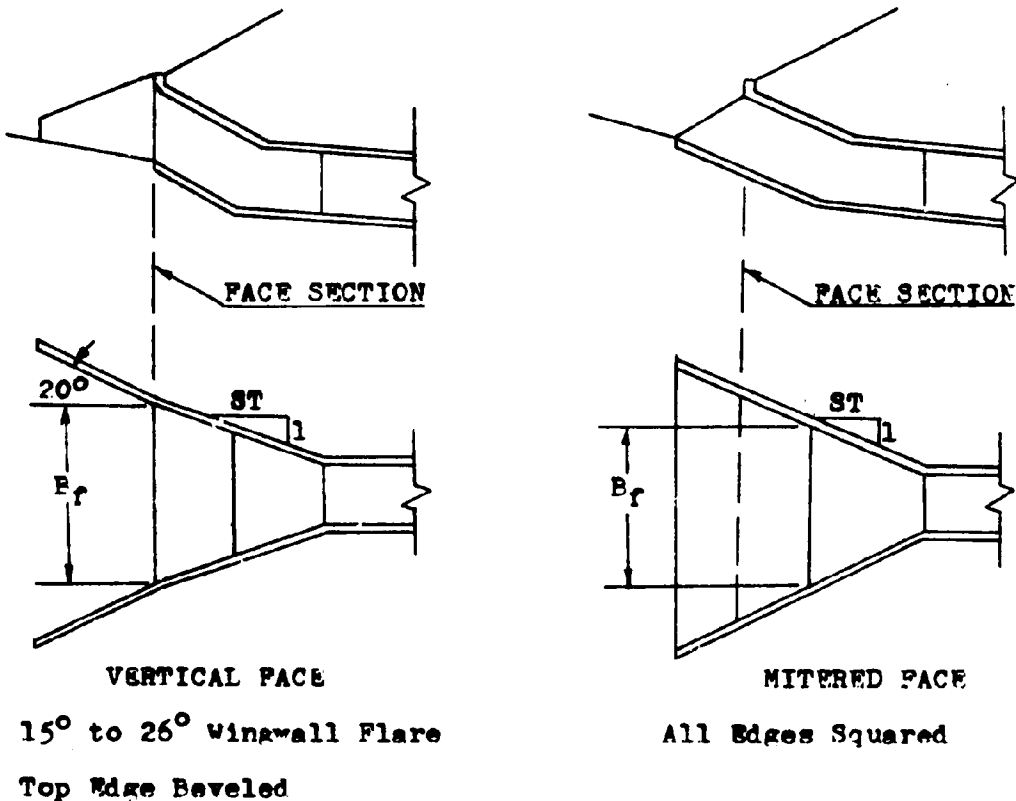

The bevel edged program, #21, pertains to inlets with wing-wall flare angles of  $26^\circ$  to  $45^\circ$  with their top edges beveled, and to inlets with wingwall flare angles from  $45^\circ$  to  $90^\circ$  with both top and side edges beveled. For further inlet descriptions refer to the diagrams below.

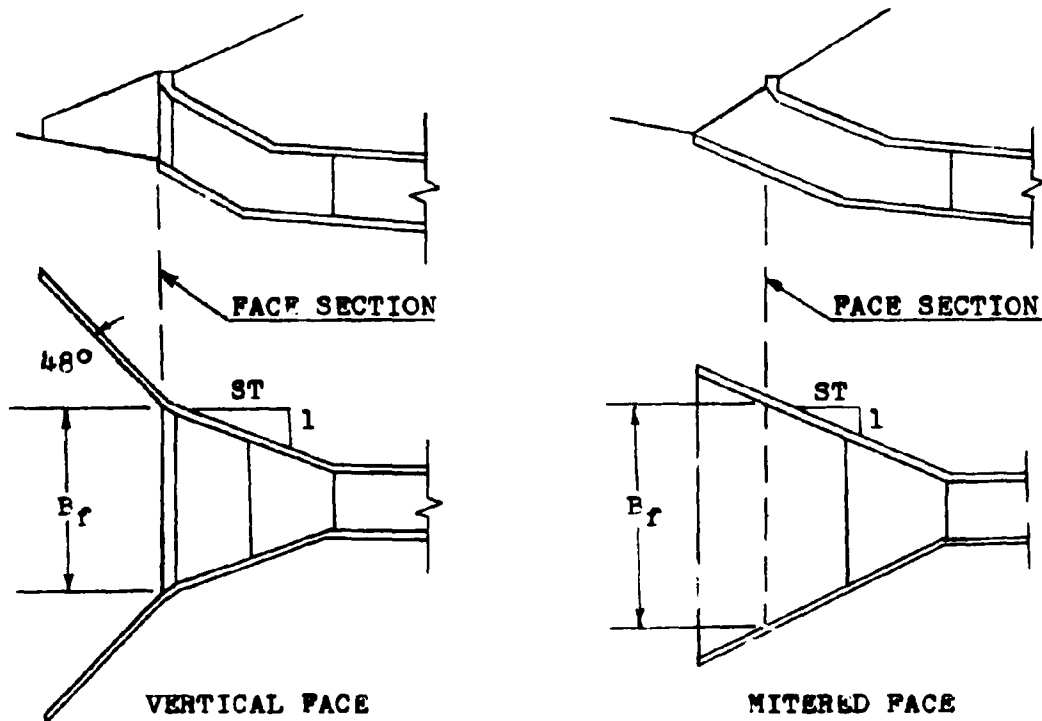

VERTICAL FACE  
 $45^\circ$  to  $90^\circ$  Wingwall Flare  
 Both Top and Side Edges Beveled

MITERED FACE  
 Top Edge Beveled

As can be noted from the diagrams, these programs can be applied to either vertical or mitered face inlets. Since the mitered face inlet generally has no wingwalls, the distinction between the use of these two programs as they pertain to the mitered inlet is whether the top edge is to be beveled or squared.

The bevel to be applied to the face section can be either a 1:1 bevel or a 1½:1 bevel.

These programs can be applied to either box or pipe culverts.

#### EQUATIONS

Program #20

$$B_f = Q / (D^{1.5} (-1.353 + 5.15X - 1.131X^2 + 0.1578X^3 - 0.0144X^4 + 0.0011X^5))$$

Program #21

$$B_f = Q / (D^{1.5} (-2.265863 + 7.942441X - 4.0350294X^2 + 1.619481X^3 - 0.3458214X^4 + 0.02846767X^5))$$

Both

$$X = (HW\ EL. - EL.FACE) / D$$

$$ST = (L_2 + L_3) / ((B_f - B \times N) / 2)$$

#### REMARKS

The value of  $L_3$  is not calculated but is usually set equal to one-half the culvert width ( $B/2$ ). Values slightly larger than  $B/2$  may be used, but smaller values are not recommended.

The culvert width ( $B$ ) and the number of culvert barrels ( $N$ ), are stored together as a product in register #4.

Since the calculation of the sidewall taper ( $ST$ ) uses the face width dimension ( $B_f$ ), the  $B_f$  calculation should be performed first. Label 'A' before Label 'F'.

The headwater elevation (HW EL.) used in the program can be obtained from program #11 for box culverts and from programs #34 and #35 for pipe culverts.

To use the programs for the vertical face condition, the face elevation (EL.FACE) and the length  $L_2$  should come from vertical face calculations from previous programs. For the mitered faced inlet, these two values should correspondingly come from mitered faced programs.

STEP	INSTRUCTIONS	INPUT	KEYS	DISPLAY
1	Load program			
2	Input register values	Q	STO 1	Q
		D	STO 2	D
		$L_3$	STO 3	$L_3$
		P	ENTER	R
		N	x STO 4	RxN
		HW EL.	STO 5	HW EL.
		EL.FACE	STO 6	EL.FACE
		$L_2$	STO 7	$L_2$
3	Calculate face width		A	$B_f$
4	Calculate sidewall taper		B	ST
5	To change any of these variables go to step #2 and alter only the necessary data.			
6	To change from square edged to bevel edged inlet, or vice versa, load the appropriate program and go to step #3.			

EXAMPLE #1

For a 6x6 box culvert with a design flowrate of 800 cfs., determine the face width and sidewall taper. The headwater elevation is 180.00 feet and for a mitered faced inlet, the face elevation is 176.40 feet and a length of 23.70 feet is given to the dimension  $L_2$ . All edges are to be squared.

Load program #20.

<u>KEYSTROKES</u>	<u>DI3PLAY</u>
800 STO 1 . . . . .	800.00
6 STO 2 . . . . .	6.00
6 ENTER 2 + STO 3 . . .	3.00
6 ENTER 1 x STO 4 . . .	6.00
180 STO 5 . . . . .	180.00
176.4 STO 6 . . . . .	176.40
23.7 STO 7 . . . . .	23.70
A . . . . .	39.96 ft. B <sub>f</sub>
B . . . . .	1.57 ST

EXAMPLE #2

A 60-inch pipe culvert with a design flowrate of 480 cfs. is to be used with a slope-tapered inlet. The headwater elevation is set at 214.60 feet and the face elevation of 209.40 feet exists for the vertical faced situation. An  $L_2$  length of 14.96 feet has been determined. Find the width of the face section and the sidewall taper. The pipe is to have a 90° wingwall flare. All edges are to be beveled.



Load program #21

<u>KEYSTROKES</u>	<u>DISPLAY</u>
480 STO 1 . . . . .	480.00
60 ENTER 12 + STO 2 . .	5.00
2 + STO 3 . . . . .	2.50
5 STO 4 . . . . .	5.00
214.6 STO 5 . . . . .	214.60
209.4 STO 6 . . . . .	209.40
14.96 STC 7 . . . . .	14.96
A . . . . .	13.93 ft. B <sub>f</sub>
B . . . . .	3.91 ST

LISTING - PROGRAM #20

```

LBL A RCL 5 RCL 6 - RCL 2 + ENTER ENTER ENTER 1 .
1 x 1 4 . 4 - x 1 5 7 . 8 + x 1 1 3 1 - x
5 1 5 0 + x 1 3 5 3 - 3 r-1 LOG + RCL 2 ENTER
f  $\sqrt{x}$  x x RCL 1 g x $\rightarrow$ y + STO 8 RTN LBL B RCL 8 RCL 4
- 2 + g 1/x RCL 7 RCL 3 + x RTN (73 STEPS)

```

LISTING - PROGRAM #21

```

LBL A RCL 5 RCL 6 - RCL 2 + ENTER ENTER ENTER 2 8
4 6 7 . 6 x 3 4 5 8 2 1 . 4 - x 1 6 1 9 4
8 1 + x 4 0 3 5 0 2 9 . 4 - x 7 9 4 2 4 4
1 + x 2 2 6 5 8 6 3 - 6 r-1 LOG + RCL 2 ENTER
f  $\sqrt{x}$  x x RCL 1 g x $\rightarrow$ y + STO 8 RTN LBL B RCL 8 RCL 4
- 2 + g 1/x RCL 7 RCL 3 + x RTN (94 STEPS)

```

PROGRAM #22 - CR#ST CHECK EVALUATION

SLOPE-TAPERED MITERED INLET

In order for this inlet design to operate efficiently, the weir configuration at the inlet must be operating properly. This program establishes the width of the sidewall opening and the sidewall taper necessary to insure the appropriate hydraulic conditions.

This program can be used for either box or pipe culverts and for either square or bevel edged inlets.

The diagrams below indicate the locations of the dimensions determined by this program.

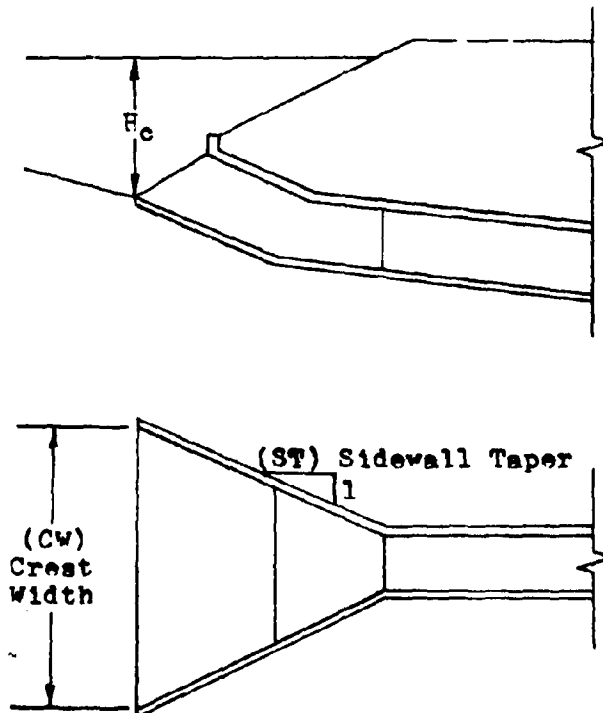

Slope-Tapered Mitered Faced Inlet

### EQUATIONS

$$H_c = HW\ EL. - EL.FACE$$

$$CW = Q / (2H_c)^{1.5}$$

$$ST = 2L_u / (CW - B_f)$$

### REMARKS

For the program to operate properly, the crest width (CW) must be calculated before the sidewall taper (ST) can be determined.

<u>STWP</u>	<u>INSTRUCTIONS</u>	<u>INPUT</u>	<u>KEYS</u>	<u>DISPLAY</u>
1	Load program			
2	Input register values	Q	STO 1	Q
		L <sub>u</sub>	STO 4	L <sub>u</sub>
	(Throat)	HW EL.	STO 5	HW EL.
	(Mitered)	EL.FACE	STO 7	EL.FACE
	(Square or Beveled)	B <sub>f</sub>	STO 8	B <sub>f</sub>
3	Calculate crest height		A	H <sub>c</sub>
4	Calculate crest width		B	CW
5	Calculate sidewall taper		C	ST
6	For a change in any of these culvert properties, go to step #2 and reenter the desired item plus the value of B <sub>f</sub> .			

EXAMPLE #1

What is the recommended sidewall taper for a mitered face slope-tapered inlet to insure throat and not crest control of the hydraulic performance. The culvert is to handle 3000 cfs. and has a predetermined  $L_u$  value of 10.0 feet. The headwater elevation is 98.4 feet and the elevation of the face section of the culvert is 83.2 feet. For a beveled edged inlet the face width is 8.12 feet.

<u>KEYSTROKES</u>	<u>DISPLAY</u>
3000 STO 1 . . . . .	.3000.00
10 STO 4 . . . . .	10.00
98.4 STO 5 . . . . .	98.40
83.2 STO 7 . . . . .	83.20
8.12 STO 8 . . . . .	8.12
A . . . . .	15.20 ft. $H_c$
B . . . . .	17.90 ft. CW
C . . . . .	2.05 ST

If the sidewalls are built on a 2:1 or larger taper, the culvert will operate in throat control.

LISTING - PROGRAM #22

```
LBL A RCL 5 RCL 7 - RTN LBL B RCL 1 A 2 x 1 . 5
x yx + STO 6 RTN LBL C RCL 4 2 x RCL 6 RCL 8 - +
0 x xy g xy g NOP RTN (34 STEPS)
```

## PROGRAMS #23 & #24 - BOX CULVERT; INLET CONTROL OUTLET VELOCITY

Due to the complexity of the calculations involved in computing this outlet velocity, the program has been divided into two parts, program #23 and program #24.

Together these programs contain polynomial equations which approximate the normal depth curve for a rectangular cross-sectional area. The set of curves involved were taken from "Open Channel Hydraulics" by Chow. See reference #4.

Program #23 determines the abscissa for the curves (called 'X' in the equation section), as well as one of the polynomial equations required. Program #24 compares the values produced by program #23 and completes the second polynomial expression if necessary.

To run these programs, the desired inputs are stored in their appropriate registers and then Label 'A' is pressed for program #23. The value of (X) is displayed. Program #24 is then loaded and Label A is immediately pressed again. The value of the outlet velocity for the culvert operating in inlet control is then displayed.

### EQUATIONS

Program #23

$$X = (Qn / (1.486NS \cdot S)) / P^{8/3}$$

If  $X < 0.22$

$$d_n = B(0.036402 + 3.6483784X - 15.152238X^2 + 64.991913X^3 - 110.31635X^4)$$

### EQUATIONS

#### Program #24

If  $0.22 \leq X < 1.1$

$$d_n = B(0.084468 + 2.34061X - 1.53643X^2 + 1.636594X^3 - 0.677621X^4) \quad d_n \text{ is limited to } 2B$$

If  $X \geq 1.1$

$$d_n = D$$

$$V = Q/(Bnd_n)$$

### REMARKS

Once the register values have been stored for program #23, they do not have to be restored for the running of program #24.

The calculators register values should not be tampered with between the running of the two programs.

<u>STEP</u>	<u>INSTRUCTIONS</u>	<u>INPUT</u>	<u>KEYS</u>	<u>DISPLAY</u>
1	Load program #23			
2	Input register values	Q	STO 1	Q
		D	STO 2	D
		B	STO 3	B
		N	STO 4	N
		n	STO 5	n
	(ADJ.S or S)	S	STO 6	S
3	Calculate 'X'		A	X
4	Load program #24			
5	calculate outlet velocity		A	V
6	For a change in any data, goto step #1.			

EXAMPLE #1

Find the outlet velocity for a 6x5 box culvert operating in inlet control. The design discharge is 100 cfs, and the channel slope has been adjusted to 0.015. The box is to be constructed out of concrete making the value for Manning's  $n = 0.012$ .

<u>KEYSTROKES</u>	<u>DISPLAY</u>
100 STO 1 . . . . .	100.00
5 STO 2 . . . . .	5.00
6 STO 3 . . . . .	6.00
1 STO 4 . . . . .	1.00
.012 STO 5 . . . . .	0.01
.015 STO 6 . . . . .	0.02
Load program #23	
A . . . . .	0.06
Load program #24	
A . . . . .	13.74 fps. $V_o$

EXAMPLE #2

Evaluate the same culvert for a flowrate of 500 cfs.

<u>KEYSTROKES</u>	<u>DISPLAY</u>
500 STO 1 . . . . .	500.00
Load program #23	
A . . . . .	0.28
Load program #24	
A . . . . .	21.49 fps. $V_o$

LISTING - PROGRAM #23

LBL A RCL 1 RCL 5 x 1 . 4 8 6 + RCL 6 r  $\sqrt{x}$  +  
RCL 4 + RCL 3 8 ENTER 3 + g  $y^x$  + STO 7 . 2 2  
g  $x \leq y$  RCL 7 RTN RCL 7 ENTER ENTER ENTER 1 1 0 3  
1 6 4 CHS x 6 4 9 9 1 9 + x 1 5 1 5 2 2  
- x 3 6 4 8 4 + x 3 6 4 . 0 2 + 4  $r^{-1}$  LOG  
+ 2 g  $x > y$  g  $x \geq y$  g NOP RCL 3 x RCL 2 g  $x \geq y$  g  $x > y$   
g  $x \geq y$  g NOP RCL 4 RCL 3 x x RCL 1 g  $x \geq y$  + STO 8  
RCL 7 RTN (100 STEPS)

LISTING - PROGRAM #24

LBL A . 2 2 RCL 7 g  $x \leq y$  GTO 1 1 . 1 g  $x > y$  GTO 2  
RCL 1 RCL 2 RCL 3 RCL 4 x x + RTN LBL 1 RCL 8 R/S  
LBL 2 RCL 7 ENTER ENTER ENTER 6 7 7 6 2 1 CHS x  
1 6 3 6 5 9 4 + x 1 5 3 6 4 3 0 - x 2 3 4  
0 6 1 0 + x 8 4 4 6 8 + 6  $r^{-1}$  LOG + 2 g  $x > y$   
g  $x \geq y$  g NOP RCL 3 x RCL 2 g  $x \geq y$  g  $x > y$  g  $x \geq y$  g NOP  
RCL 4 RCL 3 x x RCL 1 g  $x \geq y$  + R/S (97 STEPS)



PROGRAM #25 - PIPE CULVERT; CRITICAL DEPTH

The approach by this program to determine the critical depth for pipe culvert is to use polynomial best-fit equations of the critical depth curve given in, "Open Channel Hydraulics", by Chow. The program computes a 'Z' value which corresponds to the abscissa of the curve. This value is then applied to one of two equations which are used to approximate different reaches of the curve. Continuing through the calculations, the critical depth is determined.

EQUATIONS

$$Z = (Q / (N(32.2/\alpha)^{.5})) / D^{2.5}$$

$$X = \text{Log } Z$$

If  $X \leq \text{Log } .7$

$$d_c = D(10)^Y$$

$$Y = (-0.0051657 + 0.407362X - 0.1830236X^2 - 0.0915565X^3)$$

If  $X > \text{Log } .7$

$$Y = (-.0244603 + 0.2017057X - 0.64009815X^2 + 0.695619X^3)$$

<u>STEP</u>	<u>INSTRUCTIONS</u>	<u>INPUT</u>	<u>KEYS</u>	<u>DISPLAY</u>
1	Load program			
2	Input register values	Q	STO 1	Q
		D	STO 2	D
		N	STO 3	N
		$\alpha$	STO 4	$\alpha$

STEP	INSTRUCTIONS	INPUT	KEYS	DISPLAY
3	Calculate critical depth		A	$d_c$
4	To change any of the input data, go to step #2 and change only the necessary item.			

EXAMPLE #1

Find the critical depth for a corrugated metal pipe (CMP) of a 36-inch diameter. The flow through the pipe is 100 cfs. For a CMP the value for alpha is 1.12.

<u>KEYSTROKES</u>	<u>DISPLAY</u>
100 STO 1 . . . . .	100.00
36 ENTER 12 + STO 2 . .	3.00
1 STO 3 . . . . .	1.00
1.12 STO 4 . . . . .	1.12
A . . . . .	2.92 ft. $d_c$

EXAMPLE #2

How would the critical depth change if concrete was used instead of the corrugated metal. The value of alpha for concrete is 1.04.

<u>KEYSTROKES</u>	<u>DISPLAY</u>
1.04 STO 4 . . . . .	1.04
A . . . . .	2.90 ft. $d_c$

Not much of a significant change results.

LISTING - PROGRAM #25

```
LBL A RCL 1 RCL 3 + 3 2 . 2 RCL 4 + RCL 2 x f  $\sqrt{x}$ 
+ RCL 2 RCL 2 x + f LOG ENTER ENTER ENTER . 7 f
LOG g xsy g R+ B g R+ 9 1 5 6 CHS x 1 8 3 0 2
- x 4 0 7 3 6 + x 5 1 7 - C LBL B 6 9 5 6
2 x 6 4 0 1 0 - x 2 0 1 7 1 + x 2 4 4 6 -
LBL C 5 f-1 LOG + f-1 LOG RCL 2 x RCL 2 g x>y
g x>y g NOP R/S (100 STOPS)
```

PROGRAM #26 - PIPE CULVERT; SIZE AND OUTLET CONTROL PERFORMANCE

This program has two functions. First, it can be used to select the appropriate pipe culvert size. Second, once this pipe size has been selected, the program will evaluate the performance of the culvert for various flowrates. The outlet control performance curve can be made by plotting these flowrates versus the generated headwater elevations (HW EL.).

In determining the best pipe culvert size, the designer must first select a trial diameter (D). For this value, the program computes the water surface elevation of the headwater pool at the culvert inlet. A visual comparison of this value to the allowable headwater elevation (AHW EL.) is made and the designer adjusts the diameter (D) accordingly.

Once the pipe size has been determined, various flowrate values can be used with the program to obtain a performance curve.

The following diagram indicates the location of the energy losses associated with the culvert design.

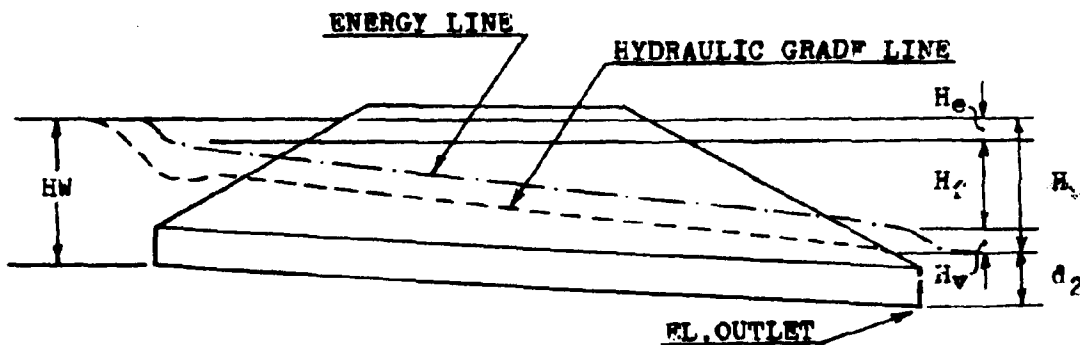

### EQUATIONS

$$H_e = k_e V^2 / 2g$$

$$H_f = 29n^2 LV^2 / 2gR^{1.33}$$

$$H_v = V^2 / 2g$$

$$H = H_e + H_f + H_v$$

$$= (1 + k_e + 29n^2 L / (D/4)^{1.33}) (4Q / ND^2 \pi)^2 / 2g$$

$$d_2 = (d_c + D) / 2 \text{ or the Tailwater depth, whichever is largest}$$

$$\text{HW WL.} = H + d_2 + \text{EL. OUTLET}$$

### REMARKS

The critical depth ( $d_c$ ) cannot be greater than the diameter of the pipe (D). The program includes a test for this situation.

Since the water at the inlet is considered to be a pool, the velocity at this point is assumed to be approximately zero.

This allows the hydraulic grade line to be equated to the energy line.

For the program to operate properly, the number of barrels (N) and the barrel roughness value (n), must be stored together as a sum in register #3. The limitations on the equations above, require that the number of barrels (N), be limited to a value of either 1 or 2.

Label A (HW WL.) must be executed before Label C ( $d_2$ ).

STEP	INSTRUCTIONS	INPUT	KEYS	DISPLAY
1	Load program			
2	Input register values	Q	STO 1	Q
		D	STO 2	D
		N	ENTER	N
		n	+ STO 8	N+n
		EL.OUT	STO 4	EL.Outlet
		$k_e$	STO 5	$k_e$
		TW	STO 6	TW
		L	STO 7	L
		$d_c$	STO 8	$d_c$
3	Calculate headwater elevation		A	HW EL.
4	Calculate total head loss		B	H
5	Calculate depth of water at outlet	C		$d_2$
6	To evaluate another pipe size, reenter the new value and go to step #3. *			
7	To obtain outlet control performance curve coordinates, input various flowrates and calculate the corresponding headwater elevations. **			
	* If the length, critical depth, and outlet elevation of the culvert change with the diameter, they must also be reentered.			
	** If the tailwater depth, and the critical depth change with the new flowrates, they must also be reentered.			

EXAMPLE #1

For a flowrate of 420 cfs., and an entrance loss coefficient of 0.5, find the appropriate pipe culvert size. The tailwater depth for this flowrate is 3.61 feet. From the site conditions, it has been determined that for a twin 48-inch CMP, a 253.70 foot barrel is required. The outlet elevation for this size of pipe would be 119.43 feet. The corresponding critical depth is 3.90 feet. If a twin 54-inch CMP is selected for the site, the length would change to 248.56 feet, the outlet elevation would rise to 119.75 feet, and the critical depth would raise to 4.16 feet. For corrugated metal, Manning's n is 0.024. The allowable headwater elevation is set at 140.4 feet.

<u>KEYSTROKES</u>	<u>DISPLAY</u>
420 STO 1 . . . . .	420.00
2 ENTER .024 + STO 3 . .	2.02
.5 STO 5 . . . . .	0.50
Try the 48-inch culvert	
48 ENTER 12 + STO 2 . .	4.00
119.43 STO 4 . . . . .	119.43
3.61 STO 6 . . . . .	3.61
253.7 STO 7 . . . . .	253.70
3.9 STO 8 . . . . .	3.90
A . . . . .	148.26 ft. HW EL.

This HW EL. is larger than the allowable, try 54-inch pipes.

54 ENTER 12 + STO 2 . .	4.50
119.75 STO 4 . . . . .	119.75

KEYSTROKES

DISPLAY

248.56 STO 7 . . . . . 248.56

4.16 STO 8 . . . . . 4.16

A . . . . . 137.75 ft. HW EL.

This HW EL. is below the allowable. Use it.

B . . . . . 13.67 ft. H

C . . . . . 4.33 ft. d<sub>2</sub>

Use the twin 54-inch pipe culverts.

EXAMPLE #2

Evaluate the outlet performance curve for the pipe designed above. Plot the four points on the curve which correspond to the 0.6Q, 0.8Q, Q, and the 1.2Q. The tailwater depths are 3.42 feet, 3.55 feet, 3.61 feet, and 3.72 feet respectively. Similarly the critical depths are 3.39, 3.87, 4.16 and 4.32 feet.

KEYSTROKES

DISPLAY

420 ENTER .6 x STO 1 . . 252.00

54 ENTER 12 + STO 2 . . 4.50

2 ENTER .024 + STO 3 . . 2.02

119.75 STO 4 . . . . . 119.75

.5 STO 5 . . . . . 0.50

3.42 STO 6 . . . . . 3.42

248.56 STO 7 . . . . . 248.56

3.39 STO 8 . . . . . 3.39

A . . . . . 128.62 ft. HW EL. @ 0.6Q

420 ENTER .8 x STO 1 . . 336.00



<u>KEYSTROKES</u>	<u>DISPLAY</u>
3.55 STO 6 . . . . .	3.55
3.87 STO 8 . . . . .	3.87
A . . . . .	132.68 ft. HW EL. @ 0.08Q
420 ENTER 1.2 x STO 1 .	504.00
3.72 STO 6 . . . . .	3.72
4.32 STO 8 . . . . .	4.32
A . . . . .	143.84 ft. HW EL. @ 1.2Q

LISTING - PROGRAM #26

```

LBL A RCL 8 RCL 2 g xSy RCL 2 g NOP + 2 + RCL 6 g xSy
g xSy g NOP STO 9 B RCL 4 + RCL 9 + RTN LBL B 2
9 RCL 3 f-1 INT ENTER x x RCL 7 x RCL 2 4 + 4 ENTER
3 + g yx + RCL 5 + 1 + 4 RCL 1 x RCI 3 f INT +
RCL 2 ENTER x + g π + ENTER x 6 4 . 4 + x RTN
LBL C RCL 9 RTN (77 STEPS)

```

Plot of the performance of a twin 54-inch pipe culvert operating in outlet control.

Plotting Coordinates

Q	252.00	336.00	420.00	504.00
HW EL.	128.62	132.68	137.75	143.84

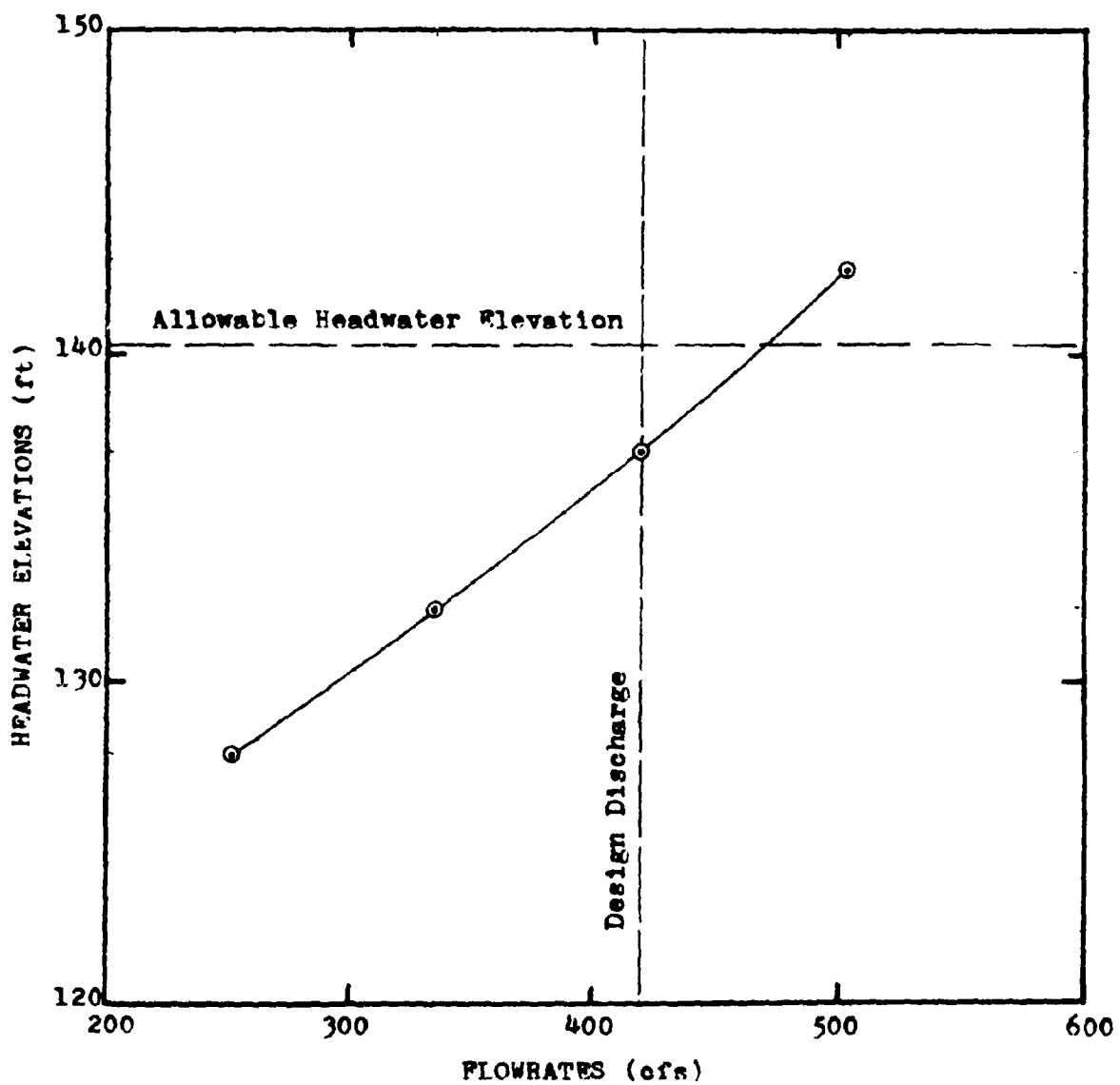

PROGRAM #27 - PIPE CULVERT; OUTLET CONTROL OUTLET VELOCITY

This program determines the outlet velocity of a pipe culvert operating in outlet control.

The depth of flow used in the computation of the cross-sectional area of the flow through the culvert is equal to the critical depth or the tailwater depth, whichever is greater. However, if this depth is found to be larger than the diameter of the pipe culvert, the depth of flow is set equal to the diameter of the pipe.

EQUATIONS

$$V = Q/AN$$

$$d_u = d_c \text{ or } TW, \text{ whichever is greater, not to exceed } D$$

$$R = D/2$$

$$r = \text{ABS}(R-d_u)$$

$$\text{If } d_u < R$$

$$A = (\pi R^2 \cos^{-1}(r/R)/180) - r(R^2 - r^2) \cdot 5$$

$$\text{If } d_u \geq R$$

$$A = \pi R^2 - (\pi R^2 \cos^{-1}(r/R)/180) + r(R^2 - r^2) \cdot 5$$

REMARKS

The calculator should be set in the degree mode for this program to operate properly.

<u>STPP</u>	<u>INSTRUCTIONS</u>	<u>INPUT</u>	<u>KEYS</u>	<u>DISPLAY</u>
1	Load program			
2	Input register values	Q	STO 1	Q
		D	STO 2	D
		N	STO 3	N
		TW	STO 6	TW
		$d_c$	STO 8	$d_c$
3	Calculate outlet velocity		A	V
4	For a change in any of the culvert properties go to step #2 and change only the necessary item.			

EXAMPLE #1

What is the outlet velocity of a 48 inch pipe culvert with a discharge of 200 cfs.? The tailwater depth is 3.28 feet and the critical depth is 3.88 feet.

<u>KEYSTROKES</u>	<u>DISPLAY</u>
200 STO 1 . . . . .	200.00
48 ENTER 12 + STO 2 . .	4.00
1 STO 3 . . . . .	1.00
3.28 STO 6 . . . . .	3.28
3.88 STO 8 . . . . .	3.88
A . . . . .	16.06 fps V

LISTING - PROGRAM #27

```
LBL A RCL 8 RCL 6  $\pi$  xSy  $\pi$  xSy  $\pi$  NOP RCL 2  $\pi$  x>y  $\pi$  x>y  
 $\pi$  NOP RCL 2 2 + STO 4  $\pi$  xSy f SP 1 --  $\pi$  ABS STO 5  
RCL 4 +  $r^{-1}$  COS RCL 4 RCL 4 x x  $\pi$   $\pi$  x 1 8 0 +  
RCL 4 RCL 4 x RCL 5 RCL 5 x -  $r \sqrt{x}$  RCL 5 x -  $r^{-1}$   
TF 1 GTO 1 RCL 4 RCL 4 x  $\pi$   $\pi$  x  $\pi$  x>y -  $r^{-1}$  SP 1  
LBL 1 RCL 3 x RCL 1  $\pi$  x>y + RTN (71 STEPS)
```

PROGRAMS #28-33 PIPE CULVERTS; INLET CONTROL PERFORMANCE

- Program #28: CMP with Projecting Edge
- Program #29: CMP or Concrete with Standard End Section
- Program #30: CMP or Concrete with Beveled Edges (Type A)
- Program #31: Concrete with Square Edges in a Headwall
- Program #32: Concrete with Projecting Socket Edge
- Program #33: Concrete with Socket Edge in a Headwall

Information is also provided for the design of the following inlets.

- CMP Mitered to Conform to Slope
- CMP in a Headwall
- CMP or Concrete with Beveled Edges (Type B)
- Concrete with Projecting Square Edges

The programs named above evaluate the hydraulic performance for the described inlet configurations operating in inlet control. Although the shape of the inlet faces differ dramatically, the analysis formulas are very similar. For this reason, these programs are grouped together. A more detailed explanation of the geometry of these inlets is provided below:

Program #28

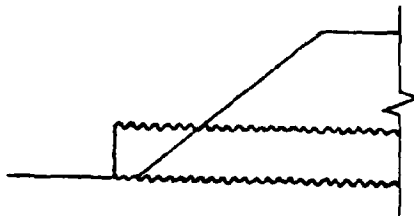

CMP - Projecting Edge

Program #29

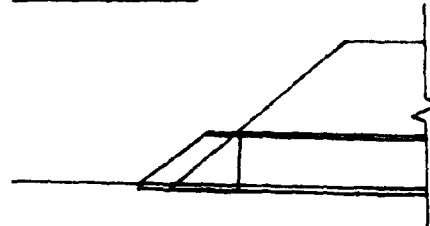

CMP/Concrete - End Section

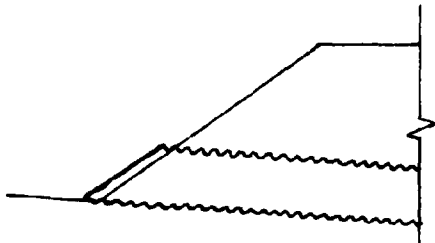

CMP - Mitered to Conform to Slope

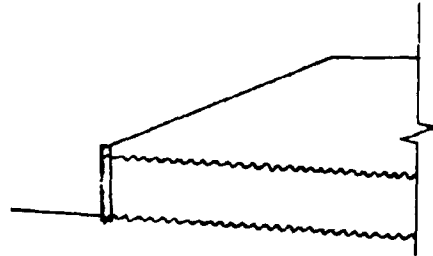

CMP - In a Headwall

Program #30

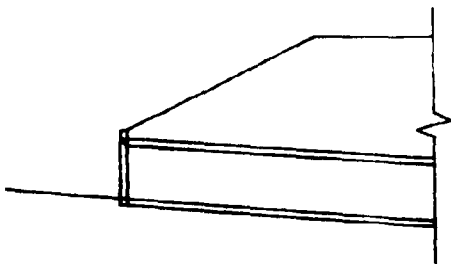

CMP/Concrete - Beveled Edges  
Type A and B

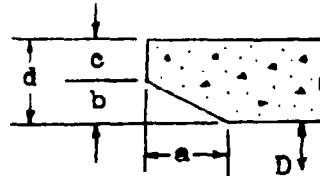

TYPE	$\frac{b}{D}$	$\frac{a}{D}$	$\frac{c}{D}$	$\frac{d}{D}$
A	0.042	0.042	0.042	0.083
B	0.083	0.125	0.042	0.125

The beveled ring should extend a minimum of 300° around the face.

Program #31

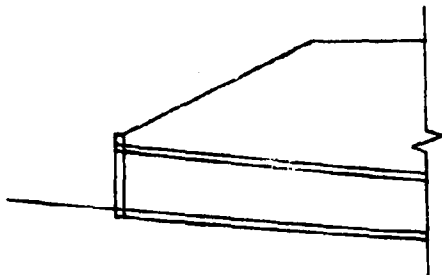

Concrete - Square Edge  
in Headwall

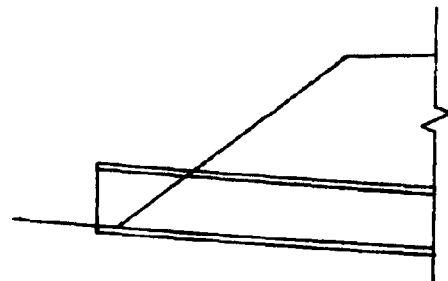

Concrete - Projecting  
Square Edge

Program #32

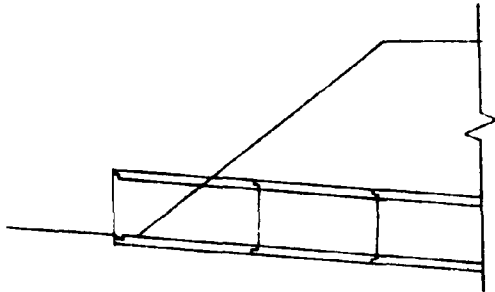

Concrete - Projecting  
Socket Edge

Program #33

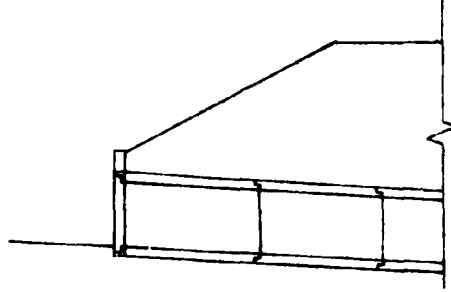

Concrete - Socket Edge  
in Headwall

For each particular inlet, the program calculates the height of the water at the face of the culvert ( $H_f$ ). This value is then added to the culvert inlet invert elevation ( $H_f + \text{FL.IN}$ ). If this sum is less than the allowable headwater elevation (AHW FL.), then the inlet elevation becomes the elevation of the face (FL.FACE). However, if the sum of the height of the water at the face of the culvert plus the elevation of the inlet exceeds the allowable headwater elevation, the difference between this sum and the allowable headwater elevation is subtracted from the inlet invert elevation. This new elevation is now called the elevation of the face (FL.FACE). For the culvert to operate properly, the inlet invert must be reset to this elevation. The drop in elevation of the inlet invert is called the FAII. The diagrams on the following page graphically show this occurrence. It should be noted that as the inlet invert elevation drops, the culvert barrel rotates about the outlet invert.



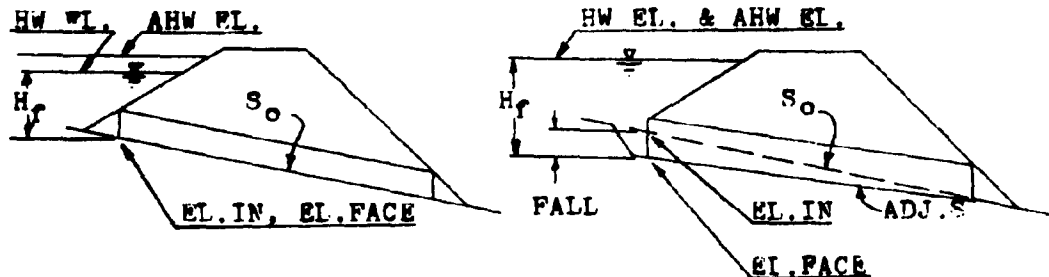

No FALL Required

$$EL.IN + H_f < AHW EL.$$

FALL Required

$$EL.IN + H_f \geq AHW EL.$$

As indicated in the diagrams, when the calculated headwater elevation is above the allowable headwater elevation, the headwater elevation is set equal to the allowable value and the difference is taken up by the FALL.

The invert elevation of the culvert face can always be thought of as the elevation of the face (EL.FACE). The original elevation of the culvert inlet invert, before considering the affects of inlet control and possible FALL, can be taken as the elevation of the inlet (EL.INLET).

Once the culvert has been sized for the design flowrate conditions, the same program can be used to evaluate the performance of the culvert for other flowrate values. In this manner a performance curve for the culvert operating in inlet control can be drawn.

#### EQUATIONS

$$\begin{aligned}
 EL.FACE &= AHW EL. - H_f && \text{(With FALL)} \\
 &= EL.INLET && \text{(Without FALL)}
 \end{aligned}$$

$$HW \text{ EL.} = EL.FACE + H_f$$

$$FALL = EL.FACE - EL.INLET$$

Note: The FALL is measured in a downward direction  
and therefore is always a positive value.

$$X = Q / (ND^{2.5})$$

Program #28

$$H_f = D(0.187321 + 0.567710X - 0.156544X^2 + 0.0447052X^3 \\ - 0.00343602X^4 + 0.000089661X^5)$$

Program #29

$$H_f = D(0.120659 + 0.630768X - 0.218423X^2 + 0.0591815X^3 \\ - 0.00599169X^4 + 0.000229287X^5)$$

Program #30

$$H_f = D(0.063343 + 0.766512X - 0.316097X^2 + 0.0876701X^3 \\ - 0.00983695X^4 + 0.000416760X^5)$$

Program #31

$$H_f = D(0.087483 + 0.706578X - 0.253295X^2 + 0.0667001X^3 \\ - 0.00661651X^4 + 0.000250619X^5)$$

Program #32

$$H_f = D(0.108786 + 0.662381X - 0.233801X^2 + 0.0579585X^3 \\ - 0.00557890X^4 + 0.000205052X^5)$$

Program #33

$$H_f = D(0.114099+0.653562X-0.233615X^2+0.0597723X^3 \\ -0.00616338X^4+0.000242832X^5)$$

CMP Mitered to Conform to Slope

$$H_f = D(0.107137+0.757789X-0.361462X^2+0.1233932X^3 \\ -0.01606422X^4+0.000767390X^5)$$

CMP in a Headwall

$$H_f = D(0.167433+0.538595X-0.149374X^2+0.0391543X^3 \\ -0.00343974X^4+0.000115882X^5)$$

CMP or Concrete with Beveled Edges (Type B)

$$H_f = D(0.081730+0.698353X-0.253683X^2+0.0651250X^3 \\ -0.00719750X^4+0.000312451X^5)$$

Concrete with Projecting Square Edges

$$H_f = D(0.167287+0.558766X-0.159813X^2+0.0420069X^3 \\ -0.00369252X^4+0.000125169X^5)$$

REMARKS

In evaluating these inlets, the pipe size must be determined before the culvert performance values can be generated. Once the pipe size has been fixed and the elevation of the face (W.L.FACE) established using the design flowrate, the program can then be used for performance evaluations. In calculating the performance curve values, the elevation of the face must

remain a constant. To insure that this value is not altered, Label A on the calculator should not be used during the performance curve evaluation.

These programs have been written with the input values stored in the same registers for each program. This allows the designer to store the input data once and evaluate all of the inlet configurations by just loading another program card.

Whenever applicable, a bevel edged inlet is recommended for use in lieu of a square edged inlet. The large increase in hydraulic performance gained by using a beveled edged inlet over a square edged inlet, greatly outweighs the small additional cost.

To insure the proper operation of these inlets, the FALL value is limited to a minimum value of  $\frac{1}{4}D$  and a maximum value of  $1\frac{1}{2}D$ . If the minimum value is exceeded, i.e.,  $FALL = 0.2D$ , one of three alternatives should be considered. First, since the FALL is so small, the culvert will operate as though no FALL is occurring. A side-tapered should be considered. Second, the pipe size could be reduced for the same inlet configuration. This would increase the amount of FALL required. And third, the same pipe size could be used with another inlet type.

If the maximum value for FALL,  $1\frac{1}{2}D$ , is exceeded, either a larger pipe size or a more efficient inlet is required.

Polynomial best-fit equations are used to determine the headwater depths for these inlets. Since these equations are

an approximation for the curves in HFC #13, they are subject to the same limitations. Therefore, the headwater depth ( $H_f$ ) is limited to a maximum of  $4\frac{1}{2}D$  and a minimum of  $\frac{1}{2}D$ . To avoid the possibility of culvert failure due to buoyancy forces, it is recommended that  $H_f$  be limited to a value of around  $2D$ .

STEP	INSTRUCTIONS	INPUT	KEYS	DISPIAY
1	Load program			
2	Input register values	Q	STO 1	Q
		D	STO 2	D
		N	STO 3	N
		FL.IN	STO 5	EL.IN
		AHW EL.	STO 6	AHW EL.
3	Calculate the FL.FACE		A	EL.FACE
4	Calculate the headwater elev.		B	HW FL.
5	Calculate the FAIL		C	FAIL
6	Calcualte the headwater depth		D	$H_f$
7	To evaluate the same inlet with different design criteria, go to step #2.			
8	To evaluate another inlet, load the desired program card and go to step #3.			
9	To obtain the performance curve coordinates, input the selected flowrates in register #1 and press label B to obtain the headwater elevations. Note: Label A must not be used during the performance curve evaluation.			

EXAMPLE #1

For a 50-year discharge of 200 cfs., an allowable headwater elevation of 72.00 feet, and an inlet elevation of 63.00 feet, determine the appropriate pipe culvert size. The design to be considered is a projecting CMP.

Load program #28

<u>KEYSTROKES</u>	<u>DISPLAY</u>
200 STO 1 . . . . .	200.00
1 STO 3 . . . . .	1.00
63 STO 5 . . . . .	63.00
72 STO 6 . . . . .	72.00

Try a 42 inch pipe.

3.5 STO 2 . . . . .	3.50
A . . . . .	45.61 ft. WL.FACE
C . . . . .	17.39 ft. FALL

This FALL value is larger than the allowable value of 5.25 feet.

Try a 48 inch pipe.

4 STO 2 . . . . .	4.00
A . . . . .	55.41 ft. WL.FACE
C . . . . .	7.59 ft. FALL

This FALL is larger than the allowable ( $1\frac{1}{2}D$ ) value of 6.00 feet.

Try a 54 inch pipe.

4.5 STO 2 . . . . .	4.50
A . . . . .	60.61 ft. WL.FACE
C . . . . .	2.39 ft. FALL

This FALL value is within the limits ( $\frac{1}{4}D$ ) and ( $1\frac{1}{2}D$ ).

Check the limits of  $H_f$ .

D . . . . . 11.39 ft.  $H_f$

This value of  $H_f$  is below the maximum value of  $20.25 = 4\frac{1}{2}D$ .

A 54 inch CMP culvert will work for the conditions specified.

EXAMPLE #2

Consider the same design criteria only change the pipe from a projecting inlet to a bevel edged inlet.

Load program #30.

KEYSTROKES

DISPLAY

With the design data already in the calculator from the previous example, just proceed with the calculations.

A . . . . . 63.00 ft. WL.FACE

C . . . . . 0.00 ft. FALL

This design uses the 54 inch diameter. With a bevel edged inlet no FALL is required. In order to maximize the design a smaller size of pipe will be evaluated. Try 48 inch diameter.

b STO 2 . . . . . 4.00

A . . . . . 60.50 ft. WL.FACE

C . . . . . 2.50 ft. FALL

This FALL value is within the allowable range. Check  $H_f$ .

D . . . . . 11.50 ft.  $H_f$

This value is also within the allowable range.

Use 48 inch diameter pipe. The bevel edged inlet reduces the required diameter by one half of a foot.

EXAMPLE #3

Evaluate the performance of a twin 30 inch concrete pipe culvert entrance. The design flowrate is 100 cfs., and the allowable headwater elevation is 86.50 feet. The elevation of the inlet invert is 80.20 feet. Use program #31.

<u>KFYSTROKES</u>	<u>DISPLAY</u>
100 STO 1 . . . . .	100.00
2.5 STO 2 . . . . .	2.50
2 STO 3 . . . . .	2.00
80.2 STO 5 . . . . .	80.20
86.5 STO 6 . . . . .	86.50
A . . . . .	80.20 ft. EL.FACE
B . . . . .	85.98 ft. HW EL.
C . . . . .	0.00 ft. FALL
D . . . . .	5.78 ft. H <sub>f</sub>

No excavation is required for this culvert design. The headwater elevation is just below the allowable value. For the performance curve coordinates use 0.6Q, 0.8Q, and 1.2Q.

60 STO 1 . . . . .	60.00
B . . . . .	83.37 ft. HW EL. @ 0.6Q
80 STO 1 . . . . .	80.00
B . . . . .	84.49 ft. HW EL. @ 0.8Q
120 STO 1 . . . . .	120.00
B . . . . .	87.81 ft. HW EL. @ 1.2Q

Note: After the face elevation was originally determined, Label A, this button was not pressed again. To do so would



produce an error in the calculation of the performance curve coordinates. Label A should only be used when the design flowrate is in register #1.

A plot of this performance is on the final page of this section.

LISTING - PROGRAM #28

```

LBL A D RCL 6 RCL 5 - g xsy g xzy g NOP RCL 6 g xzy
- STO 8 RTN LBL B D RCL 8 + RTN LBL C RCL 5 RCL 8
- RTN LBL D RCL 1 RCL 3 + RCL 2 2 . 5 g yx +
ENTER ENTER ENTER 8 9 . 6 6 1 x 3 4 3 6 . 0 2
- x 4 4 7 0 5 . 2 + x 1 5 6 5 4 4 - x 5 6
7 7 1 0 + x 1 8 7 3 2 1 + 6 r-1 LOG + RCL 2
x RTN (96 STEPS)

```

LISTING - PROGRAM #29

```

LBL A D RCL 6 RCL 5 - g xsy g xzy g NOP RCL 6 g xzy
- STO 8 RTN LBL B D RCL 8 + RTN LBL C RCL 5 RCL 8
- RTN LBL D RCL 1 RCL 3 + RCL 2 2 . 5 g yx +
ENTER ENTER ENTER 2 2 9 . 2 8 7 x 5 9 9 1 . 6
9 - x 5 9 1 8 1 . 5 + x 2 1 8 4 2 3 - x 6
3 0 7 6 8 + x 1 2 0 6 5 9 + 6 r-1 LOG + RCL 2
x RTN (97 STEPS)

```

LISTING - PROGRAM #30

```

LBL A D RCL 6 RCL 5 - g xsy g xzy g NOP RCL 6 g xzy
- STO 8 RTN LBL B D RCL 8 + RTN LBL C RCL 5 RCL 8
- RTN LBL D RCL 1 RCL 3 + RCL 2 2 . 5 g yx +
ENTER ENTER ENTER 4 1 6 . 7 6 x 9 8 3 6 . 9 5

```

LISTING - PROGRAM #30 (cont)

- x 8 7 6 7 0 . 1 + x 3 1 6 0 9 7 - x 7 6  
6 5 1 2 + x 6 3 3 4 3 + 6 f<sup>-1</sup> LOG + RCL 2 x  
RTN (95 STEPS)

LISTING - PROGRAM #31

LBL A D RCL 6 RCL 5 - g x<y g x>y g NOP RCL 6 g x>y  
- STO 8 RTN LBL B D RCL 8 + RTN LBL C RCL 5 RCL 8  
- RTN LBL D RCL 1 RCL 3 + RCL 2 2 . 5 g y<sup>x</sup> +  
ENTER ENTER ENTER 2 5 0 . 6 1 9 X 6 6 1 6 . 5 1 - X  
6 6 7 0 0 . 1 + X 2 5 3 2 9 5 - X 7 0 6 5 7 8 +  
X 8 7 4 8 3 + 6 f<sup>-1</sup> LOG + RCL 2 X RTN (96 STEPS)

LISTING - PROGRAM #32

LBL A D RCL 6 RCL 5 - g x<y g x>y g NOP RCL 6 g x>y  
- STO 8 RTN LBL B D RCL 8 + RTN LBL C RCL 5 RCL 8  
- RTN LBL D RCL 1 RCL 3 + RCL 2 2 . 5 g y<sup>x</sup> +  
ENTER ENTER ENTER 2 0 5 . 0 5 2 x 5 5 7 8 . 9  
- x 5 7 9 5 8 . 5 + x 2 3 3 8 0 1 - x 6 6  
2 3 8 1 + x 1 0 8 7 8 6 + 6 f<sup>-1</sup> LOG + RCL 2  
x RTN (96 STEPS)

LISTING - PROGRAM #33

LBL A D RCL 6 RCL 5 - g x<y g x>y g NOP RCL 6 g x>y  
- STO 8 RTN LBL B D RCL 8 + RTN LBL C RCL 5 RCL 8  
- RTN LBL D RCL 1 RCL 3 + RCL 2 2 . 5 g y<sup>x</sup> +

LISTING - PROGRAM #33 (cont)

```

ENTER ENTER ENTER 2 . 4 2 . 8 3 2 x 6 1 6 3 . 3
8 - x 5 9 7 7 2 3 + x 2 3 3 6 1 5 - x 6 5
3 5 6 2 + x 1 1 4 0 9 9 + 6 r-1 LOG + RCL 2
x RTN (96 STEPS)
    
```

Plot of the performance of a twin 30 inch concrete pipe culvert operating in inlet control with square edges in a headwall.

Plotting Coordinates

Q	60.00	80.00	100.00	120.00
HW WL.	83.37	84.49	85.98	87.81

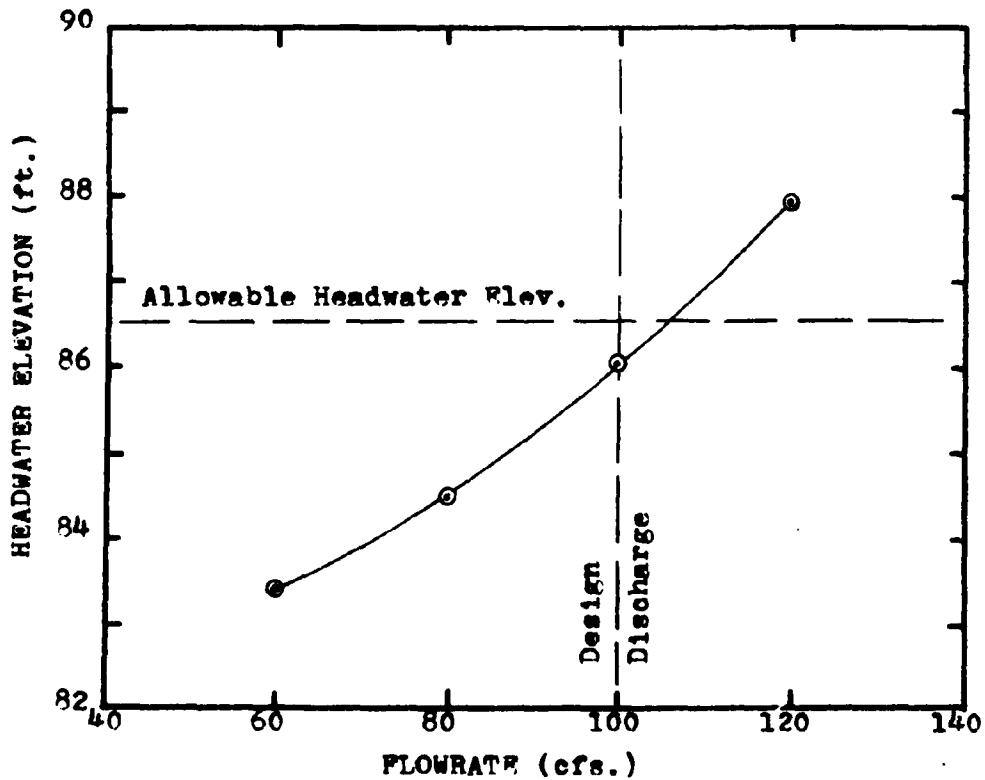

PROGRAMS #34 & 35 - PIPE CULVERTS; SIDE-TAPERED THROAT CONTROL

SIDE-TAPERED WITH SMOOTH THROAT

SIDE-TAPERED WITH ROUGH THROAT

A culvert with a smooth throat pertains to pipe culverts made of concrete or of a smooth metal. Rough throated culverts apply to corrugated metal structures.

These programs evaluate the performance of a culvert operating in throat control. The formulas incorporated in these programs apply only to side-tapered inlets for pipe culverts. Like the improved inlet programs, these throat control programs often can use FALL to increase the flow capacity of a culvert. The following diagrams describe the throat control inlets.

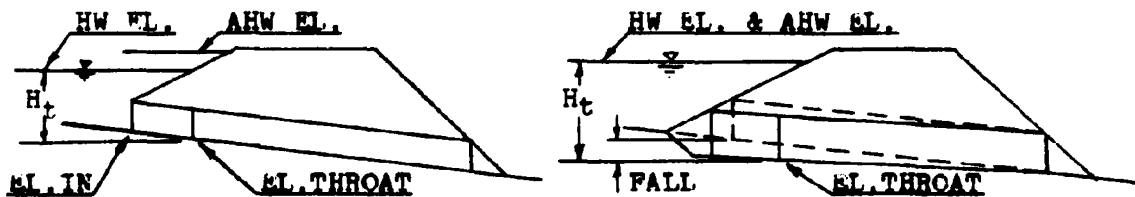

ELEVATION VIEW

ROUGH THROAT

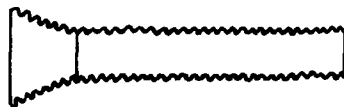

SMOOTH THROAT

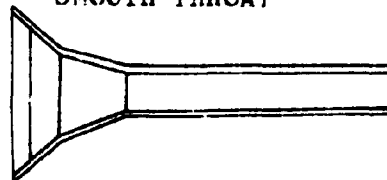

PLAN VIEW

SIDE-TAPERED INLET

NO FALL, HW EL. < AHW EL.

SIDE-TAPERED INLET

WITH FALL AND WINGWALLS

### EQUATIONS

$$\begin{aligned} \text{EL.THROAT} &= \text{AHW EL.} - H_t && \text{(With FALI.)} \\ &= \text{EL.INLET} && \text{(Without FALI.)} \end{aligned}$$

$$\text{HW EL.} = \text{EL.THROAT} + H_t$$

$$\text{FALL} = \text{EL.INLET} - \text{EL.THROAT}$$

$$X = \text{LOG}(Q/(ND^{2.5}))$$

### Program #34

$$H_t = D^{10} (-0.237139 + 0.146792X + 2.189321X^2 - 4.354114X^3 + 4.210539X^4 - 1.347032X^5)$$

### Program #35

$$H_t = D^{10} (-0.233392 + 0.489125X + 1.068638X^2 - 3.074435X^3 + 3.711165X^4 - 1.32836X^5)$$

### REMARKS

As mentioned before, these programs are only to be used with side-tapered pipe culverts. To evaluate the performance of a pipe culvert with a slope-tapered inlet, the designer should use program #11. This program evaluates the performance of box culverts with both side-tapered and slope-tapered inlets. The slope-tapered inlet for a pipe culvert is designed as if it were going to be used with a box culvert. A transition section is then fabricated to connect the box shaped inlet to the pipe culvert barrel. The diagrams on the next page will further explain this situation.

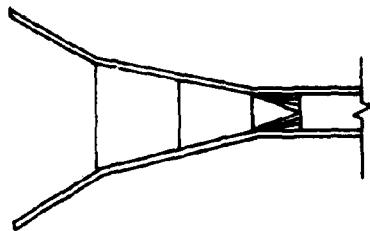
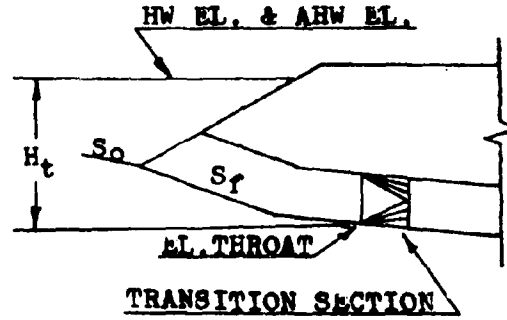
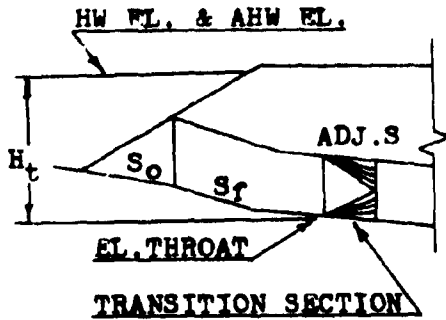

SLOPE-TAPERED INLET  
VERTICAL FACE, WINGWALLS

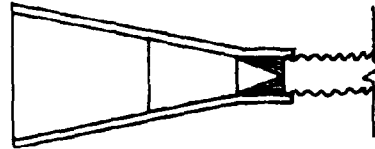

SLOPE-TAPERED INLET  
MITERED FACE

The width values (B) in program #11 will have to be translated into a diameter size. This can be accomplished by setting B equal to the diameter and then proceeding with the design as if the box culvert in question had a square cross-section.

Label A is used during the culvert size determination part of the program. Once a culvert size has been selected, it is stored in the calculator and Label A evaluates the appropriate throat elevation for the given design flowrate. When using flowrates other than the design value for the performance curve coordinates, Label A must not be pressed.

Since the input registers have the same identity as the ones used for the inlet control programs (#28-33), these two programs

can be run in succession after the inlet control programs have been evaluated. If all of the inlet control programs have their calculated FALL values exceeding the maximum limit ( $1\frac{1}{2}D$ ), the designer can immediately load these programs and proceed with the design of the culverts for throat control, without changing any of the register values.

Due to the size limitations of this calculator, a small error results in the computation of the FALL. The programs assume that the elevation of the inlet and the elevation of the throat are equal before determining the value of the headwater elevation. This equality is false and a small difference, equal to the channel slope times the vertical distance between the inlet and the throat section ( $S_o \times L_1$ ) exists. This  $L_1$  distance is an unknown value in these programs. It is determined by the next programs. By understanding this error condition, a correction, if necessary, can be made.

The limits placed on the FALL value for the inlet control programs applies to the throat control designs also. A minimum value of  $\frac{1}{2}D$  and a maximum value of  $1\frac{1}{2}D$  still apply. If the upper limit is exceeded, a larger culvert size should be tried. If the minimum value is exceeded, the culvert will essentially operate as if there was no FALL present. A larger, or smaller culvert, or another inlet configuration should be considered.

Polynomial best-fit equations are used in determining the headwater depths for these inlets. Since the equations are an approximation for the curves in HEC #13, they are subject to

the same restrictions. The headwater depth ( $H_t$ ) is limited to  $4\frac{1}{2}D$  maximum and  $\frac{1}{2}D$  minimum. It is recommended that the value of  $H_t$  be kept below a value of  $2D$  to protect the culvert from buoyancy forces.

The number of barrels ( $N$ ) is limited to a value of 1 or 2.

<u>STEP</u>	<u>INSTRUCTIONS</u>	<u>INPUT</u>	<u>KEYS</u>	<u>DISPLAY</u>
1	Load program			
2	Store register values	Q	STO 1	Q
		D	STO 2	D
		N	STO 3	N
		WL.IN	STO 5	EL.IN
		AHW EL.	STO 6	AHW EL.
3	Calculate throat elevation		A	WL.THROAT
4	Calculate headwater elevation		B	HW WL.
5	Calculate the FALL		C	FALL
6	Calculate headwater depth		D	$H_t$
7	For a change in any of these culvert properties, go to step #2 and change only the necessary items.			
8	To obtain the performance curve coordinates, input the selected flowrates in register #1 and press Label B to obtain the headwater elevations.  Note: Label A must not be used during this calculation.			
9	To evaluate another inlet, load the desired program card and go to step #3.			



EXAMPLE #1

Size and evaluate the throat control performance of a CMP with a 300 cfs. flowrate. The inlet elevation is 135.00 feet and the allowable headwater elevation is 144.50 feet.

Load program #35

<u>KEYSTROKES</u>	<u>DISPLAY</u>
300 STO 1 . . . . .	300.00
1 STO 3 . . . . .	1.00
135 STO 5 . . . . .	135.00
144.5 STO 6 . . . . .	144.50

Try a 48 inch pipe.

4 STO 2 . . . . .	4.00
A . . . . .	129.00 ft. EL.THROAT
C . . . . .	6.00 ft. FALL

The FALL is within its allowable limits. Check  $H_t$ .

D . . . . .	15.50 ft. $H_t$
-------------	-----------------

This value is within the allowable but not the recommended range.

Try a 54 inch diameter.

4.5 STO 2 . . . . .	4.50
A . . . . .	133.02 ft. EL.THROAT
C . . . . .	1.98 ft. FALL
D . . . . .	11.48 ft. $H_t$

Both the FALL and  $H_t$  are within their allowable ranges.  $H_t$  equals 2.55 times the diameter. This value is above the recommended value of 2D but with proper anchoring it can be used.

The performance curve coordinates will be found for the 0.6Q, 0.8Q, and the 1.2Q values.

<u>KEYSTROKES</u>	<u>DISPLAY</u>
300 ENTER .6 x STO 1 . .	180.00
b . . . . .	139.78 ft. HW EL. @ 0.6Q
300 ENTER .8 x STO 1 . .	240.00
b . . . . .	141.87 ft. HW EL. @ 0.8Q
300 STO 1 . . . . .	300.00
b . . . . .	144.50 ft. HW EL. @ Q
300 ENTER 1.2 x STO 1 .	360.00
b . . . . .	147.75 ft. HW EL. @ 1.2Q

LISTING - PROGRAM #34

```

LBL A D RCL 6 RCL 5 - g xSy g xzy g NOP RCL 6 g xzy
- STO 8 RTN LBL B D RCL 8 + RTN LBL C RCL 5 RCL 8
- RTN LBL D RCL 1 RCL 3 + RCL 2 2 . 5 g yx + f
LOG ENTER ENTER ENTER 1 3 4 7 0 3 CHS x 4 2 1 0
5 4 + x 4 3 5 4 1 1 - x 2 1 8 9 3 2 + x 1
4 6 7 9 + x 2 3 7 1 4 - 5 f-1 LOG + f-1 LOG
RCL 2 x RTN (97 STEPS)

```

LISTING - PROGRAM #35

```

LBL A D RCL 6 RCL 5 - g xSy g xzy g NOP RCL 6 g xzy
- STO 8 RTN LBL B D RCL 8 + RTN LBL C RCL 5 RCL 8
- RTN LBL D RCL 1 RCL 3 + RCL 2 2 . 5 g yx + f
LOG ENTER ENTER ENTER 1 3 2 8 3 6 CHS x 3 7 1 1
1 7 + x 3 0 7 4 4 4 - x 1 0 6 8 6 4 + x 4

```

LISTING - PROGRAM #35 (cont)

8 9 1 3 + x 2 3 3 3 9 - 5 r<sup>-1</sup> LOG + r<sup>-1</sup> LOG  
 RCL 2 x RTN (97 STEPS)

---

Plot of the performance curve of a 54 inch corrugated metal pipe culvert operating in throat control.

Plotting Coordinates

Q	180.00	240.00	300.00	360.00
HW WL.	139.78	141.87	144.50	147.75

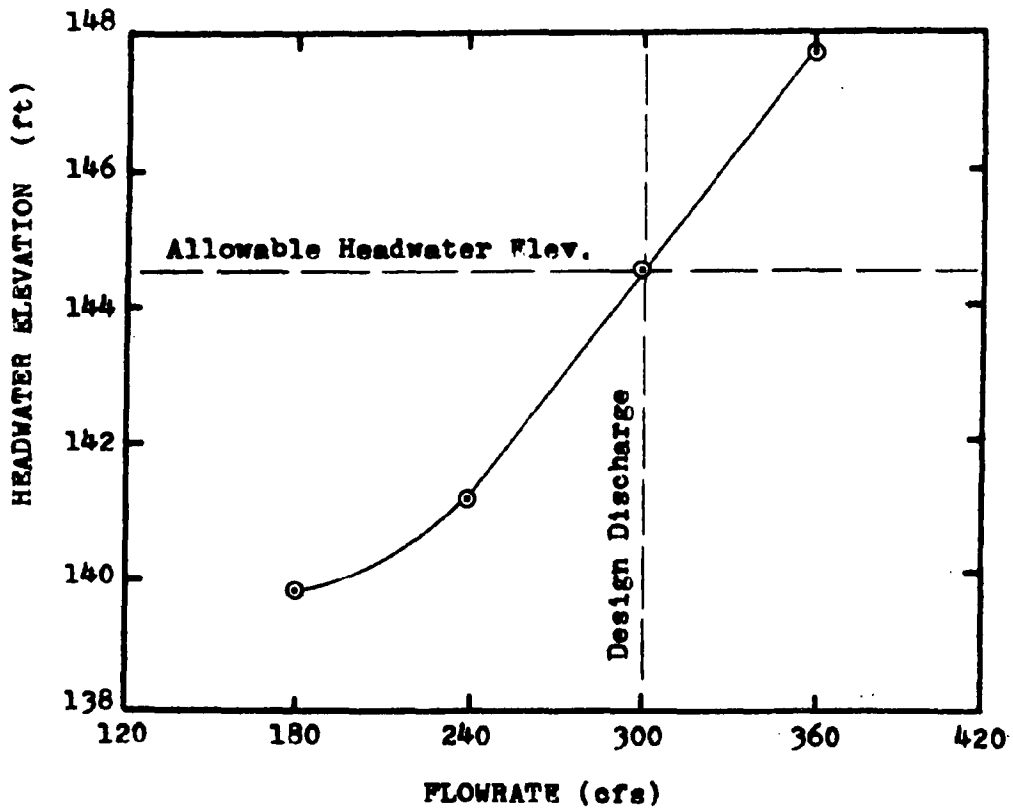

PROGRAMS #36-38 PIPE CULVERTS; FACE DIMENSIONS

Program #36: Side-Tapered CMP with Projecting Edge

Program #37: Side-Tapered Square Edges in a Headwall

Program #38: Side-Tapered Beveled Edges in a Headwall

These programs continue with the design of a culvert operating in throat control. For the side-tapered entrance, these programs compute the face width ( $B_f$ ) and the horizontal distance between the entrance and the throat control section ( $L_1$ ). See the diagrams below for a further explanation.

PROGRAM #36

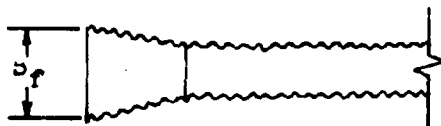
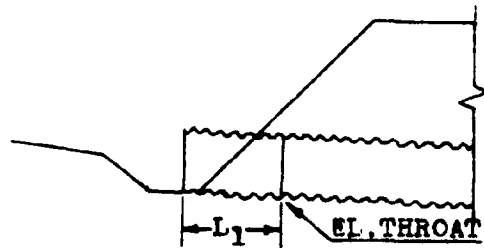
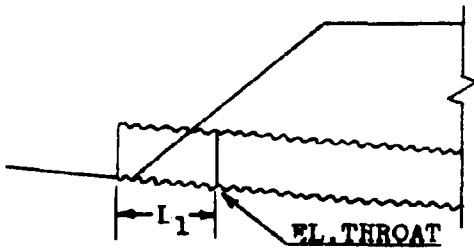

Side-Tapered, Projecting Edge  
No FALL

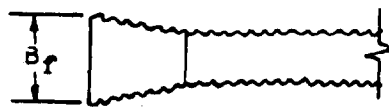

Side-Tapered, Projecting  
Edge, With FALL

Program #37

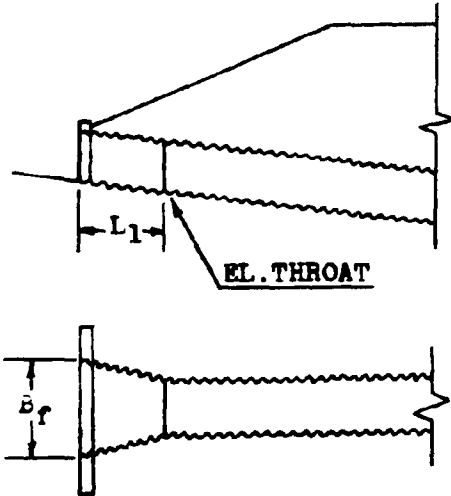

Side-Tapered, Square Edges  
In a Headwall, CMP or Concrete  
With or Without FALL

Program #38

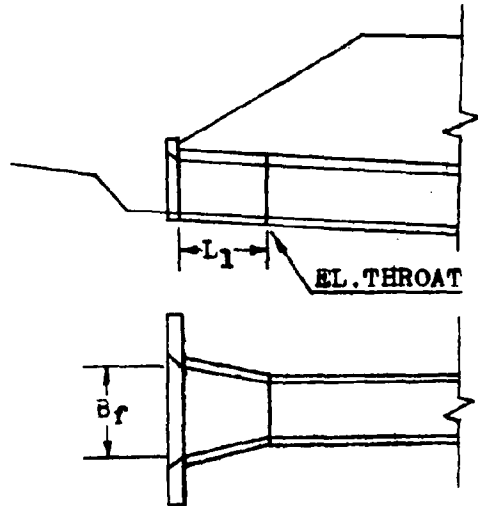

Side-Tapered, Beveled Edges  
In Headwall, CMP or Concrete  
With or Without FALL

An additional dimension from the face of the side-tapered inlet is required as one of the program inputs. This is the value of the height of the side-tapered face. It is referred to as the value  $E$  in the diagram below.

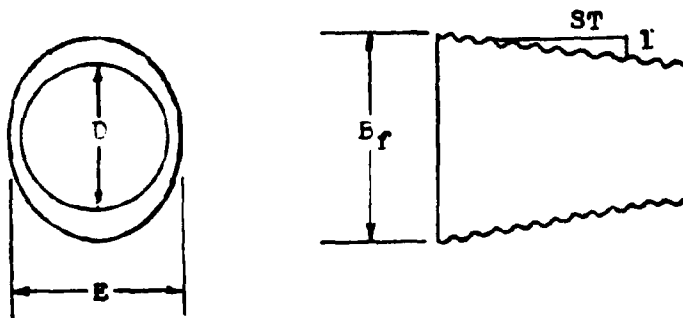

The limitations on the value of  $E$  are a minimum of the diameter and a maximum of 1.1 times the diameter. The sidewall taper (ST) should be kept between a value of 4:1 to 6:1 for the program to operate properly.

The determination of  $B_f$  and  $L_1$  is a lengthy computation which exceeds the capacity of the HP-65 calculator. An extra program card is needed to compute these values. This extra program, #14, computes the adjusted slope of a culvert which has FALL incorporated in its design. Program #14 uses the value  $L_1$  in its computations.  $L_1$  is determined by these programs, #36-38, but they need the value of the adjusted slope to compute  $L_1$ . The method used to solve this dilemma is to alternately use either programs #36 and #14, #37 and #14, or #38 and #14 in an alternating manner until the values of  $B_f$ ,  $L_1$  and ADJ.S stabilize. This process usually only requires two or three cycles.

For the initial calculation of  $B_f$  and  $L_1$ , the adjusted slope is approximated by using the original channel slope. A number slightly smaller than the original slope may be used to decrease the time of convergence.

Where prefabricated inlet sections are available,  $B_f$  and  $L_1$  have generally been fixed by the manufacturing company. These values are normally set at  $1\frac{1}{2}$  times the culvert diameter. If this type of design is desired, the given values of  $B_f$  and  $L_1$  can be used in lieu of programs #36-38. The value of  $L_1$  can be directly used in program #14 to determine the adjusted slope.

### EQUATIONS

$$L_1 = ((B_f - DxN)/2)ST$$

$$H_f = HW \text{ EL.} - \text{EL. THROAT} - L_1 \text{ ADJ. S} = H_t - L_1 \text{ ADJ. S}$$

$$X = H_f/D$$

### Program #36

$$B_f = 4Q/((\pi E^{1.5})(0.0144 + 1.1505X + 1.8167X^2 - 0.9642X^3 \\ + 0.1974X^4 - 0.0148X^5))$$

### Program #37

$$B_f = 4Q/((\pi E^{1.5})(-0.0048 + 0.9426X + 2.9784X^2 - 1.792X^3 \\ + 0.4228X^4 - 0.0357X^5))$$

### Program #38

$$B_f = 4Q/((\pi E^{1.5})(0.73932X + 3.2994X^2 - 1.746X^3 \\ + 0.3744X^4 - 0.0287X^5))$$

### REMARKS

The number of barrels (N) is limited to a value of 1 or 2.

As mentioned before, for the initial value of the adjusted slope (ADJ.S), the channel's original slope ( $S_o$ ) should be used as an approximation. This value is stored in register #4.

Side taper values (ST) less than the specified value of 4:1 are unacceptable. Under this condition, the culvert would operate as if it were a regular culvert and there was no taper

present. Side tapers in excess of the recommended value of 6:1 will perform better than the design will indicate. Therefore with this larger value, the programs will produce conservative results.

The value of  $L_1$ , determined by these programs is a horizontal measurement. This is in comparison with the adjusted length ADJ.L, which is measured along the slope of the culvert.

<u>STEP</u>	<u>INSTRUCTIONS</u>	<u>INPUT</u>	<u>KEYS</u>	<u>DISPLAY</u>
1	Load program			
2	Input register values	Q	STO 1	Q
		D	STO 2	D
		N	STO 3	N
	Initially use $S_0$	ADJ.S	STO 4	ADJ.S
		$H_t$	STO 5	$H_t$
		ST	STO 6	ST
		E	STO 7	E
3	Calculate the face width		A	$B_f$
4	Calculate the inlet length		B	$L_1$
5	Run program #14			
6	Repeat steps #2, #3, #4, and #5 until the values of $B_f$ , $L_1$ , and ADJ.S stabilize.			

#### EXAMPLE #1

In the design of a 48 inch CMP culvert with a 25-year discharge of 190 cfs., the throat elevation was determined to be 79.30 ft. 



EXAMPLE #1 (cont)

The headwater elevation for this site was 70.90 feet. This gives a headwater depth of 8.40 feet. The original channel slope was 5% and a side taper of 6:1 is to be used. The E value will be 1.05D or 4.2 feet. Find the face width and the inlet length. The culvert is not to have a headwall but to be projecting from the fill slope.

Load program #36

<u>KWYSTROKES</u>	<u>DISPLAY</u>
190 STO 1 . . . . .	190.00
4 STO 2 . . . . .	4.00
1 STO 3 . . . . .	1.00
.05 STO 4 . . . . .	0.05
8.4 STO 5 . . . . .	8.40
6 STO 6 . . . . .	6.00
4.2 STO 7 . . . . .	4.20
A . . . . .	6.42 ft. $B_f$
B . . . . .	7.26 ft. $L_1$

These are just two estimates of  $B_f$  and  $L_1$  based on the approximation of ADJ.S by  $S_o$ . Using this  $L_1$  value in program #14, a value of ADJ.S = 0.02495 is obtained. Using this value in program #36.

190 STO 1 . . . . .	190.00
4 STO 2 . . . . .	4.00
1 STO 3 . . . . .	1.00

<u>KEYSTROKES</u>	<u>DISPLAY</u>
.02495 STO 4 . . . . .	0.02
8.4 STO 5 . . . . .	8.40
6 STO 6 . . . . .	6.00
4.2 STO 7 . . . . .	4.20

Note: These values must be restored since the running of program #14 has altered their original values.

A . . . . .	6.28 ft.	$B_f$
B . . . . .	6.84 ft.	$L_1$

Again taking the value of  $L_1$  to program #14. A value of 0.024907 for ADJ.S is obtained. Using this value in program #36.

190 STO 1 . . . . .	190.00	
4 STO 2 . . . . .	4.00	
1 STO 3 . . . . .	1.00	
.024907 STO 4 . . . . .	0.02	
8.4 STO 5 . . . . .	8.40	
6 STO 6 . . . . .	6.00	
4.2 STO 7 . . . . .	4.20	
A . . . . .	6.28 ft.	$B_f$
B . . . . .	6.84 ft.	$L_1$

The face width is 6.28 feet and the inlet length is 6.84 feet.

The corresponding values used in program #14 are as follows:

$S_o = 0.05$ , FALL = 6.0 feet,  $S_{pu} = 3:1$ ,  $L = 250$  feet,  
 $D = 4$  feet.

LISTING - PROGRAM #36

```
LBL A 1 LBL 1 CHS RCL 5 + RCL 7 + ENTER ENTER ENTER
1 4 8 CHS x 1 9 7 4 + x 9 6 4 2 - x 1 8 1
6 7 + x 1 1 5 0 5 + x 1 4 4 + 4 r-1 LOG +
RCL 1 g x↔y + 4 x g π + RCL 7 ENTER f √x x + RCL
9 g x↔y g x=y GTO 2 RCL 2 RCL 3 x - 2 + RCL 6 x
STO 8 RCL 4 x GTO 1 LBL B RCL 8 RTN LBL 2 DSP . 2
RCL 2 g x↔y g x↔y g NOP RTN (99 STEPS)
```

LISTING - PROGRAM #37

```
LBL A 1 LBL 1 CHS RCL 5 + RCL 7 + ENTER ENTER ENTER
3 5 7 CHS x 4 2 2 8 + x 1 7 9 2 0 - x 2 9
7 8 4 + x 9 4 2 6 + x 4 8 - 4 r-1 LOG + RCL 1
g x↔y + 4 x g π + RCL 7 ENTER f √x x + RCL 9
g x↔y g x=y GTO 2 RCL 3 RCL 2 x - 2 + RCL 6 x
STO 8 RCL 4 x GTO 1 LBL B RCL 8 RTN LBL 2 DSP . 2
RCL 2 g x↔y g x↔y g NOP RTN (98 STEPS)
```

LISTING - PROGRAM #38

```
LBL A 1 LBL 1 CHS RCL 5 + RCL 7 + ENTER ENTER ENTER
2 8 7 CHS x 3 7 4 4 + x 1 7 6 4 0 - x 3 2
9 9 4 + x 7 3 9 3 . 2 + x 4 r-1 LOG + RCL 1
g x↔y + 4 x g π + RCL 7 ENTER f √x x + RCL 9
g x↔y g x=y GTO 2 RCL 3 RCL 2 x - 2 + RCL 6 x STO 8
RCL 4 x GTO 1 LBL B RCL 8 RTN LBL 2 DSP . 2 RCL 2
g x↔y g x↔y G NOP RTN (97 STEPS)
```

#### PROGRAMS #39 & 40 - PIPE CULVERT; INLET CONTROL OUTLET VELOCITY

These two programs determine the outlet velocity for circular pipe culverts by first calculating the normal depth of flow within the barrel. Once this depth is determined, the waterway area is calculated and the velocity is found by dividing the discharge by the area.

Due to the length of the polynomial equations employed and the limited number of program steps of the HP-65 calculator, two programs must be used.

Normally as the depth of water within a pipe culvert increases, the discharge correspondingly increases. However, after the depth of flow reaches a little over 90 percent of the culvert height, the discharge begins to decrease as the depth increases. This decrease in flow is a result of the large increase in the wetted perimeter (barrel roughness) with only a small increase in the waterway area. This decrease in discharge continues until the barrel flows full. For a given discharge requiring a flow depth greater than 82 percent of the pipe diameter, two depths of flow may exist. One value will be between 82 percent and 93 percent of the pipe diameter and the other depth will be between 93 percent and 100 percent full. Correspondingly there exist two values for the waterway area and two values for the flow velocity. The calculator programs determine the smaller flow depth. This action will produce the smaller areas and the higher outlet velocities.

The equations used in the programs are polynomial expressions which approximate the normal depth curve for circular cross sections as found in Figure 6-1 of reference #4.

To operate these programs, program #39 is loaded into the calculator and the input values are stored in their appropriate registers. Label A is then pressed and an intermediate value is displayed. This number will vary depending upon which subroutine the calculator has exited from. Program #40 is then loaded into the calculator and Label A is again pressed. The outlet velocity value for this particular pipe culvert operating in inlet control will then be displayed.

#### EQUATIONS

$$X = (Q_n / (1.486NS^5)) / D^{8/3}$$

$$Z = \text{LOG}(X)$$

If  $X < 0.06$

$$d_n = D \times 10^{(0.136525 + 0.57114Z + 0.02362Z^2)}$$

If  $0.06 \leq X < 0.24$

$$d_n = D \times 10^{(0.3063639 + 0.907884Z + 0.192615Z^2)}$$

If  $0.24 \leq X < 0.34$

$$d_n = D \times 10^{(0.685734 + 2.097532Z + 1.125836Z^2)}$$

If  $X \geq 0.34$

$$d_n = D$$

$$\theta = \text{arc cosine (radians)} (1 - 2d_n/D)$$

$$A = (D/2)^2 (\theta - \sin \theta \cos \theta)$$

$$V = Q/(NA)$$

#### REMARKS

Once the input values have been stored for program #39, they do not have to be re-entered for program #40.

The calculator may be used between the running of programs as long as registers #1, #3, #4, and #7 and Flags #1 and #2 are not altered.

STEP	INSTRUCTIONS	INPUT	KEYS	DISPLAY
1	Load program #39			
2	Input register values	Q	STO 1	Q
		D	STO 2	D
		N	STO 3	N
		n	STO 5	n
		S	STO 6	S
3	Calculate "X"		A	X
4	Load program #40			
5	Calculate outlet velocity		A	V
6	For a change in any of the design data, go to step #1.			

#### EXAMPLES #1

Find the outlet velocity for a CMP of diameter 54 inches, with a slope of 0.032 and a flow rate of 100 cfs. Manning's n is 0.024.

#### Load program #39

<u>KEYSTROKES</u>	<u>DISPLAY</u>
100 STO 1	100.00
4.5 STO 2	4.50
1 STO 3	1.00
.024 STO 5	0.02
0.32 STO 6	0.03
A	0.24

EXAMPLE #1 (cont.)

Load program #40

<u>KEYSTROKES</u>	<u>DISPLAY</u>
A	12.12 fps.

EXAMPLE #2

What would be the outlet velocity for example #1 if the flow rate was 200 cfs?

Load program #39

200 STO 1	200.00
4.5 STO 2	4.50
1 STO 3	1.00
.024 STO 5	0.02
.032 STO 6	0.03
A	-0.07

Load program #40

A	13.78 fps.
---	------------

LISTING - PROGRAM #39

```
LBL A RCL 1 RCL 3 DIV STO 1 RCL 2 2 DIV STO 3 g x>y RCL 5
X 1 . 4 8 6 DIV RCL 6 f SRX DIV RCL 2 8 ENTER 3 DIV g y^x
DIV f LOG STO 7 g LST x . 0 6 g x>y GTO 1 g x>y . 2 4
g x>y GTO 2 g x>y . 3 4 g x>y RCL 7 E 0 STO 4 RTN LBL
E 1 . 1 2 5 8 3 6 x 2 . 0 9 7 5 3 2 + RCL 7 x . 6 8
5 7 3 4 + STO 4 R/S LBL 1 f SF 1 RTN LBL 2 f SF 2 RTN
(100 STEPS)
```

LISTING PROGRAM #40

```
LBL A f TF 1 RCL 7 D f-1 TF 2 RCL 4 E RCL 7 . 1 9 2 6
1 5 X . 9 0 7 8 8 4 + RCL 7 X . 3 0 6 3 6 3 9 +
E LBL D . 0 2 3 6 2 X . 5 7 1 1 4 + RCL 7 X . 1
3 6 2 5 + LBL E f-1 LOG 2 X 1 - CHS g RAD g COS-1
ENTER ENTER f COS g X2y f SIN X - RCL 3 ENTER X X RCL
1 g X2y DIV g DEG f-1 SF 1 f-1 SF 2 R/S (100 STEPS)
```



**APPENDIX A**

**Derivations of Equations  
Used in Programs**

PROGRAM #2

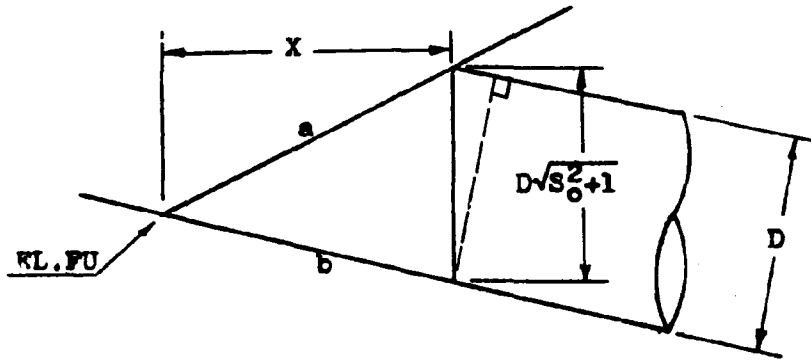
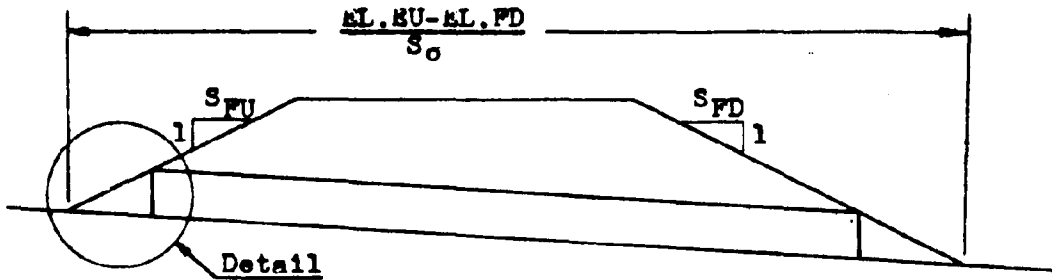

The equation for the fill slope (line a) is:

$$Y_a = \frac{X}{S_{FU}} + RL.FU$$

Similarly, the equation for the channel slope (line b) is:

$$Y_b = -S_0 X + RL.FU$$

At the face of the culvert, the difference between these two equations equals the height of the culvert.

PROGRAM#2 (cont)

$$D\sqrt{S_o^2+1} = Y_a - Y_b = \frac{X}{S_{FU}} + \text{EL.FU} + S_o X - \text{EL.FU} = \frac{X}{S_{FU}} + S_o X$$

Solving for the unknown value X;

$$X = \frac{D\sqrt{S_o^2+1}}{\left(\frac{1}{S_{FU}} + S_o\right)} = \frac{S_{FU}D\sqrt{S_o^2+1}}{(1+S_o S_{FU})}$$

For the downstream condition, a similar value for X would be;

$$X = \frac{S_{FD}D\sqrt{S_o^2+1}}{(1-S_o S_{FD})}$$

Multiplying these values by the channel slope will give the change in elevation across the distance X. From this, the inlet and outlet elevations can be determined.

$$\text{EL.INLET} = \text{EL.FU} - \frac{S_o S_{FU} D \sqrt{S_o^2+1}}{(1+S_o S_{FU})}$$

$$\text{EL.OUTLET} = \text{EL.FD} + \frac{S_o S_{FD} D \sqrt{S_o^2+1}}{(1-S_o S_{FD})}$$

From these two values, the culvert length can be determined.

$$L = \frac{(\text{EL.INLET} - \text{EL.OUTLET})\sqrt{S_o^2+1}}{S_o}$$

PROGRAM #9

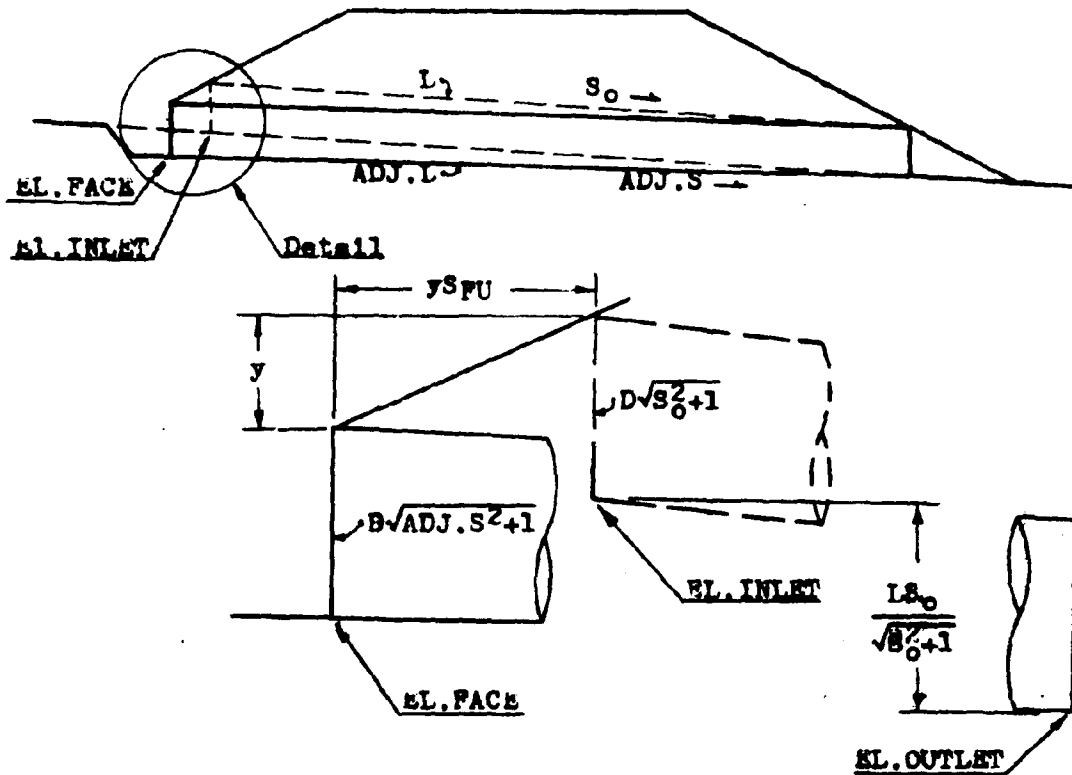

There are three unknowns to be solved for in this program. ADJ.L, ADJ.S, and the vertical distance y. Knowing that the FALL is the difference between the inlet and face elevations, an expression for y can be obtained.

$$y = \text{FALL} + D\sqrt{S_0^2+1} - D\sqrt{\text{ADJ.S}^2+1}$$

Using a rise/run relationship, the value of ADJ.S becomes:

$$\text{ADJ.S} = \frac{(LS_0/\sqrt{S_0^2+1}) - \text{FALL}}{(L/\sqrt{S_0^2+1}) + ySpU} = \frac{LS_0 - \text{FALL}\sqrt{S_0^2+1}}{L + ySpU\sqrt{S_0^2+1}}$$

PROGRAM #9 (cont)

Due to the complexity of these two equations they are solved by a trial and error method by the calculator.

Once the adjusted slope is found the adjusted length can be obtained by multiplying the difference in elevation between the face invert and the outlet invert by the cosecant of the adjusted slope.

$$ADJ.L = \left( \frac{LS_o}{\sqrt{S_o^2+1}} - FALL \right) \frac{\sqrt{ADJ.S^2+1}}{ADJ.S}$$

PROGRAM #10

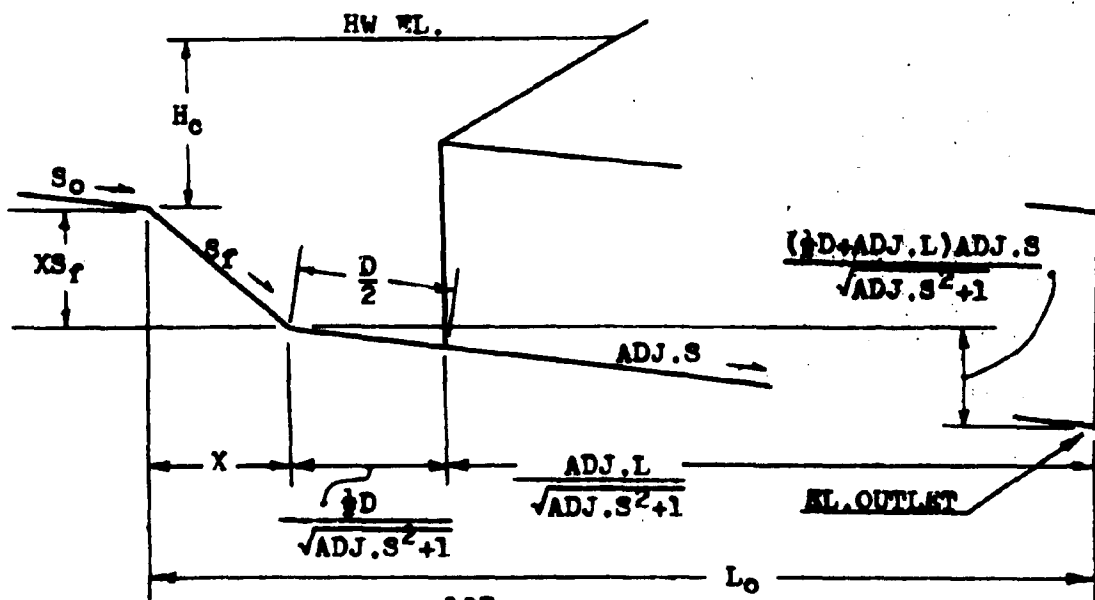
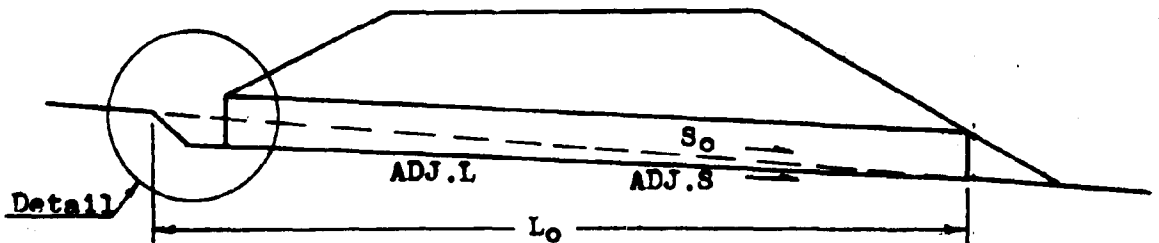

PROGRAM #10 (cont)

From the diagrams the value of  $L_0$  can be determined.

$$L_0 = X + \frac{\frac{1}{2}D}{\sqrt{ADJ.S^2+1}} + \frac{ADJ.L}{\sqrt{ADJ.S^2+1}}$$

Since the value of X is also an unknown, an expression for it is also required. Summing vertical distances produces;

$$L_0 S_0 = X S_f + \frac{(\frac{1}{2}D+ADJ.L)ADJ.S}{\sqrt{ADJ.S^2+1}}$$

Combining these two equations, an expression for  $L_0$  without the value of X in it, is obtained.

$$L_0 = \frac{(S_f-ADJ.S)(\frac{1}{2}D+ADJ.L)}{(S_f-S_0)\sqrt{ADJ.S^2+1}}$$

Substituting this value in an expression for  $H_0$ ;

$$H_0 = HW \text{ WL.} - EL. \text{ OUTLET} - L_0 S_0$$

$$H_0 = HW \text{ EL.} - EL. \text{ OUTLET} - \frac{S_0(S_f-ADJ.S)(\frac{1}{2}D+ADJ.L)}{(S_f-S_0)\sqrt{ADJ.S^2+1}}$$

The crest width can be calculated using this value of  $H_0$ .

The formula relating crest width to the depth of water at the crest is taken from the references and is not derived here.

$$CW = \frac{Q}{(2H_0)^{1.5}}$$

PROGRAM #10 (cont)

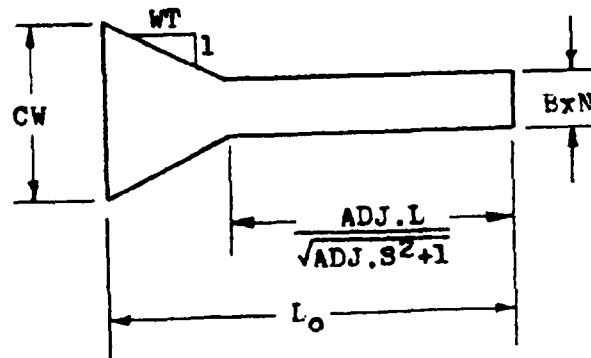

From this diagram, the wingwall taper is determined.

$$WT = \frac{(L_0 - L / \sqrt{ADJ.S^2 + 1})}{(CW - BxN) / 2}$$

The wingwall angle is just  $90^\circ$  - the arctangent of the wing-wall taper.

PROGRAM #14

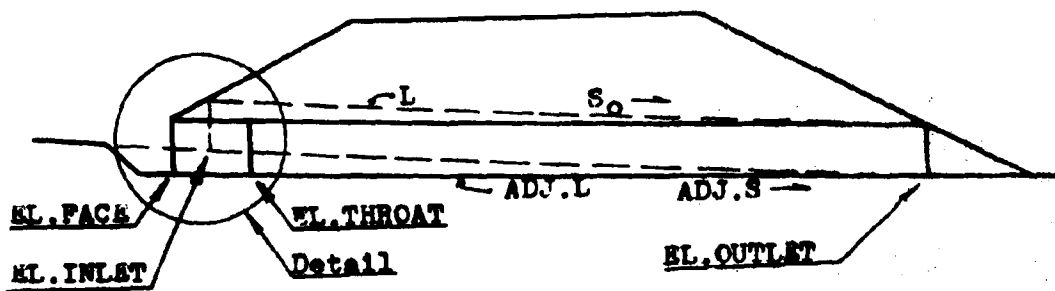

PROGRAM #14 (cont)

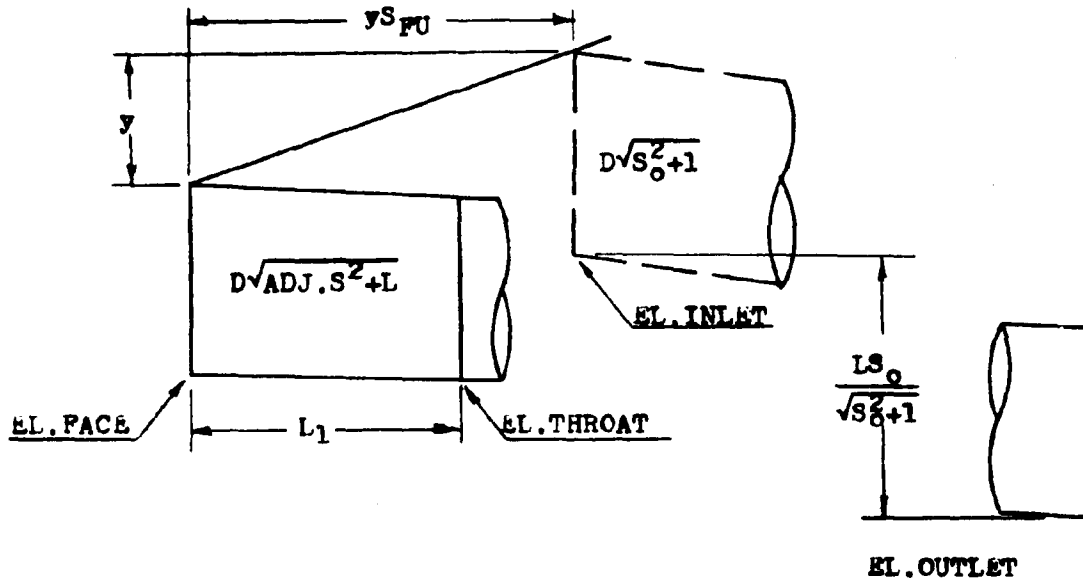

The formulas given here are similar to those given in program #9, except a new unknown  $L_1$  has been introduced. The meaning of FALL has changed also. It now equals the difference between the elevation of the inlet and the elevation of the throat. The expressions for  $y$  and ADJ.S now equal;

$$y = \text{FALL} + D\sqrt{S_0^2+1} - D\sqrt{\text{ADJ.S}^2+1} - L_1\text{ADJ.S}$$

$$\text{ADJ.S} = \frac{LS_0 - \text{FALL}\sqrt{S_0^2+1} + L_1\text{ADJ.S}\sqrt{S_0^2+1}}{L + yS_{FU}\sqrt{S_0^2+1}}$$

Substituting:

$$0 = (\text{FALL} + D\sqrt{S_0^2+1} - D\sqrt{\text{ADJ.S}^2+1})S_{FU}\text{ADJ.S}\sqrt{S_0^2+1} - LS_0 \\ + \text{FALL}\sqrt{S_0^2+1} - L_1\text{ADJ.S}\sqrt{S_0^2+1} + L\text{ADJ.S} - L_1\text{ADJ.S}^2S_{FU}\sqrt{S_0^2+1}$$



### PROGRAM #15

The adjusted length computations used in program #15 can be derived using the diagrams of program #14. Once the adjusted slope is calculated by program #14, it is used by this program to find the new culvert length.

As was the case in program #9, the adjusted length is the product of the cosecant of the adjusted slope and a difference in elevations. In program #9, the difference was between the face invert elevation and the outlet invert elevation. For this program the difference is between the throat invert and the outlet invert. Although this difference in definition exists, it has little effect on the formula below. This difference is resolved by the two different definitions of the FALL. In program #9, the FALL is the difference in elevation between the inlet invert and the face invert. In program #15, it is the difference in elevation between the inlet invert and the throat invert. After the culvert length is found, the length of the improved inlet is subtracted off.

$$ADJ.L = \left( \frac{LS_o}{\sqrt{S_o^2+1}} - FALL \right) \left( \frac{\sqrt{ADJ.S^2+1}}{ADJ.S} \right) - L_1 \sqrt{ADJ.S^2+1}$$

Sliding back up the adjusted slope from the throat section:

$$EL.FACE = EL.THROAT + L_1 ADJ.S$$

PROGRAM #16

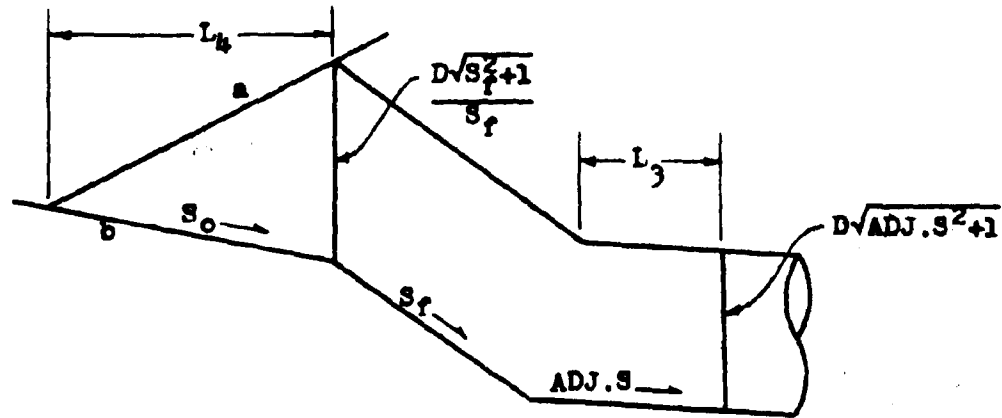
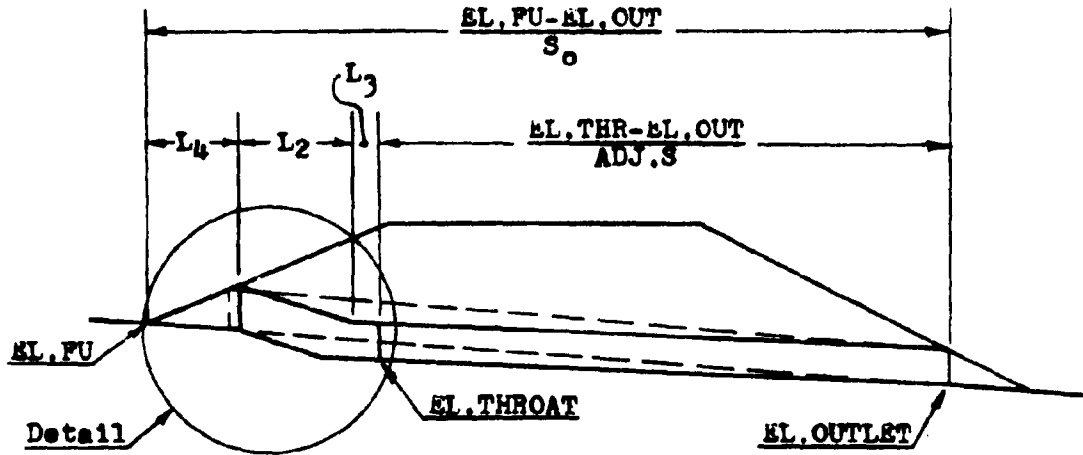

The equation for the fill slope (line a) is;

$$Y_a = \frac{L_4}{S_{FU}} + \text{EL.FU}$$

Similarly, the equation for the channel slope (line b) is;

$$Y_b = -S_0 L_4 + \text{EL.FU}$$

PROGRAM #16 (cont)

At the face of the culvert, the difference between these two equations equals the height of the culvert.

$$\frac{D\sqrt{S_f^2+1}}{S_f} = Y_a - Y_b = \frac{L_4}{S_{FU}} + \text{EL.FU} + S_o L_4 - \text{EL.FU}$$

Solving this expression for  $L_4$ :

$$L_4 = \frac{S_{FU} D \sqrt{S_f^2 + 1}}{S_f (1 + S_o S_{FU})}$$

From the first diagram, it can be determined that:

$$L_2 = \frac{\text{EL.FU} - \text{EL.OUT}}{S_o} - L_4 - L_3 - \frac{\text{EL.THR} - \text{EL.OUT}}{\text{ADJ.S}}$$

By summing measurements in the vertical direction, the following expression was obtained.

$$\text{EL.THR} = \text{EL.FU} + \frac{L_4}{S_{FU}} - \frac{L_2}{S_f} - L_3 \text{ADJ.S} - D\sqrt{\text{ADJ.S}^2 + 1}$$

Combining these last three equations, an expression for the adjusted slope can be obtained.

$$0 = \text{EL.FU} + \frac{(S_f + S_{FU}) D \sqrt{S_f^2 + 1}}{S_f^2 (1 + S_o S_{FU})} + \frac{L_3}{S_f} + \frac{\text{EL.OUT} - \text{EL.FU}}{S_o S_f} - L_3 \text{ADJ.S} \\ + \frac{\text{EL.THR} - \text{EL.OUT}}{S_f \text{ADJ.S}} - D\sqrt{\text{ADJ.S}^2 + 1} - \text{EL.THR} - \text{EL.OUT}$$

PROGRAM #17

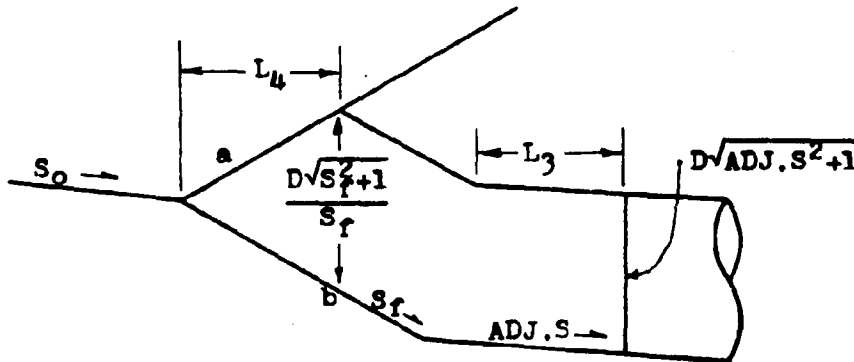
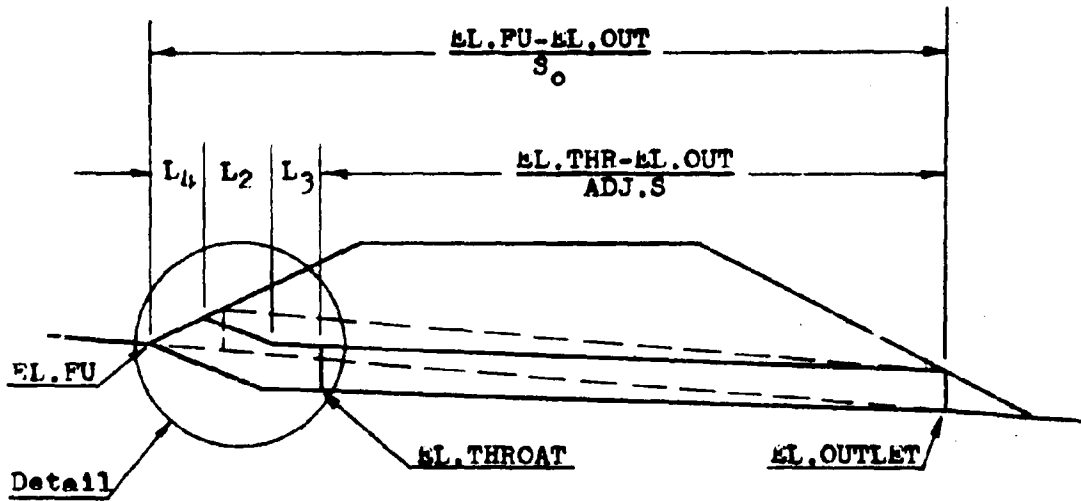

The equation for the fill slope (line a) is:

$$Y_a = \frac{L_4}{S_{FU}} + EL.FU$$

Similarly, the equation for the fall slope (line b) is:

$$Y_b = \frac{-L_4}{S_f} + EL.FU$$

PROGRAM #17 (cont)

At the face of the culvert, the difference between these two equations equals the height of the culvert face.

$$\frac{D\sqrt{S_f^2+1}}{S_f} = Y_a - Y_b = \frac{L_4}{S_{FU}} + \text{EL.FU} + \frac{L_4}{S_f} - \text{EL.FU}$$

Solving this expression for  $L_4$ :

$$L_4 = \frac{S_{FU}D\sqrt{S_f^2+1}}{S_{FU}+S_f}$$

From the first diagram on the previous page:

$$L_2 = \frac{\text{EL.FU}-\text{EL.OUT}}{S_o} - L_4 - L_3 - \frac{\text{EL.THR}-\text{EL.OUT}}{\text{ADJ.S}}$$

By summing the measurements in the vertical direction, the following expression was obtained.

$$\text{EL.THR} = \text{EL.FU} + \frac{L_4}{S_{FU}} - \frac{L_2}{S_f} - L_3\text{ADJ.S} - D\sqrt{\text{ADJ.S}^2+1}$$

Combining these last three equations, an expression for the adjusted slope can be obtained.

$$0 = \text{EL.FU} + \frac{D\sqrt{S_f^2+1}}{S_f} + \frac{L_3}{S_f} + \frac{\text{EL.OUT}-\text{EL.FU}}{S_o S_f} + \frac{\text{EL.THR}-\text{EL.OUT}}{S_f \text{ADJ.S}} \\ - L_3\text{ADJ.S} - D\sqrt{\text{ADJ.S}^2+1} - \text{EL.THROAT}$$

PROGRAM #18

For the derivations of the equations for  $L_2$  and  $L_4$  refer to the derivations for program #16.

The WL.FACE equation can be taken from the diagrams of program #16. The ADJ.L is equal to the cosecant of the adjusted slope times the change in elevation between the throat section and the outlet section.

PROGRAM #19

Refer to the derivation equations for program #17 for an explanation of how  $L_2$  and  $L_4$  were obtained.

The WL.FACE equation can be taken from the diagrams of program #17. The ADJ.L is equal to the cosecant of the adjusted slope times the change in elevation between the throat invert and the outlet invert.

## REFERENCES

1. "Hydraulic Charts for the Selection of Highway Culverts," HEC No. 5, U.S. Department of Transportation, Federal Highway Administration, December 1965.
2. "Hydraulic Design of Improved Inlets for Culverts," HEC No. 13, U.S. Department of Transportation, Federal Highway Administration, August 1972.
3. "Electronic Computer Program for Hydraulic Analysis of Culverts," HY-6, U.S. Department of Transportation, Federal Highway Administration, June 1975.
4. "Open Channel Hydraulics," V. T. Chow, McGraw-Hill Book Company, Inc., New York, 1959.
5. "Open Channel Flow," F. M. Henderson, The MacMillan Company, New York, 1966.