

Department  
of Transportation  
**Federal Highway  
Administration**

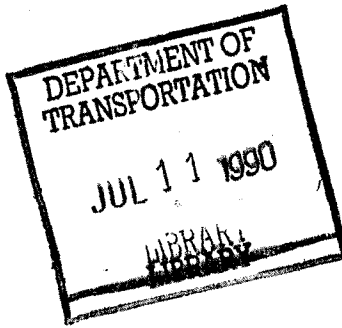

Pub. No. FHWA-HI-90-001

October 1989

**Revised April 1990**

---

NHI Course No. 13213

## **Geotextile Design & Construction Guidelines**

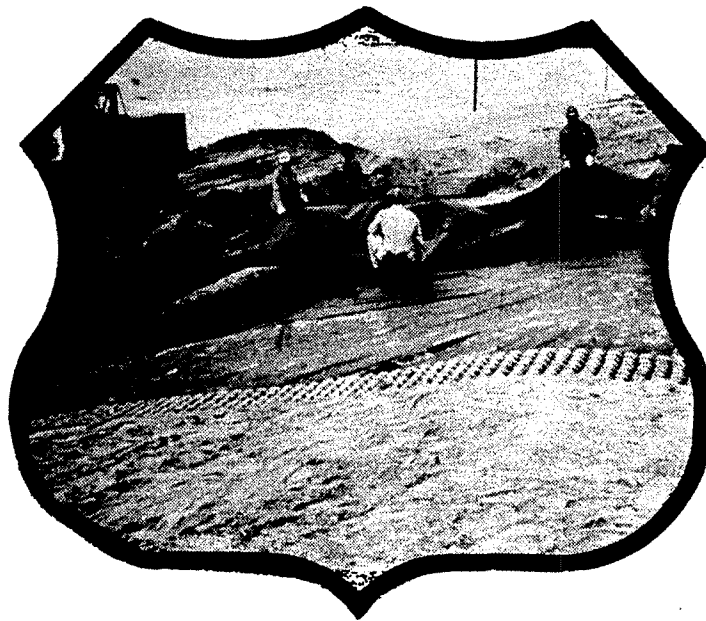

**National Highway Institute**

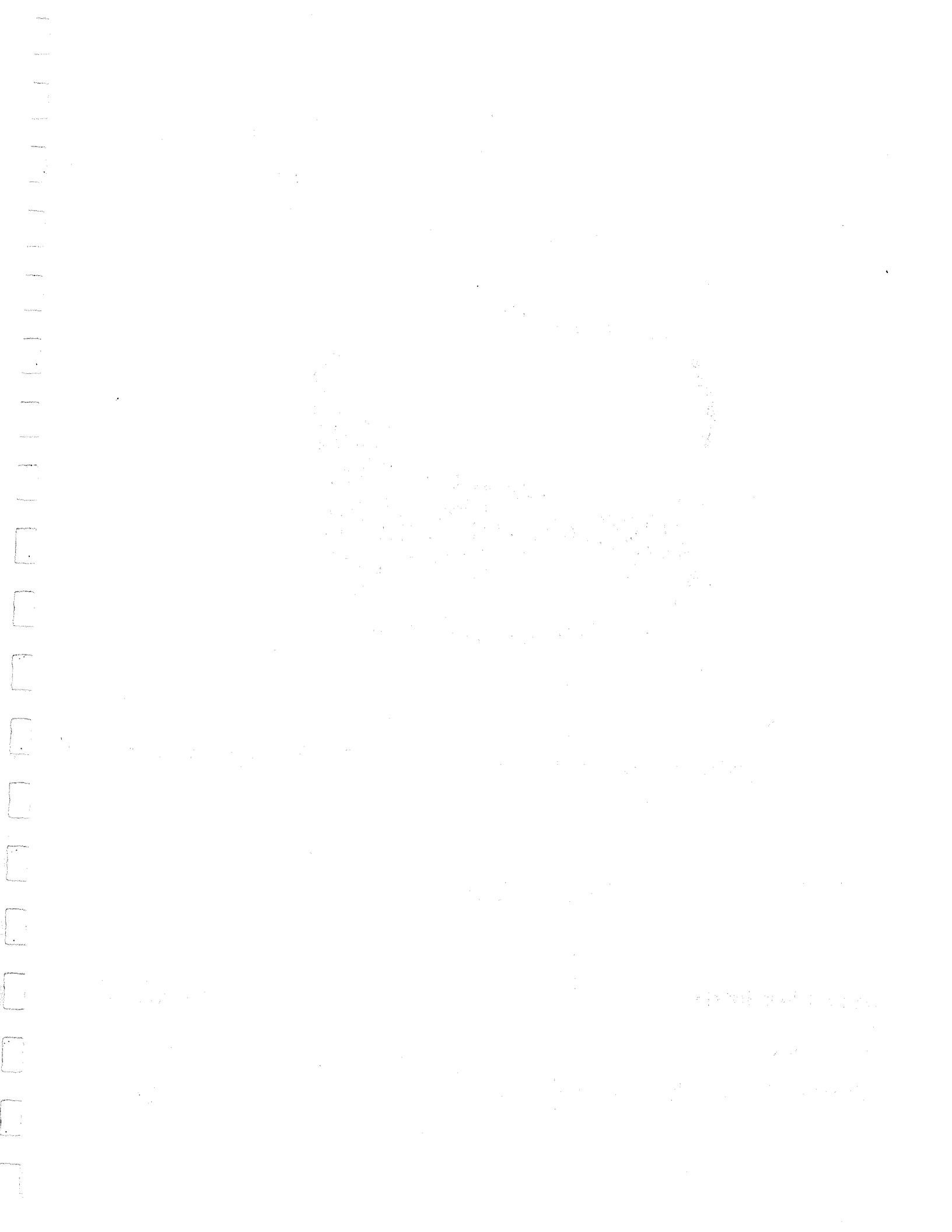

TA  
455  
G44647  
1990

Federal Highway Administration Research Library  
Turner-Fairbank Highway Research Center  
6300 Georgetown Pike  
McLean, VA 22101-2296

**GEOTEXTILE DESIGN & CONSTRUCTION GUIDELINES**

Revised April 1990.

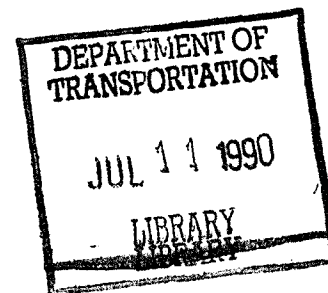

Prepared for

Federal Highway Administration  
National Highway Institute  
Washington, D.C.

by

STS Consultants, Ltd.  
111 Pfingsten Road  
Northbrook, IL 60062

GeoServices Inc.  
1200 South Federal Highway  
Boynton Beach, FL 33435

Contract No. FHWA DTFH61-86-C-00102

Part of a copy of the original document  
has been made available to the public  
under the provisions of the  
Access to Information Act.

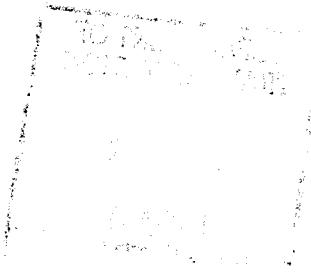

1  
2  
3  
4  
5  
6  
7  
8  
9  
10  
11  
12  
13  
14  
15  
16  
17  
18  
19  
20  
21  
22  
23  
24  
25  
26  
27  
28  
29  
30  
31  
32  
33  
34  
35  
36  
37  
38  
39  
40  
41  
42  
43  
44  
45  
46  
47  
48  
49  
50  
51  
52  
53  
54  
55  
56  
57  
58  
59  
60  
61  
62  
63  
64  
65  
66  
67  
68  
69  
70  
71  
72  
73  
74  
75  
76  
77  
78  
79  
80  
81  
82  
83  
84  
85  
86  
87  
88  
89  
90  
91  
92  
93  
94  
95  
96  
97  
98  
99  
100



# **GEOTEXTILE DESIGN AND CONSTRUCTION GUIDELINES**

- CHAPTER 1. INTRODUCTION, IDENTIFICATION & EVALUATION**
  - 1.1 Scope
  - 1.2 Approach to Design
  - 1.3 Geotextile Definitions, Functions and Applications
  - 1.4 Identification of Geotextiles
  - 1.5 Evaluation of Geotextile Properties
  - 1.6 Specifications
  - 1.7 Field Inspection
  - 1.8 Field Seaming
  
- CHAPTER 2. GEOTEXTILES FILTERS IN DRAINAGE SYSTEMS**
  - 2.1 Background
  - 2.2 Applications
  - 2.3 Geotextile Design
    - 2.3.1 Retention Criteria (For Steady State Flow)
    - 2.3.2 Permeability Criteria
    - 2.3.3 Clogging Resistance
    - 2.3.4 Survivability and Endurance Criteria
  - 2.4 Drainage System Design Guidelines
  - 2.5 Design Example
  - 2.6 Cost Considerations
  - 2.7 Specifications
  - 2.8 Installation Procedures
  - 2.9 Field Inspection
  - 2.10 Geotextile Selection Considerations
  - 2.11 In-Plane Drainage; Prefabricated Drains
    - 2.11.1 Design Criteria
    - 2.11.2 Construction Considerations
  
- CHAPTER 3. GEOTEXTILES IN EROSION CONTROL SYSTEMS**
  - 3.1 Background
  - 3.2 Applications
  - 3.3 Geotextile Design
  - 3.4 Erosion Control System Design Guidelines
  - 3.5 Design Example
  - 3.6 Cost Considerations
  - 3.7 Specifications
  - 3.8 Installation Procedures
  - 3.9 Field Inspection
  - 3.10 Geotextile Selection Considerations
  
- CHAPTER 4. TEMPORARY EROSION CONTROL USING GEOTEXTILES**
  - 4.1 Background
  - 4.2 Geotextile Selection
  - 4.3 Constructability Requirements
  - 4.4 Specifications
  - 4.5 Installation Procedures

# **GEOTEXTILE DESIGN AND CONSTRUCTION GUIDELINES (con't)**

## **CHAPTER 5. USING GEOTEXTILES AS SEPARATORS IN ROADWAYS**

- 5.1 Background
- 5.2 Applications
- 5.3 Roadway Design Using Geotextiles
- 5.4 Design Guidelines for Temporary Roads
- 5.5 Design Example
- 5.6 Design Guidelines for Permanent Roads and Highways
- 5.7 Design Example
- 5.8 Geotextile Survivability
- 5.9 Cost Considerations
- 5.10 Specifications
- 5.11 Installation Procedures
  - 5.11.1 Overlaps
  - 5.11.2 Seams
- 5.12 Field Inspection
- 5.13 Selection Considerations

## **CHAPTER 6. PAVEMENT OVERLAYS**

- 6.1 Background and Application
- 6.2 Specifications: Geotextile Considerations and Installation Procedures
- 6.3 Field Inspection

## **CHAPTER 7. REINFORCED EMBANKMENTS ON SOFT FOUNDATIONS**

- 7.1 Background
- 7.2 Applications
- 7.3 Reinforced Embankment Design Considerations
  - 7.3.1 Design Requirements
  - 7.3.2 Establish Design Criteria
  - 7.3.3 Overall Bearing Capacity
  - 7.3.4 Internal Stability Analysis
  - 7.3.5 Lateral Embankment Spreading (Sliding Type Failure)
  - 7.3.6 Longitudinal Strength Requirements
- 7.4 Geosynthetic and Fill Considerations
  - 7.4.1. Geotextile and Geogrid Strength Requirements
  - 7.4.2. Drainage Requirements
  - 7.4.3 Environmental Considerations
  - 7.4.4 Stiffness and Workability
  - 7.4.5 Fill Considerations
- 7.5 Design Guidelines for Reinforced Embankments on Soft Foundations
- 7.6 Specifications
- 7.7 Cost Considerations
- 7.8 Construction Sequence
- 7.9 Field Inspection
- 7.10 Reinforcement of Embankments Covering Large Areas

# **GEOTEXTILE DESIGN AND CONSTRUCTION GUIDELINES (con't)**

## **CHAPTER 8. REINFORCED SLOPES**

- 8.1 Background
- 8.2 Applications
- 8.3 Geotextile & Geogrid Design Considerations
  - 8.3.1 Design Requirements
  - 8.3.2 Design Properties
  - 8.3.3 Research Needs
- 8.4 Design of Reinforced Slopes
- 8.5 Guidelines for Reinforced Slope Design
- 8.6 Design Example
- 8.7 Cost Considerations
- 8.8 Specifications
- 8.9 Installation Procedures
- 8.10 Field Inspection

## **CHAPTER 9. REINFORCED RETAINING WALLS AND ABUTMENTS**

- 9.1 Background
- 9.2 Applications
- 9.3 Selection of Geotextile and Geogrid Properties
  - 9.3.1 Mechanical Properties
  - 9.3.2 Constructability (Survivability)
  - 9.3.3 Durability
- 9.4 Design Guidelines for Reinforced Walls
  - 9.4.1 Approaches and Models
  - 9.4.2 Design Steps
- 9.5 Design Example
- 9.6 Cost Considerations
- 9.7 Specifications
- 9.8 Construction Procedures
- 9.9 Field Inspection

## **REFERENCES**

## **APPENDIX**

- A.1 Notations
- A.2 Glossary
- A.3 Representative List of Geotextile Manufacturers and Suppliers
- A.4 General Range of Strength and Permeability Properties for Representative Types of Geotextiles
- A.5 NHI/FHWA Geotextile Engineering Workshop Lecture Outline: Construction Course



## LIST OF FIGURES

- 1.1 Classification of Geotextiles
- 1.2 Types of (a) Stitches and (b) Seams, According to Federal Standard No. 751a (1965). (c) Improper Seam Placement
  
- 2.1 Filter Bridge Formation
- 2.2 Methods of Clogging and Blinding
- 2.3 Gradient Ratio Device
- 2.4 Typical Gradations and Darcy Permeabilities of Several Aggregate and Graded Filter Materials
- 2.5 Sequential Procedure for Fabric-Lined Underdrain Construction
- 2.6 Construction of Geotextile Drainage System
- 2.7 Composite Systems
- 2.8 Prefabricated Edge Drain Construction
  
- 3.1 Erosion Control Installations
- 3.2 Construction of Erosion Control System
- 3.3 Special Construction Requirements Related to Specific Erosion Control Applications
  
- 4.1 Installation Procedures for Silt Fences
  
- 5.1 Primary and Secondary Functions of Geotextiles in Roadway Applications
- 5.2 U.S. Forest Service Thickness Design Curve for Single Wheel Load
- 5.3 U.S. Forest Service Thickness Design Curve for Dual Wheel Load
- 5.4 U.S. Forest Service Thickness Design Curve for Tandem Wheel Load
- 5.5 Forming Curves Using Geotextiles
- 5.6 Construction Sequence Using Geotextiles
- 5.7 Repair of Rutting with Additional Base Material
  
- 7.1 Reinforced Embankment Applications
- 7.2 Unsatisfactory Behavior That Can Occur in Reinforced Embankments
- 7.3 Reinforcement Required to Provide Internal Stability
- 7.4 Reinforcement Required to Limit Lateral Embankment Spreading
- 7.5 Construction Sequence for Geosynthetic Reinforced Embankments for Extremely Weak Foundations
- 7.6 (a) Placement of Fill Between Toe Berms on Extremely Soft Foundations  
(b) Fill Placement to Tension Fabrics on Moderate Ground Conditions
- 7,7 Reinforced Embankment Construction

## LIST OF FIGURES (con't)

- 8.1 Slope Reinforcement using Geosynthetics to Provide Increased Slope Stability
  - 8.2 Requirements for Design of Reinforced Design
  - 8.3 Rotational Shear Approach to Determine Required Strength of Reinforcing Geogrids
  - 8.4 Sliding Wedge Approach Determination of The Coefficient of Earth Pressure K
  - 8.5 Spacing and Embedment Requirements for Slope Reinforcement
  - 8.6 Construction of Reinforced Slopes
  - 8.7 Reinforced Slope Construction Photos
- 
- 9.1 Component Parts and Key Dimensions of Reinforced Earth Wall
  - 9.2 Reinforced Soil Retaining Wall Using Geotextiles
  - 9.3 Photos of Geosynthetic Reinforced Soil Walls
  - 9.4 Actual Geosynthetic Reinforced Soil Wall in Contrast to the Design Model
  - 9.5 Requirements for Design of Reinforced Soil Wall
  - 9.6a Meyerof's Stress Distribution Approach to Determine Horizontal Stress for Uniform Surcharge Load
  - 9.6b Meyerof's Stress Distribution Approach to Determine Horizontal Stress for Inclined Surcharge Load
  - 9.7a External Sliding Stability of a Geosynthetic Soil Wall with a Uniform Surcharge Load
  - 9.7b External Sliding Stability of a Geosynthetic Soil Wall with a Inclined Surcharge Load
  - 9.8a Bearing Capacity for External Stability of a Geosynthetic Soil Wall with Uniform Surcharge Load
  - 9.8b Bearing Capacity for External Stability of a Geosynthetic Soil Wall with an Inclined Surcharge Load
  - 9.9a External Overturning Stability of a Geosynthetic Reinforced Soil Wall with a Uniform Surcharge Load
  - 9.9b External Overturning Stability of a Geosynthetic Reinforced Soil Wall with an Inclined Surcharge Load
  - 9.10 Potential Slip Surfaces for Geogrid Reinforced Walls
  - 9.11 Horizontal Stress Increase Due to Seismic Loading
  - 9.12 Embedment Length for Reinforcement Required to Resist Pullout
  - 9.13 Cost Comparison of Reinforced Systems
  - 9.14 Lift Construction Sequence for Engineering Fabric-Reinforced Soil Walls
  - 9.15 Typical Geogrid Face Construction Detail for Vertical Geogrid-Reinforced Retaining Wall Faces
  - 9.16 Types of Geotextile Reinforced Wall Facing

## LIST OF TABLES

- 1-1 Representative Applications and Controlling Functions of Geotextiles
- 1-2 Important Criteria and Principal Properties Required for Geotextile Evaluation
- 1-3 Geotextile Properties and Parameters for Geotextile Selection
  
- 2-1 Guidelines for Evaluating the Critical Nature or Severity of Drainage and Erosion Control Applications
- 2-2 Physical Requirements for Drainage Geotextiles
  
- 3-1 Summary of Geotextile Design and Selection Criteria for Drainage, Filtration, and Erosion Control Applications
  
- 4-1 AASHTO-AGC-ARTBA Physical Requirements for Temporary Silt Fence Geotextiles
  
- 5-1 Bearing Capacity Factors for Different Ruts and Traffic Conditions Both With and Without Geotextile Separators
- 5-2 Relationship of Construction Elements to Severity of Loading Imposed on Geotextile in Roadway Construction
- 5-3 Geotextile Strength Required for Survivability During Construction
- 5-4 Geotextile Drainage and Filtration Requirements
- 5-5 Recommended Minimum Overlap Requirements
  
- 7-1 Required Degree of Fabric Survivability as a Function of Subgrade Conditions and Construction Equipment
- 7-2 Required Degree of Fabric Survivability as a Function of Cover Material and Construction Equipment
- 7-3 AASHTO-AGC-ARTBA Joint Committee Minimum Fabric Properties Required for Fabric Survivability
  
- 8-1 Relationship of Construction Elements to Severity of Loading Imposed on Geotextile in Slope Construction
- 8-2 Geotextile Strength Required for Survivability During Construction
  
- 9-1 Relationship of Construction Elements to Severity of Loading Imposed on Geotextiles in Roadway Construction
- 9-2 Geotextile Strength Required for Survivability During Construction
- 9-3 Failure Modes of Geotextiles or Geogrids in Reinforced Soil Walls
- 9-4 Recommended Gradation Limits for Reinforced Fill





# GEOTEXTILE DESIGN AND CONSTRUCTION GUIDELINES

## CHAPTER 1

### INTRODUCTION, IDENTIFICATION & EVALUATION

#### 1.1 Scope

These "guidelines" were prepared to assist design engineers, specification writers, estimators, construction personnel, inspectors, and maintenance personnel with the design, selection, and installation of geotextiles and related products. In addition to providing a general overview of these materials and their application, the guidelines provide step by step procedures for the use of geotextiles and related products in drainage and erosion control systems, roadways, and as reinforcement. Although only geotextiles are included in the title, design using other geosynthetic products such as geogrids for reinforcement and geocomposites for drainage applications are mentioned where appropriate.

These guidelines are based on the procedures and background information in the FHWA Geotextile Engineering Manual (Christopher and Holtz, 1985). If you are not already familiar with geotextiles, you are encouraged to review that manual, especially if you are attempting to design with geotextiles for the first time. The FHWA Manual is our basic reference for this document, although occasionally we will refer to other published information. We will also assume that you are already familiar with the basics of highway engineering, pavement design, and geotechnical engineering. We have tried to use common symbols and notation throughout, and a list is provided in the Appendix for easy reference.

In addition to notations, the Appendix includes a glossary of terms relating to geosynthetics, a list of representative geosynthetic manufacturers and suppliers, and general range of strength properties for representative types of geotextiles.

Specifications included in the design sections were in several cases developed by Task Force No. 25 of the Joint Committee on Materials of the American Association of State Highway and Transportation Officials (AASHTO), the Association General Contractors (AGC), and the American Road and Transportation Builders Association (ARTBA), along with representatives from the geosynthetic industry. Important input has also been obtained from the AASHTO-AGC-ARTBA Task Force 27 on Ground Modification Systems. Finally, sample specifications were obtained from some state highway agencies. These specifications are meant to serve only as a guide and should be supplemented as required by engineering judgment and experience.

Chapter 1 of the Guidelines will introduce you to the functions and applications of geotextiles and related products, to the identification of the materials themselves, and to the methods used to evaluate their properties. The remaining eight chapters give specific details about each of the important applications of geotextiles in highway engineering. Each chapter provides a systematic approach to designing with geotextiles so that successful design and installation can be achieved.

## 1.2 Approach to Design

Our recommended approach to designing with geotextiles includes the following steps:

1. Define the purpose and establish the scope of the project.

2. Investigate and establish the geotechnical conditions at the site (geology, subsurface exploration, laboratory and field testing, etc.).
3. Formulate trial designs and compare several alternatives.
4. Establish the models to be analyzed, determine the parameters, and carry out the analysis.
5. Compare results and select the most appropriate design; consider alternatives versus cost, construction feasibility, etc. Modify the design if necessary.
6. Prepare detailed plans and specifications including:
  - a. Specific property requirements for the geotextile.
  - b. Detailed installation procedures.
7. Observe construction.

By following this systematic approach to designing with geotextiles, cost effective designs can be achieved, along with improved performance, increased service life, and reduced maintenance costs. It is imperative throughout the design and selection process that good communication and interaction exist between all concerned parties and the design engineer.

### 1.3 Geotextile Definitions, Functions and Applications

A geotextile is any permeable textile material used with soil, rock, etc. in civil engineering construction. Although technically not textiles, a number of other materials such as webs, grids, nets, meshes, and composites available today are used in combination with or in place of geotextiles. We refer to these in the guidelines as geotextile-related materials. Geotextiles

and related materials all fall under the principal category of geosynthetics. Geomembranes are also a type of geosynthetic, but they are not included in these guidelines.

The four primary functions of geotextiles and related materials are:

1. Filtration
2. Drainage
3. Separation
4. Reinforcement

Geotextile applications are usually defined by the principal function of the geotextile for the particular application. For example, geotextiles are used as filters to prevent soils from migrating into drainage aggregate or pipes, while maintaining water flow through the system. They are similarly used below rip-rap and other armor materials in coastal and stream bank protection systems to prevent soil erosion.

Geotextiles can also be used as drainage or transmission media by allowing water to drain from or through soils of lower permeability. Applications would include dissipation of pore water pressures at the base of an embankment. For situations with higher flow requirements, prefabricated drains and other geo-composites have been developed. These materials are used as pavement edge drains, interceptor drains in slopes, and for drains behind abutments and retaining walls.

Geotextiles often find application as separators to prevent road base materials from penetrating into the underlying soft subgrade, thus maintaining the design thickness and integrity of the roadway.

Geotextiles and related materials such as geogrids can also be used as reinforcement to add tensile strength to a soil matrix, and thereby provide a more competent structural material.

Reinforcement enables stable embankments to be constructed over very soft foundations and permits the construction of steep slopes and retaining walls.

One other geotextile function, that of waterproofing after appropriate treatment, should also be mentioned, as it finds wide application in asphalt pavement overlays.

All these functions are covered in detail in the FHWA Geotextile Engineering Manual. In actual practice in addition to the primary function, the geotextile usually performs one or more other functions (called secondary functions) to make up the total contribution of the geotextile in a particular application. Table 1-1 is a listing of a number of common applications according to primary and secondary functions. It is important to consider both the primary and secondary function in the design computations and geotextile specifications.

#### 1.4 Identification of Geotextiles

Geotextiles or geotextile-related products should be identified by:

1. Polymer
2. Type of fiber or yarn, if appropriate
3. Type of geotextile or geotextile related product
4. Mass per unit area
5. Any additional information necessary to describe the material

Two examples are:

1. Polypropylene stable fiber needlepunched nonwoven, 350 g/m<sup>2</sup> (10 oz/yd<sup>2</sup>).
2. Polyethylene net, 440 g/m<sup>2</sup> (13 oz/yd<sup>2</sup>) with 8 mm (5/16 in.) openings.

TABLE 1-1

REPRESENTATIVE APPLICATIONS AND CONTROLLING FUNCTIONS OF GEOTEXTILES

<u>PRIMARY FUNCTION</u>	<u>APPLICATION</u>	<u>SECONDARY FUNCTION(S)</u>
Separation	Unpaved Roads (temporary & permanent)	Filter, drains, reinforcement
	Paved Roads (secondary & primary)	Filter, drains
	Construction Access Roads	Filter, drains, reinforcement
	Working Platforms	Filter, drains, reinforcement
	Railroads (new construction)	Filter, drains, reinforcement
	Railroads (rehabilitation)	Filter, drains, reinforcement
	Landfill Covers	Reinforcement, drains
	Pre-Loading (stabilization)	Reinforcement, drains
	Marine Causeways	Filter, drains, reinforcement
	General Fill Areas	Filter, drains, reinforcement
	Paved & Unpaved Parking Facilities	Filter, drains, reinforcement
	Cattle Corrals	Filter, drains, reinforcement
	Coastal & River Protection	Filter, drains, reinforcement
	Sports Fields	Filter, drains
Drainage-Transmission	Retaining Walls	Separation, filter
	Vertical Drains	Separation, filter
	Horizontal Drains	Reinforcement
	Below Membranes (drainage of gas & water)	Reinforcement
	Earth Dams	Filter
	Below Concrete (decking & slabs)	-----
Reinforcement	Pavement Overlays	-----
	Concrete Overlays	-----
	Subbase Reinforcement in Roadways & Railways	Filter
	Retaining Structures	Drains
	Membrane Support	Separation, drains, filter
	Embankment Reinforcement	Drains
	Fill Reinforcement	Drains
	Foundation Support	Drains
	Soil Encapsulation	Drains, filter, separation
	Net Against Rockfalls	Drains
	Fabric Retention Systems	Drains
	Sand Bags	-----
	Reinforcement of Membranes	-----
	Load Redistribution	Separation
	Bridging Non-Uniformity Soft Soil Areas	Separation
	Encapsulated Hydraulic Fills	Separation
Bridge Piles for Fill Placement	-----	
Filter	Trench Drains	Separation, drains
	Pipe Wrapping	Separation, drains
	Base Course Drains	Separation, drains
	Frost Protection	Separation, drainage, reinforcement
	Structural Drains	Separation, drains
	Toe Drains in Dams	Separation, drains
	High Embankments	Drains
	Filter Below Fabric-Form	Separation, drains
	Silt Fences	Separation, drains
	Silt Screens	Separation
	Culvert Outlets	Separation
	Reverse Filters for Erosion Control:	Separation
	Seeding and Mulching	
	Beneath Gabions	
	Ditch Amoring	
	Embankment Protection, Coastal	
	Embankment Protection, Rivers & Streams	
Embankment Protection, Lakes		
Vertical Drains (wicks)		

A convenient classification scheme for geotextiles and related materials is given in Fig. 1.1. For details on the composition, materials, and manufacturing processes for geotextiles and related materials, see the books by Koerner and Welsh (1980), Rankilior (1981), and Koerner (1986). The article by Giroud and Carroll (1983), reprinted in the Geotextile Engineering Manual, also provides good descriptive material. As Fig. 1.1 indicates, a number of processes can be used to manufacture geotextiles. Most geotextiles, as with most of the related products, are made from polymers such as polypropylene, polyester, polyethylene, polyamides (nylon) and glass fibers. These materials are highly resistant to biological and chemical degradation. Natural fibers such as cotton, jute, etc. could also be used as geotextiles, especially for temporary applications, but they have not been promoted nor has research been performed as widely as for polymeric geotextiles.

In manufacturing geotextiles, elements such as fibers or yarns are combined into planar structures called fabrics. The fibers can be continuous filaments, which are very long thin strands of a polymer or staple fibers in which the filaments are rather short, typically 2 to 5 cm long. The fibers may also be produced by slitting an extruded plastic sheet or film to form thin flat tapes. In both filaments and slit films, the extrusion or drawing process elongates the polymers in the direction of the draw and increases in the strength of the filaments.

The type of geotextile is determined by the method used to combine the filaments into the planar structure. The great majority of geotextiles are either woven or nonwoven. The weaving process is as old as Homo Sapiens have been making textiles for clothing. Nonwoven textile manufacture is a modern development, a "high tech" process industry, in which synthetic polymer filaments are extruded or spun onto a moving belt. Then the mass of filament or fibers are either needlepunched in which the filaments are

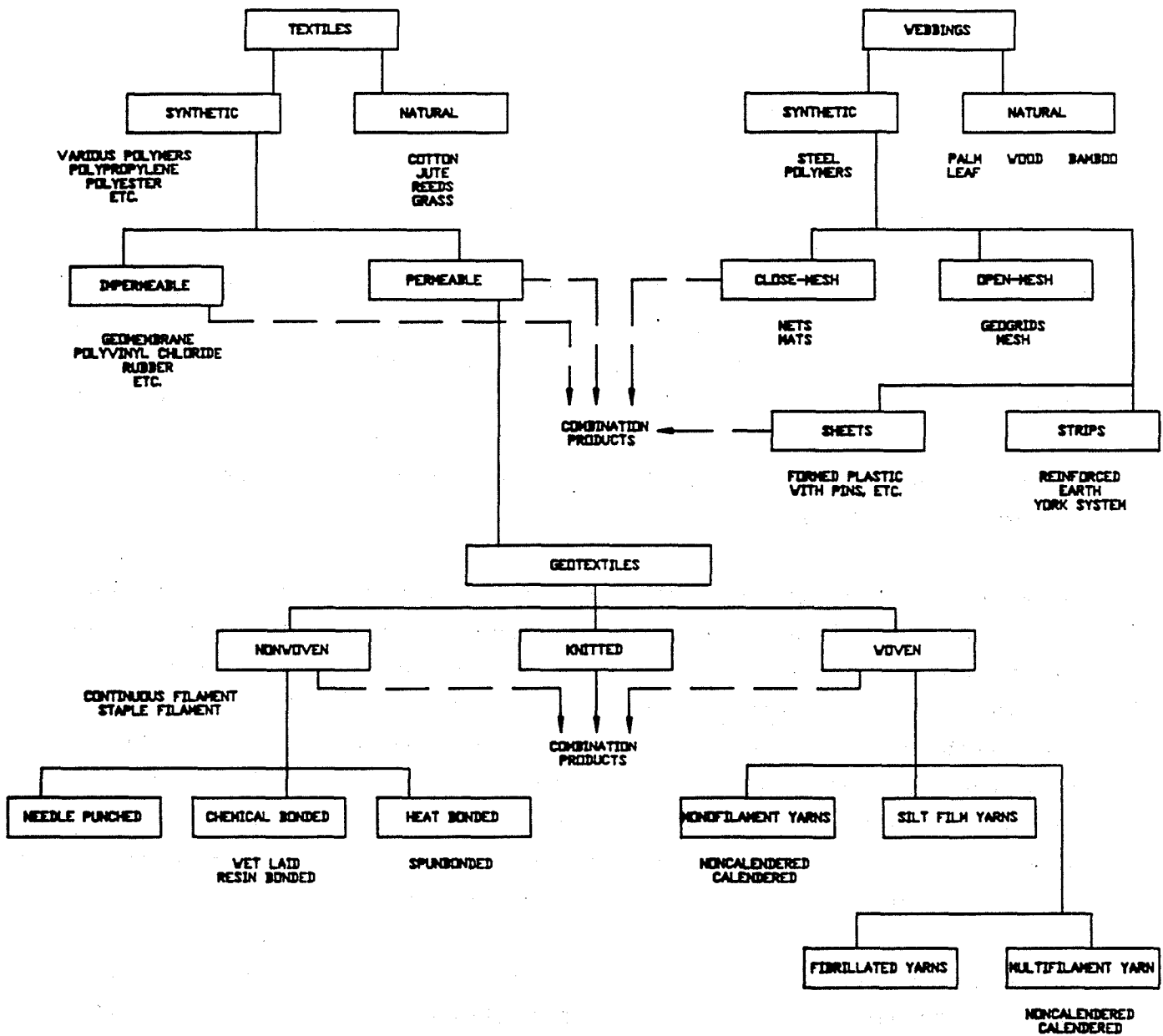

Fig. 1.1 Classification of Geotextiles  
(adapted from Rankilor, 1981)



entangled by a series of small needles, or heat bonded in which the fibers are "welded" together by temperature and pressure at the points of contact in the nonwoven mass.

The manufacture of geotextile-related products is as varied as the products themselves. Geonets, geomats, geogrids, etc. can be made from large and rather stiff filaments formed into a mesh and welded or glued at the crossover points, or they may be extruded from plastic sheets with holes punched in them.

A number of composite materials also exist. These may consist of two or more geotextiles combined in the manufacturing process or a combination of a geotextile and a geotextile related product. One of the more common geo-composites are prefabricated drains, which are formed by either wrapping or covering a fluted or dimpled polymeric sheet, to act as a conduit for water, with a geotextile to perform as a filter.

#### 1.5 Evaluation of Geotextile Properties

Today in the U.S. there are probably 250-350 different geotextiles or geotextile related materials available. Because of the wide variety of materials available, with their different polymers, filaments, weaving (or nonwoven) patterns, bonding mechanisms, thicknesses, masses, etc., they have a large range of physical and mechanical properties. Thus, the process of comparison and selection of geotextiles and related materials is somewhat difficult for the designer. A further complicating factor is the variability of some properties, even within the same manufactured lot or roll. As many test methods for geotextiles have only recently been standardized, there also may be differences in test procedures for some properties reported in the literature. The FHWA Geotextile Engineering Manual discusses geotextile testing in detail and gives the complete test procedures for geotextile properties listed in this section and mentioned throughout the guidelines.

The particular properties of the geotextile required for design will depend on the specific applications. The properties listed in Table 1-2 cover the range of important criteria and properties required to evaluate the suitability of the geotextile for most applications. It should be noted that all of the requirements listed will not be required for all applications. For properties required for a specific application, refer to the specific chapter covering that application.

A listing of all geotextile properties and parameters that may require consideration for specific project are listed in Table 1-3. Again, the test procedures for each specific property is discussed in detail in the FHWA Geotextile Engineering Manual.

The tests listed in Table 1-3 include "index" tests and "performance" tests. Index tests in most cases do not produce an actual property, but they generally provide a value from which the property of interest can be qualitatively assessed. When determined using identical test procedures, index tests can be used as a means of product comparison and can be used for specifications and quality control evaluation.

Performance tests require testing of the geotextile with soil to obtain a direct assessment of the property of interest. Since performance tests should be performed in conjunction with site soils under specific design conditions, it cannot be expected that manufacturers should have the capability nor should they be required to perform such tests.

These tests should be performed under the direction of the design engineer in his own or his representative's soils laboratory. Performance tests should not be used in specifications; rather, geotextiles should be preselected for performance testing based on index values or performance test results should be correlated to index values for use in specifications.

TABLE 1-2

IMPORTANT CRITERIA AND PRINCIPAL PROPERTIES REQUIRED FOR GEOTEXTILE EVALUATION

<u>Criteria and Parameter</u>	<u>Property (See Table 1-3 for Specific Procedures)</u>	<u>Application</u>			
		<u>Filtration</u>	<u>Drainage</u>	<u>Separation</u>	<u>Reinforcement</u>
<u>Design Requirements</u>					
<u>Mechanical Strength</u>					
Tensile Strength	Wide Width Strength	--	--	--	✓
Tensile Modulus	Wide Width Modulus	--	--	--	✓
Seam Strength	Wide Width	--	--	--	✓
Tension Creep	Creep	--	*	--	✓
Soil-Fabric Friction	Friction Angle	--	--	--	✓
<u>Hydraulic</u>					
Flow Capacity	Permeability	✓	✓	✓	✓
	Transmissivity	--	✓	--	--
Piping Resistance	Apparent Opening Size (AOS)	✓	--	✓	✓
Clogging Resistance	Porimetry	✓	--	--	--
	Gradient Ratio	✓	--	--	--
<u>Constructability Requirements</u>					
Tensile Strength	Grab Strength	✓	✓	✓	✓
Seam Strength	Grab Strength	✓	✓	✓	--
Bursting Resistance	Mullen Burst	✓	✓	✓	✓
Puncture Resistance	Rod Puncture	✓	✓	✓	✓
Tear Resistance	Trapezoidal Tear	✓	✓	✓	✓
<u>Longevity (Durability)</u>					
Abrasion Resistance**	Reciprocating Block Abrasion	✓	--	--	--
UV Stability***	UV Resistance	✓	--	--	✓
Soil Compatability****	Chemical	✓	✓	?	✓
	Biological	✓	✓	?	✓
	Wet-Dry	✓	✓	--	--
	Freeze-Thaw	✓	✓	--	--

\*Compression Creep

\*\*Erosion control applications where armor stone may move

\*\*\*Exposed fabrics only

\*\*\*\*Where required

TABLE 1-3

## GEOTEXTILE PROPERTIES AND PARAMETERS FOR GEOTEXTILE SELECTION

<u>PROPERTY</u>	<u>TEST METHOD</u>	<u>UNITS OF MEASUREMENT</u>
<b>I. GENERAL PROPERTIES (FROM MANUFACTURERS)</b>		
Type and Construction	N/A	----
Polymer	N/A	----
Weight	ASTM proposed (FHWA Manual*)	oz/yd
Thickness	ASTM proposed (FHWA Manual*)	in.
Roll Length	Measure	ft
Roll Widths	Measure	ft
Roll Weight	Measure	ft
Roll Diameter	Measure	ft
Specific Gravity & Density	FHWA Manual*	lb/ft <sup>3</sup>
Absorption	FHWA Manual*	percent
Surface Characteristics	N/A	----
Geotextile Isotropy	N/A	----
<b>II. INDEX PROPERTIES</b>		
Mechanical Strength - Uniaxial Loading		
a) Tensile Strength		
1) Grab Strength	ASTM D-4632	lbs
2) Strip Tensile Strength	ASTM D-1682 - Sections 18 and 20 using a CRE of 12-inch/min	lb/in.
3) Wide Width Strength	ASTM D-4595 (FHWA Manual*)	lb/in.
b) Poisson's Ratio	No Test	
c) Stress-Strain Characteristics	ASTM D-4595 (FHWA Manual*)	lb/in.
d) Dynamic Loading	No standard	
e) Creep Resistance	(FHWA Manual*)	lb (at rupture)
f) Friction/Adhesion (slick, rough, smooth)	Modified Corps of Engineers EM 1110 -2-1906, using Ottawa 20-30 sand	degrees
g) Seam Strength	See II a) Tensile Strength above; use 1), 2), or 3) depending on requirements)	lb (grab) or lb/in. (strip) as required
h) Tear Strength	ASTM D-4533	lb (at peak strength)

\*See FHWA Geotextile Engineering Manual (Appendix B) for detailed procedures

TABLE 1-3 (con't)

## GEOTEXTILE PROPERTIES AND PARAMETERS FOR GEOTEXTILE SELECTION

<u>PROPERTY</u>	<u>TEST METHOD</u>	<u>UNITS OF MEASUREMENT</u>
<u>Mechanical Strength - Rupture Resistance</u>		
a) Burst Strength	Mullen Burst - ASTM D-3786, (Fed. Std. 191A, Method 5122)	lb/in. <sup>2</sup>
b) Puncture Resistance	ASTM D-4833	lb
c) Penetration Resistance (Dimensional Stability)	No standard	----
d) Fabric Cutting Resistance	No standard	----
e) Flexibility (Stiffness)	Modified ASTM D-1388 - Option A using 2-in. x 12-in. sample (FHWA Manual*) (Fed. Std. 191A, Method 5206)	mg/cm <sup>2</sup>
<u>Endurance Properties</u>		
a) Abrasion Resistance	ASTM D-4886	Percent retained in weakest direction (2-in. strip test)
b) Ultraviolet (UV) Radiation Stability	ASTM D-4355	Percent strength retained (2-in. strip test)
c) Chemical and Biological Resistance	No standard for geotextiles (For textiles: Fed. Std. 191A, Methods 5760, 5762, 2015, 2016, and 2053)	----
e) Wet and Dry Stability	No standard	----
f) Temperature Stability	No standard	----
<u>Hydraulic</u>		
a) Opening Characteristics		
1) Apparent Opening Size (AOS)	ASTM D-4751 (FHWA Manual*)	U.S. sieve equivalent in mm (and sieve no.)
2) Porimetry (pore size distribution)	Use AOS for O <sub>9.5</sub> , O <sub>8.5</sub> , O <sub>5.0</sub> , O <sub>1.5</sub> , and O <sub>5</sub>	mm
3) Percent Open Area (POA)	(FHWA Manual*)	Percent
4) Porosity (n)	No standard	----

\*See FHWA Geotextile Engineering Manual (Appendix B) for detailed procedures

TABLE 1-3 (con't)

GEOTEXTILE PROPERTIES AND PARAMETERS FOR GEOTEXTILE SELECTION

<u>PROPERTY</u>	<u>TEST METHOD</u>	<u>UNITS OF MEASUREMENT</u>
b) Permeability (k) and Permittivity (Υ )	ASTM D-4491 (FHWA Manual*)	cm/sec sec <sup>-1</sup>
c) Soil Retention Ability	Empirical Relations to Opening Characteristics	-----
d) Clogging Resistance	No standard - See Soil-Fabric Tests	-----
e) In-Plane Flow Capacity (Transmissivity, Θ )	ASTM D-4716	gal/min per ft width
<b>III. PERFORMANCE PROPERTIES FOR SOIL-GEOTEXTILE SYSTEMS</b>		
<u>Stress-Strain Characteristics:</u>	Tension Test in Soil - McGown, et al., (1982) Triaxial Test Method - Holtz, et. al., (1982) California Bearing Ratio on Soil Fabric System - Christopher (1983) Tension Test in Shear Box - FHWA Manual	lb/in. and percent strain
<u>Creep Tests:</u>	Extension Test in Soil - McGown, et al., (1982) Triaxial Test Method - Holtz, et al., (1982) Extension Test in Shear Box - Christopher, (1983)	creep strength (lb/in.)  creep strain  percent
<u>Friction/Adhesion:</u>	Direct Shear Method - Modified, Corps of Engineers Procedure EM1110-2-1906; Bell -2- 1906; FHWA Manual* Pull-Out Method - Holtz, (1977)	-----
<u>Dynamic and Cyclic Loading Resistance:</u>	No standard procedures	
<u>Soil Retention and Filtration Properties:</u>	Soil-Fabric Permeameter Gradient Ratio - (FHWA Manual*) Slurry Method - CALTRANS, Hover (1982) Application Model - e.g., Virginia HTRC Silt Fence Method (FHWA Manual*)	

\*See FHWA Geotextile Engineering Manual (Appendix B) for detailed procedures

## 1.6 Specifications

Specifications should be based on the specific geotextile properties required for design and installation. "Standard" geotextiles may result in uneconomical or unsafe designs. To specify a particular type of geotextile or its equivalent can also be very misleading and may result in selection of a fabric by the contractor which has completely different properties than intended by the designer.

All specifications should include the following:

- General requirements
- Specific geotextile properties
- Seams and overlaps
- Placement procedures
- Repairs
- Requirements for testing and placement observations

General requirements include the types of geotextiles, acceptable polymeric materials, and comments related to the stability of the material. Other items that should be specified in this section are instructions on storage and handling so that the geotextile will be protected from ultraviolet exposure, dust, mud or any other elements that may effect its performance. Guidelines concerning on site storage and handling of geotextiles are contained in a proposed ASTM standard. If pertinent, roll weight and dimensions may also be specified. Finally, certification requirements should be included in this section.

Specific geotextile physical, index and performance properties required by the design must be listed. Properties should be given in terms of minimum average roll values along with the required test methods. Minimum average roll values are simply the smallest anticipated average value that would be obtained for any roll tested. This average property value must exceed the minimum value

specified for that property based on a particular test. It is ordinarily possible to obtain a manufacturer's certification for minimum average roll values. If performance tests have been performed as part of the design, a list of approved products could be provided. Use of "or equal" geotextiles should be avoided unless equivalency is spelled out in terms of the index properties and performance criteria that were required to meet the approved list.

Approved lists can also be developed based on experience with reoccurring problem conditions. Once an approved list has been established, new geotextiles can be added as they are approved. Geotextiles should be periodically obtained from the manufacturers so that they can be examined alongside the original tested specimens to make sure that the manufacturing process has not varied since the product was approved. This type of program will take considerable initial effort, but once established, it should provide a method of specifying geotextiles with confidence.

Seam and overlap requirements should be specified along with the design properties for both factory and field seams. A minimum overlap of 1 ft is recommended for all applications, but overlaps may be increased due to site and construction requirements. Sewing of seams may be required for special conditions discussed in Section 1.8. Also, certain geotextiles may have factory seams. For confidence that the seams will perform as intended, the seam strengths specified should be greater than or equal to the strength required for the geotextile using the same test procedures. For the case of survivability where grab tests are performed, test results may be influenced by the presence of the seam. For designs where wide width tests are used, the seam strength is a calculated design value. Therefore, whether they are required for survivability or design, seam strengths should not be specified as a percent of the geotextile strength.



Like the geotextile, the thread should consist of polymeric materials and the type of thread used should have the same or greater durability as the fabric. For example, nylon thread which is often used for seams, unless treated, may reduce in strength with time as it absorbs water.

Placement procedures should be given in detail. These should include grading and ground clearing requirements, aggregate specifications, aggregate lift thickness and equipment requirements. These requirements are especially important if the geotextile was selected on the basis of survivability.

Repair procedures for damaged sections of geotextiles (i.e., rips and tears) should be detailed. Such repairs should include requirements for overlaps or sewn seams or replacement requirements. For overlap repairs, the geotextile should extend from the edge of the tear or rip, a minimum of the overlap length requirement (i.e., if a 1 ft overlap is required, the geotextile should extend 1 ft minimum from all edges of the tear).

Requirements for testing and placement observations should be stated clearly in the specifications. It is very important that all installations be observed by a representative of the designer who is knowledgeable in the placement procedures for geotextiles and who is aware of the design requirements. Sampling and testing requirements which will be required during construction should also be specified. Guidelines for acceptance and rejection of geotextile shipments are contained in ASTM D-4759.

Sometimes for small projects, the cost of testing to meet the ASTM acceptance/rejection criterism is a significant portion of the total project cost and may even be greater than the cost of geotextiles itself. In such cases, some type of approved list type specifications should be used.

## 1.7 Field Inspection

The following is a checklist for field technicians responsible for observing a geotextile installation.

1. Read the specifications.
2. If previously approved, obtain the name, geotextile type, and style along with a small sample of material from the engineer.
3. Check geotextile type and style number to see if it matches approved material. If the geotextile has not previously been approved, call the engineer with a description of the material for approval.
4. On site, check the rolls of geotextiles to see that they are properly stored; check for any damage.
5. Check roll and lot numbers to see if they match certification documents.
6. Cut two samples 4 to 6 in. square from a roll. Staple one to your copy of the specifications for comparison with future shipments and send one to the design engineer for approval.
7. Observe materials in each roll to make sure they are the same. Observe rolls for flaws and nonuniformity.
8. Obtain test samples according to specification requirements from randomly selected rolls. Mark the machine direction on each sample and note the roll number.

9. Observe construction to see that the contractor complies with specification requirements for installation.
10. Check all seams, both factory and field, for any flaws or missed stitches. If necessary, either re sew or reject materials.
11. If possible, check geotextile after aggregate or rip rap placement for damage. This can be done by having the contractor perform a trial installation or after placement and compaction of the aggregate at the beginning of the project, remove a small section of aggregate and observe the geotextile. If perforations, tears or other damage has occurred, call the engineer.
12. Check future shipments against the initial approved shipment and collect additional test samples. Collect samples of seams, both factory and field, for testing. For field seams, the contractor can sew several yards of a dummy seam for testing and evaluation.

#### 1.8 Field Seaming

To obtain continuity between adjacent rolls of fabric, some form of seaming will be required. Seaming techniques include overlapping, sewing, stapling, bolting, riveting, tying, heat bonding, and gluing. However, the most efficient and widely used methods at this time are overlapping and sewing.

The first technique, the simple overlap, will be suitable for most projects. A minimum overlap of 1 foot is always required with increases in overlap determined by specific applications. If stress transfer is required between adjacent rolls, the only strength provided by the overlap is the friction between adjacent

sheets. Unless overburden pressures are large and the overlap substantial, very little stress can actually be transferred through the overlap.

The second technique, sewing, offers a practical and economical alternative when overlaps become excessive or stress transfer is required between two adjacent rolls of fabric. A simple cost analysis generally indicates sewing to be economical when overlaps of 3 feet or greater are required. To obtain good quality effective seams, the user should be aware of sewing requirements. Sewing details include (after Koerner, 1986):

- Thread Type - Kevlar, nylon, polyester, polypropylene (in order of decreasing strength and decreasing cost). Durability of the thread should be consistent with the project requirements.
- Thread Tension - Usually adjusted in the field so as to be sufficiently tight but not cut the fabric.
- Stitch Density - Three to five stitches per inch are typically used.
- Stitch Type - Usually single or double thread with double thread lock type stitch preferred as it is less likely to unravel (Fig. 1.2a).
- Seam Type - Flat or prayer seam, J-type seams, or butterfly seams, with flat and J-seams most widely used (Fig. 1.2b).
- Number of Rows - Usually two or more parallel rows preferred for increased safety.

When constructed correctly, sewn seams can provide good stress transfer between adjacent sheets of geotextile. However, there

a) TYPES OF STITCHES

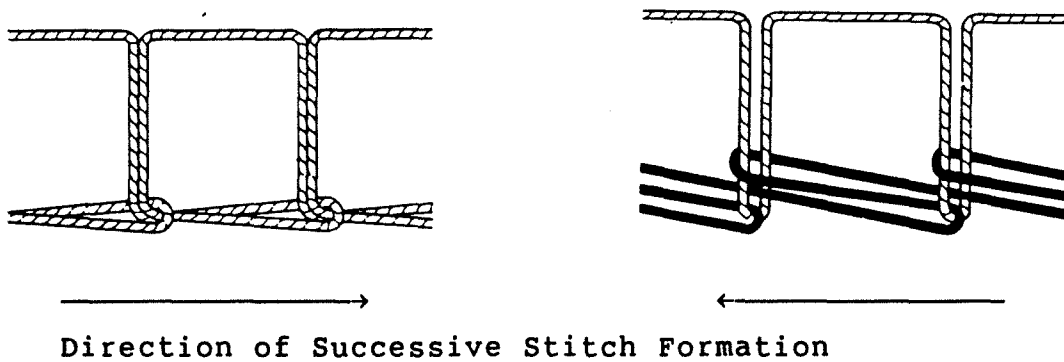

Type 101; Single Thread Chain Stitch

Type 401; Double Thread Chain or "Lock" Stitch

b) TYPES OF SEAMS



"Flat" or "Prayer Seam"  
Type SSa-2

"J" Seam  
Type SSn-2

"Butterfly" Seam  
Type SSd-2

c) IMPROPER PLACEMENT: Cannot Inspect or Repair

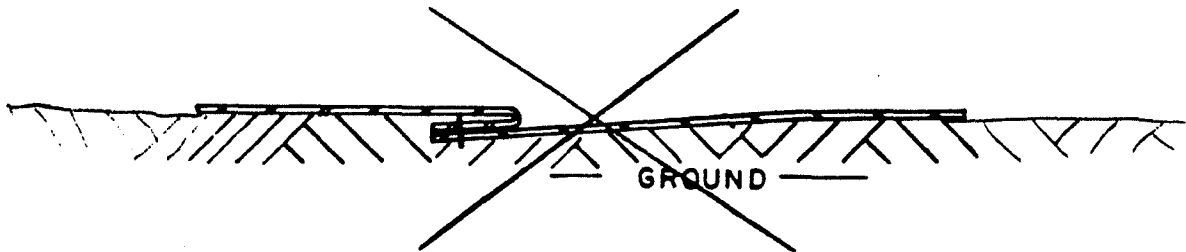

Fig. 1.2 Types of (a) Stitches and (b) Seams, According to Federal Standard No. 751a (1965). (c) Improper Seam Placement

are several points with regard to seam strength that should be understood by the user.

1. Due to needle damage and stress concentrations at the stitch, sewn seams are weaker than the fabric (good, high quality seams have on the order of 60% of the actual fabric strength based on wide width tests).
2. Grab strength results are influenced by the seam, usually producing artificially high seam strength to fabric strength ratios.
3. The maximum seam strengths achievable at the time of this writing are on the order of 800 lbs/in. under factory conditions, and these are on 2,000 lbs/in. geotextiles.
4. Field seam strengths will most likely be lower than laboratory or factory seam strengths.
5. Most stitches can unravel, including lock type stitches (although less likely to do so).
6. Unraveling can be avoided by careful inspection of all stitches and by using two or more rows of stitches.

Actual field sewing is relatively simple and usually requires two or three laborers depending on the seam type and sewing machine. However, field conditions can easily complicate sewing operations.

Good seams require careful control of the operation, cleanliness, and protection from the elements. Pneumatic equipment is available for operating in wet environments.

As the seam is the weakest link in the fabric, all seams, including factory seams, should be inspected. To facilitate inspection and repair, the geotextile should be placed with all seams up (Fig. 1.2c).

## CHAPTER 2

### GEOTEXTILES FILTERS IN DRAINAGE SYSTEMS

#### 2.1 Background

One of the major areas of geotextile use is as filters in applications such as trench and interception drains, blanket drains, pavement edge drains, and structure drains, to name just a few. Geotextiles are also used as filters in erosion control systems, but this application will be discussed in Chapter 3.

Because of their comparable performance, improved economy, consistent properties, and ease of placement, geotextiles have been used successfully to replace graded granular filters in almost all drainage applications. Thus, they must successfully perform the same functions as graded granular filters, which are to:

1. Allow water to flow through the filter into the drain, and be able to continue doing this throughout the life of the project; and
2. Retain the soil particles in place and prevent their migration ("piping") through the filter. If some soil particles do move, they must be able to pass through the filter without clogging or plugging it during the life of the project.

Geotextiles, like graded granular filters, require proper engineering design or they may not work as desired. Unless flow requirements, piping resistance, clogging resistance and constructability requirements (defined later) are properly specified, it is doubtful that a filter will perform as anticipated. In addition, construction must be monitored to see that materials are installed correctly.



In most drainage and filtration applications, use of a geotextile can be justified over a conventional graded granular filter material because of cost advantages from:

1. The use of less or lower quality drainage aggregate;
2. The possible use of smaller sized drains;
3. The possible elimination of collector pipes;
4. Expediency of construction;
5. Lower risk of contamination and segregation of drainage aggregate during construction;
6. Reduced excavation; and
7. Less wasted materials.

## 2.2 Applications

Properly designed geotextiles can be used as replacement for or in conjunction with conventional graded granular filters in almost any drainage application. A number of examples are:

- Protective filters around trench drains and edge drains to prevent soil from migrating into the drainage aggregate or system while allowing the water to exit from the soil.
- Blanket drains and pavement base course or edge drains.
- Drains for structures such as retaining walls and bridge abutments. They separate the drainage aggregate or system from the backfill soil, while allowing free drainage of ground and infiltration water.

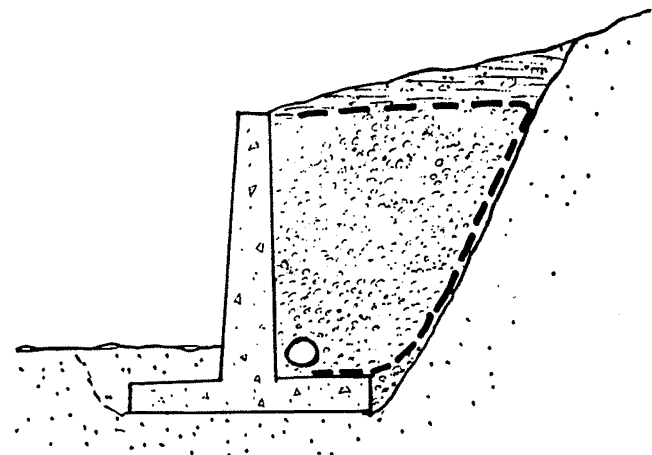
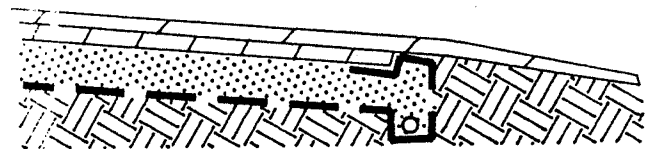
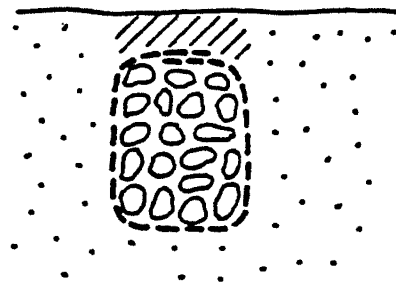

- Wraps for slotted or jointed drain and well pipes, to prevent the filter aggregate from entering into the pipe while allowing the free flow of water into the pipe.

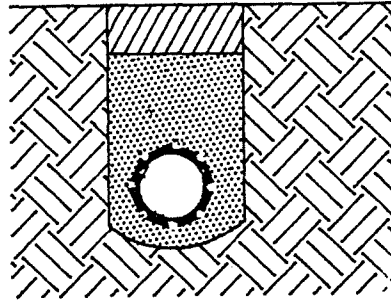

- Interceptor, toe drains and surface drains to aid in the stabilization of slopes by allowing excess pore pressures to dissipate in the slope and preventing erosion.

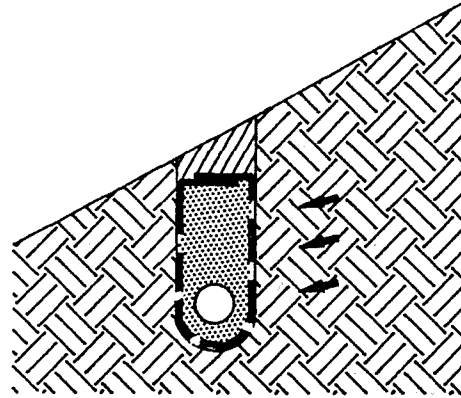

- Chimney and toe drains for earth dams and levees to provide seepage control.

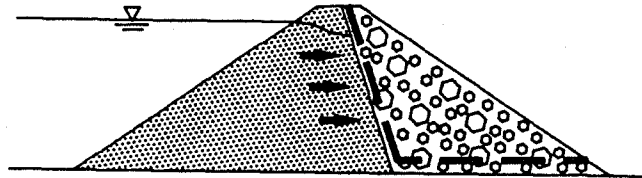

In all these applications, flow is through the geotextile, that is, perpendicular to the plane of the fabric. In other applications such as vertical drains in soft foundation soils, lateral drains below slabs and behind retaining walls, and gas transfer media, flow may be both perpendicular to and transversely in the plane of the fabric. In many of these applications, prefabricated or composite drains may be appropriate. Design of these systems will be covered in Section 2.10.

Before designing a project, the application should be reviewed to determine the critical nature of the design and the severity of the conditions (see Table 2-1).

TABLE 2-1

GUIDELINES FOR EVALUATING THE CRITICAL NATURE  
OR SEVERITY OF DRAINAGE AND EROSION CONTROL APPLICATIONS

A. Critical Nature of the Project Summary (Carroll, 1983)

	<u>Item</u>	<u>Critical</u>	<u>Noncritical</u>
1.	Risk of loss of life and/or structural damage due to drain failure:	High	None
2.	Repair costs vs. installation costs of drain:	>>	= or <
3.	Evidence of drain clogging before potential catastrophic failure:	None	Yes

B. Severity of the Conditions Summary (after Carroll, 1983)

	<u>Item</u>	<u>Severe</u>	<u>Nonsevere</u>
1.	Soil to be drained	Gap-graded/ pipable/ dispersible	Well-graded/ uniform
2.	Hydraulic gradient	High	Low
3.	Flow conditions	Dynamic cyclic or pulsating	Steady state

### 2.3 Geotextile Design

Designing with geotextiles for filtration is essentially the same as designing graded granular filters. A geotextile is similar to a soil in that it has voids (pores) and particles (filaments and fibers). However, with geotextiles, the geometric relationships between filaments and voids is more complex than in soils because of the shapes and compressibility of the filaments. In geotextiles, we generally try to measure the pore size directly instead of, as with soils, using the particle size to estimate the pore size. Since the pore size is directly measured, relatively simple relationships between the pore sizes and the particle sizes of the soil to be retained can be developed. Looking at particle retention, three simple filtration concepts are:

1. If the size of the largest pore in the geotextile filter is smaller than the larger particles of soil, the soil will not pass the filter. As with graded granular filters, the larger particles of soil will form a filter bridge over the hole, which in turn, filters smaller particles of soil, in turn, retaining the soil and preventing piping (Fig. 2.1).
2. If the smaller openings in the geotextile are sufficiently large such that the smaller particles of soil are able to pass through the filter, then the geotextile will not "clog" or "blind" (see Fig. 2.2).
3. A large number of openings should be present in the geotextile so that proper flow can be maintained even if some of the openings later become plugged.

These simple concepts and analogies with soil filter design criteria are used to establish design criteria for geotextiles.

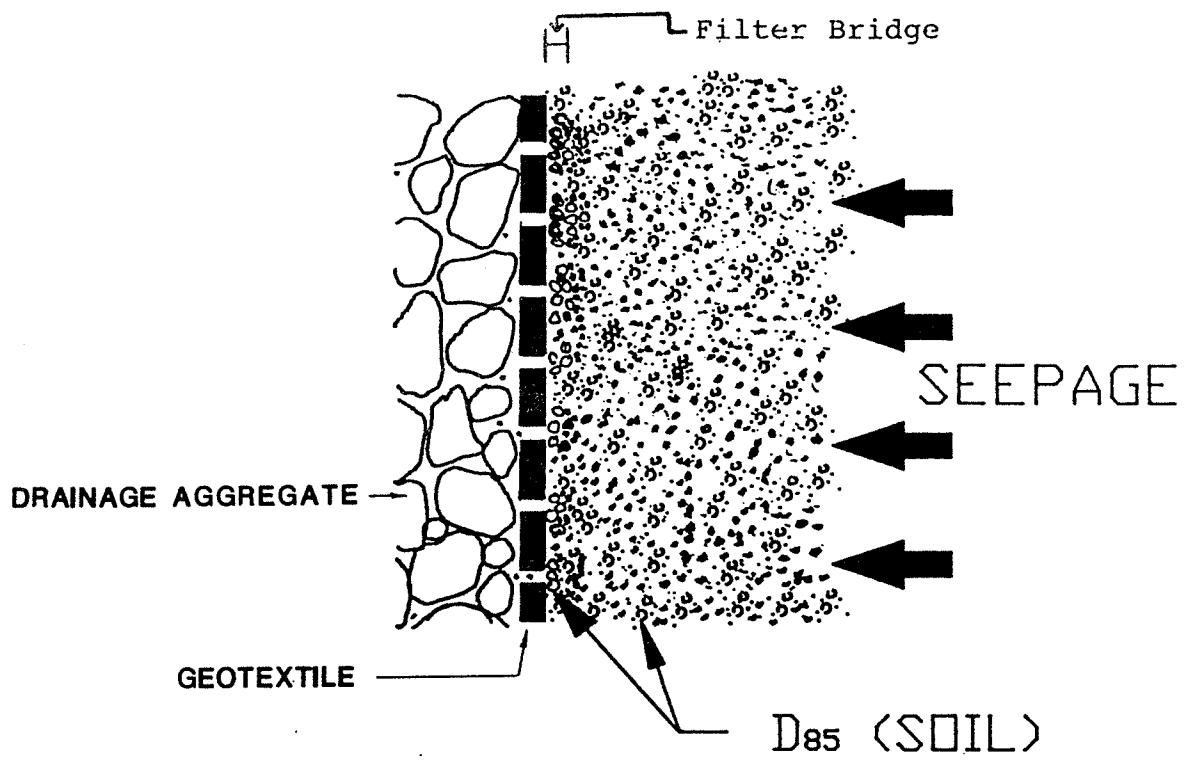

Fig. 2.1 Filter Bridge Formation

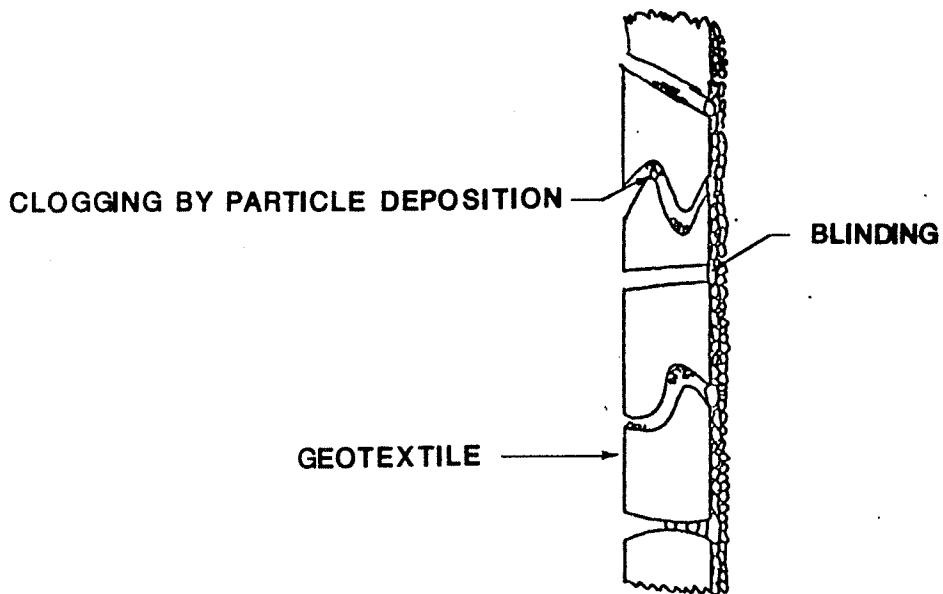

Fig. 2.2 Methods of Clogging and Blinding (Bell and Hicks, 1980)

Specifically, the criteria are:

- The geotextile must retain the soil (retention criterion) while
- Allowing water to pass (permeability criterion) during
- The life of the structure (clogging resistance criterion).

To perform effectively, the geotextile must also survive the installation process (survivability criterion). For a detailed discussion of the development and background for the recommended geotextile filter criteria, see the FHWA Geotextile Engineering Manual.

### 2.3.1 Retention Criteria (For Steady State Flow)

$$\text{AOS or } O_{95(\text{geotextile})} < B D_{85(\text{soil})} \quad (1)$$

where: AOS = apparent opening size (see Table 1-3), mm;  
 $O_{95}$  = opening size in the geotextile for which 95% are smaller, mm;  
B = a coefficient; and  
 $D_{85}$  = particle size for which 85% are smaller, mm.

The coefficient B ranges from 1 to 2 and is a function of the type of soil to be filtered, its density, the uniformity coefficient  $C_u$  if the soil is granular, the type of geotextile (woven or nonwoven) and the flow conditions.

For sands, gravelly sands, silty sands, and clayey sands (with less than 50% passing the No. 200 sieve), B is a function of the uniformity coefficient,  $C_u$ ; therefore, for

$$C_u \leq 2 \text{ or } \geq 8: B = 1 \quad (3a)$$

$$2 \leq C_u \leq 4: B = 0.5 C_u \quad (3b)$$

$$4 < C_u < 8: B = 8/C_u \quad (3c)$$

where  $C_u = D_{60}/D_{10}$ .

Sandy soils which are not uniform tend to bridge across the openings and thus the larger pores may actually be up to twice as large ( $B \leq 2$ ) as the larger soil particles because quite simply, two particles cannot pass through the same hole at the same time. Therefore, using  $B = 1$  would be a conservative design for retention. Such a criterion has been used by, e.g.; the Corps of Engineers.

For silts and clays (more than 50% passing a No. 200 U.S. sieve),  $B$  is a function of the type of geotextile:

$$\text{For } \underline{\text{wovens}}, B = 1: O_{9.5} \leq D_{8.5} \quad (4)$$

$$\text{For } \underline{\text{nonwovens}}, B = \cancel{1.8}: O_{9.5} \leq 1.8 D_{8.5} \quad (5)$$

$$\text{And } \underline{\text{for both}}, \text{ the AOS or } O_{9.5} \leq 0.3 \text{ mm (No. 50 U.S. Sieve)} \quad (6)$$

Due to their random pore characteristics and, in some types, their felt-type nature, nonwovens will generally retain finer particles than a woven geotextile of the same AOS. Therefore, the use of  $B = 1$  will be conservative for both wovens and nonwovens.

If the geotextile is not properly weighted down, soil particles can move behind the geotextile and we recommend that  $B$  be reduced to 0.5; or:

$$O_{9.5} \leq 0.5 D_{8.5} \quad (7)$$

In this case, the use of  $B = 1$  is nonconservative as the bridging network will not develop and the geotextile will be required to retain even the finer particles. This condition is most likely to occur under wave action in places where the geotextile may be loose between riprap, where it spans joints between sheet pile walls, and where geotextiles are used under temporary sandbag revetments. For these reversing inflow-outflow situations, it is best to maintain sufficient weight on the system to prevent particle movement and thus  $B = 1$  will again apply. Erosion control systems are discussed in Chapter 3.

### 2.3.2 Permeability Criteria

For non-critical applications and less severe conditions:

$$k_{\text{geotextile}} \geq k_{\text{soil}} \quad (8)$$

For critical applications and severe conditions:

$$k_{\text{geotextile}} \geq 10 k_{\text{soil}} \quad (9)$$

In these equations,  $k$  = Darcy coefficient of permeability, m/s.

For actual flow capacity, the permeability criteria for noncritical applications is conservative, since an equal quantity of flow through a relatively thin geotextile would take much less time than through a much thicker granular filter. Even so, some pores in the fabric may become blocked or plugged with time; therefore, for critical or severe applications, the more conservative relation is recommended to provide an extra factor of safety. Equation 8 may also be used where clogging is judged not to be a problem, such as in clean, medium to coarse sands and gravels.

The required flow rate  $q$  through the system should also be determined, and the geotextile and drainage stone selected to provide adequate flow capacity. As indicated above, flow



capacities should not be a problem for most applications, provided the permeability is greater than the permeability of the soil. However, in certain situations such as where geotextiles are used to span joints in rigid structures and where they are used as pipe wraps, portions of the geotextile may be blocked. For these applications, the following criteria should be used together with the permeability criteria:

$$q_{\text{required}} = q_{\text{geotextile}} (A_f/A_t) \quad (10)$$

where:  $A_f$  = fabric area available for flow, and  
 $A_t$  = total fabric area

### 2.3.3 Clogging Resistance

For less critical/less severe conditions:

$$O_{95} \text{ (geotextiles)} \geq 3 D_{15} \text{ (soil)} \quad (11)$$

The above applies for soils with  $C_u > 3$ . For  $C_u \leq 3$ , maximize the AOS value from Section 2.3.1.

In situations where clogging is a possibility (e.g., gap graded or silty soils), the following optional qualifiers may be applied:

For nonwovens:

$$\text{porosity of the geotextile (n)} \geq 30\% \quad (12)$$

For monofilament and slit film wovens:

$$\text{percent open area (POA)} \geq 4\% \quad (13)$$

Another option in this case that should always be considered especially by inexperienced users, is to conduct filtration tests.

For critical/severe conditions, filtration tests, which are performance tests, should be conducted. One type of filtration test is the gradient ratio test, which is applicable for sandy and silty soils with coefficients of permeability greater than  $10^{-2}$  cm/sec. In this case, the U.S. Army Corps of Engineers recommends:

$$\text{gradient ratio} \leq 3 \quad (14)$$

Long term gradient ratio or other filtration tests should also be performed.

For less critical/less severe conditions, a simple solution to avoid clogging would be to allow fine particles already in suspension to pass through the fabric and let the "bridge network" (Fig. 2.2) formed by the larger retained particles provide retention for the smaller particles. As the bridge network should develop rather quickly, the quantity of particles that would actually pass through the geotextile would be relatively small. The less critical/less severe clogging resistance criteria is thus required to have an AOS ( $O_{9.5}$ ) sufficiently larger than the finer soil particles ( $D_{1.5}$ ) such that those particles will pass through the fabric. Unfortunately, the AOS value only indicates the size and not the number of  $O_{9.5}$  holes available. Thus, the finer soil particles can still be retained by the smaller holes in the fabric, and if they are sufficient in number, it could lead to significant reduction in flow rate. Consequently, it may be desirable to use other qualifiers to control the number of holes in the fabric such as the porosity and open area requirements. There should always be a sufficient number of holes in the geotextile so that many of them will remain open even if some of them clog.

Although several empirical methods have been proposed to evaluate the filtration characteristics of a geotextile, the most realistic approach for all applications is to perform a laboratory test

which simulates or models field conditions. One model test that is gaining wide acceptance is the gradient ratio test. This test utilizes a soil permeameter with piezometer taps which allows for simultaneous measurement of the head losses in the soil and the head loss at the soil/geotextile interface (Fig. 2.3). The ratio of the head loss over the soil/geotextile interface to the head loss in the soil is termed the gradient ratio. As fine soil particles adjacent to the fabric become trapped in or blind the fabric, an increase in the gradient ratio will result. A gradient ratio less than 3 (Eq. 14) is recommended by the U.S. Army Corps of Engineers (1977). Detailed test procedures are included in the Geotextile Engineering Manual. The test is limited to soils with  $k \geq 10^{-5}$  cm/sec. References for other test methods are included in the Geotextile Engineering Manual. For soils with permeabilities less than about  $10^{-5}$  cm/sec, long term filtration test should be conducted in triaxial type cells (to insure that flow is through the soil rather than along the sides of the specimen). It should be noted that these tests are performance type tests and must be performed with samples of soil from the project site. As such, this test is the responsibility of the engineer because the manufacturers generally do not have soils laboratories nor will they have samples of on-site soil. Therefore, realistically they are unable to certify as to the clogging resistance of a geotextile.

#### 2.3.4 Survivability and Endurance Criteria

Certain geotextile strength and endurance properties are required for filtration and drainage applications to have confidence that the geotextile will survive the construction process. These requirements are shown in Table 2-2.

It is important to realize that these survivability specifications are not based on any systematic research but on the properties of existing geotextiles which are known to have performed

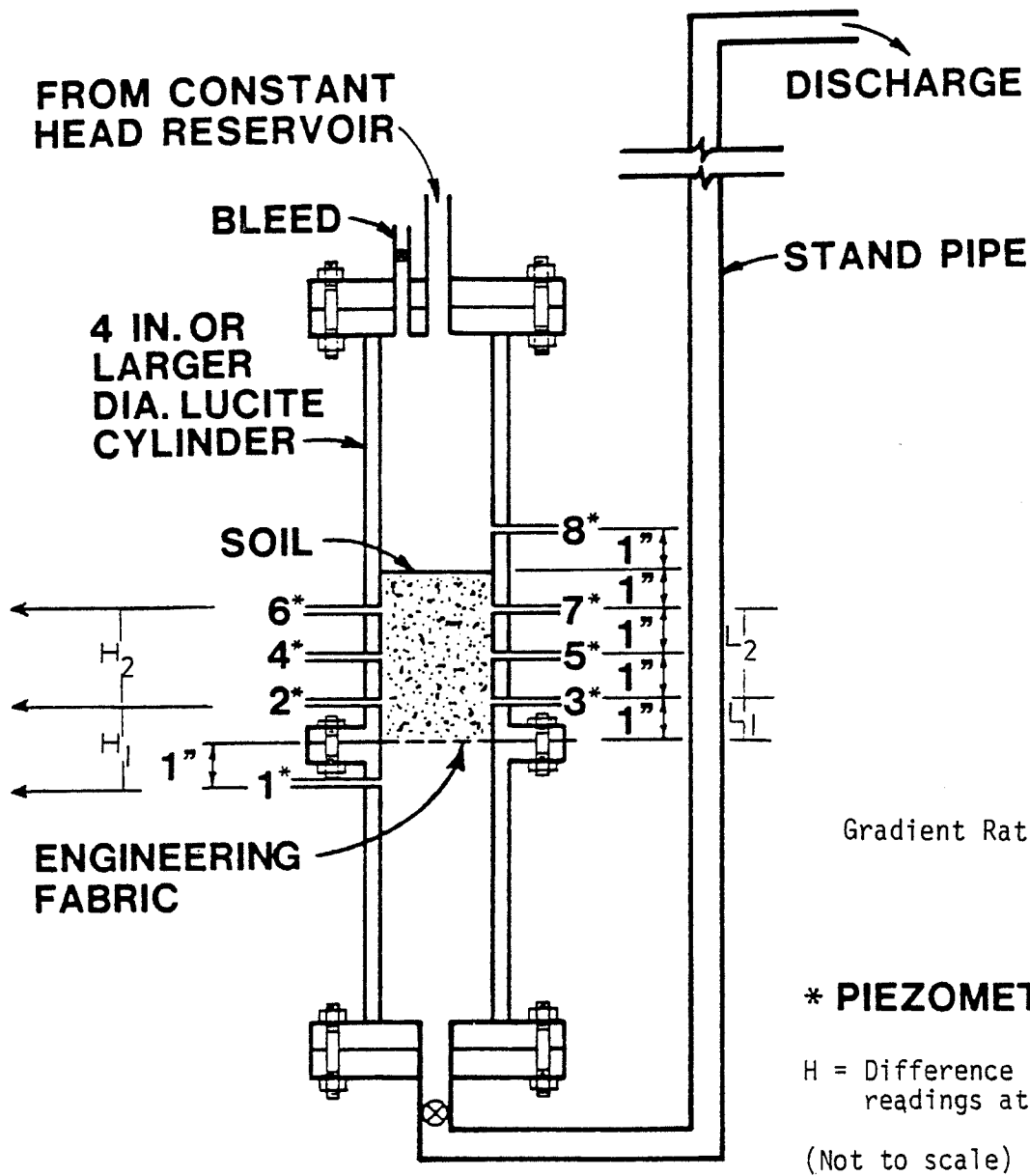

**CORPS OF ENGINEER-TYPE GRADIENT RATIO TEST DEVICE**

Fig. 2.3 Gradient Ratio Device

**TABLE 2-2**  
**PHYSICAL REQUIREMENTS<sup>1, 2</sup> FOR**  
**DRAINAGE GEOTEXTILES**  
**(AASHTO-AGC-ARTBA TASK FORCE 25, JULY, 1986)**

<u>Property</u>	<u>Drainage<sup>3</sup></u>		<u>Test Method</u>
	<u>Class A<sup>4</sup></u>	<u>Class B<sup>5</sup></u>	
Grab Strength (lbs)	180	80	ASTM D4632
Elongation (%)	n/a	n/a	ASTM D4632
Seam Strength <sup>6</sup> (lbs)	160	70	ASTM D4632
Puncture Strength (lbs)	80	25	ASTM D4833
Burst Strength (psi)	290	130	ASTM D3786
Trapezoid Tear (lbs)	50	25	ASTM D4533

1. Acceptance of geotextile material shall be based ASTM D-4759.
2. Contracting agency may require a letter from the supplier certifying that its geotextile meets specification requirements.
3. Minimum; Use value in weaker principal direction. All numerical values represent minimum average roll value (i.e., test results from any sampled roll in a lot shall meet or exceed the minimum values in the Table). Stated values are for non-critical, non-serve applications. Lot samples according to ASTM D4354.
4. Class A drainage applications for fabrics are where installation stresses are more severe than Class B applications, i.e., very coarse sharp angular aggregate is used, a heavy degree of compaction (>95% AASHTO T99) is specified or depth of trench is greater than 10 ft.
5. Class B drainage applications are those where fabric is used with smooth graded surfaces having no sharp angular projections, no sharp angular aggregate is used; compaction requirements are light, (<95% AASHTO T99), and trenches are less than 10 ft in depth.
6. Values apply to both field and manufactured seams.

satisfactorily in drainage applications. The values are meant to serve as guidelines for inexperienced users in selecting geotextiles for routine projects. They are not intended to replace site specific evaluation, testing and design.

Geotextile endurance relates to its longevity. Geotextiles have been shown to be basically inert materials for most environments and applications. However, certain applications may expose the fabric to chemical or biological activity that could drastically influence the filtration properties of the fabric or its durability. For example, geotextiles (as well as granular filters) can become chemically clogged by iron, carbonate, and some organic deposits. In some erosion control applications, riprap or stones may continuously be moving on the surface of the fabric causing abrasion. The specific site conditions should be reviewed and if such conditions exist, testing and specifications should be written around these requirements. A standard test using a sliding block (Modified Flex Stoll) abrasion apparatus has been developed by ASTM (D4886). No reduction in piping resistance, permeability criteria, or clogging resistance should be allowed after exposure to abrasion. Allowable physical property reduction due to abrasion should be specified.

#### 2.4 Drainage System Design Guidelines

In this section, step by step design procedures are given. As with the links of a chain, one's confidence in the resulting design will depend on the weakest link, and thus no steps should be compromised or omitted.

Step 1 - Evaluation of the application -- critical nature and site conditions (see Section 2.1).

Reasonable judgment should be used in categorizing a project since a significant cost difference may exist between geotextiles required for critical/severe conditions. Final

selection should not be based on the lowest material cost alone, nor should cost be reduced by eliminating laboratory soil-geotextile performance testing, if such testing is deemed appropriate.

Step 2 - Obtain soil samples from the site

A. Perform grain size analyses

Select the "worst case" soil for retention (i.e. soil with smallest  $D_{85}$ )

$$\text{Calculate } C_u = D_{60}/D_{10} \quad (3)$$

NOTE: When the soil contains particles 1 in. and larger, use only the gradation of soil passing the U.S. No. 4 sieve in selecting the geotextile (i.e., scalp off the +No.4 material).

B. Perform field or laboratory permeability tests

Select worst case soil (i.e. soil with highest coefficient of permeability,  $k$ ).

Permeability of clean sands with  $0.1 \text{ mm} < D_{10} < 3 \text{ mm}$  and  $C_u < 5$  can be estimated by the Hazen formula,  $k = D_{10}^2$  ( $k$  in cm/sec;  $D_{10}$  in mm). This formula should not be used for finer grained soils.

C. Select drainage aggregate

Use free draining open graded material and determine permeability (e.g. Fig. 2.4)

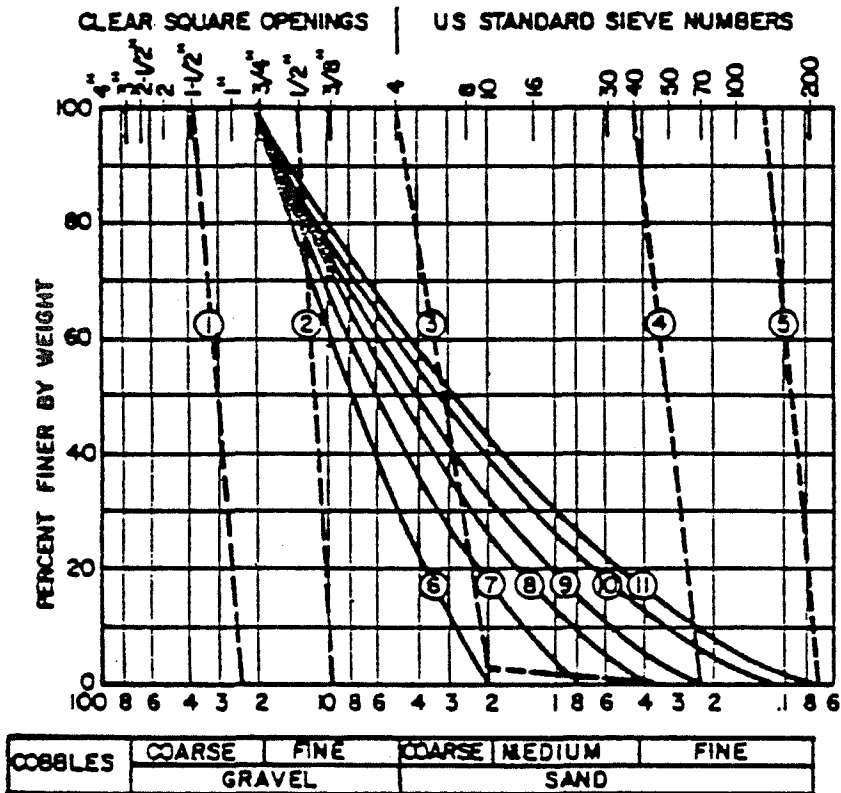

COEFFICIENT OF PERMEABILITY  
FOR CLEAN COARSE-GRAINED  
DRAINAGE MATERIAL

CURVE	K, FT/MIN.	K, cm/sec
①	73.7	37
②	56.9	29
③	5.41	2.7
④	0.13	0.07
⑤	0.01	0.006
⑥	2.08	1.0
⑦	1.81	0.92
⑧	0.70	0.04
⑨	0.22	0.11
⑩	0.08	0.04
⑪	0.01	0.006

Fig. 2.4 Typical Gradations and Darcy Permeabilities of Several Aggregate and Graded Filter Materials (U.S. Navy, 1982)



If possible, sharp angular aggregate should be avoided. If it must be used, then a geotextile meeting the properties requirements for Class A, "high survivability", fabrics in Table 2-1 should be specified. For an accurate design cost evaluation, compare cost of open graded aggregate with select well-graded free draining filter aggregate.

Step 3 - Calculate anticipated flow into and through drainage system and dimension system. Use collector pipe to reduce size of drain.

A. General Case: Use Darcy's Law

$$q = kiA \quad (15)$$

where:  $q$  = Infiltration rate ( $L^3/T$ )

$k$  = Effective permeability of soil (from Step 2B above) ( $L/T$ )

$i$  = Average hydraulic gradient in soil and in drain ( $L/L$ )

$A$  = Area of soil and drain material normal to the direction of flow ( $L^2$ )

Use conventional flow net analysis (Cedergren, 1977) and Darcy's Law for estimating infiltration rates into drain, then use Darcy's Law to design drain (i.e. calculate  $A$  for flow through open graded aggregate).

B. Specific Drainage Systems

Estimates of surface infiltration, runoff infiltration rates, and drainage dimensions can be determined using accepted principles of hydraulic engineering (Moulton, 1980). Specific references are:

1. Flow into trench - (Mansur and Kaufman, 1962)
2. Horizontal blanket drains - (Cedergren, 1977)
3. Slope drains - (Cedergren, 1977)

Step 4 - Determine geotextile requirements

A. Retention Criteria

From Step 2.A, obtain  $D_{85}$  and  $C_u$ ; then determine largest pore size allowed.

$$AOS \leq B D_{85} \quad (2)$$

where  $B = 1$  for a conservative design. For a less conservative design and for  $\leq 50\%$  passing U.S. No. 200 sieve:

$$B = 1 \quad \text{for } C_u \leq 2 \text{ or } \geq 8 \quad (3a)$$

$$B = 0.5 C_u \quad \text{for } 2 \leq C_u \leq 4 \quad (3b)$$

$$B = 8/C_u \quad \text{for } 4 < C_u < 8 \quad (3c)$$

and, for  $\geq 50\%$  passing U.S. No. 200 sieve:

$$B = 1 \quad \text{for wovens}$$

$$B = 1.8 \quad \text{for nonwovens}$$

$$\text{and } AOS \text{ (geotextile)} \leq 0.3 \text{ mm} \quad (6)$$

B. Permeability Criteria

1. Less Critical/Less Severe

$$k_{\text{geotextile}} \geq k_{\text{soil}} \quad (8)$$

2. Critical/Severe

$$k_{\text{geotextile}} \geq 10 k_{\text{soil}} \quad (9)$$

### 3. Flow Capacity Requirement

$$q_{\text{required}} = q_{\text{geotextile}}/A_f \text{ or} \quad (10)$$

$$(k_{\text{geotextile}}/t) h A_f \geq q_{\text{required}} \quad (16)$$

where,  $q_{\text{required}}$  is obtained from Step 3 (Eq. 15) above.

$$k_{\text{geotextile}}/t = \Psi = \text{permittivity}$$

$h$  = average head in field

$A_f$  = area of fabric available for flow (i.e. if 80% of fabric covered by the wall of a pipe,  $A_f = 0.2 \times$  total area)

### C. Clogging Criteria

#### 1. Less Critical/Less Severe

- a. From Step 2A obtain  $D_{15}$ ; then determine minimum pore size requirement from

$$O_{95} \geq 3 D_{15} \quad (11)$$

- b. Other qualifiers:

Nonwovens:

$$\text{Porosity (geotextile)} > 30\% \quad (12)$$

Wovens:

$$\text{percent open area} > 4\% \quad (13)$$

Alternative: Run filtration tests

#### 2. Critical/Severe

Select fabrics that meet retention, permeability, and survivability criteria as well as the criteria in Step 4.C.1 above and perform a filtration test.

Suggested filtration test and criteria for sandy and silty soils:

$$\text{gradient ratio} \leq 3 \quad (14)$$

Alternative: Long-term filtration tests.

D. Survivability

Select geotextile properties required for survivability from Table 2-2. Add durability requirements if applicable.

Step 5 - Estimate costs

Calculate the pipe size (if required), the volume of aggregate and the area of the geotextile. Apply appropriate unit cost values.

Pipe (if required)	_____
Aggregate:	_____
Geotextile:	_____
Geotextile placement:	_____
Construction:	_____
Total Cost:	_____

Step 6 - Prepare Specifications

Include for the geotextile:

- A. General requirements
- B. Specific geotextile properties
- C. Seams and overlaps
- D. Placement procedures
- E. Fabric repairs
- F. Testing and placement observation requirements

See Sections 1.6 and 2.7 for specification details.

Step 7 - Collect samples of aggregate and geotextile before acceptance

Step 8 - Monitor installation during and after construction

Observe drainage system during and after storm events.

## 2.5 Design Example

Relevant examples are included in the FHWA publications, "Geotextile Engineering Workshop Design Examples (FHWA-HI-89-002) and Geotextile Engineering Manual FHWA-86-203.

## 2.6 Cost Considerations

Determining the cost effectiveness of using geotextiles and conventional drainage systems is a straight forward process. Just compare the cost of the geotextile with the cost of a conventional granular filter layer, while keeping in mind the following:

- Overall material costs including a geotextile versus a conventional system - For example the geotextile system will allow the use of poorly graded (less select) aggregates which may reduce the need for a collector pipe, provided the amount of fines is small (Q decreases considerably if % minus No. 200 sieve is greater than 5%, even in gravel).
- Construction requirements - There is, of course, a cost for placing the geotextile, but in most cases, it is less than the cost of constructing dual granular layered filters.
- Possible dimensional design improvements - If a more open-graded aggregate is utilized (especially with a collector pipe), a considerable reduction in the

physical dimensions of the drain can be made without a decrease in flow efficiency. Such a size reduction also reduces the volume of the excavation, the volume of filter material required, and the construction time necessary per unit length of drain.

In general, the cost of a geotextile itself in drainage applications will typically range from \$0.50 to \$1.00 per square yard (1987 dollars), depending upon the type of fabric specified and quantity ordered. Installation costs will depend upon the project difficulty and contractor's experience, and will typically range on the order of \$0.40 to \$1.00 per square yard of geotextile. Higher costs should be anticipated for below water placement. Labor costs to install the geotextile are regained because the construction can proceed at a faster pace, because less care is needed to prevent segregation and contamination of granular filter materials and because multilayered granular filters are typically not necessary.

## 2.7 Specifications

The following guide specifications are provided as an example. They have been developed by the AASHTO-AGC-ARTBA Task Force 25 for routine drainage and filtration applications. The actual hydraulic and physical properties of the geotextile must be selected by proper consideration of the nature of the project (critical/noncritical), hydraulic conditions (severe/nonsevere), soil conditions at the site, and construction and installation procedures appropriate for the project.

**AASHTO-AGC-ARTBA  
TASK FORCE 25  
SPECIFICATION GUIDE FOR  
DRAINAGE GEOTEXTILES  
(JULY, 1986)**

1. Description

- 1.1 This work shall consist of furnishing and placing a geotextile for the following drainage applications: edge of pavement drains, interceptor drains, wall drains, recharge basins, and relief wells. The geotextile shall be designed to allow passage of water while retaining in-situ soil without clogging. The quantities of drainage geotextiles as shown on the plans may be increased or decreased at the direction of the Engineer based on construction procedures and actual site conditions that occur during construction of the project. Such variations in quantity will not be considered as alterations in the details of construction or a change in the character of the work.

2. Materials

- 2.1 Fibers used in the manufacture of geotextiles, and the threads used in joining the geotextiles by sewing, shall consist of long chain synthetic polymers composed of at least 85% by weight polyolefins, polyesters, or olyamides. They shall be formed into a network such that the filaments or yarns retain dimensional stability relative to each other, including selvages. These materials shall conform to the performance requirements for soil retention, permeability, and clogging resistance (Section 2.3) and the physical requirements of Table 2-1 (Section 2.3.4.) constructability, survivability, and durability.
- 2.2 Geotextile rolls shall be furnished with suitable wrapping for protection against moisture, and extended ultraviolet exposure prior to placement. Each roll shall be labeled or tagged to provide product identification sufficient for inventory and quality control purposes. Rolls shall be stored in a manner which protects them from the elements. If stored outdoors, they shall be elevated and protected with a waterproof cover.

3. Construction Requirements

3.1 Geotextile Exposure Following Placement - Exposure of geotextiles to the elements between lay down and cover shall be a maximum of 14 days to minimize damage potential.

3.2 Geotextile Placement - In trenches, after placing the backfill material, the geotextile shall be folded over the top of the filter material to produce a minimum overlap of 12 inches for trenches greater than 12 inches wide. In trenches less than 12 inches in width, the overlap shall be equal to the width of the trench. The geotextile shall then be covered with the subsequent course.

Successive sheets of geotextiles shall be overlapped a minimum of 12 inches in the direction of flow.

3.3 Seams - Where seams are required in the longitudinal trench direction, they shall be joined by either sewing or overlapping. All seams shall be subject to the approval of the Engineer.

Overlapped seams shall have a minimum overlap equal to the width of the trench.

3.4 Repair - A geotextile patch shall be placed over the damaged area and extend 3 feet beyond the perimeter of the tear or damage.

4. Method of Measurement

4.1 The geotextile shall be measured by the number of square yards computed from the payment lines shown on the plans or from the payment lines established in writing by the Engineer. This excludes seam overlaps.

4.2 Excavation, backfill, bedding, and cover material are separate pay items.

5. Basis of Payment

5.1 The accepted quantities of geotextiles shall be paid for at the contract unit price per square yard in place.

5.2 Payment will be made under:

<u>Pay Item</u>	<u>Pay Unit</u>
Drainage Geotextile	Square Yard



## 2.8 Installation Procedures

For all drainage applications, the following construction steps should be followed:

1. The surfaces on which the geotextile is to be placed should be excavated to design grade to provide a smooth, graded surface free of debris and large cavities.
2. Between the preparation of the subgrade and the construction of the system itself, the geotextile should be well protected to prevent any possible degradation due to the elements.
3. After excavating to design grade, the geotextile should be cut to the desired width, including allowances for "non-tight" placement in trenches and overlaps of the ends of adjacent rolls, or at the top of the trench after the placement of the drainage aggregate.
4. Care should be taken during construction to avoid contamination of the geotextile. If it becomes contaminated, it must be removed and replaced with new material.
5. The geotextile should be placed with the machine direction in the direction of water flow in the drainage system. It should be placed loosely (not taut), but with no wrinkles or folds. Care should be taken to place the geotextile in intimate contact with the soil so that no void spaces occur behind it.
6. The ends for subsequent rolls and parallel rolls of geotextile should be overlapped a minimum of 1 to 2 ft, depending on the severity of hydraulic flow

anticipated and the placement conditions. For high hydraulic flow conditions and heavy construction such as with deep trenches or large stone, the overlaps should be increased. For large open sites using base drains, overlaps should be pinned or anchored to hold the geotextile in place until placement of the aggregate. The upstream geotextile should always be overlapped over the downstream.

7. Placement of drainage aggregate should proceed immediately following placement of the geotextile to limit exposure of the geotextile to sunlight, dirt, damage, etc. The geotextile should be covered with a minimum of 12 in. of loosely placed aggregate prior to compaction. If thinner lifts are used, higher survivability fabrics may be required. For drainage trenches, several inches of drainage stone should be placed as a bedding layer below the slotted collector pipe (if required), with additional aggregate then placed to the minimum required construction depth. Compaction is necessary to seat the drainage system against the natural soil and to reduce settlement within the drain. The aggregate should be compacted with vibratory equipment to a minimum of 95% Standard AASHTO density unless the trench is required for structural support. If higher compactive efforts are required, the geotextiles meeting the property values listed under the high survivability category in Table 2-1 should be utilized.
8. For trench drains, after compaction, the two protruding edges of the geotextile should be overlapped at the top of the compacted granular drainage material. A minimum overlap of 12 in. is recommended to insure complete coverage of the width of the trench. The overlap is

important as it will protect the granular material from surface contamination. After completing the overlap, the improved shoulder subbase, topsoil or other material should be placed and compacted to the desired final grade.

A schematic of the construction procedures for a geotextile lined underdrain trench is shown in Figure 2.5. Construction photos of several applications are shown in Fig. 2.6.

## 2.9 Field Inspection

The field inspector should review the field inspection guidelines in Chapter 1, Section 1.7. Special attention should be given to aggregate placement and potential for fabric damage. In addition, maintaining the appropriate fabric overlap at the top of the trench and at roll ends is especially important.

## 2.10 Geotextile Selection Considerations

The late Dr. Allen Haliburton, a geotextile pioneer, noted that all geotextiles will work in some applications, but no one geotextile will work in all applications. Even though several types of geotextiles (monofilament wovens and an array of light to heavy weight nonwovens) may meet all of the desired design criteria, it may be preferable to use one type over another to enhance the performance of the system. Selection will depend on the actual soil and hydraulic conditions as well as the intended function of the design. Intuitively, the following considerations seem appropriate for the soil conditions given.

1. Graded gravels and coarse sands - Very open monofilament or multifilament wovens may be required to permit high rates of flow and a low risk of blinding.

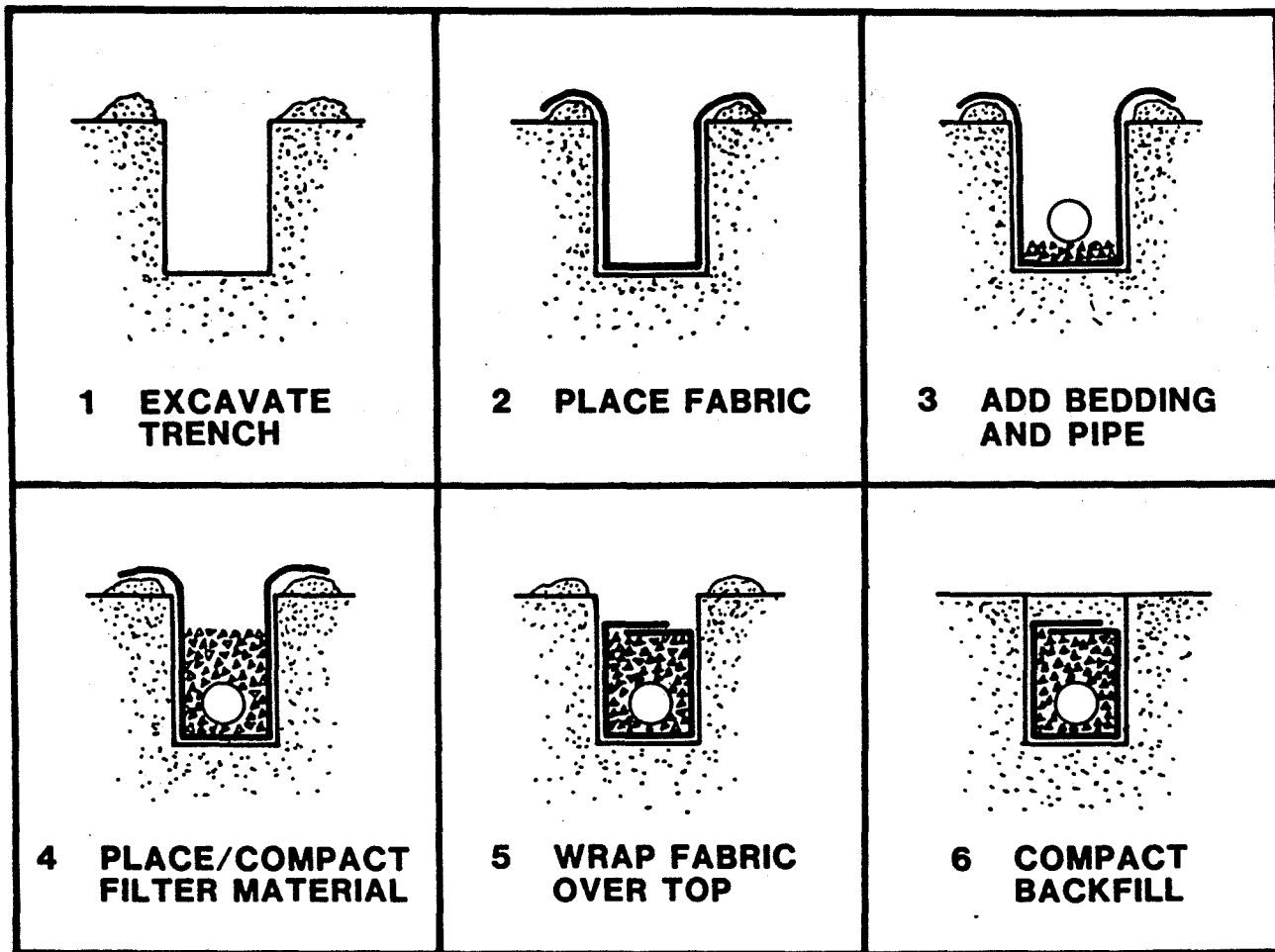

Fig. 2.5 Sequential Procedure for Fabric-Lined Underdrain Construction



a) Geotextile Placement in Drainage Trench



b) Aggregate Placement



c) Compaction of Aggregate



d) Geotextile Overlap prior to Final Cover

Fig. 2.6 Construction of Geotextile Drainage System

2. Sands and gravels with less than 20% fines - Open monofilament wovens and needlepunched nonwovens with large openings are preferable to reduce the risk of blinding. For thin heat bonded geotextiles and thick needlepunched nonwoven geotextiles, filtration tests should be performed.
3. Soils with 20% to 60% fines - Filtration tests should be performed on all fabric types.
4. Soils with greater than 60% fines - Heavy weight needlepunched geotextiles and heat bonded geotextiles tend to work best as fines will not pass. If blinding does occur, the permeability of the blinding cake would equal that of the soil.
5. Gap graded cohesionless soils - Consider using a uniform sand filter with a woven geotextile as a filter for the sand.
6. Silts With sand seams - Consider using a uniform sand filter over the soil with a woven geotextile to prevent movement of the filter sand; alternatively, consider using a heavy weight (thick) needlepunched nonwoven directly against soil as water can flow laterally through the geotextile should it become locally clogged.

These general observations are not meant as recommendations but to provide some insight into the various considerations for selecting the optimum material. They are not intended to exclude other possible geotextiles that you may want to consider.

#### 2.11 In-Plane Drainage; Prefabricated Drains

Geotextiles with high in-plane drainage ability and prefabricated composite drains are potentially quite effective in several applications.

The ability of geotextiles to transmit water in the plane of the geotextile itself may be an added benefit in certain drainage applications where lateral transmission of water is desirable or reduction of pore water pressures in the soil can be accelerated. These applications include interceptor drains, transmission of seepage water below pavement base course layers, vertical strip drains to decrease consolidation times of soft foundation soils, dissipation of seepage forces in earth and rock slopes, as part of chimney drains in earth dams, dissipaters of pore water pressures in embankments and fills, etc. However, it should be realized that the seepage quantities transmitted by in-plane flow of geotextiles (typically on the order of  $0.01 \text{ ft}^3/\text{min}/\text{linear foot}$  width of fabric under a pressure equivalent to a couple of feet of soil) are relatively small when compared to 6 to 12 in. of sand or other typical filter materials. Therefore, geotextiles should not be assumed capable of replacing such layers unless seepage quantities are of a magnitude that can be handled by the geotextile. Remember, too, that seepage quantities are highly affected by compressive forces, incomplete saturation and hydraulic gradients.

In recent years, special composite drains have been developed with cores of extruded and fluted plastics sheets, three-dimensional meshes and mats, plastic waffles, nets and channels to convey water, and covered by a geotextile on one or both sides to act as a filter. Composite drains may be prefabricated or fabricated on site. They generally range in thickness from  $1/4$  in. to 1 in. or greater and have transmission capabilities of between 0.1 and  $10 \text{ ft}^3/\text{min}/\text{linear width of drain}$ . Some composite systems are shown in Figure 2.7. Transportation engineers have used prefabricated drains in five major areas:

1. Edge drains for pavements.
2. Interceptor trenches on slopes.
3. Drainage behind abutments and retaining structures.
4. Relief of water pressures on buried structures.
5. Substitute for conventional sand drains.

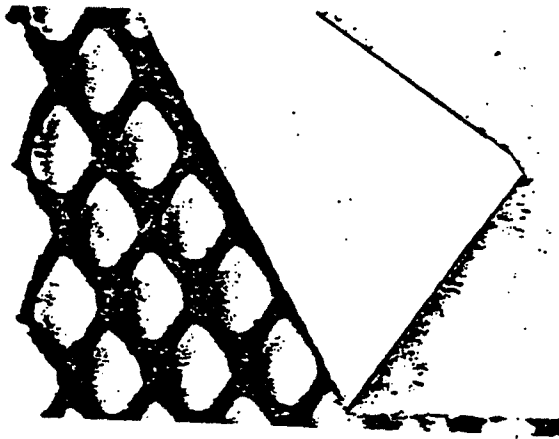

a. Grid

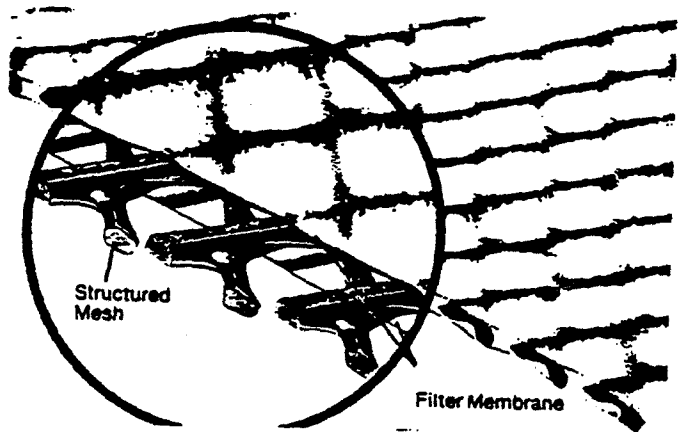

b. Grid

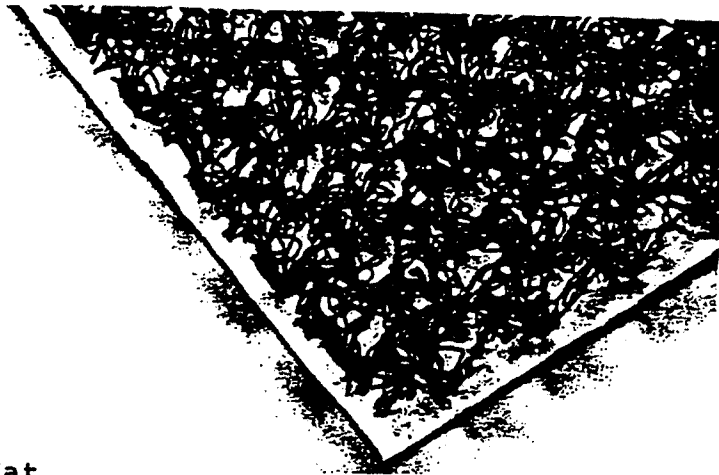

c. Mesh or Mat



c. Formed Plastic Sheet

Fig. 2.7 Composite Systems



Prefabricated drains are essentially used to replace or support conventional drainage systems. According to Hunt (1982), prefabricated drains offer: a readily available material with known filtration and hydraulic flow properties; easy installation, and thereby construction economies; and a protection of any water proofing applied to the exterior of a structure. Cost of prefabricated drains typically range from \$3.00 to \$15.00 per square yard. The high material cost is usually offset by expedient construction and reduction in quantities of select granular materials required. For example, prefabricated drains used for pavement edge drains typically cost \$.50 to \$1.50/linear foot for an installed drain.

#### 2.11.1 Design Criteria

For the design and selection of geotextiles with in-plane drainage capabilities and prefabricated drainage systems, three basic design considerations are:

1. Adequate filtration without clogging or piping.
2. Adequate inflow/outflow capacity under design loads to meet maximum anticipated seepage during design life.
3. System performance considerations.

As with conventional drainage systems, the geotextile should be selected on the basis of the grain size of the material to be protected, permeability requirements, clogging resistance, and physical property requirements as described in Section 2.3. If, for example, the geotextiles used on the prefabricated drainage systems are not appropriate for your design conditions, the safety of the system should not be compromised and alternate geotextiles should be required. This is important especially when prefabricated drains are used in critical situations where failure of the system could lead to failure of the structure.

The maximum seepage flow into the system must be estimated and the geotextile or prefabricated fabric system selected on the basis of seepage requirements. The flow capacity of the prefabricated drain or geotextile can be determined from the transmissivity of the material. The test for transmissivity is ASTM D-4716. The flow capacity per unit width of the geotextile or geocomposite can then be calculated using Darcy's Law:

$$q = k_p iA = k_p iBt \quad (17)$$

or,

$$q/B = \Theta i \quad (18)$$

where:

- q = flow rate ( $L^3/T$ )
- $k_p$  = in-plane coefficient of permeability for the geotextile ( $L/T$ )
- B = width of geotextile (L)
- t = thickness of the geotextile (L)
- $\Theta$  = transmissivity of the geotextile ( $= k_p t$ ) ( $L^2/T$ )
- i = hydraulic gradient (L/L)

The flow rate per unit width of the geosynthetic can then be compared with the flow rate per unit width required of the drainage system. It should be recognized that the in-plane flow capacity for geotextiles or prefabricated drains reduces significantly under compression (Giroud, 1980). Additional decreases in transmissivity may occur with time due to creep. Therefore, the material should be evaluated under the design loading conditions (with a factor of safety) and the design life of the project.

Finally, special consideration must be given to the location of the drain and the pressures on the wall when using geotextiles or prefabricated drains to drain earth retaining structures and abutments. It is important that the drain be located away from the back of the wall and appropriately inclined so that it can

intercept any seepage before it impinges on the back of the wall. Placement of a thin vertical drain directly against a retaining wall may actually increase the seepage forces on the wall due to rainwater infiltration (Terzaghi and Peck, 1967; and Cedergren, 1977). For further discussion of this point, see the FHWA Geotextile Engineering Manual.

#### 2.11.2 Construction Considerations

The following are construction considerations specific to prefabricated drains:

1. As with all geotextile applications, care should be taken during storage and placement to avoid damage of the material.
2. Placement of the backfill directly against the geotextile must be closely observed and compaction of soil directly against the material should be avoided. Otherwise, loading during placement of backfill could damage the filter or even crush the drain. Use of clean granular backfill reduces the compaction energy requirements.
3. Where drainage materials butt together, the geotextile must be overlapped to prevent soil infiltration at the joints. Also, the geotextile should be extended beyond the ends of the drain to prevent soil from entering at the edges of the drain.
4. Specific details must be provided on how the prefabricated drains tie into the collector drainage systems.

Construction of a typical edge drain installation is shown in Fig. 2.8.



a) Prefabricated Edge Drain for Automated Installation

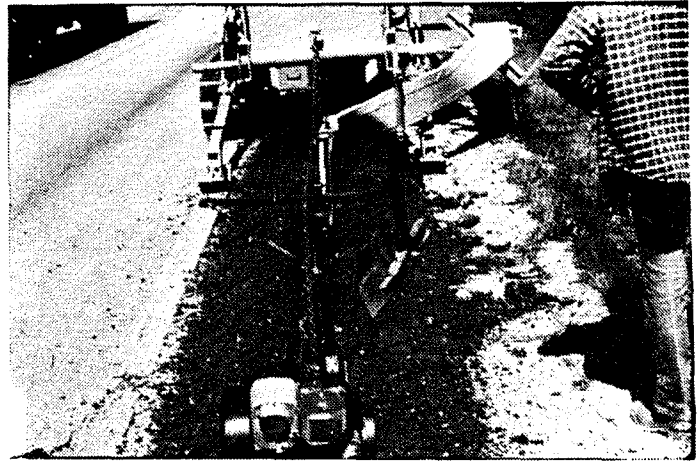

b) Prefabricated Drain Installation



c) Compaction of Drainage Backfill

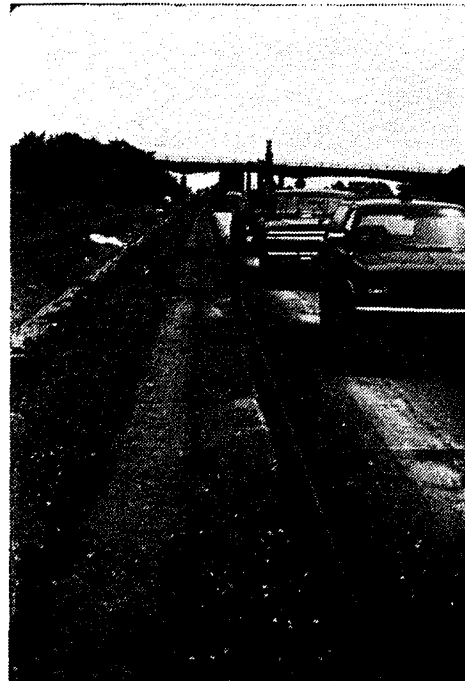

d) Completed Edge Drain Trench

Fig. 2.8 Prefabricated Edge Drain Construction

## CHAPTER 3

### GEOTEXTILES IN EROSION CONTROL SYSTEMS

#### 3.1 Background

As in drainage systems, geotextiles can be effectively used as a replacement for graded granular filters typically used beneath riprap or other armor materials in revetment type erosion control systems. This was one of the first applications of geotextiles in the United States; rather extensive use started in the early 1960's. Numerous case histories have shown this approach to be very effective compared to riprap-only systems and equally effective while providing a cost savings over conventional graded granular filter designs.

Since the early developments in coastal and lake shoreline erosion control, the same design concepts and construction procedures have subsequently been applied to stream bank protection, cut and fill slope protection, protection of various small drainage structures and ditches, wave protection for causeway and shoreline roadway embankments, and scour protection for structures such as bridge piers and abutments. This chapter provides the design guidelines and construction procedures for these and other similar permanent erosion control applications. Temporary erosion control including the use of geotextiles as silt fences for the interception of sediment laden runoff water is covered in Chapter 4.

As indicated above, geotextiles have been successfully used as a filter in numerous erosion control systems to prevent fines from migrating through the armor system.

### 3.2 Applications

- Geotextiles may be used in slope protection to prevent or reduce erosion from precipitation, surface runoff and internal seepage or piping. In this instance, the geotextile may replace one or more layers of granular filter materials which would be placed on the slope in conventional applications.

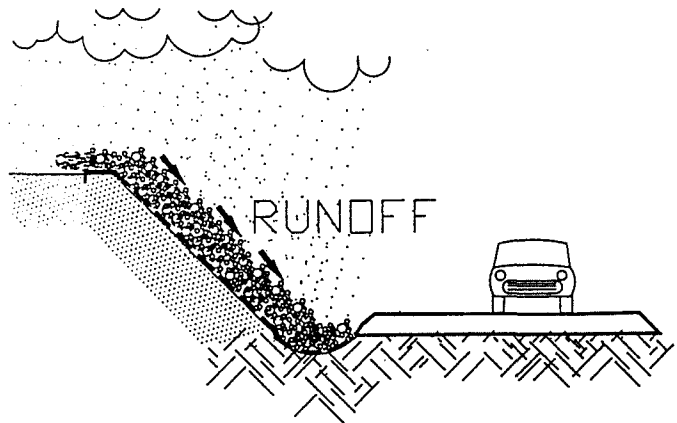

- Riprap/geotextile systems have also found successful application in protecting precipitation runoff collection and diversion ditches from erosion.

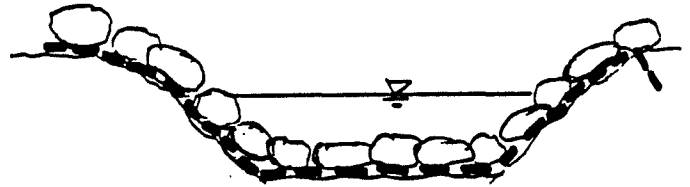

- Erosion control systems with geotextiles may also be required along streambanks to prevent encroachment of roadways or appurtenant structures.

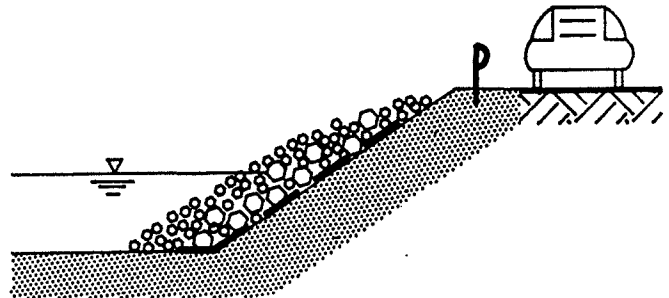

- Similarly, they may be used for scour protection around structures.

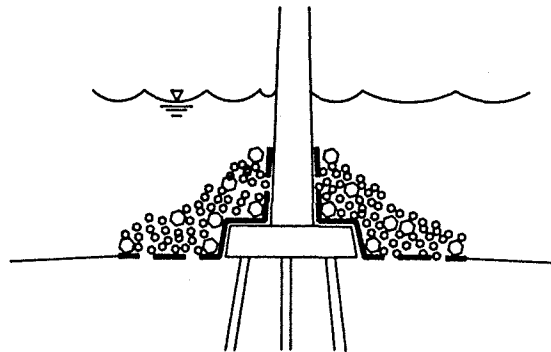

- A riprap geotextile system can also be effective in reducing erosion caused by wave attack or tidal variations when roadways are constructed across or adjacent to large bodies of water.

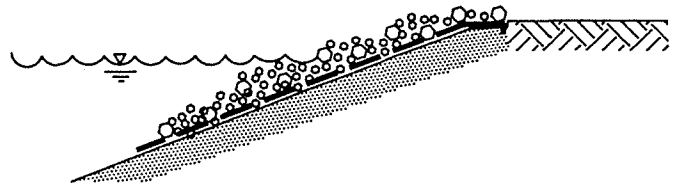

- Finally, hydraulic structures such as culverts, drop inlets and artificial stream channels associated with road construction may also require protection from erosion. In such applications, if vegetation cannot be established or the natural soil is highly erodable, a geotextile can be used beneath armor materials to increase erosion resistance.

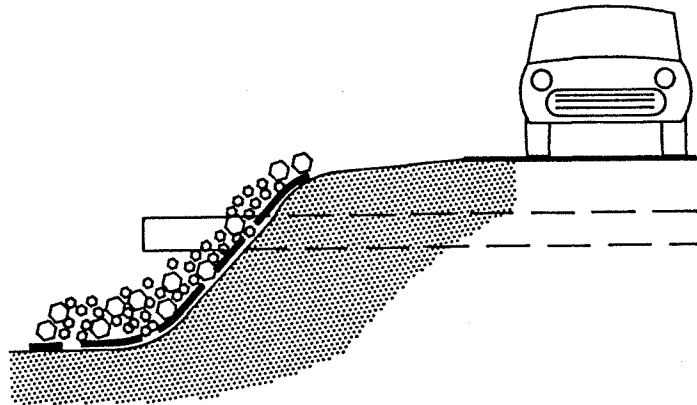

In many of the above applications, placement of the filter layer may be required below water. Geotextiles can offer considerable advantages over granular filter layers in terms of placement procedures and assured continuity of the filter medium.

### 3.3 Geotextile Design

Geotextile design for erosion control systems is essentially the same as geotextile design for filters in drainage systems discussed in Section 2.3. Table 3-1 reiterates the design criteria and highlights special considerations for erosion control systems.

**TABLE 3-1**

**SUMMARY OF GEOTEXTILE DESIGN AND SELECTION CRITERIA FOR DRAINAGE, FILTRATION, AND EROSION CONTROL APPLICATIONS**

**I. SOIL RETENTION (PIPING RESISTANCE CRITERIA)<sup>1</sup>**

Soils	Steady State Flow	Dynamic, Pulsating, and Cyclic Flow (if geotextile can move)
<50% Passing <sup>2</sup> U.S. No. 200 Sieve	AOS or $O_{9.5} \leq BD_{8.5}$	
	$C_u \leq 2$ or $\geq 8$ : $B=1$	
	$2 \leq C_u \leq 4$ : $B=0.5 C_u$	$O_{9.5} \leq 0.5D_{8.5}$
	$4 \leq C_u < 8$ : $B = \frac{8}{C_u}$	
$\geq 50\%$ Passing	Woven: $O_{9.5} \leq D_{8.5}$	$O_{9.5} \leq 0.5D_{8.5}$
	Nonwoven: $O_{9.5} \leq 1.8D_{8.5}$	
	$O_{9.5}$ (fabric) $\leq 0.3\text{mm}$ (No. 50 sieve)	

- NOTE: 1. When the protected soil contains particles from 1 in. size to those passing the U.S. No. 200 sieve, use only the gradation of soil passing the U.S. No. 4 sieve in selecting the fabric.
2. Select fabric on the basis of largest opening value required (smallest AOS).

**II. PERMEABILITY CRITERIA<sup>1</sup>**

**A. Critical/Severe Applications**

$$k \text{ (fabric)} \geq 10k \text{ (soil)}$$

**B. Less Critical/Less Severe Applications (with Clean Medium to Coarse Sands and Gravels)**

$$k \text{ (fabric)} \geq k \text{ (soil)}$$



**TABLE 3-1 (con't)**

**SUMMARY OF GEOTEXTILE DESIGN AND SELECTION CRITERIA FOR DRAINAGE, FILTRATION, AND EROSION CONTROL APPLICATIONS**

**NOTE:** 1. Permeability should be based on the actual fabric open area available for flow. For example, if 50% of fabric area is to be covered by flat concrete blocks, the effective flow area is reduced by 50%.

**III. CLOGGING CRITERIA**

**A. Critical/Severe Applications<sup>1</sup>**

Select fabrics meeting I, II, IIIB, and perform soil/fabric filtration tests before specification, prequalifying the fabric, or after selection before bid closing. Alternative: use approved list specification for filtration applications. Suggested performance test method: Gradient Ratio  $\leq 3$

**B. Less Critical/Non-Severe Applications**

1. Perform soil/fabric filtration tests.
2. Alternative:  $0_{9.5} > 3D_{1.5}$  for  $C_u > 3$
3. For  $C_u \leq 3$ , fabric with maximum opening size possible (lowest AOS No.) from retention criteria should be specified.
4. Apparent Open Area Qualifiers<sup>2</sup>

Woven fabrics: Percent Open Area:  $\geq 4\%$

Nonwoven fabrics: Porosity<sup>2</sup>  $\geq 30\%$

- NOTE:**
1. Filtration tests are performance tests and cannot be performed by the manufacturer as they depend on specific soil and design conditions. Tests to be performed by specifying agency or his representative. **NOTE:** Experience required to obtain reproducible results in gradient ratio test.
  2. Porosity requirement based on graded granular filter porosity.

**TABLE 3-1 (con't)**

**SUMMARY OF GEOTEXTILE DESIGN AND SELECTION CRITERIA FOR DRAINAGE, FILTRATION, AND EROSION CONTROL APPLICATIONS**

**IV. SURVIVABILITY REQUIREMENTS**

**PHYSICAL REQUIREMENTS<sup>1, 2</sup>  
FOR EROSION CONTROL GEOTEXTILES  
(From AASHTO-AGC-ARTBA Task Force 25)**

<u>Property</u>	<u>Erosion Control<sup>3</sup></u>		<u>Test Method</u>
	<u>Class A<sup>4</sup></u>	<u>Class B<sup>5</sup></u>	
Grab Strength (lbs)	200	90	ASTM D4632
Elongation (%) (min)	15	15	ASTM D4632
Seam Strength (lbs) <sup>6</sup>	180	80	ASTM D4632
Puncture Strength (lbs)	80	40	ASTM D4833
Burst Strength (psi)	320	140	ASTM D3786
Trapezoid Tear (lbs)	50	30	ASTM D4533
Ultraviolet Degradation at 150 hours	70% Strength Retained for all classes		ASTM D4355

- NOTE:
1. Acceptance of geotextile material is to be based on TF 25 Acceptance/Rejection Guidelines (ASTM D4759).
  2. Contracting agency may require a letter from the supplier certifying that its geotextile meets specification requirements.
  3. Minimum - Use value in weaker principal direction. All numerical values represent minimum average roll value (i.e., test results from any sampled roll in a lot shall meet or exceed the minimum values in the table). - Stated values are for non-critical, non-severe conditions. Lot sampled according to ASTM D4354.
  4. Class A Erosion Control applications are those where fabrics are used under conditions where installation stresses are more severe than Class B, i.e., stone placement height should be less than 3 ft and stone weights should not exceed 250 pounds.
  5. Class B Erosion Control applications are those where fabric is used in structures or under conditions where the fabric is protected by a sand cushion or by "zero drop height" placement of stone.
  6. Values apply to both field and manufactured seams.

The following is a discussion of these special considerations.

#### Retention Criteria for Cyclic or Dynamic Flow

In cyclic or dynamic flow conditions, if the geotextile is not properly weighted down, soil particles may be able to move behind the fabric. In this case, the coefficient  $B = 1$  is not conservative as the bridging network may not develop and the geotextile will be required to retain even the finer particles of soil. In this case, it is recommended that the  $B$  value be reduced to 0.5 or less; that is, the largest hole in the fabric will be small enough to retain the smaller particles of soil.

This condition is most likely to occur under wave or tidal action in places where the geotextile must span between large armor stone on the joints in sheet pile walls, and in sandbag revetments. For the first application, it is recommended that an intermediate layer of finer stone or gravel be placed over the geotextile and that a sufficient weight of riprap be placed on the system to prevent either stone or geotextile movement and thus particle movement behind the filter. By using these procedures, higher  $B$  coefficient values may be used. For all applications where the fabric can move, and especially in the sandbag application, it is recommended that samples of the soils from the site be washed through the geotextile under consideration to determine its particle retention capabilities.

#### Permeability and Effective Flow Capacity Requirements

In certain erosion control systems, portions of the geotextile may be blocked by the armor stone (e.g. concrete block revetment systems) or may be used to span joints in rigid structures (e.g. sheet pile bulkheads). For such systems, it is especially important to evaluate the flow rate required through the open portion of the system and select a geotextile to meet those flow

requirements. Again, since flow is restricted through the geotextile, the required flow capacity is based on the flow capacity of the area available for flow; or

$$q_{\text{required}} = q_{\text{geotextile}} (A_f/A_t) \quad (10)$$

where  $A_f$  = fabric area available for flow, and  
 $A_t$  = total fabric area

### Clogging Resistance

Since erosion control systems are often used on highly erodible soils with reversing and cyclic flow conditions, severe hydraulic conditions often exist. Accordingly, designs should reflect these conditions, and soil-fabric filtration tests should be conducted in all such situations. As these are performance tests requiring samples of soils from the project site, they must be conducted by the engineer or his representative and not by the fabric manufacturers or suppliers. One popular filtration test is the gradient ratio test, which is described in the FHWA Geotextile Engineering Manual. This test is suitable for sandy and silty soils ( $k \geq 10^{-5}$  cm/sec), and the maximum recommended gradient ratio is 3 (U.S. Army Corps of Engineers, 1977). The FHWA Manual also describes other filtration tests, some of which are appropriate for fine soils.

### Survivability Criteria

The construction procedures for erosion control systems are considerably different than for drainage systems. Thus, the geotextile property requirements for survivability in Table 3-1 differ somewhat from those discussed in Section 2.3 for drainage system design. As placement of armor stone is generally felt to be more severe than placement of aggregate, the values required are slightly higher for each category of geotextile.

### 3.4 Erosion Control System Design Guidelines

#### Step 1 - Application Evaluation

##### A. Critical/Noncritical

1. If the erosion control system fails will there be a risk of loss of life?
2. Does the erosion control system protect a significant structure and will failure lead to significant structural damage?
3. If the geotextile clogs, will failure occur with no warning? Will failure be catastrophic?
4. If the erosion control system fails will the repair costs greatly exceed installation costs?

##### B. Severe/Nonsevere

1. Are soils to be protected gap graded or pipable soils?
2. Are soils present which consist primarily of silts and uniform sands with 85% passing the No. 100 sieve?
3. Will the erosion control system be subjected to reversing or cyclic flow conditions such as wave action or tidal variations?
4. Will high hydraulic gradients exist in the soils to be protected? Will rapid drawdown conditions or seeps or weeps in the soil exist, and whose blockage would produce high hydraulic pressures?

5. Will high velocity conditions exist such as in stream channels?

NOTE: If answer is yes to any of the above questions, the design should proceed under the critical/severe requirements; otherwise use the noncritical/nonsevere design approach.

Step 2 - Obtain soil samples from the site

A. Perform grain size analyses

1. Obtain  $D_{85}$  for each soil and select worse case soil for retention (i.e. soil with smallest  $D_{85}$ ).
2. Calculate  $C_u = D_{60}/D_{10}$ . Note: When the protected soil contains particles from 1 in. to those passing the U.S. No. 200 sieve, use only the gradation of soil passing the U.S. No. 4 sieve in selecting the geotextile (i.e., scalp off the +No. 4 material).

B. Perform field or laboratory permeability tests

1. Select worse case soil (i.e. soil with highest coefficient of permeability  $k$ ). Permeability of clean sands with  $0.1 \text{ mm} < D_{10} < 3 \text{ mm}$  and  $C_u < 5$  can be estimated by Hazen's formula,  $k = D_{10}^2$  ( $k$  in cm/sec;  $D_{10}$  in mm). This formula should not be used for finer grained soils.

Step 3 - Evaluate armor material

Design references include: Highway Research Board (1970), U.S. Navy (1982), U.S. Army Corps of Engineers (1978) and Hydraulic Engineering Circulars.

A. Size armor stone or riprap

Where minimum size of stone exceeds 4 in. or greater than a 4 inch gap exists between blocks, an intermediate gravel layer 6 in. thick should be used between the armor stone and geotextile. Gravel should be sized such that it will not wash through the armor stone (i.e.  $D_{85} \text{ gravel} > D_{15} \text{ riprap}/5$ ).

B. Determine armor stone placement technique (i.e. maximum height of drop).

Step 4 - Calculate anticipated reverse flow through erosion control system.

Here we need to estimate the maximum flow from seeps and weeps, maximum flow from wave runout, or maximum flow from rapid drawdown.

A. General Case - use Darcy's law

$$q = kiA \quad (15)$$

where:  $q$  = outflow rate ( $L^3/T$ )

$k$  = effective permeability of soil (from Step 2B above) ( $L/T$ )

$i$  = average hydraulic gradient in soil (e.g. tangent of slope angle for wave runoff)(dimensionless)

$A$  = area of soil and drain material normal to the direction of flow ( $L^2$ ). Can be evaluated using a unit area.

Use a conventional flow net analysis (Cedergren, 1977) for seepage through dikes and dams or from a rapid drawdown analysis.

- B. Specific erosion control systems - Hydraulic characteristics depend on expected precipitation, runoff volumes and flow rates, stream flow volumes and water level fluctuations, normal and maximum wave heights anticipated, direction of waves and tidal variations. Detailed information concerning the determination of these parameters are available in the U.S. Army Engineer Engineering Manual 1110-2-1913, (1978); Middleton, (1976); and U.S. Bureau of Reclamation, (1973).

Step 5 - Determine geotextile requirements

A. Retention Criteria

From Step 2.A, obtain  $D_{85}$  and  $C_u$ ; then determine largest pore size allowed.

$$\text{AOS or } O_{95} \leq B D_{85} \quad (2)$$

where  $B = 1$  for a conservative design. For a less conservative design and for  $\leq 50\%$  passing U.S. No. 200 sieve:

$$B = 1 \quad \text{for } C_u \leq 2 \text{ or } \geq 8 \quad (3a)$$

$$B = 0.5 C_u \quad \text{for } 2 \leq C_u \leq 4 \quad (3b)$$

$$B = 8/C_u \quad \text{for } 4 < C_u < 8 \quad (3c)$$

and, for  $\geq 50\%$  passing U.S. No. 200 sieve:

$$B = 1 \quad \text{for wovens}$$

$$B = 1.8 \quad \text{for nonwovens}$$

$$\text{and AOS or } O_{95} \text{ (geotextile)} \geq 0.3 \text{ mm} \quad (6)$$

$B = 0.5$  if geotextile and soil retained by it can move.



B. Permeability Criteria

1. Less Critical/Less Severe

$$k_{\text{geotextile}} \geq k_{\text{soil}} \quad (8)$$

2. Critical/Severe

$$k_{\text{geotextile}} \geq 10 k_{\text{soil}} \quad (9)$$

3. Flow Capacity Requirement

$$q_{\text{required}} = q_{\text{geotextile}}/A_f \text{ or} \quad (10)$$

$$(k_{\text{geotextile}}/t) h A_f \geq q_{\text{required}} \quad (16)$$

where,  $q_{\text{required}}$  is obtained from Step 3 (Eq. 15) above.

$$k_{\text{geotextile}}/t = \Psi = \text{permittivity}$$

$h$  = average head in field

$A_f$  = area of fabric available for flow (i.e., if 50% of fabric covered by flat rocks or riprap,  $A_f = 0.5A_{\text{total area}}$ )

C. Clogging Criteria

1. Less Critical/Less Severe

a. Perform soil/fabric filtration tests.

b. Alternative: From Step 2A obtain  $D_{15}$ ; then determine minimum pore size requirement from

$$O_{95} \geq 3 D_{15} \quad (11)$$

c. Other qualifiers

Nonwovens:

Porosity (geotextile) > 30% (12)

Wovens:

Percent open area > 4% (13)

2. Critical/Severe

Select fabrics that meet retention, permeability, and survivability criteria as well as the criteria in Step 5.C.1 above and perform a filtration test.

Suggested filtration test and criteria for sandy and silty soils:

gradient ratio  $\leq$  3 (14)

Alternative: Perform long term filtration tests.

D. Survivability

Select geotextile properties required for survivability from Table 3-1. Add durability requirements if applicable.

Step 6 - Estimate costs

Calculate the volume of armor stone, the volume of aggregate and the area of the geotextile. Apply appropriate unit cost values.

Grading & Site Preparation: \_\_\_\_\_  
Geotextile: \_\_\_\_\_  
Geotextile Placement: \_\_\_\_\_  
Aggregate Bedding Layer  
(in place): \_\_\_\_\_  
Armor Stone: \_\_\_\_\_  
Armor Stone Placement: \_\_\_\_\_  
  
Total Cost: \_\_\_\_\_

Step 7 - Prepare Specifications

Include for the geotextile:

- A. General requirements
- B. Specific geotextiles properties
- C. Seams and overlaps
- D. Placement procedures
- E. Fabric repairs
- F. Testing and placement observation requirements

See Sections 1.6 and 3.7 for specification details.

Step 8 - Collect samples of the fabric before acceptance.

Step 9 - Monitor installation during and after construction

Observe erosion control systems during and after storm events.

**3.5 Design Example**

Relevant examples are included in the FHWA publications, "Geotextile Engineering Workshop Design Examples (FHWA-HI-89-002) and Geotextile Engineering Manual FHWA-86-203.

### 3.6 Cost Considerations

The total cost of a riprap-geotextile revetment system will depend on the actual application and type of revetment selected. The following items should be considered:

1. Grading and site preparation;
2. Cost of geotextile including cost of overlapping and pins versus cost of sewn seams;
3. Cost of placing geotextile including special considerations for below-water placement;
4. Bedding materials, if required, including placement;
5. Armor stone, concrete blocks, sand bags, etc.; and
6. Placement of armor stone (dropped versus hand or machine placed).

For Item No. 2, cost of overlapping includes the extra material required for the overlap, cost of pins, and labor considerations versus the extra cost of field and factory seaming plus the additional cost of laboratory testing of seams. These costs can be obtained from manufacturers. Alternatively, the contractor can be required to supply the cost on an "in-place" basis. As a guideline, current U.S. Army Corps of Engineers Specifications (CW-02215, 1977) specify measurement of payment for geotextiles in streambank and slope protection to be made on an "in-place" basis without allowance for fabric material in laps and seams. Further, the unit price includes furnishing all plant, labor, material, equipment, securing pins, etc. and performing all operations in connection with placement of the fabric, including prior

preparation of banks and slopes. Of course, field performance should also be considered with sewn seams generally preferred to overlaps.

Items Nos. 2, 4 and 6 can be compared with respect to using Class B (Table 3-1) versus Class A (Table 3-1) geotextiles based on the cost of bedding materials and placement requirements for armor stones.

To determine cost effectiveness, benefit-cost ratios should be compared for the riprap-geotextile system versus conventional riprap granular filter systems or other available alternatives of equal technical feasibility and operational practicality. Average cost (1987 dollars) for geotextile protection systems placed above the water level, including slope preparation, fabric cost, cost of seaming or securing pins and placement, is on the order of \$1.00 per square foot, excluding the armor protective covering. Placement below the water level can vary considerably depending on the site conditions and the contractor's experience. For below water placement, it is recommended that prebid meetings be held with contractors to explore ideas for placement and discuss the anticipated cost of placement.

### 3.7 Specifications

In addition to the general recommendations concerning specifications in Chapter 1, the specifications must include the construction details (see Section 3.8) as the appropriate type of geotextile will depend on the placement technique. In addition, under the observation and testing section of the specification, it is recommended that the specifications require the contractor to make trial sections to demonstrate that placement techniques will not damage the geotextile.

Many erosion control projects may be better served if performance filtration tests are performed to provide an evaluation of anticipated long-term performance. As such, in many cases, these types of applications lend themselves to approved list specifications as was discussed in Section 1.6 in Chapter 1. To develop the list of approved geotextiles, filtration studies as suggested in the FHWA Geotextile Engineering Manual should be performed using particular problem soils in conditions that exist in the localities where geotextiles will be used. An approved list for each particular condition should be established. In addition, geotextiles should be classified as suitable for Class A or Class B geotextiles in accordance with the index properties listed in Table 3-1 and used accordingly as dictated by construction conditions.

The following is an example specification developed by the AASHTO-AGC-ARTBA Task Force 25. The example was selected as it covers the requirements discussed in Section 1.6 for a good specification. It is not necessarily presented for format, but is included for content.

AASHTO-AGC-ARTBA  
TASK FORCE 25  
SPECIFICATION GUIDE FOR EROSION CONTROL GEOTEXTILES  
(JULY, 1986)

1. Description

- 1.1 This work shall consist of furnishing and placing a geotextile for the following erosion control applications: cut and fill slope protection, protection for various small drainage structures and ditches, wave protection for causeways and shore line roadway embankments, and scour protection for structures such as bridge piers and abutments. The geotextile shall be designed to allow passage of water while retaining in-situ soil without clogging. The quantities of erosion control geotextiles as shown on the plans may be increased or decreased at the direction of the Engineer based on construction procedures and actual site conditions that occur during construction of the project. Such variations

in quantity will not be considered as alterations in the details of construction or a change in the character of the work.

2. Materials

- 2.1 Fibers used in the manufacture of geotextile, and the threads used in polymers, composed of at least 85% by weight polyolefins, polyesters, or polyamides. They shall be formed into a network such that the filaments or yarns retain dimensional stability relative to each other, including selvages. These materials shall conform to the performance requirements for soil retention, permeability, and clogging resistance and the physical requirements for constructability, survivability, and durability of Table 3-1 (Section 3.3).
- 2.2 Geotextile rolls shall be furnished with suitable wrapping for protection against moisture, and extended ultra-violet exposure prior to placement. Each roll shall be labeled or tagged to provide product identification sufficient for inventory and quality control purposes. Rolls shall be stored in a manner which protects them from the elements. If stored outdoors, they shall be elevated and protected with a waterproof cover.

3. Construction Requirements

- 3.1 Geotextile Exposure Following Placement - Exposure of geotextiles to the elements between lay down and cover shall be a maximum of 14 days to minimize damage potential.
- 3.2 Erosion Control Placement - The geotextile shall be placed and anchored on a smooth graded surface approved by the Engineer. The geotextile shall be placed in such a manner that placement of the overlying materials will not excessively stretch or tear the fabric. Anchoring of the terminal ends of the geotextile shall be accomplished through the use of key trenches or aprons at the crest and toe of slope.

NOTE: In certain applications to expedite construction, 18 in. long anchoring pins placed on 2 to 6 ft centers depending on the slope of the covered area have been used successfully.

### 3.2.1 Slope Protection Placement

Successive geotextile sheets shall be overlapped in such a manner that the upstream sheet is placed over the downstream sheet and/or upslope over downslope. In underwater applications, the geotextile and required thickness of backfill material shall be placed the same day. The backfill placement shall begin at the toe and proceed up the slope.

Rip rap and heavy stone filling shall not be dropped onto the geotextile from the height of more than 1 ft. Slope protection and smaller sizes of stone filling shall not be dropped onto the geotextile from a height exceeding 3 ft. Any geotextile damaged during placement shall be replaced as directed by the Engineer at the Contractor's expense.

- 3.3 Seams - The geotextile shall be joined by either sewing or overlapping. All seams shall be subject to the approval of the Engineer.

Overlapped seams shall have a minimum overlap of 12 in. except where placed underwater where the overlap shall be a minimum of 3 ft.

- 3.4 Repair - A geotextile patch shall be placed over the damaged area and extend 3 ft beyond the perimeter of the tear or damage.

## 4. Method of Measurement

- 4.1 The geotextile shall be measured by the number of square yards computed from the payment lines shown on the plans or from payment lines established in writing by the Engineer. This excludes seam overlaps, but shall include geotextiles used in crest and toe of slope treatments.

- 4.2 Slope preparation, excavation and backfill, bedding, and cover material are separate pay items.

## 5. Basis of Payment

- 5.1 The accepted quantities of geotextile shall be paid for per square yard in place.

- 5.2 Payment will be made under:

<u>Pay Item</u>	<u>Pay Unit</u>
Erosion Control Geotextile	Square Yard



### 3.8 Installation Procedures

Construction requirements will depend on the specific application and site conditions. Photos of several installations are shown in Fig. 3.1. The following general construction considerations apply for most riprap-geotextile erosion protection systems. Special considerations related to specific applications and alternate riprap designs will follow.

1. Grade area and remove debris to provide smooth, fairly even surface.
  - a. Depressions or holes in the slope should be filled so that the fabric will not have to bridge them and possibly be torn when cover materials are placed.
  - b. Large stones, limbs and other debris should be removed prior to placement to prevent fabric damage from tearing or puncturing during stone placement.
2. Place fabric loosely, laid with machine direction in the direction of anticipated water flow or movement.
3. Seam or overlap fabric as required.
  - a. For overlaps, adjacent rolls of fabric should be overlapped a minimum of 18 inches. Overlaps should be in the direction of water flow and stapled or pinned to hold the overlap in place during placement of stone. Pins are normally 3/16 in. diameter, 18 in. long steel pins, pointed at one end, and fitted with 1.5 in. diameter washers at the other end. Pins should be spaced along all overlap alignments at a distance of approximately 3 ft center to center.



a) Installation in Wave Protection  
Revetment (Laying Geotextile)



b) Shoreline Application  
(Key Trench)

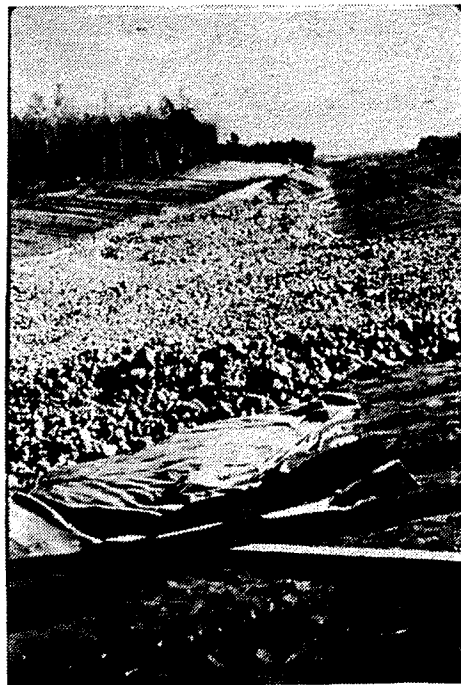

c) Drainage Ditch Installation  
(armor cover)

Fig. 3.1 Erosion Control Installations

The fabric should be pinned in a loose condition so that it easily conforms to ground surface and will "give" when the stone is placed.

- b. If seamed, seam strength should equal the minimum required strength of the fabric as well as the seam requirements indicated in the specification section of Chapter 1.
4. The maximum allowable slope on which a riprap-geotextile system can be placed is equal to the lowest soil-fabric friction angle for the natural ground or stone-fabric friction angle for cover (armor) materials. Additional reductions in slope may be necessary due to considerations of hydraulic and possible long-term stability conditions. For slopes greater than 2.5 to 1, special construction procedures will be required, including toe berms to provide reaction against slippage, loose placement of fabric sufficient to allow for downslope movement, elimination of pins at overlaps, increase in overlap requirements, and possible consideration of slope benching. Additional details and references on steep slope placement are included in the FHWA Geotextile Engineering Manual.
5. For streambank and wave action applications, the fabric must be keyed in at the bottom of the slope. If the riprap-geotextile system can not be extended several feet above the anticipated maximum high water level, the geotextile should also be keyed in at the crest of the slope. Alternative key details are shown in Fig. 3.2.
6. Place revetment (cushion layer and/or riprap) over the geotextile width, taking care to avoid puncturing or tearing it.

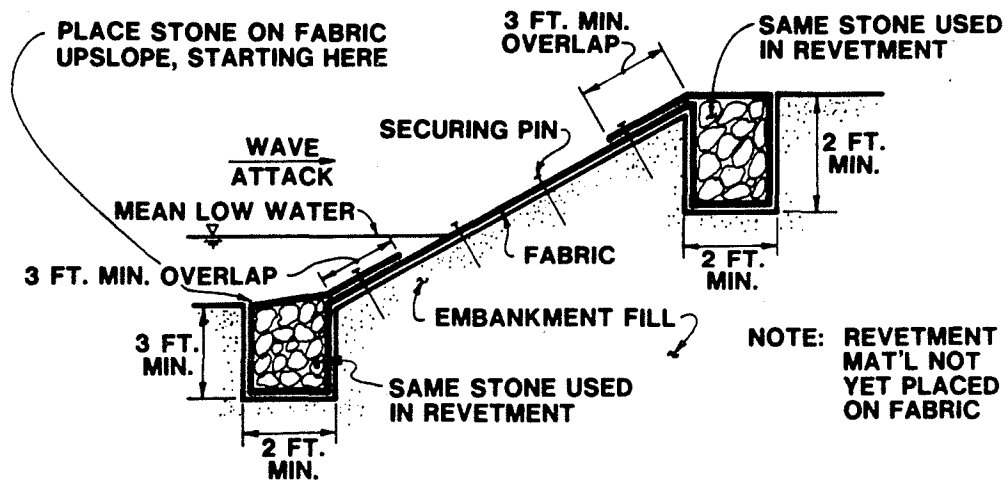

a) CROSS-SECTION OF REVETMENT AND KEY TRENCHES

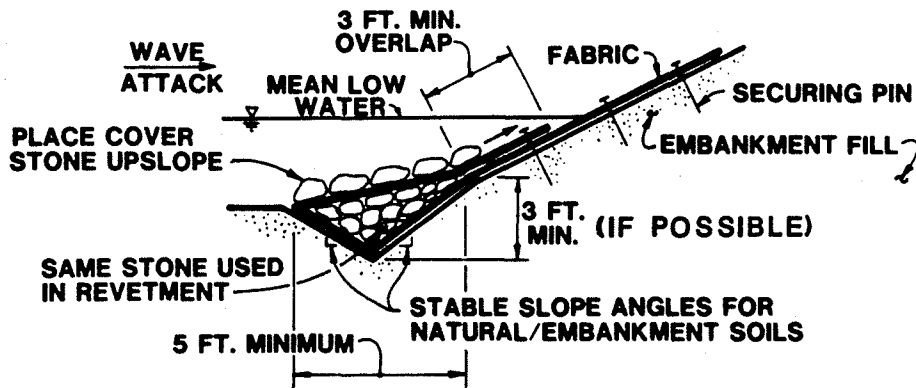

b) CROSS-SECTION USING KEY TRENCH WHEN SOIL CONDITIONS DO NOT PERMIT VERTICAL WALL CONSTRUCTION

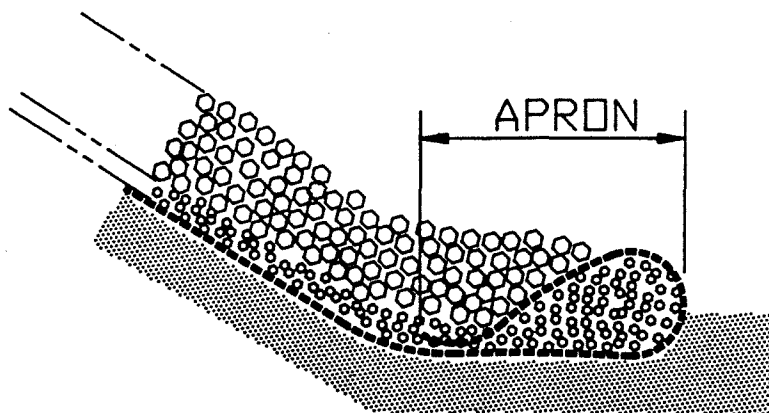

(C) DUTCH METHOD TOE DESIGN

Fig. 3.2 Construction of Erosion Control System

- a. Revetment should be placed on the geotextile within 5 days for untreated UV susceptible geotextiles and within 14 days for UV-treated and low UV susceptible geotextiles.
- b. Placement of armor cover will depend on the type of riprap, whether quarry stone, sandbags (which may themselves be constructed of geotextiles), soil cement-filled bags, interlocked or articulating concrete blocks, or other suitable slope protection are used.
- c. For sloped surfaces, placement should always start from the base of the slope, moving up slope and preferably from the center outwards.
- d. In no case should stone weighing more than 100 lb be allowed to roll downslope.
- e. Field trials should be performed to determine if placement techniques will damage the fabric and to determine the maximum height of safe drop without damaging the fabric. As a general guideline, for Class B fabrics (Table 3-1) with no cushion layer, height of drop for stones less than 250 lb should be less than 1 ft. For Class A fabrics (Table 3-1) or Class B fabrics with a cushion layer, height of drop for stones less than 250 lb should be less than 3 ft. Stones greater than 250 lb should be placed with no free fall unless field trials demonstrate that they can be dropped without damaging the fabric.
- f. Grading of slopes should be performed during placement of riprap and grading should not be allowed after placement if grading results in stone movement directly on the fabric.

As previously indicated, construction requirements will depend on the specific application and site conditions. In some cases, the selection of the geotextile is affected by construction procedures. For example, if the system must be placed below water, a fabric that will facilitate such placement must be chosen. The geotextile may also affect the construction procedures. For example, the geotextile must be completely covered with riprap for protection from long-term exposure to ultraviolet radiation. Sufficient anchorage must also be provided by the riprap for "weighting" the fabric in below water applications. Other special requirements related to specific applications are depicted in Fig. 3.3 and are discussed in detail in the FHWA Geotextile Engineering Manual.

### 3.9 Field Inspection

In addition to the general field inspection guidelines provided in Chapter 1, Section 1.7, the field inspector should pay close attention to the construction procedures. If significant movement of stone riprap (greater than 6 in.) occurs during or after placement, stone should be removed to inspect overlaps to make sure they are still intact. As indicated in Section 3.8, field trials should be performed to demonstrate that placement procedures will not damage the geotextile. If damage is observed, the engineer should be contacted and the contractor should change the placement procedure.

For below water placement or placement adjacent to structures requiring special installation procedures, the inspector should discuss placement details with the engineer, and inspection requirements and inspection methods should be worked out in advance of construction.

### 3.10 Geotextile Selection Considerations

Special consideration should be given to the type of fabric chosen for certain soil and hydraulic conditions to enhance the

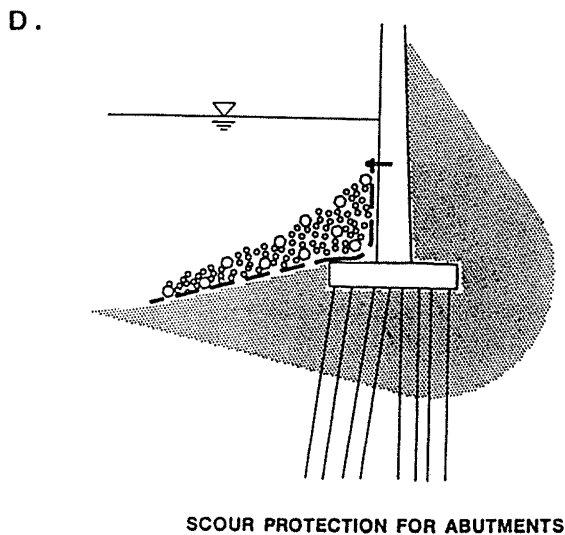
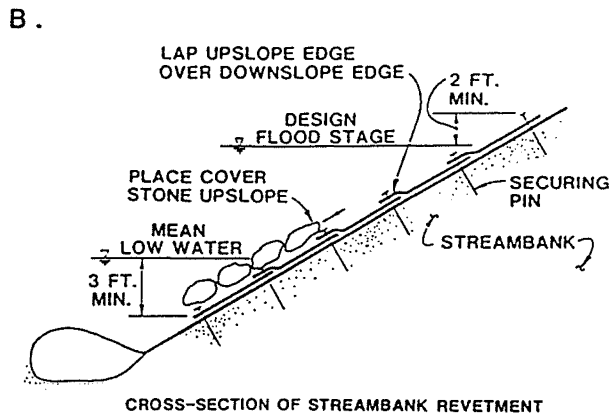
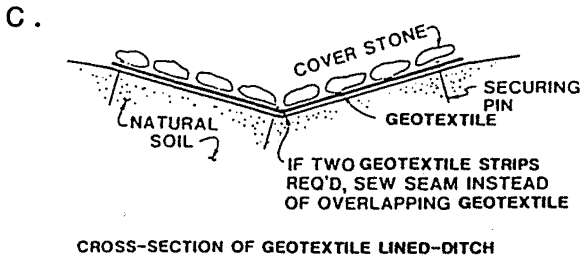
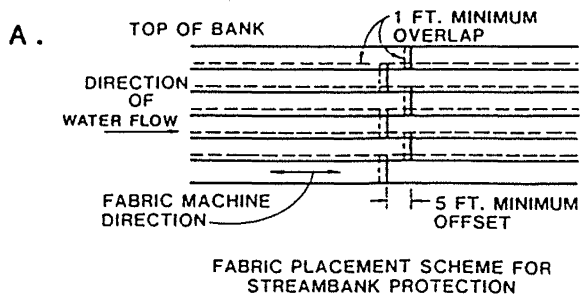

**Fig. 3.3 Special Construction Requirements Related to Specific Erosion Control Applications**

performance of the system. The considerations listed in Section 2.10 also apply to erosion control systems. Special attention should be given to gap graded soils and silts with sand seams. Consideration should also be given to using multiple filters consisting of a sand layer over the soil with the geotextile then designed as a filter for the sand only and with sufficient openings and opening size to allow any fines that reach the geotextile to pass through it.

Another special consideration for erosion control applications relates to preference given to felted versus slick geotextiles on steep slope sections. In any case, for steep slopes, the potential for riprap to slide on the geotextile must be assessed either through field trials or laboratory tests.



## CHAPTER 4

### TEMPORARY EROSION CONTROL USING GEOTEXTILES

#### 4.1 Background

Geotextiles and related products can be used to temporarily control and minimize erosion and sediment transport during highway construction. Four specific application areas have been identified:

- Special grids, meshes, nets, and webbings have been used to provide tractive resistance and water velocity decrease while retaining seeds and mulch to promote the establishment of a vegetative cover.
- Geotextiles in conjunction with riprap can be used to control ditch erosion of diversion ditches and designed as discussed in Chapter 3. Alternatively, grids, meshes or nets can be used for temporary erosion control until vegetation can be established in the ditch.
- Geotextiles can be used as a substitute for hay bales or brush piles as silt fences to remove suspended particles from sediment laden runoff water.

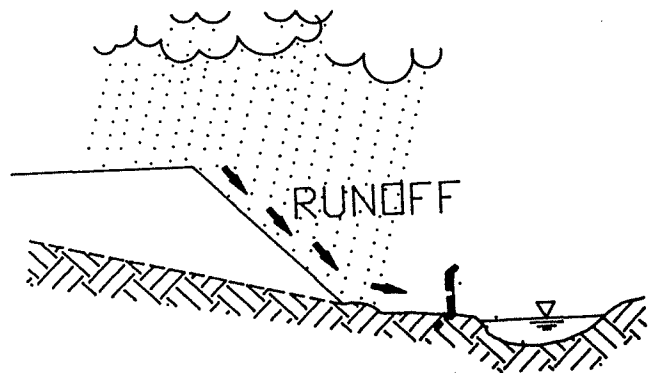
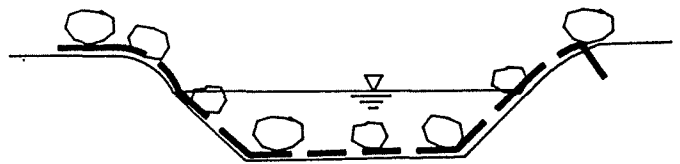
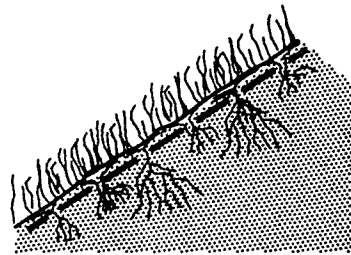

Geotextiles can be used as a silt curtain placed within a stream, lake or other body of water to retain suspended particles and allow sedimentation to occur.

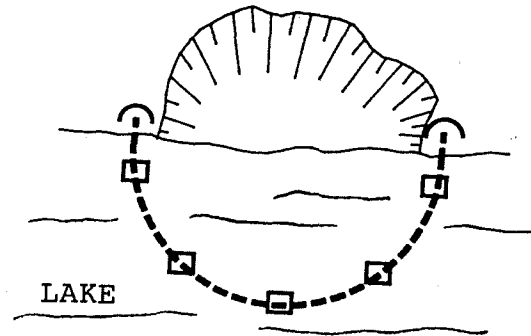

The main advantages of using a geotextile over conventional techniques in all the above applications include:

- A. Empirically predictable performance over less sure techniques such as establishment of vegetation, mulch covers and brush or hay bale barriers.
- B. Applications can be more easily controlled by material specifications.
- C. In the case of a silt fence, the geotextile can be designed for the specific application while conventional techniques are basically on a trial basis.
- D. Better continuity of protection is generally realized over the entire protected area.
- E. The techniques also may prove to be very cost-effective, especially in relation to the ease of installation and material cost when hay bales must be imported to the site.

Special products used to promote vegetative growth are usually evaluated by trial sections. As there are very few published record of comparative use, it is left to the user to decide on the preferable system. You should just be aware that a variety of systems exist and should consult manufacturers and other agencies about their experiences, as an aid to selecting the best system.

Design of geotextiles in riprap-geotextile systems to control ditch erosion on a temporary basis follows the Chapter 3 design guidelines. The following sections review geotextile selection, specifications and installation procedures for geotextiles used as silt fences and silt curtains.

#### 4.2 Geotextile Selection

For silt fence applications, the permeable geotextile is placed across a permanent or temporary diversion ditch or downslope from a bare soil area. The permeable geotextile allows water to flow through the fence and then off-site, while any sediment in the water is retained against the fabric. Likewise, in a silt curtain application, the geotextile is placed to intercept sediment laden water to remove the sediment while allowing the water to pass. Thus, for maximum performance efficiency, a silt fence or silt curtain should pass a maximum amount of water and retain a maximum amount of sediment. Unfortunately, such optimum performance is normally not possible as the filtering out of the sediments will eventually blind or clog the geotextile. To maximize the performance of the geotextile, the following soil, site and environmental conditions should be established and the geotextile selected to provide a specific filtering efficiency while maintaining the required flow rate (Bell and Hicks, 1980).

##### Silt Fence

- A. Grain size distribution of soil to be filtered,
- B. Estimation of the volume of soil expected to be eroded during construction to determine the number of fences that may eventually be needed to protect the slope.
- C. Flow conditions, anticipated runoff, and water level fluctuations, and

- D. Expected environmental conditions including temperature and duration of exposure to sunlight.

### Silt Curtains

In addition to the silt fence requirements, the following conditions should be considered for silt curtain selection:

- A. Current velocity, direction and quantity of discharge water,
- B. Water depth and levels of turbidity,
- C. Survey of the bottom sediment and vegetation at the site, and
- D. Wind conditions.

On the basis of the above considerations, the geotextile can then be selected either according to the properties required to maximize particle retention and flow capacity while resisting clogging or selected by performing filtration model studies. The first approach follows the criteria used in Chapter 2 for drainage systems. As silt fence and silt curtain applications are generally concerned with fine grained soils, the following criteria could be considered in selecting the fabric.

#### A. Retention Criteria

$$\text{A.O.S. or } O_{9,5} = D_{8,5} \text{ (soil) for woven geotextiles.} \quad (4)$$

$$\text{A.O.S. or } O_{9,5} = 1.8 D_{8,5} \text{ (soil) for nonwoven geotextiles.} \quad (5)$$

Note: The  $D_{8,5}$  should be determined on soils passing a No. 10 U.S. standard sieve since larger particles are not likely to be transported by runoff water.

## B. Flow Capacity Criteria

$$Y = 10q/A_p \quad (19)$$

Where:  $Y$  = permittivity of geotextile ( $T^{-1}$ )

$q$  = runoff flow rate, ( $L^3/T$ )

$A_p$  = cross sectional area of ditch ( $L^2$ )

10 = factor of safety for unit head (2)

## C. Clogging Resistance

Maximize A.O.S requirements using largest opening possible from A above.

The second approach uses model studies to estimate filtration efficiency for particular site conditions. This method was developed by Wyant (1980) for the Virginia Highway and Transportation Research Council (VHTRC) and was based on observed field performance and sediment-fabric laboratory testing. The procedures for this method are discussed in detail in the FHWA Geotextile Engineering Manual. The laboratory model consists of a flume with an outflow opening similar to the size of a hay bale and positioned at a fixed slope. The fabric is strapped across the end of the flume. A representative soil sample is then suspended in water and poured through the flume. Based on the performance of the fabric and the test, appropriate geotextiles can be selected to provide filtering efficiencies on the order of 65% to 75% and flow rates on the order of 0.2 to 0.3 gallons/min/ft<sup>2</sup> after three repetitions of the test.

The model study approach provides a system performance evaluation by utilizing actual soils from the local area of interest. Thus, it cannot be performed by manufacturers and the procedure lends itself to the approved list specification approach. It is recommended that the agency or their representatives perform the test using their particular problem soils and prequalify

geotextiles that meet the filtering efficiency and flow criteria requirements. Qualifying geotextiles can be placed on an approved list which is then provided to contractors. For any approved list, fabrics should be periodically retested because changes are often made in the manufacturing process.

#### 4.3 Constructability Requirements

The geotextile used as a silt fence must have sufficient strength to enable it to be properly installed. AASHTO-AGC-ARTBA Task Force 25 property recommendations are indicated in Table 4-1. It is important to recognize that these specifications are not based on research but on properties of existing geotextiles which are known to perform satisfactorily in silt fence and silt curtain applications. Also given are requirements for resistance to ultraviolet degradation. Although the applications are temporary, still the geotextile must have sufficient UV resistance to be able to function throughout its anticipated design life.

#### 4.4 Specifications

The following specifications were developed by the AASHTO-AGC-ARTBA Task Force 25 and are included herein for your reference. They are meant to serve as guidelines for selecting and installation of geotextiles for routine projects. They are not intended to replace site specific evaluation, testing, and design.

**TABLE 4-1**

**AASHTO-AGC-ARTBA  
PHYSICAL REQUIREMENTS<sup>1, 2</sup>  
FOR TEMPORARY SILT FENCE GEOTEXTILES**

<u>Property</u>	<u>Test Method</u>	<u>Wire Fence Supported Requirements</u>	<u>Self Supported Requirements</u>
Tensile Strength (lb)	ASTM D4632	90 minimum <sup>3</sup>	90 minimum
Elongation at 50% minimum tensile strength (45 lb)	ASTM D4632	N/A	50 lb maximum
Ultraviolet Degradation <sup>4</sup>	ASTM D4355	Minimum 70% Strength Retained	Minimum 70% Strength Retained

- Notes:
1. Acceptance of geotextile material to be based on TF 25 Acceptance/Rejection Guidelines.
  2. Contracting agency may require a letter from the supplier certifying that its geotextile meets specification requirements.
  3. Minimum - Use value in weaker principal direction. All numerical values represent a minimum average roll value (i.e., test results from any sampled roll in a lot shall meet or exceed the minimum values in the table) - Stated values are for non-critical, non-severe conditions. Lot samples according to ASTM D4534.
  4. Strength retained after 500 hours of ultraviolet exposure when tested according to ASTM D4355. This method specifies tensile testing by 2 in. strip (or ravelled strip) for both control and exposed samples.

AASHTO-AGC-ARTBA  
TASK FORCE 25  
SPECIFICATION GUIDE - TEMPORARY SILT FENCE  
(JULY, 1986)

1. Description

1.1 This work shall consist of furnishing, installing, maintaining, and removing a geotextile barrier-fence designed to remove suspended particles from the water passing through it. The quantities of temporary silt fence shown on the plans may be increased to decreased at the direction of the Engineer based on weather, construction procedures, and actual site conditions that occur during construction of the project. Such variations in quantity will not be considered as alterations in the details of construction or a change in the character of the work.

2. Materials

2.1 This specification provides criteria for wire supported geotextile silt fence as well as a self supporting geotextile silt fence.

2.2 Fibers used in the manufacture of geotextiles shall consist of long-chain synthetic polymers, composed of at least 85% by weight polyolefins, polyesters, or polyamides. They shall be formed into a network such that the filaments or yarns retain dimensional stability relative to each other, including selvages. The geotextile shall conform to the requirements shown in Table 4-1. The geotextile shall be free of any treatment or coating which might adversely alter its physical properties after installation.

2.3 Geotextile rolls shall be furnished with suitable wrapping for protection against moisture and extended ultraviolet exposure prior to placement.

Each roll shall be labeled or tagged to provide product identification sufficient for inventory and quality control purposes. Rolls shall be stored in a manner which protects them from the elements.

2.4 Posts: Either wood, steel, or synthetic posts may be used. Posts shall have a minimum length of 36 inches plus burial depth and be of sufficient strength to resist damage during installation and to support applied loads.



- 2.5 Support Fence: Wire or other support fence shall be at least 32 in. high and strong enough to support applied loads.
- 2.6 Prefabricated Fence: Prefabricated fence systems may be used provided they meet all of the above material requirements.

Remarks

It has been found that oak post dimensions of at least 1-1/4 in. x 1-1/4 in. or steel posts of U, T, L or C shape weighing 1.3 lbs per linear foot have performed satisfactorily. In soft ground, swamps, etc. a wider post is advantageous as additional passive resistance needs to be developed. Wire support fence having at least 6 horizontal wires, and being at least 12-gauge wire have performed satisfactory. Vertical wires should be spaced a maximum of 6 in. apart.

3. Construction Requirements

- 3.1 The Contractor shall install a temporary silt fence as shown on the plans, and at other locations as directed by the Engineer. Fence construction shall be adequate to handle the stress from sediment loading. Geotextile at the bottom of the fence shall be buried a minimum of 6 in. in a trench so that no flow can pass under the barrier. The trench shall be backfilled and the soil compacted over the geotextile. Fence height shall be as specified by the Engineer but in not case shall exceed 36 in. above ground surface. The geotextile shall be spliced together only at a support post with a minimum 6-in. overlap.

Remarks

It is recommended that posts be spaced a maximum of 8 ft apart and where possible placed or driven a minimum of 18 in. into the ground. Where an 18 in. depth is impossible to achieve, the posts should be adequately secured to prevent overturning of the fence due to sediment loading.

- 3.2 When wire support fence is used, the wire mesh shall be fastened securely to the up slope side of the post. The wire shall extend into the trench a minimum of 2 in. and extend a maximum of 36 in. above the original ground surface.
- 3.3 When self supported fence is used, the geotextile shall be securely fastened to fence posts.

## Remarks

Typical locations include the toe of fill slopes, the downhill side of large cut areas, along streams, and at natural drainage areas. Silt fences should be continuous and transverse to the flow, and limited to handle an area equivalent to 1,000 sq ft per 10 ft of fence. Caution should be used where the site slope is steeper than 1:1, and water flow rates exceed 1 cu ft per sec per 10 ft of fence.

3.4 It is the Contractor's responsibility to maintain the integrity of silt fences as long as they are necessary to contain sediment runoff. The Contractor shall inspect all temporary silt fences immediately after each rainfall and at least daily during prolonged rainfall. Any deficiencies shall be immediately corrected by the Contractor. In addition, the Contractor shall make a daily review of the location of silt fences in areas where construction activities have changed the natural contour and drainage runoff to ensure that the silt fences are properly located for effectiveness. Where deficiencies exist, additional silt fences shall be installed as directed by the Engineer. Should the silt fence become damaged or otherwise ineffective while the barrier is still necessary, it shall be repaired promptly.

3.5 Sediment deposits shall either be removed when the deposit reaches approximately 1/2 of the height of the silt fence or a second silt fence shall be installed as directed by the Engineer.

3.6 The silt fence shall remain in place until the Engineer directs that it be removed. Upon removal, the Contractor shall remove and dispose of any excess silt accumulations, dress the area to give a pleasing appearance, and vegetate all bare areas in accordance with the contract requirements. The fence materials will remain the property of the Contractor and may be used at other locations provided the materials meet the requirements in Table 4-1.

## 5. Method of Measurement

5.1 Temporary silt fence will be measured in linear feet, complete in place.

5.2 Removed sediment will be measured by the cubic yard.

## 6. Basis of Payment

6.1 Temporary silt fence will be paid for per linear foot which shall be full compensation for completing the

work specified. Such payment shall be full compensation of furnishing all materials, erecting, maintaining, and removing the fence.

- 6.2 Removing the accumulated silts shall be paid for by cubic yards.
- 6.3 Dressing and grassing will be paid for by acre.
- 6.4 Payment will be made under:

<u>Pay Item</u>	<u>Pay Unit</u>
Silt fence	Linear Foot
Removing Sediments	Cubic Yards
Grassing	Acre

#### 4.5 Installation Procedures

Silt fences are rather simple to construct; the normal construction sequence is shown in Fig. 4.1.

1. Drive in wooden or steel fence posts or large wooden stakes in a row, with normal spacing between 2 ft to 10 ft, center to center. Most prefabricated fences have posts spaced approximately 7 to 10 ft apart, which is usually adequate.
2. Construct a small (minimum 6 in. deep and 6 in. wide) trench on the upstream side of the silt fence. Bury and anchor the lower portion of the fabric and prevent precipitation runoff under the fence.
3. Attach reinforcing wire, if required, to the post.
4. If a prefabricated silt fence is not being used, the fabric must be attached to the post using staples, reinforcing wire, or other attachments provided by manufacturers. Sufficient fabric should be extended below the ground surface to allow for burying at least 6 in. of fabric in the ground.

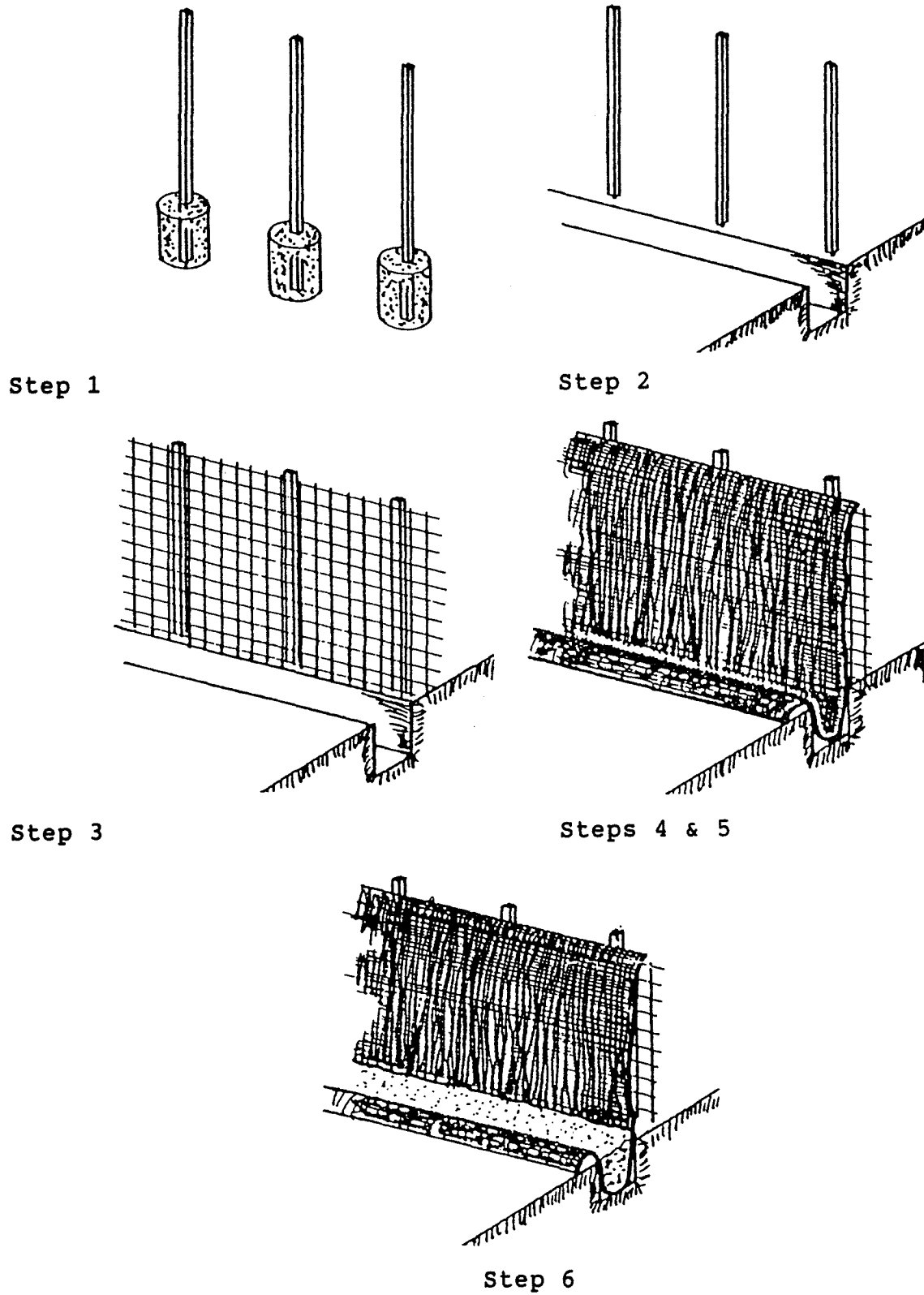

Fig. 4.1 Installation Procedure for Silt Fences  
 (See Text for Description of Individual Steps) 100

work specified. Such payment shall be full compensation of furnishing all materials, erecting, maintaining, and removing the fence.

- 6.2 Removing the accumulated silts shall be paid for by cubic yards.
- 6.3 Dressing and grassing will be paid for by acre.
- 6.4 Payment will be made under:

<u>Pay Item</u>	<u>Pay Unit</u>
Silt fence	Linear Foot
Removing Sediments	Cubic Yards
Grassing	Acre

#### 4.5 Installation Procedures

Silt fences are rather simple to construct; the normal construction sequence is shown in Fig. 4.1.

1. Drive in wooden or steel fence posts or large wooden stakes in a row, with normal spacing between 2 ft to 10 ft, center to center. Most prefabricated fences have posts spaced approximately 7 to 10 ft apart, which is usually adequate.
2. Construct a small (minimum 6 in. deep and 6 in. wide) trench on the upstream side of the silt fence. Bury and anchor the lower portion of the fabric and prevent precipitation runoff under the fence.
3. Attach reinforcing wire, if required, to the post.
4. If a prefabricated silt fence is not being used, the fabric must be attached to the post using staples, reinforcing wire, or other attachments provided by manufacturers. Sufficient fabric should be extended below the ground surface to allow for burying at least 6 in. of fabric in the ground.

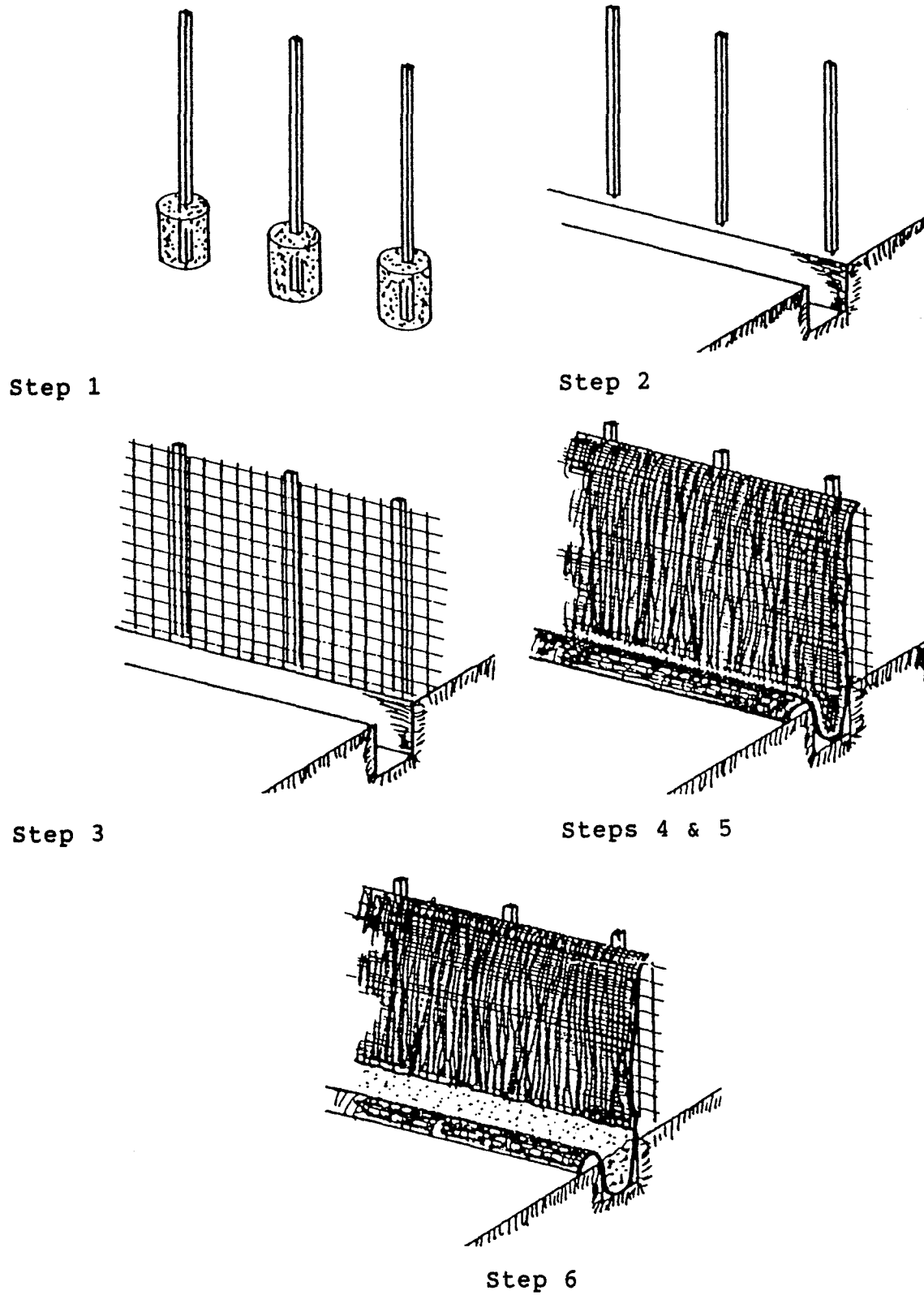

Fig. 4.1 Installation Procedure for Silt Fences  
 (See Text for Description of Individual Steps) 100

work specified. Such payment shall be full compensation of furnishing all materials, erecting, maintaining, and removing the fence.

- 6.2 Removing the accumulated silts shall be paid for by cubic yards.
- 6.3 Dressing and grassing will be paid for by acre.
- 6.4 Payment will be made under:

<u>Pay Item</u>	<u>Pay Unit</u>
Silt fence	Linear Foot
Removing Sediments	Cubic Yards
Grassing	Acre

#### 4.5 Installation Procedures

Silt fences are rather simple to construct; the normal construction sequence is shown in Fig. 4.1.

1. Drive in wooden or steel fence posts or large wooden stakes in a row, with normal spacing between 2 ft to 10 ft, center to center. Most prefabricated fences have posts spaced approximately 7 to 10 ft apart, which is usually adequate.
2. Construct a small (minimum 6 in. deep and 6 in. wide) trench on the upstream side of the silt fence. Bury and anchor the lower portion of the fabric and prevent precipitation runoff under the fence.
3. Attach reinforcing wire, if required, to the post.
4. If a prefabricated silt fence is not being used, the fabric must be attached to the post using staples, reinforcing wire, or other attachments provided by manufacturers. Sufficient fabric should be extended below the ground surface to allow for burying at least 6 in. of fabric in the ground.

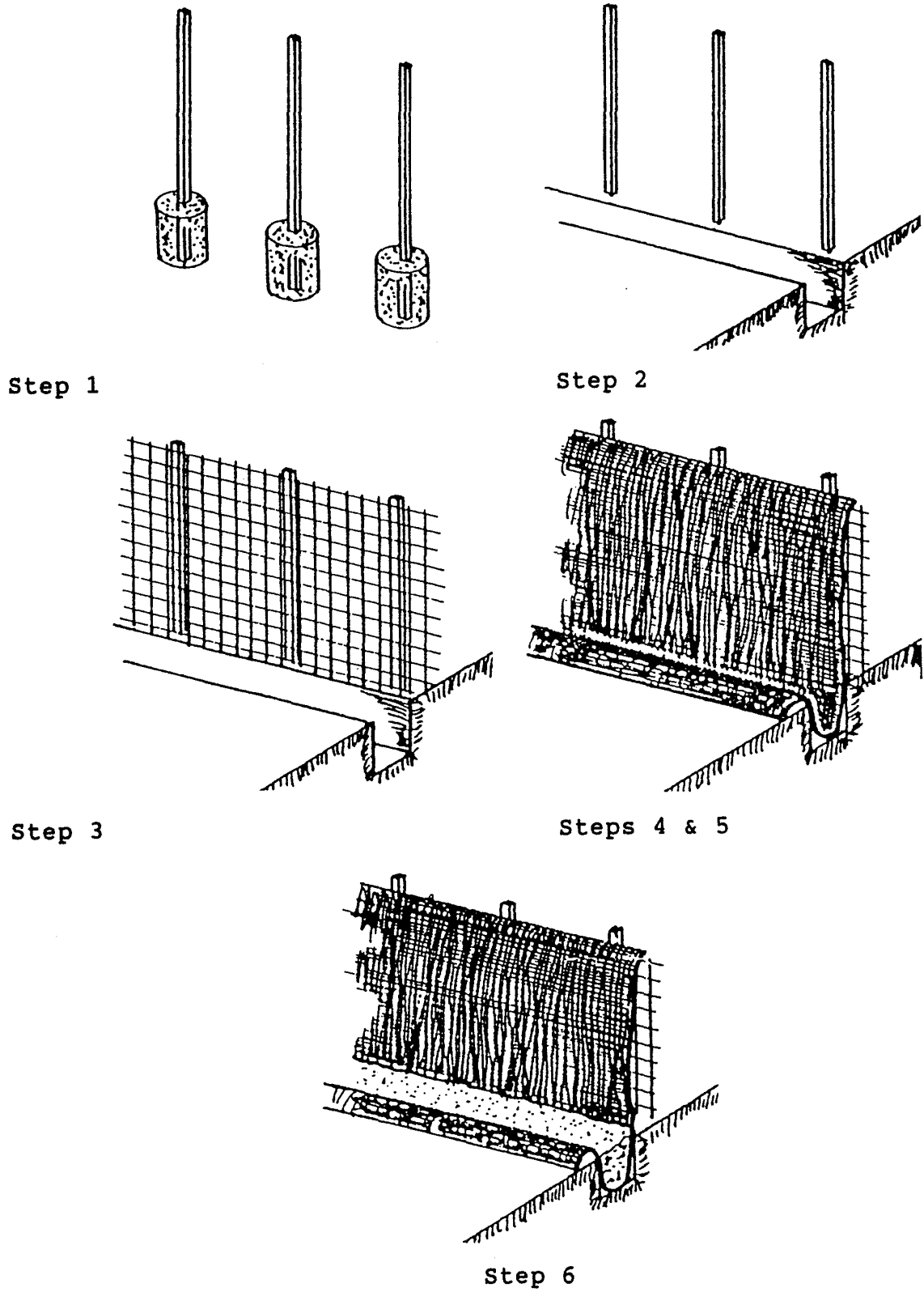

Fig. 4.1 Installation Procedure for Silt Fences  
 (See Text for Description of Individual Steps) 100



work specified. Such payment shall be full compensation of furnishing all materials, erecting, maintaining, and removing the fence.

- 6.2 Removing the accumulated silts shall be paid for by cubic yards.
- 6.3 Dressing and grassing will be paid for by acre.
- 6.4 Payment will be made under:

<u>Pay Item</u>	<u>Pay Unit</u>
Silt fence	Linear Foot
Removing Sediments	Cubic Yards
Grassing	Acre

#### 4.5 Installation Procedures

Silt fences are rather simple to construct; the normal construction sequence is shown in Fig. 4.1.

1. Drive in wooden or steel fence posts or large wooden stakes in a row, with normal spacing between 2 ft to 10 ft, center to center. Most prefabricated fences have posts spaced approximately 7 to 10 ft apart, which is usually adequate.
2. Construct a small (minimum 6 in. deep and 6 in. wide) trench on the upstream side of the silt fence. Bury and anchor the lower portion of the fabric and prevent precipitation runoff under the fence.
3. Attach reinforcing wire, if required, to the post.
4. If a prefabricated silt fence is not being used, the fabric must be attached to the post using staples, reinforcing wire, or other attachments provided by manufacturers. Sufficient fabric should be extended below the ground surface to allow for burying at least 6 in. of fabric in the ground.

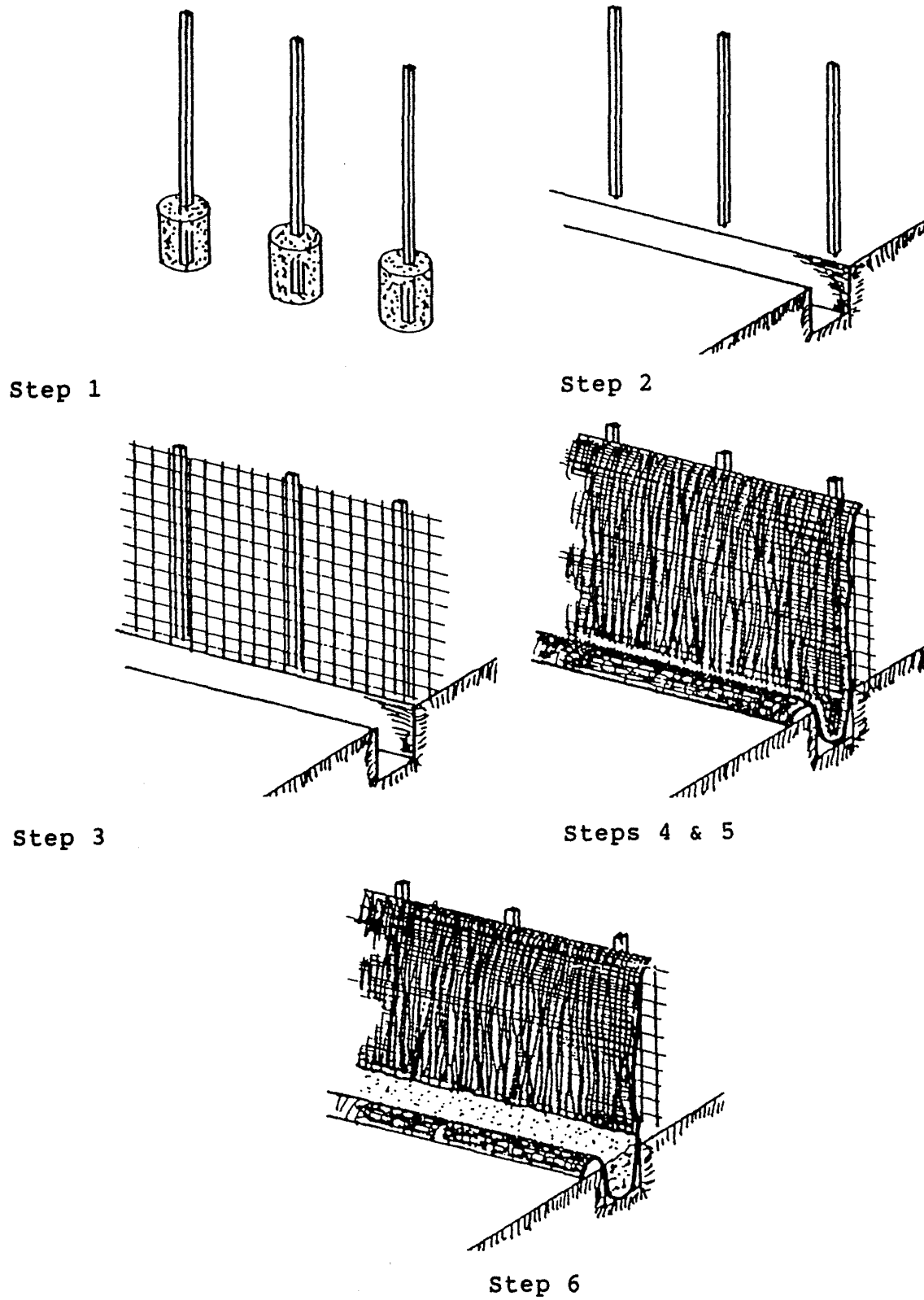

Fig. 4.1 Installation Procedure for Silt Fences  
 (See Text for Description of Individual Steps) 100

5. Bury the lower end of the geotextile in the upstream trench and backfill with natural material, tamping the backfill to provide good anchorage.
6. Silt fences should be checked periodically, especially after a rainfall, and excessive build-ups of sediment must be removed so that the silt fence can continue to function as intended.

For construction of silt curtains, the geotextile forming the curtain is maintained in a vertical position by flotation segments at the top and a ballast along the bottom (Bell and Hicks, 1980). A tension cable is often built into the curtain immediately above or below the flotation segments to absorb stress imposed by currents and other hydraulic forces. Barrier sections are usually about 30 m long and of any required width. Silt curtains can also be constructed within shallow bodies of water using silt fence type construction methods. Geotextiles have also been attached to soldier piles and draped across riprap barriers to perform as semipermanent silt curtains.

The U.S. Army Corps of Engineers (1977) indicate that silt curtains should not be used for:

- A. Operations in open ocean.
- B. Operations in currents exceeding 1 knot.
- C. In areas frequently exposed to high winds and large breaking waves.
- D. Around hopper or cutter head dredges where frequent curtain movement would be necessary.

The field inspector should review the field inspection guidelines in Chapter 1, Section 1.7.

## CHAPTER 5

### USING GEOTEXTILES AS SEPARATORS IN ROADWAYS

#### 5.1 Background

A major cause of failure of roadways constructed over soft foundations is contamination of the aggregate base courses with the underlying soft subgrade soils. Contamination occurs both due to:

- Penetration of the aggregate into the weak subgrade due to localized bearing capacity failure under stresses exerted by the wheel loads, and
- Intrusion of fine-grained soils into the aggregate because of pumping or subgrade weakening due to excess pore water pressures.

The associated subgrade weakening and loss in aggregate thickness result in inadequate structural support which often leads to premature failure of the system. Subgrade stabilization problems most often occur at sites with fine-grained soils (silts and clays) with a high water content, some sensitivity to remolding, and low undrained shear strength. If the ground water table is also at or near the surface, problems during construction can occur.

A geotextile can be placed between the aggregate and the subgrade to act as a separator to prevent the subgrade and aggregate base course from mixing and, thus, maintain the desired design thickness of the roadway. As such, the primary function of the geotextile in roadway applications is separation. The system may also be influenced by secondary functions of the geotextile including filtration, drainage, and reinforcement. The geotextile

acts as a filter to prevent fines from migrating into the aggregate due to high water pressures and as a drain by allowing pore water dissipation in the underlying soil through the geotextile. In addition, the geotextile may provide reinforcement through:

1. Lateral restraint of the base and subgrade through friction between the aggregate, soil and the geotextile,
2. Increase in the bearing capacity of the system by interfering with the incipient bearing capacity failure surface, which forces the failure surface along an alternate surface.
3. A membrane support of the wheel loads.

These mechanisms are also applicable to geogrids when they are used in roadways. However, grids are not able to provide the separation and filtration functions, and therefore they must be used together with a geotextile in roadway applications.

The primary and secondary functions of geotextiles in roadway applications are shown in Fig. 5.1.

These geotextile functions, when considered in the design of roadways over soft subgrades, can lead to several possible cost and performance benefits including:

1. Reducing the intensity of stress on the subgrade and preventing the subbase aggregate from penetrating into the subgrade (function: separation).
2. Preventing subgrade fines from pumping into the subbase (function: separation and filtration).

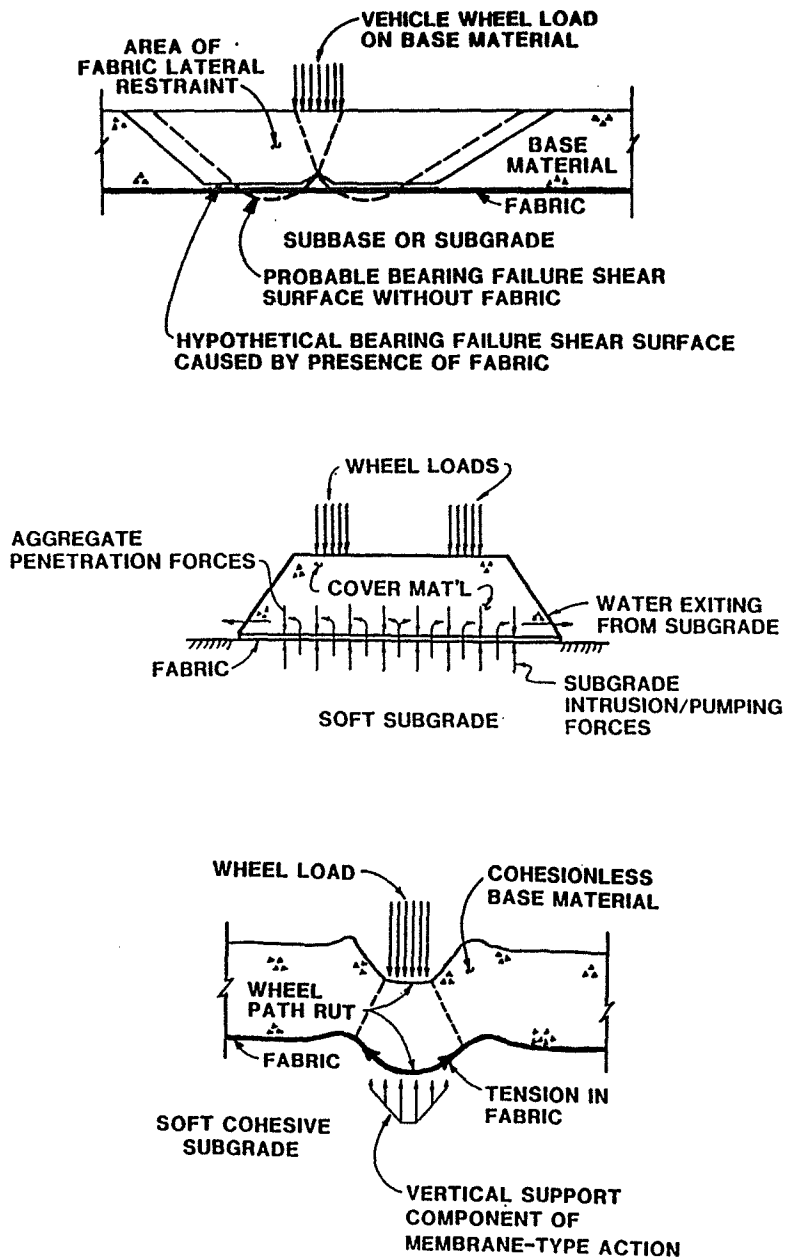

Fig. 5.1 Primary and Secondary Functions of Geotextiles in Roadway Applications

3. Preventing contamination of the subbase materials which may allow more open-graded free draining aggregate to be considered in the design (function: filtration).

4. Reducing the depth of excavation required for removal of unsuitable subgrade materials (function: separation and reinforcement).

5. Reducing aggregate thickness required to stabilize the subgrade (function: separation and reinforcement). (Aggregate reduction in the structural design may or may not be considered.)

6. Providing for less subgrade disturbance during construction (function: separation and reinforcement).

7. Maintaining the integrity and uniformity of the pavement should settlement of the subgrade occur (function: reinforcement). The geotextile does not prevent settlement of the subgrade, but its use can result in more uniform settlement (Boutrup and Holtz, 1983). Geotextiles will also aid in reducing differential settlement in transition areas from cut to fill.

8. Reducing maintenance and extending the life of the pavement (functions: all)

The following sections will discuss geotextile selection and design methodology to take advantage of the above possible benefits.

### 5.2 Applications

On the basis of service life, traffic, or desired performance roads are broadly classified into two categories, permanent and temporary. Permanent roads include both paved and unpaved systems

which are required to remain in service over a number of years, usually 10 or more. Permanent roads may be required to handle well over one million vehicles during the design life of the road (typically more on the order of  $1 \times 10^9$  vehicles). On the other hand, temporary roads, such as haul roads and access roads are, in most cases, unpaved, required to remain in service for short periods of time (usually less than one year) and are usually required to support less than 10,000 vehicles during the life of the system. Temporary roads also include detours, construction platforms, and stabilized working tables required for the construction of permanent roads and embankments over soft subgrades.

One of the most significant geotextile applications is allowing access of construction equipment into sites where the soils are too weak to support the initial construction efforts. It is often the case that even if the finished road section could be supported by the subgrade, there may be no way of actually placing the construction excavation and replacement with select granular materials. Such sites require stabilization through demucking, placement of stabilization aggregate, lime stabilization or other similar expensive operations. Geotextiles can often be a cost-effective alternate to these procedures.

### 5.3 Roadway Design Using Geotextiles

Certain principles are common to all types of roadway systems, regardless of the design method. Basically, the design of any roadway involves a study of each of the components of the system, including the pavement, aggregate base courses and subgrade, as to their behavior under load and their ability when placed in the roadway section to carry that load under various climatic and environmental conditions. All roadway systems, whether permanent or temporary, derive their support from the underlying subgrade. Thus, the geotextile functions are similar for either temporary or



permanent roadway applications. However, due to roadway performance requirements, design methodologies for temporary roads cannot be used to design permanent roads. The main difference in the design is related to the performance requirements. Temporary roadway design usually allows for some rutting to occur over the design life as rutting may not necessarily impair service. Obviously, ruts are not desirable in permanent roadways. Therefore, the design of geotextiles in these two applications will be presented separately.

#### 5.4 Design Guidelines For Temporary Roads

There are two main approaches to design of unpaved roads. The first approach assumes no reinforcing effect of the geotextile; that is, the geotextile acts as a separator only. The second approach does take a possible reinforcing effect of the geotextile into consideration. It appears that the separation function is more important for low embankments with relatively small live loads where ruts, on the order of 2 to 4 in., are anticipated. In these cases, a design which assumes no reinforcing effect is generally conservative. On the other hand, for large live loads on thin embankments where deep ruts (>4 in.) may occur and for higher embankments on softer subgrades, the reinforcing function becomes increasingly more important if stability is to be maintained. It is for these latter cases that analyses considering reinforcing have been developed and appear to be appropriate.

The method presented in these guidelines considers mainly the separation function. It was selected because it can be adapted to a wide variety of conditions. Other design methods considering reinforcing are covered in the FHWA Geotextile Engineering Manual. For roadway embankments where stability of the foundation is questionable, you should refer to Chapter 5 in the Manual and Chapter 7 in these guidelines for information on reinforced embankments.

The design method presented herein was developed by Steward, Williamson and Mohny (1977) for the U.S. Forest Service (USFS). The method allows the designer to consider:

- Number of vehicle passes (up to 10,000)
- Equivalent axle loads
- Axle configurations
- Tire pressures
- Subgrade strengths
- Rut depths

The following limitations apply:

- The aggregate layer must be:
  - a) Compacted to CBR 80
  - b) Cohesionless (non-plastic)
- Vehicle passes are limited to 10,000
- Geotextile survivability criteria must be considered
- Subgrade shear strength as measured by the CBR, less than 3

For subgrades stronger than CBR of 3, geotextiles are rarely required for separation, although they may provide for some drainage and filtration. In this case, the principles developed in Chapter 2 are applicable, just as they are for weaker subgrades.

The design method is based on both theoretical analysis and empirical (laboratory and field) tests. Based on these results, Steward, et al. (1977) determined that a certain amount of rutting would occur under different traffic conditions, both with and without a geotextile separator, for a given stress level acting on the subgrade. They present this stress level in terms of a classical bearing capacity factor. These factors and conditions are given in Table 5-1.

TABLE 5-1

BEARING CAPACITY FACTORS FOR DIFFERENT RUTS  
AND TRAFFIC CONDITIONS BOTH WITH AND WITHOUT  
GEOTEXTILE SEPARATORS

(After Steward, Williamson, and Mohny, 1977)

	Ruts (in.)	Traffic (Passes of 18 kip axle equivs.)	Bearing Capacity Factor, $N_c$
Without Geotextile:	<2	>1000	2.8
	>4	<100	3.3
With Geotextile:	<2	>1000	5.0
	>4	<100	6.0

The following design procedure is recommended:

- Determine the subgrade soil strength in the field using the field CBR test, cone penetrometer, or vane shear test. The undrained shear strength of the soil,  $c$ , can be obtained from the following relationships:

- For field CBR,  $c$  in psi = 4 X CBR.
- For the WES cone penetrometer,  $c$  = cone index divided by 10 or 11.
- For the vane shear test,  $c$  is directly measured

Other in-situ tests such as the Dutch cone penetrometer test (CPT) may be used, provided local correlations with undrained shear strength exist. Use of the Standard Penetration Test (SPT) is not recommended for soft clays.

2. Make the strength determinations at several locations where the soil appears to be the weakest. Strength should be evaluated at a depth of 0 to 9 in. and from 9 to 18 in.; 6 to 10 strength measurements recommended at each location to obtain a good average value.
3. Determine the maximum single wheel load, maximum dual wheel load and the maximum dual tandem wheel load anticipated for the road during the design period. For example, a 10 yd<sup>3</sup> dump truck with tandem axles will have a dual wheel load of approximately 8,000 lb. A motor grader has a wheel load of approximately 5,000 to 10,000 lb.
4. Estimate the maximum amount of traffic anticipated for each design vehicle class.
5. Establish the amount of tolerable rutting during the design life of the roadway. For example, 2 to 3 in. of rutting is generally acceptable during construction.
6. Obtain appropriate subgrade stress level in terms of the bearing capacity factors in Table 5-1.
7. Determine the required aggregate thickness from the USFS design (Figs. 5.2, 5.3, and 5.4) for each maximum loading. Enter the curve with bearing capacity factors ( $N_c$ ) of 2.8, 3.3, 5.0 and 6.0 times the design subgrade undrained shear strength ( $c$ ) to evaluate each required stress level ( $c \cdot N_c$ ).
8. Select the design thickness based on the design requirements. The design depth should be given to the next highest 1 in. thickness as obtained from Step 5.

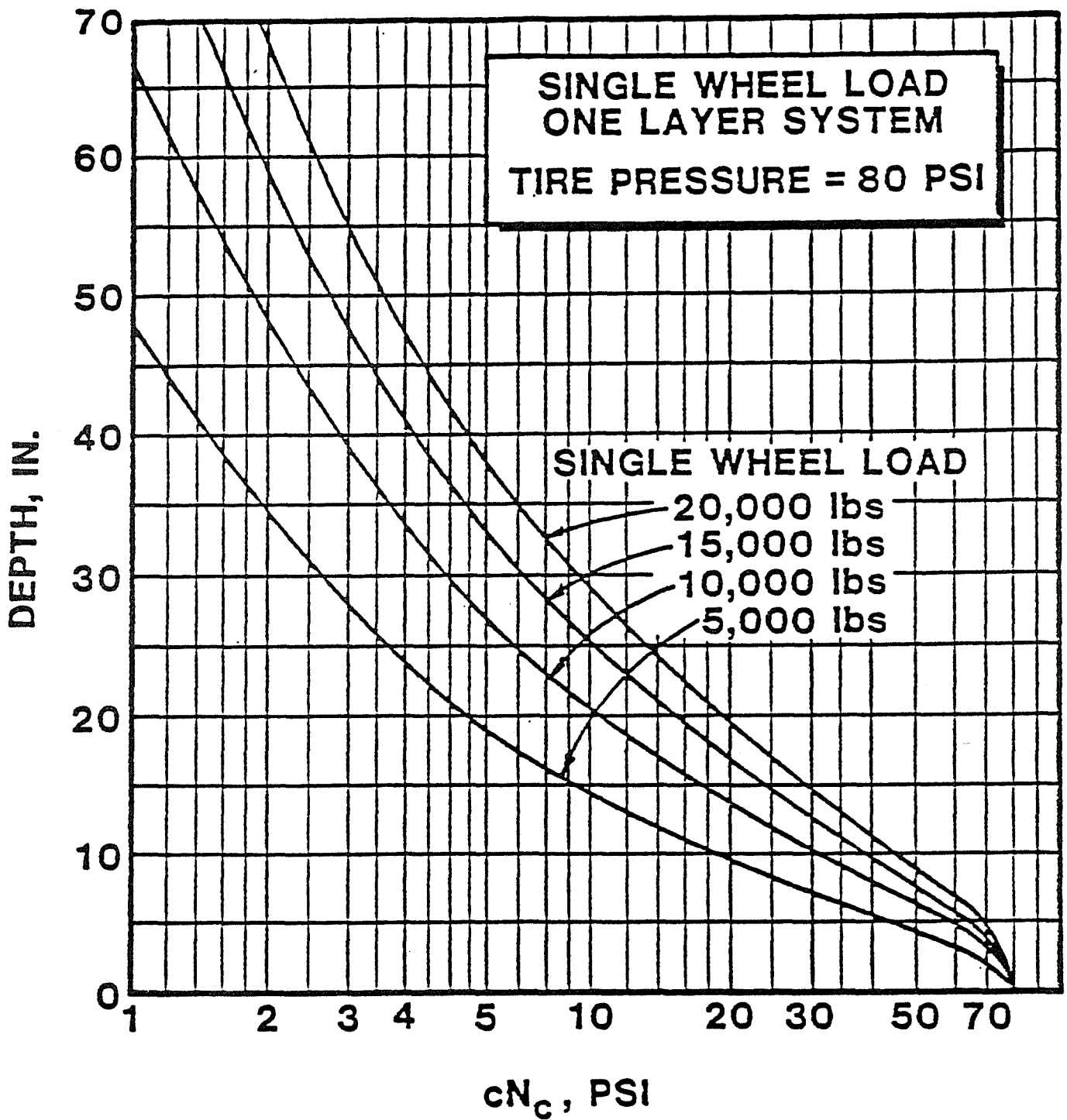

Fig. 5.2 U.S. Forest Service Thickness Design Curve for Single Wheel Load (Stewart, et. al., 1977)

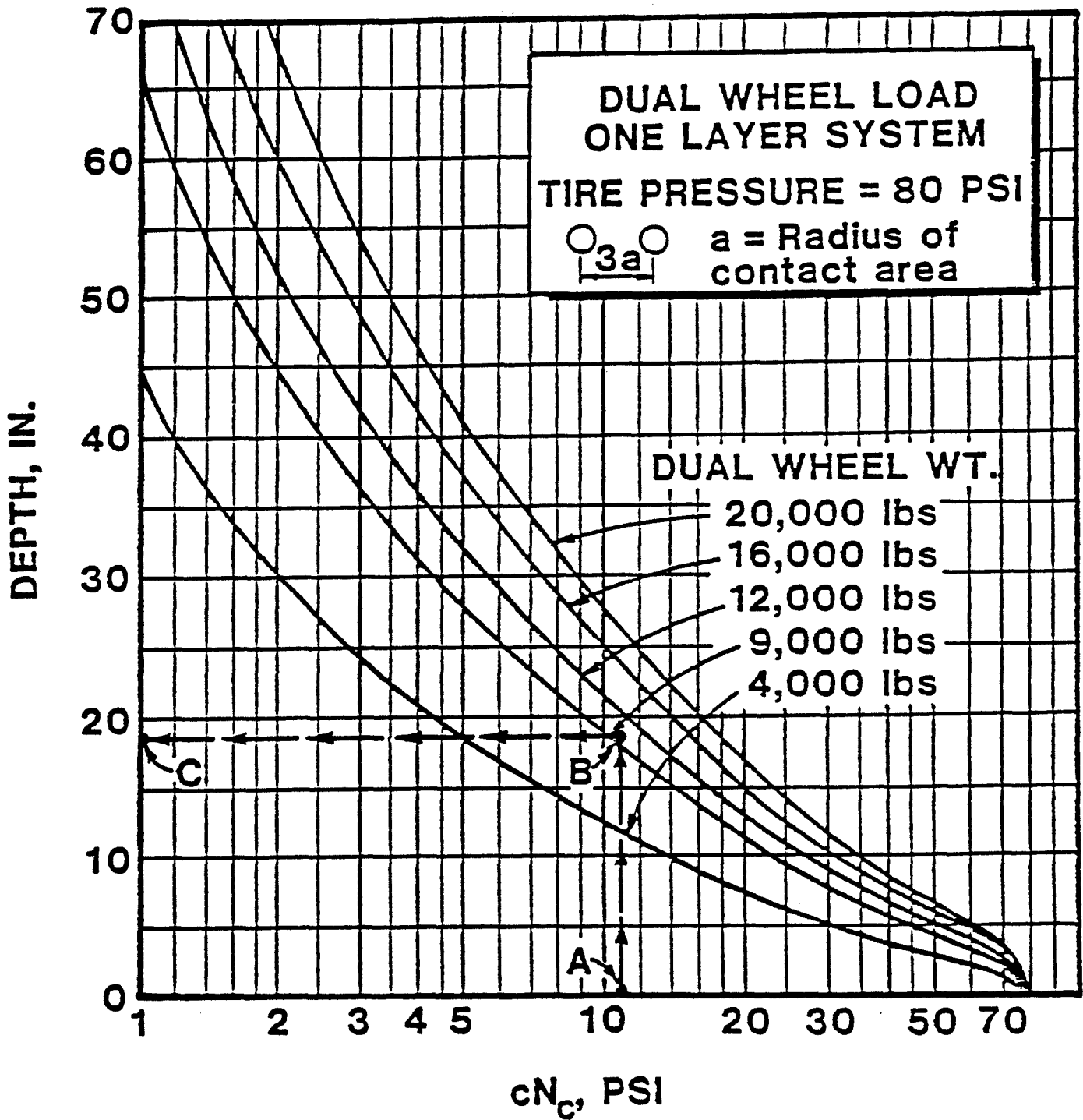

Fig. 5.3 U.S. Forest Service Thickness Design Curve for Dual Wheel Load (Stewart, et. al., 1977)

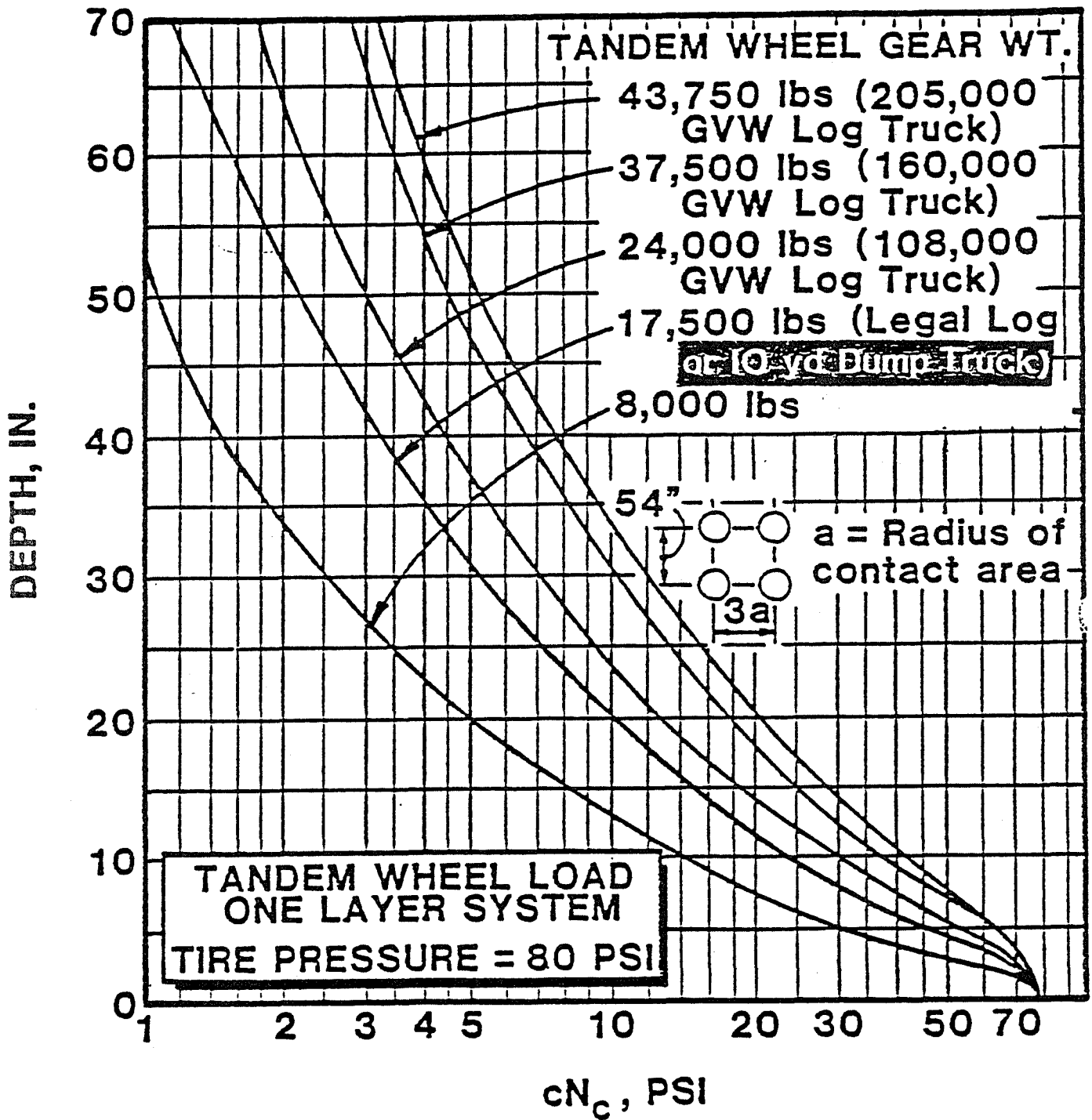

Fig. 5.4 U.S. Forest Service Thickness Design Curve for Tandem Wheel Load (Stewart, et. al., 1977)

9. Check the geotextile drainage and filtration requirements gradation of the subgrade, the permeability of the subgrade, the water table conditions, and the retention and permeability criteria given in Chapter 2. In high water table conditions, filtration criteria may also be required.
10. Check the survivability criteria as discussed in Section 5.7.
11. Specify geotextiles which meet or exceed these criteria.
12. Follow construction recommendations as covered in Section 5.11.

#### 5.5 Design Example

Relevant examples are included in the FHWA publications, "Geotextile Engineering Workshop Design Examples (FHWA-HI-89-002) and Geotextile Engineering Manual FHWA-86-203.

#### 5.6 Design Guidelines For Permanent Roads and Highways

The recommended design methods for permanent roads, as discussed in the FHWA Geotextile Engineering Manual, is based on the following concepts:

1. No structural support is assumed to be provided by the geotextile and therefore no reduction is allowed in aggregate thickness required for structural support.
2. Aggregate savings will be achieved through a reduction in the required stabilization aggregate not used for structural support.
3. Standard methods are used to design the overall pavement system (i.e. AASHTO, CBR, R-value, etc.).



4. The design method is actually used to design the first lift, which is called the "stabilizer lift" since it provides sufficient stabilization to the subgrade to allow access of normal construction equipment for the remaining lifts.
5. Once the stabilizer lift is complete, the construction can proceed normally as per standard road design methods.
6. The method does not include evaluation of settlement or drainage requirements, which must also be considered as in a conventional design.

Basically, the method assumes that the stabilizer lift is actually an unpaved road which will be exposed to relatively few vehicle passes (i.e., construction equipment only) and which can tolerate 2 to 3 in. of rutting under the equipment loads.

The design consists of the following steps:

1. Estimate the need for a geotextile based on the subgrade strength (CBR<3) and by past performance in similar types of soils.
2. Design the roadway for structural support using your normal permanent pavement design methods; provide no allowance for the geotextile.
3. Determine if additional subbase over that required for structural support has been added due to susceptibility of soils to pumping and subbase intrusion. If so, reduce that subbase by 50% and include a geotextile in the design at the subbase/subgrade interface.

4. Determine additional subbase required for stabilization of subgrade during construction activities using a 3 in. rutting criteria for construction equipment and the procedures outlined in Section 5.4, Design Guidelines for Temporary Roads.
5. Compare the subbase geotextile system determined for constructability in Step 4 with the geotextile subbase system determined in Step 3 and use the system with the greatest thickness.
6. Check the geotextile strength requirements for survivability as will be discussed in Section 5.8.
7. Check the geotextile filtration characteristics on the basis of the gradation and permeability of the subgrade, the water table conditions and the retention and permeability criteria given in Chapter 2.
8. Follow installation procedures covered in Section 5.11.

Other design methods for improving the structural capacity of permanent roads using geotextiles (e.g., Hamilton and Pearce, 1981) and geogrids (e.g., Haas, 1986; Haas, et. al., 1988) have been proposed. NCHRP research currently underway at the Georgia Institute of Technology is directed towards answering the remaining questions regarding geosynthetics in permanent roadways.

#### 5.7 Design Example

Relevant examples are included in the FHWA publications, "Geotextile Engineering Workshop Design Examples (FHWA-HI-89-002) and Geotextile Engineering Manual FHWA-86-203.

#### 5.8 Geotextile Survivability

The selection of the geotextile to be used for either permanent or temporary roads is basically the same. If the roadway system is designed correctly, then the stress at the level of the geotextile

due to the weight of the aggregate and the traffic should be not greater than the bearing capacity of the soil, which is relatively low (maximum of 30 psi) for subgrades where geotextiles are used. However, the stresses applied to the subgrade and the geotextile during construction may be well in excess of those applied to the materials in service. Therefore, selection of the geotextile is usually governed by the anticipated construction stresses. This is the concept of geotextile survivability that the geotextile must survive the construction operations if it is to perform its intended function.

Table 5-2 relates the construction elements (i.e. equipment, aggregate characteristics, subgrade preparation and subgrade strength) to the severity of the loading imposed on the geotextile.

If one or more of these items falls with a particular severity category (i.e., low, moderate, or high to very high), then geotextiles meeting these survivability requirements should be considered. However, some judgment is required in using these criteria. For example, if you were going to have a heavy weight dozer operating on a cleared but soft subgrade using coarse, angular aggregate fill in lifts of 12 in., then a moderate to high survivability geotextile probably should be specified.

The strength of the geotextile required to survive the most severe conditions anticipated during construction can then be determined from Table 5-3 provided by Task Force 25. Geotextiles that meet or exceed the survivability requirements could thus be considered acceptable for the project. It is important to realize that these survivability requirements were not based on any systematic research but on the properties of geotextiles which apparently have performed satisfactorily as separators in temporary roads and similar applications. There is currently some question as to the validity of the numbers with current research indicating that elongation may also be a factor. However, in the absence of any

TABLE 5-2

RELATIONSHIP OF CONSTRUCTION ELEMENTS  
TO SEVERITY OF LOADING IMPOSED ON  
GEOTEXTILE IN ROADWAY CONSTRUCTION

CONSTRUCTION SURVIVABILITY RATINGS

SITE SOIL CBR AT INSTALLATION	<1		1-2		>2	
	>50	<50	>50	<50	>50	<50
EQUIPMENT GROUND CONTACT PRESSURE (PSI)						
COVER THICKNESS (IN) <sup>1</sup> (COMPACTED)						
4 <sup>2,3</sup>	NR	NR	H	M	M	M
6	NR	NR	H	H	M	M
12	NR	H	M	M	M	M
18	H	M	M	M	M	M

H - HIGH

M - MEDIUM

NR - NOT RECOMMENDED

<sup>1</sup> Maximum aggregate size not to exceed one half the compacted cover thickness.

<sup>2</sup> For low volume unpaved road (ADT < 200 vehicles)

<sup>3</sup> The four inch minimum cover is limited to existing road bases and not intended for use in new construction.

TABLE 5-3  
Geotextile Strength Required for  
Survivability During Construction

PHYSICAL PROPERTY REQUIREMENTS  
< 50% GEOTEXTILE ELONGATION / >50% GEOTEXTILE ELONGATION<sup>2,3</sup>

SURVIVABILITY LEVEL	GRAB STRENGTH ASTM D 4632 (LBS)	PUNCTURE RESISTANCE ASTM D 4833 (LBS)	TRAPEZOID TEAR STRENGTH ASTM D 4533 (LBS)
HIGH	270/180	100/75	100/75
MEDIUM	180/115	70/40	70/40

ADDITIONAL REQUIREMENTS  
APPARENT OPENING SIZE

TEST METHODS  
ASTM D 4751

1. <50% soil passing a No. 200 US sieve, AOS <0.6 mm.
2. >50% soil passing a No. 200 US sieve, AOS <0.3 mm.

PERMEABILITY

ASTM D 4491

1.  $k$  of the fabric  $>k$  of the soil (permeability times the nominal geotextile thickness).

ULTRAVIOLET DEGRADATION

ASTM D 4355

1. At 150 hours exposure, 70% strength retained for all cases.

GEOTEXTILE ACCEPTANCE

ASTM D 4759

- <sup>1</sup> Values shown are minimum roll average value  
Strength values are in the weaker principle direction
- <sup>2</sup> Elongation as determined by ASTM D 4632.
- <sup>3</sup> The values of geotextile elongation do not imply the allowable consolidation properties of the subgrade soil. These must be determined by a separate investigation.

other information, they can be used as minimum interim values. The user is cautioned to use judgment and experience in selecting final specification values and should verify the geotextile survivability for major projects by conducting field tests under site specific conditions.

These field tests would involve trial sections using several geotextile samples on a couple of typical subgrades at the site, and with different types of construction equipment. After construction, the samples would be exhumed and examined as to how well or how poorly they tolerated the imposed construction stresses. These tests could be done during design or after the contract was let, similarly to what is recommended for riprap placement (Section 3.8, Item 6e). In this case, the contractor is required to demonstrate that the proposed subgrade condition, equipment, and aggregate placement will not damage the geotextile. Then, if necessary, additional subgrade cleaning, increased lift thickness, and/or possibly different construction equipment could be utilized. In rare cases, the contractor may even have to supply a different geotextile.

The geotextile must also be selected so that it will retain the underlying subgrade and so that it will allow the underlying subgrade to freely drain. Thus, the geotextile must be checked using the drainage and filtration requirements discussed previously in Chapter 2 and as summarized in Table 5-4.

## 5.9 Cost Considerations

Once the decision has been made regarding the geotextile requirements, it is important that the minimum required properties be specified in detail so that substitution of fabrics with lower performance properties and lower cost will not occur. Fabric selection based on cost alone will not in most cases provide successful results.

TABLE 5-4

GEOTEXTILE DRAINAGE AND  
FILTRATION REQUIREMENTS

I. RETENTION

Wovens:  $O_{9.5} \leq D_{8.5}$

Nonwovens:  $O_{9.5} \leq 1.8 D_{8.5}$

For both:  $O_{9.5} \geq 0.3 \text{ mm}$  (U.S. No. 50 sieve)

II. PERMEABILITY

$k_{\text{geotextile}} \geq k_{\text{soil}}$

III. CLOGGING

Filtration tests may be warranted in high water table situations. See Section 2.3.3.

Estimation of construction cost and benefit-cost ratios for geotextile-stabilized road construction is straight forward and basically the same as that required for reviewing alternative pavement designs. Primary factors include:

- The geotextile cost
- Cost of constructing the conventional design versus a geotextile design (i.e. stabilization requirements for conventional design versus geotextile design)
  - stabilization aggregate requirements
  - overexcavation and replacement requirements
  - operational and technical feasibility
  - construction equipment and time requirements
- Cost of conventional maintenance during road service life versus improved service anticipated by using geotextile; estimated through pavement management programs.
- Regional past experience

Annual cost formulas such as the Baldock method (Illinois Department of Transportation, 1982) can be used, utilizing an appropriate present worth factor to obtain the present worth of future expenditures.

Cost tradeoffs should also be evaluated for different construction and fabric combinations. This would include subgrade preparation and equipment control versus geotextile survivability. In general, higher cost geotextiles with a higher survivability on the existing subgrade will be less expensive than the additional subgrade preparation cost necessary to use geotextiles with a lower survivability.

#### 5.10 Specifications

Specifications should generally follow the guidelines in Section 1.6. The main considerations include of course the minimum geotextile requirements for design and those obtained from the survivability, retention and filtration requirements in Section 5.8, as well as the construction requirements covered in Section 5.11. As with other applications, it is very important for an engineer's representative to be on site during placement to observe that the correct geotextile has been delivered, that the specified construction sequence is being followed in detail, and that no damage to the geotextile is occurring. The following guide specification from AASHTO-AGC-ARTBA Task Force 25 is an example.



GUIDE SPECIFICATION FOR GEOTEXTILES IN SEPARATION APPLICATIONS -  
MAY 1989

1. DESCRIPTION

1-1 This work shall consist of furnishing, and placing a geotextile for use as a permeable separator to prevent mixing of dissimilar materials such as subgrades and surfaced and unsurfaced pavement structures, zones in embankments, foundations and select fill materials. The geotextile shall be designed to allow passage of water while retaining in-situ soil without clogging. This specification does not address reinforcement applications which require an engineered design.

2. MATERIALS

2.1 Fibers used in the manufacture of geotextiles, and the threads used in joining geotextiles by sewing, shall consist of long chain synthetic polymers, composed of at least 85% by weight polyolefins, or polyesters. Both the geotextile and threads shall be resistant to chemical attack, mildew, and rot. These materials, based on construction survivability conditions listed in Table 1, shall conform to the physical requirements of Table 2.

3. CONSTRUCTION METHODS/REQUIREMENTS

3.1 Geotextile Packaging and Storing - The geotextile rolls shall be furnished with suitable wrapping for protection against moisture, and extended ultra-violet exposure prior to placement. Each roll shall be labeled or tagged to provide product identification sufficient for field identification as well as inventory and quality control purposes. Rolls shall be stored in a manner which protects them from the elements. If stored outdoors, they shall be elevated and protected with a waterproof cover.

3.2 Geotextile Exposure Following Placement - Exposure of geotextiles to the elements between lay down and cover shall be a maximum of 14 days to minimize damage potential.

3.3 Site Preparation - The installation site shall be prepared by clearing and grading the area as required. Remove all sharp objects, large stones, and cut trees and shrubs flush with the subgrade. Removal of top soil and vegetation mat is not necessary.

REMARK

When appropriate, soft spots and unsuitable areas shall be identified during site preparation or subsequent proof rolling. These areas shall be excavated and backfilled with select material which is compacted to a depth such that the area provides equal stability as the adjacent area. Stabilization of these areas may be enhanced by use of a geotextile at the bottom of the excavation before backfill. Other applications may require less site preparation than indicated here. Survivability conditions in these instances are outside the scope of this document.

- 3.4 Installation - The geotextile shall be unrolled as smoothly as possible on the prepared subgrade in the direction of construction traffic. Adjacent geotextile rolls shall be overlapped in the direction of subbase placement using the guidelines in Table 3. Sewing is recommended where subgrade soils have a CBR <1. The geotextile may be held in place prior to subbase placement by pins, staples, or piles of fill or rock. On curves, the geotextile may be folded or cut to conform to the curve as illustrated in Figure 1. The fold or overlap shall be in the direction of construction and held in place as prescribed above.
- 3.5 Sewn or Sealed Seams - Both factory and field sewn or sealed seams shall conform to the strength requirements of Table 2. All seams shall be subject to approval of the Engineer.
- 3.6 Subbase Placement - The subbase shall be placed by end dumping onto the geotextile from the edge of the geotextile, or over previously placed subbase aggregate. On subgrades having a < CBR 1, the subbase aggregate should be spread simultaneously with dumping to minimize the potential of a localized subgrade failure. Where possible avoid traffic directly on the geotextile along with any sudden stops, starts, or turns on the subbase material by construction equipment. Using a motor grader or bulldozer, spread the subbase material from the back-dumped pile. Except in the case of low volume roads as defined in Table 1, maintain a minimum lift thickness of six inches. Use a smooth drum roller to achieve the specified density. Any ruts occurring during construction shall be filled with additional subbase material and compacted to the specified density.

REMARK

Use of vibratory compaction is not recommended with initial lifts of subbase material as it may cause damage to the geotextile.

3.7 Damage Repair - Damaged geotextiles, as identified by the Engineer, shall be repaired immediately. Clear the damaged area plus an additional three feet around the damaged area of all fill material. Cover the damaged area with a geotextile patch extending three feet beyond the perimeter of the damage. Replace the removed subbase material compacting to the specified density.

4. METHOD OF MEASUREMENT

4.1 The geotextile shall be measured by the number of square yards from the payment lines shown on the plans, or from the payment lines established in writing by the Engineer. This excludes seam overlaps.

4.2 Excavation, backfill, bedding, and cover material are separate pay items.

5. BASIS OF PAYMENT

5.1 The accepted quantities of geotextile shall be paid for at the contact unit price per square yard in place.

5.2 Payment shall be made under:

Pay Item	Pay Unit
Separation Geotextile	Square Yard

**TABLE 1**  
**CONSTRUCTION SURVIVABILITY RATINGS**

SITE SOIL CBR AT INSTALLATION	<1		1-2		>2	
	>50	<50	>50	<50	>50	<50
EQUIPMENT GROUND CONTACT PRESSURE (PSI)	>50	<50	>50	<50	>50	<50
COVER THICKNESS (IN) <sup>1</sup> (COMPACTED)						
4 <sup>2,3</sup>	NR	NR	H	M	M	M
6	NR	NR	H	H	M	M
12	NR	H	M	M	M	M
18	H	M	M	M	M	M

H - HIGH

M - MEDIUM

NR - NOT RECOMMENDED

- <sup>1</sup> Maximum aggregate size not to exceed one half the compacted cover thickness.
- <sup>2</sup> For low volume unpaved road (ADT < 200 vehicles)
- <sup>3</sup> The four inch minimum cover is limited to existing road bases and not intended for use in new construction.

TABLE 2  
Geotextile Strength Required for  
Survivability During Construction

PHYSICAL PROPERTY REQUIREMENTS  
< 50% GEOTEXTILE ELONGATION / >50% GEOTEXTILE ELONGATION<sup>2,3</sup>

SURVIVABILITY LEVEL	GRAB STRENGTH ASTM D 4632 (LBS)	PUNCTURE RESISTANCE ASTM D 4833 (LBS)	TRAPEZOID TEAR STRENGTH ASTM D 4533 (LBS)
HIGH	270/180	100/75	100/75
MEDIUM	180/115	70/40	70/40

ADDITIONAL REQUIREMENTS  
APPARENT OPENING SIZE

TEST METHODS  
ASTM D 4751

1. <50% soil passing a No. 200 US sieve, AOS <0.6 mm.
2. >50% soil passing a No. 200 US sieve, AOS <0.3 mm.

PERMEABILITY

ASTM D 4491

1.  $k$  of the fabric  $>k$  of the soil (permeability times the nominal geotextile thickness).

ULTRAVIOLET DEGRADATION

ASTM D 4355

1. At 150 hours exposure, 70% strength retained for all cases.

GEOTEXTILE ACCEPTANCE

ASTM D 4759

- <sup>1</sup> Values shown are minimum roll average value  
Strength values are in the weaker principle direction
- <sup>2</sup> Elongation as determined by ASTM D 4632.
- <sup>3</sup> The values of geotextile elongation do not imply the allowable consolidation properties of the subgrade soil. These must be determined by a separate investigation.

Figure 1

**FORMING CURVES USING GEOTEXTILES**

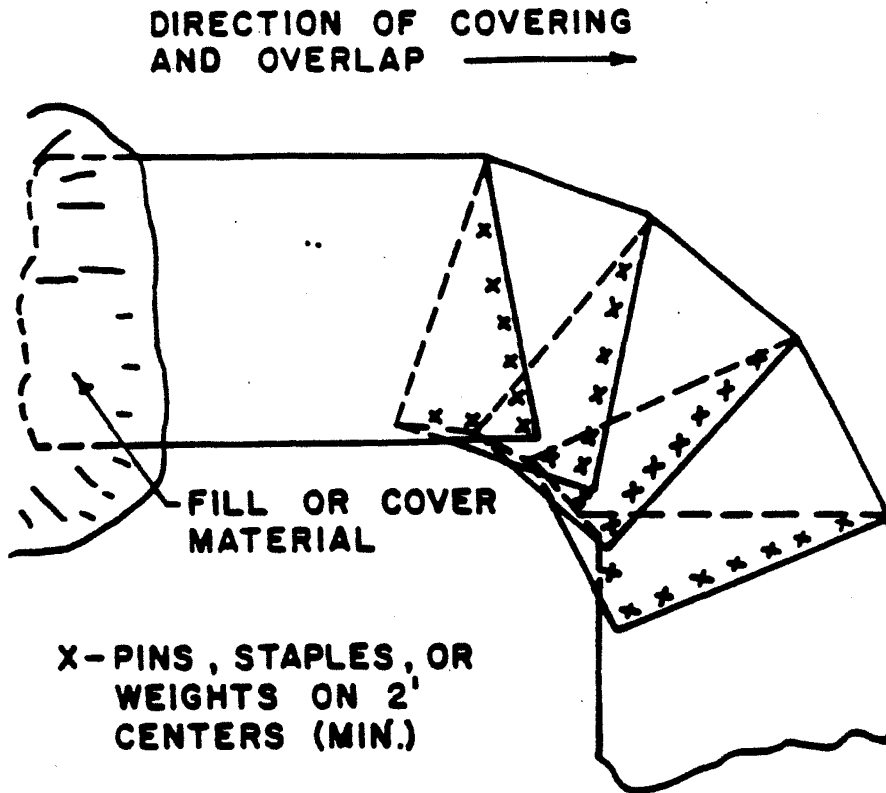

**FORMING A CURVE USING FOLDS**

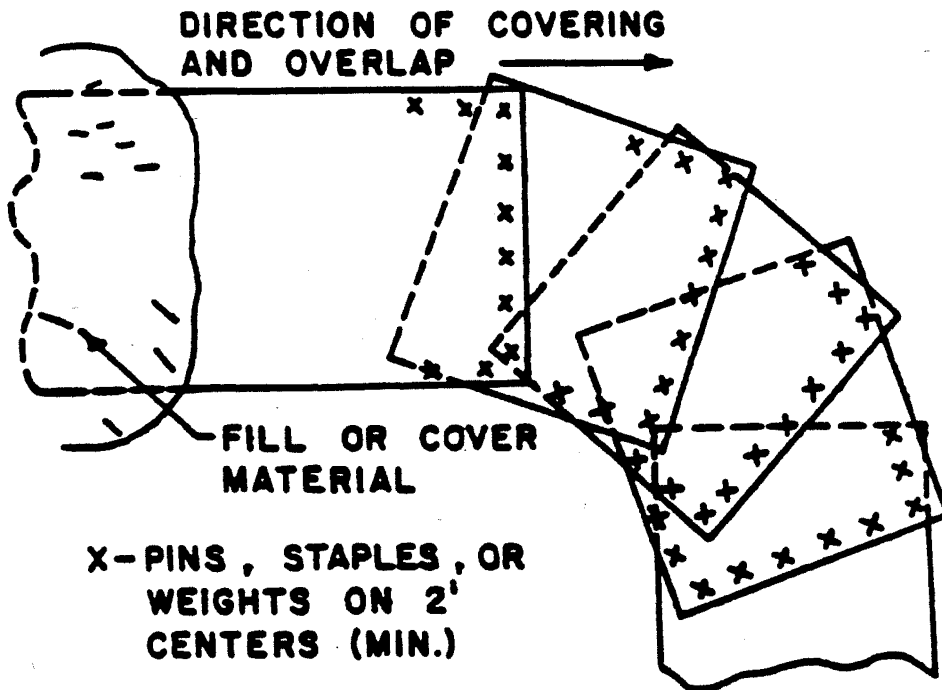

**FORMING A CURVE USING CUT PIECES**

## 5.11 Installation Procedures

Successful use of geotextiles in roadways requires proper installation. Figure 5.6 shows the proper sequence of construction when using geotextiles. Even though the installation techniques appear fairly simple, a majority of the problems with geotextiles in roadways have occurred as the result of improper construction techniques. If the geotextile is ripped or punctured during construction activities, it will not likely perform as desired. If the geotextile is placed with a lot of wrinkles or folds, it will not be tensioned, and therefore will not provide any reinforcing effect. Other problems occur due to insufficient cover over the fabric, rutting of the subgrade prior to placing the fabric, and placing lift thicknesses such that the bearing capacity of the soil is exceeded. The following step-by-step procedures should be followed, along with good engineering observations of all construction activities.

1. The site should be cleared, grubbed, and excavated to design grade, taking care to strip all topsoil, soft soils, or any other unsuitable materials (Fig. 5.6a). If moderate site conditions exist, i.e., CBR greater than 1, lightweight proofrolling operations should be considered to aid in locating unsuitable materials to be removed. Isolated pockets where overexcavation is required should be pitched and backfilled so as to promote positive drainage. Optionally, special drain tiles with outlets installed to drain these isolated areas could be used.
2. During stripping operations, care should be taken not to disturb the subgrade. This may require the use of lightweight dozers or grade-alls for low strength, saturated noncohesive and low cohesive soils. For extremely soft ground, such as peat bog areas,

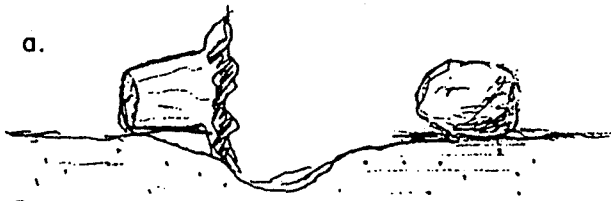

1. PREPARE THE GROUND BY REMOVING STUMPS, BOULDERS, ETC.; FILL IN LOW SPOTS.

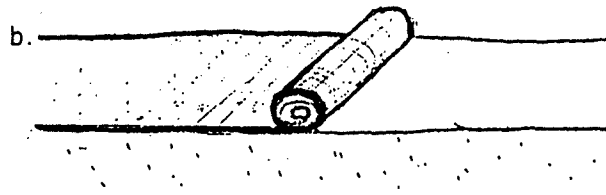

2. UNROLL THE GEOTEXTILE DIRECTLY OVER THE GROUND TO BE STABILIZED. IF MORE THAN ONE ROLL WIDTH IS REQUIRED, OVERLAP ROLLS. INSPECT GEOTEXTILE.

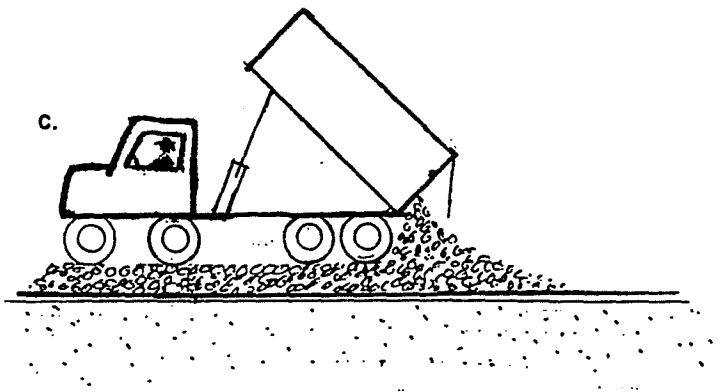

3. BACK DUMP AGGREGATE ONTO PREVIOUSLY PLACED AGGREGATE. DO NOT DRIVE DIRECTLY ON THE GEOTEXTILE. MAINTAIN AT LEAST 6" TO 1' COVER BETWEEN TRUCK TIRES AND GEOTEXTILE.

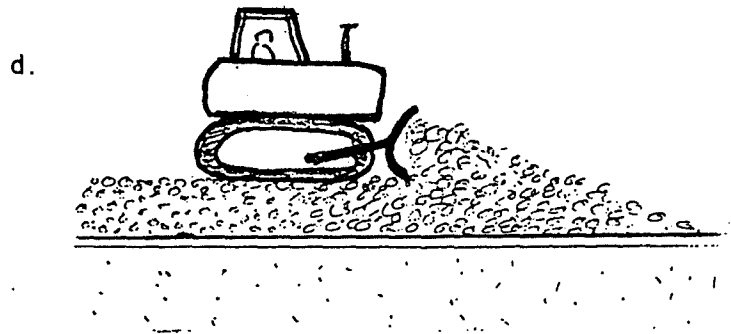

4. SPREAD THE AGGREGATE OVER THE GEOTEXTILE TO THE DESIGN THICKNESS.

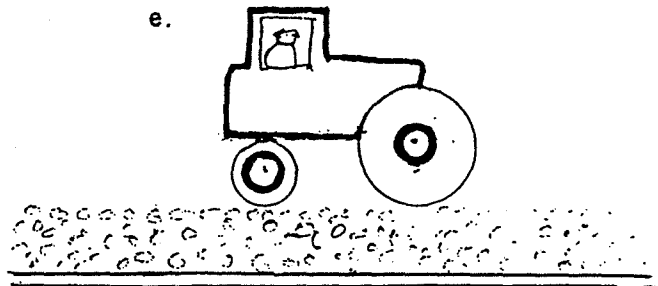

5. COMPACT THE AGGREGATE USING DOZER TRACKS OR VIBRATORY ROLLER.

Fig. 5.6 Construction Sequence Using Geotextiles



consideration should be given to not overexcavate the surface materials such that advantage can be taken of the root mat, if it exists. In this case, all vegetation should be cut off square at the ground surface. Sawdust or sand can be placed over stumps or roots that extend above the ground surface to cushion the geotextile. Remember, the subgrade preparation must correspond to the survivability properties of the geotextile.

3. Once the subgrade along a particular segment of the road alignment has been prepared, the geotextile should be rolled in line with the placement of the new roadway aggregate (Fig. 5.6b). Field operations can be expedited if the geotextile is pre-sewn in the factory to design widths such that it can be unrolled in one continuous sheet. The geotextile should not be dragged across the subgrade. The entire roll should be placed and rolled out as smoothly as possible. Wrinkles and folds in the fabric should be removed by stretching and staking as required.
4. Parallel rolls of geotextiles should be overlapped, sewn or tied as required. Specific requirements are reviewed in detail later in the section.
5. For curves, the geotextile should be folded or cut and overlapped in the direction of the turn (previous fabric on top)(Fig. 5.5). Folds in the geotextile should be stapled or pinned 5 ft on center.
6. When geotextile intersects an existing pavement area, the fabric should extend to the edge of the old system. For widening or intersecting existing roads where fabric has been used, consideration should be given to

anchoring the fabric at the roadway edge. Ideally, the edge of the roadway should be excavated down to the existing fabric and the existing fabric sewn to the new fabric. Overlaps, staples, and pins could also be utilized.

7. Before covering, the condition of the geotextile should be observed by a qualified inspector experienced in the use of these materials to determine that no holes, rips, tears, etc., have occurred in the fabric. If any defects are observed, the section of the fabric containing the defect should be repaired by placing a new layer of fabric extending beyond the defect in all directions a minimum of the overlap required for parallel rolls. Alternatively, the defective section can be replaced.
8. The subbase aggregate should be end-dumped on the fabric from the edges of the fabric or on the previously placed aggregate (Fig. 5.6c). For very soft subgrades, pile heights should be limited to prevent possible subgrade failure. The maximum placement lift thickness for such soils should not exceed the design thickness of the road.
9. The first lift of aggregate should be spread and graded down to 12 in. or to the design thickness if less than 12 in. prior to compaction (Fig. 5.6d). At no time should equipment be allowed on the road with less than 8 in. (6 in. for  $CBR \geq 2$ ) of compacted aggregate over the fabric. For extremely soft soils, lightweight construction vehicles will likely be required for access on the first lift. Construction vehicles should be limited in size and weight such that rutting in the initial lift is no greater than 3 in. If rut depths

exceed 3 in., it will be necessary to decrease the size and/or weight of the construction vehicles or to increase the lift thickness. For example, it may be necessary to reduce the size of the dozer required to blade out the fill or possibly to deliver the fill in half-loaded rather than fully loaded trucks.

10. The first lift of subbase aggregate should be compacted by "tracking" with the dozer and then compacted with a smooth-drum vibratory roller to obtain a minimum compacted density (Fig. 5.6e). For very soft soils, design density should not be anticipated for the first lift and in this case, compaction requirements should be reduced. One possible recommendation would be to allow compaction of 5% less than the required specification density.
11. Construction should be performed parallel to the road alignment. Turning should not be permitted on the first lift of subbase aggregate. Turn-outs may be constructed at the road edge to facilitate construction.
12. If the geotextile is to provide some reinforcing, pretensioning of the fabric should be considered. For pretensioning, the area should be proof-rolled by a heavily loaded rubber-tired vehicle such as a loaded dump truck. The wheel load should be equivalent to the maximum expected for the site. The vehicle should make at least four passes over the first lift in each area of the site. Alternatively, once the design aggregate has been placed, the roadway could be used for a time prior to paving such that prestressing the fabric in key areas could be obtained.

13. Any ruts that form during construction should be filled in as shown on Fig. 5.7 to maintain adequate cover over the fabric. In no case should ruts be bladed down as this would decrease the amount of aggregate cover between the ruts.
  
14. All remaining subbase aggregate should be placed in lifts not exceeding 9 in. in loose thickness and compacted to the appropriate specification density.

#### 5.11.1 Overlaps

Overlaps can be used to provide continuity between adjacent geotextile rolls, through frictional resistance between the overlaps. Also, a sufficient overlap is required to prevent soil from squeezing into the aggregate at the fabric joint. The amount of overlap depends primarily on the soil conditions and the potential for equipment to rut the soil. If the subgrade will not rut under construction activities, only a minimum overlap sufficient to provide some pullout resistance is required. As the potential for rutting and squeezing of soil increases, the required overlap increases. Since rutting potential can be related to CBR, it can be used as a guideline for the minimum overlap required, as shown in Table 5-5.

TABLE 5-5

Recommended Minimum Overlap Requirements

<u>CBR</u>	<u>Minimum Overlap</u>
Greater than 2	1 - 1.5 ft
1 - 2	2 - 3 ft
0.5 - 1	3 ft or sewn
Less than 0.5	Sewn
All roll ends	3 ft or sewn

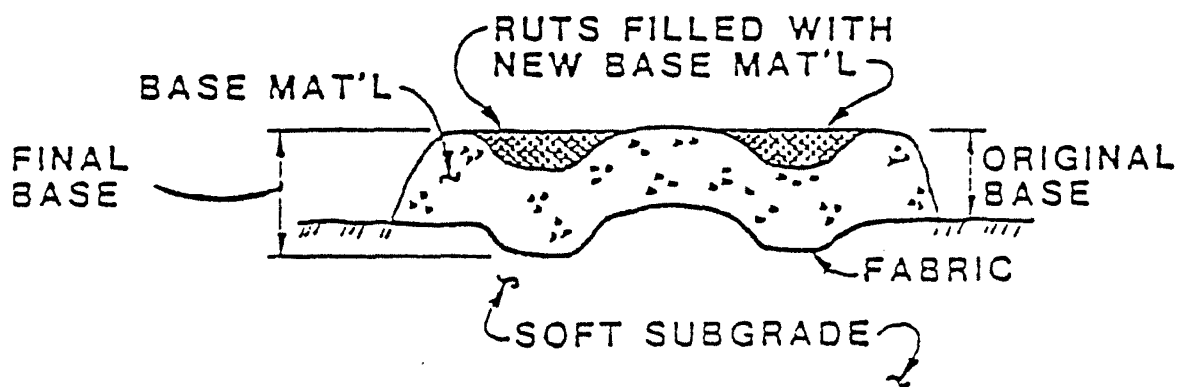

Fig. 5.7 Repair of Rutting with Additional Base Material

The geotextile can be stapled or pinned at the overlaps to maintain them during construction activities. Ten to 12 in. long nails should be placed at a minimum of 50 ft on centers for parallel rolls and 5 ft on centers for roll ends.

Fabric widths should be selected such that overlaps of parallel rolls occur at the center line and at the shoulder. Overlaps should not be placed along anticipated main wheel path locations.

Overlaps at the end of rolls should be in the direction of the aggregate placement (previous roll on top).

#### 5.11.2 Seams

When seams are required for separation applications, it is recommended that the seams meet the same tensile strength requirements for survivability as required for the geotextile, Table 5-3 in the direction perpendicular to the seam (as determined by the same testing methods). (Seaming IS discussed in detail in Chapter 1). All factory or field seams should be sewn with thread having the same or greater durability and strength as the material in the fabric. "J-seams" with interlocking stitches are recommended. Alternatively, if bag-type stitches, which can unravel, or butt-type seams are used, seams should be double-sewn with parallel stitching spaced no more than 1/4 to 1/2 in. apart. Double sewing is required to provide a safety factor against undetected missed stitches. The strength of the geotextile may actually have to be greater than specified, in order to provide seam strengths equal to the specified tensile strength.

For certain types of geotextiles, such as nets, webs, and grids, tying or interlocking with wire cables, plastic pipe, etc. may be required. Consult the manufacturer.

## 5.12 Field Inspection

The field inspector should review the field inspection guidelines in Chapter 1, Section 1.7. Particular attention should be paid to the factors that affect geotextile survivability: subgrade condition, aggregate placement, lift thickness, and equipment operations.

## 5.13 Selection Considerations

For the geotextile to perform its intended function as a separator in roadways, it must be able to tolerate the stresses imposed on it during construction; i.e., the geotextile must have sufficient survivability to survive the anticipated construction operations. Geotextile selection for roadways is usually controlled by survivability and the guidelines given in Section 5.8 are most important in this regard. As mentioned, the specific geotextile property values given in Table 5-3 have been questioned and are subject to revision. In the meantime, for important projects, you are strongly encouraged to conduct your own field trials, as described in Section 5.8.

## CHAPTER 6

### PAVEMENT OVERLAYS

#### 6.1 Background and Application

Geotextiles can be used as alternatives to stress relieving layers, seal coats, rubberized asphalts, etc., in retarding reflection cracks and controlling surface moisture infiltration in pavement overlay applications. Properly installed, geotextiles provide a moisture barrier that protects the underlying pavement structure from further degradation. In addition, the fabric may provide reinforcement to the overlay which is characteristically weak in tension. The reinforcement mechanism is not well understood at this time and there is some indication that the reflection crack is retarded by a cushioning effect, providing stress relief as opposed to or in combination with reinforcement. The period of retardation may or may not be significant, however, even after the cracks reflect to the surface, the geotextile will continue to provide a moisture barrier. Regardless of the mechanisms, fabrics used under the right conditions and installed correctly will retard reflection cracking in flexible pavement systems and provide a moisture barrier.

After a pavement cracks, its longevity is quickly reduced due to water infiltration and other environmental factors. Water infiltration causes a reduction in shear strength and the subgrade which in turn leads to a rapid deterioration of the roadway system. The sealing function of the asphalt impregnated geotextile is intended to reduce the surface water infiltration even after the cracks reappear at the surface of the overlay.

The right conditions refer to the condition of the asphalt, cause of the original distress, and climatic conditions. Geotextiles have been found effective in controlling alligator cracking,



random cracking and longitudinal joint cracks in flexible pavements. Geotextiles have also been found effective when used in conjunction with "cracking and seating" of rigid pavements.

Geotextiles cannot be expected to perform when the roadway systems are structurally inadequate. Nor will such surface treatments do anything to solve a ground water problem which is causing subgrade softening and base course contamination. Surface treatments cannot be expected to solve freeze-thaw problems. These problems must be corrected before resurfacing, whether or not a geotextile is used. Geotextiles have also been found ineffective in reducing thermal cracking.

Pavement overlay systems have also had limited success in areas of heavy rainfall and heavy freeze-thaw regions (FHWA Manual, 1982). In fact, if the tack coat is not properly applied and the geotextile absorbs moisture, the fabric itself could lead to spalling or "popping off" of the surface treatment due to freeze-thaw action within the fabric.

To obtain a successful project, carefully controlled construction procedures must be followed including:

- Pavement surface preparation
- Tack coat application
- Fabric placement
- Asphaltic wear surface application

Items that influence the operation include ambient temperature at the time of placement of asphalt, the rate of tack coat application, the condition and texture of the pavement to be overlain, and careful placement of the fabric such that wrinkles and folds do not occur. The recommended design and construction considerations are included in the following specification section.

## 6.2 Specifications: Geotextile Considerations and Installation Procedures

Specific geotextile considerations, physical property requirements and construction procedures are detailed in a specification prepared by the AASHTO-AGC-ARTBA Task Force 25 and are included herein. The specification was based on experience of the Texas and California Department of Transportations, which have had the most success in using geotextiles in pavement overlays.

AASHTO-AGC-ARTBA  
TASK FORCE NO. 25  
SPECIFICATIONS FOR PAVING FABRICS  
(JANUARY 13, 1987)

### 1. Description

Work shall consist of furnishing and placing a fabric between pavement layers for the purpose of incorporating a waterproofing and stress relieving membrane within the pavement structure. This specification guide is applicable to fabric membranes used for full coverage of the pavement, or as strips over transverse and longitudinal pavement joints. It is not intended to describe membrane systems specifically designed for pavement joints and localized (spot) repairs.

### 2. Materials

2.1 Paving Fabric - The fabric used with this specification shall be constructed of nonwoven synthetic fibers; resistant to chemical attack, mildew, and rot; and shall meet the following physical requirements:

<u>Property</u>	<u>Requirements</u>	<u>Task Method</u>
Tensile Strength, lbs.	80 minimum*	ASTM D-4632
Elongation-at-break, %	50 minimum	ASTM D-4632
Asphalt Retention, gal./sq. yd.	0.2 minimum	Task Force 25 Method 8
Melting Point, degrees F	300 or greater	ASTM D-276

\*Minimum - Value in weaker principal direction. All numerical values represent minimum average roll values (i.e., any roll in a lot shall meet or exceed the minimum values in the table).

2.2 Asphalt Sealant - The material used to impregnate and seal the fabric, as well as bond it to both the base pavement and overlay, shall be a paving grade asphalt recommended by the fabric manufacturer and approved by the engineer.

Uncut asphalt cements are the preferred sealant; however, cationic and anionic emulsions may be used provided the precautions outlined in Section 4.4 are followed. Cutbacks and emulsions which contain solvents shall not be used.

#### REMARKS

The grade of asphalt cement specified for hot-mix design in each geographic location is generally the most acceptable material.

2.3 Aggregate - Washed concrete sand may be spread over asphalt-saturated fabric to facilitate movement of equipment during construction or to prevent tearing or delamination of the fabric. Hot-mix broadcast in front of construction vehicle tires may also be used to serve this purpose. If sand is applied, excess quantities shall be removed from the fabric prior to placing the surface course.

#### REMARKS

Sand is not usually required. However, ambient temperatures are occasionally sufficiently high to cause bleed-through of the asphalt sealant resulting in undesirable fabric adhesion to construction vehicle tires.

### 3. Equipment

3.1 Asphalt Distributor - The distributor shall be capable of spraying the asphalt sealant at the prescribed uniform application rate. No streaking, skipping or dripping will be permitted. The distributor shall be also equipped with a hand spray having a single nozzle and positive shut-off valve.

3.2 Fabric Handling Equipment - Mechanical or manual laydown equipment shall be capable of laying the fabric smoothly.

3.3 Miscellaneous Equipment - Stiff bristle brooms or squeegees to smooth the fabric, scissors or blades to cut the fabric, and brushes for applying asphalt sealant at fabric overlaps shall be provided. Pneumatic rolling equipment to smooth the fabric into the sealant and sanding equipment may be required for certain jobs.

#### REMARKS

Rolling is especially required on jobs where thin lifts or chip seals are being placed. Rolling helps ensure fabric to adjoining pavement layers in the absence of the heat and weight associated with thicker lifts of asphaltic pavement. An example of when rolling is extremely important is when the ambient temperature is so low that the normal wicking of the asphalt sealant into the fabric does not occur.

#### 4. Construction Methods/Requirements

4.1 Fabric Packaging and Storing - Fabric rolls shall be furnished with suitable wrapping for protection against moisture and extended ultra-violet exposure prior to placement. Each roll shall be labeled or tagged to provide product identification sufficient for inventory and quality control purposes. Rolls shall be stored in a manner which protects them from the elements. If stored outdoors, they shall be elevated and protected with a waterproof cover.

4.2 Weather Limitations - Neither the asphalt sealant nor fabric shall be placed when weather conditions, in the opinion of the engineer, are not suitable. Air and pavement temperatures shall be sufficient to allow the asphalt sealant to hold the fabric in place. For asphalt cements, air temperatures shall be 50°F and rising. When using asphalt emulsions, air temperature shall be 60°F and rising.

4.3 Surface Preparation - The surface on which the fabric is to be placed shall be reasonably free of dirt, water, vegetation, or other debris. Cracks exceeding 1/8 inch in width shall be filled with a suitable crack filler and potholes shall be properly repaired as directed by the engineer. The crack fillers shall be allowed to cure prior to fabric placement.

#### REMARKS

If the condition of the existing pavement is such that a simple crack fill operation is not adequate for surface preparation, then it may be more economical to place a leveling course prior to placing the fabric.

4.4 Application of Asphalt Sealant - The asphalt shall be uniformly spray applied to the prepared dry pavement surface at the rate 0.20 to 0.30 gallons per square yard or as recommended by the fabric manufacturer and approved by the engineer.

Application of the sealant shall be the distributor spray bar, with hand spraying kept to a minimum. Temperature of the asphalt sealant shall be sufficiently high to permit a uniform spray pattern.

For asphalt cements, the minimum temperature shall be 290°F. To avoid damage to the fabric, however, distributor tank temperatures shall not exceed 325°F. Spray patterns for asphalt emulsion are improved by heating. Temperatures in the 130 to 160°F range desirable. A temperature of 160°F shall not be exceeded since higher temperatures may break the emulsion.

The target width of asphalt sealant application shall be fabric width plus 6 inches. The asphalt sealant shall not be applied any farther in advance of fabric placement than the contractor can maintain free of traffic.

Asphalt spills shall be cleaned from the road surface to avoid flushing and fabric movement.

When asphalt emulsions are used, the emulsion shall be cured (essentially no moisture remaining) prior to placing the fabric and final wearing surface.

#### REMARKS

The rate specified must be sufficient to satisfy the asphalt retention properties of the fabric and bond the fabric and overlay to the old pavement. In order to account for the variables in pavement texture and precision of distributor truck operation, a rate of at least 0.20 gallons per square yard should be specified. Rough and raveled surfaces may require a higher application rate. Within street intersections, on steep grades or in other zones where vehicle speed changes are commonplace, the normal application rate should be reduced by about 20 percent, but no less than 0.20 gallons per square yard or as specified by the manufacturer. NOTE: When using emulsions, the application rate must be increased to offset water content of the emulsion.

4.5 Fabric Placement - The fabric shall be placed into the asphalt sealant with minimum wrinkling prior to the time the asphalt has cooled and lost tackiness. As directed by the engineer, wrinkles or folds in excess of 1 inch shall be slit and laid flat. Brooming and/or pneumatic rolling will be required to maximize fabric contact with the pavement surface.

Overlap of the fabric joints shall be sufficient to ensure full closure of the joint, but should not exceed 6 inches. Transverse joints shall be lapped in the direction of paving to prevent edge pickup by the paver. A second application of asphalt sealant to fabric overlaps will be required if in the judgment of the engineer additional asphalt sealant is needed to ensure proper bonding of the double fabric layer.

Removal and replacement of fabric that is damaged will be the responsibility of the contractor.

#### REMARKS

The problems associated with wrinkles are related to thickness of the asphalt lift being placed over the fabric. When wrinkles are large enough to be folded over, there usually is not enough asphalt available from the tack coat to satisfy the requirement of the multiple layers of fabric. Therefore, wrinkles should be slit and laid flat. Sufficient asphalt sealant should be sprayed on the top of the fabric to satisfy the requirement of the lapped fabric. In overlapping adjacent rolls of fabric, it is desirable to keep the lapped dimension as small as possible and still provide a positive overlap. If the lapped dimension becomes too large, the problem of inadequate tack to satisfy the two lifts of fabric and the old pavement may occur. If this problem does occur, then additional asphaltic sealant should be added to the lapped areas. In the application of additional asphalt sealant, care should be exercised not to apply too much since an excess will cause flushing.

4.6 Fabric Trafficking - Trafficking the fabric will be permitted for emergency or construction equipment only.

4.7 Asphalt Overlay - Placement of the hot mix overlay should closely follow fabric laydown. The temperature of the mix shall not exceed 325°F. In the event asphalt bleeds through the fabric causing construction problems before the overlay is placed, the affected areas shall be blotted by spreading sand or hot mix. To avoid movement or damage to the fabric membrane, turning of the paver and other vehicles shall be gradual and kept to a minimum.

4.8 Seal Coats - Prior to placing a seal coat (or thin overlay such as an open-graded fiction course), lightly sand the fabric at a spread rate of 1½ to 2 pounds per square yard and pneumatically roll the fabric tightly into the sealant.

REMARKS

The task force believes that trafficking of the fabric should not be allowed due to safety considerations. If the contracting agency policy allows trafficking of the fabric, then the following verbage is recommended:

"If approved by the engineer, the membrane may be opened to traffic for 24 to 48 hours prior to installing the surface course. Warning signs shall be placed which advise the motorist that the surface may be slippery when wet. The signs shall also post the appropriate safe speed. Excess sand shall be broomed from the fabric surface prior to placing the overlay. If, in the judgment of the engineer, the fabric surface appears dry and lacks tackiness following exposure to traffic, a light tack coat shall be applied prior to the overlay".

5. Method of Measurement

- 5.1 The paving fabric will be measured by the square yard.
- 5.2 Asphalt sealant for the paving fabric will be measured by the gallon.

6. Basis of Payment

- 6.1 The accepted quantities of paving fabric will be paid for at the contract unit price per square yard in place.
- 6.2 The accepted quantities of asphalt sealant for the paving fabric will be paid for at the contract unit price per gallon complete in place.
- 6.3 Payment will be made under:

<u>Pay Item</u>	<u>Pay Unit</u>
Paving Fabric	square yard
Asphalt Sealant for Paving Fabric	gallon

### 6.3 Field Inspection

Prior to construction, the field inspector should review the guidelines in Chapter 1, Section 1.7. Some geotextile manufacturers and suppliers will provide free technical assistance during the initial stages of a fabric overlay project. This assistance may be particularly beneficial to inexperienced inspectors and contractors.



## CHAPTER 7

### REINFORCED EMBANKMENTS ON SOFT FOUNDATIONS

#### 7.1 Background

Embankments constructed on soft foundation soils have a tendency to spread laterally because of horizontal earth pressures acting within the embankment. These earth pressures cause horizontal shear stresses at the base of the embankment which must be resisted by the foundation soil. If the foundation soil does not have adequate shear resistance, failure can result. Properly designed horizontal layers of high modulus geotextiles or geogrids can provide reinforcement to increase the stability and prevent such failures. Both materials can be used equally well, provided they have the requisite design properties. There are some differences in how they are installed, however, especially with respect to seaming and field workability. At some very soft sites, geogrids may require a geotextile separator in order to provide filtration and to prevent contamination of the first aggregate layer.

It is also possible that the reinforcement may reduce horizontal and vertical displacements of the underlying soil and thus reduce differential settlement. It should be noted that the reinforcement will not reduce long term consolidation or secondary settlement.

The use of reinforcement in embankment construction may allow for:

- An increase in the design factor of safety.
- An increase in the height of the embankment.
- A reduction in embankment displacements during construction, thus reducing fill requirements.

An improvement in embankment performance due to increased uniformity of post-construction settlement.

## 7.2 Applications

Reinforced embankments over weak foundations typically fall into one of two situations (Bonaparte, Holtz, and Giroud, 1987). The more common is embankments, dikes, or levees constructed over very soft, saturated silt, clay or peat layers (Fig. 7.1a). In this situation, the reinforcement is usually placed with its strong direction perpendicular to the centerline of the embankment and plane strain conditions are assumed to prevail. Additional reinforcement with its strong direction oriented parallel to the centerline may also be required at the ends of the embankment.

The second reinforced embankment situation includes those where the foundations below the embankment are locally weak or contain voids. These zones or voids may be caused by sink holes, thawing ice, old stream beds, or pockets of silt, clay, or peat (Fig. 7.1b). In this application, the role of the reinforcement is to bridge over the weak zones or voids, and tensile reinforcement may be required in more than one direction. Thus the strong direction of the reinforcing must be placed in proper orientation with respect to the embankment centerline (Bonaparte and Christopher, 1987).

Geotextiles may also be used as separators for displacement type embankment construction; however, in this application, the geotextile does not provide any reinforcement but only acts as a separator to maintain the integrity of the embankment as it displaces the subgrade soils. In this case, higher elongation geotextiles may be selected, and design considerations are mainly those concerning constructability.

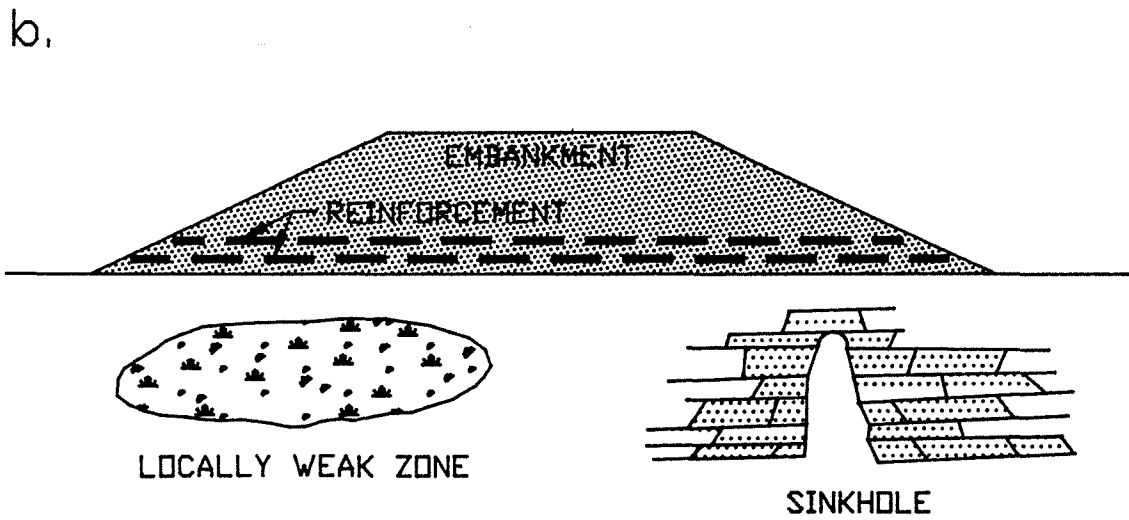
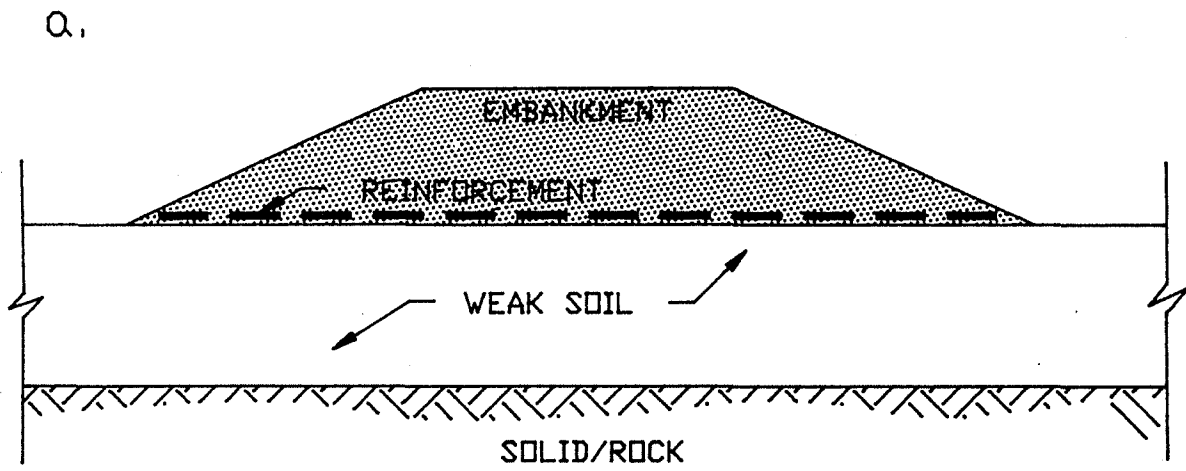

Fig. 7.1 Reinforced Embankment Applications (After Bonaparte and Christopher, 1987)

### 7.3 Reinforced Embankment Design Considerations

As with ordinary embankments, the basic design approach for reinforced embankments is to design against failure. The ways in which embankments constructed on soft foundations can fail have been described by Terzaghi and Peck (1967); Haliburton, Anglin and Lawmaster (1978 a and b); Fowler (1981); and Christopher and Holtz (1985). Figure 7.2 shows unsatisfactory behavior that potentially can occur in reinforced embankments. The three possible modes of failure indicate the kinds of design analysis that are required.

The steps necessary to evaluate failure potential and reinforcing requirements are:

1. Establish design requirements.
2. Check overall bearing capacity.
3. Check internal stability - i.e., edge bearing capacity or slope stability.
4. Check lateral embankment spreading (sliding failure):
  - Determine geosynthetic strength and soil-geosynthetic friction to resist sliding
  - Determine reinforcement strain limits to control embankment cracking.
5. Determine geosynthetic strength requirements in the longitudinal directions.

Although strictly not part of the stability analysis, the settlement of the embankment and potential creep of the reinforcement must also be considered.

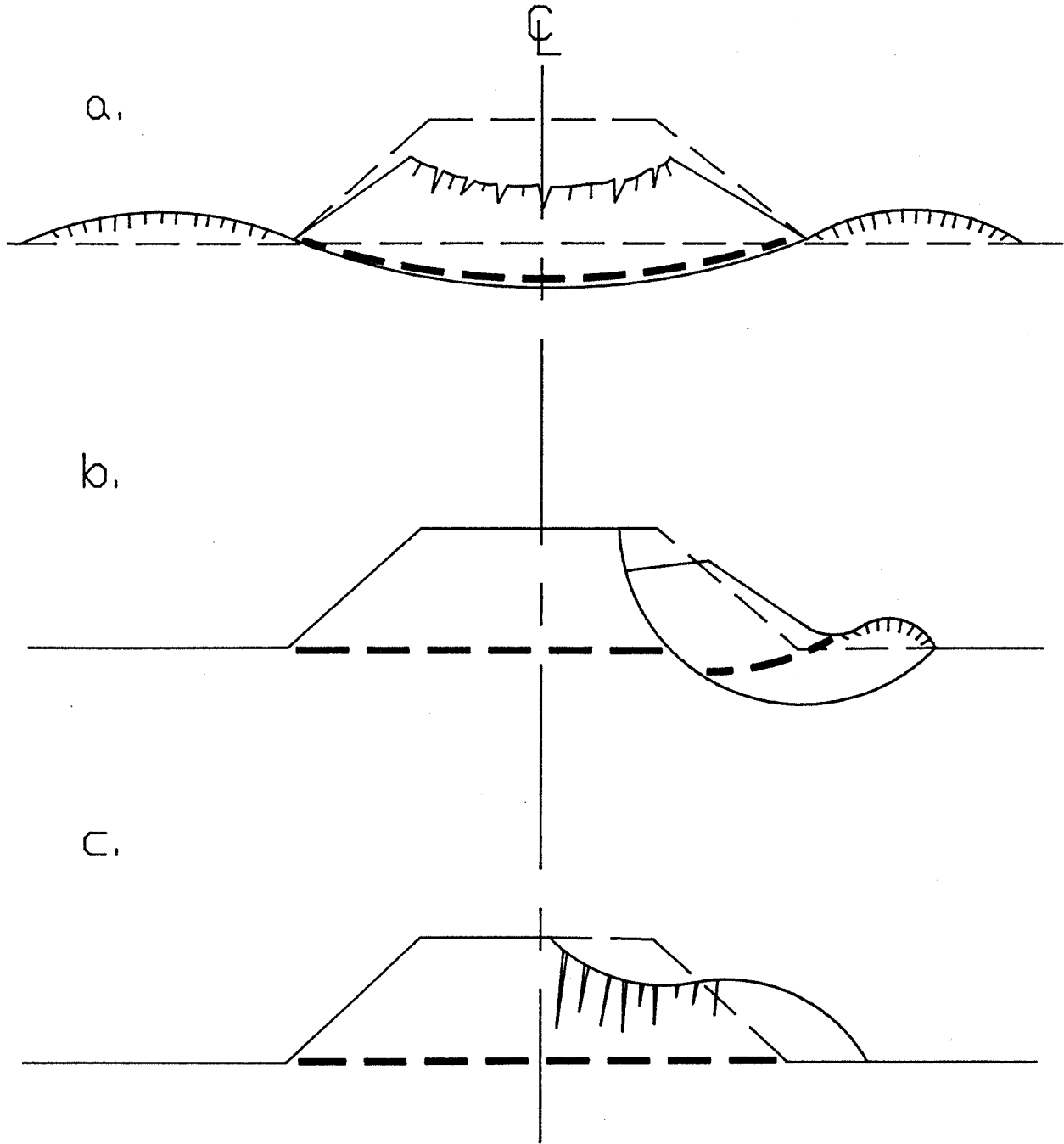

Fig. 7.2 Unsatisfactory Behavior That Can Occur in Reinforced Embankments (After Haliburton, Anglin, and Lawmaster, 1978)

The calculations required for each of these steps utilize conventional geotechnical design methods modified for the presence of the reinforcement. The design steps and methodology recommended are detailed in the following section.

### 7.3.1 Design Requirements

The first step in the design of an embankment over a weak foundation is to define the design requirements. These requirements include:

- 1) Embankment dimensions: height, length, width of crest, and side slopes.
- 2) External loadings: surcharge loads, traffic loads, and potential seismic loading.
- 3) Engineering properties of the foundation soil: stratigraphic profile, location and fluctuation of the ground water table, drained and undrained shear strength parameters and consolidation parameters.
- 4) Properties of the available fill: gradation, moisture-density relations, shear strength properties.
- 5) Chemical composition of embankment fill and foundation soil with respect to possible detrimental effects on the geosynthetic reinforcement, if the reinforcement is required for long term support. The reinforcement must work at least until the foundation has gained sufficient strength to support the embankment without reinforcement.

### 7.3.2 Establish Design Criteria

The next step is to establish tolerable factors of safety for overall bearing capacity and short and long term stability. Recommended minimum factors of safety are:

- 1) Overall bearing capacity: 2
- 2) Local (rotational) shear stability at the end of construction: 1.3
- 3) Local shear stability, long-term: 1.5
- 4) Dynamic loading: 1.1
- 5) Maximum tolerable post construction settlement: depends on project requirements.

These minimum factors of safety are recommended for projects with reasonably good current state-of-the-practice geotechnical site investigations and laboratory testing. Those factors may be adjusted depending on how well the subsurface conditions are known, the quality of the samples and soils testing, cost of failure, probability of occurrences such as earthquakes, and previous experience on similar projects and sites. In short, all of the uncertainties in loads, analyses, and soil properties influence the choice of appropriate factors of safety.

### 7.3.3 Overall Bearing Capacity

Reinforcement does not improve the overall bearing capacity of the foundation soil. If the foundation soil cannot support the embankment, then the embankment cannot be built. Thus, the overall bearing capacity of the embankment must be satisfactory before considering any reinforcement. This can be accomplished by

flattening the side slopes, adding berms at the toes of the embankment, or improving the foundation soil through stage construction, drainage enhancement, or other means.

As the reinforcement is designed to provide internal stability (as will be shown in the following sections), the failure mechanism becomes one of bearing capacity of the entire embankment. As such, the vertical stress due to the embankment can be treated as an average stress over the entire width of the embankment, similarly to a semi-rigid mat foundation.

The bearing capacity can be calculated using classical soil mechanics methods (Terzaghi and Peck, 1967; Vesic, 1975; Perloff and Baron, 1976; and U.S. Navy, 1982) which use limiting equilibrium type analyses for strip footings, assuming logarithmic spiral or circular failure surfaces. Consideration must be given to the thickness of the underlying soft deposit with respect to the width of the embankment. High lateral stresses in a confined soft stratum beneath the embankment could lead to a lateral squeeze type failure. The shear forces developed under the embankment should be compared to the corresponding shear strength of the soil. Approaches discussed by Jürgenson (1934), Silvestri (1983), and Bonaparte, Giroud and Holtz (1987) are appropriate.

#### 7.3.4 Internal Stability Analysis

The next step is to calculate the factor of safety against a circular failure through the embankment and foundation using classical limiting equilibrium type stability analyses. If the factor of safety does not meet the minimum design requirements, then the reinforcing tensile force required to increase the factor of safety to a tolerable level must be estimated. This is done by assuming that the reinforcement acts as a stabilizing tensile force at its intersection with the slip surface being considered. The reinforcement thus provides an additional resisting moment required to obtain the minimum required factor of safety. The analysis is shown in Fig. 7.3.



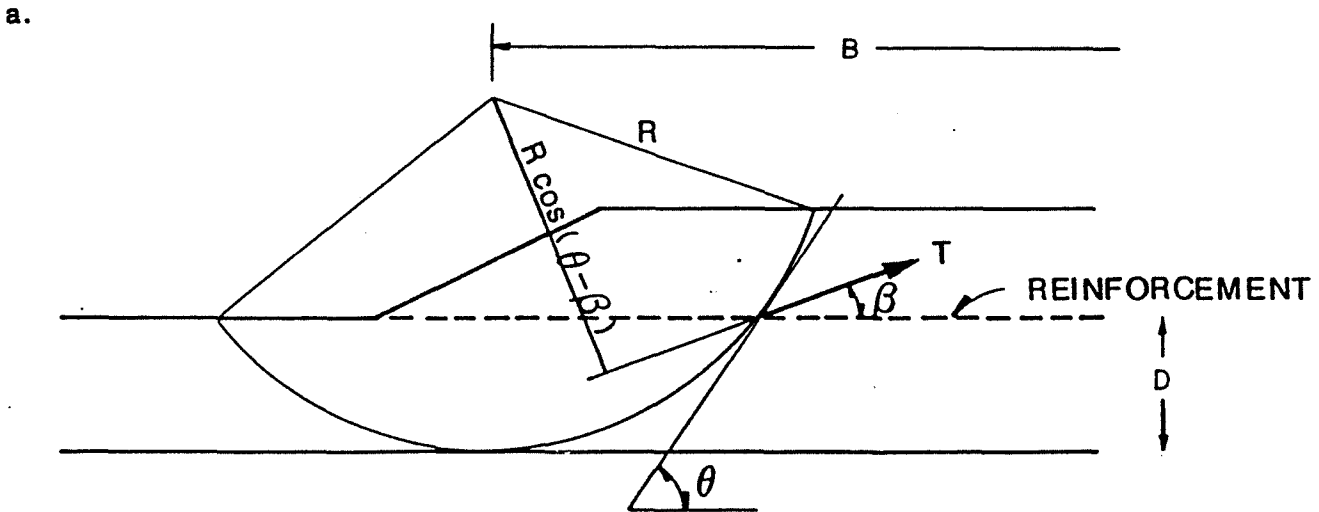
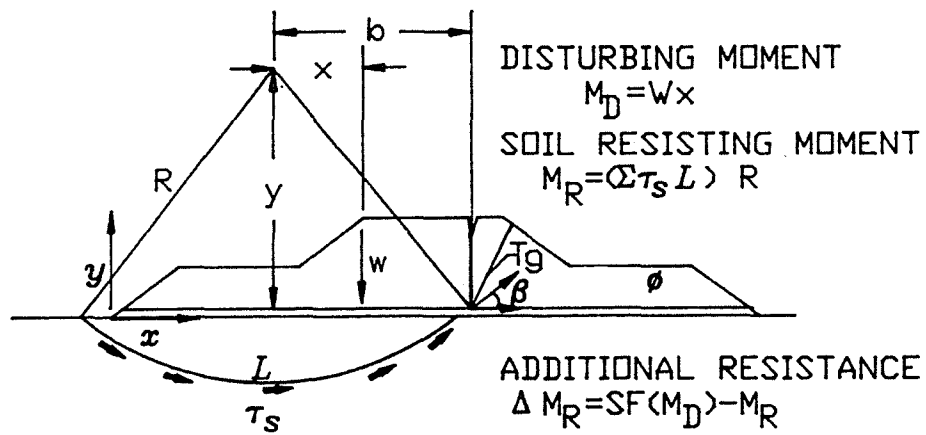

b.

$$M_r = T_g [R \cos(\theta - \beta)]$$

$$0 \leq \beta \leq \theta$$

Fig. 7.3 Reinforcement Required to Provide Internal Stability

The analysis consists of determining the most critical failure surface(s) using conventional limiting equilibrium analysis methods. For each critical sliding surface, the driving moment ( $M_d$ ) and soil resisting moment ( $M_r$ ) are determined as shown in Fig. 7.3a. The additional resisting moment  $\Delta M_r$  to provide the required factor of safety is calculated as shown in Fig. 7.3b. Then one or more layers of geotextiles or geogrids with sufficient tensile strength at tolerable strains are added at the base of the embankment to provide the required additional resisting moment. If multiple layers are used, they must be separated by a granular layer and they must have compatible stress-strain properties (e.g. use the same reinforcement for each layer).

A number of procedures have been proposed for determining the required additional reinforcement, and these are summarized in the FHWA Geotextile Engineering Manual. The basic difference between the approaches is the orientation of the reinforcement force at the location of the critical slip surface (the angle  $\beta$  in Fig. 7.3). It is conservative to assume that the reinforcing force acts horizontally at the location of the reinforcement ( $\beta = 0$ ). In this case, the additional reinforcing moment is equal to the geotextile strength,  $T_g$ , times the vertical distance,  $y$ , from the plane of the reinforcement to the center of rotation or:

$$\Delta M_R = T_g y \quad (20)$$

as determined for the most critical failure surface shown in Fig. 7.3. This approach is conservative in that it neglects any possible reorientation of the reinforcement along the alignment of the failure surface as well as any confining effect of the reinforcement.

A less conservative approach would be to assume that the reinforcement bends due to local displacements of the foundation soils at the onset of failures with the maximum possible

reorientation located tangent to the slip surface ( $\beta = \theta$  in Fig. 7.3b). Limited field evidence indicates that it is actually somewhere in between the horizontal and tangential (Bonaparte and Christopher, 1987) depending on the foundation soils, the depth of soft soil in relation to the width of the embankment (D/B ratio), and the stiffness of the reinforcement. Based on the skimpy information available, the following suggestions are provided for selecting the orientation:

$\beta = 0$  for brittle, strain-sensitive foundations soils (e.g., leached marine clays);

$\beta = \theta/2$  for  $D/B < 0.4$  and moderate to highly compressible soils (e.g., soft clays, peats)

$\beta = \theta$  for  $D/B < 0.4$  highly compressible soils (e.g., soft clays, peats), reinforcement with high elongation potential ( $\epsilon_{design} \geq 10\%$ ), and large tolerable deformations.

$\beta = 0$  When in doubt!

Other approaches require a more rigorous analysis of the deformation characteristics of the foundation soils and the strength compatibility of the reinforcement as discussed by Bonaparte and Christopher, 1987.

#### 7.3.5 Lateral Embankment Spreading (Sliding Type Failure)

A simplified analysis for calculating the reinforcement required to limit lateral embankment spreading is illustrated in Fig. 7.4 (Bonaparte and Christopher, 1987). For unreinforced as well as reinforced embankments, the driving forces result from the lateral earth pressures within the embankment which must, for equilibrium, be transferred to the foundation by shearing stresses (Holtz, 1985). Instability occurs in the embankment when either:

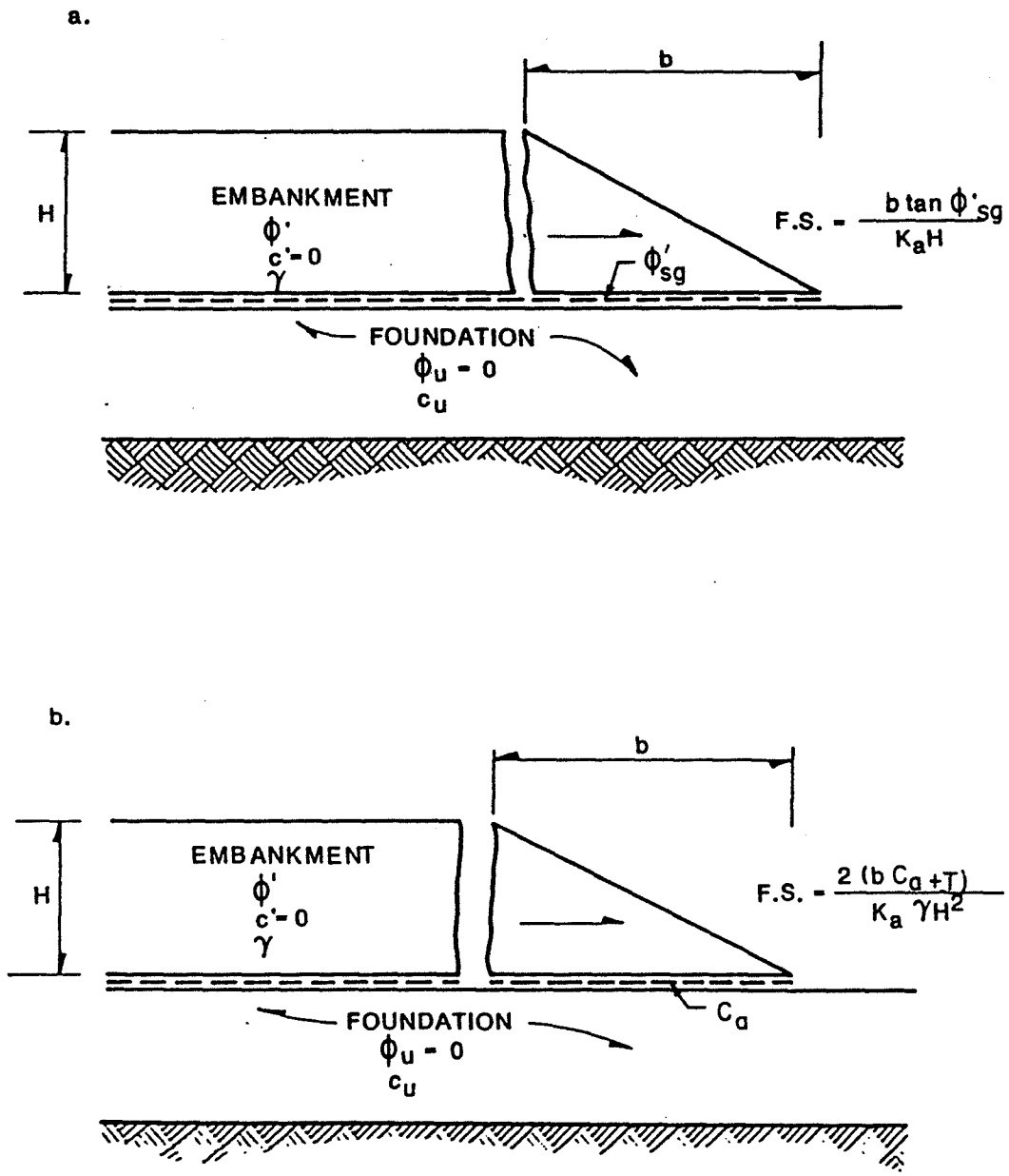

Fig. 7.4 Reinforcement Required to Limit Lateral Embankment Spreading (Bonaparte and Christopher, 1987)

- 1) The embankment slides on the reinforcement (Fig. 7.4a)
- 2) The reinforcement fails in tension and the embankment slides on the foundation soil (Fig. 7.4b).

Thus, the reinforcement must have sufficient friction to resist sliding on the plane of the reinforcement, and its tensile strength must be sufficient to resist rupture and tearing. The important reinforcement properties for design against sliding are the soil-reinforcement interface friction ( $\tan\phi_{sg}$ ) or adhesion characteristics ( $c_a$ ) determined from direct shear tests, and the limiting reinforcement tensile force per unit width,  $T_1$ .

In order to control embankment cracking,  $T_1$  is usually selected based on a limiting strain criteria, depending on the intended use of the embankment and the tolerable amount of lateral deformation. Christopher and Holtz (1985) suggest strain limits ( $\epsilon_1$ ) between 5% and 10% for embankments constructed with cohesionless fill and not more than 2% for those constructed with compacted cohesive soils.

Of course, if embankment cracking is not a concern, then these limiting reinforcement strain values could be increased. Keep in mind, however, that if cracking occurs, no resistance to sliding is provided in the analysis. Further, the cracks could possibly fill with water which would add to the driving forces.

It should be noted that the sliding resistance provided by the foundation soil can be increased through staged embankment construction.

#### 7.3.6 Longitudinal Strength Requirements

In addition to the transverse reinforcement, geosynthetic strength and elongation requirements must also be evaluated in the

direction of the embankment alignment. Reinforcement is required for loadings that may occur:

1. During construction over very weak subgrades when mudwaves are created;
2. At the end(s) of an embankment as it is advanced across the site;
3. At abutments; and
4. Due to differential settlements and bending of the embankment, especially over nonuniform foundation conditions and at the edges of a soft soil deposit.

The strength and elongation requirements determined from lateral sliding analysis (Section 7.3.5) should be sufficient to resist forces induced during construction and should tend to reduce embankment bending after construction. Therefore, the strength for the geosynthetic should be at least equal to that determined from the sliding resistance analysis in Section 7.3.5. Because the usual placement of the geosynthetic is in strips perpendicular to the centerline, the longitudinal strength requirements are those of the seams between the strips of geosynthetic. In addition, a complete analysis (i.e. edge bearing capacity and slope stability) should be performed for the ends of the embankment and at abutments.

#### 7.4 Geosynthetic and Fill Considerations

Once the design strength requirements have been established, the appropriate geosynthetic must be selected. In addition to the strength of the material, drainage requirements, construction conditions, and environmental factors must also be considered. The selection of appropriate fill materials is also an important aspect of the design.

#### 7.4.1 Geotextile and Geogrid Strength Requirements

Selection of a limiting value of reinforcement tensile force is a key step in design (Bonaparte and Christopher, 1987). The magnitude of this force depends on conditions at failure of the embankment-foundation system and on the force-elongation behavior of the reinforcement, including reinforcement creep. The following relationships will be used to establish the required geotextile strength and deformation requirements:

Tensile Strength for Rotational Stability:

$$T_r \leq 0.6 T_{ult}$$

Limiting Strength ( $T_1$ ) for Lateral Stability:

$$T_1 \text{ at } \epsilon_1 \leq T_a \text{ at } \epsilon_1 \leq 0.3 T_{ult}$$

or if Creep Test performed

$$T_1 \text{ at } \epsilon_1 \leq T_L$$

Longitudinal Strength =  $T_1$  requirements

Limiting Strain ( $\epsilon_1$ ):  $\epsilon_1 \leq 0.6 \epsilon_{ult}$

where:

$T_{ult}$  = Ultimate geotextile strength as obtained from the wide width method (ASTM D-4595).

$\epsilon_{ult}$  = Strain at  $T_{ult}$  from wide width test.

$T_a$  = Available strength at required strain (e.g. 2% to 10%) from wide width test.

$T_L$  = Creep limit strength as determined from Creep Test (FHWA Manual - Method III.0.84)

Depending on the strength requirements, geosynthetic availability, and seam efficiency, more than one layer of reinforcement may be utilized to obtain the required tensile strength. If multiple layers are used, a granular layer of minimum lift thickness must be placed between each successive geosynthetic layer or the layers must be mechanically connected (e.g. sewn together). Also, the geosynthetics must be strain compatible; it is recommended that the same type of geosynthetic be used for each layer.

In addition to the design strength requirements, the geotextile or geogrid must also have sufficient strength to survive construction. If the geotextile is ripped, punctured or torn during construction, the strength available for support of the structure will be reduced and failure of the system could result. As the construction of the first lift of the embankment is analogous to construction of a temporary haul road, similar survivability requirements discussed in Section 5.8 are appropriate here also. Tables 7-1 to 7-3 have been developed specifically for reinforced embankment construction. As mentioned in Section 5.8, the specific property values in Table 7-3 are subject to revision. For all critical applications, high to very high survivability geotextiles and geogrids should be considered for all critical applications.

#### 7.4.2 Drainage Requirements

The geosynthetic must allow for free vertical drainage of the subgrade to reduce pore pressure buildup below the embankment. It is recommended that the permeability of the geosynthetic be at least ten times that of the underlying soil. The opening size should be maximized to reduce the risk of clogging, while still providing retention of the underlying soil. The opening size should be selected based on the requirements of Section 2.3.



TABLE 7-1

REQUIRED DEGREE OF FABRIC SURVIVABILITY AS A FUNCTION OF  
SUBGRADE CONDITIONS AND CONSTRUCTION EQUIPMENT

<u>Subgrade Conditions</u>	<u>Construction Equipment and 6 in. to 12 in. Cover Material Initial Lift Thickness</u>		
	<u>Low Ground Pressure Equipment (<math>\leq 4</math> psi)</u>	<u>Medium Ground Pressure Equipment (<math>&gt;4</math> psi, <math>\leq 8</math> psi)</u>	<u>High Ground Pressure Equipment (<math>&gt; 8</math> psi)</u>
Subgrade has been cleared of all obstacles except grass, weeds, leaves, and fine wood debris. Surface is smooth and level such that any shallow depressions and humps do not exceed 6 in. in depth and height. All larger depressions are filled. Alternatively, a smooth working table may be placed.	Low	Moderate	High
Subgrade has been cleared of obstacles larger than small to moderate size tree limbs and rocks. Tree trunks and stumps should be removed or covered with a partial working table. Depressions and humps should not exceed 18 in. in depth and height. Larger depressions should be filled.	Moderate	High	Very High
Minimal site preparation is required. Trees may be felled, delimited, and left in place. Stumps should be cut to project not more than 6 in. $\pm$ above subgrade. Fabric may be draped directly over the tree trunks, stumps, large depressions and humps, holes, stream channels, and large boulders. Items should be removed only if placed the fabric and cover material over them will distort the finished road surface.	High	Very High	Not Recommended

NOTE:

1. Recommendations are for 6 in. to 12 in. initial thickness. For other initial lift thickness:
  - 12 in. to 18 in.: Reduce survivability requirement 1 level
  - 18 in. to 24 in.: Reduce survivability requirement 2 levels
  - > 24 in: Reduce survivability requirement 3 levels
2. For special construction techniques such as pre-cutting, increase survivability requirement 1 level.
3. Placement of excessive initial cover material thickness may cause bearing failure of soft sbugrades.

**TABLE 7-2**

**REQUIRED DEGREE OF FABRIC SURVIVABILITY  
AS A FUNCTION OF COVER MATERIAL AND CONSTRUCTION EQUIPMENT**

	6 in. to 12 in. Initial Lift <u>Thickness</u>		12 in. to 18 in. Initial Lift <u>Thickness</u>		18 in. to 24 in. Initial Lift <u>Thickness</u>		>24 in. Initial Lift <u>Thickness</u>	
	Low Ground Pressure Equipment ( $\leq 4$ psi)	Medium Ground Pressure Equipment ( $> 4$ psi, $\leq 8$ psi)	Medium Ground Pressure Equipment ( $> 4$ psi, $\leq 8$ psi)	High Ground Pressure Equipment ( $> 8$ psi)	High Ground Pressure Equipment ( $> 8$ psi)	High Ground Pressure Equipment ( $> 8$ psi)	High Ground Pressure Equipment ( $> 8$ psi)	High Ground Pressure Equipment ( $> 8$ psi)
Fine sand to +2 in. diameter gravel, rounded to subangular	Low	Moderate	Low	Moderate	Low	Low	Low	Low
Coarse aggregate with diameter up to one half proposed lift thickness, may be angular	Moderate	High	Moderate	High	Moderate	Moderate	Low	Low
Some to most aggregate with diameter greater than one half proposed lift thickness, angular and sharp edged, few fines	High	Very High	High	Very High	High	High	Moderate	Moderate

**NOTE:**

1. For special construction techniques such as pre-rutting, increase fabric survivability requirement 1 level.
2. Placement of excessive initial cover material thickness may cause bearing failure of soft subgrades.

TABLE 7-3  
 Geotextile Strength Required for  
 Survivability During Construction

PHYSICAL PROPERTY REQUIREMENTS  
 < 50% GEOTEXTILE ELONGATION / >50% GEOTEXTILE ELONGATION<sup>2,3</sup>

SURVIVABILITY LEVEL	GRAB STRENGTH ASTM D 4632 (LBS)	PUNCTURE RESISTANCE ASTM D 4833 (LBS)	TRAPEZOID TEAR STRENGTH ASTM D 4533 (LBS)
HIGH	270/180	100/75	100/75
MEDIUM	180/115	70/40	70/40

ADDITIONAL REQUIREMENTS  
 APPARENT OPENING SIZE

TEST METHODS  
 ASTM D 4751

1. <50% soil passing a No. 200 US sieve, AOS <0.6 mm.
2. >50% soil passing a No. 200 US sieve, AOS <0.3 mm.

PERMEABILITY

ASTM D 4491

1.  $k$  of the fabric  $>k$  of the soil (permeability times the nominal geotextile thickness).

ULTRAVIOLET DEGRADATION

ASTM D 4355

1. At 150 hours exposure, 70% strength retained for all cases.

GEOTEXTILE ACCEPTANCE

ASTM D 4759

- <sup>1</sup> Values shown are minimum roll average value  
 Strength values are in the weaker principle direction
- <sup>2</sup> Elongation as determined by ASTM D 4632.
- <sup>3</sup> The values of geotextile elongation do not imply the allowable consolidation properties of the subgrade soil. These must be determined by a separate investigation.

#### 7.4.3 Environmental Considerations

For most reinforcement situations, geosynthetics have a high resistance to chemical and biological attack, and thus, chemical and biological compatibility is not a concern. However, in unusual situations such as low or high pH soils, or other unusual chemical environments, such as industrial areas or near mine or other waste dumps, the compatibility of the geosynthetic should be checked to make sure it will have the design strength at least until the underlying subsoil has gained sufficient strength to support the structure without reinforcement.

#### 7.4.4 Stiffness and Workability

For extremely soft soil conditions, geotextile stiffness or workability may be an important consideration. The workability of a geotextile is its ability to support workmen during initial placement and sewing operations and construction equipment during the first lift placement. Workability is generally related to geotextile stiffness; however, good stiffness evaluation techniques and correlations with field workability are not well established. In the absence of any other stiffness information, ASTM Standard D-1388 (75) with modifications as discussed in Appendix B of the FHWA Geotextile Engineering Manual has been recommended. The values obtained should be compared with actual field performance to establish future design criteria. The Task Force 25 suggested workability guidelines based on subgrade CBR given in the FHWA Manual are satisfactory for  $CBR \approx 1.0$ . For very soft subgrades, much stiffer geotextiles will likely be required. The FHWA Manual also discusses other aspects of field workability such as water absorption and bulk density.

#### 7.4.5 Fill Considerations

The first few lifts of fill material just above the geosynthetic should be free draining granular materials. This requirement provides the best frictional interaction between the geosynthetic

and fill, as well as providing a drainage layer for excess pore water dissipation of the underlying soils. Other fill materials may be used above this layer as long as the strain compatibility of the geosynthetic is evaluated with respect to the backfill materials, as discussed in Section 7.3.5.

To minimize displacement of the underlying soil, the first lift should also not be overly thick. As previously indicated, the first lift is analogous to construction of a temporary haul road. As such, it is recommended that the thickness of the first lift be based on the haul road design methods in Chapter 5. The design should be based on a tolerable rut depth of 2 to 4 in. and low traffic volumes.

#### 7.5 Design Guidelines for Reinforced Embankments on Soft Foundations

The following is a step by step checklist for design of reinforced embankments.

1. Define embankment dimensions and loading conditions.
2. Obtain subsurface profile and design strength properties.
  - a) Undrained shear strength,  $c_u$ , for end of construction.
  - b) Drained shear strength parameters,  $c'$  and  $\phi'$ , for long-term conditions.
3. Obtain  $\gamma$  and  $\phi$  for embankment fill materials.
4. Check bearing capacity.

- a) Overall bearing capacity.

$$q_{ult} = c N_c$$

- b) Lateral squeeze (or plastic flow).

See Jürgenson (1934), Silvestri (1983), and Bonaparte, Holtz and Giroud (1987) for suggestions as to how to approach this problem. The designer should be aware that the analysis for lateral squeeze is only approximate, and no method is completely accepted by geotechnical engineers at present.

If the factor of safety for bearing capacity is sufficient, then continue with next step. If not, consider increasing the width of the embankment, flattening the slopes, adding toe berms, using stage construction, or consider other alternatives such as relocating the alignment or placing the roadway on a elevated structure.

- 5. Perform a rotational slip surface analysis on the unreinforced embankment to determine the factor of safety against local shear instability.

- a) If the calculated factor of safety is greater than the minimum required, then reinforcement is not needed. Check lateral embankment spreading (Step 6).

- b) If the factor of safety is less than required minimum, then calculate the reinforcement strength required to provide an adequate factor of safety from Fig. 7.3 or alternative solutions (see Section 7.3.3).

6. Determine reinforcement required to obtain lateral embankment stability from Fig. 7.4.
  - a) Check strength of reinforcement required.
  - b) Check sliding above reinforcement.
  - c) Establish tolerable deformation requirements based on type of fill materials.
    - Cohesionless soils -  
 $\epsilon_{\text{geosynthetic}} = 5 \text{ to } 10\%$
    - Cohesive soils -  
 $\epsilon_{\text{geosynthetic}} = 2\%$
7. Evaluate strength required in the direction of the embankment alignment.
  - a) Use strength and elongation determined from Step 6 for embankment spreading during construction and to control bending at end of construction.
  - b) Check edge bearing and slope stability at the ends of the embankment (Steps 4 and 5).
  - c) Seam strength requirements are the higher of the strengths determined from Steps 6a or 6b.
8. Establish geosynthetic requirements from Section 7.4.1.
  - a) Design strength and elongation based on ASTM D-4595, wide width method.
  - b) Seam strength based on ASTM D-4595, wide width method, and equal to the strength required in the longitudinal direction.

- c) Soil-geosynthetic adherence based on direct shear tests with on site soils or estimate using  $2/3\phi$ .
- d) Geotextile stiffness based on site conditions and experience.
- e) Select survivability and constructability requirements for geosynthetics based on surface conditions at the site, backfill materials, and equipment using Tables 7-1, 7-2, and 7-3.

9. Establish construction sequence requirements.

- a) NOTE: Both deep seated and lateral spreading stability may be increased by staged construction. Typically, three or four stages are used. Evaluate the design requirements for the maximum embankment height at the end of each stage. Consider prefabricated vertical drains to speed up consolidation of each stage.
- b) Establish lift thickness requirements.
  - For the first lift, use minimum lift thickness requirements to support construction equipment with 2 to 4 in. ruts; i.e., design the first lift as a temporary haul road using the methods in Ch. 5.
  - If more than one layer of reinforcement is used, separate them by the minimum lift thickness.
  - Track in the first lift with minimal compaction.
  - Use conventional lift thicknesses for the successive layers.



10. Establish embankment construction observation requirements.

a) Instrumentation. As a minimum install piezometers and settlement survey points. Consider also inclinometers.

b) Geosynthetic inspection. Check:

- Geosynthetic submittal for prior acceptance
- Testing requirements
- Fill placement observations
- Seam integrity
- Placement of fill to tension geosynthetic

11. Hold preconstruction meetings

12. Observe construction and build with confidence (if the procedures outlined in these guidelines are followed!)

#### 7.6 Specifications

As a majority of the reinforcement requirements will be job specific, standard specifications which include specific geosynthetic properties are not recommended for reinforcement applications. Rather, special provisions should be used for such applications. The following special provision example includes most of the items that should be considered in a reinforcement embankment project.

**SPECIAL PROVISIONS FOR GEOTEXTILE REINFORCED EMBANKMENT  
(AFTER WASHINGTON STATE DEPARTMENT OF TRANSPORTATION)**

Construction Fabric for Embankment Reinforcement

Where shown on the plans or where directed by the Engineer, the Contractor shall furnish and place construction fabric for embankment reinforcement in accordance with the details shown on the plans, these special provisions, or as directed by the Engineer.

Materials

The material shall be a woven or non-woven fabric consisting only of a long chain polymeric filaments or yarns formed into a stable network such that the filaments or yarns retain their position relative to each other during handling, placement, and long-term service. The fabric shall have complete resistance to acid and alkaline conditions, shall be indestructable by micro-organisms and insects, and shall meet or exceed the properties as indicated in the plans. The fabric shall also be free of defects or tears.

1. Source Approval

Prior to installation of the proposed fabric, the contractor shall submit to the Engineer a copy of a mill certificate or affidavit signed by a legally authorized official from the company manufacturing the fabric. If the fabric has not been previously tested for source approval by the State, sample(s) of the fabric shall be submitted to and approved by the WSDOT Materials Laboratory in Tumwater. Each sample shall have minimum dimensions of 1 yard by the full roll width of the fabric. A total of five samples per lot shall be submitted to the Engineer for testing. Two additional samples shall be submitted which contain a minimum length of 5 ft of sewn seam each, and a minimum width of 1 ft of fabric on each side of the seam. The fabric samples shall be cut from the fabric roll with scissors, sharp knife, or other suitable method which produces a smooth fabric edge and does not cause fabric ripping or tearing.

The mill certificate or affidavit shall attest that the fabric meets the chemical, physical, and manufacturing requirements stated in this specification. The sample shall be labeled with the lot and batch number, date of sampling, project number, property specifications, manufacturer, and product name.

## 2. Control Testing

As soon as the fabric arrives at the project site, samples will be randomly selected by the Engineer or his representative and submitted to the Materials Laboratory for testing to confirm that the correct fabric was received and that it meets the property values specified. The Engineer or his representative will be present at the site during installation, and the Engineer reserves the right to collect samples periodically for confirmation testing.

## 3. Shipment and Storage

During periods of shipment and storage, the fabric shall be placed in a dry place off the ground. Rolls shall be placed straight in piles. Under no circumstances, either during shipment, storage, or placement, shall the material be exposed to sunlight, or other form of light which contains ultraviolet rays, for more than 40 hours.

## Construction Requirements

The subgrade or area to be covered shall be graded to a smooth, uniform condition free from ruts, potholes, and protruding objects such as rocks or sticks. If this is not possible, then a working platform shall be constructed. If a working platform is needed, all stumps shall be cut flush with the ground surface and the working platform constructed before the first fabric layer is placed. The working platform shall cover all stumps, logs, etc. with at least 6 inches of material. Logs greater than 6 inches in diameter shall be removed. This working platform shall serve to protect the first layer of fabric. The working platform shall be graded to a smooth, uniform condition free from ruts, and protruding objects such as rocks or sticks.

The fabric shall be laid smooth without excessive wrinkles. The fabric will be covered with material designated in the plans or directed by the Engineer. The fill material shall be placed on the fabric in such a manner that there will be no vehicles or equipment driven directly on the fabric. Under no circumstances shall fill or base course material be dropped on unprotected fabric from a height greater than 5 ft above the surface of the fabric.

Pegs, pins, or the manufacturer's recommended method shall be used to hold the fabric in place until the specified cover material is placed.

Should the fabric or sewn joints be torn or punctured, the backfill around the damaged area shall be removed and the damaged area repaired by the Contractor at no cost to the State. The repair shall consist of a patch of the same type of fabric which replaces the ruptured area. All fabric within 2 ft of the ruptured area shall be removed from the fabric by cutting the fabric using a method which produces a smooth fabric edge and does not cause fabric ripping or tearing. The patch shall be sewn onto the fabric.

The fabric seams shall be sewn. A double seam "J" seam, Type SSn-1, with parallel stitching spaced approximately 0.5 inches apart, shall be used for both factory and field sewn seams. The seams shall be sewn in such a manner that the seam can be inspected readily by the Engineer or his representative. High strength polypropylene, polyester, or Kevlar thread shall be used. If a patch of fabric is to be placed on damaged fabric for the purpose of repairing the fabric, then a double sewn "flat" or "prayer" seam, 1 inch from the edge of the fabric, Type SSa-1, may be used for this repair.

The bottom fabric reinforcing layer shall be placed such that all longitudinal fabric joints are transverse to the centerline of the embankment, i.e., the fabric machine direction should be transverse to the embankment centerline. The fabric rolls shall be cut into lengths such that the seams perpendicular to the longitudinal fabric seams will not be required.

If multiple fabric reinforcing layers are required by the contract plans, each alternate layer above the bottom layer of fabric shall be constructed with the fabric machine direction (i.e., the longitudinal fabric joints) parallel to the embankment centerline.

The fabric shall be "pretensioned" during installation using either Method 1 or Method 2 as described below. The method selected will depend on whether or not a mudwave forms during placement of the first one to two lifts. If a mudwave forms as fill is pushed onto the first layer of fabric, Method 1 shall be used. Method 1 shall continue to be used until the mudwave ceases to form as fill is placed and spread. Once mudwave formation ceases, Method 2 shall be used until the uppermost fabric layer is covered with a minimum of 1.5 ft of fill. These special construction methods are not needed to fill construction above this level. If a mudwave does not form as fill is pushed on to the first layer of fabric, then Method 2 shall be used initially and until the uppermost fabric layer is covered with at least 1.5 ft of fill.

Method 1. After the working platform has been constructed, lay the first layer of fabric in continuous transverse strips and sew the joints together. Stretch the fabric manually to ensure that no wrinkles are present in the fabric. Begin end-dumping fill and spreading fill at the edge of the fabric. The fill shall first be placed along the outside edges of the fabric to form access roads. These access roads will serve three purposes: To lock the edges of the fabric in place, to contain the mudwave, and to provide access as needed to place fill in the center of the embankment. These "access roads" should be a minimum of 15 ft wide. The access roads at the edges of the fabric shall have a height of 2.5 ft when completed. Once the access roads are approximately 50 ft in length, begin placing and compacting fill between the two haul roads. Continue filling between the two haul roads, keeping the mudwave ahead of the filling operation and keeping the access roads 50 ft ahead of this filling operation as shown in the plans. Keeping the mudwave ahead of the filling operation and keeping the edges of the fabric from moving by use of the access roads will effectively pre-tension the fabric. The fabric should be laid out no more than 20 ft ahead of the end of the access roads at any time to prevent overstressing of the fabric seams.

Method 2. After the working platform has been constructed, lay and sew the first layer of fabric as in Method 1. Begin spreading the first lift of material at the end of the fabric, keeping the center of the advancing fill lift ahead of the outside edges of the lift as shown in the plans. The fabric shall be manually pulled taut prior to fill placement. Continue constructing the embankment in this manner in subsequent lifts until the uppermost fabric layer is completely covered with 1.5 ft of compacted fill.

Embankment construction shall be kept symmetrical at all times to prevent lateral tipping or sliding of the embankment. Any fill placed directly on the fabric shall be spread immediately. A minimum cover of 9 inches shall be maintained at all times between the spreading and/or hauling equipment and each fabric layer.

The embankment shall be compacted using Method B of Section 2-03.3(14)C of the Standard Specifications, except that the first lift above each fabric layer shall have a depth of 12 inches before compaction. Vibratory or sheepfoot rollers shall not be used to compact the

fill until at least 3 ft of fill is covering the bottom fabric layer and until at least 1 ft of fill is covering each subsequent fabric layer above the bottom layer.

#### Construction Requirements of Fabric Around Pile Supported Abutments

Holes shall be cut in each fabric layer at each pile location to allow the piles to pass through the fabric layers during driving. This requirement shall only apply if one or more fabric layers within the reinforced fill passes directly beneath a pile supported bridge abutment. The holes shall be cut in a square shape and shall have sides either parallel or perpendicular to the bridge centerline, as shown in the plans. The sides of each square shall have a length equal to 1.5 ft plus the diameter of the pile. The fabric shall be cut using a method which produces a smooth fabric edge and does not cut fabric ripping or tearing.

Each fabric layer with holes cut in it shall be reinforced in the vicinity of the abutment with a patch of the same fabric which also has holes cut in it, as shown in the plans. The patch of fabric shall extend at least 3 ft from the edges of all of the holes in the fabric abutment. The fabric patch shall be sewn to the fabric layer it reinforces using two parallel seams 0.5 inches apart around the edges of the patch and around each fabric hole. The center of the fabric holes shall be located within  $\pm 1$  inch of the locations shown in the plans. If a seam is required to form a fabric patch to the width and length shown in the plans, the seam shall be parallel to the bridge centerline, and shall be a double-sewn "J" seam, Type SSn-1, as specified elsewhere in these special provisions.

#### Method of Measurement

Construction fabric shall be measured by the square yard for the ground surface area actually covered.

#### Basis of Payment

The unit contract price per square yard for "Construction Fabric for Embankment Reinforcement" shall be full compensation for all required surface preparation; furnishing and placement of the fabric; the sewing of joints; repairing torn or damaged fabric; for all pegs, pins, staples, clips, wire, or other attachment and hold-down devices; and for all labor, tools, equipment, and incidentals necessary for placement of the construction fabric in accordance with these specifications.

TABLE 1: Fabric Properties Required for Fabric Used in Fabric Reinforced Embankments

Fabric Property	Test Method	Minimum Roll Average Values	
		Polyester	All Other Polymers
AOS (U.S. Sieve Size)	WSDOT Method 11: Apparent Maximum Opening Size of Geotextiles - (ASTM D4751)	*	*
Water Permeability (cm/sec)	WSDOT Method 13: Water Permeability of Geotextiles - Permittivity (ASTM D-4491)	*	*
Wide Strip Strength, Min. in Machine or X-Machine Direction (lbs/in.)	WSDOT Method 5: Method for Wide Width Tensile (ASTM D-4595)	*	*
Wide Strip Secant Modulus at 10%* Strain (lbs/in.) *(NOTE: Project specific)	WSDOT Method 5: Method for Wide Width Tensile Strength (ASTM D-4595)	*	*
Wide Strip Seam Breaking Strength	WSDOT Method 6 and Method 5 (Wide Width Strength Test)	*	*
Burst Strength (psi)	WSDOT Method 8: Diaphragm Bursting Strength of Geotextiles (ASTM D-3786)	*	*
Puncture Resistance (lbs)	WSDOT Method 9: Puncture Strength of Geotextiles	*	*
Tear Strength, Min. in Machine or X-Machine Direction (lbs)	(ASTM D-4533)	*	*

\*Requirements are site specific

## 7.7 Cost Considerations

The cost analysis for a geosynthetic reinforced embankment includes:

1. Geosynthetic cost: including purchase price, factory prefabrication, and shipping.
2. Site preparation: including clearing and grubbing, and working table preparation.
3. Geosynthetic placement: related to field workability (See FHWA Geotechnical Engineering Manual):
  - a) With no working table.
  - b) With a working table.
4. Fill material: including purchasing, hauling, dumping, compaction, allowance for additional fill due to embankment subsidence. (Note: select free draining granular fill for the lifts adjacent to geosynthetic to provide good adherence and drainage)

## 7.8 Construction Sequence

The construction sequence for reinforced embankments on soft subgrades is extremely important. Improper fill procedures can lead to damage of the geosynthetic, nonuniform settlement, and even failure of the embankment if fill placement is not carefully controlled so that excess pore pressures can dissipate. By the use of low ground pressure equipment, a properly selected geosynthetic, and proper procedures for placement of the fill, these problems can essentially be eliminated. The following outlines the essential construction details. The Washington State DOT Special Provision in Section 7.6 provides additional details for some of the construction requirements.



1. Prepare subgrade

- a) Cut trees and stumps flush with ground surface.
- b) Do not remove or disturb root mats.
- c) Leave small vegetative cover, such as grass and reeds, in place.
- d) For undulating sites or areas where there are many stumps and fallen trees, consider a working table for placement of the reinforcement. In this case, a lower strength sacrificial geosynthetic designed only for constructability can be used to construct the working table.

2. Geosynthetic placement procedures

- a) To provide maximum support, the geosynthetic should be oriented with the machine direction perpendicular to the embankment alignment. No seams should be allowed parallel to the alignment. Therefore,
  - The geosynthetic rolls should be shipped in unseamed machine direction lengths equal to 1 or more multiples of the embankment design base width.
  - The geosynthetic should be manufactured with the largest machine width possible.
  - These widths should be factory sewn to provide the maximum width compatible with shipping and field handling.

- b) The geosynthetic should be unrolled transverse to the alignment, as smoothly as possible (without dragging it).
- c) The geotextile should be sewn as required with all seams up and every stitch inspected. Geogrids should be positively joined by clamps, cables, pipes, etc.
- d) The geosynthetic should be pulled taut manually to remove wrinkles. Weights or pins may be required to hold the fabric in position to prevent lifting by wind.
- e) After placement, the geosynthetic should be covered within 48 hours.
- f) Before covering, the condition of the geosynthetic should be observed by the engineer or his representative to determine that no holes, rips, tears, etc. have occurred in the material. If any, defects should be repaired by:
- The entire panel should be replaced for large defects by cutting along the seam and resewing in a new panel.
  - For smaller defects, the section can be cut out and a new panel re sewn into that section if possible.
  - For defects less than 6 in., the geosynthetic can be overlapped a minimum of 3 ft or more in all directions from the defective area. (Additional overlap may be required to provide

strength in the material, as evaluated using a sliding analysis and the geosynthetic to geosynthetic friction angle).

- NOTE: If a "weak link" exists in the geosynthetic, either through a defective seam or tear, the system generally has a very dramatic way of telling the engineer about it in the form of a spectacular failure! (Holtz, 1985).

3. Fill placement, spreading and compaction procedures for extremely soft foundations, where a mudwave exists. The sequence of construction is shown on Fig. 7.5.

a) End-dump fill along edges of geosynthetic to form toe berms or access roads.

- Use trucks and equipment compatible with constructability design assumptions (Table 7-1).
- End-dump on the previously placed fill; do not dump directly on the geosynthetic.
- Limit height of dump pile to e.g. less than 3 ft above the lower geosynthetic layer to avoid local bearing failure. Spread piles immediately to avoid local depressions.
- Use light weight dozers and/or front end loaders to spread the fill.
- Toe berms should extend 1 to 2 panel widths ahead of the remainder of the embankment fill placement.

b) After constructing the toe berms, spread fill in the area between the toe berms.

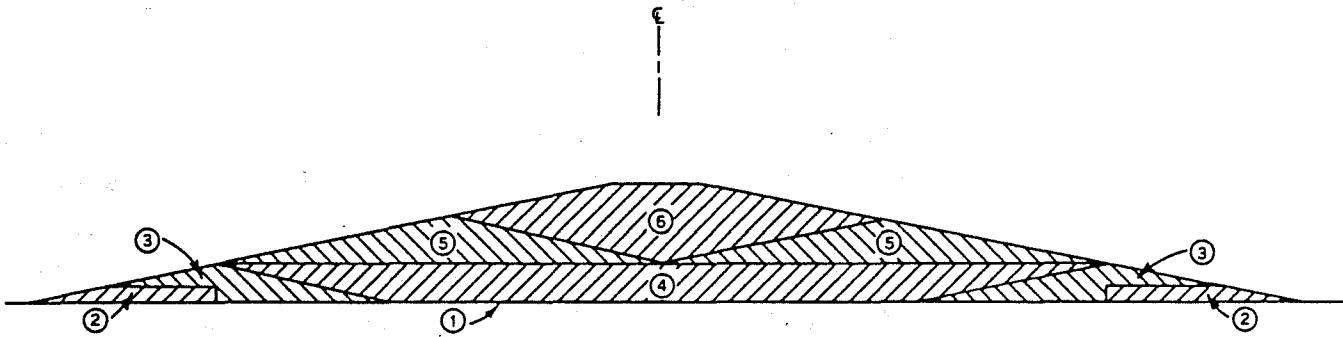

### SEQUENCE OF CONSTRUCTION

- ① **LAY GEOTEXTILE IN CONTINUOUS TRANSVERSE STRIPS,  
SEW STRIPS TOGETHER.**
- ② **END DUMP ACCESS ROADS.**
- ③ **CONSTRUCT OUTSIDE SECTIONS TO ANCHOR GEOTEXTILE**
- ④ **CONSTRUCT INTERIOR SECTION TO "SET" GEOTEXTILE.**
- ⑤ **CONSTRUCT INTERMEDIATE SECTIONS TO  
TENSION GEOTEXTILE.**
- ⑥ **CONSTRUCT FINAL CENTER SECTION.**

Fig. 7.5 Construction Sequence for Geosynthetic Reinforced Embankments for Extremely Weak Foundations (Haliburton, Douglas and Fowler, 1977)

- Placement should be parallel to the alignment and symmetrically from the toe berm inward towards the center to maintain a "U" shaped (concave outwards) leading edge to contain the mudwave (Fig. 7.6a).
- c) Traffic on the first lift should be parallel to the embankment alignment, no turning of construction equipment should be allowed.
- Construction vehicles should be limited in size and weight such that rutting of the initial lift is no greater than 3 in. If rut depths exceed 3 in., it is necessary to decrease the size and/or weight of the construction vehicles.
- d) Densification of the first lift should be accomplished only by "tracking in place" with dozers or end loaders.
- e) Once the embankment is at least 2 ft. above the subgrade, subsequent lifts could be compacted with smooth drum vibratory roller or other suitable compactor. If localized quick or liquefied conditions are encountered, the vibrator should be turned off and the weight of the drum alone should be used for compaction. Other types of compaction equipment should of course be used for nongranular fill.
- B. Fill placement, etc., for less severe conditions (i.e., when no mudwave forms).
- a) It is very important that the geosynthetic be placed with no wrinkles or folds and manually pulled taught prior to placement of fill.

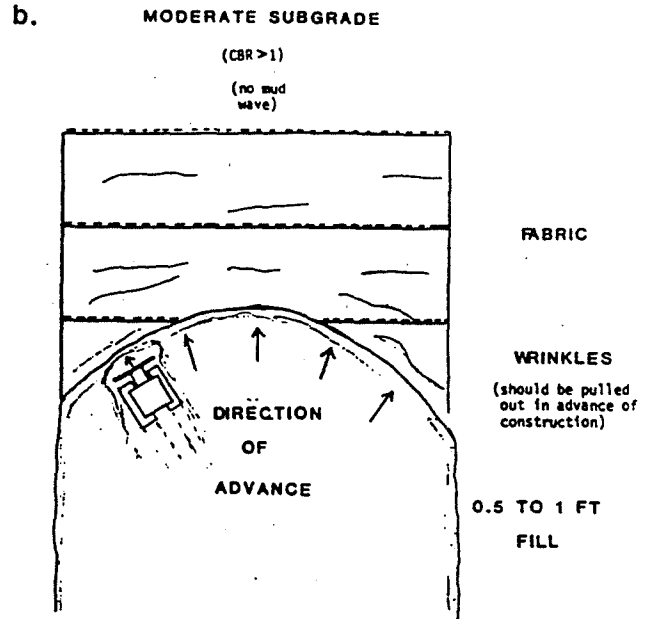
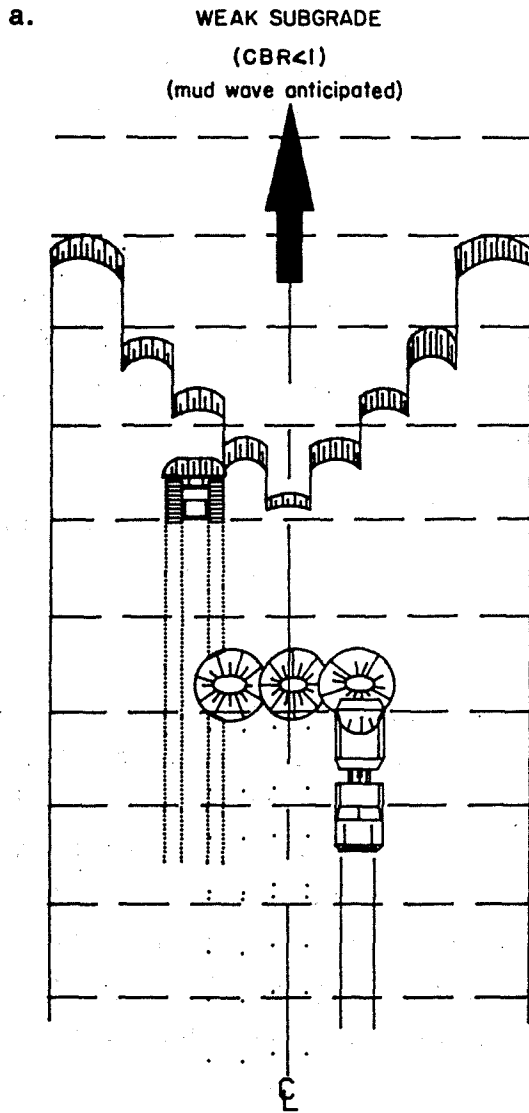

Fig. 7.6 (a) Placement of Fill Between Toe Berms on Extremely Soft Foundations  
(b) Fill Placement to Tension Fabric on Moderate Ground Conditions

- b) Place fill symmetrically from the center outwards in an inverted "U" (convex outward) construction process as shown in Fig. 7.6b, using fill placement to maintain tension in the geosynthetic.
- c) Minimize pile heights to avoid localized depressions.
- d) The construction vehicles in size and weight such that rutting in initial lift is no greater than 3 in.
- e) Smooth drum or rubber tired rollers may be considered for compaction of first lift; however, care should be taken not to overcompact. If weaving or localized quick conditions are observed, compaction of the first lift should only be performed by tracking it with construction equipment.

#### 4. Construction monitoring

- a) Monitoring program must include piezometers to indicate the magnitude of excess pore pressure developed during construction. If excessive pore pressures are observed, construction should be halted until the pressure drops to a predetermined safe value.
- b) Settlement plates should be installed at the geosynthetic level to monitor settlement during construction and adjust fill requirements appropriately. If more settlement occurs than anticipated during construction, the design should be checked for the new final height of the embankment.

- c) Inclinometers should be considered at the toe of the embankment to monitor lateral displacement.

Photos of several projects under construction are shown in Fig. 7.7.

## 7.9 Field Inspection

Since the construction sequence for reinforced embankments on very soft foundations is so crucial to their success, competent and professional field inspection is absolutely essential. Field personnel must be properly trained to observe every phase of the construction to make sure that the specified material is delivered to the project, that the geosynthetic is not damaged during construction, and that the specified sequence of construction operations are explicitly carried out. Field personnel should review the checklist in Section 1.7.

## 7.10 Reinforcement of Embankments Covering Large Areas

Special considerations are required for the construction of large reinforced areas such as parking lots, toll plazas, storage yards for maintenance materials and equipment, and construction pads. Loads are more biaxial than conventional highway embankments, and design strengths and strain considerations are required to be the same in all directions. Analytical techniques for geosynthetic reinforcement requirements are the same as those discussed in Section 7.3. As the geosynthetic strength requirements will be the same in both directions, including across the seams, special techniques must often be considered for seaming to meet required strength requirements. Ends of rolls may also require butt seaming. In this case, rolls of different lengths should be used to stagger the butt seams. Consideration should be given to using two layers of fabric, with the bottom layer placed with seams in one direction, and the top layer placed in the direction perpendicular to the bottom layer. The layers should again be separated by a minimum lift thickness soil layer.





a) Geosynthetic Placement

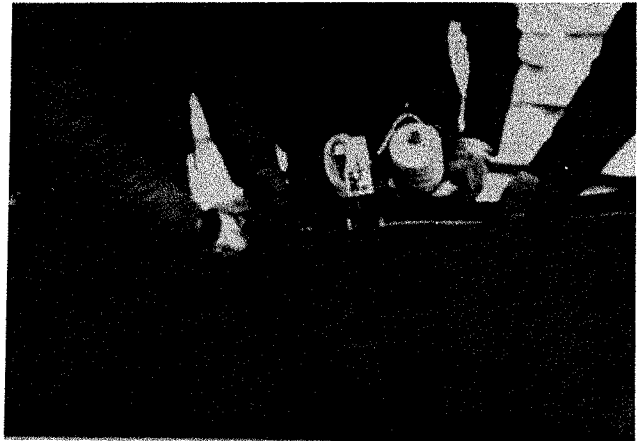

b) Field Sewing

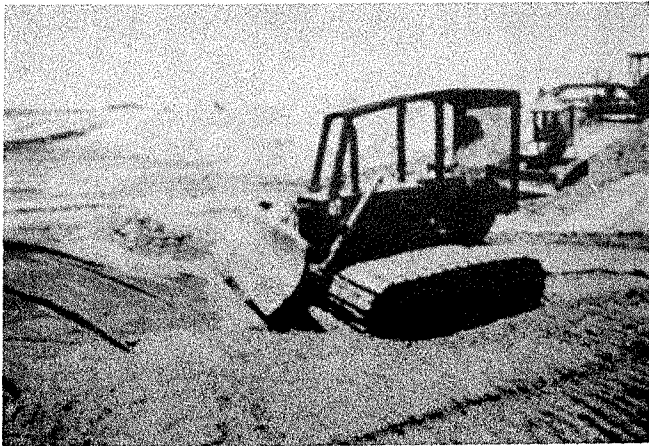

c) First Lift Placement

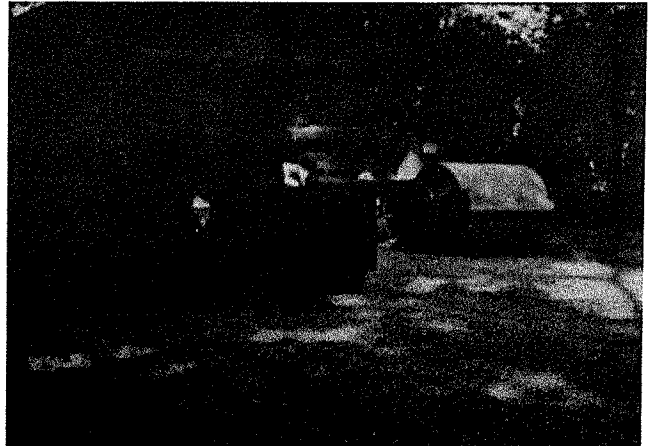

d) Fill Placement and Compaction

Fig. 7.7 Reinforced Embankment Construction

For extremely soft subgrades, the construction sequence must be well planned to consider the formation and movement of mudwaves. Uncontained mudwaves moving outside of the construction can create stability problems at the edges of the embankment. It may be desirable to construct the fill in parallel embankment sections, then connect the embankments together to form the entire construction. Another method staggers the embankment load by constructing a wide low embankment with a higher embankment in the center. The outside low embankments are constructed first and act as berms for the center construction. Next an adjacent low embankment is constructed from the outside into the existing embankment and then the central high embankment is spread over the internal adjacent low embankment. Other construction schemes can be considered depending on the specific design requirements. In all cases, a perimeter berm system should be used to contain the mudwave.

## CHAPTER 8

### REINFORCED SLOPES

#### 8.1 Background

Even if foundation conditions are satisfactory, slopes may be unstable at the desired slope angle. For new construction, the cost of fill, right-of-way, and other considerations may make a steeper slope desirable. Existing slopes, natural or manmade, may also be unstable as is usually painfully obvious when they fail. Multiple layers of geotextiles or geogrids may be placed in the slope as shown in Fig. 8.1 during construction or reconstruction to reinforce the soil and provide increased slope stability.

In this chapter, the analysis of the reinforcement and construction details required to provide a safe slope will be reviewed. The design methods referenced in this chapter are contained in detail in the FHWA Geotextile Engineering Manual. An FHWA research study is currently underway to prepare definitive design guidelines on reinforced soil slopes. As that study is not yet completed, this chapter will present an overview of the design methods as outlined in the FHWA Geotextile Engineering Manual.

#### 8.2 Applications

There are two purposes for using geosynthetics in slopes. The first is to increase the stability of the slope, particularly after a failure has occurred or if a steeper than "safe" unreinforced slope is desirable. The second purpose is to provide improved compaction at the edges of a slope, thus decreasing the tendency for surface sloughing.

The advantages of constructing a steeper slope than would normally be possible are obvious. For the case of repairing a slope

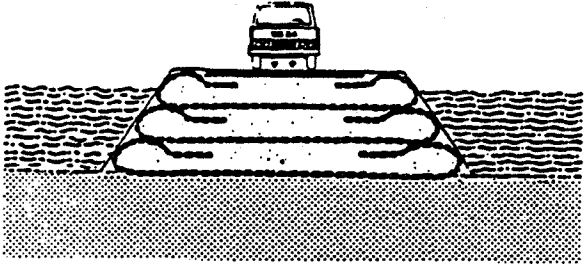
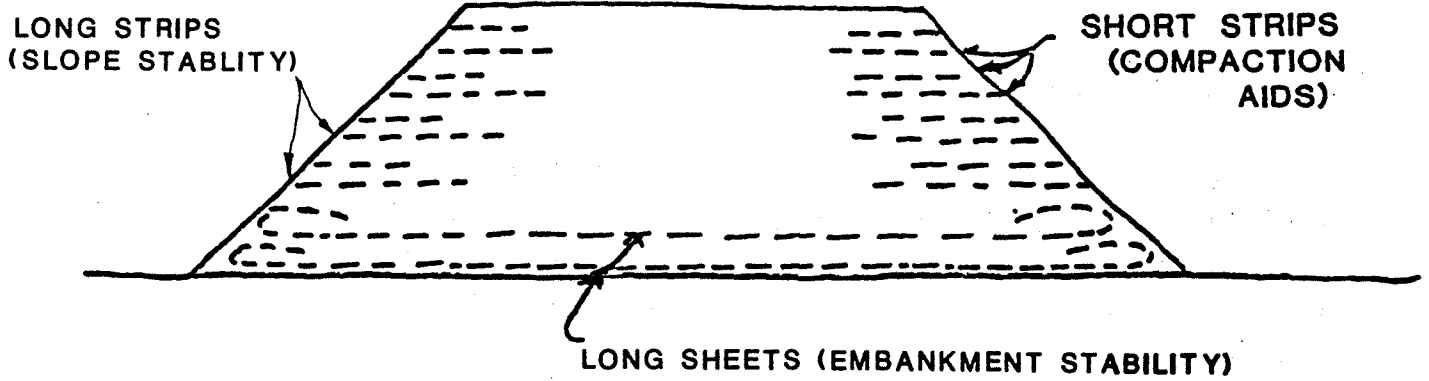

saturated fills

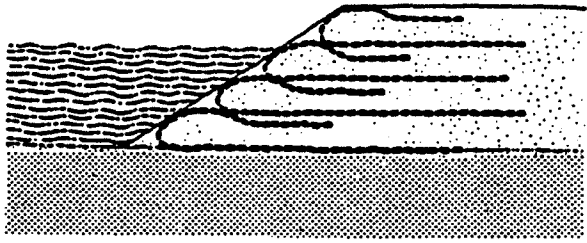

coastal protection

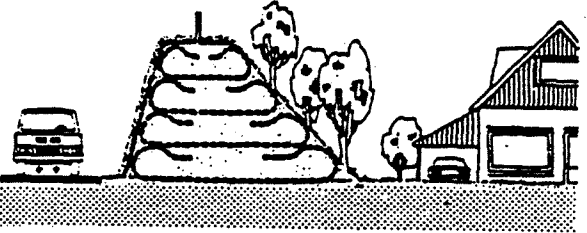

sound absorbing walls

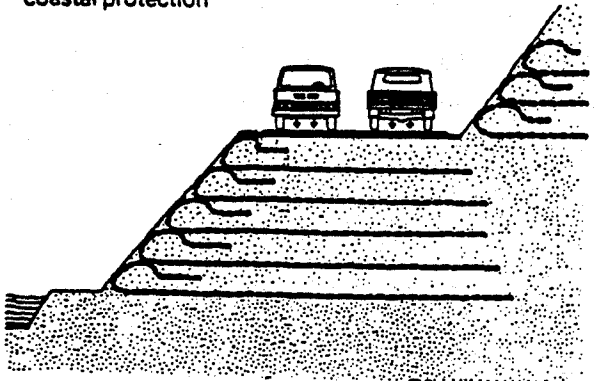

embankment slope stability

Fig. 8.1 Slope Reinforcement Using Geotextiles to Provide Increased Slope Stability

failure, not only will the new slope be safer, but reuse of the slide debris rather than the import of more competent backfill may result in substantial cost savings. In either case, the design of reinforcement for this application is critical as failure of the reinforcement would result in failure of the slope.

For the second application, geosynthetics placed at the edges of a slope have been found to provide lateral resistance during compaction, thus allowing for an increase in compaction density over that normally achieved. Even modest amounts of reinforcement in compacted slopes have been found to reduce sloughing and slope erosion. For this application, the design is simple; place any geotextile or geogrid that will survive construction at every lift or every other lift along the slope. Only narrow strips, about 3 to 6 ft. in width are required. Assuming the slope is safe without reinforcement, no reinforcement design is required. Therefore, the remainder of the chapter will concentrate on the first application: providing stable slopes.

### 8.3 Geotextile and Geogrid Design Considerations

#### 8.3.1 Design Requirements

The overall design requirement for reinforced slopes are similar to those for unreinforced slopes: The factor of safety against sliding must be adequate for both the short term and long term conditions and for all possible modes of failure.

#### 8.3.2 Design Properties

Although geogrids have been used as the reinforcement in the vast majority of reinforced slopes constructed so far, there is no fundamental reason why a geotextile would not have worked just as well in these projects. For example, a number of vertically faced reinforced walls have been successfully constructed with geotextiles (Chapter 9). For modest slopes, less than 1 horizontal to 1 vertical, only a small additional resisting moment

is required to adequately increase the factor of safety; thus only a relatively modest amount of reinforcement is needed. Of course, as the slope steepens, reinforcement requirements increase accordingly. The use of geogrids and high strength geotextiles may be preferred by designers because of their relatively high modulus, which should result in lower deformations at working stress levels. Of course, these higher strength and higher modulus materials are more expensive.

The geosynthetic properties required for reinforced slope design are:

- Tensile Strength ( $T_{ult}$ ): Wide Width Test (ASTM-4595). Confined stress-strain tests may also be used.
- Soil-Geosynthetic Adherence: Pullout, Direct Shear, or  $2/3 \phi_{soil}$
- Creep Strength or Limit State Reinforcement Tensile Strength ( $T_L$ ): See FHWA Geotextile Engineering Manual for polymer evaluation

Elongation characteristics of the geosynthetic, even though important, are not usually included in the design because confinement effects are difficult to assess and slope design methods do not consider deformations prior to failure. Until design methods are established that incorporate deformation, the design strength should be found from the stress at a specific value of strain, e.g., 5%. Recent research suggests that the confined tensile strength-strain relations for a nonwoven geotextile are significantly improved over that measured in the wide width test. Therefore, when nonwoven geotextiles are used, it is recommended that if at all possible, confined stress-strain properties be used for design. The design strength also should be well below the creep limit ( $T_L$ ) of the geosynthetic. One way to handle this is to use the results of confined creep tests to

decrease the ultimate strength requirements. Alternatively, in the absence of test data, the ultimate strength should be at least four times the design strength value, or

$$T_{ult} \geq 4T_L \quad (21)$$

In addition to the design properties, the reinforcement must survive installation. Table 8-1 provides relationships for the severity of loading imposed on the geotextile or geogrid to various construction conditions. To provide guidance in geotextile selection, the severity of the loading conditions can then be related to the strength requirements for geotextiles anticipated to survive those conditions (see Section 5.8 for information on the use of this table). Table 8-2 which was developed for haul road and embankment construction could be used to provide interim guidance until values specifically related to slope reinforcement construction are available (currently under development by FHWA).

Even if the geosynthetic meets or exceeds the criteria listed in Table 8-2, some minor damage to the reinforcement may still occur. Any damage due to construction operations, sometimes called "site damage", will decrease its strength. Preliminary evidence indicates that this strength reduction is 10% to 30% for materials meeting the survivability requirements of Table 8-2. Therefore, in addition to meeting the requirements in Table 8-2, to account for possible construction damage, it is recommended that the limit strength for the geotextile ( $T_L$ ) be reduced by 10% to 30%, depending on the survivability requirements and experience. For example, if the design indicates strengths close to the requirements of Table 8-2, in the absence of any other information, you should decrease the allowable strength of the geosynthetic by 25% (or increase the required design strength by a factor of 4). However, if the design indicates strengths that are well above the requirements of Table 8-2, use a 10% reduction factor.

TABLE 0-1  
Relationship of Construction Elements  
to Severity of Loading Imposed on  
Geotextile in Roadway Construction

Variable Equipment	Severity Category		
	Low Light weight dozer (8 psi)	Moderate Medium weight dozer; light wheeled equip. (8-40 psi)	High to Very High Heavy weight dozer; loaded dump truck (>40 psi)
Aggregate	Rounded sandy	Coarse angular	Cobbles, blasted rock
Lift Thickness (in.)	18	12	6

TABLE 0-2  
Geotextile Strength Required for  
Survivability During Construction

PHYSICAL PROPERTY REQUIREMENTS < 50% GEOTEXTILE ELONGATION / >50% GEOTEXTILE			
ELONGATION <sup>2,3</sup> SURVIVABILITY LEVEL	GRAB STRENGTH ASTM D 4632 (LBS)	PUNCTURE RESISTANCE ASTM D 4833 (LBS)	TRAPEZOID TEAR STRENGTH ASTM D 4533 (LBS)
HIGH	270/180	100/75	100/75
MEDIUM	180/115	70/40	70/40
ADDITIONAL REQUIREMENTS APPARENT OPENING SIZE			TEST METHODS ASTM D 4751
1. <50% soil passing a No. 200 US sieve, AOS <0.6 mm.			
2. >50% soil passing a No. 200 US sieve, AOS <0.3 mm.			
PERMEABILITY			ASTM D 4491
1. $k$ of the fabric $>k$ of the soil (permeability times the nominal geotextile thickness).			
ULTRAVIOLET DEGRADATION			ASTM D 4355
1. At 150 hours exposure, 70% strength retained for all cases.			
GEOTEXTILE ACCEPTANCE			ASTM D 4759
<sup>1</sup> Values shown are minimum roll average value strength values are in the weaker principle direction			
<sup>2</sup> Elongation as determined by ASTM D 4632.			
<sup>3</sup> The values of geotextile elongation do not imply the allowable consolidation properties of the subgrade soil. These must be determined by a separate investigation.			



In all cases, the contractor should demonstrate that the proposed construction techniques will not severely damage the reinforcement.

Other properties that require consideration are related to durability and longevity, because, unlike embankments, the soils in slopes are not increasing in strength with time. The polymer of the geosynthetic must be compatible with the chemistry of the backfill. The backfill should be checked for such items as high and low pH, chlorides, organics and oxidation agents such as ferruginous soils which contain  $Fe_2SO_3$ , calcareous soils, and acid sulfate soils which may result in deterioration of the geosynthetic with time. Other possible detrimental environmental factors include chemical solvents and diesel and other fuels. Each geosynthetic is different in its resistance to aging and attack by different chemical and biological agents. Therefore, each product must be investigated individually to determine the effects of these durability factors. As such, the manufacturer of the geosynthetic should supply the results of exposure studies on the specific product including, but not limited to, strength reduction due to aging of the microstructure, chemical attack, microbiological attack, environmental stress cracking, hydrolysis and any possible synergism between individual factors. AASHTO-AGC-ARTBA Task Force 27 on Ground Modification Systems tentatively recommends that the allowable strength of the geosynthetic ( $T_L$ ) be decreased by a factor of 2.0 unless such information is provided, and in all cases it should be decreased by a minimum of 10%. Durability of geosynthetics is the subject of important ongoing FHWA research. Task Force 27 also has some recommendations as to the specific data to be requested from reinforcement suppliers.

Ultraviolet stability is only of concern during construction and when the geosynthetic is used to wrap the slope face. If so, then the geosynthetic should be protected with coatings or facing units

to prevent UV deterioration. Vegetative covers could also be considered in the case of open weave geotextiles or geogrids. Thicker geosynthetics with ultraviolet stabilizers can be left exposed for several years or more without protection; however, long term maintenance should be anticipated because of both UV deterioration and possible vandalism.

One other property, that of transmissivity (in-plane flow), may be considered for construction with wet and poorly drained soils. Geotextiles with this capability may be considered by themselves or in conjunction with other reinforcement to aid in dissipating construction pore pressures, allowing consolidation, thus increasing the stability of the slope. However, since wet and poorly drained soils are not normally recommended for slopes, their use should be carefully evaluated.

### 8.3.3 Research Needs

Further research is needed on both the design analyses and properties for reinforced slopes. As mentioned previously, a design method that considers deformation of the slope and elongation of the reinforcement would allow selection of the design strengths on a more rational basis. Needed also are improved testing methods and interpretation for the determination of the strengths and soil-geosynthetic friction or adherence design parameters for both short term and long term (creep) design requirements.

Additional research is also needed on the influence of construction operations on the allowable strength of the reinforcement, the so-called "site damage" reduction factors, as well as on the durability and longevity of common slope reinforcement materials.

## 8.4 Design of Reinforced Slopes

Just as for the analysis of unreinforced slopes, classical limiting equilibrium methods are conventionally used for designing reinforced slopes. Essentially, the relationships between driving and resisting forces are analyzed (through either moment or force equilibrium). A circular arc or sliding wedge type failure surface is usually assumed. The critical surface is assumed to pass through the layers of reinforcement and usually through the toe of the slope, although deep seated surfaces should also be checked. The number of reinforcing layers can thus be calculated on the basis of the design strength of the reinforcing material and the reinforcement necessary to provide a stable slope with an adequate factor of safety. A sufficient embedment length beyond the critical failure surface must also be provided such that the geotextile or geogrid will not pull out at the design loads.

## 8.5 Guidelines for Reinforced Slope Design

The following provides a step by step procedure for the design of reinforced soil slopes.

1. Establish the requirements for design (see Fig. 8.2).
  - a. Slope height,  $H$ .
  - b. Slope angle,  $\beta$ .
  - c. External loads:
    - Temporary live loads,  $\Delta q$
    - Surcharge loads,  $q$
    - Seismic loads,  $\alpha q$
2. Determine the engineering properties of the natural soils in the slope.
  - a. Determine foundation soil profile below the base of the slope and along the alignment to a

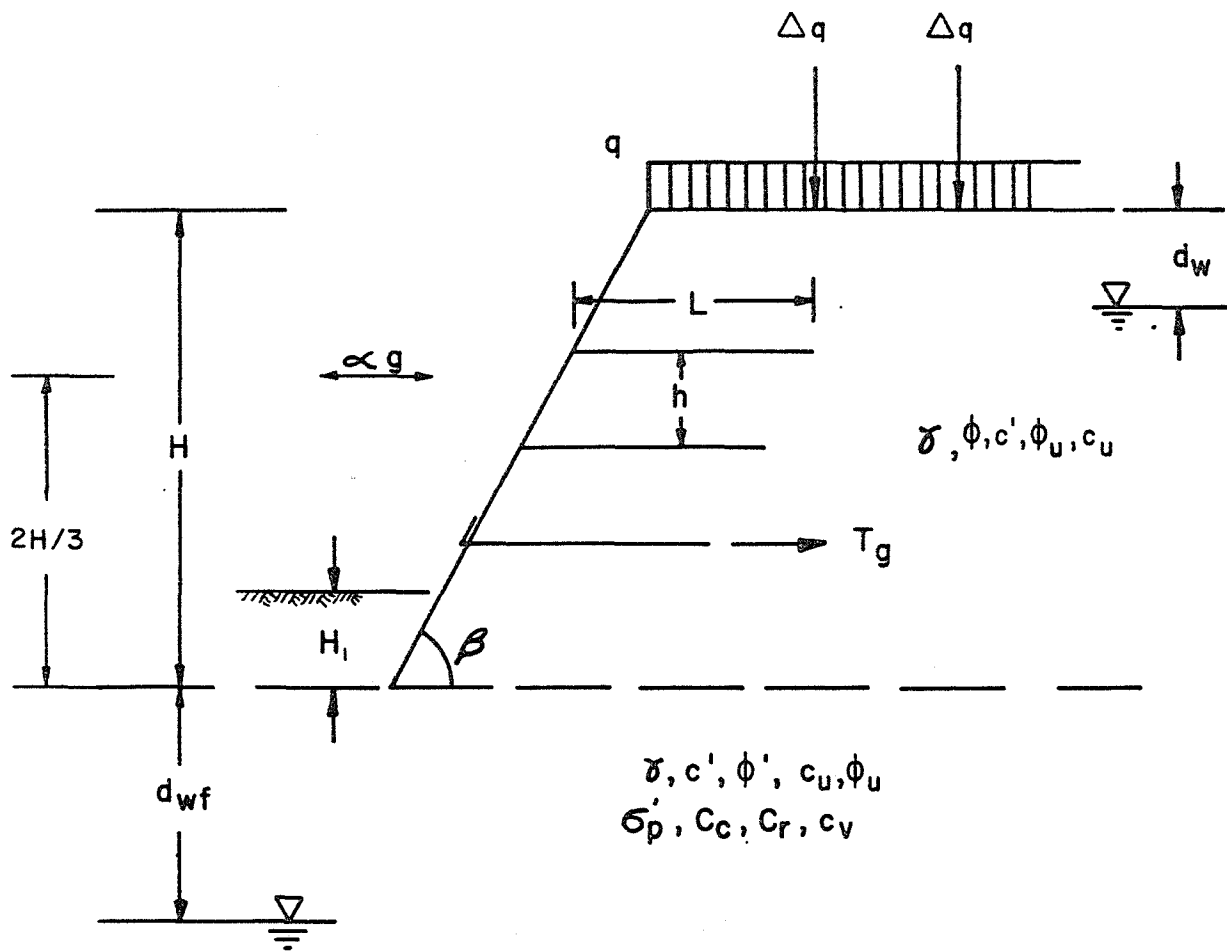

Fig. 8.2 Requirements for Design of Reinforced Slope

sufficient depth to evaluate a potential deep seated failure (recommended exploration depth is twice the height of the slope or to refusal).

- b. Determine the foundation soil strength parameters ( $c_u$ ,  $\phi_u$  or  $c'$  and  $\phi'$ ), unit weight (wet and dry) and consolidation parameters ( $C_c$ ,  $C_r$ ,  $c_v$  and  $\sigma'_p$ ).
- c. Location of the ground water table  $d_w$  (especially important if water will exit slope).
- d. If the slope has previously failed, make sure that the cause of failure and location of the failure surface has been determined.

3. Determine properties of available fill.

- a. Gradation and plasticity index.

Recommended backfill requirements for reinforced slopes:

<u>Sieve Size</u>	<u>Percent Passing</u>
3 inch	100
No. 4	100 - 20
No. 40	0 - 60
No. 200	0 - 50

Plasticity Index (PI)  $\leq$  20 (AASHTO T-90)

Soundness: Magnesium sulfate soundness loss less than 30% after 4 cycles.

Geosynthetic strength reduction factors for site damage should be checked in relation to the largest partical size to be used and the angularity of the larger particles.

- b. Compaction characteristics,  $\gamma_d$  and  $w_{opt}$ .
- c. Shear strength parameters,  $c_u$ ,  $\phi_u$  or  $c'$ ,  $\phi$ .

For granular materials with less than 5% minus the No. 200 sieve, use consolidated-drained (CD) triaxial or direct shear tests. Determine and use effective stress strength parameters,  $c'$  and  $\phi'$ .

For all other soils, determine effective stress strength parameters,  $c'$  and  $\phi'$ , and total stress strength parameters,  $c_u$  and  $\phi_u$ . Use CD direct shear tests (sheared slowly enough that they are drained) or consolidated-undrained (CU) triaxial tests with pore pressures measured.

- d. Chemical composition of soil that may affect durability of geosynthetics (pH, chloride, oxidation agents, etc.); see Section 8.3.2. Do not use soils with  $\text{pH} > 11$  or  $12$  or  $\text{pH} < 3$ .
4. Establish design factors of safety (recommended minimums; local codes may require greater values).
    - a. External stability and settlement
      - Sliding: F.S. = 1.5 or greater.
      - Deep seated (overall stability): F.S. = 1.3 or greater.
      - Dynamic loading: F.S. = 1.1 or greater, depending on local codes.
      - Settlement--maximum based on project requirements.

b. Internal stability

- Slope stability: F.S. = 1.3 or greater.
- Design Tensile Strength ( $T_d$ ):  $T_d @ 5\% \text{ strain} < T_a$
- Allowable Geosynthetic Strength,  $T_a =$  creep limit strength ( $T_L$ )  $\div$  safety factors for construction and durability:
  - Creep: F.S. = 4 or from creep tests.
  - Construction: F.S. = 1.1 to 1.3 plus meets Table 8-2 requirements.
  - Durability: F.S. = 1.1 to 2.0 depending on product information and environmental conditions.

NOTE: In the absence of creep tests or any other product information, the AASHTO-AGC-ARTBA Task Force 27 recommends the following default values:

$$T_a = T_{ult} \div (4 \times 1.3 \times 2.0)$$
$$\text{or } T_{ult} \geq (4 \times 1.3 \times 2.0) T_d$$

- Pullout Resistance: F.S. = 1.5 with a 3 ft minimum for granular soils. Use F.S. = 2 for cohesive soils.

5. Check unreinforced stability.

Perform a stability analysis using conventional stability methods (see FHWA Soils and Foundations Workshop Manual, 1982) to determine potential critical failure surface. Use both circular arc and sliding wedge methods, and consider failure through the toe, through the face, and deep seated below the toe. The

computer program STABL5M developed at Purdue University and available through FHWA allows for rapid evaluation by defining the exit points within each of the three potential failure zones.

Other stability analysis programs are available. In all cases, you should do a few calculations by hand to be sure the computer program is giving reasonable results.

6. Design reinforcement to provide for a stable slope.

Several approaches are available for the design of slope reinforcement, many of which are contained in the FHWA Geotextile Engineering Manual (see Chapter 5 and Appendix D of that manual). Research sponsored by FHWA is currently underway that will provide definitive guidelines for slope reinforcement design. Until that time, the methods shown in Figs. 8.3 and 8.4 could be used. The procedure in Fig. 8.3 uses conventional rotational slip surface methods and can accommodate fairly complex conditions depending on the analytical method used (e.g. Bishop, Janbu, etc.). Figure 8.4 presents a simplified method based on a two-part wedge type failure surface. This method is limited by the assumptions noted on the figure. Note that Fig. 8.4 should only be used for a quick check of computer generated results; it is not intended to be a single design tool. Judgment in selection of the appropriate design (i.e. most conservative or most experience) is required. The following design steps are necessary:

- a. Determine the strength of reinforcement,  $T_d$ , required to provide an adequate factor of safety. (Use the two shown in Figs. 8.3 and 8.4 or additional approaches from Geotextile Engineering Manual).



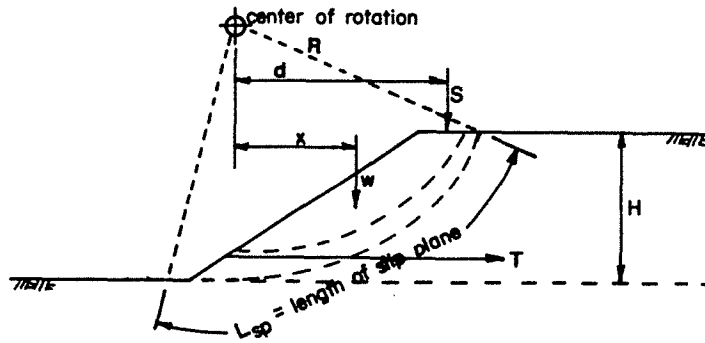

Step 1. Locate most critical surface through the toe of the slope (e.g. use STABL4) and find  $M_R$  available.

$$\text{Factor of unreinforced safety: } F.S._u = \frac{\text{Resisting Moment } (M_R)}{\text{Driving Moment } (M_D)} = \frac{\tau_f L_{sp} R}{(Wx + qd)}$$

where:  $W$  = weight of earth segment  
 $L_{sp}$  = length of slip plane  
 $q$  = surcharge  
 $\tau_f$  = shear strength of soil

Step 2. Once the critical surface and factor of safety have been found, if the program does not calculate  $M_R$ , it can be easily calculated from  $M_D$ , where:

$$M_R = F.S._u (Wx + qd)$$

$F.S._u$  = calculated from computer program for several slip circles

Step 3. To determine strength of reinforcement, T:

$$T_{total} = \frac{F.S._R M_D - M_R}{R} = \frac{F.S._R M_D - F.S._u M_R}{R} = \frac{(F.S._R - F.S._u) M_D}{R}$$

Where:  $F.S._R$  = Factor of safety required (e.g.  $F.S._R = 1.5$ )  
 $R$  = Radius of slip surface

Step 4. Strength of geosynthetic required  $T_d = T_{total} + \text{spacing requirements}$ .

Step 5. Repeat for failure above each layer to make sure distribution is adequate.

Step 6. For large  $H$  (e.g.  $H > 30$  ft), increase  $T$  in lower half and use Step 3 to decrease reinforcement in upper half to decrease overall reinforcement requirements.

Fig. 8.3 Rotational Shear Approach to Determine Required Strength of Reinforcement

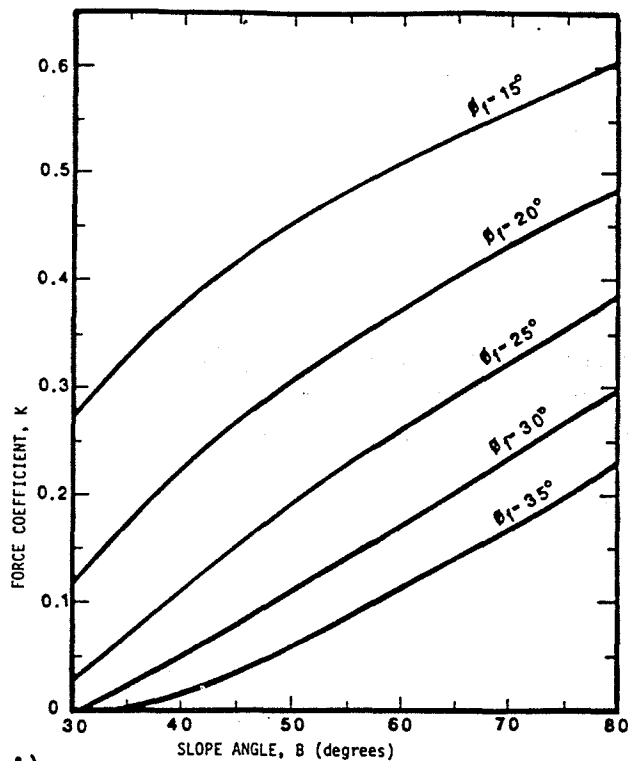

A)

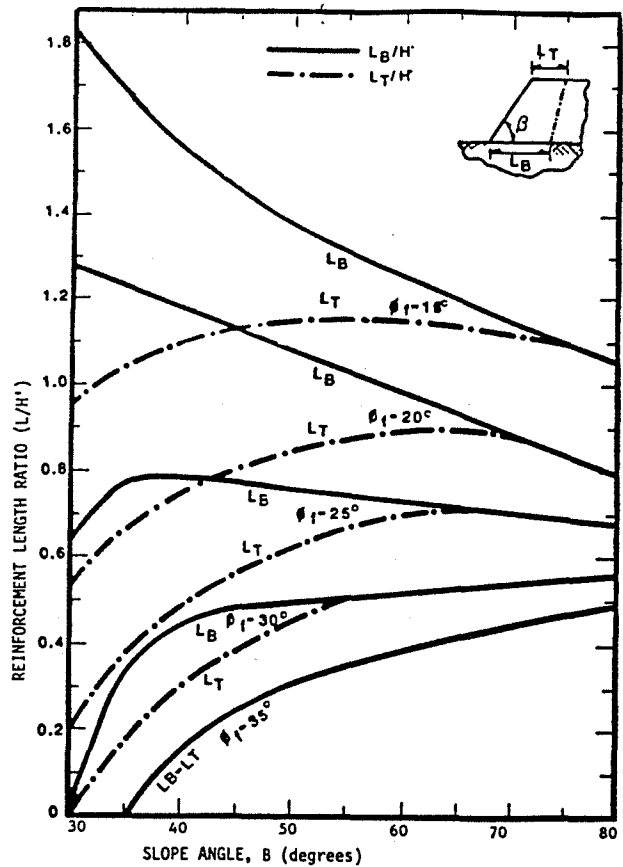

B)

©The Tensar Corporation  
Used by Permission

Chart Design Procedure (to be used to check other methods)

Limiting Assumptions:

- Slopes constructed with cohesionless free draining soil
- Competent level foundation soils
- No seismic forces
- Uniform surcharge
- For Fig. B,  $\phi_{s g} = 90\% \phi_{s o i l}$  (may not be appropriate for some geotextiles)

1. Determine force coefficient K from Fig. A above where  $\phi_f = \frac{\phi_{s o i l}}{S.F._R}$
2. Determine  $T = 0.5K\gamma H^2$

If there is a uniform surcharge at the top of the reinforced geogrid slope,  
 $H = H + q/\gamma$  where q is the uniform surcharge.

3. Determine length of reinforcement required from Fig. B.

204

Fig. 8.4 Sliding Wedge Approach Determination of the Coefficient of Earth Pressure K (Netlon Limited, 1984 as modified by Schmertmann, et. al., 1987)

b. Select the spacing of the reinforcement, S (Fig. 8.5).

- Layer spacing, S: in equal multiples of the compaction layer thickness.
- The strength of the reinforcing  $T_d$  required for each layer = total strength required for stability  $T_{total}$  divided by the number of layers N or

$$T_d = T_{total}/N \quad (22)$$

Where:  $N = H/S$

- To minimize reinforcement requirements, use short 4 to 6 ft lengths of reinforcement in alternating layers to maintain  $S \leq 2$  ft for face support and compaction aids (see Fig. 8.5).

c. Check embedment length beyond critical sliding surface to provide pullout resistance. For the Fig. 8.3 method use:

$$L_e = P_A (FS)/2\sigma_0 \tan \phi_{sg} \quad (23)$$

where:

$P_A$  = required pullout strength

FS = safety factor of 1.5 or more  
(use FS = 2 for cohesive soils)

$\sigma_0$  = overburden pressure above the reinforcing layer.

$\phi_{sg}$  = soil-reinforcement friction or adherence--determine from pullout tests.

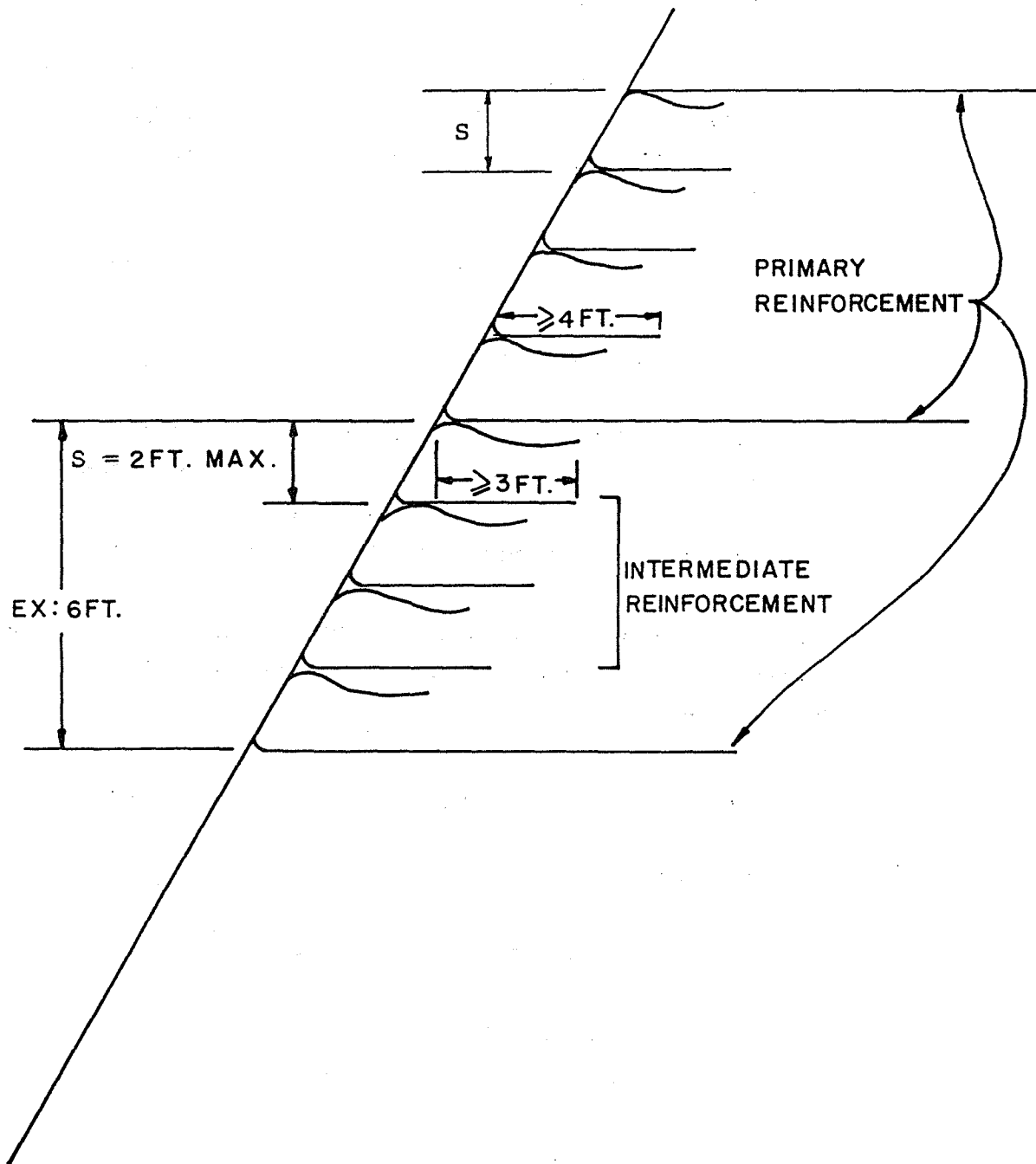

Fig. 8.5 Spacing and Embedment Requirements for Slope Reinforcement

A minimum value of  $L_0 = 3$  ft is recommended.

For Fig. 8.4 method,  $L_0$  is already included in  $L_{total}$  from Chart B.

7. Check external stability.

The external stability of a reinforced soil mass depends on the ability of the mass to act as a stable block and withstand all external loads without failure. Failure possibilities include sliding and deep seated overall instability.

a. Sliding resistance

The reinforced mass must be sufficiently wide at the base to resist sliding along the reinforcement. The length of the reinforcement from the toe can be checked to make sure it is sufficient to resist sliding from the following relationships:

Resisting Force = F.S. x Sliding Force

$$(W + P_a \sin \phi) \tan \phi_{sg} = \text{F.S. } P_a \cos \phi$$

with:  $W = 1/2 L^2 \gamma \tan \beta$  for  $L < H$

$$W = \left[ LH - \frac{H^2}{2 \tan \beta} \right] \gamma \text{ for } L > H$$

where: L = Length of bottom reinforcing layer  
H = Height of slope  
FS = Factor of safety for sliding (>1.5)  
 $P_a$  = Active earth pressure  
 $\phi_{sg}$  = Angle of shearing friction between soil and geosynthetic  
 $\beta$  = Slope angle  
 $\sigma_0$  = Overburden stress

b. Overall rotational stability.

An analysis should be performed to evaluate potential deep seated failure surfaces behind the reinforced soil mass. Classical rotational slope stability methods such as simplified Bishop (1955), Morgenstern and Price (1965), Spencer (1981), or others may be used. Appropriate computer programs also may be used.

c. Foundation Settlement.

The magnitude of foundation settlement should be determined by using classical geotechnical engineering procedures. If the calculated settlement exceeds project requirements, then foundation soils must be improved.

d. Dynamic stability.

If the slope is located in an area subject to potential seismic activity, then some type of dynamic analysis is warranted. Usually a simple pseudo-static type analysis is carried out using a seismic coefficient and obtained from local building codes. For critical projects in areas of potentially high seismic risk, a complete dynamic analysis should be carried out. If you don't know how to do this, get a good geotechnical consultant with experience in doing dynamic analyses.

## 8.6 Design Example

Relevant examples are included in the FHWA publications, "Geotextile Engineering Workshop Design Examples (FHWA-HI-89-002) and Geotextile Engineering Manual FHWA-86-203.

## 8.7 Cost Considerations

As with any other reinforcement application, an appropriate benefit to cost ratio analysis should be carried out to see if the steeper slope with the reinforcement is justified economically over the alternate flatter slope with its increased right-of-way and materials costs, etc. It should be kept in mind that guardrails are often necessary for steeper embankment slopes. In some cases, however, the height of the embankment will be controlled by grade requirements, and the slope might as well be made as steep as possible.

## 8.8 Specifications

As with all reinforcement designs, standard specifications are discouraged and special provisions should be provided on a project specific basis. The following special provision were developed by the Utah DOT and were included on a recent slope reinforcement project using geogrids.

### SPECIAL PROVISION

#### SECTION XXXX - GEOGRIDS

1. Description: The contractor shall install the geogrid reinforcement in accordance with the typical sections and plans.
2. Material Specification:
  - 2.1 The geogrid reinforcement shall be a uniaxially or biaxially oriented polymer an grid structure composed of polypropylene, polyester or high density polyethylene.
  - 2.2 The grid spacing shall be such to provide an opening between the grid elements no smaller than \_\_\_\_\_\* inch and no larger than \_\_\_\_\_\* inches in either direction. The joints at crossover points of grid elements must be integrally connected through extrusion of the mesh itself

or welding of crossover points in such a manner that the elements will not separate under handling and construction activities, nor under stress levels and environmental conditions anticipated over the life of the structure.

2.3 The geogrid to be used shall meet or exceed the following minimum property values:

TABLE 1

GEOGRID MINIMUM PROPERTY REQUIREMENTS<sup>1</sup>

<u>Geogrid</u>	<u>Direction<sup>2</sup></u>	<u>T-Design<sup>2</sup></u> (lbs/in)	<u>T-Ultimate<sup>3</sup></u> (lbs/in)	<u>T-Allowable<sup>4</sup></u> (lbs/in)	<u>P-Resistance<sup>5</sup></u> (lbs/in)
High Strength at base	Principal	___ * @ 5%ε	___ *	___ *	___ * (normal stress = psf)
	Minor	___ * @ 5%ε	___ *	___ *	
Normal Strength at Slope	Principal	___ * @ 5%ε	___ *	___ *	___ * (normal stress = psf)
	Minor	___ * @ 5%ε	___ *	___ *	

\*Project specific information

NOTES:

1. All numerical values represent minimum average roll values required in the designated direction.
2. The principal direction is the direction of the grid to be placed perpendicular to the embankment side slope (whether cross or machine direction), which will be determined by the length, width and strength in both directions of available grids. Contractor shall indicate in writing, the dimensional characteristics of the grid selected and the proposed placement details.
3. Geogrid strength, T, tested in accordance with ASTM D-4595.
4. Allowable strength is the strength extrapolated to a minimum 75 year design life based on creep strength, aging degradation, chemical and biological effects, and influence of construction site damage. The contractor will present evidence from the manufacturer in the form of creep tests (minimum of 1000 hours), durability data, and chemical and biological compatibility test



information on the grid polymer to substantiate that the product meets the allowable strength requirement.

5. The pullout resistance (P) in the principal direction must meet or exceed two times the design strength under the indicated normal stress and a 4 ft embedment length in fine to coarse gravel.

6. The junction shear strength (in pounds force) in principal strength direction will be such to provide the P-resistance strength for the geogrid:

i.e.,  $T_{\text{junction}} \geq P\text{-resistance}/(\text{elements per inch width})^*$

(NOTE: Current Task Force 27 draft guidelines relate junction strength to the number of elements per length of embedment).

2.4 For each consignment, the Contractor shall furnish a sample of the geogrid and two copies of a certificate signed by a legal authorized officer of the geogrid manufacturer certifying that the product meets the requirements of this Specification prior to commencing construction. Proof of test results shall be submitted with the certificates. Samples and product certificate for the facing materials shall also be submitted. At the direction of the Engineer, at least two weeks prior to construction, the Contractor shall provide suitable samples of the geogrid and facing materials (taken from actual rolls that will be delivered to the site) so that the Engineer may perform independent tests to check the material properties. Any geogrid materials which are found to not be in compliance with this Specification shall not be used on this job. The Engineer's representative will be present at the site during installation and the Engineer reserves the right to collect samples periodically for confirmation testing.

### 3. Construction Requirements:

3.3 The Contractor shall be responsible for the following:

a. After delivery to the site, all geogrid material shall be protected from mud or other materials which may affix themselves to the geogrid.

b. The geogrid shall be placed at the levels shown on the plans, and the Engineer shall observe all geogrid placement. The geogrid shall be laid at the proper elevation with the principal strength (see material specification) oriented perpendicular to the embankment slopes shown on the plans or as directed by

the Engineer. The geogrid shall be pulled taut to remove wrinkles or folds and secured in place with staples, pins, backfill, or as approved by the Engineer.

- c. Adjacent geogrid sheets shall be placed with their edges perpendicular to the embankment side slopes touching (butted edge to edge).
  - d. Parallel to the embankment side slopes, edges of adjacent geogrid sheets shall be mechanically fastened such that the connections meet the principal strength design requirements. Alternatively, continuous sheets of geogrid shall be used.
  - e. Fill material shall be placed on top of the geogrid and compacted in lifts as indicated on the plans, and in the Standard Specifications and applicable Special Provisions. All fill materials shall be placed, spread and compacted in such a manner that does not result in the development of wrinkles in and/or movement of the geogrid. No construction equipment shall be allowed to operate directly on the geogrid. A minimum fill thickness of 12 inches shall be maintained between the tracks and wheels of construction vehicles and the geogrid at all times. Turning of vehicles on the lift directly above the geogrid should be kept to a minimum and sharp turns (45° or greater) will not be allowed. Sudden braking shall also be avoided. The Contractor will be responsible for any damage to the geogrid resulting from his method and replaced at the direction of the Engineer at the Contractor's expenses.
4. Method of Measurement: Quantities of geogrid reinforcement shall be measured by the square yard, separately, for bid items high strength and normal strength geogrid. The total quantity shall be computed based on the total area of geogrid shown on the construction plans, including the area of geogrid used in overlaps. Measurements will include specified overlaps. No payment will be made for geogrid reinforcement placed outside of the lines shown on the plans, unless approved in writing by the Engineer.
5. Basis of Payment: The accepted quantities shall be paid for at the contract unit price per square yard for "High Strength Geogrid" and "Normal Strength Geogrid", which price shall include all work necessary to complete this item.

## 8.9 Installation Procedures

As the reinforcement layers are easily incorporated between the compacted lifts of fill, construction of reinforced slopes is very similar to normal slope construction. The following is the usual construction sequence:

### a. Site preparation.

- Clear and grub site.
- Remove all slide debris (if a slope reinstatement project).
- Prepare level subgrade for placement of first level of reinforcing.
- Proof-roll subgrade at the base of the slope with roller or rubber tired vehicle.

### b. Place the first reinforcing layer.

- Reinforcement should be placed with the principal strength direction perpendicular to face of slope.
- Secure reinforcement with retaining pins to prevent movement during fill placement.
- A minimum overlap of 6 in. is recommended along the edges perpendicular to the slope for wrapped face structures. Alternatively, with geogrid reinforcement, the edges may be clipped or tied together. When geosynthetics are not required for face support, no overlap is required and edges should be butted.

c. Place backfill on reinforcement.

- Place fill to required lift thickness on the reinforcement using a front end loader operating on previously placed fill or natural ground.
- Maintain a minimum of 6 in. between reinforcement and wheels of construction equipment.
- Compact with a vibratory roller or plate type compactor for granular materials or a rubber tired vehicle for cohesive materials.
- When placing and compacting the backfill material, care should be taken to avoid any deformation or movement of the reinforcement.
- Use lightweight compaction equipment near the slope face to help maintain face alignment.

d. Compaction control.

- Provide close control on the water content and density of the backfill. It should be compacted at at least 95% of the standard AASHTO T99 maximum density within 2% of optimum moisture.
- If the backfill is a coarse aggregate, then a relative density or a method type compaction specification should be used.

e. Face construction.

If slope facing is required to prevent sloughing (i.e., slope angle  $\beta$  is greater than  $\phi_{soil}$ ) or erosion,

sufficient reinforcement lengths should be provided for the face wrap. The following procedures are recommended for wrapping the face.

- Turn up reinforcement at the face of the slope and return the reinforcement a minimum of 3 to 4 ft into the embankment below the next reinforcement layer (see Fig. 8.6).
  - For steep slopes, form work may be required to support the face during construction, especially if lift thicknesses of (1.5 to 2.0 ft. or greater) are used.
  - For geogrids, a fine mesh screen or geotextile may be required at the face to retain backfill materials.
- f. Continue with additional reinforcing materials and backfill.

Note: If drainage layers are required, they should be constructed directly behind or on the sides of the reinforced section.

Several construction photos from reinforced slope projects are shown in Fig. 8.7.

### 8.10 Field Inspection

As with all geosynthetic construction and especially with critical structures such as reinforced slopes, competent and professional field inspection is absolutely essential for successful construction. Field personnel must be properly trained to observe every phase of the construction to make sure that the specified material is delivered to the project, that the geosynthetic is not

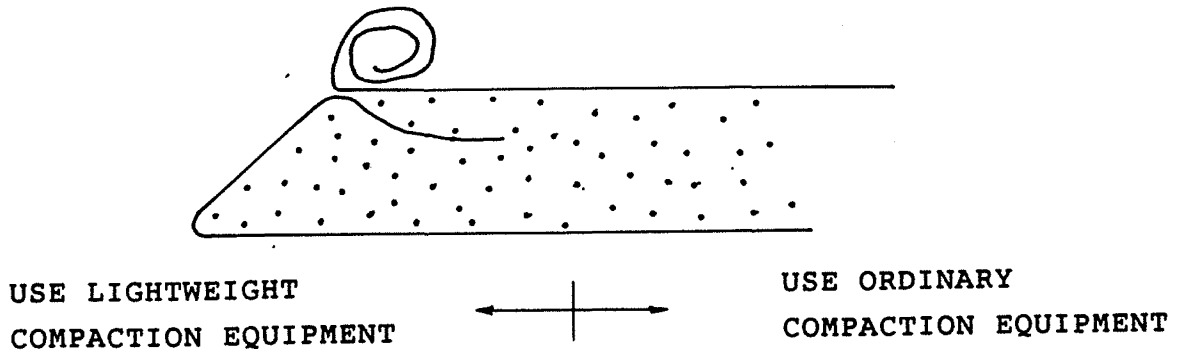

a. Lift 1 plus reinforcing for Lift 2

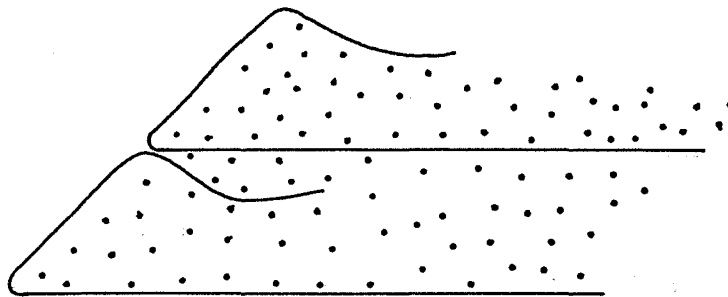

b. Lift 2 with face wrapped

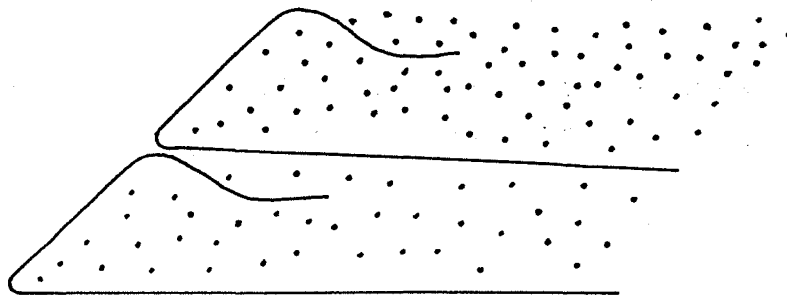

c. Lift 2 completed

Fig. 8.6 Construction of Reinforced Slopes

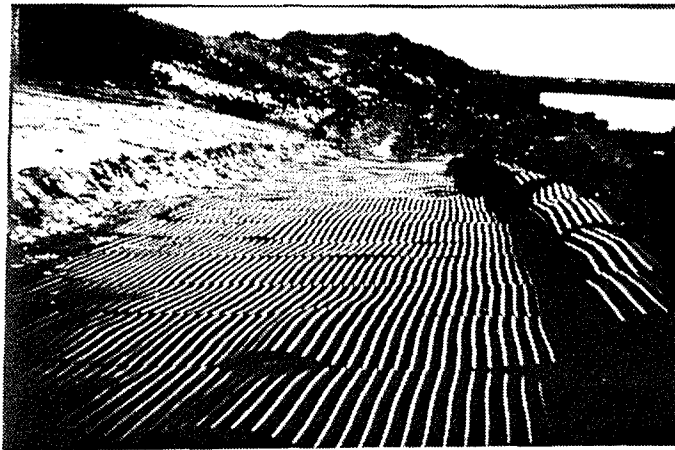

a) Initial Reinforcement Placement



b) Fill Placement

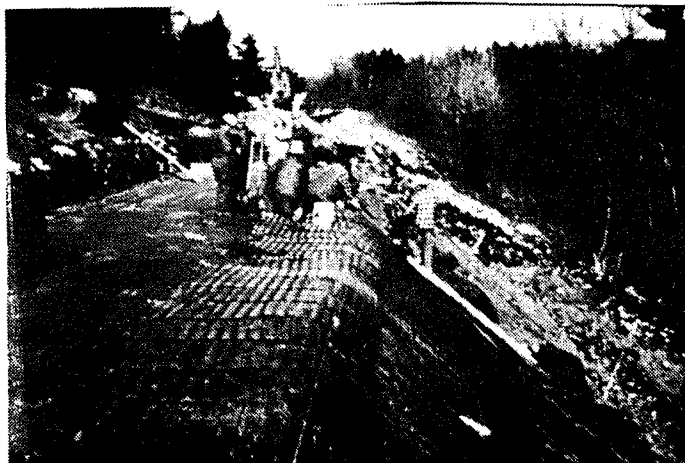

c) Subsequent Reinforcing Layers Constructed

Fig. 8.7 Reinforced Slope Construction Photos  
(Courtesy of Tensar Corporation)

damaged during construction, and that the specified sequence of construction operations are explicitly carried out. Field personnel should review the items on the checklist in Section 1.7. Other important details include construction of the slope face and application of the facing treatment to minimize exposure of the geosynthetic to ultraviolet light.

Often, geosynthetic reinforced slopes are considered "experimental" and thus should be instrumented. As a minimum, settlements and outward movements of the slope at its top should be determined by ordinary levels and triangulation surveys. Sometimes inclinometers and/or multiple point borehole extensometers are used for observing potential horizontal movements at intermediate levels within the slope.



## CHAPTER 9

### REINFORCED RETAINING WALLS AND ABUTMENTS

#### 9.1 Background

Retaining walls in highway engineering are quite common. They are required at any place where a slope is uneconomical or not technically feasible. When considering an earth retaining wall, you should also consider a reinforced soil retaining wall. Reinforced soil walls basically consist of placing some type of reinforcing elements in the soil to resist the lateral earth pressures. When compared with conventional construction, there are often significant advantages to using retaining walls with reinforced backfills. Reinforced soil walls are very cost effective, especially for higher walls required to retain backfills. Furthermore, they are more flexible than conventional earth retaining walls such as reinforced concrete cantilever or gravity walls, and therefore, they are very suitable for poor foundations.

The idea of reinforcing the backfill behind retaining walls was developed by H. Vidal in France in the mid-1960's. The Vidal system, called Reinforced Earth<sup>®</sup>, used metal strips for reinforcement; it is shown in Fig. 9.1. The use of geotextiles or geogrids rather than metallic strips (ties), shown conceptually in Fig. 9.2, is really an additional development of the Reinforced Earth concept. Today, the design and construction of walls with reinforced backfills is quite well established, and 12,000 have been successfully built around the world in the last 20 years.

Polymeric geotextiles and geogrids offer an alternative to metallic reinforcement for both permanent and temporary walls, especially under certain environmental conditions. Of course, with all types of reinforcement, the chemical and biological conditions must be evaluated for each site and backfill. It must

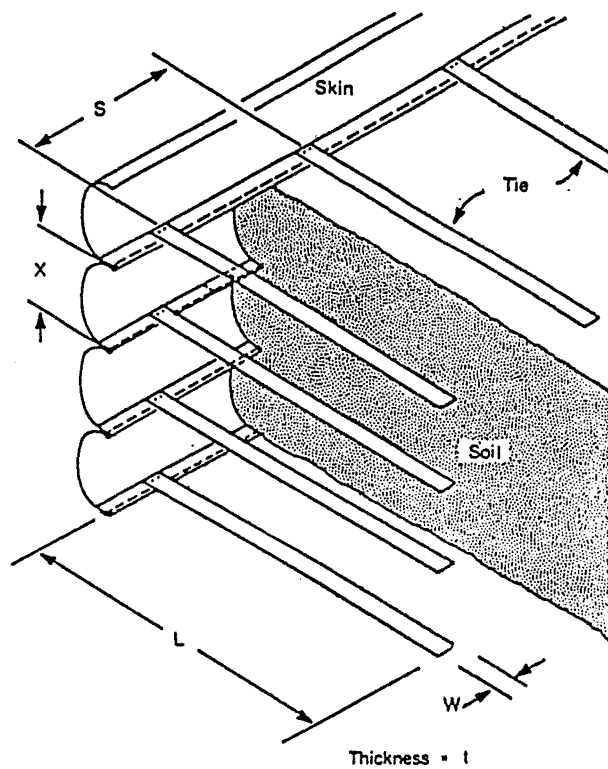

Fig. 9.1 Component Parts and Key Dimensions of Reinforced Earth Wall (Lee, Adams, and Vagneron, 1973)

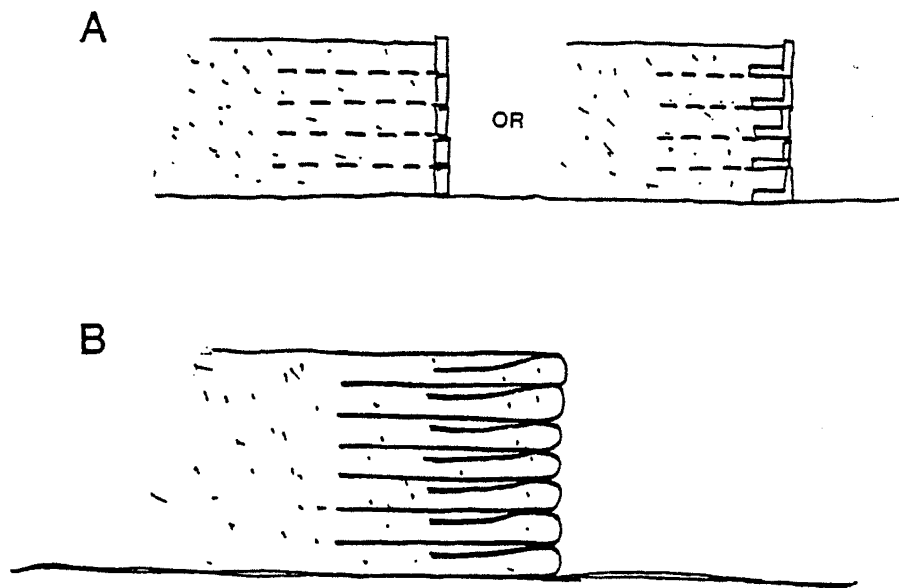

Fig. 9.2 Reinforced Soil Retaining Walls Using Geotextiles  
 (A) With Concrete Facing  
 (B) With Geotextile Facing

be noted that reinforcing with geosynthetics is relatively new and there is less construction experience than with conventional walls. Also, the maximum heights so far constructed are less than 40 ft, whereas Reinforced Earth® walls have approached 100 ft in height. The use of geosynthetics as the facing (Fig. 9.2b) is generally less expensive than more permanent type facings, although these systems may be aesthetically less attractive. Alternate facing systems will be discussed in Section 9.8.

A number of other reinforcing elements besides metal strips, geotextiles, and geogrids have been tried, and some of these are described in the FHWA Geotextile Engineering Manual. As indicated in Chapter 8, FHWA has a study underway now to develop concise design guidelines for reinforced soil slopes and walls using all types of reinforcement.

## 9.2 Applications

Flexible reinforced soil structures including those reinforced with geotextiles or geogrids should be considered as cost effective alternates for all applications where gravity, reinforced concrete cantilever or bin-type retaining walls would be used. This, of course, includes bridge abutments as well as areas where the right-of-way is restricted, such that a conventional earthen embankment at the desired height and side slopes necessary for stability or traffic considerations cannot be constructed. Figure 9.3 shows several completed projects where geosynthetic reinforcement was used to construct retaining walls.

Flexible retaining walls with reinforced backfills may often be less expensive than conventional construction methods, especially as the height of the wall increases. The use of geotextiles or geogrids as the reinforcement may be less expensive than conventional Reinforced Earth® construction with concrete facing panels, especially for small to medium sized projects. They may be most cost effective in temporary or detour construction, and in low volume road construction, national forests and parks, etc.



a) Geotextile Wrapped Face  
Temporary Wall

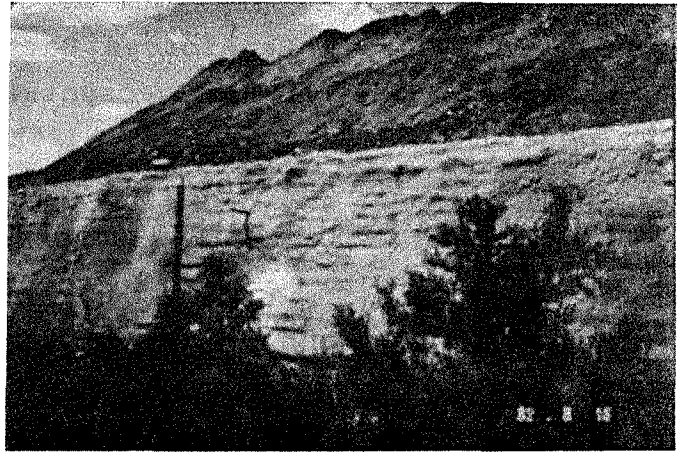

b) Glenwood Canyon, Colorado  
Geotextile Test Wall

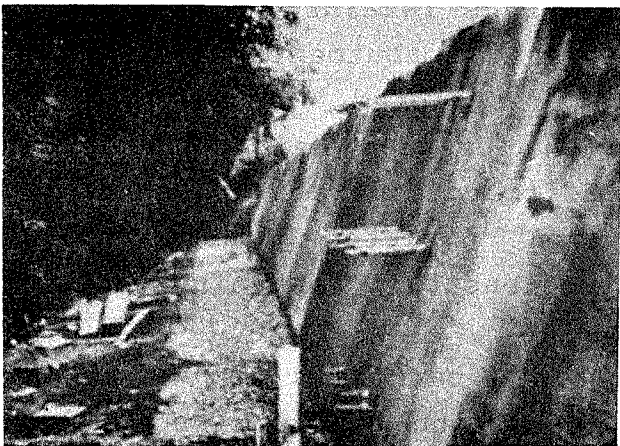

c) New York Department of Transportation  
Wall with Nonwoven Geotextiles

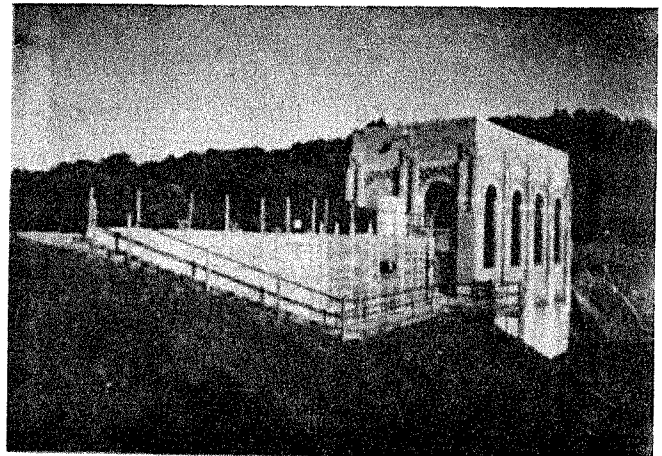

d) Cascade Dam, Michigan  
Geogrid Wall

Fig. 9.3 Photos of Geosynthetic Reinforced Soil  
Walls

Reinforced soil walls offer significant technical advantages over conventional retaining structures such as concrete gravity or reinforced concrete cantilever walls, concrete or steel faced tie back walls, etc., at sites with poor foundation and/or slope conditions. In such cases, the cost of conventional construction plus the necessary foundation improvements such as piles and pile caps, excavation and replacement of the unsatisfactory materials, or other foundation improvement techniques are unacceptably high.

### 9.3 Selection of Geotextile and Geogrid Properties

When used in reinforced retaining structures, geosynthetic properties (tensile strength, modulus, soil-geosynthetic friction, and creep resistance) are required for the mechanical design and for constructability, survivability and durability.

#### 9.3.1 Mechanical Properties

For the design tensile strength ( $T_d$ ), conventional practice uses the stress as determined by the wide width test, ASTM D-4595, generally taken at 5% strain. The use of a tensile stress at 5% strain usually results in an unrealistically low design value for nonwoven geotextiles, as demonstrated by several walls that have been successfully constructed out of lightweight nonwovens to much higher working stress levels. Recent research suggests that the confined tensile resistance of a nonwoven geotextile can be significantly greater than that measured in the wide width test. Therefore, for designs using nonwoven geotextiles, it is recommended that, if at all possible, confined stress-strain properties be used.

If there are temporary live loads, then the allowable stress can be higher than permanent loads without distress, as has been shown by the performance of full scale walls.

Designers may prefer to use materials such as geogrids and high strength geotextiles because of their relatively high modulus,

which results in lower deformations at working stress levels. The design decision is whether these higher strength and higher modulus materials are worth their higher cost.

The property of soil-geosynthetic friction ( $\phi_g$ ) is also required for design. Tests for this property are described in the FHWA Geotextile Engineering Manual. In lieu of actual tests, friction properties may be conservatively assumed to be 2/3 of the friction angle,  $\phi$ , of the backfill. Depending on the size of the backfill soil particles relative to the openings in the grids or geotextile, using 2/3  $\phi$  can be very conservative.

Creep is difficult to design for, although the FHWA Geotextile Engineering Manual mentions some approaches to the creep problem. Substantial creep of the reinforcement could be unsightly and detrimental to the performance of the wall, because a wall which tilts outward looks very unstable, even if the amount of tilt is relatively small. Creep may be more important with high retaining walls reinforced with low strength, extensible geotextiles, although excellent creep performance has been obtained in walls up to 15 to 20 ft high reinforced with relatively weak nonwoven geotextiles at low factors of safety. Polypropylene and polyethylene fibers tend to creep at lower working tensile stress levels than polyesters. In the absence of creep test data, it is recommended that all geotextiles and geogrids be conservatively designed at a creep limit tensile stress level ( $T_L$ ) of 25% of the ultimate resistance.

### 9.3.2 Constructability (Survivability)

As with other geotextile and geogrid installation, it is important that the reinforcing material survive and be able to tolerate the stresses imposed on the reinforcement during construction. Recommendations in Chapter 8 are appropriate, and these are repeated in Tables 9-1 and 9-2 (also see Section 5.8). As before, the level of construction stresses in Table 9-1 are compared with

TABLE 9-1  
Relationship of Construction Elements  
to Severity of Loading Imposed on  
Geotextile in Roadway Construction

Variable Equipment	Severity Category		
	Low Light weight dozer (8 psi)	Moderate Medium weight dozer; light wheeled equip. (8-40 psi)	High to Very High Heavy weight dozer; loaded dump truck (>40 psi)
Aggregate	Rounded sandy	Coarse angular	Cobbles, blasted rock
Lift Thickness (in.)	18	12	6

TABLE 9-2  
Geotextile Strength Required for  
Survivability During Construction

PHYSICAL PROPERTY REQUIREMENTS  
< 50% GEOTEXTILE ELONGATION / >50% GEOTEXTILE

ELONGATION <sup>2,3</sup> SURVIVABILITY LEVEL	GRAB STRENGTH ASTM D 4632 (LBS)	PUNCTURE RESISTANCE ASTM D 4833 (LBS)	TRAPEZOID TEAR STRENGTH ASTM D 4533 (LBS)
HIGH	270/180	100/75	100/75
MEDIUM	180/115	70/40	70/40

ADDITIONAL REQUIREMENTS  
APPARENT OPENING SIZE

TEST METHODS  
ASTM D 4751

1. <50% soil passing a No. 200  
US sieve, AOS <0.6 mm.

2. >50% soil passing a No. 200  
US sieve, AOS <0.3 mm.

PERMEABILITY

ASTM D 4491

1.  $k$  of the fabric  $>k$  of the soil  
(permeability times the nominal  
geotextile thickness).

ULTRAVIOLET DEGRADATION

ASTM D 4355

1. At 150 hours exposure, 70%  
strength retained for all cases.

GEOTEXTILE ACCEPTANCE

ASTM D 4759

<sup>1</sup> Values shown are minimum roll average value  
strength values are in the weaker principle direction

<sup>2</sup> Elongation as determined by ASTM D 4632.

<sup>3</sup> The values of geotextile elongation do not imply the allowable  
consolidation properties of the subgrade soil. These must be determined  
by a separate investigation.

geotextiles that are anticipated to survive construction in Table 9-2. In addition, to account for minor damage that may reduce the strength of the reinforcement, the allowable strength of the reinforcement should be decreased by a safety factor of 1.1 to 1.3. The actual factor used will depend on how close the design property values are to the requirements of Table 9-2. Performance data from other projects may also be used to determine construction damage reduction factors. As before, the contractor should demonstrate that the proposed construction techniques will not damage the reinforcement. An ongoing FHWA study is currently underway to better quantify field survivability.

### 9.3.3 Durability

With reinforced retaining walls, durability of the exposed geosynthetic material is an important consideration. The face of the wall must be protected from ultraviolet radiation, both during construction as well as permanently. The most common procedures for protecting the wall face are to use shotcrete (gunite) and precast concrete panels attached to the reinforcement. Sod and other vegetation are sometimes used with geogrids or open weave geotextiles. If an impervious facing is used, adequate backfill drainage must be provided.

The durability and longevity of the reinforcement is especially important in reinforced walls because unlike embankments on soft foundations, the soils in the backfill are not increasing in strength with time. Further, failure of the reinforcement usually results in a catastrophic type collapse of the wall. Finally, many retaining walls are still in use years beyond their design lifetimes. Thus, except for obviously temporary structures, the service life may turn out to be much longer than the design life of the wall.

As with reinforced slopes, the polymer of the geosynthetic must be compatible with the chemistry of the backfill soils. As a minimum, the backfill should be checked for such items as high and



low pH, high chlorides content, oxidation agents such as  $Fe_2SO_3$ , calcareous soils and acid sulfate soils. These are known to be problem environments for certain polymers.

Other possible detrimental environmental factors include chemical solvents and diesel and other fuels. Each geosynthetic is different with respect to its resistance to aging and attack by different chemical and biological agents. Therefore, especially for permanent construction, each reinforcing product must be investigated individually to determine the effects of these durability factors. As such, the manufacturers of geosynthetics should supply the results of exposure studies on their specific products including, but not limited to, strength reduction due to aging of the microstructure, chemical attack, microbiological attack, environmental stress cracking, hydrolysis and any possible synergism between individual factors. The AASHTO-AGC-ARTBA Task Force 27 on Ground Modification Systems has recommendations as to the specific information to request. Also, the Task Force tentatively recommends that the allowable strength of the geosynthetic ( $T_L$ ) be decreased by a factor of 2.0 unless this durability information is available. In all cases, it should be decreased by a minimum of 10%. Durability of reinforcing geosynthetics is an important current research topic.

#### 9.4 Design Guidelines for Reinforced Walls

##### 9.4.1 Approaches and Models

A number of approaches to the design of geotextile and geogrid reinforced retaining walls have been proposed, and these are mentioned in the FHWA Geotextile Engineering Manual and NCHRP Synthesis of Highway Practice No. 290 "Reinforcement of Earth Slopes and Embankments" (Mitchell and Villet, 1987). However, the method that has been primarily used so far is classical earth pressure theory combined with tensile-resistant "tiebacks", in which the reinforcement extends beyond an assumed failure plane.

Figure 9.4 shows the actual system versus the model typically analyzed. This approach, with some variation, has been followed by Broms (1978), Steward, Williamson, and Mohny (1977), Murray (1980), and Koerner and Welsh (1981). The U.S. Forest Service procedure, developed by Steward et al. (1977) and the Murray procedure can also be found in the FHWA Geotextile Engineering Manual.

The basic approach for internal stability is a limiting equilibrium analysis, with consideration of the possible failure modes of the reinforced soil mass as given in Table 9-3. These failure modes are patterned after the conventional Reinforced Earth design approach.

In addition, the length of the geosynthetic beyond the assumed failure plane, the so-called "adherence length", must be considered. Finally, as with conventional retaining structures, the overall stability and settlement of the wall must also be satisfactory. In fact, external stability considerations generally control the length of the reinforcement required.

#### 9.4.2 Design Steps

The following is a step-by-step procedure for the design of geosynthetic reinforced walls. Additional comments on each step can be found in Section 9.4.3. The design steps are:

- Step 1. Establish design limits, scope of project, and external loads (Fig. 9.5):
- a. Wall height,  $H$
  - b. Wall length,  $L$
  - c. Face batter angle,  $\beta$
  - d. External Loads:
    - Temporary live loads,  $\Delta q$
    - Surcharge loads,  $q$
    - Seismic loads,  $\alpha g$

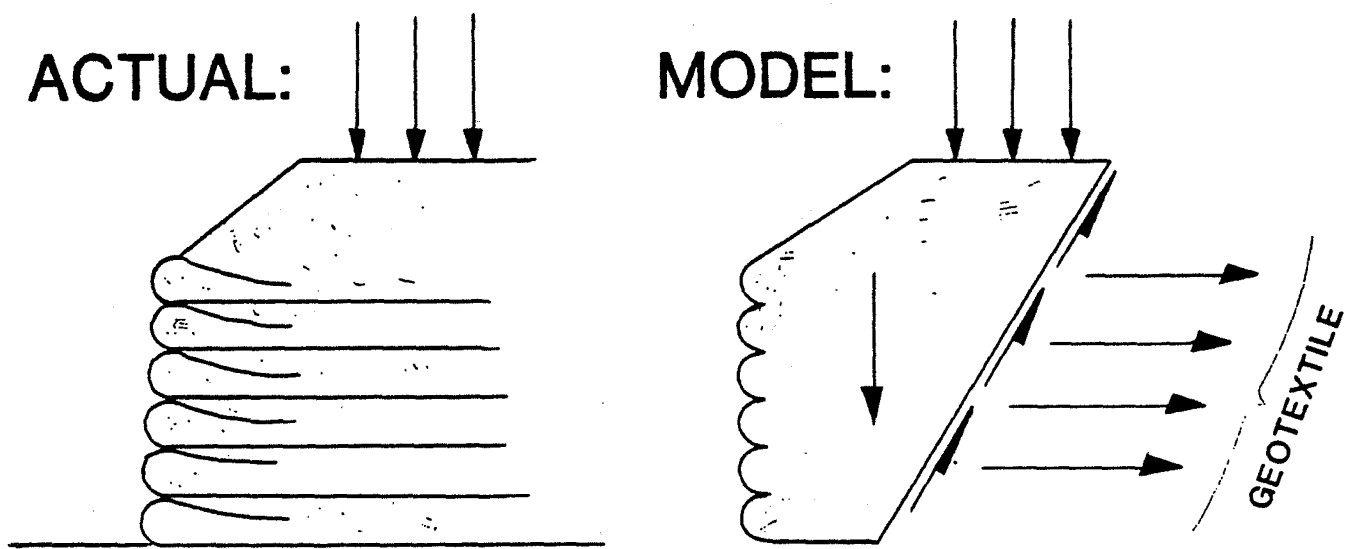

Fig. 9.4 Actual Geosynthetic Reinforced Soil Wall in Contrast to the Design Model

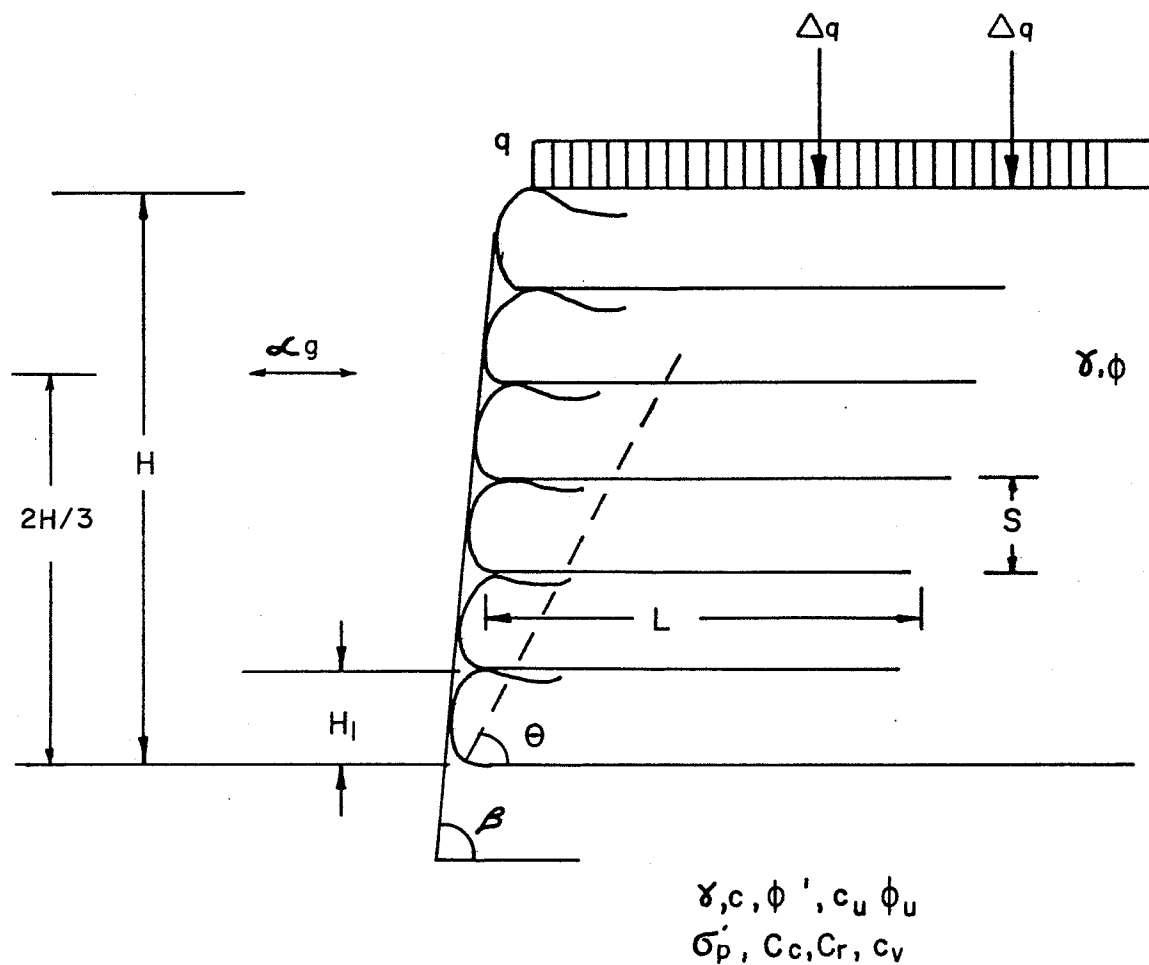

Fig. 9.5 Requirements for Design of Reinforced Soil Wall

TABLE 9-3

Failure Modes of Geotextiles or Geogrids in Reinforced Soil Walls

<u>Geosynthetic Failure Mode</u>	<u>Corresponding Reinforced Earth<sup>®</sup> Failure Mode</u>	<u>Property Required</u>
Geosynthetic rupture	Ties break	Geosynthetic tensile strength
Geosynthetic pull-out	Ties pull-out	Soil-geosynthetic interaction
Creep	Creep	Creep resistance

- e. Spacing requirements, S, (if any) based on facing connections, lift thickness and place considerations, i.e. maximum of 1.5 ft for geotextile wrapped faced walls)
- f. Consider environmental conditions such as frost action, drainage, seepage, rainfall runoff, chemical nature of backfill and seepage water (e.g. pH range, hydrolysis potential, chlorides, sulfates, chemical solvents, diesel fuel and other hydrocarbons, etc.), etc.
- g. Establish design and service life periods

Step 2. Determine engineering properties of foundation soil (Fig. 9.5).

- a. Determine the soil profile below the base of the wall; recommended exploration depth to at least twice the height of the wall or to refusal. Borings should be spaced at least every 100 to 150 ft along the alignment of the wall.

- b. Determine the foundation soil strength parameters ( $c_u$ ,  $\phi_u$ ,  $c'$ , and  $\phi'$ ), unit weight ( $\gamma$ ), and consolidation parameters ( $C_c$ ,  $C_r$ ,  $c_v$  and  $\sigma'_p$ ) for each foundation stratum.
- c. Establish location of groundwater table. Check need for drainage behind and beneath the wall.

Step 3.

Determine backfill properties of both reinforced section and random backfill (see Section 9.4.3 for recommended backfill requirements).

- a. Water content, gradation and plasticity (Note: Soils with appreciable fines [silts and clays] are not recommended for reinforced soil walls).
- b. Compaction characteristics, dry unit weight,  $\gamma_d$ , and optimum water content  $w_{opt}$  or relative density.
- c. Angle of internal friction,  $\phi_r$ .
- d. pH, chlorides, oxidation agents, etc. (For a discussion of chemical and biological characteristics of the backfill that may affect geosynthetic durability, see Section 9.3.3).

Step 4.

Establish Design Factors of Safety (recommended minimums; local codes may require greater values)

- a. External stability
  - Sliding: F.S.  $\geq 1.5$
  - Bearing capacity: F.S.  $\geq 2$
  - Overturning: F.S.  $\geq 2$
  - Deep seated (overall) stability: F.S.  $\geq 1.3$
  - Settlement--Maximum allowable total and differential based on performance requirements of the project.
  - Dynamic loading: F.S.  $\geq 1.1$  or greater, depending on local codes.

b. Internal stability

- Determine the design tensile strength of reinforcement,  $T_d$ , required at  $\leq 5\%$  strain.

$$T_d \leq T_a$$

- Allowable geosynthetic strength,  $T_a$  = creep limit strength ( $T_L$ )  $\div$  factors of safety (F.S.) for construction durability and uncertainty
  - Creep:  $T_L = T_{ult} \cdot CRF$ , or from creep test where CRF = creep reduction factor, nominally 0.25. The AASHTO-AGC-ARTBA Task Force 27 provides CRF values ranging from 0.4 (polyester) to 0.2 (polypropylene and polyethylene)
  - Construction: F.S. = 1.1 to 1.3 (Task Force 27 recommendations)
  - Durability: F.S. = 1.1 to 2.0 (Task Force 27 recommendations), depending on product information and environmental conditions.
  - Uncertainty (Lateral Resistance Factor of Safety): F.S. = 1.5

NOTE: In the absence of product information, the AASHTO-AGC-ARTBA Task Force 27 recommends you use the maximum factors of safety given above.

- Pullout resistance: F.S.  $\geq$  1.5 (minimum length is 3 ft)
- Durability--Maintain  $T_d$  over design life of project. Consider possibility of a much longer service life, especially for permanent structures.

Step 5. Determine preliminary wall dimensions.

For the first trial section to be analyzed, assume that the length of the reinforced section  $L = 0.7H \geq 8$  ft.

Step 6. Determine wall embedment depth.

Minimum embedment depth  $H_1$  at the front of the wall (Fig. 9.5):

<u>Slope in Front of Wall</u>	<u>Minimum <math>H_1</math></u>
horizontal (walls)	H/20
horizontal (abutments)	H/10
3H:1V	H/10
2H:1V	H/7
3H:2V	H/5

Consider possible frost action, shrinkage and swelling of foundation soils, and seismic activity. Minimum in any case is 1.5 ft.

Step 7. Develop the lateral earth pressure diagrams for both the reinforced section and the random backfill; e.g. using method shown in Fig. 9.6a and 9.6b (see Section 9.4.3 for additional comments).

- a. Consider the backfill.
- b. Consider dead load surcharges and live loads.
- c. Combine earth, surcharge, and live load pressure diagrams into a composite diagram for design.

Step 8. Check external wall stability (see Section 9.4.3 for additional comments).



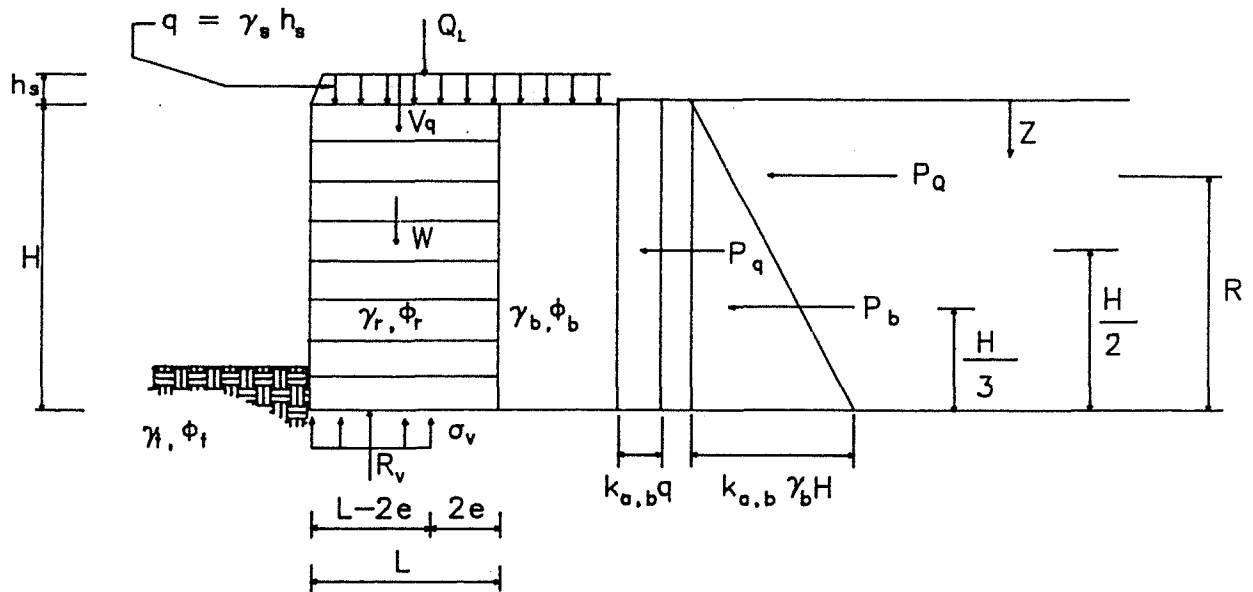

The vertical stress at any level Z :

$$\sigma_v = (\gamma_r Z + \gamma_s h_s) / (1 - 2e/L)$$

where:

$$e = \frac{k_{a,b} Z^2 (\gamma_b Z + 3\gamma_s h_s) + P_q R}{6L (\gamma_r Z + \gamma_s h_s)}$$

To determine the horizontal stresses in the reinforced soil at any depth Z below the surface:

$$\sigma_H = k \sigma_v$$

$$\text{or } \sigma_H = \frac{k (\gamma_r Z + \gamma_s h_s)}{1 - \left[ \frac{k_{a,b} Z^2 (\gamma_b Z + 3\gamma_s h_s) + P_q R}{3L^2 (\gamma_r Z + \gamma_s h_s)} \right]}$$

where:

$$k = \text{stress ratio} = k_{a,b}$$

Fig. 9.6a Meyerof's Stress Distribution Approach to Determine Horizontal Stress for Uniform Surcharge Load

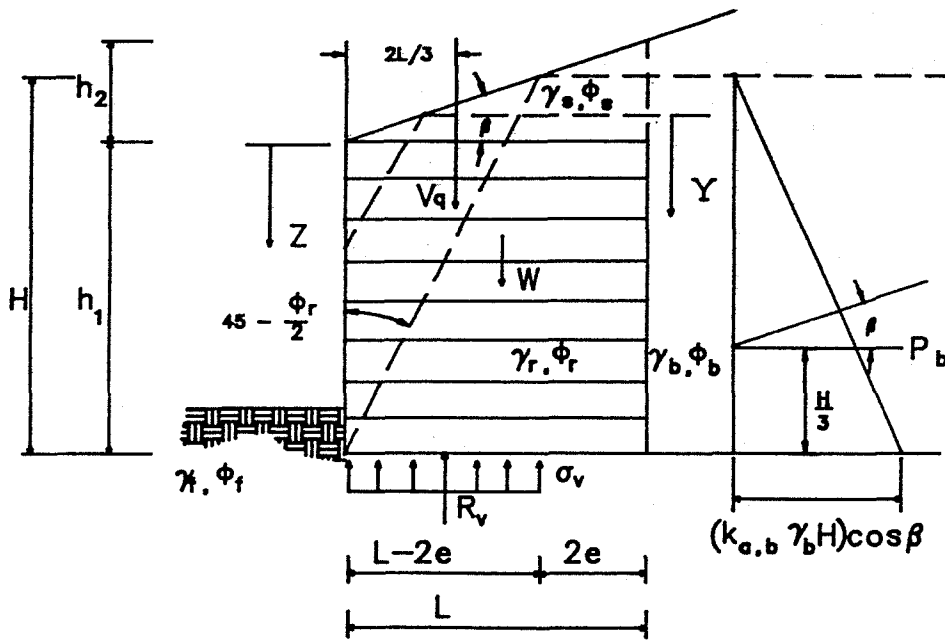

The vertical stress at any level Z :

$$\sigma_v = [ (\gamma_s h_2) / 2 + \gamma_r h_1 ] / ( 1 - 2e/L )$$

where:

$$e = \frac{Y^3 k_{a,b} \gamma_b \cos \beta}{( 3\gamma_s h_2 + 6\gamma_r h_1 ) L}$$

To determine the horizontal stresses in the reinforced soil at any depth Z :

$$\sigma_H = k \sigma_v$$

$$\sigma_H = \frac{k [ (\gamma_s h_2) / 2 + \gamma_r h_1 ]}{1 - \left[ \frac{2Y^3 k_{a,b} \gamma_b \cos \beta}{( 3\gamma_s h_2 + 6\gamma_r h_1 ) L^2} \right]}$$

where:

$$k = \text{stress ratio} = k_{a,b}$$

Fig. 9.6b Meyerhof's Stress Distribution Approach to Determine Horizontal Stress for Inclined Surcharge Load

- a. Sliding resistance (Fig. 9.7a or 9.7b). Check with and without surcharge.
- b. Bearing capacity of the foundation (Fig. 9.8a or 9.8b).
- c. Overturning of the wall (Fig. 9.9a or 9.9b).
- d. Stability of the slope created by the wall (Fig. 9.10 and for example, STABL4).
- e. Seismic analysis (Fig. 9.11).

**Step 9.** Estimate the settlement of the reinforced section (see Section 9.4.3).

**Step 10.** Check internal stability and determine reinforcement requirements (see Section 9.4.3).

Use the lateral earth pressure diagrams developed in Step 7 for the reinforced section.

- a. Determine the strength of the reinforcement  $T_d$  and vertical spacings,  $S$ , (Fig. 9.5) of reinforcing layers to resist the internal lateral pressures.  
 $\sigma_h$  from Fig. 9.6a or 9.6b where:  
 $T_d = S\sigma_h$  (F.S.)
- b. Determine length of the reinforcement  $L_o$  required to develop pull-out resistance beyond the Rankine failure wedge (Fig. 9.12).
- c. Determine overlap length  $L_o$  for the folded portion of the geosynthetic at the face.

**Step 11.** Establish durability requirements.

$T_{ult} \geq T_d \times \text{construction factor} \times \text{environmental aging factor} \times \text{uncertainty factor of safety} + \text{creep reduction factor}$

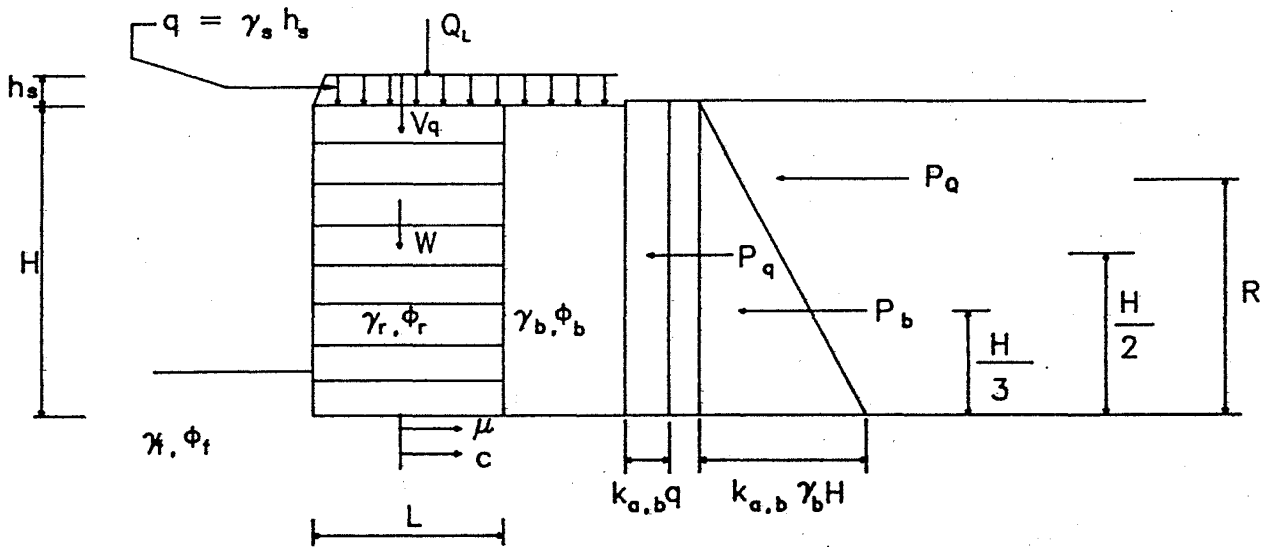

To Calculate  $FS_{SLIDING}$  :

$$V_q = \gamma_s h_s L$$

$$W = \gamma_r HL$$

$$P_b = 0.5 k_{a,b} \gamma_b H^2$$

$c$  = Cohesion of foundation soil or adhesion between soil and reinforcement

$P_q$  = As determined from Boussinesq equation

$\mu$  = Minimum of  $\tan \phi_r$ ,  $\tan \phi_f$ , or  $\tan \phi_{sq}$

$$k_{a,b} = \tan^2 (45 - \phi_b / 2)$$

$$P_q = k_{a,b} \gamma_s h_s H$$

$$FS_{SLIDING} = \frac{\sum \text{Horizontal Resisting Forces}}{\sum \text{Horizontal Sliding Forces}} = \frac{(V_q + W) \mu + cL}{P_b + P_q + P_o}$$

$$= \frac{[(\gamma_s h_s + \gamma_r H) \mu + c] L}{k_{a,b} H (0.5 \gamma_b H + \gamma_s h_s) + P_o} \geq 1.5$$

Fig. 9.7a External Sliding Stability of a Geosynthetic Soil Wall with a Uniform Surcharge Load

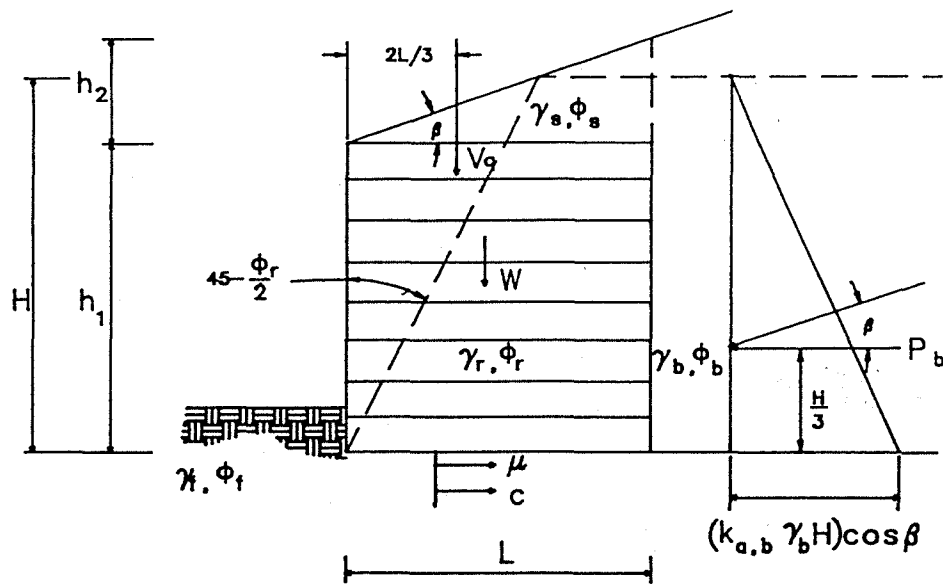

To Calculate FS<sub>SLIDING</sub> :

$$V_q = (\gamma_s h_2 L) / 2$$

$\mu$  = Minimum of  $\tan \phi_r$ ,  $\tan \phi_f$ , or  $\tan \phi_{sg}$

$$W = \gamma_r h_1 L$$

$$P_b = (0.5 k_{a,b} \gamma_b H^2) \cos \beta$$

$$k_{a,b} = \cos \beta \left( \frac{\cos \beta - \sqrt{\cos^2 \beta - \cos^2 \phi_b}}{\cos \beta + \sqrt{\cos^2 \beta - \cos^2 \phi_b}} \right)$$

$c$  = Cohesion of foundation soil or adhesion between soil and reinforcement

$$FS_{SLIDING} = \frac{\sum \text{Horizontal Resisting Forces}}{\sum \text{Horizontal Sliding Forces}} = \frac{(V_q + W) \mu + cL}{P_b}$$

$$= \frac{[(\gamma_s h_2 + 2 \gamma_r h_1) \mu + 2c] L}{k_{a,b} \gamma_b H^2 \cos \beta} \geq 1.5$$

Fig. 9.7b External Sliding Stability of a Geosynthetic Soil Wall with a Inclined Surcharge Load

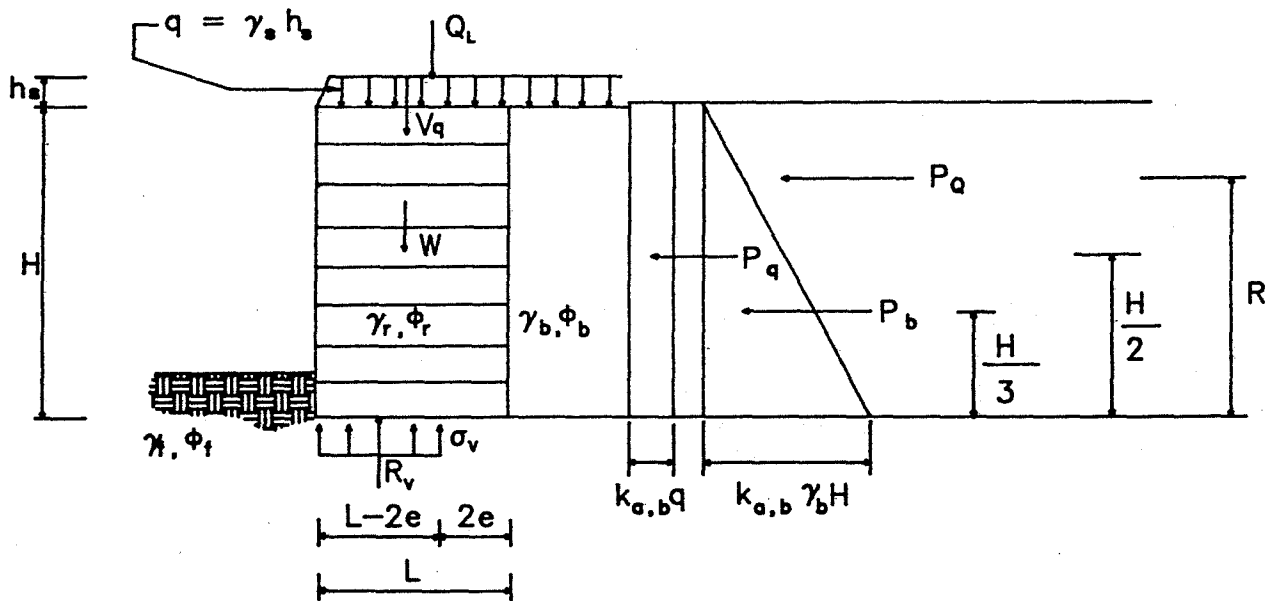

To calculate the bearing capacity :

$$V_q = \gamma_s h_s L$$

$$W = \gamma_r HL$$

$$P_b = 0.5 k_{a,b} \gamma_b H^2$$

$$P_q = k_{a,b} \gamma_s h_s H$$

$P_o$  and  $R$  = As determined from Boussinesq equation

$$k_{a,b} = \tan^2 ( 45 - \phi_b / 2 )$$

$q_o$  = allowable bearing capacity of the soil.

1) The eccentricity ,  $e$  , of the resultant loads :

$$e = \frac{\sum \text{Driving Moments}}{\sum \text{Resisting Forces}} = \frac{P_b (H/3) + P_q (H/2) + P_o R}{W + V_q}$$

$$= \frac{k_{a,b} H^2 ( \gamma_b H + 3 \gamma_s h_s ) + P_o R}{6L ( \gamma_r H + \gamma_s h_s )} \leq L/6$$

2 ) The magnitude of the maximum vertical stress ,  $\sigma_{v \max}$  :

$$\sigma_{v \max} = \frac{V_q + W}{L - 2e} = \frac{\gamma_r H + \gamma_s h_s}{1 - 2e/L} \leq q_o$$

where :

$$q_o = q_{ult} / 2$$

Fig. 9.8a Bearing Capacity for External Stability of a Geosynthetic Soil Wall with Uniform Surcharge Load

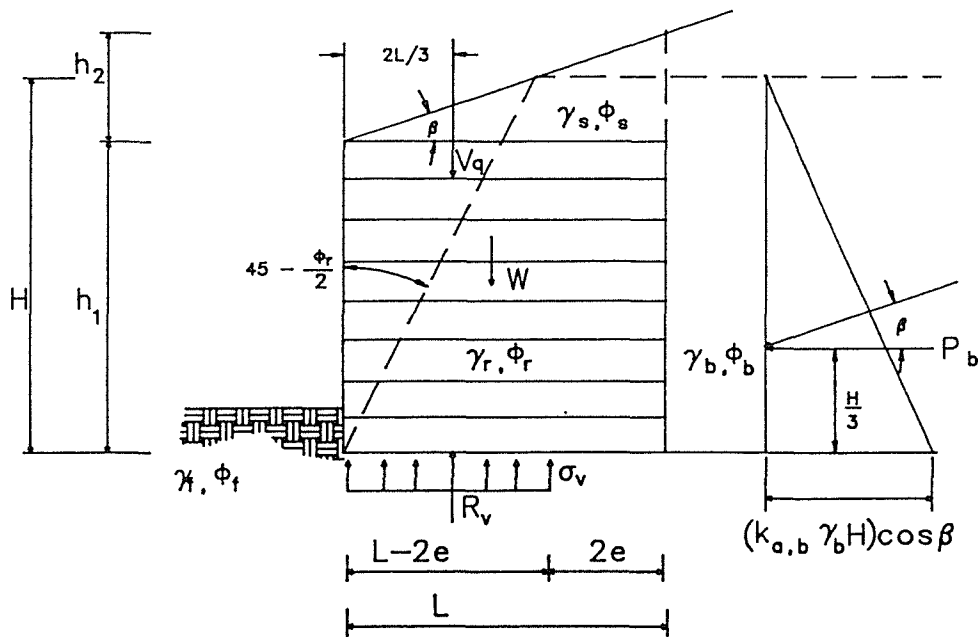

To calculate bearing capacity :

$$V_q = (\gamma_s h_2 L) / 2$$

$$P_b = (0.5 k_{a,b} \gamma_b H^2) \cos \beta$$

$$W = \gamma_r h_1 L$$

$$k_{a,b} = \cos \beta \left( \frac{\cos \beta - \sqrt{\cos^2 \beta - \cos^2 \phi_b}}{\cos \beta + \sqrt{\cos^2 \beta - \cos^2 \phi_b}} \right)$$

$q_a$  = allowable bearing capacity of the soil.

1) The eccentricity ,  $e$  , of the resultant loads :

$$e = \frac{\sum \text{Driving Moments}}{\sum \text{Resisting Forces}} = \frac{P_b (H/3)}{V_q + W} = \frac{H^3 k_{a,b} \gamma_b \cos \beta}{(3 \gamma_s h_2 + 6 \gamma_r h_1) L} \leq L/6$$

2 ) The magnitude of the maximum vertical stress ,  $\sigma_{v \max}$  :

$$\sigma_{v \max} = \frac{V_q + W}{L - 2e} = \frac{(\gamma_s h_2)/2 + \gamma_r h_1}{1 - 2e/L}$$

where :

$$q_a = q_{ult} / 2$$

Fig. 9.8b Bearing Capacity for External Stability of a Geosynthetic Soil Wall with an Inclined Surcharge Load

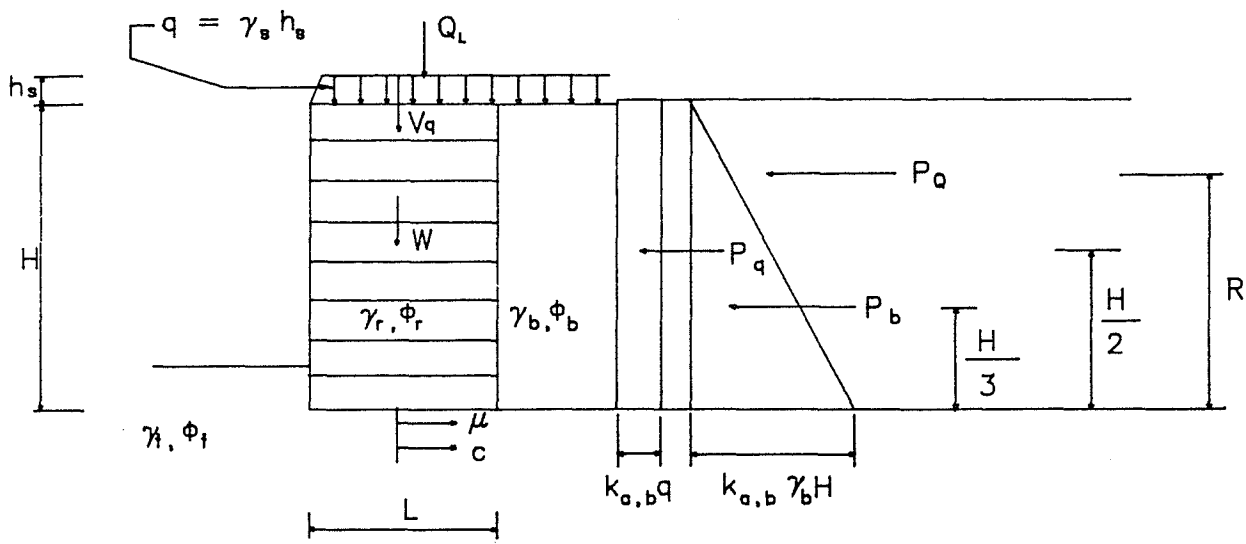

To Calculate FS<sub>OVERTURNING</sub> :

$$V_q = \gamma_s h_s L$$

$$\mu = \tan \phi_r \text{ or } \tan \phi_f$$

$$W = \gamma_r H L$$

$$k_{a,b} = \tan^2 ( 45 - \phi_b / 2 )$$

$$P_b = 0.5 k_{a,b} \gamma_b H^2$$

$$P_q = k_{a,b} \gamma_s h_s H$$

$c$  = Cohesion of foundation soil or adhesion between soil and reinforcement

$P_o$  = As determined from Boussinesq equation

$$\begin{aligned}
 FS_{\text{OVERTURNING}} &= \frac{\sum \text{Moments Resisting}}{\sum \text{Moments Overturning}} = \frac{(V_q + W) (L/2)}{P_b(H/3) + P_q(H/2) + P_o R} \\
 &= \frac{3L^2 (\gamma_s h_s + \gamma_r H)}{H^2 k_{a,b} (H_b + 3 \gamma_s h_s) + P_o R} \geq 2.0
 \end{aligned}$$

Fig. 9.9a External Overturning Stability of a Geosynthetic Reinforced Soil Wall with a Uniform Surcharge Load



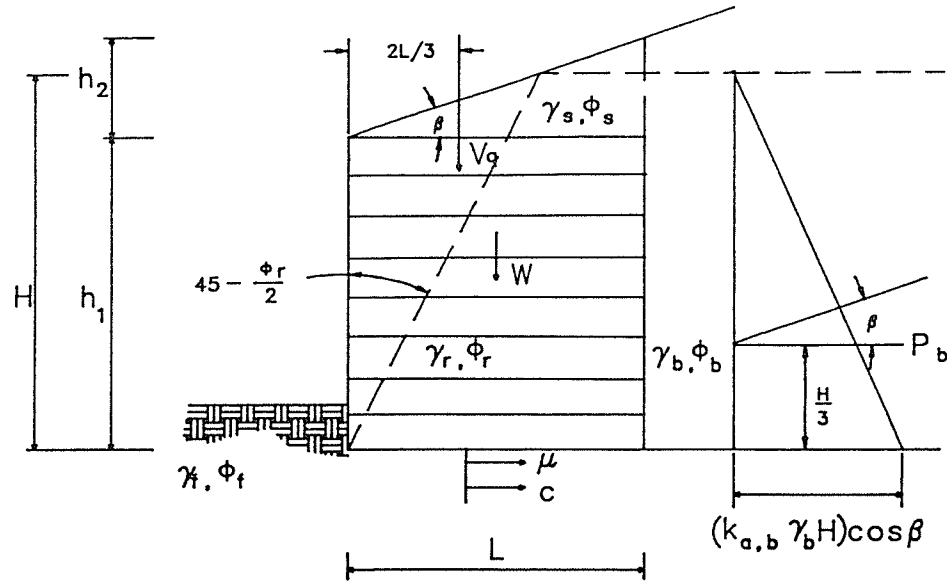

To Calculate FS<sub>OVERTURNING</sub> :

$$V_q = (\gamma_s h_2 L) / 2$$

$$\mu = \text{Tan} \phi_r \text{ or } \text{Tan} \phi_f$$

$$W = \gamma_r h_1 L$$

$$P_b = (0.5 k_{a,b} \gamma_b H^2) \cos \beta$$

$$k_{a,b} = \cos \beta \left( \frac{\cos \beta - \sqrt{\cos^2 \beta - \cos^2 \phi_b}}{\cos \beta + \sqrt{\cos^2 \beta - \cos^2 \phi_b}} \right)$$

c = Cohesion of foundation soil or adhesion between soil and reinforcement

$$FS_{\text{OVERTURNING}} = \frac{\sum \text{Moments Resisting}}{\sum \text{Moments Overturning}} = \frac{V_q (2L/3) + W(L/2)}{P_b (H/3)}$$

$$= \frac{(2\gamma_s h_2 + 3\gamma_r h_1) L^2}{k_{a,b} \gamma_b H^3 \cos \beta} \geq 2.0$$

Fig. 9.9b External Overturning Stability of a Geosynthetic Reinforced Soil Wall with an Inclined Surcharge Load

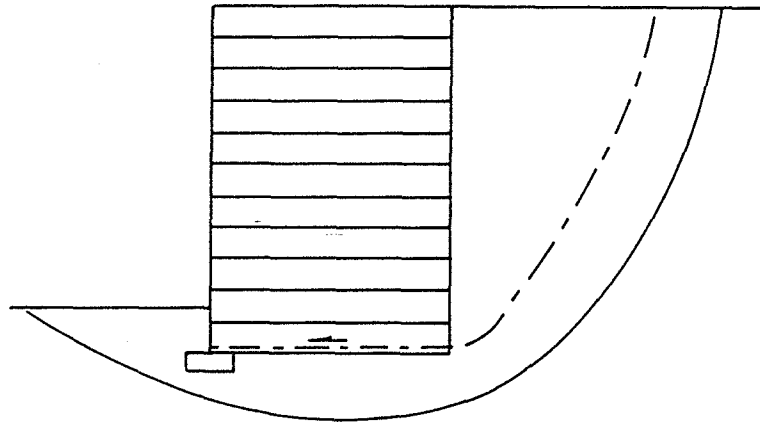
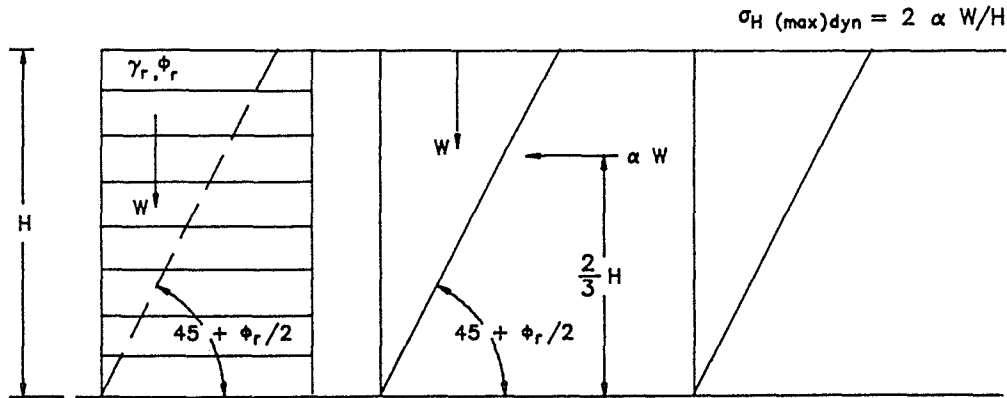

Fig. 9.10 Potential Slip Surfaces for Geogrid Reinforced Walls



$$\alpha = 0.1g - 0.2g$$

$W$  = Weight of soil mass in the active zone

$$W = \frac{\gamma_r H^2}{2 \tan ( 45 - \phi_r / 2 )}$$

Total Dynamic Force =  $\alpha W$

$$\sigma_{H(max)dyn} = 2 \alpha W/H$$

Distribution of Dynamic Force  $\alpha W$

Fig. 9.11 Horizontal Stress Increase Due to Seismic Loading

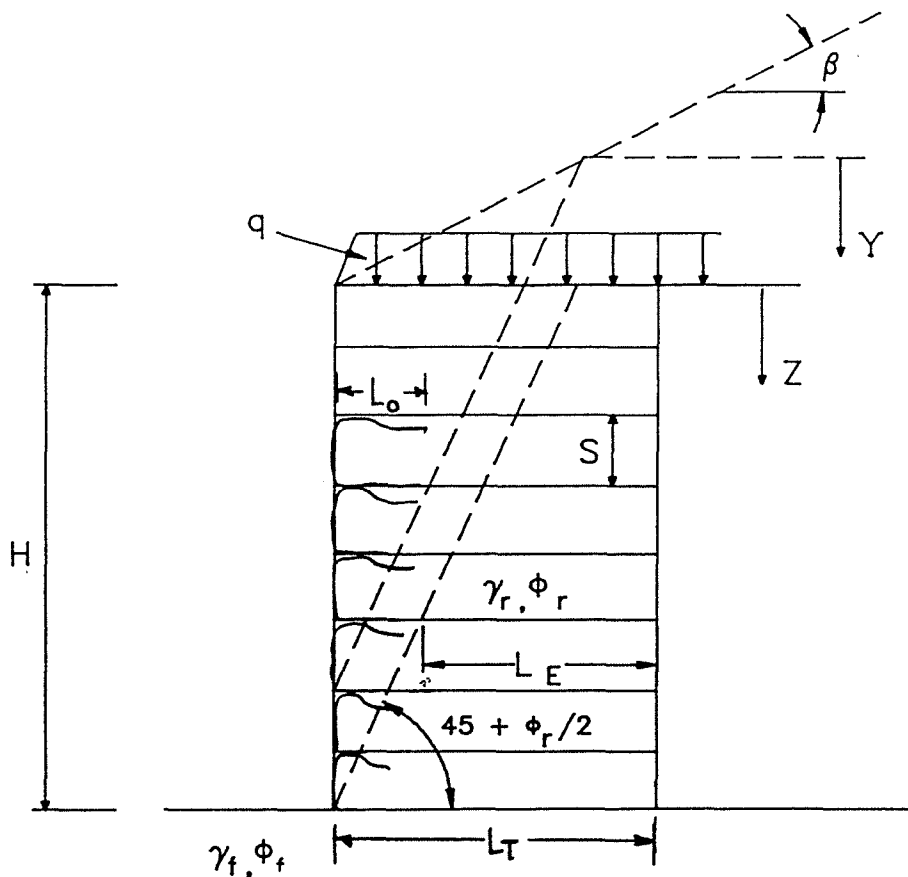

To calculate embedment length, to resist pullout :

$$L_E = \frac{T_d \text{ (F.S.)}}{2\gamma_r Z\mu^*} > 3 \text{ feet}$$

where :

$$L_o = \frac{\sigma_h \text{ (F.S.)}}{2\gamma_r Z\mu^*} > 3 \text{ feet}$$

$\mu^*$  = the pullout resistance of shearing friction between soil and geogrid. ( in absence of pullout data ,  $\mu^* = \tan \phi_{sg}$  )

$\sigma_h$  = total horizontal stress at considered depth as determined by figure 6a or 6b

$$L_T \geq L_{SLIDING}$$

Fig. 9.12 Embedment Length for Reinforcement Required to Resist Pullout

### 9.4.3 Comments on the Design Procedure

Steps 1 and 2. need no further elaboration.

Step 3. Determine backfill properties:

Only free draining materials should be considered for the reinforced soil section. Based on the recommendations of the Reinforced Earth Company and FHWA (see the FHWA Geotextile Engineering Manual, Table 5-13), the gradation limits in Table 9-4 are recommended.

TABLE 9-4

Recommended Gradation Limits for Reinforced Fill

<u>Sieve Size</u>	<u>Percent Passing</u>
3 in.	100
No. 4	100 - 20
No. 40	60 - 0
No. 200	15 - 0

The geosynthetic strength reduction factor for site damage should be checked in relation to the largest particle size to be used and the angularity of the larger particles.

Cohesive or silty materials are not recommended for geotextile-reinforced wall backfills. Consequently, the soil's plastic limit should be less than 6. In addition, the backfill should be free of organic materials, shale, or otherwise soft or deleterious materials of poor durability. A magnesium sulfate soundness test is recommended. Maximum allowable loss is 30% after 4 cycles. The pH should be between 3 and 11 or 12.

The unit weight  $\gamma$  can be determined from the standard Proctor test (AASHTO T-99) or alternatively, a vibratory type compaction

relative density test may be used. For a conservative determination of  $\gamma$ , soak the material overnight and allow it to drain a few minutes before weighing it in a mold of known volume.

The angle of internal friction  $\phi$  should be consistent with the design value of unit weight. Conservative estimates can be made for granular materials, or alternatively for major projects, this soil property can be determined by direct shear and/or drained triaxial tests. For reinforced soil walls, the FHWA recommends a friction angle of no greater than  $34^\circ$  be used for the reinforced backfill.

Conventional compaction control density measurements should be performed for backfills where a majority of the material passes a No. 10 U.S. Standard Sieve. For coarse gravelly backfills, use either relative density for compaction control or a method type compaction specification for backfill placement. The latter is appropriate if the backfill contains more than 30% of 3/4 in. or larger materials.

**Step 4. Establish design factors of safety**

Review local codes and experience for safe and economic design criteria.

**Step 5. Determine preliminary wall dimensions**

As the design process is trial and error, it is necessary to assume a set of trial wall dimensions to analyze initially. The recommended value of  $L = 0.7H$  is a good place to start. Holtz and Broms (1978) found from model tests without surcharge that  $L/H$  could be as low as 0.4 to 0.5 and still be stable ( $F.S. = 1+$ ). Surcharges, of course, will increase the reinforcement length requirements.

The minimum L of 8 ft comes from the Reinforced Earth® Company design procedures. For low ( $H \ll 8$  ft) walls, you may wish to use  $L < 8$  ft; in this case, be sure from overall stability consideration (Step 8) that shorter lengths are definitely satisfactory.

Step 6. Determine wall embedment depth

Unless the foundation is on rock, a minimum depth of embedment is required to provide adequate bearing capacity and for environmental considerations such as possible frost penetration, shrinkage and swelling clays, or earthquakes. The recommendations given earlier under Step 6 are conservative.

Embedment of the wall also helps to resist the lateral earth pressure exerted by the backfill by passive resistance at the toe. However, this resistance must be neglected for design purposes because it may not always be there, depending on the backfilling sequence, possible scour or excavation at the front of the wall, etc.

Step 7. Develop the lateral earth pressure diagrams for both the reinforced section and random backfill

a. Consider the backfill

Using the backfill properties as determined in Step 3, calculate the lateral earth pressure coefficient and develop the lateral earth pressure diagrams for the design height of the wall. Be sure to use the correct backfill properties for internal and external stability. For internal stability, use the properties of the select backfill of the reinforced section. For external stability, use the properties of the random backfill.

In conventional retaining wall design, active earth pressure conditions ( $K_A$ ) are normally assumed. There may be some situations, however, in which the wall is prevented from moving

(examples: abutments of some rigid frame bridges; walls on rock), and "at rest" earth pressure conditions ( $K_0$ ) are appropriate. In Reinforced Earth®, at rest conditions are normally assumed at the top of the wall because measurements of actual Reinforced Earth® walls showed at rest conditions. A few of the geotextile design methods also assume  $K_0$  conditions, but this appears to be overly conservative because the construction procedure tends to produce an active earth pressure state. In typical construction (Section 9.8), the compaction equipment pushes backfill against the geosynthetic reinforcement and the reinforcement yields sufficiently such that the soil can achieve active conditions. If a relatively rigid facing is used with high modulus geogrid reinforcing elements, then  $K_0$  conditions may be appropriate. Note that it is conservative to use  $K_0$  conditions instead of  $K_A$ .

$K_0$  may be estimated from the Jaky (1948) relationship:

$$K_0 = 1 - \sin\phi \quad (26)$$

$K_A$  may be estimated from Rankine or Coulomb earth pressure theory, (Terzaghi and Peck, 1967; Wu, 1975; Perloff and Baron, 1976; and U.S. Navy, 1982). For horizontal backfill:

$$K_A = \tan^2 (45^\circ - \phi/2) \quad (27)$$

For backfill at an angle  $\beta$ ,

$$K_A = \cos\beta \left[ \frac{\cos\beta - \sqrt{\cos^2\beta - \cos^2\phi}}{\cos\beta + \sqrt{\cos^2\beta - \cos^2\phi}} \right] \quad (28)$$

Again, be sure to use the appropriate  $\phi$  in these equations.

Determine the triangularly shaped lateral earth pressure distribution diagram for the design height of the retaining wall (Fig. 9.6a or 9.6b).

- b. Consider the dead load surcharges and live loads

Various approaches for considering the lateral earth pressures due to distributed surcharges, concentrated surcharges and live loads are discussed in the FHWA Geotextile Engineering Manual. Terzaghi and Peck (1967), Wu (1975), Perloff and Baron (1976), the U.S. Forest Service (Steward, et. al., 1977), and the U.S. Navy DM-7 (1982) give suitable and recommended methods.

- c. Develop the composite pressure diagram

The earth pressure and live load pressure diagrams are combined to develop a composite earth pressure diagram which will be used for design. See Fig. 9.6a or 9.6b or the above standard references for procedures on how to locate the resultant forces.

Step 8. Check external wall stability

As with the design of conventional retaining walls, the overall stability of a geosynthetic reinforced wall must also be satisfactory. There are four potential modes of failure to be considered:

- a. Sliding of the wall
- b. Bearing capacity of the wall foundation
- c. Overturning of the wall
- d. Stability of the slope created by the wall

These modes and how to design against them are discussed in the FHWA Geotextile Engineering Manual as well as in standard geotechnical engineering literature such as Terzaghi and Peck (1967), Wu (1975), Perloff and Baron (1975) and U.S. Navy (1982).



Sliding along the base is checked by equating the external horizontal forces with the shear stress operative at the base of the wall. Sliding must be evaluated with respect to the minimum frictional resistance provided by either the reinforced soil,  $\phi_r$ , the foundation soil,  $\phi_f$ , or the interaction between the geosynthetic and the soil,  $\phi_{sg}$ . Often, external stability, particularly sliding, controls design, and reinforcement layers at the base of the wall must be considerably longer than would be required by internal earth pressure considerations alone. Practically speaking, this means that generally, all the reinforcement layers will be of the same length throughout the entire height of the wall. The factor of safety against sliding should be at least 1.5.

Design for bearing capacity is the same as for an ordinary shallow foundation. The entire reinforced soil mass is assumed to act as a footing. Because there is a horizontal earth pressure component in addition to the vertical gravitational component, the resultant is inclined and must pass through the middle third of the foundation to insure there is no tension in the base. Appropriate bearing capacity factors or allowable bearing pressures must be used as in usual geotechnical practice. The ultimate bearing capacity  $q_{ult}$  is determined using classical soil mechanical methods:

$$q_{ult} = c_f N_c (1-2e/L) + 0.5 \gamma_f L N_\gamma (1-2e/L)^2$$

( $N_c$  and  $N_\gamma$  are dimensionless bearing capacity coefficients and can be obtained from most soil mechanics textbooks.)

Due to the flexibility of reinforced soil walls, the bearing capacity factor of safety is lower than normally used for more rigid reinforced concrete cantilever or gravity structures. The factor of safety must be at least 2 with respect to the ultimate bearing capacity.

Loads tending to cause overturning are developed from the resultants of the horizontal earth pressure, surcharges, and live load diagrams for the random backfill portion of the wall. Overturning is checked by summing moments of the external forces about the toe of the wall, and the factor of safety must be greater than 2.

Other foundation design considerations include environmental factors such as frost action, drainage, shrinkage or swelling of the foundation soils, and potential seismic activity at the site. All these items must be checked so that adequate wall performance is maintained throughout its design and service life.

Overall stability of the slope in which the wall sits typically requires a factor of safety of at least 1.5 for long term stability conditions.

Step 9. Estimate the settlement of the reinforced section

Conventional settlement analyses for shallow foundations should be carried out to insure that immediate, consolidation, and secondary settlement of the wall are less than the performance requirements of the project. Both total and differential settlements should be considered.

Step 10. Check internal stability and determine reinforcement requirements:

Use the lateral earth pressure diagrams developed in Step 7 for the reinforced section.

- a. Determine the strength of the reinforcement  $T_d$  and vertical spacings of the geosynthetic reinforcing layers to resist the internal lateral pressures.

The design tensile strength,  $T_d$ , of the geosynthetic is controlled by the vertical spacing of the layers of the reinforcing, and it is obtained from:

$$T_d = S \sigma_h \quad (30)$$

where:  $S$  = maximum vertical spacing  
 $\sigma_h$  = horizontal earth pressure at middle of the layer

A vertical spacing should be selected based on multiples of the compacted backfill lift thickness. From Eq. 30, it is obvious that a greater vertical spacing between the horizontal layers is possible if stronger geosynthetics are used. This will reduce the cost of the reinforcement to some extent; however, the construction costs may actually increase because of external scaffolding and form work that may be required to support the face during construction. Typical reinforcement spacing for reinforced walls with lower strength geotextiles and geogrids are 8 to 12 in. while moderate to high strength geosynthetics often have 2 ft or greater spacing. For spacings greater than 2 ft, unless the wall has a rigid face, intermediate layers will be required to prevent excessive bulging of the face between the layers.

For design, a spacing based on these considerations is assumed, and the required tensile strength is calculated from Eq. 30. Since the largest horizontal stress will be at or near the bottom of the wall, this equation will yield the maximum required strength of the geosynthetic. Although this is conservative, usually for construction simplicity, layer spacings are kept constant and the same strength material is used throughout the reinforced section. For relatively high walls ( $H > 15$  ft), it is possible that using two or three different geosynthetics and some variation in layer spacing will result in a more economical design, but it will be more complex to build and it will require careful inspection to avoid construction mistakes.

- b. Determine the length of  $L_o$  of geosynthetic reinforcement required to develop pull-out resistance beyond the Rankine failure wedge

This design step is necessary to develop the adherence or embedment length  $L_o$  behind the assumed failure plane (Fig. 9.12). In most designs, the angle of the assumed failure plane is taken to be the Rankine failure angle, or  $45^\circ + \phi/2$ . Also, this plane is usually assumed to initiate from the toe of the wall and proceed upward at that angle. This assumption results in conservative embedment lengths. The formula for the embedment length  $L_o$  is:

$$L_o = \frac{T_d}{2\gamma_r z \tan \phi_{sg}} \quad (\text{F.S.}) \quad (31)$$

where:  $T_d$  = design tensile strength of the geosynthetic  
 $z$  = depth of the layer being designed  
 $\gamma_r$  = unit weight of backfill (reinforced section)  
 $\phi_{sg}$  = soil-geosynthetic friction or interaction angle, and  
 F.S. = factor of safety

The factor of safety for embedment should be 1.5, with a minimum length of 3 ft.

- c. Determine overlap length  $L_o$  of geosynthetic for the folded portion of the geosynthetic at the face

The overlap length  $L_o$  must be long enough to transfer the stresses from the lower portion to the longer layer above it. The equation for geosynthetic overlap length  $L_o$  is:

$$L_o = \frac{\sigma_h \text{ (F.S.)}}{2\gamma_r z \tan \phi_{sg}} \quad (32)$$

All other terms are defined as above.

Again, a minimum value of 3 ft is recommended for  $L_o$  to insure adequate contact between layers.

#### Step 11. Establish durability requirements

See Section 9.3.3 on durability. Consult the geosynthetic manufacturer for information about the resistance of their particular products to the chemical, biological, and environmental factors determined in Steps 1 and 3.

#### 9.5 Design Example

Relevant examples are included in the FHWA publications, "Geotextile Engineering Workshop Design Examples (FHWA-HI-89-002) and Geotextile Engineering Manual FHWA-86-203.

#### 9.6 Cost Considerations

At the FHWA-Colorado Department of Highways test walls in Glenwood Canyon using geotextiles (Bell, et. al., 1983), the cost of the geotextile was only about 25% of the total cost of the wall. Therefore, a conservative choice of geosynthetic strength is not necessarily excessively expensive. A major part of the wall costs involved the hauling and placement of backfill as well as the gunite facing. In some situations, especially where contractors are unfamiliar with geosynthetic reinforcement, artificially high unit costs have been placed on bid items such as the gunite facing, which effectively has made the reinforced soil wall uneconomical. Figure 9.13 provides a comparison of costs for reinforced versus other types of retaining walls.

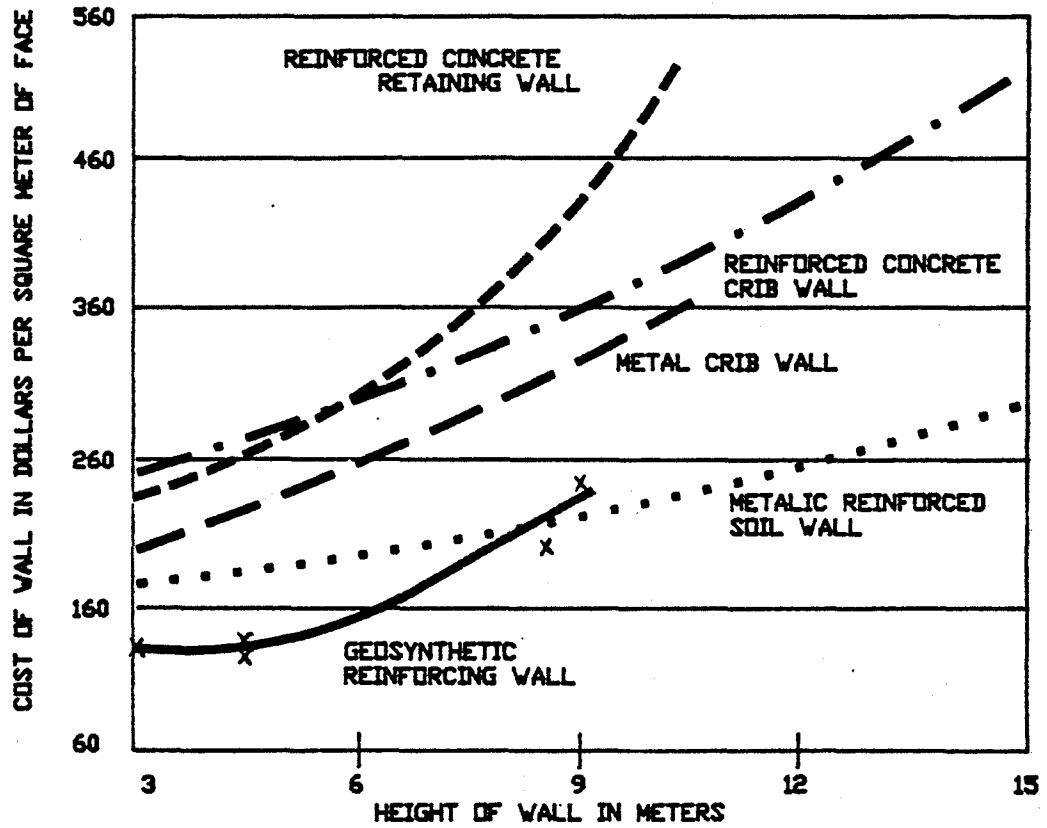

Fig. 9.13 Cost Comparison of Reinforced Systems

Other factors involved in cost comparison include site preparation, cost of the facing especially if precast panels or other special treatments are required, special drainage required behind the backfill, instrumentation, etc.

## 9.7 Specifications

The following is a special provision for materials and construction of a geosynthetic-reinforced soil retaining wall (obtained from Washington State D.O.T.).

### GEOTEXTILE RETAINING WALL

#### Description

The contractor shall construct geotextile retaining walls in accordance with the details shown in the plans, these special provisions, or as directed by the engineer.

#### Materials

##### Geotextiles and Thread for Sewing

The material shall be woven or nonwoven geotextile consisting only of long chain polymeric filaments or yarns formed into a stable network such that the filaments or yarns retain their position relative to each other during handling, placement, and design service life. At least 95 percent by weight of the long chain polymers shall be polyolephins, polyesters, or polyamides. The material shall be free of defects and tears. The geotextile shall conform to the properties as indicated in Tables 1 and 2. The geotextile shall be free from any treatment or coating which might adversely alter its physical properties after installation.

Thread used shall be high strength polypropylene, polyester, or Keylar thread. Nylon threads will not be allowed. The thread used must also be resistant to ultraviolet radiation if the sewn seam is exposed at the wall face.

##### Geotextile Approval and Acceptance

The contractor shall submit to the engineer a manufacturer's certificate of compliance which shall include the following information:

Manufacturer's name and current address, full product name, and geotextile polymer type(s).

If more than one style, merge, or product code number (i.e., this number being representative of a geotextile whose properties are different from a geotextile with the same product name and different style, merge or product code number) has been produced

**TABLE 1**

**Minimum Properties Required for  
Geotextiles Used in Geotextile Retaining Walls**

<u>Geotextile Property</u>	<u>Test Method<sup>2</sup></u>	<u>Minimum Geotextile<sup>1</sup> Property Requirements</u>
Water permeability	WSDOT Test Method 924: Water Permeability of Geotextiles - Permittivity Method	cm/sec
AOS	WSDOT Test Method 922: Geotextiles	maximum
Grab Tensile Strength, min. in machine and x-machine direction	WSDOT Test Method 916: Method for Grab Strength Elongation of Geotextiles	<u>    </u> *    lbs
Burst Strength	WSDOT Test Method 920: Diaphragm Bursting Strength of Geotextiles	<u>    </u> *    psi
Puncture Resistance	WSDOT Test Method 921: Puncture Strength of Geotextiles	<u>    </u> *    lbs
Tear Strength, min. in machine and x-machine direction	WSDOT Test Method 919: Test Method for Trapezoid Tearing Strength of Geotextiles	<u>    </u> *    lbs
Ultraviolet (UV) Radiation Stability (% Strength Retained)	ASTM D-4355	<u>    </u> *    %
Seam Breaking <sup>3</sup> Strength	WSDOT Test Method 918 and WSDOT Test Method 916 (Grab Test)	<u>    </u> *    lbs

\*Project specific values

<sup>1</sup>All geotextile properties are minimum average roll values (i.e., the test results for any sampled roll in a lot shall meet or exceed the minimum values in the table).

<sup>2</sup>WSDOT Test Methods 916, 917, 919, and 924 are in conformance with ASTM geotextile test procedures, except for geotextiles sampling and specimen conditioning. Copies of all WSDOT geotextile test methods are available at the WSDOT Headquarters Materials Laboratory in Tumwater.

<sup>3</sup>Applies only to seams perpendicular to the wall face.



TABLE 2

Wide Strip Tensile Strength Required  
for the  
Geotextile Used in Geotextile Retaining Walls

Surcharge Conditions	Wall Locations	Distance from top of Wall	Minimum Wide Strip Tensile Strength <sup>1</sup> for Geotextile Polymer Type	
			Strength	Polymer
XXXXX	XX	XX	XX	XX

Note: These geotextile strengths are for a vertical geotextile layer spacing of \_\_\_\_\_. These geotextile strengths are minimum average roll values (i.e., the test results for any sampled roll in a lot shall meet or exceed the minimum values shown in the table).

<sup>1</sup>WSDOT Test Method 917: Method for Wide Width Tensile Strength. This strength requirement only applies in the geotextile direction perpendicular to the wall face. WSDOT Test Method 917 is in conformance with ASTM D-4595 for geotextile sampling and specimen conditioning. Copies of all WSDOT geotextile test methods are available at the WSDOT Headquarters Materials Laboratory in Tumwater.

under the same product name, the style, merge or product code number of the geotextile to be approved must also be specified. If the geotextile has not been previously tested for source approval by the State, the contractor shall submit sample(s) of the geotextile for approval by the Headquarters Materials Laboratory in Tumwater. Source approval will be based on conformance to the applicable values from Tables 1 and 2. Each sample shall have minimum dimensions of 1.5 yards by the full roll width of the geotextile. A minimum of 6 square yards of geotextile shall be submitted to the engineer for testing. The geotextile machine direction shall be marked clearly on each sample submitted for testing. The machine direction is defined as the direction perpendicular to the axis of the geotextile roll.

The geotextile samples shall be cut from the geotextile roll with scissors, sharp knife, or other suitable method which produces a smooth geotextile edge and does not cause geotextile ripping or tearing. The samples shall not be taken from the outer wrap of the geotextile nor the inner wrap of the core.

If the geotextile seams are to be sewn at the factory, at least one sewn sample, with a minimum of 2 yards of seam length per sample and with a minimum of 18 in. of geotextile width on each side of the seam, shall also be submitted for each geotextile direction (i.e., machine or cross-machine direction) proposed to be sewn.

### Acceptance Samples

Samples will be randomly taken by the engineer at the job site to confirm that the geotextile meets the property values specified. The contractor shall provide a manufacturer's certificate of compliance to the engineer which includes the following information about each geotextile roll to be used.

- Manufacturer's name and current address
- Full product name
- Style, merge, or product code number
- Geotextile roll number
- Geotextile polymer type, and
- Certified test results

Approval will be based on testing of samples from each lot. A "lot" shall be defined for the purposes of this specification as all geotextile rolls within the consignment (i.e., all rolls sent to the project site) which were manufactured at the same manufacturing plant, have the same product name, and have the same style, merge, or product code number. A minimum of 14 calendar days after the samples have arrived at the Headquarters Materials Laboratory in Tumwater will be required for this testing. If the results of the testing show that a geotextile lot, as defined, does not meet the properties required in Tables 1 and 2, the roll or rolls which were sampled shall be rejected. Two additional rolls from the lot previously tested will then be selected at random by the engineer for sampling and retesting. If the retesting shows that either or both rolls do not meet the required properties, the entire lot shall be rejected. All geotextile which has the defects, deterioration, or damage, as determined by the engineer, will also be rejected. All rejected geotextile shall be replaced at no cost to the State.

If the geotextile samples tested for the purpose of source approval came from the same geotextile lot as defined which is proposed for use at the project site, acceptance will be by manufacturer's certificate of compliance only.

### Approval of Seams

If the geotextile seams are to be sewn in the field, the contractor shall provide a section of sewn seams before the geotextile is installed which can be sampled by the engineer. The seam sewn for sampling shall be sewn using the same equipment and procedures as will be used to sew the production seams. The seams sewn for sampling must be at least 2 yards in length. If the seams are sewn in the factory, the engineer will obtain samples of the factory seam at random from any of the rolls to be used.

### Shotcrete Wall Facing

(Appropriate shotcrete specifications including gradation requirements, proportioning concrete, and shotcrete testing).

## Construction Requirements

### Shipment and Storage of Geotextiles

During periods of shipment and storage, the geotextile shall be kept dry at all times and shall be stored off the ground. Under no circumstances, either during shipment or storage, shall the materials be exposed to sunlight, or other form of light which contains ultraviolet rays, for more than five calendar days.

### Wall Construction

The base for the wall shall be graded to a smooth, uniform condition free from ruts, potholes, and protruding objects such as rocks or sticks. The geotextile shall be spread immediately ahead of the covering operation.

Wall construction shall begin at the lowest portion of the excavation and each layer shall be placed horizontally as shown in the plans. Each layer shall be completed entirely before the next layer is started. Geotextile splices transverse to the wall face will be allowed provided the minimum overlap is 2 ft or the splice is sewn together. Geotextile splices parallel to the wall face will not be allowed. The geotextile shall be stretched out in the direction perpendicular to the wall face to ensure that no slack or wrinkles exist in the geotextile prior to backfilling.

Under no circumstances shall the geotextile be dragged through mud or over sharp objects which could damage the geotextile. The fill material shall be placed on the geotextile in such a manner that a minimum of 4 in. of material will be between the vehicle or equipment tires or tracks and the geotextile at all times. Particles within the backfill material greater than 3 in. in size shall be removed. Turning of vehicles on the first lift above the geotextile will not be permitted. End-dumping fill directly on the geotextile will not be permitted.

Should the geotextile be torn or punctured or the overlaps or sewn joints disturbed as evidenced by visible geotextile damage, subgrade pumping, intrusion, or distortion, the backfill around the damaged or displaced area shall be removed and the damaged area repaired or replaced by the contractor at no cost to the State. The repair shall consist of a patch of the same type of geotextile which replaces the ruptured area. All geotextile within 1 ft of the ruptured area shall be removed from the smooth geotextile edge in such a way as to not cause additional ripping or tearing. The patch shall be sewn onto the geotextile.

If geotextile seams are to be sewn in the field or at the factory, the seams shall consist of two parallel rows of stitching. The two rolls of stitching shall be 0.5 in. apart with a tolerance of  $\pm 0.25$  in. and shall not cross, except for restitching. The stitching shall be a lock-type stitch. The minimum seam allowance, i.e., the minimum distance from the geotextile edge to the stitch line nearest to that edge, shall be 1.5 in. if a flat or prayer seam, Type SSA-2, is used. The minimum seam allowance

for all other seam types shall be 1.0 in. The seam, stitch type, and the equipment used to perform the stitching shall be as recommended by the manufacturer of the geotextile and as approved by the engineer.

The seams shall be sewn in such a manner that the seam can be inspected readily by the engineer. The seam strength will be tested and shall meet the requirements stated in this Special Provision.

A temporary form system shall be used to prevent sagging of the geotextile facing elements during construction. A typical example of a temporary form system and sequence of wall construction required when using this form are shown in the plans.

Pegs, pins, or the manufacturer's recommended method, in combination with the forming system shall be used as needed to hold the geotextile in place until the specified cover material is placed.

The wall backfill shall be placed and compacted in accordance with the wall construction sequence shown in the plans. The minimum compacted backfill lift thickness of the first lift above each geotextile layer shall be 4 in. The maximum compacted lift thickness anywhere within the wall shall be 6 in. or one half of the geotextile layer spacing, whichever is least.

Each layer shall be compacted to 95% of maximum density. The water content of the wall backfill shall not deviate above the optimum water content by more than 3%. Sheepsfoot rollers or other rollers with protrusions as well as vibratory rollers shall be achieved using light mechanical tampers approved by the engineer and shall be done in a manner to cause no damage or distortion to the wall facing elements or reinforcing layer.

If corners must be constructed in the geotextile wall due to abrupt changes in alignment of the wall face as shown in the plans, the method used to construct the geotextile wall corner(s) shall be submitted to the engineer for approval at least 14 calendar days prior to beginning construction of the wall. The corner must provide a positive connection between the sections of the wall on each side of the corner such that the wall backfill material cannot spill out through the corner at any time during the design life of the wall. Furthermore, the corner must be constructed in such a manner that the wall can be constructed with the full geotextile embedment lengths shown in the plans in the vicinity of the corner.

The base of the excavation shall be completed to within  $\pm 3$  in. of the staked elevations unless directed by the engineer. The external wall dimensions shall be placed within  $\pm 2$  in. of that staked on the ground. Each layer and overlap distance shall be completed to within  $\pm 1$  in. of that shown in the plans.

The maximum deviation of the face from the batter shown in the plans shall not be greater than 3 in. for permanent walls and 5 in. for temporary walls. The face batter measurement shall be made at the midpoint of each wall layer. Each wall layer depth shall be completed to within  $\pm 1$  in. of that shown in the plans.

If the wall is to be a permanent structure, the entire wall face shall be coated with a reinforced shotcrete facing as detailed in the plans and as described in this Special Provision.

#### Placement of Shotcrete Fall Facing

(Includes qualification of craftsman, equipment, placing wire reinforcement, placing concrete, and curing specification).

#### Measurement

Geotextile retaining wall will be measured by the square foot of face of completed wall. Shotcrete wall facing will be measured by the square foot of \_\_\_\_\_.

#### Payment

The unit contract prices per square foot for "Geotextile Retaining Wall" and "Shotcrete Wall Facing", per ton for "Gravel Borrow Incl. Haul" and per cubic yard for "Structure Excavation Class A" shall be full pay for furnishing all labor, tools, equipment, and materials necessary to complete the work in accordance with these specifications, including compaction of the backfill material and the temporary forming system.

#### INSTRUCTIONS FOR THIS SPECIAL PROVISION

This special provision for geotextile retaining walls does not provide a complete design of the geotextile wall. It does provide material and construction requirements which are true for all geotextile walls. The Headquarters Materials Laboratory is responsible for all geotextile wall designs. Therefore, the Headquarters Materials Laboratory must provide the information needed to complete the geotextile wall design as presented in the plans attached with the special provisions. The information which must be provided by the Headquarters Materials Laboratory is as follows:

1. Geotextile wall base width,
2. Geotextile wall embedment depth,
3. Geotextile wall face batter,
4. Geotextile layer vertical spacing,
5. Geotextile wall backfill material requirements,
6. Maximum slope of fill above the geotextile wall,
7. and, the minimum geotextile wide strip strength requirements.

The District should, of course, provide a wall plan and profile for each geotextile wall proposed for a given contract.

Please note that the unit of measure for the geotextile retaining wall and the shotcrete wall facing is per square foot of wall face. This unit of measure should always be used.

## 9.8 Construction Procedures

Construction procedures for geosynthetic reinforced walls are fairly straight forward. Experience of the U.S. Forest Service, the New York Department of Transportation, and the Colorado Department of Highways have been very valuable in developing technically feasible and economical construction procedures. These procedures, detailed in the FHWA Geotextile Engineering Manual as well as the other references, are outlined below:

### 1. Wall Foundation

- a. The foundation should be excavated to the grade as shown on the plans. It should be graded level for a width equal to the length of reinforcement plus 1 ft.
- b. The excavated areas should be carefully inspected. Any loose or soft foundation soils should be compacted or excavated and replaced with compacted backfill material.
- c. Foundation soil at the base of the wall excavation should be proof-rolled with vibratory or rubber tired roller.
- d. If required for facing support, a concrete leveling pad should be constructed at the toe of the wall.

### 2. Placement of geosynthetic reinforcement

- a. The geosynthetic should be placed with the principal strength (machine) direction perpendicular to the face of the wall. It should be secured in place to prevent movement during fill placement.

- b. It may be more convenient to unroll the geosynthetic with the machine direction parallel to the wall alignment (as has been done in some walls). If this is done, then the cross machine tensile strength must be  $\geq$  the design tensile strength.
- c. Because most of the movement is perpendicular to the wall face, a minimum of 6 in. overlap is recommended along edges parallel to the reinforcement for wrapped faced walls.
- d. If large foundation settlements are anticipated which might result in separation between overlap layers, then field sewing of adjacent geotextile sheets is recommended. Geogrids should be mechanically fastened in that direction.

### 3. Backfill placement in reinforced section

- a. The backfill material should be placed over the reinforcement with a compacted lift thickness of 9 in. or as determined by the engineer.
- b. The backfill material should be compacted to at least 90% of the ASTM D-1557 or AASHTO T99 Standard Proctor maximum density at or below the optimum moisture. Alternatively, a relative density compaction specification could be used. For coarse gravelly backfills, a method type compaction specification is appropriate.
- c. When placing and compacting the backfill material, care should be taken to avoid any folding or movement of the geosynthetic.
- d. A minimum thickness of 6 in. of fill must be maintained between the wheels of the construction equipment and the reinforcement at all times.

#### 4. Face construction and connections

- a. Place the geosynthetic layers using face forms as shown in Fig. 9.14, unless permanent facing is to be used.
- b. For temporary support of forms at the face to allow compaction of the backfill against the wall face, form holders should be placed at the base of each layer at 4 ft horizontal intervals. Details of temporary form work for geosynthetics are shown in Fig. 9.14.
- c. When using geogrids, it may be necessary to use a geotextile to retain the backfill material at the wall face.
- d. When compacting backfill within 2 ft of the wall face, a hand operated vibratory compactor is recommended.
- e. The return-type method shown in Fig. 9.15 can be used for facing support. The geosynthetic is folded at the face over the backfill material, with a minimum return length of 4 ft to insure adequate pullout resistance.
- f. Apply facing treatment (shotcrete, precast facing panels, etc.). Figure 9.16 shows several facing alternatives for geosynthetic walls.

#### 9.9 Field Inspection

As with all geosynthetic construction and especially with critical structures such as reinforced walls and abutments, competent and professional field inspection is absolutely essential for the successful construction procedures to make sure that the specified material is delivered to the project, that the geosynthetic is not damaged during construction, and that the specified sequence of construction operations are explicitly carried out. Technicians should be instructed to do the items on the checklist in Section



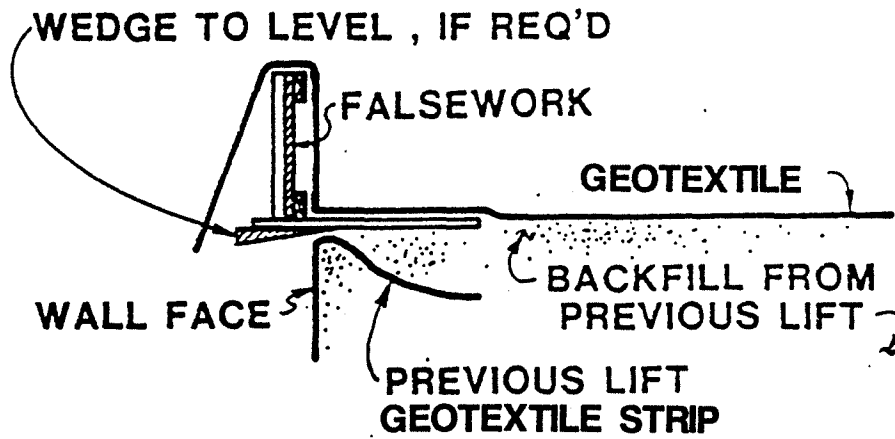

① PLACE FALSEWORK AND GEOTEXTILE ON PREVIOUS LIFT

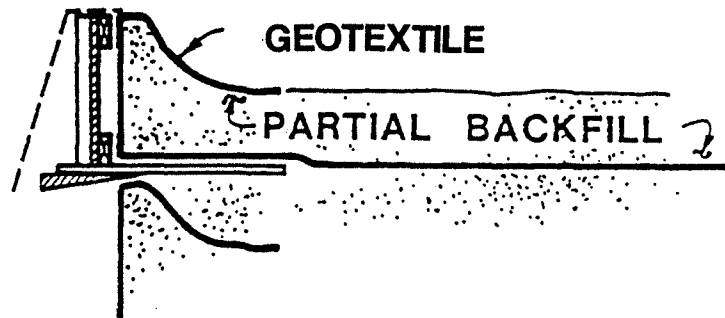

② PLACE/COMPACT PARTIAL BACKFILL AND OVERLAP FABRIC

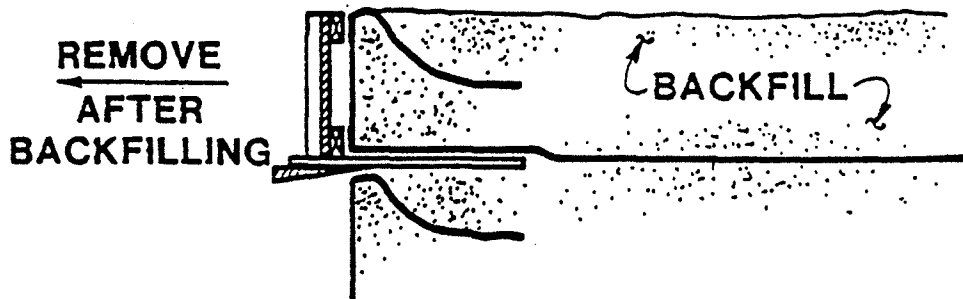

③ PLACE/COMPACT REMAINDER OF BACKFILL LIFT

Fig. 9.14 Lift Construction Sequence for Engineering Fabric-Reinforced Soil Walls (Steward, et.al., 1977)

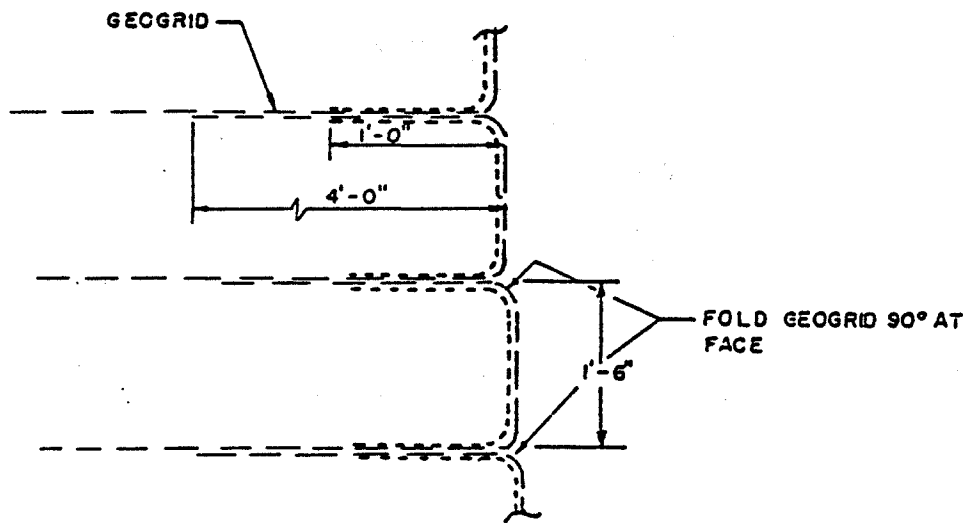

**Fig. 9.15 Typical Geosynthetic Face Construction Detail for Vertical Geogrid - Reinforced Retaining Wall Faces**

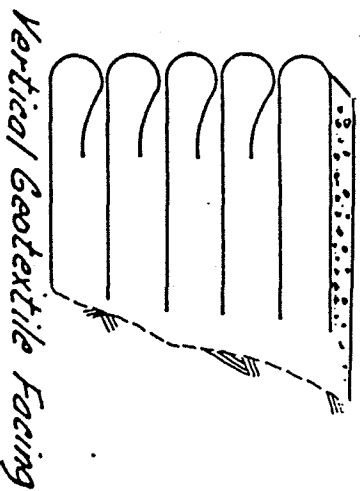

*Vertical Geotextile Facing*

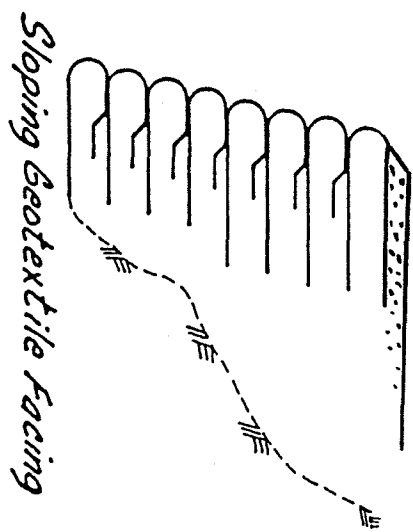

*Sloping Geotextile Facing*

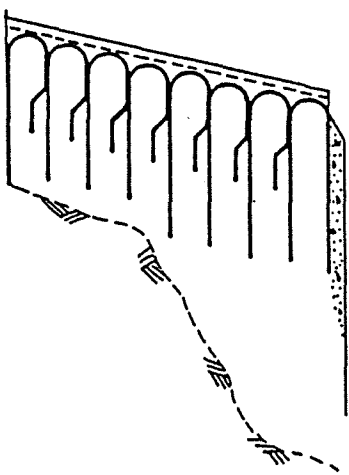

*Sloping Buntite or Structural Facing*

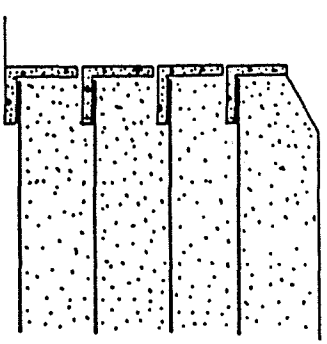

*Vertical Precast Concrete Element Facing*

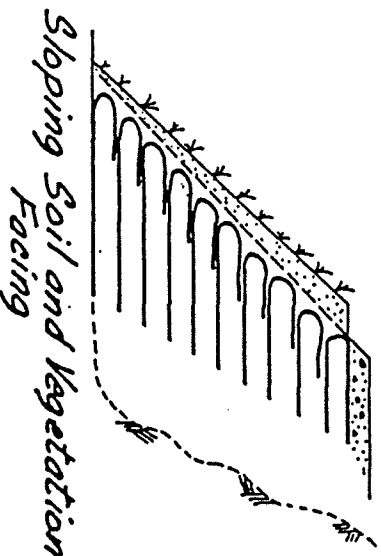

*Sloping Soil and Vegetation Facing*

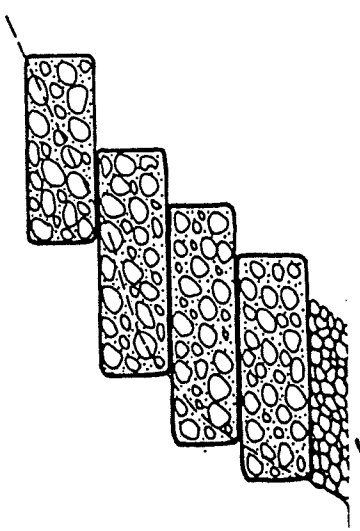

*Geotextile Gabion*

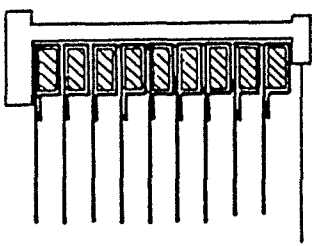

*Vertical Cast In-place Concrete/Masonry Facing*

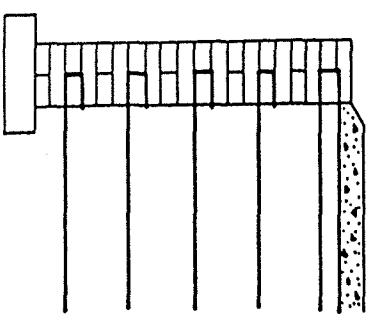

*Vertical Masonry Facing*

Fig. 9.16 Types of Geotextile Reinforced Wall Facing

1.7. Other important details include construction of the wall face and application of the facing treatment to minimize exposure of the geosynthetic to ultraviolet light.

Often, geosynthetic reinforced retaining walls are considered "experimental", often such walls are instrumented. As a minimum, settlements and outward movements of the wall at its top are determined by ordinary levels and triangulation surveys. Sometimes inclinometers and/or multiple point borehole extensometers are used for observing potential horizontal movements.

## REFERENCES

- ASTM (1988), "Soil and Rock; Building Stones", *Annual Book of ASTM Standards, Section 4, Volume 04.08*, American Society for Testing and Materials, Philadelphia, Pennsylvania.
- ASTM (1988), "Textiles - Yarns, Fabrics, and General Test Methods", *Annual Book of ASTM Standards, Section 7, Volume 07.01*, American Society for Testing and Materials, Philadelphia, Pennsylvania.
- Bell, J.R., R.K. Barrett and A.C. Ruckman (1983), "Geotextile Earth-Reinforced Retaining Wall Tests: Glenwood Canyon, Colorado", *Transportation Research Record* 916, pp. 59-69.
- Bell, J.R., R.G. Hicks, et.al. (1980-1982), "Evaluation of Test Method and Use Criteria for Geotechnical Fabrics in Highway Applications", Interim Report No. FHWA/RD-80/021, Federal Highway Administration, Offices of Research and Development, Structures and Applied Mechanics Division, Washington, D.C.
- Bishop, A.W. (1955), "The Use of the Slip Circle in the Stability Analysis of Slopes", *Geotechnique*, Vol. 5, No. 1.
- Bonaparte, R. and B.R. Christopher (1987), "Design and Construction of Reinforced Embankments Over Weak Foundations", Proceedings of the Symposium on Reinforced Layered Systems, Transportation Research Board, Washington, D.C.
- Bonaparte, R., R.D. Holtz, and J.P. Giroud (1987), "Soil Reinforcement Design Using Geotextiles and Geogrids", in *Geotextile Testing and The Design Engineer*, Special Technical Publication 952.
- Broms, B.B. (1978), "Design of Fabric Reinforced Retaining Structures". *Proceedings of the ASCE Symposium on Earth Reinforcement*, Pittsburgh, pp. 282-303.
- Carroll, R.G. (1983), "Geotextile Filter Criteria". *Transportation Research Record* 916, Transportation Research Board, Washington, D.C.
- Cedergren, H.R. (1977), *Seepage, Drainage, and Flow Nets*, Second Edition, John Wiley and Sons, New York, New York.
- Christopher, B.R. and R.D. Holtz (1985), *Geotextile Engineering Manual*, STS Consultants, Ltd., Northbrook, Illinois; Report to Federal Highway Administration, No. FHWA-TS-86/203, 1044 pp.
- Federal Highway Administration (1982), "Report on Performance of Fabrics in Asphalt Overlays, Experimental Application and Evaluation", Office of Highway Operation, FHWA, 39 pp.

## REFERENCES (con't)

- Federal Standards (1965), "Federal Standard Stitches, Seams, and Stitching", No. 751a, 25 January.
- Giroud, J.P. (1980), "Introduction to Geotextiles and Their Applications", *Proceedings of the First Canadian Symposium on Geotextiles*, Las Vegas, Vol. 1, pp. 103-108.
- Giroud, J.P. and R.G. Carroll, Jr. (1983), "Geotextile Products", *Geotechnical Fabrics Report*, Vol. 1, No. 1, IFAI, St. Paul, Minnesota, pp. 12-15.
- Haas, R. (1986), "Granular Base Reinforcement of Flexible Pavements Using Tensar Geogrids", *Technical Note BR1*, The Tensar Group, 22 pp.
- Haas, R., J. Walls, and R.G. Carroll (1988), "Geogrid Reinforcement of Granular Base in Flexible Pavements", presented at the 67th Annual Meeting, Transportation Research Board, Washington, D.C.
- Haliburton, T.A., C.C. Anglin, and J.D. Lawmaster (1978), "Selection of Geotechnical Fabrics for Embankment Reinforcement", *Report to U.S. Army Engineer District, Mobile*, Oklahoma State University, Stillwater, 138 pp.
- Halibuton, T.A., P.A. Douglas, and J. Fowler (1977), "Feasibility of Pinto Island as a Long-Term Dredged Material Disposal Site", *Miscellaneous Paper, D-77-3*, USAE Waterways Experiment Station, Vicksburg, MS.
- Hamilton, J.S. and R.A. Pearce (1981), "Guidelines for Design of Flexible Pavements using Mirafi Woven Stabilization Fabrics", *Law Engineering Testing Co. Report to Celanese Corp.*, 47 pp.
- Highway Research Board (1970), *Tentative Design Procedures for Riprap Lined Channels*, Washington, D.C.
- Holtz, R.D. (1977), "Laboratory Studies of Reinforced Earth Using a Woven Polyester Fabric", *Proceedings of the International Conference on the Use of Fabrics in Geotechnics*, Paris, Vol. 3, pp. 149-154.
- Holtz, R.D. (1985), "Soil Reinforcement with Geotextiles", *Proceedings of the Third International Geotechnical Seminar on Soil Improvement Methods*, Nanyang Technological Institute, Singapore, pp. 55-74.
- Holtz, R.D. and B.B. Broms (1978), "Small Scale Model Tests of Fabric-Reinforced Retaining Walls", *Proceedings of the Symposium on Soil Reinforcing and Stabilizing Techniques in Engineering Practice*, Sydney, pp. 151-158.

## REFERENCES (con't)

- Holtz, R.D., W.R. Tobin, and W.W. Burke (1982), "Creep Characteristics and Stress-Strain Behavior of a Geotextile-Reinforced Sand", *Proceedings of the Second International Conference on Geotextiles*, Las Vegas, Nevada, Vol 3, pp. 805-809.
- Hoover, T.P. (1982), "Laboratory Testing of Geotextile Fabric Filters". *Proceedings of the Second International Conference on Geotextiles*, Las Vegas, Nevada, Vol. 3, pp. 839-844.
- Hunt, J.R. (1982), "The Development of Fin Drains for Structure Drainage". *Proceedings of the Second International Conference on Geotextiles*, Las Vegas, Nevada, Vol. 1, pp. 25-36.
- Hydraulic Engineering Circulars (HEC), (1967), *HEC 11 - Use of Riprap for Bank Protection*, Federal Highway Administration, FHWA Nr. EPD-86-108, NTIS Nr. PB86-179793/AS
- Hydraulic Engineering Circulars (HEC), (1975), *HEC 15 - Design of Roadside Channels with Flexible Linings*, Federal Highway Administration, FHWA Nr. EPD-86-184835/AS
- Illinois Department of Transportation, State of (1982), *Design Manual - Section 7 Pavement Design*, I-82-2, Bureau of Design
- Jaky, J. (1948), "Earth Pressure in Silos", *Proceedings of the Second International Conference on Soil Mechanics and Foundation Engineering*, Rotterdam, Vol. I, pp. 103-107.
- Jurgenson, L. (1934), "The Shearing Resistance of Soils". *Journal of the Boston Society of Civil Engineers*. Also in *Contribution to Soil Mechanics*, 1925-1940, BSCE pp. 134-217.
- Koerner, R.M. (1986), *Designing with Geosynthetics*, Prentice-Hall, Inc., Englewood Cliffs, N.J.
- Koerner, R.M. and J.P. Welsh (1980), *Construction and Geotechnical Engineering Using Synthetic Fabrics*, John Wiley & Sons, New York, 1980.
- Koerner, R.M. and J.P. Welsh (1981), "Construction and Geotechnical Engineering Using Synthetic Fabrics (Geotextiles)". Supplementary Course Notes for ASCE Continuing Education Course, Revision No. 5, 66 pp.
- Lee, K.L., B.D. Adams, and J.M.J. Vagneron (1973), "Reinforced Earth Retaining Walls", *Journal of the Soil Mechanics and Foundations Division*, ASCE, Vol. 99, No. SM10, pp. 745-764.

## REFERENCES (con't)

- C.I. and R.I. Kaufman (1962), "Dewatering", Ch. 3 in *Foundation Engineering*, G.A. Leonards, Ed., McGraw Hill, pp. 241-350.
- McGown, A., K.Z. Andrawes, and M.H. Kabir (1982), "Load-Extension Testing of Geotextiles Confined in Soil". *Proceedings of the Second International Conference on Geotextiles*, Las Vegas, Nevada, Vol. 3, pp. 793-798.
- Middelton, L.M. (1976), "Manual for Soil Erosion and Sediment Control", *Report*, Region XV, Federal Highway Administration.
- Mitchell, J.K. and W.C.B (1987), *Reinforcement of Earth Slopes and Embankments*, NCHRP Report 290, 323 pp.
- Morgenstern, N. and V.E. Price (1965), "The Analysis of the Stability of General Slip Surfaces", *Geotechnique*, Vol. 15, No. 1, pp. 79-93.
- Moulton, L.K. (1980), "Highway Subdrainage Design". Report No. FHWA-TS-80-224, Federal Highway Administration, Offices of Research and Development, Washington, D.C. 20590.
- Murray, R.T. (1980), "Fabric Reinforced Earth Walls: Development of Design Equations". *Ground Engineering*, Vol. 13, No. 7, (October), pp. 29-36. See also discussion by Jones and Broadbent and reply by Murray in *Ground Engineering*, 1981.
- Netlon, Ltd. (1984), "Guidelines for the Design and Construction of Embankments over Stable Foundations using Geogrids", 27 pp.
- Perloff, W.H. and W. Baron (1976), *Soil Mechanics: Principles and Applications*, Ronad, 745 pp.
- Rankilor, P.R. (1981), *Membranes in Ground Engineering*, John Wiley & Sons, Inc., London, England, pp. 377.
- Schmertmann, G.R., V.E. Chouery-Curtis, R.D. Johnson, and R. Bonaparte (1987), "Design Charts for Geogrid-Reinforced Soil Slopes", *Proceedings of Geosynthetics '87*, New Orleans, Vol. 1, pp. 108-120.
- Silvestri, V. (1983), "The Bearing Capacity of Dykes and Fills Founded on Soft Soils of Limited Thickness", *Canadian Geotechnical Journal*, Vol. 20, No. 3, pp. 428-436.
- Spencer, E. (1981), "Slip Circles and Critical Shear Planes", *Journal of the Geotechnical Engineering Division*, ASCE, Vol. 107, No. GT7, pp. 929-942.



## REFERENCES (con't)

- Steward, J., R. Williamson, and J. Mohney (1977), "Guidelines for Use of Fabrics in Construction and Maintenance of Low-Volume Roads". USDA, Forest Service, Portland, Oregon. Also published as Report No. FHWA-TS-78-205.
- Terzaghi, K. and R.B. Peck (1967), *Soil Mechanics in Engineering Practice*, John Wiley & Sons, New York, 729 pp.
- U.S. Bureau of Reclamation (1973), *Design of Small Dams*, U.S. Department of the Interior, U.S. Government Printing Office
- U.S. Bureau of Reclamation (1974), Department of the Interior, *Earth Manual*, 2nd Ed., U.S. Government Printing Office, Washington, D.C.
- U.S. Army Corps of Engineers (1972), "Development of Design Criteria and Acceptance Specifications for Plastic Filter Cloth", Technical Report F-72-7 Prepared by C.C. Calhoun, Jr., U.S. Army Engineer Waterways Experiment Station, Vicksburg, Mississippi.
- U.S. Army Corps of Engineers (1977), Civil Works Construction Guide Specification for Plastic Filter Fabric". *Corps of Engineer Specifications No. CW-02215*, Office, Chief of Engineers, U.S. Army Corps of Engineers, Washington, D.C.
- U.S. Army Corps of Engineers (1978), "Engineering and Design: Design and Construction of Levees". Engineer Manual 1110-2-1913, Washington, D.C.
- U.S. Department of the Navy (1982), *Soil Mechanics*, Design Manuals 7.1 and 7.2, Alexandria, Virginia.
- Vesic, A.S. (1975), "Bearing Capacity of Shallow Foundation". Chapter 3 in *Foundation Engineering Handbook*, Winterkorn and Fang, Eds. Van Nostrand Reinhold, pp. 121-147.
- VSL Corporation (1981), "VSL Retained Earth, Technical Data", Rock and Soil Stabilization Systems, Los Gatos, CA.
- Wu, T.H. (1975), "Retaining Walls". Chapter 12 in *Foundation Engineering Handbook*, Winterkorn and Fang, Eds. Von Nostrand Reinhold, pp. 402-417.
- Wyant, D.C. (1980), "Evaluation of Filter Fabrics for Use as a Silt Fences". Report No. VHTRC 80-R49, Virginia Highway and Transportation Research Council, Charlottesville, June.

## **APPENDIX**

- A.1 Notations**
- A.2 Glossary**
- A.3 Representative List of Geotextile  
Manufacturers and Suppliers**
- A.4 General Range of Strength and Permeability  
Properties for Representative Types of  
Geotextiles**
- A.5 NHI/FHWA Geotextile Engineering  
Workshop Lecture Outline: Construction  
Course**

## A.1 NOTATIONS

a	=	Radius of tire contact area
A	=	Area
AOS	=	Apparent opening size
b	=	A dimension; horizontal length of embankment slope
B	=	A coefficient; width of geotextile or embankment
c	=	Undrained shear strength ("cohesion") in terms of total stresses
c'	=	Effective stress strength parameters
c <sub>a</sub>	=	Soil-geosynthetic adhesion
c <sub>v</sub>	=	Coefficient of consolidation
C <sub>c</sub>	=	Compressive index
C <sub>r</sub>	=	Recompression index
C <sub>u</sub>	=	Uniformity coefficient, $D_{60}/D_{10}$
CBR	=	California bearing ratio
d	=	Depth
D	=	Grain size (subscript indicates percent smaller than); depth of embankment; thickness of soft layers
e	=	Eccentricity
FS	=	Factor of safety
g	=	Acceleration due to gravity
G <sub>L</sub>	=	Lower strength geogrid
G <sub>H</sub>	=	Higher strength geogrid
GVW	=	Gross vehicle weight
H	=	Head difference (gradient ratio test); embankment, slope or wall height
i	=	Hydraulic gradient
k	=	Coefficient of permeability
K	=	Stress ratio; force coefficient
K <sub>A</sub>	=	Active earth coefficient of the retained backfill

## NOTATIONS (con't)

L	=	Length (subscript indicates length in inches); length of reinforcement; length of failure arc
L <sub>E</sub>	=	Embedment length to resist pullout
M	=	Moment
n	=	Porosity
N	=	Number of layers
N <sub>C</sub>	=	Bearing capacity factor for cohesive soils
O	=	Opening size; subscript indicates percent smaller than
P <sub>a</sub>	=	Active earth pressure
P <sub>b</sub>	=	Resultant active earth pressure due to the retained backfill
P <sub>q</sub>	=	Resultant active earth pressure due to the uniform surcharge
P <sub>Q</sub>	=	Resultant of live load
q	=	Flow rate; surcharge load
q <sub>a</sub>	=	Allowable bearing capacity
q <sub>ult</sub>	=	Maximum bearing capacity
Q <sub>L</sub>	=	Live load
R	=	Radius of critical failure circle
R <sub>v</sub>	=	Resisting force (Meyerhof's approach)
S	=	Vertical spacing between horizontal geogrid layer
SF	=	Safety factor
t	=	Thickness of geogrid
T	=	Tensile strength of the geosynthetic
T <sub>a</sub>	=	Allowable tensile strength of the geosynthetic
T <sub>d</sub>	=	Design tensile strength of the geosynthetic (usually at a given strain)
T <sub>ult</sub>	=	Ultimate tensile strength of a geosynthetic
T <sub>1</sub>	=	Limit tensile strength of a geosynthetic

## NOTATIONS (con't)

$T_L$	=	Creep limit tensile strength of a geosynthetic
$V_q$	=	Vertical force due to surcharge
$w$	=	Water content
$W$	=	Vertical force due to the weight of the fill
$x$	=	A dimension or coordinate
$y$	=	A dimension or coordinate
$\alpha$	=	Peak horizontal acceleration for seismic loading
$\beta$	=	Slope of soil surface; angle of reinforcement force
$\gamma$	=	Unit weight
$\Delta$	=	Change in some parameter or quantity
$\epsilon$	=	Strain
$\theta$	=	Inclination of the wall face
$\mu$	=	Friction coefficient along the sliding plane, which depends on the location plane, i.e., $\tan \phi_r$ or $\tan \phi_f$
$\mu^*$	=	The pullout resistance of shearing friction between soil and geogrid
$\Psi$	=	Permittivity
$\theta$	=	Transmissivity; an angle; angle of failure plane
$\sigma_H$	=	Horizontal stress
$\sigma_o$	=	Overburden stress
$\sigma_p'$	=	Preconsolidation stress
$\sigma_v$	=	Vertical stress
$\phi$	=	Angle of internal friction
$\phi'$	=	Effective angle of internal friction
$\tau$	=	Shear resistance

## A.2 GLOSSARY

from  
Department of Army Technical Manual (Draft)

### "ENGINEERING USE OF GEOTEXTILES"

1987

**ABRASION RESISTANCE** - The ability of a fabric surface to resist wear by friction.

**ABSORPTION** - The process of a gas or liquid being incorporated into the fibers of a fabric. See **MOISTURE REGAIN**.

**ACID RESISTANCE** - See **CHEMICAL STABILITY**.

**ALKALI RESISTANCE** - See **CHEMICAL STABILITY**.

**AOS** - See **APPARENT OPENING SIZE**.

**APPARENT OPENING SIZE (AOS)** - A measure of the size of the largest openings in a geotextile. The AOS is the "retained on" sieve size of narrowly sized, rounded sand or glass beads of which 5 percent or less by weight passes through the fabric when the particles are shaken on the fabric in a prescribed manner. The AOS is usually expressed as the US Standard Sieve Number, but may also be expressed in millimeters.

**ARMOR** - A protective covering.

**BIAS** - A direction diagonal to the warp and fill.

## A.2 GLOSSARY (con't)

**BIOLOGICAL STABILITY** - Ability to resist degradation from exposure to microorganisms.

**BLINDING** - Plugging of a fabric by partial penetration of particles into surface pores, i.e., the formation of a surface crust or cake.

**BONDING** - A process of binding fabric fibers by means of adhesive or by welding with heat and pressure.

**BURST STRENGTH** - The resistance of a fabric to rupture from pressure applied at right angles to the plane of the fabric under specified conditions, usually expressed as the pressure causing failure. Burst results from tensile failure of the fabric.

**CALENDER** - To press between heated rollers or plates in order to smooth and stabilize the positions of fibers in a fabric or bond several layers of material.

**CHEMICAL BONDING** - A bonding process in which the individual fibers in the fabric web are cemented together by chemical interaction.

**CHEMICAL STABILITY** - Ability to resist chemicals, such as acids, bases, solvents, oils and oxidation agents, and chemical reactions, including those catalyzed by light.

**CLOGGING** - The plugging of a fabric by deposition of particles within the fabric pores (other than blinding).

**COMPRESSIBILITY** - Property of a fabric describing the ease with which it can be compressed normal to the plane of the fabric.

(blank)



## A.2 GLOSSARY (con't)

CONSTRUCTABILITY - See WORKABILITY.

CONSTRUCTION, FABRIC - The way the fibers, filament, and/or yarns are oriented and bonded to produce a fabric.

COUNT - The number of warp yarns and filling yarns per inch.

CREEP, CYCLIC - Unrecoverable strain accumulated with repeated loading.

CREEP, STATIC - Time-dependent elongation under constant stress.

CREEP LIMIT - The constant tensile stress below which a geotextile will not creep to failure.

CROSS DIRECTION - The axis within the plane of a fabric perpendicular to the direction of motion in the final forming step.

CROSS-MACHINE DIRECTION - See CROSS DIRECTION.

CUTTING RESISTANCE - The resistance of the fabric or fiber to cutting when struck between two hard objects.

DENIER - A measure of the fineness or size of a yarn expressed in terms of a mass per unit length; numerically equal to the number of grams per 9,000 meters. See TEX.

EOS - See EQUIVALENT OPENING SIZE.

EPOXY BONDING - A bonding process in which the fabric web is impregnated with epoxy resin which serves to coat and cement the fibers together.

## A.2 GLOSSARY (con't)

**EQUIVALENT OPENING SIZE (EOS)** - A measure of the size of the largest openings in a geotextile; gradually being replaced by the term "apparent opening size."

**FABRIC, BONDED** - A textile structure wherein the fibers are bonded together with an adhesive or by welding with heat and pressure.

**FABRIC, KNITTED** - Textile made up of loops of fibers connected by straight segments.

**FABRIC, NONWOVEN** - A textile structure produced by bonding or interlocking of fibers, or both, accomplished by mechanical, chemical or solvent means, and combinations thereof, excluding woven and knitted fabrics.

**FABRIC, WOVEN** - A textile structure comprising two or more sets of filaments or yarns interlaced in such a way that the elements pass each other essentially at right angles and one set of elements is parallel to the fabric axis.

**FATIGUE RESISTANCE** - The ability to withstand stress repetitions without suffering a loss in strength.

**FELT** - A sheet of matted fibers made by a combination of mechanical and chemical action, pressure, moisture, and heat.

**FIBER** - Basic element of fabrics and other textile structures, characterized by having a length at least 100 times its diameter or width, which can be spun into a yarn or otherwise made into a fabric.

## A.2 GLOSSARY (con't)

**FIBRILLATED YARN** - A yarn made from a film which has been nicked and broken up into fibrous strands which are then bundled together. The fibers can still be partially attached to one another.

**FILAMENT** - A fiber of extreme length, not readily measured. Sometimes called "continuous filaments."

**FILL** - Fibers or yarns placed at right angles to the warp or machine direction in a woven fabric.

**FILTER CAKE** - A thin layer of fine soil particles accumulated in the soil adjacent to the fabric as a result of smaller soil particles being washed through the soil pores.

**FILTRATION** - The process of allowing water to easily escape from soil while retaining soil in place.

**FLEXIBILITY** - The ability to bend around a small radius with the application of only a small flexural stress. Low stiffness.

**FREEZE-THAW RESISTANCE** - Ability to resist degradation caused by freeze-thaw cycles.

**FRICITION ANGLE** - An angle, the tangent of which is equal to the ratio of the friction force per unit area to the normal stress between two materials.

**GRAB TENSILE STRENGTH** - A modified tensile strength of a fabric. The strength of a specific width of fabric together with the additional strength contributed by adjacent areas.

Typically, grab strength is determined on a 4-inch wide strip of fabric, with the tensile load applied at the midpoint of the fabric width through 1-inch wide jaw faces.

## A.2 GLOSSARY (con't)

**GEOMEMBRANE** - A synthetic impermeable membrane used in geotechnical engineering.

**GEOTEXTILE** - A textile, almost invariably synthetic, used in geotechnical engineering. Also referred to as: "filter fabric", "filter cloth", "geotechnical fabric", "engineering fabric", and "geofabric".

**GRADIENT RATIO** - The ratio of the average hydraulic gradient across the fabric and the 1 inch of soil immediately next to the fabric to the average hydraulic gradient across the 2 inches of soil between 1 and 3 inches above the fabric, as measured in a constant head permeability test.

**HEAT BONDING** - A process by which fabric filaments are welded together at their contact points by subjection to a relatively high temperature.

**IRRADIATION** - Quantity of radiant energy impinging a given surface, usually expressed in  $\text{KJ/m}^2$ .

**KEVLAR** - The registered trademark for a manufactured fiber in which the fiber-forming substance is an aramid.

**LATERAL DRAINAGE ABILITY** - The capacity of a fabric to transmit water flow within the plane of the fabric.

**LOT** - A portion of a production run that differs from other portions in specifications, style, or physical characteristics. Also, the portion run received by a purchaser.

**MACHINE DIRECTION** - The axis within the plane of the fabric parallel to the direction in which a fabric is processed onto rolls as the final step of production.

## A.2 GLOSSARY (con't)

MELT BONDING - See HEAT BONDING.

MINIMUM ROLL AVERAGE VALUE - Or roll average value.

MODULUS - A measure of the resistance to elongation under load.  
The ratio of the change in tensile load per unit width to the corresponding change in strain.

MODULUS, OFFSET TANGENT - A tensile stress-strain modulus obtained using a straight line to represent the stress-strain curve drawn parallel to and offset by a prescribed distance from a line tangent to the initial portion of the actual stress-strain curve.

MODULUS, SECANT - A tensile stress-strain modulus obtained using a straight line (to represent the stress-strain curve), drawn from the origin through a coordinate representing a stress measured at a specified strain.

MODULUS, TANGENT - A tensile stress-strain modulus obtained using a straight line (to represent the stress-strain curve), drawn tangent to a specified portion of the stress-strain curve.

MOISTURE REGAIN - The amount of water in a material determined under prescribed conditions and expressed as a percentage of the mass of the water-free specimen.

MONOFILAMENT - A single filament of a man-made fiber, usually of a denier higher than 15.

MULTIFILAMENT - A yarn consisting of many continuous filaments or strands.

NAP - A hairy or downy surface on a fabric.

## A.2 GLOSSARY (con't)

**NONWOVEN FABRIC** - A textile structure produced by bonding or interlocking of fibers, or both, accomplished by mechanical, chemical, or solvent means.

**NEEDLE PUNCHING** - Subjecting a web of fibers to repeated entry of barbed needles that compact and entangle individual fibers to form a fabric.

**NEEDED** - A fabric constructed by needed punching.

**PENETRATION RESISTANCE** - The fabric property determined by the force required to penetrate a fabric with a sharp pointed object. Initial penetration is by separating the fibers. Further penetration is essentially a tearing process.

**PERCENT OPEN AREA (POA)** - The net area of a fabric that is not occupied by fabric filaments, normally determinable only for woven and nonwoven fabrics having distinct visible and measurable openings that continue directly through the fabric.

**PERMEABILITY, LONGITUDINAL OR IN PLANE** - The fabric property which permits a fluid, normally water, to flow in the plane of the fabric. See TRANSMISSIVITY.

**PERMEABILITY, TRANSVERSE** - The fabric property which allows a fluid, normally water, to flow through a fabric perpendicular to the plane of the fabric. See PERMITTIVITY.

**PERMEABILITY, COEFFICIENT OF** - A measure of the permeability of a porous media such as soil or geotextile to water. It is the ratio of discharge velocity to the hydraulic gradient under laminar flow conditions. Also referred to as the Darcy coefficient; hydraulic conductivity.

## A.2 GLOSSARY (con't)

**PERMITTIVITY** - For a fabric, the volumetric flow rate of water per unit cross-sectioned area, per unit head, under laminar flow conditions, in the direction perpendicular to the plane of the material.

**PIPING** - The process of soil removal due to seepage in which tunnel-like openings or pipes form in the soil mass.

**PLANE STRAIN** - A loading condition where strains in the plane of the fabric occur in only one direction.

**PLUGGING** - The partial or total closure of fabric pores as a result of particle or chemical deposition or biological growth within or on a fabric. Plugging can consist of clogging, blinding, or both.

**POA** - See PERCENT OPEN AREA.

**POLYESTER FIBER** - A manufactured fiber in which the fiber-forming substance is any long chain synthetic polymer composed of at least 85 percent by weight of an ester of dihydric alcohol and terephthalic acid.

**POLYETHYLENE FIBER** - A manufactured fiber in which the fiber-forming substance is an olefin made from polymers or copolymers of ethylene.

**POLYMER** - A high molecular chainlike structure from which man-made fibers are derived; produced by linking together molecular units called monomers, consisting predominantly of nonmetallic elements or compounds.

## A.2 GLOSSARY (con't)

**POLYPROPYLENE FIBER** - A manufactured fiber in which the fiber-forming substance is an olefin made from polymers or copolymers or propylene.

**PORE SIZE** - The size of an opening between fabric fibers. Because of the variability of opening sizes for different fabrics, the equivalent opening size (EOS) is used to determine the approximate size of the largest pores of fabric.

**PUNCTURE RESISTANCE** - Resistance to failure of a fabric from a blunt object applying a load over a relatively small area. Failure results from tensile failure of the fibers.

**REINFORCEMENT** - Strengthening of a soil-fabric system by contributions of the fabric inclusion.

**RESIN BONDING** - A bonding process in which fabric web is impregnated with a resin which serves to coat and cement the fibers together.

**SAMPLE, LOT** - A portion of a lot taken to represent the lot. The portion is usually taken using some statistical sampling technique and for geotextiles, usually consists of one or more rolls of fabric. Samples for laboratory tests or for record purposes taken from the lot sample.

**SCRIM** - A woven fabric to which nonwoven fibers are bonded or needle-punched to form a composite fabric.

**SELVAGE** - The woven edge portion of a fabric parallel to the warp.

**SEPARATION** - Function of fabric as a partition between two adjacent materials to prevent mixing of the two materials.



## A.2 GLOSSARY (con't)

**SLIT-FILM FILAMENT** - A filament with a width many times its thickness.

**SOIL-FABRIC FRICTION** - The resistance to sliding between engineering fabric and soil, excluding the resistance from soil cohesion. Soil-fabric friction is usually quantified in terms of a friction angle.

**SPECIFIC GRAVITY** - The ratio of the density of a fabric to the density of water obtained by weighing both items in air. A specific gravity less than one implies that the fabric will float.

**SPINNING** - a. The process of making a yarn (bundle of fibers) from staple fibers interlaced and twisted together.

b. The process of extrusion through a spinneret to make a filament.

**SPUN** - Made by spinning.

**SPUNBONDED** - Any nonwoven fabric made in a continuous line process in which filaments are extruded, drawn, formed into a loose web, and bonded. The bonding process can be mechanical, thermal, or chemical.

**STAPLE FIBERS** - Fibers having a short length, typically 1 to 4 inches.

**STIFFNESS** - The ability of a fabric to resist bending when flexural stress is applied.

**STRENGTH** - Load at failure. Depending on usage, load may be expressed in stress, force per unit width, or force.

## A.2 GLOSSARY (con't)

**SURVIVABILITY** - The ability of a fabric to be placed and to perform its intended function without undergoing degradation.

**TENACITY, BREAKING** - The breaking load of a fiber or yarn, in force per unit linear density of the unstrained specimen, customarily expressed as grams-force per denier (gf/den.) or grams-force per tex (gf/tex).

**KNOT BREAKING STRENGTH** - The breaking strength of a strand with a knot tied in the portion of the specimen between the clamps.

**TAPE FILAMENT** - A slit-film filament.

**TENSILE MODULUS** - See MODULUS.

**TENSILE STRENGTH** - The strength shown by a fabric subjected to tension as distinct from torsion, compression, or shear.

**TENSILE STRESS-STRAIN MODULUS** - See MODULUS.

**TENSILE TEST** - A test in which a fabric is subjected to known tensile forces and the resultant elongations are measured. The results are used to identify the tensile load carrying and stress-strain behavior of the fabric. There are several variations of the tensile test, the most widely used of which are the grab test, cut strip test, wide-width test, and the raveled strip test. All of the above tests are considered uniaxial tensile tests.

**TENSILE TEST, BIAXIAL** - A tensile test in which a fabric specimen is subjected to tensile forces in two directions 90 degrees to each other, usually the machine and cross-machine directions.

## A.2 GLOSSARY (con't)

**TENSILE TEST, UNIAXIAL** - A tensile test in which a fabric specimen is subjected to tensile forces in one direction only.

**TEX** - A measure of the fineness or size of a yarn expressed in terms of mass per unit length; numerically equal to the number of grams per 100 meters. See DENIER.

**THERMAL STABILITY** - The ability of fibers and yarns to resist changes in properties at extreme temperatures.

**THICKNESS** - The normal distance between two surfaces of a fabric. Thickness is usually determined as the distance between an anvil, or base, and a presser foot used to apply a specified compressive stress.

**TOUGHNESS** - The property of a fabric by which it can absorb work energy. When determined from a tensile test, it is equal to the area under the load-elongation curve from origin to breaking point per unit surface area of test specimen between the grips.

**TRANSMISSIVITY** - For a fabric, the volumetric flow rate of water per unit width per unit head under laminar flow conditions in a direction in the plane of the material.

**ULTRAVIOLET (UV) RADIATION STABILITY** - The ability of fabric to resist deterioration from exposure to sunlight. Actinic resistance.

**WARP** - Fibers or yarns parallel to the fabric machine direction in a woven fabric.

**WEB** - The sheet or mat of fibers or filaments before bonding or needle-punching to form a nonwoven fabric.

**WEIGHT, FABRIC** - The mass of a fabric expressed in weight per unit area.

**WICKING** - The process whereby a fabric raises water above a free water surface by capillary action.

**WORKABILITY** - The ease with which a fabric can be controlled, handled, laid, and seamed.

**YARN** - A generic term for a continuous strand of textile fibers, filaments, or material in a form suitable for weaving or otherwise intertwining to form a textile fabric.

**YARN NUMBER** - A measure of the fineness or size of a yarn expressed either as mass per unit length or length per unit mass depending on the yarn numbering systems. Two widely used numbering systems are denier and tex.

### **A.3 REPRESENTATIVE LIST OF GEOTEXTILE MANUFACTURERS AND SUPPLIERS**

**Amoco Fabrics Company (Propex)**  
900 Circle 75  
Parkway, Suite 550  
Atlanta, GA 30339  
(404) 956-9025

**Belton Industries, Inc. (Beltech)**  
8613 Roswell Road, Suite 200  
Atlanta, GA 30350  
(800) 225-4099

**Bethlehem Rebar Industries, Inc. (Ban-Tex)**  
P.O. Box 2900  
Lehigh Valley, PA 18001-2900  
(215) 266-9640

**Bradley Materials Company, Inc. (Filterweave)**  
101 John Sims Parkway  
P.O. Box 368  
Valparaiso, FL 32580  
(904) 678-1105

**Carthage Mills, Inc. (Poly-Filter)**  
Erosion Control Division  
1821 Summit Road  
Cincinnati, OH 45237  
(513) 761-4141

**Contech Construction Products Inc.**  
1001 Grove Street  
Middletown, OH 45044  
(513) 425-2165

**Delaware Valley Corp. (Tenamat)**  
500 Broadway  
Lawrence, MA 01841  
(617) 688-6995

**Exxon Chemical (GTF)**  
2100 River Edge Parkway, Suite 1025  
Atlanta, GA 30328  
(404) 955-2300

**Foss Manufacturing Company, Inc. (Geomat)**  
P.O. Box 227  
Havenhill, MA 01830  
(617) 374-0121

**Geo-Synthetics, Inc.**  
24817 W. Blue Mound Road  
Pewaukee, WI 53072  
(414) 542-5523

**GeoTech Systems Corp.**  
100 Powers Court  
Sterling, VA 22170  
(703) 450-2366

**Hoechst Celanese Corp. (Trevira)**  
Box 5887  
Spartanburg, SC 29304  
(800) 845-7597

**ITW High Performance Plastics (TNX & CTX)**  
3640 W. Lake Avenue  
Glenview, IL 60025  
(800) 992-6890

**James River Corp. (Fibretex)**  
101 Locke Lane  
Mauldin, SC 29662  
(800) 772-7771

**Lutravil Sales Company**  
One Federal Street, 24th Floor  
Boston, MA 02110

**Mirafi, Inc. (Mirafi)**  
P.O. Box 240967  
Charlotte, NC 28224  
(800) 438-1855

**Nicolon Corporation (Nicolon & Geolon)**  
3150 Holcomb Bridge Road, Suite 300  
Norcross/Atlanta, GA 30071  
(404) 447-6272

**Philips Fibers Corp. (Supac and Petromat)**  
P.O. Box 66  
Greenville, SC 29602  
(803) 242-6600

**A.3 REPRESENTATIVE LIST OF GEOTEXTILE MANUFACTURERS AND SUPPLIERS (con't)**

**Polyfelt, Inc.**  
P.O. Box 727  
Evergreen, AL 36401  
(800) 225-4547

**Reemay Inc. (Typar)**  
P.O. Box 511  
Old Hickory, TN 37138  
(615) 847-7059

**The Tensar Corporation (Tensar Geogrid)**  
1210 Citizens Parkway  
Morrow, GA 30260  
(404) 968-3255

**Webtec, Inc. (Terra Tex)**  
P.O. Box 240302  
Charlotte, NC 28224  
(800) 438-0027

**Wellman Quline, Inc. (Quline)**  
P.O. Box 7809  
10801 Nations Ford Road  
Charlotte, NC 28241  
(800) 222-1075

A.4 GENERAL RANGE OF STRENGTH AND PERMEABILITY PROPERTIES<sup>1, 2</sup>  
FOR REPRESENTATIVE TYPES OF GEOTEXTILES

Geotextile Type	Weight <sup>3</sup> (oz/yd <sup>2</sup> )	Ultimate Tensile <sup>4</sup> Strength (lb/in)	Strain at Ultimate <sup>4</sup> Tensile Strength (%)	Secant <sup>4</sup> Modulus at 10% Strain (lbs/in)	Grab <sup>5</sup> Strength (lbs)	Puncture <sup>6</sup> Strength (lbs)	Burst <sup>7</sup> Strength (psi)	Tear <sup>8</sup> Strength (lbs)	Equivalent <sup>9</sup> Darcy Permeability (cm/sec)
<b>Woven</b>									
Monofilament-Polypropylene	5-10	100-400	20-40	400-1500	150-500	75-150	400-700	50-100	10 <sup>-2</sup> - 10 <sup>-1</sup>
Silt-Film	2-7	75-250	20-40	300-1500	75-350	20-130	200-700	50-180	10 <sup>-2</sup> - 10 <sup>-1</sup>
Fibrillated Tape and Multi-Filament Polypropylene	10-32	200-1200	15-40	1000-4000	150-1400	150-250	600-1500*	100-400	10 <sup>-2</sup> - 10 <sup>-1</sup>
Multifilament-Polyester	6-30	150-2000*	10-30	1000-6000*	150-2000*	50-300	500-1500*	80-500	10 <sup>-2</sup> - 10 <sup>-1</sup>
<b>Non-Woven</b>									
Continuous Filament-Melt Bonded	2-10	20-200	30-100	100-500	40-400	20-100	80-500	30-200	10 <sup>-2</sup> - 1
Needlepunched (lightweight)	3-10	20-100	40-150	10-150	40-250	50-125	150-400	30-150	10 <sup>-1</sup> - 1
Needlepunched (heavyweight)	10-36	40-200	40-150	50-300	150-500	100-250	300-1000	75-200	10 <sup>-2</sup> - 1
<b>Geogrid</b>									
Polypropylene	6-10	50-200	10-20	500-1300	N/A	N/A	N/A	N/A	>10
High Density Polyethylene	10-30	50-500	10-20	300-400	N/A	N/A	N/A	N/A	>10
Polyester	10-30	200-800	5-15	2000-15,000	N/A	N/A	N/A	N/A	>10

1. Data was obtained from numerous sources, in some cases estimated, and represents an average range. There may be products outside this range. No relation should be inferred between maximum and minimum limits for different tests.

2. Both directions

3. Method 1.1.84, Appendix B, FHWA Geotextile Engineering Manual

4. Wide Width Method, ASTM D-4595

5. ASTM D-4632

6. ASTM D-4833

7. ASTM D-3786

8. ASTM D-4533

9. ASTM D-4491

\* Limited by test machine

**A.5 NHI/FHWA GEOTEXTILE ENGINEERING WORKSHOP**

**LECTURE OUTLINE: CONSTRUCTION COURSE**

**Lecture Number: 1**

**TITLE: Introduction to Course**

**Time: 15 min.**

- I. Introduction of Instructors**
- II. Introduction of Participants**
- III. Administrative Procedures**
- IV. Facilities**
- V. Course Materials**
  - Sample products**
  - Text**
  - Outline**
- VI. Course Objectives**



LECTURE OUTLINE: CONSTRUCTION COURSE

Lecture Number: 2

TITLE: Introduction to Geotextiles; Manufacturing; Applications.

Time: 45 min.

I. Historical Review

II. Geosynthetics

III. Geotextiles

A. Types

1. Composition

- Polypropylene
- Polyester
- Polyethylene
- Polyamide

## **2. Manufacturing**

## **3. Nonwoven Fabric**

### **Fibers**

- **Filaments**
  
- **Staple Fibers**

## **4. Woven Fabric**

## **5. Yarns**

- **Monofilament**
  
- **Multifilament**
  
- **Spun**

- Slit Film
- Fibrillated

**B. Identification**

- Identification Method
  - Fiber or yarn
  - Product type
  - Mass per unit area
- Polypropylene Staple Fiber
  - Needlepunched nonwoven 10 oz/yd<sup>2</sup>

**IV. Geosynthetic Functions**

**A. Separation**

**1. Description**

**2. Design elements**

**B. Filtration**

**1. Description**

**2. Design elements**

**C. Transmission**

**1. Description**

**2. Design elements**

**D. Cushion**

**1. Description**

**2. Design elements**

## **E. Reinforcement**

### **- Tensile member**

#### **1. Description**

#### **2. Design elements**

### **- Tensioned membrane**

#### **1. Description**

**2. Design elements**

**F. Isolation**

**1. Description**

**2. Design elements**

**G. Functions and Types**

**LECTURE OUTLINE: CONSTRUCTION COURSE**

**Lecture Number: 3**

**TITLE: Properties of Geotextiles**

**Time: 1 hour**

**I. Evaluation of Geotextiles**

**A. Properties required to provide design characteristics for comparison and selection**

**B. Properties evaluated to ensure proper material is sent to job**

**C. Properties should be reviewed from:**

**1. Engineering significance -- variability of properties**



2. Data sources -- disparity between published data

3. Methods of evaluation -- procedural variation

**D. Variability of properties**

1. Currently over 200 different geotextiles

2. Properties vary due to manufacturing technique, polymer, filament type, weaving pattern, bonding methods, thickness, and mass per unit area

---

"The facts stated and the recommendations made herein, based on our research and research of others, are offered free of charge, and are believed to be accurate. No guarantee of their accuracy is made, however, and the products discussed are distributed without warranty, expressed or implied, and upon condition that recipients shall make their own tests to determine the suitability of such products for their particular purposes. Likewise, statements concerning the possible uses of our product are not intended as a recommendation to use it in the infringement of any patent, whether owned by \_\_\_\_\_ or by others."

---

## II. Specific Properties Evaluation

### A. General Properties

### B. Index Properties

### **C. Endurance Properties**

- Most fabrics can be exposed to UV radiation for  $\pm$  30 days without deterioration - some much longer
- Essentially all engineering fabrics have satisfactory chemical and biological stability
- Fabrics normally have satisfactory fatigue, freeze-thaw, and low-high temperature resistance

### **D. Hydraulic Properties**

**LECTURE OUTLINE: CONSTRUCTION COURSE**

**Lecture Number: 4**

**Title: Specifications; compliance testing requirements;  
conformance testing requirements; field marking**

**Time: 1 hour**

**I. Selection and Specification**

**A. Specification Basis**

**1. Design Property Values**

**2. Survivability Property Values**

**3. Durability Property Values**

**B. Procedure for Selecting Values**

- 1. Conduct analytical design and determine design values**
  
- 2. Use survivability tables to determine survivability values**
  
- 3. Specify highest of (1) and (2) above**
  
- 4. Specify that supplier must certify that all property values meet specified values**
  
- 5. Specify conformance testing frequency and minimum average roll values**

**C. Minimum Average Roll Values**

**D. Types of Specifications**

**E. Sample Specification**

**II. Selection Criteria**

**A. Certification**

**B. Experience**

**C. Cost**

**III. Acceptance and Rejection**

**A. Conformance Testing**

**B. Rejection Process**

**18 Mar 88**

**LECTURE OUTLINE: CONSTRUCTION COURSE**

**Lecture Number: 5**

**Title: Host State Presentation**

**Time: 30 min.**

**I. Host State Experience**

**II. Host State Specifications**



**LECTURE OUTLINE: CONSTRUCTION COURSE**

**Lecture Number: 6**

**Title: Installation of Geotextiles in Drainage Applications**

**Time: 30 min.**

**I. Filtration and Drainage Applications**

- **Conventional drains**
  
- **Fabric & Prefabricated drains**
  
- **Erosion Control**
  
- **Sediment Control**

## **II. Concept**

### **A. Conventional granular filters vs. geotextiles**

### **B. Conventional Alternatives:**

One or more granular soil layers to

- 1. Retain natural soil in place**
- 2. Provide water removal capacity**

### **C. Examples:**

**D. Pavement Drainage**

1. Edge drains
2. Base/subbase drains
3. Construction procedures with geotextiles

**- Construction Procedures**

**E. Underdrains/Trench drains**

1. With and without collector pipes
2. Construction procedures with geotextiles

## **F. Interceptor Drains**

### **III. Transmission Drainage Applications**

#### **A. Examples**

- **Drainage behind retaining structures - to prevent hydrostatic pressure development**

#### **B. Construction Considerations**

- **Lateral drainage construction**
  - **Storage**
  - **Backfilling**

- **Overlaps**

- **Boundary effects**

- **Collector drains**

**LECTURE OUTLINE: CONSTRUCTION COURSE**

**Lecture Number: 7**

**Title: Installation of Geotextiles in Erosion Control Applications**

**Time: 30 min.**

**I. General Problem -**

- **Flowing external water erodes the soil**
  
- **Seeping internal water exits and pipes the soil**

**II. Erosion Control Applications -**

- **Revetments**
  
- **Cut and fill slopes**
  
- **Ditches and channels**

- Streambank protection

- Scour protection

### III. Concept

Fabric must perform same functions as granular layer(s) it replaces -

- Retain natural soil
- Remain more permeable than natural soil

### IV. Installation

#### A. Shore line protection

- Place/Secure Fabric -
  - Place machine direction of fabric with slope

- Overlap or sew seams
- Secure with steel pins
- Do not pull too taut
- Place cover stone, blocks, etc.-
  - Place from bottom to top
  - Minimize drop height, 1 ft or less
- Place fabric machine direction parallel with the bank-direction of streamflow

#### **B. Runoff and Sediment Control**

**(Note: These are temporary applications)**



**LECTURE OUTLINE: CONSTRUCTION COURSE**

**Lecture Number: 8**

**Title: Installation of Geotextiles in Roadway Applications**

**Time: 30 min.**

**I. Permanent Roads and Highways**

**A. Purpose of Geotextile**

**When conventional road construction/operation hindered by:**

- 1. Poor equipment mobility**
  
- 2. Subgrade intrusion**
  
- 3. Subgrade bearing failure**

**B. Important Fabric Design Concept -**

**Fabric cannot perform any function unless it survives placement, covering, and initial traffic.**

**C. Permanent Roads**

**Applications in Permanent Road Construction**

**D. Temporary Roads**

**Construction of Temporary Roads**

**LECTURE OUTLINE: CONSTRUCTION COURSE**

**Lecture Number: 9**

**Title: Installation of Geotextiles in Pavement Rehabilitation Applications**

**Time: 30 min.**

**I. Rehabilitation/Maintenance Construction**

**A. Purpose:**

**1. Prevent reflective cracking**

**2. Extend life of overlay**

**3. Reduce overlay thickness??**

## **B. Variables**

- **Pavement Problem Variables**

1. **Cause of cracking**

2. **Climate**

3. **Geotextile selection**

4. **Construction procedure**

- **Construction Guidelines**

1. **Pavement surface**

2. **Tackcoat**

3. Fabric placement

4. Weather

5. Traffic

## II. Roadway Repair

**LECTURE OUTLINE: CONSTRUCTION COURSE**

**Lecture Number: 10**

**Title: Installation of Geotextiles in Reinforced Embankment Applications**

**Time: 30 min.**

**I. Embankments on Soft Soils**

**A. Concept and Function of Geotextile**

**1. Prevent instability**

**2. Prevent excessive vertical/horizontal deformation subgrade reinforcement**

**B. Construction Considerations**

- **Construction**

- **Equipment selection**

- **Site preparation**

- **Fill placement:**

**Extremely soft ground**

**Moderate ground >1**

- **Site preparation -**

- **Working table not usually justified**

- **Fabric-reinforced access roads may be required**

- **Construction concepts -**

**Fabric reinforcement properties are irrelevant unless the fabric survives placement -**

**(Fabric survivability)**

- **Fabric placement-**

- **Sew all seams**

- **Place fairly flat**

- **Use "Mud Wave" technique on very soft foundation**

- **Field workability may determine rate of placement**

- **Construction concepts -**

**Rate of fabric placement is often proportional to its ability to support contractor's workman -**

**(Fabric field workability)**



- Placement/compaction of fill -
  - Use-low-ground-pressure equipment
  - Use cohesionless fill
  - Keep "U" shaped leading edge

- Working on the Mud Wave -

Construction technique used on very soft foundation

- Place/compaction of fill -
  - Bring fill in along "toe" roads
  - Move dumped fill from outside to inside of section
  - Maintain balanced or symmetric fill placement

**LECTURE OUTLINE: CONSTRUCTION COURSE**

**Lecture Number: 11**

**Title: Installation of Geotextiles in Reinforced Vertical Walls and  
Reinforced Slopes**

**Time: 30 min.**

**I. Reinforced Walls and Abutments**

**A. Concept**

**B. Examples**

**II. Backfill properties**

**A. Conventional**

**B. Local materials**

**C. Cohesive?**

**III. Construction Considerations**

**IV. Reinforced Slopes**

**A. Stability**

18 Mar 88

**B. Steepen slopes**

**C. Compaction aid**

**D. Construction Guidelines**

18 Mar 88

## F O R E W O R D

These guidelines have been condensed from the FHWA Geotextile Engineering Manual (1985) for use as an implementation document for project managers and highway designers. It will also be useful as a design reference guide for pavement and geotechnical specialists. The guidelines when used in conjunction with the FHWA Geotextile Engineering Manual will enable the highway engineer to properly design, select, test, specify, and construct with geotextiles and related products such as geogrids and geocomposite drainage materials. After a general introductory chapter, application chapters are presented on drainage, erosion control (permanent and temporary), roadways, pavement overlays, and reinforced embankments, slopes, and retaining walls and abutments. Each chapter presents step-by-step procedures for design, selection, and installation of geotextiles for these applications. For additional information, references are provided to supplement those given in the FHWA Geotextile Engineering Manual.

## N O T I C E

The contents of this report reflect the views of the author who is responsible for the facts and the accuracy of the data presented herein. The contents do not necessarily reflect the policy of the Department of Transportation. This report does not constitute a standard, specification, or regulation. The United States Government does not endorse products or manufacturers. Trade or manufacturer's names appear herein only because they are considered essential to the object of this document.

FHWA Research Library



1000035773