

TE
5600
.445
no.3

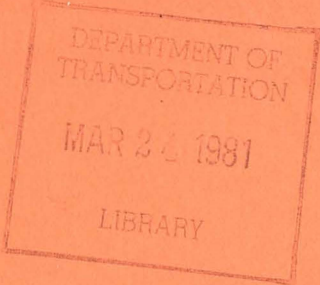

Hydraulic Design of Improved Inlets for Culverts
using
Programable Calculators



TEXAS INSTRUMENTS

TI-59



Calculator Design Series #3

October 1980

U. S. DEPARTMENT OF TRANSPORTATION
FEDERAL HIGHWAY ADMINISTRATION

FEDERAL HIGHWAY ADMINISTRATION

Hydraulic Design Publications

The first hydraulic design publications were developed in the early 1960's to aid in the design of highway drainage structures. Since that time, the list of publications has expanded as research results and actual experience became available. Some material is preliminary or tentative, subject to change upon further research. Criticisms and suggestions on material contained in the publications are welcomed.

The publications listed below are available for purchase at the listed prices from the Superintendent of Documents, U.S. Government Printing Office, Washington, D.C. 20402. Payment should accompany orders to the Government Printing Office. Stock numbers should be used in ordering the publications.

THIS IS NOT AN ORDER FORM FOR THE GOVERNMENT PRINTING OFFICE (GPO)

Hydraulic Design Series

HDS No. 1 HYDRAULICS OF BRIDGE WATERWAYS - Second Edition - Revised 1978 - \$3.00 (Stock No. 050-001-00133-1)

Hydraulic Engineering Circulars

HEC No. 5 HYDRAULIC CHARTS FOR THE SELECTION OF HIGHWAY CULVERTS - December 1965 - 95 cents (Stock No. 050-002-00010-1)

HEC No. 12 DRAINAGE OF HIGHWAY PAVEMENTS - March 1969 - \$1.55 (Stock No. 050-002-00043-8)

HEC No. 14 HYDRAULIC DESIGN OF ENERGY DISSIPATORS FOR CULVERTS AND CHANNELS - December 1975 - \$4.70 (Stock No. 050-002-00102-7)

HEC No. 15 DESIGN OF STABLE CHANNELS WITH FLEXIBLE LININGS - October 1975 - \$2.75 (Stock No. 050-002-00101-9)

(Continued on inside of back cover)

TE
5600
. A45
no.3

TABLE OF CONTENTS

	PAGE
Introduction	iii
Program Limitations	v
List of Symbols	vii
Program Outlines: Box Culverts	x
Program Outline: Pipe Culverts	xi
Program Index	xii
Programs	1
Storage Registers	82
Worksheets	83
Example Problems	92
Appendix	119
References	133

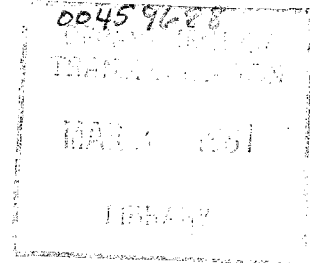

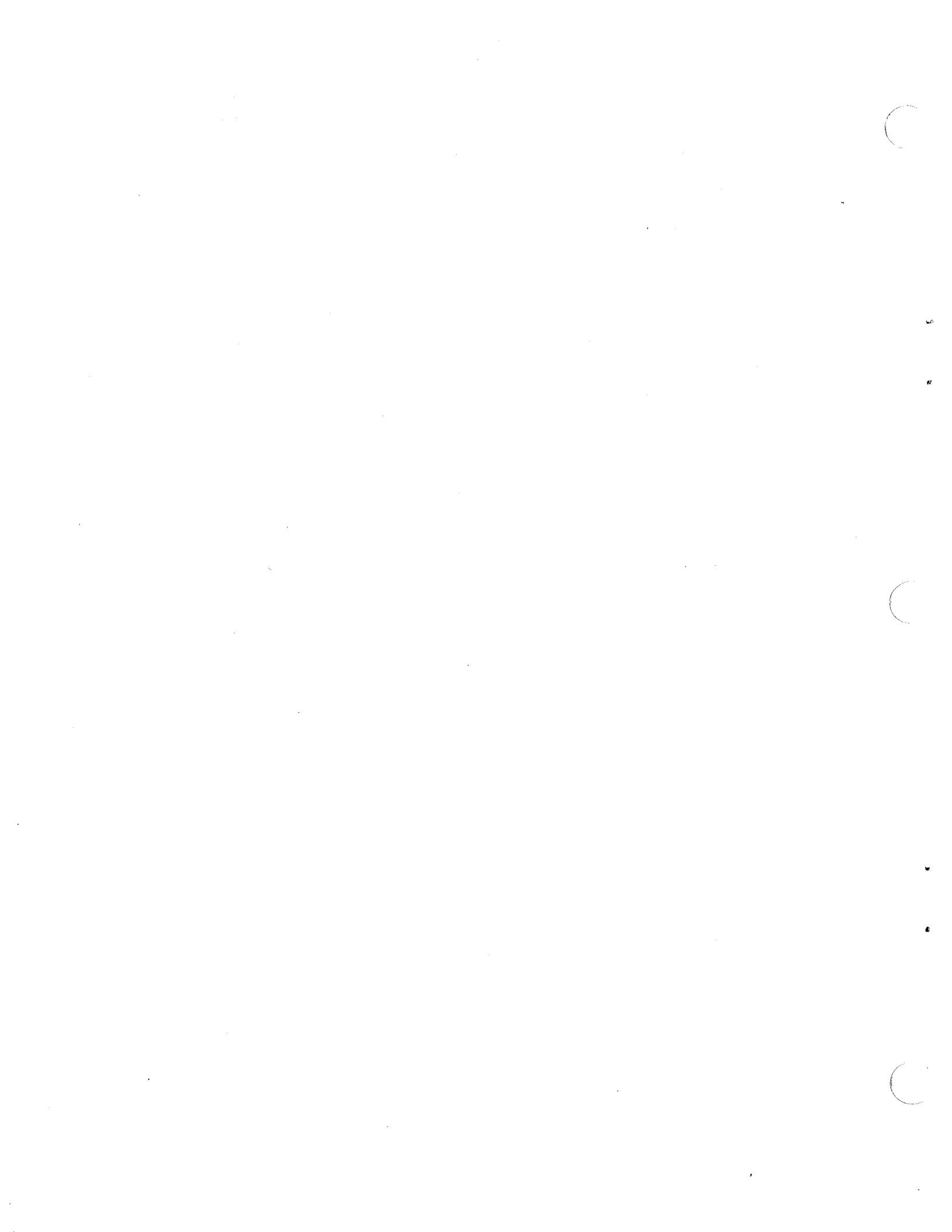

INTRODUCTION

The programable calculator as a culvert designing tool offers many desirable features. Compared with the hand method, the calculator is more accurate, less time consuming, and eliminates all the searching through charts and nomographs. In one quarter of the time it takes to design one culvert by hand, the designer could use the calculator to design the culvert, checking four or five different sizes to find the best one, while also evaluating several inlet configurations including both side- and slope-tapered inlets.

In an office where it is not feasible to use a computer for culvert design, the programable calculator becomes a desirable alternative. The accuracy remains the same, and the calculator method offers a segment by segment design approach. This method allows the culvert design parameters to be changed as the design is proceeding along.

The procedure herein covers both box and circular pipe culverts and follows the culvert design methods presented in "Hydraulic Design of Improved Inlets for Culverts," Hydraulic Engineering Circular No. 13 (HEC 13), dated August 1972. The programs begin with the computation of tailwater, proceed through the design of the culvert barrel, and conclude with the design of the culvert inlet most applicable to the site. The programs produce detailed inlet dimensions, performance curve data, and the outlet velocity.

Since the procedure is subdivided into a series of programs, the designer may enter the sequence at any point, provided the necessary input data is available, and obtain the desired design results.

These box and pipe culvert programs have been written for use on the Texas Instrument - 59 calculator. It is expected that with the equations, examples, and program listings, a designer will be able to write similar programs for any other calculator he may have available.

Terminology used in this publication assumes that the designer is familiar with HEC 13 and understands the principles and design philosophy expressed therein.

This document was written by Mr. Patrick Wlaschin, edited by Mr. Philip L. Thompson and typed by Ms. Barbara Driver.

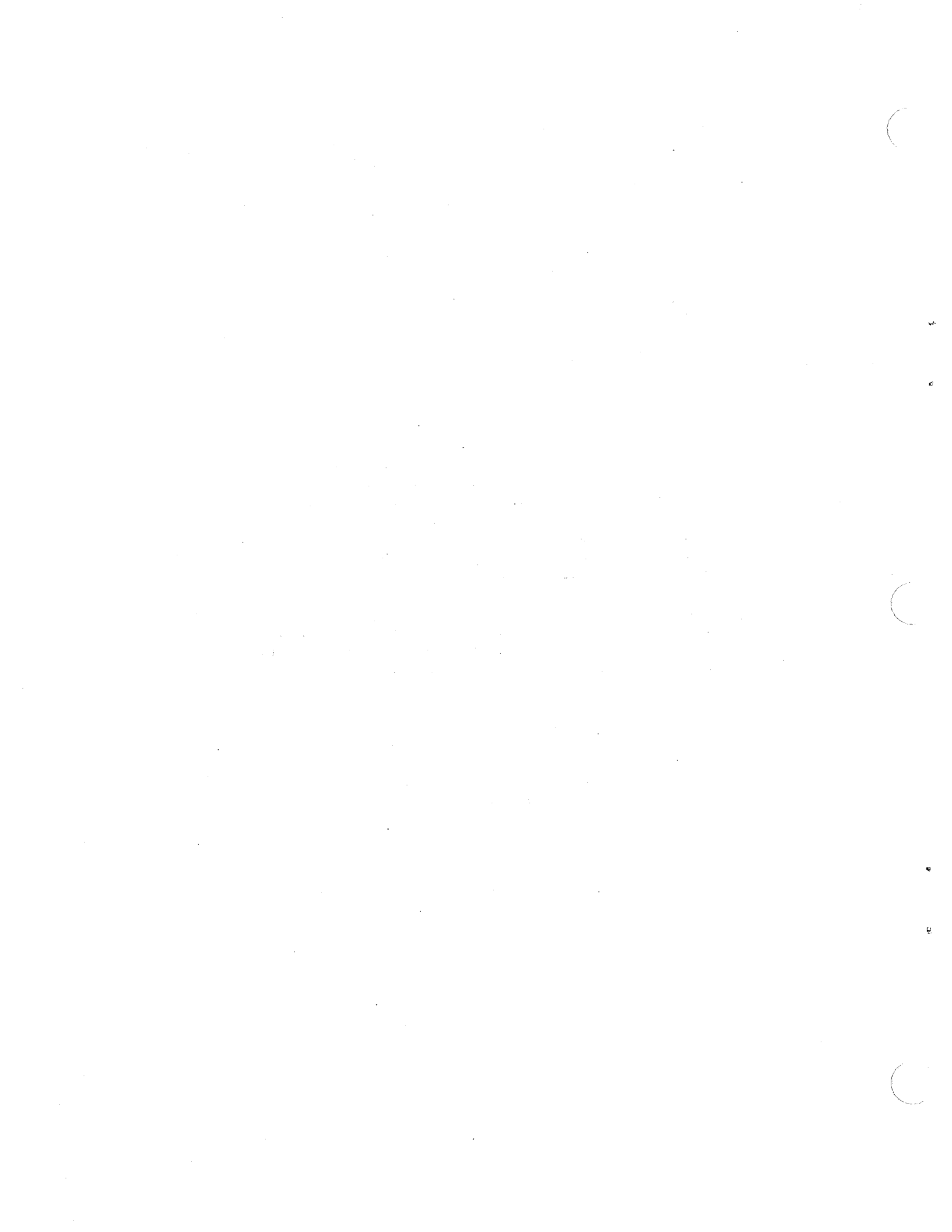

PROGRAM LIMITATION

When computing headwater depths, H_f and H_t , the upper and lower limits for these values are $4.5 D$ and $0.5 D$. These limits indicate the range over which research was performed on these culverts. Because polynomial best-fit equations are used to produce the chart values from HEC 13, values outside these limits can be obtained. Since the programs do not check for these conditions, it is left to the designer.

When designing either a side-tapered or slope-tapered inlet, the number of barrels, N , is limited to two for boxes. For multiple barrel pipe installations, each barrel should be designed individually.

In programs for circular pipes where d_n/D is greater than 0.89, the program assumes the pipe to be flowing full in calculating the outlet velocity.

In calculating the "H" value in the outlet control performance programs, it is assumed that the culvert is flowing full.

In the design of slope-tapered inlets, the FALL slope, S_f , must range between a 2:1 and a 3:1 ratio.

In the programs which use FALL, this value is limited to a range of $0.25 D$ to $1.5 D$ for slope tapered inlets.

For side-tapered inlets the value of side taper, ST , must be between 4:1 and 6:1.

The value of L_3 must be greater than or equal to $0.5 B$. This value has been set so that control will occur at the throat section rather than at the bend section.

In addition to the design limitations given previously for box culverts with slope-tapered inlets, the following criteria apply to slope-tapered and rectangular side-tapered inlets for pipe culverts:

The rectangular throat of the inlet must be a square section with sides equal to the diameter of the pipe-culvert.

The transition from the square throat section to the circular throat section must be no shorter than half the culvert diameter. If excessive lengths are used, the frictional losses within this section of the culvert should be considered in the design.

The design of multiple barrels for circular culverts using slope-tapered improved inlets can be performed the same as that for box culverts except the center wall must be flared in order to provide adequate space between the pipes for proper compaction of the backfill. The amount of flare required will depend on the size of the pipes and the construction techniques used. An alternative would be to design a series of individual circular culverts with slope-tapered inlets. This permits the use of an unlimited number of barrels and the design programs are applicable.

The wingwall flare angles used in side-tapered inlets are limited from 15° to 26° with the top edge beveled, and from 26° to 90° with or without bevels.

The socket entrance used in these programs refers to the bell and spigot type of pipe.

All the dimensions used in these programs are in English units. The programs require all of their inputs to be in this type of format.

The use of slopes equal to a value of zero will produce incorrect results.

These programs do not check for errors in input values.

For the most part, these limitations are repeated in the discussion segment of each program.

In typing the program listings, the following notation was used: DIV = divide, SRT = square root and PI = the Greek symbol for pi.

To execute one of the prerecorded programs, load the program into the calculator and press Label A. The calculator will print the program title and then issue a data prompt. Whichever input data corresponds to this prompt should then be entered into the calculator. To enter the data press the value and then the Run/Stop button. The calculator will either prompt for another entry or will proceed with the calculations.

LIST OF SYMBOLS

<u>Symbols</u>	<u>Units</u>	<u>Description</u>
A	sq. ft.	Area, generally the cross-sectional area of flow
a	ft.	Bevel dimension used for circular pipe culverts
ADJ.L	ft.	Adjusted length of a culvert, after its original length has been altered by the addition of a improved inlet
Alpha		Velocity distribution factor used with pipe culverts, 1.04 for concrete, 1.12 for corrugated metal
B	ft.	Width of the box culvert barrel or the diameter of a pipe culvert
b	ft.	Bevel dimension used for circular pipe culverts
B_f	ft.	Width of the face section of an improved inlet
BW	ft.	Base width of a rectangular or trapezoidal channel section
c	ft.	Bevel dimension used for circular pipe culverts
CW	ft.	Width of the weir crest
D	ft.	Height of a box culvert or the diameter of a pipe culvert
d	ft.	Bevel dimension used for circular pipe culverts
d_c	ft.	Critical depth of flow
DHW EL.	ft.	Design headwater elevation at the culvert entrance
d_n	ft.	Normal depth of flow
d_2, d_3, d_4	ft.	Variable depths of flow

LIST OF SYMBOLS

<u>Symbols</u>	<u>Units</u>	<u>Description</u>
E	ft.	Height of side-tapered pipe culvert face section, excluding bevel dimension
EL.FACE	ft.	Invert elevation of the face section of a culvert
EL.FD	ft.	Catch point elevation of the fill slope at the downstream end of the cross section
EL.FU	ft.	Catch point elevation of the fill slope at the upstream end of the cross section
EL.IN	ft.	Inlet invert elevation of the culvert before any improved inlet adjustments
EL.OUT	ft.	Invert elevation of the culvert outlet
EL.THR	ft.	Invert elevation of the culvert throat section
FALL	ft.	Distance between the culvert inlet and the control section. Measured in a downward direction
g	ft/sec ²	Acceleration of gravity: 32.2
H	ft.	Head or energy required to pass a given quantity of water through a culvert flowing in outlet control
H _c	ft.	The depth of pool, or head, above the weir crest
H _e	ft.	Head loss at a culvert due to the entrance configuration
H _f	ft.	Depth of pool, or head, above the face section invert
H _t	ft.	Depth of pool, or head, above the throat section invert
H _v	ft.	Head due to velocity
HW EL.	ft.	Headwater elevation at the entrance to a culvert
k _e	ft.	Entrance energy loss coefficient
L	ft.	The length of the culvert, measured along the barrel

LIST OF SYMBOLS

<u>Symbols</u>	<u>Units</u>	<u>Description</u>
L_1, L_2 L_3, L_4	ft.	Dimensions relating to the improved inlet as shown in sketches of the different inlet types
N		Number of culvert barrels
n		Manning's roughness coefficient
Q	cfs.	The volume rate of flow
R	ft.	Hydraulic radius
r	ft.	Variable parameter equal to the absolute value of the difference between the flow depth in a pipe culvert and the radius
S	ft./ft.	Slope of the culvert barrel
S_{FD}	ft./ft.	Downstream fill slope
S_{FU}	ft./ft.	Upstream fill slope
S_f	ft./ft.	Slope of FALL for slope-tapered inlets, (ratio of horizontal to vertical) See design sketches
S_o	ft./ft.	Slope of the natural channel
ST	ft./ft.	Sidewall taper
TW	ft.	Tailwater depth at the culvert outlet
V	fps.	Mean velocity of flow
WA	degree	Wingwall taper angle
WP	ft.	Wetted perimeter
WT	ft./ft.	Wingwall taper
X		Variable parameters used to simplify calculations
Y, y		Variable parameters used to simplify calculations
Y_a, Y_b	ft.	Parameters used to indicate the equations of various slope lines
Z		Variable parameter used to simplify calculations
Z_1, Z_2	ft./ft.	Side slopes of a channel section

PROGRAM OUTLINE

	<u>Program #</u>
A. Box Culverts	
1. Tailwater Calculations	1
2. Culvert Length	2
3. Culvert Size	3
4. Outlet Control: Performance Curve	3
5. Outlet Control: Outlet Velocity	3
6. Inlet Control: Performance Curve	4
a. Square Edge with Headwalls	
b. Square Edge with Wingwalls	
c. Bevel Edge with Headwalls	
d. Bevel Edge with Wingwalls	
1) Slope and Length Adjustments	5
2) Crest Evaluation	6
e. Tapered Throat Sections	7
1) Side Tapered: Square Edges	
2) Side Tapered: Bevel Edges	
a) Slope and Length Adjustments	8
b) Crest Evaluation	6
3) Slope Tapered: Vertical Face	
4) Slope Tapered: Mitered Face	
a) Slope and Length Adjustments	9
b) Face Dimensions	10
c) Crest Evaluation	10
7. Inlet Control: Outlet Velocity	11

PROGRAM OUTLINE

	<u>Program #</u>
B. Pipe Culverts	
1. Tailwater Calculations	1
2. Culvert Length	2
3. Critical Depth	12
4. Culvert Size	12
5. Outlet Control: Performance Curve	12
6. Outlet Control: Outlet Velocity	12
7. Inlet Control: Performance Curve	
a. CMP Projecting Inlet	13
b. CMP in a Headwall	13
c. Type A, Beveled Inlet	13
d. Type B, Beveled Inlet	13
e. Standard End Section	14
f. Square Edges in Headwall	14
g. Projecting Socket Edge	14
h. Socket Edge in Headwall	14
1) Slope and Length Adjustments	5
2) Crest Evaluation	6
i. Tapered Inlet: Rough Throat	15
j. Tapered Inlet: Smooth Throat	16
1) Side Tapered: Projecting	
2) Side Tapered: Square Edges	
3) Side Tapered: Bevel Edges	
a) Slope and Length Adjustments	17, 18
b) Crest Evaluation	6
4) Slope Tapered: Vertical Face	
5) Slope Tapered: Mitered Face	
a) Slope and Length Adjustments	9
b) Face Dimensions	10
c) Crest Evaluation	10
8. Inlet Control: Outlet Velocity	19

PROGRAM INDEX

	<u>Page</u>
#1. Normal Depth	2
#2. Culvert Length	5
#3. Box Culvert: Outlet Control Performance	8
#4. Box Culvert: Inlet Control Performance	13
#5. Inlet Control: Slope and Length Adjustments	20
#6. Crest Evaluation	23
#7. Box Culvert: Throat Control Performance	26
#8. Box Culvert: Side-Tapered Inlet Dimensions	30
#9. Slope-Tapered Inlet Dimensions	36
#10. Slope-Tapered Face Dimensions	41
#11. Box Culvert: Inlet Control, Outlet Velocity	47
#12. Pipe Culvert: Outlet Control Performance	49
#13. Pipe Culvert: Inlet Control Performance I	55
#14. Pipe Culvert: Inlet Control Performance II	55
#15. Pipe Culvert: Throat Control Performance I	66
#16. Pipe Culvert: Throat Control Performance II	66
#17. Pipe Culvert: Side-Tapered Inlet Dimensions	71
#18. Pipe Culvert: Side-Tapered Length Adjustments	77
#19. Pipe Culvert: Inlet Control, Outlet Velocity	79

Texas Instrument: TI-59

Programs

PROGRAM #1 - NORMAL DEPTH

The tailwater depth is required in calculating the performance of a culvert. This tailwater depth is used in determining the water surface elevation at the outlet of the culvert. One method of estimating this depth is to set it equal to the normal depth of the flow in the channel.

Program #1 calculates the normal depth of water flowing in a natural channel. For the program to operate, the channel cross section is assumed to be prismatic in shape. Depending upon the inputs, a triangular, rectangular, or trapezoidal section may be evaluated. These various shapes are dimensioned as follows:

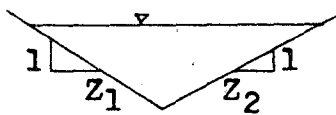

triangular

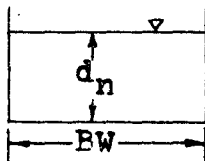

rectangular

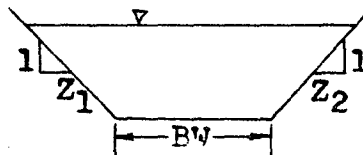

trapezoidal

EQUATIONS

$$Q = \frac{1.486 AR^{.67} S_o^{.5}}{n}$$

$$A = d_n \left(BW + \frac{d_n}{2} (Z_1 + Z_2) \right)$$

$$WP = BW + d_n \left[(Z_1^2 + 1)^{.5} + (Z_2^2 + 1)^{.5} \right]$$

$$R = \frac{A}{WP}$$

$$V = Q/A$$

INSTRUCTIONS

#1 Load program #1

#2 Press Label A

#3 Enter: 1. n - Manning's roughness coefficient for the stream

2. S_o - Slope of natural channel

3. BW - Width of streambed

4. Z_1 - Horizontal distance for side slope

5. Z_2 - Horizontal distance for side slope

6. Q - Flow rate

#4 Read d_n - (TW) - Normal depth

V - Channel velocity

CARD FORMAT

<input type="text" value="1"/>	TEXAS INSTRUMENTS	<input type="text" value="4"/>
NORMAL DEPTH		#1
		479.59
START		

LISTING - PROGRAM #1

LBL INV RC* 8 OP 28 RTN LBL LNX SBR INV OP 1 SBR INV OP
2 SBR INV OP 3 SBR INV OP 4 ADV OP 5 RTN LBL A 6 X<T
1 STO 9 STO 07 1 1 STO 8 SBR LNX ADV 5 1 0 2 STO 0 RCL
0 OP 4 RCL 9 X=T 0 72 R/S OP 6 ST* 9 OP 29 OP 20 GTO 0
51 R/S OP 6 STO 6 FIX 4 CLR X<T RCL 7 X (RCL 3 + RCL 7
DIV 2 X (RCL 4 + RCL 5 = STO 0 DIV (RCL 3 + RCL 7 X
((RCL 4 X² + 1) SRX + (RCL 5 X² + 1) SRX = X² y^X 3
1/X X RCL 0 X RCL 2 SRX X 1 . 4 8 6 DIV RCL 1 - RCL 6 = EE
INV EE X=T 1 84 EXC 10 - RCL 10 = X=T 1 84 1/X X RCL 10 X
RCL 9 = STO 9 INV SUM 7 GTO 0 77 SBR LNX 2 1 3 7 FIX 2 OP
4 RCL 7 OP 6 SBR 0 13 2 1 6 3 3 6 OP 4 RCL 6 DIV RCL 0
= OP 6 INV FIX SBR LNX SBR LNX ADV 5 1 0 7 OP 04 1 5
STO 08 6 GTO 0 72

DATA REGISTERS - PROGRAM #1

11.	3132353013	20.	2732152437
12.	2700161733	21.	4500243600
13.	3723002000	22.	2132350032
14.	3322300002	23.	3723173500
15.	1523133131	24.	1624361523
16.	1727001617	25.	1335221736
17.	3337230024	26.	1731371735
18.	3600000000	27.	21273243
19.	1727004217	28.	3513371700
		29.	15213600

PROGRAM #2 - CULVERT LENGTH

This program uses the site characteristics to determine the culvert length for a given barrel height. The inlet and outlet elevations for the culvert are also calculated by this program.

Both box and pipe culverts can be evaluated by this program.

The necessary input data are indicated in the diagram below:

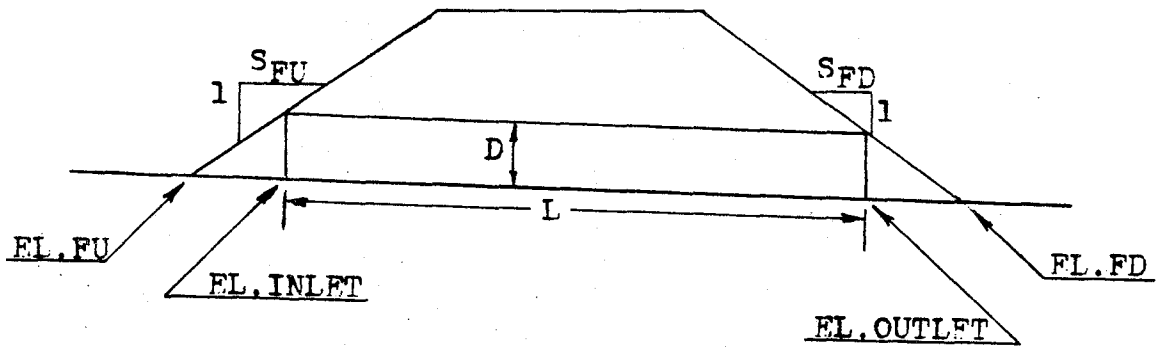

Roadway Cross section

The length of the culvert (L) is measured along the barrel and is not a horizontal dimension.

The ends of the culvert are assumed to be vertical.

EQUATIONS

$$L = \frac{(EL.INLET - EL.OUTLET) (S_o^2 + 1)^{.5}}{S_o}$$

$$EL.INLET = EL.FU - \frac{D S_o S_{FU} (S_o^2 + 1)^{.5}}{1 + S_o S_{FU}}$$

$$EL.OUTLET = EL.FD + \frac{D S_o S_{FD} (S_o^2 + 1)^{.5}}{1 - S_o S_{FD}}$$

The derivations of these equations are found in the appendix.

INSTRUCTIONS

#1 Load program #2

#2 Press Label A

- #3 Enter:
1. S_o - Slope of natural channel
 2. S_{FU} - Upstream fill slope
 3. S_{FD} - Downstream fill slope
 4. EL.FU - Upstream fill catch point elevation
 5. EL.FD - Downstream fill catch point elevation
 6. D - Height of culvert

- #4 Read:
- L - Culvert length
 - El.In - Inlet elevation
 - El.Out - Outlet elevation

CARD FORMAT

<input type="text" value="1"/>	TEXAS INSTRUMENTS	<input type="text" value="4"/>
CULVERT LENGTH		#2
		479.59
START		

LISTING - PROGRAM #2

LBL INV RC* 8 OP 28 RTN LBL LNX SBR INV OP 1 SBR INV OP 2
SBR INV OP 3 SBR INV OP 4 ADV OP 5 RTN LBL CE 2 1 3 7 FIX
2 OP 4 RCL 7 OP 6 INV FIX RTN LBL CLR ((RCL 1 X^2 + 1)
SRX X RCL 6 X RCL 1 X RTN LBL A 6 X²T 1 STO 09 1 1 STO
8 RCL 14 EXC 15 STO 14 SBR LNX EXC 15 STO 14 1 1 STO 8 ADV
5 1 0 2 STO 0 RCL 0 OP 4 RCL 9 X=T 1 20 R/S OP 6 ST* 9 OP
29 OP 20 GTO 0 99 R/S OP 6 STO 6 SBR CLR RCL 2 DIV (1 +
RCL 1 X RCL 2) +/- + RCL 4) STO 9 SBR CLR RCL 3 DIV (1
- RCL 1 X RCL 3) + RCL 5) STO 0 +/- + RCL 9 = DIV RCL 1
X (RCL 1 X^2 + 1) SRX = STO 7 SBR LNX SBR CE OP 28 RCL 9
STO 7 SBR LNX SBR CE RCL 0 STO 7 OP 38 SBR INV OP 4 SBR INV
OP 1 ADV OP 5 SBR CE SBR LNX SBR LNX ADV 5 1 0 7 OP 04 1 1
STO 08 6 GTO 1 20

DATA REGISTERS - PROGRAM # 2

11. 1541274217	20. 3241372717
12. 3537002717	21. 2132350016
13. 3122372300	22. 2421211735
14. 2436000000	23. 1731370036
15. 3322300003	24. 2446173600
16. 24312717	25. 1731371735
17. 3700172717	26. 15412742
18. 4213372432	27. 1735370023
19. 3100243600	28. 1724222337

PROGRAM #3 - BOX CULVERT: OUTLET CONTROL PERFORMANCE

This program can be used to select an appropriate box culvert size, evaluate the performance of this culvert for various flow rates and determine the velocity of the flow at the outlet.

In determining the best box culvert size, the designer must first select a trial height and width. For these and the other input values, the program computes the water surface elevation of the headwater pool at the culvert inlet. A visual comparison of this value to the design headwater elevation is then made. The designer then adjusts the trial height and width accordingly. If the culvert height is altered, the length and outlet elevation may also have to be adjusted. The program requires all four of these values to be restored during the culvert sizing operations.

Once the box size has been determined, various flow rate values, along with the corresponding tailwater depths, can be placed into the calculator to obtain the performance curve headwater elevations.

The formula used for the outlet control outlet velocity is simply $V = Q/A$. The depth of flow used in the computation of the cross-sectional area is equal to the critical depth or the tailwater depth, whichever is larger. However, if this depth is found to be greater than the height of the box culvert, then the box culvert height is used as the depth of flow.

Since the water at the inlet is considered to be a pool, the velocity at this point is assumed to be zero. This allows the hydraulic grade line to be equated to the energy line.

The number of barrels to be used in the calculations is limited to two.

The following diagram indicates the location of the energy losses associated with the culverts operation.

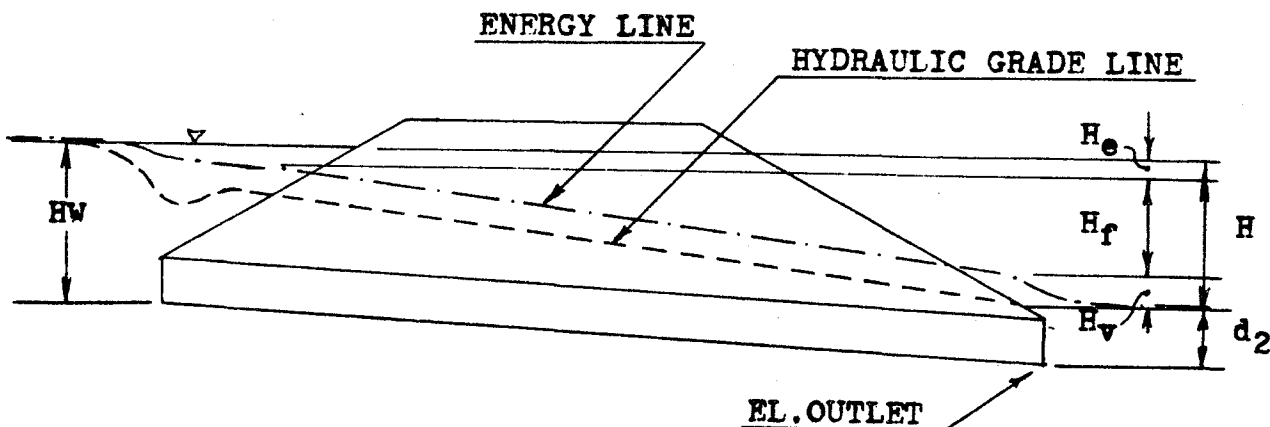

EQUATIONS

$$H_e = k_e V^2 / 2g$$

$$H_f = 29n^2 L V^2 / 2gR^{4/3}$$

$$H_v = V^2 / 2g$$

$$H = H_e + H_f + H_v$$
$$= \left[1 + k_e + \frac{29n^2 L}{\left(\frac{BD}{2(B+D)} \right)^{4/3}} \right] \left(\frac{Q}{\frac{DBN}{2g}} \right)^2$$

$$d_2 = \frac{(d_c + D)}{2} \text{ or the tailwater depth, whichever is largest}$$

$$\text{HW EL.} = H + d_2 + \text{EL.Outlet}$$

$$d_c = 0.315 \left(\frac{Q}{BN} \right)^{2/3}$$

$$V = \frac{Q}{A} = \frac{Q}{BNd_3}$$

$$d_3 = d_c \text{ or TW, whichever is largest, not to exceed D}$$

INSTRUCTIONS

#1 Load program #3 (2 cards)

#2 Press Label A

- #3 Enter:
1. Q - Flow rate
 2. N - Number of barrels
 3. k_e - Entrance loss coefficient
 4. n - Manning's roughness coefficient for the barrel
 5. TW - Tailwater depth
 6. B - Culvert width
 7. D - Culvert height
 8. EL.Outlet - Outlet elevation
 9. L - Culvert length

Read: HW. EL. - Headwater elevation

#4 Press Label B

Read: d_c - Critical depth

#5 Press Label C

Read: H - Total head loss

#6 Press Label D

Read: V - Outlet velocity

#7 Press Label E

Enter: Q - Flowrate
TW - Tailwater depth

Read: HW EL. - Headwater elevation

CARD FORMAT

1		TEXAS INSTRUMENTS			2	
BOX: OUTLET CONTROL PERFORMANCE				#3		
				479.59		
START	d_c	H	VELOCITY	PERFORMANCE		

3		TEXAS INSTRUMENTS			4	
DATA - PROGRAM #3						
				479.59		

LISTING - PROGRAM #3

```

LBL INV RC* 0 OP 20 RTN LBL LNX INV FIX SBR INV OP 1 SBR INV
OP 2 SBR INV OP 3 SBR INV OP 4 ADV OP 5 RTN LBL CE RCL 1
DIV RCL 2 DIV RCL 6 = Yx ( 2 DIV 3 ) X . 3 1 5 = RTN LBL
CLR 2 1 3 7 Fix 2 OP 4 RTN LBL X<T ( 1 + RCL 3 + 2 9 .
1 6 4 X RCL 4 X2 X RCL 11 DIV ( RCL 6 X RCL 7 DIV ( 2 X
( RCL 6 + RCL 7 ) ) ) Yx ( 4 DIV 3 ) ) X ( RCL 1 DIV RCL
7 DIV RCL 6 DIV RCL 2 ) X2 DIV 6 4 . 3 4 8 = RTN LBL X2
SBR CE X<T RCL 7 INV X>T 1 50 X<T + RCL 7 = DIV 2 =
X<T RCL 5 X>T 1 64 X<T STO 10 SBR LNX SBR CLR SBR X<T
+ RCL 8 + RCL 10 = OP 6 RTN LBL A 1 2 STO 0 SBR LNX ADV 9
X<T 1 STO 09 5 1 0 2 STO 0 RCL 0 OP 4 RCL 9 X=T. 2 23
R/S OP 6 ST* 9 OP 29 OP 20 GTO 2 02 R/S X<T 5 1 1 2 OP
4 X<T OP 6 STO 11 1 6 STO 0 SBR X2 SBR LNX SBR LNX ADV
9 X<T 6 STO 09 5 1 0 7 GTO 2 00 LBL B 2 8 STO 0 SBR
LNX SBR CLR SBR CE OP 6 RTN LBL C 3 2 STO 0 SBR LNX SBR CLR
SBR X<T OP 6 RTN LBL D 4 4 STO 0 SBR LNX RCL 48 OP 4 SBR
CE X<T RCL 5 INV X>T 3 11 X<T RCL 7 INV X>T 3 18
X<T X RCL 6 X RCL 2 DIV RCL 1 = 1/x Fix 2 OP 6 RTN
LBL E 3 6 STO 0 SBR LNX SBR LNX ADV 5 1 0 2 OP 04 1 =
R/S STO 1 OP 06 5 1 0 6 OP 04 5 = R/S STO 5 OP 06 1
6 STO 0 SBR X2 4 0 STO 0 GTO 3 42

```

DATA REGISTERS - PROGRAM #3

12.	1541274217	31.	2436000000
13.	3537003624	32.	3732371327
14.	4617002000	33.	8023171316
15.	3322300004	34.	8027323636
16.	2317131643	35.	8024360000
17.	1337173500	36.	3317352132
18.	1727174213	37.	3530133115
19.	3724323100	38.	1700154135
20.	2132350030	39.	4217000000
21.	3235170036	40.	1731371735
22.	2446173600	41.	8065346500
23.	1731371735	42.	1331160065
24.	6514570016	43.	3743650000
25.	5700172740	44.	3241372717
26.	3241370013	45.	3700421727
27.	3116002765	46.	3215243745
28.	1535243724	47.	8024360000
29.	1513270016	48.	216336
30.	1733372300		

PROGRAM #4 - BOX CULVERT: INLET CONTROL PERFORMANCE

This program evaluates the hydraulic performance of four different inlet configurations. A detailed explanation of the geometry of these inlets is depicted in the diagrams below:

Square Edged Inlet with Headwalls

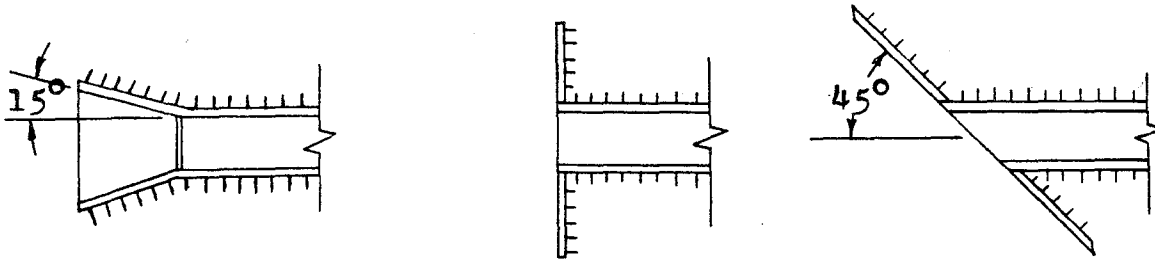

90° and 15° Wingwalls,
Square Edges

Headwalls - Normal or Skewed to 45°,
Square Edges

Square Edged Inlet with 30° - 75° Wingwalls

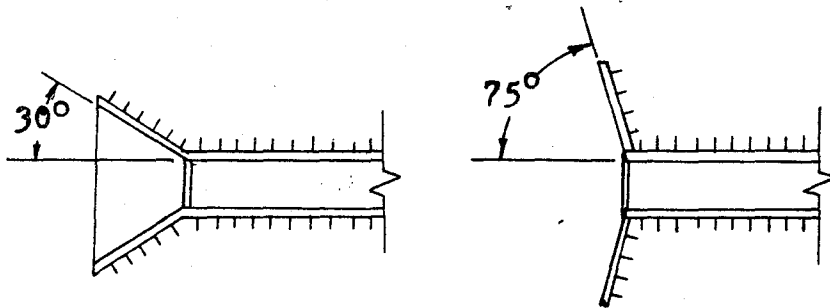

Wingwalls 30° - 75° Flare, Square Edges

1:1 Bevel Edged Inlet with Headwalls

(Note: variable bevel on acute angle of skewed headwall)

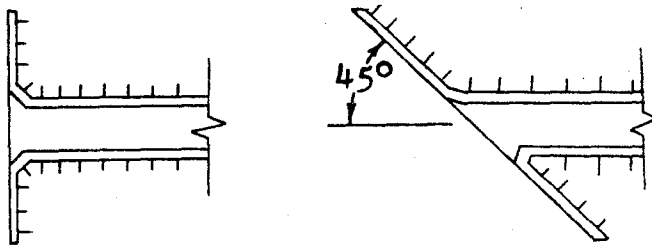

1:1 Bevel Edged Inlet with 45° Wingwalls or

1 1/2:1 Bevel Edged Inlet with 18°-33.7° Wingwalls

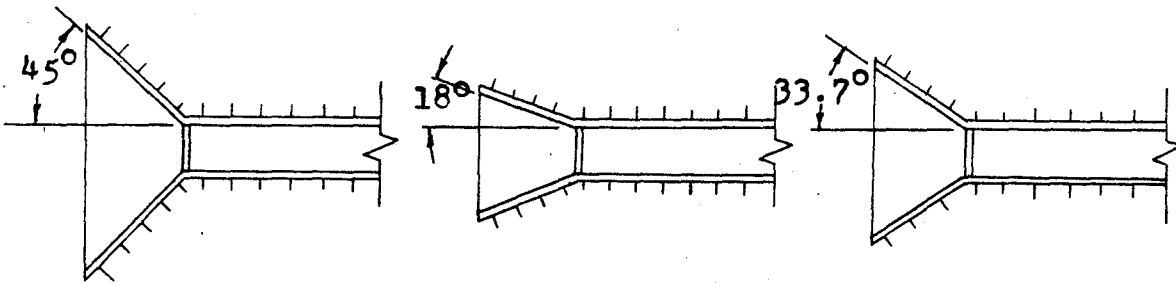

For whichever inlet is chosen, the program calculates the depth of the water at the face of the culvert. This value is then added to the culvert inlet invert elevation. If this sum is less than the design headwater elevation, the inlet elevation becomes the elevation of the face. If, however, this sum exceeds the design headwater elevation, the difference between this sum and the design headwater elevation is subtracted from the inlet invert elevation. This new elevation is now called the elevation of the face. For the culvert to operate properly,

the inlet invert must be reset to this face elevation. The drop in elevation of the inlet invert is called the FALL. The diagrams below graphically show this occurrence. It should be noted that as the inlet invert drops, the culvert barrel rotates about the outlet invert.

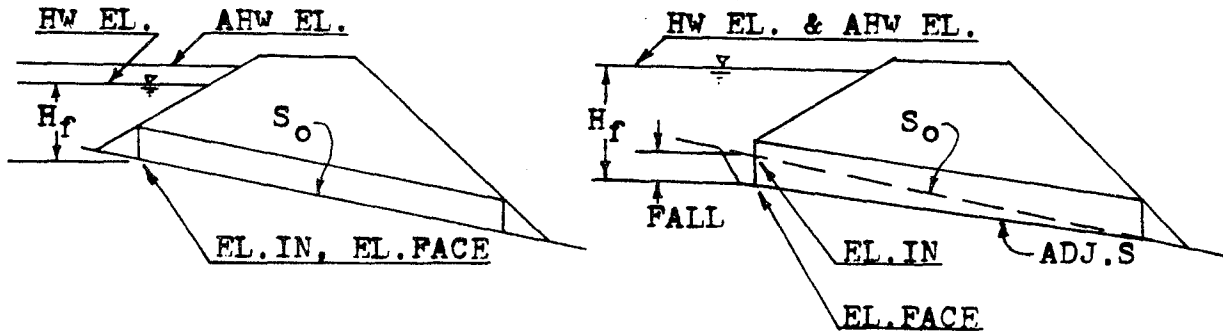

No FALL Required
 $EL.IN + H_f < AHW EL.$

FALL Required
 $EL.IN + H_f \geq AHW EL.$

The diagrams clearly indicate that when the calculated headwater elevation is above the design headwater elevation, the headwater elevation is set equal to the design value and the difference is taken up by the FALL.

The inlet invert elevation of the culvert can always be thought of as the elevation of the face. The original elevation of the culvert inlet invert, before considering the affects of inlet control and FALL, can be taken as the "inlet elevation."

The program does not perform checks on the restrictions to the FALL or the headwater depth. Both of these values must be checked by the designer.

Once the culvert has been sized for the design flowrate, the performance of the inlet for other flow rates can be determined. In performing the performance evaluation the calculator determines the headwater elevation for any given flow rate.

Whenever applicable, a bevel edged inlet is recommended for use in lieu of a square edged inlet. The large increase in hydraulic performance gained by the bevel edged inlet, greatly outweighs the small, if any, additional construction cost.

EQUATIONS

$$\begin{aligned} \text{EL.FACE} &= \text{DHW EL.} - H_f \quad (\text{with FALL}) \\ &= \text{EL.INLET} \quad (\text{without FALL}) \end{aligned}$$

$$\text{HW EL.} = \text{EL.FACE} + H_f$$

$$\text{FALL} = \text{EL.FACE} - \text{EL.INLET}$$

Note: The FALL is measured in a downward direction and therefore is always a positive value.

$$X = Q / (\text{BND}^{1.5})$$

Square Edged Inlet with Headwalls

$$H_f = D(0.122117 + 0.505435X - 0.108560X^2 + 0.02070809X^3 - 0.00136757X^4 + 0.00003456X^5)$$

Square Edged Inlet with Wingwalls

$$H_f = D(0.0724927 + 0.507087X - 0.117474X^2 + 0.0221702X^3 - 0.00148958X^4 + 0.0000380X^5)$$

A-28

Bevel Edged Inlet with Headwalls

$$H_f = D(0.1566086 + 0.3989353X - 0.0640392X^2 + 0.01120135X^3 - 0.0006449X^4 + 0.000014566X^5)$$

Bevel Edged Inlet with Wingwalls

$$H_f = D(0.0895633 + 0.4412465X - 0.0743498X^2 + 0.01273183X^3 - 0.0007588X^4 + 0.00001774X^5)$$

INSTRUCTIONS

- #1 Load program #4 (2 cards)
- #2 Press Label A
- #3 Enter: 1. B - Culvert width
2. D - Culvert height

3. N - Number of barrels
4. EL.INLET - Inlet elevation
5. DHW EL. - Design headwater elevation
6. Q - Flow rate

#4 Select inlet type

Label A' - SQ. Edge w/Headwalls

Label B' - SQ. Edge w/Wingwalls

Label C' - Bevel Edge w/Headwalls

Label D' - Bevel Edge w/Wingwalls

Read: EL.FACE - Elevation of face

FALL

#5 Press Label D

Read: H_f - Headwater depth

#6 Run Performance Elevation

Press Label E

Enter: Q - Flow rate

Read: HW EL.- Headwater elevation

CARD FORMAT

1		TEXAS INSTRUMENTS			2	
BOX: INLET CONTROL PERFORMANCE				#4		
S W/H	S W/W	B W/H	B W/W	319.79		
START	HW EL.	FALL	H _f	PERFORMANCE		

3		TEXAS INSTRUMENTS			4	
DATA - PROGRAM #4						
319.79						

LISTING - PROGRAM #4

```

LBL INV = X RCL 7 + LBL LNX RC* 8 OP 28 RTN LBL CE INV FIX
SBR LNX OP 1 SBR LNX OP 2 SBR LNX OP 3 SBR LNX OP 4 ADV OP
5 RTN LBL CLR EXC 8 X>T SBR CE 2 1 3 7 FIX 2 OP 4 X>T
STO 8 RTN LBL X>T RCL 6 DIV RCL 3 DIV RCL 1 DIV ( RCL
2 Yx 1 . 5 = STO 7 SBR LNX SBR INV SBR INV SBR INV SBR INV
SBR INV = X RCL 2 = X>T 6 INV SUM 8 X>T STO 9 RTN
LBL A 1 0 STO 8 SBR CE ADV 7 X>T 1 STO 09 5 1 0 2 STO
0 RCL 0 OP 4 RCL 9 X=T 1 45 R/S OP 6 ST* 9 OP 20 OP 29
GTO 1 24 OP 0 SBR 0 26 CLR RTN LBL B 6 4 SBR CLR SBR X>T
+ RCL 0 = OP 6 RTN LBL A' 1 0 + LBL B' 1 0 + LBL C' 1 0
+ LBL D' 1 6 = STO 8 SBR CE 6 8 SBR CLR SBR X>T X>T RCL 5
- RCL 4 = X>T 2 08 X>T +/- + RCL 5 = STO 0 OP 6 LBL C 7 2
SBR CLR RCL 4 - GTO 1 61 LBL D 7 6 SBR CLR SBR X>T OP 6
RTN LBL E 5 6 SBR CLR 6 0 SBR CLR 6 INV FIX R/S PRT STO 6
SBR B GTO 2 46

```

DATA REGISTERS - PROGRAM #4

10.	1432446200	45.	0.0724927
11.	2431271737	46.	3634400017
12.	15323137	47.	1640004363
13.	3532270000	48.	2317131643
14.	2431271737	49.	1327273600
15.	37453317	50.	0.00003456
16.	1442400017	51.	-0.00136757
17.	1640004363	52.	0.0207809
18.	4324312243	53.	-0.10856
19.	1327273600	54.	0.505435
20.	0.00001744	55.	0.122117
21.	-0.0007588	56.	3317352132
22.	0.01273103	57.	3530133115
23.	-0.0743498	58.	1700154135
24.	0.4412465	59.	4217000000
25.	0.0895633	60.	1731371735
26.	1442400017	61.	21273243
27.	1640004363	62.	3513371700
28.	2317131643	63.	15213600
29.	1327273600	64.	2317131643
30.	0.000014566	65.	1337173500
31.	-0.0006449	66.	1727174213
32.	0.01120135	67.	3724323100
33.	-0.0640392	68.	172717
34.	0.3989353	69.	4213372432
35.	0.1566086	70.	3100322100
36.	3634400017	71.	2113151700
37.	1640004363	72.	372317
38.	4324312243	73.	35173441
39.	1327273600	74.	2435171600
40.	0.000038	75.	2113272700
41.	-0.00148958	76.	2317
42.	0.0221702	77.	1316431337
43.	-0.117474	78.	1735001617
44.	0.507087	79.	3337230000

PROGRAM # 5 - INLET CONTROL, SLOPE AND LENGTH ADJUSTMENTS

Once a culvert has been designed to operate in inlet control with FALL, an adjustment must be made to both the slope and the length of the original culvert. The need for a slope adjustment results from the lowering of the elevation of the culvert inlet while keeping the elevation of the outlet a constant. The culvert pivots about the outlet invert while the slope decreases. The length of the culvert must be adjusted because when the inlet is lowered the culvert must be lengthened so the top of the culvert inlet again intersects the fill slope.

This program can be used to evaluate either box or pipe culverts. The diagram below indicates the changes in slope and length.

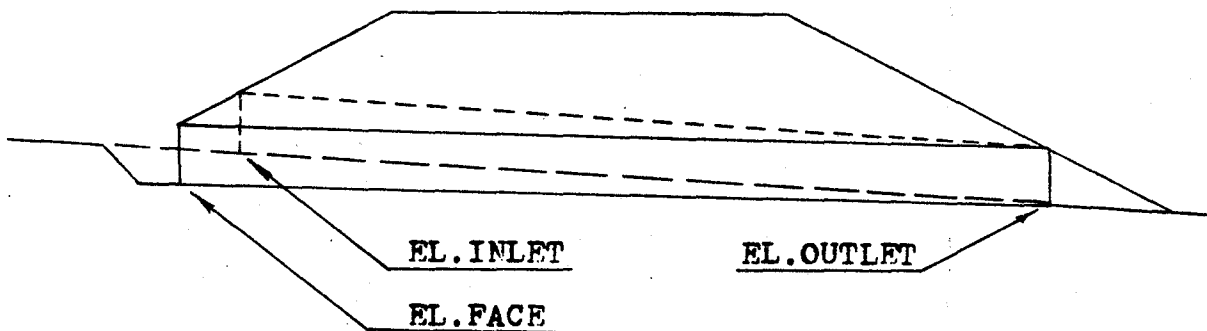

Since this program does not use the width of the culvert in any of the equations, the program can be applied to multiple barrel applications.

Both, the original culvert length and the adjusted culvert length, are measured along the barrel. They are not horizontal measurements.

In the design of the streambed entrance to the culvert, the adjusted slope should be extended a minimum distance of $1/2 D$ in front of the culvert. The transition slope which connects the original streambed slope to the adjusted culvert slope should range between a 3:1 and a 2:1 ratio. This transition slope is referred to as the FALL slope. The performance of this weir construction is evaluated in another program.

EQUATIONS

$$ADJ.S = \frac{LS_0 - FALL (S_0^2 + 1)^{.5}}{L + S_{FU} (S_0^2 + 1)^{.5} (FALL + D[(S_0^2 + 1)^{.5} - (ADJ.S^2 + 1)^{.5}]}$$

$$ADJ.L = \frac{\left(\frac{LS_0}{(S_0^2 + 1)^{.5}} \right) - FALL}{\frac{(ADJ.S^2 + 1)^{.5}}{ADJ.S}}$$

The derivations of these equations are found in the appendix.

INSTRUCTION

- #1 Load program #5
- #2 Press Label A
- #3 Enter: 1. D - Culvert height
2. S₀ - Channel slope
3. FALL
4. S_{FU} - Upstream fill slope
5. L - Culvert length
- Read: ADJ.S - Adjusted slope
ADJ.L - Adjusted length

CARD FORMAT

<input type="text" value="1"/>	TEXAS INSTRUMENTS	<input type="text" value="4"/>
INLET CONTROL: SLOPE & LENGTH ADJUSTMENTS		#5
		479.59
Start		

LISTING - PROGRAM #5

LBL INV RC* 8 OP 28 RTN LBL LNX (X² + 1) SRX RTN LBL CE
SBR INV OP 1 SBR INV OP 2 SBR INV OP 3 SBR INV OP 4 OP 5
RTN LBL A INV FIX 6 X>T 1 STO 09 1 1 STO 8 ADV SBR CE
SBR CE ADV 5 1 0 2 STO 0 RCL 0 OP 4 RCL 9 X=T 0 83 R/S OP 6
ST* 9 OP 29 OP 20 GTO 0 62 1 STO 0 CP FIX 6 RCL 5 X RCL 2
- (RCL 2 SBR LNX X RCL 3 = DIV (RCL 2 SBR LNX X RCL 6
X RCL 4 + RCL 5 = STO 7 SBR LNX X RCL 1 +/- + RCL 3 + (
RCL 2 SBR LNX X RCL 1 = - RCL 6 = EE INV EE X=T 1 76 EXC 10
- RCL 10 = X=T 1 76 1/X X RCL 10 X RCL 0 = STO 0 INV SUM 6
GTO 0 87 RCL 7 X>T ADV SBR CE X>T PRT SBR LNX DIV RCL 7
X (RCL 5 X RCL 2 DIV RCL 2 SBR LNX - RCL 3 = FIX 2 X>T
ADV SBR CE 2 1 3 7 0 0 OP 4 X>T OP 6 RTN

DATA REGISTERS - PROGRAM #5

11. 2431271737
12. 15323137
13. 3532276200
14. 3627323317
15. 1331160027
16. 1731223723
17. 13162541
18. 3637400000
19. 3723170013
20. 1625413637
21. 1716003627
22. 3233170064
23. 3723170013
24. 1625413637
25. 1716002717
26. 3122372300

PROGRAM #6 - CREST EVALUATION

If not properly designed, the transition section between the streambed and the culvert entrance could adversely affect the operation of the culvert. To insure that the culvert operates in the proper manner, this program computes the required inlet dimensions.

This program is designed to evaluate the crest control dimensions for both box and pipe culverts. These culverts can be operating under either inlet control or side-tapered throat-control.

The diagrams below indicate the dimensions determined by the program.

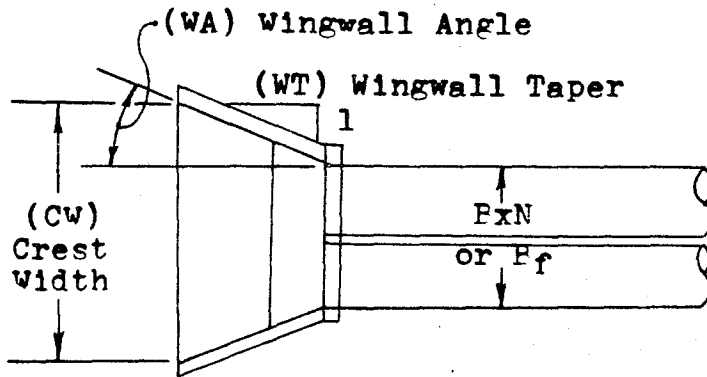
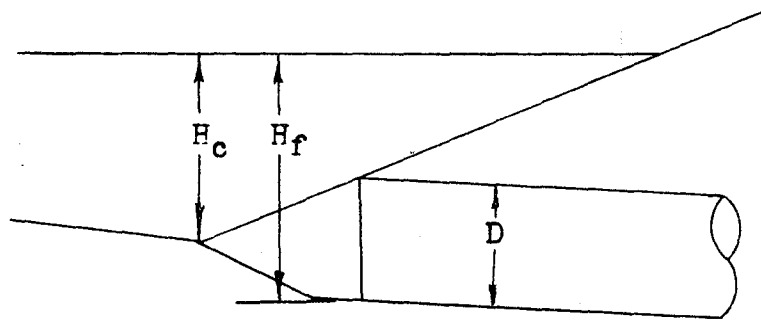

For conventional culverts, the culvert width is input as item #3. When a side tapered inlet is used, the face width value is input for prompt #3.

EQUATIONS

$$H_c = \text{HW EL.} - \text{EL.Outlet} - \frac{S_o(S_f - \text{Adj.S})(D/2 + \text{Adj.L})}{(S_f - S_o)(\text{Adj. } S^2 + 1)^{.5}}$$

$$\text{CW} = \frac{Q}{(2H_c)^{1.5}}$$

$$\text{WT} = L_o - \frac{L}{(\text{Adj. } S^2 + 1)^{.5}} \\ (\text{CW} - \text{BN})/2$$

$$\text{WA} = 90^\circ - \text{ARCTANGENT}(\text{WT})$$

The derivations of these equations are found in the appendix.

INSTRUCTIONS

- #1 Load program #6
- #2 Press Label A
- #3 Enter:
 1. Q - Flow rate
 2. D - Culvert height
 3. B or Bf - Culvert width or face width
 4. S_o - Channel slope
 5. HW EL. - Headwater elevation
 6. S_f - FALL slope
 7. ADJ.L - Adjusted length
 8. ADJ.S - Adjusted slope
 9. N - Number of barrels
 10. EL.OUTLET - Outlet elevation

Read:
 H_c - Crest height
CW - Crest width
WT - Wingwall taper
WA - Wingwall angle

CARD FORMAT

1	TEXAS INSTRUMENTS	4
CREST CONTROL EVALUATION		#6
		479.59
Start		

LISTING - PROGRAM # 6

```

LBL INV RC* 0 OP 20 RTN LBL LNX INV FIX SBR INV OP 2
SBR INV OP 3 SBR INV OP 4 ADV OP 5 RTN DIV ( RCL 8 X2
+ 1 ) SRX = RTN = X>T SBR LNX RCL 29 FIX 2 OP 4 X>T
OP 6 RTN LBL A INV FIX 1 0 STO 0 SBR INV OP 1 SBR LNX
OP 0 ADV 5 1 0 2 STO 00 9 X>T 1 STO 9 RCL 0 OP 4 RCL
9 X=T 1 01 R/S OP 6 ST* 9 OP 29 OP 20 GTO 0 80 R/S X>T
5 1 1 2 OP 4 X>T OP 6 PRD 03 1 0 = R/S X>T RCL 26
OP 4 X>T OP 6 INV SUM 05 1 4 STO 0 RCL 7 SBR 0 27 STO
9 + ( RCL 2 DIV 2 SBR 0 27 X ( RCL 6 - RCL 8 = DIV (
RCL 6 - RCL 4 = INV SUM 9 X RCL 4 +/- + RCL 5 SBR 0 38
X 2 = YX 1 . 5 = 1/X X RCL 1 SBR 0 38 - RCL 3 = DIV
2 DIV RCL 9 +/- = 1/X CP X>T 2 10 0 X>T SBR LNX RCL 27
SBR 0 44 INV TAN - 9 0 = +/- X>T SBR LNX RCL 28 SBR
0 44 CLR RTN

```

DATA REGISTERS - PROGRAM #6

10.	1535173637	21.	1327270037
11.	15323137	22.	1333173500
12.	3532270017	23.	4324312243
13.	4213274000	24.	1327270013
14.	1535173637	25.	3122271700
15.	23172422	26.	510201
16.	2337000000	27.	620002
17.	1535173637	28.	161722
18.	43241637	29.	213700
19.	2300000000		
20.	4324312243		

PROGRAM #7 - BOX CULVERT: THROAT CONTROL PERFORMANCE

Another method which can be used to increase a culverts performance is to redesign the throat. Two different types of throat improvements can be evaluated with this program, side- and slope-tapered inlets.

Like the improved inlet programs, throat control programs often can use FALL to increase the flow capacity of a culvert. The following diagrams describe the throat control inlets.

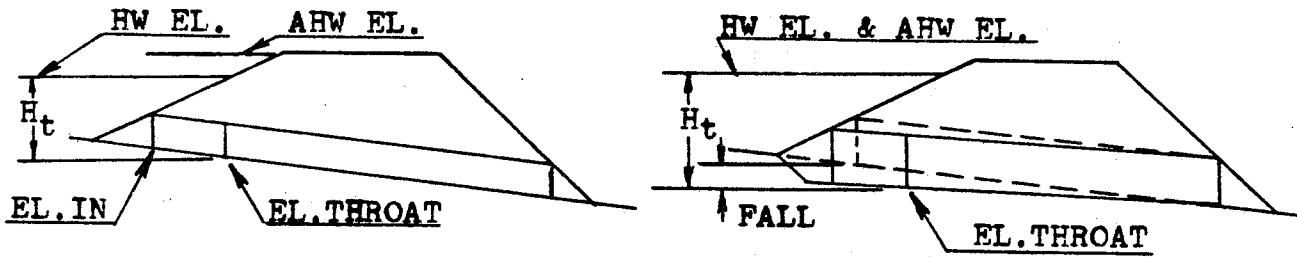

ELEVATION VIEW

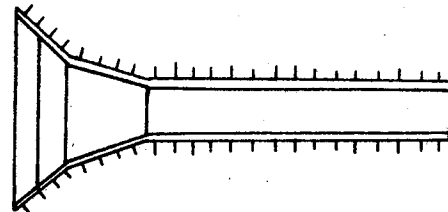
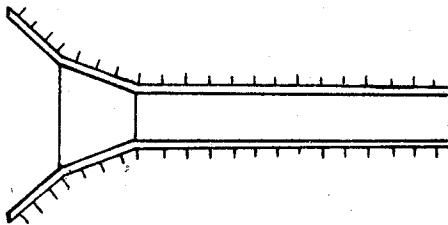

PLAN VIEW

SIDE-TAPERED INLET
NO FALL, AHW EL. > HW.EL.

SIDE-TAPERED INLET
WITH FALL, AHW EL. ≤ HW.EL.

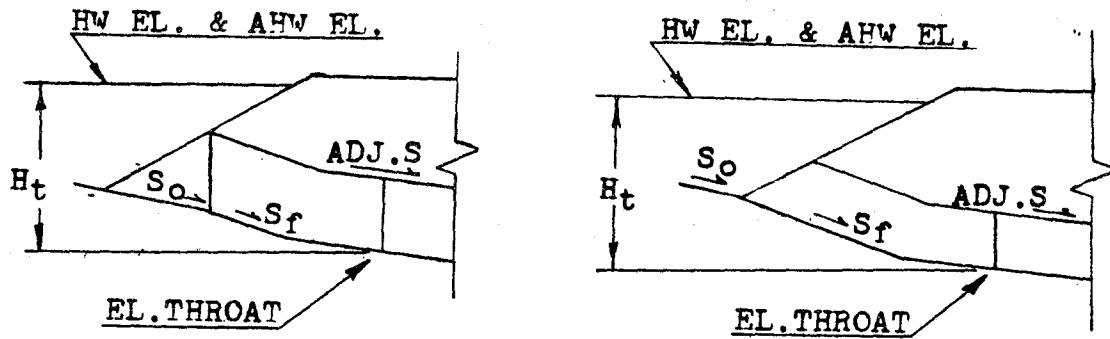

ELEVATION VIEW



PLAN VIEW

SLOPE-TAPERED INLET
VERTICAL FACE

SLOPE-TAPERED INLET
MITERED FACE

The limits placed on the FALL value for the improved inlet programs also apply to the throat control design. These are a minimum of $1/4 D$ and a maximum of $1 1/2 D$. If the upper limit is exceeded, a larger size should be evaluated. If the minimum value is not achieved, the presence of FALL will not significantly increase the capacity of the culvert.

The designer should be aware that a small error results in the computation of the FALL. The program assumes that the elevation of the inlet and the elevation of the throat are equal before determining the value of the headwater elevation. This assumption is false and a small difference equal to the channel slope times the vertical distance between the inlet and the throat section, is present. This vertical distance is an unknown value and is determined in a later program. By understanding this error, a correction, if necessary, can be made.

EQUATIONS

$$\begin{aligned} \text{EL.THROAT} &= \text{DHW EL.} - H_t \quad (\text{with FALL}) \\ &= \text{EL.INLET} \quad (\text{without FALL}) \end{aligned}$$

$$\text{HW EL.} = \text{EL.THROAT} + H_t$$

$$\text{FALL} = \text{EL.INLET} - \text{EL.THROAT}$$

$$H_t = D(0.1295033 + 0.3789445X - 0.0437778X^2 + 0.00426329X^3 - 0.000106358X^4)$$

$$X = Q/(\text{NBD}^{1.5})$$

INSTRUCTIONS

#1 Load program #7

#2 Press Label A

#3 Enter: 1. B - Culvert width
2. D - Culvert height
3. N - Number of Barrels
4. EL.INLET - Inlet elevation
5. DHW EL. - Design headwater elevation
6. Q - Flow rate

Read: EL.THROAT - Throat elevation

FALL

#4 Check FALL limitations for slope-tapered inlet

$$1/4 D \leq \text{FALL} \leq 1 1/2 D$$

#5 Press Label D

Read: H_f - Headwater depth

36 Run Performance evaluation

Press Label E

Enter: Q - Flow rate

Read: HW EL. - Headwater elevation

CARD FORMAT

<div style="display: flex; justify-content: space-between;"> 1 TEXAS INSTRUMENTS 4 </div>				
BOX: THROAT CONTROL PERFORMANCE				#7
-				479.59
Start	HW EL.	FALL	H_t	Performance

LISTING - PROGRAM #7

```

LBL INV = X RCL 7 + LBL LNX RC* 8 OP 28 RTN LBL CE INV
FIX SBR LNX OP 2 SBR LNX OP 3 SBR LNX OP 4 ADV OP 05 2
1 3 7 FIX 2 OP 4 RTN LBL CLR 1 9 STO 8 RCL 6 DIV RCL
3 DIV RCL 1 DIV ( RCL 2 YX 1 . 5 = STO 7 SBR LNX SBR
INV SBR INV SBR INV SBR INV = X RCL 2 = STO 9 RTN LBL A 1
0 STO 8 SBR CE SBR CE ADV INV FIX 7 X>T 1 STO 09 5 1
0 2 STO 0 RCL 0 OP 4 RCL 9 X=T 1 30 R/S OP 6 ST* 9 OP
29 OP 20 GTO 1 09 SBR CE SBR CLR X>T RCL 5 - RCL 4 =
X>T 1 45 X>T +/- + RCL 5 = STO 0 OP 6 LBL C OP 00 2 1
1 3 2 7 2 7 OP 2 SBR 0 30 RCL 4 - GTO 1 88 LBL B 2 4
STO 8 SBR CE SBR CLR + RCL 0 = OP 6 RTN LBL D RCL 24
OP 2 RCL 25 OP 03 1 6 1 7 3 3 3 7 2 3 SBR 0 28 SBR
CLR OP 6 RTN LBL E 2 7 STO 8 SBR CE 6 = R/S PRT STO 6
SBR B GTO E
    
```

DATA REGISTERS - PROGRAM #7

10. 3723353213	20. 0.00426329
11. 3700153231	21. -0.0437778
12. 3735322700	22. 0.3789445
13. 3713331735	23. 0.1295033
14. 1716002431	24. 2317131643
15. 2717370000	25. 1337173500
16. 1727174240	26. 1727174240
17. 32210037	27. 1731371735
18. 2335321337	28. 21273243
19. -0.000106358	29. 3513371700

PROGRAM #8 - BOX CULVERT: SIDE-TAPERED INLET DIMENSIONS

This program continues with the design of a culvert operating in throat control. The inlet dimensions for either a square or bevel edged face can be obtained.

Inlets which fall into the square edged category include those with wingwall flare angles from 15° to 26° with only a top beveled edge and those with wingwall flare angles from 26° to 90° with all edges squared. These inlets are shown below.

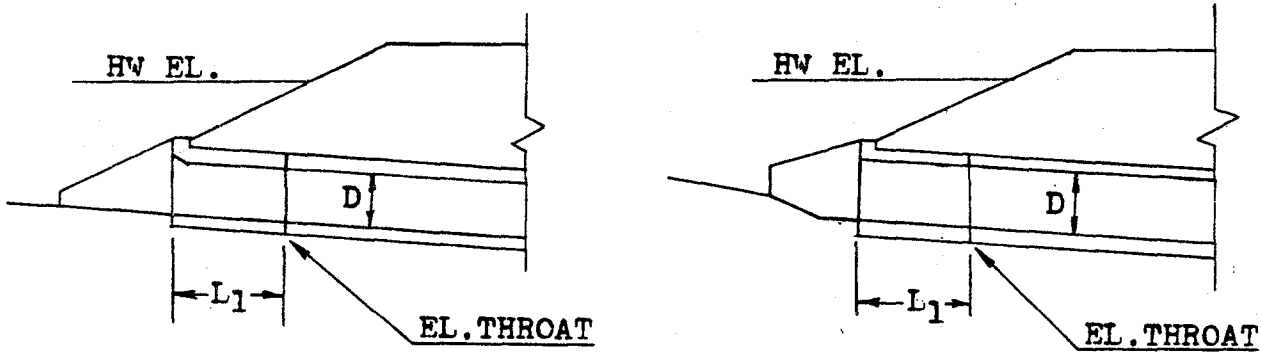

ELEVATION VIEW

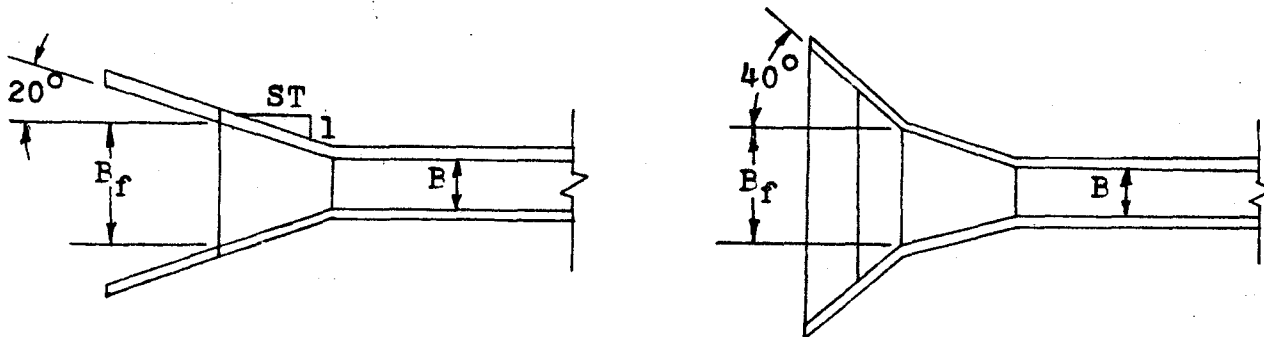

PLAN VIEW

15° to 26° Wingwall Flare
Top Edge Beveled - No FALL

26° to 90 Wingwall Flare
All Edges Square - With FALL

The bevel edged inlets have wingwall flare angles of 26° to 45° with top edges beveled or inlets with wingwall flare angles of 45° to 90° with both top and side edges beveled. For further details, refer to the diagrams below.

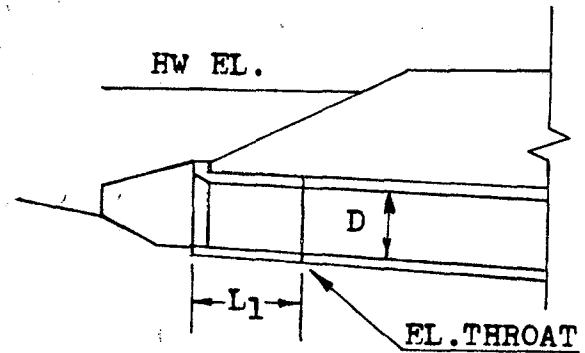
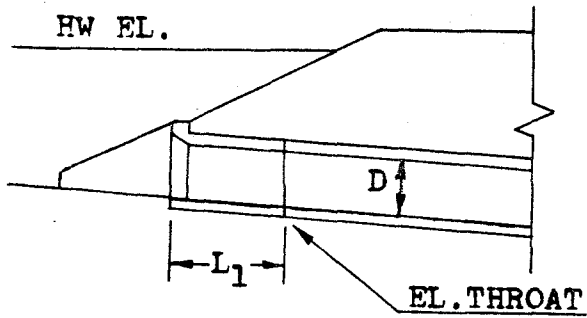

ELEVATION VIEW

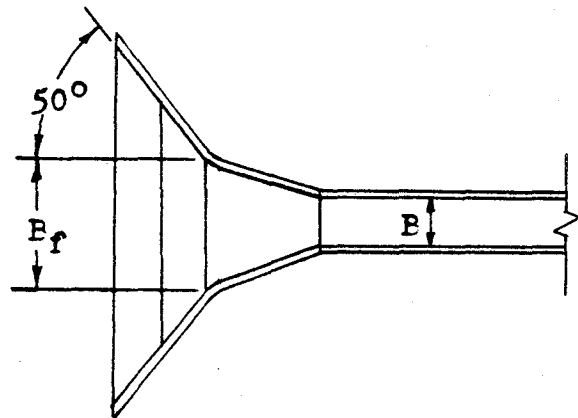
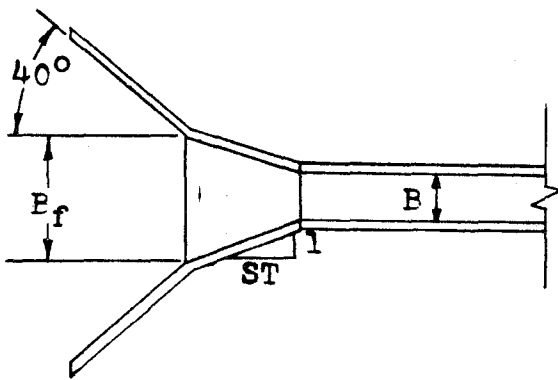

PLAN VIEW

26° to 45° Wingwall Flare
Top Edge Beveled - No FALL

45° to 90° Wingwall Flare
Top and Sides Beveled - FALL

This program determines five different inlet dimensions for a side-tapered inlet. These are the adjusted culvert slope, the adjusted length, the culvert face width, the inlet length, and the elevation of the face. The face width and inlet length are a direct result of using the side-tapered inlet. The change in slope, length and face elevation are a result of using FALL in the inlet design.

The adjusted length computed by the calculator does not include the length of the improved inlet.

Where prefabricated inlet sections are available, both the face width and the inlet length have usually been set by the manufacturing company. These values are normally set at 1 1/2 times the culvert diameter.

The sidewall taper chosen for the culvert inlet is limited to a ratio between a 4:1 and a 6:1. Ratios less than 4:1 are unacceptable and will not operate as side-tapered inlets. Values greater than 6:1 will perform better than the design will indicate. With this larger value the design will be conservative.

The value for the inlet length determined by this program is a horizontal measurement. The values of culvert length and the adjusted culvert length are both culvert distances measured along the culvert barrel.

EQUATIONS

$$(ADJ.S)L = L_1 ADJ.S (S_0^2 + 1)^{.5} + S_0 L - FALL (S_0^2 + 1)^{.5} - (FALL + D[(S_0^2 + 1)^{.5} - (ADJ.S^2 + 1)^{.5}]) - L_1 ADJ.S [S_{fu} (S_0^2 + 1)^{.5} ADJ.S]$$

$$L_1 = (B_f - BN)ST/2$$

$$H_f = H_t - L_1 (ADJ.S)$$

$$X = H_f/D$$

Square Edges

$$B_f = Q/[D^{1.5}(-1.219 + 4.3X - 0.6153X^2 + 0.0273X^3 + 0.0027^4)]$$

Bevel Edges

$$B_f = Q/[D^{1.5}(-1.13607 + 0.0256923X^4 + 0.12128X^2 - 0.205339X^3 + 0.0256923X^4)]$$

B_f , L_1 and $ADJ.S$ are computed simultaneously by trial and error.

$$ADJ.L = \left[\frac{S_0 L}{(S_0^2 + 1)^{.5}} - FALL \right] \frac{[(ADJ.S^2 + 1)^{.5}]}{ADJ.S} - L_1 (ADJ.S^2 + 1)^{.5}$$

$$EL.FACE = EL.THROAT + L_1 ADJ.S$$

The derivations for these equations can be found in the appendix.

INSTRUCTIONS

- #1 Load program #8 (2 cards)
- #2 Press Label A
- #3 Enter:
1. Q - Flow rate
 2. D - Culvert height
 3. N - Number of barrels
 4. H_t - Headwater depth at the throat
 5. ST - Sidewall taper
 6. S_o - Channel slope
 7. FALL
 8. S_{FU} - Upstream fill slope
 9. L - Original culvert length
 10. B - Culvert Width
 11. EL.THROAT - Throat elevation
- #4 Choose inlet type
- Label B - Square edges
- Label C - Bevel edges
- #5 Read: ADJ.S - Adjusted slope
- ADJ.L - Adjusted length
- B_f - Face width
- L_1 - Inlet length
- EL.FACE - Face elevation

CARD FORMAT

1		TEXAS INSTRUMENTS		2	
BOX: SIDE-TAPERED INLET DIMENSIONS					#8
					479.59
Start	SQ.EDGES	BV.EDGES			

3		TEXAS INSTRUMENTS		4	
DATA-PROGRAM # 8					
					479.59

LISTING - PROGRAM #8

```

LBL INV = X RCL 10 + LBL LNX RC* 0 OP 20 RTN LBL CE INV
FIX SBR LNX OP 1 SBR LNX OP 2 SBR LNX OP 3 SBR LNX OP 4
ADV OP 05 2 1 3 7 FIX 2 OP 4 RTN LBL CLR ( RCL 6 X2
+ 1 ) SRX RTN LBL XST NOP ( RCL 12 SBR 0 51 RTN LBL A 3
5 STO 0 SBR CE OP 0 INV FIX SBR LNX OP 1 SBR LNX OP 2 OP
5 ADV 9 XST 1 STO 09 5 1 0 2 STO 0 RCL 0 OP 4 RCL
9 X=T 1 22 R/S OP 6 ST* 9 OP 29 OP 20 GTO 1 01 R/S
XST 5 1 1 2 OP 4 XST OP 6 STO 09 1 0 = R/S XST
5 1 0 2 0 1 STO 0 OP 4 XST OP 6 PRD 3 OP 20 RCL 0
OP 04 1 1 = R/S OP 6 STO 16 OP 00 4 1 STO 0 SBR 0 26
CLR RTN LBL B 9 + LBL C 1 7 = STO 0 RCL 6 STO 12 SBR CE
1 CP +/- + RCL 4 = DIV RCL 2 = STO 10 SBR LNX SBR INV SBR
INV SBR INV SBR INV = 1/x X RCL 1 DIV RCL 2 YX 1 . 5 =
FIX 3 EE INV EE X=T 2 69 - XST RCL 3 = DIV 2 X RCL 5 =

```

```

STO 11 X RCL 12 = STO 13 5 INV SUM 0 RCL 13 GTO 1 99
XST RCL 3 XST 2 81 XST STO 10 GTO 2 88 0 STO 11 RCL
3 STO 10 CP . 1 STO 13 RCL 12 STO 14 RCL 2 X ( SBR CLR
- SBR XST = + RCL 7 - RCL 12 X RCL 11 = X SBR CLR
X RCL 8 X RCL 12 - RCL 6 X RCL 9 + SBR CLR X RCL 7 -
SBR CLR X RCL 12 X RCL 11 + RCL 9 X RCL 12 = FIX 6 EE
INV EE INV X=T 3 78 RCL 15 XST RCL 12 X=T 4 02 STO 15
RCL 11 GTO 2 54 EXC 14 - RCL 14 = X=T 3 63 1/x X RCL 14
X RCL 13 = STO 13 SUM 12 GTO 2 97 4 3 STO 0 SBR CE RCL
12 FIX 6 PRT SBR 0 26 RCL 9 X RCL 6 DIV SBR CLR - RCL 7 =
X SBR XST DIV RCL 12 - RCL 11 X SBR XST = OP 6 SBR
CE RCL 10 OP 6 SBR 0 22 RCL 11 OP 6 SBR CE RCL 16 + RCL
12 X RCL 11 = OP 6 RTN

```

DATA REGISTERS - PROGRAM #8

17.	3624161720	39.	1624301731
18.	3713331735	40.	3624323136
19.	14424000	41.	2431271737
20.	1716221736	42.	37453317
21.	0.0256923	43.	3723170013
22.	-0.205339	44.	1625413637
23.	0.12128	45.	1716003637
24.	3.69853	46.	3233170064
25.	-1.13607	47.	1716002717
26.	3624161720	48.	3122372300
27.	3713331735	49.	1541274217
28.	36344000	50.	3537002113
29.	1716221736	51.	1517004324
30.	0.0027	52.	1637230000
31.	0.0273	53.	3537002431
32.	-0.6153	54.	2717370027
33.	4.3	55.	1731223723
34.	-1.219	56.	1727174213
35.	1432440015	57.	3724323100
36.	4127421735	58.	3221002113
37.	3700200024	59.	1517000000
38.	3127173700		

PROGRAM #9 - SLOPE-TAPERED INLET DIMENSIONS

The slope-tapered inlet is the second type of improvement which uses throat control. This program evaluates the change in slope and length to the culvert resulting from the use of FALL in the hydraulic design. It also determines the elevation of the face and two inlet dimensions.

The program will calculate these inlet features for either a vertical face inlet or a mitered face inlet. The diagrams below show the differences between these two configurations.

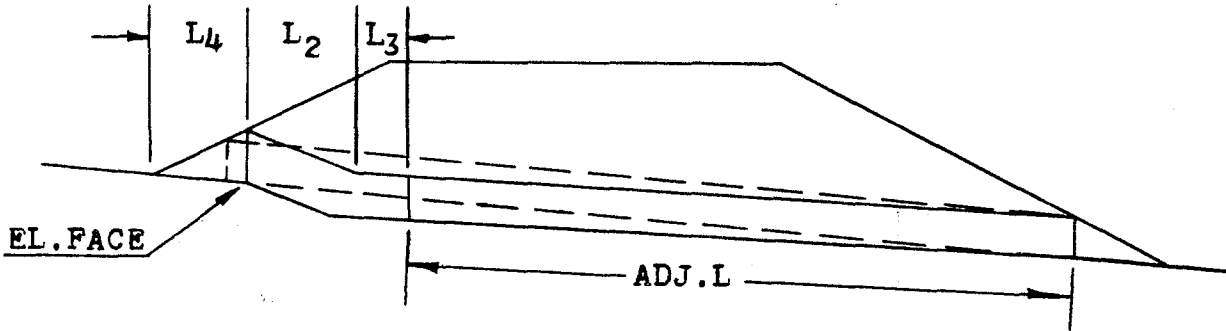

SLOPE-TAPERED, VERTICAL FACE INLET

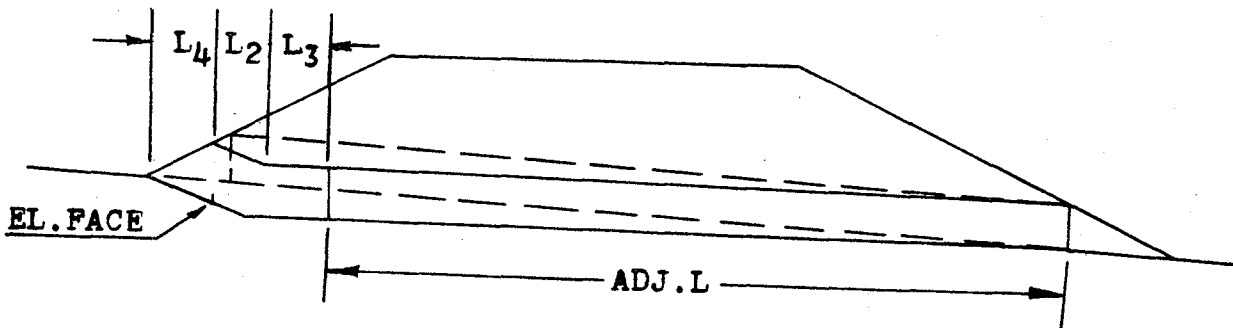

SLOPE-TAPERED, MITERED FACE INLET

The value of L_3 , prompt #2, is not calculated by the program but is usually set equal to one-half the culvert width. Values larger may be used but smaller values cannot.

The adjusted length value is measured along the culvert barrel and does not include the length of the improved inlet.

This program can be applied to either box or pipe culverts.

It should be noted that even though the face elevation is calculated for the mitered face inlet, there is no break in the culvert slope to mark this elevation.

EQUATIONS

Vertical Face

$$L_3 \text{ ADJ.S} = \text{EL.FU} + \frac{D(S_f^2 + 1)^{.5} (S_{FU} + S_f)}{(S_{FU} S_o + 1) S_f^2} + \frac{L_3}{S_f} + \frac{\text{EL.OUT} - \text{EL.FU}}{S_o S_f}$$

$$+ \frac{\text{EL.THROAT} - \text{EL.OUT}}{S_f \text{ ADJ.S}} - D(\text{ADJ.S}^2 + 1)^{.5} - \text{EL.THROAT}$$

$$\text{EL.FACE} = \text{EL.FU} - L_4 S_o$$

$$L_4 = \frac{S_{FU} D(S_f + 1)^{.5}}{S_f (S_o S_{FU} + 1)^{.5}}$$

Mitered Face

$$L_3 \text{ ADJ.S} = \text{EL.FU} + \frac{D(S_f^2 + 1)^{.5}}{S_f} + \frac{L_3}{S_f} + \frac{\text{EL.OUT} - \text{EL.FU}}{S_o S_f}$$

$$+ \frac{\text{EL.THR} - \text{EL.OUT}}{(\text{ADJ.S}) S_f} - D(\text{ADJ.S}^2 + 1)^{.5} - \text{EL.THROAT}$$

$$\text{EL.FACE} = \text{EL.FU} - L_4 / S_f$$

$$L_4 = \frac{S_{FU} D(S_f + 1)^{.5}}{S_{FU} + S_f}$$

Both

$$L_2 = \frac{\text{EL.FU} - \text{EL.OUT}}{S_o} - L_4 - L_3 - \frac{\text{EL.THR} - \text{EL.OUT}}{\text{ADJ.S}}$$

$$\text{ADJ.L} = \frac{(\text{EL.THROAT} - \text{EL.OUT})(\text{ADJ.}^2 + 1)^{.5}}{\text{ADJ.S}}$$

The derivations of these equations can be found in the appendix.

INSTRUCTIONS

- #1 Load program #9 (2 cards)
- #2 Press Label A
- #3 Enter:
1. D - Culvert height
 2. L_3 - One-half the culvert width
 3. S_0 - Channel slope
 4. EL.OUTLET - Outlet elevation
 5. S_{FU} - Upstream fill slope
 6. EL.FU - Upstream fill slope catch point elevation
 7. S_f - FALL slope
 8. EL.THROAT - Throat elevation
- #4 Choose inlet type
- Label B - Vertical face
- Label C - Mitered face
- #5 Read:
- ADJ.S - Adjusted slope
- ADJ.L - Adjusted length
- EL.FACE - Face elevation
- L_4 - Inlet dimension
- L_2 - Inlet dimension

CARD FORMAT

1		TEXAS INSTRUMENTS		2	
BOX: SLOPE-TAPERED INLET DIMENSIONS				#9	
				479.59	
Start	VERT.FACE	MIT. FACE			

3		TEXAS INSTRUMENTS		4	
DATA-PROGRAM #9					
				479.59	

LISTING - PROGRAM #9

```

LBL INV RC* 0 OP 20 RTN LBL LNX INV FIX SBR INV OP 1 SBR
INV OP 2 SBR INV OP 3 SBR INV OP 4 ADV OP 05 2 1 3 7
FIX 2 OP 4 RTN LBL CE ( X2 + 1 ) SRX RTN LBL A 1 4
STO 0 SBR LNX INV FIX OP 0 SBR INV OP 1 SBR INV OP 2
OP 5 ADV 9 X<T 1 STO 09 5 1 0 2 STO 0 RCL 0 OP 4
RCL 9 X=T 1 03 R/S OP 6 ST* 9 OP 29 OP 20 GTO 0 82 OP
00 2 0 STO 0 SBR 0 19 CLR RTN LBL B 2 2 STO 0 SBR LNX
RCL 7 SBR CE X RCL 1 X ( RCL 5 + RCL 7 ) DIV RCL 7 X2
DIV ( RCL 5 X RCL 3 + 1 = GTO 1 75 LBL C 2 6 STO 0 SBR
LNX RCL 7 SBR CE X RCL 1 DIV RCL 7 = STF 1 CP + RCL 6 -
RCL 8 + RCL 2 DIV RCL 7 + ( RCL 4 - RCL 6 ) DIV RCL 7 DIV
RCL 3 STO 10 STO 9 STO 11 = STO 12 RCL 8 - RCL 4 = DIV

```

```

RCL 7 = STO 13 FIX 6 RCL 1 X RCL 9 SBR CE + RCL 2 X RCL 9 -
RCL 13 DIV RCL 9 - RCL 12 = EE INV EE X=T 2 78 EXC 10 - RCL
10 = X=T 2 78 1/x X RCL 10 X RCL 11 = STO 11 SUM 9 GTO 2 25
3 0 STO 0 SBR LNX RCL 9 FIX 6 PRT SBR 0 19 RCL 9 SBR CE DIV
RCL 9 X ( RCL 8 - RCL 4 = OP 6 SBR LNX RCL 1 X RCL 7 SBR CE
IFF 1 3 36 DIV RCL 7 DIV ( RCL 3 + RCL 5 1/x GTO 3 46 X RCL
5 DIV ( RCL 5 + RCL 7 = STO 11 IFF 1 3 59 X RCL 3 GTO 3 65
INV STF 1 DIV RCL 7 +/- + RCL 6 = OP 6 SBR LNX RCL 11 OP 6
SBR 0 23 RCL 6 - RCL 4 = DIV RCL 3 - RCL 11 - RCL 2 - (
RCL 8 - RCL 4 ) DIV RCL 9 = OP 6 CLR RTN

```

DATA REGISTERS - PROGRAM #9

14.	3627323317	30.	3723170013
15.	2037133317	31.	1625413637
16.	3517160024	32.	1716003627
17.	3127173700	33.	3233170064
18.	1624301731	34.	1716002717
19.	3624323136	35.	3122372300
20.	2431271737	36.	172717
21.	37453317	37.	4213372432
22.	4217353724	38.	3100322100
23.	1513270021	39.	2113151700
24.	1315170024	40.	24312717
25.	3127173700	41.	3700271731
26.	30243717	42.	2237236200
27.	3517160021	43.	2705006400
28.	1315170024	44.	2703006400
29.	3127173700		

PROGRAM #10 - SLOPE-TAPERED FACE DIMENSIONS

This program continues with the design of the slope-tapered inlet. The face width and sidewall taper for either a square edged or bevel edged inlet is determined. For a mitered face condition, the designer should evaluate the possibility of crest control. The calculator also performs this operation within program #10 and produces the crest height, the crest width and the minimum sidewall taper which ensures crest control. As long as this last value is exceeded, the culvert will operate properly in throat control.

Inlets with square edges have wingwall flare angles of 15° to 26° with a top beveled edge, or a wingwall flare angle of 26° to 90° with all edges squared. See diagram below

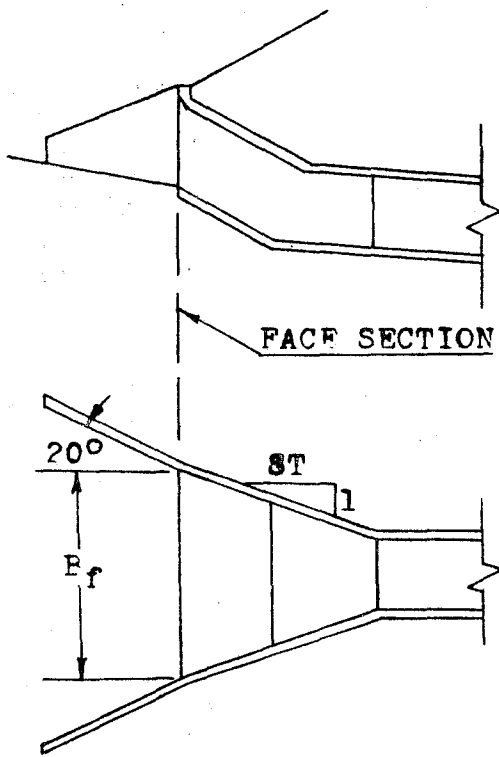

Vertical Face
 15° to 26° Wingwall Flare
Top Edge Beveled

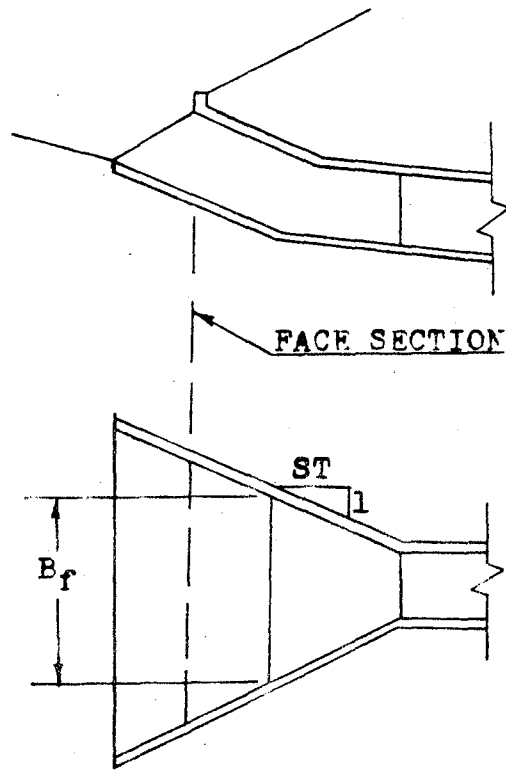

Mitered Face
All edges Square

The bevel edged segment of this program pertains to inlets with wingwall flare angles of 26° to 45° with their top edges beveled and to inlets with wingwall flare angles of 45° to 90° with both top and side beveled edges. For a more detailed description, see diagram below.

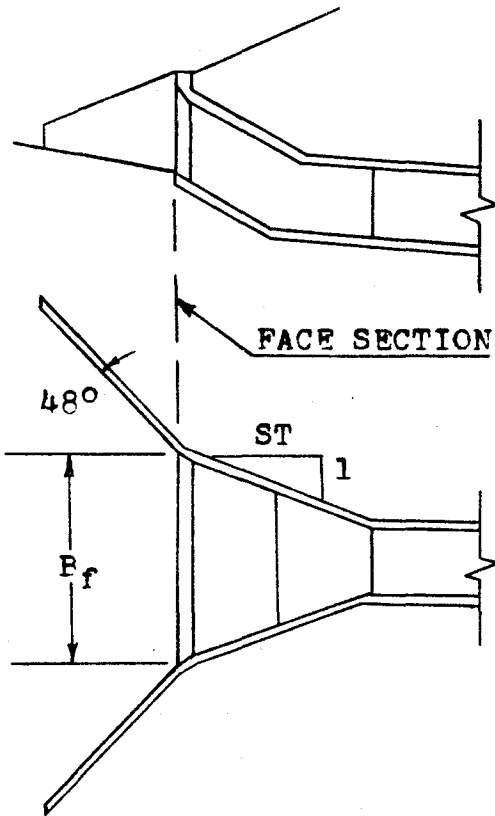

Vertical Face
 45° to 90° Wingwall Flare
 Both Top & Side Edges Beveled

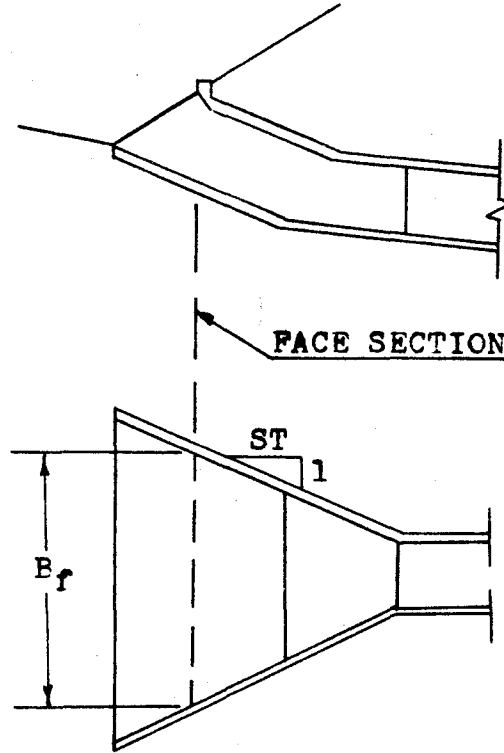

Mitered face
 Top Edge Beveled

As mentioned before and as seen in the diagrams, this program can be applied to either vertical or mitered face inlets. Since the mitered face inlet generally has no wingwalls, the distinction between the use of these two selections as they pertain to the mitered inlet is whether the top edge is to be beveled or squared.

To use the program for the vertical face condition, the face elevation and the length L_2 should come from the vertical face calculations from the previous programs. For the mitered face inlet, these two values should correspondingly come from mitered faced programs.

EQUATIONS

$$ST = \frac{L_2 + L_3}{\frac{B_f - BN}{2}}$$

$$X = \frac{HW \text{ EL.} - \text{EL. FACE}}{D}$$

Square Edges

$$B_f = Q/[D^{1.5} (-1.353 + 5.15X - 1.131X^2 + 0.1578X^3 - 0.0144X^4 + 0.0011X^5)]$$

Bevel Edges

$$B_f = Q/[D^{1.5} (-2.265863 + 7.942441X - 4.0350294X^2 + 1.61981X^3 - 0.3458214X^4 + 0.02846767X^5)]$$

Crest Evaluation

$$H_c = HW \text{ EL.} - \text{EL. FACE}$$

$$CW = \frac{Q}{(2H_c)^{1.5}}$$

$$\text{Minimum } ST = \frac{2L_4}{CW - B_f}$$

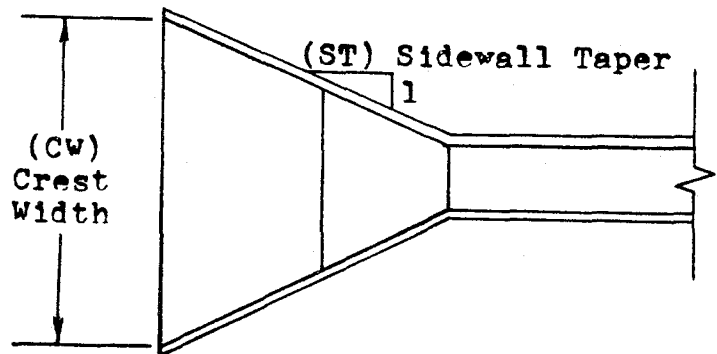
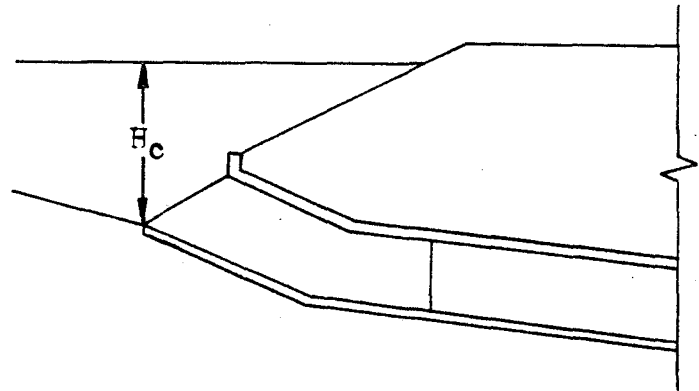

Slope-tapered, Mitered-face Inlet

INSTRUCTIONS

- #1 Load program #10 (2 cards)
- #2 Press Label A
- #3 Enter:
1. Q - Flow rate
 2. D - Culvert height
 3. L_3 - One-half the culvert width
 4. N - Number of barrels
 5. B - Culvert width
 6. HW.EL - Headwater elevations
 7. EL.FACE - Face elevation
 8. L_2 - An inlet dimension from previous programs
 9. L_4 - An inlet dimension from previous programs
- #4 Choose inlet type
- Label B - Square Edges
- Label C - Beveled Edges
- #5 Read: B_f - Face width
- ST - Sidewall taper
- #6 For Crest Evaluation, Mitered Inlet
- Press Label D
- #7 Read: H_c - Crest height
- CW - Crest width
- ST - Minimum sidewall taper

CARD FORMAT

1		TEXAS INSTRUMENTS		2	
BOX: SLOPE-TAPERED FACE DIMENSIONS				#10	
				399.69	
Start	SQ.EDGES	BV.EDGES	MIT.CREST		

3		TEXAS INSTRUMENTS		4	
DATA-PROGRAM # 10					
				399.69	

LISTING - PROGRAM #10

```

LBL INV = X RCL 10 + LBL LNX RC* 0 OP 20 RTN LBL CE INV
FIX SBR LNX OP 1 SBR LNX OP 2 SBR LNX OP 3 SBR LNX OP 4
OP 05 2 1 3 7 FIX 2 OP 4 RTN LBL A 1 2 STO 0 SBR CE SBR
CE ADV INV FIX 9 X $\int$ T 1 STO 09 5 1 0 2 STO 0 RCL 0 OP
4 RCL 9 X=T 0 90 R/S OP 6 ST* 9 OP 29 OP 20 GTO 0 69
R/S X $\int$ T 5 1 1 2 OP 4 X $\int$ T OP 6 STO 9 ADV OP 00 2 0
STO 0 SBR 0 26 CLR RTN LBL B 1 0 + LBL C 2 2 = STO 0 ADV
SBR CE ADV RCL 6 - RCL 7 = DIV RCL 2 = STO 10 SBR LNX SBR
INV SBR INV SBR INV SBR INV SBR INV = 1/x X RCL 1 DIV RCL 2
YX 1 . 5 = STO 11 4 2 STO 0 SBR CE RCL 11 OP 6 ADV -
RCL 4 X RCL 5 = DIV 2 = 1/X X ( RCL 8 + RCL 3 = X $\int$ T OP
0 INV FIX SBR 0 22 6 2 0 0 0 2 SBR 0 40 X $\int$ T OP 6 ADV

```

CLR RTN LBL D 4 9 STO 0 SBR CE SBR CE ADV OP 0 CP INV FIX
 SBR 0 22 RCL 6 - RCL 7 = OP 6 ADV X 2 = Y^X 1 . 5 =
 1/X X RCL 1 = STO 10 INV FIX SBR 0 26 RCL 10 OP 6 ADV -
 RCL 11 = DIV 2 DIV RCL 9 = 1/X INV X>T 2 92 X<T OP 0 INV
 FIX SBR LNX OP 2 SBR LNX OP 3 OP 05 4 6 STO 0 GTO 2 03

DATA REGISTERS - PROGRAM #10

12.	3627323317	38.	0.1578
13.	2037133317	39.	-1.131
14.	3517160024	40.	5.15
15.	3127173700	41.	-1.353
16.	2113151700	42.	2431271737
17.	1624301731	43.	21131517
18.	3624323136	44.	43241637
19.	0	45.	2300000000
20.	2431271737	46.	36241617
21.	37453317	47.	4313272700
22.	3627323317	48.	3713331735
23.	2037133317	49.	3024
24.	3500144240	50.	3717351716
25.	17164000	51.	24312717
26.	0.02846767	52.	3700000000
27.	-0.3458214	53.	153517
28.	1.619481	54.	3637001742
29.	-4.0350294	55.	1327411337
30.	7.942441	56.	2432310000
31.	-2.265863	57.	1535173637
32.	3627323317	58.	23172422
33.	2037133317	59.	2337000000
34.	3500363440	60.	43241637
35.	17164000	61.	2300000000
36.	0.0011	62.	30243124
37.	-0.0144	63.	3041300000

PROGRAM #11 - BOX CULVERT: INLET CONTROL, OUTLET VELOCITY

As is stated in the title, this program computes the velocity of the flow at the outlet of a box culvert which is operating in inlet control. The inlet control mentioned here also includes box culverts operating under throat control.

In performing this velocity computation, this program employs two polynomial equations which approximate the normal depth curve for a rectangular cross-sectional area. The curve referred to was taken from "Open Channel Hydraulics" by Chow. See reference #4.

EQUATIONS

$$X = \frac{Qn}{1.486NS \cdot B^{5/8/3}}$$

If $X < 0.22$

$$d_n = B (0.036402 + 3.648374X - 15.152238X^2 + 64.991913X^3 - 110.31635X^4)$$

If $0.22 \leq x \leq 1.1$

$$d_n = B (0.084468 + 2.34061X - 1.53643X^2 + 1.636594X^3 - 0.677621X^4)$$

Note: $\frac{d_n}{B}$ is limited to a maximum of 2.

If $X > 1.1$

$$d_n = D$$

$$V = \frac{Q}{BNd_n}$$

INSTRUCTIONS

#1 Load program #11

#2 Press Label A

#3 Enter: 1. Q - Flow rate

2. D - Culvert height

3. N - Number of barrels

4. n - Manning's roughness coefficient

5. S - Culvert slope

6. B - Culvert width

Read: V - Outlet velocity

CARD FORMAT

1	TEXAS INSTRUMENTS	4
BOX: INLET CONTROL, OUTLET VELOCITY		#11
		479.59
Start		

LISTING - PROGRAM #11

```

LBL INV = X RCL 7 + LBL LNX RC* 0 OP 20 RTN LBL CE INV
FIX SBR LNX OP 1 SBR LNX OP 2 SBR LNX OP 3 SBR LNX OP 4 OP
5 RTN LBL A 8 STO 0 SBR CE SBR CE ADV 7 X<T 1 STO 07 5
1 0 2 STO 0 RCL 0 OP 4 RCL 7 X=T 0 79 R/S OP 6 ST* 7 OP
27 OP 20 GTO 0 58 ADV RCL 1 X RCL 4 DIV 1 . 4 8 6 DIV RCL 5
SRX DIV RCL 3 DIV RCL 6 Y^X ( 8 DIV 3 = STO 7 X<T 1 . 1 X>T
1 50 RCL 1 DIV RCL 2 DIV RCL 6 DIV RCL 3 = X<T 1 2 STO 0
SBR CE 2 1 6 3 3 6 FIX 2 OP 4 X<T OP 6 ADV RTN . 2 2
X>T 1 58 5 + 1 6 = STO 0 SBR LNX SBR INV SBR INV SBR INV
SBR INV = X<T 2 INV X>T 1 81 X<T X RCL 6 = X<T
RCL 2 INV X>T 1 93 X<T X RCL 3 X RCL 6 = 1/x X RCL 1 =
GTO 1 28

```

DATA REGISTERS - PROGRAM #11

8.	1432446200	17.	64.991913
9.	2431271737	18.	-15.152238
10.	15323137	19.	3.6483784
11.	3532270000	20.	0.036402
12.	0	21.	-0.677621
13.	3241372717	22.	1.636594
14.	3700421727	23.	-1.53643
15.	3215243745	24.	2.34061
16.	-110.31635	25.	0.084468

PROGRAM #12 - PIPE CULVERT: OUTLET CONTROL PERFORMANCE

This program can be used to select an appropriate pipe culvert size, evaluate the performance of this culvert for various flow rates and determine the velocity of the flow at the outlet.

In determining the best pipe size, the designer must first select a trial diameter. For this value, the program computes the water surface elevation of the headwater pool at the culvert inlet. A visual comparison of this value to the design headwater elevation is made and the designer adjusts the diameter accordingly.

Once the pipe size has been determined, various flow rate values can be used with this program to obtain a performance curve.

The following diagram indicates the location of the energy losses associated with the culvert design.

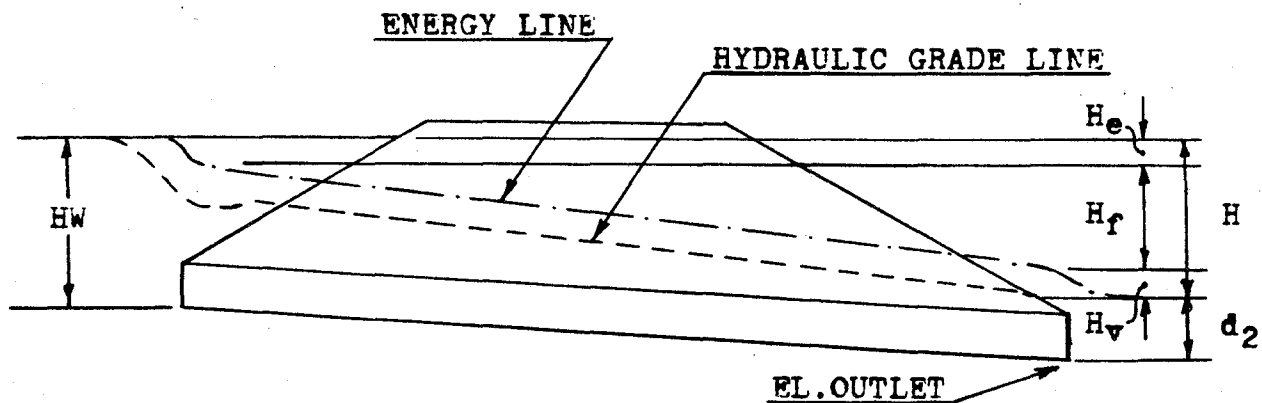

This program also calculates the outlet velocity of a pipe culvert operating in outlet control.

The depth of flow used in the computation of the cross-sectional area of flow through the culvert is equal to the critical depth or the tailwater depth, whichever is greater. However, this value cannot exceed the diameter of the pipe.

Since, the water at the inlet is considered to be a pool, the velocity at this point is assumed to be approximately zero. This allows the hydraulic grade line to be equated to the energy line.

The computations of the outlet velocity require that the calculator be placed in the degree mode. This is normally the mode the calculator is in when it is turned on.

For the sizing and performance curve operations to perform properly, the number of culvert barrels is limited to two.

EQUATIONS

$$Z = \frac{Q}{N (32.2/\alpha)^{.5} D^{2.5}}$$

$$X = \text{Log } Z$$

$$\text{If } X \leq \text{Log } 0.7$$

$$Y = (-0.0051657 + 0.407362X - 0.1830236X^2 - 0.0915565X^3)$$

$$\text{If } X > \text{Log } 0.7$$

$$Y = (-0.0244603 + 0.2017057X - 0.64009815X^2 + 0.695619X^3)$$

$$d_c = D 10^Y$$

Note: d_c has been limited to a maximum value of D

$$H_e = \frac{k_e V^2}{2g}$$

$$H_f = \frac{29 n^2 L V^2}{2g R^{4/3}}$$

$$H_v = \frac{V^2}{2g}$$

$$H = H_e + H_f + H_v$$

$$d_2 = \frac{d_c + D}{2} \quad \text{or the tailwater depth, whichever is largest}$$

$$\text{HW EL.} = H + d_2 + \text{EL. OUTLET}$$

$$d_4 = d_c \text{ or TW, whichever is larger and does not exceed } D$$

$$X = D/2$$

$$r = (X - d_4)$$

Using the Radian Mode

$$\theta = \text{Cos}^{-1} (r/X)$$

$$A = X^2 (\theta - \text{Sin } \theta \text{ Cos } \theta)$$

$$V = Q/AN$$

INSTRUCTIONS

#1 Load program #12

#2 Press Label A

#3 Enter: 1. Q - Flow rate

2. N - Number of barrels

3. k_e - Entrance loss coefficient

4. n - Manning's roughness coefficient

5. TW - Tailwater depth

6. Alpha - Kinetic energy coefficient

= 1.12 for corrugated metal

= 1.04 for concrete

7. D - Culvert diameter

8. EL.OUTLET - Outlet invert elevation

9. L - Culvert length

Read: HW EL. - Headwater elevation

#4 Press Label B

Read: d_c - Critical depth

#5 Press Label C

Read: H - Total head loss

#6 Press Label D

Read: V - Outlet control velocity

#7 Press Label E

Enter: Q - Flow rate

TW - Tailwater depth

Read: HW EL. - Headwater elevation

CARD FORMAT

1		TEXAS INSTRUMENTS			2	
PIPE: OUTLET CONTROL PERFORMANCE				#12		
				479.59		
Start	d_c	H	VELOCITY	PERFORMANCE		

CARD FORMAT

3		TEXAS INSTRUMENTS			4	
DATA - PROGRAM #12						
				479.59		

LISTING PROGRAM #12

```

LBL INV = X RCL 11 + LBL LNX RC* 0 OP 20 RTN LBL CE INV
FIX SBR LNX OP 1 SBR LNX OP 2 SBR LNX OP 3 SBR LNX OP 4
ADV OP 05 2 1 3 7 FIX 2 OP 4 RTN LBL CLR STO 0 SBR CE
RTN LBL X<T RCL 1 DIV RCL 2 DIV ( 3 2 . 2 DIV RCL 6 )
SRX = DIV RCL 7 Y^X 2 . 5 = LOG STO 11 X<T . 7 LOG
X>T 0 92 4 + 4 8 = STO 0 SBR LNX SBR INV SBR INV SBR INV
= INV LOG X<T 1 INV X>T 1 15 X<T X RCL 7 = RTN LBL
X^2 2 9 . 1 6 4 X RCL 4 X^2 X RCL 59 DIV ( RCL 7 DIV 4
) Y^X ( 4 DIV 3 = + RCL 3 + 1 = X ( 4 X RCL 1 DIV RCL
2 DIV RCL 7 X^2 DIV PI ) X^2 DIV 6 4 . 4 = RTN LBL SRX
1 6 SBR CLR SBR X<T X<T RCL 7 + X<T INV X>T 1 97
RCL 7 = DIV 2 = X<T RCL 5 X>T 2 08 X<T STO 10 SBR
X^2 + RCL 8 + RCL 10 = OP 6 CLR RTN LBL A 1 2 SBR CLR INV
FIX ADV 9 X<T 1 STO 9 RCL 56 STO 0 RCL 0 OP 4 RCL 9 X=T 2
62 R/S OP 6 ST* 9 OP 29 OP 20 GTO 2 41 R/S X<T 5 1 1 2
OP 4 X<T OP 6 STO 59 SBR SRX 2 0 SBR CLR SBR CE ADV 9
X<T 7 STO 09 5 1 0 8 GTO 2 39 LBL B 2 8 SBR CLR SBR
X<T OP 6 RTN LBL C 3 2 SBR CLR SBR X^2 OP 6 RTN LBL D 4
4 SBR CLR RCL 57 FIX 2 OP 4 SBR X<T X<T RCL 5 X>T 3 39
X<T X<T RCL 7 X>T 3 46 X<T RCL 7 DIV 2 = STO 10 -
X<T = Div X<T = RAD INV COS STO 11 - RCL 11 SIN X RCL
11 COS = DEG X RCL 10 X^2 = 1/x DIV RCL 2 X RCL 1 = OP 6
RTN LBL E 3 6 SBR CLR SBR CE ADV RCL 56 OP 04 1 = R/S STO 1
OP 6 RCL 58 OP 04 5 = R/S STO 5 OP 6 SBR SRX 4 0 STO 0
GTO 3 96

```

DATA REGISTERS - PROGRAM #12

12.	3324331762	36.	3317352132
13.	15412742	37.	3530133115
14.	1735370036	38.	1700154135
15.	2446170000	39.	4217000000
16.	2317131643	40.	1731371735
17.	1337173500	41.	65346500
18.	1727174213	42.	1331160065
19.	3724323100	43.	3743650000
20.	2132350013	44.	3241372717
21.	3132372317	45.	3700153231
22.	3500362446	46.	3735322700
23.	1700000000	47.	4217274000
24.	1731371735	48.	-0.0915565
25.	65165700	49.	-0.1830236
26.	1727403241	50.	0.407362
27.	3757002765	51.	-0.0051657
28.	1535243724	52.	0.695619
29.	1513270016	53.	-0.64009815
30.	1733372300	54.	0.2017057
31.	2436000000	55.	-0.0244603
32.	3732371327	56.	5102
33.	23171316	57.	216336
34.	27323636	58.	5106
35.	24360000		

PROGRAMS #13 and #14 - PIPE CULVERT: INLET CONTROL PERFORMANCE

These programs evaluate the hydraulic performance of eight different pipe culvert inlet configurations. A detailed explanation of the geometry of these inlets is depicted in the diagrams below:

PROGRAM #13

Corrugated Metal Pipe with a Projecting Edge

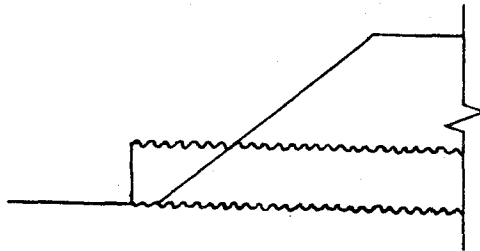

Corrugated Metal Pipe in a Headwall

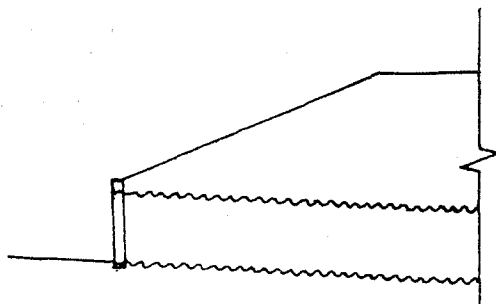

Corrugated Metal or Concrete Pipe with Beveled Edges - Type A and B

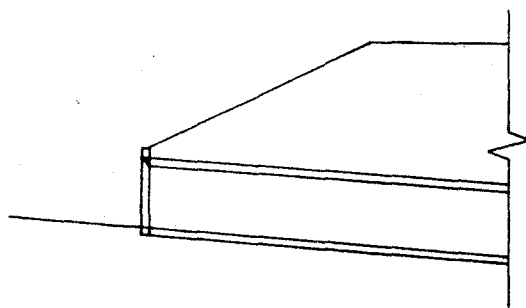

CMP/Concrete - Beveled Edges

Type A and B

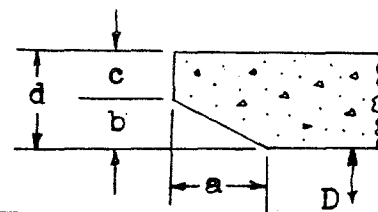

TYPE	$\frac{b}{D}$	$\frac{a}{D}$	$\frac{c}{D}$	$\frac{d}{D}$
A	0.042	0.042	0.042	0.083
B	0.083	0.125	0.042	0.125

Corrugated Metal or Concrete Pipe with a Standard End Section

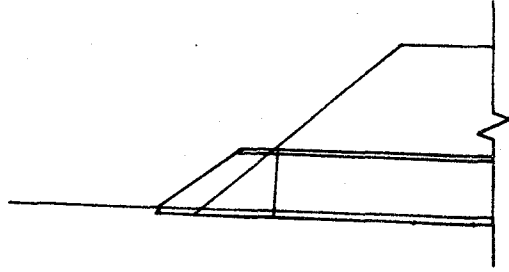

Concrete Pipe with Square Edges in a Headwall

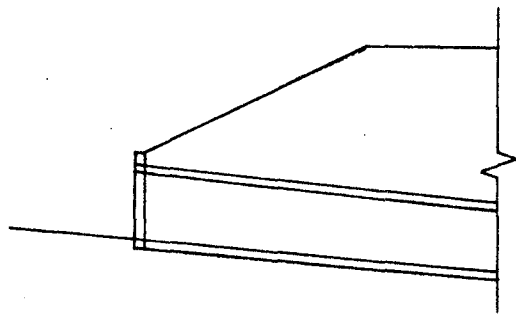

Concrete with a Projecting Socket Edge

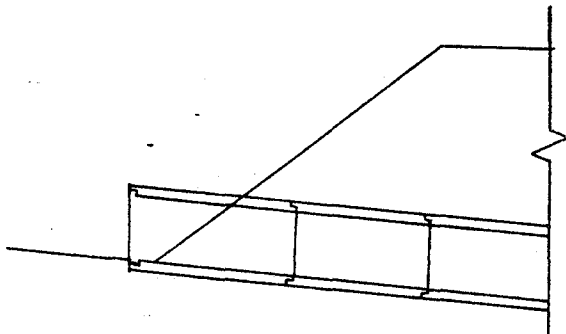

Concrete with a Socket Edge in a Headwall

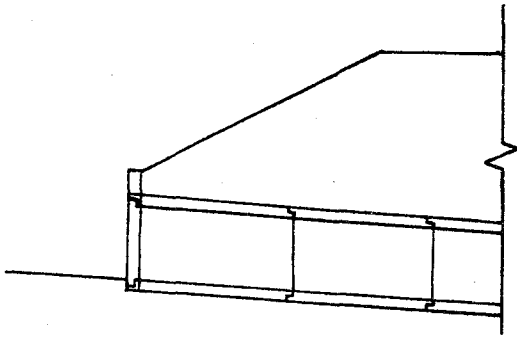

Equations for two other inlets are provided here in the documentation. The two inlets are as follows:

Corrugated Metal Pipe Mitered to Conform to the Slope

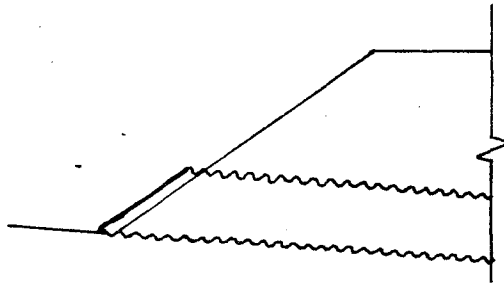

Concrete with Projecting Square Edges

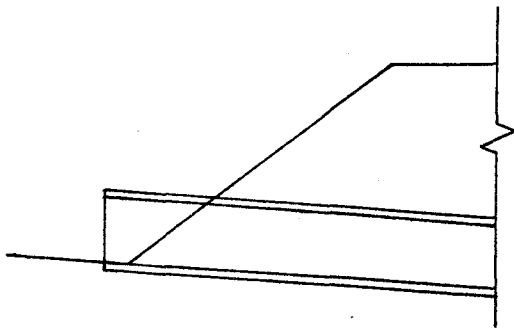

For each particular inlet the program calculates the depth of the water surface at the face of the culvert. This value is then added to the culvert inlet invert elevation. If this sum is less than the design headwater elevation then the inlet elevation becomes the elevation of the face. If this sum exceeds the design headwater elevation, the difference between this sum and the design headwater elevation is subtracted from the inlet invert elevation. This new elevation is now called the elevation of the face. For the culvert to operate properly, the inlet invert must be reset to this elevation. The drop in elevation of the inlet invert is called the FALL. The diagrams below graphically show the occurrence. It should be noted that as the inlet invert elevation drops, the culvert barrel rotates about the outlet invert.

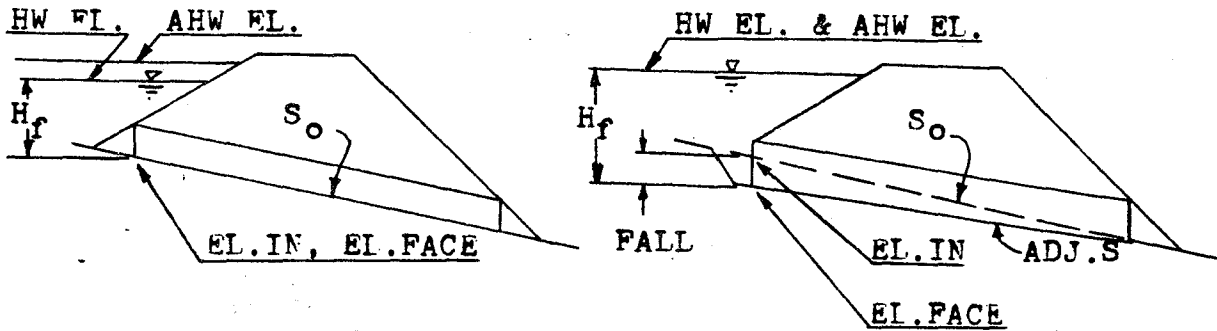

No FALL Required
 $EL.IN + H_f < AHW EL.$

FALL Required
 $EL.IN + H_f \geq AHW EL.$

The diagrams clearly indicate that when the calculated headwater elevation is above the design headwater elevation, the headwater elevation is set equal to the design headwater elevation and the difference is taken up by the FALL.

The inlet invert elevation of the culvert can always be thought of as the elevation of the face. The original inlet invert elevation, before considering the affects of FALL, can be taken as the "inlet elevation." After the design information has been entered and the inlet type selected, the calculator determines the face elevation and the required FALL.

These programs do not perform the checks on restrictions on the FALL and the headwater depth. Both of these values must be checked by the designer.

Once the culvert has been sized for the design flow rate, the performance of the inlet for other flow rates can be determined. In doing the performance evaluation, the calculator determines the headwater elevation for any given flow rate.

Whenever applicable, a bevel edged inlet is recommended for use in lieu of a square edged inlet. The large increase in hydraulic performance gained by the bevel edged inlet, greatly outweighs the small, if any, additional cost.

EQUATIONS

$$\begin{aligned}\text{EL. FACE} &= \text{DIM EL.} - H_f \text{ (with FALL)} \\ &= \text{EL. INLET} \text{ (without FALL)}\end{aligned}$$

$$\text{HW EL.} = \text{EL. FACE} + H_f$$

$$\text{FALL} = \text{EL. FACE} - \text{EL. INLET}$$

NOTE: The FALL is measured in a downward direction and therefore is always a positive value.

$$X = \frac{Q}{(ND^{2.5})}$$

PROGRAM #13

CMP with a Projecting Edge

$$\begin{aligned}H_f &= D(0.187321 + 0.567710X - 0.156544X^2 + 0.0447052X^3 - 0.00343602X^4 \\ &\quad + 0.000089661X^5)\end{aligned}$$

CMP in a Headwall

$$\begin{aligned}H_f &= D(0.167433 + 0.538595X - 0.149374X^2 + 0.0391543X^3 - 0.00343974X^4 \\ &\quad + 0.000115882X^5)\end{aligned}$$

CMP/CONC. with Bevel Type A

$$\begin{aligned}H_f &= D(0.063343 + 0.766512X - 0.316097X^2 + 0.0876701X^3 - 0.00983695X^4 \\ &\quad + 0.000416760X^5)\end{aligned}$$

CMP/CONC. with Bevel Type B

$$\begin{aligned}H_f &= D(0.081730 + 0.698353X - 0.253683X^2 + 0.0651250X^3 - 0.00719750X^4 \\ &\quad + 0.000312451X^5)\end{aligned}$$

PROGRAM #14

CMP /CONC with a Standard End Section

$$H_f = D(0.120659 + 0.630768X - 0.218423X^2 + 0.0591815X^3 - 0.00599169X^4 + 0.000229287X^5)$$

CONC. with Square Edges in a Headwall

$$H_f = D(0.087483 + 0.706578X - 0.253295X^2 + 0.0667001X^3 - 0.00661651X^4 + 0.000250619X^5)$$

CONC. with a Projecting Socket Edge

$$H_f = D(0.108786 + 0.662381X - 0.233801X^2 + 0.0579585X^3 - 0.00557890X^4 + 0.000205052X^5)$$

CONC. with Socket Edge in Headwall

$$H_f = D(0.114099 + 0.653562X - 0.233615X^2 + 0.0597723X^3 - 0.00616338X^4 + 0.000242832X^5)$$

Optional Inlets

CMP Mitered to Conform to Slope

$$H_f = D(0.107137 + 0.757789X - 0.361462X^2 + 0.1233932X^3 - 0.01606422X^4 + 0.000767390X^5)$$

CONC with a Projecting Square Edge

$$H_f = D(0.167287 + 0.558766X - 0.159813X^2 + 0.0420069X^3 - 0.00369252X^4 + 0.000125169X^5)$$

With a small amount of programming experience, an operator can insert these last two optional formulas into either program #13 or #14.

INSTRUCTIONS

- #1 Load program #13 (2 cards)
or program #14 (2 cards)
- #2. Press Label A
- #3 Enter: 2. D - Culvert diameter
3. N - Number of Barrels
4. EL.INLET - Inlet elevation
5. DHW EL - Design headwater elevation
6. Q - Flow rate

#4 Select inlet type

Program #13

Label A' - CMP w/Projecting End
Label B' - CMP w/Headwalls
Label C' - CMP/CONC; Bevel A
Label D' - COM/CONC; Bevel B

Program #14

Label A' - CMP/CONC Standard End Section
Label B' - CONC w/SQ ED in Headwall
Label C' - CMP/CONC W/Projecting Socket
Label D' - CONC Socket in headwall

Read EL.FACE - Elevation of face
FALL

#5 Check FALL

#6 Press Label D

Read: H_f - Headwater depth

#7 Run Performance Evaluation

Press Label E

Enter Q - Flow rate

Read: HW EL. - Headwater elevation

CARD FORMAT

1	TEXAS INSTRUMENTS	2
PIPE : INLET CONTROL PERFORMANCE		#13 and #14
		319.79

3	TEXAS INSTRUMENTS	4		
DATA PROGRAM #13				
CMP PROJ	CMP W/H	C/C Bevel A	C/C Bevel B	319.79
Start	HW EL.	FALL	H_f	PERFORMANCE

3	TEXAS INSTRUMENTS	4		
DATA PROGRAM #14			#14	
STD. END	SQ. W/HW	PROJ. SOCKET	SOCKET W/HW	319.79
Start	HW EL.	FALL	H_f	PERFORMANCE

LISTING PROGRAM #13 & 14

LBL INV = X RCL 7 + LBL LNX RC* 8 OP 28 RTN LBL CE INV
FIX SBR LNX OP 1 SBR LNX OP 2 SBR LNX OP 3 SBR LNX OP 4
ADV OP 5 RTN LBL CLR EXC 8 X<T SBR CE 2 1 3 7 FIX
2 OP 4 X<T STO 8 RTN LBL X<T RCL 6 DIV RCL 3 DIV
(RCL 2 Y^x 2 . 5 = STO 7 SBR LNX SBR INV SBR INV SBR
INV SBR INV SBR INV = X RCL 2 = X<T 6 INV SUM 8 X<T
STO 9 RTN LBL A 1 0 STO 8 SBR CE ADV 7 X<T 2 STO 09
5 1 0 3 STO 0 RCL 0 OP 4 RCL 9 X=T 1 42 R/S OP 6 ST* 9
OP 29 OP 20 GTO 1 21 OP 0 SBR 0 26 CLR RTN LBL B 6 4 SBR
CLR SBR X<T + RCL 0 = OP 6 RTN LBL A' 1 0 + LBL B' 1 0 +
LBL C' 1 0 + LBL D' 1 6 = STO 8 SBR CE 6 8 SBR CLR SBR
X<T X<T RCL 5 - RCL 4 = X>T 2 05 X<T +/- + RCL 5 =
STO 0 OP 6 LBL C 7 2 SBR CLR RCL 4 - GTO 1 58 LBL D 7
6 SBR CLR SBR X<T OP 6 RTN LBL E 5 6 SBR CLR 6 0 SBR
CLR 6 INV FIX R/S PRT STO 6 SBR B GTO 2 43

DATA REGISTERS - PROGRAM #13

10.	3324331762	42.	0.0391543
11.	24312717	43.	-0.149374
12.	3700153231	44.	0.538595
13.	3735322700	45.	0.167433
14.	2431271737	46.	1530336200
15.	37453317	47.	3335322517
16.	3745331700	48.	1537243122
17.	1400141742	49.	17162217
18.	1727171600	50.	0.000089661
19.	1716221736	51.	-0.00343602
20.	0.000312451	52.	0.0447052
21.	-0.0071975	53.	-0.156544
22.	0.065125	54.	0.56771
23.	-0.253683	55.	0.187321
24.	0.698353	56.	3317352132
25.	0.08173	57.	3530133115
26.	3745331700	58.	1700154135
27.	1300141742	59.	4217000000
28.	1727171600	60.	1731371735
29.	1716221736	61.	21273243
30.	0.00041676	62.	3513371700
31.	-0.00983695	63.	15213600
32.	0.0876701	64.	2317131643
33.	-0.316097	65.	1337173500
34.	0.766512	66.	1727174213
35.	0.063343	67.	3724323100
36.	1530330024	68.	172717
37.	3100130023	69.	4213372432
38.	1713164313	70.	3100322100
39.	2727000000	71.	2113151700
40.	0.00015882	72.	372317
41.	-0.00343974	73.	35173441
		74.	2435171600
		75.	2113272700
		76.	2317
		77.	1316431337
		78.	1735001617
		79.	3337230000

DATA REGISTERS - PROGRAM #14

10.	3324331762	42.	0.0667001
11.	24312717	43.	-0.253295
12.	3700153231	44.	0.706578
13.	3735322700	45.	0.087483
14.	2431271737	46.	3637133116
15.	37453317	47.	1335160017
16.	3632152617	48.	3116003617
17.	3700243100	49.	1537243231
18.	1300231713	50.	0.000229287
19.	1643132727	51.	-0.00599169
20.	0.000242832	52.	0.0591815
21.	-0.00616338	53.	-0.218423
22.	0.0597723	54.	0.630768
23.	-0.233615	55.	0.120659
24.	0.653762	56.	3317352132
25.	0.114099	57.	3530133115
26.	3335322517	58.	1700154135
27.	1527243122	59.	4217000000
28.	36321526	60.	1731371735
29.	1737000000	61.	21273243
30.	0.000205052	62.	3513371700
31.	-0.0055789	63.	15213600
32.	0.0579585	64.	2317131643
33.	-0.233801	65.	1337173500
34.	0.662318	66.	1727174213
35.	0.108786	67.	3724323100
36.	3634400017	68.	172717
37.	1640002431	69.	4213372432
38.	23171316	70.	3100322100
39.	4313272700	71.	2113151700
40.	0.000250619	72.	372317
41.	-0.00661651	73.	35173441
		74.	2435171600
		75.	2113272700
		76.	2317
		77.	1316431337
		78.	1735001617
		79.	3337230000

PROGRAMS #15 and #16 - PIPE CULVERT: THROAT CONTROL PERFORMANCE

These programs evaluate the performance of a pipe culvert operating in throat control. The formulas incorporated in these programs apply only to side-tapered inlets for pipe culverts. Program #15 evaluates the performance of corrugated metal inlets whereas program #16 evaluates concrete inlets. Like the improved inlet programs, these throat control programs often can use FALL to increase the flow capacity of a culvert. The following diagrams describe the throat control inlets.

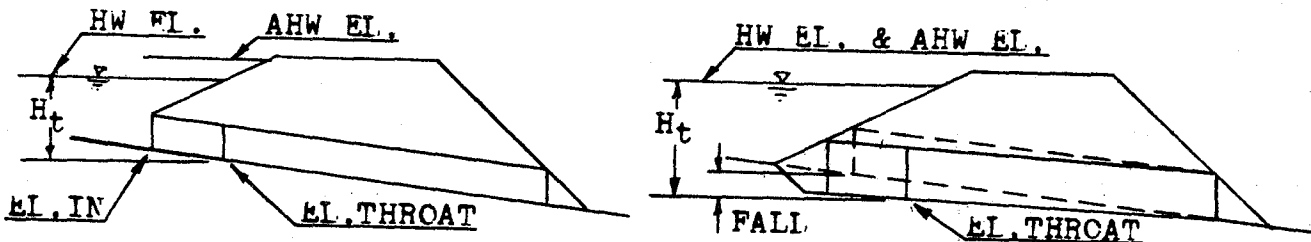

ELEVATION VIEW

ROUGH THROAT

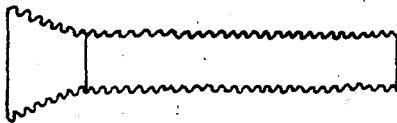

SMOOTH THROAT

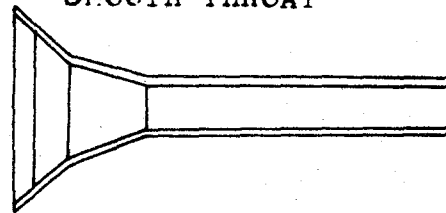

PLAN VIEW

SIDE-TAPERED INLET
ROUGH THROAT
NO FALL, HWEL. < AHWEL.

SIDE-TAPERED INLET
SMOOTH THROAT
WITH FALL AND WINGWALLS

To evaluate the performance of a pipe culvert with a slope-tapered inlet, program #7 should be used. Program #7 evaluates the performance of box culverts with either a side- or slope-tapered inlet. The slope-tapered inlet for a pipe culvert is designed as if it were going to be used with a box culvert. A transition section is then fabricated to connect the box shaped inlet to the pipe culvert barrel. The following diagrams will further explain this situation.

SLOPE-TAPERED INLETS

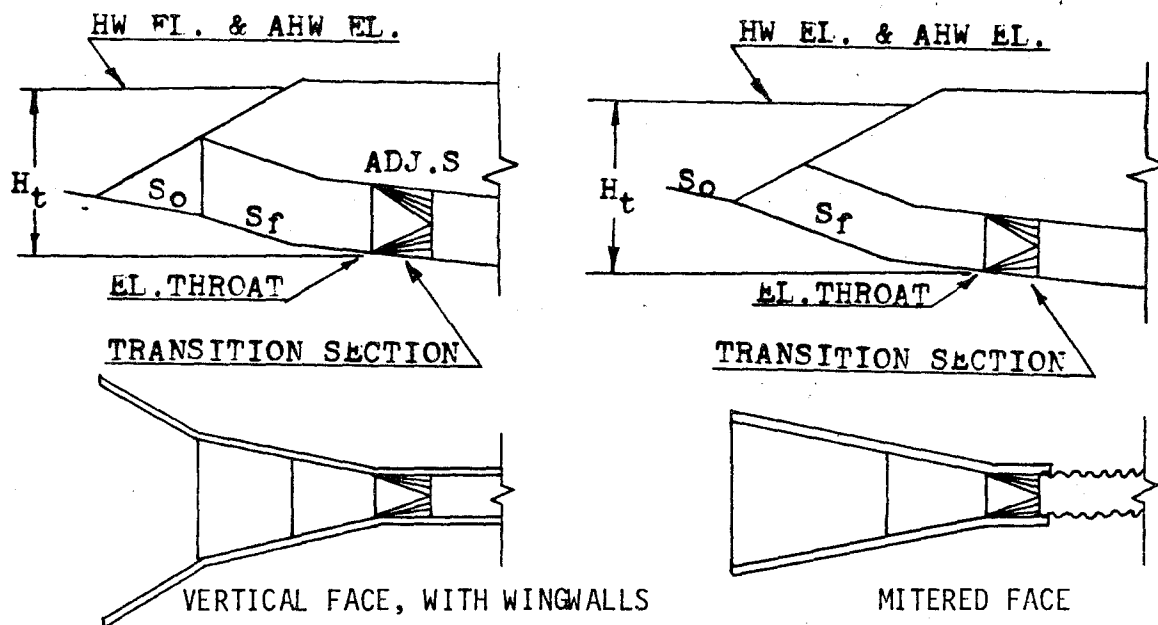

Due to the limitations of this calculator, a small error results in the computation of the FALL. The programs assume that the elevation of the inlet and the elevation of the throat are equal before determining the value of the headwater elevation. This equality is false and a small difference, equal to the channel slope times the vertical distance between the inlet and the throat section, exists. This vertical distance is an unknown value and is determined by the next program. By understanding the error condition; a correction, if necessary, can be made.

EQUATIONS

$$\begin{aligned} \text{EL.THROAT} &= \text{DHW EL.} - H_t \text{ (with FALL)} \\ &= \text{EL.INLET} \text{ (without FALL)} \end{aligned}$$

$$\text{HW EL.} = \text{EL.THROAT} + H_t$$

$$\text{FALL} = \text{EL.INLET} - \text{EL.THROAT}$$

$$X = \text{LOG}(Q/ND^{2.5})$$

PROGRAM #15

$$H_t = D 10^{(- 0.233392 + 0.489125X + 1.068638X^2 - 3.074435X^3 + 3.711165X^4 - 1.32836X^5)}$$

PROGRAM #16

$$H_t = D 10^{(- 0.237139 + 0.146792X + 2.189321X^2 - 4.354114X^3 + 4.210539X^4 - 1.347032X^5)}$$

INSTRUCTIONS

- #1 Load program #15
or program #16
- #2. Press Label A
- #3 Enter: 2. D - Culvert diameter
3. N - Number of Barrels
4. EL.INLET - Inlet elevation
5. DHW EL - Design Headwater elevation
6. Q - Flow rate
- #4 Read EL.THROAT - Throat elevation
FALL
- #5 Check FALL
- #6 Press Label D
Read: H_t - Headwater depth
- #7 Run Performance Elevation
Press Label E
Enter Q - Flow rate
Read: HW EL. - Headwater elevation

CARD FORMAT

PROGRAM #15

1		TEXAS INSTRUMENTS			4	
CMP: THROAT PERFORMANCE				#15		
				479.59		
Start	HW EL.	FALL	H _f	PERFORMANCE		

PROGRAM #16

1		TEXAS INSTRUMENTS			4	
CONCRETE PIPE: THROAT PERFORMANCE				#16		
				479.59		
Start	HW EL.	FALL	H _f	PERFORMANCE		

LISTING PROGRAM #15 & #16

```

LBL INV = X RCL 7 + LBL LNX RC* 8 OP 28 RTN LBL CE INV FIX
SBR LNX OP 2 SBR LNX OP 3 SBR LNX OP 4 ADV OP 05 2 1 3 7
FIX 2 OP 4 RTN LBL CLR 1 8 STO 8 RCL 6 DIV RCL 3 DIV. RCL
2 Yx 2 . 5 = LOG STO 7 SBR LNX SBR INV SBR INV SBR INV SBR
INV SBR INV = INV LOG X RCL 2 = RTN LBL A OP 00 9 STO 8 SBR
CE SBR CE ADV INV FIX 7 X>T 2 STO 01 5 1 0 3 STO 0 RCL 0
OP 4 RCL 1 X=T 1 30 R/S OP 6 ST* 1 OP 21 OP 20 GTO 1 09 SBR
CE SBR CLR X>T RCL 5 - RCL 4 = X>T 1 45 X>T +/- + RCL 5 =
STO 0 OP 6 LBL C OP 00 2 1 1 3 2 7 2 7 OP 2 SBR 0 30 RCL
4 - GTO 1 88 LBL B 2 4 STO 8 SBR CE SBR CLR + RCL 0 = OP
6 RTN LBL D RCL 24 OP 2 RCL 25 OP 03 1 6 1 7 3 3 3 7 2 3
SBR 0 28 SBR CLR OP 6 RTN LBL E 2 7 STO 8 SBR CE 6 = R/S
PRT STO 6 SBR B GTO E

```

DATA REGISTERS - PROGRAM #15

9.	3017371327	20.	-3.074435
10.	33243317	21.	1.068638
11.	6200000000	22.	0.489125
12.	3723353213	23.	-0.233392
13.	3700153231	24.	2317131643
14.	3735322700	25.	1337173500
15.	1727174240	26.	1727174240
16.	32210037	27.	1731371735
17.	2335321337	28.	21273243
18.	-1.32836	29.	3513371700
19.	3.711165		

DATA REGISTERS - PROGRAM #16

9.	1532311535	20.	-4.354114
10.	1737170033	21.	2.189321
11.	2433176200	22.	0.146792
12.	3723353213	23.	-0.237139
13.	3700153231	24.	2317131643
14.	3735322700	25.	1337173500
15.	1727174240	26.	1727174240
16.	32210037	27.	1731371735
17.	2335321337	28.	21273243
18.	-1.347032	29.	3513371700
19.	4.210539		

PROGRAM #17 - PIPE CULVERT: SIDE TAPERED INLET DIMENSIONS

This program continues with the design of a culvert operating in throat control. For the side-tapered entrance, this program computes the adjusted slope (if required by the use of FALL in the inlet design) the inlet face width and the inlet length.

The program evaluates either a projecting corrugated metal pipe, a square edged culvert in a headwall or a bevel edged inlet in a headwall. A graphical description of these inlets is as follows.

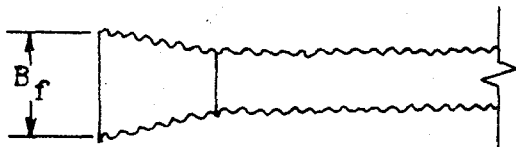
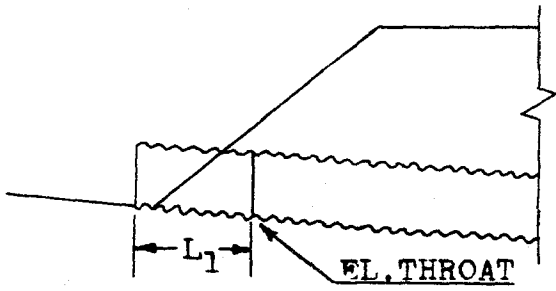

SIDE-TAPERED, PROJECTING EDGE
(NO FALL)

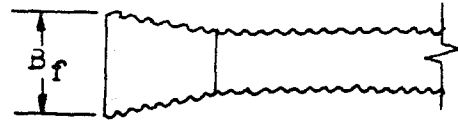
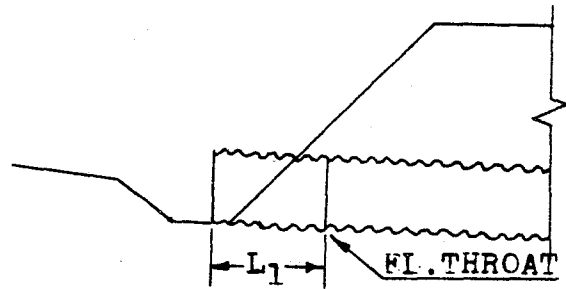

SIDE-TAPERED, PROJECTING EDGE
(WITH FALL)

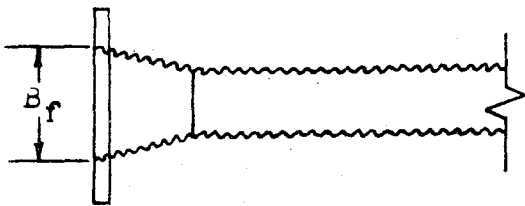
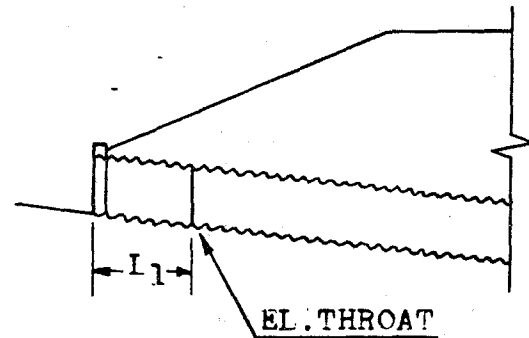

SIDE-TAPERED, SQUARE EDGES
(IN A HEADWALL, CMP OR CONCRETE
WITH OR WITHOUT FALL)

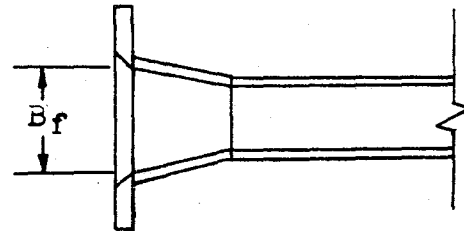
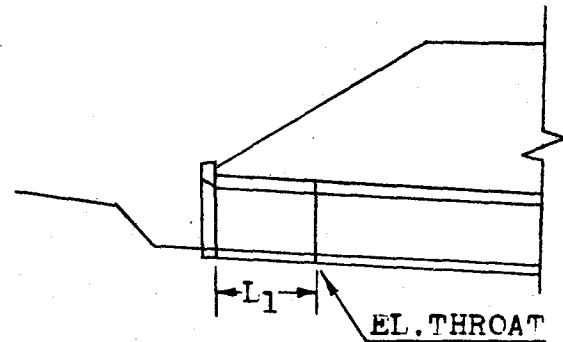

SIDE-TAPERED, BEVELED EDGE
(IN A HEADWALL, CMP OR CONCRETE
WITH OR WITHOUT FALL)

One of the values which must be entered into the calculator is the height of the side-tapered inlet face. It is referred to as the value E in the diagram below.

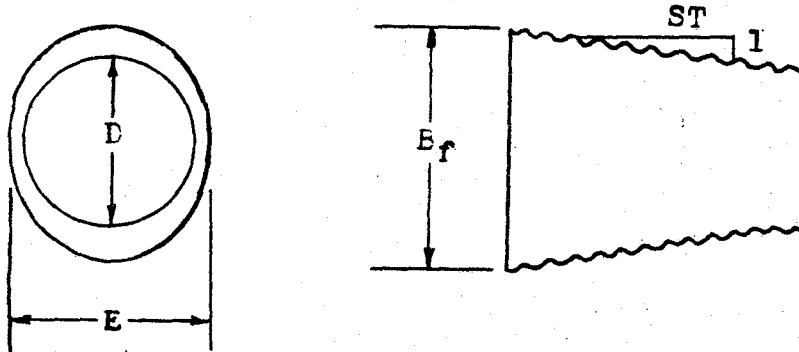

The limitations on the value of E are as a minimum the culvert diameter and 1.1 times the diameter as a maximum.

The sidewall taper should be kept between a value of 4:1 and 6:1 for the program to operate properly.

Where prefabricated inlet sections are available, both the face width and the inlet length have been set by the manufacturing company. These values are normally set at 1 1/2 times the culvert diameter.

The value for the inlet length determined by this program is a horizontal measurement. This is in contrast to the culvert length and the adjusted culvert length values which are measured along the culvert barrel.

EQUATION

$$(ADJ.S)L = L_1 ADJ.S (S_0^2+1)^{.5} + S_0 L - FALL (S_0^2+1)^{.5} \\ - [FALL + D[(S_0^2+1)^{.5} - (ADJ.S^2 + 1)^{.5}] - ADJ.S L_1] [S_{FU}/(S_0^2+1)^{.5} ADJ.S]$$

$$L_1 = \frac{(B_f - DN) ST}{2}$$

$$H_f = H_t - L_1 ADJ.S$$

$$X = H_f/E$$

CMP Projecting Edges

$$B_f = 4Q/[PI E^{1.5}](0.0144 + 1.1505X + 1.8167X^2 - 0.9642X^3 + 0.1974X^4 \\ - 0.0148X^5)]$$

Square Edges in a Headwall

$$B_f = 4Q/[PI E^{1.5}](-0.0048 + 0.9426X + 2.9784X^2 - 1.792X^3 + 0.4228X^4 \\ - 0.0357X^5)]$$

Bevel Edges in a Headwall

$$B_f = 4Q/[PI E^{1.5}](0.73932X + 3.2994X^2 - 1.746X^3 + 0.3744X^4 - 0.0287X^5)]$$

INSTRUCTIONS

- #1 Load program #17 (2 Cards)
- #2 Press Label A
- #3 Enter:
 1. Q - Flow rate
 2. D - Culvert diameter
 3. N - Number of Barrels
 4. H_t - Headwater depth @ throat
 5. ST - Sidewall taper
 6. S₀ - Channel slope

INSTRUCTIONS

- 7. FALL
- 8. S_{FU} - Upstream fill slope
- 9. L - Culvert length
- 10. E - Face height of inlet

#4 Choose Inlet Type

Label B - CMP Projecting

Label C - Square Edges in a Headwall

Label D - Bevel Edges in a Headwall

#5 Read: ADJ.S - Adjusted slope

B_f - Inlet face width

L_1 - Inlet length

CARD FORMAT

<input type="text" value="1"/>		TEXAS INSTRUMENTS			<input type="text" value="2"/>
PIPE: SIDE-TAPERED INLET DIMENSIONS				#17	
				479.59	
Start	PROJ.EDGE	SQ.EDGE	BV.EDGE		

<input type="text" value="3"/>		TEXAS INSTRUMENTS			<input type="text" value="4"/>
DATA - PROGRAM #17					
				479.59	

LISTING PROGRAM #17

```

LBL INV = X RCL 15 + LBL LNX RC* 0 OP 20 RTN LBL CE INV
FIX SBR LNX OP 1 SBR LNX OP 2 SBR LNX OP 3 SBR LNX OP 4
ADV OP 5 RTN LBL CLR ( RCL 6 X2 + 1 ) SRX RTN LBL X>T
2 1 3 7 FIX 2 OP 4 RTN LBL A 4 7 STO 0 SBR CE OP 00 1 6
2 4 3 0 1 7 3 1 OP 01 3 6 2 4 3 2 3 1 3 6 OP 2 OP 5
ADV 9 X>T 1 STO 00 5 1 0 2 STO 11 RCL 11 OP 4 RCL 0 X=T
1 30 R/S OP 6 ST* 00 1 SUM 11 OP 20 GTO 1 08 R/S X>T
5 1 1 2 OP 4 X>T OP 6 STO 09 1 0 = R/S X>T 5 1 0 2
0 1 OP 4 X>T OP 6 STO 10 OP 00 2 4 3 1 2 7 1 7 3 7
OP 01 3 7 4 5 3 3 1 7 OP 2 ADV OP 5 CLR RTN LBL B 1 0
+ LBL C 1 0 + LBL D 1 7 = STO 0 RCL 6 STO 11 SBR CE 1
CP +/- + RCL 4 = DIV RCL 10 = STO 15 SBR LNX SBR INV SBR
INV SBR INV SBR INV SBR INV = 1/x X RCL 1 X 4 DIV PI DIV RCL
10 Yx 1 . 5 = FIX 2 EE INV EE X=T 2 94 - X>T RCL 2 X
RCL 3 = DIV 2 X RCL 5 = STO 16 X RCL 11 = STO 15 6 INV SUM
0 RCL 15 GTO 2 15 X>T RCL 3 X RCL 2 = X>T 3 10 X>T
STO 15 GTO 3 21 0 STO 16 RCL 3 X RCL 2 = STO 15 CP . 1 STO
12 RCL 2 X ( SBR CLR - ( RCL 11 SBR 0 43 = + RCL 7 - RCL
11 X RCL 16 = X SBR CLR X RCL 8 X RCL 11 - RCL 6 X RCL
9 + SBR CLR X RCL 7 - SBR CLR X RCL 11 X RCL 16 + RCL 9 X
RCL 11 = FIX 6 EE INV EE INV X=T 4 11 RCL 14 X>T RCL 11 X=T
4 35 STO 14 RCL 16 GTO 2 79 EXC 13 - RCL 13 = X=T 3 96 1/X
X RCL 13 X RCL 12 = STO 12 SUM 11 GTO 3 26 5 1 STO 0 SBR
CE RCL 11 FIX 6 PRT OP 0 SBR LNX OP 2 SBR LNX OP 3 ADV OP
5 FIX 2 SBR X>T RCL 15 OP 6 INV FIX SBR 0 22 SBR X>T
RCL 16 OP 6 RTN

```

DATA REGISTERS - PROGRAM #17

17.	14424000	39.	1537243122
18.	1716400024	40.	17162217
19.	3100231713	41.	-0.0148
20.	1643132727	42.	0.1974
21.	-0.0287	43.	-0.9642
22.	0.3744	44.	1.8167
23.	-1.746	45.	1.1505
24.	3.2994	46.	0.0144
25.	0.73932	47.	3324331700
26.	0	48.	1541274217
27.	36344000	49.	3537002000
28.	1716400024	50.	2431271737
29.	3100231713	51.	3723170013
30.	1643132727	52.	1625413637
31.	-0.0357	53.	1716003627
32.	0.4228	54.	3233170064
33.	-1.792	55.	2113151700
34.	2.9784	56.	4324163723
35.	0.9426	57.	2431271737
36.	-0.0048	58.	27173122
37.	1530336200	59.	3723000000
38.	3335322517		

PROGRAM #18 - PIPE CULVERT: SIDE - TAPERED LENGTH ADJUSTMENTS

When a culvert is improved with a side-tapered inlet, as in the previous programs, the length of the culvert barrel will be affected. If the new inlet is designed with FALL, the barrel length will increase due to the rotation of the culvert. It will also be shortened by the addition of the inlet section. If no FALL is applied, the original culvert length will be shortened by the length of the improved inlet. This program computes these changes and adjusts the pipe culvert length accordingly.

With the changes in the culvert length, the elevation of the face of the improved inlet may also be affected. This calculation is also handled by the program.

The adjusted length measurement determined by the program is measured along the culvert barrel.

EQUATIONS

$$\text{ADJ.L} = \left[\frac{S_0 L}{(S_0^2 + 1)^{.5}} - \text{FALL} \right] \left[\frac{(\text{ADJ.S}^2 + 1)^{.5}}{\text{ADJ.S}} \right] - L_1 (\text{ADJ.S}^2 + 1)^{.5}$$

$$\text{EL. FACE} = \text{EL. THROAT} + L_1 \text{ADJ.S}$$

INSTRUCTIONS

- #1 Load program #18
- #2 Press Label A
- #3 Enter:
 - 1. EL.THROAT - Throat Elevation
 - 2. ADJ.S - Adjusted Slope
 - 3. S_0 - Channel slope
 - 4. FALL
 - 5. L - Original culvert length
 - 6. L_1 - Improved inlet length

Read: ADJ.L - Adjusted length

EL.FACE - Face elevation

CARD FORMAT

1	TEXAS INSTRUMENTS	4
PIPE: SIDE-TAPERED LENGTH ADJUSTMENT		#18
		479.59
START		

LISTING PROGRAM #18

```
LBL INV RC* 0 OP 20 RTN LBL LNX INV FIX SBR INV OP 1 SBR
INV OP 2 SBR INV OP 3 SBR INV OP 4 OP 05 2 1 3 7 FIX 2 OP 4
RTN LBL CE X2 + 1 ) SRX RTN LBL A 9 STO 0 SBR LNX SBR LNX
ADV INV FIX 7 X2T 1 STO 07 5 1 0 2 STO 8 RCL 8 OP 4 RCL 7
X=T 0 90 R/S OP 6 ST* 7 OP 27 OP 28 GTO 0 69 ADV SBR LNX RCL
3 X RCL 5 DIV ( RCL 3 SBR CE - RCL 4 = X ( RCL 2 SBR CE
DIV RCL 2 = - RCL 6 X ( RCL 2 SBR CE = OP 6 ADV SBR LNX RCL
1 + RCL 6 X RCL 2 = OP 6 CLR RTN
```

DATA REGISTERS - PROGRAM #18

9.	3324331700	17.	3723170013
10.	1541274217	18.	1625413637
11.	3537620027	19.	1716002717
12.	1731223723	20.	3122372300
13.	13	21.	1727174213
14.	1625413637	22.	3724323100
15.	3017313736	23.	3221002113
16.	0	24.	1517000000

PROGRAM #19 - PIPE CULVERT: INLET CONTROL, OUTLET VELOCITY

This program computes the outlet velocity of a pipe culvert which is operating in inlet control. The program first determines the depth of flow in the culvert and then uses this depth to find the cross-sectional area. The outlet velocity is then calculated using this area.

EQUATIONS

$$X = [Qn/(1.486Ns \cdot 5)]/D^{8/3}$$

$$Z = \text{LOG}(X)$$

If $x < 0.24$

$$d_n = D[10^{(0.3063639 + 0.907884Z + 0.192615Z^2)}]$$

If $0.24 \leq x < 0.34$

$$d_n = D[10^{(0.6857349 + 2.097532Z + 1.125836Z^2)}]$$

If $x \geq 0.34$

$$d_n = D$$

$$X = D/2$$

$$r = (X - d_n)$$

Using the radian mode

$$\theta = \cos^{-1}(r/X)$$

$$A = X^2 (\theta - \sin \theta \cos \theta)$$

$$V = Q/AN$$

INSTRUCTIONS

#1 Load program #19

#2 Press Label A

- #3 Enter:
1. Q - Flow rate
 2. D - Culvert diameter
 3. N - Number of barrels
 4. n - Manning's roughness coefficient
 5. S - Culvert slope

Read: V - Outlet velocity

CARD FORMAT

1	TEXAS INSTRUMENTS	4
PIPE: INLET CONTROL - OUTLET VELOCITY		#19
		497.59
START		

LISTING PROGRAM #19

```

LBL INV = X RCL 6 + LBL LNX RC* 0 OP 20 RTN LBL CE INV FIX
SBR LNX OP 1 SBR LNX OP 2 SBR LNX OP 3 SBR LNX OP 4 OP 5
RTN LBL A ADV 9 STO 0 SBR CE SBR CE ADV 6 X<T 1 STO 06 5
1 0 2 STO 8 RCL 8 OP 4 RCL 6 X=T 0 80 R/S OP 6 ST* 6 OP 26
OP 28 GTO 0 59 ADV SBR CE RCL 28 FIX 2 OP 4 RCL 1 X RCL 4
DIV 1 . 4 8 6 DIV RCL 5 SRX DIV RCL 3 DIV RCL 2 Y^X ( 8 DIV
3 = LOG STO 6 INV LOG X<T . 3 4 X>T 1 32 1 GTO 1 50 . 2 4
X>T 1 41 3 SUM 0 SBR LNX SBR INV SBR INV = INV LOG X RCL 2 =
X<T RCL 2 DIV 2 = STO 7 - X<T = DIV X<T = RAD INV
COS STO 27 - RCL 27 SIN X RCL 27 COS = DEG X RCL 7 X^2 = 1/x
DIV RCL 3 X RCL 1 = OP 6 RTN

```

DATA REGISTERS - PROGRAM #19

8.	5107	19.	2732152437
9.	3324331700	20.	4500243600
10.	1541274217	21.	0.192615
11.	3537002000	22.	0.907884
12.	2431271737	23.	0.3063639
13.	1532313735	24.	1.125836
14.	3227002000	25.	2.097532
15.	4217273215	26.	0.685734
16.	2437450000	27.	0
17.	32413727	28.	216336
18.	1737004217		

STORAGE REGISTERS USED FOR VARIABLES

PROGRAM NUMBER	STORAGE REGISTER NUMBER									OTHER	
	1	2	3	4	5	6	7	8	9		
1	n	S ₀	BW	Z ₁	Z ₂	Q					
2	S ₀	S _{FU}	S _{FD}	EL.FU	EL.FD	D					
3	Q	N	k _e	n	TW	B	D	EL.OUT			L in 11
4	B	D	N	EL.IN	AHW.EL	Q					
5	D	S ₀	FALL	S _{FU}	L						
6	Q	D	BN B _f N	S ₀	HW.EL- EL.OUT	S _f	ADJ.L	ADJ.S			
7	B	D	N	EL.IN	AHW.WL	Q					
8	Q	D	BN	H _t	ST	S ₀	FALL	S _{FU}	L		EL.THR in 16
9	D	L ₃	S ₀	EL.OUT	S _{FU}	EL.FU	S _f	EL.THR			
10	Q	D	L ₃	N	B	HW.EL	EL.FAC	L ₂	L ₄		
11	Q	D	N	n	S	B					
12	Q	N	k _e	n	TW	ALPHA	D	EL.OUT			L in 59
13		D	N	EL.IN	AHW.EL	Q					
14		D	N	EL.IN	AHW.EL	Q					
15		D	N	EL.IN	AHW.EL	Q					
16		D	N	EL.IN	AHW.EL	Q					
17	Q	D	N	H _t	ST	S ₀	FALL	S _{FU}	L		E in 10
18	EL.THR	ADJ.S	S ₀	FALL	L	L ₁					
19	Q	D	N	n	S						

WORK SHEETS

STEP #1
CALCULATE TAILWATER

Use Program #1

- Enter: 1. $n =$ _____ (channel)
 2. $S_o =$ _____
 3. $BW =$ _____
 4. $Z_1 =$ _____
 5. $Z_2 =$ _____

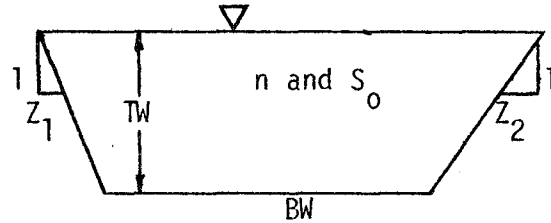

6.	Enter Q	TW, Based on d_n	Channel Velocity	COMMENTS

STEP #2
DETERMINE CULVERT LENGTH

Use Program #2

- Enter: 1. $S_o =$ _____
 2. $S_{FU} =$ _____
 3. $S_{FD} =$ _____
 4. $EL.FU =$ _____
 5. $EL.FD =$ _____

6.	Enter D	L	EL. INLET	EL. OUTLET	COMMENTS

STEP #3
DETERMINE AN ACCEPTABLE CULVERT SIZE

Use Program #3 for Box Culverts
 Use Program #12 for Pipe Culverts

- Enter: 1. $Q =$ _____
 2. $N =$ _____
 3. $k_e =$ _____
 4. $n =$ _____
 5. $TW =$ _____

6. Enter B - for Box or alpha for Pipe	7. Enter D	8. Enter EL.OUTLET	9. Enter L	Read. HW.EL.	COMMENTS

Read

- $d_c =$ _____
 $H =$ _____
 $V =$ _____ for Outlet Control

OUTLET CONTROL PERFORMANCE

1. Enter Q	5. Enter TW	Read HW EL.	COMMENTS

STEP #4
INLET CONTROL: DESIGN AND PERFORMANCE

Box Culverts

- Program #4 - Square Edged Inlet with Headwalls
 - Square Edged Inlet with Wingwalls
 - Bevel Edged Inlet with Headwalls
 - Bevel Edged Inlet with Wingwalls
 Program #7 - Tapered Throat Inlet

Pipe Culverts

- Program #13 - CMP with Projecting Edges
 - CMP in a Headwall
 - CMP or Conc. with type A Bevel
 - CMP or Conc. with type B Bevel
 Program #14 - CMP or Conc. with Standard End Section
 - Conc. with Square Edges in a Headwall
 - Conc. with a Projecting Socket End
 - Conc. with a Socket End in a Headwall
 Program #15 - CMP with a Tapered Throat Inlet
 Program #16 - Conc. with a Tapered Throat Inlet

- Enter: 1. B = _____ (For Boxes Only)
 2. D = _____
 3. N = _____
 4. EL. INLET = _____
 5. DHW EL. = _____

6.	Enter Q	Read EL. FACE, EL. THROAT	Read FALL	Read H _f , H _t	Read HW EL.	COMMENTS
Inlet type _____						
Inlet type _____						

STEP #4
INLET CONTROL: DESIGN AND PERFORMANCE
 (CONTINUED)

6.	Enter Q	Read EL.FACE, EL.THROAT	Read FALL	Read H_f, H_t	Read HW EL.	COMMENTS
----	------------	-------------------------------	--------------	--------------------	----------------	----------

Inlet type _____

Inlet type _____

Inlet type _____

Inlet type _____

STEP #5
CONVENTIONAL INLETS

Use Program #5

Enter: 1. $D =$ _____ 4. $S_{FU} =$ _____
2. $S_0 =$ _____ 5. $L =$ _____
3. $FALL =$ _____

Read: $ADJ.S =$ _____
 $ADJ.L =$ _____

STEP #6
CREST EVALUATION

Use Program #6

Enter: 1. $Q =$ _____ 6. $S_f =$ _____
2. $D =$ _____ 7. $ADJ.L =$ _____
3. B or $B_f =$ _____ 8. $ADJ.S =$ _____
4. $S_0 =$ _____ 9. $N =$ _____
5. $HW EL =$ _____ 10. $EL.OUTLET =$ _____

Read: $H_C =$ _____ $WT =$ _____
 $CW =$ _____ $WA =$ _____

STEP #7
INLET CONTROL, OUTLET VELOCITY

Box Culverts - program #11
Pipe Culverts - program #19

Enter: 1. $Q =$ _____ 4. $n =$ _____
2. $D =$ _____ 5. $S =$ _____
3. $N =$ _____ 6. $B =$ _____ (Boxes Only)

Read: $V =$ _____

STEP #5
SIDE-TAPERED INLETS

Box Culverts - Use Program #8

Pipe Culverts - Use program #17

Enter: 1. $Q =$ _____ 6. $S_o =$ _____
2. $D =$ _____ 7. FALL = _____
3. $N =$ _____ 8. $S_{FU} =$ _____
4. $H_t =$ _____ 9. $L =$ _____
5. ST = _____

Boxes

Pipes

10. $B =$ _____ 10. $E =$ _____
11. EL.THROAT = _____

Read: Boxes
INLET TYPE: SQ.ED., BV.ED.
ADJ.S = _____
ADJ.L = _____
 $B_f =$ _____
 $L_1 =$ _____
EL.FACE = _____

Pipes
SELECT INLET TYPE
PROJ., SQ.ED., BV.ED.
ADJ.S = _____
 $B_f =$ _____
 $L_1 =$ _____

Pipe Culverts - use program #18

Enter: 1. EL.THROAT = _____ 4. FALL = _____
2. ADJ.S = _____ 5. $L =$ _____
3. $S_o =$ _____ 6. $L_1 =$ _____

Read: ADJ.L = _____ EL.FACE = _____

CREST EVALUATION AND OUTLET VELOCITY

Go to Step 6 previous page

STEP #5
SLOPE-TAPERED INLETS

Program #9

Enter: 1. D = _____ 5. S_{FU} = _____
2. L_3 = _____ 6. EL.FU = _____
3. S_0 = _____ 7. S_f = _____
4. EL.OUTLET = _____ 8. EL.THROAT = _____

Select Inlet Type: Vertical Face, Mitered Face

Read: ADJ.S = _____ L_4 = _____
ADJ.L = _____ L_2 = _____
EL.FACE = _____

Program #10

Enter: 1. Q = _____ 5. B = _____ (for pipe use D)
2. D = _____ 6. HW.EL. = _____
3. L_3 = _____ 7. EL.FACE = _____
4. N = _____ 8. L_2 = _____
9. L_4 = _____

Select Inlet Type: Square Edges, Beveled Edges

Read: B_f = _____ ST = _____

STEP #6
Mitered Face Crest Evaluation

Read: H_c = _____ CW = _____
ST = _____

STEP #7
INLET CONTROL OUTLET VELOCITY

Box Culverts - Program #11
Pipe Culverts - Program #19

Enter: 1. Q = _____ 4. n = _____
2. D = _____ 5. S = _____
3. N = _____ 6. B = _____ (Boxes only)

Read: V = _____

EXAMPLE PROBLEMS

BOX CULVERT EXAMPLE NO. 1

Given: Design Discharge (Q) = 1,000 cfs, for a 50-year recurrence interval

Slope of stream bed (S_o) = 0.05 ft./ft.

Allowable Headwater Elevation = 200

Elevation Outlet Invert = 172.5

Culvert Length = 350 ft.

Downstream channel approximates an 8' wide trapezoidal channel with 2:1 side slopes and a Manning's "n" of 0.03.

Requirements: This box culvert will be located in a rural area where the allowable headwater elevation is not too critical; that is, the damages are low due to exceeding that elevation at infrequent times. Thus, the culvert should have the smallest possible barrel to pass the design Q without exceeding the AHW EL. Use a reinforced concrete box with $n = 0.012$.

STEP #1
CALCULATE TAILWATER

Use Program #1

- Enter: 1. $n = \underline{0.03}$ (channel)
 2. $S_o = \underline{0.05}$
 3. $BW = \underline{8}$
 4. $Z_1 = \underline{2}$
 5. $Z_2 = \underline{2}$

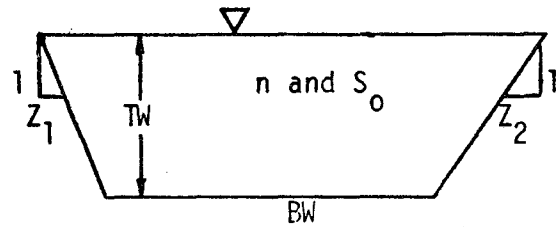

6. Enter Q	TW, Based on d_n	Channel Velocity	COMMENTS
1000	3.52	18.90	Design Flow
600	2.72	16.45	
800	3.15	17.80	
1200	3.85	19.84	

STEP #2
DETERMINE CULVERT LENGTH

Use Program #2

- Enter: 1. $S_o = \underline{0.05}$
 2. $S_{FU} = \underline{3:1}$
 3. $S_{FD} = \underline{3:1}$
 4. $EL.FU = \underline{190.78}$
 5. $EL.FD = \underline{171.44}$

6. Enter D	L	EL. INLET	EL. OUTLET	COMMENTS
5	356.5	190.1	172.3	
6	350.4	190.0	172.5	
7	344.2	189.9	172.7	

STEP #3
DETERMINE AN ACCEPTABLE CULVERT SIZE

Use Program #3 for Box Culverts
 Use Program #12 for Pipe Culverts

- Enter: 1. $Q = \underline{1000}$
 2. $N = \underline{1}$
 3. $k_e = \underline{0.2}$ (beveled edge)
 4. $n = \underline{0.012}$
 5. $TW = \underline{3.52}$

6. Enter B - for Box or alpha for Pipe	7. Enter D	8. Enter EL. OUTLET	9. Enter L	Read. HW. EL.	COMMENTS
6	5	172.3	356.5	215.1	Exceeds Design
6	6	172.5	350.4	203.2	" "
7	6	172.5	350.4	195.9	OK < 200 ft.
7	7	172.7	344.2	191.9	

Read (Reload TX6 Data Into Calculator)

$d_c = \underline{8.61}$
 $H = \underline{17.41}$
 $V = \underline{23.8}$ for Outlet Control

OUTLET CONTROL PERFORMANCE

1. Enter Q	5. Enter TW	Read HW EL.	COMMENTS
600	2.72	184.77	
800	3.15	189.64	
1000	3.52	195.91	
1200	3.85	203.57	

(Plot: Q vs. HW. EL.)

STEP #4
INLET CONTROL: DESIGN AND PERFORMANCE

Box Culverts

- Program #4 - ~~Square Edged Inlet with Headwalls~~
~~Square Edged Inlet with Wingwalls~~
~~Bevel Edged Inlet with Headwalls~~
~~Bevel Edged Inlet with Wingwalls~~
 Program #7 - Tapered Throat Inlet

Pipe Culverts

- ~~Program #13 - CMP with Projecting Edges~~
~~- CMP in a Headwall~~
~~- CMP or Conc. with type A Bevel~~
~~- CMP or Conc. with type B Bevel~~
 Program #14 - ~~CMP or Conc. with Standard End Section~~
~~- Conc. with Square Edges in a Headwall~~
~~- Conc. with a Projecting Socket End~~
~~- Conc. with a Socket End in a Headwall~~
 Program #15 - ~~CMP with a Tapered Throat Inlet~~
 Program #16 - ~~Conc. with a Tapered Throat Inlet~~

- Enter: 1. B = 7 (For Boxes Only)
 2. D = 6
 3. N = 1
 4. EL. INLET = 190
 5. DHW EL. = 200

6.	Enter Q	Read EL. FACE, EL. THROAT	Read FALL	Read H_f X	Read HW EL.	COMMENTS
----	---------	------------------------------	-----------	-------------------------	-------------	----------

Inlet type Bevel Edged Inlet with Wingwalls

1000	177.3	12.7	22.7	200	
	Fall too large try tapered Inlet				

Inlet type Tapered Throat Inlet
 El. Throat H_t

1000	184.1	5.86	15.86	200	From curve,
600				193.6	H can be seen
800				196.4	that 2.5' of >
1200				204.5	FALL can be applied.

STEP #4
INLET CONTROL: DESIGN AND PERFORMANCE
 (CONTINUED)

6.	Enter Q	Read EL. FACE, EL. THROAT	Read FALL	Read $\frac{N}{K} \cdot H_t$	Read HW EL.	COMMENTS
----	------------	--	--------------	---------------------------------	----------------	----------

Inlet type Throat Tapered Inlet (7.4' of FALL)

	1000	181.6	7.4	22.7	197.5	
	600	(5.9+2.5)			191.1	
	800				193.9	
	1200				202.0	

Inlet type _____

Inlet type _____

Inlet type _____

STEP #5
SIDE-TAPERED INLETS

Box Culverts - Use Program #8

~~Pipe Culverts - Use program #17~~

Enter: 1. Q = 1000 6. S_0 = 0.05
2. D = 6 7. FALL = 7.4
3. N = 1 8. S_{FU} = 3
4. H_t = 22.7 9. L = 350
5. ST = 4:1

Boxes

10. B = 7
11. EL.THROAT = 181.6

~~Pipes~~

~~10. E = _____~~

Read: Boxes
INLET TYPE: ~~SQ.ED.~~, BV.ED.
ADJ.S = 0.0272
ADJ.L = 368.6
 B_f = 7.8
 L_1 = 1.6
EL.FACE = 181.64

~~Pipes~~
~~SELECT INLET TYPE~~
~~PROJ., SQ.ED., BV.ED.~~
~~ADJ.S = _____~~
 ~~B_f = _____~~
 ~~L_1 = _____~~

~~Pipe Culverts - use program #18~~

~~Enter: 1. EL.THROAT = _____ 4. FALL = _____
2. ADJ.S = _____ 5. L = _____
3. S_0 = _____ 6. L_1 = _____
Read: ADJ.L = _____ EL.FACE = _____~~

CREST EVALUATION AND OUTLET VELOCITY

Go to Step 6 previous page

STEP #5
CONVENTIONAL INLETS

Use Program #5

Enter: 1. D = _____ 4. S_{FU} = _____
2. S_o = _____ 5. L = _____
3. FALL = _____

Read: ADJ.S = _____
ADJ.L = _____

STEP #6
CREST EVALUATION

Use Program #6

Enter: 1. Q = 1000 6. S_f = 3:1
2. D = 6 7. ADJ.L = 368.6
3. ~~B~~ or B_f = 7.8 8. ADJ.S = 0.027
4. S_o = 0.05 9. N = 1
5. HW EL = 197.5 10. EL.Outlet = 172.5

Read: H_c = 6.28 WT = 8.1
CW = 22.45 WA = 51.2

STEP #7
INLET CONTROL, OUTLET VELOCITY

Box Culverts - program #11
~~Pipe Culverts - program #19~~

Enter: 1. Q = 1000 4. n = 0.012
2. D = 6 5. s = 0.027
3. N = 1 6. B = 7 (Boxes Only)

Read: V = 31.9 fps.

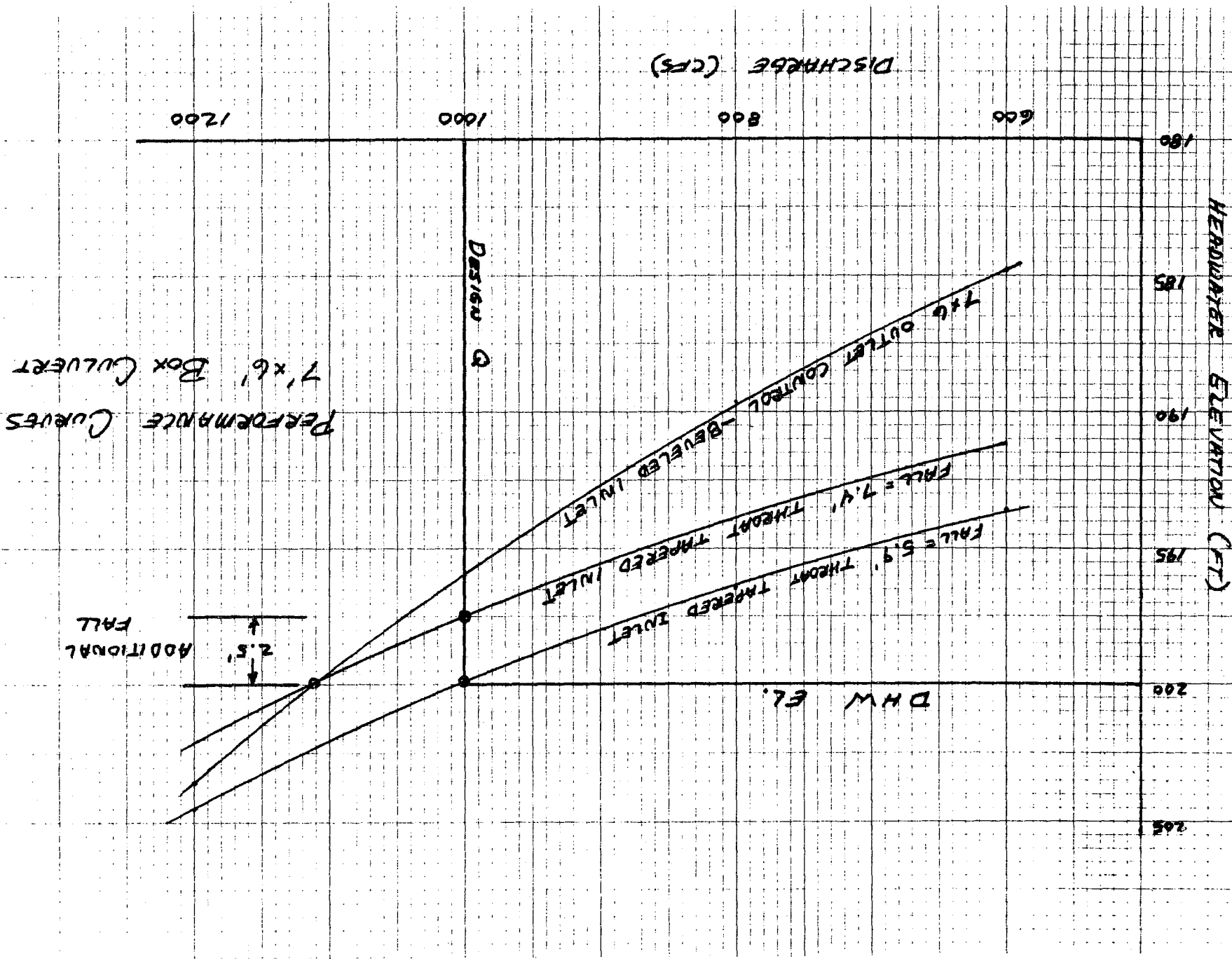

PERFORMANCE CURVES
7'x6' Box CULVERT

DISCHARGE (CFS)

HEADWATER ELEVATION (FT)

Design Q

D.M.W. El.

ADDITIONAL FALL

2.5'

CONCLUSIONS

Since the requirements called for the smallest possible reinforced concrete box culvert, the barrel should be a single 7' by 6'.

Selection of the inlet would be based on cost. The additional 2.5' of FALL gains 110 cfs at the AHW EL. of 200 ft. It appears that a side- or slope-tapered inlet which would meet the design requirements would be adequate and the least expensive.

Examination of the outlet shows that it will not be the governing flow regime above the AHE EL. up to about EL. 205 unless the additional 2.5' of FALL is applied.

PIPE CULVERT EXAMPLE NO. 2

Given: Design Discharge (Q) = 150 cfs, for a 50-year recurrence interval

Slope of stream bed (S_0) = 0.05 ft./ft.

Allowable Headwater Elevation = 100

Elevation Outlet Invert = 75.0

Culvert Length = 350 ft.

Downstream channel approximates a 5' wide trapezoidal channel with 2:1 side slopes and a Manning's "n" of 0.03.

Requirements: This pipe culvert will be located in a suburban area where the allowable headwater elevation may be exceeded by 2 to 3 ft. without extreme damage. However, headwater elevations greater than 103.0 ft. should be avoided for flows significantly higher than the design Q of 150 cfs.

STEP #1
CALCULATE TAILWATER

Use Program #1

- Enter: 1. $n = \frac{0.03}{\text{channel}}$
 2. $S_o = \frac{0.05}{\text{channel}}$
 3. $BW = \frac{5}{\text{channel}}$
 4. $Z_1 = \frac{2}{\text{channel}}$
 5. $Z_2 = \frac{2}{\text{channel}}$

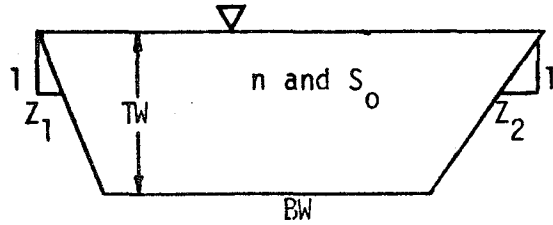

6.	Enter Q	TW, Based on d_n	Channel Velocity	COMMENTS
	90	1.21	10.03	
	120	1.41	10.89	
	150	1.58	11.59	
	180	1.74	12.19	

STEP #2
DETERMINE CULVERT LENGTH

Use Program #2

- Enter: 1. $S_o = \frac{0.05}{\text{channel}}$
 2. $S_{FU} = \frac{3:1}{\text{slope}}$
 3. $S_{FD} = \frac{3:1}{\text{slope}}$
 4. $EL.FU = \frac{93.02}{\text{elevation}}$
 5. $EL.FD = \frac{74.29}{\text{elevation}}$

6.	Enter D	L	EL. INLET	EL. OUTLET	COMMENTS
	3.5	353.53	92.56	74.91	
	4.0	350.45	92.50	75.00	
	4.5	347.38	92.43	75.09	

STEP #3
DETERMINE AN ACCEPTABLE CULVERT SIZE

~~Use Program #3 for Box Culverts~~
 Use Program #12 for Pipe Culverts

- Enter: 1. $Q = \underline{150}$
 2. $N = \underline{1}$
 3. $k_e = \underline{0.25}$ (Beveled Edge) 0.5 (Square Edge)
 4. $n = \underline{0.024}$
 5. $TW = \underline{1.58}$

6. Enter B for Box or alpha for Pipe	7. Enter D	8. Enter EL. OUTLET	9. Enter L	Read. HW. EL.	COMMENTS
1.12	3.5	74.91	353.53	109.87	Beveled Edge Exceeds AHW. EL.
	4.0	75.0	350.45	94.62	Ok

Read

$d_c = \underline{3.66}$
 $H = \underline{15.79}$
 $V = \underline{12.45}$ for Outlet Control

OUTLET CONTROL PERFORMANCE

1. Enter Q	5. Enter TW	Read HW EL.	COMMENTS
90	1.21	84.16	84.36 HW. EL. for Square Edge
120	1.41	88.80	89.15
150	1.58	94.62	95.17
180	1.74	101.65	102.44

STEP #4
INLET CONTROL: DESIGN AND PERFORMANCE

Box Culverts

- ~~Program #4 - Square Edged Inlet with Headwalls~~
~~- Square Edged Inlet with Wingwalls~~
~~- Bevel Edged Inlet with Headwalls~~
~~- Bevel Edged Inlet with Wingwalls~~
~~Program #7 - Tapered Throat Inlet~~

Pipe Culverts

- ~~Program #13 - CMP with Projecting Edges~~
~~- CMP in a Headwall~~
~~- CMP or Conc. with type A Bevel~~
~~- CMP or Conc. with type B Bevel~~
~~Program #14 - CMP or Conc. with Standard End Section~~
~~- Conc. with Square Edges in a Headwall~~
~~- Conc. with a Projecting Socket End~~
~~- Conc. with a Socket End in a Headwall~~
~~Program #15 - CMP with a Tapered Throat Inlet~~
~~Program #16 - Conc. with a Tapered Throat Inlet~~

- Enter: 1. B = _____ (For Boxes Only)
 2. D = 4
 3. N = 1
 4. EL. INLET = 92.50
 5. DHW EL. = 100

6.	Enter Q	Read EL. FACE, EL. THROAT	Read FALL	Read H_f, H_t	Read HW EL.	COMMENTS
Inlet type <u>CMP in a Headwall</u>						
	150	91.43	1.07	8.57	100	FALL Req.
		FALL is required try beveled Edge				
Inlet type <u>CMP with Type "A" Bevel</u>						
	150	92.26	0.24	7.74	100	FALL Req.
		Minor FALL is required try Type "B" Bevel				

STEP #4
INLET CONTROL: DESIGN AND PERFORMANCE
 (CONTINUED)

6.	Enter Q	Read EL. FACE, EL. THROAT	Read FALL	Read H_f, H_t	Read HW EL.	COMMENTS
----	---------	---	-----------	-----------------	-------------	----------

Inlet type CMP Type "B" Bevel

150	92.50	0	6.88	99.38	OK-Use
90	Run performance curve analysis & proceed to check throat tapered inlets			96.87	
120				98.00	
180				101.01	

Inlet type CMP with Tapered Throat

150	92.50	0	6.62	99.12	OK
90	Try a 3.5' Diameter			96.99	
120				98.00	
180				100.42	

Inlet type CMP with Tapered Throat (3.5' = DIA)
(EL. IN = 92.56)

150	91.77	0.79	8.23	100	
90	Note: Culvert is in outlet control with DIA = 3.5'			96.75	
120				98.20	
180				102.21	

Inlet type _____

STEP #5
CONVENTIONAL INLETS

Use Program #5

Enter: 1. D = _____
2. S_o = _____
3. FALL = _____

4. S_{FU} = _____
5. L = _____

Read: ADJ.S = _____
ADJ.L = _____

STEP #6
CREST EVALUATION

Use Program #6

Enter: 1. Q = _____
2. D = _____
3. B or B_f = _____
4. S_o = _____
5. HW EL = _____

6. S_f = _____
7. ADJ.L = _____
8. ADJ.S = _____
9. N = _____
10. EL.Outlet = _____

Read: H_c = _____
CW = _____

WT = _____
WA = _____

STEP #7
INLET CONTROL, OUTLET VELOCITY

~~Box Culverts - program #11~~
Pipe Culverts - program #19

Enter: 1. Q = 150
2. D = 4
3. N = 1

4. n = 0.024
5. S = 0.05
~~6. B = _____ (Boxes Only)~~

Read: V = 15.56 .

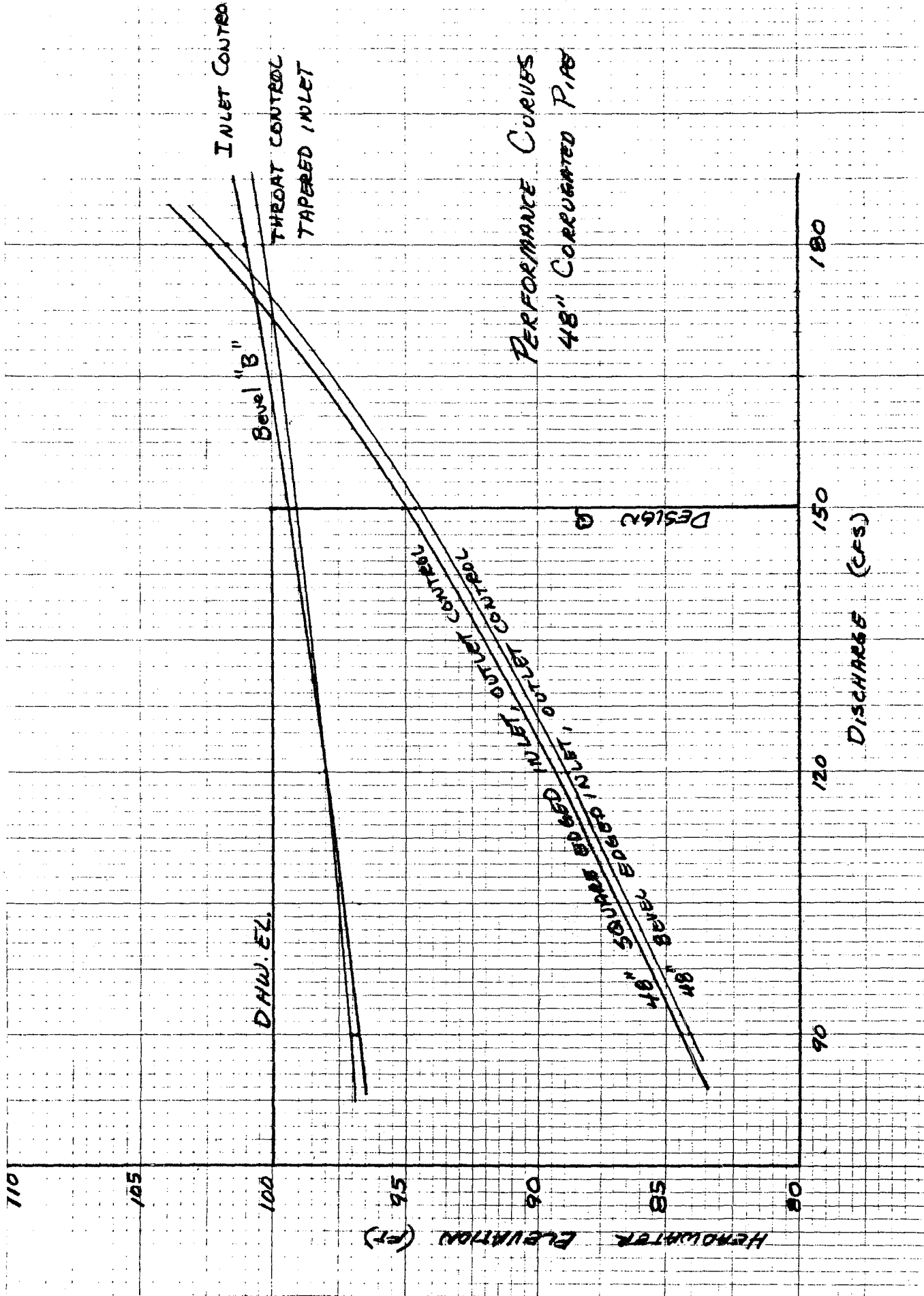

CONCLUSIONS

From the performance curves, beveled edges meet the AHW EL. of 100 ft. and $Q = 150$ cfs. While the use of a side-tapered inlet would increase Q to 173 cfs at the AHW EL. = 100 ft., in both cases the FALL = 0, it appears that the beveled edge inlet would be sufficient and the least costly in this case, since the culvert performance curve does not exceed 103.0 ft. until Q is 183 cfs.

PIPE CULVERT EXAMPLE NO. 3

Given: Design Discharge (Q) = 150 cfs, for a 50-year recurrence interval

Slope of stream bed (S_0) = 0.05 ft./ft.

Allowable Headwater Elevation = 96

Elevation Outlet Invert = 75.0

Culvert Length = 350 ft.

Downstream channel approximates a 5' wide trapezoidal channel with 2:1 side slopes and a Manning's "n" of 0.03.

Requirements: Hydrologic estimates are accurate and exceeding the AHW EL. at higher discharges is not important at this site. Therefore, use the smallest barrel possible.

The outlet control curves of problem 2 are applicable in this situation. The 48" C.M.P. is the smallest barrel which will meet the AHW EL. of 96.0 and $Q = 150$ cfs.

From the inlet control curves, it is clear that a FALL must be used on the tapered inlet to meet the AHW EL. Try a side-tapered inlet, with FALL, and a slope-tapered inlet.

STEP #1
CALCULATE TAILWATER

Use Program #1

- Enter: 1. $n = \frac{0.03}{\text{channel}}$
 2. $S_o = \frac{0.05}{\text{channel}}$
 3. $BW = \frac{5}{\text{channel}}$
 4. $Z_1 = \frac{2}{\text{channel}}$
 5. $Z_2 = \frac{2}{\text{channel}}$

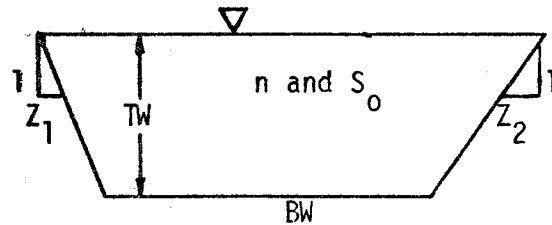

6. Enter Q	TW, Based on d_n	Channel Velocity	COMMENTS
90	1.21	10.03	
120	1.41	10.89	
150	1.58	11.59	
180	1.74	12.19	

STEP #2
DETERMINE CULVERT LENGTH

Use Program #2

- Enter: 1. $S_o = \frac{0.05}{\text{channel}}$
 2. $S_{FU} = \frac{3:1}{\text{channel}}$
 3. $S_{FD} = \frac{3:1}{\text{channel}}$
 4. $EL.FU = \frac{93.02}{\text{channel}}$
 5. $EL.FD = \frac{74.29}{\text{channel}}$

6. Enter D	L	EL. INLET	EL. OUTLET	COMMENTS
3.5	353.53	92.56	74.91	
4.0	350.45	92.50	75.00	
4.5	347.38	92.43	75.09	

STEP #3
DETERMINE AN ACCEPTABLE CULVERT SIZE

~~Use Program #3 for Box Culverts~~
 Use Program #12 for Pipe Culverts

- Enter: 1. $Q = \underline{150}$
 2. $N = \underline{1}$
 3. $k_e = \underline{0.25}$ (Beveled Edge), 0.5 (Square Edge)
 4. $n = \underline{0.024}$
 5. $TW = \underline{1.58}$

6. Enter B for Box or alpha for Pipe <u>CMP</u>	7. Enter D	8. Enter EL. OUTLET	9. Enter L	Read. HW. EL.	COMMENTS
1.12	3.5	74.91	353.53	109.87	Beveled Edge Exceeds AHW.EL
	4.0	75.0	350.45	94.62	OK

Read

$d_c = \underline{3.66}$
 $H = \underline{15.79}$
 $V = \underline{12.45}$ for Outlet Control

OUTLET CONTROL PERFORMANCE

1. Enter Q	5. Enter TW	Read HW EL.	COMMENTS
			Beveled Edge HW. EL. Square Edge
90	1.21	84.16	84.36
120	1.41	88.80	89.15
150	1.58	94.62	95.17
180	1.74	101.65	102.44

STEP #4
INLET CONTROL: DESIGN AND PERFORMANCE

~~Box Culverts~~

- ~~Program #4 - Square Edged Inlet with Headwalls
 - Square Edged Inlet with Wingwalls
 - Bevel Edged Inlet with Headwalls
 - Bevel Edged Inlet with Wingwalls
 Program #7 - Tapered Throat Inlet~~

Pipe Culverts

- Program #13 - ~~CMP with Projecting Edges
 - CMP in a Headwall
 - CMP or Conc. with type A Bevel
 - CMP or Conc. with type B Bevel~~
 Program #14 - ~~CMP or Conc. with Standard End Section
 - Conc. with Square Edges in a Headwall
 - Conc. with a Projecting Socket End
 - Conc. with a Socket End in a Headwall~~
 Program #15 - CMP with a Tapered Throat Inlet
 Program #16 - Conc. with a Tapered Throat Inlet

Enter: 1. B = _____ (For Boxes Only)
 2. D = 4
 3. N = 1
 4. EL. INLET = 92.5
 5. DHW EL. = 96.0

6.	Enter Q	Read EL. FACE, EL. THROAT	Read FALL	Read H_f, H_t	Read HW EL.	COMMENTS
----	---------	---------------------------	-----------	-----------------	-------------	----------

Inlet type CMP Type "B"

150	89.12	3.38	6.88	96.0	
90	Try tapered throat			93.49	
120				94.62	
180				97.63	

Inlet type Tapered Throat, CMP

150	89.38	3.12	6.62	96.0	Use
90	Plot Performance			93.87	
120				94.88	
180				97.30	

STEP #4
INLET CONTROL: DESIGN AND PERFORMANCE
 (CONTINUED)

6.	Enter Q	Read EL. FACE, EL. THROAT	Read FALL	Read H _f , H _t	Read HW EL.	COMMENTS
----	---------	---------------------------	-----------	--------------------------------------	-------------	----------

Inlet type Tapered Throat, Concrete

150	89.63	2.87	6.37	96.00	
90	0.25 less FALL, using a concrete side-tapered inlet			93.85	
120				94.88	
180				97.26	

Inlet type _____

Inlet type _____

Inlet type _____

STEP #5
SIDE-TAPERED INLETS

~~Box Culverts - Use Program #8~~

Pipe Culverts - Use program #17

Enter: 1. $Q = \underline{150}$ 6. $S_o = \underline{0.05}$
 2. $D = \underline{4}$ 7. $FALL = \underline{3.12}$
 3. $N = \underline{1}$ 8. $S_{FU} = \underline{3:1}$
 4. $H_t = \underline{6.62}$ 9. $L = \underline{350.45}$
 5. $ST = \underline{4:1}$

~~Boxes~~

~~10. $B = \underline{\hspace{2cm}}$
 11. $EL.THROAT = \underline{\hspace{2cm}}$~~

Pipes

10. $E = \underline{44}$

~~Read: Boxes
 INLET TYPE: SQ.ED., BV.ED.
 ADJ.S =
 ADJ.L =
 $B_f = \underline{\hspace{2cm}}$
 $L_1 = \underline{\hspace{2cm}}$
 EL.FACE =~~

Pipes
 SELECT INLET TYPE
~~PROJ., SQ.ED., BV.ED.~~
 $ADJ.S = \underline{0.0402}$
 $B_f = \underline{4.59}$ } MINIMUM
 $L_1 = \underline{1.18}$ } values

Pipe Culverts - use program #18

Enter: 1. $EL.THROAT = \underline{89.38}$ 4. $FALL = \underline{3.12}$
 2. $ADJ.S = \underline{0.0402}$ 5. $L = \underline{350.45}$
 3. $S_o = \underline{0.05}$ 6. $L_1 = \underline{1.18}$
 Read: $ADJ.L = \underline{356.84}$ $EL.FACE = \underline{89.43}$

CREST EVALUATION AND OUTLET VELOCITY

Go to Step 6 previous page

STEP #5
CONVENTIONAL INLETS

Use Program #5

Enter: 1. D = _____ 4. S_{FU} = _____
2. S_o = _____ 5. L = _____
3. FALL = _____

Read: ADJ.S = _____
ADJ.L = _____

STEP #6
CREST EVALUATION

Use Program #6

Enter: 1. Q = 150 6. S_f = 3:1
2. D = 4 7. ADJ.L = 356.84
3. B or B_f = 4.59 8. ADJ.S = 0.0402
4. S_o = 0.05 9. N = 1
5. HW EL = 96.0 10. EL.Outlet = 75.00

Read: H_c = 3.01 WT = 1.15:1
CW = 10.14 WA = 41°

STEP #7
INLET CONTROL, OUTLET VELOCITY

~~Box Culverts - program #11~~
~~Pipe Culverts - program #19~~

Enter: 1. Q = 150 4. n = 0.024
2. D = 4 5. s = 0.0402
3. N = 1 6. B = _____ (~~Boxes Only~~)

Read: V = 14.13

STEP #5
SLOPE-TAPERED INLETS

Program #9

Enter: 1. D = 4 5. S_{FU} = 3
 2. L_3 = 2 6. EL.FU = 93.02
 3. S_0 = 0.05 7. S_f = 3:1
 4. EL.OUTLET = 75.0 8. EL.THROAT = 89.38

Select Inlet Type: ~~Vertical Face~~, Mitered Face

Read: ADJ.S = 0.0414 L_4 = 6.32
 ADJ.L = 347.39 L_2 = 4.99
 EL.FACE = 90.91

Program #10

Enter: 1. Q = 150 5. B = 4 (for pipe use D)
 2. D = 4 6. HW.EL. = 96.0
 3. L_3 = 2 7. EL.FACE = 90.91
 4. N = 1 8. L_2 = 4.99
 9. L_4 = 6.32

Select Inlet Type: ~~Square Edges~~, Beveled Edges

Read: B_f = 4.89 ST = 15.7:1

STEP #6
Mitered Face Crest Evaluation

Read: H_c = 5.09 CW = 4.62
 ST = 0

STEP #7
INLET CONTROL OUTLET VELOCITY

Box Culverts - Program #11
 Pipe Culverts - Program #19

Enter: 1. Q = 150 4. n = 0.024
 2. D = 4 5. S = _____
 3. N = 1 6. B = _____ (Boxes only)

Read: V = 14.31 fps

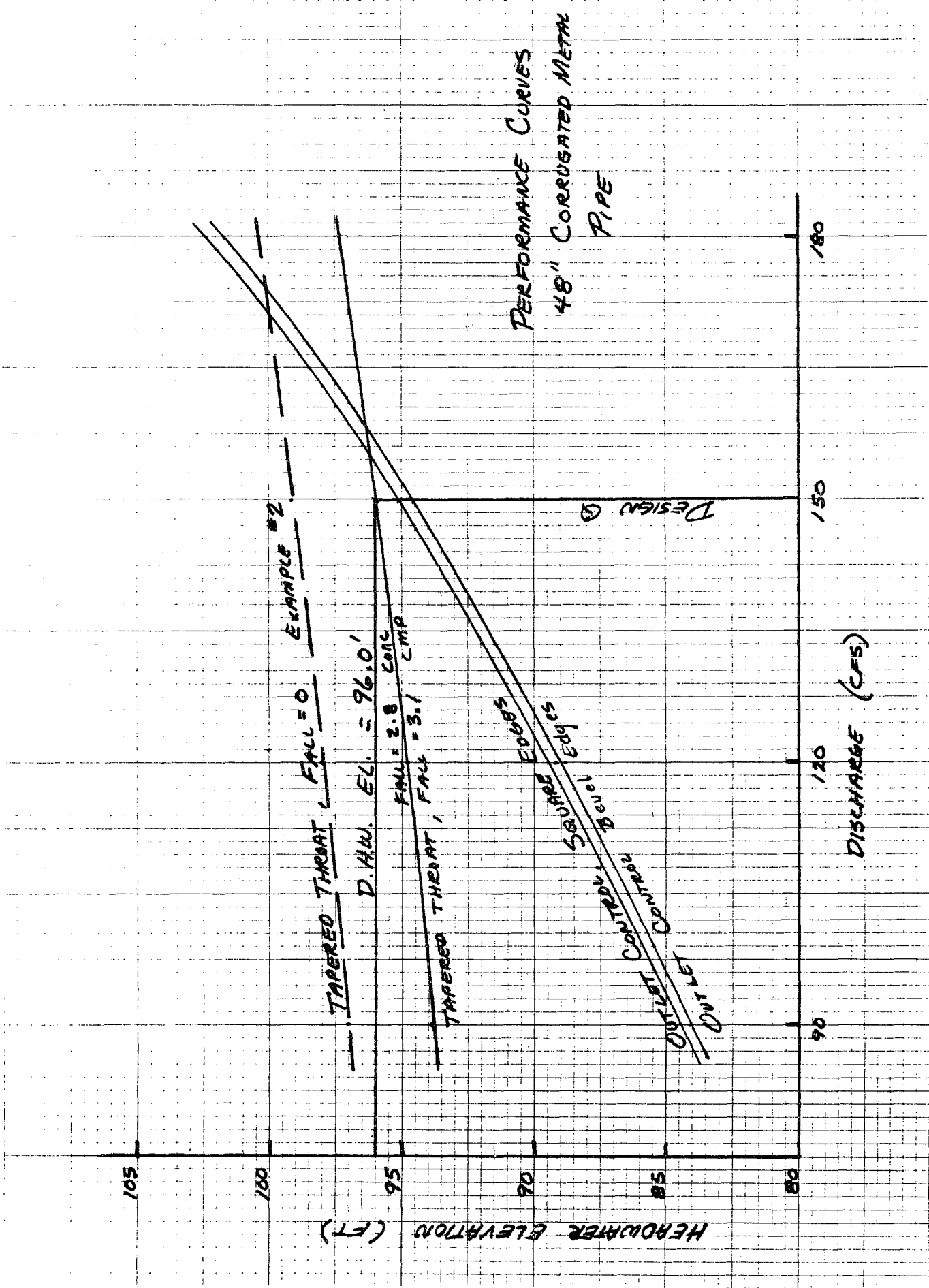

PERFORMANCE CURVES
48" CORRUGATED METAL
PIPE

CONCLUSIONS

Selection of a side- or slope-tapered inlet must be based on economics, as either will perform the required function. Additional Fall is not warranted at this site. Face design was selected to pass 150 cfs at the AHW EL. = 96.0.

The culvert performance curves for the example illustrate that when a prefabricated side-tapered inlet (rough) of a cast-in-place slope-tapered inlet (smooth) may be chosen for the installation, both the smooth and rough inlet throat control curves should be plotted. The difference between the throat control curves represents the difference in friction losses between the face and throat sections of the inlet.

APPENDIX A

DERIVATIONS OF EQUATIONS

USED IN PROGRAMS

PROGRAM #2

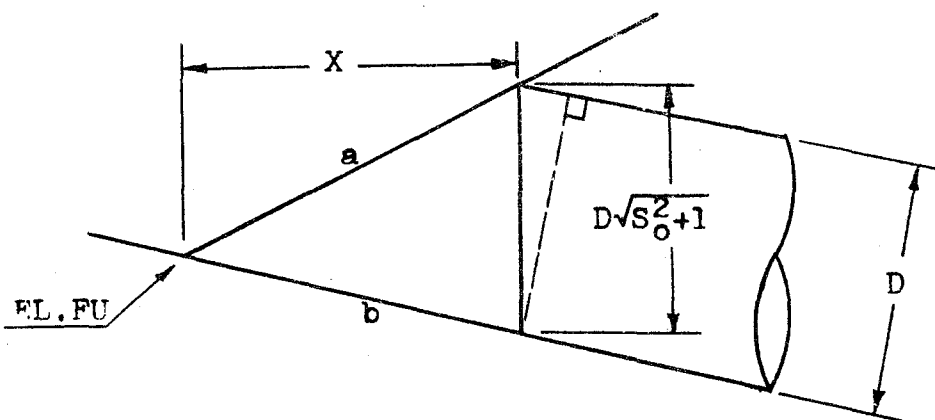
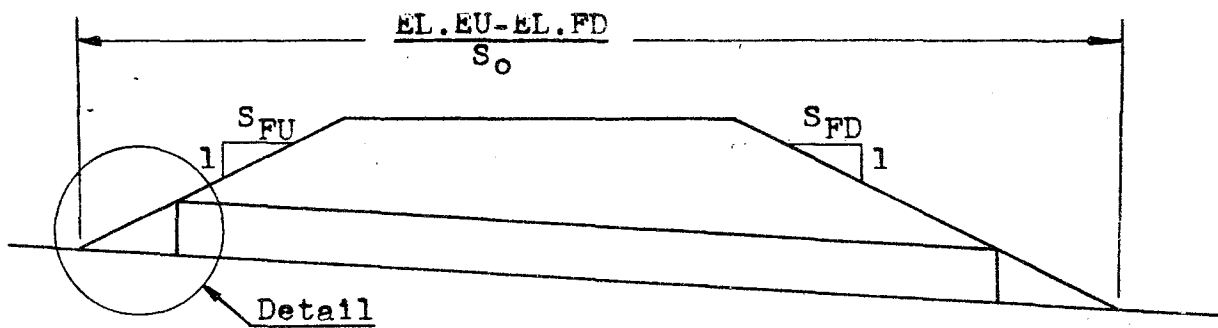

The equation for the fill slope (line a) is:

$$Y_a = \frac{X}{S_{FU}} + EL.FU$$

Similarly, the equation for the channel slope (line b) is:

$$Y_b = -S_0 X + EL.FU$$

At the face of the culvert, the difference between these two equations equals the height of the culvert.

PROGRAM#2 (cont)

$$D\sqrt{S_o^2+1} = Y_a - Y_b = \frac{X}{S_{FU}} + \text{EL.FU} + S_o X - \text{EL.FU} = \frac{X}{S_{FU}} + S_o X$$

Solving for the unknown value X;

$$X = \frac{D\sqrt{S_o^2+1}}{\left(\frac{1}{S_{FU}} + S_o\right)} = \frac{S_{FU}D\sqrt{S_o^2+1}}{(1+S_o S_{FU})}$$

For the downstream condition, a similar value for X would be;

$$X = \frac{S_{FD}D\sqrt{S_o^2+1}}{(1-S_o S_{FD})}$$

Multiplying these values by the channel slope will give the change in elevation across the distance X. From this, the inlet and outlet elevations can be determined.

$$\text{EL.INLET} = \text{EL.FU} - \frac{S_o S_{FU} D \sqrt{S_o^2+1}}{(1+S_o S_{FU})}$$

$$\text{EL.OUTLET} = \text{EL.FD} + \frac{S_o S_{FD} D \sqrt{S_o^2+1}}{(1-S_o S_{FD})}$$

From these two values, the culvert length can be determined.

$$L = \frac{(\text{EL.INLET} - \text{EL.OUTLET})\sqrt{S_o^2+1}}{S_o}$$

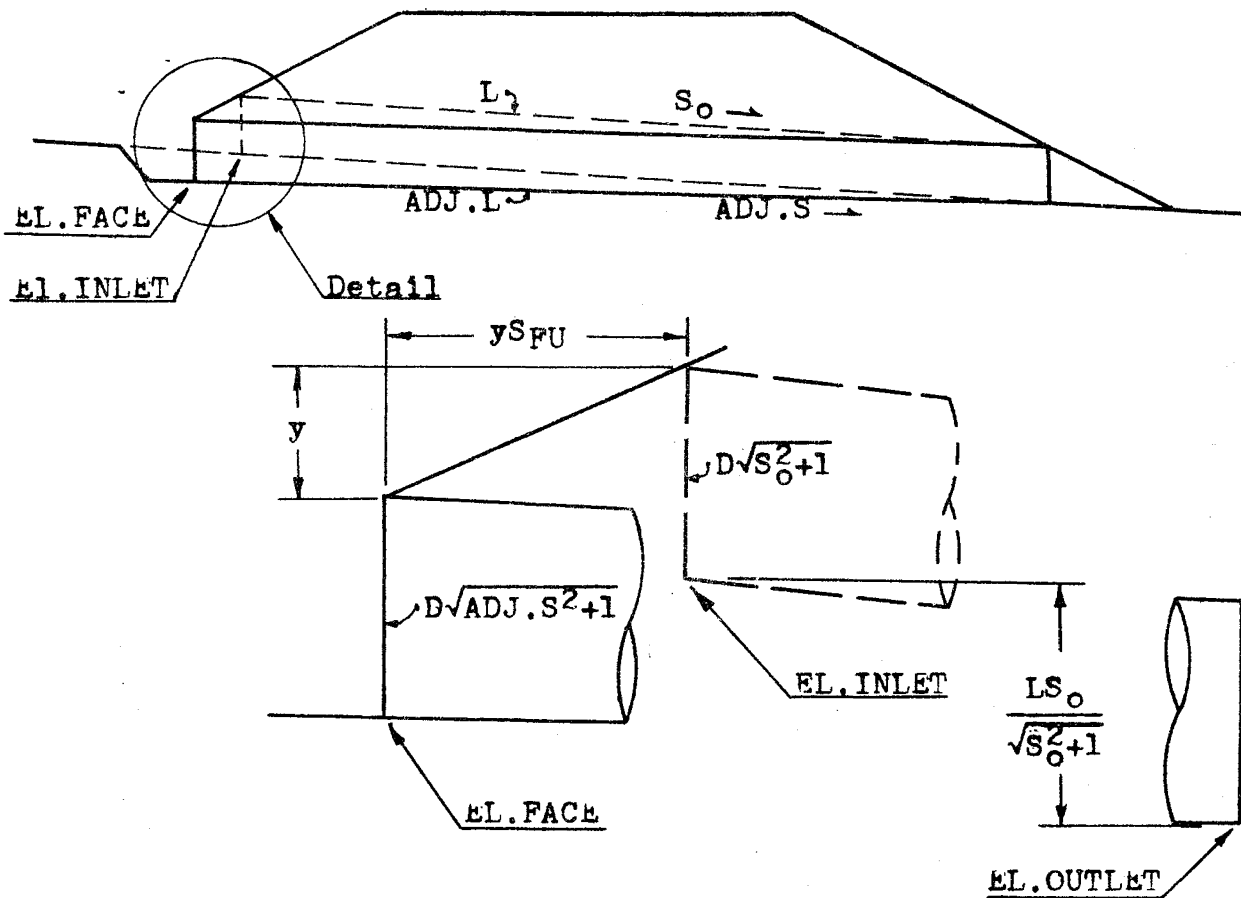

There are three unknowns to be solved for in this program. $ADJ.L$, $ADJ.S$, and the vertical distance y . Knowing that the FALL is the difference between the inlet and face elevations, an expression for y can be obtained.

$$y = FALL + D\sqrt{S_0^2+1} - D\sqrt{ADJ.S^2+1}$$

Using a rise/run relationship, the value of $ADJ.S$ becomes:

$$ADJ.S = \frac{(LS_0/\sqrt{S_0^2+1}) - FALL}{(L/\sqrt{S_0^2+1}) + yS_{FU}} = \frac{LS_0 - FALL\sqrt{S_0^2+1}}{L + yS_{FU}\sqrt{S_0^2+1}}$$

PROGRAM #9 (cont)

Due to the complexity of these two equations they are solved by a trial and error method by the calculator.

Once the adjusted slope is found the adjusted length can be obtained by multiplying the difference in elevation between the face invert and the outlet invert by the cosecant of the adjusted slope.

$$ADJ.L = \left(\frac{LS_o}{\sqrt{S_o^2+1}} - FALL \right) \frac{\sqrt{ADJ.S^2+1}}{ADJ.S}$$

PROGRAM #10

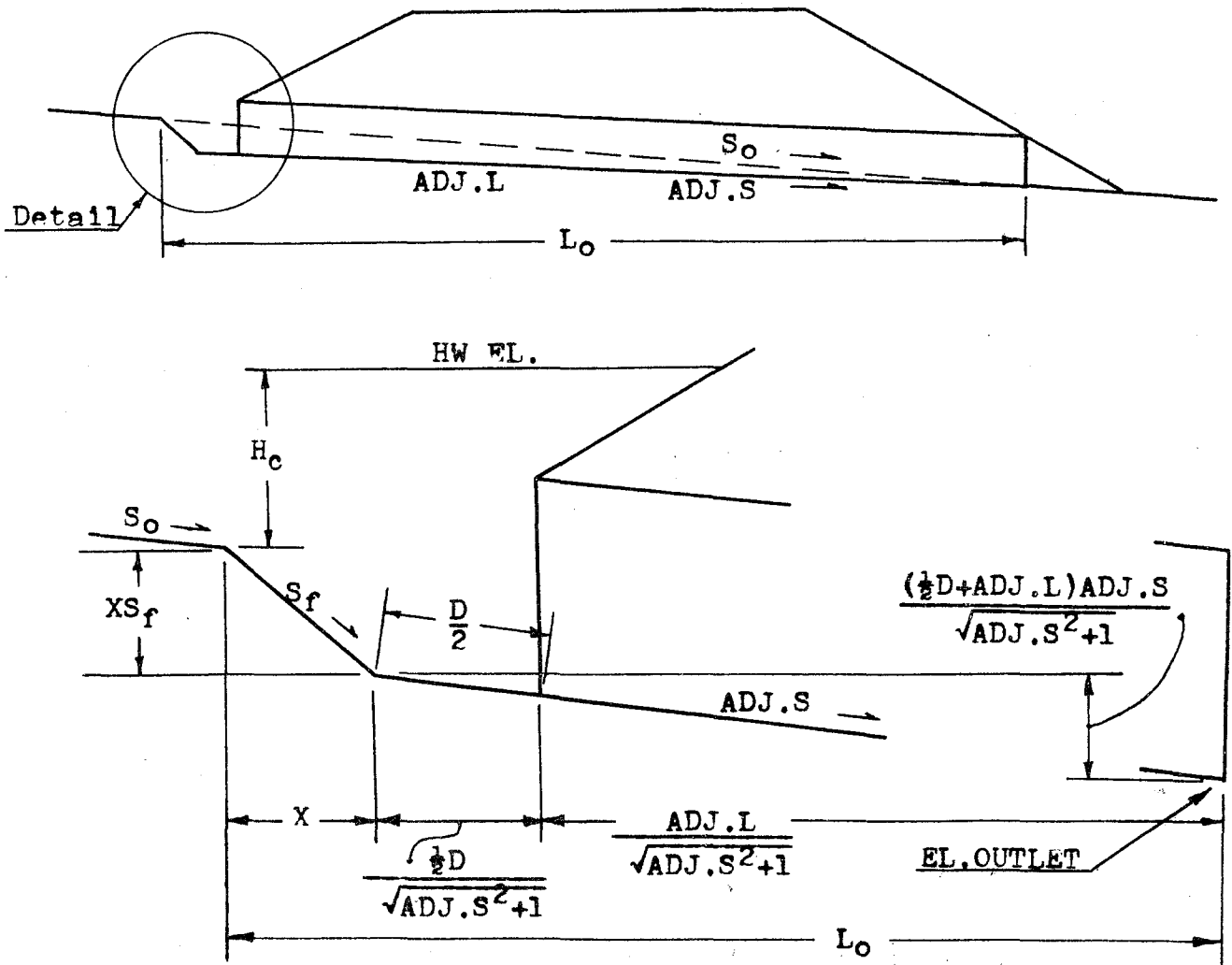

PROGRAM #10 (cont)

From the diagrams the value of L_o can be determined.

$$L_o = X + \frac{\frac{1}{2}D}{\sqrt{ADJ.S^2+1}} + \frac{ADJ.L}{\sqrt{ADJ.S^2+1}}$$

Since the value of X is also an unknown, an expression for it is also required. Summing vertical distances produces;

$$L_o S_o = X S_f + \frac{(\frac{1}{2}D+ADJ.L)ADJ.S}{\sqrt{ADJ.S^2+1}}$$

Combining these two equations, an expression for L_o without the value of X in it, is obtained.

$$L_o = \frac{(S_f-ADJ.S)(\frac{1}{2}D+ADJ.L)}{(S_f-S_o)\sqrt{ADJ.S^2+1}}$$

Substituting this value in an expression for H_c ;

$$H_c = HW \text{ EL.} - EL.\text{OUTLET} - L_o S_o$$

$$H_c = HW \text{ EL.} - EL.\text{OUTLET} - \frac{S_o(S_f-ADJ.S)(\frac{1}{2}D+ADJ.L)}{(S_f-S_o)\sqrt{ADJ.S^2+1}}$$

The crest width can be calculated using this value of H_c .

The formula relating crest width to the depth of water at the crest is taken from the references and is not derived here.

$$CW = \frac{Q}{(2H_c)^{1.5}}$$

PROGRAM #10 (cont)

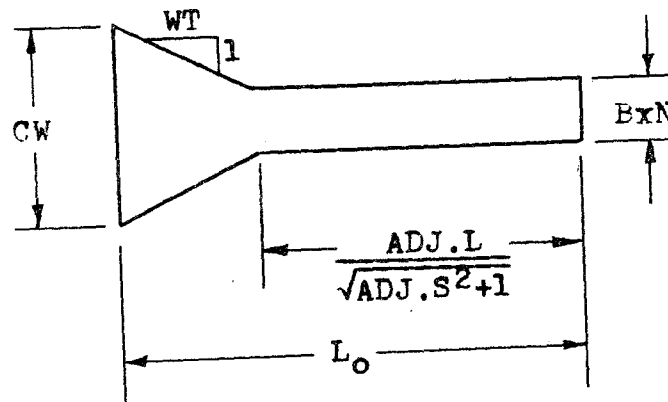

From this diagram, the wingwall taper is determined.

$$WT = \frac{(L_0 - L / \sqrt{ADJ.S^2 + 1})}{(CW - BxN) / 2}$$

The wingwall angle is just 90° - the arctangent of the wing-wall taper.

PROGRAM #14

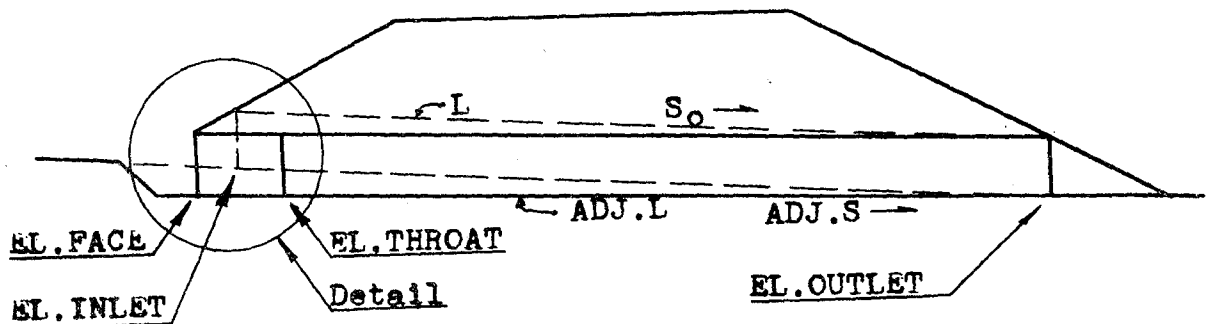

PROGRAM #14 (cont)

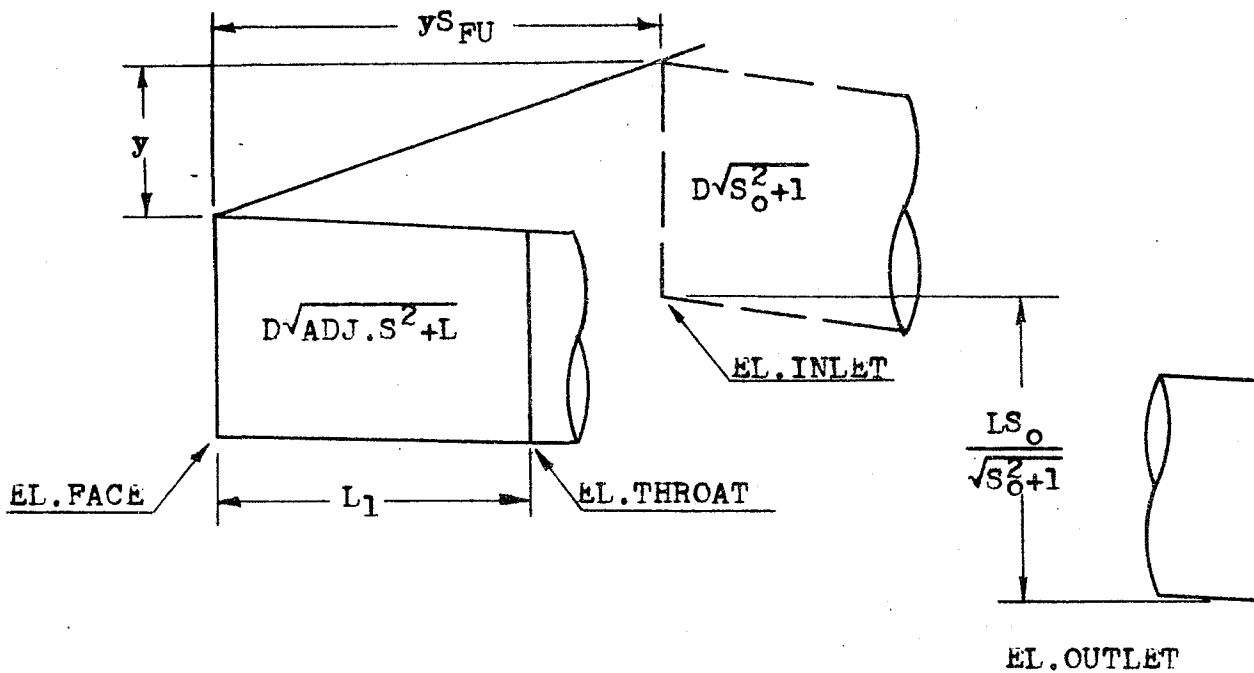

The formulas given here are similar to those given in program #9, except a new unknown L_1 has been introduced. The meaning of FALL has changed also. It now equals the difference between the elevation of the inlet and the elevation of the throat. The expressions for y and ADJ.S now equal;

$$y = FALL + D\sqrt{S_0^2+1} - D\sqrt{ADJ.S^2+1} - L_1ADJ.S$$

$$ADJ.S = \frac{LS_0 - FALL\sqrt{S_0^2+1} + L_1ADJ.S\sqrt{S_0^2+1}}{L + yS_{FU}\sqrt{S_0^2+1}}$$

Substituting:

$$0 = (FALL + D\sqrt{S_0^2+1} - D\sqrt{ADJ.S^2+1})S_{FU}ADJ.S\sqrt{S_0^2+1} - LS_0 \\ + FALL\sqrt{S_0^2+1} - L_1ADJ.S\sqrt{S_0^2+1} + LADJ.S - L_1ADJ.S^2S_{FU}\sqrt{S_0^2+1}$$

PROGRAM #15

The adjusted length computations used in program #15 can be derived using the diagrams of program #14. Once the adjusted slope is calculated by program #14, it is used by this program to find the new culvert length.

As was the case in program #9, the adjusted length is the product of the cosecant of the adjusted slope and a difference in elevations. In program #9, the difference was between the face invert elevation and the outlet invert elevation. For this program the difference is between the throat invert and the outlet invert. Although this difference in definition exists, it has little effect on the formula below. This difference is resolved by the two different definitions of the FALL. In program #9, the FALL is the difference in elevation between the inlet invert and the face invert. In program #15, it is the difference in elevation between the inlet invert and the throat invert. After the culvert length is found, the length of the improved inlet is subtracted off.

$$ADJ.L = \left(\frac{LS_0}{\sqrt{S_0^2+1}} - FALL \right) \frac{\sqrt{ADJ.S^2+1}}{ADJ.S} - L_1 \sqrt{ADJ.S^2+1}$$

Sliding back up the adjusted slope from the throat section:

$$EL.FACE = EL.THROAT + L_1 ADJ.S$$

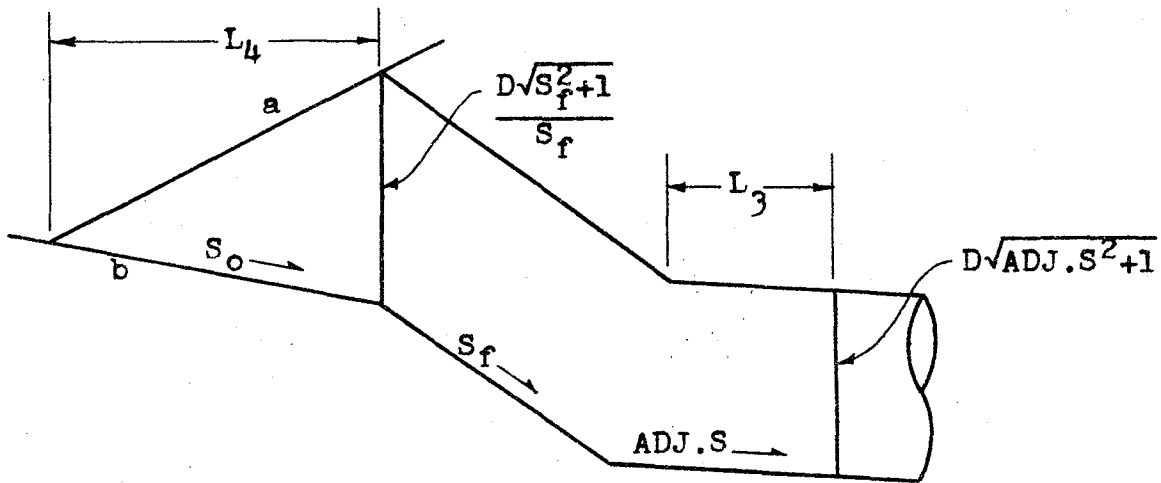
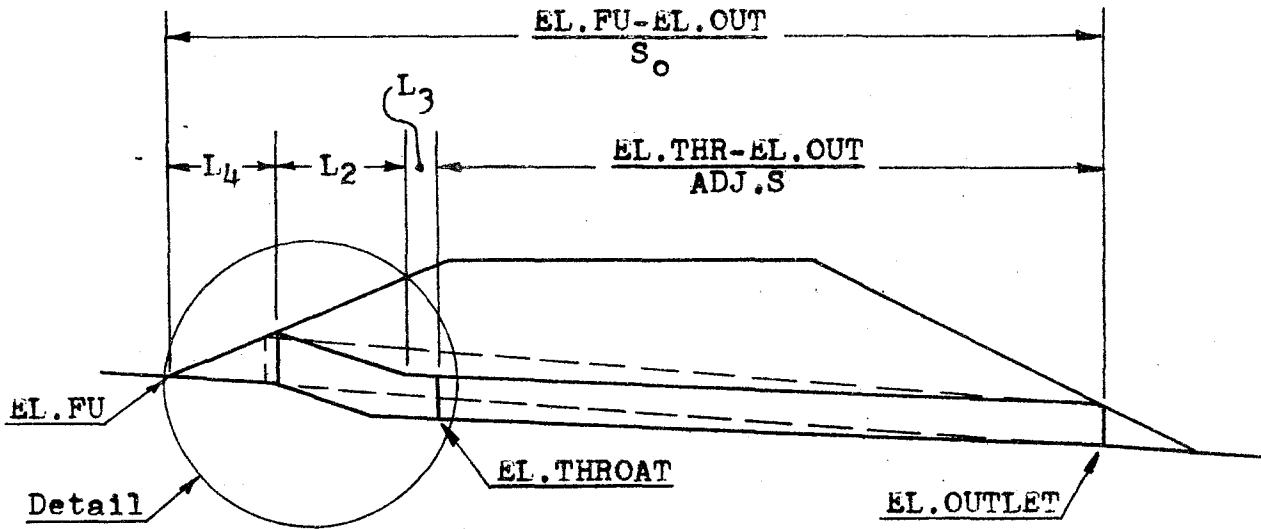

The equation for the fill slope (line a) is;

$$Y_a = \frac{L_4}{S_{FU}} + EL.FU$$

Similarly, the equation for the channel slope (line b) is;

$$Y_b = -S_0 L_4 + EL.FU$$

PROGRAM #16 (cont)

At the face of the culvert, the difference between these two equations equals the height of the culvert.

$$\frac{D\sqrt{S_f^2+1}}{S_f} = Y_a - Y_b = \frac{L_4}{S_{FU}} + \text{EL.FU} + S_o L_4 - \text{EL.FU}$$

Solving this expression for L_4 :

$$L_4 = \frac{S_{FU} D \sqrt{S_f^2+1}}{S_f (1+S_o S_{FU})}$$

From the first diagram, it can be determined that;

$$L_2 = \frac{\text{EL.FU}-\text{EL.OUT}}{S_o} - L_4 - L_3 - \frac{\text{EL.THR}-\text{EL.OUT}}{\text{ADJ.S}}$$

By summing measurements in the vertical direction, the following expression was obtained.

$$\text{EL.THR} = \text{EL.FU} + \frac{L_4}{S_{FU}} - \frac{L_2}{S_f} - L_3 \text{ADJ.S} - D\sqrt{\text{ADJ.S}^2+1}$$

Combining these last three equations, an expression for the adjusted slope can be obtained.

$$0 = \text{EL.FU} + \frac{(S_f+S_{FU})D\sqrt{S_f^2+1}}{S_f^2(1+S_o S_{FU})} + \frac{L_3}{S_f} + \frac{\text{EL.OUT}-\text{EL.FU}}{S_o S_f} - L_3 \text{ADJ.S} \\ + \frac{\text{EL.THR}-\text{EL.OUT}}{S_f \text{ADJ.S}} - D\sqrt{\text{ADJ.S}^2+1} - \text{EL.THROUT}$$

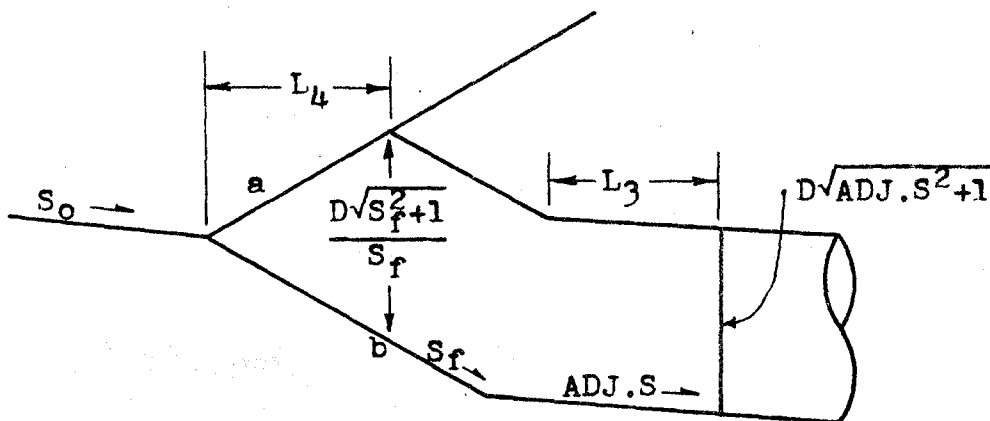
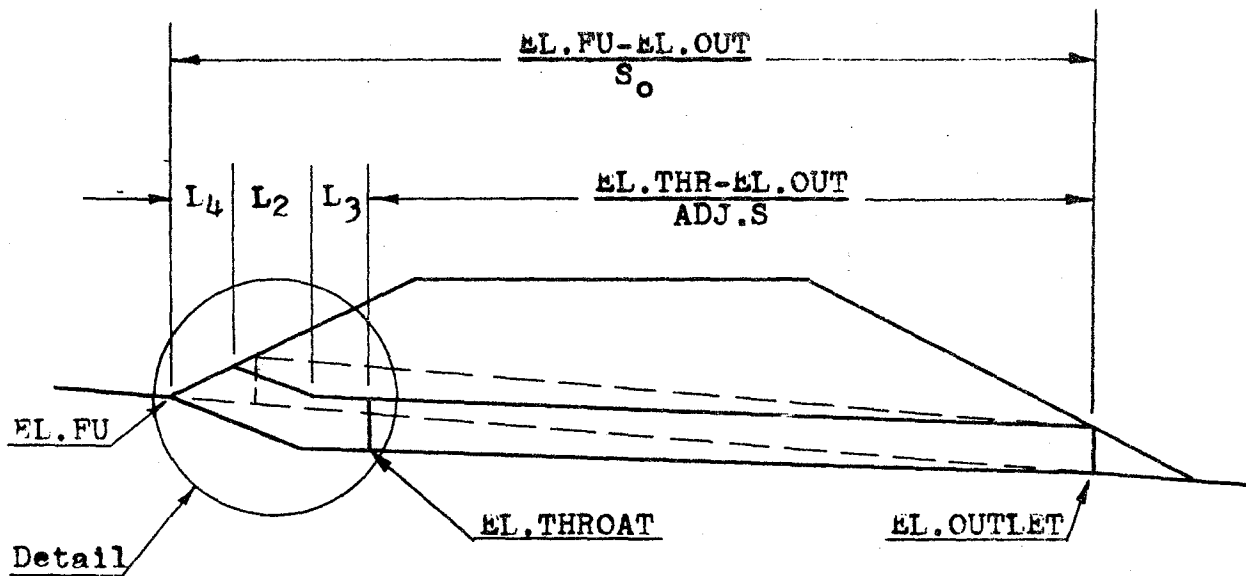

The equation for the fill slope (line a) is;

$$Y_a = \frac{L_4}{S_{FU}} + EL.FU$$

Similarly, the equation for the fall slope (line b) is;

$$Y_b = \frac{-L_4}{S_f} + EL.FU$$

PROGRAM #17 (cont)

At the face of the culvert, the difference between these two equations equals the height of the culvert face.

$$\frac{D\sqrt{S_f^2+1}}{S_f} = Y_a - Y_b = \frac{L_4}{S_{FU}} + \text{EL.FU} + \frac{L_4}{S_f} - \text{EL.FU}$$

Solving this expression for L_4 :

$$L_4 = \frac{S_{FU}D\sqrt{S_f^2+1}}{S_{FU}+S_f}$$

From the first diagram on the previous page:

$$L_2 = \frac{\text{EL.FU}-\text{EL.OUT}}{S_o} - L_4 - L_3 - \frac{\text{EL.THR}-\text{EL.OUT}}{\text{ADJ.S}}$$

By summing the measurements in the vertical direction, the following expression was obtained.

$$\text{EL.THR} = \text{EL.FU} + \frac{L_4}{S_{FU}} - \frac{L_2}{S_f} - L_3\text{ADJ.S} - D\sqrt{\text{ADJ.S}^2+1}$$

Combining these last three equations, an expression for the adjusted slope can be obtained.

$$0 = \text{EL.FU} + \frac{D\sqrt{S_f^2+1}}{S_f} + \frac{L_3}{S_f} + \frac{\text{EL.OUT}-\text{EL.FU}}{S_o S_f} + \frac{\text{EL.THR}-\text{EL.OUT}}{S_f \text{ADJ.S}} - L_3\text{ADJ.S} - D\sqrt{\text{ADJ.S}^2+1} - \text{EL.THROAT}$$

PROGRAM #18

For the derivations of the equations for L_2 and L_4 refer to the derivations for program #16.

The EL.FACE equation can be taken from the diagrams of program #16. The ADJ.L is equal to the cosecant of the adjusted slope times the change in elevation between the throat section and the outlet section.

PROGRAM #19

Refer to the derivation equations for program #17 for an explanation of how L_2 and L_4 were obtained.

The EL.FACE equation can be taken from the diagrams of program #17. The ADJ.L is equal to the cosecant of the adjusted slope times the change in elevation between the throat invert and the outlet invert.

REFERENCES

1. "Hydraulic Charts for the Selection of Highway Culverts," HEC No. 5, U.S. Department of Transportation, Federal Highway Administration, December 1965.
2. "Hydraulic Design of Improved Inlets for Culverts," HEC No. 13, U.S. Department of Transportation, Federal Highway Administration, August 1972.
3. "Electronic Computer Program for Hydraulic Analysis of Culverts," HY-6, U.S. Department of Transportation, Federal Highway Administration, June 1975.
4. "Open Channel Hydraulics," V. T. Chow, McGraw-Hill Book Company, Inc., New York, 1959.
5. "Open Channel Flow," F. M. Henderson, The MacMillan Company, New York, 1966.

Publications listed below are not available from the Government Printing Office. These publications are available in limited numbers to State highway agencies and other public agencies from the Federal Highway Administration. Requests for these documents and suggestions on the contents of any publications should be addressed to the Federal Highway Administration, Office of Engineering, Bridge Division, HNG-31, Washington, D.C. 20590

Hydraulic Design Series

- HDS No. 2 Discontinued
HDS No. 3 DESIGN CHARTS FOR OPEN-CHANNEL FLOW - 1961, Reprinted 1973
HDS No. 4 DESIGN OF ROADSIDE DRAINAGE CHANNELS - 1965

Hydraulic Engineering Circulars

- HEC No. 1 SELECTED BIBLIOGRAPHY OF HYDRAULIC AND HYDROLOGIC SUBJECTS - December 1979
HEC No. 2, 4, 6, 7 and 8 Discontinued
HEC No. 3 HYDROLOGY OF A HIGHWAY STREAM CROSSING - January 1961
HEC No. 9 DEBRIS-CONTROL STRUCTURES - March 1971
HEC No. 10 CAPACITY CHARTS FOR THE HYDRAULIC DESIGN OF HIGHWAY CULVERTS - November 1972
HEC No. 11 USE OF RIPRAP FOR BANK PROTECTION - June 1967
HEC No. 13 HYDRAULIC DESIGN OF IMPROVED INLETS FOR CULVERTS - August 1972
HEC No. 17 THE DESIGN OF ENCROACHMENTS ON FLOOD PLAINS USING RISK ANALYSIS - October 1980

Electronic Computer Programs

- HY-1, 3 and 5 Discontinued
HY-2 HYDRAULIC ANALYSIS OF PIPE-ARCH CULVERTS
HY-4 HYDRAULICS OF BRIDGE WATERWAYS
HY-6 HYDRAULIC ANALYSIS OF CULVERTS (Box and Circular)

Calculator Design Series

- CDS No. 1 HYDRAULIC DESIGN OF IMPROVED INLETS FOR CULVERTS USING PROGRAMABLE CALCULATORS, (COMPUCORP 325) - October 1980
CDS No. 2 HYDRAULIC DESIGN OF IMPROVED INLETS FOR CULVERTS USING PROGRAMABLE CALCULATORS, (HP-65) - October 1980
CDS No. 3 HYDRAULIC DESIGN OF IMPROVED INLETS FOR CULVERTS USING PROGRAMABLE CALCULATORS, (TI-59) - October 1980