



Report No. FHWA-TS-80-205

PROPOSED DESIGN SPECIFICATIONS FOR STEEL BOX GIRDER BRIDGES



January 1980
Final Report

Document is available to the public through
the National Technical Information Service,
Springfield, Virginia 22161

REPRODUCED BY
U.S. DEPARTMENT OF COMMERCE
NATIONAL TECHNICAL INFORMATION SERVICE
SPRINGFIELD, VA. 22161

Prepared for
FEDERAL HIGHWAY ADMINISTRATION
Offices of Research & Development
Washington, D. C. 20590

REPRODUCED BY

| | | | | | |
|---|--|--|---------------------------|---|--|
| 1. Report No. FHWA-TS-80-205 | | 2. Government Accession No. | | 3. Recipient's Catalog No. | |
| 4. Title and Subtitle PROPOSED DESIGN SPECIFICATIONS FOR STEEL BOX GIRDER BRIDGES | | | | 5. Report Date January 1980 | |
| | | | | 6. Performing Organization Code | |
| 7. Author(s) Wolchuk and Mayrbaurl Consulting Engineers | | | | 8. Performing Organization Report No. S-444 | |
| 9. Performing Organization Name and Address Wolchuk and Mayrbaurl Consulting Engineers 432 Park Avenue South New York, N.Y. 10016 | | | | 10. Work Unit No. (TRIS) | |
| | | | | 11. Contract or Grant No. DOT-FH-11-9259 | |
| 12. Sponsoring Agency Name and Address U.S. Department of Transportation Federal Highway Administration Office of Development Washington, D.C. 20590 | | | | 13. Type of Report and Period Covered Final Report | |
| | | | | 14. Sponsoring Agency Code P-0246 | |
| 15. Supplementary Notes FHWA Contract Manager - John M. Hooks Technical Review - ASCE Steel Box Girder committee chaired by Andrew Lally of AISC. | | | | | |
| 16. Abstract Specification for design, of steel box girder bridges are proposed for the AASHTO Specification for Highway Bridges. Load Factor Design approach is used. In the design of compression flanges residual stresses and geometric imperfections are considered. For unstiffened flanges a new strength curve is proposed. Strength of stiffened flanges is given as a function of geometric parameters by interaction diagram based on second order analysis. Strength of webs is obtained as a sum of elastic buckling strength, and a lower limit of tension field strength. Web stiffeners are proportioned by strength and rigidity criteria to remain straight up to ultimate web capacity. Also given are rules for design of tension flanges, diaphragms, cross frames and other members, recommended fabrication tolerances and erection provisions. Discussion of principal problems, review of current U.S. and European specifications and commentary are included. Appendix A contains bibliography; Appendix B contains review of design codes. | | | | | |
| 17. Key Words Steel Box Girders Bridges Specifications | | | Flanges Webs Design | | 18. Distribution Statement Document is available to the public through the National Technical Information Service, Springfield, Va. 22161 |
| 19. Security Classif. (of this report) Unclassified | | 20. Security Classif. (of this page) Unclassified | | 21. No. of Pages | 22. Price |

PREFACE

The proposed specifications for steel box girder bridges grew out of the engineering profession's need for a set of design rules reflecting the current state of the art. The U.S. Department of Transportation, Federal Highway Administration, responded to a request made in 1975 by the ASCE-AASHTO Committee on Box Girder Bridges by sponsoring this work and inviting proposals for its execution. The FHWA contract was awarded to the firm of Wolchuk and Mayrbaurl.

The project was subdivided into four major tasks:

Task A - Compiling a bibliography of the subject;

Task B - Review of current specifications on steel box girder bridges;

Task C - Discussion of problems requiring clarification;

Task D - Recommendations for the AASHTO specification provisions for steel box girder bridges, based on conclusions reached.

This report presents the results of this work. It contains updated summaries of Tasks B and C (with full report on Task B enclosed as Appendix B), recommended provisions for the design, fabrication and erection of steel box girder bridges, with commentary, in fulfillment of the requirements of Task D, and bibliography, given in Appendix A. Also included in this report are conclusions and suggestions for further work to be done to improve the proposed rules and to extend their applications.

Proposed specification provisions are being submitted to the FHWA and the AASHTO Subcommittee on Bridges and

NOTICE

This document is disseminated under the sponsorship of the Department of Transportation in the interest of information exchange. The United States Government assumes no liability for its contents or use thereof.

The content of this report reflect the views of the firm of Wolchuk and Meybaur1, which is responsible for the facts and the accuracy of the data presented herein. The contents do not necessarily reflect the official views or policy of the Department of Transportation.

This report does not constitute a standard, specification, or regulation.

Structures for further consideration and possible inclusion in the 1980 AASHTO Interim Specifications.

References to literature given in parentheses, e.g., (G1), refer to bibliography, Appendix A.

Acknowledgment is due to the ASCE-AASHTO Subcommittee on Box Girders, chaired by T.V. Galambos, and the ASCE-AASHTO Subcommittee on Ultimate Strength of Box Girders, chaired by C.G. Culver, for their prior work on reviewing the state of the art of box girder bridge design (G97, G39, G40).

Work on this project was carried out under the guidance of the ASCE-TCCS Committee on Steel Box Girder Bridges chaired by A. Lally, consisting of J.L. Durkee, M. Elgaaly, D.A. Firmage, G.F. Fox, T.V. Galambos, D.H. Hall, A.W. Hedgren, Jr., C.P. Heins, J. Hooks, B.O. Kuzmanovic, R.L. Mion, J. Nishanian, B.G. Schiller, C.G. Schilling, F.D. Sears, C. Seim, C.E. Thunman, Jr., A.C. Van Tassel and B.T. Yen.

The reports and proposed specifications were prepared in the office of Wolchuk and Mayrbaurl by Roman Wolchuk, principal investigator of this project, and Hsioh-Yih Wang.

Professor A. Ostapenko (Lehigh University) was acting as a consultant to Wolchuk and Mayrbaurl. The writers gratefully acknowledge his thorough review and comments on the reports and the proposed specification provisions and the many suggested solutions to the problems encountered in this project.

The writers also wish to thank all the members of the ASCE-TCCS Committee for their contributions and constructive criticism, with special appreciation due to A. Lally for his continued help as a chairman and J. Durkee for his thorough editorial work.

Thanks are due to Dr. G.H. Little (University of Birmingham, U.K.) for extension of his investigations

of stiffened plates and computer calculations of the stiffener strengths made specially for this project.

In fulfillment of the requirements of Tasks B and C it was necessary for the writers to acquaint themselves with work currently under way on new specifications in European countries. This would not have been possible without cooperation and assistance of the respective specification committees responsible for this work. The writers are much indebted to Dr. O.A. Kerensky, Chairman of the British Standard Institute's Committee for Steel and Concrete Bridges, Dr. A.R. Flint, Chairman of the BSI Subcommittee on Steel Bridges, B. Godfrey, CONSTRADO, Professor J. Scheer, Chairman of the Subcommittee on Plate Structures of the German Committee on Stability of Steel Structures, Dr. H. Nölke, Member of the Subcommittee, and Professor C. Massonnet, Chairman, Task Group on Box Girders of the European Convention of Constructional Steelwork, for their time and assistance in obtaining information and the exchange of opinions.

The writers also wish to express their appreciation to Professor M. Horne (University of Manchester), J.B. Dwight (Cambridge University) and Dr. P. Dowling (Imperial College) for their advice on the problems of strength of plate elements, and to Professor K.C. Rockey (Cardiff University College), for his most valuable guidance on the design of webs and web stiffeners.

CONTENTS

| | Page |
|--|------|
| A. PREFACE | ii |
| B. SUMMARY OF TASK B: CURRENT SPECIFICATIONS APPLICABLE TO BOX GIRDER BRIDGES | |
| B.1. American Specifications | 1 |
| B.2. British Specifications | 2 |
| B.3. German Specifications | 3 |
| B.4. ECCS Design Rules | 4 |
| C. SUMMARY OF TASK C: DISCUSSION OF PROBLEMS REQUIRING CLARIFICATION | |
| C.1. Problems Studied | 5 |
| C.1.1. Basic Design Philosophy | 5 |
| C.1.2. Design of Bottom Flanges in Compression | 7 |
| C.1.3. Design of Webs | 9 |
| C.1.4. Miscellaneous Design Problems | 12 |
| C.1.5. Incorporation of Proposed Provisions in the AASHTO Specifications | 12 |
| C.1.6. Design Analysis | 13 |
| C.1.7. Provisions for Fabrication and Erection | 14 |
| C.2. Recommendations | 15 |
| D. RECOMMENDED PROVISIONS FOR DESIGN, WORKMANSHIP AND ERECTION OF STEEL BOX GIRDER BRIDGES | |
| DIVISION I - DESIGN | |
| Proposed Rearrangement of AASHTO Specifications, Section 7, Load Factor Design | 17 |
| Proposed Modifications of Current General Design Provisions of the Load Factor Design Method | 20 |

| | Page |
|--|------|
| 1.7.52 - Scope | 20 |
| 1.7.53 - Notation | 20 |
| 1.7.55 - Design Theory | 23 |
| 1.7.56 - Assumptions | 23 |
| 1.7.64 - Composite Box Girders | 23 |
| 1.7.74 - Deflection | 23 |

Proposed New Provisions of the Load Factor Design
Method, Subsection: Box Girders 25

| | |
|---|-----|
| 1.7.200 - Scope | 25 |
| 1.7.201 - Applicable General Provisions | 25 |
| 1.7.202 - Design Analysis | 25 |
| 1.7.203 - Multi-box Composite Girders | 26 |
| 1.7.204 - Effective Width of Flanges | 27 |
| 1.7.205 - Unstiffened Bottom Flanges in Compression | 31 |
| 1.7.206 - Stiffened Bottom Flanges in Compression | 37 |
| 1.7.207 - Longitudinal Stiffeners of Compression Flanges | 44 |
| 1.7.208 - Bottom Flanges in Tension | 46 |
| 1.7.209 - Top Flanges | 49 |
| 1.7.210 - Unstiffened Webs | 52 |
| 1.7.211 - Transversely Stiffened Webs | 56 |
| 1.7.212 - Transversely and Longitudinally Stiffened Webs | 69 |
| 1.7.213 - Web Stiffeners | 74 |
| 1.7.214 - Webs of Hybrid Girders | 86 |
| 1.7.215 - Diaphragms | 88 |
| 1.7.216 - Transverse Structural Members of Flanges | 98 |
| 1.7.217 - Miscellaneous Details of Box Girders | 101 |

DIVISION II - CONSTRUCTION

Proposed Modifications and Additions, Section 10,
Steel Structures

| | |
|--|-----|
| 2.10.46A - Dimensional Tolerance Limits | 103 |
| 2.10.47 - Orthotropic Deck Superstructures | 107 |
| 2.10.55A - Erection of Box Girders | 108 |
| 2.10.63 - Basis of Payment | 110 |

| | Page |
|--|------|
| COMMENTARY ON DESIGN PROVISIONS | |
| Commentary on Modifications of General Design Provisions | |
| 1.7.52 | 111 |
| 1.7.55 | 111 |
| 1.7.56 | 112 |
| 1.7.64 | 112 |
| 1.7.74 | 112 |
| Commentary on Proposed New Design Provisions | |
| 1.7.200 | 113 |
| 1.7.201 | 113 |
| 1.7.202 | 113 |
| 1.7.203 | 114 |
| 1.7.204 | 115 |
| 1.7.205 | 116 |
| 1.7.206 | 118 |
| 1.7.207 | 123 |
| 1.7.208 | 125 |
| 1.7.209 | 127 |
| 1.7.210 | 129 |
| 1.7.211 | 134 |
| 1.7.212 | 143 |
| 1.7.213 | 146 |
| 1.7.214 | 157 |
| 1.7.215 | 158 |
| 1.7.216 | 162 |
| 1.7.217 | 165 |
| COMMENTARY ON CONSTRUCTION PROVISIONS | |
| 2.10.46A | 166 |
| 2.10.47 | 173 |
| 2.10.55A | 173 |
| ADDENDUM # 1 | 176 |
| APPENDIX A - BIBLIOGRAPHY | A-1 |
| APPENDIX B - REVIEW OF DESIGN CODES | B-1 |

B. SUMMARY OF TASK B: CURRENT SPECIFICATIONS APPLICABLE TO STEEL BOX GIRDER BRIDGES

In this section, information given in Report on Task B (Appendix B) on design specifications applicable to steel box girder bridges is briefly summarized and updated.

A more detailed discussion may be found in Appendix B and in the Commentaries on the proposed AASHTO specification provisions in this report.

B.1. AMERICAN SPECIFICATIONS

The current AASHTO Standard Specifications for Highway Bridges (G136) contain specific provisions only for composite multi-box girder bridges of moderate spans, conforming to geometric limitations stipulated in the specifications.

Transverse distribution of live loads is given by a simple formula based on treatment of the bridge as a folded plate (G38).

Design of unstiffened and longitudinally stiffened bottom flanges in compression is based on elastic theory of plate buckling. A transition curve is used between the elastic and the inelastic range, based on assumed analogy between column and plate buckling.

Design rules for webs in accordance with the allowable stress method are based on elastic theory of plates in shear or in flexure. Effect of combined shear and flexure is considered indirectly, by an empirical interaction formula. Design of webs by the ultimate load method utilizes tension field strength, according to Basler. It is assumed that this approach is valid for both plate girder and box girder webs. Longitudinal stiffening is limited to one stiffener only. Webs are subject to slenderness limitations based on empirical considerations of fatigue.

The railroad bridge specifications of the AREA (G5) have no provisions for box girders.

A broader overview of the American box girder specifications and design practice may be found in (G64).

B.2. BRITISH SPECIFICATIONS

Design provisions applicable to box girder bridges are contained in the new general bridge specification BS 5400, Part 3 (in preparation) (G151). This specification is based on the limit state design principles.

Design of bottom flanges in compression is based on ultimate strength of plate with consideration of imperfections and residual stresses. Stiffened bottom flanges are designed as a sum of individual stiffener-struts, acting with an effective width of plate, which is generally smaller than the stiffener spacing. The Perry-type strut formula is used, with parameters corresponding to an assumed stiffener out-of-straightness of $L/750$. Tentative comparisons indicate that the British rules for stiffened flanges are approximately 10-15% more conservative than those proposed for AASHTO in this report.

In the design of webs distinction is made between the "unrestrained" panels adjacent to flanges, and the interior "restrained" panels. The strength of webs is given by equations, graphs, and numerical tables based on studies of strength of plate panels subject to combined axial compression and shear done at the Imperial College, London. Tension field strength (Rockey's model) is used fully only for webs without longitudinal stiffeners. If longitudinal stiffeners are present, either in the web or in the box girder flanges, tension field considerations are limited to the interior "restrained" web panels.

The design of web stiffeners is based on the "strength" approach, using fictitious destabilizing forces stipulated in the specification.

The new British design specification is influenced

to a large degree by the general design philosophy of the "Interim Design and Workmanship Rules" (the Merrison Rules) (G11-G13) which it supersedes, however, the formulation of the new provisions has been simplified. The Merrison Rules and the interim drafts of British specifications are discussed in Appendix B.

The history and development of the new specification BS 5400 is summarized in (G149).

B.3. GERMAN SPECIFICATIONS

The general highway bridge specifications, DIN 1073 (G110), do not contain specific provisions for steel box girders. For the design of plate elements in compression and shear references are made to the general provisions for structural stability, DIN 4114, and their revisions (G16, G17, G101, G102). In 1978 the plate buckling provisions of the DIN 4114 specifications have been superseded by the new provisions for stability of plate elements, DAST Richtlinie 12, (G140).

The new provisions, applicable to the flanges of box girders and the webs, are based on the elastic linear buckling theory, with plate strength in the transition zone given by a straight line for $0.7 < \lambda_{pl} < 1.29$, replacing the Engesser transition curve of DIN 4114.

Stiffened flanges in compression are designed as elastic struts consisting of individual stiffeners with an appropriate portion of effective flange plate acting with each stiffener. Strut out-of-straightness equal to tolerance shall be considered in design. The "interaction diagram" (Fig. B-6, Report on Task B) is used only for axially loaded column members consisting of stiffened plate panels, but not for compression flanges of box girders.

Webs are designed as plate panels subject to simultaneous shear and axial stresses by elastic interaction equations. Tension field strength of webs is not used. This is partially compensated by the use of a lower factor of safety for webs of about 1.4.

For longitudinally stiffened webs the use of "flexible" longitudinal stiffeners, having a relative rigidity, γ , smaller than the "minimum required theoretical rigidity", γ^* , is preferred.

The values of the plate buckling coefficients, k , and the relative stiffener rigidity coefficients, γ , are not given in the specification; the use of references (G107, G108) is suggested.

A commentary on these provisions is given in (G67).

B.4. ECCS DESIGN RULES

The design recommendations of the European Convention for Constructional Steelwork are described in Section 6 of (G31). The design rules for plate elements are given in (G98) and (G99).

These rules are given as "provisional". They are based on elastic buckling theory, with correction coefficients, c , suggested to account for deleterious effects of residual stresses and imperfections.

In the design of stiffened panels the use of "rigid" stiffeners is suggested. The relative rigidity coefficients, γ^* , should be used with a multiplier, m , to assure that the stiffeners remain straight up to the maximum load in the stiffened plate.

C. SUMMARY OF TASK C: DISCUSSION OF PROBLEMS REQUIRING CLARIFICATION

C.1. PROBLEMS STUDIED

In accordance with the outlines of the "Statement of Work" for this project, the following principal subjects were studied for the purposes of preparation of the proposed specification provisions. Discussion of additional problems not covered in this summary may be found in commentaries on the proposed provisions in Part D of this report.

C.1.1. Basic Design Philosophy

As stipulated in this contract's "Statement of Work" the recommended rules are structured according to the Load Factor Design Method (Strength Design Method) to conform with the design approach used in the AASHTO Specifications as an alternate to the Allowable Stress Design method.

(a) Load Factor Design of Present AASHTO Specifications

The Load Factor Design method requires that the ultimate strength of any member or element be greater than or equal to the calculated force in the member due to applied loads multiplied by the appropriate load factors γ and β (AASHTO, Art. 1.2.22). Thus this design method is based on a "limit state" approach, with ultimate strength considered to be the limiting condition.

Coefficients γ and β represent the safety factors that cover both the uncertainty as to the magnitude of the loadings and the probability of attainment of their nominal values, and the uncertainty as to the strength of material that may be affected by the variation of the yield strength, residual stresses and geometric imperfections. In some current design codes (e.g. the British Code BS 5400 (G142)) the "load" and the "material resistance" factors are given separately, which is a refine-

ment of the simpler approach used in the current AASHTO Specifications. Since the stipulations of this contract do not encourage radical departures from the basic load factor philosophy used in the current AASHTO provisions, no attempt was made to judge the relative merits of the various alternative approaches.

However, the writers believe that the numerical values of the load factors of the current specifications should be subject to review. Since the factors $\hat{\gamma}$ and β already include implicit allowances for the deleterious effects of residual stresses and geometric imperfections, and in the proposed provisions the strength of plate members in compression is derived with consideration of these effects, the use of unchanged present AASHTO $\hat{\gamma}$ and β factors in conjunction with the new proposed design criteria would, in effect, increase the actual safety of such members. However, such increase would be unwarranted, since the safety margins of the present AASHTO Specifications are considered to be ample. Therefore the load factors to be used with the new provisions ought to be appropriately adjusted; otherwise the design of compression elements would be too conservative and uneconomical.

The writers recommend that such re-evaluation of the load factors be considered by the AASHTO Subcommittee on Bridges and Structures.

(b) Limit State of Serviceability

Another limit state is that of "serviceability", which is a condition beyond which a loss of utility or cause for public concern may be expected, and remedial action required. This includes permanent deformations, excessive deflections, unacceptable vibrations, etc. Current AASHTO provisions ensure serviceability by specifying the various limits for overloads, deflections, slenderness of elements, etc. The writers feel that these provisions are adequate and that a separate set for design criteria for the serviceability limit state are not necessary.

(c) Fatigue

Provisions for the limit state of fatigue are given in Art. 1.7.2 of the AASHTO Specifications. These provisions specify the allowable stress ranges for members subject to fluctuating tension or stress reversal, depending on the type of detail and the specified number of cycles of the maximum design loading. The resulting values of allowable stresses are rather restrictive, and, therefore, the design of most members of box girder bridges (including bottom flanges in tension or subject to stress reversal, webs, orthotropic decks) is likely to be controlled by fatigue rather than by ultimate strength.

The writers feel that provisions based on the assumption of constant amplitude cycles of the theoretical maximum stresses do not accurately reflect the fatigue conditions, and are too conservative, as has been pointed out in (S25), where a more realistic "effective stress range" approach is proposed, based on the variable amplitude of actual stresses in bridge members. The writers recommend that this approach be considered in future revisions of AASHTO fatigue provisions.

Similarly, the writers believe that the web slenderness limitations of the current AASHTO Specifications based on fatigue ought to be liberalized, see Commentary on proposed Art. 1.7.211(D)(1).

C.1.2. Design of Bottom Flanges in Compression

(a) Unstiffened Flanges

Current AASHTO Specifications define the strength of unstiffened plate panels in compression by elastic buckling curve for slender panels, and a transition curve for stocky panels. This transition curve is based on analogy with column behavior, but not on actual plate strength tests.

Theoretical and experimental studies of plate behavior show that the strength of actual plate members is affected by geometric imperfections and residual stresses

in the plate. The actual strength of stocky plates is smaller than that given by the AASHTO transition curve; on the other hand the strength of very slender plates is greater than that predicted by elastic theory. The writers have studied the results of recent plate strength research (see Fig. B-3 in Appendix B) and concluded that a curve close to the strength of a "lightly welded plate" (Fig. 1.7.205(A) in proposed Art. 1.7.205) is appropriate for the design of unstiffened bottom flanges. Strength reduction due to coincident shear is obtained by the modified von Mises formula.

Further discussion of unstiffened plate strength is given in Section B.2 of Appendix B and in the commentary on Art. 1.7.205.

(b) Stiffened Flanges

Strength of longitudinally stiffened plate panels is similarly affected by imperfections and residual stresses in the flange plate. In addition, the strength also depends on the out-of-straightness of the longitudinal stiffeners and the residual stresses in the stiffeners due to rolling of stiffener sections and welding of the stiffeners to the plate.

In stiffened box girder bottom flanges of common proportions the effect of longitudinal edge support of the flange panels at the webs is not significant; thus the flange behaves, essentially, as a column. In view of this "column behavior" it is sufficient to consider separately the individual stiffener struts, consisting of one stiffener with a corresponding width of flange plate. The strength of the entire flange is then obtained by multiplying the ultimate stress of the strut by the total area of the flange.

Study and comparison of the various design methods included the "Merrison Rules" method (G11, G12), several variations of the "effective width" method (F19, F20, F21, F27), the "effective yield" method (F10, F11, F12, F18) and the "interaction diagram" method (G111, G140). Available tests were also studied and compared with theoretical

results. The various approaches to the design were discussed with their proponents. Based on these studies the conclusion was reached that a simple, yet adequate, method of design would be given by presentation of the strength predictions by Little's numerical method (F17) (underlying the "effective yield" approach) in the form of an interaction diagram similar to that in (G111, G140). In this diagram the strength of a stiffened panel is given as a function of two geometric parameters: the "column slenderness" of the stiffener strut, and the "plate slenderness" of the plate between the stiffeners.

Implementation of this approach required much additional numerical computer work to cover the variation of the stiffener types, steel yield strength, and residual stresses in the plate and in the stiffeners. Both positive and negative out-of-straightness of the stiffeners were considered. Study of the effects of the individual parameters led to gradual simplification of the interaction diagram to its final form given on Fig. 1.7.206(A) of the proposed design rules. The results obtained from this diagram correlate well with test data, and are considered appropriate for conservative design.

For cases where "plate behavior" rather than "column behavior" prevails (as may be the case in "narrow flanges" of multi-box short and medium span bridges) a formula gives an "effective length" of stiffener to be used in the interaction diagram.

A more detailed discussion and background material on the proposed design method for stiffened compression flanges is given in the commentary on Art. 1.7.206 in this report and in the interim reports by the writers to the ASCE-TCCS Review Committee (G152, G153, G154).

C.1.3. Design of Webs

The design criteria for webs of the current AASHTO Specifications are based on considerations of rolled beams and plate girders, treating the webs in conjunction with the flanges. The effect of shear and flexural stresses acting simultaneously is dealt with by an interaction

relationship between the moment and the shear capacity of an entire beam section. Since this approach is not suitable for adaptation to the webs of larger box girders, a different design method was necessary to determine the elastic and the postbuckling contributions to the web strength independently of the flange properties.

The following problems had to be clarified:

- a) the elastic buckling strength (beam shear strength);
- b) the postbuckling strength (tension field strength);
- c) the required stiffener properties.

(a) Elastic Buckling Strength

First the basic shear strength curves (shear buckling stress vs. plate slenderness) were established, with the values of the elastic buckling coefficient, $k = 7$ for "unstiffened" and 5.34 for "stiffened" webs (for the limiting case of aspect ratio $\alpha = \infty$), with a transition curve between the elastic and the inelastic range, see Fig. 1.7.210-C in Commentary and Figs. 1.7.210 and 1.7.211(A) in proposed rules.

Next, based on the basic strength curves, the values of the critical stresses F_{vcr}^o , F_{bcr}^o and F_{ccr}^o , for shear, flexure and compression stresses acting alone, were calculated and presented graphically (Figs. 1.7.211(A), (B)). With these values known, the critical shear stress, F_{vcr} , for shear and flexure acting simultaneously is computed by the interaction equations given in Art. 1.7.211(B)(4).

Subpanels of longitudinally stiffened webs are treated in a similar manner, with critical beam shear strength of the web determined by the F_{vcr} value of the weakest subpanel. The case of a subpanel subject to shear and tension has also been considered (Art. 1.7.212(B)(4)).

(b) Postbuckling Strength

Utilization of tension field strength has been long established in the design of plate girders, where the flange rigidity is generally sufficient to ensure anchorage of tension field forces, and these forces do not endanger the stability of the flange. However, applicability of this design to box girder webs had to be examined, because of danger of destabilizing the compression flange by the fully developed tension field action. The conclusion reached was that the use of tension field concept is permissible, however, it should be applied with caution. Therefore the proposed provisions utilize only the lower limit of the tension field strength, corresponding to the assumption of negligible flange rigidity (the "true Basler" solution, Art. 1.7.211(B)(1)). The weakening effect of coincident flexural tension in the web is also considered in a conservative manner (see Art. 1.7.211(B)(5) and Commentary).

Application of tension field design to longitudinally stiffened webs is based on tension field developing across the entire web panel between the flanges, unaffected by the longitudinal stiffeners.

Where webs are designed with utilization of tension field action, a part of the web axial compression force must be shed to the flanges. Proposed provisions contain formulas for additional flange forces due to this action (Art. 1.7.211(E) and 1.7.212(D)).

(c) Web Stiffeners

The design of webs in accordance with the proposed provisions is based on the assumption that the individual web panels or subpanels are rigidly supported around their periphery by the transverse and the longitudinal stiffeners at all stages of loading. Therefore the stiffeners must remain straight and not deflect out of the web plane during the web buckling and postbuckling stages, up to reaching the ultimate web strength.

There is no general agreement as to the proper design of the web stiffeners and their required rigidity. (See Commentary on Art. 1.7.213). Therefore a conservative approach was chosen, requiring the relative stiffener rigidity to be the theoretical "minimum rigidity" of the elastic theory, γ^* , multiplied by an empirical factor, m. The values of γ^* needed in practical design have been obtained from literature and condensed into two diagrams (Fig. 1.7.213(A), (B)). These values are subject to reduction, in cases where factored design stresses are lower than the web panel capacities, by formulas given in Art. 1.7.213.

Stiffeners shall also satisfy the strength criteria, and must be designed as compression struts under actual forces to which they are subject.

Many questions regarding web stiffeners are not yet sufficiently clarified and remain to be answered by further research. Therefore the proposed rules for stiffener design should be regarded tentative and subject to future revisions.

C.1.4. Miscellaneous Design Problems

Additional problems requiring study and clarification were: local torsional stability of compression flange stiffeners, design of box girder diaphragms at supports, design of transverse stiffeners of compression flanges, design of box girder cross frames, etc. In preparation of the specification provisions for these members the writers have relied, mainly, on the results of recent British research on box girders. A more detailed discussion of these problems may be found in the commentaries on the respective proposed design rules in this report.

C.1.5. Incorporation of Proposed Provisions in the AASHTO Specifications and Correlation with Current Provisions

Incorporation of the new design provisions for box girders, tentatively numbered 1.7.200-1.7.217, into Section 7, Structural Steel Design, Sub-section: Load

Factor Design, necessitated rearrangement of this Sub-section, with sub-headings as proposed in the introduction to Part D of this report.

Having included multi-box composite girders in the new rules (Art. 1.7.203), the writers originally intended to propose deletion of present Art. 1.7.64, Composite Girders, based on currently used design approach. However, the ASCE-TCCS Review Committee's preference was to permit the use of both design methods for multi-box composite girders as alternatives, and, therefore, the proposed rules are formulated accordingly.

Introduction of the new material on box girders required some adjustment of the "general" provisions of the Load Factor Design sub-section, see proposed modifications.

The proposed provisions for the design of webs and web stiffeners of box girders differ considerably from those for webs of plate girders given in the current AASHTO Specifications, see Section C.1.3.b above, and commentaries on Articles 1.7.55 and 1.7.210-213 in this report. However, with the exception of the degree of utilization of tension field strength, there should not be any reason for different treatment of the box girder and the plate girder webs. Therefore, the writers suggest that the design approach proposed in this report for box girder webs be considered in the course of future revisions of the AASHTO Specifications for the design of plate girder webs, for the sake of consistency.

C.1.6. Design Analysis

Since the design analysis of eccentrically loaded box girders, including the necessary determination of the stresses due to torsion and distortion of box girder cross sections, may be complex, the question arose whether basic procedures and formulas for such calculations should be given in the proposed provisions, as a convenience for the designers. However, it was recognized that satisfactory guidance in design analysis of box girders could not well be given within the format of the AASHTO Specifications, which serve the purpose of ensuring structural adequacy of bridges, but are not intended to be a comprehensive

"code of good practice".

C.1.7. Provisions for Fabrication and Erection

(a) Fabrication

Fabrication imperfections (plate out-of-flatness and stiffener out-of-straightness) and residual stresses due to welding affect the ultimate compression strength of members. These effects are accounted for by the allowances for residual stresses and the geometric tolerance limits assumed in the design.

Effects of residual stresses have been conservatively included in the strength criteria for unstiffened and stiffened plate elements in compression (see Sect. C.1.2. above, and Articles 1.7.205, 206 of the proposed provisions, with commentaries). Therefore, residual stresses do not have to be calculated directly by the designer, nor are any specific limitations of residual stresses included in the fabrication provisions of the proposed specifications.

Regarding dimensional tolerances the conclusion was reached that tolerances normally achieved in conventional fabrication are adequate, and that more stringent controls would be economically unwarranted and of little benefit in strength. Therefore the proposed tolerance limits are generally in line with the current requirements of the AASHTO and AWS Specifications. Proposed tolerances also satisfy the assumptions made in the strength calculations of compression members (see Articles 1.7.205, 206).

It should be noted that definitions of geometric imperfections and methods of their measurements are different in the various specifications; thus, comparisons of tolerance standards are difficult. The writers feel that simple and uniform tolerance standards would be desirable.

Further discussion of these problems is given in commentary on Art. 2.10.46A.

(b) Erection

The need for care in the erection of box girders has been underscored by the failure during construction of four box girder bridges abroad (see commentary on Art. 2.10.55A). The common cause of these failures was insufficient attention to stability of partly erected box girders under stress conditions widely different from those under working loads of completed structures. One of the lessons learned was the importance of a clear allocation of the responsibilities of the Engineer and the Contractor and co-ordination of their work during construction.

C.2. RECOMMENDATIONS

Based on studies made under Task C of this project the provisions for design, workmanship and erection of steel box girder bridges have been prepared, and are given in Part D of this report. These proposed provisions are being submitted to the FHWA and the AASHTO Subcommittee on Bridges and structures for further consideration and possible inclusion in the 1980 AASHTO Interim Specifications.

With reference to problems discussed in the Summary of Task C, Section C.1 of this report, the following additional recommendations are made for future work:

C.2.1. Suggested Revisions of the AASHTO Specifications

a) Adjustment of the load factors γ and β of Art. 1.2.22 to be used with the proposed provisions for bottom flanges in compression, to account for inclusion of the effects of imperfections and residual stresses in the design strength curves for the unstiffened and the stiffened flanges.

b) Extension of the design approach proposed for the webs of box girders to the webs of plate girders, with appropriate adjustment of tension field strength contribution in plate girder webs.

c) Revision and liberalization of the web slenderness provisions, to be based on the actual web stress range.

d) General revision of the fatigue provisions based on the concept of "effective stress range".

e) Unification and simplification of the fabrication tolerance standards and methods of measurements.

C.2.2. Suggested Design Studies and Further Research

a) Parametric studies of applications of the proposed design rules for webs, web stiffeners, unstiffened and stiffened flanges in compression are very desirable. Such studies will permit evaluation of the range of plate and stiffener sizes, determine which of the various parameters are of principal importance in practical design, and may indicate ways to improve, and simplify the proposed rules.

b) It is generally recognized that many questions pertaining to the design of stiffened webs and, particularly, the web stiffeners are still not definitively solved and remain to be answered by continuing research. Further theoretical and experimental work on these problems is much needed.

D. RECOMMENDED PROVISIONS FOR DESIGN, WORKMANSHIP,
AND ERECTION OF STEEL BOX GIRDER BRIDGES

PROPOSED REARRANGEMENT* AND ADDITIONS** TO

DIVISION I - DESIGN

SECTION 7 - STRUCTURAL STEEL DESIGN

STRENGTH DESIGN METHOD

LOAD FACTOR DESIGN

AASHTO Std. Specifications for Highway Bridges, 12th Ed.1977

General

| | Page |
|--|------|
| 1.7.52 Scope | 215 |
| 1.7.53 Notations | 215 |
| 1.7.54 Loads | 216 |
| 1.7.55 Design Theory | 216 |
| 1.7.56 Assumptions | 217 |
| 1.7.57 Design Stress for Structural Steel | 217 |
| 1.7.58 Maximum Design Loads | 217 |
| 1.7.69 Compression Members | 232 |
| (A) Axial Loading | 232 |
| (B) Combined Axial Load and Bending | 233 |
| 1.7.70 Solid Rib Arches | 234 |
| (A) Moment Amplification and Allowable Stresses .. | 234 |
| (B) Web Plates | 234 |
| (C) Flange Plates | 235 |
| 1.7.71 Splices, Connections and Details | 235 |
| (A) Connectors | 235 |
| (B) Bolts Subjected to Prying Action by Connected Parts | 236 |
| (C) Rigid Connections | 237 |
| 1.7.72 Overload | 238 |
| (A) Noncomposite Beams | 238 |
| (B) Composite Beams | 238 |
| (C) Friction Joints | 238 |
| 1.7.73 Fatigue | 238 |
| (A) General | 238 |
| (B) Composite Construction | 239 |
| (C) Hybrid Beams and Girders | 239 |
| 1.7.74 Deflection | 239 |
| 1.7.75 Orthotropic Superstructures | 239 |

*) Rearrangement of this section is proposed in connection with the addition of the new provisions for steel box girders.

***) See new provisions tentatively numbered 1.7.200-217.

Beams and Girders

| | | |
|--------|---|-----|
| 1.7.59 | Symmetrical Beams and Girders | 217 |
| | (A) Compact Sections | 217 |
| | (B) Braced Noncompact Sections | 219 |
| | (C) Transition | 220 |
| | (D) Unbraced Sections | 220 |
| | (E) Transversely Stiffened Girders | 221 |
| | (F) Longitudinally Stiffened Girders | 223 |
| | (G) Bearing Stiffeners | 224 |
| 1.7.60 | Unsymmetrical Beams and Girders | 224 |
| | (A) General | 224 |
| | (B) Unsymmetrical Sections with Transverse Stiffeners | 224 |
| | (C) Longitudinally Stiffened Unsymmetrical Sections | 224 |
| 1.7.61 | Composite Beams and Girders | 224 |
| 1.7.62 | Positive Moment Sections of Composite Beams and Girders | 225 |
| | (A) Compact Sections | 225 |
| | (B) Noncompact Sections | 226 |
| 1.7.63 | Negative Moment Sections of Composite Beams and Girders | 227 |
| 1.7.64 | Composite Box Girders | 227 |
| | (A) Maximum Strength | 227 |
| | (B) Lateral Distribution | 227 |
| | (C) Web Plates | 227 |
| | (D) Tension Flanges | 227 |
| | (E) Compression Flanges | 228 |
| | (F) Diaphragms | 229 |
| 1.7.65 | Shear Connectors | 230 |
| | (A) General | 230 |
| | (B) Design of Connectors | 230 |
| | (C) Maximum Spacing | 230 |
| 1.7.66 | Hybrid Girders | 230 |
| 1.7.67 | Noncomposite Hybrid Girders | 231 |
| | (A) Compact Sections | 231 |
| | (B) Braced Noncompact Sections | 231 |
| | (C) Unbraced Noncompact Sections | 231 |
| | (D) Transversely Stiffened Girders | 232 |
| 1.7.68 | Composite Hybrid Girders | 232 |

Box Girders

| | |
|---------|--|
| 1.7.200 | Scope |
| 1.7.201 | Applicable General Provisions |
| 1.7.202 | Design Analysis |
| 1.7.203 | Multi-box Composite Girders |
| 1.7.204 | Effective Width of Flanges |
| 1.7.205 | Unstiffened Bottom Flanges in Compression |
| 1.7.206 | Stiffened Bottom Flanges in Compression |
| 1.7.207 | Longitudinal Stiffeners of Compression Flanges |

- 1.7.208 Bottom Flanges in Tension
- 1.7.209 Top Flanges
- 1.7.210 Unstiffened Webs
- 1.7.211 Transversely Stiffened Webs
- 1.7.212 Transversely and Longitudinally Stiffened Webs
- 1.7.213 Web Stiffeners
- 1.7.214 Webs of Hybrid Girders
- 1.7.215 Diaphragms
- 1.7.216 Transverse Structural Members of Flanges
- 1.7.217 Miscellaneous Details of Box Girders

PROPOSED MODIFICATIONS OF CURRENT GENERAL DESIGN PROVISIONS OF THE LOAD FACTOR DESIGN METHOD

Art. 1.7.52 - Scope

Delete the words "of moderate length" from the first sentence.

Art. 1.7.53 - Notation

Add the following notation:

- A_o = area of one longitudinal stiffener in flange (in²) (m²)
- A_f = area of one box girder flange or effective area of box girder tension flange (in²) (m²)
- b = width of flange plate between adjacent webs of box girder (in) (m)
- b' = width of flange projection beyond outer web of box girder (in) (m)
- C_s = effective slenderness coefficient of a longitudinal stiffener in compression flange
- C'_s = effective slenderness coefficient of a web stiffener
- D = clear depth of box girder web, measured along web, or diaphragm depth between top and bottom supported edges (in) (m)
- D' = depth of web subpanel (in) (m)
- D_c = clear distance between neutral axis and compression flange (in) (m)
- F_u = ultimate strength of flange panel in compression (psi) (MPa)

- f_1, f_2, f_{1w}, f_{2w} = axial in-plane stresses in a plate panel (psi) (MPa)
- f_v = shear stress in a plate panel (psi) (MPa)
- F_T = tension field stress (psi) (MPa)
- $F_{vcr}^o, F_{bcr}^o, F_{ccr}^o$ = critical buckling stress of a web panel or subpanel in the case of shear, pure bending or pure compression acting alone, respectively. (psi) (MPa)
- $F_{vcr}, F_{bcr}, F_{ccr}$ = individual (shear, pure bending, pure compression) stress components which cause buckling of a web panel or subpanel when acting simultaneously (psi) (MPa)
- I_R = reduced moment of inertia of box girder section computed by removing portions of web in compression (in⁴) (m⁴)
- k = buckling coefficient of plate panel in pure bending or pure compression
- k_v = buckling coefficient of plate panel in pure shear
- L = panel length of stiffened compression flange (spacing of transverse stiffeners or members) (in) (m)
- L' = reduced effective length of stiffened compression flange panel (in) (m)
- L_o = buckling length of stiffened compression flange in absence of transverse stiffeners or members (in) (m)

- m_T, m_L = multipliers used in computing required rigidities of web stiffeners
- P_u = ultimate capacity of box girder flange (lb) (N)
- t_D = thickness of diaphragm plate (in) (m)
- t' = thickness of outstanding stiffener element (in) (m)
- V_B = buckling shear capacity of web panel (beam action) (lb) (N)
- V_T = tension field shear capacity of web panel (tension field action) (lb) (N)
- V_u = ultimate shear capacity of web panel (lb) (N)
- w = spacing of longitudinal stiffeners in compression flange (in) (m)
- α = aspect ratio of plate panel
- γ_T^*, γ_L^* = relative rigidity coefficients of transverse and longitudinal web stiffeners, respectively
- θ = angle of inclination of web plate to vertical
- θ_d = angle of inclination of web panel diagonal to horizontal
- $\lambda, \lambda_v, \lambda_{pl}$ = non-dimensional plate slenderness parameter
- λ_{col} = non-dimensional column slenderness parameter

Ψ = effective width coefficient due to the effect of shear lag.

Additional symbols are defined where they are used in the formulas.

Art. 1.7.55 - Design Theory

Add at end of first paragraph:

"....as modified in Article 1.7.59(A) (3) for plate girder structures only."

Revise the second paragraph to read as follows:

"The members shall be proportioned by the methods specified in Articles 1.7.59 through 1.7.71, or 1.7.200 through 1.7.217 so that their computed maximum strengths shall be at least equal to the total effects of design loads multiplied by their respective load factors specified in Article 1.2.22."

Art. 1.7.56 - Assumptions

Add the following at the end of assumption (1):

"....except where shear lag is considered in the design of wide flanges of box girders."

Art. 1.7.64 - Composite Box Girders

Add after the introductory paragraph and before the heading (A) Maximum Strength:

"New provisions for box girders given in Articles 1.7.200 to 1.7.217 may be utilized alternatively."

Art. 1.7.74 - Deflection

Add the following paragraphs to this article:

"The deflections of orthotropic-deck plate girder or box girder bridges due to service live load plus impact may exceed the limitations in Art. 1.7.6, but preferably shall not exceed $1/500$ of their span.

The effective width of the steel flange used in the computation of deflections of box girder bridges and orthotropic-deck plate girder bridges shall be determined in accordance with Art. 1.7.204."

PROPOSED NEW PROVISIONS OF THE LOAD FACTOR DESIGN METHOD
SUB-SECTION: BOX GIRDERS

1.7.200 Scope

These provisions apply to (1) girder bridges which have a single steel box cross section consisting of one or more cells, with deck design of either orthotropic steel plate or composite concrete, and to (2) short and medium span multi-box bridges with composite concrete decks.

Special provisions necessary for horizontally curved girder bridges, girders with haunches over the supports, skewed girder bridges, cable-stayed girder bridges or girder stiffened suspension bridges are not included in these specifications.

1.7.201 Applicable General Provisions

The general provisions for load factor design outlined in Articles 1.7.52 through 1.7.58 and 1.7.69 through 1.7.75 shall apply in the design of box girders, unless specifically modified by provisions of Articles 1.7.200 through 1.7.217 of this section.

1.7.202 Design Analysis

An appropriate method of elastic analysis (such as the thin-walled-beam method) that accounts for the effects of torsional distortions of the cross-sectional shape shall be used in designing the girders of box girder bridges. The box girder design shall be checked for lane or truck loading arrangements that produce maximum distortional (torsional) effects.

Designer's attention is called to the need to consider stresses due to erection conditions, see Art. 2.10.55 A .

Composite box girder bridges of moderate length consisting of two or more single cell girders may be designed in accordance with the special provisions of Art. 1.7.203.

1.7.203 Multi-Box Composite Girders

This Article pertains to the design of simple and continuous bridges of moderate length supported by two or more single-cell composite box girders. It is applicable to box girders, having width center-to-center of top steel flanges approximately equal to the distance center-to-center of adjacent top steel flanges of adjacent box girders. The cantilever overhang of the deck slab, including curbs and parapet, shall be limited to 60 percent of the distance between the centers of the adjacent top steel flanges of adjacent box girders, but shall in no case be greater than 6 feet (1.8 m).

(A) Lateral Distribution

The live load bending moment for each box girder shall be determined in accordance with Article 1.7.49(B).

(B) Maximum Strength

The maximum strength of box girders shall be determined in accordance with applicable provisions of Articles 1.7.204 through 1.7.213.

(C) Diaphragms

Diaphragms, cross-frames, or other such devices shall be provided within the box girders at each support to resist transverse rotation, displacement and distortion.

Intermediate diaphragms or cross-frames are not required for service conditions of box girder bridges designed in accordance with this specification.

For bracing requirements for erection refer to Article 2.10.55 A .

1.7.204 Effective Width of Flanges

Longitudinal stresses in flanges under working loads (as may be required for fatigue calculations, or for consideration of non-uniform stress distribution due to shear lag) and deflections shall be computed by taking effective width as follows:

(A) Box Girder Flanges

(1) The effective width of the flange shall be the sum of the effective widths of the portions of the flange on each side of each web considered separately.

(2) The effective width of flange elements shall be taken as follows (see Fig. 1.7.204(a)):

For portion between webs: Ψb

For portions projecting beyond outer webs:
 $2 \times 0.85 \Psi b'$

where

b = width of flange between webs

b' = width of flange projection beyond outer web

Ψ = effective width coefficient for flange between webs

0.85Ψ = effective width coefficient for flange projection

The values of Ψ shall be obtained from Fig. 1.7.204 (d) using the values of the equivalent simple span, L , as follows:

For simply supported girders, or for midspan portions between points of inflection of continuous girders: use $L = L_1$ = length of span or distance between points of inflection and obtain Ψ from curves (1) for midspan portions and from curves (2) for portions near supports or inflection points.

For portions near supports of continuous girders:
 use $L = L_2 =$ distance between points of inflection
 on each side of support and obtain ψ from curves (3).
 If distances between support and points of inflec-
 tion on each side of support, C_1 and C_2 , are unequal,
 obtain ψ as average of values of ψ for $L_2 = 2C_1$ and
 $L_2 = 2C_2$.

For portions near supports of cantilevers:
 obtain ψ by the above procedure, using $C_1 =$ length
 of cantilever and $C_2 =$ distance to point of inflec-
 tion on other side of support.

For cantilevers fixed at support:
 use $L_2 = 2$ times length of cantilever.

The effect of flange orthotropy is expressed by
 parameters $2A_s/bt$ or $A'_s/b't$, where A_s and A'_s are cross-
 sectional areas of stiffeners within $b/2$ and b' , re-
 spectively.

The values of ψ shall be obtained by interpolation
 between the curves for $2A_s/bt$ or $A'_s/b't$ equal to 0 and
 equal to 1.

The values of ψ along the span of the girder shall
 be assumed to vary linearly between the points at which
 they were determined, see Fig. 1.7.204(c).

(3) Stresses obtained by using the resulting effec-
 tive section properties are the longitudinal stresses,
 f_{max} , at the flange-web junctions. Stress distribution
 over other parts of the flange shall be assumed as shown
 in Fig. 1.7.204(a).

The distribution of the stresses in the flange is
 given by the equation

$$f_x = f_{max} \left\{ (2x/b)^4 + \left[(5\psi - 1)/4 \right] \left[1 - (2x/b)^4 \right] \right\}$$

$$\text{or } f_x = f_{max} \left\{ (x/b')^4 + \left[(4.25\psi - 1)/4 \right] \left[1 - (x/b')^4 \right] \right\}$$

where $x =$ distance from center of flange or from edge
 of projecting flange.

(B) Transverse Members of Flanges

(1) The effective width of the flange acting with a transverse deck floorbeam, or with a transverse bottom flange stiffener shall be computed by the rules of Art. 1.7.204(A), with the "span" and "spacing" designations appropriately altered.

(2) The following limitations of the effective flange width shall apply:

The maximum effective flange width of the transverse member at its midspan between box girder webs shall not exceed one-third of the transverse member's span, nor shall it exceed the spacing of the transverse members.

The maximum effective flange width of a cantilevered transverse member near its support shall not exceed 15 percent of the distance between box girder webs, nor shall it exceed one-half of the spacing of the transverse members.

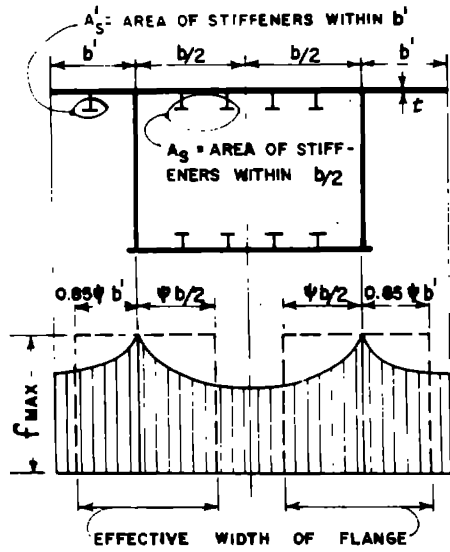

a) STRESS DISTRIBUTION
ACROSS GIRDER FLANGE

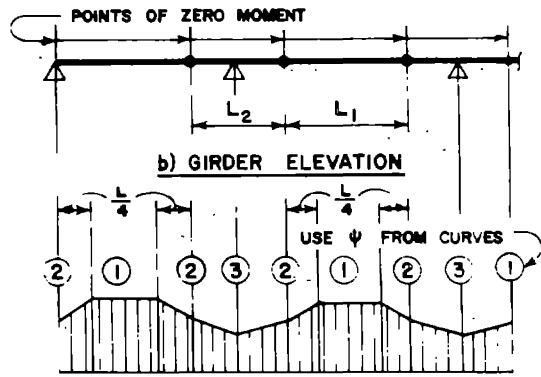

c) VARIATION OF ψ ALONG GIRDER SPAN

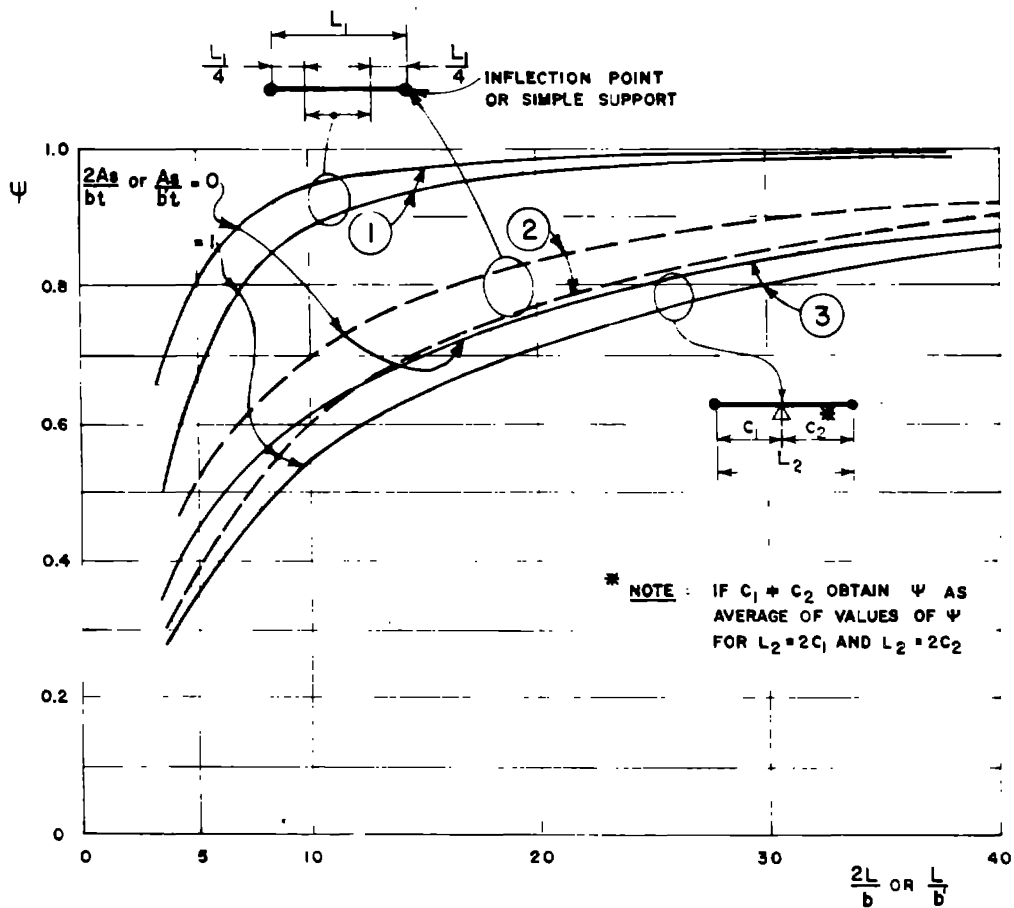

d) VALUES OF ψ

FIG I.7.204. EFFECTIVE WIDTH OF FLANGE

1.7.205 Unstiffened Bottom Flanges in Compression

(A) Scope

This article applies to bottom flanges in compression without longitudinal stiffeners. These provisions are not intended to apply to plate panels between longitudinal stiffeners of stiffened flanges.

(B) Strength of Flange

(1) The ultimate capacity of flange, P_u , shall be computed as

$$P_u = F_u A_f \text{ or } F'_u A_f$$

where A_f = cross-sectional area of flange, as defined in Section (F)

F_u = ultimate strength of flange panel in compression

F'_u = modified ultimate strength of flange panel in combined axial compression and shear, see Art. 1.7.205(C).

(2) For flange panels with aspect ratio $a/b \geq 1$, the ultimate strength, F_u , shall be computed as a function of the plate slenderness parameter

$$\lambda_{pl} = \sqrt{\frac{F_y}{F_{cr}}} = \frac{b}{t} \sqrt{\frac{10.92 F_y}{\pi^2 k E}} = \frac{b/t}{1.9} \sqrt{\frac{F_y}{E}}$$

where a = length of plate panel (taken as the spacing, L , between transverse flange stiffeners)

b = width of plate panel

t = thickness of flange plate

F_y = yield strength of steel

F_{cr} = elastic buckling stress of plate panel

E = modulus of elasticity of steel
= 29,000,000 psi (200,000 MPa)

k = plate buckling coefficient (taken as 4
for plate panels simply-supported along
the longitudinal edges)

(3) For flange panels having a slenderness parameter λ_{pl} equal to or less than 0.65, the value of $F_u = F_y$.

(4) For flange panels having λ_{pl} greater than 0.65 but not exceeding 1.5, the value of F_u shall be computed by the formula

$$F_u = F_y \left[0.50 + 0.43(\lambda_{pl} - 1.73)^2 \right]$$

(5) For flange panels having λ_{pl} exceeding 1.5, the value of F_u shall be computed by the formula

$$F_u = F_y (0.82 - 0.20 \lambda_{pl})$$

The values of F_u may also be read from Fig. 1.7.205(A).

(6) The strength of a flange panel at the higher-stressed end shall be limited by the yield strength, F_y (without considering shear).

(C) Effects of Combined Stresses

(1) Combined Axial Compression and Shear

The effect of combined axial compressive stress and shear, f_v , acting simultaneously shall be considered as follows:

If $f_v \leq 0.175 F_y$: $F'_u = F_u$

If $f_v > 0.175 F_y$ the modified ultimate strength, F'_u , of the flange is

$$F'_u = 1.05 F_u \sqrt{1 - \frac{3f_v^2}{F_y^2}}$$

where f_v = governing shear stress in flange computed with factored loading, as defined in Art. 1.7.205(D).

(2) Combined Axial Compression in Longitudinal and Transverse Direction

Where transverse stress is due to flexure of a transverse stiffener or diaphragm, or to the effect of inclined webs at the girder supports, the effect of this stress may be taken to be restricted to the effective width of plate associated with the transverse member; and the combined effect of the transverse and the longitudinal stresses may be ignored.

If transverse stress in the panel extends over the entire length of the panel, a special investigation shall be required.

(D) Stress Values to be Used in Design

(1) The governing values of the load-factored simultaneous compressive and shear stresses, f_1 and f_v , to be used in the design of a panel subject to varying stress intensity, shall be computed at a distance of $0.4b$ from the transverse support at the higher-stressed end, or from the point of reduction of plate thickness, in a thinner plate.

The shear stress due to box girder flexure shall be taken as

$$f_v = \frac{1}{3}f_v \text{ max}$$

The shear stresses due to other causes (torsion, warping) shall be taken at their average values.

These provisions are illustrated in Fig. 1.7.205(B).

(2) The design force in flange panels adjacent to webs designed with utilization of tension field action shall include an additional compression force, ΔF_1 , computed in accordance with the provisions of Art. 1.7.211(E) or 1.7.212(D).

(E) Slenderness Limitations

Except in areas of low stress near points of dead-load contraflexure, the slenderness parameter, λ_{pl} , of unstiffened flanges shall not exceed 1.3. This corresponds to b/t ratios of 70 and 60 for steels with yield strength, F_y , equal to 36,000 psi (250 MPa) and 50,000 psi (350 MPa), respectively.

(F) Cross-Sectional Area of Flange

The cross-sectional area of flange, A_f , shall include the width, b , of the flange plate between the webs, plus the flange projections, b' , on each side beyond the webs, with b' not exceeding

$$b'_{\max} = 0.3t / \sqrt{F_y/E}$$

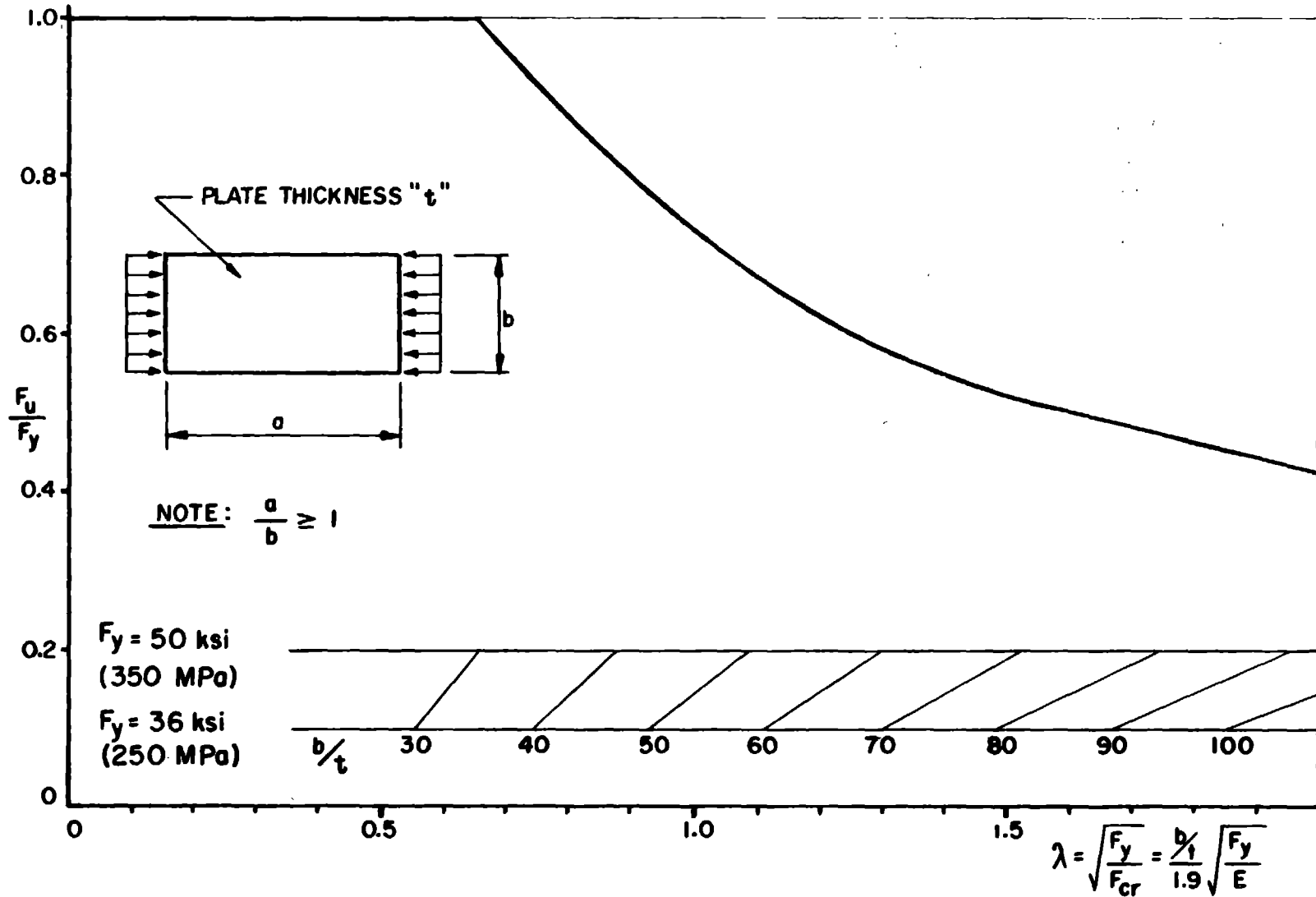
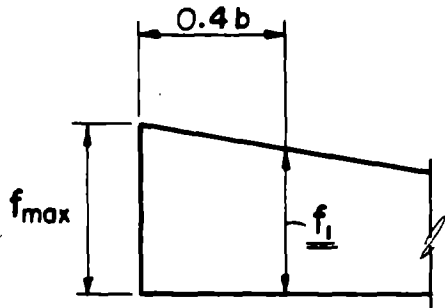
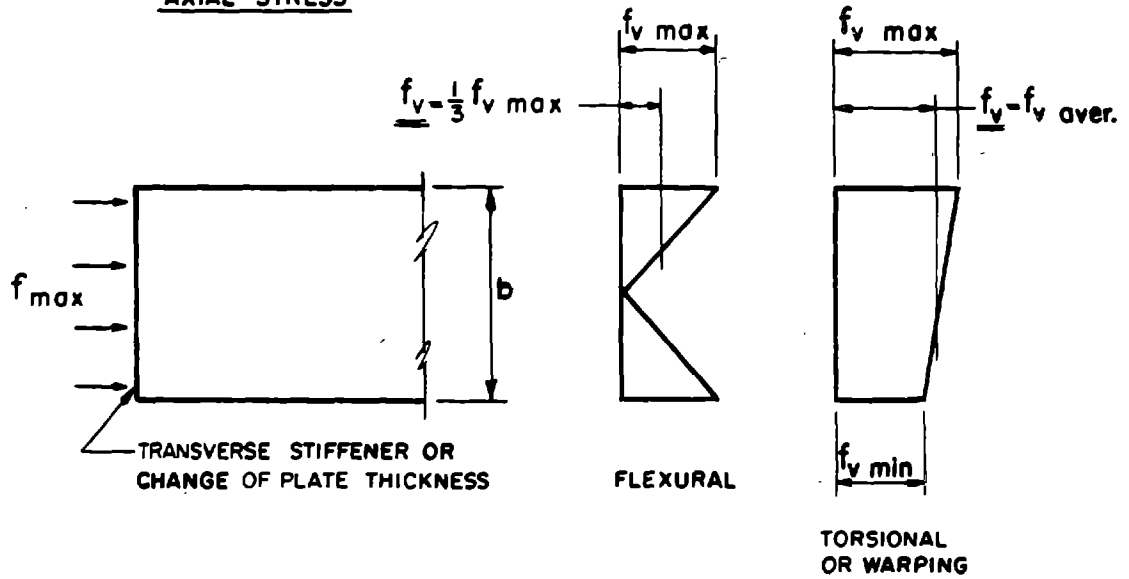

FIG I.7.205 (A) STRENGTH OF UNSTIFFENED PLATE PANEL



AXIAL STRESS



PLAN OF FLANGE PANEL

SHEAR STRESSES

FIG. 1.7.205 (B) GOVERNING STRESSES IN THE DESIGN OF UNSTIFFENED FLANGE IN COMPRESSION

1.7.206 Stiffened Bottom Flanges in Compression

(A) Scope

This article applies to bottom flanges with longitudinal stiffeners, in compression.

(B) Strength of Flange

(1) The ultimate capacity of the flange shall be computed as

$$P_u = F_u A_f \text{ or } F'_u A_f, \text{ whichever is less}$$

where A_f = cross-sectional area of flange, including flange plate, all longitudinal stiffeners, and flange overhangs beyond webs, subject to limitations of Art. 1.7.205(F)

F_u = ultimate strength of a stiffener strut consisting of one stiffener and the associated portion of flange plate with width w equal to stiffener spacing, as given by interaction diagram, Fig. 1.7.206(A)

F'_u = modified ultimate strength of a stiffener strut under combined axial compression and shear, as defined in Art. 1.7.206(B)
(2)

λ_{pl} = plate slenderness parameter, defined as

$$\lambda_{pl} = \sqrt{\frac{F_y}{F_{cr}}} = \frac{w}{t} \sqrt{\frac{10.92 F_y}{\pi^2 k E}} = \frac{w/t}{1.9} \sqrt{\frac{F_y}{E}}$$

λ_{col} = column slenderness parameter, defined as

$$\lambda_{col} = \sqrt{\frac{F_y}{F_{cr}}} = \frac{1}{\pi} \sqrt{\frac{F_y}{E}} \frac{L}{r}$$

where

w = spacing of longitudinal stiffeners, or distance between longitudinal stiffener and web

L = spacing of transverse stiffeners supporting longitudinal stiffeners. A reduced effective length, L' , may be used where applicable, see Art. 1.7.206(B)(3)

r = radius of gyration of stiffener strut composed of one longitudinal stiffener and associated portion of the flange plate of width w

and all other terms are as defined in Art. 1.7.205(B)(1).

Gross cross-sectional areas of plate shall be used in all calculations.

(2) The effects of combined axial compressive stress and shear, or combined axial stress in longitudinal and transverse direction shall be evaluated in accordance with the provisions of Art. 1.7.205(C), except that the symbols F_u and F'_u shall denote the ultimate strengths as defined in Art. 1.7.206(B)(1), and the governing shear stress, f_v , shall be determined in accordance with Art. 1.7.206(C)(3).

(3) The effect of longitudinal edge restraint provided by the web in elongated stiffened flange panels (i.e. panels with a large L/b ratio, or flanges having no transverse stiffeners) may be allowed for by using a reduced effective length, L' , instead of the transverse stiffener spacing, L , in computing the column slenderness parameter, λ_{col} , as defined in 1.7.206(B)(1). L' is given by the equation

$$L' = \frac{L_1}{\sqrt{1 + \frac{[2 + (L_1/b)^2](L_1/b)^2}{18 (r/t)^2}}}$$

where b = flange width between webs

t = flange thickness

$L_0 = 2 b \sqrt{r/t}$ = buckling length of stiffener strut in absence of transverse stiffeners

L_1 = the smaller of L or L_0

L, r , are as defined in 1.7.206(B)(1)

(4) The effect of nonuniform longitudinal stress distribution due to shear lag, computed in accordance with Art. 1.7.204, is considered as follows:

Where the peak stress (at the webs) does not exceed the average stress by more than 20%, uniform distribution of stresses in the ultimate condition is assumed, and the effect of the shear lag may be neglected.

Where the peak stress exceeds the average stress by more than 20%, the flange capacity at the web shall be increased to accommodate an additional force computed as the load-factored stress in excess of 120% of the average times the flange area affected by the excess.

(5) Where the flange is subjected to compression stress varying linearly across the flange, the assumption of uniform distribution of stresses is not permitted, and each stiffener strut must be adequate to carry its calculated force.

(6) Where the stiffeners vary in size, or where their spacing is nonuniform, the ultimate flange capacity shall be obtained as the sum of the ultimate capacities of the individual struts and the remaining portions of the flange plate, provided that the capacities of the individual struts do not vary by more than 20%.

(7) The ultimate strength of any stiffened flange panel shall be limited by the stub strength at the higher-stressed end of the panel, $F_{u,stub}$, defined as

$$F_{u,stub} = \frac{wtF_{u,plate} + A_oF_y}{wt + A_o}$$

where $F_{u,plate}$ = ultimate strength of an unstiffened plate panel having width b equal to the stiffener spacing, w , as given in Art. 1.7.205(B)(1)

A_o = cross-sectional area of one stiffener

(8) A separate strength check of the plate panels between the stiffeners (in accordance with Art. 1.7.205) is not required.

(C) Design Force in Flange

(1) The design force in a flange panel shall be taken as the governing axial stress under factored loading, times the flange area, A_f , as defined by Art. 1.7.206(B)(1). The governing axial stress shall be calculated at the mid-plane of the flange plate in accordance with elastic design theory.

(2) The design force in flange panels adjacent to webs designed with utilization of tension field action shall include an additional compression force, ΔF_1 , in accordance with the provisions of Art. 1.7.211(E) or 1.7.212(D).

(3) The governing values of the factored compressive and shear stresses in a flange panel shall be calculated at a distance from the higher stressed end of the panel of $0.4L$ or $0.4L'$ from the transverse stiffener, or from the point of reduction of cross-section of the panel, where the values of L or L' are as defined in Art. 1.7.206(B)(1) or (B)(3).

(4) The governing shear stress due to box girder flexure shall be taken as the greater of the following

$$f_v = \frac{1}{3} f_{v,\max} \quad \text{or} \quad f_v = \left(1 - \frac{4}{n+1}\right) f_{v,\max}$$

where $f_{v,\max}$ = maximum value of flexural shear in flange at web

n = number of longitudinal stiffeners

The governing shear stresses due to other causes (torsion, warping) shall be taken as their average values.

Definitions of governing stresses are illustrated in Fig. 1.7.206(B).

(D) Slenderness Limitations

(1) Longitudinal stiffeners of flanges designed in accordance with the provisions of this Article shall satisfy the requirements for safety against local torsional buckling given in Art. 1.7.207.

(2) The slenderness of flange plate panels between stiffeners shall not exceed the limits specified in Art. 1.7.205(E).

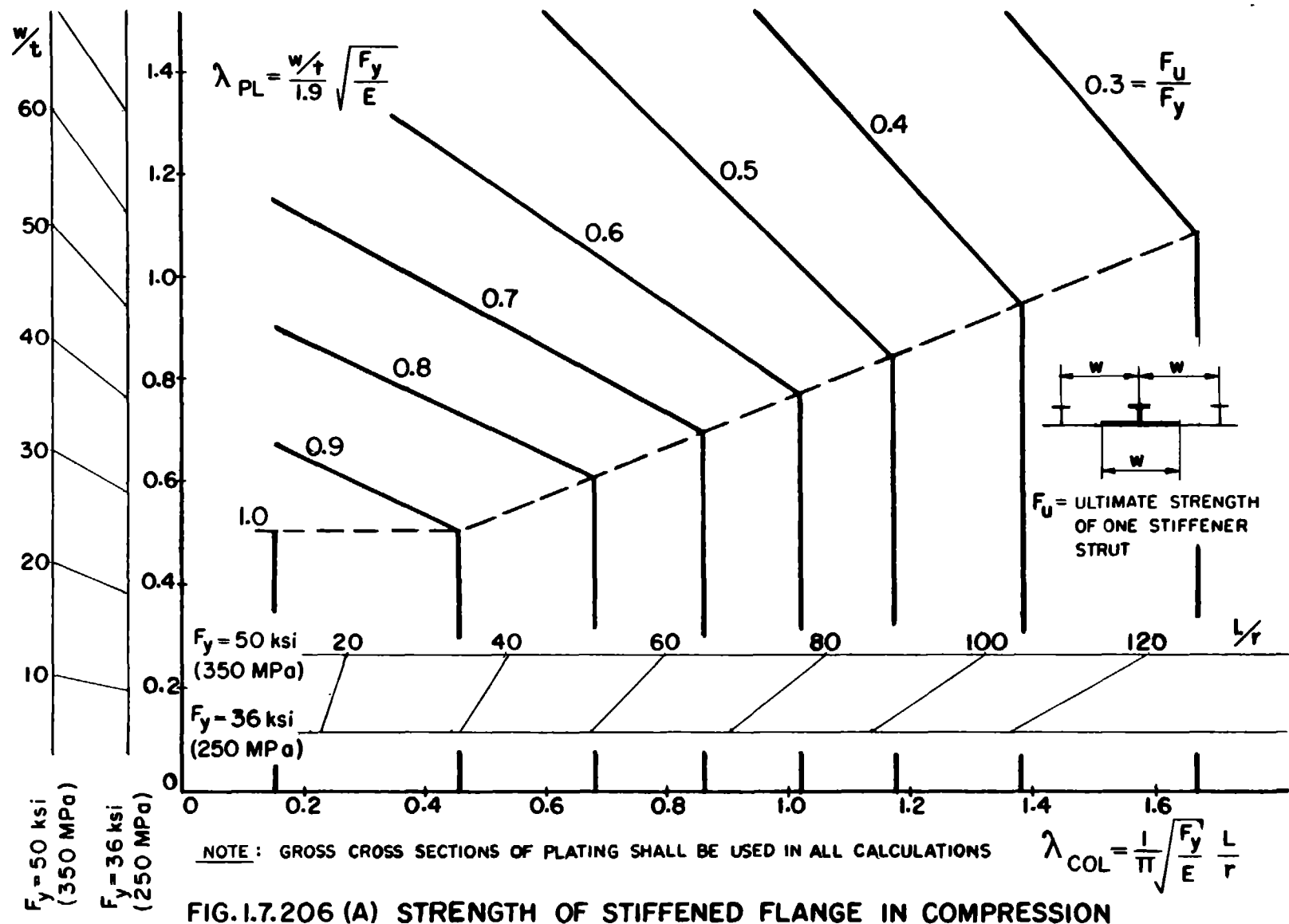

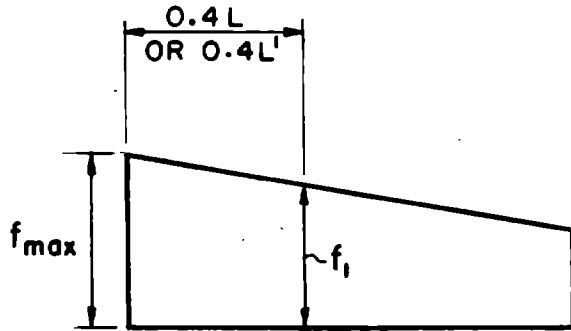

AXIAL STRESS

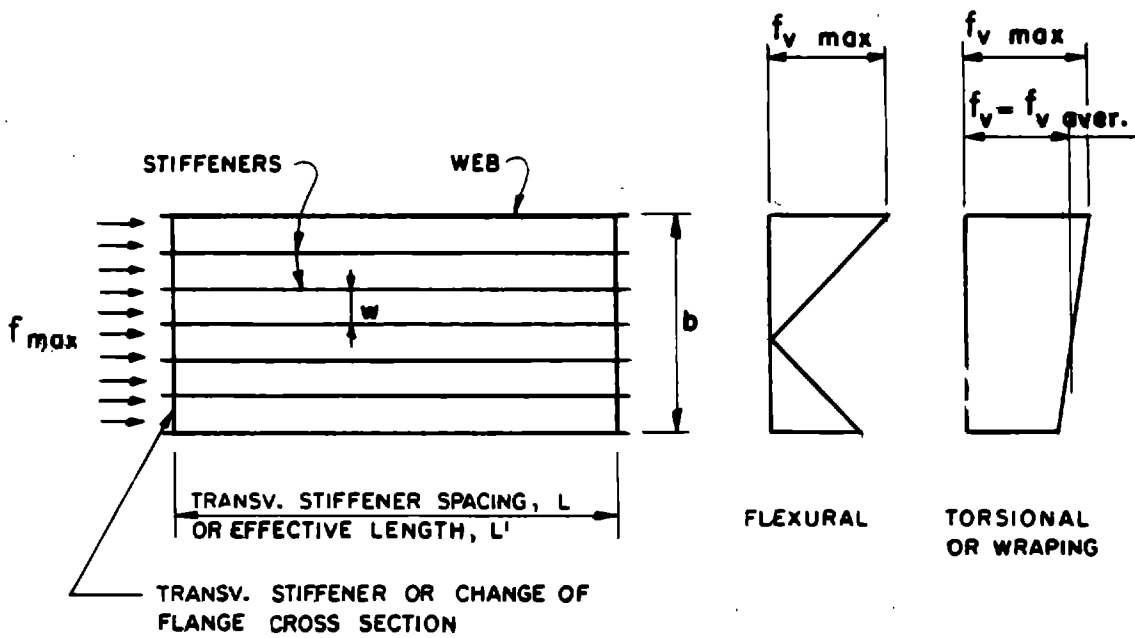

PLAN OF FLANGE PANEL

SHEAR STRESSES

NOTE: FOR GOVERNING VALUES OF SHEAR SEE ART. 1.7. 206 (C)(3)

FIG.1.7.206 (B) GOVERNING STRESSES IN THE DESIGN OF STIFFENED FLANGE IN COMPRESSION

1.7.207 Longitudinal Stiffeners of Compression Flanges

(A) Open Stiffeners

(1) The effective-slenderness coefficient, C_s , of a longitudinal stiffener in a stiffened compression flange shall not exceed the values given by the following formulas:

$$\text{where } f_{\max} > 0.5F_y : \quad C_s \leq \frac{0.40}{\sqrt{F_y/E}}$$

$$\text{where } f_{\max} < 0.5F_y : \quad C_s \leq \frac{0.65}{\sqrt{F_y/E}}$$

where f_{\max} = maximum calculated factored compression stress in a compression panel, with consideration of shear lag in accordance with Article 1.7.204

$$C_s = \frac{d}{1.5t_o} + \frac{w}{12t} \quad \text{for flat-plate stiffeners}$$

$$C_s = \frac{d}{1.35t_o + 0.56r_y} + \frac{w}{12t} \quad \text{for tee or angle stiffeners}$$

d = stiffener depth

t_o = plate-stiffener thickness, or stem thickness of tee or angle stiffener

t = flange-plate thickness

r_y = stiffener radius of gyration, without effective width of plate, about axis perpendicular to flange plate

w = width of flange plate between stiffeners; where stiffener spacing is unequal the average of the two adjacent spacings shall be used

(2) The width-to-thickness ratio of any outstanding element of a stiffener shall not exceed the limit

$$\frac{b'}{t'} \leq \frac{0.48}{\sqrt{F_y/E}}$$

where b' = width of outstanding stiffener element

t' = thickness of outstanding stiffener element

(B) Closed Stiffeners

For closed stiffeners, the width-to-thickness ratio of plate elements shall be such that the strength of each plate element, calculated in accordance with Article 1.7.205(B), shall not be less than the strength of the stiffened flange, calculated in accordance with Article 1.7.206(B).

1.7.208 Bottom Flanges in Tension

(A) Scope

This article applies to bottom flanges stressed predominantly in tension.

(B) Strength of Flange

(1) Ultimate strength in tension

(a) The ultimate capacity, P_u , of a tension flange shall be taken as

$$P_u = F_y A_f \text{ or } F'_y A_f, \text{ whichever is less}$$

where

F_y = yield strength of steel

F'_y = reduced equivalent yield strength due to the effect of combined axial and shear stress, see Art. 1.7.208(C)

A_f = effective cross sectional area of flange, see Art. 1.7.208(F)

(b) The effect of nonuniform stress distribution due to shear lag, calculated in accordance with Art. 1.7.204 shall be considered as stipulated in Art. 1.7.206 (B)(4).

(2) Repetitive loading and toughness considerations

Tension flanges shall satisfy the fatigue and impact requirements of Art. 1.7.2.

The axial stresses under working loads to be used in fatigue calculations shall be calculated with consideration of nonuniform stress distribution in accordance with Art. 1.7.204.

(3) Strength in compression

Tension flanges shall be checked for compression that may occur near inflection points of the box girder, or during box girder erection, in accordance with Art. 1.7.205 or 1.7.206.

(C) Effect of Combined Stresses

The reduced equivalent yield stress, F'_y , due to the effect of combined axial and shear stresses shall be taken as

$$F'_y = F_y \sqrt{1 - \frac{3f_{v,avg}^2}{F_y^2}}$$

where

$f_{v,avg}$ = the average magnitude of sum of flexural and torsional shear stresses across width of flange, computed with factored loading

(D) Design Forces in Flange

(1) Governing axial and shear stresses, f_2 and f_v , shall be computed with factored loading at the cross section under consideration in accordance with elastic design theory.

Axial stresses shall be computed at the mid-plane of the flange plate.

(2) The design force of tension flange panels adjacent to webs designed with utilization of tension field action shall include an additional force ΔF_2 , computed in accordance with Art. 1.7.211(E) or 1.7.212(D).

(E) Dynamic Stability

Slender and flexible tension flanges which may be subject to dynamic excitation shall possess sufficient rigidity, or be suitably damped, to withstand such excitation.

Tension flanges of multi-box composite girders designed under the provisions of Art. 1.7.203 shall be deemed to satisfy the dynamic stability requirements.

(F) Effective Cross Sectional Area

The effective cross sectional area of tension flanges shall be the gross cross sectional area, including the areas of continuous longitudinal stiffeners.

The effective cross sectional area of sections containing rivet or bolt holes shall be computed in accordance with the requirements of Art. 1.7.44 (M).

(G) Slenderness Limitations

(1) The width-to-thickness ratio, b/t , of longitudinally unstiffened tension flanges, or w/t of longitudinally stiffened tension flanges, shall not exceed 120, where b is spacing between webs and w is spacing between longitudinal stiffeners.

(2) The width-to-thickness ratio of the tension flange projection beyond the web, b'/t , shall not exceed 20.

(3) The slenderness ratio, L/r , of the longitudinal stiffeners of a tension flange shall not exceed 120, where L is the spacing of the transverse supports of the longitudinal stiffeners and r is the radius of gyration of the stiffener in combination with an effective width of flange plate. For the purposes of this calculation the effective width may be taken as the spacing between the stiffeners.

1.7.209 Top Flanges

(A) Scope

This article applies to top flanges of box girder bridges in tension or compression.

(B) Orthotropic Steel Plate Decks

Orthotropic steel plate decks shall be designed in accordance with Art. 1.7.75 and 1.7.51. The design analysis shall consider the effects of axial compression, axial tension, and shear in the orthotropic deck acting as the top flange of the box girder, combined with the effects of flexure in the deck system (floorbeams, ribs and deck plate) due to wheel loads.

(C) Composite Concrete Decks in Positive Moment Sections

(1) Strength of steel flanges

(a) Separate steel flange for each web

Where the box girders are not provided with temporary supports during concrete slab placement, the sum of the flange stresses produced by the factored dead load acting on the steel section alone, and the flange stresses produced by the factored superimposed dead load and service live load acting on the composite girder, shall not exceed the yield strength of the flange.

Where the box girders are provided with effective intermediate supports which are kept in place until the concrete deck slab has attained 75 percent of its required 28-day strength, the total flange stresses produced by the factored initial dead load, superimposed dead load and service live load, acting on the composite girder, shall not exceed the yield strength of the flange.

For bracing requirements for erection refer to Art. 2.10.55A.

(b) Solid steel top flange connecting two or more webs.

The ultimate capacity of the solid steel flange in compression, acting compositely with a concrete deck, shall be determined by a rational analysis taking into consideration the sizes and spacings of the longitudinal and the transverse flange stiffeners, the number and arrangement of shear connectors, and the effect of local flange stresses due to wheel loads.

Where the box girders are not provided with temporary supports during concrete slab placement, the steel flange acting alone must be adequate for the axial stresses caused by dead loads and erection loads, with additional consideration of the local flexural stresses due to these loads, see Art. 2.10.55A.

(2) Strength of concrete deck

The strength of concrete deck and the number and arrangement of the shear connectors shall be determined in accordance with applicable provisions for composite girders of these specifications, with the following modification:

Where the top flange plate consists of a single steel plate extending between two or more webs, and where the slab is adequately anchored to the flange plate, the effective slab width may be taken as

$$b + 12t_s$$

where b = flange-plate width between webs

t_s = least thickness of slab

(D) Composite Concrete Decks in Negative Moment Sections

Composite tension flanges shall be designed in accordance with applicable provisions of these specifications. It shall be assumed that the concrete slab does not carry

tensile stresses. In cases where the slab reinforcement is continuous over interior supports, the reinforcement may be considered to act compositely with the steel section.

Solid steel top flanges may be treated in accordance with Art. 1.7.208, with the additional consideration of effects of wheel loads.

(E) Design Stresses in Flanges

(1) The governing axial and shear stresses and the local flexural stresses in orthotropic, composite or concrete decks shall be determined in accordance with the elastic theory.

(2) The design force in orthotropic steel plate deck panels or composite deck panels adjacent to webs designed with utilization of tension field action shall include additional forces, ΔF_1 or ΔF_2 , calculated in accordance with Art. 1.7.211(E) or 1.7.212(D).

(3) For stresses during erection refer to Art. 2.10.55A.

1.7.210 Unstiffened webs

(A) Scope

This article applies to box girder webs without stiffeners, except bearing stiffeners at supports.

(B) Carrying Capacity of Web

(1) General

The carrying capacity of an unstiffened web is given as the value of the buckling shear, V_B , which the web can carry under the combined effects of the shear and axial stress. The postbuckling strength shall be disregarded.

The value of V_B shall be obtained from the equation

$$V_B = F_{vcr} D t_w, \text{ where}$$

F_{vcr} = critical shear buckling stress, see Art. 1.7.210 (B)(2).

D = clear depth of web between the flanges, measured along the web.

t_w = web thickness

The maximum value of V_B shall not exceed the yield shear strength of the web with consideration of the effect of coincident axial stress, as follows

$$V_{B \text{ max}} = 0.58 D t_w \sqrt{F_Y^2 - \left(\frac{2}{3} f_{av}\right)^2}$$

where f_{av} is the average numerical value of the flexural axial stresses at the opposite longitudinal edges of the web, f_{1w} and f_{2w} , as defined in Art. 1.7.211(B)(4), disregarding the sign of the stress.

The ultimate shear capacity of an inclined web, V_B' , is

$$V_B' = V_B \cos \theta$$

where θ is the angle of inclination of the web to the vertical.

(2) Calculation of critical shear buckling stress, F_{vcr}

The value of F_{vcr} shall be determined in accordance with Article 1.7.211(B)(2), (3) and (4), except for the following provision applying to the case of unstiffened web:

F_{vcr}^o , the critical web buckling stress under shear stress acting alone, shall be calculated as a function of the web plate slenderness parameter

$$\lambda_v = 0.30 \frac{D}{t_w} \sqrt{\frac{F_y}{E}}$$

The values of F_{vcr}^o are found from equations in Table 1.7.211(B)(2), or from Fig. 1.7.210.

(C) Design Stresses in Web

The governing load-factored coincident shear and flexural or direct stresses to be used in the design of an unstiffened web shall be calculated at the following locations:

- (a) at distance $D/2$ from support
- (b) at location of maximum positive moment between the supports of box girder
- (c) at distance $D/2$ from location of change of thickness or yield stress of web material, on side of smaller thickness or yield stress

The shear stresses due to flexure or other effects shall be assumed uniformly distributed over the depth of the web panel. Direct stresses due to flexure or other effects shall be computed in accordance with elastic theory.

(D) Slenderness Limitations

The thickness of unstiffened webs shall meet the following requirements, but shall not be less than $3/8$ " (10mm).

$$D_c \leq D/2: \quad \frac{D_c}{t_w} \leq \frac{3.4}{\sqrt{F_y/E}}$$

$$D_c > D/2: \quad \frac{D}{t_w} \leq \frac{6.8}{\sqrt{F_y/E}}$$

where D_c = distance between neutral axis and compression flange

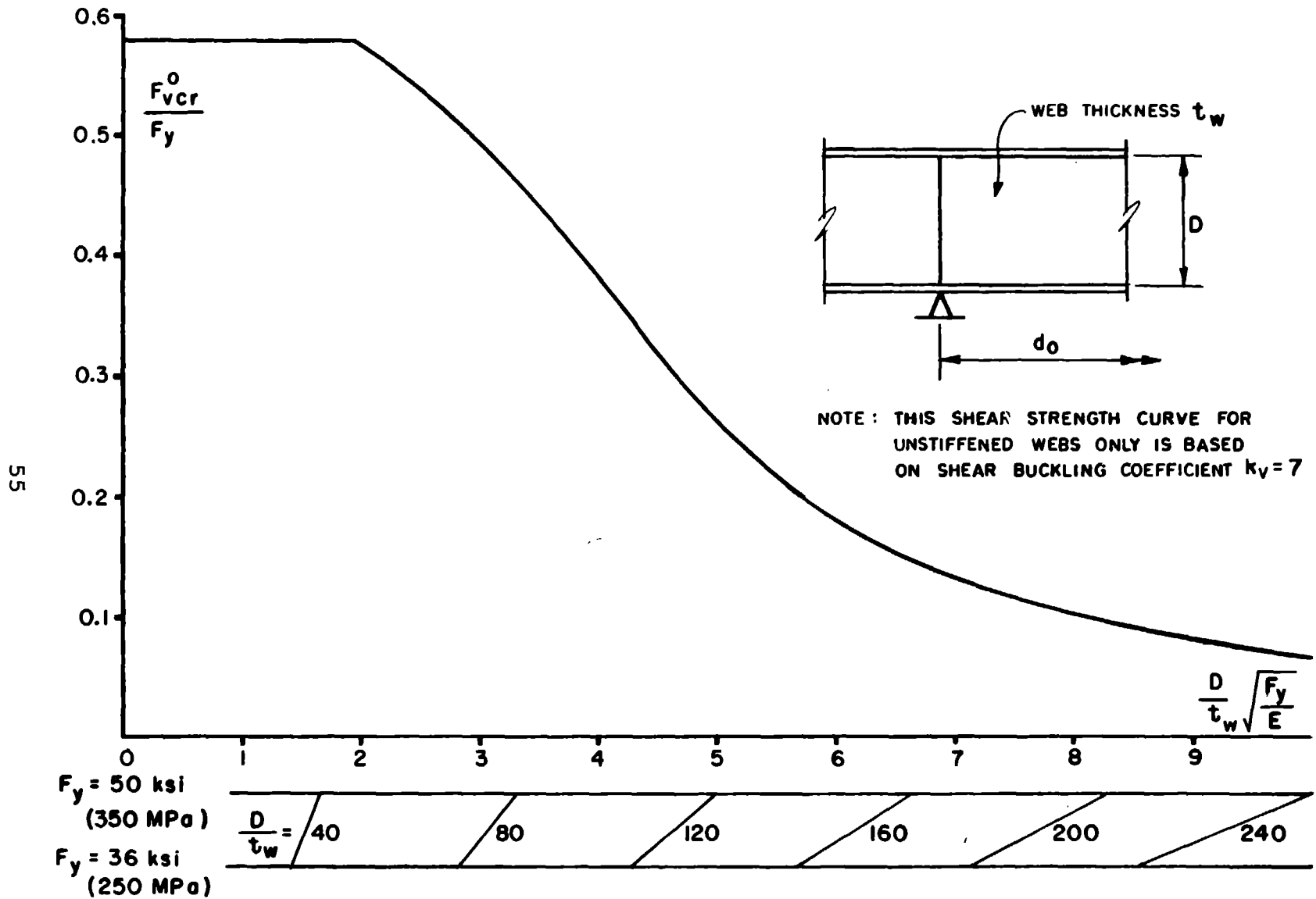

FIG. I.7.210 CRITICAL BUCKLING STRESS OF UNSTIFFENED WEB DUE TO SHEAR ACTING ALONE

1.7.211 Transversely Stiffened Webs

(A) Scope

This article applies to box girder webs with transverse stiffeners but without longitudinal stiffeners.

(B) Carrying Capacity of Web

(1) General

The carrying capacity of a web is given as the value of the ultimate shear, V_u , which the web can carry under the combined effects of the shear and axial stresses.

The value of V_u is obtained as the sum of the buckling strength, V_B , (beam action of the web), and the tension field strength, V_T (tension field action).

$$V_u = V_B + V_T$$

with

$$V_B = Dt_w F_{vcr}$$

$$V_T = \frac{Dt_w F_T}{2 \left(\sqrt{1 + \alpha^2} + \alpha \right)}$$

where D = depth of web between flanges measured along web

d_o = distance between transverse stiffeners

α = d_o/D

t_w = web thickness

F_{vcr} = critical buckling shear stress, see Art. 1.7.211(B)(4)

F_T = tension field stress, see Art. 1.7.211(B)(5)

The postbuckling strength, V_T , may be disregarded if its utilization in accordance with the provisions of Articles 1.7.211 - 1.7.213 is not advantageous in the design.

The maximum value of V_u shall not exceed the yield shear strength of the web with consideration of coincident axial stress:

$$V_{u \max} = 0.58 D t_w \sqrt{F_y^2 - \left(\frac{2}{3} f_{av}\right)^2}$$

where f_{av} is the average numerical value of the flexural axial stresses at the opposite longitudinal edges of the web panel, f_{1w} and f_{2w} , as defined in Article 1.7.211(B)(4), disregarding the sign of the stress.

The ultimate shear capacity of an inclined web, V_u' , is

$$V_u' = V_u \cos \theta$$

where θ is the angle of the web plate with the vertical.

(2) Critical shear buckling stress

Critical buckling stress in the case of shear stress acting alone, F_{vcr}° , shall be computed as a function of the plate slenderness parameter

$$\lambda_v = \frac{D}{t_w} \sqrt{\frac{10.92}{\pi^2 \sqrt{3} k_v} \frac{F_y}{E}} = 0.8 \frac{D}{t_w} \sqrt{\frac{F_y}{E k_v}}$$

where k_v is the plate buckling coefficient defined as:

$$k_v = 5 + \frac{5}{\alpha^2}$$

the values of F_{vcr}° are given by the equations given in the table, or may be obtained from Fig. 1.7.211(A)

Table 1.7.211(B)(2)

| web slenderness, λ_v | critical shear stress, F_{vcr}° |
|---------------------------------|--|
| $\lambda_v \leq 0.58$ | $F_{vcr}^{\circ} = 0.58 F_y$ |
| $0.58 \leq \lambda_v \leq 1.41$ | $F_{vcr}^{\circ} = \left[0.58 - 0.357(\lambda_v - 0.58)^{1.18} \right] F_y$ |
| $\lambda_v > 1.41$ | $F_{vcr}^{\circ} = 0.58 F_y / \lambda_v^2$ |

(3) Critical flexural buckling stress

Since any unsymmetrical axial stress distribution in the web can be represented as a combination of pure compression (or tension) and pure bending, critical stresses for these basic cases only are needed in the computation of the critical buckling stress for combined shear and axial stress (see Art. 1.7.211(B)(4)).

The critical stresses F_{ccr}^o for Case (1), compression acting alone, and F_{bcr}^o for Case (2), bending acting alone, are given by the following equations:

$$0.65 \leq \lambda \leq 1.5: F_{cr}^o/F_y = 0.072(\lambda - 5.62)^2 - 0.78$$

$$\lambda \geq 1.5: F_{cr}^o/F_y = 1/\lambda^2$$

where

$$\lambda = \frac{D/t_w}{0.95} \sqrt{\frac{F_y}{E k}}$$

The value of k shall be taken as

$$\text{Case (1): } \alpha > 1, k = 4; \alpha < 1, k = (\alpha + 1/\alpha)^2$$

$$\text{Case (2): } \alpha > 2/3, k = 24; \alpha < 2/3, k = 24 + 73(2/3 - \alpha)^2$$

The values of critical stresses F_{ccr}^o for $\alpha > 1$ and F_{bcr}^o for $\alpha > 2/3$ may also be read from Fig. 1.7.211(B).

(4) Critical buckling stress for combined shear and axial stress

The critical buckling stress of panels subject to simultaneous shear and axial stresses shall be computed from the interaction equation

$$\left(\frac{F_{vcr}}{F_{vcr}^0} \right)^2 + \left(\frac{F_{bcr}}{F_{bcr}^0} \right)^2 + \left(\frac{F_{ccr}}{F_{ccr}^0} \right)^2 = 1$$

where

F_{vcr}^0 = critical shear buckling stress in the case of shear stress acting alone, obtained from equations in Table 1.7.211(B)(2) or from Fig. 1.7.211(A)

F_{bcr}^0 = critical bending buckling stress in the case of bending acting alone, to be obtained from equations in Art. 1.7.211(B)(3) or from Fig. 1.7.211(B) Curve (2)

F_{ccr}^0 = critical compressive buckling stress in the case of pure axial compression acting alone, to be obtained from equations in Art. 1.7.211(B)(3) or from Fig. 1.7.211(B) Curve (1)

F_{vcr} , F_{bcr} , and F_{ccr} are individual (shear, pure bending and pure compression) stress components which cause buckling of the web panel when acting simultaneously. These stress components are interdependent and may be expressed in terms of F_{vcr} by the following expressions:

$$F_{bcr} = \frac{1-R}{2} \mu F_{vcr}$$

$$F_{ccr} = \frac{1+R}{2} \mu F_{vcr}$$

where

$$R = \frac{f_{2w}}{f_{1w}}$$

$$\mu = \frac{f_{1w}}{f_v}$$

with

f_{1w} = governing axial compressive stress at longitudinal edge of web panel at location of the design stress (see Arts. 1.7.210(C) or 1.7.211(C)) due to moment, M_v , coincident with maximum design shear, V , used in design of web panel

f_{2w} = axial stress at opposite edge of panel coincident with f_{1w} . Compression is designated positive, tension negative.

f_v = governing shear stress = V/Dt_w

These stresses are illustrated in Fig. 1.7.211(C).

The value of R may be positive or negative, depending on the signs of stresses f_{1w} and f_{2w} .

When the maximum tensile stress is numerically greater than the compressive stress, f_{1w} ($R < -1$), the interaction equation reduces to the following form:

$$\left(\frac{F_{vcr}}{F_{vcr}^{\circ}} \right)^2 + \left(\frac{F_{bcr}}{F_{bcr}^{\circ}} \right)^2 = 1$$

where $F_{bcr} = \mu F_{vcr}$

(5) Tension field stress

The tension field stress of a web panel, F_T , to be used for determination of the tension field strength of the panel in accordance with Art. 1.7.211(B)(1) shall be found from the following formula:

$$F_T = F_y - \sqrt{0.25 f_{2w}^2 + 3F_{vcr}^2}$$

with the notation as given in Art. 1.7.211(B)(4).

(6) Web panels adjacent to end support of girder

Web panels adjacent to end supports of the box girder may be designed with or without the utilization of the tension field strength.

If tension field strength is utilized, the end bearing stiffeners shall be designed in accordance with Article 1.7.213(B)(3).

(C) Design Stresses in Web Panel

The governing load-factored coincident shear and flexural or direct stresses for web panel design shall be calculated at the cross section of the panel midway between transverse stiffeners.

Shear stresses due to flexure or other effects shall be assumed uniformly distributed over the web depth.

Direct stresses due to flexure or other effects shall be computed in accordance with elastic theory.

(D) Slenderness Limitations

(1) The thickness of transversely stiffened webs shall meet the requirements, but shall not be less than 3/8" (10 mm).

$$D_c \leq D/2: \quad D/t_w \leq 6.8/\sqrt{F_y/E}$$

$$D_c > D/2: \quad D_c/t_w \leq 3.4/\sqrt{F_y/E}$$

where D_c = distance between neutral axis and compression flange

(2) Web stiffener sizes shall be governed by the requirements of Art. 1.7.213.

(E) Additional Forces in Flanges due to Post-Buckling Behavior of Webs

Since the capacity of the web to carry compressive stresses is limited by compressive stress corresponding to web buckling, any additional axial stress assigned to web under the assumption of linear stress distribution must be carried by the flanges. Also, additional flange forces due to assumptions used in formulating the tension field action must be considered.

The additional flange forces, ΔF , to be added to the flange forces computed in accordance with elastic analysis, shall be calculated in the web panel at the box girder cross section used for design of the flange panel under consideration by the following formulas

Compression flange:

$$\Delta F_1 = \left(\frac{V_M - \sum V_B}{V_M} \right) \left[(f_{1R} - f_1) A_{fc} + \frac{1}{2} V_M \cot \left(\frac{\theta_d}{2} \right) \right]$$

Tension flange:

$$\Delta F_2 = \left(\frac{V_M - \sum V_B}{V_M} \right) \left[(f_{2R} - f_2) A_{ft} - \frac{1}{2} V_M \cot \left(\frac{\theta_d}{2} \right) \right]$$

In the above formulas the term $\frac{1}{2} V_M \cot \frac{\theta_d}{2}$ is compression, which is added to compression flange force and subtracted from tension flange force.

Notation is as follows:

V_M = total load factored shear force acting on box girder coincident with maximum moment, M , at the same box girder cross section

$\sum V_B$ = $\sum D t_w F_{vcr}$ = sum of buckling (beam action) shear capacities of all webs at box girder cross section under consideration, determined for combined action of V_M and M in accordance with Art. 1.7.211(B)(4)

f_1, f_2 = stress in compression or in tension flange, respectively, due to moment calculated by elastic theory, assuming fully participating webs

f_{1R}, f_{2R} = stress in compression or tension flange respectively, due to moment M calculated by elastic theory, assuming reduced moment of inertia, I_R , of box girder cross section

I_R = moment of inertia of box girder cross section obtained by removing those portions of web in compression. For purposes of calculation of ΔF it may be assumed that this removal does not change position of the box girder neutral axis.

A_{fc} , A_{ft} = compression or tension flange area, respectively, see Arts. 1.7.205(B)(1), 1.7.206(B)(1) or 1.7.208; or equivalent steel area of a composite flange, see Art. 1.7.209

$\theta_d = \cot^{-1}(\alpha) =$ angle of inclination of web panel diagonal to the horizontal

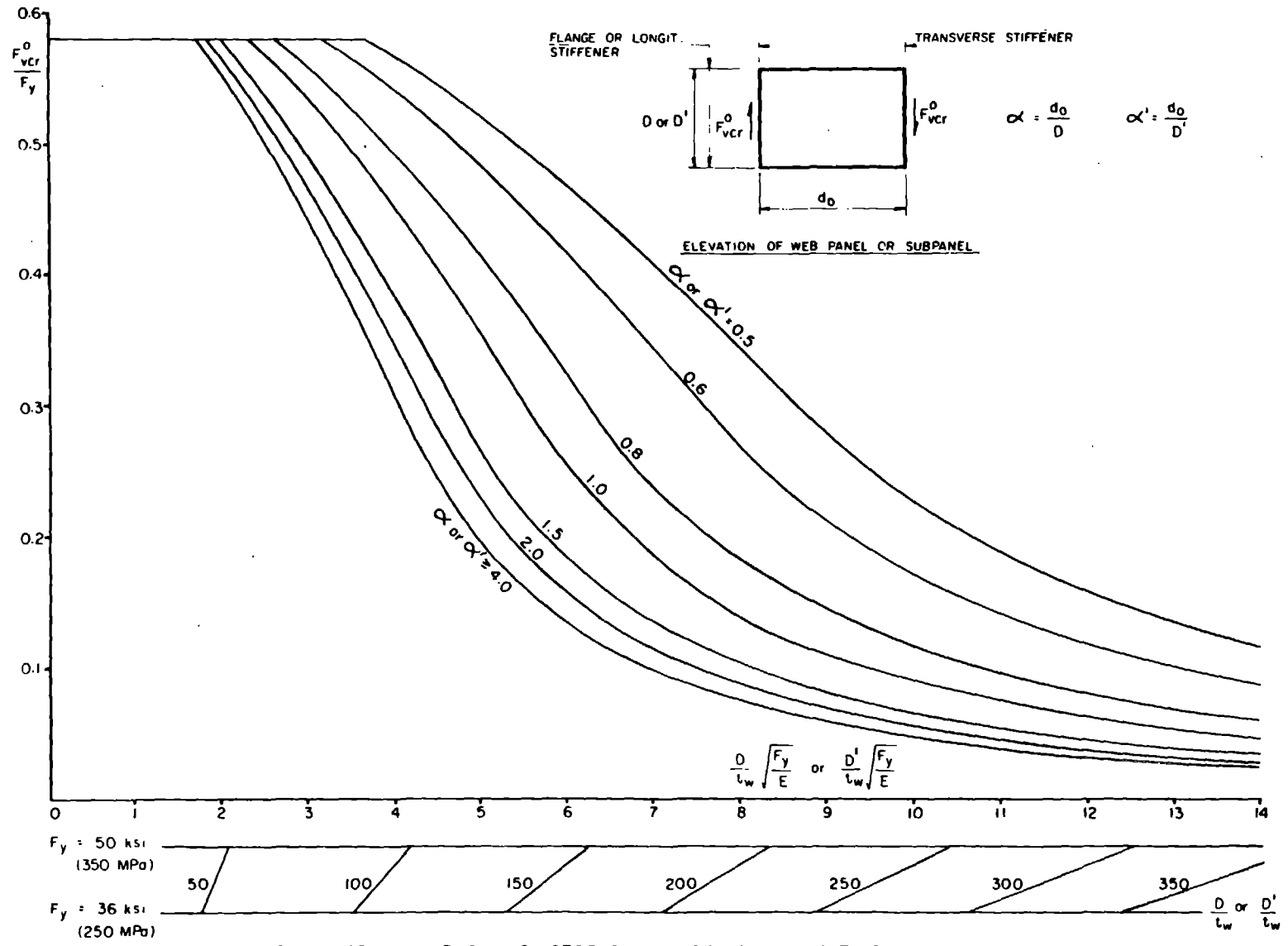

FIG. I.7.211 (A) CRITICAL BUCKLING STRESS DUE TO SHEAR ACTING ALONE

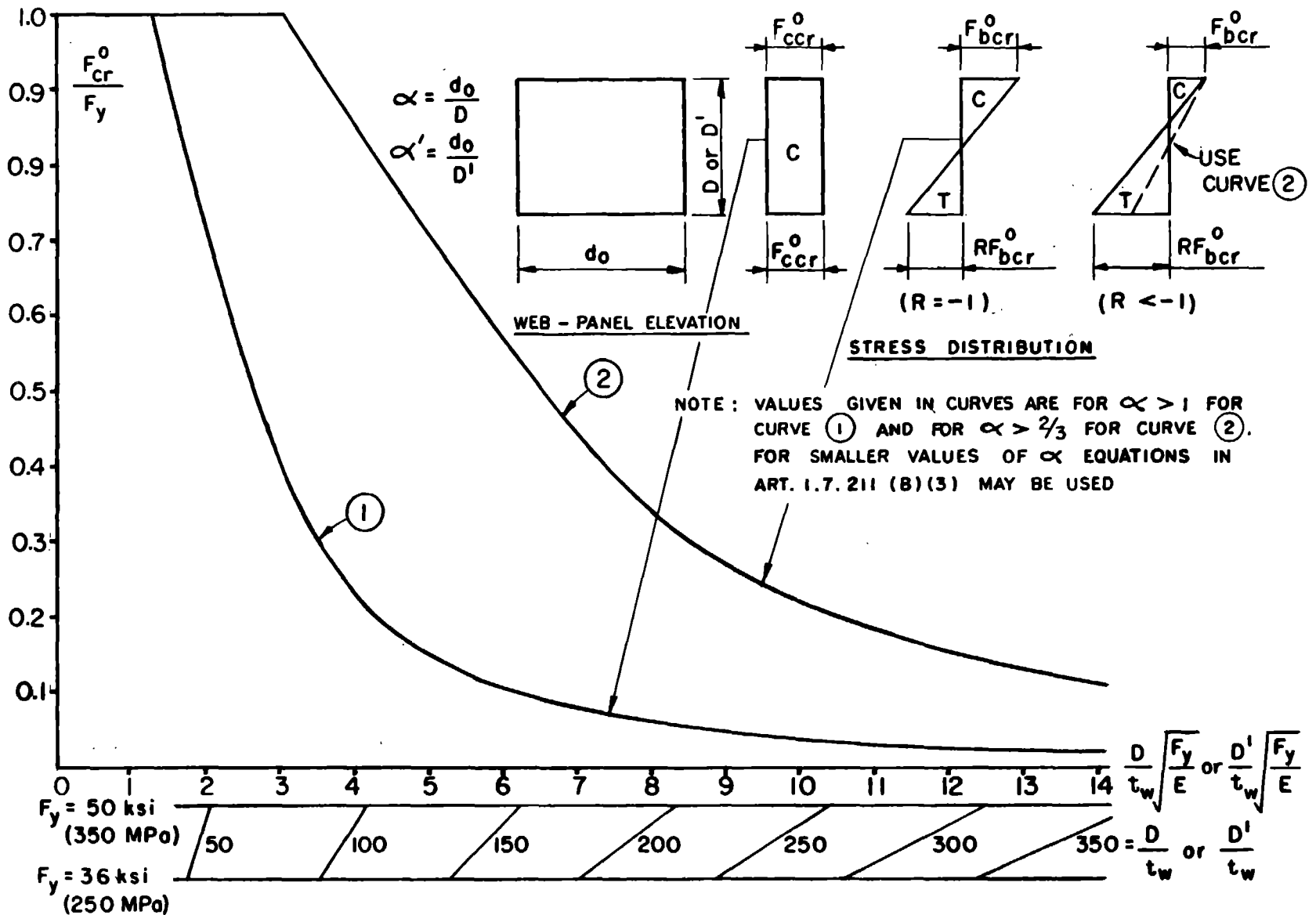
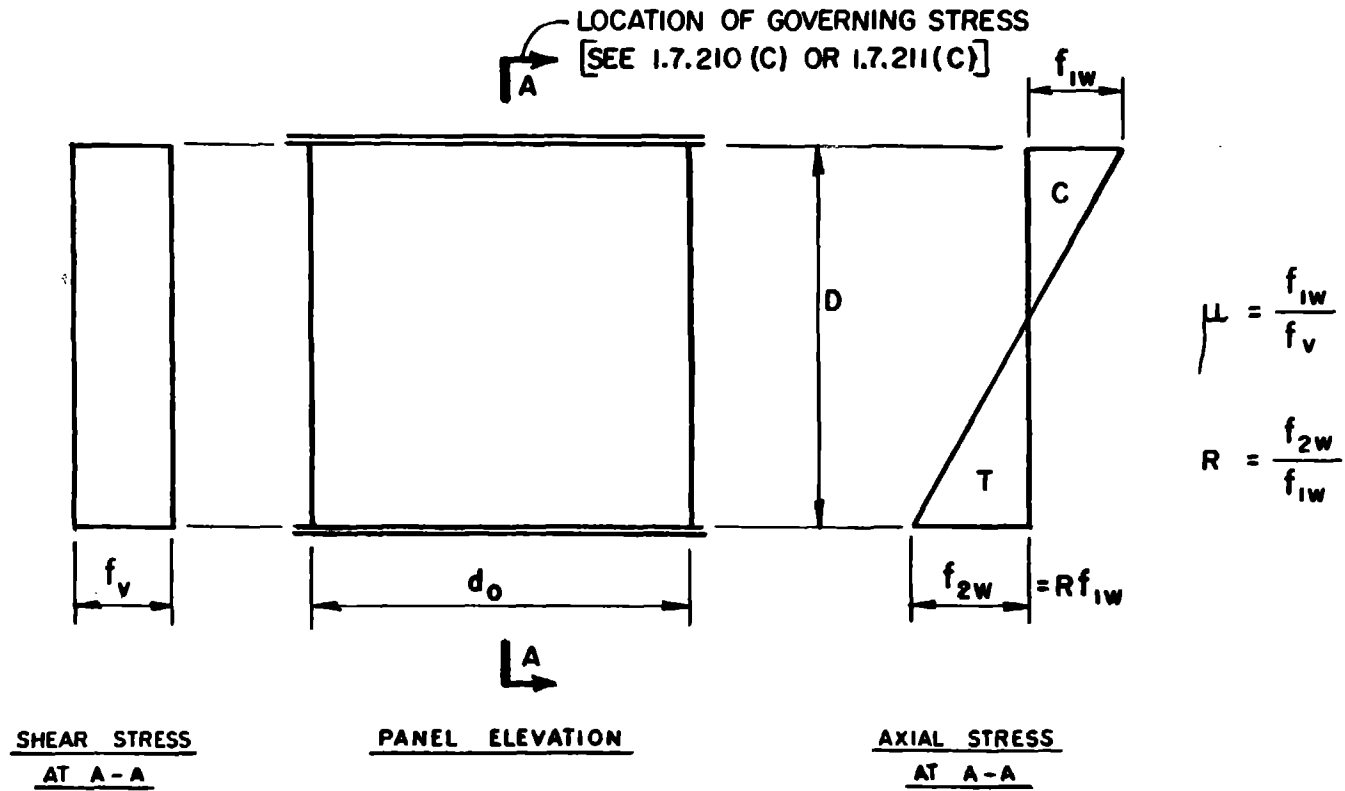

FIG. 1.7.211 (B) CRITICAL BUCKLING STRESS DUE TO AXIAL STRESSES ACTING ALONE



FOR DEFINITIONS OF f_{1w} , f_{2w} , f_v SEE ART. 1.7.211 (B)(4)

FIG. 1.7.211 (C) DEFINITION OF μ AND R FOR UNSTIFFENED AND TRANSVERSELY STIFFENED WEBS

1.7.212 Transversely and Longitudinally Stiffened Webs

(A) Scope

This article applies to box girder web panels with transverse and longitudinal stiffeners.

(B) Carrying Capacity of Web

(1) The carrying capacity of a web is given as the value of the ultimate shear, V_u , which the web can carry under the combined effects of the shear and axial stresses. The value of V_u is obtained as the sum of the buckling strength, V_B , and the post-buckling strength, V_T , in accordance with the procedures given in Art. 1.7.211(B) and (C) with modifications as given in (2), (3), (4) and (5) hereunder.

(2) In the determination of the buckling strength of the web, V_B , the critical shear buckling stress, F_{vcr} , under combined shear and axial stresses shall be determined separately for each web subpanel between the flange and the longitudinal stiffener, or between two longitudinal stiffeners. Longitudinal stiffeners are treated as rigid supports. The minimum value of F_{vcr} of the critical subpanel, $F_{vcr \min}$, shall govern the buckling strength of the web.

$$V_B = D t_w F_{vcr \min}$$

where D = clear depth of web between flanges measured along web

(3) In calculation of the shear buckling stress, F_{vcr} , of the subpanels under combined shear and flexural compression (such as subpanels 1 and 2 in Fig. 1.7.212) or shear and flexural compression and tension (such as subpanel n in Fig. 1.7.212) the following notation shall apply:

$$\alpha' = d_o/D'$$

$$R = f'_{2w} / f'_{1w}$$

$$\mu = f'_{1w} / f_v$$

where

D' = depth of subpanel

f'_{1w} = governing axial compressive stress at longitudinal edge of subpanel, computed midway between transverse stiffeners, due to the moment, M_v , coincident with maximum design shear, V , used in design of web panel

f'_{2w} = axial stress coincident with f'_{1w} at opposite edge of subpanel. Compression is designated positive, tension negative

f_v = governing shear stress = V/Dt_w

(4) The shear buckling stress, F_{vcr} , of the subpanels under combined shear and flexural tension (no compression stress in the subpanel) is given by the following equations:

$$\begin{aligned} \text{for } \lambda_v < 0.58: & F_{vcr} = 0.58 F_y \\ \text{for } 0.58 \leq \lambda_v \leq 1.41: & F_{vcr} = \left[0.58 - 0.357 (\lambda_v - 0.58)^{1.18} \right] F_y \\ \text{for } \lambda_v > 1.41: & F_{vcr} = 0.58 F_y / \lambda_v^2 \end{aligned}$$

where

$$\lambda_v = 0.8 \frac{D'}{t_w} \sqrt{\frac{F_y}{E k_v^*}}$$

with k_v^* , the plate buckling coefficient for combined shear and tension, to be taken as:

for $0.5 \leq \alpha' \leq 1$: $k_v^* = 5 + 5/\alpha'^2 + (4 + 3/\alpha'^2) \left[-f_t/f_v + (f_t/f_v)^2 \right]$

for $\alpha' > 1$: $k_v^* = 5 + 5/\alpha'^2 + (1.5 + 5.5/\alpha'^2) \left[-f_t/f_v + (f_t/f_v)^2 \right]$

where

f_t = the average value of the tension stresses, coincident with governing shear stress, at the two longitudinal edges of the subpanel, computed midway between transverse stiffeners. Tension stress is designated negative; therefore the ratio f_t/f_v is always negative.

f_v and α' are defined in Art. 1.7.212(B)(3)

(5) The tension field strength, V_T , of the web shall be determined for the entire web panel between transverse stiffeners, with horizontal stiffeners disregarded.

(C) Slenderness Limitations

(1) Webs with one line of longitudinal stiffeners

The web thickness shall meet both of the following requirements:

$$\frac{D}{t_w} \leq \frac{13.6}{\sqrt{F_Y/E}} \quad \text{and} \quad \frac{D'}{t_w} \leq \frac{2.7}{\sqrt{F_Y/E}}$$

where D = clear depth of web between the flanges

D' = the depth of subpanel adjacent to compression flange $\geq 2D_c/5$

where D_c = clear distance between neutral axis and compression flange

The horizontal stiffener shall not be placed impractically close to the compression flange.

(2) Webs with two or more lines of longitudinal stiffeners

The web thickness shall meet the following requirement for each subpanel in the compression zone

$$\frac{D'_n}{t_w} \leq \frac{8.1}{\sqrt{F_y/E}} \frac{\eta_n D}{D_c}$$

where D'_n = depth of subpanel between compression flange and stiffener, or between two stiffeners in the compression zone

$\eta_n D$ = distance between compression flange and stiffener n, see Fig. 1.7.212.

The depth of subpanel between compression flange and the first stiffener shall meet the requirement

$$D'_1 \leq \frac{2D}{5} C$$

(3) Minimum web thickness shall be 3/8" (10mm)

(4) The sizes of stiffeners shall be governed by the requirements of Art. 1.7.213.

(D) Additional Forces in Flanges due to Post-Buckling Behavior of Webs

(1) Additional axial forces in the flanges due to load shedding and tension field action of the webs shall be determined by the formulas for ΔF given in Art. 1.7.211 (E), except that if longitudinal stiffeners are continuous, the reduced moment of inertia, I_R , of the longitudinal stiffeners including appropriate effective widths of the web plate.

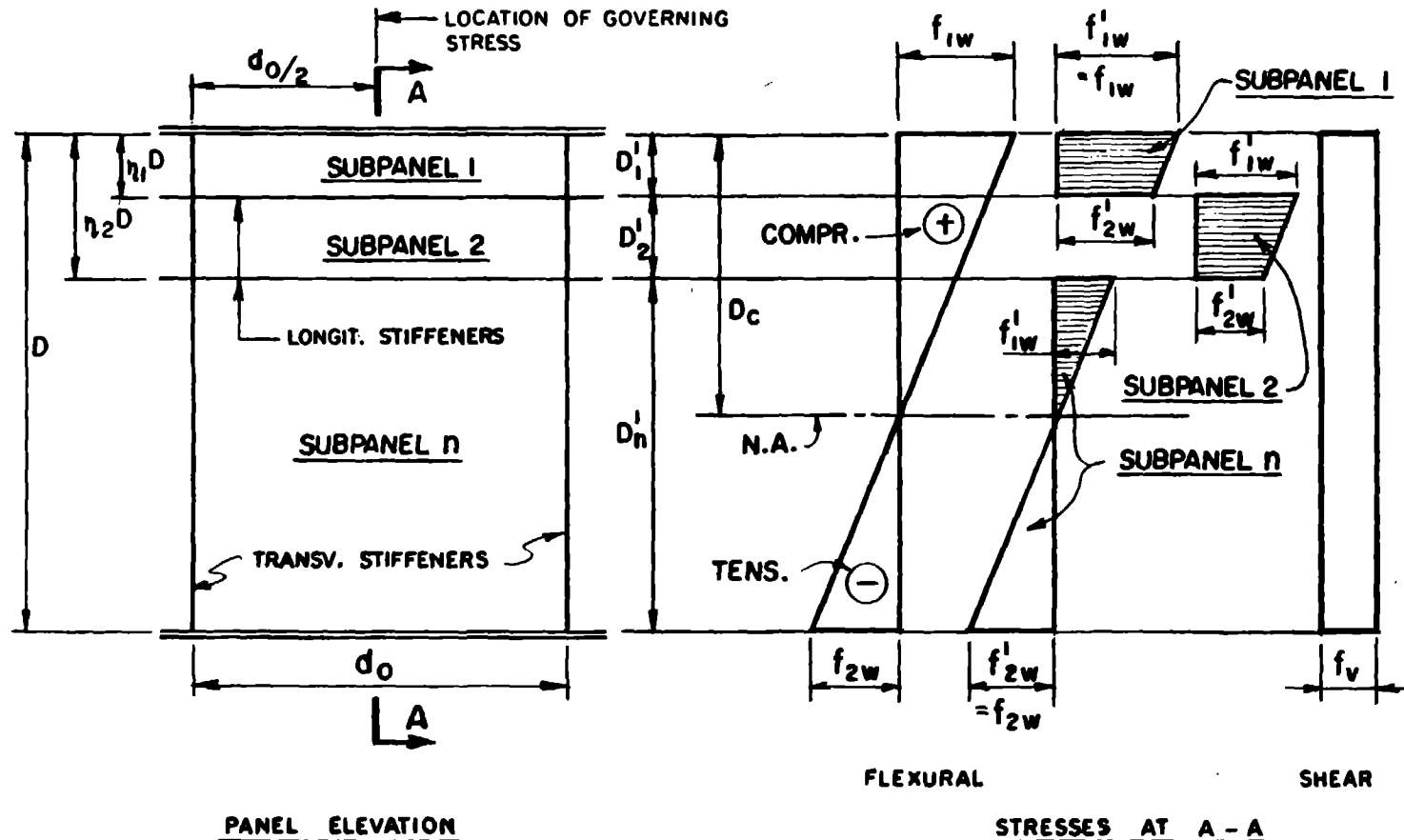

$$\alpha = \frac{d_0}{D} \quad \alpha'_n = \frac{d_0}{D'_n} \quad \mu = \frac{f'_{1w}}{f_v} \quad R = \frac{f'_{2w}}{f'_{1w}}$$

FOR DEFINITIONS OF f_{1w} , f_{2w} , f_v SEE ART. 1.7.211 (B)(4)

FIG. 1.7.212 TRANSVERSELY AND LONGITUDINALLY STIFFENED WEBS

1.7.213 Web Stiffeners

(A) Scope

This article applies to the transverse and the horizontal stiffeners of the box girder webs.

(B) Transverse Stiffeners at Box Girder Supports

(1) If box girders are designed with diaphragms at the supports, the transverse stiffeners, if any, shall be designed in conjunction with the support diaphragms in accordance with Art. 1.7.215.

(2) If no support diaphragms are present and the bearings are provided under each web of the box girder, the stiffeners shall be designed to transmit the entire support reaction due to the direct and the torsional loading to the bearing, acting as centrally or eccentrically loaded columns, depending on the placement of the stiffeners on one or on both sides of the web. The bearing stiffeners shall also be designed for the distortional effects, in accordance with Art. 1.7.216.

In addition, the bearing stiffeners shall satisfy all strength and rigidity requirements of Art. 1.7.213(C).

(3) Stiffeners at end supports and web extension beyond the end bearings shall be designed to resist the horizontal component, P_{HT} , of the tension field force used in the design of the web panel adjacent to the end support, see Arts. 1.7.211(B)(6) and 1.7.212(B)(5). Force P_{HT} may be considered to be distributed over a distance of $D/3$ from the top flange of the girder, and shall be taken as

$$P_{HT} = (V - V_B) \cot \left(\frac{\theta_d}{2} \right)$$

with notation as defined in Art. 1.7.211.

In addition, bearing stiffeners at end supports shall satisfy the requirements of (1) and (2) above.

(C) Intermediate Transverse Stiffeners

Intermediate transverse stiffeners may be placed on one or both sides of the web and shall satisfy the following requirements (1) through (3):

(1) Strength

(a) Intermediate transverse stiffeners at deck floorbeams or at crossframes or cross bracing shall be designed for the directly applied axial and flexural loads, in accordance with Art. 1.7.216.

(b) In addition, in the portions of the web designed with utilization of the tension field strength, stiffeners shall be designed as columns subject to the tension field vertical force, P_{VT} :

$$P_{VT} = \frac{F_T t_w d_o}{2} \left[1 - \frac{\alpha}{\sqrt{1 + \alpha^2}} \right] \frac{V - V_B}{V_T}$$

with notation as defined in Art. 1.7.211. The larger of the P_{VT} values in the two panels adjacent to the stiffener shall be used.

The force P_{VT} shall be assumed to act in the mid-plane of the web plate. Stiffener eccentricity shall be taken as the distance between the mid-plane of the web and the center of gravity of the stiffener cross section, including the effective width of web plate acting with the stiffener.

(c) The effective width of the web plate, b_e , acting with a stiffener shall be

$$b_e = 18 \left(1 - \frac{V - V_B}{2V_T} \right) t_w$$

(d) The effective length of the stiffener column shall be taken as

$$L' = 0.7D$$

(e) In addition to the above forces and moments, where longitudinal stiffeners are present in the adjacent web panels, the intermediate stiffener shall be designed for a lateral force equal to 2 percent of the axial force capacity of the stronger of the two horizontal stiffeners abutting the transverse stiffener. Such a lateral force shall be determined for each line of horizontal stiffeners, see Art. 1.7.213(D).

(2) Rigidity

(a) The minimum rigidity of an intermediate transverse stiffener, I_T , shall be

$$I_T = m_T \gamma_T^* \frac{Dt_w^3}{12(1-\nu^2)} \frac{f'_v}{F'_{OVcr}} = 0.09m_T \gamma_T^* Dt_w^3 \frac{f'_v}{F'_{OVcr}}$$

where

I_T = moment of inertia of stiffener and effective web plate, according to Art. 1.7.213(C) (1) (c), with respect to center of gravity of combined cross section

D = clear distance between flanges measured along web

t_w = web thickness

m_T = multiplier
 for $D/t_w \leq 75$, $m_T = 1$; for $D/t_w \geq 150$, $m_T = 3$; *
 for $75 < D/t_w < 150$, interpolate linearly

γ_T^* = minimum relative rigidity coefficient of transverse stiffener, taken from Fig. 1.7.213(A)

f'_v = smaller of the following:

* See Addendum # 1
 on page 176

f_v = governing actual shear stress in adjacent web panel as defined in Art. 1.7.211(B)(4)

F_{vcr} = critical buckling stress of the same web panel or subpanel, as defined in Art. 1.7.211(B)(4)

F_{vcr}^0 = critical buckling stress of web panel or subpanel in the case of shear stress acting alone, as defined in Art. 1.7.211(B)(2)

Stresses f_v' and F_{vcr}^0 shall be determined for the adjacent web panel or subpanel with the greater value of F_{vcr}

(b) Alternatively, for webs having horizontal stiffeners, the minimum rigidity coefficient of an intermediate transverse stiffener, I_T , may be obtained by using the following value of γ_T^*

$$\gamma_T^* = \gamma_T^{*'} \left(\frac{t_e}{t_w} \right)^3$$

where

$\gamma_T^{*'}$ = minimum relative rigidity coefficient of transverse stiffener for web having a thickness, t_w , with no longitudinal stiffeners

t_e = thickness of longitudinally unstiffened web having same elastic buckling capacity under shear acting alone, as longitudinally stiffened web with thickness t_w

(3) Local torsional buckling stability

The effective slenderness coefficient, C'_S , of the web stiffener shall be governed by the following formulas:

$$f_{\max} > 0.5F_Y: \quad C'_S \leq \frac{0.48}{\sqrt{F_Y/E}}$$

$$f_{\max} < 0.5F_Y: \quad C'_S \leq \frac{0.8}{\sqrt{F_Y/E}}$$

where

f_{\max} = maximum calculated factored compression stress in the stiffener outstand under loading in accordance with Art. 1.7.213 (C) (1)

$$C'_S = \sqrt{I_O/J}$$

I_O = polar moment of inertia of the stiffener cross section without effective width of web plate, about attached edge

J = torsional constant of stiffener cross section

For flat stiffeners $C'_S = d/t_o$

where

d = stiffener depth

t_o = stiffener thickness

(4) Details of Transverse Stiffeners

Transverse stiffeners need not be in bearing against the tension flange; however, the distance between the end of the stiffener and the near edge of the web-to-flange fillet weld shall be not less than $4t_w$ nor more than $6t_w$

Transverse stiffeners shall be continuous at intersections with longitudinal stiffeners.

(D) Longitudinal Stiffeners in Compression Zone of Web

(1) General

(a) Longitudinal stiffeners conforming to the requirements of this section shall be assumed to enforce nodal lines in the web plate at buckling and remain straight until the ultimate web capacity is reached, as defined in Art. 1.7.212(B).

(b) One or several longitudinal stiffeners may be used, placed at any appropriate location.

(c) Longitudinal stiffeners may be continuous or discontinuous at the transverse stiffeners. Continuous longitudinal stiffeners may be included as elements of the box girder cross section.

(d) Longitudinal stiffeners shall satisfy all of the strength and rigidity requirements of Art. 1.7.213(D) (2), (3) and (4).

(2) Strength

Longitudinal stiffeners shall be designed as columns having length equal to the spacing of the transverse stiffeners. An effective width of web plate equal to $18t_w$, but not greater than the distance between the stiffener and the flange or the adjacent stiffener, may be used with the longitudinal stiffener.

(a) Discontinuous longitudinal stiffeners

The design axial force shall be the product of the effective web plate area acting with the stiffener (without the area of the stiffener) and the governing web compression stress at the stiffener location, see Fig. 1.7.212. The force shall be assumed to act in the mid-plane of the web plate. The design eccentricity shall be the distance between the mid-plane of the web and the center of gravity of the combined area of the stiffener and the effective web plate, plus the out-of-straightness tolerance of $d_o/500$.

(b) Continuous longitudinal stiffeners

The design axial load shall be as the product of the cross sectional area of the stiffener including the effective area of the web acting with the stiffener, and the governing web compression stress at the stiffener location, see Fig. 1.7.212. The force shall be assumed to act in the center of gravity of the combined area of the stiffener and the effective web plate. The design eccentricity shall be the out-of-straightness tolerance of $d_o/500$.

Alternatively, the stiffener strength may be checked by the interaction diagram, Fig. 1.7.206(A), taking w equal to the effective width of web plate acting with the stiffener.

(3) Rigidity

The rigidity of the longitudinal stiffener, I_L , shall be no less than

$$I_L = n m_L \int_L^* (\sigma + \tau) \frac{Dt_w^3}{12 (1-\nu^2)} = 0.09 n m_L \int_L^* (\sigma + \tau) Dt_w^3$$

where

I_L = moment of inertia of stiffener and effective web plate, according to Art. 1.7.213(D) (2), with respect to the center of gravity of combined cross section

n = multiplier. For one line of longitudinal stiffeners $n = 1$. For two or more lines of longitudinal stiffeners $n = 0.8$

m_L = multiplier

For webs with $D/t_w > 240$:

Stiffener at 0.2D from compression flange: $m_L = 7$ *

Stiffener at neutral axis of the box girder: $m_L = 3$ *

Stiffeners in between, obtain m_L by interpolation

For webs with $D/t_w < 120$: $m_L = 1$

For webs with $120 < D/t_w < 240$, obtain m_L by interpolation

$\gamma_{L(\sigma+\tau)}^*$ = minimum relative rigidity coefficient of longitudinal stiffener of web subject to axial and shear stresses:

$$\gamma_{L(\sigma+\tau)}^* = \sqrt{\left[\gamma_{L\sigma}^* \left(\frac{f'_c}{F_{ccr}^0} + \frac{f'_b}{F_{bcr}^0} \right) \right]^2 + \left(\gamma_{L\tau}^* \frac{f'_v}{F_{vcr}^0} \right)^2}$$

where

$\gamma_{L\sigma}^*$, $\gamma_{L\tau}^*$ = minimum relative rigidity coefficient of longitudinal stiffeners of web subject to axial or shear stress acting alone, respectively, required to ensure that web subpanel adjacent to stiffener will reach its elastic buckling strength (with stiffener acting as rigid edge support).

$\gamma_{L\sigma}^*$ and $\gamma_{L\tau}^*$ are given in Fig. 1.7.213(B)

f'_c , f'_b , f'_v = smaller of f_c , f_b , f_v or F_{ccr} , F_{bcr} , F_{vcr} , respectively

f_c , f_b , f_v = actual compression, bending and shear, respectively, in web subpanel adjacent to stiffener. Axial stresses in any web subpanel (see Fig. 1.7.212) may be represented as sum of pure axial stress and pure bending. If pure axial stress is tension, disregard term f'_c/F_{ccr}^0 in formula

F_{ccr} , F_{bcr} , F_{vcr} = individual compression, bending and shear stress components, respectively, which cause buckling of web subpanel adjacent to stiffener when acting simultaneously, as defined in Art. 1.7.212(B) and 1.7.211(B)(4)

F_{ccr}^o , F_{bcr}^o , F_{vcr}^o = critical buckling stress in web sub-panel for compression, bending or shear acting alone, respectively, as defined in Arts. 1.7.212(B) and 1.7.211(B) (2) and (3)

All above stresses shall be calculated in the sub-panel with the lower value of F_{vcr}

(4) Local torsional buckling stability

The provisions of Art. 1.7.213(C) (3) shall apply, except that the stress f_{max} shall be determined in accordance with Art. 1.7.213(D) (2) (a) or (b), for discontinuous or continuous stiffeners, respectively.

(E) Longitudinal Stiffeners in Tension Zone of Web

(1) General

The provisions of Art. 1.7.213(D) (1) (a), (b) and (c) shall apply.

(2) Rigidity

The rigidity of the longitudinal stiffener, I_L , in tension zone of web shall be no less than

$$I_L = 0.09 \gamma_{L,Tens}^* D t_w^3 f_v' / F_{vcr}^o$$

where

- I_L = moment of inertia of stiffener and effective web plate, according to Art. 1.7.213 (C) (1) (c), with respect to center of gravity of combined cross section
- $\gamma_{L,Tens}^*$ = minimum relative rigidity coefficient of longitudinal stiffener in tension zone of web, taken from Table 1.7.213(E)
- D = clear distance between flanges measured along web
- t_w = web thickness

f'_v = smaller of the following:

f_v = governing actual shear stress in web as defined in Art. 1.7.212(B)(3)

$F_{vcr, \min}$ = the minimum value of critical shear buckling stress as defined in Art. 1.7.212(B)(2), determined according to Art. 1.7.212(B)(3) (combined shear and flexure) or Art. 1.7.212(B)(4) (combined shear and tension), whichever case applies.

F_{vcr}^0 = critical buckling stress in the case of shear stress acting alone, determined according to Art. 1.7.211(B)(2) for the adjacent web subpanel having the lower value of F_{vcr}

Table 1.7.213(E)

Minimum Relative Rigidity Coefficients, $\gamma_{L, \text{Tens}}^*$,
of Longitudinal Stiffeners in Tension Zone of Web

| $\alpha = d_o/D$ | 0.5 | 0.7 | 1.0 | 1.5 |
|------------------|-----|-----|-----|-----|
| $\eta = 0.5$ | 1 | 3 | 8 | 22 |
| $\eta = 0.66$ | 7 | 16 | 40 | 100 |

where d_o = distance between transverse web stiffeners
 η = ratio of distance between compression flange and stiffener to total web depth, D.

The values of $\gamma_{L, \text{Tens}}^*$ for other locations of stiffeners in tension zone of web shall be determined by interpolation or extrapolation.

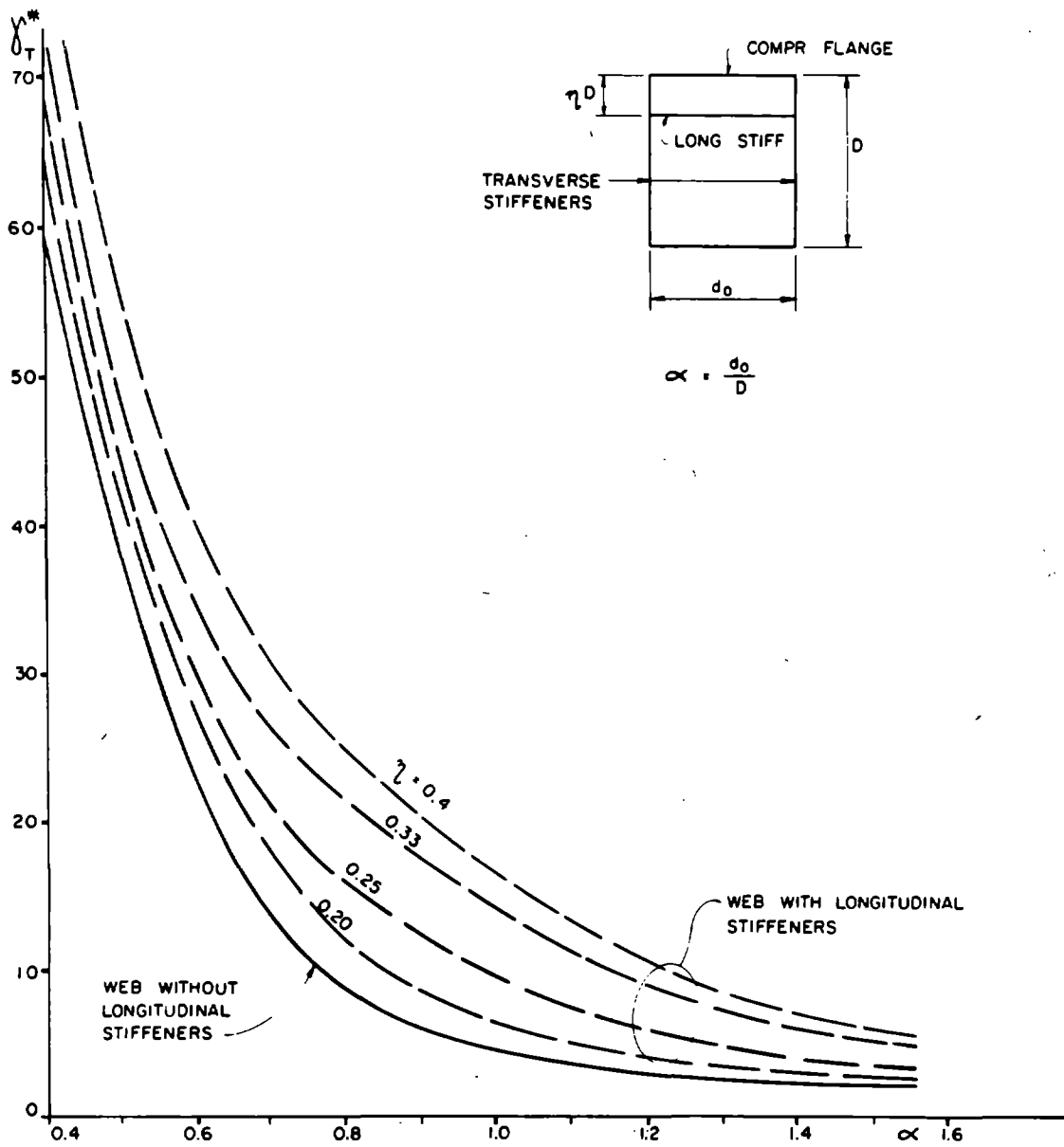

FIG. 1.7. 213 (A) RIGIDITY COEFFICIENTS γ_T^* FOR TRANSVERSE WEB STIFFENERS

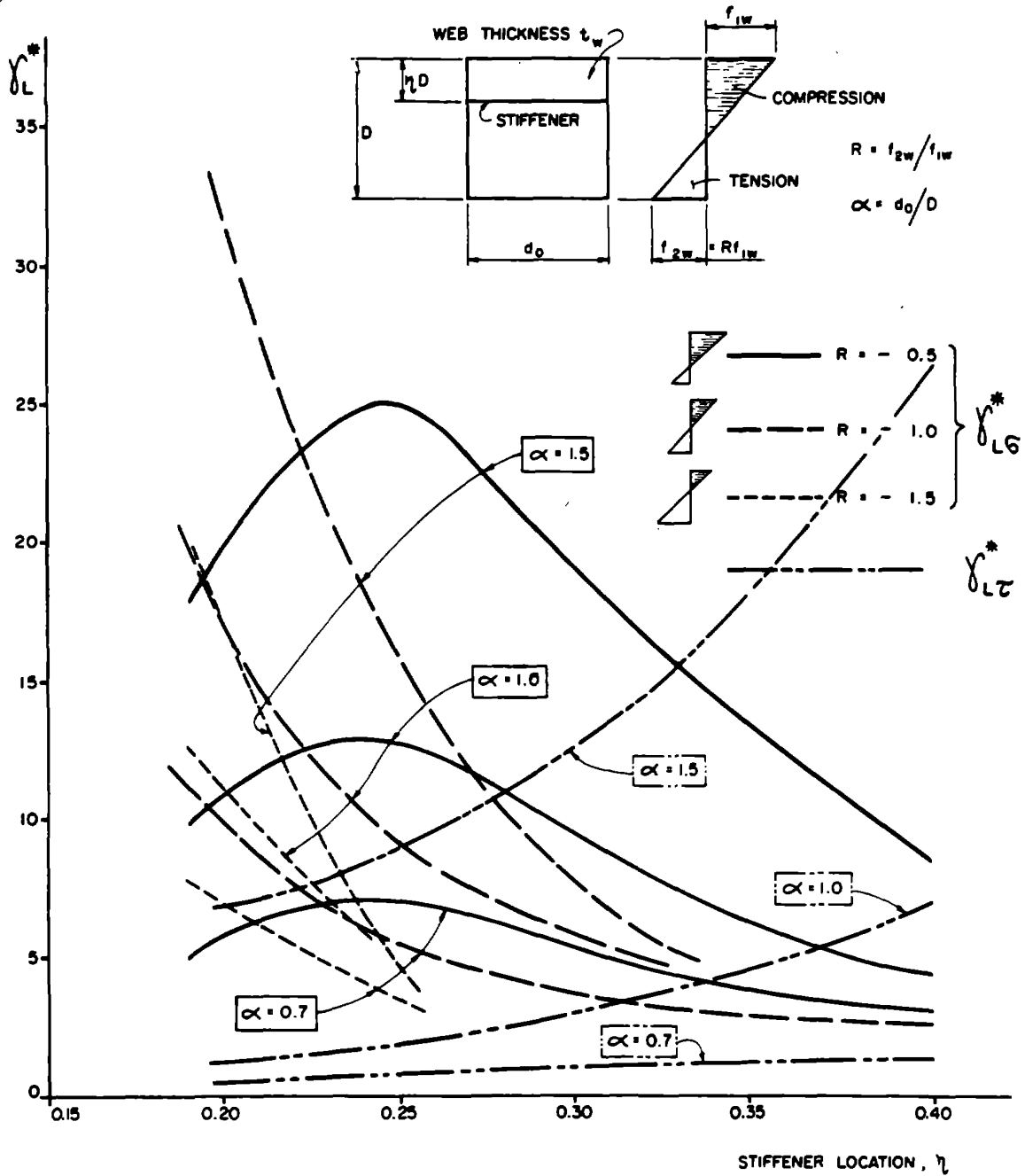

FIG. 1.7.213 (B) RIGIDITY COEFFICIENTS γ_L^* FOR LONGITUDINAL WEB STIFFENERS

1.7.214 Webs of Hybrid Girders

(A) Scope

This article applies to box girder webs having the specified yield strength lower than that of one or both flanges.

(B) Carrying Capacity of Web

(1) Webs of hybrid box girders may be designed in accordance with Articles 1.7.210 through 1.7.213, provided that the governing axial stresses at the longitudinal edges of the web panel, f_{1w} and f_{2w} , as defined in Art. 1.7.211, do not exceed the yield stress of the web material.

(2) Where axial stresses in portions of web panels adjacent to flanges exceed the yield stress of the web material, the web carrying capacity shall be taken as the buckling shear strength, V_B , and the postbuckling strength shall be disregarded.

The value of V_B shall be obtained with consideration of the buckling and yielding interaction relationships of the axial and shear stresses, as follows:

(a) The value of V_B , as determined by buckling:

$$V_B = F_{vcr} D t_w$$

where the critical shear stress, F_{vcr} , for shear acting simultaneously with axial stresses, is obtained by rational application of buckling interaction equations given in Art. 1.7.211(B)(4).

(b) The maximum value of V_B shall be

$$V_{B \max} = D t_w f'_{v \text{ avg}}$$

where

D = depth of web between flanges

t_w = web thickness

$f'_{v \text{ avg}}$ = average value of f'_v over the depth D

$$f'_v = 0.58 \sqrt{F_y^2 - f^2}$$

where

f'_v = maximum shear stress theoretically available at given distance from neutral axis of critical section

f = web axial stress at the same distance from neutral axis

F_y = yield stress of web material

1.7.215 Diaphragms

(A) Scope

This article applies to load bearing diaphragms at supports of box girders and to intermediate diaphragms between supports

(B) General

(1) The primary function of bearing diaphragms at supports of box girders is to transmit the vertical and the horizontal forces (due to applied loads on the box girder) from the webs and flanges to the bearings.

(2) Stresses in support diaphragms cannot be accurately determined by simple analytical methods because of complexities caused by the shape of the diaphragm, interaction with webs and flanges, biaxial loading, and stress concentrations at bearings. Therefore design methods must be based on rational conservative simplifications.* Generally, support diaphragms shall be stocky, with adequate capacity for local stress redistribution by yielding without buckling.

(3) Support diaphragms may be stiffened or unstiffened. Unstiffened diaphragms shall be assumed incapable of resisting out-of-plane bending moments.

* The design criteria for diaphragms given in "Inquiry into the Basis of Design and Method of Erection of Steel Box Girder Bridges, Report of the Committee - Appendix I, Interim Design and Workmanship Rules, H. M. Stationery Office, London, 1973 and 1974", may be used for general reference.

(C) Loads and Stresses in Support Diaphragms

(1) Loading on support diaphragms

The loads and forces to be considered in the design of support diaphragms shall include those deriving from the following sources of stresses, as applicable:

(a) Vertical and horizontal shear forces in box girder webs and flanges due to vertical, horizontal and torsional loads that must be transmitted to the bearings, and the corresponding vertical and horizontal reactions at bearings.

(b) Dead load and live load applied directly to the diaphragm, including torsional and distortional effects.

(c) Friction at bearings in the plane of the diaphragm due to temperature change.

(d) Creep and shrinkage of concrete deck.

(e) Friction and horizontal reaction on bearings in the direction of the span.

(f) Bearing misalignment in the direction perpendicular to the plane of diaphragm, and movement of bearing relative to the diaphragm due to movement of the structure under stress and temperature change.

Designer's attention is also called to the need to consider stresses due to erection conditions, see Art. 2.10.55A.

(g) Horizontal tension field forces perpendicular to the plane of diaphragm at end supports, see Article 1.7.213(B)(3).

(2) Vertical compression stresses

(a) Direct vertical compression stresses in a diaphragm are due to vertical reactions at bearings.

Vertical reaction force may be assumed to vary linearly from the maximum value at the bottom to zero at the top of diaphragm.

(b) The effective width of diaphragm at the bottom edge shall be taken as the width of bearing beneath the bottom flange plus 2 times the flange thickness, less the width of any diaphragm cutouts for longitudinal stiffeners within the bearing width.

(c) Compression stresses above the base of diaphragm shall be calculated using a rational effective width of diaphragm at the level considered.

(d) Vertical reactions may be assumed to be resisted jointly by the diaphragm plate and load-bearing stiffeners (full-length bearing stiffeners and stub stiffeners) within the bearing width.

(e) The effect of coincident torque causing non-uniform stress distribution must be taken into consideration, particularly in the case where diaphragm is supported on a single bearing.

(3) Horizontal axial stresses

(a) Horizontal axial stresses are due to bending of the diaphragm in its own plane. The distribution of these stresses is generally non-linear, with compression stress at the bottom higher than tension stress at the top of the diaphragm; however, for design purposes a linear stress distribution in accordance with simple flexural theory may be assumed.

(b) In trapezoidal diaphragms horizontal compression stresses at the bottom are increased by the horizontal component of the inclined web forces at box girder supports. This additional compression must be considered in the design.

(c) The effective widths of box girder top and bottom flange plates to be considered as the diaphragm flanges shall be determined as follows:

At centerline of the box girder the maximum effective width shall be one-fourth of the spacing of webs. The effective width shall vary linearly between the maximum value at centerline to zero at the webs.

For diaphragm at end supports the maximum effective width at centerline shall be one-eighth of the spacing of webs plus the distance between the diaphragm and the end of the flange plate, but not greater than one-fourth of the spacing of webs, decreasing linearly to zero at the webs.

(4) Shear stresses

(a) Diaphragm shear stresses are due to the transfer of the vertical shear in the webs, and the horizontal shear in the flanges, to the bearings. The shear distribution along the web-diaphragm boundary is generally non-uniform, with higher shears in the lower part of the diaphragm, see Art. 1.7.215(G)(2).

(b) The assumption of uniform shear distribution across the diaphragm depth is permissible; however, in checking the stability of lower portions of the stiffened diaphragm the average shear values shall be multiplied by a factor of 1.3.

(5) Out-of-plane flexural stresses

(a) In computing out-of-plane flexural stresses, an additional eccentricity, e_n , shall be added to those effects given in Art. 1.7.215(C)(1)(e), (f) and (g):

For steel bearings with flat bearing surface, e_n = one-half the bearing width in the direction of the span; for bearings with cylindrical bearing surface, $e_n = \frac{1}{2}$ " (12 mm).

(b) Out-of-plane flexural stresses shall be resisted by bearing stiffeners extending full depth of the diaphragm; stub stiffeners shall not be considered effective in resisting out-of-plane flexural stresses.

(c) For structural adequacy of the diaphragms during erection, particularly when jacking is anticipated, reference is made to Art. 2.10.55A in Division II.

(D) Unstiffened Support Diaphragms

(1) The sum of vertical bearing reactions calculated with factored loading, ΣR_v , on an unstiffened diaphragm without an access opening shall not exceed 2/3 of the critical buckling capacity, P_{cr} , of the diaphragm plate, computed by the formula

$$P_{cr} = \frac{KEt_D^3}{D}$$

where t_D = thickness of diaphragm plate
 D = depth of diaphragm between top and bottom supported edges
 E = modulus of elasticity of steel
 K = buckling coefficient,

$$K = \left(0.4 + \frac{j}{2B_B} \right) \left(3.4 + \frac{2 \cdot 2D}{B_B} \right) \left(1 - \frac{\theta}{100} \right)$$

where j = contact width of a single bearing, or distance between outer edges of bearings in case where diaphragm is supported on two bearings
 B_B = width of box girder bottom flange, measured between webs
 θ = inclination of box girder web to vertical in degrees

Alternatively, the buckling capacity of the unstiffened diaphragm may be calculated by any rational method.

(2) The maximum bearing stress in the diaphragm calculated in accordance with Art. 1.7.215(C) (2) (b) and (e) shall not exceed the yield stress of the material of the diaphragm or of the bottom flange of the box girder. Stub stiffeners may be used to reduce bearing stresses, but such stiffeners shall not be considered effective in resisting out-of-plane bending moments.

Stub stiffeners shall be proportioned in accordance with Art. 1.7.215(E) (3) (b).

(3) The effective equivalent stress, f_e , shall not exceed the yield stress at any point of the diaphragm,

$$f_e = \sqrt{f_1^2 + f_2^2 - f_1 f_2 + 3f_v^2}$$

where

f_1 and f_2 = the horizontal and the vertical axial stresses, respectively. Tension is taken as positive, compression as negative value

f_v = shear stress

Stresses shall be calculated with factored loading in accordance with the assumption of Art. 1.7.215(C) (2), (3) and (4). Local stress concentrations shall be disregarded.

(4) The maximum shear in any vertical section through the diaphragm between the bearing and the box girder web shall not exceed the value of V/B_{max} given in Art. 1.7.210(B) (1), with the stresses f_{1w} and f_{2w} designating the top and the bottom flexural stresses in the diaphragm at the cross section considered.

(E) Stiffened Support Diaphragms

(1) General

(a) The strength and stability of a stiffened

support diaphragm shall be determined by rational analysis, in accordance with the general provisions of this article.

(b) The diaphragm carrying capacity in shear shall be taken as the buckling strength, V_B . Tension field strength shall be disregarded.

(2) Strength and stability

(a) The stability of the diaphragm subpanels between the edge supports and the stiffeners, or between the stiffeners, shall be checked with consideration of the governing compression and shear stresses, in accordance with the applicable provisions of Art. 1.7.211 and 1.7.212, with the values of stresses taken in accordance with Art. 1.7.215(C)(2), (3) and (4).

Outer panels in trapezoidal diaphragms having side slope of less than 30° to the vertical may be treated as equivalent rectangular panels of width equal to the mean panel width.

(b) Diaphragm shall satisfy the strength requirements of Art. 1.7.215(D)(2), (3) and (4).

(3) Stiffeners

(a) Bearing stiffeners shall be designed as compression members to resist the bearing reactions and out-of-plane bending moments. In determining the section properties of the compression member, an effective strip of the diaphragm plate of $18t_D$ may be included with each line of bearing stiffeners; however, the total effective width shall not exceed the distance between two outer lines of stiffeners plus $18t_D$. Bearing reactions may be assumed to diminish linearly from the maximum value at the base to zero at the top of the diaphragm.

Bearing stiffeners shall be placed symmetrically on both sides of the diaphragm, shall extend the full depth of the diaphragm, and shall be connected to the top and

bottom flanges of the box girder. Connections shall be designed to resist transverse shears equal to 2% of bearing reaction, plus shears due to any out-of-plane bending moments. Diaphragms supported on a single bearing shall preferably have two pairs of bearing stiffeners symmetrically placed within the bearing width.

Bearing stiffeners shall also satisfy the applicable rigidity and torsional stability requirements of Art. 1.7.213(C), except that the multiplier M_T may be taken as unity.

(b) Stub stiffeners may be used in conjunction with bearing stiffeners to resist the bearing reactions. Length of stub stiffeners shall be determined on the basis of vertical compression stresses in the diaphragm, and preferably shall be not less than 3 times the stiffener width.

The slenderness ratio of a flat stub stiffener shall meet the requirement

$$\frac{d}{t_o} \leq \frac{0.48}{\sqrt{F_y/E}}$$

where d = stiffener width,

t_o = stiffener thickness

(c) Additional vertical and horizontal intermediate stiffeners may be used to subdivide the diaphragm into subpanels. These stiffeners may be placed on both sides, or on one side, of the diaphragm.

Vertical intermediate stiffeners shall meet the applicable provisions of Art. 1.7.213(C), except that the multiplier M_T shall be taken as unity, and the strength requirements of Art. 1.7.213(C) (1) (b) need not be considered.

Horizontal intermediate stiffeners shall meet the applicable provisions of Art. 1.7.213(D), except that the multiplier M_L shall be taken as unity.

(d) Stiffeners shall be provided on all sides of the access openings in the support diaphragm, with either the vertical or the horizontal pair of stiffeners continuous between the flanges or the webs of the box girder and connected to these members.

The distance between such stiffeners and the edge of the opening shall not exceed $8t_D$.

(F) Intermediate Diaphragms

Intermediate diaphragms between the supports of box girders shall be designed to resist distortional loads and the applicable local loads in accordance with Art. 1.7.216(B).

(G) Details of Diaphragms

(1) In composite box girders having a separate steel flange for each web, the diaphragms shall extend the full depth of the box girder and shall be provided with a steel top flange plate adequately anchored to the concrete deck.

(2) The distance between the web and the edge of bearing at support diaphragms shall preferably be not smaller than 0.2 times the depth of the diaphragm, in order to avoid excessive shear stress concentration at the web-diaphragm boundary, see Art. 1.7.215(C)(4)(a).

(3) The slenderness ratio, b/t_D , of the subpanels of stiffened support diaphragms in the lower corners and the bottom portion of the diaphragm shall preferably not exceed 40, with b designating the smaller dimension of the subpanel.

(4) Access openings through support diaphragms shall be located in low stress areas, preferably above the neutral axis of the diaphragm, and shall be framed by stiffeners, see Art. 1.7.215(E)(3)(c).

(5) The total effective thickness of the web-diaphragm welds of stiffened diaphragms shall be not less than 2 times the web thickness at intermediate supports,

and one web thickness at end supports; but in any event not more than the diaphragm plate thickness.

(6) Vertical and horizontal stiffeners shall be connected at their intersections if they are placed on the same side of the diaphragm.

1.7.216 Transverse Structural Members of Flanges

(A) Scope

This article applies to transverse structural members of the top and the bottom flanges acting as deck floorbeams, members of the crossframes or bracing systems, and transverse stiffeners subdividing the flanges into panels.

(B) Loading on Transverse Members

The loading to be used for transverse members depends on their structural function, and shall include the following sources of stress:

- (1) Direct dead and live loads on deck.
- (2) Axial and flexural distortional loads in transverse member acting as a part of crossframe or bracing.
- (3) Curvature or change of slope in longitudinal elevation of box girder flange.
- (4) Stresses in the bottom crossframe members at supports due to the vertical and horizontal components of the support reactions.
- (5) In the case of sloping webs, horizontal component of inclined web forces in bottom crossframe members at supports, and at top crossframe members where loads are introduced.
- (6) Transverse distribution of live load between box girders.
- (7) Creep and shrinkage of concrete deck and temperature effects.

Transverse members in flange compression zones shall also satisfy the strength and rigidity requirements of Art. 1.7.216(C) and (D).

(C) Strength

The effect of destabilizing forces in the compression flange with consideration of geometric imperfections in longitudinal and transverse stiffeners shall be taken into account by assuming the transverse stiffeners or cross-frame members to be loaded either upward or downward by a uniformly distributed load equal to one percent of the average compressive force in the flange calculated under factored loading. Alternatively, the force on the transverse member may be determined by a rational analysis with consideration of second-order effects introduced by transverse and the longitudinal geometric imperfections.

The forces so determined shall not be added to the forces of Art. 1.7.216(B) but shall be used to check independently the adequacy of transverse members.

(D) Rigidity

The minimum moment of inertia I_t of a transverse member in the flange compression zone shall be

$$I_t = 0.04b^3 A_f f / Ea$$

where

I_t = moment of inertia of transverse member about an axis through centroid of its section and parallel to its bottom edge. If member is connected to flange plate, an effective width of plate at midspan of transverse stiffener determined in accordance with Art. 1.7.204(B) shall be included.

b = spacing between webs, or between vertical supports of transverse member in the case of a trussed crossframe

A_f = cross-sectional area of compression flange between webs, or between vertical supports of transverse members, including longitudinal stiffeners

f = average axial stress in compression flange at transverse member, computed under factored loading

a = spacing of transverse members

E = modulus of elasticity of steel

(E) Location of Transverse Members

The location and spacing of transverse members shall be governed by the following criteria:

- (1) as required by direct loading on deck
- (2) as required by spacing of crossframes needed to control distortion of box girder cross section, to be determined by design analysis
- (3) at changes of slope in longitudinal elevation of flange
- (4) as required by strength considerations of flange panels in compression
- (5) transverse stiffeners and crossframes may be omitted in multi-box composite girders designed in accordance with Art. 1.7.203; however, the need for appropriate bracing during construction shall be considered, see Art. 2.10.55A

(F) Details of Transverse Members

- (1) Transverse members shall be connected to longitudinal flange stiffeners at their intersections. In compression zones of flanges, the connections shall be designed to transmit the forces determined in accordance with Art. 1.7.216 (C).
- (2) Transverse member cutouts shall be considered in the calculation of the rigidity and the stresses in the transverse member.

Art. 1.7.217 Miscellaneous Details of Box Girders

(A) Web to Flange Welds

The total effective thickness of the web-flange welds shall not be less than the web thickness. If fillets are used, they shall be on both sides of the connecting flange or web plate.

(B) Lateral Bracing and Crossframes between Box Girders

Generally no bracing system is required between composite box girders of multi-box bridges of moderate length; however, horizontal or vertical bracing may be needed for the stability of box girders during erection.

In multi-box bridges of longer spans, bracing or cross frames between box girders shall be provided as may be required by design analysis for transfer of vertical loading between the box girders or transfer of lateral loading to the supports.

(C) Longitudinal Stiffeners at Transverse Splices

Longitudinal stiffeners at transverse splices of compression flanges shall be continuous.

Longitudinal stiffeners at transverse splices of webs shall preferably be continuous, but may be discontinuous if stability of the web panel containing the splice is proven by special investigation.

Longitudinal stiffener splices in compression zones shall satisfy the following requirements:

(1) Stiffener splices shall preferably be symmetrical.

(2) Maximum length of cutouts in longitudinal stiffeners at welded transverse flange or web splices shall be 6 times the thickness of the thinner plate spliced.

(3) Where continuous transverse splice plates are used inside the box girder, the longitudinal stiffeners shall be connected to the splice plates.

PROPOSED MODIFICATIONS AND ADDITIONS

TO

DIVISION II - CONSTRUCTION

SECTION 10 - STEEL STRUCTURES

AASHTO Std. Specifications for Highway Bridges, 12th Ed.1977

After Article 2.10.46 - Painting, and before heading "ERECTION", insert Art. 2.10.46A, as follows:

2.10.46A - Dimensional Tolerance Limits

(A) General

Dimensional tolerance limits for all bridge members shall be applied to each completed but unloaded member and shall be as specified in the AWS Specification referred to in Article 2.10.23, except as modified hereinafter. The deviation from detailed flatness, straightness, or curvature at any point shall be the perpendicular distance from that point to a templet edge having the detailed straightness or curvature and which is in contact with the element at two other points.

(B) Tolerance Limits of Plate Panels

(1) Web Panels

Flatness tolerances of web panels or subpanels shall be in accordance with the AWS Specification, Articles 9.23.1.1-4.

(2) Bottom flanges of box girders

(a) The term panel as used in this section is defined as follows:

Unstiffened flanges: clear area of steel plate bounded by webs

Longitudinally stiffened flanges: clear area of steel plate bounded by longitudinal stiffeners.

(b) The templet edge length shall be the spacing of webs for unstiffened flanges, or the spacing of longitudinal stiffeners for stiffened flanges.

The deviation shall be measured on the concave face of the panel between adjacent points of contact of the templet edge with the panel; the templet shall be placed in the direction of the shorter edge of the panel.

(c) The maximum deviation from detailed flatness of the panel shall not exceed $D/200$, where D is the shorter dimension of the panel.

(d) In portions of bottom flange never subjected to compression (including stresses during erection), the permissible deviation from flatness specified in section (c), above, may be doubled, subject to approval by the Engineer.

(3) Orthotropic Decks

(a) The term panel as used in this section means a clear area of steel plate bounded by stiffeners, webs, or plate edges and not further subdivided by such elements. This includes the total clear width on the side without stiffeners as well as the panels between stiffeners on the side with stiffeners.

(b) The templet edge may have any length not exceeding the longer dimension of the panel, nor 1.5 times the shorter dimension of the panel; it may be placed

anywhere within the boundaries of the panel, in any direction. The deviation shall be measured between adjacent points of contact of the templet edge with the panel; the distance, D' , between these adjacent points of contact shall be used in the formula in Art. 2.10.46A(B)(1) (c) whenever this distance is less than the shorter dimension of the panel.

(c) The maximum deviation from detailed flatness or curvature of the panel shall not exceed the greater of:

3/16 inch (4.8 mm)

or

$D'/144 \sqrt{T}$ (inch) ($D'/906 \sqrt{T}$ (m))

where D' is the smaller of:

the least dimension in inches (m) along the boundary of the panel

or

distance between adjacent points of contact of templet edge with panel, as defined in Art. 2.10.46A(B)(1)(b).

T = the minimum thickness in inches (m) of the plate comprising the panel

(C) Tolerance Limits of Stiffeners

(1) Maximum deviation

The maximum deviation from detailed straightness, Δ_s , or deviation from detailed curvature, Δ_c , shall be as follows:

(a) Longitudinal stiffeners of box girder bottom compression flanges, designed as nominally straight

members:

$$\Delta_s = L/500$$

where

L = the smaller of:
spacing of transverse flange stiffeners
or
the value of L_o , the actual buckling length,
as defined in Art. 1.7.206(B)(3), to be
determined by the Engineer

Measurement of out-of-straightness, Δ_s , shall include the effect of vertical curvature of the flange, if any.

(b) Longitudinal stiffeners in portions of box girder bottom flanges never subjected to compression (including stresses during erection); longitudinal stiffeners of orthotropic decks in tension or compression; longitudinal stiffeners in vertically curved box girder bottom flange haunches designed with consideration of curvature:

$$\Delta_c = L/250$$

where L = spacing of transverse flange stiffeners

(c) Longitudinal web stiffeners in compression zone; transverse web stiffeners in webs designed with utilization of tension field strength, or subjected to calculated axial forces:

$$\Delta_s = L/500$$

where L = spacing of transverse web stiffeners, or distance between flanges measured along web, respectively.

(d) Transverse web stiffeners not subjected to calculated axial forces:

$$\Delta_s = L/250$$

(e) Transverse stiffeners of box girder bottom flanges in flange compression zones:

$$\Delta_s = L/500$$

where L = distance between webs

(f) Transverse stiffeners of box girder bottom flanges in flange tension zones:

$$\Delta_s = L/250$$

(2) Deviation measurement

The templet edge length shall be L , as defined in Art. 2.10.46A(C)(1)(a) through (f). Deviation shall be measured on the concave side of stiffener or stiffened panel. In measurements of deviation from straightness, Δ_s , other methods of measurement are permissible.

2.10.47 - Orthotropic Deck Superstructures

Retain Section (A) Protection of Deck Plate after Sand Blasting.

Delete Section (B) Dimensional Tolerance Limits.

After Art. 2.10.55 - Bearing and Anchorages insert the following new Article 2.10.55A:

2.10.55A - Erection of Box Girders

(1) Box girders during the various erection phases will be subjected to loadings entirely different from those for which the structure has been designed. Further, the box girder under erection will probably be in a state of partial assembly (flange plates or deck slab not yet in place, continuity not yet established, etc.), such that its structural behavior is markedly different from that in the service condition. Thus, both its loading and its structural behavior will be different from those conditions for which the structure was designed.

Since it is usually not possible for the designer to anticipate erection methods, box girder structures will normally be designed for service condition only, with no provision for strength and stability requirements during erection. The structural adequacy and safety of the box girders during erection shall be the sole responsibility of the Contractor. The Contractor's attention is directed to the provisions of Section 2.10.54, Methods and Equipment, of these Specifications.

The Contractor shall prepare and submit to the Engineer for approval complete erection plans, calculations, and procedure implementing his proposed erection method, giving detailed consideration to the loading, geometric conditions, the strength and stability of the structure and each of its component parts, at each successive phase of erection. Where necessary, the Contractor shall strengthen and stabilize the structure or its component parts in order to provide an adequate degree of safety at each phase of erection. Complete details with respect to such strengthening and stabilizing shall be submitted to the Engineer for approval. Approval of the Contractor's plans, calculations, erection procedure and strengthening and stabilizing measures shall not be considered as relieving the Contractor of any responsibility.

(2) Loading and geometric conditions to be considered during erection shall include the following:

- (a) Dead load, including weight of erection strengthening material not provided for during design;
- (b) Loads of erection equipment and devices;
- (c) Wind loads on partially completed structure;
- (d) Effects of temperature, field misalignment, field welding and torsional and distortional deformation of partially completed structure;
- (e) Loads associated with temporary positioning, temporary eccentricities, jacking and erection manipulations, and closing of the structure.

(3) Structural components to be reviewed for strength and stability during erection shall include the following:

- (a) Tension flanges stressed temporarily in compression;
- (b) Top flanges prior to placement of concrete deck slabs; temporary bracing;
- (c) Web panels subjected to biaxial stress and shear, as during rolling-in or launching;
- (d) Support diaphragms under temporary eccentric loading;
- (e) Web and flanges wherein stiffeners are not yet attached or spliced.

2.10.63 - Basis of Payment

Add the following statement to the first paragraph:

Where erection strengthening or stabilizing of the structure is required, the cost thereof shall be included by the Contractor in his contract price for the work.

Commentary on Modifications of General Design Provisions

Art. 1.7.52 This restriction is unnecessary, since load factor design principles are also applicable to box girder and plate girder bridges of longer spans.

Art. 1.7.55 The 10% reduction of negative moments over supports stipulated in Art. 1.7.59(A)(3) is based on an assumption of plastic hinges over supports, and is applicable to compact beam and girder sections only. No such hinges are permissible in box girders.

The design criteria for webs given in existing AASHTO provisions 1.7.59 through 1.7.63 are based on considerations of rolled beams and plate girders, treating the webs in conjunction with the beam flanges. Strength of web is given in terms of shear stress only; the effect of coincident axial stresses is accounted for indirectly by a semi-empirical relationship for the moment-shear interaction in the beam.

The use of these web provisions has been extended to moderate length multi-box composite bridges, see Art. 1.7.64. Since these provisions are regarded to be expedient and satisfactory for the design of such bridges, the ASCE-TCCS Committee on Steel Box Girder Bridges recommends that the existing provisions shall remain valid for structures of this type, and the new proposed rules may be used on optional basis.

However the existing provisions are not suitable for adaptation to deep webs of larger box girders. Therefore, the web design rules proposed in Articles 1.7.210-212 and 214 are based on a different approach, in which the strength of web is determined independently from the bending strength of the entire girder cross section, and is based on direct evaluation of the effects of shear and axial stresses acting simultaneously. Web stiffener criteria proposed in Art. 1.7.213 also differ from those of the existing AASHTO provisions.

It is suggested that the web design provisions for beams and plate girders be reviewed and adjusted in the

course of future revisions of the AASHTO specifications with the purpose of achieving a uniform approach to web design.

Art. 1.7.56 Assumption (1) may not be valid in the case of box girders with wide flanges, see proposed Art. 1.7.204.

Art. 1.7.64 Alternative use of the existing and the new provisions for the design of moderate span multi-box bridges has been recommended by the ASCE-TCCS Committee on Steel Box Girder Bridges for reasons stated in commentary on Art. 1.7.55.

Art. 1.7.74 The added provision, based on Art. 1.7.51(H)(1), should generally apply to all plate girder or box girder structures designed in accordance with the load factor design method.

Commentary on Articles 1.7.200, 201, 202

1.7.200 This corresponds to the scope outlined in the FHWA "Statement of Work" for this project, except that multi-box composite bridges have been also included by the writers for the reasons of consistency in the design of steel box girders.

1.7.201 Certain adjustments are proposed in the general provisions of the load factor design in order to make them applicable to the proposed design rules for box girders, see commentaries on modifications of Articles 1.7.52, 55, 56, 64 and 74.

All Article numbers are subject to revision at the time of final editing of the AASHTO specification.

1.7.202 The first paragraph is adapted from the provisions for "Allowable Stress Design", Art. 1.7.51(A). This is equally applicable to box girders designed in accordance with "Load Factor Design".

For commentary on erection stress analysis see commentary on Article 2.10.55 A .

The last paragraph refers to simplified method of analysis of multi-box composite girders used in the AASHTO specifications.

Commentary on Article 1.7.203

This article may be used as an alternative to Art. 1.7.64 for the design of moderate span multi-box composite bridges, see commentary on Art. 1.7.64 and 1.7.55.

The definition of scope and the simplified method for live load analysis, as given in Art. 1.7.64 are retained, however, strength has to be computed in accordance with the new provisions, Articles 1.7.200-217.

Commentary on Art. 1.7.204

(A) These provisions are based on a paper by Moffatt and Dowling and its discussion by Wolchuk (F16). This paper also provides the basis for the effective width provisions of the proposed British specification for Steel, Concrete and Composite Bridges, BS 5400(G151). More extensive comments are given in a report by Wolchuk and Mayrbaur1 (F13).

Paper (F16) proposes to use different effective widths for stresses and for deflections; however, Moffatt subsequently agreed that the "stress effective width" may be used for both purposes (private communication).

(B) The limitations of effective width for transverse members are based on stipulations of the proposed British specification BS 5400.

Commentary on Article 1.7.205

(B)(1) - (5) The strength curve given in Fig. 1.7.205(A) lies between Dwight's curves "O" (low residual stress, $\bar{\sigma}_R = 0.7$ ksi) and "P" (for "lightly welded" plate, $\bar{\sigma}_R = 3.6$ ksi) (F11). Dwight's curves are supported by earlier theoretical work by Moxham (F5, F6, F66) and by box column tests by Little and Dwight (F61). This strength curve is considered appropriate for "unstiffened flanges" having no longitudinal stiffeners, which are the main source of residual stresses. Note that for stiffened flanges a more conservative curve "Q" was used (F11), see commentary on Art. 1.7.206.

The writers gratefully acknowledge the mathematical formulation of the proposed curve by Mr. Wei Hsiung of Illinois Department of Transportation. A second equation for $\lambda > 1.5$ was added to give plate strength values in the postbuckling range. The straight line gives a value of $F_u/F_y = 0.22$ for $\lambda = 3.0$, which agrees reasonably well with the AISI formula for the effective width of "stiffened" plate components (G155, G156), modified for the presence of welding residual stresses according to (F75, G154).

Slenderness of a plate panel is given in the proposed specification by the nondimensional parameter λ , which is a function of b/t times the square root of yield strain. Nondimensional slenderness parameters are also used in the new British, German and ECCS specifications (G15, G98, G99, G140, G151). Expressing slenderness as a function of b/t and $\sqrt{F_y}$, in accordance with the current AASHTO practice, has the disadvantage of necessitating dual expressions (in English and in SI units), which are avoided in a nondimensional formula. It is recognized that engineers think in terms of b/t , but this value can easily be computed from the simple formula for λ . For convenience, a graphic b/t scale is included in Fig. 1.7.205(A).

(B)(6) This provision gives yield squashing as the upper limit of strength at the plate cross section at the support. Only an axial stress limitation is used, see comments about effect of shear under (C)(1) below.

(C)(1) Generally, the "maximum stress-at-a-point" criterion expressed by the von Mises equivalent-stress formula is being replaced by the concept of "strength-in-a-region" (see(F74), discussion by Faulkner). It has been recognized that simultaneous shear has some effect on strength of axially compressed panels; however, the values obtained by the von Mises formula, with the maximum values of the stresses used, are too conservative. Dwight (F18) has suggested a modified expression, disregarding shear up to the value of $0.175 F_y$; this is used here.

The use of the "governing shear" (not its maximum value) computed at approximately mid-panel location is in line with the "strength-in-a-region" approach. For this reason the writers felt that inclusion of shear considerations in (B)(6) above (maximum-stress section) would be unwarranted and unduly restrictive.

(D)(1) The location of the governing stress at a distance of $0.4b$ from the end of a panel corresponds to a similar distance used in Art. 1.7.206(C)(3) for stiffened flanges. Plate thickness may be reduced at a certain distance from the support, in which case adequacy of the thinner panel is checked again at the distance of $0.4b$ from the splice.

The value of $1/3 f_{v \max}$ has been suggested to the writers by Prof. Ostapenko.

(D)(2) See commentary on Art. 1.7.211(E).

(E) These slenderness limitations are in line with the current AASHTO specifications, and should discourage the designer from using too uneconomical (low strength) flanges, except where strength may not be required (i.e. at points of inflection).

(F) The overhang provision corresponds to the present AASHTO limitation for "compact sections" (Art. 1.7.59 (A)(a)), and is conservative.

Commentary on Article 1.7.206

Background of the Interaction Diagram Method for Design of Stiffened Flanges

The proposed interaction diagram method of determination of the ultimate capacity of stiffened flanges in compression is based on theoretical work by Little (F17). Little analyzed the interaction between the local buckling of the plate between the stiffeners and the overall buckling of the complete plate-stiffener combination by means of an improved iterative numerical method for inelastic column analysis, using the moment-curvature-thrust relationships for one buckle length of stiffened plating between transverse stiffeners.

The original investigation described in (F17) assumed positive (plate concave) initial strut out-of-straightness of $L/800$ and two levels of plate residual stresses 3.6 ksi (25 MPa) and 10.6 ksi (73 MPa). Based on these assumptions, strengths of flange panels stiffened with bulb-flat stiffeners were calculated for the plate slenderness ratios, b/t , of 25, 41.7 and 62.5, and for strut slenderness of the plate-stiffener combination, L/r , ranging from 20 to 120.

Subsequently, Little (at the University of Birmingham, U.K.) has investigated, for the purposes of this project, the strength of stiffened panels with various parameters, as needed for design. Investigations included panels with positive out-of-straightness (F46, F65) and with negative out-of-straightness (F70). In the former case plate compression strength governs, while the latter case is controlled by stiffener buckling. Four representative shapes and sizes of the stiffeners were used (two flat bar stiffeners and two T-stiffeners) with initial out-of-straightness of $L/500$, corresponding to the fabrication tolerance that will be used for this specification.

The effects of initial out-of-flatness of flange plate panels between stiffeners and of plate residual stress are accounted for by using plate strength curve

Q (F11), which is somewhat more conservative than the "unstiffened plate" strength curve in Art. 1.7.205. The assumptions used in the derivation of curve Q are as follows: the governing out-of-flatness ("ripple component") of the plate, δ_o , = 0.001 times the stiffener spacing; the residual stress in the plate, σ_R = 10.6 ksi (73MPa).

In addition, in calculations for strength of struts with a negative out-of-straightness, the inherent self-equilibrating residual stresses in the stiffeners prior to welding were superimposed on the welding residual stresses. The values of the inherent residual stresses were established by the writers, in consultation with the members of the ASCE-TCCS Review Committee representing the steel industry, as follows.

T-stiffeners: 10.1 ksi (70 MPa) compression at the flange tips and tension of the same magnitude in the flange at the web, with appropriate corresponding self-equilibrating stresses in the T-stems;

Flat bar stiffeners: 8.7 ksi (60 MPa) compression at the tips and 4.35 ksi (30 MPa) tension in the middle portion.

All calculations were made for two grades of steel, with the yield strength of 36 ksi (250 MPa) and 50 ksi (350 MPa). Additional sample calculations were made with a residual plate stress of 3.6 ksi (25 MPa) and stiffener out-of-straightness of L/1000, in order to assess the sensitivity of the results to the variation of these parameters.

All results were evaluated by the writers and strength curves for the various types of stiffeners and the two strengths of steel used were drawn. The simplified strength curves were then constructed, averaging these values (G153). The effects of the positive and the negative stiffener out-of-straightness and the effects of stiffener continuity were considered following recommendations made by Prof. A. Ostapenko (G154). The results are presented in a form of an "interaction diagram",

Fig. 1.7.206(A), first used for a similar application in the proposed new German specification (G111).

For low w/t ratios the lower limit of strength was assumed to be given by Lehigh column curve 2 (G30) applicable to light welded columns.

The results obtained from the proposed interaction diagram have been found to be in line with strength predictions by other methods (F18, F19, G111). Comparisons with the available applicable test results (F9, F50, F54, F55, F57, G50, G53, F74) indicate that the strengths obtained from the interaction diagram are appropriate and conservative.

A more detailed discussion and further background material on the proposed design method and the reasons for its selection may be found in the Final Report to the FHWA (Report No. DOT-FH-11-9259) by Wolchuk and Mayrbaur1, and in the following interim reports by the writers to the ASCE-TCCS Review Committee:

"Commentary on Proposed Interaction Diagram for the Design of Stiffened Compression Flanges", Part I, November 15, 1977 (G152)

"Commentary on Proposed Interaction Diagram for the Design of Stiffened Compression Flanges", Part II, March 30, 1978 (G153)

"Addendum 1 to Commentary on Proposed Interaction Diagram, Part II", April 20, 1978 (G154)

Specific Provisions

(B)(1) It is necessary to introduce the strength, F_u , in terms of individual struts because of the sub-articles (B)(5) and (B)(6) below.

It should be noted that the method for the design of compression flanges given in this article is valid only for nominally straight flange panels, including those having vertical curve camber not exceeding normal stiffener

straightness tolerances; however this method is not applicable to vertically curved flange panels at haunches, see Art. 1.7.200. In such cases the curved panels shall be treated as beam columns subjected to axial compression and bending, with radial forces resisted by transverse stiffeners.

(B)(2) There is some evidence of deleterious effect of simultaneous shear; however, the effect on ultimate compression strength does not seem to be proven. Thus, these provisions are conservative.

(B)(3) The formula for effective length, L' , is by Rogers (F 63), (F 18). It has been derived for the elastic range without consideration of second order effects, however, in the opinion of the writers, the results give a sufficiently good approximation for design purposes.

The designer may also use the formulas for L_0 or L' to determine the design length of the stiffener strut in the absence of transverse flange stiffeners.

(B)(4) This is similar to the provision of B/116/3, 1975 draft (G 15). The general idea is to set some reasonable limit on stress variation across the flange due to shear lag, as a safety precaution, although, according to some authors, shear lag does not affect ultimate strength. The problem is somewhat academic, since very short spans with disproportionately wide flanges (causing large shear lag effects) ought to be avoided in design.

(B)(5) This condition may occur in the case of strongly unsymmetrical loading, or lateral bending, of the box girder.

(B)(6) Reasoning similar to (B)(4) above.

(B)(7) The maximum stress at the end of any panel (at the cross frame or diaphragm) must be limited by the local strength, independent of overall strut buckling, defined as "stub strength" by Dwight (F 18).

(B)(8) This provision will preclude unnecessary analysis of the plate strength between the stiffeners.

The effect of plate strength on the strength of the stiffener strut is already accounted for (Little's method, (F 17)) in the derivation of the interaction diagram.

(C)(1) The stipulation that the design stresses in the flange shall be calculated at mid-plane of the plate is conservative, and is based on recommendation by Dwight (F 18) and other researchers.

(C)(2) Regarding "load shedding" from web to flanges and additional forces in flanges due to tension field action of webs, see commentary on Art. 1.7.211(E).

The design procedure used is consistent with the requirement of compatibility of strains at the flange-web intersection. The writers have confirmed this conclusion by discussions with Prof. A. Ostapenko. In practical cases of box girders the theoretical compressive flange capacity, and the web combined shear and flexure capacity (including the tension field action), can be developed virtually independently from each other, since the predominantly shear-type deformation of the web needed to develop its capacity does not depend on the amount of axial deformation (shortening) of the flange.

(C)(3) Using the governing axial stress at the distance of $0.4L$ has been suggested by Dwight (F 18).

The governing shear stress of $\frac{1}{3} f_{v \max}$ is consistent with Art. 1.7.205(D), unstiffened flanges, and governs in the case of a flange with a small number of stiffeners. The expression involving the number of flange panels follows a recommendation by Dwight (F 18).

For general comment regarding relative importance of shear see (B)(2) above.

Commentary on Article 1.7.207.

(A) The basic assumption made in the design of stiffened compression flanges (Article 1.7.206) is that the local torsional buckling of the stiffeners does not govern. Thus the critical stress for local torsional buckling of the stiffener must always be greater than the critical stress of the stiffener strut acting as a column for the stiffener failure mode (negative out-of-straightness, see (G 153)).

The proposed British Code B/116/3 (G 15) requires open stiffener sections to be capable of reaching the yield stress, and sustaining this stress over a strain of one yield strain, without failure by torsional buckling.

The critical local torsional buckling stress of the stiffener is a function of the "effective outstand slenderness", which depends on geometric properties of the stiffener cross section and on the degree of torsional restraint offered by the flange plate between stiffeners. Formulas for effective outstand slenderness have been proposed by Rogers and Dwight (F28) based on research at Cambridge University. The somewhat simpler formulas used in this Article are given in (G 15) and yield similar results.

The first formula corresponds to the requirement that the torsional buckling stress shall be greater than the yield stress. This is a reasonable requirement for stiffeners in flange zones, where the overall ultimate compressive strength is high. However, in flange zones subject to lower compressive stresses (near the inflection points) the high torsional buckling stress requirement would be too conservative and uneconomical, since it would make it impossible to "thin out" the stiffeners in low stress zones by omitting every other stiffener. This can be seen by inspection of the formula for C_s , where the second term will drastically increase the value of C_s as the stiffener spacing, w , is doubled and the flange thickness, t , decreased. Therefore, a second

formula for the maximum value of C_s is proposed for the low compression stress zones of flanges. The corresponding critical torsional stress values are lower than the yield stress, but still higher than one-half of the yield stress, and thus sufficient to ensure that local torsional buckling of the stiffener does not occur prior to overall stiffener failure.

(B) This provision ensures that failure due to buckling of the individual plate elements of the stiffener does not occur prior to overall failure.

Closed stiffeners are not endangered by local torsional buckling.

Commentary on Article 1.7.208

(A) While tension is the predominant stress in bottom tension flanges, compression may also occur near inflection points or during construction, see provision (B)(3).

(B)(1)(b) Nonuniform stress distribution due to shear lag is much less pronounced in bottom flanges near midspan than in compression flanges near supports, see Fig. 1.7.204(A). Provision for excessive non-uniformity of stress, Art. 1.7.206(B)(4) applies to tension flanges as well, but will be needed only in rare cases.

(B)(2) Fatigue provisions are based on stress range under working loads, therefore actual stress distribution with consideration of shear lag effects shall be used.

(C) In calculating the effect of combined shear and tension the equivalent stress is obtained by the von Mises formula, because the effect of shear on tension yielding seems to be definitely established. Note that in Articles 1.7.205(C)(1) and 1.7.206(B)(6) a modification of the von Mises formula proposed by Dwight was used, since the effect of shear on compression strength appears to be less certain, see commentary on Art. 1.7.205(C)(1).

Flange axial stresses in the transverse direction appear to be insignificant in the design of tension flanges. Such stresses can only be derived from resistance of the box girder cross section to distortion, either by frame action (in the case of transverse stiffening members around the periphery of a box section), or by truss action (in the case of diagonal bracing). The flange axial stresses in the first case are due to flexure of the cross frame, with the effective width of flange plate acting with the transverse stiffeners. These stresses are generally low because of the unsymmetrical cross section, and generally change sign across the flange; thus their effect, combined with the governing axial tension, tends to cancel out across the flange. In the second case (diagonal bracing) the distortional stresses in the flange are even smaller than in the first case.

It should also be noted that the maximum governing flange tension is usually associated with symmetrical loading of the box girder, and not with the unsymmetrical loading that causes distortional stresses; and further, that the design of the tension flange is likely to be governed by fatigue considerations, rather than by ultimate strength.

For these reasons the writers feel that flange transverse axial stresses can be disregarded.

(D)(2) It should be noted that the additional force, ΔF_2 , is generally compressive, and thus reduces the design force in the tension flange, see commentary on Art. 1.7.211 (E).

(E) Provision for dynamic stability has been included because it may be a problem in very wide and flexible flanges. However, according to a study by Mattock et al. (G 37) the stresses obtained in dynamic analysis are moderate, and would generally be lower for spans greater than 50 ft since fundamental bridge frequency and consequently the acceleration decrease with increasing span.

The conclusion that in bridges conforming to the criteria of Art. 1.7.203, secondary stresses due to plate vibrations need not be considered, is based on the findings by Mattock (G 38).

Should this provision on dynamic stability be found unnecessary and baffling to the designer, it may be removed from the final specification.

(G) The slenderness limitations for the plate panels and the stiffeners are arbitrary. The value of 120 has been proposed in the British specification draft (G 15). The purpose of these limitations is to provide the minimum rigidity necessary to overcome the "bending reluctance" of a wide flange, that is the tendency of the flange to avoid the overall curvature of the box girder, adopting instead a greater radius away from the web. The minimum rigidity is also necessary to check the dynamic excitability of the flange, see (E) above.

Commentary on Article 1.7.209

(B) The general outline provision pertaining to the design of orthotropic steel plate decks for both plate girder and box girder bridges has been retained, with only a brief amplifying statement added. It should be noted that no comprehensive method for the design of orthotropic decks based on the Strength Design Method has yet been formulated. It is not clear whether a practical method based on this approach is feasible, because of a great disparity between the characteristic strength reserves of the individual elements of the deck and the importance of fatigue considerations governed by stresses in the elastic range. The writers feel that, at present, the design method for orthotropic decks given in Art. 1.7.51 of the "working stress design" section should be considered satisfactory.

(C)(1)(a) These design rules correspond to the present AASHTO provisions Art. 1.7.62(B) for non-compact sections. Note that plastic hinges in box girders designed under the proposed provisions are not permissible, and, therefore the compact-sections provisions (involving full plastification of the web) are not applicable.

(C)(1)(b) An example of such structure is the Stanislaus River Bridge in California (G64). Note that detailed rules for design in such cases would be difficult to establish because of the many variables and uncertainties involved.

Treatment as an orthotropic deck in accordance with Art. 1.7.209(B) may be applicable.

(C)(2) Inclusion of the full cross section of concrete deck between the webs in the effective deck width is justified by the capacity of the solid steel flange to distribute the axial stresses over the entire width of the flange.

(D) Regarding treatment of solid steel flanges see comment (C)(1)(b) above.

(E)(3) The structural adequacy and safety of the box girders under erection shall be the responsibility of the Contractor, however, his erection method and stresses during erection shall be reviewed by the Engineer, see commentary on Art. 2.10.55A.

Commentary on Article 1.7.210

General Comments on the Existing AASHTO Web Design Provisions

Existing AASHTO provisions for unstiffened webs, Art. 1.7.59(A), (B), (C), and (D) are based on considerations of rolled sections and plate girders. In these provisions the webs are not treated separately, but only in conjunction with the flanges. The effect of the flexural stresses on the shear carrying capacity of the web is given by the moment-shear interaction equation. However, this formulation and other provisions of Art. 1.7.59 do not lend themselves to adaptation to box girder webs. Therefore the proposed provisions for the unstiffened and stiffened webs, Art. 1.7.210, 211 and 212, treat the webs as, essentially, independent structural elements.

The basic strength curves for the design of webs in accordance with the present AASHTO provisions are shown on Fig. 1.7.210-C. The shear buckling strength curve (1) for unstiffened webs, Art. 1.7.59(B)(e), is the elastic shear buckling curve divided by a factor of 1.38. Thus, in effect, the specification requires a double factor of safety - one given by the factor 1.38, the other by the load factor. This corresponds to the high factor of safety prescribed for unstiffened webs in the "elastic design" section of AASHTO, Art. 1.7.43(D). The reason for such conservative approach is not clear to the writers.

The shear strength curve (2) for the design of transversely stiffened webs in accordance with present Art. 1.7.59(E)(3) is based on adaptation of the shear strength curve proposed by Basler (W1). Basler's curve is, essentially, the elastic curve, with a slight correction for critical stresses in the inelastic range. The fact that curve (2) lies partly above the elastic curve does not reflect any postbuckling strength; it is merely the result of the mathematical simplifications used in establishing the value of $C = F_{vcr} / \tau_y$. (G105, pg. 29).

The proposed shear strength curve for unstiffened webs is discussed in commentary on provision 1.7.210(B)(2).

Specific Provisions

(B)(1) In keeping with the presently accepted design approach for unstiffened bridge girder webs only the buckling strength (beam action of the web) is considered, and the postbuckling strength is disregarded. It should be noted that postbuckling strength of unstiffened webs is considerable and has been reported to be of the order of 3 to 4 times the buckling strength, especially for high D/t ratios (G30, pg. 167). Thus the proposed design rules for unstiffened webs are conservative.

The limitation of the ultimate value of shear $V_{B \max}$ is based on shear capacity reduction due to presence of the axial stresses in the web (W43) in accordance with the von Mises yielding criterion for combined stresses. The value of $(2/3)f_{ay}$ used in the formula is a good average measure of the effect of the axial bending stresses for symmetrical or nearly symmetrical flexure in the web.

(B)(2) The shear strength curve selected for use in the proposed web design provisions is based on the semi-empirical Chern-Ostapenko basic strength curve (W27). This curve, defined mathematically in Table 1.7.211(B)(2), was originally intended for use in conjunction with the assumption of clamped longitudinal edges of the web, corresponding to the shear buckling coefficient, $k_v = 8.98$. For the condition of longitudinal edges of the web simply supported ($k_v = 5.34$) this curve is shown as Curve (3) on Fig. 1.7.210-C. It consists of the elastic buckling curve for slender webs (up to the value of $F_{vcr}^0 / \tau_y = 0.5$) and of a transition curve for more stocky webs.

Curve (3) has been selected for the calculation of the beam shear strength of stiffened webs. This assumption is generally conservative but proper for stiffened webs designed in accordance with Arts. 1.7.211 and 1.7.212, since the lower critical beam shear strength obtained with the assumption of longitudinal edges simply supported is to considerable extent compensated by the correspondingly higher tension field stress (see formula in Art. 1.7.211 (B)(5)). Thus, in effect, there is not much difference in the total ultimate shear strength obtained as the sum of

the beam and the tension field action.

However, in the case of unstiffened webs, the tension field strength is not utilized and there is no compensation for the conservative assumption of the k_v value. Furthermore, unstiffened webs are generally used in medium span composite box girders, where the boundary at the upper (concrete) flange is definitely fixed, while the junction at the bottom flange may be considered almost simply supported. Therefore, in consultation with Prof. A. Ostapenko, the writers propose to use $k_v = 7$, which is an approximate average value between the "fixed" ($k_v = 8.98$) and the "supported" ($k_v = 5.34$) conditions. The curve in Fig. 1.7.210 (curve (4) in Fig. 1.7.210-C), proposed for unstiffened webs, is based on this assumption.

The formula for the slenderness parameter of an unstiffened web, λ_v , results from substituting $k_v = 7$ into the general equation in Art. 1.7.211(B)(2).

Regarding calculation of the critical buckling stress F_{vcr} for combined shear and axial stress see comments on Art. 1.7.211.

(C)(a) The governing stresses are not those at the higher-stressed edge of the panel, but at the middle of the potential first buckling bulge, which is approximately at the distance of $D/2$ from the support (G112).

(C)(b) Web shall also be checked near midspan, for the effects of maximum compression stress at the top flange combined with shear, if necessary.

(C)(c) This provision implies the possibility of reducing the web thickness at an appropriate distance from the support.

(D)(1) Because of basic similarity of the "unstiffened" and "transversely stiffened" webs, the writers see no justification for slenderness criteria other than those in the present AASHTO specifications, which are based on fatigue considerations. Therefore these provisions are

proposed in Art. 1.7.210 for unstiffened webs without change.

Although the minimum slenderness criteria of the present AASHTO specifications may be not too restrictive for the unstiffened webs, they may, in the writers' opinion, unduly restrict the minimum web thickness and the design economy of deep stiffened webs in the low stress range zones of the box girders; see further comments on this in Commentary on Art. 1.7.211.

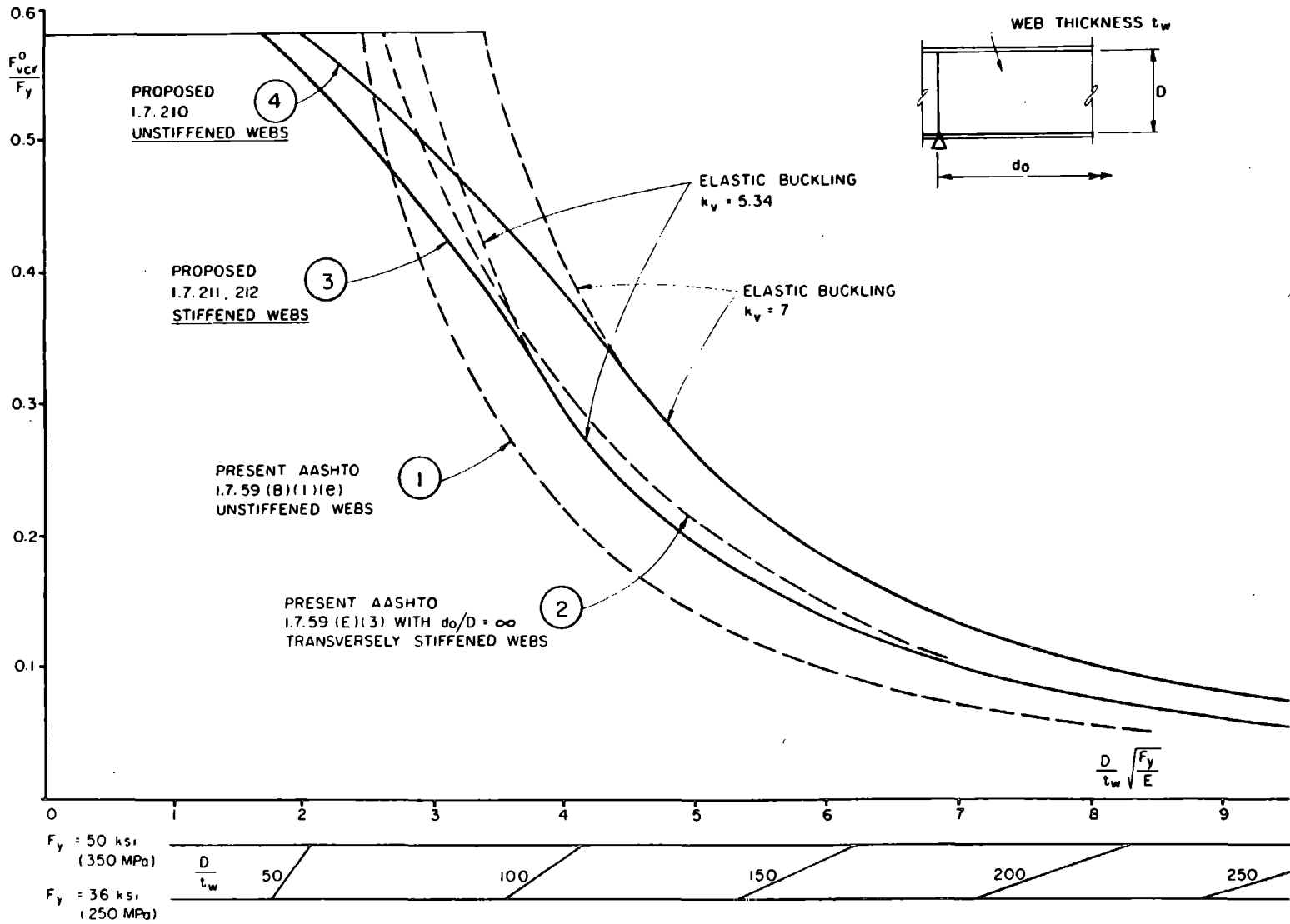

FIG. 1.7.210 - C COMPARISON OF BUCKLING STRENGTH CURVES FOR WEBS IN PURE SHEAR

Commentary on Article 1.7.211

General

This article presents general rules for design of webs under combined effects of shear and axial stresses. These rules are also applicable to the unstiffened webs (Art. 1.7.210) and the longitudinally and transversely stiffened webs (Art. 1.7.212); therefore these Articles contain references to the provisions of Art. 1.7.211.

These provisions are given in a form that should help the designer's understanding of the basic principles and assumptions used. Such form is felt desirable since the AASHTO specifications do not include an explanatory commentary, unlike some other design codes.

Specific Provisions

(B)(1) The shear carrying capacity of a web panel is given as the sum of the beam shear strength (elastic buckling), V_B , and the tension field strength, V_T , and these two components of strength are clearly separated in the proposed specification. This has the advantage of better clarity and gives the designer the option to disregard the tension field strength, if he so desires.

However, it must be kept in mind that the representation of the web strength as the sum of the "elastic buckling strength" and the "tension field strength" and the strict separation of these two strength contributions does not quite correspond to the physical reality and is therefore somewhat artificial. The classical elastic buckling theory, based on its idealized assumptions, does not give reliable results for plates in actual construction (see report on Task B of this contract, Sept. 1977, "Review of Design Codes", Section B.2; also G28), and the computed theoretical strengths depend on the assumptions made (degree of web fixity at flanges, etc.). Furthermore, the "beam" and the "tension field" strength contributions do not develop sequentially, but simultaneously, due to the initial imperfections of the web panels. For these reasons the demarcation between the two components

is somewhat uncertain, and so are the relative proportions of each at the intermediate and the ultimate loading stage. Thus, tests on webs can only indicate whether the total strength, calculated as the sum of the two, has been predicted with reasonable accuracy. However, it is perhaps unreasonable to expect a test confirmation of the "correctness" of the formulas or theories used in the calculation of the individual V_B and V_T web strength components. Therefore the formulas proposed for the calculation of the "beam" and the "tension field" strengths must be treated merely as convenient design tools based on the best knowledge currently available, with the understanding that they may be modified or replaced with a different approach in the future, as may be indicated by continuing research. However, the writers feel that the ultimate strength of box girder webs, obtained under the proposed rules as a sum of the two strength components, is conservative and reasonable.

The ultimate-strength formulas for webs contained in the current AASHTO specifications are given in terms suitable for rolled beams and plate girders, and are not adaptable to box girder webs, see commentary on Article 1.7.210 (General Comments). It should be noted that the proposed method of computation of the web shear capacity already includes the effects of the simultaneous flexural axial stresses acting with the shear, and no additional interaction formula for reduction of the shear capacity on account of the moment is needed.

The basic question to be decided is, whether and to what extent the tension field approach should be permitted in the design of box girder webs, where the boundary characteristics are different from those of plate girders. The objections are based on the generally lower flexural rigidity of the box girder flange portions providing the anchorage of the tension field, and the danger of destabilizing the compression flange by the fully developed tension field action. The writers have discussed these questions with the authorities in this field, including Prof. A. Ostapenko of Lehigh University and Prof. K.C. Rockey of Cardiff University. The conclusion reached

was that the use of the tension field concept in the design of box girder webs is justified; however, it should be applied with caution. Therefore the utilization of the tension field contribution to the shear strength should be limited to its lower-bound value known as the "true Basler" solution (W29, W43) which is based on the assumption of a negligible flange rigidity. The expression for V_T in accordance with this solution is given by the formula in Art. 1.7.211(B)(1). It should be noted that this approach lends itself to future extension to plate girder webs by simply adding to the expression for tension field strength those terms contributed by flange rigidity.

In those cases, where shear is low, or where vertical components of tension field forces require heavy transverse stiffeners that may be undesirable, the "beam" shear strength alone may be used in the design. The advantages and the economy of the design with or without the utilization of the tension field must be evaluated by the designer.

The formula for the maximum value of the ultimate shear strength, $V_{u \max}$, is the same as for the unstiffened webs, see commentary on Art. 1.7.210(B)(1).

(B)(2) The values of the critical shear buckling stress, F_{vcr}^0 , are based on the basic shear buckling curve proposed by Chern-Ostapenko (W27), see commentary on Art. 1.7.210(B)(2). This curve is preferred to the present AASHTO shear strength curve (see Fig. 1.7.210-C, Curve (2)) because it seems to be more correct in defining the strength in the transition region from elastic to inelastic range, see a similar strength curve for pure compression, Fig. 1.7.205(A). The present AASHTO shear strength curve does not provide for any transition from the elastic to the inelastic range. As is seen from Fig. 1.7.210-C, the difference between the present and the proposed basic shear strength curve is of significance only in a narrow range of web slenderness corresponding to $D/t_w \sqrt{F_y/E}$ value of about 2.5.

The value of k_v used for transversely stiffened webs corresponds to the assumption of simply supported longitudinal edges of the web, see commentary on Art. 1.7.210 (B)(2). The simplified AASHTO formula for k_v (see G105, pg. 30) is used rather than the more exact formula, which requires two equations.

(B)(3) Curves (1), and (2) in Fig. 1.7.211(B) are buckling stress curves (beam action of the web only) and not strength curves. Therefore the values for curve (1) ($R = 1$, pure compression) ought to be below the strength values given in Fig. 1.7.205(A) (strength of unstiffened plate panel). However, the distinction between "buckling stress" and "strength" in the inelastic range is difficult to make, and the "strength curve" might be used as the "buckling curve" in the low λ range. For high λ values the use of the elastic buckling curve is appropriate. In order to provide a smooth transition between the strength curve given in Fig. 1.7.205(A) and the elastic buckling curve, a new transition curve is introduced for $0.65 < \lambda < 1.5$. This new curve closely approximates the plate strength curve in Fig. 1.7.205(A) for $0.65 < \lambda < 1.2$, and then transitions smoothly to the elastic buckling curve at $\lambda = 1.5$. Thus the buckling curve in 1.7.211(B) (3) can be defined by two equations; the second equation, for $\lambda \geq 1.5$, is the elastic buckling curve.

Curves (1) and (2) in Fig. 1.7.211(B) are obtained from identical source equations by using the appropriate values of the buckling coefficient, $k = 4$, and $k = 24$, respectively. These values correspond to panel aspect ratios $\alpha = d_o/D > 1$, or $\alpha > 2/3$, respectively. For web panels with smaller aspect ratios more advantageous values of the critical buckling stresses can be obtained from the equations by using the appropriate k - values from the formulas given.

For the case of $R < -1$ the use of curve (2) for pure bending is recommended for design simplicity, as indicated by the dashed line on the stress distribution diagram in Fig. 1.7.211(B). It should be noted that in such cases of unsymmetrical flexural stress distribution in the

web the compression is relatively small, and the inaccuracy resulting from the suggested simplification is of no practical consequence in design. This procedure is conservative.

(B)(4) Interaction formula for the critical buckling stress for combined shear and axial stresses is the generally used formula from the elastic theory. (G30 Eq. 4.40, p. 109).

Because of the many parameters involved, the procedure presented looks complex at first, but is actually not difficult in practical use.

The definitions of the stresses and the stress ratios are illustrated in Fig. 1.7.211(C).

First the designer has to establish the ratio $\mu = f_{lw} / f_v$ of the maximum compressive stress at the edge of the panel under consideration to governing simultaneous shear. In subsequent computations all axial stresses are expressed in terms of shear, by the use of ratio μ . The general case of unsymmetrical axial stress distribution in the web ($1 > R > -1$, see Fig. 1.7.211(B)) can always be expressed as a sum of pure compression and pure bending, by means of the ratio R , which the designer has to determine for the case considered. Thus the values of F_{bcr} and F_{ccr} are expressed in terms of F_{vcr} , μ and R by the formulas given. The remaining parameters F_{vcr}^0 , F_{bcr}^0 , F_{ccr}^0 are obtained from Fig. 1.7.211(A) and (B), and then the needed value of F_{vcr} is computed by solving the quadratic interaction equation. The value of F_{vcr} is then used in formula given in Art. 1.7.211(B)(1).

The writers are much indebted to Prof. A. Ostapenko for helpful suggestions leading to formulation of the elastic buckling relationships in a form suitable for design.

Interaction equations in Section (B)(4) are applicable to web panels or subpanels subject to shear and axial flexural stresses, including tension and compression in the panel (Fig. 1.7.211(C)) or compression only (Fig.

1.7.212). For the case of panel under shear and tension only (no compression stress), the above procedure does not apply. Design provisions for such cases that may occur in longitudinally stiffened webs are proposed in Art. 1.7.212(B)(4).

The effect of vertical axial compression stresses in the web, such as may be caused by wheel loads on the deck, is disregarded. The writers have investigated the admissibility of such simplified treatment for both orthotropic steel deck bridges and concrete deck bridges and find that the vertical stresses in the webs due to direct wheel loads of the AASHTO specifications are low and are subject to rapid attenuation with increasing distance from the top flange. Thus, the conclusion was reached that such stresses may safely be disregarded in these specifications.

However, the situation is different in webs of box girders to be erected by launching (B3). In such cases the webs are subject to large concentrated reactions and their adequacy for such conditions should be checked. Methods for such investigation have been proposed by Bergfelt (W13). These are, obviously, special cases, outside the scope of the AASHTO specifications.

(B)(5) The stress in the yield band of the tension field panel is equal to the yield stress of the material. In the portion of the web subject to flexural tension and shear stress the tension, F_T , available for the development of the tension field action is decreased by the equivalent tension already present in the web. The magnitude of the decrease is calculated by the von Mises equivalent stress formula, using the governing tension and shear stresses in the web. The shear stress in the web in the post-buckling stage is equal to the value of the critical buckling shear stress in the panel, F_{vcr} . The flexural tensile stress in the web is taken at its average value, $f_{2w}/2$, that is, one-half of the actual maximum tension stress in the web.

Webs acting as tension fields are incapable of carrying direct local vertical compression stresses; the

British "Merrison Rules" (G11) contained elaborate provisions to preclude occurrence of such stresses in the webs. However, proposed provisions disregard the effects of vertical compression stresses in webs, see commentary on Art. 1.7.211(B)(4).

(C) The assumptions regarding the location of the governing stresses and their distribution correspond to those used in tension field theories by various researchers (W27, W43).

(D)(1) These provisions correspond to AASHTO limitations 1.7.59(E)(1) and 1.7.60(B) based on fatigue considerations, see (G105) pp. 27 and 34, and are given unchanged, except for using a nondimensionalized formula.

The writers feel that since the present web slenderness limitations are based on fatigue, they ought to be related to the governing stress range in the web panel under consideration. The present rules make no reference to stress and may be too restrictive for (a) web areas with relatively low stress near inflection points of the box girders, or (b) for webs of longspan bridges where dead load stresses are predominant and the stress range due to live load is small. In such cases the present rules may affect the economy by making it impossible to reduce the web thickness in accordance with the actual strength requirements.

Regarding condition (a), allowable slenderness could possibly be modified by a coefficient $\sqrt{F_{vcr}/f_v}$, where F_{vcr} is the critical shear stress and f_v is the actual shear (suggested by Prof. A. Ostapenko). In case (b) a modification based on the ratio of total stress to live-load stress could be used. However, the writers did not attempt to liberalize the existing provisions, since such revisions must be supported by definite recommendations based on research in the field of web fatigue. In the meanwhile the designers should be permitted to exercise their judgment in cases where existing rules may result in excessive web thickness.

(D) (2) No maximum spacing of transverse stiffeners is stipulated. The present maximum spacing requirement of the AASHTO specifications is arbitrary and is not supported by any design considerations, see (G105). Since welding of stiffeners is one of the most expensive cost items in fabrication, a greater freedom in placing the stiffeners only where they are needed will contribute to the economy of box girder construction.

(E) The forces in the box girder flanges are determined (Art. 1.7.205, 206, 208) in accordance with the assumption of linear elastic stress distribution by the usual Mc/I formula, with I including the entire web. However, when the web buckles, its compressive part becomes unable to resist further compressive flexural stresses, and the "excess moment" is resisted by a reduced cross section of the box girder, with a corresponding reduced moment of inertia, I_R . Consequently, the force in flanges is increased, and this effect is reflected in the formulas for ΔF by the term $(f_{LR} - f_1)$.

In addition, a further compressive component of the flange forces must be added since the moment in excess of that at which web buckling theoretically occurs is carried by "truss action", with the tension band acting as a diagonal, rather than by beam action. In flange design, the moment near midpanel is used to compute the flange force; however, with the girder acting as a truss the force in the flange acting as a chord is correctly determined using the moment at the intersection of the tension diagonal and the opposite flange. Therefore, the governing flange force computed by the Mc/I formula underestimates the force in the compression flange and overestimates the force in the tension flange. The additional correction required is equal to one-half of the horizontal component of the tension field stress in the panel, and is given by the second term in the formula for ΔF . In accordance with the "true Basler" tension field model the angle of inclination of the tension field force is approximately equal to $\theta_d/2$. This force is added to the compression flange force and subtracted from the tension flange force.

The excess moment is defined by the expression $(V_M - \sum V_B)/V_M$, which is the ratio of actual shear in

excess of beam-action capacity remaining to be carried by postbuckling strength, to total actual shear. Note that only the actual "demand" and not the postbuckling capacity (which in practical cases is always greater than the "demand") is used in the proportion, thus minimizing the additional flange force to be used in the design.

Note also that the entire box girder cross section with all webs (usually two) is considered, and not individual webs. Therefore the total moment and the total shear acting on the entire box girder are used. It should be kept in mind that any unsymmetrical loading on box girder is represented in the analysis as a sum of a symmetrical loading (causing symmetrical flexural stresses) and an antisymmetrical loading (causing torsional and distortional shear stresses and opposite bending in webs). Thus the shear distribution in box girder webs may be unsymmetrical, but this does not matter in the determination of the total additional flange forces, ΔF .

Adjacent flange and web panels are often of different lengths, since the latter are usually subdivided by transverse stiffeners spaced closer than the cross beams that stabilize the flanges. In such cases the correct determination of the "additional flange forces" is more complex than that given herein; however, such a rigorous treatment would be too complicated for design. The representative values of ΔF obtained for the web subpanel at the cross section where the critical stresses for the flange design are computed are considered adequate for design purposes.

Commentary on Article 1.7.212

(B)(1)-(B)(3) At this time there is no general agreement among the researchers on utilization of the postbuckling strength in webs stiffened with one or more longitudinal stiffeners. Provisions proposed in Sections (B)(1)-(3) and (B)(5) are based on suggestions made to the writers by Prof. K.C. Rockey of Cardiff University and on the results of his continuing testing and theoretical work on the problems of web design (W40, W41, W43, W45).

The "beam shear strength" is governed by the elastic buckling stress of the web subpanel with the lowest critical stress. In order to fully utilize the beam shear strength the longitudinal stiffeners must be counted upon to act as rigid supports of the edges of the subpanels and to remain straight throughout the elastic and the postbuckling phases of web loading (see Art. 1.7.213).

(B)(4) Tension has a stabilizing effect on panels in shear; therefore elastic buckling stresses calculated for shear only without considering coincident tension stress are overly conservative. Proposed formulas for buckling stresses of panels under shear and tension are based on formulas derived by Scheer (W50), simplified by the writers. The shear buckling coefficient, k_y^* , already includes the effect of coincident tension; therefore the values of F_{vcr} are obtained directly, and the use of an interaction equation is not necessary. Equations for F_{vcr} are analogous to those for F_{vcr}^0 in Art. 1.7.211(B)(2).

Because of the beneficial effect of tension, only the tension stress coincident with maximum shear shall be used in the calculations, and not the maximum tension in the subpanel.

Methods of calculating critical elastic buckling stresses are the same as given in Art. 1.7.211, except that each subpanel must be handled separately, and the symbols and definition must be modified as noted in Art. 1.7.212(B)(3) and Fig. 1.7.212.

(B)(5) Tests on longitudinally stiffened girder webs (W40, W41, W43) have indicated that ultimately the tension field tends to develop diagonally across the entire web panel between the flanges, regardless of the relative rigidity of the longitudinal stiffeners. Thus, the tension field strength of the longitudinally stiffened webs is obtained in the same manner as given in Art. 1.7.211 for webs with transverse stiffeners only.

(C)(1) Slenderness limitations for webs with one longitudinal stiffener correspond to those given in AASHTO, Art. 1.7.59(F)(1) and 1.7.60(C). These provisions permit doubling the allowable slenderness for longitudinally unstiffened webs, provided that the axial stresses are symmetrical and the longitudinal stiffener is placed at a distance of $D/5$ from the compression flange.

For webs loaded unsymmetrically, an "effective depth" of web equal to $2D_c$ is, in effect, used in determining the web thickness in accordance with the present specification. Thus, thicker webs are required for unsymmetrical cross sections, or, by implication, for all cases where the stiffener is not placed at the most appropriate location for prevention of web fatigue effects. This is reflected in the two requirements of Art. 1.7.212(C)(1). Since the proposed rules do not prescribe the location of the stiffener, the condition $D' \geq 2D_c/5$ becomes necessary to prevent placement of the stiffener too close to the compression flange where, in the case of $D_c > D/2$ it would not be properly effective against fatigue. On the other hand, if $D_c < D/2$, the designer shall not place the stiffener too close to the compression flange, for practical reasons.

(C)(2) Provisions are based on logical extension of the rules of (C)(1) to the webs with multiple longitudinal stiffeners.

For the first stiffener in the "correct" location of $2D_c/5$ for a symmetrical section, the allowable slenderness was arbitrarily established to be 20% greater than in that of a similar case with one stiffener only. For unsymmetrical cases with $D_c < D/2$, the percentage increase in

allowable slenderness will be larger. The writers feel that these provisions are justified by the beneficial effect of additional longitudinal stiffeners on lateral web deflections due to buckling, and the associated fatigue effects. Generally, multiple longitudinal stiffeners are used for the purpose of obtaining thinner webs, and this aim should not be thwarted by the minimum thickness provisions.

The requirement for the maximum D'_n/t_w ratio is given as a function of the ratio of the longitudinal stiffener distance from the compression flange to the depth, D_c , of the compression zone. This makes the requirement^c less restrictive in the web zones subject to a lower stress range, and reflects the fact that the width of the subpanels usually increases with their distance from the compression flange. Without such a provision the web thickness would be governed by the deeper subpanels near the neutral axis, which would be incorrect.

Slenderness requirements for web portions in tension have not been formulated by the writers because of lack of sufficient research data on this subject.

The writers feel that the slenderness limitation rules, as proposed, may be restrictive, and should be re-examined in light of additional research on web fatigue, see commentary on Art. 1.7.211(D)(1).

(D) For discussion of additional forces in flanges see commentary on Art. 1.7.211(E).

Commentary on Article 1.7.213

General

The purpose of the web stiffeners in webs designed in accordance with the classical elastic buckling theory is to provide support at the boundaries of the web panels consistent with the assumptions used in the design of the panels. In order to achieve this the stiffeners must have the necessary minimum rigidity, which can be determined by the methods of elastic theory. For webs with initial imperfections, and where postbuckling strength is used in the design, such calculated rigidity values are generally not sufficient, and the strength of the stiffeners must also be considered. In addition to their function of supporting and stabilizing the web panels and resisting the forces generated in the web by tension field action in the postbuckling stage, the transverse stiffeners also transmit vertical deck loads into the web, resist support reactions, and form a part of the crossframe or cross bracing system resisting lateral loads and distortional moments of the box girder cross section. Therefore proportioning of the transverse and the longitudinal web stiffeners is not a simple problem.

The existing AASHTO provisions for transverse and longitudinal stiffeners prescribe minimum rigidities of stiffeners based on elastic theory. The moment of inertia of a stiffener is taken about the web face, implying a very large effective width of web plate acting with the stiffener. In addition, a formula is given for assessing the vertical force on a transverse stiffener due to tension field action.

The new German specifications (G140) are based on elastic design only, and disregard the postbuckling strength of the web. The effective width of the web plate acting with the stiffener is based on the effective slenderness of the stiffener. The rigidity of a longitudinal stiffener may be smaller than the theoretically required minimum rigidity, γ^* . In such cases the stiffeners do not remain straight when the web buckles,

but bend with the web plate. The critical buckling stresses of the web subpanels bounded with flexible stiffeners are lower than the optimum theoretical values obtained with rigid stiffeners. The specification recommends the use of published values of the buckling coefficient k (G107, G108) depending on the rigidity and arrangement of the stiffeners used and on the stress distribution in the web. The use of stiffeners with a rigidity greater than the "optimal theoretical rigidity", γ^* , is considered unnecessary and uneconomical (G67).

The proposed British specification BS 5400 (G151) (in preparation) is based on partial utilization of the web postbuckling strength and recognizes the need for stiffener strength greater than that resulting from elastic theory. Stiffeners are designed, essentially, by strength criteria. In order to ensure their adequacy, fictitious "destabilizing thrusts" of considerable magnitude are added to the actual compression and flexural forces in the stiffeners. A Perry-type formula, also applied in this specification to compression flanges, is used in the design of the stiffeners as compression members. The design values of the destabilizing forces are given as a function of the axial and the shear stresses in the web. This treatment is partly based on the approach used earlier in the Merrison Rules (G11, G12).

It is seen that current design criteria for web stiffeners vary widely, depending on the philosophy of web design, and are geared to calculation procedures traditionally used in the individual countries.

The design provisions for web stiffeners proposed by the writers are consistent with the design method for the webs given in Articles 1.7.211 and 212, based on maximum utilization of the elastic beam strength of the web subpanels (requiring rigid stiffeners) and partial utilization of the tension field strength. In general, the writers followed the recommendations made by Prof. K.C. Rockey of Cardiff University.

It is generally recognized that many questions regarding the design of stiffened webs still remain unre-

solved, and remain to be answered by continuing research. Therefore some of the proposed provisions are necessarily arbitrary and conservative.

Specific Provisions

(B) (1) Note that there may be no need for exterior transverse stiffeners at supports where diaphragms are used.

(B) (2) These provisions are consistent with AASHTO provisions for bearing stiffeners and with the additional requirements of Art. 1.7.213(C).

(B) (3) The horizontal component of tension field force actually used in the end panel is calculated assuming the inclination of the tension field force as $\theta_d/2$, see commentary on Art. 1.7.211. The distance of $D/3$ from the top flange is conservative.

(C) (1) (b) The vertical force on the transverse stiffener due to tension field action is calculated according to Basler (W1), adjusted for the tension field strength actually utilized. Note that the effective force on the stiffener is smaller than the vertical force in an equivalent Pratt truss, because the opposite shear contributions from the two adjacent panels partially cancel out in the middle portion of the stiffener.

(C) (1) (c) For a tension field utilized to its full theoretical value ($V - V_B = V_T$), no effective width of web plate should be used in the design of the stiffener, according to Prof. K.C. Rockey, because of plastification of the web material adjacent to the stiffener. However, since full web plastification will occur only over a part of the stiffener length, it would be too conservative to exclude any web contribution to stiffener rigidity. The proposed formula limits the effective width to $9t_w$ in the case of a fully utilized tension field, and permits the normally accepted effective width of $18t_w$ where tension field strength is not utilized.

(C) (1) (d) The reduced effective column length of the stiffener is based on the compressive stress in the stiffener being introduced gradually over the stiffener length.

(C) (1) (e) Longitudinal stiffeners enforce nodal lines in the web plate and are subject to lateral destabilizing forces exerted by the plate, which would, in the absence of the stiffeners, deflect laterally at the stiffener locations. These lateral destabilizing forces have to be resisted at the transverse stiffeners. A rigorous determination of the destabilizing forces, which must be based on second-order theory, is very complex and would be impractical in the design. An investigation by Leonhardt (G48) indicates destabilizing forces of the order of 2 - 6 percent of the longitudinal stiffener capacity. However, these results are based on rather severe assumptions of the most unfavorable combination of the assumed initial imperfections of the longitudinal and the transverse stiffeners, and must be regarded as very conservative. The writers chose 2 percent of the longitudinal stiffener capacity for the design of web transverse stiffeners and one percent for the design of flange transverse stiffeners, see commentary on Art. 1.7.216(C).

(C) (2) (a) The relative rigidity coefficient γ^* denotes the minimum relative rigidity of a stiffener required to ensure that the web subpanel adjacent to the stiffener may reach its maximum theoretical elastic buckling strength. γ^* is a function of the geometric parameters of the plate panel and the type of loading, and is calculated by the methods of the classical elastic plate buckling theory, based on assumptions of ideal plate flatness, absence of residual stresses, and unlimited validity of the Hooke's law. Thus, application of these values to plates in the inelastic range requires caution and appropriate adjustment. For further comments regarding the relative rigidity coefficient, γ , and the "minimum required rigidity", γ^* , see Report on Task B of this project, pg. 5.

The buckling and rigidity coefficients for stiffened plates are obtained by the energy method, involving application of double Fourier series. Calculations are very laborious and require the use of large capacity computers. The values of the buckling and rigidity coefficients for various load cases and stiffener arrangements have been presented in the two-volume work by Kloeppe-Scheer-Moeller (G107, G108).

The minimum rigidity coefficients for transverse stiffeners, γ_T^* , depend mainly on the panel aspect ratio, α , and the magnitude of the critical shear stress, axial stresses being of small importance (G108). Therefore the proposed values of γ_T^* are obtained without consideration of axial stresses.

In view of the large number of parameters involved and the complexities of the mathematical operations in the calculation of γ_T^* values, there is considerable uncertainty regarding the "correct" and appropriate values of these coefficients. The values given in literature (G17, G107, G108, G113) vary, depending on the assumptions and simplifications used. Reference (G108) gives γ_T^* for $\alpha > 0.7$ for webs without longitudinal stiffeners.

γ_T^* for webs with longitudinal stiffeners based on (G108) were obtained by the writers indirectly. For $\alpha < 0.7$ the writers have extrapolated the values from (G108), using values computed by the provisions of (G113) for comparison. The values for longitudinally stiffened webs were similarly obtained. The results are presented graphically in Fig. 1.7.213(A).

Tests and theoretical investigations by Massonnet (W46) and other researchers (W11, W47, W48) have shown that even where stiffeners satisfy the minimum rigidity, γ_T^* , obtained from the linear theory of plate buckling, there is no assurance that the stiffeners will remain effective in the postbuckling range of web behavior. In order to ensure that the stiffeners will remain straight and provide the required support of web subpanels, it is necessary to use a multiple, $m \gamma_T^*$, of the theoretical rigidity.

For transverse stiffeners a value of $m = 3$ has been recommended for slender web panels (W49, W11). This value is used in the new Czechoslovak specification (G113). However, in stocky webs, postbuckling behavior is of smaller importance, and the critical plate buckling stresses, associated with appropriate stiffener rigidities, exceed the yield stress of the material and cannot be utilized. Therefore, the value of m_T is decreased in the transitional zone of plate slenderness, and is taken as unity for web panels with $D/t < 75$ (W11, G113).

The coefficient f'_v / F_{vcr}^0 introduced by the writers in the formula for I_T is based on the interaction formula suggested by Djubek and Skaloud (W11), and reflects the fact that transverse stiffeners need not be governed by the maximum shear capacity of the adjacent web panels if the actual maximum value of shear is lower than capacity. This permits a logical reduction of the size of transverse stiffener, and is in interest of design economy.

Stresses f'_v and F_{vcr}^0 used in the formula are already known from web strength calculations in accordance with Art. 1.7.211 or 1.7.212. In the case of a longitudinally unstiffened web the stresses in the adjacent panel with the higher value of critical shear, F_{vcr} , shall be used to ensure transverse stiffener adequacy for the stronger adjacent web panel. Similarly, in longitudinally stiffened webs, stresses f'_v and F_{vcr}^0 shall be calculated in the critical subpanel having the higher value of $F_{vcr \min}$, as defined in Art. 1.7.212(B)(2). These rules are conservative.

(C)(2)(b) The alternative formula for evaluation of the desired rigidity of a transverse stiffener in a web with longitudinal stiffeners follows a similar provision in (G113).

(C)(3) Proposed criteria for local torsional buckling stability are based on considerations similar to those given in Art. 1.7.207 for flange stiffeners, except that the restraining effect of the plate on the stiffener has been neglected, and the stiffener is assumed hinged

along the web plate. The writers believe that the proposed formulas are conservative.

(C) (4) The first requirement corresponds to AASHTO provision 1.7.59(E) (5) (d). The second ensures the capability of the transverse stiffeners to act as columns under the added effects of flexure.

(D) (1) (a) This assumption underlies the proposed method of design of longitudinally stiffened webs, see Art. 1.7.212.

(D) (1) (b) Massonnet has suggested that in the case of more than one longitudinal stiffener, the required rigidity of each stiffener shall be determined independently, without consideration of the presence of other stiffeners (W46). Such a procedure is also used in (G113). However, this approach is conservative, as is indicated by comparing γ^* values for a single stiffener with those required for the stiffener in the same position when another longitudinal stiffener is added. The values for only two such comparisons are available in (G107), namely for one stiffener located at $\eta_1 = 0.25$ or 0.33 , and the other stiffener added at $\eta_2 = 0.50$ or 0.66 , respectively (see Fig. 1.7.212 for designations). In both cases the required value of γ^* in the case of two stiffeners decreases by a factor of approximately 0.8, compared with the value needed for a single stiffener.

A rigorous calculation of the required rigidities of multiple longitudinal stiffeners for the range of stiffener locations used in design would be extremely difficult, see comments (C) (2) (a). Therefore the writers propose the use of a coefficient n to approximately account for the beneficial effect of added longitudinal stiffeners, see Art. 1.7.213(D) (3).

(D) (2) The writers feel that the use of an effective width of web with longitudinal stiffeners in the web compression zone should be permissible, since tension-field tension in the web strip adjacent to the stiffener is generally reduced by the flexural compression and results in a stress in the direction of the stiffener

lower than yield. However, the use of an effective width with a stiffener in the web tension zone must be subject to restrictions, see comments 1.7.213(E). It should be noted that the use of an effective width of web plate is of considerable help in keeping the longitudinal stiffeners designed in accordance with these provisions within reasonable sizes.

The value of $18t_w$ is used in the AASHTO specifications. A slightly different value, $20t_w$, is recommended by Massonnet (W46).

(D)(2)(a) Because of stiffener discontinuity at transverse stiffeners, the longitudinal stiffener in such cases is discounted in the overall stress carrying capacity of the box girder, and there is no need to design it for such a condition. However, the effect on the stiffener of the axial stress in the web plate must be considered.

(D)(2)(b) A continuous stiffener is designed as a stress carrying element of the box girder cross section. Since, in such a case, its structural behavior is essentially similar to that of a compression flange stiffener, the procedure for checking stiffener strength (including the effect of out-of-straightness) given in Art. 1.7.206 is basically applicable.

(D)(3) For general comments regarding the minimum relative rigidity coefficient, γ^* , see (C)(2)(a) above.

Values of γ^* of a longitudinal stiffener, γ_L^* , are calculated and given in literature separately for plates under pure axial stress and plates in shear, and are designated in the provisions of this section as $\gamma_{L\sigma}^*$ and $\gamma_{L\tau}^*$, respectively. Numerical values of these coefficients have been adapted from data by Kloeppe, Scheer and Moeller (G107, G108) for the range of stiffeners located between 0.2D and 0.4D from the compression flange, and represented graphically for design use in Fig. 1.7.213(B).

The values of $\gamma_{L\sigma}^*$ are given for three representative patterns of flexural stress distribution in the web ($R = -0.5, -1.0$ and -1.5), for panel aspect ratios, α , of 0.7, 1.0 and 1.5. The smallest aspect ratio for which buckling and rigidity coefficients have been calculated in (G107, G108) is $\alpha = 0.7$ however, design values of γ^* for $\alpha < 0.7$ may be obtained from Fig. 1.7.213(B) by extrapolation.

The values of $\gamma_{L\tau}^*$ are given in Fig. 1.7.213(B) as relative rigidity coefficients corresponding to 90% of the theoretical critical buckling stress of the plate panel in shear, and not as the values corresponding to full buckling capacity. This is based on observation by Rockey and Cook (W47, W48) that the theoretical shear buckling coefficient, k_v , first increases very rapidly with an increase in γ^v , but then increases very slowly with increasing values of γ . Thus a small increase beyond a certain value in theoretical shear buckling strength could be achieved only at the expense of very large increase in stiffener rigidity, which would be uneconomical. It should also be noted that longitudinal stiffeners are governed primarily by the axial stress and not shear stress.

Under service conditions both axial and shear stresses occur simultaneously. The appropriate values of γ_L^* for combined flexural and shear loading, designated as $\gamma_{L(\sigma+\tau)}^*$, can be expressed only by means of approximate interaction formulas, depending on the proportions of the stress components. The writers adapted for use in these provisions an interaction formula by Djubek and Skaloud (W11) which is also used in the Czechoslovak specification (G113). A somewhat similar logic is employed in the tentative formula of the German DIN 4114 specification (G16); however, this formula involves much more calculation work and is geared to other provisions of (G16). Evaluation of the proposed formula indicates that under practical combined stress conditions the governing values of $\gamma_{L(\sigma+\tau)}^*$ may be considerably lower than the theoretical values of $\gamma_{L\sigma}^*$ and $\gamma_{L\tau}^*$, based on the assumption

that the component axial and shear stresses, acting separately, reach their critical values of F_{ccr}^0 and F_{vcr}^0 .

Similarly as in the case of transverse stiffeners, the values of γ_L^* must be magnified by a coefficient m_L , see commentary on (C)(2)(a) above. The use of values proposed by Massonnet was recommended to the writers by Prof. K.C. Rockey. Similar values are used in (G113).

The reduction of the m_L values with a decreasing plate slenderness is based on considerations discussed under (C)(2)(a) of this commentary. A similar reduction is used in (G113).

Regarding reduction coefficient n for multiple longitudinal stiffeners see commentary on (D)(1)(b).

Stresses f' and F^0 used in the interaction formula are known from web strength calculations in accordance with Art. 1.7.212. However, unlike in the case of transverse stiffener (Art. 1.7.213(C)(2)(a)) stresses in the adjacent subpanel with a lower value of F_{vcr} shall be used in calculations. This is based on the fact that the beam shear strength of a longitudinally stiffened web panel is determined by the subpanel with the lowest value of critical buckling stress, $F_{vcr \min}$, see Art. 1.7.212 (B)(2). Thus it is not necessary to have stiffener rigidity required to ensure a higher critical stress in the subpanel. It is possible to further refine this procedure, however, the writers feel that in view of general uncertainty regarding the γ^* values, the simple proposed rule should suffice.

(E)(1) Paper by Scheer (W50) underlying the design of web panels under shear and tension of the proposed rules, Art. 1.7.212(B)(4), does not address the problem of required longitudinal stiffener properties in such cases. The writers feel that the use of criteria for shear alone, disregarding the stabilizing effect of coincident tension, is probably very conservative. The values of γ_{LT}^* given in Table 1.7.213(E) are obtained from (G107) for the case of "two longitudinal stiffeners" in a panel under

shear alone. Similarly as in Art. 1.7.213 (D)(3), the writers used the $\gamma_{L\tau}^*$ values corresponding to 90% of the theoretical buckling stress.

The effect of stabilizing tension on the stiffener rigidity requirements is difficult to assess. It should be noted that the stiffener in tension zone is likely to be located near the web neutral axis, where tension is small. However, it appears that there is no justification for using the multiplier m , which is associated with destabilizing effects in the web compression zone.

The multiplier f'_v/F_{vcr}^0 in the formula for \bar{I}_L corresponds to that used with the shear term of the interaction equation in Art. 1.7.213(D)(3), with f'_v denoting the actual maximum shear stress in the adjacent critical web subpanel. Because coincident tension enhances the beam shear capacity, F_{vcr} , of the subpanel, the value of f'_v/F_{vcr}^0 may possibly be greater than unity.

Regarding effective width of web acting with the stiffener, the writers feel that the formula used for transverse stiffener, Art. 1.7.213(C)(1)(c), giving effective width as a function of tension field intensity, is appropriate.

Commentary on Article 1.7.214

Box girders having webs of a lower specified yield stress than the flanges need design limitations for webs only; no design limitations are necessary for the flanges.

(B)(1) Calculation of web shear strength in accordance with Articles 1.7.210-212 is based on the assumption of linear distribution of axial stresses in the web in accordance with the elastic bending theory. This condition is satisfied if the maximum flexural stresses in the web do not exceed the yield stress. This may occur where governing overall design stresses in the flanges are kept low, as in the case of orthotropic steel decks, or slender bottom compression flanges with low critical stress.

(B)(2) Disregarding postbuckling strength is justified by deleterious effects of large tensile flexural stresses on tension field capacity, see Art. 1.7.211(B)(5).

(B)(2)(a) The buckling interaction formulas in Art. 1.7.211(B)(4) are based on linear distribution of stresses. These formulas would have to be rationally extended or adapted by the designer if this assumption is not satisfied in the case of partial yielding of web.

(B)(2)(b) The maximum value of V_B shall be limited by the condition that at any point of the governing cross section of the web panel the theoretically allowable shear stress, f'_v , cannot exceed the value that, combined with axial stress, will cause yielding. This value is given by the von Mises yield criterion. The formula for f'_v corresponds to that given for the maximum permissible value of V_B in Art. 1.7.210(B)(1) and 1.7.211(B)(1). This is considered to be the safe lower bound value of shear capacity (G133).

Commentary on Article 1.7.215

(B)(2) A good discussion of structural functions and complexities of design analysis is given by Horne (G112). "Rigorous" calculations (such as finite element method of analysis) of stress distribution in diaphragm are not warranted, since results of such calculations are of limited value and give the designer a false sense of accuracy (S8). An adequate load redistribution capacity, achieved by making diaphragm panels stocky, is essential (G112, D2).

Design criteria for diaphragms in the British "Interim Design Rules" (G11) may be too complicated for practical application; yet they are the only design provisions for diaphragms currently available. The new design rules for diaphragms in the new British bridge specifications BS 5400 (G151) have not yet (April 1979) been published. These provisions, prepared by the firm of Flint & Neill in London, were not available to the writers, but should certainly be considered in future improvements of the proposed provisions. In the meanwhile, the writers believe that the "IDR" (G11) may be suggested, in the footnote, as a general reference, however, it must be understood that these rules do not reflect the latest thinking on the subject.

(C)(1) Several other sources of stresses have not been mentioned, such as the Poisson's effect at the flange-diaphragm boundary, which generally causes stress relief in diaphragm acting in flexure (G112), and the effects of vertical misalignment of bearings, which are practically incalculable and should be precluded by careful field fitting of the bearings at box girder supports, see Division II, Construction, of these specifications.

(C)(2) Vertical stress at diaphragm bearings is distributed non-uniformly, which is also true at bearings under the webs. This does not significantly affect the diaphragm ultimate strength as long as it possesses sufficient stress redistribution capacity.

(C)(3)(a) The assumption of linear flexural stress distribution is also used in the "Interim Design Rules" (G11).

(C)(3)(c) Effective widths proposed are based on stipulations of the "Interim Design Rules" (G11).

(C)(4)(a) Shear stress concentration at the web-diaphragm boundary is greatest when the edge of bearing is close to the web, and decreases with increasing distance between the bearing and the web, while the flexural stresses in the diaphragm increase. An optimum condition is achieved in a "balanced" position of the bearings (D2, G44), see suggested location of bearings stipulated in Art. 1.7.215(G)(2).

(C)(4)(b) The maximum value of shear at the web-diaphragm intersection may reach about 1.4 times the average shear (G11, D2, D8, G112) under unfavorable geometric conditions. The arbitrary factor of 1.3 is introduced to achieve more stocky bottom panels of the diaphragm, conducive to better stress redistribution.

(C)(5)(a) The inclusion of an additional eccentricity is necessary because the resultant of bearing reaction may not be in the plane of the diaphragm, either due to misalignment of the bearing contact surfaces, or due to deflection under load, particularly in the case of steel bearings with flat contact surfaces. The proposed eccentricities are similar to those prescribed in the "Interim Design Rules" (G11).

(C)(5)(c) Failure to consider out-of-plane stresses in the diaphragm was the cause of collapse of the Milford-Haven bridge during erection (B5). This underscores the importance of out-of-plane stresses in design of diaphragm.

(D)(1) The formula for buckling strength of an unstiffened diaphragm is adapted, with some simplifications, from the "Interim Design Rules" (G11). Similar results are obtained from paper by Rockey and El-Gaaly (D8). The factor of $2/3$ is somewhat larger than that recommended in (G11), which also includes the "material factor" smaller

than unity. The formula is reported to be conservative (G44).

It should be noted that since the formula does not apply to diaphragms with access openings or subject to out of plane bending, its applicability is limited. The designer may, with proper judgment, use the formula as a guide in investigating the stability of a diaphragm provided with bearing stiffeners.

(D) (3), (4) Checks stipulated in these sections are conservative and will assure a stocky diaphragm.

(E) (1) (b), (E) (2) These conservative provisions are felt to be necessary for the design of diaphragms that will be capable of achieving the required stress redistribution.

The writers believe that, if the stability of all diaphragm subpanels, as well as the stability of all bearing and intermediate stiffeners can be assured, the overall stability of the stiffened diaphragm need not be a design consideration. Prof. A. Ostapenko, with whom the writers discussed this problem, expressed a similar opinion.

(E) (3) Design of diaphragm stiffeners should be based on the same principles as that of the web stiffeners. However, since no tension field strength is utilized, and since relatively heavy plate thickness will generally be used in diaphragms designed in accordance with these recommendations, there appears to be little justification for the use of multiplier m .

Proposed limiting proportions of stub stiffeners are similar to those of "bracket plates" (see (G35) chapter 17).

(G) (2) See commentary on (C) (4) (a).

(G) (3) See commentary on (B) (2).

(G) (5) The weld at web-diaphragm boundary shall be at least as strong as required by the shear capacity of

the webs or the diaphragm at the joint, because of the need for accommodation and redistribution of the shear concentrations.

Commentary on Article 1.7.216

(B)(3) This item pertains to planned curvature or change of slope of flange, such as the overall vertical curve of the bridge, or a haunch in the bottom flange. Effects of geometric imperfections are presumed to be covered by item (C).

(C) Criteria for the transverse-member strength required to enforce a nodal line in the compression flange during its overall buckling, as given in literature, are based on a single continuous strut on elastic supports (G32, G37) or on treatment of the compression flange as an orthotropic plate (G11, G15, G48, G112). The results and practical recommendations for the design vary widely, depending on the approach and the assumptions used.

AASHTO specifications (G136) for compression flanges based on the "strut on elastic supports" (G32, G37) approach do not prescribe a lateral force, but give the minimum rigidity of the transverse stiffener, see commentary on item (D). The German DIN 4114 buckling specifications (G16) stipulate a lateral force at the supports of a compression strut of about one percent of the axial force.

Leonhardt has made an investigation of the compression flange of a box girder (G48) and has found that the lateral forces on transverse stiffeners may range from 2 to 6 percent of the axial force in the flange, see commentary on Art. 1.7.213(C)(1)(e). However, it appears that his assumptions are unrealistically severe, and the resulting strengths and stiffnesses of the transverse members would by far exceed those of the bottom flanges of box girder bridges as commonly designed in this country and in Germany.

On the other hand, research in Britain based on the orthotropic plate approach (G112) has resulted in a recommendation by Horne of a lateral force on transverse stiffeners of the order of $1/400$ of the factored axial flange force, P (private communication), to be multiplied by a magnification factor of about 1.3 in practical cases.

Based on this recommendation the current (1978) draft of the new British bridge design specification BS 5400 (G151) stipulates a transverse force equal to $P/200$, multiplied by a similar magnification factor.

The writers believe that the recommended transverse force of one percent of the axial load is appropriate and conservative. The resulting sizes of transverse stiffeners appear to be reasonably consistent with those obtained by the "minimum rigidity" rule, Art. 1.7.216(D).

It should be noted that these criteria are mostly academic in the design of the top flange transverse members, since such members are governed in most cases by the local traffic load requirements.

(D) The "minimum rigidity" requirement is given to provide another check on the design of the transverse members, and as a check on the rather uncertain value of the "minimum strength" required. It is based on the "strut on elastic supports" considerations (G32, G37) as used in AASHTO, Art. 1.7.49, with modifications required by the ultimate-load approach of the proposed rules. Another modification relates to the number of consecutive flange panels subject to the maximum compressive stress. The AASHTO formula is based on the infinite number of panel spans, corresponding to the coefficient of 0.25 (see G32, eq. 2-30) used in the derivation of the formula. The formula proposed herein is based on a more realistic assumption of three consecutive flange panels subject to constant stress, with a corresponding coefficient of 0.33. This leads to a somewhat smaller value for the required minimum rigidity.

(E) (4) Spacing of transverse members of the top flange is governed primarily by the direct local loading. Spacing of the deck floorbeams will also be reflected in the spacing of the bottom flange transverse members. Bottom flange panels in compression may be further divided into subpanels, as may be desirable to satisfy criterion (4); however, the theoretically optimal close spacing of the transverse stiffeners may not necessarily be most economical. Proposed provisions for the design

of bottom flanges in compression, Arts. 1.7.205 and 1.7.206, permit the design of the flange panels with any spacing of the stiffeners, with the economy of the various possible arrangements left to the judgment of the designer. Therefore the specific requirements of the AASHTO specifications, Art. 1.7.49(D)(4), regarding spacing of transverse flange stiffeners have been replaced by the more general wording of criterion (E)(4).

(E)(5) Intermediate crossframes or transverse bottom flange stiffeners are not required in short to medium span composite box girder bridges of the proportions defined in Art. 1.7.203 where design is in accordance with folded plate theory (G37, G38).

Commentary on Art. 1.7.217

(A) This provision corresponds to AASHTO Art. 1.7.49 (E).

(B) The need for proper bracing of composite box girders during construction has been emphasized in a paper by Poellot (G43).

(C) Continuity of longitudinal stiffeners at transverse splices of compression flanges is essential to ensure the design strength of the flange. Where field bolted flange splices are used, the splice plates at inside faces of flange plate may be made discontinuous at longitudinal stiffeners; alternatively longitudinal stiffeners may be cut on both sides of the transverse flange splice plate and the gap overbridged by a stiffener splice member.

Longitudinal web stiffeners provide rigid supports for web subpanels and, therefore, their continuity is also essential; however, the compression strength requirements are less critical in the web than in the flange.

It has been pointed out to the writers that continuity of longitudinal web stiffeners may unduly increase the cost of the web field splices. Since web splice plates enhance the buckling strength of panels at splices, the writers feel that exceptions to the longitudinal stiffener continuity rule should be permitted if adequacy of the web panel under consideration can be proven by rational analysis.

Provisions (1), (2) and (3) are similar to Art. 14.10 of the new German specification (G140). It is worth noting that the collapse during erection of the Koblenz bridge (B14, B15) was caused by the 18" long unwelded gaps between longitudinal stiffeners and the bottom flange plate at splice.

Commentary on Article 2.10.46A

General

AASHTO Specifications (1977 Edition) contain provisions for dimensional tolerance limits in Art. 2.10.47(B) in Division II - Construction, Section 10 - Steel Structures, Subsection: Erection. Art. 2.10.47(B) pertains to "Orthotropic-Deck Superstructures" only. The writers propose to extend this Article to include box girders with any type of deck, and to place this Article in Subsection: Fabrication, following Art. 2.10.46, and tentatively designated 2.10.46A. Inasmuch as the AASHTO web tolerance provisions are based on the AWS specifications referred to in Art. 2.10.23, the proposed provisions of Art. 2.10.46A should also apply to plate girder bridges. Thus, this set of proposed rules may cover all steel plate bridge structures.

Comparison of Dimensional Tolerance Specifications

It is of interest to compare and discuss briefly the flatness and straightness tolerance provisions of the various bridge specifications.

(A) AWS Specifications

Plate flatness provisions are given by the AWS specifications (G157) for web panels only. The permissible web panel deviations from flatness (AWS Art. 9.23.1.2) are quite liberal and range from $d/130$ to $d/67$, depending on transverse stiffener arrangement and the web slenderness, where d is the least panel dimension. The deviation is measured from a straight edge of any length greater than d , placed in any position on the web panel.

No provisions are given for box girder flanges.

Straightness provisions are given for "welded columns" in AWS Art. 3.5.1.1. The permissible out-of-straightness is given as $1/8$ in. per 10 ft. length of column, which is equivalent to a tolerance $\Delta = L/960$. This is close to the $L/1000$ tolerance for axially loaded

members of the AISC specifications. Straightness of transverse web stiffeners is governed by Art. 3.5.1.11 specifying a tolerance of 1/2 in.

(B) AASHTO Specifications

Generally, the AWS dimensional tolerance limits govern (see AASHTO Art. 2.10.47(B)), however, these provisions have been modified for the web and flange panels of "orthotropic deck superstructures" (Art. 2.10.47(B)(1)). The maximum out-of-flatness is given as the greater of $D/144\sqrt{T}$ (inch), or 3/16 inch, where T is plate thickness and D is least dimension of the panel, or the distance between points of contact of templet edge with panel, as stipulated in the last sentence of the introductory paragraph 2.10.47(B). The straight edge templet description differs somewhat from that of the AWS specifications; it may be any length not exceeding 1.5 times the least dimension of the panel, and may be placed in any position.

These out-of-flatness provisions are liberal, especially for subpanels of webs or flanges with close spacing of stiffeners, where the minimum value of 3/16 in. governs. For example, if stiffener spacing, w, is 18 inches (460 mm), the permissible tolerance of 3/16" is w/96.

Stiffener straightness tolerance is given as L/480 for "longitudinal stiffeners subject to calculated compressive stress" (Art. 2.10.47(B)(2)), and L/240 for "transverse web stiffeners and other stiffeners not subject to calculated compressive stress" (Art. 2.10.47(B)(3)). These values are appropriate (except, in the writers' opinion, for transverse web stiffeners that may be subject to compressive stress), if gage length, L, is the length of stiffener between cross members. However, if a shorter gage length, $G < L$, is used in establishing the tolerance, as permitted in the last sentence of Art. 2.10.47(B), the actual out-of-straightness of the stiffener at mid-length will be greater than L/480, which may be unsafe for compression members. The writers eliminated the possibility of such interpretation by stating in proposed provision that the gage length must always be L and not shorter.

(C) British Specifications

The tolerance provisions of the "Interim Design and Workmanship Rules" (the "Merrison Rules"), Part IV (G13) are very detailed and elaborate.

Plate panel flatness is measured by means of a special adjustable scanning device consisting of a bar with two prongs that may be positioned at a desired gage length and a dial gage in between calibrated with respect to straight line datum between the two prongs that have to be in contact with the measured panel. In measuring the governing plate imperfection $[\Delta X]$ the gage length is constant. For panels with $a/b > 3$ the gage length is $2b$, where a and b are the longer and the shorter dimension of the panel, respectively. The scanner is always positioned parallel to the longer panel side and may be placed in any location. The original idea behind this method of out-of-flatness measurement was to check the governing "ripple component", see Report on Task B of this contract, pg. 28, and Fig. B-5. Additionally, the imperfection $[\Delta y]$ has to be measured in direction of the shorter panel side, within a distance $b/6$ from the transverse stiffener, with a gage length equal to greatest length practicable within stiffener spacing. The permissible deviations from flatness is given by a formula that is a function of b , plate thickness t , and gage length G . These tolerances are quite small, and were considered restrictive. A meaningful comparison with the AASHTO tolerances of Art. 2.10.47 (B)(2) is not possible because of differences in out-of-flatness definition and methods of measurement.

The stiffener straightness tolerances of (G13) were given as $L/1200$ to $L/900$, with gage length L equal to stiffener length between supports.

These flatness and straightness provisions have been criticised as difficult to satisfy in practice and unduly increasing cost of box girder fabrication.

The fabrication provisions of the new British bridge specifications, BS 5400, Part 6, have not yet (April 1979)

been issued. According to the writers' information, the stiffener straightness tolerance of $L/750$ will be stipulated; the flatness provisions for plate panels will be similar to those of (G13), but will be more liberal.

(D) German, Belgian, ECCS Specifications

The plate out-of-flatness tolerance for both webs and flanges is specified as $b/250$ in the new German specification (G140) and in the Belgian specification (as reported in (C14)), and $b/250$ with a maximum value of 4 mm in the ECCS specification (G99), where b is the shorter dimension of the panel. In the above specifications the out-of-flatness is defined as the maximum offset from the line perpendicular to the longer edges of the panel.

The stiffener out-of-straightness is limited to $L/500$ in the Belgian and ECCS specifications, and $L/400$ in the German specification.

It should be noted that definitions and methods of measurement of plate out-of-flatness are different in each of the specifications A, B, C and D discussed above.

Specific Provisions

(A) The wording of this paragraph is taken unchanged from Art. 2.10.47(B).

(B)(1) The writers believe that there should be no distinction between tolerance requirements for webs of orthotropic deck bridges and webs of box- or plate girder structures with concrete decks, and propose that all box- and plate girder webs be treated uniformly and subject to current AWS Specifications, in accordance with the intent of the AASHTO Specifications, Art. 2.10.47(B).

Web strength is not much affected by out-of-flatness (C14). Therefore the writers feel that the rather liberal current AWS provisions for webs are adequate.

(B)(2)(b) It is intended that out-of-flatness should be measured as the distance from the surface through the edge supports of the panel, with reference to a constant gage length, $D = b$, similarly as in European specifications discussed above.

(B)(2)(c) Bottom flange panels in compression need somewhat tighter tolerances than those given in current AASHTO specifications, Art. 2.10.47 (B)(1), in order to satisfy the assumptions made in determination of strength in Articles 1.7.205 and 1.7.206. The value of $b/200$ is considered appropriate (C14, F37). This tolerance is somewhat more liberal than the $b/250$ value of European specifications, see "Comparison", above.

Such tolerance limits are expected to be achieved in normal fabrication of bottom flanges without special precautions, as may be concluded from some measurements made on actual bridgework.

Massonnet and Janss made measurements on the web and bottom plates of a composite box girder bridge under construction in Polleur, Belgium (C15). The mean value of Δ/b was $1/518$ for web panels ($b = 750$ mm) and $1/479$ for flange panels ($b = 600$ mm). Out of 166 web and 83 flange measurements made only in 3 cases the specification tolerance of $b/250$ was exceeded, and in no case was the out-of-flatness greater than $b/200$.

Nölke reports on stereo-photogrammetric measurements of geometric imperfections of two German long span box girder bridges (C17). Out of 2055 panel imperfection measurements, 469 were on the 10 mm thick bottom flange plate stiffened at intervals of 460 mm. The mean value of Δ/b was $1/384$; 5% of all panels measured had the out-of-flatness greater than $1/127$. The specification requirement of $\Delta/b < 1/250$ was not met in 25% of all flange measurements. This may be explained by the thinness of the flange plate and the close spacing of stiffener welds causing flange plate distortions, that would not be expected with generally thicker flange plates and a wider stiffener spacing in usual American construction practice.

(B)(2)(d) Panel flatness is not essential in tension flanges, except for aesthetic reasons. However, it is important to note that portions of bottom flanges in tension under working conditions may be in compression during cantilever erection. Therefore application of this provision should be subject to Engineer's approval.

(B)(3) These provisions are taken unchanged, except for clarification of distance D between points of templet contact, from AASHTO specifications Art. 2.10.47(B)(1). This article was originally intended for orthotropic decks and webs of orthotropic deck structures. The writers propose, for reasons given in commentary on Art. 2.10.46A(B)(1), to limit these provisions to orthotropic decks only, and to treat all webs uniformly in accordance with AWS specifications.

These provisions are somewhat more restrictive than the AWS web tolerances, yet they are still rather liberal (see "Comparison of Dimensional Tolerances", above). The writers saw no reason for tighter tolerances for orthotropic deck plates, since their design is governed primarily by local out-of-plane flexural stresses, the in-plane axial compression strength being of secondary importance.

The writers suggest that consideration be given in future revisions of AASHTO Specifications to simpler rules, of the kind proposed in Art. 2.10.46A(B)(2), for the sake of uniformity in tolerance measurements.

(C)(1)(a) Straightness tolerance of $L/500$, close enough to the AASHTO tolerance of $L/480$, is the stiffener out-of-straightness assumed in determination of stiffened panel strength in compression in Art. 1.7.206 (see commentary). This value is also in line with tolerances of the new European specifications.

The value of L_0 in cases of elongated flange panels (large L/b ratio, see Art. 1.7.206) is the approximate actual buckling length of the stiffener, and should be used as gage length in such cases. The value of L_0 is

known from design and should be noted on contract drawings, or given to the fabricator by the Engineer.

Vertical curvature contributes to the overall out-of-straightness of the stiffener and should be included in the L/500 allowance. Generally, this effect will be small.

(C)(1)(b) Justification for doubled tolerance in these cases is unimportance of straightness in tension members, and, in haunches, presence of curvature accounted for in the design. Longitudinal stiffeners of orthotropic decks are governed by local flexural stresses, and much less so by overall deck compression, which is usually far from critical magnitude.

(C)(1)(c) Reasoning same as for (C)(1)(a)

(C)(1)(d) This case applies to intermediate transverse web stiffeners in panels not utilizing tension field strength.

(C)(1)(e) It is important to keep longitudinal stiffeners in proper alignment to minimize secondary flexural effects, see Art. 1.7.216.

(C)(1)(f) The above reasoning does not apply in tension zone of flange, hence increased tolerance.

(C)(2) Importance of gage length not smaller than actual length of stiffener between supports has been discussed in comments on AASHTO Specifications, above.

Commentary on Article 2.10.47

Deleted Section (B) Dimensional Tolerance Limits, is replaced by Art. 2.10.46A in Subsection: Fabrication, see commentary.

Commentary on Article 2.10.55A

Provisions of this Article and the commentary are based on a draft prepared by J. Durkee, with modifications by the writers.

The need for thorough consideration of box girder erection engineering and field supervision has been underscored by the failure during construction of four box girder bridges abroad:

a) The Fourth Danube Bridge, Vienna, where buckling of bottom flange plates under differential temperature conditions resulted in the sagging and near collapse of the structure, in November 1969 (B4);

b) The Milford Haven Bridge, Wales, where failure of a bearing diaphragm over a pier, under unanticipated erection stresses, caused collapse of the cantilevered side span, in June 1970 (B5);

c) The West Gate Bridge, Melbourne, where careless erection, improper alignment sequences, along with deficiencies in communication between the Engineer's design office, the Engineer's field representative and the Contractor, led to collapse of a high-level 367-ft. span, in October 1970 (B6 through B10);

d) The Koblenz Bridge, West Germany, where bottom flange plate buckled under temporary compression loading at the 18-inch long unwelded gaps between the flange plate and the stiffeners at a field splice, precipitating collapse of a 177-ft. cantilevered portion of the main span, in November 1971 (B13 through B18).

The erection engineering of bridge structures is a specialized technical art, not necessarily governed by the same specifications for strength and stability applicable to design; nor can the differences be covered properly by simply "factoring" the provisions of the design specifications. In normal U.S. practice the safety and adequacy of a bridge structure under service loadings is the responsibility of the design engineer, whereas the safety and adequacy of the structure during construction is the responsibility of the Contractor. Customary practice therefore calls for the Engineer to review and comment on the Contractor's erection methods, procedures, and strengthening and stabilizing measures, but not to accept responsibility for the success of the total erection program, since this depends heavily on careful field implementation of the Contractor's erection procedures.

Accordingly, the general erection provisions and cautionary clauses given in this article are offered as guidelines to alert all concerned to some of the erection engineering problems on which successful box-girder construction may depend.

It may be noted that the use of the term "approval" in the third paragraph of Art. 2.10.55A(1) is not strictly correct in the writer's opinion (J.D.); however, this term, and in addition the statements incorporating it, are used as shown in order to retain consistency with the usage in AASHTO Articles 2.10.53 and 2.10.54.

The writers believe that the following wording, suggested by J. Durkee, would be more appropriate for the third paragraph of Art. 2.10.55A (changes are underlined):

"The Contractor shall prepare and submit to the Engineer for review and comment complete erection plans

..... Complete details with respect to such strengthening and stabilizing shall be

submitted to the Engineer for review and comment.
No work shall be done by the Contractor until
Engineer's comments on erection procedures or
erection strengthening have been obtained. Any
differences of opinion between the Engineer and
the Contractor as to the structural adequacy
and safety of the box girders during erection
shall be resolved prior to the start of erection.
The concurrence of the Engineer shall not be
considered as relieving the Contractor of any
responsibility."

In the event that this revised wording is adopted for proposed Article 2.10.55A, the wording of Articles 2.10.53 and 2.10.54 should be revised to be consistent therewith. It is possible that statements elsewhere in AASHTO Specifications would also have to be revised similarly for consistency.

Bracing needs for composite girder bridges under erection are discussed in (G43).

Article Number 2.10.55A is tentative. At the time of adoption of these proposed provisions Articles in Division II, Section 2.10 may have to be re-numbered and re-arranged.

ADDENDUM 1

PROPOSED REVISIONS OF REQUIREMENTS FOR WEB STIFFENER RIGIDITIES

October 30, 1979

The following revisions are proposed in Art. 1.7.213:

Art. 1.7.213(C)(2) (pg. 76): revise $m_T=3$ to read $m_T=1.5$

Art. 1.7.213(D)(3) (pg. 80): revise $m_L=7$ to read $m_L=3$

$m_L=3$ to read $m_L=1.5$

COMMENTARY

1. LONGITUDINAL STIFFENERS

The use of magnification factor "m" in conjunction with the coefficient γ^* (the theoretical minimum rigidity coefficient) was suggested by Massonnet (W46) and, subsequently by Owen, Rockey, Skaloud (W54) and other researchers.

From tests on plate girders Massonnet has found that longitudinal stiffeners having rigidity γ^* do not remain straight, but begin to deflect laterally even under loading smaller than the elastic critical buckling load. Lateral deflection was satisfactorily eliminated by increasing the stiffener rigidities by factors ranging from 3 to 7. Massonnet's tests have also shown that such an increase of stiffener rigidity resulted in an increase of the ultimate strength of the girders up to 25%. Although the ultimate strength was found to be of the order of 2 to 3 times that of the values obtained by the elastic buckling theory,

this additional increase of strength was considered to be of value, in view of the fact that the safety factors against the theoretical web buckling stresses then in use were 1.15 or 1.25 (W46). It should be noted that under ultimate loads obtained in Massonnet's tests the stresses computed by means of the usual formulas for elastic stress analysis exceeded the yield strength of the material.

Based on test results Massonnet recommended increasing the theoretically required stiffener rigidities for the following reasons: (a) need to limit the lateral deformations of stiffened webs in the postbuckling range, in view of the low factors of safety employed in customary design; (b) desirability of increasing the ultimate strength of plate girders.

Qualitative data on similar tests on horizontally stiffened plate girders subject to flexure were reported by Owen, Rockey, and Skaloud (W54). Girders with one line and with two lines of horizontal stiffeners were tested. Theoretical calculated stresses under the ultimate loads were considerably in excess of the yield stress of the material. In this connection it should be noted that according to the proposed design provisions for box girders, the ultimate strength of a box girder is governed by the critical flange stress, F_u , which is always smaller than the yield stress, see Fig. 1.7.206(A).

According to numerical data presented in (W54) the increase in girder ultimate strength due to increase of the longitudinal stiffener rigidity was as follows: for girders with a single stiffener, with stiffener rigidities increased by factors of 2 and 6, the corresponding increase of the ultimate strength was about 3 and 7 percent, respectively, compared with a strength corresponding to that of a girder with the stiffener having the theoretically required minimum rigidity, γ^* . For girders with two lines of horizontal stiffeners, having rigidities multiplied by factors of 3, 5, and 8, the corresponding strength increases were obtained as 10, 12, and 14%, respectively. Regarding deformations, tests show that lateral deflections of the

stiffeners, beginning at low load values, tend to decrease with increasing stiffener rigidities, and are effectively checked by the higher values of the rigidity multiplier.

It is seen from the above data that the increase of girder ultimate strength due to increasing longitudinal stiffener rigidities above the theoretically required γ^* values is not very significant, and, when the multiplier exceeds the value of 3, very little additional strength accrues with further increase of the stiffener rigidity. Also, it should be noted that there is no real need to increase the ultimate strength of box girder webs to the utmost limits, since, in accordance with the proposed rules, the webs of box girders are designed with ample factors of safety of about 2.0 against "design strength" set deliberately short of the probable true ultimate web strength, as discussed in Commentary on Art. 1.7.211. Therefore it appears that ultimate web strength considerations do not provide sufficient justification for the use of the increased stiffener rigidities.

However, while the overall ultimate strength of the web will certainly not be significantly impaired by stiffeners with less than complete rigidity, the ratio of the two web strength contributions, the "elastic" strength and the "postbuckling" strength may be affected by the degree of stiffener rigidity. According to the design model of web behavior used in the proposed provisions (see Articles 1.7.211, 1.7.212 and Commentaries) the elastic buckling stresses, supplying the "elastic strength", shall develop in the individual sub-panels and shall remain "locked in" through both the "elastic" and the "postbuckling" stages of web loading. Therefore, to satisfy this assumption, some control of excessive stiffener flexibility seems to be indicated, to ensure formation and maintenance of the nodal lines in the web. Otherwise, the "postbuckling" strength contribution (in the web portions loaded in flexure combined with shear) may be unduly increased and may tax the capacities of the transverse stiffeners in excess of the values for which they were designed.

The writers feel that, for this purpose, the use of the m-multipliers ranging from 1.5 to 3 (or about one-half of the values proposed by Massonnet) should be adequate.

2. TRANSVERSE STIFFENERS

The use of magnification factor $m=3$ with the rigidity coefficient γ^* for transverse web stiffeners was made by Massonnet, Skaloud, and Donea based on theoretical investigations of a square plate loaded in shear with a single vertical stiffener (W49, W53). Calculations made by equations of large-deflection second order elastic theory indicated that the theoretical critical elastic buckling stress may be increased up to 20% above the theoretical critical stress obtained by the first-order elastic buckling theory when the stiffener rigidity, γ^* , is increased by a factor of $m=3$, or greater. Calculations, confirmed by tests, have also shown that, while with $m=1$ about 95% of the critical stress (first-order theory) is reached, the stiffener does not remain straight but deflects laterally. However, if the stiffener rigidity is increased by a factor of 3, the stiffener remains "practically straight". Since straightness is of importance in the post-buckling (inelastic) range, where the stiffener is subject to axial stresses, Massonnet recommends that the transverse stiffener rigidity should be $\gamma = 3 \gamma^*$.

Regarding application of this recommendation in the proposed design rules for box girder webs the following observations are pertinent:

a) the values of theoretical optimum rigidity, γ^* , for transverse web stiffeners are not well defined and the formulas given in literature (G-16, G107, G108, G113) vary considerably. The writers chose γ^* values that should be regarded conservative for the usual cases of relatively closely spaced transverse stiffeners (see Art. 1.7.213 and Commentary).

b) Proposed design provisions for the design of box girder webs do not take full advantage of tension field

strength reserves, and utilize only its lower-bound value (the "true Basler" solution, see Commentary on Art. 1.7.211), which may develop less than one-half of the web strength of a comparable plate girder with rigid flanges.

It follows that, if a multiplication factor of 3 is regarded appropriate for webs designed with full utilization of tension field strength, a smaller factor should be sufficient for webs with tension field capacity only partly utilized.

Therefore the writers suggest the use of multiplier $m_T=1.5$ for transverse stiffeners of box girder webs.

According to provisions of proposed Art. 1.7.211(B)(1) the designer has the option of disregarding tension field strength altogether and using only the beam shear strength of the web. In such cases additional stiffening of transverse stiffeners ought not be required. However, since, in reality, there always may be some tension field action in the web (see Commentary on Art. 1.7.211(B)(1)), it appears prudent to use the m_T multiplier in all cases.

In summary, a closer scrutiny of the background and justification of the "m"-factors seem to warrant their reduction, in application to box girder webs, from the values proposed by the writers in the original report of June, 1979. This problem should be further re-evaluated in light of future research and parametric studies of web designs to be made. In all cases, the application of the "m"-factors in the design should be subject to engineer's judgment, depending on the conditions at hand.

ADDITIONAL REFERENCES

- W53. Massonnet, Ch., Škaloud, M., and Donéa, J. "Effet de la Rigidité d'un Raidisseur Vertical sur la Déformée Postcritique d'une Plaque Carrée, Cisailée", Acta Technica CSAV, 1968, pp. 292-316.

- W54. Owen, D.R.J., Rockey, K.C., Škaloud, M., "Behaviour of Longitudinally Reinforced Plate Girders", Final Report, 8th Congress I.A.S.B.E., 1968, pp. 415-425.

APPENDIX A- BIBLIOGRAPHY

PREFACE

This bibliography lists books, specifications, reports, papers and other source material utilized by the writers in preparation of the report on Design Specifications for Steel Box Girders. In addition, other references are listed that were considered relevant. Additional bibliography on the subject of steel box girder bridges may be found in references given.

References are listed in the following groups:

G. GENERAL

This group includes design codes, general reference works, design analysis and papers treating more than one aspect of steel box girder bridge design.

S. SAFETY

Safety factors, load and resistance factor design, basic design philosophy, ultimate design, fatigue design.

F. FLANGE DESIGN

Strength of unstiffened and stiffened plating under axial compression and shear, effective width, design of stiffeners as compression struts, design of top flanges with consideration of local transverse loads.

W. WEB DESIGN

Strength of unstiffened and stiffened plating under predominant shear, ultimate (tension field) theories, design of transverse and longitudinal stiffeners.

D. DIAPHRAGMS AND CROSS FRAMES

Design of diaphragms and transverse frame members, special local stress conditions.

C. CONSTRUCTION

Fabrication, erection, tolerances, residual stresses.

B. BRIDGES

Examples of box girder bridge structures, reports on box girder failures.

ABBREVIATIONS

In bibliographical references to monographs and conference proceedings containing several papers quoted in this bibliography the following abbreviations have been used:

| | |
|---|---|
| Proc. I.C.S.B.G.B., 1973 | Proceedings of the International Conference on Steel Box Girder Bridges, The Institution of Civil Engineers, London, 1973. |
| C.C.M.R., 1974 | Constructional Steel Research and Development Organisation (CONSTRADO), Course on Merri-son Rules, London, January, 1974. |
| Proc. I.C.S.P.S., 1976 | Proceedings of the International Conference on Steel Plated Structures, London, July, 1976, Crosby Lockwood Staples, London. |
| Introductory Report, S.I.C.S. - ECCS, Tokyo, 1976 | Second International Collo- quium on Stability, European Convention for Constructional Steelwork, Introductory Re- port, Second Edition, Tokyo, Sept. 9, 1976. |
| Preliminary Report, S.I.C.S. - ECCS, Tokyo, 1976 | Second International Collo- quium on Stability, European Convention for Constructional Steelwork, Preliminary Report, Tokyo, Sept. 9, 1976. |
| Preliminary Report, S.I.C.S. - ECCS, Liege, 1977 | Second International Collo- quium on Stability, European Convention for Constructional Steelwork, Preliminary Report, Liege, April 13-15, 1977. |

G. GENERAL

- G1. American Association of State Highway and Transportation Officials, Standard Specifications for Highway Bridges, Eleventh Edition, AASHTO, Washington, D.C., 1973.
- G2. Interim Specifications, Bridges, AASHTO, Washington, D.C., 1974.
- G3. Interim Specifications, Bridges, AASHTO, Washington, D.C., 1975.
- G4. Interim Specification, Bridges, AASHTO, Washington, D.C., 1976.
- G5. Specifications for Steel Railway Bridges, American Railway Engineering Association, Chicago, 1976.
- G6. Specification for Steel Girder Bridges, BS 153: Part 3A, Loads, British Standards Institution, London, October, 1972.
- G7. Specification for Steel Girder Bridges, BS 153: Part 3B, Stresses, Part 4, Design and Construction, British Standards Institution, London, October, 1972.
- G8. Inquiry into the Basis of Design and Method of Erection of Steel Box Girder Bridges, Interim Report, H.M. Stationery Office, London, 1971.

- G9. Inquiry into the Basis of Design and Method of Erection of Steel Box Girder Bridges, Appendix A - Interim Design Appraisal Rules, September, 1971.
- G10. Inquiry into the Basis of Design and Method of Erection of Steel Box Girder Bridges, Report of the Committee, H.M. Stationery Office, London, 1973.
- G11. Inquiry into the Basis of Design and Method of Erection of Steel Box Girder Bridges, Report of the Committee - Appendix I, Interim Design and Workmanship Rules, Part I: Loading and General Design Requirements, Part II: Design Rules, H.M. Stationery Office, London, 1973.
- G12. Inquiry into the Basis of Design and Method of Erection of Steel Box Girder Bridges, Report of the Committee - Appendix I, Interim Design and Workmanship Rules, Part III: Basis for the Design Rules and for the Design of Special Structures Not Within the Scope of Part II, H.M. Stationery Office, London, 1974.
- G13. Inquiry into the Basis of Design and Method of Erection of Steel Box Girder Bridges, Report of the Committee - Appendix I, Interim Design and Workmanship Rules, Part IV: Materials and Workmanship, H.M. Stationery Office, London, 1973.
- G14. British Standard Specification for the Design and Specification for Steel, Concrete and Composite Bridges, B/116 Part 2: Loads, Draft for Public Comment, British Standards Institution, Document 72/13234 DC, January, 1973.
- G15. B/116/3/3, Part 3: The Design of Steel Bridges, British Standards Institution, Document 75/11722, July, 1975, (Draft Proposal, Private Circulation).
- G16. Stabilitätsfälle: Berechnungsgrundlagen Vorschriften, (Stability - Basis for Design, Design Specifications), DIN 4114, Blatt 1, Deutscher Normenausschuss, Beuth Vertrieb, Berlin, West Germany, 1952.

- G17. Stabilitätsfälle: Berechnungsgrundlagen Richtlinien (Stability - Basis for Design, Commentary) DIN 4114, Blatt 2, Deutscher Normenausschuss, Beuth Vertrieb, Berlin, West Germany, 1953.
- G18. Berechnungsgrundlagen für Stählerne Eisenbahnbrücken (BE), (Design Specifications for Steel Railroad Bridges), DV804, Deutsche Bundesbahn, 1965 edition, West Germany.
- G19. Grundsätze für die Bauliche Durchbildung Stählerner Eisenbahnbrücken (GE), (Rules for Design Details of Steel Railroad Bridges), 805, Deutsche Bundesbahn, 1955 edition, West Germany.
- G20. Vorschriften für Geschweisste Eisenbahnbrücken, (Specifications for Welded Railroad Bridges), 848, Deutsche Bundesbahn, 1955 edition, West Germany.
- G21. Règles de Calcul des Constructions en Acier, (Design Rules for Steel Construction), Société de Diffusion des Techniques du Batiment et des Travaux Publics, Paris, 1966.
- G22. Czechoslovak Standard ČSN 73 1401, Design of Steel Structures (1975 Draft), (in Czech).
- G23. Mukhanor, K.K., Design of Steel Structures (in Ukranian), Government Printing Office for Structures and Architecture of the Ukr. S.S.R., Kiev, 1958.
- G24. Manual of Steel Construction, Seventh Edition, American Institute of Steel Construction, New York, 1970.
- G25. Highway Structures Design Handbook Volume I, United States Steel Corporation, Pittsburgh, 1965.
- G26. Highway Structures Design Handbook Volume II, United States Steel Corporation, Pittsburgh, 1965.
- G27. Design Manual for Orthotropic Steel Plate Deck

Bridges, American Institute of Steel Construction, New York, 1963.

- G28. Wolchuk, R., "Steel-Plate Deck Bridges," Section 18, Part 2, Structural Engineering Handbook, Second Edition, McGraw-Hill Book Co. in publication (1978), (Text revised and updated, new section on design of box girders added).
- G29. Column Research Council, Guide to Design Criteria for Metal Compression Members, Second Edition, John Wiley & Sons, Inc., New York, 1966.
- G30. Structural Stability Research Council, Guide to Stability Design Criteria for Metal Structures, Third Edition, John Wiley & Sons, New York, 1976.
- G31. European Convention for Constructional Steelwork, "Manual on the Stability of Steel Structures," in Introductory Report, Second Edition, S.I.C.S. - ECCS, Tokyo, 1976.
- G32. Timoshenko, S.P. and Gere, J.M., Theory of Elastic Stability, Second Edition, McGraw-Hill Book Co., Inc., New York, 1961.
- G33. Bleich, F., Buckling Strength of Metal Structures, McGraw-Hill Book Co., Inc., New York, 1952.
- G34. Kollbrunner, C.F. and Basler, K., Torsion in Structures, Springer Verlag, New York, 1969.
- G35. Tall, L., et al., Structural Steel Design, Second Edition, Ronald Press Co., New York, 1974.
- G36. O'Connor, C., Design of Bridge Superstructures, John Wiley & Sons, Inc., New York, 1971.
- G37. Mattock, A.H., et al., Criteria for Design of Steel Concrete Composite Box Girder Highway Bridges, Report of the Committee, August, 1967 (unpublished).
- G38. Mattock, A.H., "Development of Design Criteria for Composite Box Girder Bridges," Developments in

Bridge Design and Construction, Crosby Lockwood & Son, London, 1971.

- G39. Progress Report on Steel Box Girder Bridges, by the Subcommittee on Box Girders of the ASCE-AASHTO Task Committee on Flexural Members, Journ. of Struc. Div. ASCE, Vol. 97, No. ST4, 1971, pp. 1175-1186.
- G40. Subcommittee on Ultimate Strength of Box Girders of the ASCE-AASHTO Task Committee on Flexural Members of the Committee on Metals, "Steel Box Girder Bridges - Ultimate Strength Considerations," Journal of the Structural Division, ASCE, Vol. 100, No. ST12, Dec., 1974, pp. 2433-2448.
- G41. Feature Review: "Inquiry into the Basis of Design and Method of Erection of Steel Box-Girder Bridges," (Reviewed by R. Wolchuk), Civil Engineering - ASCE, February, 1974, pp. 26-28.
- G42. Kavanagh, T.C., "Box Girder Bridge Design," Engineering Journal of the American Institute of Steel Construction, Vol. 4, 1967, pp. 100-106.
- G43. Poellot, W.N., "Special Design Problems Associated with Box Girders," Proceedings, Specialty Conference on Metal Bridges, St. Louis, November, 1974, ASCE, New York, 1974.
- G44. Dowling, P.J., Strength of Steel Box-Girder Bridges, Journ. of Struct. Div., ASCE, Vol 101, Sept., 1975, pp. 1929-1946.
- G45. Commentary on Orthotropic-Deck Bridge Specifications, Report by the Task Committee, Journ. Struct. Div., Proc. Am. Soc. Civ. Engrs., Vol. 100, 1974, pp. 109-128.
- G46. Seim, C., "Practical Considerations in Design of Orthotropic Decks," ASCE National Structural Engineering Convention, April 14-18, 1975, New Orleans, Louisiana, Meeting Preprint 2480.

- G47. Kerensky, O.A., "Conception," (Structural Concept), in Proc. I.C.S.B.G.B. 1973, pp. 7-10, Discussion, pp. 33-44.
- G48. Leonhardt, F., and Hommel, D., "The Necessity of Quantifying Imperfections of all Structural Members for Stability of Box Girders," in Proc. I.C.S.B.G.B. 1973, pp. 11-19, Discussion, pp. 33-44.
- G49. DeMiranda, F., and Mele, F., "Some Basic Design Principles for Steel Box Girder Bridges," in Proc. I.C.S.B.G.B. 1973, pp. 21-31, Discussion, pp. 33-44.
- G50. Dowling, P.J., Chatterjee, S., Frieze, P.A., and Moolani, F.M., "Experimental and Predicted Collapse Behaviour of Rectangular Steel Box Girders," in Proc. I.C.S.B.G.B. 1973, pp. 77-94, Discussion, pp. 145-172.
- G51. Dibley, J.E., and Manoharan, A., "Experimental Behaviour of Two-Span Continuous Box Girder," in Proc. I.C.S.B.G.B. 1973, pp. 119-130, Discussion, pp. 145-172.
- G52. Massonnet, C., and Maquoi, R., "New Theory and Tests on the Ultimate Strength of Stiffened Box Girders," in Proc. I.C.S.B.G.B. 1973, pp. 131-143, Discussion, pp. 145-172.
- G53. Flint, A.R., and Horne, M.R., "Conclusions of Research Programme and Summary of Parametric Studies," in Proc. I.C.S.B.G.B., 1973, pp. 173-191, Discussion, pp. 209-229.
- G54. Steinhardt, O., "Recent Revisions to German Standard DIN 4114," in Proc. I.C.S.B.G.B. 1973, pp. 203-208, Discussion, pp. 209-229.
- G55. Horne, M.R., "Basic Principles," in C.C.M.R. 1974.
- G56. Flint, A.R., "Background to the Rules," in C.C.M.R. 1974.
- G57. Dowling, P.J., "Analysis," in C.C.M.R. 1974.

- G58. Ogle, M.H., "Residual Stresses Due to Welding," in C.C.M.R. 1974.
- G59. Clark, P.J., and Elliott, P., "Imperfections," in C.C.M.R. 1974.
- G60. Clark, P.J., "Connections," in C.C.M.R. 1974.
- G61. Chatterjee, S., "Stability," in C.C.M.R. 1974.
- G62. Parsons, M.F., "Design Concepts," in C.C.M.R. 1974.
- G63. Rockey, K.C. and Evans, H.R., "The Nodal Section Method for the Analysis of Box Girders," Publications, I.A.B.S.E., Vol. 35-I, 1975, pp. 185-216.
- G64. Lally, A., and Wolchuk, R., "American Design Practice for Steel Box Girder Bridges," Paper 6, in Proc. I.C.S.P.S., 1976, pp. 142-168.
- G65. Dubas, P., "Plated Structures with Closed-Section Stiffeners," Paper 11, in Proc. I.C.S.P.S. 1976, pp. 265-283.
- G66. Elliott, P., and Rochester, T.A., "A Background to Research on Plated Structures," Paper 17, in Proc. I.C.S.P.S. 1976, pp. 421-428.
- G67. Scheer, J., and Nölke, H., "The Background to the Future German Plate Buckling Design Rules," Paper 21, in Proc. I.C.S.P.S. 1976, pp. 503-523.
- G68. Bjorhovde, R., "North American Column Research and Design Practice," in Introductory Report, Second Edition, S.I.C.S.- ECCS, Tokyo, 1976, pp. 337-344.
- G69. Springfield, J., "Beam Column," in Introductory Report, Second Edition, S.I.C.S.- ECCS, Tokyo, 1976, pp. 345-364.
- G70. Fukumoto, Y., Kajita, N., and Aoki, T., "Evaluation of Column Curves Based on Probabilistic Concept," in Preliminary Report, S.I.C.S. - ECCS, Tokyo, 1976, pp. 1-38.

- G71. Beedle, L.S., "Discussion on Centrally Compressed Members," in Preliminary Report, S.I.C.S. - ECCS, Tokyo, 1976, pp. 39-40.
- G72. Lindner, J., "Contribution to the Problem of Lateral Buckling of Beams," in Preliminary Report, S.I.C.S. - ECCS, Tokyo, 1976, pp. 113-119.
- G73. Fox, G.F., "Discussion on Lateral Buckling of Beams," in Preliminary Report, S.I.C.S. - ECCS, Tokyo, 1976, pp. 121-122.
- G74. Dubas, P., "Discussion on Plate & Box Girders," in Preliminary Report, S.I.C.S. - ECCS, Tokyo, 1976, pp. 167-176.
- G75. Durkee, J.L., "Discussion on Plate Girders," in Preliminary Report, S.I.C.S. - ECCS, Tokyo, 1976, pp. 177-178.
- G76. Mateescu, D., "The Influence of Residual Stresses on the Stability of a Steel Member Subjected to Compression," in Preliminary Report, S.I.C.S. - ECCS, Liege, 1977, pp. 5-11.
- G77. Adams, P.F., and Beaulieu, D., "A Statistical Approach to the Problem of Stability Related to Structural Out-of-Plumbs," in Preliminary Report, S.I.C.S. - ECCS, Liege, 1977, pp. 23-29.
- G78. Dwight, J.B., and White, J.D., "Prediction of Weld Shrinkage Stresses in Plated Structures," in Preliminary Report, S.I.C.S. - ECCS, Liege, 1977, pp. 31-37.
- G79. Ivanyi, M., "Experimental Analysis of the Influence of Luders-Hartmann Lines on Stability of Steel Members," in Preliminary Report, S.I.C.S. - ECCS, Liege, 1977, pp. 45-50.
- G80. Kato, B., "Column Curve for Cold-Formed and Welded Steel Tubular Members," in Preliminary Report, S.I.C.S. - ECCS, Liege, 1977, pp. 53-60.

- G81. Yeomans, N.F., "Investigation of the Buckling Strength of Different Types of Structural Hollow Sections and Comparison with the Non-Dimensional Buckling Curves of the E.C.C.S.," in Preliminary Report, S.I.C.S. - ECCS, Liege, 1977, pp.71-75.
- G82. Ballio, G., Finzi, L., and Urbano, C., "Centrally Compressed High Strength Steel Round and Square Tubes; Theoretical and Experimental Investigations," in Preliminary Report, S.I.C.S. - ECCS, Liege, 1977, pp. 77-84.
- G83. Matsui, C., and Yagi, K., "On the Lateral Bracing Required for Compression Members," in Preliminary Report, S.I.C.S. - ECCS, Liege, 1977, pp. 101-106.
- G84. Djalaly, H., "Reliable Strength of Compression Members," in Preliminary Report, S.I.C.S. - ECCS, Liege, 1977, pp. 107-112.
- G85. Uhlmann, W., "Some Problems Concerning Design Recommendations for Centrally Compressed Built-up Members," in Preliminary Report, S.I.C.S.- ECCS, Liege, 1977, pp. 121-130.
- G86. Ballio, G., Finzi, L., and Zandonini, R., "A Theoretical Approach to the Behaviour of Centrally Compressed Built-up Struts," in Preliminary Report, S.I.C.S. - ECCS, Liege, 1977, pp. 131-136.
- G87. Yoshida, H., "Buckling Curves for Welded Beams," in Preliminary Report, S.I.C.S. - ECCS, Liege, 1977, pp. 191-196.
- G88. Nethercot, D.A., and Taylor, J.C., "Use of a 'Modified Slenderness' in the Design of Laterally Unsupported Beams," in Preliminary Report, S.I.C.S. - ECCS, Liege, 1977, pp. 197-202.
- G89. Kato, B., and Akiyama, H., "Lateral Buckling of Beams Under Practical Loadings and Restraints," in Preliminary Report, S.I.C.S. - ECCS, Liege, 1977, pp. 203-212.

- G90. Lindner, J., and Bamm, D., "Influence of Realistic Yield Stress Distribution on Lateral Torsional Buckling Loads," in Preliminary Report, S.I.C.S. - ECCS, Liege, 1977, pp. 213-216.
- G91. Jarnot, F.T., and Young, B.W., "The Ultimate Load Capacity of Laterally Unsupported Beams Subjected to Equal and Unequal Terminal Moments," in Preliminary Report, S.I.C.S. - ECCS, Liege, 1977, pp.217-222.
- G92. Fukumoto, Y., and Kubo, M., "A Survey of Tests on Lateral Buckling Strength of Beams," in Preliminary Report, S.I.C.S. - ECCS, Liege, 1977, pp.233-240.
- G93. Roik, K., and Bergmann, R., "Steel Column Design," in Preliminary Report, S.I.C.S. - ECCS, Liege, 1977, pp. 339-348.
- G94. Chen, W.F., "Design of Box Columns Under Biaxial Bending," in Preliminary Report, S.I.C.S. - ECCS, Liege, 1977, pp. 355-361.
- G95. Frey, F., "Non Linear Analysis of Metal Structures," in Preliminary Report, S.I.C.S. - ECCS, Liege, 1977, pp. 635-640.
- G96. Schroeder, P., "Dynamical Plate Buckling with Structural Damping," in Preliminary Report, S.I.C.S. - ECCS, Liege, 1977, pp. 641-646.
- G97. Subcommittee on Box Girder Bridges of the ASCE-AASHO Committee on Flexural Members, "Trends in the Design of Box Girder Bridges," Journ. of the Struct. Div., ASCE, Vol. 93, No. ST3, June, 1967, pp. 165-180.
- G98. European Convention for Constructional Steelwork, "Recommendations," Section R6, Design of Structures and Their Components. (Based on G31, ECCS Manual.)
- G99. European Convention for Constructional Steelwork, "Recommendations," Section R6, Appendix 4, Conventional Design Rules Based on the Linear Buckling Theory. (Based on G31, ECCS Manual.)

- G100. ASCE-AASHTO Task Committee on Longitudinally Stiffened Plate Girders of the ASCE-AASHTO Committee on Flexural Members, "Theory and Design of Longitudinally Stiffened Plate Girders - State of the Art Report.", 1977.
- G101. Ergänzungsbestimmungen zur DIN 4114, November 1973, Allgem. Rundschreiben Strassenbau Nr. 11/1973, Der Bundesminister für Verkehr, Bonn.
- G102. Erläuterungen zum Ergänzungserlass zu DIN 4114, Mitteilungen, Institut für Bautechnik, Anstalt des Oeffentlichen Rechts, 1 October, 1974, pp. 129-139.
- G103. American Welding Society, 1976 Revisions to Structural Welding Code, AWS D1.1-Rev. 1-76.
- G104. Dowling, P.J., "Recent Developments on the Inelastic Analysis and Design of Plate and Box Girders," International Colloquium on Stability of Structures, Washington, May, 1977.
- G105. Vincent, G.S., "Tentative Criteria for Load Factor Design of Steel Highway Bridges," Bulletin No. 15, American Iron and Steel Institute, March 1969.
- G106. Pelikan W. and Esslinger, M., Die Stahlfahrbahn, Berechnung und Konstruktion, M. A. N. Forschungsheft No. 7, 1957.
- G107. Klöppel, K. and Scheer, J., Beulwerte Ausgesteifter Rechtecksplatten, Vol. I, Wilhelm Ernst & Sohn, Berlin, West Germany, 1960.
- G108. Klöppel, K. and Möller, M., Beulwerte Ausgesteifter Rechtecksplatten, Vol. II, Wilhelm Ernst & Sohn, Berlin, West Germany, 1968.
- G109. Berechnungsgrundlagen für Stählerne Strassenbrücken, DIN 1073, Deutscher Normenausschuss, Beuth Vertrieb, Berlin, 1941.
- G110. Berechnungsgrundlagen für Stählerne Strassenbrücken, DIN 1073, Deutscher Normenausschuss,

Beuth Vertrieb, Berlin, July 1974.

- G111. Beulsicherheitsnachweise für Platten, DAST Richtlinie 12 , Deutscher Ausschuss für Stahlbau, Draft, June 1977.
- G112. Horne, M.R., "Structural Action in Steel Box Girders," CIRIA Guide 3, Construction Industry Research and Information Association, London, April 1977.
- G113. Czechoslovak Standard CSN 73 1401, Design of Steel Structures, 1976, (in Czech).
- G114. Nakai, H., and Heins, C.P., "Analysis Criteria for Curved Bridges," Journ. of the Struct. Div., ASCE, Vol. 103, No. ST7, July 1977, pp. 1419-1427.
- G115. Chapman, J.C., Dowling, P.J., Lim, P.T.K. and Billington, C.J., "The Structural Behavior of Steel and Concrete Box Girder Bridges," Structural Engineer, Road Research Laboratory, Vol. 49, No. 3, March, 1971.
- G116. Poellot, W.N., "Design of Box Girders", CEPA Conference, Washington, D.C. March 31, 1971
- G117. Komatsu, S., Nakai, H. and Nakanishi, M., "Statistical Analysis of Horizontally Curved Skew Box Girder Bridges," Transactions of the Japanese Society of Civil Engineers, Vol. 3, Part 2, 1971.
- G118. Sakai, F. and Okumura, T., "Influence of Diaphragms on Behavior of Box Girders with Deformable Cross Section," Publications, International Association for Bridge and Structural Engineering, May, 1972.
- G119. Das, P.C., "Analysis of Box Type Structures," Proceedings of the Institution of Civil Engineers, Vol. 53, June, 1972.
- G120. Heins, C.P. and Blank, D., "Box Beam Stiffening Using Cold Formed Decks," University of Missouri Report, Specialty Conference on Cold Formed Steel, St. Louis, MO, October, 1973.

- G121. El-Amin, R.M., "Thin-Walled Box Girders of Deformable Cross Section", Thesis presented to the University of Manchester Institute of Science and Technology at Manchester, England, in 1973, in partial fulfillment of the requirements for the degree of Doctor of Philosophy.
- G122. Radley, P.G., "Structural Behavior of a Box Girder Bridge," Thesis presented to the Auckland University of Auckland, New Zealand, in 1973 in partial fulfillment of the requirements for the degree of Master of Engineering, 1973.
- G123. Sisodiya, R.G. and Chali, A., "Analysis of Box Girder Bridges of Arbitrary Shape," Publications, International Association for Bridge and Structural Engineering, Vol. 33-1, 1973.
- G124. Scordelis, A.C., "Analytical Solutions for Box Girder Bridges," Development in Bridge Design and Construction, University College, Cardiff, Crosby, Lockwood and Son, Ltd., April, 1974.
- G125. Williamson, D.M., "BEF Analysis for Cross-Sectional Deformation of Curved Box Girders With Internal Diaphragms," M.S. Thesis, Carnegie-Mellon University, April, 1974.
- G126. Oleinik, J.C. and Heins, C.P., "Diaphragm Spacing Requirements for Curved Steel Box Beam Bridges," Civil Engineering Report, No. 58, University of Maryland, August, 1974.
- G127. Bazant, Z.P. and Nimeiri, M.E., "Stiffness Method for Curved Box Girders at Initial Stress," Journ. of the Struct. Div., ASCE, Vol. 100, No. ST10, October, 1974.
- G128. Armstrong, W.L., Buchanan, J., and Heins, C.P., "Loading Response of a Continuous Box Beam Bridge", Proceedings ASCE Specialty Conference on Metal Bridges, St. Louis, MO, November, 1974.

- G129. Yoo, C.H., Buchanan, J., Heins, C.P., Armstrong, W.L., "An Analysis of a Continuous Curved Box Girder Bridge," Highway Research Record, No. 579, Highway Research Board, January, 1975.
- G130. Heins, C.P., "Bending and Torsional Design in Structural Members," Lexington Books, D.C. Heath Co., Lexington, Mass., Sept. 1975.
- G131. Oleinik, J.C. and Heins, C.P., "Diaphragms for Curved Box Beam Bridges," Journ. of the Struct. Div., ASCE, Vol. 101, No. ST10, October, 1974, pp. 2161-2178.
- G132. Nakai, H., Kotoguchi, H. and Tani, T., "Matrix Structural Analysis of Thin-Walled Curved Girder Bridges Subjected to Arbitrary Loads," Proceedings of Japanese Society of Civil Engineers, No. 255, November, 1976.
- G133. ASCE-WRC Joint Committee, "Plastic Design in Steel - A Guide and Commentary," ASCE Manual No. 41, 2nd Ed., ASCE, 1971.
- G134. Beulsicherheitsnachweise für Platten, DAST Richtlinie 12, Deutscher Ausschuss für Stahlbau, Draft, January 1978.
- G135. Proceedings of the International Conference on Steel Plated Structures (July 1976) - General Reports, Discussion and Authors' Replies, Constructional Steel Research and Development Organization, Croydon, January 1978 (note: refers to G139).
- G136. American Association of State Highway and Transportation Officials, Standard Specifications for Highway Bridges, Twelfth Edition, AASHTO, Washington, D.C., 1977.
- G137. Heins, C.P., "Box Girder Bridges Design - State of the Art," AISC National Engineering Conference, Los Angeles, California, May 1978.

- G138. Herzog, M., "The Ultimate Strength of Stiffened Steel Box Girders," unpublished manuscript.
- G139. Steel Plated Structures. An International Symposium. Crosby Lockwood Staples, London, 1977 (note: contains papers listed in the Task A Bibliography under Proc. I.C.S.P.S., 1976, see page iii.)
- G140. Beulsicherheitsnachweise für Platten, DAST-Richtlinie 12, Deutscher Ausschuss für Stahlbau, Draft, April 1978 (see G134).
- G141. Interim Rules for Design and Construction of Plate Girder and Rolled Section Beams in Bridges, Technical Memorandum (Bridges) No. BE 3/76, Department of Environment, Highway Directorate, London, March 1976.
- G142. British Standard for Steel, Concrete and Composite Bridges, BS 5400, Part 1: General Statement, British Standard Institution, London, 1978.
- G143. British Standard for Steel, Concrete and Composite Bridges, BS 5400, Part 2: Specification for Loads, British Standard Institution, London, 1978.
- G144. Scheer, J., and Nölke, H., "Traglastversuche an torsionsbelasteten, dünnwandigen Kastenträgermodellen," Bauingenieur 51, 1976, pp. 381-386.
- G145. Scheer, J., "Stabilität von Platten aus Stahl," Lecture at Consulting Engineer Convention, Freudenstadt, June 3, 1978.
- G146. Scheer, J., and Böhm, M., "Auswertung von Traglastversuchen an gedrückten kastenstützen mit dünnwandigen, unausgesteiften Platten aus Stahl," IABSE Proceedings, P-13/78, Zürich, 1978.
- G147. Scheer, J., and Böhm, M., "Traglastversuche an dünnwandigen Kastenträgermodellen mit Biegemomentenbeanspruchung," Bauingenieur 53, 1978.

- G148. Kuzmanovic, B.O., "Some Design Problems of Large Box Girder Bridge," Journal of the Struct. Div., ASCE, Vol. 98, No. ST. 9, Sept. 1972, pp. 2059-2077.
- G149. Kerensky, O.A., "Major British Standard Covers Design and Construction of Bridges," British Standards Institution News, July 1978, pp. 10-11.
- G150. "Comprehensive British Bridge Code Aims at Paring Design Excesses," Engineering News-Record, July 27, 1978, p. 14.
- G151. British Standards Institution, "Steel, Concrete and Composite Bridges," BS 5400, Part 3, Code of Practice for Design of Steel Bridges, BSI, London (in preparation).
- G152. Wolchuk and Mayrbaurl, "Commentary on Proposed Interaction Diagram for the Design of Stiffened Compression Flanges," Report to the ASCE-TCCS Committee on Steel Box Girder Bridges, Part I, November 15, 1977.
- G153. Wolchuk and Mayrbaurl, "Commentary on Proposed Interaction Diagram for the Design of Stiffened Compression Flanges," Report to the ASCE-TCCS Committee on Steel Box Girder Bridges, Part II, March 30, 1978.
- G154. Wolchuk and Mayrbaurl, "Addendum 1 to Commentary on Proposed Interaction Diagram," Report to the ASCE-TCCS Committee on Steel Box Girder Bridges, Part II, April 20, 1978.
- G155. American Iron and Steel Institute, "Specification for the Design of Cold-Formed Steel Structural Members," AISI, New York, 1968.
- G156. Winter, G. : "Commentary on the 1968 Edition of the Specification for the Design of Cold-Formed Steel Structural Members," AIS, New York, 1970.

- G157. American Welding Society, 1977 Revisions to Structural Welding Code, AWS D1.1 - Rev. 2-77.
- G158. Kerensky, O.A., Henderson, W. and Brown, C.W., "Erskine Bridge," Journal Institution of Structural Engineers, April 1972, pp. 147-170; Discussion, November 1972, pp. 461-462.
- G159. Wolchuk, R., "New Steel Box Girder Design Specifications," AISC National Engineering Conference, Chicago, May 1979.

S. SAFETY

- S1. Freudenthal, A.M., Garrelts, J.M., and Shinozuka, M., "The Analysis of Structural Safety," Journal of the Struc. Div., ASCE, Vol. 92, No. ST2, Feb., 1966, pp. 267-325.
- S2. Benjamin, J.R., "Probabilistic Structural Analysis and Design," Journal of the Struct. Div., ASCE, Vol. 94, No. ST7, July, 1968, pp. 1665-1679.
- S3. Ang, A.H.-S., and Amin, M., "Safety Factors and Probability in Structural Design," Journal of the Struct. Div., ASCE, Vol. 95, No. ST7, July, 1969, pp. 1389-1405.
- S4. Flint, A.R., and Edwards, L.S., "Limit State Design of Highway Bridges," The Structural Engineer, Vol. 48, March, 1970, pp. 93-138.
- S5. Henderson, W., Burt, M.E., and Goodearl, K.A., "Bridge Loading," in Proc. I.C.S.B.G.B. 1973, pp. 193-201, Discussion, pp. 209-229.
- S6. Henderson, W., "Loading," in C.C.M.R. 1974.
- S7. Steinhardt, O., Valtinat, G., and Rubin, H., "Limit State Design Rules for Box Girders," Paper 9, in Proc. I.C.S.P.S. 1976, pp. 229-247.
- S8. Wex, B.P., and Brown, C.W.; "Limit States - Real or Imaginary in Box Girder Bridges," Paper 10, in Proc. I.C.S.P.S. 1976, pp. 248-264.

- S9. Faulkner, D., "Safety Factors?," Paper 32, in Proc. I.C.S.P.S. 1976, pp. 764-790.
- S10. Lenzen, K.H., et al., "Analysis and Interpretation of Fatigue Data," Journal of Struc. Div., ASCE, Vol. 94, No. ST12, Dec. 1968, pp. 2665-2677.
- S11. Mindlin, H., "Influence of Details on Fatigue Behavior of Structures," Journal of Struc. Div., ASCE, Vol. 94, No. ST12, Dec. 1968, pp. 2679-2698.
- S12. Reemsnyder, H.S., and Fisher, J.W., "Service Histories and Laboratory Testing," Journal of Struc. Div., ASCE, Vol. 94, No. ST12, Dec., 1968, pp. 2699-2712.
- S13. Fountain, R.S., Munse, W.H., and Sunbury, R.D., "Specifications and Design Relations," Journal of Struc. Div., ASCE, Vol. 94, No. ST12, Dec., 1968, pp. 2751-2767.
- S14. Hall, D.H., and Viest, I.M., "Design of Steel Structures for Fatigue," Journal of Struc. Div., ASCE, Vol. 94, No. ST12, Dec., 1968, pp. 2769-2797.
- S15. Reemsnyder, H.S., "Procurement and Analysis of Structural Fatigue Data," Journal of the Struc. Div., ASCE, Vol. 95, No. ST7, July, 1969, pp. 1533-1551.
- S16. Fisher, J.W., et al., "Effects of Weldments on the Fatigue Strength of Steel Beams," National Cooperative Highway Research Program Report 102, Lehigh University, Bethlehem, Pa., 1970.
- S17. Fisher, J.W., Guide to 1974 AASHTO Fatigue Specifications, American Institute of Steel Construction, New York, 1974.
- S18. Seim, C. and Ferwerda, R., "Fatigue Study of Orthotropic Bridge Deck Welds," State of California, Div. of Highways, Materials and Research Dept., Research Report CA-HWY-MR666473(1)-72-22, 1972.

- S19. Halse, W., "Fatigue," in C.C.M.R., 1974.
- S20. Wolchuk, R., and Mayrbaurl, R.M., Discussion of "Commentary on Orthotropic - Deck Bridge Specification," by the Task Committee on Orthotropic Plate Bridges of the Committee on Metals of the Structural Division, Journal of the Struct. Div., ASCE, Vol. 100, No. ST12, Dec., 1974, pp. 2525-2526.
- S21. Wolchuk, R., and Mayrbaurl, R.M., "Stress Cycles for Fatigue Design of Railroad Bridges," Journal of the Struct. Div., ASCE, Vol. 102, Jan., 1976, pp. 203-213.
- S22. Mazzolani, F.M., and Faella, C., "Analysis of High Strength Steel Bars Under Repeated Axial Loading," in Preliminary Report, S.I.C.S. - ECCS, Liege, 1977, pp. 95-100.
- S23. Frangopol, D., and Nguyen Dang Hung, "A Probabilistic Approach for Checking Safety of Centrally Loaded Steel Columns," in Preliminary Report, S.I.C.S. - ECCS, Liege, 1977, pp. 113-118.
- S24. "Load and Resistance Factor Design - A New Option for Steel Structures," Civil Engineering - ASCE, Vol. 48, No. 9, September 1978, pp. 75-77.
- S25. Schilling, C.G., and Klippstein, K.H., "New Method for Fatigue Design of Bridges," Journal of the Structural Division, ASCE, Vol. 104, No. ST3, March 1978, pp. 425-438.

F. FLANGE DESIGN

- F1. Falconer, B.H., and Chapman, J.C., "Compressive Buckling of Stiffened Plates," *The Engineer*, 1953, pp. 789-791 & 822-825.
- F2. Taschenbuch für Bauingenieure (Handbook for Structural Engineers), Second Edition Part I, pp. 843-846, J. Springer, Berlin, 1955.
- F3. Wolchuk, R., "Steel Deck Bridges with Long Rib Spans," *Civil Engineering ASCE*, Vol. 34, pp. 53-55, 1964.
- F4. Graves Smith, T. R., "The Ultimate Strength of Locally Buckled Columns for Various Slenderness Ratios," Confidential Construction Industry Research and Information Association Research Report No. 12, Part II, London, May, 1968.
- F5. Moxham, K.E., "Theoretical Prediction of the Strength of Welded Steel Plates in Compression," University of Cambridge, Dept. of Engineering, Techn. Report CUED (C-Struct), TR.2, 1971.
- F6. Moxham, K.E., Further Computed Results Using Moxham's Program (private communication).
- F7. Moffatt, K.R., and Dowling, P.J., "Parametric Study on the Shear Lag Phenomenon in Steel Box Girder Bridges," CESLIC Report BG17, Engineering Structures Laboratories, Imperial College, London, 1972.

- F8. Dwight, J.B., "Use of Perry Formula to Represent the New European Strut-Curves," University of Cambridge, Dept. of Engineering, Techn. Report CUED (C-Struct) TR.30, 1972.
- F9. Dorman, A.P., and Dwight, J.B., "Tests on Stiffened Compression Panels and Plate Panels," in Proc. I.C.S.B.G.B. 1973, pp. 63-75, Discussion, pp. 145-172.
- F10. Dwight, J.B., Little, G.H., and Rogers, N.A., "An Approach to Stiffened Steel Compression Panels," University of Cambridge, Dept. of Engineering, Techn. Report CUED (C-Struct) TR.32, 1973.
- F11. Dwight, J.B., and Little, G.H., "Stiffened Steel Compression Panels-a Design Approach," University of Cambridge, Dept. of Engineering, Techn. Report CUED (C-Struct), TR.38, 1974.
- F12. Dwight, J.B., et al., "A Possible Design Procedure for Stiffened Compression Panels," Steel Construction, Vol. 9, No. 3, 1975, Australian Institute of Steel Construction.
- F13. "Commentary on Effective Width Provisions for Design of Steel Box Girders," Report for the ASCE Subcommittee on Steel Box Girder Bridges, April, 1975, by Wolchuk and Mayrbaurl (unpublished).
- F14. Canning, D.J., and Lewis, M., "Design of Flanges," in C.C.M.R. 1974.
- F15. Moolani, F.M., and Dowling, P.J., "Tests to Study the Effects of Shear Lag on the Collapse of Steel Box Girders," Civ. Eng. Dept, Imperial College, London, CESLIC Report BG34, August 1975.
- F16. Moffatt, K.R., and Dowling, P.J., "Shear Lag in Steel Box Girder Bridges," The Structural Engineer, London, Oct., 1975, pp. 439-447, Discussion, The Structural Engineer, August, 1976, pp. 285-297.

- F17. Little, G., "Stiffened Steel Compression Panels-Theoretical Failure Analysis," *The Structural Engineer*, Vol. 54, No. 12, December, 1976, pp. 489-500.
- F18. Dwight, J.B., and Little, G.H., "Stiffened Steel Compression Flanges-A Simple Approach," *The Structural Engineer*, Vol. 54, No. 12, December, 1976, pp. 501-509.
- F19. Horne, M.R., and Narayanan, R., "An Approximate Method for the Design of Stiffened Steel Compression Panels," *Proc. Institution of Civil Engineers, Part 2*, September, 1975, pp. 501-514, Discussion, *Proc. Institution of Civil Engineers, Part 2*, June, 1976, pp. 454-474.
- F20. Chatterjee, S., and Dowling, P.J., "Proposed Design Rules for Longitudinal Stiffeners in Compression Flanges of Box Girders," *Civ. Eng. Dept., Imperial College, London, CESLIC Report BG40*, May, 1975.
- F21. Horne, M.R., and Narayanan, R., "Ultimate Strength of Stiffened Panels Under Uniaxial Compression," Paper 1, in *Proc. I.C.S.P.S.*, 1976, pp. 1-23.
- F22. Frieze, P.A., Dowling, P.J., and Hobbs, R.E., "Ultimate Load Behaviour of Plates in Compression," Paper 2, in *Proc. I.C.S.P.S.* 1976, pp. 24-50.
- F23. Moolani, F.M., and Dowling, P.J., "Ultimate Load Behaviour of Stiffened Plates in Compression," Paper 3, in *Proc. I.C.S.P.S.* 1976, pp. 51-88.
- F24. Maquoi, R., and Massonnet, Ch., "Interaction Between Shear Lag and Post-Buckling Behaviour in Box Girders," Paper 4, in *Proc. I.C.S.P.S.* 1976, pp. 89-107.
- F25. Dowling, P.J., Moolani, F.M., and Frieze, P.A., "The Effect of Shear Lag on the Ultimate Strength of Box Girders," Paper 5, in *Proc. I.C.S.P.S.* 1976, pp. 108-141.

- F26. Roik, K., "Effective Breadth and Shear Lag in Plate Girder Bridges with Elastic and Elasto-Plastic Material Behaviour," Paper 7, in Proc. I.C.S.P.S. 1976, pp. 169-195.
- F27. Chatterjee, S., and Dowling, P.J., "The Design of Box Girder Compression Flanges," Paper 8, in Proc. I.C.S.P.S. 1976, pp. 196-228.
- F28. Rogers, N.A., and Dwight, J.B., "Outstand Strength," Paper 12, in Proc. I.C.S.P.S. 1976, pp. 284-310.
- F29. Dean, J.A., and Dowling, P.J., "Ultimate Load Behaviour of Stiffened Plates under Combined In-Plane and Lateral Loading," Paper 31, Proc. I.C.S.P.S. 1976.
- F30. Fujita, Y., "The Influence of Initial Imperfection on the Compressive Strength of Plate," in Preliminary Report, S.I.C.S. - ECCS, Tokyo, 1976, pp. 123-142.
- F31. Nishino, F., and Hasegawa, A., "Review of Strength of Transversely Stiffened Plate Girders," in Preliminary Report, S.I.C.S. - ECCS, Tokyo, 1976, pp. 143-165.
- F32. Carlsen, C.A., Søreide, T.H., and Nordsve, N.T., "Ultimate Load Analysis of the Compression Flange of Box Girder," in Preliminary Report, S.I.C.S. - ECCS, Liege, 1977, pp. 257-265.
- F33. Fok, W.C., and Walker, A.C., "The Inelastic Ultimate Load of Stiffened Plate with Stiffener Failure," in Preliminary Report, S.I.C.S. - ECCS, Liege, 1977, pp. 267-272.
- F34. Rouve, Bertrand, "Comportement Non-linéaire des Plaques Comprimees Munies de Raidisseurs en Caisson," in Preliminary Report, S.I.C.S. - ECCS, Liege, 1977, pp. 273-278.

- F35. Bergfelt, A., "Influence of Web Inclination on Compression Flange Buckling," in Preliminary Report, S.I.C.S. - ECCS, Liege, 1977, pp. 279-288.
- F36. Chan, K.S., Law, C.L., and Smith, D.W., "Stability of Stiffened Compression Flanges Under In-plane Forces and Wheel Loads," in Preliminary Report, S.I.C.S. - ECCS, Liege, 1977, pp. 289-294.
- F37. Dowling, P.J., Frieze, P.A., and Harding, J.E., "Imperfection Sensitivity of Steel Plates Under Complex Edge Loading," in Preliminary Report, S.I.C.S. - ECCS, Liege, 1977, pp. 305-314.
- F38. Bradfield, C.D., "Collapse of Rectangular Outstands Loaded in Compression," in Preliminary Report, S.I.C.S. - ECCS, Liege, 1977, pp. 315-320.
- F39. Skaloud, M., Naprstek, J., "Limit State of Compressed Thin-walled Steel Column and Plate Buckling," in Preliminary Report, S.I.C.S. - ECCS, Liege, 1977, pp. 405-414.
- F40. Reis, A.J., and Roorda, J., "The Interaction Between Lateral-torsional and Local Plate Buckling in Thin-walled Beams," in Preliminary Report, S.I.C.S. - ECCS, Liege, 1977, pp. 415-425.
- F41. Puthli, R.S., Crisfield, M.A., and Supple, "Interactive Collapse of Plate Assemblages in Relation to the Strength of Box Girder," in Preliminary Report, S.I.C.S. - ECCS, Liege, 1977, pp. 427-432.
- F42. Basu, A.K., Djahani, P., and Dowling, P.J., "Elastic Post-buckling Behaviour of Discretely Stiffened Plates," in Preliminary Report, S.I.C.S. - ECCS, Liege, 1977, pp. 433-438.
- F43. Rhodes, J., and Harvey, J.M., "Interaction Behaviour of Plain Channel Columns Under Concentric or Eccentric Loading," in Preliminary Report, S.I.C.S. - ECCS, Liege, 1977, pp. 439-444.

- F44. Frieze, P.A., Dowling, P.J., and Hobbs, R.E., "Parametric Study on Plates in Compression," CESLIC Report BG39, Imperial College, London, 1975.
- F45. Moolani, F.M., and Dowling, P.J., "Parametric Study on Stiffened Plates in Compression," CESLIC Report BG41, Imperial College, London, 1976.
- F46. Little, G.H., "Stiffened Steel Compression Panels - Some Additional Theoretical Results," July, 1977, (unpublished).
- F47. Dwight, J.B., and Moxham, K.E., "Compressive Strength of Welded Plates, " International Colloquium on Stability of Structures, Washington, May, 1977.
- F48. Harding, J.E. et. al. "Parametric Study on Plates under Combined Direct and Shear In-Plane Loading," CESLIC Report BG44, Imperial College, London, 1976.
- F49. Djubek, J., and Škaloud, M., "Czechoslovak Approach to the Design of Longitudinally Stiffened Compression Flanges of Steel Box-Girder Bridges," in Preliminary Report, S.I.C.S. - ECCS, Liege, 1977, pp. 249-304.
- F50. Horne, M.R., and Narayanan, R., "Further Tests on the Ultimate Load Capacity of Longitudinally Stiffened Panels," Simon Engineering Laboratories, University of Manchester, July 1974.
- F51. Horne, M.R., and Narayanan, R., "Influence of the Weld Size and Spacing on the Strength of Stiffened Panels," Simon Engineering Laboratories, University of Manchester, December 1974.
- F52. Horne, M.R., and Narayanan, R., "Tests on Spliced Stiffened Panels," Simon Engineering Laboratories, University of Manchester, January 1975.
- F53. Horne, M.R., and Narayanan, R., "An Approximate Method for the Design of Stiffened Steel Compression Panels," Simon Engineering Laboratories, University of Manchester, February 1975.

- F54. Horne, M.R., Montague, P., and Narayanan, R., "Ultimate Capacity of Axially Loaded Stiffened Plates Collapsing by Outstand Failure," Simon Engineering Laboratories, University of Manchester, January 1976.
- F55. Horne, M.R., Montague, P., and Narayanan, R., "The Influence of Stiffener Spacing and Weld/Gap Ratio on the Ultimate Capacity of Axially Loaded Stiffened Plates," Simon Engineering Laboratories, University of Manchester, February 1976.
- F56. Horne, M.R., and Narayanan, R., "The Influence of Rectification Procedures on the Strength of Welded Steel Stiffened Plates," Simon Engineering Laboratories, University of Manchester, March, 1976.
- F57. Horne, M.R., and Narayanan, R., "Ultimate Capacity of Longitudinally Stiffened Plates Used in Box Girders," Proc. Institution of Civil Engineers, Part 2, June 1976, pp. 253-280.
- F58. Horne, M.R., Montague, O., and Narayanan, R., "Influence on Strength of Compression Panels of Stiffener Section, Spacing and Welded Connection," Proc. Institution of Civil Engineers, Part 2, March 1977, pp. 1-20.
- F59. Fukumoto, Y., Usami, T., and Yamaguchi, K., "Inelastic Buckling Strength of Stiffened Plates in Compression," I.A.B.S.E. Proceedings P-8/77, August 1977.
- F60. Horne, M.R., and Narayanan, R., "Design of Axially Loaded Stiffened Plates," Journal of the Structural Division, ASCE, Vol. 103, No. ST11, November 1977, pp. 2243-2257.
- F61. Little, G.H., and Dwight, J.B., "Compressive Tests on Plates with Transverse Welds," University of Cambridge, Department of Engineering, Technical Report CUED/C-Struct/TR.31, 1972.

- F62. Little, G.H., "Plate Failure in Stiffened Steel Compression Panels," University of Cambridge, Department of Engineering, Technical Report CUED/C-Struct./TR.33, 1972.
- F63. Rogers, N.A., "Outstand Failure in Stiffened Steel Compression Panels," University of Cambridge, Department of Engineering, Technical Report CUED/C-Struct./TR.54, 1975.
- F64. Walker, A.C., and Murray, N.W., "Analysis for Stiffened Plate Panel Buckling," Civil Engineering Research Report No. 2, Monash University, Melbourne, Australia, September 1974.
- F65. Little, G.H., "Stiffened Steel Compression Panels-Plate Failure Results for Plain Flat Stiffeners and T-Section Stiffeners," Preliminary Report, Birmingham, July 6, 1977 (Unpublished).
- F66. Moxham, K.E., and Bradfield, C.D., "The Strength of Welded Steel Plates under In-Plane Compression," University of Cambridge, Department of Engineering, Technical Report CUED/C-Struct./TR.65, 1977.
- F67. Smith, C.S., "Influence of Local Compressive Failure on Ultimate Longitudinal Strength of a Ship's Hull," Symposium on Practical Design in Shipbuilding, Tokyo, October 1977/
- F68. "AISC Strut Formulas," Letters to the Editors, Civil Engineering, Vol. 47, No. 7, July 1977.
- F69. Schmidt, H., Discussion of "Shear Lag in Steel Box Girder Bridges," (F16), Unpublished manuscript.
- F70. Little, G.H., "Stiffened Steel Compression Panels - Strength Predictions for Plain Flat Stiffeners and T-Section Stiffeners Having Negative Initial Out-of-Straightness," Preliminary Report, Birmingham, February 24, 1978 (Unpublished).

- F71. Rogers, N.A., "Theoretical Prediction of the Behavior of Plain Flat Outstands in Compression," University of Cambridge, Dept. of Engineering, Technical Report No. CUED/C-Struct./TR.51, 1976.
- F72. Rogers, N.A., "Compression Tests on Plain Flat Outstands," University of Cambridge, Dept. of Engineering, Technical Report No. CUED/C-Struct./TR.52, 1976.
- F73. Rogers, N.A., "Compression Tests on Bulb Flat Cruciforms," University of Cambridge, Dept. of Engineering, Technical Report No. CUED/C-Struct./TR.53, 1975.
- F74. Smith, C.S., "Compressive Strength of Welded Steel Ship Grillages," Trans. Royal Institution of Naval Architects, Vol. 117, 1975.
- F75. Ostapenko, A., "Ultimate Strength Design of Wide Stiffened Plates Loaded Axially and Normally," Symposium on Non-Linear Techniques and Behavior in Structural Analysis, Transport and Road Research Laboratory, Crowthorne, Dec. 11 and 12, 1974 (Published in TRRL Supplementary Report 164 Uc, 1975).

7

W. WEB DESIGN

- W1. Basler, K., "Strength of Plate Girders in Shear," Journal of the Structural Division, ASCE, Vol. 87, No. St7, Oct., 1961, pp. 151-180.
- W2. Basler, K., "Strength of Plate Girders in Combined Bending and Shear," Journal of the Structural Division, ASCE, Vol. 87, No. St7, Oct., 1961, pp. 181-197.
- W3. Cooper, P.B., Lew, H.S., and Yen, B.T., "Welded Constructional Alloy Steel Plate Girders," Journal of the Structural Division, ASCE, Vol. 90, No. ST 1, Feb., 1964, pp. 1-36.
- W4. Cooper, P.B., "Strength of Longitudinally Stiffened Plate Girders," Journal of the Structural Division, ASCE, Vol. 93, No. ST2, Apr., 1967, pp. 419-451.
- W5. Rockey, K.C., Evans, H.R., and Porter, D.M., "Ultimate Load Capacity of Stiffened Webs Subjected to Shear and Bending," in Proc. I.C.S.B.G.B. 1973, pp. 45-61, Discussion, pp. 145-172.
- W6. Rockey, K.C., Porter, D.M., and Evans, H.R., "Ultimate Load Capacity of the Webs of Thin-walled Members," Proc. Second Speciality Conference on Cold Formed Steel Structures, University of Missouri, St. Louis, 1973, pp. 169-200.
- W7. El-Gaaly, M.A., and Rockey, K.C., "Ultimate Strength of Thin-walled Members Under Patch Loading and Bending," Proc. Second Specialty Conference on Cold Formed Steel Structures, University of Missouri, St. Louis, 1973, pp. 139-167.

- W8. Porter, D.M., Rockey, K.C., and Evans, H.R., "The Collapse Behaviour of Plate Girders Loaded in Shear," *The Structural Engineer*, Vol. 53, Aug., 1975, pp. 313-325.
- W9. Evans, H.R., Porter, D.M., and Rockey, K.C., "Ultimate Load Behaviour of Plate and Box Girder Webs," Paper 14, in *Proc. I.C.S.P.S. 1976*, pp. 338-368.
- W10. Harding, J.E., Hobbs, R.E., and Neal, B.G., "Ultimate Load Behaviour of Plates under Combined Direct and Shear In-plane Loading," Paper 15, in *Proc. I.C.S.P.S. 1976*, pp. 369-403.
- W11. Djubek, J., and Škaloud, M., "Post-buckled Behaviour of Web Plates in the New Edition of Czechoslovak Design Specifications," Paper 16, in *Proc. I.C.S.P.S. 1976*, pp. 404-420.
- W12. Rockey, K.C., "The Design of Web Plates for Plate and Box Girders - A State of the Art Report," Paper 19, in *Proc. I.C.S.P.S. 1976*, pp. 459-485.
- W13. Bergfelt, A., "The Behaviour and Design of Slender Webs Under Partial Edge Loading," Paper 20, in *Proc. I.C.S.P.S. 1976*, pp. 486-502.
- W14. Richmond, B., "Design of Web," in *C.C.M.R. 1974*.
- W15. Hasegawa, A., "Consideration on Basler's Shear Strength Theory," in *Preliminary Report, S.I.C.S. - ECCS, Liege, 1977*, pp. 243-248.
- W16. Wagner, H., "Flat Sheet Metal Girder with Very Thin Metal Web," *N.A.C.A. Tech. Memo. Nos. 604, 605, 606, 1931*.
- W17. Rockey, K.C., Evans, H.R., and Porter, D.M., "Tests on Longitudinally Reinforced Plate Girders Subjected to Shear," in *Preliminary Report, S.I.C.S. - ECCS, Liege, 1977*, pp. 295-304.

- W18. Frey, F., and Anslijn, R., "Shear Tests on Unstiffened Plate Girders," in Preliminary Report, S.I.C.S. - ECCS, Liege, 1977, pp. 321-326.
- W19. Brozzetti, J., "Experimental Behaviour of Two Slender Girders - A Criterion for a 'Serviceability' Limit Load," in Preliminary Report, S.I.C.S. - ECCS, Liege, 1977, pp. 327-332.
- W20. Plumier, A., "The Improvement of the Load Carrying Capacity of Webs by Means of Appropriate Residual Stresses," in Preliminary Report, S.I.C.S. - ECCS, Liege, 1977, pp. 333-336.
- W21. Ostapenko, A., Yen, B.T., and Beedle, L.S., "Research on Plate Girders at Lehigh University," I.A.B.S.E., Eighth Congress, New York, 1968.
- W22. Dimitri, J.R., and Ostapenko, A., "Pilot Tests on the Static Strength of Unsymmetrical Plate Girders," Bulletin 156, Welding Research Council, November, 1970.
- W23. Schueller, W., and Ostapenko, A., "Tests on a Transversely Stiffened and on a Longitudinally Stiffened Unsymmetrical Plate Girder," Bulletin 156, Welding Research Council, November, 1970.
- W24. Parsanejad, S., and Ostapenko, A., "On the Fatigue Strength of Unsymmetrical Steel Plate Girders," Bulletin 156, Welding Research Council, November, 1970.
- W25. Parsanejad, S., and Ostapenko, A., "Fatigue Strength of Unsymmetrical Plate Girders," Fritz Engineering Laboratory Report No. 328.15, Lehigh University, May, 1970.
- W26. Basler, K., and Thurlimann, B., "Strength of Plate Girders in Bending," Trans. ASCE, Vol. 128, Part II, 1963, pp. 655-682.
- W27. Chern, C., "Ultimate Strength of Transversely and Longitudinally Stiffened Plate Girders," dissertation presented to Lehigh University in 1969, in

partial fulfillment of the requirements for the degree of Doctor of Philosophy.

- W28. Ostapenko, A., Chern, C., and Parsanejad, S., "Ultimate Strength Design of Plate Girders," Cardiff Conference, 1971, Crosby Lockwood & Son, London, 1971.
- W29. Fujii, T., "On an Improved Theory for Dr. Basler's Theory," Final Report of the Eighth Congress of I.A.B.S.E. New York, Sept. 1968.
- W30. Herzog, M., "Die Traglast unversteifter und versteifter, dünnwandiger Blechträger unter reinem Schub und Schub mit Biegung nach Versuchen," Der Bauingenieur, October, 1974.
- W31. Höglund, T., "Design of Thin-Plate I Girders in Shear and Bending," Royal Inst. Technol. Bulletin 94, Stockholm, 1973.
- W32. Critchfield, M.O., "An Ultimate Strength Analysis Technique for Cross-Stiffened Bulkheads Under Combined Inplane Bending and Shear," Structures Department, Research and Development Report 4611, Naval Ship Research and Development Center, Bethesda, Md. May 1975.
- W33. Chern, C., and Ostapenko, A., "Unsymmetrical Plate Girders under Shear and Moment," Fritz Engineering Laboratory Report No. 328.9C, Lehigh University, October, 1970.
- W34. Ostapenko, A., and Chern, C., "Strength of Longitudinally Stiffened Plate Girders under Combined Loads," Fritz Engineering Laboratory Report No. 328.10C, Lehigh University, December, 1970.
- W35. Ostapenko, A., and Chern, C., "Ultimate Strength of Longitudinally Stiffened Plate Girders under Combined Loads," Fritz Engineering Laboratory Report No. 328.10A, Lehigh University, June 1971.

- W36. Rockey, K.C., and Cook, I.T., "Shear Buckling of Clamped and Simply-Supported Infinitely Long Plates Reinforced by Transverse Stiffeners and a Central Longitudinal Stiffener," *Aeronautical Quarterly*, Vol. XIII, Royal Aeronautical Society, May 1962, pp. 95-114.
- W37. Rockey, K.C., and Cook, I.T., "Shear Buckling of Orthogonally Stiffened, Infinitely Long Simply-Supported Plates - Stiffeners having Torsional and Flexural Rigidities," *Aeronautical Quarterly*, Vol. XX, Royal Aeronautical Society, February 1969, pp. 75-87.
- W38. Rockey, K.C., and Leggett, D.M.A., "The Buckling of a Plate Girder Web under Pure Bending when Reinforced by a Single Longitudinal Stiffener," *Proc. Institution of Civil Engineers*, Vol. 21, January 1962, pp. 161-188.
- W39. Owen, D.R.J., Rockey, K.C., and Skaloud, M., "Ultimate Load Behaviour of Longitudinally Reinforced Webplates Subjected to Pure Bending," *IABSE Vol. 30-I*, Zurich, 1970.
- W40. Rockey, K.C., Evans, H.R., and Porter, D.M., "The Ultimate Shear Load Behaviour of Longitudinally Reinforced Plate Girders," *Proceedings, Symposium on Non-Linear Techniques and Behaviour in Structural Analysis*, TRRL, Dec. 1974.
- W41. Rockey, K.C., Porter, D.M., and Evans, H.R., "The Prediction of the Ultimate Load Capacity of Unsymmetrical Plate Girders using 'the Cardiff Solution'," Report, University College, Cardiff, 1975/76.
- W42. Huslid, J.M., and Rockey, K.C., "The Influence of End Post Rigidity upon the Collapse Behaviour of Plate Girders," Report, University College, Cardiff, 1977.

- W43. Rockey, K.C., Evans, H.R., and Porter, D.M., "A Design Method for Predicting the Collapse Behaviour of Plate Girders," Proc. Institution of Civil Engineers, Part 2, Vol. 65, March 1978, pp. 85-112.
- W44. "Vergleichende Untersuchung verschiedener Verfahren zur Bestimmung der Grenzquerkraft von Vollwandträgern," Report No. 7645, Technical University of Braunschweig, 1976.
- W45. Evans, H.R., Porter, D.M., and Rockey, K.C., "The Collapse Behaviour of Plate Girders Subjected to Shear and Bending", IABSE Proceedings P-18/78, Zurich, Nov. 1978.
- W46. Massonnet, C.E., "Stability Considerations in the Design of Steel Plate Girders", Trans. ASCE, Vol. 127, Part II, 1962, pp. 420-447.
- W47. Cook, I.T., and Rockey, K.C., "Shear Buckling of Clamped and Simply Supported Infinitely Long Plates Reinforced by Transverse Stiffeners", Aero. Quarterly, Feb. 1962, 13, pp. 41-70.
- W48. Rockey, K.C., and Cook, I.T., "Shear Buckling of Clamped and Simply Supported Infinitely Long Plates Reinforced by Closed Section Transverse Stiffeners", Aero. Quarterly, August 1962, 13, pp. 212-222.
- W49. Skaloud, M., Donea, J., and Massonnet, C.E., "Post Critical Behaviour of a Stiffened Square Plate Subjected to Uniform Shear", First Part, General Solution and Buckling Pattern of the Plate, 20th Vol. Publications - IABSE, 1967, pp. 187-210.
- W50. Scheer, J., "Der stabilisierende Einfluss von Zugspannungen auf die Beulung schubbeanspruchter, unausgesteifter Rechteckplatten," Der Stahlbau No. 8, 1962, pp. 233-238.

D. DIAPHRAGMS AND CROSS FRAMES

- D1. Dowling, P.J., Loe, J.A., and Dean, J.A., "The Behaviour up to Collapse of Load Bearing Diaphragms in Rectangular and Trapezoidal Stiffened Steel Box Girders," in Proc. I.C.S.B.G.B. 1973, pp. 95-117, Discussion, pp. 145-172.
- D2. Wood, J.G.M., "Design of Diaphragms," in C.C.M.R. 1974.
- D3. Simpson, B., "Design of Diaphragms," in C.C.M.R. 1974.
- D4. Williams, G.T., "Design of Cross Frames," in C.C.M.R. 1974.
- D5. Crisfield, M., and Puthli, R., "A Finite Element Method Applied to the Collapse Analysis of Stiffened Box Girder Diaphragms," Paper 13 in Proc. I.C.S.P.S. 1976, pp. 311-337.
- D6. Wood, J.G.M., and Flint, A.R., "The Design of Box Girder Diaphragms," Paper 18 in Proc. I.C.S.P.S. 1976, pp. 429-458.
- D7. Dean, J.A., and Dowling, P.J., "Unstiffened Load Bearing Diaphragms, Analysis of Test Results," Civil Engineering Department, Imperial College, London, CESLIC Report BG32, February 1976.
- D8. Rockey, K.C., and El-Gaaly, M.A., "Stability of Load Bearing Trapezoidal Diaphragms," IABSE Vol 32-II, Zurich, 1972.

- D9. El-Gaaly, M.A., "Stability of Orthogonally Stiffened Load-Bearing Trapezoidal Diaphragms," IABSE Vol. 34 - II, Zurich, 1974.

C. CONSTRUCTION

- C1. Young, B.W., Elliott, P., and Bowers, G., "Residual Stresses and Measurement of Tolerances," in Proc. I.C.S.B.G.B. 1973, pp. 231-240, Discussion, pp. 263-277.
- C2. Thompson, J.D., "The Fabrication of Steel Box Girder Bridges," in Proc. I.C.S.B.G.B. 1973, pp. 241-248, Discussion, pp. 263-277.
- C3. Naruse, T., "Fabrication of Box Girders," in Proc. I.C.S.B.G.B. 1973, pp. 249-253, Discussion, pp. 263-277.
- C4. Langhoff, H.J., and Granzen, H., "Fabrication of Box Girder Bridges," in Proc. I.C.S.B.G.B. 1973, pp. 255-262, Discussion, pp. 263-277.
- C5. Harper, W.J., and Upstone, T.J., "Erection of Box Girder Bridges," in Proc. I.C.S.B.G.B. 1973, pp. 279-284, Discussion, pp. 303-313.
- C6. Heckel, R., "Some Remarks on Box Girder Erection," in Proc. I.C.S.B.G.B. 1973, pp. 285-290, Discussion, pp. 303-313.
- C7. Lally, A., "Steel Box Girder Erection," in Proc. I.C.S.B.G.B. 1973, pp. 291-301, Discussion, pp. 303-313.
- C8. Pratt, J.L., "Workmanship," in C.C.M.R. 1974.

- C9. White, J.D., "Longitudinal Shrinkage of a Single Pass Weld," University of Cambridge, Department of Engineering, Technical Report CUED/C-Struct/TR.57, 1977.
- C10. White, J.D., "Longitudinal Stresses in a Member Containing Non-Interacting Welds," University of Cambridge, Department of Engineering, Technical Report CUED/C-Struct/TR.58, 1977.
- C11. White, J.D., "Longitudinal Shrinkage of Multi-Pass Welds," University of Cambridge, Department of Engineering, Technical Report CUED/C-Struct/TR.59, 1977.
- C12. White, J.D., "Longitudinal Stresses in Welded T-Sections," University of Cambridge, Department of Engineering, Technical Report CUED/C-Struct/TR.60, 1977.
- C13. Bradfield, C.D., "Analysis of Measured Distortions in Steel Box-Girder Bridges," University of Cambridge, Department of Engineering, Technical Report CUED/C-Struct/TR.42, 1974.
- C14. Massonnet, C., and Janss, J., "Geometric Rolling and Workmanship Imperfections of Steel Bridge Elements and their Effects on their Ultimate Strength, with Emphasis on Plate Structures," paper to be presented at Cardiff Conference, Sept. 25-27, 1978 (Conference postponed until Sept. 1979).
- C15. Massonnet, C., and Janss, J., "Pre-Erection Measurements of Initial Imperfections of the Panels of a Composite Box-Girder Bridge," paper prepared for IABSE Task Group on Effects of Imperfections of Steel Plated Structures on their Ultimate Strength, 1978.
- C16. Durkee, J.L., "Railway Box Girder Bridge Erected by Launching," Jour. of the Struct. Div., ASCE, Vol. 98, No. ST7, July 1972, pp. 1443-1463.

C17. Nölke, H., "Measurements of Geometrical Imperfections of Two Box Girder Bridges," Document of Commission 8, Working Group 3 of ECCS, 1978.

B. BRIDGES

- B1. Bouwkamp, J.G., Analysis of the Orthotropic Steel Deck of the San Diego-Coronado Bridge, Report No. 67-20, Structural Engineering Laboratory, University of California, Berkeley, California, 1967.
- B2. Foley, E.R. and Murphy, J.P., "World's Longest Orthotropic Section Feature of San Mateo-Hayward Bridge," Civil Engineering-ASCE, Vol. 38, 1968, pp. 54-58.
- B3. Wolchuk, R., and Bridgefarmer, J.C., "Long-Span Steel Deck Railroad Bridge," Civil Engineering-ASCE, Vol. 40, 71-74, 1970.
- B4. "New Danube Bridge Sags, Buckles," Engineering News-Record, No. 13, 1969, p. 11.
- B5. "Cantilevered Box Girder Bridge Collapses During Construction," Engineering News-Record, June 11, 1970, p. 9.
- B6. "Australian Box Girder Span and Pier Collapse," Engineering News-Record, Oct. 22, 1970, p. 19.
- B7. "Westgate Bridge Inquiry," Engineering News-Record, Nov. 12, 1970, p. 11.
- B8. "Australian Bridge Collapse Pinned on Designers," Engineering News-Record, Aug. 12, 1971, p. 13.
- B9. Report of the Royal Commission into the Failure of West Gate Bridge, C.H. Rixon, Government Printer, Melbourne, Australia, 1971.

- B10. Kozak, J.J. and Seim, C., "Poor Structural Design Brings West Gate Bridge Failure," Civil Engineering, ASCE, Vol. 42, No. 6, June, 1972, pp. 47-50.
- B11. "Britain Restricts Traffic on Steel Box Girder Spans," Engineering News-Record, June 24, 1971, p. 11.
- B12. "Cracks in Stiffeners Found in Severn Bridge," Engineering News-Record, Nov. 18, 1971, p. 17.
- B13. "Steel Box Girder Bridge Collapses as Section is Hoisted from Barge," Engineering News-Record, Nov. 18, 1971, p. 17.
- B14. "Koblenz November 1971," The Consulting Engineer, Jan., 1972, pp. 23-24.
- B15. "Rib Gaps Blamed for Bridge Failure," Engineering News Record, May 18, 1972, p. 25.
- B16. "Bridge Collapse Report Faults Common Design Theory," Engineering News-Record, Nov. 23, 1972, p. 10.
- B17. Bisse, W.H., "Zur Ursache des Stahlbrücken-Absturzes Koblenz-Horchheim," Tiefbau-Ingenieurbaustrassenbau, No. 1, 1973, pp. 12-18. (In German).
- B18. District Attorney's Office Koblenz, (West Germany), "Final Press Release of the District Attorney's Office Koblenz Regarding Collapse of the Rhine Bridge Koblenz on Nov. 10, 1971," dated Nov. 15, 1972.
- B19. "Steel Box-Girders Need Design Care," Engineering News-Record, March 22, 1973.
- B20. Smith, D.W., "Why do Bridges Fail," Civil Engineering - ASCE Vol. 47, No. 11, November 1977, pp. 58-62.

APPENDIX B- REVIEW OF DESIGN CODES

CONTENTS

| | Page |
|--|------|
| B.1. INTRODUCTION | B-3 |
| B.2. APPLICATION OF CLASSICAL ELASTIC THEORY OF BUCKLING IN THE DESIGN OF STEEL BOX GIRDERS | B-5 |
| B.3. AMERICAN BRIDGE DESIGN SPECIFICATIONS | B-12 |
| B.3.1. General Design Philosophy | B-12 |
| B.3.2. Design of Webs | B-14 |
| a) Provisions Based on Classical Theory | |
| b) Provisions Based on Ultimate Load Principle | |
| B.3.3. Flanges | B-17 |
| a) Bottom Flanges | |
| b) Top Flanges | |
| B.3.4. Design Details, Fabrication, Erection | B-19 |
| B.3.5. Conclusions | B-20 |
| B.4. BRITISH SPECIFICATIONS | B-22 |
| B.4.1. Historical Background | B-22 |
| B.4.2. Interim Design and Workmanship Rules (Merrison Rules) | B-24 |
| a) General, Design Philosophy | |
| b) Design of Flanges | |
| c) Design of Webs | |
| d) Design of Diaphragms | |
| e) Residual Stresses | |
| f) Fabrication Tolerances | |
| g) General Evaluation and Conclusions | |
| B.4.3. B/116/3 Specification, 1975 Draft | B-32 |
| a) General | |
| b) Design Philosophy, General Provisions | |
| c) Effective Sections | |
| d) Compression Flanges | |
| e) Tension Flanges | |
| f) Orthotropic Decks | |
| g) Webs | |
| h) Specific Provisions for Box Girders | |
| B.4.4. B/116/3 Specification, Final Version (1978) | B-42 |

CONTENTS (Cont'd)

| | Page |
|---|------|
| B.5. GERMAN SPECIFICATIONS | B-44 |
| B.5.1. General Steel Highway Bridge | B-44 |
| Specification DIN 1073 | |
| a) General | |
| b) Provisions Applicable to Box Girders | |
| B.5.2. Design of Plating in Compression | B-46 |
| According to DIN 4114 Specifications | |
| a) DIN 4114, 1952-53 Edition | |
| b) Interim DIN 4114 Provisions of 1973 | |
| B.5.3. Proposed New Provisions for Plate Buckling Calculations (DASt Richtlinie 12) | B-48 |
| a) General | |
| b) Specific Provisions | |
| B.5.4. Summary and Conclusions | B-51 |
| B.6. ECCS DESIGN RULES | B-53 |
| B.7. SUMMARY AND CONCLUSIONS | B-56 |
| FIGURES B-1 THROUGH B-6 | B-58 |

B.1. INTRODUCTION

Steel box girder bridges are an excellent solution for moderate to long spans because of their structural efficiency and aesthetic advantages. Recent research has supplied much information on structural behavior and on new design methods of box girders; however, this information is not generally available to bridge engineers. Current American design specifications do not adequately reflect the new developments in the field of design of box girder bridges and do not offer sufficient guidance to the designers of such structures.

This project was initiated with the purpose of alleviating this deficiency. The project is subdivided into four major tasks:

- Task A - Compiling a bibliography of the subject;
- Task B - Review of current specifications on steel box girder bridges;
- Task C - Discussion of problems requiring clarification;
- Task D - Recommendations for the AASHTO specification provisions for steel box girder bridges, based on conclusions reached.

This report covers the objectives of Task B. It gives a review and comparison of the provisions applicable to steel box girder bridges as contained in the existing and proposed American, British, German and ECCS (European Convention for Constructional Steelwork) design specifications. A brief review of the classical theory of buckling of plates is also given since the design provisions of most of the existing design codes are based on this theory.

The design problems characteristic of box girders are discussed in conjunction with their treatment by the specific provisions of these specifications. Some of these problems will be further discussed in the subsequent report on Task C.

References to literature given in parentheses, e.g. (G1), refer to bibliography in the report on Task A of this project.

This report was prepared by Roman Wolchuk, assisted by H.Y. Wang. The writers wish to thank Prof. A. Ostapenko of Lehigh University for his review of the report and helpful suggestions.

B.2. APPLICATION OF CLASSICAL ELASTIC THEORY OF BUCKLING IN THE DESIGN OF STEEL BOX GIRDERS

In the design of steel box girders the investigation of structural stability is required, mainly, for the following structural elements:

- a) webs (subject to shear stress, flexural stress, or combination of both);
- b) compression flanges (subject primarily to axial stresses).

The traditional tool for investigation of these components of box girders has been the classical linear elastic theory of buckling of plates (subsequently referred to as "classical theory"). This theory is based on the concept of instantaneous "bifurcation", or branching, of the load--lateral deflection diagram at the point of reaching the "critical buckling load" at which more than one equilibrium position of the compressed element is possible. The value of the theoretical critical stress, or "Euler" buckling stress, is given by the familiar Euler hyperbola which is a function of the slenderness of the compressed element. The mathematical theory of buckling of plates and its application to the various specific problems have been developed by Timoshenko (G32), Bleich (G33) and many others. A thorough discussion of these developments is given in the "Guide to Stability Design Criteria for Metal Structures" by the Structural Stability Research Council (G30) and other sources (G35).

The engineering design application of the classical theory of plate buckling is based on the assumption that

critical buckling stress = ultimate collapse stress

The classical theory rests on two basic assumptions:

- 1) unlimited validity of Hooke's law (i.e. material with no plastic yield under high stress);
- 2) perfect flatness and purely axial loading of the member.

The last condition requires that the plate elements have no local dishing or other imperfections that would cause secondary flexural stresses; stiffeners, if used, must be placed symmetrically on both sides of the plate, and must be perfectly straight. The member must also be free from any non-uniformly distributed residual stresses.

The boundary conditions for plate elements are usually given as "simply supported edges," or "edges restrained against rotation." These boundary conditions require that the edges of the plate remain straight, and are restrained against movement perpendicular to the direction of the applied axial load; however, there should be no restraint of the plate edges against longitudinal movement in the direction of the load. This condition is important and must be kept in mind in the design of the individual plate panels between longitudinal stiffeners.

The results obtained by the classical theory are valid only if all above conditions are satisfied.

The design in accordance with the classical theory, which assumes that all stresses and deformations in the structure are linearly proportional to the applied loading, up to the critical value of the loading, is usually based on the "allowable stress" approach. Critical buckling stress of the element under consideration is computed from theoretical formulas, and the allowable stress is obtained by dividing the critical value by the prescribed factor of safety.

In the design of webs under predominant shear, optimum design requires transverse (vertical) stiffeners to be placed at appropriate intervals. In the web zones near midspan of the girder axial flexural stress predominates, and the stability of the web panels between transverse stiffeners has to be checked by formulas given in various references (G33, G16). For compressive zones of the webs the value of critical buckling stress may be substantially enhanced by longitudinal web stiffeners. If only one longitudinal stiffener is used in the web portion under pure flexural stress, its optimum location for a symmetrical girder has been determined to be at a distance of $1/5$ of the web depth from the compression flange. Deep girder webs may require the use of several longitudinal stiffeners.

For combined bending and shear stresses in the webs, in the vicinity of the supports of continuous girders, elastic stability of the web is checked by interaction formulas based on the "equivalent stress" concept (G33, G16). Interaction formulas are also available for the condition of biaxial compression without or with shear (G12, G99, G111).

Formulas for the required rigidity of the transverse and the longitudinal stiffeners are given in several sources (G32, G33, G107, G108), and have been incorporated in the design codes (G1, G16, G17). The stiffeners may be of two general types: a) "rigid" stiffeners, having sufficient rigidity to remain straight under a load causing buckling of the plate enclosed between the stiffeners. Such stiffeners have a "minimum rigidity," characterized by the relative stiffener/plate rigidity coefficient, designated γ^* , and, according to elastic theory, are sufficiently rigid to enforce a nodal line in the plate. The second type b), "flexible stiffeners," have a rigidity, γ , smaller than γ^* of type "a", and bend together with the plate at buckling, but enforce a higher critical buckling stress of the entire stiffened plate panel than that of the unstiffened panel. Diagrams giving the buckling coefficient, k , of the stiffened panel as a function of the panel aspect ratio and the various values of the stiffener rigidity coefficient, γ , have been presented by Kloeppe, Scheer and Moeller for various load cases and stiffener arrangements (G107, G108).

These methods have been developed primarily for the design of plate girder webs. It is interesting to note that all provisions for plate stability of the German buckling specifications DIN 4114 (G16, G17) are given under the heading "Web Buckling of Plate Girders"; flanges are not mentioned at all, since a wide box girder is a relatively recent type of construction.

For flanges of box girders subjected to predominant compression combined with shear the same formulas and design procedures developed for webs can be used.

However, in the design of the web panels subject to predominant compression, the aspect ratio a/b ("a" and "b" being the length of the unloaded and the loaded edge, respectively) is usually much greater than unity. For wide flanges, the aspect ratio, a/b , of the flange panels between the transverse

cross frames and the webs may be small (here "a" is the transverse cross frame spacing and "b" is the width between the webs). In such cases the "column behavior" rather than the "plate behavior" may predominate as the value of a/b decreases.

For an unstiffened flange with $a/b = 1$ the theoretical "plate buckling load" is still 4.4 times greater than that of a column of length a and width b. However, this ratio decreases drastically when the panel is stiffened longitudinally, as is usually the case in practical design, and the elastic buckling stress of the whole panel treated as a plate will be only slightly greater than the critical stress of the panel treated as a stiffened plate, since the significance of support along the longitudinal edges "a" becomes very small under such conditions. Thus, for a stiffened flange, the "column behavior" is generally predominant, even for panel aspect ratio greater than unity.

Therefore, such panels may be treated as a series of columns, each consisting of a stiffener with an appropriate effective width of the flange plate. Such method of design of wide flanges, within the classical elastic approach, has been introduced in the supplementary provisions of November 1973 to the DIN 4114 buckling specifications (G101, G102).

In application of the mathematical elastic theory to the investigation of stability of steel structures the first adjustment necessary is due to the fact that the elastic behavior of steel is limited by its characteristic yield stress, σ_y . If a structural element of steel were geometrically perfect and free from residual stresses, as discussed above, its critical buckling stress would be given by the Euler curve, up to the point where $\sigma_{cr} = \sigma_y$ (Point B, Fig. B-1), and would be constant and equal to the yield stress for all values of the slenderness coefficient, λ , smaller than that corresponding to point B. However, in actual structural elements, instead of such ideal elastic--ideal plastic behavior, buckling at lower critical stresses is observed for λ values between 0.6 and 1.2, because of the effects of geometric imperfections and residual stresses.

For steel columns various "transition curves" between the Euler curve and the yield stress plateau have been established for design purposes, based on theoretical consider-

ations of the effects of the residual stresses, initial crookedness, loading eccentricity, etc. (G30, G35). Similar transition curves for plates have also been given in current codes (G1, G16); however these are based on assumed similarity of plate buckling and column buckling, and not on rigorous attempts to evaluate actual plate behavior. More recent work on axially loaded plates (F5, F22) has shown that the correlation between these curves in the transition zone, actual tests, and computer simulated results on welded plates is not very good, with transition curves giving generally too optimistic results. However for plates of high slenderness ratio, with λ greater than about 1.3 (corresponding to b/t ratio of 70 for mild steel) the actual strength of plate elements has been known to be greater than that indicated by the elastic Euler curve.

The reason for these discrepancies is in the fact that the behavior of actual plate elements under load is essentially non-linear, that is: the stresses, strains, and deformations of the plate panels generally do not increase at the same rate as the applied load. The non-linearity is due to the changes of geometry under increasing loading (caused by initial deformations), and the changes of material properties (partial yielding, affected by residual stresses (G28)).

Unlike a column, which loses its compressive rigidity and strength very rapidly and completely when the critical load is reached, the plate loses its rigidity gradually as it squashes or bows out, and it still retains considerable strength after reaching the maximum value. Very slender plate panels may exhibit no characteristic strength peak at all, and may reach a load many times greater than the theoretical elastic Euler critical load ("post-buckling strength"), as is shown schematically by the heavy line in Fig. B-1. One factor in such behavior is transverse membrane action mobilized in the buckled plate due to the rigid supports at its unloaded edges. Typical stress-strain curves of a plate panel, based on computer generated results with consideration of initial out-of-flatness and local yielding, are given in Fig. B-2. Some plate strength curves, obtained similarly, are shown in Fig. B-3.

Because, as discussed above, the plate generally does not exhibit the "snappy" behavior at failure, the term

"buckling", usually associated with sudden loss of strength, is not quite appropriate in describing structural failure of actual plate elements. For the same reason such occasionally used terms as "non-linear buckling theory" or "second order buckling theory" applied to stability investigations with consideration of geometric and material imperfections should be considered misnomers, since buckling by bifurcation can occur only in perfect plates. Thus, in treatment of actual plates used in construction it is more appropriate to speak of "plate strength" rather than "plate buckling".

Behavior of plate elements under pure shear, such as in the webs of the plate and box girders, is also non-linear, and shows even greater discrepancies between the strength predicted by the classical buckling theory and actual test results. This is due to the well known "tension field action", which has been first treated by Wagner (W16), then by Basler (W1) and further refined by several other researchers (W5, W21, W27, W28, W29, W30, W31). A web plate collapse model in shear according to Rockey (W5) is shown in Fig. B-4.

The recognition that webs in shear are much stronger than predicted by the elastic theory and that web "buckling" entails no catastrophic consequences in properly designed plate girders has been reflected in lower factors of safety against theoretical elastic buckling for girder webs than for other parts of structures in all design codes.

Provisions based upon tension field approach have been incorporated into the AISC (G24), AASHTO (G1), and permitted by several European specifications.

As is seen from the above discussion, the classical buckling theory is a poor guide to strength prediction of strength of steel plate members in compression. To quote from the conclusions of the 8th Congress of IABSE in 1968: "The linear theory of plate stability is not an adequate basis for the design of struts and girders consisting of thin-walled sections" (G31).

Yet, the classical theory still remains a handy reference tool in engineering calculations because of its relatively simple design formulas which are well familiar to engineers. This is especially true in some European countries, like Germany, where much painstaking work has been accomp-

lished in the past on developing elastic plate buckling formulas for various cases (G107, G108), and where such formulas have been incorporated for several decades in the design specifications.

Therefore, in view of the fact that comprehensive ultimate strength models are not yet fully developed, and the proposed new design methods are still far from perfect (G31, G67, G104), the reluctance in such countries to make a radical departure from the customary methods is understandable. Instead, as a temporary expedient, provisions have been proposed to correct the shortcomings of the design methods based on elastic theory by means of correction coefficients, or by empirical adjustment of the safety factors for the various cases (G31, G99, G67, G111).

These methods are further discussed in Sections B.5 and B.6 of this report.

In this country plate design by ultimate methods has been already introduced for webs of plate girders (G1, G24). Therefore it would be in the interest of consistency to attempt to formulate the design methods based on ultimate load considerations also for other plate elements of the box girders.

B.3. AMERICAN BRIDGE DESIGN SPECIFICATIONS

The AASHTO Standard Specifications for Highway Bridges (G1) contain specific provisions for steel box girders only for steel-concrete composite multi-box girder bridges of "moderate length", subject to certain geometric limitations. In practice the spans of such bridges range from 60 up to about 200 feet. No specific design rules are given for box girder bridges of other types and longer spans, but the general design approach stipulated in the AASHTO code, and some design provisions pertaining to plate girder bridges can be applied to the design of steel box girders, with appropriate modifications as judged necessary by the bridge designers. These provisions are briefly discussed in this section.

B.3.1. General Design Philosophy

Section 7 on "Structural Steel Design" of Division I of the present AASHTO Code is, essentially, based on the design in accordance with the classical theory, with the "allowable stresses" based on a "factor of safety" against reaching certain limiting stress values. These are: yield stress, F_y , for axial or flexural tension; yield stress in shear, equal to $0.58 F_y$, for members in shear; buckling stress, computed in accordance with classical theory and using the AASHTO column and plate buckling curves, for members in compression. The values of the factors of safety, F.S., vary, and are as follows:

| <u>Stress Condition</u> | <u>F.S.</u> |
|--|--------------------------|
| tension | $F_y/0.55F_y = 1.82$ |
| compression in columns (Interim 7, 1974, Table 1.7.1) | 2.12 |
| compression, flg. of box girders (Art. 1.7.105) | 1.82 |
| shear, girder webs, gross sect. | $0.58F_y/0.35F_y = 1.76$ |
| web buckling, shear (minimum value) | 1.48 |
| web buckling, bending (minimum value) | 1.18 |

To account for certain less frequent load combinations of dead load, live load, wind earth pressure, longitudinal forces, and other effects, increased allowable stresses, ranging from 125% to 150% of the basic allowable stress values, are permitted as stipulated in Table 1.2.22 (Interim 3, 1975).

Alternatively, for simple and continuous beam and girder structures of "moderate" length (Art. 1.7.117) the "load factor design" is permitted. Under this method, the members are proportioned for prescribed multiples of the design loads. The strength of each member must be at least equal to the sum of individual load effects times their respective multipliers. Thus, according to Art. 1.2.22 (Interim 3, 1975),

$$\text{Strength} = \gamma (\beta_D D + \beta_L (L + I) + \beta_C CF \dots)$$

where γ is called the "load factor", equal to 1.3 for the most important load cases; D, L, I, CF, etc. are the effects of dead load, live load, impact, centrifugal force, and other load cases, and β_i are the "load coefficients" to be used with the individual load cases.

This method results in a more logical design and a more consistent margin of safety of the structure since it permits better evaluation of the relative uncertainty of the individual loads. Thus, a lower load coefficient is assigned to the dead load than to the live load.

However, actual safety of the structure depends, in an equal degree, on the correct evaluation of the left side of the equation, the "strength", which is the maximum value of the axial load, the moment, the shear, or the combination of these effects which the member is capable of carrying. If, for example, the strength of a plate element is defined as reaching a "critical buckling stress" computed by the classical buckling theory (as is done in Art. 1.7.129 of the AASHTO specifications), the true safety of the member may be under- or overestimated, as discussed in Section B.2 of this report.

The "load factor design" becomes the "ultimate strength design" only if the strength of the member is estimated correctly, with consideration of actual ultimate behavior, af-

ected by such factors as geometric imperfections, residual stresses, post-buckling strength, etc.

Generally, the design theory and assumptions stipulated for the "load factor design" in Art. 1.7.120 and 1.7.121 (elastic behavior of the structure, strain in flexural members directly proportional to the distance from the neutral axis) are not consistent with the ultimate behavior of the elements of steel box girders (carrying capacity of steel orthotropic decks, ultimate strength of webs, stresses and ultimate strength of bottom flanges of the boxes, and other cases of non-linear behavior).

A detailed discussion of the problems of ultimate design, as applied to box girders, will be given in Part C of this report.

B.3.2. Design of Webs

a) Provisions Based on Classical Theory

These provisions are contained in Section on "Plate Girders" and are given in Art. 1.7.70 through 1.7.73.

Provisions for maximum web slenderness for the various grades of steel (depth/thickness ratio, D/t) are based on formulas for plate buckling under pure bending stress. Spacing of transverse stiffeners is governed by the consideration of web buckling under pure shear.

The web slenderness may be increased if a longitudinal stiffener is used, placed at a distance of $D/5$ from the compression flange. This corresponds to the optimum location for the case of pure flexure in the web. There is no provision for more than one longitudinal stiffener.

The required rigidities of the transverse and the longitudinal stiffeners are given by formulas derived from the classical theory of plate buckling.

In practical design based on these provisions the factors of safety against reaching the theoretical plate buckling stress depend on the actual stresses in the web and the spacing of the stiffeners, and may be as small as 1.18 for pure bending and 1.48 for pure shear. Such relatively low

values are justified by the inherent postbuckling strength of the web.

A thorough discussion of the origin of these provisions is given in (G35), Chapter 8.

The web design specifications in this section of the AASHTO code, obviously intended for simple span girders, do not contain any provisions for the interaction of the shear and the longitudinal stresses. Thus, if these rules were applied to continuous girders, the combination of flexural compression and shear over supports, with the factor of safety against flexural buckling alone already being low, may cause a stress condition exceeding the theoretical buckling value.

It should also be noted that these web design provisions, particularly regarding longitudinal stiffeners, would not be applicable to girders with strongly unsymmetrical sections, such as composite girders, or girders with orthotropic steel decks, where a large portion of the web depth may be in tension (or in compression).

b) Provisions Based on Ultimate Load Principle

Rules for the design of webs by a "tension field" method are given in Section on "Load Factor Design", Art. 1.7.124 through 1.7.128. The method used is based on the theory developed by Basler (W1, W2, W26).

The web capacity for shear is made up of two parts: the beam action strength, given by the web carrying capacity prior to buckling, and the postbuckling strength, developed by the action of a diagonal tension field. The equations for the ultimate strength of the web in shear given in Art. 1.7.124 (E) are based on somewhat simplified expressions of the original formulas by Basler (G105).

For the simultaneous action of shear and bending an interaction formula is given which calls for appropriate reduction of the shear capacity if certain proportion of the ultimate moment is reached.

In its post-buckled, bent-out condition the portion of the web in axial compression will lose some of its capacity

to carry longitudinal flexural stress. The resultant shift of the neutral axis toward the tension flange results in an increase of the stress in the compression flange. The extent of this loss of capacity depends primarily on the lateral deflection of the web, which ordinarily is a function of the web slenderness ratio.

The slenderness ratio for webs stiffened with transverse stiffeners only has been limited in the specification by the criterion of fatigue of the web subject to fluctuating "flapping" (out-of-plane deflection) under repeated loading. It has been found that for web slenderness values governed by this criterion the loss of longitudinal stress carrying capacity is very small and may be neglected (G105).

If a longitudinal stiffener is used, placed at a distance of $D/5$ from the compression flange, the allowable web slenderness is twice that for the webs without longitudinal stiffeners, since it has been found that an appropriately strong stiffener sufficiently controls the lateral deflection of the web to assure acceptably linear stress distribution in the post-buckling range. Formulas for the strength of the longitudinal stiffener are based on the requirement that it should act as a column to carry its share of the longitudinal compressive stress in the web.

Minor modifications of these rules are given for the webs of unsymmetrical and composite girders, and short span composite box girders.

These provisions were intended for plate girders and composite box girders of moderate spans, and are not adequate for long span plate girders requiring very deep webs, and for longer span box girders.

Among the problems requiring consideration for such cases are: the question of axial load shedding from the web to compression flange in cases of deep and slender webs, the design of deep webs with multiple longitudinal stiffeners, the effect of direct loads on the webs from the wheels of the vehicles over the webs in orthotropic steel plate deck bridges.

B.3.3 Flanges

a) Bottom Flanges

The AASHTO specifications did not contain any provisions for bottom flanges of steel box girders until 1967 when provisions for composite box girder bridges were introduced in the Interim Specifications. These were based on the recommendations of the ad hoc committee chaired by A.H. Mattock (G37, G38).

These provisions apply only to multi box composite box girders subject to the following limitations: the boxes must be straight, the skew, if any, should be small, the top width of the box should be approximately equal to the distance at the top between two adjacent boxes, the inclination of the webs to the vertical shall not exceed 1 to 4. The box span should be "moderate", which is generally interpreted as not exceeding 150 to 200 ft.

The design of flanges is based on elastic theory of plate buckling discussed in Section B.2. Unstiffened flanges are designed as plates simply supported by the webs and subjected to axial stress only. The "critical buckling stress" is determined by the plate buckling curve defined in Art. 1.7.129 (E). The curve has been based upon the assumed behavior of plates in compression; however, as is seen from Fig. B-3, it does not adequately reflect the actual behavior of welded plates as established by subsequent research.

The specification recommends consideration of longitudinal stiffeners when the b/t ratio of the panels exceeds 45. The design formulas for longitudinally stiffened panels are based upon the treatment of ribbed plates by Timoshenko (G32). Derivation of the design formulas is given in (G37). Expressions for the buckling of the deck plate are given in terms of the stiffener spacing, w . The rigidity of the longitudinal stiffeners is determined by the chosen buckling coefficient for the plate k . If $k = 4$, the stiffener rigidity is obtained such that the plate buckles between the stiffeners, which remain straight. For smaller values of k lighter longitudinal stiffeners are obtained, and the stiffeners bend with the plate at buckling. The required rigidity of the longitudinal stiffeners is considerably smaller if they are used in conjunction with transverse stiffeners (G64).

Aside from the basic shortcomings of the classical design approach, discussed under B.2., the design formulas do not take into account the effects of the flexural and torsional shear in the bottom flanges coincident with the axial flexural stress over the supports of continuous box girders, possibly combined with the effects of compression in the transverse direction of the flange due to the reactions of the sloping webs at girder supports. However, in practical cases, such effects of combined stresses may not be very important in short span structures of this type.

Secondary flexural stresses in the webs and in the bottom flanges will occur due to the local transverse bending of the deck, the torsional distortion of the boxes, and also due to the vibrations that may be induced in the bottom flanges by passing loads. Such stresses were investigated by the committee, and the conclusion was reached that, for the boxes with geometric limitations described above, and with bottom flanges not wider than 20% of the span, such additional stresses may be disregarded (G37, G38, G105).

The effective width of flange, according to AASHTO, is taken as the full flange width if the ratio of girder span (or the equivalent simple span) to the width between the webs exceeds five and shall be limited to one fifth of the span if this ratio is smaller than five. This provision may be unconservative, especially over the supports of continuous girders (F13, F16, G28).

The AASHTO provisions for short span multicell box girders should not be applied to large steel box girder structures for which they were not intended. However, it should be noted that in the section on "Orthotropic Deck Bridges". Art. 1.7.143 ("Thickness of Plate Elements"), Paragraph (B) on "plate elements of box girders, plate girders and transverse beams" contains a reference to Art. 1.7.105, which specifies the design of bottom flanges for short span boxes, as described above. This could possibly imply that the above method could be applicable to bottom flanges of box girders in general. Such erroneous misinterpretation should be prevented by proper clarification in the specification.

b) Top Flanges

Top flanges of steel box girders may be either concrete

or orthotropic steel decks. The discussion of the former is outside the scope of this report; however, the design of the steel deck is more directly connected with the design problems of other elements of steel box girders, and will be discussed here briefly.

Provisions for orthotropic decks are given in Section "Orthotropic-Deck Bridges", Art. 1.7.139 through 1.7.148.

The design provisions for the deck design, based on the Pelikan-Esslinger method (G106), follow essentially the recommendations of the AISC "Design Manual for Orthotropic Steel Plate Deck Bridges" (G27). Commentary on these provisions is given in (G45).

The AASHTO provisions are based on the "allowable stress" approach, with a 25% stress increase permitted for superposition of the local and the overall longitudinal stress in the deck. Since future provisions for steel box girders will be based on "load factor design", the steel deck provisions should be also appropriately revised, for consistency.

The heavily stiffened decks generally do not present stability problems when subjected to longitudinal stresses. However the characteristic feature of the deck design is the combined action of the stresses in the plane of the deck acting as the box girder flange, and the flexural stresses in the deck plate and the ribs due to the wheel loads acting perpendicularly to the deck surface. Since the deck under local loads behaves non-linearly and possesses a large overload capacity (G27), the definition of the "design strength" and the formulation of the load factor design rules may present some problems.

B.3.4. Design Details, Fabrication, Erection

Provisions pertaining to the minimum thickness of plate material, the maximum permissible slenderness of outstanding ribs, and other detail specifications that may be applicable to the design of steel box girders and their elements are contained in many articles of the AASHTO specifications, under various sections of the code. It would be advisable to select and summarize such provisions applicable to box girders in a new section on "Box Girders".

General fabrication tolerances for welded structures (flatness of plate panels, straightness of compression members) are given in the AASHTO Specifications, Art. 2.10.23 (A), by reference to the current AWS provisions for bridges (G103). The AWS provisions give only the flatness requirements for girder webs. However, in AASHTO Art. 2.10.48 (B) special tolerances are stipulated for flatness of plate members of orthotropic plate bridges, and also for straightness of stiffeners of such structures. Since large orthotropic deck bridges are, in most cases, box girders, the tolerances of Art. 2.10.48 (B) would apply to such structures, including the decks, the webs and the bottom flanges. These tolerances are regarded to be consistent with "normal bridge fabricating methods" (G45). They are considerably more liberal than those specified in Britain under the "Merrison Rules", yet are generally more restrictive than the AWS specifications for bridge work. Since it is considered impractical and undesirable to relate the specified tolerances to the design provisions of box girders (G45, G64), the question arises whether it is necessary and justified to have smaller tolerances for box girders than for plate girder bridges.

The provisions for erection given in Art. 2.10.55 are generally adequate; however, in view of special problems and past mishaps during erection of box girders, additional provisions delineating more clearly the engineer's and the contractor's responsibilities might be considered.

B.3.5. Conclusions

The present American specifications are not adequate for the design of large steel box girder bridges. The provisions of the AASHTO specifications are limited to multi-box composite girders of moderate spans. The railroad bridge specifications of the AREA (G5) have no provisions for box girders.

The necessary additions and modifications of the AASHTO specifications for box girder bridges are:

- new provisions for design of wide flanges subjected to compression (with consideration of the effect of the flexural and torsional shear);

--adaptation of the web design specifications based on ultimate design approach to suit the particular requirements of large box girders.

Further, provisions may be needed for the design of the intermediate and bearing diaphragms and their interaction with the webs and the flanges.

The design rules for orthotropic steel decks as parts of box girder bridges should be made consistent with other provisions for box girders.

Present AASHTO specifications contain general instructions regarding design analysis of box girders (Art. 1.7.139). Whether and to what degree these instructions should be expanded remains to be decided.

Fabrication tolerances for box girders should be reviewed with the objective of making them similar to those for plate girders.

All provisions pertaining to steel box girders (both composite and steel deck) should preferably be grouped in one new section of the code on "Box Girders". This may require major editorial revisions of the entire AASHTO specification for steel bridges. Suggestions regarding this will be presented in Part D of this report.

B.4. BRITISH SPECIFICATIONS

B.4.1. Historical Background

The current British design specification for bridges BS 153 (G6, G7) has provisions for solid web girders and for plates in compression, but contains no specific design rules for steel box girders.

Attention was focused on box girder bridges following tragic collapses during construction of the Milford Haven bridge in Wales (June 1970, 4 dead, 6 injured) and the West Gate bridge in Australia (October 1970, 35 dead, 16 injured), preceded by a non-fatal erection failure of the bridge over the Danube in Vienna (November 1969), and followed by the erection collapse of the Koblenz bridge in Germany (November 1971, 13 dead). These collapses will be discussed in more detail in Part C of this report.

An investigative committee was appointed by the British government in December 1970 with the purpose of examining the circumstances leading to the collapse of the two British designed structures, and the need for specific design and erection rules to prevent such catastrophes in the future. The committee was chaired by A.W. Merrison, Vice Chancellor of the University of Bristol, and hence the guidelines for the design and construction of box girder bridges resulting from the work of this committee became known as the "Merrison Rules".

Under the general guidance of the committee, a very intense research effort was conducted with the participation of several universities and consulting firms. The first "Interim Report" of the committee (G8) was issued in 1971. The report included, as its "Appendix A", the "Interim Design Appraisal Rules" (G9) which were to be used for the evaluation of the safety of British bridges of this type, already in service or under construction. This is a very voluminous document, to which numerous "addenda" and "corrigenda" were being continuously added, due to the rush nature of the committee's work and the desire to make the results of new research immediately available. The "Appraisal Rules" were meant to serve primarily for checking existing designs and not as a guide to new designs. Because of the unfortunate circumstances that prompted their formulation, the rules

were quite conservative, and much additional stiffening work on existing structures had to be done as a result of their application.

The final report of the committee was issued in 1973 (G10). The report emphasizes the need to make the knowledge of structural behavior of box girder structures and its components more readily accessible to the engineers designing them through appropriate guidelines. Several procedural and contractual recommendations are included in the report, such as an independent check of the engineer's design by another engineering organization, and an increased participation and responsibility of the design engineer for the erection of the box girder structures (G41).

The "Interim Design and Workmanship Rules" presented by the Merrison Committee are given in Appendix 1 to the report (G11, G12, G13). The report recommendations and the "Interim Rules" have been made mandatory in Britain, until a new British Standard for bridges is issued.

The general outlines of these rules, which resulted from two years of very intense theoretical and experimental research work in Britain, were first presented and publicly discussed at the international Conference on Steel Box Girder Bridges in London, 1973 (B19). It was recognized that the rules cover all important aspects of steel box girder design and fill a vital need. However, the suitability of the rules for practical design needs was questioned, because of their large bulk (a total of 377 large size pages of text, formulas and graphs) and mathematical complexity. Also, several provisions were judged to be difficult to comprehend, or impractical.

Therefore, the Merrison Rules were not incorporated in the interim draft of the new British bridge specification B/116 which will supersede the old BS 153 specification and will govern bridges of all types, including box girders; however much of the Merrison material was utilized.

The first draft of the new section on steel bridges, B/116/3, was completed in 1975 (G15). In this draft the treatment of box girder structures has been considerably simplified, compared with the Merrison Rules, by using a different basis for the design of compression flanges, and by

omitting or modifying several controversial provisions. However, this draft has not been found completely satisfactory to the code committee, which has been since reorganized.

Work on the final draft of the British B/116 specification is now underway and is scheduled to be completed in 1978.

B.4.2. Interim Design and Workmanship Rules (Merrison Rules)

a) General, Design Philosophy

The Interim Design and Workmanship Rules (IDWR) (G11, G12, G13) consist of four parts:

Part I - Loading and General Design Requirements

Part II - Design Rules

Part III - Basis for the Design Rules and for the Design of Special Structures not within the scope of Part II

Part IV - Materials and Workmanship

Part II presents "simplified rules" which may be used, provided that tolerances specified in Part IV are maintained. Part III contains the more complex formulas on which the rules of Part II are based, and it may be used for more accurate analysis.

The design is based on the load factor method of limit state design. Two "limit states" are considered: collapse and unserviceability. The factors used in the calculations are:

γ_s = factors on load

γ_m = factors on strength

The design of the members in accordance with IDWR may be described by the general expression:

$$\frac{\text{strength}}{\gamma_m} \geq (\text{actions}) \times (\gamma_s)$$

where "strength" is the capacity of the member at its limit condition being used as a criterion, and "actions" are the forces, moments, shears or their combinations in the members caused by applied loads. Factors γ_m and γ_s vary, depending on loads and their combinations. Different values of γ coefficients are given for the "collapse" and for the "unserviceability" conditions.

Evaluation of "collapse strength" requires determination of the ultimate load capacity of the member, while serviceability investigation must be based on stresses determined by the elastic theory. Fatigue, which is considered a "serviceability" condition, also requires the knowledge of the stresses under working loads. Thus, both "ultimate design" and "working stress design" are necessary.

It should be noted that under the IDWR rules fatigue considerations are not limited to fluctuating tensile stresses or alternating tension and compression, but include fluctuating compression as well, which is treated with equal severity. This, in practice, may lead to situations where the design of the compression elements of box girders may be governed by fatigue considerations, especially if severe stress range restrictions on common welded details are imposed. This may result in a design for generally low stress levels. In such cases, considering the usual requirements for minimum practical plate thicknesses and slenderness ratios, the ultimate strength of the panels in compression, calculated by the very elaborate methods presented, could be hardly utilized economically.

In Section 6 on "Analysis" the special stress conditions are listed which are to be considered in the design of box girders (such as the effects of the torsional and distortional warping stresses, torsional shear stresses, etc.) and some formulas are given for such calculations.

This section also contains provisions for the "effective width" of box girder flanges, based on the paper by Moffatt and Dowling (F7, F16). However, the tabular values given are applicable only to simple span girders. In order to obtain the important values of effective widths over supports of continuous girders fairly elaborate calculations are necessary.

b) Design of Flanges

The design of unstiffened flange plates in compression is based on an elastic large-deflection analysis of initially imperfect plates presented by Falconer and Chapman (F1). The most unfavorable condition for out-of-plane deformation of such a plate occurs when the initial imperfections have a sinusoidal shape with a half-wave length equal to the theoretical length of the buckling mode, b (Fig. B-5). For plates with a random dishing only the local "ripple component" of the out-of-flatness within the length " b " matters in determining the elastic behavior of the plate. The effect of residual stresses is accounted for by assuming an equivalent additional geometric imperfection.

An axial load applied to such a plate caused not only axial but also local flexural stresses in the plate, due to its initial imperfections. According to the IDWR rules the limit of "serviceability" is reached when the combined axial and local flexural stresses reach yield stress in the surface of the plate.

Computation of "serviceability" is based on purely elastic considerations, not involving plasticity. For "strength" of a panel a semi-empirical formula is given, based on an ultimate behavior model of the plate, with consideration of combined action of axial stress and shear, if shear is also present.

Design calculations based on this method are very laborious, requiring the use of complex formulas, numerous graphs and iteration procedures.

The treatment of stiffened panels starts from determination of the panel properties as an orthotropic plate. The panel is then treated as a series of individual struts consisting of the stiffening ribs and an appropriate width of the deck plate. The participation of the deck plate is obtained using the concept of "tangent stiffness", K_T , of the plate, which changes with the level of the stress. The stresses in the individual struts are magnified by the effect of the assumed initial curvature of the strut and by the effect of residual stresses. The limiting condition is deemed to be reached when the maximum "boundary stress" in the plating reaches the yield stress, or the maximum stress at the

top of the stiffener reaches the torsional buckling stress of the stiffener. Again, all calculations are within the elastic theory only. Thus the plastic strength reserves are not utilized.

The design formulas and procedures for stiffened plate calculations are exceedingly complex, and certainly too cumbersome to be adopted for engineering office use. Numerical tables provided in Part II of IDWR, derived from these formulas, partly alleviate this situation.

It is interesting to note that the Merrison Rules, which are otherwise so comprehensive in treatment of the various components of box girders, do not contain any provisions for orthotropic steel plate decks acting as top flanges of box girder bridges.

c) Design of Webs

Webs may be designed for combined flexural and shear stresses, or, alternatively, for shear stresses alone, in which case the flexural stress from the web must be assumed to be shed to the flanges. The design for an arbitrary proportion of the longitudinal flexural stress in the web, from zero to full flexural capacity of the web, is also permitted.

Distinction is made between web panels unrestrained and restrained against in-plane deformation, depending on the panel location in the web and the relative rigidity of the flange.

The strength check of the individual web panels in Part II of the rules is based on parametric studies of plates under combined action of axial stress and shear prepared for the Merrison Committee by Richmond (W14, G53). Design charts based on these criteria for the determination of the web strength under various conditions of loading (combinations of axial stress with shear), edge restraint of the panels and stiffener arrangement are given in Part II, Section 9. Comparison with the theoretical strengths based on conventional elastic buckling design shows that the IDWR charts give somewhat lower values for low slenderness ratios and higher values for high slenderness ratios (b/t over about 70 for carbon steel), which indicates that post-buckling strength has been given consideration.

Web design in accordance with Part III is based on essentially the same criteria as presented for the design of the unstiffened flange panels.

The web panels are assumed to be incapable of carrying the wheel loads or other loads causing direct compressive stresses perpendicular to the longitudinal flexural stresses, and, at the same time to participate in the tension field action.

Therefore, the web sections at the web/flange junctions must be specially reinforced in order to act as beams between the nearest deck cross frames, or else additional longitudinal deck members must be placed parallel to the web.

Special attention is paid to the design of the webs at the web/diaphragm junctions at the supports of box girders. Theoretical studies conducted in connection with the Merrison research program (G53, W14) have shown that the shear distribution in the web at these locations is non-uniform, and that the bottom portion of the web is subject to high shear stress peaks. For this reason additional web stiffening over the supports is required by the specification.

The web design method used in the IDWR has been judged to be conservative, in comparison with the results obtained by the ultimate load methods (G53).

d) Design of Diaphragms

Because of the diaphragm failure which caused the collapse of the Milford-Haven bridge during erection (G8, G10), the design of diaphragms has received much attention in the research programs of the Merrison Committee. Many tests, two- and three-dimensional finite element stress analyses and parametric design studies have been conducted for the unstiffened and the stiffened diaphragms to determine the stress distribution and the interaction of the diaphragms with the webs and the flanges of the girders. The rules given in Part II and Part III of the IDWR are the result of this research.

The formulas and design graphs given in Part II pertain to rectangular or trapezoidal support diaphragms having edges inclined not more than 30° to the vertical. Formulas and

rules are given for the distribution of the vertical stresses due to the bearing reactions as a function of the height of the diaphragm, the horizontal stresses in the diaphragm acting as a deep beam, depending on the location of the bearings, the irregular shear flow distribution along the web/diaphragm intersection, the out-of-plane bending of the diaphragm due to bearing eccentricities, etc. The rules for the required minimum rigidities of the primary and secondary stiffeners are also given. The Part II rules result in a generally conservative design.

Diaphragms with the sides inclined more than 30° to the vertical (boxes of such shapes have been often used by British designers), and diaphragms of multi-cell boxes present special problems and must be designed in accordance with the general rules of Part III of the specifications. These rules allow for plastic redistribution of stresses and permit more economical design (D6).

As in most other parts of the Merrison Rules, the formulas and expressions derived both from theoretical considerations and empirical findings, are lengthy and involved, and the rules are far from simple in their application. Some clues to their interpretation are given in numerical examples that were given at the CONSTRADO seminars on Merrison Rules (D2, D3).

A more detailed discussion of the design problems of diaphragms will be given in Part C of this report.

e) Residual Stresses

Section 7 on "Residual Stresses due to Welding" gives formulas for the calculation of the expected magnitude of the residual stresses in compressive plate elements with welded stiffeners, as a function of the weld size, number of welding passes, the method of welding (continuous or intermittent, one or both sides of stiffeners simultaneously), etc. The designer should consider the effects of residual stresses on the strength of the compression members and shall fully specify on his drawings the weld dispositions, sizes and details of all welds, or "shall require the fabricator to demonstrate [in accordance with the provisions of Part IV] that the welding arrangements to be used will not produce calculated residual stresses in excess of those allowed for

in the design".

In the design of compression elements in accordance with Part II, the "characteristic strengths" of the panels may be obtained from graphs and tables in which an allowance for the residual stresses is already included, but corrections are required if residual stresses exceed the assumed values.

These provisions were strongly criticized at the 1973 steel box girder conference in London (G53, discussion). It has been pointed out that the welding residual stresses, depending on very many variables, cannot be reliably predicted by theoretical formulas, that the designer has no knowledge of the welding methods that may be employed by the fabricator, and that the effect of the welding residual stresses on the strength of the plating is altogether too little known and too uncertain to be individually calculated for each case.

f) Fabrication Tolerances

The tolerances for the flatness of plate panels and the straightness of stiffeners given in Part IV are very restrictive. For measuring plate flatness special scanning gages must be used with a gage length dependent on the spacing of the stiffeners, in order to assess the "ripple components" of the imperfections, discussed under B.4.2.b., above. The IDWR rules for tolerance implementation are quite elaborate. Therefore, a direct comparison between the IDWR and the AASHTO tolerances (as given in AASHTO Art. 2.10.48 B) is difficult to make because of different criteria used. However, generally the IDWR plate tolerances are from 1.5 to 4 times smaller than those of AASHTO.

For stiffener straightness the IDWR rules prescribe a maximum deviation of $L/900$ or $L/1200$, for direction towards the inside of the box, or away from it, respectively, as against $L/480$ of AASHTO.

The Merrison tolerance provisions have been criticized by fabricators as very costly and impractical. It should also be kept in mind that there is a trade-off between the geometric imperfections and the residual stresses, and that any attempts to flatten or straighten the fabricated elements

by spot heating or by mechanical bending will introduce additional residual stresses whose magnitude and effects are impossible to assess.

g) General Evaluation and Conclusions

No design specification, its intent and the meaning and origin of its formulas can be fully understood without a properly detailed commentary. Such commentary to the Merrison Rules was intended to be prepared, but, as it became clear that the rules, as given in the IDWR, could not become the final specification for steel box girder bridges, the project of writing the commentary was abandoned.

The closest clue to the design philosophy, the origin of the rules and the research directly supporting them is given in the basic paper by the two members of the Merrison Committee who were the actual authors of the Rules, Dr. A.R. Flint and Prof. M.R. Horne (G53). In this paper, which was certainly the highlight of the 1973 Conference on Box Girders in London, the authors summarize the astonishingly great amount of research done on the individual problems of box girder design and indicate in a general way its application in the IDWR to the design of the webs, flanges, diaphragms, etc.

Much explanatory information can also be found in the lectures of the 5-day seminars organized one year later by CONSTRADO to acquaint the engineers with the new and little understood rules (see bibliography entries referring to the Course on Merrison Rules, 1974); however, these lectures dealt more with design applications of the Rules rather than with explaining their background.

Thus, when the IDWR were first presented in 1973, they were received with a mixture of admiration for the immensity of the research work accomplished within a short period of time, and bafflement at the complexity and general incomprehensibility of the rules. This attitude is best expressed in the words of the official Reporter General (A.J. Harris) of the 1973 Conference Session at which the Flint-Horne paper was presented (G53, discussion, pg. 209-210), who summarized his impressions as follows:

"How can I summarize a summary? Let me therefore say,

not that I could not understand a word, which would be quite wrong, for the words are eminently comprehensible, but that these are a series of design rules, based on extensive research and its analytical investigations, which I find recondite, arcane, if not hermetic. . . . The draft design rules are first class. The tests have added immensely to the understanding of box girder bridges. My only reservation is that the deeper one gets into the document the more remote one seems to be from the realities; those expressions do perhaps conceal rather than reveal."

The general significance of the Merrison research and the Merrison Rules may be not as much in their practical use for the engineering design purposes, as in the fact that many characteristic features of the box girder structural behavior were first correctly identified, and an attempt has been made to present and to treat these features in a comprehensive manner, thus paving the way for further development of more practical design specifications.

B.4.3. B/116/3 Specification, 1975 Draft

a) General

This draft was completed on behalf of B/116 Specification Committee in July 1975 (G15), and was discussed at the committee meeting in December 1975. Because of the divergence of opinions among the committee members on several basic questions, the draft was not approved, and work on a new draft was started after the committee was reorganized. Nevertheless, this draft is discussed here because it gives an indication of the general design philosophy of the "post-Merrison" period and illustrates the treatment of the various specific problems.

Specification B/116/3 is for the "Design of Steel Bridges" and includes all types of steel structures, not only box girders. Some problems are treated in other Parts of the general B/116 bridge specification (Part 2 - Loading, Part 4 - Fatigue, Part 9 - Supplement to Part 3 for special cases of steel bridges), and references are made to these Parts in Part 3 which is discussed here.

Part 3 contains 15 sections, and only a brief Section 13 is devoted specifically to box girders. However, provisions

relevant to box girder design problems are contained in several other sections, and will be discussed briefly. The draft does not present the specification in its proposed final form; it is incomplete in several clauses, occasionally inconsistent or unclear in its provisions (for example in its treatment of tension field action in the design of the webs), and contains many editorial remarks suggesting future formulation or refinements to be added later.

The B/116/3 code is meant to cover "the bridges and bridge components in common use". Clauses related to "less common design problems" and alternative approaches to design are contained in Part 9 (Special Cases).

b) Design Philosophy, General Provisions

These subjects are treated in Section 1 (Scope, Definitions, and Limit State Philosophy) and 2 (Design, General).

The "limit state" design approach uses two basic "limit states": the "ultimate limit state" and the "unserviceability limit state". However, the "unserviceability" condition is downplayed in this draft; the proof of "serviceability" is required in only a few cases. Clause 1.6.2. states: "in most situations this {serviceability} limit state is automatically satisfied when the prior requirements of the ultimate limit state are met".

The basic design formula, which may be expressed as:

$$(\text{factored strength}) \geq (\text{factored actions of loads})$$

is the same as in the Merrison Rules (see Section B.4.2.a. of this report); however, the nomenclature and designations are considerably more complex.

On the left ("strength") side of the equation distinction is being made between the "characteristic strength" and the "design strength". Thus there is the "characteristic yield strength", σ_y , corresponding to F_y , or nominal yield stress, such as 36 ksi (250 N/mm²) for A36 steel, and σ_y , designated as "design yield strength", which is defined as σ_y/γ_{mc} , γ_{mc} being the "partial safety factor on steel strength". It is suggested that only the latter value be used in all calculations, and that, to avoid confusion,

only the term "design yield strength" be used throughout the code.

On the right hand side of the equation the contribution of each load has to be multiplied not by one (as in Merrison) but by two "partial safety factors on loads", namely γ_s which accounts for the variability of loading, and γ_f , to account for "variability in analyzing the effects of the loads" (2.7.1.2) (The numbers in brackets refer to clauses of B/116/3.) This "analysis uncertainty factor" is suggested to be not less than 1.1.

The factors γ_s and γ_m come in two varieties -- for "strength" and for "serviceability" computations.

The right hand side of the equation is generally called the "design stress" (1.4.10).

The semantics, although carefully explained, appears to be rather confusing to the engineer, and the piling up of the partial γ factors seems to be unwarranted and needlessly complicating the design calculations.

In an attempt at consistency, fatigue is also interpreted as a limit state concept (1.6.3), and both the "ultimate" and "serviceability" limits are expressed as percentages of probability of failure. How this concept should be translated in terms of acceptable stress ranges is not explained. In view of the generally vague and uncertain knowledge of fatigue phenomena and even more cloudy forecasting of loads likely to occur during the service life of a bridge, this refined two-stage approach to fatigue design must be termed academic.

"Global analysis" of the structure should be in accordance with "elastic analysis methods" (2.6.1.1). In calculation of moments, axial forces and shears, the effects of shear lag may be ignored (2.6.1.2).

In computing deflections the effective section with consideration of shear lag has to be considered. In addition, "a permanent set of up to 10% of the elastic deflection" should be assumed for welded structures to allow for the relaxation of welding residual stresses during first loading. This permanent set should also be allowed for in

erection calculations" (2.6.1.4).

Design formulas and detailed instructions on the application of specific methods of analysis are not given in this code. (2.1.1)

Residual stresses and imperfections are recognized only implicitly, through the appropriate values of the γ -factors. Thus, unlike under Merrison Rules, no quantitative computations of these effects by the designer are required (2.4.5).

c) Effective Sections

In this code the reduction of the strength or stiffness of an element due to a) local buckling, b) effect of shear lag or c) bolt holes is accounted for by an appropriate "effective section" of the member (4.1). An "effective section" for strength is always treated as such section that does not have its capacity reduced by local buckling, so that its strength equals to "effective cross section" times the yield stress (5.1.4.2). Applied to plate panels, this corresponds to a b/t ratio of about 22 for carbon steel (see Fig. B-3).

The reduced effective width of plate elements due to local buckling (4.2) is based on the Horne-Narayanan concept of plate strength expressed in terms of "effective width" (F19). Provisions of this clause make distinction between two kinds of effective width: the "strength effective width", $K_s b$, and the "secant effective width", $K_t b$, the latter being in turn defined in terms of the "tangent effective width". However, according to the note to these provisions, the differentiation between K_s and K_t is not really essential. (To the writer's knowledge only one kind of K for the purposes of local buckling considerations has been used in subsequent drafts.)

The end result for design purposes is a diagram (Fig. 4.1 of Clause 4) showing the relationship between the K -coefficients and the b/t ratio of the plate element. These are, in effect, "plate strength curves", similar to those given in Fig. B-3 of this report. In the draft reviewed here Fig. 4.1 is given only in a schematic way. The effect of coincident shear (based on the Von Mises "equivalent stress" formula) is considered by means of a correction diagram.

Effective width due to shear lag (4.3) is based on the tabular values given in the paper by Moffatt and Dowling (F16). These tables are, indirectly, applicable to continuous spans, and, in this sense, they constitute an improvement over the procedures given in the Merrison Rules (see B.4.2a of this report). Further simplification of the effective width data by means of curves has been suggested (F13, F16-discussion).

The use of separate effective width values for the stress and for the deflection calculations is proposed (4.3.2).

d) Compression Flanges

These are treated under Section 5 on "Compression Elements".

The strength of an unstiffened panel under axial compression, or compression with shear is given by:

$$P_D = K_s b t \sigma_y \quad (5.3.5),$$

where K_s is the effective width coefficient to be taken from Fig. 4.1 (see above).

It should be noted that the concept of the plate strength based on the maximum surface stress equal to yield, as used in the Merrison Rules (see Sect. B.4.2.6), has been abandoned.

The design of stiffened panels (5.4) is based on treatment of the panel as a series of struts, with the effective width of plate acting with each stiffener determined in accordance with Fig. 4.1 of the specification. The struts are designed by the modified Perry formula (F8, F19), which is based on consideration of a column with an initial curvature. The value of the coefficient α to be used in the Perry formula applied to struts given in (5.4.5.1) is a function of the strut geometry, length, and assumed geometrical out-of-straightness, Δ . Because these parameters are subject to wide variations, depending on the design case, a wide range of the values of α is obtained, which is equivalent to as many "column curves" to be used by the designer. Because of the several over-conservative assumptions inherent in this

method, the results obtained appear to be very much on the safe side.

The effect of the non-uniform stress distribution across the flange due to shear lag is ignored if the peak stress at the webs does not exceed the mean stress by more than 20% (5.4.5.2). Where the peak stress exceeds the mean stress by more than 20% "the design capacity {of the flange} should be increased to carry an extra design load of 80% of such excess". These rules are arbitrary, although there is evidence that plastic redistribution of stresses in the flange under ultimate load conditions may take place without prior failure of the more highly stressed stiffeners (G44, F25). However, the conditions under which such redistribution may be safely counted upon remain to be clarified.

Slenderness limitations of compressed elements are imposed as follows (5.1.2):

| Element | Grade of Steel | | |
|--|---|----|----|
| | 43 | 50 | 55 |
| | ($\sigma_y = 215-280 \text{ N/mm}^2$) (325-355) (400-450) | | |
| Plate panels, welded, $b/t < 80$ | | 70 | 60 |
| Plate panels, stress relieved $b/t < 90$ | | 80 | 70 |
| Stiffened panels as struts, $l/r < 85$ | | 75 | 70 |
| Orthotropic deck ribs, incl. eff. width of plate, $l/r < 60$ (11.2.4) | | 55 | 50 |

Open stiffener sections should be capable of reaching yield stress without local torsional buckling (5.1.2.4). Limiting values of the "effective slenderness" of such stiffeners and formulas for the effective slenderness are given.

e) Tension Flanges

In determining the design capacity of box girder tension flanges two options are permitted:

Method 1 (7.4.3.1) stipulates computation of the stress by linear elastic theory, with consideration of shear lag and the effects of out-of-plane loads. The design strength is determined by a condition under which the maximum equivalent stress, σ_e , reaches the design yield stress.

Method 2 (7.4.3.2) permits any arbitrary redistribution of stress across the flange (i.e. the shear lag effect may be ignored).

It is interesting to note that the ultimate design treatment of a tension flange is different from that of a compression flange. In the design of a tension flange the designer is given a choice (Method 1 or 2) whether to use or not to use plastic redistribution of the stresses, while in the treatment of a compression flange plastic redistribution is to be taken for granted. The reason for the more cautious treatment of the tension flange is not explained; however the clue may possibly be in (7.4.2.1) where it is stipulated that "the yielding zone should be kept well clear of any bolted or riveted splice. Any splices in the neighborhood of such a zone should be designed to have a design capacity 20% in excess of the factored design load of the splice". This may be due to a possible loss of the friction-type splice efficiency caused by the thinning of the gripped plate under the effects of the local yielding at the bolts (G60).

Fatigue and brittle fracture should be investigated with consideration of the shear lag effects.

Maximum slenderness of the tension flange elements is stipulated as follows: $l/r \leq 120$ for stiffeners, $b/t < 120$ for plate panels (7.2.1, 7.2.3). This is based upon the "bending reluctance" of wide flanges, which is the tendency of a flange to avoid following the curvature of the beam by pulling closer to the neutral axis of the box girder and adopting a greater radius of curvature away from the webs ("flange curling").

Dynamic stability of tensile flanges subject to dynamic excitation should also be considered.

f) Orthotropic Decks

Welded steel decks are treated in Section 11 of the specification.

Similarly as in the AISC Manual (G27), distinction is made between primary (girder flange action), secondary (rib grillage bending) and tertiary stresses (local plate bending).

In the calculation of primary stresses shear lag should be considered (11.3.2).

In combining the primary and secondary stresses in stringers the following interaction formula should be used (11.4):

$$\frac{P_a}{P_D} + \frac{M}{M_D} \leq 1$$

where P_a and M are actual load-factored axial force and moment in ribs, and P_D and M_D are the respective capacities.

The axial load capacity, P_D , shall be determined in the same manner as prescribed for stiffened bottom flanges (see B.4.3.d, above). The moment capacity, M_D , is defined by reaching the yield stress in the deck plate or in the tip of the stiffener.

It should be noted that for the combination of the primary and secondary stresses the AASHTO code permits a 25% stress increase, to account for the small probability of such stress combination and the large overload capacity of the deck (G27).

No such attempt is visible here, unless lower load factors have been prescribed to be used in computing the values of P_a and M ; however, the intended γ -values are not available.

Similarly, in the design of the deck plate under combined effects of all three stress systems it is stipulated that the combined equivalent stress, σ_e , should not exceed σ_y . However, in calculating the stresses for fatigue assessment, the effect of the wearing surface acting compositely with the deck may be considered (11.6.2).

The deck plate deflection between the ribs is limited to 1/300 of the plate span, similarly as in the AASHTO specifications.

g) Webs

Compared with other sections of this draft of B/116 Code, Section 6 on "Design of Plate Webs" appears to be rather tentative and incomplete. It is understood that major revisions will be made in the final version.

Similarly as in the Merrison Rules (see Section B.4.2.c above), the designer has the option of designing the web for combined flexure and shear, or for shear only, with the longitudinal stresses shed (fully or partially) to the flanges (6.1c).

No distinction is made between "plate girder" and "box girder" webs.

Because the tension field strength is partially utilized, the webs are considered to be incapable of carrying direct transverse wheel loads, and special reinforcement for such loads is required (6.2.2). However, in an editorial note, the question is raised whether this provision should be relaxed for stocky webs.

Design rules are given for unstiffened, transversely stiffened, and transversely and longitudinally stiffened webs.

For unstiffened webs (subject to slenderness limitations) an interaction table 6.1 gives the allowable values of shear with coincident axial stress.

Transversely stiffened web panels (6.5) are treated as "panels restrained against in-plane deformation" for which strength curves for the various load combinations and slenderness ratios are given in interaction diagrams Fig. 6.5 through 6.8. These have been taken over directly from the Merrison Rules Part II (see Section B.4.2.c of this report). To satisfy the condition of web panel restraint the flanges must have a certain minimum relative rigidity (6.5.1).

Transversely and longitudinally stiffened webs (6.6)

have to be designed with the panels next to compression flanges to be "compact", i.e. they must reach yield in shear, or combined compression and shear prior to reaching the theoretical buckling load (6.6.2a). This requires a very low slenderness ratio of the outside panels in the web compression zones. The inside web panels are designed as "restrained" panels, in accordance with the rules discussed above.

The stiffeners must be designed to assure that each web sub-panel may develop its full individual strength. Thus, both the transverse and the longitudinal stiffeners are to be designed for the effects of destabilizing forces (given by equivalent axial loads and bending moments on the stiffeners). In addition, the longitudinal stiffeners are also designed as compressive struts for the appropriate share of the longitudinal force in the web, which is not subject to shedding to the flange. The transverse stiffeners must also be designed for the transverse components of the tension field force. Formulas for the design values of these forces are given.

h) Specific Provisions for Box Girders

These are contained in Section 13 on "Design of Box Girders".

Attention is called to the special stress conditions in box girders (torsional and distortional warping stresses, torsional shear stresses, etc.); however, no formulas are given.

In the design of transverse web stiffeners, attention is called to the flexure due to transverse distortion of the box (13.5).

In web-to-flange connections the membrane forces in the webs due to tension field action have to be considered. Formulas for these forces are given (13.6).

The diaphragm design rules are given only for rectangular diaphragms; for other types the designer is directed to Part 9 of the Code ("Special Cases"). In the design of the web-to-diaphragm connections the shear may be assumed to be uniformly distributed over the diaphragm-web boundary, pro-

vided the webs are designed with "restrained boundaries" (13.7.2.2).

Rules pertaining to transverse frames inside the boxes are given in Section 8. This section contains rather elaborate rules, formulas and charts to establish the minimum required rigidity of the frames to prevent the overall buckling of the compression flange and the distortion of the cross section.

B.4.4. B/116/3 Specification, Final Version (1978)

According to information received from Dr. O. Kerensky, Chairman of the British B/116 Committee in a letter dated July 25, 1977, the contents of the final specification have been agreed upon, and the drafters are at work. However, the specification B/116/3 on steel bridges is not expected to be completed before the middle of 1978.

The general design philosophy used in the new specification is outlined in the paper by Dowling presented in May, 1977 in Washington, D.C. (G104).

The design of the stiffened compression flanges of box girders will be based on the "strut approach", described under Section B.4.3.d of this report, using the "effective width" of flange plate concept to account for the local buckling effects; however several simplifications will be used, which will make the design less cumbersome. As in the original draft (G15), the Perry strut formula will be used in treatment of the stiffener-struts, with somewhat less conservative assumptions regarding the design eccentricities used in computing the parameter α . Formulation of the design provisions for flanges will be based, mainly, on the new research done at the Imperial College in London (F20, F25, F44, F45), in continuation of the earlier work done in the Merri-son stage.

Since no comprehensive ultimate load theory has been developed for the design of the webs which would cover all practical cases of load combinations and stiffening systems, the various ultimate behavior models available (including tension field design) are used in the new specifications with caution and to a limited extent. The basic approach is the same as used for the web design in the Merrison Rules and the

1975 draft of the B/116/3 specifications; however, further simplifications have been introduced, with the aid of the inelastic studies recently completed on plate panels under combined axial and shear loading (F48).

The general principle of the design of the web stiffeners is the same as used in the 1975 draft.

In the design of diaphragms effort is being made to produce simple rules for the more common cases of stiffened diaphragms. The background to these rules is given by work described in (D5, D6, D7, and F41).

Regarding other provisions, they will be, no doubt, similar to the 1975 draft, with necessary streamlining and simplifications.

B.5. GERMAN SPECIFICATIONS

B.5.1. General Steel Highway Bridge Specification DIN 1073

a) General

The design of steel highway bridges is covered by the specification DIN 1073 "Basis for Design of Highway Bridges in Steel" which covers all types of steel highway bridges. Until 1974 the 1941 edition of this code was in force (G109), which has been superseded by a completely revised new version dated July, 1974 (G110).

In this specification references are made to other codes and DIN standards which refer to subjects not treated in the DIN 1073 specification (such as bridge loading-DIN 1072, structural stability-DIN 4114, railway bridges, etc.).

The design is based on the "allowable stress" approach, with stresses computed in accordance with the elastic theory. The prescribed factors of safety against reaching the nominal yield stress of steel for the "principal loads" (dead and live load) are 1.5 for tension and flexural tension and compression where stability is not a problem and 1.7 for compression where stability is a criterion (subject to further qualification according to DIN 4114). For the case of "principal and additional loads" the corresponding factors of safety are 1.33 and 1.5, respectively.

It must be emphasized that comparisons of the values of the safety factors, or load factors, used in bridge design are meaningful only if made in conjunction with the live load provisions (weight of the design vehicle, number and placement of the vehicles on the bridge, uniformly distributed load, etc.). Thus, a specification with a seemingly "low" factor of safety, but with a conservatively heavy design truck, may, in effect, result in a safety margin equivalent to that of a specification with more conservative safety factors but with less severe live load assumptions.

The methods of analysis are left to the discretion of the designer. Three significant figures are considered adequate in all bridge design calculations (Clause 3.3).

It is worth noting that the introductory clause empha-

sizes the need for "thorough professional knowledge" in the design of bridges and requires that only properly qualified engineers and firms should be entrusted with the design of bridge structures. (Similar reminders are also found in the Merrison Rules and in the introduction to the new B/116 British code.)

b) Provisions Applicable to Box Girders

The effective width of flanges of the plate girders and the box girders (3.6.1) is given by means of three curves showing the effective width ratio of the flange as a function of its width-to-effective span ratio, for a) midspan portions of girders; b) portions near simple supports; and c) portions near supports of continuous girders. The presentation and treatment is essentially similar to that proposed by the writer to the ASCE sub-committee on Box Girders (F13), which was based on the Moffatt-Dowling paper (F16); however, the effective width values given in DIN 1073 are less conservative. The stress distribution across the flange of a girder in the shear lag zone is stipulated to be linear, from maximum at the web to minimum at the mid-width of the box girder flange, which is a welcome simplification, compared with a curved distribution suggested in (F13) and (F16).

Effective width ratios are also given for the design of the orthotropic deck ribs (3.6.2). These values are more conservative than those recommended in the AISC Manual (G27).

In the design of orthotropic decks (6.3) the case of combined stresses due to the overall girder action and the local rib flexure may be treated as that of "principal and additional loading", with a correspondingly reduced factor of safety. This is similar to the current AASHTO provision.

Local flexural stresses in the plate and the rib walls of orthotropic plate decks may be disregarded. In the design of the deck plate only the "equivalent stress" (by the Von Mises formula) in the middle surface of the plate has to be considered.

All stability calculations have to be made in accordance with the DIN 4114 code.

B.5.2. Design of Plating in Compression According to DIN 4114 Specifications

a) DIN 4114, 1952-53 Edition

The latest complete revision of this general stability specification has been issued in 1952-53. It consists of two parts: Blatt 1 (G16), which contains the specifications for the design of members in compression, and Blatt 2 (G17), which gives general commentary, derivation of some formulas and formulas for additional cases not treated in Blatt 1. DIN 4114 specification covers the entire range of members in compression including concentrically and eccentrically loaded columns, frame members, arches, beams subject to torsional buckling of flanges and plates. The treatment of the latter is given in the last three sections of the specification, 16 through 18, devoted to "Buckling of the Webs of Plate Girders".

The general approach is based strictly on the classical linear theory of elastic stability, discussed in Section B.2 of this report. Inelastic behavior of stocky members under stresses close to yield is accounted for by a transition curve based on the "reduced modulus of elasticity", $T < E$ (the "Engesser's buckling modulus", see Art. Ri. 7.42 in (G17)). The transition curves, given in Table 7 of (G16) and Fig. 9 of (G17) depart from the Euler hyperbola at the value of stress $\sigma = 0.8\sigma_y$, which is deemed to be the "proportionality limit" for elastic computations. This curve of "Engesser's buckling stresses" is used for all stability computations, including both columns and plate structures. The values of these stresses lie above the "transition curves" used for columns in other countries. For the design of columns the actual compressive stress is multiplied by a factor " ω ", based on the Euler's (or Engesser's) critical stress, with consideration of certain eccentricities of loading (Ri. 7.22 of (G17)) and a safety factor ranging from 1.7 to 2.5.

Rules for stability computations of plates are limited to the considerations of plate girder webs, since at the time when the DIN Specifications were first compiled these were the only plate elements thought to be in need of a separate stability investigation. Wide box girder flanges were not yet used, and thin container and silo walls were considered to be subject to special design rules, outside the

scope of specifications for ordinary structures. The stability of thin elements of compression members (in columns, trusses or arches) is dealt with briefly in Section 9 of (G16) by a table limiting the width-to-thickness ratios of the plate elements.

For unstiffened web panels formulas for critical buckling stresses are given in Table 6 (G16) for the cases of pure compression, pure bending or pure shear. For combined axial and shear stresses the "equivalent critical stress" is computed by means of the interaction formulas given. The required factors of safety against the critical (Engesser's or Euler's) stress in webs are prescribed to be 1.35 for the "principal loads" and 1.25 for the "principal plus additional loads" (compare with Section B.5.2a, above).

In the design of "stiffened web panels" (Section 18 of (G16)) the designer may use either "rigid" or "flexible" stiffeners, see Section B.2 of this report. References are made in (G16) to the formulas for the required rigidities and the buckling coefficients "k" given in Tables 9 and 10 of (G17), and to the much more extensive charts for stiffened panels by Klöppel, Scheer and Möller (G107, G108).

These specifications, meant for the webs, give no clear guidance for the design of the wide box girder flanges. The low factors of safety, quite adequate for webs (see Sect. B.2) were clearly inadequate for the flanges, for which they were not intended. This, combined with a faulty detail and a faulty design calculation, contributed to the collapse during erection of the Koblenz bridge in November, 1971 (B13, B16, G67).

b) Interim DIN 4114 Provisions of 1973

Prompted by the Koblenz disaster new complementary regulations were added to the DIN 4114 specifications by the West German Ministry of Transportation in November, 1973 (G101, G102).

The minimum factors of safety for flanges of box girders were given as 1.7 or 1.5 (for "principal" or "principal plus secondary" load cases, respectively). The factors of safety for the webs were similarly raised, with the provision that old values could be used if shedding of longitudinal stresses

from the webs to flanges is properly considered.

Attention is called to the "column behavior" of longitudinally stiffened plate panels in compression. (See Section B.2 of this report.) For such cases the design of the flange as a series of struts is stipulated, with consideration of the appropriate effective width of the flange plate. In addition, such flanges must be fabricated with rib imperfection tolerances not exceeding the load eccentricities assumed for columns under Clause Ri. 7.22 of DIN 4114 (G17).. This clause stipulates that the load in a compression strut acts at a distance from its center of gravity, $u=i/20 + s/500$, where "i" is the radius of gyration and "s" is the length of the column.

Further, special attention is called to proper details at splices and the effects of common fabrication and erection imperfections on the local stresses at the splices.

These 1973 interim provisions remain in force until the new revised DIN 4114 specification is issued.

B.5.3. Proposed New Provisions for Plate Buckling Calculations (DASt Richtlinie 12)

a) General

The proposed new provisions for the design of plates in compression are contained in the "DASt Richtlinie (12)" on "Calculations of the Buckling Safety for Plates" (G111), issued by the German Committee for Steel Structures, Working Group "Plate Buckling" under the chairmanship of Prof. J. Scheer of the Technical University Braunschweig. The date of the first draft of this document is June 1977. It will supersede the sections of DIN 4114 related to plate buckling only; other parts of DIN 4114, including column buckling, remain valid. The new "Richtlinie" also supersedes the 1973 Interim Provisions (G101).

The general design philosophy and commentary to the new provisions is given in the paper by Scheer and Nölke on "The Background to the Future German Plate Buckling Design Rules" presented at the 1976 Conference on Steel Plated Structures in London (G67). The rules, which are considered to be provisional, are based on the classical linear buckling theory.

The authors state that in Germany "confidence in the methods of bridge design based on the linear theory has not been diminished" and that the DIN 4114 Specifications cannot be blamed for the construction failures which were due to misapplication of the rules, calculation errors and mistakenly applied low safety factors.

The authors feel that for the time being, the discrepancies between the actual and the theoretical load carrying capacities of steel plating in compression can be sufficiently accounted for by a proper choice of the factors of safety. Regarding the required rigidities, γ^* , of the stiffeners, the authors agree that using increased values of the rigidities, $m\gamma^*$, will increase the carrying capacity of the panels; however, they consider such rules uneconomical and unnecessary.

In view of the Committee, while considerable progress has been made in developing ultimate design methods, they are not yet comprehensive and simple enough for immediate practical use. Therefore, until such rules are adequately improved, the use of the design based on the classical approach must suffice for engineering needs.

b) Specific Provisions

The "interaction formulas" given in the original DIN 4114 specifications for combined axial stress and shear have been expanded to include simultaneous effects of biaxial compression with shear.

For considerations of stiffened panels the effective width, b' , of a plate in compression was introduced as a function of the panel slenderness, λ , of the panel between the stiffeners. The effective width of plate diagram, which is also considered to be the "plate strength curve" is given in Fig. 6 and Table 2 of (G111), and is also shown in Fig. B-3 of this report. In its original version (G67) the "transition curve" was given by a parabola, virtually identical with the AASHTO plate strength curve (Fig. B-3). In the final draft this curve has been replaced by a straight line intersecting the yield stress level at a slenderness $\lambda = 0.7$ and joining the Euler curve at a point where $\sigma_{cr} = 0.6\sigma_y$. As can be seen from Fig. B-3, this simplified version of the transition curve lowers the plate strength somewhat in the

imperfection sensitive area. This new curve replaces the "Engesser" transition curve of the DIN 4114 specification only for plate calculations.

In connection with the new subjects introduced in (G111) the nomenclature has been very considerably expanded.

No distinction is being made between the "web" and the "flange" panels, both being treated as panels under combined action of axial stresses and shear. However, the prescribed factors of safety vary as functions of the type of stress (compression, shear) and the stress distribution across the panel (Table 6 of (G111)). Thus, for panels under uniform compression (which may correspond to a flange case) F.S.=1.7, while for a panel under pure shear F.S. = 1.32. For combined stress cases intermediate values of the factors of safety are obtained from formulas that are rather complex.

For longitudinally stiffened panels approaching "column behavior" (see B.5.2, above) provisions for "column buckling" are implemented in Section 4.3. Column behavior has to be considered when the ratio "r" of the "column critical stress" (panel with longitudinal edges unsupported) to the "plate critical stress" (panel supported all around) is greater than 0.5.

The required factor of safety varies from a minimum of about 1.7 for the ratio of $r = 0.5$ to a maximum, prescribed for columns (about 2.5) for a full column behavior.

In the original proposal it was suggested to treat the interaction of the local and the overall buckling of a "stiffener column" by using the "effective width of plate" (Fig. 6 of (G111)) and designing the column by the European column curve "b" (G67). However, the rules given in the final draft call for computing the "stiffener column" slenderness with undiminished cross-section values of the plate and then using the interaction diagram given in Fig. 9 of (G111) to determine the critical stress for the plating assembly. The interaction diagram, reproduced in this report as Fig. B-6, makes use of both the "plate strength curve" described above (on the vertical axis) and the European column curve "b" (on the horizontal axis) and distinguished between four interaction zones. This is certainly a very interesting attempt to present the complex interrelationships in a compact manner.

The validity of this concept (which was originally meant for thin gage members, (G67)) remains to be verified by comparison with other design methods (F18, F19, F20) proposed for handling of the stiffened plate problem.

The specification also contains general provisions for the design of plate panels with elastically supported or unsupported edges, and for curved plates with a large radius of curvature.

For plate panels subject to loading perpendicular to plate surface (such as water pressure), such loading may be ignored in elastic stability calculations; however, it must be considered in calculations of safety against reaching yield under the combined effects of all (in-and-out-of-plane) loads.

Fabrication tolerances are given as follows: maximum deviation from flatness = $1/250$ of the shorter dimension of the unstiffened panel; stiffener out-of-straightness = $1/500$ of the stiffener length.

Rules are also given for construction details of stiffened plates. Longitudinal stiffeners can be counted upon to carry longitudinal stress only if they are continuous, properly spliced, and connected to cross frames. Cutouts in stiffeners shall be considered in all local strength calculations. Maximum permissible cutout openings for the longitudinal stiffeners crossing the transverse stiffeners are given.

B.5.4. Summary and Conclusions

At the present time German specifications applicable to steel box girder bridges are firmly based on elastic design methods and the classical linear buckling theory.

However, in treatment of the stiffened flange panels, the "column design" approach, with the use of plate and column strength curves partially reflecting the effects of structural imperfections, is essentially similar to that proposed in the new British specification draft.

The future revision of the DIN 4114 buckling specifications will be based on the plate buckling test program, now

underway at five German universities. This work is expected to take several more years.

It is worth noting that in the recent editions of the codes discussed above all units are expressed in the SI system, mandatory in Germany as of January, 1978. The transition from the old metric to the new SI system is remarkably smooth, due to the quite sensible and enviable simplification of setting 1 kg-force (= 1 kilopond = 1 kp) equal to 10 Newtons, rather than 9.80665 Newtons (theoretically correct at the sea level). The stresses are converted as $10 \text{ kp/cm}^2 = 1 \text{ N/mm}^2$ (G109) or $1 \text{ kp/mm}^2 = 1 \text{ kN/cm}^2$ (G111). A similar conversion using a factor of 10 rather than 9.81 was adopted in 1965 in France (G21). Thus, in spite of the good intentions of having one international system of measurements, we now have two Newtons, differing by 2% -- the "heavy" one, now used in the United Kingdom and in Australia and the "light" variety now in force in France and in Germany. It is likely that all countries of continental Europe and all other countries of the world now using the metric units will eventually adopt the conversion based on the factor of 10. The choice for the U.S., whether to join the minority or the likely majority of the rest of the world is still open.

B.6. ECCS DESIGN RULES

The design recommendations for plate and box girders of the European Convention for Constructional Steelwork (ECCS) are described in Section 6 on Plate and Box Girders of the "Manual on the Stability of Steel Structures" (G31).

The "Manual" is a collection of comprehensive reports on the various problems of the stability of structures and their components, and includes brief reviews of the currently available design methods for simple compression members, built-up members, beam-columns, thin-walled members and plated structures. The Manual has been compiled by the members of Committee 8 "Stability" of the ECCS.

Section 6 has been prepared by Working Group 8/3 (Plate Buckling) under the chairmanship of Prof. C. Massonnet (Belgium). This section contains reviews of the recently proposed methods for the design of the compression flanges of box girders and of the webs of plate and box girders, and gives the background of the suggested ECCS design rules for steel plate elements in compression. The design rules are presented in Section R.6.2.15 "Buckling of Plates" of the "ECCS Recommendations for the Design and Construction of Steel Structures" (G98) and its "Appendix 4 -- Conventional Design Rules Based on the Linear Buckling Theory" (G99).

As is indicated by the title of "Appendix 4", the rules are based on the classical elastic design approach. In the report of Working Group 8/3 (G31) the need for such rules, considered to be "provisional", is justified by stating that "it will take a long time to develop completely comprehensive ultimate strength models". It is proposed that, for the time being, the rules based on elastic theory should be used for the design, modified by correction coefficients which should account for the discrepancies between the theory and the actual behavior of the plating. Such correction coefficients, c^* , by which the computed critical buckling stresses are to be multiplied, should be greater than 1.0 where post-buckling strength reserves exist, and smaller than 1.0 where this reserve is small and where imperfections and residual stresses have deleterious effect.

However the "correction factor" approach has not been practically implemented in the draft of the Rules (99), where

the suggested values of the correction coefficients, c^* , are given as constants for different cases of loading, but do not reflect the effect of such parameters influencing the deviation from the theoretical strength as the b/t ratio, imperfections, etc.

In the design of stiffened plate panels it is suggested that the theoretically required minimum rigidity of the stiffeners, γ^* , be increased in order to assure that the stiffeners remain straight under ultimate loading conditions, thus making it possible to utilize the post-buckling strength reserve of the plating between the stiffeners. Therefore the minimum rigidity of the stiffeners should be $m\gamma^*$, with the value of the Massonnet coefficient, m , suggested to be 4 for open stiffeners and 2.5 for closed stiffeners.

The design with the lower values of γ is also admissible, but in such cases the correction coefficients c^* should have lower values, corresponding to smaller strength reserves. However, this is not reflected in the values of c^* given in the draft.

The rules consider the Euler buckling curve for plates to be valid up to the critical stress $\sigma_{cr} = 0.8 \sigma_y$, above which value a "transition curve" is used. This approach corresponds to the old DIN 4114 specification (see Section B.5.2.a).

In the design of stiffened plating the use of effective width given by the Von Karman formula, expressing the effective width as a function of the plate thickness and the yield strength, is considered sufficient. This results in $b_e = 54t$ for steel with $\sigma_y = 36$ Ksi (250 N/mm²) and $b_e = 46t$ for $\sigma_y = 50$ Ksi (345 N/mm²) (Section 3 of (G99)).

The rules contain interaction formulas for critical buckling stresses for various cases of combined axial and shear stresses. These formulas are also included in the latest German provisions (G111), see B.5.3.b.

Attention is called to the "column-like" behavior of stiffened plate panels, discussed in Section B.2 of this report. Higher safety factors are recommended as column behavior is approached; however, no specific instructions are given on the design of such panels.

The rules also contain suggestions regarding details of stiffened plating and a table of fabrication tolerances. The latter is virtually the same as the table in the German Specifications (G111).

B.7. SUMMARY AND CONCLUSIONS

The most important design problem of steel box girder bridges is the stability and strength of thin plate elements subject to compression and shear. Traditionally, this problem has been treated by the methods of the classical elastic theory of plate buckling.

New research has established that the classical theory of plate buckling, even with the modifications used to account for inelastic behavior at low slenderness ratios, is not satisfactory in predicting the actual strength of plating. This approach underestimates the strength of plating in cases where post-buckling strength reserves are present (web panels in shear, or shear combined with compression; compressed flange panels with high slenderness ratio), and overestimates the strength of panels in compression in the practical design range of medium slenderness, where the deleterious effects of geometric imperfections and residual stresses are important.

The new proposed design methods attempt to take into account the actual ultimate strength of the plating. However, because of the complexity of the interrelation between the individual components of box girders, a comprehensive model of the ultimate behavior of a box girder is difficult to establish, and even partial ultimate strength models (for webs, flanges) are far from simple, and sometimes do not cover all practical loading cases (webs under simultaneous action of longitudinal stresses and direct transverse loads). Yet, such methods while subject to further improvement and simplification can serve the purposes of engineering design.

This is the approach taken in the drafts of proposed specifications in Britain, where most of the recent research on the problems of steel box girders has been conducted.

A different viewpoint prevails in Germany, where much work has been done in the past on developing plate buckling formulas based on the classical theory, which had been incorporated for decades in the DIN 4114 buckling specifications. While the progress in developing ultimate strength methods is recognized, these methods are considered still not sufficiently developed and verified. Therefore, before the new methods are perfected, the new draft of the German

plate buckling specifications, to be used in the interim period, is still based on the classical approach, with adjustable factors of safety partially compensating for the discrepancies between the actual and the theoretical plate behavior.

The design rules of the ECCS, similarly based on the classical theory, suggest using empirical coefficients to correct the theoretical results; however, this idea has not been adequately implemented.

The steel box girder provisions of the American highway bridge specifications (AASHTO) are limited to multi-box composite girders of moderate spans and are not adequate for the design of large steel box girder bridges. New provisions are needed for the effective width of the box girder flanges; design of the unstiffened and stiffened wide flanges in compression; design of deep box girder webs and webs subject to simultaneous flexural and local transverse loads; diaphragms and their interaction with the webs and the flanges. A review of the fabrication tolerances would be desirable. All provisions pertaining to steel box girders should preferably be contained in one new section on "Box Girders".

The present AASHTO design provisions for the flanges of composite box girders are based on the classical approach. However, in the design of the webs the ultimate strength design based on research at Lehigh University is already permitted. Furthermore, the "allowable stress" method is being gradually replaced in this country by the "load factor design". Therefore it would be appropriate to base all new provisions for the design of box girders on the ultimate strength methods, in line with the current developments.

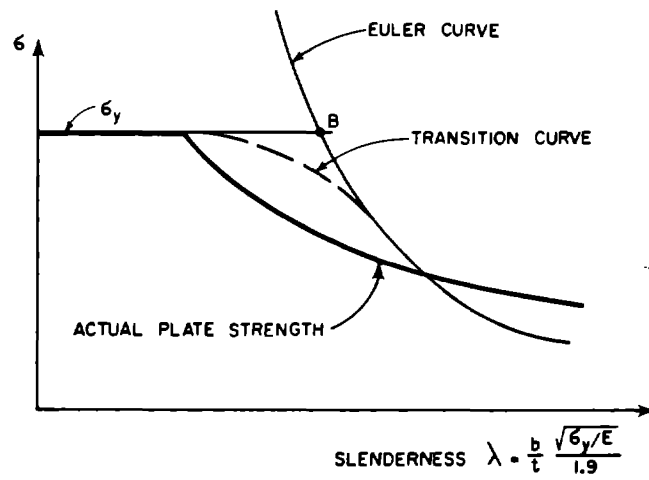

FIG. B-1. SCHEMATIC PRESENTATION OF PLATE STRENGTH IN COMPRESSION

B-59

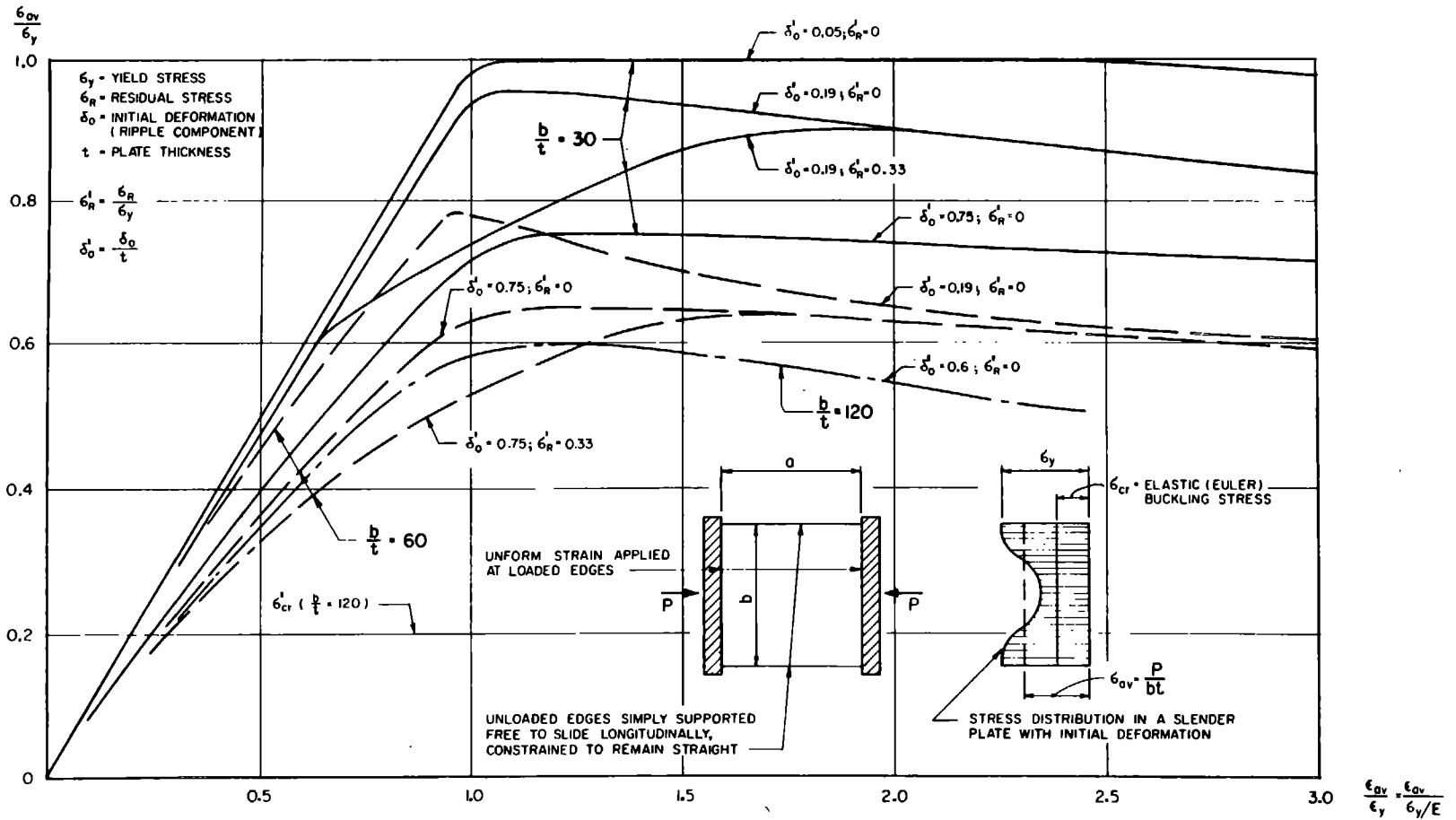

FIG. B-2. TYPICAL AVERAGE STRESS - AVERAGE STRAIN CURVES OF UNSTIFFENED PLATE PANELS IN AXIAL COMPRESSION
 (SOURCES: F22, WIO)

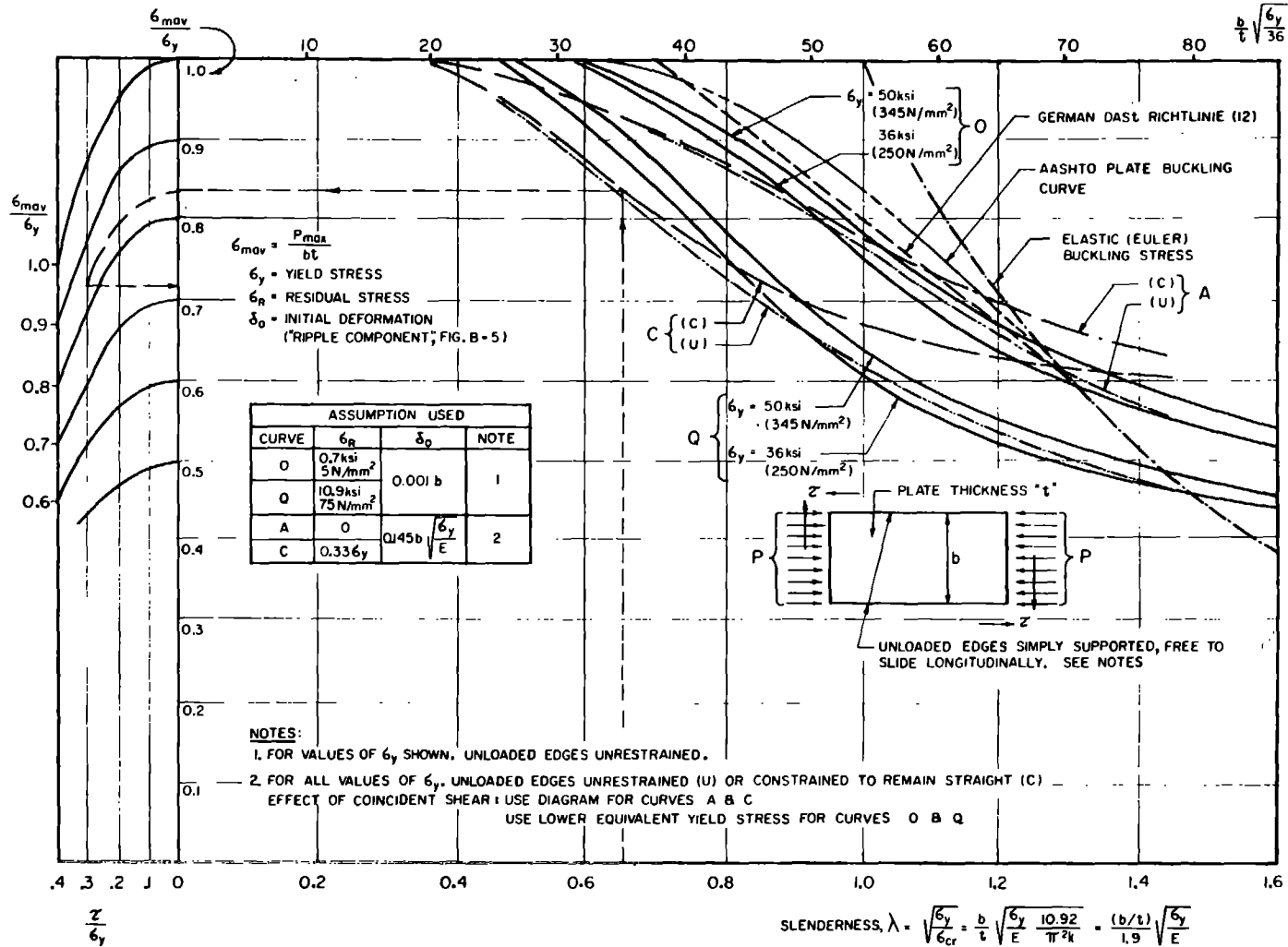

FIG. B-3. PLATE STRENGTH CURVES FOR UNSTIFFENED PANELS

CURVES O & A FOR "UNWELDED PLATES"; CURVES Q & C FOR "HEAVILY WELDED PLATES"
 O & Q BY DWIGHT, LITTLE & ROGERS (F11); A & C BY FRIEZE, DOWLING & HOBBS (F22)

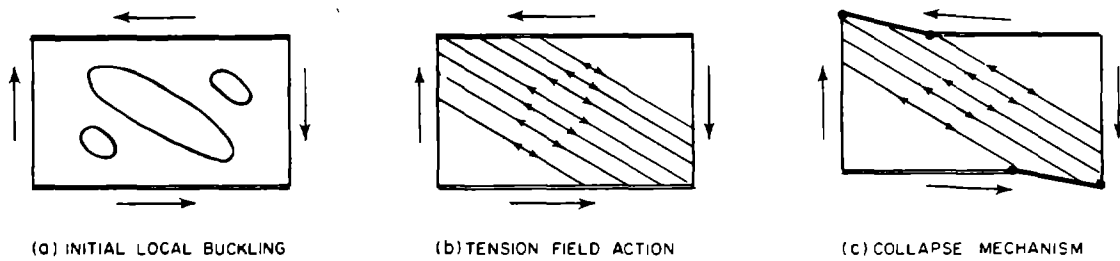
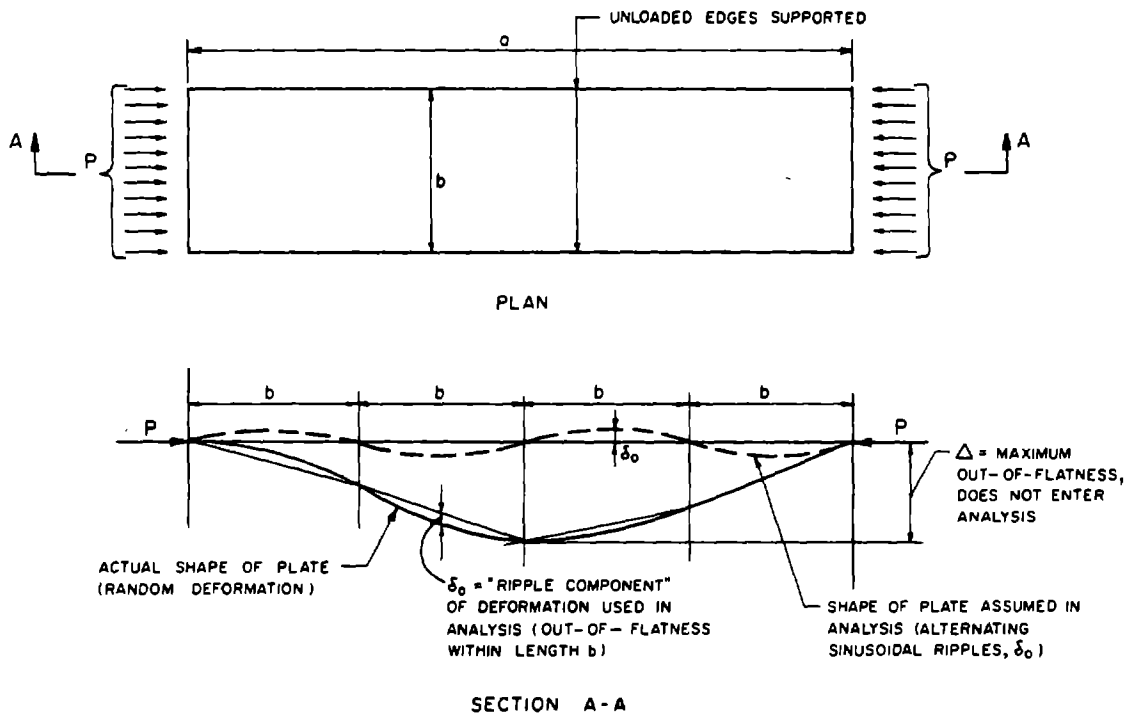
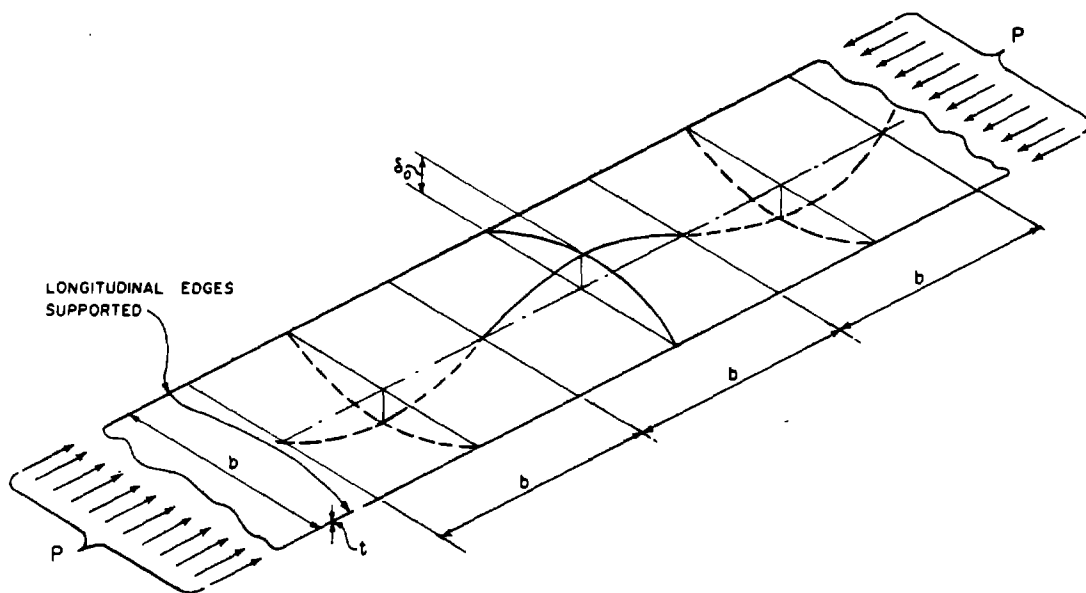

FIG. B-4. ULTIMATE BEHAVIOR OF PLATE PANEL IN SHEAR
(AFTER ROCKEY, W5)



(a) DEFINITION OF "RIPPLE COMPONENT" OF PLATE IMPERFECTION



(b) THEORETICAL MODEL USED IN ANALYTICAL TREATMENT (F1)

FIG. B-5 INITIAL DEFORMATIONS ASSUMED IN THE ANALYSIS OF PLATE PANELS

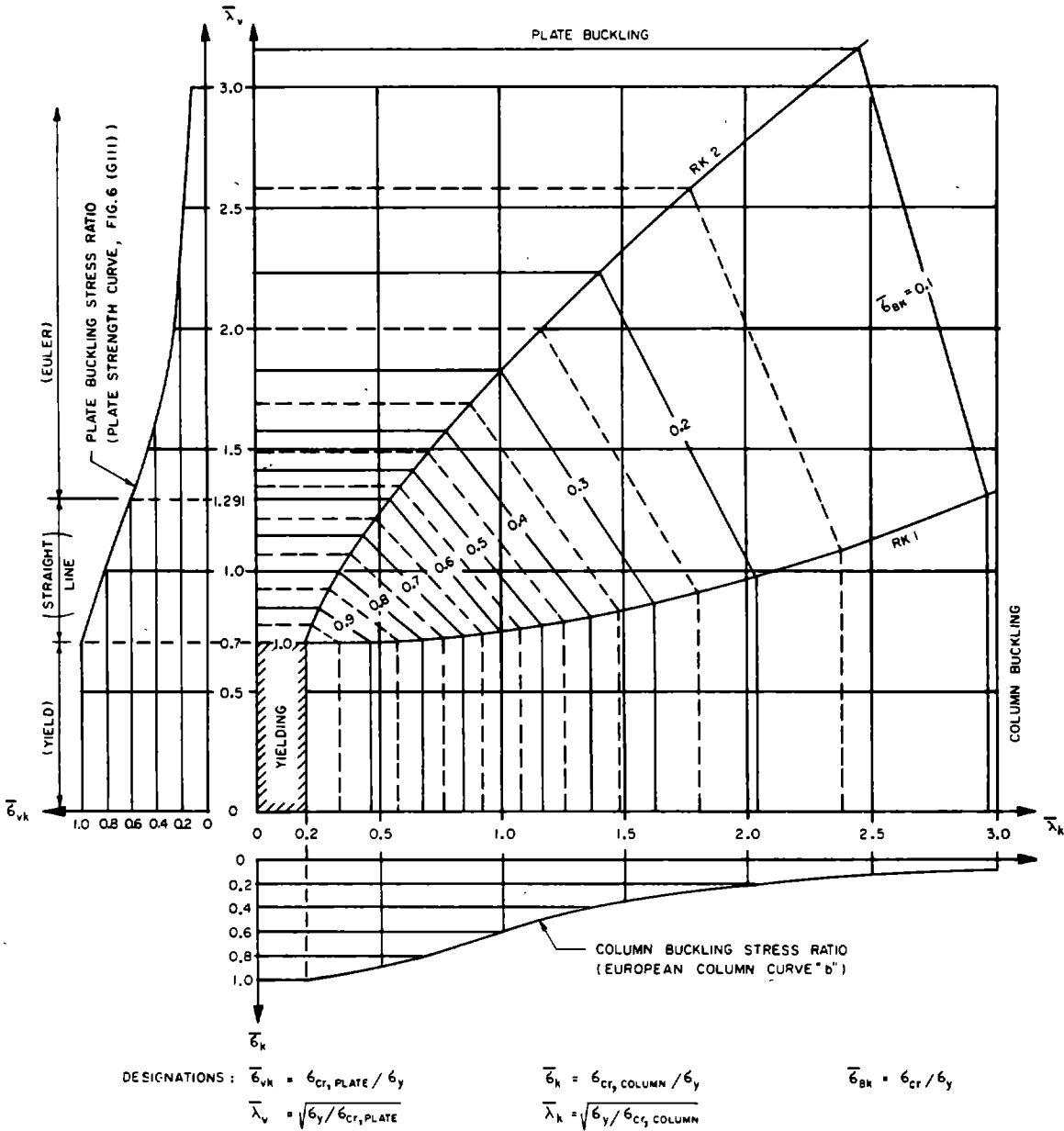

NOTE: ALL SLENDERNESS VALUES AND STRESSES COMPUTED WITH FULL GROSS SECTION OF PLATING

FIG. B-6. INTERACTION BETWEEN LOCAL (FLANGE PLATE) AND OVERALL (COLUMN) STRENGTH OF STIFFENED PLATING

DAST RICHTLINE 12, CLAUSE 4.3, FIG. 9 (G111)

