

**MARITIME TRANSPORTATION RESEARCH AND EDUCATION CENTER
TIER 1 UNIVERSITY TRANSPORTATION CENTER
U.S. DEPARTMENT OF TRANSPORTATION**



**The Changing Legal Landscape of Intermodalism:
Supply Chains in Crisis: An Assessment of Chassis Availability and Intermodal Goods
Movement at Inland and Ocean Ports in the U.S.
March 2021-December 2023**

Principal Investigator

Bethany Stich (PhD)

Department of Planning & Urban Studies

University of New Orleans, LA 70148

bstich@uno.edu

Janey Camp (PhD)

Department of Civil & Environmental Engineering

Vanderbilt University, TN 37235

janey.camp@vanderbilt.edu

Co-Authors

Craig Philip (PhD)

Faisal Mallum

Brittany Waggener

Bailey Bullock

Miguel Moravec

FINAL RESEARCH REPORT

Prepared for:

Maritime Transportation Research and Education Center

**University of Arkansas
4190 Bell Engineering Center
Fayetteville, AR 72701
479-575-6021**

Acknowledgment

“This material is based upon work supported by the U.S. Department of Transportation under Grant Award Number 69A3551747130. The work was conducted through the Maritime Transportation Research and Education Center at the University of Arkansas.”

Disclaimer

"The contents of this report reflect the views of the authors, who are responsible for the facts and the accuracy of the information presented herein. This document is disseminated under the sponsorship of the Department of Transportation, University Transportation Centers Program in the interest of information exchange. The U.S. Government assumes no liability for the contents or use thereof."

Table of Contents

<i>Acknowledgment</i>	2
<i>Disclaimer</i>	2
<i>List of Figures and Tables</i>	5
ABSTRACT	7
INTRODUCTION	9
LITERATURE REVIEW	10
Box rules, chassis ownership, availability, interoperability, and mismatch issues	10
Chassis Regulations	12
<i>Federal Maritime Commission (FMC)</i>	12
<i>Shipping Act of 2022</i>	13
<i>U.S. Department of Transportation Activities</i>	13
<i>U.S. International Trade Commission Investigation</i>	14
<i>Federal Maritime Commission Ruling (2023)</i>	15
<i>Improving Memphis Supply Chain Act (Pending)</i>	17
Impacts of the steel and aluminum tariff hike, antidumping, and domestic production ..	18
Impacts of the pandemic	19
Safety Issues	21
Billing Issues	22
Recent Changes in U.S. Chassis Provisioning	22
METHODOLOGICAL APPROACH	23
New Orleans, Louisiana	24
Memphis, Tennessee.....	27
ANALYSIS	30
Theme A. Chassis Availability, Interoperability, and Mismatch Issues	31
Theme B. Operational Cost Vulnerabilities	37
Theme C. Billing System Complexities	39
Theme D. Steel & Aluminum Tariff Hike/Antidumping/Domestic Production Impacts ..	40
Theme E. Pandemic Issues	41
Theme F. Safety Issues	42
Theme G. Suggested System Improvement	43
FINDINGS	47
BENEFITS of IMPLEMENTATION	49
RECOMMENDATIONS & CONCLUSIONS	50
REFERENCES	52

Appendix I 60

List of Figures and Tables

Figure 1: A diagram of a 23.5-foot slider chassis..... 10

Figure 2. Crashes Involving a Large Truck with Intermodal Chassis 22

Figure 3: Ports Along the Lower Mississippi River. 25

Figure 4: Infrastructure in the Greater New Orleans Region..... 26

Figure 5: Memphis Intermodal Routes. 28

Figure 6: The BNSF Intermodal Facility in Memphis, TN.. 29

Figure 7: Wheeled Vehicle Operations..... 29

Figure 8: A side-loader mounts a 40’ container onto a compatible intermodal chassis.. . 30

Figure 9: Chassis Subprocess..... 31

This page is intentionally left blank

ABSTRACT

International trade requires the efficient delivery of goods between exporting and importing countries, normally via ocean vessels. About 90% of these cargoes are transported in shipping containers to the port by truck or rail, then discharged the same way. The intermodal chassis is necessary to accomplish this shoreside transport and is thus a critical component of the supply chain. This report provides an overview of the nuances and challenges associated with the current provisioning of chassis in the U.S. that is unique among trading nations, and informs this assessment based on case studies in New Orleans, Louisiana and Memphis, Tennessee, through in-depth interviews with industry professionals. The report supports a widespread belief that the current system of chassis provisioning at critical U.S. coastal and inland intermodal freight hubs is inefficient, leading to wasted time and money, delays and lost productivity, and higher costs to consumers. A valuable next step would be the appointment of an inclusive public-private working group to develop a roadmap to improve the performance and equity of the U.S. goods movement system.

Keywords: Chassis; Global Supply Chain; Intermodalism

This page is intentionally left blank

INTRODUCTION

Approximately \$1.5 trillion worth of goods are imported and exported through the ports of the United States on an annual basis (National Oceanic and Atmospheric Administration, 2023). Shipping containers filled with these goods are loaded onto trucks, trains, and ships for transport around the globe. The COVID-19 pandemic highlighted the importance and vulnerability of these global supply chains and the many ways that intermodal transportation impacts the health, safety, and economic wellbeing of individuals around the world.

As a result, freight logistics is receiving renewed media attention and there is a federal inquiry by the Federal Maritime Commission (GAO, 2021) into the issues surrounding intermodal chassis. The need for new chassis has grown as older fleets require replacement and freight volumes increase; this resource is often in short supply, improperly maintained, or experiencing changes in provisioning. While there is no clear understanding of how many chassis are needed in the U.S., estimates range from 35,000 to 75,000 new marine chassis per year based upon the number of marine chassis registered with U.S. government agencies annually (Ashe A., 2022b).

Historically, in the United States, chassis were provided by the steamship lines, but this process began to phase out in the early 2000s (Wilson, 2023). To create a more efficient chassis pooling system, in 2005 some of the world's largest ocean carriers, under the Ocean Carrier Equipment Management Association (OCEMA), created Consolidated Chassis Management, LLC (CCM) to manage their cooperative pool (ibid). By 2008, shipping lines began to shift away from their role in provisioning chassis, selling their equipment to leasing companies which opened a door for the unique chassis provisioning system currently used in the U.S. (ibid). Some stakeholders in the industry argue that the 2008 recession was the major driving factor for this shift in chassis provisioning and by 2016 the old system was phased out and favored "chassis pools" and third-party leasing companies controlled most shipping container chassis in use. These companies took over the investment, storage, and logistical components of chassis ownership and production (TRAC, 2023).

In the new system, chassis leasing companies, also known as Intermodal Equipment Providers (IEPs) or chassis lessors own fleets of chassis, and lease them to shipping companies, which then rent them to their various motor carriers. The lessors wanted guarantees that all the chassis purchased from the ocean carriers would be used. Exclusive contracts were established between the chassis lessors and the ocean carriers. Renewal of these contracts has led to a legacy of exclusivity (Stich, Amdal, & Webb, 2019). Previously, the cost of the chassis was included in the price the ocean carrier charged the domestic trucking companies for bringing the containers to, or taking them from, the ocean vessels. However, recent shifts in international chassis management are creating gridlock at key transportation hubs, financially rewarding international ocean carriers while overburdening domestic motor carriers (trucking companies), and inflating transport costs (ibid). This change in management processes, along with trade wars, chassis dumping in the U.S. by China (which resulted in antidumping duty by the Department of Commerce), and port congestion have all contributed to the chassis crisis that has emerged in recent years.

Most of the attention on issues surrounding the intermodal chassis system has been focused on the major seaport regions around the country. However, this research analyzes the

recent issues with chassis provisioning in New Orleans, Louisiana and Memphis, Tennessee. It investigates how the current provisioning system affects the workings of the supply chain system within the region and explores ways to mitigate the issues. The study also assesses other important factors that may have further exacerbated the challenges faced by players in the intermodal sector like the COVID-19 pandemic, the steel and aluminum tariff increase during President Trump’s administration, and other legislation such as the antidumping and antitrust laws that were applied to Chinese producers of the chassis equipment.

The report is organized into five sections, which include an introduction, a literature review, methodological approach, analysis, and the findings and conclusions. Section one lays out the background of the study, presenting the questions, scope, and purpose of the research. Section two consists of the literature review that covers chassis regulations, legislations, box rules, ownership, availability, interoperability, and mismatch issues. It also covers the impacts of the steel and aluminum tariff, impacts of the pandemic, safety issues, billing issues, and proposed ways of improving chassis provisioning. Section three discusses the methodological approach to the research and describes the study area. Section four analyzes the data collected, while section five presents findings and conclusions of the research.

LITERATURE REVIEW

In this document, a “chassis,” is defined as the intermodal trailer used to transport 20’ and 40’ marine containers as illustrated in Figure 1. The available literature on chassis is limited but does highlight several challenges that affect the workings of the chassis system in the U.S. with so-called “box rules” being one of the most emphasized as they are often linked to the box rules, such as the increase in the cost of operations, chassis availability, interoperability, and mismatch issues, complicated billing systems, and safety issues as it regards chassis users (White, 2021, Ashe, 2021, Berger, 2021 Manning, 2023). Recent developments, especially with respect to the regulation of chassis by various stakeholders are summarized below.

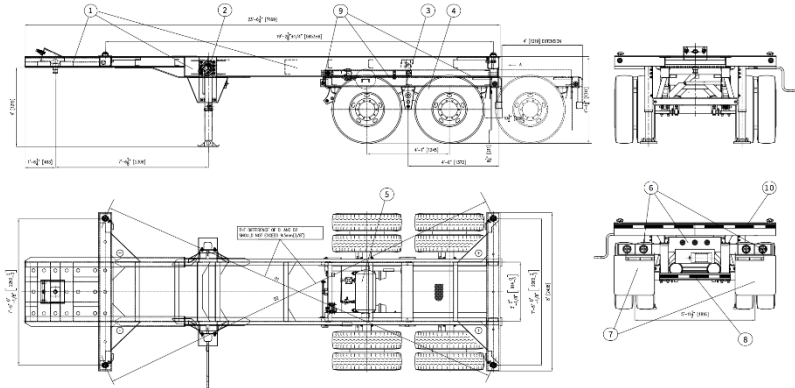

Figure 1: A diagram of a 23.5-foot slider chassis. Source: DCLI (2023).

Box rules, chassis ownership, availability, interoperability, and mismatch issues

America’s chassis system is unique compared to other parts of the globe due to ownership type (White, 2021). Prior to the early 2000’s, intermodal chassis were historically provided by the

steamship companies that were also the container owner or lessee. These companies typically covered chassis maintenance and logistics as an expense that was factored into the shipping rate offered to cargo owners either directly or indirectly through intermediaries (U.S. Department of Transportation, 2022b; Levinson, 2008). Due to a variety of factors including the complexities of storing and maintaining chassis, the steamship companies began to move away from this model after the 2008 recession and third-party, intermodal equipment providers (IEP's) stepped in to offer chassis services. Under this new business model, chassis are leased by truckers and motor carriers from IEPs who own a bigger share of the market, and in most part dictate or control chassis operations. This led to the creation of a restrictive method of provisioning termed "Box Rules." A White House Fact Sheet (2022) describes box rules "*as rules that require truckers to use only certain trailers to haul their containers- thus forcing truckers to wait for the 'right' kind of trailer to become available.*" The transaction can occur at depots, railyards, container yards, or directly at port facilities as drivers check out of the facility. Truckers ultimately pass the cost of leasing the chassis to the cargo owner. Some ocean carriers maintain special relationships with IEPs that impact which ocean containers are allowed to be connected to which IEP's chassis, even though all intermodal chassis are physically compatible with all ocean boxes of the same length (Ashe, 2021). The largest U.S. IEP is Direct ChassisLink, Incorporated, (DCLI) that was originally a spinoff from shipping company Maersk that now only allows its containers to be moved on DCLI chassis. DCLI operates 140,000 of the U.S. industry's total of 600,000 chassis (DCLI, 2023a).

However, TRAC Intermodal, another of the major IEPs, defines box rules differently than other stakeholders in the industry. TRAC describes box rules as "a methodology that ensures that equipment contributors that invested the capital to purchase and supply the chassis can effectively and efficiently invoice for the use of their assets, thereby improving fluidity" (TRAC, 2023a). Again, unlike other stakeholders who maintain that box rules are a traditional practice of the IEPs across the nation, TRAC Intermodal argues that box rules exist in only two operational environments in the country including, the CCM network of contributor pools, representing a small share of chassis provisioning and the pool of pools provisioning which is found in the San Pedro Port complex. They further contend that motor carriers have no restrictions on choosing the type of chassis to use at any terminal (ibid).

DCLI has more than doubled its fleet size in the last decade. but its fleet size is now limited by U.S. manufacturing capacity, which is still ramping up to fill the gap from limits placed on Chinese-manufactured chassis units in 2020 (U.S. Department of Transportation, 2022a). DCLI and other large IEPs including TRAC, NACPC, and Flexi-van have made substantial investments in chassis upgrades such as light emitting diode (LED) lights, radial tires, and global positioning system (GPS) monitoring to modernize aging fleets (Maiden, 2021). In addition to IEPs, there are other regional, cooperatives, and private pools, that engage in the chassis business mostly due to changes that took place when steamship companies exited the chassis provisioning business. For example, at the Ports of Los Angeles and Long Beach in California, 58,000 chassis are privately leased while 57,000 are leased from a common pool primarily stocked with DCLI chassis (Berger, 2021). Similarly, the North American Chassis Pool Cooperative (NACPC) was formed by a group of 12 U.S. motor carrier companies with the approval from the USDOT Surface Transportation Board to run a joint venture chassis pool cooperative. Their major aim was to provide a cheaper, interoperable, and efficient chassis pool

model previously established by the ocean carriers under their agreement, the Ocean Carrier Equipment Management Association, Inc. (Manning, 2023).

When motor carriers face higher turnaround time because of chassis shortages, the shippers incur high detention and demurrage charges¹. According to Taube (2022), one of the major causes of such shortages is the “box rules” guidelines which restrict which chassis a trucker can use at the terminal. Some rail companies, like BNSF, charge demurrage fees because of the shortage of chassis equipment in various locations around the U.S., while some ports add to the burden by imposing an emergency fee for container dwell time at their terminals (Taube 2022). In an effort to manage the movements of containers and alleviate the challenges posed by chassis shortage in the ports of New York, New Jersey, and Virginia, Norfolk Southern (NS) offers a \$75-per-container incentive to ocean carriers to ensure a balance in the number of containers leaving or entering the ports (Ashe, 2022a). The program, called the Port Balance Incentive Program was launched on July 1, 2022 to reward ocean carriers that reach an 85% threshold of containers leaving or arriving at the ports for the next six months. Similarly, chassis trips have also increased because of higher cargo volumes due to the pandemic and trips are said to take three times longer than pre-pandemic times. However, some chassis providers have also blamed chokeholds because of congestion on roads leading to the ports or out of the ports as major causes of challenges in chassis provisioning (Salgado, 2022).

Although the model for chassis management differs from port to port, the lack of available chassis at peak times has been perhaps the single most important driver of port congestion in recent years. Data that would help measure the actual range of chassis availability for deployment include:

- Total number of “good order” chassis available for interchange at terminal gate daily opening (by size-20ft or 40ft);
- Percent of chassis that are issued “trouble tickets,” which must be processed prior to leaving the facility;
- Average number of chassis Out of Service (OOS);
- Average chassis provider-facility equipment utilization rate; and
- Average chassis to container ratio by location to measure the disconnect between the location of chassis and the location of containers (Bureau of Transportation Statistics, 2017).

Chassis Regulations

Federal Maritime Commission (FMC)

The FMC issued a final interpretation ruling on provisions of the Shipping Act of 1984 in May 2020 (FMC, 2020). This interpretation came at the request of the Coalition for Fair Port

1. Detention refers to the charge that the merchant pays for the use of the container outside of the terminal or depot, beyond the free time period. Demurrage refers to the charge that the merchant pays for the use of the container within the terminal beyond the free time period.

Practices, a section of the industry that encompasses draymen, freight forwarders, customs brokers, and importers and exporters (Booth, et. al., 2020). The request highlighted concerns over the demurrage and detention charges when delays in equipment return and/or cargo pickup were out of the control of the entities required to pay the charges. The nearly 100-page ruling offers guidance on what factors the FMC will now consider when assessing potentially unjust or unreasonable demurrage and detention practices (Booth, et. al., 2020). While the rule contains a suggested list of factors the Commission could take into consideration when determining reasonableness in delays, the guiding principle of the interpretation is that the Commission should also consider the purposes these charges have as incentives to increase freight fluidity (Booth, et. al., 2020).

From June to September 2020, the Federal Motor Carrier Safety Administration (FMCSA) issued a waiver to the Intermodal Association of North America (IANA) acting on behalf of railroads, motor carriers, leasing companies, and ocean carriers with chassis listed in IANA's global registry. Approximately 90% of chassis operated and managed in North America are included in this database (Gallagher, 2020). A three-month waiver was granted as an attempt to reduce the disruptions caused by the COVID-19 pandemic and potential chassis shortages across the country. Chassis that had inspection decals that expired March 31, 2020 or later would be able to continue to operate in revenue service (Gallagher, 2020). The Act expired on September 1, 2020 and has not been renewed.

Shipping Act of 2022

In June 2022, President Biden signed the Ocean Shipping Reform Act of 2022 (OSRA) into law. Introduced by Senators Amy Klobuchar (D-Minn.) and John Thune (R-S.D.), OSRA is the first reauthorization of the Shipping Act since 1998 and allows the FMC the capabilities to “eliminate unfair charges, prevent unreasonable denial of American exports, and improve the oversight and enforcement tools needed to crack down on unfair practices facing American consumers” (Cantwell, 2022). During the pandemic, exporters saw a 750% increase in shipping rates from \$1,300 to \$11,000 per container by September 2021 and faced supply chain backlogs that increased prices for consumers (ibid). The act clarified FMC's authority to prevent international ocean carriers from unreasonably declining American cargo, self-initiate any investigations and enforce measures regarding ocean carrier business practices, shift the burden of proof on demurrage and detention charges to international ocean carriers, require international ocean carriers to report empty containers in transport, stop retaliation against exporters and importers by international shipping companies, collect data during any time of emergency congestion, collect data on dwell times for chassis, initiate studies on the best practices for chassis management, and establish a Consumer Affairs and Dispute Resolution Services for U.S. businesses requesting assistance (U.S. Senate Committee on Commerce, Science, and Transportation, 2022).

U.S. Department of Transportation Activities

Various federal policies have been proposed to address chassis supply chain issues. The U.S. Department of Transportation (USDOT) recently released a report as the result of an executive order by the Biden Administration to investigate the supply chain crisis and has two policy recommendations that directly address the chassis shortage (U.S. Department of Transportation, 2022a; Miller, 2022). The first recommendation, considered medium impact, is to support deployment of technology to track containers and chassis and coordinate with U.S. Customs and Border Patrol (CBP) on data collection efforts. The second, considered of highest impact, is to focus on increasing domestic manufacturing of new chassis, containers, zero-emission equipment, and gantry cranes. The USDOT considered incentivizing these changes with techniques such as enhanced price preference in Federal Acquisition Regulations (FARs) updates, tax breaks, or by allocating grant money for industry use (U.S. Department of Transportation, 2022a).

U.S. International Trade Commission Investigation

On July 30, 2020, The Coalition of American Chassis Manufacturers filed petitions with the U.S. Department of Commerce (Commerce) and the U.S. International Trade Commission (ITC) alleging that “unfairly traded imports of chassis from China are materially injuring the American container chassis industry” (Jones, 2020). This action, which pits a group of U.S.-based chassis manufacturers against the Chinese firm, CIMC Vehicles (Group), the world’s largest chassis manufacturer, sought antidumping and countervailing duty relief to allow the U.S. domestic market to compete more fairly with Chinese competitors.

CIMC has a huge presence on multiple continents and manufactures a variety of goods including shipping and storage containers and oil rigs. CIMC manufactures 80% to 90% of the container chassis used in North America. China Merchants Group and China Cosco Shipping are the largest shareholders; both companies are state-owned, according to their websites and corporate filings (Horowitz, 2018). According to Wiley Rein LLP, attorneys for the Coalition of American Chassis Manufacturers, CIMC is “a Chinese state-owned enterprise (SOE) used by the Government of China to transfer manufacturing jobs out of the U.S. into China through subsidies, including tax breaks and discounted raw materials, and other unfair tactics” (Wiley Rein LLP, 2020). In October 2018, the CIMC imported more than 18,000 chassis to the U.S. This amount was approximately three times the imports in September of that year. The surge in October alone, which dropped quickly back to approximately 6,000 units in November, accounted for 27% of the total volume of imports for 2018 (Jones, 2020). The imports of Chinese container chassis sold in the U.S. market increased in cost up to 211.49% in 2020 compared to 2018 (Wiley Rein LLP, 2020).

Robert E. DeFrancesco, III, an international trade attorney and the counsel to the petitioners, said that “the industry needs 30,000 new chassis a year to maintain replacement levels, and that between 60,000 and 80,000 Chinese-made chassis were brought into the U.S. during the past year” (Wiley Rein LLP, 2020). “This is far more than the replacement number,” DeFrancesco said. “They brought in so many chassis, they had to move them into inventory and some of them are still sitting in warehouses” (Ronan, 2020). However, Frank Sonzala, CEO for the defendant in the case, insisted that the CIE Manufacturing Inc. only produced 19,052 chassis that year taking issue with the figure (60,000 to 80,000) cited by the group (Ronan, 2020).

Additionally, the quality of chassis has been a critical issue in the American trucking industry for years. American Trucking Associations' (ATA) Intermodal Motor Carrier Conference voted overwhelmingly in early 2020 to form a subcommittee to study how to improve chassis quality in the U.S. market and provide more choice for trucking companies in leasing chassis at ports or other intermodal facilities (Ronan, 2020).

After the filing, the ITC issued a unanimous vote concluding that “there is ‘a reasonable indication’ U.S. trailer manufacturers are ‘materially injured’ by the import of container chassis that are allegedly subsidized by the government of China and sold in the U.S. at ‘less than fair value’” (Jones, 2020b). On July 1, 2021, in accordance with sections 735(b)(1)(A)(i) and 735(d) of the Act, the ITC notified Commerce that this was its final determination. Therefore, in accordance with sections 736(a)(1) of the Act, Commerce directed the CBP to assess antidumping duties equal to the amount by which the normal value of the merchandise was assessed on unliquidated entries of chassis from China entered, or withdrawn from the warehouse, for consumption on or after March 4, 2021. On May 12, 2021, Commerce assessed a dumping rate of 188.05%. After adding the new percentage to the previous subsidy rate, the total rate is 221.37% (Wiley Rein LLP, 2021). The order from Commerce will remain in effect for five years or longer. An annual administrative review process can also increase the duty rates retroactively (Wiley Rein LLP, 2021).

According to J.M. Rodgers Co., Inc (2022), the nationwide chassis shortage that continues to impact supply chains throughout the U.S. does not have any end in sight after the imposed duties on Chinese-made chassis in 2020 have brought the import of new chassis into the country to a halt. The chassis shortage has left many shippers and supply chain professionals frustrated as there are not enough chassis to prevent cargo from dwelling for much longer at ports and inland checkpoints. Following President Biden’s efforts in October 2021 to help get America’s supply chain moving again, the Coalition of American Chassis Manufacturers sent a letter to the President calling on the Administration to maintain antidumping and countervailing duty tariffs on imports of intermodal container chassis from China,” the statement said. The letter notes that since the imposition of the orders, America’s chassis manufacturers have hired hundreds of new workers, with plans to hire hundreds more, invested millions of dollars to increase production and capacity, and increased production and capacity by over 400% with additional planned expansions. However, JMR notes although there have been efforts to ramp up production from other sources—including those within the U.S.—long lead times for both new orders and the construction of new facilities means there will be little positive impact in the near term. According to the Journal of Commerce, there will not be enough marine chassis produced to make a dent in the supply shortage until late 2023 or early 2024 because of rising volume, longer street dwells, and supply chain slowdowns affecting manufacturers (CNL Worldwide, 2022).

Federal Maritime Commission Ruling (2023)

On February 6, 2023, the FMC Office of Administrative Law issued an initial decision (FMC, 2023) that partially granted summary decision in favor of the complainant in the case of Intermodal Motor Carriers Conference, American Trucking Company, Inc. (*Complainant*), v. Ocean Carrier Equipment Management Inc.; Consolidated Chassis Management, LLC; CMA

CGMA S.A.; COSCO Shipping Lines, Co. Ltd.; Evergreen Line Joint Service Agreement, FMC No. 011982; Hapag-Lloyd AG; HMM Co. Ltd.; Maersk A/S; MSC Mediterranean Shipping Company S.A.; Ocean Network Express Pte. Ltd.; Wan Hai Lines Ltd.; Yang Ming Marine Transport Corp.; and Zim Integrated Shipping Services (*Respondents*).

The ruling pertains to a complaint filed by the Intermodal Motor Carriers Conference, American Trucking Associations, Inc. (IMCC) against Ocean Carrier Equipment Management Association Inc. (OCEMA), Consolidated Chassis Management, LLC (CCM), and eleven ocean common carriers (OCCs). IMCC alleges that the Respondents engaged in unjust and unreasonable practices by mandating motor carriers to use default chassis providers affiliated with OCEMA and by restricting motor carriers from choosing a chassis provider for merchant haulage movements. IMCC argues that these practices violate 46 U.S.C. § 41102(c) of the Shipping Act of 1984, as amended.

There are two kinds of movements being considered in this case: Port-to-port moves and door-to-door (also known as “through”) moves. For port-to-port moves, the customer arranges and pays for transportation from the port to the customer’s location. This is called merchant haulage (MH), which contrasts with carrier haulage (CH) in which the ocean carrier arranges and pays for transportation between the port and the customer’s location as part of door-to-door service. Generally, MH constitutes a larger share of movements than does CH. The proceeding under consideration examines practices related to MH and specifically covers four geographic areas: the intermodal rail facilities of Chicago, Illinois; the port facilities at Los Angeles/Long Beach, California; the intermodal rail facilities of Memphis, Tennessee; and the port facilities at Savannah, Georgia.

The FMC issued a cease-and-desist order directed at Respondents’ conduct in the four geographic regions identified. The practices considered unreasonable include:

CCM [Pool] Operating Rules which limit motor carrier choice of chassis providers for MH; the contractual linkage of CH price with MH volume; the designation of IEPs by Respondent ocean carriers for MH when motor carriers cannot unilaterally select a chassis provider of their choice; and ocean carrier designation of an IEP in the [pool of pools] at the ports of Los Angeles and Long Beach, while such designation cannot be altered by motor carriers for MH. (FMC, 2023)

By limiting motor carriers’ choice to select a provider, ocean carriers are in effect creating mini-monopolies by giving an IEP the exclusive right to provide chassis (Galagher, 2023). The linkage of CH and MH is problematic because the ocean carriers are contracting with IEPs for CH and MH rates, but motor carriers are not party to these contracts, and ocean carriers are not responsible for paying the MH price. Therefore, by requiring motor carriers to use a default chassis provider, this increases the leverage that IEPs have on MH prices, and the increased MH rates subsidize the lower CH rates enjoyed by ocean carriers (FMC, 2023). The IMCC did not allege that ocean carriers were setting MH prices, but instead contended that requiring a motor carrier to use the default provider limits competition, allowing the IEP to charge higher MH rates.

Although the FMC granted a summary decision on the unjust and unreasonable practices mentioned above, it denied IMCC's motion for summary decision regarding the reasonableness

of preferred or default IEPs for MH movements. According to the ruling, ocean carriers can designate a preferred or default IEP as long as these arrangements are not exclusive and do not restrict motor carriers from choosing their preferred chassis provider. However, certain actions could not be adjudicated in this proceeding. Future proceedings will address allegations concerning whether withdrawing from an interoperable pool violates section 41002(c). IMCC argues that when ocean carriers enter contracts with non-interoperable proprietary pools, it grants pricing power to IEPs over MH movements (ibid). Moreover, removing assets from an interoperable pool limits the availability of units for other ocean carriers and can lead to the collapse of such a pool. Though the FMC lacks jurisdiction to require IEPs to contribute chassis to an interoperable pool for the benefit of motor carriers, it may order Respondents to cease and desist from withdrawing from interoperable CCM pools if IMCC can demonstrate that such withdrawals violate the Shipping Act of 1984.

This ruling is being appealed. On March 7, 2023, Respondents filed an exception to the Initial Decision Partially Granting Summary Decision (ID). The arguments put forth by Respondents emphasize an alleged misapplication of summary judgment standards in the ID and call for a reversal of the granting of summary judgment. They assert that according to applicable law, reasonableness of conduct cannot be determined where material facts are in dispute. The ID is criticized for deeming certain conduct unreasonable without assessing its factual impact or identifying any Respondents engaged in such conduct at specific locations. Respondents challenge the approach taken in the ID, contending that it improperly weighs evidence and draws conclusions regarding the alleged linkage of CH/MH volumes, overlooking evidence of motor carriers being able to negotiate discounts. Moreover, Respondents assert that the ID's treatment of exclusive dealing agreements reflects an outdated interpretation of antitrust laws and erroneously imposes the burden of justification on the Respondents (ibid). Exclusive arrangements are recognized as often procompetitive and generally lawful, yet the ID seeks to compel Respondents to justify their conduct. In calling for the ID to be reversed, Respondents assert that either the Complaint should be dismissed or that the case should be remanded for the court to resolve material issues of fact and apply the 'end in view' standard (ibid).

Respondents contend that the orders put forth in the ID are not within the FMC's statutory authority. They point out that the ruling would divest carriers from IEP agreements for MH movements and direct motor carriers and IEPs, neither of whom are subject to FMC jurisdiction, to enter into contracts for those services (ibid). Legislative intent of applicable law supports the FMC's primary purpose of minimizing regulation and government involvement in shipping operations while protecting carriers, shippers, and ports from unfair or discriminatory practices. Respondents assert that motor carriers, like railroads, fall outside of this zone of protection as surface transportation providers (ibid). Moreover, Respondents emphasize that the ID jeopardizes the fundamental business model of IEPs, who have made substantial investments in chassis assets and operational costs and may subject Respondents to liability for breach of chassis supply agreements with the IEPs.

Improving Memphis Supply Chain Act (Pending)

The Improving Memphis' Supply Chain Act was introduced in the U.S. Senate in November 2021 by a bipartisan team of Tennessee legislators (U.S. Senate, 2021). The bill's

main provision is to enact a gray² chassis pool in Memphis, and to empower the DOT and FMC to determine chassis rates, depot facilities, and the pool administrator (Ashe, 2021). The bill is endorsed by some Memphis stakeholder groups including ATA (American Trucking Association) and IMC (which owns the IMC Depot). The bill also contained provisions for regulating D&D fees, although these have since been partially addressed by the recently passed OSRA-22 law (U.S. Senate, 2022). The Improving Memphis' Supply Chain Act would effectively eliminate alliances between ocean carriers and IEPs in Memphis, earning it formal opposition from IEPs who operate in the region including DCLI and TRAC. The IEPs claim that the bill will stifle innovation and won't resolve issues where cargo owners use chassis as storage in light of labor shortages at distribution centers (Ashe, 2021). The Legislators and carrier groups maintain that too much time is lost on chassis splits and that labor issues would be alleviated by implementing a gray pool in Memphis. The last action on the bill was on November 19, 2021, when it was read twice and referred to the Committee on Commerce, Science, and Transportation.

Impacts of the steel and aluminum tariff hike, antidumping, and domestic production

The 25% tariff on steel imports and 10% tariff on aluminum initiated by President Trump's Executive Order 232, which continues under President Biden, has impacted the U.S. economy (Bureau of Industry and Security (2023)). From manufacturing, to transportation, to retail, the steel and aluminum tariffs have led to an increase in the cost of production and prices of commodities. Consumers of imports from China have been against the tariffs, leading to several hearings over the items on the tariff list. Although a few items, such as cranes used in the ports, have been exempted, chassis are not among the exemptions (Vineyard, 2018). Ashe (2018) contends that sparing marine terminals the burden of the tariffs translates into multimillion-dollar savings, without which port expansion projects would have been severely impacted. However, without an exemption for chassis, shortages of equipment are exacerbating port congestion.

The United States International Trade Commission (ITC) found China guilty of abusing its monopoly over chassis supply with unfair trade practices in March of 2020. More specifically, CIMC was found guilty of "dumping" chassis into the U.S. by flooding the market with units to manipulate prices (Maiden, 2021). The ITC responded by imposing antidumping levies which, when combined with Trump Administration tariffs, raised the price of Chinese chassis by 200% and effectively removed internationally produced CIMC chassis from the American marketplace (Berger, 2021; JOC Staff, 2021; Szakonyi, 2021).

At the same time, however, the increase in steel and aluminum tariffs has actually increased the domestic capacity of chassis production, albeit at a substantial increase in the cost of production. The U.S. owned manufacturers that produce chassis domestically are ramping up production to try and match demand. Several domestic manufacturers were expected to deliver thousands of new units by the fourth quarter of 2022, but that did not materialize due to shortages

² A gray pool is one in which multiple IEPs contribute chassis to a single pool, allowing truckers to use any of the contributed IEPs' chassis for any move, regardless of the ocean carrier's container being moved.

in parts needed to produce this equipment. Stoughton Chassis is the primary producer of U.S. chassis for IEPs like DCLI and Class I Rail such as Union Pacific and Norfolk Southern (Ashe, 2021). Based in Wisconsin, Stoughton built 10,000 chassis per year in 2020 and planned to ramp up production to 25,000 units per year by 2022, but the company was incapable of meeting its target due to inconsistencies in supplies of parts (Ashe, 2021; Transportation Topics, 2022). Other U.S. companies that produce intermodal chassis include Cheetah, Hercules, Pitts Enterprises, and Pratt Industries. Pratt Industries initially planned on growing its production capacity by 50% to 6,000 units by 2022, but had to push orders to 2023. Dave Manning, the CEO of NACP, the owners of Pratt Intermodal noted that:

Nobody is hitting the targets that they thought they would this year, and so the goal of getting on top of the chassis shortage by 2023 is probably moving more into 2024, even though chassis are being added every week... I believe it'll be 2024 before we start to feel there's an adequate supply of marine chassis (Ashe, 2022b).

The Coalition of American Chassis Manufacturers (CACM) reports that due to increased hiring and investment, domestic chassis production and capacity increased 400% in 2021 (Ashe, 2021). In addition, as of 2022, many important chassis subcomponents are on backorder, including axles, air tanks, and suspension parts. (*ibid*). Orders for new U.S. made chassis units have lead times of 9-12 months, and orders are already full through the fourth quarter of 2023 (Tirschwell, 2022). As such, counting on domestic replacements for Chinese-made chassis is not considered a viable solution by many stakeholders (Berger, 2021).

Over time, it is possible that the improving domestic production capacity of chassis in the U.S. will be able to satisfy demands, which in turn supports indigenous companies (Horowitz, 2018). Garry Hartman, the president of Cheetah Chassis, hopes that the tariffs will help revive their chassis manufacturing company, which he claimed was negatively impacted by cheap Chinese imports (Horowitz, 2018). In a letter to the U.S. Trade Representative Mr. Hartman's lawyer wrote:

Cheetah Chassis has already been forced into a small portion of the market. If CIMC's unfair practices are left unchecked, it is likely that CIMC will quickly take over the entire U.S. market for container chassis, effectively creating a virtual monopoly of the domestic chassis market controlled by the Chinese state-owned enterprises (Horowitz, 2018).

Impacts of the pandemic

Multiple aspects of the COVID-19 pandemic have dramatically impacted the supply chain and required its reconfiguration in many locations. As the pandemic set in, most consumers slashed their spending in restaurants, movie theaters, and sporting events, and bought goods like laptops and bicycles. Similarly, manufacturers and retailers raced to stock up on inventories needed to satisfy demands and avoid impacts of the pandemic (Lynch, 2021). Both activities created an avalanche of imports that congested ports and led to increased demand for chassis. This created a dilemma as meeting the spiking demand in the short term may not yield a positive return on investment when imports returned to pre-pandemic levels, thereby, discouraging extra

expenditure on chassis. Emphasizing on the demand issues for chassis, Ryan Houfek, Chief Commercial Officer at DCLI, stresses that:

There were comprehensive capacity shortages in 2020 — shortages of containers, shortages of rail cars, shortages of drayage drivers, shortages of chassis in certain markets... Just look at the numbers: demand between the trough and apex jumped 100 percent. In other words, the usage of our chassis fleet doubled over an extremely short period of time (Ashe, 2020).

The heightened demand for chassis has also been affected by the increasing average “dwell time,” which measures the actual time of picking up a chassis and returning it. Beneficial Cargo Owners (BCO) are seeing increased dwell time in ports. Nathaniel Seeds, Chief Operating Officer for Flexi-Van Leasing, notes that “...across the supply chain, ocean carriers, railroads, trucking companies, ports, and warehouse operators face the same dilemma whereby assets which are fully utilized in peak season sit idle during slack periods. There is no silver bullet to solve this long-standing issue” (Ashe, 2020). Larry Gross, founder of Gross Transportation Consulting and a JOC analyst, also added that:

Intermodal is a complex ballet, with a lot of different pieces that must be moving in a formation. Whether it’s chassis availability, having enough terminal labor, the train leaving on schedule, or having enough drayage, all the pieces need to be moving in sync, and any problem in any one of these components reverberates across the supply chain and creates congestion way beyond the immediate market (Ashe, 2020).

Similarly, stakeholders have identified pandemic related labor shortages as a significant cause of increased chassis dwell times (Maiden, 2021; Miller, 2022). Reduced workforces at distribution centers cause chassis to idle under loaded containers, while reduced staff at rail yards and ports further contributes to delays maintaining and staging chassis.

Meanwhile, employees for chassis manufacturers are also in short supply domestically. Plant operators have tried a wide range of hiring strategies to attract employees with limited success, including increasing wages, adding referral bonuses, and switching to weekly payrolls (Ashe, 2021). Stoughton Chassis, based in Wisconsin, has enacted processes to recruit laborers from as far away as Puerto Rico. Some industry players, such as port directors and IEPs, suggest that the pandemic-fueled import surge is a primary cause of declining equipment availability (Berger, 2021) (Ashe, 2021). The import surge incentivizes shippers to use chassis as storage while labor to unload is tight and yard space is dwindling (Berger, 2021; Tirschwell, 2022). According to the Journal of Commerce (2022), “Asian imports were up more than 30 percent in the first five months of the year versus the same period in 2019, and still more growth is expected.” (Tirschwell, 2022).

As the pandemic pressures ease up, dwell times are seen to reduce significantly across the nation. According to Ashe (2023), marine chassis providers have recently noted there has been reduced pressure on their capacity for provisioning because of the prompt returns of equipment. They claim that this development has allowed them to re-evaluate their strategies for more effective provisioning in the event of a future increase in cargo volumes, as in the case of the

pandemic-induced demand. Lessors believe that the key to effective provisioning is by utilizing data to make forecasts on how to position and realign their fleet so that they are readily available when required by the market (*ibid*).

Safety Issues

The Federal Motor Carrier Safety Administration's regulations mandate IEPs, motor carriers, and drivers operating intermodal equipment to establish programs that ensure regular inspection and maintenance of every intermodal chassis; to maintain proper documentation for the inspection and maintenance program; display a USDOT identifier on each intermodal chassis offered for transportation in interstate commerce; establish effective ways of responding to motor carriers complaints about defects on intermodal chassis, and guarantee that intermodal chassis are roadable before providing the equipment to the driver (Federal Motor Carrier Safety Administration, 2008). However, Watson, et. al. (2009) argue that the usual day to day walk-around or video camera inspection of chassis at check in or check out does not provide for a comprehensive inspection of chassis since some major defects might go unnoticed. Further, since drayage companies do not have control over this equipment, they are not necessarily responsible for these systematic inspections and maintenance; therefore, drivers are pressured to handle minor chassis repairs.

Another major challenge concerning intermodal chassis safety is the lack of quality data on chassis in relation to highway safety. A Feasibility Study on Collection Intermodal Chassis Crash and Inspection Data by the John A. Volpe Transportation Systems Center (2004) shows that there is no adequate annual data of marine container drays or miles traveled by these trucks, making it hard to analyze the potential safety impacts of intermodal chassis on highway safety. According to Watson, et. al. (2009), most chassis owners also save money by avoiding using steel reinforced, tubeless radial tires. They opt to use less expensive bias ply, tube-type, nylon reinforced tires which are an obsolete design that often leads to tire failure, a recurrent challenge of chassis. The report further noted that a typical chassis may also have obsolete five-spoke wheel hubs instead of the Hub Pilot system with ten studs and flange nuts, obsolete axles which are prone to failing, and lack of anti-lock brakes which are basic standards for a semi-trailer. They concluded that new chassis, not refurbished chassis, are required to meet safety standards. These factors could be related to the higher fatality rates in crashes involving trucks carrying intermodal chassis as shown in the FMCSA reports of 2023 (Ajayi, 2023). Figure 2 shows crash data involving large trucks with intermodal chassis and crash figures in comparison to fatalities from 2018 to 2022.

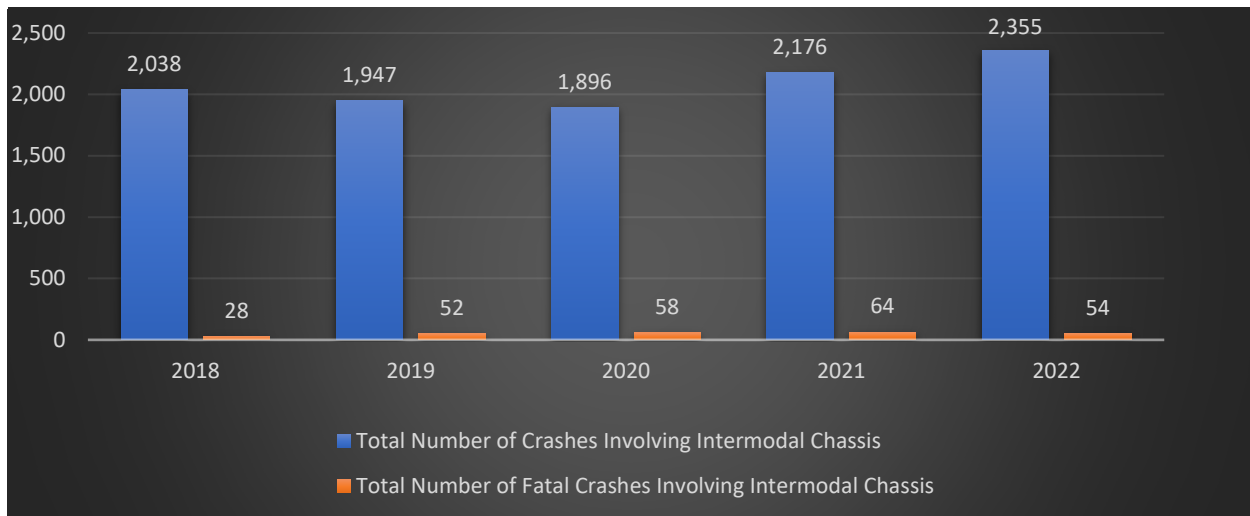

Figure 2. Crashes Involving a Large Truck with Intermodal Chassis (Ajayi, 2023)

Billing Issues

Most of today’s chassis provisioning requires various entities to settle payment tabs for each chassis utilized by truckers. Multiple invoices for several chassis owners and several chassis providers are required for those that have rendered a service to drayage companies. The current process makes it difficult to determine what entity gets what invoice. Therefore, the Port of Virginia implemented a direct-to-beneficial cargo owner billing system that simplifies the billing process through direct leasing and provision of chassis via their subsidiary, the Hampton Roads Chassis Pool (HRCP) (The Port of Virginia, 2023). HRCP uses the International Asset Systems’ (IAS) ChassisManager, a transportation technology solution that provides a neutral chassis provisioning and billing platform for its services. John F. Reinhart, the former Chief Executive Officer of the port notes “offering BCO’s the option to take control of their chassis usage and manage the associated costs is an important step in this progression” (Johnson, 2022). HRCP processes also include a pre-billing and invoicing stage where pre-bill invoices are generated for motor carriers for their review before they are transmitted to ensure that discrepancies are fixed before final invoices are issued (ibid).

Recent Changes in U.S. Chassis Provisioning

According to the U.S. Department of Transportation (2022a), the gray pool model is an efficient system to implement. The gray pool model uses a single pool manager who oversees a fleet of units contributed by multiple IEPs and unit owners. The Port Authority of New York and New Jersey implemented this model, and the Port Authority of Georgia will soon be implementing it (U.S. Department of Transportation, 2022a). The most significant attribute of gray pool management is that IEP-carrier service agreements do not apply, so any chassis can be matched to any box. Many Memphis stakeholders agree that allowing interoperable gray pool management of chassis would be the most impactful model to constructively address the chassis shortage. A Memphis supply chain stakeholder meeting led by FMC commissioner Rebecca Dye

in 2021 confirmed the local preference for a move to a single gray chassis pool (Symonanis, 2021). Associations representing Memphis stakeholders, including the American Cotton Shippers Association (ACSA), Greater Memphis Chamber; Agricultural Transportation Coalition (AgTC), and American Trucking Association (ATA) wrote to the Ocean Carrier Equipment Management Association (OCEMA) to publicly support a proposed single gray pool initiative for the region (Symonanis, 2021).

Beginning in 2021, Norfolk Southern introduced the Dual Mission Reward Program in Kansas City, Chicago, and Charleston. The program offers cash incentives to truckers who drop off one container and pick up another in a single trip (Ashe, 2022a). This move will help ease congestion at the ports.

Some ports around the country are introducing innovative ways to solve interoperability problems, but their solutions have generated even greater issues. For instance, the Port of Los Angeles Return Signal Solutions is said to create additional need for resources that are not available, without solving the problem itself (Port of Los Angeles, 2020). White (2021) describes Return Signal as a visibility platform that notifies truckers on locations and time to return empty containers. Freight Waves Senior Retail Analyst, Andrew Cox, describes the port's recent move as sticking a Band-Aid to the problem. He contends that the major issues with the return signal solutions are the lack of existing structure and staffing to manage it (*ibid*). His contention buttresses other major challenges facing America's chassis system, such as the lack of space and proximate locations for parking chassis that are inefficient for the overall system. Kempisty contends that the government should give grants to drayage companies to build capacity and acquire necessary chassis that will make their jobs much more efficient (*ibid*). In a move to curtail chassis shortages and boost agricultural exports, which have been on the decline since 2021, the U.S. Department of Agriculture (USDA) set aside funds to provide incentives to the Ports of Houston and Tacoma agricultural shippers (Angell, 2022b). The funds will be used to purchase more than 1,000 chassis for the Port of Houston, while providing incentives to the Port of Tacoma for using "pop-up" yards to stage their shipments.

METHODOLOGICAL APPROACH

The study area consists of two major global supply chain hubs in the inland southern region of the United States: New Orleans, Louisiana, and Memphis, Tennessee. To acquire a thorough understanding of the issues facing the various entities that utilize chassis in the study areas, the researchers utilized several qualitative methods. These methods allow for the flexibility of acquiring and analyzing data from multiple sources and collection methods to form a more complete picture of the entire issue (Creswell, 2014, p. 185).

Researchers interviewed various stakeholders including port officials, industry professionals, and rail representatives associated with chassis provisioning and usage in New Orleans and Memphis. Using open-ended questions, interviewees were able to guide and highlight issues because of their first-hand experience in the industry. Interviews were conducted either in person or over a video communication service (i.e., Zoom). The researchers opted to have a core set of open-ended questions as well as more targeted sets of follow-up questions depending on the occupation of the interviewee and what contact the individual has with chassis

at the port. This process allows the researcher to provide the interviewee with the opportunity to expound upon items that the individual finds important to the question, provide historical information related to the question, while still allowing the researcher to retain control over the line of questioning (Creswell, 2014, p. 191). Researchers utilized a purposeful sampling selection technique to select sixteen interviewees from the following groups: drayage providers, terminal operators, depot owners, major chassis providers (IEP), a regional chassis pool, railroad companies, a container on barge company, private chassis providers, and chassis manufacturers. Researchers opted to purposefully select interviewees rather than engage in random sampling or large pools of interviewees because it allows for the selection of participants “that will best help the researcher understand the problem and research question” (Creswell, 2014, p. 189).

The selection of key individuals also allows the researcher to keep responses from becoming overly saturated. Allowing the researcher to control when to stop collecting data when additional data no longer produces insights or is no longer helpful to the research questions (ibid, p. 189). This allows the researchers to judiciously use their time and resources to answer research questions in a timely and efficient manner.

Responses to the interview questions were recorded in person, by the video call service (Zoom), or via an audio recording device. The advantages of using both in person and video call procedures are ease of access to interviewees, the ability to allow the interviewee to provide historical information on the issue, and the broader control this type of process gives the interviewer to control the interview (ibid, p. 191). The limitations of both in-person and video interviews are the potential for the interviewer to gather indirect information from the view of the interviewees, the loss of observation or interaction in a natural field setting, the potential for the interviewer to bias the responses by their interaction with the interviewee, and the potential for loss of information due to an interviewees interview skill (Creswell, 2014, p. 191). Zoom transcriptions are time stamped and access controlled to allow the researcher to easily access key points in the interview and to control who has access to the information (Zoom Support, 2022). Interviews recorded using other devices were transcribed using Microsoft 365 transcriber. Transcribed interviews were then cleaned to remove data unrelated to the study. Data collected from both New Orleans and Memphis interviews were categorized into thematic narratives.

Finally, researchers engaged in participant observation at the Port of New Orleans and the Port of Memphis. They chose to visit both ports to view firsthand operations with chassis in the port setting and to better inform the questions used in the interview portion of the research. In these visits, the teams acted as complete observers, meaning the researchers observe without participating (Creswell, 2014). This observation style requires the researcher to take notes “on the behavior and activities of individuals at the research site” (ibid). The researcher then takes these observations and catalogs these activities for further analysis to inform his/her research. This technique allowed the researchers to gain a better understanding of daily interactions with the current chassis systems to identify questions that would be vital to understanding the problem at hand.

New Orleans, Louisiana

The Port of New Orleans is a deep-water port strategically located on the Mississippi River as a crucial gateway for cargo traffic entering and exiting the United States through the Gulf of Mexico. It has the capability to service the needs of ocean carriers and shippers at an annual rate of one million twenty-foot equivalent units (TEU) (Port of New Orleans, 2023). and is currently the only container port in the State of Louisiana., (Port of New Orleans, 2023). In addition, the port has access to more than 30 major inland hubs such as Memphis and Chicago via 14,500 miles of waterways, Class I railroads, and interstate highways including I-10 and I-12 See Figure 3.

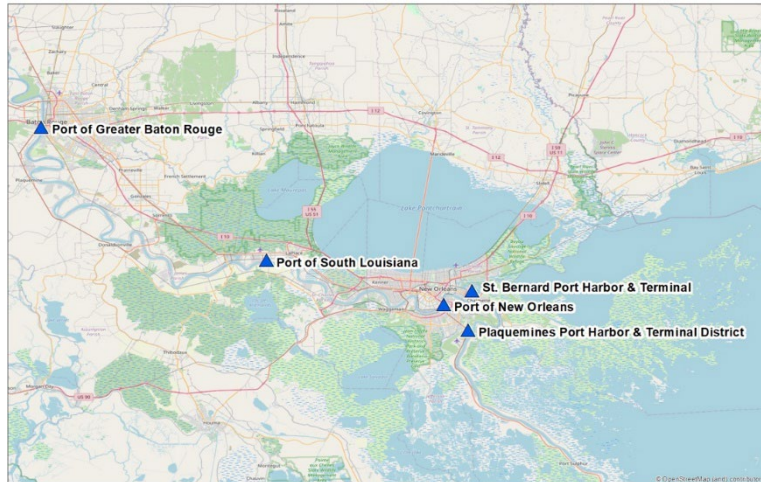

Figure 3: Ports Along the Lower Mississippi River.

New Orleans is the only seaport in the United States served by six Class I railroads: Burlington Northern Santa Fe (BNSF), Canadian National (CN), Canadian Pacific Kansas City (CPKC), CSX Transportation, Inc. (CSX), Norfolk Southern (NS), and Union Pacific (UP) (New Orleans Public Belt Railroad, 2023). These railroads are connected by the New Orleans Public Belt Railroad (NOPB) and comprise a 132,000-plus mile network of track, which ties the New Orleans port community and local industries directly to every major North American market (New Orleans Public Belt Railroad, 2023). Due to its unique combination of location, intermodal connectivity, capacity, and industry specialization, as well as the other ports that make up the Lower Mississippi River Port Complex make the New Orleans region a competitive option for shippers and carriers looking to move cargo through the inland waterways of the United States and the Gulf of Mexico (Port of New Orleans, 2023). See Figure 4.



Figure 4: Infrastructure in the Greater New Orleans Region.

The U.S. Department of Transportation, Bureau of Transportation Statistics (2023) includes New Orleans among the “Top 25 Ports by Tonnage, Dry Bulk, and Container.” The Port of New Orleans is ranked fifth for total tonnage, second for dry bulk tonnage, and eighteenth for container throughput by TEU., Furthermore, the report notes that New Orleans has a total of nine cranes for container ships, with four being Super Post-Panamax and five being “other.” On-dock rail access is also available in New Orleans.

The Mississippi River plays a critical role in freight movement in the United States. In 2020, more than half of the 165.5 million tons of freight that moved between the 12 states touching the Upper Mississippi System and Louisiana were carried by the river (ibid.). The report noted that the percentage of freight carried by the river to Louisiana is much higher for some states, such as Indiana, Missouri, Illinois, and Kentucky. However, low water levels on the Lower Mississippi River have hampered the flow of freight, especially on the stretch between Cairo, Illinois, and Memphis, Tennessee.

New Orleans and Memphis are both critical links in the freight supply chain, as they have both rail and road connections. However, the lower water issues in 2022 have presented a challenge to the ability of the land modes to absorb demand from maritime, as a significant amount of freight is carried from other states to Louisiana by the river (Bureau of Transportation Statistics, 2023). Inland ports have become more important than ever as bottlenecks on the West Coast have triggered backups at East Coast gateways over the past several years, creating a new context for demand at a port such as the Port of New Orleans (Berger, 2022). Inland ports can improve the movement of imports and exports by shifting time-consuming sorting and handling farther inland, away from congested seaports (Comerford, 2020). This can help alleviate some of the congestion at coastal ports and provide a more efficient alternative for shippers looking to

move their cargo. Insufficient access to chassis due to inefficiencies and shortages undercuts these advantages by slowing down movement of freight by truck, exacerbating supply chain issues.

Chassis pools in New Orleans include the Gulf Consolidated Chassis Pool, LLC (GCCP), the TRAC Gulf Regional Pool (TGRP), and Direct ChassisLink Pools (DCLP). IEPs include the New Orleans Chassis Pool Cooperative (NACPC), TRAC Intermodal, DCLI, and Evergreen. NACPC equipment is available in CCM-managed pools such as GCCP (NACPC, n.d.), and DCLI and Evergreen both operate out of the DCLP which is a proprietary pool (DCLI, 2020). TRAC Intermodal chassis are available at six different TGRP locations in New Orleans (TRAC Connect, n.d.). Additionally, FlexiVan has a depot for managed fleet or term lease chassis (FlexiVan, 2023).

Memphis, Tennessee

The city of Memphis is one of the largest freight centers in the U.S. (Bearth, 1999). The confluence of two significant interstates (I-55 and I-40), five Class I railroads (BNSF, UP, CN, CSX, and NS), the country's largest cargo airport (which anchors FedEx), and a major inland waterway port make it one of the United States' most important intermodal hubs (Bearth, 1999). For the purposes of this report, researchers primarily considered the infrastructure that facilitates the movement of containerized ocean imports into Memphis and the export of other goods and assets. The locations of these facilities are presented in Figure 5 and are discussed further below. The intermodal routes are represented as blue lines which depict common chassis moves, or "splits," between depots containing chassis pools and railyards. Stars represent depot locations while labeled dots represent railyard locations.

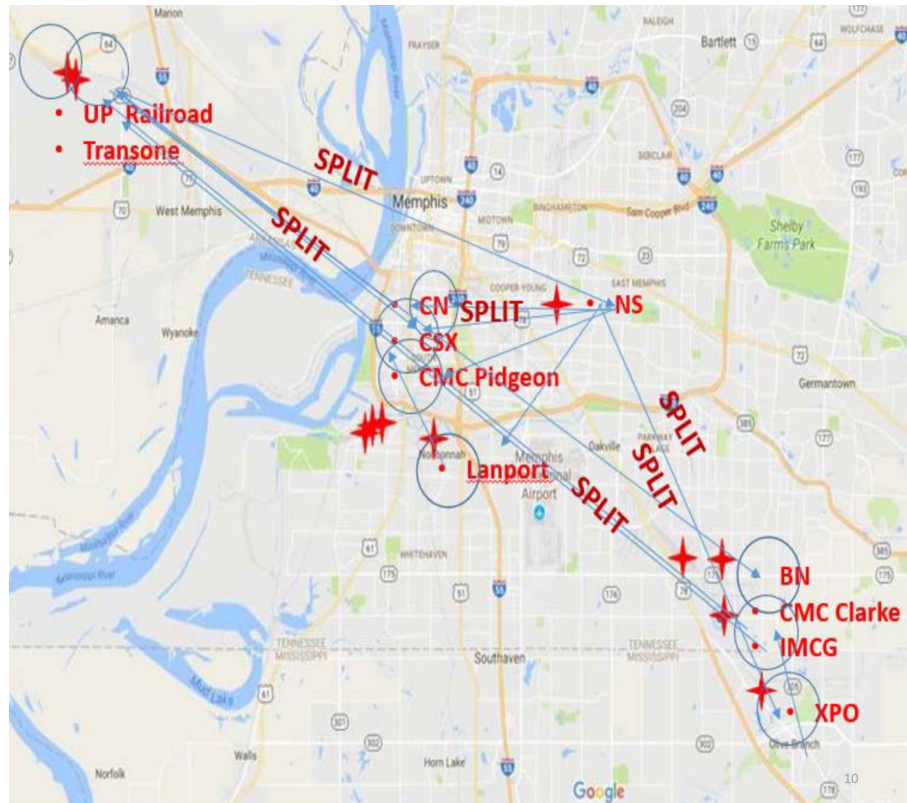

Figure 5: Memphis Intermodal Routes Source: (Symonanis, 2021).

Five Class I rail lines, (BNSF, UP, CN, CSX, and NS) operate in Memphis, and each has at least one intermodal container terminal. CN, CSX, and NS are grounded facilities, meaning that containers are taken off incoming trains and then stacked on site. When the containers are ready for subsequent movement by truck, the containers are loaded onto chassis for inbound truckers via cranes, side-loaders, and transporters so that truckers need only hook up to the loaded chassis and then depart. Most countries other than the United States use grounded operations to handle intermodal rail operations (Gross, 2021). On the other end of the spectrum, UP's and BNSF's terminals are designed to be fully wheel-based. This involves aligning street chassis beside loaded train cars, where cranes then transfer boxes directly onto the chassis units. Truckers may position the chassis alongside the train themselves, or yard transporter and hostler vehicles may move the loaded chassis to a drayage truck pick up area for a theoretically frictionless handoff to drayage operators. BNSF's Memphis railyard (Figure 6) for example has 5 cranes, 20 workers per shift, and 10 transporters to complete wheeled freight transfers. An example of a wheeled transfer is shown in Figure 7 where a gantry crane completes a container transfer from a railcar onto a waiting chassis at the BNSF Intermodal Facility. Note that a drayage truck positioned the chassis, rather than a yard vehicle. The primary difference between wheeled and grounded facilities is that, in the former, truckers are not expected to bring chassis to the yard, while in the latter, truckers must bring their own chassis or find a pooled chassis on the yard during the pick-up. Although designed for operations where cranes load containers

directly on or off wheeled chassis, BNSF’s railyard in Memphis has adapted and now also stacks containers when chassis are unavailable. As such, it is considered a hybrid facility.



Figure 6: The BNSF Railway Intermodal Facility in Memphis, TN.



Figure 7: Wheeled Vehicle Operations.

Memphis is home to hundreds of container yards and depots that store, maintain, and lease intermodal containers and chassis. The IMC Depot is Memphis’ largest intermodal depot and boasts a large number of freight services (IMC, 2022). The 160-acre facility has capacity for 2,500 grounded units and capacity for 3,500 wheeled units. To manage the containers, the depot operates four side loaders and/or top picks and two hostler tractors. An example of IMC side loader operations is shown in Figure 8. In terms of drayage services, IMC’s Memphis location has approximately 70 company fleet drivers and 135 owner operators providing intermodal

drayage services, primarily within thirty miles of the facility, while third party vendors are used to move freight beyond this radius. IMC also maintains satellite terminals in Nashville, Tennessee, Birmingham, Alabama, and other locations to support the movement of freight from the Memphis market. IMC provides depot services for nearly all the regional IEPs and the nonprofit Mid-South Chassis Consolidated Pool (MCCP) chassis pool. IMC acknowledges the impact of the chassis shortage on its operations and boasts that its side loaders and top picks differentiate it from smaller drayage providers that are unable to access chassis stuck under boxes. Indeed, many local Memphis drayage providers employ 10-20 drivers and rely on railyards and depots as a source of chassis units.



Figure 8: A side-loader mounts a 40' container onto a compatible intermodal chassis.

The Memphis region hosts approximately five major chassis pools, which provide approximately 25,000 total units to the Memphis area. The MCCP is unique in that it is the only non-profit pool in Memphis. It boasts a fleet size of about 10,000 units, is experiencing 94% utilization of its fleet, and average dwell times between 21 to 26 days for its marine units. These dwell times substantially exceed the preferred dwell time of three to four days for a well-functioning supply chain (U.S. Department of Transportation, 2022) (Consolidated Chassis Management, LLC, 2023). The other four chassis pools are operated by for-profit IEPs, such as DCLI. However, DCLI did report that it increased its overall Memphis fleet size from 1,500 units to 5,000 units between 2020 and 2021 in response to elevated demand (Ashe, 2021).

ANALYSIS

Sixteen major stakeholders in the logistics supply chain were interviewed concerning the chassis system in New Orleans and Memphis. It is important to note that some of the respondents engage in multiple lines of business within the logistics supply chain as it concerns the chassis system in the region. Respondents were asked a series of questions related to the chassis system, its challenges, and remedial ways to address those challenges. A copy of the questions can be found

in Appendix I. For reasons of business confidentiality, all responses are anonymous except where the interviewee is specifically identified.

Data collected were categorized into the following thematic narratives:

- Theme A. Chassis Availability, Interoperability, and Mismatch Issues
- Theme B. Operational Cost Vulnerabilities
- Theme C. Billing System Complexities
- Theme D. Steel and Aluminum Tariff Hike/Antidumping/Domestic Production Impacts
- Theme E. Pandemic Issues
- Theme F. Safety Issues
- Theme G. Suggested System Improvement

Theme A. Chassis Availability, Interoperability, and Mismatch Issues

The main difference between a chassis from one pool to another is a spray-painted acronym along its beams denoting a chassis’ ownership. According to the majority of interviewees, chassis-container matching agreements create artificial shortages of chassis at wheeled rail yards and can result in unproductive moves for drivers. Figure 9 depicts a typical iteration of this process as follows: a truck enters the yard to pick up an assigned container; the driver is assigned a row and location to receive containers from the train but is not given the location of the appropriate chassis that would match up with that container. Instead, the driver is expected to search the yard’s pools for the appropriate chassis before pulling up to the ramp to receive the container. In many cases, there are numerous chassis available, but they predominately belong to a single IEP’s pool. If this IEP’s pool is contractually incompatible with the incoming freight’s containers, drivers are left scrambling to find compatible chassis wherever available.

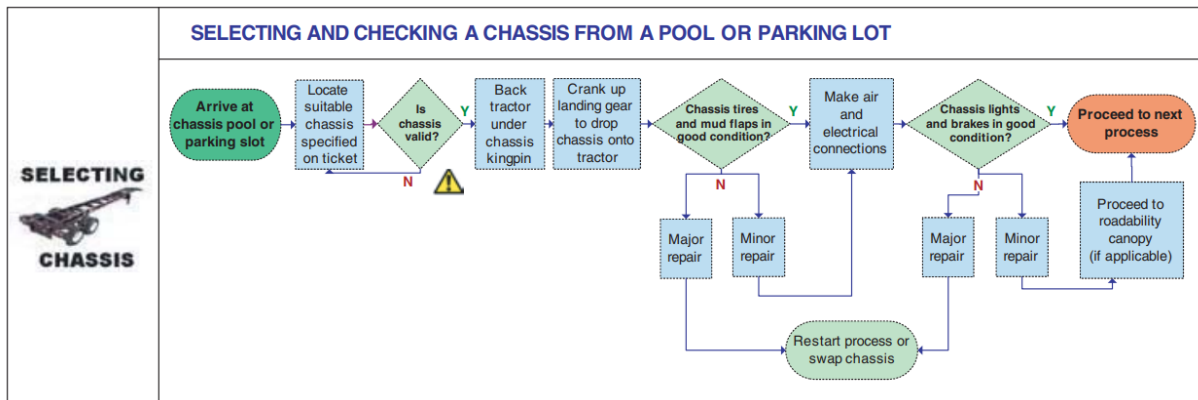

Figure 9: Chassis Subprocess (National Cooperative Freight Research Program, 2011).

A major drayage company operating within 300 miles of Memphis noted that drivers usually first interface with chassis at the railyard, and that grounded terminals are most often where the largest issues arise with chassis. All Class I rail lines have at least one intermodal container terminal in Memphis. CN, CSX, and NS are ground-operated facilities. It was noted that drivers can usually count on containers to be mounted, so trucks will show up “bobtailing,”

or without anything in tow. Further, when returning empty containers to these facilities, truckers should expect to forfeit the chassis on which the empty is mounted. For wheeled operations in UP and BNSF facilities, it is impossible to leave with a mismatched container-chassis combo due to automated exit portal technology. While all intermodal chassis are physically compatible with all intermodal containers, due to contractual deals between steam liners and IEPs, automated portals do not allow drivers to exit the yard with mismatched container chassis combos.

Another drayage company in the Memphis area echoed similar challenges with chassis availability at the terminals, causing significant headaches for the company's depot. They blame the IEP chassis-container combination contracts and the import surge that was caused by the pandemic as the causal factors for chassis shortages. Further, it was noted that near the beginning of the crisis caused by the chassis shortage containers were being left at the railyard due to the lack of availability of compatible chassis. Customers became frustrated by the high cost of railyard storage fees and decided to take any measure to get containers off the yard, including using chassis as "warehouses" due to their lower leasing rates. In order to clear their ramps, three of the Memphis region's five rail yards chose not to enforce proper container to chassis mounting. These three facilities are wheeled and mount the containers onto chassis for the drivers, who pull up, hook up to the load, and depart. The hybrid and wheeled rail yard facilities enforce chassis-container combinations but do not set aside the correct chassis for drivers, which forces truckers to do the railyard's hosteling for them by driving around the yard in search of compatible and serviceable chassis units. In some cases, the drivers even dismount empty boxes from chassis then take the chassis for their next movement, which is typically a yard hostler's responsibility. According to the interviewee, this reduces truck move productivity by 21% and is a source of significant frustration for drivers, who believe that the process is unfair (since truckers are not paid for their yard hosteling moves) and should be streamlined to be as simple as possible. One of the interviewees provided the analogy of a customer at a rental car company who expects to drive a car off the lot that is in working order and ready to go.

In similar fashion, some drayage companies complained that the present system hurts their productivity. One operator mentioned the difficulties of competing with the railroads and steamship companies, who set the rules and restrictions of moving freight, arguing that this phenomenon has also led to the decline of the intermodal markets in Memphis and New Orleans, with the blame solely placed on the steamship companies' control of what happens and how it should happen. Speaking on mismatch and inoperability of the chassis system, it was noted that:

New Orleans has evolved over the last 10 to 12 years to 15 years. It had a pool chassis that was universal on the river that you can use across all lines. As the ocean liners decided to get out of the markets, things have become much more complicated. You now have a pool that does barely exist. In New Orleans for instance, it is dominated by two major third party providers, each representing different shipping lines but the same customer base. With that type of system, we don't have interoperability between ocean lines and their different chassis providers. And it's the reason why we think it's more difficult to operate. We go into a port in New Orleans, and you turn in the TRAC with a CMA ocean liner, and you now need to pick up a DCLI chassis so you can go get a MAERSK or MSC box. Whether they have them or not, which is another problem, right? You are

dropping one and you need another, but they don't have the other. It's just inefficient.

Due to these inefficiencies, the motor carriers had to start buying their own chassis to keep things moving. The interviewee also noted that:

So, in my operations. I have almost 300 chassis that I control myself. They're private chassis and when it's a private chassis the terminal operations on behalf of the ocean liners cannot restrict you from using your own equipment but can restrict you from using a third-party chassis provider. To certain ocean liners, they may need an approval. But if I go in with my own chassis, which I do, they can't tell me what I can pick up or what I can't pick up. So, I am getting improved efficiency with my own equipment. Whereas I can't get similar efficiency with an ocean liner control third party chassis.

It was also mentioned that although the steamship companies do not really like what the company is doing, they cannot stop them from doing it.

In many ways, the drayage companies are living with the rules that the steamship companies are making without taking into consideration the impacts it may have on trucking operations concerning availability, interoperability, or even safety. A motor carrier also raised concerns about the complete separation of chassis systems between New Orleans and Memphis, which has impacted productivity at the Port of New Orleans. The rail service and what they demand in Memphis is a totally unique situation compared to what is obtainable in New Orleans' port. Further noted, "so you won't integrate those two chassis systems. As long as Memphis is getting cargo from FedEx, the East Coast and West Coast, which they are, I don't see that in a robust way changing until the two systems are integrated."

Another drayage company operating out of Memphis and New Orleans also agreed with the other truckers on the challenges they face, noting that 30% of their driver's time is spent chasing down the right chassis, thereby wasting productive time. Memphis has a gray pool with MCCP and a private pool, with the railroad having wheeled and grounded facilities, while the ports have a grounded facility which allows for private chassis to go in and out and have control of that chassis. However, Memphis and Kansas City went to their knees throughout COVID. It was stated that:

The problem of chassis supply, which was exacerbated by chassis restrictions was at a critical level way before COVID. We have been talking about the problem with chassis restrictions, specifically something we call box rules. Box rules is a predetermined usage by ocean carriers for chassis when train arrives at the terminal. What happened in Memphis during COVID, and I'll take 2021 for example, is that we appealed to the Surface Transportation Board (STB) for urgency or relief of storage and appealed to the Federal Maritime Commission (FMC) for immediate relief on jurisdiction on IEP through movement of containers, all due to lack of chassis supply. When that train arrived for MSC and MAERSK there were no DCLI chassis, so the container was grounded. When the train arrived for CMA, there were no TRAC chassis available, so the boxes were grounded too, yet the storage and

demurrage clock continued. The detention charges on those boxes continued. We estimate that an over 8000% increase in costs for our shippers occurred. Even when there was a chassis that was available in Kansas City, for example if TRAC chassis was available, we couldn't go get it because DCLI was the preferred carrier by the ocean carrier. Similarly, the railroad follows the ocean carriers' rules, entering contracts with the ocean carriers on their chassis preference. Therefore, when the train arrives. and there is not enough chassis, those containers go to the ground. For us as motor carriers, can you imagine the frustration when you go to the railroad, and you have this type of process?

It was emphasized that motor carriers must wait for notices on chassis availability through emails or by going to a website to track chassis availability. In that process, they might get a DCLI email that says, "here is your availability of chassis today," also pointing out what chassis they may accept or not accept. Similarly, a motor carrier might continue to get email after email showing zero availability or get an availability, but by the time the driver gets to the terminal they are not there anymore. Further noting, "it's just silly. This experience for the driver doesn't make sense."

A drayage company with a large presence in New Orleans and Mobile also maintained that the challenge with the chassis supply system is mostly that of a mismatch, that there are days when there are plenty chassis available, and there are days when it is not even a concern. But in those days, where there is a concern, it comes with delays. The company's dispatchers and operations staff must juggle schedules and get a plan laid out for future days, but they may end up not having any chassis which distorts their operations. This forces them to push dispatches out on the calendar, which could mean additional chassis usage days that incur additional charges. Sometimes the company is forced to go to court for demurrages, which can be very expensive. It is common to have ocean carriers delay arrival after informing the port terminal, and other stakeholders in the multimodal system. The drayage company notes that:

Ocean carriers give you an open date when they are going to receive export containers, so you may access the right chassis and container, but the ship does not arrive on time, and they close the gate with that particular ship. Those containers must dwell on our depot until another ship going to that part of the world is available.

It was emphasized that sometimes they could have up to 80 export containers in their yard in New Orleans, just sitting and waiting for a ship to arrive. In this situation, the truckers must hold onto the chassis they are provided, and wait until the ship arrives, because getting rid of the equipment will make no sense. This complication means that the major chassis providers are also facing similar challenges as the truckers. The drayage company owner argues that "So you talk about chassis shortages, you know, I cannot throw sticks and stones at TRAC leasing or DCLI because their chassis are being tied up because nobody can get containers on the right shift, because it doesn't exist."

A container on barge company noted similar challenges in the container on barge business, although they claim it is rather a recent development. While the chassis issue is a small piece of their business, it has caused significant disruption to their daily operations. The issue the

company has is the inability to reload their barge with containers from Point C back to Point A because their competitor owns the chassis and would not allow them to use the containers unless they pay a premium. The container on barge company notes that:

The way it has worked so far is we load up 66 containers for one customer in New Orleans, we shuttle those to Houston, discharge in Houston, then reload a set of 72 empties of 20ft containers from Houston and bring them to Port Allen. We then discharge empties in Port Allen, and the intent is to reload loaded containers at Port Allen and bring them to New Orleans for export. Where these chassis come into play is that we now can't reload at Port Allen, because the containers came in on chassis that belongs to someone else, and they want compensation for bringing them. So, you would have to pay, and they're not getting it from us. Again, we have nothing to do with chassis, and that's an ownership issue, not so much a shortage issue.

Similarly, a major regional chassis pool organization reports that the chassis shortage has significantly impacted its operations. The organization contended that at least 10% of its chassis units were in a depot being repaired at any given time prior to the pandemic. In addition, the average chassis dwell time was about seven days. Now, a full 94% of the organization's chassis are deployed by clients, and the average dwell time has tripled to at least 20 days. A special portion of the staff which had been dedicated to following up with clients whose chassis have been out for 90 days, was recently redesignated to follow up with clients that had units checked out over 120 days. Due to rail line storage fees and BCO labor shortages, it was put forward that chassis are being used as cheap storage options, which causes dwell time increase and hampers unit supply.

One of the largest providers of intermodal chassis in the U.S. has refuted most of the claims of the drayage companies on the scarcity of chassis and the claim that they are supplying old and unsafe equipment to the truckers. It was also stated that the Port of New Orleans has not been much of a challenge because it is a smaller marine gateway compared to other marine gateway markets such as Southern California, Oakland, Houston, New York, New Jersey, Savannah, and Charleston. However, it was emphasized that there were some spot shortages during the two-year pandemic demand curve. The company argued that they always made sure the Port of New Orleans had plenty of chassis to be able to operate at a comfortable level, and that the company strategically positions their daily operations to accommodate varying levels of chassis by using a network with neutral pools and geographic areas, making chassis fungible, enabling them to quickly respond to their customers' needs and reposition assets. The company has moved 80,000 chassis across the country to meet commercial demand based on peaks and valleys of respective markets across the network during the pandemic. The interviewee notes:

So currently we provide a chassis pool of equipment that can be used by any of our clients, our clients being ocean carriers, or drayage companies, and those chassis can be used either in a wheeled environment or in a grounded environment. We also provide enough equipment to satisfy our ocean carrier demands wherever we are the selected IEP, both from a merchant haulage and a carrier haulage perspective, and we clearly understand that we may not get all that business because a carrier may opt to use a chassis of their choice for merchant haulage, but we take

on the financial responsibility of making sure we're properly fleeted to handle 100% of that business. That's the risk that we as an IEP take when we agree to supply an ocean carrier with chassis provisioning.

The interviewee also emphasized traffic congestion as a major hinderance especially for drayage companies, which face delays and increased insurance premiums, comparing the situation in New Orleans to a terminal in Seattle, which also faces similar challenges due to its location in the heart of downtown.

A terminal operator notes that they are responsible for seeing that everything runs smoothly, and that the organization is meeting its productivity and safety goals. The terminal spends a lot of time communicating with its team and with customers to make sure that they are meeting their needs, including collating, and analyzing data and adjusting their operations to optimize productivity and efficiency. However, the interviewee argued that the biggest challenge they face is managing the unpredictable nature of the business, talking about uncertainties for the arrival of ships and the lack of knowledge of how much cargo they may carry. This means the terminal must be very flexible and adaptable in their operations. This issue of unpredictability has been echoed by other stakeholders, including the drayage providers and major chassis providers. The terminal operator also contended that chassis availability at the terminal often changes depending on the flow of cargo, noting that:

You can go from having started the day off with 100 good chassis and by the end of the day you have none on the terminal. So, it all depends on the flow of cargo. That's my understanding. Right now, a lot of the other ports are starting to get excess chassis because the imports are down.

Another issue the terminal operators raised is the opposite side of chassis scarcity; when chassis come back to the terminal, they consume so much space that otherwise could be utilized for other port activities, and chassis storage spaces are typically not paid for by the chassis owners or users. The terminal operators prefer a system whereby the chassis are stored in a separate location away from the terminal to go to those depots to get their chassis before coming into the terminal. Major chassis providers agree with a similar system of chassis storage too. Contending that:

I will say this, that our company is a big believer in not allowing chassis to reside on marine terminals. We support a marketplace where chassis are off terminal; it frees up valuable waterfront property to allow for incremental growth on import-export business, and we like to be able to control our equipment, so that we ensure we put a safe and reliable piece of equipment out on the road. We built that model in New York- New Jersey, and we helped implement that along with many other key stakeholders. In New York and New Jersey, which is now the largest gateway marine gateway in North America, every chassis resides at chassis distribution points, no chassis are on any marine terminal, and it allows us to effectively compete against our competitors, also allows the drayage community to have true choice in what they want to pick up.

On the other hand, according to motor carriers, to implement a similar system in New Orleans or Memphis would be an extra cost in their operations because the trucker will have to waste time going to different points before coming to get cargo at the port.

Theme B. Operational Cost Vulnerabilities

The drayage companies believe that the current chassis system unnecessarily increases their cost of doing business, an issue that they believe also affects the BCO. Another major challenge is that of the quality of the chassis available, a problem that could lead to additional expenditures in repairs and maintenance of equipment that is not their own. A drayage company owner operating from New Orleans noted that because they spend a significant amount of money to service other company's chassis, in addition to the scarcity and inefficiency of the current system, it makes better sense to invest and own their own chassis. Citing an example on their expenditures on third party chassis, the interviewee notes that, "as recently as 5 years ago, in a \$20 million per year business, we spent up to \$500,000 annually to service third party equipment." The drayage company owner contends that the major chassis providers continue to use old style rims that are outdated, with brakes that may be in the region of 50% efficiency, stating that:

They don't change any other mechanics on the chassis, they may repair the lights if it is necessary, but not replace the light. For the long term, if I'm going to have to maintain my piece of equipment that I own, I would not do that kind of half repair patch work, right? But the providers do that and then put the chassis back out there for the trucks and then they're going to make the truckers do their own repairs on the road. When that tire goes out or that brake locks up and suddenly, the two tires get flat, the providers will make you bear the cost. They blame us for everything that they are not doing right. They blame us for it, and then I'm going to have to replace those two tires. So, owning my own chassis saves me most of these troubles, hence the \$500,000 expense that I had for fixing other people's equipment five years ago, now goes down to about \$150,000 of maintenance cost for my own equipment.

Correspondingly, the interviews show that owning chassis means additional cost of doing business for the drayage companies because it may mean divesting from their core business functions. A drayage company owner contended that:

Because of short supply and what occurs in our markets, something that nobody in the world does, when we ran into chassis shortages, we had to continue to buy our own equipment. How that affects us is that we continue to carry tens of thousands of dollars on our balance sheet. Today we own about 110 chassis, but the balance which comes from the port pools does not come close to what we usually need.

Another drayage company owner operating in the same region also voiced similar concerns about chassis provisioning, noting:

We ask our drivers anytime they hook a chassis to the truck to do a maintenance inspection on the unit, check the tire condition, and tire pressure because they're outrageously expensive if you blow one out. Sometime ago, the major chassis providers would help us doing some maintenance because they know that they're

running bad tires, so they would cover normal usage of wear and tear and of maintenance parts, but typically not tire purchase, but it was just so bad that they started covering a certain number of tires for us. But we just got an announcement last week that one of the major providers is stopping that program, meaning all the cost is going to fall back on us. So, then you can spend thousands of dollars on one chassis on the side of the highway, waiting on roadside service and buying new tires.

The interviews suggest that motor carriers waiting for a chassis predetermined by an ocean carrier is detrimental to business, a waste of time, and leads to loss of income for the drivers and the drayage company. In some railroad terminals, the railroad would not allow motor carriers to choose the chassis they use even if the motor carriers have their own private chassis, because the ocean carriers have predetermined what major chassis company provides chassis on their behalf. However, some of the railroad companies have relaxed this criterion following a recent ruling by the administrative law judge of the Federal Maritime Commission that says choice must be allowed. While some railroad companies agreed and implemented that change, some have argued that if they allow a trucker to come in the yard with their private chassis, the container they need will already be on another chassis that was predetermined when the train arrived. This forces the truckers to go into a flip line and wait for two to three hours for the container to get off the predetermined chassis and then be reloaded onto the trucker's private chassis. Some railroads charge anywhere from \$75 to \$100 for this process, which the truckers believe is an unreasonable practice. For clarification, a flip is where the driver brings the boxed chassis to a crane or side loader and has the box removed so that the driver may return to the ramp line with the now free chassis and receive the intended container. This is a laborious, time-consuming process that the driver is not compensated for, nor the drayage company, and affects timely delivery of cargo to a BCO. In an even worse case, the driver may erroneously select a chassis from the wrong pool without the crane operator noticing, resulting in a mismatched container-chassis combo.

Furthermore, railyards may not have the compatible chassis a trucker needs but may still charge the trucker for failing to pick up a container. A motor carrier reported that rail lines require that containers must be picked up within one to two days to avoid expensive storage fees. As time goes on, the container may get buried in increasingly large stacks such that even once a trucker returns with a compatible chassis, the rail liner no longer considers it cost effective to remove or cherry-pick the container "from the bottom" of the stack. The trucker is instead instructed to return during the next off-peak period, which incurs additional storage fees, which are ultimately passed to the customer. The extra time and money spent on these containers would have been saved if the trucker was allowed to mount the container onto any available chassis.

Drayage companies are of the opinion that the intense competition between the major chassis providers and the race to make as much profit as possible could be a major factor leading to the imposition of varying charges on stakeholders within the supply chain system. They argue that this is one reason why they all seek opportunities to charge the port, the ocean carrier, or the trucker for repair fees that are astronomical. A drayage company owner mentions that "with the IEPs, it only gets on and on, the conversation is always about who's going to get that repair bill. So, you know, it's great if the pools were gray then you know their waters will get muddied."

Theme C. Billing System Complexities

The interviews show that port terminals and railroads are the major sources of transaction data in the entire system. Interviewees claim that the data is usually riddled with inaccuracies, thereby complicating billing processes. Billing is often a nightmare for small motor carriers who are forced, as per the insurance rules of the Uniform Intermodal Interchange and Facilities Access Agreement (UIAA), to pay for chassis usage upfront. Drayage company interviewees point out these complexities of the billing process, which often disincentivizes chassis providers from cleaning the data. A motor carrier owner noted:

My head hurts thinking about how many times they've changed their strategy, and I know for a fact that there's mostly a form of over billing for exorbitant amount of money, and I'm glad that you have interviewed some of these people that have gotten bills a year later for over \$1,000,000 on usage because the data is a mess, and they couldn't keep track of the data.

Due to the complicated billing systems, drayage companies must spend an excessive amount of time and money on data sourcing, billing, and chassis audits. One interviewee noted "I have to pay a lady here in our office every day, you know, 40 hours a week to do nothing but to go through chassis bills. It costs us a ton of money." The billing process is such that when a trucker checks out a container, whether an import load or for export, the motor carrier is matched up to the box and the chassis coming out of the terminal through the terminal system. The terminal system feeds back information to the steamship companies and the third-party chassis providers. If it is a private chassis that is loaded on a truck, the system goes blank on any kind of billing.

In another scenario, when a trucker picks a chassis belonging to DCLI or TRAC and it then gets identified that that chassis went out with that truck carrying a CMA container, for example, the system goes ahead and identifies it as such. If the ocean carrier does not give any chassis provisioning to that customer (BCO), it means that the trucker is taking on the expense of that chassis as a motor carrier and the trucker's relationship with that customer will dictate whatever terms there are for that container and chassis. If the same truck with a CMA box and DCLI or TRAC chassis could fall under more sets of rules, such as the trucker has a particular customer, and CMA has same customer, the trucker is still billing the said customer for trucking. But CMA, the ocean carrier, now gives the chassis provisioning costs as part of their ocean bill of lading. Therefore, the trucker does not have the responsibility of that chassis, but the ocean line does. The ocean line is supposed to pay the chassis costs, and now the BCO pays the trucker just for trucking, but then pays the ocean line for the ocean and the chassis provision.

A third example is that the same truck, same chassis, same ocean line, the BCO is going to pay the ocean carrier for all the expenses, including the inland. Therefore, the trucker will bill the ocean carrier, and the ocean carrier also pays for the chassis, while the BCO pays one bill to the ocean carrier. This presents three different examples of the same gate interchange, but there are many more other scenarios according to the interviewees. Now, drayage companies must decipher different scenarios multiple times daily, a complicated and tedious job. A drayage company notes that "the billing system is confusing, and I think it was intentionally made confusing by the ocean liners or the IEPs or both. But it is easy to fix if they want it fixed."

Interviewees indicated that the ocean carriers do not talk about these issues, but they may dictate part of the control with third party chassis provider on sending all their invoices to the motor carrier. In these instances, the motor carriers often dispute it, which leads to some kind of reassessments to see who pays what, to whom and how much to be paid. One of the respondents noted:

One of the major chassis providers just recently had me cut off provisioning that they were arguing with me about being exempt because the shipper is paying them for the chassis. For six months now they have been trying to force me to pay hundreds of thousands of dollars that they would not acknowledge that they were responsible for until last week. They go back and forth to the BCO, and finally I got to the point of the providers cutting me off literally this week. Whether I agree with the billing or not, they will still bill me for the charges. Now I have to go to the BCO and say, look, these people are harassing me, and I don't care anymore but you're going to pay me because they forced me to pay them and if you want your money back, you have to go back to the ocean liner who's forcing all of this on me because they want control. That's why they're so freaked out over the FMC looking over their shoulder.

Theme D. Steel and Aluminum Tariff Hike/Antidumping/Domestic Production Impacts

Interview participants across the board emphasized the impacts of the steel and aluminum tariff increases on chassis provisioning, stating that it has caused issues in the supply chain, including delays in chassis manufacturing and supplies and a three-fold increase in costs. One of the major IEP representatives stressed the gravity of the impacts of the steel and aluminum tariffs and the U.S. Department of Trade antidumping duty on availability and quality of chassis in the country. The interviewee noted that 80 to 85% of their new built chassis come from China, and due to countervailing duty and taxes imposed, their cost tripled and are now unavailable for purchase. Unfortunately, domestic manufacturers did not ramp up their production as quickly as they agreed to during the antidumping hearings, leading to acute shortages. The logistics industry relied heavily on Chinese manufacturers, especially CIMC. The drayage companies, who have mostly been at the receiving end of the chassis scarcity issues, ended up on the side of the Chinese. In fact, a group of the drayage companies supported and funded litigations against the rulings. A carrier owner noted that:

The demand for chassis is through the roof and we have multiple limitations on supplies. So, what happens, to me, is a very illogical thing to do. We know supply is a mess. We know we can't get our hands on chassis. We know that the price of chassis has escalated and what we're saying is take the restrictions off and let's better use the supply that we have. It just makes sense. So, does it impact our business, all this other stuff going on? Of course, it does. What is happening now is, you know, truckers, shippers all trying to say, well, my God, I got to buy chassis because if I don't have private chassis, I don't have the ability to go in and out of the ports or rail terminals. I don't have the ability to pick up my own freight, the result was this decision, this FMC decision. People just didn't have a choice. I personally call shippers throughout the nation to invest in private chassis anywhere

they can. But these restrictions still exist. That is why we are basically saying for the first time in over a decade or decades, we're going to have to change our model.

Although domestic production has not caught up to the high demand for chassis, there has been continuous investment in local production, which is steadily increasing supplies. An executive from an IEP noted that:

The tragedy is that the domestic manufacturers never ramped up to the level that they had said they would at the hearings with the U.S. Trade Commission and unfortunately, our industry over the last couple of years has suffered because price has skyrocketed, and availability has declined significantly. However, we are committed to trying to meet our customer needs, a result, we partnered with a family-owned steel company in the Midwest to start up a company that makes American made chassis. We manufacture 100% American made components with 100% American labor, and those chassis are produced in a little suburb outside Chicago. But without a doubt, the countervailing duty taxes were a big negative for our industry.

Similarly, some drayage companies are also investing in manufacturing of chassis domestically. A drayage company, with private ownership of a chassis pool, has recently invested in chassis manufacturing, buying an intermodal manufacturing company from a U.S. manufacturer in Michigan, taking over the debt obligations and assets. However, even with the continuous growth in domestic production, motor carriers continue to look for available chassis in the market. A trucker noted: “These things are radically more expensive. You know, again, I'm an old guy in the market, and before the tariff we could get a chassis for about \$12,000, but these days, you may have to spend as much as \$25,000 to \$35,000 for a piece of equipment. That is outrageous.”

A regional depot with a small fleet of drayage agreed that the leading manufacturer of Chinese chassis, CIMC, deserved to be penalized for unfair business practices, but expects that CIMC will soon be allowed back in the market. They emphasized that CIMC was essentially shipping chassis units to the U.S. “with everything but the paint” installed and claiming to have manufactured the units domestically. As a result, the Department of Commerce punished CIMC with expensive duties. Those who support lifting tariffs believe that American manufacturing is only making enough units to replace what was missing due to the shortage, which would be insufficient to fill orders for future demand (Tirschwell, 2022; JOC Staff, 2021). However, American chassis manufacturers such as Cheetah Chassis and Milestone Chassis state that the import surge is not a reason to forgive unfair business practices from international producers, pointing to their considerable progress generating more units as evidence that the disruption will eventually end. (Berger, 2021). Stakeholders do not believe that the reintroduction of CIMC chassis imports would hurt American manufacturers that are presently ramping up their own production to meet demand, because American manufacturing is only making enough units to “replace what was missing,” which would be insufficient to fill orders for future demand.

Theme E. Pandemic Issues

Although many drayage providers believe that their biggest challenges have not necessarily been related to COVID, they do agree that COVID exacerbated problems in certain areas. Mostly, they do not believe that their chassis predicament can be blamed totally on the pandemic. Many motor carrier drivers left the container market and moved to flatbeds or domestic vans. Port congestion kept drivers in lines for hours, where they could not make any money. A drayage company owner stated that “many drivers left the intermodal drayage market because of congestion, and I am not sure if that connects to chassis availability.” Additionally, because of the pandemic, ocean carriers changed their schedules by using a smaller fleet to consolidate their savings and enable them to charge higher ocean rates. For instance, \$6,000 haulage from Asia increased to about \$20,000. According to respondents, the phenomenon reduced ship schedules which in turn affected trucking activities. However, a trucker acknowledged that the pandemic affected drayage companies differently. In their case, it gave a good balance to their business since their New Orleans’ traffic is 60% import and 40% export.

For major terminal operators the pandemic created a huge amount of cargo, but one major terminal operator believes that the storm of cargo that was caused by the pandemic is subsiding, and that the demand for chassis which shot up during this period is beginning to level out again. The interviewee believes that the chassis issues may soon fizzle out.

Theme F. Safety Issues

Discussions with drayage companies suggest that there are concerns about the safety and quality of chassis that are being offered by the providers. They express a lack of confidence in chassis providers’ units that are not rotated out or repaired in such a way that they are safe to use. This often leaves the repair or replacement of parts on the shoulders of the motor carriers. A major motor carrier noted:

We don't have quality chassis provided by the major chassis companies, because they're not rotating out these assets, they're either redoing them or allowing the market to redo them based on us paying the expense. Even though the chassis providers do not meet our expectations, no one holds them accountable.

Similarly, a motor carrier owner in the region argues that since steel is so expensive these days, it is possible to refurbish a 30- or 35-year-old chassis to look new and work well. But the process may entail taking it down to its bare bones, down to the steel. The process may involve removing the wiring, brakes, and all the lights, then sandblasting the equipment before putting on a coat of paint, new brakes, and axles. The interviewee stated that what the major IEPs do is to take the same old chassis and put on some new tires, without replacing the brakes nor putting a new coat of paint on the equipment then call it a “refurb.” For motor carriers, it means handling a dangerous piece of equipment that is highly susceptible to fatal accidents. A drayage company owner notes that:

If you go on your bicycle, normally you've got a tube in the tires, and for your cars, you can put air in it but not a tube in the tire. So, can you imagine a loaded container sitting on a set of eight tires that got tubes in those tires? That's why we want better, safer equipment. That's why we've been pushing the needle on our whole leasing.

We wouldn't have gotten into the chassis business if we had safe pieces of equipment provided.

Theme G. Suggested System Improvement

The stakeholders interviewed presented various ways to correct chassis provisioning to improve efficiency in the supply chain. One common response, especially among the drayage companies, is that the U.S. needs to change the entire chassis provisioning system to allow for truckers to provide their own chassis, which is the global standard. America is the only nation with this unique system of chassis provisioning which many stakeholders have criticized. One motor carrier company insists that the best way to go about the chassis business in the U.S. is for the U.S. to adopt the global standard practice, noting:

The truckers should be the principal owners of chassis just like it is in other parts of the world. I have once asked a Northeast port executive this question, what would changing the U.S. chassis system do to the productivity at your various terminals? She said it will improve it by 50%.

Similarly, a drayage company owner notes:

Quite literally, we're the only place in the world that is practicing this type of provisioning. You would think if you had a good system and it worked as well as everybody says outside the motor carriers, obviously, there would be at least one other country that would emulate, like, even Canada is like, don't bring that broken system to my door.

Another trucker who has divested into private chassis rentals and manufacturing believes that the way forward is by matching demand with supply in equal terms. The company's provisioning style is customer specific and prioritizes according to the number of chassis demanded by a customer. Noting that:

If I have 175 pieces of equipment, and three carriers ABC each wants 25, 50, and 100 pieces respectively, I will not provide 26 pieces of equipment to carrier A if they had a change of mind on their first order, unless carrier C changed their order to require only 99 pieces of that equipment. This is absolutely a selling source for me because I'm one of the few in town that does this. I'm trying to make it on chassis now, that is the reason we bought a factory, so we are not only leasing or buying chassis, but also manufacturing. We were buying Chinese made chassis before now, but the tariff situation changed everything.

Stakeholders also believe improving chassis supplies through the removal of the antitrust laws and tariffs will help. They believe that domestic producers of the equipment may not be able to satisfy the market fully even though there has been improvement in domestic production of chassis, and further that these new sets of trade policies have added another layer to the already challenged system, making it hard to do business efficiently because the system is so complex.

Additionally, stakeholders stress that it is very difficult to trace responsibility and accountability in the entire system which often exacerbates interoperability and mismatch

challenges. They believe that it is essential to allow for the use of the “next available chassis” rather than to wait in line and waste productive time while there is other equipment available. A drayage company owner notes that “the rules that are out there are self-imposed rules, which often makes us miss out on a lot of opportunities for efficiency and that barrier needs to come down.” Again, improving domestic production will help boost chassis supplies. This could also be boosted through incentivizing production further by the government. A major trucker-turned-manufacturer of chassis is ramping up production and hopes to keep improving their capacity. The factory owner stated that the company will be producing close to 5,000 chassis this year, up from when they took over the factory, which was making fewer than 2,000 at that time. Noting that:

These improved efficiencies are all because of the money infusion, we've done a lot of investment. So, we are talking about trying to do these things with responsibility and accountability, to try and figure out this very complicated system. We're not there yet, but I know it's getting better. American manufacturing was not just prepared for a complete stoppage, so this antitrust battle hurts the system further.

Stakeholders operating in the New Orleans region also suggested that it is vital to fix the multimodal supply chain connections between New Orleans and Memphis. New Orleans and Memphis have been disconnected for some time and until those gaps in interoperability are resolved, it is not possible to get the traffic back between the regions. Improving interoperability between New Orleans and Memphis will help New Orleans regain some of its lost freight volumes.

Another solution discussed was for the railroads to move to grounded operations, which would require significant investment on their part, and require yard space to enable the operations. Some stakeholders recommended that there should be an additional handling fee on the rail price for using the grounded operation. The fee could cover the cost of investment for the railroad companies, while such improvements would help solve the issues of costly chassis flipping on railyards.

Some drayage companies argue their industry should have a regulatory body, to oversee their activities and to advocate for them at all levels of government. They feel that their voices are not heard whenever they have challenges within the industry. They believe their voices are muffled because they are the tail end of the supply chain system. The argument is that the ocean carriers and other marine stakeholders have the FMC, the railroads have the Federal Railroad Administration (FRA), while the airlines have the FAA that provides regulation in those industries, but motor carriers only have a safety body, the Federal Motor Carrier Safety Administration. A drayage company owner posits:

If I have a problem with an intermodal partner, I do not have a place to go to and lodge a complaint. Just like FMC controls the ocean lines, we also need a body that takes an active role for us on anything. The government says we do this and that, operate safely and we do, and I am not against safety, but who would I complain to if I have a problem with bad chassis? Where do I go to get some satisfaction, to fix the chassis problem? And I have asked someone at the FMC, and they couldn't give

me a good answer. I think the ocean Shipping Reform Act has taken some positive steps to enabling FMC. I think they have got some good commissioners too that generally take an interest on the workings of the system, like the latest Congressional Committee set up to look at the chassis issue. But what are they going to do with the report that comes out of the committee? Who knows, right?

It is interesting to see truckers advocating for such a body that may regulate them, to make better rules, and provide better environment for their operations. Another drayage company owner notes:

And we all clamor for regulators even though we mostly have big red labels over our heads, right, and Republicans are not supposed to want more government. They're not supposed to want more regulation. They're not supposed to want government interference and all of this, yet we're coming in with exactly that. We have no one to be an advocate for the motor carrier in DC, to help fight against other agencies. All we have is a Federal Motor Carrier Safety Administration, which is a good one, but we need better, to also get the justice that we deserve. That's why we have the Shipping Reform Act, and I don't think it hit all the bases the way we wanted it to, but it's a step in the right direction. You put 10 kids in a room, somebody's got to tell the kids do this and don't do that, right? But then if nine others get told what to do when one kid says I don't have to listen to the teacher, something is wrong then. That's where we're at the latency question.

Some participants in the interview also believe that ports and rail terminals need to be proactive, more inclusive, and continuously looking for opportunities to improve their processes. They note that some ports are still a little antiquated, exacerbating challenges for smooth operations. Drayage companies also wish that the Congress would help set a standard fee for chassis provisioning, so that no matter whose chassis they use, or at whichever port, charges will be standard. They also wish that there would be some type of guideline on what fee could be charged so the customer would understand the drayage companies are not making any money on chassis. A drayage company owner contended that:

The reality is that we need each other in the business, we rely on each other always, but if we don't work, and this is not a threat, but if every trucking company in the world or in the country threw their hands on the ocean carrier and say, we're not going to move anything for the next two days until all of this is figured out, it will shut down the country.

The majority of the stakeholders interviewed expressed a view that a gray chassis pool would be the most beneficial system to implement in a move to alleviate the chassis challenges at this point. Some stakeholders also believe that one of the major challenges exacerbating chassis issues in the country is the non-timely arrival of ships at the dock. They believe that it is paramount to have ships show up on time at the docks so that stakeholders can keep track of the chassis demand and supply dynamics. Several of the interviewees similarly noted that the box rules continue to create numerous challenges for motor carriers and should be eliminated. On the other hand, truckers also believe that they should not bear the cost of maintenance of chassis even if this system persists. A motor carrier notes "let the big chassis guys fight that out amongst

themselves. You know it's a greedy play on their part, if it were a gray pool, it would change everything for us, it really would.”

Just like the motor carrier, a regional chassis pool provider also unilaterally supports the implementation of a gray chassis pool in the region. They suspect that large retail BCO's in the region also support the move and have contributed to the drafting of bipartisan legislation to mandate the gray pool. Speaking to their experience in the Southeast market, they predicted that the gray pool would not be enacted without the support of the rail lines, who have the extensive leverage over intermodal shipping in the region. They shared that rail lines may be more supportive of the change than they let on and provided data that one local rail yard had allowed over 60 chassis-container combination mismatches that day. They concluded that the only obstacle to gray chassis pool management, even if implemented that day, would be recapturing units for organization into the pool as fleets are still highly utilized. Other than the IEPs, they stated that all stakeholders would benefit from a regional gray pool and dismissed arguments that competing pools provide a higher quality of service, noting that most IEPs charge about the same price to lease their units.

Another regional depot with a small fleet of drayage agrees that rail yards should have operable chassis units designated for drivers as they arrive at their terminals. They acknowledged that the strict IEP unit combinations complicated the railyard's ability to achieve this, and blamed the profit seeking motives of IEP owners, often private equity companies, for significantly exacerbating the issue.

Concurrently, leadership of a regional depot and drayage company not only endorsed gray pools as the ideal short-term solution to chassis shortage, but also outlined several ways in which it was lobbying for that change. They rejected the idea that focusing on labor issues would resolve the chassis shortage. The organization provided an example with their latest company hires who quit within a week of hiring. They claimed the labor does not exist to resolve the bottlenecks in the supply chain, and even if it did, it would take far too long to find it, while gray pool implementation would have positive effects immediately. In addition, a gray pool system would boost labor retention by eliminating a significant source of frustration for drivers: case in point, chassis splits. According to the stakeholders, gray pools would reshape the industry, have no tangible downsides, and are the obvious “endgame” for freight. However, there are cautionary factors to consider in implementing a gray pool chassis system. The most important one being that a neutral, non-IEP party should be selected to manage the gray pool, such as a regional chassis pool organization. Stakeholders also recommended that other non-profit competitors, if they exist, could also manage gray pools successfully. They pointed to the southeast ports upcoming adoption of a gray pool to be operated by a regional CCM affiliate regional pool, as an example of what is to come.

Similarly, another major drayage company also declared that a gray pool of chassis would be the best model to resolve the chassis shortage. In addition to eliminating flips and streamlining intermodal terminal operations, the company is confident that a shared pool would still promote the best incentives for IEPs to compete and properly maintain and repair their units. While it was agreed that improving the speed with which containers and chassis were loaded, either at the warehouse or the terminal, would help ease shortage, there was doubt that the

existing labor force could increase to meet the demand of the supply chain anytime soon, whereas the gray pool option would fix the shortage “overnight.”

According to one of the largest providers of intermodal chassis in the nation, stakeholders need to come together to address the challenges in the transportation industry. They cited an example using the situation in New Jersey and how the expansion of roadways has helped ease traffic, enhance transportation efficiency and their ability to reposition assets in a timely fashion.

FINDINGS

Findings from this research reinforce most of the salient issues around chassis provisioning in the U.S. All of the stakeholders interviewed, IEPs, motor carriers, railroads, regional pools, chassis manufacturers, terminal operators, and container on barge companies, have experiences related to chassis provisioning. The majority of the stakeholders, in particular the drayage providers, considered box rules as the major challenge to chassis provisioning in the two regions studied. Box rules generate cascading challenges especially to drayage providers, significantly affecting their productivity. The study finds that grounded terminals experience the largest issues with chassis availability. This is because truckers at these terminals often face more difficulties in finding appropriate chassis that match the assigned container at grounded rail yards. The analysis found that drivers may spend up to 30% of their time just searching for appropriate equipment to use, and the longer it takes, the higher the probability that they may not be able to get their cargo the same day. This is because the driver’s container could be buried in stacks of containers by the time they locate an appropriate chassis, and railroad companies do not find it cost-effective to cherry-pick containers from the bottom, meaning extra charges for the drayage company since they may have to leave the containers for another day. Chassis splits affect the activities of truckers in a similar way, reducing productivity of the drivers.

Respectively, stakeholders also highlight the interoperability issues between New Orleans and Memphis that have lingered for years, causing significant decline in the intermodal market of both regions. The core reason for this situation is the complete separation of chassis systems between the two regions. Box rules and mismatch issues also affect the container on barge business which connects New Orleans and Memphis in such a way that they are not able to reload their vessels with other containers after offloading a given haulage at a terminal since these containers were moved on chassis owned by a different company.

The study also finds that the provisioning system in the country has led to increased costs of doing business. One hundred percent of motor carrier businesses interviewed believed that the current chassis system unnecessarily raises their costs, a cost that is eventually borne by the BCOs and ultimately, by the consumer. This factor had led to some of the motor carriers to acquire their own chassis, or even going further to become chassis lessors and manufacturers. Motor carriers generally believe that investing in their own chassis is more cost-effective than leasing from an IEP where they become responsible for repairs on the IEP’s equipment, with no guaranty of quality, consistency, and safe equipment. This change would improve efficiency in the supply chain and has been estimated to potentially improve productivity at the terminals by more than 500%. While owning a chassis may resolve certain issues, it also means incurring

additional costs for drayage companies as the purchase and maintenance of chassis requires diverting resources from their core business functions.

The issue of low quality and aged chassis provisioning by the IEP's is a factor that has been emphasized by all truckers interviewed. Despite FMCSA regulations that mandate IEPs, motor carriers, and drivers operating intermodal equipment establish programs that ensure regular inspection and maintenance of every intermodal chassis, much of the equipment is left unchecked. In many cases, chassis repairs fall on the drayage companies, increasing their cost of doing business. These findings underscore the concerns raised by drayage companies regarding the safety and quality of the chassis provided by the IEPs. The lack of confidence, accountability, and proper refurbishment practices contributes to the perception that the equipment is not up to required standards, posing potential risks for motor carriers and their operations. Again, drayage companies believe that intense competition between major IEPs leads to varying and multiple charges imposed on them and other stakeholders. They argue that repair fees and cost disputes are prevalent in the system, and that there is a lack of transparency and accountability in the process.

Findings from the research also highlight the challenges and complexities of the billing process regarding chassis provisioning. Transaction data from port terminals and railroads, which serve as major sources of information, are often riddled with inaccuracies. Similarly, the data are obtained from different sources depending on factors such as the type of chassis used, and the responsibilities assigned to the various actors such as motor carriers and BCOs. This complicates the billing process, particularly for small motor carriers who are required to pay upfront for chassis usage. The messy data and complexities involved in the billing system disincentivizes chassis providers from cleaning the data. Therefore, drayage companies must invest a significant amount of money and time in data sourcing, billing, and audits.

The pandemic caused a major disruption in the global supply chain system, with cargo surges inducing higher demand for chassis, higher dwell time, port congestion, and provisioning challenges and that the various transportation stakeholders were affected differently. While drayage providers in the New Orleans region do not attribute all their challenges to the pandemic, they acknowledge that the pandemic worsened certain issues. COVID-19 amplified problems in certain areas but cannot be solely blamed for the chassis predicament faced by drayage providers. Findings suggest that the impacts of the pandemic led to shifts within the industry, such as motor carrier drivers leaving the container market and transitioning to other sectors such as flatbeds or domestic vans. Similarly, ocean carriers modified their schedules during the pandemic, opting for smaller fleets to save costs and increase ocean rates. This shift resulted in reduced ship schedules, which had a subsequent impact on trucking activities. In Memphis, the mismatch issues coupled by the surge in cargo during the pandemic deeply affected drayage providers' productivity by increasing storage and demurrage charges for containers that were laying fallow at the railroad terminals. The pandemic had varying effects on drayage companies, with the impact depending on a motor carrier's traffic mix, which is the ratio between exports and imports haulage. For motor carriers with a lower export haulage going through the New Orleans port, the pandemic brought stability to their operations.

Getting containers on the right shift is a major issue for all the stakeholders interviewed. The uncertain arrival schedules of ocean carriers' affect the entire chain of stakeholders as far as

chassis provisioning is concerned. For terminal operators, it extends the dwell time of containers on their terminals, while for the IEP's it affects their ability to provide effective provisioning because their equipment could be tied up with other stakeholders.

All the stakeholders interviewed agreed that increases in steel and aluminum tariffs put in place by the Trump Administration, and the antidumping laws in relation to domestic capacity for chassis, had significant impact on the entire supply chain ecosystem. As indicated in the literature and reiterated by the stakeholders, over 80% of chassis were supplied by Chinese manufacturers, especially CIMC, and the tariff increases, increased the prices of the equipment tremendously. Similarly, the antidumping policies implemented have further hindered the supply capacity of new chassis into the system. This research showed that drayage providers, who have mostly been at the receiving end of the impacts of the chassis shortage, supported the lifting of the antidumping and countervailing duties on the Chinese producers. A group of drayage companies funded litigation against the rulings. Some drayage providers are now venturing into chassis manufacturing because of the shortages caused by the tariff increases and antidumping regulations. By encouraging investments locally, the tariffs and the antidumping laws have thus achieved their purpose. However, most of the domestic producers have not been able to meet the demand because of scarcity of parts and labor shortages in the chassis producing industry. Drayage providers are of the opinion that allowing CIMC to return to production will not affect domestic producers, since there is a high demand for the equipment that can hardly be satisfied by domestic producers alone.

BENEFITS of IMPLEMENTATION

To mitigate chassis challenges in the U.S., respondents, particularly drayage companies, suggest that the U.S. should adopt the global standard practice of allowing truckers to provide their own chassis. Ninety-five percent of stakeholders, including chassis providers, interviewed agree that removing antitrust laws and tariffs would help improve chassis supplies, arguing that domestic producers will not be able to fully satisfy the market demand, and the current trade policy just adds complexity to the system. Similarly, drayage providers advocate for the establishment of a regulatory body specifically for motor carriers as they believe that their industry lacks representation and advocacy at various levels of government. They point out that other transportation stakeholders have regulatory bodies overseeing their activities and motor carriers should have a similar body to address their concerns and issues. Importantly, motor carriers call for proactive and inclusive efforts by ports and rail terminals to continuously improve their process.

Antiquated systems at some ports are seen as a hinderance to smooth operations, therefore, it is important for terminal operators to upgrade their facilities. Respondents also suggested setting a standard fee for chassis provisioning across different ports to ensure consistency and transparency. The majority of respondents also support the implementation of a gray chassis pool system as a solution to alleviate chassis challenges. A gray pool system would involve a shared pool of chassis managed by a neutral, non-IEP party. They believe that this system would improve efficiency, eliminate flips, and incentivize proper maintenance and repair of chassis. Stakeholders highlight the importance of improved chassis scheduling techniques, such as dual or two-way chassis transactions, to increase unit utilization and reduce

inefficiencies. Examples of successful implementation, such as the appointment system at the Port of Long Beach, are mentioned. Lastly, the IEPs emphasize the need for collaboration and addressing challenges collectively. They point out the importance of infrastructure improvements, such as expanding roadways, which will help enhance transportation efficiency and the timely repositioning of assets.

RECOMMENDATIONS & CONCLUSIONS

Overall, this research highlights the complex and multifaceted nature of chassis provisioning in the United States. The findings underscore the need for comprehensive reforms, transparency, and collaboration among stakeholders to enhance efficiency, reduce costs, and ensure a resilient and sustainable supply chain system. By addressing these key findings, the industry can work towards overcoming the challenges and improving the overall performance of chassis provisioning in the country.

This study provides valuable insights into the chassis provisioning system in the U.S. informed by the assessment of stakeholders throughout the New Orleans and Memphis regions. The qualitative data suggests that the box rules system creates gridlock in the entire supply chain system, reducing efficiency, impacting productivity, and increasing cost of doing business for stakeholders. Ultimately, these increased costs are borne by the consumer. This calls for an urgent system re-evaluation, and subsequent changes in the entire system to mirror global standard practices where every motor carrier will own their chassis. But there are questions to how this may impact small drayage providers, especially those who do not have adequate capacity to own their chassis, as well as what happens to the IEPs if the system is overhauled. The research team recommends the implementation of a mix of solutions that would cater to the various stakeholders involved in these two study areas. A new system may entail abandoning the box rules in their entirety, government incentivizing the ownership of chassis, encouraging the gray pool system managed by established non-profit organizations, and creating a business model to ensure that the present IEPs do not go out of business. In the short term, the government can work on removing hinderances to the production and procurement of chassis from around the world by allowing companies like CIMC to participate in the U.S. marketplace. Such measures must be taken in such a way that domestic production is not be negatively impacted by these multinational firms.

Considering the present system, some of the major hinderances to efficiency are infrastructure deficiencies in areas around which terminals are located, usually city centers, narrower road systems, and congestion. Other important factors include ship arrival schedules, which are usually very uncertain, and the pandemic, which has caused cargo surge and induced higher demand for chassis, leading to port congestion that translates to longer dwell times for chassis. However, dwell times are generally reducing because of the declining pandemic-induced cargo surge. This calls for a more pragmatic approach to forecasting and planning for unforeseen circumstances that may impact the supply chain system in the future. A working group should be formed to address these issues.

REFERENCES

- Ajayi, O. (2023, February 28). Intermodal Chassis Analysis. Retrieved from Federal Motor Carrier Safety Administration, presentation to the Committee on Best Practices for the Efficient Supply of Chassis for Transporting Intermodal Containers- Meeting 2, The National Academies of Sciences, Engineering, and Medicine, February 28, 2023.
- Angell, M. (2022a, April 1). China's chassis, container role 'entrenched' by government: FMC's Bentzel. *Journal of Commerce*. Retrieved from https://www.joc.com/rail-intermodal/intermodal-shipping/china%E2%80%99s-chassis-container-role-%E2%80%98entrenched%E2%80%99-government-fmc%E2%80%99s-bentzel_20220401.html [Accessed 8/20/2023].
- Angell, M. (2022b, June 16). USDA Offers Funds for Houston Chassis, Tacoma ag Shippers. *Journal of Commerce*. Retrieved from https://www.joc.com/port-news/us-ports/port-houston/usda-offers-funds-houston-chassis-tacoma-ag-shippers_20220616.html?utm_source=Eloqua&utm_medium=email&utm_campaign=CL_JOC%20Daily%206%2F17%2F22%20SUBSCRIBER%20_PC015255_e-production_E-140127_TF_0617_0617 [Accessed 8/20/2023].
- Ashe, A. (2018, August 27). US shipping industry: Tariffs will crimp demand, increase equipment costs. *Journal of Commerce*. Retrieved from https://www.joc.com/regulation-policy/us-shipping-industry-tariffs-will-crimp-demand-increase-equipment-costs_20180827.html?destination=node/3444511 [Accessed 8/21/2023].
- Ashe, A. (2020, December 24). Outlook 2021: Chassis providers eye equipment investments, regulatory cases. *Journal of Commerce*. Retrieved from https://www.joc.com/trucking-logistics/trucking-equipment/outlook-2021-chassis-providers-eye-equipment-investments-regulatory-cases_20201224.html [Accessed 8/21/2023].
- Ashe, A. (2021, December 9). Congress wading into Memphis chassis dispute. *Journal of Commerce*. Retrieved from https://www.joc.com/article/congress-wading-memphis-chassis-dispute_20211209.html [Accessed 8/28/2023].
- Ashe, A. (2022, June 9). *NS metering volumes in five markets amid chassis shortage*. Retrieved from *Journal of Commerce*: https://www.joc.com/article/ns-metering-volumes-five-markets-amid-chassis-shortage_20220609.html [Accessed 8/28/2023].
- Ashe, A. (2022a, 21 June). NS Offers Incentives to Ocean Carriers to Balance Container Flows. *Journal of Commerce*. Retrieved from https://www.google.com/url?sa=t&rct=j&q=&esrc=s&source=web&cd=&cad=rja&uact=8&ved=2ahUKEwiJi6Lm07L-AhV-g4QIHS59Az8QFnoECB4QAQ&url=https%3A%2F%2Fwww.joc.com%2Farticle%2Fns-offers-incentives-ocean-carriers-balance-container-flows_20220621.html&usq=A0vVaw3mba [Accessed 8/21/2023].

- Ashe, A. (2022b, August 12). *Lack of parts, labor to extend US chassis shortages into 2024*. Retrieved from Journal of Commerce: https://www.joc.com/article/lack-parts-labor-extend-us-chassis-shortages-2024_20220812.html [Accessed 8/21/2023].
- Ashe, A. (2023, June 2). *US Chassis Lessors Learning from Pandemic Surge as Demand Wanes*. Retrieved from Journal of Commerce: https://www.joc.com/article/us-chassis-lessors-learning-pandemic-surge-demand-wanes_20230602.html [Accessed 8/21/2023].
- Bearth, D. (1999, February 17). *Memphis Moves the Freight*. Retrieved from Transport Topics: <https://www.ttnews.com/articles/memphis-moves-freight> [Accessed 8/28/2023]
- Berger, P. (2021, October 28). A Simple Piece of Steel and Wheels Is Holding Up the Global Supply Chain. *The Wall Street Journal*. Retrieved from <https://www.wsj.com/articles/a-simple-piece-of-steel-and-wheels-is-holding-up-the-global-supply-chain-11635452843> [Accessed 8/20/2023].
- Booth, K., Tutrone, J., & Bilge, K. (2020, April 30). FMC Issues Final Guidance on Unreasonable Demurrage and Detention Practices to Improve Ocean Freight Fluidity. *Lexology*. Retrieved from <https://www.lexology.com/library/detail.aspx?g=0b639d0b-d340-4ecc-b450-d977edb2feb7> [Accessed 8/20/2023].
- BTS (U.S. Department of Transportation, Bureau of Transportation Statistics). (2017, August 25). Multi Association Letter on Port Performance Metrics to the Department of Transportation. *Bureau of Transportation Statistics*. Retrieved from <https://www.bts.gov/learn-about-bts-and-our-work/about-bts/multi-association-letter-port-performance-metrics-department> [Accessed 8/20/2023].
- BTS. (2022). *Low Water on the Mississippi Slows Critical Freight Flows*, available at "[Low Water on the Mississippi Slows Critical Freight Flows](https://www.bts.gov/learn-about-bts-and-our-work/about-bts/low-water-on-the-mississippi-slows-critical-freight-flows)" ([bts.gov](https://www.bts.gov)) as of November 2022.
- BTS. 2023. *2023 Port Performance Freight Statistics Program: Annual Report to Congress* (Washington, DC: 2023). <https://doi.org/10.21949/1528357> [Accessed 8/19/2023]
- BTS. (2023). *Ocean Shipping Reform Act of 2022*. *Bureau of Transportation Statistics*. Retrieved from <https://www.bts.gov/osra> [Accessed 8/20/2023].
- Bureau of Industry and Security (2023). Section 232 National Security Investigation of Steel Imports Information on the Exclusion Process. BIS, U.S. Department of Commerce, 2023. Retrieved from <https://www.bis.doc.gov/index.php/232-steel#:~:text=In%20President%20Trump's%20proclamation%20establishing,the%20Unit ed%20States%20in%20a> [Accessed 9/15/2023].
- Cantwell, M. (2022). *S. 3580 Ocean Shipping Reform Act of 2022*. Retrieved from: <https://www.cantwell.senate.gov/imo/media/doc/Ocean%20Shipping%20Reform%20Act%20of%202022%20One-Pager.pdf> [Accessed 8/20/2023].

- Comerford, M. (2020, April). *Inland Ports: An Efficient Alternative*. Retrieved from Inbound Logistics: <https://www.inboundlogistics.com/articles/inland-ports-an-efficient-alternative/> [Accessed 8/28/2023].
- Consolidated Chassis Management, LLC. (2023, August 24). *Pool Metrics MCCP*. Retrieved from Consolidated Chassis Management, LLC: <https://ccmpool.com/chassis-pool/pool-metrics-mccp/> [Accessed 8/28/2023].
- CNL Worldwide. *Chassis Shortage: Is There an End In Sight* (2022). Retrieved from <https://www.clnusa.com/post/chassis-shortage-is-there-an-end-in-sight> [Accessed 8/20/2023].
- Creswell, J. W. (2014). *Research Design: Qualitative, Quantitative, and Mixed Methods Approaches*. SAGE Publications.
- DCLI. (2023). Container Chassis Diagrams and Specifications. *DCLI*. Retrieved from <https://dcli.com/chassis-fleet/container-chassis-specification/> [Accessed 8/19/2023].
- DCLI. (2023a). About DCLI. <https://dcli.com/about/overview/> *DCLI*. Retrieved from <https://dcli.com/about/overview/> [Accessed 8/28/2003].
- FlexiVan. (2023, August 24). *Locations*. Retrieved from FlexiVan: <https://flexivan.com/locations/> [Accessed 8/28/2023].
- FMC (Federal Maritime Commission). (2020, May 18). *Interpretive Rule on Demurrage and Detention Under the Shipping Act*. Retrieved from Federal Maritime Commission: <https://www.federalregister.gov/documents/2020/05/18/2020-09370/interpretive-rule-on-demurrage-and-detention-under-the-shipping-act> [Accessed 8/20/2023].
- FMC. (2023). *DOCKET NO. 20-14, Initial Decision Partially Granting Summary Decision*. in DECISIONS OF THE FEDERAL MARITIME COMMISSION, Second Series, VOLUME 6, January 2023 – June 2023 Issuance, pp.45-105. Retrieved from Federal Maritime Commission: www.fmc.gov/wp-content/uploads/2023/08/LawReporterVol6.pdf [Accessed 8/20/2023].
- Gallagher, J. (2020, June 2). FMCSA issues intermodal chassis inspection waiver. *FreightWaves*. Retrieved from <https://www.freightwaves.com/news/fmcsa-issues-intermodal-chassis-inspection-waiver> [Accessed 8/20/2023].
- Galagher, J. (2023). Intermodal Truckers Secure Win Against Ocean Carriers. Judge Rules Container Lines Most Not Limit Chassis Choices in 4 U.S. Regions. *Freight Waves*, February 6, 2023. Retrieved from <https://www.freightwaves.com/news/intermodal-truckers-secure-win-against-ocean->

[carriers#:~:text=A%20maritime%20law%20judge%20has%20ruled%20that,limit%20container%20chassis%20choices%20for%20intermodal%20truckers](#) [Accessed 12/11/2023].

- GAO. (Government Accountability Office). (2021). Commercial Shipping: Information on How Intermodal Chassis Are Made Available and the Federal Government's Oversight Role. (GAO Publication No. 21-315R). Washington, D.C.: U.S. Government Printing Office.
- Gross, L. (2021, October 6). Further inaction on 'chassis problem' not an option. *Journal of Commerce*. Retrieved from https://www.joc.com/article/further-inaction-chassis-problem-not-option_20211006.html [Accessed 8/21/2023].
- Horowitz, J. (2018, June 14). China is killing his business. Tariffs could make or break it. *CNN Business*. Retrieved from <https://money.cnn.com/2018/06/14/news/economy/trade-tariffs-cheetah-chassis-china/index.html> [Accessed 8/20/2023].
- JOC Staff. (2021, September 22). Home. *Journal of Commerce*. Retrieved from https://www.joc.com/article/only-import-relief-will-ease-us-chassis-availability-providers_20210922.html [Accessed 8/21/2023].
- Johnson, E. (2022, June 10). *Data helping drivers achieve higher LA-LB dual transaction rates: Dray Alliance*. Retrieved from *Journal of Commerce*: https://www.joc.com/article/data-helping-drivers-achieve-higher-la-lb-dual-transaction-rates-dray-alliance_20220610.html [Accessed 8/21/2023].
- Jones, K. (2020a, September 3). *Coalition looks to 'level playing field' with container chassis imports from China*. Retrieved from <https://www.trailer-bodybuilders.com/whats-in-print/article/21139388/coalition-looks-to-level-playing-field-with-container-chassis-imports-from-china> [Accessed 8/20/2023].
- Jones, K. (2020b, October 5). *Trade commission finds cause in intermodal chassis dispute*. Retrieved from *Fleet Owner*: <https://www.fleetowner.com/equipment/trailers/article/21143725/trade-commission-finds-cause-in-intermodal-chassis-dispute> [Accessed 8/20/2023].
- Levinson, M. (2008). *The Box: How the Shipping Container Made the World Smaller and the World Economy Bigger*. Princeton University Press.
- Lynch, D. J. (2021, October 2). Inside America's Broken Supply Chain - *Washington Post*. Retrieved from <https://www.washingtonpost.com/business/interactive/2021/supply-chain-issues> [Accessed /21/2023].
- Maiden, T. (2021, September 30). Pick your bottleneck: Ports, chassis, containers, labor. *FreightWaves*. Retrieved from <https://www.freightwaves.com/news/pick-your-bottleneck-ports-chassis-containers-labor> [Accessed 8/21/2023].
- Manning, D. (2023). Best Practices for the Efficient Supply of Chassis. presentation to the

- Committee on Best Practices for the Efficient Supply of Chassis for Transporting Intermodal Containers, The National Academies of Sciences, Engineering, and Medicine, February 28, 2023.
- Miller, E. (2022, March 1). DOT Report Offers Ideas to Ease Supply Chain Disruptions. *Transport Topics*. Retrieved from: <https://www.ttnews.com/articles/dot-report-offers-ideas-ease-supply-chain-disruptions> [Accessed 8/20/2023].
- National Cooperative Freight Research Program. (2011). *NCFRP Report 11: Truck Drayage Productivity Guide*. Retrieved from The Tioga Group: <http://tiogagroup.com/docs/NCFRP-TRB-011.pdf> [Accessed 8/21/2023].
- National Oceanic and Atmospheric Administration. (2023, 05 30). *Fast Facts/ Ports*. Retrieved from Office for Coastal Management: <https://coast.noaa.gov/states/fast-facts/ports.html> [Accessed 8/18/2023].
- New Orleans Public Belt (2023, August 24). *Our System. We are connected*. Railnola.com. Retrieved from <https://www.railnola.com/business/our-system> [Accessed 8/24/23].
- Port of Los Angeles (2020). Port of Los Angeles Introduces a New Data Tool, “the Signal.” Port of LA Board Agenda, September 3, 2023. Retrieved from https://www.portoflosangeles.org/references/news_090320_signal [Accessed 12/11/2023].
- Port of New Orleans (2023, August 24). *Port Nola Advantage*. Portnola.com. Retrieved from <https://portnola.com/info/port101#:~:text=DIVERSE%20CARGO%20CAPABILITIES&text=Containerized%20Cargo%20Momentum%3A%20Port%20NOLA,six%20years%20in%20a%20row> [Accessed 8/24/23].
- Port of New Orleans (2023, August 24). *Capabilities*. Portnola.com. Retrieved from <https://portnola.com/business/cargo/capabilities> [Accessed 8/24/23].
- Rodgers, J.M. (2022). *Still No Immediate Remedy for US Chassis Shortage*. Retrieved from: J.M. Rodgers: <https://www.jmrogers.com/supply-chain-roundup-6-28-2022/> [Accessed 8/18/2023].
- Ronan, D. (2020, September 15). US Chassis Group Gains Initial Win Against Chinese Company. *Transport Topics*. Retrieved from <https://www.ttnews.com/articles/us-chassis-group-gains-initial-win-against-chinese-manufacturers> [Accessed 8/20/2023].
- Salgado, A. (2022, October 21). *FMC initiates chassis overhaul study, part of Ocean Shipping Reform Act*. Retrieved from Transport Dive: <https://www.transportdive.com/news/FMC-osra-ocean-shipping-reform-act-chassis-study/634691/> Accessed 8/21/2023].

- Stich, B., Amdal, J., & Webb, P. (2019). Chassis: The Unsung Linchpin in the Global Supply Chain. In Smirnova, *Building a Sustainable Transportation Infrastructure for Long-Term Economic Growth*. East Carolina University.
- Symonanis. (2021). WHY WE NEED A SINGLE GRAY CHASSIS POOL. *The University of Memphis*. Retrieved from <https://caeser.memphis.edu/wp-content/uploads/2021/01/symonanis-2.pdf> [Accessed 8/28/2023].
- Szakonyi, M. (2021, October 27). FMC nominee gets rare Senate grilling amid US shipping disruption. *Journal of Commerce*. Retrieved from [FMC nominee gets rare Senate grilling amid US shipping disruption | Journal of Commerce \(joc.com\)](https://www.joc.com/news/fmc-nominee-gets-rare-senate-grilling-amid-us-shipping-disruption) [Accessed 8/28/2023].
- Taube, D. (2022, September 12). *Flashback: The U.S. Chassis Crisis*. Retrieved from Transport Dive: <https://www.transportdive.com/news/flashbac-us-chassis-crisis/631614/> [Accessed 8/28/2023].
- The White House. (2022, February 28). *FACT SHEET: Lowering Prices and Leveling the Playing Field in Ocean Shipping*. Retrieved from The White House: <https://www.whitehouse.gov/briefing-room/statements-releases/2022/02/28/fact-sheet-lowering-prices-and-leveling-the-playing-field-in-ocean-shipping/> [Accessed 8/28/2023].
- Tirschwell, P. (2022, June 22). No short-term fix seen for US chassis shortage. *Journal of Commerce*. Retrieved from https://www.joc.com/international-logistics/no-short-term-fix-seen-us-chassis-shortage_20220622.html [Accessed 8/21/2023].
- TRAC. (2023). *White Paper: The Evolution of Chassis Pool Models*. Retrieved from: <https://www.tracintermodal.com/blog/white-paper-the-evolution-of-chassis-pool-models> [Accessed 8/20/2023].
- TRAC. 2023a). TRAC Intermodal Investor Relations. Intermodal Industry Overview. Retrieved from <https://www.tracintermodal.com/wp-content/uploads/PDFs/Introduction%20to%20Intermodal%20Industry%20-%20TRAC.pdf> [Accessed 8/18/2023].
- U.S. Department of Transportation, Bureau of Transportation Statistics, *2023 Port Performance Freight Statistics Program: Annual Report to Congress* (Washington, DC: 2023). <https://doi.org/10.21949/1528357> [Accessed 8/19/2023]
- U.S. Department of Transportation, Bureau of Transportation Statistics, *Low Water on the Mississippi Slows Critical Freight Flows*, available at [Low Water on the Mississippi Slows Critical Freight Flows \(bts.gov\)](https://www.bts.gov/news-press/low-water-on-the-mississippi-slows-critical-freight-flows) as of November 2022.
- US Department of Transportation. (2022a, February 24). DOT Lays Out Actions to Strengthen Supply Chains and Revitalize the Economy | US Department of Transportation. *Department of Transportation*. Retrieved from <https://www.transportation.gov/briefing->

- room/dot-lays-out-actions-strengthen-supply-chains-and-revitalize-economy [Accessed 8/20/2023].
- US Department of Transportation. (2022b, March 4). Supply Chain Assessment of the Transportation Industrial Base: Freight and Logistics | US Department of Transportation. *Department of Transportation*. Retrieved from <https://www.transportation.gov/supplychains> [Accessed 8/20/2023].
- U.S. Senate. (2022). *Ocean Shipping Reform Act of 2022. S.3580 - 117th Congress (2021-2022)*: Retrieved from Congress.gov: <https://www.congress.gov/bill/117th-congress/senate-bill/3580> [Accessed 4/18/2023].
- U.S. Senate. (2021). Improving Memphis' Supply Chain Act. S.3268. 117th Congress. (2021). Retrieved from Congress.gov: <https://www.congress.gov/bill/117th-congress/senate-bill/3268/all-info?r=76&s=1>. [Accessed 8/18/2023].
- U.S. Senate Committee on Commerce, Science, and Transportation. (2022, June 16). *President Biden Signs Cantwell-Championed Ocean Shipping Reform Act*. Retrieved from U.S. Senate Committee on Commerce, Science, & Transportation: <https://www.commerce.senate.gov/2022/6/president-biden-signs-cantwell-championed-ocean-shipping-reform-act> [Accessed 8/18/2023].
- Vineyard, J. (2018, September 27). Will Chassis Tariff Increase Costs for Shippers Or Benefit U.S. Manufacturers? *Universal Cargo*. Retrieved from <https://www.universalcargo.com/will-chassis-tariff-increase-costs-for-shippers-or-benefit-u-s-manufacturers/> [Accessed 8/20/2023].
- Volpe, John A. Transportation Systems Center. (2004). *Feasibility Study on Collecting Intermodal Chassis Crash and Inspection Data*, prepared for FMCSA, September 29, 2004.
- Watson, J., Chatterjee, A., & Clark, D. (2009). *Safety Issues Involving Marine Containers on Chassis*. Retrieved from United States Department of Transportation National Transportation Library: <https://rosap.ntl.bts.gov/view/dot/17210> [Accessed 8/28/2023].
- White, C. (2021, July 12). Disunified chassis leasing system exacerbates port congestion. *FreightWaves*. Retrieved from <https://www.freightwaves.com/news/disunified-chassis-leasing-system-exacerbates-port-congestion> [Accessed 8/28/2023].
- Wiley Rein LLP. (2020, July 30). American Producers of Chassis File Trade Petitions to Combat Illegal and Unfair Dumping and Subsidies from China, Wiley Reports. *PR Newswire*. Retrieved from <https://www.prnewswire.com/news-releases/american-producers-of-chassis-file-trade-petitions-to-combat-illegal-and-unfair-dumping-and-subsidies-from-china-wiley-reports-301103430.html> [Accessed 8/20/2023].

Wiley Rein LLP. (2021, May 13). U.S. Department of Commerce Makes Affirmative Final Determination That Chassis from China Are Dumped at Rates of 188.05%. *Wiley Rein LLP*. Retrieved from <https://www.wiley.law/pressrelease-US-Department-of-Commerce-Makes-Affirmative-Final-Determination-That-Chassis-from-China-Are-Dumped-at-Rates-of-188-05-per-cent> [Accessed 8/20/2023].

Wilson, M. (2023, January 26). *The evolution of container chassis provisioning in the US*. Retrieved from American Journal of Transportation: <https://www.ajot.com/insights/full/the-evolution-of-container-chassis-provisioning-in-the-us> [Accessed 8/21/2023].

Zoom Support. (2022, October 13). *Audio transcription for cloud recordings*. Retrieved from <https://support.zoom.us/hc/en-us/articles/115004794983-Audio-transcription-for-cloud-recordings> [Accessed 8-20-2023].

Appendix I

SURVEY QUESTIONS

1. Please provide your information below. Personal information provided are in confidence and would not be relayed to the public.

Name:

Position:

Organization:

Email:

2. What does your organization do? Tell us about your organization. What is your role in said organization?

3. How do chassis affect you or your organization's daily duties? And have these changed since the start of the pandemic?

4. What chassis related challenges does the Port of New Orleans and Terminals in Memphis currently face?

5. Has chassis availability affected your company? If yes, how has it affected your business?

A. Has your company had to make any changes in daily operations to accommodate varying levels of chassis availability?

6. How are chassis currently handled at the terminal?

A. Working within the current infrastructure, what (if any) improvement to the process could be made?

7. Does the New Orleans and Memphis currently suffer chassis shortage? If yes, do you encounter chassis challenges at the ports because of shortages or compatibility issues?

8. How has the steel tariff and the USDOT antidumping duty affected chassis availability and quality?

9. How do you think the issues associated with chassis in the supply chain could best be remedied?