



**pennsylvania**

DEPARTMENT OF TRANSPORTATION

# Microbial Concrete Sealer

FINAL REPORT

5/8/23

Bashear El-Hajj  
Sarah Pitell  
Steven Sachs, Ph.D.  
Sarah Haig, Ph.D.

University of Pittsburgh

COMMONWEALTH OF PENNSYLVANIA  
DEPARTMENT OF TRANSPORTATION

CONTRACT # 4400018535  
WORK ORDER # PIT WO 022



<b>1. Report No.</b> FHWA-PA-2023-007-PITT WO 022		<b>2. Government Accession No.:</b> N/A		<b>3. Recipient's Catalog No.:</b> N/A	
<b>4. Title and Subtitle</b>  Microbial Concrete Sealer				<b>5. Report Date</b> 5/8/23	
				<b>6. Performing Organization Code:</b> N/A	
<b>7. Author(s)</b>  Bashear El-Hajj, Sarah Pitell, Steven Sachs, and Sarah Haig				<b>8. Performing Organization Report No.:</b> N/A	
<b>9. Performing Organization Name and Address</b>  University of Pittsburgh Department of Civil and Environmental Engineering 738 Benedum Hall 3700 O'Hara Street Pittsburgh, PA 15261				<b>10. Work Unit No. (TRAIIS):</b> N/A	
				<b>11. Contract or Grant No.</b>  4400018535	
<b>12. Sponsoring Agency Name and Address</b>  The Pennsylvania Department of Transportation Bureau of Planning and Research Commonwealth Keystone Building 400 North Street, 6 <sup>th</sup> Floor Harrisburg, PA 17120-0064				<b>13. Type of Report and Period Covered</b>  Final Report 8/8/22 – 5/8/23	
				<b>14. Sponsoring Agency Code:</b> N/A	
<b>15. Supplementary Notes:</b> N/A					
<b>16. Abstract</b> Portland Cement Concrete (PCC) is the most widely used construction material due to its versatility, durability, and economy (Mindess et al. 2003). However, PCC is also a quasi-brittle material that has low tensile strength and ductility, as well as weak resistance to the propagation of cracks. Also, problems related to shrinkage, durability and workability have caused a multitude of issues during construction. This research project builds on the work of Pitell et al. (2020). Its objective is to investigate the feasibility of mitigating the deterioration of deck, parapet, and substructure concrete by applying a bio-inspired mortar that instigates Microbially Induced Carbonate Precipitation (MICP). Additionally, a testing procedure for applying the mortar is developed, and the effectiveness of the application regimen is assessed. This review is intended to introduce the current knowledge surrounding methods for application of MICP materials and improved test procedures to measure permeability. Health and safety issues are also be addressed.					
<b>17. Key Words</b>  Bi concrete, Microbially induced carbonate precipitation				<b>18. Distribution Statement</b> No restrictions. This document is available from the National Technical Information Service, Springfield, VA 22161	
<b>19. Security Classif. (of this report)</b>  Unclassified		<b>20. Security Classif. (of this page)</b>  Unclassified		<b>21. No. of Pages</b>  33	<b>22. Price:</b> N/A

# Table of Contents

<b>1. Literature Review .....</b>	<b>4</b>
<b>1.1 Microbially Induced Carbonate Precipitation .....</b>	<b>4</b>
1.1.1 Ureolysis as the optimal MICP pathway.....	6
1.1.2 Ureolysis substrate considerations .....	7
1.1.3 Current MICP applications .....	8
1.1.4 Considerations for MICP application in-situ .....	12
<b>1.2 Permeability Test Procedures .....</b>	<b>13</b>
ASTM C1585 .....	13
Sorptivity .....	14
ASTM C1202 .....	15
AASHTO T259 .....	15
Jing et al. (2020) .....	16
Palin et al. (2016).....	16
Gluchowski et al. (2018).....	17
Ultrasound Tomography .....	17
<b>1.3 Health, Safety, and Environmental Impact .....</b>	<b>18</b>
<b>2. Revised Testing Procedure Development.....</b>	<b>20</b>
2.1 Summary of Specimens Treated from Pitell et al. (2020).....	20
2.2 Revised Permeability Test Procedure .....	21
2.3 Evaluation of Safety Concerns due to Skid Resistance.....	28
2.4 Discussion and Conclusions.....	28
<b>References.....</b>	<b>30</b>

## **Disclaimer**

The contents of this report reflect the views of the authors who are responsible for the facts and the accuracy of the data presented herein. The contents do not necessarily reflect the official views or policies of the U.S. Department of Transportation, Federal Highway Administration, or the Commonwealth of Pennsylvania at the time of publication. This report does not constitute a standard, specification, or regulation.

## **Acknowledgements**

The authors would like to acknowledge the U.S. Department of Transportation, the Federal Highway Administration and the Pennsylvania Department of Transportation who sponsored the work. Thank you to Jeremy Hughes, the project technical advisor, Shelley Scott, the project manager, and Lars Delorenzi for contributions for project oversight.

# 1. Literature Review

Portland Cement Concrete (PCC) is the most widely used construction material due to its versatility, durability, and economy (Mindess et al. 2003). However, PCC is also a quasi-brittle material that has low tensile strength and ductility, as well as weak resistance to the propagation of cracks. Also, problems related to shrinkage, durability and workability have caused a multitude of issues during construction. This research project builds on the work of Pitell et al. (2020). Its objective is to investigate the feasibility of mitigating the deterioration of deck, parapet, and substructure concrete by applying a bio-inspired mortar that instigates Microbially Induced Carbonate Precipitation (MICP). Additionally, a testing procedure for applying the mortar will be developed, and the effectiveness of the application regimen will be assessed. This review is intended to introduce the current knowledge surrounding methods for application of MICP materials and improved test procedures to measure permeability. Health and safety issues will also be addressed.

## 1.1 Microbially Induced Carbonate Precipitation

As an alternative to current repair techniques, microbially induced carbonate precipitation (MICP) has been studied for its potential as a biologically active binding agent. When a microbe is capable of MICP, it produces calcium carbonate from environmental calcium and bioavailable carbon, which can act as a mortar when applied to structural cracks by filling the available space with calcium carbonate crystals. This application of calcium carbonate crystals has been shown to slightly increase the strength of the once compromised material, but typically provides structural integrity by preventing further water ingress and hence slowing further crack formation. The MICP phenomenon occurs through a variety of metabolic pathways, including ureolysis, photosynthesis, sulfate reduction, nitrate reduction, and ammonification (Table 1) (Dhimi et al. 2017) (Sohanghpurwala 2019). However, each pathway has varying pros and cons and hence suitability towards application for PCC rehabilitation. Across all of the metabolic pathways (Table 1), the degree of carbonate production is governed by environmental calcium concentrations, concentration of dissolved inorganic carbon, and pH. Moreover, calcium carbonate is not just a metabolic product of MICP. Microorganisms can also produce carbonate by using their cell walls as nucleation sites. This increases the overall rate of carbonate production (Obst et al. 2006).

When determining the optimal metabolic pathway for microbes used in PCC bioremediation, a variety of factors must be considered, including the ability of the microbe to survive under anaerobic and basic conditions, to grow quickly, and to produce enough calcium carbonate to make PCC bioremediation a more sustainable and safe option than conventional techniques. The photosynthesis MICP pathway requires small environmental inputs and creates harmless metabolites, but is not a feasible pathway for concrete bioremediation due to its low rate of calcium

carbonate precipitation within the cracks where sunlight cannot penetrate (Thompson and Ferris 1990). Ammonification and denitrification produce calcium carbonate at a rapid rate, but are not environmentally sustainable pathways because they yield basic nitrogenous byproducts, which can affect the environment in quantities as little as 1 ppm (Warthmann et al. 2000)(Van Paassen et al. 2010). In addition, the microbes that precipitate calcium carbonate via denitrification and could “heal” cracks in PCC grow much slower than other potential MICP organisms, and ammonifying organisms cannot grow in the anaerobic conditions of the PCC cracks (Zhu and Dittrich 2016). Conversely from the ammonification and denitrification pathways, sulfate reduction and methane oxidation pathways precipitate calcium carbonate rapidly, but produce acidic sulfuric byproducts and can be pathogenic (Warthmann et al. 2000)(Reeburgh 2007).

**Table 1: Comparison of MICP metabolic pathways** (Rodriguez-Navarro et al. 2006)(De Muynck et al. 2010) (Obst et al. 2006) (Thompson and Ferris 1990) (Warthmann et al 2000)(Van Paassen et al. 2010)

Metabolic Pathway	Simplified Reaction	Byproducts	Advantages	Disadvantages	Feasibility of PCC Application
Photosynthesis	$\text{HCO}_3^- + \text{Ca}^{2+} \rightarrow \text{CaCO}_3$	$\text{H}_2\text{O}$ & $\text{O}_2$	No harmful byproducts	Light must penetrate deeply	Cannot survive in dark cracks
Ureolysis	$\text{CO}(\text{NH}_2)_2 + \text{H}_2\text{O} + \text{Ca}^{2+} \rightarrow \text{CaCO}_3$	$\text{NH}_4^+$	Rapid rate of $\text{CaCO}_3$ precipitation. Many non-pathogenic bacteria Aerobic and anaerobic	Byproducts can be toxic	Meets all parameters
Ammonification	Amino acids + $\text{O}_2$ + $\text{Ca}^{2+} \rightarrow \text{CaCO}_3$	$\text{NH}_3$	Many non-pathogenic bacteria	Byproducts can be toxic	Cannot survive in anaerobic PCC matrix
Denitrification	Multiphase reaction, Final reaction: $\text{CO}_2 + \text{OH}^- + \text{Ca}^{2+} \rightarrow \text{CaCO}_3$	$\text{CO}_2$ & $\text{N}_2$	Facultative anaerobes	Byproducts can be toxic Slow growing organisms	Production is too slow to be feasible
Sulfate Reduction	$\text{SO}_4^{2-} + \text{CH}_2\text{O} + \text{Ca}^{2+} \rightarrow \text{CaCO}_3$	$\text{CO}_2 + \text{HS}^-$	Can create $\text{Ca}^{2+}$ by degrading parts of other organisms	Byproducts can be toxic Decrease pH	pH decrease is not conducive to PCC $\text{HS}^-$ is corrosive and odorous
Methane Oxidation	Anaerobic: $\text{CH}_4 + \text{SO}_4^{2-} + \text{Ca}^{2+} \rightarrow \text{CaCO}_3$ Aerobic $\text{CH}_4 + 2\text{O}_2 + \text{Ca}^{2+} \rightarrow \text{CaCO}_3$	$\text{H}_2\text{S}$	Aerobic and anaerobic	Byproducts can be toxic Decrease pH	$\text{H}_2\text{S}$ is poisonous, flammable, and corrosive

### 1.1.1 Ureolysis as the optimal MICP pathway

Previous research has found the synthesis of microbial calcium carbonate via ureolysis to be the best method of PCC remediation, due to the wide variety of microbes that undergo ureolysis, availability of necessary substrate, and rapid calcium carbonate precipitation (Zhu and Dittrich 2016)(Siddique and Chahal 2011). Ureolytic organisms do not require oxygen in order to produce calcium carbonate, and therefore can function in aerobic and anaerobic conditions. Concrete provides a highly basic environment for microorganisms, which many ureolytic organisms are able to survive in (Zhu and Dittrich 2016)(De Muynck et al. 2010). Nonpathogenic bacteria such as *Sporosarcina pasteurii*, *Pseudomonas calcis*, and *Pseudomonas denitrificans* are capable of MICP and have been found in natural and built environments, which makes their application to PCC favorable (Zhu and Dittrich 2016)(De Muynck et al. 2010). Most importantly, ureolytic microorganisms precipitate calcium carbonate readily under the conditions found in RC, which makes them ideal candidates for remediation use (Zhu and Dittrich 2016)(Siddique and Chahal 2011).

In order to precipitate calcium carbonate, ureolytic organisms contain a higher concentration of the enzyme urease that catalyzes the MICP reaction (Zhu and Dittrich 2016)(De Muynck et al. 2010). Urease has a strong affinity for calcium ions, so in a calcium-saturated environment, urease can cleave urea and form a bond with the resulting carbonate and calcium (Equations 1-6) (De Muynck et al. 2010)(Stocks-Fischer et al. 1999)(Achal et al. 2011). The resulting ammonium from the reaction then increases the pH directly around the microbe, which enhances the conversion of carbon dioxide to carbonate ions in the vicinity and catalyzes the process further.

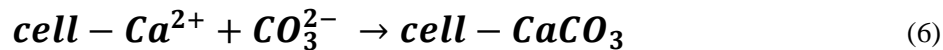
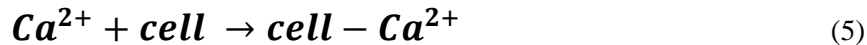
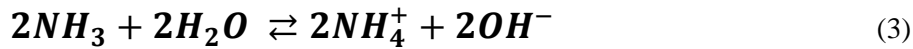
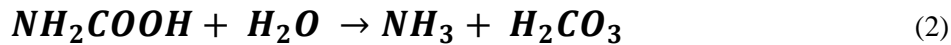
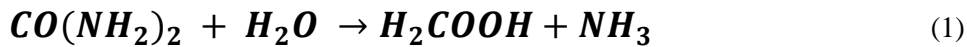

**Equations 1-6: Urease-catalyzed hydrolysis of urea to form calcium carbonate**

Ureolytic microbes need both urea and calcium sources in order to undergo the reaction described in equations 1-6. Both of these nutrients must be applied along with the microbe as neither of these compounds pre-exist in concrete. However, as urea is a well-defined substrate needed by these organisms, there are a variety of potential calcium sources that they can utilize.

Among these are the simple salt calcium chloride and more complex compounds such as calcium acetate, calcium nitrate, and calcium formate. Either type can be used as a calcium source in the MICP pathway, but there are advantages and disadvantages to each type. Using calcium chloride lets the compound dissociate readily and thus speeds up the overall reaction time during ureolysis, but the resulting chloride ion from the dissociation can cause further chemical damage of the cracked concrete (De Muynck et al. 2010). The other complex compounds are more difficult for microbes to use as calcium sources, but don't release the corrosive chloride ion (De Muynck et al. 2010). These variations in starting materials also impact the precipitated structure: calcium chlorite makes crystals with rhombohedral geometry, whereas calcium acetate makes spherulitic crystals (Anbu et al. 2016).

Another harmful compound involved in ureolysis that may cause more damage to cracked concrete is ammonium. Urease releases 2 moles of ammonium for every mole of calcium carbonate it creates, which contributes to the basic environment. In order to microbially remediate 1 m<sup>2</sup> of cracked concrete, 10 g/L of urea is necessary. This yields 4.7 g/L of nitrogen-containing compounds (De Muynck et al. 2010)(Anbu et al. 2016). In context, this output is one-third of the daily nitrogen load of one person, so the large amounts of additional nitrogen output are a major concern for application of ureolytic MICP. Hence, the potential of ammonium leachate from rehabilitated PCC must be assessed before application. Ammonium in high concentrations can volatilize into nitrogen oxide, which is a potent greenhouse gas and contributes to ozone depletion (Andu et al. 2016)(Mansch and Bock 1998). This metabolite could also be detrimental to the structural integrity of the concrete due to secondary reactions within the concrete matrix (e.g., formation of nitrogenous salts (De Muynck et al. 2010), or nitric acid by nitrifying bacteria (Mansch and Bock 1998)). While these nitrogenous salts and acids can impact the surrounding concrete, there is no data currently available on how these metabolites leach from rehabilitated PCC or impact the strength of PCC.

### **1.1.2 Ureolysis substrate considerations**

The concrete industry already uses urea and calcium chloride as admixtures to alter some of the properties of PCC during its fabrication. Calcium chloride is added to a concrete mixture as an accelerator to shorten setting times, and has been proven to improve short term strength in PCC (Rapp 1935). These benefits are only observed at concentrations lower than 2% due to ion corrosion of the internal rebar, so increasing the concentrations for the microbial feed source may not be feasible. Urea, on the other hand, can be added to concrete mixes to lower their hydration and casting temperatures, and has been shown to have no effect on the concrete's performance even at saturation conditions (Sadegzadehm and Page 1993). To the author's knowledge, no studies have investigated the synergistic effects of calcium chloride and urea, so it is unclear



whether the two chemicals could be added as a microbial feed stock without compromising the structural integrity of PCC.

### 1.1.3 Current MICP applications

There are numerous different methodologies for introducing microbes capable of MICP into PCC to potentially seal/heal cracks (Table 2). Broadly speaking, these techniques can be separated into two main categories: biodeposition and biocementation.

Biodeposition describes MICP that forms a surface-level barrier of calcite that protects the structure underneath, whereas MICP classified as biocementation uses the precipitated calcite within the structure's matrix to increase adhesion of the internal components (Figure 1) (De Muynck et al. 2010)(Achal et al. 2011).

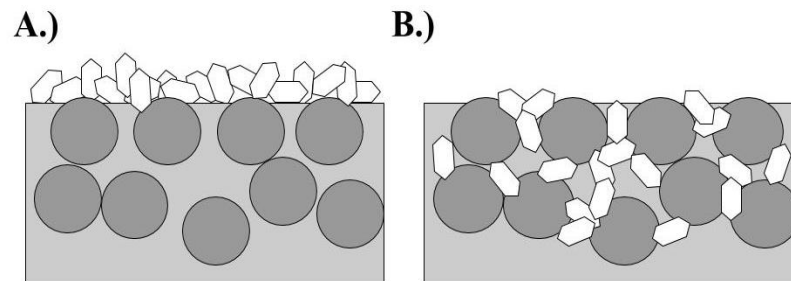

**Figure 1: General categories of MICP application to concrete.** Biodeposition (A.) results in a layer of calcium carbonate on the surface of the porous cement matrix, whereas biocementation (B.) adheres the cement matrix components together with calcium carbonate.

Biodeposition can be achieved relatively simply by spraying liquid bacterial culture onto the matrix or immersing the matrix in liquid bacterial culture. However, it has the disadvantage of only treating the material's exterior (De Muynck et al. 2010)(De Muynck et al. 2008)(Dick et al. 2006). In contrast, biocementation can treat more than superficial cracks and can potentially increase the strength of PCC. However, it is more difficult to implement due to difficulties in evenly mixing the microorganisms within the cementitious slurry and maintaining a suitable environment for them to precipitate calcium carbonate (De Muynck et al. 2010)(Jonkers et al. 2010)( Ramachandran et al. 2001).

MICP can also be categorized as either biostimulation or bioaugmentation, depending on the origin of the organisms that are used (Dhami et al. 2017). Biostimulation techniques provide an

environment that is conducive for calcium carbonate precipitation for the microbiota already present in the concrete. This technique does not introduce new bacteria to the structure, so the time and cost constraints of microbial culturing are not a factor (De Muynck et al. 2010). However, biostimulation only succeeds if bacteria capable of MICP are already abundant in PCC. Given the lack of knowledge pertaining to which, if any, viable microbes naturally reside within PCC, bioaugmentation has been the approach typically investigated. Bioaugmentation is a technique in which microorganisms with a desirable trait (e.g., MICP properties) are added to the matrix (Dhami et al. 2017). These microorganisms require culturing prior to application and need to be supplied with appropriate resources to allow them to grow in their new environment.

### ***MICP-mediated biodeposition as a surface level sealant***

Because biodeposition only treats the surface of a material, it is less useful for cementitious materials, such as PCC, that need proactive treatment for cracks. It is most useful for remediating materials that need to be protected from erosion by an exterior layer (e.g., limestones, ornamental stone). Furthermore, limestone and other stones used to construct statues and historic buildings are compatible with calcium carbonate, so initially, MICP application was focused on their protection (Table 2). One of the first research groups to explore this concept developed a patented system of biologically active biodeposition and biocementation products, called the Calcite Bioconcept, to repair superficial cracking and seal these types of structures (De Muynck et al. 2010). These systems are implemented by spraying or brushing a liquid culture of MICP-capable organisms onto the surface of the ornamental stone for a number of days until the calcin layer is established. This surface treatment does not change the aesthetics of the stone and can be effective for years, depending on the type of environment (De Muynck et al. 2010). For the superficial biomortar produced by the Calcite Bioconcept, liquid culture with MICP-capable organisms is mixed with a binding agent, then applied to the small cracks in limestone objects. The resulting seal decreases water permeability and also aids in aesthetics. This type of in-situ remediation for historic limestone buildings is used due to its low visual impact, lighter environmental footprint, and ease of application, but is only economically viable for projects with historic or sentimental value. Traditional practices are much more cost-effective, but they change the visual attributes of the structure and require a high level of maintenance in re-applications (Rodriguez-Navarro et al. 2003)(De Muynck et al. 2010).

**Table 2: Application methods of MICP-mediated remediation. (Adapted from De Muynck et. al., 2010).**

<b>Biodeposition</b>						
<b>Method</b>	<b>Advantages</b>	<b>Disadvantages</b>	<b>Ref.</b>	<b>Matrix Type</b>	<b>Microbe</b>	<b>Metabolic Pathway</b>
Spraying	<ul style="list-style-type: none"> <li>• Easy application</li> <li>• Site-specific</li> <li>• Applicable for pre-existing structures</li> </ul>	<ul style="list-style-type: none"> <li>• Superficial treatment</li> <li>• Requires frequent re-applications</li> </ul>	Le Métayer-Levrel et al. 1999	Limestone	<i>B. cereus</i>	Ammonification
			Tiano et al. 1999	Limestone	<i>Micrococcus Sp.</i> <i>Bacillus subtilis</i>	Ammonification Ureolysis
Brushing		<ul style="list-style-type: none"> <li>• Patented</li> </ul>	Tiano et al. 1999	Limestone	<i>Micrococcus Sp.</i> <i>Bacillus subtilis</i>	Ammonification Ureolysis
Immersing in liquid culture	<ul style="list-style-type: none"> <li>• Even coverage</li> <li>• Conductive growth Conditions</li> <li>• Potential pore infiltration</li> </ul>	<ul style="list-style-type: none"> <li>• Not applicable for pre-existing structures</li> <li>• Requires large culture</li> </ul>	Rodriguez-Navarro et al. 2003	Limestone	<i>Myxococcus xanthus</i>	Ammonification Ureolysis
			Dick et al. 2006	Limestone	<i>B. sphaericus</i>	Ureolysis
			Tiano et al. 1999	Limestone	<i>Micrococcus Sp.</i> <i>Bacillus subtilis</i>	Ammonification Ureolysis
			De Muynck et al. 2008	Concrete	<i>B. sphaericus</i>	Ureolysis
			Ramachandran et al. 2001	Limestone	Biostimulated native microbiota	n/a
<b>Biocementation</b>						
Biomortar	<ul style="list-style-type: none"> <li>• PCC compatible</li> <li>• Effective in-situ</li> </ul>	<ul style="list-style-type: none"> <li>• Requires application to cracks</li> <li>• Patented tech</li> </ul>	Le Métayer-Levrel et al. 1999	Binder	<i>B. cereus</i>	Ammonification
Bacterial concrete	<ul style="list-style-type: none"> <li>• Potential to increase PCC strength</li> <li>• Changes PCC microstructure</li> </ul>	<ul style="list-style-type: none"> <li>• No crack remediation</li> </ul>	Ramachandran et al. 2001	Concrete mix	<i>S. pasteurii</i>	Ureolysis
					<i>Shewanella</i>	Varied
Self-healing concrete	<ul style="list-style-type: none"> <li>• Spontaneously heals cracks</li> </ul>	<ul style="list-style-type: none"> <li>• Difficult to keep bacteria alive</li> </ul>	Zhu and Dittrich 2016		<i>S. pasteurii</i>	Ureolysis
			Dick et al. 2006		<i>B. sphaericus</i>	Ureolysis

---

• Difficult to distribute bacteria evenly	Jonkers et al. 2010	<i>B. pseudofirmus</i>	Denitrification
---	---------------------	------------------------	-----------------

---

For smaller objects or projects not yet fully assembled into their final structures, biodeposition can also be utilized on a smaller scale by completely immersing the item of interest into a liquid culture of MICP-capable organisms (Rodriguez-Navarro et al. 2003)(De Muynck et al. 2010)(Dick et al. 2006). This method ensures even application of the calcite deposition in ideal environmental conditions and may even improve water resistance by encouraging microorganisms to infiltrate the surface-level pores. This method is, however, impractical due to the size limitations of the item being treated: the material must be fully submerged to ensure the even application of calcite, so a large volume of the MICP culture must be grown and maintained. Further, the material must remain submerged until the calcin layer forms, which can be time-intensive. Most importantly for in-situ remediation, it is impossible to submerge a pre-existing structure in order to achieve biodeposition (Rodriguez-Navarro et al. 2003)(De Muynck et al. 2010)(Dick et al. 2006).

***MICP-mediated biocementation as a promising PCC technique***

While biodeposition can help preserve ornamental stones, it has very little relevance to remediating cracks in PCC. Concrete has a higher resistance to environmental weathering but is more prone to structurally significant cracks, which cannot be prevented with a biodeposited layer. In this case, biocementation treatments for PCC focus on expanding its serviceable lifetime by either improving its overall strength or mitigating the potential for the formation or growth of cracks, all while attempting to minimize the further environmental impact of PCC (Table 2).

The biocementation method that is most similar to traditional concrete remediation techniques for pre-existing structures is biomortar, a microorganism-enriched mortar that seals cracks like a traditional mortar but also forms MICP crystals on the first few micrometers of the sealed crack. These crystals provide a stronger seal between the mortar and concrete by increasing the compatibility of the two materials and decreasing water permeability, but also function like a traditional remediation technique in which the crack must first be identified and then treated directly (De Muynck et al. 2010). A more efficient approach is necessary due to the difficulty of identifying remediation sites on a structure and the manpower required to monitor and retreat as needed.

Adding MICP-capable microbes into the concrete prior to casting (i.e., as admixtures) circumvents the monitoring and remediation costs associated with traditional PCC restoration. While these technologies are not applicable to pre-existing structures, they could be instrumental

in increasing the lifetime of PCC materials in the future and are thus paramount to study. Currently, there are two main MICP admixture approaches: bacterial concrete and self-healing concrete. Bacterial concrete is PCC whose mix contains a small percentage of microorganisms that can change the PCC's internal pore structure through MICP. The altered pore structure then provides the cured concrete with more compressive and tensile strength, which makes it more resistant to cracking (Ramachandran et al. 2001)(De Muynck et al. 2008). Because bacterial concrete is more resistant to microcracking, it requires less frequent treatment for cracks, although the treatment method is the same as for traditional PCC.

The most promising novel MICP-mediated PCC material is self-healing concrete. However, it should be stressed that this is still a hypothetical system, with early results coming from carefully controlled laboratory experiments. While similar in fabrication to bacterial concrete, self-healing concrete can heal cracks as they form, which would eliminate the need for screening or external maintenance (De Muynck et al. 2010)(Jonkers et al. 2010)(Schreiber 1990). In a self-healing PCC system, a crack in the surface would still allow water seepage into the internal PCC matrix. However, instead of seeping further into the concrete and potentially corroding the rebar, the water would activate dormant MICP microorganisms, which would then begin producing calcium carbonate to heal the crack in its early stages (Jonkers et al. 2010)(Schreiber 1990). For both bacterial concrete and self-healing concrete, a major challenge is to distribute the biological agent evenly within the mix, or else the MICP properties will be unevenly applied through the material. Even more broadly, the MICP microorganisms must be able to withstand the hostile environment of curing, so spore-forming bacteria are likely the only feasible option (Jonkers et al. 2010). These bacteria often undergo ureolysis as their MICP metabolic pathway, so they live optimally in an anaerobic and alkophilic environment, such as that found in PCC, but urea and calcium need to be supplied to allow calcium carbonate production. For bacterial concrete, these nutrients can be added externally during curing (Ramachandran et al. 2001). Conversely, for self-healing concrete, the nutrients cannot be applied externally. Therefore, these compounds must be added to the mix so that the microorganisms embedded in the PCC have access to the resources they need to survive and produce calcium carbonate. To date, the optimal PCC mixture formulations for sustaining MICP have not been explored – both from a microbial viability and a PCC mechanical perspective.

#### **1.1.4 Considerations for MICP application in-situ**

While there are a variety of MICP techniques with different uses, a suite of factors need to be considered to fully determine the feasibility of wide-scale application to PCC. Some significant factors include effectiveness, reproducibility, cost, remediation lifetime, and environmental impact compared to conventional treatments. While the cheapest and most effective treatments are usually chosen for implementation, some applications, such as the remediation of historic limestone buildings mentioned previously, are more concerned with other aspects of the treatment, such as

material compatibility and treatment detection in the final product. Materials with these attributes may be more desirable, even if they cost slightly more than traditional limestone treatment (Rodriguez-Navarro et al. 2003).

## **1.2 Permeability Test Procedures**

Permeability is the most important property for a concrete structure exposed to weather or other severe exposure conditions. It is defined as either the amount of water migration through concrete when the water is under pressure or the ability of concrete to resist penetration by water or other substances (Kosmatka et al. 2011). The overall permeability of PCC to water is a function of: (1) the permeability of the paste; (2) the permeability and gradation of the aggregate; (3) the quality of the paste and aggregate transition zone; (4) the relative proportion of paste to aggregate; and (5) the w/c ratio (Mindess et al. 2003). As seen in Figure 5, the permeability of PCC decreases as the w/c ratio decreases. Decreased permeability improves concrete's resistance to freezing and thawing, chloride-ion penetration, and other chemical attacks (Kosmatka et al. 2011).

Cracked specimens in the original IRISE study were dried for 1 week, then submerged in tap water for half an hour. After 7 days, the process was repeated, with the cracks now sealed with biomortar. Specimens were weighed before and after submerging to measure the weight of water absorbed. While intuitive, this is not a standardized test for absorption and permeability, and results were inconclusive (Pitell et al. 2020). The objective is thus to devise a more suitable permeability test. Several candidate tests are examined and identified below. These tests will be evaluated to establish an improved test procedure to evaluate the effectiveness of MICP.

### **ASTM C1585**

The ASTM standard test for permeability and absorption tests both the surface and interior concrete. Samples are 50mm-long, 100mm-diameter discs, either cut from cast cylinders or drilled cores. They are placed either in an environmental chamber capable of maintaining a temperature of 50°C and a relative humidity of 80%, or in a 50°C oven and a desiccator with relative humidity controlled by a solution of potassium bromide (not to come into direct contact with the specimens). After 3 days the specimens are removed, with the sides sealed (with epoxy paint, tape, or adhesive sheets), and the non-water exposed surface covered with a plastic sheet. Specimens are then placed in a pan on supports and submerged under up to 3mm of water. The specimen is weighed over the course of 6h for the first day, then daily over the course of a week (ASTM C1585).

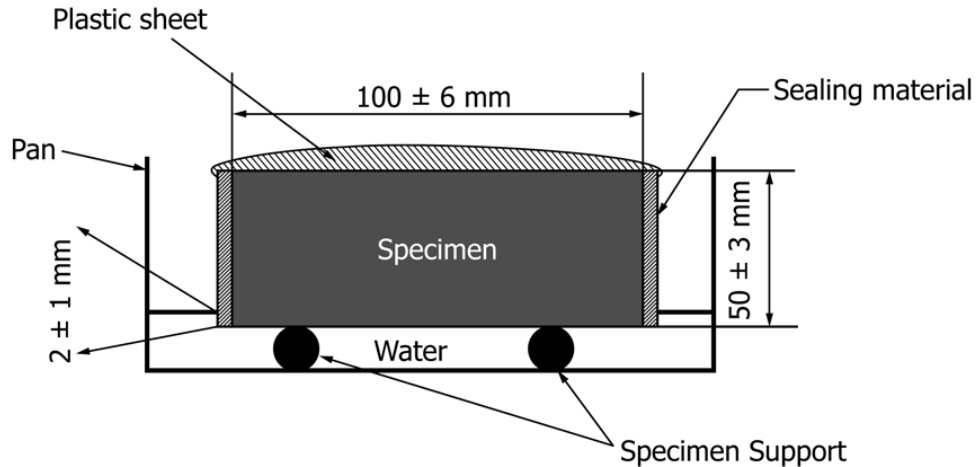
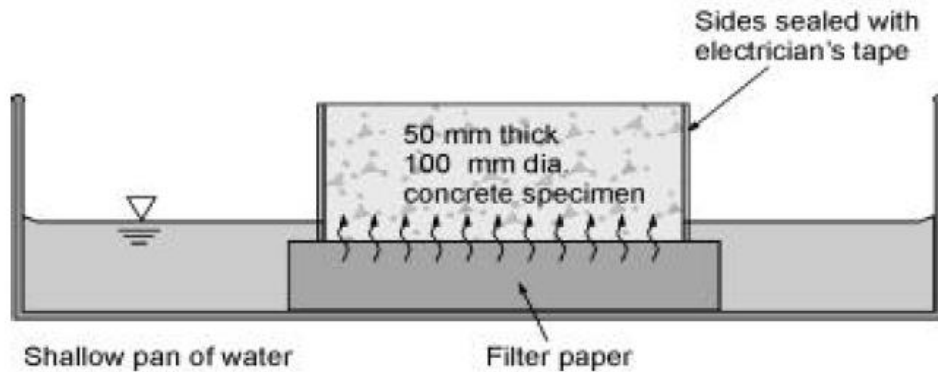

**Figure 2. ASTM C1585 Test Setup (ASTM C1585)**

This is likely the easiest method, although a concerning risk is that prolonged time in the oven or environmental room may prove detrimental to the microbes. The biomortar should be either applied in a thin layer over the water-exposed surface, or potentially used to seal two discs together. A similar method, ASTM C642, tests the maximum amount of water that can be absorbed by dry specimens. In that test, the specimens are oven-dried, immersed in 21°C water, and then boiled underwater for 5 hours. This may prove a simpler method, provided the boiling does not impact the microbes.

## Sorptivity

Not to be confused with absorption, sorptivity is “a material’s ability to absorb and transmit water through capillary suction.” The ASTM field test is relatively simple: a sample is dried for 7 days at 50°C and cooled for 3 days in a sealed container, then sealed on the sides with electrical tape. Similar to the absorption test above, the sample is placed in a container immersed in 5-10 mm of water, although placed on filter paper. The sample is periodically (over the course of minutes) removed and weighed to determine the amount of water absorbed. The cumulative water absorbed versus time can be plotted, and the sorptivity is calculated by finding the best fit line.



**Figure 3. Sorptivity Test Setup (Stanish et al. 1997)**

### **ASTM C1202**

ASTM C1202 is a test that uses electric current to determine the resistance of the concrete to chloride ion penetration, and thus may help determine general permeability. The test involves 50mm thick, 100mm diameter specimens similar to the test described above. After 28 days of curing, the specimen's sides are coated with sealant and the specimen is treated in a vacuum desiccator, followed by 18h of submerging in water. Afterwards, the specimen's exposed ends are covered with rubber or plastic and mounted in test cells, one of which is filled with sodium chloride solution and the other with sodium hydroxide solution. The specimen is then subjected to 60V for 6 hours, with current over time recorded every half hour.

However, the standard warns of misleading results when used on surface-treated concretes or concretes with penetrating sealers: such concretes typically show poor ion penetration resistance in this test while showing high resistance in chloride ponding tests. Furthermore, the multitude of chemicals may prove a poor combination with the microbes.

### **AASHTO T259**

The abovementioned chloride ponding test is performed on specimens of at least 75mm in thickness and 300mm<sup>2</sup> surface area. The slabs are moist cured for 14 weeks and then stored for 28 days at 50% relative humidity. The slabs' sides are sealed with one face exposed to a drying environment and the other submerged under a 13mm pond of 3% NaCl solution for 90 days. At the end of this lengthy period, successive 0.5-inch slices are taken from the slabs and the average chloride concentration is determined. However, this resultant chloride penetration profile is very crude and is not purely the result of chloride diffusion.



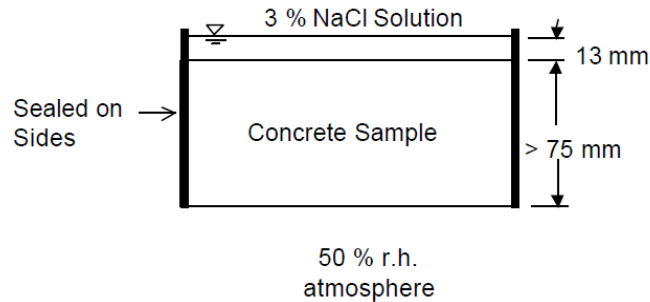

**Figure 4. AASHTO T259 Test Setup (Stanish et al. 1997)**

A suggested improvement on the chloride ponding test is the bulk diffusion test, which aims to eliminate other mechanisms of infiltration. The drying period is replaced by saturation in limewater. All sides are sealed except the exposed top, and the entire specimen is submerged in 2.8 M NaCl solution for 35 days. At the end of this period, 0.5mm layers of the specimen are ground into powder with a mill or lathe. The powder can then be analyzed for chloride content. While this is normally a faster test, higher-quality tests often require a full 90-day period.

#### **Jing et al. (2020)**

In a study on the permeability of mortar using waste glass as fine aggregate, mortar cones were evaluated with a test based on the Chinese National standard JGJ/T70-2009. The specimens were truncated cones with a diameter of 70mm (reduced from 80mm) and a height of 30mm. A specialized testing machine (not identified) tested eighty groups of six specimens each. Specimens were subjected to a water pressure of 0.2 MPa from below for 2 hours, with water pressure increasing by 0.1 MPa per successive hour. The top surfaces of the specimens were sealed with humidity-sensing paper that would change color upon contact with water, indicating seepage. The time required to wet the third specimen per group was taken as the group's impermeability value. While interesting, this method requires its own specialized equipment and a large test group.

#### **Palin et al. (2016)**

A study of particular interest examined the self-healing properties of mortar submerged in seawater. Mortar cylinders were wrapped in polyethylene and subjected to tensile cracking. They were placed under 1 to 1.05m of synthetic seawater, with the water seeping through the cracks to be collected and weighed in a catchment bucket. However, the paper's explanation of the testing procedure is somewhat unclear. It says the specimens were submerged and vacuumed for 2 hours, then submerged in 4 L of seawater for either 28 or 56 days, then dried for 28 days, with permeability measurements taken at each interval.

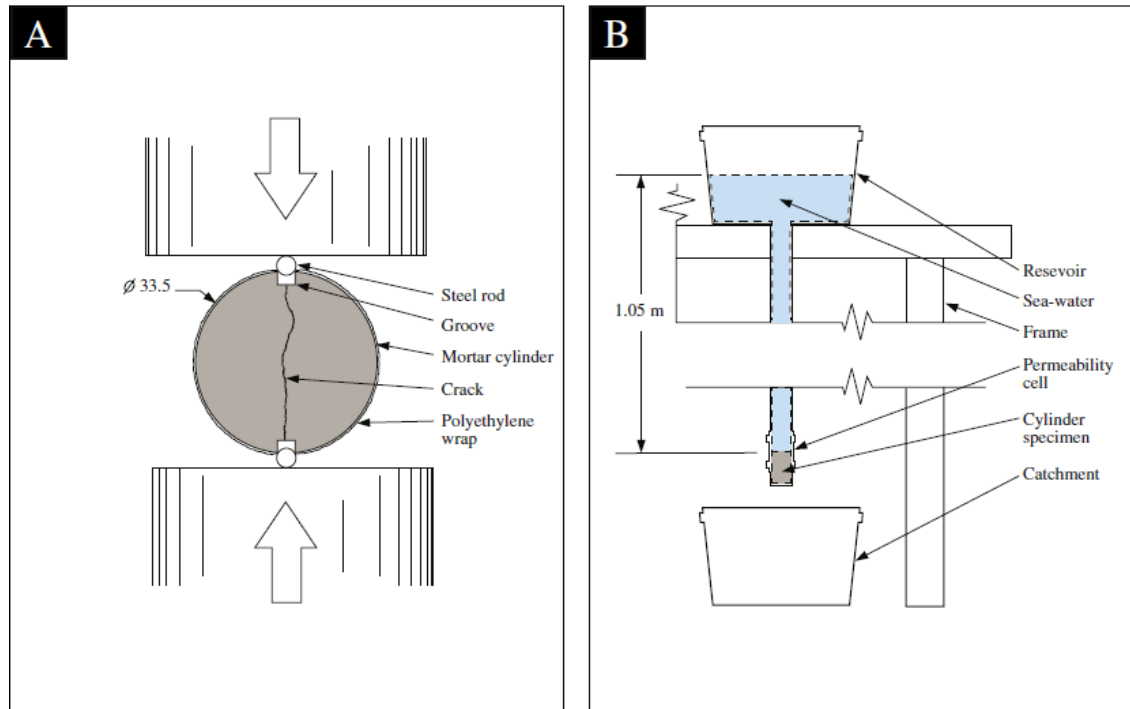

**Figure 5. Test Setup (Palin et al. 2016)**

### **Gluchowski et al. (2018)**

This study measured the permeability of recycled concrete aggregates of varying sizes with a permeameter (constant head device). The permeameter was constructed of two stainless steel cylinders connected by a perforated permeability mold containing the aggregate. Water flowed from the outer cylinder to the inner one through the sample, with the difference in water table height indicating the hydraulic gradient. The inner water table was fixed, while the outer water table changed.

This method might work for a solid concrete block if measurements were taken over a longer period, but the procedure apparently required several updates. The aggregate was compacted using the Proctor method at a moisture content of 8% and saturated with 24 hrs. of exposure to aerated water at a rate of 0.25mm/hr. of the water table. Movement of fine particles within the sample had to be restricted by adding weight to the top of the perforated cover, and permeability gradients had to be tested using the hydraulic gradients used for dam construction (at 40 trials per gradient for each blend).

### **Ultrasound Tomography**

Ultrasound tomography is an option for nondestructive evaluation of the changes in the acoustic impedance of concrete specimens (measured using the linear array handheld ultrasonic device,

MIRA). This relationship between the change in impedance and the different MICP treatments then serves as a model to relate the field-measured impedance to the effectiveness of the MICP-capable microbes. The effectiveness of MICP-capable microbes for crack healing is quantified with the generalized Kirchhoff migration-based synthetic aperture focusing technique (SAFT) and reverse time migration (RTM). MIRA devices have been shown to be both highly accurate and convenient to use in the field for evaluation of concrete pavements.

### **1.3 Health, Safety, and Environmental Impact**

One of the main goals for equipping PCC with MICP technologies is to minimize the material's environmental impact. As mentioned, PCC production can account for up to 10% of all carbon dioxide emissions and requires a large amount of energy (Zabalza Bribián et al. 2011). In addition to these significant upfront environmental impacts, the short functional lifetime of a PCC structure requires using a variety of environmentally harmful compounds to extend the structure's lifespan. These products are typically chemical resins or epoxies that emit volatile contaminants and often leak into the surrounding environment via runoff from the structure. While biodeposition and biocementation products may not decrease the environmental impact of PCC production, they can minimize additional environmental damage during the lifespan of the structure. Biodeposition techniques create a small layer of calcium carbonate either over a structure's surface or superficially over a crack, which reduces water and compound permeability but does not contaminate the surrounding atmosphere and water table (De Muynck et al. 2010). In the case of biocementation, the water and chemical resistance can be observed in the biomortar treatments, but the bacterial concrete does not require potentially harmful admixtures to create similar strength additions, and self-healing concrete negates the need for additional structural maintenance completely. In terms of structural upkeep alone, these biological treatments are superior to conventional systems.

Additional factors must be considered when implementing bacterial and/or self-healing concrete in particular. For example, MICP-capable organisms need appropriate nutrients if they are to precipitate calcium carbonate. These organisms are either naturally present within PCC (biostimulation) or added into PCC (bioaugmentation). Bioaugmentation radically changes the native microbiota of the PCC, so it could have unknown impacts on the physical properties of the PCC, as the significance of the native microbial population in PCC has not been studied. Biostimulation, on the other hand, is vulnerable to the same problems mentioned earlier: potential failure due to the endogenous microbial community not capable of MICP, slow precipitation when MICP organisms are present, and the need for maintenance.

Even when the implementation of bacterial and/or self-healing concrete is feasible, the precipitate can only form at the concrete's surface due to lack of transport throughout the material. Therefore, adding MICP nutrients directly into PCC mixes would maximize the potential

advantages for using MICP. Besides the difficulty of evenly mixing the biologically active constituents throughout the concrete, the components themselves can carry significant environmental impacts. For example, the nitrogen source of ureolytic MICP is urea, and the most commonly used calcium source is calcium chloride, which can contribute ammonium and chloride ions, respectively, into the environment in the form of runoff. This can cause eutrophication and react with other environmental components to form more dangerous compounds (De Muynck et al. 2010)(Anbu et al. 2016)(Jonkers et al. 2010). The environmental impact of these systems can be diminished by substituting synthesized urea with urea isolated from municipal waste, either in the context of a separated sewer system or via resource recovery using source-separated urine streams (Jonkers et al. 2010). This integration of infrastructure would minimize the energy consumption and cost of both the PCC and wastewater treatment sectors and make bioconcrete a more attractive option for implementation. Even after self-healing concrete production, the ureolytic metabolic reaction converts nearly half of the starting nitrogen concentration into ammonia. Since ammonia can corrode PCC, and chloride accelerates the curing of PCC, their impacts on PCC design and mechanics must be investigated. Pitell et al. (2020) demonstrated that the leaching of ammonia should not be problematic at the concentrations of urea being used for MICP, and that there should be little to no issue introducing the nutrients into the mixture to induce MICP.

## 2. Revised Testing Procedure Development

This section describes a set of laboratory tests carried out in an attempt to identify an improved method for determining permeability.

### 2.1 Summary of Specimens Treated from Pitell et al. (2020)

The following discussion describes the previous attempts to determine the reduction in water ingress from Pitell et al. (2020). Specimens with induced cracks in the original IRISE study were allowed to dry for 1 week, weighed, then submersed in tap water for 30 minutes. At the end of this period, the blocks were weighed again to determine the weight change when saturated with water. This protocol was repeated 7 days after the biomortar was applied to determine how water ingress potential had changed due to the crack treatment.

After numerous iterations of biomortar design, the final biomortar was prepared by creating a 3:8 mixture of 7-day old MICP culture and sterile sand to make a paste which was put in the lower half of the crack using a sterile spatula. The upper section of the crack was then filled with a slurry comprised of a 5:2:0.4 mixture of sterile sand, 7-day old culture of MICP microorganisms (Figure 10), and binder. The microbial dose in the biomortar was approximately  $3.39 \times 10^9$  colony-forming units /mL. This two-phase application provided the best visual seal in the RC cracked specimens, likely because the foundational paste acted as scaffolding to the slurry that had a greater proportion of microorganisms in the lower half of the crack. Over the 7 days the biomortar was allowed to set, the consolidation was apparent on the biomortar's surface, which was likely a thin calcin layer created by the microorganisms (Figure 6).

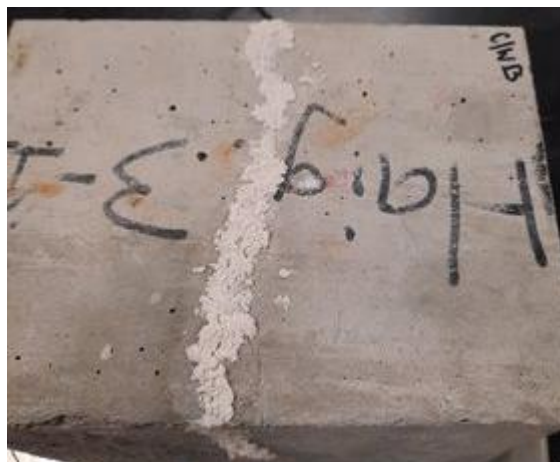

**Figure 6. Photo showing a representative example of the biomortar after setting**

The permeability results, however, did not reflect these visual observations. Out of the 5 environmental isolates and the conventionally used MICP organism, only four showed a reduction of water ingress after being submerged. On average, the four MICP-isolated organisms reduced water ingress by 37.7%

While intuitive, this is not a standardized test for absorption and permeability, and results were inconclusive (Pitell et al. 2020). The methodology of these absorption tests should also be re-evaluated to test more exactly the location of application of the microbes on the specimen. This will allow just the surface of application to be tested for water intake to determine more exclusively the effects of the MICP. The objective is thus to devise a more suitable permeability test. Of the candidate tests evaluated in the literature review, a modified version of ASTM C1585 is best suited to this purpose. It is presented in the following section.

## **2.2 Revised Permeability Test Procedure**

Concrete specifications were the same as in Pitell et al. (2020) and accorded with PennDOT Publication 408 (2020) section 704.1(b) specifications for Bridge Deck Concrete. Type I Portland cement was used, with a water-cement ratio of 0.44. Natural Type A sand and crushed #57 limestone were used for fine and coarse aggregate, respectively, with an overall mix ratio of 0.44:1:1.87:2.58. All specimens were cast in accordance with ASTM C192 procedures: four cylindrical specimens, 8 inches tall and 4 inches in diameter, and six beam specimens, 6-in. by 6-in. by 21-in.

In the modified procedure from ASTM C1585, cylindrical specimens are cured for 7 days and stored in a 100°C oven for 24 hrs., before storage in dry sealed containers for a further 5 days. After this storage period, each of the four cylinders is cut into four 2-in. tall cylinders, giving 16 specimens for testing. Biomortar is then applied to the circular faces of eight of these specimens, while the other eight are left untreated as a control group. After 16 hours, the biomortar on the treated and untreated specimens is hard enough for the specimens to be returned to a curing room for moist curing for 7 more days. Upon maturation of the biomortar, the sides of the specimens are painted with waterproof commercial sealant, and the untreated faces are covered with plastic. The specimen is then placed biomortar-side down on supports partially submerged in water, as depicted in Figure 7. This prevents any water ingress except through the exposed surface treated with biomortar. Over the next seven days, the specimens are weighed at regular intervals (over the course of 6 hours on the first day and once daily on each following day) to determine the weight increase from absorbed water. Both the control specimens and the specimens treated with the biomortar are tested.

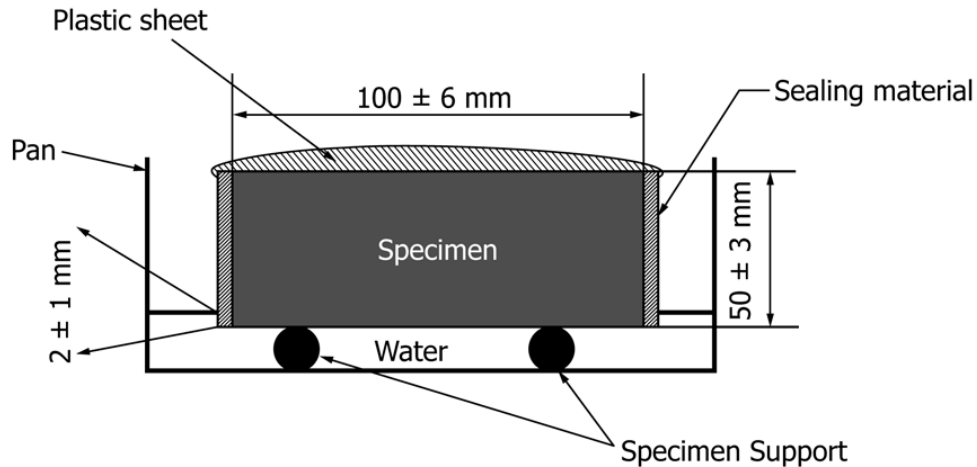

**Figure 7. ASTM C1585 Test Setup (ASTM C1585)**

Next, the absorption of water into the water-exposed surface is determined. The absorption is the change in mass divided by the product of the cross-sectional area of the test specimen and the density of water. For the purposes of this test, the density of water was assumed to be  $.001 \text{ g/mm}^3$ ; the temperature dependence of the density of water was neglected. The absorbance is calculated using the equation below.

$$I = \frac{m_t}{a * d}$$

Where  $I$  = absorption (mm),  $m_t$  = the change in specimen mass (grams at time  $t$ ),  $a$  = the exposed area of the specimen ( $\text{mm}^2$ ), and  $d$  = the density of the water ( $\text{g/mm}^3$ ).

The rate of water absorption ( $\text{mm/s}^{1/2}$ ) is defined as the slope of the line that is the best fit to plotted against the square root of time. The slope is determined using a linear regression of the points from 1 minute to 6 hours. To determine the initial rate of water absorption, points for times after the plot shows a clear change in slope are excluded. The secondary rate of water absorption is defined as the slope from the linear regression of the best fit line using the points from 1 day to 7 days. By comparing the rate of water absorption into the specimens, the resulting difference in permeability can be determined, as defined by the absorption directly at the treated surface.

Due to required consistency with previous experiments and the impracticality of oven-drying such a large specimen, the beam specimens were allowed to cure for 12 days before cutting. Each beam was cut into three 6-in. cubes. To simulate a crack, a groove (approximately 5 mm wide and 5 mm deep) was cut through the top faces of three of these new cubes. The grooves were then filled with biomortar. Three more specimens were cut with grooves, which were left unfilled, so

the specimens could be used as controls. These cubic specimens were subjected to the same treatment as the cylindrical ones.

*Sporosarcina pasteurii* (*S. pasteurii*), a commonly used microorganism used to study MICP technologies and was used as the MICP organism in these experiments. *S. pasteurii* was revived from frozen stock on media plates containing nutrient broth, urea, and calcium carbonate and grown overnight at 28°C to ensure purity. Colonies from this plate were then used to inoculate liquid NBUC media that was incubated at 28°C for 7 days before being implemented into the biomortar. After 7-day incubation, *S. pasteurii* liquid culture was used to make the biomortar. Briefly, this 2 phase biomortar comprises of an initial layer 2:5 ratio of *S. pasteurii* and sand, and a top layer of 0.2:2:5 ratio of commercially available concrete binder, *S. pasteurii* culture, and sterile sand.

Type A sand was initially used for the mortar due to material availability, with curing taking place in a misting chamber. Significant amounts of mortar washout occurred, requiring mortar to be applied. The replacement mortar was made using a sand finer than Type A and similar to the sand used in the previous study. This also led to mortar washout. The ratio of the biomortar was then modified several times in an attempt to find a solution that would adhere to the concrete. Unfortunately, while each biomortar application remained cohesive during the curing process, it lost cohesion when submerged in water during the main experiment. Large amounts of biomortar detached from the cylindrical specimens into the water, with most specimens losing all of their mortar after 30 minutes of exposure. Mortar in the grooves of the cubical specimens proved more resilient, but also suffered significant washout by the first 30 minutes and near complete washout by the third day of measurements. The results are presented for a 0.4:2:5 ratio of commercially available concrete binder, *S. pasteurii* culture, and sterile sand.

Once the mortar was applied to all specimens and cured, the sides of each specimen were painted with Blue Max liquid rubber commercial waterproofing sealant, which was left to cure for an additional 24 hours to prevent additional water absorption. The remaining mortar-free face of each specimen was then sealed with plastic held in place by rubber bands in the case of cylindrical specimens and duct tape for cubic specimens. The specimens were then placed mortar-side down on a wire shelf support partially submerged in water, thus preventing any water ingress except through the biomortar. Specimens were removed, with excess water being blotted away, and weighed at regular intervals to measure the weight change due to water absorption. Weighing was carried out at intervals of 1, 5, 10, 20, and 30 minutes, followed by hourly measurements for five hours (four in the case of the cubical specimens). After the first day, further weighing was carried out once daily over the course of the next seven days. Tables 3 and 4 below summarize the specimen properties. The results of the absorption as a function of the square root of time are displayed in Figures 8, 9, and 10.

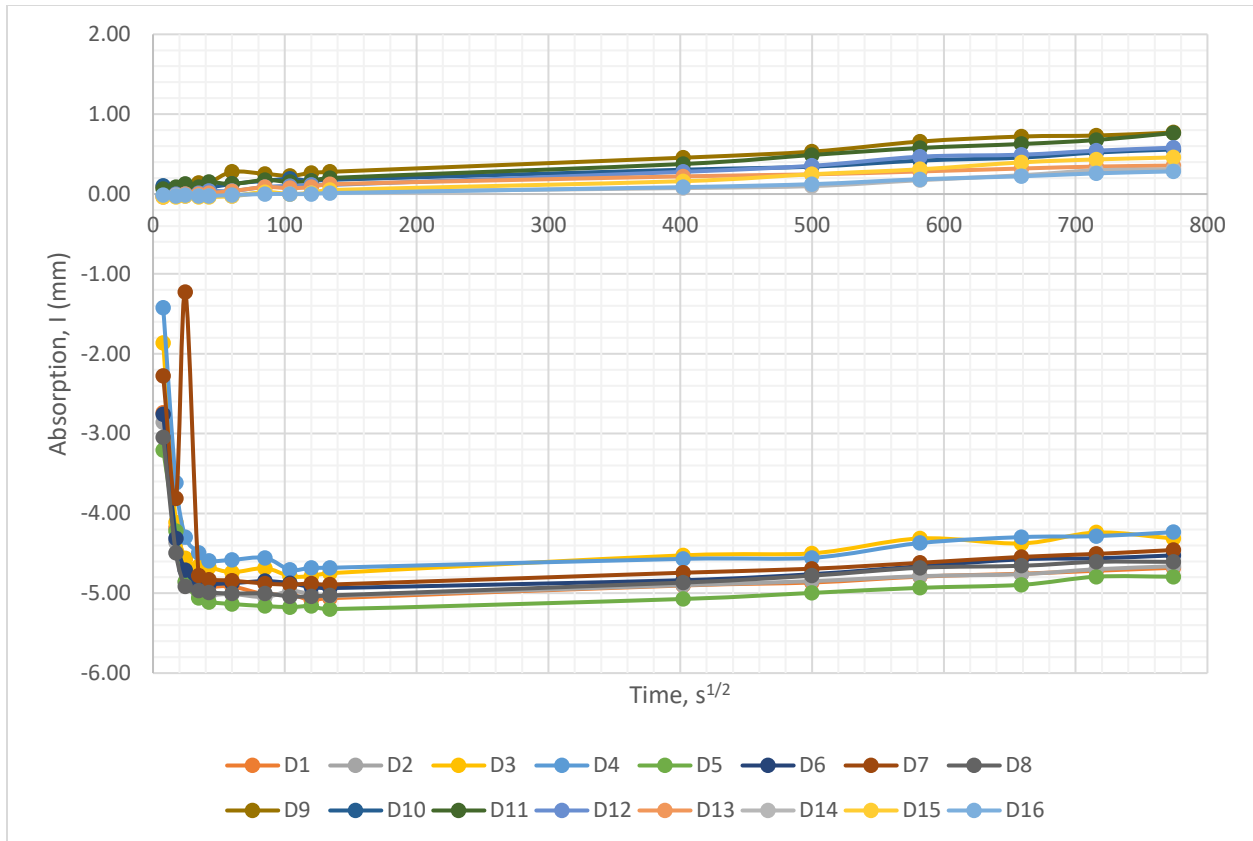

**Table 3. Cylindrical Specimen Properties**

<b>Specimen</b>	<b>Coating</b>	<b>Initial Mass (g)</b>	<b>Exposed Area (mm<sup>2</sup>)</b>
D1	Mortar	957.9	8139.020
D2	Mortar	857.8	8044.105
D3	Mortar	956.3	8044.105
D4	Mortar	934.5	8075.681
D5	Mortar	991.5	7887.151
D6	Mortar	910.4	8044.105
D7	Mortar	884.3	8075.681
D8	Mortar	895.1	8075.681
D9	Control	875.8	7918.418
D10	Control	991.5	7887.151
D11	Control	942.1	7981.138
D12	Control	892.5	7918.418
D13	Control	931.8	8139.020
D14	Control	850.6	8075.681
D15	Control	829.4	8075.681
D16	Control	906.8	8107.320

**Table 4. Cubical Specimen Properties**

<b>Specimen</b>	<b>Coating</b>	<b>Initial Mass (g)</b>	<b>Exposed Area (mm<sup>2</sup>)</b>
C1	Control	7510.598	24927.146
C2	Control	7730.652	25976.175
C3	Mortar	7969.346	23307.080
C4	Mortar	7853.129	23135.034
C5	Mortar	7712.645	23005.684
C6	Control	8101.636	28356.436



**Figure 8. Water Absorption of Cylindrical Specimens**

While the cylindrical control specimens exhibit reasonably linear behavior, the absorption values of the biomortar-coated specimens are offset by the mortar washout across the first day of testing. The biomortar washout decreases the starting mass far more than absorption of water increases it, resulting in apparently negative values for absorption. Results stabilize to more linear behavior over the following week, allowing the calculation of initial and secondary rates of water absorption  $S_i$  and  $S_s$ , by obtaining the slopes of the absorption graph via least squares linear regression analysis. Initial rate is calculated using absorption values of the first day and secondary rate is calculated with the remaining values. These results are displayed below in Table 5.

**Table 5. Absorption Equations by Linear Regression Analysis (Cylindrical Specimens)**

<b>Specimen</b>	<b>S<sub>i</sub>: Initial Rate of Absorption (mm/s<sup>1/2</sup>) I = S<sub>i</sub>√t + b</b>	<b>S<sub>s</sub>: Secondary Rate of Absorption (mm/s<sup>1/2</sup>) I = S<sub>s</sub>√t + b</b>	<b>Average Rates of Water Absorption</b>
D1	-1.07E-02	6.12E-04	S <sub>i</sub> = -1.094E-02 S <sub>s</sub> = 7.66E-04
D2	-8.47E-03	6.34E-04	
D3	-1.10E-02	7.00E-04	
D4	-1.36E-02	9.99E-04	
D5	-9.25E-03	7.87E-04	
D6	-8.43E-03	8.76E-04	
D7	-1.84E-02	7.92E-04	
D8	-7.71E-03	7.28E-04	
D9	1.66E-03	8.84E-04	S <sub>i</sub> = 8.82E-04 S <sub>s</sub> = 7.34E-04
D10	1.02E-03	7.04E-04	
D11	8.37E-04	9.89E-04	
D12	1.14E-03	8.23E-04	
D13	1.17E-03	3.89E-04	
D14	3.77E-04	7.04E-04	
D15	6.20E-04	8.30E-04	
D16	2.40E-04	5.53E-04	

The rates of water absorption are offset by the biomortar washout on the first day, but stabilize and remain consistent for the secondary rates for all specimens.

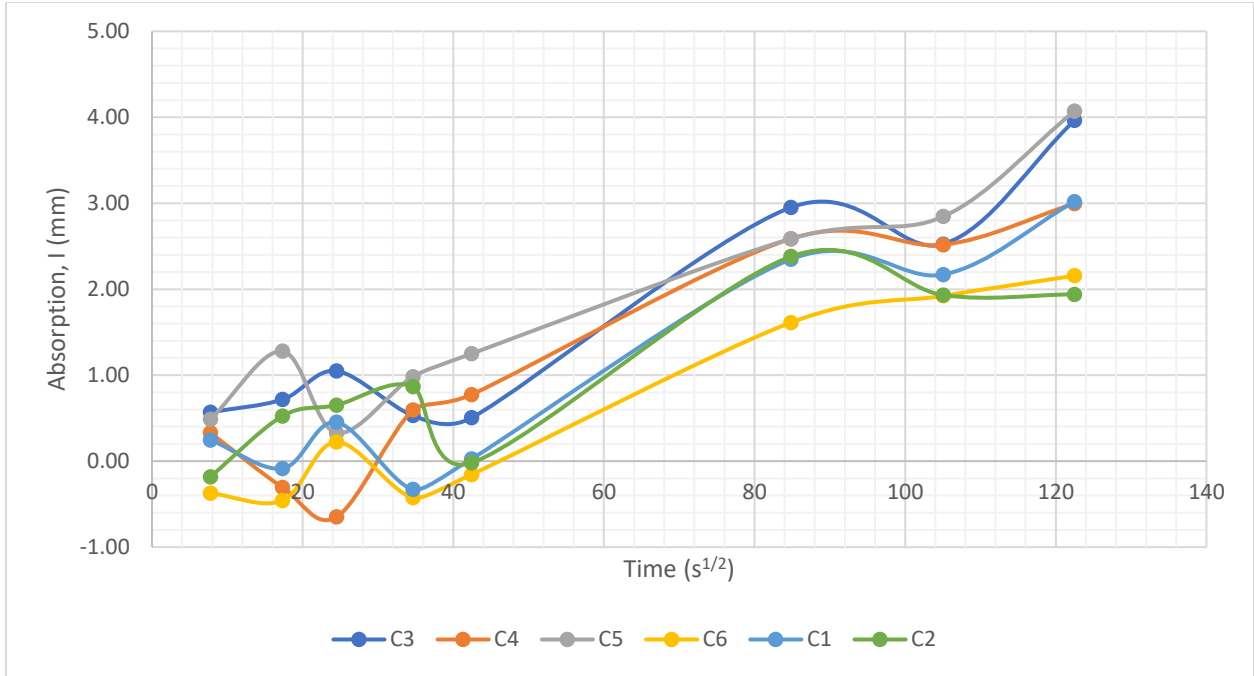

**Figure 9. First Day Water Absorption of Cubic Specimens**

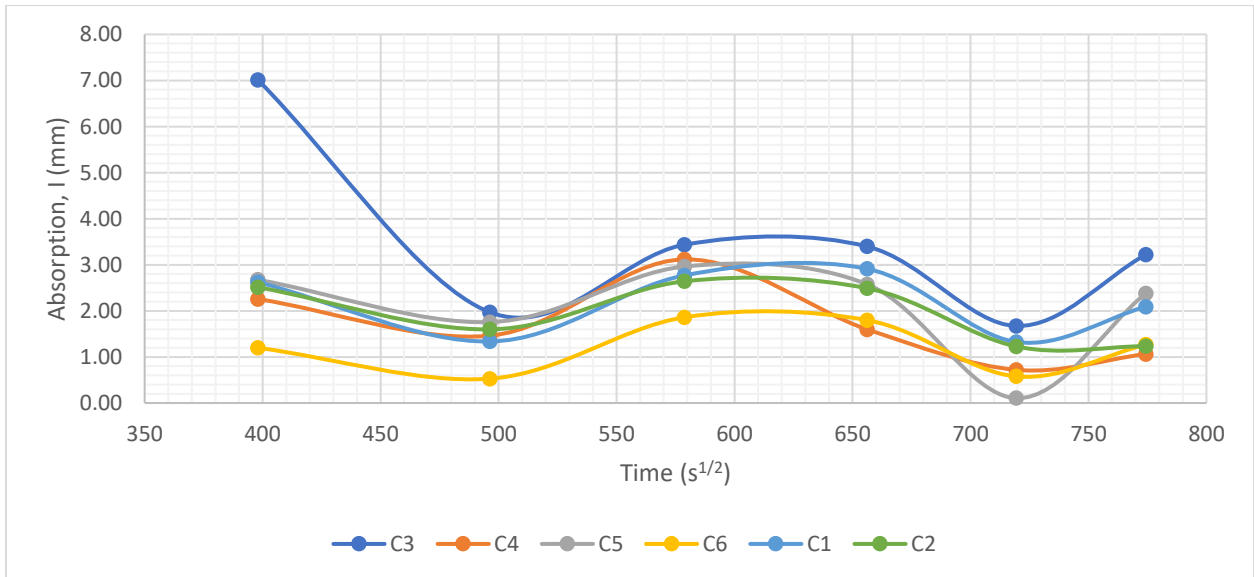

**Figure 10. First Week Water Absorption of Cubic Specimens**

Although the biomortar remained cohesive for up to three days in the grooves of the cubic specimens, and consistency between specimens in terms of long-term results was greater overall, the absorption values of the cubes varied erratically in the first 30 minutes of testing due to mortar washout. Specimen C4 in particular suffered heavy washout, resulting in the offset in absorption values. Results stabilized during the remaining week of measurements, but the results were

decidedly nonlinear, and the biomortar-filled and control specimens were not significantly different.

### 2.3 Evaluation of Safety Concerns due to Skid Resistance

The microbes themselves pose no safety concerns. Moreover, Pitell et al. (2020) demonstrated that the leeching of ammonia should not be problematic at the concentrations of urea being used for MICP and that there should be little to no issue introducing the nutrients into the mixture to induce MICP. However, Pitell et al. did not measure skid resistance or the friction between a tire and a treated section of a bridge deck. To address this concern, the coefficients of friction between a rubber surface and the surfaces of the cylindrical specimens were evaluated. Both the biomortar-treated cylinders and the untreated cylinders were tested. To establish the level of friction, the amount of force required to initiate sliding between the concrete specimen and a rubber surface was measured with a spring scale. The coefficient of static friction was calculated by dividing the spring force by the weight of the block. Because most of the biomortar was eroded prior to testing, little variation was observed, as can be seen in Table 6, which presents the average and standard deviation.

**Table 6. Friction Results**

	Coefficient of Static Friction	
	Average	Standard Deviation
Bio-mortar	0.882	0.046
Control	0.888	0.040

### 2.4 Discussion and Conclusions

Previous studies have established viability of MICP-biomortar for preventing water ingress to cracks in concrete specimens. However, these cracks in previous studies were very thin flexural cracks of approximately 1mm, contrasted with the over 5mm wide and deep groves of current specimens and the application of the biomortar as a surface coating. As such, the biomortar in this experiment was significantly more exposed to water and thus more vulnerable to washout. As a coating on the cylindrical specimens, washout occurred within 30 minutes of submergence, leading to offset and inconsistent water absorption values and rates as the loss of mass from biomortar washout offset any mass increase from water absorption. Absorption occurred more regularly and consistently for later measurements. For cubic specimens where biomortar was applied as a crack sealant in a larger groove, washout was less severe for the first day, leading to more consistent

absorption values and rates between the mortared and control specimens. However, absorption rates varied significantly for cubic specimens as the week proceeded, in contrast to the greater consistency in cylindrical specimens.

While the current mixture of MICP-biomortar remains viable for preventing water ingress to smaller cracks, the current results indicate it would be heavily vulnerable to high-exposure events such as flooding or heavy rainfall when exposed as a coating or for larger cracks. More experimentation is required before field testing can be approved. The next phase should be to continue to adjust the mixture design and application to develop an application that is resistant to wash out and repeatable. Then the process can be implemented on samples from in-service structures to determine its efficacy. Additionally, viability testing during the biomortar setting period should be conducted to ensure that the microorganisms are still alive in the matrix.

## References

- Achal, V.; Mukherjee, A.; Reddy, M. S. Microbial Concrete: Way to Enhance the Durability of Building Structures. *Journal of Materials in Civil Engineering* 2011, 23 (6), 730–734. [https://doi.org/10.1061/\(ASCE\)MT.1943-5533.0000159](https://doi.org/10.1061/(ASCE)MT.1943-5533.0000159).
- Anbu, P.; Kang, C.-H.; Shin, Y.-J.; So, J.-S. Formations of Calcium Carbonate Minerals by Bacteria and Its Multiple Applications. *Springerplus* 2016, 5. <https://doi.org/10.1186/s40064-016-1869-2>.
- Assessment of a Biostimulated or Bioaugmented Calcification System with *Bacillus pasteurii* in a Simulated Soil Environment, SpringerLink <https://link.springer.com/article/10.1007/s00248-012-0137-4>.
- ASTM International, ASTM C192-14 Standard Practice for Making and Curing Concrete Test Specimens in the Laboratory, West Conshohocken, PA 19428: ASTM International, 2014.
- ASTM International, ASTM C1202-12 Standard Test Method for Electrical Indication of Concrete's Ability to Resist Chloride Ion Penetration, West Conshohocken, Pennsylvania: ASTM International, 2012.
- ASTM International, ASTM C1585-20 Standard Test Method for Measurement of Rate of Absorption of Water by Hydraulic-Cement Concretes, West Conshohocken, PA 19428: ASTM International, 2020.
- De Muynck, W.; Debrouwer, D.; De Belie, N.; Verstraete, W. Bacterial Carbonate Precipitation Improves the Durability of Cementitious Materials. *Cement and Concrete Research* 2008, 38 (7), 1005–1014. <https://doi.org/10.1016/j.cemconres.2008.03.005>.
- De Muynck, W.; De Belie, N.; Verstraete, W. Microbial Carbonate Precipitation in Construction Materials: A Review. *Ecological Engineering* 2010, 36 (2), 118–136. <https://doi.org/10.1016/j.ecoleng.2009.02.006>.
- Dick, J.; De Windt, W.; De Graef, B.; Saveyn, H.; Van der Meeren, P.; De Belie, N.; Verstraete, W. Bio-Deposition of a Calcium Carbonate Layer on Degraded Limestone by *Bacillus* Species. *Biodegradation* 2006, 17 (4), 357–367. <https://doi.org/10.1007/s10532-005-9006-x>.
- Dhami, N. K.; Alsubhi, W. R.; Watkin, E.; Mukherjee, A. Bacterial Community Dynamics and Biocement Formation during Stimulation and Augmentation: Implications for Soil Consolidation. *Front. Microbiol.* 2017, 8. <https://doi.org/10.3389/fmicb.2017.01267>.
- Formations of calcium carbonate minerals by bacteria and its multiple applications, SpringerPlus, Full Text <https://springerplus.springeropen.com/articles/10.1186/s40064-016-1869-2>.
- Głuchowski, A.; Sas, W.; Dzięcioł, J.; Soból E.; Szymański, A. Permeability and Leaching Properties of Recycled Concrete Aggregate as an Emerging Material in Civil Engineering, Applied Sciences, 2019.

- Jing, G.; Huang, G.; Zhu, W. An Experimental Study on Water Permeability of Architectural Mortar Using Waste Glass as Fine Aggregate, *Materials*, 2020.
- Jonkers, H. M.; Thijssen, A.; Muyzer, G.; Copuroglu, O.; Schlangen, E. Application of Bacteria as Self-Healing Agent for the Development of Sustainable Concrete. *Ecological Engineering* 2010, 36 (2), 230–235. <https://doi.org/10.1016/j.ecoleng.2008.12.036>.
- Kosmatka, S.H., Kerkhoff, B. and W.C. Panarese, *Design and Control of Concrete Mixtures*, 15<sup>th</sup> Edition, Portland Cement Association, Skokie, Illinois, 2011.
- Le Métayer-Levrel, G.; Castanier, S.; Oriol, G.; Loubière, J.-F.; Perthuisot, J.-P. Applications of Bacterial Carbonatogenesis to the Protection and Regeneration of Limestones in Buildings and Historic Patrimony. *Sedimentary Geology* 1999, 126 (1), 25–34. [https://doi.org/10.1016/S0037-0738\(99\)00029-9](https://doi.org/10.1016/S0037-0738(99)00029-9).
- Mansch, R.; Bock, E. Biodeterioration of Natural Stone with Special Reference to Nitrifying Bacteria. *Biodegradation* 1998, 9 (1), 47–64. <https://doi.org/10.1023/A:1008381525192>.
- Mindess, S., Young, J.F., and D. Darwin, *Concrete*, Prentice Hall, 2nd Edition, 2003.
- Obst, M.; Dittrich, M.; Kuehn, H. Calcium Adsorption and Changes of the Surface Microtopography of Cyanobacteria Studied by AFM, CFM, and TEM with Respect to Biogenic Calcite Nucleation. *Geochemistry, Geophysics, Geosystems* 2006, 7 (6). <https://doi.org/10.1029/2005GC001172>.
- Palin, D.; Jonkers, G.; Wiktor, V. Autogenous healing of sea-water exposed mortar: Quantification through a simple and rapid permeability test, *Cement and Concrete Research* 84, pp. 1-7, 2016.
- Pitell, S.; El-Hajj, B.; Sachs, S.G.; Haig, S. Towards using Microbes for Sustainable Construction Materials: A Feasibility Study. Pittsburgh, PA: University of Pittsburgh, 2020.
- Publication 408 – Construction Specifications. Pennsylvania Department of Transportation. 2020.
- Ramachandran, S.; Ramachandran, V.; Bang, S. Remediation of Concrete Using Micro-Organisms. *American Concrete Material Journal* 2001, 98, 3–9.
- Rapp, P. Effect of Calcium Chloride on Portland Cements and Concretes. *National Bureau of Standards* 1935, 14, 499–517.
- Reeburgh, W. S. Oceanic Methane Biogeochemistry. *Chem. Rev.* 2007, 107 (2), 486–513. <https://doi.org/10.1021/cr050362v>.
- Rodriguez-Navarro, C.; Rodriguez-Gallego, M.; Chekroun, K. B.; Gonzalez-Muñoz, M. T. Conservation of Ornamental Stone by Myxococcus Xanthus-Induced Carbonate Biomineralization. *Appl. Environ. Microbiol.* 2003, 69 (4), 2182–2193. <https://doi.org/10.1128/AEM.69.4.2182-2193.2003>.



- Sadegzadeh, M.; Page, C. L.; Vassie, P. R. W. Effects of Urea on Durability of Reinforced Concrete. *Magazine of Concrete Research* 1993, 45 (164), 179–186. <https://doi.org/10.1680/macr.1993.45.164.179>.
- Schreiber, J. Springer Series in Materials Science 11. *Zeitschrift für Kristallographie - Crystalline Materials* 1990, 190 (3–4). <https://doi.org/10.1524/zkri.1990.190.3-4.315>.
- Siddique, R.; Chahal, N. K. Effect of Ureolytic Bacteria on Concrete Properties. *Construction and Building Materials*. October 2011, pp 3791-.
- Sohanghpurwala, A. *NCHRP Synthesis 398: Cathodic Protection for Life Extension of Existing Reinforced Concrete Bridge Elements*; Transportation Research Board: Washington, D.C., 2009.
- K. Stanish, R. Hooton and M. Thomas, Testing the Chloride Penetration Resistance of Concrete: A Literature Review, 01 01 1997. [https://www.researchgate.net/publication/237321599\\_Testing\\_the\\_Chloride\\_Penetration\\_Resistance\\_of\\_Concrete\\_A\\_Literature\\_Review/citation/download](https://www.researchgate.net/publication/237321599_Testing_the_Chloride_Penetration_Resistance_of_Concrete_A_Literature_Review/citation/download).
- Stocks-Fischer, S.; Galinat, J. K.; Bang, S. S. Microbiological Precipitation of CaCO<sub>3</sub>. *Soil Biology and Biochemistry* 1999, 31 (11), 1563–1571. [https://doi.org/10.1016/S0038-0717\(99\)00082-6](https://doi.org/10.1016/S0038-0717(99)00082-6).
- Tiano, P.; Biagiotti, L.; Mastromei, G. Bacterial Bio-Mediated Calcite Precipitation for Monumental Stones Conservation: Methods of Evaluation. *Journal of Microbiological Methods* 1999, 36 (1), 139–145. [https://doi.org/10.1016/S0167-7012\(99\)00019-6](https://doi.org/10.1016/S0167-7012(99)00019-6).
- Thompson, J. B.; Ferris, F. G. Cyanobacterial Precipitation of Gypsum, Calcite, and Magnesite from Natural Alkaline Lake Water. *Geology* 1990, 18 (10), 995–998. [https://doi.org/10.1130/0091-7613\(1990\)018<0995:CPOGCA>2.3.CO;2](https://doi.org/10.1130/0091-7613(1990)018<0995:CPOGCA>2.3.CO;2).
- van Paassen, L. A.; Daza, C. M.; Staal, M.; Sorokin, D. Y.; van der Zon, W.; van Loosdrecht, Mark. C. M. Potential Soil Reinforcement by Biological Denitrification. *Ecological Engineering* 2010, 36 (2), 168–175. <https://doi.org/10.1016/j.ecoleng.2009.03.026>.
- Warthmann, R.; Lith, Y. van; Vasconcelos, C.; McKenzie, J. A.; Karpoff, A. M. Bacterially Induced Dolomite Precipitation in Anoxic Culture Experiments. *Geology* 2000, 28 (12), 1091–1094. [https://doi.org/10.1130/0091-7613\(2000\)28<1091:BIDPIA>2.0.CO;2](https://doi.org/10.1130/0091-7613(2000)28<1091:BIDPIA>2.0.CO;2).
- Weiler L.; Vollpracht, A. Leaching of Carbon Reinforced Concrete—Part 1: Experimental Investigations, *Materials*, 2020.
- Zhu, T.; Dittrich, M. Carbonate Precipitation through Microbial Activities in Natural Environment, and Their Potential in Biotechnology: A Review. *Frontiers in Bioengineering and Biotechnology* 2016, 4 (4). <https://doi.org/10.3389/fbioe.2016.00004>.
- Zabalza Bribián, I.; Valero Capilla, A.; Aranda Usón, A. Life Cycle Assessment of Building Materials: Comparative Analysis of Energy and Environmental Impacts and Evaluation of the

Eco-Efficiency Improvement Potential. *Building and Environment* 2011, 46 (5), 1133–1140.  
<https://doi.org/10.1016/j.buildenv.2010.12.002>.