

662  
-A25  
NO.  
FHWA-  
DP-  
39-8

Demonstration Projects Program  
Technology Transfer  
FHWA-DP-39-8  
January 1978

DEPARTMENT OF  
TRANSPORTATION  
APR 16 1979  
LIBRARY

DEMONSTRATION PROJECT NO. 39

# RECYCLING ASPHALT PAVEMENTS

Elkhart County, Indiana

Prepared for  
and  
Contributed by

U.S. DEPARTMENT OF TRANSPORTATION  
FEDERAL HIGHWAY ADMINISTRATION  
REGION 15  
DEMONSTRATION PROJECTS DIVISION  
4000 NORTH GLEBE ROAD  
ARLINGTON, VIRGINIA 22204

APR 16 1979

LIBRARY

FINAL REPORT

EVALUATION OF RECYCLED BITUMINOUS PAVEMENTS .

by

Barry L. Elkin

Indiana State Highway Commission  
Research and Training Center  
1205 Montgomery Street  
West Lafayette, Indiana

In Cooperation With

Elkhart County

and the

U. S. Department of Transportation  
Federal Highway Administration  
Region 15  
Demonstration Projects Division

August 1978

The opinions, findings, and conclusions expressed  
in this report are those of the author and not  
necessarily those of the sponsoring agencies.

## ABSTRACT

The study was initiated to evaluate the performance of recycled bituminous material as the base course of reconstructed county roads. The cold recycling process has been used in recent years by Elkhart County, Indiana to upgrade sections of distressed roads. The evaluation is based on a comparison of the material from laboratory extraction and gradation tests and the pavement structure from Dynaflect tests before and after treatment. Dynaflect tests and PCA Roadmeter tests were also run six, eight, eleven, and seventeen months after construction to evaluate the performance of the recycled pavement under traffic.

Gradation results indicate that the before and after treatment material is very similar. An excess of asphalt was present in the treated material. Also, the gradations both before and after were quite dense and both indicated a deficiency of material greater than  $\frac{1}{2}$ ". Considerable variability was noticed relative to gradation and asphalt content indicating that the processed material was not homogeneous. The Dynaflect parameters developed from tests on the treated material verified the lack of uniformity.

A simple comparative cost analysis clearly shows the cold recycling process is significantly less expensive than the hot mixed, hot placed material. In this study the cost in place of a plant mixed base such as Indiana's HAC #5 Base was three times more than the recycled material.

## TABLE OF CONTENTS

	Page
I. INTRODUCTION	1
II. SITE DESCRIPTION AND TESTING PROCEDURE	2
A. Contractor's Progress and Site Inspection	4
B. Dynaflect Testing	5
C. Roadmeter Testing for Pavement Smoothness	7
III. TEST RESULTS	8
A. Laboratory Test of Roadway Samples - Before and After Treatment	8
B. Results of Extraction Tests - CR-28A	8
C. Results of Extraction Tests - CR-30B	10
D. Dynaflect Results - CR-28A	11
E. Dynaflect Results - CR-30B	13
F. Results of Roadmeter Tests	16
G. Observations from Visual Inspections	17
IV. DISCUSSION OF RESULTS	19
V. COMPARATIVE COST ANALYSIS	27
VI. CONCLUSIONS	29
REFERENCES	31
TABLE 1: Summary of Roadmeter Results	32
FIGURES 1 thru 22	33-53
DETAILS OF THE COLD RECYCLING PROCESS	54
FIGURE 23: Proposed Typical Roadway Section	57

## I. INTRODUCTION

Construction costs for both materials and labor have increased at an alarming rate. Cost and availability of satisfactory engineering materials have always been major considerations in roadway construction and maintenance. Conventional methods of construction and maintenance are becoming prohibitive due to these continued across-the-board increases. All agencies responsible for the construction and maintenance of all types of roadways have become very conscious of the cost necessary to provide safe, convenient roadways for the travelling public. Because of this, any material or procedure which reduces the costs of construction or maintenance is now investigated in-depth, whereas in the past this was rarely the case.

Resurfacing a distressed or tired bituminous pavement with a thin bituminous layer on top of patches with little structural integrity is relatively quick and easy compared to complete reconstruction but is only a stop-gap effort which is generally not cost effective.

One method which is being investigated by the FHWA and several other highway agencies is the cold recycling of existing roadway material. The existing pavement is scarified, pulverized, and in some cases further reduced with the aid of chemicals. This material is then reconstituted by adding a small percentage of asphalt, and the reconstituted mix is replaced and compacted on the original roadway. This is proving to be one method of effectively reducing materials, equipment, and labor costs and producing a very satisfactory pavement with an extended service life because the pavement structure is reconstructed to its full depth and is continuous.

The Indiana State Highway Commission through its Research and Training Center at West Lafayette entered into an agreement with the

FHWA's Demonstration Projects Division to test and evaluate sections of cold recycled bituminous county roads in Elkhart County located in north-central Indiana.

The scope of this investigation is limited to the evaluation of two 1-mile sections on two different county highways. The evaluation is based on a comparison of results from the sampling and testing of the roadway prior to reconstruction, immediately after the final pavement system was opened to traffic, and after more than one year of service. It was not possible or within the scope of the study to determine the cost or efficiency of the procedure or equipment used by the contractor.

Described in this report is the evaluation of the physical properties and performance of recycled and rejuvenated bituminous material from Dynaflect and roadmeter data obtained at selected county highway locations and aggregate gradations and asphalt determinations from laboratory extraction tests on samples of material obtained just before and just after the recycling process.

## II. SITE DESCRIPTION AND TESTING PROCEDURE

Recycling low traffic volume roadways is not a new experience in Elkhart County, Indiana. This procedure which is outlined on pages 54-56 has been used for the past few years to upgrade various sections of rural bituminous surfaced roadways in the county. A number of sections had been set up for recycling in the 1976 construction season. <sup>(1)</sup> Two of these projects were selected for the study. A section of County Road 28 which is an east-west oriented road beginning at SR-19 and running one mile west and five miles north of Wakarusa. This test area has been identified as CR-28A.

The second test and evaluation area is on County Road 30 which is one mile south of County Road 28. The test section begins two miles east of State Road 19 and runs one mile east. This section has been identified as CR-30B.

The sites were first visited on June 7, 1976. At this time a general visual inspection of each of the sites was made to determine the initial condition of the roadway. The existing condition of both CR-28A and CR-30B were similar. Both were distressed bituminous pavements exhibiting the classic failure patterns - ravelling, rutting, and alligator cracking in addition to a variety of patches, mainly the outer wheelpaths and along the centerline construction joint. The probable cause of the major failures along these two roads is poor drainage. All sites exhibited narrow and high shoulders, encroachment of vegetation at the pavement edge and insufficient side ditches. The pavement was crowned, however, which probably helped extend its life quite a bit. Both sections CR-28A and CR-30B are straight in alignment and somewhat rolling. Both roads carry small volumes of farm traffic ranging from passenger vehicles to light trucks. The total average daily traffic probably does not exceed 700 vehicles per day and less than 1% of this volume are heavy trucks or trucks with tandem axles. Every once in a while a caravan of recreational vehicle chassis are driven over these roads between factories. In any case, traffic volume and wheel loading is not a major consideration.

Samples of the roadway were taken from five sites selected at random within each of the sites to be reconstructed. Two sub-samples were taken from each of the five sites. The first sub-sample identified as the surface sample consisted of bituminous material taken from the top three

inches of the roadway which was broken up using a pick so that large pieces could be obtained. The second sub-sample was taken from three inches below the surface to a depth of six inches maximum. This sub-sample identified as the base sample was obtained by clearing away the top three inches and using a spoon and scoop to remove the material from the three to six inch level. Sample cans were marked appropriately to indicate surface material and base material taken from test sites CR-28A and CR-30B. These samples were sealed and returned to the laboratory for asphalt extraction and gradation of the extracted aggregate.

A. Contractor's Progress and Site Inspection

On June 17, the Center was informed that the contractor would begin work on County Road 28 the following Monday. It was expected that paving could be completed in three to four weeks. On June 28, phone contact was made with the Elkhart County Engineer who informed the Center that the contractor had attempted some preliminary work on County Road 28 but had not really gotten started due to equipment problems. Rain at the time also caused further work delays. By July 22, it was determined that progress was minimal - one lane of County Road 28 had been prepared for base stabilization but rain had again interrupted progress. It was estimated at this time that the reconstructed base would probably be relayed and compacted by August 6. At this time nothing had been started on County Road 30.

On August 16, 1976, a trip was made to inspect, sample, and test the recycled and reconstituted material on County Road 28A. It was hoped that a pair of six inch diameter cores could be obtained at each of the five sampling locations established prior to construction. Upon



arrival at the site it was obvious that cores could not be obtained since the material had little structural integrity which appeared to be mainly due to the minimal bitumen content. The material crumbled easily in the hand. The appearance of the roadway was that of a ravelled and weathered, dirty bituminous stabilized gravel. The road was open to traffic and there was a conglomeration of aggregate particles and asphalt in the wheelpaths. Isolated concentrations of bitumen were evident indicating that the distribution of the added AP-3 was not uniform. This was after the existing roadway had been scarified, pulverized, and mixed with the SA-1 and three inches of the existing gravel base and reconstituted with additional asphalt and compacted. The material was to have seasoned for three to four days and was supposedly ready for testing and sampling.

Coring was attempted at the first sampling site - 28 A-5 - but without success since the core completely disintegrated into a liquid mass of muddy, sandy gravel. It was decided at this point to break up the material with a pick and collect as many chunks as would fill two one gallon cans. This was done at each of the sampling sites. The sample material was easily broken down with careless handling. It was hard to get any sizeable chunks for the sample. The material had an earthy smell with little or no organic odor. Also, the treatment appeared to be only about four inches deep and not six inches as proposed.

#### B. Dynaflect Testing

The Dynaflect is a two-wheeled towed trailer which is capable of applying a one thousand pound vertical load at eight cycles per second through two special force wheels. See Figure 1. A set of five geophones, distributed uniformly along the trailer tongue, sense the pavement

deflection and define the deflection basin due to the loading transmitted by the force wheels as shown in Figures 2 and 3. Sensor 1 is located closest to the force wheels and is used to determine the maximum deflection (DMD). The numerical difference between Sensor 1 and Sensor 2 gives the Surface Curvature Index known as the SCI. The SCI is an indication of the load carrying capability of the surface course. A greater difference between these values indicates a weaker surface or one that is not adequately transferring the load down through the pavement system. The difference between the pavement deflections at Sensor 4 and Sensor 5 is defined as the Base Curvature Index (BCI). The BCI is an indication of the relative strength of the subbase or lower level of the pavement structure. The strength or suitability of the base course is inversely proportional to the BCI. The deflections are recorded in mils or one-thousandths of an inch.

Dynaflect tests were performed on one-half mile sections in both the east and west bound lanes of County Road 28A and County Road 30B. Eleven test sites were marked at 250 foot intervals in the one-half mile section as shown in Figures 4 and 5. Initial testing of both roads took place on June 17, 1976. Tests in both directions were performed on a line between the center of lane and the right wheelpath. Readings were recorded for all five sensors for each predetermined test location if the road was too rough or if a sizable defect was situated at the test area so that the test wheel or the sensors could not be seated properly on the surface, the Dynaflect was moved forward until testing was possible on a relatively smooth and suitable surface. The results of the initial testing of the existing pavement - before construction - for both CR-28A and CR-30B are shown in Figures 6 and 7 respectively. These

figures show a continuous plot from test station  $D_0$  through and including  $D_{10}$  of the three descriptors: Maximum Deflection (DMD), the Surface Curvature Index (SCI), and the Base Curvature Index (BCI). Both the eastbound and westbound values for each are plotted. The overall average for each descriptor is shown for each direction. Figures 8 and 9 show the plot of the Dynaflect results for the same three descriptors for both test sites immediately after construction November 17, 1976. Both sites were again tested on July 14, 1977, eight months after construction. The results of these tests are shown in Figure 10 for CR-28A and Figure 11 for CR-30B. The sites were revisited on October 6, 1977, and the last visit was made on April 12, 1978, or approximately one and a half years after construction. The results of the October 1977 tests on CR-28A are shown in Figure 12 while Figure 13 shows the results of the tests on CR-30B.

### C. Roadmeter Testing for Pavement Smoothness

Pavement smoothness tests were performed on the two recycled pavements using a PCA Roadmeter mounted in a 1973 AMC Stationwagon as shown in Figure 16. The roadmeter records vertical movement of the rear axle in both directions in one-eighth increments and distance travelled so that pavement roughness can be indexed as counts per mile and averaged with respect to the length of runs in each direction to produce a weighted counts per mile value for the project. The weighted mean value represents the relative response of the vehicle to the roughness of the pavement surface.

The roadmeter was run on each of the county roads on May 26, 1977, July 14, 1977, October 6, 1977, and April 12, 1978. The weighted values for both test sections obtained on the four dates are shown in Table 1.

### III. TEST RESULTS

#### A. Laboratory Tests of Roadway Samples - Before and After Treatment

Laboratory extraction tests and aggregate gradations were performed on the initial samples obtained at each of the five sampling sites of both test sections; the surface samples and the base samples. All extraction tests were performed by the reflux method in accordance with AASHTO T164, Method B.<sup>(2)</sup> The gradations of the extracted aggregate from the initial surface and base samples for County Road 28A are shown in Figures 17 and 18 and Figures 19 and 20 for County Road 30B.

After-treatment samples were taken from the five sites on County Road 28A on August 13, 1976, while the treated material was curing and before the wearing surface was placed. The average gradation and asphalt content from the laboratory extraction tests of the five surface samples are shown in Figure 21. After treatment samples of CR-30B were obtained on September 29, 1976. The average gradation curve for this site is shown in Figure 22.

#### B. Results of Extraction Tests - CR-28A

The gradation limits for subbase with  $\frac{1}{2}$ " top size as found in ISHC Standard Specifications<sup>(3)</sup> has been plotted with the gradation of the extracted aggregate for comparison purposes. All gradation plots show the average gradation of the extracted aggregate for the sieves from  $1\frac{1}{2}$  inch down to the #200. Figure 17 shows the results for samples of material from the top three inches of CR-28A. The range of data is indicated by the vertical bars. The average asphalt content of the five samples is also shown on the plot. A comparison of the plot with the limits of the subbase material indicates that the maximum size obtained was three-quarters of an inch and in fact 99% of the material was finer

than three-quarters of an inch. Material from three-quarters of an inch to the #30 sieve splits the gradation limits of the  $\frac{1}{2}$ " top size subbase. From the #30 sieve down to the #200 the material generally falls within the band of the subbase gradation. The average asphalt content of the top three inches of the original pavement was relatively uniform and somewhat high. The average was 7.2% and the range of the 5 samples was from 5.6% to 8.8%. The gradation of the initial samples of CR-28A taken from the three to six inch depth as shown in Figure 18 was very similar to the surface samples except for the average percent passing the  $\frac{3}{8}$ " and the #4 sieves. In fact all four of the top sieve sizes exhibit a large amount of variability. The average asphalt content of this material was 3.2% with a range of 1.3% to 5.2% which is in the expected range of asphalt content for material of this nature. This material was also somewhat finer at the top end of the gradation than would be expected for a foundation or base material.

The results of the gradation and asphalt content determination for the recycled material as shown in Figure 21 indicates that the material remains somewhat finer than is specified and expected for the top range of material to be used as a base. The gradation is very comparable to the material sampled from the top three inches of the existing pavement except for a few sizes in the middle range - from the #8 sieve to the #50 sieve. A comparison of the gradations of the surface portion of the initial samples and the recycled samples shows the maximum differential is 9% on the #16 sieve and overall the recycled material is somewhat finer. The average asphalt content of the recycled material was 6.0%. The range of the 10 samples was from 1.3 to 9.7 percent which was unexpectedly high. This is an indication that the distribution of the

added bituminous material is non-uniform. The fineness of the material is an indication that some degradation of the aggregate occurred during the processing which is to be expected. The degree of degradation does not appear to be significant and probably is not critical for this particular section of roadway. Over an extended period of service the road might become prematurely unstable in the wheelpaths as indicated by some degree of rutting.

#### C. Results of Extraction Tests - CR-30B

The gradation of the extracted aggregate and asphalt content of the material sampled from the top three inches of the existing pavement at the five sampling sites is shown in Figure 19. The average asphalt content of the material taken from these sites was 6.8%. The range was from 6.2% to 7.4% which is very uniform considering the condition of the surface. The average gradation of this material was similar to that designated for  $\frac{1}{2}$ " top size subbase by the Indiana Specifications except for the very top and the very bottom. The maximum top size is actually one-half inch and approximately 96% of the material passed the  $\frac{3}{8}$ " sieve. The bottom most portion of the gradation from the #100 to the #200 sieve falls on the clean side of  $\frac{1}{2}$ " top size material. Considerable variability is evident on most of the sieves. The material sampled from the three inch to the six inch depth follows the mean gradation of the  $\frac{1}{2}$ " top size subbase very closely as seen in Figure 20. The average asphalt content dropped to 3.7% as would be expected for material sampled 3" below the surface.

The average gradation curve of the samples of the recycled material from CR-30B, Figure 22, is very similar to the curve shown in Figure 20 for the initial samples taken from the three to six inch level. The

average asphalt content of the recycled material was 10.3% with a range of 6.7% to 15.5%. The asphalt content appears to be quite high and while this may provide for a very durable roadway it will no doubt exhibit rutting in a very short period of time.

#### D. Dynalect Results - CR-28A

The three characteristics obtained from initial dynaflect measurements on CR-28A are shown in Figure 6 for test obtained on June 17, 1976. The maximum deflection or the deflection of Sensor 1 for all sites in both the east and west bound lanes is represented by the uppermost plot. The Surface Curvature Index, SCI, is plotted in the middle and the Base Curvature Index, BCI, is the bottom plot. It is readily seen that the average deflection in mils for the east and west bound lanes of CR-28A is very similar - 2.24 and 2.37, respectively. Very uniform values were obtained at all of the individual test locations and it is also readily seen that variations in both lanes were quite similar for the most part. These values, however, are quite high and indicate that the pavement is not capable of transmitting the load down through the pavement system. The large maximum deflections is supported by the plot of the SCI values for both lanes. The average SCI value for the westbound lane is .79 mils, while the average for the eastbound lane is .73, both of which are quite a bit higher than the maximum allowable SCI for a suitable pavement which is generally accepted as being .48 mils.<sup>(4)</sup> The bottom plot shows the BCI for both lanes and again uniform results were obtained. The westbound average value is .18 and the eastbound average is .16 mils. A comparison of these values with a maximum allowable BCI of .11 indicates that the base is not suitable - not strong enough to properly distribute the load. In fact, the

overall analysis based on the limiting values for the maximum deflection, the maximum SCI, and the maximum BCI indicates that both the pavement and the subgrade are weak.

The results of the Dynaflect testing performed on CR-28A immediately after construction on November 17, 1976, as shown in Figure 8, indicate that the average maximum deflection in the westbound lane was 1.48 mils while the eastbound maximum was 1.47 mils. The results appear to be very uniform and very similar for both the eastbound and the westbound readings. The average SCI for both east and west bound lanes of CR-28A was very similar and within the allowable SCI limit. The individual values are somewhat erratic. The plot of the BCI values for both east and west bound lanes shows both average values to be .13 mils compared to the maximum allowable BCI of .11 mils for a satisfactory base course. The BCI for CR-28A immediately after construction appears to be fairly uniform. The overall indication of the Dynaflect descriptors is that the subgrade was weak and the pavement marginal immediately following construction.

The site was revisited and tested on July 14, 1977. The air temperature on this date was 85<sup>0</sup>F and the pavement temperature was 130<sup>0</sup>F. The recycled pavement had been through one winter and was in the middle of its first summer. The Dynaflect plots, Figure 10, for the July tests on CR-28A show the maximum deflections for both east and west bound to be very uniform. The average maximum deflection for the eastbound lane is 1.54 mils and in the westbound it is 1.61 mils. The SCI also appears to be relatively uniform except for test site D<sub>0</sub>. The average SCI in the eastbound direction was .53 mils and the average for the westbound lane was .54 mils. The average BCI values are shown on



the bottom plot. The average for the eastbound lane is .13 mils and .14 mils for the westbound lane. The overall indication of these values is that both the pavement and subgrade are weak.

The site was visited again on October 6, 1977. The air temperature on this date was a little cooler than in July. The maximum deflections as shown in Figure 12 were very uniform in both lanes. The average maximum deflection in the westbound direction was 2.07 mils and 1.93 mils in the eastbound direction. The SCI's again were erratic. The average SCI value in the westbound direction was .63 mils and .56 mils in the eastbound direction. The range of SCI values in the westbound lane was from .40 to .80 mils while the range in the eastbound lane was from .23 to .78 mils. The average BCI value for both eastbound and westbound tests was .17 mils. The indication in this case is that both the pavement and the subgrade are weak.

A final set of deflection measurements for CR-28A was taken on April 12, 1978. The weather conditions and pavement surface temperature were similar to those of October 6, 1977. The average maximum deflection of CR-28A on April 12, 1978, was 2.47 in the westbound lane and 2.50 in the eastbound lane. The SCI values again were very consistent; 0.55 mils in the westbound lane and .58 mils in the eastbound lane. The BCI values are also very comparable in both lanes. The westbound average is .19 mils and the eastbound value is .20 mils. The increase of all three descriptors from the October 1977 tests, substantiates the indication that both the pavement and subgrade are weak and, therefore, probably will have a shortened maintenance free service life.

#### E. Dynaflect Results - CR-30B

The plots of the initial - before construction - Dynaflect results for CR-30B obtained on June 17, 1976, as shown in Figure 7, reveal some

extreme variations in the DMD's at a few of the sites. The average maximum deflection in the eastbound direction was 3.43 mils, and the average in the westbound direction was 3.06 mils. The plot of the SCI values shows an even greater variation in the results obtained for both lanes. The average SCI for the eastbound lane is 1.74 mils and 1.11 mils for the westbound lane. The BCI for the pre-construction condition of CR-30B is plotted at the bottom and the average eastbound value is .14 mils while the average of the westbound lane is .18 mils. The air temperature on this date was 76<sup>0</sup>F and the pavement temperature was 109<sup>0</sup>F.

Dynalect tests performed on CR-30B immediately after construction on November 17, 1976, produced the plots which are shown in Figure 9. This series of plots shows quite an improvement for all three of the Dynalect descriptors. First, the maximum deflection shown at the top of the figure indicates fairly uniform results within the lane and between the east and west bound lanes. The average maximum deflection of the westbound lane was 1.45 mils and the average in the eastbound lane was 1.33 mils. The SCI plot indicates a continued variation between the lanes which is fairly extreme in the case of at least four of the test sites. The average SCI value for the westbound lane was .43 mils while the average SCI in the eastbound lane was .29 mils. The BCI values for CR-30B were very spotty. The plots are not continuous because some of the values were not meaningful. The average BCI value of the plots shown was .09 mils for the westbound lane and .11 mils for the eastbound lane.

CR-30B was retested almost a year after construction on July 14, 1977. The air temperature at the time of test was 85<sup>0</sup>F and the pavement temperature was 123<sup>0</sup>F. The maximum deflections in both east and west

bound lanes were very similar. The westbound average was 2.20 mils and the average maximum deflection in the eastbound lane was 2.16 mils. The SCI values continued to be somewhat erratic and varied between the lanes. However, the average SCI values were relatively similar. The average westbound SCI value was .79 mils and the average of the eastbound lane was .73 mils. The BCI values also appeared to be somewhat erratic, however, the average BCI values for the westbound and eastbound lanes were also very similar; .16 mils and .15 mils, respectively.

Dynaflect tests were again performed on CR-30B on October 6, 1977, approximately one year after construction. The plots for the three Dynaflect characteristics are shown in Figure 13 for the tests on this date. The maximum deflections of both lanes were fairly uniform. The westbound average maximum deflection was equal to 1.82 mils and the eastbound average was 1.75 mils.

The individual SCI plots appear to be very irregular, however, the average SCI values are nearly equal. The westbound lane was .55 mils while the eastbound lane was .54 mils. The BCI average values are relatively uniform. The average westbound value was .14 mils on this date and the average BCI value in the eastbound lane was .15 mils.

Final testing was performed on April 12, 1978, about one and one-half years after construction. The results of the Dynaflect values for tests run on this date were very similar between lanes. The average maximum deflection was 2.03 mils for the westbound lane and the average for the eastbound lane was 2.02 mils. The average SCI values were .54 mils and .53 mils for the westbound and eastbound lanes, respectively. The average BCI value in the westbound lane was .17 mils and .16 mils in the eastbound lane.

#### F. Results of Roadmeter Tests

No roadmeter testing was performed on either county road in 1976 due to the lateness of the application of the final road surface. Initial roadmeter tests were performed on May 26, 1977. The final roadmeter value as summarized in the table is given as a weighted mean value for each lane from a series of runs in both directions at the standard test speed of 50 mph. The weather on May 26, 1977, was sunny and breezy with an air temperature of 75<sup>0</sup>F and a pavement temperature ranging from 114<sup>0</sup> to 125<sup>0</sup>F. The weighted mean value for the eastbound lane of CR-30B was 1166 counts per mile, while the weighted mean value for the westbound was 945 counts per mile, which gives an overall average roadmeter value for CR-30B on this date of 1053 counts per mile. The weighted mean value for the eastbound lane of CR-28A was 642 counts per mile and the westbound weighted mean value was equal to 579 counts per mile which gives an overall value of 611 counts per mile for CR-28A on May 26, 1977.

Both sites were revisited and tested on July 14, 1977. The weather conditions were recorded as hot and humid with an air temperature of 85<sup>0</sup>F and a pavement temperature of 130<sup>0</sup>F. The method of testing was similar to that of May 26, and produced the roadmeter values shown in the table. The weighted mean value for the eastbound lane of CR-30B was 828 counts per mile while the value of the westbound lane was 746 counts per mile. This gives an overall average of 787 counts per mile for the CR-30B on this date. The value for the eastbound lane of CR-28A was 491 counts per mile and 484 counts per mile for the westbound lanes on July 14, 1977. These produce an average overall value of 488 counts per mile.

The roadmeter tests were again run on October 6, 1977, or about one year after construction. From these runs the weighted mean value for the eastbound lane of CR-30B was 1058 counts per mile and 1029 counts per mile for the westbound lane which gives an overall average roadmeter value of 1043 counts per mile for CR-30B. The values for CR-28A were 559 counts per mile for the eastbound lane and 478 counts per mile in the westbound lane which gives an overall average roadmeter value of 518 counts per mile for CR-28A on October 6, 1977. The weather for this date was cool with scattered clouds, air temperature was 58<sup>0</sup>F.

A final series of roadmeter tests was run on April 12, 1978. The weather on this date was cloudy and windy with an air temperature of 60<sup>0</sup>F. The counts per mile for the eastbound lane of CR-30B was 618 and 664 for the westbound lane. This gives an overall average of 641 counts per mile for CR-30B on April 12, 1978. The values for CR-28A came out to 557 and 535 counts per mile for the eastbound and westbound lanes, respectively. These values produce an overall average roadmeter value of 546 counts per mile for CR-28A.

#### G. Observations from Visual Inspections

The first visit to the sites after construction was made on May 19, 1977. Inspection of CR-28A revealed that the overall surface was in very good condition. There was no rutting in the wheelpaths and no cracking along the centerline joint or between wheelpaths in either lane. The surface was very uniform and appeared to have satisfactorily weathered its first winter. The only apparent defect in CR-28A was a massive shoving failure at Dynaflect Site D<sub>4</sub> in the westbound lane. This appears to be due to an insufficient amount of tack coat on the recycled material prior to surfacing since the interface was very clean with a somewhat

glassy film which was relatively slick. CR-30B also appeared to have weathered its first winter very well. The only apparent distress was near Dynaflect Site D<sub>1</sub> where a crack perpendicular to the centerline was readily visible running from the edge of pavement to the centerline in the eastbound lane. This area is at the break where a hill meets a flat grade. The material on the surface appears to be somewhat soft in this area. It is noted that the forcewheels of the Dynaflect sink approximately  $\frac{1}{4}$ " into the surface at some isolated areas at the east end of the project.

Very little change was noted in the physical condition of either road section during visits made in July and October of 1977. The shoving failure described previously on CR-28A appeared to heal itself somewhat. This self-healing is probably attributed to the heat of the season combined with the traffic. The visit on April 12, 1978, revealed significant surface deterioration of CR-30B and evidence that some repairs had already been made. A series of longitudinal cracks and what appeared to be rust stains bleeding through the cracks were visible at the west end. The wheelpaths of both lanes through the entire test area were rutting. One area of the westbound lane of CR-30B near the entrance to a private drive approximately 20' east of Dynaflect Site D<sub>g</sub> had already been patched. The centerline joint was not ravelled as was noted along CR-28A, however, some potholes were noted in a concentrated area just west of Dynaflect Site D<sub>g</sub> in the westbound lane which caused some problems during the roadmeter runs. Also a three foot transverse crack centered in the eastbound lane was 25' east of Dynaflect Site D<sub>1</sub> was readily visible. This is the same crack that was noted during the May visit. CR-28A on the other hand showed very little apparent distress

except for the area near Dynaflect Site D<sub>4</sub> in the westbound lane when the shoving failure was noted on the May visit. This failure area still had not been repaired but was no worse than when it was first discovered.

#### IV. DISCUSSION OF RESULTS

First, it should be remembered that the purpose of this study was the evaluation of recycled bituminous material and its performance as the base course of a reconstructed full depth bituminous county roadway. The evaluation is based on the comparison of the material before and after construction and the response of the roadway structure to Dynaflect tests both before and after recycling. The evaluation also includes a comparison of relative pavement smoothness of the recycled roadway to values obtained on similar pavements around the state as determined from the PCA roadmeter tests.

A closer look at the gradation curves - Figures 17 through 22 - reveals that only 5% of the before treatment material sampled from the 3"-6" level, the "base" level, on CR-28A was greater than 3/4". While on CR-30B, less than 2% of the untreated material was greater than 3/4". It is also interesting to note that, as an average, approximately 58% of the material sampled from the 3"-6" level of CR-28A passed the #6 sieve which is used in Indiana to distinguish between the coarse and fine aggregate fractions of bituminous mixes. Figure 20 indicates that an average of about 65% of the material from the 3"-6" level of CR-30B was finer than the #6 sieve. Of the initial samples taken from the top three inches of the existing roadway, the top size on CR-28A was 3/4" with slightly more than 60% passing the #6 sieve, and at CR-30B the top size was 1/2" with 67% passing the #6 sieve. The gradation curve of the

aggregate extracted from the recycled material of CR-28A shows the top size was 1" with 90% passing the  $\frac{1}{2}$ " sieve and that approximately 62% was finer than the #6 sieve. Figure 22 shows that the top size was  $\frac{3}{4}$ " for all practical purposes with 92% passing the  $\frac{3}{8}$ " sieve and 68% finer than the #6 sieve.

The 1974 Indiana Standard Specifications indicate that a Hot Asphaltic Concrete Base mixture should have no more than 28%  $\pm 2\%$  passing the #6 sieve, and no more than 18%  $\pm 2\%$  if the material is a Hot Asphaltic Emulsion mixture. A basic bituminous pavement design relationship is that stability of the mix is derived from the coarse aggregate which provides the framework and structure. In other words, stability is directly proportional to aggregate size. However, a comparison of the gradation curves of samples of material before and after recycling indicate that no attempt was made to improve the gross deficiency of coarse aggregate greater than  $\frac{1}{2}$ ".

The asphalt content of the recycled material for both CR-28A and CR-30B appears to be quite high when compared to those specified for base course mixes by the Indiana Specifications. The specified bitumen content for bases made from emulsified asphalt is between 3.0% and 4.1% of the total weight of mixture while the bitumen content specified for Hot Asphalt Concrete type base mixtures is between 4.0% and 5.1% of the total weight of mixture. The average asphalt content of the recycled material on CR-28A was 6.0%. This is about 25% more asphalt than is needed to produce a stable and suitable course for any type of roadway. A little closer look at the asphalt content data reveals the very broad range of values from a low of 1.3% to a high of 9.7% which indicates that the asphalt content was not very uniform throughout the recycled



material. The average asphalt content of 10.3% of recycled CR-30B is twice the amount necessary. Again, the range is quite extreme. The low for the recycled material on CR-30B was 6.7% which is too high, and the high value was 15.5% which is totally ridiculous. It is generally accepted that too much asphalt reduces stability. Considering both aspects, namely, the extremely high asphalt contents coupled with the lack of coarse aggregate between the 1½" and 3/8" sieve, it is reasonable to assume that rutting or displacement of the roadway in the wheelpaths will definitely occur. Bleeding is also a possibility at various isolated spots and some shoving and washboarding could be expected to occur at other locations in a very short period of time. All of these defects are expected even though the volume of traffic is relatively low, the percent of trucks relatively small, and there is a two inch bituminous binder course and a one inch bituminous wearing surface over the recycled material.

Also, the average amount of recycled material finer than the #200 sieve for both CR-28A and CR-30B was slightly more than the five percent maximum of the Standard Specifications. A minor excess of fines alone is not critical but coupled with a dense gradation, as indicated by the slope and range of the curves, reduces the availability of sufficient and necessary voids. This means that the action of traffic and the effects of high ambient temperatures could contribute to the expected bleeding and rutting problem.

The information relative to the gradation of the extracted aggregate and the asphalt content of the recycled material on both county road sections is supported by the Dynaflect data obtained before and after recycling. Using the Utah deflection criteria for

the Dynaflect which is summarized in Figure 3, the tests performed on CR-28A before recycling indicate without doubt that both the pavement and the subgrade are weak. In Figure 6 the DMD's for all eleven Dynaflect sites in both lanes were much greater than the suggested 1.25 mil maximum. The SCI's were very high and very erratic. The BCI's were also high but relatively uniform.

The results of Dynaflect tests run on CR-28A immediately after construction indicate a noticeable improvement for all three Dynaflect parameters. The maximum deflections dropped to 1.47 mils and 1.48 mils for the east and west bound lane, respectively. The DMD's appear to be very uniform along the eleven test sites. The SCI's remain erratic but have been reduced by a factor greater than two. The BCI was almost reduced to the acceptable maximum limit. The BCI is probably the most important indicator because it describes the strength and stability of the base course by its ability to transmit load. Dynaflect results obtained immediately after construction shows little improvement. The subgrade is weak and the pavement is marginal. The next tests were run July 1977, and they indicate a progressive weakening of the pavement system of CR-28A. The average maximum DMD's increased somewhat as did the SCI's, while the BCI's remain relatively constant. Compared to the acceptance criteria, these test results indicate that both the pavement and the subgrade are weak. Dynaflect tests performed three months later reveal a continued weakening of both pavement and base.

The final set of Dynaflect tests for CR-28A were run April 1978, seventeen months after construction. The DMD's of both lanes were greater than the DMD's obtained before construction. These values are very consistent in both lanes and twice the maximum allowable DMD for a suitable pavement. The SCI's were somewhat high and remain erratic,

but they were not much above the maximum allowable SCI value for a suitable surface. This may be due to the fact that the surface course is less than one and one-half years old and consists of three inches of very good material. The BCI values obtained on both lanes for the eleven Dynaflect sites in April were quite high, well above the maximum, indicating continued weakening and instability of the recycled base course.

It is readily seen from the progression of increasing BCI and DMD values that the reconstructed roadway is not performing as expected and definitely would not be suitable under heavier daily traffic volume with a higher percentage of trucks.

Both CR-28A and CR-30B produced very large and non-uniform SCI values along the roadway as well as between the lanes indicating that the pavement surface lacked continuity and was quite variable. However, the BCI values for CR-30B were equal to those obtained on CR-28A and while they were above the maximum allowable they certainly were not extreme.

The DMD's immediately after construction show a marked improvement. Even though the average DMD was virtually cut in half for both lanes they were still above the recommended maximum. The SCI's were very much improved - below or equal to the allowable - but still quite erratic and variable. The Base Curvature Index was reduced to an acceptable level for the most part. These results indicate that even though the subgrade and pavement apparently were greatly improved compared to the before treatment test results, they are only marginal according to the acceptance criteria.

Dynaflect tests of July 1977 for CR-30B, eight months after construction, indicate the pavement surface and base are weakening.

All three Dynaflect descriptors increased considerably, and all were in excess of the maximum allowable values. The October 1977 values show an improvement of the DMD and the SCI values. However, the BCI remains unchanged for this three month period. The improvement of average DMD and SCI may be due to the fact that the July tests were taken when the pavement was 123<sup>0</sup>F, while the October tests were taken on a much cooler pavement. The high pavement temperature recorded during the July tests probably was the cause of the increased deflections since performance of the Dynaflect is a function of pavement temperature.

The April 1978 Dynaflect tests on CR-30B are very similar to the October 1977 test results. While the DMD's and the SCI's were greatly improved by the reconstruction, the BCI's one and one-half years after construction are almost equal to the BCI's obtained before construction. Because the BCI is the critical parameter which can predict the ability of the base to perform satisfactorily, values in excess of the acceptable limit indicate that the roadway will not have the projected service life.

A comparison of the BCI values of certain Dynaflect sites before and after treatment on both county roads reveals an interesting condition. Before treatment tests on CR-30B produced extremely high BCI values at sites D<sub>0</sub>, D<sub>3</sub>, D<sub>9</sub> and D<sub>10</sub>. The BCI at site D<sub>5</sub>, on the other hand, was relatively low. After treatment test results indicate no lasting improvement of sites D<sub>0</sub>, D<sub>9</sub> and D<sub>10</sub>. However, the base course at site D<sub>3</sub> was greatly strengthened or stabilized by the treatment while the BCI at site D<sub>5</sub> worsened significantly. Most BCI values on CR-28A are high for any test date. Dynaflect sites D<sub>2</sub>, D<sub>7</sub>, and D<sub>10</sub> were high both before and after recycling. Lack of improvement of the high BCI's is indicative of the existence of a base problem which was not corrected by the reconstruction process. The probability that a base failure will occur at the sites which continue to produce BCI values well above

0.11 mils only eighteen months after construction is very high. In fact it is predicted that untimely failures will occur in these areas. The BCI values and therefore the recycled base could have been greatly improved if the recycled aggregate had been "sweetened" with coarse aggregate ranging in size from  $1\frac{1}{2}$ " to  $\frac{1}{2}$ ". Also, it appears that more control must be exercised over the amount and distribution of bituminous material added to rejuvenate the recycled material. Adequate coarse aggregate greater than  $\frac{1}{2}$ ", optimum bitumen content, and uniform distribution of bitumen are critical factors that must be considered before and during construction.

The results of roadmeter tests indicate that CR-28A is smoother than CR-30B. The results of roadmeter tests hold up well from May through October 1977 for both sites. However, the April 1978 tests, while consistent for CR-28A, show a gross reduction in counts per mile for CR-30B. The change is greater than can be explained, especially in light of the fact that there were visible areas of distress and repair on CR-30B at the time of the April tests. Looking at Table 1, which summarizes the roadmeter results, reveals considerable difference in roadmeter values for CR-28A and CR-30B. CR-28A is in the 500 cpm to 600 cpm range, while CR-30B is in the 800 to 1000 counts per mile range.

The PCA Roadmeter has been used in Indiana to determine pavement smoothness since 1973. Three categories of pavements are tested each year. Category A covers Bituminous Resurfaced Pavements, Category B includes New Flexible Pavements, and Category C is for New Rigid Pavements. Over the past five years the roughness index or the counts per mile obtained on the top five new flexible pavement ranged between 176 and 386 counts per mile. The largest index obtained of all of the projects tested in this category over the past five years was 672 counts

per mile. For pavements in the bituminous resurfacing category, the average indexes for the five years ranged from 280 to 350 counts per mile. The range for new rigid pavements ran from a low of 470 counts per mile to a high of 1018 counts per mile. This provides a basis for comparison and it can be said that CR-28A is at least 200 counts per mile rougher than the average new flexible pavements tested in Indiana since 1973. At the same time, CR-28A is smoother by about 200 counts on the average than the new rigid pavements tested with the PCA Roadmeter since 1973. CR-30B on the other hand has about the same level of smoothness, as determined by the PCA Roadmeter, as the new rigid pavements tested in Indiana over the past five years.

The roadmeter values obtained on CR-30B on April 12, 1978, show a dramatic improvement of 200 to 400 counts per mile while the values obtained on CR-28A on the same date are what would have been expected. This sudden improvement of CR-30B came as a real surprise at first. However, consideration of such variables as pavement condition, pavement surface temperatures, weather conditions, and the fact that the road had been in service through a severe winter since the last tests helped to provide a reasonable explanation. The improvement in smoothness is attributed for the most part to two major considerations. First, repairs had been made to the ravelled and potholed areas near the west end of the CR-30B test section. Also, some of the rough areas overlaying isolated, soft spots in the subgrade apparently had smoothed out due to the action of traffic in the interval since the last roadmeter tests were performed.

Another surprise came from the Dynaflect results. The plots of the Dynaflect parameters indicate that CR-30B is just a little bit better as far as strength and stability of the pavement and subgrade are concerned.

However, the visual inspection of the test roads most definitely reveals that CR-28A is performing better than CR-30B. Less distress in the form of ravelling joints, chuckholes, cracking and wheel rutting was evident on CR-28A than on CR-30B. One possible explanation for this apparent puzzlement is that the sections are relatively short and because the contractor's procedure was not continuous throughout the construction period, there is relatively little continuity and uniformity along the sections of recycled and reconstructed roadway.

#### V. COMPARATIVE COST ANALYSIS

The plan of study called for a cost analysis of the cold recycling process which was to include all material, labor, and equipment costs of subbase treatment, base processing and stabilization, application of additional bitumen, and application of special chemicals furnished by the county. A description of the details of the cold recycling process begins on page 54. This process was to be compared to the cost-in-place of six inches of compacted hot mixed, hot placed bituminous base material described in Indiana State Highway Standard Specifications as HAC #5 Base. The unit of comparison was 100 feet of roadway twenty-five feet wide.

The following information was obtained from the construction records of the two Elkhart County projects evaluated in this study - CR-28 and CR-30. Both projects were bid and constructed in 1976.

ITEM	COUNTY ROAD 28 COST PER 100 ft.	COUNTY ROAD 30 COST PER 100 ft.
Base Processing and Stabilization	\$ 96.00	\$ 94.00
Additional Base Bitumen (AP-3)**	69.44	138.88
ClaPak-ClaSet	81.20	81.20
Chemicals:		
ClaPak	(6 gal) 105.00	(1.9 gal) 33.25
ClaSet	(3 gal) 52.50	(0.9 gal) 15.75
SA-1	(1.1 gal) 27.50	(0.4 gal) 10.85
TOTALS	\$ 431.64/100 ft.	\$ 373.93/100 ft.

\*\*IMPORTANT NOTE: The application rates for CR-28 and CR-30 were 0.5 gal/syd. and 1.0 gal/syd., respectively. Results of the extraction tests of the recycled material verified this difference and pointed out that the rate on CR-30 was grossly overestimated. Determination of the amount of additional bitumen appears to be somewhat arbitrary.

Itemized Proposals of Highway Commission contracts awarded in 1976 were reviewed to determine a reasonable and representative unit price for HAC #5 Base. Prices ranged from \$11.95/ton to \$22.00/ton. Recognizing that unit price is dependent on quantity, an effort was made to select a unit price based on a proposed quantity of 4,900 tons. This produced what is hoped to be a fair rate of \$14.00/ton.

Therefore, the cost of producing, placing and compacting a six inch course of HAC #5 Base is:

$$91.67 \text{ tons} @ \$14.00/\text{ton} = \$1,283.38/100 \text{ ft.}$$

$$* \left( \frac{100 \times 25}{9} \right) \left( \frac{660}{2000} \right) = 91.67 \text{ tons}$$

assuming a square yard of bituminous base one inch thick weighs 110 lbs.



Of course, the cold process recycled material is less expensive than the hot mixed, hot placed material. However, a factor of three, as in the case of CR-30, appears to be very significant. Also, if the application rate of additional bitumen was reduced on CR-30B and the existing treated aggregate was "sweetened" with aggregate between 1½" and ½" the strength and stability of the recycled base would be greatly improved at a still lower cost. As for CR-28, a reduction of chemical application with "sweetened" aggregate might produce a more stable base at a lower cost.

## VI. CONCLUSIONS

The following conclusions are drawn from the results of Dynaflect tests, laboratory extraction tests and aggregate gradations, PCA Roadmeter tests and visual inspections of two county road cold recycling projects over a period of almost two years from June 1976 to April 1978.

1. The recycled material of both county roads did not contain a sufficient amount of the aggregate fraction between 1½" and ½" to perform satisfactorily as a base course.
2. The bitumen content of the treated material appeared to be quite variable on both roads and excessive on CR-30B. The application rates of bitumen added to the base listed in the project specifications should be considered as approximations only. Rates should not be established until tests indicate the amount of residual bitumen in the untreated material.

3. The purpose and value of the ClaPak-ClaSet chemicals and process appears to be questionable since there was no improvement of BCI values a short time after treatment. While it was not within the scope of this study to evaluate the performance of ClaPak-ClaSet and data was not sufficient to do so, it is mentioned because of the significant additional cost per unit length relative to its contribution to performance.
4. Tighter controls are needed in the field on cold recycled materials to overcome the inherent variability associated with the process. The use of chemicals to aid in the reduction of the material, the addition of bitumen, and the mixing process required continuous inspection and attention to insure uniformity and quality.
5. Material recycled by the cold process and placed as the base course is significantly less expensive than hot mixed, hot placed HAC #5 Base per unit volume. However, the recycled base may not be as durable and stable as the plant mixed material depending on aggregate gradation, bitumen content, and homogeneity of the recycled material.
6. Both CR-28A and CR-30B are predicted to have a shortened service life based on the Dynaflect parameters.
7. A longer evaluation period might have provided more conclusive information on the performance of the recycled sections.

## REFERENCES

1. Project Specifications for Road and Street Projects, Elkhart County, May 13, 1976
2. AASHTO Materials, Part II, Methods of Sampling & Testing, 11th Edition, September 1974
3. Indiana State Highway Commission, Standard Specifications, 1974
4. Deflection Analysis of Flexible Pavements, Final Report, Utah State Highway Department, January 1972
5. Roughness Testing with the PCA Roadmeter, Informational Memorandum, Indiana State Highway Commission Research and Training Center, February 22, 1978
6. Sargent, H. Jack, "Recycling 50 Miles of Bituminous Pavement Saves Dollars - Expands Road Program" Engineering Bulletin: Proceedings of the 63rd Annual Road School March 8-10, 1977, pp. 198-209; Engineering Extension Series No. 148 Purdue University

Table 1

## SUMMARY OF ROADMETER RESULTS

Test Date	Weighted Average, Counts Per Mile	
	EB Lane	WB Lane
	<u>County Road 28A</u>	
5/26/77	642	579
7/14/77	491	484
10/6/77	559	478
4/12/78	557	535
	<u>County Road 30B</u>	
5/26/77	1166	945
7/14/77	828	746
10/6/77	1058	1029
4/12/78	618	664

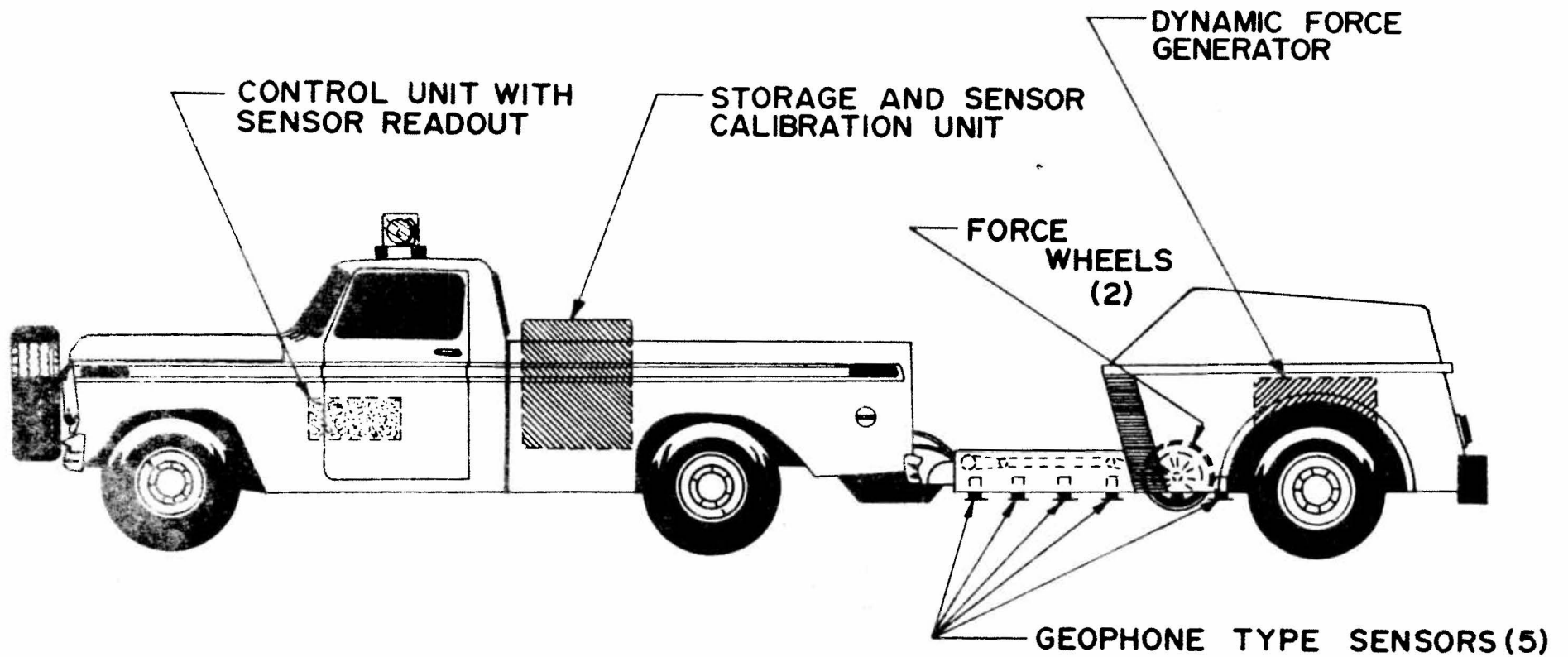

FIGURE 1: THE DYNAFLECT SYSTEM

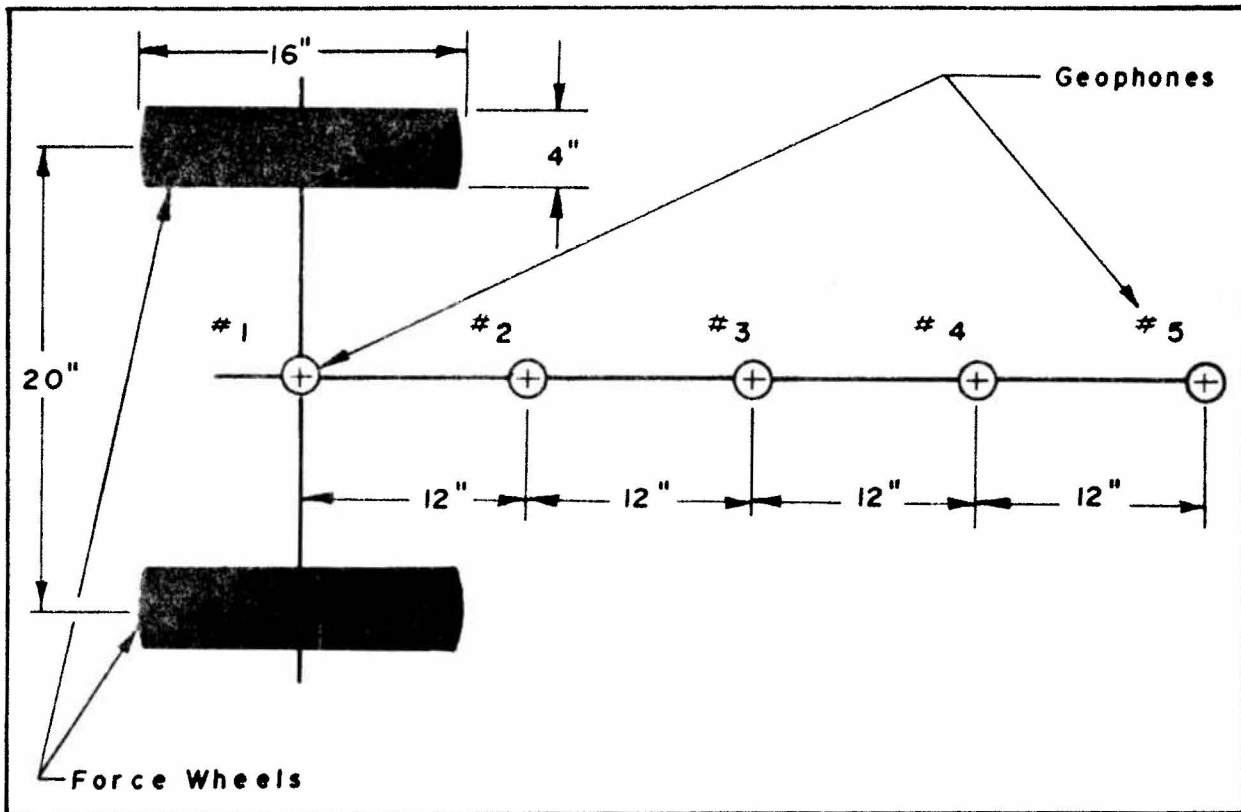

FIGURE 2 : DYNAFLECT CONFIGURATION (After Utah)

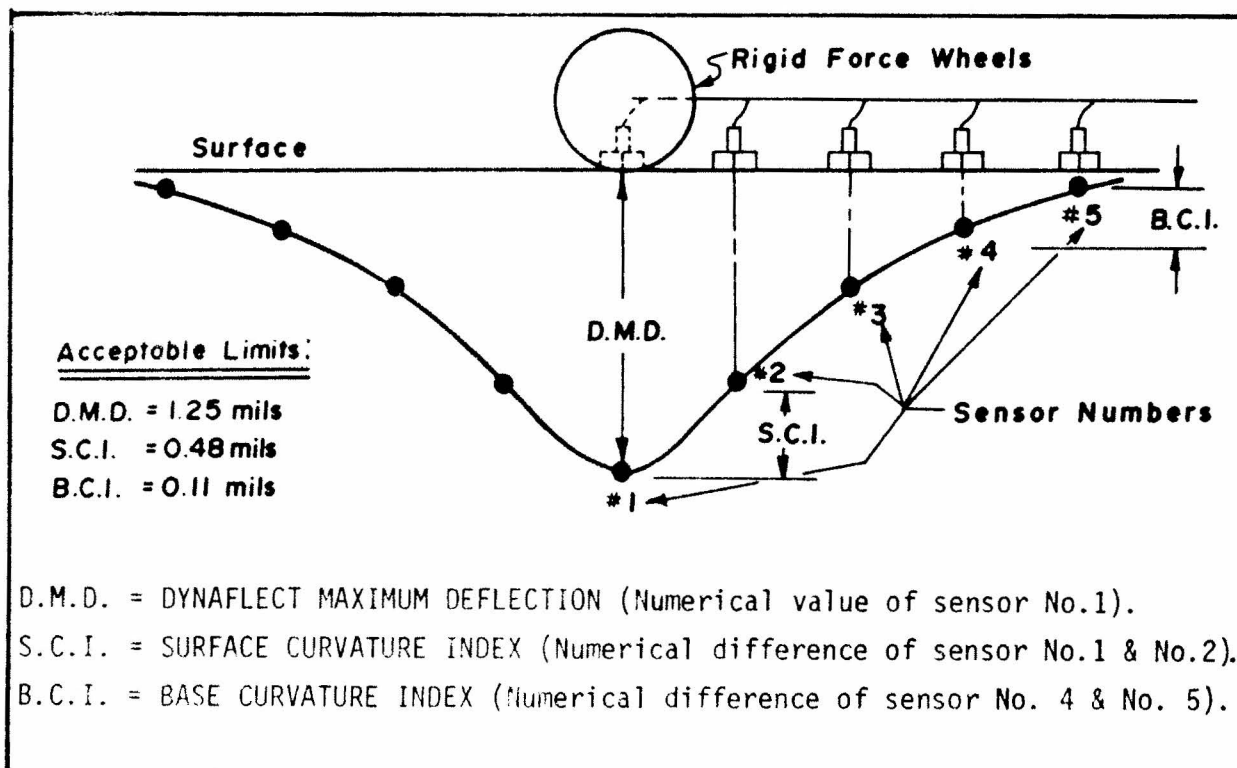

FIGURE 3: DEFLECTION BASIN PARAMETERS (After Utah)

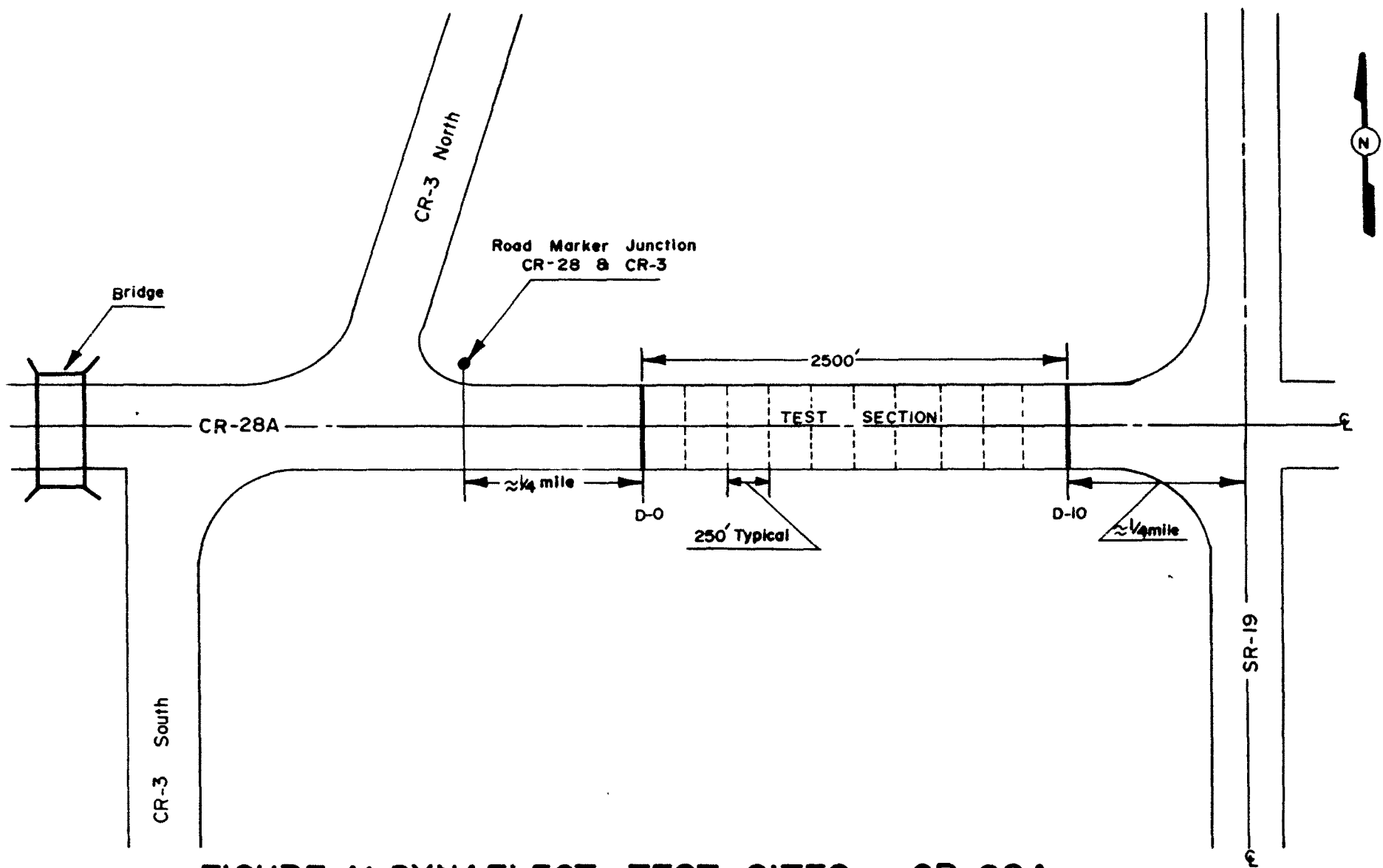

FIGURE 4: DYNAFLECT TEST SITES , CR-28A

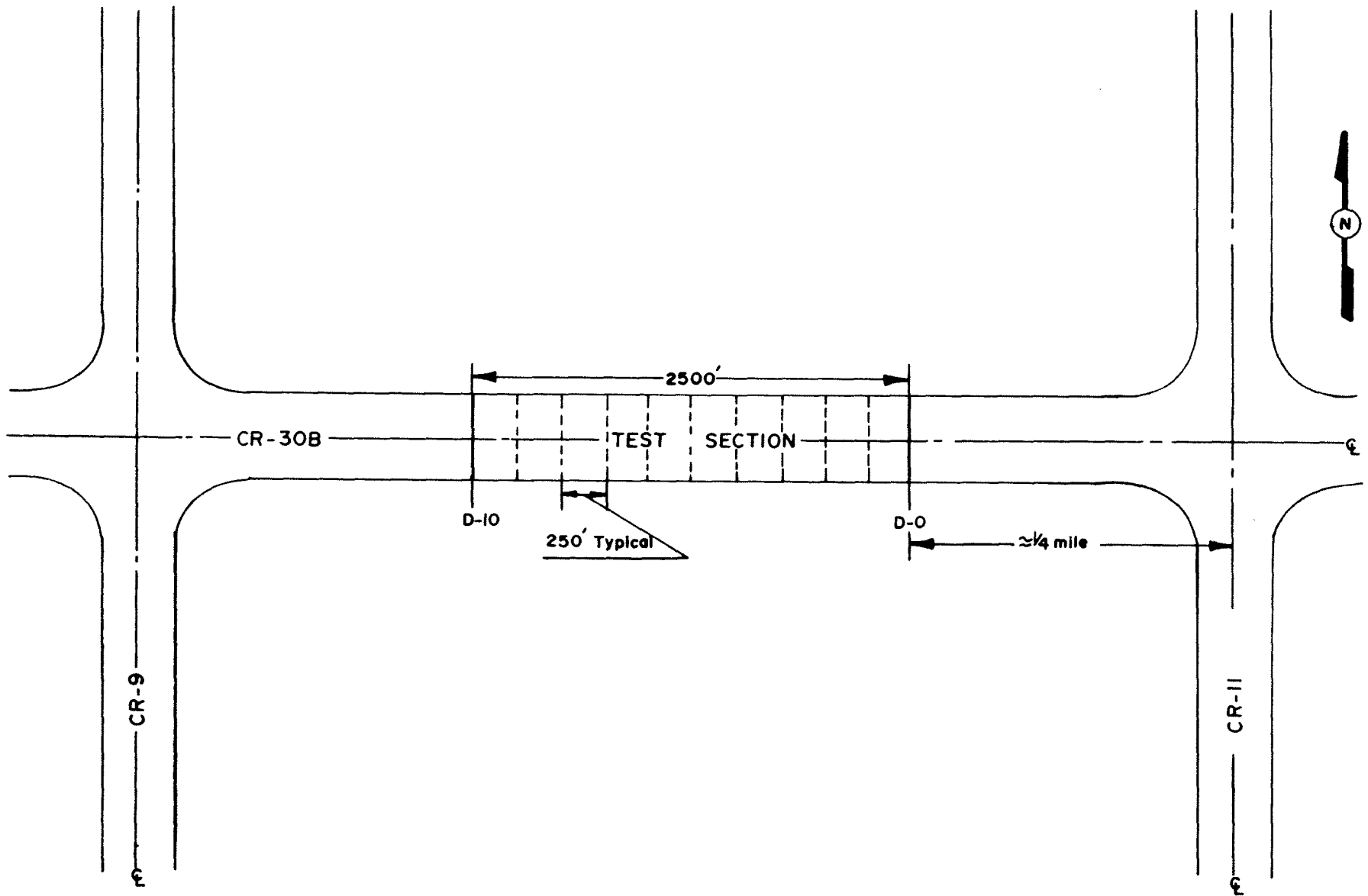

FIGURE 5: DYNAFLECT TEST SITES , CR-30B



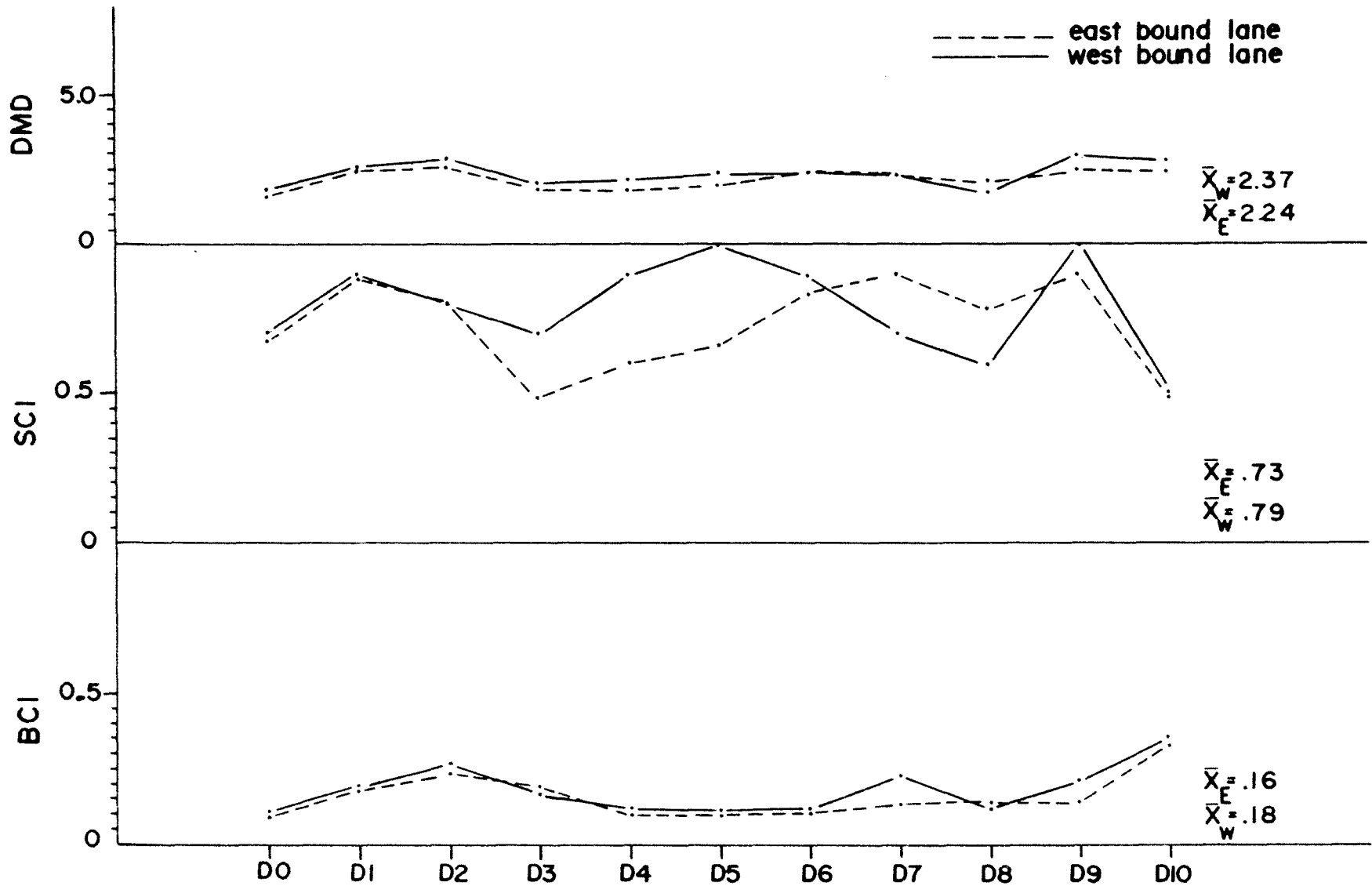

FIGURE 6 : DYNAFLECT RESULTS CR-28A - both lanes

DATE TESTED 6/17/76  
 (before construction)

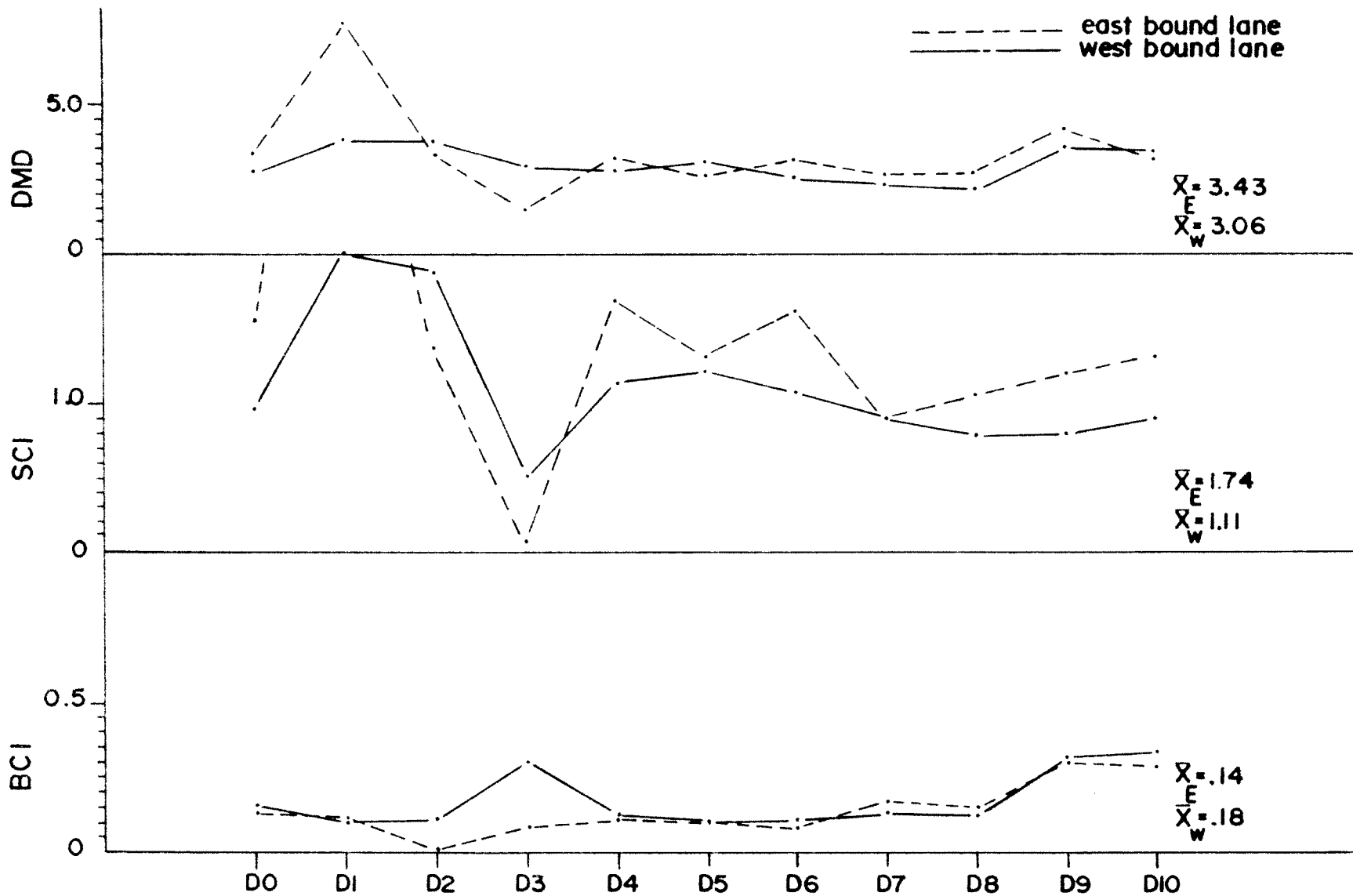

FIGURE 7: DYNAFLECT RESULTS CR-30B-both lanes

DATE TESTED 6/17/76  
(before construction)

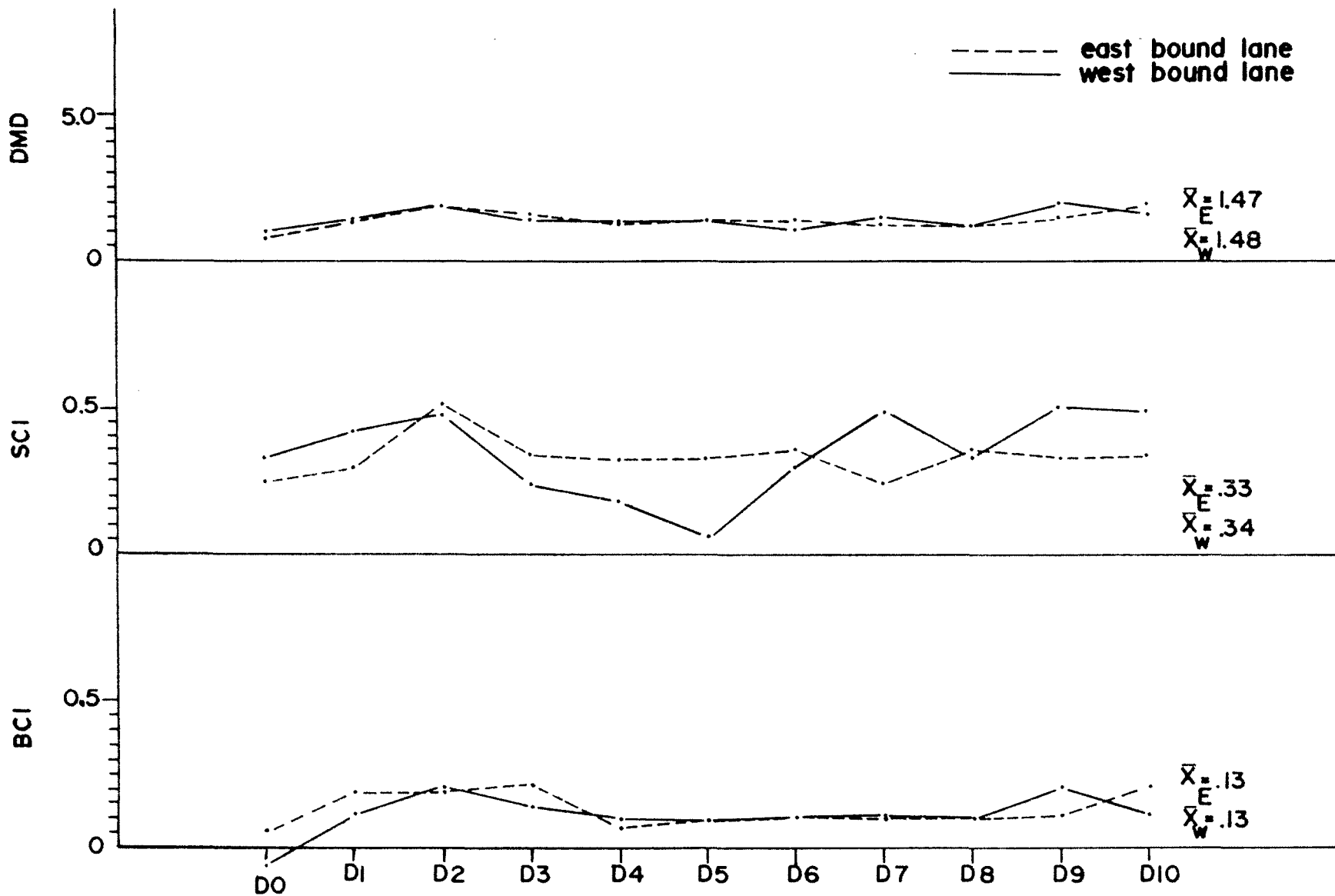

FIGURE 8 : DYNAFLECT RESULTS CR-28A- both lanes

DATE TESTED 11/17/76  
(immediately after construction)

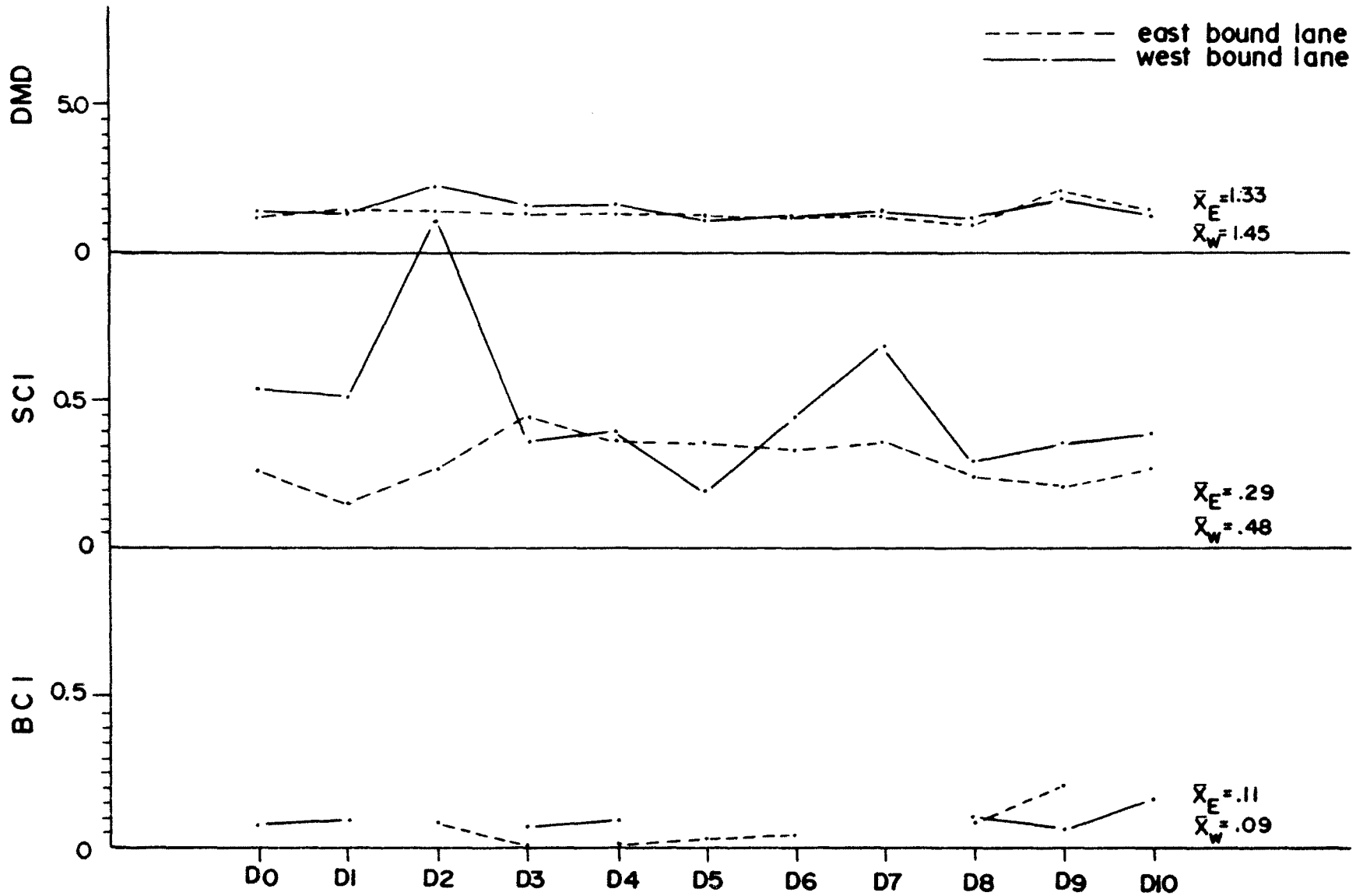

FIGURE 9 : DYNAFLECT RESULTS CR-30B-both lanes DATE TESTED 11/17/76 (immediately after construction)

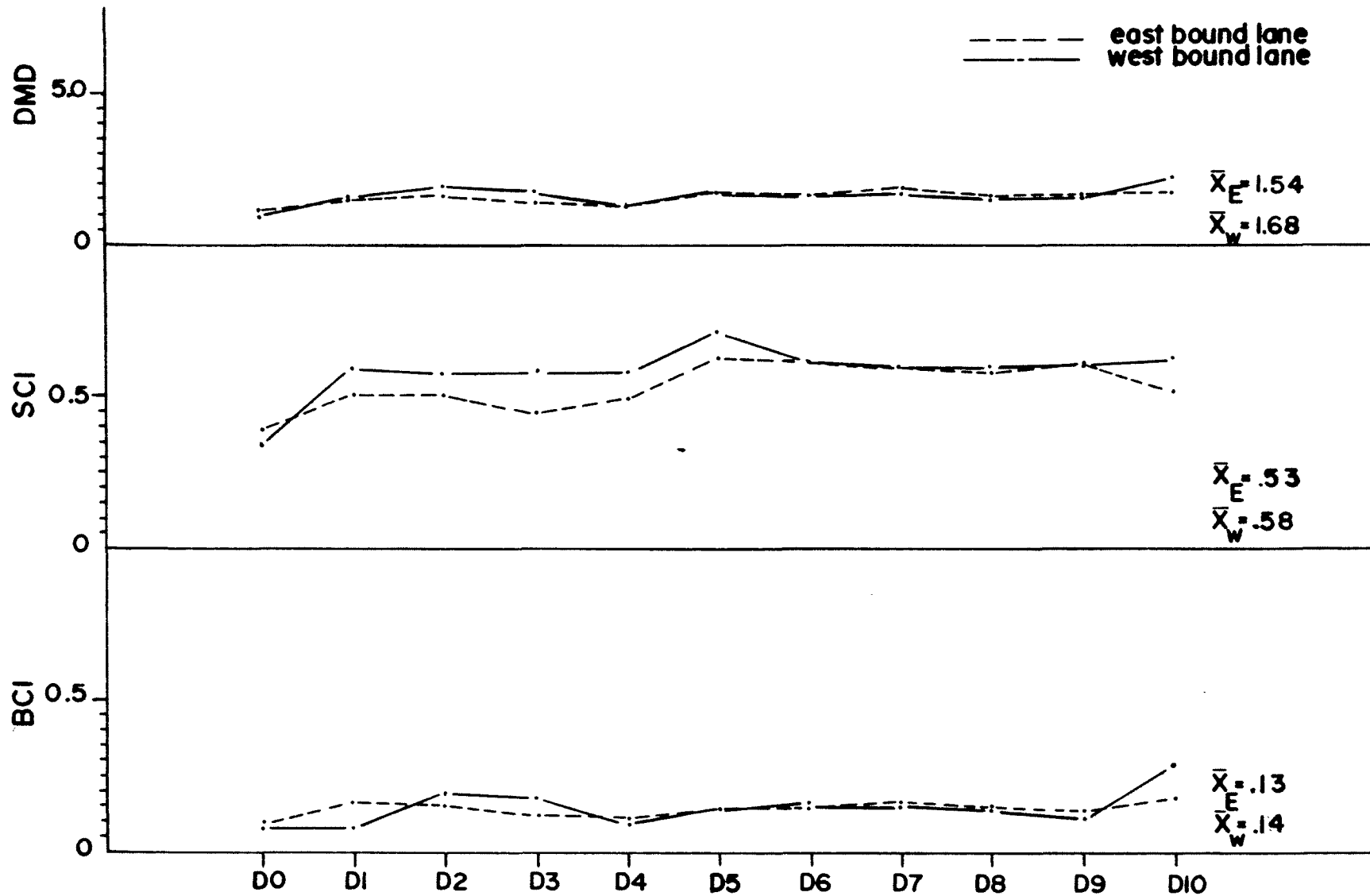

FIGURE 10: DYNAFLECT RESULTS CR-28A-both lanes DATE TESTED 7/14/77 (8 months after construction)

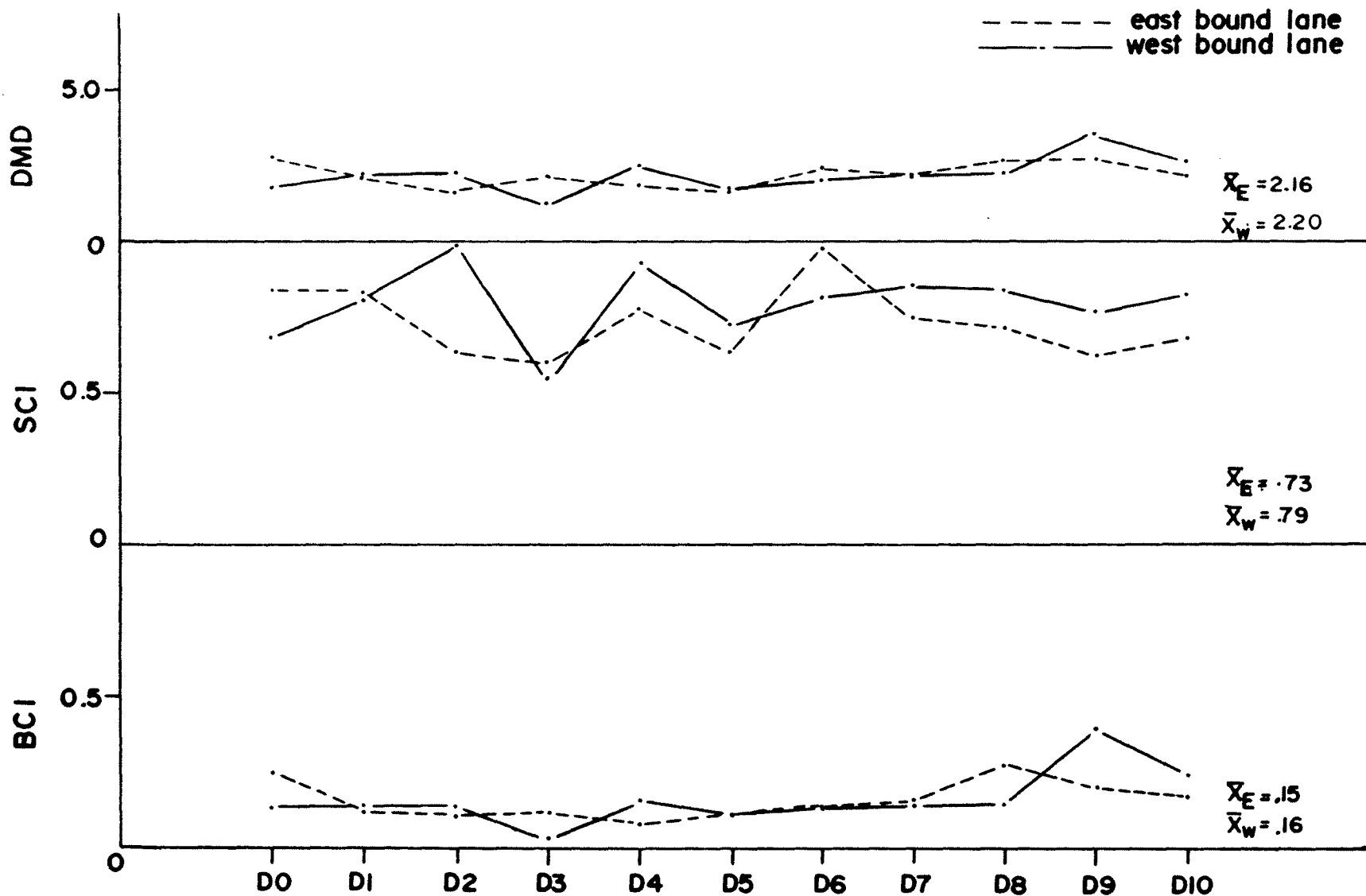

FIGURE II : DYNAFLECT RESULTS CR-30B- both lanes DATE TESTED 7/14/77  
 (8 months after construction)

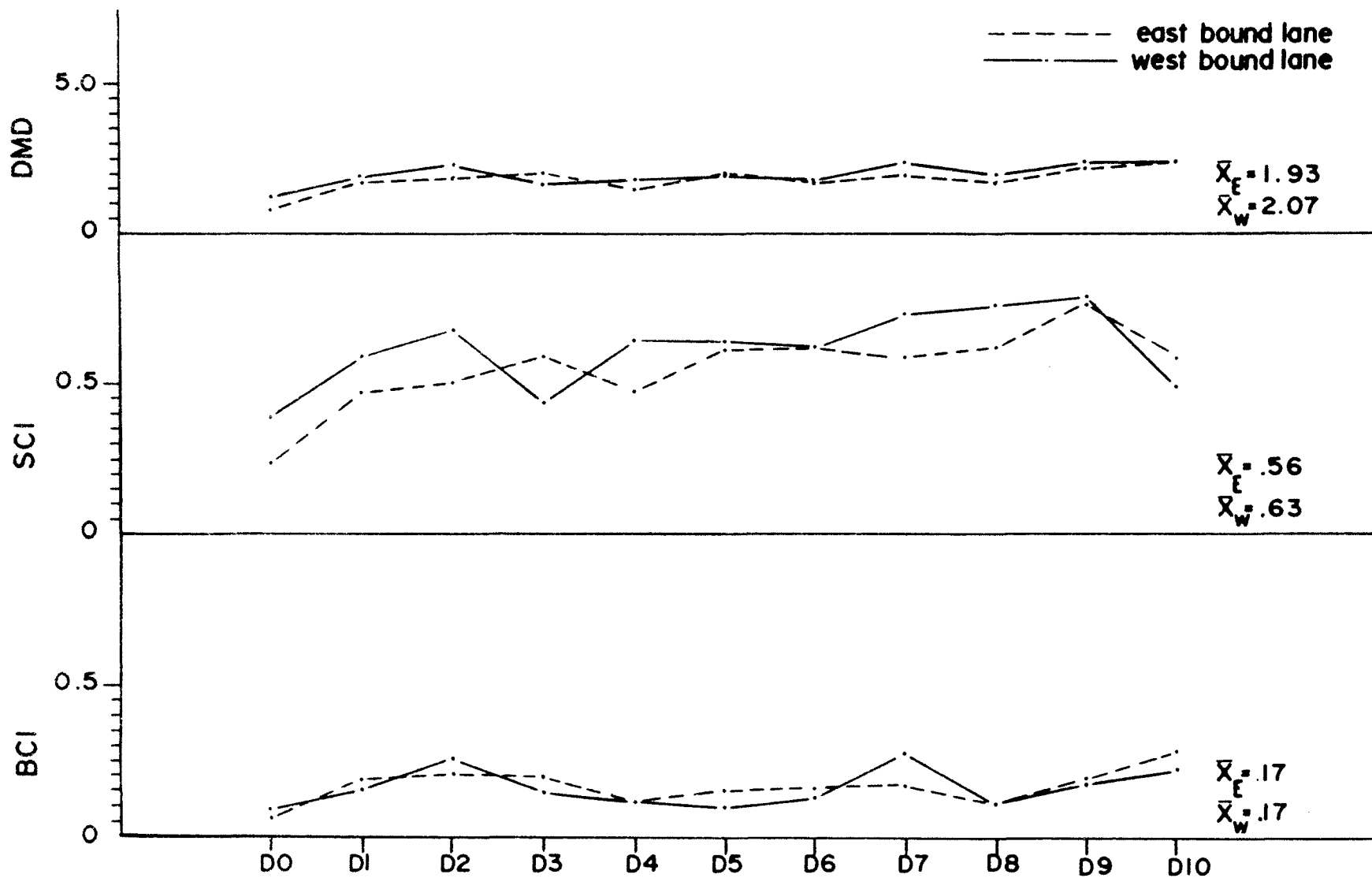

FIGURE 12 : DYNAFLECT RESULTS CR-28A-both lanes

DATE TESTED 10/6/77  
 (11 months after construction)

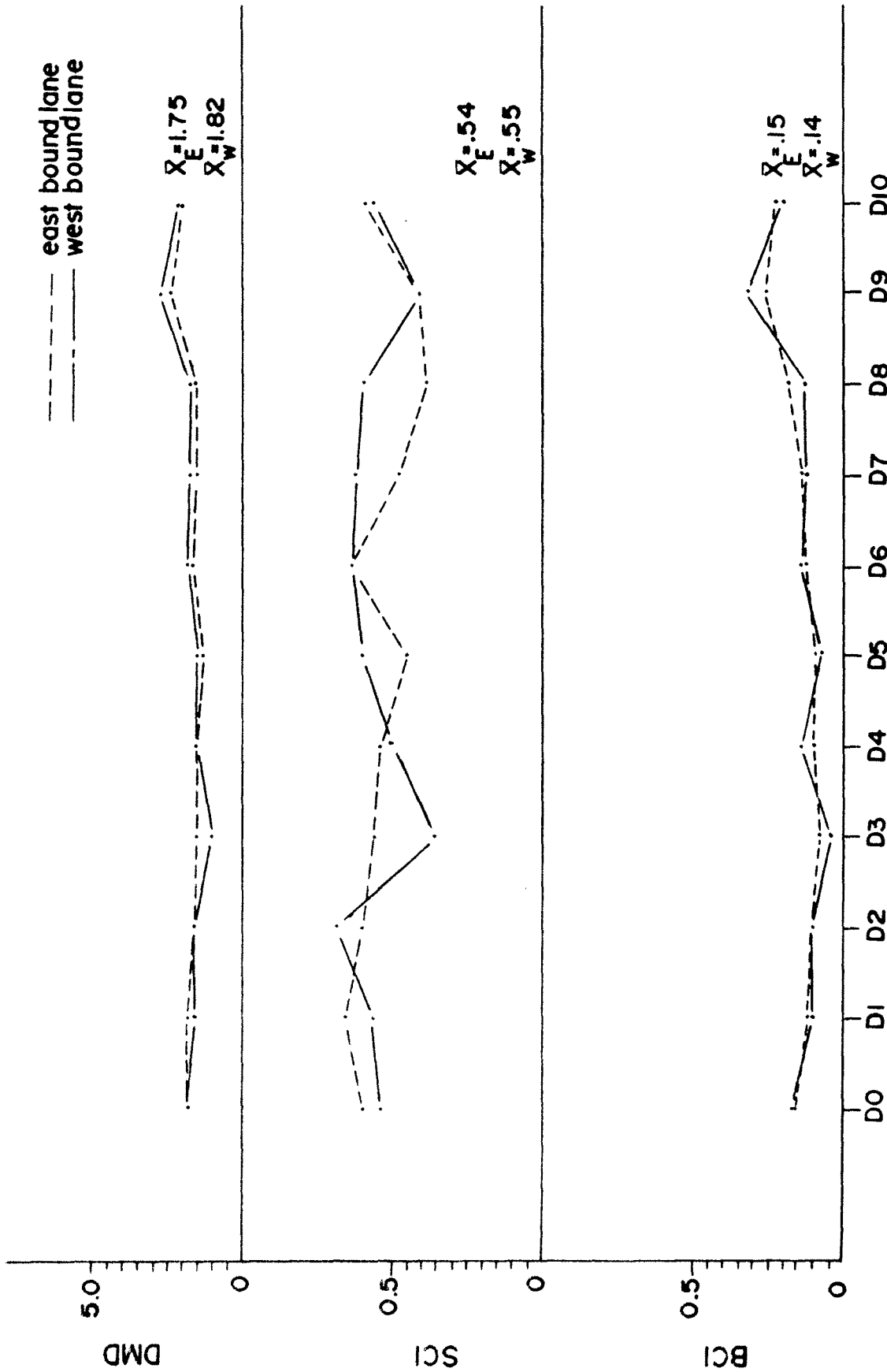

FIGURE 13: DYNAFLECT RESULTS CR-30B - both lanes DATE TESTED 10/6/77 (11 months after construction)



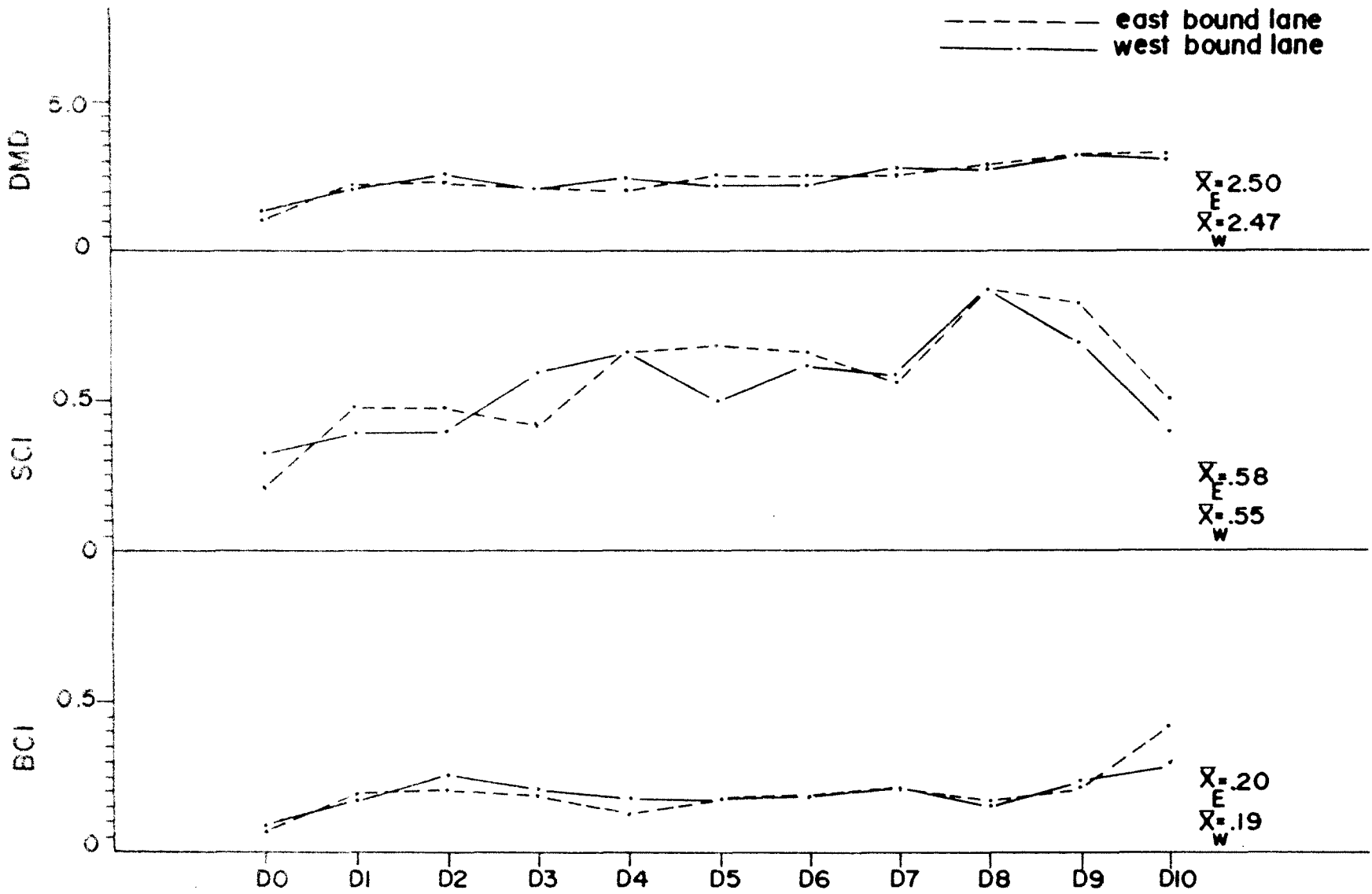

FIGURE 14 : DYNAFLECT RESULTS CR-28A -both lanes

DATE TESTED 4/12/78  
 (17 months after construction)

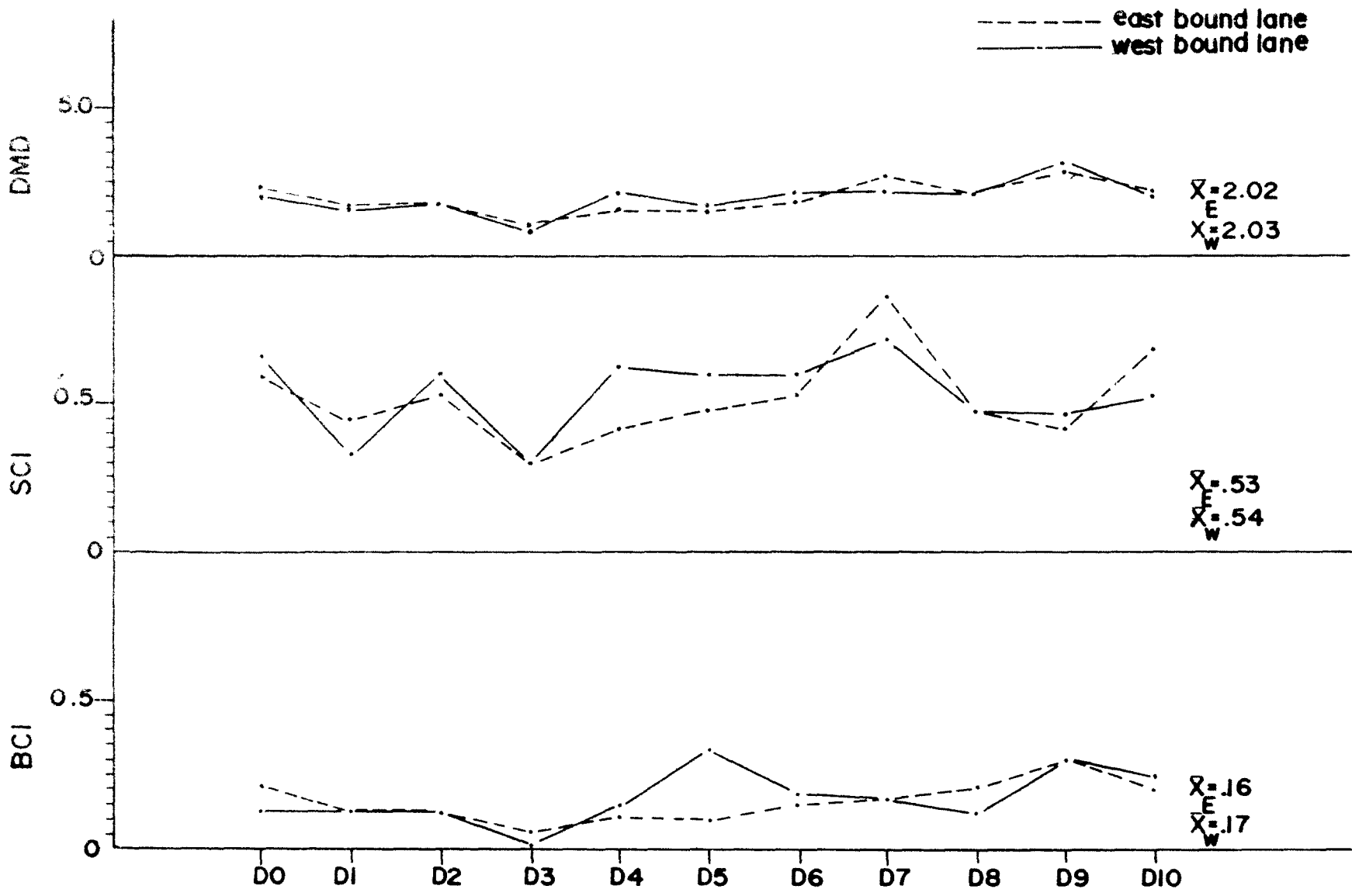

FIGURE 15 : DYNAFLECT RESULTS CR-30B - both lanes

DATE TESTED 4/12/78  
( 18 months after construction )

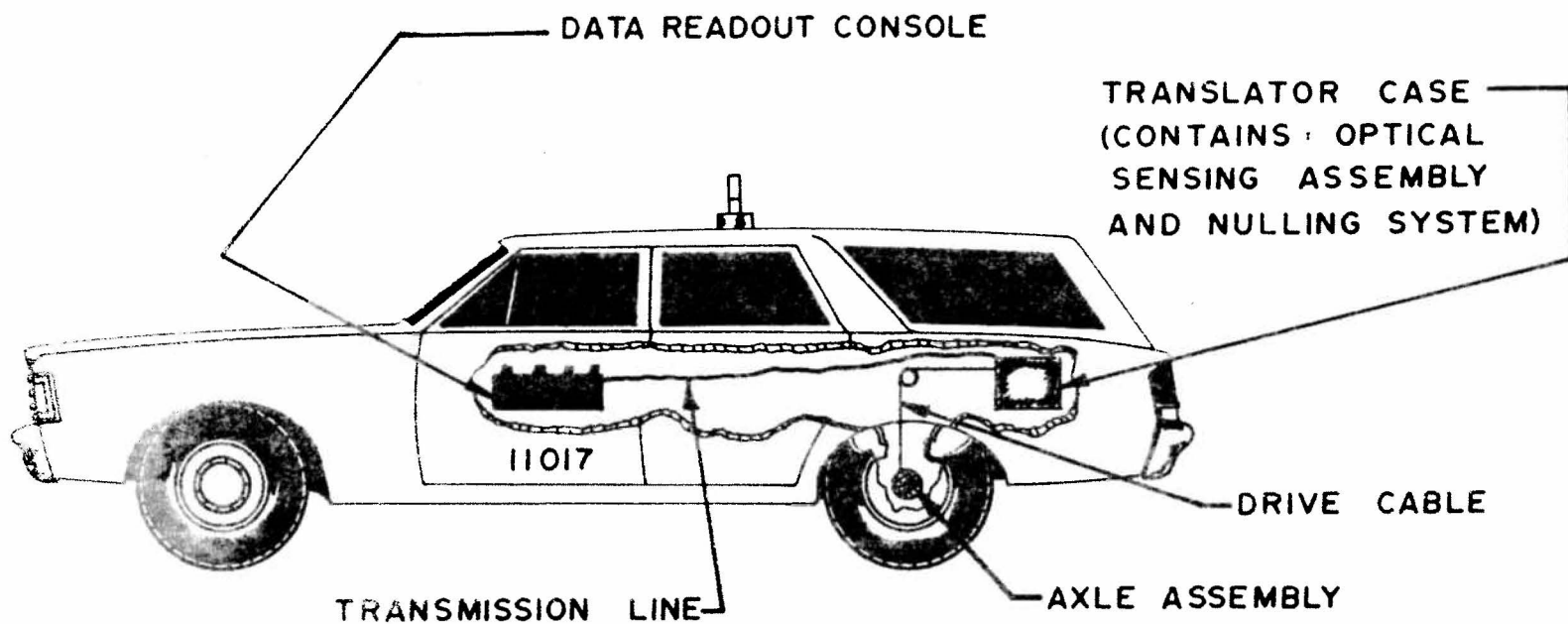
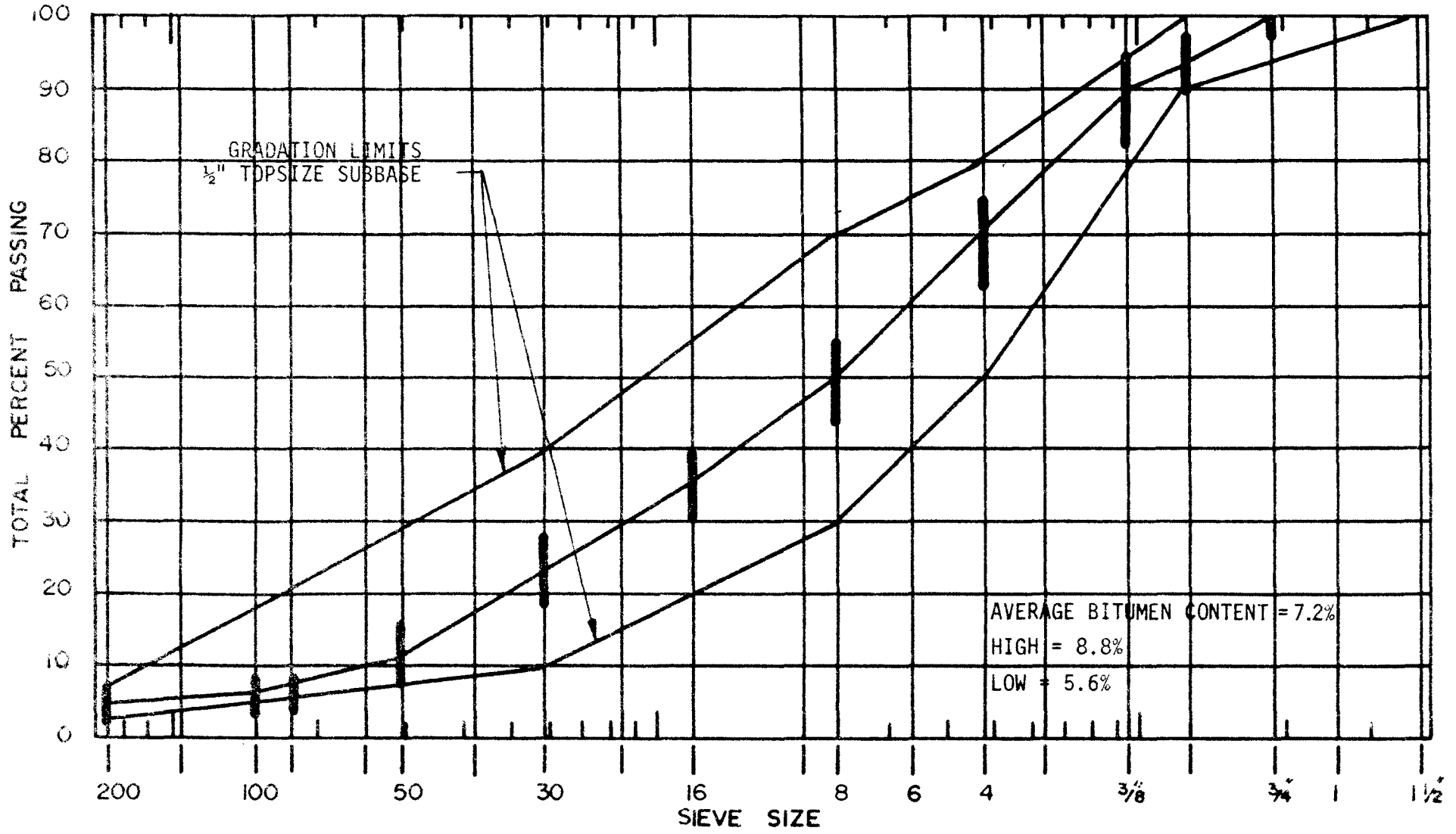
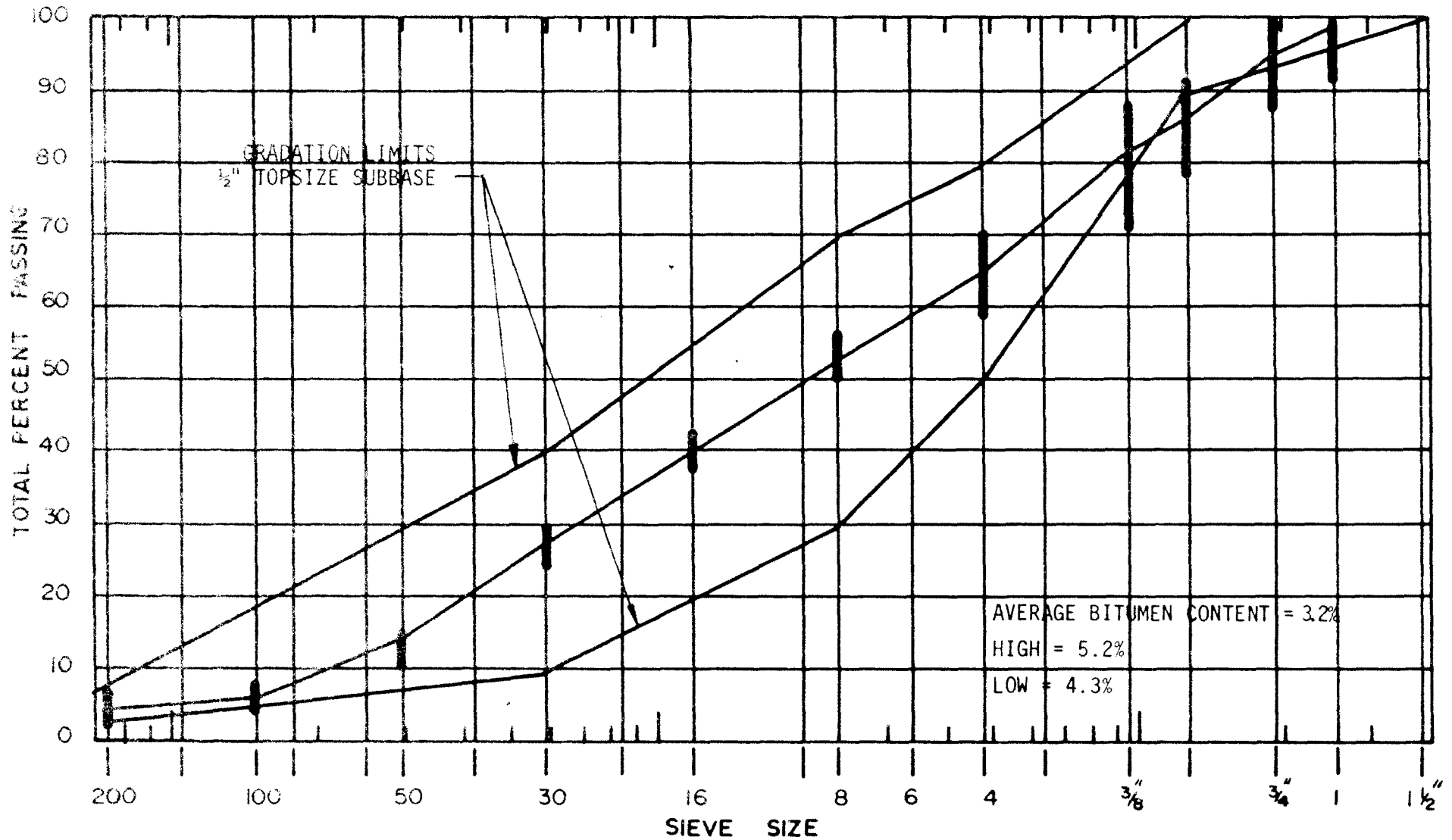

FIGURE 16:  
PCA ROADMETER IN 1973 AMC STATION WAGON



**FIGURE 17 : GRADATION OF EXTRACTED AGGREGATE  
CR-28A - INITIAL SAMPLES (0" - 3")**



**FIGURE 18 : GRADATION OF EXTRACTED AGGREGATE  
CR-28A- INITIAL SAMPLES (3"-6")**

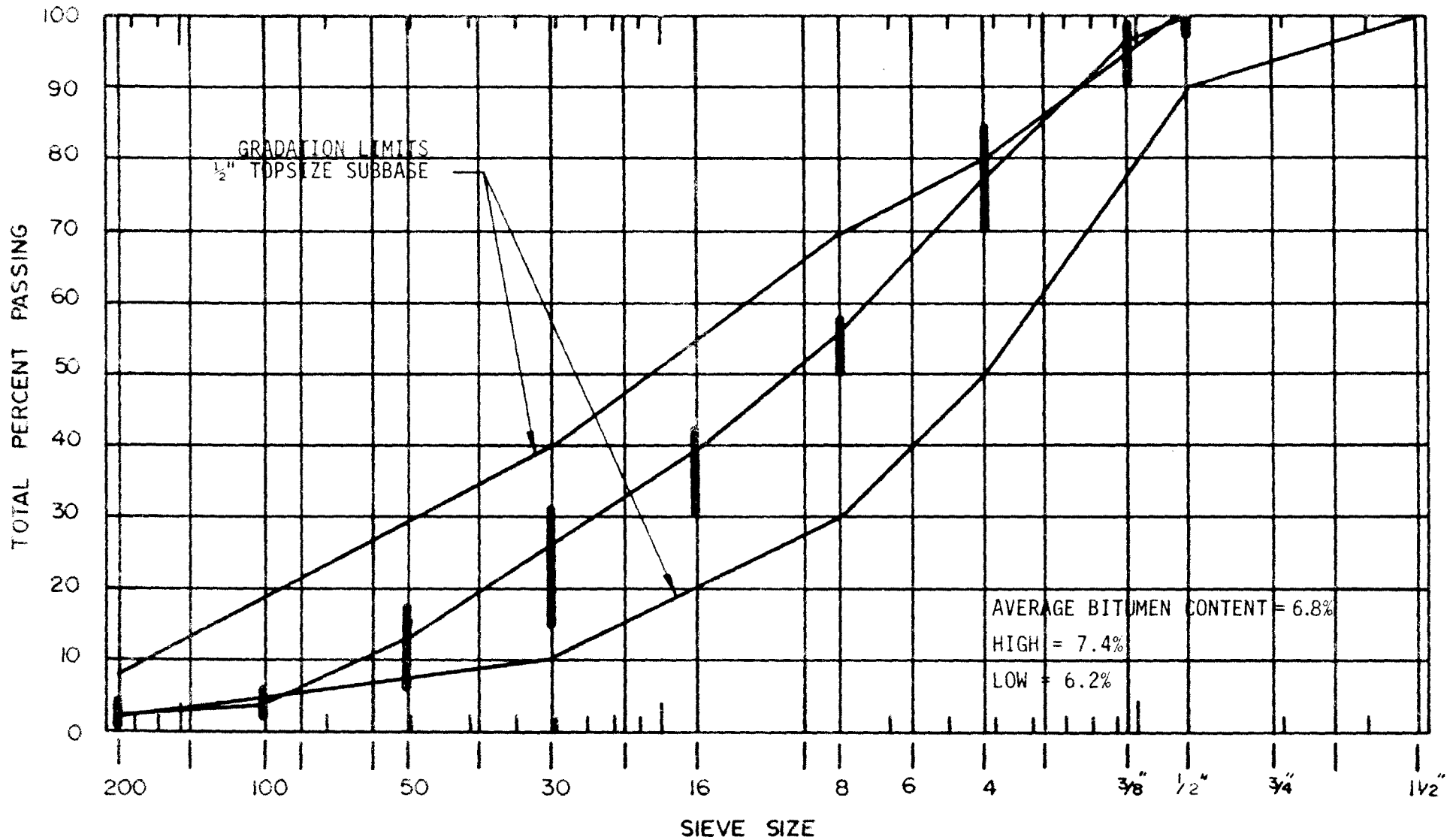

**FIGURE 19 : GRADATION OF EXTRACTED AGGREGATE  
CR-30B - INITIAL SAMPLES (0"-3")**

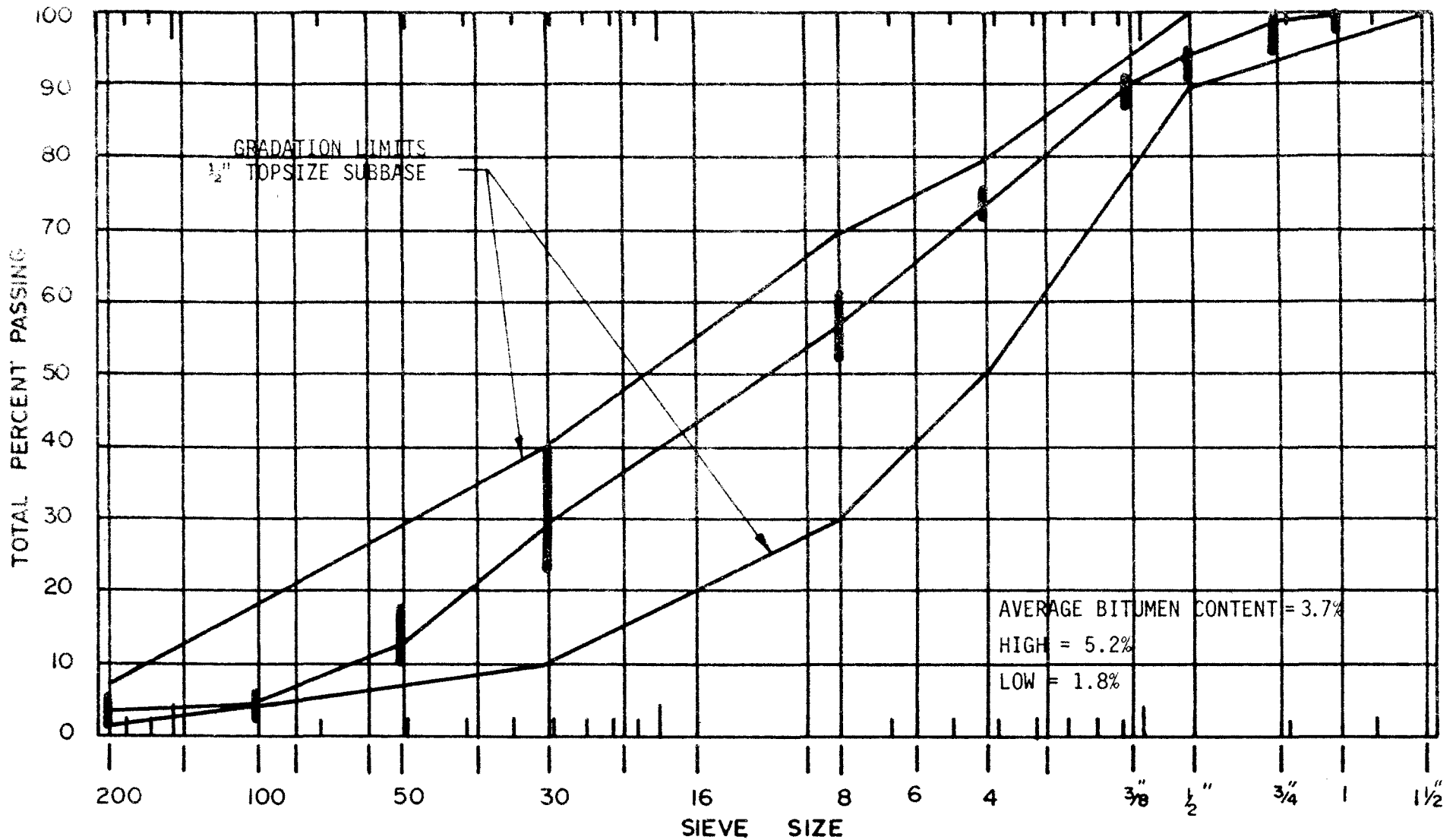
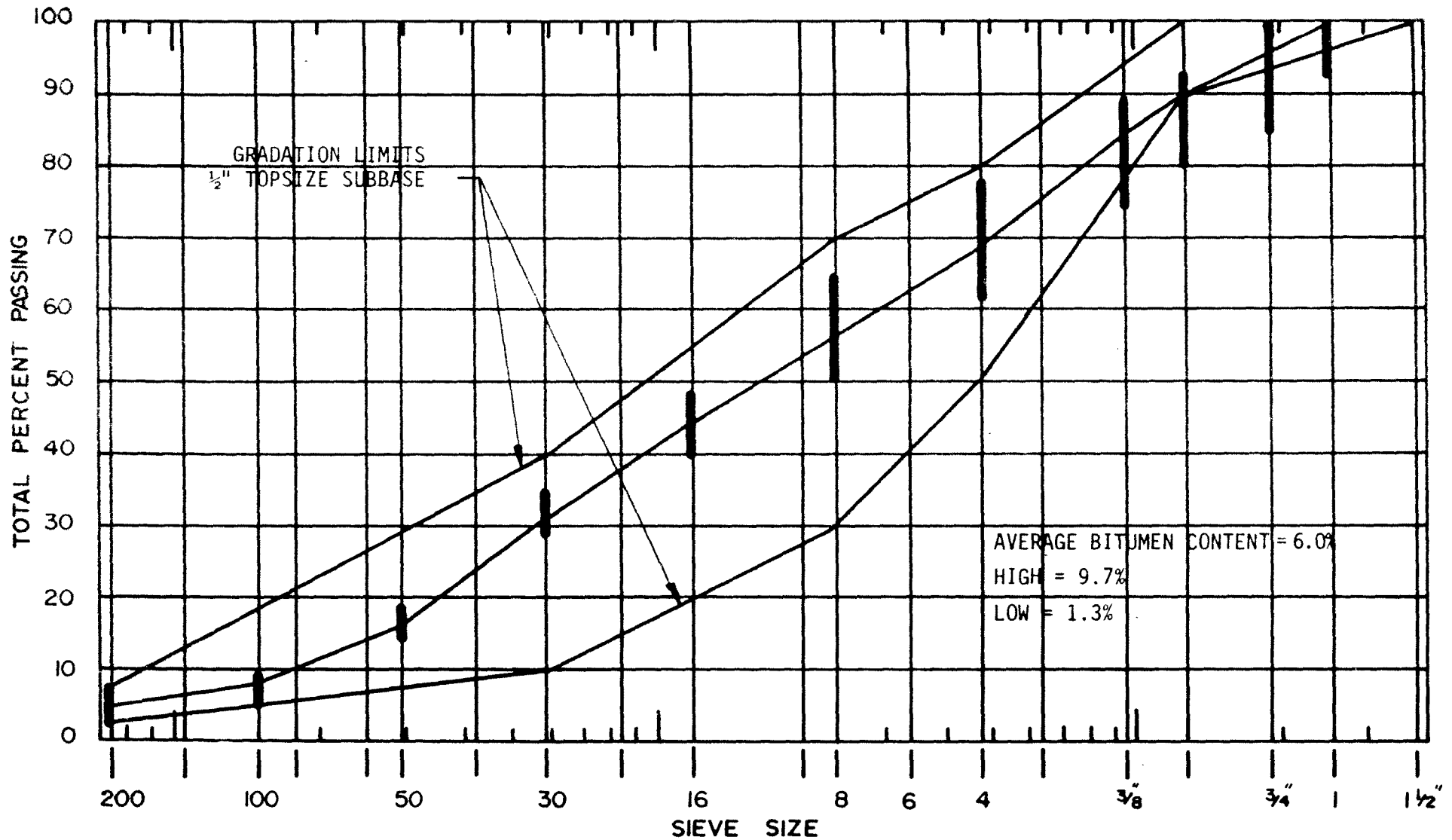

FIGURE 20 : GRADATION OF EXTRACTED AGGREGATE  
CR-30B-INITIAL SAMPLES (3"-6")



**FIGURE 21 : GRADATION OF EXTRACTED AGGREGATE  
CR-28A-AFTER RECYCLING**



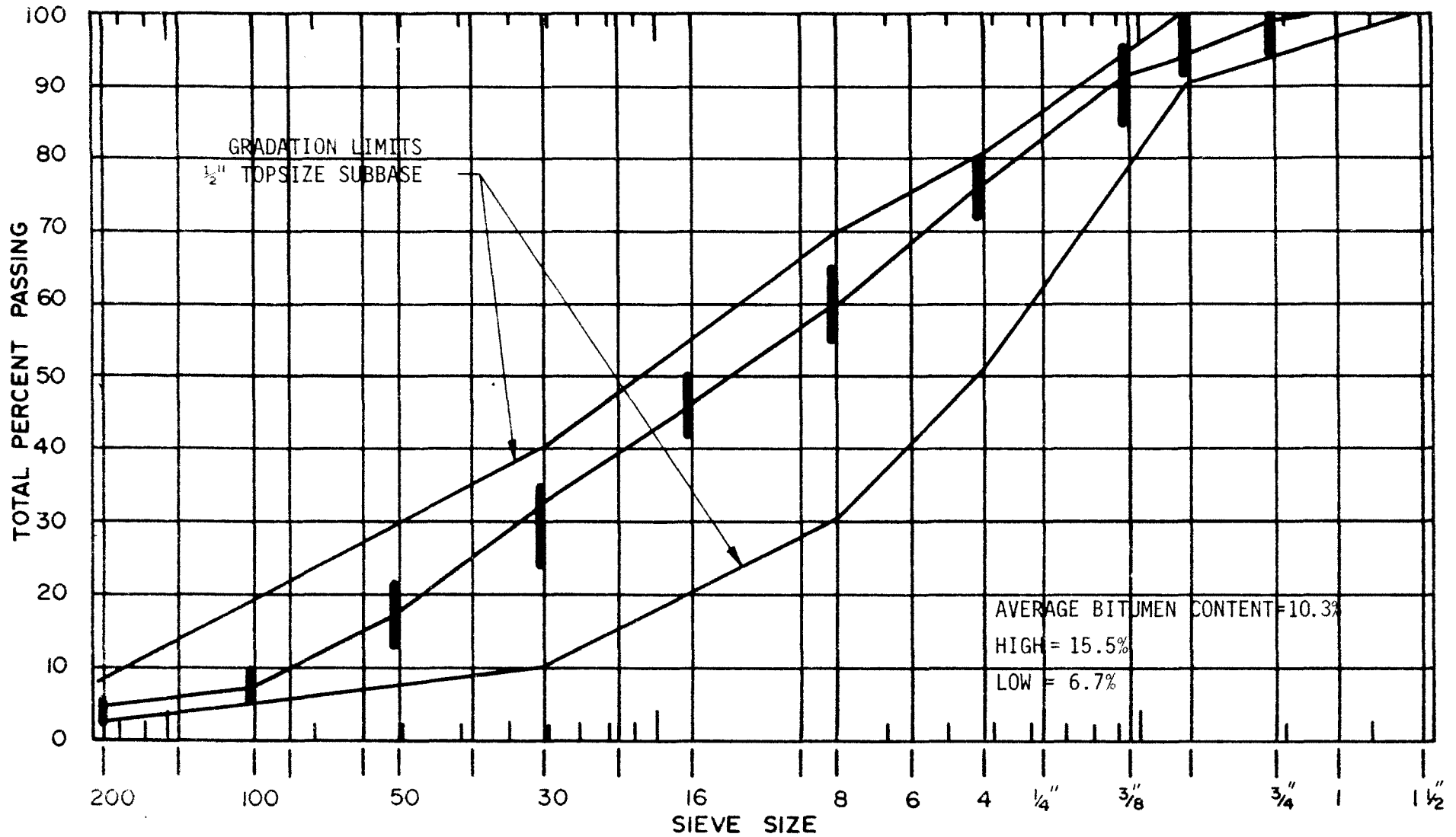

FIGURE 22 : GRADATION OF EXTRACTED AGGREGATE  
CR-30B - AFTER RECYCLING

## DETAILS OF THE COLD RECYCLING PROCESS

The construction procedure actually began with the cleaning and shaping of the side ditches and notching of both sides of the existing roadway as necessary to provide for the specified width of the reconstructed pavement. The contractor employed a Cat 12G motor grader for this phase of the work. The excess material from the ditch areas and widening was bladed onto the pavement surface, loaded into trucks, and hauled away.

The first step of the actual recycling process was the scarification of the pavement surface to a depth of three inches. This was accomplished with the scarifying teeth of the grader in areas which had been sealed and chipped or where the bituminous surface had lost its integrity. A D8 dozer with a ripper tooth was used to scarify areas where the pavement was in relatively good shape or consisted of a hot mixed, hot placed material.

Scarification was begun early in the morning and limited to one-half mile of roadway per day. It had been established from experience that one-half mile is the optimum length for the type of operation and amount of equipment involved. Also from experience, it was found that starting the work cycle with scarification early in the day allowed the reaction period of the SA-1 and the asphalt to take place during the hottest part of the day to take advantage of the ambient heat to speed up the chemical reduction of the chunks of bituminous concrete.

The scarified surface material was immediately sprayed with the SA-1 mixed with water in the proportion of one gallon of the chemical in 1000 gallons of solution. The water was obtained from a local creek and the solution was applied at the rate of 0.10 to 0.20 gallon per square foot of roadway with one of the water trucks. The capacities of the two water

trucks were 1500 and 3000 gallons. Additional plain water was applied to keep the SA-1 active to promote effective chemical breakdown of the material.

The physical reduction process continued after the application of SA-1. First, the chemically treated material was bladed into a windrow with the motor grader to stand the larger pieces up on end. The grader was followed by the D8 dozer equipped with grouser tracks towing a sheepsfoot roller. The tracking action of the dozer and the sheepsfoot further reduced the size of the bituminous concrete chunks allowing the SA-1 solution to work on a greater surface area. Virgin aggregate was not added.

Application of additional asphalt immediately followed the primary breakdown by dozer and sheepsfoot. The AP-3 was applied with an 1800 gallon capacity Etnyre distributor truck at a rate as directed by the county engineer based on the results of extraction tests.

A pulvimixer with only half the teeth set to a three inch depth made a pass to mix and reduce the material to 1½" maximum size. A second pulvimixer employing a full complement of teeth set to a depth of six inches followed to further reduce size and mix an additional three inches of the underlying aggregate with the reconstituted material.

After the final pass of the pulvimixer the material was shaped with the grader and compacted with a minimum of two passes with a Rex single drum vibratory roller.

After final rolling, the recycled base was allowed to cure for ten days to two weeks before a hot mixed, hot placed binder and wearing surface was applied. Local traffic was allowed to ride on the recycled base during this period.

The labor crew employed to accomplish the construction procedure consisted of two operators, one foreman, one laborer and two teamsters as a minimum.

It should be noted that the pulvimixer is a high maintenance item and there were many times when large rocks or chunks of material caused the shaft to shear which was a major breakdown and very time consuming. Also, it should be noted that the teeth of the pulvimixer had to be changed daily which required a lot of downtime.

When subgrade stabilization is specified, the process begins after the top six inches has been recycled and is ready for compaction. The recycled material is windrowed to one side to expose at least one-half of the subgrade. The area to be treated is then loosened to a depth of approximately six inches with the scarification teeth on the motor grader. This is followed with the application by water truck of the ClaPak-ClaSet chemicals which are diluted with water in varying amounts depending on the moisture content of the existing subgrade. The rate of application is dependent on the plasticity index of the subgrade soil. The treated soil is then processed with a pulvimixer to thoroughly mix the chemicals. When the material appears homogeneous the moisture content is adjusted to optimum by adding water or aerating with additional passes of the pulvimixer. The subgrade is then shaped and compacted to at least 95% of the maximum density as determined by ASTM D-698.

The windrow of recycled material is bladed on top of the treated and compacted one-half of the subgrade and the stabilization process is repeated. Following compaction of the remaining half of the subgrade, the recycled material is spread to a specified uniform depth and width and compacted to at least 95% of maximum density as determined in accordance with ASTM D-698.

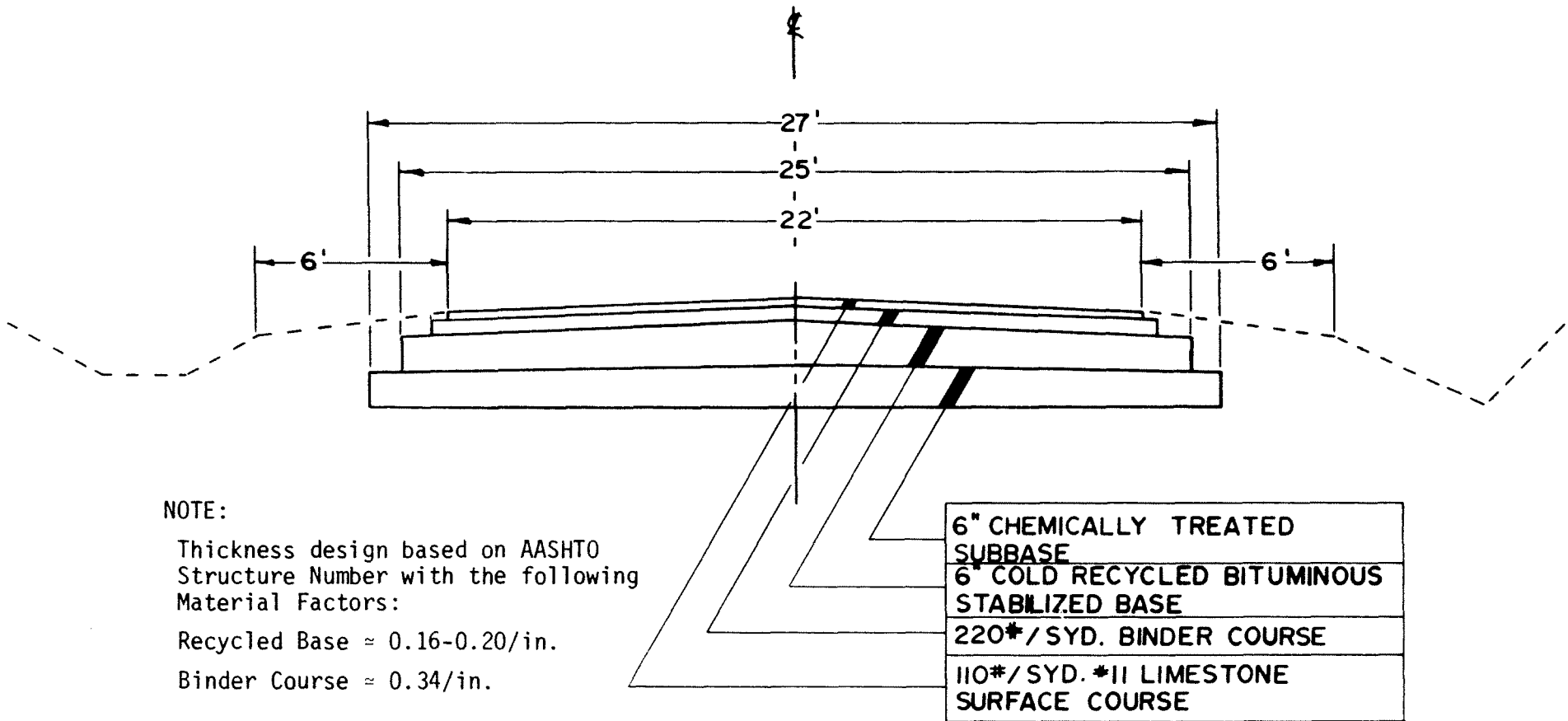

**NOTE:**

Thickness design based on AASHTO  
Structure Number with the following  
Material Factors:

Recycled Base  $\approx$  0.16-0.20/in.

Binder Course  $\approx$  0.34/in.

**FIGURE 23: PROPOSED TYPICAL ROADWAY SECTION**