

# Obstruction Marking and Lighting

DEPARTMENT OF  
TRANSPORTATION  
MAY 1985  
LIBRARY  
FOB PEA BRANCH

ADVISORY CIRCULAR  
70/7460-1G

OCTOBER 1985



U.S. Department  
of Transportation  
Federal Aviation  
Administration

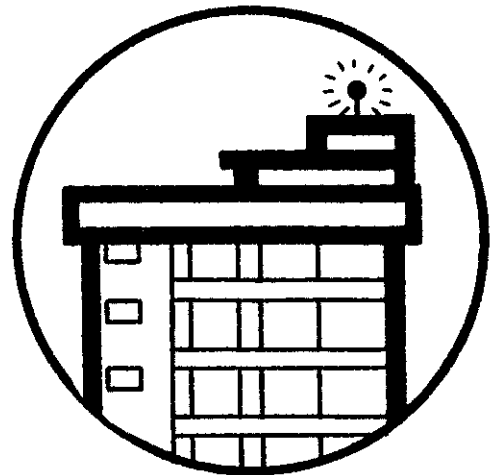
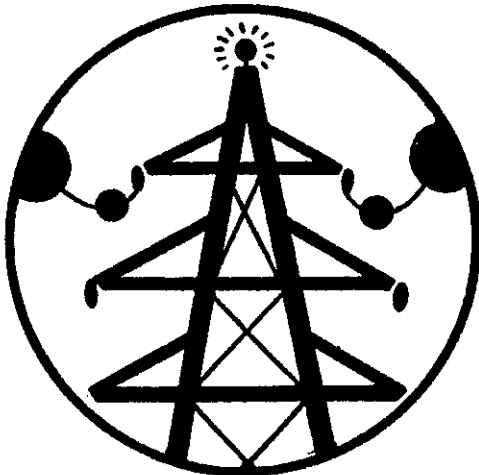
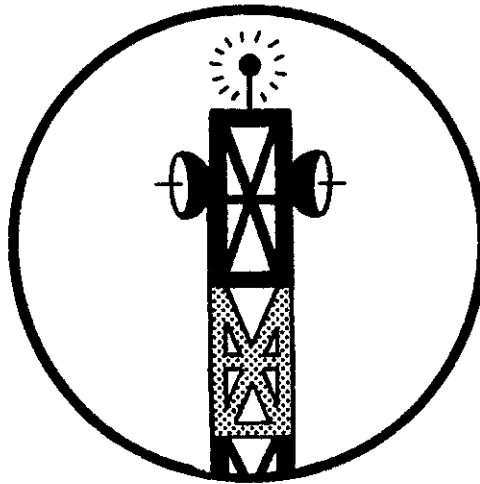



U.S. Department  
of Transportation  
**Federal Aviation  
Administration**

# Advisory Circular

---

**Subject:** OBSTRUCTION MARKING  
AND LIGHTING

**Date:** 10/22/85  
**Initiated by:** ATO-210

**AC No:** 70/7460-1G  
**Change:**

- 
1. **PURPOSE.** This Advisory Circular (AC) describes the Federal Aviation Administration's (FAA) standards for marking and lighting of obstructions as identified by Federal Aviation Regulations (FAR) Part 77.
  2. **CANCELLATION.** AC 70/7460-1F, Obstruction Marking and Lighting, dated September 27, 1978 is canceled by this revision.
  3. **PRINCIPLE CHANGES.** This circular has been amended to include:
    - a. Provisions for marking and lighting wind turbine generators.
    - b. Reduction of nighttime intensity standard and clarification of recommendations on high intensity white obstruction lighting.
    - c. Deletion of detailed descriptions of specific obstruction lights.
    - d. Increase in visibility range of markers.
    - e. Changes in spherical marker size, spacing and color.
    - f. Modification of lower level lighting standard.
    - g. Addition of a new standard for medium intensity (L-866) white lights.
    - h. Increase in the distance allowed between the top obstruction light and the top of a structure.
    - i. Clarification and increase of standard to top level of lights for supporting structures for catenary wires, chimneys and similar solid structures.
    - j. Increase in distance between two adjacent structures before lighting is recommended.
    - k. Editorial changes.
    - l. Revised charts in Appendix.
-

4. RELATED FEDERAL AVIATION REGULATIONS (FAR) PART 77. This regulation sets forth the requirements for notice to the Administrator of certain proposed construction or alteration. This circular gives overall guidance on how to mark or light a structure for aviation safety. The FAA will respond to each notice received under provisions of Part 77 with recommendations on how to mark or light any particular structure when deemed necessary or with no recommendations when appropriate.
5. FEDERAL COMMUNICATIONS COMMISSION (FCC) SPECIFICATIONS. This circular is compatible with the specifications for obstruction marking and lighting antenna structures contained in Part 17 of the FCC Rules and Regulations.
6. METRIC UNITS. To promote an orderly transition to metric units, the specification includes both English and metric (SI units) dimensions. The metric conversions may not be exact equivalents, and until there is an official changeover to the metric system the English dimensions will govern.



John R. Ryan  
Director, Air Traffic  
Operations Service

FOREWORD

1. MARKING AND LIGHTING EQUIPMENT. It is suggested that only those lighting systems and paint materials be used that meet the minimum technical standards established by FAA. Considerable effort and research have been expended in determining the minimum systems or quality of materials that will produce an acceptable level of safety in marking and lighting obstructions to air navigation. While additional lights may be desirable to identify an obstruction to air navigation and may, on occasion, be recommended, the FAA has specified the minimum level in these standards in the interest of economy, ecology and energy conservation. Therefore, to provide an adequate level of safety, obstruction lighting systems should be installed, operated and maintained as stated in these standards.
2. RATIONALE FOR OBSTRUCTION LIGHT INTENSITIES. Sections 91.70, 91.79 and 91.105 of the FAR Part 91, General Operating and Flight Rules, prescribe aircraft speed restrictions, minimum safe altitudes, and basic visual flight rules (VFR) weather minimums for governing the operation of aircraft, including helicopters, within the United States.
3. GUYED STRUCTURES. Increased conspicuity and properly maintained marking and lighting are important since the guys of a structure are difficult to see until aircraft get dangerously close. The guys of a 2,000 foot (610m) skeletal tower are anchored from 1,600 feet (488m) to 2,000 feet (610m) from the base of the structure. This places a portion of the guys 1,500 feet (458m) from the tower at a height of between 125 feet (38m) to 500 feet (153m) above ground level (AGL). FAR Section 91.79 requires pilots to remain at least 500 feet (153m) from man-made structures. Therefore, the tower must be cleared by 2,000 feet (610m) horizontally to avoid all guy wires.
4. MINIMUM OPERATING CONDITIONS. A "worst case" situation, i.e., the minimum conditions under which an aircraft can legally be operated and which requires the greatest intensity for an obstruction light to be effective, is considered to be an operation at any altitude above the surface, in one statute mile flight visibility, at a maximum speed of 250 knots (288mph/463kph), and remaining at least 2,000 feet (610m) horizontally from the lighted structure.

5. INTENSITY REQUIREMENTS. For an aircraft travelling at 165 knots (190mph/306kph) to respond and avoid an object by 2,000 feet (610m), it requires 1.18 statute miles for the pilot to see, recognize the light as identifying an obstruction, and initiate evasive action. An aircraft travelling at 250 knots (288mph/463kph) requires 1.48 statute miles to avoid an obstruction by 2,000 feet (610m) horizontally. FAA approved obstruction lights meet or exceed the following intensity requirements:

<u>PERIOD</u>	<u>TYPE LIGHT</u>	<u>COLOR</u>	<u>INTENSITY</u>
NIGHT:	Flashing Beacon..(L-866)	Red	1,500 candelas
	High Intensity...(L-856)	White	2,000 (+25%)
	Medium Intensity.(L-866)	White	2,000 (+25%)
	Steady Burning...(L-810)	Red	32.5 candelas
DAY:	High Intensity (Tall Structures)	White	200,000 candelas
	High Intensity (Catenary)	White	100,000 candelas
	Medium Intensity	White	20,000 (+25%)
TWI- LIGHT:	High Intensity	White	20,000 (+25%)
	Medium Intensity	White	20,000 (+25%)

6. DISTANCE VERSUS INTENSITIES. The following table depicts the distance the various intensities can be seen under one and three statute miles meteorological visibilities:

<u>TIME PERIOD</u>	<u>METEOROLOGICAL VISIBILITY STATUTE MILES</u>	<u>DISTANCE STATUTE MILES</u>	<u>INTENSITY CANDELAS</u>	<u>OBSTRUCTION LIGHT</u>
NIGHT	1 (1.6km)	1.1 (1.8km)	1,500	L-866
		1.2 (1.9km)	2,000	L-856, L-866
		.6 (1.0km)	32	L-810
NIGHT	3 (4.8km)	2.9 (4.7km)	1,500	L-866
		3.1 (4.9km)	2,000	L-856, L-866
		1.4 (2.2km)	32	L-810
DAY	1 (1.6km)	1.5 (2.4km)	200,000	L-856
		1.4 (2.2km)	100,000	L-856
		1.0 (1.6km)	20,000	L-866
DAY	3 (4.8km)	3.0 (4.8km)	200,000	L-856
		2.7 (4.3km)	100,000	L-856
		1.8 (2.9km)	20,000	L-866
TWI- LIGHT	1 (1.6km)	1.0 (1.6km) to 1.5 (2.4km)*	20,000	L-856, L-866
		3 (4.8km)	1.8 (2.9km) to 4.2 (6.7km)*	20,000

\* Distance depends on north sky illuminance

7. CONCLUSION. Aircraft travelling at 165 knots (190mph/306kph) or less should be able to see obstruction lights in sufficient time to avoid the structure by at least 2,000 feet (610m) horizontally under all conditions of operation, provided the pilot is operating in accordance with FAR Part 91. Aircraft operating between 165 knots (190mph/306kph) and 250 knots (288mph/463kph) should be able to see the obstruction lights unless the weather deteriorates to 1 statute mile visibility at night during which time period 2,000 candelas would be required to see the lights at 1.2 statute miles (1.9 km). A higher intensity, with 3 statute miles visibility at night, could generate a residential annoyance factor. In addition, aircraft in these speed ranges can normally be expected to operate under instrument flight rules (IFR) at night when the visibility is 1 statute mile.
8. DEFINITIONS.
  - a. Flight Visibility. The average forward horizontal distance, from the cockpit of an aircraft in flight, at which prominent unlighted objects may be seen and identified by day and prominent lighted objects may be seen and identified by night. (Airman's Information Manual, Pilot/Controller Glossary.)
  - b. Meteorological Visibility. A term that denotes the greatest distance, expressed in statute miles, that selected objects (visibility markers) or lights of moderate intensity (25 candelas) can be seen and identified under specified conditions of observation. (IES Lighting Handbook, Volume 1984, Chapter 3, page 25.)



...



...



## CONTENTS

	<u>Page No.</u>
CHAPTER 1. ADMINISTRATIVE PROCEDURES	1
1. Reporting Requirements	1
a. Preconstruction Notice	1
b. FAA Acknowledgement	1
c. Supplemental Notice	1
d. Supplemental Completion Notice	1
CHAPTER 2. GENERAL RECOMMENDATIONS	3
2. Objects to be Marked and Lighted	3
3. Marking and Lighting Equipment	3
4. Notification of Light Failure	3
5. Notification of Lights Returning to Normal Operation	3
6. Modifications and Deviations	4
a. Modifications	4
b. Deviations	4
c. FCC Approval	4
CHAPTER 3. MARKING	5
7. Purpose	5
8. Paint Colors	5
9. Painting	5
a. Materials and Application	5
b. Surfaces Not Requiring Paint	5
c. Skeletal Structures	5
10. Patterns	5
a. Solid Pattern	5
b. Checkerboard Pattern	6
c. Alternate Bands	6
d. Teardrop Pattern	8
e. Community Names	8
11. Markers	8
a. Spherical Markers	8
b. Flag Markers	9
12. Special Markings	10
a. Vehicles	10
b. FAA Facilities	10
c. Unusual Complexities	10
13. Omission or Alternatives to Standard Marking	10
a. High Intensity Lighting Systems	10
b. Medium Intensity Lighting Systems	10



	<u>Page No.</u>
CHAPTER 4. GENERAL APPLICATION OF LIGHTING	11
14. Purpose	11
15. Systems	11
a. Standard System Configuration	11
b. Special System Configuration	11
c. Nonstandard Lights	12
16. Application	13
a. Heights	13
b. Determining Number of Light Levels	13
c. Adjacent Structures	13
d. Shielded Lights	14
e. Monitoring of Obstruction Lighting	14
f. Interference	14
g. Manufacturers	14
h. System Reliability	15
i. Lighting System Configuration	15
CHAPTER 5. RED OBSTRUCTION LIGHTING STANDARDS	17
17. Purpose	17
18. Standards for Lighting Obstructions with Red Lights	17
a. Flashing Red Beacon	17
b. Steady Burning Red Lights	17
c. Maintenance	18
d. Operation of Red Lights	18
e. Poles, Towers, and Similar Skeletal Structures	19
f. Chimneys, Flare Stacks and Similar Solid Structures	20
g. Prominent Buildings and Similar Extensive Obstructions	21
h. Wind Turbine Structures	22
i. Temporary Construction Equipment	22
j. Group of Obstructions	22
k. Alternate Methods of Displaying Obstruction Lights	22
CHAPTER 6. HIGH AND MEDIUM INTENSITY WHITE OBSTRUCTION LIGHTING STANDARDS	23
19. Purpose	23
20. Standards For Lighting Structures With High Intensity White Obstruction Lights	23
a. High Intensity Obstruction Light	23
b. Flashtube Replacement	24
c. Installation Guidance	25
d. High Intensity Light Units	26
e. Relocation or Omission of Light Units	26

	<u>Page No.</u>
f. Chimneys, Flare Stacks, and Similar Solid Structures	27
g. Radio and Television Towers and Similar Skeletal Structures	28
h. Hyperbolic Cooling Towers	29
i. Prominent Buildings, Observation Towers, and Similar Extensive Obstructions	29
j. Supporting Structures for Catenary Wires	30
21. Standards For Lighting Obstructions With Medium Intensity White Obstruction Lights	32
a. Levels	32
b. Top Levels	32
c. Other Levels	32
d. Structures 500 Feet (153m) AGL or Less	32
e. Structures Exceeding 500 Feet (153m) AGL	32
f. Operational Characteristics	32
g. Flashtube Replacement	32
CHAPTER 7. DUAL LIGHTING SYSTEMS	33
22. Purpose	33
23. Installation	33
24. Operation	33
CHAPTER 8. MARKING AND LIGHTING OF MOORED BALLOONS AND KITES	35
25. Purpose	35
26. Application	35
27. Marking	35
a. Display	35
b. Shape	35
c. Color Patterns	35
28. Lighting	35
a. Systems	35
b. Light Distribution	35
c. Display	36
d. Exceptions	36
29. Light Control Device	36

	<u>Page No.</u>
CHAPTER 9. OBSTRUCTION MARKING AND LIGHTING EQUIPMENT	37
30. Purpose	37
31. Colors	37
a. Orange	37
b. White	37
c. Yellow	37
d. Availability of Specifications	37
32. Lights and Associated Equipment	37
a. Aviation Red Obstruction Lighting System	37
b. High and Medium Intensity White Obstruction Lighting Systems	37
c. Approved Equipment	37
d. Installation and Maintenance	38
e. Availability	38
f. Tolerance Chart	38

ILLUSTRATIONS

	<u>Page No.</u>
APPENDIX 1.	
Figure 1. Types of Red Obstruction Lights	1
Figure 2. Types of High and Medium Intensity White Obstruction Lights	2
Figure 3. Painting and Lighting of Chimneys, Poles, Towers and Similar Obstructions	3
Figure 4. Painting and Lighting of Water Towers, Storage Tanks and Similar Obstructions	4
Figure 5. Painting and Lighting of Water Towers and Similar Obstructions	5
Figure 6. Painting of Single Pedestal Water Towers by Teardrop Pattern	6
Figure 7. Examples of Installation of High Intensity Obstruction Lights on Chimneys	7
Figure 8. Same as Figure 7.	8
Figure 9. Same as Figure 7.	9
Figure 10. Hyperbolic Cooling Tower	10
Figure 11. Bridge Lighting	11
Figure 12. Wind Turbine Generator	12

	<u>Page No.</u>
Figure 1. 150 Feet (45m) to 2,200 Feet (671m) AGL Aviation Red Obstruction Lights Standards for Lighting Obstructions	1
Figure 2. 200 Feet (61m) to 2,200 Feet (671m) AGL High Intensity White Obstruction Lights Standards for Lighting Obstructions Day and Night	2
Figure 3. 200 Feet (61m) to 2,200 Feet (671m) AGL High and Medium Intensity White Obstruction Lights Standards for Lighting Obstructions Day and Night With an Appurtenance Exceeding 40 feet (12m)	3
Figure 4. 200 Feet (61m) to 2,200 Feet (671m) AGL Medium Intensity White Obstruction Lights Standards for Lighting Obstructions Day and Night	4
Figure 5. 150 Feet (45m) to 2,200 Feet (671m) AGL Dual Lighting Systems Standards for Lighting Obstructions With an Appurtenance 40 Feet (12m) or Less	5
Figure 6. 150 Feet (45m) to 2,200 Feet (671m) AGL Dual Lighting Systems Standards for Lighting Obstructions With an Appurtenance Exceeding 40 Feet (12m)	6

"FAA STANDARDS FOR OBSTRUCTION MARKING AND LIGHTING"

CHAPTER 1. ADMINISTRATIVE PROCEDURES

1. REPORTING REQUIREMENTS. Each person proposing any type of construction or alteration under the provisions of FAR Part 77 is required to notify the FAA by completing FAA Form 7460-1, Notice of Proposed Construction or Alteration. This form should be sent to the Air Traffic Division, FAA regional office, having jurisdiction over the area within which the construction or alteration will be located. Copies of Form 7460-1 may be obtained from the FAA headquarters and the regional offices.
  - a. Preconstruction Notice. The notice required under FAR Part 77 must be submitted:
    - (1) At least 30 days before the date the proposed construction or alteration is to begin.
    - (2) On or before the date an application for a construction permit is filed with the FCC.
  - b. FAA Acknowledgment. The FAA acknowledges in writing the receipt of each notice (FAA Form 7460-1) received under FAR 77.13.
  - c. Supplemental Notice. Each person who is requested to provide supplemental notice must send a completed copy of FAA Form 7460-2, Notice of Actual Construction or Alteration, to the Air Traffic Division, FAA regional office, having jurisdiction over the area involved. Such notice shall be received by the FAA at least 48 hours, or as otherwise instructed, before the start of construction. A blank set of FAA Forms 7460-2 is provided routinely with a copy of an FAA determination. This notification process is designed to permit the FAA ample time to assure charting of the structure, when appropriate. The charting process promotes aviation safety by alerting pilots to the location of the structures.
  - d. Supplemental Completion Notice. When the FAA requires supplemental notice for the completion of construction, such notification shall be made in the same manner and form as that required at the beginning of construction and within the specified time frame.



A  
.  
.  
.



..  
.



## CHAPTER 2. GENERAL RECOMMENDATIONS

2. OBJECTS TO BE MARKED AND LIGHTED. To assure aeronautical conspicuity, any temporary or permanent object, or portion thereof, that exceeds an overall height of 200 feet (61m) AGL (including all appurtenances such as lights, rods, antennas, etc.), or exceeds any obstruction standard contained in FAR Part 77, Subpart C, should normally be marked and/or lighted in accordance with the herein described standards. An object that does not exceed any Subpart C standard may indicate, by its particular location, a need to be marked and/or lighted in order to promote aviation safety. Conversely, an FAA aeronautical study may reveal that the absence of such marking and/or lighting will not impair aviation safety. When considering the need for marking and lighting of a structure, normal outside or commercial lighting is not sufficient reason to delete recommended marking and/or lighting.
3. MARKING AND LIGHTING EQUIPMENT. The FAA recommends use of only those lighting systems and paint materials which meet the minimum technical standards established by the FAA. On occasion brighter or additional lights may be recommended to further identify an obstruction to air navigation. In the interest of safety, economy, ecology, and energy conservation, the standards specified are the minimum. Therefore, to provide an adequate level of safety, obstruction lighting systems should be installed, operated, and maintained as stated in these standards.
4. NOTIFICATION OF LIGHT FAILURE. Although some lighting systems have redundant features incorporated in them to prevent total failure, partial outages of equipment or marking deterioration decreases the margin of safety since the necessary conspicuity is only achieved with all lights on and working. Therefore, outages should be corrected through replacement or repairs as soon as possible. In the meantime, any failure or malfunction which will last more than 30 minutes effecting a top steady burning light or the flashing obstruction light(s) regardless of its position on a natural or man-made obstruction, should be immediately reported. Such reports should be made by telephone or telegraph to the nearest Flight Service Station (FSS) and should set forth the condition of the light or lights, the circumstances which caused the failure, and the probable date that normal operation will be resumed. The type of structure, location, and the height AMSL should also be reported if known. Persons or organizations reporting light failures should furnish their name, address and telephone number. Failure or malfunctioning of a steady burning side or intermediate light or lights installed on a natural or man-made obstruction should be corrected as soon as possible, but notification is not required.
5. NOTIFICATION OF LIGHTS RETURNING TO NORMAL OPERATION. As soon as normal operation is restored notification by telephone or telegraph should be given to the same FSS that received the notification of failure.



6. MODIFICATIONS AND DEVIATIONS. When a request for a modification or deviation is submitted to the FAA after an initial determination is made, a further determination may be made on whether the marking and lighting can be modified or a deviation from the standards permitted. The final determination for a modification or deviation must be based on a study showing that an acceptable level of safety is achieved.
- a. Modifications. Modifications may be recommended when, in the opinion of the FAA Official conducting the study, the proposed modification would provide adequate protection for air commerce. Some examples of modification are:
- (1) Marking and/or Lighting Only a Portion of an Object. The object may be located with respect to other objects or terrain so that only a portion of it needs to be marked or lighted.
  - (2) No Marking and/or Lighting. The object may be so located with respect to other objects or terrain, or may be so removed from the general flow of air traffic, or may be so conspicuous by its shape, size, or color that marking or lighting would serve no useful purpose.
  - (3) Marking or Lighting an Object in Accordance with the Standards for an Object of Greater Height or Size. The object may present such an extraordinary hazard potential that higher standards may be recommended for increased conspicuity to ensure the safety to air navigation.
- b. Deviations. The Air Traffic Operations Service Director may permit deviations after receiving the recommendations of the FAA Regional Office based on an aeronautical study. Examples of deviations are changes in the:
- (1) Colors of objects.
  - (2) Dimensions of color bands or rectangles.
  - (3) Colors/types of lights.
  - (4) Basic signals and intensity of lighting.
  - (5) Night/day lighting combinations.
  - (6) Flashing rate of lights.
- c. FCC Approval. All modifications and/or deviations associated with an FCC regulated structure must be coordinated with the FCC for approval.

## CHAPTER 3. MARKING

7. PURPOSE. Marking is done to warn pilots on a potential collision course with a structure of its presence during daylight hours. This may be accomplished by coloring the structure or indicating its presence by the use of suitable markers.
8. PAINT COLORS. Alternate sections of aviation orange (Federal Standard Number 12197) and aviation white (Federal Standard Number 17875) paint provide maximum visibility of an obstruction by contrast in colors. The chromaticity and luminance standards of aviation orange and white paint should conform to Federal Standard FED-STD-595.  
(See Chapter 9, paragraph 31.)
9. PAINTING. The paint referred to in paragraph 8 meets the specific color requirements when freshly applied to a structure. However, all outdoor paints deteriorate with time. While it is not practical to give a maintenance schedule for all climates, surfaces should be repainted whenever the color changes noticeably or its effectiveness is reduced by scaling, oxidation, or chipping. An orange color tolerance chart is available upon request (See Chapter 9.) for determining when repainting is required. The color should be sampled on the upper half of the structure, since weathering is greater there.
  - a. Materials and Application. Quality paint and materials should be selected, since the extra cost will result in extra years of service. The paint should be compatible with the surfaces to be painted, including any previous coatings. In addition, the paint should be suitable for the environmental conditions to which it will be subjected. Surface preparation and paint application should be in accordance with recommendations by the manufacturer.
  - b. Surfaces Not Requiring Paint. Ladders, decks, and walkways of steel towers and similar structures need not be painted if a smooth surface presents a potential danger to maintenance personnel. Paint may also be omitted from precision or critical surfaces if it would have an adverse effect on the transmission or radiation characteristics of a signal. However, the overall marking effect on the structure should not be reduced.
  - c. Skeletal Structures. To be effective paint should be applied to all inner and outer surfaces of the framework. This applies to supporting structures of overhead transmission lines, radio and television transmitters and similar skeletal structures.
10. PATTERNS. Paint patterns of various types are used to mark structures. The pattern to be used is determined by the size and shape of the structure.
  - a. Solid Pattern. Obstructions should be colored aviation orange if the side of the structure has both horizontal and vertical dimensions less than 10.5 feet (3.2m).

- b. Checkerboard Pattern. Alternating rectangles of aviation orange and white are normally displayed on structures as follows:
- (1) Normal uses.
    - (a) Water, gas, and grain storage tanks.
    - (b) Buildings, if recommended in an FAA determination.
    - (c) Large structures of 10.5 feet (3.2m) or more across having a horizontal dimension that is equal to or greater than the vertical dimension.
  - (2) Size of Rectangles. The sides of the checkerboard rectangles should measure not less than 5 feet (1.5m) nor more than 20 feet (6m), and should be as nearly square as possible. However, if it is impractical because of the size or shape of a structure, the rectangle may have sides less than 5 feet (1.5m). When possible, corner surfaces should be colored orange.
  - (3) Exceptions. If it is not practical to color the roof of a structure in a checkerboard pattern, it may be colored solid orange. If part or all of a spherical shaped structure does not permit the exact application of a checkerboard pattern, the shape of the rectangles may be modified to fit the shape of the spherical surface. (See Appendix 1, Figure 4.) If the shape of a storage tank does not permit use of a checkerboard pattern, then the structure should be colored by alternating bands of orange and white, or a limited checkerboard pattern applied to the upper one-third of the structure. The skeletal framework of certain water, gas, and grain storage tanks may be excluded from the checkerboard pattern. An FAA aeronautical study must indicate that the modified marking will provide adequate protection for air navigation.
- c. Alternate Bands. Alternate bands of aviation orange and white are normally displayed on the following structures.
- (1) Normal Uses.
    - (a) Communication towers and supporting structures of overhead transmission lines.
    - (b) Poles.
    - (c) Smokestacks.
    - (d) Skeletal framework of storage tanks and similar structures.

- (e) Structures which appear narrow from a side view, that are 10.5 feet (3.2m) or more across, and the horizontal dimension is less than the vertical dimension.
  - (f) Wind turbine generator support structures including the nacelle or generator housing.
  - (g) Buildings with horizontal siding.
- (2) Width of Bands. The width of bands for structures of any height should be equal, provided that each band has a width not less than 1 1/2 feet (0.5m) nor more than 100 feet (31m). The bands should be perpendicular to the vertical axis with the bands at the top and bottom ends colored orange. There should always be an odd number of bands on the structure. For structures 700 feet (214m) AGL or less each band should be approximately one-seventh the height of the structure. For each additional 200 feet (61m) of the height, or fraction thereof, one (1) additional orange and one (1) additional white band should be added. The width of all bands should be equal and in proportion to the structure's height AGL. (See Appendix 1, Figure 3.) For example, if a structure is:

<u>Greater Than</u>	<u>But Not More Than</u>	<u>Band Width</u>
10.5 feet (3.2m)	700 feet (214m)	1/7 of height of structure
701 feet (214m)	900 feet (275m)	1/9 of height of structure
901 feet (275m)	1,100 feet (336m)	1/11 of height of structure
1,101 feet (336m)	1,300 feet (397m)	1/13 of height of structure

If the top of the structure has a cover or roof, the highest orange band should be continued to cover the entire top of the structure. If the object under study is a flagpole, skeletal structure or similar object erected on top of a building, the combined height of the object and building will determine whether marking is recommended; however, only the height of the object under study determines the width of the color bands.

- (3) Partial Marking. If marking is recommended only on a portion of a structure because of shielding by other objects or terrain, the width of the bands should be determined by the overall height of the structure. A minimum of three bands should be displayed on the upper portion of the structure.
- (4) Wind Turbine Rotor Blades. Each rotor blade should be marked, front and back, with three bands of orange and white paint beginning with an orange band at each tip. The bands should be approximately the same width as those on the tower. The remaining (inner) blade area may be any color.

d. Teardrop Pattern. Spherical shaped water storage tanks with a single circular standpipe support may be marked in a teardrop striped pattern. (See Appendix 1, Figure 6.) The tank should be colored to show alternate stripes of aviation orange and white. The stripes should extend from the top center of the tank to its supporting standpipe.

(1) Width of Stripes. The width of the stripes should be equal and the width of each stripe at the greatest girth of the tank should not be less than 5 feet (1.5m) nor more than 15 feet (4.6m).

e. Community Names. If it is desirable to paint the name of the community on the side of the tank, the stripe pattern may be broken to serve this purpose. This open area should have a maximum height of 3 feet (0.9m).

11. MARKERS. Markers should be used to highlight obstructions when it has been determined that it is impracticable to make them conspicuous by painting. Markers may also be used in addition to aviation orange and white paint when it has been determined that additional conspicuity is necessary for aviation safety. They should be displayed in conspicuous positions on or adjacent to the obstructions so as to retain the general definition of the obstruction, and be recognizable in clear air from a distance of at least 4,000 feet (1219m) in all directions from which an aircraft is likely to approach. Markers should be distinctively shaped so they are not mistaken for items that are used to convey other information and replaced when faded or otherwise deteriorated.

a. Spherical Markers. Spherical markers are normally displayed on overhead wires.

(1) Size and Color. The diameter of the spherical markers used on extensive catenary wires across canyons, lakes, rivers, etc. should be not less than 36 inches (91cm). Smaller 20 inch (51cm) spheres are permitted on less extensive power lines, or on power lines in approaches to airports, below 50 feet (15m) above the ground and within 1500 feet (458m) of the runway end. Each marker should be of a solid color such as aviation orange, white or yellow. (See Chapter 9, paragraph 31 for color standards.)

(2) Installations.

(a) Spacing. Spherical markers should be spaced equally along the wire at intervals of 200 feet (61m), or fraction thereof. More markers should be used in critical areas such as on power lines near approach and departure ends of runways. The spheres should be displayed on the highest wire, or by another means at the same height as the highest wire. Where there is more than one wire at the highest point, the spheres may be installed alternately along each wire if the distance between adjacent spheres meets the spacing standard. This method will allow the weight and wind loading factors to be distributed.

(b) Pattern. An alternating color scheme provides the most conspicuity against all backgrounds. Mark overhead wires by alternating solid colored spheres of aviation orange, white, and yellow. Normally an orange sphere is placed at each end of a line and the spacing is adjusted (not to exceed 200 feet) to accommodate the rest of the spheres. When less than four spheres are used, they should all be aviation orange.

b. Flag Markers. Flags may be used to mark certain obstructions when it has been determined that the use of spherical markers or painting is technically impractical. Temporary construction equipment, cranes, derricks, oil and other drilling rigs are some examples. Catenaries must use spherical markers.

(1) Color Patterns. Flags should be one of the following patterns:

(a) Solid Color. Aviation orange not less than 2 feet (0.6m) on a side.

(b) Orange and White. Arrange two triangular sections, one aviation orange and the other white, combined to form a rectangle not less than 2 feet (0.6m) on a side.

(c) Checkerboard. A checkerboard pattern of aviation orange and white squares, each 1 foot (0.3m) plus or minus 10 percent on a side, should be combined to form a rectangle not less than 3 feet (1m) on a side.

(2) Shape. Flags should be rectangular in shape and have stiffeners to keep them from drooping in calm wind.

(3) Display. Flag markers should be displayed around, on top, or along the highest edge of the obstruction. When flags are used to mark extensive or closely grouped obstructions, they should be displayed approximately 50 feet (15m) apart. The flag stakes should be of such strength and height that they will support the flags above all surrounding ground, structures, and/or objects of natural growth.

12. SPECIAL MARKINGS. The following documents contain additional marking recommendations for special circumstances. Ordering information may be found in Chapter 9, paragraph 32.
  - a. Vehicles. AC 150/5210-5, Painting, Marking and Lighting of Vehicles Used on an Airport, contains provisions for marking vehicles principally used on airports.
  - b. FAA Facilities. Obstruction marking for FAA facilities shall conform to FAA Drawing Number D-5480, referenced in FAA Standard, FAA-STD-003, Paint Systems for Structures.
  - c. Unusual Complexities. The FAA may also recommend appropriate marking in an area where obstructions are so grouped as to present a common obstruction to air navigation.
  
13. OMISSION OR ALTERNATIVES TO STANDARD MARKING. There are two alternatives to standard marking.
  - a. High Intensity Lighting Systems. The high intensity lighting systems are considered under certain conditions to be more effective than the aviation orange and white paint and may therefore be recommended in lieu of standard marking. This is particularly true under certain ambient light conditions involving the position of the sun relative to the direction of flight. When high intensity lighting systems are operated during daytime and twilight, other methods of marking may be omitted. When operated 24 hours a day, other methods of marking and lighting may be omitted. (See Chapter 6, paragraph 20.)
  - b. Medium Intensity Lighting Systems. When medium intensity lighting systems on structures 500 feet (153m) AGL or less are operated 24 hours a day, other methods of marking and lighting may be omitted. (See Chapter 6, paragraph 21.)

## CHAPTER 4. GENERAL APPLICATION OF LIGHTING

14. PURPOSE. Lighting is done to warn pilots on a potential collision course with a structure. The lighting standards herein comprise the minimum necessary for safety, and therefore should be adhered to as described.
15. SYSTEMS. Red obstruction lights are used during the hours of darkness and periods of limited daytime illuminance and/or reduced meteorological visibility. Red obstruction lighting systems and aviation orange and white paint are the minimum obstruction marking and lighting standards. The standards outlined in this AC are predicated upon the use of lighting units that meet specified intensities, beam patterns, color and flash rates (if appropriate). However, in some instances high or medium intensity white obstruction lights may be recommended in lieu of red obstruction lights and aviation orange and white paint. Obstruction lighting may be displayed on structures in any of the following combinations:
  - a. Standard System Configuration.
    - (1) Aviation Red Obstruction Lights. Use flashing aviation red beacons and steady burning aviation red lights during nighttime. Aviation orange and white paint should be used for daytime marking.
    - (2) High Intensity White Obstruction Lights. Use flashing high intensity white obstruction lights during daytime with automatically selected reduced intensity for twilight and nighttime operation. When this type of system is used, other methods of marking and lighting the structure may be omitted. This system should not be recommended on structures 500 feet (153m) AGL or less unless an FAA aeronautical study shows otherwise.
    - (3) Medium Intensity White Obstruction Lights. During daytime medium intensity white obstruction lights with automatically selected reduced intensity for night operation may be used. When this type of system is used on structures 500 feet (153m) AGL or less in height other methods of marking and lighting the structure may be omitted. Aviation orange and white paint should be used for daytime marking on structures exceeding 500 feet (153m) AGL. This system should not be recommended on structures less than 200 feet (61m) AGL unless an FAA aeronautical study shows otherwise.
  - b. Special System Configuration.
    - (1) Dual Lighting. Use a combination of flashing aviation red beacons and steady burning aviation red lights for nighttime, and high or medium intensity white lights for daytime. Other methods of marking the structure may be omitted.



- (2) Temporary Obstruction Lights. When an obstruction to air navigation is presented during the construction of a structure, at least two lights should be installed at the uppermost part of the structure so as to ensure unobstructed viewing of at least one light by a pilot on a potential collision course. Whenever an FAA determination recommends aviation red obstruction lights as a permanent installation, the temporary lighting should be aviation red obstruction lights. Conversely, temporary high or medium white obstruction lights should be used on the structure when high or medium intensity white lights are recommended. In addition, as the height of the structure exceeds each level at which permanent obstruction lights will be required, two or more similar lights should be installed at that level. The lights should be positioned so as to ensure unobstructed viewing of at least one light at each level by a pilot on a potential collision course. Except for periods when they would interfere with construction, temporary red lights should be operated during periods of darkness and reduced flight visibility. Temporary high or medium intensity white lights should be operated 24 hours a day or until all of the permanent lights are in operation. If practical, the permanent obstruction lights should be installed and operated at each level as construction progresses. If a structure with red lights requires temporary daytime marking, flag markers should be used.
- (a) Aviation Red Obstruction Lights. Each steady burning temporary light should emit at least 32.5 candelas of aviation red light in all horizontal directions, or conform to type L-810. (See Chapter 9, paragraph 32.)
- (b) White Obstruction Lights. Each temporary light should be equivalent to an L-866 (white) light. The flashes of various fixtures on a structure do not have to be simultaneous. If battery-operated, the batteries should be replaced or recharged at regular intervals to preclude failure during the scheduled period of operation. (See Chapter 9, paragraph 32.)
- c. Nonstandard Lights. Obstruction lights other than those described herein may be utilized provided such lighting installations offer light intensity equal to that specified for approved obstruction light assemblies, in all angles of azimuth and elevation. They should afford equal or greater dependability of operation, possess the color characteristics prescribed, and flash as required for approved obstruction light assemblies. Moored balloons, chimneys, church steeples, and similar obstructions may be floodlighted by fixed search light projectors installed at three or more equidistant points around the base of each obstruction. The searchlight projectors should provide an average illumination of at least 15 footcandles over the top one-third of the obstruction.

16. APPLICATION. Whenever obstruction lights are displayed on any structure, they should be of sufficient intensity and installed in a manner that will warn pilots on a potential collision course with the obstruction of its presence. Obstruction lighting may be displayed in addition to marking (paint) for daytime operation. The following factors should be considered when determining the placement of obstruction lights on a structure:
- a. Heights. All heights referred to herein pertain to the obstruction's height above ground or water level.
  - b. Determining Number of Light Levels. The number of light levels used is dependent upon the height of the structure AGL.
    - (1) Red Obstruction Lighting Systems. The overall height of the structure including all appurtenances such as rods, antennas, obstruction lights, etc., is used to determine the number of light levels. (See Appendix 2, Figure 1.)
    - (2) High Intensity White Obstruction Lighting Systems. The overall height of the main structure, excluding all appurtenances, is used to determine the number of light levels that should be installed on that structure. In addition, if required, a medium intensity L-866 (white) omnidirectional light should be displayed on the highest portion of any antenna or other appurtenance supported by the main structure. (See Appendix 2, Figures 2 and 3.)
    - (3) Medium Intensity White Obstruction Lighting Systems. The overall height of the structure including all appurtenances such as rods, antennas, obstruction lights, etc., is used to determine the number of light levels. (See Appendix 2, Figure 4.)
    - (4) Dual Obstruction Lighting Systems. The overall height of the structure excluding all appurtenances such as rods, antennas, obstruction lights, etc. is used to determine the number of light levels. In addition, if required, a medium intensity L-866 (white) and L-866 (red) omnidirectional light should be displayed on the highest portion of any antenna or other appurtenance supported by the main structure. (See Appendix 2, Figures 5 and 6.)
  - c. Adjacent Structures. The elevation of the tops of the buildings in congested areas may be used as the equivalent of the ground level when determining the proper number of light levels required to adequately mark an obstruction.

- d. Shielded Lights. If any light is shielded by an adjacent object, additional lights should be mounted on that object to retain the general definition of the obstruction. However, the additional lights may be omitted if they do not contribute to the definition of the obstruction.
- e. Monitoring of Obstruction Lighting. Although some obstruction lighting systems have redundant features, they must be closely monitored by visual or automatic means. It is extremely important to visually inspect obstruction lighting in each operating intensity at least once every 24 hours on systems without automatic monitoring. In the event obstruction lighting is not readily accessible for visual observation, a properly maintained automatic monitor should be used to provide an indication that such lights are functioning properly. This monitor should be designed to register the malfunction of any light on the obstruction regardless of its position. The monitor output (aural or visual) should be located in an area generally occupied by responsible personnel. In some cases, this may require remoting the monitor output via telephone lines or by other means to an attended location. Both red and white light systems should be monitored. All obstruction lighting should be visually inspected on a regular basis. Lamps should be replaced after being operated for not more than 75 percent of their rated life. Flashtubes are exempted from this replacement standard. (See Chapter 2, paragraph 4 for reporting requirements in case of failure.)
- f. Interference. Where obstruction lights might distract operators of aircraft, railway trains, surface vessels, and other vehicles, or if the lights will be in a congested residential area, consideration should be given to minimizing the adverse effects of the lights by external shielding. Steady burning lights may be made to flash, or the lower level of lights may be extinguished. When FCC regulated structures are involved the FAA shall coordinate such actions with the FCC. Dual lighting systems described in Chapter 7 are frequently used to reduce interference. In the proximity of a navigable waterway, the light installation must be coordinated with the Commandant, U.S. Coast Guard, to avoid interference with marine navigation. The address for marine information is:
- Chief Short Range Aids to Navigation Division (G-NSR)  
U.S. Coast Guard Headquarters  
2100 2nd Street, SW.  
Washington, DC 20593  
Telephone: (202) 426-0980
- g. Manufacturers. The names of manufacturers and their approved equipment are listed in the current edition of AC 150/5345-1, Approved Airport Lighting Equipment. (See Chapter 9.) These manufacturers have submitted test data to the FAA to demonstrate their compliance with the required specifications.

- h. System Reliability. A high reliability level is imperative in all obstruction lighting systems. In order to maintain a quality check on all equipment supplied by manufacturers, all repetitive outages or persistent system malfunctions should be reported to the following address.

Department of Transportation  
Federal Aviation Administration  
Airports Engineering and Specifications Division, AAS-200  
800 Independence Avenue, SW.  
Washington, DC 20591  
Telephone: (202) 426-3824

The notification should include the type of structure being lighted, the sponsor's name and address, equipment type, model number, manufacture's name, and the telephone number of a person knowledgeable of the problem encountered.

- i. Lighting System Configuration. A method of designating the specific type of lighting configuration to be employed on a structure, and previously used to designate the number of levels and type of red obstruction lights to be used, has been expanded to cover the high and medium intensity lighting system configurations. (See Appendix 2, Figures 1-6.)

(1) Lighting Systems.

- (a) Configuration A - Red lighting system
- (b) Configuration B - High intensity lighting system
- (c) Configuration C - High intensity lighting system with an appurtenance exceeding 40 feet (12m) above the top of the structure
- (d) Configuration D - Medium intensity lighting system
- (e) Configuration E - Dual lighting system
- (f) Configuration F - Dual lighting system with an appurtenance exceeding 40 feet (12m) above the top of the structure
- (g) Configuration G - Catenary lighting system with three levels, a unique flashing sequence and intensity

- (2) Number of Levels. The numerical designator immediately following the letter designator, identifies the number of levels of each type of light.



## CHAPTER 5. RED OBSTRUCTION LIGHTING STANDARDS

17. PURPOSE. Lighting with red lights is done to warn pilots on a potential collision course with a structure during periods of darkness and reduced flight visibility. Red lights are used in conjunction with marking to increase conspicuity during both day and night.
18. STANDARDS FOR LIGHTING OBSTRUCTIONS WITH RED LIGHTS. Structures may be identified with a system composed of L-866 (red) omnidirectional and L-810 side lights. (See Appendix 1, Figure 1.)
  - a. Flashing Red Beacon. This is a flashing beacon which produces aviation red light. The peak effective intensity should not be less than 1,500 candelas (in red) when measured at any horizontal angle. The flashing mechanism should not permit more than 40 nor less than 20 flashes per minute. The fixture should be lighted from one-half to two-thirds of the total cycle. The beacons should conform to FAA type L-866 (red) or Military Specification L-6273.
  - b. Steady Burning Red Lights. These obstruction lights consist of one or more steady burning lamps ranging from 45 to 116 watts and are enclosed in an aviation red globe. The intensity should not be less than 32.5 candelas at all horizontal angles. If a flashing mechanism is installed it is preferable for all lights to flash simultaneously. These lights should conform to FAA type L-810 or Military Specification L-7830.
    - (1) Single Obstruction Light. A single unit may be used when more than one obstruction light is required either vertically or horizontally to identify an obstruction or where maintenance can be accomplished within a reasonable time period.
      - (a) Top Level. A single unit may be used to identify low structures such as airport ILS buildings and long horizontal structures such as perimeter fences and building roof outlines.
      - (b) Intermediate Level. Single units may be used on skeletal and solid structures when more than one level of lights is installed and there are two or more single units per level.

- (2) Double Obstruction Light. A double light unit should be installed when used as a top light, at each end of a row of single obstruction lights and in areas or locations where the failure of a single unit could cause an obstruction to be totally unlighted when viewed by a pilot on a potential collision course.
- (a) Top Level. Structures 150 feet (46m) AGL or less, should have one or more double units installed at the highest point and should be operated simultaneously.
- (b) Intermediate Level. Double units should be installed at intermediate levels when a malfunction of a single unit could create an unsafe condition, and in remote areas where maintenance cannot be performed within a reasonable time period. Both units may be operated simultaneously, or a transfer relay may be used to switch to the spare light source should the active side fail.
- c. Maintenance. To ensure the proper light output, the operating voltage provided at the lamp socket should not vary by more than 3 percent from the rated voltage of the lamp. This voltage should be measured during the hours of normal operation. When the lamp is replaced, the same lamp or an approved alternate should be used. Maintenance procedures for red obstruction lighting systems may be found in AC 150/5340-26. (See Chapter 9, paragraph 32 for ordering.)
- d. Operation of Red Lights. Red obstruction lights should be operated by a satisfactory control device (e.g. photo cell, timer, etc.) adjusted so the lights will be turned on when the northern sky illuminance reaching a vertical surface falls below a level of approximately 35 footcandles (376.7 lux). They should also be turned on when the flight visibility is restricted during daylight hours when less than 35 footcandles of illuminance can be attained. In Alaska, however, the lights should be turned on during daytime when a prominent unlighted object cannot be seen from a distance of 3 statute miles. The control device should turn the lights off when the northern sky illuminance rises to a level of not less than 60 footcandles (645.8 lux). The lights may also remain on continuously. The sensing device should, if practical, face the northern sky in the Northern Hemisphere.

- e. Poles, Towers, and Similar Skeletal Structures. The following standards apply to radio and television towers, supporting structures for overhead transmission lines and similar structures.

(1) Top Mounted Obstruction Light.

(a) Structures 150 Feet (46m) AGL or Less.

Two or more steady burning L-810 lights should be installed in a manner to ensure an unobstructed view of one or more lights by a pilot on a potential collision course.

(b) Structures Exceeding 150 Feet (46m) AGL. At least one L-866 (red) beacon should be installed in a manner to ensure an unobstructed view of one or more lights by a pilot on a potential collision course.

(c) Special Cases.

(A) Appurtenances 40 Feet (12m) or Less. If a rod, antenna, or other appurtenance 40 feet (12m) or less in height is incapable of supporting a beacon, then it may be lighted by a single L-866 (red) beacon placed at the base of the appurtenance. If the mounting location does not allow unobstructed viewing of the beacon by a pilot on a potential collision course, then additional beacons should be added.

(B) Appurtenances Exceeding 40 Feet (12m). If a rod, antenna or other appurtenance exceeding 40 feet (12m) in height is incapable of supporting a beacon, a supporting mast with one or more beacons should be installed adjacent to the appurtenance. Installation should be at a height which does not exceed the tip of the appurtenance and not more than 40 feet (12 m) from the tip, so as to permit an unobstructed view of at least one beacon by a pilot on a potential collision course.



(2) Mounting Intermediate Levels. The recommended number of levels of lights may be obtained from Appendix 2, Figure 1. The number of lights on each level is determined by the shape and height of the structure. These lights should be mounted so as to ensure an unobstructed view of at least one light by a pilot on a potential collision course.

(a) Steady Burning Lights.

(A) Structures 350 Feet (107m) AGL or Less. Two or more steady burning lights should be installed on diagonally or diametrically opposite positions.

(B) Structures Exceeding 350 Feet (107m) AGL. Install steady burning lights on each outside corner of each level.

(b) Flashing Beacons.

(A) Structures 350 Feet (107m) AGL or Less. These structures normally do not require intermediate levels of flashing beacons.

(B) Structure Exceeding 350 Feet (107m) AGL. A flashing beacon should be installed within the structure proper. If the structural members impair the viewing of the beacon, then two beacons should be mounted on the outside of diagonally or diametrically opposite positions of each level.

f. Chimneys, Flare Stacks and Similar Solid Structures.

(1) Top Mounted Obstruction Lights.

(a) Structures 150 Feet (46m) AGL or Less. At least three steady burning obstruction lights should be installed at regular intervals on the horizontal plane at or near the top, in a manner to ensure an unobstructed view of at least two lights by a pilot on a potential collision course.

(b) Structure Exceeding 150 Feet (46m) AGL. Two or more flashing L-866 (red) beacons should be installed in a manner to ensure an unobstructed view by a pilot on a potential collision course.

(c) Chimneys. Lights may be displayed as low as 20 feet (6m) below the top of chimneys to avoid the obscuring effect of the deposits generally emitted by this type of structure. It is important that these lights be readily accessible for cleaning and lamp replacement. (See Appendix 1, Figure 3.)

(2) Mounting Intermediate Levels.

- (a) Steady Burning Lights. The recommended number of light levels may be obtained from Appendix 2, Figure 1. At least three lights should be installed on each level. These lights should be mounted so as to ensure an unobstructed view of at least two lights on each level.
- (b) Flashing Beacons. The recommended number of beacon levels may be obtained from Appendix 2, Figure 1.
- (A) Structures 350 Feet (107m) AGL or Less. These structures normally do not need intermediate levels of flashing beacons.
- (B) Structures Exceeding 350 Feet (107m) AGL. Two or more flashing beacons should be installed on each level in a manner to allow an unobstructed view of at least one beacon.

g. Prominent Buildings and Similar Extensive Obstructions. When individual objects within a group of obstructions are approximately the same overall height above the surface, and are located not more than 150 feet (46m) apart, the group of obstructions may be considered an extensive obstruction. These should display steady burning lights to indicate the extent of the obstruction as follows:

- (1) Structures 150 Feet (46m) or Less in Any Horizontal Direction. If the structure/extensive obstruction is 150 feet (46m) or less in either horizontal dimension, at least one steady burning obstruction light should be displayed on the highest point at each end of the major axis of the obstruction. If this method of lighting is impracticable because of the shape of the obstruction, then a double obstruction light may be displayed in the center of the highest point. (See paragraph 18.b.)
- (2) Structures Exceeding 150 Feet (46m) in at Least One Horizontal Direction. If the structure/extensive obstruction exceeds 150 feet (46m) in either or both horizontal dimensions, at least one steady burning obstruction light should be displayed for each 150 feet (46m), or fraction thereof, of the overall length of the major axis of the obstruction. At least one of these lights should be displayed on the highest point at each end of the obstruction. Additional lights should be displayed at approximately equal intervals not to exceed 150 feet (46m) on the highest points along the edge between the end lights. If there are two or more edges of the same height on an obstruction located near a landing area, the edge nearest the landing area should be lighted.

- (3) Structures Exceeding 150 Feet (46m) AGL. Steady burning obstruction lights should be installed at the top as specified in paragraphs (1) or (2) above. At intermediate levels, steady burning lights should be displayed for each 150 feet (46m), or fraction thereof. The position of these lights on the vertical plane should be equidistant between the top lights and the ground level as the shape and type of obstruction will permit. One such light should be displayed at each outside corner on each level with the remaining lights evenly spaced between the corner lights.
- (4) Exceptions. Flashing red beacons may be used in lieu of steady burning obstruction lights if early or special warning is considered necessary. Such beacons should be displayed on the highest points of an extensive obstruction at intervals not exceeding 3,000 feet (915m). At least three beacons should be displayed on one side of the extensive obstruction to indicate a line of lights.
- h. Wind Turbine Structures. The structure should be lighted by mounting one flashing L-866 (red) beacon on the highest fixed point. The recommended number of intermediate light levels may be obtained from Appendix 2, Figure 1. At least three steady burning red lights should be installed so as to ensure unobstructed viewing of at least two lights on each level. It may be possible to omit some lighting at locations where several structures are closely grouped. This is dependent on an FAA aeronautical study and its recommendations.
- i. Temporary Construction Equipment. Since there is such a variance in construction cranes, derricks, oil and other drilling rigs each case should be considered individually. Lighting should be installed according to the standards given in Chapter 4, paragraph 15.b.(2), and Chapter 5 as it would apply to permanent structures. For cases where high intensity white lighting is recommended, follow the standards set forth in Chapter 6. (See Chapter 3 for daytime marking.)
- j. Group of Obstructions. If individual objects within a group of obstructions are not the same height and are spaced more than 150 feet (46m) apart, the prominent objects within the group should be lighted in accordance with the standards for individual obstructions of a corresponding height. In addition, at least one flashing red beacon should be installed at the top of a prominent center obstruction or on a special tower located near the center of the group of obstructions.
- k. Alternate Method of Displaying Obstruction Lights. When recommended in an FAA aeronautical study, lights may be placed on poles equal to or of slightly greater height than the obstruction and installed on or adjacent to the structure, in lieu of installing lights on the obstruction.

CHAPTER 6. HIGH AND MEDIUM INTENSITY WHITE  
OBSTRUCTION LIGHTING STANDARDS

19. PURPOSE. Lighting with high intensity white obstruction lights is done to provide a high degree of conspicuity necessary to warn pilots on a potential collision course with a structure during both day and night.
20. STANDARDS FOR LIGHTING OBSTRUCTIONS WITH HIGH INTENSITY WHITE OBSTRUCTION LIGHTS. An FAA aeronautical study will be conducted to determine if high intensity white lights are recommended in order to make the structure conspicuous. When high intensity white lights are operated during daytime and twilight, other methods of marking may be omitted. When operated 24 hours a day, other methods of marking and lighting may be omitted. The overall height of the main structure, excluding all appurtenances, is used to determine the number of light levels recommended on a structure. In addition, a white omnidirectional light should be displayed on the highest portion of any antenna or other appurtenance exceeding 40 feet (12m) supported by the main structure. (See Appendix 1, Figure 2.)
- a. High Intensity Obstruction Light. High intensity lighting systems should conform with the applicable provisions of AC 150/5345-43, Specification for Obstruction Lighting Equipment, current edition. The following are the minimum recommended standards for high intensity obstruction lighting systems applied to structures. However, for supporting structures of overhead transmission lines the intensity, flash rate, sequence and placement of light units are unique. (See paragraph 20.j.)
- (1) Effective Intensity.
- (a) Day Mode - no less than 200,000 candelas  
(100,000 candelas for transmission line supporting structures)
- (b) Twilight Mode - approximately 20,000 candelas
- (c) Night Mode - approximately 2,000 candelas

- (2) Intensity Step Changing. The systems should automatically change intensity steps when the northern sky illumination in the Northern Hemisphere on a vertical surface is as follows:
    - (a) Day-To-Twilight. This should not occur before the illumination drops to 60 footcandles (645.8 lux), but should occur before it drops below 35 footcandles (376.7 lux). The illuminance sensing device should, if practical, face the northern sky in the Northern Hemisphere.
    - (b) Twilight-to-Night. This should not occur before the illumination drops to 5 footcandles (53.8 lux), but should occur before it drops below 2 footcandles (21.5 lux).
    - (c) Night-to-Day. The intensity changes listed in (a) and (b) above should be reversed when changing from the night to day mode.
  - (3) Flash Rate. All light units should flash simultaneously at 40 pulses per minute. (See paragraph 20.j. for flash rate and unique sequencing of catenary systems.)
  - (4) Beam Spread. A relatively narrow vertical beam spread is specified to provide full light intensity at possible collision altitudes with the structure while persons on the ground or at altitudes sufficiently above the structure will receive only minimum light. The horizontal beam spread may be 90 or 120 degrees; therefore, depending on the manufacturer either three or four lights are required at each level to achieve a full 360 degree coverage.
  - (5) Antenna or Similar Appurtenance Light. When a structure marked by a high intensity lighting system is topped with an antenna or similar appurtenance exceeding 40 feet (12m) in height, a medium intensity omnidirectional L-866 (white) light should be placed on top of the appurtenance. This light should operate 24 hours a day and flash in synchronism with the rest of the lighting system.
- b. Flashtube Replacements. The flashtubes in a light unit should be replaced immediately upon failure, when the peak effective daytime intensity falls below 200,000 candelas (100,000 candelas for systems installed on the supporting structures of overhead catenary wires), when the fixture begins skipping flashes, or at the manufacturer's recommended intervals.

- c. Installation Guidance. The manufacturing specifications provide for the peak intensity of the light beam to be adjustable from zero to 8 degrees above the horizon. The normal installation would be for the top light to remain at zero degrees to the horizontal and all other light units to be installed in accordance with the following table:

<u>Height of Light Unit Above Terrain</u>	<u>Degrees of Elevation</u>
Exceeding 500 feet AGL	0°
401 feet - 500 feet AGL	1°
301 feet - 400 feet AGL	2°
300 feet AGL or less	3°

Figures indicate degrees of elevation above the horizontal.

- (1) Vertical Aiming. Where terrain, nearby residential areas or other situations dictate, the light beam may be elevated further above the horizontal. The main beam of light at the lowest level should not strike the ground closer than 3 statute miles (5km) from the structure. If additional adjustments are necessary, the lights may be individually adjusted upward, in 1 degree increments, starting at the bottom. Excessive elevation of the light may reduce its conspicuity by raising the beam above a collision course flight path.
- (2) Special Cases. Where lighting systems are installed on structures located near highways, waterways, airport approach areas, etc., caution should be exercised to ensure that the lights do not distract or otherwise cause a hazard to motorists, vessel operators or pilots on an approach to an airport. In these cases, shielding or an adjustment to the vertical or horizontal light aiming may be necessary. This adjustment should not derogate the intended purpose of the lighting system. Such adjustments may require review action as described in Chapter 2, paragraph 6.

- d. High Intensity Light Units. Type L-856 high intensity light units are not omnidirectional. Therefore, more than one light unit is required in order to obtain a full 360 degree horizontal coverage about a structure.
- (1) Number of Light Levels. The number of light levels used is dependent upon the overall height of the structure AGL without appurtenances. (See Appendix 2, Figure 2.) For structures having an antenna or similar appurtenance exceeding 40 feet (12m) above the main structure, such as a radio or television antenna, the lights should be installed at the levels indicated in Appendix 2, Figure 3. The light levels recommended for other structures, i.e., cooling towers, supporting structures of catenaries and buildings, may be found under the appropriate subject paragraph.
  - (2) Number of Light Units Per Level. The number of light units recommended per level (except for the supporting structures of catenary wires and buildings) is dependent upon the horizontal coverage from each light unit and is further dependent upon the average outside diameter of the specific structure and the horizontal beam width of the light fixture. The light units should be installed on each level in a manner to ensure an unobstructed view of the system by a pilot on a potential collision course. The number of lights recommended in the following table are the minimum. When the structure diameter is:
    - (a) 20 Feet (6m) or Less. Three light units per level.
    - (b) Exceeding 20 Feet (6m) But Not More Than 100 Feet (31m). Four light units per level.
    - (c) Exceeding 100 Feet (31m) But Not More Than 200 Feet (61m). Six light units per level.
    - (d) Exceeding 200 Feet (61m). Eight light units per level.
- e. Relocation or Omission of Light Units. Light units should not be installed in such a manner that the light pattern/output is disrupted by the structure.
- (1) Lowest Level. The lowest level of light units may be installed at a higher elevation than normal on a structure if the surrounding terrain, trees, or adjacent building(s) would obscure the lights. (See Appendix 1, Figure 8.) In certain instances, as determined by an FAA aeronautical study, the lowest level of lights may be eliminated.

- (2) Two Adjacent Structures. Where two structures are situated within 500 feet (153m) of each other and the light units installed at the same levels, the sides of the structures facing each other need not be lighted; therefore, the inboard lights may be eliminated. However, all lights on both structures must flash synchronously. Minor adjustments in the vertical placement of the lights to either or both of the structure's intermediate levels of lights may be made in order to place the lights on the same horizontal plane. Where one structure is higher than the other, complete level(s) of lights should be installed on that part of the higher structure which extends above the top of the lower structure. If the structures are of such heights that the levels of lights cannot be placed in identical horizontal planes, then the light units should be placed such that the center of the horizontal beam patterns do not face toward the adjacent structure. For example, structures situated north and south of each other should have the light units on both structures installed on a northwest/southeast and northeast/southwest orientation. (See Appendix 1, Figures 7, 8, and 9.)
- (3) Three or More Adjacent Structures. The treatment of a cluster of structures as an individual or a complex of structures will be determined by the FAA as the result of an aeronautical study, taking into consideration the location, heights, and spacing with other structures.
- f. Chimneys, Flare Stacks and Similar Solid Structure. The number of levels of lights recommended depends on the height of the structure and may be obtained from Appendix 2, Figure 2. The number of light units recommended for each level is dependent on the horizontal coverage of each unit and on the outside diameter of the structure. At least three lights should be installed on the outside diameter of the structure. The units should be installed in such a manner to ensure that pilots approaching from any normal angle would be within the horizontal beam spread of at least one light. Normally, the top level of light units is installed on the highest point of a structure. However, in the case of chimneys, the top level of lights may be installed as low as 20 feet (6m) below the top. This is to minimize the deposit buildup due to the emission from this type structure.



g. Radio and Television Towers and Similar Skeletal Structures.

- (1) Mounting of Lights. The number of levels recommended depends on the height of the structure, excluding antennas and similar appurtenances, and may be obtained from Appendix 2, Figures 2 and 3. At least three lights should be installed on each level and mounted so that the effective intensity over the full horizontal beam coverage is not impaired by the structural members. They should be mounted in a manner to ensure an unobstructed view by a pilot on a potential collision course.
- (2) Ice Shields. Where icing is likely to occur, metal grates or similar protective ice shields should be installed directly over each light unit to prevent accumulations of, or falling ice from damaging the light units. However, the light should not be obscured from view by a pilot on a potential collision course.
- (3) Top Level of Lights. One level of lights should be installed at the highest point of the structure. If the highest point is a rod or antenna incapable of supporting a lighting system then the top level of lights should be installed at the highest portion of the main skeletal structure. However, due to the construction of some towers where the guy wires come together at the top it may be necessary to install this level of lights as low as 10 feet (3m) below the top. If the rod or antenna exceeds 40 feet (12m) above the main structure, a medium intensity omnidirectional L-866 (white) light should be mounted on the highest point. If the appurtenance (such as a whip antenna) is incapable of supporting a medium intensity light, one or more lights should be installed on a pole adjacent to that part of the structure so as to permit an unobstructed view of at least one light.  
(See paragraph 20.a.(5).)

h. Hyperbolic Cooling Towers.

- (1) Mounting of Obstruction Lights. The light units should be installed in a manner to ensure an unobstructed view of at least two lights by a pilot on a potential collision course. (See Appendix 1, Figure 10.) The number of light units recommended depends on the diameter of the structure at the top. (See paragraph 20.d.(2).)
- (2) Structures Exceeding 600 Feet (183m) AGL. Structures exceeding 600 feet (183m) AGL should have a second level of light units installed approximately at the mid-point of the structure and in a vertical line with the top level of lights.

i. Prominent Building, Observation Towers, and Similar Extensive Obstructions. Install light units on the same horizontal plane at the highest portion or edge of prominent obstructions. Aim the units to ensure that the light is visible to a pilot on a potential collision course.

- (1) If the Obstruction is 200 Feet (61m) or Less in Either Horizontal Dimension, there should be installed at the highest portion of the structure three or more light units in a manner to ensure that at least one light is visible to a pilot on a potential collision course. They may be mounted on a single pedestal at or near the center of the obstruction. If the light units are placed more than 20 feet (6m) from the center point, a minimum of four light units should be used.
- (2) If the Obstruction Exceeds 200 Feet (61m) in One Horizontal Dimension, but is 200 feet (61m) or less in the other, two light units should be placed on each of the shorter sides. These light units may either be installed adjacent to each other at the mid-point of the edge of the obstruction or at or near each corner and directed horizontally so as to give 180 degrees of coverage to each end of the obstruction. One or more light units should be installed along the overall length of the major axis. These lights should be installed at approximately equal intervals not to exceed a distance of 100 feet (31m) from the corners or from each other.
- (3) If the Obstruction Exceeds 200 Feet (61m) in Both Horizontal Dimensions, light units should be equally spaced along the overall perimeter of the obstruction at intervals of 100 feet (31m) or fraction thereof.

j. Supporting Structures for Catenary Wires.

- (1) Purpose. A unique sequentially flashing light system is used to warn pilots on a potential collision course with the supporting structures and associated catenary wires.
- (2) Mounting of Obstruction Lights. A system of three levels of sequentially flashing light units should be installed on each supporting structure or adjacent terrain. One level should be installed at the top of the structure, one at the height of the lowest point in the catenary, and one level at approximately midway between the other two lights. The middle level should normally be a minimum of 50 feet (15m) from the other two levels. If the installation presents a potential danger to maintenance personnel, or when necessary for lightning protection, the top level of lights may be mounted as low as 20 feet (6m) below the highest point of the structure.
  - (a) Flash Sequence. The flash sequence should be middle level, top level, and bottom level with all lights on the same level flashing simultaneously. The time delay between flashes of levels is designed to present a unique system display.
  - (b) Flash Rate. Each series of flashes is repeated 60 times every minute.
  - (c) Synchronization. Although desirable, the corresponding light levels on associated supporting towers of a catenary crossing need not flash simultaneously.
  - (d) Effective Intensity. The effective intensity should be no less than 100,000 candelas for the day mode. The twilight mode should be approximately 20,000 candelas, and the night mode approximately 2,000 candelas.
  - (e) Horizontal Coverage. The light units should be installed so as to provide a minimum of 180 degrees coverage centered perpendicular to the flyway. Where a catenary crossing is situated near a bend in a river, canyon, etc., or is not perpendicular to the flyway, the horizontal beam pattern should be directed as necessary to provide the most effective light coverage to warn pilots approaching from either direction of the catenary wires.

- (f) Variation. The vertical and horizontal arrangements of the lights may be subject to the structural limits of the towers and/or adjacent terrain. A tolerance of 20 percent from uniform spacing of the bottom and middle light is allowed. If the base of the supporting structure(s) is higher than the lowest point in the catenary, such as a canyon crossing, one or more lights should be installed on the adjacent terrain at the level of the lowest point in the span.
- (3) Area Surrounding Support Structures. The area in the immediate vicinity of the base of the supporting structures should be clear of all items and/or objects of natural growth that could interfere with the line-of-sight between a pilot and the obstruction lights.
- (4) Omission of Marking and Red Obstruction Lights. Catenary wire supporting structures that are obstruction lighted as outlined under paragraph 20.j.(2) may omit the standard marking and red obstruction lighting provided:
- (a) Top Level. At least three light units are installed on the top level and situated so as to provide 360 degrees coverage about the structure. Four light units may be required to effectively cover the approach to the structure dependent upon the beam pattern of the light units and possible directions of approach.
- (b) Middle Level. Structures exceeding 500 feet (153m) above the surrounding terrain have at least three light units installed at the middle level to provide 360 degrees coverage.
- (c) Flash Sequence. The vertical levels of lights flash sequentially; the lights at each level should flash simultaneously.
- (5) Three or More Supporting Structures. Where a catenary wire crossing requires three or more supporting structures, the inner structures should be equipped with three or four light units per level to provide a full 360 degree coverage. The number of units required per level will depend upon the beam pattern of the particular manufacturer's light and the area to be covered as determined by the possible directions of approach. Additionally, the number of light units per level depends on the effective diameter of the obstruction at the level. (See paragraph 20.d.(2).) Structures equipped with a lighting system providing 360 degrees of coverage about the structure may delete the standard marking and red obstruction lighting system.

21. STANDARDS FOR LIGHTING OBSTRUCTIONS WITH MEDIUM INTENSITY WHITE OBSTRUCTION LIGHTS. Structures may be identified with a system composed of L-866 (white) omnidirectional lights.
- a. Levels. The overall height of the structure including all appurtenances such as rods, antennas, obstruction light(s), etc., is used to determine the number of light levels. (See Appendix 2, Figure 4.)
  - b. Top Levels. At least one light should be installed at the highest point to provide 360 degree coverage ensuring an unobstructed view by a pilot on a potential collision course with the structure.
  - c. Other Levels. These lights should be mounted in a manner to ensure an unobstructed view by a pilot on a potential collision course with the structure. This may require two or more lights on each level so that the effective intensity is not impaired by the structural members. The lowest light level should not be less than 200 feet (61m) AGL.
  - d. Structures 500 Feet (153m) AGL or Less. When the L-866 (white) light(s) are used only during twilight and nighttime, painting is required for daytime marking. When the L-866 (white) light(s) are operated 24 hours a day, painting is not required.
  - e. Structures Exceeding 500 Feet (153m) AGL. The L-866 (white) lights should be used during twilight and nighttime and may be used 24 hours a day. Painting is always required for daytime marking. (See Chapters 2 and 3.)
  - f. Operational Characteristics. The L-866 (white) lights should conform to the applicable provisions of AC 150/5345-43, current edition, and with the appropriate portions of paragraph 20.a.(2) and (3). The effective intensity should be no less than 20,000 candelas for the day and twilight mode. The night mode should be approximately 2,000 candelas.
  - g. Flashtube Replacement. The flashtubes in a light unit should be replaced when the peak effective intensity falls below 15,000 candelas.

## CHAPTER 7. DUAL LIGHTING SYSTEMS

22. PURPOSE. Dual obstruction lighting systems include red lights that are used for nighttime, and high or medium intensity white lights for daytime and twilight. This lighting system may be recommended when an aeronautical study determines it is not feasible to operate a high or medium intensity white lighting system at night.
23. INSTALLATION. The light units should be installed as specified in the appropriate portions of Chapters 4, 5, and 6. The number of light levels used may be obtained from Appendix 2, Figures 5 and 6. When high intensity white lights are operated during daytime and twilight, other methods of marking may be omitted. When medium intensity white lights on structures 500 feet (153m) AGL or less are operated during daytime and twilight, other methods of marking may be omitted.
24. OPERATION. Lighting systems should be operated as specified in Chapters 4, 5, and 6. Both systems should not be operated at the same time; however, there should be no more than a two second delay when changing from one system to the other.



.  
. .  
. .  
. .



. .  
. .



## CHAPTER 8. MARKING AND LIGHTING OF MOORED BALLOONS AND KITES

25. PURPOSE. The purpose of marking and lighting standards for moored balloons and kites is to indicate the presence and general definition of these objects to pilots when converging from any normal angle of approach.
26. APPLICATION. This chapter pertains to all moored balloons and kites which require marking and lighting under FAR Part 101.
27. MARKING. Flag markers should be used on mooring lines to warn airmen of their presence during daylight hours.
- a. Display. Markers should be displayed at not more than 50 foot (15m) intervals and should be visible for at least 1 statute mile.
  - b. Shape. Markers should be rectangular in shape and not less than 2 feet (0.6m) on a side. Stiffeners should be used in the borders so as to expose a large area, prevent drooping in calm wind, or wrapping around the cable.
  - c. Color Patterns. One of the following color patterns should be used:
    - (1) Solid Color. Aviation orange.
    - (2) Orange and White. Two triangular sections, one of aviation orange and the other white, combined to form a rectangle.
28. LIGHTING. Flashing obstruction lights should be used on moored balloons or kites and their mooring lines to warn airmen of their presence during the hours between sunset and sunrise and during periods of reduced visibility. These lights may be operated continuously.
- a. Systems. Flashing obstruction lights, L-866 (red or white) beacons may be used to light moored balloons or kites. The use of lights meeting the L-856 specifications is not recommended.
  - b. Light Distribution. The intensity of each light should be approximately 2,000 effective candelas at every point in the horizontal plane (and a minimum of 2 degrees in the vertical plane) with a flash rate of 40 pulses per minute.



- c. Display. Flashing lights should be displayed on the top, nose section, tail section, and on the tether cable approximately 15 feet (4.6m) below the craft so as to define the extremes of size and shape. Additional lights should be equally spaced along the cable's overall length for each 350 feet (107m) or fraction thereof.
  - d. Exceptions. When the requirements of this chapter cannot be met, floodlighting may be used. (See Chapter 4, paragraph 15.c.)
29. LIGHT CONTROL DEVICE. The operation of each light may be controlled by a photocell controller which automatically turns the light on when the illumination on a vertical surface facing the northern sky in the Northern Hemisphere drops to 60 footcandles (645.8 lux) but before reaching 35 footcandles (376.7 lux). The reverse order should apply in changing from nighttime to daytime operation.

## CHAPTER 9. OBSTRUCTION MARKING AND LIGHTING EQUIPMENT

30. PURPOSE. This chapter lists all of the documents relating to the obstruction marking and lighting of objects and advises where they may be obtained.
31. COLORS. Paint and aviation colors referred to in this publication should conform to Federal Standard FED-STD-595. Colors are as follows:
- a. Orange. Number 12197 (Aviation Orange).
  - b. White. Number 17875 (Aviation White).
  - c. Yellow. Number 13538 (Aviation Yellow).
  - d. Availability of Specifications. FED-STD-595 and other Federal specifications describing the technical characteristics of various paints and their application techniques may be obtained from:  
  
GSA - Specification Section  
Room 6039  
7th & D Street, SW.  
Washington, DC 20407  
Telephone: (202) 472-2205
32. LIGHTS AND ASSOCIATED EQUIPMENT. The lighting equipment referred to in the standards set forth in this publication should conform with the applicable provisions of the latest issue of the following specifications and their related drawings.
- a. Aviation Red Obstruction Lighting System.
    - (1) Flashing Beacons. AC 150/5345-43, FAA Specification for Obstruction Lighting Equipment. Type L-866 (red) light. (Military specification L-6273)
    - (2) Double and Single Obstruction Lights.
      - (a) AC 150/5345-43. Type L-810.
      - (b) Military specifications MIL-L-7830, Light, Navigational Boundary and Obstruction Markers.
  - b. High and Medium Intensity White Obstruction Lighting Systems. AC 150/5345-43, FAA Specification for Obstruction Lighting Systems. Type L-856 and L-866 (white) light.
  - c. Approved Equipment. AC 150/5345-1, Approved Airport Lighting Equipment, lists the approved airport lighting equipment and manufacturers qualified to supply their product in accordance with the indicated specification requirements. The manufacturers listed in this circular have demonstrated compliance with the specification requirements of AC 150/5345-43. However, other manufacturers' equipment may be used provided it meets the specification requirements.

- d. Installation and Maintenance. AC 150/5340-21, Airport Miscellaneous Lighting Visual Aids, provides guidance for the installation, maintenance, testing, and inspection of the red beacon and steady burning obstruction lighting. AC 150/5340-26, Maintenance of Airport Visual Aid Facilities provides guidance on the maintenance of these fixtures.
- e. Availability. The standards and specifications listed above may be obtained free of charge from the designated office:

(1) Military Specifications:

Commanding Officer  
Naval Publications and Forms Center  
5801 Tabor Avenue  
Attention: NPFC-105  
Philadelphia, PA 19120  
Telephone: (215) 697-2000, Ext. 3321 to place orders,  
Ext. 4834 for information

(2) FAA Specifications:

Manager, Directives Management Branch, APM-11  
Department of Transportation  
Federal Aviation Administration  
800 Independence Avenue, SW.  
Washington, DC 20591  
Telephone: (202) 426-8617

(3) FAA Advisory Circulars:

Department of Transportation  
Subsequent Distribution Section, M-494.3  
400 7th Street, SW.  
Washington, DC 20590  
Telephone: (202) 472-3447

- f. Tolerance Chart. In-Service Aviation Orange Color Tolerance Charts are available to determine when the paint has faded beyond acceptable limits, and when repainting is required. The tolerance charts are available, free of charge, from:

Manager, Flight Information and  
Obstructions Branch, ATO-210  
Department of Transportation  
Federal Aviation Administration  
800 Independence Avenue, SW.  
Washington, DC 20591  
Telephone: (202) 426-8777

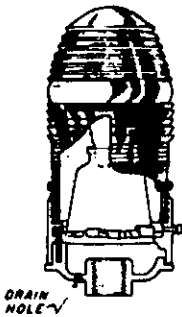

**L-810  
SINGLE OBSTRUCTION  
LIGHT FITTING  
(Fresnel Globe)**

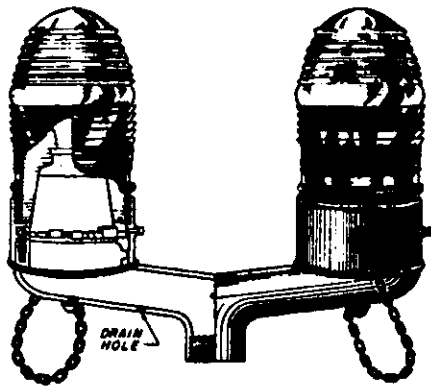

**L-810  
DOUBLE OBSTRUCTION  
LIGHT FITTING  
(Fresnel Globe)**

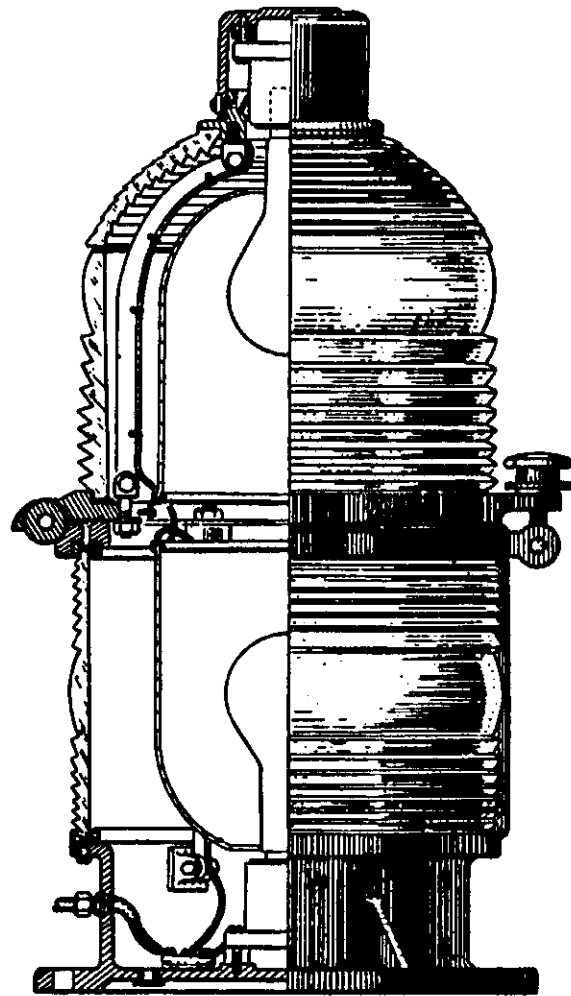

**L-866 RED BEACON  
(Fresnel Lens)**

**TYPES OF RED OBSTRUCTION LIGHTS**

Fig. 1

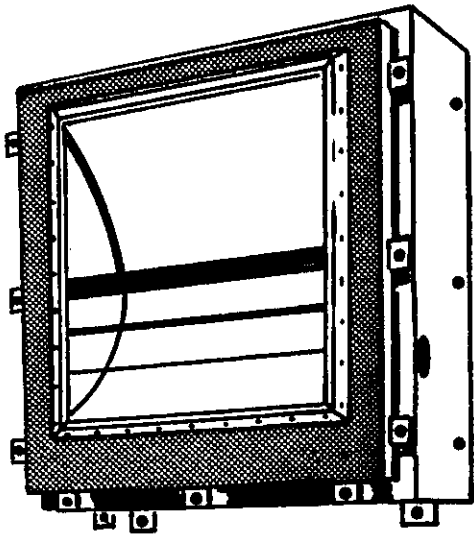

L-856 WHITE LIGHT

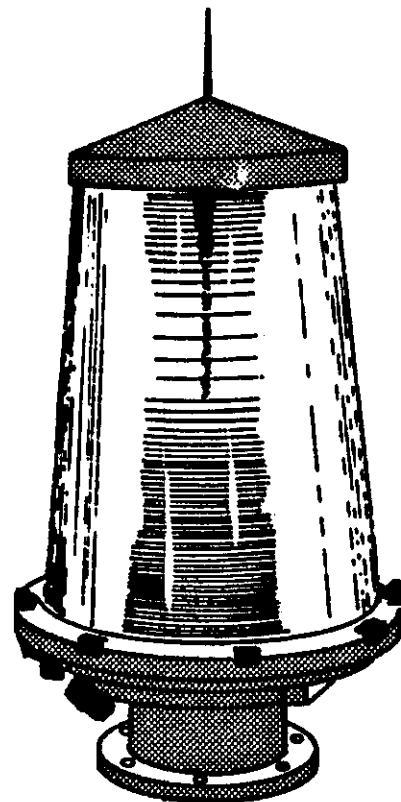

L-866 WHITE LIGHT

**TYPES OF HIGH AND MEDIUM INTENSITY  
WHITE OBSTRUCTION LIGHTS**

Fig. 2

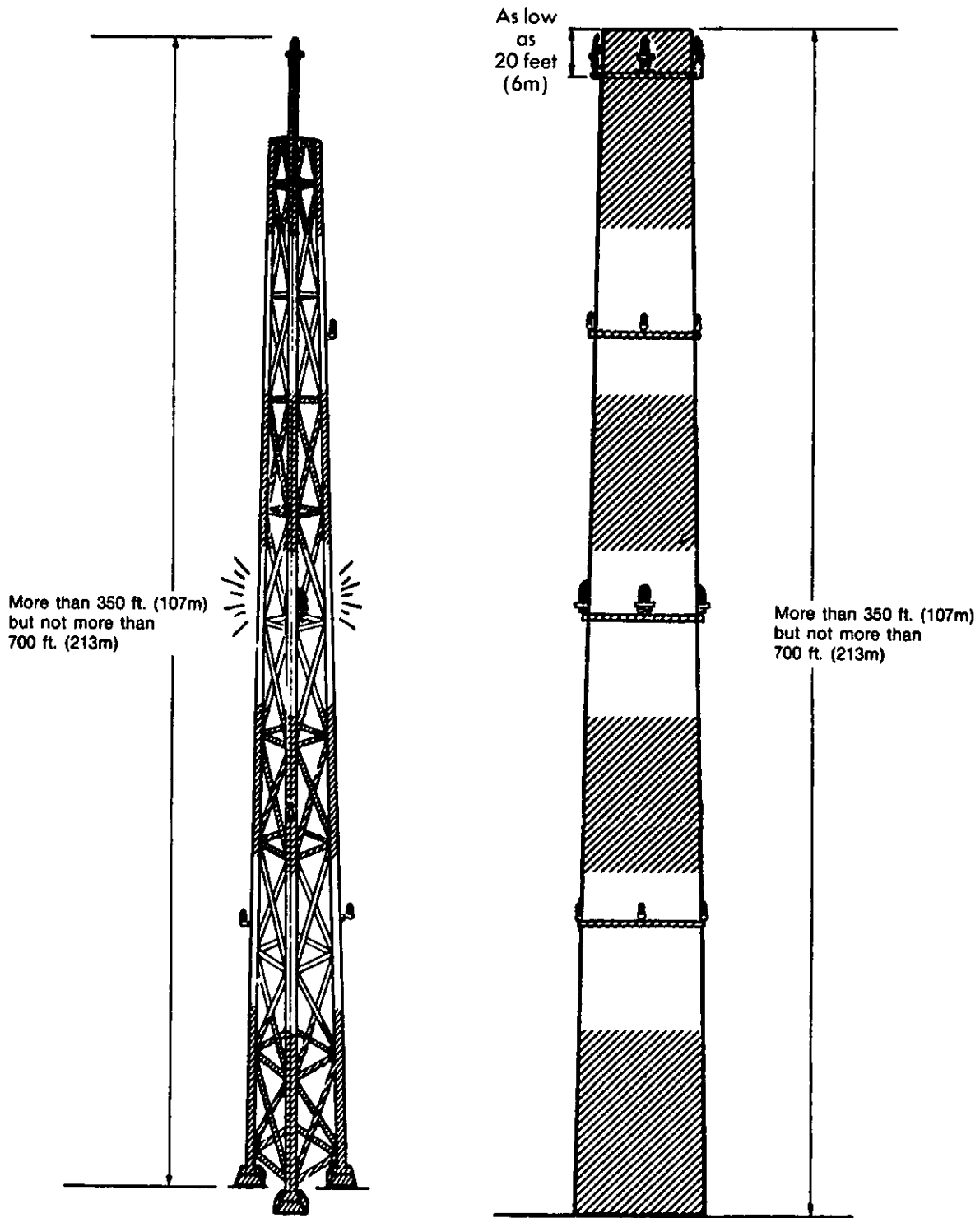

PAINING AND LIGHTING OF CHIMNEYS, POLES, TOWERS  
AND SIMILAR OBSTRUCTIONS

Fig. 3

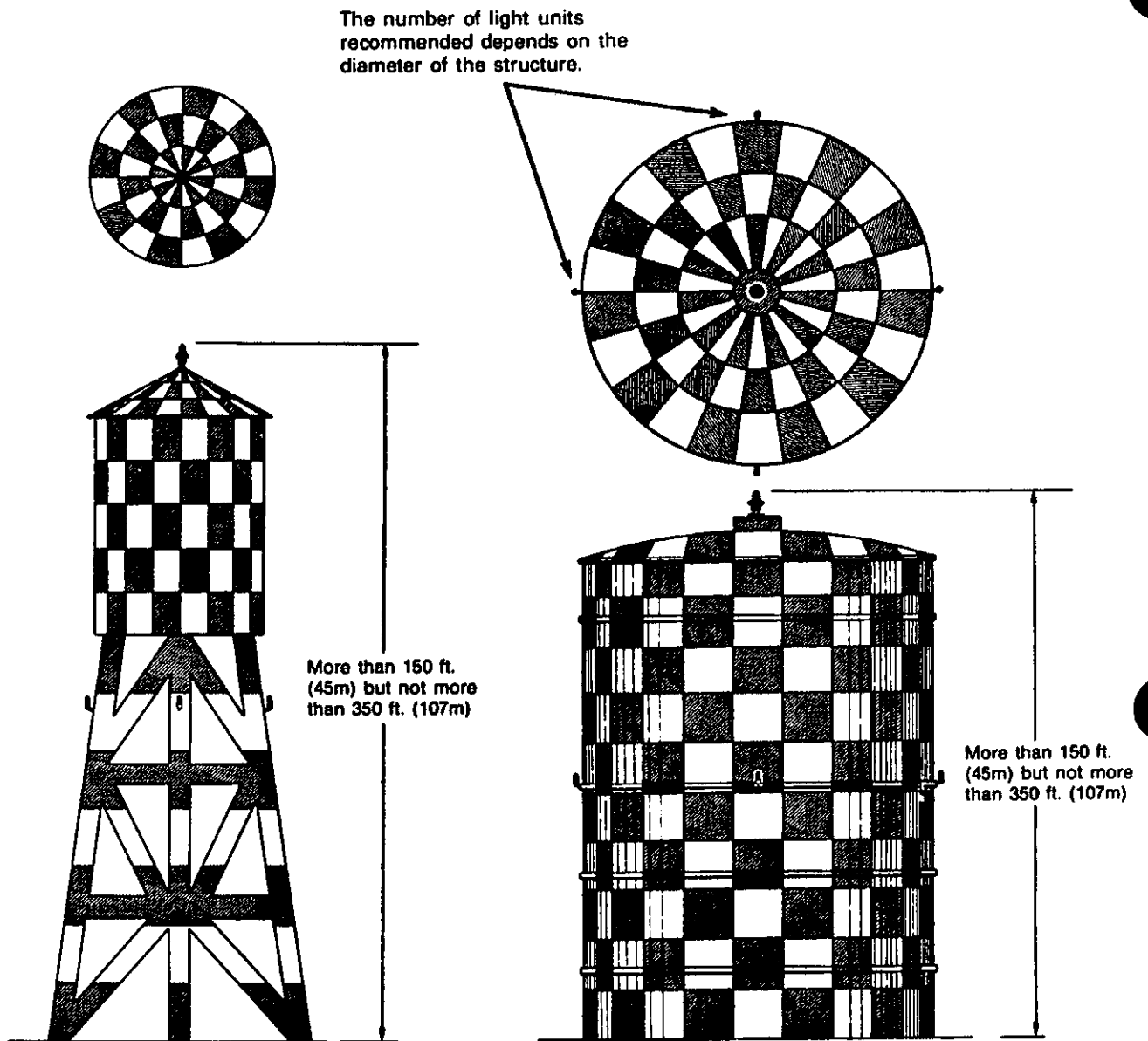

PAINING AND LIGHTING OF WATER TOWERS, STORAGE TANKS  
AND SIMILAR OBSTRUCTIONS

Fig. 4

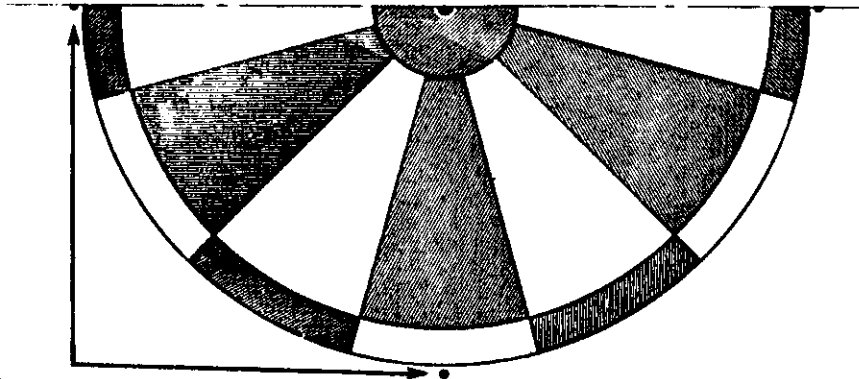

The number of light units recommended depends on the diameter of the structure.

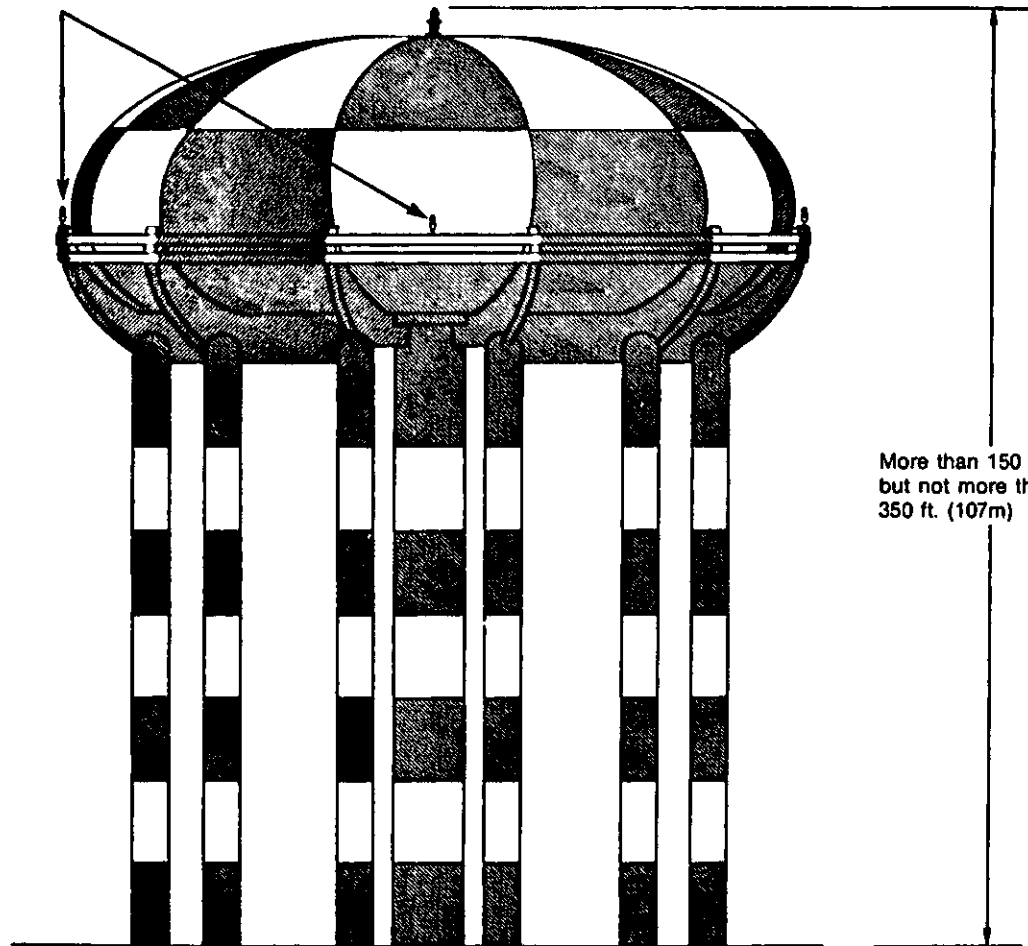

More than 150 ft. (45r  
but not more than  
350 ft. (107m)

PAINING AND LIGHTING OF WATER TOWERS AND SIMILAR OBSTRUCTIONS

Fig. 5



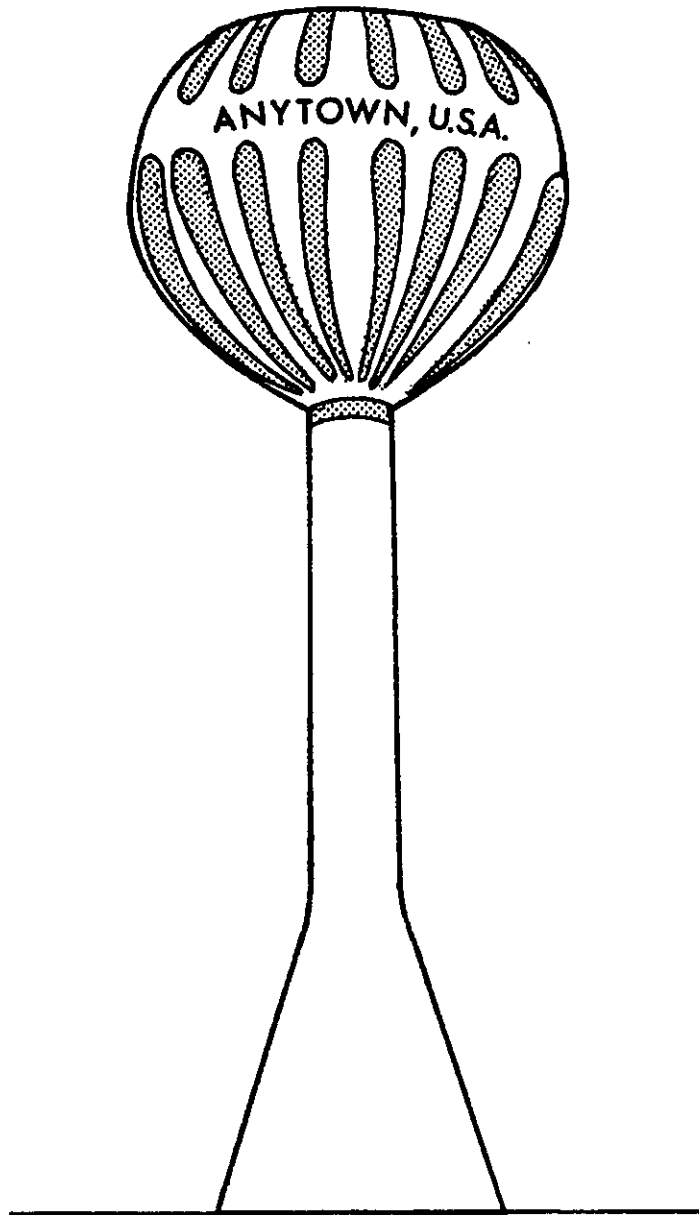

**PAINTING OF SINGLE PEDESTAL WATER TOWER BY TEARDROP PATTERN**

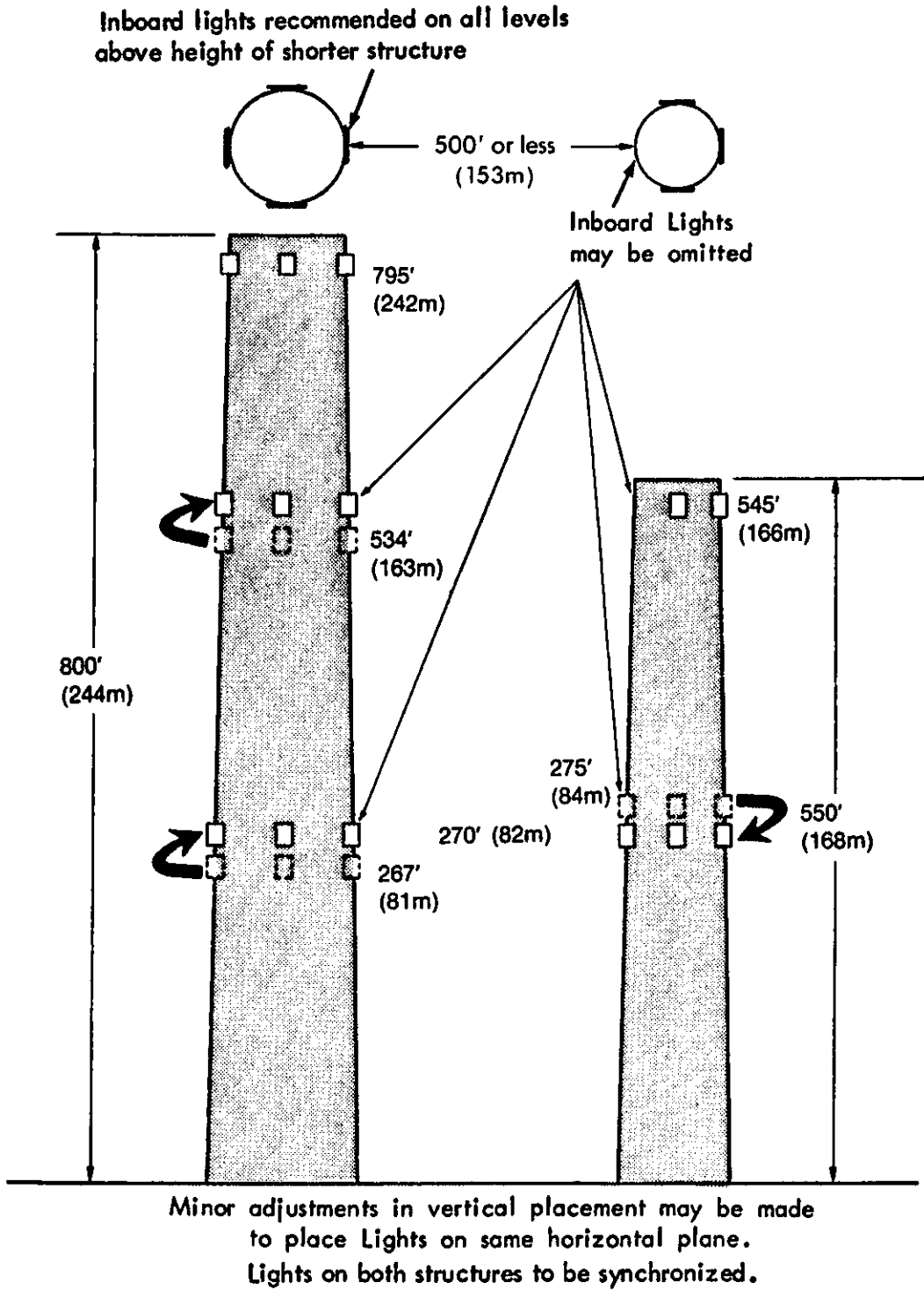

Fig. 7

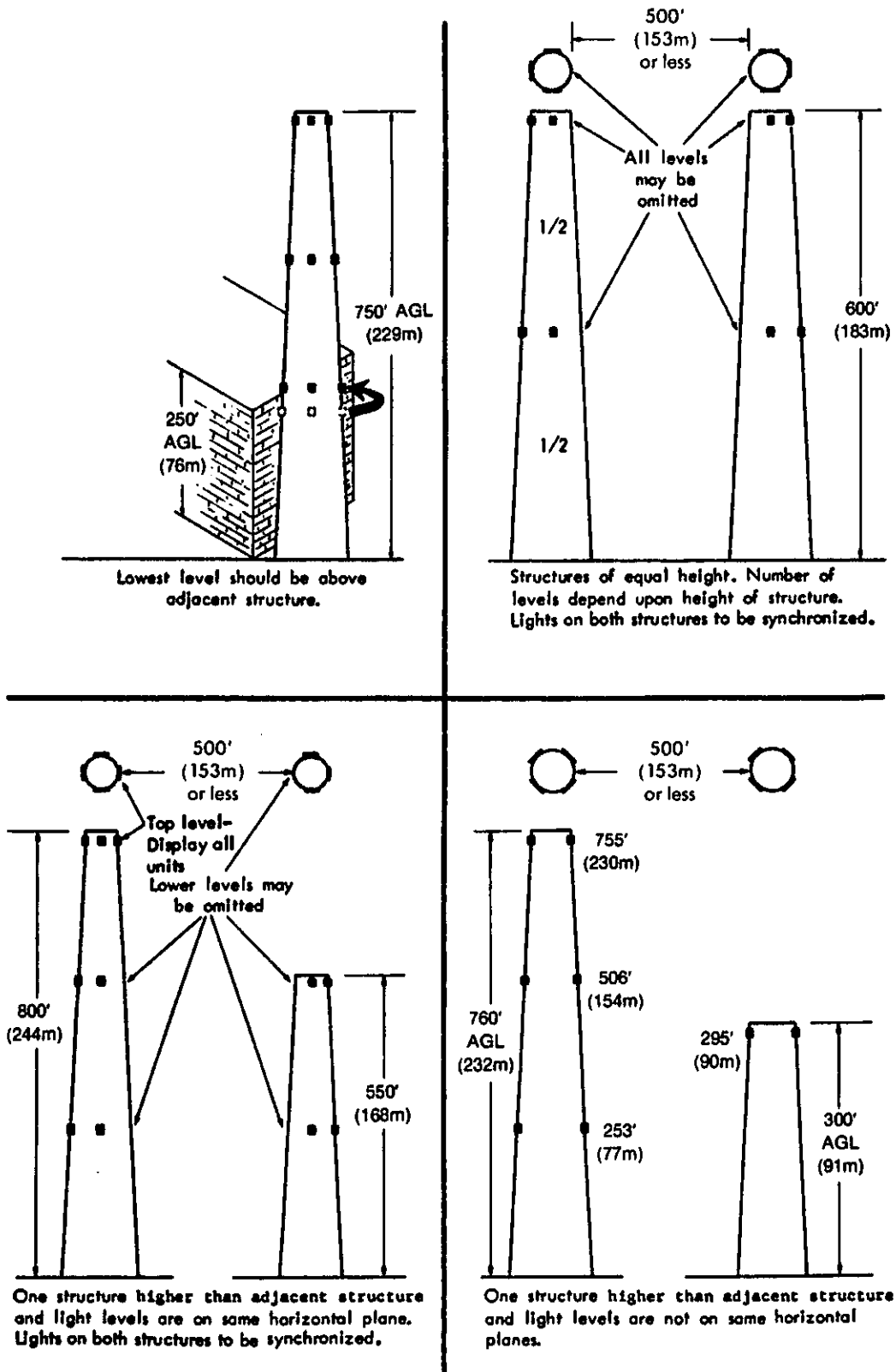

Fig. 8



a - 20' (6m) or less



b - Exceeding 20' (6m)  
but not more than 100' (31m)

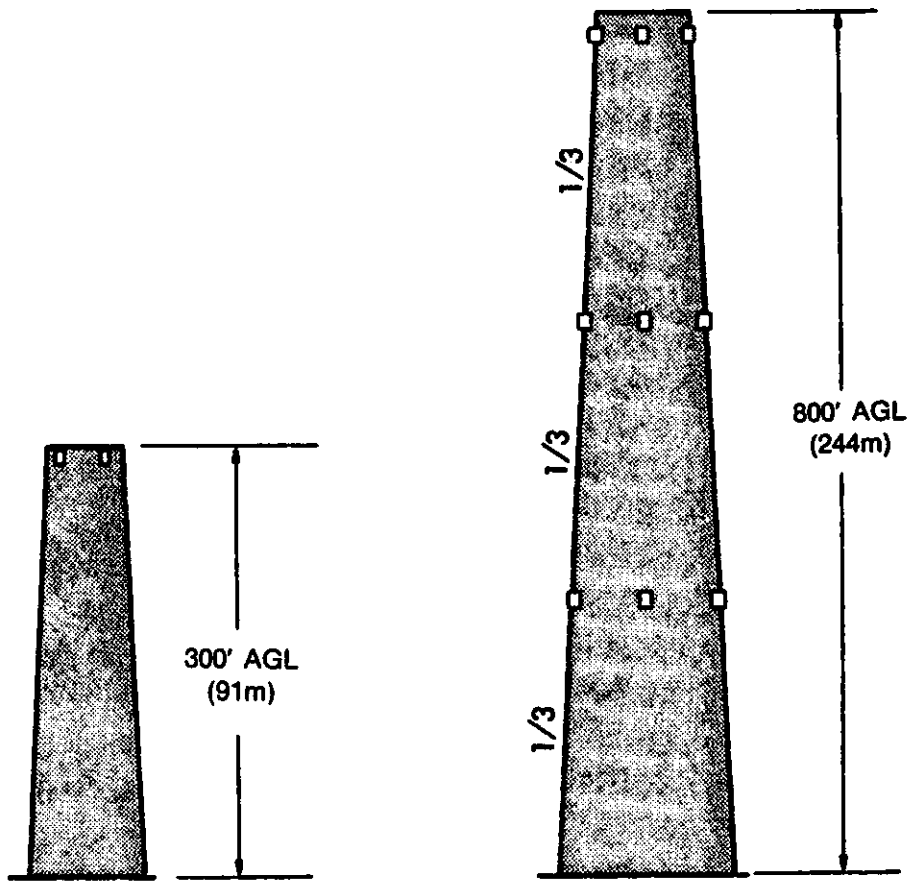
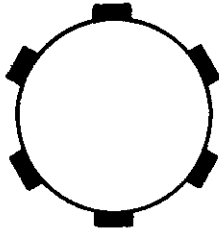
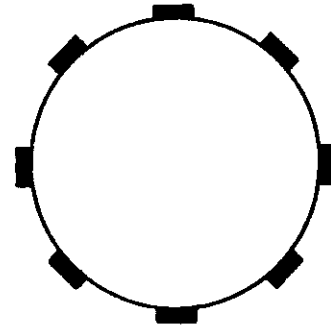

Fig. 9



a - Exceeding 100' (31m)  
but not more than 200' (61m)



b - Exceeding 200' (61m)

The number of light units  
recommended depends on the  
diameter of the structure

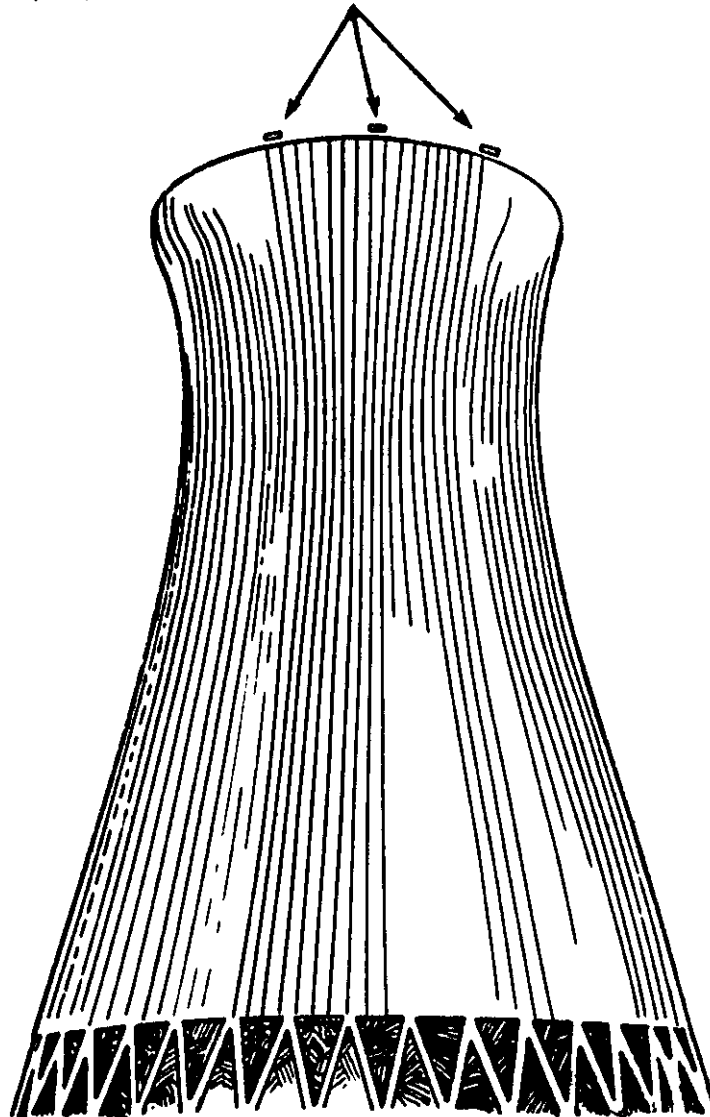

HYPERBOLIC COOLING TOWER

Fig. 10

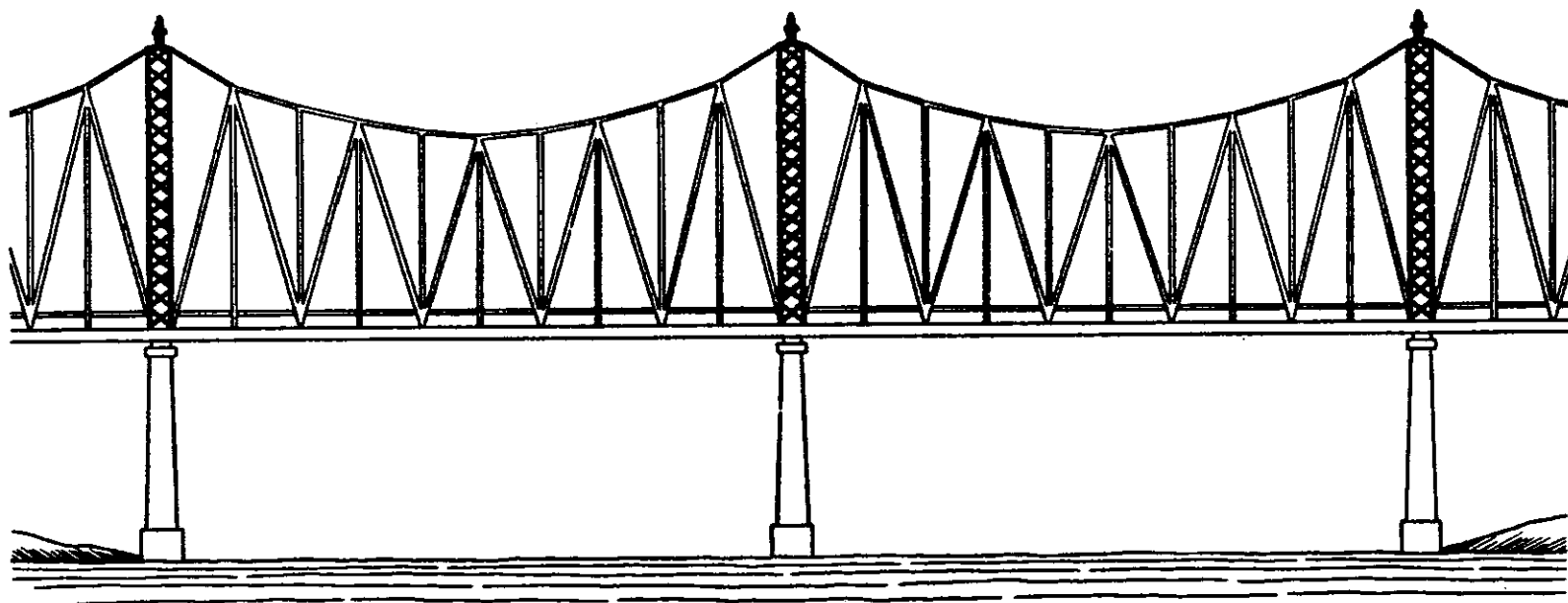

11

**BRIDGE LIGHTING**

Fig. 11

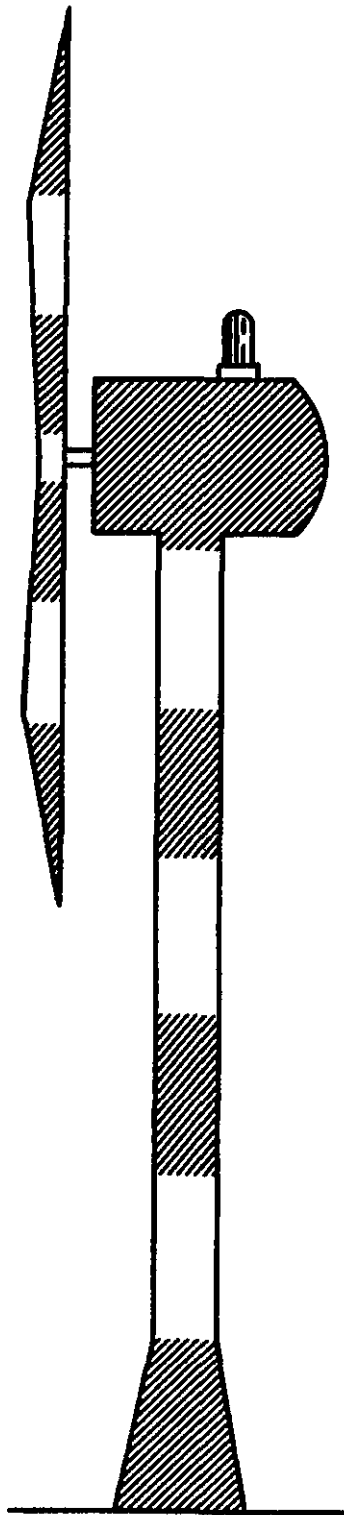

WIND TURBINE GENERATOR

Fig. 12

CHAPTER 5  
 AVIATION RED OBSTRUCTION LIGHTS  
 STANDARDS FOR  
 LIGHTING OBSTRUCTIONS

HEIGHT OF LIGHTS ON STRUCTURE IN FEET (METERS) ABOVE GROUND LEVEL

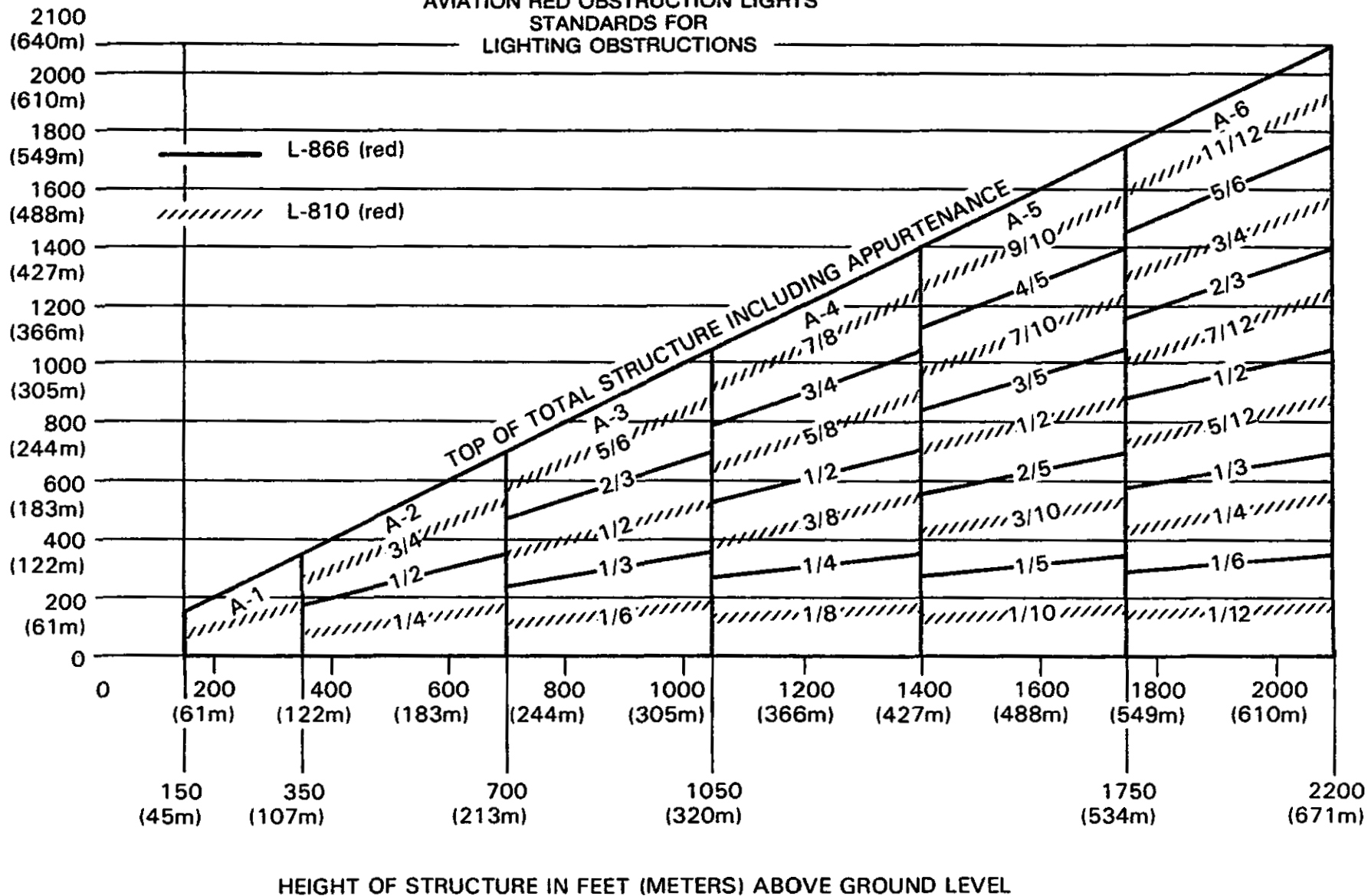

Fig. 1



CHAPTER 6  
HIGH INTENSITY WHITE OBSTRUCTION LIGHTS  
STANDARDS FOR  
LIGHTING OBSTRUCTIONS

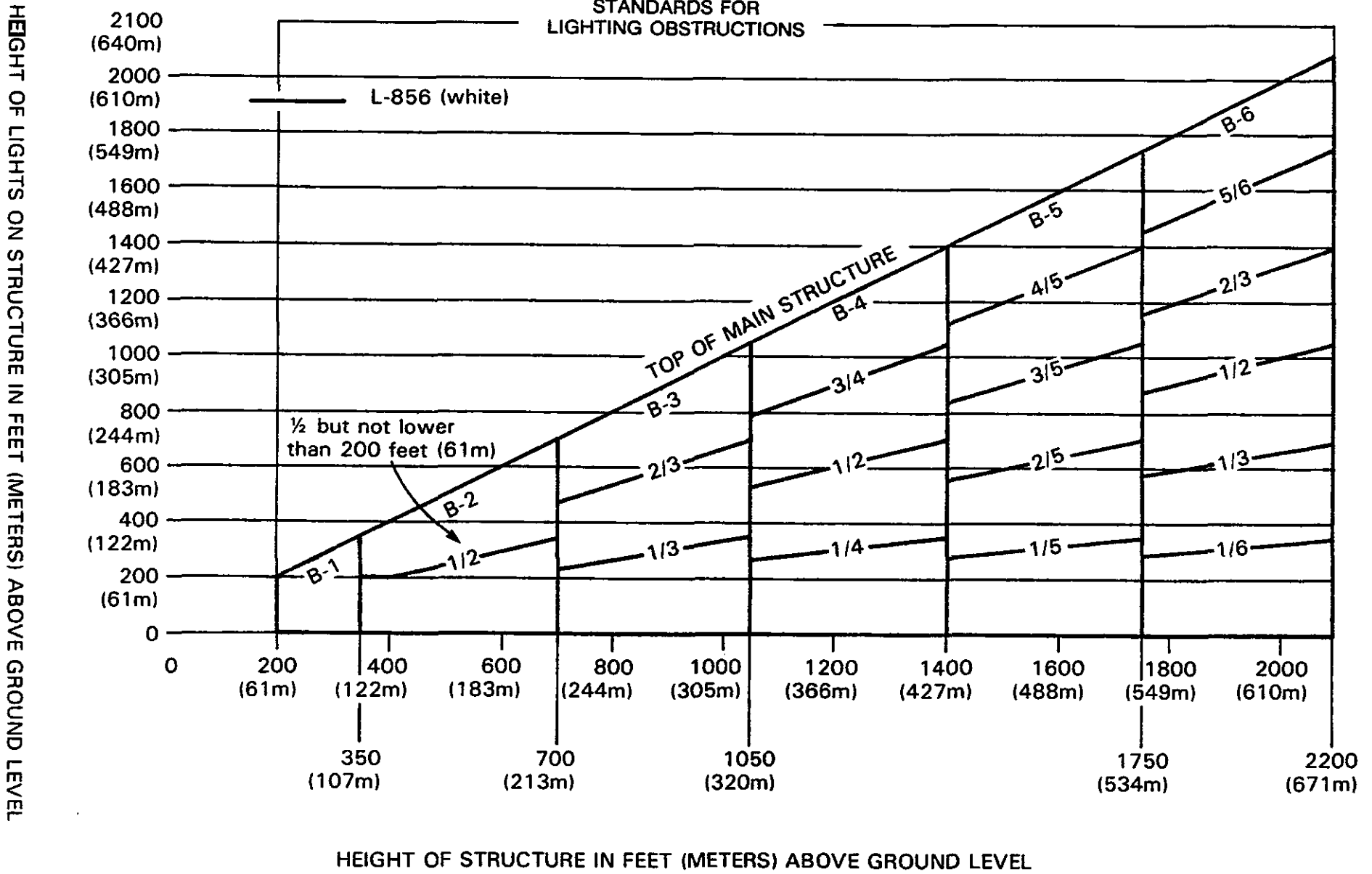
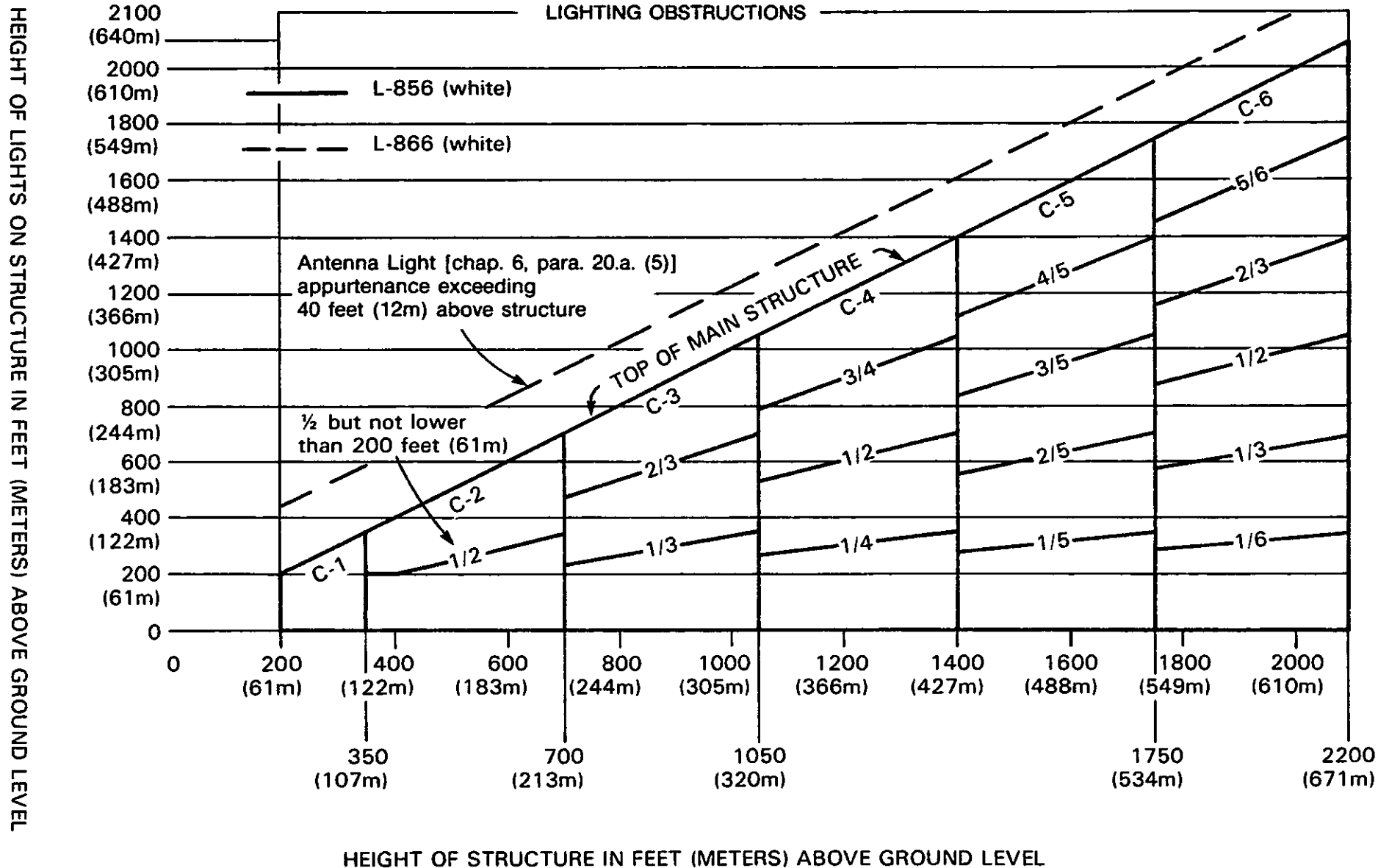

Fig. 2

CHAPTER 6  
HIGH AND MEDIUM INTENSITY WHITE OBSTRUCTION LIGHTS  
STANDARDS FOR  
LIGHTING OBSTRUCTIONS



3

Fig. 3

CHAPTER 6  
 MEDIUM INTENSITY WHITE OBSTRUCTION LIGHTS  
 STANDARDS FOR  
 LIGHTING OBSTRUCTIONS

HEIGHT OF LIGHTS ON STRUCTURE IN FEET (METERS) ABOVE GROUND LEVEL

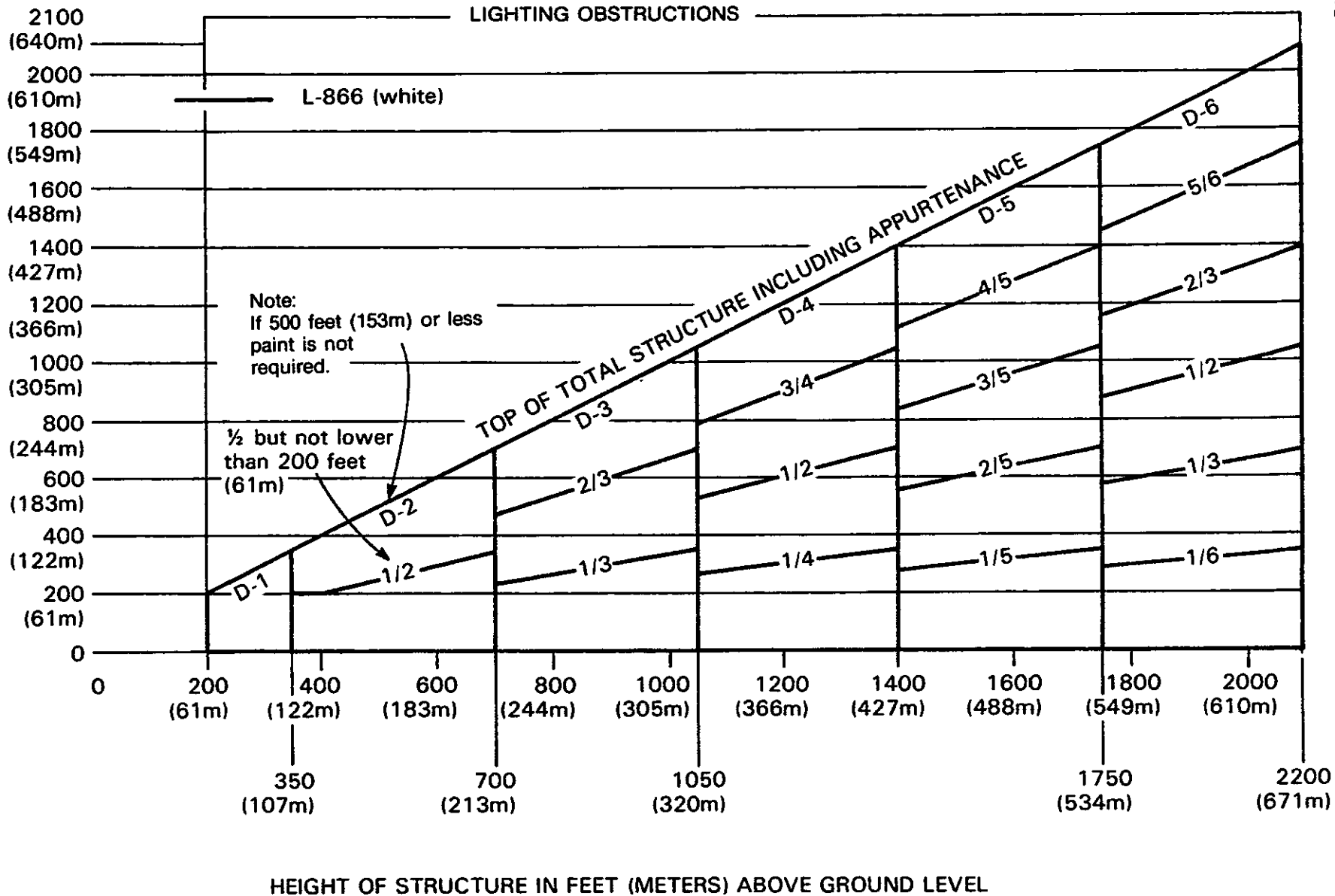
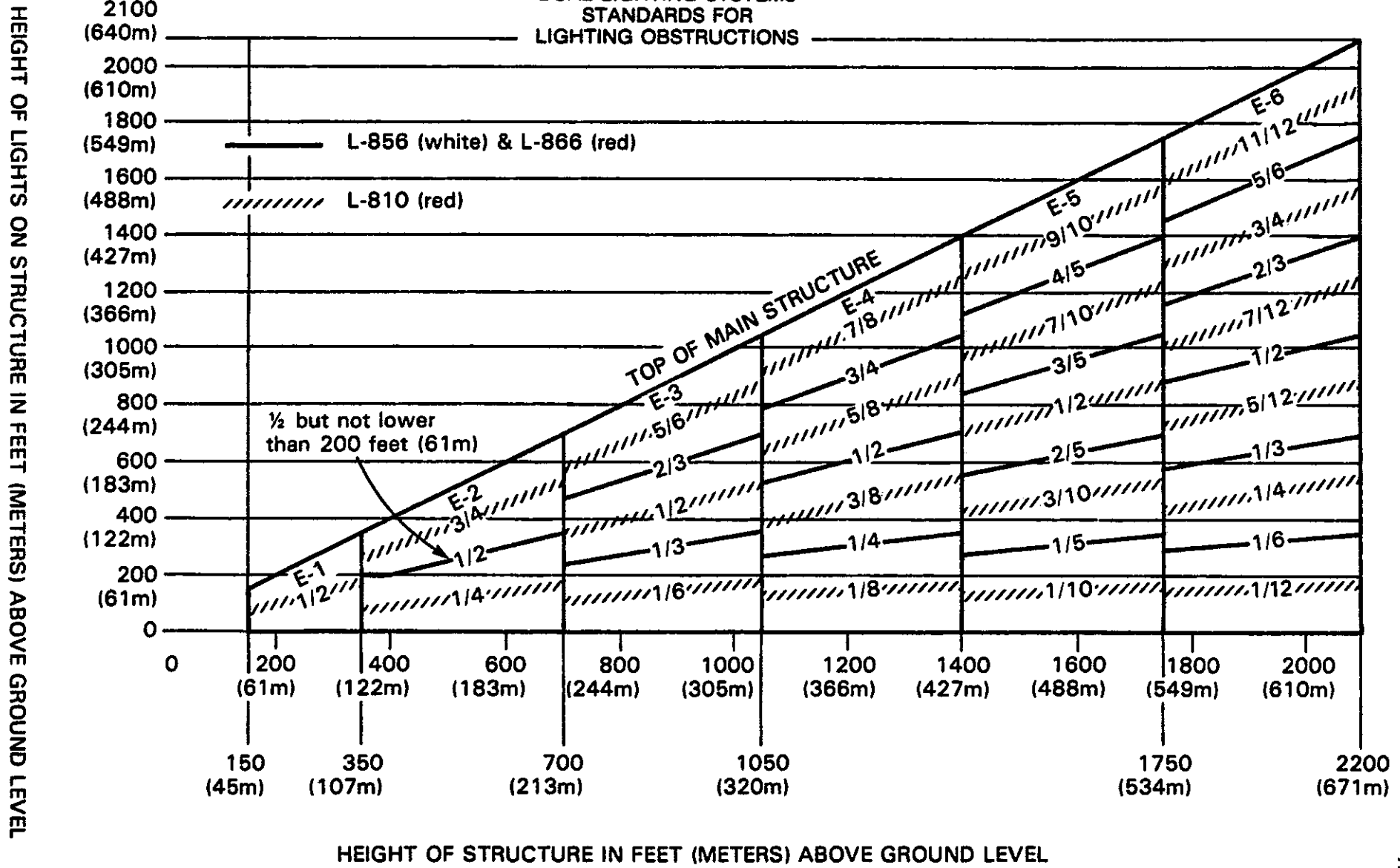

Fig. 4

CHAPTER 7  
DUAL LIGHTING SYSTEMS  
STANDARDS FOR  
LIGHTING OBSTRUCTIONS



5

Fig. 5

CHAPTER 7  
DUAL LIGHTING SYSTEMS  
STANDARDS FOR  
LIGHTING OBSTRUCTIONS

HEIGHT OF LIGHTS ON STRUCTURE IN FEET (METERS) ABOVE GROUND LEVEL

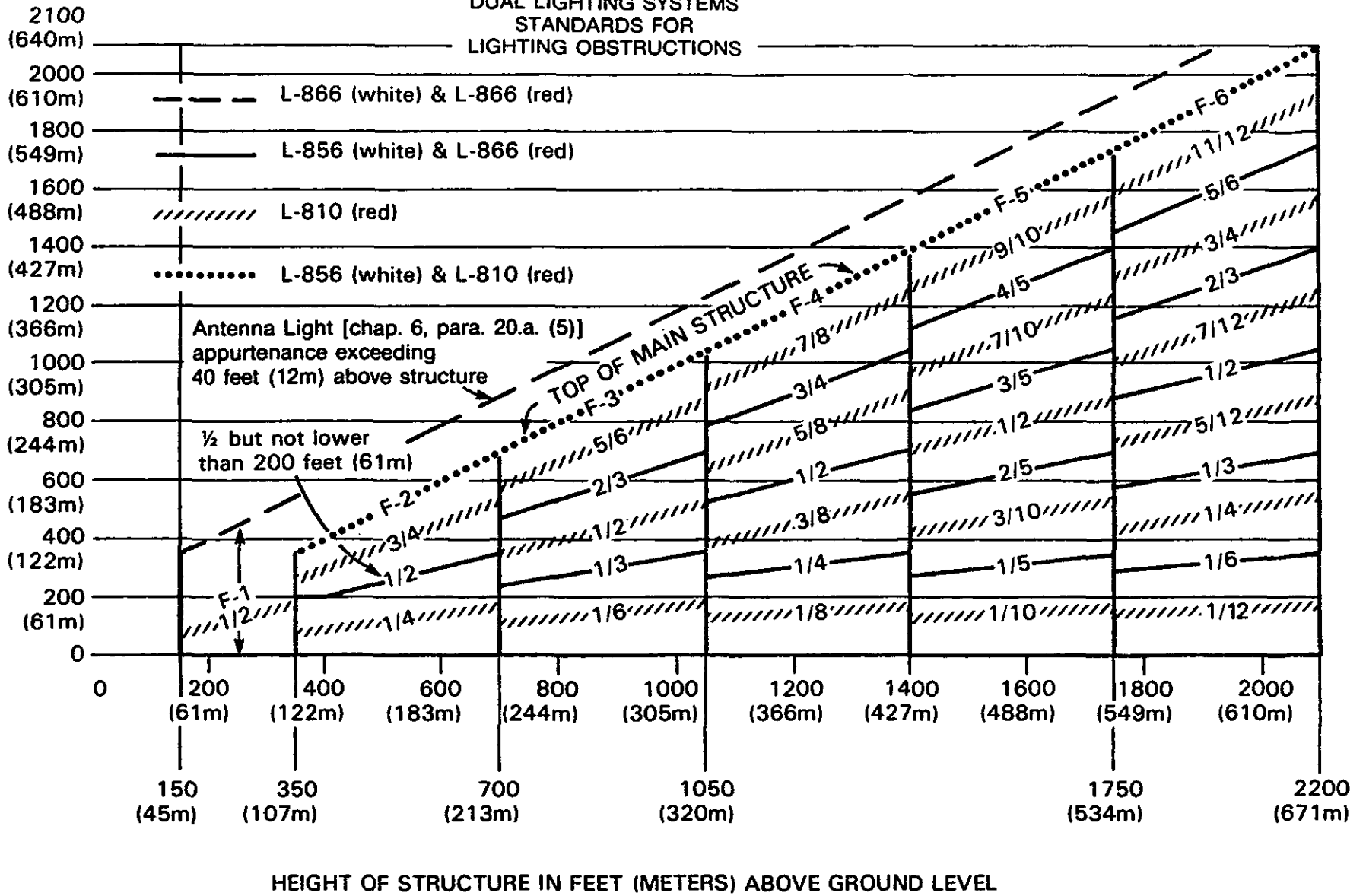

Fig. 6