

Cancelled See 35B

AC NO: 20-35A

DATE: 10/29/68



ADVISORY CIRCULAR

DEPARTMENT OF TRANSPORTATION
FEDERAL AVIATION ADMINISTRATION

SUBJECT: TIE-DOWN SENSE

1. PURPOSE. This advisory circular provides information of general use on aircraft tie-down techniques and procedures.
2. CANCELLATION. AC 20-35, dated April 29, 1965, is cancelled.
3. BACKGROUND. Each year numerous aircraft are needlessly damaged by windstorms because of negligence and improper tie-down procedures. There is no doubt about it, Mother Nature can turn a local airport into a junkyard in a matter of minutes. Whether you are willing to admit it or not - we will have windstorms - more so in some parts of the country than in others. If your airplane is damaged during a windstorm, chances are the airplane was improperly secured, or it wasn't tied down at all.

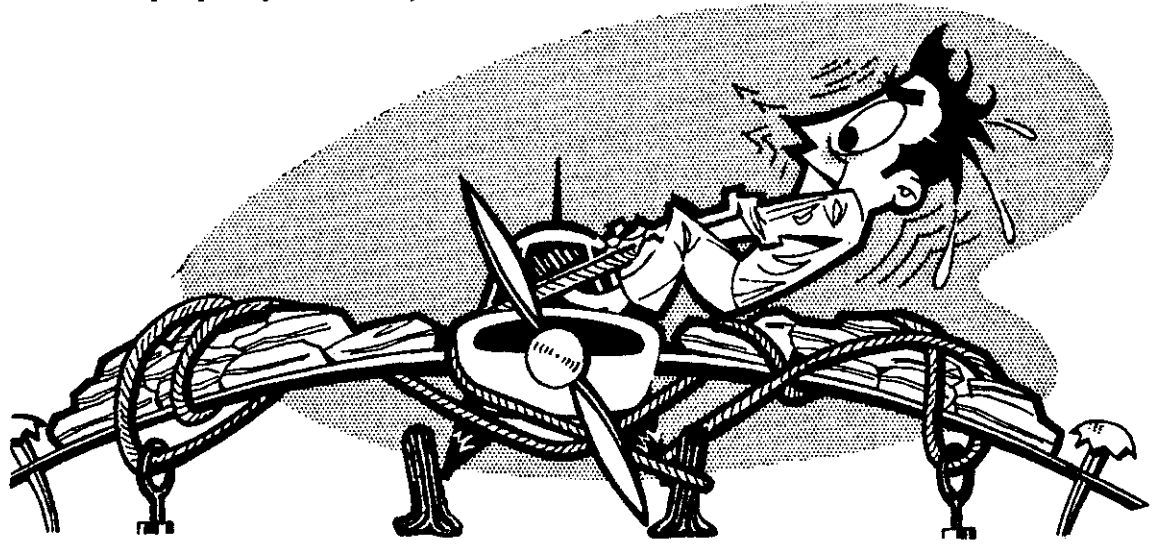

4. STORMS. The bulk of windstorm damage occurs during the early summer months but continues with lessening frequency throughout the year. As a general rule, the large and very severe windstorms cause less damage than the small local ones. The reason being that there is usually sufficient advance warning for the former, while the latter build up quickly and give little warning of their coming.

According to available weather records, Tampa, Florida, is the storm center of this country, with an average of 94 thunderstorms a year. Santa Fe, New Mexico, is second with a yearly average of 73. Other cities are less frequently visited by such storms. The West Coast States average only one to four such storms a year. Generally speaking, thunderstorms and tornadoes are accompanied by high surface winds which account for most of the damage to aircraft on the ground. (See Tornado Map on page 3.)

Although most storms are generated in the daytime, many sections of the United States, including the Southwest, the lower Michigan Peninsula, and an extensive area centered in eastern Nebraska, are plagued with night storms during the summer months. Thunderstorms are bothersome in the Central States during the months of July, August, and September. On the other hand, in the winter the greatest storm activity takes place in the lower Mississippi Valley.

Average number of

Thunderstorm days

per year

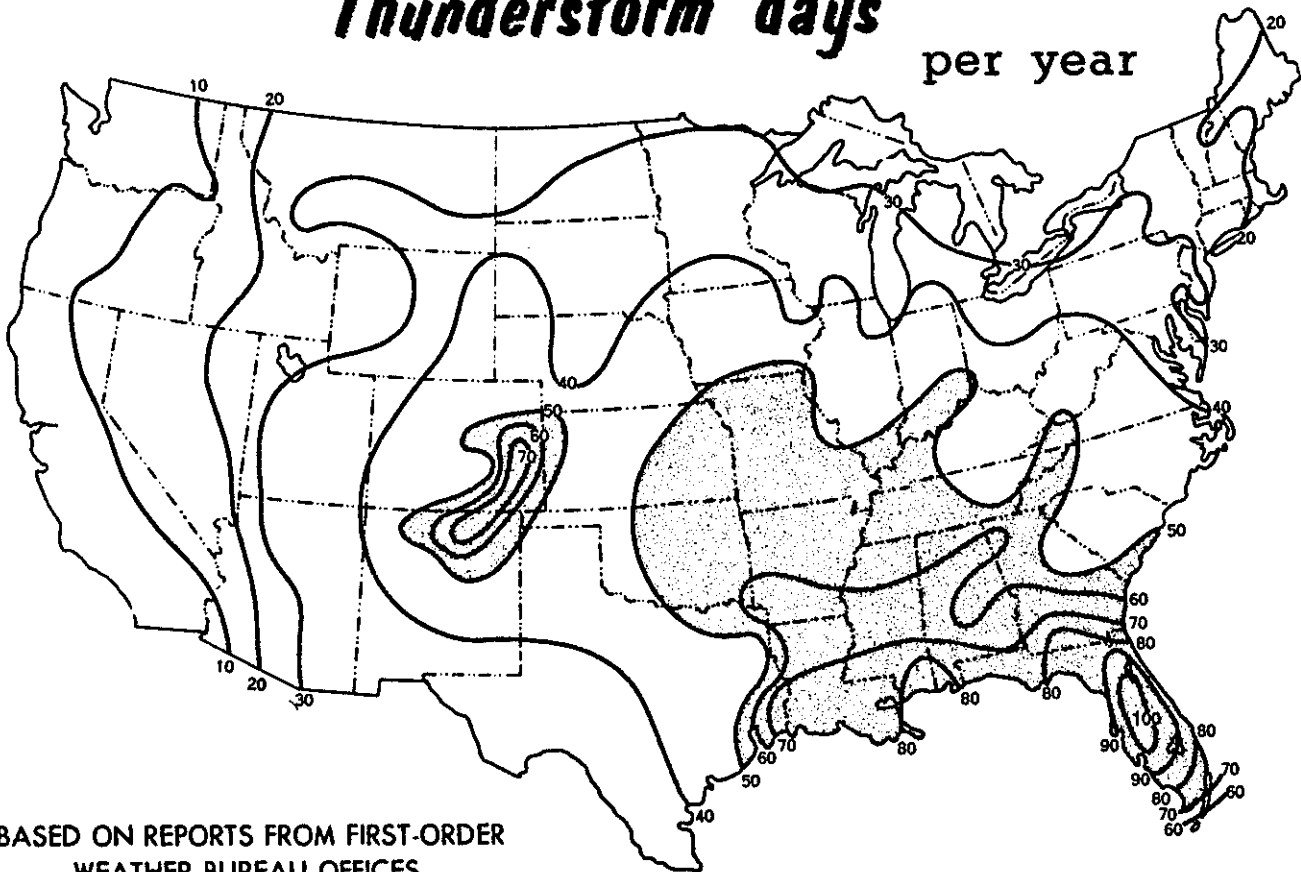

BASED ON REPORTS FROM FIRST-ORDER
WEATHER BUREAU OFFICES

The map above shows the yearly average number of days with thunderstorms based on observations from all U.S. Weather Bureau first-order stations in the United States. A thunderstorm day is considered any day during which one or more thunderstorms occur. It should be realized, however, that

there probably are variations which do not show on this map because of the local nature of thunderstorms and the sparsity of observations from some areas. July and August are the months with the greatest number of thunderstorms over most sections of the United States while December and January have the least number.

TORNADO FREQUENCY BY STATES 1953-1962

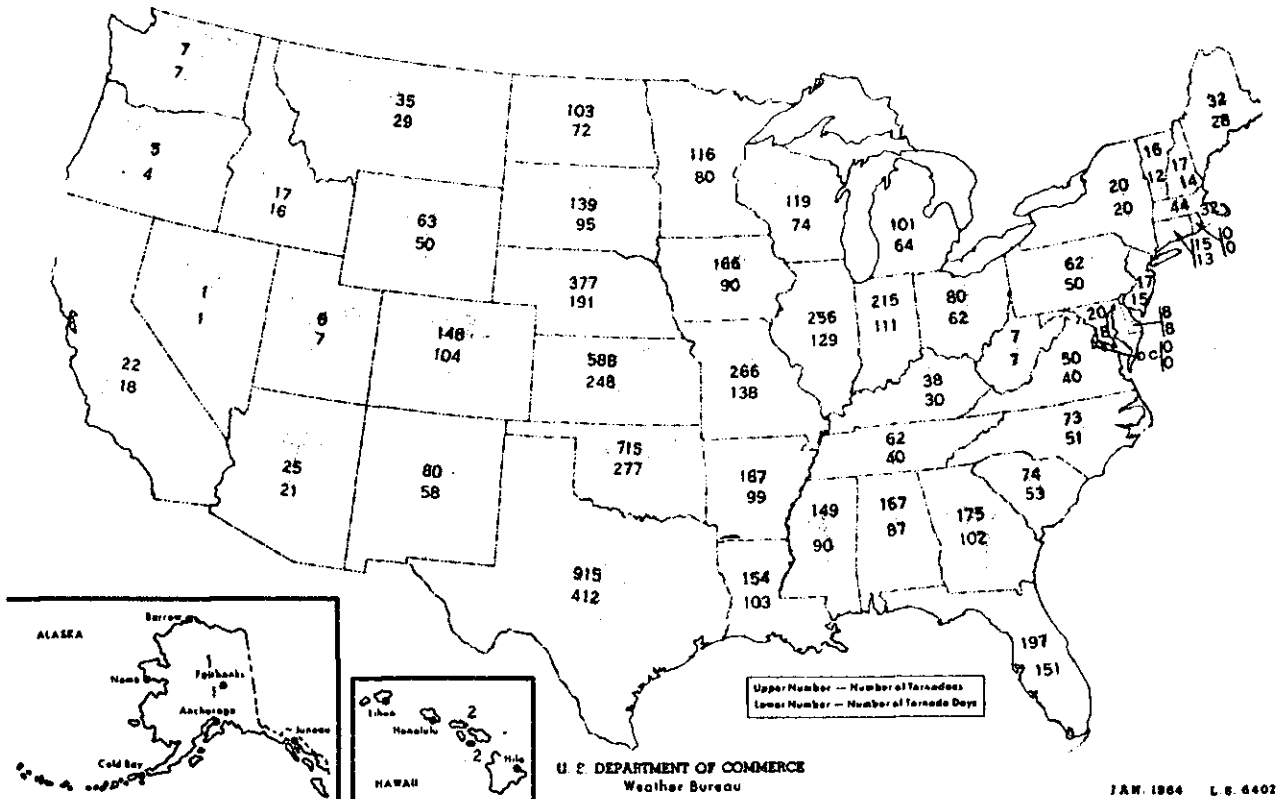

5. WINDY, WICKED WOMEN. Thunderstorms are not the only concern of aircraft owners, fixed-base operators, airport service crews, etc., from a tie down sense. There are also those windy, wicked women who inhabit the Gulf and East Coast during the hurricane season of August, September, and October. (See Storm Belt Map on page 4.)

Hurricane Cleo struck the Miami area with gusts in excess of 110 mph, August 27, 1964. The Miami Weather Bureau reported gusts as high as 125 mph. The lowest pressure of 28.71 inches/972.3 millibars occurred on the 27th. Hurricane Dora struck the city of St. Augustine with gusts of 100 mph, September 10, 1964. Gusts battered the city for nearly 15 hours. During the height of the storm gusts up to 110 mph were recorded. The barometer dropped to 28.52"/965.8 mb at 0100 on the 10th.

The illustrations at the bottom of page 4 show samples of havoc left in the path of Hurricane Cleo.

STORM BELTS

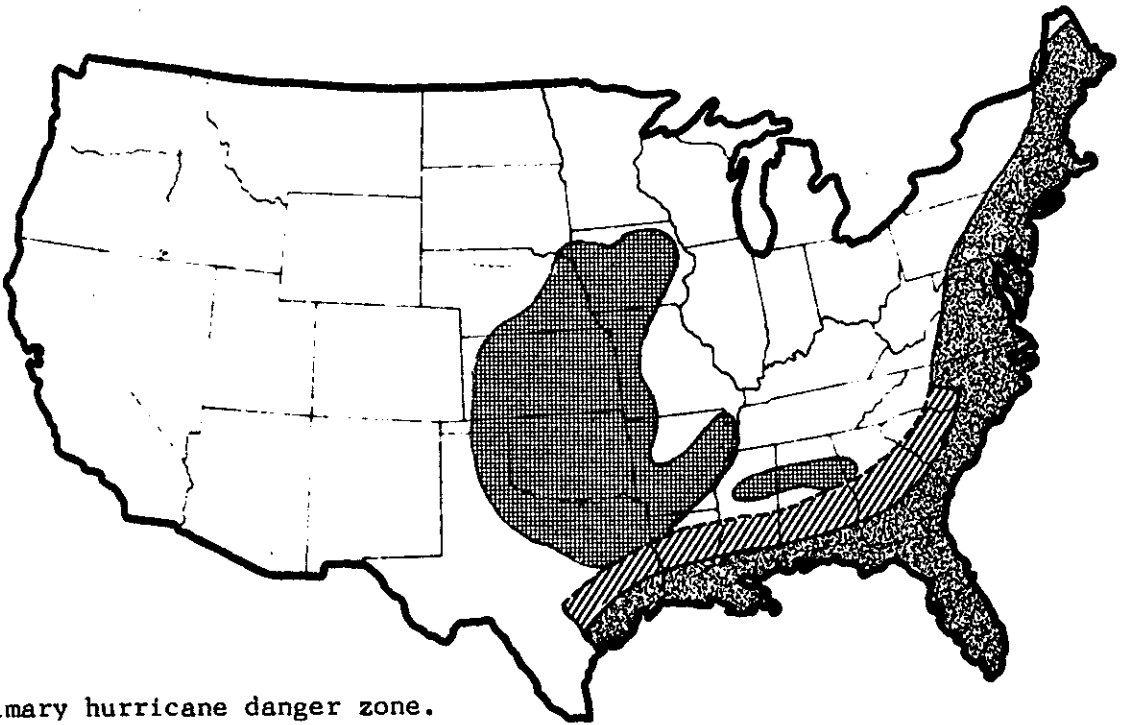

- Primary hurricane danger zone.
- /// Fringe area.
- Tornado belt.

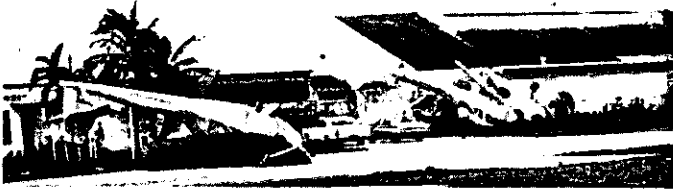

HURRICANE CLEO DAMAGE



6. PREVENTING WINDSTORM DAMAGE. The best protection against windstorm damage is, of course, to fly the aircraft out of the impending storm area provided you have sufficient warning time. The next best protective measure is to secure the aircraft in a stormproof hangar or other suitable shelter. The remaining alternative is to assure that the aircraft is tied down securely. When securing your aircraft, it is considered good practice to fasten all doors and windows properly, thereby minimizing damage inside the airplane. Engine openings (intake and exhaust) for both reciprocating and gas turbine type should be covered to prevent entry of foreign matter. Pitot-static tubes should also be covered to prevent damage.
7. ADVANCE PLANNING. Be prepared for the worse conceivable windstorm conditions: for example, pouring rain, gusty winds ranging from 30 mph and up, with intermittent sheets of water blowing across the runways, ramps, and parking areas, and with no hangar facilities available. With such conditions in mind, aircraft owners and operators should plan in advance by learning their (aircraft) manufacturer's instructions for tie down, location and/or installation of tie-down rings for attachment of tie-down ropes; any special instructions for securing nose wheel type aircraft vs. tail wheel type aircraft; and manufacturer's charts and graphs denoting aircraft weights and relative wind velocities that would make varied tie-down procedures necessary for pending weather emergencies.
8. TIE-DOWN FACILITIES. Any airplane parking area should be equipped for three-point tie downs. Aircraft should be tied down at the end of each flight to preclude damage from sudden storms. The direction in which the aircraft are to be parked and tied down will be determined by prevailing or forecast wind direction.
 - a. Aircraft should be headed into the wind, or as nearly as possible, depending upon the locations of the fixed, parking area mooring points.

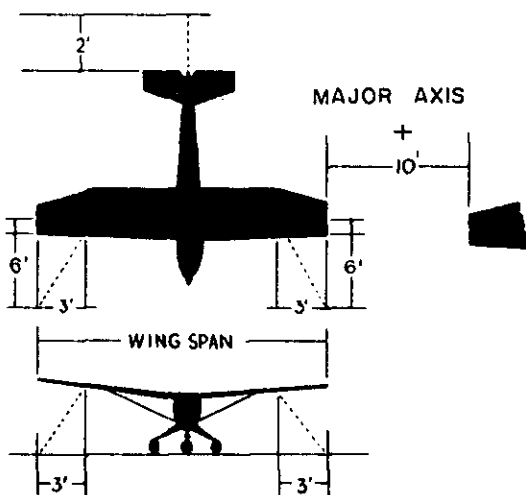

- b. Spacing of tie downs should allow for ample wingtip clearance. Spacing should be equal to the major axis (wing span or fuselage length) of the largest aircraft usually operated plus ten feet.
- c. After the aircraft is properly located, lock the nose wheel or the tail wheel in the fore and aft position.

- (1) **Anchors.** Tie-down anchors for single engine aircraft should provide a minimum holding power (strength) of approximately 3,000 pounds each. The type of anchors in use varies depending upon the type of parking area - whether for a concrete paved surface, a bituminous paved surface, or an unpaved turf area. Location of tie downs are usually indicated by some suitable means, either white or yellow paint, or a painted tire which has been fastened into the ground, or surrounding the tie-down anchor with crushed stone. The tie-down anchor eye should not protrude more than one inch above ground.

TIE-DOWN ANCHORS FOR CONCRETE PAVED AREAS

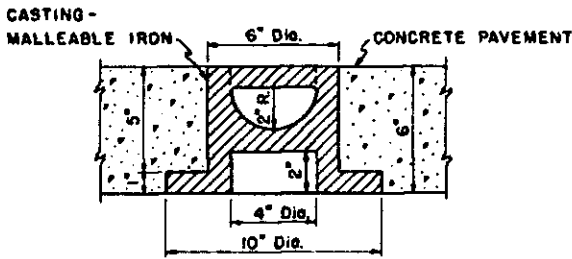
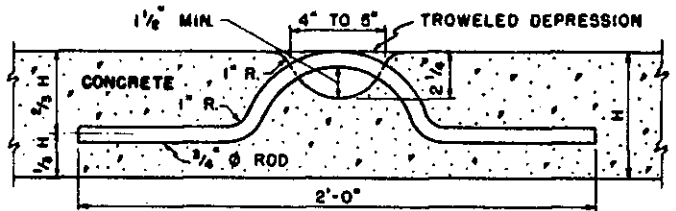
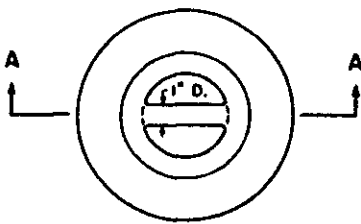

SECTION A-A

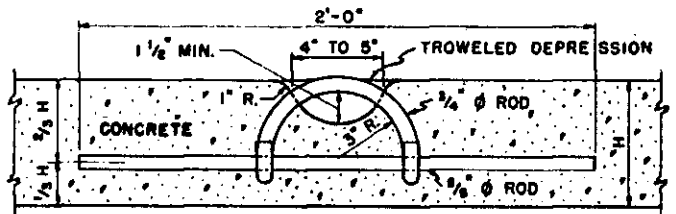

TIE-DOWN ANCHOR FOR BITUMINOUS PAVED AREAS

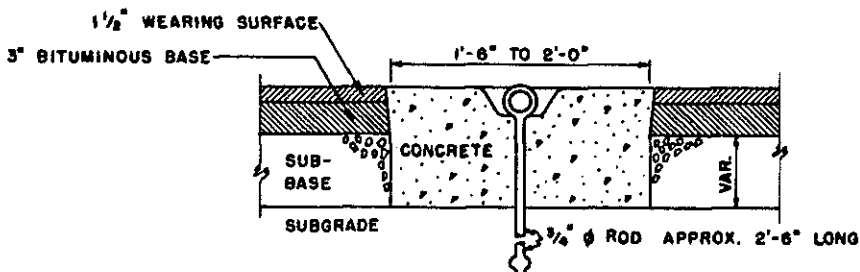

TIE-DOWN ANCHORS FOR TURFED AREAS

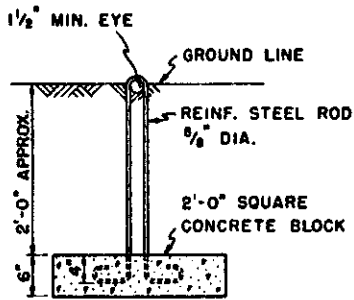

ROD AND BLOCK ANCHOR

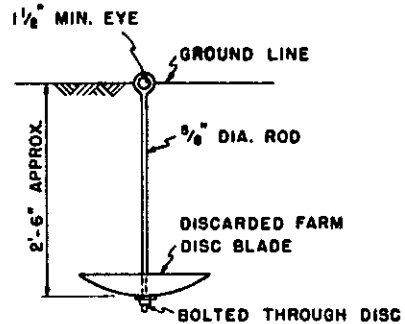

MUSHROOM TYPE ANCHOR

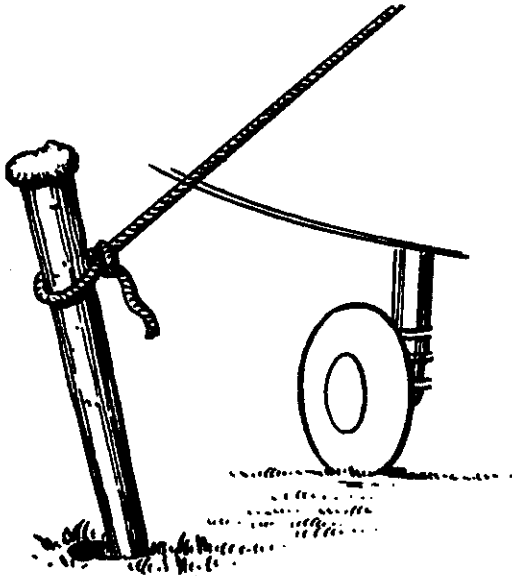

DON'T depend on wooden stakes.

Stake-driven tie downs such as depicted above will almost invariably pull out when the ground becomes soaked from torrential rains which accompany hurricanes and some thunderstorms.

- (2) Tie-Down Ropes. Tie-down ropes capable of resisting a pull of approximately 3,000 pounds should be used. Manila ropes should be inspected periodically for mildew and rot. Nylon or dacron tie-down ropes are preferable over manila rope. The objection to manila rope is that it shrinks when wet, is subject to mildew or rot, and has considerably less tensile strength than either nylon or dacron.

COMPARISON OF TIE-DOWN ROPES

Size in Inches	Manila	Nylon	Dacron		Yellow Polypropylene	
	Minimum Tensile Strength	Minimum Tensile Strength	(Twist) Minimum Tensile Strength	(Braid) Minimum Tensile Strength	(Twist) Minimum Tensile Strength	(Braid) Minimum Tensile Strength
3/16	-	960	850	730	800	600
1/4	600	1500	1440	980	1300	1100
5/16	1000	2400	2220	1650	1900	1375
3/8	1350	3400	3120	2300	2750	2025
7/16	1750	4800	4500	2900	-	-
1/2	2650	6200	5500	3800	4200	3800
5/8	4400	10,000	-	-	-	-
3/4	5400	-	-	-	-	-
1	9000	-	-	-	-	-

- (3) Securing Aircraft. Tie only at the tie-down rings provided for that purpose. Never tie to a strut itself. The practice of tying to lift struts has in itself caused frequent damage. Ropes slip to a point where even slight pressure may bend the struts.

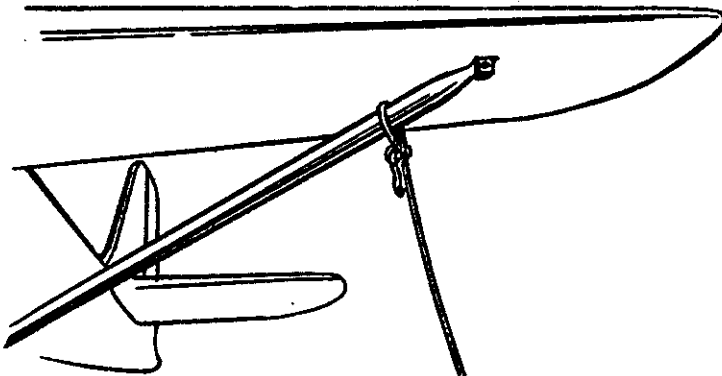

DON'T tie ropes on struts so that it is possible for them to slip down.

Allow for about one inch of movement, and remember that manila rope shrinks when it gets wet. Too much slack will allow the aircraft to jerk against the ropes. Avoid tightening the ropes too much. Tight tie-down ropes actually put inverted flight stresses on the aircraft, and many of them are not designed to take such loads. A tie-down rope holds no better than the knot. Antislip knots such as a bowline or a square knot are quickly tied, and easy to untie. (See illustrations at

the bottom of this page for tying knots.) Aircraft not equipped with tie-down fittings should have them installed in accordance with manufacturers' instructions.



DO tie ropes to outer ends of struts on high wing monoplanes. Provide suitable rings, where structural conditions permit, if manufacturer has not already provided them.

TYING A BOWLINE



UP THROUGH AND AROUND BACK



BACK DOWN THROUGH

TYING A SQUARE KNOT

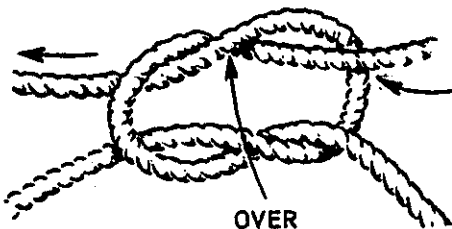

UNDER

OVER

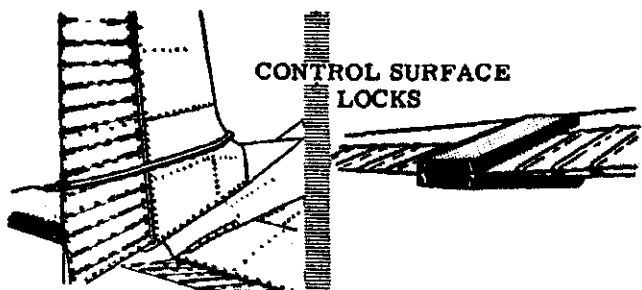

All f
locke
bangi
aircr
gral
cockp
neces
batte
or se
rudde

When using external surface locks, it is advisable that red streamers, weights, or a line to the tie-down anchor be fastened to the locks. This will provide a means of alerting airport service employees and pilots to remember to remove the external locks prior to takeoff. Secure ailerons and rudders in neutral. Tail wheel type aircraft headed into the wind should have their elevators secured in the "up" position by securing the control column or "down" position. Tail wheel type aircraft "tailed" into the wind should have their elevators secured in the "down" position by securing the control column or "up" position.

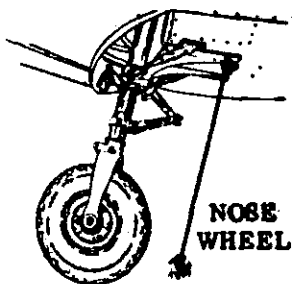
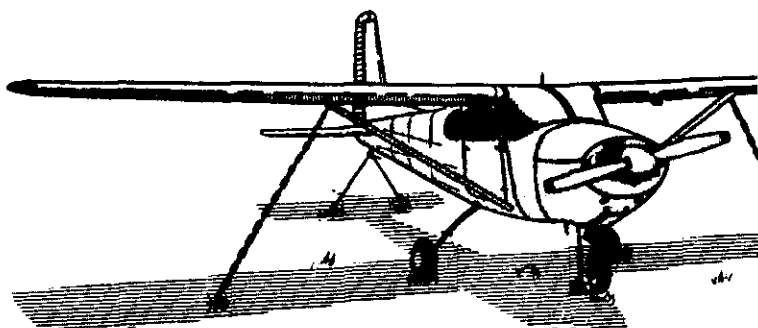

Pull each end of the rope away from the airplane to ground anchors at each side of the airplane. The rope should be secured parallel to the ground. It is good practice to also secure the tail wheel if the airplane is tailed into the wind.

Chocks should be placed and secured behind the nose wheel. Wooden chocks may be substituted for metal chocks from chock to chock on each side. Metal chocks may be substituted if wood cleats are used. A piece of 2 x 4 are poor excuse for chocks.

9. RECOMMENDED PRACTICES. The following practices are recommended for day-out use regardless of the inconvenience of the practices are principally for protection of the aircraft.

and result from experiences with the "windy, wicked women of 1964." Adoption of the following recommendations should materially reduce aircraft damage from windstorms.

- a. Partially disassembled aircraft which are outdoors, particularly light aircraft with engines removed, should be hangared as soon as storm warnings are received. Loose wings should never be tied against a fuselage; they should be stored inside a hangar.

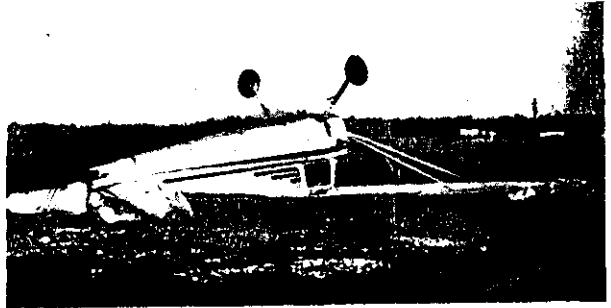

- b. Wherever possible, fly aircraft out of anticipated storm danger zones. If impossible, hangar the aircraft in a stormproof hangar.
- c. The minimum recommended tie-down rope is one which will resist a pull of approximately 3,000 pounds. (Many users of plastic tie-down rope, yellow polypropylene, 1/2-inch and larger, reported little or no rope failure because of its elasticity. In some instances, nylon and hemp rope failed. In others, steel cables were snapped while hemp lines, due to their elasticity, held. In many cases both hemp and steel cable tie downs failed due to chafing.)
- d. A single row of properly secured sandbags or 2 x 2s (spoiler boards) on the top of a wing's leading edge will serve as an effective spoiler and reduce the lifting tendency of the wings. Do not overload the wings with sandbags. If the anticipated winds will exceed the lift-off speed of the aircraft wings, then the makeshift spoilers should run the entire length of the wings.

The 2 x 2 homemade spoiler is very easily constructed and may be used for all types of light aircraft. Drill a number of 3/8-inch holes across the length of the 2 x 2. Cement a strip of 1-inch foam rubber to the entire length of the 2 x 2. This will prevent damaging the wing's surface. Avoid nailing the foam rubber to the spoiler since the nailheads may damage the wing's skin.

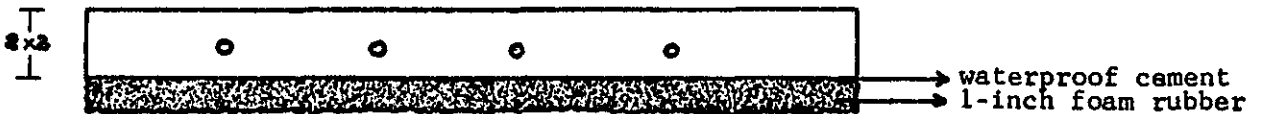

Thread a length of nylon rope through each of the drilled holes. To facilitate threading the nylon rope through the holes, it is suggested that the ends of the lines be seared. This will prevent fraying of the ends to be threaded through the 3/8-inch holes.

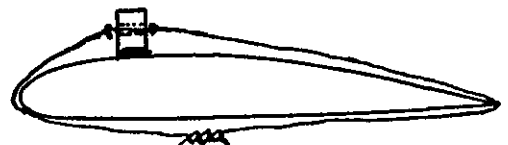

To prevent the spoiler from shifting position due to the wind, it is suggested that knots be tied in the rope on either side of the drilled holes. The spoiler should then be tied onto an aircraft's wings at the 25 percent chord point. To prevent damaging the wing's leading and trailing edges, it is suggested that a piece of foam rubber, or carpet, or even rags be placed under the nylon rope before tying. Some people may like to substitute bungee (elastic) cords for the long length of nylon rope.

10. ALTERNATE METHOD. Another means for tying down aircraft of various types and sizes is by utilizing continuous lengths of parallel wire ropes passed through U-bolt anchors and fastened at the ends of the line with wire rope clips. Tie-down chains are attached to the wire rope with roundpin galvanized anchor shackles. This allows the tie-down chains to "float" along the wire rope and gives a variable distance between anchor points so that a variety of large, medium, and small aircraft can use a vertical tie down without loss of space. The vertical anchor reduces significantly impact loads that may occur during gusty wind conditions.

TYPICAL AIRCRAFT TIE DOWN USING A WIRE ROPE SYSTEM

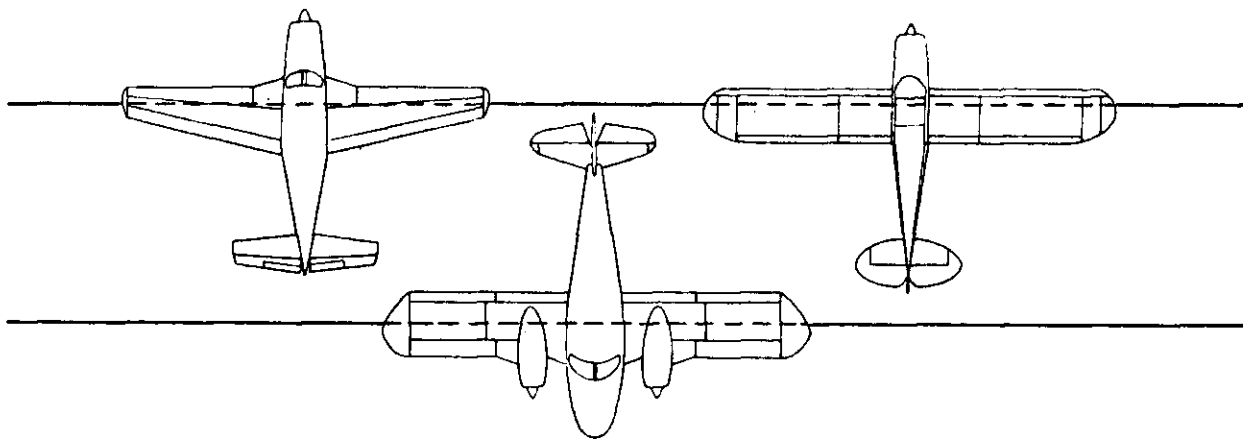

The distance between wire ropes will depend upon the types of aircraft which will use the tie-down area. This distance can vary from 22 feet and upward.

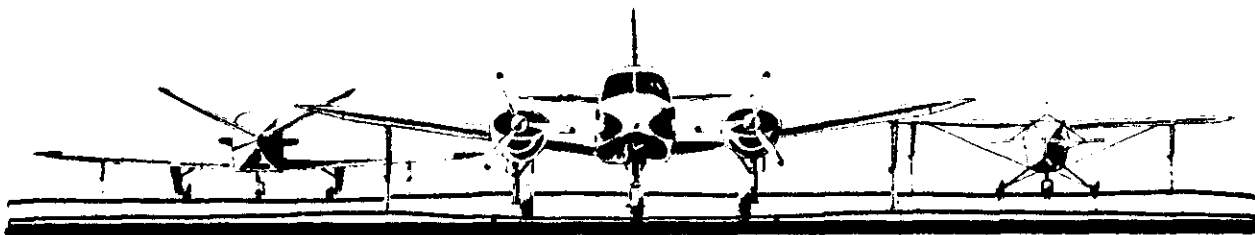

The diagram on the left shows a proper vertical anchor using wire rope tie-down line, straight link coil chain for connection between the wire rope and aircraft wing. One link on the free end is then passed through a link of the taut portion and a safety snap is used to keep the link from passing back through. Any load on the chain is borne by the chain itself instead of the snap.

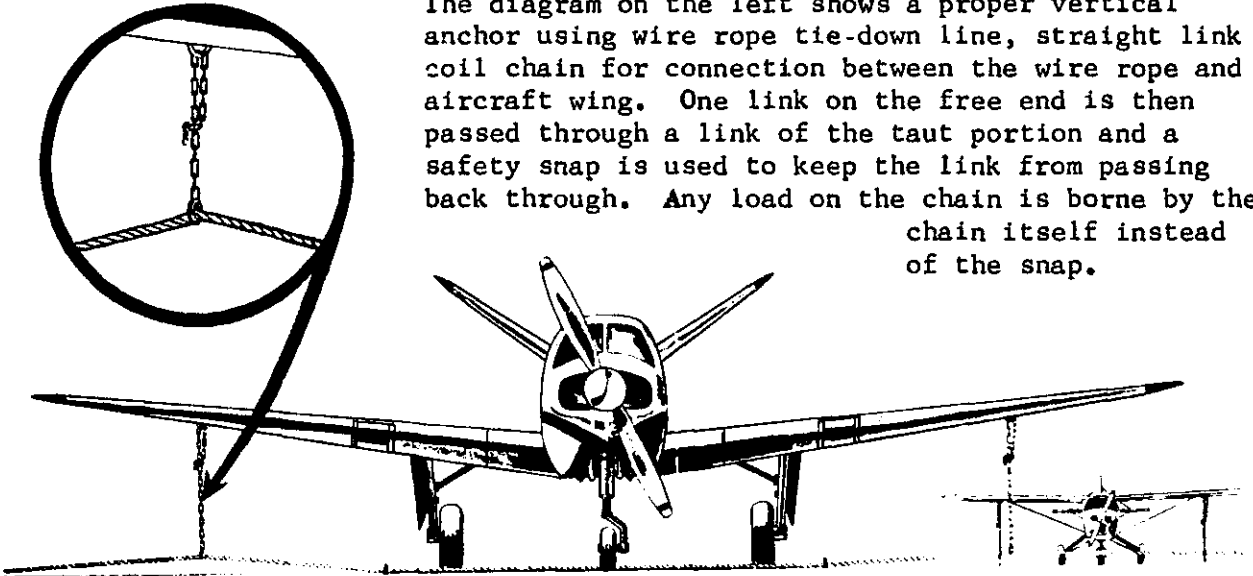

11. SECURING MULTIENGINE AIRCRAFT. Multiengine aircraft will obviously require stronger tie-down facilities because of the additional weight of these aircraft. The anchors should be capable of a holding power of 4,000 pounds each for the lighter executive twin-engine aircraft. Much higher load capacity would be required for the heavier transport type aircraft.

Do not depend on the multiengine aircraft's weight to protect it from damage by windstorms. It is quite possible for a sudden, severe windstorm to move, damage, or even overturn such aircraft.

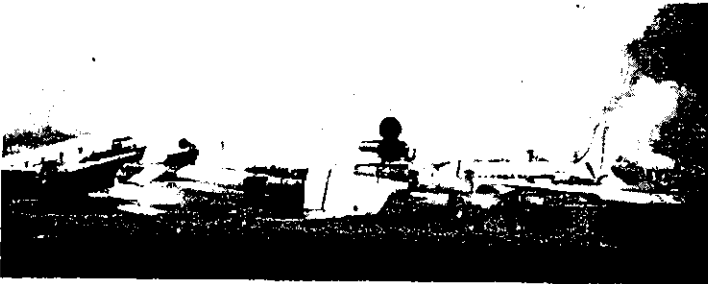

10/29/68

Multiengine aircraft should, therefore, always be tied down and chocked when they are to be left unattended for any length of time. Gust locks should be used to protect control surfaces. Be sure that gust locks are foolproof; a takeoff with gust locks on is not only embarrassing but could prove to be disastrous. If the landing gear makes use of down lock safety pins, then these pins should be inserted when the aircraft is being secured.

12. SECURING HELICOPTERS. Structural damage can occur from high velocity surface winds. Therefore, if at all possible, helicopters should be evacuated to a safe weather area if tornado, hurricane, or winds above 65 mph are anticipated. If helicopters can be hangared, do so. If not, then they should be tied down securely. Helicopters that are tied down can usually sustain winds up to approximately 65 mph. Winds in excess of 65 mph will usually cause damage to helicopters.



When high winds are anticipated, and helicopters are to be tied down, then they should be secured as follows:

- a. Head the helicopter in the direction from which the highest forecasted wind or gusts are anticipated.
- b. Spot the helicopter slightly more than rotor-span distance from other aircraft.
- c. Place wheel chocks fore and aft of all wheels (if available). Secure the chocks by nailing wood cleats from chock to chock on each side of each wheel. Ropes may be substituted if wood cleats are not available.
- d. Position the main rotor blades so that one blade is positioned slightly to one side of the tail cone. (See page 15.)
- e. Install a rotor blade cover over the tip of each main rotor. Secure a tie-down rope to each blade cover and the other end of the rope to the applicable mooring point on the aircraft. Remember not to leave too much slack and to use antislip knots when tying the mooring ropes.
- f. Fasten the tie-down ropes to the fuselage mooring points and extend them to the ground mooring anchors. Again be aware of slack and antislip knots.
- g. Place the tail rotor in a vertical position and install a cover over the lower blade tip. Tie the lower blade cover rope to the tail skid to prevent possible damage by flapping tail blades.

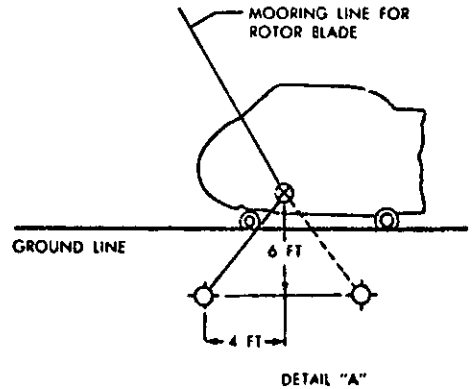
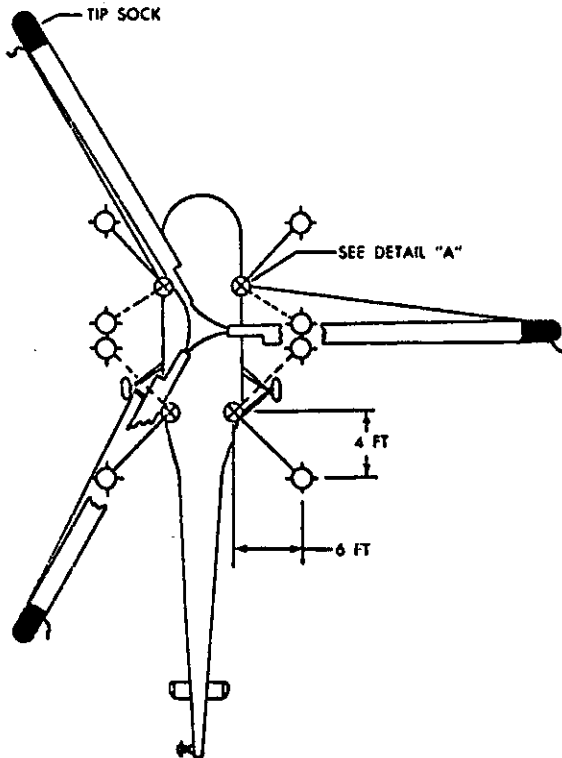
MOORING TO DEAD-MAN-TYPE ANCHORS



NOTE
MOORING POINT LOCATION FOR DEAD-MAN ANCHOR ON UN-PAVED AREA. OPTIMUM TIE-DOWN IS SHOWN BY DOTTED LINES.

-  GROUND MOORING ANCHOR
-  AIRCRAFT MOORING POINT

13. SECURING SEAPLANES AND AIRCRAFT ON SKIS. Aircraft mounted on floats or skis should be secured in the usual manner - to tie-down anchors or "deadmen" sunk under the water or ice. When warning of an impending storm is received, some pilots have been known to partially flood the floats of their aircraft, thereby partially sinking the aircraft. In addition, the airplane is tied down securely to anchors. Seaplanes moored on land have been saved from high-wind damage by filling the floats with water in addition to tying down the wings. Pilots of ski-equipped aircraft sometimes pack soft snow around the skis, pour water on the snow, and permit the skis to freeze to the ice. This in addition to the usual tie-down procedures aids in preventing damage from windstorms.



14. CONCLUSION. The simplest way to prevent windstorm damage to your airplane is to fly it out of any impending storm area provided there is sufficient warning time. If that is impossible or impractical, shelter the airplane in a stormproof hangar. Should this prove impossible, then tie down your airplane securely. Aircraft parked outdoors should be tied down securely after each flight. Use the tie-down techniques discussed in this advisory circular. Learn to tie a bowline or a square knot during fair weather; don't wait until the wind and rain are adding to your difficulties. Should you desire additional information, we suggest that you contact the manufacturer of your airplane.

K. P. Sliff

Director,
Flight Standards Service

acting

23733

Official Business

Washington, D.C. 20590

DEPARTMENT OF TRANSPORTATION
FEDERAL AVIATION ADMINISTRATION

POSTAGE AND FEES PAID
FEDERAL AVIATION ADMINISTRATION