

ADVISORY CIRCULAR



DEPARTMENT OF TRANSPORTATION
Federal Aviation Administration
Washington, D.C.

FAR GUIDANCE MATERIAL

Subject: AIRCRAFT POSITION LIGHT AND ANTICOLLISION LIGHT INSTALLATIONS

1. PURPOSE. This circular sets forth acceptable means, but not the only means, of showing compliance with the Federal Aviation Regulations (FAR) applicable to installed position lights and anticollision lights.
2. CANCELLATION. AC 20-30A dated April 18, 1968, is canceled.
3. RELATED FAR SECTIONS.
 - a. Sections .1385 through .1401 of FAR Parts 23, 25, 27, and 29.
 - b. Sections (.33) and (.73) of FAR Part 91.
4. RELATED READING MATERIAL.
 - a. Advisory Circular AC 20-74, Aircraft Position Lights and Anticollision Light Measurements.
 - b. Advisory Circular AC 43.13-2A, Acceptable Methods, Techniques, and Practices, Aircraft Alterations.
 - c. Technical Standard Order (TSO) C30b, Aircraft Position Lights.
5. BACKGROUND. Airworthiness regulations and Technical Standard Orders prescribe minimum intensities, light distribution, overlap limits, allowable obstructions to light visibility, and color for position lights and anticollision lights.
6. LABORATORY MEASUREMENTS. Measurements of intensity, light distribution, and light color are normally made under laboratory conditions before installation. Advisory Circular 20-74 contains information concerning measurements of intensity, distribution, and color.

7. POSITION LIGHT SYSTEM INSTALLATION.

a. Location. In determining whether forward position lights have been "spaced laterally as far apart as practicable," and whether the rear position light has been "mounted as far aft as practicable," as required by the FAR's, each installation may be evaluated for special considerations. Examples of special consideration are:

(1) Would the number of malfunctions be significantly increased due to increased vibration or other environmental conditions if the lights were spaced farther apart, or mounted farther aft?

(2) Would accessibility for maintenance be significantly reduced if the lights were spaced farther apart or farther aft?

b. Rear Position Light Obstructions. A small light obstruction is permitted within dihedral angle A (aft) described in § .1387(d) of Parts 23, 25, 27, and 29. That obstruction is limited in size to 0.04 steradian and in position to the 30° cone described in § .1387(e) of Parts 23, 25, 27, and 29 and shown in Figure 1. Measurements to show compliance with the regulations can be made on actual aircraft or on appropriate scale drawings. The following procedure is one means of showing compliance with the regulations:

(1) On the side view drawing, draw a line through the light center perpendicular to the aircraft longitudinal axis. Draw a second line upward through the light center to the most aft point on the vertical stabilizer. The angle Z between the two lines is limited by the airworthiness rules to 30°. Figure 1 shows an example of angle Z.

(2) On the rear view drawing, draw angle W which is formed by two lines drawn upward from the light center to the maximum right and left obstructions within angle Z. When a protrusion causes a very small zone of obstruction it may be discounted unless total obstructions are near the regulatory limit. When a rear view drawing is not available, a combination of other drawings or measurements on the actual aircraft can be used to determine angle W.

(3) Multiply angle Z degrees by angle W degrees to obtain the amount of obstruction in square degrees. The method is conservative, as obstructions as wide as angle W may not exist throughout angle Z. Convert the measurement to steradians by dividing the square degree value by 3284. The number 3284 is a conversion factor to obtain steradians from square degrees.

8. ANTICOLLISION LIGHTS

a. Airworthiness Requirements. Appendix 1, Tables 3 through 6., summarize the airworthiness requirements for anticollision lights and lists them according to the applicable amendments to the CAR's/FAR's. The airworthiness requirements for a specific aircraft can usually be determined by entering the applicable table with the latest amendment shown for the certification basis in the aircraft's type certificate data sheet.

FIGURE 1. REAR POSITION LIGHT OBSTRUCTIONS

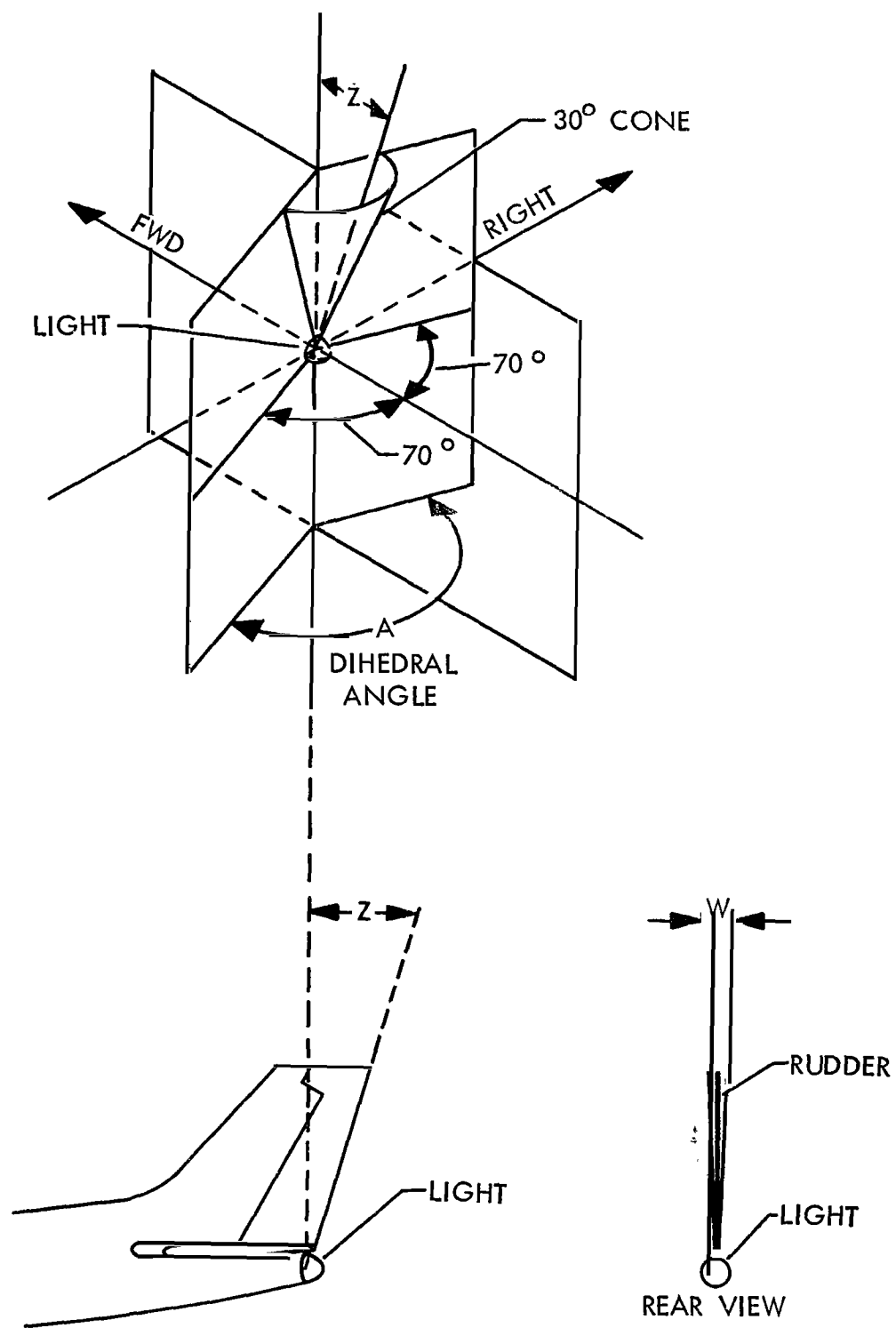

b. Operational Requirements. Some airworthiness requirements have been made retroactive by Amendment 91-90, which amended § 91.33(c)(3) of the FAR. The term "initially installed" used in this section refers to new installations based on newly-approved design data or any installation which includes a major change as defined in FAR 21.93(a) to the previously approved design data. In effect, new designs which have had no previous FAA approval are considered initially installed systems. Anticollision light installations approved by Major Repair and Alteration (Airframe, Powerplant, Propeller, or Appliance), FAA Form 337, supplemental type certificate or amended type certificate prior to August 11, 1971, may be duplicated on like make and model aircraft without being considered initially installed.

c. Obstruction Measurements. When anticollision light obstructions are allowed within the required field of coverage, measurements on shadows, scale drawings or actual aircraft can be used to substantiate that solid angles of obstruction do not exceed regulatory limits. When masking is used to prevent the impairment of crew vision, the mask becomes an additional light obstruction. The amount of obstruction caused by the mask depends not only on the physical size of the mask, but also on the type and size of the light source. With rotating beacons, the mask obstruction may be slightly larger than indicated by the physical size of the mask. This condition results from the lack of a sharp cutoff of light at the mask edges. As the reflector rotates, there is a gradual reduction of light near the mask edges due to the relatively large size of the light source. Accurate measurement of mask obstruction can best be accomplished during the laboratory measurement of intensity and field of coverage. Otherwise, total obstructions measured very near the regulatory limit may actually exceed that limit.

d. The following procedures refer to the example shown in Figure 2. Scale drawings and measurements from the light unit are used in substantiating compliance with the anticollision light requirements. The procedure with variations can be applied to other aircraft. Variations include other shapes and vertical coverage requirements. The procedure converts scale drawing obstructions to a plot of horizontal versus vertical degrees where area units become square degrees. By counting the squares within obstructions and converting the sum to steradians, compliance can be shown. Scale drawings should be large enough to assure reasonable accuracy in the measurements. For the example, the vertical coverage requirement is $\pm 30^\circ$.

(1) Fuselage and Wings.

(i) Point selection. On the top view, establish enough points to adequately follow the shape of obstructions. In the example of Figure 2, seven points are established and numbered to represent the left half of the fuselage and the left wing. Because of symmetry, measurements are limited to one side, and the measured obstructed area is doubled to account for the other side of the aircraft. Additional obstructions, not represented by the seven numbered points, include mask, wing struts, landing gear, and rudder. These additional obstructions are considered separately.

FIGURE 2. ANTICOLLISION LIGHT OBSTRUCTIONS

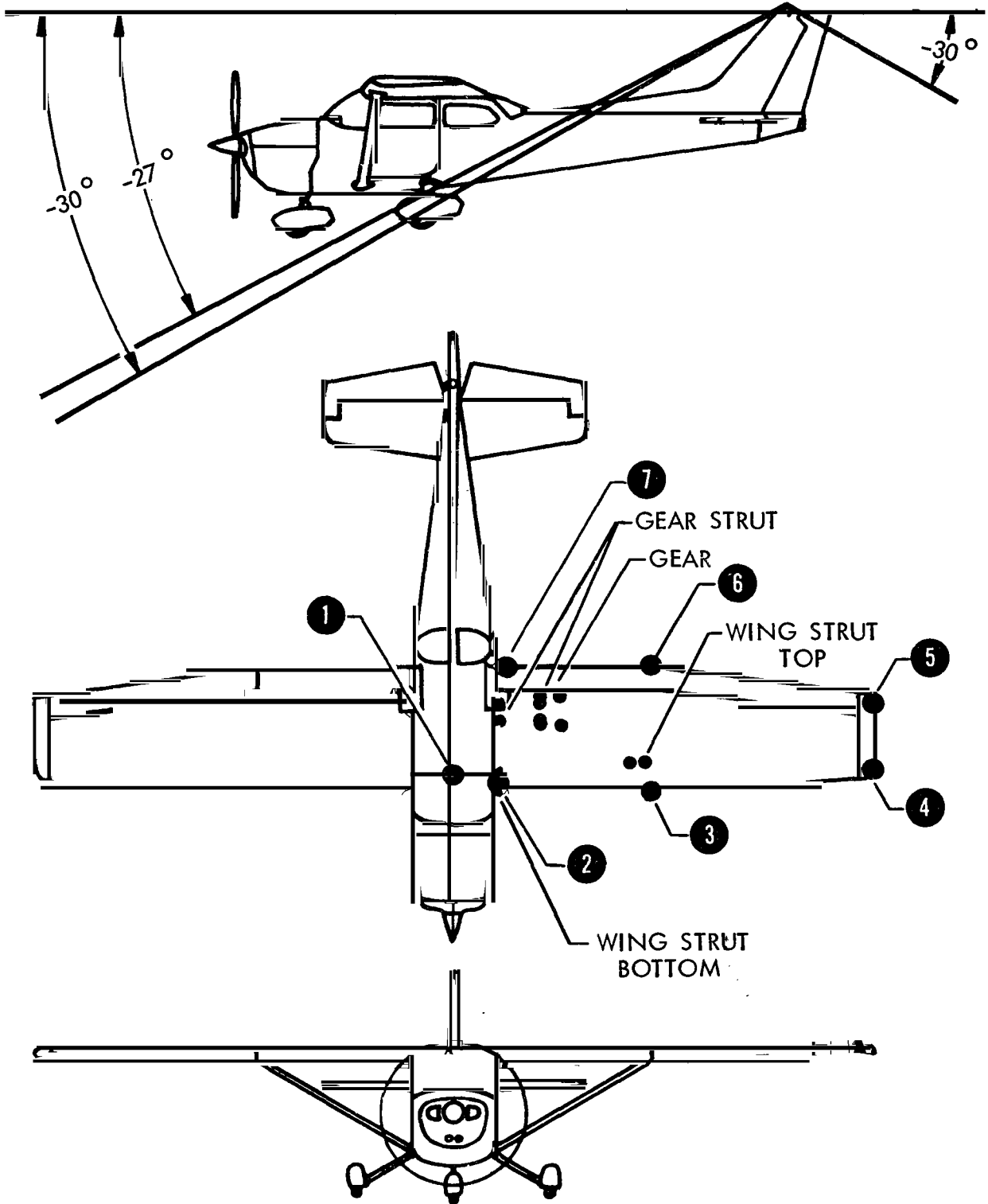

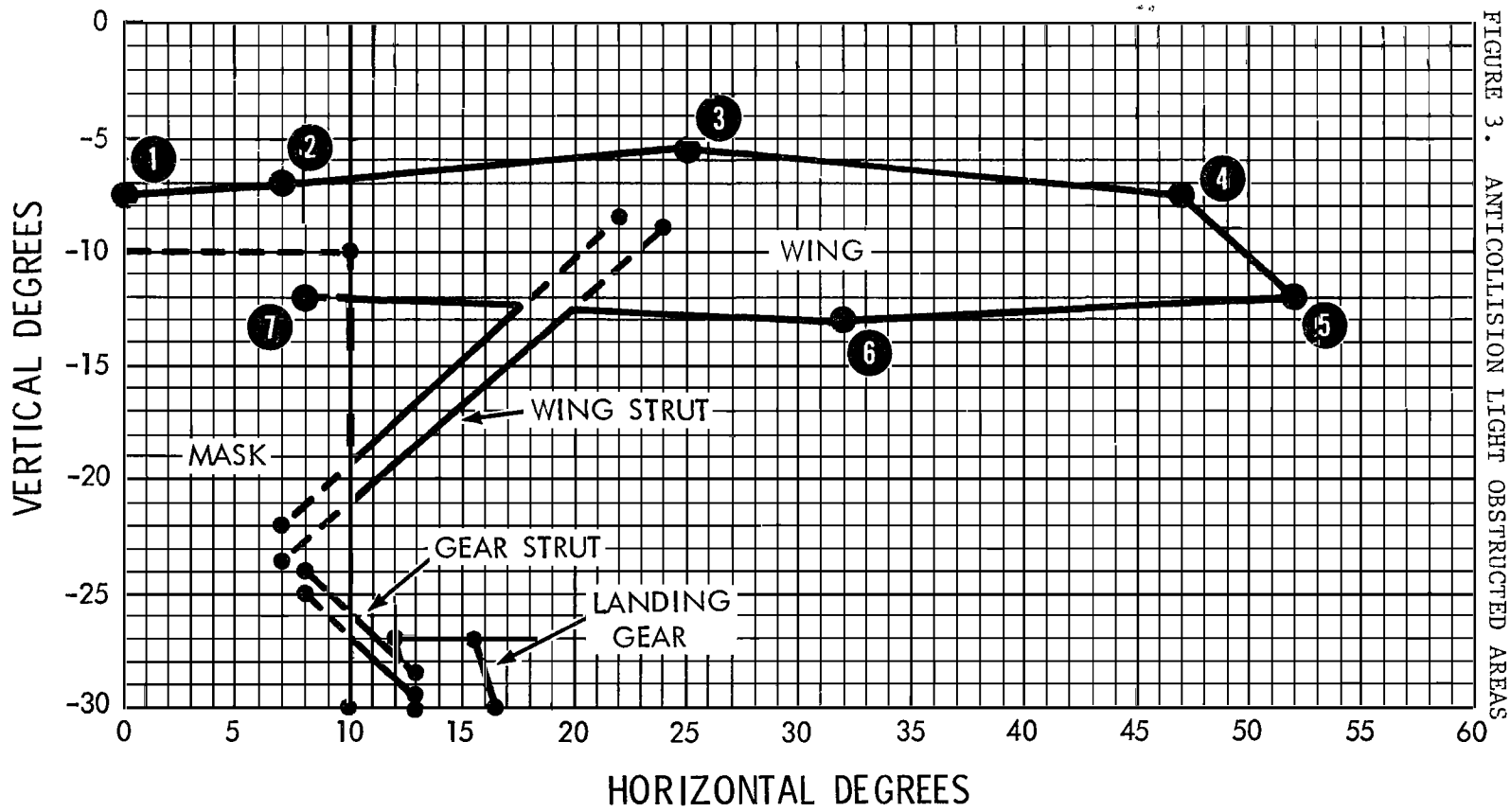

FIGURE 3. ANTICOLLISION LIGHT OBSTRUCTED AREAS

(ii) Horizontal angles. On the top view of Figure 2, measure the horizontal angles between the aircraft centerline and lines connecting the anticollision light center to the numbered points.

(iii) Vertical angles. On the side view of Figure 2, measure the vertical angles from the horizontal plane passing through the anticollision light center to lines connecting the light center to the numbered points.

(iv) Tabulation. Tabulate the measured horizontal and vertical angles as shown in Table 1.

NOTE: In lieu of direct angle measurements, distance measurements may be used to calculate the angles using trigonometry relationships.

(2) Wing strut angles. On the top view of Figure 2, establish right and left points for the strut top and fore and aft points for the strut bottom. Horizontal angles for the strut bottom points are approximately equal. Measure the horizontal and vertical angles to the four points and tabulate as shown in Table 1.

(3) Main gear fairing. On the top of Figure 2, establish four points for the main gear fairing obstruction. The rear obstruction limit is the -30° vertical coverage requirement, and the forward obstruction extends to vertical angles of -27° . The effect of wheel fairing rounding is slight and is neglected. Measure the horizontal angles to the four points, and tabulate as shown in Table 1.

(4) Main gear strut. On the top view of Figure 2, establish four points for the main gear strut. Measure the horizontal and vertical angles to the four points, and tabulate as shown in Table 1.

(5) Rudder obstructions. On the side view of Figure 2, rudder obstructions occur aft of the anticollision light while all other obstructions are forward. Therefore, it is practical to measure rudder obstructions independently. On the side view of Figure 2, the rudder obstructs for 30 vertical degrees. On the top view, the obstruction is 3 horizontal degrees on the left side. The left side rudder obstruction is 90 square degrees; i.e., $30^\circ \times 3^\circ = 90$ square degrees.

(6) Calculating obstructions. The graph of Figure 3 shows plotting of the collected data of Table 1 as vertical degrees versus horizontal degrees. Each square is equal to one square degree so that obstructions can be measured by counting squares. Obstruction areas can be counted in zones bounded by vertical lines through the numbered points. Table 2 shows the counts including the rudder obstruction which was measured independent of the graph. Square degrees are converted to steradians by dividing by 3284.



M. C. Beard
Director of Airworthiness

TABLE 1. OBSTRUCTION POINT ANGLES

<u>OBSTRUCTION</u>	<u>POINT</u>	<u>HORIZONTAL ANGLE</u>	<u>VERTICAL ANGLE</u>
Wing/Fuselage	1	0°	-7.5°
	2	7°	-7.0°
	3	25°	-5.5°
	4	47°	-7.5°
	5	52°	-12°
	6	32°	-13°
	7	8°	-12°
Strut	Top Right	22°	-8.5°
	Top Left	24°	-9.0°
	Bottom Upper	7°	-22°
	Bottom Lower	7°	-23.5°
Gear	Front Right	12°	-27°
	Front Left	15.5°	-27°
	Rear Right	13°	-30°
	Rear Left	16.5°	-30°
Gear Strut	Top Front	8°	-24°
	Top Rear	8°	-25°
	Bottom Front	13°	-28.5°
	Bottom Rear	13°	-29.5°
Mask (Positioned to eliminate reflections from prop)	Top Centerline	0°	-10°
	Top Left	10°	-10°
	Bottom Centerline	0°	-30°
	Bottom Left	10°	-30°

TABLE 2. OBSTRUCTION COUNT

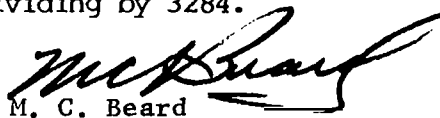
<u>ZONE</u>	<u>SQUARE DEGREES</u>
Point 1 to Point 2	159
Point 2 to Point 3	198
Point 3 to Point 4	132
Point 4 to Point 5	<u>14</u>
Total Graph	503
Rudder	<u>90</u>
Total Left Side	593
TOTAL AIRPLANE	1186
Steradians: $(1186/3284) = 0.36$	

TABLE 3. FAR 23/CAR 3

<u>APPLICABLE AMENDMENTS</u>	<u>INTENSITY (CANDLES)</u>	<u>VERTICAL COVERAGE</u>	<u>COLOR SPECS.</u>	<u>FLASH RATE</u>	<u>LIGHT OBSTRUCTION</u>	<u>REMARKS</u>
1. Before 3-1 (4/1/57)						No Anticollision Light Requirements
2. Thru 3-1 (4/1/57)	100	<u>+30</u>	Aviation Red	40-100 Overlap 180	0.03 STER. 0.15 STER.	Position of Allowable Obstruction Limited
3. Thru 3-7 (5/3/62)	100	<u>+30</u>	Aviation Red	40-100 Overlap 180	0.5 STER.	
4. Thru 23-11 (8/11/71)	400	<u>+30</u>	Aviation Red or Aviation White	40-100 Overlap 180	0.5 STER.	New Aviation White Limits
5. Thru 23-20 (9/1/77)	400	<u>+75</u>	Aviation Red or Aviation White	40-100 Overlap 180	0.5 STER.	

NOTE: 91.33(c)(3) of the FAR also applies to anticollision light installations and allows the color to be either aviation red or aviation white.

TABLE 4. FAR 25/CAR 4b

<u>APPLICABLE AMENDMENTS</u>	<u>INTENSITY (CANDLES)</u>	<u>VERTICAL COVERAGE</u>	<u>COLOR SPECS.</u>	<u>FLASH RATE</u>	<u>LIGHT OBSTRUCTION</u>	<u>REMARKS</u>
1. Before 4b-8 (5/16/53)						No Anticollision Light Requirements
2. Thru 4b-8 (5/16/53)			If Used Aviation Red	If Used 40-100		If Used, On-Off ratio Not less than 1:75
3. Thru 4b-3 (3/13/56)			If Used Aviation Red	If Used 40-100		If Used, On-Off ratio Not less than 1:75 If Extra Light Installed, No Flash Rate Limit in Overlaps
4. Thru 4b-4 (4/1/57)	100	<u>+30</u>	Aviation Red	40-100 Overlap 180	0.03 STER. 0.15 STER.	Position of Allowable Obstruction Limited
5. Thru 25-27 (8/11/71)	400	<u>+30</u>	Aviation Red or Aviation White	40-100 Overlap 180	0.03 STER. 0.15 STER.	New Aviation White Limits
6. Thru 25-41 (9/1/77)	400	<u>+75</u>	Aviation Red or Aviation White	40-100 Overlap 180	0.03 STER. 0.15 STER.	

NOTE: 91.33(c)(3) of the FAR also applies to anticollision light installations and allows the color to be either aviation red or aviation white.

TABLE 5. FAR 27/CAR 6

<u>APPLICABLE AMENDMENTS</u>	<u>INTENSITY (CANDLES)</u>	<u>VERTICAL COVERAGE</u>	<u>COLOR SPECS</u>	<u>FLASH RATE</u>	<u>LIGHT OBSTRUCTION</u>	<u>REMARKS</u>
1. Before Part 6 (4/1/57)						No Anticollision Light Requirements
2. Thru 6-1 (4/1/57)	100	<u>+30</u>	Aviation Red	40-100 Overlaps 180	0.03 STER.	
3. Thru 6-5 (5/3/62)	100	<u>+30</u>	Aviation Red	40-100 Overlaps 180	0.05 STER.	
4. Thru 27-6 (8/11/71)	400	<u>+30</u>	Aviation Red or Aviation White	40-100 Overlaps 180	0.5 STER	New Aviation White Limits
5. Thru 27-10 (2/5/76)	150	<u>+30</u>	Aviation Red	40-100 Overlaps 180	0.5 STER.	Aviation White not acceptable

NOTE: 91.33(c)(3) of the FAR also applies to anticollision light installations and allows the color to be either aviation red or aviation white.

TABLE 6. FAR 29/CAR 7

<u>APPLICABLE AMENDMENTS</u>	<u>INTENSITY (CANDLES)</u>	<u>VERTICAL COVERAGE</u>	<u>COLOR SPECS.</u>	<u>FLASH RATE</u>	<u>LIGHT OBSTRUCTION</u>	<u>REMARKS</u>
1. Before Part 7 (8/1/56)						No Anticollision Light Requirement
2. Adopt. Part 7	None	None	None	None	None	Approved Anticollision Light Required
3. Thru 7-1 (4/1/57)	100	<u>+30</u>	Aviation Red	40-100 Overlaps 180	0.03 STER.	Obstruction Position Not limited
4. Thru 7-5 (5/5/62)	100	<u>+30</u>	Aviation Red	40-100 Overlaps 180	0.5 STER.	
5. Thru 29-7 (8/11/71)	400	<u>+30</u>	Aviation Red or Aviation White	40-100 Overlaps 180	0.5 STER.	New Aviation White Limits
6. Thru 29-11 (2/5/76)	150	<u>+30</u>	Aviation Red	40-100 Overlaps 180	0.5 STER.	Aviation White not acceptable

NOTE: 91.33(c)(3) of the FAR also applies to anticollision light installations and allows the color to be either aviation red or aviation white.