



U.S. Department  
of Transportation  
**Federal Aviation  
Administration**

# Heliport Design

Advisory Circular 150/5390-2

Date: January 4, 1988

LIBRARY MAR 2 1988  
TGA TECHNICAL UNIT





U.S. Department  
of Transportation  
**Federal Aviation  
Administration**

# Advisory Circular

---

**Subject:** HELIPORT DESIGN

**Date:** 1/4/88  
**Initiated by:** AAS-110

**AC No:** 150/5390-2  
**Change:**

---

**1. PURPOSE.** This Advisory Circular (AC) contains Federal Aviation Administration (FAA) guidelines, recommendations, and design standards for heliports and helistops developed after the date of this publication.

**2. CANCELLATION.** Advisory Circular (AC) 150/5390-1B, Heliport Design Guide, dated August 22, 1977, is cancelled.

**3. APPLICATION.** The FAA recommends the use of the guidance contained herein in the development of any heliport or helistop. The guidance is predicated on average sites and will require adaptation to meet limitations of a specific site. For capital development projects receiving Federal grant-in-aid assistance, the standards identified in chapter 3 are minimum requirements.

**a. Differing Needs.** Persons using this AC must recognize that there are differences in heliport or helistop functions and needs. A minimal helicopter facility requires a cleared area, at least one approach and departure route, and a means of indicating the wind's direction. A minimal facility may suffice for private usage, whereas a more extensive facility would be required to function as a public-use heliport.

**b. Local Use.** Because of the wide variations in heliport or helistop requirements, community officials should recognize that the guidance, recommendations, and design standards herein will need to be adapted to meet the needs of the users and the limitations of the site. For this reason, it is recommended that the guidance, recommendations, and design standards of this AC not be adopted verbatim. Instead, it is recommended that a coordinated approach be taken to heliport and helistop development requiring adaptation of the guidance, recommendations, and design standards herein. Users should establish specific site requirements following a thorough study, analysis, and consultation of their needs with FAA and state aviation officials, helicopter operators, consultants, manufacturers, and associations.

Leonard E. Mudd  
Director, Office of Airport Standards

---

# CONTENTS

## CHAPTER 1. INTRODUCTION

1.	GENERAL.....	1
2.	BASIS.....	1
3.	EXPLANATION OF TERMS.....	1
	a. Heliport.....	1
	b. Helistop.....	1
	c. Public Use Heliport.....	1
	d. Private use Heliport.....	1
	e. Hospital Heliport.....	1
	f. Final Approach and Takeoff Area (FATO).....	1
	g. Takeoff and Landing Area.....	1
	h. Helipad.....	1
	i. Helideck.....	1
	j. Primary Surface.....	2
	k. Approach and Departure Surface.....	2
	l. Transitional Surfaces.....	2
	m. Obstruction to Air Navigation.....	2
	n. Hazard to Air Navigation.....	2
	o. Heliport Elevation.....	2
	p. Ground Effect.....	2
4.	NOTICE TO FAA OF HELIPORT DEVELOPMENT.....	4
	a. Notification Procedures.....	4
	b. FAA Action.....	4
	c. Notice Exemption.....	4
	d. Penalty for Failure to Provide Notice.....	4
5.	NOTICE TO FAA OF OFF-HELIPORT CONSTRUCTION.....	8
	a. Penalty for Failure to Provide Notice.....	8
	b. FAA Aeronautical Study.....	8
6.	FAA AERONAUTICAL STUDY OF EXISTING OBJECTS.....	8
7.	FEDERAL ASSISTANCE.....	8
8.	SITE CONSIDERATIONS.....	8
	a. Ground Level Sites.....	8
	b. Elevated Sites.....	8
9.	ENVIRONMENTAL ASSESSMENTS.....	9
	a. Assessment Items.....	9
	b. Guidance.....	9
10.	STATE ROLE.....	9
11.	LOCAL ROLE.....	9

## CHAPTER 2. PRIVATE USE HELIPORTS

12.	GENERAL.....	11
13.	TAKEOFF AND LANDING AREA.....	11
	a. Location.....	11
	b. Size.....	11
	c. Surface Characteristics.....	11

14.	HELIPADS AND HELIDECKS .....	11
a.	Size .....	11
b.	Surface Characteristic.....	11
15.	APPROACH AND DEPARTURE ROUTE12 .....	12
a.	Configuration.....	12
b.	Protection .....	12
16.	PARKING .....	12
17.	HELIPORT MARKINGS.....	12
a.	Boundary Markings .....	12
b.	Identification Markings.....	13
c.	Weight Limitation.....	13
d.	Closed Heliport .....	13
18.	HELIPORT LIGHTING.....	14
a.	Perimeter Lights .....	14
b.	Elevated Floodlights.....	15
19.	WIND DIRECTION INDICATOR .....	15
20.	FENCES .....	15

### CHAPTER 3. PUBLIC USE HELIPORTS

21.	GENERAL.....	17
22.	TAKEOFF AND LANDING AREAS.....	17
a.	Location.....	17
b.	Size .....	17
c.	Surface Characteristics .....	17
23.	FINAL APPROACH AND TAKEOFF AREA .....	17
a.	Size .....	17
b.	Surface Characteristics .....	17
c.	Separation Between Adjacent FATOs .....	17
24.	APPROACH AND DEPARTURE ROUTES .....	18
a.	Objects and Noise Sensitive Areas.....	18
b.	Prevailing Wind .....	18
c.	Heliport Imaginary Surfaces.....	18
d.	Visual Glide Path Indicator Obstacle Clearance Plane.....	18
e.	Hazards to Air Navigation.....	18
25.	APPROACH AND DEPARTURE PROTECTION AREAS.....	18
26.	PARKING AREAS.....	19
a.	Location.....	19
b.	Helipads .....	19
c.	Helidecks.....	19
d.	Tie-Downs and Static Grounding.....	20
27.	TAXI ROUTES .....	20
a.	Widths.....	20
b.	Parallel Taxi Route Separations .....	20
28.	TAXIWAYS.....	21
29.	HELIPORT MARKINGS.....	21
a.	Takeoff and Landing Area Markings.....	21
b.	FATO Markings .....	21
c.	Heliport Identification Markings .....	21
d.	Weight Limitations .....	21
e.	Closed Heliport .....	22
f.	Helipad and Helideck Markings .....	22
g.	Apron Markings.....	22
h.	Taxi Route Markings.....	22
i.	Taxiway Markings .....	22

30.	HELIPORT LIGHTING.....	24
	a. Takeoff and Landing Area Lighting.....	24
	b. Taxi Route and Taxiway Lighting.....	25
31.	VISUAL AIDS.....	25
	a. Wind Direction Indicator.....	25
	b. Landing Direction Lights.....	26
	c. Visual Glide Path Indicator.....	26
	d. Heliport Identification Beacon.....	26
	e. Obstruction Marking and Lighting.....	26
32.	HELIPORT FACILITIES.....	27
	a. Fueling.....	27
	b. Maintenance.....	27
	c. Terminal Facilities.....	27
	d. Transportation and Parking.....	27
33.	SAFETY FEATURES.....	27
	a. Fences.....	27
	b. Rescue and Firefighting Services.....	27
	c. Passenger Walkways.....	27
	d. Automatic Weather Observing/Reporting System (AWOS).....	28
	e. Radio Communications.....	28
	f. Snow and Ice Control.....	28
34.	ZONING AND COMPATIBLE LAND USE.....	28
	a. Height Zoning.....	28
	b. Compatible Land Use.....	28

#### CHAPTER 4. HELICOPTER FACILITIES AT AIRPORTS

35.	GENERAL.....	29
36.	REQUIREMENT.....	29
37.	LOCATION.....	29
38.	RUNWAY CLEARANCE.....	29

#### CHAPTER 5. VFR HELIPOINTS

39.	GENERAL.....	31
40.	PRIVATE USE VFR HELIPOINTS.....	31
41.	PUBLIC USE VFR HELIPOINTS.....	31
42.	EMERGENCY EVACUATION FACILITIES.....	31
43.	TEMPORARY LANDING SITES.....	31

#### CHAPTER 6. HELIPOINTS WITH NON-PRECISION INSTRUMENT APPROACH PROCEDURES

44.	GENERAL.....	33
45.	LIGHTING SYSTEM.....	33

#### CHAPTER 7. HELIPOINTS WITH PRECISION INSTRUMENT PROCEDURES

46.	GENERAL.....	35
47.	AIRSPACE.....	35
48.	NAVIGATIONAL AIDS.....	38
	a. Microwave Landing System (MLS).....	38
	b. Enhanced Lighting System.....	39

c. Approach Lighting System..... 40

**CHAPTER 8. HELIPORT SURFACE DESIGN**

49. GENERAL..... 41  
 50. GRADIENTS..... 41  
 51. DESIGN LOADS..... 42  
     a. Static Load ..... 42  
     b. Dynamic Load ..... 42  
     c. Downwash Load..... 42  
 52. SOIL STABILIZATION AND PAVEMENT DESIGN..... 42  
     a. Soil Stabilization..... 43  
     b. Pavements..... 43

**APPENDICES**

Appendix 1. Helicopter Data (4 pages)  
 Appendix 2. Aviation Organizations (4 pages)  
 Appendix 3. Federal Aviation Administration Regional Airport Division Offices  
                     (2 pages)

**FIGURES**

Figure 1-1 FAR Part 77 Subpart C Heliport Imaginary Surfaces ..... 3  
 Figure 1-2 Example of Notice Required FAR Part 157 ..... 5  
 Figure 1-3 Example of a Heliport Location Map ..... 6  
 Figure 1-4 Example of a Heliport Layout Sketch ..... 7  
 Figure 2-1 Example of a Private Use Heliport..... 11  
 Figure 2-2 Helicopter Parking ..... 12  
 Figure 2-3 Marking of Unpaved Surfaces..... 13  
 Figure 2-4 Hospital Heliport..... 13  
 Figure 2-5 Emergency Evacuation Facility..... 14  
 Figure 2-6 A Closed Heliport ..... 14  
 Figure 2-7 Heliport Lighting System ..... 15  
 Figure 3-1 Overlapping Takeoff and Landing Areas..... 18  
 Figure 3-2 Visual Approach and Departure Protection Area ..... 19  
 Figure 3-3 Helideck with a Safety Net ..... 20  
 Figure 3-4 Taxi Route and Taxiway Relationship ..... 21  
 Figure 3-5 Public Use Heliport..... 22  
 Figure 3-6 Hospital Heliport..... 23  
 Figure 3-7 In Ground Markings ..... 23  
 Figure 3-8 Closed Heliport..... 24  
 Figure 3-9 Lighting System for Night Operations..... 25

Figure 3-10	Visual Glide Path Indicator Siting and Clearance Criteria.....	26
Figure 3-11	Walkway and Sign .....	28
Figure 7-1	Shielding.....	35
Figure 7-2	Precision Instrument Approach Surfaces.....	36
Figure 7-3	Precision Instrument Departure Surfaces.....	37
Figure 7-4	MLS Antenna Sites .....	38
Figure 7-5	MLS Critical Area .....	39
Figure 7-6	Enhanced Lighting System .....	40
Figure 7-7	Possible Heliport Approach Light Systems.....	40
Figure 8-1	Heliport Gradients.....	41
Figure 8-2	Rapid Runoff Shoulder .....	41
Figure 8-3	Helicopter Landing Gear Loading .....	42



DOWNTOWN HELIPORT, INDIANAPOLIS, INDIANA



## CHAPTER 1. INTRODUCTION

**1. GENERAL.** This chapter explains terms used in this advisory circular (AC), and addresses matters relating to heliport development.

**2. BASIS.** This AC implements the objective set forth in Section 103 of the Federal Aviation Act of 1958 as amended. That states, in part:

"In the exercise and performance of his power and duties under this Act, the Secretary of Transportation shall consider the following, among other things, as being in the public interest:

- (a) The regulation of air commerce in such manner as to best promote its development and safety and fulfill the requirements of defense;
- (b) The promotion, encouragement, and development of civil aeronautics;
- (c) The control of the use of the navigable airspace of the United States and the regulation of both civil and military operations in such airspace in the interest of the safety and efficiency of both."

**3. EXPLANATION OF TERMS.** The Pilot/Controller Glossary of the Airman's Information Manual defines terms used in the Air Traffic Control system such as air taxi, hover taxi, instrument flight rules (IFR), and visual flight rules (VFR). Copies of the Airman's Information Manual are available from the Superintendent of Documents, U.S. Government Printing Office, Washington, D.C. 20402. The following subparagraphs define terms used in this publication:

**a. Heliport.** A heliport is an identifiable area on land, water, or structure, including any building or facilities thereon, used or intended to be used for the landing and takeoff of helicopters. The term heliport as used in this advisory circular, in Federal Aviation Regulation (FAR) Part 77, Objects Affecting Navigable Airspace, and in FAR Part 157, Notice of Construction, Alteration, Activation, and Deactivation of Airports, applies to all sites, including helistops, used or intended to be used for the landing and takeoff of helicopters.

**b. Helistop.** A helistop is an area used or intended to be used for the landing and takeoff of helicopters engaged in dropping-off or picking-up passengers or cargo.

**c. Public Use Heliport.** A public use heliport is available for the takeoff or landing of helicopters without prior authorization being required to use the facility.

**d. Private use Heliport.** A private use heliport is a facility for exclusive use by the owner or other persons having prior authorization to use the facility.

**e. Hospital Heliport.** A hospital heliport is a public use or private use heliport supporting helicopter air ambulance services.

**f. Final Approach and Takeoff Area (FATO).** A defined area over which the final phase of the approach maneuver to hover or landing is completed and from which the takeoff maneuver is commenced.

**g. Takeoff and Landing Area.** The takeoff and landing area is a cleared area containing a FATO.

**h. Helipad.** The helipad is a surface used for parking helicopters. It may be located inside or outside of the FATO or the takeoff and landing area.

**i. Helideck.** The helideck is an elevated surface used for parking helicopters. It may be located inside or outside of the FATO or the takeoff and landing area.

**j. Primary Surface.** The primary surface is an FAR Part 77, Subpart C, heliport imaginary surface which overlies the designated takeoff and landing area. FAR 77.29 (a) defines the primary surface as follows: "The area of the primary surface coincides in size and shape with the designated takeoff and landing area of a heliport. This surface is a horizontal plane at the elevation of the established heliport elevation." See figure 1-1.

**k. Approach and Departure Surface.** The approach surface is an FAR Part 77 Subpart C heliport imaginary surface which is centered on each designated approach and departure route. The approach surface also serves as a departure surface. FAR 77.29 (b) defines the approach surface as follows: "The approach surface begins at each end of the heliport primary surface with the same width as the primary surface, and extends outward and upward for a horizontal distance of 4,000 feet where its width is 500 feet. The slope of the approach surface is 8 to 1 for civil heliports ... ." See figure 1-1.

**l. Transitional Surfaces.** The transitional surfaces are FAR Part 77 Subpart C heliport imaginary surfaces which extend outward from the lateral boundaries of the primary and approach surfaces. FAR 77.29 (c) defines the transitional surfaces as follows: "These surfaces extend outward and upward from the lateral boundaries of the heliport primary surface and from the approach surfaces at a slope of 2 to 1 for a distance of 250 feet measured horizontally from the centerline of the primary and approach surfaces." See figure 1-1.

**m. Obstruction to Air Navigation.** An obstruction to air navigation is an object which exceeds the obstruction standards of FAR 77.23.

**n. Hazard to Air Navigation.** A hazard to air navigation is an object having a substantial adverse effect upon the safe and efficient use of the navigable airspace by aircraft or upon the operation of an air navigation facility. Obstructions to air navigation are presumed to be hazards to air navigation until an FAA aeronautical study has determined otherwise.

**o. Heliport Elevation.** The heliport elevation is the elevation of the highest point on the takeoff and landing area expressed in feet above mean sea level.

**p. Ground Effect.** An improvement in flight capability that develops whenever the helicopter flies or hovers near the ground or other surface. It results from the cushion of air built up between the ground and the helicopter by the air displaced downward by the rotor.

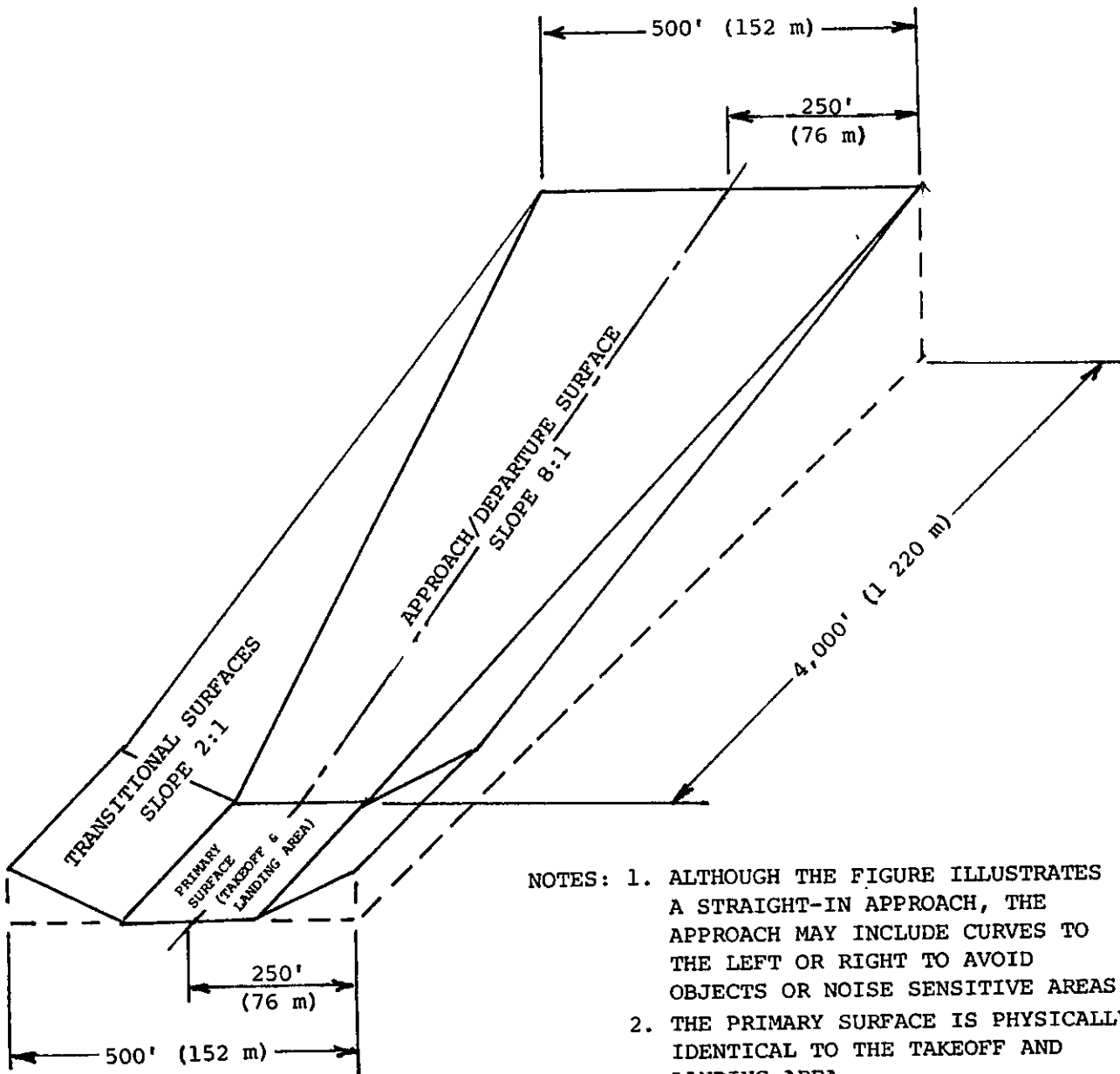

Figure 1-1. FAR Part 77 Subpart C Heliport Imaginary Surfaces

**4. NOTICE TO FAA OF HELIPORT DEVELOPMENT.** Persons proposing to construct, activate, or deactivate a heliport are required by FAR Part 157 to give the FAA notice of their intent. Notice is also required when a heliport is altered by a change in the takeoff and landing area, an approach or departure route, or heliport use, e.g., from private use to public use.

**a. Notification Procedures.** Notification, when required, is accomplished by forwarding a completed FAA Form 7480-1, a layout sketch, and a location map to the appropriate FAA Regional or District Airports Office. The submission should be made at least 90 days prior to construction, alteration, or the date when the proposed use is to begin. In an emergency involving essential public service, health, or safety, or when delay would result in an unreasonable hardship, a proponent may notify the FAA by telephone and submit Form 7480-1 within 5 days. FAA Airports Office addresses are listed on the Form. A section of a 7.5 minute U.S. Geological Survey Quadrangle Map is recommended for the location map. The layout sketch needs to show the heliport takeoff and landing area configuration and the proposed approach and departure routes in relation to buildings, trees, fences, power lines, etc.. Figure 1-2 through 1-4 are an example of a notice submission.

**b. FAA Action.** The FAA will evaluate a heliport proposal for its impact upon the safe and efficient use of navigable airspace; for its impact upon the operation of air navigation facilities; and for its effect on the safety of persons and property on the ground. Proponents will be notified of the results of the FAA evaluation.

**c. Notice Exemption.** The following are exempt from FAA's Part 157 notice requirement; however, the appropriate FAA Air Traffic Facility should be made aware of the aeronautical activity. This exemption does not apply to notifications or approvals required by state law or local ordinance.

**(1) Federally Obligated Heliports.**

**(2) Temporary Landing Sites.** Sites intended to be used only under VFR weather conditions, for a period of less than 30 consecutive days, and with no more than 10 operations per day.

**(3) Medical Emergency Sites.** Helicopters are capable of taking off and landing at unprepared landing sites, such as the scene of an accident. In the case of medical emergencies, the pilot weighs the helicopter's performance and capability, the site's constraining features, and his or her piloting ability and experience against the operational need to land.

**(4) Emergency Evacuation Facilities.** A designated and cleared area at rooftop or ground level intended exclusively for emergency evacuation operations by helicopters.

**d. Penalty for Failure to Provide Notice.** Failure to provide notice is a violation of Section 901 of the Federal Aviation Act and subjects the violator to a civil penalty not to exceed \$1,000 for each violation.

NOTICE OF LANDING AREA PROPOSAL									
US Department of Transportation Federal Aviation Administration									
<b>NAME OF PROPONENT, INDIVIDUAL OR ORGANIZATION</b> Friendly Fellows Aviation ADDRESS (No. Street, City, State, Zip Code) 800 Independence Ave. Washington, DC 20591					<input checked="" type="checkbox"/> Establishment or Activation <input type="checkbox"/> Alteration <input type="checkbox"/> Deactivation or Abandonment <input type="checkbox"/> Change of Status				
					OF <input type="checkbox"/> Airport <input type="checkbox"/> Ultralight Flightpark <input checked="" type="checkbox"/> Heliport <input type="checkbox"/> Seaplane Base <input type="checkbox"/> Other (Specify) _____				
<b>A. Location of Landing Area</b>									
1. NEAREST CITY OR TOWN Washington D.C.			2. COUNTY NA		3. STATE NA		4. DISTANCE AND DIRECTION TO NEAREST CITY OR TOWN Miles Direction		
5. NAME OF LANDING AREA Friendly Fellows Heliport			6. LATITUDE 38° 53' 27.7"		7. LONGITUDE 76° 58' 00.0"		8. ELEVATION 12'		3 West
<b>B. Purpose</b>									
Type Use <input checked="" type="checkbox"/> Public <input type="checkbox"/> Private <input type="checkbox"/> Personal		Type Ownership <input type="checkbox"/> Public <input checked="" type="checkbox"/> Private		If Change of Status or Alteration, Describe Change.				Construction Dates To Begin/Began Est. Completion 02/25/88 01/03/89	
<b>C. Other Landing Areas</b>			Ref. A5 Above		<b>D. Landing Area Data</b>				
		Direction from Landing Area	Distance from Landing Area	1.	Existing (If any)			Proposed	
National Airport		SW	4.6	Airport, Seaplane base, or Flightpark	Magnetic Bearing of Runway(s) or Sealane(s)	Rwy #1	Rwy #2	Rwy #3	Rwy
Bolling AFB Heliport		SSW	2.7		Length of Runway(s) or Sealane(s) in Feet				
Andrews AFB		SE	7.0		Width of Runway(s) or Sealane(s) in Feet				
					Type of Runway Surface (Concrete, Asphalt, Turf, Etc.)				
				2.	Dimensions of Landing and Takeoff Area in Feet	None			150/150
				Heliport	Dimensions of Touchdown Area in Feet	None			50/50
					Magnetic Direction of Ingress/Egress Routes				20 /180
					Type of Surface (Turf, rooftop, etc.)				Concrete
<b>E. Obstructions</b>			Direction from Landing Area	Distance from Landing Area	3. Description of Lighting (If any)				Direction of Prevailing Wind
Type		Height Above Landing Area			All Perimeter Edge				N/S
None					<b>F. Operational Data</b>				
1. Estimated or Actual Number Based Aircraft									
Airport, Flightpark, Seaplane base		Present (If est. indicate by letter "E")	Anticipated 5 Yrs. Hence	Heliport	Present (If est. indicate by letter "E")	Anticipated 5 Yrs. Hence			
Multi-Engine				Under 3500 lbs. MGV	0	20			
Single-Engine				Over 3500 lbs. MGV	0	10			
Glider									
<b>G. Noise Considerations</b>			Direction from Landing Area	Distance from Landing Area	2. Average Number Monthly Landings				
Identification					Present (If est. indicate by letter "E")	Anticipated 5 Yrs. Hence	Helicopter	Present (If est. indicate by letter "E")	Anticipated 5 Yrs. Hence
River Terrace Sch		NE	.5	Jet			Helicopter	0	800
Kimball Sch		SE	.6	Turboprop			Ultralight		
DC Gen'l Hospital		SSW	.5	Prop			Glider		
RFK Stadium		WSW	.2	3. Are IFR Operations Anticipated					
Schools		W	.6	<input type="checkbox"/> No <input checked="" type="checkbox"/> Yes Within <u>5</u> Years Type Navaid: MLS					
Schools		NNW	.6	<b>H. Application for Airport Licensing</b>					
				<input type="checkbox"/> Has Been Made <input type="checkbox"/> Not Required <input type="checkbox"/> County		<input checked="" type="checkbox"/> Will Be Made <input type="checkbox"/> State <input checked="" type="checkbox"/> Municipal Authority			
<b>I. CERTIFICATION: I hereby certify that all of the above statements made by me are true and complete to the best of my knowledge.</b>									
Name, title, (and address if different than above) of person filing this notice— type or print.					Signature (In ink)				
Jack H. Burke, CEO					Jack H. Burke Date of Signature: 10/31/87 Telephone No. (Precede with area code): (202) 267-8763				

Figure 1-2. Example of Notice Required FAR Part 157

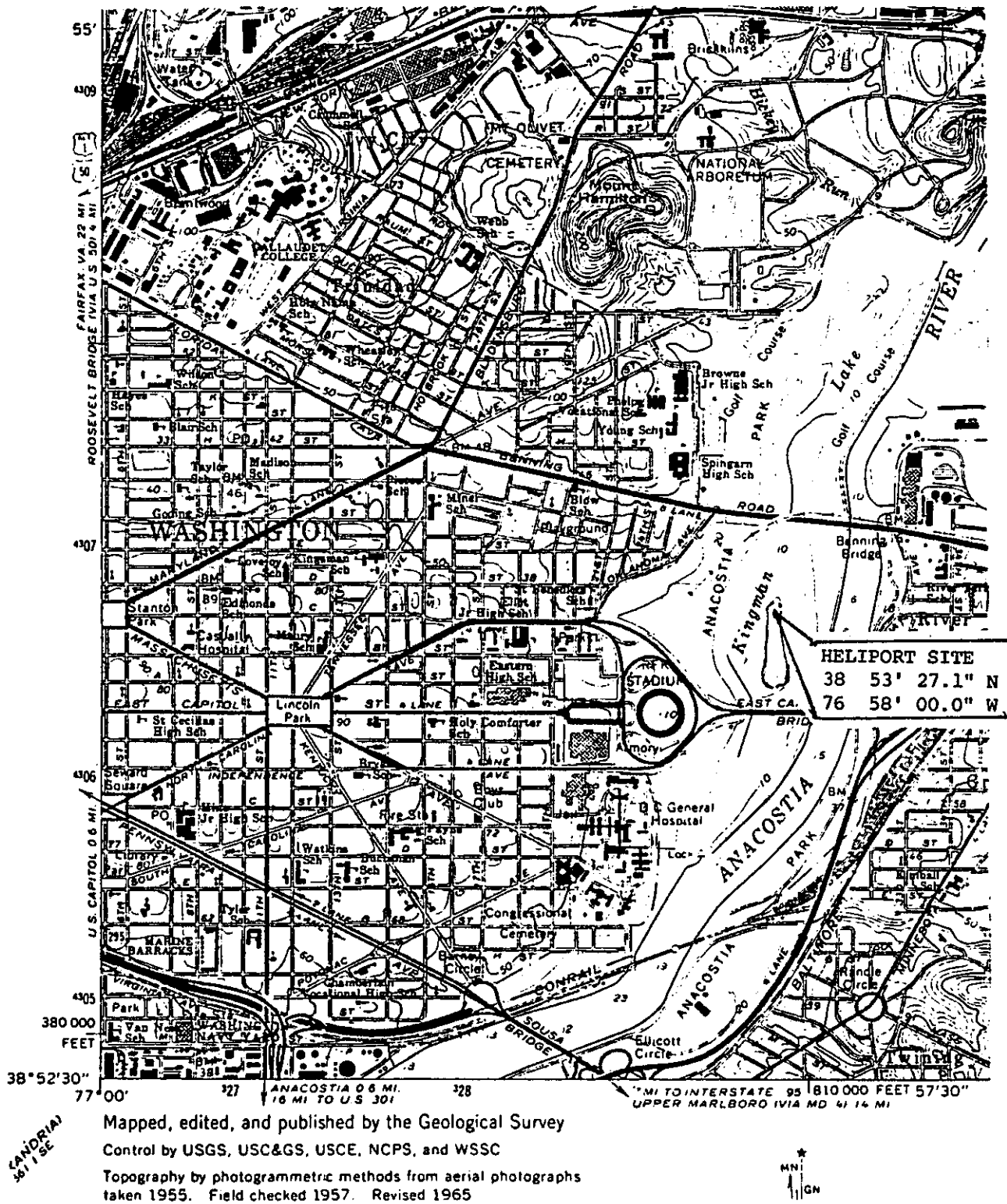

Mapped, edited, and published by the Geological Survey  
 Control by USGS, USC&GS, USCE, NCPS, and WSSC  
 Topography by photogrammetric methods from aerial photographs  
 taken 1955. Field checked 1957. Revised 1965

Figure 1-3. Example of a Heliport Location Map

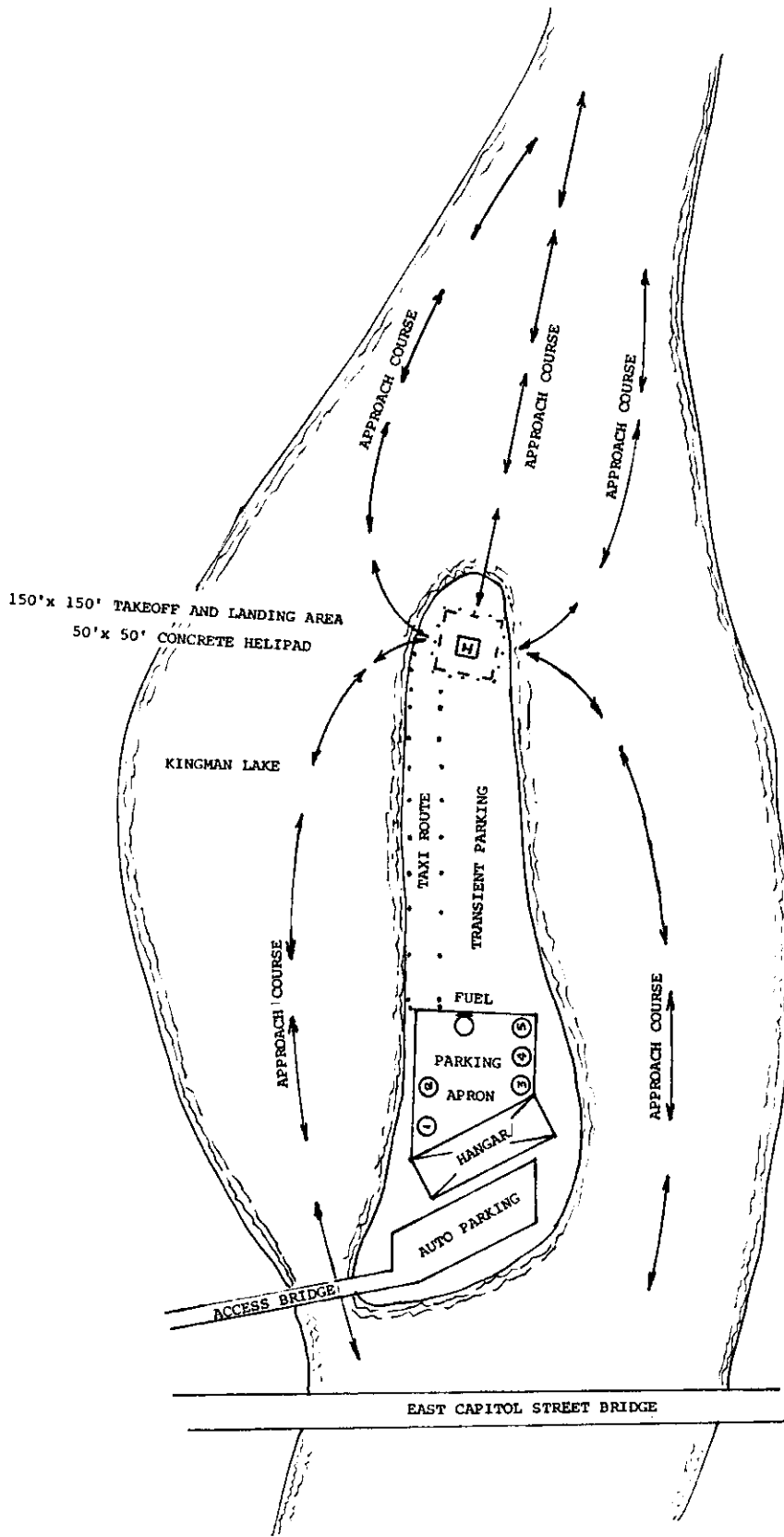

Figure 1-4. Example of a Heliport Layout Sketch

**5. NOTICE TO FAA OF OFF-HELIPORT CONSTRUCTION.** Persons proposing to construct a building or other object which will be more than 200 feet (60 m) above ground or might penetrate an imaginary surface extending outward and upward at a slope of 25 to 1 for a horizontal distance of 5,000 feet (1 500 m) from the nearest point of a public use heliport are required to give the FAA notice of the proposed construction. Information on the FAA's role in conducting an aeronautical study is found in AC 70/7460-2, Proposed Construction or Alteration of Objects That May Affect the Navigable Airspace.

a. **Penalty for Failure to Provide Notice.** Persons who knowingly and willingly fail to give such notice are subject to criminal prosecution and are liable to a fine of \$500 for the first offense with increased penalties thereafter as provided by Section 902 (a) of the Federal Aviation Act of 1958, as amended.

b. **FAA Aeronautical Study.** The location, configuration, and elevation of each public use takeoff and landing area, and the location and configuration of each approach and departure route need to be on file with the FAA. The determinations resulting from any aeronautical study of proposed objects is dependent upon the information on file with the FAA.

**6. FAA AERONAUTICAL STUDY OF EXISTING OBJECTS.** The FAA also conducts aeronautical studies of existing objects. These studies, which consider aircraft capabilities, are conducted whenever there is a need to determine the physical or electromagnetic effect of an obstruction to air navigation upon aeronautical operations. Requests for such a study may be initiated by anyone with a valid interest in the matter. Studies include, but are not necessarily limited to the following:

a. A determination as to whether an existing obstruction to air navigation has a substantial adverse effect upon the safe and efficient use of navigable airspace;

b. A change in an aeronautical procedure;

c. A proposal to construct or enlarge a heliport; or

d. A determination as to whether an object should be altered, removed, marked, or lighted.

**7. FEDERAL ASSISTANCE.** The FAA administers a grant program that provides financial assistance for developing heliports that will be open to the public. Persons interested in this program can obtain information from AC 150/5100-16, Airport Improvement Program Grant Assurance Number One-General Federal Requirements. FAA Regional Airport Divisions and Airport District or Field Offices can provide advice and information on program eligibility requirements and on heliport or helistop design and construction. Addresses of Airport Offices are listed in AC 150/5000-3, Address List for Regional Airports and Airport District/Field Offices.

**8. SITE CONSIDERATIONS.** The optimum location for a heliport is in close proximity to the desired origination or destination of the potential users. Industrial, commercial, and business operations in urban locations both generate the demand for helicopter service and vie for available space. One alternative is multi-function land use, i.e., siting the heliport where the land uses are shared and compatible. Sites adjacent to a river, lake, flood plain, railroad, freeway, or highway, which lend themselves to multi-function or compatible land use, also have the potential of offering relatively unobstructed airspace which can be protected from object penetrations of the approach and departure routes. Hospitals may utilize a lawn, automobile parking area, or building rooftop with quick and convenient access to the emergency room or shock-trauma facilities to support helicopter air ambulance services.

a. **Ground Level Sites.** Ground level sites away from buildings, trees, or significant terrain features are preferred to avoid possible air turbulence sometimes caused by those features. Guidance on wind effect on helicopter operations at heliports is found in the report, Evaluating Wind Flow Around Buildings on Heliport Placement. Copies of this report are available from the National Technical Information Service, Springfield, Virginia 22161.

b. **Elevated Sites.** Rooftops or other elevated sites normally have the advantage of being above the level of most objects that may obstruct the approach and departure routes to the takeoff and landing area. Elevating the takeoff and landing area on a platform 6 feet (2 m), or more, above the level of the roof will generally reduce the turbulent effect of air currents. Operational areas should not be constrained by parapets or raised objects that adversely affect flight safety.



**9. ENVIRONMENTAL ASSESSMENTS.** The National Environmental Policy Act of 1969 requires an environmental assessment prior to certain Federal actions relating to heliport development. Actions which may require an environmental assessment are normally associated with Federal grant assistance or heliport layout plan approval for new heliport construction or major expansion.

**a. Assessment Items.** An environmental assessment must address noise, land usage, water and air quality, socio-economic issues, viable alternatives, etc., and the action taken to ensure public involvement and citizen participation in the planning process. An opportunity for public hearing is required for all federally funded development of, or major improvement to, an existing heliport.

**b. Guidance.** FAA Order 5050.4, Airport Environmental Handbook, available at any FAA Airports office, provides guidance on environmental assessments. State and local governments may require an environmental report and should be contacted for guidance. Proponents of nonfederally assisted heliports are encouraged to work closely with local governmental authorities concerning environmental issues. The procedures in AC 150/5020-1, Noise Control and Compatibility Planning for Airports, and in AC 150/5020-2, Noise Assessment Guidelines for New Heliports, offer a means of assessing the noise impact of a new heliport.

**10. STATE ROLE.** Many state aeronautics commissions or similar authorities require prior approval, and in some instances a license, for the establishment and operation of a heliport. A few states administer a financial assistance program similar to the Federal program. Some states also provide technical advice. Proponents are encouraged to contact their respective state aeronautics commissions or departments for particulars on licensing and assistance programs.

**11. LOCAL ROLE.** Most communities have zoning laws, building codes, fire regulations, etc.. Some have or are in the process of developing codes or ordinances regulating environmental issues such as noise and air pollution. A few may have specific rules governing the establishment of a heliport.

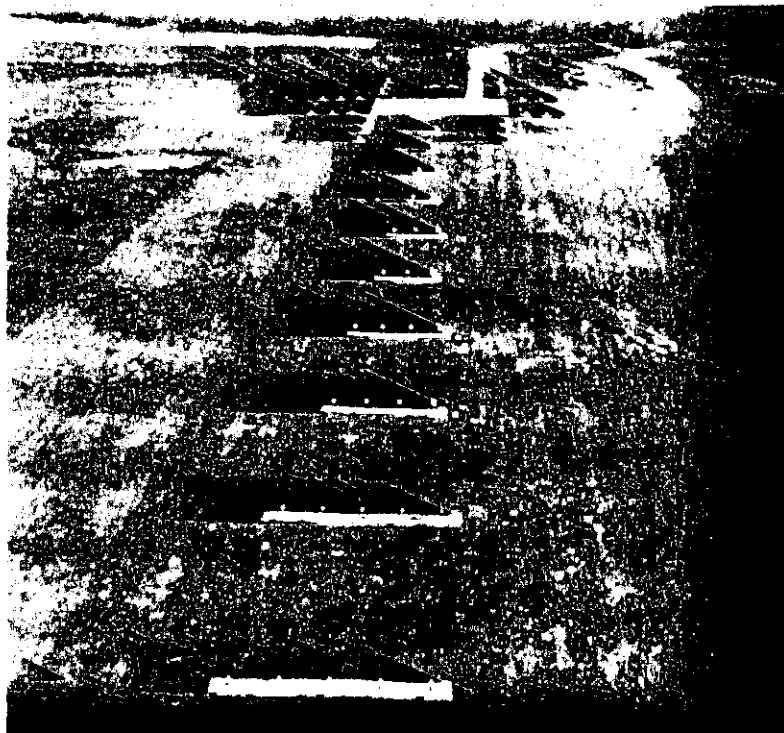

FAA TECHNICAL CENTER EXPERIMENTAL HELIPORT

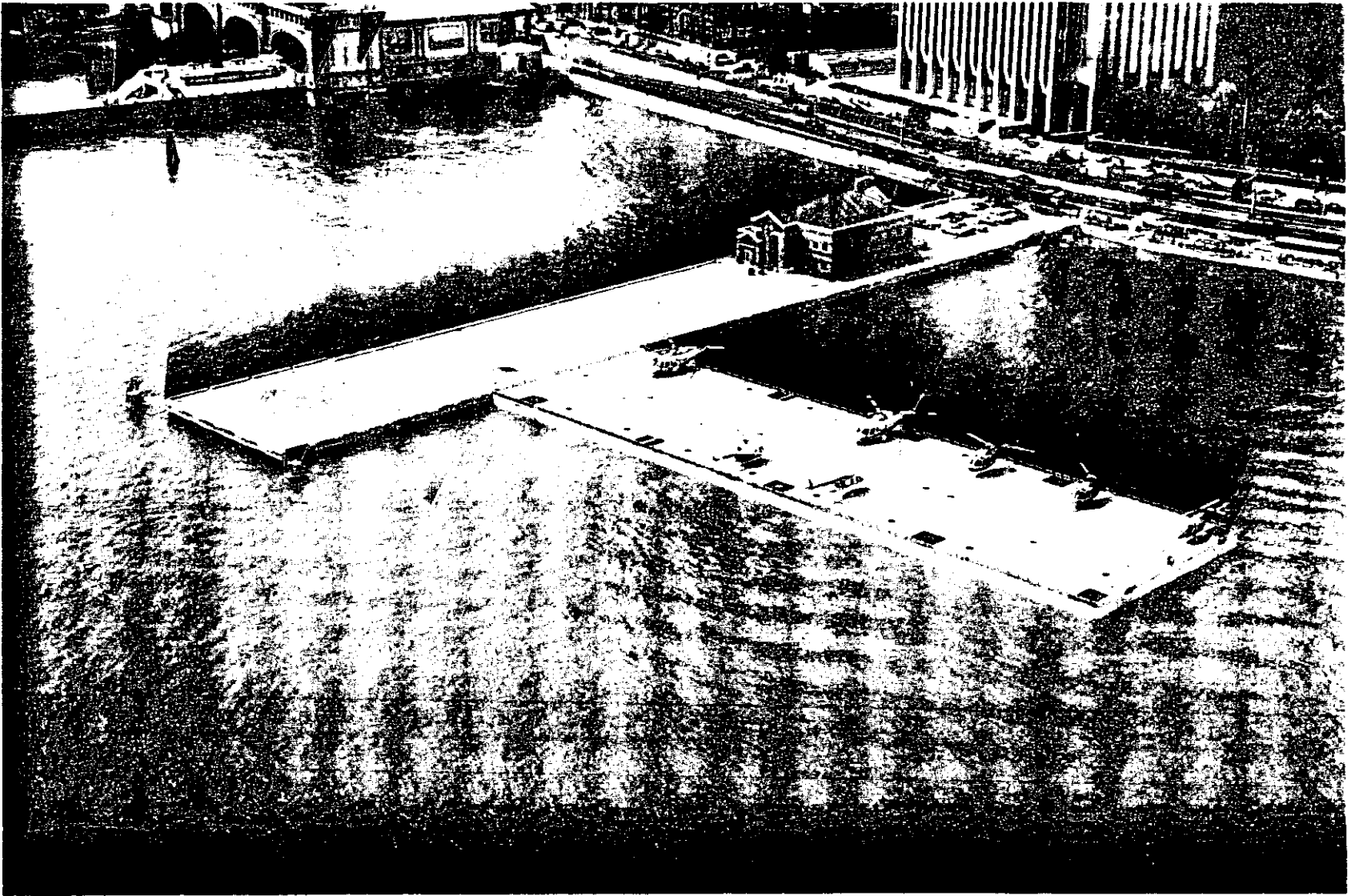

WALL STREET HELIPORT, NEW YORK, NEW YORK

## CHAPTER 2. PRIVATE USE HELIPORTS

12. **GENERAL.** This chapter contains guidance relating to the development of private use heliports.

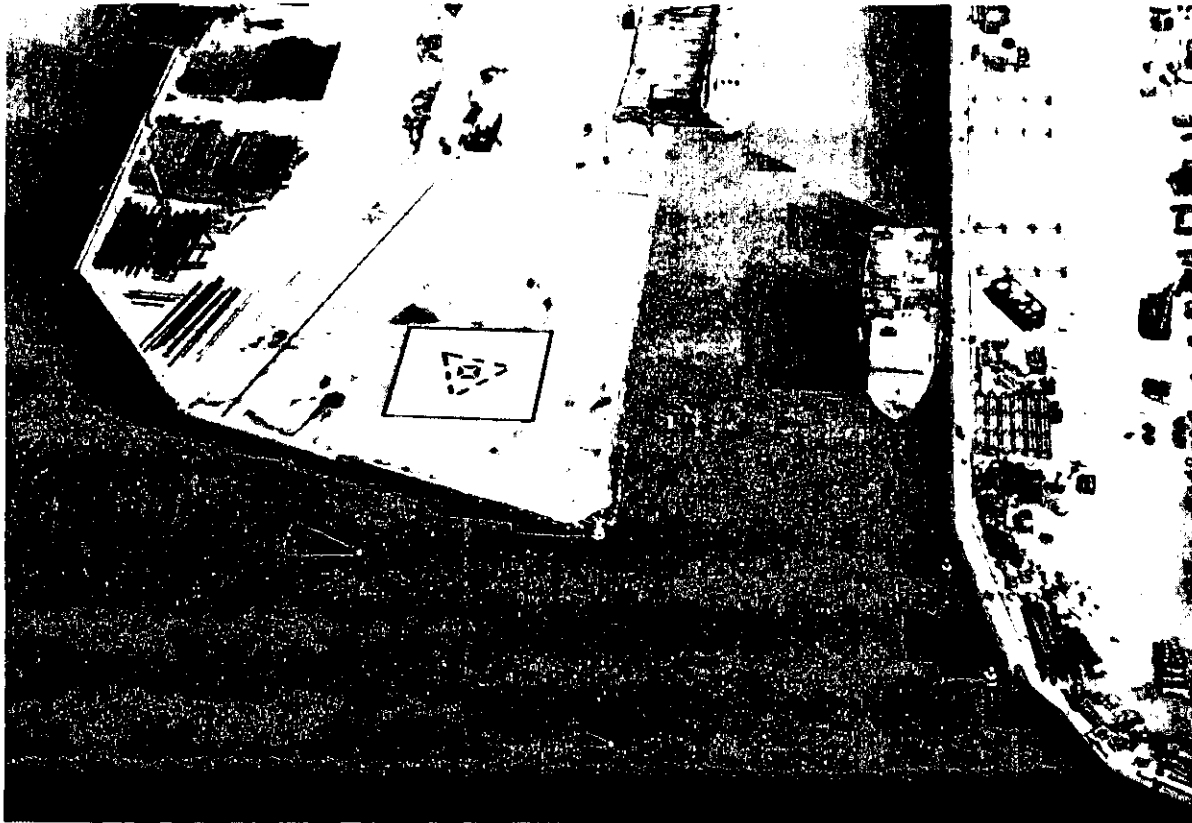

ARCO OIL COMPANY HELIPORT, AMELIA, LOUISIANA

Figure 2-1. Example of a Private Use Heliport

13. **TAKEOFF AND LANDING AREA.** A private use heliport should have an unobstructed area available for the takeoff and landing of helicopters.

a. **Location.** The takeoff and landing area may be located on the ground, on a water surface, a roof of a building, or an elevated platform. The location should provide at least 1/3 rotor diameter, but not less than 10 feet (3 m), horizontal clearance between the takeoff and landing area and buildings, fences, parapets, curbs, and objects which could be struck by main or tail rotors.

b. **Size.** The takeoff and landing area length and width, or diameter, should be at least twice the rotor diameter of the design helicopter.

c. **Surface Characteristics.** The portion of the takeoff and landing area surface outboard of the helipad or helideck may be clear airspace. Except for essential frangible heliport visual aids which may be located in this area, the surface of the takeoff and landing area should be clear of objects, including parked helicopters, while a helicopter is landing or taking off.

### 14. HELIPADS AND HELIDECKS.

a. **Size.** The minimum length and width, or diameter, of the helipad or helideck should be at least 1.5 times the design helicopter's undercarriage length or width, whichever is greater.

b. **Surface Characteristics.** The helipad of a ground level heliport can vary from a turf to an all paved surface and normally is load bearing. Helidecks and paved helipads should have a skid-resistant sur-

face and be designed to support 1.5 times the design helicopter's maximum takeoff weight. To assure the safety of personnel, the perimeter of a helideck raised 4 feet (1.2 m) or more above the surrounding surface should have a horizontal safety net or "shelf" installed.

**15. APPROACH AND DEPARTURE ROUTE.** At least one unobstructed approach and departure route is required. When surrounding conditions permit, additional approach and departure routes are desirable to allow the helicopter to take advantage of the wind direction in making a landing or takeoff.

**a. Configuration.** The designated approach and departure routes may curve to avoid objects or noise sensitive areas.

**b. Protection.** FAR Part 77 does not require persons contemplating the construction of objects or buildings in the vicinity of a private use heliport to give the FAA notice of their intent. Therefore, acquisition of sufficient property interests, air rights, or zoning is recommended to assure protection of at least the innermost portion of the approach and departure routes.

**16. PARKING.** A parking area should be provided if more than one helicopter at a time is to be accommodated. The helicopter parking area should be of a size and location such that parked helicopters will not obstruct the clear area used for takeoffs and landings or the approach and departure routes. See figure 2-2. Grounding rods should be provided if fueling is to be conducted at the heliport. Tie downs may be warranted.



INDUSTRIAL HELICOPTERS INC. HELIPORT NORTHWEST OF LAFAYETTE, LOUISIANA

Figure 2-2. Helicopter Parking

**17. HELIPORT MARKINGS.** If owners wish to identify their heliport and the boundaries of the takeoff and landing area, helipad, or helideck, these surfaces can be marked as follows:

**a. Boundary Markings.**

**(1) Markers.** The edges of the takeoff and landing area may be marked as illustrated in figures 2-3 and 2-4. In-ground markers are located at the edges of the surface. Above-ground markers should be located clear of and approximately 10 feet (3 m) outboard of the takeoff and landing area. When used, above-ground markers should be as low as possible, be secured, and, if practical, be on breakaway mounts to prevent their becoming a hazard or being blown over.

**(2) Paint.** Lines may be painted on the boundaries of hard surfaced takeoff and landing areas, helipads, or helidecks as illustrated in figures 2-4 and 2-5. While white is the most commonly used color, other colors may be used. To increase conspicuity, lines may be outlined with a stripe of a contrasting color. Paint may be reflective or nonreflective.

b. **Identification Markings.** Any recognizable letter, logo, initial, symbol, etc., may be used to identify the heliport and the desired touchdown location. The dimensions of the identifying marking should be as large as practical but should not be less than 10 feet (3 m) in height. The marking should be oriented to be legible from the preferred direction of approach. To assure recognition, hospital heliports and emergency evacuation facilities should be marked as illustrated in figures 2-4 and 2-5.

c. **Weight Limitation.** A weight limit, in thousands of pounds, may be indicated by a number located to the right and below the heliport symbol as viewed from the preferred direction of approach as illustrated in figure 2-4.

d. **Closed Heliport.** The markings of a permanently closed heliport should be obliterated, if practicable. As a minimum, a yellow X, as illustrated in figure 2-6, shall be painted over the existing markings. The X must be large enough to ensure early pilot recognition.

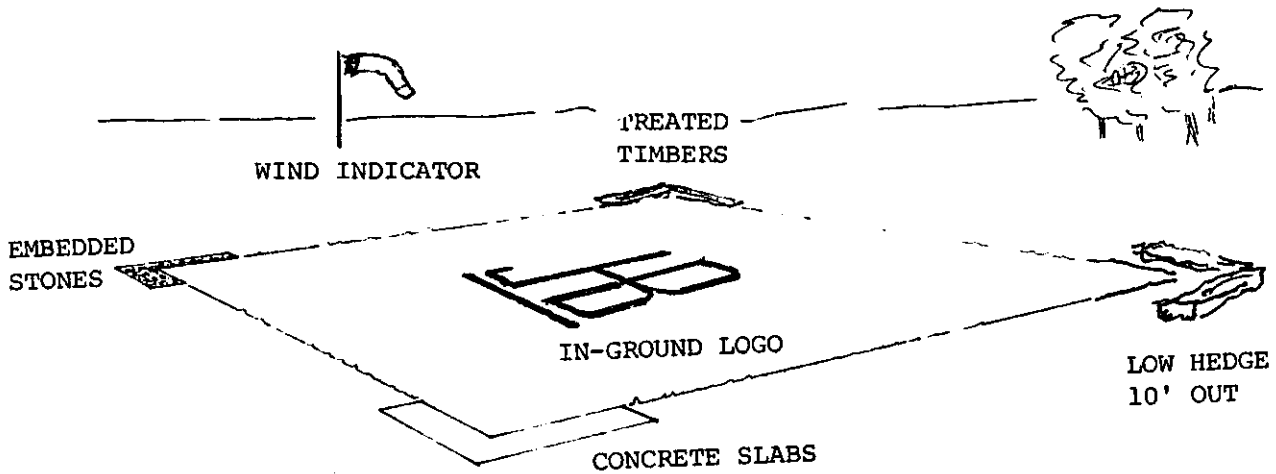

Figure 2-3. Marking of Unpaved Surfaces

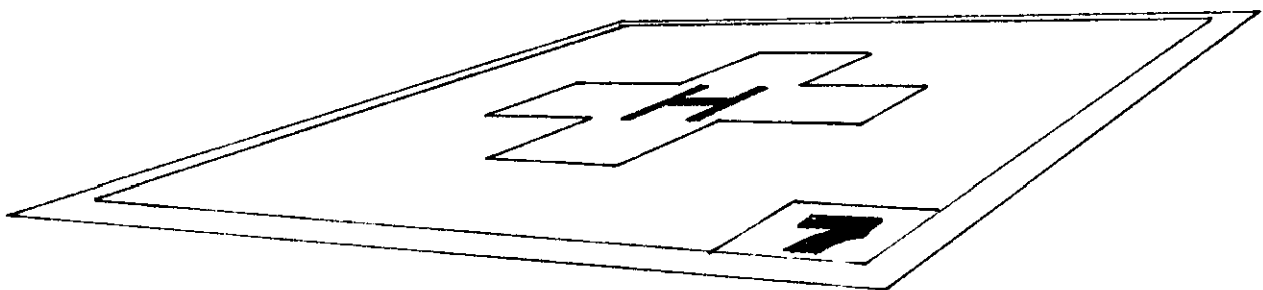

Figure 2-4. Hospital Heliport

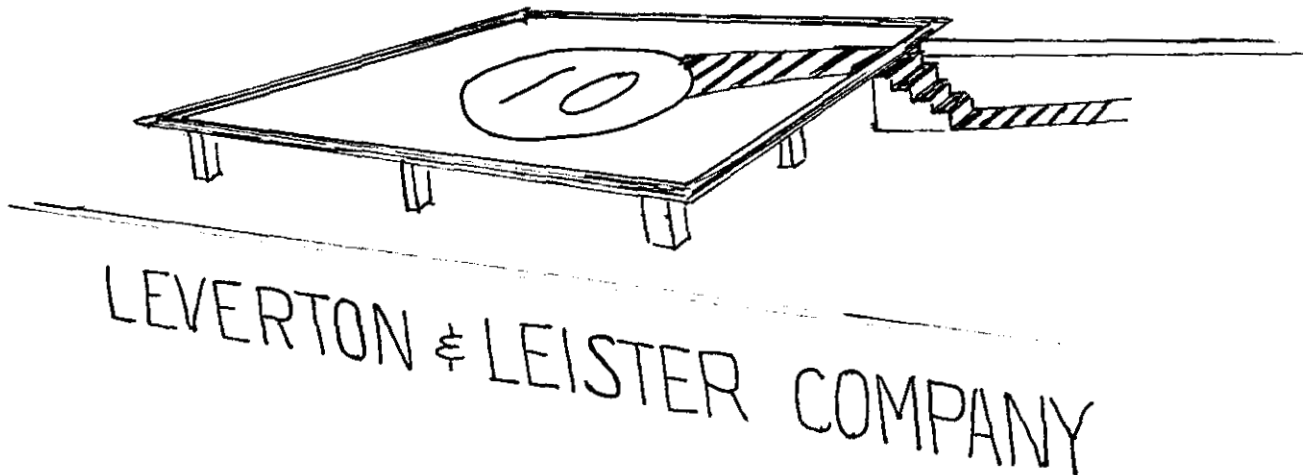

Figure 2-5. Emergency Evacuation Facility

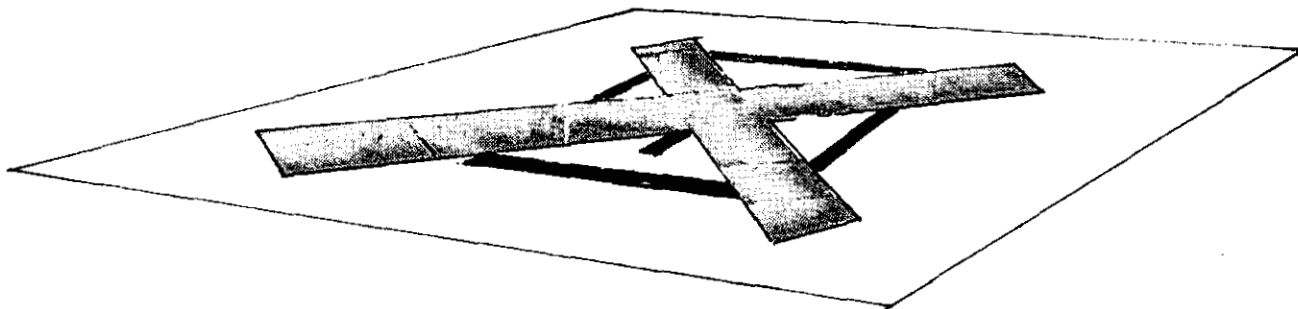

Figure 2-6. A Closed Heliport

**18. HELIPORT LIGHTING.** If night operations are contemplated and ambient light is inadequate, the takeoff and landing area should be defined by perimeter lights, floodlights, or a combination thereof.

**a. Perimeter Lights.** An odd number but not less than three (15 to 60 watt) lights per side is recommended for square or rectangular surfaces and 8 equally spaced lights for round surfaces. Flush in-pavement lights should be positioned no more than one foot (30 cm) in from the pavement edge. Frangible above-ground fixtures should be not more than 10 inches (25 cm) in height and located clear of and within 10 feet (3 m) of the takeoff and landing area. When necessary for snow clearance, 18 inches (45 cm) height fixtures may be located 10 feet (3 m) outboard of the takeoff and landing area. Figure 2-7 illustrates a perimeter lighting system. For helidecks, it may be desirable to light the perimeter of the helideck and use reflective markings to ensure the helideck can be clearly identified.

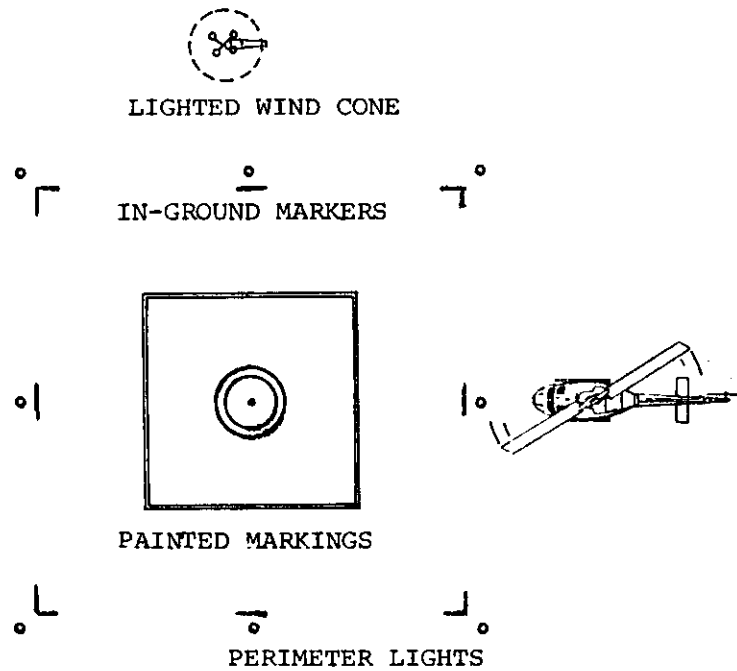
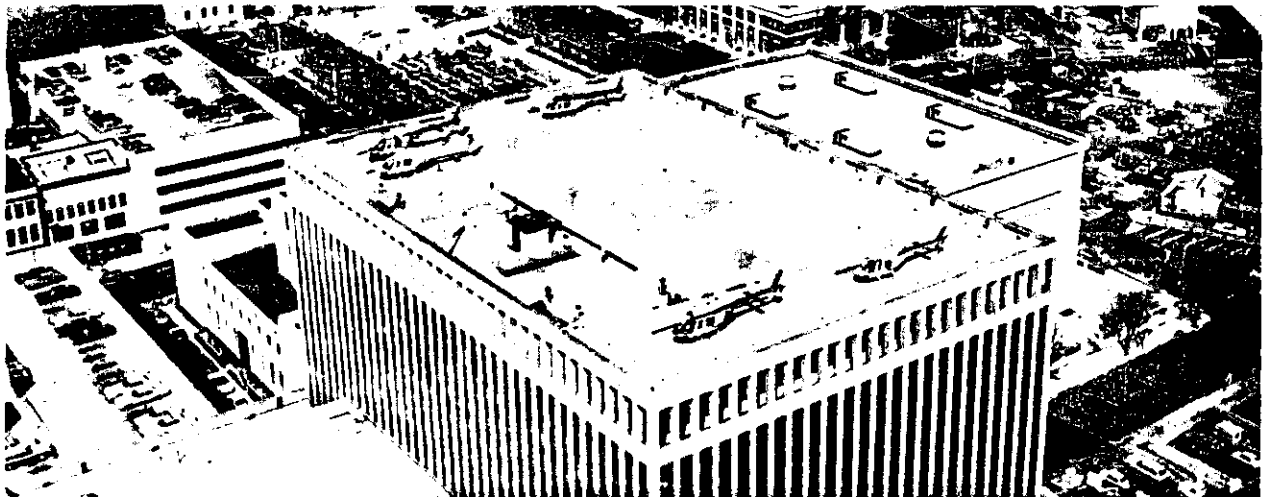

Figure 2-7. Heliport Lighting System

b. **Elevated Floodlights.** Floodlights should illuminate the operational area and should, to the extent practicable, be mounted on buildings or poles which do not to interfere with flight operations.

**19. WIND DIRECTION INDICATOR.** A means of indicating wind direction is essential. The preferred indicator is a wind cone but may be as simple as a flag on a pole. The indicator should be located so as not to interfere with flight operations and yet be able to give a true indication of the wind's direction and relative magnitude. For night operations, the wind indicator should be located in an illuminated area or be lighted.

**20. FENCES.** When needed, fences should be as low as practicable, not be a hazard to flight operations, not obstruct the approach departure routes, and yet be able to prevent inadvertent or unauthorized entry. Hedges may be as effective as fences.



ROOFTOP HELIPORT, BALTIMORE, MARYLAND, POLICE DEPARTMENT



**MARATHON OIL COMPANY HELIPORT, BERWICK, LOUISIANA**

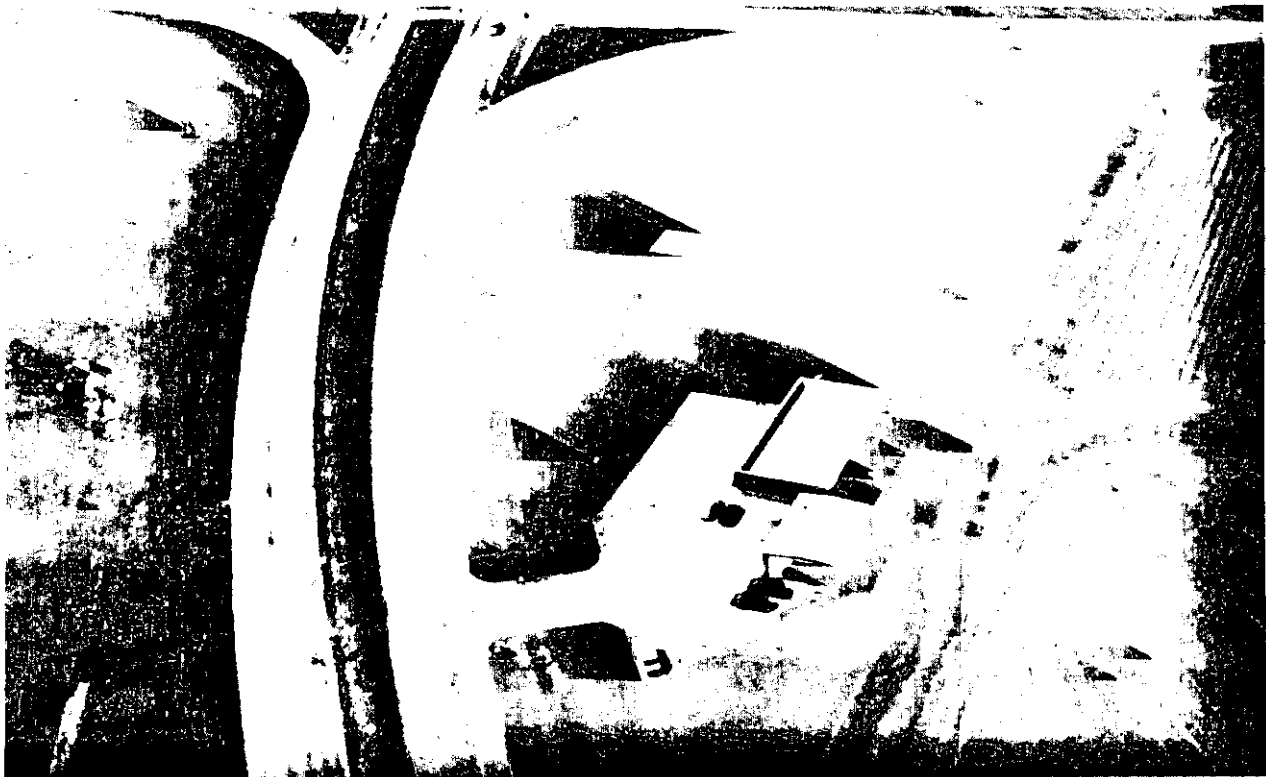

**PRIVATE HELIPORT, FRANKLIN, LOUISIANA**



### CHAPTER 3. PUBLIC USE HELIPORTS

**21. GENERAL.** *The contents of paragraphs 22 through 24 and 26 through 31 are design standards for takeoff and landing areas, final approach and takeoff areas (FATOs), approach and departure routes, parking areas, taxi routes, taxiways, heliport markings, heliport lighting, and visual aids.*

**22. TAKEOFF AND LANDING AREAS.** Each public use heliport or helistop shall have at least one takeoff and landing area. For heliports where 10 or more operations per hour are anticipated, multiple takeoff and landing areas should be provided.

**a. Location.** The takeoff and landing area may be located on the ground, on a water surface, on a roof of a building, or on an elevated platform. The location shall provide at least 1/3 rotor diameter, but not less than 10 feet (3 m), horizontal clearance between the takeoff and landing area and buildings, fences, parapets, curbs, and objects which could be struck by main or tail rotors.

**b. Size.** For heliports serving single rotor helicopters exclusively, the length and width, or diameter of the takeoff and landing area shall be at least equal to twice the rotor diameter of the design helicopter. For heliports serving tandem rotor helicopters, the length and width, or diameter of the takeoff and landing area shall be at least one rotor diameter greater than the overall length of the design helicopter. When site conditions permit, a longer takeoff and landing area will increase the operational capability of the heliport.

**c. Surface Characteristics.** If the FATO is marked, the portion of the takeoff and landing area outboard of the FATO may be nothing more than unobstructed airspace. If the FATO is not marked, the takeoff and landing area surface shall be capable of producing ground effect. The surface of the takeoff and landing area should be clear of objects, except for essential and frangible heliport visual aids and fire suppression equipment which is required therein.

**23. FINAL APPROACH AND TAKEOFF AREA (FATO).** The FATO is normally centered within a takeoff and landing area. When not centered, its center is at least one rotor diameter from the edge of the takeoff and landing area.

**a. Size.** The length and width, or diameter of the FATO shall be at least equal to the rotor diameter of the design single rotor helicopter. The length and width, or diameter of the FATO shall be at least equal to the overall length of the design tandem rotor helicopter.

**b. Surface Characteristics.** The FATO surface shall be capable of producing ground effect.

**c. Separation Between Adjacent FATOs.** When more than one FATO is provided and simultaneous same direction (side by side) diverging operations are to be conducted, a center to center separation distance of at least 200 feet (60 m) shall be provided. For sequential operations, the takeoff and landing areas containing the FATOs may overlap if the helicopters in the FATOs are clear of the approach and departure surfaces in use and are at least 1/3 rotor diameter, but not less than 10 feet (3 m), from the overlapped takeoff and landing area. Figure 3-1 illustrates overlapping takeoff and landing areas for sequential operations.

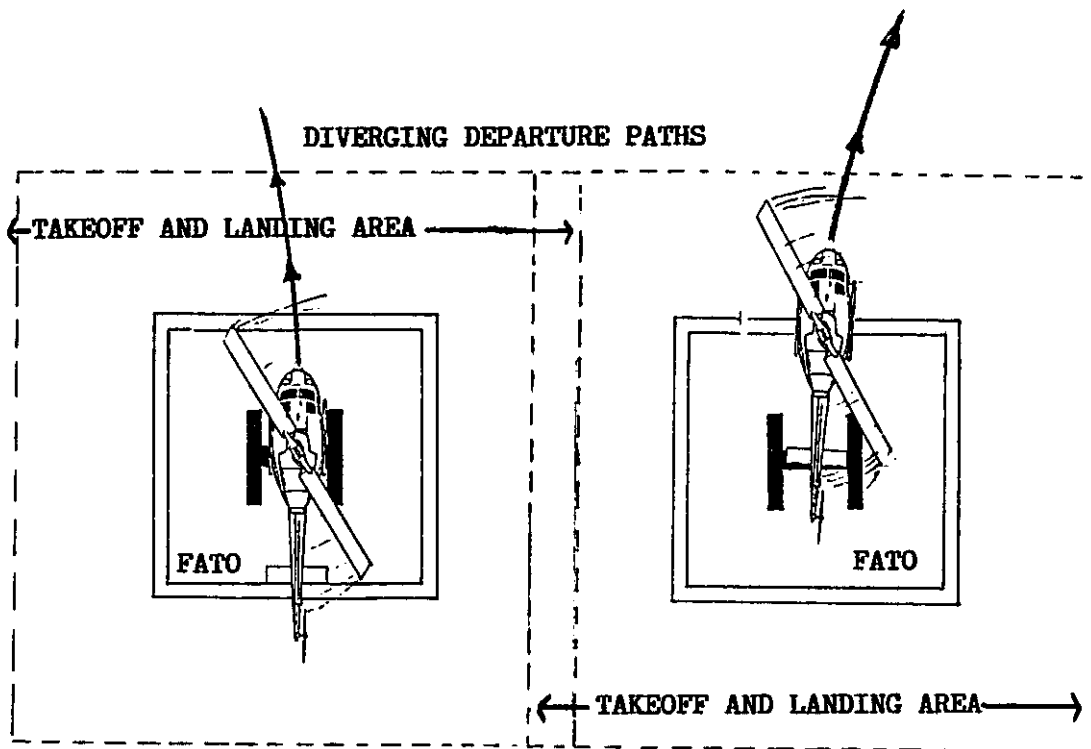

Figure 3-1. Overlapping Takeoff and Landing Areas

**24. APPROACH AND DEPARTURE ROUTES.** Each takeoff and landing area shall have at least one approach and departure route. However, as many approach and departure routes as practical, separated by arcs of 90 to 180 degrees, are recommended. In configuring the routes, the heliport owner shall consider the following:

a. **Objects and Noise Sensitive Areas.** The approach and departure routes should take advantage of unobstructed airspace above roadways, railroads, waterways, etc.. The routes may curve to avoid objects or noise sensitive areas.

b. **Prevailing Wind.** The routes should be oriented to align as near as practicable with the prevailing winds.

c. **Heliport Imaginary Surfaces.** The routes locate the FAR Part 77 Subpart C heliport approach and transitional surfaces emanating from the primary surface.

d. **Visual Glide Path Indicator Obstacle Clearance Plane.** If a visual glide path indicator is installed, the configuration of its approach route is fixed by the visual guide path indicator siting and clearance criteria as noted in paragraph 31c.

e. **Hazards to Air Navigation.** Objects, including parked helicopters, penetrating the imaginary surfaces are obstructions to air navigation and as such are presumed to be hazards to air navigation. The adverse effect of hazards to air navigation are mitigated by:

- (1) Removing the object.
- (2) Obstruction lighting and marking, if an FAA aeronautical study finds that the object would not be a hazard to air navigation if lighted and marked.
- (3) Realigning the approach and departure routes.

**25. APPROACH AND DEPARTURE PROTECTION AREAS.** Where practicable, the heliport owner should control the property underlying the innermost portion of the approach and departure surface. This area underlies the approach and departure surface from the edge of the primary surface out to a point where the approach and departure surface is 35 feet (10.5 m) above the landing surface. Figure 3-2 illustrates a typical configuration of a visual approach and departure protection area. While it is desirable for this area to

be reasonably free of surface irregularities or objects, heliport related uses which do not create a hazardous condition are permitted. Ownership is the most effective means to protect the approach and departure routes and to provide protection to persons and property on the ground.

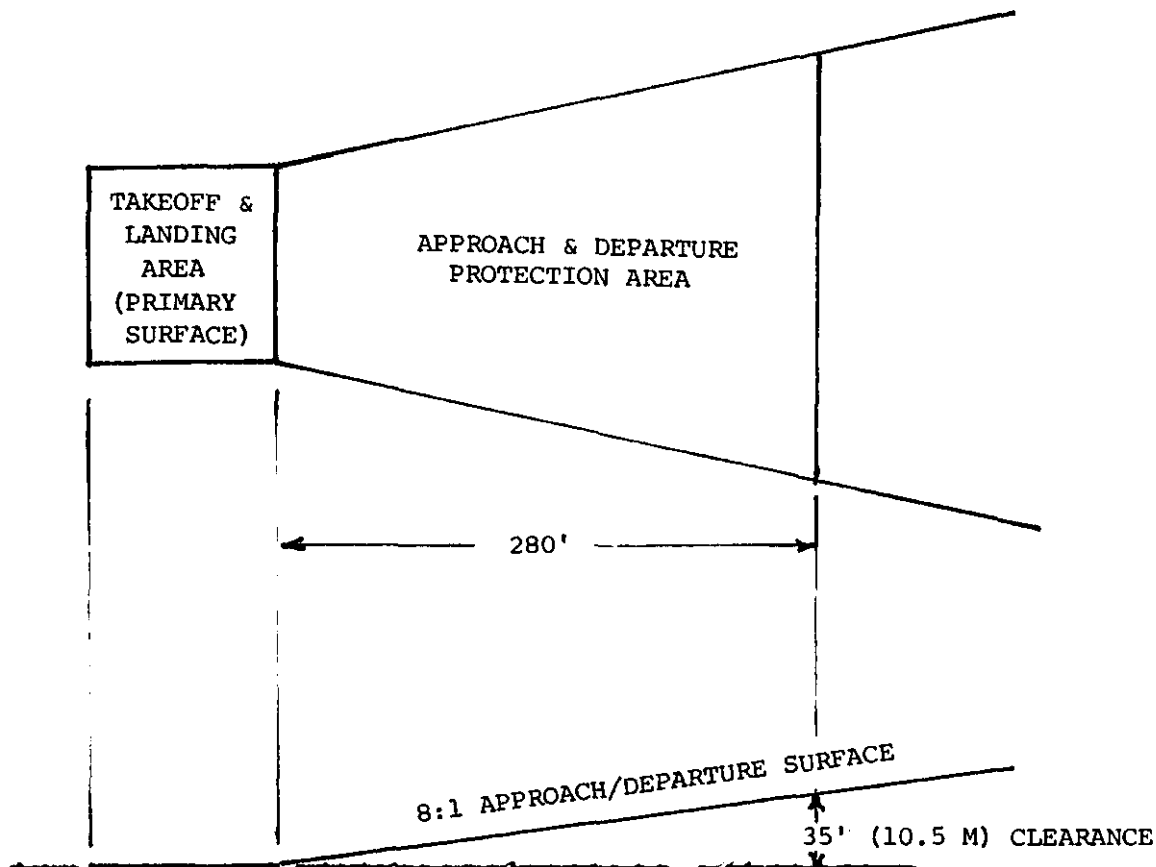

Figure 3-2. Visual Approach and Departure Protection Area

**26. PARKING AREAS.** Helicopter parking shall be adequate to accommodate the number of helicopters to be served. Parking may be accomplished on a paved or unpaved apron, a helipad, or a helideck. If necessary, helipads and helidecks may be located in the FATO or the takeoff and landing area. However, a design which requires a helicopter to park in the FATO or takeoff and landing area makes that area unavailable for takeoffs or landings by other helicopters.

**a. Location.** Except for helipads and helidecks located in the FATO or takeoff and landing area, the parking area shall be located such that parked helicopters are clear of the approach and departure surfaces and have at least  $1/3$  rotor diameter but not less than 10 foot (3 m) clearance from a takeoff and landing area or a fixed or movable object.

**b. Helipads.** The minimum length and width, or diameter, of the helipad shall be at least 1.5 times the design helicopter's undercarriage length or width, whichever is greater. To facilitate loading or unloading of passengers or baggage or for fueling and maintenance servicing, larger pads may be desired. The helipad surface shall be designed to support 1.5 times the design helicopter's maximum takeoff weight. If hard surfaced, it should be textured or skid-resistant.

**c. Helidecks.** The length and width, or diameter of the helideck shall be at least equal to the rotor diameter of the design single rotor helicopter or the overall length of the design tandem rotor helicopter. The helideck surface shall be designed to support 1.5 times the design helicopter's maximum takeoff weight

and should have a textured or skid-resistant surface. To provide protection for personnel, the perimeter of a helideck raised 4 feet (1.2 m) or more above the surrounding surface shall have a 5 foot (1.5 m) wide horizontal safety net or "shelf." Figure 3-3 illustrates a horizontal safety net.

d. **Tie-Downs and Static Grounding.** Tie-downs may be warranted. Grounding rods shall be provided at fueling locations.

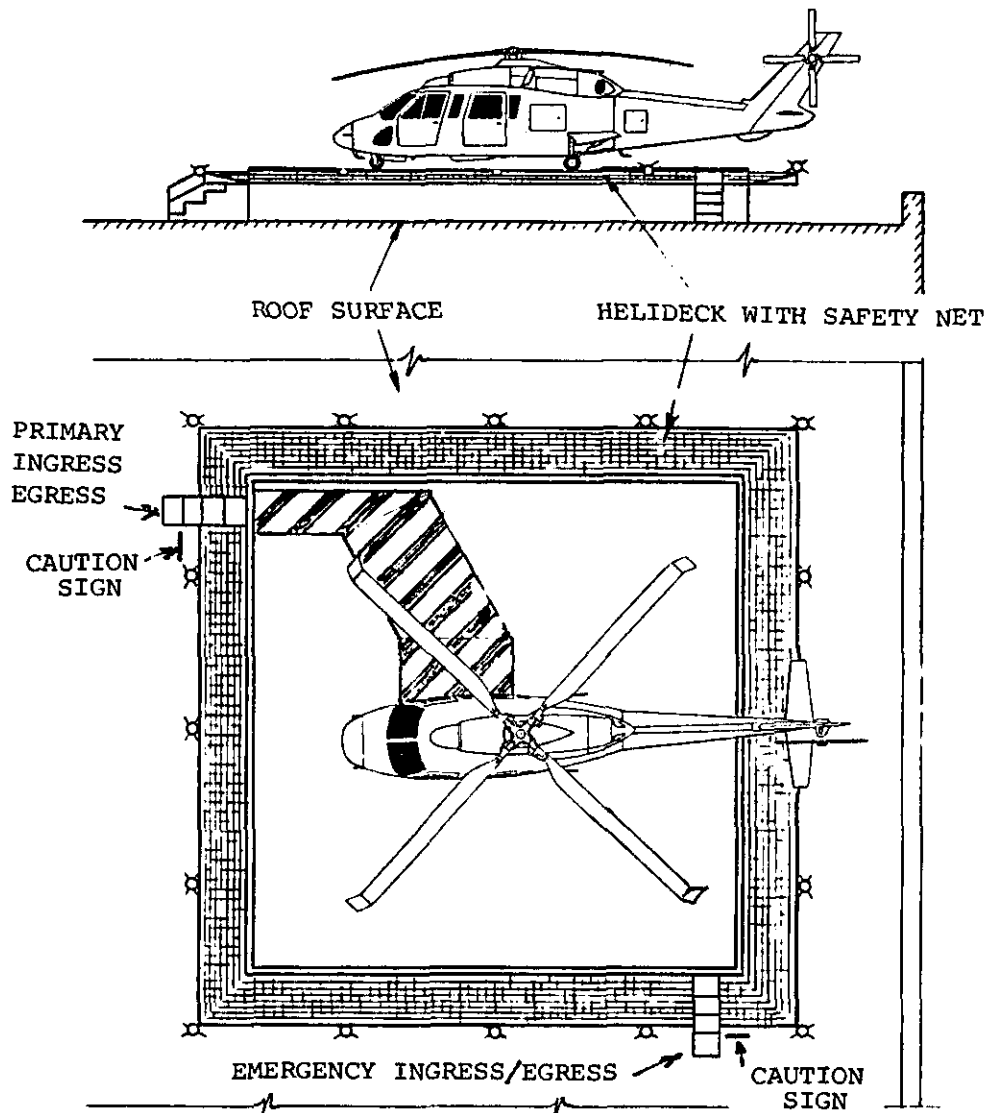

Figure 3-3. Helideck with a Safety Net

27. **TAXI ROUTES.** A cleared right-of-way for taxiing shall be provided between a takeoff and landing area and a parking area, as illustrated in figure 3-4.

a. **Widths.** The taxi route width shall be at least the larger of:

- (1) twice the rotor diameter of the largest helicopter which is expected to hover taxi, or
- (2) one and one-half rotor diameters of the largest helicopter which is expected to ground taxi, plus 14 feet (4 m).

b. **Parallel Taxi Route Separations.** The centerline-to-centerline separation distance shall be at least the larger of:

- (1) one and one-half rotor diameters of the largest helicopter which is expected to hover taxi, or
- (2) one and one-quarter rotor diameters of the largest helicopter which is expected to ground taxi, plus 7 feet (2 m).

**28. TAXIWAYS.** When a hard surface taxiway is provided, it shall be centered within a taxi route and shall be at least twice the width of the undercarriage of the design helicopter.

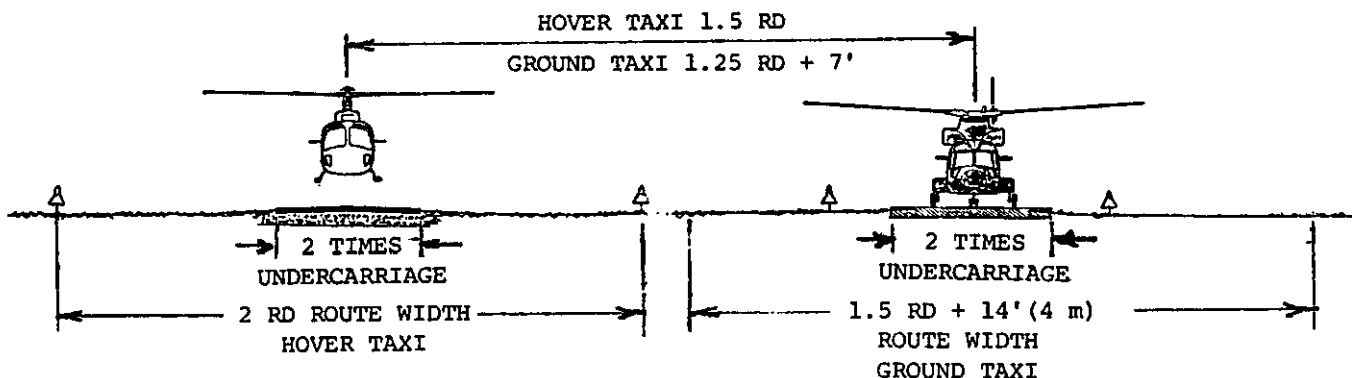

Figure 3-4. Taxi Route and Taxiway Relationship

**29. HELIPORT MARKINGS.** Markings shall be painted on surfaces which are practical to paint. Paints may be reflective or nonreflective. Painted markings may be outlined with a 6-inch (15 cm) wide strip of a contrasting color to enhance their conspicuity. In-ground markers, providing color and textural differences from the natural surface, shall be used to mark turfed surfaces.

**a. Takeoff and Landing Area Markings.** The edges of takeoff and landing areas not containing a marked FATO shall be painted with a 16-inch (45 cm) wide solid white line as illustrated in figure 3-5 or marked with in-ground markers as illustrated in figure 3-7. If practical, the edges of takeoff and landing areas containing a marked FATO should be painted with a 16-inch (45 cm) wide dashed white line as illustrated in figure 3-6 or marked with in-ground markers as illustrated in figure 3-7.

**b. FATO Markings.** If marked, the edges of the FATO shall be painted with a 16-inch (45 cm) wide solid white line as illustrated in figure 3-6.

**c. Heliport Identification Markings.** The takeoff and landing area shall be identified by a letter centered on the FATO, if marked, or otherwise centered on the takeoff and landing area. The letter shall be as large as practical, but not less than 10 feet (3 m) in height. The letter shall be oriented as viewed from the preferred direction of approach. Letter line widths shall be proportional to the letter's height. Figures 3-5 through 3-7 illustrate identification markings.

(1) Public use heliports, except hospital heliports, shall be marked with a white capital letter H, as illustrated in figure 3-5. This represents a change from the previously recommended markings. Existing markings may remain until repainting is required.

(2) Hospital heliports shall be marked with a red capital letter H centered in a white cross, as illustrated in figure 3-6. To increase conspicuity, the cross may be superimposed on a red background enclosed within standard edge marking.

**d. Weight Limitations.** Surfaces which are limited in weight-carrying ability must be marked with a number, in thousands of pounds, indicating the weight limit. A zero indicates less than 1,000 pound load capability. Markings must be large enough to be legible from an approaching helicopter. On a FATO or

takeoff and landing area, the number is located inside a box to the right and below the heliport symbol as viewed from the preferred direction of approach. A weight limit marking is illustrated in figure 3-5.

e. **Closed Heliport.** The markings of a permanently closed heliport should be obliterated, if practicable. As a minimum, a yellow X, as illustrated in figure 3-8, shall be painted over the existing markings. The X must be large enough to ensure early pilot recognition.

f. **Helipad and Helideck Markings.** The edges of a helipad or helideck which is not analogous with a takeoff and landing area or FATO shall be painted with a 16-inch (45 cm) wide solid yellow line.

g. **Apron Markings.** Parking positions for scheduled air carrier passenger service should be clearly identified and provide one rotor diameter clearance between adjacent positions.

h. **Taxi Route Markings.** Routes used for hover/air taxiing should be marked with cylindrical above-ground markers having 3 equal width horizontal bands of yellow-green-yellow. Markers should be placed along each edge of the taxi route at intervals not in excess of 100 feet (30 m) on straight sections and 50 feet (15 m) on curved sections. Markers should conform to AC 150/5345-39, FAA Specification L-853, Runway and Taxiway Retro-reflective Markers.

i. **Taxiway Markings.** The centerline of a taxiway is marked with a continuous 12 inch (30 cm) wide yellow stripe and/or with green retro-reflective centerline markers meeting the requirements in AC 150/5345-39 for Type II markers. The taxiway edges may be marked with a continuous white stripe and blue reflective markers located at the taxiway entrance and exit points and along each edge at intervals not in excess of 50 feet (15 m).

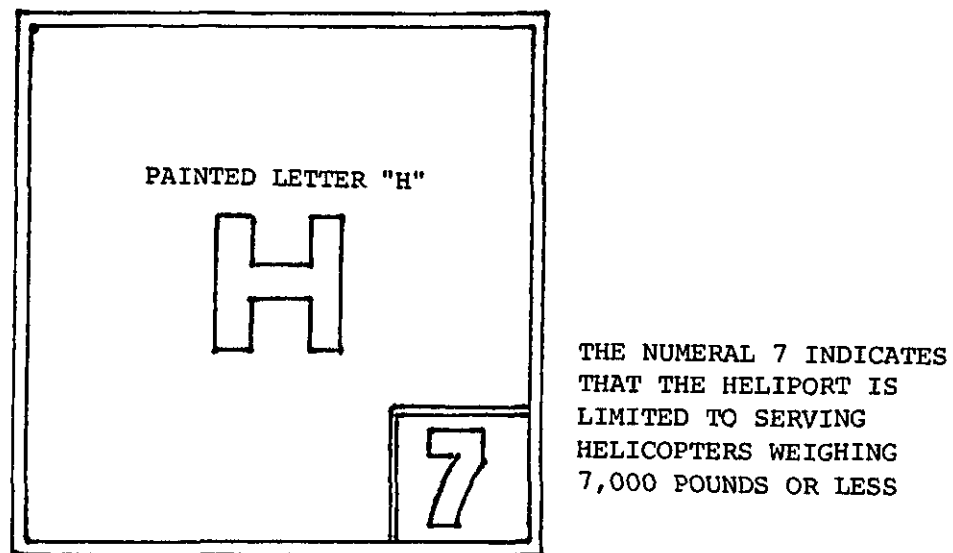

A 16' (45 cm) WIDE PAINTED LINE IS USED TO MARK THE EDGE OF A HARD SURFACED TAKEOFF AND LANDING AREA OR FATO

Figure 3-5. Public Use Heliport

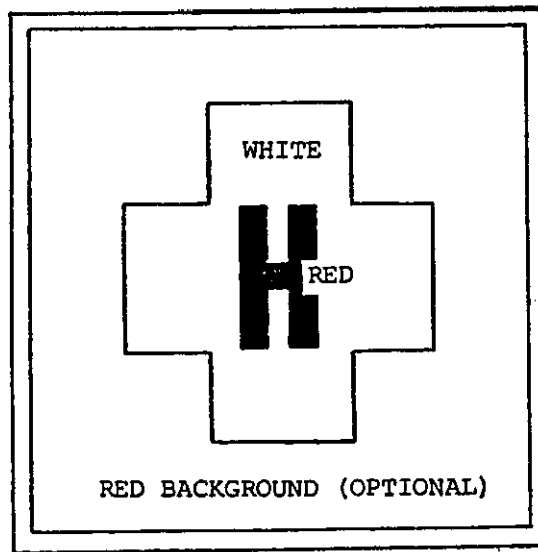

A 16' (45 cm) WIDE WHITE PAINTED LINE IS USED TO MARK THE EDGES OF A HARD SURFACED TAKEOFF AND LANDING AREA OR FATO

Figure 3-6. Hospital Heliport

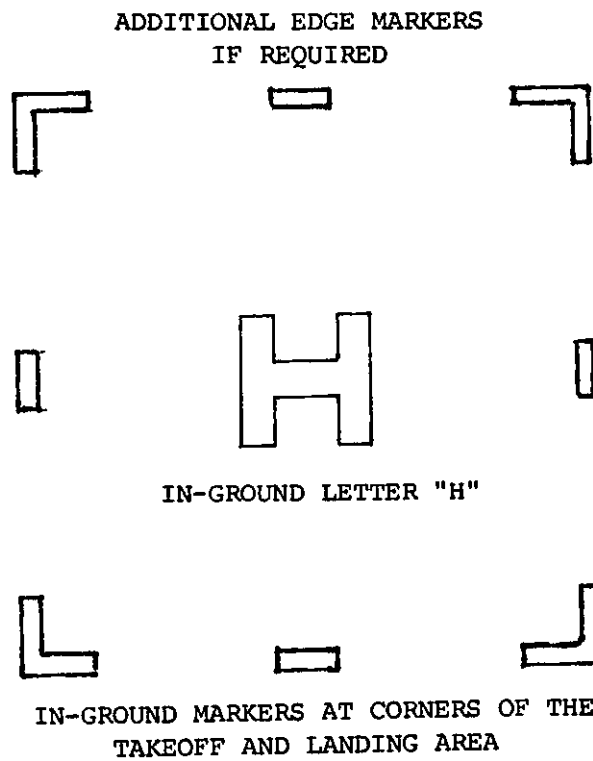

Figure 3-7. In Ground Markings

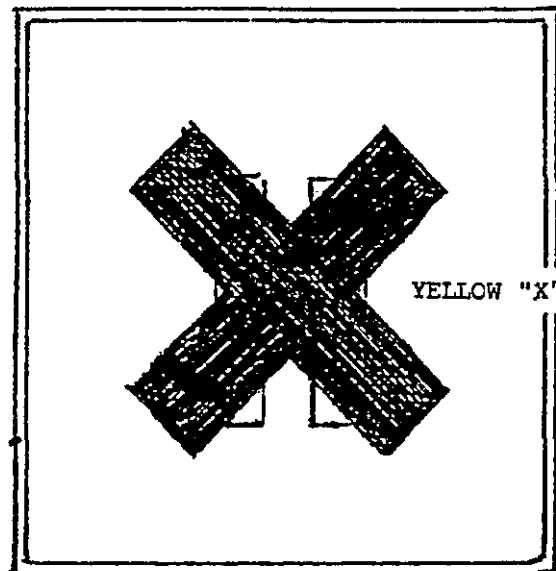

Figure 3-8. Closed Heliport

### 30. HELIPORT LIGHTING.

a. **Takeoff and Landing Area Lighting.** If night operations are contemplated and ambient light is inadequate, the FATO or takeoff and landing area shall be defined with perimeter lights, elevated flood lights, or a combination thereof. In some cases, it may be desirable to define the perimeter of the FATO with reflective markings to ensure the FATO can be clearly identified.

(1) **Perimeter lights.** Yellow omni-directional lights meeting the requirements of AC 150/5345-46, Specification for Runway and Taxiway Light Fixtures, or flood lights providing at least 3 foot candle (32 lux) of illumination over the operational area, define the boundary of the FATO or the takeoff and landing area. For a square or rectangular area, an odd number of lights (3, 5, 7, etc.) shall be placed along each edge. For a circular area, at least 8 uniformly spaced lights shall be placed along its circumference. The maximum spacing between lights in either case must not exceed 30 feet (9 m).

(a) Flush in-pavement lights shall be positioned no more than one foot (30 cm) in from the edge of a paved FATO or takeoff and landing area.

(b) Care should be taken to ensure that perimeter lights do not create a potentially hazardous situation by being located where they may be struck by a tail rotor or skids. To minimize the potential, frangible above-ground lights shall be no more than 10 inches (25 cm) in height and located clear of but within 10 feet (3 m) of the FATO or takeoff and landing area. When necessary for snow clearance, 18 inch (45 cm) high, frangible fixtures may be located 10 feet (3 m) outboard of the takeoff and landing area. Figure 3-9 illustrates a perimeter lighting system for night operations.

(c) Lights on the perimeter of a helideck may be placed on the periphery of the safety net.



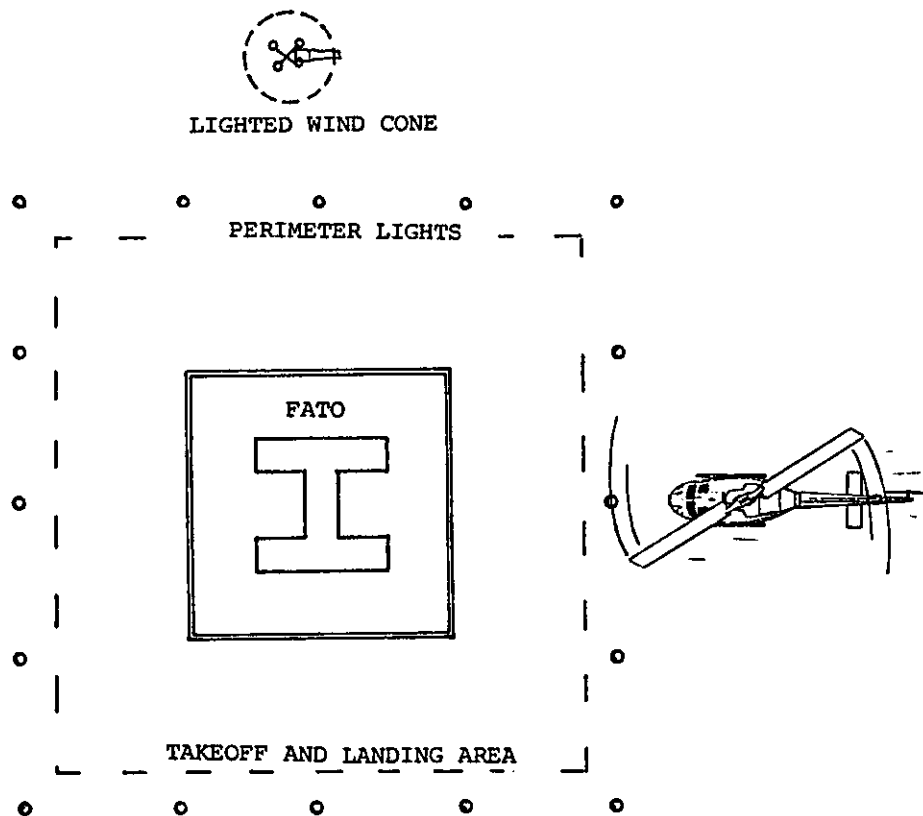

Figure 3-9. Lighting Systems for Night Operations

(2) **Elevated Floodlights.** When used, elevated floodlights shall provide at least 3-foot candle (32 lux) of illumination over all operational areas and be situated and/or hooded to prevent direct or reflected light from blinding pilots. The spectral distribution of the floodlights shall be such that the colors used for surface and obstruction marking are conspicuous. Floodlights, to the extent practicable, should be mounted on buildings or poles which do not interfere with flight operations.

b. **Taxi Route and Taxiway Lighting.** Guidance for designing a taxiway lighting system is found in AC 150/5345-24, Runway and Taxiway Edge Lighting Systems. Equipment specifications are found in AC 150/5345-46, Specification for Runway and Taxiway Light Fixtures. An alternative system uses L-852 centerline lights as described in AC 150/5340-19, Taxiway Centerline Lighting Systems. Another alternative utilizes the above-ground edge or in-pavement centerline reflective markers described in AC 150/5345-39, Runway and Taxiway Centerline Retro-reflective Markers.

(1) **Taxi Route Lighting.** L-861T omni-directional blue lights may be used to mark the limits of a taxi route. Above-ground lights shall be spaced at a maximum interval of 100 feet (30 m) for straight sections and 50 foot (15 m) for curved sections. A minimum of three lights shall be used to define a curve.

(2) **Taxiway Edge Lights.** L-861T omni-directional blue lights shall be used to mark the edges of a taxiway. Above-ground lights shall be placed no more than 10 feet (3 m) out from the pavement edge.

(3) **Taxi Guidance Signs.** Taxi guidance signs meeting the requirements of AC 150/5345-44, Specification for Taxiway and Runway Signs, are recommended. Size 1 signs need to be installed in accordance with AC 150/5340-18, Standards for Airport Sign Systems.

### 31. VISUAL AIDS.

a. **Wind Direction Indicator.** A wind cone meeting the standards of AC 150/5345-27, Specification for L-807 Eight-foot and Twelve-Foot Unlighted and Externally Lighted Wind Cone Assemblies, is recommended. The wind cone shall be located adjacent to the takeoff and landing area but not interfere with helicopter operations or be shielded by buildings or other objects that prevent it from showing a true indica-

tion of the wind's direction and relative magnitude. The wind cone shall provide the best possible color contrast to the heliport background. Wind indicators shall be lit for night operations.

b. **Landing Direction Lights.** Landing direction lights may be used to identify the alignment of the approach route. Landing direction lights consist of a line of five L-860 or five L-861 lights with omnidirectional yellow lenses spaced at 15 foot (4.5 m) intervals. Lesser spacing is permissible where physical constraints make the standard interval impractical. Landing direction lights extend out from the line of perimeter lights in the direction of the approach.

c. **Visual Glide Path Indicator.** A visual glide path indicator may be used to indicate the approach path. The indicator's lowest on-course signal must provide clearance over any object in the approach path that is lying within 10 degrees of the approach course centerline. The optimum location of a visual glide path indicator is near the takeoff and landing area. Figure 3-10 illustrates the visual glide path indicator siting and clearance criteria.

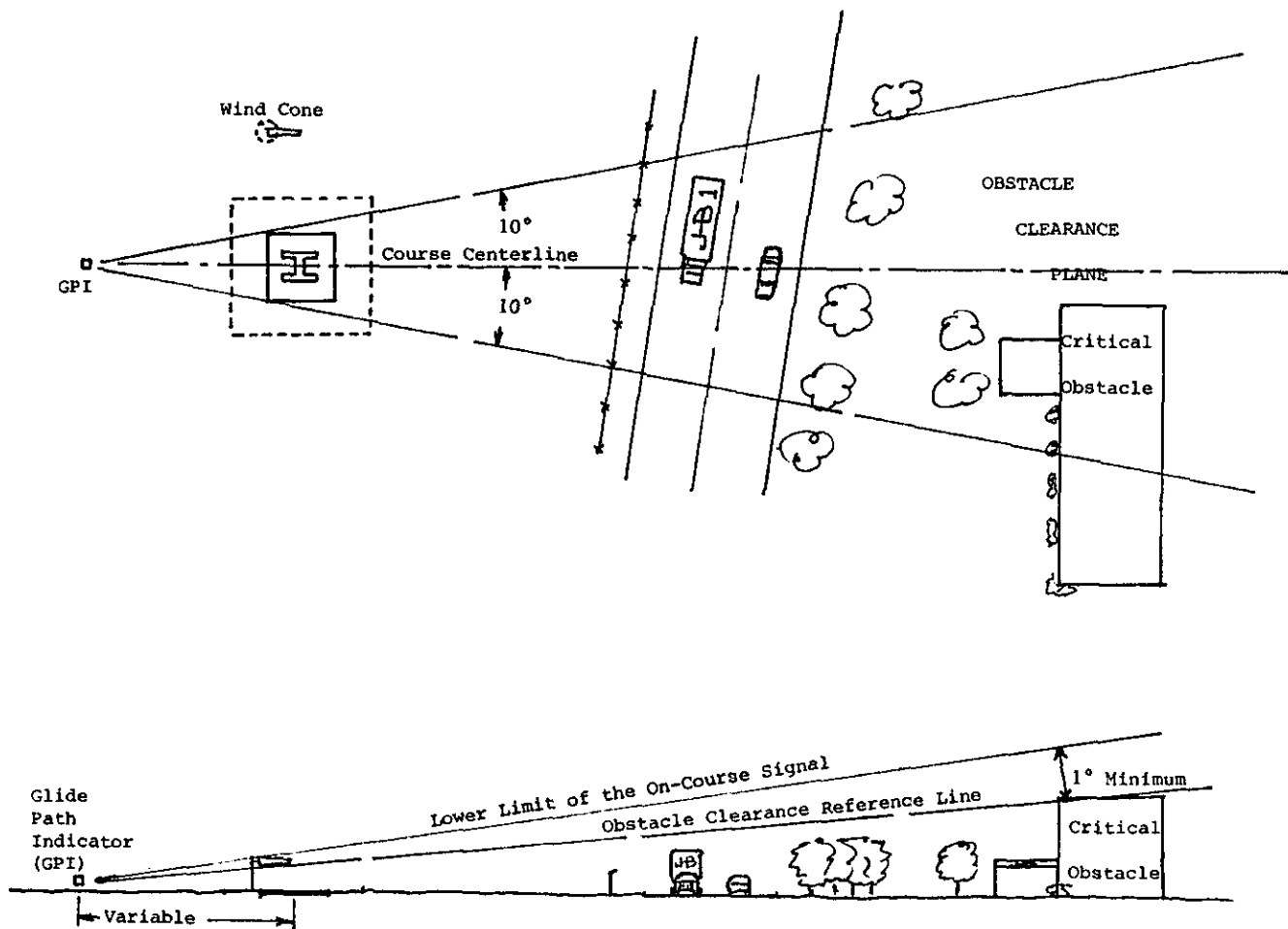

Figure 3-10. Visual Glide Path Indicator Siting and Clearance Criteria

d. **Heliport Identification Beacon.** When required to aid in locating the heliport, an identification beacon flashing white-green-yellow at the rate of 30 to 53 flashes per minute should be located on or within one quarter mile (0.4 km) of the heliport. Information on heliport beacons is found in AC 150/5345-12, Specification for Airport and Heliport Beacons.

e. **Obstruction Marking and Lighting.** Unless an FAA aeronautical study has determined that the absence of such marking or lighting will not impair safety, obstructions to air navigation and objects exceeding a height of 200 feet (120 m) above the level of the ground within 1 nautical mile of the heliport shall be

marked and lighted. AC 70/7460-1, Obstruction Marking and Lighting, contains guidance on how to mark and light these objects.

**32. HELIPORT FACILITIES.** The amount of property to be acquired depends upon the need to provide for helicopter fueling, maintenance, and storage, and passenger amenities such as terminal buildings, ground transportation, and automobile parking.

a. **Fueling.** If provided, systems for storing and dispensing fuel must conform to federal, state, and local requirements for petroleum handling facilities.

b. **Maintenance.** At larger heliports, hangars may be needed for helicopter storage and maintenance purposes.

c. **Terminal Facilities.** A terminal building or sheltered waiting area should be simple, attractive, and functional to accommodate the needs of current and forecasted traffic. AC 150/5360-9, Planning and Design of Airport Terminal Facilities at Nonhub Locations, contains useful information on the design of a terminal facility.

d. **Transportation and Parking.** Features such as curb side discharge and pickup areas, taxicab and rental car services may be desirable. Automobile parking areas should be large enough to accommodate employee and passenger needs. Availability of public transportation will normally reduce the requirement for vehicle parking spaces.

### **33. SAFETY FEATURES.**

a. **Fences.** When needed, fences should be as low as practical, not be a hazard to flight operations, and still be able to prevent inadvertent or unauthorized entry. When scheduled operations by certificated carries are planned, fences must meet the requirements of FAR Part 107, Airport Security.

b. **Rescue and Firefighting Services.** Rescue and firefighting service requirements are as follows:

(1) Heliports certificated under FAR Part 139, Certification and Operations: Land Airports Serving CAB Certificated Air Carriers, must provide the level of rescue and firefighting services specified in that regulation.

(2) The National Fire Protection Association's (NFPA) Pamphlets 403, Aircraft Rescue Services, or 418, Roof-Top Heliports, provide fire protection recommendations.

(3) To meet the NFPA recommended level of fire fighting protection, a fire hose cabinet or an extinguisher should be provided at each gate used for scheduled passenger service and near each fueling location. Cabinets and extinguishers should be located within 20 feet (6 m) of the takeoff and landing area and should not penetrate any heliport imaginary surface. Fire hose cabinets and extinguishers at helidecks should be located adjacent to but below the level of the deck.

c. **Passenger Walkways.** Passenger access to operational areas must be controlled. Walkways should be marked and the primary and secondary or emergency exits should be identified with a cautionary sign similar to that illustrated in figure 3-11. Surfaces shall slope away from passenger walkways to prevent spilled fuel from draining in these areas.

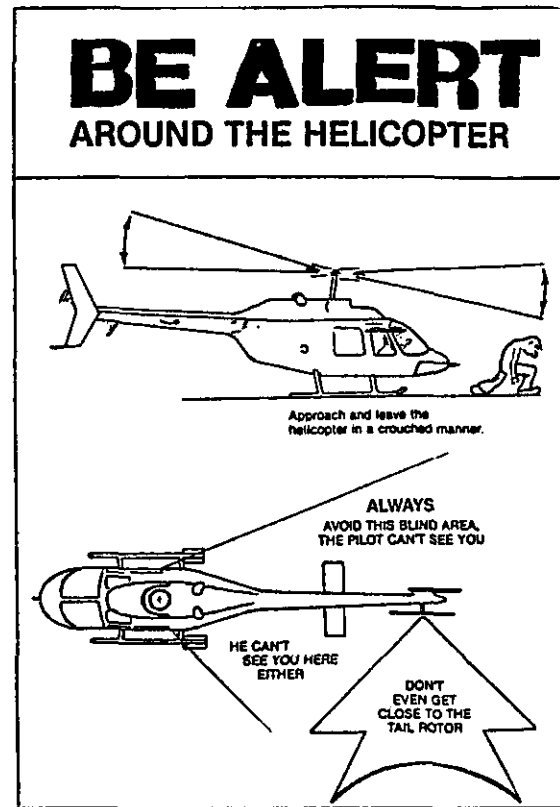
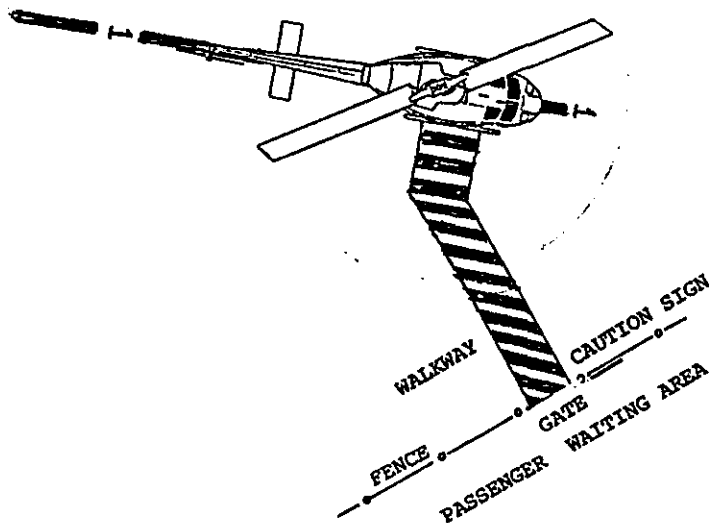

Figure 3-11. Walkway and Sign

d. **Automatic Weather Observing/Reporting System (AWOS).** An AWOS measures and automatically reports weather conditions at the site. If automated weather reporting is needed, an AWOS should be provided. It should be located from 100 to 700 feet (30 to 215 m) from the edge of the takeoff and landing area and sited to avoid or minimize penetrations of the heliport imaginary surfaces and minimize downwash from helicopter operations. AC 150/5220-16, Automated Weather Observing Systems (AWOS) for Non-Federal Applications should be consulted for guidance.

e. **Radio Communications.** A "UNICOM" radio may be used to provide heliport and air traffic advisory information but may not be used for air traffic control. UNICOM radios require a Federal Communications Commission (FCC) license.

f. **Snow and Ice Control.** Heliport operational surfaces should be kept free and clear of ice and snow. AC 150/5200-23, Airport Snow and Ice Control, should be consulted for guidance.

**34. ZONING AND COMPATIBLE LAND USE.** Communities should adopt a zoning ordinance limiting the height of buildings and other structures and control the type of development in the heliport area.

a. **Height Zoning.** AC 150/5190-4, A Model Zoning Ordinance to Limit Height of Objects Around Airports, provides guidance on how to draft such an ordinance.

b. **Compatible Land Use.** AC 150/5050-6, Airport Land Use Compatibility Planning, provides generalized guidance for developing noise and land use control plans.

## CHAPTER 4. HELICOPTER FACILITIES AT AIRPORTS

**35. GENERAL.** This chapter contains references and considerations relating to helicopter facilities on airports.

**36. REQUIREMENT.** Helicopters may operate on airports without separate helicopter facilities being provided. However, separate helicopter facilities, e.g. takeoff and landing areas, taxi routes, parking areas, etc., should be considered when there is a clearly demonstrated potential for interference between helicopter and airplane operations.

**37. LOCATION.** Helicopter facilities should be located as near as practical to the intended destination of the passengers.

**38. RUNWAY CLEARANCE.** If simultaneous, same direction diverging helicopter and airplane operations are to be conducted, a runway centerline to takeoff and landing area center separation of at least 400 feet shall be provided. Helicopter parking areas shall meet the same runway clearance standards as required for airplane parking.



HELICOPTER FACILITIES, WILLIAMS MEMORIAL AIRPORT, PATTERSON, LOUISIANA

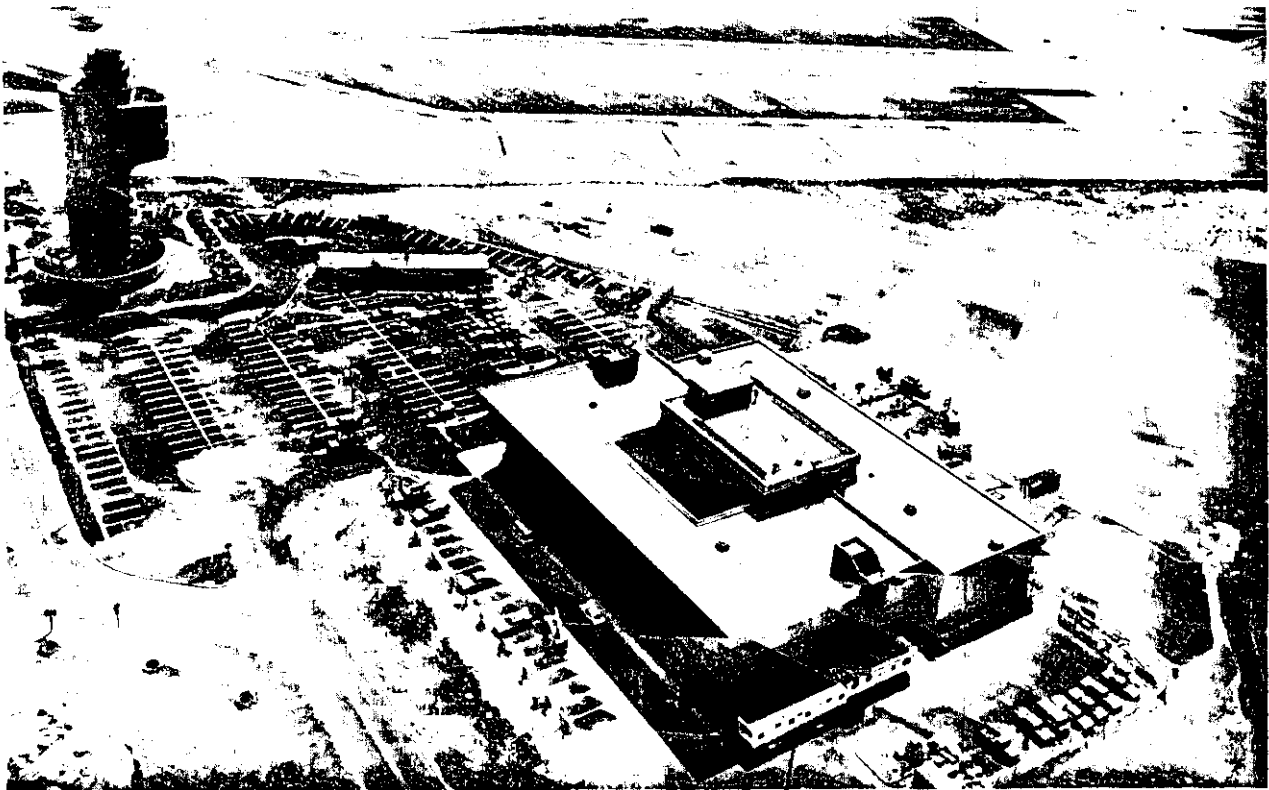

**BUILDING 10, NEWARK AIRPORT, NEWARK, NEW JERSEY**



**LAFAYETTE REGIONAL AIRPORT, LAFAYETTE, LOUISIANA COMPANY FACILITIES**

## CHAPTER 5. VFR HELIPORTS

**39. GENERAL.** This chapter contains references relating to the establishment of a heliport serving helicopters operating under visual flight rules (VFR). With airspace availability and appropriate navigational aids, nonprecision instrument approach procedures may be established at these heliports. Further, if additional airspace and the ground area required for precision instrument navigational approach and departure aids is available, these heliports can be planned or improved to accommodate precision instrument approach and departure procedures.

**40. PRIVATE USE VFR HELIPORTS.** A private-use VFR heliport should meet the recommendations and guidance in chapters 1, 2, and 8.

**41. PUBLIC USE VFR HELIPORTS.** A public use VFR heliport should meet the design standards, recommendations, and guidance in chapters 1, 3, and 8.

**42. EMERGENCY EVACUATION FACILITIES.** Emergency evacuation facilities should meet the recommendations and guidance in chapters 1, 2, and 8.

**43. TEMPORARY LANDING SITES.** Temporary landing sites should meet the recommendations and guidance in chapters 2 and 8.

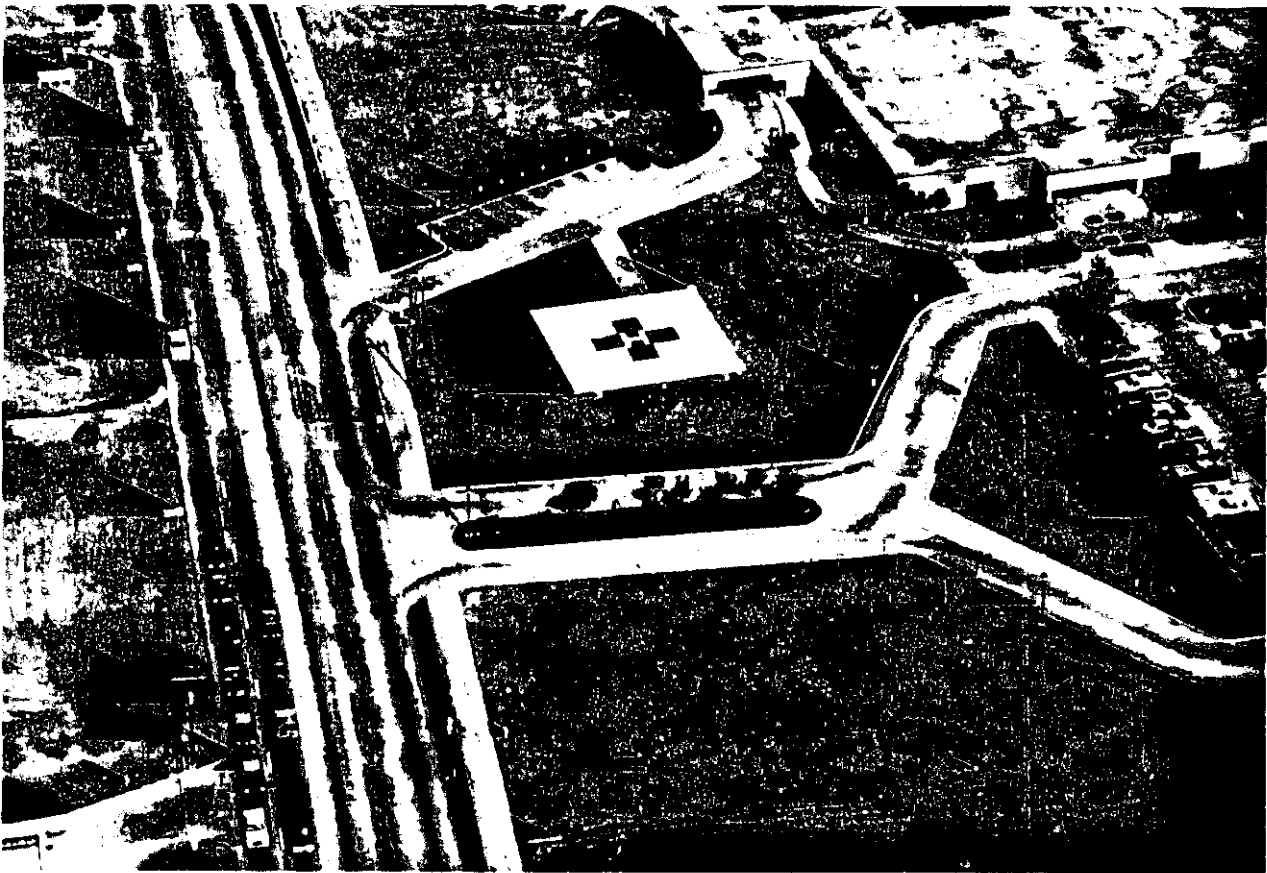

UNIVERSITY MEDICAL CENTER HOSPITAL, LAFAYETTE, LOUISIANA

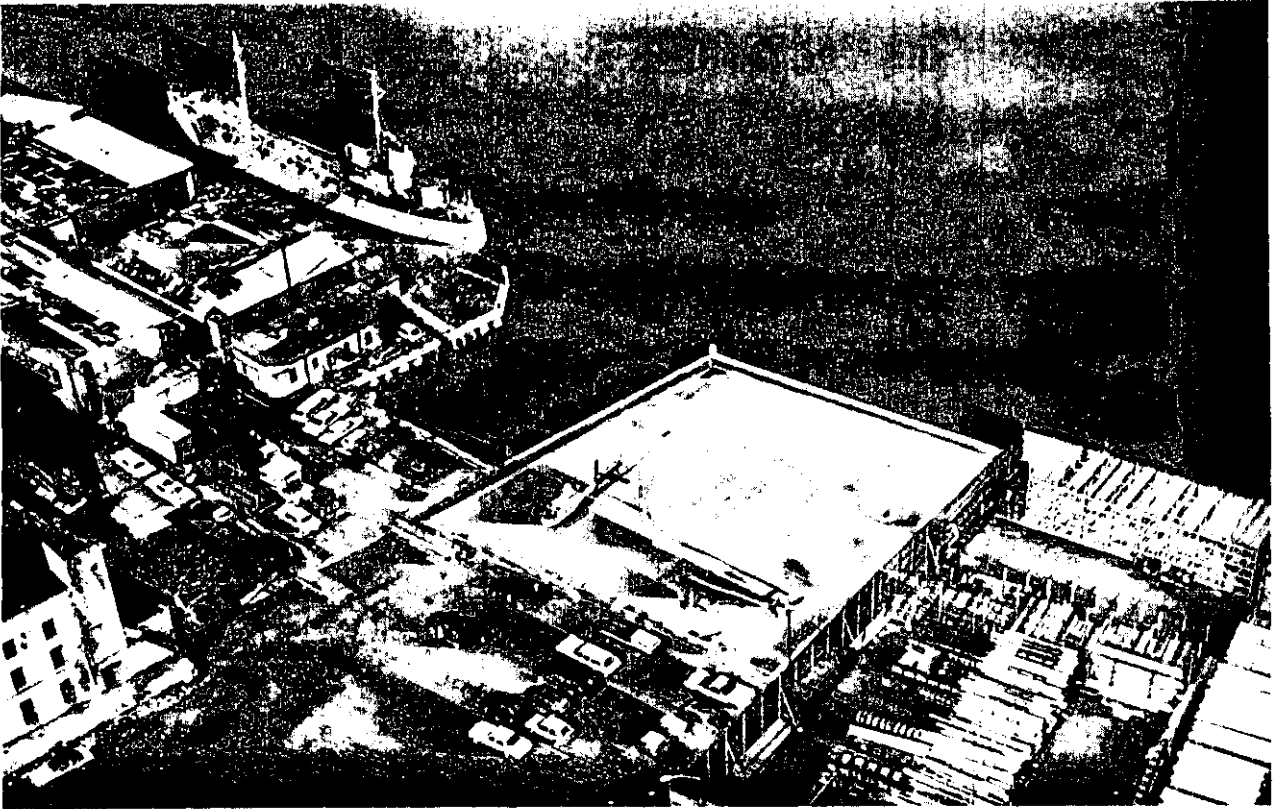

**DOWNTOWN NEWARK HELISTOP, NEWARK, NEW JERSEY**



**HYATT REGENCY HELIPORT, DEABORN, MICHIGAN**



## CHAPTER 6. HELIPORTS WITH NONPRECISION INSTRUMENT APPROACH PROCEDURES

**44. GENERAL.** With airspace availability and appropriate navigational aids, non-precision instrument approach procedures may be established at heliports developed as specified in chapter 5.

**45. LIGHTING SYSTEM.** A heliport lighting system is not a prerequisite for establishing a nonprecision instrument approach procedure. However, the enhanced lighting system described in chapter 7 normally permits lower minimums to be established and should be used in lieu of the lighting systems described in chapters 2 and 3 which cannot be used to lower minimums.



**PASSENGER ACCESS SHOULD BE CONVENIENT FOR USERS**

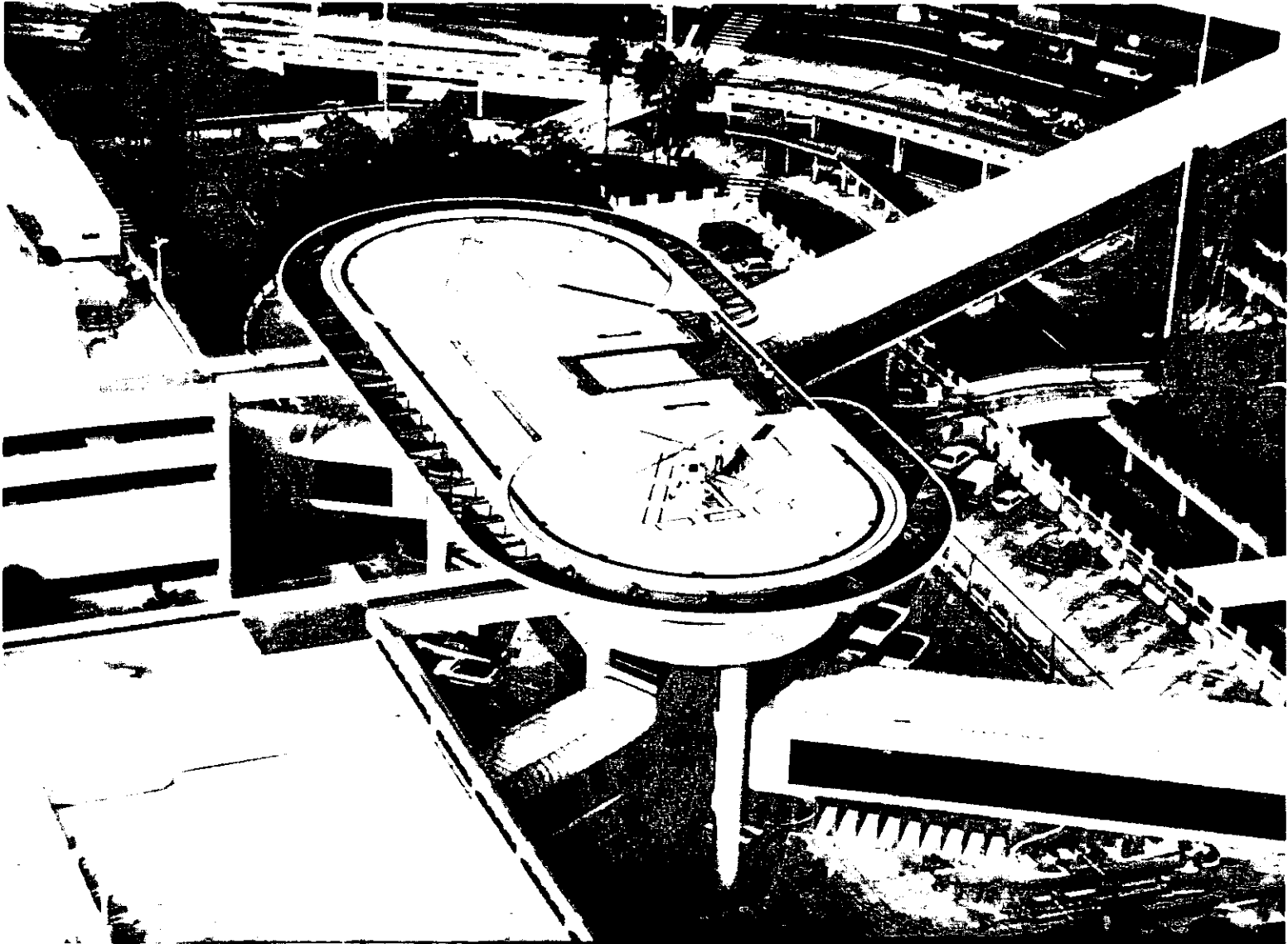

ELEVATED HELIPORT, MIAMI INTERNATIONAL AIRPORT, MIAMI, FLORIDA

## CHAPTER 7. HELIPORTS WITH PRECISION INSTRUMENT PROCEDURES

46. **GENERAL.** This chapter contains guidance relating to the establishment of a heliport which will support a precision instrument procedure. If additional airspace and the ground area required for precision instrument navigational approach and departure aids is available, heliports developed as specified in chapter 5 may be improved to accommodate precision instrument approach and departure procedures.

47. **AIRSPACE.** The heliport owner, in concert with the FAA, should identify unshielded object penetrations of the precision instrument approach, missed approach, and departure surfaces and determine the landing minimums benefits, if any, which may be realized if the objects were removed or lowered. Figure 7-1 illustrates the concept of shielding. Figure 7-2 illustrates the MLS precision instrument approach and missed approach surfaces utilized in an airspace evaluation. Figure 7-3 illustrates the MLS precision instrument departure surfaces utilized in an airspace evaluation.

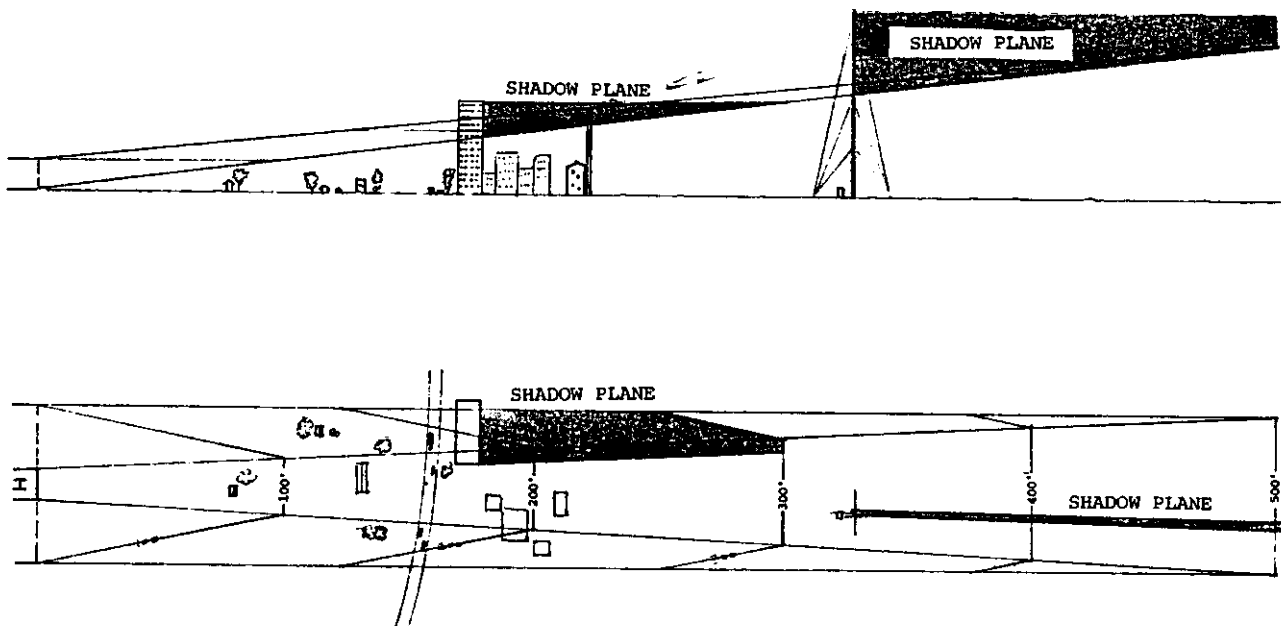

Figure 7-1. Shielding



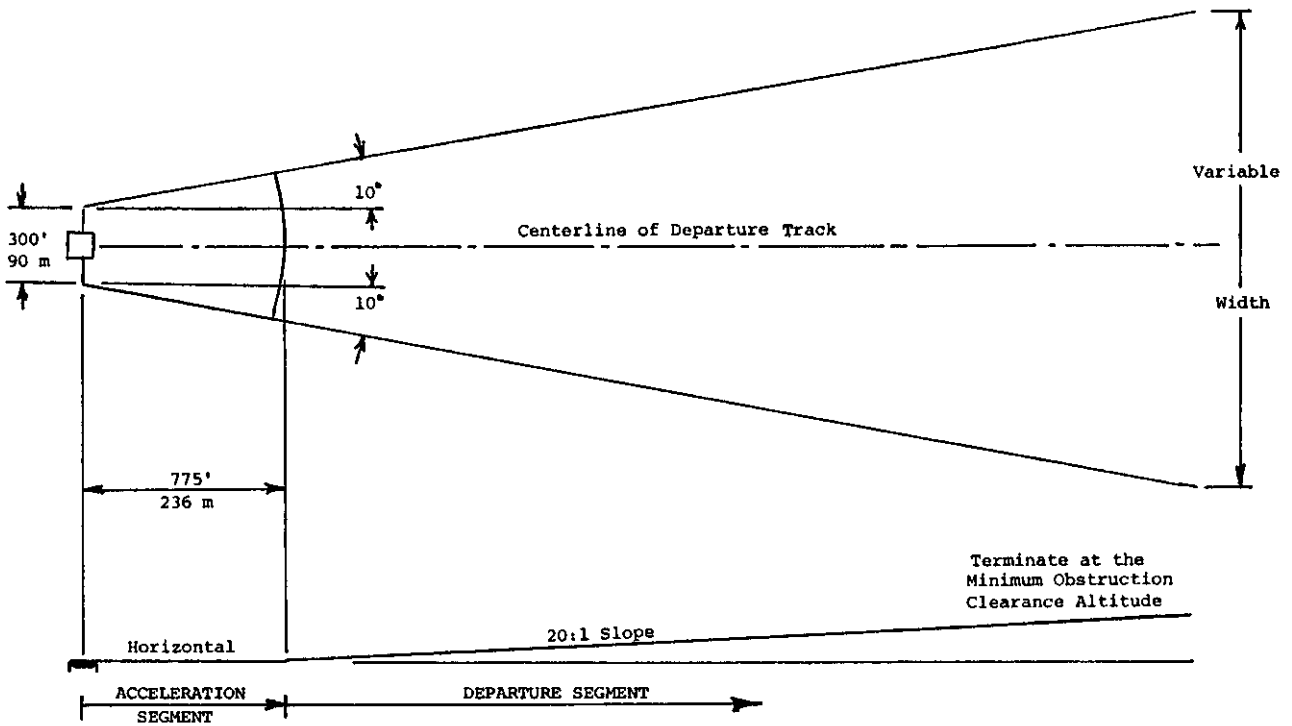

Figure 7-3. Precision Instrument Departure Surfaces

48. NAVIGATIONAL AIDS.

a. **Microwave Landing System (MLS).** An MLS is proposed to be the primary navigational aid for a precision instrument procedure to a heliport. It consists of an azimuth (AZ) and an elevation (EL) antenna, monitors, and a precision distance measuring equipment (PDME) antenna collocated with the AZ antenna. The AZ and EL antennas of the MLS are normally sited within the areas illustrated in figure 7-4. An MLS requires that a clear line-of-sight exists between the antennas and the approaching helicopter. The ground area, which must be free and clear of objects to monitor the AZ and EL signal, is illustrated in figure 7-5. EL monitors are normally located 20 to 30 degrees right or left of beam center. AZ monitors are normally located on the 0 degree azimuth; however, they can be located with the EL monitor.

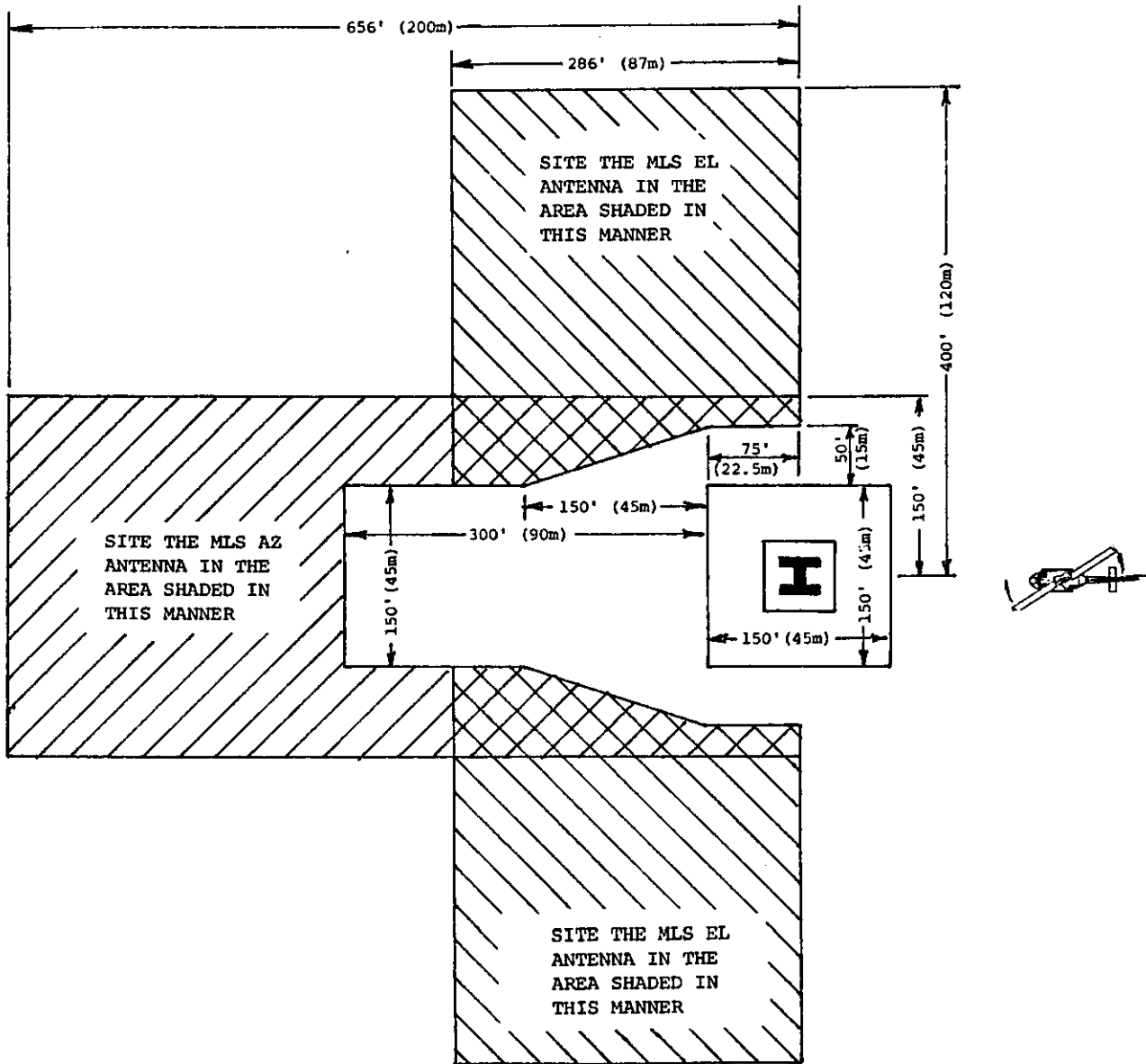

Figure 7-4. MLS Antenna Sites

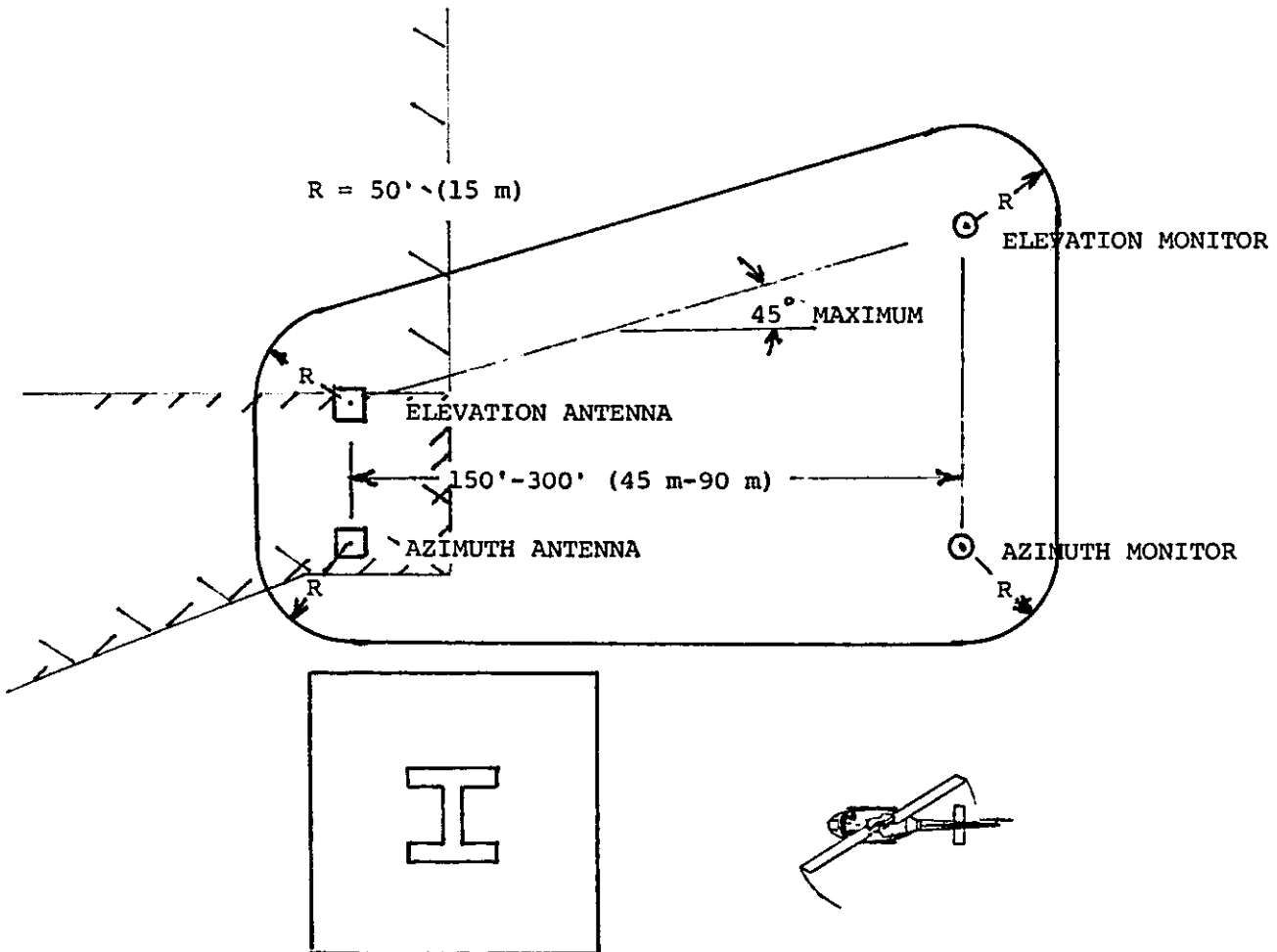

Figure 7-5. MLS Critical Area

**b. Enhanced Lighting System.** The enhanced lighting system described below and illustrated in figure 7-6 may permit lower operational minimums. If used, the lighting fixtures in the enhanced lighting system shall meet the requirements of AC 150/5345-46. The system includes:

(1) **Perimeter Lights.** A minimum of five L-861SE yellow omni-directional lights is used to mark the edges of the takeoff and landing area. The front and back row of lights are augmented with an additional light between each fixture to provide enhanced brilliance in the direction of approach.

(2) **Edge Light Bars.** Three unidirectional PAR 56, 200 watt lights are used to extend the right and left line of perimeter lights forward and rearward on each side of the takeoff and landing area. These lights are spaced at 50 foot (12.5 m) intervals as measured from the line of perimeter lights.

(3) **Wing Light Bars.** Three unidirectional PAR 56, 200-watt, lights are used to extend the front and rear line of perimeter lights outward on each side of the takeoff and landing area. These lights are spaced at 15-foot (4.5 m) intervals as measured from the line of perimeter lights.

(4) **Optional Touchdown Area Lights.** A line of seven bi-directional flush lights may be installed in the takeoff and landing pad. The lights are aligned in the direction of approach to provide close-in directional guidance and a measure of surface definition.

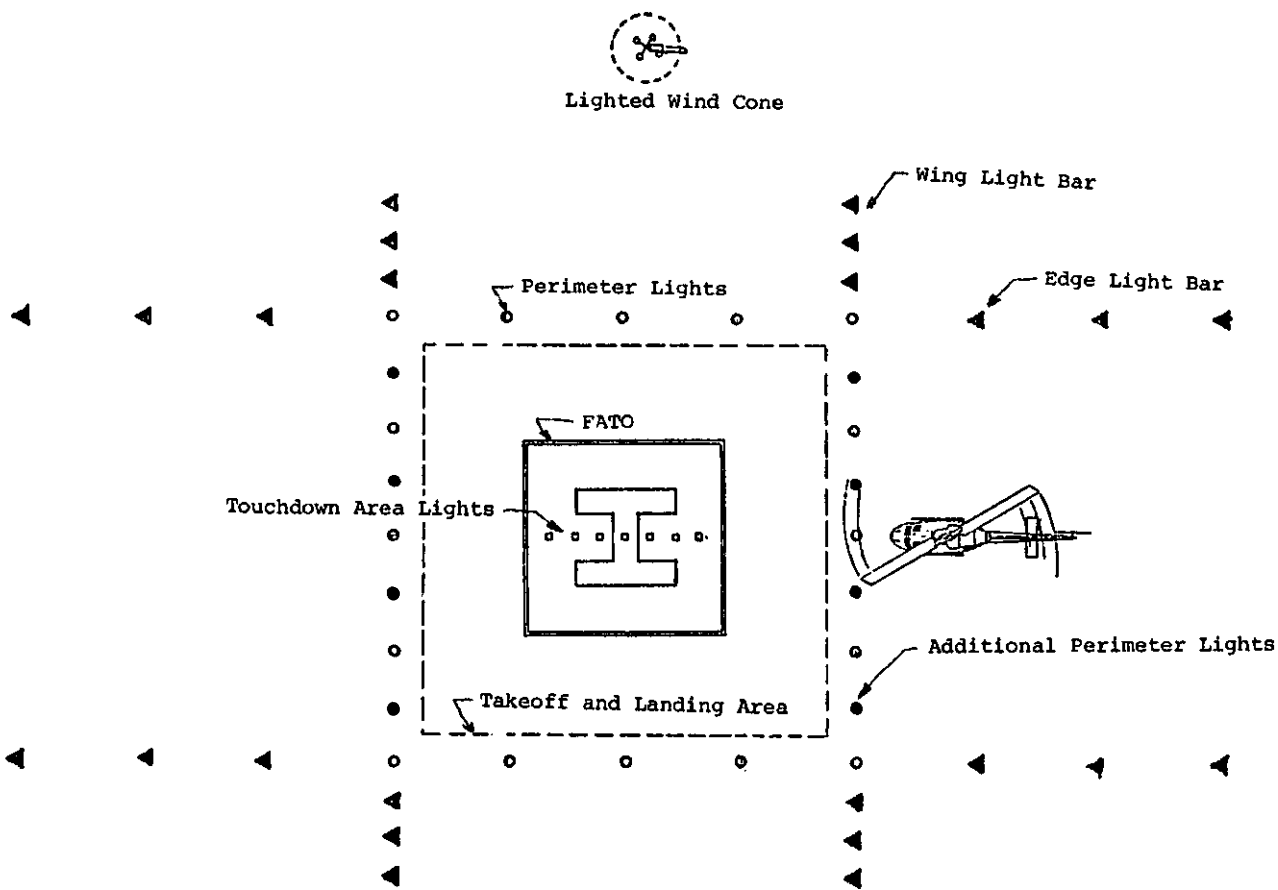

Figure 7-6. Enhanced Lighting System

c. Approach Lighting System. In order to attain the lowest possible IFR visibility minimums, an approved approach lighting system may be required. The FAA is investigating alternative approach lighting systems that are distinctive from the approach light systems serving an airport runway for their effectiveness in reducing operational minimums. Figure 7-7 illustrates approach light systems under consideration.

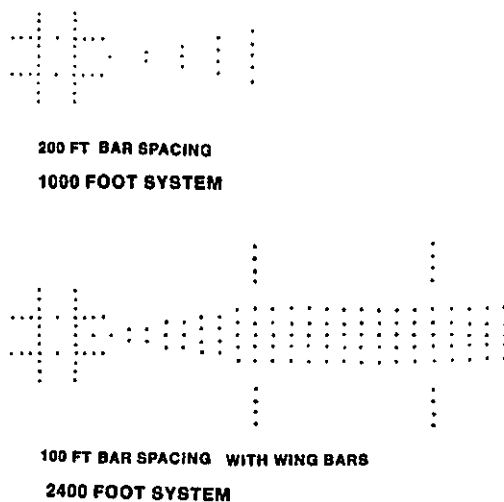

Figure 7-7. Possible Heliport Approach Light Systems



## CHAPTER 8. HELIPORT SURFACE DESIGN

**49. GENERAL.** This chapter provides recommendations for gradients, drainage, design loads, soil stabilization, and pavement design for heliport operational surfaces which are load bearing or are capable of producing ground effect.

**50. GRADIENTS.** Operational surfaces such as the takeoff and landing area, helipad, helideck, parking area, taxi-route, and taxiway should present a reasonably uniformly graded surface. The longitudinal and transverse grades of these surfaces should provide positive drainage, but should not exceed 2 percent in fueling areas and should not exceed 5 percent in other areas. Figure 8-1 illustrates these surfaces. A rapid runoff shoulder, as illustrated in 8-2, is recommended at the edge of all paved surfaces to ensure that water is carried away from the pavement.

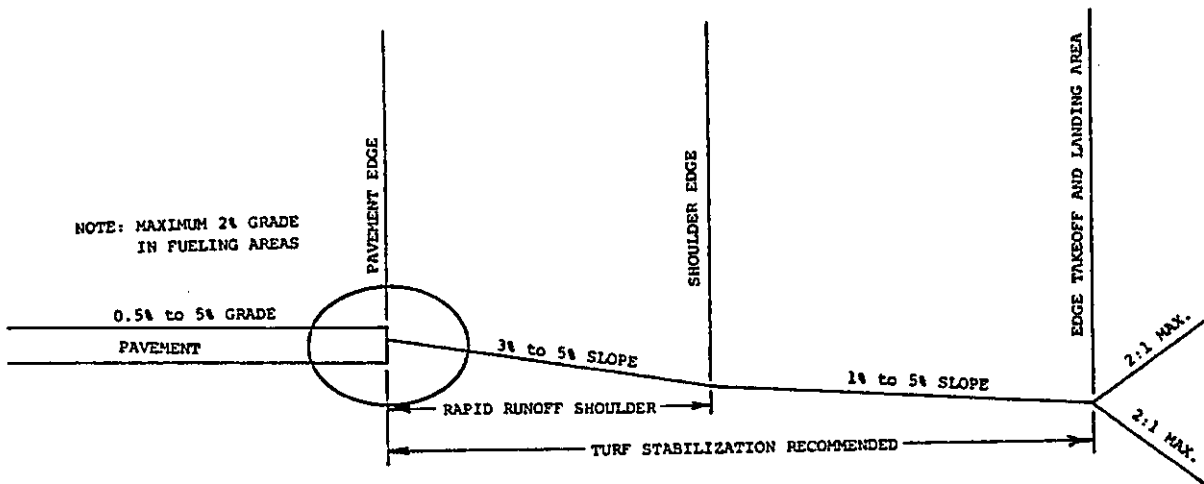

Figure 8-1. Heliport Gradients

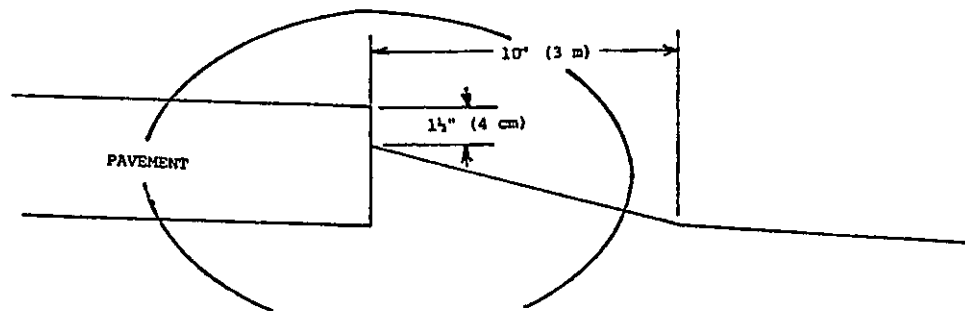

Figure 8-2. Rapid Runoff Shoulder

**51. DESIGN LOADS.** Heliport load bearing surfaces should be constructed to support the design helicopter, with the load applied through landing gear configurations as illustrated in Figure 8-3. Point loads are transmitted to the surface through the contact area of the landing gear tire(s) for a wheel equipped helicopter, or the contact area of the strengthened "cross tube" attachment for a skid equipped helicopter.

**a. Static Load.** For design purposes, the static load is the concentrated dead load (helicopter weight) applied through the contact area of the wheels or skids. If more specific data is not readily available, assume 75 percent of the design helicopter takeoff weight is applied through the main gear of a wheel-equipped helicopter, or through the aft cross tube area of a skid equipped helicopter.

**b. Dynamic Load.** Short duration (1/5 second or less) loads occur during hard landings. For design purposes, this dynamic load is assumed to be 150 percent of the design helicopter takeoff weight and has the same load distribution as in the static load.

**c. Downwash Load.** Downwash, ground effect, or disk loads are approximately equal to the weight of the helicopter distributed over the area of the rotor. Normally, this is less than the snow, rain, or wind loads used for structural design.

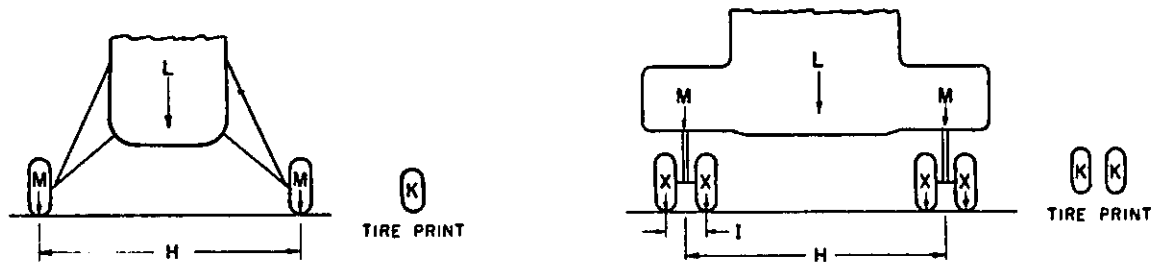

**A. TYPICAL SINGLE-WHEELED CONFIGURATION**  
(CONCEPT APPLIES TO SKID/FLOAT EQUIPPED HELICOPTERS)

**B. TYPICAL DUAL-WHEELED CONFIGURATION**

L = GROSS WEIGHT  
M = GROSS WEIGHT/GEAR  
X = GROSS WEIGHT/WHEEL

H = TREAD  
I = WHEEL SPACING  
K = TIRE CONTACT AREA

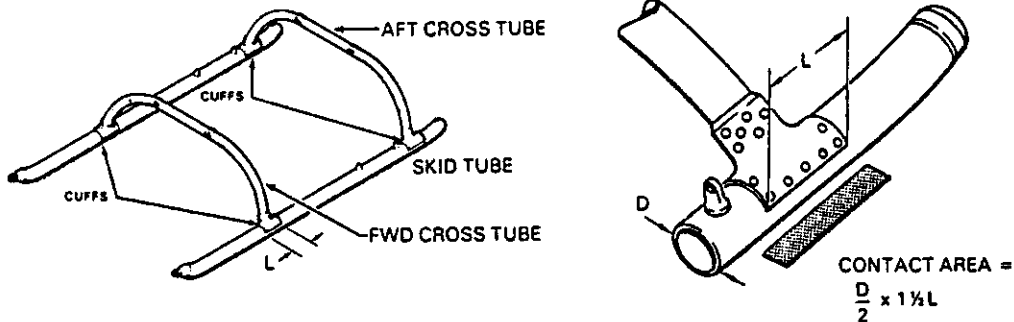

**Figure 8-3. Helicopter Landing Gear Loading**

**52. SOIL STABILIZATION AND PAVEMENT DESIGN.** Paving or stabilizing the takeoff and landing area, or at least the takeoff and landing pad, is recommended to improve load carrying ability, to minimize the erosive effects of rotor downwash, and to facilitate surface runoff. Technical guidance on soil stabilization or pavement design is contained in AC 150/5320-6, Airport Pavement Design and Evaluation, and AC 150/5370-10, Standards for Specifying Construction of Airports.

a. **Soil Stabilization.** Types of soil stabilization are:

(1) **Turf Stabilization.** A dense, smooth, well-drained turf with an adequately stabilized subgrade is normally capable of supporting helicopters and provides reasonable protection against erosion. Climatic and solid conditions will dictate the appropriate grass species.

(2) **Aggregate-Turf Stabilization.** Soils having poor load carrying capability may be improved by mixing selected granular materials such as crushed stone, pit-run gravel, coarse sand, oyster shell, etc. into the upper 12 inches (30 cm) of the soil. The aggregate to soil ratio must be sufficient to improve stability yet retain the soil's ability to support grass.

(3) **Formed Materials.** Pre-cast or prefabricated material can be embedded in the soil to improve its load carrying ability. Architectural and engineering catalogs identify different materials and shapes that are commercially available for this purpose.

b. **Pavements.** Pavements distribute the weight of a helicopter over a larger subsurface area and provide a water impervious, skid-resistant wearing surface.

(1) **Flexible Pavements.** A design analysis is recommended for asphaltic or bituminous concrete pavements. The base course plus wearing surface thickness depend upon the subgrade strength and the construction materials. High density and special aggregate gradations should be used to preclude rutting in pavements used by skid equipped helicopters. Except under unusually hot climatic conditions, a tar emulsion seal coat is recommended to protect asphaltic or bituminous pavements in areas subject to fuel or solvent spills.

(2) **Rigid Pavements.** The typical rigid pavement, 6 inches (15 cm) of Portland cement concrete, is capable of supporting operations by 20,000 pound (9 216 kg) helicopters. A design analysis is usually not required unless heavier helicopters are expected, or the quality of the subsurface soil is questionable. Under hot climatic conditions, rigid pavement is recommended in fueling locations.

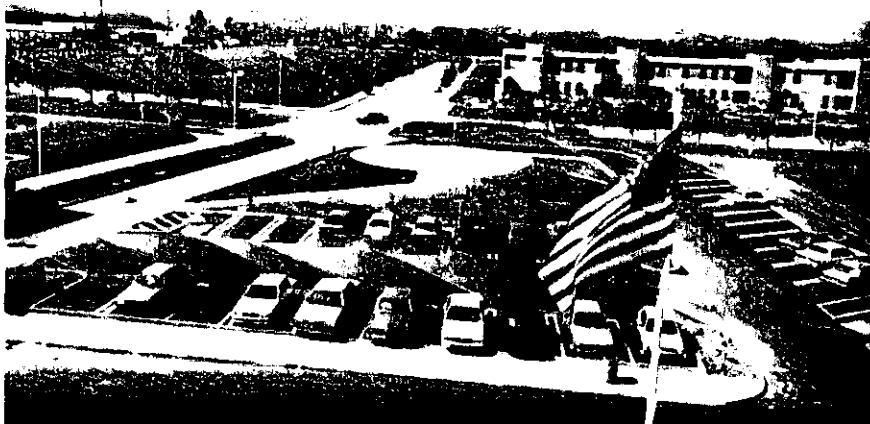

A HELIPORT ON A MOUND, VAN NUYS, CALIFORNIA

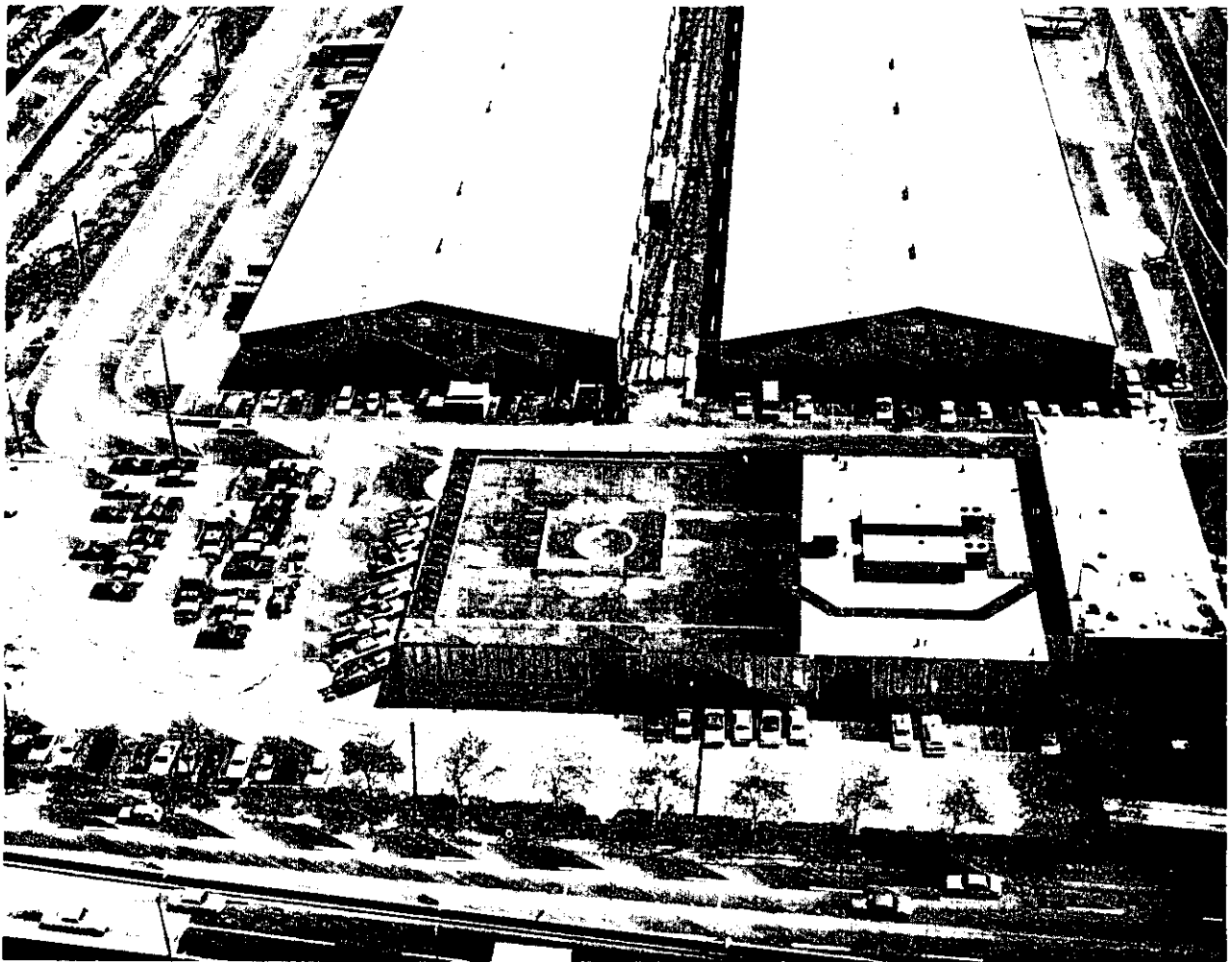

HELIPORT, PORT ELIZABETH, NEW JERSEY

## APPENDIX 1—HELICOPTER DATA

This appendix contains helicopter data of value to a heliport designer. The information has been verified by the helicopter manufactures and is current as of the date of publication. Manufactures should be contacted for information on models not listed herein, or for possible changes in the information herein.

1. **Manufacturer and Helicopter Model.**
2. **Hover ceiling.** In ground effect and out of ground effect.
3. **Maximum takeoff weight.**
4. **Overall length.** The distance from the tip of the main or forward rotor to the tip of the tail rotor or fin with rotors at their maximum extension.
5. **Overall height.**
6. **Main rotor.** The number of blades and rotor diameter.
7. **Tail rotor diameter.** An "F" indicates a shrouded tail rotor.
8. **Landing gear type.** A depiction of skid or tire foot-print.
9. **Wheelbase.** Distance between front and rear axles for wheel equipped helicopters. Distance between front and rear attachment points for skid equipped helicopters.
10. **Tread.** Distance between tire or skid centers.
11. **Contact area.** Contact area per tire, forward and aft. For skid-equipped helicopters this is the strengthened area at each strut attachment point.
12. **Number and type of engines.**
13. **Number of crew and passengers.**
14. **Standard fuel capacity.**

Table 1. Helicopter Data

Manufacturer Model #	Hover Ceiling		Maximum Takeoff Weight	Overall		Main Rotor		Tail Rotor Dia.	Landing Gear				No. & Type of Engines	No. of Crew/Pass.	Std. Fuel (gal)	
	IGE	OGE		Length	Height	Blades	Diam.		Type	Wheel Base	Tread	Contact Area				
	(000 ft)	(000 ft)	(ft)	(ft)	(#)	(ft)	(ft)	(ft)				(ft)	Forward (in <sup>2</sup> )	Aft (in <sup>2</sup> )		
AEROSPATIALE 315 B	22.9	22.9	5,070	42.4	10.1	3	36.2	6.3		5.3	7.8	56.0	56.0	1-T	1/ 4	152
330 J	7.5	5.6	16,315	59.8	16.9	4	49.5	10.0		13.2	7.9	46.5	41.5	2-T	2/19	414
332 C	8.9	6.9	18,410	61.4	16.2	4	51.2	10.0		17.2	9.8	36.0	57.0	2-T	2/19	411
332 L	8.9	6.9	18,410	61.4	16.2	4	51.2	10.0		17.2	9.8	36.0	57.0	2-T	2/24	544
341	7.6	4.4	3,968	39.3	10.4	3	34.5	F		6.4	-	45.0	45.0	1-T	1/ 4	120
350 B	9.7	7.4	4,300	42.6	10.3	3	35.1	6.1		4.7	7.2	43.0	43.0	1-T	1/ 5	137
350 D	8.9	5.6	4,300	42.6	10.3	3	35.1	6.1		4.7	7.2	-	-	1-T	1/ 5	137
355 E	10.3	7.8	4,630	42.6	10.6	3	35.1	6.1		4.5	6.6	-	-	2-T	1/ 5	195
AS 355 F	6.9	2.4	5,071	42.6	10.6	3	35.1	6.1		4.5	6.6	43.0	43.0	2-T	1/ 5	195
AS 355 F1	7.8	6.5	5,290	42.6	10.1	3	35.1	6.1		4.5	7.1	-	-	2-T	1/ 5	193
360 C	8.0	5.7	6,615	43.3	11.5	4	37.7	F		23.7	6.4	16.5	19.0	1-T	1/13	169
365 C	7.4	3.1	7,495	43.7	11.4	4	38.3	F		23.7	6.4	-	-	2-T	1/13	169
365 N	2.0	2.0	8,818	44.2	13.1	4	39.1	F		11.8	6.6	19.0	33.0	2-T	1/13	302
AGUSTA 109 A	7.9	0.0	5,730	42.8	10.8	4	36.1	6.7		11.6	8.0	14.0	22.0	2-T	1/ 7	146
109 HK II	7.9	4.9	5,730	42.8	10.8	4	36.1	6.7		11.6	8.0	14.0	22.0	2-T	1/ 7	146

F = Enclosed tail rotor

















Table 1. Helicopter Data (continued)

Manufacturer Model #	Hover Ceiling		Maximum Takeoff Weight	Overall		Main Rotor		Tail Rotor Dia.	Landing Gear				No. & Type of Engines	No. of Crew/ Pass.	Std. Fuel (gal)	
	IGE	OGE		Length	Height	Blades	Diam.		Type	Wheel Base	Tread	Contact Area				
	(000 ft)	(lbs)	(ft)	(ft)	(#)	(ft)	(ft)	(ft)	(ft)	(ft)	(in <sup>2</sup> )	(in <sup>2</sup> )	(#)	(#)	(gal)	
BELL 47 G *	18.0	15.0	2,950	43.6	9.3	2	37.1	5.8	≡	-	-	-	-	1-P	1/3	53
205 A-1 *	10.4	6.0	9,500	57.1	14.4	2	48.0	8.5	≡	-	-	-	-	1-T	1/14	215
206 B	12.8	8.8	3,200	39.2	11.6	2	33.3	5.4	≡	4.5	6.0	13.5	13.5	1-T	1/4	91
206 L	12.3	5.3	4,150	42.5	11.7	2	37.0	5.4	≡	6.8	7.2	13.5	13.5	1-T	1/6	110
212	11.0	4.9	11,200	57.3	13.0	2	48.0	8.6	≡	7.6	8.3	24.0	24.0	2-T	1/14	215
214 B *	15.0	10.5	13,800	60.4	13.4	2	50.0	9.6	≡	-	-	-	-	1-T	1/15	204
214 ST	6.4	1.0	17,500	62.2	13.2	2	52.0	9.7	≡	8.1	8.3	38.3	45.0	2-T	2/18	435
222	4.2	4.6	7,850	47.5	11.0	2	39.8	6.5	≡	12.2	9.1	18.9	31.8	2-T	1/9	187
222 B	7.1	6.4	8,250	50.3	11.3	2	42.0	6.9	≡	12.2	9.1	19.1	32.0	2-T	1/9	187
222 UT	7.1	6.4	8,250	50.3	10.5	2	42.0	6.9	≡	7.9	7.8	24.0	24.0	2-T	1/9	246
412	4.3		11,900	56.2	10.9	4	46.0	8.6	≡	7.9	8.3	24.0	24.0	2-T	1/14	212
BOEING VERTOL 107-II **	10.6	9.4	20,000	83.3	16.9	3	50.0	50.0	≡	24.9	12.9	21.5	25.0	2-T	3/25	350
234 **	8.5	2.7	48,500	99.0	18.7	3	60.0	60.0	≡	25.8	10.5	98.0	124.0	2-T	3/44	2,090
360 **	12.9	10.5	36,160	83.7	19.4	4	49.7	49.7	≡	32.7	11.4	51.0	51.0	2-T	3/30	1,537
E.H. INDUSTRIES EH 101	8.3	3.6	31,500	75.3	21.3	5	61.0	13.1	≡	22.9	14.1	27.0	80.0	3-T	3/30	805
ENSTROM 280C	8.8	4.1	2,350	28.8	9.2	3	32.0	4.7	≡	-	7.4	-	-	1-P	1/2	40
F28C-2	8.8	4.1	2,350	29.4	9.2	3	32.0	4.7	≡	-	7.4	-	-	1-P	1/2	40
F28F/280FX	7.8	0.0	2,600	29.4	9.2	3	32.0	4.7	≡	-	7.4	-	-	1-P	1/2	40
280F	7.8	0.0	2,600	28.8	9.2	3	32.0	4.7	≡	-	7.4	-	-	1-P	1/2	40

\* No longer in production

\*\* Twin rotored helicopters

Table 1. Helicopter Data (continued)

Manufacturer Model #	Hover		Maximum Takeoff Weight	Overall		Main Rotor		Tail Rotor Dia.	Landing Gear				No. & Type of Engines	No. of Crew/ Pass.	Std. Fuel (gal)	
	Ceiling			Length	Height	Blades	Diam.		Type	Wheel Base	Tread	Contact Area				
	IGE	OGE	(ft)					(ft)				(#)	(ft)	(ft)	(ft)	Forward (in <sup>2</sup> )
MBB B0105-CB/CBS	5.0	1.5	5,512	38.8	12.5	4	32.3	6.3		8.3	14.1	14.0	14.0	2-T	1/ 5	151
B0105-LS A-2	14.0	10.5	5,732	38.8	12.5	4	32.3	6.2		8.3	14.8	14.0	14.0	2-T	1/ 5	151
MBB/KAWASAKI MBB/BK-117	8.2	2.0	7,056	42.7	12.6	4	36.1	6.4		8.2	10.6	16.0	16.0	2-T	1/10	157
McDONNELL DOUGLAS 300 C	10.8	8.6	2,050	30.8	8.7	3	26.8	4.3		-	6.5	11.3	11.3	1-P	1/ 2	30
550 D	12.0	9.6	3,000	30.5	8.9	4	26.4	4.6		-	6.8	15.0	19.0	1-T	1/ 4	35
ROBINSON R-22	7.0	-	1,370	28.8	8.8	2	25.2	3.5		-	6.3	-	-	1-P	1/ 1	20
SIKORSKY S-76 A	2.5	1.1	10,500	52.5	14.5	4	44.0	8.0		16.4	8.0	22.5	24.0	2-T	2/12	281
S-76 B	8.3	5.4	11,400	52.5	14.5	4	44.0	8.0		16.4	8.0	22.5	24.0	2-T	2/12	281
S-70 C	14.2	10.0	22,000	64.8	16.8	4	53.9	11.0		29.0	8.9	82.5	37.0	2-T	2/19	362
S-61 N	3.8	0.9	20,500	73.0	18.9	5	62.0	10.6		23.5	14.0	58.0	43.0	2-T	3/28	654
S-58 T	10.4	6.5	13,000	65.8	15.9	4	56.0	9.5		28.3	12.0	80.0	45.0	2-T	2/16	283
S-64	6.4	2.4	42,000	88.5	25.4	6	72.0	16.0		24.4	19.8	74.0	157.0	2-T	2/ 3	1,345
S-62	6.6	6.6	7,900	62.3	16.0	3	53.0	8.8		17.8	12.2	54.0	54.0	1-T	2/11	182
WESTLAND 30-100-60	5.8	2.8	12,800	52.1	15.5	4	43.7	8.0		17.9	10.1	21.0	35.0	2-T	2/19	348
30-200	6.6	2.8	12,800	52.1	15.4	4	43.7	8.0		17.9	10.1	21.0	35.0	2-T	2/19	348
30-300	6.3	4.2	16,000	52.1	16.3	5	42.5	9.0		17.8	9.3	23.0	45.0	2-T	2/19	341



**APPENDIX 2—AVIATION ORGANIZATIONS****ALABAMA**

Alabama Department of Aeronautics  
817 South Court Street  
Montgomery, AL 36130-0101

**ALASKA**

Department of Transportation & Public Facilities  
P.O. Box 196900  
Anchorage, AK 99519-6900  
P.O. Box Z  
Juneau, AK 99811

**ARIZONA**

Division of Aeronautics  
Arizona Department of Transportation  
1801 W. Jefferson, Room 426  
Phoenix, AZ 85007

**ARKANSAS**

Department of Aeronautics  
Regional Airport Terminal Building  
3rd Floor  
No. 1 Airport Drive  
Little Rock, AR 72202

**CALIFORNIA**

Division of Aeronautics  
California Department of Transportation  
P.O. Box 942874  
Sacramento, CA 95814-0001

**COLORADO**

Aviation Planning Staff  
Colorado Department of Local Affairs  
1313 Sherman Street, Suite 520  
Denver, CO 80203

**CONNECTICUT**

Bureau of Aeronautics  
Connecticut Department of Transportation  
P.O. Drawer A - 24 Wolcott Hill Road  
Wethersfield, CT 06109

**DELAWARE**

Aeronautics Administration  
Delaware Transportation Authority  
Department of Transportation  
P.O. Box 778  
Dover, DE 19903

**FLORIDA**

Bureau of Aviation  
Florida Department of Transportation  
605 Suwannee Street, M.S.46  
Tallahassee, FL 32301-8064

**GEORGIA**

Bureau of Aeronautics  
Georgia Department of Transportation  
2017 Flightway Drive  
Chamblee, GA 30341

**HAWAII**

Airports Division  
Hawaii Department of Transportation  
Honolulu International Airport  
Honolulu, HI 96819

**IDAHO**

Bureau of Aeronautics & Public Transportation  
Idaho Department of Transportation  
3483 Rickenbacker Street  
Boise, ID 83705

**ILLINOIS**

Division of Aeronautics  
Department of Transportation  
Capital Airport - One Langhorne Bond Dr.  
Springfield, IL 62707-8415

**INDIANA**

Division of Aeronautics  
Indiana Department of Transportation  
143 West Market Street, Suite 300  
Indianapolis, IN 46204

**IOWA**

Air and Transit Division  
Iowa Department of Transportation  
International Airport  
Des Moines, IA 50321

**KANSAS**

Kansas Department of Transportation  
State Office Building  
Topeka, KS 66612-1568

**KENTUCKY**

Office of Aeronautics  
Kentucky Transportation Cabinet  
U.S. 127 S. Annex Building, Suite 1  
Frankfort, KY 40622

**LOUISIANA**

Office of Aviation & Public Transportation  
Department of Transportation & Development  
P.O. Box 94245  
Baton Rouge, LA 70804-9245

**MAINE**

Division of Aeronautics  
Maine Department of Transportation  
State Office Building  
Augusta, ME 04333

**MARYLAND**

State Aviation Administration  
Maryland Department of Transportation  
P.O. Box 8766  
Baltimore/Washington Intl. Airport  
MD 21240

**MASSACHUSETTS**

Massachusetts Aeronautics Commission  
10 Park Plaza, Room 6620  
Boston, MA 02116-3966

**MICHIGAN**

Michigan Aeronautics Commission  
Department of Transportation  
2nd Floor, Terminal Building  
Capital City Airport  
Lansing, MI 48906

**MINNESOTA**

Aeronautics Division  
Minnesota Department of Transportation  
Transportation Building  
St. Paul, MN 55155

**MISSISSIPPI**

Mississippi Aeronautics Commission  
1701 Walter Sillers State Office Building  
P.O. Box 5  
Jackson, MS 39205

**MISSOURI**

Department of Highways and Transportation  
Aviation Unit  
P.O. Box 270  
Jefferson, MO 65102

**MONTANA**

Aeronautics Division  
Department of Commerce  
P.O. Box 5178  
Helena, MT 59604

**NEBRASKA**

Nebraska Department of Aeronautics  
P.O. Box 82088  
Lincoln, NB 68501

**NEVADA**

Nevada Department of Transportation  
1263 South Stewart Street  
Carson City, NV 59712

**NEW HAMPSHIRE**

Division of Aeronautics  
New Hampshire Aeronautics Commission  
Municipal Airport-65 Airport Road  
Concord, NH 03301-5298

**NEW JERSEY**

Division of Aeronautics  
New Jersey Department of Transportation  
1035 Park Avenue  
Trenton, NJ 08625

**NEW MEXICO**

Aviation Division  
New Mexico State Highway and Transportation  
Department  
P.O. Box 579  
Santa Fe, NM 87504-0579

**NEW YORK**

Aviation Division  
New York State Department of Transportation  
1220 Washington Avenue  
Albany, NY 12232

**NORTH CAROLINA**

Division of Aviation  
North Carolina Department of Transportation  
P.O. Box 25201  
Raleigh, NC 27611

**NORTH DAKOTA**

North Dakota Aeronautics Commission  
Box 5020 - Bismarck Airport  
Bismarck, ND 58502

**OHIO**

Division of Operations  
Ohio Department of Transportation  
25 South Front Street  
Columbus, OH 43216-0899

**OKLAHOMA**

Oklahoma Aeronautics Commission  
Department of Transportation Building  
200 N.E. 21st Street, B-7 1st Floor  
Oklahoma City OK 73105

**OREGON**

Division of Aeronautics  
Oregon Department of Transportation  
3040 25th Street, S.E.  
Salem, OR 97310

**PENNSYLVANIA**

Bureau of Aviation  
Pennsylvania Department of Transportation  
Transportation and Safety Building  
Room 716  
Harrisburg, PA 17120

**PUERTO RICO**

Puerto Rico Ports Authority  
G.P.O. Box 2829  
San Juan, PR 00936-2829

**RHODE ISLAND**

Division of Airports  
Rhode Island Department of Transportation  
Theodore Francis Green State Airport  
Warwick, RI 02886

**SOUTH CAROLINA**

South Carolina Aeronautics Commission  
Drawer 1987  
Columbia, SC 29202

**SOUTH DAKOTA**

South Dakota Department of Transportation  
700 Broadway Avenue East  
Pierre, SD 57501-2586

**TENNESSEE**

Office of Aeronautics  
Tennessee Department of Transportation  
P.O. Box 17326  
Nashville, TN 37217

**TEXAS**

Texas Aeronautics Commission  
P.O. Box 12607  
Austin, TX 78711

**UTAH**

Aeronautical Operations Division  
Utah Department of Transportation  
135 North 2400 West  
Salt Lake City, UT 84116

**VERMONT**

Operations Division  
Agency of Transportation  
State Administration Building  
133 State Street  
Montpelier, VT 05602

**VIRGINIA**

Department of Aviation  
P.O. Box 7716  
Richmond, VA 23231

**WASHINGTON**

Division of Aeronautics  
Washington Department of Transportation  
8600 Perimeter Road--Boeing Field  
Seattle, WA 98108

**WEST VIRGINIA**

Office of Community and Industrial Development  
Building 6, Room B-553  
State Capitol Complex  
Charleston, WV 25305

**WISCONSIN**

Bureau of Aeronautics  
Division of Transportation Assistance  
Wisconsin Department of Transportation  
P.O. Box 7914  
Madison, WI 53707

**WYOMING**

Wyoming Aeronautics Commission  
State of Wyoming  
Cheyenne, WY 82002-0090

**AEROSPACE INDUSTRIES ASSOCIATION OF AMERICA**

1725 DeSales Place, NW  
Washington, D.C. 20036  
(202) 429-4600

**AIRPORT CONSULTANTS COUNCIL**

918 F Street, Northwest, Suite 312  
Washington, DC 20004  
(202) 639-6376

**AMERICAN HELICOPTER SOCIETY**

217 N. Washington St.  
Alexandria, VA 22314  
(703) 684-6777

**HELICOPTER ASSOCIATION INTERNATIONAL**

1619 Duke Street  
Alexandria, VA 22314-3406  
(703) 683-4646

**HELICOPTER SAFETY ADVISORY  
CONFERENCE**

1695 JFK Boulevard  
Houston, TX 77032  
(713) 757-8100

**NATIONAL ASSOCIATION OF STATE  
AVIATION OFFICIALS**

777 14th Street NW, Suite 717  
Washington, D.C. 20005  
(202) 783-0588

**NATIONAL BUSINESS AIRCRAFT  
ASSOCIATION**

1200 18th Street, NW, Suite 200  
Washington, DC 20036  
(202) 783-9000

## APPENDIX 3—FEDERAL AVIATION ADMINISTRATION REGIONAL AIRPORT DIVISION OFFICES

### NEW ENGLAND REGION

Maine, New Hampshire, Vermont, Massachusetts,  
Rhode Island, and Connecticut  
Airport Division, ANE-600  
Federal Aviation Administration  
12 New England Executive Park  
Burlington, MA 01803  
(617) 273-7044

### EASTERN REGION

New York, New Jersey, Pennsylvania, Delaware,  
Maryland, Virginia, West Virginia, and District  
of Columbia  
Airport Division, AEA-600  
Federal Aviation Administration  
Fitzgerald Federal Building, Room 329  
John F. Kennedy International Airport  
Jamaica, NY 11430  
(718) 917-1239

### SOUTHERN REGION

Georgia, North Carolina, South Carolina, Florida,  
Puerto Rico, Virgin Islands, Tennessee,  
Kentucky, Mississippi, and Alabama  
Airport Division, ASO-600  
Federal Aviation Administration  
3400 Norman Berry Drive  
East Point, GA 30344  
(404) 763-7288  
Mail: Airport Division, ASO-600  
Federal Aviation Administration  
P.O. Box 20636  
Atlanta, Georgia 30320

### GREAT LAKES REGION

Illinois, Indiana, Michigan, Wisconsin, Minnesota,  
Ohio, North Dakota, and South Dakota  
Airport Division, AGL-600  
Federal Aviation Administration  
2300 East Devon Avenue  
Des Plaines, IL 60018  
(312) 694-7272

### CENTRAL REGION

Kansas, Missouri, Iowa, and Nebraska  
Airport Division, ACE-600  
Federal Aviation Administration  
Federal Building  
601 East 12th Street  
Kansas City, MO 64106  
(816) 374-5278

### SOUTHWEST REGION

Arkansas, Texas, Oklahoma, New Mexico, and  
Louisiana  
Airport Division, ASW-600  
Federal Aviation Administration  
4400 Blue Mound Road  
Fort Worth, TX 76131  
(817) 624-5600  
Mail: Airport Division, ASW-600  
Federal Aviation Administration  
P.O. Box 1689  
Fort Worth, TX 76106

### NORTHWEST MOUNTAIN REGION

Washington, Idaho, Oregon, Colorado, Wyoming,  
Utah, and Montana  
Airport Division, ANW-600  
Federal Aviation Administration  
17900 Pacific Highway South  
C-68966  
Seattle, WA 98168  
(206) 431-2600

### ALASKAN REGION

Airport Division, AAL-600  
Federal Aviation Administration  
Anchorage Federal Office Building  
701 C Street, Box 14  
Anchorage, AL 99513  
(907) 271-5438

**WESTERN-PACIFIC REGION**

California, Arizona, Nevada, Hawaii, Trust  
Territory of the Pacific Islands, American  
Samoa, Guam, and Commonwealth of Northern  
Marianas Islands

Airport Division, AWP-600  
Federal Aviation Administration  
15000 Aviation Boulevard  
Lawndale, CA 90261  
(213) 297-1240

**Mail:** Airport Division, AWP-600  
Federal Aviation Administration  
P.O. Box 92007  
Worldway Postal Center  
Los Angeles, CA 90009

U.S. Department  
of Transportation

**Federal Aviation  
Administration**

800 Independence Ave., S.W.  
Washington, D.C. 20591

**RETURN POSTAGE GUARANTEED**

Official Business  
Penalty for Private Use \$300

**BULK MAIL**  
POSTAGE & FEES PAID  
FEDERAL AVIATION  
ADMINISTRATION  
PERMIT NO G-44