



U.S. Department
of Transportation
Federal Aviation
Administration

10A TECHNICAL UNIT

SEP 19 1986

DOT LIBRARY M493.2

Advisory Circular

Subject:
SPECIFICATION FOR L-821 PANELS
FOR REMOTE CONTROL OF AIRPORT LIGHTING

Date: 8/8/86
Initiated by: AAS-200

AC No: 150/5345-3D
Change:

1. PURPOSE.

a. This advisory circular (AC) contains the specification requirements for panels used for remote control of airport lighting systems.

b. This AC has been editorially updated for reprint/stock purposes only. There were no changes made to the content of the AC, except to update related reading material and to renumber the document to AC 150/5345-3D.

2. CANCELLATION. AC 150/5345-3C, Specification for L-821 Panels for Remote Control of Airport Lighting, dated March 30, 1977, is cancelled.

3. APPLICATION. The standards contained herein are recommended by the Federal Aviation Administration (FAA) in all applications involving airport development of this nature. The standards are mandatory for Federally-funded projects.

Leonard E. Mudd

LEONARD E. MUDD
Director, Office of Airport Standards

**SPECIFICATION FOR L-821 PANELS FOR
REMOTE CONTROL OF AIRPORT LIGHTING**

1. SCOPE AND CLASSIFICATION.

1.1 Scope. This specification sets forth the manufacturing requirements for a panel to be used for control of various airport lighting facilities.

1.2 Classification. Two types, three classes, and three styles of panels are covered by this specification.

1.2.1 Type. Panels of the following types are covered by this specification:

Type I - Conventional panels as illustrated in figures 1, 2, 3, 4, and 5a.

Type II - Facsimile panels as illustrated in figures 5b and 6.

1.2.2 Class. Panels of the following classes are covered by this specification:

Class F - A flush mounted panel with a top plate and case as illustrated in figure 7 for mounting in a console panel as used at airport traffic control towers.

Class S - A surface mounted panel with a top plate and case as illustrated in figure 7 for installation on a desk or counter top.

Class W - A wall or surface mounted panel with a top plate as illustrated in figure 3 used in conjunction with a commercial outlet or pull box for mounting in an electrical vault or other convenient control point at a small airport.

1.2.3 Style. Panels of the following styles are covered by this specification:

Style 1 - Unlighted (Type I or II)

Style 2 - Backlighted (Type I)

Style 3 - Backlighted (Type II)

2. APPLICABLE DOCUMENTS.

2.1 General. The following documents, of the issue in effect on the date of application for qualification, form part of this specification and are applicable to the extent specified herein.

2.1.1 Federal Specification.

TT-E-527, Enamel, Alkyd, Lusterless

2.1.2 Federal Standard.

595, Colors

2.1.3 FAA Advisory Circulars.

- (a) AC 150/5000-3 Address List for Regional Airports Divisions and Airports District Offices.
- (b) AC 150/5340-4 Installation Details for Runway Centerline and Touchdown Zone Lighting Systems
- (c) AC 150/5340-17 Standby Power for Non-FAA Airport Lighting Systems
- (d) AC 150/5340-19 Taxiway Centerline Lighting System
- (e) AC 150/5340-24 Runway and Taxiway Edge Lighting System
- (f) AC 150/5345-1 Approved Airport Lighting Equipment

Federal specifications and standards may be obtained from General Services Administration Offices in Washington, D.C., Atlanta, Boston, Chicago, Denver, Kansas City, New York, Los Angeles, San Francisco, and Seattle.

FAA advisory circulars may be obtained from the Department of Transportation, Subsequent Distribution Unit, M-494.3, Washington, D.C. 20590.

3. REQUIREMENTS.

3.1 General Functional Requirements. The panels specified herein are intended for use in controlling various airport lighting facilities as described in the documents listed in 2.1.3. The panels are generally installed in airport traffic control towers. Airports without towers will have the panel located at some convenient control location such as a hangar, office, or electrical vault.

3.2 Panel Configurations. The configuration of the panel layout will be made to accommodate user requirements. Typical layouts using different switches and arrangements are shown in figures 1 to 6. These figures are furnished only to assist the manufacturer in visualizing a typical design. Conformance thereto may not insure that the resulting product will meet specification requirements.

3.2.1 Type I, Conventional Panels. Switching of airport lighting and auxiliary aids may be accomplished in several ways. The following arrangements are furnished for illustration purposes:

- (a) Figures 1 and 5a, panel layout utilizing toggle switches for all control except five-step brightness. Figure 8 illustrates the wiring of the panel in figure 1.
- (b) Figures 2 and 3, panel layouts utilizing rotary switches for all runway and/or taxiway lighting control.
- (c) Figure 4, panel layout using pushbutton switches for all control.
- (d) Figure 9, some typical individual switch connections.

3.2.2 Type II, Facsimile Panels. Type II panel plates will be used primarily with Class F panels. The layout of the airport operating surfaces (runways, taxiways, etc.) for which lighting is being controlled shall be engraved, painted, overlaid by decal, or shown by other approved method on Style 1 panel plates. Color coding of the section of lighting being controlled by a switch is illustrated in figure 5b. Style 3 panel plates shall have sections of an imposed facsimile backlighted as the controlling switches are actuated. Figure 6 illustrates an example of this panel using colored strips that are illuminated as each lighting circuit is activated.

3.3 Panel Components.

3.3.1 Panel Plate. Class F and S panel plates shall be made of 0.094-inch (2.5 mm) steel or of other material of thickness or design that will provide like stiffness. The plate is to be attached to the case by means of a continuous hinge along its top edge. A latch shall be mounted inside the case to support the panel plate, when open, at a near vertical position. No part of the plate or its attachments should project behind the plane of the back of the case during opening and closing. The panel plate for Class W panels may be a commercially available utility or outlet box cover which is usually attached to the case or box by screws. Therefore, no latch or hinge is required.

3.3.2 Case or Box. Class F and S panels shall have a suitable case made of not less than 0.078-inch (2 mm) (nominal) sheet steel or aluminum of equal rigidity; see figure 7 for examples. Commercially available outlets or pull boxes may be provided in lieu of a manufactured case for Class W panel plates. A grounding lug, capable of handling at least a No. 12 AWG conductor, shall be supplied in each case or box.

3.3.3 Switches. Switches are used to turn on and off airport lighting regulators, beacons, obstruction lights, lighted wind indicators, apron lights, emergency power generators, VASIs, REILs, etc., and are used to control light intensities. The switches may be wired, programmed, or ganged for simultaneous control of several lighting circuits. Switches shall have a contact rating equal to or greater than the load current and voltage requirements. The life expectancy of the switches, at rated load, shall be at least 25,000 operations. Switches shall have screw, solder, or push-on type terminals.

3.3.3.1 Toggle Switches. Toggle switches shall have either two or three positions and, for most applications, be detented to provide positive-feel switching. Mount the switches to operate left to right, rather than up and down, and wire them so that they are either off or on a low intensity setting when in the far left position. Switches shall be mounted on the panel plate by means of a hexagonal nut above and below the panel plate using an internal-tooth lockwasher and a locking ring to assure permanent mounting.

3.3.3.2 Rotary Switches. Rotary switches, used for the control of runway and taxiway lighting, shall have three to six detent positions with one, two, or more poles as required to turn regulators on and off (optional) and control lighting circuits with up to five steps of brightness. The switches shall have a minimum angular throw of 30 degrees between detents and be equipped with a stop to prevent rotation past the last position and continuous rotation in either direction.

3.3.3.3 Pushbutton Switches. Momentary or alternate action pushbutton switches are used to control any or all functions of airport lighting. The use of pushbutton switches for brightness control will require auxiliary relays or nonradio interference solid state circuitry. Switches should be wired so that upon deenergizing an intensity controlled system, the intensity setting automatically returns to the lowest position. When the circuit is again energized, it will be at the lowest intensity setting. All illuminated push-buttons should be softly backlit in an off position and glow brighter when engaged.

3.3.4 Backlighting. Backlighting of facsimile panels, switches, or switch designations shall be made with light sources with a life expectancy of at least 10,000 hours. A control to reduce the brightness of the backlighting up to 90 percent shall be provided. This brightness control shall not cause any radio interference.

3.3.5 Emergency Generator Control. Each control consists of a switch and red pilot light which, when energized, indicates that the emergency power supply has assumed the power load.

3.3.6 Wire and Wiring. Use as a minimum No. 19 AWG wire having standard copper conductors with 90°C rated insulation suitable for 120 volts. All leads shall be properly trained and cabled and long enough so that there will be adequate spare lead when the plate is raised to the extent permitted by the latch. Wire all panels with terminal connections in accordance with the applicable combination of components. See figure 8 for the wiring diagram of the panel illustrated in figure 1.

3.3.7 Terminal Blocks. Use terminal blocks rated for at least 10 amperes and 600 volts. Use pressure type terminal blocks capable of holding wires from No. 19 AWG to No. 10 AWG. Identify the individual terminals with permanent marks in accordance with the wiring diagram furnished with the unit. Terminal blocks may be omitted in Type W panels.

3.3.8 Marking. Mark the switch designations in characters not less than 3/16 inch (0.5 cm) or not over 5/16 inch (0.8 cm) high formed by engraving, etching, or stamping. Fill unlighted characters with a permanent, durable white material when a white character is not produced in the material itself. Place the markings either on the plate or on small separate plates securely fastened to the plate. When pushbutton switches are used, the marking may be placed on the switch itself.

3.3.9 Painting. For Type F and S panels, the color and gloss of the case and panel plate shall conform to Federal Standard 595, brown No. 30372. Apply a hard lusterless alkyd baked enamel finish having a smooth matte texture. Prepare the surface application of primer and enamel, including baking procedures, so that the finished surface will meet the water-resistant test specified in Federal Specification TT-E-527. The surface shall be free of runs, sags, holidays, etc., to provide a satisfactory finish. For Type W panels, the commercially applied finish to the utility box and cover will be acceptable.

3.3.10 Wiring Diagram. Supply three copies of a wiring diagram with each panel. The wiring diagram is to show the color code or number identification of each wire.

3.3.11 Parts List and Installation Instructions. Furnish a component parts list and installation instructions with each control panel. Provide sufficient drawings or illustrations to indicate clearly the method of installation.

3.3.12 Nameplate. Attach a nameplate to the panel and include the following information thereon:

- (1) Airport Lighting Control Panel.
- (2) Identification: FAA L-821
- (3) Type _____, Class _____, Style _____.
- (4) Manufacturer's Part No. _____
- (5) Manufacturer's name or trademark.

4. TESTING

4.1 Qualification Requirements. Procedures for obtaining qualification approval are contained in AC 150/5345-1, Approved Airport Lighting Equipment. The following tests are required to demonstrate compliance with the specification.

4.1.1 Examination. In this examination, use the form of a checkoff list to certify that the material used, dimensions, component parts, calibration, quantities, etc., are in accordance with the detail requirements of this specification.

4.1.2 Operation. Connect the panel to a pilot-light test board and check each component and switch for proper operation.

4.1.3 Dielectric. Subject all terminals on the terminal block to a potential of at least 500 volts, rms, 60 Hz, applied for a period of 1 minute between the terminal and the grounded case. No breakdown of the insulation will be acceptable.

4.1.4 Production Testing. Each panel is to be inspected and tested by the manufacturer as specified in paragraph 4.1 above.

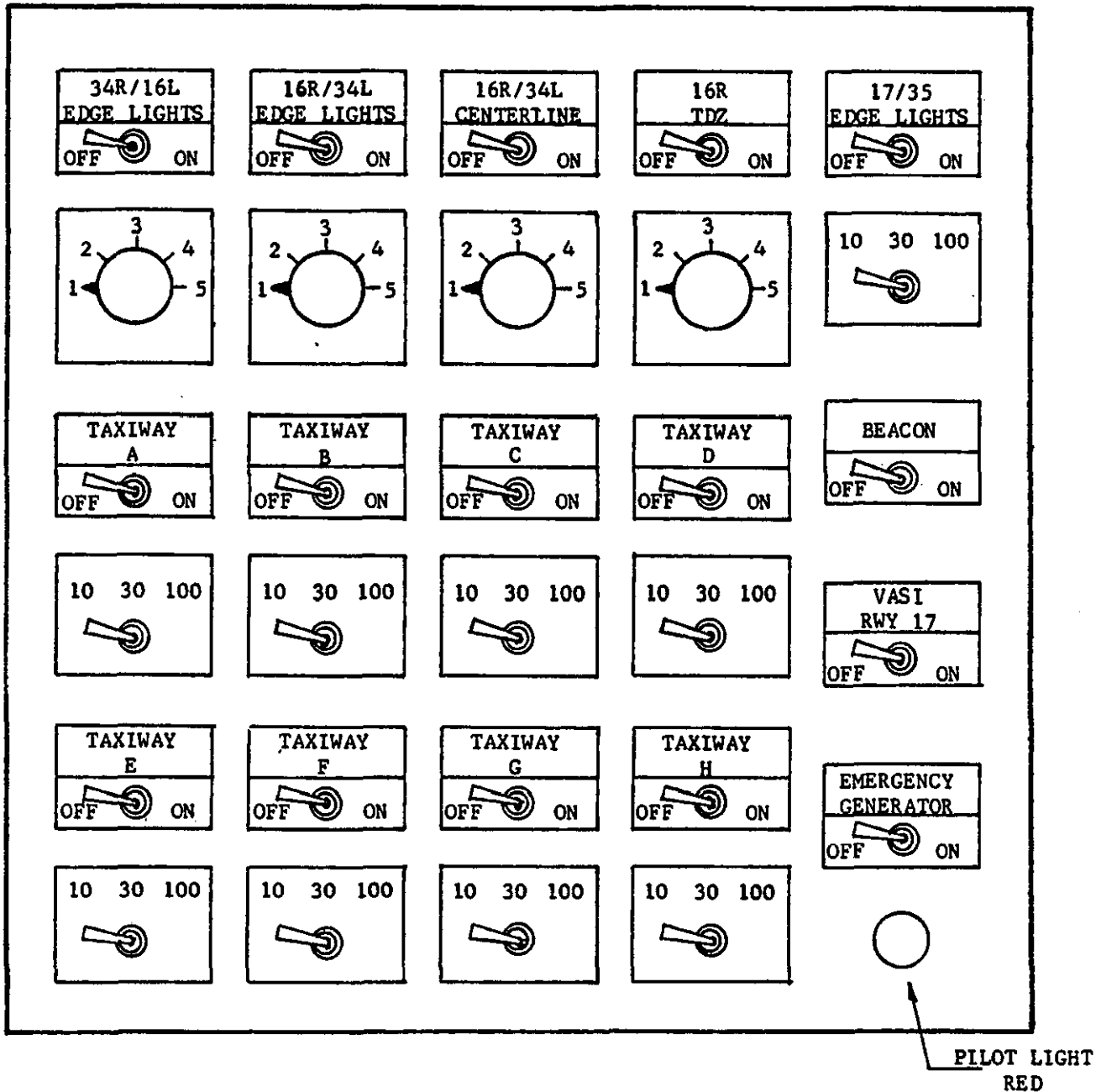

FIGURE 1. TYPICAL CONVENTIONAL LIGHTING CONTROL PANEL LAYOUT.
(With Toggle Switch Power Control)

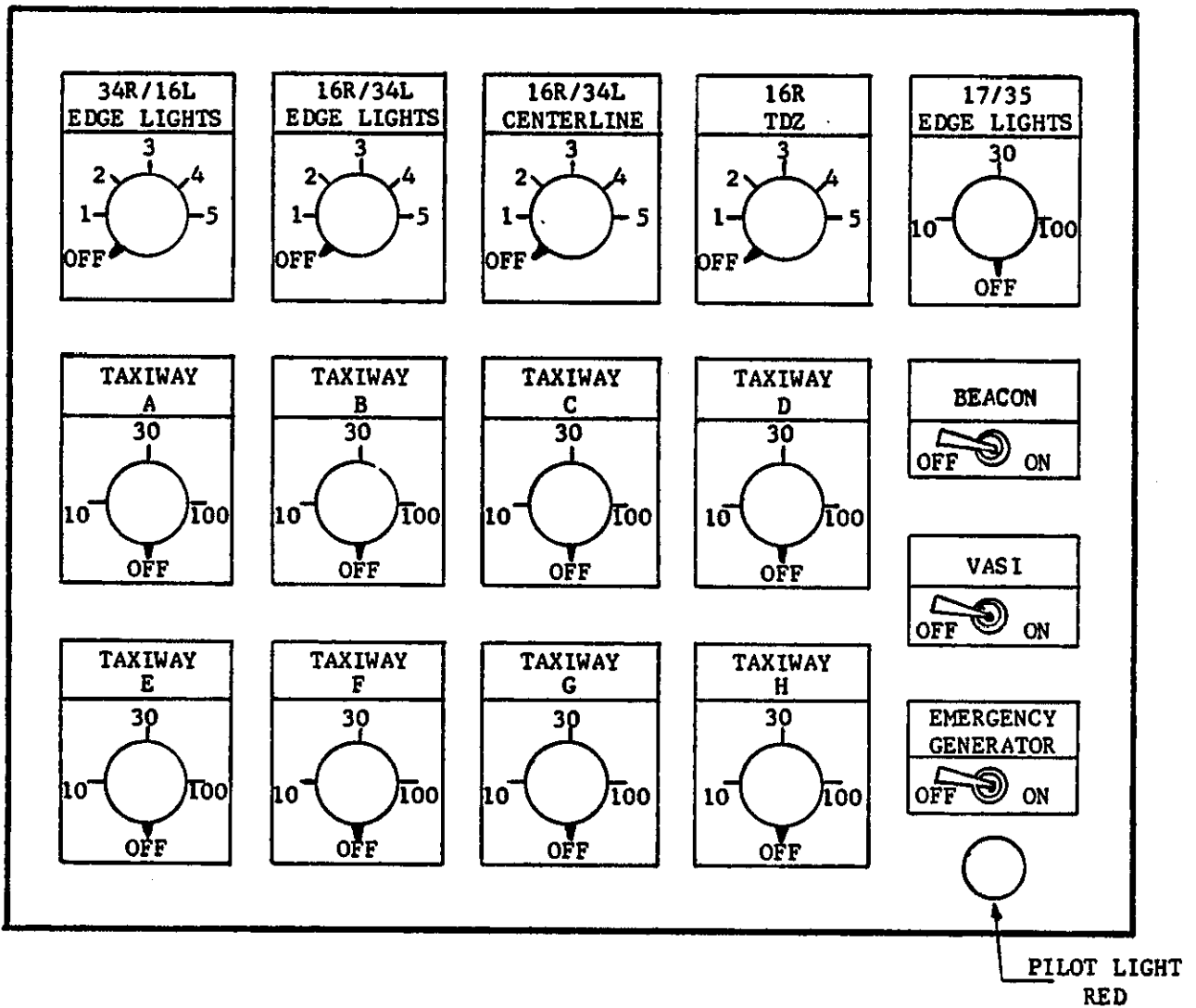

FIGURE 2. TYPICAL CONVENTIONAL LIGHTING CONTROL PANEL LAYOUT.
(With Rotary Switch Power Control)

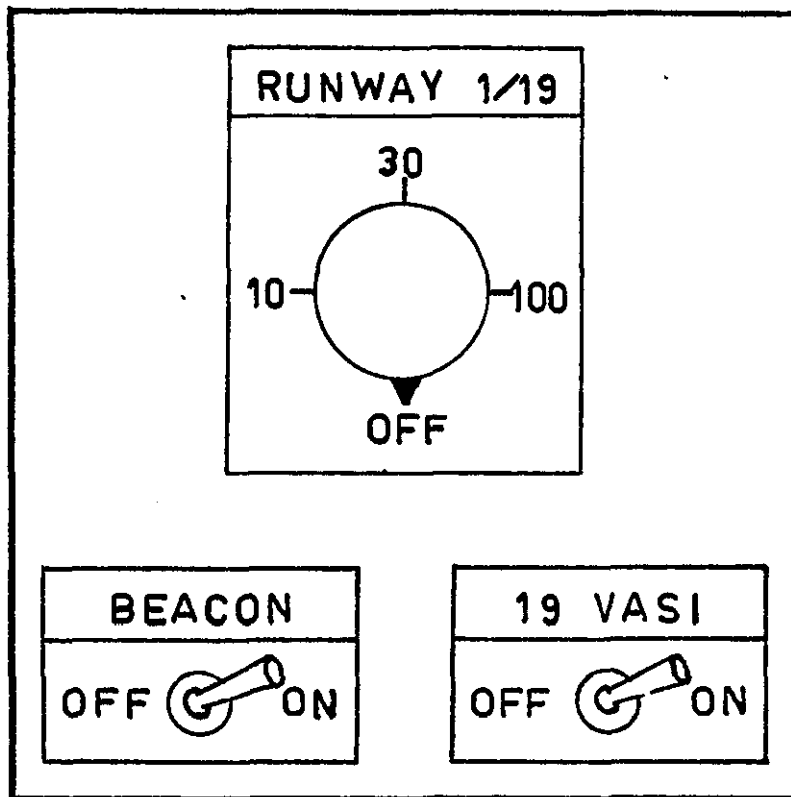

FIGURE 3. TYPICAL TYPE W CONTROL PANEL.

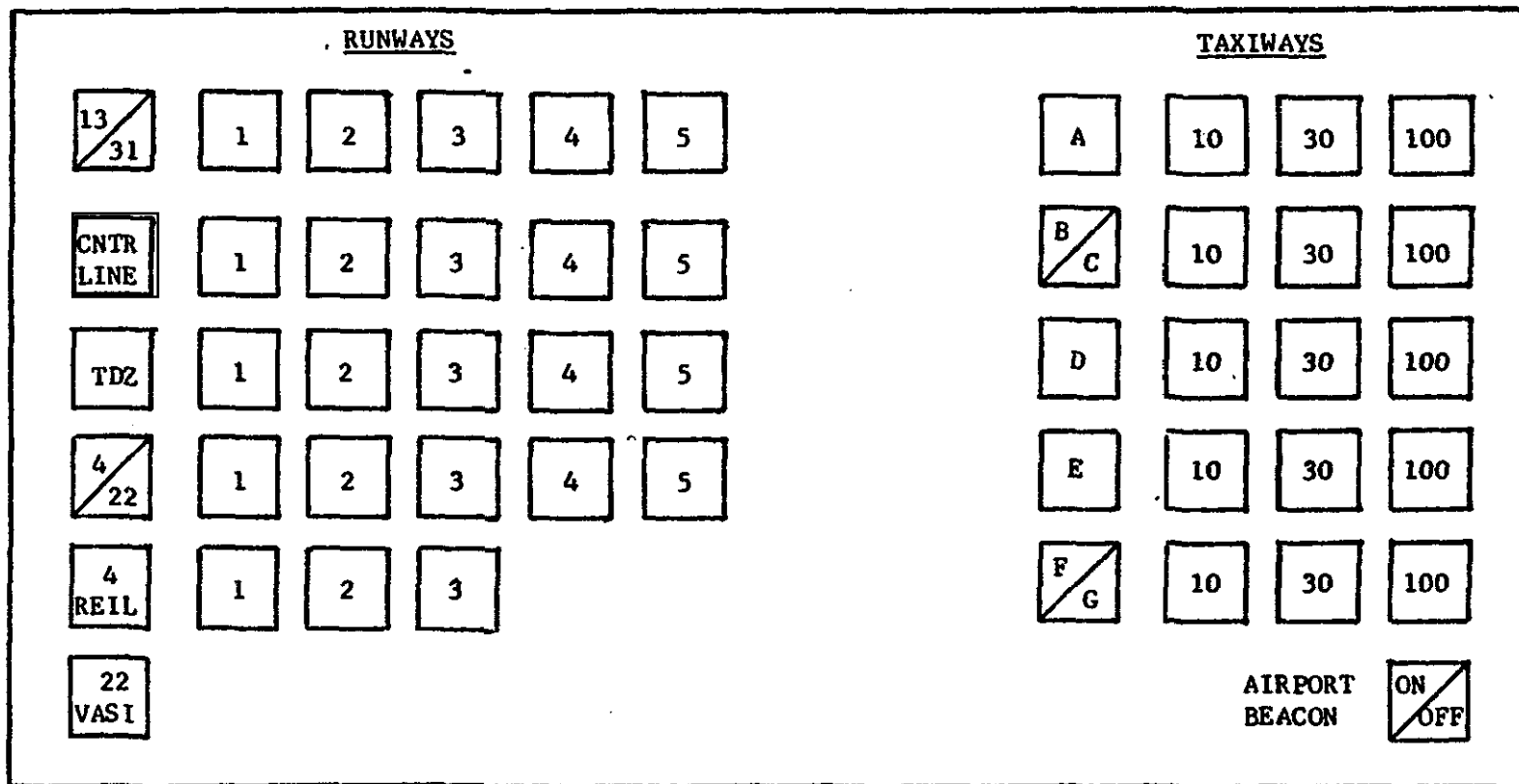
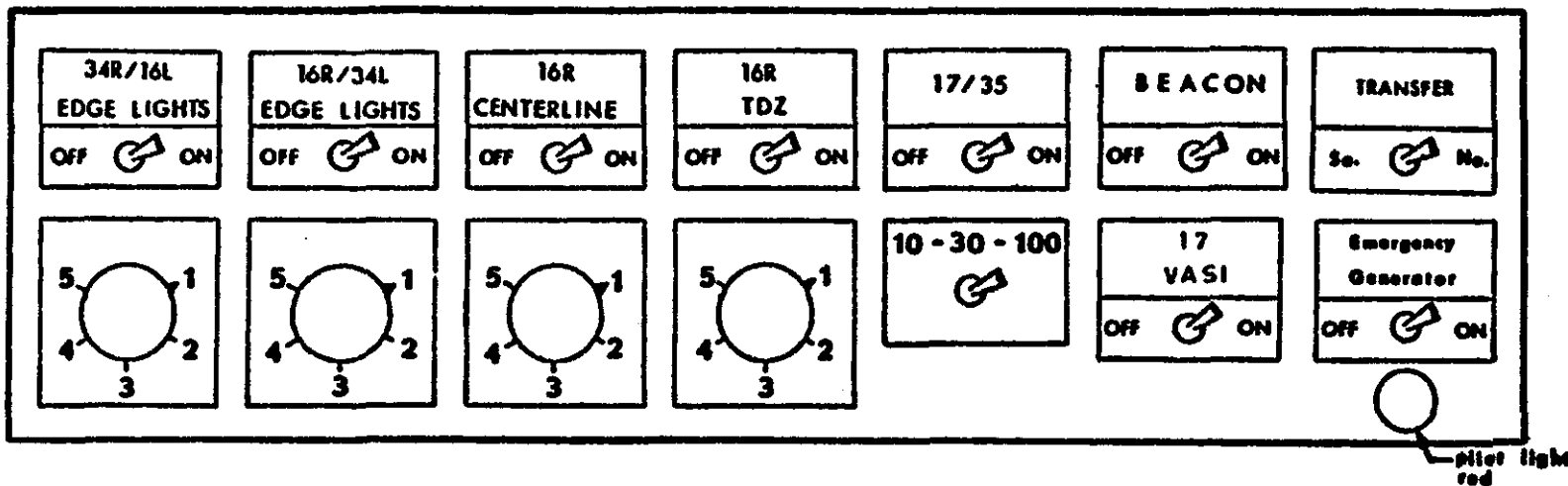
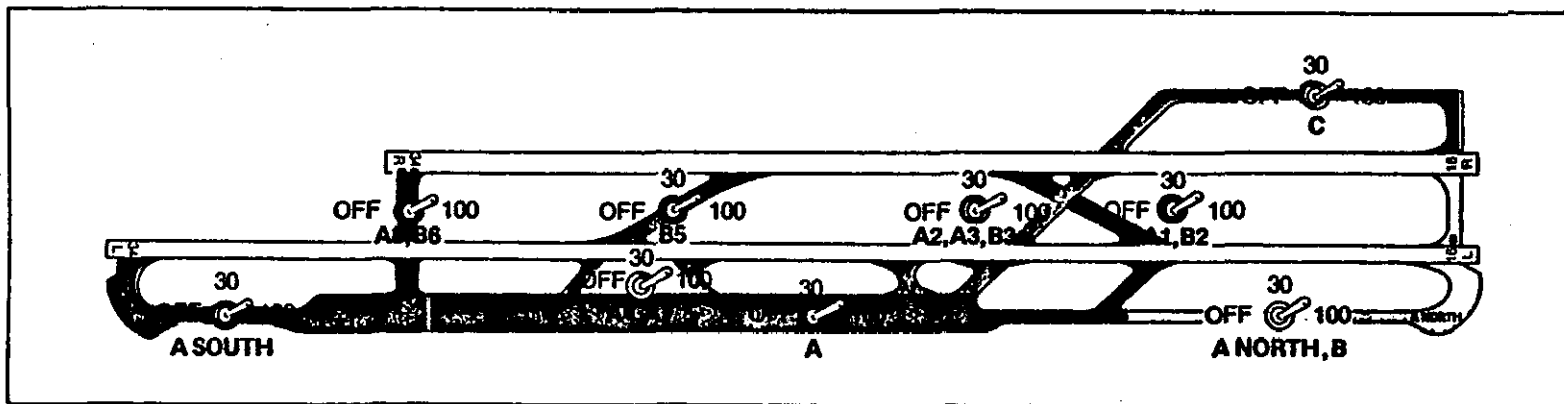

FIGURE 4. TYPICAL CONTROL PANEL WITH PUSHBUTTON SWITCHES.



a. Conventional Panel For Control of Runway Lights



b. Facsimile Panel For Control of Taxiway Lights

FIGURE 5. TYPICAL CUSTOMIZED LIGHTING CONTROL PANELS.

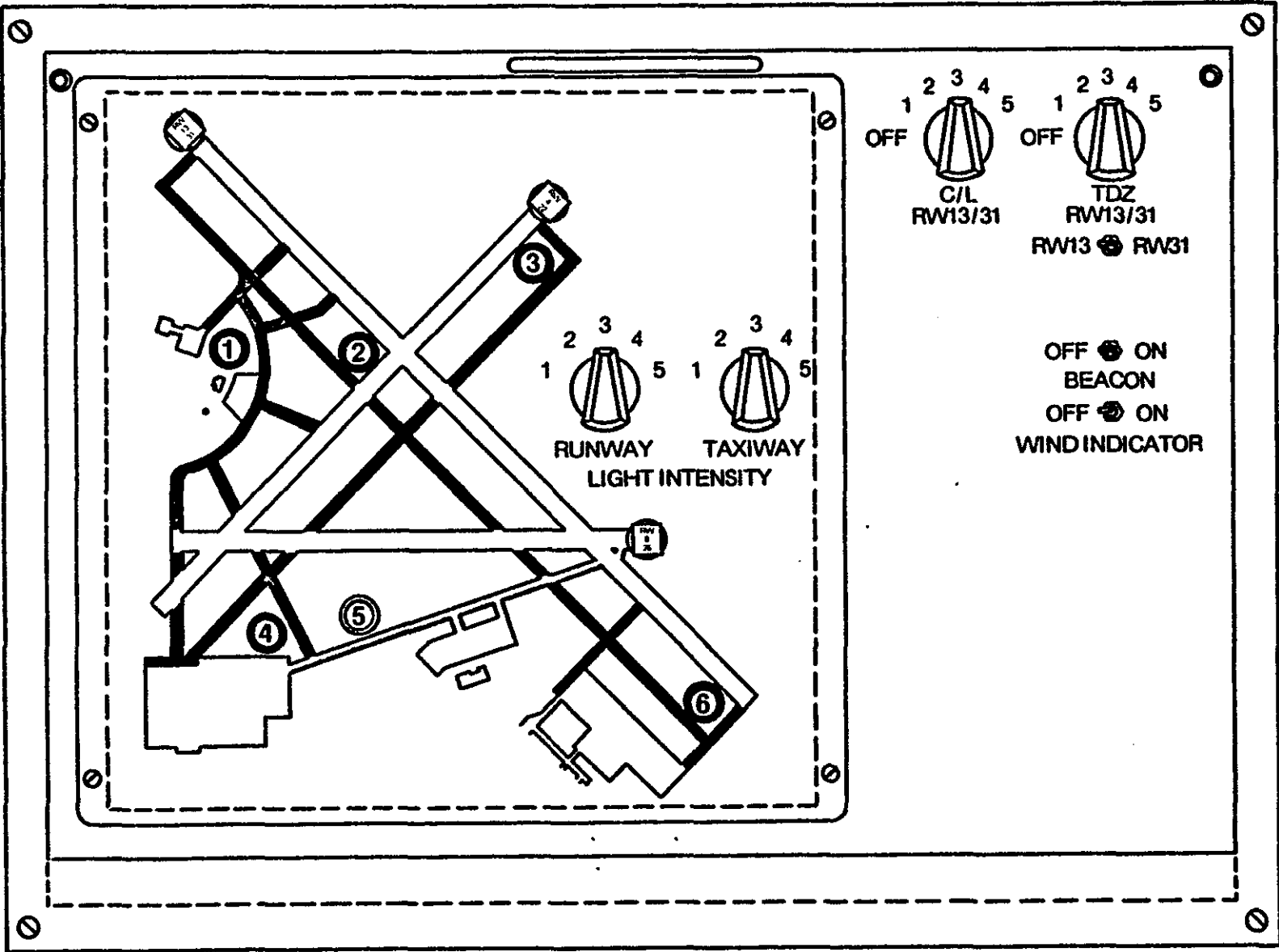
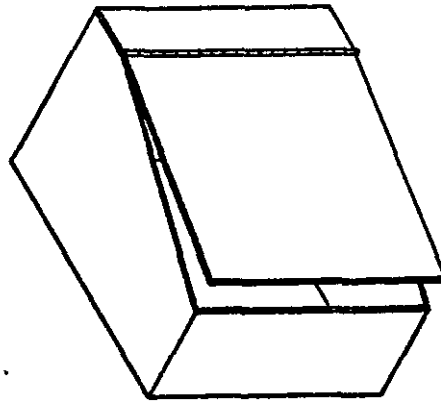
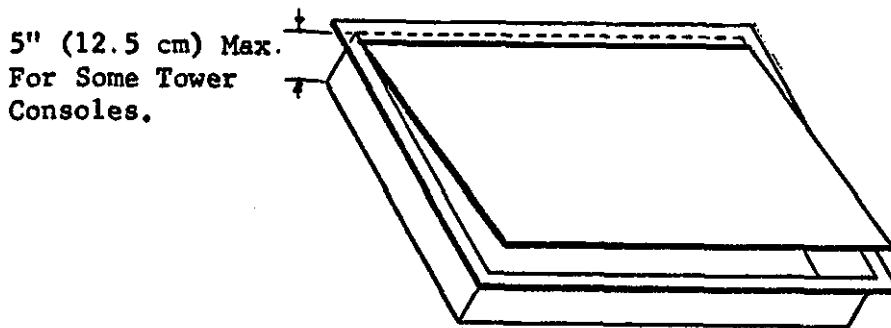

FIGURE 6. TYPICAL BACKLIGHTED FACSIMILE LIGHTING CONTROL PANEL.



Type "S" For Surface Mounting.



Type "F" For Flush Mounting.

FIGURE 7. TYPICAL CASE LAYOUTS.

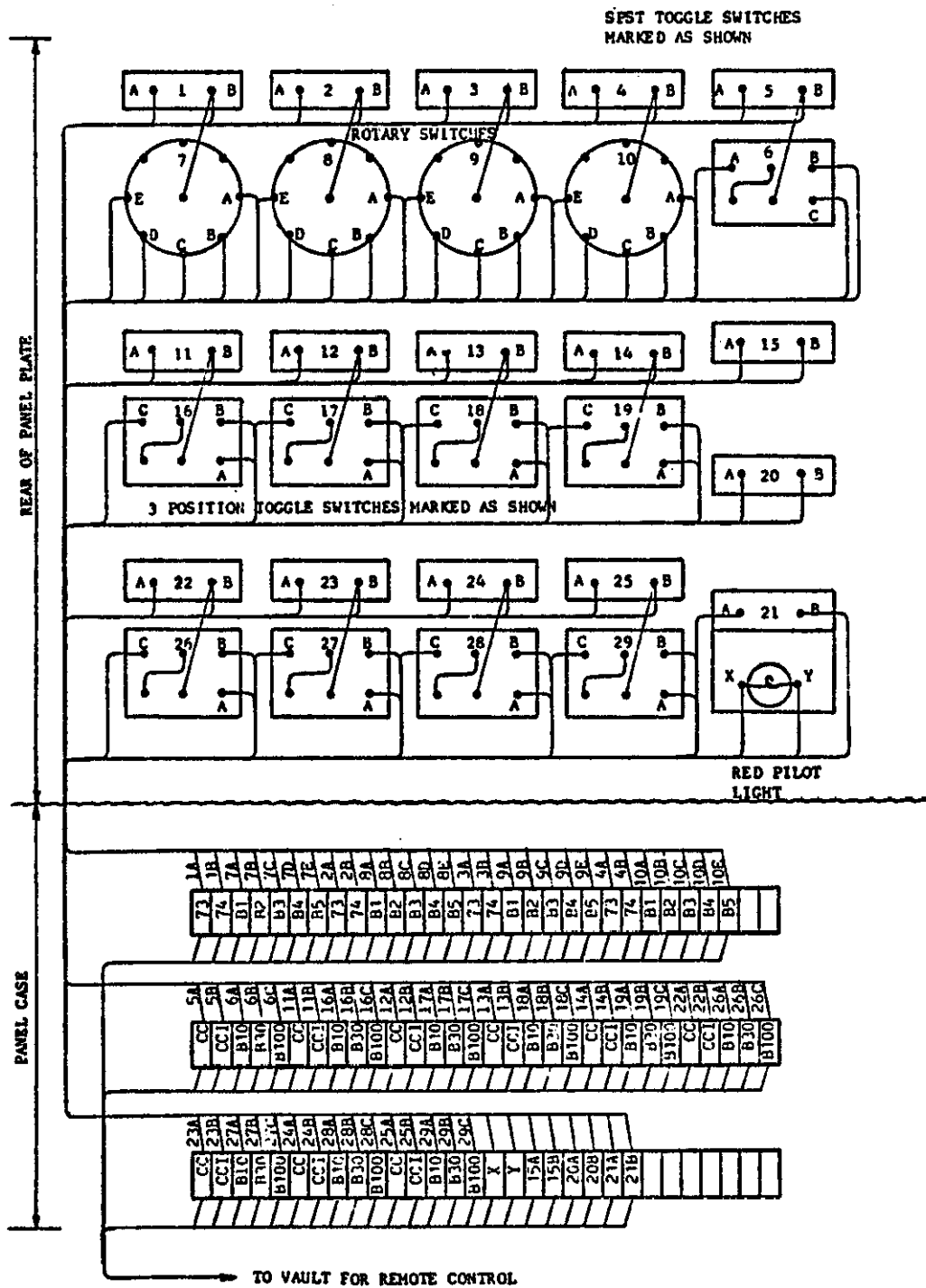
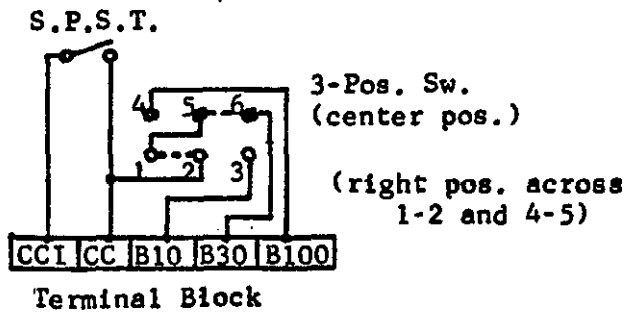
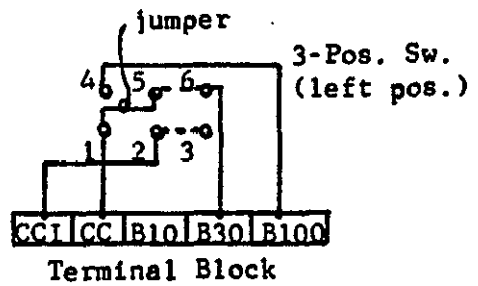

FIGURE 8. TYPICAL WIRING DIAGRAM FOR FIGURE 1 PANEL.



(a) For 3-step Brightness



(b) For 2-step Brightness

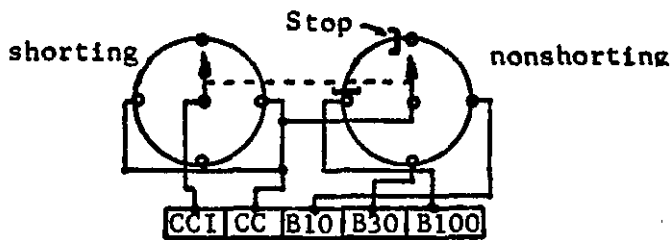

(c) Rotary Switch Alternate to (a) or (b)

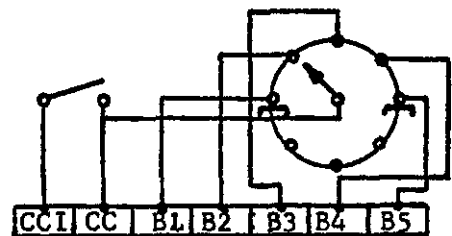

(d) For 5-step Brightness

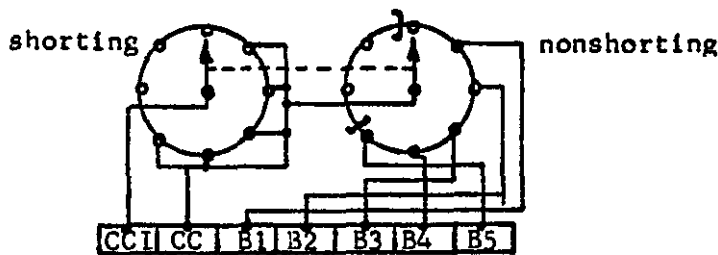

(e) Alternate to (d)

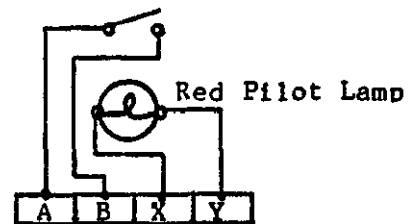

(f) Standby Power Control

FIGURE 9. TYPICAL SWITCH CONNECTIONS.