

CHANGE



615

AAS-500
63224
IMBATES

AC NO:

DATE:

TAD-494.6
150/5345-26A CHG 1

September 11, 1975

ADVISORY CIRCULAR

DEPARTMENT OF TRANSPORTATION FEDERAL AVIATION ADMINISTRATION

SUBJECT: CHANGE 1 TO ADVISORY CIRCULAR 150/5345-26A, SPECIFICATION FOR L-823 PLUG AND RECEPTACLE, CABLE CONNECTORS

- PURPOSE. This change transmits page changes to the basic advisory circular.
- EXPLANATION OF CHANGES. The uniform outside diameter of the single conductor plug and receptacle kit illustrated by figure 14 of Appendix 1 has been modified. This modification was necessary to accommodate vertical molding requirements.
- HOW TO OBTAIN ADDITIONAL COPIES OF THIS CHANGE. Additional copies of this Change 1 to Advisory Circular 150/5345-26A, Specification for L-823 Plug and Receptacle, Cable Connectors may be obtained free of charge from the Department of Transportation, Publications Section, TAD-443.1, Washington, D.C. 20590.
- PAGE CONTROL CHART.

Remove Pages	Dated	Insert Pages	Dated
Appendix 1 Pages 3 and 4	5/4/71	Appendix 1 Page 3 Page 4	5/4/71 9/11/75

William V. Vitale
WILLIAM V. VITALE
Director, Airports Service

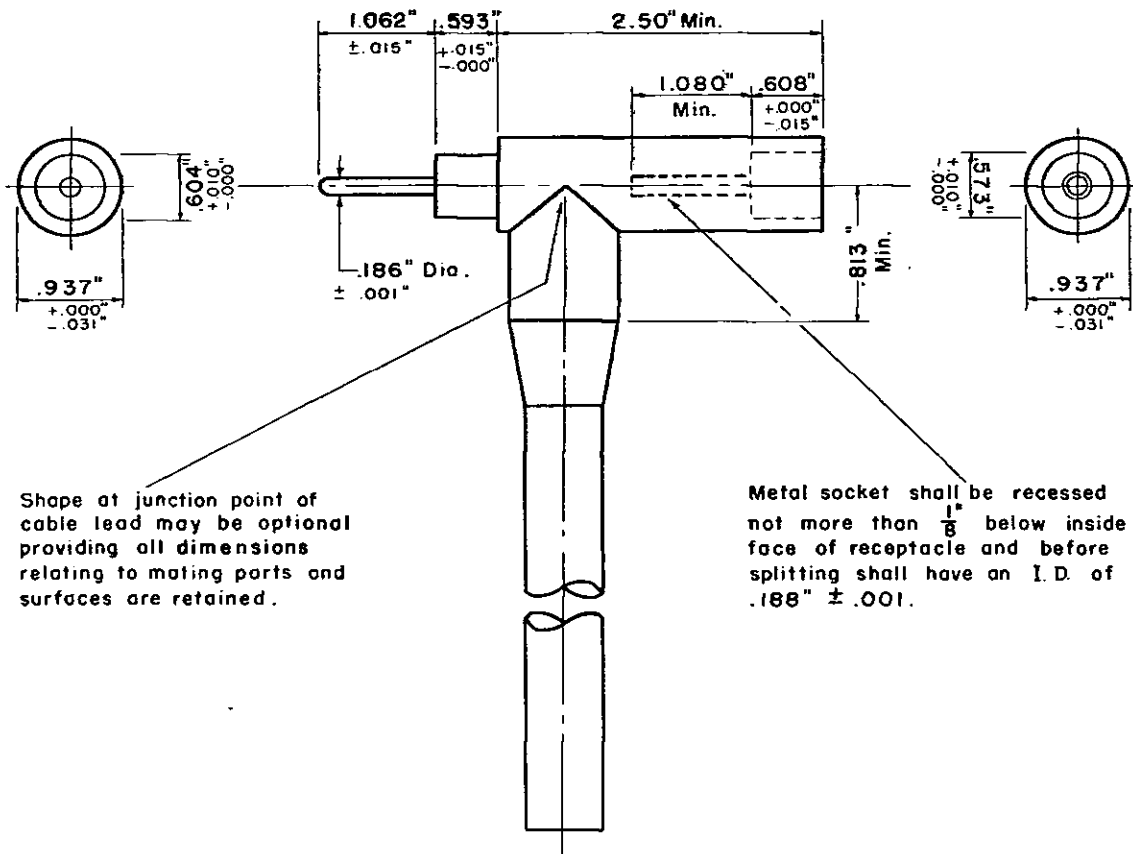
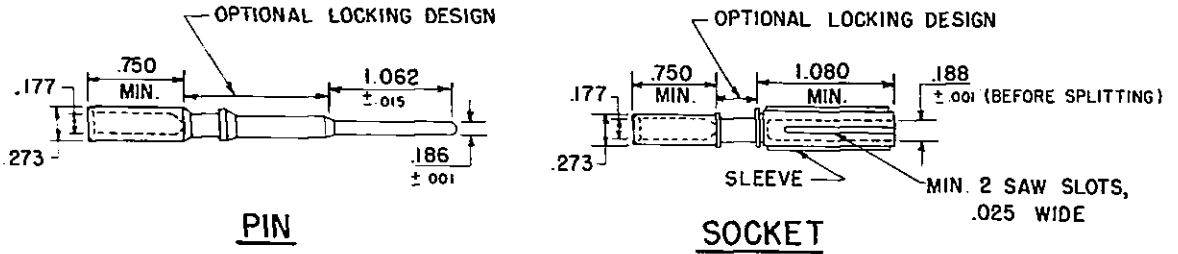

FIGURE 11. PLUG AND RECEPTACLE (SINGLE CONDUCTOR, 25 AMPERE, 5000 VOLTS TO GROUND.)



PIN **SOCKET**

NOTE: ● ALTHOUGH THE CROSS-SECTION IS SHOWN TO BE OF UNIFORM WIDTH, THIS DIMENSION MAY VARY ALONG THE LENGTH EXCEPT FOR THE MATING ENDS.

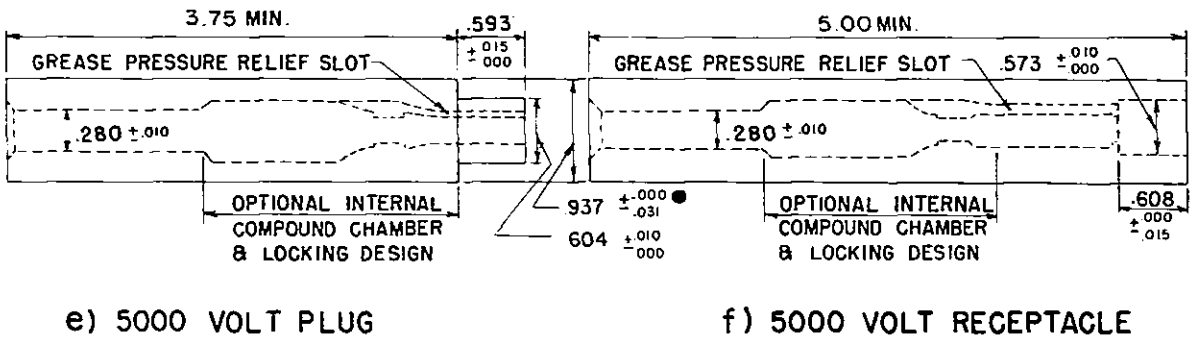
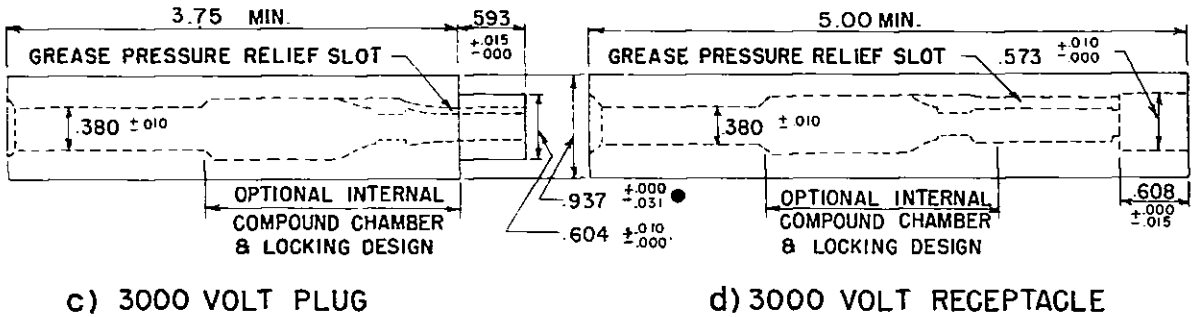
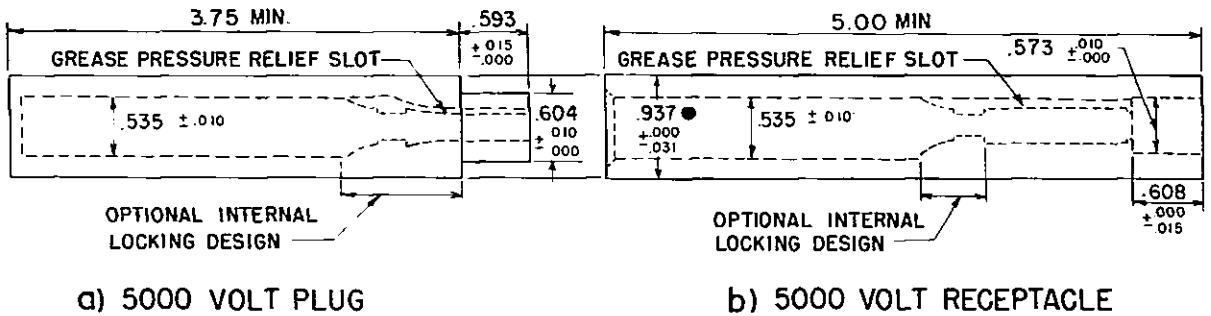

FIGURE 14. PLUG AND RECEPTACLE KIT (SINGLE CONDUCTOR, 25 AMPERE).