

PB88-168513



INFLUENCE OF SIZE AND WEIGHT VARIABLES ON THE STABILITY AND CONTROL PROPERTIES OF HEAVY TRUCKS



U.S. Department
of Transportation
**Federal Highway
Administration**

Research, Development,
and Technology

Turner-Fairbank Highway
Research Center
6300 Georgetown Pike
McLean, Virginia 22101

Report No.
FHWA/RD-83/029

Final Report
July 1986



REPRODUCED BY
U.S. DEPARTMENT OF COMMERCE
NATIONAL TECHNICAL
INFORMATION SERVICE
SPRINGFIELD, VA. 22161

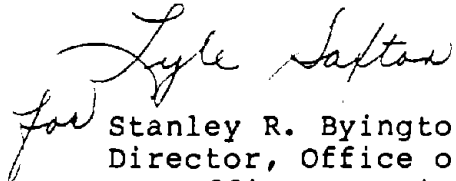
This document is available to the U.S. public through the National Technical Information Service, Springfield, Virginia 22161

FOREWORD

This study was initiated to determine the effect of specific changes in size and weight on the braking and handling ability of large trucks. The study involved extensive vehicle simulation as well as full-scale testing.

These reports provide detailed information about the control properties of large trucks. Specific size and weight issues are treated individually by chapter. Interactions among size and weight changes are also addressed. The final report is written in terms that highway engineers, policy makers and others not expert in vehicle dynamics can understand.

These reports describe the results of a study in Project 1U, "Large Truck Safety", in the Nationally Coordinated Program of Highway Research.


for Stanley R. Byington
Director, Office of Safety and
Traffic Operations R&D

NOTICE

This document is disseminated under the sponsorship of the Department of Transportation in the interest of information exchange. The United States Government assumes no liability for the contents or use thereof.

The contents of this report reflect the views of the contractor, who is responsible for the accuracy of the data presented herein. The contents do not necessarily reflect the official policy of the Department of Transportation.

This report does not constitute a standard, specification, or regulation.

The United States Government does not endorse products of manufacturers; trade or manufacturers' names appear herein only because they are considered essential to the objective of this document.

1. Report No. FHWA/RD-83/029		2. Government Accession No. PB88 168513IAS		3. Recipient's Catalog No.	
4. Title and Subtitle INFLUENCE OF SIZE AND WEIGHT VARIABLES ON THE STABILITY AND CONTROL PROPERTIES OF HEAVY TRUCKS		Report Date July 1986		6. Performing Organization Code	
7. Author(s) R.D. Ervin, R.L. Nisonger, C.C. MacAdam, P.S. Fancher		8. Performing Organization Report No. UMTRI-83-10/1		10. Work Unit No. 31U4 044	
9. Performing Organization Name and Address Transportation Research Institute The University of Michigan 2901 Baxter Road Ann Arbor, Michigan 48109		11. Contract or Grant No. FH-11-9577		13. Type of Report and Period Covered Final 4/5/79 - 4/30/83	
12. Sponsoring Agency Name and Address Federal Highway Administration U.S. Department of Transportation Washington, D.C. 20590		14. Sponsoring Agency Code T-0659			
15. Supplementary Notes Contract Manager - Dr. R. Hegmon (HNR-20)					
16. Abstract This study has determined the influence of variations in truck size and weight constraints on the stability and control properties of heavy vehicles. The size and weight constraints of interest include axle load, gross vehicle weight, length, width, type of multiple-trailer combinations, and bridge formula allowances. Variations in location of the center of gravity of the payload were also considered as a separate subject. The influence of these parametric variations on stability and control behavior was explored by means of both full-scale vehicle tests and computer simulations. In Volume I, the findings of the study are presented in a manner which is intended to inform the non-technical reader and, specifically, the persons concerned with formulating policies and laws regarding truck size and weight. For each size and weight issue, the stability and control problem areas are addressed and the influence of size and weight variations is quantified. The results are then reviewed in the light of their potential implications for traffic safety. Volumes II and III provide (a) background information concerning test procedures and analytical methods and (b) detailed data.					
17. Key Words size and weight, heavy trucks, stability and control, traffic safety			18. Distribution Statement No restrictions. This document is available to the public through the National Technical Information Service, Springfield, Virginia 22161.		
19. Security Classif. (of this report) NONE		20. Security Classif. (of this page) NONE		21. No. of Pages 203	22. Price

TABLE OF CONTENTS

CHAPTER		
1	INTRODUCTION.	1
2	OVERVIEW OF THE STUDY METHODOLOGY	5
	2.1 The Size and Weight Issues.	6
	2.2 A Means for Evaluating the Influence of Size and Weight Constraints on the Stability and Control Properties of Trucks.	21
	2.3 Test and Simulation Methods	46
3	PRESENTATION OF FINDINGS.	51
	3.1 Axle Load Limits.	51
	3.2 Gross Vehicle Weight.	73
	3.3 Simple Variations in Payload Placement.	87
	3.4 Influence of Length Variations.	121
	3.5 Types of Multiple-Trailer Combinations.	152
	3.6 Vehicle Width	162
	3.7 Bridge Formula Considerations	177
4	CONCLUSIONS AND RECOMMENDATIONS	183
	REFERENCES.	191

LIST OF FIGURES

<u>Figure</u>		
1	Axle loading variation.	8
2	Gross weight variations	10
3	Cases covering variations in payload c.g. height and lateral offset.	12
4	Cases of partial unloading.	13
5	Length variations	16
6	Types of multiple trailer combinations.	17
7	Vehicle width variation	19
8	Three types of braking instability occurring with articulated vehicles	24
9	Layout of J-turn maneuver	26
10a	Normal lane-change maneuver	30
10b	Emergency obstacle-avoidance maneuver	30
11	Tractor yaw response defining the jackknife divergence measure, DELTA T	32
12	Articulation angle response showing the divergency slope measure, AR(2-3).	34
13	Example yaw rate responses of tractor and semitrailer to an abrupt steer input.	35
14	Definition of response time measure	36
15	Handling diagram showing the understeer measure	38
16	Typical axle liftoff sequence on figure defining rollover threshold.	40
17	Illustration of rollover threshold for two example vehicles.	41
18	Low-speed offtracking in a 90° intersection turn.	43
19	High-speed offtracking in a steady turn	44
20	Lateral acceleration responses in an obstacle- avoidance maneuver defining the amplification ratio	45

Figure

21	Influence of axle load variations on stopping distance.	54
22	Influence of axle load variations on understeer level.	57
23	Influence of axle load variations on rollover threshold.	63
24	Percent of single-vehicle accidents in which rollover occurs as a function of the vehicle's inherent rollover threshold, in g's	66
25	Overlay of rollover thresholds representing axle load variations onto curve derived from accident data.	68
26	Amplification of lateral acceleration at the <u>rear trailer</u> relative to the peak value of lateral acceleration at the tractor as a function of the frequency of the steering input wave.	70
27	Amplification of lateral acceleration at the <u>semitrailer</u> relative to the peak value of lateral acceleration at the tractor as a function of the frequency of the steering input wave.	72
28	The influence of gross weight variations on stopping distance performance	75
29	Influence of gross weight variations on understeer level.	77
30	Influence of gross weight variations on rollover threshold.	80
31	Overlay of rollover thresholds representing gross weight variations onto curve derived from accident data	83
32	Influence of gross weight variation on rearward amplification.	86
33	Relationship between payload c.g. height and composite (sprung mass) c.g. height—tractor with 45-ft. semitrailer.	89
34	Illustration of payload height variations	90
35	Influence of payload c.g. height on stopping distance performance.	93
36	Influence of payload c.g. height on understeer	95

Figure

37	Two aspects of the influence of payload c.g. height on roll stability.	97
38	Influence of payload c.g. height on rollover threshold	99
39	Overlay of rollover thresholds representing payload c.g. height variations onto accident data curve	100
40	Influence of payload offset on understeer level	104
41	Illustration of payload offset relative to the effective half-track dimension.	106
42	Influence of payload offset on rollover threshold	107
43	Sketch of tractor-semitrailer with trailer listing 1.2° to its right side (as occurs with a payload offset of 6 inches, with full-weight load).	109
44	Differences in steering wheel inputs needed to negotiate a 12-foot lane change with differing payload offsets	111
45	Influence of 6 inch payload offset on the roll response of the rear trailer of conventional double in severe lane change.	112
46	Roll angle responses for varying payload offsets - 80,000 lb gross weight.	113
47	Roll angle responses for varying payload offsets - 88,000 lb gross weight.	114
48	Influence of partial unloading on stopping distance.	119
49	Influence of partial unloading on amplification ratio	122
50	Influence of length parameters on stopping distance.	125
51	Influence of wheelbase on understeer for 3-axle truck, fully loaded	128
52	Influence of wheelbase on the transient yaw response of a 3-axle truck to an abrupt steer input.	130
53	Influence of tractor and semitrailer length parameters on the transient yaw response of the tractor to an abrupt steer input.	132

Figure

54	Influence of trailer length on the transient yaw response of both tractor and semitrailer to an abrupt steer input.	133
55	Influence of tractor wheelbase on jackknife doubling time	136
56	Influence of tractor wheelbase on jackknife articulation rate	137
57	Influence of length parameters on rearward amplification	139
58	Influence of length parameters on low-speed offtracking (swept path).	147
59	Relationship between wheelbase and high-speed offtracking for differing path radii.	149
60	Influence of length parameters on high-speed offtracking	151
61	Influence of combination type on high-speed offtracking	155
62	Influence of combination type on low-speed offtracking (swept path).	157
63	Diagram of obstacle-avoidance maneuver, identifying obstacle "width," Y	159
64	Influence of combination type on rearward amplification using three methods of analysis	161
65	Influence of combination type on the width of obstacle which can be cleared in a 2-second maneuver at 55 mph without approaching rollover.	163
66	Sketch of trailer or truck showing width parameters	165
67	Influence of width parameters on understeer level	167
68	Influence of width parameters on rollover threshold	170
69	Overlay of rollover thresholds for differing width parameters onto curve derived from accident data.	175
70a	Gross weights allowed by bridge formula "B" for various vehicles (assuming maximum axle loading - 20K single, 34K tandem)	178
70b	Gross weights allowed by bridge formula "B" for various vehicles (assuming maximum axle loading - 20K single, 34K tandem)	179

CHAPTER 1

INTRODUCTION

This document constitutes the final report on Contract Number FH-11-9577, entitled "The Measurement of Pavement/Truck Interaction Under Experimental Conditions." The project has addressed a very broad objective, namely, to determine the manner in which changes in the size and weight of heavy trucks and truck combinations will affect the controllability of such vehicles. The project has endeavored to apply the current state of the art in vehicle dynamics research to this examination of the mechanical performance of heavy vehicles. The vehicle configurations of interest involve those truck types which are the largest among commercial highway vehicles. It is this class of vehicles which is peculiarly subject to constraint in size and weight dimensions as a result of both federal and state laws.

Size and weight laws come in a great variety of types. Weight-constraining laws, in general, are motivated by concerns for protecting the pavement, itself, or the bridge structures from the damage accruing from repeated intense loading. The length, width, and height of commercial vehicles are constrained so as to limit the degree to which trucks present an obstacle to other road traffic and, of course, to assure that trucks will fit under bridge overpasses. Other laws are imposed to restrict the specific types of multiple-trailer combinations which are allowed. In many cases, individual states have written laws which impose restrictions on the lengths, weights, and even axle configurations of specific vehicle combinations. All such laws are subject to continual modification due to the evolution of trucking technology, the experience which a given jurisdiction has had with truck accidents (and, perhaps, with pavement damage), and the ambitions of the trucking industry toward improved operating efficiency.

Since so many size- and weight-constraining laws exist and since many pressures exist for their continuing modification, there is a frequently-recurring need for technical information pertaining to the possible repercussions to changes in the constraints. A host of technical issues demand consideration whenever changes in size and weight constraints are being contemplated. Among these areas are the following:

Pavement and Bridge Deterioration

Transportation Economics

Energy Consumption

Inter-Modal Shift

Air Quality

Noise

Traffic Safety

This study has been concerned only with the last item on the above list. Further, this work has been confined only to that portion of the traffic safety subject involving the stability and control qualities of heavy trucks that influence the truck driver's ability to control the motions of his vehicle. The basic structure of this research has involved the following steps:

- 1) The identification of size and weight "issues" which hold the potential for changing truck dimensional and loading limits in the future. (Such issues embrace each of the "size and weight variables" such as axle load, gross vehicle weight, vehicle length, etc.)
- 2) The selection of candidate values which are likely to be promoted for consideration as changes in the size and weight variables. (For example, there has been a recent change, at this writing, in the federal allowance for truck width, from 96 to 102 inches (244 to 259 cm).)
- 3) The identification of specific vehicle types which are likely to be influenced by the change in the variable under consideration.

- 4) The formulation of hypotheses linking the considered changes in size and weight variables to the stability and control properties of vehicles.
- 5) The identification of specific maneuvering scenarios in which the altered vehicle properties would be manifested.
- 6) The conduct of full-scale vehicle tests and computer simulations employing the above maneuvers as a means of characterizing the altered vehicle properties.

Clearly, the bulk of effort in the study has entailed the actual testing and simulation work mentioned in Item 6. The primary result of this work is a compiled set of measures of stability and control characteristics of heavy vehicles, as they illustrate the influence of changes in size and weight variables. This first volume of the report has been prepared in such a way as to render these results of maximum utility to those directly concerned with decisions and policy making in the area of size and weight legislation. It is assumed that the majority of persons making up this group have no background in the stability and control behavior of motor vehicles. Further, it is supposed that, while this group is interested, to some degree, in the research methodology and data-processing techniques employed, they are willing to let those having more technical expertise examine those facets of the work in detail.

Accordingly, Volume I is configured to provide only an overview of the study methodology, in Chapter 2, and a condensed presentation of the findings, in Chapter 3. The findings are organized according to categories of size and weight issues. This structure is seen as being most useful to those concerned with future policy or law making since it is usually a specific size and weight constraint which is being considered. Thus, for example, if one is concerned with a prospective change in a gross weight limitation, the section illustrating all of the influences of gross weight on truck stability and control properties will afford a convenient reference. (The general reader will note, however, that this format leads to some redundancy, from one section of the report to the next.) Although

the essential findings pertaining to each size and weight issue are summarized within each of the respective parts of Chapter 3, an overall conclusions and recommendations discussion is also presented in Chapter 4.

Volumes II and III of the final report provide detailed coverage of the methods employed and also present more technically-complete representations of the data showing vehicle response properties.

All engineering units presented in the text of this report are shown in both the English and metric systems of units. Where vehicle weights are expressed, the metric unit, m ton (metric ton), is used in deference to common practice, although the standard scientific term for this metric unit is actually the megagram.

CHAPTER 2

OVERVIEW OF THE STUDY METHODOLOGY

In this chapter, certain elements of the structure of the research will be discussed so as to give the reader the means to understand the results presented in Chapter 3. As outlined in the Introduction, the project was guided by a set of size and weight issues which were defined early in the project. These issues are discussed, and the respective vehicle configurations involved with each issue are identified, in Section 2.1.

For each vehicle type, a baseline configuration was identified, representing more-or-less conventional vehicle characteristics, together with the current maximum loading found in interstate trucking. Of course, it is recognized that (a) a great deal of variation in vehicle design details prevails in service and (b) many very significant variations in load placement occur simply as a result of the diversity of products carried by motor trucks. For purposes of keeping the project scope within manageable bounds, however, the truck configurations studied here are confined to only the most popular varieties found across the U.S. Also, truck payloads were considered to constitute only homogeneous commodities whose center-of-gravity location resided at the geometric center of the payload volume (unless otherwise specified).

The influence of size and weight changes was considered only in terms of the impact of such changes on the stability and control characteristics of existing vehicles. That is, there was no attempt to consider vehicle designs which might, hypothetically, come into production in the future in response to liberalized size or weight constraints. On the other hand, the "existing" types of vehicle configurations were represented (in all cases, unless otherwise specified) with tire and suspension load capacities sufficient for the increased loads which were considered.

Following an outline of the size and weight issues, below, and a listing of the vehicle types considered, the means for evaluating the stability and control implications of size and weight changes is discussed in Section 2.2. In this discussion, the format for data presentation will be presented. Since the ultimate interest in stability and control characteristics is in connection with their implied influence on traffic safety, a portion of Section 2.2 is devoted to outlining the rationale making this connection.

2.1 The Size and Weight Issues

Six general issues have been identified as embodying the types of size and weight constraints which are placed upon heavy trucks either by state or federal law. The issues are as follows:

- 1) Load allowed on a single or tandem pair of axles
- 2) Gross weight of a vehicle combination
- 3) Length of either individual vehicle elements or of an overall combination of elements (where an "element" refers to a power unit or a trailer)
- 4) Types of multiple trailer combinations
- 5) Width of a vehicle
- 6) Constraints in axle placement imposed by a bridge formula

An additional category of vehicle dimensions for which all of the states have imposed constraints is the vehicle's overall height. Height, per se, has not been included as a variable in this study, although the height of the payload center of gravity is included. Since the vehicle's height is only of significance to the stability and control properties insofar as it permits loading of freight to produce differing values of composite height of center of gravity (c.g. height), the height issue can be presumed to be addressed by the findings pertaining to c.g. height.

The six issues listed above have been addressed using full-scale tests as well as simulation methods. The values of each size and weight variable, together with the choices of baseline vehicle configurations, are explained for each "issue" below.

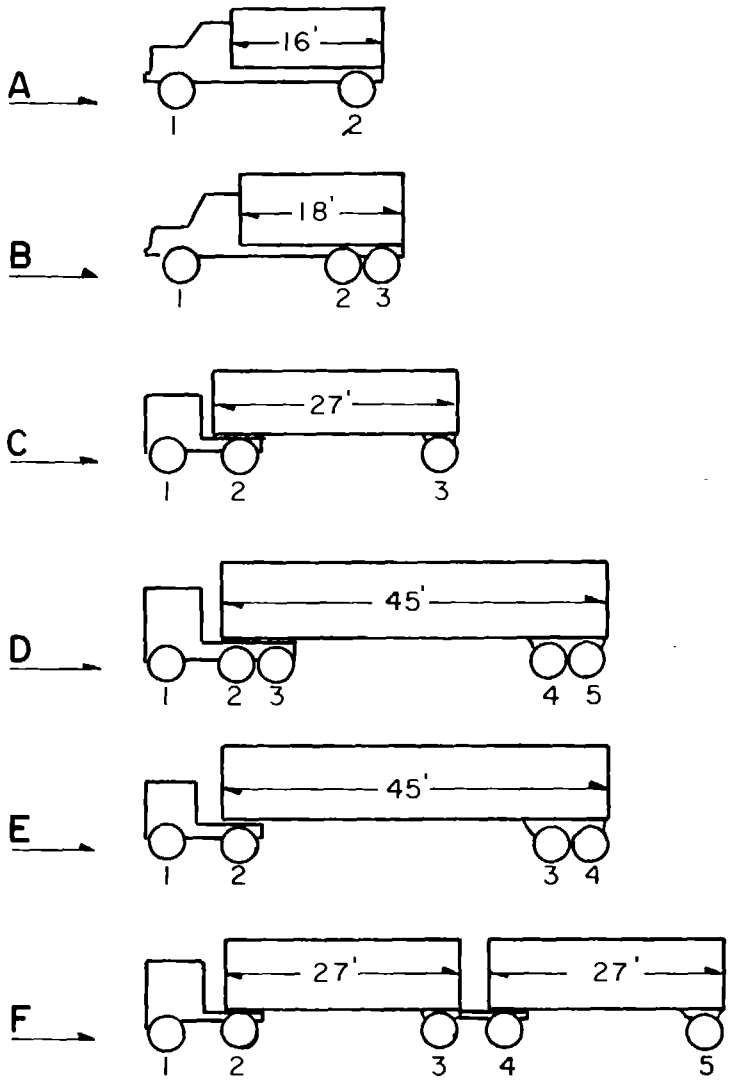
2.1.1 Axle Loading. Axle load laws are written to constrain the loading on both single- and tandem- (i.e., closely-spaced pair) axle arrangements. The current federal limits for axle loading on vehicles using the Interstate Highway System, for example, is 20,000 lbs (9.07 m tons) for single axles and 34,000 lbs (15.42 m tons) for tandems. In choosing vehicles with which to explore the influence of changes in axle load limits, it is necessary to identify vehicles whose loading is currently constrained, in normal service, by the limitations placed upon axle loading.

Shown in Figure 1 is the vehicle set selected for the study of axle loading influence. Of these vehicles, the maximum payload which can be carried by the first five vehicle types is frequently constrained by axle load levels, although the maximum loading of the five-axle tractor-semitrailer (D) is often simultaneously constrained by both the maximum allowable tandem load and the maximum allowable gross weight. For vehicles A, B, C, and E, the gross weight is not directly constrained by the federal limitation on gross weight. Thus, the axle load limitations represent a de facto constraint on gross vehicle weight.

In the case of the five-axle double (F), it would be very rare for axle load limitations to serve as the direct constraint on vehicle loading. Since the axles are spread sufficiently from one another, the single-axle load limitations apply such that a maximum of 20,000 lbs (9.07 m tons) could be legally carried on any of the axles aft of the steering axles. Nevertheless, a rather large fore/aft bias in axle load distribution would be required in order to reach the 20,000-lb (9.07-m tons) axle load limit (while the gross weight otherwise remains within the federal allowance of 80,000 lbs (36.28 m tons).

In all cases which were studied, the steering axle was taken to be "under-loaded," from a legal point of view, recognizing that steering axles

Vehicles Involved



Axle Loads/1000lb

Vehicles / Case		Axle Number	1	2	3	4	5
<u>A</u>	1	(Baseline)	12	20			
	2		12	22			
	3		12	18			
	4		12	24			
<u>B</u>	1	(Baseline)	12	17	17		
	2		12	19	19		
	3		12	16	16		
	4		12	18	18		
<u>C</u>	1	(Baseline)	10.5	20	20		
	2		10.5	22	22		
	3		10.5	18	18		
	4		10.5	24	24		
<u>D</u>	1	(Baseline)	12	17	17	17	17
	2		12	19	19	19	19
	3		10	17.5	17.5	17.5	17.5
	4		9.3	16	16	16	16
	5		10	20	20	19	19
<u>E</u>	1	(Baseline)	10.5	20	17	17	
	2		10.5	22	19	19	
	3		10.5	18	19	19	
<u>F</u>	1	(Baseline)	10	17.5	17.5	17.5	17.5
	2		10	20	15	20	15
	3		10	15	15	20	20
	4		10	15	20	15	20
	5		10	15	22	15	22

Figure 1. Axle Loading Variation

are operated at relatively light loads for a variety of reasons encompassing safety, ride, economics, and ease-of-steering considerations.

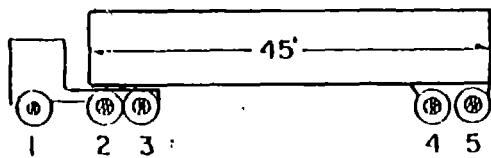
The loading cases which were covered for each vehicle were chosen to provide:

- 1) a common baseline case
- 2) cases which increment the axle load levels both up and down from the currently federally-allowed maximums
- 3) cases which serve to illustrate the possibilities which exist for inducing a fore/aft bias in load distribution and which may become exaggerated through increased axle load allowances in the future.

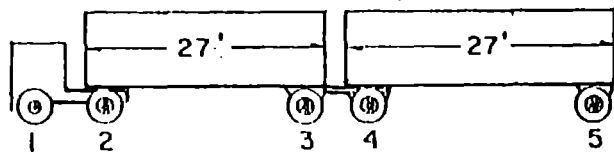
2.1.2 Gross Vehicle Weight. Only a certain few of the commonly-applied vehicle configurations have a sufficient number of axles that they are able to reach the levels of total load for which gross vehicle weight limitations are set. Shown in Figure 2 are two vehicles which are able to be loaded up to the federally-specified gross load limit of 80,000 lbs (36.28 m tons). Although higher values of gross vehicle weight are permitted in certain states, under the "grandfather clause" of the Federal Aid Highway Act [1], this study has considered gross weight variations only as perturbations about the 80,000-lb (36.28-m ton) limit which nominally applies to the vehicle types shown in the figure. These types are by far the most popular in interstate service and thus have received a greater degree of study here.

The loading variations which are listed in Figure 2 were chosen to provide:

- 1) a common baseline (cases A-1 and B-1)
- 2) cases which simply increment the gross weight up from 80,000 lbs (36.28 m tons) (cases A-6,2,7 and B-5,2,4)
- 3) cases covering the situation in which the tractor-semitrailer is loaded to its gross weight with uniform tandem loads, and then the fifth wheel position is moved



10



Vehicle / Case	Axle No. →	Axle Loads/1000 lb.					GVW	
		1	2	3	4	5		
<u>A</u> (Tractor Semitrailer)	1	(Baseline)	12	17	17	17	17	(80)
	2		12	19	19	19	19	(88)
	3		9.3	16	16	16	16	(73.3)
	4		10	17.5	17.5	17.5	17.5	(80)
	5		10	20	20	19	19	(88)
	6		12	18	18	18	18	(84)
	7		12	20	20	20	20	(92)
	8		10	18.5	18.5	18.5	18.5	(84)
	9		10	21	21	20	20	(92)
<u>B</u> (Conventional Double)	1	(Baseline)	10	17.5	17.5	17.5	17.5	(80)
	2		10	19.5	19.5	19.5	19.5	(88)
	3		9.3	17	15	17	15	(73.3)
	4		12	20	20	20	20	(92)
	5		10	18.5	18.5	18.5	18.5	(84)

Figure 2. Gross Weight Variations

aft on the tractor (to represent the common practice on the part of truck drivers seeking a better ride) (cases A-5 and A-9)

- 4) a hypothetical alternative to the baseline tractor-semitrailer case, by which the current 80,000 lb (36.28 m tons) gross weight is carried in a more aft-biased load distribution, with 35,000 lbs (15.87 m tons) on each tandem suspension (case A-4)
- 5) tractor-semitrailer and doubles cases representing the pre-1974 value for federally-allowed gross weight of 73,280 lbs (33.23 m tons) (cases A-3 and B-3).

In the portion of the study pertaining to length variations and to types of multiple-trailer combinations, vehicles having higher than 80,000 lb (36.28 m ton) gross weight capacity are considered. These vehicles are each considered at one loading condition, however, and are not examined in terms of their sensitivity to variations in gross weight.

In addition to the various gross weight conditions listed in the table in Figure 2, variations in location of the payload mass center were also examined. While payload placement variations cannot be cited as size and weight issues, per se, it is apparent that the sensitivity of vehicle behavior to such variations will be influenced by the absolute magnitude of the payload weight which accompanies the gross weight allowances. The examined variations included a range of vertical and lateral placements of the payload for cases of both 80,000 lb (36.28 m ton) and 88,000 lb (39.91 m ton) gross weight. Shown in Figure 3, payload placement variations were implemented only on the two most popular line-haul vehicle configurations, the five-axle tractor-semitrailer and the five-axle double.

Shown in Figure 4 are a set of variations in the longitudinal location of the payload mass center such as come about when a portion of the load is removed at an intermediate destination. Again, these latter variations in payload placement were examined using values of 80,000 lbs (36.28 m tons) and 88,000 lbs (39.91 m tons) for the original gross vehicle weight (prior to partial unloading).

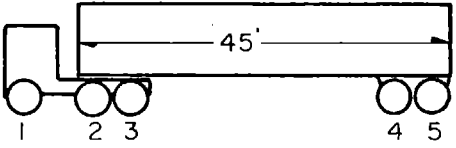
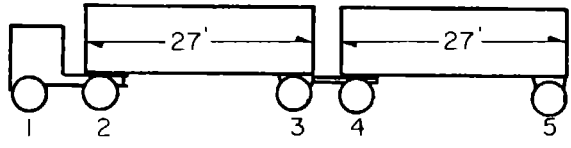
Axle no.	Axle Load/1000lb					Payload C.G. Height		Payload Offset		GVW lbs
	1	2	3	4	5	Case	C.G. Hgt. inches	Case	Offset inches	
A. (Tractor Semitrailer) 	12	17	17	17	17	1	70	1	0	80K
						2	80	2	-3	
						3	90	3	-6	
						4	100	4	-9	
						5	110	5	-12	
	12	19	19	19	19	6	70	6	0	88K
						7	80	7	-3	
						8	90	8	-6	
						9	100	9	-9	
						10	110	10	-12	
B. (Conventional Doubles) 	10	17.5	17.5	17.5	17.5	1	70	1	0	80K
						2	80	2	-3	
						3	90	3	-6	
						4	100	4	-9	
						5	110	5	-12	
	10	19.5	19.5	19.5	19.5	6	70	6	0	88K
						7	80	7	-3	
						8	90	8	-6	
						9	100	9	-9	
						10	110	10	-12	

Figure 3. Cases Covering Variations in Payload C.G. Height and Lateral Offset

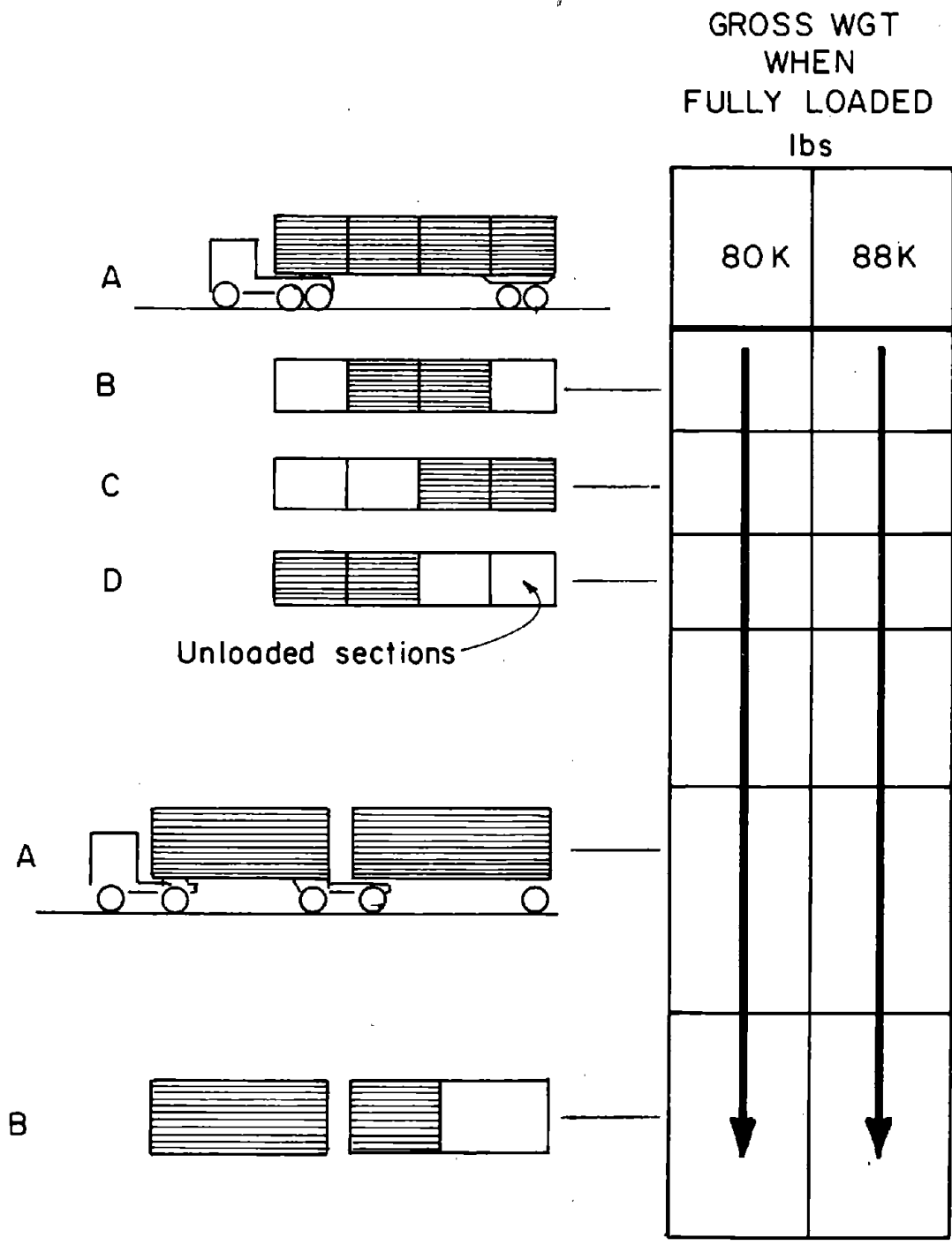


Figure 4. Cases of Partial Unloading

In addition to the insight which the payload placement variation cases give to the general issue of gross weight allowance, the results of these exercises have also been used simply to scale payload influences such as are being borne by the range of normal trucking operations currently. For example, it is helpful in interpreting the significance of a change in gross weight to compare the relative magnitude of the resulting performance change with the change which occurs at the current gross weight limit, simply due to variations in payload c.g. height. Since all kinds of freight are carried every day, ranging in payload c.g. heights from approximately 70 inches (178 cm) to as much as 110 inches (279 cm), we can look upon the magnitude of the implied changes in stability and control as indicating performance variations which are being more-or-less "coped with" in trucking operations, today. (Although comparative data of this sort will be presented later, the reader is advised that it is probably not justified to assume that all vehicle operating conditions which are being "coped with" today are, in fact, offering equal levels of safety performance.)

2.1.3 Vehicle Length. While prior to 1983, the federal government specified no constraints on vehicle length, all of the states have regulated various length limits for many years. The most popular form of length restriction, over the years, has been simply a limitation on the maximum overall length allowed for a given style of vehicle configuration. For example, all of the states have, in the past, imposed some restriction on the overall length of tractor-semitrailer combinations. More recently, because of apparent conflicts which have arisen in the manner in which overall length allowances are utilized, there have been more state regulations adopted for limiting the maximum length of trailers, directly.

Pre-emptive federal legislation effective in 1983 prohibits the states from regulating overall length on tractor-semitrailers and conventional doubles combinations. Also, the states are prevented from limiting trailer lengths to less than specific values for these two respective types of combinations. These federal statutes may also have a major effect upon the configuration of tractor designs since there will no longer be

competition between the tractor and the trailer in the apportionment of overall length. In the minds of many, this competition was at the root of the evolutionary design process which led to the shortest of the tractor cab and wheelbase dimensions in the past.

Moreover, the issue of vehicle length constitutes a major portion of modern size and weight controversies. In this study, test and simulation efforts have addressed a broad range of vehicle types which have traditionally been involved in controversies over vehicle length. Since the length issues are most often prompted by the concerns of the trucking community for the carriage of low-density freight, the study of length implications in this project has embraced the unusual "high-cube" combinations such as the so-called "Rocky Mountain Doubles," "Turnpike Doubles," and Triples.

The array of vehicles studied with regard to the influence of length parameters on stability and control performance are shown in Figure 5. The cases shown include various vehicle types which are currently found in one form or another in various jurisdictions around the U.S. Please note that vehicle configuration G includes, in one variation, a "quadruples" combination which is not known to have been operated anywhere in North America, but which is included for study here for the sake of comprehensiveness.

Each nominal configuration is examined for various values of length of the cargo-carrying elements, and, in the cases of vehicles A, B, and C, for various values of the wheelbase of the power unit. For the longer, multiple-trailer combinations, tractor wheelbase is not considered as a variable since analysis has shown [8,10] that tractor wheelbase is of little importance to the dynamic properties which are of primary interest with these vehicle types.

2.1.4 Types of Multiple-Trailer Combinations. One very general size and weight issue simply concerns the nominal types of multiple-trailer configurations which are allowed within a given jurisdiction. In this study, a number of basic configurations were identified, and their nominal stability and control characteristics were evaluated. Shown in Figure 6 are the

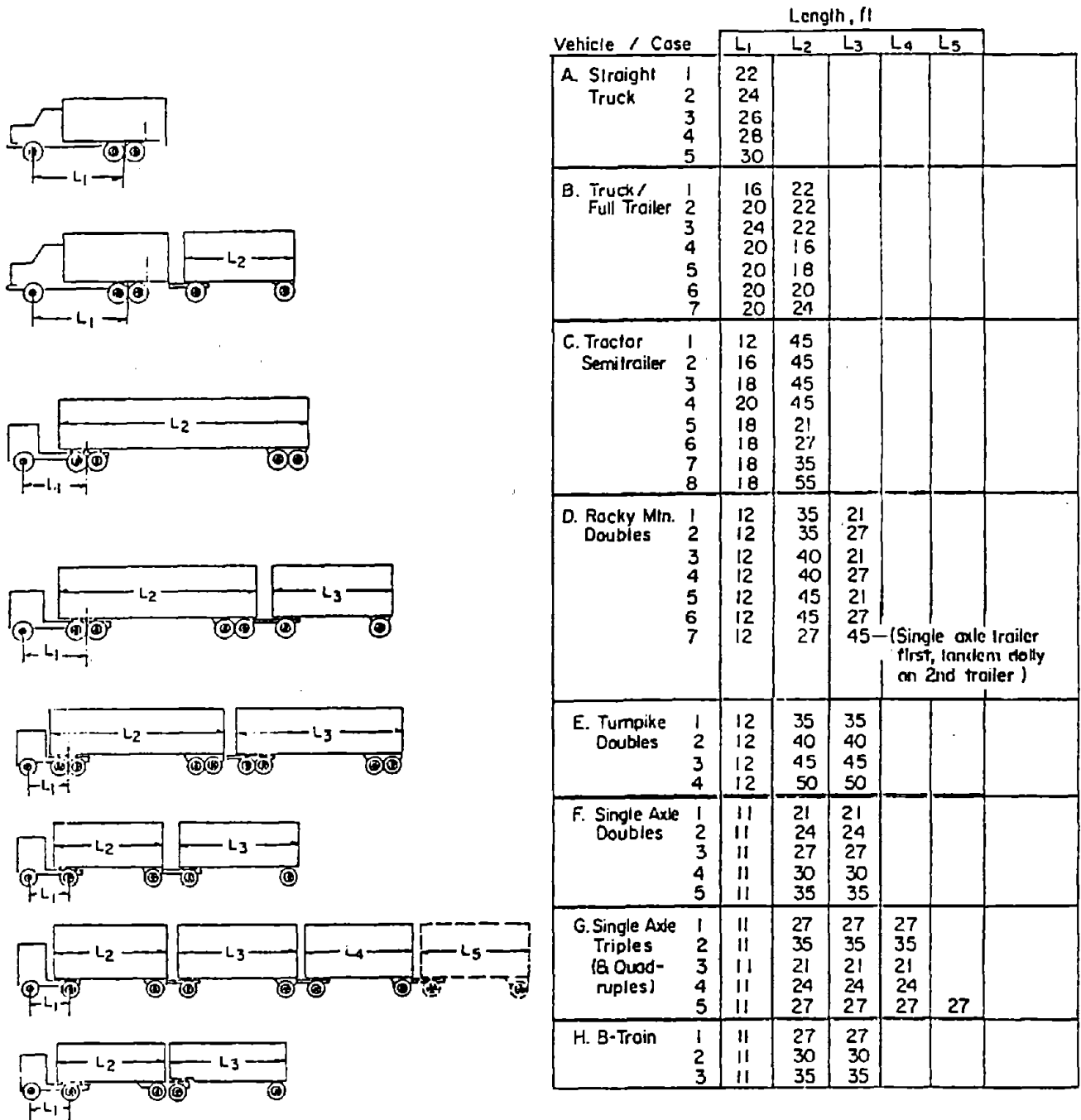
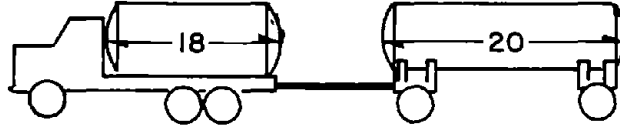
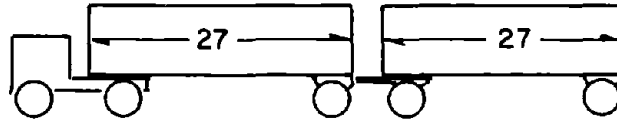


Figure 5. Length Variations

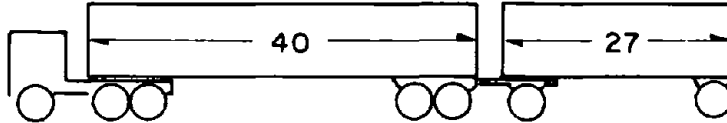
A. Truck Full Trailer on 5 axles



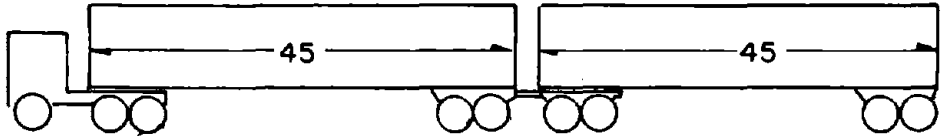
B. 5 Axle Double



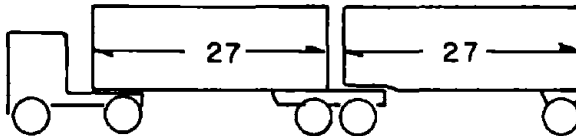
C. Rocky Mountain Double



D. Turnpike Double



E. B-Train



F. Triple

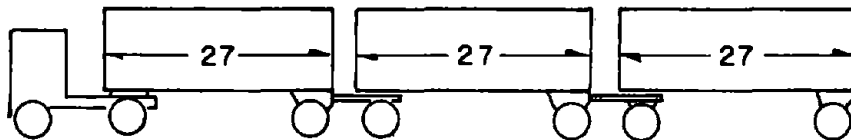


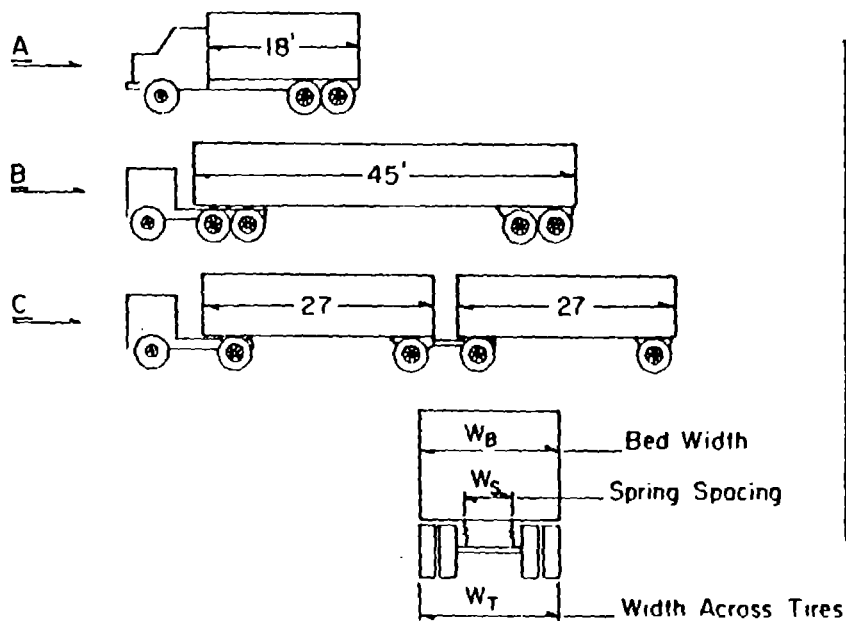
Figure 6. Types of Multiple Trailer Combinations

vehicle types to be addressed. Note that the first vehicle only incorporates one trailer, but does employ two articulation points (thereby constituting a "full" trailer rather than a semitrailer). Although the next four vehicle combinations could be simply classed as "doubles," each is distinguished either by the peculiar values of trailer lengths in which they are commonly found or by the numbers of axles employed. Also, the "B-train" configuration shown as item E differs generically from the others insofar as both trailers are hitched as semitrailers, with no independent dolly element.

The inclusion of "type of multiple-trailer combinations" as a separate issue in the study is done primarily for the convenience of the user of this document who may have only this subject on his mind. Clearly, the reporting of results for each of the vehicle types in Figure 6 simply draws from the extensive data developed previously in behalf of the vehicle length issue. Thus, the "types of combinations" issue is included simply for the sake of comparing the dynamic behavior of the different types, as if the type, itself, was the subject of controversy (which has occasionally been the case in the past).

2.1.5 Width of Vehicles. For many years, the national convention for the maximum width of road vehicles in the U.S. was 96 inches. Certain states have allowed greater widths, but very few trucks were ever constructed to widths greater than 96 inches (244 cm). Federal legislation enacted in 1983 has preempted the state limitations on width with a general allowance of 102-inch (259-cm) width for vehicles on roads having lane widths of 12 ft (3.7 m) or more.

In this study, the subject of width variations has been covered using the vehicle arrangements shown in Figure 7. The figure identifies vehicle configurations embodying various schemes by which a greater width allowance might be implemented. For an "ideal" scenario, the study considered vehicles which might be constructed using axles, tires, spring placement, and load bed which were all dimensioned to make full use of, say, a 102-inch (259-cm) allowance. Such an arrangement is termed "ideal" insofar as it offers the greatest improvements in dynamic performance—particularly roll stability. Other possible implementations of a 102-inch (259-cm) allowance include the mere widening of the load bed without widening the tire track or spring spacing.



Cases	W_B	W_S	W_T	Gross Wgt Veh. B & C	Gross Wgt Vehicle A	Tractor Width
1* (Baseline)	96	38	96	80k	46 k	96
2*	102	38	96	80k	46 k	96
3	102	38	96	88k	50k	96
4*	102	38	102	80k	46k	96
5*	102	44	102	80k	46k	96
6*	102	44	102	80k	46k	102
7	102	44	102	88k	50k	96
8	102	44	102	88k	50k	102
9	99	41	99	80k	46k	96
10	105	47	105	80k	46k	102
11	108	50	108	80k	46k	102

*These cases of the tractor semitrailer were also examined for the condition involving low-density, cube full loads.

Figure 7. Vehicle Width Variation

As an additional variant on the width question, the study has considered combination vehicles in which the trailer is at a 102-inch (259-cm) width, while the tractor is only 96 inches (244 cm) wide. This configuration is of interest since there appears to be very little commercial incentive for widening tractors following a liberalized width allowance, given that such widening may imply a rather costly vehicle redesign process.

2.1.6 Constraints in Axle Placement Imposed by a Bridge Formula. Many states and the federal government currently constrain truck axle placement and loading by means of a so-called "bridge formula." Such formulas represent the civil engineer's accounting of the bridge stresses deriving from the multi-point loading of bridge beams by the axles of a truck combination. In general, bridge formulas promote the greatest possible spreading of the axles on vehicles. For example, the gross weight, W (lbs), which can be carried on the Interstate Highway System is limited by the following formula:

$$W = 500\left(\frac{LN}{N-1} + 12N + 36\right)$$

where

L is the distance in feet between the extremes of any group of two or more consecutive axles

N is the number of axles under consideration

Clearly, the load allowance goes up as the distance between axles gets larger and as the total number of axles increases. Although there are a number of subtle interactions between the layout of a set of axles and the bridge formula allowance, it can be stated fairly simply that the bridge formula promotes longer wheelbase tractors and trailers. At the same time, the current federal bridge formula constitutes a redundant load limit with single and tandem load limitations and with arbitrary gross vehicle weight limits. Moreover, the bridge formula is seen as serving, primarily, to influence the placement of axles on vehicles meant to carry high levels of gross weight. In fact, some propose that the bridge formula be used as the only criterion for limiting gross weight, thereby abandoning any arbitrary gross weight limits. In regard for this proposition, the gross weights which

would be allowed for various combinations under a bridge-formula-only gross weight limitation are determined here and the significance of such a constraint scheme discussed.

2.2 A Means for Evaluating the Influence of Size and Weight Constraints on the Stability and Control Properties of Trucks

Given that the above issues describe the variations in vehicle loading and configuration which are of interest here, the study is designed to provide a methodical sorting out of the relationship between changes in these vehicle descriptions and the resulting stability and control characteristics. Clearly, the interest in stability and control characteristics stems from the conviction that they are somehow related to safety performance. This premise is defended by the rationale that the driver's ability to control the vehicle—to make it go in the direction he chooses at the speed he chooses—is ultimately limited by the physics which determine the response of the vehicle to steering and braking inputs. Accordingly, the authors hypothesize that limitations in the dynamic maneuvering capabilities of heavy trucks serve to limit (1) the viable options which are open to the truck driver in braking or steering to avoid the traffic conflicts produced by other vehicles and (2) the tolerance which is available to compensate for any inattentiveness or indiscretion on the part of the truck driver, himself.

In certain cases, the accident record has been shown to correlate very closely with certain of the stability and control characteristics of heavy trucks. The most dramatic of such correlations has been made between the rollover involvement of tractor-semitrailers and the nominal level of roll stability possessed by accident-involved vehicles [15]. In this case, the involvement of tractor-semitrailers in rollovers has been seen to increase by ten-fold due to the change in inherent roll stability which follows from the loading extremes—empty to fully loaded. Because this relationship is rather well defined, this study has made a particular point of illustrating the influence of size and weight factors on the roll stability levels of vehicles.

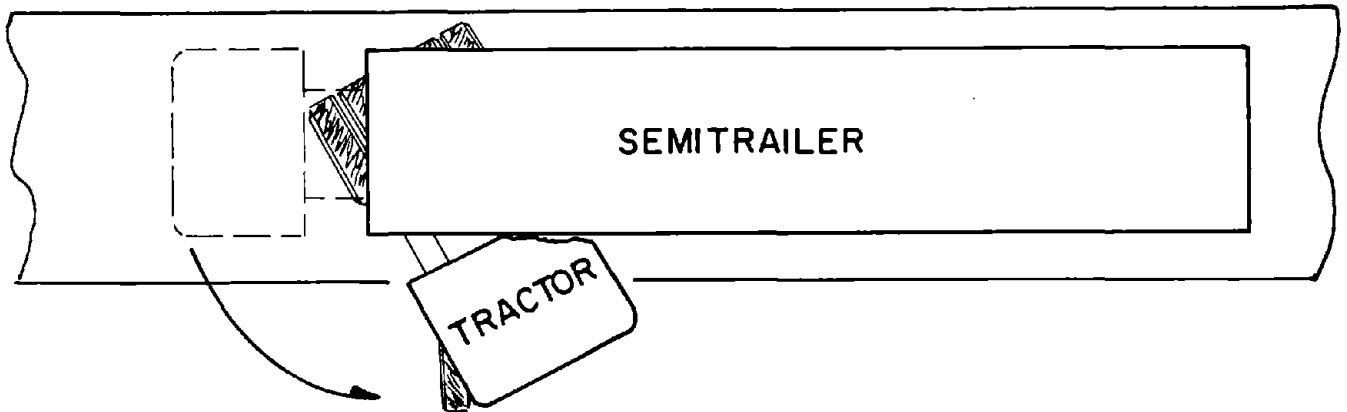
Another case in point concerns a dynamic response characteristic which is known to be particularly manifested by the multiply-articulated truck combinations—truck/full trailers, doubles, and triples. This phenomenon will be defined later as the "rearward amplification" characteristic by which a snaking action is set up in multiple-element trains during rapid steering maneuvers such as may be undertaken to suddenly avoid an obstacle. This phenomenon is such that the rearmost trailer element experiences an amplified tendency to be rolled over in the maneuver. The accident record is known to contain various examples of multiple-trailer configurations which have suffered an extraordinarily high incidence of accidents in which only their rearmost trailer has overturned [2,3,4]. Thus, in the examination of the various types of multiple-trailer combinations and the sensitivity of these combinations to loading and length variations, the "rearward amplification" characteristic has been quantified as a key indicator of stability and control behavior.

Other indicators of dynamic performance will also be defined. With each indicator, there is an underlying hypothesis that the indicator can be interpreted on a scale of more/less safety quality. In the two cases just cited, we know that (a) when the value of the measure increases the vehicle's safety quality is declining, and (b) some basis exists for assigning a nominal scale of importance to the measure which is obtained. In other words, in these cases, the hypothesis has been proven to a substantial degree. Other measures will be used, however, for which the connection between the performance indicator and the accident record has not been effectively demonstrated—mostly because of insufficient detail in the coding of accident data. The use of such indicators is rationalized, here, only on the strength of a preponderance of professional opinion which holds these to be important measures of safety quality—fully recognizing that some will argue that no measure is acceptable until its connection with accident involvement is clearly demonstrated. Nevertheless, the purpose of this research is to give the policy-maker the benefit of the best evaluations available within the current state of the art. Accordingly, the results constitute a blend of measures having a demonstrated relationship to safety, together with those measures which are simply held as persuasive to the safety research professional.

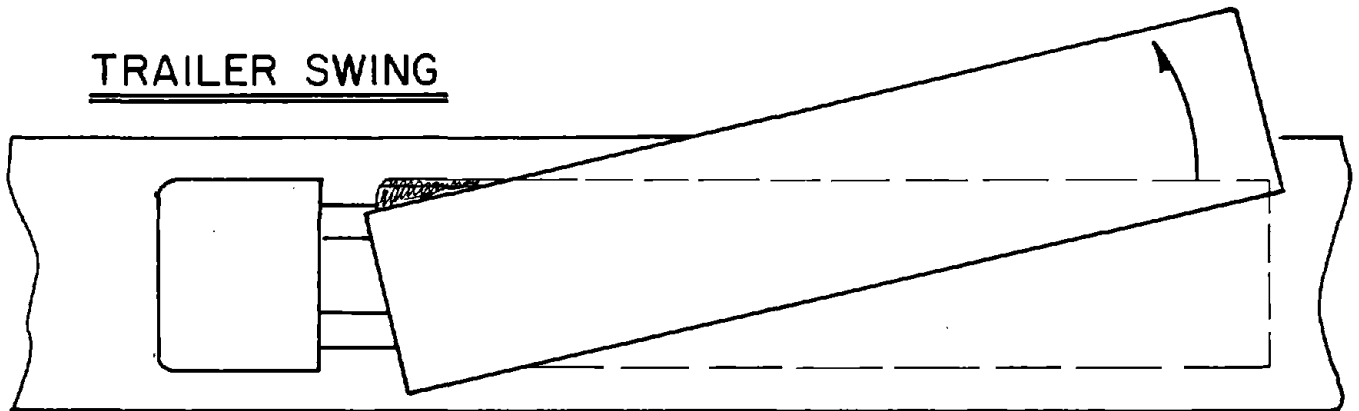
2.2.1 Maneuvering Scenarios Employed in Simulation and Vehicle Tests. The stability and controllability of vehicles, under the influence of variations in size and weight variables, was assessed by extracting measures of performance from the response of vehicles in simulated or tested maneuvers. That is, the vehicles were subjected to prescribed conditions of speed and control input and then the response to those conditions was quantified by means of the "measures," such as discussed earlier. In each case, the maneuvering condition was sufficiently standardized that differences in the behavior of vehicles in various size and weight configurations could be attributed to the size and weight variables themselves. Five basic types of maneuvers were employed in the study. These maneuvers are listed below, with the variations in method needed to determine the differing response properties of interest. The measures of performance will be introduced here, and then defined more completely in the next section.

2.2.2.1 Straight-line braking. This classic maneuver involves braking from a defined initial speed, with braking input held constant throughout the stop. In successive stops, the braking input level is increased until a "controllability limit" is reached. This limit is defined as the condition in which lockup is achieved at all wheels on any single or tandem axle set. The limitation in controllability which follows from this condition derives from the fact that the pneumatic tire is unable to produce the lateral forces needed for directional control when the tire has ceased to rotate. When this condition has occurred on all wheels of a single or tandem axle set, the vehicle is either (a) unsteerable, if front wheels are locked, or (b) is unstable to the point of producing a divergent yaw motion in either the power unit or trailer, such as shown in Figure 8, if the wheels on a non-steering axle set are locked. If the wheels on a dolly axle lock up, the dolly becomes unstable in yaw and rotates about its pintle hook causing the rear trailer to strike the lead unit. If the wheels on the tractor's rear axle are locked, the tractor becomes unstable in yaw, producing the so-called "jackknife" divergency by which the tractor cab swings around the fifth wheel center and eventually strikes the side of the trailer. If the wheels on a semitrailer are locked, a rather sluggish

TRACTOR JACKKNIFE



TRAILER SWING



DOLLY JACKKNIFE

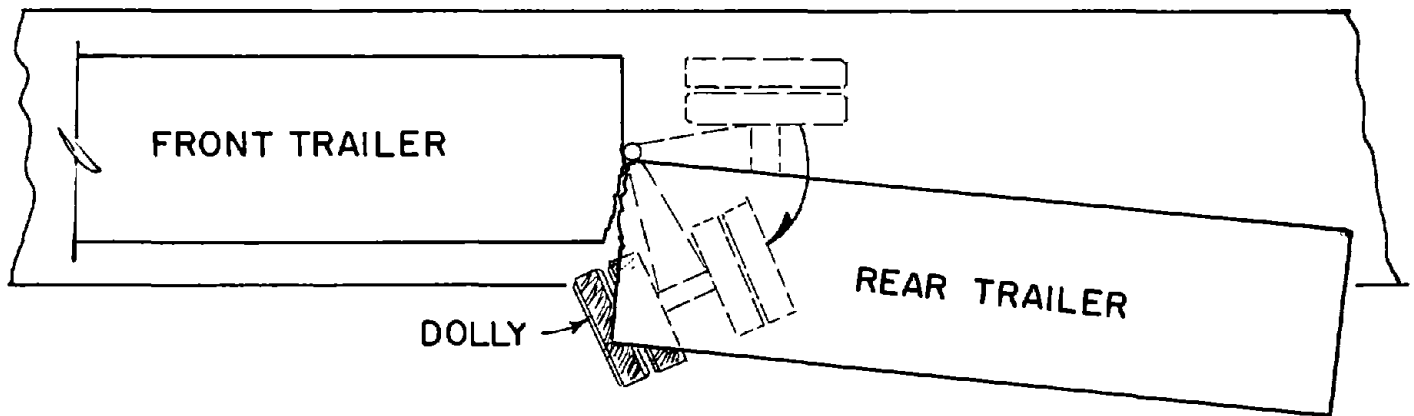


Figure 8. Three Types of Braking Instability Occuring with Articulated Vehicles

instability, termed "trailer swing," occurs—with the semitrailer rotating about the fifth wheel connection.

In this study, the straight-line braking maneuver was employed only for the sake of characterizing limit stopping distance, where the occurrence of "axle lockup," as discussed above, was taken to define the limit condition. Maneuvers of this type were conducted in both the full-scale test activities and using computerized simulation. The straight-line braking of vehicles was examined for cases involving variations in axle load, gross weight, height of payload center of gravity, and length of vehicle elements.

2.2.1.2 Braking in a turn. When a vehicle is in a fairly normal, steady turn condition and then is subjected to a severe braking input, the ensuing loss of control accompanying wheel lockup conditions, such as summarized above, occurs very rapidly. One can employ the braking-in-a-turn test for characterizing either stopping capability or the directional control implications of the "axle lockup" conditions. In this study, full-scale testing showed that stopping distances achieved in a mild severity turn were indistinguishable from those achieved during braking in a straight line. Accordingly, this type of maneuver was employed in computer simulations only as a means of describing the influence of tractor wheelbase on the rapidity of the jackknife response resulting from lockup of the tractor's drive wheels.

2.2.1.3 Abrupt (J-turn) steering. An abruptly-applied steer input, such as a driver may execute upon electing, at the last moment, to follow a freeway exit ramp, produces both an initial transient motion and, subsequently, a quasi-steady turn, as shown in Figure 9. Various control issues are raised by the vehicle's response to such steer inputs. Regarding the transient phase of the maneuver, it is well recognized that controllability degrades when the vehicle's response begins to lag excessively, in time, behind the driver's control input.

When the more-or-less steady response is achieved, the classic response item of interest concerns a rather subtle property which the dynamist calls "understeer." This property describes the relationship between

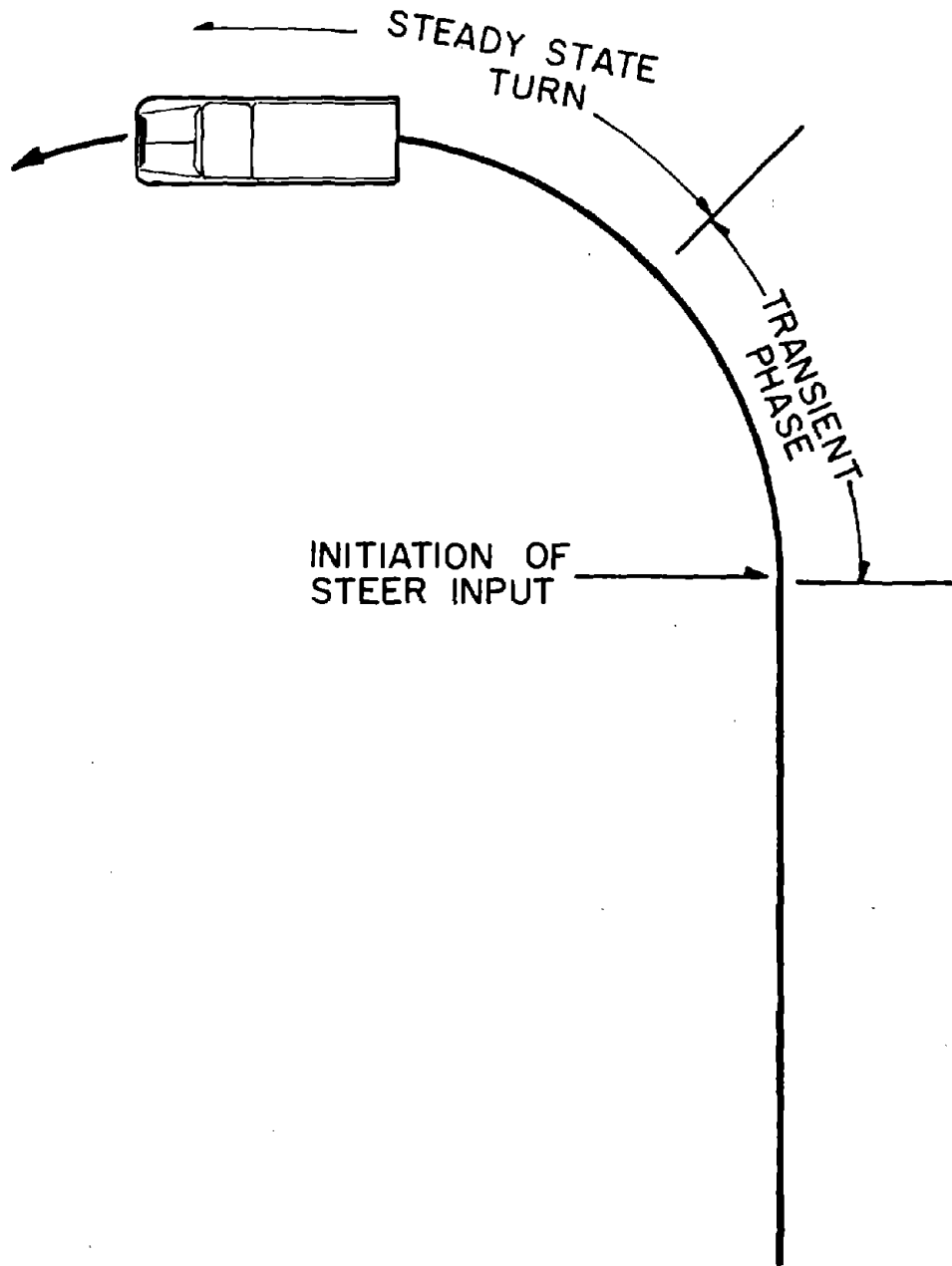


Figure 9. Layout of J-Turn Maneuver

the amount of steering that the driver applies, and the tightness of the turn which is produced. For example, let us consider a fixed-ratio path which can be negotiated at near-zero speed by means of a certain input angle at the steering wheel. If an increasing steering-wheel angle must be applied to negotiate the same curve when speed is increased, the vehicle is said to exhibit an understeer behavior. The magnitude of the additional steer input needed per unit of increasing lateral acceleration describes the "understeer gradient" (expressed herein in units of degrees of steer input at the front wheels per g of lateral acceleration). When a vehicle requires a decreasing steer input to track a fixed-radius path at increasing speed, it is said to exhibit an oversteer behavior. The oversteer characteristic is apparent in data presented in this report whenever the "understeer gradient" exhibited by a vehicle takes on a negative value.

While a great body of literature has been developed on the understeer subject (e.g., [5,6,7]), it suffices to say here that small or negative values of the understeer gradient become of concern insofar as a very small steering input suffices to produce a very tight turn. In an extreme case, the vehicle may become unstable in yaw such that a moderately-rapid jack-knife type of motion is produced in response to an infinitesimally small increase in steer input.

To permit characterization of the understeer property, test maneuvers were conducted using a rather rapid application of steering up to a preset steering input which was mechanically limited. In successive test runs, the steer level was incremented upwards until the rollover condition was achieved. For the very large matrix of vehicle conditions examined using computer simulation, the understeer property was examined by means of a steer input which was slowly increased from zero up to the rollover level. Thus the computerized maneuvers were implemented by means of an efficient "sweep" through the range of turning responses.

2.2.1.4 Steady turning. In addition to the above turning condition in which a quasi-steady-state turn is sought for examining the understeer characteristic, three other measures are obtained from a strictly steady-turn maneuver. Each of these will be discussed in turn.

- a) The so-called "static roll stability" measure describes the maximum severity turn which the vehicle will tolerate without suffering rollover. While test measurements of this property were obtained by observing roll behavior in the "quasi-steady" portion of the J-turn maneuver described above, the simulation used for this type of analysis simply imposed a sweep of turn severity level until rollover occurred. The simulation model assumes, however, that the vehicle responds to each increment of turn severity as if the input condition were being steadily maintained. The static roll stability property was evaluated for cases involving variation in axle load, gross vehicle weight, height and lateral placement of the payload center of gravity, and vehicle width.
- b) The low-speed offtracking of vehicle combinations expresses the relative ease with which tight-radius turns are negotiated given that all trailing elements in a vehicle combination tend to track inboard in such turns. The involved maneuver simply establishes how far off of the path of the tractor's steering tires is the path subtended by the tires on the rearmost axle of the combination during travel around a 90-degree intersection turn. The specific turn condition which was employed assumes that a 35-ft (10.7-m) radius turn is subtended by the outer tire on the tractor's steering axle. The low-speed offtracking analysis was applied only in cases involving variations in vehicle length.
- c) The high-speed offtracking of vehicles involves the tendency of trailing units to "fling out" away from the center of a turn when the centripetal acceleration level is high. The actual distance outside of the path of the tractor tires at which trailer tires might be tracking is not large—on the order of 2 feet (.6 m). Nevertheless, the phenomenon is of interest because it suggests the possibility of trailer tires striking a curb while traversing, say, an exit ramp on an urban expressway (thus, perhaps, inciting a rollover of the

combination vehicle). A simplified analysis of high-speed offtracking behavior was employed during the study to show the influence of semitrailer length, and the configuration of multiple-trailer combinations, on this characteristic.

2.2.1.5 Emergency steering to avoid an obstacle. The conduct of a normal lane-change maneuver requires, first, a counterclockwise and then a clockwise rotation of the steering wheel, as shown in Figure 10a. This steering sequence accounts for the initial redirection of the vehicle so that it becomes pointed toward the target lane and later provides for the recovery of the initial heading as the target lane is achieved. When a steering input of this type is conducted very rapidly, such as shown in Figure 10b—attempting to avoid striking an obstacle—the left-then-right sequence tends to set up a "crack-the-whip" motion in vehicle combinations having multiple articulation points. This type of motion response is of safety interest, as suggested earlier, because of the increased likelihood that the rearmost trailer in such combination vehicles will experience a rollover. Since this phenomenon is of practical significance only in the case of multiply-articulated vehicles, the "obstacle-avoidance" maneuvering scenario has only been applied to vehicles of this type.

In full-scale tests, one set of obstacle-avoidance maneuvers was conducted using a pre-established course through which a test driver guided the vehicle. The course provided an "obstacle" which was 12 feet (3.55 m) wide. The test speed and length dimensions of the course were such that the left-then-right steering sequence took place within a nominal period of approximately 4 seconds. Another set of maneuvers of this basic type were conducted using a mechanical steering limiter device which aided the driver in applying balanced left- and right-going steer inputs within a nominal 2-second period. The amplitude of the steer input was sequenced from run to run in order to seek out the condition which first produced rollover of the rearmost trailer in the vehicle combination.

Simulations covering a broad array of vehicle configurations were conducted using a simplified analysis program which solved for the extent of the magnified response which is experienced by the rearmost trailer. The measure of performance, termed "rearward amplification," describes how much more severe is the rollover impetus experienced at the last trailer than at the tractor.

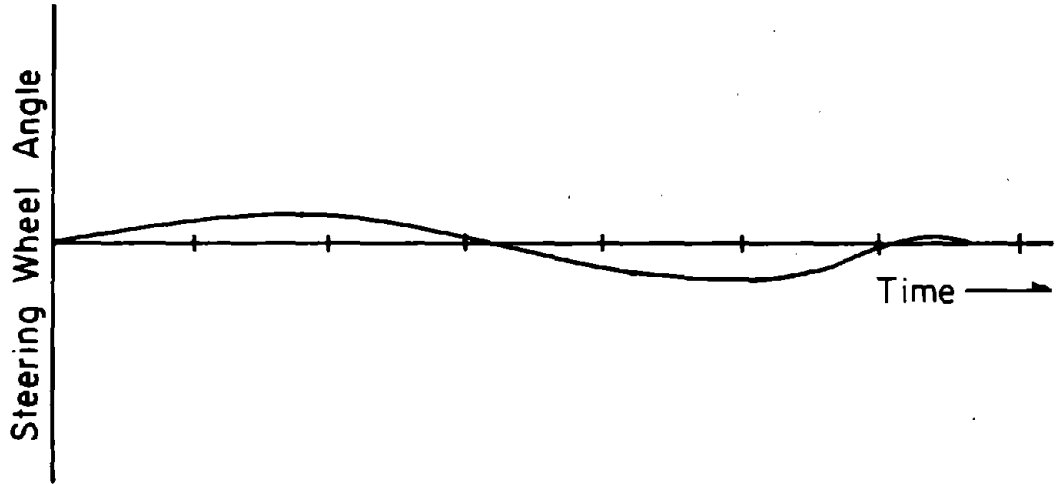


Figure 10a. Normal Lane Change Maneuver

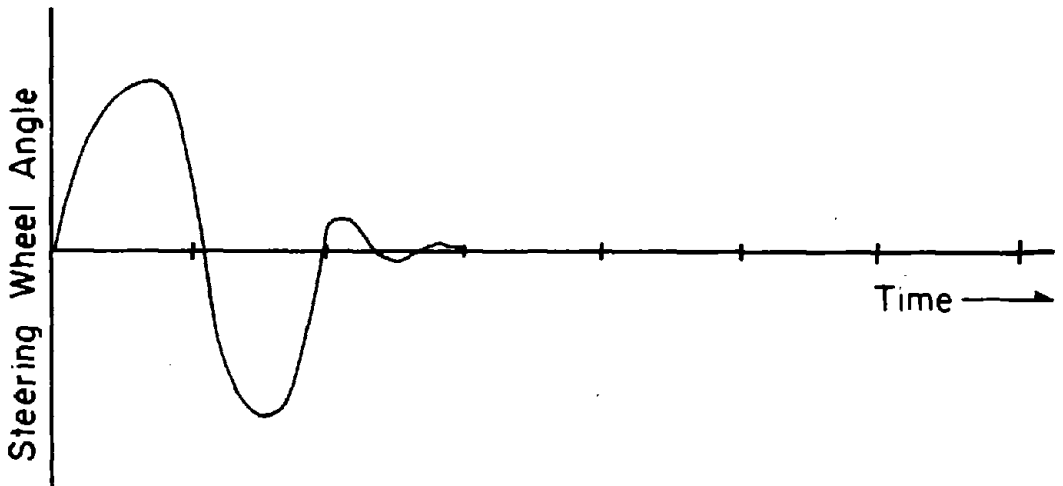


Figure 10b. Emergency Obstacle Avoidance Maneuver

2.2.2 Measures of Performance. In this section, the measures of performance used to evaluate vehicle response in each of the various maneuver types will be described. In general, the response of the vehicle in time is first expressed in terms of time histories of the pertinent variables defining the instantaneous speed, position on the road, roll angle, lateral acceleration, etc. This unwieldy format is then reduced into, perhaps, a plot of one response variable versus another. Finally, a scheme is devised for assigning a single numerical value as an aggregate measure of the overall response. This measure can then be used in a direct display of the influence of some parameter, such as length or gross weight for example, on vehicle stability and control. In the discussion which follows, the measures used to evaluate size and weight influences in this study will be explicitly defined. In most cases, these measures have been reduced to single-number kinds of characterizations such as just described. In a few cases, only a qualitative interpretation is made directly from data in the time history format.

2.2.2.1 Straight-line braking. Straight-line braking performance was measured in the field tests simply by means of the stopping distance covered from the instant of pedal application to the end of the stop. Simulated stopping performances reported in this document were conducted using an initial velocity value of 55 mph (88 km/h).

2.2.2.2 Braking in a turn. Although full-scale tests were run measuring stopping distances obtained while braking in a curved path, the braking-in-a-turn results reported here pertain only to the case of tractor jackknife response in a turn. The vehicle was put into a steady turn and then braked such that all wheels on the drive axles of the tractor were locked. The purpose of the maneuver was to evaluate the rapidity with which the jackknife motions ensued, for tractors of differing wheelbase.

Shown in Figure 11 is a typical yaw rate response of the tractor in this maneuver. The yaw rate variable indicates the rate at which the vehicle is rotating about its vertical axis. Note that the yaw rate signal rises to the initial steady-turn value and then diverges upward after the brakes are applied. The performance of the vehicle is evaluated in this maneuver by two measures—one which is derived from the yaw rate signal and

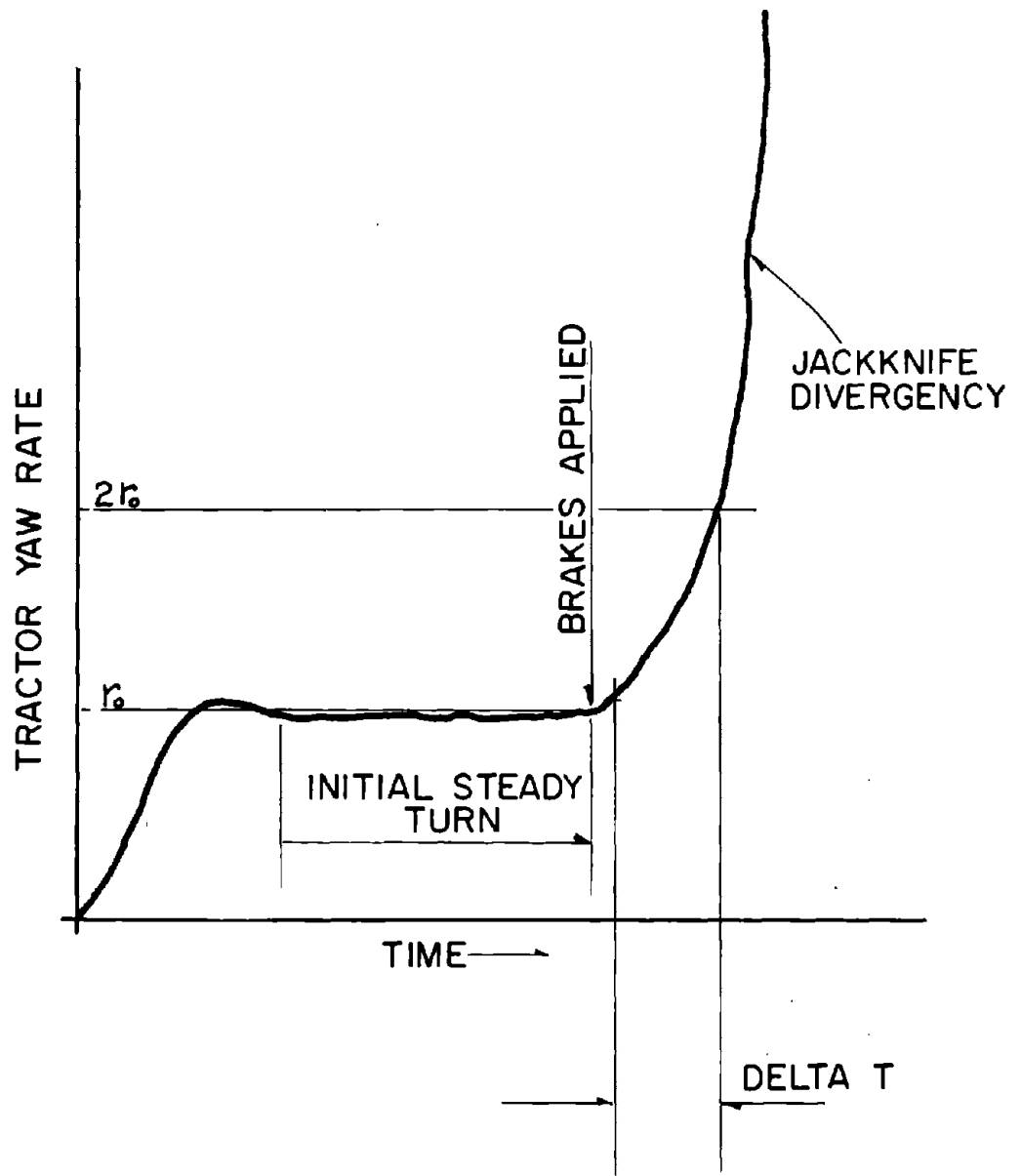


Figure II. Tractor Yaw Response Defining The Jackknife Divergence Measure, Delta T

one which is derived from the articulation angle signal. The first measure, DELTA-T, describes the time which elapses while the yaw rate diverges from an initial threshold of 1.05 times the initial steady-turn value to 2.0 times that value, as shown in Figure 11. This measure was selected to provide some insight into the differences in time response demanded of the driver if he is to take corrective action to prevent a jackknife.

The second measure, AR(2-3), describes the average rate of yaw rotation of the tractor prevailing over the interval in which the articulation angle went from twice to three times its initial steady-turn value, as diagrammed in Figure 12. (Note that the articulation angle in question is the included angle between the centerline of the tractor and the centerline of the semitrailer.) In other words, the measure describes how rapidly the articulation angle is changing, a short time after the jackknifing instability has begun. Clearly, larger values of this measure imply that the driver must act, not only more quickly, but also with greater corrective control action, if he is to avoid a complete jackknife result, with the tractor cab impacting the side of the trailer and the vehicle proceeding out of control.

The larger the value of either of the measures used to describe the onset of jackknifing, the poorer the vehicle's presumed safety quality.

2.2.2.3 Non-constant and quasi-constant radius turning. Shown in Figure 13 are example yaw rate time histories for the response of tractor-semitrailers to an abruptly-applied (and then held) steering input. In one set of vehicle response data to be shown later in the report, such time histories will be inspected directly as a means of showing that trailer length variations have very little influence on the response of tractors. In general, however, vehicle response in this type of maneuver will be characterized by one of two measures. The first of these is a measure of transient behavior and is illustrated in the tractor yaw rate signal shown in Figure 14. The figure illustrates a response time measure which is defined by the time needed to reach 90% of the steady-state value of yaw rate. This measure is of interest insofar as long values of response time generally imply that the driver must adopt a more anticipatory method of steering, since the vehicle takes longer to respond.

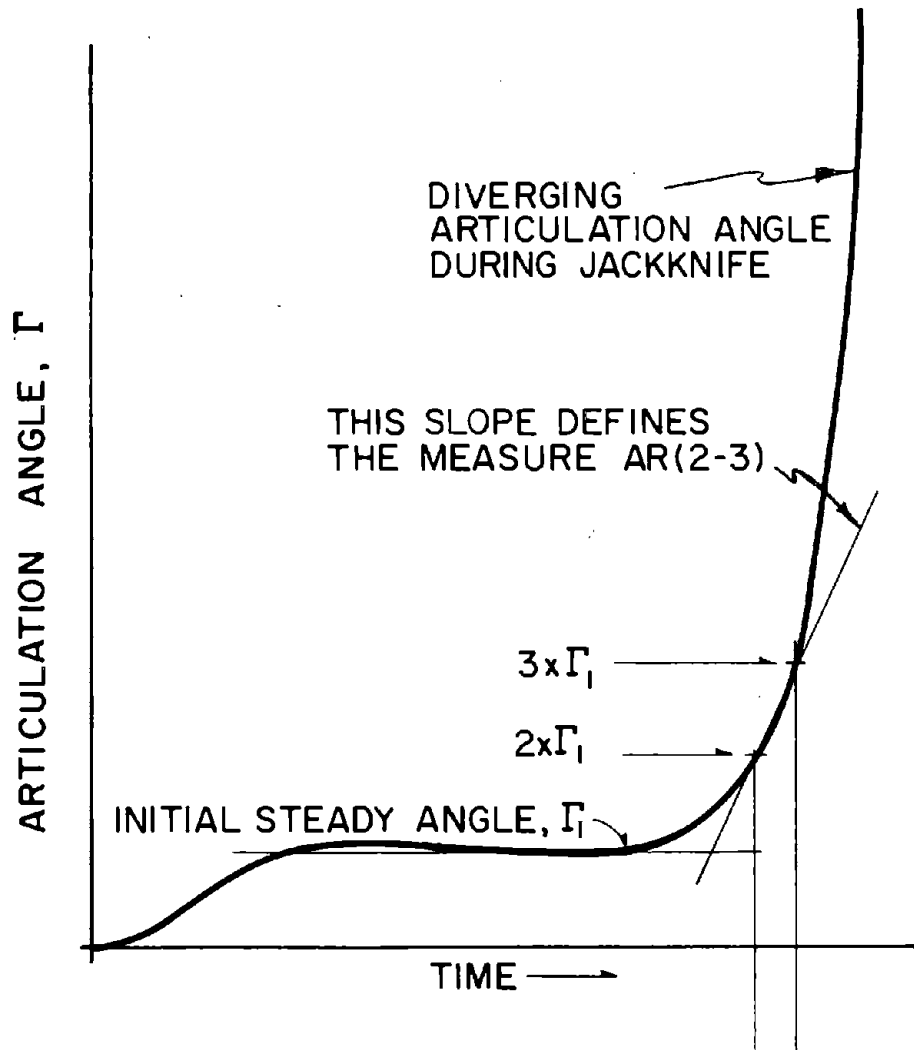


Figure 12. Articulation Angle Response Showing The Divergency Slope Measure, AR(2-3)

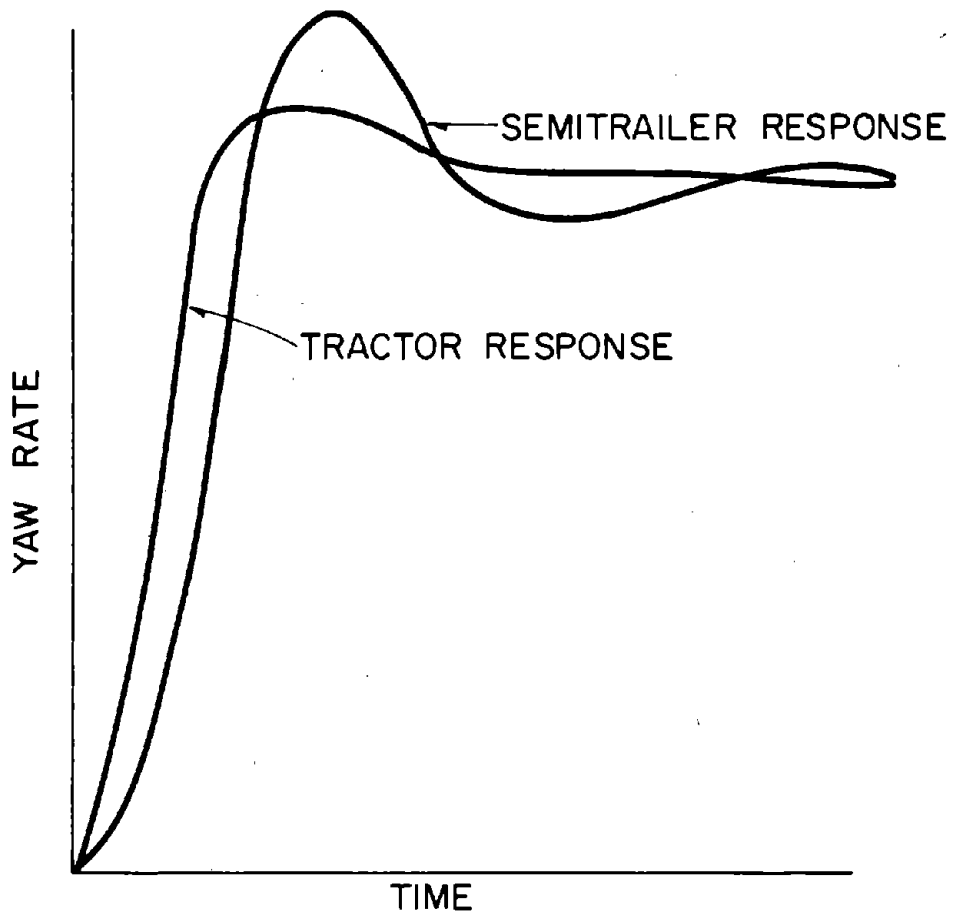


Figure 13. Example Yaw Rate Responses of Tractor and Semitrailer to an Abrupt Steer Input

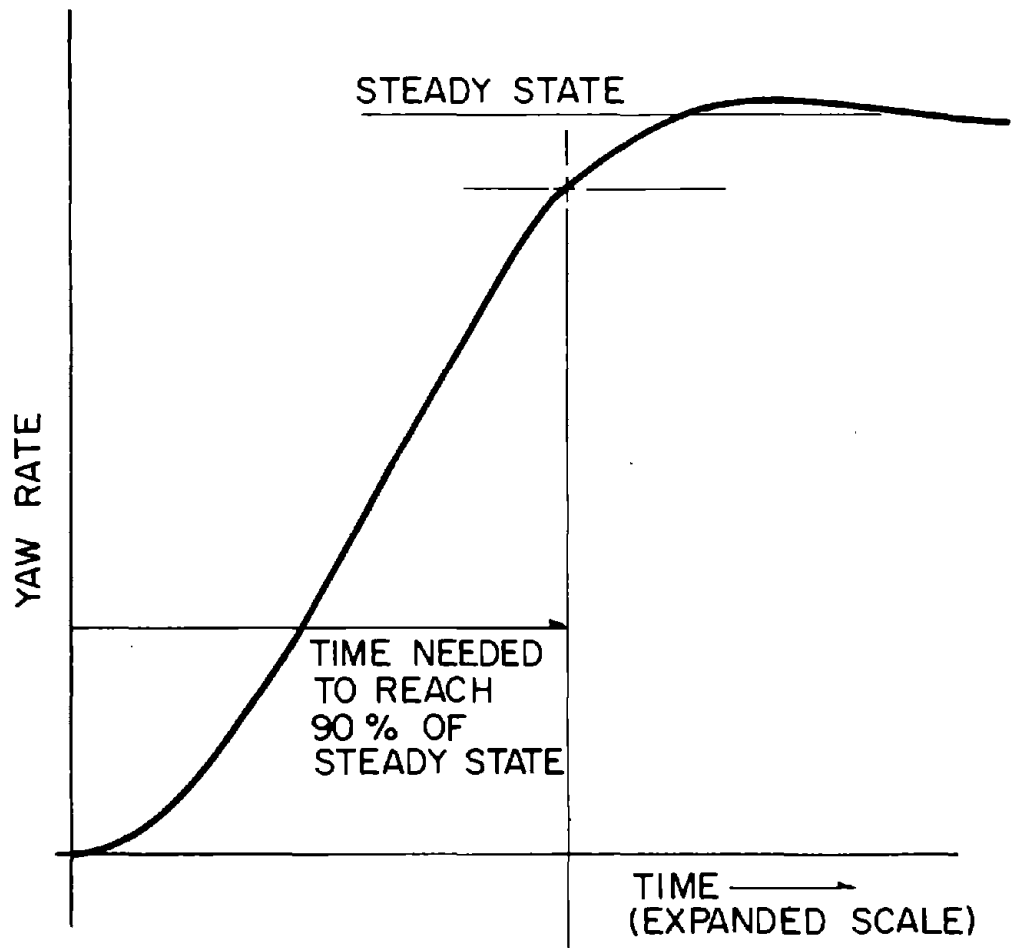


Figure 14. Definition of Response Time Measure

The second measure, and the one used most widely in this report to characterize the tendency toward yaw instability in response to steering, is shown in Figure 15. The figure shows a plot of the so-called "handling diagram" of a truck or tractor's yaw response. The plot is constructed using a set of response variables and vehicle parameters which have a certain special relationship to one another in the classical analysis of vehicle yaw behavior (see, e.g., [6,7]). Basically, the handling diagram shows how the steering gain changes with increasing levels of lateral, or centripetal, acceleration. If a vehicle exhibits a behavior which is curving upward and toward the right on the handling diagram as lateral acceleration increases, it could be said to illustrate an increasing steering gain with increasing severity of turn. In fact, the local slope at any point along the handling curve directly reveals the level of the so-called "understeer gradient" which was discussed in Section 2.2.1. For purposes of presenting results in a condensed form in this report, the value of understeer gradient prevailing at an arbitrary lateral acceleration level of 0.25 g's will be evaluated for each of the conditions involving size and weight variations. Note that the understeer gradient is defined as the negative inverse of the local slope of the handling diagram.

The concern which prompts the selection of such a measure is to identify vehicles for which the steering gain increases inordinately with increased turn severity. Such a behavior implies that the driver will be confronted with a highly sensitive, and possibly even unstable, response to steering during a severe cornering maneuver such as occurs upon entering an interchange ramp at excessive speed. A response characteristic of this type is shown at the right-hand curve of Figure 15. In fact, the slope of this curve in the vicinity of .25 g lateral acceleration is such that the understeer gradient has approached a value of -3.47 at which the vehicle operating at 55 mph (88 km/h) is directionally unstable. That is, when such a vehicle is being operated at this speed and turn severity, the vehicle will exhibit a continuously growing yaw motion in response to any steering perturbation. To successfully drive such a vehicle at this operating point, the driver must be continuously compensating for the inherent tendency to jackknife throughout the cornering maneuver.

It should be pointed out here that the person concerned only with the safety aspects of policy making on size and weight issues may have little

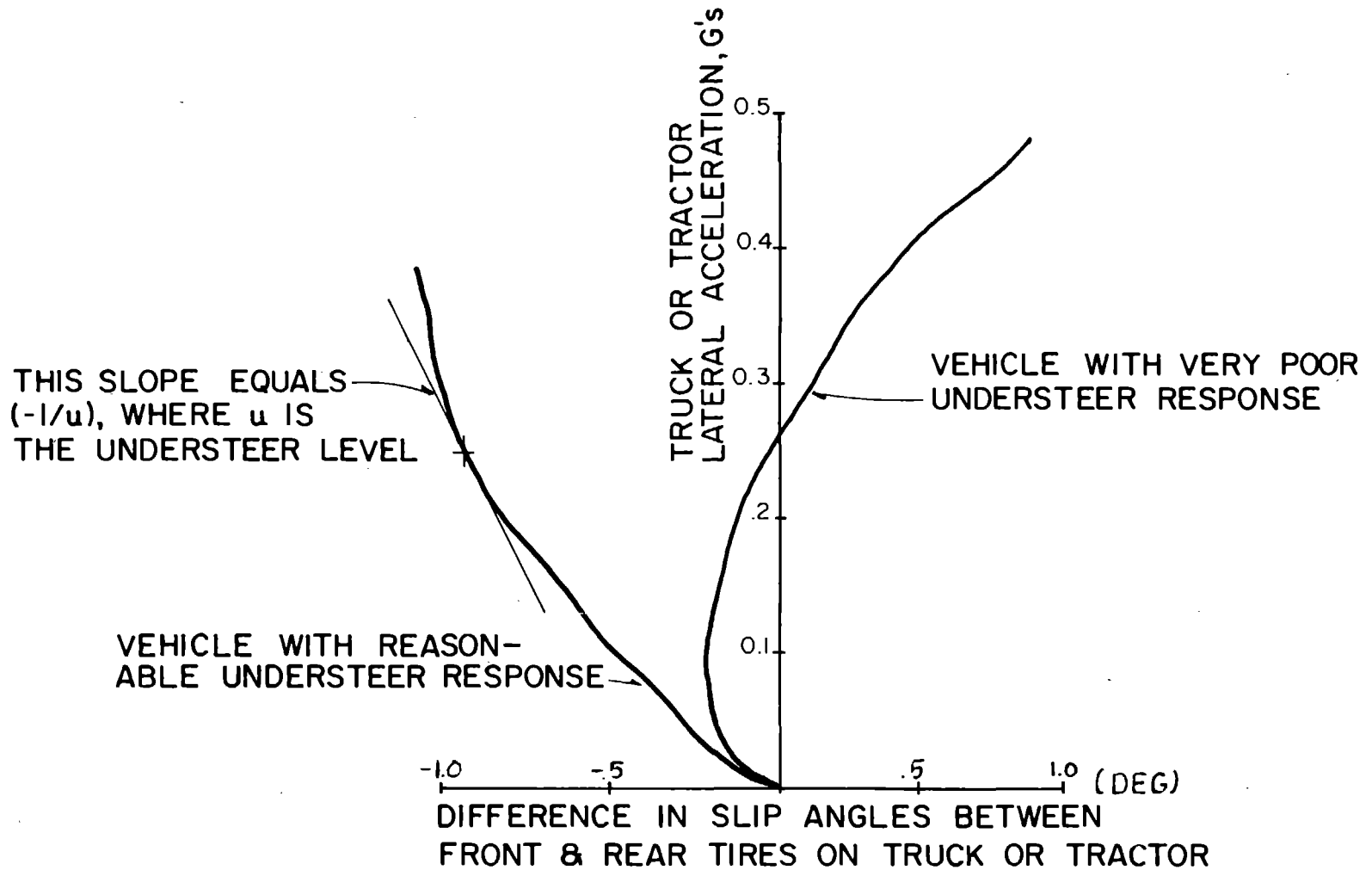


Figure 15. Handling Diagram Showing the Understeer Measure

or no interest in the details of the analysis of vehicle yaw response. Thus, to serve the needs of these readers, the rather complex matter of steering gain at higher turn severities has been reduced to a single measure, the understeer gradient appearing at 0.25 g's tractor lateral acceleration. Given the manner in which simulated steering inputs were applied to investigate these phenomena (that is, in a quasi-steady ramp fashion), the value of the understeer gradient likely to be found on a typical tractor-semitrailer is in the vicinity of +2.5 deg/g. When we find that a change in some size and weight variable produces a lower, and perhaps even negative, value of this measure, we can conclude that the steering control quality of the vehicle is degrading. As in all other measures used to present results here, however, the final evaluation of performance change rests upon a comparison between measures obtained in, say, a baseline case versus measures obtained with a size or weight change.

2.2.2.4 Constant-radius turning. Three measures of performance were derived from different maneuvering scenarios employing nominally-constant-radius turns.

The first of these measures quantifies the "static rollover threshold" of the vehicle. Shown in Figure 16 is an illustration of the lateral acceleration versus roll angle relationship for a tractor-semitrailer that is subjected to steady turning in progressively tighter turns. The figure shows that, as lateral acceleration increases, "wheel liftoff" occurs at one axle and then another until rollover occurs. That is, the typical case is that the wheels on the inside of the turn do not become unloaded simultaneously, but rather in a progressive sequence depending upon the suspension, tire, and vehicle structural stiffnesses involved. It follows, then, that wheel liftoff, per se, is an insufficient indicator of the imminent rollover condition.

Accordingly, a measure of the rollover resistance which a vehicle provides has been defined in terms of the peak value of lateral acceleration which the vehicle can tolerate without proceeding to a complete rollover—regardless of which wheels may have lifted off of the ground at the occasion of reaching this peak. Shown in Figure 17 is a plot of the lateral acceleration versus roll angle response for two tractor-semitrailers. The vehicle labeled "A" shows a peak lateral acceleration value of 0.325 g, and

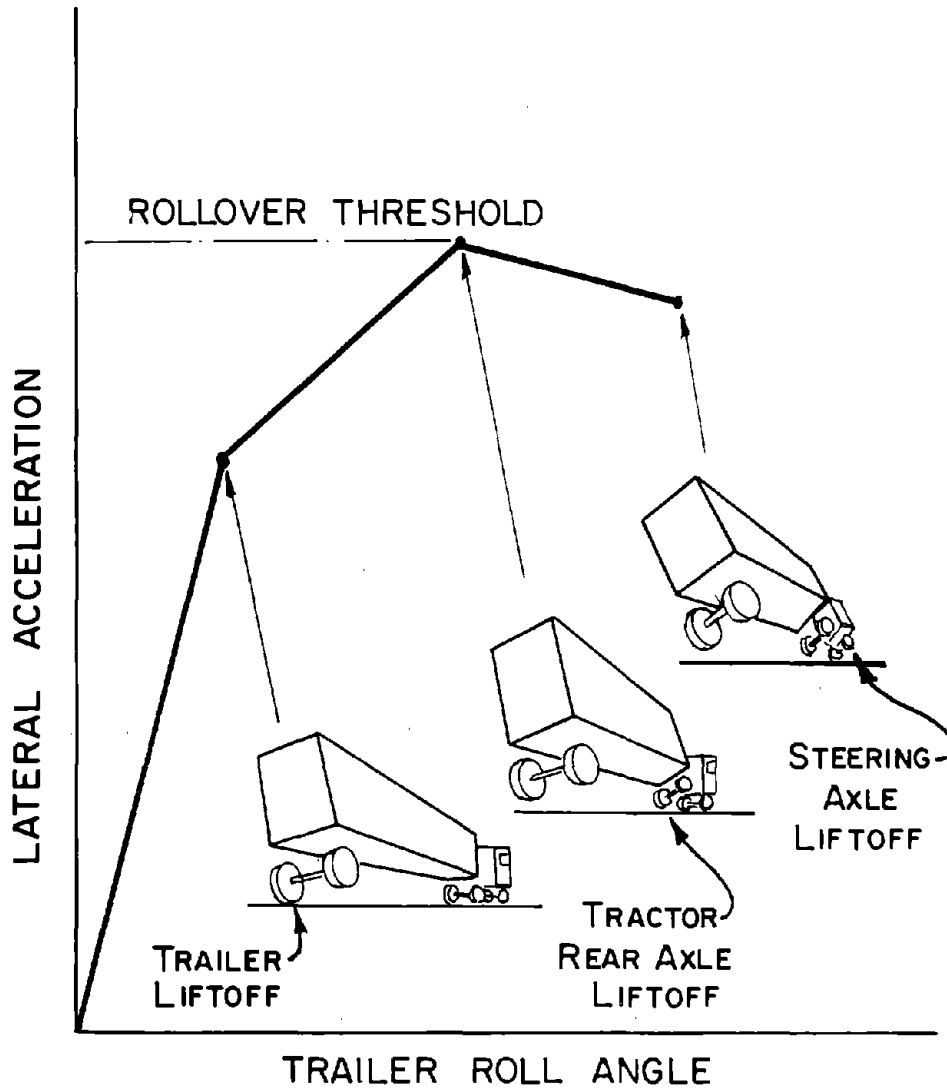


Figure 16. Typical Axle Liftoff Sequence on Figure Defining Rollover Threshold

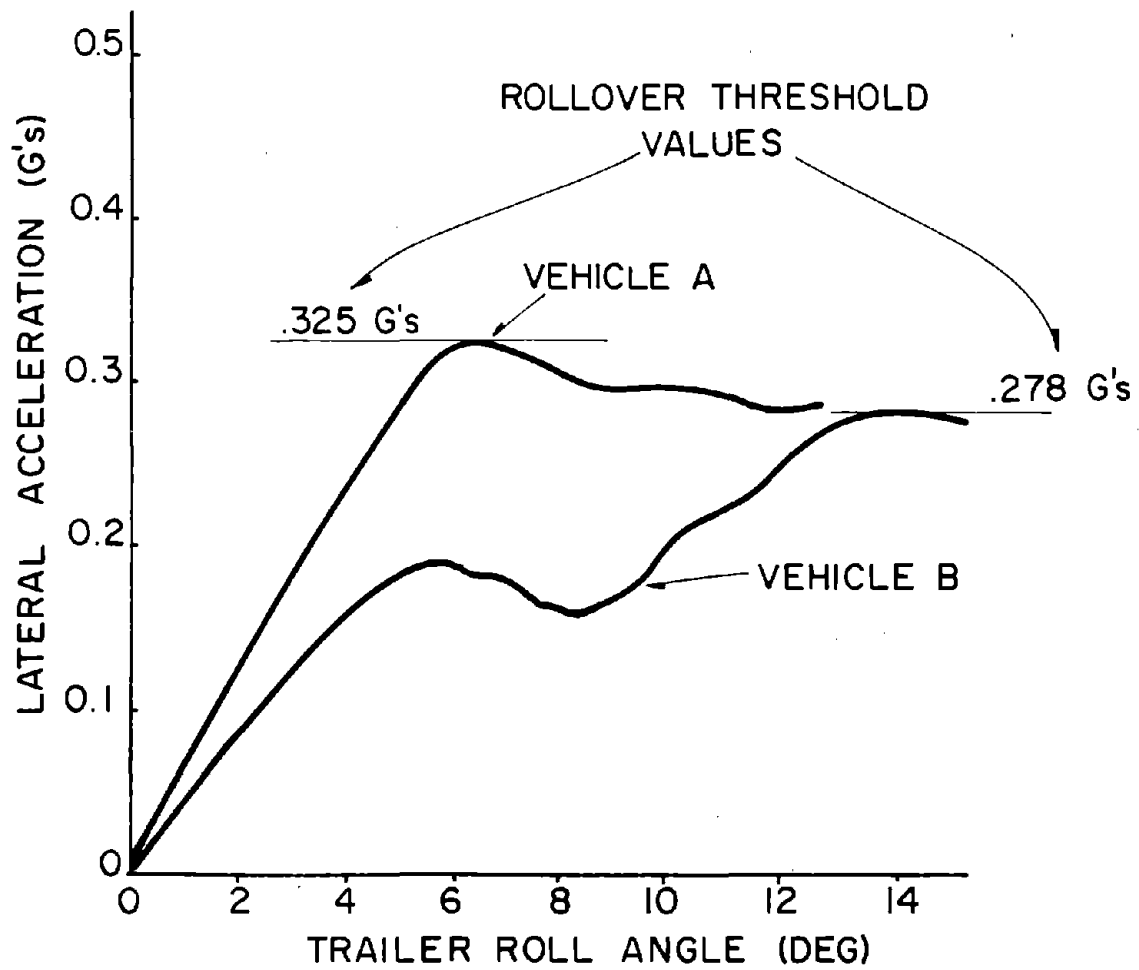


Figure 17. Illustration of Rollover Thresholds for Two Example Vehicles

the peak condition involves a rather low, 6-degree, value of trailer roll angle. The vehicle labeled "B" shows an intermediate peaking behavior in the vicinity of a 6-degree roll angle and then reaches an overall peak value of 0.278 g at around 14 degrees of trailer roll angle. The roll stability of both vehicles would be reported, here, simply in terms of the respective maximum values of lateral acceleration which define their "rollover thresholds."

The "low-speed offtracking" behavior of articulated vehicles was characterized according to the wheel paths exhibited during the travel of the vehicle around a 90-degree intersection corner. Shown in Figure 18 is an example set of inner- and outer-most wheel paths for a tractor-semitrailer combination negotiating the intersection. The figure defines the "maximum path width" which is used to report the low-speed offtracking results in this report.

"High-speed offtracking" was examined in this study only by means of a simplified analysis looking at the behavior of one trailer at a time. The accumulated offtracking attained on a multiple-unit combination was simply obtained by adding the contributions to offtracking introduced by the sum of the vehicle elements. The high-speed offtracking measure is simply the radial distance from the path inscribed by the outside tire on the tractor's steering axle to that of the outside, rearmost trailer tire, as shown in Figure 19.

2.2.2.5 Emergency steering to avoid an obstacle. Computerized simulations have been conducted to evaluate the so-called "rearward amplification" behavior of multiply-articulated combinations in various length and weight configurations. The key response variable upon which the rearward amplification measure is based is the lateral acceleration response. As shown in Figure 20, the left-then-right steering input produces a similar type of lateral acceleration response from each of the vehicle elements. The rearward amplification measure is obtained by comparing the lateral acceleration response of the tractor with that of the rearmost trailer. This measure defines the ratio of the peak value of lateral acceleration at the rear trailer to the peak value of lateral acceleration occurring at the tractor. By this ratio, we obtain a measure which describes the vehicle's ability to amplify, at the last trailer, the severity of the maneuver which was initiated at the tractor.

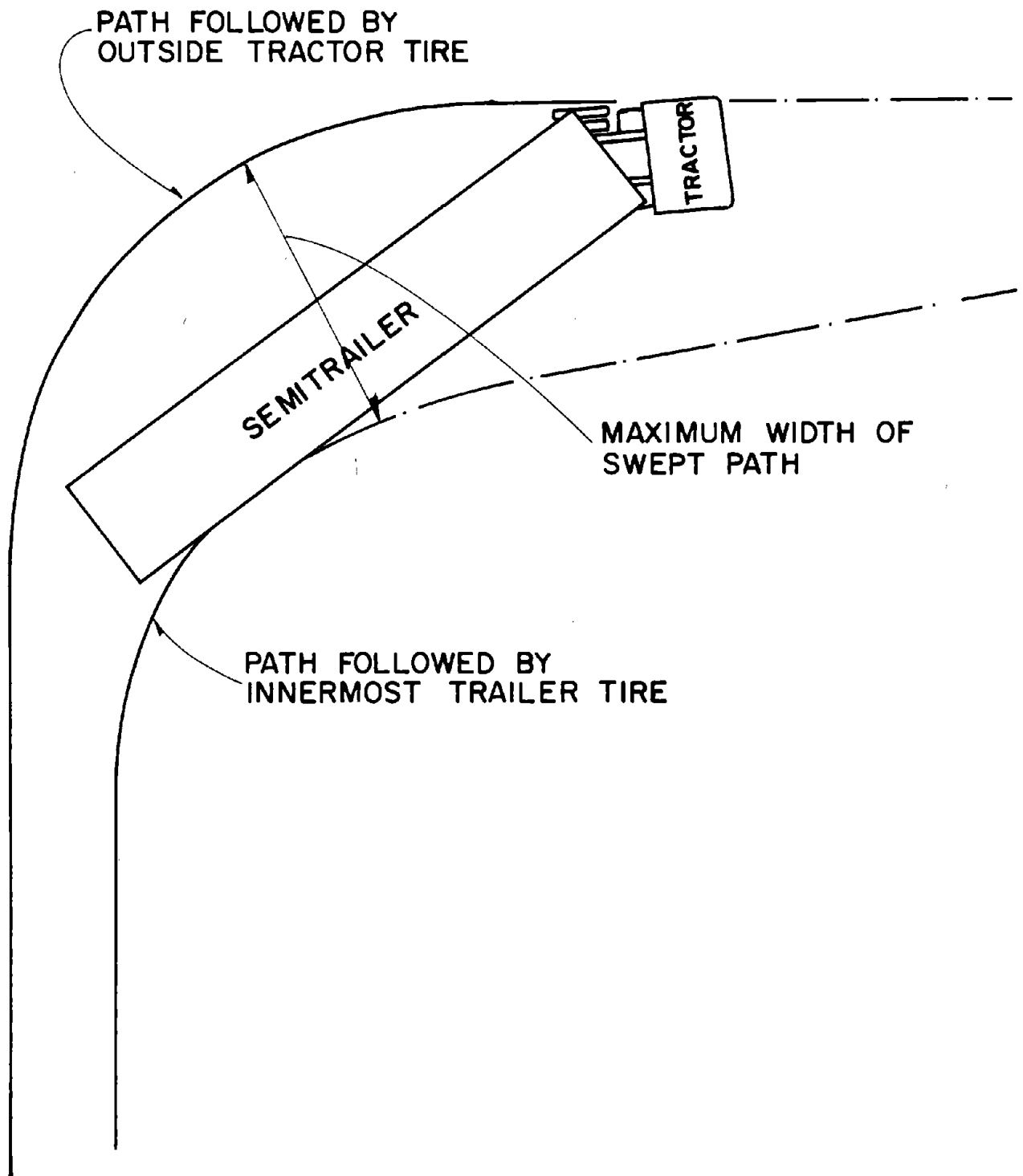


Figure 18. Low Speed Offtracking in a 90° Intersection Turn

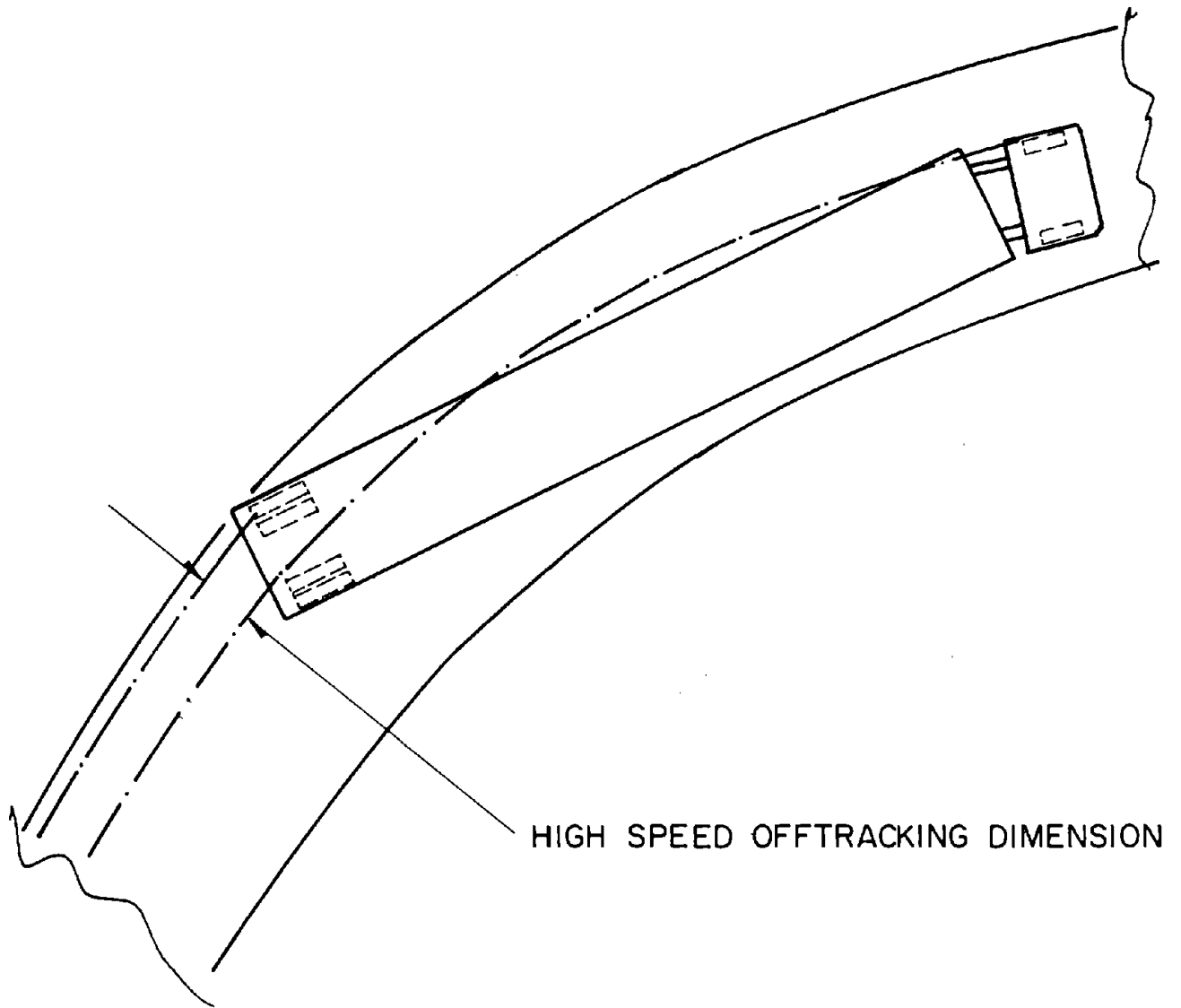


Figure 19. High Speed Offtracking in a Steady Turn

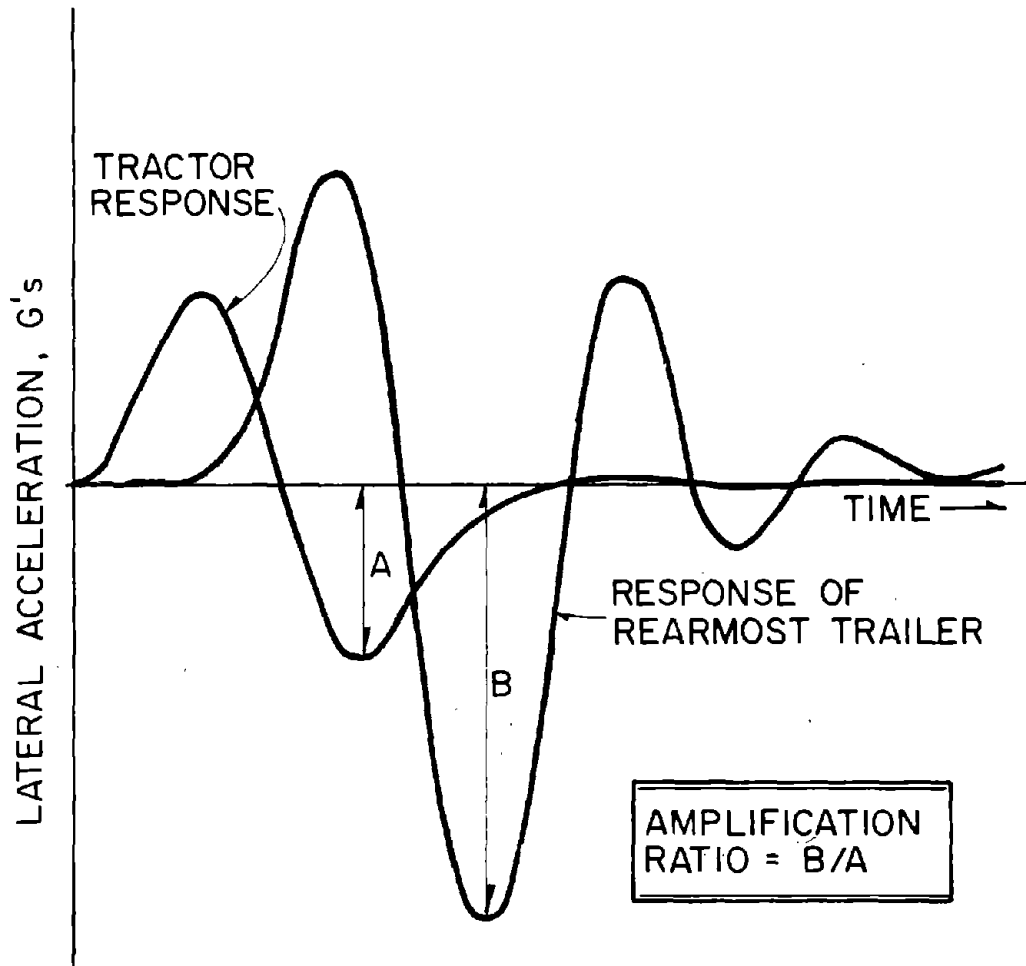


Figure 20. Lateral Acceleration Responses in an Obstacle Avoidance Maneuver Defining the Amplification Ratio.

To the degree that differing obstacle-avoidance emergencies impose differing levels of demand for the severity of the avoidance maneuver which is needed, the vehicle showing a lower level of rearward amplification will be able to achieve a wider lateral displacement to clear an obstacle without suffering rollover of its last trailer. Thus lower values of rearward amplification are desirable and are expected to result in fewer incidences of rear-trailer rollover in actual service.

2.3 Test and Simulation Methods

The influence of size and weight variables on the dynamic behavior of trucks and truck combinations was studied by means of both full-scale tests and computerized simulation. A total of nine different vehicle combinations were set up for full-scale testing, covering a total of 24 cases addressing size and weight variables. The vehicles, test equipment, procedures, and detailed results pertaining to the test program are presented in Volume II. The test data have been scrutinized and compared with the results obtained using computer simulations. Various comparisons of these data sets are presented in Section 2.3 of Volume II, showing that the test results basically confirm the simulation findings in the major areas studied.

A total of 12 different vehicle configurations were examined using computerized simulations, covering some 156 size and weight conditions. Since the test and simulation results have been found to be in broad agreement and since the simulated matrix of conditions is much more complete (and, of course, more cleanly controlled) than that covered by full-scale tests, the data presented in this volume of the report will be drawn almost exclusively from the simulation results.

2.3.1 Simulation Models Used. The simulation results were obtained using eight different computer programs, ranging over a broad scale of complexity. These basic computerized tools are listed below.

- 1) Simplified Braking Model -- used in calculating the nominal influence of loading and length parameters on stopping distance performance.
- 2) Simplified "Rearward Amplification" Analysis [8] -- employing a specialized linear analysis for calculating the rearward amplification exhibited by each vehicle element and by the total combination of elements comprising a multiple-unit train.
- 3) Low-Speed Offtracking Model -- used to calculate wheel paths of multiple-unit trains when negotiating a 90-degree intersection at zero speed.
- 4) High-Speed Offtracking Analysis [9] -- used to calculate the extent of outboard offtracking of semitrailers during cornering at highway speeds.
- 5) Linear Yaw Plane Model [10] -- used for evaluating the rearward amplification of multiple-unit trains in those cases in which a load bias exists such that front- and rear-located tires are not being loaded uniformly.
- 6) Static Roll Model [11] -- for evaluating the static rollover threshold on vehicles having differing loading and width configurations.
- 7) Yaw/Roll Model [12] -- used for evaluating yaw stability and other transient and steady-state characteristics of vehicle response to steering input.
- 8) "Complete" Handling/Braking Model [13] -- used for confirming the braking performance results obtained using the simplified braking program and for evaluating the dynamics of tractor jackknife during braking in a turn.

The broad matrix of cases to be studied by means of simulation necessitated a plan for efficiently evaluating a large number of vehicle configurations and maneuvering conditions. Accordingly, the multiplicity

of models which were used here simply reflects the authors' view of the best approach toward accomplishing the work. As indicated above, models 1 and 3 were developed in the course of this work, while models 2 and 4 through 8 were developed previously and have been documented in the cited references.

2.3.2 Conventions Pertaining to Vehicle Descriptions. In order to conduct the simulation exercise in a fashion which reveals the influence of size and weight variables with a minimum of confusing cross-influences from other variables, a number of conventions were adopted. In general, these conventions were intended to standardize vehicle descriptions and payload-placement practices so that more or less "typical" commercial trucking operations were represented. Since, of course, there exists a tremendous range of equipment design and payload placements prevailing in actual service, the findings of this study must be viewed as representing some sort of "median" sensitivities to size and weight variables. Although the degree of generality of these findings is not explored here, the authors suggest that the cases in which payload placement was purposely varied in all three dimensions (see Section 3.3) should provide useful data for those concerned with trucks having "non-median" loading.

Unless otherwise specified in the reporting of results, the following conventions were adopted.

Tires -- All vehicles were equipped with a rib-tread radial tire, size 10.00R20/load range G.

Suspensions -- Steering axles on tractors and trucks were represented with properties typifying 12,000 lb (5.44 m ton) gross axle weight ratings (GAWR). Single axles on the rear of tractors or trucks or on trailers or dollies were represented with properties typifying 23,000 lb (10.43 m ton) GAWR equipment. Tandem axles on trucks, tractors, trailers, and dollies were represented with properties typifying conventional four-spring suspensions having 38,000 lb (17.23 m ton) GAWR. Of course, the unsprung axle weights characterizing drive axles were appropriately higher than the weights of trailer axles.

Brakes -- Brake torque output was proportioned among the axles according to a typical practice of sizing torque capacity to the axle weight rating. This practice distinguishes between the tractor steering axle, tractor drive axles, and trailer axles, providing brake torque gains, per lb of GAWR, which are ratioed: 1.0 to 0.8 to 0.9 for the three respective axle locations. These proportions were applied uniformly, according to the GAWR of both single and tandem axle sets. (Note that this practice would appear, at first glance, to imply a rather strong braking capability at the tractor steering axle. In fact, the front brakes are typically found to be quite inefficient contributors to the vehicle's overall stopping capability, given that these brakes are capable of supporting only a small level of retardation force at the front tires in comparison with the high level of dynamic load which prevails at the front axle during a stop.)

Payload Placement -- In all baseline vehicle configurations, trailers were represented with a composite c.g. height of 80 inches (203 cm). The "composite" mass was defined to include the trailer body plus the payload. In general, this convention implies a payload c.g. height of approximately 84 inches (213 cm). When vehicle loading was increased to represent a greater gross weight or axle weight allowance, the new payload c.g. height was calculated as follows:

- Given the interior volume of the involved trailer, the density of a homogeneous payload which yields the baseline value of c.g. height was determined.
- The additional volume of a payload of this density needed to reach the new weight level was determined.
- This additional amount of "freight" was considered to be added on top of the existing load of freight.

Thus, whenever load was increased, using this convention, both the weight and the c.g. height of the payload increased. The rationale for this convention is that those trucking operations which can utilize an increased gross or axle weight allowance are the ones which are currently transporting freight in non-cube-full loads. That is, they can make use of the additional allowance because they still have room left in their trailers.

When the allowance is granted, however, the additional freight is, figuratively speaking, placed on top of the existing load. While it is recognized that the actual loading scheme becomes modified in the case of mixed-density freight for which the denser products are loaded on the bottom, the homogeneous case is used as a reference because it is both the simplest and one of the most destabilizing, from the point of view of elevating the composite c.g. height.

In addition to the use of the above convention for establishing c.g. height, the yaw, pitch, and roll moments of inertia of loaded trailers were determined using the same assumptions for payload distribution.

Many other parameters describing geometric, inertial, kinematic, and compliance characteristics of the vehicle types under study were fixed to represent typical equipment. These descriptions are documented in Volume II.

CHAPTER 3
PRESENTATION OF FINDINGS

This chapter of the report presents the results of computerized simulations which illustrate the findings relating size and weight variables to measures of stability and control. This presentation is organized according to size and weight issues. That is, having arranged the simulation study to examine the influence of specific changes in axle load, gross vehicle weight, etc., on the behavior of specific vehicle types, the results can be presented according to the "axle load issue," the "gross weight issue," and so on. For each issue, results will be presented and the apparent significance to traffic safety will be discussed. For each issue, all of the results available pertaining to that issue will be presented, even though certain portions of those data may also appear under the heading of another size and weight issue. For example, certain of the increases in axle load which were studied cause the gross vehicle weight to exceed current gross weight limitations. Thus the data pertaining to vehicles in such a configuration would appear in the presentations covering both the axle load and gross weight issues.

3.1 Axle Load Limits

Variations in the maximum load permitted on either single or tandem axles were examined using six different vehicle configurations. The following performance categories were hypothesized to be of interest in connection with axle load allowances:

- 1) Stopping Distance
- 2) Yaw Stability
- 3) Roll Stability
- 4) Rearward Amplification

The influences of axle load limit on each of these performance categories is presented below.

3.1.1 Stopping Distance. The minimum stopping distance performance of any road vehicle depends upon the following factors:

- 1) The dynamic loads imposed upon each tire during the stop
- 2) The brake torque which is developed at each wheel
- 3) The prevailing tire/road friction level.

In general, differences in braking performance due to the design of differing vehicles, or due to differing load conditions on the same vehicle, derive from differences in the relationship between the loads imposed at each wheel and the respective brake torque levels which are developed. The key issue in determining performance, then, involves the "balance" between the imposed wheel loads and the applied torques. When the torque level becomes too great, given the wheel load, lockup occurs, with its attendant threat of loss of control. When the wheel load is large relative to the available brake torque, the brake will "saturate" in its torque output such that the maximum stopping potential will not be realized.

Heavy trucks have many difficult problems in regard to the torque balance issue, in part because of the tremendous changes in the level and distribution of load, from axle to axle, which occur due to changes in loading state. Further, there are very large differences in the braking performances of differing trucks. It is known, for example, that wide variations exist in (a) the braking performance capabilities measured among differing truck braking systems, under carefully controlled conditions (see for example, [16]), (b) the torque performance of individual truck brakes, from day to day [24], and (c) the state of maintenance of truck braking systems on the road [25].

As will be shown, then, it is possible that increased axle load will serve to increase the stopping distances achieved by certain trucks and decrease the stopping distances achieved by others. In fact, to put it simply, as long as the changes in loading which are being considered are reasonably small (say, 10 to 20%), trucks can be found which will give almost any level of braking performance that one could reasonably expect. Given

this state of affairs, it is disconcerting that there are no survey data available showing how the actual brake system behavior of trucks is distributed over the prevailing truck population. One concludes, then, that it is not possible to provide a definitive assessment of the likely influence of any weight change on the stopping performance of trucks in service today. Thus, the objectives of this study, as they apply to braking performance, can only be met in the context of examples of truck braking system performance.

The reader will note that this situation is seen as peculiar to the braking performance subject and does not apply to the other aspects of truck stability and control behavior which will be treated. In the authors' assessment of the state of knowledge on these matters, the braking performance of trucks stands out as peculiarly eluding an orderly examination of "representative behavior."

Simulations run in this study involved vehicles which were outfitted with brake systems as described in Section 2.3.2. These cases are seen as representing typical practice in new vehicle design as it was practiced in accordance with the federal braking standard, FMVSS 121, over the period 1978 through 1982. These brake systems are relatively high in torque capacity except for brakes on the steering axle. Thus the vehicle's stopping distance performance is typically limited by the occurrence of wheel lockup rather than by saturation in brake torque. Vehicles subjected to full-scale tests in this study were characterized by a mix of brakes, some of which could produce the torque levels needed for wheel lockup on dry road surfaces, and some of which were limited in torque capacity such that lockup could not be reached.

Shown in Figure 21, simulation results are supplemented with samples of test data so as to give a broad view of the possible influences of axle load variations on stopping distance capability. The figure shows minimum stopping distances achieved from 55 mph (88 km/h) without lockup of the wheels on any axle. Simulation results are given for stopping on both a dry, high-friction, pavement and a slippery pavement. The so-called "mu" values shown for the respective surfaces represent the ratio of the maximum tire traction force which can be sustained to the vertical load on the tire.

STOPPING DISTANCE FROM 55mph (88 kph), feet

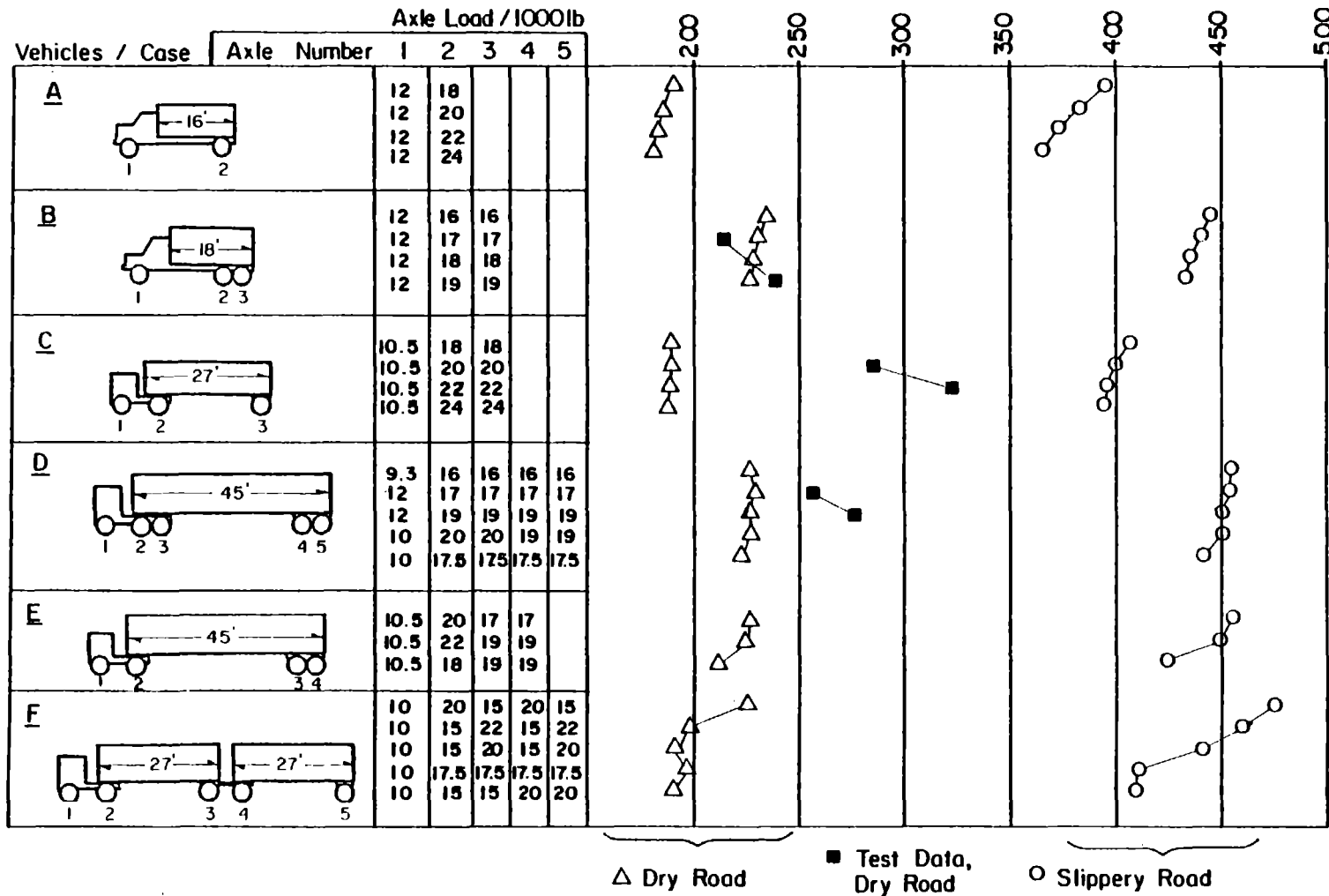


Figure 21. Influence of Axle Load Variations on Stopping Distance

Observations

1) For trucks having the "representative, as-designed" type of brake system behavior, increased axle loading results in small reductions in stopping distance.

2) This type of vehicle especially benefits when the increased loading is applied toward the rear of the vehicle, since it is typically the trailer brakes which produce excessive torque levels and which otherwise tend to limit stopping distance capability by causing "premature" wheel lock-up. As a case in point, note the simulation results for the tractor-semitrailer in condition E-3.

3) For trucks with brake systems which, either through design, random variability, or lack of maintenance exhibit limitations in torque output (such that wheel lockup cannot be attained), increased axle loading results in increases in stopping distance. Note the increases in stopping distance accompanying increased axle loads in the test cases shown. If all of the brakes on a vehicle are torque-limited, in both the baseline and increased-axle-load cases, the stopping distance will increase approximately in proportion to the change in total gross weight incurred with the increase in axle load. For example, if the increased axle loading causes the gross vehicle weight to rise by 10%, the vehicle will exhibit minimum stopping distances which are approximately 10% longer. (It is possible, of course, that the vehicle might be torque-limited in its stopping behavior on a high-friction surface but is able to achieve wheel lockup on a low-friction surface. In such cases, an increase in axle load could be seen to increase stopping distances on dry roads, but decrease stopping distances on slippery roads.)

4) Although not pertinent to the axle load issue, per se, it should be noted that vehicles B, D, and E exhibit relatively long stopping distances due to a characteristic which is peculiar to the four-spring-type tandem axle arrangements employed on these vehicles. Because there is a "transfer of load" from the front axle of a tandem pair to the rear during braking, the tandem-equipped vehicles tend to incur premature lockup of the wheels on the lightly-loaded (front) axle of the pair. Thus, when the stopping distance measure uses wheel lockup as its limiting criterion, tandem-axle vehicles exhibit poorer performance, as shown.

Interpretation

The differences in brake system behavior exhibited by the simulated versus tested vehicles suggest that one cannot confidently generalize on the likely influence of increased axle load on stopping performance. Clearly, a generalization would be possible only if the distribution of the highly-variant braking properties of the truck population were known. Perhaps it is useful to the policy-maker to know that, in the worst case (represented by torque-limited braking systems), stopping distances will increase as loading increases, by the ratio of the gross vehicle weights involved.

One cannot show how increases in stopping distance will tend to change the likelihood of a vehicle's overall accident involvement. The only known data which speak, even indirectly, to this subject have come from a study sponsored by the National Highway Traffic Safety Administration which examined the influence of the higher performance "121"* braking systems on accident experience [26]. The study showed that the improved nature of the "121" systems yielded no discernible benefits, in terms of accident involvement.

3.1.2 Yaw Stability. In Section 2.2.2.3, a measure of the so-called "understeer" factor was defined. By the definition used here, this indicator of the vehicle's steady turn response to steering is evaluated at a lateral acceleration level of 0.25 g. Shown in Figure 22 are the values of the understeer measure for differing vehicles which are loaded up to various maximum axle load limits. It is important to note that axle loads were not considered to approach the "limit" values on the steering axles of any of these vehicles. Rather, steering axle loads were set to represent more-or-less typical conditions for "fully loaded" vehicles.

In addition to the axle load variations on each vehicle, the figure also includes the results of calculations for a peculiar reference condition

*Pertaining to air-braked trucks and trailers built to meet the Federal Motor Vehicle Safety Standard (FMVSS) 121.

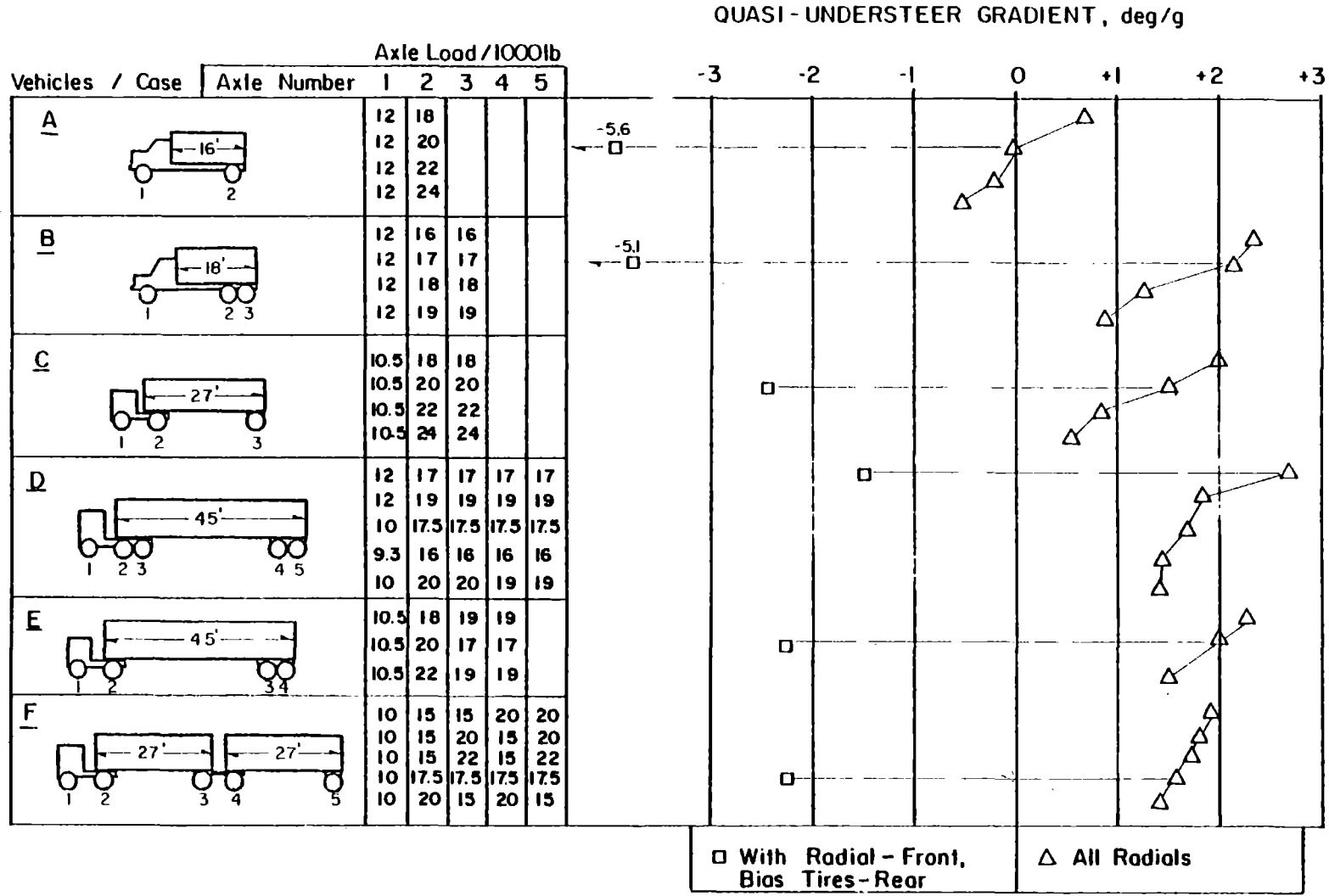


Figure 22. Influence of Axle Load Variations on Understeer Level

which is known to occur occasionally in trucking practice and which very seriously degrades yaw stability. This condition involves the placement of radial tires on the steering axle of a truck or tractor and bias-ply, lug-tread tires on the drive axles. While such practices may occur most frequently when a fleet is in the process of changing from bias tire usage to radials, it is also known that various purchasers of new vehicles specifically request such a tire mix when the vehicle is assembled by the manufacturer. While the wisdom of such a request seems dubious, at best, the influence of this tire mix on the understeer measure serves as a convenient point against which to compare the results showing the influence of axle load variation.

The suggestion here is that since the tire mix case represents a known, and very powerful, disturbance on yaw stability in current practice, any size or weight allowance that might reduce the understeer level into the range produced by this tire mix would be, in the view of the authors, deserving of serious concern, indeed. Unfortunately, it is not possible, given the current state of knowledge, to form a complete logical argument by which the maximum "acceptable" reduction in understeer level is identified.

Another point of reference was provided in a previous research study [14] which included the examination of yaw stability for tractors outfitted with bias-ply, rib-tread tires on the front axle and bias-ply, lug-tread tires on the drive axle(s). This case is known to have been a very common, if not the single most common, tire arrangement employed on heavy-duty vehicles through the end of the 1970's. The resulting influence of this rib/lug mix on understeer gradient was shown to be the single most powerful item serving to reduce understeer from among a number of other common in-service variations. It is pertinent to note that the rib/lug mix of bias-ply tires introduces an understeer reduction which is on the order of one-half of the magnitude of reduction accruing with the mix of radial-rib and bias-lug tires considered in the simulations reported in Figure 22.

Finally, it was pointed out in Section 2.2.2.3 that the understeer behavior was examined using simulations in this study by means of the so-called "ramp input" of steer angle. That is, the simulation merely represented a gradually increasing steer input so as to provide a "scan" of the

whole range of lateral acceleration up to the rollover level. As is discussed in Volume II (Section 2.3.2.1), this maneuver condition yields values of the understeer measure which fall 3 to 5 deg/g above the values obtained in steady-state turns. Thus, data obtained in quasi-steady-state turning tests of actual vehicles, reported in Volume II, show understeer gradients whose absolute values are, indeed, well below the levels shown in Figure 22, although the relative influence of size and weight variations found from test data are essentially identical to those obtained in the "ramp-steer" simulations.

Observations

Looking over the results presented in Figure 22, the following observations can be made:

1) Increases in axle load limit, implemented by simply increasing the load carried on non-steering axles, consistently result in a reduction in the understeer quality of trucks and tractors.

2) The influences of increased axle load on understeer level are much smaller than the reference influence of the radial/bias tire mix. On the average, a 10% increase in axle load level results in an understeer reduction that is less than 20% of the reduction resulting when the baseline-loaded vehicle is equipped with the mixed-tire arrangement.

3) A key factor in the influence of increased axle load allowance is the decrease in the fraction of the total load borne by the front axle of the unit in question. The data in Figure 22 can be reduced to illustrate the relationship between the fraction of total truck or tractor load borne on the steering axle versus the loss in understeer below the baseline value. Examining such relationships reveals that the two-axle power units lose an average of 1 deg/g of understeer for every 0.06 reduction in the ratio of front axle load to total load. The three-axle power units were seen to lose an average of 1 deg/g of understeer for every 0.025 reduction in the ratio of front axle load to total load (reflecting the greater total load carried by the baseline three-axle power units).

4) A few cases involving variations in axle load for the five-axle tractor-semitrailer were examined for the sake of their historical

interest. For example, Figure 22 shows Case D-4 labeled 9.3/32/32 which represents the common distribution employed prior to 1974 when the gross allowance on the federal highway system was 73,280 lbs (33.2 m tons). (The 9.3/32/32 designation refers to a loading scheme in which 9.3K lbs (4.2 m tons) is the load on the steering axle and 32K lbs (14.5 m tons) is the load on both the tractor and trailer tandem axle sets.) We see that this rather rear-biased load distribution yielded a relatively low value of the understeer measure. When the law changed in 1974, the axles on this vehicle type were to be loaded to 12/34/34 (Case D-1) in order to realize the maximum allowable gross weight of 80,000 lbs (36.3 m tons). We see from the figure that this arrangement yielded a considerably higher value of the understeer measure, because of the more forward weight distribution. During the late seventies, drivers began to complain against the more forward weight bias, alleging front tire blowout problems, harder steering, and poorer ride vibrations such that union lobbyists sought to promote the 10/35/35 distribution (Case D-3) which is also shown in the figure [27]. Although this arrangement still provides a gross weight value of 80,000 lbs (36.3 m tons), the rearward bias does have the negative effect of reducing the understeer level—to a value which is approaching the pre-1974 performance characteristic (Case D-4).

The 10/40/38 distribution (Case D-5), shown yielding the lowest understeer level for this vehicle configuration, was included to illustrate the behavior of a vehicle which:

- a) is loaded to a higher gross weight value of 88K lbs (39.9 m tons) by means of a nominal 12/38/38 distribution, but which
- b) is then subjected to a common, though illegal, "adjustment" which truck drivers use as a means of improving ride quality when they are traveling down the road, removed from weighing stations. This "adjustment" practice involves moving the fifth wheel aft, by means of the so-called "slider" fifth wheel mounting, thus imposing a larger portion of the trailer kingpin load on the rear axles of the tractor.

Interpretation

Moreover, the examined increases in axle load limit were seen to cause measurable reductions in understeer level. This finding is inherently worthy of attention because it is known that many heavy trucks and tractors suffer from a strong natural tendency to decline in understeer level with increasing level of lateral acceleration [14]. Although this problem is undoubtedly of greater concern with certain vehicle designs than with others, the prospect that an increase in axle load allowance might promote a further reduction in truck understeer levels, generally, suggests that the control quality of the trucking fleet would decline under the influence of such a change.

We note, however, that the comparison of the understeer losses deriving from increases in axle load with those deriving from the tire mix arrangement indicate that the magnitude of the decline in understeer (such as might accompany, say, a 10% increase in axle load limit) is relatively small. One might conjecture that such a change in understeer level is unlikely to startle the typical truck driver—many of whom already cope with substantial day-to-day variations in understeer level as a result of differences in trailer loading, fifth wheel placement, and, in the case of fleet drivers, due to operating different tractors. On the other hand, there is sound reason for concern that, even though truck drivers may be "coping" with certain sub-optimum vehicle properties each day, the extent of the control task posed by current vehicles may play a significant role in the production of the large number of single-vehicle accidents seen with heavy trucks. Since no data base exists for showing the statistical significance of the influence of understeer level on truck accidents, however, the results presented in Figure 22 are proposed simply as qualitative indicators of a possible safety problem.

3.1.3 Roll Stability. Roll stability has been characterized in Section 2.2.2.4 by a static measure termed the "rollover threshold." This measure expresses the maximum sustained level of lateral acceleration, in g's, which the vehicle will tolerate without rolling over. This measure of performance becomes influenced by variations in axle loading insofar as such variations alter any of the following parameters:

- 1) the height of the payload center of gravity
- 2) the total payload weight
- 3) the longitudinal distribution of the payload, such that axles having differing suspension properties are caused to carry a larger or smaller fraction of the total load.

Calculations of rollover threshold were done considering that variations in axle loading limits would cause certain specific changes in the way actual trucks would be loaded. As was discussed in Section 2.3.2, any increase in axle loading that provides for a greater payload weight was implemented in this study by a scheme in which the additional payload was imagined to be added to the top of the baseline load of freight. Thus, in some of the cases addressing axle load variations, payload c.g. height as well as payload weight are increased. In other cases, the weight imposed by a constant payload is simply distributed differently.

Shown in Figure 23 are the variations in rollover threshold which are calculated to result from the indicated axle loading cases. For the first three vehicles shown, the cases involve various levels of load imposed upon the rear-placed (non-steering) single and tandem axles. In each case with these vehicles, the gross weight of the vehicle is directly affected by the variation in axle loading. In the cases shown for the five-axle tractor-semitrailer, certain cases involve an increased axle load limit which results in an increase in the gross weight of the vehicle, while other cases involve only a redistribution of load among axles.

Observations

The following observations can be drawn from the results shown in Figure 23:

- 1) The rollover threshold is decidedly reduced by increases in axle load limit.
- 2) The decreases are approximately in proportion to the fractional change in the axle load limit which is represented. For the first three vehicles shown in the figure, a 10% increase in axle load limit yields an average of 0.025 g reduction in the rollover threshold.

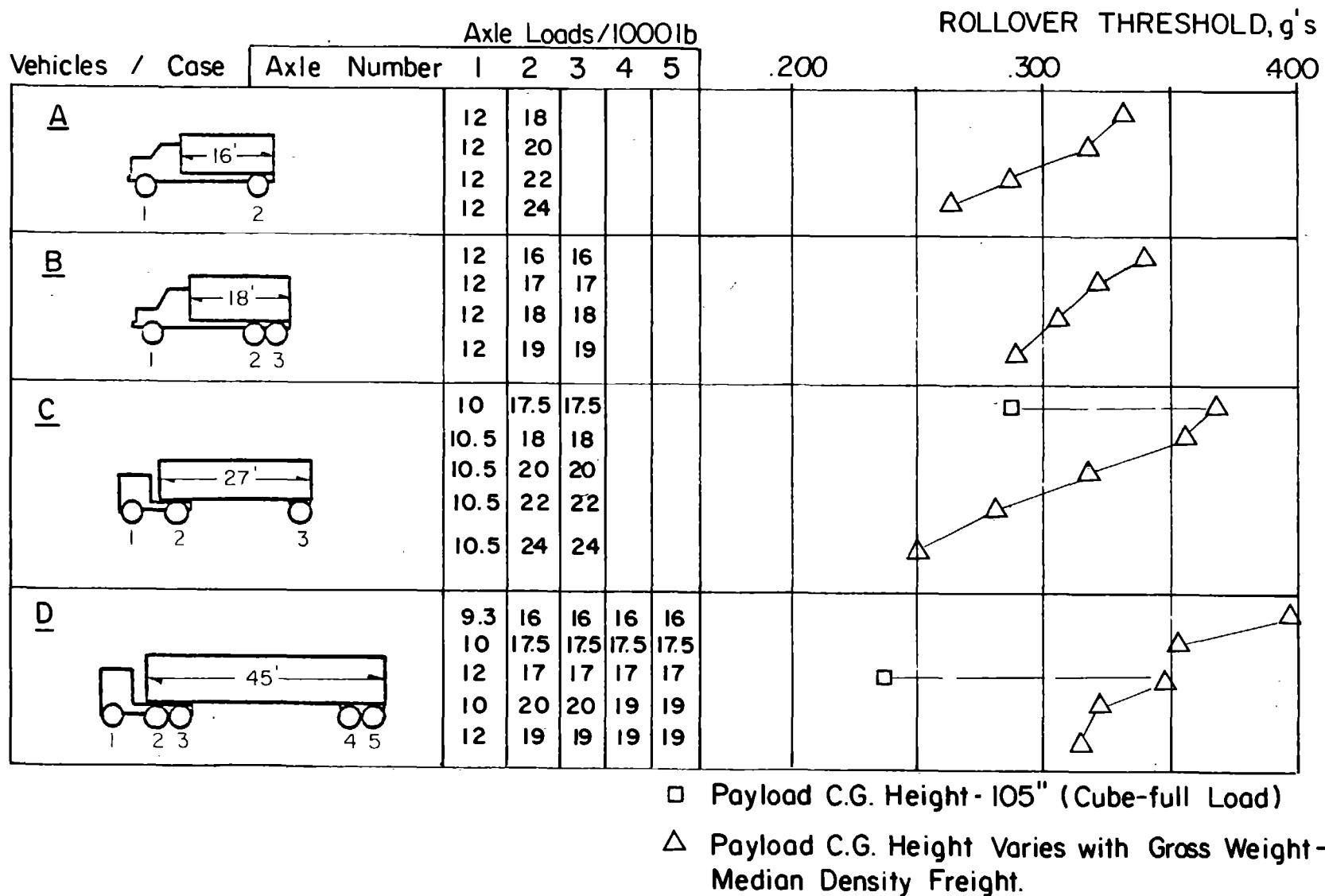


Figure 23. Influence of Axle Load Variations on Rollover Threshold

3) The steepest sensitivity of rollover threshold to axle loading is seen in the case of the three-axle tractor-semitrailer. This result is partially explained by observing that with only a 27-foot trailer length, the rise in the payload c.g. height accompanying an increase in axle load on the tractor rear and trailer axles is the greatest of any of the vehicles shown. (Also note that the increase in loading on single axles considered here is twice as large, per axle, than the increase for tandem axles.)

4) Results for the five-axle tractor-semitrailer show that rollover threshold reduces, at a given value of gross vehicle weight, as the tractor's load becomes distributed more towards the front. This observation reflects the fact that road tractors commonly employ front suspensions which are quite soft in comparison to the rear suspensions. Thus, when a greater fraction of the load is borne by a suspension which is less able to contribute roll-resistance, the vehicle is permitted to roll through a larger angle as lateral acceleration increases such that a lower net rollover threshold results.

5) The sensitivity to load distribution is of the opposite sense, from a safety point of view, to that observed above regarding the influence of loading on understeer quality. That is, a more forward-biased loading on a truck or tractor tends to increase understeer level but decrease rollover threshold. Note in the results for the five-axle tractor-semitrailer, however, that the influence of load distribution, per se, is not as strong as the influence of the payload weight and c.g. height changes that accompany the increased loading. For example, consider the cases involving the load distributions 12/34/34 and 12/38/38 which yield 80,000 and 88,000 lbs (36.3 and 39.9 m tons) gross weights. Although the latter case involves a more rear-biased load distribution on the tractor, the rollover threshold is lower by 0.03 g's than in the 12/34/34 case, i.e., the effect of increased axle load (Item 1) is stronger than the effect of shifting more load to the front.

Interpretation

The above results provide one set of measures describing the influence of axle load limits on rollover threshold. These measures reflect a

particular baseline loading condition and also a specific scheme for relating the increased loading arrangement to a new placement of the payload. Clearly, the actual influence of a load increase on the payload c.g. height could vary tremendously such that the range of possible influences of axle load limits on rollover threshold is great indeed. For example, one can imagine a trucking operation that commonly hauls a dense commodity, having a low c.g. height, and which later utilizes an increased axle load allowance by carrying some low-density freight on top of the "old" load. The net increase in the elevation of the payload c.g. would be markedly greater than the influences represented here. Moreover, the motor freight system in the U.S. is remarkably versatile and, in certain cases, could conceivably include cases in which a net reduction in the c.g. height would accrue as a result of an increased axle load limit. Thus, the above data showing the influence of axle load limit on rollover threshold are seen as merely representing one example, namely, the case involving median freight densities and homogeneous-density commodities.

The crucial question beyond the issue of generality is that of the importance of the rollover threshold of vehicles to traffic safety. Shown in Figure 24 is a plot of accident data which provides an unusually clear, although simplified, view of the importance of the rollover threshold performance of heavy vehicles. This curve derived from accident data reported to the Bureau of Motor Carrier Safety (BMCS) of the U.S. Department of Transportation over the years 1976 through 1979. The figure shows that a remarkable correlation exists between the percent of rollovers occurring among single-vehicle accidents* (SVA) involving tractor-semitrailers and the rollover threshold of each vehicle. This plot represents some 9,000 single-vehicle accidents involving three-axle tractors pulling two-axle, van-type semitrailers. Among these 9,000 accidents, more than 2,000 rollovers were recorded. These data were resolved into the illustrated format of Figure 24 with the aid of a computerized procedure for calculating the rollover threshold of such vehicle combinations, given the value of gross vehicle weight which is reported to BMCS with each accident. Knowing the

*The accident data are plotted in this percentage fashion in order to express an accident rate-type of measure and also because rollover events are recorded in the BMCS data file only if they occur in single-vehicle accidents.

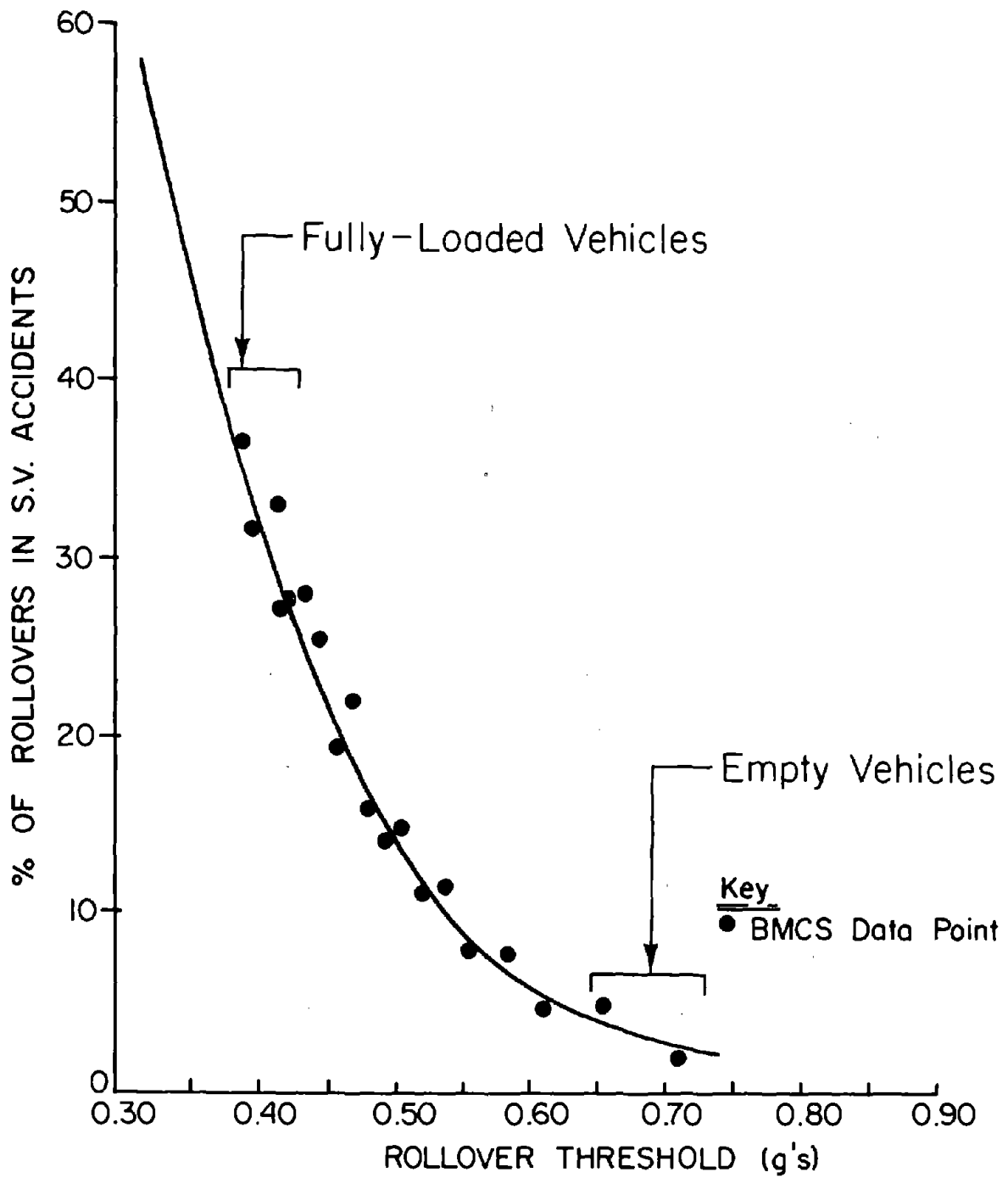


Figure 24. Percent of single-vehicle accidents in which rollover occurs as a function of the vehicle's inherent rollover threshold, in g's.

gross vehicle weight, the analysis assumed that payload was placed in a fashion representing medium-density freight. Typical values for tires, spring, and geometric properties were then employed to calculate rollover thresholds for each increment of gross weight in the accident file.

From Figure 24, we see that the typical empty tractor-semitrailers experience rollover in approximately five percent of their SVA's. When such vehicles are loaded, on the other hand, the reduction in roll stability due to the greater weight and higher c.g. location causes an eight- to nine-fold increase in the incidence of rollover. The figure clearly establishes that the rollover of tractor-semitrailers is highly sensitive to the vehicle's inherent rollover threshold in the 0.3 to 0.4 range pertaining to typical, fully loaded units. The slope of the sensitivity in this range can be nominally evaluated at an approximate three percent change in rollovers/SVA per 0.01 g change in rollover threshold.

Looking at the rollover threshold results obtained for the cases involving the five-axle tractor-semitrailer, Figure 25 shows the implied influence of axle loading limits on the fraction of rollovers/SVA. Because of the steep slope of the accident data curve, we see that the examined range of axle load variations could be interpreted as yielding a 33% to 60% range of rollovers/SVA. Noting that rollover of heavy trucks is predominantly a single-vehicle accident problem [15], one can take the incremental increase in rollovers/SVA and produce a crude estimate of the possible increase in the total number of rollovers which would be experienced by vehicles for a subject loading case. For example, in Figure 25 we could surmise that a change from the 12/34/34 loading to the 12/38/38 case would result in an estimated 25% increase in the incidence of rollover accidents (for five-axle tractor-van semitrailer combinations*-loaded to the GVW limit and dispatched with median-density, homogeneous freight).

*Note again that all estimations of the influence of size and weight variables on performance assume existing vehicles which are being employed to carry increased loads without altering their design characteristics. Unless otherwise noted, however, tires, springs, etc., are not loaded in excess of their load ratings.

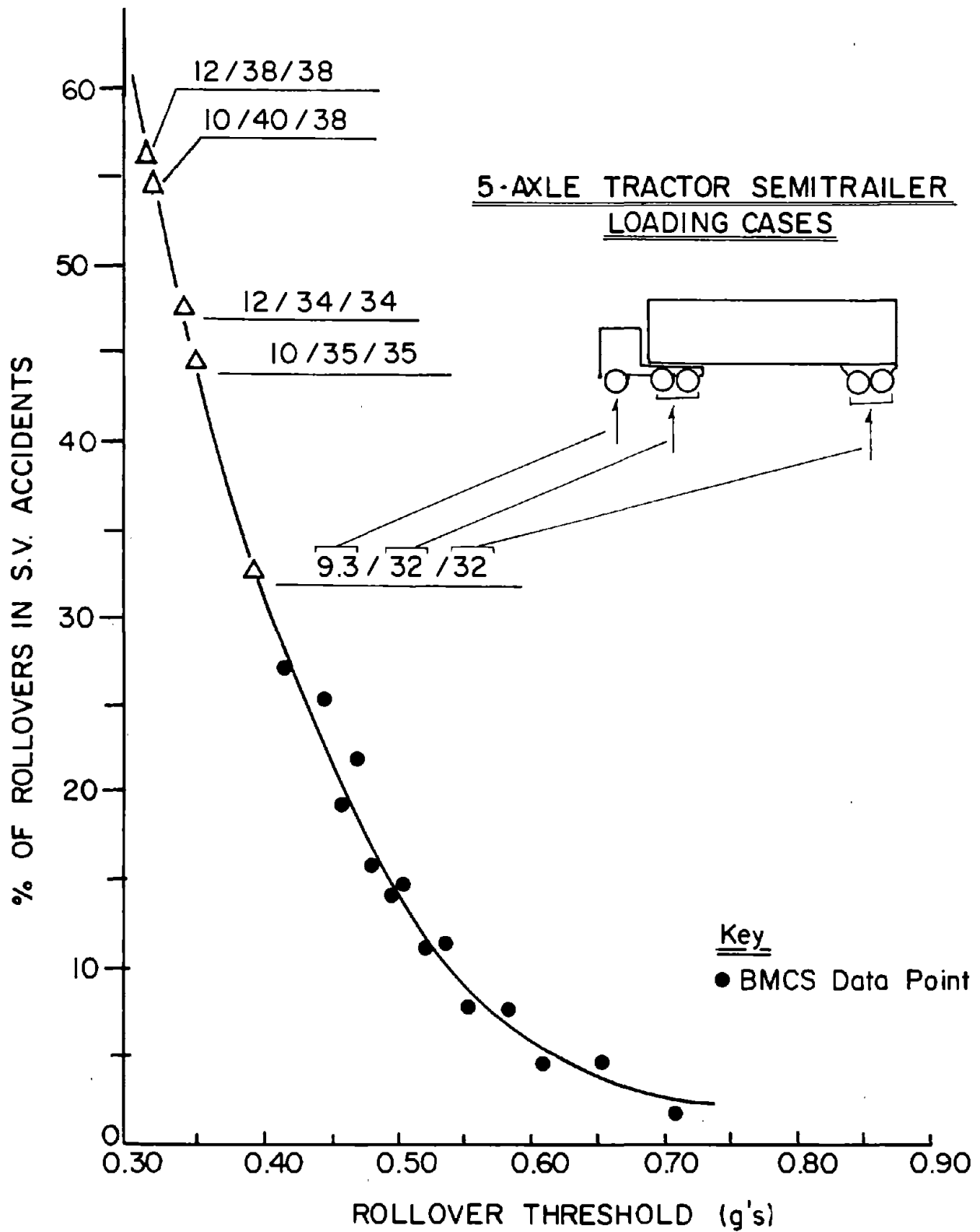


Figure 25. Overlay of Rollover Thresholds Representing Axle Load Variations onto Curve Derived from Accident Data.

While example cases such as this become rather tenuous due to all of the qualifiers which define the specific case, the major point here is that the accident record clearly indicates that the rollover threshold value is a remarkably powerful determinant of truck rollover involvement. Accordingly, the rollover threshold results shown previously are seen as indicators of a central safety concern.

3.1.4 Rearward Amplification. Axle load allowances have been shown in the foregoing presentation to be implemented in a manner which, in certain cases, induce a bias in the fore/aft distribution of load on a vehicle element. The rearward load bias which is incurred on three-axle tractors, for example, as a result of an increase in the tandem load allowance, was seen to degrade understeer level. A more subtle influence of an increased axle load allowance is that it may be utilized in certain cases by means of fore/aft biasing of the placement of payload in a trailer.

Such biasing of load placement might take place inadvertently, of course, or might accrue due to the need to ship an awkward combination of payloads by loading them onto a single trailer, perhaps at sequential loading facilities, in order to achieve a full trailer load for interstate shipment. On the conventional doubles combination, the fact that the gross weight is typically limited to 80,000 lbs (36.3 m tons) suggests that the single axles at the rear of the tractor and at the trailer and dolly positions are typically "underloaded," with respect to axle load allowances. Note that this situation prevails because the doubles combination employs all single axles and thus accrues the higher axle load allowances provided for single axles (as opposed to the lesser per-axle allowances for closely spaced tandem axle pairs). Thus, the axles on the conventional double have a certain "reserve" capacity for tolerating biases in the longitudinal placement of the payload center of gravity.

One possible influence of fore/aft load bias on a doubles combination involves the rearward amplification behavior. While this mode of response is most sensitive to length parameters, and is discussed in that capacity more thoroughly in Section 3.4.4, it suffices here to say that there is some evidence in the literature that a severe load bias can degrade the rearward amplification behavior of a double-type vehicle [2]. Shown in Figure 26 is a plot of the rearward amplification responses covering

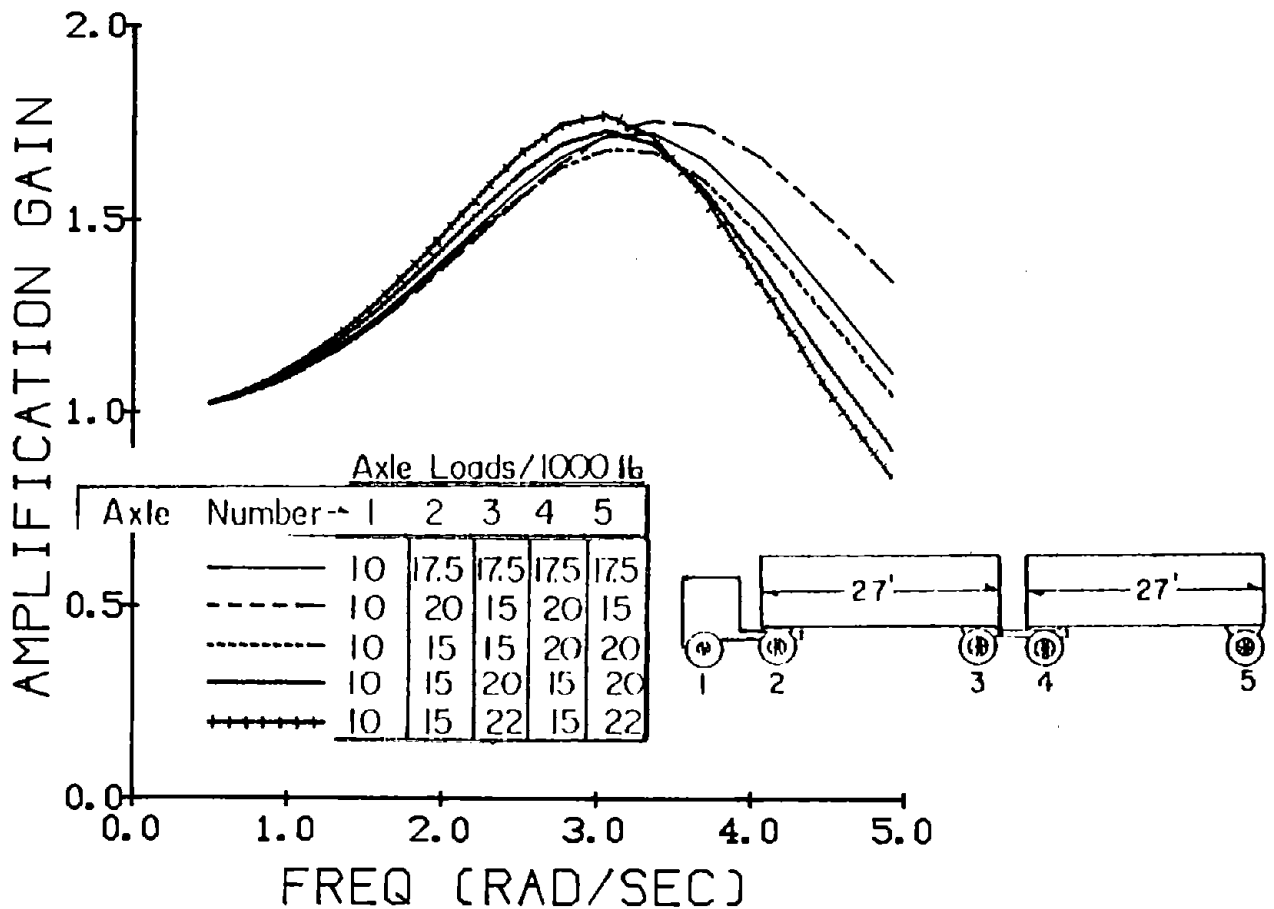


Figure 26. Amplification of lateral acceleration at the rear trailer relative to the peak value of lateral acceleration at the tractor as a function of the frequency of the steering input wave.

five cases of varied axle loading on the conventional double. The plot shows the rearward amplification ratio as it varies over a range of steering input frequencies which span the entire scope of steering reversal maneuvers—from normal lane changes, with steering frequencies between 0 and 1 rad/sec, to emergency obstacle-avoidance maneuvers, for which the steer input frequency approaches 0.5 Hz, or 3.14 rad/sec.

Also of some interest with regard to axle load variation (although bias loading is not involved), is the three-axle tractor-semitrailer which constitutes the front unit of the doubles combination. Since this vehicle is also known to exhibit a small level of rearward amplification, its sensitivity to variations in axle load allowance were examined, and the results presented in Figure 27.

Observations

1) The influence of the various biased loading conditions on the rearward amplification behavior of the double is relatively small. Given that the rearward amplification measure is defined as the peak value of the ratio achieved within a 0.5 Hz (3.14 rad/sec) steering frequency, we see that the worst-case loading causes an approximate five percent increase in the measure over the baseline value.

2) It is seen that the more rear-biased load distributions cause the peak condition to occur at a lower frequency. Although the downward shifts in frequency are not large, such shifts are seen as generally undesirable since they cause the amplification phenomenon to be more prominent at frequencies which are closer to those found in normal driving activity.

3) Although some increase in the peak level of the amplification ratio is seen to derive from forward-biased loads, the curve-shift toward the right renders this effect of little practical significance since the band of steering frequency lying above the 3.14 rad/sec value is thought to be rather unattainable by normal drivers.

4) Increased axle loading on the three-axle tractor-semitrailer is seen to increase the amplification ratio without particularly adjusting the placement of the curve with respect to steer input frequency. The peak loading condition produces a five percent increase in the amplification measure.

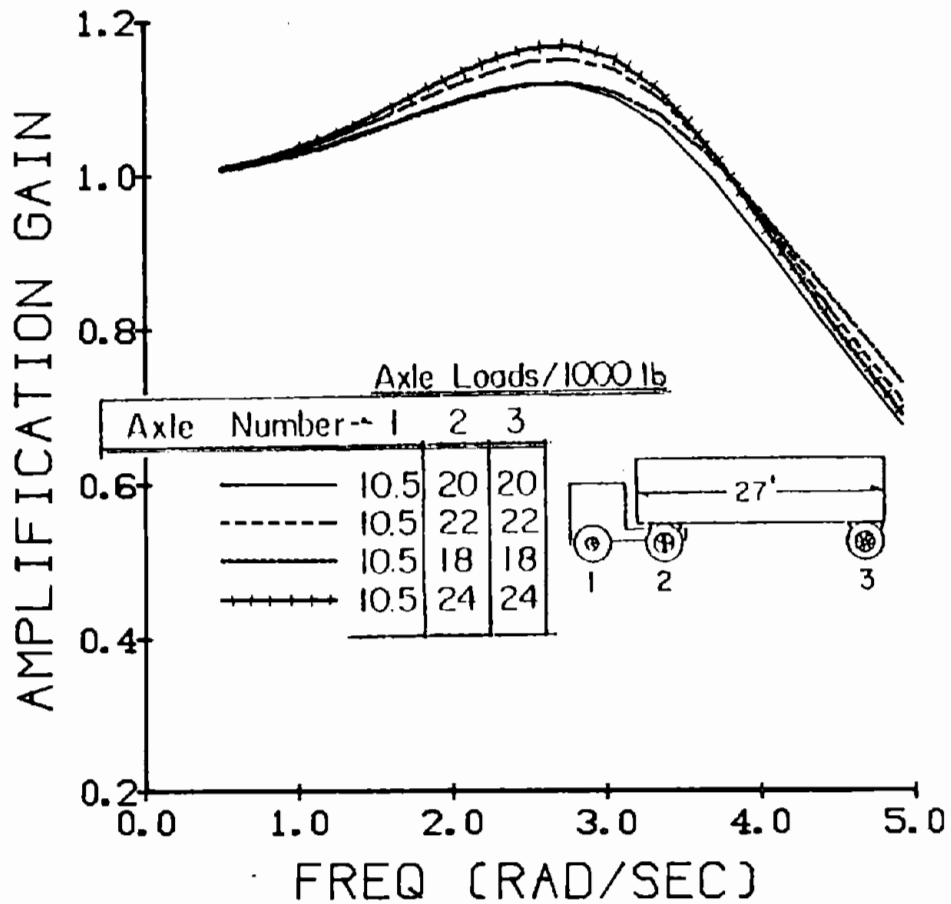


Figure 27. Amplification of lateral acceleration at the semitrailer relative to the peak value of lateral acceleration at the tractor as a function of the frequency of the steering input wave.

Interpretation

The variations in amplification ratio seen here are not particularly large, as this phenomenon is generally accounted. Given that the loading conditions needed to obtain five percent increases in amplification ratio constitute rather extreme cases, it would seem appropriate to dismiss axle load allowance as a size and weight variable likely to significantly influence rearward amplification.

3.2 Gross Vehicle Weight

Two basic vehicle configurations have been examined for illustration of the influence of gross vehicle weight limits on stability and control performance. The two vehicle types are the five-axle tractor-semitrailer and the five-axle double. These vehicles constitute the most popular configurations currently operated at loads approaching 80,000 lbs (36.3 m tons) gross weight. They would, conceivably, be the configurations most affected by an increase in the gross weight allowance beyond 80,000 lbs (36.3 m tons) (recognizing, again, that a host of other less numerous truck combinations are currently used in intrastate transportation at gross weights exceeding this level).

The following performance categories were studied with regard to variations in gross vehicle weight:

- 1) Stopping distance
- 2) Yaw stability
- 3) Roll stability
- 4) Rearward amplification

In examining the influence of gross weight changes, a baseline condition providing an 80,000-lb (36.3-m ton) gross weight was first defined for each vehicle. As was outlined in Section 2.3.2, this baseline case involved a value of 80 inches (203 cm) for the height of the composite center of gravity of trailers. Load changes up or down from the 80,000-lb (36.3-m tons) value were then accompanied by changes in payload height according to the outlined scheme.

3.2.1 Stopping Distance. The influence of gross weight level on stopping distance performance was studied in the same fashion as that described earlier for the study of axle load influences. The reader is advised to refer to Section 3.1.1 in order to assess the peculiar nature of the problems posed by truck braking characteristics as they bear on the concerns of this study. As in the case of the observed influences of axle load changes, it will be shown below that changes in gross weight can either favorably or unfavorably influence limit stopping capability. Cases illustrating both possible results will be described.

Shown in Figure 28 are minimum stopping distances obtained from an initial velocity of 55 mph (88 km/h). Simulation results are shown for cases representing both a dry, high friction, road surface and a slippery surface. In addition to the simulation results, test data are also shown for two cases of the tractor-semitrailer and doubles combination at differing values of gross weight.

Observations

1) There is a very minor, but favorable, influence of increased gross weight on the stopping distance performance of the simulated vehicle. This result reflects the fact that the brake systems of these vehicles are represented as having a sufficient torque capability for achieving wheel lockup at each axle position except the steering axle. Thus, the immediate effect of increasing gross weight is to apply heavier loads to the wheels which were being "overbraked" in the reference condition, thereby rendering a net improvement in the overall efficiency of the braking system.

2) Since the trailer brakes are represented as producing the highest levels of brake torque, the loading cases yielding the longest stopping distances are those in which the overbraked trailer axle(s) are least heavily loaded. The case most clearly illustrating this condition is the B-1 loading of the doubles configuration. In this case, the rear-most trailer axle is the least heavily loaded due to (a) a low value of static load (15,000 lbs -- 6.8 m tons) and (b) the greatest dynamic reduction in load during the braking process.

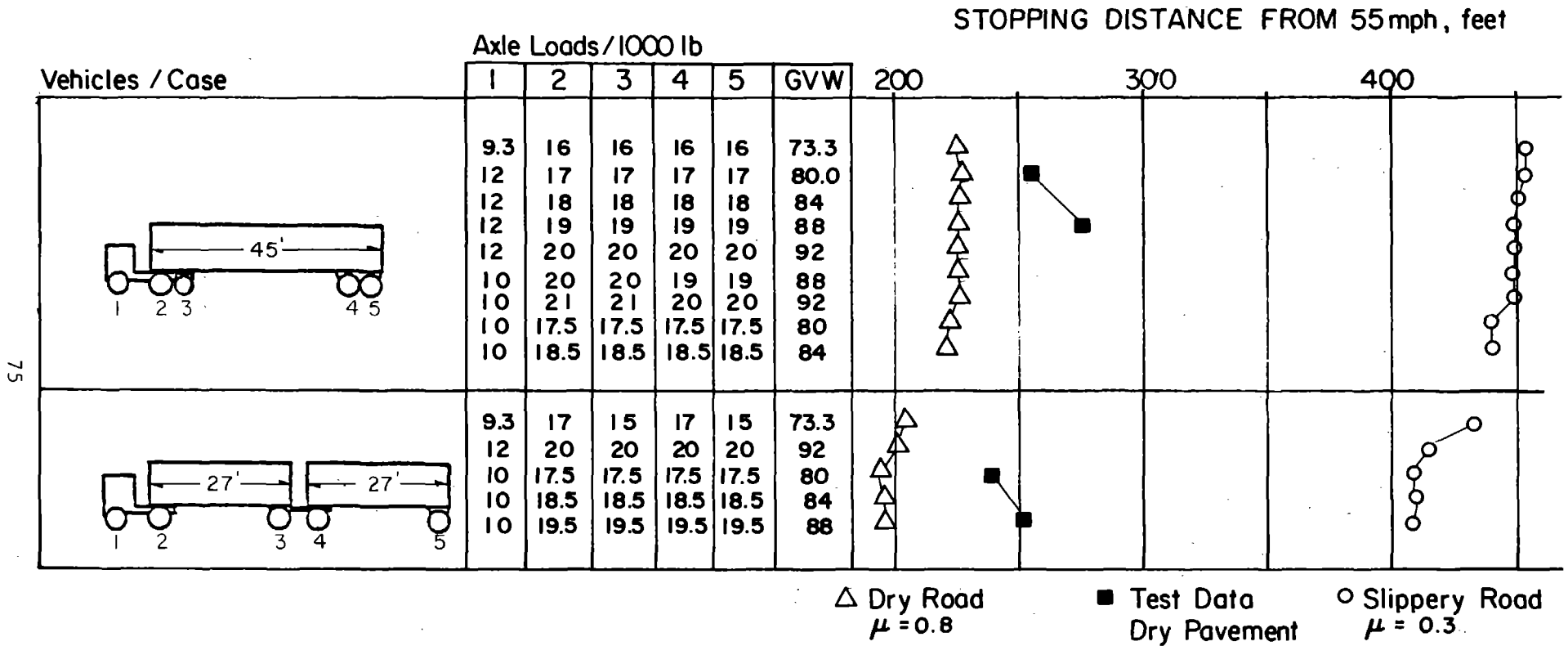


Figure 28. The Influence of Gross Weight Variations on Stopping Distance Performance

3) The test data points show that increased gross weight results in an increase in stopping distance. As discussed in Section 3.1.1, this result reflects the fact that the test vehicles incorporated brakes which were not generally capable of achieving wheel lockup during braking on a dry pavement. As a result, when a greater load is applied, the brakes become saturated at a given level of torque output such that a longer stopping distance is obtained. These data represent the type of vehicle and brake system arrangement which suffers a net loss in braking capability as a result of increased gross weight.

Interpretation

As in the case of the influence of increases in axle load, it is not possible to generalize on the influence of increased gross weight on limit stopping capability. If gross weight is increased by, say, 10%, some vehicles will show a small reduction in minimum stopping distance while, in the worst case, others will suffer an increase in stopping distance of the order of the fractional increase in gross weight. Since this latter case poses a potential degradation in vehicle safety quality, it should merit the attentions of those concerned with how increased load allowances might negatively influence the accident record.

3.2.2 Yaw Stability. Yaw stability is characterized here by means of the understeer measure defined earlier in Section 2.2.2.3. The behavior of each of two selected vehicle configurations was examined for various cases of gross vehicle weight and also for a case in which the baseline loading condition is degraded by the installation of radial-ply tires on the tractor's steering axle and bias-ply, lug-tread tires on the tractor's rear axles. This variation was discussed in Section 3.1.2. The results presented below serve to illustrate the influence of gross weight changes as compared against the influence of a common, in-service practice represented by the tire mix cited above.

Shown in Figure 29 are the understeer measures obtained for the selected vehicles as a function of the axle load arrangements which accompany various gross weight limits.

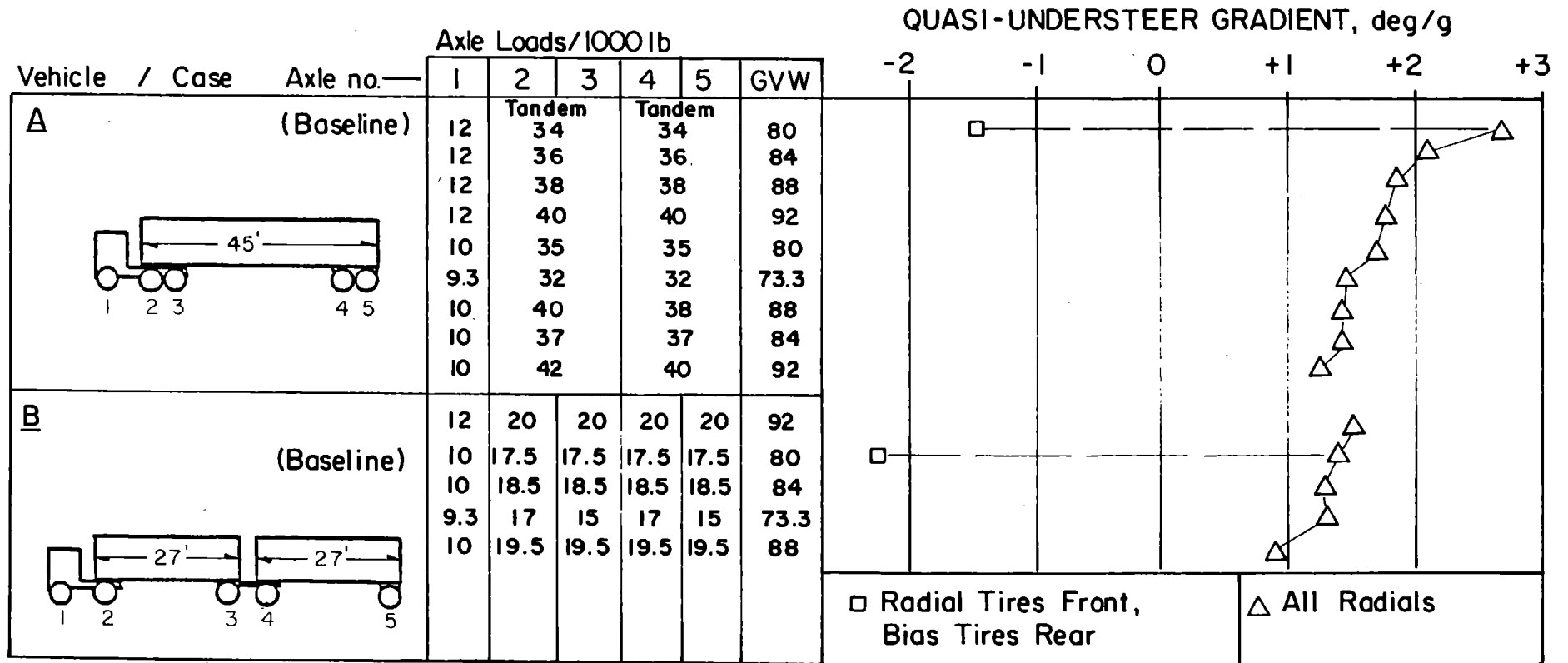


Figure 29. Influence of Gross Weight Variations on Understeer Level

Observations

1) Regarding the five-axle tractor-semitrailer, we note that the baseline condition produces the highest value of understeer and that all of the considered variations cause the performance to degrade with respect to that baseline.

2) It is interesting to note that the case labeled 9.3/32/32, which constituted the typical load distribution for reaching the pre-1974 federal gross weight limit of 73,280 lbs (33.2 m tons), results in an understeer level which is virtually at the bottom of all the cases considered.

3) As was pointed out in Section 3.1, the understeer level is influenced strongly by the fore/aft distribution of loading on the tractor—and only in a secondary manner by the absolute level of gross weight, itself. Thus, the cases which generally appear the most favorable (i.e., offering the highest value of understeer) are those which show the highest values of the ratio, front axle load/total tractor load. Thus, gross weight increases, per se, do not categorically reduce understeer level, but do cause a degradation in understeer if a more rear-biased load distribution results. The most dramatic case supporting this point is the 92,000 lbs (41.7 m tons) gross weight condition of the doubles combination. We see that this loading condition (which yields the highest gross weight considered) produces the highest understeer level of all for this vehicle since the 12/20 distribution of tractor load is the most forward-biased of all the indicated load arrangements.

4) The changes in understeer imposed by the examined gross weight variations are small compared to the influence of the cited tire mix condition. For both vehicle types, the tire mix causes a loss of approximately 4 deg/g of understeer with respect to the baseline condition, while a 10% increase in gross weight above the baseline value results in only 0.5 to 0.8 deg/g reductions in understeer.

Interpretation

The results show that a gross weight increase will not necessarily degrade understeer level. The more rear-biased the tractor load distribution accompanying an increased gross weight, however, the greater will be the negative influence on understeer.

The extent of understeer losses due to increased loading were seen to be rather small in contrast to those deriving from the common tire mix condition. The discussion presented in Section 3.1.2, however, suggests that heavy-duty trucks provide only marginal levels of understeer, at best, in intermediate-severity maneuvers. Thus any change in vehicle loading allowances which may serve to degrade the understeer level of a broad portion of the truck population should be considered seriously. It should also be noted that the more forward weight distributions which appear to make a gross weight increase more tolerable, from an understeer point of view, will also bring about a reduced roll stability performance, as shown in the next section.

3.2.3 Roll Stability. The influence of gross weight changes on roll stability involves the same mechanisms as were outlined for cases of axle weight variations, in Section 3.1.3. That is, gross weight variation will influence roll stability in accordance with the accompanying change in (1) payload c.g. height, (2) payload weight, and (3) the distribution of axle load among the differing suspensions on the vehicle. Shown in Figure 30 are values of rollover threshold calculated for the two selected vehicle types as a function of the various gross weight loading schemes.

Observations

1) Gross weight increases, as implemented here, categorically reduce the roll stability of the vehicles studied.

2) For a given value of gross weight, the arrangement of load distribution among axles influences the rollover threshold. The greater reductions in rollover threshold derive from the placement of a greater fraction of the load on the tractor's steering axle. This influence is a result of the characteristically softer suspensions employed on tractor steering axles.

ROLLOVER THRESHOLD, g's

LBS/1000

200

.250

.300

.350

.400

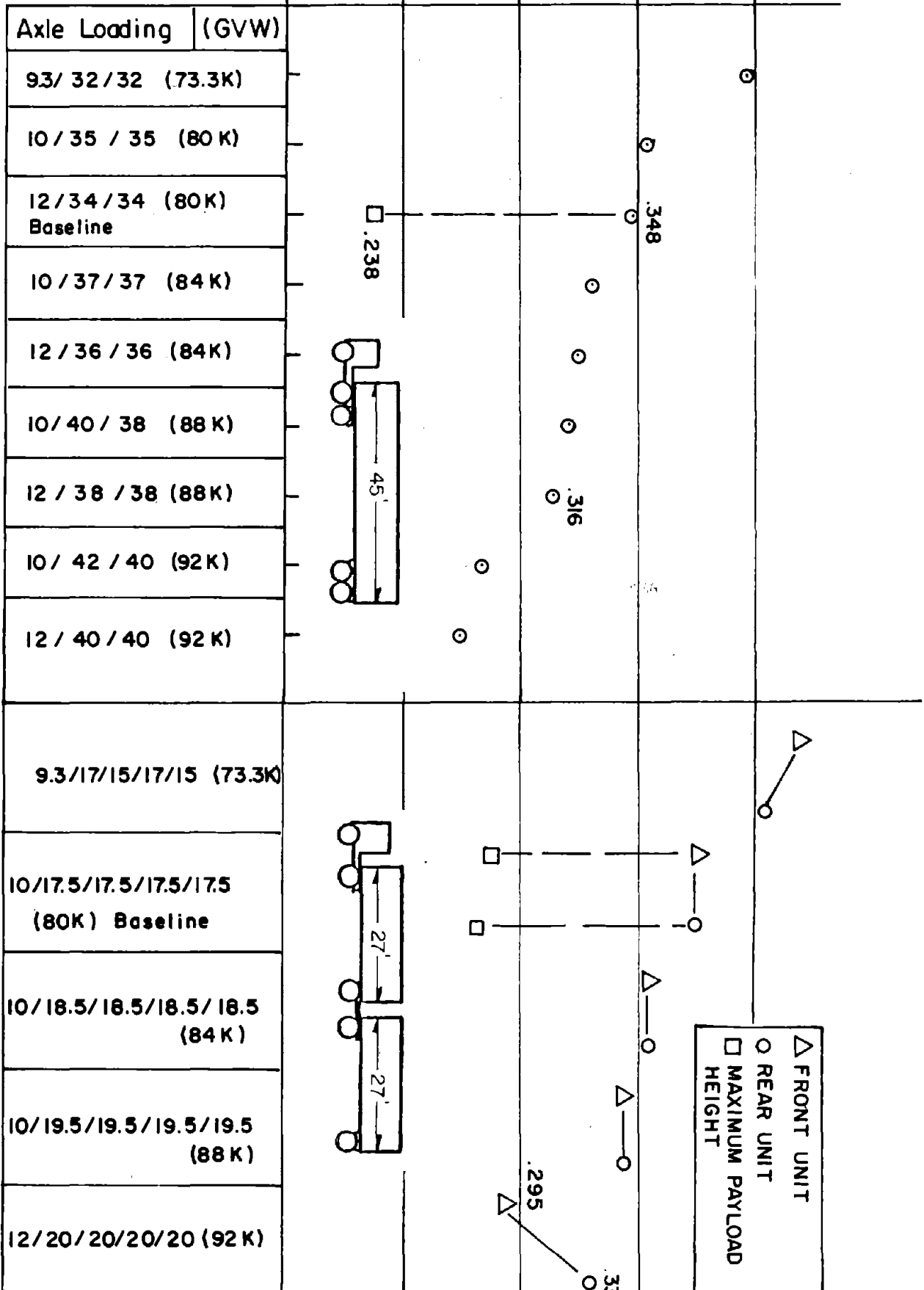


Figure 30. Influence of Gross Weight Variations on Rollover Threshold

3) Somewhat differing rollover thresholds are exhibited by the front trailer (and tractor) as opposed to the rear trailer (and dolly) of the doubles configuration. Of course, it is rational to be considering separate rollover thresholds for the front and rear units since they are decoupled, in roll, due to the nature of the pintle hitch device which connects the dolly to the lead trailer. The differences in rollover threshold values derive from a number of distinctions in the parameters describing the respective units. These parameters include suspension spring rates, freeplay in leaf suspensions, and the composite c.g. heights of the respective front and rear "units." To summarize these differences in a most general way, one observes that the rear trailer has a relatively high composite center of gravity but is supported on relatively 'stiff' suspensions, while the lead trailer and tractor assembly has a lower composite c.g. height but is supported to a large degree by the softer tractor suspensions.

The most conspicuous difference between the rollover thresholds of front and rear units of the double is seen in the case of the 92,000 lbs (41.7 m tons) gross weight. The observed difference (viz., .295 g's for the front unit versus .331 g's for the rear unit) comes about due to the dominant influence of the front-biased load on the tractor. That is, the front-bias in loading is sufficiently great in the 92,000 lbs (41.7 m tons) load case that it dominates the other roll-related influences which distinguish the roll stability levels of the front and rear vehicle units.

4) Figure 30 also shows the low level of rollover threshold which is obtained in the 80,000 lbs (36.3 m tons) gross weight condition, when the center of gravity of the payload is placed at the highest location which occurs in normal service. The indicated value of 0.238 g's, for example, in the case of the five-axle tractor-semitrailer derives from a payload c.g. height of 105 inches (267 cm). This "highest c.g." condition is included in the figure in order to provide some relative scaling to the influences deriving from gross weight changes.

Firstly, the 0.283 g value can be compared to the baseline loading condition involving an 84-inch* (213-cm) value for payload c.g. height, for which a rollover threshold of 0.348 g's is obtained. We see that the indicated reduction in rollover threshold deriving from payload height is rather large in comparison, say, to the reduction deriving from a 10% increase in gross vehicle weight (compare, for example, the .348 g value to the .316 g value obtained in the case labeled 12/38/38—88,000 lbs). Thus, while gross weight increases are seen to have a definite and consistently degrading influence on rollover threshold, it is instructive to compare the magnitude of these influences with the rather large range of rollover thresholds occurring in normal service due to variations in payload c.g. height.

Looking at the data for the double, the reduction in the rollover threshold of the baseline configuration due to the 105-inch c.g. height condition is seen to be somewhat less than that observed with the five-axle tractor-semitrailer. This reduction is, nevertheless, still relatively large in comparison to the reduction in rollover threshold deriving from the 10% increase in gross vehicle weight (for comparison, contrast the baseline double with the case labeled 10/19.5/19.5/19.5/19.5—88,000 lbs).

Interpretation

Rollover threshold was seen to be consistently degraded by increases in gross weight. The importance of the observed influences to the question of safety performance can, again, be examined with the aid of the accident data analysis which was outlined in Section 3.1.3. Shown in Figure 31 are the rollover threshold results for the five-axle tractor-semitrailer plotted onto the accident data curve discussed earlier. This figure illustrates that the gross weight changes which were considered have the potential for introducing dramatic changes in the incidence of rollover with this type of vehicle. As was discussed in Section 3.1.3, the basic curve, derived from BMCS accident data, is so steep in the 0.3-0.4 g range

* Note that the "baseline loading condition" involves an 80-inch (203-cm) value for the composite height of the sprung mass of trailers—including the trailer body tare mass and the payload mass. For this condition, the characteristic height of the center of gravity of the payload, itself, is approximately 84 inches (213 cm).

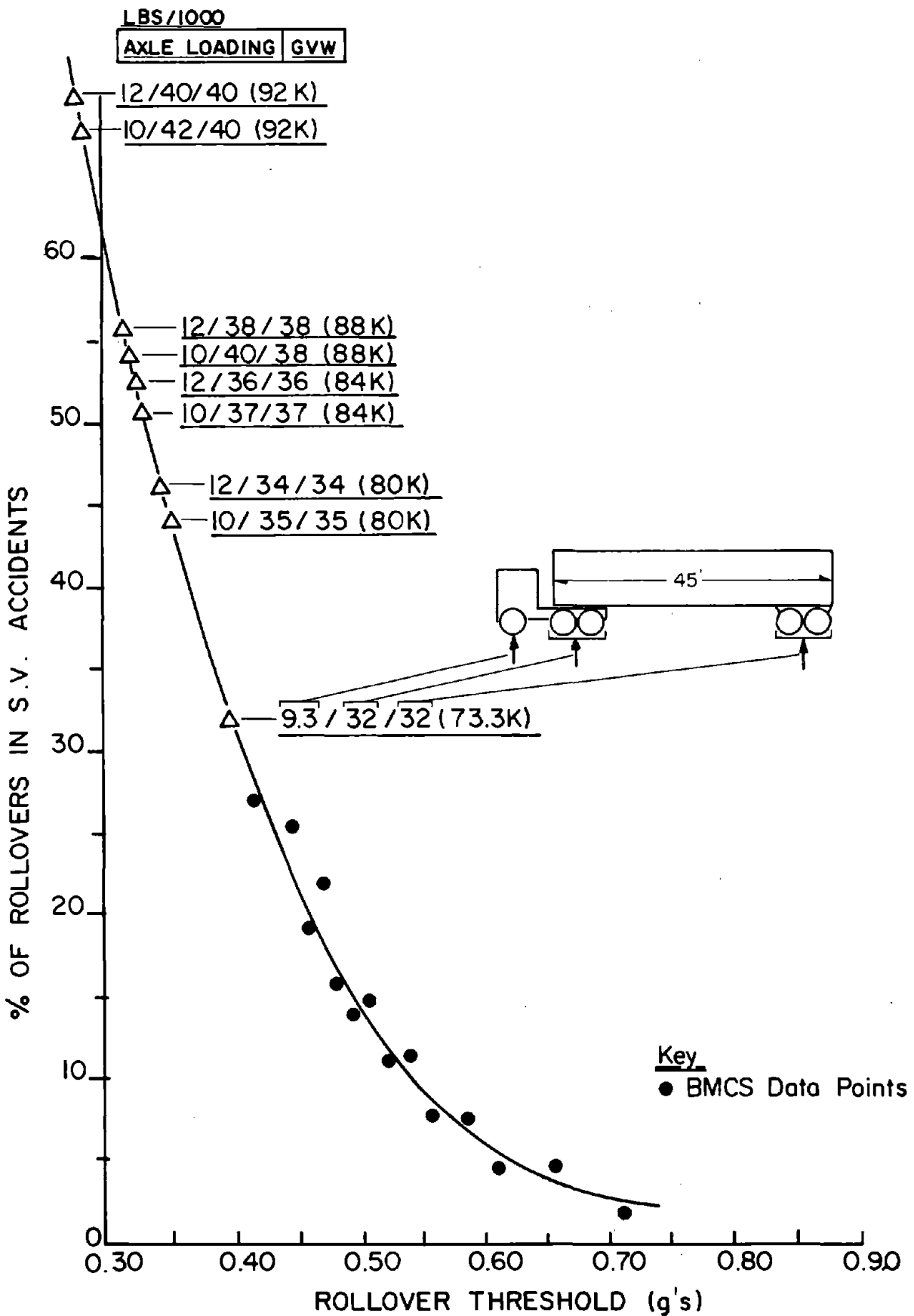


Figure 31. Overlay of Rollover Thresholds Representing Gross Weight Variations onto Curve Derived from Accident Data.

which is occupied by many fully-loaded vehicles that even relatively small variations in rollover threshold suggest substantial changes in rollover accident involvement. We see, for example, that the change from the pre-1974 gross weight value of 73,280 lbs (33.2 m tons) to the 80,000 lbs (36.3 m tons) value after 1974 implied a potential increase of 44% in the rollover rate of fully-loaded units. Of course, this result applies, in a strict sense, only to those operations involving payloads which approximate the special payload case employed in these analyses. Nevertheless, the results indicate that gross weight variations are powerfully capable of influencing rollover accident involvement.

It should also be pointed out that the cases of the five-axle tractor-semitrailer having a gross vehicle weight of 92,000 lbs (41.7 m tons) represent an overloading of the tandem suspensions whose parameters were selected to represent 38,000 lbs (17.2 m tons) ratings. It is useful to note, however, that suspension stiffnesses represented here were, if anything, on the higher end of the large range of stiffnesses found in the field, for the given value of suspension load rating. Thus, while the 92,000 lbs (41.7 m tons) gross weight imposes tandem loads exceeding 38,000 lbs (17.2 m tons), the specific spring stiffness values used to represent 38,000-lb-rated suspensions are seen as overlapping the range of values likely to be found in suspensions which are suitably rated for the higher load.

3.2.4 Rearward Amplification. The influence of gross weight variation on the rearward amplification exhibited by multiple-unit combinations was examined using the conventional doubles configuration. The rearward amplification measure was defined in section 2.2.2.5, and was applied to results obtained in the discussion of axle load influences, in Section 3.1.4. This measure basically scales the severity of the rollover threat which prevails during a rapid obstacle-avoidance maneuver. Values near 1.0 indicate that the threat is no different than that which may prevail under steady-turn conditions. Values greater than 1.0 can be looked upon as implying a proportionately greater threat of rolling over the last trailer of the vehicle combination as a result of the dynamic "amplification" phenomenon.

As will be shown below, the influence of gross vehicle weight on rearward amplification is quite low such that the results serve merely to establish a "negative finding." Of course, there were many other conceivable interactions between size and weight variables and vehicle performance which were not examined in this study because they were hypothesized to be of negligible importance. In this particular case, however, the influence was hypothesized to be low, but there was a desire that it be quantified because of the large level of interest which exists, generally, in the properties of the conventional doubles configuration. Shown in Figure 32 are results illustrating the influence of gross weight on rearward amplification.

Observations

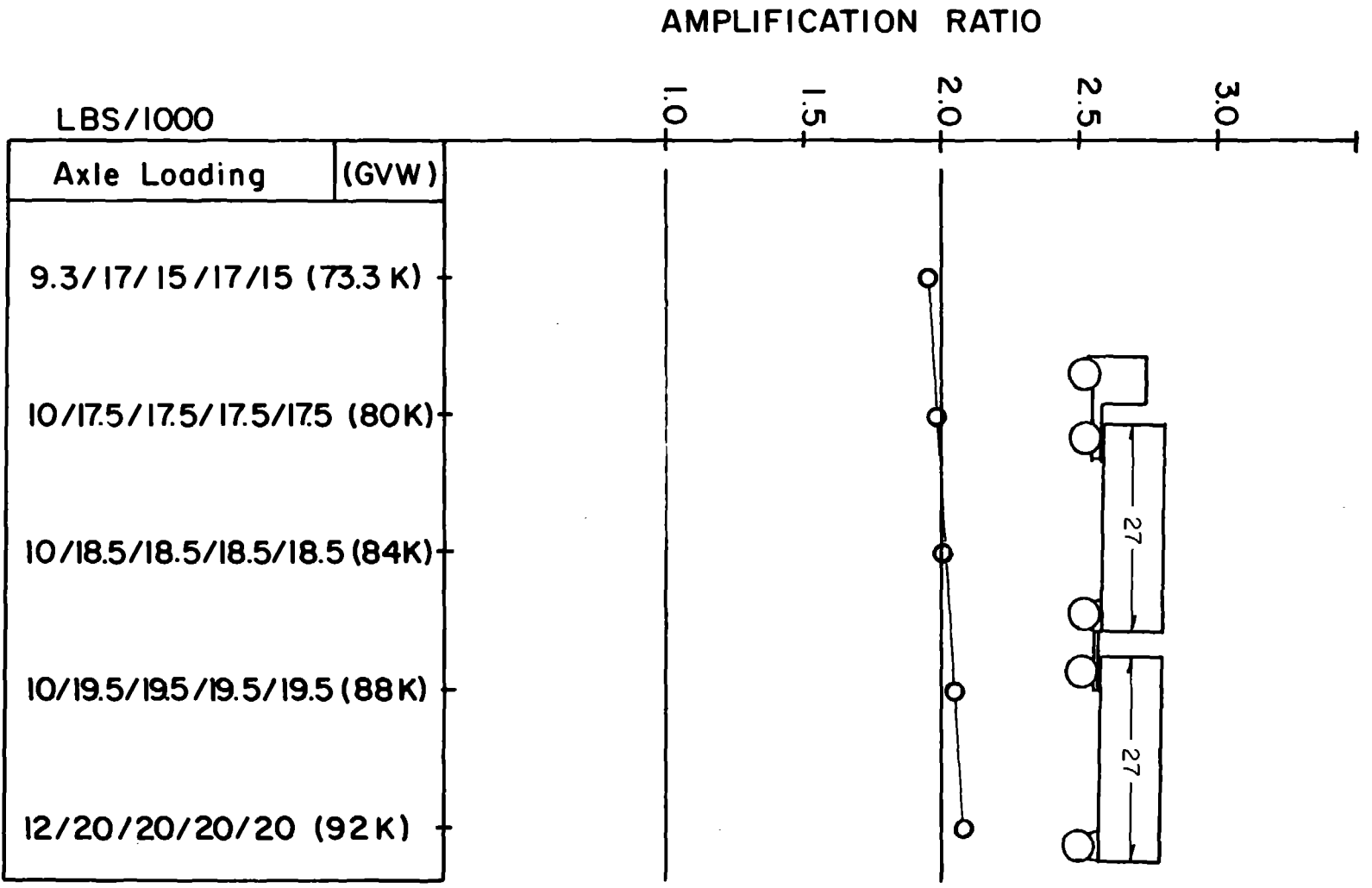
1) Increasing values of gross weight tend to increase the value of rearward amplification exhibited by a conventional doubles configuration comprised of two 27-foot, single-axle trailers.

2) The extent of this influence is rather minor. A 10% increase in gross weight, from 80,000 to 88,000 lbs (36.3 to 39.9 m tons) is seen to yield only a 1.5% increase in amplification ratio.

Interpretation

Although the conventional doubles configuration is seen to exhibit a very substantial level of rearward amplification at 55 mph, the specific level of gross weight to which it is loaded is of little consequence. Of course, since the rollover threshold of the vehicle declines strongly with increased gross weight (see preceding section), the potential for rolling over the last trailer in a rapid obstacle-avoidance maneuver definitely increases as gross weight increases. In fact, since this vehicle shows such a strong amplification behavior, one might be inclined to view a given reduction in the rollover threshold of the rear trailer of a double as having more importance than it would in the case of the five-axle tractor-semitrailer which exhibits rearward amplification values near 1.0.

Figure 32. Influence of Gross Weight Variation on Rearward Amplification.



3.3 Simple Variations in Payload Placement

In the previous section, the influence of various gross weight limits was examined. With each increase in gross weight above the baseline value, the height of the center of gravity of the payload was increased. The increase in c.g. height was determined on the basis of an assumption that a constant-density freight was involved such that a greater payload weight meant a greater payload height. Accordingly, results showing the influence of gross weight variations actually reflect the combined influence of the weight level, itself, as well as the height of the payload c.g. which rises when more load is added.

Beyond this formal scheme of interconnecting weight and payload height parameters, there was an interest in illustrating the influences of payload placement, per se, without an interdependence upon weight. Accordingly, a set of simulations was conducted to show, independently, the influence of the vertical, lateral, and longitudinal placements of the payload. The cases which were studied could be said to constitute "simple variations" in payload placement position since no other parametric variations were linked to the position parameters. Nevertheless, these simple variations were examined for vehicles having both 80,000-lb (36.3 m tons) and 88,000-lb (39.9 m tons) values of gross vehicle weight. In order to bound the investigation of payload placement, only the five-axle tractor-semitrailer and the five-axle conventional double were considered.

Although the payload placement subject does not stem directly from a size and weight "issue," per se, results showing the influence of payload position are seen as having significance to those concerned with size and weight policy making. Since payload placement variations occur commonly in day-to-day trucking operations, one might surmise that any degradations in control qualities which accrue due to size and weight changes may be exacerbated by the influences of payload placement. Further, it is very possible that liberalized size and weight allowances may lead to certain trucking practices which cause typical payload placements to change—and in a manner which cannot be anticipated now. A later review of the

implications of such changes may be aided by the data documented here. Also, those charged with granting permits for specialized trucking operations may be interested in the results because they are concerned with the implications of specific payload arrangements on stability and control performance.

3.3.1 Variation of Payload C.G. Height. Payloads comprising packaged freight are typically stacked on the loading floor of the vehicle such that they establish a particular height of center of gravity depending upon the density and overall stacked height of the freight. It is useful to describe this "payload c.g. height" parameter independently from the center of gravity of the empty vehicle, itself, since payloads vary tremendously as an inherent feature of the trucking enterprise. Further, since tractors and trailers are relatively uniform, with regard to the location of their centers of gravity in the empty condition, the net height of the composite (vehicle plus payload) center of gravity can be defined rather closely by simply identifying the payload weight and the payload c.g. height.

Shown in Figure 33, for example, we see the simple straight-line relationship between the c.g. height of the payload and the height of the center of gravity of the composite mass comprised of the van body of a 45-foot (13.7-m) semitrailer plus the payload. The vehicle dynamicist would call this latter variable the height of the composite "sprung mass" of the trailer since it describes the total mass resting upon the suspension springs (and the tractor fifth wheel).

Simulations were conducted with variations in payload c.g. height over the range of 70 to 110 inches (178 to 279 cm). One can interpret the practical significance of this range by referring to Figure 34. Since the load floor of the typical trailer is 52 to 55 inches (132 to 140 cm) above the ground, there is obviously some minimum value for payload c.g. height. The figure illustrates the approximate height to which homogeneous freight must be loaded to achieve payload c.g. heights having the values shown. Of course, mixed-density freight will have a lower net height of the payload than shown, for the same nominal overall height to the top of the stack of

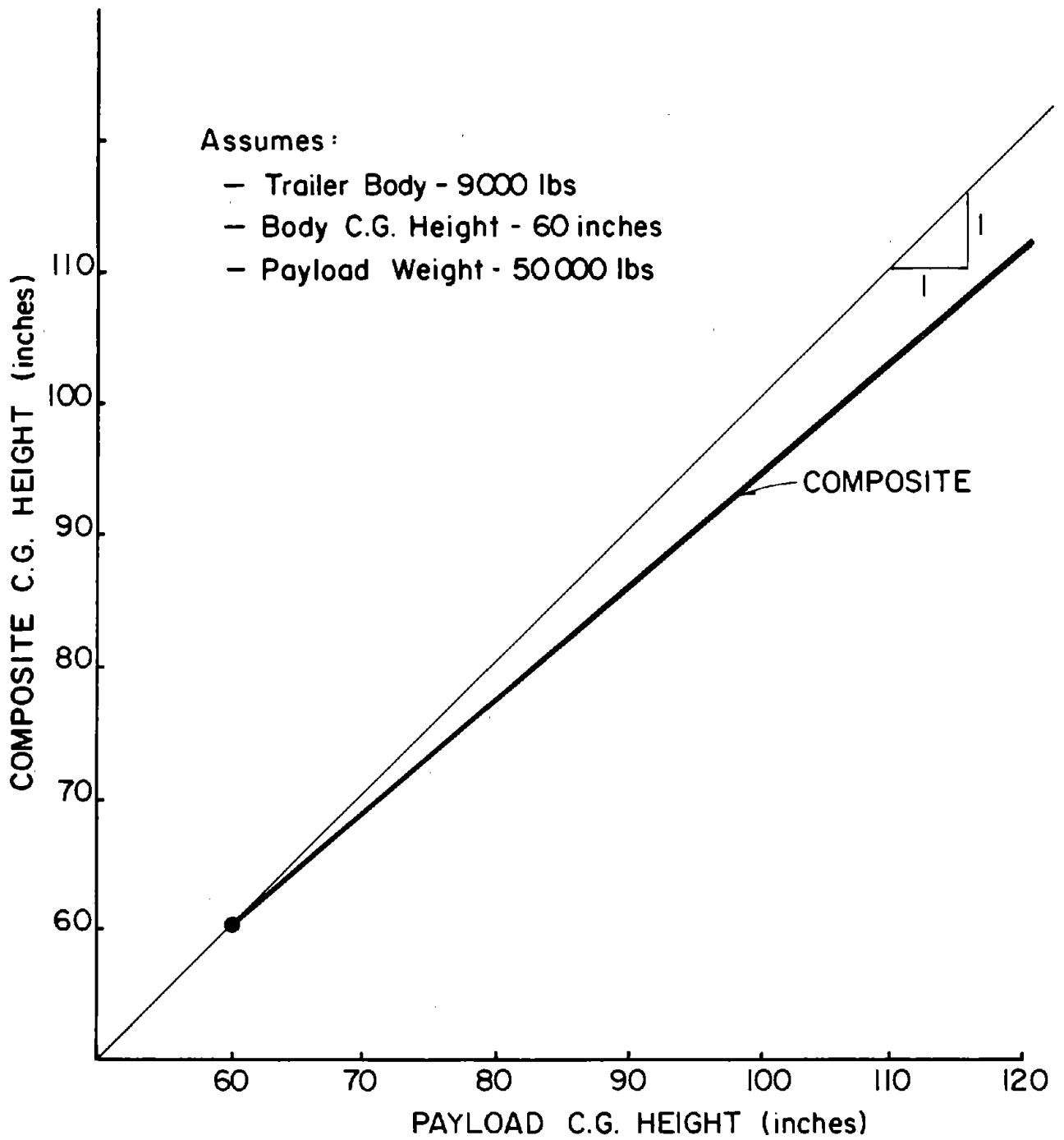


Figure 33. Relationship Between Payload C.G. Height and Composite (Sprung Mass) C.G. Height — Tractor with 45 ft. Semitrailer.

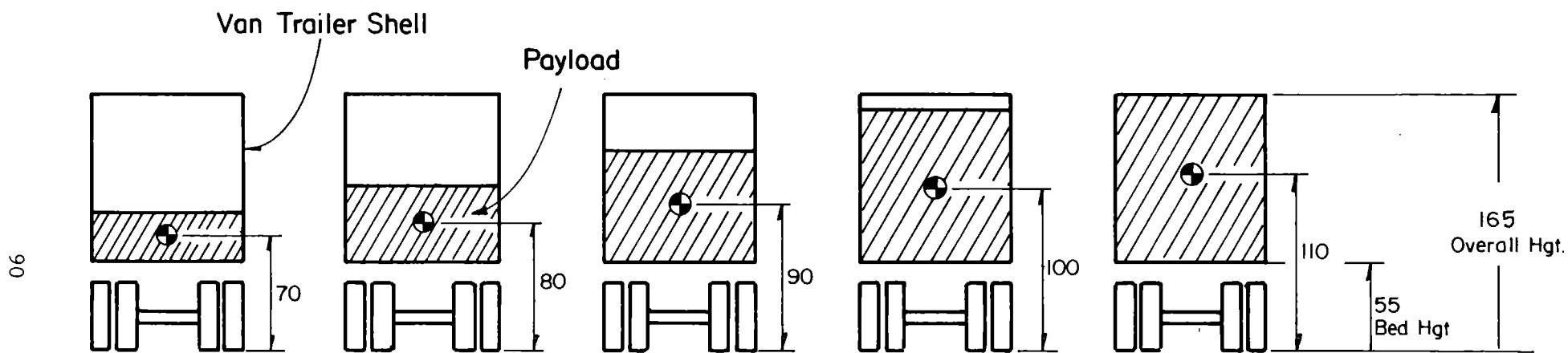


Figure 34. Illustration of Payload Height Variations

freight. The 110-inch (279-cm) value is the upper extremity in payload c.g. heights achievable on road vehicles—except for odd cases involving, say, fabricated machinery which may be peculiarly top-heavy. The maximum height of payload c.g. which is thought to be commonly achieved in the loading of van-type semitrailers is approximately 105 inches (267 cm).

The influence of payload c.g. height on vehicle performance has been characterized according to stopping distance, yaw stability, and roll stability properties. Measures expressing the sensitivity of these properties to payload c.g. height are presented below.

3.3.1.1 Stopping distance. The height of the payload center of gravity is of importance to braking behavior insofar as the dynamic changes in axle load which occur during braking depend upon this parameter. When the vehicle is decelerating, the load borne on the rear axle decreases while load applied to the front axle increases. If a vehicle is equipped with brakes which are capable of producing large levels of torque at the rear axle, with respect to the rear-axle load, one will typically find that the lockup of rear wheels will constitute the common limitation on that vehicle's stopping capability. For the case of an increase in the height of the payload center of gravity on such a vehicle, the reduction in load on the rear axle will be even greater than in some baseline case such that rear-wheel lockup will occur at an even lower level of deceleration. Accordingly, vehicles having such braking systems of this type will show increasing stopping distances with increases in payload c.g. height.

For vehicles incorporating "torque-limited" braking systems, as mentioned in Section 3.1.1, changes in payload c.g. height may have little or no influence on stopping distance performance. Clearly, if the additional changes in dynamic axle load deriving from an increased height of the payload c.g. do not render the rear brakes capable of achieving wheel lockup, the change in c.g. height will not have affected stopping distances. On the other hand, if an increased height of payload causes the rear axle to become sufficiently lightly loaded that rear-wheel lockup is achieved, the result will be an increase in stopping distance.

Shown in Figure 35 are the results of simulations representing the influence of payload c.g. height on the stopping distance performance of the five-axle tractor-semitrailer and the five-axle double. The data illustrate conditions covering both dry and slippery road surfaces for both the 80,000- and 88,000-lb (36.3- and 39.9-m tons) levels of gross vehicle weight. As discussed in Section 3.1.1, the simulated vehicles incorporated brake systems which are seen as representing typical practice in new vehicle design. That is, these vehicles incorporate trailer brakes which are relatively high in torque capability, given the levels of load which prevail at the respective axles during braking. Thus, such vehicles are commonly limited in stopping distance performance, per the criterion used here, by the incidence of wheel lockup at the trailer axle(s).

Observations

1) There is a 3 to 6% increase in stopping distance for the tractor-semitrailer as payload c.g. height increases over the range which was examined.

2) There is a 5 to 11% increase in the stopping distance for the doubles combination over the examined range of payload c.g. heights. The double exhibits greater sensitivity to c.g. height because, with its shorter trailer wheelbases, it suffers a greater dynamic change in axle load with each incremental change in payload height. Thus, for the higher levels of payload c.g. height, the "overbraked" rear axle of the second trailer achieves lockup at a lesser value of deceleration than is attained, before lockup, with the five-axle tractor-semitrailer.

Interpretation

It is possible to generalize, to some degree, upon the influence of an increased height of the payload c.g. on stopping distance performance. That is, if an increase in the height of the payload has any effect upon the stopping capability of vehicles, it will generally cause the stopping distance to increase. As the results show, the degree of this influence will not be major for common types of commercial vehicles.

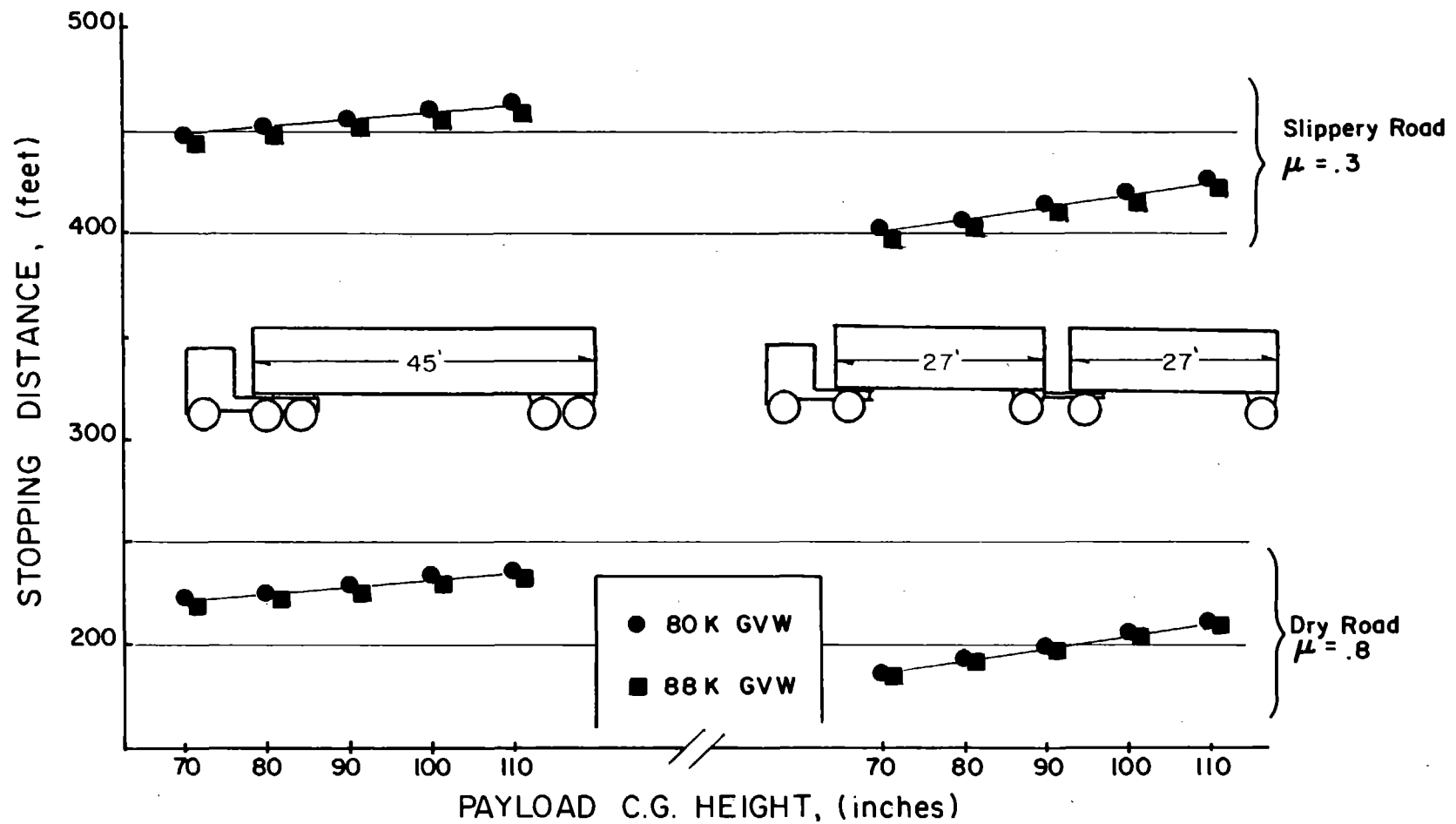


Figure 35. Influence of Payload C.G. Height on Stopping Distance Performance

As the wheelbase of the vehicle becomes shorter, however, the degradation in braking capability will become greater. In the case of a straight truck having a very short wheelbase, for example, the influence of the height of the payload c.g. could constitute a major determinant of the vehicle's emergency braking capability. Perhaps the greater concern with high c.g. locations on short-wheelbase trucks is that the greater likelihood of locking the rear wheels poses a greater threat of the vehicle producing a "spin-out" type of yaw instability. Such an instability quickly exposes the vehicle to the large "sideslip" attitude which promotes roll-over. Since the greater c.g. height also reduces the inherent roll stability of the vehicle (see Section 3.3.1.3, below), the elevated c.g. condition is seen as especially hazardous to the operation of short-wheelbase trucks.

3.3.1.2 Yaw stability. Payload c.g. height is a parameter which has the potential for influencing the steady-cornering response of trucks and tractors. This potential stems from the peculiar nature of the pneumatic tire in response to changes in vertical load. The height of the payload c.g. determines the extent to which the loads carried by right- and left-side tires tend to change whenever the vehicle travels through a curve. The higher the c.g., the greater will be the difference between the loads carried by the tires on the inside of the turn (that is, on the side of the vehicle which is closest to the turn center) as opposed to the tires on the outside of the turn. Due to peculiarities in truck suspension design, the rear tires on a truck or tractor generally bear "more than their fair share" of this load change than do the front tires [14]. As a result, the rear tires suffer a net loss in their ability to develop the lateral forces which assure a stable yaw response. Thus, it can be said that an increase in payload c.g. height has the potential for degrading the yaw stability of heavy vehicles.

In Figure 36, the influence of payload c.g. height on the understeer measure is illustrated for cases involving the five-axle tractor-semitrailer and the five-axle double. Results are shown for both the 80,000- and 88,000-lb (36.3- and 39.9-m tons) gross weight conditions.

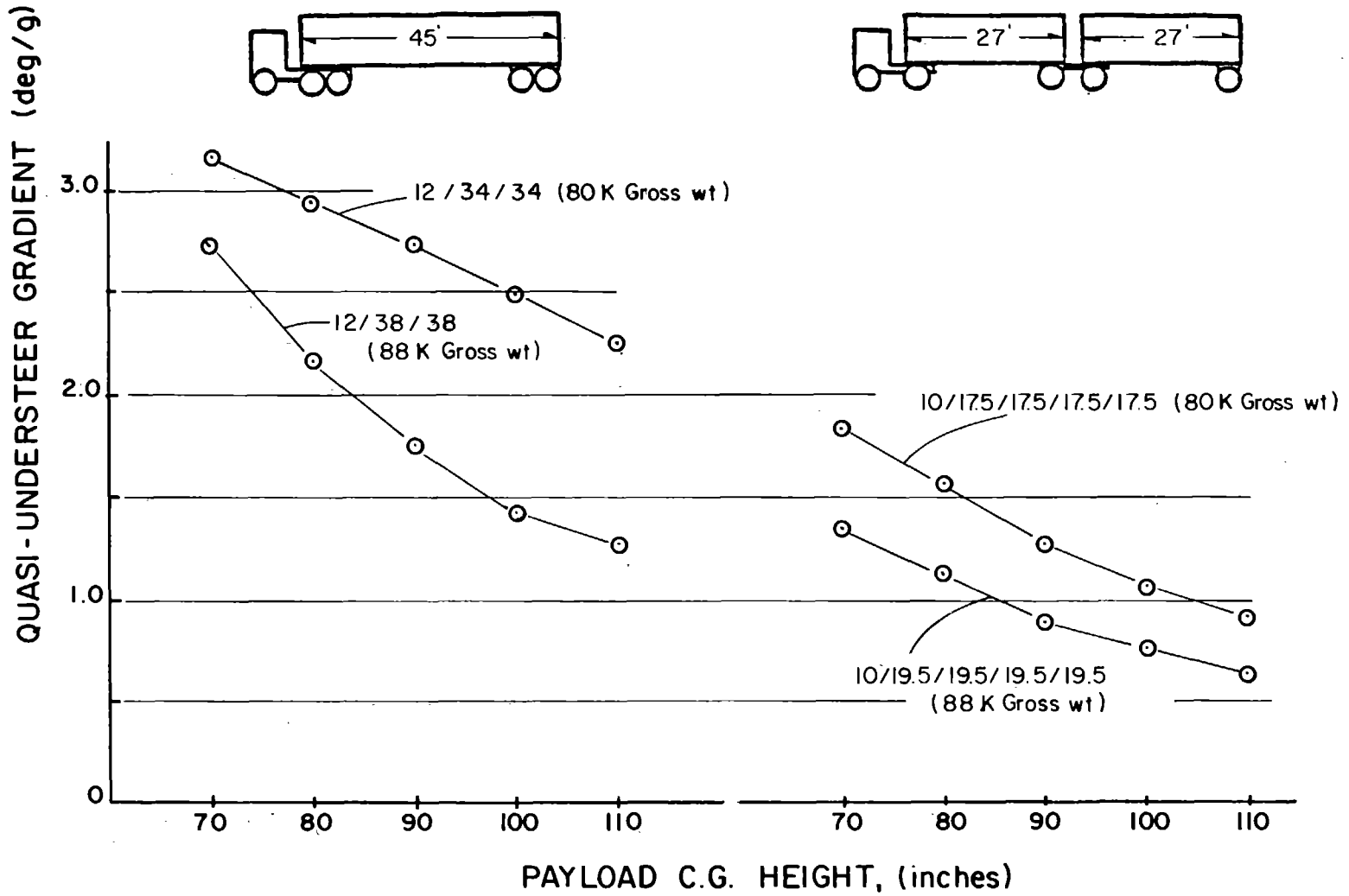


Figure 36. Influence of Payload C.G. Height on Understeer

Observations

1) The results for both the tractor-semitrailer and the double show a declining understeer level with increasing c.g. height. These limited results show an influence of payload c.g. height on the "quasi-understeer measure" ranging from -0.015 to -0.040 deg/g per inch of payload c.g. height, for the fully-loaded condition.

2) Gross weight variations do not have a consistent influence upon the sensitivity of the understeer property to changes in payload c.g. height.

Interpretation

As discussed earlier, the understeer level exhibited by heavy trucks in the intermediate range of maneuver severity (between, say, normal driving and the level needed for rollover) is rather low, and tends toward an unstable yaw response in certain cases. Clearly, the influence of increases in payload c.g. height is to promote this tendency. Thus, if a change in size and weight allowances causes the understeer level of typically-loaded vehicles to degrade, the condition will be further exacerbated by an increase in payload c.g. height beyond the "typical" value.

3.3.1.3 Roll stability. Clearly, increases in c.g. height impose a strong negative influence upon the roll stability of commercial vehicles. This influence derives from two mechanisms, as sketched in Figure 37. The first involves the fact that the centripetal acceleration arising during cornering produces a reaction force which "acts" through the center of gravity. The higher that the center of gravity is above the ground, the greater is the lever arm available for this reaction force to produce a rollover torque, or moment.

Secondly, since the payload (and trailer body) rest on suspension springs and ultimately, tires as well, the action of this "rollover moment" is able to deflect the body laterally, rolling it toward the outside of the turn. As the roll motion proceeds, the center of gravity of the suspended

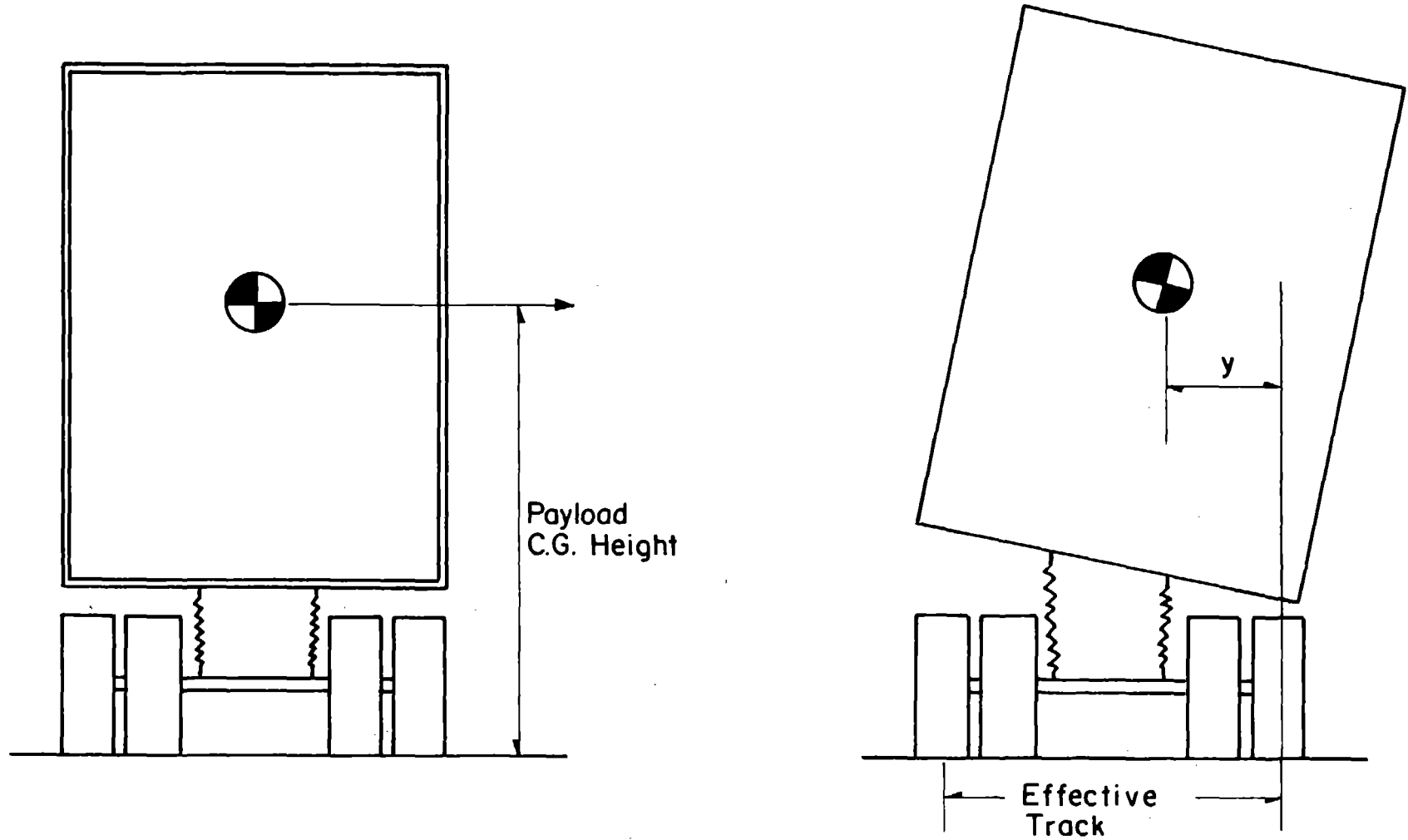


Figure 37. Two Aspects of the Influence of Payload C.G. Height on Roll Stability

body and payload becomes translated sideways, since the rotation takes place about a rather low "roll center." The higher the center of gravity, the greater is this lateral translation, per unit of roll angle. Clearly, as the lateral translation of the center of gravity increases, the vehicle approaches a rollover condition. Indeed, when the "y" dimension in Figure 37 becomes zero, the point is reached at which rollover motion will proceed, even without the centripetal acceleration of a turning maneuver.

Shown in Figure 38 are results illustrating the influence of payload c.g. height on the rollover threshold of the five-axle tractor-semitrailer and the five-axle double.

Observations

1) We see that the obvious influence of this parameter produces profound numerical results over the range of payload c.g. height. The strength of the influence is nominally -0.01 g's per inch of payload c.g. height.

2) The influence of the gross weight difference is (a) relatively small in comparison to the influence of payload c.g. height over the range and (b) not instrumental, for cases of 80,000 and 88,000 lbs (36.3 and 39.9 m tons) GVW, in altering the basic sensitivity to changes in payload c.g. height.

3) Payload c.g. height is not seen to influence the small differences in rollover threshold exhibited by the front and rear trailer units of the double.

Interpretation

Looking again at the results of the accident data analysis presented in Section 3.1.3, we can crudely link the rollover threshold results to a projection of rollover accident involvement. Shown in Figure 39 is an overlay of the rollover threshold values obtained with the tractor-semitrailer, at 80,000 lbs (36.3 m tons) gross weight, onto the curve derived from rollover accident data involving five-axle tractor-semitrailers. The overlay suggests that the profound influence which payload c.g. height

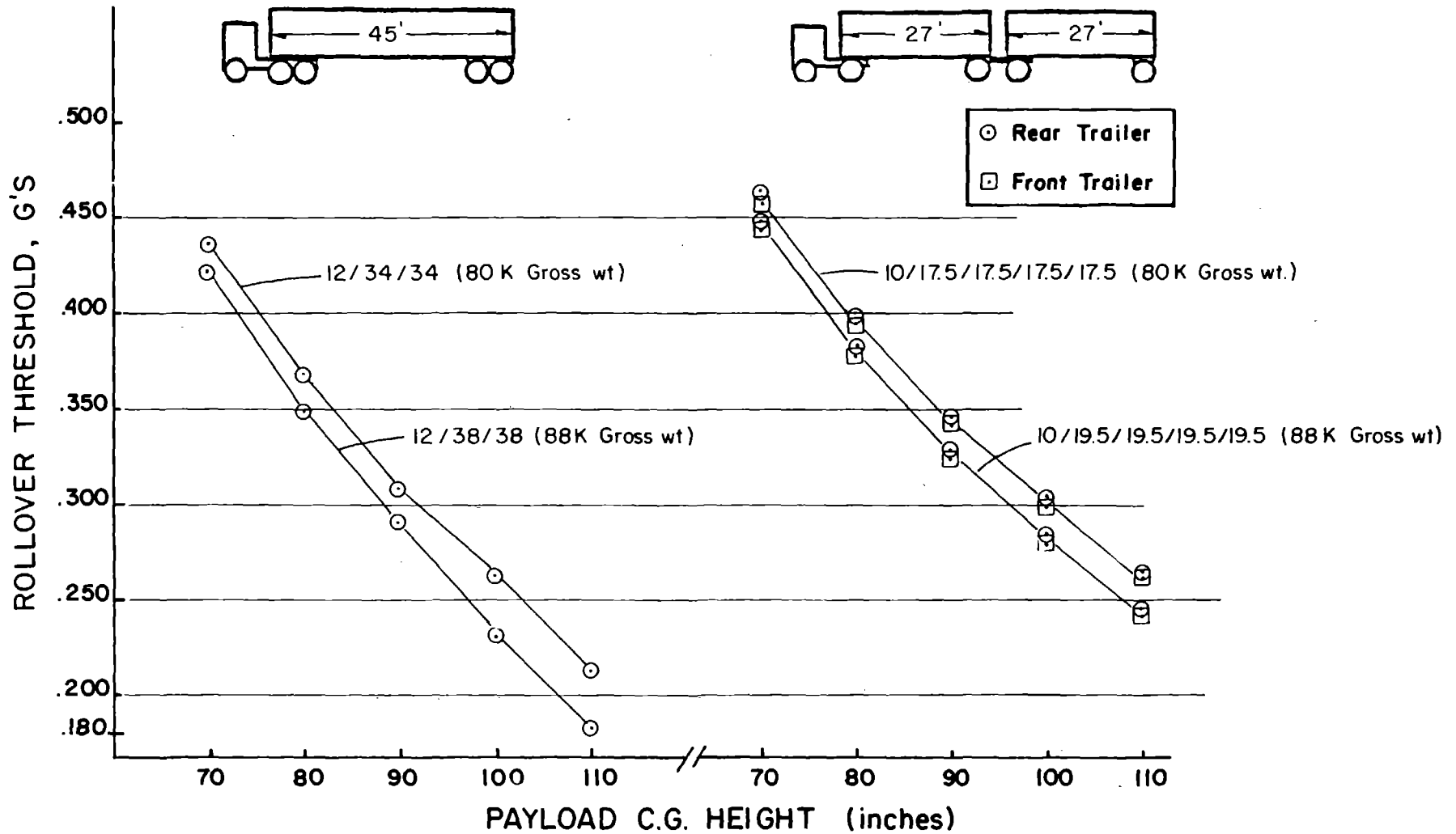


Figure 38. Influence of Payload C.G. Height on Rollover Threshold

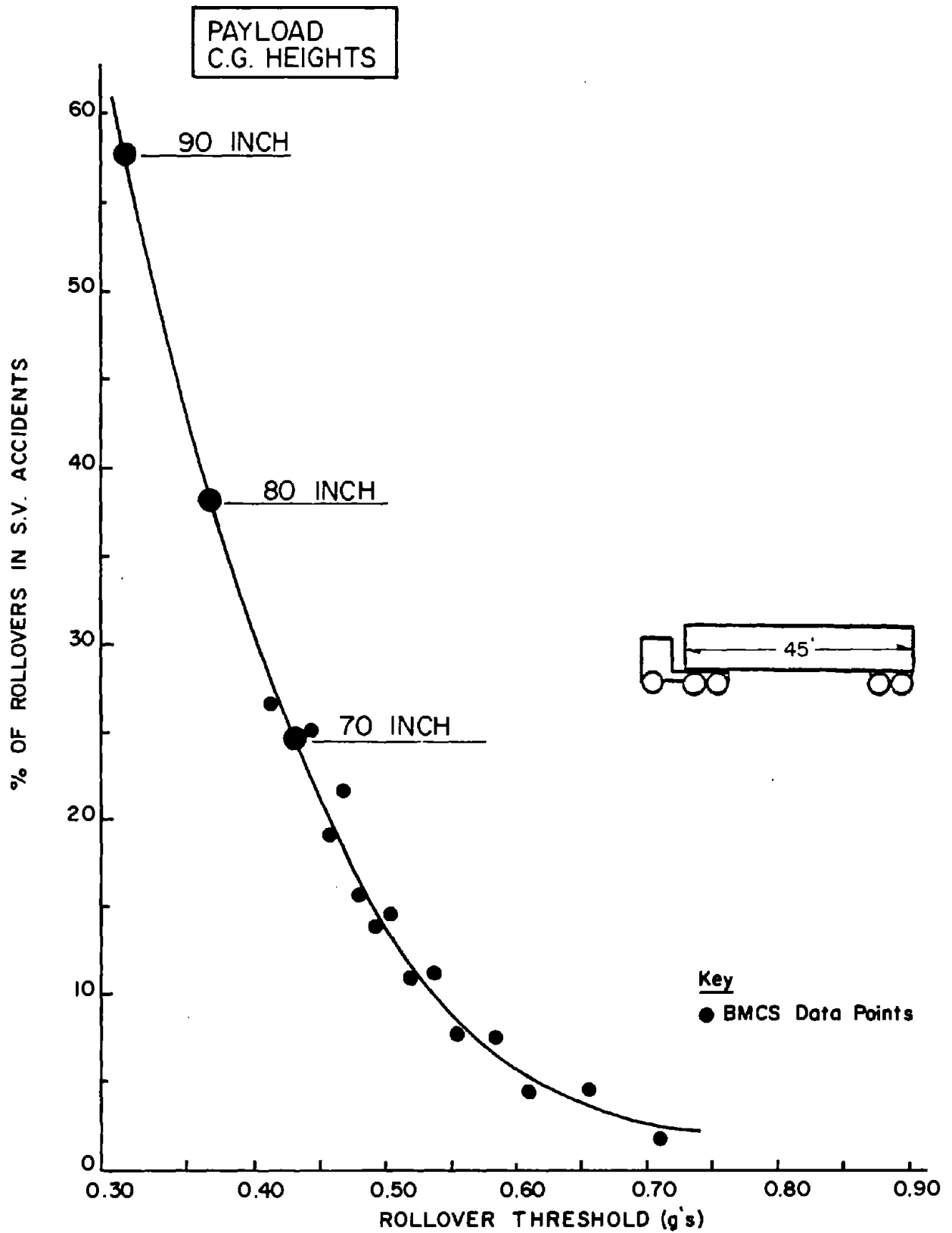


Figure 39. Overlay of Rollover Thresholds Representing Payload C.G. Height Variations onto Accident Data Curve

has on a vehicle's rollover threshold would cause changes in this parameter to have a major effect on rollover accident involvement in the field.

The values of rollover threshold obtained for the 100- and 110-inch (254- and 279-cm) levels of payload c.g. height are so low that they cause the rollover involvement percentage to fall above the top of the curve, as plotted. For extreme cases such as this, in which rollover threshold values go below 0.30 g or so, the accident data are seen as having little meaning. This view stems from the realization that as rollover threshold gets very low, vehicles most likely begin to "produce" rollover accidents simply as a result of the low level of stability, itself, rather than as a probabilistic consequence of being exposed to the contingencies of highway travel. When this phenomenon begins to dominate the mechanics of accident production, the ratioing of rollovers to single-vehicle accidents fails to be meaningful because the total number of single-vehicle accidents is rising.

Notwithstanding these observations, it is, perhaps, useful to consider that there is certain to be some low value of truck rollover threshold, below which rollover swamps all other types of accident experience. Such an hypothesis could be drawn from extrapolating the BMCS data; namely, that vehicles having rollover thresholds approaching 0.200 will experience an exceedingly high rollover rate such that rollover becomes the dominant accident type. It appears from the results presented in Figure 38 that a conventional five-axle tractor-semitrailer having a payload c.g. height of 110 inches (279 cm) and a gross weight of 80,000 lbs (36.3 m tons) essentially achieves this asymptotic condition.

3.3.2 Variation in Lateral Offset of Payload C.G. The behavior of the five-axle tractor-semitrailer and the five-axle double was examined for sensitivity to a lateral offset in the placement of the payload center of gravity. Such cases are thought to occur in normal service either as a result of (a) improper placement of freight at the loading dock, (b) the carriage of an inherently asymmetric load, or (c) the lateral shifting of cargo as permitted by either free space in a cargo container or looseness in tie-down elements. The subject was examined only from the viewpoint of

a rigid, fixed cargo. Thus, for example, the dynamic shifting of solid cargoes or the sloshing of liquids was not considered.

The two selected vehicle types were considered for cases of both 80,000 lbs (36.3 m tons) and 88,000 lbs (39.9 m tons) gross weight. Composite c.g. heights representing the combined masses of the trailer body and the payload were fixed at the baseline value of 80 inches (203 cm). Within these constraints, the lateral position of the payload c.g. was varied from 0 to 12 inches (30.5 cm) off of the trailer centerline.

The influence of a lateral offset in the c.g. position was evaluated in terms of yaw stability and roll stability as defined earlier. Also, the influence of the offset condition on the symmetry of vehicle response in an obstacle-avoidance steering maneuver was investigated. In both the yaw and roll stability examinations, the turn direction was selected such that the offset aggravated stability. That is, the payload was offset in all cases toward the outside of the turn.

3.3.2.1 Yaw stability. When a vehicle is loaded asymmetrically, from right to left, there exists a static differential in the loads borne by the right- and left-side tires. As mentioned earlier, the pneumatic tire is sensitive to load change in such a way that an equal up- and down-going change in load on the tires mounted at opposite ends of an axle results in a net loss in the ability of those tires, taken collectively, to generate the lateral forces needed to negotiate curves. If a vehicle's payload is offset in such a way that the change in tire load due to asymmetry adds to the change deriving from cornering, the "net loss" in lateral force due to the offset payload will add to the loss arising simply from the cornering process. Due to conventions in the design of front and rear suspensions on trucks and tractors, the rear-mounted tires will experience the primary load changes as a direct result of both the cornering process and the offset payload. Since the rear tires must be capable of producing suitable levels of side force, relative to the side forces produced by front tires, in order to assure a yaw-stable response, any mechanism serving to reduce the lateral force capability of rear tires tends to promote instability. An offset payload will thus have a

destabilizing effect on yaw behavior whenever the offset is toward the outside of the turn, thereby serving to increase the total difference in loads borne by right- and left-side tires.

Shown in Figure 40 are values of the understeer measure obtained for cases of increasing lateral offset in the placement of payload.

Observations

1) The offset payload tends to degrade the level of understeer which is exhibited.

2) The influence of the payload offset on the roll response of the vehicle is so profound, however, that the ramp-steer type of maneuver used to evaluate the understeer measure begins to pose certain interpretation difficulties at the higher values of offset for the tractor-semitrailer vehicle. In particular, the simulated maneuver exhibits a distinctly non-steady-state character for cases in which the payload offset has caused the vehicle's rollover threshold to drop near the 0.25 g level of lateral acceleration at which the understeer measure, itself, is evaluated. Accordingly, the understeer measures for the tractor-semitrailer at offset values of 9 and 12 inches (23 and 30 cm) are not shown since the offset is leading to an imminent rollover in the vicinity of 0.25 g's.

3) There is no clear connection between the 10% variation in gross weight level and the sensitivity of understeer behavior to payload offset.

4) The differences in the response of the two vehicles is apparently due to the contrast in suspension stiffnesses and the distribution of load among the tractor axles.

Interpretation

The observed influences of lateral offset on understeer are very substantial over the large range of offset values examined. Note, however, that the results which were presented cover the specific case of cornering maneuvers in which the offset of the payload is towards the outside of the turn. Thus, while this turn direction will indicate a reduced level of understeer, the opposite direction of turn will indicate an increased level. Accordingly, another problem posed by large lateral offsets in payload

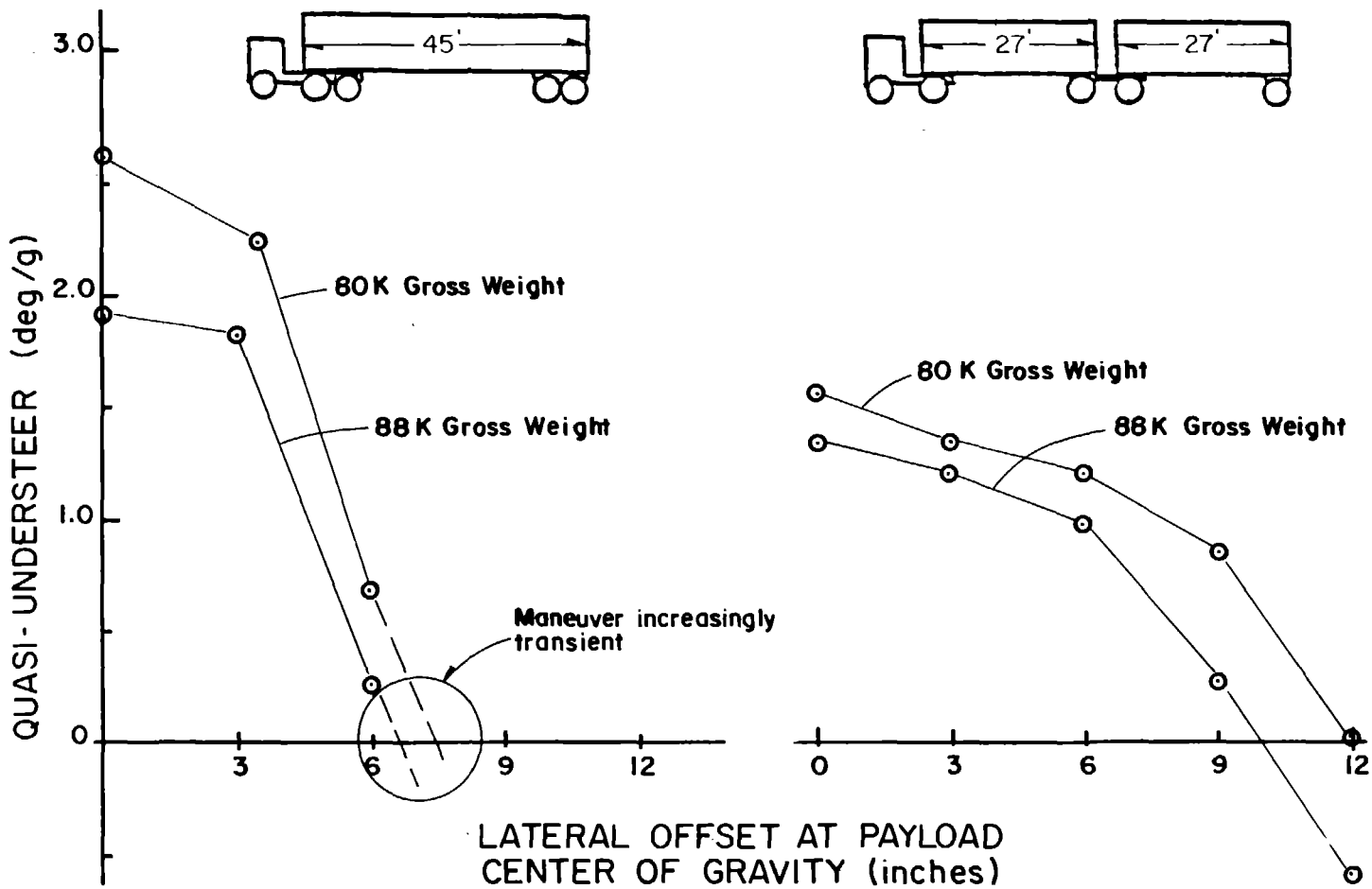


Figure 40. Influence of Payload Offset on Understeer Level

placement may be the asymmetry of the vehicle's cornering behavior, thus calling for especially adaptable driver actions in order to achieve suitable control. Certain dynamic aspects of the asymmetry question are discussed below, in Section 3.3.2.3.

3.3.2.2 Roll stability. Clearly, any lateral shift in the placement of the payload c.g. will tend to facilitate the rollover of the vehicle in the direction of the offset. Looking at Figure 41, for example, it can be easily shown that the rollover threshold of the vehicle should decline approximately by the ratio of the offset to the "effective half-track" dimension. For conventional vehicles and for the largest value (12 inch--43 cm) of offset considered here, this decline should approach 30% of the baseline value of rollover threshold.

Shown in Figure 42 are results indicating the influence of payload offset on the rollover threshold of the two selected vehicle types.

Observations

1) The rollover threshold is found to decline strongly with increasing payload offset—although somewhat less than the ratio of offset to half-track would indicate.

2) No interaction is seen between the level of gross weight and the influence of payload offset on rollover threshold.

3) Payload offsets can seriously degrade roll stability without inducing large, and obviously-noticeable roll angles to the vehicle at rest. An offset of 6 inches (15 cm), for example, produces a static roll angle of approximately 1.2 degrees.

Interpretation

Since the "effective half-track" dimension of commercial vehicles is in the vicinity of 40 inches (102 cm), relatively small values of offset will cause a significant reduction in roll stability. This observation should be noted by those trucking operations which commonly deal with transporting either asymmetric objects or freight which is packaged in

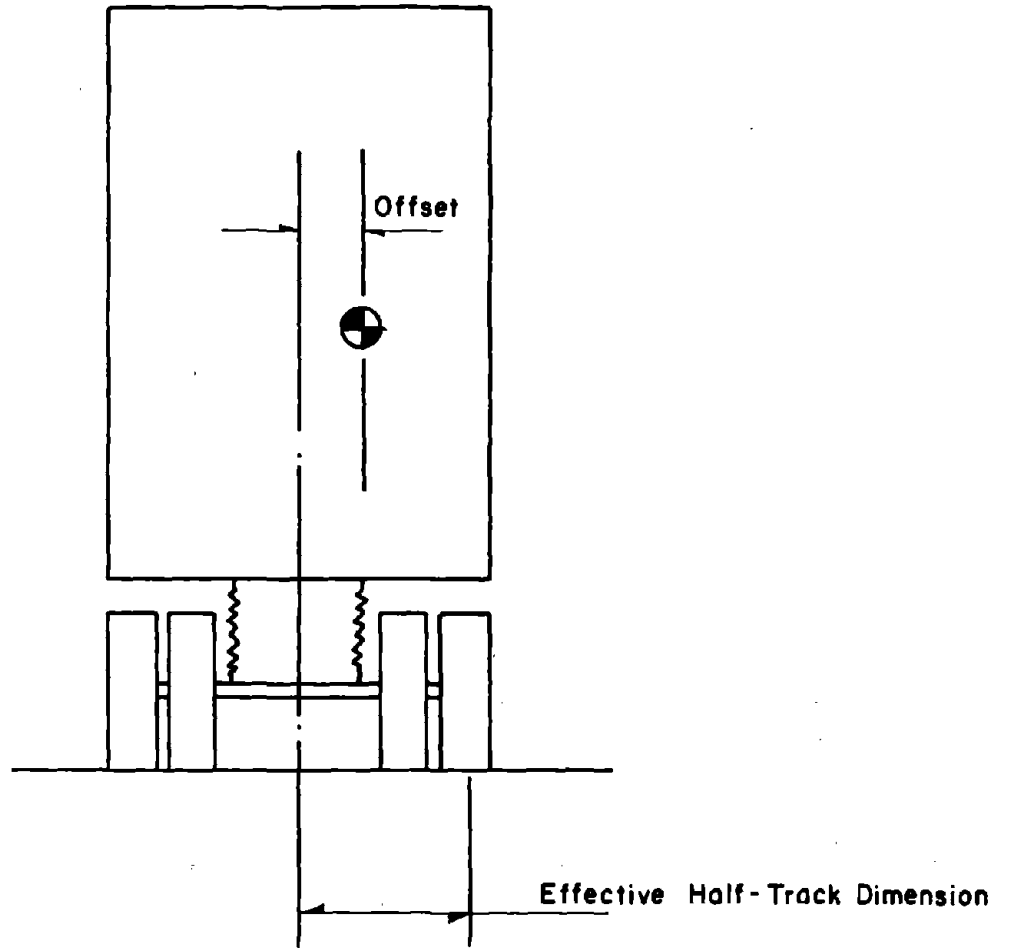


Figure 41. Illustration of Payload Offset Relative to the Effective Half-Track Dimension

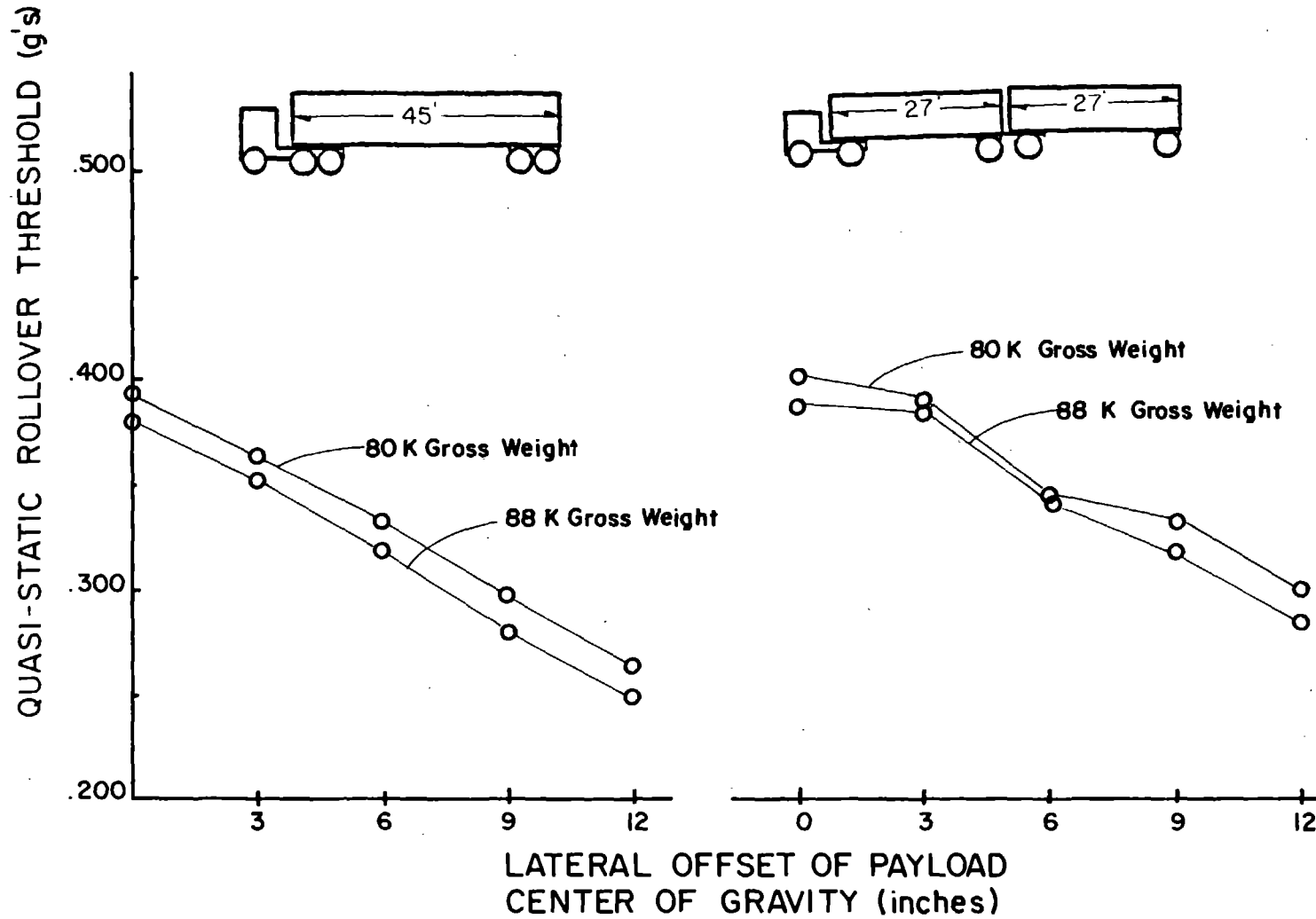


Figure 42. Influence of Payload Offset on Rollover Threshold

such a way that either dunnage or tie-downs are required to secure the load from shifting laterally during transit.

Making the connection, again, with the data relating rollover threshold to involvement in rollover accidents, one observes that even a 6-inch (15-cm) lateral offset in payload position would appear to threaten a 40% greater likelihood of rolling over—in the direction of the offset. Of course, it should also be acknowledged that the offset will improve roll stability in one direction and reduce it in the other. Thus, while there is certain to be a strong influence on rollover involvement regardless of the right/left polarity of the payload offset, the actual net outcome on the probability of rollover involvement depends upon the shape of the accident data curve relating rollover threshold to rollover involvement.

The static roll angle which a trailer would assume due to an offset payload may not be readily noticeable. Shown in Figure 43 is a drawing, to scale, of the front view of a tractor-semitrailer with the 1.2 degree trailer roll angle which would accrue from a 6-inch (15-cm) offset in a payload of full gross weight. The question is, could a driver readily detect, simply by visual observation, that his vehicle had been asymmetrically loaded (or had suffered a load shift while traveling)? While the human eye is known to be especially able to detect small discrepancies in relative angle, detection of the condition shown in the figure would appear, at minimum, to call for a distinct level of attentiveness on the part of the driver.

While it is clearly recognized that payload c.g. height varies over a broad range from truckload to truckload, the extent to which lateral offsets in payload placement occur in normal service is unknown.

3.3.2.3 Asymmetry of response to steering. Lateral offset of the payload c.g. suggests that the yaw response to steering may be different to the left than to the right. While comments to this effect were presented above, in relation to the understeer matter, there was special interest in the asymmetry of vehicle response for the case of a rapid lane-change maneuver. Simulation of such a maneuvering condition has produced results which address, qualitatively, the control issues involved.

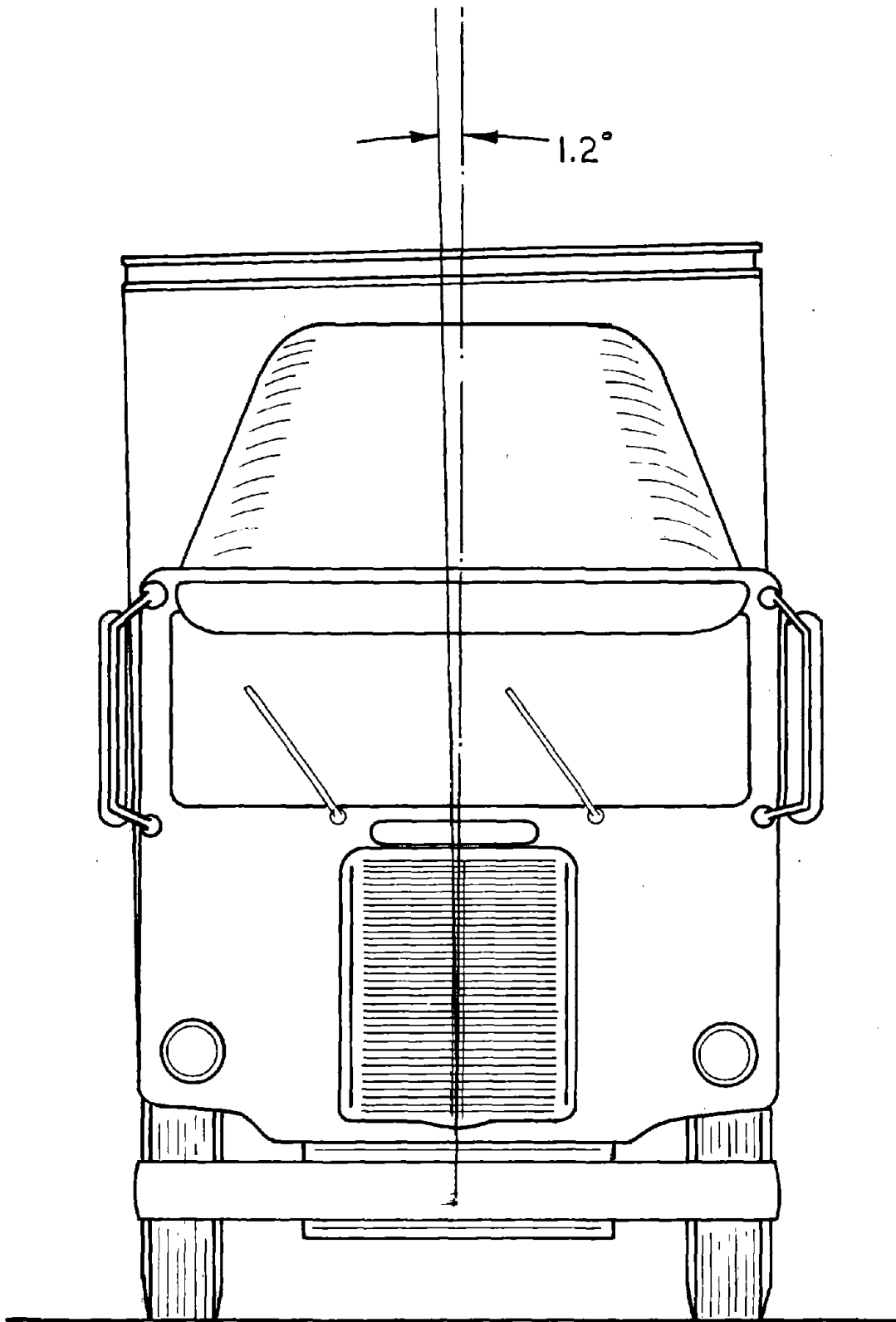


Figure 43. Sketch of Tractor Semitrailer with Trailer Listing 1.2° to Its Right Side (As Occurs with a Payload Offset of 6 inches, with Full-Weight Load)

Shown in Figure 44 are multiple records of the steering wheel input applied by a simulated driver for differing conditions of payload offset and for a fixed gross weight value of 80,000 lbs (36.3 m tons). The vehicle represented in these calculations is a five-axle conventional double. These signals indicate the form of steering input which was needed to achieve a specific maneuver involving a rapid lateral displacement of 12 feet (3.6 m) at 55 mph (88 km/h). Supplementing the steering input data are results shown in Figures 45, 46, and 47 illustrating, for various offset cases, the roll angle of the rear trailer in the doubles combination throughout the maneuver. Together, these results provide insight into the dynamic implications of the payload offset conditions.

Observations

1) The steering input data of Figure 44 show that rather little difference in steering action is required in order to achieve the same lane-change trajectory with differing levels of payload offset.

2) The roll angle records shown in Figure 45 show that, while an identical lane-change maneuver was being conducted in each case, there is a tremendous difference in the roll angle response of the rear trailer of the doubles combination for cases of 0 and 6-inch (15-cm) payload offset. The peak value of roll angle reached in the second phase of the maneuver is twice as large, in the case of the 6-inch (15-cm) offset, as that attained in the baseline case.

3) The roll angle records shown in Figure 46 illustrate that a large range of peak values of trailer roll angle are attained as a result of the increasing payload offset. Although the baseline, zero-offset, case produces a moderate 4 degree peak in roll angle, the 12-inch (30-cm) value of offset produces a temporarily-unstable roll response which causes the vehicle to roll through some 25 degrees before the recovery phase of the steering input brings the vehicle back down onto its tires.

4) Shown in Figure 47 is an illustration of the roll angle responses of the rear trailer when the payload offsets are employed on a doubles combination having a gross weight of 88,000 lbs (39.9 m tons).

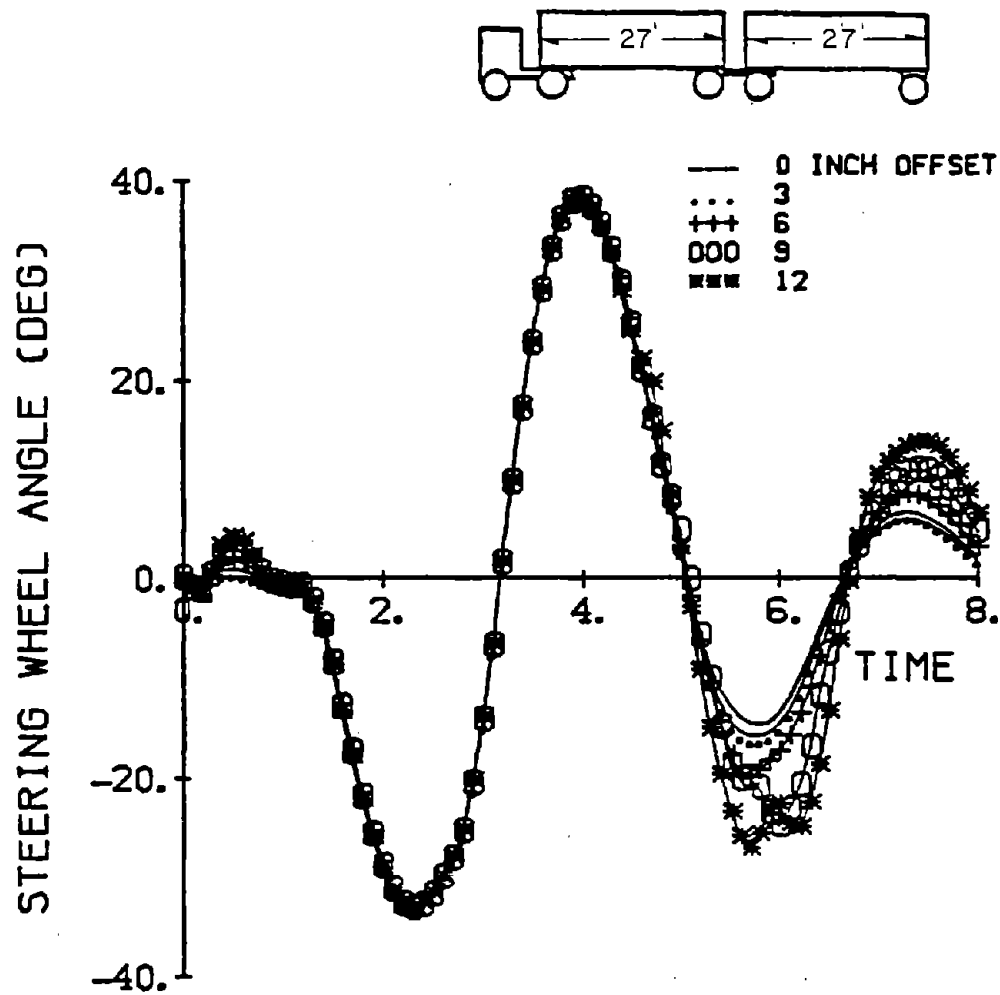


Figure 44. Differences in Steering Wheel Inputs Needed to Negotiate a 12 Foot Lane Change with Differing Payload Offsets.

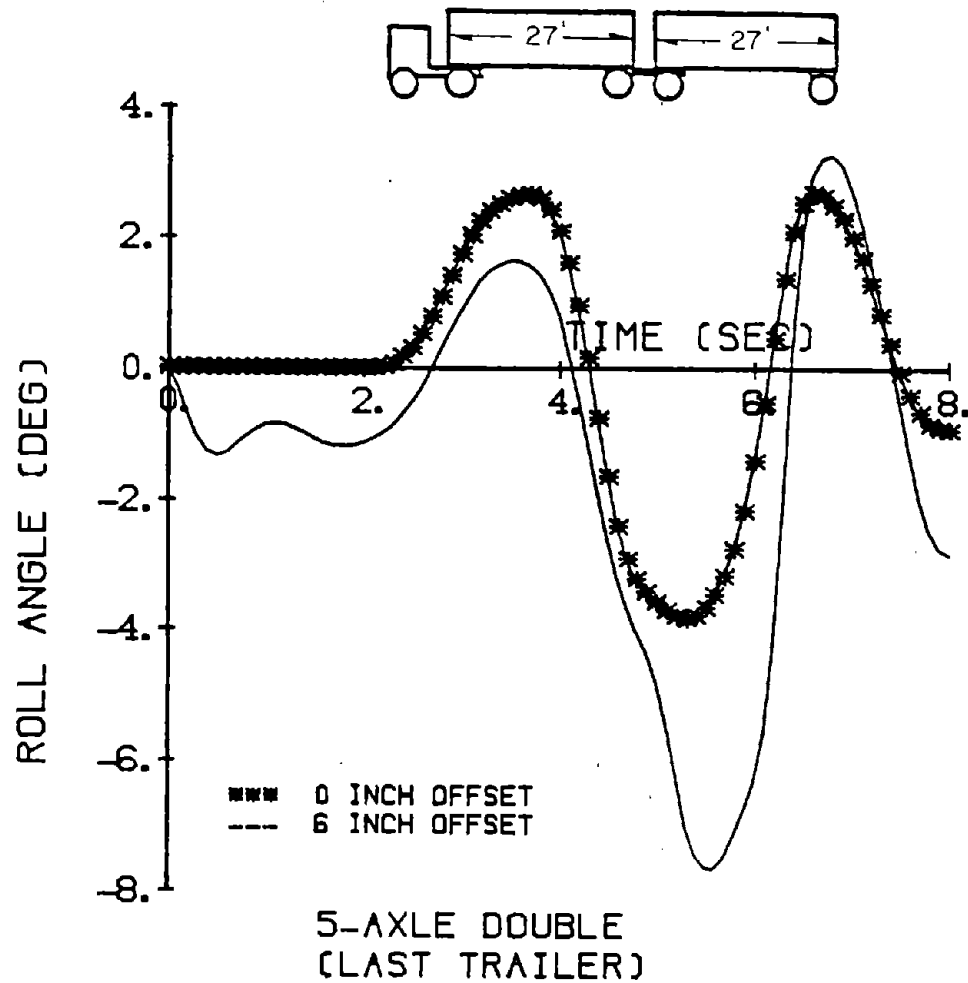


Figure 45. Influence of 6 Inch Payload Offset on the Roll Response of the Rear Trailer of Conventional Double in Severe Lane Change.

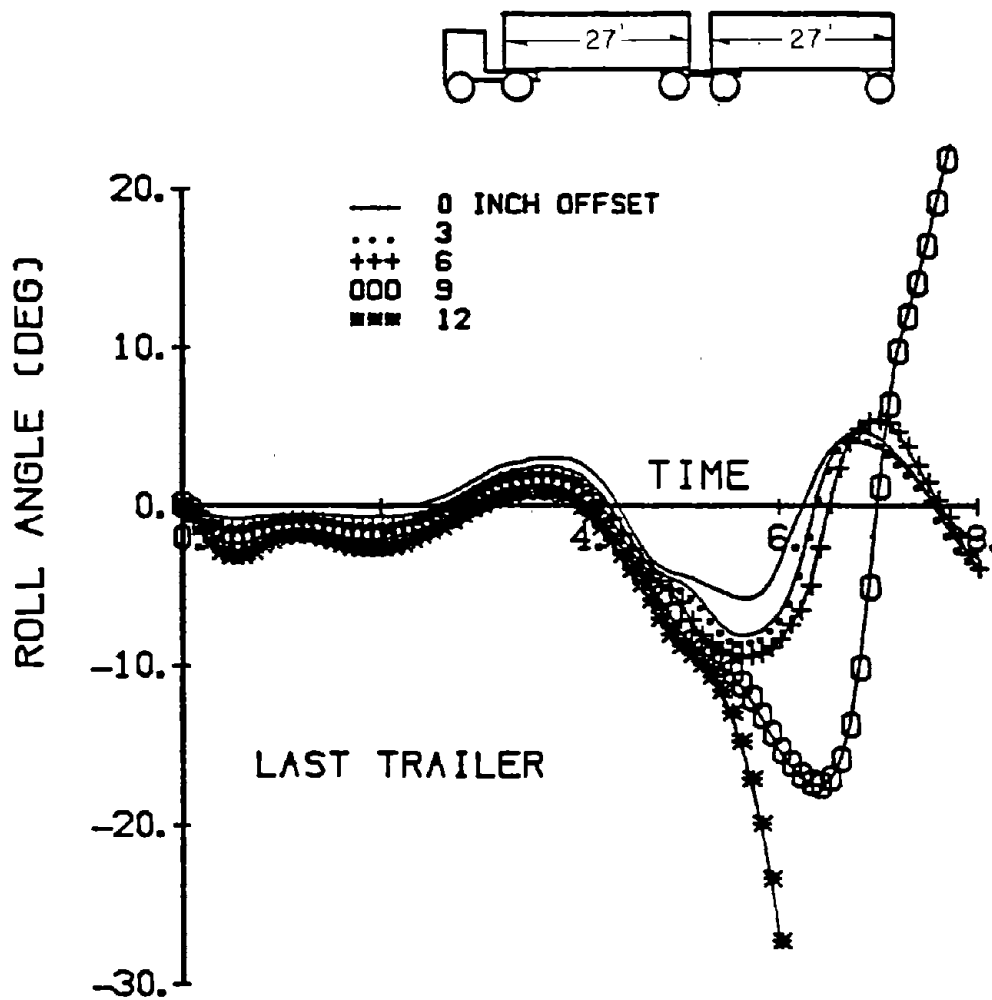


Figure 47. Roll Angle Responses for Varying Payload Offsets - 88 000 lb Gross Weight.

The figure shows that the increased gross weight level provides for a more destabilized roll response such that rollover occurs in both the 9- and 12-inch (23- and 30-cm) offset cases.

5) Together, the four figures show that the dynamic lane-change, or accident-avoidance behavior, for a doubles combination will be dramatically destabilized when a full-weight payload is offset by 6 inches or more—and when the offset is in the direction that promotes rollover in the second phase of the maneuver. (This "direction" criterion is met, for example, when a vehicle with its payload c.g. offset to the left of the trailer centerline attempts a rapid maneuver from the right to the left lane of the highway.)

Interpretation

The lack of distinction in the steering inputs needed to negotiate the rapid lane change for cases of differing payload offset (Fig. 44) suggests that drivers would not be taxed, from a steering control point of view by the presence of large offsets. Thus, it appears that the vehicle's yaw response to steering input is rather effectively immune to payload offset over the range of maneuvers which are likely to be encountered in normal driving. Of importance, then, is the prospect that drivers may remain unaware of the presence of a serious payload offset since there appears to be no significant feedback mechanism in the normal driving process for alerting the driver of the situation. This state of affairs is unfortunate since the roll stability level deteriorates rapidly with payload offset.

The influence of payload offset on the static rollover threshold was found, in Section 3.3.2.2, to be very significant, with the 6-inch (15-cm) offset value resulting in a nominal 13% reduction in the rollover threshold of the doubles combination. In the rapid lane-change maneuver cited above, the influence of the 6-inch (15-cm) offset was seen to be dramatically magnified, doubling the peak value of roll angle with respect to that obtained in the zero offset case. Because of nonlinear spring stiffnesses in the suspensions of these vehicles, however, the doubling of peak roll angle does not quite amount to an effective halving in stability level.

Nevertheless, there still appears to be a strong dynamic mechanism serving to magnify the influence of payload offset on roll stability in a rapid maneuver of the type examined.

One scenario by which the incidence of offset, or shifted, payloads might increase in the U.S. involves the apparently inevitable transition in the trailer fleet from an overall width of 96 inches (244 cm) to 102 inches (259 cm). With an additional 6 inches (15 cm) of lateral dimension available on the inside of van trailers, there may be a substantial number of packaging and palletizing methods which had been set up for the 96-inch (244-cm) width and which will require either dunnage or tie-down treatments in order to take up the additional space. In fact, while the trailer population is still dominated by 96-inch (244-cm) vehicles, there will be no incentive for packaging and palletizing methods to convert to a wider standard since such conversion would render the freight package unworkable in the narrower trailer. Thus, there may be some increased potential for offset load problems while this transition period prevails (say, for the next 10-20 years). Also, note that if a uniform-density payload is permitted to rest against one wall of a 102-inch (259-cm) trailer, leaving a 6-inch (15-cm) gap at the other wall, a 3-inch (7.5-cm) payload offset results.

Referring to Figure 47, one should not infer that the 88,000-lb (39.9-m ton) gross weight condition leads to a dramatically greater influence of payload offset on rollover in a dynamic maneuver. It is clear from examining, in Figure 46, the influence of payload offset on the roll behavior of the vehicle loaded to 80,000 lbs (36.3 m tons) that the trailer roll angle was approaching the critical 10 degree value, for a payload offset of 9 inches (23 cm). Thus, the observation that the 9-inch (23-cm) offset case yielded a large roll excursion when the gross weight was increased to 88,000 lbs (39.9 m tons) merely confirms that this case was marginally stable at the baseline loading level.

3.3.3 Partial Loading. A number of cases involving changes in the longitudinal location of the payload c.g. were covered within the examination of axle load variations, in Section 3.1. It was shown that changes in

the load levels allowed on either single or tandem axles influenced, to some degree, braking, yaw stability, and the rearward amplification behavior of articulated vehicles. Another case of interest involves the partial unloading of a vehicle at an intermediate destination, such that a distinct bias in load distribution occurs. In the context of size and weight interests, this general case was studied for two values of what we shall call "initial gross vehicle weight." That is, the partial unloading will be presumed to have occurred with vehicles initially loaded to gross weight levels of 80,000 and 88,000 lbs (36.3 and 39.9 m tons), respectively.

As the most generally-applicable situation, it is further presumed that the partial unloading of van-type trailers involves removal of freight through the rear doors, leaving half of the initial load intact in the front of the trailer. For the case of a five-axle double, only the rear trailer is considered to be half unloaded. Another tractor-semitrailer case which was considered involves the partial unloading of compartmented, bulk, tankers. Since a number of compartments may be present in, say, a petroleum-liquids tanker, a variety of unloading possibilities exist.

Since the partial-unloading practice can only result in less load being carried by the tractor, there is no concern for the influence of such a change on tractor yaw stability behavior. Further, with the total payload reduced, the roll stability of the vehicle can only improve with respect to the fully-loaded baseline (except for some extreme cases for which the loading conditions are thought to be of unlikely application to commerce). Thus, the influence of partial unloading has been examined only in regard to (a) the stopping distance performance of tractor-semitrailers and the conventional doubles configuration and (b) the rearward amplification behavior of the double.

3.3.3.1 Stopping distance. When the payload in a combination vehicle is loaded in such a way that the trailer axles become less heavily loaded, the so-called "premature lockup" of the trailer wheels is more likely. Thus, partial unloading which leaves the rear section of the trailer empty, while the front is full, tends to result in lockup of the trailer wheels at a lower level of deceleration than can be achieved without lockup in the fully-loaded state. Conversely, if the forward compartments of a

bulk tank semitrailer are emptied while the rear compartments remain full, the tractor drive axles become lightly loaded such that premature lockup of those axles may serve to limit the vehicle's stopping capability.

Shown in Figure 48 are results illustrating the influence of partially-unloaded conditions on stopping distance performance. The figure shows minimum stopping distances obtained on both dry and slippery road surfaces for partial unloading cases which assumed initial gross weight levels of either 80,000 or 88,000 lbs (36.3 or 39.9 m tons). Cases D for the tractor-semitrailer and B for the double represent the condition in which half of the payload has been removed from the rear of the trailer (where only the rear trailer is involved in the case of the double). Cases B and C of the tractor-semitrailer represent alternative half-unloaded conditions of a bulk tank trailer.

Observations

- 1) Partial unloading is seen to consistently degrade the stopping capability of the vehicles examined.
- 2) The worst case, from the viewpoint of stopping distance performance, involves the removal of freight from the rear half of trailers. The lockup of the trailer rear axles under these conditions occurs at such low levels of braking input that stopping distances are approximately doubled with respect to the performance achievable in the fully-loaded state.
- 3) The emptying of the forward compartments of a bulk tank semitrailer results in such light loading of the tractor drive axles that stopping distance is increased by some 35% over the fully-loaded case.
- 4) Symmetric (i.e., equal front and rear) partial unloading of tankers results in a significant increase in stopping distance over the baseline condition, although the increase is considerably smaller than either the forward- or rearward-biased partial load cases.
- 5) The 10% variation in gross weight which was represented in the simulated cases is seen to have a negligible influence on the sensitivity of braking performance to partial unloading conditions.

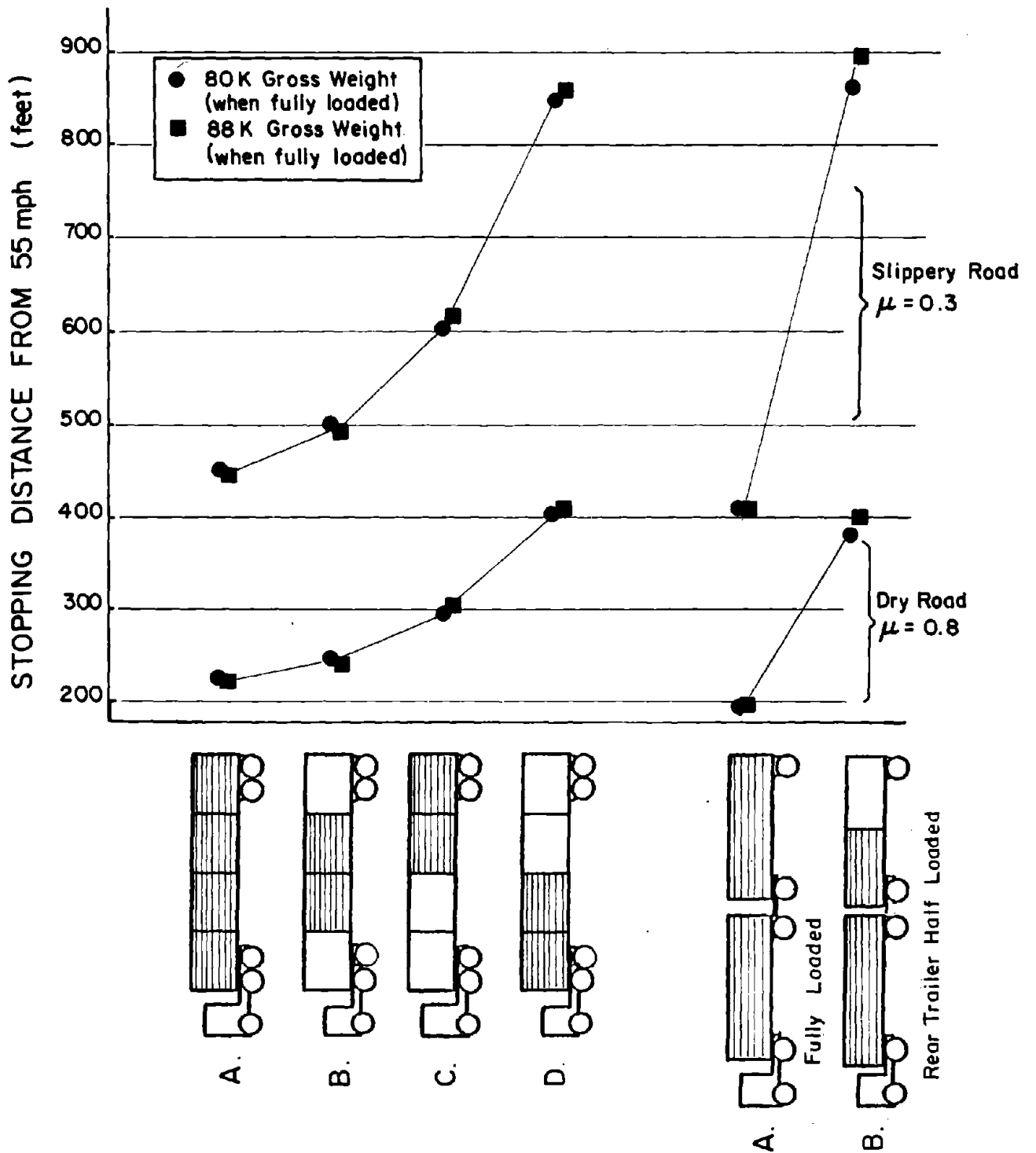


Figure 48. Influence of Partial Unloading on Stopping Distance

Interpretation

The rear-unloaded cases of both vehicle types are seen to cause tremendous increases in the minimum stopping distance. These results speak not only to stopping distance performance, however, but also to the greater likelihood of initiating the so-called "trailer swing" instability during braking. That is, the tendency toward locking the rear wheels on the partially-unloaded trailer implies a tendency toward inducing the unstable trailer yawing motion which causes the trailer to sweep a large path along the roadway, menacing other traffic and threatening a rollover if the driver should suddenly release the brakes. The "trailer swing" instability does involve a rather slowly-growing articulation angle, however, such that the driver may perceive its occurrence and take corrective action before the trailer articulation angle grows to a menacing level.

In case C of the tractor-semitrailer, with the forward compartments of a hypothetical tank semitrailer emptied, the tractor rear axles become lightly loaded and, thus, easily locked during braking. The lockup of tractor rear wheels not only limits stopping distance capability, but also leads to the other classic instability which articulated vehicles are known to encounter during braking, namely, the "jackknife" response. As will be shown in Section 3.4.3.2, the jackknife instability involves a very rapid rotation of the tractor about its fifth wheel connection. Since the jackknife response is seen as a virtually uncontrollable form of instability, any partial-unloading practice which promotes jackknife should be especially avoided.

3.3.3.2 Rearward amplification. The partial unloading of the trailers of a doubles combination has the potential for disturbing rearward amplification behavior since this practice effects a substantial longitudinal shift in the payload mass center. Analysis shows, for example, that the longitudinal location of the trailer center of gravity with respect to the hitch locations is a primary determinant of vehicle behavior [8].

This issue was investigated for the case of a conventional doubles combination. As above, the partial unloading scheme involved removal of half of the payload from the rear trailer in the combination. The

significance of this adjustment on rearward amplification behavior was examined for initial (full) loading states involving gross weight levels of both 80,000 and 88,000 lbs (36.3 and 39.9 m tons). The results of these calculations are shown in Figure 49.

Observations

1) The partial-unloading condition is seen to increase the overall peak level of the rearward amplification curve with respect to the baseline levels.

2) The peaking in this function occurs in a considerably higher range of steer input frequency for the partially-unloaded vehicle than for the case of the baseline vehicle. The increased-frequency shift in rearward amplification tends to put the higher amplitudes out of the range of frequencies which are thought to be achievable by typical drivers. Thus, as listed in the numerical values shown, the partially-unloaded cases yield lower net values for the amplification measure.

3) Although rearward amplification increases slightly with gross vehicle weight, the influence of a partially-unloaded condition is not adversely altered by an increase in the weight level.

Intepretation

The rightward shift in the peak of the amplification curve tends to reduce the amplification levels appearing in the lower frequency regime (and specifically, below the nominal "human limit" frequency of 3.14 rad/sec). Thus, the partial loading cases can be assumed to pose less hazard than the baseline case.

3.4 Influence of Length Variations

Federal and state constraints placed upon the lengths of vehicle elements and the overall lengths of various types of combinations constitute a major factor in the economics of truck transportation. The portions of the trucking industry most affected by length limitations are those

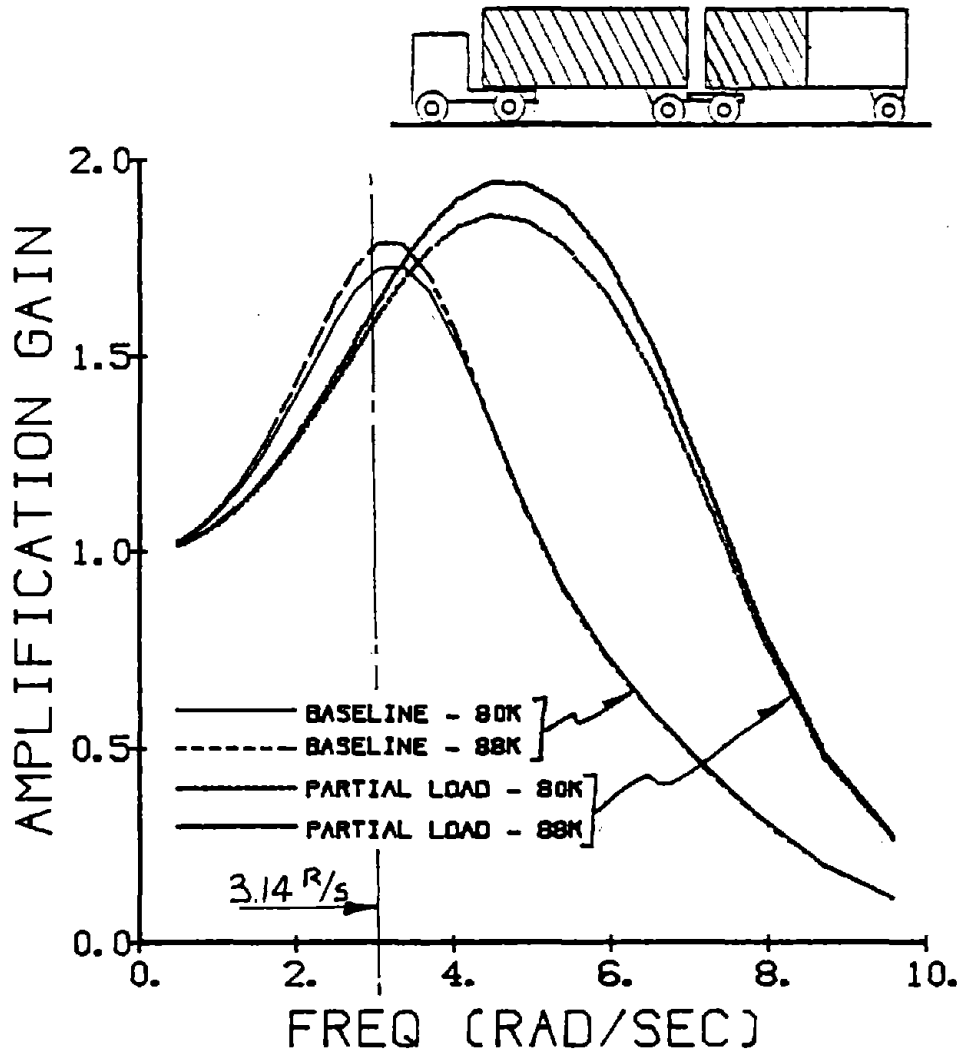


Figure 49. Influence of Partial Unloading on Amplification Ratio

which are hauling relatively low-density freight and which are thus typically loading the vehicle to its full cubic capacity. In testimony presented to a U.S. Senate committee on transportation in 1978, a sampling of the freight bills of one hundred carriers was summarized to show the mix of truck loading configurations occurring over one week's time [17]. From over 100,000 trailer loads surveyed, the following data were reported:

- 26 percent were dispatched with the vehicle loaded to the maximum permissible gross weight
- 45 percent were dispatched with the vehicle loaded to maximum cubic capacity
- 29 percent were dispatched to provide some type of special service entailing a non-full load.

These data underscore the major role played by the cubic capacity limitations placed upon trucking. If the maximum height is taken to be rather fixed by bridge clearance considerations, only the width and length dimensions are left for possible modification to achieve increased cubic capacity. Since length has, historically, been the vehicle parameter of greater interest to the "cube-conscious" sectors of the trucking industry, this study has attempted to provide a fairly broad treatment of length-related influences on performance.

Although certain of the performance categories discussed below are identical to those presented in connection with loading issues presented previously, additional subjects have also been raised. These performance categories were not addressed in regard to loading issues since it was hypothesized that the respective influences would be insignificant. Notwithstanding this general approach, certain length-related subjects were addressed here simply because, in the authors' view, they have been cited either directly or indirectly in various forums concerned with regulating vehicle length and thus deserve specific attention. The questions of stopping distance, yaw stability in steady turns, and yaw response time are treated below in keeping with this rationale.

3.4.1 Stopping Distance. The influence of the length of vehicle elements on stopping distance performance involves the same mechanisms which were discussed earlier in regard to the influence of the height of the payload c.g. (see Section 3.3.1.1). Namely, both parameters, together, contribute to determining the dynamic changes in axle load which occur during braking. Conceptually, one can effect the same change in braking capability by making a given percentage decrease in the vehicle's composite c.g. height or the same percentage increase in the wheelbase of the truck or trailer unit in question. For example, halving the c.g. height of a straight truck will have the same effect as doubling the wheelbase. Accordingly, we expect to find length influences on stopping distance which relate directly to the c.g. height results presented earlier.

Length variations have been examined for both tractor-semitrailer and doubles configurations. For the tractor-semitrailer, both the tractor wheelbase and the trailer lengths have been varied, as shown in Figure 50. The doubles combination was represented only with differing-length trailers. The figure illustrates minimum stopping distances achievable from an initial speed of 55 mph (88 km/h) on both dry and slippery road surfaces.

Observations

1) For vehicles outfitted with the relatively high-torque braking capacities represented in simulations in this study, increases in trailer wheelbase tend to improve stopping capability. The reason for this improvement is that the longer trailer suffers a smaller dynamic load change at its rear axle(s) during braking, thus making it possible to achieve a higher level of deceleration before encountering lockup of the rear trailer wheels.

2) Variation in tractor wheelbase has a negligible influence on the stopping performance of the simulated tractor-semitrailers. As long as the limit condition is determined by the occurrence of lockup at the rear trailer axle(s), the distribution of load between tractor axles during braking (as influenced by tractor wheelbase) is of no consequence. Of course, tractor wheelbase could, conceptually, become short enough that

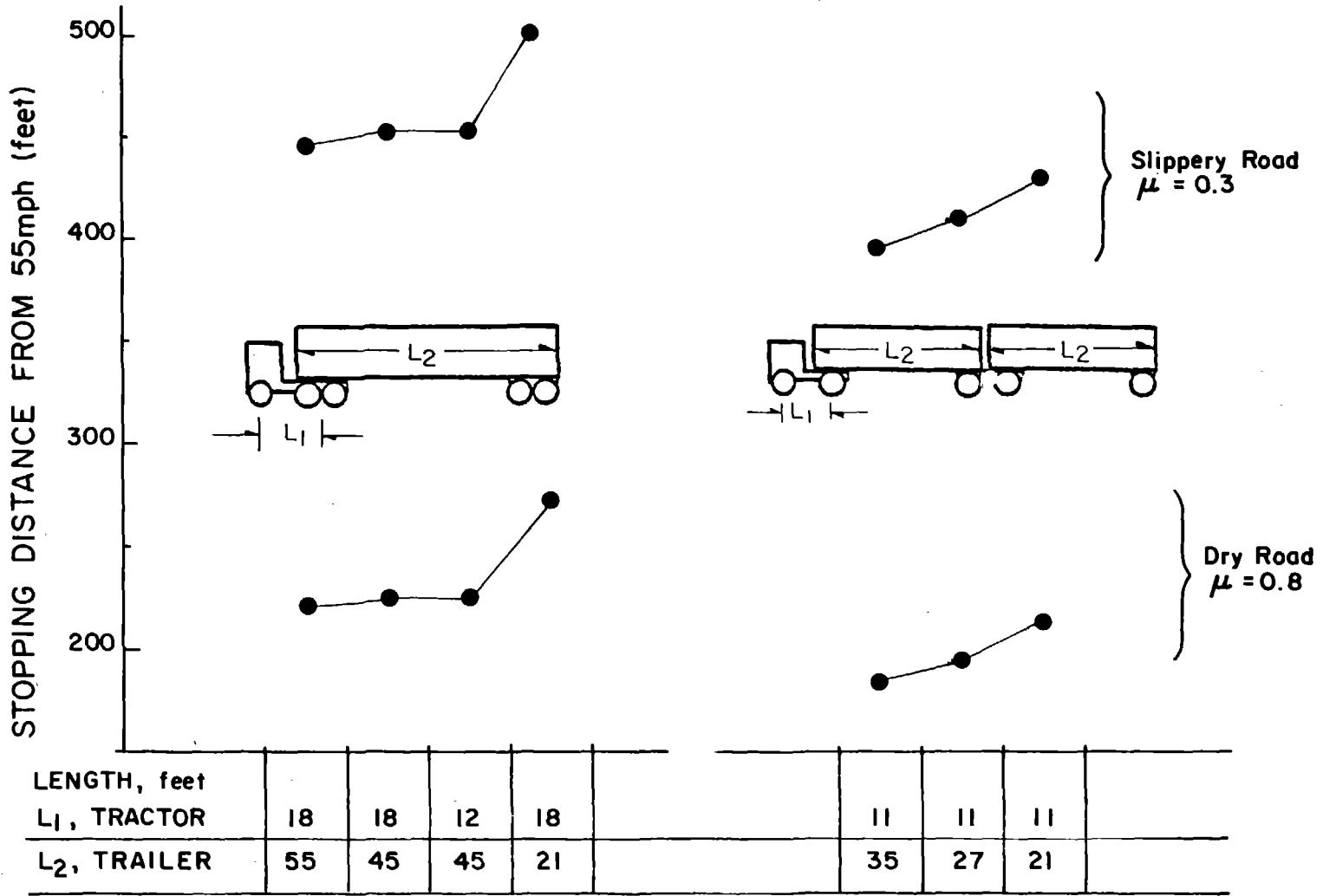


Figure 50. Influence of Length Parameters on Stopping Distance

lockup of the tractor rear axles would constitute the mechanism for limiting performance. The 12- and 18-foot (3.6- and 5.5-m) values of tractor wheelbase which were selected here represent the two most common ranges of wheelbase distinguishing the short cab-over-engine (COE) tractors from the long-nose conventional cab design.

Interpretation

Extensions in trailer length beyond the values which are commonly found in single and double trailer configurations, can be looked upon as inconsequential to stopping distance capability. While tractor wheelbase was also shown to be of no significance to stopping distance performance, it will be shown in Section 3.4.3.2 that tractor wheelbase has a distinct effect upon the dynamics with which the jackknife instability proceeds, upon locking up the tractor rear axles.

An issue which was not addressed here, but which is also known to have been of historical concern regarding the braking of long combinations, involves the issue of the transmission time of air brake signals. That is, the delay in the arrival of the brake actuation signal at rear-placed axles tends to lengthen stopping distance and to pose certain problems concerning the articulation stability of the combination vehicle. The transmission time characteristic is known to be the peculiar result of a number of design details in the air brake system [28]. Although it is apparent that differences exist in the transmission times achieved on various multiple-unit trains, the delay mechanism is seen as relating more to the fittings, valving, and tubing sizes involved than to the length of the lines, per se.

3.4.2 Yaw Stability in Steady Turns. As in examining previous issues, the quasi-understeer measure can be used as an indicator of the influence of length variation on the static yaw stability of trucks or tractors. The length dimension which is pertinent to this discussion is the wheelbase of such vehicle units. This subject is included here although it has long been recognized within the vehicle dynamics community that length has no direct relationship to understeer level. For some who

may have an incomplete understanding of the definition of understeer, however, such a conclusion may not be apparent. Further, it may seem, intuitively, that the wheelbase of a vehicle is certainly related to the amount of turning response that one obtains per unit of steer input. (One easily reckons, for example, that a large steering input is needed to cause a truck with a very long wheelbase to negotiate a tight corner.) If confusion does exist here, it can be traced to the difference between the terms "steering gain" and "understeer."

In order to clarify these matters, then, let us say that steering gain defines the rate of change of path radius with steering wheel angle, at a fixed value of speed. "Understeer," on the other hand, simply defines the variation in this gain level as a function of lateral acceleration. That is, when the vehicle encounters an increasing severity turn condition, as described by an increasing level of lateral acceleration, the steering gain is seen to change according to the level of understeer which is present.

It is quite straightforward to show that the wheelbase of a vehicle is a direct determinant of the steering gain property. The understeer behavior, however, derives from a variety of rather subtle details concerning tire properties, c.g. position, and steering and suspension characteristics—but not wheelbase. Thus, if we are ultimately concerned about understeer, from a safety point of view, insofar as large reductions in this property may threaten steering controllability and promote an unstable yaw response at highway speeds, we can generally eliminate the wheelbase length as a parameter influencing these control characteristics.

As an illustration that wheelbase does not significantly influence understeer level, the results shown in Figure 51 have been produced. These data show that a large range in the wheelbase of a three-axle truck causes a minimal adjustment in understeer level. (Even the slight effect which does appear in the figure is not the direct result of the wheelbase, per se, but rather derives from an interaction between the wheelbase parameter and the spread between the tandem pair of rear axles [29]. Although this interaction is not strictly an understeer effect, the calculation method was not able to extract it from the understeer measure.) Moreover, one can conclude that changes in the wheelbase of trucks and tractors, generally,

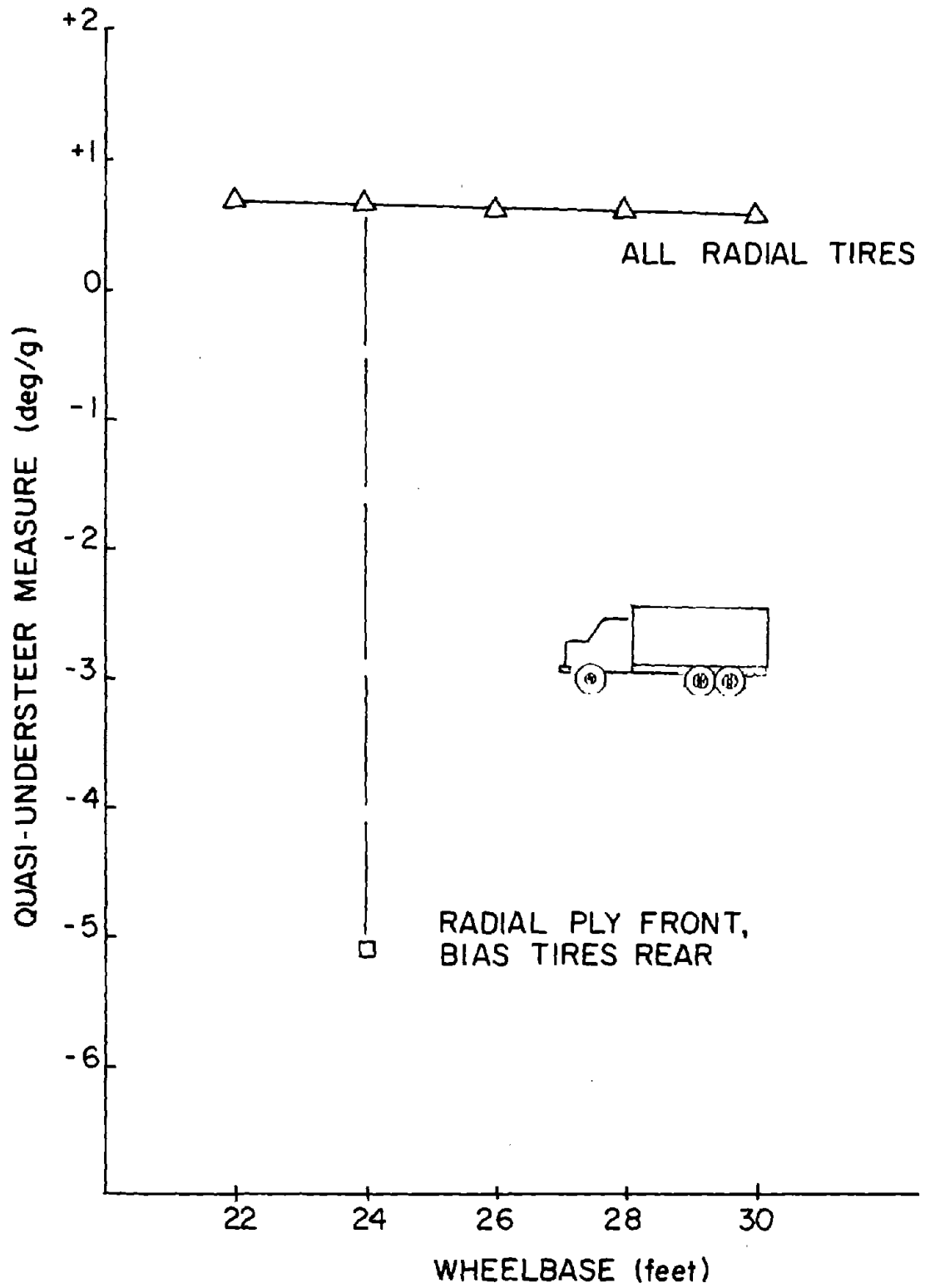


Figure 51. Influence of Wheelbase on Understeer for 3-Axle Truck, Fully Loaded.

have an insignificant influence on understeer and on the potential for unstable yaw response during cornering. Of course, the manufacturer of such vehicles must assure that a reasonable level of steering gain exists, regardless of the prevailing wheelbase, by installing the proper steering gearbox and connecting linkages.

3.4.3 Yaw Response Dynamics. As the wheelbase of a truck or tractor increases, the inertial resistance to yawing increases, tending to make for more sluggish response to steering. On the other hand, the tires become located at greater distances from the center of gravity of the vehicle, thereby tending to improve responsiveness. Since the responsiveness of a vehicle is generally taken to be related to the ease of maintaining steering control [21], there was an interest here in illustrating the net influence of wheelbase variations on the dynamic response of trucks and tractors to steering input.

An additional subject concerning yaw dynamics involves the rapidity with which a tractor jackknife condition proceeds, once the rear wheels have been locked up during severe braking. In this regard, the more rapid the response, the more difficult the driver's control task is presumed to be. Indeed, many truck drivers state a preference for longer wheelbase tractors partially on the grounds that they believe that jackknife can be more easily avoided in such vehicles. Accordingly, additional calculations were performed to clarify the influence of tractor wheelbase on the "jackknife dynamics."

Presented below are results addressing each of these issues.

3.4.3.1 Responsiveness to steering. The most useful response variable for characterizing the dynamic yaw response to steering is the yaw rate of the unit in question. The yaw rate variable simply expresses the rate of rotation of the vehicle about its vertical axis. The yaw rate response of a three-axle truck and a three-axle tractor (with tandem axle semitrailer) have been examined in regard to the influence of the wheelbase parameter. Shown in Figure 52 are the yaw rate responses, versus time, for a three-axle truck loaded with a load distribution of 12/34 K-lbs

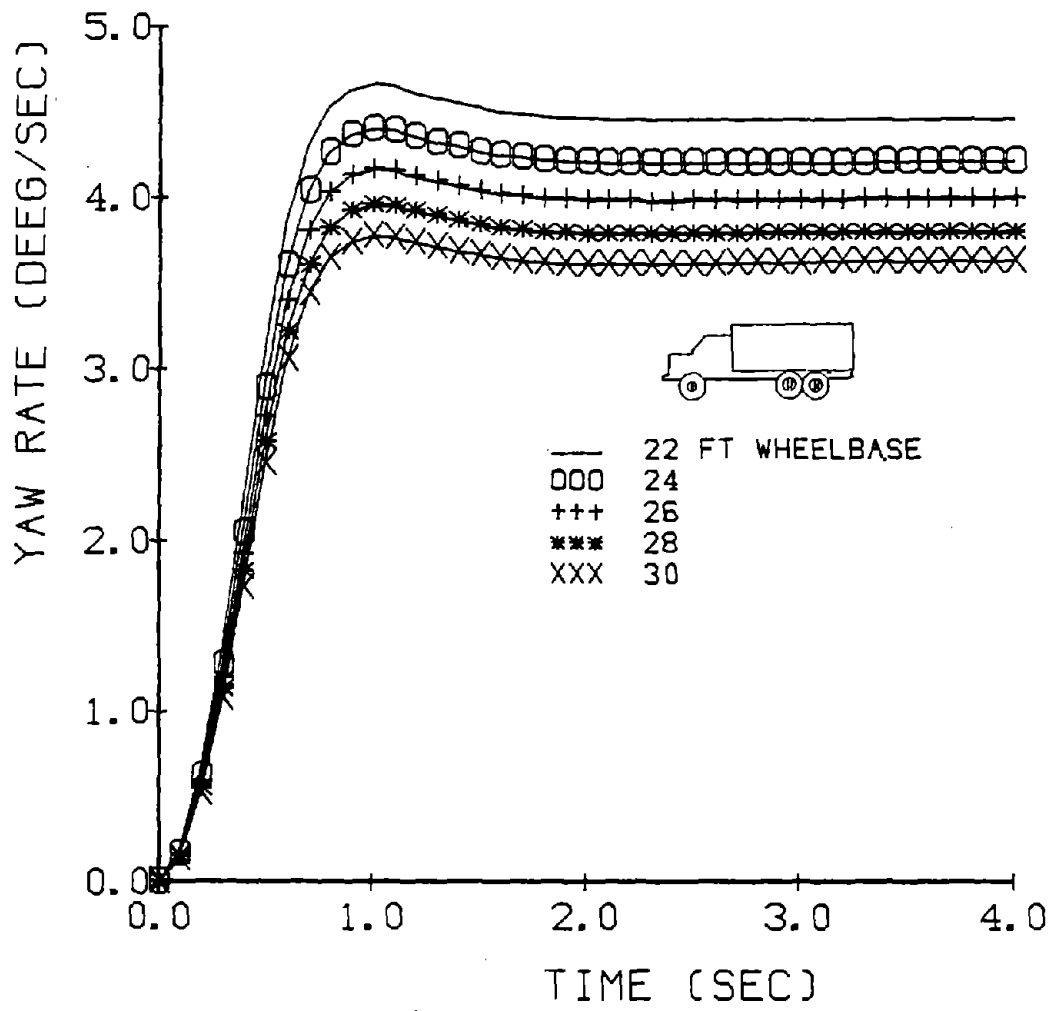


Figure 52. Influence of Wheelbase on the Transient Yaw Response of a 3-Axle Truck to an Abrupt Steer Input.

(5.4/15.4 m tons). Five values of wheelbase are shown. The results depict the transient and steady-state behavior resulting from the rapid input of a 60 degree steering wheel angle at 55 mph (88 km/h).

Shown in Figures 53 and 54 are the yaw rate responses of tractor-semitrailers having differing values of tractor wheelbase and overall length of semitrailer. Figure 53 shows tractor yaw rates for five combinations of tractor-semitrailer configurations. Figure 54 shows the yaw rate responses of both tractor and semitrailer for cases in which a given tractor is coupled to semitrailers which vary in overall length.

Observations

1) Although wheelbase has the obvious effect on steering gain (as evidenced by the decreasing yaw rate level, for a fixed steer input, with increasing wheelbase of truck or tractor), there is only a very small influence of wheelbase on the rapidity of the transient. The "rapidity" characteristic is conveniently quantified in terms of a so-called "yaw rate response time" measure. (This measure basically quantifies the time needed to reach 90% of the steady-state value. If this response time were to get very long, steering control would become difficult to maintain.) The yaw rate time constants observed for both the truck and tractor are seen to increase by less than 0.05 seconds over the range of wheelbases investigated. By way of comparison, the mix of radial-ply tires on the steering axle and bias-ply tires on the rear axles, such as mentioned previously, causes an increase of 0.20 seconds in the yaw rate time constant of typical tractors.

2) Variations in semitrailer length are inconsequential to the dynamics of tractor yaw response. Figure 53 shows, for example, that variations in semitrailer length ranging from 21 to 55 feet (6.4 to 16.8 m) result in a negligible change in the yaw rate response of the tractor whose wheelbase dimension is 18 feet (5.5 m). It is interesting to note, however, that the yaw rate responses of the semitrailers vary widely with semitrailer length. In fact, these variations are closely related to the rearward amplification phenomena which are discussed in Section 3.4.4.

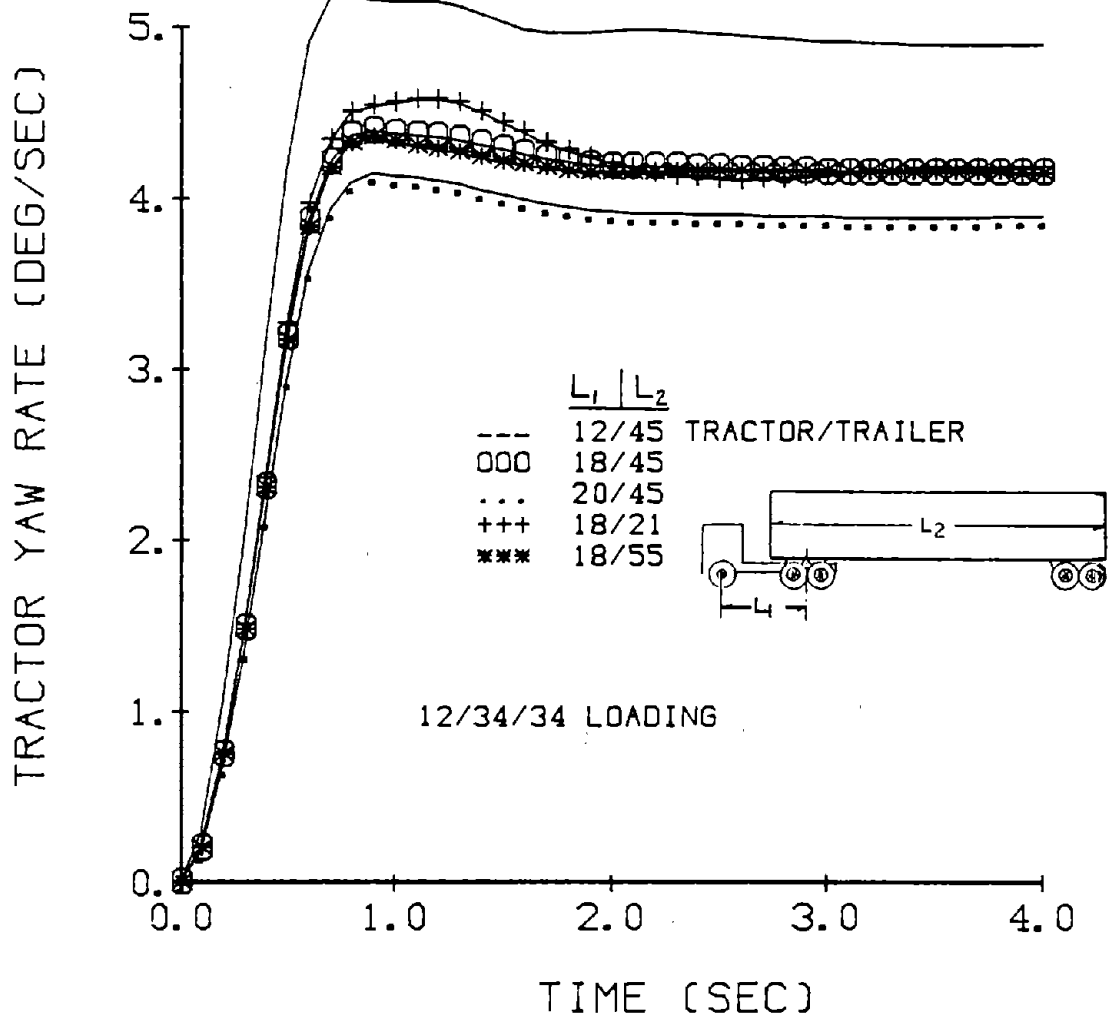


Figure 53. Influence of Tractor and Semitrailer Length Parameters on the Transient Yaw Response of the Tractor to an Abrupt Steer Input.

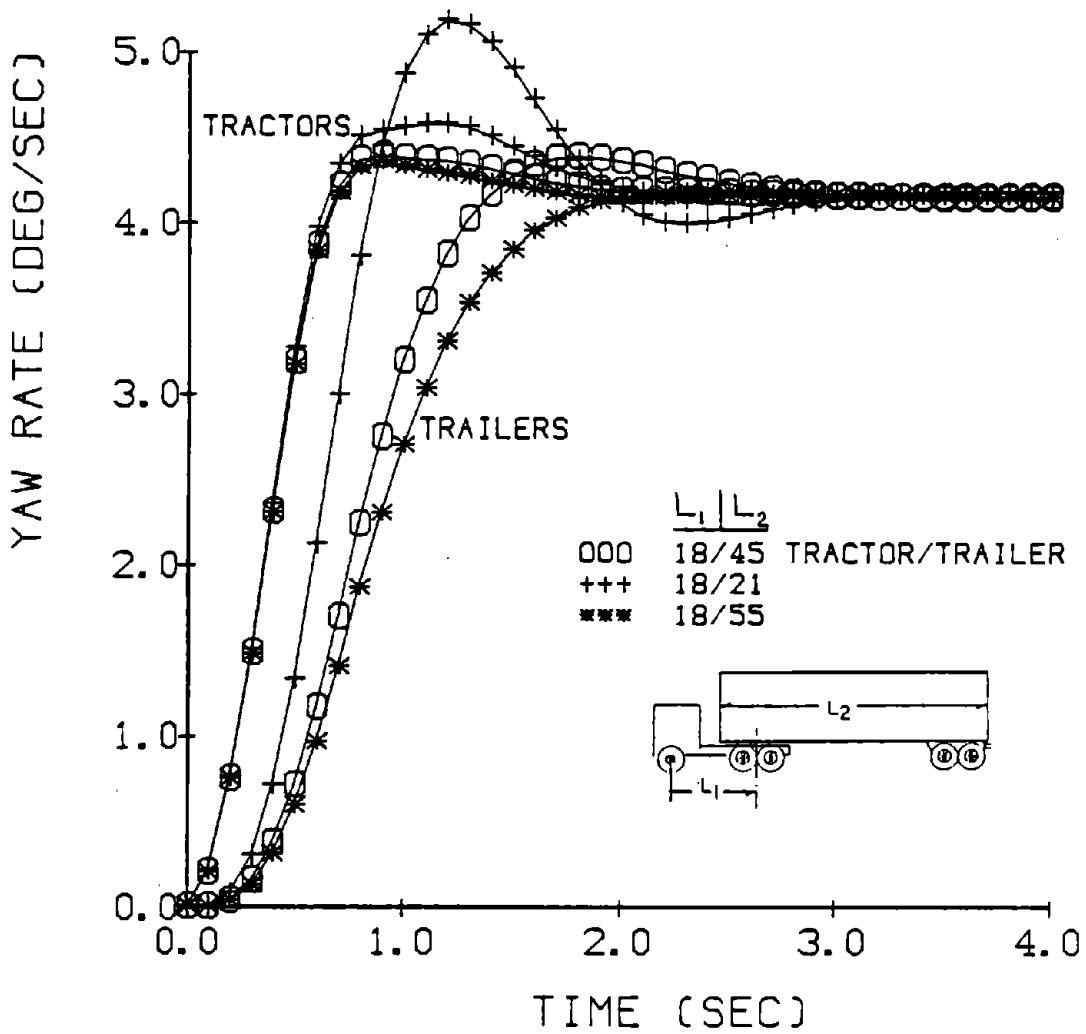


Figure 54. Influence of Trailer Length on the Transient Yaw Response on Both Tractor and Semitrailer to an Abrupt Steer Input.

Interpretation

Variations in truck and tractor wheelbase are seen to have little influence upon the rapidity of yaw response to steering. This result should be qualified by saying that it applies to cases in which the vehicles employ geometric layouts which are typical of trucks and tractors. Clearly, it is possible to make a long wheelbase truck which differs markedly in yaw response properties from certain short-wheelbase trucks having dramatically differing mass distributions. For "normal" freight-transporting vehicles, however, the results shown here have broad generality.

The insensitivity of tractor yaw behavior to trailer length is a fortuitous result given that tractors are called upon to tow semitrailers having a broad range of lengths for meeting the needs of various trucking missions.

3.4.3.2 Influence of tractor wheelbase on jackknife dynamics. When a tractor-semitrailer is subjected to severe braking such that the wheels on the tractor's rear axle lock up, the so-called "jackknife" instability is obtained. Since the front tires are typically underbraked, and thus still rolling, they are able to produce large levels of lateral force as the tractor begins to rotate out of alignment with the semitrailer. A rapidly increasing rotational rate ensues, unless the driver reacts to the situation by releasing the brakes. The driver may also opt to apply corrective steering, but the jackknife mode of motion is so highly unstable that the prospect of manual stabilization is remote.

It is hypothesized that the tractor's yaw response at the onset of the jackknife instability is crucial to the driver's ability to react and to regain control. Two measures were defined in Section 2.2.2.2 for characterizing the tractor response at the onset of jackknife. Both measures are derived from a maneuvering condition in which the vehicle is first steered into a moderate, steady turn, and then the brakes are applied so as to cause lockup of the tractor's rear wheels. The first measure describes the time which elapses while the yaw rate diverges from an initial threshold of 1.05 times the initial steady turn value to 2.0 times that

value. This measure basically indicates the time needed for the yaw rate to double in value. It constitutes a measure of the relative amount of time which the driver has in which to react to an impending jackknife.

A second measure defines the rate of articulation prevailing while the articulation angle goes from 2.0 to 3.0 times its initial steady-turn value. In other words, the measure describes how rapidly the jackknife rotation is proceeding a short time after the instability has begun. Clearly, the larger values of this measure imply that the jackknife rotation will be more difficult to arrest, once the driver has reacted to the emergency.

These measures have been employed to examine the influence of tractor wheelbase on the jackknife response. Calculations have been done representing a five-axle tractor-semitrailer in the empty condition. The empty state was selected since accident data show that approximately 3/4 of all jackknife accidents occur with unloaded, or very lightly loaded, vehicles [14]. Shown in Figures 55 and 56 are the doubling time and articulation rate measures as influenced by tractor wheelbase.

Observations

1) The time required to nominally double the tractor yaw rate at the onset of jackknife is favorably improved by increased tractor wheelbase. However, significant benefits were only seen for the case of stopping on a dry surface. Over the range of wheelbases likely to be found on three-axle tractors in the U.S., namely, 12 to 20 feet (3.7 to 6.1 m), the doubling time increases by 25%.

2) On both low- and high-friction surfaces, the articulation rate of the jackknifing motion is seen to reduce with increasing wheelbase. The articulation rate measure is seen to decline by some 30% over the examined range of wheelbases.

Interpretation

By the stated hypothesis, one would conclude that longer tractor wheelbases will enhance the driver's ability to arrest jackknife motion. This finding tends to confirm what appears to be a broadly-perceived

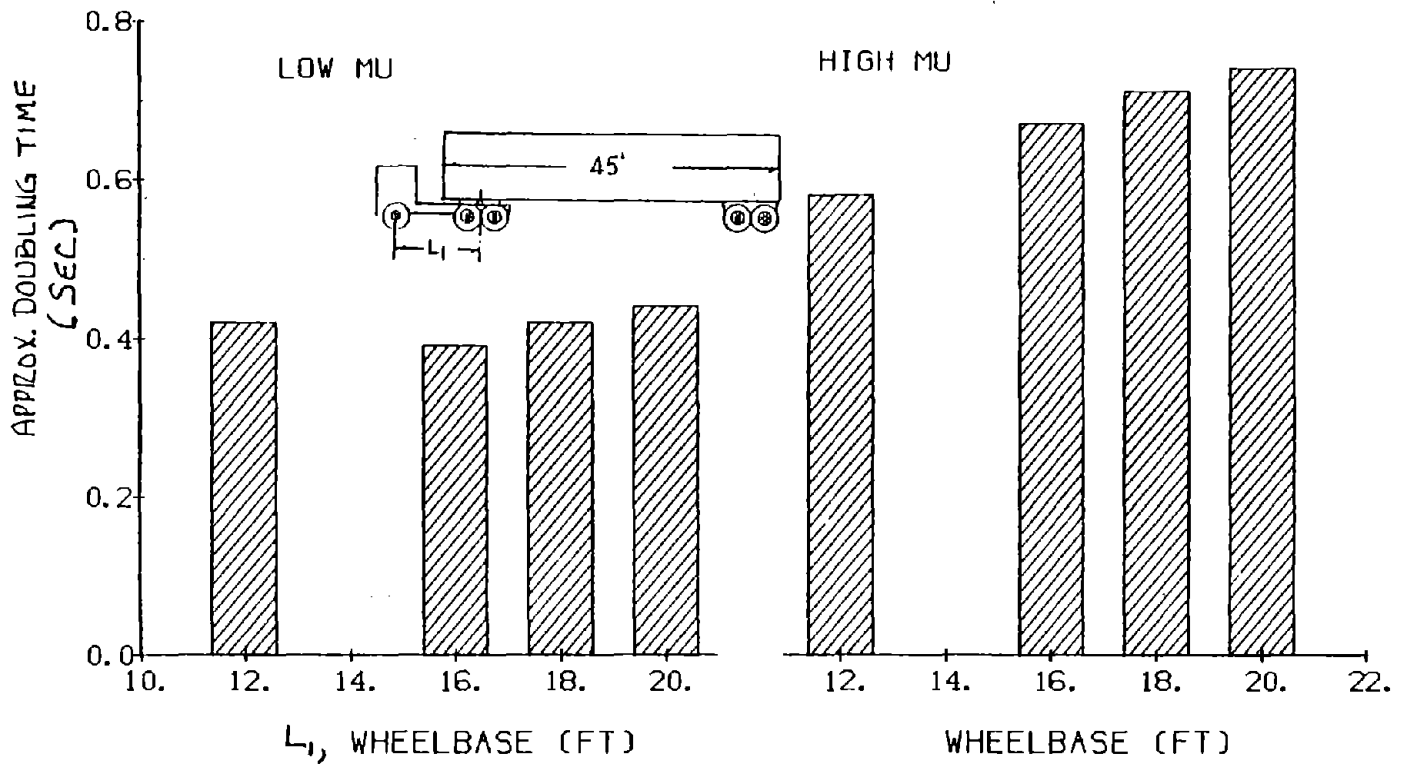


Figure 55. Influence of Tractor Wheelbase on Jackknife Doubling Time

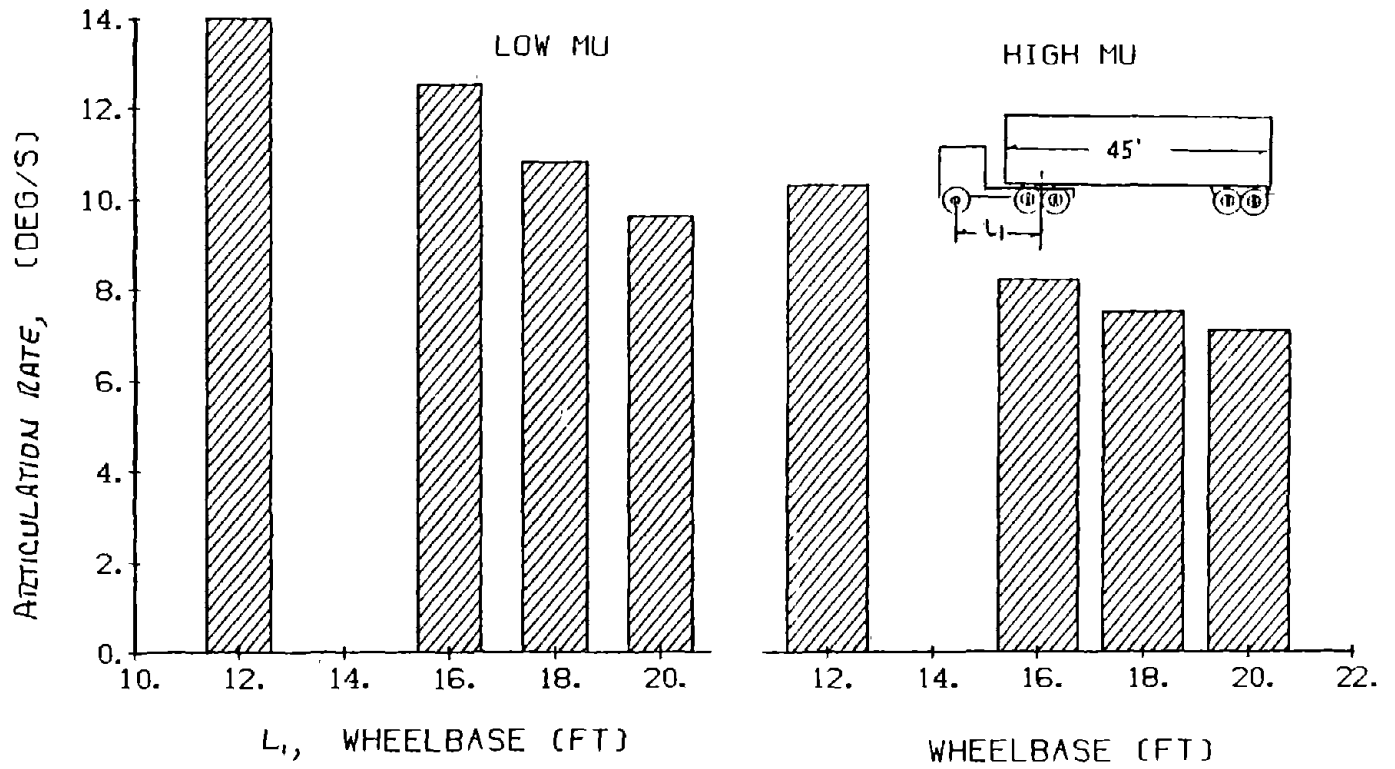


Figure 56. Influence of Tractor Wheelbase on Jackknife Articulation Rate.

observation on the part of the professional truck drivers. Thus, changes in vehicle size constraints which permit the use of tractors with longer wheelbases are seen as tending to reduce the threat of jackknife accidents. The significance of this relationship to the probability of jackknife accident involvement, however, is unknown.

3.4.4 Rearward Amplification. Perhaps the most significant truck research findings relating a length parameter to an apparently safety-related performance property concern the rearward amplification of multiple-unit trains. Certain fundamentals of the rearward amplification phenomenon render length parameters the primary determinants of performance [8]. Thus, the length issue, as it pertains to the wheelbases of trucks and trailers, the location of pintle hitches, and the lengths of dolly drawbars has been addressed in this study for all of the types of multiple-unit combinations which appear in significant numbers in the U.S.

Shown in Figure 57 are the rearward amplification ratios calculated for each of seven categories of combination vehicles. In each category, a "baseline" configuration is identified. This configuration is seen as representing the most popular version among vehicles currently found in that category. (Of course, the "popular" configurations simply reflect the designs which are dictated by the existing size and weight constraints.) Cases A and B represent essentially one style of vehicle combination, namely, the "truck/full trailer" configuration, but they incorporate different schemes for relating the respective lengths of the truck, dolly drawbar, and trailer. In Case A, the dolly drawbar length was fixed at the practical minimum value of 6 feet (1.8 m). Thus, variations in the length of either the truck or trailer in Case A also involve variations in the overall vehicle length. Case B (in which the vehicle configurations are more representative of those operated in the western states where truck/trailer combinations are popular) assumes an overall length constraint of 65 feet (19.8 m). In these cases, the length of the dolly drawbar varies over a rather wide range in order to accommodate variations in the length of the truck or trailer. In both Cases A and B, a set of conventions were adopted to relate the truck wheelbase dimension to other length parameters which fix the length of the truck's load bed and, thus, the location of the pintle hook.

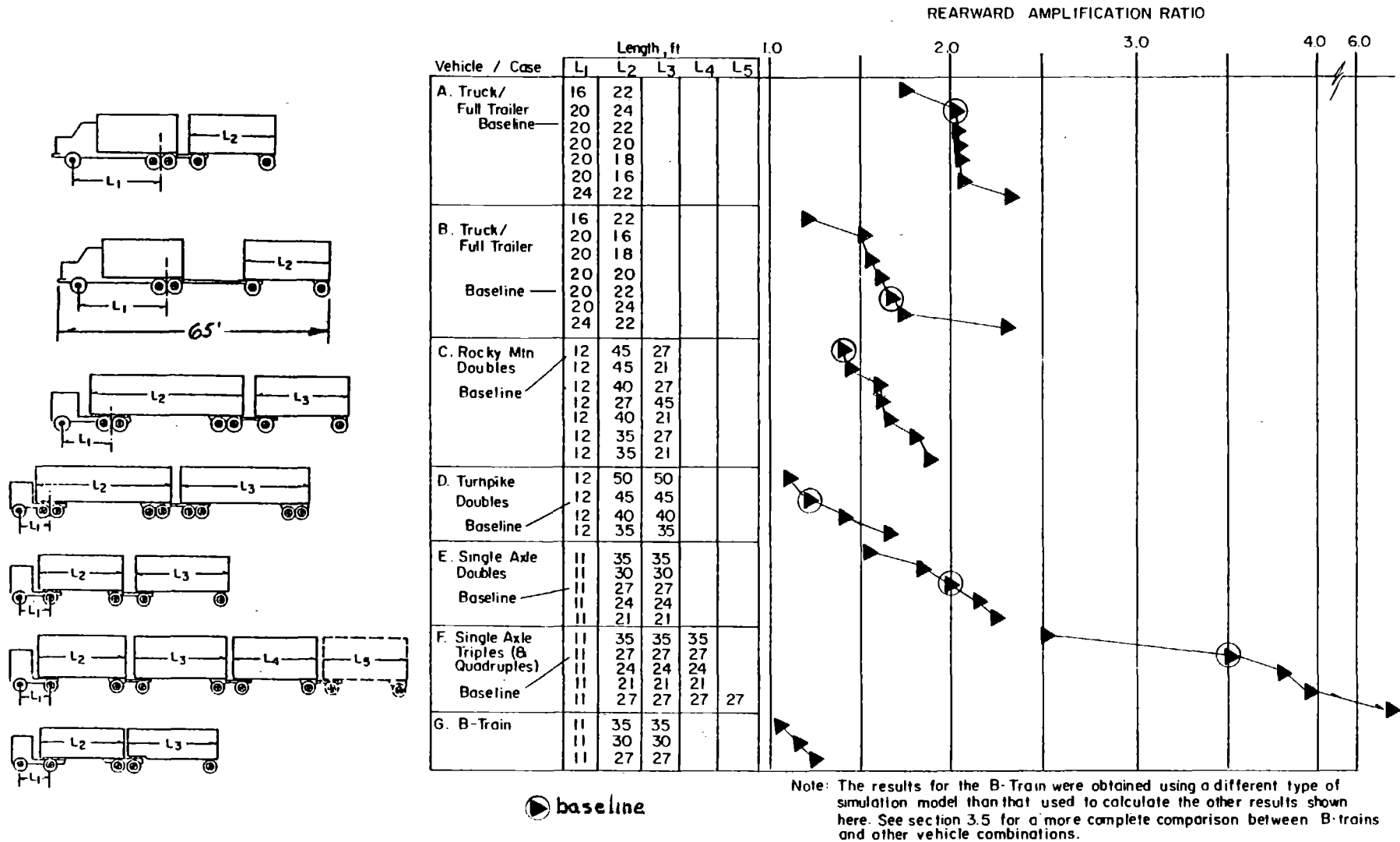


Figure 57. Influence of Length Parameters on Rearward Amplification

In Cases C through G, the lengths of the tractor wheelbases were fixed to reflect what is seen as fairly representative equipment. It is pertinent to note, however, that tractor wheelbase has rather little influence on the determination of the rearward amplification behavior of the combinations shown. All of the full trailers employ conventional dolly designs, with the typical pintle hook connection to the rear of the preceding unit. The "B-train" configuration, however, comprises a tractor-semitrailer-semitrailer combination and does not employ a dolly between the first and second trailer. Aside from the distinction concerning the means for locating the fourth axle, the B-train has been modeled to correspond in all weight and length dimensions to respective cases of the "single-axle double" (Case E). For example, the B-train with 27-foot (8.2-m) trailers is identical to the single-axle (or "conventional") double having 27-foot trailers in every respect but the coupling mechanism. The B-train cases have been included here primarily for their academic interest, since they are found only in very small numbers in the U.S. Vehicles of this type have broad acceptance in Canada, however, and on the basis of their performance there are seen as being potentially attractive for wider use in this country.

The category labeled "single-axle doubles," Case E, includes the twin 27-foot (8.2-m) trailer combination which has been increasingly prevalent across the U.S. and which is specifically allowed in all states since the preemptive federal legislation effective in 1983. The results shown for this vehicle also apply to a popular version in which the actual length of the trailer van bodies is 28 feet (8.5 m), but which incorporates the same nominal trailer wheelbases.

Note also that the "quadruples" combination, included as a variant on the triple with 27-foot trailers, is included in the study only on academic grounds, since it is not permitted within any jurisdiction.

Observations

1) Amplification ratio generally goes up with number of articulation points and goes down as either dolly tongue length or trailer length increases.

2) The length of the truck in a truck/full trailer combination is a strong determinant of amplification ratio. Increasing truck length causes amplification ratio to increase primarily because the pintle hitch becomes located further from the truck c.g. and thus undergoes more severe lateral movements during rapid maneuvers [8]. The exaggerated lateral movement at the pintle hitch leads to the greater motions of the trailer which register as higher values of amplification ratio. (Note that this influence of truck length constitutes the only case in which an increase in the length of a unit causes an increase in amplification ratio.)

3) The cases (C) of the so-called "Rocky Mountain Double" are seen to yield relatively low values of rearward amplification due to the long trailers typically employed as the first, tandem-axled, unit in the combination. Interestingly, when the shorter unit is put first, as in the case listed with the length values 12/27/45, the amplification is higher than in the normal configuration (viz., 12/45/27). (It should be noted that in the 12/27/45 case, the required dolly incorporates a tandem axle in order to carry the higher load at the lead end of the long trailer. The tractor then carries the lighter load imposed by the short, single-axle semitrailer. This configuration, with the shorter trailer placed first, is included for academic interest and is not known to have been suggested for actual use.)

4) The so-called "Turnpike Double," Case D, provides the lowest values of amplification among all of the "high-cube" combinations. Again, the long wheelbases incorporated in both trailers account for a minimum of amplified motion at the rear unit.

5) The baseline version of the "single-axle double," with two 27-foot (8.2-m) trailers, produces an amplification ratio of 2.0 by this scheme of measurement. This relatively high value of amplification ratio distinguishes this vehicle among configurations which operate nationally in interstate transportation.

6) The amplification of a multiple-unit train derives from the product of a series of individual amplification factors introduced by each of the elements in the train. Each of these factors is determined by a

number of vehicle parameters, but primarily by length parameters. The value of 3.5 obtained as the overall amplification ratio for the baseline triple, for example, can be broken down into the following contributions:

Amplification introduced from:

tractor c.g. to semitrailer c.g.	<u>1.148</u>
semitrailer c.g. to first pintle hook	<u>1.382</u>
1st pintle hook to c.g. of 1st full trailer	<u>1.256</u>
1st trailer c.g. to 2nd pintle hook	<u>1.402</u>
2nd pintle hook to c.g. of 2nd full trailer	<u>1.256</u>

The overall amplification ratio is obtained as the produce of the above factors. (See Volume III for a complete listing of these factors for each of the vehicles in Figure 57.)

7) Recognizing that the factors listed above identify individual elements of the vehicle train, one can easily see how the rearward amplification level accumulates with the addition of full trailers. The last two factors listed for the case of the 27-foot (8.2-m) trailer above, in fact, define a multiplier which distinguishes the triple from a double comprised of the same length trailers. Listed below are such "multipliers" for each of the lengths of single-axle trailers considered.

<u>Length Feet (Meters)</u>	<u>Multiplication Factor</u>
35 (10.7)	1.62
27 (8.2)	1.76
24 (7.3)	1.78
21 (6.4)	1.77

Thus, each of the amplification ratios shown for the differing-length triples represent the product of the appropriate factor, above, times the value of amplification ratio obtained for the corresponding double. Likewise, the remarkable value of 6.2 shown in Figure 57 for the amplification ratio of the quadruple combination derives from the product of the above multiplier for the 27-foot (8.2-m) trailer, squared, times the 2.0 value shown for the amplification of the baseline single-axle double.

8) The amplification behavior of the B-train is seen to be markedly less than that exhibited by the more conventional "single-axle doubles" having corresponding values of trailer length. Clearly, the advantage derives simply from the elimination of an articulation point. In addition to the improved resistance to rollover implied by the reduced amplification ratios, another roll-stabilizing benefit of the B-train construction has been reported to derive from the roll-rigid coupling of the two trailers [15]. This benefit derives from the fact that, during a rapid evasive maneuver such as produces large amplifications, the first and second trailers experience their peak levels of lateral acceleration at different times. That is, there exists a substantial difference in the phase of the two lateral acceleration conditions. The result is that the rear trailer is "able" to contribute roll support to the first trailer at the time when the first trailer needs it most and, conversely, the first trailer provides roll support for the second at the occasion of its critical peak acceleration condition. Such a mutual support mechanism does not prevail in vehicles hitched with conventional dolly-and-pintle-hitch hardware since no "roll support" can be passed from one trailer to the next.

Interpretation

Clearly, the length of the vehicle elements and the number of articulation points in a combination provide the primary influence upon rearward amplification behavior. In fact, as long as vehicles are considered to be loaded in a more or less uniform fashion, from front to rear, the distinctions in amplification ratio from one vehicle configuration to another will be determined simply by the length and articulation factors.

Having found that a large range in amplification levels exists across the spectrum of baseline vehicles, not to mention the influences of length variations, the key interpretation problem concerns the connection between amplification level and the likelihood of involvement in rollover accidents. Here, the projection of an accident connection cannot be guided by a broadly-based correlation such as was presented in the context of the simple rollover of tractor-semitrailers. In fact, there is some evidence that vehicles with very high values of amplification ratio have been admitted onto specially-designated routes, with special maintenance and driver-selection agreements, and have reported good safety records [18]. Thus, it cannot be said, categorically, that vehicles with high levels of amplification ratio will necessarily exhibit an undue number of rollovers in actual service.

One should not generalize, however, on the significance of a vehicle's amplification behavior by reference to controlled-permit scenarios in which the regulating authority has "compensated," so to speak, for a high level of amplification ratio by implementing a very restrictive set of operating constraints. As was mentioned in Section 2.2, limited accident data do exist showing that truck/full trailers and doubles having substantial levels of amplification ratio have, indeed, suffered apparently-high rates of rollover of their rearmost trailers [2,3,4]. These cases pertain to truck/full trailers in bulk tanker configurations in California, double tanker configurations in Michigan, and conventional single-axle doubles, with 27-foot (8.2-m) van trailers, in service across much of the nation.

In addition to accident data showing a high incidence of rear trailer rollovers, there are statistically meaningful accident data showing that the conventional single-axle double has exhibited a very high total rate of rollover involvement, per vehicle mile, compared to tractor-semitrailers [4]. While these data do not support a quantitative correlation of amplification ratio with rollover rate, they establish that a strong connection exists.

A practical aspect of the safety problem posed by the presence of a rearward amplification tendency concerns the particular nature of the threat imposed by the type of rollover which results. On the basis of

the California [3] and Michigan [2] tanker experience (and believed to be supported by the accident experience of common carriers operating conventional single-axle doubles), the rear-trailer rollover event occurs predominantly as a single-vehicle accident. That is, no other vehicles are typically struck. Further, the truck driver, himself, is not physically threatened by the rear-trailer rollover incident. Thus, such accidents are primarily property-damage incidents, except for the cases in which hazardous commodities, such as are carried in bulk tanks, may become released through the rollover impact. Such hazardous commodity problems were the focus of the cited California and Michigan tanker concerns.

Although it appears that most of the accident over-involvement, with non-hazardous payloads, would be confined to property-damage accidents, it should be recognized that other accident scenarios can also develop in which vehicle occupants or pedestrians may be in jeopardy.

Moreover, the rearward amplification behavior of multiple-unit vehicle trains is seen as a peculiar deficiency which is safety-related. The problem is lessened by adopting configurations which involve trailers that are as long as otherwise practicable (see, also, offtracking results which are presented in the next section). Additionally, B-style configurations offer substantial reductions in amplification compared to conventional dolly-equipped vehicles [2,15]. Finally, future improvements in amplification behavior may be obtained through the development of other alternative schemes for hitching trailers [19,20].

3.4.5 Low-Speed Offtracking. The low-speed offtracking of commercial vehicles is not generally included on a list of safety-related properties. Although it is certain that many property-damage incidents (and presumably even pedestrian involvements) occur due to the lateral encroachment of trailers during intersection maneuvers and the like, the zero-speed context of this performance measure rules out impacts at appreciable energy levels. Nevertheless, the subject of low-speed offtracking does involve the mechanical behavior of the vehicle and is an important consideration in policy making concerning vehicle length and articulation features. Thus, calculations have been made in this study to

illustrate the influence of length on the low-speed offtracking characteristic of the selected set of multiple-unit vehicles.

The measure employed here describes the width of the path which is swept by each vehicle combination as it negotiates a right-angle turn in which the outside front tire on the tractor tracks a reference circular arc of 35-foot (10.7-m) radius between the entry and exit tangents. The swept-path width is defined as the maximum outside width measured across the inner- and outermost tires on the vehicle. Shown in Figure 58 are the swept-path data obtained for various values of length of the elements of the combination.

Observations

1) It is seen that the magnitude of the swept path increases with length (or wheelbase) of trucks, tractors, and trailers. This nominal increase is approximately proportional to the square root of the wheelbases of the units involved [30]. That is, the offtracking result can be shown to result from the sum of the offtracking contributions of the constituent parts of the vehicle. The influence of a change in the length of any constituent part (say, a trailer, for example) is approximately proportional to the square root of the wheelbase of that part. The rearward overhang of pintle hitch locations, however, has an inverse effect on offtracking and this effect is, again, related to the square root of the overhang distance involved.

2) The general trends relating unit length to swept path do not appear to apply to the result of the truck/full trailer having the "65-foot (19.8-m) designation." Since the overall length of this vehicle has been held fixed, however, an increase in the length of the truck or trailer will result in a decrease in the length of the drawbar. Thus, in a number of cases we see the swept path reducing with increasing length of trailer since this increase is resulting in a more favorable reduction in the drawbar length. The net balance between the "savings" in swept path gained by shortening the drawbar versus the "cost" incurred by lengthening the trailer determines the effect on the swept path of this vehicle configuration.

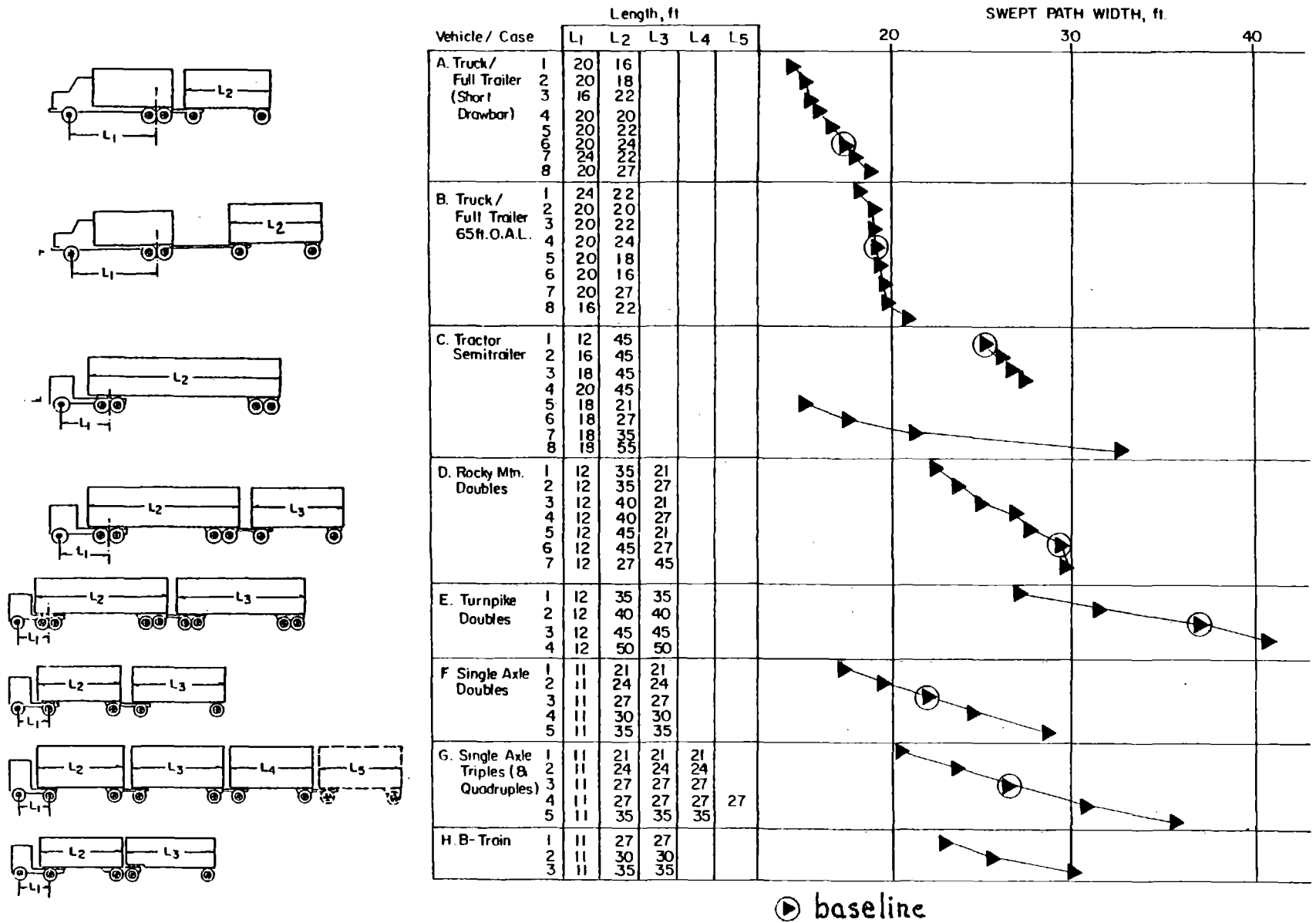


Figure 58. Influence of Length Parameters on Low-speed Offtracking (Swept Path)

3) Among the so-called "baseline" vehicles, the one combination which stands out is the twin 45-foot (13.7-m) turnpike double. Of course, the special offtracking problem with this vehicle is dealt with, in real practice, by confining its use to certain limited-access highways. To provide logistical support for these operations, marshalling yards have been constructed adjacent to the access ramps so that the double can be broken down into two single units for carrying the freight over other road systems.

Interpretation

Since low-speed offtracking is not seen as presenting a significant safety problem, the interpretation of these results must be made simply in the context of the suitability of the road system for the vehicles which will use it.

3.4.6 High-Speed Offtracking. When articulated vehicles travel around curves at low speed, the trailing elements articulate so that their tires track inboard of the paths of the tires on the towing unit. As speed increases, and specifically as lateral acceleration increases, the tires on the trailing units begin to travel along paths which more closely approach the paths of the towing vehicle's tires. At a sufficient speed, and lateral acceleration, the trailing tires begin to track outboard of the paths of the towing vehicle's tires. The difference in radius between the path subtended by the outboard tire on the steering axle of the tow vehicle and the path subtended by the most outboard trailer tire is defined as the high-speed offtracking dimension.

Shown in Figure 59 is a plot of the high-speed offtracking measure versus the wheelbase of an individual trailing unit. These data represent three values of turn radius for a steady speed of 55 mph (88 km/h) and for a selected set of tire properties representing a typical radial-ply truck tire. Given the 55 mph (88 km/h) speed, these data pertain to turn radii which represent the intermediate-to-severe range of cornering maneuvers for a loaded truck, with the 600-foot (183-m) radius value approaching the rollover condition. Using these data for individual

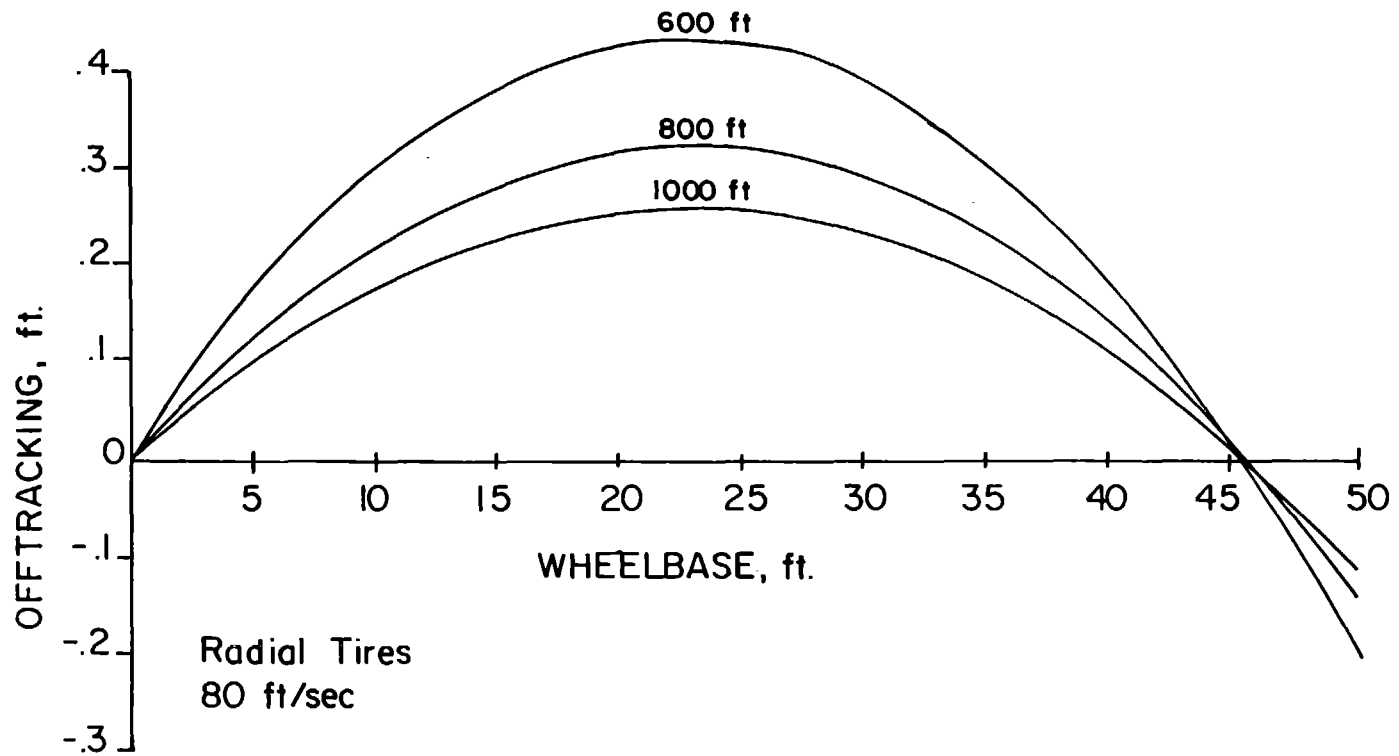


Figure 59. Relationship Between Wheelbase and High Speed Offtracking for Differing Path Radii

trailing units, the selected set of multiply-articulated vehicles has been examined to illustrate the high-speed offtracking achieved at a 600-foot (183-m) radius, with assembled combinations. Shown in Figure 60 are the calculated values of high-speed offtracking for various values of the length of the individual units. (Please note that Figure 59 incorporates wheelbase as the length variable, while Figure 60 distinguishes among vehicles primarily by total length dimensions.)

Observations

1) Since the maximum values of high-speed offtracking are achieved with vehicle units having wheelbases in the vicinity of 23 feet (7.0 m), as shown in Figure 59, the combinations exhibiting the largest total offtracking are those having the most trailing units in that range of wheelbase. Thus, the conventional triple and quadruple exhibit relatively high values of high-speed offtracking while the conventional tractor-semitrailer, with 45-foot (13.7-m) trailer length, shows a relatively low value.

2) Recognizing that the basic curve for individual vehicles, Figure 59, shows high-speed offtracking passing through zero for wheelbases exceeding 45 feet (13.7 m), it is notable that the lowest value shown for any vehicle combination in Figure 60 is obtained with the tractor and 55-foot (16.8-m) semitrailer. Interestingly, this vehicle registered one of the very highest values of low-speed offtracking, shown earlier in Figure 58.

3) While the results shown in Figures 59 and 60 derive from the case of typical radial-ply tires, the high-speed offtracking performance achieved when bias-ply tires are installed is considerably poorer. Vehicles equipped with typical bias-ply tires will exhibit high-speed offtracking values on the order of 70% greater than the results shown.

Interpretation

The high-speed offtracking phenomenon requires that a substantial level of lateral acceleration be present before a net outboard path is achieved at the trailer tires. Thus, this characteristic is only of

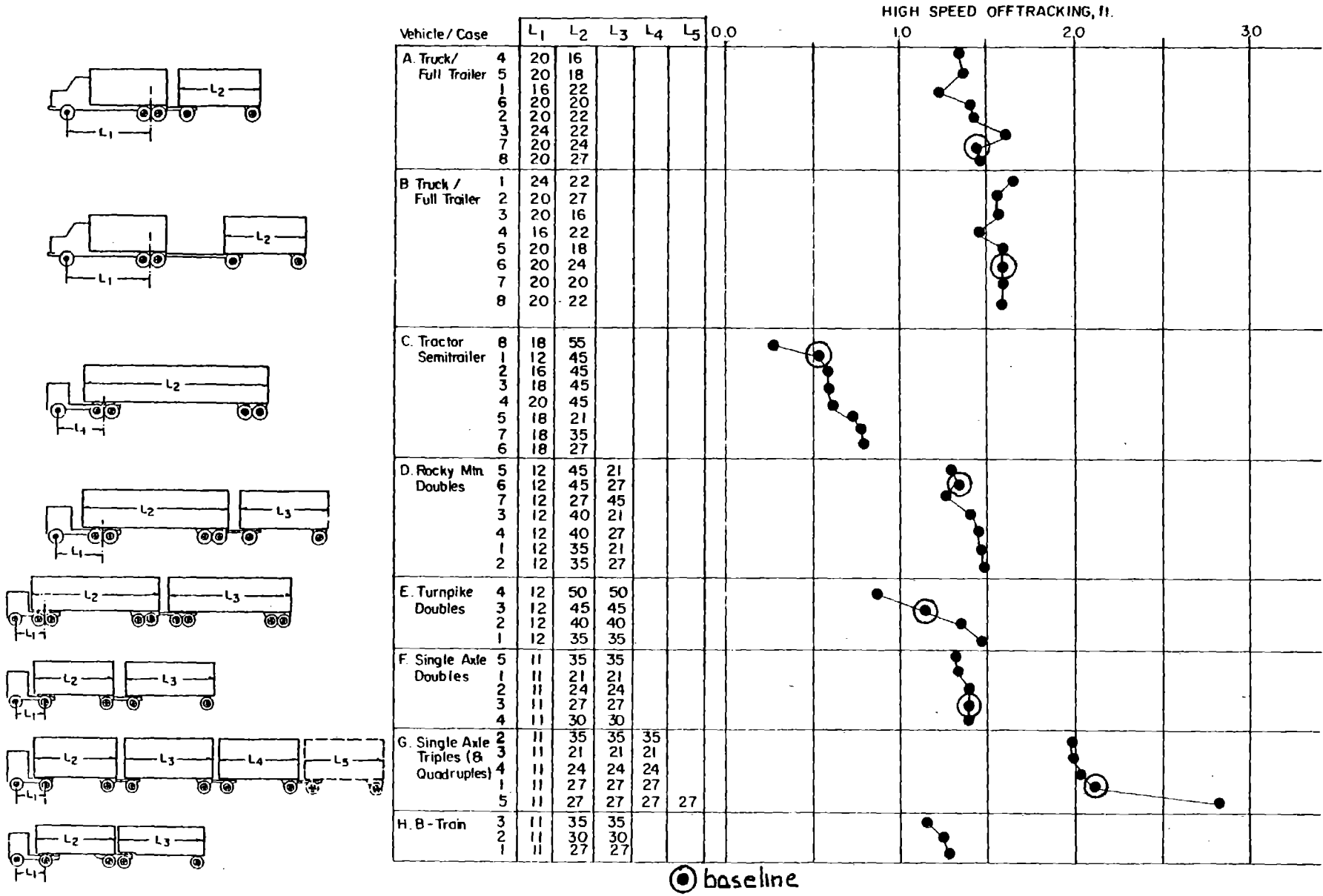


Figure 60. Influence of Length Parameters on High Speed Offtracking

significance for rather severe turning conditions, such as may occur when a vehicle negotiates a freeway exit ramp at an excessive speed. One threat posed by outboard offtracking is that the trailer tires may impact a curb due to their outboard path such that a strong rollover stimulus is imparted to the vehicle. Another possibility is that the rear trailer may strike a guardrail or another vehicle.

It is important to notice, however, that even for the rather extreme maneuver represented here, the outboard dimension is generally a relatively small fraction of the lane width. Thus, it would appear that high-speed offtracking would have little safety significance in most circumstances. Of course, if there is a risk of the trailer tires striking a curb, the outboard offtracking behavior may decide the issue of "rollover or not"—introducing a very great safety significance in a particular situation. For the case of bias-ply tires, as mentioned in observation (3), above, the offtracking dimensions are considerably more substantial and certainly imply a more significant safety hazard.

3.5 Types of Multiple-Trailer Combinations

In previous sections of this report, various types of multiple-unit truck combinations have been considered as subjects for studying the influence of individual size and weight variables. In many jurisdictions, however, a major subject of controversy simply concerns the issue of whether to allow certain specific types of multiple-unit trains on the highway. For example, certain of the toll highways allow a specific "turnpike double" which couples two 45-foot (13.7-m) trailers having tandem axles, and others do not. Likewise, some western states permit the operation of the triples combination which couples three 27-foot (8.2-m) trailers having single axles, but most states do not. It is the purpose of this section to assemble in one place the findings concerning the stability and control properties of these "conventional" or most popular configurations of the multiple-trailer combinations used in the U.S. The data which will be presented can, in general, be found elsewhere in the report—in sections dealing with individual size and weight influences. The properties of interest here are only those which are peculiarly determined by the basic type of vehicle configurations which are presented.

3.5.1 Braking Performance. There appears to be very little basis for expecting a significant difference in the stopping-distance performance of various types of combinations. This conclusion does not imply that differences in the stopping distances of individual vehicle specimens might not be observed (for example, see Volume II of this study and references [16] and [31]), but rather that such differences will derive more likely from random variations in brake behavior than from the distinctions in basic vehicle configuration.

Three primary features distinguish the common multiple-trailer combinations from one another. These features are (a) gross weight, (b) the lengths of individual trailers, and (c) number of trailers in the combination. With regard to item (a), it was shown in Section 3.2.1 that gross weight is an insignificant determinant of vehicle stopping distance, if the vehicle's brake system was originally designed to provide the torque levels needed for the loads being carried. Regarding item (b), it was shown in Section 3.4.1 that variations in trailer length could have a mild influence on stopping-distance performance, with the shorter trailers suffering greater amounts of load transfer such that stopping distances were increased. Regarding item (c), this study has not specifically addressed the number of trailers in a combination, per se, as a braking issue, but this feature is not seen as relevant to stopping-distance performance except insofar as the number of trailers is likely to influence the value of the transmission time needed to propagate the air signal to the rear-most trailer. This study has not produced data which speak to this latter source of potential difference in stopping-distance performance.

Notwithstanding differences in stopping distance measured, in this and other studies, with individual samples of differing types of vehicles it is the authors' view that differing vehicle types cannot be meaningfully distinguished by their basic stopping-distance capability. On the other hand, it is certainly true that vehicles with more articulation joints present a greater set of possible motion instabilities in event of wheel lockup. There appears to be no means of quantifying the significance of this latter characteristic, however, except to consider that fewer articulations is probably better.

3.5.2 Yaw Stability. Distinctions in the various types of multiple-trailer combinations are seen as having virtually no significance to the yaw stability issue (which has been presented, herein, as essentially a problem involving the tractor's understeer level). That is, the differences existing in the various types of combination vehicles do not include variations in the parameters which are known to determine the understeer characteristic. Thus, the "type of combination" can be dismissed as an issue bearing upon tractor yaw stability.

3.5.3 The Dynamics of Tractor Yaw Response to Steering. It was shown in Section 3.4.3 that the length of an attached trailer has an insignificant influence upon the dynamic response of a tractor to steering input. Since multiple-unit trains simply involve the coupling of various additional trailers onto the rear of a conventional semitrailer, there is no means by which the specific configuration of a multi-trailer combination can modify the dynamics of the tractor's yaw response.

One possible exception to this rule is the B-train type of combination. Since this type of vehicle provides a rigid coupling between successive trailers, each trailer has some potential for influencing the behavior of the preceding unit. Research reported in Reference [15], however, reveals virtually no difference in tractor response measured at highway speeds between cases involving a simple tractor-semitrailer configuration and a B-train. It is believed that this result has broad generality for B-trains having no more than two closely-spaced axles at the rear of the first semitrailer.

3.5.4 High-Speed Offtracking. There is a definite relationship between the high-speed offtracking characteristic and the type of multiple-trailer configuration. Shown in Figure 61 is an illustration of the high-speed offtracking measure for a selected set of common multiple-trailer configurations. This measure, defined earlier in Section 2.2.2.4, describes the extent to which the rearmost trailer axle tracks outboard of the tractor's path in a specific cornering maneuver at 55 mph (88 km/h). The figure ranks the vehicles shown, from top to bottom, according to the

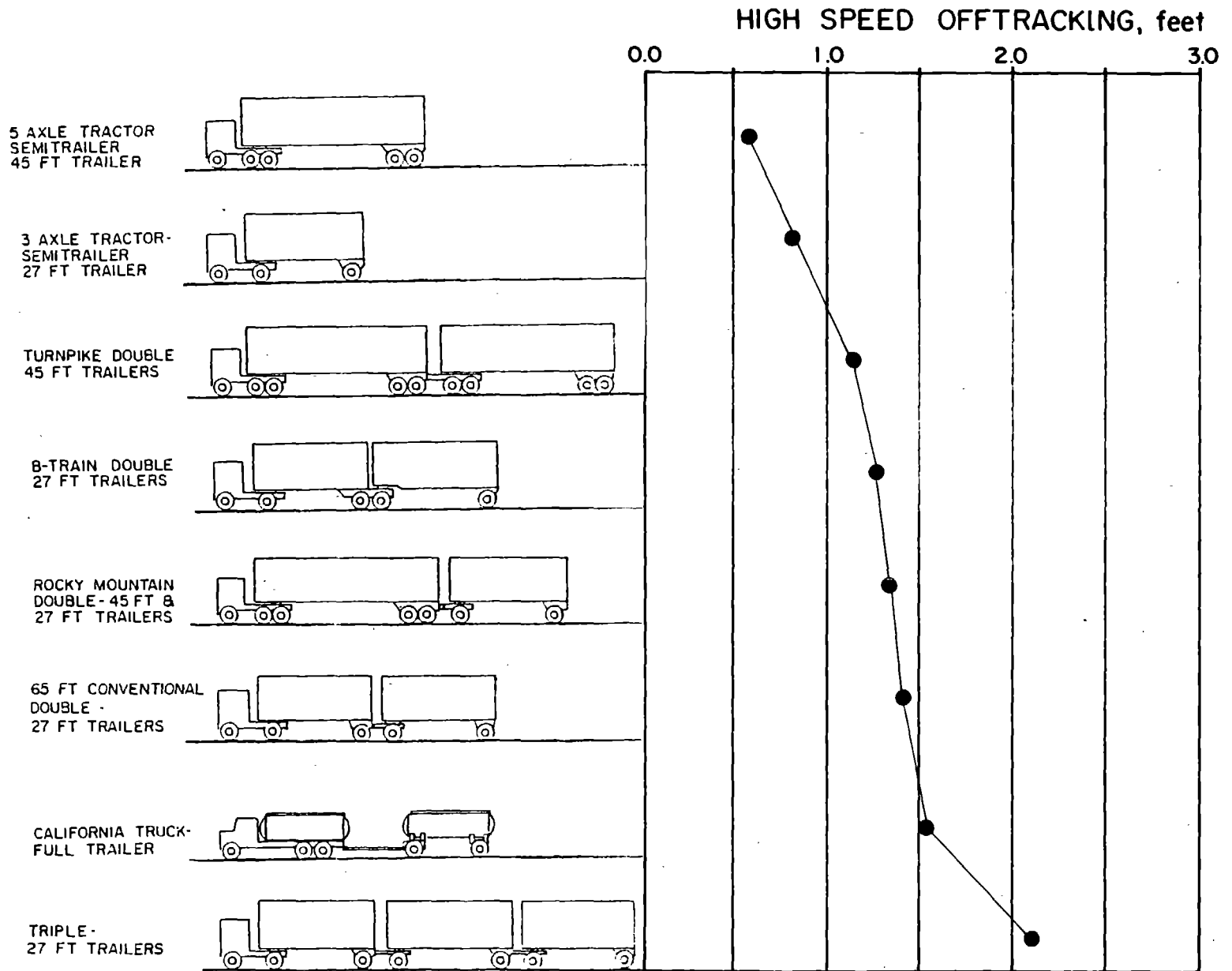


Figure 61. Influence of Combination Type on High Speed Offtracking

indicated values of high-speed offtracking. According to the proposed interpretation for this measure of performance, the "better" vehicles exhibit the lowest values of high-speed offtracking.

As was explained in Section 3.4.7, the highest values of high-speed offtracking are obtained, for vehicles equipped with radial tires, when the trailer wheelbase is around 23 feet (7.3 m). Thus, we see that some of the longer combinations, like the turnpike double, do better than shorter combinations which employ shorter-length trailers, such as the conventional single-axle double. The triple does the poorest of all because it incorporates the greatest number of the relatively short trailers.

As stated in Section 3.4.7, the significance of the high-speed offtracking characteristic to traffic accident production is unknown. One can only say that there is no benefit gained from the outboard offtracking motion of trailers in curves. Since the outboard path implies that a curb, guardrail, or roadside object might be struck by the rearmost trailer during an intermediate-severity cornering maneuver, however, greater values are definitely seen as detrimental. It should also be noted that the offtracking dimensions listed will be increased by approximately 70% when bias-ply tires are used in place of the radials considered here.

3.5.5 Low-Speed Offtracking. In Section 3.4.6, a swept-path measure was employed to show the influence of tractor and trailer length parameters on low-speed offtracking behavior. This measure describes the maximum width projected by the vehicle as it negotiates a 90-degree intersection at near-zero speed. While the low-speed offtracking phenomenon is not necessarily seen as a safety issue, it does constitute a matter of practical concern in size and weight policy-making. Further, it is a characteristic which sharply discriminates one type of multiple-trailer combination from another.

Shown in Figure 62 is an illustration of the swept-path values obtained for each of the selected types of vehicle combinations. Again, the vehicles are ranked from top to bottom according to the relative "quality"

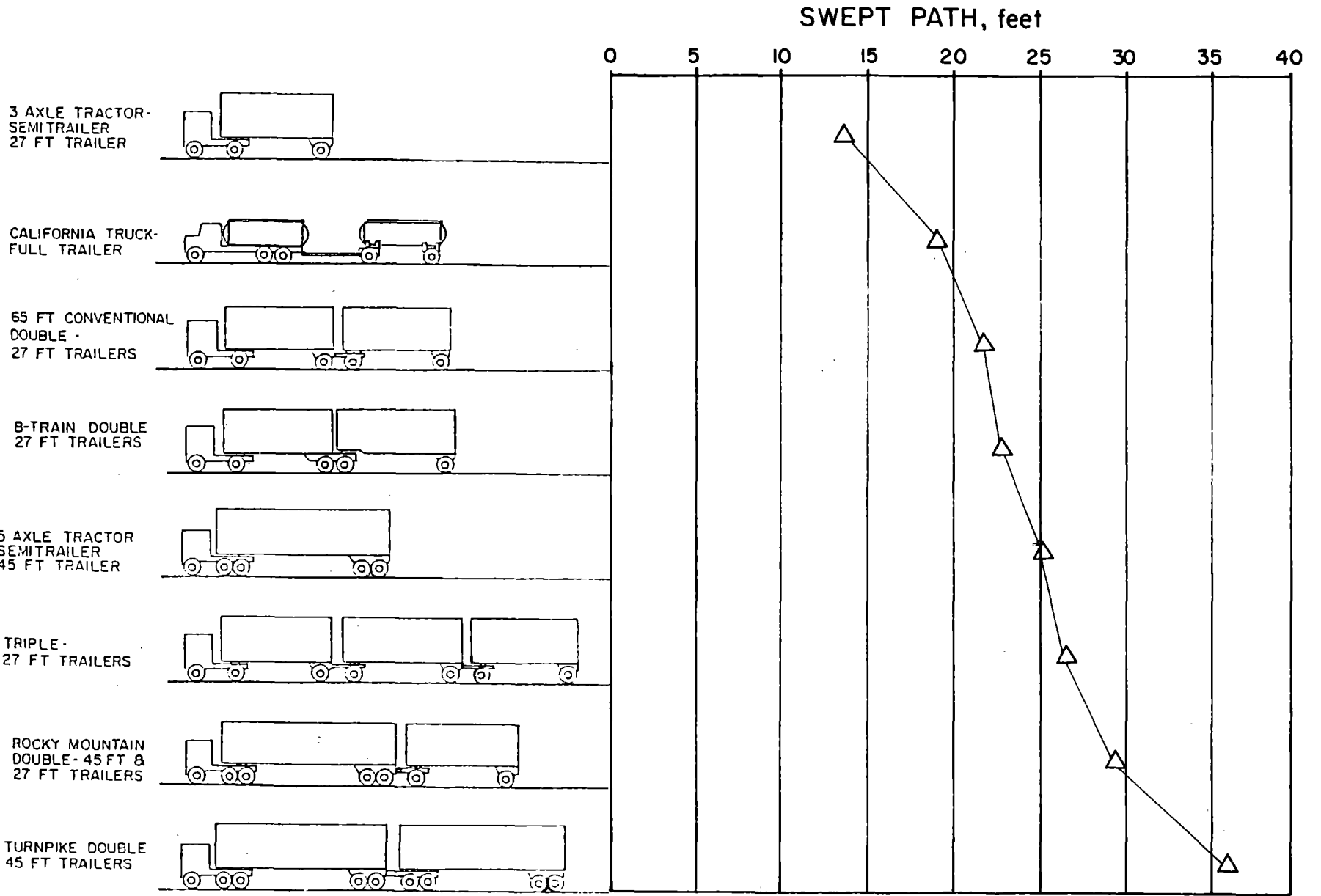


Figure 62. Influence of Combination Type on Low Speed Offtracking (Swept Path)

of their swept-path behavior. The significance of these data, of course, are that some vehicle combinations can reasonably negotiate a given road system, given the geometric constraints existing at intersections and access points of the roadway, and others cannot.

3.5.6 Rearward Amplification. In addition to the low- and high-speed offtracking characteristics, the rearward amplification behavior is known to sharply distinguish one type of multiple-trailer combination from another. This property has been discussed earlier in the report in terms of a measure termed the "amplification ratio." Values of this measure presented previously were derived using two differing simulation methods which considered the vehicle's response to a steady oscillation at the steering wheel. While this type of steering input was not proposed as a realistic condition which a driver might apply, it has long been recognized as useful for this type of analysis (see, for example, [2, 8, 19, and 32]). In fact, the vehicle's response to a steady oscillatory steering input is of interest precisely because it reveals modes of motion which could be excited by any of a broad variety of realistic inputs.

In the course of this study, however, another analysis was conducted specifically for the purpose of comparing the amplification behavior of differing types of multiple-trailer combinations in response to one realistic set of input conditions. This portion of the work has been presented to the Society of Automotive Engineers in the form of a technical paper which is cited as Reference [33]. This analysis produced a type of amplification measure which was identical in concept to that produced by the other analysis methods—ratioing the maximum lateral acceleration experienced at the rearmost trailer to that acceleration level which was experienced at the tractor. The maneuvering condition, however, involved steering the vehicle to just miss an obstacle in the roadway, as diagrammed in Figure 63. In this maneuver, there is nominally only one cycle of steering input applied rather than a continuous series of steering cycles. As in the other analyses, the maneuvering speed was 55 mph (88 km/h).

It is useful to consider the contrast in the rearward amplification behavior of the various vehicle combinations using the results from each

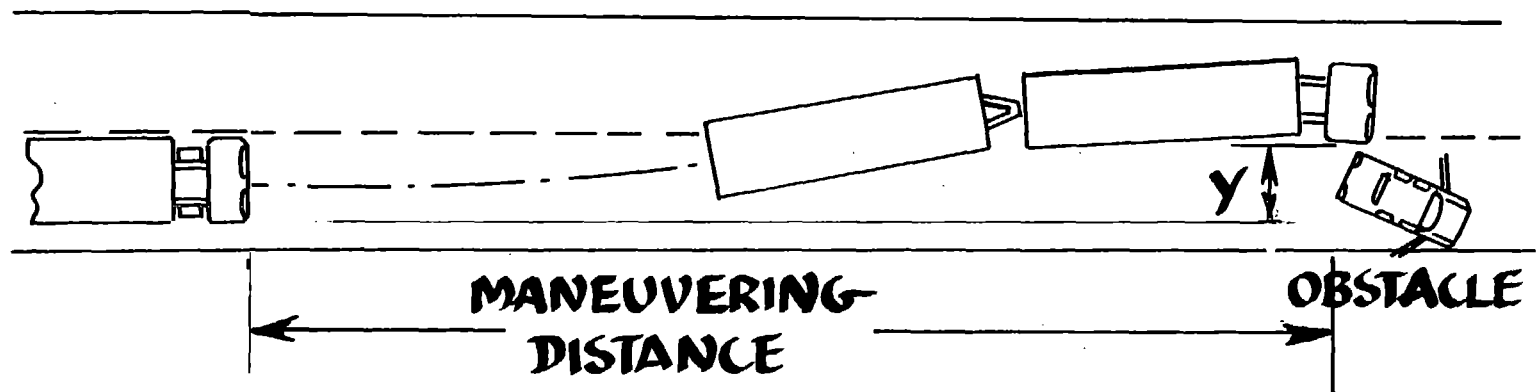


Figure 63. Diagram of Obstacle Avoidance Maneuver, Identifying Obstacle "Width", Y

of these analyses. Shown in Figure 64 is an approximate ranking of the selected combinations according to the values of amplification ratio obtained using the three different calculation methods. The triangle and circle markers indicate results obtained from analyses in which steady steering oscillations were applied. These are termed "frequency response" results. The square markers indicate results from the obstacle-avoidance maneuver.

It is suggested that the results from the three methods differ from one another for certain reasons which may be of interest to those seeking to understand the mechanics of the vehicles' responses. In cases in which large differences exist among the three results for a given vehicle, there appears to be a distinct sensitivity of the vehicle's response to the transient character of the obstacle-avoidance maneuver. These distinctions in response are discussed in some detail in Reference [33]. The person concerned with overall safety implications of these data is simply advised to consider the whole range of values which are exhibited for each vehicle and to compare respective vehicles on that basis. (It should be noted, however, that one data point is missing in the sets for the B-train and the triple since (a) the "simplified analysis" method was unable to represent the B-train configuration and (b) the "complete linear analysis" did not have the capacity to handle the extra vehicle elements in the triples combination.)

To supplement these results, the amplification behavior calculated in the obstacle-avoidance maneuver has also been described in terms of another very simple measure. This measure indicates the width of the obstacle (in feet) which can be successfully "avoided" at 55 mph (88 km/h) without approaching rollover at the rearmost trailer of the combination. This width dimension appears in the diagram of Figure 63. To determine the "approaching rollover" condition, the simulation runs were set up to find that obstacle width which, when successfully steered around, caused the rearmost trailer to achieve a peak lateral acceleration level of 0.3 g's— a value which is within approximately 15% of the level needed for rollover. Further, the maneuver was constrained such that the "driver" was presumed to begin his steering activity with only 2.0 seconds of travel time available, at 55 mph (88 km/h), prior to reaching the obstacle.

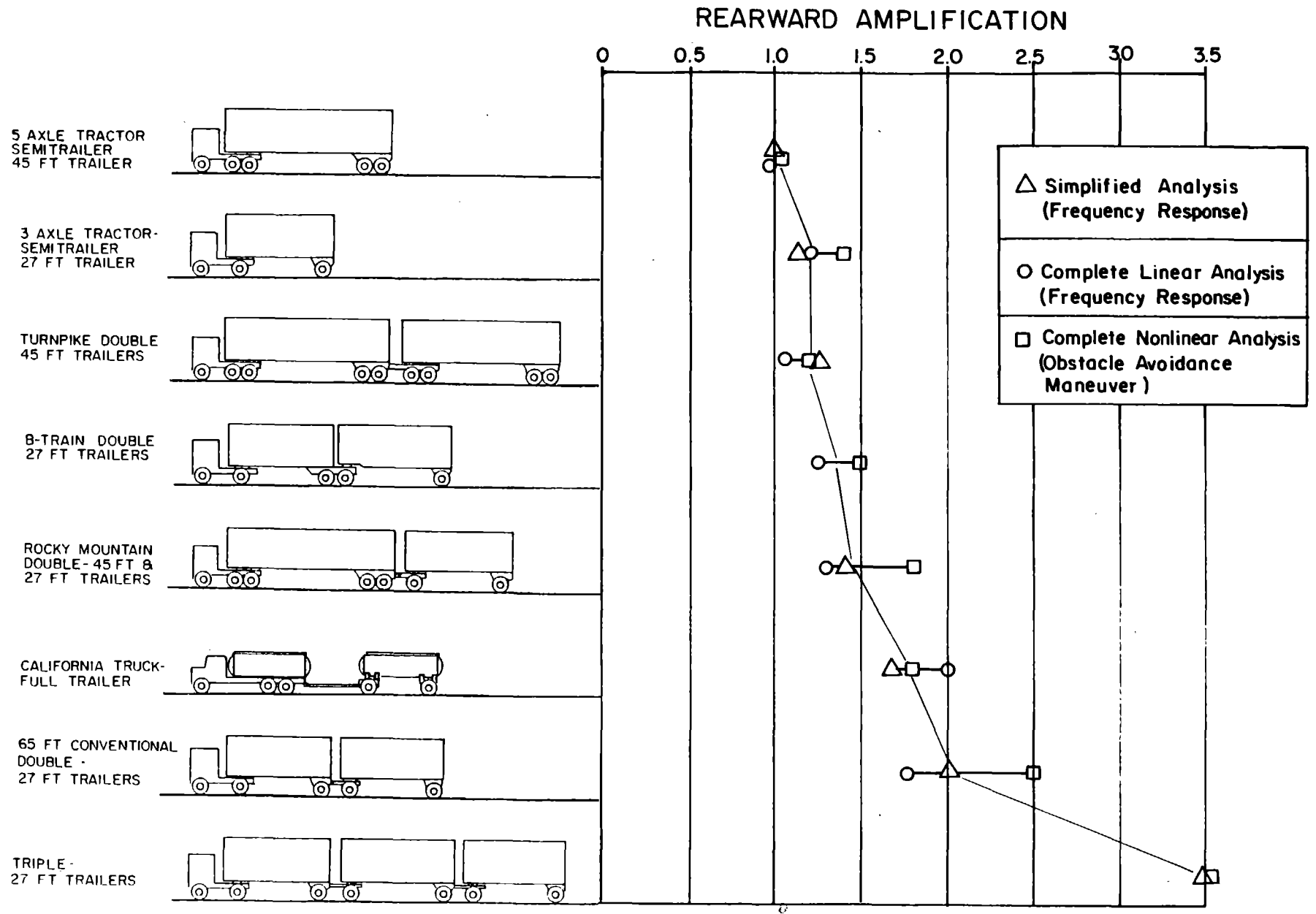


Figure 64. Influence of Combination Type on Rearward Amplification Using 3 Methods of Analysis.

For vehicles exhibiting low levels of amplification at their rear trailers, a relatively wide obstacle can be successfully cleared without approaching a rollover condition. Vehicles exhibiting large levels of amplification cause their rear trailers to approach rollover even when a relatively small value of lateral displacement is initiated at the tractor. Shown in Figure 65 is a ranking of the selected vehicle types according to the width of obstacle that each can clear in the 2.0-second maneuver, at 55 mph (88 km/h), before reaching a 0.3 g level of lateral acceleration at the rear trailer. The figure provides a rather graphic display of the contrasts among the vehicles.

While the obstacle-avoidance maneuver is seen as realistic, the reader should recognize that it does represent an emergency type of condition and would be called for only rarely on the highway. Thus, to interpret the results in Figure 65 by saying that the B-train, for example, with its 4-foot (1.2-m) measure, is only "half as safe" as the five-axle tractor-semitrailer, with its 8-foot (2.4-m) value for obstacle width, would be completely unfounded. Nevertheless, these results are seen as revealing a certain characteristic which is inherently present, to the degree shown, in the design configurations of the respective vehicles. To the degree that maneuvers involving steering activity in the higher frequency range occur in the actual service of these vehicles on the road, these results suggest that distinct differences in the incidence of rear-trailer rollover will be found.

3.6 Vehicle Width

The limitations on the maximum outside width of commercial vehicles serves to limit the width of the load bed on truck and trailers which, in turn, directly affects the volume of the payload space. Thus, vehicle width immediately impacts upon the productivity of units transporting low-density freight. Accordingly, one can be sure that a large portion of the trucking industry will utilize any liberalization in width allowance by at least assuring that the bed or box width on newly-purchased equipment is at the new allowance value. But to allow a certain maximum width is not

WIDTH OF OBSTACLE CLEARED AT 55mph , feet

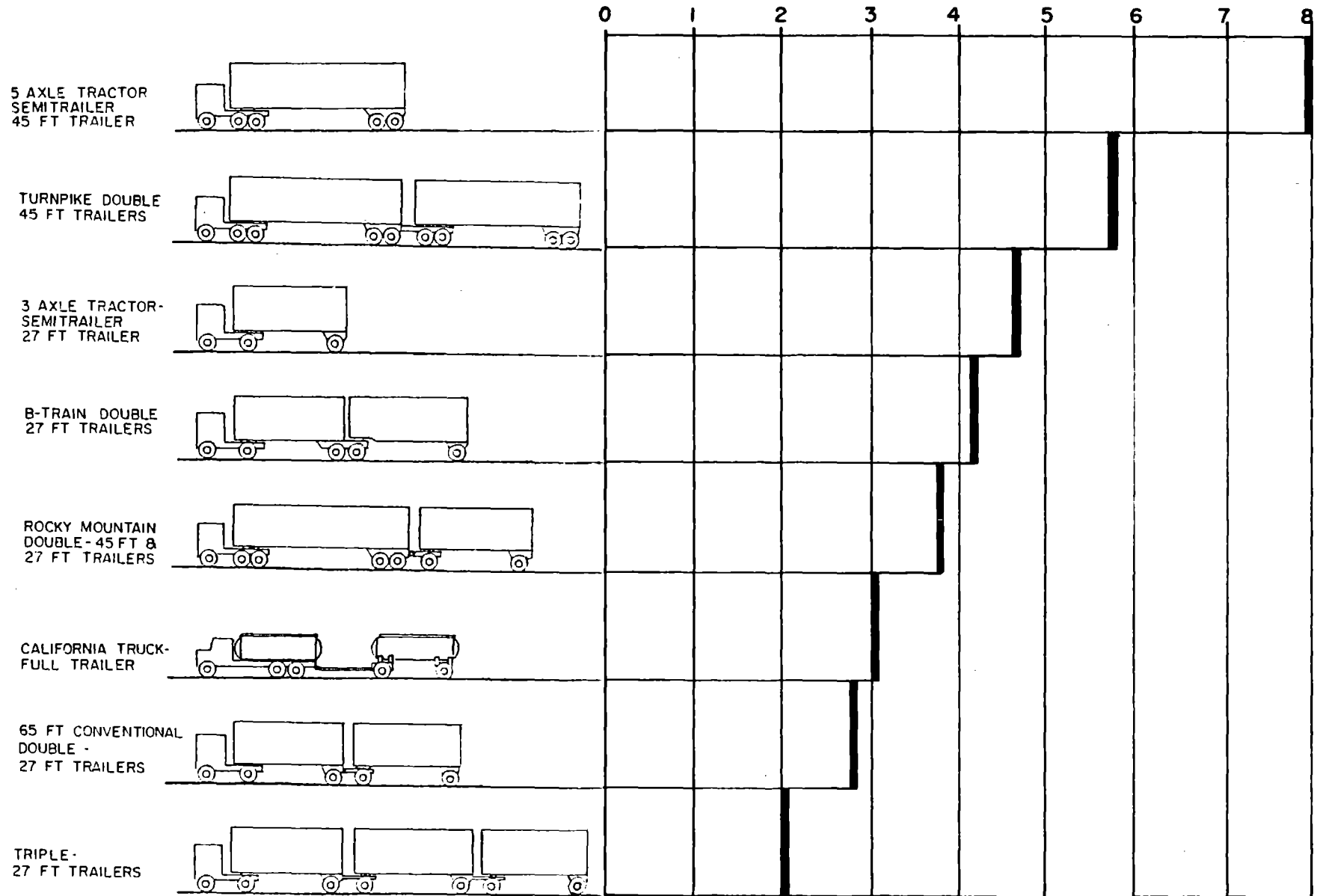


Figure 65. Influence of Combination Type on the Width of Obstacle Which Can Be Cleared in a 2-Second Maneuver at 55mph Without Approaching Rollover

necessarily to require that the width allowance be utilized in a manner most conducive to stability and control qualities.

A case in point concerns the anticipated transition of the American trucking industry following the federal legislation effective in 1983 preempting state constrictions on maximum width so as to allow a 102-inch (259-cm) width. Considering a tractor-semitrailer, for example, a trucking fleet could select vehicles having any of the following design features in combination:

- width of trailer load bed, 96 or 102 inches (244 or 259 cm)
- width across outside of trailer tires, 96 or 102 inches (244 or 259 cm)
- spread between spring centers on trailer, 38 or 44 inches (97 or 112 cm)
- width across outside of tractor tires, 96 or 102 inches (244 or 259 cm)
- width between rear spring centers on tractor, 38 or 44 inches (97 or 112 cm)

While the width of the load bed has only a rather remote connection to the stability and control properties of vehicles, as will be shown, the width prevailing across the outside of the tires constitutes a very important parameter. Of lesser, but not insignificant, importance is the lateral spread between the spring centers which determines the suspension's nominal resistance to the roll motion of the load bed. These respective width parameters are illustrated in Figure 66. (Note that the "spring spacing" parameter pertains to conventional leaf-spring suspensions and has no meaning in connection with, say, air suspensions, or other suspension types which do not depend upon any particular width-like dimension in establishing their ability to "resist roll motion of the load bed.")

Since the tractor and trailer are purchased in completely separate transactions, it is possible that trucking fleets would specify the width parameters of the tractor rather differently than they would the trailer parameters. Nevertheless, the width across the tractor tires, as well as the spread between spring centers, also represent parameters of importance to stability and control behavior.

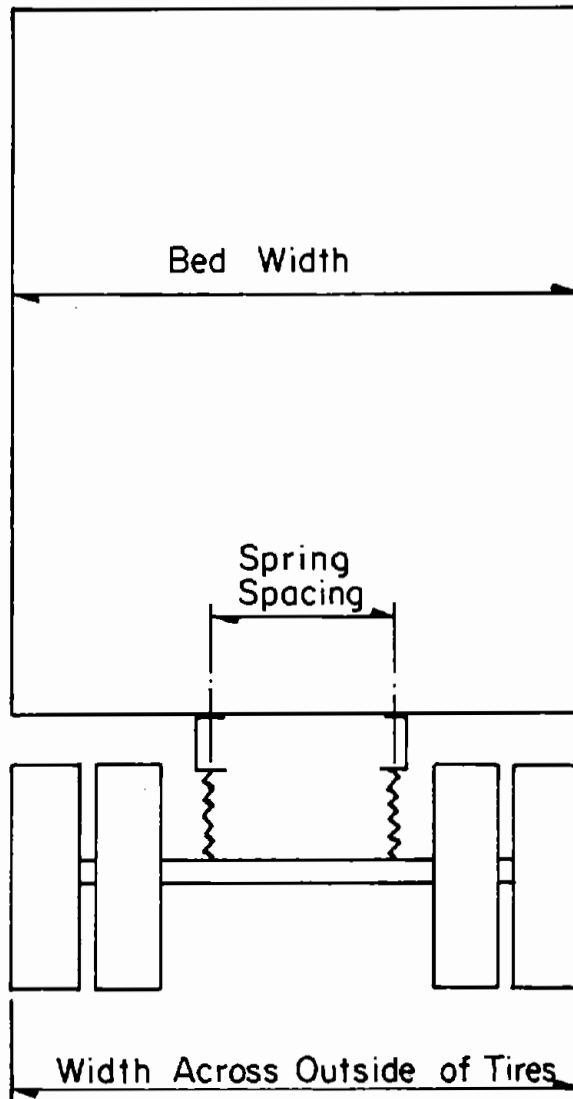


Figure 66. Sketch of Trailer or Truck Showing Width Parameters

Simulations were conducted in this study to evaluate the influence of a number of combinations of the above width parameters on the yaw and roll stability properties of selected vehicles. Most of the cases were configured to address the prospect of a transition from a width allowance of 96 inches (144 cm) to 102 inches (259 cm). The cases represent situations in which the load bed, only, the load bed and trailer tires, and the load bed, tires, and springs are spread to the maximum widths achievable within the outside constraint of 102 inches (259 cm). In each of these cases, the trailer is considered to be coupled to a tractor having width parameters corresponding to either the 96- or 102-inch (244- or 259-cm) outside dimension. Please note that tractor springs and tires were placed, together, at either their wide or narrower locations and were not varied separately here.

3.6.1 Yaw Stability. The influence of width variations on yaw stability was examined for the case of a five-axle tractor-semitrailer. The vehicle was considered in cases involving gross combination weights of both 80,000 and 88,000 lbs (36.3 and 39.9 m tons). It was hypothesized that increases in the width measured across the outside of the tires would improve yaw stability (by means of increasing the understeer level obtained at higher levels of lateral acceleration). This result was expected due to the fact that a smaller change in loads experienced by left- and right-side tires during cornering would prevail, for a given level of lateral acceleration, when the tire track width was increased. Since, as discussed earlier, it is this load change or "load transfer" which gives rise to the characteristic loss in the understeer of trucks in moderate severity maneuvers, increases in width can be expected to yield a lesser amount of this "loss."

Shown in Figure 67 are the results of calculations showing the understeer measure (evaluated at 0.25 g's lateral acceleration) for each of 11 cases of width variation.

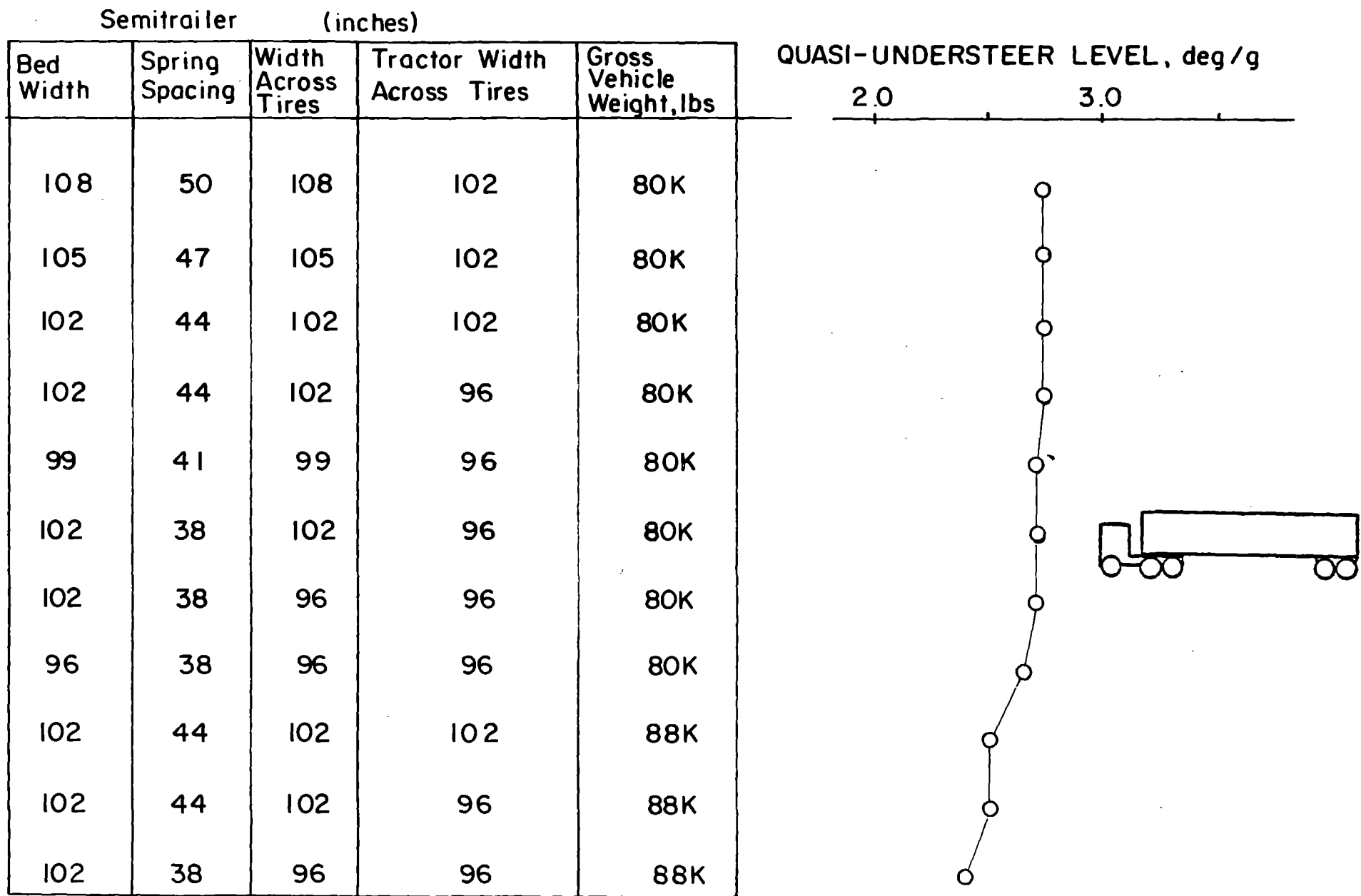


Figure 67. Influence of Width Parameters on Understeer Level.

Observation

-Over the cases shown, there is very little influence of width on the understeer measure. The understeer measure does decline slightly for the narrowest of the tire placement widths, but the influence of width is seen to be notably smaller than the influence of the gross weight variation which is shown.

Interpretation

Since width changes are seen to have no significant influence on the understeer measure, over the range of values at issue with contemporary vehicles, one can conclude that differences in the means for implementing a liberalized width allowance are likely to be of no consequence to yaw stability considerations.

3.6.2 Roll Stability. Clearly, the width of the tire placement constitutes a first-order determinant of vehicle roll stability. For a given axle load, the contribution of that axle to the overall roll stability of the vehicle is directly proportional to the width of the tire placement. Since the lateral spread between spring centers only influences the amount of the total resistance to body roll which is generated at the axle in question, the net effect of this parameter cannot be generalized, and depends upon other characteristics of the vehicle. It is further known that the relative distribution of roll stiffness and width parameters between a tractor and semitrailer will have a significant influence on total roll stability [22].

A large number of cases were examined in order to define the influence of the various width parameters on the rollover threshold measure. Cases were identified for a three-axle straight truck, a five-axle tractor-semitrailer, and for a five-axle conventional double. In general, these cases involved the assumption of a median-density freight, as in much of the baseline conditions discussed throughout this report. This assumption provided for a composite c.g. height of 80 inches (203 cm) and represents the case of a gross-weight-limited load. When this load condition is to be

applied to a vehicle whose load bed has an outside width exceeding the baseline value of 96 inches (244 cm), the same volume of freight is then thought to be situated at a somewhat lower c.g. height. Thus, in this scenario, the influence of a widened bed is to lower the center of gravity of the payload.

In a few cases of the tractor-semitrailer combination, an alternative loading scenario was also examined in order to evaluate the influence of a widened load bed on cube-full trailer loads. In this scenario, the baseline vehicle is defined as being 96 inches (244 cm) wide and loaded with a material which fills the cubic capacity of the trailer, but which leaves the total vehicle weight slightly below the maximum permissible gross weight level. With a widened load bed, then, more of the same type of freight can be added such that a greater payload weight is obtained. The center of gravity of this new payload is still located at the original value of height since only the width dimension has been changed. However, the composite c.g. height rises slightly since the payload mass constitutes a larger fraction of the total and thus serves to bias the composite c.g. position upward.

Shown in Figure 68 are the rollover threshold values for each of the cases of width variation. For cases involving the doubles combination, variations of width parameters at the trailer axles are accompanied by adjustments at the dolly axle as well.

In order to facilitate observations pertaining to the cases involving a change in overall width from 96 to 102 inches (244 to 259 cm), the applicable data from the tractor-semitrailer and doubles configurations have been compiled to produce Table 1. This table lists the percentage improvements in the rollover threshold, with respect to the performance of the 96-inch (244-cm) baseline case, which accrue due to:

- a) increasing the width across all trailer tires from 96 to 102 inches (244 to 259 cm)
- b) the combination of (a), above, plus the widening of the trailer spring spacing dimension from 38 to 44 inches (97 to 112 cm)

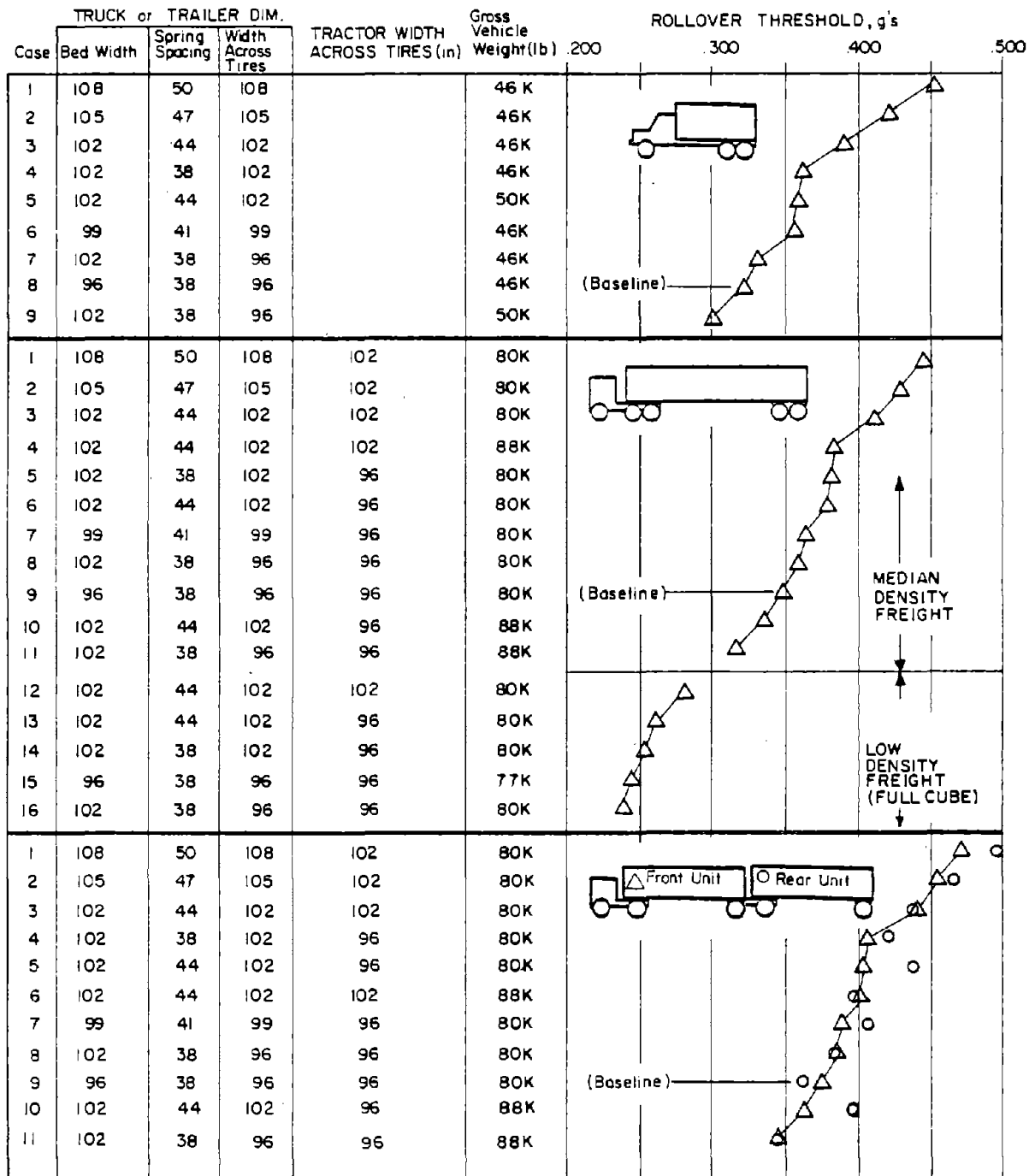
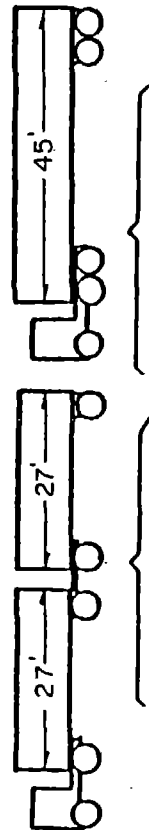


Figure 68. Influence of Width Parameters on Rollover Threshold



VEHICLES	A Width across trailer tires 96" - 102"	B = (A + Trailer spring spacing 38" - 44")	C Tractor width only 96" - 102"	D=(A+B+C) Complete widening of tractor & trailer
Tractor Semi Medium density Freight	+ 9%	+ 9%	+ 9%	+18%
Tractor Semi Light Freight (Full Cube)	+ 4%	+ 7%	+ 8%	+15%
Double — 1st Unit only Medium density Freight	+ 8%	+ 8%	+10%	+18%
Double — 2nd Unit only Medium density Freight	+12%	+16.5%	0%	+16.5%

Table I. Improvements in Rollover Threshold Resulting from Widening Vehicles from 96 to 102 inches.

- c) adopting 102-inch-wide (259-cm) tractors (which have been designed to place both tires and spring centers at the maximum width dimensions)
- d) the sum of all of the above width improvements on both tractor and trailer(s).

Observations

1) Extension of the trailer bed width, alone, without any widening of tire or suspension spacing, can have a small positive or negative influence upon rollover threshold, depending upon the loading scenario. This observation can be drawn from the tractor-semitrailer cases in which the width of the load bed is increased from 96 to 102 inches (244 to 259 cm). In the case of the median-density freight, for which the c.g. height drops slightly when a wider load bed is considered, the rollover threshold improves by approximately 3%. For the converse case of a lighter-density freight which is loaded to the cubic capacity of the trailer, the increase in payload weight which is made possible by a wider load space reduces the rollover threshold by approximately 2.5%.

2) When both the trailer's load bed and its tires are placed to attain an outside dimension of 102 inches (259 cm), the rollover threshold improves by 4 to 12%, depending upon vehicle configuration and loading scenario. The lower yield of 4% accrues in the case of the tractor-semitrailer with the "full cube" loading scenario. Since the payload c.g. height in this case is approximately 105 inches (267 cm), the rollover threshold is determined primarily by the large amount of roll motion which is occurring on the suspension springs. Thus, extension in the width across the trailer tires is of lesser value.

The 12% improvement was seen in the case of the full trailer of the doubles configuration, with the "median-density freight" scenario. The large payoff, here, is due to the fact that both ends of the full trailer become supported on wider-track axles—one at the dolly and one at the rear of the trailer. Clearly, this arrangement yields a much greater improvement in rollover threshold than accrues from widening only the semitrailer

axle(s) of a tractor-semitrailer combination. If one considered a full trailer employing a 96-inch-wide (244-cm) dolly, together with a 102-inch (259-cm) axle at the rear of the trailer, the rollover threshold would be improved by only about half of the 12% value.

3) Increasing the spring spacing on trailer axles which have already been widened to provide the 102-inch (259-cm) width across the tires provides an additional 0 to 4-1/2% improvement in rollover threshold. The 0% improvements are seen with tractor-semitrailer in cases involving the "median-density freight" scenario. To explain the matter simply, increasing the roll stiffness at the trailer axle(s) by widening the spring spacing fails to improve the rollover threshold because the characteristically-low roll stiffness of the tractor suspensions is controlling the result. (For a complete discussion of these mechanisms, see Reference [22].)

A 4-1/2% improvement in rollover threshold was seen with the full trailer of the doubles configuration. Again, the calculations assumed that both the dolly and trailer axles were outfitted with wider-spaced springs. Since full trailers are supported by "trailer-like suspensions" at both extremities, such vehicles enjoy "balanced" restraint of their rolling motions. Thus, since there exists no peculiarly "soft" suspensions as in the case of tractor-semitrailers, increased spring spacing produces a major improvement in the rollover threshold of full trailers.

4) Tractors which are widened to the 102-inch (259-cm) dimension provide an additional 8 to 10% improvement in the roll stability of tractor-semitrailers. This improvement derives from the sum of the tire- and spring-placement mechanisms. Both of these mechanisms tend to lessen a characteristic "problem" in achieving good roll stability with tractor-semitrailers—namely, that the tractor suspensions are typically "softer," in roll, than is the trailer suspension. Note, of course, that the roll stability of the tractor-semitrailer has no means of influencing the stability level of a full trailer in a doubles combination.

5) The implementation of the maximum width allowance by appropriate placement of tires and springs on both tractors and trailers provides total

improvements in rollover threshold amounting to 15 to 20%, depending upon vehicle configuration and loading scenario.

6) Increases in vehicle width beyond the 102-inch (259-cm) dimension continue to offer very substantial improvements in roll stability.

Interpretation

It is clear that increases in the width at which tires and springs are placed constitute one of the most powerful means of improving the rollover resistance of heavy vehicles. The implications of the above results to the issue of rollover accident involvement are tremendous, given the evidence which is available linking the roll stability of vehicles to rollover accident involvement. In particular, Figure 69 shows the improvements in percent rollovers per single-vehicle accident (SVA) accruing from the widening of trailer and tractor running gear from 96 to 102 inches (244 to 259 cm).

The figure suggests that the incidence of rollovers with tractor-semitrailers operating within the "median-freight" load scenario could be reduced by some 35% by adopting tractors and semitrailers which are fully widened to utilize a 102-inch (259-cm) width allowance. (Please note that the "35%" figure is obtained by observing that the "rollover/SVA" measure drops from the baseline value of 47% to 30%, thus incurring a net 35% drop from the rollover/SVA value of the baseline case. This 35% reduction is then seen as indicating the approximate level of reduction in the total rate at which rollovers are produced per vehicle mile. As mentioned previously, rollover data derived from single-vehicle accidents are useful for approximating total rollover involvement since some 80% of truck rollovers occur as single-vehicle events [15].)

When only the semitrailer is "fully widened" (that is, with wider tire placement and spring spacing), the reduction in rollover accident rate for this vehicle category is predicted to be on the order of 20%.

In the context of these potential safety improvements, let us consider the implications of certain of the "shortcut" means of utilizing a liberalized width allowance. The simulation results showed that widening

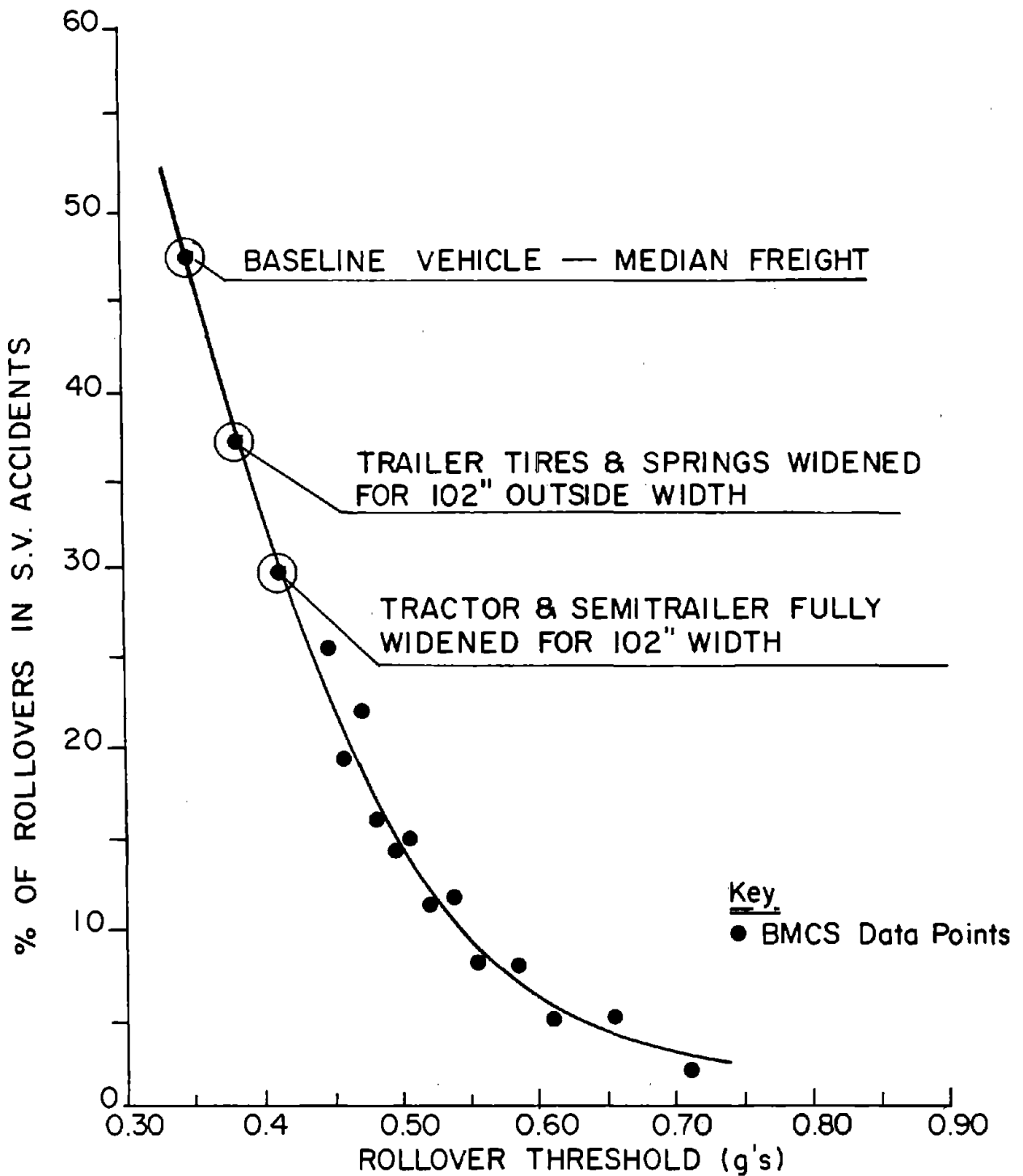


Figure 69. Overlay of Rollover Thresholds for Differing Width Parameters onto Curve Derived from Accident Data.

the load bed alone, without also widening the tire track and spring spread dimensions, introduces a small and somewhat mixed effect upon roll stability. In general, the action of widening the bed, alone, can be looked upon simply as a "missed opportunity" to dramatically upgrade a vehicle's roll stability. Accordingly, whenever width regulations are being liberalized, it would appear that the approach which most benefits traffic safety is to require that the increased width at the load bed be accompanied by appropriately widened tire and spring placements. Such changes are understood to be relatively inexpensive, although sufficient reluctance for purchasing widened axle hardware has existed in Canadian trucking operations that an estimated 90% of the vehicles having 102-inch (259-cm) load beds incorporate only 96-inch-wide (244-cm) tire placements [23].

Notwithstanding the large benefit which widened tractors contribute to the roll stability of tractor-semitrailer combinations, it is recognized that extending tractor width involves a much more costly development process than is implied by widening trailers or dollies. Presumably, wider tractors would become available if a market developed following a liberalized width allowance. Those concerned with maximizing safety are well advised to promote such development. In the meantime, it should be noted that there are no known detrimental effects of coupling trailers having one width dimension to tractors having a narrower width.

The single most beneficial application of an increased width allowance is in the case of full trailers. It was seen in the results shown above that the rollover threshold of the full trailer of a conventional doubles configuration increases by 16.5% when the dolly and trailer axle hardware (tires and springs) is widened from 96 to 102 inches (244 to 259 cm). Since, as mentioned in Section 3.4.4, conventional doubles experience the majority of their rollover incidents as rear-trailer-only rollovers, the prospect for making large improvements in the roll stability of full trailers seems especially important to safety. When one considers that the inclusion of the wider axle hardware in the construction of new dollies and trailers is rather straightforward (especially in comparison to the widening of tractors), the scenario by which a 102-inch (259-cm) width allowance would lead to much-improved roll stability for full trailers seems particularly achievable. No accident data are available which speak

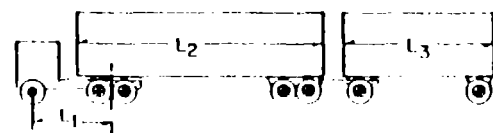
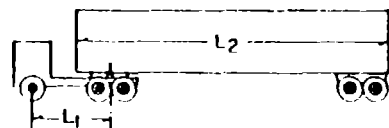
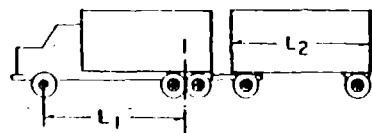
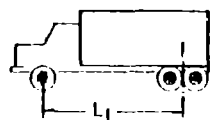
directly to the relationship between the rollover threshold of full trailers and their rollover accident involvement. Nevertheless, there is good reason to suspect that the rollover involvement of these vehicles would be sensitive to the rollover threshold property in approximately the same fashion as found for tractor-semitrailers. If this were so, we could expect that the observed reduction in the rollover threshold of conventional (27-28-foot, 8.2-8.5-m) full trailers would serve to markedly reduce the rollover involvement of doubles hauling full-weight, median-density loads.

As a final point, it should be noted that an extension in the allowable vehicle width is likely to be followed by a considerable transition period in which both the old, narrower trailers as well as the new, wider trailers will be in service together. The reader is referred to the end of Section 3.3.2.3 for a discussion of the possible implications of this transition on the likelihood of lateral offsets in payload c.g. and thus the likelihood of inadvertently-degraded levels of roll stability.

3.7 Bridge Formula Considerations

The current Bridge Formula B is employed as one of the constraints on the loading of vehicles which use the federal highway system in the U.S. The formula was defined in Section 2.1.6. The limitation which this formula places on the gross vehicle weights of various combinations has been evaluated and is presented in Figures 70a and 70b. These data were calculated for the purpose of illustrating the gross weight levels which could be achieved if the bridge formula, alone, served as the constraint on the gross weight. The reader will note that the figure covers essentially all of the vehicle configurations which were covered in Section 3.4 in which length variations were considered.

When one looks closely at the bridge formula and the effects which it has on vehicle design, he sees that all of the parameters of the vehicle which determine where axles are placed influence the load allowance. In deriving a means for calculating bridge formula allowances for the configurations shown in Figure 70, for example, it was necessary to establish conventions for such dimensions as pintle overhang distances, clearance between successive trailers, the "bumper-to-back-of-cab (BBC)," and front axle "setback" dimensions of tractors, and the like. That is, the specific



* BBC = 90"

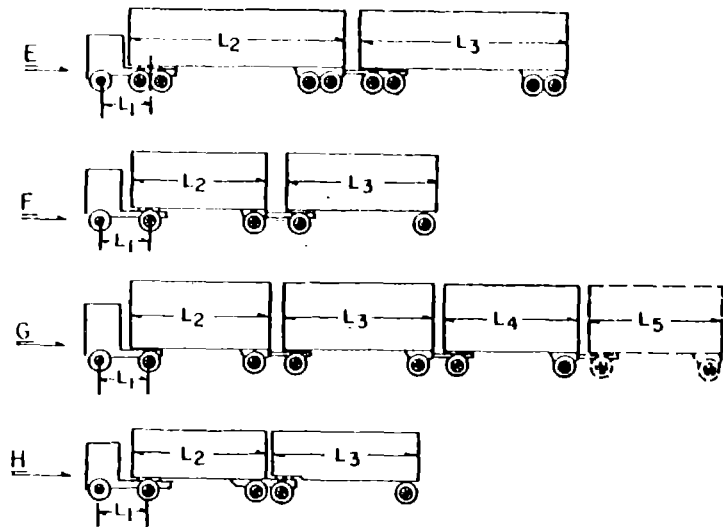
* BBC = 129"

Vehicle / Case	Length, ft					Max. GCW lbs.	Min. Total Length, ft.	Max. GCW lbs.	Min. Total Length, ft.
	L ₁	L ₂	L ₃	L ₄	L ₅				
A. Straight Truck	1	22				46 000.0	36.614	46 000.0	33.364
	2	24				46 000.0	40.216	46 000.0	36.966
	3	26				46 000.0	43.817	46 000.0	40.567
	4	28				46 000.0	47.133	46 000.0	44.168
	5	30				46 000.0	50.333	46 000.0	47.770
B. Truck/ Full Trailer	1	16	22			75 540.3	50.810	73 373.7	47.560
	2	20	22			77 675.4	58.013	75 508.7	54.763
	3	24	22			79 810.5	65.216	77 643.8	61.966
	4	20	16			73 675.4	52.013	71 508.7	48.763
	5	20	18			75 008.7	54.013	72 842.1	50.763
	6	20	20			76 342.1	56.013	74 175.4	52.763
	7	20	24			79 008.7	60.013	76 842.1	56.763
C. Tractor Semitrailer	1	12	45			79 648.3	55.137	79 554.5 **	54.987 **
	2	16	45			80 000.0	58.739		
	3	18	45			80 000.0	60.539		
	4	20	45			80 000.0	62.340		
	5	18	21			64 692.8	36.539		
	6	18	27			68 692.8	42.539		
	7	18	35			74 026.2	50.539		
	8	18	55			80 000.0	70.539		
D. Rocky Mtn Doubles	1	12	35	21		97 705.1	69.137	Trailer Rear Overhang : 26"	Truck/ Tractor Front Setback : 28"
	2	12	35	27		101 205.1	75.137		
	3	12	40	21		100 621.7	74.137		
	4	12	40	27		104 121.7	80.137		
	5	12	45	21		10 3538.4	79.137		
	6	12	45	27		10 7038.4	85.137		
	7	12	27	45		11 2078.4	85.137		

(Single axle trailer first, tandem dolly on 2nd trailer)

* For A & B Only
 ** L₁ = 11' - 10"

Figure 70a. Gross Weights Allowed by Bridge Formula "B" for Various Vehicles (Assuming Maximum Axle Loading - 20K Single, 34K Tandem)



Vehicle / Case	Length, ft					Max. GVW lbs	Min. Total Length, ft.
	L ₁	L ₂	L ₃	L ₄	L ₅		
E. Turnpike Doubles	1	12	35	35		116,233.5	83.137
	2	12	40	40		121,858.5	93.137
	3	12	45	45		127,483.5	103.137
	4	12	50	50		131,500.0	113.137
F. Single Axle Doubles	1	10	21	21		78,135.2	52.716
	2	10	24	24		81,885.2	58.716
	3	10	27	27		85,635.2	64.716
	4	10	30	30		89,885.2	70.716
	5	10	35	35		90,250.0	80.716
G. Single Axle Triples (& Quad- ruples)	1	10	27	27	27	112,626.2	94.716
	2	10	35	35	35	124,679.8	118.716
	3	10	21	21	21	102,126.2	76.716
	4	10	24	24	24	107,376.2	85.716
	5	10	27	27	27	139,621.7	124.716
H. B-Train	1	10	27	27		85,218.5	64.050
	2	10	30	30		86,000.0	70.050
	3	10	35	35		86,000.0	80.050

Figure 70b. Gross Weights Allowed by Bridge Formula "B" for Various Vehicles (Assuming Maximum Axle Loading - 20K Single, 34 Tandem)

values used for such dimensions directly affect the placement of axles, and thus the load levels allowed by the bridge formula. The important thing which the size and weight policy maker can learn from this observation is that a decision to permit the use of a bridge formula as the sole constraint on vehicle gross weight is likely to initiate a period of remarkable creativity in the design of motor truck combinations. This outcome would seem inevitable since such a great number of design parameters are of potential importance in the determination of the maximum load which the bridge formula would allow.

It is not within the objectives of this study, however, to consider the possible future adjustments in vehicle design which might develop as a result of changes in size and weight constraints. Rather, it has been our purpose only to consider the implications of changes in size and weight constraint on the dynamic stability and control properties of today's trucks. Thus, our question in this section of the report is simply "what effect would a bridge-formula-only constraint on gross vehicle weight have on the dynamic behavior of today's vehicles?" (where "today's vehicles" are primarily covered by the "baseline" cases in Figure 70). We can make certain cursory observations on the subject, upon inspecting Figure 70.

Observations

1) Common configurations of five-axle tractor-semitrailers (cases C-1 through C-4) are ultimately limited in load by the short spacing of the tandem axles and by an arbitrarily-chosen limit of 12,000 lbs (5.4 m tons) on the tractor steering axle. Thus, for example, increasing the trailer bed length beyond 45 feet (13.7 m) would not serve to increase the gross load as constrained by the bridge formula. Thus, if the bridge formula constituted the only constraint on gross vehicle weight, it is certainly possible that operators might begin to carry larger loads on the tractor steering axle. Such a change would have the following effects on stability and control behavior:

- a) The understeer level would improve due to the more forward load distribution on the tractor (approximately in the same proportion as it was seen to degrade, in Section 3.1, with the more rearward-biasing of load on the tractor).
- b) The roll stability level would degrade due to the more forward load distribution on the tractor (again, in approximately the same proportion as it was seen to improve due to rearward biasing of tractor load in Section 3.1).
- c) The greater gross weight would serve to further degrade roll stability insofar as the typical height of the composite center of gravity of the payload and trailer would be greater. See Section 3.2 for the influence of gross weight changes, per se.

Additionally, it is conceivable that operators might attempt to increase the spread between tandem axles so as to extend the load levels allowed on those axles. In general, the influences of such changes, insofar as they primarily affect only the gross weight level carried, will be the same as the direct influences of increased gross weight presented in Section 3.2.

2) A significant increase in the allowable gross vehicle weight of the conventional single-axle double (with 27-foot -- 8.2-m -- trailers) would be allowed by the bridge formula, simply by increasing the loads carried by existing vehicles on axles aft of the steering axle. As was shown in Section 3.2, increases in gross weight on this vehicle will result in degraded levels of both understeer and roll stability.

3) Cases number 6 and 7 of the Rocky Mountain Double combination show significantly different gross weight allowances, although the overall length is the same. This result is due to the fact that, with the 45-foot (13.7-m) trailer positioned at the rear of the train, a tandem-axle dolly is employed instead of the single-axle dolly. The additional axle which is incorporated in this configuration yields a greater gross vehicle weight allowance by the bridge formula. As stated in Section 3.4, however, this particular arrangement of trailers is not known to have been used in service.

4) The turnpike doubles incorporating two 45-foot (13.2-m) trailers is limited by the bridge formula to a gross vehicle weight of 127,483 lbs (57.8 m tons). This value is essentially identical to the 127,400 lb (57.8 m tons) value which is the allowed gross weight for these combinations on most of the toll highways on which they operate.

Moreover, a projection of the likely influence of a bridge-formula-only constraint on gross vehicle weight can be summarized by two observations, namely:

- a) The increases in gross weight, themselves, which would result, would affect vehicle stability and control essentially in the various ways shown in Section 3.2, and,
- b) The possibilities for alteration in the way load is distributed among axles, or the dimensions at which axles are placed, seem countless. Although many such possibilities may well serve to degrade some stability or control property, speculation on these possible changes is beyond the scope of this study.

CHAPTER 4

CONCLUSIONS AND RECOMMENDATIONS

This study has shown the manner and extent to which changes in truck size and weight can influence the stability and control properties of heavy vehicles. The primary conclusion of the work is that there are, indeed, very strong degradations in these properties which can occur due to certain prospective changes. There are also certain other changes in size and weight allowance which, if properly implemented by the trucking industry, could very significantly improve stability and control characteristics.

Although the various influences of size and weight variables reported herein are too numerous to list in these concluding remarks, Table 2 has been constructed to provide an overview. This table gives a crude scaling of the "importance" of each size and weight variable in terms of its possible influence on each of a list of stability and control properties. The table is proposed as an aid to identifying the performance categories which are likely to be disturbed by "reasonable" changes in the respective size and weight variables. For most cases, the entries in the table showing non-negligible levels of importance are based upon either the results presented in this report or the accompanying discussions concerning the state of knowledge.

The performance categories which have been most firmly related to accident involvement are (a) the roll stability exhibited by all types of vehicles and (b) the rearward amplification behavior of multiple-unit vehicle combinations. It is instructive to note that the entries in Table 2 for these two performance categories include a number of "1's," indicating that there are opportunities for a "strong" influence among the examined size and weight variations. Given the apparent connections with accident data, then, we might deduce that there are "reasonable" variations in virtually all size and weight areas which have the potential for a strong influence on the safety record. As mentioned above, some of these influences are negative and some are positive.

	Axle Load	Gross Vehicle Weight	Payload C.G. Location			Length	Type of Combination	Width	Bridge Formula
			C.G. Height	C.G. Offset	Partial Unloading				
Stopping Distance	2	2	2	—	1	3	—	—	3
Stability during Braking	3	—	1	—	1	2	2	—	3
Rapidity of Jackknife	—	—	—	—	—	1	—	—	—
Dynamic Response of Tractor to Steering	3	3	2	—	—	—	—	—	3
Yaw Stability in Steady Turn	1	1	1	2	—	—	—	3	2
Static Roll Stability	1	1	1	1	—	—	—	1	1
High Speed Offtracking	—	—	—	—	3	1	1	—	—
Low Speed Offtracking	—	—	—	—	—	1	1	—	—
Rearward Amplification	3	—	—	—	3	1	1	—	—

DEGREE OF INFLUENCE

1 - STRONG
 2 - MODERATE
 3 - SLIGHT
 — NEGLIGIBLE

Table 2. Summary of the Nominal Influence of the Examined Variations in Size and Weight on Each Category of Dynamic Performance.

The investigations conducted here have, in general, sought to determine the influence of size and weight variations on the behavior of vehicles such as are currently in service. This approach has been directly applied in all of the cases in which load changes were considered. That is, increased loads were considered in terms of their influence on the performance of "today's trucks." This scheme also guided the analysis of vehicles so that components were always considered to be of contemporary design. Where performance is seen to degrade under the influence of a size or weight change, however, it should not be assumed that future designs will be able to nullify the degradation. For example, it would be unreasonable to presume that future trucks being designed for and operated at a higher gross weight would be able to achieve the same level of roll stability as was achieved by previous trucks operating at a lower gross weight. It should be recognized that an increased gross weight allowance, or any other changes in size and weight which cause the payload c.g. to rise (without compensatory increases in vehicle width) will very likely cause roll stability to decline, regardless of the design efforts of the vehicle manufacturer and an enlightened set of specifications on the part of the purchaser.

Another aspect of the overall safety implications of a certain change in size and weight laws involves the issue of vehicle exposure. In this context, the term "exposure" refers to the total number of vehicle-miles of truck transportation which are needed, given the carrying capacity of vehicles meeting the size and weight constraints. When either the weight or volume of the typical truck payload rises, because of a change in size and weight constraints, the total number of vehicle-miles of transportation needed to meet the commercial demand is reduced. Since it is axiomatic that involvement of trucks in accidents will decrease with a reduction in exposure (all other factors being held constant), liberalization in size and weight constraints has the potential for proportionate reductions in traffic accidents, assuming that bigger or more heavily-loaded trucks show stability and control properties, as well as other safety features, which equal or exceed those seen in conventional vehicles. Accordingly, one way in which one could follow-up on the findings presented in this report is to pose the following question: "If a size and weight increase causes

stability and control qualities to decline, how does the expected loss in safety quality compare with the improvement in safety which will come about due to the reduced exposure?" It remains for future research to attempt to illustrate the answers to such questions.

Recommendations

Certain recommendations can be made which deal with rather current size and weight controversies existing in the U.S. Other recommendations are directed at peculiar segments of the trucking industry and the groups which regulate it.

Concerning the transition to 102-inch (259-cm) width, we recommend that:

1) Trailers which are widened to 102 inches (259 cm) at the load bed also incorporate tire and spring spacing dimensions which fully utilize the greater width allowance. The practice of widening only the load bed can introduce a minor reduction in stability and control quality, but, more importantly, fails to attain the very substantial improvement in behalf of trucking safety which accrues from the wider spacing of tires and springs.

2) Operators of doubles combinations, especially the conventional single-axle double incorporating 27- or 28-foot (8.2- or 8.5-m) trailers, make a special effort to adopt the tire and spring spacings which are made possible by the 102-inch (259-cm) width allowance. An especially large improvement in the roll stability of the full trailer in such combinations is seen to accrue from the widening of both the dolly and trailer axle dimensions.

3) Steps be taken at the earliest practical time to make tractors available having tire and spring spacings which fully utilize the new width allowance. Since the tractor constitutes the "soft end" of the tractor-semitrailer combination, from a roll stability point of view, achievement of the greater degree of improvement in stability which is possible with the 102-inch (259-cm) width allowance requires that the tractor be built to the maximum width. Recognizing that some 60% of truck driver fatalities are the result of truck rollovers, the wider tractor should be promoted by all those who have a special concern for the safety of the truck driver.

4) Those who will be selecting the road systems upon which 102-inch (259-cm) trucks will be permitted should recognize that undue restrictions regarding the matter of access will curtail the purchase of the wider vehicles for usage on the "permitted" road systems, as well. The benefits which are thought to accrue by limiting the access allowed to wider trucks should be weighed against the penalty that the rest of the traffic system will bear by continuing its exposure to lower-stability vehicles.

Concerning the prospect for using the bridge formula as the only constraint on gross vehicle weight, we recommend that:

1) This change be recognized as introducing a new era in the design of commercial vehicles. If such a policy were adopted around the country, such that there was broad commercial attractiveness for redesigning vehicles to maximally utilize the new allowances, a host of new configurations would likely appear on the scene. At that juncture, there would be a large set of questions to ask concerning the stability and control properties of these new configurations. Also, there should be concern that changes in the practices by which existing vehicles become loaded under this scenario might jeopardize stability and control performance.

2) A study be undertaken to explore the possible implications of such a change on vehicle design and on operating practices. The results of this examination would serve to identify vehicle configurations which could be evaluated for their resulting stability and control characteristics.

Concerning the prospect for broader usage of multiple-unit vehicle combinations in the U.S., we recommend that:

1) The rearward amplification behavior which distinguishes between the various types of such vehicles be recognized as an important safety matter by those responsible for formulating new legislation or regulation. Those who formulate policy on such matters need to note, for example, that there is a profound difference between the amplification performance of, say, a "triples" combination and a "Rocky Mountain double," as defined herein.

2) Similarly, that the B-train style of trailer coupling be recognized by both policy makers and the American trucking industry as a configuration offering unusually great advantages for stability and control. This configuration is properly designated as a "tractor-semi-trailer-semitrailer" combination.

3) Research be conducted to develop alternative means of hitching full trailers. This type of research should not be seen simply as a hardware development endeavor, but rather as an occasion to expand the understanding of the rearward amplification issue and to identify the conceptual means by which it can be circumvented. If, for example, some jurisdiction sought in the future to allow a certain multiple-unit combination, but only on the stipulation that some low level of amplification not be exceeded, a considerable amount of "groundwork" would have to be laid. Recognizing that multiple-unit combinations offer a great advantage in increased productivity and a reduction in accident exposure, there is ample cause for exploring the means to improve on the amplification problem so that acceptable vehicle configurations can be defined and meaningful regulations implemented.

It is also recommended that the findings presented here be used to help sharpen the sensitivity of the trucking industry to stability and control issues. In particular, the following suggestions are offered:

- 1) Given the critical importance of the location of the payload c.g. height on roll stability, we recommend that:
 - a) drivers pay special attention as to how the truck or trailer has been loaded
 - b) drivers be educated to know how to deal with conditions of reduced roll stability
 - c) steps be taken, wherever possible, to adopt loading practices and vehicle designs which reduce payload c.g. height.
- 2) Given the importance of laterally-offset payload conditions, we recommend that:

- a) drivers pay special attention to whether the trailer is listing to one side or the other before they begin a trip
 - b) those who load trucks be instructed to employ dunnage to block the load whenever significant gaps exist which would permit the load to shift laterally. This practice will become especially important when freight which was palletized for 96-inch (244-cm) trailers is loaded into 102-inch (259-cm) trailers.
- 3) Recognizing the special and subtle problem posed by the rearward amplification of multiple-unit combinations, we recommend that:
- a) drivers be educated so that they understand the phenomenon and its risks and so that they are cautious to avoid the steering conditions which excite it
 - b) the industry promote the development of, and when appropriate begin to specify, alternative hitching systems which will minimize the rearward amplification problem.
- 4) The trucking industry should recognize, broadly, that any mixing of radial- and bias-ply tires between the front and rear axles of a truck or tractor may dramatically alter yaw stability.
- 5) The trucking industry should recognize that a substantial number of the specifications which it places upon tractor and trailer hardware, particularly the running gear, impacts upon dynamic stability and control performance. The industry should evolve a more measured approach toward vehicle "spec-ing" such that stability and control qualities are being optimized along with weight, durability, maintainability, cost, etc. (In European trucking practice, the

purchaser leaves it up to the vehicle manufacturer to produce a vehicle which is systems-engineered to provide the desirable qualities. As long as the American truck and trailer purchaser insists upon specifying the vehicle components and dimensions, he should become knowledgeable on the means to assure the stability and control quality of the system.)

REFERENCES

1. Federal-Aid Highway Act of 1956—Title I. Public Law 627, 84th Congress, 70 Stat. 374, June 29, 1956.
2. Ervin, R.D., et al. "Ad Hoc Study of Certain Safety-Related Aspects of Double-Bottom Tankers." Final Report to Office of Highway Safety Planning, Mich. Dept. of State Police, Contract No. MPA-78-002A, Highway Safety Research Institute, Univ. of Mich., Rept. No. UM-HSRI-78-18, May 7, 1978.
3. Heath, W.M. "California Tank Truck Accident Survey - February 1, 1980 to January 31, 1981." California Highway Patrol, December 1981.
4. Consolidated Freightways Corp. of Delaware vs. Larson, et al., Civil No. 81-1230 (M.D.PA., Filed Oct. 27, 1981), Exhibits 1010 through 1024 and 1070 through 1094.
5. Olley, M. "Road Manners of the Modern Car." Proc. Inst. Automobile Eng., Vol. 51, 1946-47, p. 147.
6. Pacejka, H.B. "Simplified Analysis of Steady Turning Behavior of Motor Vehicles. Parts 2 & 3." Vehicle System Dynamics, Vol. 2, No. 4, December 1973.
7. Ervin, R.D. and Mallikarjunarao, C. "A Study of the Yaw Stability of Tractor-Semitrailer Combinations." Proc. 7th IAVSD Symposium on the Dynamics of Vehicles on Roads and Tracks, Cambridge, England, September 7-11, 1981.
8. Fancher, P.S. "The Transient Directional Response of Full Trailers." SAE Paper No. 821259, November 1982.
9. Bernard, J.E. and Vanderploeg, M. "Static and Dynamic Offtracking of Articulated Vehicles." SAE Paper No. 800151, February 1980.
10. Mallikarjunarao, C. and Fancher P. "Analysis of the Directional Response Characteristics of Double Tankers." SAE Paper No. 781064, December 1978.
11. Mallikarjunarao, C., Ervin, R.D., and Segel, L. "Roll Response of Articulated Motor Trucks During Steady-Turning Maneuvers." ASME, Winter Annual Meeting, November 1982.
12. Mallikarjunarao, C. and Segel, L. "A Study of the Directional and Roll Dynamics of Multiple-Articulated Vehicles." Proc. 7th IAVSD Symposium on the Dynamics of Vehicles on Roads and Tracks, Cambridge, England, September 7-11, 1981.

REFERENCES (continued)

13. MacAdam, C.C., Fancher, P.S., Hu, G.T., and Gillespie, T.D. "A Computerized Model for Simulating the Braking and Steering Dynamics of Trucks, Tractor-Semitrailers, Doubles, and Triples Combinations - Users' Manual." Final Report, MVMA Proj. 1197, Highway Safety Research Inst., Univ. of Mich., Rept. No. UM-HSRI-80-58, September 1, 1980.
14. Ervin, R.D., et al. "The Yaw Stability of Tractor-Semitrailers During Cornering." Final Report, Contract No. DOT-HS-7-01602, Highway Safety Res. Inst., Univ. of Mich., Rept. No. UM-HSRI-79-21, June 1979.
15. Ervin, R.D., Mallikarjunarao, C., and Gillespie, T.D. "Future Configuration of Tank Vehicles Hauling Flammable Liquids in Michigan." Final Report to Mich. Dept. of Trans., Agree. #78-2230, Highway Safety Res. Inst., Univ. of Mich., Rept. No. UM-HSRI-80-73, December 1980.
16. Office of Heavy Duty Vehicle Research. "Stopping Distance Test Data on Air Braked Vehicles." National Highway Traffic Safety Admin., U.S. Dept. of Transp., February 7, 1980.
17. Testimony of Howard Dickerson on Behalf of Can Manufacturers Institute and Composite Can and Tube Institute Before the U.S. Senate Committee on Commerce, Science and Transportation on S. 3431. September 7, 1978.
18. Peterson, D.E. and Gull, R. "Triple Trailer Evaluation in Utah." Final Report, Utah DOT, Rept. No. UDOT-MR-75-4, September 1975.
19. Sharp, R.S. "The Steering Responses of Doubles." IAVSD Symposium, Berlin, September 1979.
20. Nisonger, R.L. and Ervin, R.D. "Dynamic Performance of B-Type Converter Dollies." April 1983.
21. Weir, D.H., DiMarco, R.J., and McRuer, D.T. "Evaluation and Correlation of Driver/Vehicle Data." Final Report, Contract DOT-HS-5-01200, Prepared by Systems Technology, Inc., Rept. No. 1068-1, April 1977.
22. Winkler, C.B., Fancher, P.S., and MacAdam, C.C. "Parametric Analysis of Heavy Duty Truck Dynamic Stability." Final Rept., Contract No. DTNH22-80-C-07344, UMTRI Rept. No. UMTRI-83-13, March 1983.
23. Damas & Smith Div. of DSL Consultants Ltd. "A Study on the Effect of Variations in Truck Weights & Dimensions on Vehicle Stability & Control Characteristics and Pavement Loadings." Final Report to RTAC/CCMTA Committee, July 1982.

REFERENCES (continued)

24. Federal Register 39:221, November 4, 1974, pp. 4016-4019.
25. Radlinski, R., Machey, J., and Williams, S. "The Importance of Maintaining Air Brake Adjustment." SAE Paper No. 821263, November 1982.
26. Campbell, K.L. and Carsten, O. "Fleet Accident Evaluation of FMVSS 121." Final Report, Contract No. DOT-HS-6-01286, Highway Safety Res. Inst., Univ. of Mich., Rept. No. UM-HSRI-81-9, August 1981.
27. "Steering Axle Study." A report to Congress as provided in Section 210 of the Federal Aid Highway Act of 1976. Bureau of Motor Carrier Safety, U.S. Dept. of Transp., July 1977.
28. Vehicle Research and Test Center. "Development of a Truck-Tractor Pneumatic Simulator and Optimization of Trailer Air Brake Plumbing." National Highway Traffic Safety Admin., U.S. Dept. of Transp., Memorandum Report CAR-5, April 1981.
29. Gillespie, T.D. and Winkler, C.B. "On the Directional Response Characteristics of Heavy Vehicles." Proc. 5th VSD-2nd IUTAM Symposium on Dynamics of Vehicles on Roads and Tracks, Vienna, September 19-23, 1977.
30. Morrison, W.R.B. "A Swept Path Model Which Includes Tyre Mechanics." Proceedings ARRB, Vol. 6, Part 1, 1972.
31. "Braking, Stability and Structural Integrity of Longer Combinations." A Technical Report on Tests Conducted at Utica, Michigan, Sponsored by the Automobile Manufacturers Association and Truck Trailer Manufacturers Association, May 8 - July 27, 1967.
32. Hazemoto, T. "Analysis of Lateral Stability for Doubles." SAE Paper No. 730688, June 1973.
33. Ervin, R.D. and MacAdam, C.C. "The Dynamic Response of Multiply-Articulated Truck Combinations to Steering Input." SAE Paper No. 820973, August 1982.

