

PB86177508



IMPACT OF SPECIFIC GEOMETRIC FEATURES ON TRUCK OPERATIONS AND SAFETY AT INTERCHANGES

Research, Development,
and Technology

Turner-Fairbank Highway
Research Center
6300 Georgetown Pike
McLean, Virginia 22101



U.S. Department
of Transportation
**Federal Highway
Administration**

PB86-177508



REPORT NO.
FHWA/RD-86/058

APPENDICES
AUGUST 1985

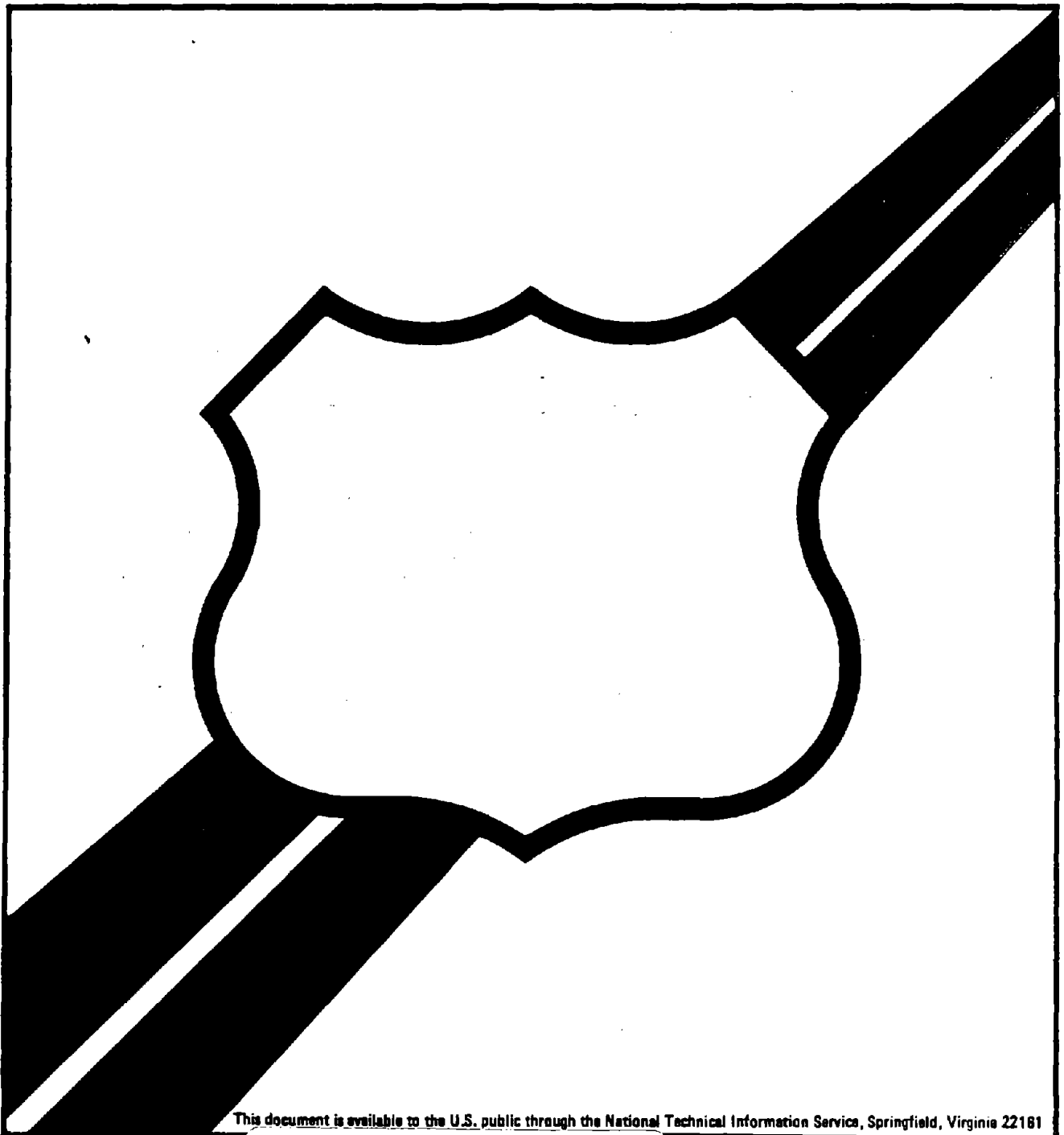

This document is available to the U.S. public through the National Technical Information Service, Springfield, Virginia 22161

REPRODUCED BY
U.S. DEPARTMENT OF COMMERCE
NATIONAL TECHNICAL
INFORMATION SERVICE

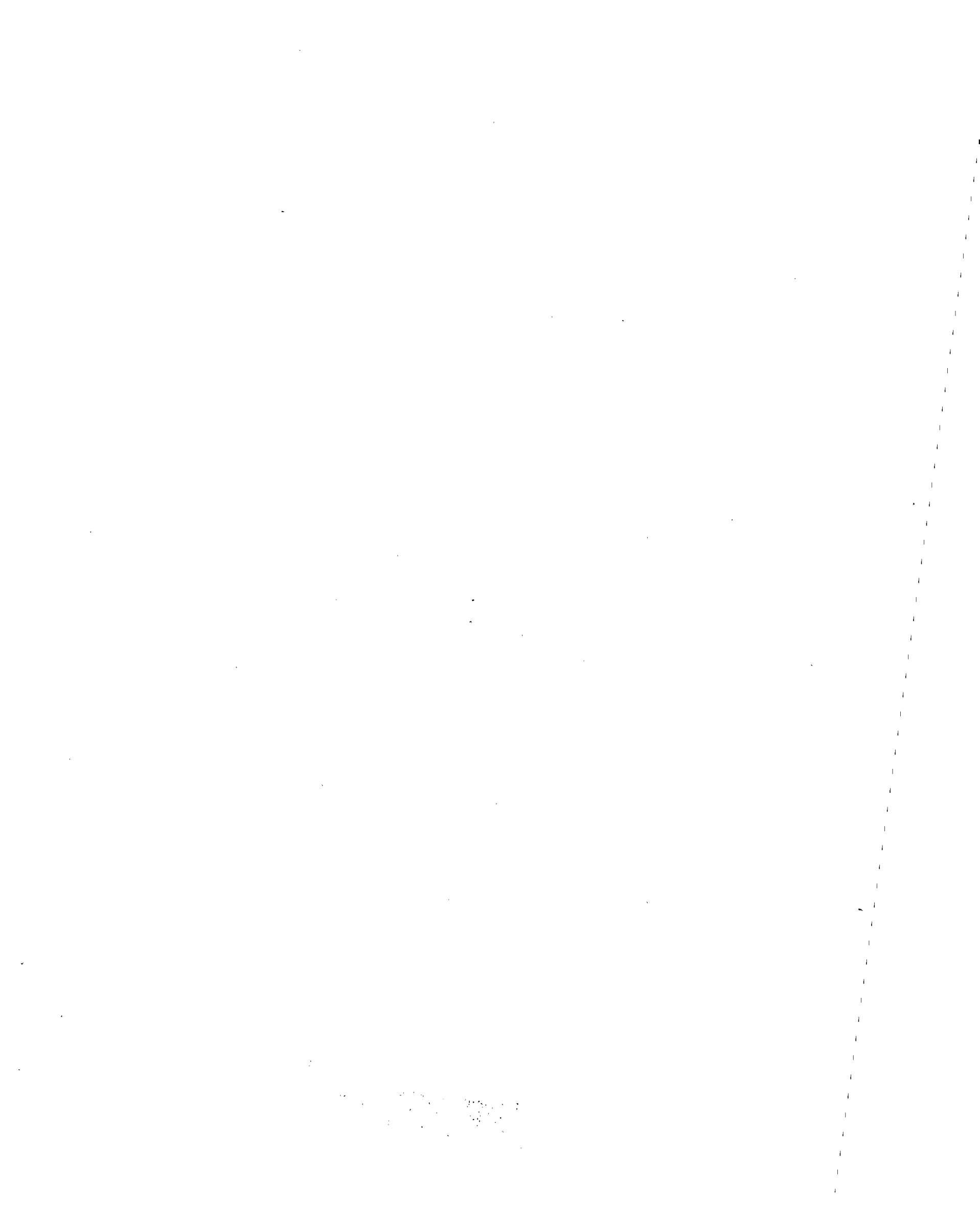

1. Report No. FHWA/RD-86/058	2. Government Accession No.	3. Recipient's Catalog No.	
4. Title and Subtitle IMPACT OF SPECIFIC GEOMETRIC FEATURES ON TRUCK OPERATIONS AND SAFETY AT INTERCHANGES Vol. II - Appendixes		5. Report Date August 1985	6. Performing Organization Code
7. Author(s) R. Ervin, M. Barnes, C. MacAdam, R. Scott		8. Performing Organization Report No. UMTRI-85-33/2	
9. Performing Organization Name and Address The University of Michigan Transportation Research Institute 2901 Baxter Road Ann Arbor, Michigan 48109		10. Work Unit No.	11. Contract or Grant No. DTEH61-82-C-00054
12. Sponsoring Agency Name and Address Federal Highway Administration U.S. Department of Transportation Washington, D.C. 20590		13. Type of Report and Period Covered Final 9/82 - 8/85	
14. Sponsoring Agency Code			
15. Supplementary Notes Mr. Michael Freitas of the Federal Highway Administration served as Contract Technical Representative			
16. Abstract The problem of truck loss-of-control accidents on interchange ramps is examined from the viewpoint of the suitability of highway geometric design, given the peculiar stability and control limitations of heavy-duty trucks. Accident records were used to identify specific ramps which were overinvolved in jackknife, rollover, and run-off-road accidents. The ramp geometries were represented in a complex simulation of the dynamic behavior of representative tractor-semitrailer combinations. The calculated responses of heavy vehicles on each ramp were studied to illustrate how highway design features may have influenced the known accident experience at the site. Results show that various aspects of the AASHTO policy on geometric design result in a very slim margin of safety for the operation of heavy trucks on exit ramps. Problem features included side friction factors, superelevation transitions, compound curves, deceleration lanes, ramp downgrades, curbs on curved ramps, and wet surface friction on high-speed ramps. Potential countermeasures for the identified problems are suggested. Recommendations include a careful scoping of the prevalence of "problem ramps," nationally, initiation of efforts by State highway engineers to apply these findings to ramps having a known truck problem, and informing truck drivers of the situation involving slim safety margins.			
17. Key Words truck safety, exit ramps, highway design, curve geometry, pavement friction, rollover, jackknife		18. Distribution Statement No restrictions. This document is available to the public through the National Technical Information Service, Springfield, Virginia 22161	
19. Security Classif. (of this report) Unclassified	20. Security Classif. (of this page) Unclassified	21. No. of Pages 205	22. Price

NOTICE

This document is disseminated under the sponsorship of the Department of Transportation in the interest of information exchange. The United States Government assumes no liability for its contents or use thereof.

The contents of this report reflect the view of the contractor, who is responsible for the accuracy of the data presented herein. The contents do not necessarily reflect the official policy of the Department of Transportation.

This report does not constitute a standard, specification, or regulation.

The United States Government does not endorse products or manufacturers. Trade or manufacturers' names appear herein only because they are considered essential to the object of this document.

CONTENTS

APPENDIX

A	GEOMETRIC ANALYSIS OF RAMP SITES	1
B	VEHICLE PARAMETERS AND EXAMPLE RUN	55
C	SIMULATION RESULTS	126

APPENDIX A

GEOMETRIC ANALYSIS OF RAMP SITES

In this section, the geometric design of each of the fifteen (15) selected ramp sites is critiqued from the viewpoint of the design policies recommended by AASHTO. Since all of the ramps in question, and of course virtually all of the U.S. highway system, was designed prior to 1984, we have chosen to evaluate ramp designs according to the "Blue Book" design policy which was stipulated in 1965 rather than the current "Green Book" published in 1984. The evaluations include review of side friction factors which characterize curves on each ramp, the shoulder, crown, and roadside features, the development of superelevation, deceleration lane provisions, traffic control devices, and summary comments on the accident picture and prospective accident countermeasures. The sites are simply evaluated relative to the design policy, in this section, and are not discussed from the viewpoint of the adequacy of the policy, given the special maneuvering limitations of heavy-duty trucks.

Please note that all references to geometric design policy refer to "A Policy on Geometric Design of Rural Highways," American Association of State Highway Officials, 1965, and that all reference to traffic signage refers to the "Manual on Uniform Traffic Control Devices for Streets and Highways," U.S. Government Printing Office, Washington, D.C., 1978.

SITE ONE

Description

Site One, shown in Figure 1, is a rural, single-lane, 16-foot outer loop ramp in a partial clover-leaf interchange. The accident concentration at this site takes place along the last of three reverse curves. Therefore, the analysis focuses on curve (3). The ramp starts with a 200-foot (61 m) spiral curve, followed by curve (1) whose radius

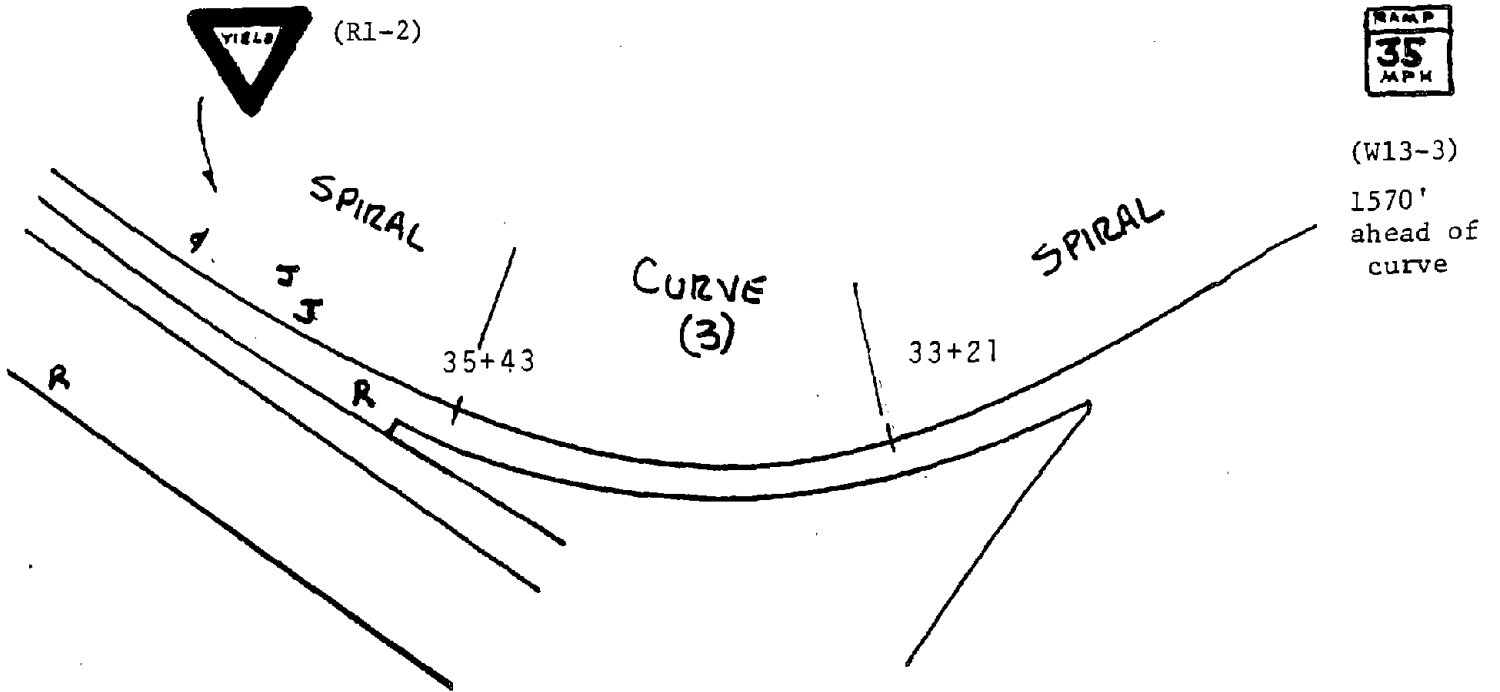

CURVE DATA

PC = 33+21.73'
 PT = 35+43.74'
 R = 342.06'
 L = 222.01'
 D = 16° 45'

R - Rollover
 J - Jackknife

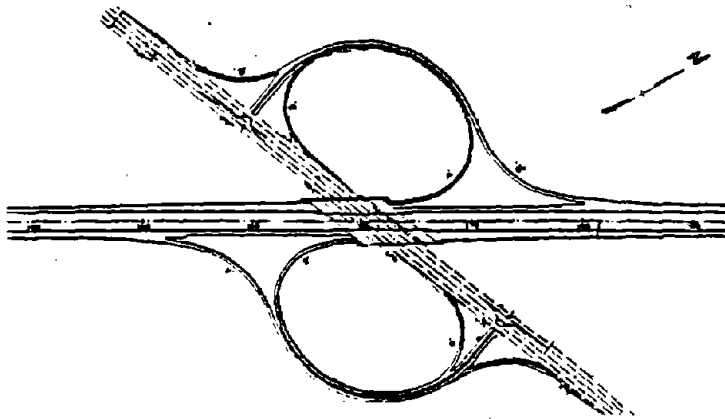

Figure 1. Layout of site 1

is 449 feet (138 m), which is equivalent to a degree of curvature of 12.8 degrees. Curve 1 is followed by two spiral curves, both 150 feet (46 m) long. Curve (2) has a radius of 520 feet (159 m), and a degree of curvature of 11 deg. Curve (3) has a radius of 342 feet (104 m), and a degree of curvature of 16.8 degrees. The curve (3) portion of the roadway splits off curve (2) and is preceded and followed by spiral curves, both 150 feet (46 m) long. The ramp is currently posted with an advisory speed of 35 mi/h (56 km/h) and was originally designed in 1956.

Geometrics

Frictional Factor. Using a maximum superelevation value of .08 feet per foot (.08 m/m), as indicated on the plans, the frictional force required at the 35 mi/h (56 km/h) advisory speed was determined to be .10, .08, and .16 for curves (1), (2), and (3), respectively. At 40 mi/h (64 km/h), the frictional factor values are .16, .13, and .23, respectively. The maximum frictional force values recommended by AASHTO are .155 and .15 at 35 and 40 mi/h (56 and 64 km/h), respectively. The difference between the AASHTO 35 mi/h (56 km/h) maximum "f" value and that demanded on curve (3) is viewed as negligible; therefore, with the ramp superelevated at .08, the 35 mi/h (56 km/h) advisory speed is appropriate. However, the frictional factor levels for superelevation values less than that taken as the nominal value along curve (3) deserve more consideration, and will be discussed in conjunction with the superelevation development below.

Shoulder/Crown and Roadside Development. The ramp has an 8-ft-wide (2.44-m) shoulder along the inner, or right, edge. This shoulder maintains the same slope as the superelevated ramp, and develops an 8-ft (2.44 m) vertical curve. Along the left side of the ramp is a 3-ft-wide (0.9-m) shoulder, with the first 1.5 ft (0.45 m) of shoulder width held at the roadway superelevated value. The remaining 1.5 ft (0.45 m) are noted on the plans as being "rounded;" this is assumed not to exceed the .07 ft/ft (.02 m/m) break in grade between the shoulder and road pavement recommended by AASHTO. Both the shoulder widths and shoulder

slope fall within the policies outlined by AASHTO. Details concerning the crown development and the back slope rate were not available.

Superelevation Development. The plans indicate that from station 32+44 to 35+00 the road is superelevated from .002 to .08, with .08 being the designated maximum superelevation value. However, the .08 ft/ft (.08 m/m) value is not attained until station 35+00 is reached. This places essentially all of the transition along curve (3) and leaves only 43 ft (13 m) of the curve at the .08 value. Since there are two connecting spirals prior to the curve, it is not clear why the transition to the maximum superelevation was not carried out along this length. These spirals are of adequate length to have fully developed the maximum superelevation prescribed for curve (3). Following the PT, a 200 ft (61 m) spiral curve is shown. This would be a more than sufficient length to return to the normal crown from a superelevation value of .08. Thus, by utilizing the two spirals shown on the plans, the whole of the curve could have been superelevated at the maximum value of .08 ft/ft (.08 m/m).

The frictional factor required at the 35 mi/h (56 km/h) advisory speed, with a maximum superelevation of .08 is .16. The frictional factor calculations previously outlined assume that essentially the entire curve was superelevated at the nominal .08 value. Using the transition information on the plans, the frictional force values were calculated for the range of superelevation values developed over the majority of the curve. The frictional factor required at the current 35 mi/h (56 km/h) are thus excessively high when compared to the nominal recommended maximum of .155 for this speed. However, at 30 mi/h (48 km/h), all of the frictional factor values fall within the AASHTO maximum of .16. Therefore, recognizing that 69 percent of the curve is not superelevated at the maximum of .08, a 30 mi/h (48 km/h) advisory speed is appropriate.

Deceleration Lane. Referring to Figure 1, some 1570 ft (479 m) of a connecting ramp is covered before reaching curve (3). In addition, there is a 500 ft (152 m) long deceleration lane along the approach to this connecting ramp. Therefore, adequate distance is available to

decelerate to the posted advisory speed from 55 mi/h (88 km/h) for the connecting ramp as well as for site 1.

Non-Geometrics

Traffic Control Devices. There are only two signs relevant to site 1. Near the PC of curve (1) at the nose of the connecting ramp (approximately 1570 ft (479 m) preceding curve (3)) is a 35 mi/h (56 km/h) exit speed advisory sign (type W 13-2, as defined in the Manual on Uniform Traffic Control Devices, MUTCD). Following this sign at the downstream end of curve (3) is a YIELD sign (R1-2). This YIELD sign is appropriately placed, as the acceleration lane is only some 480 ft (146 m) in length. The AASHTO recommended minimum acceleration lane to attain a 55 mi/h (88 km/h) highway speed is approximately 600 ft (188 m). Using the original traffic control device plan, two 4-in (0.1-m) edge lines along the ramp are indicated. It is assumed that the right, lane edge line is white, with the left edge line being yellow. This development, as well as the speed advisory and YIELD sign placements, meet the recommendations outlined in the MUTCD.

Accident Observations and Candidate Design Corrections. All of the four truck accidents included for study reported excessive speed. All occurred in daylight hours, with two taking place on wet pavement. It appears that several factors may be contributing to these accidents: (1) the lack of a speed advisory sign specifically for curve (3); (2) the lack of prescribed superelevation development, which, in turn, suggests an inappropriate advisory speed; and (3) insufficient acceleration lane length at the exit of curve (3). Referring to Figure 1, site 1 begins after traversing two relatively large-radius curves on this ramp. That is, essentially all of the connecting ramp length must be negotiated before reaching curve (3).

Countermeasures include an overlay to increase the rate of superelevation along the spiral in order to superelevate the entire curve at the .08 ft/ft (.08 m/m) value. Assuming this is done, the placement of a curve warning sign with 35 mi/h (56 km/h) speed plate

attached prior to curve (3) is appropriate. This 35 mi/h (56 km/h) speed value is within the design policy value for the properly superelevated curve, and is in keeping with the overall ramp speed advisory. If wedging curve (3) is not possible, the curve speed advisory signage should be lowered to 30 mi/h (48 km/h). Finally, an increase in the acceleration lane length would be called for according to design policy. By increasing the length of the acceleration lane by 120 ft (37 m), the YIELD sign could be removed. This may reduce the number of accidents occurring in the ramp nose area, where merging conflicts are otherwise anticipated.

SITE TWO

Description

Site Two is concerned with two of four curves found on one of the inner loops of a two-quadrant, partial clover-leaf-type rural interchange. Referring to Figure 2, curve (1) has a radius of approximately 250 ft (26 m), with curvature of 23 deg. Curve (2) has a radius of 520 ft (159 m), with curvature of 11 deg. Curves (3) and (4) will be the focus of the analysis because of the concentration of accidents. Curve (3) has a radius of 521 ft (159 m), and curvature of 11.8 degrees. The radius of curve (4) is 252 ft (77 m), with curvature of 22.8 degrees. The entire ramp is posted with an advisory speed of 25 mi/h (40 km/h), and was originally designed in 1956.

Geometrics

Frictional Factor. The amount of frictional force needed at 25 mi/h (40 km/h) was determined for all four curves on this ramp. The superelevation value used was the maximum indicated on the plans, .08 ft/ft (.08 m/m). The frictional factors for curves (1) and (2) were determined to be .09 and .00, respectively. Curves (3) and (4) have resulting "f" values of .003 and .09, respectively. All of these values

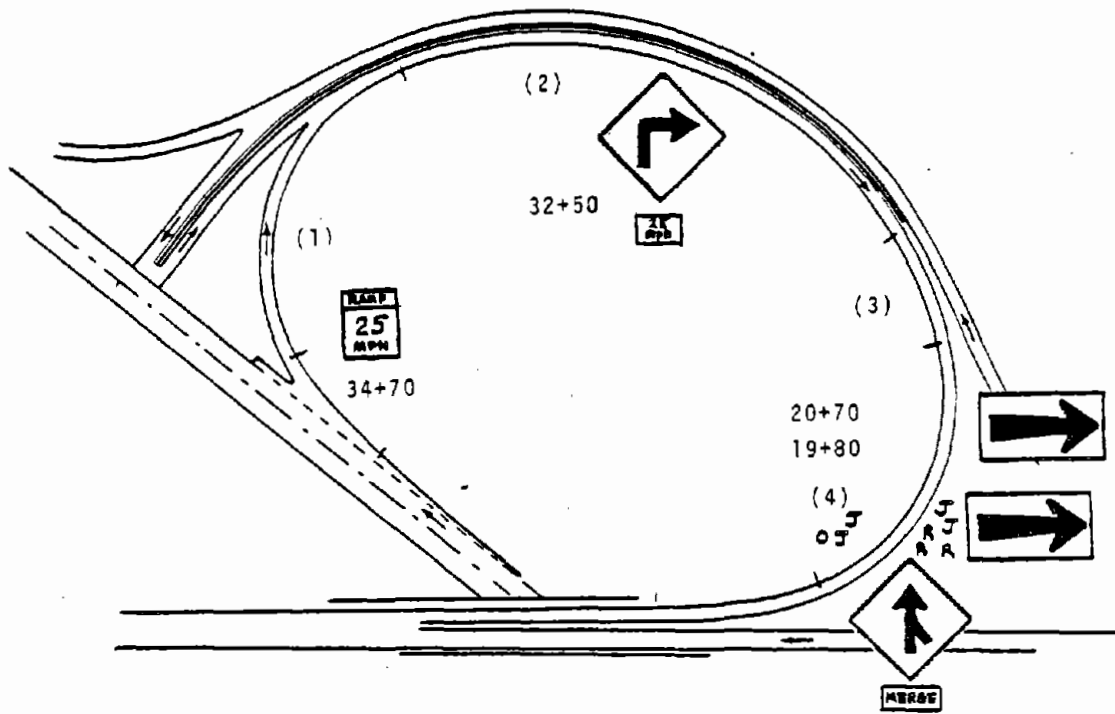

CURVE DATA

3)	R = 500.87'	4)	R = 252.30'
	L = 143.00'		L = 362'
	O = 11° 26'		O = 22° 42'
	PC = 23 + 14		PC = 21 + 70
	PT = 21 + 70		PT = 18 + 08

R - Rollover
 J - Jackknife
 O - Other

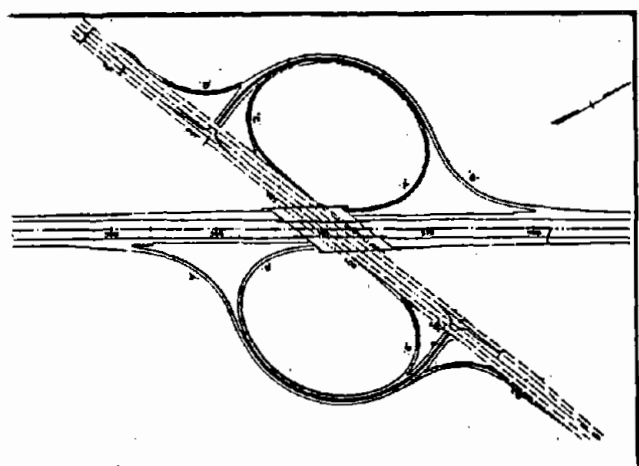

Figure 2. Layout of site 2

are low relative to design policy. Frictional factors for 30 mi/h (48 km/h) were also calculated, resulting in values of .16, .04, .04, and .16 for curves (1) through (4), respectively. The frictional factor values for both 25 and 30 mi/h (40 and 48 km/h) equal or fall within the maximum recommended values of .165 and .16 established by AASHTO for these respective speeds.

Shoulder/Crown Development. The shoulder and crown development for Site Two is identical to that discussed for Site One.

Superelevation Development. While the plans are not specific, it is assumed that a maximum superelevation value of .08 is being maintained through curves (3) and (4) after being developed at the beginning of the ramp. Following curve (4), a 200 ft (61 m) spiral curve is shown, presumably being used to return to a normal road crown. This 200 ft (61 m) length is more than adequate to gradually bank out of the maximum superelevated portion.

Deceleration Lane. The deceleration lane is approximately 355 ft (108 m) long. This is 45 ft (14 m) less than the AASHTO recommended minimum of 400 ft (122 m) which are needed to decelerate from 55 to 25 mi/h (88 to 40 km/h). However, some 1,430 ft (436 m) are traveled along the ramp before reaching the problematical curve, number (4). Therefore, while the deceleration lane is viewed as too short, the discrepancy is moot since the accidents are occurring 1,585 ft (483 m) downstream of the ramp nose.

Non-Geometrics

Traffic Control Devices. Five warning signs are placed along the entire ramp. The first is a 25 mi/h (40 km/h) ramp speed advisory sign (W13-3) at station 34+70, followed by a right curve warning sign (W1-1R) with a 25 mi/h (40 km/h) advisory speed plate attached below located at approximately station 32+50. Traveling at 25 mi/h (40 km/h), 25 seconds elapse before the driver encounters the curve. The placement of this curve warning sign is too far in advance of the curve. Since no

reduction in speed is required, placement of the warning sign approximately 200 ft (61 m) in advance of curve (4) would be sufficient. At stations 19+80 and 20+70, two 8 ft x 4 ft target arrow warning signs (W1-6) are in place, followed by a merging traffic warning sign (W4-1) with a merge plate attached below. Essentially all of the warning information is focusing on the sharp path change when traveling from curve (3) into curve (4). The 25 mi/h (40 km/h) curve advisory midway through the ramp, as well as the target arrow signs, attempt to warn drivers of this final curve. The balance of the signage placement and selection is in keeping with the Manual on Uniform Traffic Control Devices.

The pavement markings indicated on the plans include two 4-in (0.1-m) pavement edge lines along both the inner and outer lane edge. Assuming that the inner, or right, edge line is yellow and the outer one white, the treatment meets those outlined in the MUTCD for interchange ramps of this type.

Accident Observations and Candidate Design Corrections. Six of the eight truck accidents stated that excessive speed was the causal factor of the accident. Due to the generous radius of curve (2), drivers appear to be over-driving the center portion of the ramp. However, upon entering the last curve, loss-of-control is evident by the concentration of accidents in the area of curve (4). This is due to the sharp path change caused when traveling from curve (3), with a radius of some 500 ft (152 m), into curve (4), with a radius of just 252 ft (77 m). Possible countermeasures include the insertion of a 100-ft (30-m) spiral curve between curves (3) and (4). The insertion of the spiral would help to alleviate some of the discontinuity in the overall ramp design. Further, the replacement of the target arrows with six chevrons (W1-8) outlining both curves (3) and (4) may also help drivers with this path change. Finally, it appears advisable to suggest retention of the existing advisory signage, but with a change of speed advisory to 30 mi/h (48 km/h) and relocation of the curve advisory sign to a point which is 200 ft (61 m) ahead of curve (3). The 30 mi/h (48 km/h) advisory speed is seen as the closest to an overall ramp speed value, considering the variance in radii present.

SITE THREE

Description

Site Three is one portion of an inner loop, two-quadrant, partial clover-leaf-type rural interchange. It has one curve with a radius of 249 ft (76 m) and a degree curvature of 23 deg. The ramp has a single right-turning 16-ft-wide (4.9-m) lane, currently posted with an advisory speed of 25 mi/h (40 km/h). The ramp is pictured in Figure 3 and was designed in 1956.

Geometrics

Frictional Factor. Frictional factor values of .09 and .16 are required to negotiate the curve at advisory speeds of 25 and 30 mi/h (40 and 48 km/h), given a maximum superelevation value of .08 ft/ft (.08 m/m). These values are within the AASHTO recommended maximum frictional factor values of .165 and .16 for these speeds, respectively. Thus, vehicles can drive the ramp at 30 mi/h (48 km/h) and still remain within recommended frictional factor values. However, the superelevation development along the ramp is in question. Frictional factor values for less than the indicated .08 superelevation value were calculated. These values are discussed in conjunction with the superelevation development in that section.

Shoulder/Crown Development. The shoulder and crown development for Site Three is identical to that outlined for Site One.

Superelevation Development. The plans for Site Three indicate that the superelevation is developed from .04 to .08 ft/ft (.04 to .08 m/m) through 183.50 ft (56 m). One Hundred and Seventy-One feet (52 m) of this total is beyond the PC of the ramp. This leaves only 40 percent or some 264 ft (80 m) of the curve held at the maximum superelevation value of .08 ft/ft (.08 m/m). Using the transition information on the plan, the frictional force values were calculated for the range of

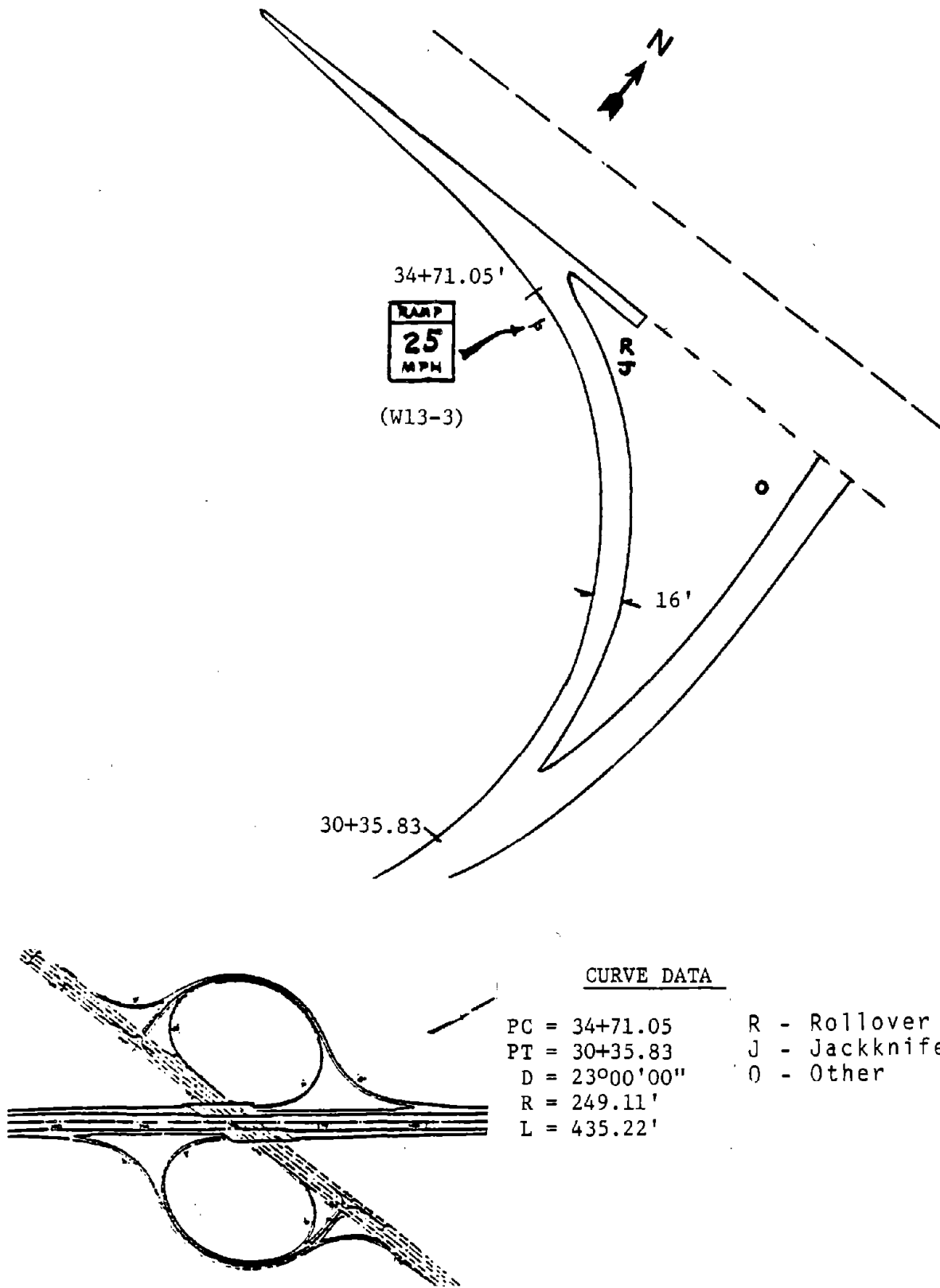

Figure 3. Layout of site 3

superelevation values developed over the majority of the curve. The frictional force required at the current 25 mi/h (40 km/h) advisory speed for these "e" values range from .11 to .13. At 30 mi/h (48 km/h), these values range from .18 to .20. The values at the 30 mi/h (48 km/h) speed exceed the AASHTO recommended maximum of .16. Also indicated is a spiral curve preceding the curve PC which is 150 ft (46 m) long. It is not clear why the entire superelevation transition was not carried out using the spiral length exclusively. A spiral curve length of 150 ft (46 m) is more than adequate for achieving the maximum superelevation value without using any of the curve itself for the transition to the maximum superelevation value. Following the PT of the ramp curve, the .08 value is held through the connecting 992 ft (302 m) curve.

Deceleration Lane. A deceleration lane approximately 375 ft (114 m) in length is provided on the approach to the ramp. This lane length is marginally less than the 400 ft minimum value recommended by AASHTO in order to reduce to 25 mi/h (40 km/h) from a highway speed of 55 mi/h (88 km/h).

Non-Geometrics

Traffic Control Devices. Only one traffic control device is in place along the ramp. A 25 mi/h (40 km/h) ramp advisory speed sign (W13-3) is located approximately 36 ft (11 m) beyond the curve PC. Remembering that less than half of the curve length is superelevated at the maximum value, the advisory speed currently posted was re-evaluated. The frictional force values at 25 mi/h (40 km/h) outlined in the superelevation development section did not exceed the AASHTO maximum value of .165 for 25 mi/h (40 km/h). Therefore, even for portions of the curve in which the superelevation is not fully developed, the currently posted advisory speed is still appropriate.

Delineator placement details were not available. Four-inch (0.1-m) edge lines along both the inner and outer lane edges are indicated on the plans.

Accident Observations and Candidate Design Corrections. All three of the accidents on the Site Three ramp occurred at night and each notes excessive speed in the report. The lack of deceleration lane length, inadequate superelevation development on the curve, and lack of advance speed advisory signage are all possible causes for the concentration of these truck accidents. Countermeasures include expanding the deceleration lane length to 400 ft (122 m), wedging in more superelevation to bring the curve up to .08 ft/ft (.08 m/m) of superelevation, and placing a ramp advisory speed sign (type W13-3) along the deceleration lane some 400 ft (122 m) in advance of the ramp nose.

SITES FOUR AND FIVE

Description

Sites Four and Five cover three curves which are part of a right-turning, four-curve, 16-ft-wide (4.9 m) ramp. This ramp is part of a trumpet-style, three-leg, rural interchange. The radii and degree of curvature for curves (1) and (2) are 460 ft (140 m), 300 ft (91 m), 12.5 degrees, and 19.1 degrees, respectively. Curves (3) and (4) have radii of 200 ft (61 m) and 600 ft (183 m), degrees of curvature of 28.6 degrees and 9.5 degrees, respectively. The ramp is currently posted with an advisory speed of 20 mi/h (32 km/h), and was originally designed in 1965. Figure 4 illustrates the ramp and includes the approximate location of the truck accidents studied.

Geometrics

Frictional Factor. The frictional factor values demanded along the ramp, considering an indicated maximum superelevation of .08, and the advisory speed of 20 mi/h (32 km/h), were determined. The frictional factor for the four curves were found to be -.02, .01, .05, and -.04, respectively. The first and fourth values describe a minor

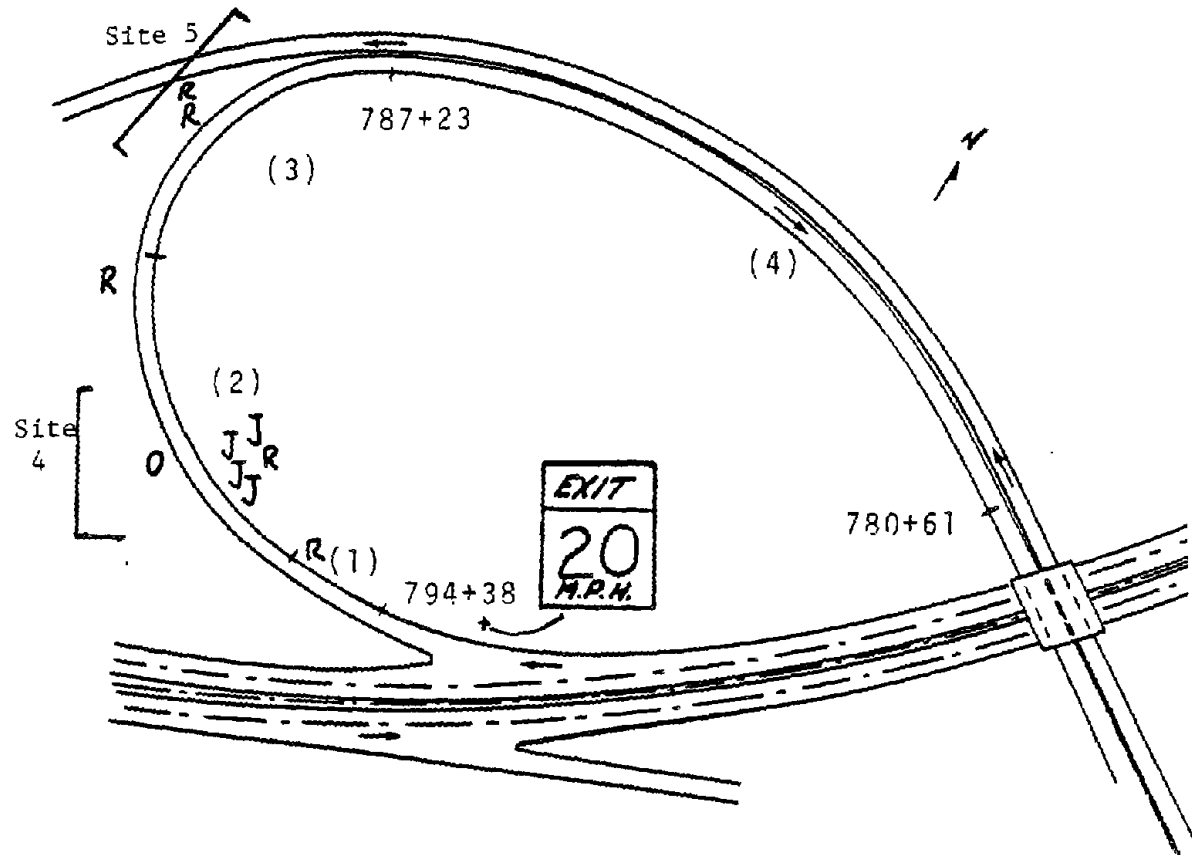

CURVE DATA

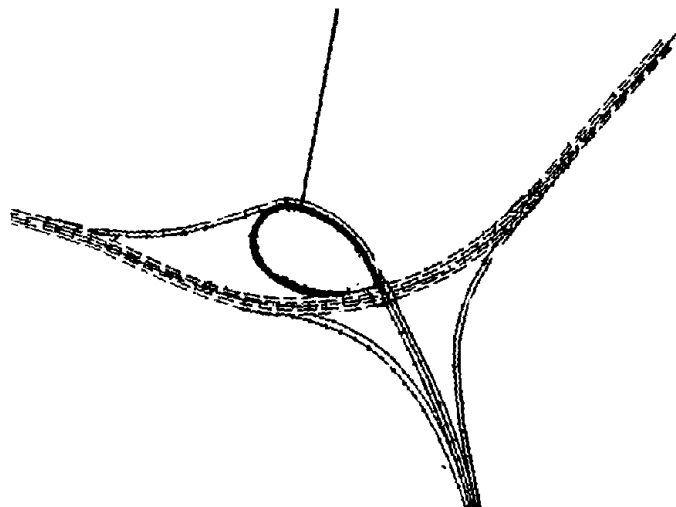

1) R = 460'	2) R = 300'
L = 120.43'	L = 25'
D = 12°27'	D = 19'
PC = 794 + 38	PC = 790 + 66
PT = 793 + 18	PT = 787 + 23
3) R = 200'	4) R = 60'
L = 343.14'	L = 66'
D = 28°38'	D = 90'
PC = 790 + 66	PC = 780 + 61
PT = 787 + 23	PT = 780 + 61

R - Rollover
 J - Jackknife
 O - Other

Figure 4. Layout of sites 4 and 5

"fall-in" condition; that is, a condition in which the superelevation value exceeds the centripetal acceleration developed due to the curvilinear motion. The frictional factor values for 25 mi/h (40 km/h) are .01, .06, .13, and -.01, respectively. At 30 mi/h (48 km/h), the frictional factor values for curves (1) through (4) are, respectively, .05, .12, .22, and .02. All of these values except the .22 value for curve (3) at 30 mi/h (48 km/h) fall well below the AASHTO suggested maximum frictional factor of .18, .165, and .16 for speeds of 20, 25, and 30 mi/h (32, 40, and 48 km/h), respectively.

Shoulder/Crown and Roadside Development. Cross-sectional information detailing the shoulder slope, sideslope, and road crown values were not available. An 8 ft (2.4 m) shoulder along the right edge of the ramp lane, with a 4 ft (1.2 m) paved shoulder along the left are indicated on the plans. These shoulder widths follow the treatment suggested by AASHTO for a ramp of this type. The ramp was bordered by a curb on both sides. While the curb profile was not defined on the plans, it appeared to be implicated in the rollover incidents occurring at curve (3).

Superelevation Development. A connecting spiral curve 400 ft (122 m) long acts as the transition length along the deceleration lane. This spiral develops a maximum superelevation value of .08 ft/ft (.08 m/m) 2 ft (.6 m) beyond the PC of curve (1). The .08 superelevation value is maintained through all four curves. The connecting spiral falls well above the minimum 100 ft (30 m) length established by AASHTO, and thus produces a gradual transition into a superelevated ramp curvature.

Deceleration Lane. The deceleration lane in place is approximately 395 ft (120 m) long, including the taper. Since AASHTO recommends a total length of 425 ft (130 m), including taper, as being necessary to decelerate from a 55 mi/h (88 km/h) highway speed to the 20 mi/h (32 km/h) advisory speed, this deceleration lane (which was probably designed with a higher ramp speed in mind) is marginal for the posted speed condition.

Non-Geometrics

Traffic Control Devices. Only one warning sign is in place on the ramp. This sign is an exit 20 mi/h (32 km/h) speed advisory sign (type W13-2). The placement of this sign is approximately 2 ft (.6 m) prior to the PC of curve (1). Details concerning pavement line markings and delineator placement were not available. The placement of this warning speed is in accordance with the MUTCD, given that curve (3) actually posed the critical requirement for the advisory speed.

Accident Observations and Candidate Design Corrections. Most of the truck accidents are occurring near the beginning of the ramp, although two rollover accidents were noted near the center of curve (3). The accidents appear as two types, namely, jackknife events which indicate heavy braking, and loss of control in curves (1) and (2). The braking derives either from a real concern associated with the critical demands of curve (3) or from a perceived problem, given the 20 mi/h (32 km/h) posted speed. Since the 20 mi/h (32 km/h) speed is unnecessarily low, given the side friction factors, some of the jackknife accidents may be preventable by increasing the advisory speed. Since the rollover accidents tend to indicate simple over-speeding in curve (3), however, it may be that an increased advisory speed would lead to increased rollovers. The contributing factor of these accidents appears to be the combination of a short deceleration lane and the diverse radii of curves (1), (2), and (3). Countermeasures include raising the existing ramp advisory speed sign to 30 mi/h (48 km/h), and adding a ramp speed advisory approximately 350 ft (102 m) in advance of the ramp, along the deceleration lane. Recognizing that curve (3) is the sharpest and most restricting ramp geometry, it may be advisable to add a curve warning sign with a 25 mi/h (40 km/h) speed plate attached, approximately 100 ft (30 m) in advance of the curve. In addition, chevrons outlining curve (3) may help emphasize the sharpness of the curve. Further countermeasures include increasing the deceleration lane to at least an overall length of 425 ft (130 m) and the insertion of a 100 ft (30 m) spiral curve between curves (1) and (2), and between curves (2) and (3). It is recognized that the original designers were dealing with difficult space restrictions. The spiral curve insertions are in keeping with the

AASHTO recommendation that compound curve designs avoid the joining of a flatter curve to a sharper curve whose radii vary by a factor of 1.5 or larger.

SITE SIX

Description

Site Six is a broken-back curve, right-turning, direct connection, rural ramp. Curves (1) and (2) (Figure 5) are connected by a 291-ft (89-m) tangent section. Both have a radius of 1400 ft (427 m) and curvature of 4 deg, with lengths of 972 ft (296 m) and 1645 ft (502 m), respectively. The roadway was originally designed in 1971, and is currently posted with an advisory speed of 45 mi/h (72 km/h) for trucks, and 55 mi/h (88 km/h) for other traffic. Since the truck accidents relevant to the study occur primarily on curve (1), the analysis will focus on the initial portion of the ramp.

Geometrics

Friction Factor. The friction factor demanded on curve (1) was determined using the minimum radius equation. The value of maximum superelevation used was .05 ft/ft (.05 m/m), as indicated on the plans. Both the current highway speed of 55 mi/h (88 km/h) and the posted advisory speed of 45 mph (72 kph) were used. The frictional factor was determined to be .09 and .05 for 55 and 45 mi/h (88 and 72 km/h), respectively. Both of these values are well below the AASHTO recommended maximums of .135 and .143 for these speeds.

Shoulder/Crown and Roadside Development. Shoulder, crown, and roadside development details covering the recent period since the roadway was resurfaced and expanded to two lanes were not available. However, using the details of these elements applying to the original design shows a 4 ft (1.2 m) paved shoulder along the left lane, a 10 ft (3 m) shoulder along the right lane for the first 1,036 ft (316 m) of the ramp, and a 17 ft (5.2 m) shoulder thereafter. The 4 ft (1.2 m)

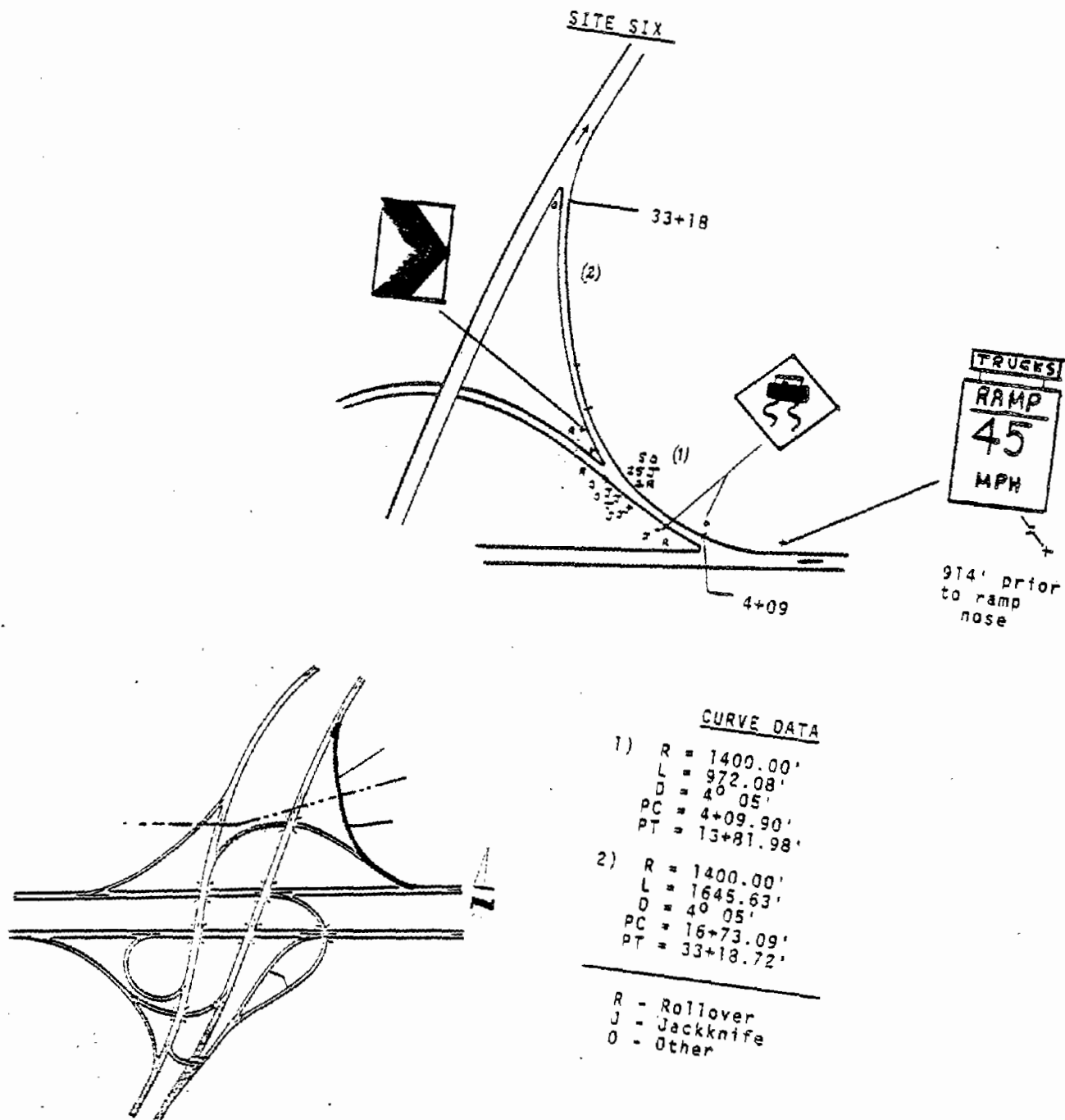

Figure 5. Layout of site 6.

shoulder slopes at a rate of 2 percent, with both the 10 ft (3 m) and 17 ft (5.2 m) shoulders sloping at 6 percent. The road crown value is 1.6 percent and both sideslopes are 6 to 1. Recent pictures suggest that these elements were not significantly modified when resurfacing and expanding the 14 ft (4.3 m) single lane section to 212 ft (3.7 m) lanes. These elements were found to fall within those recommended by AASHTO.

Superelevation Development. The details of superelevation development were available for only part of curve (1). The plans indicate a 170 ft (52 m) transition beginning at the curve PC. This is followed by 346 ft (104 m) of the curve being held at the maximum superelevation rate of .05 ft/ft (.05 m/m). Following this superelevated portion, another transition is indicated, however, its length and termination point were not established. Using the available information, essentially 35 percent of the curve is superelevated at the maximum value, with all of the transition occurring after the curve PC. The 170 ft (52 m) transition length is considered adequate when comparing it to the minimum length of 133 ft (40 m) recommended by AASHTO.

Deceleration Lane. Two of the freeway 12 ft (3.7 m) lanes taper away from the through lanes and become the 2 lanes of this exit ramp. Therefore, a deceleration lane is neither present nor warranted. Directional signage and lane-use signage starts some 1,000 ft (300 m) in advance of the final roadway split. This far exceeds the minimum 300 ft (91 m) deceleration lane length recommended by AASHTO.

Non-Geometrics

Traffic Control Devices. A total of eight warning signs are in place along or preceding the ramp. The first of these is a 45 mi/h (72 km/h) ramp speed advisory with a "trucks" plate attached above (W13-3). This sign is in place on the right side of the roadway some 914 ft (279 m) prior to the ramp nose. A second sign of this same type is in place approximately 100 ft (30 m) preceding the ramp nose, also on the right side. Just inside the ramp on either side of the roadway are two

graphic style "slippery when wet" signs, type W8-5. Curve (1) is also outlined with four chevrons (W1-8). Finally, a dashed white centerline, white edge line on the right, and a yellow edge line along the left pavement edge are in place. All paint markings are standard 4 in (.2 m) edge and centerline pavement markings. Delineators are in place and outline the ramp curvature; however, specifics on their location were not available. The above traffic control devices follow the recommended practices outlined in the MUTCD.

Accident Observation and Candidate Design Corrections. Forty-four accidents occurred along the length of curve (1), with the greatest concentration on the inside. The great majority of these accidents resulted in tractor jackknife. All of the recorded truck accidents occurred on wet pavement. Following the placement of an open-graded asphalt overlay on this site, the peculiar truck loss-of-control incidents ceased--suggesting that pavement friction was a dominant factor. After reviewing the geometric and traffic engineering data available for this ramp, no other clear deficiencies in ramp design were noted. The speed advisory signage was placed well enough in advance of the curve section, there was more than adequate length of deceleration lane, the curvature was well outlined by chevron use, the ramp curvature was quite flat, yielding low friction factors, and 2 12-ft (4-m) lanes were available. The overall accident experience at this site seemed to indicate that trucks place substantial demands for drainage and/or pavement texture when running at high speed on ramps having even a moderate side friction factor. Accordingly, resurfacing the lanes with a high-friction overlay constitutes a directly effective countermeasure.

SITE SEVEN

Description

Site Seven is a two-curve, left-bearing, urban, turning roadway. Curve (1) has a radius of 475 ft (145 m), a degree of curvature of 12.1, and on a 3.8 percent downhill grade. The radius of curve (2) is 900 ft (274 m), with the degree of curvature being 6.4. The roadway has 2 12-

ft- (3.7-m) wide lanes, was designed in 1965, and is pictured in Figure 6. The roadway is currently posted with an advisory speed of 35 mi/h (56 km/h). The accidents relevant to this study occurred exclusively along curve (1), therefore the analysis is focused on curve (1) only.

Geometrics

Frictional Factor. The needed frictional factor (f) was calculated using the minimum radius equation. The 35 mi/h (56 km/h) posted advisory speed, and the 0.12 percent maximum superelevation value indicated on the plans as well as in the State standard plans, were used. The frictional factor value at 35 mi/h (56 km/h) was determined to be .05. Frictional factors were also evaluated for 40 and 45 mi/h (64 and 72 km/h), yielding values of .10 and .23, respectively. Clearly, the friction factors pertaining to 35 and 40 mi/h (56 and 64 km/h) lie well within corresponding values of 0.155 and 0.150 recommended as maximums by AASHTO. Accordingly, the 35 mi/h (56 km/h) posting is rationalized as an apparently conservative approach reflecting concern with truck control problems on this ramp.

Shoulder/Crown and Roadside Development. Along the roadway right lane is an 8-ft- (2.4-m) wide bituminous shoulder. The left lane has a 4-ft- (1.2-m) wide shoulder. A barrier-type curb is present along the 4 ft (1.2 m) shoulder, beginning approximately upon reaching the overpass structure and extending through the remaining length of the curve. Both shoulders maintain the superelevation which is developed along the roadway, proper. Using the method outlined in the AASHTO Blue Book, the ramp was classified as Case III, Type C. Referring to the suggested shoulder widths for this classification, the existing treatment falls within the recommended 10 to 12 ft (3 to 3.7 m) sum for both shoulder widths. Crown rate and roadside development details were not available.

Superelevation Development. A 300 ft (91 m) transition length to achieve a maximum superelevation of 12 percent is prescribed in the state standard plans. A 325 ft (99 m) transition is actually used on curve (1) to reach the maximum superelevation value, with 145 ft (44 m)

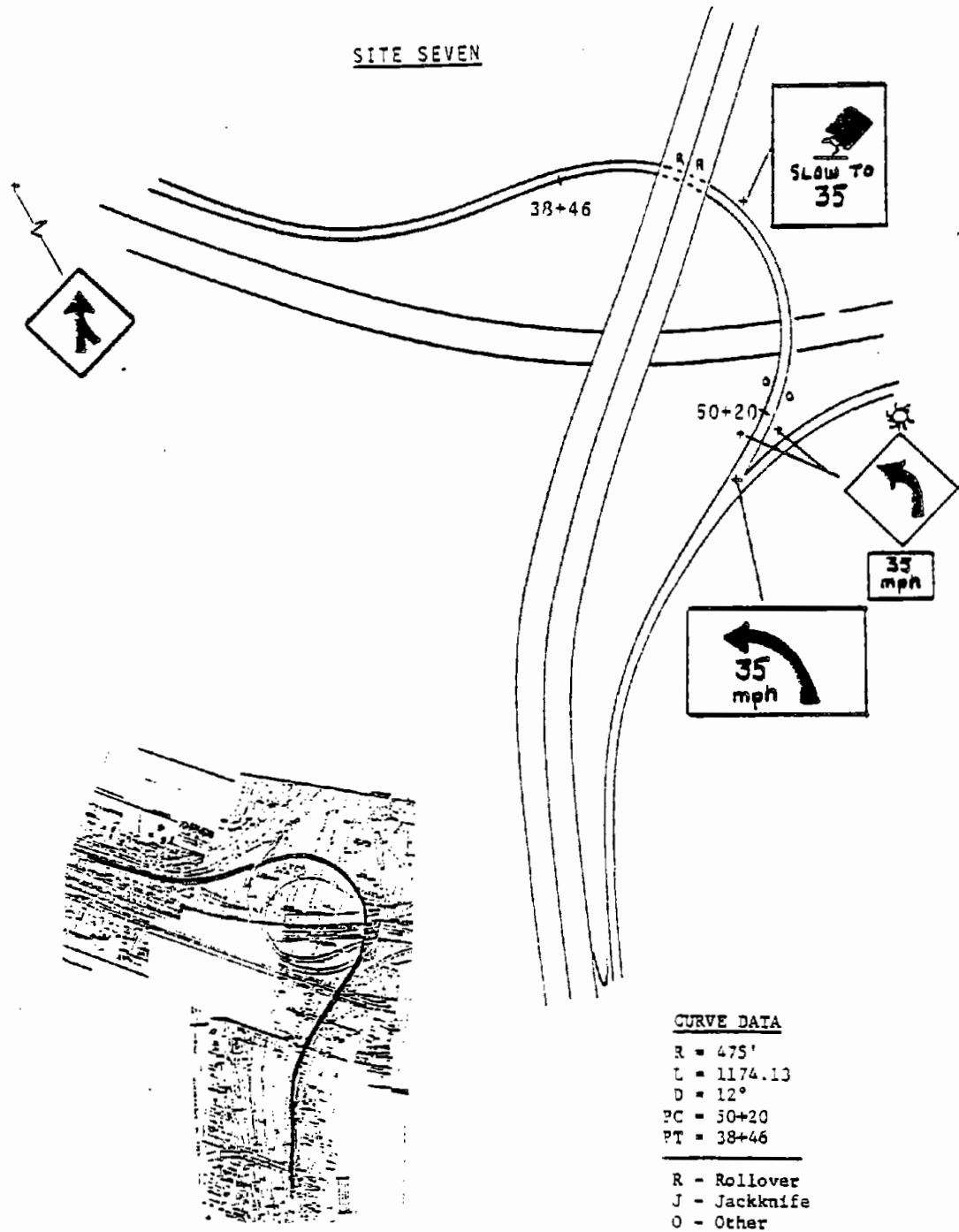

Figure 6. Layout of site 7.

of this transition occurring beyond the PC of curve (1). Some 875 ft (267 m) of the curve is then held at the maximum superelevation value of 0.12. This constant-curve portion is followed by a 450 ft (137 m) transition over which the superelevation is removed. One hundred and twenty-five ft (38 m) of this transition length is inside the PT of the curve. Both transition lengths follow the State-imposed criteria and also fall within the minimum transition lengths recommended by AASHTO. The placement of a smaller portion of the transition length within the curve PC and PT points also follows the AASHTO guidelines. Thus, the transition lengths and placement both follow accepted geometric design criteria.

Deceleration Lane. The roadway does not have a deceleration lane, being preceded by 1,500 ft (457 m) of 2-lane roadway. This preceding section provides more than an adequate length for deceleration, considering the AASHTO-recommended deceleration lane length of 340 ft (104 m).

Non-Geometrics

Traffic Control Devices. A total of five warning signs are present along the ramp. The first is a left-turning arrow with a 35 mi/h (56 km/h) speed advisory and is part of the exit directional sign located in the bifurcation where the roadway divides into 2 ramps. This sign is located approximately 150 ft (46 m) ahead of the curve (1) PC, and is not a standard warning sign discussed in the MUTCD (Fig. 6). Two left-curve warning signs (type W1-2L) with flashing yellow beacons on top and a 35 mi/h (56 km/h) speed advisory below are placed on either side of the ramp just beyond the ramp gore. Located just prior to the overpass structure is another warning sign which is also not a standard MUTCD sign. This sign has the standard yellow background, and depicts a truck tipping to one side, with the warning "SLOW TO 35." This sign is illustrated in Figure 6. Finally, a merge sign (type W4-1) is in place in the gore area at the ramp terminal. Standard 4 in (.10 m) wide yellow and white edge lines border the left and right pavement edges,

respectively. Reflective markers make up the centerline development for the two-lane turning roadway. All but three of these signs are placed in compliance with the MUTCD. However, the curve warning and speed advisory signage are not placed far enough in advance of the curve PC. The control devices manual states that this signage should be placed some 350 ft (107 m) in advance of the point of curvature. This distance assures that enough deceleration distance is available for motorists to comply with the warning.

Accident Observation and Candidate Design Corrections. The truck accidents occurring along the roadway are concentrated in two areas, the first just beyond the gore area and the second on the downhill grade portion of the curve. Considering that approximately 1,500 ft (457 m) are traveled before reaching the exit, an exit speed advisory with a truck notation plate attached may assist the truck driver. Currently, the first warning sign is located just before the gore area. This leaves only 150 ft (46 m) or so of roadway within which to decelerate to the advisory speed. The second area of accidents involves the grade and curve. Approximately 950 ft (290 m) of curve (1) is on a 3.8 percent downhill grade. A trucker choosing to coast down this grade from an initial speed of 35 mi/h (56 km/h) could exceed 45 mi/h (72 km/h) at the end of the grade--at which point a side friction factor of .23 would be demanded. Thus, the truck driver may permit the speed condition to simply rise to a level which the curve design cannot safely accommodate.

Only briefly does AASHTO discuss the combination of a downhill grade and superelevation, suggesting that a higher design speed should be used on roadways of this type. The use of the tipping truck illustration as a warning sign has been reported by the cognizant highway department to have been very effective in reducing the incidence of truck accidents at this and similar sites.

SITE EIGHT

Description

Site Eight is a two-curve, left-bearing, semi-direct, urban, turning roadway. The truck accidents relevant to this study occur primarily on curve (2) which will be the focus of the roadway analysis. Curve (1) has a radius of 1,200 ft (366 m), and a curvature of 4.8 degrees. Figure 7 illustrates curve (2) which has a radius of 350 ft (107 m) and a curvature of 16.4 degrees. Curve (2) is also placed on a 5.4 percent downhill grade. The entire turning roadway has 2 12-ft- (3.7-m) wide lanes, was designed in 1965, and currently has a posted advisory speed of 30 mi/h (48 km/h) which was also the original design speed.

Geometrics

Frictional Factor. The friction factor demanded on curve (2) was determined using the minimum radius equation. Using the currently posted advisory speed of 30 mi/h (48 km/h), and the maximum superelevation value of .08 indicated on the plans, the friction factor was determined to be .09. At 35 mi/h (56 km/h), the frictional factor value is .15. These are both below the maximum accepted values established by AASHTO of .16 and .155 for 30 and 35 mi/h (48 and 56 km/h), respectively.

Shoulder/Crown and Roadside Development. The superelevation rate developed across the roadway is maintained across both the right and left shoulders. Both shoulders are 2 ft (.6 m) wide through almost the full length of the ramp. The left shoulder is bounded by a barrier-type curb along the entire length of the roadway, with a longitudinal barrier in place along the left and right shoulder adjacent to an overpass bridge structure. Again using the method outlined in the AASHTO Blue Book, the ramp was classified as Case III, Type C. Referring to the suggested shoulder widths for this classification, the existing treatment falls within the recommended 10 to 12 ft (3 to 3.7 m) sum for

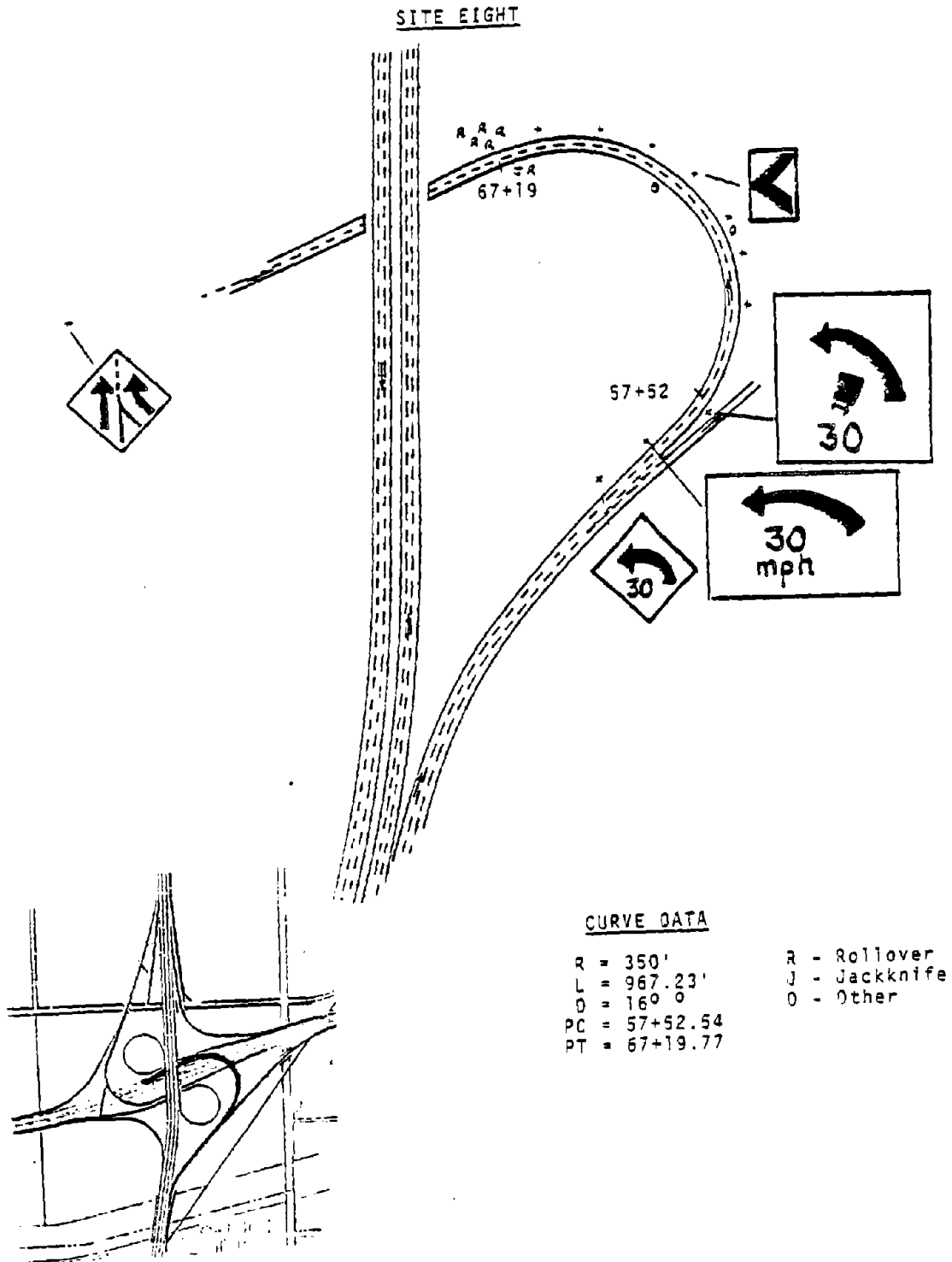

Figure 7. Layout of site 8.

both shoulder widths. Details concerning road crown and roadside development were not available.

Superelevation Development. The plans for curve (2) detail the superelevation for essentially the middle portion of the curve. This superelevation value is .08, which is held for some 282 ft (86 m) of the curve. The manner of development of this superelevation rate was not included in the plans. However, more than adequate distance along the curve is available for proper development of the .08 value since the superelevated portion is bordered by lengths of 272 ft (83 m) and 412 ft (126 m). Both of these lengths exceed the recommended minimum transition length of 205 ft (62 m) for this superelevation value, speed, and road type.

Deceleration Lane. Although this ramp does not have a deceleration lane, some 451 ft (138 m) of 3-lane roadway precede curve (2). The AASHTO recommended minimum for the speeds and highway type involved is 400 ft (122 m). Therefore, more than adequate length is available for any necessary speed changes to be made well in advance of curve (2).

Non-Geometrics

Traffic Control Devices. Currently, 11 warning signs are in place along the roadway. Three of these signs are unique designs, and therefore not outlined in the MUTCD. The first sign on the ramp is a curve warning sign (type WL-2L) with a 30 mi/h (48 km/h) speed advisory placed directly below the turning arrow. The next sign is another curve warning sign which also emulates the WL-2L turning arrow, however, it is attached directly to the overhead directional signage, is rectangular in shape, and includes the same 30 mi/h (48 km/h) speed advisory notation. Located just inside the gore area of the roadway is a third warning sign, unique in design. This sign is rectangular in shape and depicts a graphic symbol of a tipping truck, the WL-2L-type curve arrow, and finally a 30 mi/h (48 km/h) speed advisory notation. The curve is then outlined by 8 chevrons (W1-8), with a merging traffic warning sign (W4-

1) at the terminal end of the turning roadway. Reflective markings delineate the centerline, while standard 4 in (.1 m) yellow and white edge lines are in place along the left and right pavement edges, respectively. Placement of the warning signs and pavement markings follow the suggested practices outlined in the MUTCD for both standard designs as well as for othe signage designs unique to this roadway.

Accident Observation and Candidate Design Corrections. All nine truck accidents deemed relevant to this study noted excessive speed in the report, resulting in speeding citations being issued. Sufficient advisory speed warning, pavement width, shoulder area, and deceleration length are available. By standard design principles, these features should ensure that the ramp can be negotiated safely. However, while all the details concerning the superelevation on the ramp were not available, it seems pertinent that the accidents are primarily clustered along the downhill grade portion of the roadway. The downgrade begins ahead of the curve and attains a peak of 5.4 percent approximately 470 ft (143 m) before reaching the PT of the curve. Therefore, truck drivers are not only driving through a superelevated curve, but at the same time, having to adjust to a substantial downhill grade, with the prospect for a consequent increase in speed. As noted with Site Seven, the combination of grade and superelevation is briefly addressed by AASHTO, who suggest that a higher design speed be applied to downhill sections when determining superelevation and runoff lengths. Whether this adjustment was applied to this design is not known. Having reviewed and eliminated other possible causes, the combination of grade and a superelevated curve may be contributing to the truck accident rate along this ramp.

Finally, while the frictional factor at 35 mi/h (56 km/h) doesn't exceed the AASHTO maximum value, retention of the 30 mi/h (48 km/h) speed advisory, and the existing signage is recommended. Such a view is supported upon noting that an approximate 10 mi/h (16 km/h) increase in speed will be achieved by trucks which travel without braking on the downhill grade along curve (2). With a truck driver obeying the current advisory for a 30 mi/h (48 km/h) entrance speed at the curve, increases

of this magnitude will place the truck above maximum frictional factor limits.

SITE NINE

Description

This rural, right-turning ramp is one continuous curve, with a radius of 230 ft (70 m) and a length of 1,031 ft (314 m). It is one of the four inner-loop ramps of a cloverleaf interchange designed in 1959. The ramp has a single 16-ft- (4.9-m) wide concrete lane with bituminous shoulders. It is currently posted with an advisory speed of 25 mi/h (40 km/h) and had an original design speed of 35 mi/h (56 km/h). Figure 8 illustrates the ramp and includes the approximate location of the truck accidents.

Geometrics

Frictional Factor. The needed frictional factor (f) was determined using both the advisory speed and the design speed in conjunction with the recommended superelevation (e) value of .07 from the State's standard plan. The frictional factor values were determined to be .11, .19, and .29 for speeds of 25, 30, and 35 mi/h (40, 48, and 56 km/h), respectively. The AASHTO maximum frictional factor values for these speeds are .165, .16, and .155, respectively. Comparing the values, we see that the 25 mi/h (40 km/h) advisory speed is appropriate for this site.

Shoulder/Crown and Roadside Development. On the non-superelevated sections of the ramp, both shoulders are paved and are 6 ft (1.8 m) wide. The first 2 ft (0.6 m) of shoulder width, on both sides of the non-superelevated sections are held at the road crown value, with the inner (right) portion of the ramp lane having a crown development of 1/4 in (21 mm/m) and the outer (left) portion 1-3/8 in (115 mm/m) of crown. The roadside has a sideslope of 1 on 4. The superelevated section has a

SITE NINE

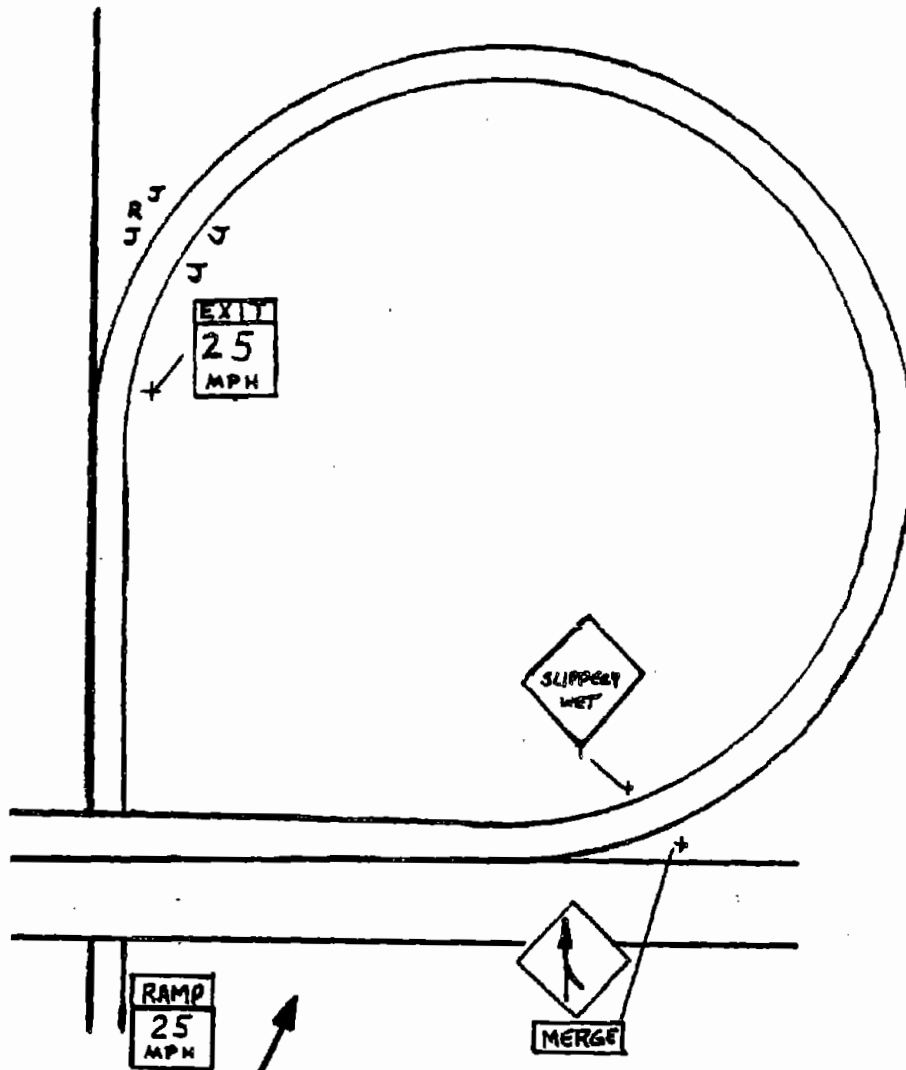

CURVE DATA

R = 230'
 L = 1031.13'
 D = 25°
 PC = 31 + 09.48
 PT = 20 + 78.35

R - Rollover
 J - Jackknife

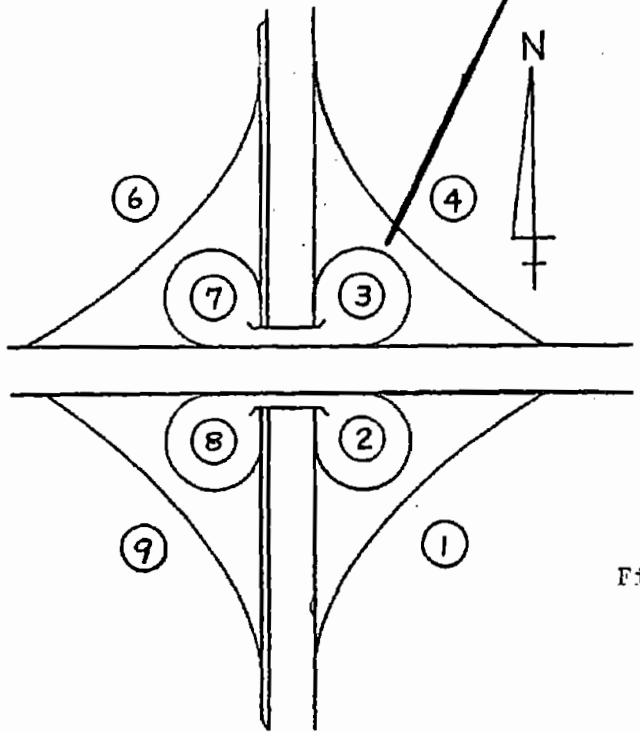

Figure 8. Layout of site 9

right shoulder 8 ft (2.4 m) wide. The first 2 ft (1.2 m) of the inner, right shoulder is maintained at the superelevation rate of the roadway lane, and it has a crown value of 3/8 in (31 mm/m). The outer or left shoulder is 6 ft (1.8 m) wide and holds the inner 2 ft (.6 m) at the crown rate of 1/4 in (21 mm/m). Both shoulders slope at a rate of 3/4 in (62 mm/m) per foot, and have 1 on 4 sideslopes. All of the elements outlined for the shoulder and crown development follow the treatment suggested by AASHTO.

Superelevation Development. While details concerning the superelevation development along the ramp were not available, it was indicated on the plans that the ramp was to conform with the State Standard Plan for Superelevation and Pavement Crown. Comparison of the ramp geometry and length with the criteria outlined in the standard, revealed that the ramp is of adequate length to follow the standard.

The standard prescribes a maximum superelevation value of .07 ft/ft (.02 m/m). Three-hundred feet (91 m) of the deceleration lane could have been used as the transition length. Thus, the maximum superelevation value would have been reached 200 ft (61 m) inside the PC of the curve. With a curve length of 1,031 ft (314 m), some 620 ft (189 m) could have therefore been maintained at the prescribed .07 maximum superelevation value. The plans indicate adherence to the standard, and since the standard follows the recommended minimums outlined by AASHTO, it is concluded that the ramp was constructed within accepted superelevation development criteria.

Deceleration Lane. In place along the highway is what is defined as a combined acceleration and deceleration lane. This 12 ft (3.7 m) concrete lane serves as both an acceleration lane and deceleration lane for the two inner-loop ramps. The combination lane length from ramp nose to ramp nose is approximately 800 ft (244 m). This falls well within the minimum deceleration lane length of 375 ft (114 m) established by AASHTO for a highway of this type.

Non-Geometrics

Traffic Control Devices. A total of four warning signs are in place along the ramp. The first of these is a 25 mi/h (40 km/h) ramp speed advisory sign (W13-3) located approximately 435 ft (133 m) preceding the curve PC. Parallel to the ramp gore on the approach is a 25 mi/h (40 km/h) exit speed advisory sign (W13-2). A "slippery when wet" (W8-5) condition warning sign is placed at the terminal end of the ramp. Finally, a merge arrow with "merge" plate attached below (W4-1) is located in the gore area at the end of the ramp. The ramp pavement markings include standard white edge lines along the deceleration lane, with white pavement line gore area development. Just inside the ramp, the outer, or left, pavement edge line is yellow, with the right pavement edge line being white. These are standard 4 in (.10 m) pavement edge line widths. Delineators also outline the ramp curvature, although placement details were not available. The use and position of the traffic control devices and treatments outlined above follow the recommendations established in the Manual on Uniform Traffic Control Devices.

Accident Observation and Candidate Design Corrections. Four of the five accidents occurring on the ramp involved a wet surface. Two of the five made mention of another vehicle either cutting off the path of the truck, or forcing the truck driver to brake suddenly. The control devices which are in place appear to provide adequate advice to drivers concerning a safe ramp speed. Thus, the primary cause of accidents in these cases appears to be drivers neglecting to adhere to the warnings in place. Therefore, major traffic control modifications would probably not reduce the ramp accident rate. Interestingly, the ramp in question constitutes a high-volume exit leading from one freeway to another. The setting is a fairly remote rural area in which much of the truck traffic has traveled for at least 100 miles (161 km) on a flat and rather straight mainline freeway prior to arrival at the site. Thus, one can speculate that the low-speed, tight-turn requirement for the ramp simply catches the truck driver unprepared for the substantial braking action required.

SITES TEN AND ELEVEN

Description

This outer connection-type ramp is comprised of three reverse horizontal curves and is part of a full cloverleaf interchange. The individual curve radii are 295, 2291, and 260 ft (90, 698, and 79 m), with the degree of curvature being approximately 16 deg, 2.5 deg, and 18.5 deg, respectively. The ramp has 2 12-ft- (3.7-m) wide concrete lanes, with bituminous shoulders. The entire ramp is posted with an advisory speed of 25 mi/h (40 km/h) and had an original design speed of 35 mi/h (56 km/h) when designed in 1959. Figure 9 illustrates the ramp and details which are pertinent to the geometric design.

Geometrics

Frictional Factor. For each of the three curves, the minimum radius equation was applied. Friction factors were computed for 25, 30, and 35 mi/h (40, 48, and 56 km/h), using a superelevation rate of .07 ft/ft (.07 m/m). The superelevation value used is the prescribed value as outlined by the State Standard Plan for Superelevation and Pavement Crowns. Curve (1) requires frictional factor values of .05, .10, and .16 at 25, 30, and 35 mi/h (40, 48, and 56 km/h), respectively. Curve (2) has "f" values of -.05, -.04, and -.03 at the three respective speeds. These values describe a "fall-in" condition. Calculating the frictional force value at 55 mi/h (88 km/h) for curve (2) resulted in an f value of only .02. The AASHTO f_{max} value at 55 mi/h (88 km/h) is .135. Indeed, curve (2) can be driven at the current highway speed of 55 mi/h (88 km/h) under essentially "hands-off" conditions. Curve (3) has the sharpest radius of all, and requires f values of .06, .12, and .19 at 25, 30, and 35 mi/h (40, 48, and 56 km/h), respectively. All but the highest of these frictional factor values fall well within the maximum values established by AASHTO for these speeds.

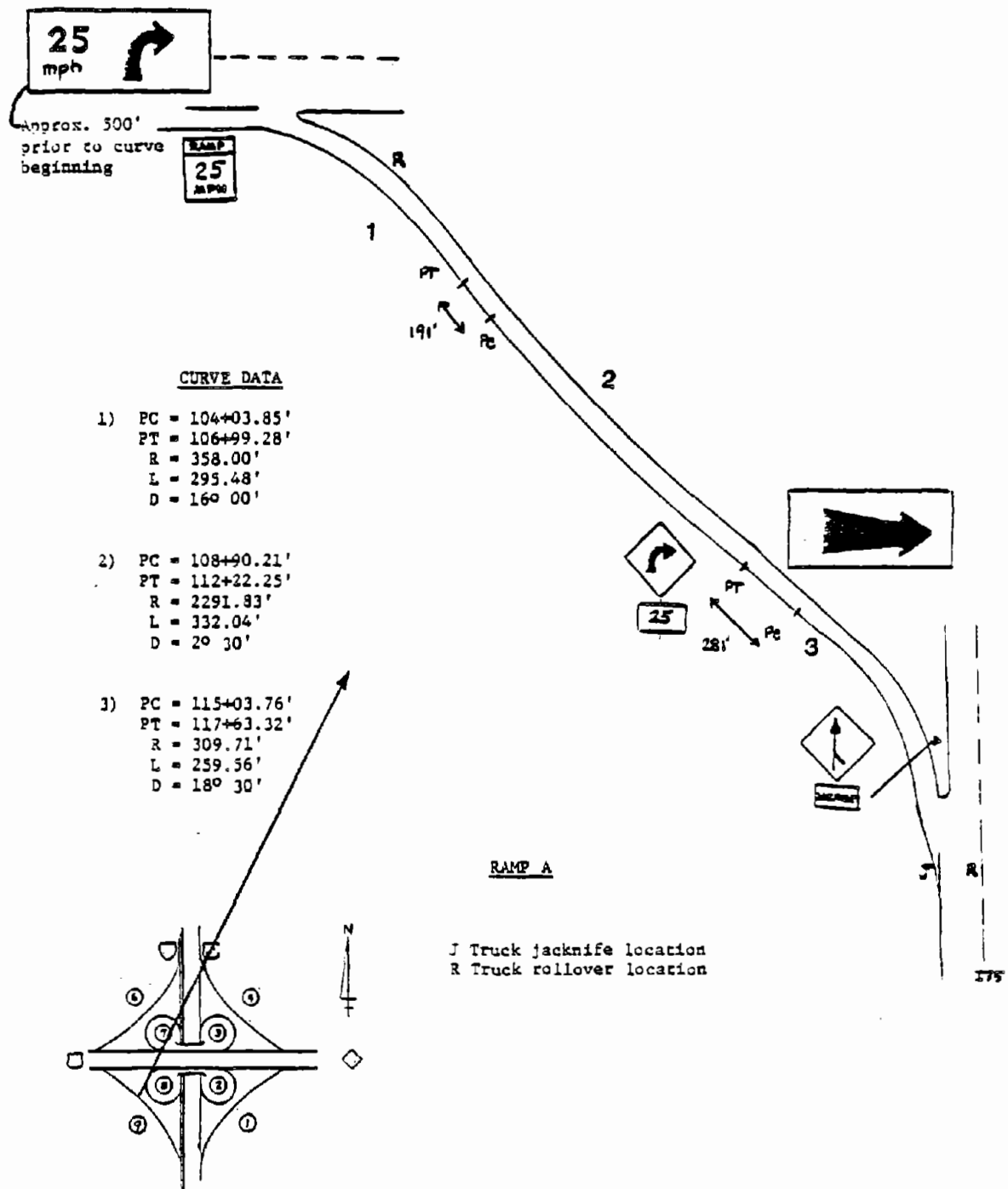

Figure 9. Layout of sites 10 and 11.

Shoulder/Crown and Roadside Development. Along the entire length of the ramp, there is a 10 ft (3 m) wide shoulder developed on the outside lane, with the inner lane having a paved shoulder width of 6 ft (1.8 m). Both shoulders maintain the inner 2 ft (.6 m) at the normal crown or superelevated rate. Both shoulders slope at a rate of 1/2 in/ft (42 mm/m), develop a 4 ft (1.2 m) vertical curve and lead to a 1 on 4 sideslope. The crown developed over the 12 ft (3.7 m) wide lanes is 1-3/8 in (115 mm/m). The above details concerning the shoulder, crown, and roadside development meet the AASHTO minimums.

Superelevation Development. Specific development of the superelevation along the ramp was not available. However, the plans do indicate that the development was to comply with the State Standard Plan for Superelevation and Pavement Crowns. With the maximum superelevation value of .07 prescribed, a 500 ft (152 m) transition is recommended.

Considering the ramp geometry and length, there is a conflict in being able to meet the required transition lengths. The two points of conflict occur after the superelevation is developed within curves (1) and (2). Curve (1) has a length of 295 ft (90 m). There is 191 ft (58 m) between the PT of curve (1) and the PC of curve (2). If one follows the State standard, and attains superelevation within 200 ft (61 m) beyond the PC of curve (1), this leaves only 95 + 191 ft, or 286 ft (87 m) of length to restore the roadway to a non-superelevated cross section. This value is 214 ft (65 m) short of the recommended 500 ft (152 m). This same conflict is present between curves (2) and (3). Assuming that sufficient distance was available to follow the standard, and thus achieve full superelevation 200 ft (61 m) beyond the PC of curve (2), only 132 ft (40 m) of the curve length remains. This amount plus the distance between curves (2) and (3) totals only 413 ft (126 m)-short of the recommended 500 ft (152 m) for gradually returning to a non-superelevated cross section.

Next, the AASHTO minimum superelevation and tangent runoff lengths were applied to the ramp. Table III-11 in the "Blue Book" was interpolated for the design speed of 35 mi/h (56 km/h) and a

superelevation rate of .07 to determine the recommended minimum transition runoff length of 130 ft (40 m). (A tangent runout length is not part of the total transition length in this case, since the State standard superelevates the roadway without removing the crown.)

The AASHTO suggested practice of placing 2/3 of the 130 ft (40 m) on the tangent portion and the remaining 1/3 on the curve was applied to the ramp in question. In order to meet this minimum, 200 ft (61 m) is needed to effect a transition out of the superelevation developed on curve (1) and into the required value for curve (2). Between the PT of curve (1) and the PC of curve (2), approximately 191 ft (58 m) are available. Some 281 ft (89 m) are available between the PT of curve (2) and the PC of curve (3). Therefore, when reviewing the superelevation development, the ramp does not meet its own State standards, but does fall within the minimums recommended by AASHTO.

Deceleration Lane. Approximately 500 ft (152 m) of roadway lie beyond the first ramp speed advisory sign along the ramp approach. This is well within the AASHTO suggested deceleration lane length of 375 ft (114 m) for this highway speed and type.

Non-Geometrics

Traffic Control Devices. A total of seven directional and warning signs are in place along the ramp. Five of the seven devices are warning signs. The first of these warning signs is of a design which is specific to this ramp. This sign warns approaching ramp users that the ramp advisory speed is 25 mi/h (40 km/h) and couples this information with a W1-1R right-turning arrow and a flashing yellow beacon mounted on the top of the sign itself. The sign precedes the PC of curve (1) by approximately 500 ft (152 m). Following this sign is a standard, 25 mi/h (40 km/h), ramp speed warning sign (W13-3). Just before entering curve (3), there is a right-turning arrow sign with a 25 mi/h (40 km/h) advisory speed plate below (W1-2R and W13-1). The remaining two signs are a standard target arrow type W1-6 and merge sign type W4-1 with a merge panel attached below. The pavement markings in place on the ramp

consist of a white dashed centerline, with white pavement edge lines developed along curves (1) and (2). On the inside, or left, pavement edge of curve (3) is a yellow pavement edge line, with a white edge line along the outer, or right, lane pavement edge. Figure 9 illustrates the locations of the above control devices. Although photos indicate that delineators are in place along the ramp, exact placement details were not available. The placement of the total set of control devices follows the recommended minimum distance and roadside locations outlined in the Manual on Uniform Traffic Control Devices.

Accident Observation and Candidate Design Corrections. While the control devices follow the suggested placement outlined in the Manual on Uniform Traffic Control Devices, the overall ramp signage is inconsistent. Essentially all warning information is in advance of curve (1). The restricting geometry is, however, presented by curve (3). It appears that drivers tend to take curve (2) too fast. This is probably related to the ease of being able to drive curve (1) at 35 mi/h (56 km/h), and curve (2) at even higher speeds. These two curves are followed by curve (3) whose radius is some seven times sharper than that of the intermediate curve (2). It is this discontinuity in design which makes the ramp use, as a whole, difficult to control by means of signage. Countermeasures include removing the target arrow sign and replacing it with four chevrons to outline curve (3) and, perhaps, removing the flashing beacon from the first ramp advisory sign and placing it on the warning sign for curve (3). If possible, a 100-ft (30-m) spiral curve should be inserted between curves (2) and (3). The fundamental problem faced by trucks, however, appears to be simply that very tight radii placed toward the end of a connecting ramp tend to impede the attainment of merging speeds and are likely to be driven at excessive speed. Especially in cases for which intermediate portions of the ramp allow considerably faster travel, the impedance posed by a final tight curve prior to a merging entrance seems particularly inadvisable.

SITE TWELVE

Description

This 24 ft (7 m) wide rural 2-lane turning roadway is comprised of 2 curves, is part of a trumpet 3-leg interchange, and pictured in Figure 10. The first left-turning curve has a radius of 450 ft (137 m), with a degree of curvature of about 12 deg 30 ft. The second, or right-turning, curve has a radius of 1,056 ft (322 m), with a degree of curvature of 5 deg 25 ft. The entire roadway is currently posted with an advisory speed of 40 mi/h (64 km/h) and had an original design speed of 35 mi/h (56 km/h) when designed in 1959.

Geometrics

Frictional Factor. The frictional factor was determined for both curves. The superelevation value used was .07 for both curves, as indicated on the standard plan. The standard plan outlines the superelevation and pavement crown development, and its criteria fall within the AASHTO guidelines for these elements. The "f" value for curve (1) at the 35 mi/h (56 km/h) design speed was determined to be .11. The AASHTO-recommended value for this speed is .155. The "f" value at 40 mi/h (64 km/h) is .16, in contrast to a value of .15 which is recommended by AASHTO for this speed.

Curve (2) has very low frictional factor values of .01 and .03 corresponding to the speeds of 35 and 40 mi/h (56 and 64 km/h), respectively.

Shoulder/Crown and Roadside Development. Beginning 160 ft (49 m) beyond the PC of curve (1), the inner lane has been expanded to 13 ft (4 m), with the outer lane remaining at a width of 12 ft (3.7 m). On the first superelevated portion of the turning roadway, a 10-ft- (3-m) wide shoulder is in place along the outer lane. The inner lane has an 8 ft (2.4 m) shoulder developed along curve (1). Two feet of the outer 10 ft (3 m) shoulder are maintained at the superelevation rate of the roadway

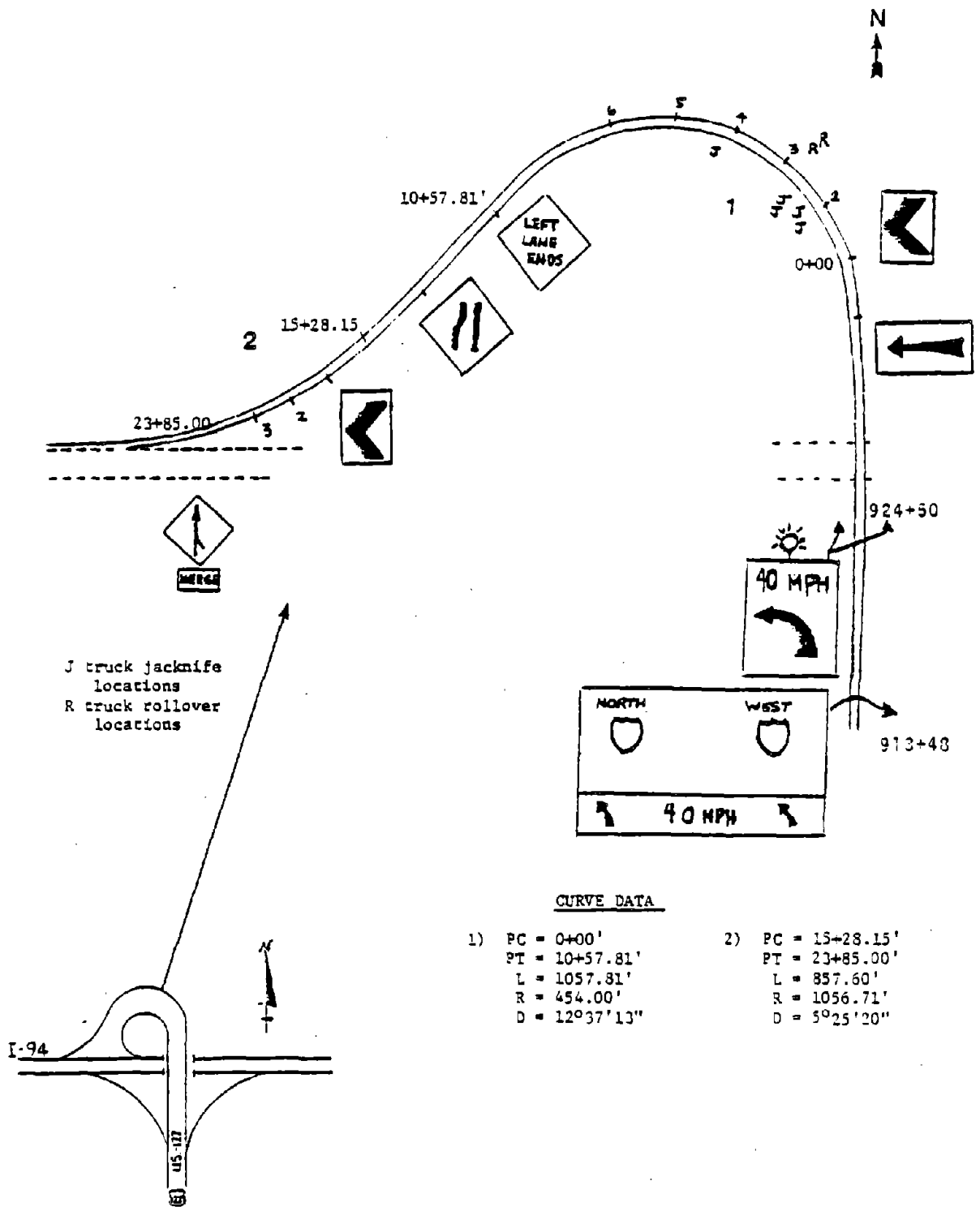

Figure 10. Layout of site 12.

lane. The inner shoulder slopes away from the roadway pavement at a rate of 1/2 in per ft (42 mm/m). Both roadway drainage channels have a sideslope of 1 on 4. The outer, or 12 ft (3.7 m) lane has a crown development of 1-3/8 in (115 mm/m), and the inner 13 ft (4 m) lane has a 1-5/8 in (135 mm/m) crown. The second superelevated portion of the roadway through curve (2) has a similar shoulder development except that the outer lane shoulder is 8 ft (2.4 m) wide, and the inner shoulder lane 10 ft (3 m) wide. Also, the inner travel lane varies from 13 ft (4 m) back down to 12 ft (3.7 m) in width. Hence, the crown rate is blended from 1-5/8 in to 1-3/8 in/ft (135 to 115 mm/m). The above shoulder and road crown characteristics follow the AASHTO Blue Book recommended criteria.

Superelevation Development. The superelevation development along the roadway for the most part falls within the State standard plan mentioned earlier. At the beginning of the ramp, 500 ft (152 m) are used to achieve the maximum superelevation rate of .07 ft/ft (.07 m/m). This maximum superelevation rate is held for 680 ft (207 m). Following this section, some 913 ft (278 m) are available between the PT of curve (1) and the PC of curve (2). This length is used to return to a non-superelevated cross section and as a transition length for the superelevation of curve (2). According to the State standard, the minimum length over which to achieve this transition is 800 ft (244 m). An additional 476 ft (145 m) is used to achieve the maximum superelevation value beyond the PC of curve (2), exceeding the recommended amount of 300 ft (91 m). Finally, 180 ft (55 m) are used to return to a non-superelevated section following the PT of curve (2), whereas the recommended length is 500 ft (152 m). Per discussions with the agency by telephone, this shorter length was necessary due to poor soil quality which restricted further development of the area.

Deceleration Lane. Since this is a turning roadway, there is no formal development for a deceleration lane with tapering qualities. However, sufficient distance along the connecting roadway is necessary to assure that any significant reductions in speed can be attained. Noting that the only speed restriction to drivers using the roadway is the first curve, approximately 1,200 ft (366 m) of roadway are available

to decelerate to the curve advisory speed of 40 mi/h (64 km/h). This provision is more than adequate considering the AASHTO-recommended value of approximately 325 ft (99 m) for a standard deceleration lane.

Non-Geometrics

Traffic Control Devices. A total of 16 warning signs are in place along the roadway. The first warning sign is a combination turning arrow and speed advisory sign attached directly to the bottom of the roadway directional sign. The total sign size is 17 ft x 12 ft (5 x 3.7 m), and is in place at Station 915+00. This sign is not a standard control device, but employs the turning arrow portion of a standard W1-2L warning sign. In addition to this speed advisory, there are two more roadway speed advisory signs located approximately 575 ft (175 m) ahead of curve (1). Both signs are 4 ft x 6 ft (1.2 x 1.8 m) in size and display a left-turning arrow with speed advisory of 40 mi/h (64 km/h), coupled with a flashing yellow light mounted to the top of each sign (see Fig. 10). These signs are also of special design, and therefore are not discussed in the MUTCD. Six chevrons and a target arrow warning sign (W1-6 and W1-8) are placed along the outer edge of curve (1). Finally, three more chevrons (W1-8) follow the outer edge of curve (2). The complete signing of the roadway is detailed in Figure 10. The pavement markings along the roadway consist of dashed white centerlines, coupled with white edge lines along both the inner and outer pavement edges. Finally, delineators outline the ramp curvature, although details concerning their exact locations were not available. The placement of the traffic control devices along the ramp follow the recommended treatments outlined in the Manual on Uniform Traffic Control Devices.

Accident Observation and Candidate Design Corrections. All of the accidents deemed relevant to this study occurred at the beginning or approximate center of curve (1), in daylight hours, on wet pavement. Only one accident report suggests that the motions of other vehicles may have caused the incident. The balance of the accident reports state

that the drivers failed to negotiate the curve, or lost control when they attempted to brake their vehicle in response to the roadway curvature. This suggests that the drivers are (1) not reducing their speeds in response to weather conditions and (2) not reducing speed sufficiently in advance of the curve to avoid the hard braking that may be needed inside of the curve. Since speed advisory and curve warning signs are placed at suitable distances from the ramp, the truck control problems are not readily explainable, although the side friction factor imposed at curve (1) is slightly above AASHTO recommendations. Also, the road section leading to this ramp is a 10-mile (16-km) segment of freeway-quality road, preceded by a 2-lane, rural trunkline. Drivers appear to be unprepared for the interchange speed reductions after only a short time traveling with the extra ease that a limited-access design affords.

SITE THIRTEEN

Description

This urban, turning roadway has 2 12 ft (3.7 m) lanes, contains one long curve with a radius of 374 ft (114 m), and is pictured in Figure 11. The degree of curvature is approximately 15.3 degrees. The roadway was originally designed in 1961 with a speed of 35 mi/h (56 km/h). The advisory speed currently posted for the roadway is 30 mi/h (48 km/h).

Geometrics

Frictional Factor. The frictional factor for both the design and posted speed was determined. The maximum superelevation value used was .05. This is the value designated on the plans, and is in keeping with the AASHTO recommended range of .05-.09 for an urban roadway of this type. The frictional factor was determined to be .17 and .11 at 35 and 30 mi/h (56 and 48 km/h), respectively. Since the AASHTO recommended

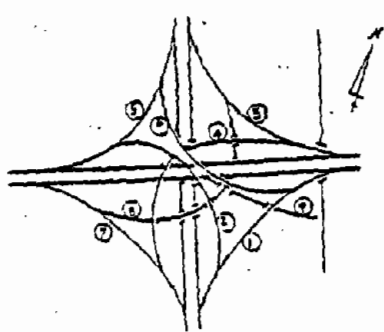
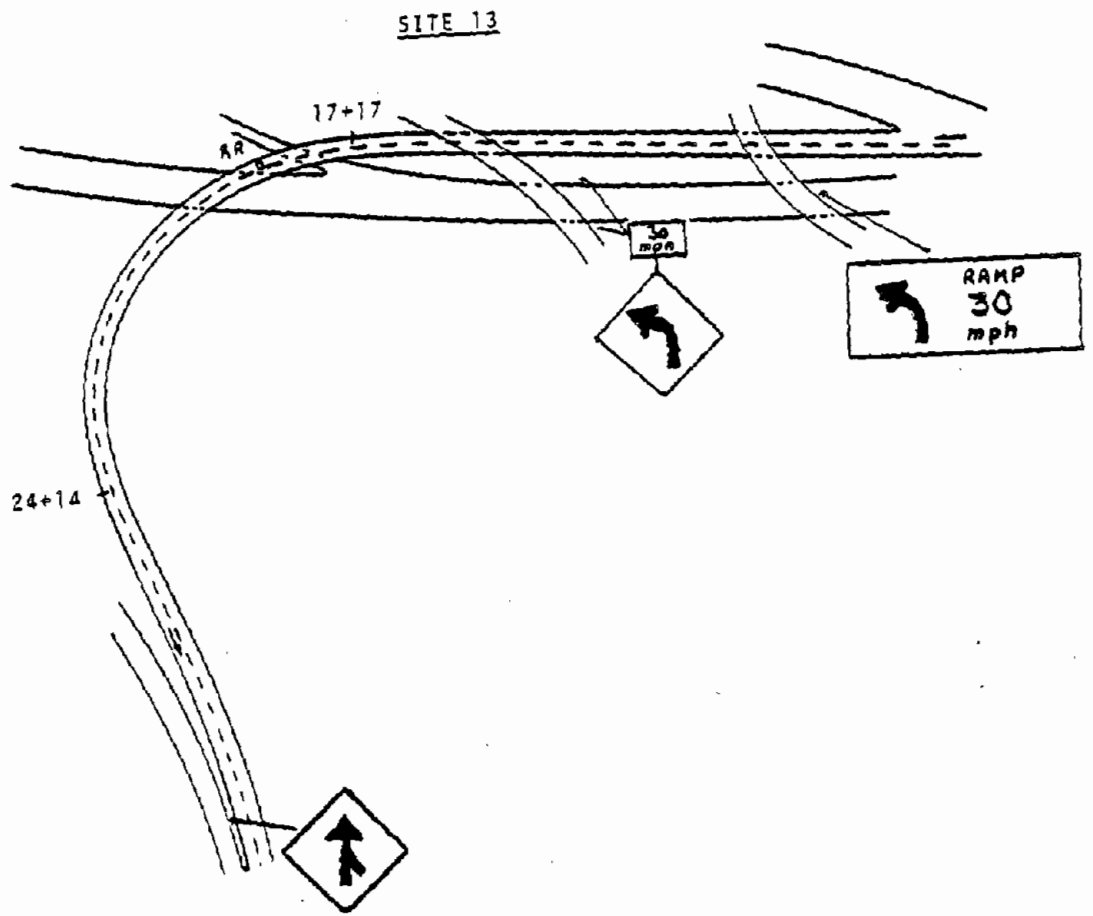

CURVE DATA

R = 374'
 L = 697.49'
 D = 15019'
 PC = 17+17.36
 PT = 24+14.85

R - Rollover
 O - Other

Figure 11. Layout of site 13.

f_{max} values at these respective speeds are .155 and .16, we see that the friction factor being demanded at 30 mi/h (48 km/h) is reasonable, while the value at the 35 mi/h (56 km/h) design speed exceeds the AASHTO maximum. For purposes of illustration, it is useful to note that the frictional force for this curve at the current highway speed of 55 mi/h (89 km/h) is .49.

Shoulder/Crown and Roadside Development. The curb and gutter which had originally been placed 2 ft (.6 m) from the right-hand edge of the travel lane was replaced more recently with a latex concrete overlay spanning the gutter out to the edge of the shoulder, as shown in Figure 12. The replacement details provided by the transportation agency indicate an original shoulder width of 6 ft (1.8 m) for the right shoulder and 3.5 ft (1.1 m) for the left. Since the renovation incorporated barriers outside of both shoulder edges, the total shoulder widths, summed from both sides, reduced from 9.5 ft to 7.5 ft (2.9 m to 2.3 m). Although the sum of the current shoulder widths is below the recommended value of 10 ft (3 m), the elimination of the curb on the outside of the curve is seen as a distinct benefit for reducing truck accidents.

Superelevation Development. The turning roadway superelevates some 598 ft (182 m) of its curvature at a maximum superelevation value of .05 ft/ft (.05 m/m). The transition into and out of the fully superelevated section takes place in 150 ft (46 m). One-third, or 50 ft (15 m) of the transition is placed inside the PC and PT points of the curve. Both the 150 ft (46 m) transition length and the placement with respect to the curve are within AASHTO recommendations for urban, lower-speed, freeway ramps.

Deceleration Lane. Turning roadways usually have 1 or 2 designated 12 ft (3.7 m) deceleration lanes with no tapering. That is the case here, as the roadway approach has 2 12 ft (3.7 m) lanes supplying approximately 425 ft (130 m) preceding the nose of the roadway at which the ramp initiates. In addition to this, there is some 580 ft (177 m) following the first advisory speed sign before reaching the PC

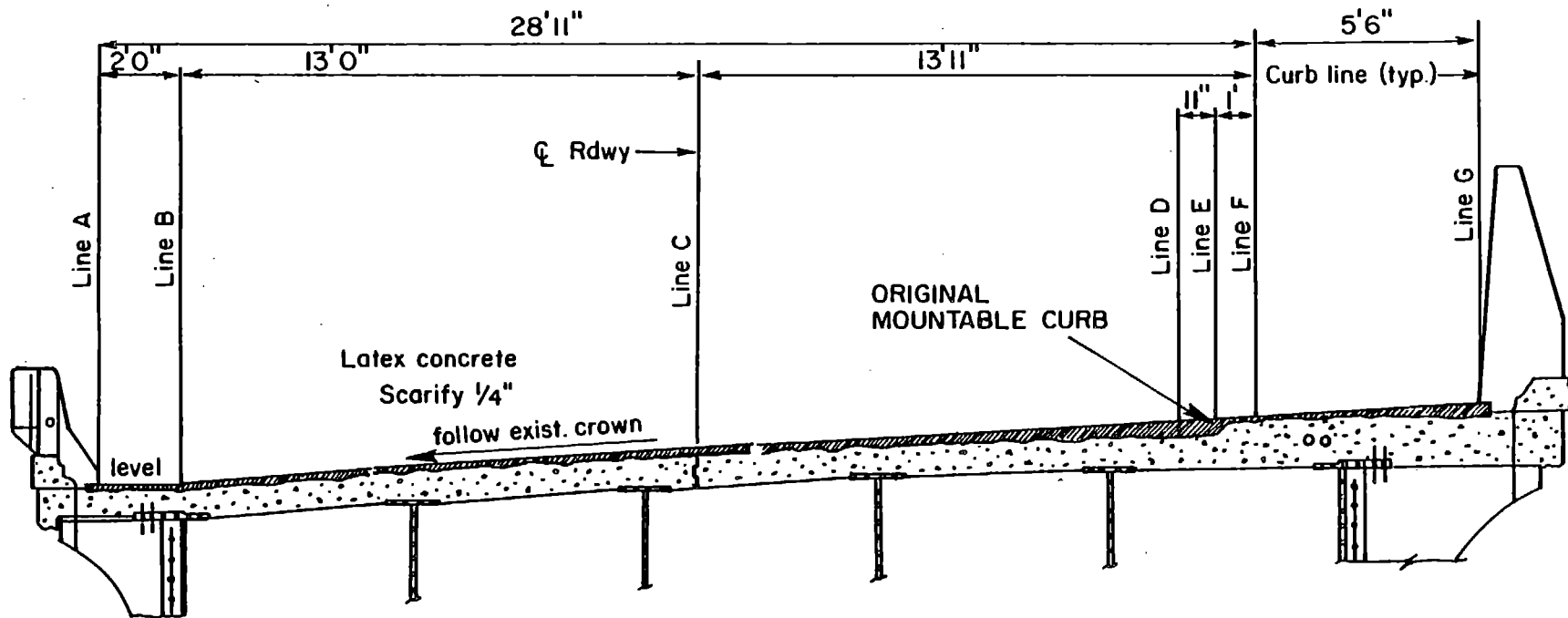

OVERLAY THICKNESS (IN)

Line	A	B	C	D	E	F	G
Thickness	1.75	1.75	1.75	6.75	7.25	2.12	7.12

Figure 12. Corrective overlay implemented at site 13

of the curve. Both provide ample allowances, since the minimum length for an urban deceleration lane recommended at these speeds is approximately 375 ft (114 m).

Non-Geometrics

Traffic Control Devices. Four warning signs are currently in place along the roadway. The first is a special design which incorporates a left-turning arrow and a 30 mi/h (48 km/h) ramp advisory speed warning. This sign is attached directly to an overpass structure which traverses the roadway, and is approximately 190 ft (60 m) ahead of the curve's PC. In place approximately 165 ft (50 m) ahead of the curve PC are 2 W1-2L type curve signs with a 30 mi/h (48 km/h) speed advisory plate (type W13-1) attached above. These two signs are opposite from each other, on either side of the roadway. Finally, a W4-1 merge sign is in place at the terminal end of the roadway.

Three of the four warning signs are unconventional in some way. The first ramp advisory sign is not of a standard design, and therefore is not described in the Manual on Uniform Traffic Control Devices. The curve warning signs have the advisory speed plate attached to the sign top; current recommended procedure is that the plate be attached below its warning sign. Also, the MUTCD recommends placement of these warning signs 300 ft (91 m) in advance of the curve. The first warning sign is only 190 ft (60 m) prior to the PC of the curve. The pavement markings along the roadway include a dashed white centerline, with a white right lane edge line. The inside, or left, pavement edge is marked with yellow edge lines. The balance of the control devices are in accordance with the policies outlined in the MUTCD.

Accident Observation and Candidate Design Corrections. All three of the accidents deemed relevant to this study reported speeds in excess of the advisory speed which is posted. One accident stated that the driver was attempting to negotiate the curve at 45 mi/h (72 km/h). All of the accidents occurred on dry pavement, during daylight hours and are clustered at the beginning of curve (1). These accidents may be related

in part to the fact that vehicles are able to negotiate the straight approach to the curve easily at highway speed. Thus, the placement of warning signs at a reduced distance ahead of the curve's PC further jeopardizes the ability of heavy trucks to make the curve safely. A possible countermeasure is to move the existing speed advisory signage approximately 85 ft (26 m) further back from the PC of the curve.

The renovation which eliminated the curb arrangement and provided a smooth obstacle-free roadway is seen as a distinct benefit for trucks which might experience a substantial degree of high-speed offtracking, as described in the text of the report. Indeed, prior to the renovation, the ramp was the site of various rollover accidents with articulated truck combinations--any one of which may have been precipitated by the contact, and "tripping," of outboard trailer tires against the outside curb.

SITE FOURTEEN

Description

Site Fourteen is one of nine turning roadways at an urban interchange. This left-bearing roadway is a "broken-back" curve configuration and is pictured in Figure 13. The first curve is the connecting approach to the ramp, for which specific geometric details were unavailable. However, using the existing plans, this curve was determined to have a radius of at least 1,600 ft (488 m). Curve (2) has a radius of 324 ft (99 m) and a curvature of approximately 17.7 degrees. Curve (3) has a radius of 1,653 ft (504 m) and a curvature of 3.5 degrees. Curves (2) and (3) are both on a 5 percent downhill grade, which is preceded by a 4 percent uphill grade along curve (1). The entire 2-lane, 24 ft (7.3 m) wide turning roadway is posted with an advisory speed of 25 mi/h (40 km/h), and had an original design speed of 35 mi/h (56 km/h) when designed in 1961.

SITE 14

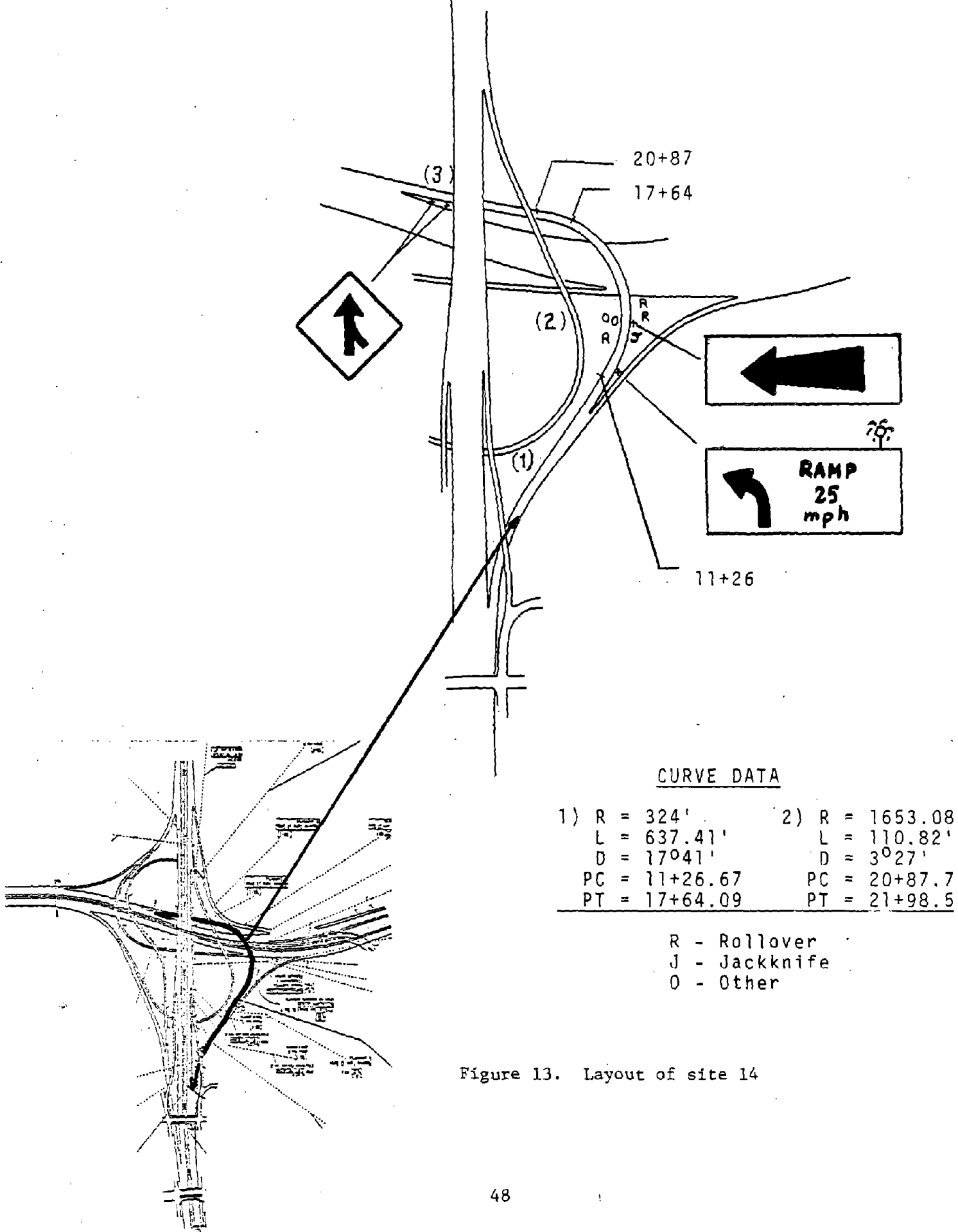

Figure 13. Layout of site 14

Geometrics

Frictional Factor. The frictional factor was determined using the minimum radius equation, and a superelevation value of .05, as stated on the plans. This value is also prescribed by the State Standard Plan for Superelevation and Pavement Crowns in force at the time. The three speeds at which friction factors were determined were the posted advisory speed, design speed, and an intermediate speed value of 30 mi/h (48 km/h).

Curve (2) has a frictional factor of .08, .14, and .18 at 25, 30, and 35 mi/h (40, 48, and 56 km/h), respectively. The AASHTO recommended maximum frictional factor values at these speeds are .165, .16, and .155, respectively. Referring to these values, curve (2) is within AASHTO recommendations in being signed at 30 mi/h (48 km/h). The "f" values for curve (3) were determined to be -.02, -.01, and -.001 for 25, 30, and 35 mi/h (40, 48, and 56 km/h), respectively. Recognizing that even the frictional factor demanded at 55 mi/h (88 km/h) is only .07, it was observed that curve (3), as well as curve (1) which has similar geometry, can easily be driven at current highway speeds.

Shoulder/Crown and Roadside Development. The shoulder along the roadway was upgraded recently, replacing the curb and gutter sections in a manner similar to that shown with Site Thirteen. In all respects, the shoulder treatment is similar to Site Thirteen, with somewhat narrow total shoulder width having been traded for the elimination of the curb and the placement of a concrete bridge barrier along the outside shoulder edge.

Superelevation Development. Detail concerning the superelevation development along the entire roadway was not available. However, the plans indicate that a superelevation maximum of .05 is reached in curve (2) at station 17+14.09, followed by a transition of 150 ft (46 m). One-third, or 50 ft (15 m) of this transition lies within curve (2), with the remaining 100 ft (31 m) on the tangent section. Assuming a similar superelevation development was carried out along the transition preceding curve (2), then some 450 ft (137 m) of fully superelevated

roadway exists in curve (2). The 150 ft (46 m) transition length and the distribution of this transition are in keeping with the AASHTO minimums outlined for a roadway of this type.

Deceleration Lane. Approximately 675 ft (206 m) of roadway exists prior to the nose of the ramp. This is ample distance to decelerate and enter the roadway at the posted advisory speed. The AASHTO recommended minimum length is approximately 400 ft (122 m).

Non-Geometrics

Traffic Control Devices. A total of four warning signs are in place along the turning roadway. The first of these is located approximately 25 ft (8 m) beyond the ramp nose. This sign combines a 25 mi/h (40 km/h) ramp speed advisory, with a W1-2L type turning arrow, and a flashing yellow beacon mounted on top of the 12 ft x 7.5 ft (3.7 m x 2.3 m) sign. This is not a standard warning sign, and is not covered in the Manual on Uniform Traffic Control Devices. A target arrow (W1-6) is placed on a concrete embankment wall within approximately 50 ft (15 m) of the first sign. The remaining two signs are merging traffic warnings, one with a merge plate mounted below (type W4-1). Both of these are located at the downstream end of the curve.

The pavement markings along the ramp consist of a dashed white centerline, with a white edge line along the outer or right lane, and a yellow edge line on the inner lane pavement edge. These are standard 4 in (.1 m) width pavement markings. The placement of the above traffic control devices is in accordance with the MUTCD, with one exception. The 25 mi/h (40 km/h) ramp speed advisory sign is not placed such that drivers are given sufficient warning. The MUTCD states that warning signs recommending this amount of deceleration be placed some 440 ft (134 m) in advance of the curve.

Accident Observation and Candidate Design Corrections. The two major causes stated in the accident reports were (1) load-shifting

problems which led to rollover and (2) braking suddenly, after having entered the curve too fast. These accidents may be explained by the discontinuous design of the ramp and the lack of sufficient advance warning for the necessary decreases in speed. The connecting approach to the ramp has a generous radius and can be easily driven at 55 mi/h (88 km/h), as can curve (3). However, placed between these generous radii portions is a tight 324 ft (99 m) radius curve. While there is a 5 percent downhill grade, the accidents are clustered at the top of the 4 percent uphill grade. It may be that truck drivers are accelerating along the approach to counteract the uphill grade such that, upon reaching the restrictive geometry of curve (2), they are entering too fast. Countermeasures at this site may include replacing the speed advisory signage with a curve warning sign, including a 25 mi/h (40 km/h) speed plate (type W1-2L) some 440 ft (134 m) in advance of curve (2). Next, the target arrow sign could be replaced with six chevrons highlighting the sharp curvature. Also, the insertion of a 110 ft (34 m) spiral between curve (1) and (2) would be very advisable. These changes may reduce the concentration of accidents and result in a more continuous overall ramp design.

SITE FIFTEEN

Description

Site Fifteen (Figure 14) is a single lane, 18-ft- (5-m) wide, urban exit ramp. The ramp is comprised of three continuous curves. The first curve is part of a tollway and the geometric details were not available; however, it appears from the plan that it has relatively flat curve geometry. The second curve has a radius of 350 ft (107 m), with a degree of curvature of 16 deg 22 ft. The third curve has a radius of 690 ft (210 m), and a degree of curvature of 8 deg 18 ft. The ramp is currently posted with an advisory speed of 30 mi/h (48 km/h); the design speed and year of design were not available.

SITE 15

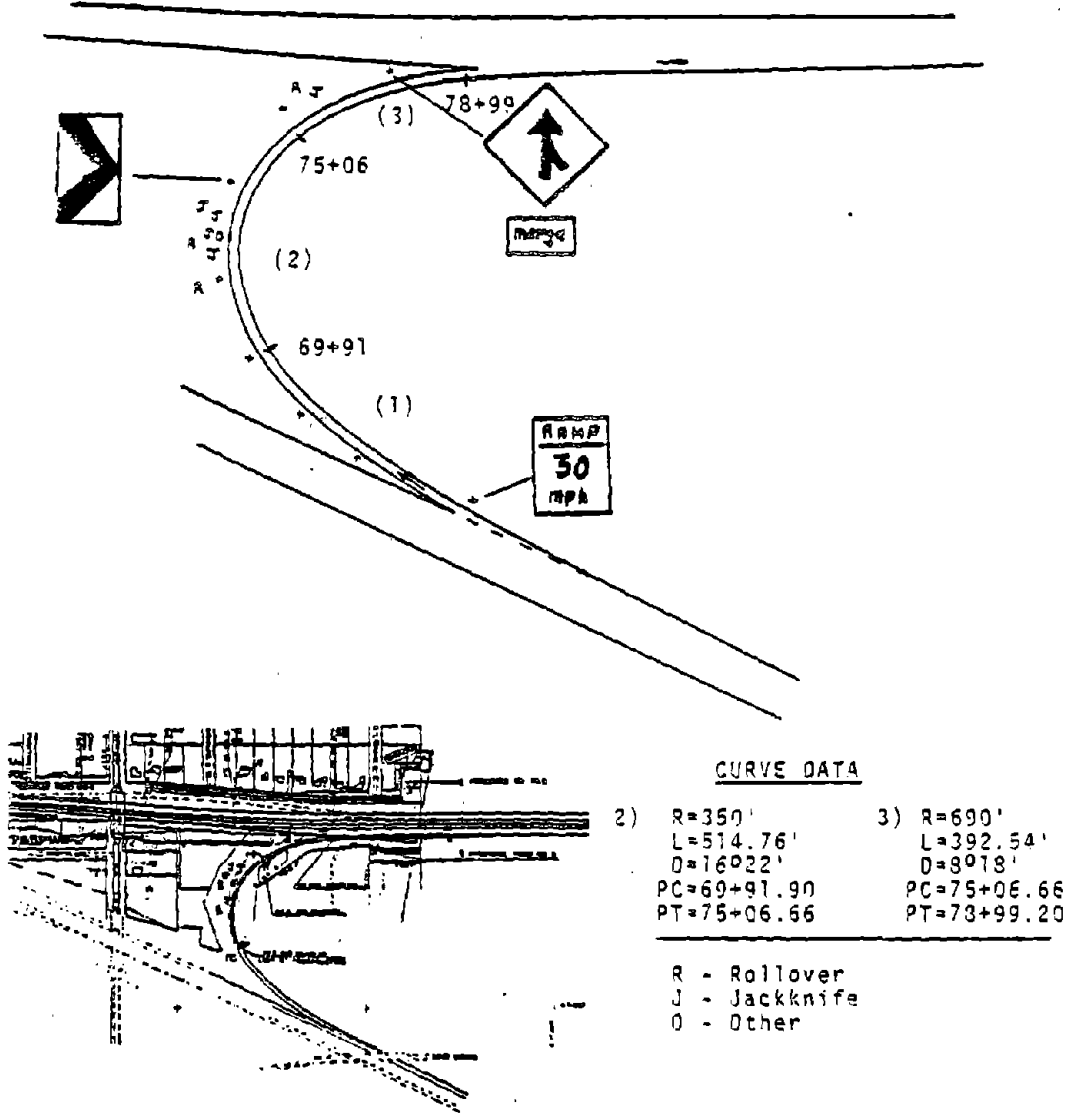

Figure 14. Layout of site 15.

Geometrics

Friction Factor. The friction factors demanded for curves (2) and (3) were calculated using the current advisory speed of 30 mi/h (48 km/h) and the maximum superelevation value of .08 ft/ft (.08 m/m) as indicated on the plans. The friction factor value demanded on curve (2) is .09, with curve (3) demanding .01. At 35 mi/h (56 km/h), the frictional factor values for curves (2) and (3) are .15 and .04, respectively. All of these values are below the AASHTO maximum frictional factor value of .16 and .155 for 30 and 35 mi/h (48 and 56 km/h), respectively.

Shoulder/Crown and Roadside Development. A maximum superelevation value of .08 ft/ft (.08 m/m) is developed across the 18 ft (5 m) roadway. This value appears to be maintained across both the paved shoulders as well. The left shoulder is approximately 6 ft (1.8 m) in width. Beginning approximately half way through the ramp, the right shoulder is bordered by a barrier-type curb and gutter. Specific information detailing shoulder slope rate, crown development, and roadside slope details for the ramp were not available. The estimated shoulder widths do, however, fall within the AASHTO recommendations.

Superelevation Development. The superelevation development achieving the .08 value along curve (1) was not available. However, it is apparent that the entire length of curves (2) and (3) are maintained at a superelevation value of .08. While the entire runoff length development beyond curve (3) was not available, 500 ft (152 m) of profile detail was included. Using this information it was determined that the superelevation was runoff from a maximum superelevation value of .08 to .02 over a distance of 500 ft (152 m). This length far exceeds the 110 ft (34 m) minimum runoff length suggested by AASHTO and it is assumed that the normal road crown was restored correctly.

Deceleration Lane. The deceleration lane preceding the ramp entrance is approximately 600 ft (183 m) long. While details concerning the deceleration lane taper were not available, comparing the 600 ft (183 m) overall length with the AASHTO recommendation that the full lane

width be maintained for 375 ft (114 m), it appears that adequate deceleration length is present.

Non-Geometrics

Traffic Control Devices. A total of eight warning signs are in place along the ramp. The first of these is a 30 mi/h (48 km/h) ramp speed advisory warning sign (type W13-3) located just prior to the ramp nose. Six chevrons outline the curvature of the entire ramp (W1-8). Finally, a merging traffic warning is placed in the gore area at the terminal end of the ramp (W4-1). Overhead lighting is also in place along the entire length of the ramp. Standard 4 in (.1 m) yellow and white pavement edge lines, with white line gore development, are present. Placement of all of the warning signs fall within the suggested practices outlined in the MUTCD.

Accident Observation and Candidate Design Corrections. The accidents reported at this site included five jackknives, two rollovers, and one accident in which the truck ran off the pavement area striking a fixed object. Five of these accidents occurred on wet pavement and the remainder occurred under dry conditions. Seven of the eight accidents are clustered along the middle portion of curve (2). This clustering may be related to the short radius in curve (2) and its placement following the initially flat curve. Recognizing the compound character of this geometry might explain the concentration of accidents in this region of curve (2). The vehicles are apparently entering curve (1) at a higher rate of speed without difficulty, but then suffer loss of control due to excessive speed in curve (2). Countermeasures include the insertion of at least a 100 ft (30 m) spiral curve between curves (1) and (2). Also, the frequent incidence of loss-of-control events on wet pavement seems to suggest a possible friction deficiency of the ramp pavement.

APPENDIX B

VEHICLE PARAMETERS AND EXAMPLE RUN

Two tractor semitrailer vehicles were represented in the computerized simulations. In those conditions citing a "baseline vehicle" the parameters represented a conventional 5-axle tractor semitrailer which was loaded to the legal maximum of 80,000 lbs, gross combination weight, with a payload c.g. height representing a median-density freight. The nominal height of the payload center of gravity in this case is 83 inches above the ground. The vehicle was also defined with a very common set of suspension properties representing popular levels of spring stiffness. A listing of the parameter set for this vehicle is presented first in this appendix, under the pages labeled Figure 15.

For those simulations involving the "high-CG" vehicle, the same tractor semitrailer vehicle was represented except that a) the payload CG height was raised to 105 inches above the ground to represent a worst-case loading which is known to occur in everyday trucking practice and b) the spring stiffnesses at the tandem suspensions of both the tractor and the semitrailer were reduced with respect to the baseline case to represent the more compliant suspension types which are known to be in common service. The parameters constituting the "high-c.g." vehicle are listed under the pages labeled Figure 16.

The printed response data from an example run of the "high-CG" vehicle is presented under the pages designated as Figure 17, as an illustration of the simulation results. The selected run represents the case of the right-hand turn through the ramp curve at site No. 1, at a velocity of 40 mi/h (5 mi/h above the posted advisory speed).

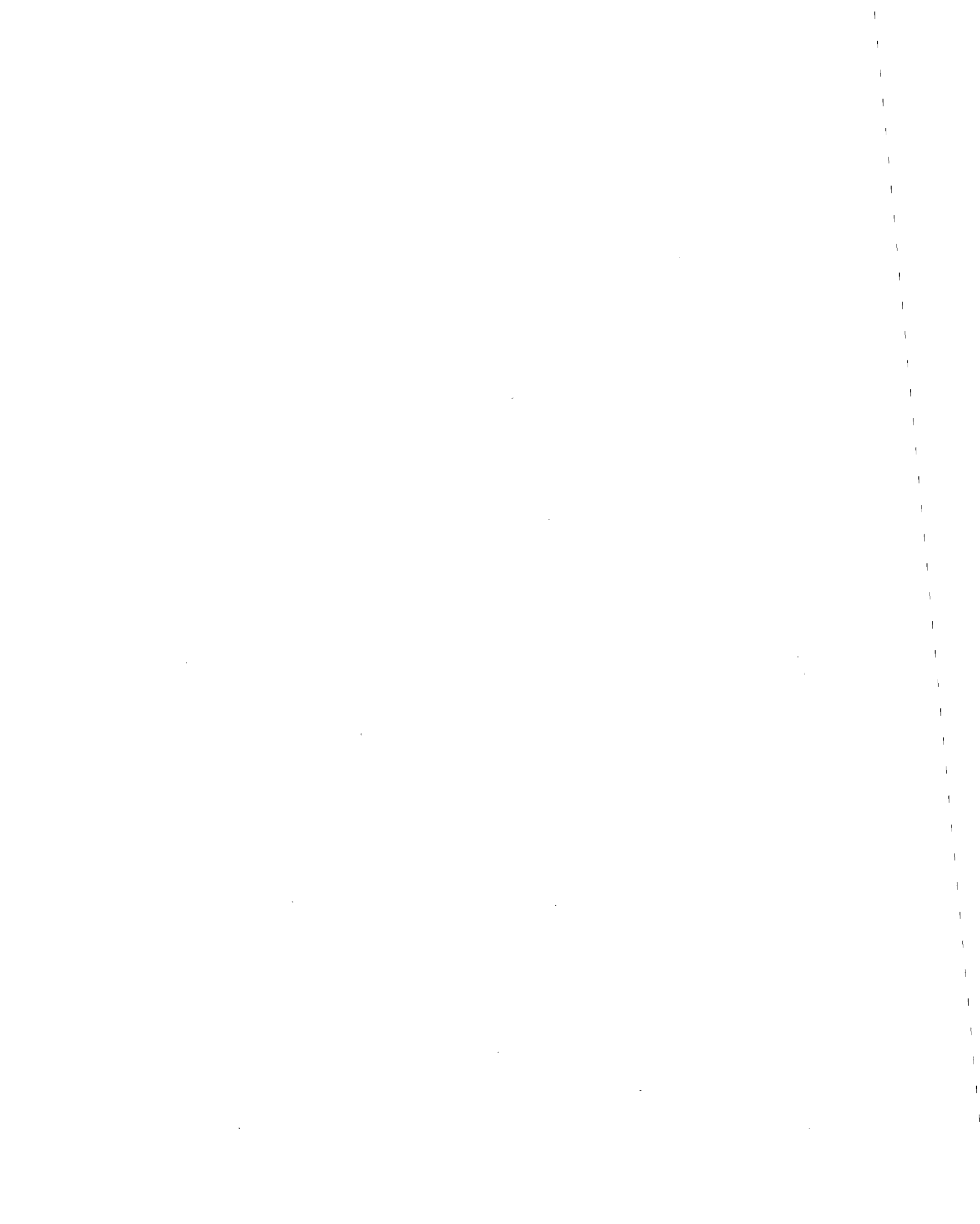

TRACTOR PARAMETERS

WHEELBASE - DISTANCE FROM FRONT AXLE TO CENTER OF REAR SUSPENSION (IN)	144.00
BASE VEHICLE CURB WEIGHT ON FRONT SUSPENSION (LB)	8960.00
BASE VEHICLE CURB WEIGHT ON REAR SUSPENSION (LB)	6540.00
SPRUNG MASS CG HEIGHT (IN. ABOVE GROUND)	44.00
SPRUNG MASS ROLL MOMENT OF INERTIA (IN-LB-SEC**2)	15000.00
SPRUNG MASS PITCH MOMENT OF INERTIA (IN-LB-SEC**2)	75000.00
SPRUNG MASS YAW MOMENT OF INERTIA (IN-LB-SEC**2)	75000.00
PAYLOAD WEIGHT (LB)	0.0
*** ZERO ENTRY INDICATES NO PAYLOAD ***	
*** FIVE PAYLOAD DESCRIPTION PARAMETERS ARE NOT ENTERED ***	
FIFTH WHEEL LOCATION (IN. AHEAD OF REAR SUSP. CENTER)	14.35
FIFTH WHEEL HEIGHT ABOVE GROUND (IN)	48.00
TRACTOR FRAME STIFFNESS (IN-LB/DEG)	50000.00
TRACTOR FRAME TORSIONAL AXIS HEIGHT ABOVE GROUND (IN)	36.00

TRACTOR FRONT SUSPENSION AND AXLE PARAMETERS

	LEFT SIDE	RIGHT SIDE
SUSPENSION SPRING RATE (LB/IN/SIDE/AXLE)	-119.00	-119.00
*** NEGATIVE ENTRY INDICATES TABLE ENTERED ***		
*** ECHO WILL APPEAR ON TABLE INDEX PAGE ***		
SUSPENSION VISCOUS DAMPING (LB-SEC/IN/SIDE/AXLE)	0.0	0.0
COULOMB FRICTION (LB/SIDE/AXLE)	0.0	0.0

AXLE ROLL MOMENT OF INERTIA (IN-LB-SEC**2)	3719.00	
ROLL CENTER HEIGHT (IN. ABOVE GROUND)	23.00	
ROLL STEER COEFFICIENT (DEG. STEER/DEG. ROLL)	0.0	
AUXILIARY ROLL STIFFNESS (IN-LB/DEG/AXLE)	1500.00	
LATERAL DISTANCE BETWEEN SUSPENSION SPRINGS (IN)	32.00	
TRACK WIDTH (IN)	80.00	
UNSPRUNG WEIGHT (LB)	1200.00	
STEERING GEAR RATIO (DEG STEERING WHEEL/DEG ROAD WHEEL)	28.00	
STEERING STIFFNESS (IN-LB/DEG)	11000.00	
TIE ROD STIFFNESS (IN-LB/DEG)	11000.00	
MECHANICAL TRAIL (IN)	1.00	
TORSIONAL WRAP-UP STIFFNESS (IN-LB/IN)	150000.00	
LATERAL OFFSET OF STEERING AXIS (IN)	3.00	

TRACTOR FRONT TIRES AND WHEELS

	LEFT SIDE	RIGHT SIDE
CORNERING STIFFNESS (LB/DEG/TIRE)	-1.00	-1.00
*** NEGATIVE ENTRY INDICATES TABLE ENTERED ***		
*** ECHO WILL APPEAR ON TABLE INDEX PAGE ***		
LONGITUDINAL STIFFNESS (LB/SLIP/TIRE)	-2.00	-2.00
*** NEGATIVE ENTRY INDICATES TABLE ENTERED ***		
*** ECHO WILL APPEAR ON TABLE INDEX PAGE ***		
CAMBER STIFFNESS (LB/DEG/TIRE)	0.0	0.0
ALIGNING MOMENT (IN-LB/DEG/TIRE)	-1600.00	-1600.00
*** NEGATIVE ALIGNING MOMENT ENTRY ***		

BASELINE VEHICLE

Figure 15. Parameters of the baseline tractor-semitrailer.

*** ALIGNING MOMENT CURVE FIT PARAMETERS: (0.0 0.0 5.0000 0.8000) (0.0 0.0 5.0000 0.8000)
 TIRE SPRING RATE (LB/IN/TIRE) 4500.00 4500.00
 TIRE LOADED RADIUS (IN) 19.50 19.50
 POLAR MOMENT OF INERTIA (IN-LB-SEC**2/WHEEL) 103.00 103.00

Figure 15. (continued)

TRACTOR REAR SUSPENSION AND AXLE PARAMETERS

	LEADING TANDEM AXLE		TRAILING TANDEM AXLE	
	LEFT SIDE	RIGHT SIDE	LEFT SIDE	RIGHT SIDE
SUSPENSION KEY - 0 INDICATES SINGLE AXLE, 1 INDICATES FOUR SPRING, 2 WALKING BEAM				1
TANDEM AXLE SEPARATION (IN BETWEEN LEADING AND TRAILING AXLES)				48.00
STATIC LOAD TRANSFER (PERCENT LOAD ON LEAD AXLE)				50.00
DYNAMIC LOAD TRANSFER (% BRAKE TORQUE REACTED AS TANDEM AXLE LOAD TRANSFER)				0.0
SUSPENSION SPRING RATE (LB/IN/SIDE/AXLE)	-121.00	-121.00	-121.00	-121.00
*** NEGATIVE ENTRY INDICATES TABLE ENTERED ***				
*** ECHO WILL APPEAR ON TABLE INDEX PAGE ***				
SUSPENSION VISCOUS DAMPING (LB-SEC/IN/SIDE/AXLE)	0.0	0.0	0.0	0.0
COULOMB FRICTION (LB/SIDE/AXLE)	0.0	0.0	0.0	0.0
AXLE ROLL MOMENT OF INERTIA (IN-LB-SEC**2)	4458.00		4458.00	
ROLL CENTER HEIGHT (IN. ABOVE GROUND)	29.00		29.00	
ROLL STEER COEFFICIENT (DEG. STEER/DEG. ROLL)	0.0		0.0	
AUXILIARY ROLL STIFFNESS (IN-LB/DEG/AXLE)	6000.00		6000.00	
LATERAL DISTANCE BETWEEN SUSPENSION SPRINGS (IN)	38.00		38.00	
TRACK WIDTH (IN)	72.00		72.00	
UNSPRUNG WEIGHT (LB)	2300.00		2300.00	

TRACTOR REAR TIRES AND WHEELS

	LEADING TANDEM AXLE		TRAILING TANDEM AXLE	
	LEFT SIDE	RIGHT SIDE	LEFT SIDE	RIGHT SIDE
DUAL TIRE SEPARATION (IN)	13.00	13.00	13.00	13.00
CORNERING STIFFNESS (LB/DEG/TIRE)	-1.00	-1.00	-1.00	-1.00
*** NEGATIVE ENTRY INDICATES TABLE ENTERED ***				
*** ECHO WILL APPEAR ON TABLE INDEX PAGE ***				
LONGITUDINAL STIFFNESS (LB/SLIP/TIRE)	-2.00	-2.00	-2.00	-2.00
*** NEGATIVE ENTRY INDICATES TABLE ENTERED ***				
*** ECHO WILL APPEAR ON TABLE INDEX PAGE ***				
CAMBER STIFFNESS (LB/DEG/TIRE)	0.0	0.0	0.0	0.0
ALIGNING MOMENT (IN-LB/DEG/TIRE)	1200.00	1200.00	1200.00	1200.00
TIRE SPRING RATE (LB/IN/TIRE)	4500.00	4500.00	4500.00	4500.00
TIRE LOADED RADIUS (IN)	19.50	19.50	19.50	19.50
POLAR MOMENT OF INERTIA (IN-LB-SEC**2/WHEEL)	115.00	115.00	115.00	115.00

Figure 15. (continued)

TRACTOR FRONT BRAKES

LEFT SIDE

RIGHT SIDE

TIME LAG (SEC)	0.0500	0.0500
RISE TIME (SEC)	0.2500	0.2500
BRAKE TORQUE (IN-LB/PSI/BRAKE)	1000.0000	1000.0000
BRAKE HYSTERESIS KEY: O ENTRY INDICATES BRAKE HYSTERESIS OPTION NOT IN USE ON VEHICLE TRAIN		0
BRAKE PROPORTIONING KEY: O ENTRY INDICATES BRAKE PROPORTIONING OPTION NOT IN USE ON VEHICLE TRAIN		0

TRACTOR REAR BRAKES

LEADING TANDEM AXLE

TRAILING TANDEM AXLE

LEFT SIDE	RIGHT SIDE	LEFT SIDE	RIGHT SIDE
-----------	------------	-----------	------------

TIME LAG (SEC)	0.0750	0.0750	0.0750	0.0750
RISE TIME (SEC)	0.2500	0.2500	0.2500	0.2500
BRAKE TORQUE (IN-LB/PSI/BRAKE)	-7.0000	-7.0000	-7.0000	-7.0000
*** NEGATIVE ENTRY INDICATES TABLE ENTERED ***				
*** ECHO WILL APPEAR ON TABLE INDEX PAGE ***				

Figure 15. (continued)

TRAILER NO. 1 PARAMETERS

WHEELBASE - DISTANCE FROM KINGPIN TO CENTER OF REAR SUSPENSION (IN)	432.00
BASE VEHICLE KINGPIN STATIC LOAD (LB)	4500.00
BASE VEHICLE CURB WEIGHT ON REAR SUSPENSION (LB)	7500.00
SPRUNG MASS CG HEIGHT (IN. ABOVE GROUND)	60.00
SPRUNG MASS ROLL MOMENT OF INERTIA (IN-LB-SEC**2)	60000.00
SPRUNG MASS PITCH MOMENT OF INERTIA (IN-LB-SEC**2)	750000.00
SPRUNG MASS YAW MOMENT OF INERTIA (IN-LB-SEC**2)	750000.00
PAYLOAD WEIGHT (LB)	52500.00
PAYLOAD DISTANCE AHEAD OF REAR SUSPENSION CENTER(IN)	213.94
PAYLOAD CG HEIGHT (IN. ABOVE GROUND)	82.00
PAYLOAD ROLL MOMENT OF INERTIA(IN-LB-SEC**2)	132000.00
PAYLOAD PITCH MOMENT OF INERTIA(IN-LB-SEC**2)	3050000.00
PAYLOAD YAW MOMENT OF INERTIA(IN-LB-SEC**2)	3100000.00

TRAILER NO. 1 REAR SUSPENSION AND AXLE PARAMETERS

LEADING TANDEM AXLE

TRAILING TANDEM AXLE

LEFT SIDE RIGHT SIDE LEFT SIDE RIGHT SIDE

SUSPENSION KEY - 0 INDICATES SINGLE AXLE, 1 INDICATES FOUR SPRING, 2 WALKING BEAM			1		
TANDEM AXLE SEPARATION (IN BETWEEN LEADING AND TRAILING AXLES)			48.00		
STATIC LOAD TRANSFER (PERCENT LOAD ON LEAD AXLE)			50.00		
DYNAMIC LOAD TRANSFER (% BRAKE TORQUE REACTED AS TANDEM AXLE LOAD TRANSFER)			0.0		
SUSPENSION SPRING RATE (LB/IN/SIDE/AXLE)	-122.00	-122.00		-122.00	-122.00
*** NEGATIVE ENTRY INDICATES TABLE ENTERED ***					
*** ECHO WILL APPEAR ON TABLE INDEX PAGE ***					
SUSPENSION VISCOUS DAMPING (LB-SEC/IN/SIDE/AXLE)	0.0	0.0		0.0	0.0
COULOMB FRICTION (LB/SIDE/AXLE)	0.0	0.0		0.0	0.0
AXLE ROLL MOMENT OF INERTIA (IN-LB-SEC**2)	4100.00			4100.00	
ROLL CENTER HEIGHT (IN. ABOVE GRDUND)	29.00			29.00	
ROLL STEER COEFFICIENT (DEG. STEER/DEG. ROLL)	0.0			0.0	
AUXILIARY ROLL STIFFNESS (IN-LB/DEG/AXLE)	10000.00			10000.00	
LATERAL DISTANCE BETWEEN SUSPENSION SPRINGS (IN)	38.00			38.00	
TRACK WIDTH (IN)	72.00			72.00	
UNSPRUNG WEIGHT (LB)	1500.00			1500.00	

TRAILER NO. 1 REAR TIRES AND WHEELS

LEADING TANDEM AXLE

TRAILING TANDEM AXLE

LEFT SIDE RIGHT SIDE LEFT SIDE RIGHT SIDE

DUAL TIRE SEPARATION (IN)	13.00	13.00	13.00	13.00
CORNERING STIFFNESS (LB/DEG/TIRE)	-1.00	-1.00	-1.00	-1.00
*** NEGATIVE ENTRY INDICATES TABLE ENTERED ***				
*** ECHO WILL APPEAR ON TABLE INDEX PAGE ***				
LONGITUDINAL STIFFNESS (LB/SLIP/TIRE)	-2.00	-2.00	-2.00	-2.00
*** NEGATIVE ENTRY INDICATES TABLE ENTERED ***				
*** ECHO WILL APPEAR ON TABLE INDEX PAGE ***				

Figure 15. (continued)

CAMBER STIFFNESS (LB/DEG/TIRE)	0.0	0.0	0.0	0.0
ALIGNING MOMENT (IN-LB/DEG/TIRE)	1200.00	1200.00	1200.00	1200.00
TIRE SPRING RATE (LB/IN/TIRE)	4500.00	4500.00	4500.00	4500.00
TIRE LOADED RADIUS (IN)	19.50	19.50	19.50	19.50
POLAR MOMENT OF INERTIA (IN-LB-SEC**2/WHEEL)	115.00	115.00	115.00	115.00

Figure 15. (continued)

TRAILER NO. 1	PAYLOAD = 52500.000 LBS.	EMPTY	LOADED
DISTANCE FROM TRAILER SPRUNG MASS CENTER TO REAR SUSPENSION (IN)		216.000	214.241
DISTANCE FROM TRAILER SPRUNG MASS CENTER TO GROUND (IN)		60.000	78.780
ROLL MOMENT OF INERTIA OF TRAILER SPRUNG MASS (IN-LB-SEC**2)		60000.000	201633.438
PITCH MOMENT OF INERTIA OF TRAILER SPRUNG MASS (IN-LB-SEC**2)		750000.000	3809717.000
YAW MOMENT OF INERTIA OF TRAILER SPRUNG MASS (IN-LB-SEC**2)		750000.000	3850083.000

TRACTOR	PAYLOAD = 0.0 LBS	EMPTY	LOADED
DISTANCE FROM TRACTOR SPRUNG MASS CENTER TO REAR SUSPENSION (IN)		115.200	115.200
DISTANCE FROM TRACTOR SPRUNG MASS CENTER TO GROUND (IN)		44.000	44.000
ROLL MOMENT OF INERTIA OF TRACTOR SPRUNG MASS (IN-LB-SEC**2)		15000.000	15000.000
PITCH MOMENT OF INERTIA OF TRACTOR SPRUNG MASS (IN-LB-SEC**2)		75000.000	75000.000
YAW MOMENT OF INERTIA OF TRACTOR SPRUNG MASS (IN-LB-SEC**2)		75000.000	75000.000

THE STATIC LOADS ON THE AXLES ARE:

AXLE NUMBER	LOAD
NS(1,1,1)	11999.371
NS(1,2,1)	17000.117
NS(1,2,2)	17000.117
NS(2,2,1)	17000.191
NS(2,2,2)	17000.191

TOTAL 79999.938

THE TRACTOR TOTAL MASS CENTER IS 60.759 INCHES BEHIND THE FRONT AXLE
 THE TOTAL YAW MOMENT OF INERTIA IS 214216.875 IN-LB-SEC**2

THE FIRST TRAILER TOTAL MASS CENTER IS 227.723 INCHES BEHIND THE KINGPIN
 THE TOTAL YAW MOMENT OF INERTIA IS 4202897.000 IN-LB-SEC**2

Figure 15. (continued)

TRAILER NO. 1 REAR BRAKES

LEADING TANDEM AXLE -----		TRAILING TANDEM AXLE -----	
LEFT SIDE -----	RIGHT SIDE -----	LEFT SIDE -----	RIGHT SIDE -----
0.1750	0.1750	0.1750	0.1750
0.2500	0.2500	0.2500	0.2500
1500.0000	1500.0000	1500.0000	1500.0000

TIME LAG (SEC)
RISE TIME (SEC)
BRAKE TORQUE (IN-LB/PSI/BRAKE)

ANTILOCK KEY: 1 INDICATES ANTILOCK WILL BE USED

-1

Figure 15. (continued)

SPRING TABLES

 NO. OF LINES

 FORCE (LB)

 DEFLECTION (IN)

 TABLE NO.

4

-20000.00 -20.00
 0.0 0.0
 9250.00 7.20
 25000.00 7.50
 (SPRING COMPRESSION ENVELOPE)

-119.00

-20000.00 -20.00
 0.0 0.0
 8040.00 7.20
 25000.00 7.50
 (SPRING EXTENSION ENVELOPE)

SUSPENSION DEFLECTION CONSTANTS = 0.08000 INCHES COMPRESSION, 0.08000 INCHES EXTENSION.

SPRING STATIC EQUILIBRIUM CONDITION: 5399.68 LB, 4.50 INCHES, UNIT 1 SUSP 1 AXLE 1

9

-20000.00 -11.00
 0.0 -1.00
 0.0 0.0
 4000.00 1.00
 6500.00 1.50
 9500.00 2.00
 13000.00 2.50
 17000.00 3.00
 50000.00 4.00
 (SPRING COMPRESSION ENVELOPE)

-121.00

-25000.00 -11.00
 0.0 -0.80
 0.0 0.20
 3000.00 1.00
 5000.00 1.50
 8000.00 2.00
 11500.00 2.50
 15500.00 3.00
 40000.00 4.00
 (SPRING EXTENSION ENVELOPE)

Figure 15. (continued)

SUSPENSION DEFLECTION CONSTANTS = 0.05000 INCHES COMPRESSION, 0.05000 INCHES EXTENSION.

SPRING STATIC EQUILIBRIUM CONDITION: 7350.06 LB, 1.77 INCHES. UNIT 1 SUSP 2 AXLE 1

SPRING STATIC EQUILIBRIUM CONDITION: 7350.06 LB, 1.77 INCHES. UNIT 1 SUSP 2 AXLE 2

9

			-122.00
-30000.00	-11.00		
0.0	-1.50		
0.0	0.0		
3375.00	0.50		
7312.00	1.00		
11812.00	1.50		
16875.00	2.00		
22500.00	2.50		
56250.00	3.00		
(SPRING COMPRESSION ENVELOPE)			

-35000.00	-11.00		
0.0	-1.30		
0.0	0.20		
1687.00	0.50		
5625.00	1.00		
10125.00	1.50		
15187.00	2.00		
20812.00	2.50		
45000.00	3.00		
(SPRING EXTENSION ENVELOPE)			

SUSPENSION DEFLECTION CONSTANTS = 0.05000 INCHES COMPRESSION, 0.05000 INCHES EXTENSION.

SPRING STATIC EQUILIBRIUM CONDITION: 7750.09 LB, 1.14 INCHES. UNIT 2 SUSP 2 AXLE 1

SPRING STATIC EQUILIBRIUM CONDITION: 7750.09 LB, 1.14 INCHES. UNIT 2 SUSP 2 AXLE 2

Figure 15. (continued)

MU-Y VS ALPHA TABLES

TABLE NO.

-1

NO. OF LOADS	NO. OF VELOCITIES		
3	1	VELOCITY = 66.00 FT/SEC	LOAD = 3000.00 LB
		ALPHA (DEG)	MU - Y
		0.0	0.0
		1.00	0.18
		2.00	0.33
		4.00	0.50
		6.00	0.50
		12.00	0.50
		VELOCITY = 66.00 FT/SEC	LOAD = 6000.00 LB
		ALPHA (DEG)	MU - Y
		0.0	0.0
		1.00	0.14
		2.00	0.25
		4.00	0.46
		6.00	0.50
		12.00	0.50
		VELOCITY = 66.00 FT/SEC	LOAD = 9000.00 LB
		ALPHA (DEG)	MU - Y
		0.0	0.0
		1.00	0.11
		2.00	0.19
		4.00	0.38
		6.00	0.50
		12.00	0.50

ROLL-OFF TABLE

ALPHA	SLIP				
	0.0	0.04	0.10	0.50	1.00
0.0	1.00	1.00	0.90	0.30	0.10
4.00	1.00	1.00	0.90	0.30	0.10
8.00	1.00	1.00	0.90	0.35	0.13

Figure 15. (continued)

12.00	1.00	1.00	0.90	0.42	0.17
16.00	1.00	1.00	0.90	0.48	0.22

Figure 15. (continued)

MU-X VS. SLIP TABLES

NO. OF LOADS	NO. OF VELOCITIES	TABLE NO.
3	1	-2
VELOCITY = SLIP	66.00 FT/SEC LOAD = MU - X	3000.00 LB
0.0	0.0	
0.10	0.50	
0.20	0.50	
0.30	0.48	
1.00	0.35	
VELOCITY = SLIP	66.00 FT/SEC LOAD = MU - X	6000.00 LB
0.0	0.0	
0.10	0.50	
0.20	0.50	
0.30	0.48	
1.00	0.35	
VELOCITY = SLIP	66.00 FT/SEC LOAD = MU - X	9000.00 LB
0.0	0.0	
0.10	0.44	
0.20	0.50	
0.30	0.48	
1.00	0.35	

ROLL-OFF TABLE

ALPHA	SLIP				
	0.0	0.04	0.10	0.50	1.00
0.0	1.00	1.00	1.00	1.00	1.00
4.00	1.00	1.00	1.00	1.00	1.00
8.00	0.75	0.75	0.75	0.95	1.00
12.00	0.50	0.50	0.60	0.90	0.95
16.00	0.40	0.40	0.45	0.85	0.95

Figure 15. (continued)

PRESSURE VS TORQUE TABLES

NO. OF LINES

PRESSURE (PSI)

TORQUE (IN-LB)

TABLE NO

2

0.0
100.00

0.0
150000.00

-7

Figure 15. (continued)

TRACTOR PARAMETERS

WHEELBASE - DISTANCE FROM FRONT AXLE TO CENTER OF REAR SUSPENSION (IN)	144.00
BASE VEHICLE CURB WEIGHT ON FRONT SUSPENSION (LB)	8960.00
BASE VEHICLE CURB WEIGHT ON REAR SUSPENSION (LB)	6540.00
SPRUNG MASS CG HEIGHT (IN. ABOVE GROUND)	44.00
SPRUNG MASS ROLL MOMENT OF INERTIA (IN-LB-SEC**2)	15000.00
SPRUNG MASS PITCH MOMENT OF INERTIA (IN-LB-SEC**2)	75000.00
SPRUNG MASS YAW MOMENT OF INERTIA (IN-LB-SEC**2)	75000.00
PAYLOAD WEIGHT (LB)	0.0
*** ZERO ENTRY INDICATES NO PAYLOAD ***	
*** FIVE PAYLOAD DESCRIPTION PARAMETERS ARE NOT ENTERED ***	
FIFTH WHEEL LOCATION (IN. AHEAD OF REAR SUSP. CENTER)	14.35
FIFTH WHEEL HEIGHT ABOVE GROUND (IN)	48.00
TRACTOR FRAME STIFFNESS (IN-LB/DEG)	50000.00
TRACTOR FRAME TORSIONAL AXIS HEIGHT ABOVE GROUND (IN)	36.00

TRACTOR FRONT SUSPENSION AND AXLE PARAMETERS

	LEFT SIDE	RIGHT SIDE
SUSPENSION SPRING RATE (LB/IN/SIDE/AXLE)	-119.00	-119.00
*** NEGATIVE ENTRY INDICATES TABLE ENTERED ***		
*** ECHO WILL APPEAR ON TABLE INDEX PAGE ***		
SUSPENSION VISCOUS DAMPING (LB-SEC/IN/SIDE/AXLE)	0.0	0.0
COULOMB FRICTION (LB/SIDE/AXLE)	0.0	0.0

AXLE ROLL MOMENT OF INERTIA (IN-LB-SEC**2)		3719.00
ROLL CENTER HEIGHT (IN. ABOVE GROUND)		23.00
ROLL STEER COEFFICIENT (DEG. STEER/DEG. ROLL)		0.0
AUXILIARY ROLL STIFFNESS (IN-LB/DEG/AXLE)		1500.00
LATERAL DISTANCE BETWEEN SUSPENSION SPRINGS (IN)		32.00
TRACK WIDTH (IN)		80.00
UNSPRUNG WEIGHT (LB)		1200.00
STEERING GEAR RATIO (DEG STEERING WHEEL/DEG ROAD WHEEL)		28.00
STEERING STIFFNESS (IN-LB/DEG)		11000.00
TIE ROD STIFFNESS (IN-LB/DEG)		11000.00
MECHANICAL TRAIL (IN)		1.00
TORSIONAL WRAP-UP STIFFNESS (IN-LB/IN)		150000.00
LATERAL OFFSET OF STEERING AXIS (IN)		3.00

TRACTOR FRONT TIRES AND WHEELS

	LEFT SIDE	RIGHT SIDE
CORNERING STIFFNESS (LB/DEG/TIRE)	-1.00	-1.00
*** NEGATIVE ENTRY INDICATES TABLE ENTERED ***		
*** ECHO WILL APPEAR ON TABLE INDEX PAGE ***		
LONGITUDINAL STIFFNESS (LB/SLIP/TIRE)	-2.00	-2.00
*** NEGATIVE ENTRY INDICATES TABLE ENTERED ***		
*** ECHO WILL APPEAR ON TABLE INDEX PAGE ***		
CAMBER STIFFNESS (LB/DEG/TIRE)	0.0	0.0
ALIGNING MOMENT (IN-LB/DEG/TIRE)	-1600.00	-1600.00
*** NEGATIVE ALIGNING MOMENT ENTRY ***		

"HIGH-CG" VEHICLE

70

Figure 16. Parameters of the high-cg tractor-semitrailer.

```

*** ALIGNING MOMENT CURVE FIT PARAMETERS: ( 0.0 0.0 5.0000 0.8000) ( 0.0 0.0 5.0000 0.8000)
TIRE SPRING RATE (LB/IN/TIRE) 4500.00 4500.00
TIRE LOADED RADIUS (IN) 19.50 19.50
POLAR MOMENT OF INERTIA (IN-LB-SEC**2/WHEEL) 103.00 103.00

```

Figure 16. (continued)

TRACTOR REAR SUSPENSION AND AXLE PARAMETERS

	LEADING TANDEM AXLE		TRAILING TANDEM AXLE	
	LEFT SIDE	RIGHT SIDE	LEFT SIDE	RIGHT SIDE
SUSPENSION KEY - 0 INDICATES SINGLE AXLE, 1 INDICATES FOUR SPRING, 2 WALKING BEAM				1
TANDEM AXLE SEPARATION (IN BETWEEN LEADING AND TRAILING AXLES)				48.00
STATIC LOAD TRANSFER (PERCENT LOAD ON LEAD AXLE)				50.00
DYNAMIC LOAD TRANSFER (% BRAKE TORQUE REACTED AS TANDEM AXLE LOAD TRANSFER)				0.0
SUSPENSION SPRING RATE (LB/IN/SIDE/AXLE)	-126.00	-126.00	-126.00	-126.00
*** NEGATIVE ENTRY INDICATES TABLE ENTERED ***				
*** ECHO WILL APPEAR ON TABLE INDEX PAGE ***				
SUSPENSION VISCOUS DAMPING (LB-SEC/IN/SIDE/AXLE)	0.0	0.0	0.0	0.0
COULOMB FRICTION (LB/SIDE/AXLE)	0.0	0.0	0.0	0.0
AXLE ROLL MOMENT OF INERTIA (IN-LB-SEC**2)	4458.00		4458.00	
ROLL CENTER HEIGHT (IN. ABOVE GROUND)	29.00		29.00	
ROLL STEER COEFFICIENT (DEG. STEER/DEG. ROLL)	0.0		0.0	
AUXILIARY ROLL STIFFNESS (IN-LB/DEG/AXLE)	6000.00		6000.00	
LATERAL DISTANCE BETWEEN SUSPENSION SPRINGS (IN)	38.00		38.00	
TRACK WIDTH (IN)	72.00		72.00	
UNSPRUNG WEIGHT (LB)	2300.00		2300.00	

TRACTOR REAR TIRES AND WHEELS

	LEADING TANDEM AXLE		TRAILING TANDEM AXLE	
	LEFT SIDE	RIGHT SIDE	LEFT SIDE	RIGHT SIDE
DUAL TIRE SEPARATION (IN)	13.00	13.00	13.00	13.00
CORNERING STIFFNESS (LB/DEG/TIRE)	-1.00	-1.00	-1.00	-1.00
*** NEGATIVE ENTRY INDICATES TABLE ENTERED ***				
*** ECHO WILL APPEAR ON TABLE INDEX PAGE ***				
LONGITUDINAL STIFFNESS (LB/SLIP/TIRE)	-2.00	-2.00	-2.00	-2.00
*** NEGATIVE ENTRY INDICATES TABLE ENTERED ***				
*** ECHO WILL APPEAR ON TABLE INDEX PAGE ***				
CAMBER STIFFNESS (LB/DEG/TIRE)	0.0	0.0	0.0	0.0
ALIGNING MOMENT (IN-LB/DEG/TIRE)	1200.00	1200.00	1200.00	1200.00
TIRE SPRING RATE (LB/IN/TIRE)	4500.00	4500.00	4500.00	4500.00
TIRE LOADED RADIUS (IN)	19.50	19.50	19.50	19.50
POLAR MOMENT OF INERTIA (IN-LB-SEC**2/WHEEL)	115.00	115.00	115.00	115.00

72

Figure 16. (continued)

TRACTOR FRONT BRAKES

LEFT SIDE

RIGHT SIDE

TIME LAG (SEC)	0.0500	0.0500
RISE TIME (SEC)	0.2500	0.2500
BRAKE TORQUE (IN-LB/PSI/BRAKE)	0.0	0.0
BRAKE HYSTERESIS KEY: 0 ENTRY INDICATES BRAKE HYSTERESIS OPTION NOT IN USE ON VEHICLE TRAIN		0
BRAKE PROPORTIONING KEY: 0 ENTRY INDICATES BRAKE PROPORTIONING OPTION NOT IN USE ON VEHICLE TRAIN		0

TRACTOR REAR BRAKES

LEADING TANDEM AXLE

TRAILING TANDEM AXLE

LEFT SIDE	RIGHT SIDE	LEFT SIDE	RIGHT SIDE
-----------	------------	-----------	------------

TIME LAG (SEC)	0.0750	0.0750	0.0750	0.0750
RISE TIME (SEC)	0.2500	0.2500	0.2500	0.2500
BRAKE TORQUE (IN-LB/PSI/BRAKE)	-7.0000	-7.0000	-7.0000	-7.0000
*** NEGATIVE ENTRY INDICATES TABLE ENTERED ***				
*** ECHO WILL APPEAR ON TABLE INDEX PAGE ***				

TRAILER NO. 1 PARAMETERS

WHEELBASE - DISTANCE FROM KINGPIN TO CENTER OF REAR SUSPENSION (IN)	432.00
BASE VEHICLE KINGPIN STATIC LOAD (LB)	4500.00
BASE VEHICLE CURB WEIGHT ON REAR SUSPENSION (LB)	7500.00
SPRUNG MASS CG HEIGHT (IN. ABOVE GROUND)	60.00
SPRUNG MASS ROLL MOMENT OF INERTIA (IN-LB-SEC**2)	60000.00
SPRUNG MASS PITCH MOMENT OF INERTIA (IN-LB-SEC**2)	750000.00
SPRUNG MASS YAW MOMENT OF INERTIA (IN-LB-SEC**2)	750000.00
PAYLOAD WEIGHT (LB)	52500.00
PAYLOAD DISTANCE AHEAD OF REAR SUSPENSION CENTER(IN)	213.94
PAYLOAD CG HEIGHT (IN. ABOVE GROUND)	105.00
PAYLOAD ROLL MOMENT OF INERTIA(IN-LB-SEC**2)	435000.00
PAYLOAD PITCH MOMENT OF INERTIA(IN-LB-SEC**2)	3050000.00
PAYLOAD YAW MOMENT OF INERTIA(IN-LB-SEC**2)	3100000.00

TRAILER NO. 1 REAR SUSPENSION AND AXLE PARAMETERS

	LEADING TANDEM AXLE		TRAILING TANDEM AXLE	
	LEFT SIDE	RIGHT SIDE	LEFT SIDE	RIGHT SIDE
SUSPENSION KEY - 0 INDICATES SINGLE AXLE, 1 INDICATES FOUR SPRING, 2 WALKING BEAM				1
TANDEM AXLE SEPARATION (IN BETWEEN LEADING AND TRAILING AXLES)			48.00	
STATIC LOAD TRANSFER (PERCENT LOAD ON LEAD AXLE)			50.00	
DYNAMIC LOAD TRANSFER (% BRAKE TORQUE REACTED AS TANDEM AXLE LOAD TRANSFER)			0.0	
SUSPENSION SPRING RATE (LB/IN/SIDE/AXLE)	-127.00	-127.00	-127.00	-127.00
*** NEGATIVE ENTRY INDICATES TABLE ENTERED ***				
*** ECHO WILL APPEAR ON TABLE INDEX PAGE ***				
SUSPENSION VISCOUS DAMPING (LB-SEC/IN/SIDE/AXLE)	0.0	0.0	0.0	0.0
COULOMB FRICTION (LB/SIDE/AXLE)	0.0	0.0	0.0	0.0
AXLE ROLL MOMENT OF INERTIA (IN-LB-SEC**2)	4100.00			4100.00
ROLL CENTER HEIGHT (IN. ABOVE GROUND)	29.00			29.00
ROLL STEER COEFFICIENT (DEG. STEER/DEG. ROLL)	0.0			0.0
AUXILIARY ROLL STIFFNESS (IN-LB/DEG/AXLE)	10000.00			10000.00
LATERAL DISTANCE BETWEEN SUSPENSION SPRINGS (IN)	38.00			38.00
TRACK WIDTH (IN)	72.00			72.00
UNSPRUNG WEIGHT (LB)	1500.00			1500.00

TRAILER NO. 1 REAR TIRES AND WHEELS

	LEADING TANDEM AXLE		TRAILING TANDEM AXLE	
	LEFT SIDE	RIGHT SIDE	LEFT SIDE	RIGHT SIDE
DUAL TIRE SEPARATION (IN)	13.00	13.00	13.00	13.00
CORNERING STIFFNESS (LB/DEG/TIRE)	-1.00	-1.00	-1.00	-1.00
*** NEGATIVE ENTRY INDICATES TABLE ENTERED ***				
*** ECHO WILL APPEAR ON TABLE INDEX PAGE ***				
LONGITUDINAL STIFFNESS (LB/SLIP/TIRE)	-2.00	-2.00	-2.00	-2.00
*** NEGATIVE ENTRY INDICATES TABLE ENTERED ***				
*** ECHO WILL APPEAR ON TABLE INDEX PAGE ***				

Figure 16. (continued)

74

CAMBER STIFFNESS (LB/DEG/TIRE)	0.0	0.0	0.0	0.0
ALIGNING MOMENT (IN-LB/DEG/TIRE)	1200.00	1200.00	1200.00	1200.00
TIRE SPRING RATE (LB/IN/TIRE)	4500.00	4500.00	4500.00	4500.00
TIRE LOADED RADIUS (IN)	19.50	19.50	19.50	19.50
POLAR MOMENT OF INERTIA (IN-LB-SEC**2/WHEEL)	115.00	115.00	115.00	115.00

Figure 16. (continued)

TRAILER NO. 1 REAR BRAKES

LEADING TANDEM AXLE		TRAILING TANDEM AXLE	
LEFT SIDE	RIGHT SIDE	LEFT SIDE	RIGHT SIDE
0.1750	0.1750	0.1750	0.1750
0.2500	0.2500	0.2500	0.2500
0.0	0.0	0.0	0.0

TIME LAG (SEC)
RISE TIME (SEC)
BRAKE TORQUE (IN-LB/PSI/BRAKE)

ANTILOCK KEY: 1 INDICATES ANTILOCK WILL BE USED

-1

Figure 16. (continued)

ODDBALL VEHICLE SITE ONE

TRAILER NO. 1	PAYLOAD = 52500.000 LBS.	EMPTY	LOADED
DISTANCE FROM TRAILER SPRUNG MASS CENTER TO REAR SUSPENSION (IN)		216.000	214.241
DISTANCE FROM TRAILER SPRUNG MASS CENTER TO GROUND (IN)		60.000	98.415
ROLL MOMENT OF INERTIA OF TRAILER SPRUNG MASS (IN-LB-SEC**2)		60000.000	535305.438
PITCH MOMENT OF INERTIA OF TRAILER SPRUNG MASS (IN-LB-SEC**2)		750000.000	3840388.000
YAW MOMENT OF INERTIA OF TRAILER SPRUNG MASS (IN-LB-SEC**2)		750000.000	3850083.000

TRACTOR	PAYLOAD = 0.0 LBS	EMPTY	LOADED
DISTANCE FROM TRACTOR SPRUNG MASS CENTER TO REAR SUSPENSION (IN)		115.200	115.200
DISTANCE FROM TRACTOR SPRUNG MASS CENTER TO GROUND (IN)		44.000	44.000
ROLL MOMENT OF INERTIA OF TRACTOR SPRUNG MASS (IN-LB-SEC**2)		15000.000	15000.000
PITCH MOMENT OF INERTIA OF TRACTOR SPRUNG MASS (IN-LB-SEC**2)		75000.000	75000.000
YAW MOMENT OF INERTIA OF TRACTOR SPRUNG MASS (IN-LB-SEC**2)		75000.000	75000.000

THE STATIC LOADS ON THE AXLES ARE:

77

AXLE NUMBER	LOAD
NS(1,1,1)	11999.371
NS(1,2,1)	17000.117
NS(1,2,2)	17000.117
NS(2,2,1)	17000.191
NS(2,2,2)	17000.191

TOTAL	79999.938

THE TRACTOR TOTAL MASS CENTER IS 60.759 INCHES BEHIND THE FRONT AXLE
 THE TOTAL YAW MOMENT OF INERTIA IS 214216.875 IN-LB-SEC**2

THE FIRST TRAILER TOTAL MASS CENTER IS 227.723 INCHES BEHIND THE KINGPIN
 THE TOTAL YAW MOMENT OF INERTIA IS 4202897.000 IN-LB-SEC**2

Figure 16. (continued)

SPRING TABLES

NO. OF LINES

FORCE (LB)

DEFLECTION (IN)

TABLE NO.

4

-20000.00 -20.00
 0.0 0.0
 9250.00 7.20
 25000.00 7.50
 (SPRING COMPRESSION ENVELOPE)

-119.00

-20000.00 -20.00
 0.0 0.0
 8040.00 7.20
 25000.00 7.50
 (SPRING EXTENSION ENVELOPE)

78

SUSPENSION DEFLECTION CONSTANTS = 0.08000 INCHES COMPRESSION, 0.08000 INCHES EXTENSION.

SPRING STATIC EQUILIBRIUM CONDITION: 5399.68 LB, 4.50 INCHES. UNIT 1 SUSP 1 AXLE 1

9

-20000.00 -11.00
 0.0 -1.00
 0.0 0.0
 3333.00 1.00
 5416.00 1.50
 7916.00 2.00
 10833.00 2.50
 14166.00 3.00
 50000.00 4.00
 (SPRING COMPRESSION ENVELOPE)

-126.00

-25000.00 -11.00
 0.0 -0.80
 0.0 0.20
 2500.00 1.00
 4166.00 1.50
 6666.00 2.00
 9583.00 2.50
 12916.00 3.00
 40000.00 4.00
 (SPRING EXTENSION ENVELOPE)

Figure 16. (continued)

SUSPENSION DEFLECTION CONSTANTS = 0.05000 INCHES COMPRESSION, 0.05000 INCHES EXTENSION.

SPRING STATIC EQUILIBRIUM CONDITION: 7350.06 LB., 2.01 INCHES. UNIT 1 SUSP 2 AXLE 1

SPRING STATIC EQUILIBRIUM CONDITION: 7350.06 LB., 2.01 INCHES. UNIT 1 SUSP 2 AXLE 2

9

-30000.00	-11.00	-127.00
0.0	-1.50	
0.0	0.0	
2437.00	0.50	
5280.00	1.00	
8530.00	1.50	
12187.00	2.00	
16250.00	2.50	
56250.00	3.00	

(SPRING COMPRESSION ENVELOPE)

-35000.00	-11.00
0.0	-1.30
0.0	0.20
1218.00	0.50
4062.00	1.00
7312.00	1.50
10968.00	2.00
15030.00	2.50
45000.00	3.00

(SPRING EXTENSION ENVELOPE)

SUSPENSION DEFLECTION CONSTANTS = 0.05000 INCHES COMPRESSION, 0.05000 INCHES EXTENSION.

SPRING STATIC EQUILIBRIUM CONDITION: 7750.09 LB., 1.47 INCHES. UNIT 2 SUSP 2 AXLE 1

SPRING STATIC EQUILIBRIUM CONDITION: 7750.09 LB., 1.47 INCHES. UNIT 2 SUSP 2 AXLE 2

79

Figure 16. (continued)

MU-Y VS ALPHA TABLES

NO. OF LOADS NO. OF VELOCITIES

TABLE NO.

3 1
 VELOCITY = 66.00 FT/SEC LOAD = 3000.00 LB
 ALPHA (DEG) MU - Y

-1

0.0 0.0
 1.00 0.18
 2.00 0.33
 4.00 0.57
 6.00 0.71
 12.00 0.83

VELOCITY = 66.00 FT/SEC LOAD = 6000.00 LB
 ALPHA (DEG) MU - Y

0.0 0.0
 1.00 0.14
 2.00 0.25
 4.00 0.46
 6.00 0.58
 12.00 0.69

VELOCITY = 66.00 FT/SEC LOAD = 9000.00 LB
 ALPHA (DEG) MU - Y

0.0 0.0
 1.00 0.11
 2.00 0.19
 4.00 0.38
 6.00 0.52
 12.00 0.69

ROLL-OFF TABLE

ALPHA	SLIP				
	0.0	0.04	0.10	0.50	1.00
0.0	1.00	1.00	0.90	0.30	0.10
4.00	1.00	1.00	0.90	0.30	0.10
8.00	1.00	1.00	0.90	0.35	0.13

Figure 16. (continued)

12.00	1.00	1.00	0.90	0.42	0.17
16.00	1.00	1.00	0.90	0.48	0.22

Figure 16. (continued)

MU-X VS. SLIP TABLES

NO. OF LOADS	NO. OF VELOCITIES	TABLE NO.
3	1	-2
VELOCITY = SLIP	66.00 FT/SEC LOAD = MU - X	3000.00 LB
0.0	0.0	
0.10	0.68	
0.20	0.80	
0.30	0.77	
1.00	0.55	
VELOCITY = SLIP	66.00 FT/SEC LOAD = MU - X	6000.00 LB
0.0	0.0	
0.10	0.59	
0.20	0.75	
0.30	0.73	
1.00	0.50	
VELOCITY = SLIP	66.00 FT/SEC LOAD = MU - X	9000.00 LB
0.0	0.0	
0.10	0.44	
0.20	0.70	
0.30	0.69	
1.00	0.45	

ROLL-OFF TABLE

ALPHA	SLIP				
	0.0	0.04	0.10	0.50	1.00
0.0	1.00	1.00	1.00	1.00	1.00
4.00	1.00	1.00	1.00	1.00	1.00
8.00	0.75	0.75	0.75	0.95	1.00
12.00	0.50	0.50	0.60	0.90	0.95
16.00	0.40	0.40	0.45	0.85	0.95

Figure 16. (continued)

PRESSURE VS TORQUE TABLES

NO. OF LINES

2

PRESSURE (PSI)

0.0
100.00

TORQUE (IN-LB)

0.0
-100000.00

TABLE NO

-7

Figure 16. (continued)

TRACTOR SPRUNG MASS POSITION

TIME (SEC)	FORWARD (FT)	LATERAL (FT)	VERTICAL (FT)	ROLL (DEG)	PITCH (DEG)	HEADING (DEG)	TURN RADIUS (FT)	SIDE SLIP (DEG)
0.0	0.0	0.0	0.0	0.0	0.0	0.0	*****	0.0
0.10	6.0474	0.0000	0.0000	-0.0001	0.0000	0.0000	*****	0.0001
0.20	11.9472	0.0000	0.0000	-0.0003	0.0000	0.0001	*****	0.0001
0.30	17.8469	0.0001	0.0000	-0.0005	-0.0000	0.0003	*****	0.0002
0.40	23.7464	0.0001	0.0000	-0.0006	-0.0001	0.0006	550484.0000	0.0003
0.50	29.6454	0.0003	0.0001	-0.0012	-0.0002	0.0011	287604.9375	0.0006
0.60	35.5431	0.0005	0.0001	-0.0028	-0.0002	0.0021	148507.8125	0.0012
0.70	41.4403	0.0010	0.0001	-0.0054	-0.0003	0.0041	85321.6250	0.0021
0.80	47.3374	0.0018	0.0001	-0.0091	-0.0002	0.0075	52506.2891	0.0036
0.90	53.2344	0.0033	0.0001	-0.0146	-0.0002	0.0132	34256.1992	0.0056
1.00	59.1314	0.0058	0.0001	-0.0225	-0.0003	0.0221	23542.7773	0.0083
1.10	65.0284	0.0097	0.0001	-0.0328	-0.0003	0.0354	16741.4180	0.0116
1.20	70.9245	0.0156	0.0001	-0.0458	-0.0003	0.0544	12367.9570	0.0154
1.30	76.8204	0.0242	0.0001	-0.0621	-0.0003	0.0808	9367.7344	0.0197
1.40	82.7164	0.0364	0.0001	-0.0828	-0.0002	0.1163	7272.5000	0.0242
1.50	88.6121	0.0533	0.0001	-0.1088	-0.0003	0.1628	5755.8984	0.0289
1.60	94.5078	0.0761	0.0001	-0.1408	-0.0003	0.2221	4622.2227	0.0338
1.70	100.4033	0.1062	0.0001	-0.1795	-0.0004	0.2963	3785.5525	0.0390
1.80	106.2986	0.1453	0.0001	-0.2266	-0.0004	0.3874	3146.0010	0.0443
1.90	112.1933	0.1952	0.0001	-0.2839	-0.0005	0.4974	2652.2188	0.0495
2.00	118.0878	0.2579	0.0001	-0.3530	-0.0008	0.6284	2262.1338	0.0545
2.10	123.9820	0.3357	-0.0000	-0.4361	-0.0009	0.7825	1948.2793	0.0592
2.20	129.8751	0.4311	-0.0009	-0.5392	0.0044	0.9620	1694.3958	0.0634
2.30	135.7679	0.5466	-0.0089	-0.6872	0.0548	1.1695	1480.6724	0.0657
2.40	141.6607	0.6850	-0.0310	-0.8521	0.1685	1.4054	1287.4446	0.0705
2.50	147.5527	0.8498	-0.0657	-0.9786	0.2963	1.6715	1153.2043	0.0777
2.60	153.4439	1.0442	-0.1075	-1.1215	0.3898	1.9710	1051.4414	0.0798
2.70	159.3370	1.2711	-0.1555	-1.3223	0.4517	2.3051	951.2051	0.0789
2.80	165.2357	1.5343	-0.2178	-1.5510	0.5443	2.6767	854.1245	0.0775
2.90	171.1376	1.8373	-0.2992	-1.7767	0.7039	3.0887	806.9871	0.0673
3.00	177.0410	2.1830	-0.3898	-2.0532	0.8682	3.5389	761.1899	0.0404
3.10	182.9474	2.5750	-0.4782	-2.3186	0.9668	4.0210	680.7698	0.0231
3.20	188.8566	3.0186	-0.5681	-2.4441	1.0080	4.5387	618.4443	0.0275
3.30	194.7684	3.5185	-0.6701	-2.5754	1.0465	5.1041	586.0518	0.0246
3.40	200.6838	4.0780	-0.7898	-2.8320	1.1341	5.7180	557.4661	0.0002
3.50	206.6001	4.7003	-0.9234	-3.0842	1.2624	6.3776	531.6311	-0.0402
3.60	212.5137	5.3892	-1.0603	-3.2561	1.3629	7.0801	496.6309	-0.0857
3.70	218.4239	6.1499	-1.1956	-3.3715	1.4003	7.8233	459.3762	-0.1157
3.80	224.3301	6.9876	-1.3359	-3.5110	1.4205	8.6121	431.9290	-0.1351
3.90	230.2286	7.9066	-1.4905	-3.6868	1.4717	9.4468	412.6160	-0.1617
4.00	236.1167	8.9104	-1.6600	-3.7807	1.5501	10.3251	402.0149	-0.2006

Figure 17. Output from example run - high-c.g. tractor-semitrailer at 40 mi/h (56 km/h) on site 1.

TIME (SEC)	TRACTOR SPRUNG MASS VELOCITY (BODY AXES)						STEERING WHEEL ANGLE (DEG)
	FORWARD (FT/SEC)	LATERAL (FT/SEC)	VERTICAL (FT/SEC)	ROLL (DEG/SEC)	PITCH (DEG/SEC)	HEADING (DEG/SEC)	
0.0	59.00	0.0	0.0	0.0	0.0	0.0	-0.0
0.10	59.00	0.00	0.00	-0.00	0.00	0.00	0.0
0.20	59.00	0.00	0.00	-0.00	-0.00	0.00	0.0
0.30	59.00	0.00	0.00	-0.00	-0.00	0.00	0.0
0.40	59.00	0.00	0.00	-0.00	-0.00	0.00	0.1
0.50	58.99	0.00	0.00	-0.01	-0.00	0.01	0.1
0.60	58.99	0.00	-0.00	-0.02	-0.00	0.01	0.3
0.70	58.99	0.00	-0.00	-0.03	0.00	0.03	0.5
0.80	58.99	0.00	-0.00	-0.05	0.00	0.04	0.8
0.90	58.99	0.01	-0.00	-0.07	-0.00	0.07	1.2
1.00	58.99	0.01	-0.00	-0.09	-0.00	0.11	1.8
1.10	58.98	0.01	-0.00	-0.12	-0.00	0.16	2.5
1.20	58.98	0.02	-0.00	-0.15	-0.00	0.22	3.4
1.30	58.98	0.02	-0.00	-0.18	0.00	0.31	4.5
1.40	58.98	0.02	-0.00	-0.23	-0.00	0.41	5.9
1.50	58.98	0.03	-0.00	-0.29	-0.00	0.53	7.4
1.60	58.98	0.03	-0.00	-0.35	-0.00	0.66	9.2
1.70	58.97	0.04	-0.00	-0.43	-0.00	0.82	11.2
1.80	58.97	0.05	-0.00	-0.52	-0.00	1.00	13.5
1.90	58.97	0.05	-0.00	-0.63	-0.01	1.20	16.0
2.00	58.97	0.06	-0.00	-0.76	-0.01	1.42	18.7
2.10	58.96	0.06	-0.00	-0.91	-0.01	1.66	21.7
2.20	58.96	0.07	-0.02	-1.22	0.17	1.93	24.9
2.30	58.97	0.07	-0.09	-1.70	0.84	2.23	28.4
2.40	58.97	0.07	-0.12	-1.47	1.26	2.52	32.2
2.50	58.96	0.08	-0.09	-1.21	1.12	2.84	36.2
2.60	58.98	0.08	-0.04	-1.73	0.64	3.18	40.1
2.70	59.03	0.08	-0.07	-2.27	0.57	3.54	44.2
2.80	59.10	0.08	-0.16	-2.29	1.17	3.95	48.7
2.90	59.14	0.07	-0.16	-2.47	1.65	4.37	52.7
3.00	59.19	0.04	-0.01	-3.08	1.20	4.71	56.8
3.10	59.25	0.02	0.12	-2.07	0.43	5.00	61.8
3.20	59.32	0.03	0.10	-0.95	0.07	5.40	66.8
3.30	59.40	0.03	-0.02	-2.13	0.31	5.92	70.8
3.40	59.49	0.00	-0.10	-2.95	0.83	6.41	74.8
3.50	59.55	-0.04	-0.07	-2.26	0.91	6.87	79.0
3.60	59.59	-0.09	0.05	-1.53	0.24	7.24	83.3
3.70	59.66	-0.12	0.09	-1.27	-0.25	7.64	87.8
3.80	59.72	-0.14	0.00	-1.95	-0.21	8.11	91.9
3.90	59.75	-0.17	-0.10	-1.72	0.14	8.57	95.5
4.00	59.80	-0.21	-0.15	-0.72	0.24	9.02	98.6

Figure 17. (continued)

TRACTDR SPRUNG MASS ACCELERATION (BODY AXES)

INERTIAL ACCEL. ALONG BODY AXES

TIME (SEC)	TRACTDR SPRUNG MASS ACCELERATION (BODY AXES)						INERTIAL ACCEL. ALONG BODY AXES	
	FORWARD (FT/SEC**2)	LATERAL (FT/SEC**2)	VERTICAL (FT/SEC**2)	ROLL (DEG/SEC**2)	PITCH (DEG/SEC**2)	HEADING (DEG/SEC**2)	LONGITUDINAL (FT/SEC**2)	LATERAL (FT/SEC**2)
0.0	0.0000	0.0000	0.0	-0.0000	0.0000	-0.0000	0.0000	0.0000
0.10	-0.0000	0.0009	0.0004	-0.0244	-0.0009	0.0092	-0.0000	0.0015
0.20	0.0036	0.0007	0.0009	0.0087	-0.0035	0.0092	0.0036	0.0022
0.30	0.0034	0.0006	0.0006	0.0159	-0.0036	0.0088	0.0034	0.0029
0.40	-0.0006	0.0022	-0.0004	-0.0649	0.0089	0.0242	-0.0006	0.0061
0.50	0.0032	0.0043	-0.0013	-0.1037	-0.0008	0.0480	0.0032	0.0116
0.60	-0.0019	0.0084	-0.0022	-0.1049	0.0105	0.0943	-0.0019	0.0226
0.70	0.0012	0.0131	-0.0013	-0.1266	0.0069	0.1537	0.0012	0.0395
0.80	-0.0007	0.0189	0.0002	-0.2141	-0.0060	0.2321	-0.0007	0.0644
0.90	-0.0003	0.0257	0.0016	-0.2809	-0.0065	0.3307	-0.0003	0.0989
1.00	-0.0009	0.0323	-0.0003	-0.2786	0.0025	0.4480	-0.0009	0.1444
1.10	0.0221	0.0394	-0.0011	-0.3441	-0.0534	0.5955	0.0220	0.2034
1.20	0.0003	0.0446	-0.0024	-0.3924	-0.0056	0.7515	0.0002	0.2759
1.30	-0.0001	0.0492	0.0008	-0.5177	-0.0107	0.9328	-0.0002	0.3649
1.40	-0.0142	0.0520	0.0002	-0.6670	0.0092	1.1255	-0.0144	0.4706
1.50	0.0043	0.0541	0.0007	-0.7015	-0.0105	1.3198	0.0040	0.5955
1.60	-0.0138	0.0583	-0.0010	-0.8106	0.0536	1.5274	-0.0142	0.7422
1.70	-0.0184	0.0600	-0.0007	-0.9843	0.0422	1.7270	-0.0190	0.9072
1.80	0.0050	0.0613	0.0031	-1.2070	-0.0068	1.9404	0.0042	1.0927
1.90	0.0287	0.0603	0.0016	-1.3674	-0.0572	2.1560	0.0277	1.2971
2.00	-0.0131	0.0579	-0.0113	-1.5982	-0.0345	2.3655	-0.0145	1.5219
2.10	-0.0493	0.0557	-0.0108	-1.9415	-0.0106	2.5887	-0.0511	1.7678
2.20	0.0560	0.0443	-0.5145	-5.1513	4.4050	2.9577	0.0538	2.0334
2.30	0.0666	0.0372	-0.6155	-2.4056	6.6217	3.0022	0.0627	2.3282
2.40	-0.0184	0.0874	0.0181	4.9834	0.6863	3.1021	-0.0243	2.6801
2.50	0.0369	0.0703	0.5416	-2.5769	-4.0739	3.3916	0.0312	2.9953
2.60	0.2246	0.0202	0.2361	-6.6739	-4.0403	3.3717	0.2195	3.2905
2.70	0.8960	0.0055	-0.7953	-3.3131	2.8350	3.8532	0.8903	3.6466
2.80	0.5517	0.0043	-0.7758	1.4666	8.4788	4.3070	0.5429	4.0709
2.90	0.3834	-0.1887	0.9348	-7.3756	0.4567	3.8898	0.3734	4.3172
3.00	0.6615	-0.2643	1.8307	-0.9887	-7.6071	2.7226	0.6579	4.6025
3.10	0.6588	-0.0061	0.5871	16.7681	-6.1152	2.9448	0.6577	5.1688
3.20	0.7417	0.1042	-0.9159	-1.9378	-0.5211	4.4647	0.7391	5.6981
3.30	1.0020	-0.1087	-1.2652	-16.2970	4.8015	4.5668	0.9992	6.0281
3.40	0.8137	-0.2948	-0.3235	0.6092	3.7446	4.2539	0.8122	6.3560
3.50	0.4975	-0.4492	1.0677	7.9096	-2.8188	3.5754	0.5015	6.6898
3.60	0.6019	-0.3524	0.9484	5.1569	-6.4515	2.6512	0.6134	7.1846
3.70	0.7499	-0.1718	-0.2018	-3.9887	-1.1707	3.4217	0.7656	7.7896
3.80	0.5361	-0.1601	-1.2631	-6.7389	2.3208	3.5301	0.5561	8.2935
3.90	0.4271	-0.2443	-0.8592	8.5178	3.2460	3.2425	0.4521	8.6942
4.00	0.6022	-0.4690	0.0882	4.7021	-0.8279	3.2409	0.6346	8.9466

Figure 17. (continued)

TRACTOR FRONT AXLE TIRE FORCES

TIME (SEC)	LEFT SIDE					RIGHT SIDE					STEER ANGLE	
	VERTICAL (LB)	LONG. (LB)	LATERAL (LB)	MU-X	MU-Y	VERTICAL (LB)	LONG. (LB)	LATERAL (LB)	MU-X	MU-Y	LEFT (DEG)	RIGHT (DEG)
0.0	5999.68	-0.0	0.0	0.0	0.0	5999.68	-0.0	0.0	0.0	0.0	0.0	0.0
0.10	5999.77	-0.00	0.29	-0.0000	0.0000	5999.48	0.00	0.24	0.0000	0.0000	0.00	0.00
0.20	5999.82	-0.01	0.44	-0.0000	0.0001	5999.34	-0.01	0.36	-0.0000	0.0001	0.00	0.00
0.30	5999.93	-0.01	0.61	-0.0000	0.0001	5999.29	-0.01	0.50	-0.0000	0.0001	0.00	0.00
0.40	6000.32	-0.01	1.24	-0.0000	0.0002	5999.05	-0.00	1.02	-0.0000	0.0002	0.00	0.00
0.50	6001.02	-0.02	2.33	-0.0000	0.0004	5998.56	-0.00	1.91	-0.0000	0.0003	0.00	0.00
0.60	6002.42	-0.03	4.55	-0.0000	0.0008	5997.36	0.01	3.72	0.0000	0.0006	0.01	0.01
0.70	6004.45	-0.02	7.99	-0.0000	0.0013	5995.45	0.03	6.52	0.0000	0.0011	0.01	0.01
0.80	6007.25	-0.04	13.07	-0.0000	0.0022	5992.19	0.04	10.67	0.0000	0.0018	0.02	0.02
0.90	6011.50	-0.06	20.12	-0.0000	0.0033	5987.40	0.06	16.42	0.0000	0.0027	0.03	0.03
1.00	6018.24	-0.08	29.52	-0.0000	0.0049	5980.95	0.08	24.07	0.0000	0.0040	0.05	0.04
1.10	6027.80	-0.16	41.95	-0.0000	0.0070	5972.01	0.06	34.18	0.0000	0.0057	0.07	0.06
1.20	6040.21	-0.14	57.39	-0.0000	0.0095	5959.82	0.13	46.69	0.0000	0.0078	0.10	0.08
1.30	6055.80	-0.17	76.61	-0.0000	0.0127	5943.63	0.17	62.19	0.0000	0.0105	0.13	0.11
1.40	6074.89	-0.17	99.67	-0.0000	0.0164	5924.20	0.25	80.72	0.0000	0.0136	0.16	0.14
1.50	6098.20	-0.26	127.04	-0.0000	0.0208	5901.09	0.23	102.62	0.0000	0.0174	0.21	0.18
1.60	6125.83	-0.26	159.29	-0.0000	0.0260	5874.02	0.30	128.25	0.0001	0.0218	0.26	0.22
1.70	6156.95	-0.27	195.72	-0.0000	0.0318	5842.96	0.36	156.99	0.0001	0.0269	0.31	0.27
1.80	6192.09	-0.38	236.89	-0.0001	0.0383	5807.32	0.33	189.22	0.0001	0.0326	0.37	0.32
1.90	6232.02	-0.47	282.66	-0.0001	0.0454	5768.05	0.32	224.72	0.0001	0.0390	0.44	0.38
2.00	6277.07	-0.38	333.31	-0.0001	0.0531	5725.45	0.49	263.57	0.0001	0.0460	0.51	0.45
2.10	6332.40	-0.29	389.13	-0.0000	0.0614	5684.39	0.67	305.87	0.0001	0.0538	0.60	0.52
2.20	6496.13	-0.66	449.38	-0.0001	0.0692	5773.08	0.43	351.13	0.0001	0.0608	0.68	0.60
2.30	6657.83	-0.83	512.39	-0.0001	0.0770	5842.43	0.29	397.45	0.0000	0.0680	0.78	0.68
2.40	6703.68	-0.50	594.41	-0.0001	0.0887	5724.83	0.64	456.19	0.0001	0.0797	0.88	0.76
2.50	6695.20	-0.70	676.48	-0.0001	0.1010	5580.70	0.57	514.27	0.0001	0.0922	0.98	0.85
2.60	6751.66	-1.27	746.33	-0.0002	0.1105	5505.55	-0.02	562.08	-0.0000	0.1021	1.08	0.94
2.70	6894.88	-3.58	825.76	-0.0005	0.1198	5464.84	-2.14	615.23	-0.0004	0.1126	1.19	1.04
2.80	6967.15	-2.66	919.53	-0.0004	0.1320	5343.48	-1.06	676.86	-0.0002	0.1267	1.31	1.14
2.90	6736.49	-1.92	980.86	-0.0003	0.1456	5046.18	-0.44	729.12	-0.0001	0.1445	1.43	1.25
3.00	6565.36	-2.64	1047.55	-0.0004	0.1596	4761.25	-1.59	777.46	-0.0003	0.1633	1.54	1.35
3.10	6786.77	-2.74	1170.96	-0.0004	0.1725	4685.82	-1.67	851.63	-0.0004	0.1817	1.66	1.46
3.20	7068.38	-3.22	1285.26	-0.0005	0.1818	4761.35	-1.58	927.52	-0.0003	0.1948	1.78	1.56
3.30	7208.14	-4.13	1339.36	-0.0006	0.1858	4779.39	-2.40	960.88	-0.0005	0.2010	1.90	1.66
3.40	7218.61	-3.56	1409.49	-0.0005	0.1953	4616.26	-1.98	994.17	-0.0004	0.2154	2.01	1.77
3.50	7078.71	-2.36	1509.61	-0.0003	0.2133	4344.09	-0.98	1041.89	-0.0002	0.2398	2.12	1.87
3.60	7096.27	-2.47	1624.96	-0.0003	0.2290	4171.18	-1.42	1098.50	-0.0003	0.2634	2.23	1.97
3.70	7336.98	-3.18	1737.36	-0.0004	0.2368	4220.35	-1.90	1167.77	-0.0005	0.2767	2.34	2.06
3.80	7573.66	-2.57	1817.13	-0.0003	0.2399	4331.49	-1.31	1222.78	-0.0003	0.2823	2.43	2.14
3.90	7681.31	-2.08	1904.10	-0.0003	0.2479	4260.73	-0.95	1264.23	-0.0002	0.2967	2.52	2.22
4.00	7620.49	-2.67	1995.54	-0.0004	0.2619	4090.26	-1.44	1293.34	-0.0004	0.3162	2.60	2.29

Figure 17. (continued)

TRACTOR REAR SUSPENSION TIRE FORCES

LEADING TANDEM AXLE

TIME (SEC)	LEFT SIDE					RIGHT SIDE				
	VERTICAL (LB)	LONG. (LB)	LATERAL (LB)	MU-X	MU-Y	VERTICAL (LB)	LONG. (LB)	LATERAL (LB)	MU-X	MU-Y
0.0	8500.06	-0.0	0.0	0.0	0.0	8500.06	-0.0	0.0	0.0	0.0
0.10	8500.04	-0.00	-0.04	-0.0000	-0.0000	8500.05	0.00	-0.04	0.0000	-0.0000
0.20	8500.01	-0.03	-0.00	-0.0000	-0.0000	8499.91	-0.02	-0.00	-0.0000	-0.0000
0.30	8500.06	-0.03	0.13	-0.0000	0.0000	8499.75	-0.02	0.13	-0.0000	0.0000
0.40	8500.18	-0.03	0.17	-0.0000	0.0000	8499.75	-0.01	0.17	-0.0000	0.0000
0.50	8500.36	-0.04	0.13	-0.0000	0.0000	8499.84	-0.01	0.13	-0.0000	0.0000
0.60	8500.73	-0.05	0.25	-0.0000	0.0000	8499.75	0.02	0.25	0.0000	0.0000
0.70	8501.42	-0.05	0.75	-0.0000	0.0001	8499.10	0.06	0.75	0.0000	0.0001
0.80	8502.84	-0.08	1.61	-0.0000	0.0002	8497.52	0.09	1.61	0.0000	0.0002
0.90	8506.12	-0.12	3.02	-0.0000	0.0004	8494.11	0.12	3.02	0.0000	0.0004
1.00	8512.78	-0.15	5.40	-0.0000	0.0006	8487.14	0.17	5.39	0.0000	0.0006
1.10	8524.50	-0.31	9.22	-0.0000	0.0011	8475.16	0.12	9.19	0.0000	0.0011
1.20	8542.21	-0.29	14.87	-0.0000	0.0017	8458.11	0.25	14.78	0.0000	0.0017
1.30	8566.13	-0.34	22.71	-0.0000	0.0027	8434.54	0.34	22.49	0.0000	0.0027
1.40	8596.77	-0.33	33.17	-0.0000	0.0039	8403.67	0.49	32.70	0.0001	0.0039
1.50	8634.79	-0.51	46.70	-0.0001	0.0054	8365.15	0.46	45.78	0.0001	0.0055
1.60	8681.46	-0.52	63.51	-0.0001	0.0073	8318.64	0.60	61.82	0.0001	0.0074
1.70	8737.04	-0.55	83.48	-0.0001	0.0096	8263.00	0.72	80.59	0.0001	0.0098
1.80	8802.47	-0.77	106.69	-0.0001	0.0121	8197.67	0.66	101.98	0.0001	0.0124
1.90	8878.95	-0.96	133.72	-0.0001	0.0151	8122.11	0.63	126.36	0.0001	0.0156
2.00	8966.80	-0.76	164.82	-0.0001	0.0184	8035.53	0.98	153.71	0.0001	0.0191
2.10	9065.60	-0.53	200.08	-0.0001	0.0221	7936.19	1.37	183.81	0.0002	0.0232
2.20	9176.26	-1.32	237.15	-0.0001	0.0258	7826.73	0.87	214.25	0.0001	0.0274
2.30	9383.22	-1.76	278.58	-0.0002	0.0297	7784.96	0.49	247.45	0.0001	0.0318
2.40	9677.97	-1.02	341.56	-0.0001	0.0353	7765.41	1.25	297.44	0.0002	0.0383
2.50	9988.33	-1.38	409.89	-0.0001	0.0410	7718.76	1.17	349.16	0.0002	0.0452
2.60	10190.44	5.74	461.48	0.0006	0.0453	7554.86	7.47	383.05	0.0010	0.0507
2.70	10391.25	183.94	522.80	0.0177	0.0503	7223.95	181.15	415.97	0.0251	0.0576
2.80	10594.32	378.56	613.97	0.0357	0.0580	6929.43	376.76	469.24	0.0544	0.0677
2.90	10934.08	510.05	722.50	0.0466	0.0661	6589.66	508.89	523.47	0.0772	0.0794
3.00	11362.68	595.55	831.78	0.0524	0.0732	6323.96	595.46	573.29	0.0942	0.0907
3.10	11855.78	653.76	975.81	0.0551	0.0823	6114.45	655.55	642.71	0.1072	0.1051
3.20	12264.46	691.57	1112.44	0.0564	0.0907	5868.13	696.40	695.39	0.1187	0.1185
3.30	12447.49	716.00	1195.17	0.0575	0.0960	5523.61	721.65	698.95	0.1306	0.1265
3.40	12630.01	735.39	1322.38	0.0582	0.1047	5167.16	742.06	719.20	0.1436	0.1392
3.50	12911.36	750.27	1534.04	0.0581	0.1188	4837.79	760.00	774.11	0.1571	0.1600
3.60	13219.68	758.31	1741.68	0.0574	0.1317	4558.71	769.78	820.43	0.1689	0.1800
3.70	13492.69	762.51	1886.56	0.0565	0.1398	4341.69	780.78	840.15	0.1798	0.1935
3.80	13844.29	767.65	1994.14	0.0554	0.1440	4171.31	789.61	847.46	0.1893	0.2032
3.90	14252.07	771.47	2142.35	0.0541	0.1503	4034.46	796.91	874.48	0.1975	0.2168
4.00	14346.02	772.14	2312.83	0.0538	0.1612	3664.88	794.11	859.05	0.2167	0.2344

Figure 17. (continued)

TRACTOR REAR SUSPENSION TIRE FORCES

TRAILING TANDEM AXLE

TIME (SEC)	LEFT SIDE					RIGHT SIDE				
	VERTICAL (LB)	LONG. (LB)	LATERAL (LB)	MU-X	MU-Y	VERTICAL (LB)	LONG. (LB)	LATERAL (LB)	MU-X	MU-Y
0.0	8500.06	-0.0	0.0	0.0	0.0	8500.06	-0.0	0.0	0.0	0.0
0.10	8500.08	-0.00	0.01	-0.0000	0.0000	8500.00	0.00	0.01	0.0000	0.0000
0.20	8500.13	-0.03	0.14	-0.0000	0.0000	8499.80	-0.02	0.14	-0.0000	0.0000
0.30	8500.23	-0.03	0.35	-0.0000	0.0000	8499.57	-0.02	0.35	-0.0000	0.0000
0.40	8500.47	-0.03	0.53	-0.0000	0.0001	8499.45	-0.01	0.53	-0.0000	0.0001
0.50	8500.95	-0.04	0.81	-0.0000	0.0001	8499.30	-0.01	0.81	-0.0000	0.0001
0.60	8501.78	-0.05	1.58	-0.0000	0.0002	8498.61	0.02	1.58	0.0000	0.0002
0.70	8503.42	-0.05	3.20	-0.0000	0.0004	8497.09	0.06	3.20	0.0000	0.0004
0.80	8506.30	-0.08	5.85	-0.0000	0.0007	8494.08	0.09	5.85	0.0000	0.0007
0.90	8511.62	-0.12	9.85	-0.0000	0.0012	8488.58	0.12	9.84	0.0000	0.0012
1.00	8521.18	-0.15	15.86	-0.0000	0.0019	8478.74	0.17	15.81	0.0000	0.0019
1.10	8536.76	-0.31	24.56	-0.0000	0.0029	8462.88	0.12	24.42	0.0000	0.0029
1.20	8559.50	-0.29	36.53	-0.0000	0.0043	8440.82	0.25	36.21	0.0000	0.0043
1.30	8589.70	-0.34	52.35	-0.0000	0.0061	8410.95	0.34	51.66	0.0000	0.0061
1.40	8628.01	-0.33	72.61	-0.0000	0.0084	8372.42	0.49	71.24	0.0001	0.0085
1.50	8675.19	-0.51	97.93	-0.0001	0.0113	8324.74	0.46	95.39	0.0001	0.0115
1.60	8732.46	-0.52	128.57	-0.0001	0.0147	8267.62	0.60	124.16	0.0001	0.0150
1.70	8800.20	-0.55	164.56	-0.0001	0.0187	8199.81	0.72	157.29	0.0001	0.0192
1.80	8879.32	-0.77	206.07	-0.0001	0.0232	8120.78	0.65	194.63	0.0001	0.0240
1.90	8971.02	-0.96	253.80	-0.0001	0.0283	8029.98	0.63	236.42	0.0001	0.0294
2.00	9075.70	-0.76	308.20	-0.0001	0.0340	7926.56	0.98	282.58	0.0001	0.0356
2.10	9192.82	-0.53	369.37	-0.0001	0.0402	7808.88	1.37	332.65	0.0002	0.0426
2.20	9323.88	-1.32	435.85	-0.0001	0.0467	7679.00	0.87	384.75	0.0001	0.0501
2.30	9487.85	-1.75	509.02	-0.0002	0.0536	7552.31	0.48	439.64	0.0001	0.0582
2.40	9825.55	-1.01	608.59	-0.0001	0.0619	7528.90	1.25	513.97	0.0002	0.0683
2.50	10159.43	-1.38	717.26	-0.0001	0.0706	7454.04	1.17	590.36	0.0002	0.0792
2.60	10386.14	5.78	809.52	0.0006	0.0779	7265.39	7.36	646.54	0.0010	0.0890
2.70	10559.33	183.86	912.23	0.0174	0.0864	6987.57	180.75	702.24	0.0259	0.1005
2.80	10802.21	378.28	1054.31	0.0350	0.0976	6619.14	376.37	770.73	0.0569	0.1164
2.90	11194.66	509.73	1219.91	0.0455	0.1090	6231.37	507.61	836.93	0.0815	0.1343
3.00	11656.32	595.08	1378.47	0.0511	0.1183	5948.45	594.00	893.44	0.0999	0.1502
3.10	12171.89	652.80	1568.35	0.0536	0.1289	5733.58	654.59	960.73	0.1142	0.1676
3.20	12589.76	690.90	1760.95	0.0549	0.1399	5450.34	694.81	1008.41	0.1275	0.1850
3.30	12802.87	715.36	1878.71	0.0559	0.1467	5110.52	720.26	1005.77	0.1409	0.1968
3.40	12963.57	734.64	2025.35	0.0567	0.1562	4733.63	741.41	1003.77	0.1566	0.2121
3.50	13248.72	749.60	2241.12	0.0566	0.1692	4422.84	759.19	1033.82	0.1717	0.2337
3.60	13565.29	757.67	2448.27	0.0559	0.1805	4179.79	772.70	1061.16	0.1849	0.2539
3.70	13801.65	761.73	2622.51	0.0552	0.1900	3927.87	779.90	1063.96	0.1986	0.2709
3.80	14170.96	767.05	2783.42	0.0541	0.1964	3754.39	789.07	1070.74	0.2102	0.2852
3.90	14503.73	770.73	2979.58	0.0531	0.2054	3500.62	793.33	1062.17	0.2266	0.3034
4.00	14748.21	771.57	3207.97	0.0523	0.2175	3189.04	788.48	1038.26	0.2472	0.3256

Figure 17. (continued)

TRACTOR FRONT SUSPENSION - LATERAL TIRE FORCE AND MOMENT SUMMARY

LEFT SIDE

RIGHT SIDE

TIME (SEC)	LEFT SIDE				RIGHT SIDE			
	TIRE SIDESLIP ANGLE (DEG)	TIRE LATERAL FORCE (LB)	MU-Y	ALIGNING TORQUE (IN-LB)	TIRE SIDESLIP ANGLE (DEG)	TIRE LATERAL FORCE (LB)	MU-Y	ALIGNING TORQUE (IN-LB)
0.0	0.0	0.0	0.0	0.0	0.0	0.0	0.0	0.0
0.10	-0.0003	0.2926	0.0000	-0.5457	-0.0003	0.2392	0.0000	-0.4460
0.20	-0.0005	0.4386	0.0001	-0.8179	-0.0004	0.3604	0.0001	-0.6721
0.30	-0.0007	0.6060	0.0001	-1.1300	-0.0006	0.4974	0.0001	-0.9274
0.40	-0.0014	1.2406	0.0002	-2.3134	-0.0012	1.0158	0.0002	-1.8940
0.50	-0.0027	2.3311	0.0004	-4.3468	-0.0022	1.9082	0.0003	-3.5572
0.60	-0.0053	4.5461	0.0008	-8.4769	-0.0043	3.7168	0.0006	-6.9266
0.70	-0.0093	7.9854	0.0013	-14.8889	-0.0076	6.5231	0.0011	-12.1497
0.80	-0.0152	13.0669	0.0022	-24.3599	-0.0124	10.6704	0.0018	-19.8571
0.90	-0.0234	20.1166	0.0033	-37.4967	-0.0192	16.4191	0.0027	-30.5178
1.00	-0.0344	29.5194	0.0049	-55.0202	-0.0281	24.0734	0.0040	-44.6715
1.10	-0.0488	41.9485	0.0070	-78.1877	-0.0399	34.1824	0.0057	-63.2892
1.20	-0.0667	57.3932	0.0095	-106.9851	-0.0546	46.6859	0.0078	-86.1886
1.30	-0.0889	76.6063	0.0127	-142.8198	-0.0728	62.1943	0.0105	-114.3891
1.40	-0.1155	99.6680	0.0164	-185.8565	-0.0946	80.7246	0.0136	-147.8030
1.50	-0.1469	127.0401	0.0208	-236.9837	-0.1205	102.6209	0.0174	-186.8906
1.60	-0.1838	159.2913	0.0260	-297.2813	-0.1509	128.2463	0.0218	-232.0952
1.70	-0.2253	195.7222	0.0318	-365.4602	-0.1852	156.9896	0.0269	-282.0840
1.80	-0.2719	236.8916	0.0383	-442.5964	-0.2238	189.2243	0.0326	-337.2349
1.90	-0.3235	282.6599	0.0454	-528.5261	-0.2667	224.7207	0.0390	-396.8884
2.00	-0.3802	333.3137	0.0531	-623.8704	-0.3139	263.5671	0.0460	-460.9128
2.10	-0.4421	389.1260	0.0614	-729.7019	-0.3655	305.8699	0.0538	-529.5273
2.20	-0.5048	449.3762	0.0692	-855.7920	-0.4165	351.1316	0.0608	-612.7478
2.30	-0.5696	512.3872	0.0770	-990.1545	-0.4688	397.4504	0.0680	-697.1191
2.40	-0.6590	594.4065	0.0887	-1146.5898	-0.5433	456.1909	0.0797	-782.4478
2.50	-0.7504	676.4822	0.1010	-1293.8066	-0.6202	514.2703	0.0922	-858.9661
2.60	-0.8251	746.3264	0.1105	-1428.4832	-0.6825	562.0842	0.1021	-924.0969
2.70	-0.9055	825.7581	0.1198	-1597.4846	-0.7499	615.2302	0.1126	-1000.0452
2.80	-1.0058	919.5259	0.1320	-1779.7703	-0.8347	676.8582	0.1267	-1073.5876
2.90	-1.1105	980.8594	0.1456	-1831.3833	-0.9279	729.1165	0.1445	-1097.9138
3.00	-1.2226	1047.5505	0.1596	-1898.3252	-1.0300	777.4583	0.1633	-1110.5991
3.10	-1.3776	1170.9561	0.1725	-2153.8904	-1.1672	851.6292	0.1817	-1188.8350
3.20	-1.5106	1285.2610	0.1818	-2419.4170	-1.2802	927.5195	0.1948	-1298.9539
3.30	-1.5723	1339.3613	0.1858	-2550.2458	-1.3324	960.8774	0.2010	-1344.0461
3.40	-1.6684	1409.4861	0.1953	-2667.3296	-1.4215	994.1724	0.2154	-1345.1172
3.50	-1.8231	1509.6062	0.2133	-2778.2183	-1.5680	1041.8933	0.2398	-1331.8066
3.60	-1.9820	1624.9644	0.2290	-2961.2046	-1.7162	1098.4958	0.2634	-1347.2817
3.70	-2.1080	1737.3638	0.2368	-3224.4580	-1.8249	1167.7734	0.2767	-1432.8530
3.80	-2.1877	1817.1279	0.2399	-3442.5938	-1.8881	1222.7769	0.2823	-1522.2480
3.90	-2.2915	1904.1033	0.2479	-3622.6201	-1.9831	1264.2302	0.2967	-1543.7644
4.00	-2.4221	1995.5444	0.2619	-3735.9639	-2.1104	1293.3445	0.3162	-1518.2024

06

Figure 17. (continued)

TRACTOR REAR SUSPENSION - LATERAL TIRE FORCE AND MOMENT SUMMARY

LEADING TANDEM AXLE

LEFT SIDE

RIGHT SIDE

TIME (SEC)	TIRE SIDESLIP ANGLE (DEG)	TIRE LATERAL FORCE (LB)	MU-Y	ALIGNING TORQUE (IN-LB)	TIRE SIDESLIP ANGLE (DEG)	TIRE LATERAL FORCE (LB)	MU-Y	ALIGNING TORQUE (IN-LB)
0.0	0.0	0.0	0.0	0.0	0.0	0.0	0.0	0.0
0.10	0.0000	-0.0374	-0.0000	0.0634	0.0000	-0.0374	-0.0000	0.0634
0.20	0.0000	-0.0032	-0.0000	0.0055	0.0000	-0.0032	-0.0000	0.0055
0.30	-0.0001	0.1290	0.0000	-0.2189	-0.0001	0.1290	0.0000	-0.2189
0.40	-0.0001	0.1727	0.0000	-0.2931	-0.0001	0.1727	0.0000	-0.2931
0.50	-0.0001	0.1256	0.0000	-0.2132	-0.0001	0.1256	0.0000	-0.2132
0.60	-0.0002	0.2492	0.0000	-0.4230	-0.0002	0.2492	0.0000	-0.4229
0.70	-0.0005	0.7515	0.0001	-1.2756	-0.0005	0.7514	0.0001	-1.2755
0.80	-0.0011	1.6082	0.0002	-2.7299	-0.0011	1.6076	0.0002	-2.7290
0.90	-0.0021	3.0190	0.0004	-5.1248	-0.0021	3.0166	0.0004	-5.1207
1.00	-0.0038	5.3989	0.0006	-9.1646	-0.0038	5.3892	0.0006	-9.1481
1.10	-0.0065	9.2232	0.0011	-15.6563	-0.0065	9.1905	0.0011	-15.6009
1.20	-0.0105	14.8688	0.0017	-25.2398	-0.0105	14.7780	0.0017	-25.0857
1.30	-0.0160	22.7101	0.0027	-38.5504	-0.0160	22.4917	0.0027	-38.1797
1.40	-0.0233	33.1745	0.0039	-56.3138	-0.0233	32.7049	0.0039	-55.5166
1.50	-0.0327	46.7042	0.0054	-79.2804	-0.0327	45.7801	0.0055	-77.7117
1.60	-0.0443	63.5132	0.0073	-107.8138	-0.0444	61.8233	0.0074	-104.9451
1.70	-0.0580	83.4826	0.0096	-141.7119	-0.0581	80.5853	0.0098	-136.7936
1.80	-0.0738	106.6902	0.0121	-181.1068	-0.0739	101.9790	0.0124	-173.1095
1.90	-0.0919	133.7227	0.0151	-226.9946	-0.0921	126.3613	0.0156	-214.4985
2.00	-0.1126	164.8199	0.0184	-279.7820	-0.1129	153.7080	0.0191	-260.9194
2.10	-0.1358	200.0814	0.0221	-339.6384	-0.1362	183.8097	0.0232	-312.0173
2.20	-0.1597	237.1497	0.0258	-402.5620	-0.1603	214.2526	0.0274	-363.6941
2.30	-0.1850	278.5767	0.0297	-472.8843	-0.1858	247.4520	0.0318	-420.0500
2.40	-0.2227	341.5615	0.0353	-579.8013	-0.2237	297.4395	0.0383	-504.9038
2.50	-0.2624	409.8943	0.0410	-695.7964	-0.2637	349.1565	0.0452	-592.6936
2.60	-0.2920	461.4819	0.0453	-783.3662	-0.2937	383.0491	0.0507	-650.2266
2.70	-0.3273	522.7974	0.0503	-887.4495	-0.3293	415.9683	0.0576	-706.1067
2.80	-0.3803	613.9680	0.0580	-1042.2119	-0.3830	469.2385	0.0677	-796.5332
2.90	-0.4402	722.4951	0.0661	-1226.4368	-0.4436	523.4736	0.0794	-888.5974
3.00	-0.4971	831.7761	0.0732	-1411.9417	-0.5013	573.2888	0.0907	-973.1587
3.10	-0.5717	975.8064	0.0823	-1656.4333	-0.5768	642.7097	0.1051	-1091.0010
3.20	-0.6414	1112.4414	0.0907	-1888.3716	-0.6476	695.3906	0.1185	-1180.4268
3.30	-0.6843	1195.1736	0.0960	-2028.8096	-0.6915	698.9524	0.1265	-1186.4729
3.40	-0.7521	1322.3813	0.1047	-2244.7449	-0.7606	719.1987	0.1392	-1220.8411
3.50	-0.8639	1534.0427	0.1188	-2604.0405	-0.8744	774.1064	0.1600	-1314.0471
3.60	-0.9710	1741.6750	0.1317	-2956.4971	-0.9835	820.4280	0.1800	-1392.6782
3.70	-1.0558	1886.5623	0.1398	-3202.4414	-1.0701	840.1521	0.1935	-1426.1599
3.80	-1.1184	1994.1428	0.1440	-3385.0605	-1.1344	847.4565	0.2032	-1438.5591
3.90	-1.2068	2142.3455	0.1503	-3636.6357	-1.2250	874.4817	0.2168	-1484.4343
4.00	-1.3217	2312.8259	0.1612	-3926.0244	-1.3427	859.0525	0.2344	-1458.2432

Figure 17. (continued)

TRACTOR REAR SUSPENSION - LATERAL TIRE FORCE AND MOMENT SUMMARY

TRAILING TANDEM AXLE

TIME (SEC)	LEFT SIDE				RIGHT SIDE			
	TIRE SIDESLIP ANGLE (DEG)	TIRE LATERAL FORCE (LB)	MU-Y	ALIGNING TORQUE (IN-LB)	TIRE SIDESLIP ANGLE (DEG)	TIRE LATERAL FORCE (LB)	MU-Y	ALIGNING TORQUE (IN-LB)
0.0	0.0	0.0	0.0	0.0	0.0	0.0	0.0	0.0
0.10	-0.0000	0.0141	0.0000	-0.0239	-0.0000	0.0141	0.0000	-0.0239
0.20	-0.0001	0.1352	0.0000	-0.2296	-0.0001	0.1352	0.0000	-0.2296
0.30	-0.0002	0.3493	0.0000	-0.5930	-0.0002	0.3493	0.0000	-0.5930
0.40	-0.0004	0.5330	0.0001	-0.9048	-0.0004	0.5330	0.0001	-0.9047
0.50	-0.0006	0.8063	0.0001	-1.3687	-0.0006	0.8062	0.0001	-1.3686
0.60	-0.0011	1.5762	0.0002	-2.6755	-0.0011	1.5758	0.0002	-2.6749
0.70	-0.0023	3.2043	0.0004	-5.4392	-0.0023	3.2028	0.0004	-5.4368
0.80	-0.0041	5.8533	0.0007	-9.9360	-0.0041	5.8482	0.0007	-9.9273
0.90	-0.0070	9.8515	0.0012	-16.7229	-0.0070	9.8351	0.0012	-16.6951
1.00	-0.0112	15.8599	0.0019	-26.9223	-0.0112	15.8109	0.0019	-26.8390
1.10	-0.0173	24.5550	0.0029	-41.6822	-0.0173	24.4216	0.0029	-41.4557
1.20	-0.0257	36.5260	0.0043	-62.0030	-0.0257	36.2057	0.0043	-61.4593
1.30	-0.0368	52.3507	0.0061	-88.8653	-0.0368	51.6580	0.0061	-87.6895
1.40	-0.0509	72.6108	0.0084	-123.2570	-0.0509	71.2368	0.0085	-120.9246
1.50	-0.0683	97.9327	0.0113	-166.2409	-0.0684	95.3950	0.0115	-161.9332
1.60	-0.0893	128.5702	0.0147	-218.2480	-0.0895	124.1617	0.0150	-210.7646
1.70	-0.1138	164.5563	0.0187	-279.3345	-0.1140	157.2939	0.0192	-267.0066
1.80	-0.1417	206.0657	0.0232	-349.7966	-0.1419	194.6260	0.0240	-330.3779
1.90	-0.1734	253.8031	0.0283	-430.8311	-0.1737	236.4170	0.0294	-401.3181
2.00	-0.2090	308.2000	0.0340	-523.1699	-0.2095	282.5798	0.0356	-479.6797
2.10	-0.2485	369.3701	0.0402	-627.0063	-0.2492	332.6453	0.0426	-564.6658
2.20	-0.2906	435.8545	0.0467	-739.8638	-0.2916	384.7549	0.0501	-653.1221
2.30	-0.3358	509.0229	0.0536	-864.0674	-0.3372	439.6448	0.0582	-746.2976
2.40	-0.3933	608.5945	0.0619	-1033.0903	-0.3950	513.9697	0.0683	-872.4646
2.50	-0.4547	717.2551	0.0706	-1217.5420	-0.4570	590.3552	0.0792	-1002.1289
2.60	-0.5069	809.5249	0.0779	-1374.1699	-0.5098	646.5444	0.0890	-1097.5103
2.70	-0.5661	912.2271	0.0864	-1548.5071	-0.5697	702.2424	0.1005	-1192.0579
2.80	-0.6464	1054.3071	0.0976	-1789.6885	-0.6510	770.7258	0.1164	-1308.3086
2.90	-0.7345	1219.9075	0.1090	-2070.7954	-0.7402	836.9297	0.1343	-1420.6897
3.00	-0.8140	1378.4707	0.1183	-2339.9568	-0.8208	893.4443	0.1502	-1516.6235
3.10	-0.9076	1568.3486	0.1289	-2662.2751	-0.9157	960.7334	0.1676	-1630.8469
3.20	-1.0038	1760.9456	0.1399	-2989.2085	-1.0135	1008.4060	0.1850	-1711.7710
3.30	-1.0807	1878.7102	0.1467	-3189.1143	-1.0920	1005.7678	0.1968	-1707.2930
3.40	-1.1803	2025.3499	0.1562	-3438.0352	-1.1937	1003.7688	0.2121	-1703.8997
3.50	-1.3223	2241.1233	0.1692	-3804.3105	-1.3383	1033.8186	0.2337	-1754.9092
3.60	-1.4539	2448.2742	0.1805	-4155.9492	-1.4726	1061.1609	0.2539	-1801.3228
3.70	-1.5647	2622.5098	0.1900	-4451.7148	-1.5859	1063.9644	0.2709	-1806.0815
3.80	-1.6576	2783.4199	0.1964	-4724.8594	-1.6813	1070.7375	0.2852	-1817.5791
3.90	-1.7760	2979.5808	0.2054	-5057.8438	-1.8029	1062.1719	0.3034	-1803.0388
4.00	-1.9200	3207.9661	0.2175	-5445.5273	-1.9505	1038.2639	0.3256	-1762.4551

Figure 17. (continued)

TRACTOR FRONT SUSPENSION - UNSPRUNG MASS SUMMARY

TIME (SEC)	AXLE MOTION					DYNAMIC SUSPENSION MOTIONS AND FORCES					
	POSITION		VELOCITY		AUXILIARY ROLL TORQUE (IN-LB)	LEFT SIDE			RIGHT SIDE		
	VERTICAL (FT)	ROLL (DEG)	VERTICAL (FT/SEC)	ROLL (DEG/SEC)		SUSP. DEFLECT. (IN)	SUSP. VELOCITY (IN/SEC)	SUSP. FORCE (LB)	SUSP. DEFLECT. (IN)	SUSP. VELOCITY (IN/SEC)	SUSP. FORCE (LB)
0.0	0.0	0.0	0.0	0.0	0.0	0.0	0.0	-0.0	0.0	0.0	-0.0
0.10	-0.0000	-0.0000	-0.0000	-0.0001	0.0	-0.0000	-0.0009	0.06	-0.0000	0.0001	0.05
0.20	-0.0000	-0.0001	0.0000	-0.0000	0.4	-0.0002	-0.0018	0.06	-0.0000	-0.0004	0.12
0.30	-0.0000	-0.0001	-0.0000	-0.0002	0.6	-0.0004	-0.0028	0.06	-0.0002	-0.0025	0.12
0.40	-0.0000	-0.0002	0.0000	-0.0014	0.6	-0.0007	-0.0036	-0.02	-0.0005	-0.0029	0.05
0.50	0.0000	-0.0004	0.0000	-0.0027	1.3	-0.0011	-0.0052	-0.28	-0.0007	-0.0005	0.05
0.60	0.0000	-0.0008	0.0000	-0.0052	3.1	-0.0017	-0.0063	-0.77	-0.0006	0.0025	0.30
0.70	0.0000	-0.0014	-0.0000	-0.0084	5.9	-0.0024	-0.0063	-1.34	-0.0002	0.0058	0.82
0.80	0.0000	-0.0024	-0.0001	-0.0116	10.0	-0.0031	-0.0087	-2.11	0.0006	0.0100	2.06
0.90	-0.0000	-0.0038	-0.0000	-0.0180	16.2	-0.0042	-0.0137	-4.06	0.0017	0.0135	4.51
1.00	-0.0000	-0.0058	0.0001	-0.0251	24.8	-0.0059	-0.0191	-8.55	0.0033	0.0177	8.69
1.10	0.0000	-0.0088	0.0000	-0.0344	35.8	-0.0080	-0.0234	-15.80	0.0053	0.0222	15.40
1.20	0.0000	-0.0126	-0.0000	-0.0460	49.5	-0.0106	-0.0276	-26.70	0.0078	0.0282	26.02
1.30	0.0000	-0.0176	-0.0000	-0.0562	66.4	-0.0136	-0.0342	-41.04	0.0110	0.0366	41.03
1.40	-0.0000	-0.0237	0.0000	-0.0689	88.1	-0.0176	-0.0451	-59.15	0.0150	0.0460	59.47
1.50	-0.0000	-0.0311	0.0000	-0.0812	116.1	-0.0228	-0.0587	-81.76	0.0202	0.0583	81.81
1.60	0.0000	-0.0397	0.0000	-0.0946	150.9	-0.0293	-0.0710	-108.46	0.0267	0.0725	108.01
1.70	0.0000	-0.0496	-0.0000	-0.1075	193.9	-0.0372	-0.0866	-138.99	0.0348	0.0912	138.49
1.80	0.0000	-0.0608	0.0000	-0.1210	247.4	-0.0469	-0.1087	-173.73	0.0450	0.1141	173.56
1.90	0.0000	-0.0733	0.0001	-0.1360	314.2	-0.0591	-0.1361	-213.66	0.0576	0.1392	212.78
2.00	0.0000	-0.0872	0.0002	-0.1477	396.5	-0.0744	-0.1666	-258.48	0.0729	0.1742	255.46
2.10	0.0000	-0.1024	-0.0028	-0.1588	497.9	-0.0927	-0.2238	-306.09	0.0924	0.1964	302.97
2.20	-0.0041	-0.1139	-0.0800	-0.0975	634.7	-0.1542	-0.8199	-434.29	0.0816	-0.1945	217.89
2.30	-0.0184	-0.1275	-0.2085	-0.2401	835.3	-0.2421	-0.7409	-575.29	0.0682	0.0726	139.55
2.40	-0.0455	-0.1529	-0.3307	-0.2946	1043.4	-0.2847	-0.1006	-635.85	0.1038	0.5544	261.76
2.50	-0.0832	-0.1744	-0.4212	-0.1984	1200.0	-0.2859	-0.0611	-630.67	0.1615	0.4972	400.52
2.60	-0.1286	-0.0964	-0.4929	0.4536	1529.6	-0.3432	-0.8443	-711.96	0.2269	0.3655	512.55
2.70	-0.1820	-0.0150	-0.5831	0.6092	1950.9	-0.4552	-1.0353	-861.59	0.2718	0.5552	575.98
2.80	-0.2461	0.0651	-0.7002	0.7160	2411.7	-0.5172	0.1091	-940.09	0.3822	1.7639	712.46
2.90	-0.3237	0.1649	-0.8371	0.9655	2897.4	-0.4828	0.5763	-670.24	0.5982	2.4652	958.63
3.00	-0.4100	0.2582	-0.8828	0.7628	3449.2	-0.4515	-0.0774	-497.19	0.8352	2.0256	1223.55
3.10	-0.5000	0.3222	-0.9266	0.5919	3940.8	-0.5115	-0.9816	-765.80	0.9606	0.4585	1362.62
3.20	-0.5964	0.3991	-1.0073	0.9593	4242.7	-0.6268	-1.1346	-1043.82	0.9600	-0.1225	1317.94
3.30	-0.7038	0.4904	-1.1291	0.8634	4575.0	-0.7338	-0.7243	-1210.76	0.9757	0.8837	1323.44
3.40	-0.8226	0.5748	-1.2527	0.7833	5083.8	-0.7747	-0.0478	-1267.45	1.1241	1.9631	1536.64
3.50	-0.9525	0.6626	-1.3364	0.8977	5591.2	-0.7603	0.2840	-1125.95	1.3294	1.9627	1774.31
3.60	-1.0885	0.7559	-1.3909	0.4024	5987.0	-0.7730	-0.5178	-1133.41	1.4658	0.4663	1926.76
3.70	-1.2288	0.8354	-1.4403	0.6991	6277.8	-0.8688	-1.3844	-1353.36	1.4793	-0.3903	1906.77
3.80	-1.3774	0.9267	-1.5343	0.7551	6622.1	-1.0223	-1.2881	-1586.18	1.4537	0.1108	1796.78
3.90	-1.5366	1.0094	-1.6699	0.7648	7008.0	-1.1253	-0.7854	-1722.56	1.4954	0.4771	1891.00
4.00	-1.7060	1.1011	-1.7411	1.0268	7284.9	-1.1369	0.1244	-1677.15	1.5890	0.9603	2042.50

Figure 17. (continued)

TRACTOR REAR SUSPENSION - UNSPRUNG MASS SUMMARY

LEADING TANDEM AXLE

TIME (SEC)	AXLE MOTION				DYNAMIC SUSPENSION MOTIONS AND FORCES						
	POSITION		VELOCITY		LEFT SIDE				RIGHT SIDE		
	VERTICAL (FT)	ROLL (DEG)	VERTICAL (FT/SEC)	ROLL (DEG/SEC)	AUXILIARY ROLL TORQUE (IN-LB)	SUSP. DEFLECT. (IN)	SUSP. VELOCITY (IN/SEC)	SUSP. FORCE (LB)	SUSP. DEFLECT. (IN)	SUSP. VELOCITY (IN/SEC)	SUSP. FORCE (LB)
0.0	0.0	0.0	0.0	0.0	0.0	0.0	0.0	0.0	0.0	0.0	0.0
0.10	-0.0000	0.0000	-0.0000	0.0000	0.0	-0.0000	-0.0011	0.0	-0.0000	0.0001	0.10
0.20	-0.0000	-0.0000	-0.0000	-0.0002	-0.1	-0.0001	-0.0016	0.0	-0.0001	-0.0001	0.24
0.30	-0.0000	-0.0000	0.0000	-0.0002	-0.0	-0.0002	-0.0017	0.0	-0.0002	-0.0013	0.24
0.40	-0.0000	-0.0000	0.0000	0.0000	0.5	-0.0004	-0.0026	-0.11	-0.0004	-0.0008	0.24
0.50	0.0000	-0.0000	0.0000	-0.0002	1.7	-0.0006	-0.0045	-0.40	-0.0005	0.0027	0.35
0.60	0.0000	-0.0001	0.0000	-0.0006	3.7	-0.0008	-0.0071	-0.84	-0.0004	0.0064	0.52
0.70	0.0000	-0.0002	-0.0000	-0.0017	7.2	-0.0010	-0.0097	-1.45	-0.0003	0.0091	1.11
0.80	0.0000	-0.0005	-0.0000	-0.0038	13.8	-0.0013	-0.0140	-3.11	0.0000	0.0135	2.81
0.90	0.0000	-0.0010	-0.0000	-0.0082	25.5	-0.0019	-0.0193	-7.34	0.0006	0.0194	7.28
1.00	-0.0000	-0.0022	-0.0000	-0.0159	44.0	-0.0028	-0.0250	-16.62	0.0015	0.0249	16.87
1.10	-0.0000	-0.0043	0.0000	-0.0251	71.5	-0.0042	-0.0294	-33.19	0.0029	0.0309	33.63
1.20	0.0000	-0.0073	0.0001	-0.0358	111.1	-0.0062	-0.0353	-57.90	0.0049	0.0377	57.61
1.30	0.0000	-0.0115	0.0000	-0.0476	165.6	-0.0090	-0.0437	-90.97	0.0078	0.0461	90.38
1.40	0.0000	-0.0169	-0.0000	-0.0603	237.1	-0.0127	-0.0563	-133.00	0.0115	0.0576	132.59
1.50	-0.0000	-0.0236	-0.0000	-0.0743	328.3	-0.0174	-0.0705	-184.42	0.0163	0.0730	184.53
1.60	-0.0000	-0.0318	0.0000	-0.0895	443.5	-0.0234	-0.0847	-246.74	0.0225	0.0891	246.96
1.70	-0.0000	-0.0415	0.0000	-0.1062	589.3	-0.0309	-0.1032	-321.35	0.0303	0.1088	321.45
1.80	0.0000	-0.0530	-0.0000	-0.1240	773.4	-0.0404	-0.1259	-409.45	0.0403	0.1367	409.18
1.90	0.0000	-0.0664	-0.0001	-0.1434	1004.0	-0.0523	-0.1529	-511.66	0.0530	0.1691	510.86
2.00	0.0000	-0.0817	0.0001	-0.1638	1291.0	-0.0670	-0.1842	-628.78	0.0690	0.2099	627.15
2.10	0.0000	-0.0992	-0.0000	-0.1852	1645.6	-0.0850	-0.2209	-761.21	0.0891	0.2606	759.63
2.20	0.0000	-0.1186	0.0006	-0.2011	2080.7	-0.1070	-0.3403	-912.38	0.1137	0.3337	907.90
2.30	-0.0003	-0.1399	-0.0265	-0.2313	2607.0	-0.1390	-0.8105	-1119.04	0.1380	0.1613	1044.05
2.40	-0.0085	-0.1661	-0.1290	-0.2927	3218.4	-0.1949	-0.9957	-1460.75	0.1491	-0.2166	1103.20
2.50	-0.0268	-0.1961	-0.2366	-0.3023	3952.0	-0.2548	-0.7739	-1814.76	0.1697	-0.1798	1211.83
2.60	-0.0560	-0.2271	-0.3472	-0.3198	4836.3	-0.3030	-0.7056	-2095.95	0.2175	0.2181	1459.18
2.70	-0.0958	-0.2516	-0.4451	0.5704	5875.8	-0.3455	-1.1218	-2343.06	0.2871	0.7413	1811.95
2.80	-0.1442	-0.1836	-0.5316	0.6822	7547.3	-0.4089	-1.1766	-2714.27	0.3849	0.7659	2303.54
2.90	-0.2016	-0.1298	-0.6203	0.4919	9184.4	-0.4910	-1.2688	-3194.24	0.4831	0.6602	2794.49
3.00	-0.2676	-0.0779	-0.7005	0.5208	10839.1	-0.5812	-1.3772	-3761.34	0.5745	0.9596	3205.38
3.10	-0.3423	-0.0268	-0.7940	0.5149	12490.6	-0.6728	-1.0168	-4366.90	0.6674	0.6423	3534.78
3.20	-0.4265	0.0282	-0.8948	0.6423	14168.2	-0.7485	-0.4242	-4869.58	0.7789	0.5675	3910.37
3.30	-0.5214	0.0939	-0.9941	0.6873	15894.9	-0.7979	-0.5508	-5197.52	0.9192	1.2419	4379.63
3.40	-0.6253	0.1609	-1.0893	0.5933	17520.4	-0.8384	-0.9852	-5467.96	1.0577	1.2768	4838.00
3.50	-0.7375	0.2204	-1.1572	0.5797	18950.6	-0.8848	-0.6778	-5777.96	1.1725	1.1047	5200.25
3.60	-0.8584	0.2829	-1.2562	0.6596	20294.5	-0.9374	-0.5555	-6130.02	1.2715	0.7838	5509.85
3.70	-0.9873	0.3541	-1.3311	0.8578	21611.3	-0.9845	-0.5398	-6444.30	1.3718	0.7459	5823.38
3.80	-1.1248	0.4218	-1.4057	0.6547	22816.1	-1.0228	-0.3753	-6954.05	1.4669	1.2194	6121.13
3.90	-1.2695	0.4999	-1.5103	0.4102	23960.4	-1.0424	-0.3775	-7398.91	1.5689	0.8866	6440.63
4.00	-1.4252	0.5730	-1.5915	0.7741	24979.9	-1.0592	0.0647	-7553.59	1.6738	0.8897	6768.80

Figure 17. (continued)

TRACTOR REAR SUSPENSION - UNSPRUNG MASS SUMMARY

TRAILING TANDEM AXLE

TIME (SEC)	AXLE MOTION			DYNAMIC SUSPENSION MOTIONS AND FORCES							
	POSITION		VELOCITY		AUXILIARY ROLL TORQUE (IN-LB)	LEFT SIDE			RIGHT SIDE		
	VERTICAL (FT)	ROLL (DEG)	VERTICAL (FT/SEC)	ROLL (DEG/SEC)		SUSP. DEFLECT. (IN)	SUSP. VELOCITY (IN/SEC)	SUSP. FORCE (LB)	SUSP. DEFLECT. (IN)	SUSP. VELOCITY (IN/SEC)	SUSP. FORCE (LB)
0.0	0.0	0.0	0.0	0.0	0.0	0.0	0.0	0.0	0.0	0.0	0.0
0.10	-0.0000	-0.0000	-0.0000	-0.0001	-0.0	-0.0000	-0.0011	0.0	-0.0000	0.0001	0.10
0.20	-0.0000	-0.0000	-0.0000	-0.0003	-0.2	-0.0001	-0.0016	0.0	-0.0001	-0.0001	0.24
0.30	-0.0000	-0.0001	0.0000	-0.0003	-0.2	-0.0002	-0.0016	0.0	-0.0002	-0.0013	0.24
0.40	-0.0000	-0.0001	0.0000	-0.0003	0.2	-0.0004	-0.0025	-0.11	-0.0004	-0.0010	0.24
0.50	0.0000	-0.0001	0.0000	-0.0008	1.1	-0.0006	-0.0044	-0.39	-0.0005	0.0024	0.34
0.60	0.0000	-0.0003	0.0000	-0.0019	2.6	-0.0008	-0.0066	-0.82	-0.0005	0.0060	0.51
0.70	0.0000	-0.0005	-0.0000	-0.0037	5.1	-0.0009	-0.0091	-1.43	-0.0003	0.0084	1.08
0.80	0.0000	-0.0011	-0.0000	-0.0068	10.2	-0.0013	-0.0129	-3.05	-0.0000	0.0126	2.76
0.90	0.0000	-0.0020	-0.0000	-0.0125	19.8	-0.0018	-0.0179	-7.22	0.0005	0.0180	7.16
1.00	-0.0000	-0.0037	-0.0000	-0.0217	35.3	-0.0027	-0.0231	-16.40	0.0015	0.0229	16.65
1.10	-0.0000	-0.0064	0.0000	-0.0329	58.7	-0.0041	-0.0269	-32.89	0.0029	0.0282	33.32
1.20	0.0000	-0.0103	0.0001	-0.0457	93.1	-0.0062	-0.0321	-57.52	0.0049	0.0343	57.23
1.30	0.0000	-0.0156	0.0000	-0.0599	141.0	-0.0090	-0.0399	-90.50	0.0077	0.0417	89.91
1.40	0.0000	-0.0223	-0.0000	-0.0751	204.5	-0.0127	-0.0519	-132.45	0.0114	0.0522	132.04
1.50	-0.0000	-0.0307	-0.0000	-0.0917	286.0	-0.0173	-0.0656	-183.80	0.0162	0.0664	183.93
1.60	-0.0000	-0.0407	0.0000	-0.1096	390.1	-0.0233	-0.0793	-246.06	0.0224	0.0811	246.31
1.70	-0.0000	-0.0526	0.0000	-0.1289	523.1	-0.0308	-0.0978	-320.63	0.0302	0.0991	320.76
1.80	0.0000	-0.0665	-0.0000	-0.1496	692.8	-0.0403	-0.1207	-408.69	0.0402	0.1249	408.46
1.90	0.0000	-0.0826	-0.0001	-0.1718	907.4	-0.0522	-0.1485	-510.88	0.0529	0.1548	510.13
2.00	0.0000	-0.1009	0.0001	-0.1948	1176.7	-0.0669	-0.1812	-627.99	0.0689	0.1923	626.43
2.10	0.0000	-0.1216	-0.0000	-0.2191	1512.0	-0.0848	-0.2202	-760.41	0.0890	0.2388	758.92
2.20	0.0000	-0.1446	0.0006	-0.2398	1925.6	-0.1068	-0.3426	-911.52	0.1136	0.3057	907.15
2.30	0.0002	-0.1701	0.0034	-0.2793	2426.4	-0.1364	-0.4586	-1102.50	0.1403	0.4814	1056.52
2.40	-0.0013	-0.2006	-0.0647	-0.3359	3012.4	-0.1866	-0.2421	-1410.90	0.1569	0.5084	1145.37
2.50	-0.0128	-0.2350	-0.1693	-0.3469	3720.3	-0.2463	0.0079	-1765.06	0.1777	0.5723	1254.25
2.60	-0.0354	-0.2698	-0.2804	-0.3579	4581.5	-0.2948	0.0572	-2047.68	0.2255	0.9556	1500.36
2.70	-0.0685	-0.3076	-0.3809	-0.4135	5541.7	-0.3355	-0.0932	-2284.61	0.2932	1.1173	1842.49
2.80	-0.1113	-0.3043	-0.4633	0.8430	6826.6	-0.4019	-0.4988	-2673.16	0.3940	1.5504	2349.41
2.90	-0.1624	-0.2580	-0.5550	0.3856	8418.9	-0.4830	-0.5631	-3147.43	0.4908	1.2954	2833.12
3.00	-0.2221	-0.2101	-0.6411	0.4727	10049.9	-0.5737	-0.7894	-3712.92	0.5816	1.5156	3232.28
3.10	-0.2906	-0.1603	-0.7313	0.5020	11693.6	-0.6649	-0.4300	-4314.30	0.6753	1.2205	3561.56
3.20	-0.3691	-0.1089	-0.8356	0.5820	13349.7	-0.7413	0.1134	-4821.50	0.7859	1.0651	3933.79
3.30	-0.4579	-0.0437	-0.9441	0.6586	15073.6	-0.7915	-0.1639	-5154.74	0.9257	1.6097	4401.11
3.40	-0.5562	0.0228	-1.0200	0.6321	16695.9	-0.8304	-0.4323	-5414.31	1.0660	1.8554	4864.45
3.50	-0.6629	0.0858	-1.1104	0.6401	18147.3	-0.8794	-0.4462	-5742.39	1.1782	1.3763	5218.02
3.60	-0.7776	0.1524	-1.1913	0.7809	19515.7	-0.9295	-0.1621	-6077.09	1.2804	1.2576	5537.48
3.70	-0.9020	0.2233	-1.2775	0.7259	20830.6	-0.9782	-0.2295	-6402.44	1.3777	0.9686	5841.89
3.80	-1.0337	0.2934	-1.3714	0.5225	22049.6	-1.0179	-0.3346	-6855.36	1.4716	1.1724	6135.68
3.90	-1.1745	0.3554	-1.4434	0.5791	23098.0	-1.0369	-0.0928	-7273.08	1.5754	1.2833	6460.98
4.00	-1.3243	0.4333	-1.5632	0.7296	24146.4	-1.0474	-0.0797	-7546.07	1.6766	0.7159	6777.10

Figure 17. (continued)

TRAILER NO. 1 SPRUNG MASS POSITION

TIME (SEC)	FORWARD (FT)	LATERAL (FT)	VERTICAL (FT)	ROLL (DEG)	PITCH (DEG)	HEADING (DEG)	TURN RADIUS (FT)	SIDE SLIP (DEG)	ARTICULATION ANGLE (DEG)
0.0	-26.5507	0.0	0.0	0.0	0.0	0.0	*****	0.0	0.0
0.10	-20.5033	-0.0000	0.0000	0.0000	-0.0000	-0.0000	*****	-0.0000	0.0000
0.20	-14.6035	-0.0000	0.0000	0.0000	-0.0000	-0.0000	*****	0.0000	0.0001
0.30	-8.7038	0.0000	0.0000	-0.0000	-0.0000	0.0000	*****	0.0000	0.0003
0.40	-2.8043	0.0000	0.0000	-0.0001	-0.0000	0.0000	*****	0.0000	0.0006
0.50	3.0946	0.0000	0.0000	-0.0003	-0.0001	0.0001	*****	0.0000	0.0010
0.60	8.9923	0.0000	0.0000	-0.0007	-0.0000	0.0002	*****	0.0000	0.0019
0.70	14.8895	0.0001	0.0001	-0.0014	-0.0000	0.0005	*****	0.0000	0.0036
0.80	20.7866	0.0001	0.0001	-0.0028	-0.0000	0.0009	550429.3750	0.0000	0.0066
0.90	26.6837	0.0003	0.0001	-0.0053	-0.0000	0.0017	305485.3125	0.0001	0.0115
1.00	32.5807	0.0005	0.0001	-0.0096	-0.0000	0.0032	172716.1875	0.0001	0.0189
1.10	38.4776	0.0010	0.0001	-0.0162	0.0000	0.0057	100469.3750	0.0002	0.0297
1.20	44.3737	0.0018	0.0001	-0.0259	-0.0000	0.0097	61605.3750	0.0005	0.0448
1.30	50.2697	0.0031	0.0001	-0.0392	-0.0000	0.0159	39716.0039	0.0013	0.0650
1.40	56.1657	0.0054	0.0001	-0.0566	-0.0000	0.0250	26819.4414	0.0026	0.0913
1.50	62.0614	0.0089	0.0000	-0.0786	-0.0000	0.0381	18939.5039	0.0047	0.1247
1.60	67.9571	0.0143	0.0000	-0.1061	-0.0000	0.0561	13919.7617	0.0076	0.1660
1.70	73.8527	0.0222	0.0000	-0.1403	-0.0000	0.0804	10580.4844	0.0113	0.2159
1.80	79.7480	0.0333	0.0000	-0.1826	-0.0000	0.1124	8260.2930	0.0157	0.2750
1.90	85.6430	0.0487	-0.0000	-0.2346	-0.0001	0.1534	6581.6563	0.0206	0.3440
2.00	91.5377	0.0693	-0.0001	-0.2980	-0.0001	0.2052	5338.5508	0.0260	0.4232
2.10	97.4322	0.0964	-0.0001	-0.3749	-0.0000	0.2693	4398.8281	0.0318	0.5132
2.20	103.3259	0.1314	-0.0002	-0.4672	0.0001	0.3475	3684.0237	0.0378	0.6145
2.30	109.2195	0.1758	-0.0005	-0.5767	0.0002	0.4413	3142.1145	0.0434	0.7281
2.40	115.1133	0.2312	-0.0015	-0.7053	0.0045	0.5523	2620.7090	0.0500	0.8531
2.50	121.0069	0.2998	-0.0061	-0.8584	0.0247	0.6837	2194.1301	0.0598	0.9877
2.60	126.9001	0.3840	-0.0186	-1.0375	0.0679	0.8388	1917.1860	0.0691	1.1322
2.70	132.7959	0.4861	-0.0400	-1.2363	0.1313	1.0177	1688.8079	0.0767	1.2874
2.80	138.6983	0.6086	-0.0671	-1.4484	0.2132	1.2205	1461.6321	0.0869	1.4562
2.90	144.6049	0.7550	-0.0965	-1.6691	0.3114	1.4499	1258.8293	0.1048	1.6388
3.00	150.5143	0.9290	-0.1293	-1.8948	0.4117	1.7088	1106.6445	0.1304	1.8301
3.10	156.4284	1.1345	-0.1720	-2.1207	0.4950	1.9981	981.0369	0.1641	2.0229
3.20	162.3471	1.3755	-0.2279	-2.3472	0.5720	2.3223	885.1421	0.2027	2.2164
3.30	168.2709	1.6558	-0.2952	-2.5712	0.6678	2.6852	824.7610	0.2344	2.4188
3.40	174.2012	1.9787	-0.3729	-2.7772	0.7715	3.0814	757.6223	0.2636	2.6365
3.50	180.1354	2.3480	-0.4605	-2.9581	0.8609	3.5081	692.5691	0.3044	2.8695
3.60	186.0706	2.7683	-0.5555	-3.1216	0.9444	3.9720	641.2507	0.3494	3.1082
3.70	192.0068	3.2441	-0.6564	-3.2720	1.0326	4.4782	595.9631	0.3924	3.3451
3.80	197.9438	3.7792	-0.7658	-3.4073	1.1132	5.0257	559.5574	0.4342	3.5864
3.90	203.8789	4.3776	-0.8867	-3.5221	1.1870	5.6128	529.2842	0.4730	3.8339
4.00	209.8097	5.0429	-1.0186	-3.6212	1.2716	6.2422	500.3872	0.5058	4.0829

Figure 17. (continued)

TRAILER NO. 1 SPRUNG MASS VELOCITY (BODY AXES)

TIME (SEC)	FORWARD (FT/SEC)	LATERAL (FT/SEC)	VERTICAL (FT/SEC)	ROLL (DEG/SEC)	PITCH (DEG/SEC)	HEADING (DEG/SEC)	ARTICULATION RATE (DEG/SEC)
0.0	59.00	0.0	0.0	0.0	0.0	0.0	0.0
0.10	59.00	-0.00	0.00	0.00	-0.00	-0.00	0.00
0.20	59.00	0.00	0.00	-0.00	-0.00	0.00	0.00
0.30	59.00	0.00	0.00	-0.00	-0.00	0.00	0.00
0.40	59.00	0.00	0.00	-0.00	-0.00	0.00	0.00
0.50	58.99	0.00	0.00	-0.00	-0.00	0.00	0.01
0.60	58.99	0.00	0.00	-0.00	0.00	0.00	0.01
0.70	58.99	0.00	0.00	-0.01	0.00	0.00	0.02
0.80	58.99	0.00	-0.00	-0.02	0.00	0.01	0.04
0.90	58.99	0.00	-0.00	-0.03	-0.00	0.01	0.06
1.00	58.99	0.00	-0.00	-0.05	0.00	0.02	0.09
1.10	58.98	0.00	0.00	-0.08	0.00	0.03	0.13
1.20	58.98	0.00	0.00	-0.11	-0.00	0.05	0.17
1.30	58.98	0.00	0.00	-0.15	0.00	0.08	0.23
1.40	58.98	0.00	-0.00	-0.20	0.00	0.11	0.30
1.50	58.98	0.00	-0.00	-0.25	-0.00	0.15	0.37
1.60	58.98	0.01	-0.00	-0.31	-0.00	0.21	0.46
1.70	58.97	0.01	-0.00	-0.38	-0.00	0.28	0.54
1.80	58.97	0.02	-0.00	-0.47	-0.00	0.36	0.64
1.90	58.97	0.02	-0.00	-0.57	-0.00	0.46	0.74
2.00	58.97	0.03	-0.00	-0.70	-0.00	0.58	0.85
2.10	58.97	0.03	-0.00	-0.84	-0.00	0.71	0.96
2.20	58.96	0.04	-0.00	-1.01	-0.01	0.86	1.07
2.30	58.96	0.04	-0.00	-1.19	-0.00	1.02	1.20
2.40	58.95	0.05	-0.02	-1.40	0.08	1.21	1.30
2.50	58.95	0.06	-0.05	-1.67	0.30	1.43	1.39
2.60	58.94	0.07	-0.10	-1.91	0.51	1.68	1.49
2.70	58.93	0.08	-0.12	-2.07	0.68	1.92	1.62
2.80	58.96	0.09	-0.07	-2.18	0.86	2.18	1.76
2.90	59.02	0.11	0.02	-2.25	0.96	2.47	1.88
3.00	59.10	0.13	0.06	-2.28	0.84	2.77	1.93
3.10	59.18	0.17	0.02	-2.28	0.64	3.08	1.93
3.20	59.26	0.21	-0.02	-2.30	0.70	3.47	1.96
3.30	59.33	0.24	-0.03	-2.23	0.87	3.85	2.10
3.40	59.40	0.27	-0.02	-1.98	0.78	4.15	2.26
3.50	59.48	0.32	-0.01	-1.78	0.60	4.47	2.38
3.60	59.54	0.36	0.02	-1.65	0.60	4.88	2.38
3.70	59.60	0.41	0.05	-1.53	0.57	5.31	2.38
3.80	59.66	0.45	0.03	-1.37	0.41	5.70	2.45
3.90	59.71	0.49	-0.00	-1.18	0.39	6.10	2.49
4.00	59.75	0.53	-0.01	-1.10	0.51	6.55	2.49

Figure 17. (continued)

TRAILER NO. 1 SPRUNG MASS ACCELERATION (BODY AXES)

INERTIAL ACCEL. ALONG BODY AXES

TIME (SEC)	TRAILER NO. 1 SPRUNG MASS ACCELERATION (BODY AXES)						INERTIAL ACCEL. ALONG BODY AXES	
	FORWARD (FT/SEC**2)	LATERAL (FT/SEC**2)	VERTICAL (FT/SEC**2)	ROLL (DEG/SEC**2)	PITCH (DEG/SEC**2)	HEADING (DEG/SEC**2)	LONGITUDINAL (FT/SEC**2)	LATERAL (FT/SEC**2)
0.0	0.0000	0.0000	0.0	-0.0000	0.0000	-0.0000	0.0000	0.0000
0.10	0.0000	-0.0000	0.0001	0.0003	-0.0005	-0.0001	0.0000	-0.0000
0.20	-0.0009	0.0001	0.0002	-0.0022	-0.0018	0.0006	-0.0009	0.0001
0.30	-0.0009	0.0002	0.0003	-0.0079	-0.0006	0.0028	-0.0009	0.0004
0.40	0.0001	0.0001	0.0003	-0.0109	0.0020	0.0041	0.0001	0.0006
0.50	-0.0008	-0.0002	0.0002	-0.0147	0.0016	0.0045	-0.0008	0.0008
0.60	0.0004	-0.0001	-0.0001	-0.0314	0.0030	0.0089	0.0004	0.0015
0.70	-0.0003	0.0002	-0.0006	-0.0662	-0.0007	0.0205	-0.0003	0.0033
0.80	0.0002	0.0003	-0.0011	-0.1151	-0.0036	0.0386	0.0002	0.0063
0.90	0.0001	0.0001	-0.0004	-0.1741	-0.0003	0.0642	0.0001	0.0114
1.00	0.0002	0.0005	0.0013	-0.2385	-0.0039	0.1010	0.0002	0.0202
1.10	-0.0056	0.0021	0.0005	-0.3022	-0.0096	0.1519	-0.0056	0.0347
1.20	-0.0002	0.0052	-0.0005	-0.3612	0.0014	0.2163	-0.0002	0.0565
1.30	-0.0002	0.0101	-0.0005	-0.4101	0.0040	0.2951	-0.0002	0.0877
1.40	0.0032	0.0172	-0.0009	-0.4570	0.0004	0.3879	0.0032	0.1298
1.50	-0.0017	0.0258	-0.0006	-0.5462	-0.0055	0.4977	-0.0017	0.1838
1.60	0.0024	0.0343	0.0012	-0.6713	0.0063	0.6250	0.0023	0.2500
1.70	0.0029	0.0418	0.0001	-0.8123	-0.0018	0.7639	0.0029	0.3288
1.80	-0.0038	0.0480	-0.0025	-0.9645	-0.0136	0.9105	-0.0039	0.4211
1.90	-0.0109	0.0536	-0.0019	-1.1429	-0.0098	1.0685	-0.0111	0.5284
2.00	-0.0020	0.0581	0.0000	-1.3406	0.0032	1.2362	-0.0022	0.6514
2.10	0.0052	0.0611	-0.0026	-1.5472	-0.0252	1.4090	0.0048	0.7904
2.20	-0.0242	0.0606	-0.0104	-1.7252	-0.0485	1.5701	-0.0248	0.9436
2.30	-0.0304	0.0560	-0.0414	-1.8726	0.2633	1.6945	-0.0312	1.1062
2.40	-0.0242	0.0858	-0.2517	-2.4694	1.6024	2.0655	-0.0254	1.3262
2.50	-0.0570	0.1074	-0.4777	-2.7259	2.3097	2.4544	-0.0589	1.5819
2.60	-0.1069	0.0823	-0.3947	-1.9493	1.9086	2.4209	-0.1099	1.8080
2.70	0.0586	0.0811	0.1711	-1.3933	1.7116	2.4272	0.0545	2.0524
2.80	0.5015	0.1399	0.7621	-0.8241	1.6007	2.7339	0.4971	2.3773
2.90	0.7757	0.2278	0.7754	-0.5829	0.1279	3.0190	0.7713	2.7703
3.00	0.8020	0.3065	-0.0242	-0.0419	-2.2682	2.9505	0.7964	3.1620
3.10	0.8390	0.3928	-0.5767	-0.1533	-1.0388	3.4671	0.8301	3.5748
3.20	0.8138	0.3856	-0.2288	-0.0305	1.9811	4.0842	0.8008	3.9701
3.30	0.7233	0.2883	0.0826	1.7772	0.6046	3.3314	0.7066	4.2726
3.40	0.7291	0.3673	0.0468	2.5463	-2.0374	2.8266	0.7090	4.6658
3.50	0.7498	0.4768	0.1773	1.4462	-0.9224	3.6967	0.7250	5.1165
3.60	0.6581	0.4664	0.3981	1.0263	0.4199	4.3019	0.6274	5.5402
3.70	0.5573	0.4521	0.1063	1.1906	-1.3098	3.9996	0.5200	5.9739
3.80	0.5466	0.4407	-0.3824	1.9195	-1.2082	3.8171	0.5019	6.3740
3.90	0.5002	0.3924	-0.2529	1.2972	0.9070	4.2230	0.4477	6.7495
4.00	0.3688	0.3186	0.0809	-0.2779	0.5399	4.4677	0.3084	7.1487

Figure 17. (continued)

TRAILER NO. 1 REAR SUSPENSION TIRE FORCES

LEADING TANDEM AXLE

TIME (SEC)	LEFT SIDE					RIGHT SIDE				
	VERTICAL (LB)	LONG. (LB)	LATERAL (LB)	MU-X	MU-Y	VERTICAL (LB)	LONG. (LB)	LATERAL (LB)	MU-X	MU-Y
0.0	8500.09	-0.0	0.0	0.0	0.0	8500.09	-0.0	0.0	0.0	0.0
0.10	8500.09	0.00	0.00	0.0000	0.0000	8500.09	-0.00	0.00	-0.0000	0.0000
0.20	8500.02	0.01	-0.01	0.0000	-0.0000	8500.04	0.01	-0.01	0.0000	-0.0000
0.30	8499.92	0.01	-0.04	0.0000	-0.0000	8499.93	0.01	-0.04	0.0000	-0.0000
0.40	8499.93	0.00	-0.06	0.0000	-0.0000	8499.90	0.01	-0.06	0.0000	-0.0000
0.50	8499.98	0.01	-0.05	0.0000	-0.0000	8499.88	0.01	-0.05	0.0000	-0.0000
0.60	8500.22	0.00	-0.09	0.0000	-0.0000	8499.92	0.01	-0.09	0.0000	-0.0000
0.70	8500.64	-0.01	-0.23	-0.0000	-0.0000	8500.02	0.01	-0.23	0.0000	-0.0000
0.80	8501.24	-0.02	-0.41	-0.0000	-0.0000	8499.88	0.01	-0.41	0.0000	-0.0000
0.90	8502.08	-0.02	-0.51	-0.0000	-0.0001	8498.30	0.02	-0.51	0.0000	-0.0001
1.00	8504.67	-0.04	-0.31	-0.0000	-0.0000	8494.63	0.04	-0.31	0.0000	-0.0000
1.10	8511.80	-0.03	0.53	-0.0000	0.0001	8488.34	0.08	0.53	0.0000	0.0001
1.20	8524.15	-0.07	2.40	-0.0000	0.0003	8475.95	0.09	2.39	0.0000	0.0003
1.30	8544.50	-0.11	5.70	-0.0000	0.0007	8455.60	0.11	5.66	0.0000	0.0007
1.40	8574.95	-0.16	10.84	-0.0000	0.0013	8426.18	0.13	10.71	0.0000	0.0013
1.50	8612.34	-0.17	17.85	-0.0000	0.0021	8388.30	0.20	17.54	0.0000	0.0021
1.60	8657.41	-0.24	26.75	-0.0000	0.0031	8341.80	0.23	26.11	0.0000	0.0031
1.70	8713.36	-0.29	37.88	-0.0000	0.0043	8287.17	0.28	36.66	0.0000	0.0044
1.80	8780.11	-0.31	51.66	-0.0000	0.0059	8221.58	0.38	49.50	0.0000	0.0060
1.90	8857.52	-0.33	68.39	-0.0000	0.0077	8142.60	0.47	64.75	0.0001	0.0080
2.00	8948.57	-0.45	88.34	-0.0001	0.0099	8050.57	0.48	82.48	0.0001	0.0102
2.10	9057.55	-0.58	111.96	-0.0001	0.0124	7946.53	0.48	102.83	0.0001	0.0129
2.20	9181.43	-0.46	139.67	-0.0000	0.0152	7823.95	0.72	125.87	0.0001	0.0161
2.30	9319.65	-0.37	171.95	-0.0000	0.0185	7678.76	0.91	151.59	0.0001	0.0197
2.40	9502.16	-0.58	207.69	-0.0001	0.0219	7536.50	0.95	178.63	0.0001	0.0237
2.50	9774.30	-0.54	250.14	-0.0001	0.0256	7425.37	1.30	209.41	0.0002	0.0282
2.60	10049.85	-0.12	306.53	-0.0000	0.0305	7250.70	1.72	248.35	0.0002	0.0343
2.70	10220.27	-1.10	374.00	-0.0001	0.0366	6926.32	0.79	290.39	0.0001	0.0419
2.80	10415.27	-4.41	453.72	-0.0004	0.0436	6588.33	-2.25	335.98	-0.0003	0.0510
2.90	10847.46	-6.68	548.83	-0.0006	0.0506	6442.35	-4.34	391.18	-0.0007	0.0607
3.00	11448.47	-6.92	649.30	-0.0006	0.0567	6436.22	-4.66	450.39	-0.0007	0.0700
3.10	11786.95	-7.31	742.03	-0.0006	0.0630	6193.85	-4.71	493.27	-0.0008	0.0796
3.20	11876.86	-7.42	849.98	-0.0006	0.0716	5732.71	-4.32	525.23	-0.0008	0.0916
3.30	12249.73	-6.50	994.86	-0.0005	0.0812	5406.69	-3.90	571.74	-0.0007	0.1057
3.40	12740.31	-6.23	1141.41	-0.0005	0.0896	5184.13	-4.06	617.91	-0.0008	0.1192
3.50	12974.02	-6.71	1264.73	-0.0005	0.0975	4702.60	-3.96	616.46	-0.0008	0.1311
3.60	13208.66	-6.31	1409.03	-0.0005	0.1067	4278.63	-3.12	620.58	-0.0007	0.1450
3.70	13709.64	-5.38	1574.89	-0.0004	0.1149	4072.22	-2.35	650.93	-0.0006	0.1598
3.80	14116.63	-5.13	1732.70	-0.0004	0.1227	3860.51	-2.23	672.17	-0.0006	0.1741
3.90	14236.27	-4.94	1882.94	-0.0003	0.1323	3503.02	-1.86	660.82	-0.0005	0.1886
4.00	14457.53	-4.06	2024.41	-0.0003	0.1400	3241.79	-0.78	656.74	-0.0002	0.2026

66

Figure 17. (continued)

TRAILER NO. 1 REAR SUSPENSION TIRE FORCES

TRAILING TANDEM AXLE

TIME (SEC)	LEFT SIDE					RIGHT SIDE				
	VERTICAL (LB)	LONG. (LB)	LATERAL (LB)	MU-X	MU-Y	VERTICAL (LB)	LONG. (LB)	LATERAL (LB)	MU-X	MU-Y
0.0	8500.09	-0.0	0.0	0.0	0.0	8500.09	-0.0	0.0	0.0	0.0
0.10	8500.09	0.00	0.00	0.0000	0.0000	8500.09	-0.00	0.00	-0.0000	0.0000
0.20	8500.01	0.01	-0.01	0.0000	-0.0000	8500.03	0.01	-0.01	0.0000	-0.0000
0.30	8499.94	0.01	-0.02	0.0000	-0.0000	8499.93	0.01	-0.02	0.0000	-0.0000
0.40	8499.98	0.00	-0.00	0.0000	-0.0000	8499.86	0.01	-0.00	0.0000	-0.0000
0.50	8500.04	0.01	0.04	0.0000	0.0000	8499.79	0.01	0.04	0.0000	0.0000
0.60	8500.32	0.00	0.06	0.0000	0.0000	8499.78	0.01	0.06	0.0000	0.0000
0.70	8500.89	-0.01	0.06	-0.0000	0.0000	8499.80	0.01	0.06	0.0000	0.0000
0.80	8501.70	-0.02	0.15	-0.0000	0.0000	8499.42	0.01	0.15	0.0000	0.0000
0.90	8502.92	-0.02	0.54	-0.0000	0.0001	8497.46	0.02	0.54	0.0000	0.0001
1.00	8506.14	-0.04	1.52	-0.0000	0.0002	8493.16	0.04	1.52	0.0000	0.0002
1.10	8514.21	-0.03	3.57	-0.0000	0.0004	8485.92	0.08	3.56	0.0000	0.0004
1.20	8527.95	-0.07	7.19	-0.0000	0.0008	8472.16	0.09	7.16	0.0000	0.0008
1.30	8550.22	-0.11	12.95	-0.0000	0.0015	8449.88	0.11	12.85	0.0000	0.0015
1.40	8583.25	-0.16	21.40	-0.0000	0.0025	8417.88	0.13	21.13	0.0000	0.0025
1.50	8623.97	-0.17	32.72	-0.0000	0.0038	8376.66	0.20	32.10	0.0000	0.0038
1.60	8673.30	-0.24	47.13	-0.0000	0.0054	8325.90	0.23	45.89	0.0000	0.0055
1.70	8734.50	-0.29	65.15	-0.0000	0.0075	8266.00	0.28	62.86	0.0000	0.0076
1.80	8807.59	-0.31	87.33	-0.0000	0.0099	8194.08	0.38	83.33	0.0000	0.0102
1.90	8892.48	-0.33	114.10	-0.0000	0.0128	8107.61	0.47	107.44	0.0001	0.0133
2.00	8992.23	-0.45	145.93	-0.0001	0.0162	8006.87	0.48	135.31	0.0001	0.0169
2.10	9111.18	-0.58	183.40	-0.0001	0.0201	7892.84	0.48	167.04	0.0001	0.0212
2.20	9246.29	-0.46	227.06	-0.0000	0.0246	7759.03	0.72	202.55	0.0001	0.0261
2.30	9396.64	-0.37	277.07	-0.0000	0.0295	7601.71	0.90	241.31	0.0001	0.0317
2.40	9593.04	-0.58	333.57	-0.0001	0.0348	7445.55	0.95	282.81	0.0001	0.0380
2.50	9882.77	-0.54	402.64	-0.0001	0.0407	7316.80	1.30	331.40	0.0002	0.0453
2.60	10176.84	-0.12	488.41	-0.0000	0.0480	7123.62	1.72	387.89	0.0002	0.0545
2.70	10363.63	-1.10	584.23	-0.0001	0.0564	6782.89	0.79	443.18	0.0001	0.0653
2.80	10575.50	-4.41	694.83	-0.0004	0.0657	6428.00	-2.25	500.83	-0.0003	0.0779
2.90	10964.61	-6.67	825.63	-0.0006	0.0753	6202.85	-4.33	568.46	-0.0007	0.0916
3.00	11586.98	-6.91	967.90	-0.0006	0.0835	6172.67	-4.65	646.47	-0.0008	0.1047
3.10	11946.81	-7.31	1101.66	-0.0006	0.0922	5911.80	-4.69	699.71	-0.0008	0.1184
3.20	12055.88	-7.42	1256.51	-0.0006	0.1042	5436.32	-4.31	731.24	-0.0008	0.1345
3.30	12417.92	-6.49	1451.60	-0.0005	0.1169	5143.91	-3.90	788.55	-0.0008	0.1533
3.40	12941.16	-6.23	1643.00	-0.0005	0.1270	4879.59	-4.05	831.43	-0.0008	0.1704
3.50	13200.98	-6.71	1806.10	-0.0005	0.1368	4364.27	-3.95	810.27	-0.0009	0.1857
3.60	13427.54	-6.31	1961.02	-0.0005	0.1460	3953.95	-3.13	795.60	-0.0008	0.2012
3.70	13936.00	-5.38	2142.50	-0.0004	0.1537	3754.12	-2.36	816.95	-0.0006	0.2176
3.80	14335.14	-5.12	2312.24	-0.0004	0.1613	3531.03	-2.23	823.58	-0.0006	0.2332
3.90	14473.66	-4.93	2480.65	-0.0003	0.1714	3188.14	-1.86	797.67	-0.0006	0.2502
4.00	14689.55	-4.06	2668.95	-0.0003	0.1817	2907.84	-0.80	781.16	-0.0003	0.2686

100

Figure 17. (continued)

TRAILER NO. 1 REAR SUSPENSION - LATERAL TIRE FORCE AND MOMENT SUMMARY

LEADING TANDEM AXLE

LEFT SIDE

RIGHT SIDE

TIME (SEC)	LEFT SIDE				RIGHT SIDE			
	TIRE SIDESLIP ANGLE (DEG)	TIRE LATERAL FORCE (LB)	MU-Y	ALIGNING TORQUE (IN-LB)	TIRE SIDESLIP ANGLE (DEG)	TIRE LATERAL FORCE (LB)	MU-Y	ALIGNING TORQUE (IN-LB)
0.0	0.0	0.0	0.0	0.0	0.0	0.0	0.0	0.0
0.10	-0.0000	0.0014	0.0000	-0.0023	-0.0000	0.0014	0.0000	-0.0023
0.20	0.0000	-0.0054	-0.0000	0.0092	0.0000	-0.0054	-0.0000	0.0092
0.30	0.0000	-0.0352	-0.0000	0.0597	0.0000	-0.0352	-0.0000	0.0597
0.40	0.0000	-0.0553	-0.0000	0.0939	0.0000	-0.0553	-0.0000	0.0939
0.50	0.0000	-0.0543	-0.0000	0.0922	0.0000	-0.0543	-0.0000	0.0922
0.60	0.0001	-0.0932	-0.0000	0.1582	0.0001	-0.0932	-0.0000	0.1582
0.70	0.0002	-0.2254	-0.0000	0.3827	0.0002	-0.2254	-0.0000	0.3827
0.80	0.0003	-0.4079	-0.0000	0.6924	0.0003	-0.4079	-0.0000	0.6924
0.90	0.0004	-0.5083	-0.0001	0.8629	0.0004	-0.5082	-0.0001	0.8626
1.00	0.0002	-0.3061	-0.0000	0.5195	0.0002	-0.3058	-0.0000	0.5191
1.10	-0.0004	0.5338	0.0001	-0.9061	-0.0004	0.5328	0.0001	-0.9045
1.20	-0.0017	2.3985	0.0003	-4.0714	-0.0017	2.3897	0.0003	-4.0566
1.30	-0.0040	5.6979	0.0007	-9.6722	-0.0040	5.6595	0.0007	-9.6070
1.40	-0.0076	10.8359	0.0013	-18.3939	-0.0076	10.7137	0.0013	-18.1864
1.50	-0.0125	17.8458	0.0021	-30.2931	-0.0125	17.5431	0.0021	-29.7793
1.60	-0.0187	26.7465	0.0031	-45.4021	-0.0187	26.1092	0.0031	-44.3203
1.70	-0.0264	37.8789	0.0043	-64.2992	-0.0264	36.6650	0.0044	-62.2386
1.80	-0.0358	51.6610	0.0059	-87.6943	-0.0358	49.5017	0.0060	-84.0290
1.90	-0.0471	68.3872	0.0077	-116.0869	-0.0471	64.7480	0.0080	-109.9094
2.00	-0.0604	88.3443	0.0099	-149.9642	-0.0605	82.4762	0.0102	-140.0030
2.10	-0.0760	111.9576	0.0124	-190.0476	-0.0761	102.8277	0.0129	-174.5496
2.20	-0.0940	139.6700	0.0152	-237.0892	-0.0942	125.8686	0.0161	-213.6614
2.30	-0.1147	171.9524	0.0185	-291.8884	-0.1149	151.5856	0.0197	-257.3159
2.40	-0.1369	207.6937	0.0219	-352.5593	-0.1372	178.6322	0.0237	-303.2273
2.50	-0.1621	250.1373	0.0256	-424.6069	-0.1626	209.4102	0.0282	-355.4729
2.60	-0.1955	306.5349	0.0305	-520.3418	-0.1961	248.3510	0.0343	-421.5747
2.70	-0.2363	373.9963	0.0366	-634.8574	-0.2371	290.3862	0.0419	-492.9294
2.80	-0.2837	453.7197	0.0436	-770.1875	-0.2848	335.9824	0.0510	-570.3289
2.90	-0.3358	548.8335	0.0506	-931.6428	-0.3372	391.1848	0.0607	-664.0347
3.00	-0.3867	649.3047	0.0567	-1102.1921	-0.3886	450.3882	0.0700	-764.5320
3.10	-0.4359	742.0310	0.0630	-1259.5950	-0.4383	493.2737	0.0796	-837.3301
3.20	-0.4976	849.9849	0.0716	-1442.8462	-0.5007	525.2334	0.0916	-891.5815
3.30	-0.5740	994.8562	0.0812	-1688.7646	-0.5779	571.7368	0.1057	-970.5210
3.40	-0.6466	1141.4072	0.0896	-1937.5344	-0.6513	617.9053	0.1192	-1048.8918
3.50	-0.7107	1264.7319	0.0975	-2146.8777	-0.7164	616.4646	0.1311	-1046.4463
3.60	-0.7858	1409.0266	0.1067	-2391.8174	-0.7926	620.5850	0.1450	-1053.4407
3.70	-0.8654	1574.8948	0.1149	-2673.3779	-0.8735	650.9346	0.1598	-1104.9587
3.80	-0.9420	1732.7014	0.1227	-2941.2542	-0.9515	672.1653	0.1741	-1140.9980
3.90	-1.0266	1882.9417	0.1323	-3196.2861	-1.0376	660.8169	0.1886	-1121.7341
4.00	-1.1177	2024.4067	0.1400	-3436.4209	-1.1306	656.7412	0.2026	-1114.8157

101

Figure 17. (continued)

TRAILER NO. 1 REAR SUSPENSION - LATERAL TIRE FORCE AND MOMENT SUMMARY

TRAILING TANDEM AXLE

TIME (SEC)	LEFT SIDE				RIGHT SIDE			
	TIRE SIDESLIP ANGLE (DEG)	TIRE LATERAL FORCE (LB)	MU-Y	ALIGNING TORQUE (IN-LB)	TIRE SIDESLIP ANGLE (DEG)	TIRE LATERAL FORCE (LB)	MU-Y	ALIGNING TORQUE (IN-LB)
0.0	0.0	0.0	0.0	0.0	0.0	0.0	0.0	0.0
0.10	-0.0000	0.0010	0.0000	-0.0017	-0.0000	0.0010	0.0000	-0.0017
0.20	0.0000	-0.0051	-0.0000	0.0087	0.0000	-0.0051	-0.0000	0.0087
0.30	0.0000	-0.0189	-0.0000	0.0321	0.0000	-0.0189	-0.0000	0.0321
0.40	0.0000	-0.0045	-0.0000	0.0076	0.0000	-0.0045	-0.0000	0.0076
0.50	-0.0000	0.0362	0.0000	-0.0614	-0.0000	0.0362	0.0000	-0.0614
0.60	-0.0000	0.0564	0.0000	-0.0958	-0.0000	0.0564	0.0000	-0.0958
0.70	-0.0000	0.0590	0.0000	-0.1001	-0.0000	0.0590	0.0000	-0.1001
0.80	-0.0001	0.1547	0.0000	-0.2626	-0.0001	0.1547	0.0000	-0.2626
0.90	-0.0004	0.5393	0.0001	-0.9154	-0.0004	0.5390	0.0001	-0.9150
1.00	-0.0011	1.5231	0.0002	-2.5854	-0.0011	1.5216	0.0002	-2.5829
1.10	-0.0025	3.5663	0.0004	-6.0539	-0.0025	3.5587	0.0004	-6.0409
1.20	-0.0051	7.1924	0.0008	-12.2090	-0.0051	7.1619	0.0008	-12.1574
1.30	-0.0091	12.9519	0.0015	-21.9858	-0.0091	12.8532	0.0015	-21.8183
1.40	-0.0150	21.3955	0.0025	-36.3187	-0.0150	21.1269	0.0025	-35.8628
1.50	-0.0229	32.7176	0.0038	-55.5380	-0.0229	32.1047	0.0038	-54.4976
1.60	-0.0329	47.1305	0.0054	-80.0039	-0.0329	45.8941	0.0055	-77.9052
1.70	-0.0453	65.1527	0.0075	-110.5964	-0.0453	62.8579	0.0076	-106.7011
1.80	-0.0604	87.3326	0.0099	-148.2468	-0.0604	83.3257	0.0102	-141.4450
1.90	-0.0784	114.1001	0.0128	-193.6844	-0.0784	107.4421	0.0133	-182.3826
2.00	-0.0995	145.9257	0.0162	-247.7084	-0.0996	135.3085	0.0169	-229.6857
2.10	-0.1241	183.4009	0.0201	-311.3223	-0.1242	167.0396	0.0212	-283.5491
2.20	-0.1522	227.0610	0.0246	-385.4351	-0.1524	202.5547	0.0261	-343.8357
2.30	-0.1839	277.0720	0.0295	-470.3286	-0.1842	241.3098	0.0317	-409.6223
2.40	-0.2186	333.5740	0.0348	-566.2405	-0.2191	282.8096	0.0380	-480.0681
2.50	-0.2593	402.6416	0.0407	-683.4824	-0.2600	331.3987	0.0453	-562.5479
2.60	-0.3093	488.4131	0.0480	-829.0793	-0.3102	387.8872	0.0545	-658.4370
2.70	-0.3663	584.2263	0.0564	-991.7219	-0.3675	443.1829	0.0653	-752.3013
2.80	-0.4308	694.8271	0.0657	-1179.4666	-0.4325	500.8320	0.0779	-850.1604
2.90	-0.5023	825.6257	0.0753	-1401.4966	-0.5045	568.4573	0.0916	-964.9541
3.00	-0.5731	967.9001	0.0835	-1643.0068	-0.5759	646.4700	0.1047	-1097.3804
3.10	-0.6433	1101.6582	0.0922	-1870.0605	-0.6468	699.7070	0.1184	-1187.7500
3.20	-0.7306	1256.5059	0.1042	-2132.9141	-0.7350	731.2393	0.1345	-1241.2759
3.30	-0.8320	1451.6006	0.1169	-2464.0867	-0.8377	788.5542	0.1533	-1338.5676
3.40	-0.9243	1643.0005	0.1270	-2788.9873	-0.9311	831.4312	0.1704	-1411.3513
3.50	-1.0098	1806.1045	0.1368	-3065.8557	-1.0177	810.2664	0.1857	-1375.4241
3.60	-1.1119	1961.0210	0.1460	-3328.8252	-1.1215	795.6003	0.2012	-1350.5286
3.70	-1.2194	2142.5042	0.1537	-3636.8906	-1.2308	816.9524	0.2176	-1386.7734
3.80	-1.3217	2312.2402	0.1613	-3925.0166	-1.3350	823.5796	0.2332	-1398.0232
3.90	-1.4326	2480.6458	0.1714	-4210.8867	-1.4480	797.6699	0.2502	-1354.0415
4.00	-1.5531	2668.9485	0.1817	-4530.5273	-1.5710	781.1553	0.2686	-1326.0081

Figure 17. (continued)

TRAILER NO. 1 REAR SUSPENSION - UNSPRUNG MASS SUMMARY

LEADING TANDEM AXLE

TIME (SEC)	AXLE MOTION				DYNAMIC SUSPENSION MOTIONS AND FORCES						
	POSITION		VELOCITY		AUXILIARY ROLL TORQUE (IN-LB)	LEFT SIDE			RIGHT SIDE		
	VERTICAL (FT)	ROLL (DEG)	VERTICAL (FT/SEC)	ROLL (DEG/SEC)		SUSP. DEFLECT. (IN)	SUSP. VELOCITY (IN/SEC)	SUSP. FORCE (LB)	SUSP. DEFLECT. (IN)	SUSP. VELOCITY (IN/SEC)	SUSP. FORCE (LB)
0.0	0.0	0.0	0.0	0.0	0.0	0.0	0.0	0.0	0.0	0.0	0.0
0.10	0.0	0.0000	0.0	0.0000	-0.0	-0.0000	-0.0000	0.02	-0.0000	-0.0000	0.01
0.20	-0.0000	0.0000	-0.0000	0.0000	-0.0	-0.0000	-0.0000	0.06	-0.0000	0.0000	0.04
0.30	-0.0000	0.0000	-0.0000	-0.0000	0.2	-0.0000	-0.0003	0.12	0.0000	0.0001	0.17
0.40	-0.0000	-0.0000	-0.0000	0.0000	1.2	-0.0001	-0.0012	0.12	-0.0000	-0.0002	0.26
0.50	-0.0000	-0.0000	0.0000	-0.0002	3.2	-0.0003	-0.0025	0.06	-0.0001	-0.0008	0.26
0.60	-0.0000	-0.0000	0.0000	-0.0002	6.7	-0.0006	-0.0040	-0.21	-0.0002	-0.0009	0.26
0.70	0.0000	-0.0001	0.0000	-0.0004	13.4	-0.0010	-0.0050	-0.78	-0.0002	0.0012	0.32
0.80	0.0000	-0.0001	0.0000	-0.0011	26.4	-0.0016	-0.0061	-1.64	0.0001	0.0056	0.76
0.90	0.0000	-0.0003	-0.0001	-0.0033	49.5	-0.0023	-0.0088	-3.11	0.0009	0.0109	2.96
1.00	-0.0000	-0.0009	-0.0000	-0.0079	86.7	-0.0034	-0.0152	-7.30	0.0022	0.0151	8.15
1.10	-0.0000	-0.0020	0.0001	-0.0159	141.4	-0.0052	-0.0218	-17.77	0.0039	0.0212	17.81
1.20	-0.0000	-0.0042	-0.0000	-0.0278	216.3	-0.0077	-0.0285	-36.52	0.0064	0.0286	36.56
1.30	-0.0000	-0.0077	0.0000	-0.0439	313.1	-0.0108	-0.0362	-67.69	0.0095	0.0358	67.76
1.40	0.0000	-0.0130	0.0000	-0.0591	433.8	-0.0147	-0.0448	-114.01	0.0134	0.0459	113.19
1.50	0.0000	-0.0196	-0.0001	-0.0732	586.7	-0.0196	-0.0548	-170.80	0.0185	0.0595	170.43
1.60	-0.0000	-0.0276	-0.0000	-0.0884	780.0	-0.0257	-0.0701	-238.90	0.0249	0.0743	239.79
1.70	0.0000	-0.0374	0.0001	-0.1065	1023.6	-0.0335	-0.0884	-321.85	0.0329	0.0932	321.50
1.80	0.0000	-0.0490	-0.0000	-0.1267	1328.9	-0.0432	-0.1075	-420.03	0.0431	0.1195	418.64
1.90	-0.0000	-0.0628	-0.0001	-0.1489	1709.4	-0.0551	-0.1314	-533.80	0.0559	0.1506	533.94
2.00	-0.0000	-0.0789	0.0001	-0.1739	2180.2	-0.0698	-0.1620	-666.68	0.0719	0.1857	667.55
2.10	0.0000	-0.0976	0.0003	-0.2017	2758.2	-0.0881	-0.1970	-823.17	0.0914	0.2280	819.40
2.20	0.0000	-0.1193	-0.0002	-0.2329	3460.6	-0.1099	-0.2264	-1001.31	0.1154	0.2869	996.45
2.30	-0.0000	-0.1443	-0.0001	-0.2666	4301.3	-0.1354	-0.2719	-1201.96	0.1449	0.3373	1203.07
2.40	0.0002	-0.1729	0.0044	-0.3081	5296.7	-0.1691	-0.4002	-1458.60	0.1765	0.3231	1417.00
2.50	0.0009	-0.2066	0.0087	-0.3682	6483.8	-0.2168	-0.5159	-1815.00	0.2065	0.3454	1616.36
2.60	0.0014	-0.2463	-0.0009	-0.4207	7871.9	-0.2666	-0.4071	-2182.00	0.2478	0.5761	1888.33
2.70	0.0007	-0.2899	-0.0105	-0.4510	9415.2	-0.3039	-0.2920	-2455.61	0.3120	0.7775	2309.52
2.80	0.0000	-0.3369	-0.0004	-0.4895	11057.5	-0.3452	-0.4489	-2757.88	0.3791	0.6658	2746.44
2.90	-0.0002	-0.3870	-0.0309	-0.5182	12755.4	-0.4142	-1.0360	-3265.45	0.4218	0.1055	3023.31
3.00	-0.0080	-0.4388	-0.1306	-0.5138	14484.7	-0.5084	-1.1100	-3956.30	0.4416	0.0489	3150.98
3.10	-0.0282	-0.4883	-0.2720	-0.4718	16240.1	-0.5685	-0.5904	-4405.90	0.4972	0.5934	3509.89
3.20	-0.0607	-0.5350	-0.3696	-0.4825	18028.4	-0.5939	-0.5533	-4604.00	0.5902	0.6307	4062.57
3.30	-0.1012	-0.5617	-0.4337	0.9175	19992.1	-0.6503	-1.2326	-5056.67	0.6594	0.8206	4458.16
3.40	-0.1496	-0.5090	-0.5429	0.4277	22565.4	-0.7276	-0.7859	-5683.10	0.7344	0.7744	4886.01
3.50	-0.2100	-0.4578	-0.6602	0.5492	24873.9	-0.7753	-0.5396	-6068.72	0.8392	0.9561	5483.80
3.60	-0.2797	-0.4009	-0.7301	0.5805	27067.0	-0.8211	-0.7269	-6440.34	0.9403	0.6964	6058.35
3.70	-0.3568	-0.3485	-0.8133	0.5333	29084.6	-0.8959	-0.8851	-7049.65	1.0009	0.4195	6391.20
3.80	-0.4435	-0.2881	-0.9293	0.6586	31030.8	-0.9562	-0.5191	-7539.31	1.0704	0.7482	6709.48
3.90	-0.5416	-0.2160	-1.0235	0.7664	32890.1	-0.9863	-0.2845	-7725.54	1.1684	0.9179	7118.15
4.00	-0.6481	-0.1422	-1.1059	0.7047	34610.3	-1.0204	-0.5801	-8010.71	1.2491	0.5206	7446.73

Figure 17. (continued)

TRAILER NO. 1 REAR SUSPENSION - UNSPRUNG MASS SUMMARY

TRAILING TANDEM AXLE

TIME (SEC)	AXLE MOTION				DYNAMIC SUSPENSION MOTIONS AND FORCES						
	POSITION		VELOCITY		AUXILIARY ROLL TORQUE (IN-LB)	LEFT SIDE			RIGHT SIDE		
	VERTICAL (FT)	ROLL (DEG)	VERTICAL (FT/SEC)	ROLL (DEG/SEC)		SUSP. DEFLECT. (IN)	SUSP. VELOCITY (IN/SEC)	SUSP. FORCE (LB)	SUSP. DEFLECT. (IN)	SUSP. VELOCITY (IN/SEC)	SUSP. FORCE (LB)
0.0	0.0	0.0	0.0	0.0	0.0	0.0	0.0	0.0	0.0	0.0	0.0
0.10	0.0	0.0000	0.0	-0.0000	-0.0	-0.0000	-0.0000	0.02	-0.0000	-0.0000	0.01
0.20	-0.0000	0.0000	-0.0000	-0.0000	-0.0	-0.0000	-0.0000	0.06	-0.0000	0.0000	0.04
0.30	-0.0000	-0.0000	-0.0000	-0.0001	0.2	-0.0000	-0.0003	0.12	0.0000	-0.0000	0.17
0.40	-0.0000	-0.0000	-0.0000	-0.0000	1.1	-0.0001	-0.0012	0.12	0.0000	-0.0002	0.26
0.50	-0.0000	-0.0000	-0.0000	-0.0002	3.1	-0.0003	-0.0027	0.06	-0.0001	-0.0010	0.26
0.60	-0.0000	-0.0000	0.0000	-0.0003	6.5	-0.0006	-0.0039	-0.21	-0.0002	-0.0009	0.26
0.70	0.0000	-0.0001	0.0000	-0.0007	13.0	-0.0010	-0.0049	-0.78	-0.0002	0.0010	0.33
0.80	0.0000	-0.0002	0.0000	-0.0016	25.6	-0.0016	-0.0057	-1.63	0.0001	0.0056	0.76
0.90	0.0000	-0.0005	-0.0001	-0.0042	48.1	-0.0023	-0.0085	-3.10	0.0009	0.0106	2.95
1.00	-0.0000	-0.0011	-0.0000	-0.0093	84.2	-0.0034	-0.0148	-7.29	0.0022	0.0146	8.13
1.10	-0.0000	-0.0024	0.0001	-0.0179	137.2	-0.0052	-0.0211	-17.73	0.0039	0.0205	17.77
1.20	-0.0000	-0.0048	-0.0000	-0.0307	209.7	-0.0077	-0.0276	-36.44	0.0063	0.0276	36.48
1.30	-0.0000	-0.0087	0.0000	-0.0478	303.2	-0.0108	-0.0350	-67.55	0.0095	0.0345	67.62
1.40	0.0000	-0.0144	0.0000	-0.0643	419.3	-0.0147	-0.0432	-113.81	0.0134	0.0440	112.99
1.50	0.0000	-0.0216	-0.0001	-0.0798	566.4	-0.0196	-0.0527	-170.55	0.0184	0.0572	170.19
1.60	-0.0000	-0.0304	-0.0000	-0.0967	752.3	-0.0257	-0.0677	-238.61	0.0249	0.0712	239.50
1.70	0.0000	-0.0411	0.0001	-0.1167	986.6	-0.0335	-0.0856	-321.51	0.0329	0.0893	321.16
1.80	0.0000	-0.0538	-0.0000	-0.1389	1280.9	-0.0432	-0.1044	-419.64	0.0430	0.1146	418.27
1.90	-0.0000	-0.0689	-0.0001	-0.1632	1648.3	-0.0551	-0.1283	-533.36	0.0559	0.1443	533.54
2.00	-0.0000	-0.0866	0.0001	-0.1903	2103.9	-0.0697	-0.1591	-666.20	0.0719	0.1777	667.11
2.10	0.0000	-0.1071	0.0003	-0.2204	2664.4	-0.0880	-0.1946	-822.66	0.0913	0.2179	818.93
2.20	0.0000	-0.1308	-0.0002	-0.2537	3347.0	-0.1098	-0.2254	-1000.76	0.1154	0.2742	995.95
2.30	-0.0000	-0.1579	-0.0001	-0.2888	4166.4	-0.1354	-0.2731	-1201.39	0.1449	0.3214	1202.57
2.40	0.0002	-0.1889	0.0044	-0.3356	5137.6	-0.1690	-0.4034	-1457.92	0.1764	0.3016	1416.39
2.50	0.0009	-0.2257	0.0087	-0.4016	6293.9	-0.2167	-0.5227	-1814.18	0.2064	0.3164	1615.63
2.60	0.0014	-0.2686	-0.0009	-0.4517	7649.3	-0.2665	-0.4222	-2181.23	0.2477	0.5405	1887.64
2.70	0.0007	-0.3152	-0.0105	-0.4790	9163.7	-0.3038	-0.3173	-2454.93	0.3119	0.7337	2308.90
2.80	0.0000	-0.3652	-0.0004	-0.5223	10776.5	-0.3451	-0.4839	-2757.08	0.3790	0.6090	2745.74
2.90	0.0007	-0.4194	0.0159	-0.5633	12433.1	-0.4097	-0.5197	-3231.74	0.4260	0.5920	3050.52
3.00	-0.0003	-0.4752	-0.0617	-0.5515	14122.2	-0.4999	-0.3473	-3894.02	0.4497	0.7867	3203.52
3.10	-0.0137	-0.5280	-0.2034	-0.4940	15844.7	-0.5602	0.1445	-4341.41	0.5056	1.3135	3561.33
3.20	-0.0394	-0.5772	-0.3025	-0.5145	17608.6	-0.5858	0.1439	-4539.32	0.5984	1.3067	4109.53
3.30	-0.0733	-0.6322	-0.3757	-0.6145	19290.5	-0.6388	-0.1731	-4962.92	0.6631	0.8640	4478.87
3.40	-0.1158	-0.6276	-0.4797	0.1952	21385.5	-0.7195	-0.1189	-5617.77	0.7422	1.2871	4930.45
3.50	-0.1699	-0.5818	-0.5969	0.5139	23640.7	-0.7674	0.0380	-6004.45	0.8468	1.5103	5527.08
3.60	-0.2336	-0.5227	-0.6712	0.6093	25855.6	-0.8140	-0.2514	-6382.46	0.9476	1.1910	6099.89
3.70	-0.3044	-0.4687	-0.7555	0.5297	27888.6	-0.8886	-0.4441	-6990.26	1.0081	0.8582	6427.27
3.80	-0.3853	-0.4084	-0.8654	0.6716	29834.2	-0.9488	-0.0402	-7478.91	1.0780	1.2357	6741.79
3.90	-0.4774	-0.3347	-0.9708	0.7480	31709.5	-0.9738	0.0392	-7680.10	1.1748	1.2293	7144.42
4.00	-0.5780	-0.2619	-1.0380	0.7006	33419.4	-1.0052	-0.1102	-7934.79	1.2575	0.9879	7480.63

104

Figure 17. (continued)

 TRACTOR SPRUNG MASS POSITION

TIME (SEC)	FORWARD (FT)	LATERAL (FT)	VERTICAL (FT)	ROLL (DEG)	PITCH (DEG)	HEADING (DEG)	TURN RADIUS (FT)	SIDE SLIP (DEG)
4.10	241.9940	10.0022	-1.8375	-3.8333	1.6171	11.2453	390.9648	-0.2585
4.20	247.8574	11.1849	-2.0181	-3.9455	1.6607	12.1996	372.9036	-0.3153
4.30	253.7019	12.4614	-2.2037	-4.0764	1.6869	13.1786	356.5623	-0.3520
4.40	259.5232	13.8356	-2.3985	-4.2034	1.7064	14.1758	347.9302	-0.3714
4.50	265.3230	15.3100	-2.6036	-4.3968	1.7303	15.1859	345.8438	-0.3901
4.60	271.0967	16.8843	-2.8175	-4.7133	1.7548	16.2021	346.2317	-0.4072
4.70	276.8401	18.5580	-3.0391	-5.1222	1.7581	17.2169	342.2698	-0.4162
4.80	282.5540	20.3320	-3.2667	-5.5949	1.7540	18.2517	343.4966	-0.4388
4.90	288.2349	22.2050	-3.4999	-6.1051	1.7644	19.3339	344.3196	-0.5158
5.00	293.8755	24.1747	-3.7379	-6.5551	1.7681	20.4840	330.3538	-0.6400
5.10	299.4709	26.2438	-3.9770	-6.8612	1.7561	21.7237	305.4636	-0.7853
5.20	305.0164	28.4193	-4.2169	-7.0574	1.7255	23.0578	285.5007	-0.9418
5.30	310.5046	30.7062	-4.4600	-7.2401	1.6512	24.4474	269.9338	-1.0679
5.40	315.9321	33.1092	-4.7110	-7.4604	1.5454	25.8501	263.2576	-1.1533
5.50	321.2954	35.6312	-4.9749	-7.7000	1.4521	27.2452	256.4961	-1.1898
5.60	326.5886	38.2701	-5.2531	-7.9503	1.4125	28.6216	275.0308	-1.2430
5.70	331.8086	41.0181	-5.5333	-8.4106	1.3626	29.9462	298.2993	-1.3295
5.80	336.9539	43.8690	-5.8123	-8.9685	1.2491	31.1960	284.5686	-1.2807
5.90	342.0242	46.8232	-6.0980	-9.4312	1.1086	32.3930	198.6967	-1.2211
6.00	347.0232	49.8744	-6.3952	-9.9962	0.9679	33.5390	376.9944	-1.2071
6.10	351.9500	53.0108	-6.6922	-10.9681	0.7805	34.6226	371.2888	-1.1127
6.20	356.8025	56.2260	-6.9961	-11.9168	0.6054	35.6542	198.1766	-1.0074
6.30	361.5864	59.5155	-7.3061	-12.7612	0.4020	36.6343	510.8782	-1.0654
6.40	366.3054	62.8739	-7.6129	-13.8209	0.1390	37.5631	725.0569	-0.9332
6.50	370.9580	66.2957	-7.9263	-14.9236	-0.0894	38.4579	1980.7871	-0.7690
6.60	375.5469	69.7739	-8.2428	-16.0327	-0.3106	39.3287	1331.0911	-0.6942
6.70	380.0757	73.3041	-8.5520	-17.2906	-0.6094	40.1691	2778.9189	-0.5768
6.80	384.5444	76.8860	-8.8629	-18.4154	-0.9046	40.9894	10738.3594	-0.4081
6.90	388.9548	80.5171	-9.1809	-19.4699	-1.1596	41.8071	-1455.1565	-0.3367
7.00	393.3096	84.1909	-9.4956	-20.7949	-1.4430	42.6171	-888.1799	-0.2682
7.10	397.6084	87.9048	-9.8122	-22.0326	-1.6963	43.4117	-598.0049	-0.1709
7.20	401.8530	91.6592	-10.1312	-23.0569	-1.9479	44.2087	-384.8804	-0.0915
7.30	406.0461	95.4524	-10.4469	-24.1949	-2.2361	45.0109	-345.8708	-0.0094
7.40	410.1870	99.2815	-10.7688	-25.3841	-2.4787	45.8085	-443.3186	0.2017
7.50	414.2761	103.1440	-11.1016	-26.5000	-2.6236	46.6074	175.4749	0.3382
7.60	418.3169	107.0404	-11.4592	-27.7475	-2.6378	47.3938	163.4628	0.3300
7.70	422.3127	110.9671	-11.8386	-29.3432	-2.5266	48.1476	172.4653	0.3048
7.80	426.2664	114.9205	-12.2397	-30.9757	-2.3037	48.8611	170.8028	0.2207
7.90	430.1765	118.9013	-12.6563	-32.5460	-2.0025	49.5321	268.6587	0.1928
8.00	434.0405	122.9092	-13.0764	-34.3195	-1.6725	50.1717	861.6711	0.1052
8.10	437.8555	126.9427	-13.4933	-36.2280	-1.3958	50.7910	-704.7271	0.1320

105

Figure 17. (continued)

TIME (SEC)	TRACTOR SPRUNG MASS VELOCITY (BODY AXES)						STEERING WHEEL ANGLE (DEG)
	FORWARD (FT/SEC)	LATERAL (FT/SEC)	VERTICAL (FT/SEC)	ROLL (DEG/SEC)	PITCH (DEG/SEC)	HEADING (DEG/SEC)	
4.10	59.85	-0.27	-0.12	-1.07	-0.07	9.38	101.1
4.20	59.87	-0.33	-0.11	-1.61	-0.34	9.66	103.8
4.30	59.87	-0.37	-0.17	-1.53	-0.43	9.86	106.3
4.40	59.90	-0.39	-0.24	-1.76	-0.54	10.01	107.9
4.50	59.94	-0.41	-0.32	-2.83	-0.48	10.13	108.7
4.60	59.92	-0.43	-0.39	-4.03	-0.75	10.09	109.0
4.70	59.91	-0.44	-0.45	-4.73	-0.91	10.13	109.2
4.80	59.93	-0.46	-0.53	-5.33	-1.08	10.42	109.3
4.90	59.88	-0.54	-0.57	-5.37	-1.02	11.03	110.0
5.00	59.79	-0.67	-0.62	-4.19	-1.23	11.79	111.3
5.10	59.71	-0.82	-0.67	-2.77	-1.79	12.69	112.5
5.20	59.61	-0.98	-0.73	-2.15	-2.01	13.49	113.5
5.30	59.50	-1.11	-0.90	-2.41	-2.73	13.66	113.5
5.40	59.41	-1.20	-1.12	-2.79	-2.81	13.63	111.3
5.50	59.31	-1.23	-1.38	-2.84	-2.44	13.57	106.7
5.60	59.17	-1.28	-1.57	-3.09	-1.75	13.35	102.9
5.70	59.00	-1.37	-1.54	-6.96	-2.99	12.46	92.6
5.80	58.83	-1.32	-1.81	-4.68	-2.94	11.68	95.2
5.90	58.71	-1.25	-2.09	-2.84	-2.28	11.39	80.8
6.00	58.58	-1.23	-2.12	-10.34	-4.20	10.46	74.8
6.10	58.38	-1.13	-2.56	-8.80	-3.18	9.91	75.8
6.20	58.19	-1.02	-2.95	-4.43	-1.98	9.68	62.6
6.30	58.06	-1.08	-2.72	-13.53	-5.23	8.49	54.5
6.40	57.89	-0.94	-3.08	-14.52	-5.65	7.75	55.1
6.50	57.70	-0.77	-3.55	-11.78	-4.73	7.62	53.5
6.60	57.51	-0.70	-3.84	-11.49	-4.87	7.07	51.1
6.70	57.33	-0.58	-4.16	-10.38	-4.40	6.89	49.6
6.80	57.16	-0.41	-4.55	-8.27	-4.36	6.63	47.8
6.90	56.99	-0.33	-4.81	-10.30	-4.45	6.50	44.5
7.00	56.80	-0.27	-5.07	-12.74	-4.86	6.11	43.6
7.10	56.61	-0.17	-5.34	-10.71	-4.95	5.87	43.3
7.20	56.46	-0.09	-5.63	-9.99	-5.73	5.58	41.7
7.30	56.28	-0.01	-5.94	-11.36	-5.18	5.68	40.0
7.40	56.07	0.20	-6.49	-7.40	-3.61	6.25	38.9
7.50	55.89	0.33	-6.90	-5.76	-1.27	7.26	37.4
7.60	55.77	0.32	-7.05	-11.53	-1.32	7.20	35.3
7.70	55.66	0.30	-7.10	-16.60	-1.35	6.92	34.8
7.80	55.56	0.21	-6.97	-18.61	-1.56	6.34	35.7
7.90	55.47	0.19	-6.83	-20.49	-2.15	5.59	36.6
8.00	55.38	0.10	-6.50	-24.35	-2.41	4.94	37.6
8.10	55.23	0.13	-6.25	-23.36	-2.96	4.39	39.6

Figure 17. (continued)

TRACTOR SPRUNG MASS ACCELERATION (BODY AXES)

INERTIAL ACCEL. ALONG BODY AXES

TIME (SEC)	FORWARD (FT/SEC**2)	LATERAL (FT/SEC**2)	VERTICAL (FT/SEC**2)	ROLL (DEG/SEC**2)	PITCH (DEG/SEC**2)	HEADING (DEG/SEC**2)	LONGITUDINAL (FT/SEC**2)	LATERAL (FT/SEC**2)
4.10	0.5148	-0.5720	0.4262	-8.4328	4.7154	1.7350	0.5591	9.2268
4.20	0.1672	-0.4018	-0.1647	-3.0254	-2.8052	-0.2168	0.2235	9.6902
4.30	0.2341	-0.1648	-0.8416	-0.2131	-4.2497	-0.4937	0.2986	10.1324
4.40	0.7888	-0.0750	-1.1431	-8.6106	-8.4247	-0.4257	0.8589	10.3829
4.50	0.1166	-0.1177	-0.6719	-15.3443	-2.5824	-1.3111	0.1914	10.4598
4.60	-0.0086	-0.0935	-0.3893	-10.2138	9.1214	-2.0715	0.0715	10.4317
4.70	0.2120	-0.0093	-0.5809	-8.1309	-0.8173	-0.5151	0.2961	10.5469
4.80	0.0998	-0.3577	-0.7509	-6.6913	0.8175	2.2570	0.1932	10.4900
4.90	-0.4542	-1.0318	-0.2295	3.6329	6.4018	4.8398	-0.3403	10.4438
5.00	-0.6380	-1.3537	-0.4203	13.2907	-8.5668	4.0636	-0.4872	10.9067
5.10	-0.5161	-1.4845	-0.6850	9.5097	-0.4679	5.3995	-0.3140	11.7052
5.20	-0.9661	-1.4290	-0.9839	-0.9656	-9.3859	1.3915	-0.7097	12.5798
5.30	-0.7608	-0.9612	-2.2413	-6.5875	-7.3669	-2.6756	-0.4533	13.1890
5.40	-0.6052	-0.5445	-2.1441	-5.9693	7.0584	-1.1522	-0.2660	13.5345
5.50	-1.1417	-0.1468	-3.4778	4.7866	-15.1065	-7.0089	-0.7910	13.8340
5.60	-1.5055	-0.9074	2.8456	-77.1824	-4.8357	-4.4739	-1.1583	12.7992
5.70	-1.7043	-0.9333	-0.0135	-26.2014	-8.7177	-11.6959	-1.3265	11.7111
5.80	-1.2631	0.3408	4.8926	-135.0475	-69.6058	-14.3443	-0.9024	12.1874
5.90	-1.5937	5.3405	-24.3871	386.8625	124.2421	9.8290	-1.2620	16.9066
6.00	-1.5651	-1.5184	4.1442	-152.5736	-46.6718	-13.5131	-1.1847	8.7921
6.10	-1.7621	-0.7479	9.5323	-240.3617	-95.0772	-23.4296	-1.4236	8.9601
6.20	-2.0367	5.7305	-20.0017	344.6035	112.0727	7.8001	-1.7620	15.3335
6.30	-1.5914	0.1758	-4.8376	57.1597	67.5564	9.3046	-1.1835	8.1345
6.40	-1.1664	-3.1653	10.3348	-248.0925	-62.8197	-13.1715	-0.7354	3.8816
6.50	-1.0232	-5.7921	18.3688	-326.9978	-38.4996	-0.2812	-0.6272	1.1511
6.60	-0.8151	-4.6579	15.3328	-397.2507	-218.2687	-62.8391	-0.4030	1.6717
6.70	-0.4375	-5.5636	18.4650	-417.5710	-201.0516	-67.3748	-0.0485	0.5759
6.80	-0.0721	-6.5843	19.3593	-462.1340	-233.1808	-78.5384	0.3213	-0.6260
6.90	-0.0567	-8.8932	21.7864	-515.9319	-238.7043	-80.5222	0.3548	-3.2943
7.00	0.0521	-9.8266	23.3630	-518.6575	-247.3666	-91.7852	0.5105	-4.8981
7.10	0.4903	-10.9119	23.3917	-524.0327	-302.2910	-110.7991	0.9687	-6.1112
7.20	1.0079	-13.7707	26.9738	-579.9441	-246.2397	-84.7541	1.5801	-9.2584
7.30	0.9110	-14.9379	29.0779	-621.7107	-246.0799	-101.3815	1.4484	-10.5378
7.40	1.0081	-15.5807	28.4392	-573.5784	-229.8306	-107.5458	1.3951	-10.3041
7.50	-2.4742	8.7499	-15.8429	207.4601	76.1827	5.9123	-2.3627	15.1367
7.60	-3.0057	11.7519	-21.4001	287.3198	104.1674	27.5233	-2.8841	17.3433
7.70	-2.8425	11.4937	-19.4661	333.4414	165.8999	71.5067	-2.7109	16.1618
7.80	-2.8570	12.2892	-18.7249	370.1885	183.3423	96.5244	-2.6914	16.1765
7.90	-2.4587	9.5398	-14.4926	324.3938	208.5994	150.5051	-2.2200	12.5052
8.00	-1.9424	5.2776	-5.9569	123.0887	55.0348	63.5860	-1.6775	7.2934
8.10	-1.2442	-2.0544	4.4920	25.0737	34.2366	68.9720	-0.9308	-0.3678

107

Figure 17. (continued)

TRACTOR FRONT AXLE TIRE FORCES												
TIME (SEC)	LEFT SIDE					RIGHT SIDE					STEER ANGLE	
	VERTICAL (LB)	LONG. (LB)	LATERAL (LB)	MU-X	MU-Y	VERTICAL (LB)	LONG. (LB)	LATERAL (LB)	MU-X	MU-Y	LEFT (DEG)	RIGHT (DEG)
4.10	7567.12	-2.26	2064.80	-0.0003	0.2729	3972.07	-1.57	1314.14	-0.0004	0.3308	2.67	2.36
4.20	7686.16	-0.81	2143.97	-0.0001	0.2789	3973.92	-0.88	1350.85	-0.0002	0.3399	2.73	2.41
4.30	7853.27	-0.80	2222.92	-0.0001	0.2831	3990.26	-1.01	1387.05	-0.0003	0.3476	2.78	2.45
4.40	7966.39	-2.51	2268.60	-0.0003	0.2848	3967.80	-2.66	1400.71	-0.0007	0.3530	2.81	2.48
4.50	7997.83	-0.67	2279.02	-0.0001	0.2850	3907.62	-1.10	1391.56	-0.0003	0.3561	2.84	2.51
4.60	8003.61	0.48	2278.96	0.0001	0.2847	3809.89	-0.47	1370.39	-0.0001	0.3597	2.86	2.53
4.70	8067.16	-0.80	2283.39	-0.0001	0.2830	3746.60	-1.17	1355.64	-0.0003	0.3618	2.87	2.55
4.80	8133.13	-1.22	2289.43	-0.0001	0.2815	3662.67	-0.88	1336.78	-0.0002	0.3650	2.87	2.56
4.90	8242.32	0.31	2345.62	0.0000	0.2846	3565.68	1.86	1337.10	0.0005	0.3750	2.88	2.57
5.00	8357.34	0.31	2462.86	0.0000	0.2947	3433.05	3.20	1356.18	0.0009	0.3950	2.88	2.58
5.10	8492.89	0.07	2595.08	0.0000	0.3056	3351.03	2.24	1391.09	0.0007	0.4151	2.88	2.57
5.20	8722.15	1.42	2719.35	0.0002	0.3118	3377.16	3.28	1445.51	0.0010	0.4280	2.87	2.55
5.30	8943.23	2.34	2798.98	0.0003	0.3130	3480.82	1.38	1502.83	0.0004	0.4317	2.82	2.49
5.40	9101.74	0.76	2830.66	0.0001	0.3110	3545.27	0.26	1520.98	0.0001	0.4290	2.74	2.41
5.50	9133.95	3.15	2767.21	0.0003	0.3030	3445.75	2.11	1462.20	0.0006	0.4243	2.62	2.31
5.60	9410.59	4.45	2777.30	0.0005	0.2951	3425.20	3.50	1425.80	0.0010	0.4163	2.48	2.18
5.70	8412.71	6.47	2462.62	0.0008	0.2927	2930.64	2.61	1221.68	0.0009	0.4169	2.31	2.07
5.80	10369.91	6.02	2814.73	0.0006	0.2714	3436.09	1.10	1335.18	0.0003	0.3886	2.17	1.90
5.90	8635.08	1.88	2262.43	0.0002	0.2620	2781.54	4.47	1079.56	0.0016	0.3881	1.98	1.78
6.00	9309.43	5.94	2065.40	0.0006	0.2219	2840.68	1.15	988.62	0.0004	0.3480	1.83	1.65
6.10	11051.75	8.89	2303.54	0.0008	0.2084	3173.85	4.38	1025.88	0.0014	0.3232	1.72	1.52
6.20	9173.11	1.78	1810.78	0.0002	0.1974	2302.57	9.80	739.85	0.0043	0.3213	1.57	1.44
6.30	8026.54	1.26	1516.36	0.0002	0.1889	1713.03	1.05	488.27	0.0006	0.2850	1.44	1.37
6.40	10300.04	5.91	1587.61	0.0006	0.1541	2268.62	-0.79	570.82	-0.0003	0.2516	1.37	1.28
6.50	11251.72	4.61	1589.39	0.0004	0.1413	2291.59	1.04	528.34	0.0005	0.2306	1.30	1.22
6.60	11590.51	15.09	1537.78	0.0013	0.1327	2079.30	-0.42	453.44	-0.0002	0.2181	1.25	1.18
6.70	12226.79	11.31	1500.85	0.0009	0.1228	1971.19	4.97	398.99	0.0025	0.2024	1.21	1.16
6.80	12659.75	15.43	1418.39	0.0012	0.1120	1804.86	4.55	334.89	0.0025	0.1856	1.18	1.14
6.90	12387.05	17.47	1211.05	0.0014	0.0978	1424.18	4.23	231.16	0.0030	0.1623	1.17	1.14
7.00	12948.08	17.77	1093.85	0.0014	0.0845	1284.95	5.71	180.57	0.0044	0.1405	1.17	1.15
7.10	13103.47	18.87	1078.06	0.0014	0.0823	1007.66	4.85	138.86	0.0048	0.1378	1.18	1.17
7.20	13145.84	15.70	990.37	0.0012	0.0753	592.48	4.75	75.26	0.0080	0.1270	1.16	1.15
7.30	13828.74	15.20	831.61	0.0011	0.0601	373.27	8.02	37.74	0.0215	0.1011	1.15	1.14
7.40	14314.40	12.16	693.01	0.0008	0.0484	0.00	0.00	-0.04	0.0436-3954.6541		1.15	1.15
7.50	13793.74	4.44	504.41	0.0003	0.0366	0.00	0.00	-0.05	0.0652-4910.8906		1.17	1.17
7.60	11616.60	1.11	242.93	0.0001	0.0209	0.00	0.00	-0.06	0.0750-6304.4102		1.19	1.19
7.70	10626.34	-7.94	106.04	-0.0007	0.0100	0.00	0.00	-0.09	0.0832-8839.3242		1.21	1.21
7.80	10276.93	-9.19	169.52	-0.0009	0.0165	0.00	0.00	-0.12	0.0901*****		1.23	1.23
7.90	10311.96	-5.47	192.32	-0.0005	0.0187	0.00	0.00	-0.16	0.0940*****		1.25	1.25
8.00	10383.50	8.48	219.52	0.0008	0.0211	0.00	0.00	-0.21	0.1025*****		1.28	1.28
8.10	10069.27	8.13	293.13	0.0008	0.0291	0.00	0.00	-0.24	0.1156*****		1.33	1.33

Figure 17. (continued)

TRACTOR REAR SUSPENSION TIRE FORCES

LEADING TANDEM AXLE

LEFT SIDE

RIGHT SIDE

TIME (SEC)	VERTICAL (LB)	LONG. (LB)	LATERAL (LB)	MU-X	MU-Y	VERTICAL (LB)	LONG. (LB)	LATERAL (LB)	MU-X	MU-Y
4.10	14468.85	774.66	2456.08	0.0535	0.1697	3372.66	800.33	839.41	0.2373	0.2489
4.20	14610.74	778.79	2580.34	0.0533	0.1766	3265.32	827.03	852.74	0.2533	0.2611
4.30	14732.99	779.92	2678.93	0.0529	0.1818	3168.90	824.05	858.01	0.2600	0.2708
4.40	14878.03	776.95	2736.04	0.0522	0.1839	3138.69	815.22	865.75	0.2597	0.2758
4.50	14927.98	781.37	2753.94	0.0523	0.1845	3099.88	828.28	859.97	0.2672	0.2774
4.60	15105.93	784.75	2747.27	0.0519	0.1819	3106.97	833.96	856.28	0.2684	0.2756
4.70	15151.21	782.36	2749.97	0.0516	0.1815	2785.76	813.25	764.07	0.2919	0.2743
4.80	15427.30	781.50	2832.95	0.0507	0.1836	2213.87	814.22	611.14	0.3678	0.2761
4.90	16155.82	784.87	3099.31	0.0486	0.1918	1780.11	841.21	518.33	0.4726	0.2912
5.00	16591.13	784.98	3493.62	0.0473	0.2106	1240.68	821.16	383.60	0.6619	0.3092
5.10	17057.69	784.54	3977.10	0.0460	0.2332	788.68	592.29	241.67	0.7510	0.3064
5.20	17547.90	786.91	4447.76	0.0448	0.2535	541.29	419.74	139.71	0.7754	0.2581
5.30	17728.05	789.28	4698.74	0.0445	0.2650	370.24	268.95	62.32	0.7264	0.1683
5.40	17637.91	787.04	4815.82	0.0446	0.2730	304.43	204.32	33.94	0.6712	0.1115
5.50	17272.98	792.22	4834.71	0.0459	0.2799	0.00	0.00	-0.03	0.6145	-2809.4165
5.60	17345.04	794.69	4878.07	0.0458	0.2812	0.00	0.00	-0.03	0.5568	-3169.7019
5.70	17669.09	798.46	4739.86	0.0452	0.2683	0.00	0.00	-0.04	0.5500	-3816.0093
5.80	17793.18	797.20	4592.54	0.0448	0.2581	0.00	0.00	-0.05	0.5500	-4692.7578
5.90	17844.56	791.17	4503.98	0.0443	0.2524	0.00	0.00	-0.06	0.5500	-5880.5508
6.00	17731.95	798.68	4026.35	0.0450	0.2271	0.00	0.00	-0.07	0.5500	-7457.7266
6.10	17595.35	803.56	3809.66	0.0457	0.2165	0.00	0.00	-0.09	0.5500	-9299.6523
6.20	17612.28	791.48	3745.69	0.0449	0.2127	0.00	0.00	-0.11	0.5500	*****
6.30	17691.67	789.55	3291.52	0.0446	0.1860	0.00	0.00	-0.14	0.5500	*****
6.40	17537.83	799.81	2905.69	0.0456	0.1657	0.00	0.00	-0.16	0.5500	*****
6.50	17818.79	796.81	2724.02	0.0447	0.1529	0.00	0.00	-0.18	0.5500	*****
6.60	17623.69	814.97	2508.11	0.0462	0.1423	0.00	0.00	-0.21	0.5500	*****
6.70	17395.23	807.16	2326.37	0.0464	0.1337	0.00	0.00	-0.24	0.5500	*****
6.80	17491.09	814.08	2088.33	0.0465	0.1194	0.00	0.00	-0.27	0.5500	*****
6.90	17485.55	816.66	1875.02	0.0467	0.1072	0.00	0.00	-0.29	0.5500	*****
7.00	17475.95	818.74	1545.28	0.0468	0.0884	0.00	0.00	-0.32	0.5500	*****
7.10	17587.20	819.91	1387.00	0.0466	0.0789	0.00	0.00	-0.35	0.5500	*****
7.20	17600.54	816.07	1193.40	0.0464	0.0678	0.00	0.00	-0.37	0.5500	*****
7.30	17509.46	814.36	1006.05	0.0465	0.0575	0.00	0.00	-0.40	0.5500	*****
7.40	17430.21	808.38	920.66	0.0464	0.0528	0.00	0.00	-0.43	0.5500	*****
7.50	17528.38	795.08	994.40	0.0454	0.0567	0.00	0.00	-0.45	0.5500	*****
7.60	17592.81	788.49	751.87	0.0448	0.0427	0.00	0.00	-0.47	0.5500	*****
7.70	17811.43	774.50	512.30	0.0435	0.0288	0.00	0.00	-0.50	0.5500	*****
7.80	17742.17	773.30	437.18	0.0436	0.0246	0.00	0.00	-0.52	0.5500	*****
7.90	17629.80	782.52	212.39	0.0444	0.0120	0.00	0.00	-0.54	0.5500	*****
8.00	17675.17	807.89	44.92	0.0457	0.0025	0.00	0.00	-0.57	0.5500	*****
8.10	17588.85	807.96	-108.49	0.0459	-0.0062	0.00	0.00	-0.59	0.5500	*****

109

Figure 17. (continued)

TRACTOR REAR SUSPENSION TIRE FORCES

TRAILING TANDEM AXLE

TIME (SEC)	LEFT SIDE					RIGHT SIDE				
	VERTICAL (LB)	LONG. (LB)	LATERAL (LB)	MU-X	MU-Y	VERTICAL (LB)	LONG. (LB)	LATERAL (LB)	MU-X	MU-Y
4.10	14898.11	774.00	3391.55	0.0520	0.2276	2970.28	811.44	1014.32	0.2732	0.3415
4.20	15041.43	778.17	3547.21	0.0517	0.2358	2791.48	827.69	981.53	0.2965	0.3516
4.30	15250.39	779.24	3677.11	0.0511	0.2411	2744.02	830.14	988.92	0.3025	0.3604
4.40	15225.02	776.10	3737.96	0.0510	0.2455	2674.36	832.92	975.72	0.3114	0.3648
4.50	15326.75	780.92	3773.08	0.0510	0.2462	2632.09	836.95	964.43	0.3180	0.3664
4.60	15547.00	783.74	3771.68	0.0504	0.2426	2727.45	863.81	995.03	0.3167	0.3648
4.70	15524.97	781.45	3774.15	0.0503	0.2431	2312.08	815.47	836.83	0.3527	0.3619
4.80	15905.09	780.84	3903.86	0.0491	0.2454	1790.68	805.72	646.11	0.4500	0.3608
4.90	16429.41	784.09	4247.31	0.0477	0.2585	1257.15	811.87	458.32	0.6458	0.3646
5.00	17030.95	784.68	4770.32	0.0461	0.2801	756.93	565.26	270.82	0.7468	0.3578
5.10	17537.99	783.29	5384.01	0.0447	0.3070	345.51	266.26	100.34	0.7706	0.2904
5.20	18099.52	787.81	6004.21	0.0435	0.3317	0.00	0.00	-0.03	0.7138	-2905.2488
5.30	18641.56	788.45	6456.88	0.0423	0.3464	0.00	0.00	-0.04	0.6569	-3620.2446
5.40	18388.12	784.09	6495.64	0.0426	0.3533	0.00	0.00	-0.05	0.6000	-4710.3203
5.50	18175.78	790.74	6467.48	0.0435	0.3558	0.00	0.00	-0.06	0.5500	-6050.2422
5.60	17974.88	793.76	6418.33	0.0442	0.3571	0.00	0.00	-0.08	0.5500	-7546.6094
5.70	18141.21	798.72	6208.72	0.0440	0.3422	0.00	0.00	-0.09	0.5500	-9033.3086
5.80	18373.34	797.69	6042.95	0.0434	0.3289	0.00	0.00	-0.11	0.5500	*****
5.90	18096.15	788.60	5828.19	0.0436	0.3221	0.00	0.00	-0.12	0.5500	*****
6.00	17980.86	797.84	5220.99	0.0444	0.2904	0.00	0.00	-0.14	0.5500	*****
6.10	17822.42	802.88	4937.86	0.0450	0.2771	0.00	0.00	-0.16	0.5500	*****
6.20	17740.64	790.86	4843.04	0.0446	0.2730	0.00	0.00	-0.16	0.5500	*****
6.30	17861.09	790.45	4250.47	0.0443	0.2380	0.00	0.00	-0.21	0.5500	*****
6.40	17444.57	800.03	3745.10	0.0459	0.2147	0.00	0.00	-0.23	0.5500	*****
6.50	17540.56	798.26	3540.74	0.0455	0.2019	0.00	0.00	-0.26	0.5500	*****
6.60	17496.41	813.73	3267.91	0.0465	0.1868	0.00	0.00	-0.28	0.5500	*****
6.70	17422.70	806.93	3069.91	0.0463	0.1762	0.00	0.00	-0.31	0.5500	*****
6.80	17431.23	813.48	2805.66	0.0467	0.1610	0.00	0.00	-0.34	0.5500	*****
6.90	17455.59	816.72	2590.32	0.0468	0.1484	0.00	0.00	-0.36	0.5500	*****
7.00	17647.09	818.57	2286.55	0.0464	0.1296	0.00	0.00	-0.39	0.5500	*****
7.10	17402.09	819.70	2132.16	0.0471	0.1225	0.00	0.00	-0.42	0.5500	*****
7.20	17795.50	815.99	1947.97	0.0459	0.1095	0.00	0.00	-0.44	0.5500	*****
7.30	17481.92	812.82	1781.09	0.0465	0.1019	0.00	0.00	-0.47	0.5500	*****
7.40	17550.85	807.76	1775.89	0.0460	0.1012	0.00	0.00	-0.50	0.5500	*****
7.50	17608.82	793.37	1976.39	0.0451	0.1122	0.00	0.00	-0.52	0.5500	*****
7.60	17595.77	789.15	1740.45	0.0448	0.0989	0.00	0.00	-0.54	0.5500	*****
7.70	17798.05	774.10	1464.95	0.0435	0.0823	0.00	0.00	-0.57	0.5500	*****
7.80	17622.42	774.23	1312.07	0.0439	0.0745	0.00	0.00	-0.59	0.5500	*****
7.90	17695.04	784.31	985.07	0.0443	0.0557	0.00	0.00	-0.61	0.5500	*****
8.00	17577.50	807.80	730.28	0.0460	0.0415	0.00	0.00	-0.64	0.5500	*****
8.10	17727.10	808.62	502.82	0.0456	0.0284	0.00	0.00	-0.66	0.5500	*****

110

Figure 17. (continued)

TRACTOR FRONT SUSPENSION - LATERAL TIRE FORCE AND MOMENT SUMMARY

LEFT SIDE

RIGHT SIDE

TIME (SEC)	LEFT SIDE			RIGHT SIDE				
	TIRE SIDESLIP ANGLE (DEG)	TIRE LATERAL FORCE (LB)	MU-Y	ALIGNING TORQUE (IN-LB)	TIRE SIDESLIP ANGLE (DEG)	TIRE LATERAL FORCE (LB)	MU-Y	ALIGNING TORQUE (IN-LB)
4.10	-2.5233	2064.8008	0.2729	-3815.2002	-2.2092	1314.1353	0.3308	-1499.0830
4.20	-2.6114	2143.9736	0.2789	-3988.3535	-2.2885	1350.8508	0.3399	-1532.5889
4.30	-2.6908	2222.9197	0.2831	-4186.8125	-2.3594	1387.0479	0.3476	-1570.2664
4.40	-2.7340	2268.6018	0.2848	-4311.3789	-2.4007	1400.7141	0.3530	-1574.5454
4.50	-2.7430	2279.0198	0.2850	-4342.8047	-2.4121	1391.5552	0.3561	-1545.7524
4.60	-2.7421	2278.9551	0.2847	-4345.6016	-2.4181	1370.3875	0.3597	-1494.0818
4.70	-2.7389	2283.3928	0.2830	-4384.1680	-2.4205	1355.6357	0.3618	-1460.1365
4.80	-2.7377	2289.4333	0.2815	-4426.4531	-2.4262	1336.7817	0.3650	-1416.2134
4.90	-2.7949	2345.6233	0.2846	-4568.0742	-2.4870	1337.1035	0.3750	-1383.8828
5.00	-2.9278	2462.8611	0.2947	-4808.2031	-2.6227	1356.1838	0.3950	-1353.6992
5.10	-3.0746	2595.0820	0.3056	-5084.1211	-2.7705	1391.0906	0.4151	-1351.2773
5.20	-3.1967	2719.3469	0.3118	-5404.3945	-2.8861	1445.5129	0.4280	-1400.3262
5.30	-3.2649	2798.9766	0.3130	-5656.6406	-2.9460	1502.8291	0.4317	-1480.6165
5.40	-3.2581	2830.6631	0.3110	-5810.1914	-2.9407	1520.9829	0.4290	-1518.4529
5.50	-3.1716	2767.2129	0.3030	-5730.8945	-2.8738	1462.2021	0.4243	-1437.6519
5.60	-3.0874	2777.2974	0.2951	-5935.5820	-2.8000	1425.8035	0.4163	-1403.2676
5.70	-2.9201	2462.6228	0.2927	-4837.3242	-2.6931	1221.6785	0.4169	-1089.7969
5.80	-2.8326	2814.7273	0.2714	-6661.1719	-2.5690	1335.1819	0.3886	-1338.6697
5.90	-2.6469	2262.4280	0.2620	-4631.7773	-2.4556	1079.5591	0.3881	-946.4993
6.00	-2.2996	2065.4009	0.2219	-4623.6016	-2.1242	988.6230	0.3480	-900.1802
6.10	-2.1552	2303.5393	0.2084	-6051.3945	-1.9656	1025.8767	0.3232	-1017.6794
6.20	-2.0366	1810.7820	0.1974	-4080.4922	-1.9222	739.8545	0.3213	-599.0627
6.30	-1.7461	1516.3606	0.1889	-3117.0381	-1.6803	488.2737	0.2850	-340.2090
6.40	-1.5418	1587.6055	0.1541	-4105.8516	-1.4575	570.8162	0.2516	-474.5435
6.50	-1.3938	1589.3875	0.1413	-4493.1328	-1.3171	528.3374	0.2306	-446.7622
6.60	-1.2951	1537.7759	0.1327	-4497.2383	-1.2339	453.4392	0.2181	-364.3315
6.70	-1.1811	1500.8452	0.1228	-4644.1211	-1.1295	398.9941	0.2024	-313.4805
6.80	-1.0580	1418.3928	0.1120	-4571.9531	-1.0171	334.8916	0.1856	-252.7656
6.90	-0.9137	1211.0520	0.0978	-3873.0645	-0.8870	231.1568	0.1623	-155.9992
7.00	-0.7896	1093.8540	0.0845	-3676.4854	-0.7680	180.5706	0.1405	-117.1877
7.10	-0.7689	1078.0620	0.0823	-3668.5547	-0.7532	138.8609	0.1378	-81.2439
7.20	-0.7041	990.3679	0.0753	-3397.9307	-0.6944	75.2559	0.1270	-36.9180
7.30	-0.5620	831.6067	0.0601	-3021.5542	-0.5531	37.7421	0.1011	-16.7703
7.40	-0.4525	693.0090	0.0484	-2621.6455	-0.4434	-0.0395	-3954.6541	0.0142
7.50	-0.3418	504.4094	0.0366	-1862.6624	-0.3292	-0.0491	-4910.8906	0.0178
7.60	-0.1955	242.9339	0.0209	-779.0471	-0.1804	-0.0630	-6304.4102	0.0231
7.70	-0.0933	106.0392	0.0100	-317.1563	-0.0770	-0.0884	-8839.3242	0.0327
7.80	-0.1543	169.5188	0.0165	-489.8264	-0.1399	-0.1232	-12315.4570	0.0454
7.90	-0.1744	192.3185	0.0187	-556.3931	-0.1618	-0.1646	-16460.1250	0.0605
8.00	-0.1978	219.5196	0.0211	-637.6565	-0.1864	-0.2074	-20738.4766	0.0761
8.10	-0.2723	293.1309	0.0291	-823.7000	-0.2624	-0.2424	-24235.7461	0.0884

111

Figure 17. (continued)

TRACTOR REAR SUSPENSION - LATERAL TIRE FORCE AND MOMENT SUMMARY

LEADING TANDEM AXLE

TIME (SEC)	LEFT SIDE				RIGHT SIDE			
	TIRE SIDESLIP ANGLE (DEG)	TIRE LATERAL FORCE (LB)	MU-Y	ALIGNING TORQUE (IN-LB)	TIRE SIDESLIP ANGLE (DEG)	TIRE LATERAL FORCE (LB)	MU-Y	ALIGNING TORQUE (IN-LB)
4.10	-1.4159	2456.0825	0.1697	-4169.2031	-1.4393	839.4133	0.2489	-1424.9058
4.20	-1.4956	2580.3364	0.1766	-4380.1250	-1.5210	852.7356	0.2611	-1447.5203
4.30	-1.5580	2678.9275	0.1818	-4547.4844	-1.5851	858.0093	0.2708	-1456.4724
4.40	-1.5908	2736.0381	0.1839	-4644.4258	-1.6189	865.7534	0.2758	-1469.6182
4.50	-1.6009	2753.9382	0.1845	-4674.8125	-1.6295	859.9700	0.2774	-1459.8008
4.60	-1.5891	2747.2737	0.1819	-4663.5000	-1.6174	856.2842	0.2756	-1453.5439
4.70	-1.5892	2749.9680	0.1815	-4668.0742	-1.6175	764.0737	0.2743	-1297.0166
4.80	-1.6346	2832.9468	0.1836	-4808.9297	-1.6646	611.1387	0.2761	-1037.4089
4.90	-1.7868	3099.3149	0.1918	-5261.0898	-1.8216	518.3313	0.2912	-879.8684
5.00	-2.0310	3493.6189	0.2106	-5930.4219	-2.0734	383.6040	0.3092	-651.1685
5.10	-2.3177	3977.0994	0.2332	-6751.1328	-2.3699	241.6750	0.3064	-410.2437
5.20	-2.5877	4447.7617	0.2535	-7550.0820	-2.6497	139.7115	0.2581	-237.1604
5.30	-2.7321	4698.7422	0.2650	-7976.1211	-2.7986	62.3216	0.1683	-105.7910
5.40	-2.8070	4815.8164	0.2730	-8174.8555	-2.8753	33.9381	0.1115	-57.6100
5.50	-2.8372	4834.7148	0.2799	-8206.9336	-2.9060	-0.0281	-2809.4165	0.0477
5.60	-2.8599	4878.0742	0.2812	-8280.5391	-2.9282	-0.0317	-3169.7019	0.0538
5.70	-2.7596	4739.8555	0.2683	-8045.9102	-2.8213	-0.0382	-3816.0093	0.0648
5.80	-2.6654	4592.5430	0.2581	-7795.8477	-2.7214	-0.0469	-4692.7578	0.0797
5.90	-2.6101	4503.9844	0.2524	-7645.5195	-2.6637	-0.0588	-5880.5508	0.0998
6.00	-2.3262	4026.3518	0.2271	-6834.7383	-2.3701	-0.0746	-7457.7266	0.1266
6.10	-2.1987	3809.6628	0.2165	-6466.9102	-2.2381	-0.0930	-9299.6523	0.1579
6.20	-2.1595	3745.6892	0.2127	-6358.3125	-2.1974	-0.1135	-11345.2578	0.1926
6.30	-1.8761	3291.5217	0.1860	-5587.3594	-1.9051	-0.1351	-13512.9180	0.2294
6.40	-1.6304	2905.6904	0.1657	-4932.4102	-1.6535	-0.1603	-16032.4453	0.2722
6.50	-1.5110	2724.0154	0.1529	-4624.0195	-1.5321	-0.1847	-18466.7695	0.3135
6.60	-1.3742	2508.1123	0.1423	-4257.5234	-1.3920	-0.2109	-21085.6055	0.3579
6.70	-1.2592	2326.3701	0.1337	-3949.0166	-1.2751	-0.2377	-23767.6055	0.4035
6.80	-1.1053	2088.3350	0.1194	-3544.9512	-1.1188	-0.2655	-26552.7813	0.4507
6.90	-0.9742	1875.0249	0.1072	-3182.8564	-0.9860	-0.2939	-29394.8477	0.4990
7.00	-0.8030	1545.2756	0.0884	-2623.1084	-0.8121	-0.3216	-32161.1992	0.5459
7.10	-0.7206	1386.9968	0.0789	-2354.4299	-0.7284	-0.3487	-34871.7031	0.5919
7.20	-0.6200	1193.4048	0.0678	-2025.8071	-0.6265	-0.3742	-37416.4883	0.6351
7.30	-0.5228	1006.0459	0.0575	-1707.7649	-0.5284	-0.4011	-40113.0859	0.6809
7.40	-0.4786	920.6560	0.0528	-1562.8154	-0.4842	-0.4265	-42651.4063	0.7240
7.50	-0.5168	994.3967	0.0567	-1687.9905	-0.5238	-0.4498	-44979.2188	0.7635
7.60	-0.3907	751.8667	0.0427	-1276.2952	-0.3961	-0.4735	-47354.0898	0.8038
7.70	-0.2663	512.3049	0.0288	-869.6384	-0.2697	-0.4972	-49724.1133	0.8441
7.80	-0.2273	437.1816	0.0246	-742.1167	-0.2300	-0.5207	-52071.3398	0.8839
7.90	-0.1106	212.3879	0.0120	-360.5288	-0.1118	-0.5423	-54234.5977	0.9206
8.00	-0.0236	44.9229	0.0025	-76.2567	-0.0238	-0.5654	-56540.0820	0.9598
8.10	0.0560	-108.4893	-0.0062	184.1609	0.0565	-0.5873	-58732.9023	0.9970

Figure 17. (continued)

TRACTOR REAR SUSPENSION - LATERAL TIRE FORCE AND MOMENT SUMMARY

TRAILING TANDEM AXLE

TIME (SEC)	LEFT SIDE				RIGHT SIDE			
	TIRE SIDESLIP ANGLE (DEG)	TIRE LATERAL FORCE (LB)	MU-Y	ALIGNING TORQUE (IN-LB)	TIRE SIDESLIP ANGLE (DEG)	TIRE LATERAL FORCE (LB)	MU-Y	ALIGNING TORQUE (IN-LB)
4.10	-2.0373	3391.5532	0.2276	-5757.1641	-2.0710	1014.3232	0.3415	-1721.8157
4.20	-2.1351	3547.2146	0.2358	-6021.4023	-2.1715	981.5288	0.3516	-1666.1470
4.30	-2.2105	3677.1079	0.2411	-6241.8984	-2.2489	988.9180	0.3604	-1678.6902
4.40	-2.2529	3737.9590	0.2455	-6345.1914	-2.2927	975.7207	0.3648	-1656.2878
4.50	-2.2702	3773.0818	0.2462	-6404.8125	-2.3107	964.4333	0.3664	-1637.1274
4.60	-2.2563	3771.6777	0.2426	-6402.4297	-2.2965	995.0322	0.3648	-1689.0691
4.70	-2.2592	3774.1509	0.2431	-6406.6289	-2.2996	836.8254	0.3619	-1420.5127
4.80	-2.3233	3903.8645	0.2454	-6626.8125	-2.3660	646.1089	0.3608	-1096.7710
4.90	-2.5160	4247.3125	0.2585	-7209.8203	-2.5650	458.3176	0.3646	-777.9949
5.00	-2.8110	4770.3164	0.2801	-8097.6211	-2.8696	270.8164	0.3578	-459.7112
5.10	-3.1574	5384.0117	0.3070	-9139.3711	-3.2284	100.3434	0.2904	-170.3332
5.20	-3.4810	6004.2148	0.3317	-10192.1641	-3.5644	-0.0291	-2905.2488	0.0493
5.30	-3.6384	6456.8828	0.3464	-10960.5703	-3.7269	-0.0362	-3620.2446	0.0615
5.40	-3.7124	6495.6367	0.3533	-11026.3555	-3.8026	-0.0471	-4710.3203	0.0800
5.50	-3.7401	6467.4766	0.3558	-10978.5508	-3.8307	-0.0605	-6050.2422	0.1027
5.60	-3.7501	6418.3320	0.3571	-10895.1289	-3.8396	-0.0755	-7546.6094	0.1281
5.70	-3.5941	6208.7188	0.3422	-10539.3086	-3.6744	-0.0903	-9033.3086	0.1533
5.80	-3.4506	6042.9531	0.3289	-10257.9258	-3.5230	-0.1069	-10694.8906	0.1815
5.90	-3.3772	5828.1914	0.3221	-9893.3672	-3.4464	-0.1236	-12358.1211	0.2098
6.00	-3.0339	5220.9922	0.2904	-8862.6445	-3.0912	-0.1421	-14208.0469	0.2412
6.10	-2.8720	4937.8555	0.2771	-8382.0156	-2.9235	-0.1632	-16324.3047	0.2771
6.20	-2.8187	4843.0352	0.2730	-8221.0586	-2.8682	-0.1854	-18543.8906	0.3148
6.30	-2.4574	4250.4688	0.2380	-7215.1758	-2.4954	-0.2107	-21069.9492	0.3577
6.40	-2.1632	3745.1028	0.2147	-6357.3164	-2.1938	-0.2346	-23459.0117	0.3982
6.50	-2.0366	3540.7390	0.2019	-6010.4063	-2.0650	-0.2590	-25899.6875	0.4396
6.60	-1.8641	3267.9070	0.1868	-5547.2773	-1.8883	-0.2836	-28360.6094	0.4814
6.70	-1.7379	3069.9148	0.1762	-5211.1836	-1.7599	-0.3105	-31053.1836	0.5271
6.80	-1.5676	2805.6589	0.1610	-4762.6094	-1.5868	-0.3383	-33830.6719	0.5743
6.90	-1.4287	2590.3159	0.1484	-4397.0625	-1.4459	-0.3645	-36452.1836	0.6188
7.00	-1.2319	2286.5496	0.1296	-3881.4199	-1.2459	-0.3931	-39305.5195	0.6672
7.10	-1.1341	2132.1558	0.1225	-3619.3389	-1.1465	-0.4178	-41780.1563	0.7092
7.20	-1.0144	1947.9712	0.1095	-3306.6826	-1.0250	-0.4442	-44418.1094	0.7540
7.30	-0.9255	1781.0859	0.1019	-3023.3970	-0.9354	-0.4703	-47025.0898	0.7983
7.40	-0.9227	1775.8889	0.1012	-3014.5752	-0.9335	-0.4960	-49598.4141	0.8419
7.50	-1.0330	1976.3928	0.1122	-3354.9287	-1.0472	-0.5198	-51984.1367	0.8824
7.60	-0.9042	1740.4492	0.0989	-2954.4163	-0.9165	-0.5426	-54264.6641	0.9211
7.70	-0.7609	1464.9504	0.0823	-2486.7563	-0.7709	-0.5670	-56697.4688	0.9624
7.80	-0.6817	1312.0701	0.0745	-2227.2415	-0.6899	-0.5901	-59011.5313	1.0017
7.90	-0.5118	985.0691	0.0557	-1672.1567	-0.5173	-0.6139	-61385.9102	1.0420
8.00	-0.3796	730.2778	0.0415	-1239.6479	-0.3832	-0.6372	-63718.5078	1.0816
8.10	-0.2614	502.8174	0.0284	-853.5334	-0.2636	-0.6606	-66062.3750	1.1214

113

Figure 17. (continued)

TRACTOR FRONT SUSPENSION - UNSPRUNG MASS SUMMARY

TIME (SEC)	AXLE MOTION				DYNAMIC SUSPENSION MOTIONS AND FORCES						
	POSITION		VELOCITY		AUXILIARY ROLL TORQUE (IN-LB)	LEFT SIDE			RIGHT SIDE		
	VERTICAL (FT)	ROLL (DEG)	VERTICAL (FT/SEC)	ROLL (DEG/SEC)		SUSP. DEFLECT. (IN)	SUSP. VELOCITY (IN/SEC)	SUSP. FORCE (LB)	SUSP. DEFLECT. (IN)	SUSP. VELOCITY (IN/SEC)	SUSP. FORCE (LB)
4.10	-1.8837	1.1964	-1.7933	1.0607	7505.6	-1.1467	-0.2442	-1632.86	1.6613	0.7956	2136.31
4.20	-2.0654	1.2874	-1.8436	0.7238	7808.8	-1.1939	-0.6037	-1747.22	1.7269	0.5388	2214.12
4.30	-2.2557	1.3555	-1.9165	0.6566	8105.9	-1.2929	-0.5495	-1920.80	1.7391	0.5079	2206.93
4.40	-2.4529	1.4227	-2.0432	0.5979	8395.6	-1.3650	-0.9680	-2024.65	1.7752	0.1777	2256.22
4.50	-2.6585	1.5002	-2.0834	0.6460	8799.8	-1.4341	-0.4628	-2117.68	1.8559	1.3033	2356.36
4.60	-2.8725	1.5730	-2.1798	0.8094	9380.8	-1.5306	-1.0567	-2244.11	1.9751	1.4670	2494.05
4.70	-3.0907	1.6438	-2.2170	0.7653	10096.6	-1.6213	-0.9664	-2361.43	2.1514	1.9148	2692.67
4.80	-3.3175	1.7108	-2.2634	0.6332	10902.1	-1.7639	-0.8077	-2545.07	2.3095	2.3283	2869.18
4.90	-3.5487	1.7717	-2.3876	0.5528	11754.1	-1.8947	-1.6707	-2713.12	2.4975	1.4315	3079.01
5.00	-3.7863	1.8266	-2.3891	0.5329	12507.7	-2.0298	-1.0029	-2886.55	2.6461	1.4146	3244.99
5.10	-4.0292	1.8933	-2.4546	0.6280	13063.9	-2.1866	-1.5443	-3088.61	2.6995	0.1251	3302.28
5.20	-4.2730	1.9660	-2.4570	1.0329	13465.2	-2.3241	-1.5570	-3265.00	2.7130	-0.0159	3312.76
5.30	-4.5226	2.0514	-2.4789	0.8696	13865.2	-2.5134	-1.2852	-3508.53	2.6731	0.3136	3220.01
5.40	-4.7746	2.1484	-2.5895	1.0276	14338.9	-2.6674	-1.7449	-3706.20	2.6959	0.1677	3259.86
5.50	-5.0325	2.2217	-2.6994	2.0416	14805.8	-2.7293	-1.3273	-4066.79	2.8086	1.1914	3417.76
5.60	-5.2917	2.3035	-2.4225	-1.4835	15301.3	-2.6145	4.8324	-3150.28	3.1086	5.5305	3771.45
5.70	-5.5633	2.4644	-3.1660	5.5403	16228.2	-2.7054	-8.8934	-3708.41	3.3591	-2.1221	4040.39
5.80	-5.8098	2.3628	-2.3149	-2.4886	16909.1	-2.5022	5.7475	-2655.12	3.8204	6.7969	4574.72
5.90	-6.1001	2.6564	-1.7191	-7.3947	18037.7	-2.8404	16.5680	*****	3.9063	13.8771	4693.89
6.00	-6.3537	2.5817	-3.9026	10.8846	18769.4	-2.5184	-18.8096	-3373.46	4.4926	-7.1422	5421.29
6.10	-6.6140	2.5300	-1.8383	-8.6450	20142.6	-2.4321	15.1290	-2452.86	5.0951	15.0498	5945.05
6.20	-6.9156	2.8064	-0.7617	-17.7273	21970.7	-2.8373	34.4730	*****	5.3786	26.9335	6243.29
6.30	-7.1943	2.8590	-4.7522	17.8025	23309.3	-2.8044	-32.2905	-7615.64	5.9008	-15.0095	6858.97
6.40	-7.4448	2.6872	-4.3618	14.5604	24634.4	-2.5081	-25.9574	-3379.52	6.6920	-9.9601	7620.57
6.50	-7.7152	2.6424	-3.6947	9.0084	26213.0	-2.4068	-12.5095	-2724.89	7.3881	-1.1125	8289.66
6.60	-7.9942	2.6811	-2.5190	-2.4178	27925.8	-2.3879	5.4260	-2377.79	8.0484	10.2677	8896.01
6.70	-8.2679	2.6610	-1.8273	-8.0599	29773.0	-2.4593	15.9827	-2502.93	8.6698	17.0581	9522.84
6.80	-8.5431	2.6480	-1.9305	-7.8724	31432.1	-2.4905	16.3233	-2594.86	9.2625	16.3644	10116.13
6.90	-8.8242	2.6959	-2.1318	-5.2363	33077.0	-2.4821	12.7626	-2544.93	9.8837	15.3326	10737.77
7.00	-9.0998	2.6540	-2.4968	-2.0430	34991.9	-2.5128	6.3684	-2644.66	10.5662	11.9665	11417.77
7.10	-9.3776	2.6539	-2.9603	1.0267	36838.5	-2.5213	0.3004	-2848.29	11.2518	6.5117	12099.70
7.20	-9.6636	2.6581	-2.9919	3.0159	38373.4	-2.5378	-0.5444	-2910.70	11.8108	6.3774	12658.30
7.30	-9.9467	2.5284	-2.6612	-0.3913	39878.1	-2.5731	4.5259	-2966.82	12.3367	10.2151	13187.46
7.40	-10.2408	2.3967	-1.4307	-17.8970	41456.1	-2.6627	29.1523	-4161.59	12.8434	23.0369	13693.18
7.50	-10.5791	1.8480	-0.8514	-36.5865	42302.6	-2.9634	45.6237	*****	12.8602	28.2545	13710.16
7.60	-10.9492	1.0437	-2.2286	-32.5899	42963.8	-3.2391	28.4857	*****	12.8238	16.1655	13691.43
7.70	-11.3398	-0.4281	-4.0385	-18.2164	43148.8	-3.3490	3.3969	*****	12.7761	1.4686	13676.21
7.80	-11.7502	-2.4294	-5.7339	-10.3276	42598.4	-3.2433	-19.4661	*****	12.6730	-16.1830	13619.52
7.90	-12.1817	-4.8143	-6.8829	5.1667	41382.6	-3.0413	-36.8240	*****	12.4174	-24.1847	13367.33
8.00	-12.6229	-7.2827	-7.1183	2.5087	40345.9	-2.9322	-40.1747	*****	12.1340	-27.4572	13077.12
8.10	-13.0539	-9.4891	-6.8960	9.1860	39901.2	-2.8799	-39.6159	*****	12.0213	-23.8960	12967.27

114

Figure 17. (continued)

TRACTOR REAR SUSPENSION - UNSPRUNG MASS SUMMARY

LEADING TANDEM AXLE

TIME (SEC)	AXLE MOTION				DYNAMIC SUSPENSION MOTIONS AND FORCES						
	POSITION		VELOCITY		AUXILIARY ROLL TORQUE (IN-LB)	LEFT SIDE			RIGHT SIDE		
	VERTICAL (FT)	ROLL (DEG)	VERTICAL (FT/SEC)	ROLL (DEG/SEC)		SUSP. DEFLECT. (IN)	SUSP. VELOCITY (IN/SEC)	SUSP. FORCE (LB)	SUSP. DEFLECT. (IN)	SUSP. VELOCITY (IN/SEC)	SUSP. FORCE (LB)
4.10	-1.5896	0.6505	-1.6843	0.9124	26000.6	-1.0624	-0.1185	-7762.89	1.7871	1.0179	7123.42
4.20	-1.7597	0.7374	-1.7276	0.7429	27067.2	-1.0788	0.1254	-7958.38	1.8998	1.4948	7324.29
4.30	-1.9391	0.8334	-1.8231	1.0256	28336.6	-1.0821	-0.0388	-8074.99	2.0048	1.4617	7346.87
4.40	-2.1248	0.9231	-1.9462	0.5262	29974.9	-1.0875	-0.0887	-8166.82	2.1671	1.2244	7349.93
4.50	-2.3188	1.0098	-1.9601	0.7069	32097.8	-1.0898	0.3765	-8208.97	2.3700	2.5141	7350.05
4.60	-2.5197	1.0838	-2.0697	1.2327	34688.6	-1.0912	0.0087	-8347.11	2.6216	3.2863	7350.06
4.70	-2.7281	1.1468	-2.1369	0.2610	37895.8	-1.1055	0.2387	-8586.38	3.0747	3.3258	7875.34
4.80	-2.9457	1.1670	-2.1803	0.0707	41361.5	-1.1286	0.6076	-9202.86	3.4345	3.9586	8756.41
4.90	-3.1661	1.1593	-2.2750	-0.1484	44520.1	-1.1604	-0.3482	*****	3.7556	2.8707	9543.19
5.00	-3.3947	1.1672	-2.3131	0.3474	47162.9	-1.1810	-0.0497	*****	4.0331	2.6981	10224.82
5.10	-3.6303	1.1870	-2.3984	0.4818	49184.3	-1.2071	0.2690	*****	4.2386	2.1545	10728.27
5.20	-3.8689	1.2275	-2.4051	0.6560	50739.6	-1.2231	0.5549	*****	4.3870	2.1350	11092.22
5.30	-4.1155	1.3010	-2.4634	0.8543	52334.5	-1.2216	1.9166	*****	4.4475	3.8051	11244.46
5.40	-4.3654	1.4152	-2.5980	0.9174	54533.2	-1.2086	1.2568	*****	4.5001	3.4549	11285.96
5.50	-4.6254	1.4523	-2.6395	-0.4048	56922.1	-1.1832	2.2039	*****	4.5500	3.5724	11289.35
5.60	-4.8932	1.3524	-2.7024	-2.0243	59214.7	-1.1860	2.0217	*****	4.5690	2.4919	11204.86
5.70	-5.1670	1.0860	-2.7964	-3.5652	61291.1	-1.2121	1.4247	*****	4.6029	3.4265	11389.96
5.80	-5.4537	0.6861	-2.8922	-0.8249	63394.8	-1.2398	3.2321	*****	4.6556	2.2657	11458.24
5.90	-5.7502	0.1054	-3.1071	-5.7535	65280.1	-1.2329	1.3038	*****	4.7516	-0.8032	11714.96
6.00	-6.0631	-0.7004	-3.1766	-9.0571	66666.5	-1.2212	1.8221	*****	4.7818	2.4514	11769.08
6.10	-6.3866	-1.6509	-3.2477	-10.6489	67750.1	-1.2453	2.6033	*****	4.8385	1.1802	11766.09
6.20	-6.7141	-2.7307	-3.3642	-11.5741	68627.3	-1.2397	2.4693	*****	4.9180	-2.4029	11960.00
6.30	-7.0513	-3.8839	-3.4490	-12.0458	69733.1	-1.2173	0.1916	*****	5.0152	0.9166	12398.66
6.40	-7.4009	-5.2412	-3.4815	-12.4837	70170.5	-1.2544	1.6075	*****	5.0318	2.6680	12135.73
6.50	-7.7481	-6.5511	-3.4805	-14.5913	71193.9	-1.2196	3.8482	*****	5.1440	1.7301	12597.87
6.60	-8.1044	-7.9698	-3.4925	-14.0878	71794.1	-1.2905	4.4506	*****	5.1628	2.4602	12402.20
6.70	-8.4617	-9.4262	-3.6413	-15.8391	72330.1	-1.2894	2.5697	*****	5.2385	-1.3126	12424.31
6.80	-8.8215	-10.9329	-3.5517	-15.6679	72709.6	-1.2832	5.0938	*****	5.3117	-0.0275	12688.92
6.90	-9.1817	-12.4820	-3.5495	-17.7936	72914.3	-1.2904	5.2166	*****	5.3320	-0.0598	12876.63
7.00	-9.5444	-13.9877	-3.5861	-16.1550	73299.4	-1.3062	3.7480	*****	5.3720	1.0363	12999.38
7.10	-9.9021	-15.4628	-3.5100	-14.5423	73669.5	-1.3023	4.6444	*****	5.4246	1.6946	12991.74
7.20	-10.2595	-16.8436	-3.5640	-15.9018	74561.3	-1.3056	6.3256	*****	5.5371	1.9985	13262.43
7.30	-10.6225	-18.3105	-3.6018	-13.4732	74785.6	-1.3142	3.3621	*****	5.5797	1.4418	13307.09
7.40	-10.9832	-19.6929	-3.5883	-15.2546	75247.6	-1.3054	4.9893	*****	5.6448	-0.5201	13467.35
7.50	-11.3413	-21.0331	-3.5635	-14.4121	75697.7	-1.3203	2.9042	*****	5.6667	-3.0150	13632.51
7.60	-11.6994	-22.4006	-3.6333	-14.9215	75812.3	-1.3068	1.9619	*****	5.6782	-0.9502	13863.08
7.70	-12.0622	-23.7682	-3.6817	-12.3355	75659.2	-1.3023	0.5559	*****	5.6335	2.1664	14150.16
7.80	-12.4252	-25.1219	-3.6579	-11.9532	75341.0	-1.2866	0.8002	*****	5.5995	3.6208	14065.48
7.90	-12.7901	-26.3728	-3.6065	-12.4931	75816.4	-1.2810	3.8667	*****	5.6159	7.1635	14092.04
8.00	-13.1568	-27.7167	-3.7040	-13.1426	75894.9	-1.3173	2.0808	*****	5.5949	6.8025	14117.35
8.10	-13.5237	-28.9853	-3.6139	-13.1130	76683.3	-1.3086	4.3366	*****	5.6929	8.2148	14312.72

115

Figure 17. (continued)

TRACTOR REAR SUSPENSION - UNSPRUNG MASS SUMMARY

TRAILING TANDEM AXLE

TIME (SEC)	AXLE MOTION				DYNAMIC SUSPENSION MOTIONS AND FORCES						
	POSITION		VELOCITY		AUXILIARY ROLL TORQUE (IN-LB)	LEFT SIDE			RIGHT SIDE		
	VERTICAL (FT)	ROLL (DEG)	VERTICAL (FT/SEC)	ROLL (DEG/SEC)		SUSP. DEFLECT. (IN)	SUSP. VELOCITY (IN/SEC)	SUSP. FORCE (LB)	SUSP. DEFLECT. (IN)	SUSP. VELOCITY (IN/SEC)	SUSP. FORCE (LB)
4.10	-1.4823	0.5173	-1.6327	0.9915	25205.2	-1.0420	-0.0523	-7688.56	1.7954	1.1366	7149.36
4.20	-1.6492	0.6042	-1.6843	0.9002	26272.0	-1.0312	0.0353	-7956.13	1.9124	1.5090	7329.96
4.30	-1.8221	0.6903	-1.8023	0.9516	27482.4	-1.0442	-0.3509	-8070.22	2.0670	1.1004	7349.14
4.40	-2.0043	0.8055	-1.8371	1.0291	29272.8	-1.0454	0.4394	-8079.95	2.2782	2.0860	7350.04
4.50	-2.1941	0.8896	-1.9392	1.0962	31380.3	-1.0551	-0.1528	-8194.02	2.5299	2.2429	7350.06
4.60	-2.3886	0.9724	-1.9819	0.7243	34023.7	-1.0551	0.5362	-8232.23	2.8545	3.4766	7388.14
4.70	-2.5952	1.0353	-2.0737	-0.0387	37230.1	-1.0703	0.3387	-8518.89	3.0823	3.2270	7893.30
4.80	-2.8064	1.0493	-2.1791	-0.1810	40658.9	-1.0978	-0.1449	-9176.48	3.4359	3.0391	8759.30
4.90	-3.0244	1.0510	-2.1891	0.0748	43874.2	-1.1236	-0.3735	-9948.09	3.7652	2.9933	9567.29
5.00	-3.2494	1.0494	-2.3156	0.5102	46459.2	-1.1430	-1.2613	*****	4.0327	1.5944	10223.50
5.10	-3.4797	1.0702	-2.3272	0.2941	48487.6	-1.1501	-0.0860	*****	4.2488	1.6751	10753.41
5.20	-3.7207	1.0379	-2.4756	-1.2641	49608.0	-1.1609	-1.0456	*****	4.3730	-0.7389	10940.48
5.30	-3.9801	0.7358	-2.7509	-3.7321	48960.8	-1.1597	-1.4576	*****	4.4196	-2.6110	10905.97
5.40	-4.2622	0.2195	-2.8948	-5.7912	47396.1	-1.1414	-1.5657	*****	4.4674	-3.8169	10770.88
5.50	-4.5571	-0.4398	-3.0061	-7.4835	45628.3	-1.1483	-1.3753	*****	4.5048	-4.7016	10664.09
5.60	-4.8568	-1.1896	-2.9785	-8.3093	44041.3	-1.1502	-0.7586	*****	4.5589	-4.4567	10688.91
5.70	-5.1584	-1.9369	-3.0378	-7.8757	43247.0	-1.1799	-1.5728	*****	4.5985	-2.4298	10986.54
5.80	-5.4643	-2.7872	-3.1209	-8.4792	42662.7	-1.2000	-0.1620	*****	4.6746	-2.8889	11092.33
5.90	-5.7776	-3.6398	-3.1594	-9.2799	42924.6	-1.2189	0.2756	*****	4.8094	-4.1702	11288.84
6.00	-6.0971	-4.6016	-3.2716	-9.4786	43380.6	-1.2284	-0.7030	*****	4.9631	-0.3533	11625.28
6.10	-6.4260	-5.7189	-3.2850	-12.4950	43468.5	-1.2101	1.1814	*****	5.0362	-1.4661	11634.94
6.20	-6.7608	-6.8875	-3.4001	-12.9076	43815.3	-1.2264	0.7953	*****	5.0929	-4.9613	11924.41
6.30	-7.1031	-8.2449	-3.5480	-11.9206	43702.2	-1.2201	-2.6186	*****	5.1068	-1.8105	12257.96
6.40	-7.4508	-9.5271	-3.4282	-11.7937	44587.8	-1.2057	0.4568	*****	5.2119	1.9749	12349.02
6.50	-7.7975	-10.8400	-3.4904	-12.7621	45593.2	-1.2354	1.4632	*****	5.3396	0.5583	12655.79
6.60	-8.1472	-12.1672	-3.4035	-15.7087	46739.7	-1.2472	4.4002	*****	5.4333	1.3348	12477.86
6.70	-8.5053	-13.6295	-3.5974	-15.0284	47240.4	-1.2635	1.0890	*****	5.4609	-2.2556	12584.27
6.80	-8.8628	-15.1417	-3.5770	-16.9818	47587.3	-1.2706	3.4418	*****	5.4747	-2.5509	12694.48
6.90	-9.2198	-16.5641	-3.5042	-16.9597	48547.8	-1.2752	3.6357	*****	5.5652	-1.0877	12998.59
7.00	-9.5790	-18.1102	-3.5942	-15.6207	48692.5	-1.2592	1.6199	*****	5.5761	-0.7373	12907.56
7.10	-9.9346	-19.4496	-3.4602	-14.5247	49872.4	-1.2940	3.3486	*****	5.6717	0.4104	13007.55
7.20	-10.2900	-20.8832	-3.5727	-15.3901	50449.2	-1.2679	4.1742	*****	5.7475	0.1866	13302.76
7.30	-10.6514	-22.2995	-3.5282	-15.7344	50975.0	-1.2485	2.9884	*****	5.7948	-0.4316	13375.18
7.40	-11.0128	-23.6951	-3.5799	-15.3070	51358.3	-1.2558	2.7892	*****	5.8383	-2.7549	13554.14
7.50	-11.3683	-25.0183	-3.5184	-16.7548	51909.8	-1.2668	1.4112	*****	5.9035	-6.0618	13691.79
7.60	-11.7271	-26.3320	-3.6057	-13.5524	52345.5	-1.2634	-1.0800	*****	5.9507	-3.0841	13884.57
7.70	-12.0872	-27.7344	-3.6965	-13.1138	51985.0	-1.2483	-2.3296	*****	5.9411	-1.2353	14211.31
7.80	-12.4525	-29.0661	-3.6815	-11.6710	51798.0	-1.2461	-2.4460	*****	5.9305	0.5617	14155.80
7.90	-12.8172	-30.4372	-3.7250	-10.8848	51555.8	-1.2389	-0.7432	*****	5.9467	3.6202	14299.05
8.00	-13.1853	-31.7973	-3.6968	-14.2037	51537.9	-1.2656	0.0436	*****	5.9005	4.0615	14526.21
8.10	-13.5541	-33.1524	-3.6513	-11.6601	51809.6	-1.2773	1.0831	*****	5.9209	5.9249	14458.40

116

Figure 17. (continued)

TRAILER NO. 1 SPRUNG MASS POSITION

TIME (SEC)	FORWARD (FT)	LATERAL (FT)	VERTICAL (FT)	ROLL (DEG)	PITCH (DEG)	HEADING (DEG)	TURN RADIUS (FT)	SIDE SLIP (DEG)	ARTICULATION ANGLE (DEG)
4.10	215.7366	5.7789	-1.1600	-3.7160	1.3632	6.9158	476.2649	0.5308	4.3295
4.20	221.6571	6.5891	-1.3117	-3.8093	1.4361	7.6301	458.8528	0.5482	4.5695
4.30	227.5664	7.4765	-1.4723	-3.9276	1.4977	8.3845	447.2197	0.5492	4.7942
4.40	233.4608	8.4431	-1.6389	-4.1143	1.5749	9.1806	431.9624	0.5295	4.9952
4.50	239.3420	9.4911	-1.8157	-4.3855	1.6450	10.0130	418.8293	0.5040	5.1729
4.60	245.2056	10.6221	-2.0078	-4.7482	1.6900	10.8773	421.1194	0.4593	5.3247
4.70	251.0478	11.8364	-2.2098	-5.2255	1.7542	11.7745	421.7717	0.3756	5.4425
4.80	256.8694	13.1338	-2.4179	-5.7896	1.8268	12.6950	409.3960	0.2774	5.5567
4.90	262.6689	14.5156	-2.6336	-6.3306	1.8673	13.6323	386.2092	0.1935	5.7016
5.00	268.4417	15.9853	-2.8529	-6.7697	1.9060	14.5964	389.4246	0.1244	5.8876
5.10	274.1846	17.5481	-3.0757	-7.0936	1.9564	15.5902	321.1018	0.0996	6.1335
5.20	279.8938	19.2097	-3.3108	-7.3194	1.9669	16.6080	343.5393	0.1365	6.4498
5.30	285.5623	20.9740	-3.5572	-7.5194	1.9697	17.6599	300.3257	0.1696	6.7876
5.40	291.1860	22.8427	-3.8148	-7.7804	1.9970	18.7588	311.7141	0.1899	7.0912
5.50	296.7605	24.8158	-4.0807	-8.1509	2.0444	19.9004	325.9910	0.1601	7.3448
5.60	302.2786	26.8936	-4.3564	-8.6428	2.0652	21.0750	284.8896	0.1459	7.5466
5.70	307.7346	29.0758	-4.6435	-9.2650	2.0404	22.2807	326.3513	0.0880	7.6655
5.80	313.1252	31.3600	-4.9400	-10.0245	2.0043	23.5155	276.2727	0.0154	7.6805
5.90	318.4509	33.7435	-5.2465	-10.9276	1.9734	24.7719	336.0657	-0.0887	7.6210
6.00	323.7131	36.2249	-5.5616	-11.9716	1.9469	26.0380	266.4785	-0.1946	7.5010
6.10	328.9075	38.8017	-5.8887	-13.1084	1.8903	27.2925	356.2295	-0.3038	7.3301
6.20	334.0298	41.4702	-6.2232	-14.3388	1.8205	28.5249	280.6060	-0.4138	7.1293
6.30	339.0854	44.2267	-6.5622	-15.6798	1.7426	29.7378	380.2991	-0.5110	6.8965
6.40	344.0762	47.0670	-6.9038	-17.1118	1.6691	30.9220	313.1470	-0.6257	6.6411
6.50	348.9983	49.9872	-7.2501	-18.5940	1.5697	32.0635	395.6450	-0.6721	6.3944
6.60	353.8555	52.9842	-7.5998	-20.1138	1.4520	33.1659	316.7761	-0.7262	6.1628
6.70	358.6504	56.0541	-7.9524	-21.6599	1.3223	34.2319	436.7310	-0.7347	5.9372
6.80	363.3828	59.1923	-8.3046	-23.2302	1.1977	35.2575	370.8579	-0.7808	5.7319
6.90	368.0552	62.3954	-8.6574	-24.8142	1.0573	36.2456	501.4006	-0.7284	5.5615
7.00	372.6707	65.6606	-9.0103	-26.3855	0.8975	37.2006	334.4160	-0.7162	5.4165
7.10	377.2268	68.9838	-9.3648	-27.9238	0.7265	38.1199	677.3948	-0.6501	5.2918
7.20	381.7292	72.3620	-9.7169	-29.4559	0.5614	39.0152	321.9792	-0.5961	5.1935
7.30	386.1812	75.7925	-10.0693	-30.9629	0.3943	39.8916	931.5193	-0.5321	5.1192
7.40	390.5798	79.2724	-10.4207	-32.4258	0.2295	40.7433	338.7769	-0.4436	5.0652
7.50	394.9275	82.7993	-10.7729	-33.8452	0.0561	41.5764	812.7815	-0.4025	5.0309
7.60	399.2273	86.3706	-11.1239	-35.2352	-0.1157	42.4017	580.7473	-0.2723	4.9921
7.70	403.4802	89.9835	-11.4760	-36.5790	-0.2775	43.2157	331.4929	-0.2126	4.9319
7.80	407.6873	93.6355	-11.8324	-37.8793	-0.4361	44.0164	2020.6111	-0.1432	4.8447
7.90	411.8486	97.3247	-12.1880	-39.2073	-0.5750	44.8141	403.0164	-0.0412	4.7181
8.00	415.9653	101.0486	-12.5448	-40.5595	-0.7362	45.6182	523.6052	-0.0320	4.5535
8.10	420.0361	104.8040	-12.9007	-41.9534	-0.9132	46.4341	702.4529	0.0427	4.3570

117

Figure 17. (continued)

TRAILER NO. 1 SPRUNG MASS VELOCITY (BODY AXES)							
TIME (SEC)	FORWARD (FT/SEC)	LATERAL (FT/SEC)	VERTICAL (FT/SEC)	ROLL (DEG/SEC)	PITCH (DEG/SEC)	HEADING (DEG/SEC)	ARTICULATION RATE (DEG/SEC)
4.10	59.78	0.55	-0.01	-1.10	0.41	6.98	2.44
4.20	59.81	0.57	-0.03	-1.16	0.13	7.35	2.34
4.30	59.84	0.57	-0.03	-1.68	0.15	7.77	2.13
4.40	59.86	0.55	-0.02	-2.51	0.22	8.18	1.89
4.50	59.87	0.53	-0.09	-3.38	-0.11	8.48	1.67
4.60	59.88	0.48	-0.18	-4.43	-0.25	8.79	1.34
4.70	59.89	0.39	-0.18	-5.62	-0.05	9.11	1.09
4.80	59.88	0.29	-0.19	-6.01	-0.36	9.25	1.23
4.90	59.88	0.20	-0.23	-5.23	-0.81	9.40	1.65
5.00	59.87	0.13	-0.20	-4.12	-0.67	9.73	2.13
5.10	59.82	0.10	-0.21	-3.09	-0.79	9.97	2.84
5.20	59.75	0.14	-0.36	-2.30	-1.36	10.15	3.42
5.30	59.65	0.18	-0.43	-2.65	-1.12	10.61	3.25
5.40	59.53	0.20	-0.56	-3.40	-1.28	11.05	2.77
5.50	59.40	0.17	-0.53	-4.83	-1.00	11.46	2.30
5.60	59.28	0.15	-0.71	-5.84	-2.04	11.59	1.70
5.70	59.16	0.09	-0.78	-7.46	-2.07	11.89	0.68
5.80	59.04	0.02	-0.99	-8.64	-2.59	12.02	-0.33
5.90	58.91	-0.09	-1.11	-10.25	-2.52	12.17	-0.88
6.00	58.77	-0.20	-1.29	-11.40	-2.91	12.04	-1.46
6.10	58.66	-0.31	-1.49	-12.20	-3.29	11.69	-1.92
6.20	58.54	-0.42	-1.67	-13.25	-3.56	11.35	-2.14
6.30	58.41	-0.52	-1.86	-14.27	-3.83	10.99	-2.38
6.40	58.28	-0.64	-1.99	-15.08	-3.72	10.56	-2.55
6.50	58.16	-0.68	-2.25	-15.22	-4.41	9.80	-2.37
6.60	58.04	-0.74	-2.42	-15.75	-4.31	9.37	-2.43
6.70	57.92	-0.74	-2.69	-15.70	-4.68	8.72	-2.25
6.80	57.79	-0.79	-2.82	-16.10	-4.33	8.36	-2.06
6.90	57.66	-0.73	-3.10	-15.90	-4.94	7.63	-1.72
7.00	57.54	-0.72	-3.28	-15.75	-4.75	7.26	-1.53
7.10	57.42	-0.65	-3.55	-15.40	-4.92	6.73	-1.31
7.20	57.29	-0.60	-3.74	-15.32	-4.85	6.47	-1.04
7.30	57.16	-0.53	-3.97	-14.95	-4.76	6.20	-0.85
7.40	57.04	-0.44	-4.22	-14.29	-4.97	5.71	-0.58
7.50	56.91	-0.40	-4.39	-14.18	-4.62	5.72	-0.47
7.60	56.77	-0.27	-4.69	-13.58	-5.00	5.31	-0.38
7.70	56.64	-0.21	-4.90	-13.16	-4.73	5.26	-0.49
7.80	56.51	-0.14	-5.14	-13.09	-4.47	5.28	-0.88
7.90	56.37	-0.04	-5.41	-13.25	-4.88	4.91	-1.24
8.00	56.24	-0.03	-5.62	-13.71	-4.75	5.05	-1.83
8.10	56.10	0.04	-5.97	-14.09	-5.12	4.78	-2.07

Figure 17. (continued)

TRAILER NO. 1 SPRUNG MASS ACCELERATION (BODY AXES)

INERTIAL ACCEL. ALONG BODY AXES

TIME (SEC)	-----						-----	
	FORWARD (FT/SEC**2)	LATERAL (FT/SEC**2)	VERTICAL (FT/SEC**2)	ROLL (DEG/SEC**2)	PITCH (DEG/SEC**2)	HEADING (DEG/SEC**2)	LONGITUDINAL (FT/SEC**2)	LATERAL (FT/SEC**2)
4.10	0.3294	0.2417	-0.1023	-0.1890	-2.4185	3.8088	0.2619	7.5205
4.20	0.3599	0.1423	-0.2980	-2.4678	-2.0798	3.7100	0.2865	7.8147
4.30	0.2641	-0.0877	0.2115	-7.6285	1.4345	4.2503	0.1862	8.0260
4.40	0.0547	-0.2254	-0.1214	-9.2106	-1.4051	3.4686	-0.0243	8.3168
4.50	0.1592	-0.2757	-1.2516	-8.5054	-4.9124	2.6181	0.0815	8.5793
4.60	0.1474	-0.6546	-0.4508	-12.7755	1.9996	3.4546	0.0745	8.5237
4.70	-0.0089	-0.9960	0.1556	-9.7575	-0.2563	2.0927	-0.0712	8.5123
4.80	-0.0556	-0.8814	-1.0168	5.0385	-9.1028	0.4206	-0.1012	8.7688
4.90	-0.0044	-0.5224	-1.9584	16.6109	-12.0767	0.8733	-0.0343	9.2808
5.00	-0.2241	-0.9587	3.8819	-1.8597	23.3153	5.6558	-0.2438	9.1908
5.10	-0.6022	0.9517	-7.2182	32.9939	-44.5423	-3.7874	-0.6174	11.3474
5.20	-0.8588	-0.2022	3.9853	-15.9378	29.8911	6.9150	-0.8756	10.3649
5.30	-1.0765	1.0006	-5.7093	9.9968	-28.1586	0.7331	-1.1008	12.0260
5.40	-1.2230	-0.2885	1.2601	-18.6000	12.5616	5.9135	-1.2486	11.1592
5.50	-1.2408	-1.0039	3.1940	-24.7995	16.8462	6.5754	-1.2647	10.8281
5.60	-1.1804	0.0401	-2.9325	-8.3101	-14.6427	0.1312	-1.1858	11.9642
5.70	-1.1573	-1.5417	2.5601	-28.1366	19.9228	7.1594	-1.1481	10.6313
5.80	-1.2988	0.1542	-6.7955	3.3635	-31.5326	-4.6248	-1.2574	12.3883
5.90	-1.3320	-2.1543	3.3879	-30.1078	26.6343	5.6847	-1.2638	10.1557
6.00	-1.2416	0.5751	-8.8086	15.3911	-46.4194	-12.5213	-1.1342	12.6682
6.10	-1.0803	-2.3460	3.0976	-27.3965	28.2454	3.6537	-0.9314	9.3048
6.20	-1.3161	0.4990	-7.5326	10.6064	-38.5690	-14.2286	-1.1290	11.7078
6.30	-1.2345	-2.2465	2.4263	-24.5344	22.9379	3.1237	-1.0105	8.4937
6.40	-1.2681	0.5240	-5.8528	6.5994	-28.5884	-14.4898	-1.0217	10.7381
6.50	-1.1294	-1.7084	1.8463	-20.4024	24.2731	4.1421	-0.8394	7.6411
6.60	-1.2955	1.6695	-6.9092	12.9785	-29.8611	-16.2816	-0.9932	10.4954
6.70	-1.1811	-1.4759	0.9800	-14.3948	20.2320	3.2496	-0.8486	6.6055
6.80	-1.3409	1.3172	-4.6722	5.8094	-18.6113	-13.6280	-1.0133	8.9570
6.90	-1.1456	-1.4738	1.8319	-13.1336	24.1981	8.1226	-0.7814	5.3446
7.00	-1.3550	3.0875	-7.3239	18.5134	-31.7966	-21.3430	-0.9919	9.4754
7.10	-1.1474	-1.9548	2.8803	-17.8152	30.7493	14.4393	-0.7665	3.8413
7.20	-1.5193	4.0205	-7.5416	17.7668	-31.5340	-19.9789	-1.1355	9.4917
7.30	-1.0006	-2.7040	3.4443	-15.5052	35.1258	17.9490	-0.6136	2.4458
7.40	-1.4021	3.5757	-6.7277	20.4893	-23.8690	-17.6258	-0.9918	8.2039
7.50	-1.2242	-0.8485	-0.0530	-3.4049	11.7278	3.2974	-0.8302	3.7501
7.60	-1.2620	-0.3845	-1.1119	3.6009	10.5993	4.8862	-0.8276	3.7637
7.70	-1.5859	4.3033	-7.6042	23.7178	-30.0549	-24.8126	-1.1621	8.3749
7.80	-0.9848	-3.9311	4.0363	-24.0093	36.7000	25.1952	-0.5713	0.1030
7.90	-1.4399	2.3134	-4.4243	3.2543	-13.7966	-7.4369	-0.9756	5.8879
8.00	-1.4068	2.4042	-4.7111	-2.8088	-18.9514	-13.4145	-0.9381	6.0123
8.10	-1.2165	-0.7037	-1.3715	-16.8129	7.3527	10.8131	-0.6862	2.5133

119

Figure 17. (continued)

TRAILER NO. 1 REAR SUSPENSION TIRE FORCES

LEADING TANDEM AXLE

TIME (SEC)	LEFT SIDE					RIGHT SIDE				
	VERTICAL (LB)	LONG. (LB)	LATERAL (LB)	MU-X	MU-Y	VERTICAL (LB)	LONG. (LB)	LATERAL (LB)	MU-X	MU-Y
4.10	14950.73	-3.40	2173.44	-0.0002	0.1454	3128.27	-0.43	675.36	-0.0001	0.2159
4.20	14904.58	-3.49	2280.21	-0.0002	0.1530	2990.01	-0.68	679.60	-0.0002	0.2273
4.30	14637.63	-3.10	2351.80	-0.0002	0.1607	2851.68	-0.01	673.91	-0.0000	0.2363
4.40	15113.39	-1.38	2443.49	-0.0001	0.1617	2863.43	1.09	696.97	0.0004	0.2434
4.50	15568.68	-1.57	2496.54	-0.0001	0.1604	2866.00	0.69	707.25	0.0002	0.2468
4.60	15045.00	-2.02	2509.98	-0.0001	0.1668	2685.43	0.48	673.69	0.0002	0.2509
4.70	15021.23	-0.38	2585.07	-0.0000	0.1721	2555.22	1.34	661.55	0.0005	0.2589
4.80	16049.35	0.65	2780.67	0.0000	0.1733	2040.39	1.35	558.60	0.0007	0.2738
4.90	16318.73	-0.16	3093.02	-0.0000	0.1895	1087.80	0.82	330.75	0.0008	0.3041
5.00	17949.38	-0.01	3554.54	-0.0000	0.1980	788.70	2.03	269.58	0.0026	0.3418
5.10	16854.52	4.04	3817.89	0.0002	0.2265	0.00	0.00	-0.03	0.0080	-2644.2180
5.20	18792.32	4.83	4200.40	0.0003	0.2235	0.00	0.00	-0.03	0.0174	-2958.9568
5.30	16057.72	5.75	3995.42	0.0004	0.2488	0.00	0.00	-0.03	0.0315	-3200.4753
5.40	17876.73	8.48	4162.18	0.0005	0.2328	0.00	0.00	-0.04	0.0477	-3655.5085
5.50	17747.68	6.81	4158.96	0.0004	0.2343	0.00	0.00	-0.04	0.0647	-3954.6448
5.60	18422.16	10.14	4205.55	0.0006	0.2283	0.00	0.00	-0.04	0.0797	-4488.7539
5.70	17752.84	5.74	4068.01	0.0003	0.2291	0.00	0.00	-0.06	0.0948	-5631.0938
5.80	17227.13	10.76	4039.38	0.0006	0.2345	0.00	0.00	-0.07	0.1095	-6964.1211
5.90	18600.86	7.97	4198.45	0.0004	0.2257	0.00	0.00	-0.09	0.1256	-8659.1641
6.00	17226.82	11.14	3969.60	0.0006	0.2304	0.00	0.00	-0.10	0.1394	*****
6.10	19170.59	7.00	4164.43	0.0004	0.2172	0.00	0.00	-0.12	0.1491	*****
6.20	16434.75	11.16	3704.32	0.0007	0.2254	0.00	0.00	-0.14	0.1592	*****
6.30	18811.71	9.17	3779.68	0.0005	0.2009	0.00	0.00	-0.17	0.1698	*****
6.40	16872.54	8.22	3449.47	0.0005	0.2044	0.00	0.00	-0.19	0.1791	*****
6.50	19115.39	9.57	3423.37	0.0005	0.1791	0.00	0.00	-0.22	0.1853	*****
6.60	16988.93	7.88	3023.88	0.0005	0.1780	0.00	0.00	-0.25	0.1933	*****
6.70	18686.98	10.69	2903.89	0.0006	0.1554	0.00	0.00	-0.28	0.1999	*****
6.80	16881.34	6.30	2632.29	0.0004	0.1559	0.00	0.00	-0.30	0.2085	*****
6.90	19094.06	9.99	2432.01	0.0005	0.1274	0.00	0.00	-0.34	0.2148	*****
7.00	16622.41	8.34	2124.05	0.0005	0.1278	0.00	0.00	-0.36	0.2224	*****
7.10	18900.83	5.48	1945.08	0.0003	0.1029	0.00	0.00	-0.39	0.2292	*****
7.20	16693.98	12.68	1616.89	0.0008	0.0969	0.00	0.00	-0.42	0.2389	*****
7.30	18730.74	1.72	1484.87	0.0001	0.0793	0.00	0.00	-0.45	0.2473	*****
7.40	17234.56	14.95	1121.40	0.0009	0.0651	0.00	0.00	-0.47	0.2545	*****
7.50	17462.29	-0.60	1073.34	-0.0000	0.0615	0.00	0.00	-0.50	0.2648	*****
7.60	18720.18	12.33	746.67	0.0007	0.0399	0.00	0.00	-0.53	0.2740	*****
7.70	16888.66	12.72	656.58	0.0008	0.0389	0.00	0.00	-0.55	0.2852	*****
7.80	18037.91	-2.12	551.40	-0.0001	0.0306	0.00	0.00	-0.58	0.2960	*****
7.90	18081.73	14.67	119.27	0.0008	0.0066	0.00	0.00	-0.60	0.3057	*****
8.00	17404.92	1.05	85.20	0.0001	0.0049	0.00	0.00	-0.62	0.3169	*****
8.10	18264.80	9.19	-282.56	0.0005	-0.0155	0.00	0.00	-0.64	0.3251	*****

120

Figure 17. (continued)

TRAILER NO. 1 REAR SUSPENSION TIRE FORCES

TRAILING TANDEM AXLE

TIME (SEC)	LEFT SIDE					RIGHT SIDE				
	VERTICAL (LB)	LONG. (LB)	LATERAL (LB)	MU-X	MU-Y	VERTICAL (LB)	LONG. (LB)	LATERAL (LB)	MU-X	MU-Y
4.10	15170.54	-3.40	2867.31	-0.0002	0.1890	2785.88	-0.43	797.43	-0.0002	0.2862
4.20	15164.62	-3.49	3012.97	-0.0002	0.1987	2653.57	-0.68	799.86	-0.0003	0.3014
4.30	14880.51	-3.10	3119.42	-0.0002	0.2096	2456.76	-0.04	773.05	-0.0000	0.3147
4.40	15356.50	-1.38	3259.73	-0.0001	0.2123	2453.96	1.04	799.62	0.0004	0.3258
4.50	15860.59	-1.57	3354.11	-0.0001	0.2115	2489.53	0.74	827.34	0.0003	0.3323
4.60	15298.98	-2.02	3386.90	-0.0001	0.2214	2237.67	0.46	757.10	0.0002	0.3383
4.70	15297.96	-0.38	3494.99	-0.0000	0.2285	2105.20	1.29	731.33	0.0006	0.3474
4.80	16233.88	0.65	3725.93	0.0000	0.2295	1559.41	1.30	562.28	0.0008	0.3606
4.90	16727.32	-0.15	4088.35	-0.0000	0.2444	750.78	0.78	290.00	0.0010	0.3863
5.00	18168.14	-0.01	4677.28	-0.0000	0.2574	202.76	0.73	85.36	0.0036	0.4210
5.10	17339.45	4.03	4920.77	0.0002	0.2838	0.00	0.00	-0.03	0.0101	-3054.0366
5.20	19669.98	4.82	5628.92	0.0002	0.2862	0.00	0.00	-0.04	0.0198	-4259.4648
5.30	16485.33	5.74	5139.14	0.0003	0.3117	0.00	0.00	-0.05	0.0339	-5243.9375
5.40	18589.45	8.69	5575.75	0.0005	0.2999	0.00	0.00	-0.06	0.0501	-6423.8750
5.50	18276.29	6.71	5532.44	0.0004	0.3027	0.00	0.00	-0.07	0.0671	-7349.2969
5.60	18843.38	10.28	5660.87	0.0005	0.3004	0.00	0.00	-0.08	0.0822	-8442.8828
5.70	18223.50	5.65	5479.65	0.0003	0.3007	0.00	0.00	-0.10	0.0973	*****
5.80	17308.83	10.76	5360.22	0.0006	0.3097	0.00	0.00	-0.12	0.1119	*****
5.90	18916.43	7.97	5711.18	0.0004	0.3019	0.00	0.00	-0.14	0.1280	*****
6.00	17404.36	11.13	5309.64	0.0006	0.3051	0.00	0.00	-0.16	0.1418	*****
6.10	19101.07	6.99	5556.71	0.0004	0.2909	0.00	0.00	-0.18	0.1515	*****
6.20	16607.27	11.15	4935.86	0.0007	0.2972	0.00	0.00	-0.20	0.1616	*****
6.30	18635.77	9.15	5043.30	0.0005	0.2706	0.00	0.00	-0.23	0.1722	*****
6.40	16772.17	8.23	4595.39	0.0005	0.2740	0.00	0.00	-0.26	0.1816	*****
6.50	19018.45	9.53	4576.71	0.0005	0.2406	0.00	0.00	-0.28	0.1877	*****
6.60	16364.23	7.90	3998.47	0.0005	0.2443	0.00	0.00	-0.31	0.1957	*****
6.70	18449.00	10.61	3851.79	0.0006	0.2088	0.00	0.00	-0.34	0.2024	*****
6.80	16558.64	6.32	3509.43	0.0004	0.2119	0.00	0.00	-0.36	0.2110	*****
6.90	18729.29	9.92	3249.68	0.0005	0.1735	0.00	0.00	-0.39	0.2173	*****
7.00	16519.62	8.35	2894.02	0.0005	0.1752	0.00	0.00	-0.42	0.2249	*****
7.10	18286.88	5.50	2644.57	0.0003	0.1446	0.00	0.00	-0.44	0.2317	*****
7.20	16476.39	12.67	2366.36	0.0008	0.1436	0.00	0.00	-0.47	0.2414	*****
7.30	18265.17	1.78	2234.31	0.0001	0.1223	0.00	0.00	-0.50	0.2498	*****
7.40	17269.39	14.93	1894.91	0.0009	0.1097	0.00	0.00	-0.52	0.2569	*****
7.50	17180.80	-0.58	1848.53	-0.0000	0.1076	0.00	0.00	-0.54	0.2672	*****
7.60	18278.16	12.19	1464.09	0.0007	0.0801	0.00	0.00	-0.57	0.2765	*****
7.70	16923.77	12.73	1373.03	0.0008	0.0811	0.00	0.00	-0.59	0.2876	*****
7.80	18002.33	-2.12	1273.37	-0.0001	0.0707	0.00	0.00	-0.61	0.2985	*****
7.90	18128.38	14.67	798.48	0.0008	0.0440	0.00	0.00	-0.63	0.3082	*****
8.00	16942.45	1.04	777.58	0.0001	0.0459	0.00	0.00	-0.66	0.3194	*****
8.10	18069.68	9.08	383.89	0.0005	0.0212	0.00	0.00	-0.69	0.3276	*****

121

Figure 17. (continued)

TRAILER NO. 1 REAR SUSPENSION - LATERAL TIRE FORCE AND MOMENT SUMMARY

LEADING TANDEM AXLE

TIME (SEC)	LEFT SIDE				RIGHT SIDE			
	TIRE SIDESLIP ANGLE (DEG)	TIRE LATERAL FORCE (LB)	MU-Y	ALIGNING TORQUE (IN-LB)	TIRE SIDESLIP ANGLE (DEG)	TIRE LATERAL FORCE (LB)	MU-Y	ALIGNING TORQUE (IN-LB)
4.10	-1.2045	2173.4417	0.1454	-3689.4082	-1.2193	675.3640	0.2159	-1146.4277
4.20	-1.2788	2280.2134	0.1530	-3870.6533	-1.2953	679.6021	0.2273	-1153.6218
4.30	-1.3372	2351.8047	0.1607	-3992.1797	-1.3555	673.9092	0.2363	-1143.9583
4.40	-1.3828	2443.4851	0.1617	-4147.8047	-1.4027	696.9719	0.2434	-1183.1072
4.50	-1.4042	2496.5391	0.1604	-4237.8633	-1.4252	707.2468	0.2468	-1200.5488
4.60	-1.4303	2509.9829	0.1668	-4260.6836	-1.4525	673.6934	0.2509	-1143.5918
4.70	-1.4823	2585.0686	0.1721	-4388.1445	-1.5061	661.5476	0.2589	-1122.9746
4.80	-1.5794	2780.6667	0.1733	-4720.1680	-1.6052	558.5952	0.2738	-948.2131
4.90	-1.7777	3093.0166	0.1895	-5250.3828	-1.8072	330.7493	0.3041	-561.4456
5.00	-2.0381	3554.5391	0.1980	-6033.8125	-2.0731	269.5840	0.3418	-457.6177
5.10	-2.2260	3817.8933	0.2265	-6480.8555	-2.2652	-0.0264	-2644.2180	0.0449
5.20	-2.3174	4200.4023	0.2235	-7130.1641	-2.3591	-0.0296	-2958.9568	0.0502
5.30	-2.3745	3995.4150	0.2488	-6782.1992	-2.4192	-0.0320	-3200.4753	0.0543
5.40	-2.4038	4162.1797	0.2328	-7065.2813	-2.4511	-0.0366	-3655.5085	0.0621
5.50	-2.4057	4158.9609	0.2343	-7059.8203	-2.4548	-0.0395	-3954.6448	0.0671
5.60	-2.3687	4205.5469	0.2283	-7138.8984	-2.4179	-0.0449	-4488.7539	0.0762
5.70	-2.3507	4068.0098	0.2291	-6905.4297	-2.4008	-0.0563	-5631.0938	0.0956
5.80	-2.3501	4039.3752	0.2345	-6856.8203	-2.4009	-0.0696	-6964.1211	0.1182
5.90	-2.3410	4198.4492	0.2257	-7126.8516	-2.3924	-0.0866	-8659.1641	0.1470
6.00	-2.3072	3969.6003	0.2304	-6738.3789	-2.3574	-0.1010	-10095.6836	0.1714
6.10	-2.2499	4164.4336	0.2172	-7069.1094	-2.2976	-0.1239	-12393.9922	0.2104
6.20	-2.1702	3704.3245	0.2254	-6288.0742	-2.2150	-0.1440	-14399.5430	0.2444
6.30	-2.0745	3779.6772	0.2009	-6415.9844	-2.1161	-0.1715	-17150.7227	0.2911
6.40	-1.9951	3449.4700	0.2044	-5855.4609	-2.0336	-0.1938	-19377.5820	0.3289
6.50	-1.8287	3423.3660	0.1791	-5811.1484	-1.8616	-0.2212	-22116.9688	0.3754
6.60	-1.7159	3023.8838	0.1780	-5133.0273	-1.7454	-0.2487	-24867.2695	0.4221
6.70	-1.5565	2903.8899	0.1554	-4929.3398	-1.5814	-0.2785	-27846.8242	0.4727
6.80	-1.4636	2632.2905	0.1559	-4468.3008	-1.4861	-0.3049	-30487.0664	0.5175
6.90	-1.2343	2432.0085	0.1274	-4128.3242	-1.2517	-0.3353	-33528.6797	0.5691
7.00	-1.1362	2124.0471	0.1278	-3605.5605	-1.1515	-0.3614	-36136.1094	0.6134
7.10	-0.9620	1945.0757	0.1029	-3301.7578	-0.9740	-0.3944	-39437.5508	0.6695
7.20	-0.8436	1616.8938	0.0969	-2744.6711	-0.8538	-0.4192	-41916.8477	0.7115
7.30	-0.7411	1484.8740	0.0793	-2520.5681	-0.7497	-0.4487	-44874.7031	0.7617
7.40	-0.5833	1121.3984	0.0651	-1903.5696	-0.5895	-0.4730	-47297.9102	0.8029
7.50	-0.5579	1073.3420	0.0615	-1821.9941	-0.5639	-0.4995	-49945.5430	0.8478
7.60	-0.3730	746.6699	0.0399	-1267.4692	-0.3767	-0.5259	-52589.2773	0.8927
7.70	-0.3423	656.5811	0.0389	-1114.5439	-0.3457	-0.5477	-54765.5703	0.9296
7.80	-0.2860	551.4001	0.0306	-935.9995	-0.2888	-0.5769	-57688.4805	0.9793
7.90	-0.0620	119.2722	0.0066	-202.4641	-0.0625	-0.5978	-59775.0234	1.0147
8.00	-0.0446	85.1985	0.0049	-144.6241	-0.0450	-0.6186	-61858.8750	1.0501
8.10	0.1443	-282.5620	-0.0155	479.6477	0.1456	-0.6438	-64379.2227	1.0928

122

Figure 17. (continued)

TRAILER NO. 1 REAR SUSPENSION - LATERAL TIRE FORCE AND MOMENT SUMMARY

TRAILING TANDEM AXLE

TIME (SEC)	LEFT SIDE				RIGHT SIDE			
	TIRE SIDESLIP ANGLE (DEG)	TIRE LATERAL FORCE (LB)	MU-Y	ALIGNING TORQUE (IN-LB)	TIRE SIDESLIP ANGLE (DEG)	TIRE LATERAL FORCE (LB)	MU-Y	ALIGNING TORQUE (IN-LB)
4.10	-1.6678	2867.3074	0.1890	-4867.2422	-1.6883	797.4277	0.2862	-1353.6306
4.20	-1.7667	3012.9736	0.1987	-5114.5078	-1.7896	799.8560	0.3014	-1357.7524
4.30	-1.8525	3119.4202	0.2096	-5295.1992	-1.8778	773.0493	0.3147	-1312.2483
4.40	-1.9247	3259.7271	0.2123	-5533.3711	-1.9524	799.6223	0.3258	-1357.3557
4.50	-1.9662	3354.1099	0.2115	-5693.5859	-1.9956	827.3386	0.3323	-1404.4043
4.60	-2.0130	3386.8994	0.2214	-5749.2461	-2.0442	757.1013	0.3383	-1285.1765
4.70	-2.0856	3494.9890	0.2285	-5932.7266	-2.1190	731.3313	0.3474	-1241.4321
4.80	-2.1922	3725.9260	0.2295	-6324.7422	-2.2280	562.2793	0.3606	-954.4668
4.90	-2.4007	4088.3540	0.2444	-6939.9609	-2.4405	289.9998	0.3863	-492.2732
5.00	-2.6822	4677.2813	0.2574	-7939.6641	-2.7282	85.3586	0.4210	-144.8959
5.10	-2.8864	4920.7656	0.2838	-8352.9805	-2.9371	-0.0305	-3054.0366	0.0518
5.20	-2.9911	5628.9219	0.2862	-9555.0703	-3.0448	-0.0426	-4259.4648	0.0723
5.30	-3.0793	5139.1445	0.3117	-8723.6758	-3.1372	-0.0524	-5243.9375	0.0890
5.40	-3.1392	5575.7461	0.2999	-9464.8047	-3.2008	-0.0642	-6423.8750	0.1090
5.50	-3.1690	5532.4375	0.3027	-9391.2891	-3.2336	-0.0735	-7349.2969	0.1248
5.60	-3.1443	5660.8711	0.3004	-9609.3047	-3.2095	-0.0844	-8442.8828	0.1433
5.70	-3.1473	5479.6523	0.3007	-9301.6875	-3.2143	-0.1015	-10154.9688	0.1724
5.80	-3.1578	5360.2227	0.3097	-9098.9531	-3.2260	-0.1187	-11870.8008	0.2015
5.90	-3.1605	5711.1797	0.3019	-9694.7031	-3.2298	-0.1397	-13965.4219	0.2371
6.00	-3.1206	5309.6406	0.3051	-9013.0938	-3.1885	-0.1576	-15761.4141	0.2675
6.10	-3.0422	5556.7148	0.2909	-9432.5000	-3.1066	-0.1824	-18237.8438	0.3096
6.20	-2.9417	4935.8555	0.2972	-8378.5938	-3.0023	-0.2048	-20483.6641	0.3477
6.30	-2.8241	5043.3047	0.2706	-8560.9883	-2.8806	-0.2322	-23224.1094	0.3942
6.40	-2.7169	4595.3945	0.2740	-7800.6641	-2.7692	-0.2552	-25523.8867	0.4333
6.50	-2.5017	4576.7070	0.2406	-7768.9414	-2.5466	-0.2830	-28301.0000	0.4804
6.60	-2.3609	3998.4653	0.2443	-6787.3789	-2.4015	-0.3087	-30870.2344	0.5240
6.70	-2.1591	3851.7917	0.2088	-6538.3984	-2.1937	-0.3394	-33938.8047	0.5761
6.80	-2.0422	3509.4250	0.2119	-5957.2344	-2.0736	-0.3640	-36397.1172	0.6178
6.90	-1.7647	3249.6782	0.1735	-5516.3125	-1.7895	-0.3903	-39033.3711	0.6626
7.00	-1.6419	2894.0239	0.1752	-4912.5938	-1.6639	-0.4156	-41558.4609	0.7055
7.10	-1.4326	2644.5701	0.1446	-4489.1445	-1.4505	-0.4440	-44400.9648	0.7537
7.20	-1.2971	2366.3572	0.1436	-4016.8828	-1.3127	-0.4686	-46858.4531	0.7954
7.30	-1.1765	2234.3110	0.1223	-3792.7324	-1.1900	-0.4961	-49608.5234	0.8421
7.40	-0.9854	1894.9136	0.1097	-3216.6064	-0.9959	-0.5190	-51895.9922	0.8809
7.50	-0.9617	1848.5283	0.1076	-3137.8682	-0.9719	-0.5449	-54493.4102	0.9250
7.60	-0.7489	1464.0925	0.0801	-2485.2917	-0.7563	-0.5685	-56854.3984	0.9651
7.70	-0.7154	1373.0320	0.0811	-2330.7166	-0.7224	-0.5908	-59084.9922	1.0030
7.80	-0.6614	1273.3667	0.0707	-2161.5352	-0.6679	-0.6143	-61432.2969	1.0428
7.90	-0.4120	798.4817	0.0440	-1355.4197	-0.4158	-0.6330	-63303.0234	1.0746
8.00	-0.4053	777.5759	0.0459	-1319.9321	-0.4091	-0.6588	-65876.2500	1.1182
8.10	-0.1989	383.8904	0.0212	-651.6523	-0.2007	-0.6866	-68659.5000	1.1655

123

Figure 17. (continued)

TRAILER NO. 1 REAR SUSPENSION - UNSPRUNG MASS SUMMARY

LEADING TANDEM AXLE

TIME (SEC)	AXLE MOTION				DYNAMIC SUSPENSION MOTIONS AND FORCES						
	POSITION		VELOCITY		AUXILIARY ROLL TORQUE (IN-LB)	LEFT SIDE			RIGHT SIDE		
	VERTICAL (FT)	ROLL (DEG)	VERTICAL (FT/SEC)	ROLL (DEG/SEC)		SUSP. DEFLECT. (IN)	SUSP. VELOCITY (IN/SEC)	SUSP. FORCE (LB)	SUSP. DEFLECT. (IN)	SUSP. VELOCITY (IN/SEC)	SUSP. FORCE (LB)
4.10	-0.7614	-0.0800	-1.1888	0.9045	36172.2	-1.0420	-0.2251	-8506.83	1.3250	0.9920	7676.94
4.20	-0.8870	0.0263	-1.3071	1.2548	38157.5	-1.0340	0.4102	-8542.45	1.4497	1.8894	7744.06
4.30	-1.0222	0.1552	-1.4114	1.2909	40617.8	-1.0120	-0.3858	-8047.29	1.6094	1.4448	7749.84
4.40	-1.1628	0.2321	-1.3924	0.1289	43239.7	-1.0394	0.3815	-8454.16	1.7213	1.9781	7750.07
4.50	-1.3117	0.3184	-1.5599	0.4902	46796.1	-1.0525	0.8305	-9134.50	1.9088	3.2296	7750.09
4.60	-1.4748	0.4614	-1.7075	2.0375	51826.3	-1.0169	0.1966	-8162.24	2.2558	4.3030	7750.09
4.70	-1.6458	0.5722	-1.6815	0.2820	57677.8	-1.0417	0.6147	-8269.91	2.6659	4.3246	7750.09
4.80	-1.8214	0.5460	-1.7907	-0.5192	63028.3	-1.0768	1.2231	*****	3.0748	4.6468	8665.75
4.90	-2.0127	0.5674	-1.5819	-4.0029	68623.9	-1.0905	7.3527	*****	3.4319	7.9407	9971.86
5.00	-2.2033	0.4868	-1.8812	-1.8182	72191.1	-0.9814	2.5012	-7996.01	3.7820	3.7907	11218.66
5.10	-2.4157	0.5867	-2.4124	3.8419	76406.0	-1.1746	-4.7026	*****	3.8391	-0.3491	10751.14
5.20	-2.6239	0.5004	-2.1735	-1.5613	77793.6	-0.9620	3.8998	-7590.95	4.0080	4.1467	11980.79
5.30	-2.8755	0.4573	-3.0521	6.2229	79355.6	-1.1414	-9.5774	*****	3.7934	-3.9479	10535.57
5.40	-3.1097	0.2936	-1.5241	-11.6738	80323.2	-1.0243	16.7210	-9165.07	3.8274	10.9538	11259.88
5.50	-3.3510	0.2199	-3.3124	10.1663	83275.7	-1.0313	-13.4378	-8450.55	3.8907	-3.7977	11303.31
5.60	-3.6139	0.0133	-1.7573	-16.1001	86114.6	-1.1023	19.5064	*****	3.8983	12.3771	11408.25
5.70	-3.8994	-0.5490	-3.8472	3.9351	86709.4	-1.0287	-12.4834	-8231.00	3.8972	-5.2722	11181.95
5.80	-4.2115	-1.2095	-2.4379	-14.8895	87694.3	-1.1478	13.7978	*****	3.7681	9.2837	10714.14
5.90	-4.5108	-2.0764	-3.3390	-5.6315	88054.3	-0.9655	-0.3713	-7577.51	3.8839	2.2898	11555.63
6.00	-4.8425	-2.7943	-3.1140	-10.9556	91299.8	-1.1841	6.3701	*****	3.8071	6.2249	10922.09
6.10	-5.1700	-4.0067	-3.6062	-11.0047	90546.2	-0.9754	2.6988	-7752.22	3.9194	3.0221	11686.95
6.20	-5.5384	-5.0532	-3.6514	-12.6150	92377.1	-1.1733	4.0015	*****	3.7952	3.9044	10715.20
6.30	-5.8899	-6.5264	-3.1882	-17.3115	91061.7	-0.9938	12.5116	-8345.52	3.8776	9.9208	11535.95
6.40	-6.2607	-7.7002	-4.3698	-4.5094	93630.5	-1.1501	-6.5410	*****	3.8825	-0.1772	10973.04
6.50	-6.6278	-9.1691	-3.1562	-23.0873	93762.2	-1.0172	18.1144	-9097.18	4.0056	12.1909	11985.57
6.60	-7.0249	-10.6461	-4.5398	-6.4347	94188.3	-1.1630	-4.5223	*****	3.9206	0.8574	11449.92
6.70	-7.4105	-12.2657	-3.2692	-24.8454	93457.6	-1.0301	19.2998	-9992.31	3.9769	12.3638	11928.21
6.80	-7.8102	-13.6841	-4.7129	-5.6337	94968.1	-1.1458	-6.3502	*****	4.0119	-0.3900	11452.32
6.90	-8.2009	-15.3350	-3.3371	-24.3537	94302.8	-1.0306	20.0486	-9846.21	4.1363	13.3745	12502.92
7.00	-8.6167	-16.7374	-4.5485	-9.2879	95982.8	-1.1794	-0.4587	*****	4.1187	2.6624	12043.64
7.10	-9.0165	-18.5411	-3.8740	-18.0704	93341.8	-1.0063	11.9758	-8672.04	4.2013	8.9584	12740.07
7.20	-9.4331	-19.8748	-4.0566	-16.0822	95316.4	-1.1975	8.6838	*****	4.1540	6.8241	12484.52
7.30	-9.8265	-21.4927	-4.1904	-10.6046	94213.6	-1.0063	5.0434	-8305.72	4.3299	6.4882	13185.84
7.40	-10.2403	-22.7961	-3.5232	-21.9753	95800.1	-1.1822	18.3529	*****	4.2597	11.7660	12899.35
7.50	-10.6402	-24.2286	-4.9538	-1.1273	95669.7	-1.0867	-8.0727	*****	4.3943	-1.0121	12992.27
7.60	-11.0465	-25.6690	-3.2492	-23.0083	95167.9	-1.0827	22.1908	*****	4.3750	14.2954	13317.04
7.70	-11.4562	-26.8337	-4.1752	-14.6848	96949.9	-1.2127	6.9288	*****	4.3822	4.2162	13317.66
7.80	-11.8530	-28.4260	-4.4443	-10.4797	94044.7	-1.0198	1.2747	-8442.70	4.4703	1.2062	13696.49
7.90	-12.2562	-29.5480	-3.2494	-21.3778	96094.3	-1.1634	21.9977	*****	4.5374	14.6618	13895.93
8.00	-12.6641	-30.7495	-4.8175	-3.7741	97593.8	-1.1602	-4.2209	*****	4.5583	0.2284	13581.14
8.10	-13.0739	-32.1939	-3.4367	-21.9403	97091.6	-1.0856	20.7356	*****	4.5506	13.1864	13924.40

124

Figure 17. (continued)

TRAILER NO. 1 REAR SUSPENSION - UNSPRUNG MASS SUMMARY

TRAILING TANDEM AXLE

TIME (SEC)	AXLE MOTION				DYNAMIC SUSPENSION MOTIONS AND FORCES						
	POSITION		VELOCITY		AUXILIARY ROLL TORQUE (IN-LB)	LEFT SIDE			RIGHT SIDE		
	VERTICAL (FT)	ROLL (DEG)	VERTICAL (FT/SEC)	ROLL (DEG/SEC)		SUSP. DEFLECT. (IN)	SUSP. VELOCITY (IN/SEC)	SUSP. FORCE (LB)	SUSP. DEFLECT. (IN)	SUSP. VELOCITY (IN/SEC)	SUSP. FORCE (LB)
4.10	-0.6864	-0.1981	-1.1252	0.7113	34997.7	-1.0419	0.2239	-8460.58	1.3327	1.3128	7687.59
4.20	-0.8057	-0.0920	-1.2640	1.1680	36981.4	-1.0298	0.5480	-8468.48	1.4926	1.9696	7747.54
4.30	-0.9361	0.0315	-1.3330	1.0944	39387.1	-1.0045	0.1745	-7977.59	1.7028	1.8748	7750.05
4.40	-1.0715	0.1114	-1.3510	0.1231	42039.0	-1.0397	0.3882	-8420.36	1.8772	1.9811	7750.09
4.50	-1.2145	0.1880	-1.4781	0.9541	45499.0	-1.0489	1.1154	-9122.89	2.1325	3.8222	7750.09
4.60	-1.3739	0.3270	-1.6615	2.4087	50489.5	-1.0125	0.0165	-8165.22	2.5221	4.3691	7750.09
4.70	-1.5384	0.4452	-1.6719	-0.2454	56414.6	-1.0332	0.2109	-8229.51	2.8477	3.5710	7883.25
4.80	-1.7098	0.4297	-1.7531	0.0278	61871.7	-1.0739	0.7116	*****	3.0821	4.4982	8691.96
4.90	-1.8953	0.4430	-1.4880	-4.4527	67385.9	-1.0846	7.7607	*****	3.4439	8.0503	10004.48
5.00	-2.0814	0.3712	-1.8543	-1.2475	71040.8	-0.9780	1.6735	-7907.89	3.7948	3.3415	11256.51
5.10	-2.2968	0.3118	-2.5355	0.7151	73671.2	-1.1770	-6.1756	*****	3.8052	-3.8959	10607.90
5.20	-2.5226	-0.2841	-2.4258	-7.0510	69989.6	-0.9720	1.6076	-7775.08	3.9037	-1.7865	11585.89
5.30	-2.7957	-0.7522	-3.1782	1.0517	67322.7	-1.1510	-10.5415	*****	3.6852	-8.3417	10182.48
5.40	-3.0465	-1.3304	-1.6296	-15.5035	64167.0	-1.0377	15.4691	*****	3.7334	7.1620	10895.76
5.50	-3.3025	-1.7615	-3.5292	5.6750	63563.3	-1.0388	-15.9144	-8808.31	3.8140	-9.2529	10940.79
5.60	-3.5817	-2.2983	-1.8582	-18.9672	63117.9	-1.1067	17.7835	*****	3.8236	8.7527	11096.13
5.70	-3.8787	-3.1774	-4.0109	1.3501	60561.5	-1.0260	-15.1977	-8237.75	3.8429	-9.7009	10977.39
5.80	-4.2019	-4.0569	-2.4920	-17.9746	59368.2	-1.1391	12.4145	*****	3.7219	5.8544	10533.64
5.90	-4.5105	-5.1520	-3.4269	-7.3461	57457.5	-0.9701	-2.7972	-7694.32	3.8489	-1.2732	11353.42
6.00	-4.8493	-6.0756	-3.2316	-12.4134	58656.5	-1.1864	3.3393	*****	3.7831	2.2272	10538.15
6.10	-5.1823	-7.3891	-3.6483	-12.1672	56897.2	-0.9695	0.3444	-7706.54	3.9263	-0.1033	11671.92
6.20	-5.5539	-8.5722	-3.6661	-12.9005	57368.3	-1.1769	1.5465	*****	3.7950	1.2600	10696.63
6.30	-5.9049	-10.0399	-3.1256	-19.6341	56108.2	-0.9834	11.5194	-8072.74	3.9105	7.3881	11616.69
6.40	-6.2775	-11.2547	-4.3779	-4.5126	58268.2	-1.1489	-9.2729	*****	3.8962	-2.9112	10987.37
6.50	-6.6408	-12.7450	-3.2432	-21.0284	58188.0	-1.0056	13.7288	-8438.25	4.0522	9.1709	12141.20
6.60	-7.0360	-14.1275	-4.5458	-6.7898	59553.9	-1.1498	-7.2269	*****	3.9647	-2.0826	11177.73
6.70	-7.4191	-15.7880	-3.2313	-23.2185	58416.0	-1.0212	16.4580	-8829.34	4.0455	10.6010	12134.68
6.80	-7.8094	-17.1010	-4.6837	-4.6560	60975.7	-1.1260	-9.1595	*****	4.0599	-2.5509	11571.38
6.90	-8.1889	-18.5188	-3.3490	-19.6296	62629.8	-1.0152	15.5766	-8681.50	4.2279	12.0356	12815.72
7.00	-8.5944	-19.8742	-4.5188	-7.6866	64776.5	-1.1785	-3.4302	*****	4.1890	0.7529	11895.77
7.10	-8.9872	-21.4138	-3.9128	-15.6753	64763.9	-0.9933	7.9708	-8238.40	4.2888	6.5419	12989.00
7.20	-9.4001	-22.7441	-3.9429	-14.0432	66771.6	-1.2016	6.5881	*****	4.2022	6.0807	12157.57
7.30	-9.7860	-24.2339	-4.2300	-10.2135	66942.9	-1.0061	1.6349	-8287.61	4.3521	3.3392	13265.30
7.40	-10.1952	-25.4592	-3.3614	-20.3751	69306.3	-1.1779	17.0602	*****	4.3399	11.5346	12901.47
7.50	-10.5930	-26.8631	-4.9429	-1.5955	69460.1	-1.0891	-10.6159	*****	4.3917	-3.8657	12836.62
7.60	-10.9913	-28.1413	-3.2803	-21.3983	70573.4	-1.0713	18.5524	*****	4.4754	11.7248	13534.59
7.70	-11.4008	-29.3362	-4.0153	-13.8985	72054.0	-1.2132	5.7774	*****	4.4150	3.5863	13317.20
7.80	-11.7917	-30.5994	-4.4244	-5.9368	72422.4	-1.0286	-2.9147	-8498.11	4.5356	0.0297	13773.27
7.90	-12.1914	-31.5979	-3.2419	-21.5327	75701.3	-1.1331	19.3283	*****	4.5749	11.8897	13974.44
8.00	-12.5972	-33.0216	-4.8331	-6.3769	74990.0	-1.1517	-6.5344	*****	4.5896	-3.8114	13274.39
8.10	-13.0036	-34.6170	-3.3641	-24.0094	72985.1	-1.0808	19.3608	*****	4.5743	10.4394	14004.26

Figure 17. (continued)

APPENDIX C

SIMULATION RESULTS

This appendix contains plotted response variables describing the dynamic behavior of tractor semitrailers operating on each of the selected ramps. The simulation runs available for each ramp site are listed in Table 1. Each run involves two pages of plotted responses, covering the following variables:

Steering Wheel Angle (in degrees) -- expressing the instantaneous steering input applied by a "driver model" portion of the simulation program. The driver model applies steering in a manner which represents the dynamic response of human operators, following the centerline of the described ramp lane up to the point of loss of control. Large fluctuations in steering during a run indicate that the "driver" is responding to abrupt changes in the vehicle's operating trim, such as when rollover or jackknife instabilities are pending.

Tractor Yaw Rate (in degrees / second) -- expressing the angular rate of rotation of the tractor about a vertical axis. Tractor yaw rate diverges when a jackknife response is produced, such as at Sites 4 and 6.

Tractor Roll Angle (in degrees) -- expressing the roll angle of the tractor about a longitudinal axis. Tractor roll angle diverges when a rollover response is produced, such as with the "High-CG" vehicle in Site 1 at a speed of 40 mi/h (64 km/h), for example.

Tractor Lateral Acceleration (in feet / second ** 2) -- expressing the acceleration component which is parallel to earth-horizontal. In a super-elevated curve, this component constitutes the centripetal acceleration associated with the curve radius and vehicle speed. The net acceleration component which is tending to overturn the vehicle is equal to the indicated lateral acceleration value, minus the instantaneous value of superelevation.

Velocity (in feet / second) -- expressing the resultant velocity of the center of mass of the tractor. Velocity changes during differing runs due to coasting on a grade, application of brakes, or an induced deceleration due to cornering forces.

Tractor Left and Right Vertical Tire Loads (in pounds) -- expressing the instantaneous vertical loads borne by the dual tire pair (total on 2 tires)



on the respective left and wheel positions of the leading tandem axle on the rear of the tractor. The tire loads indicate the load transfer condition which is roughly proportional to the net lateral acceleration level. That is, the loads on the outside tires in the curve are seen to increase while the inside tires in the curve show decreasing loads. A pending rollover condition is first indicated when the load on the inside tires goes to zero. The roll mechanics of tractor semitrailers is such that rollover is virtually assured when the inside tires on the tractor tandem reach a value of zero.

Superelevation (as a nondimensional quantity) -- expressing the tangent of the lateral inclination angle of the roadway relative to the horizontal. Ramp superelevation is expressed as a function of time in the plot, thus describing the superelevation value which prevails at the instantaneous longitudinal location of the mass center of the tractor as it travels along the ramp.

Radius of the Curve (in feet) -- expressing the instantaneous radius of the roadway along the ramp. A very high value for radius, of course, suggests a tangent section. Since infinite values are not plotted due to space limitations, tangents appear on some of the plots with values of radius equal to 10,000. Spiral sections of road appear as curved portions of the radius plot, while steady turns, of course, appear as constant radius values. As with the superelevation convention, the value of radius shown at a given time corresponds to the instantaneous longitudinal location of the tractor mass center on the roadway.

Grade (as a nondimensional quantity) -- expressing the tangent of the longitudinal inclination of the roadway relative to the horizontal. Positive values of grade are downhill. As above, the value of grade plotted at a given time corresponds to the instantaneous longitudinal location of the tractor mass center along the roadway.

Delta Y (in feet) -- expressing the extent to which the mass center of the tractor has departed from the lane centerline. This measure indicates the fidelity of the "driver model" in steering the vehicle to actually track the lane centerline. Variations in Delta Y from zero occur due to disturbances which arise from discontinuities in radius or superelevation and also from disturbances in vehicle trim due to an impending instability.

Site No.	Advisory Speed mi/h	Peculiar Site Characteristic	Simulation Speeds	
			"Baseline"	"High C-G"
1	35	tight curve, end of ramp, poor transition	34,44,40 mi/h	35,40 mi/h
2	25	compound curves, tight-flat-tight	25,35,42	25
3	25	short decel lane, then tight curve	35,25	25,35
*4	20	low advisory spd, spiral to compound curve	55 (braking)	-----
5	20	tight curve, curb on outside	35,25,20	35,30,20
**6	45/55	large radius, highspeed, slippery wet	55,70	-----
7	35	downgrade leads to sharp curve	35,45	35,45
8	30	downgrade leads to sharp curve	30	30,35
9	25	sharp curve at end of moderate decel. lane	25	-----
10	25	poor transition, sharp curve right away	25	-----
11	25	compound curve, tight-flat-tight	25	-----
12	40	tight curve on central lanes of trumpet	40	45,50
13	30	tight curve, curb on outside	35	-----
14	25	tight curve, curb on outside	40	-----
15	30	compound curve, large ratio of radii	35	-----

* Site No. 4 - Braking from 55 mi/h towards 20 mi/h on $\mu = .50$ surface

** Site No. 6 - Additional runs to simulate hydroplaning, Baseline Vehicle.

(Note: Posted advisories: 45 mi/h - trucks, 55 mi/h - others.)

	μ tractor front = 0.50
(empty)	μ tractor rear = 0.15
55 mi/h	μ trailer = 0.15
	μ tractor front = 0.50
(empty)	μ tractor rear = 0.12
55 mi/h	μ trailer = 0.12

Table 1. Simulation run conditions.

SITE 1 BASELINE

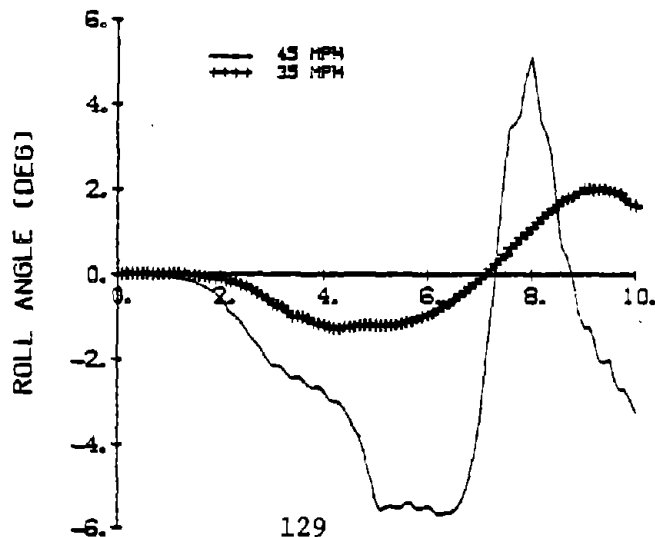
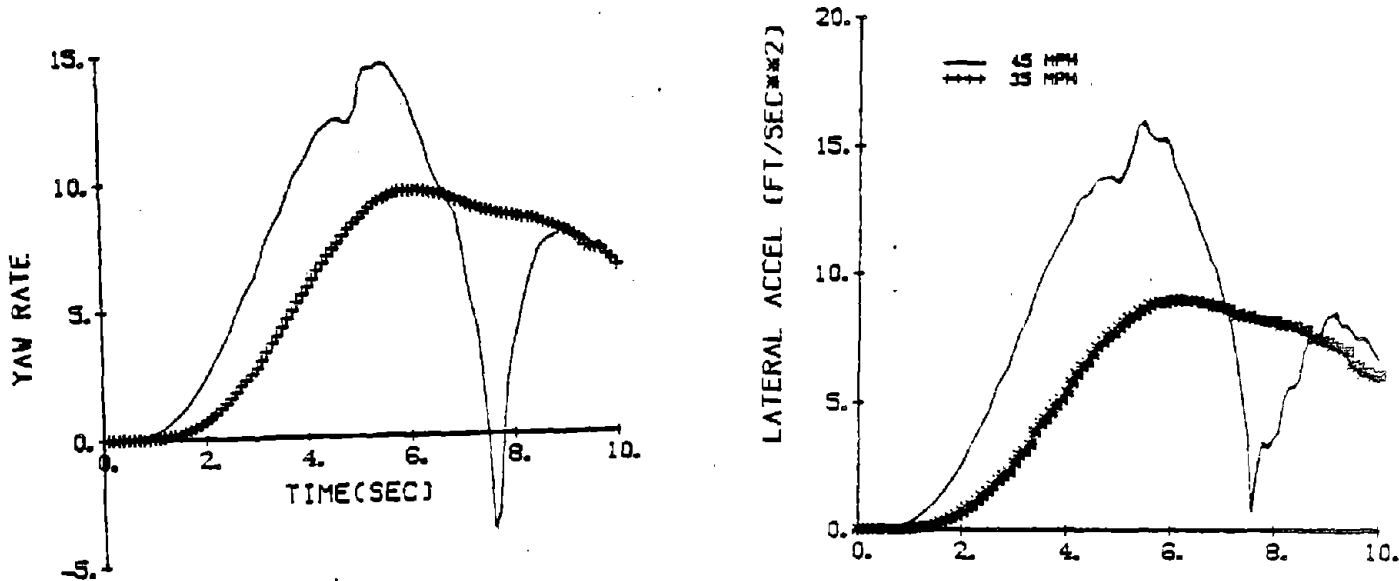
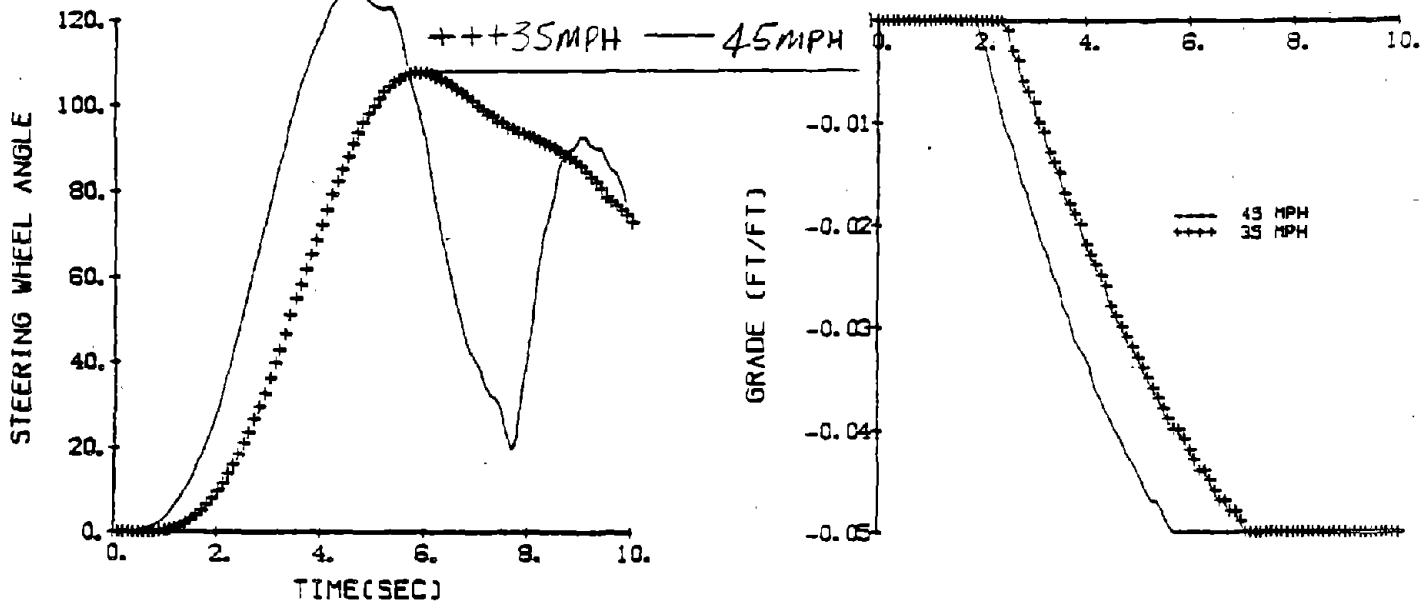
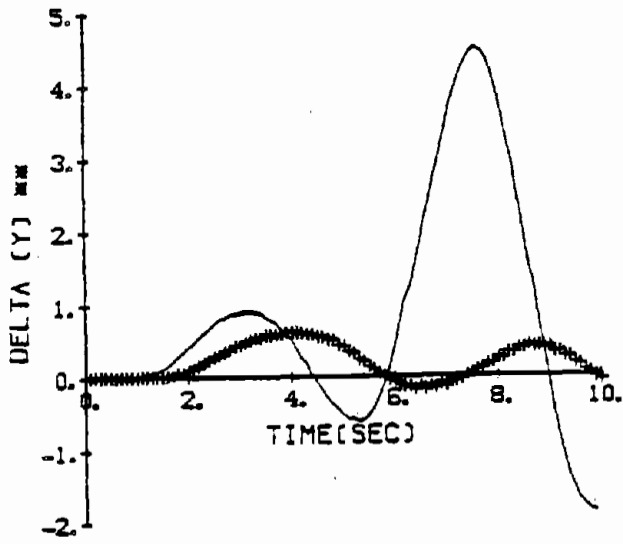
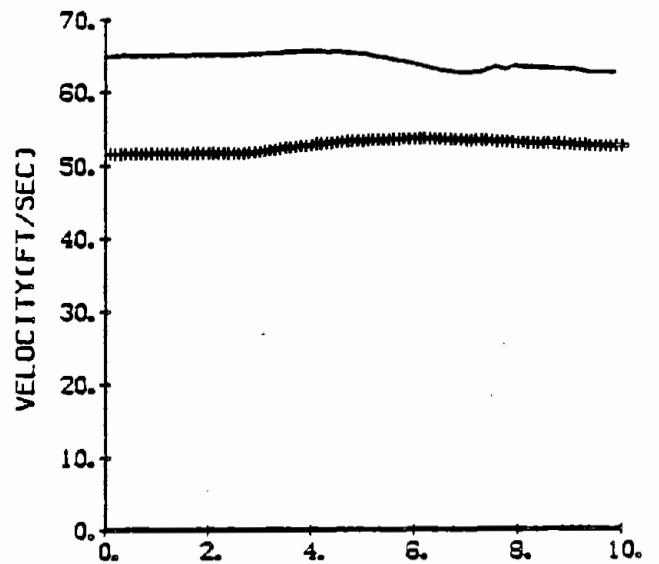
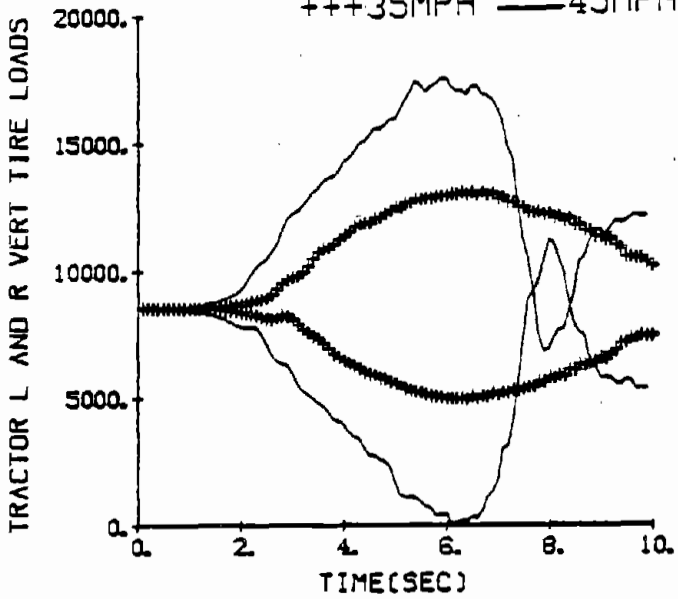

Figure 18. Site 1 baseline, 35 and 40 mi/h.

SITE 1 BASELINE

+++35MPH — 45MPH



SITE 1 BASELINE

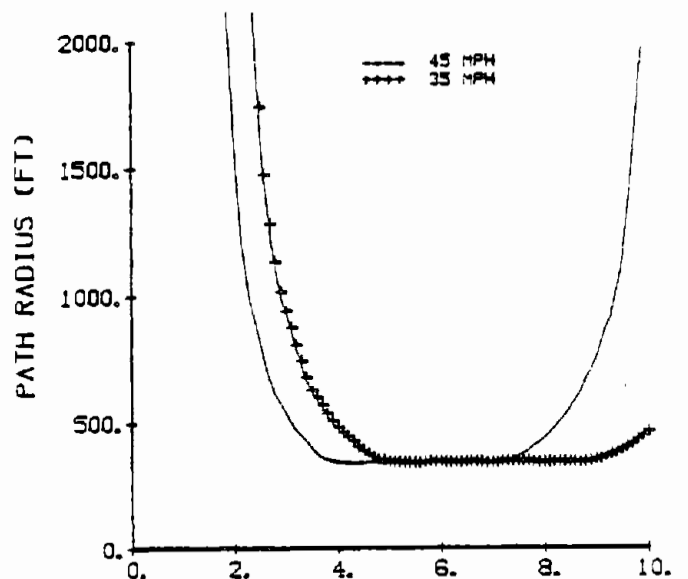
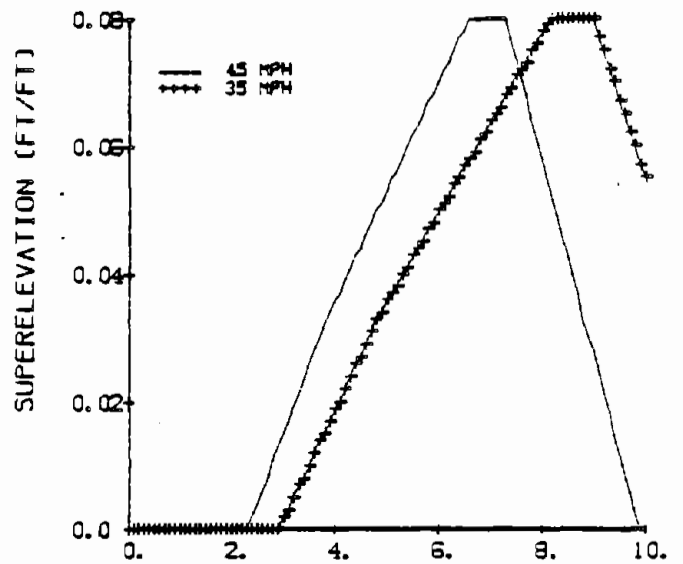

Figure 18. (continued)

SITE 1 BASELINE
40 MPH

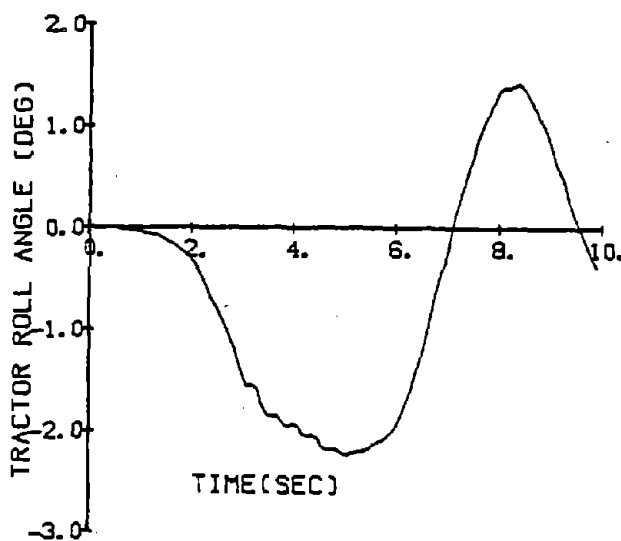
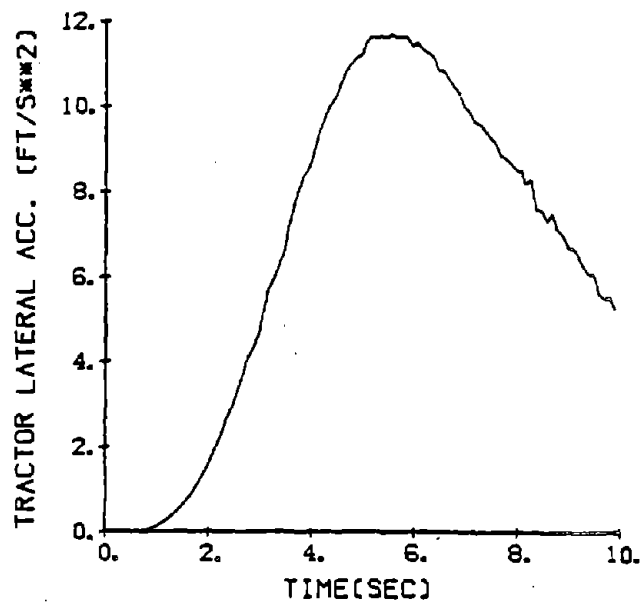
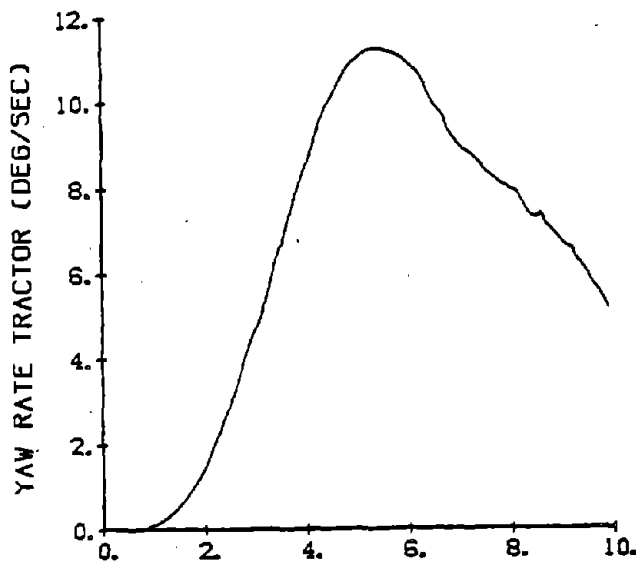
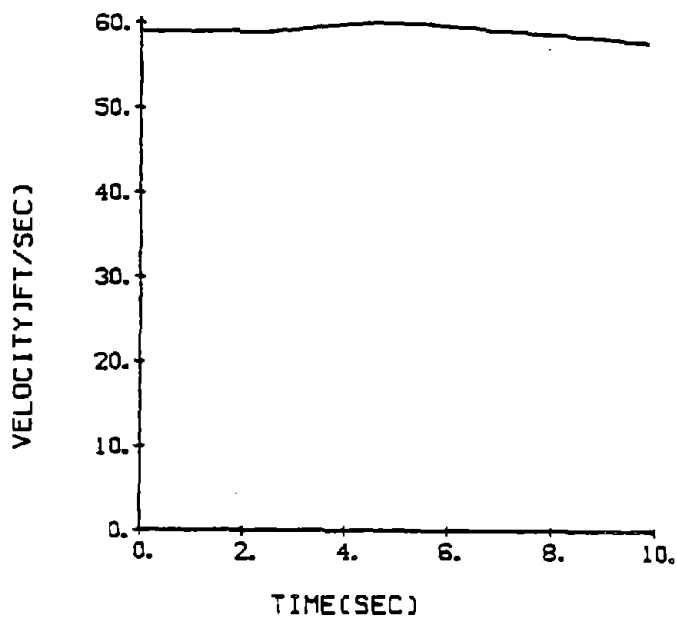
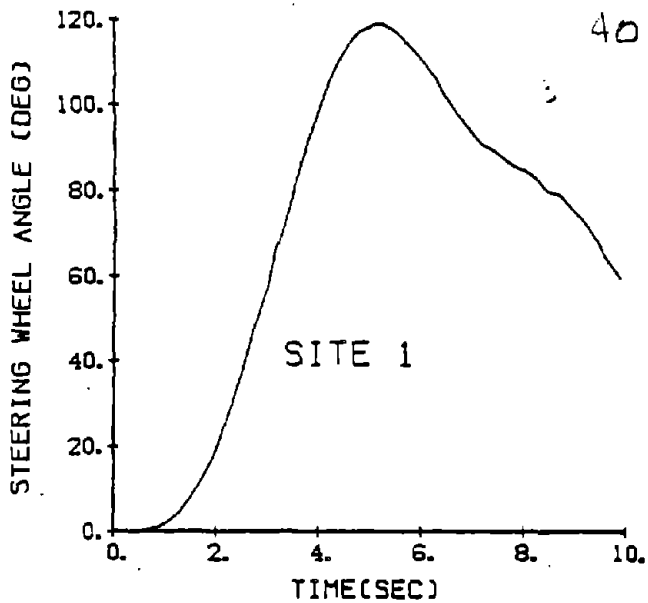

Figure 19. Site 1 base-
line, 40 mi/h.

SITE 1 BASELINE
40MPH

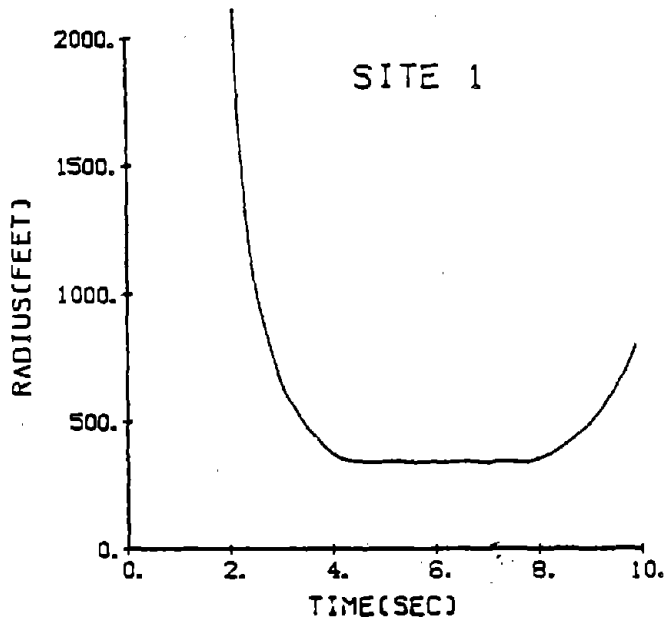
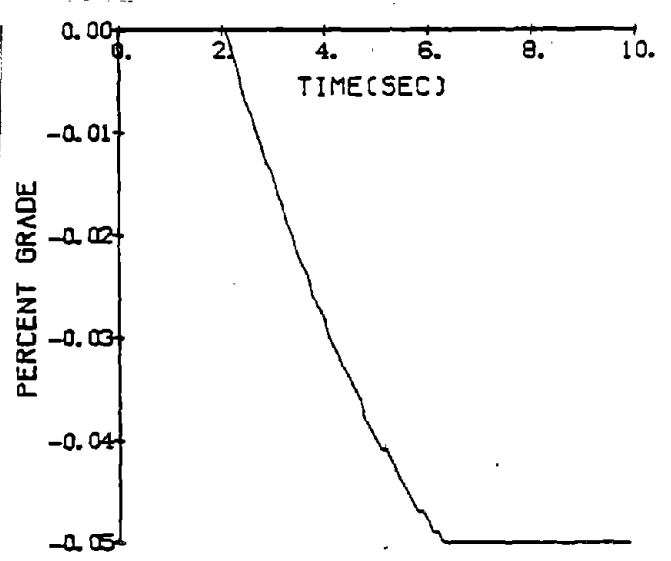
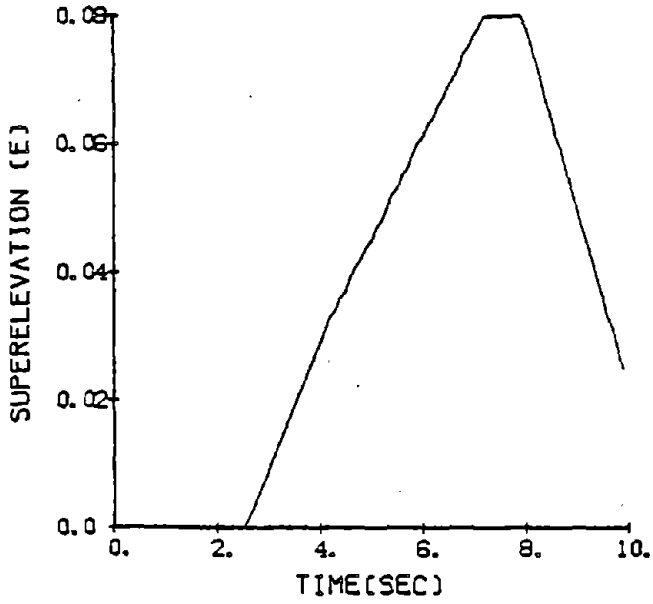
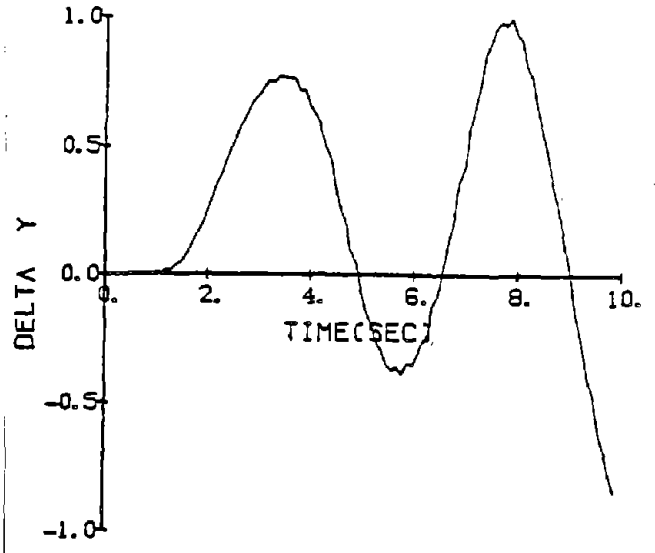
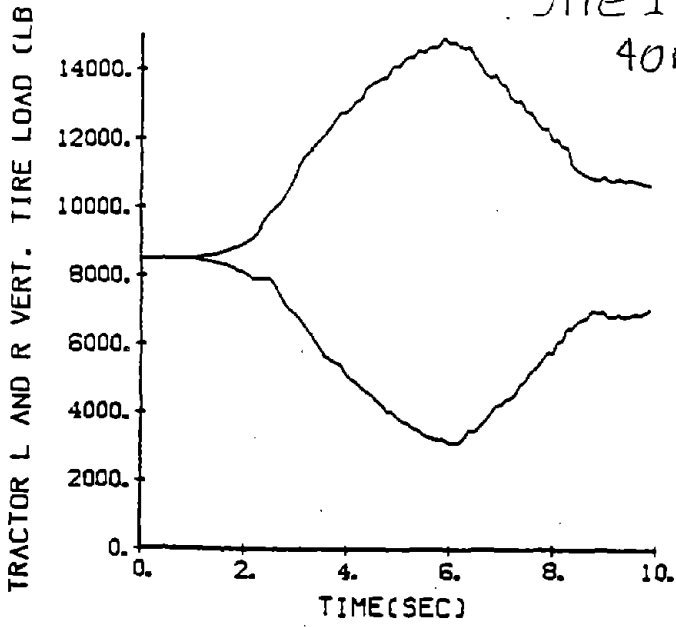

Figure 19. (continued)

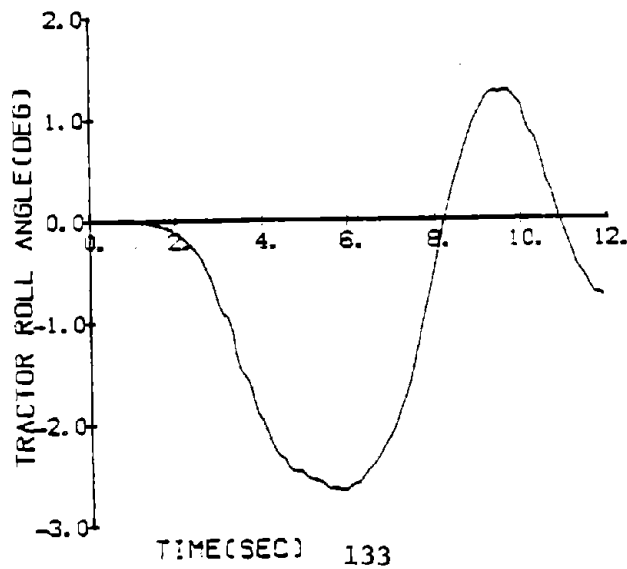
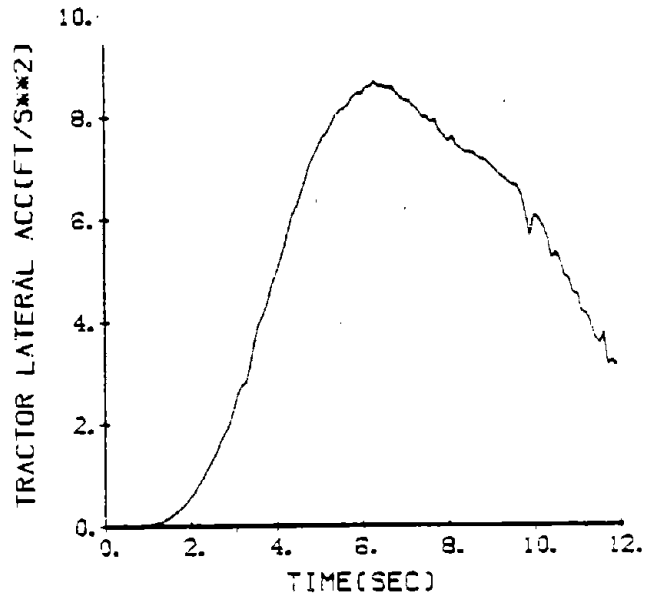
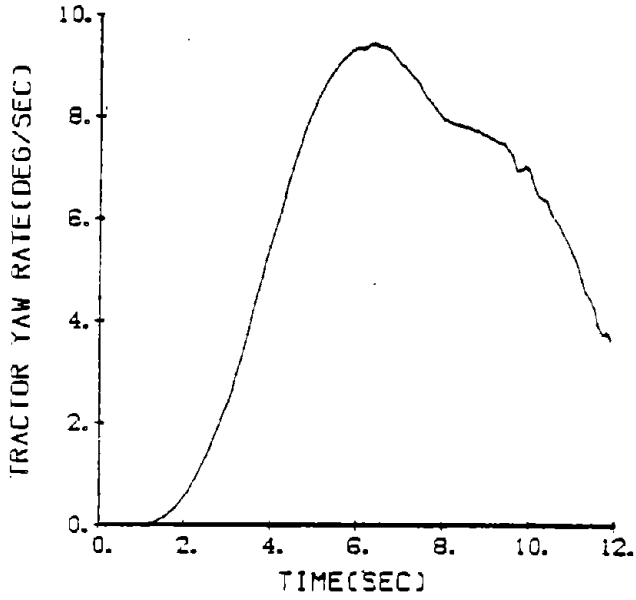
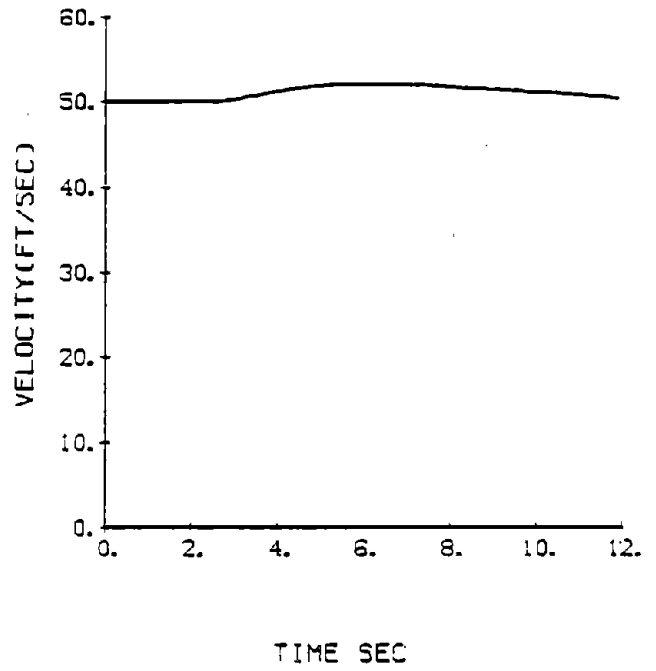
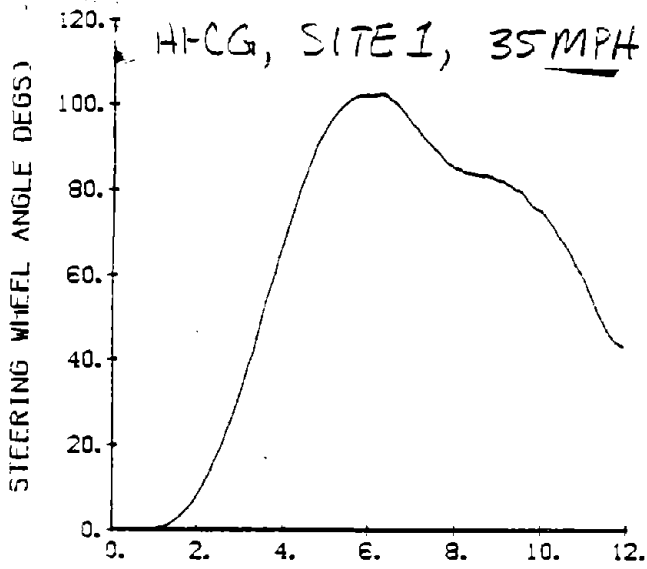

Figure 20. Site 1, hi-c.g., 35 mi/h.

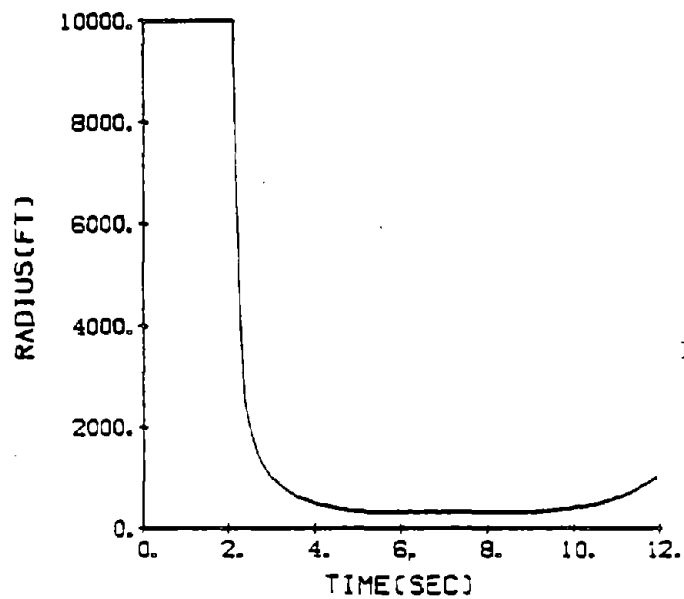
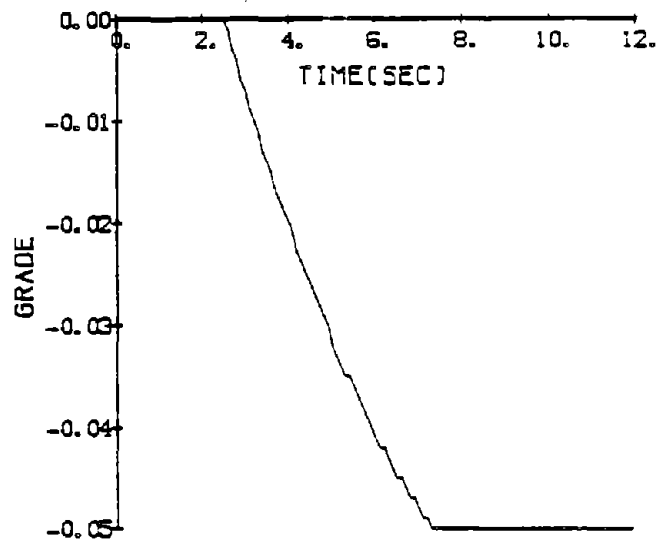
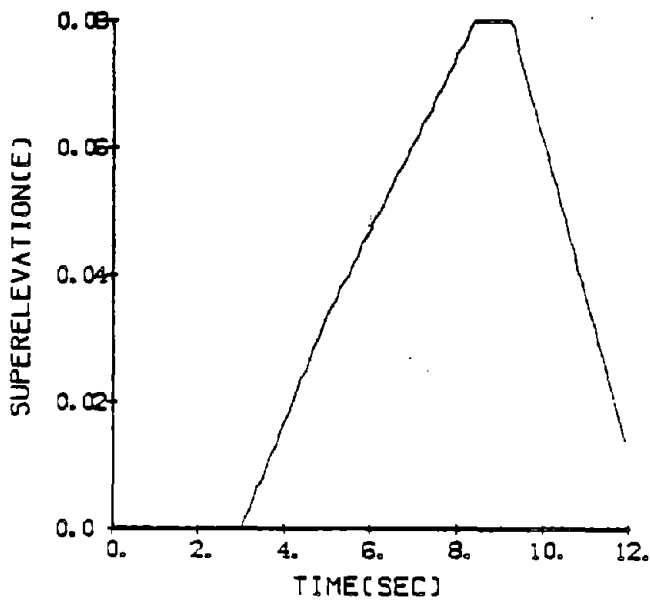
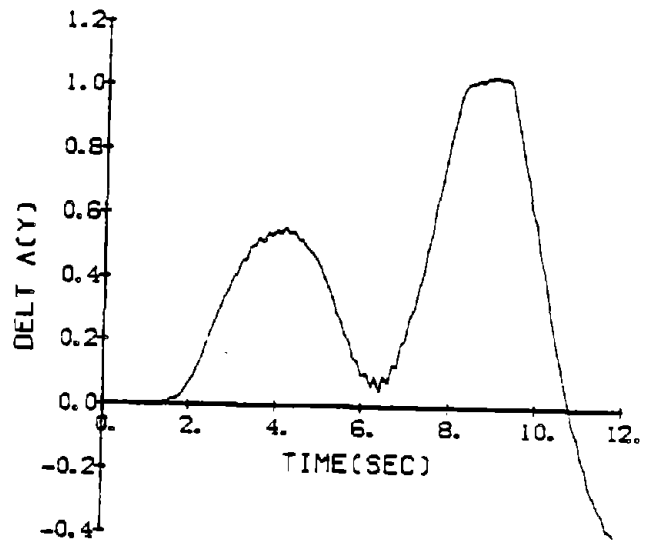
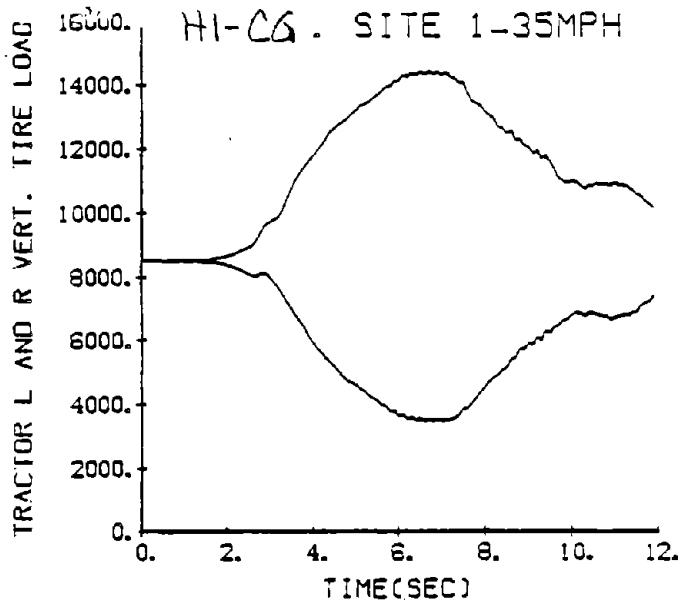

Figure 20. (continued)

HI-CG SITE 1 35MPH

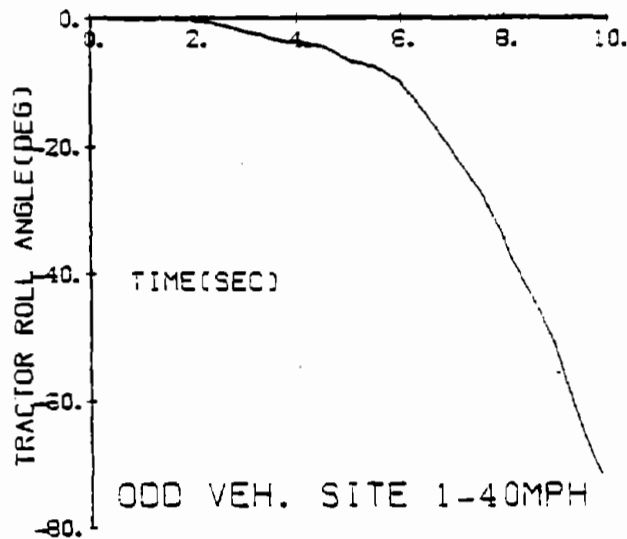
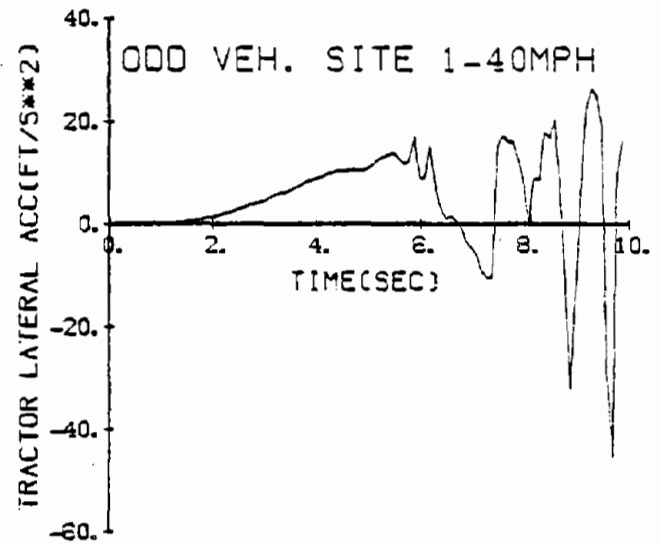
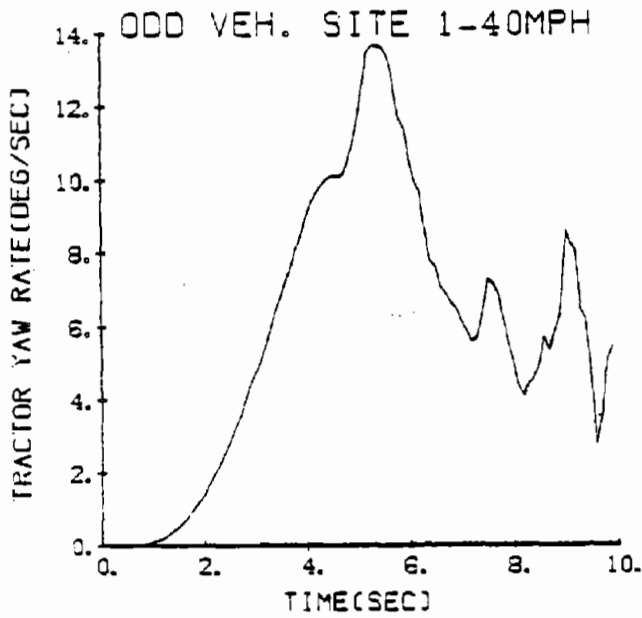
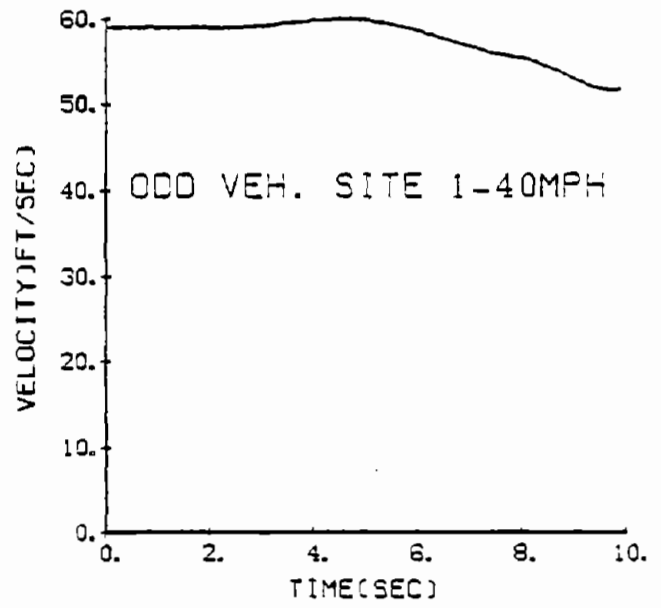
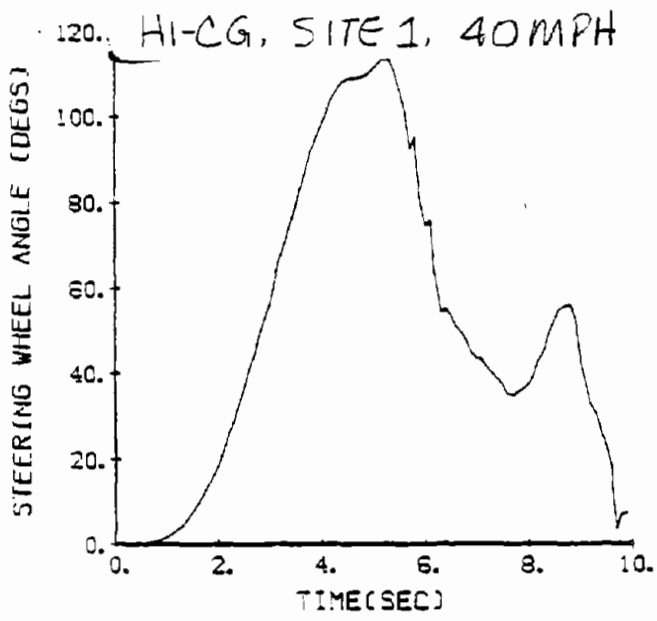

Figure 21. Site 1, hi-c.g., 40 mi/h.

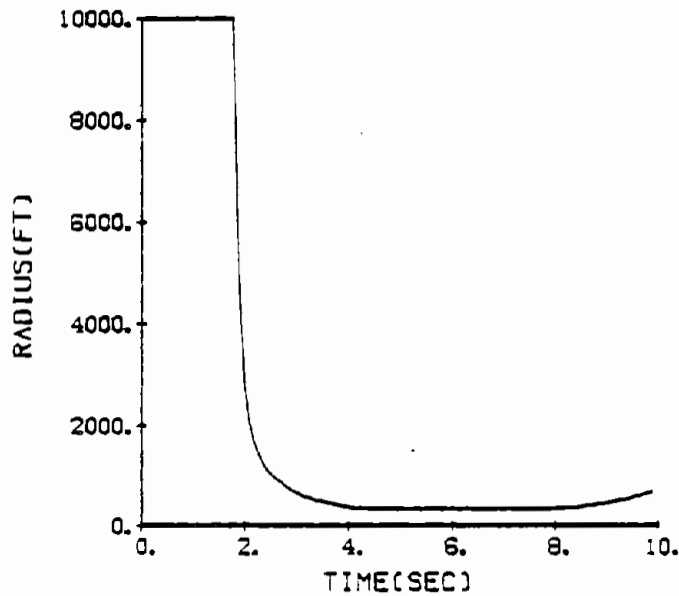
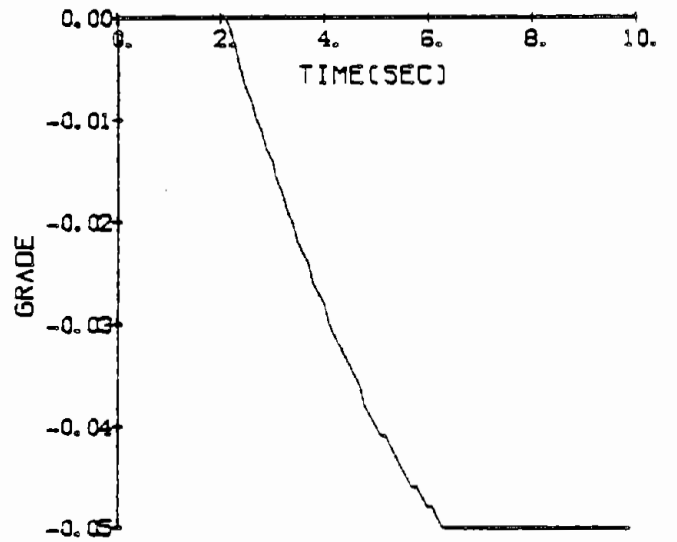
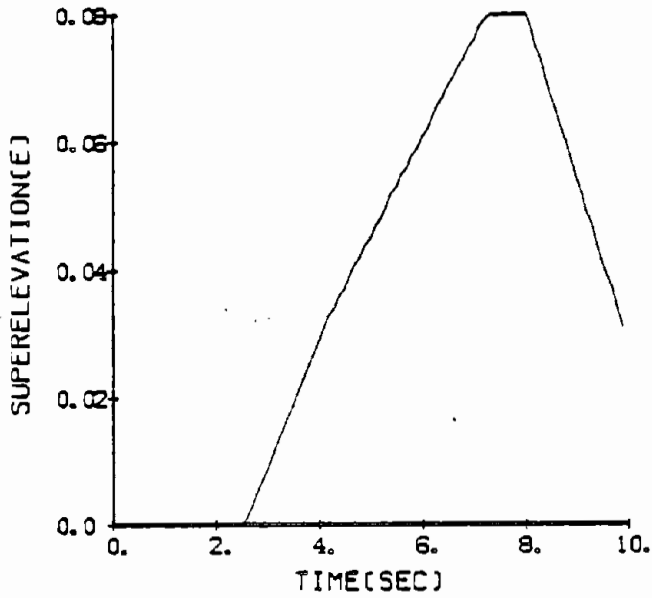
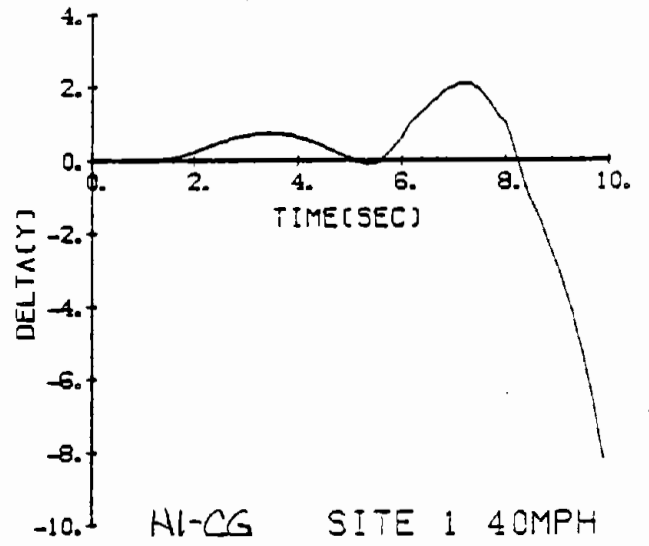
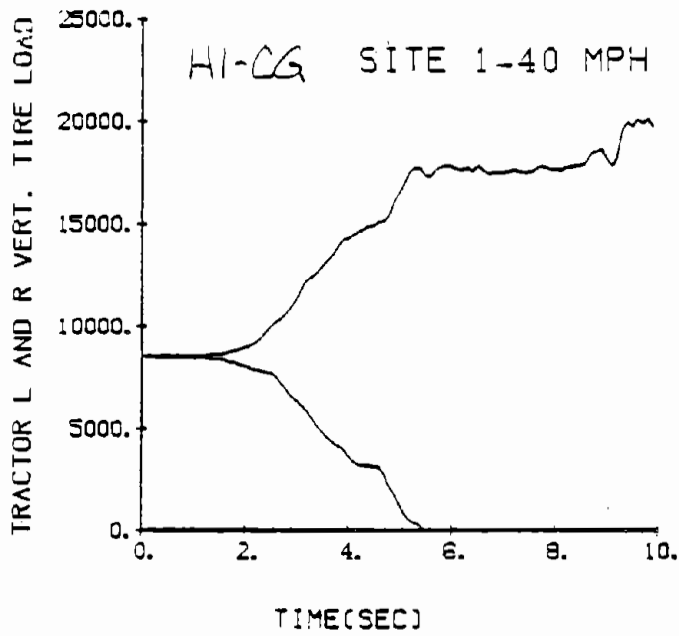

Figure 21. (continued)

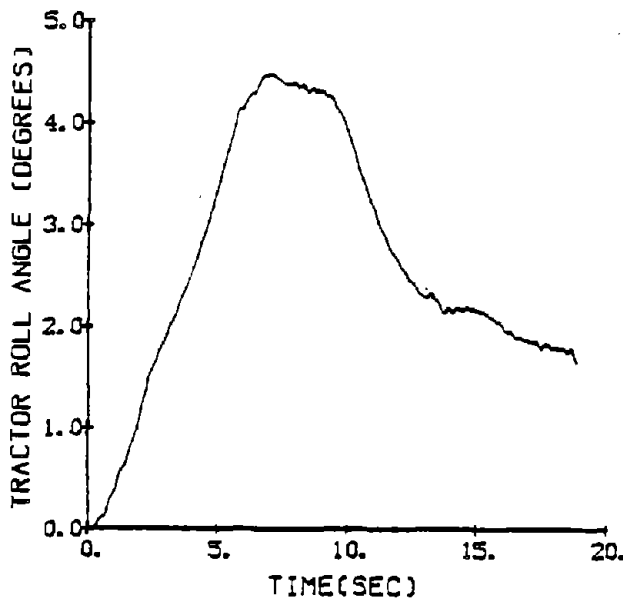
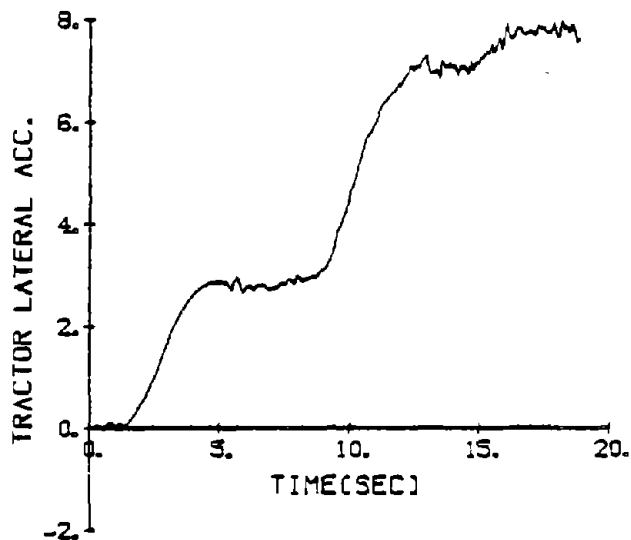
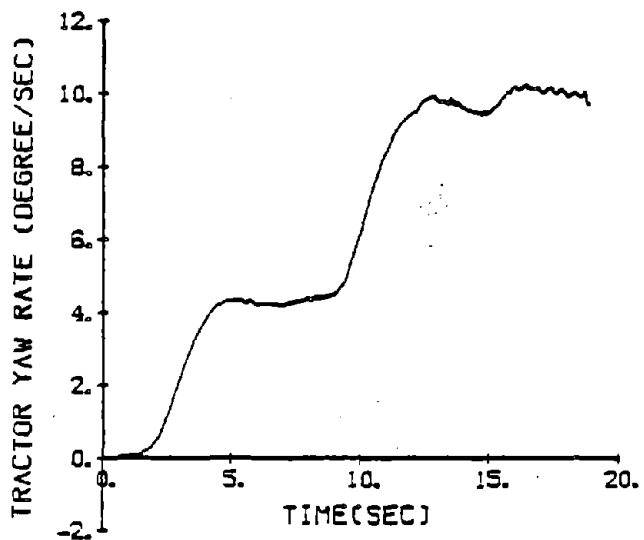
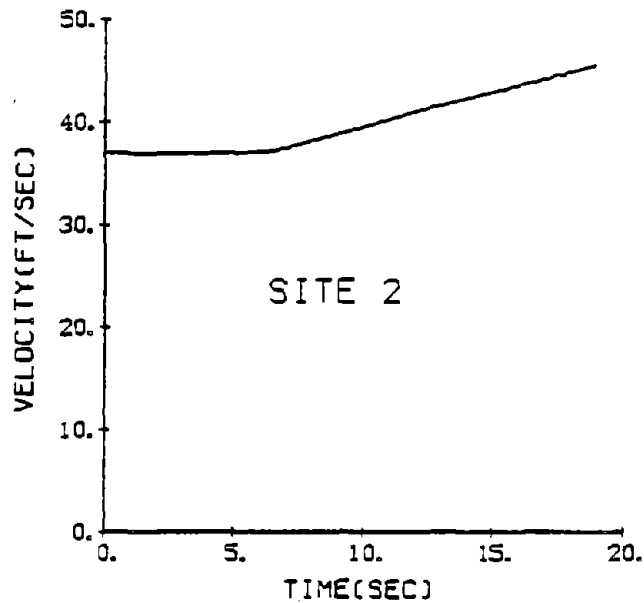
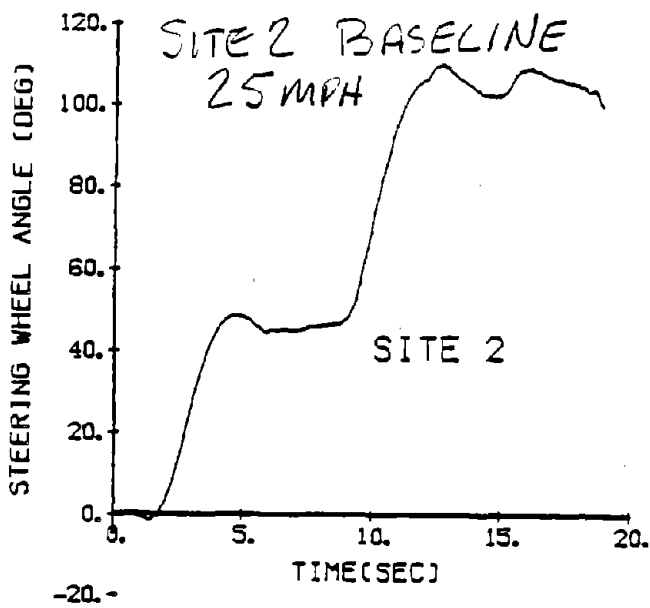

Figure 22. Site 2, baseline, 25 mi/h.

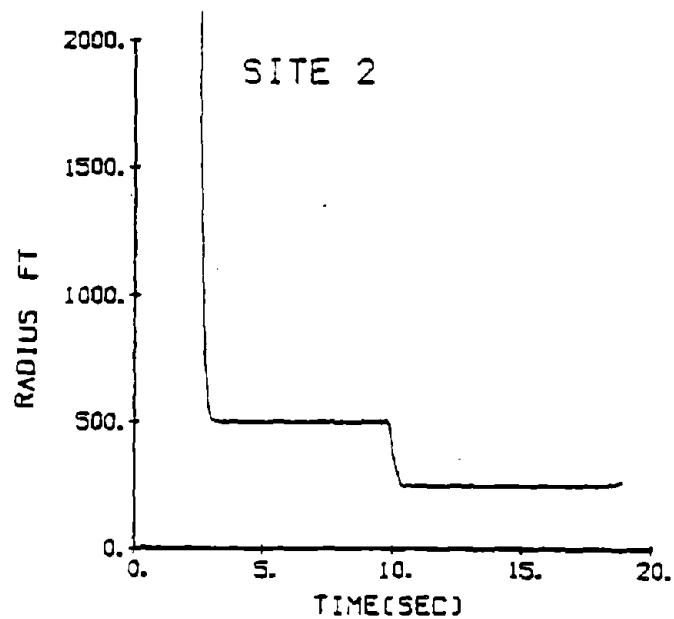
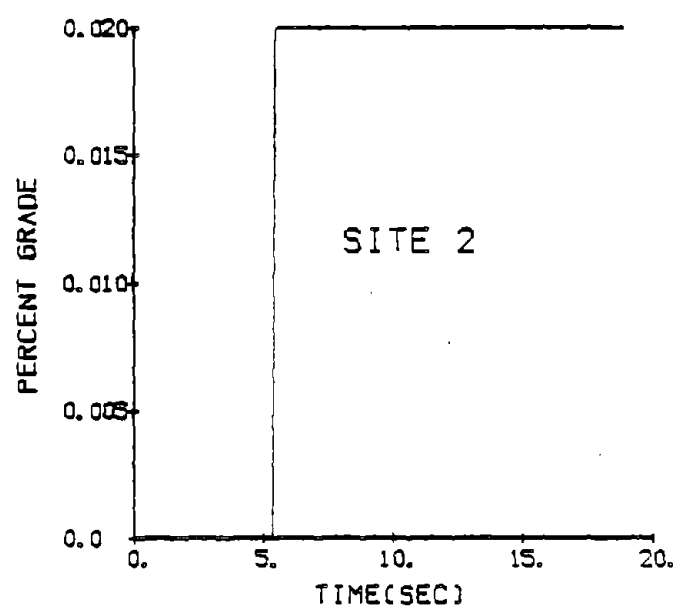
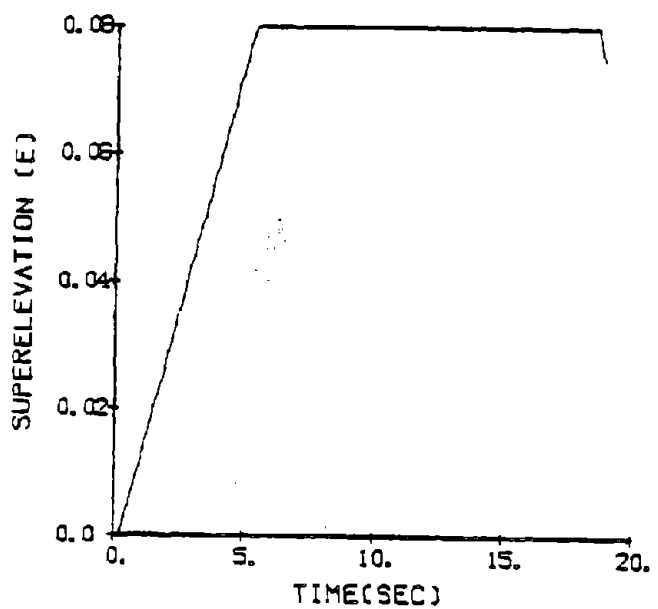
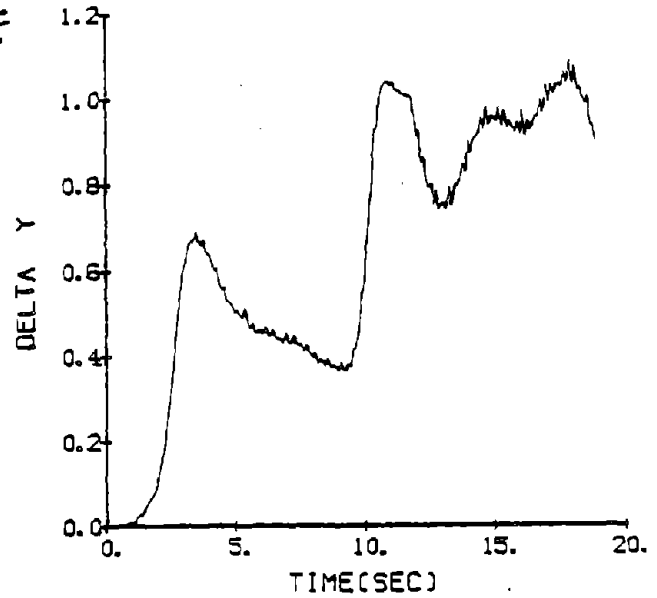
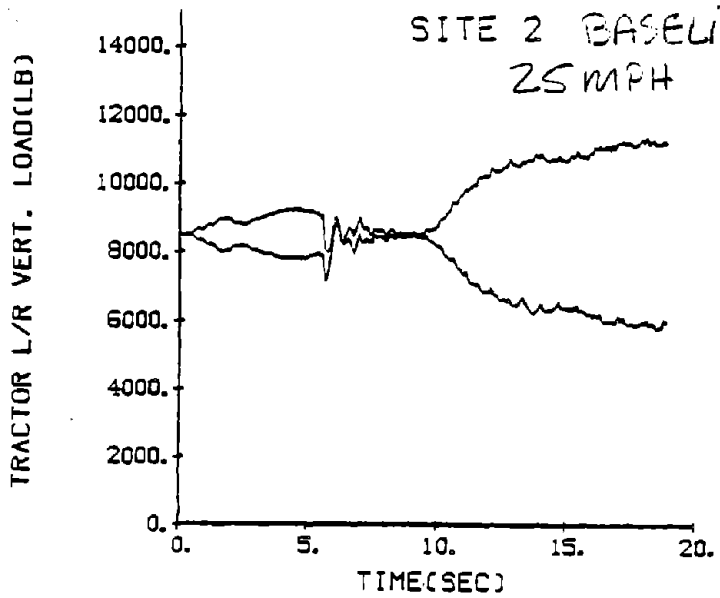
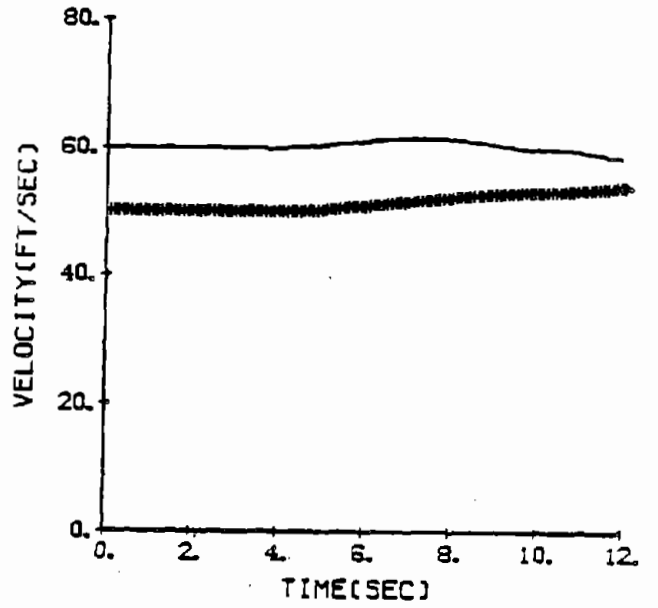
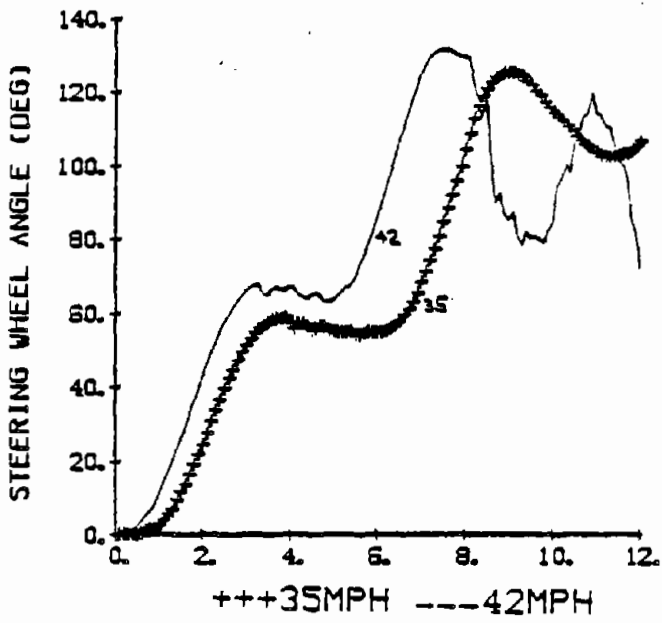

Figure 22. (continued)



SITE 2 BASELINE

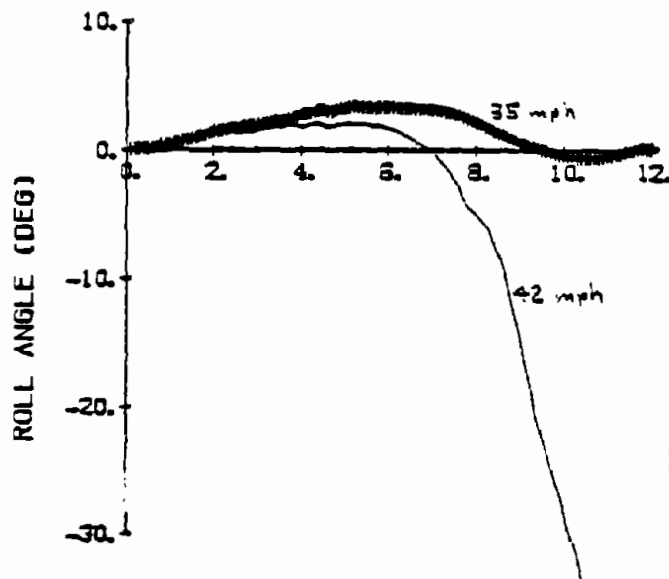
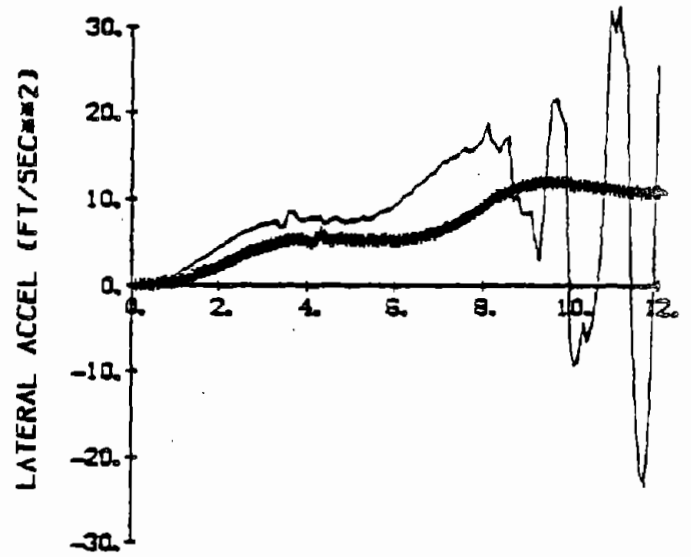
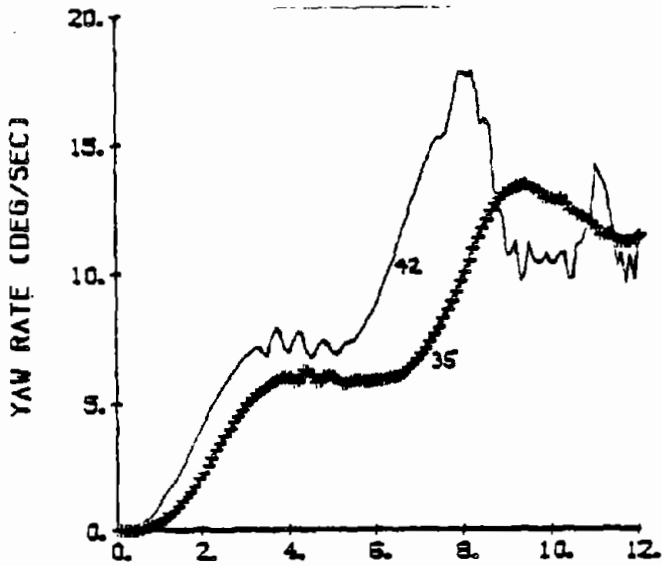

Figure 23. Site 2 baseline 35 and 40 mi/h.

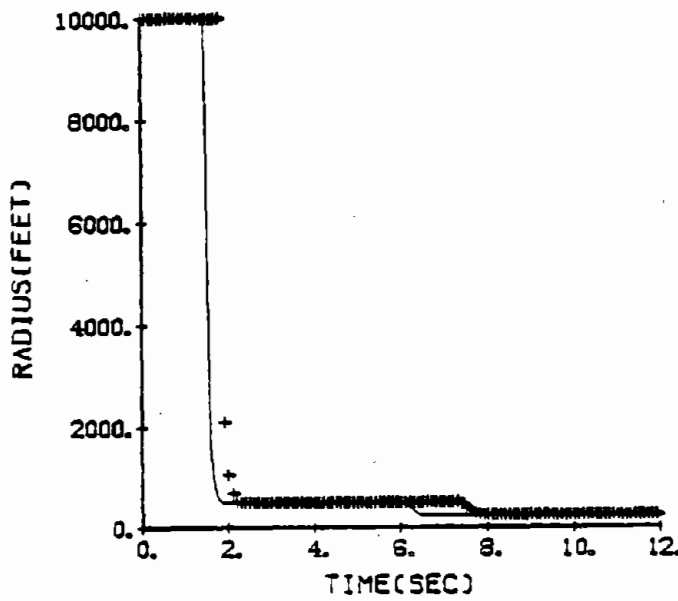
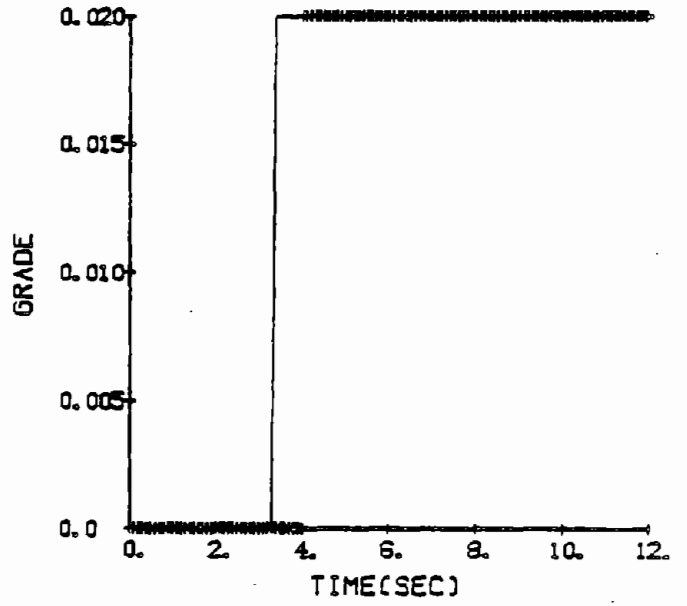
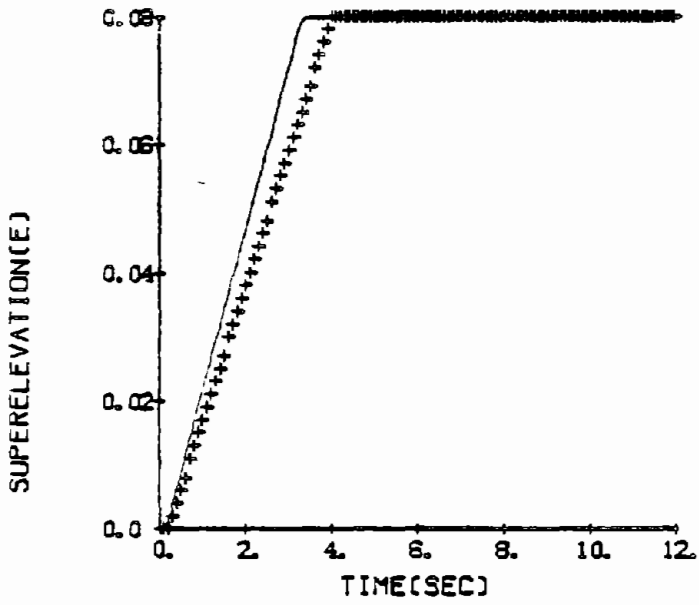
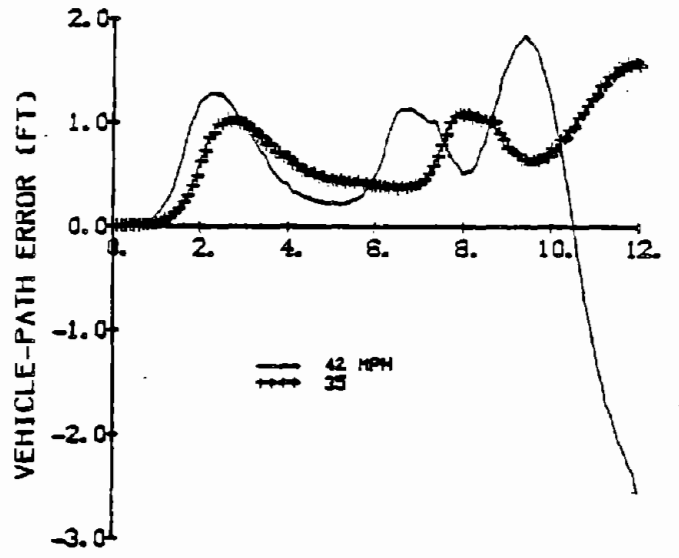
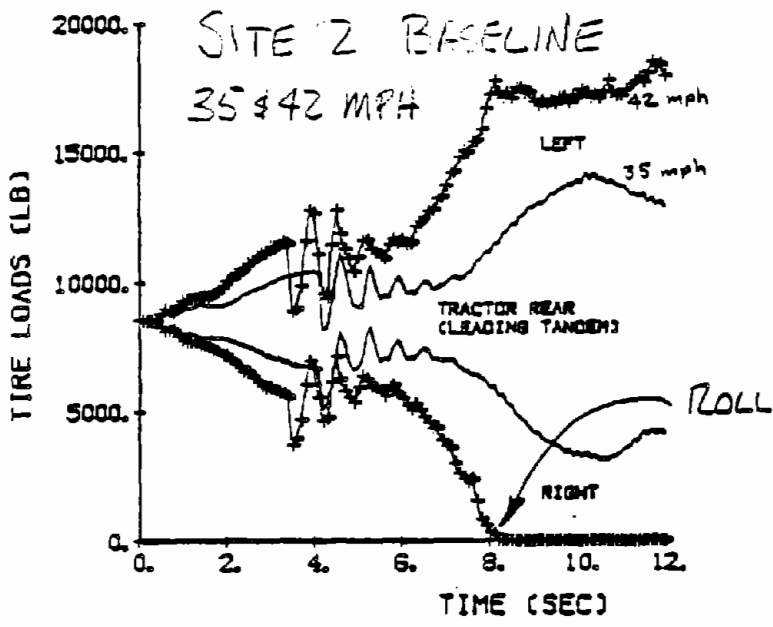

Figure 23. (continued)

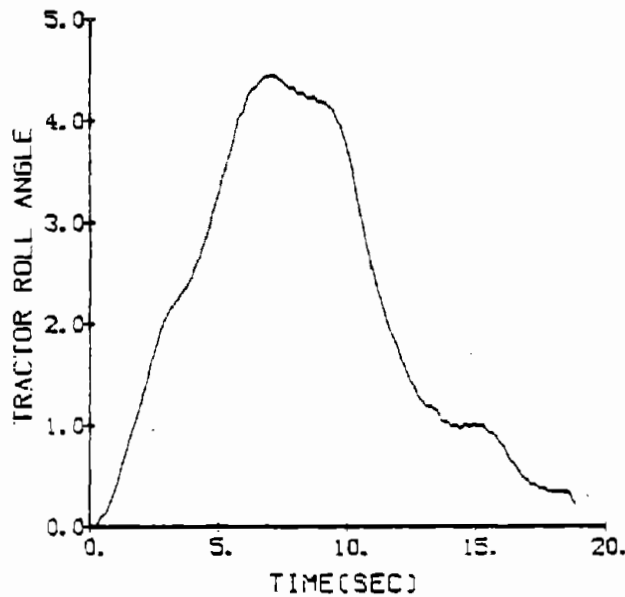
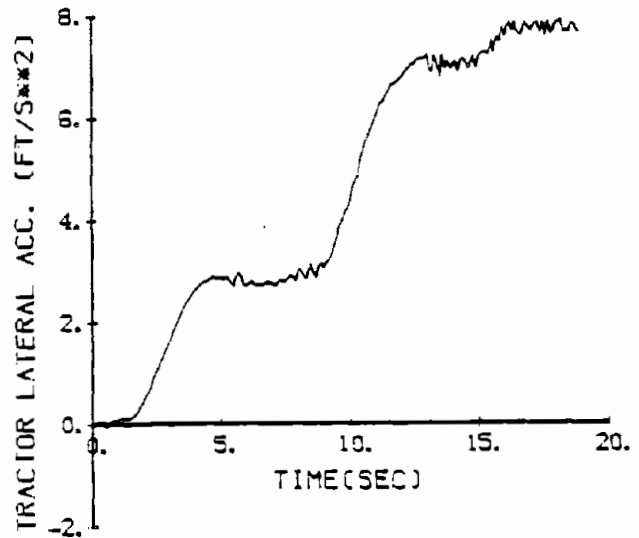
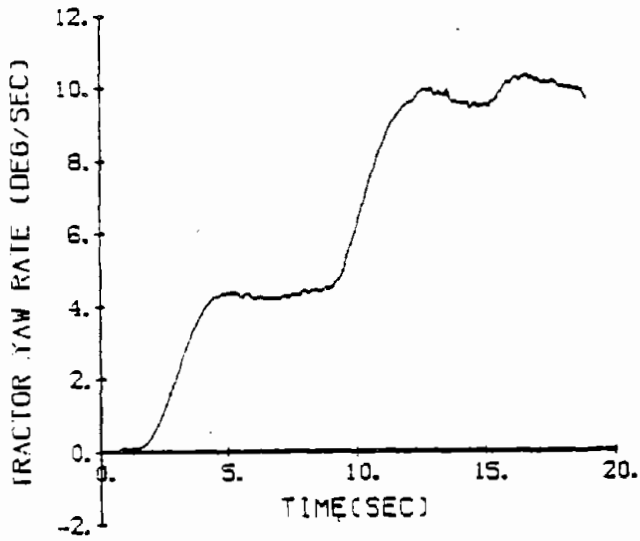
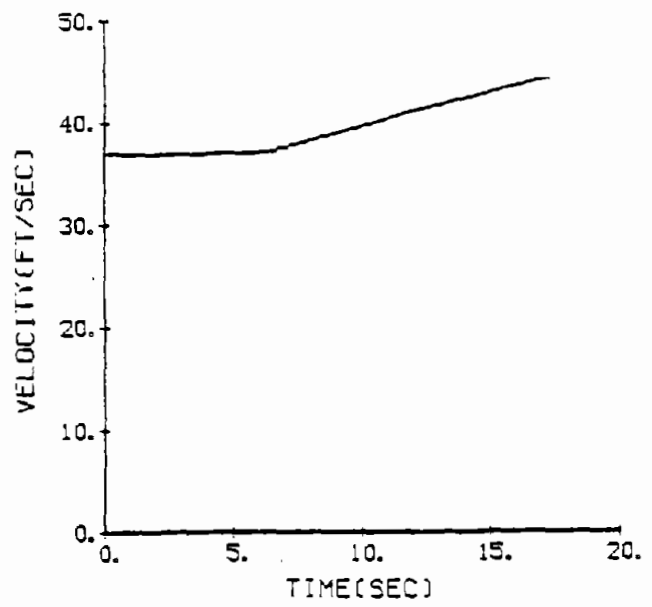
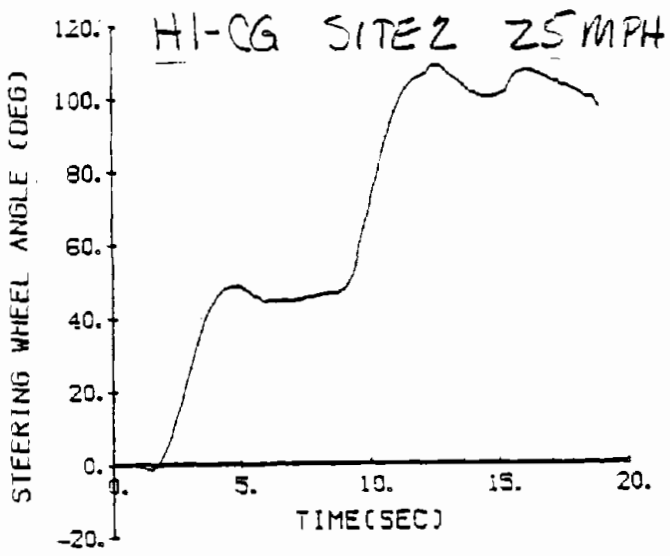

Figure 24. Site 2, hi-c.g., 25 mi/h.

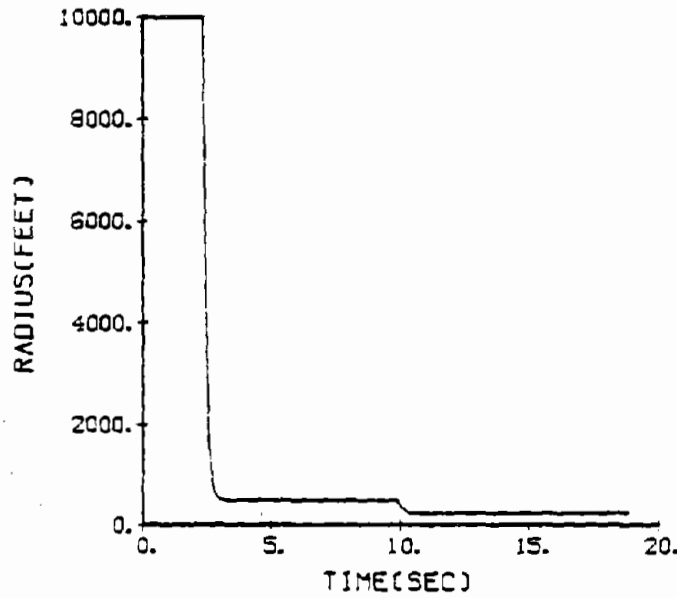
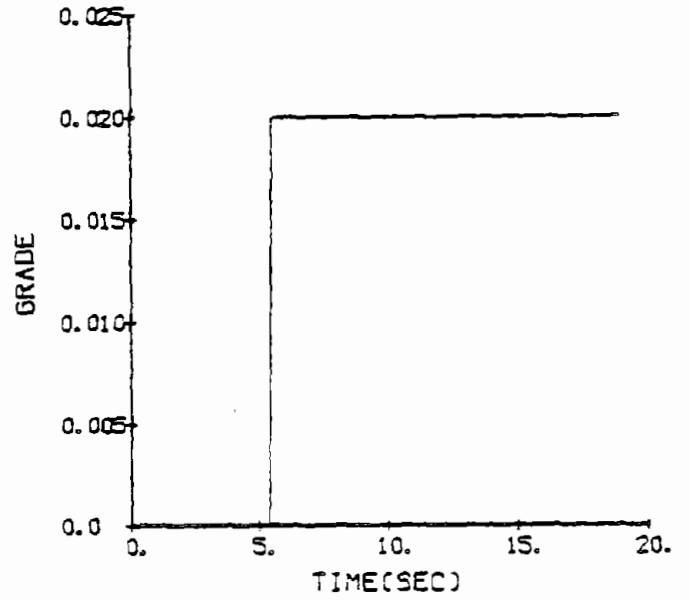
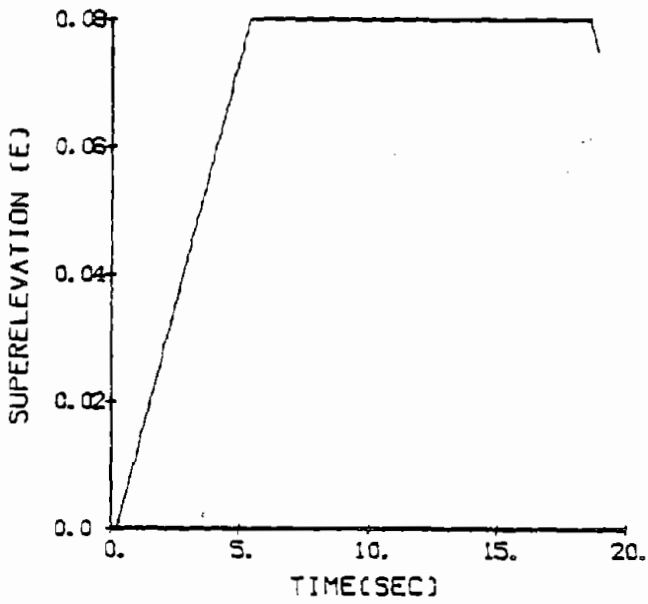
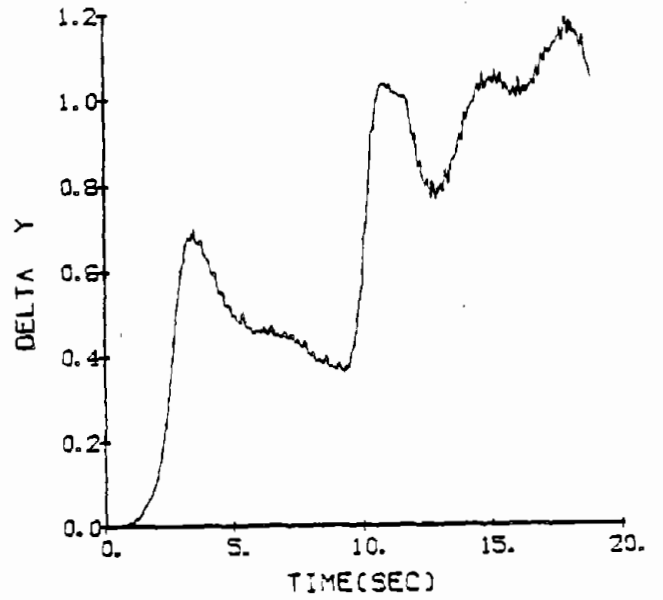
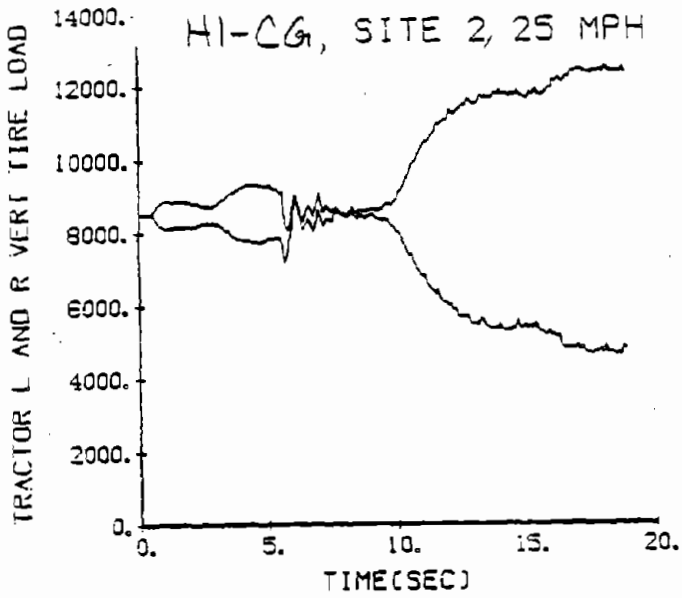

Figure 24. (continued)

SITE 3, BASELINE
 +++25MPH ---35MPH

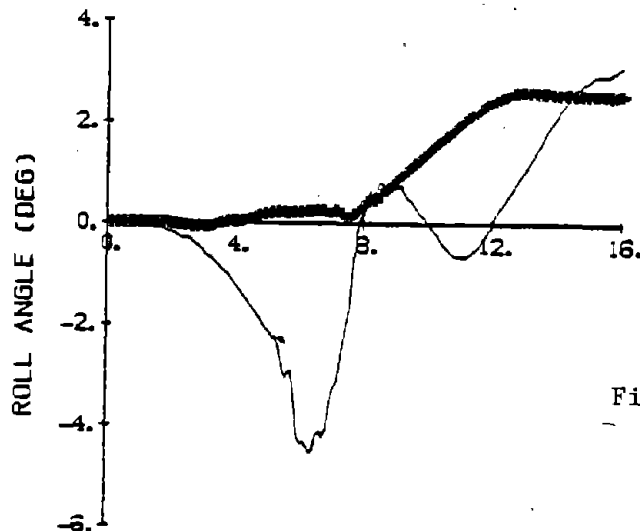
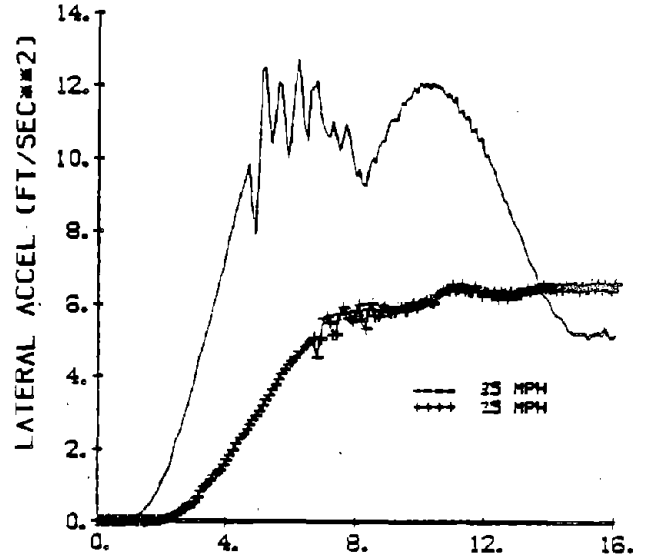
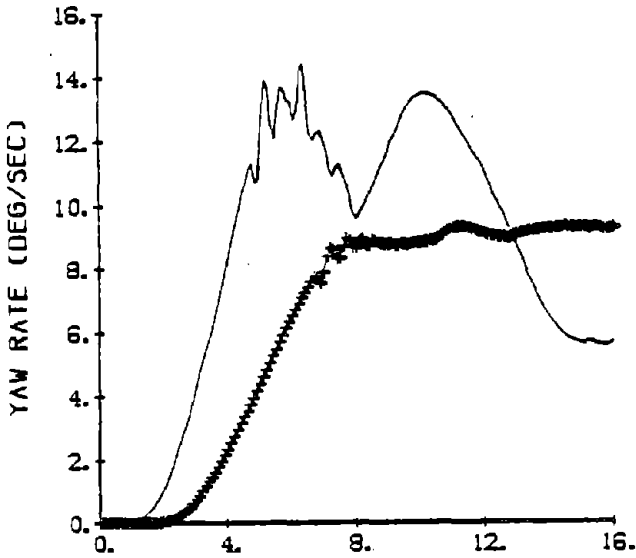
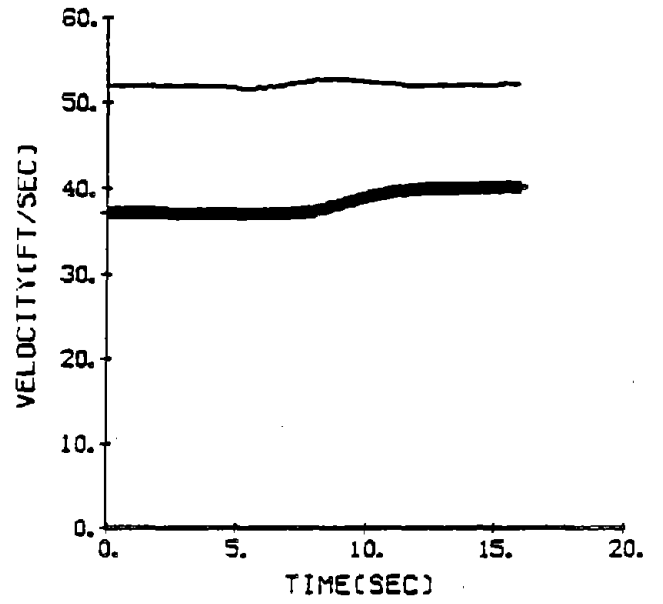
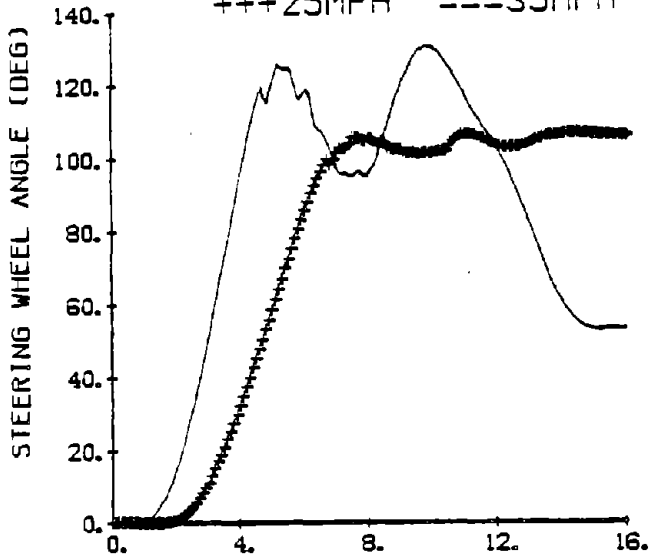

Figure 25. Site 3 baseline, 25 and 35 mi/h.

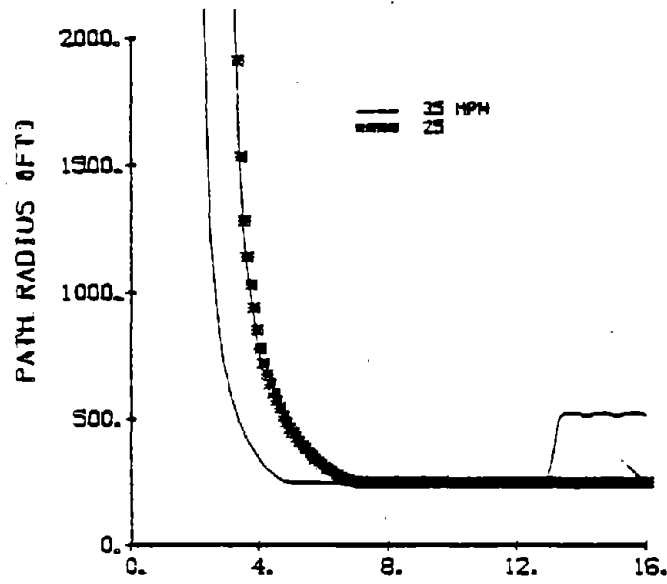
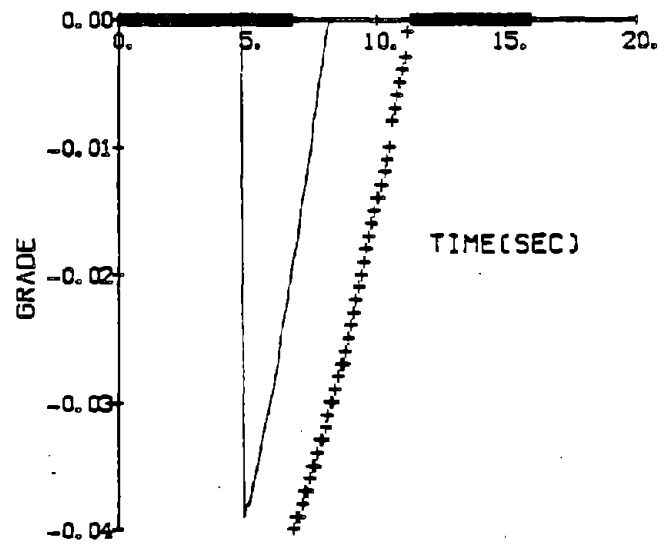
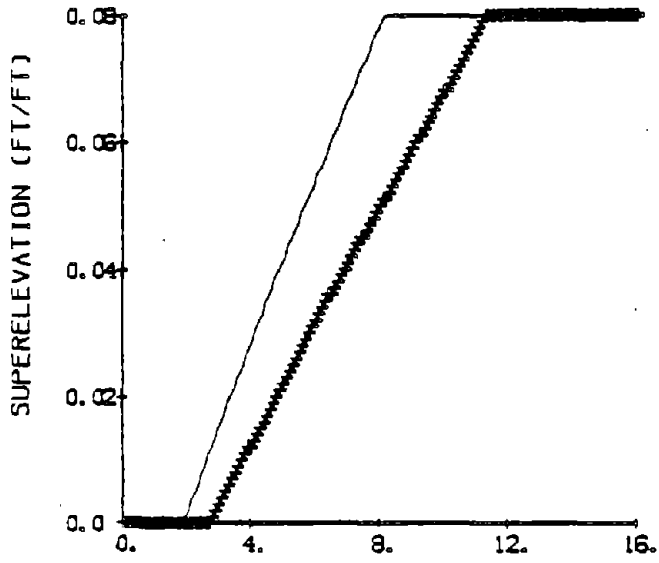
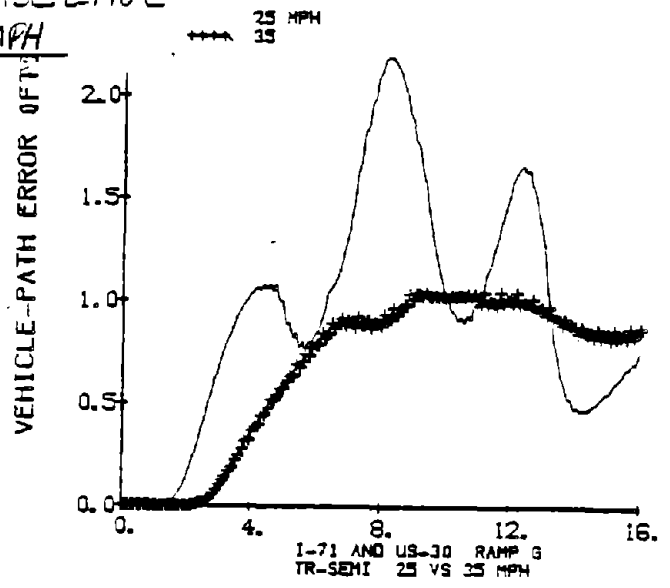
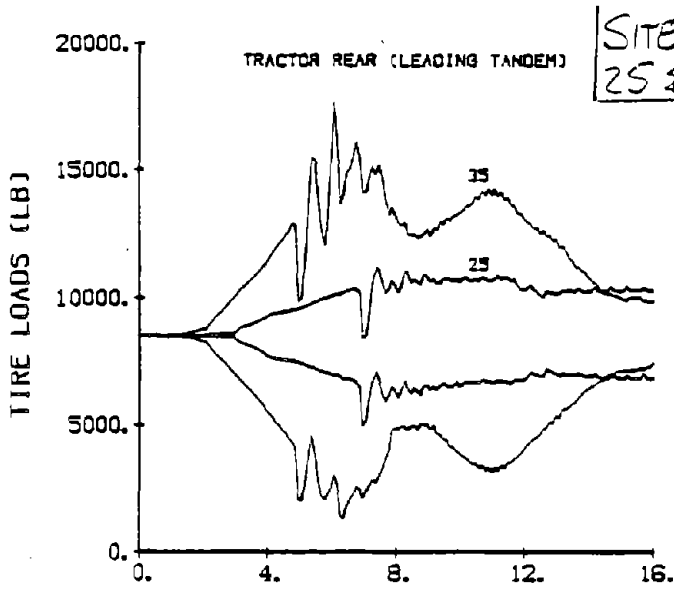

Figure 25. (continued)

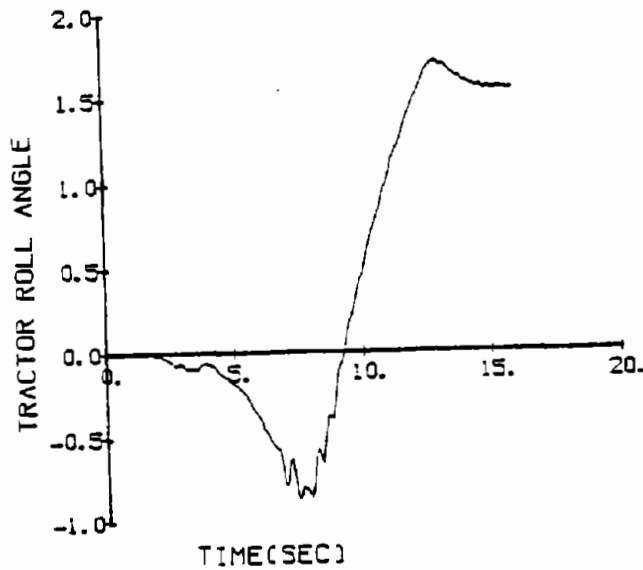
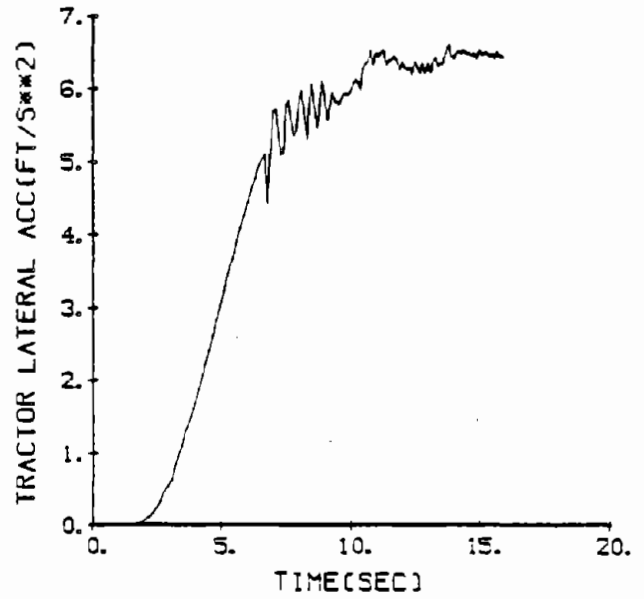
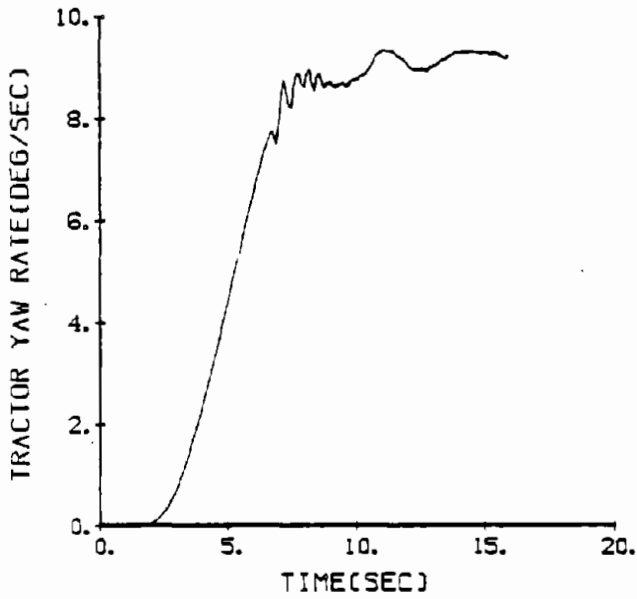
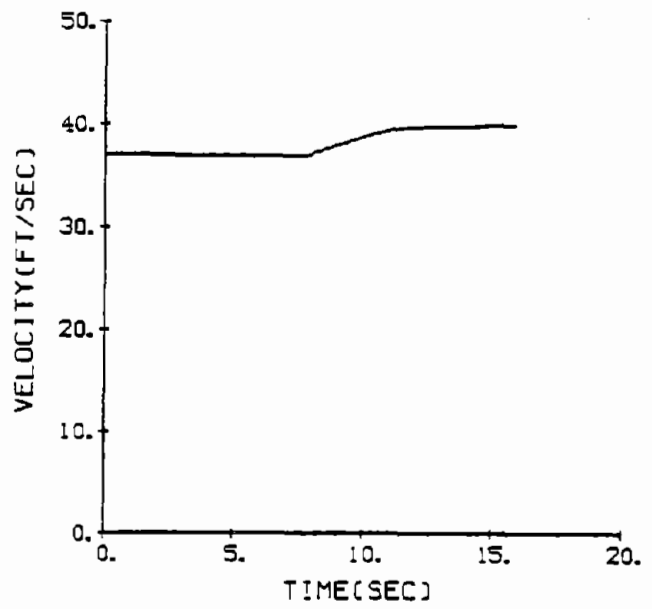
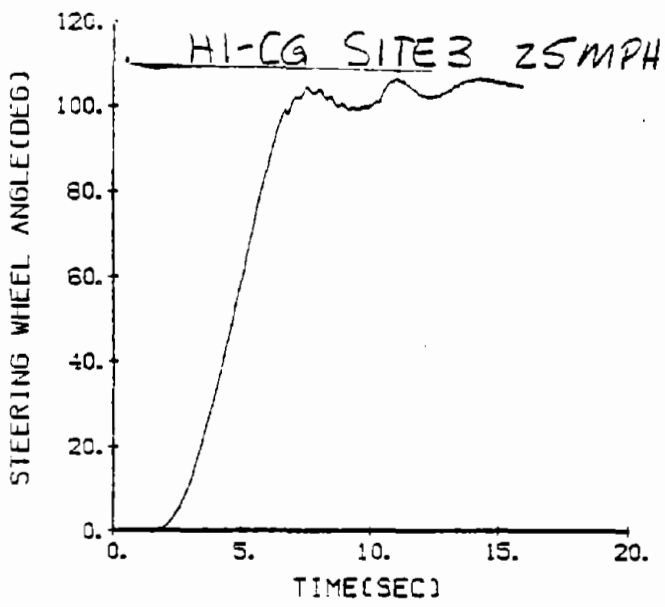

Figure 26. Site 3, hi-c.g., 25 mi/h.

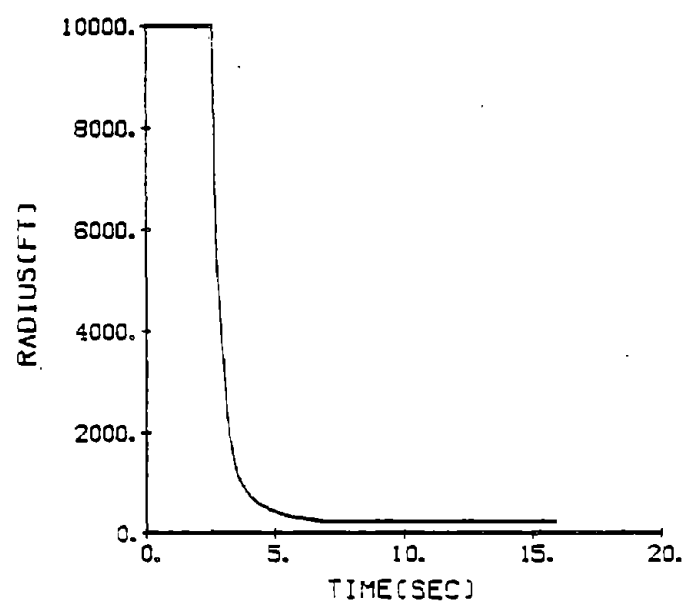
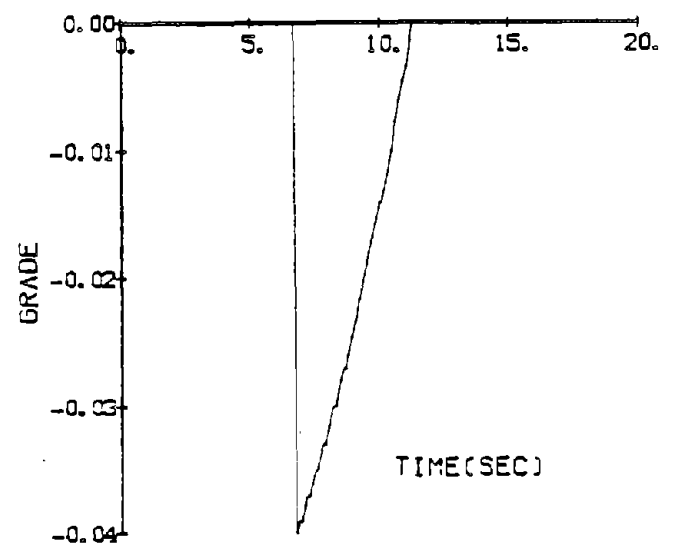
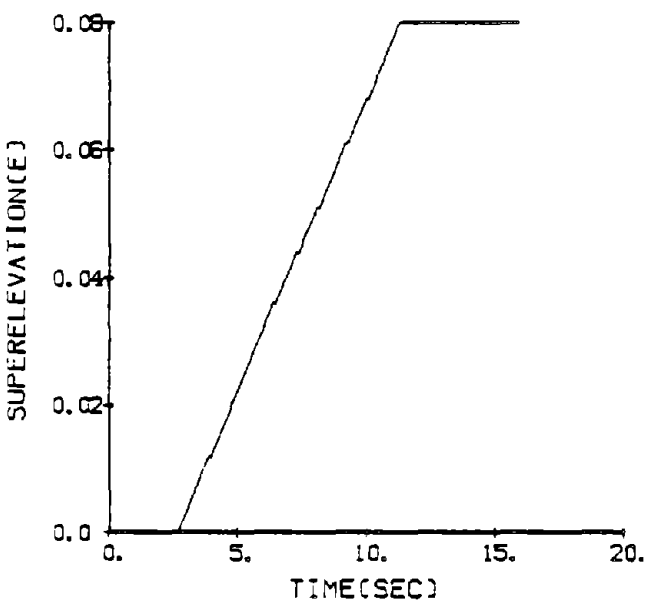
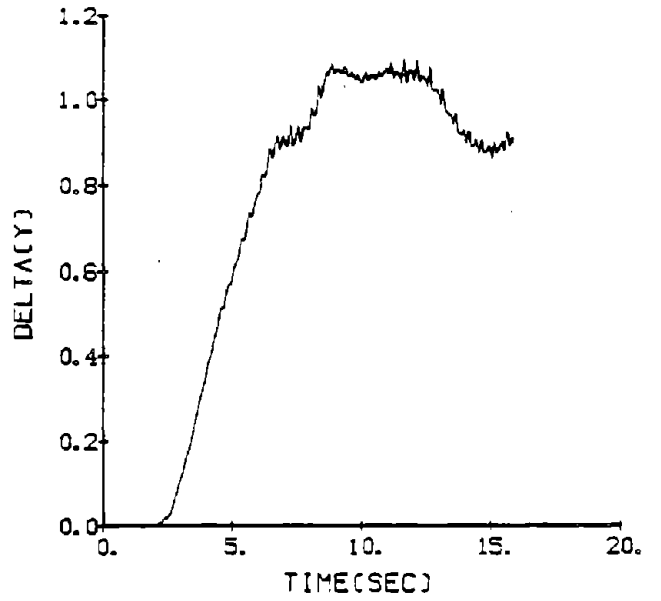
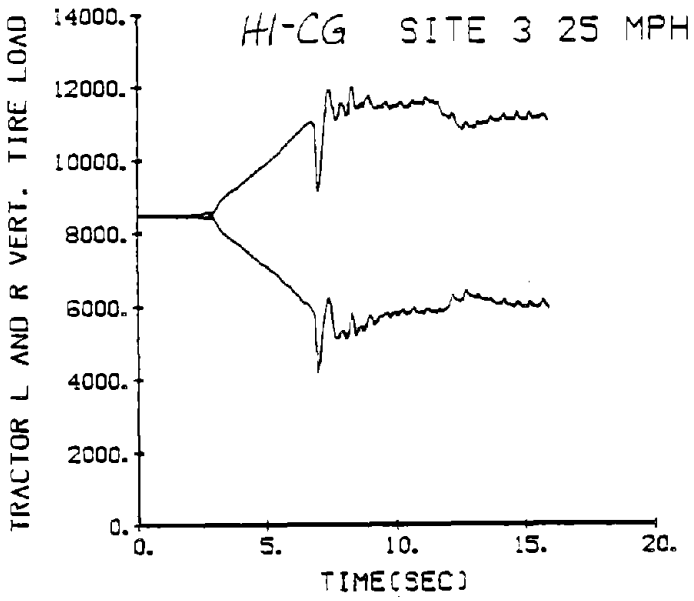

Figure 26. (continued)

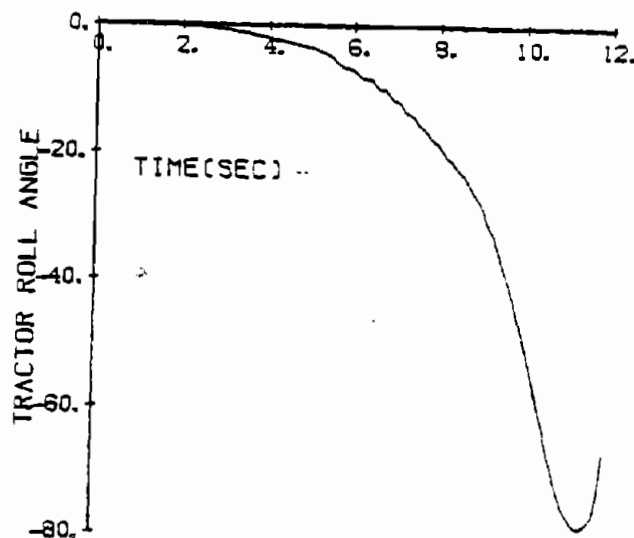
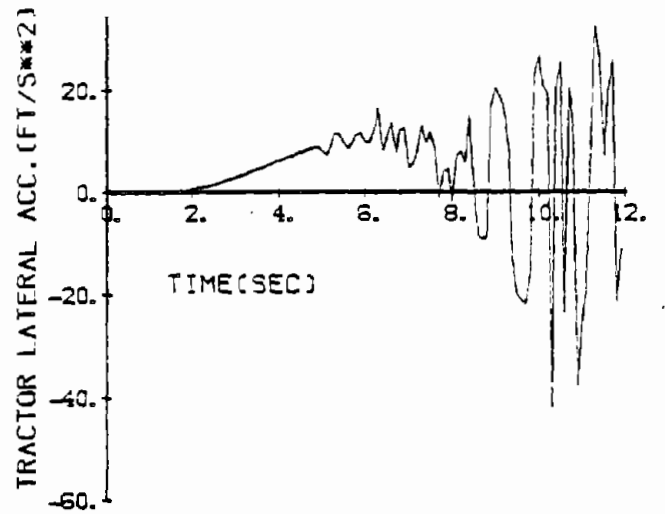
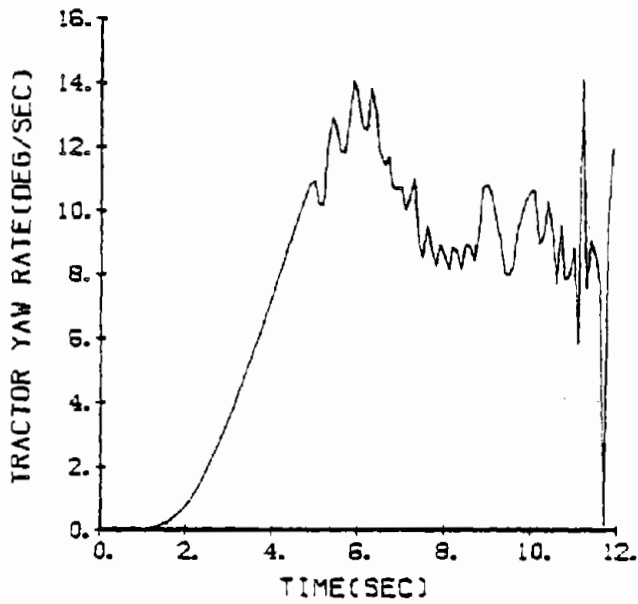
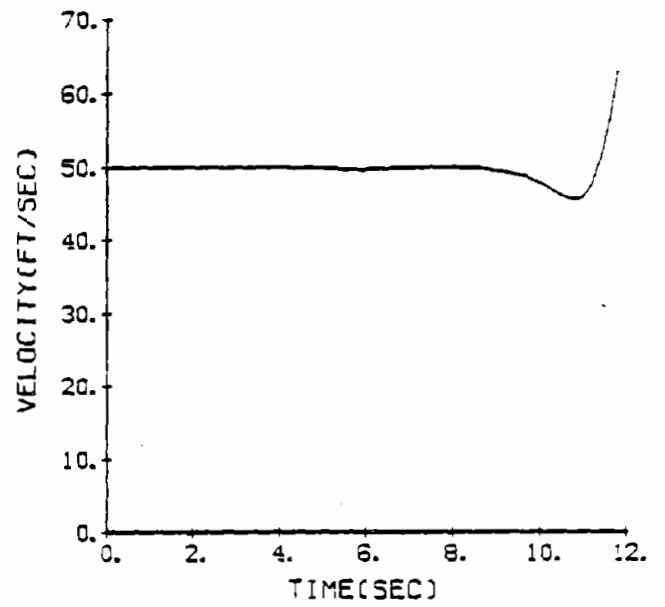
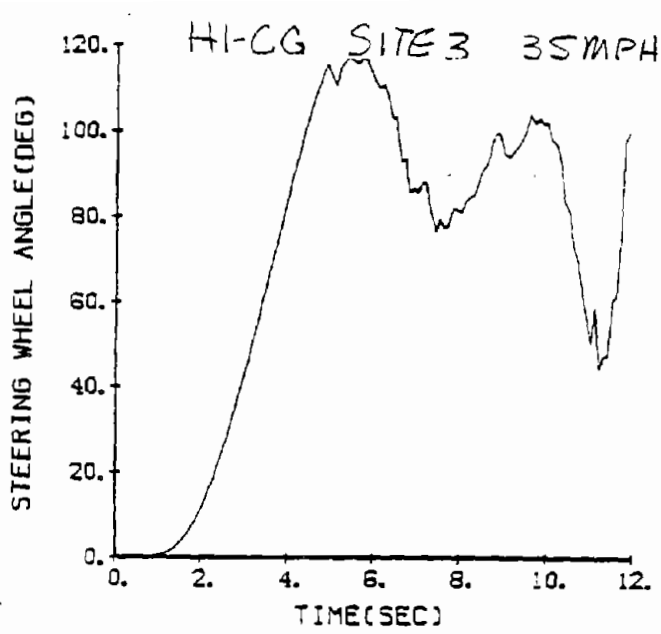

Figure 27. Site 3, hi-c.g.
35 mi/h.

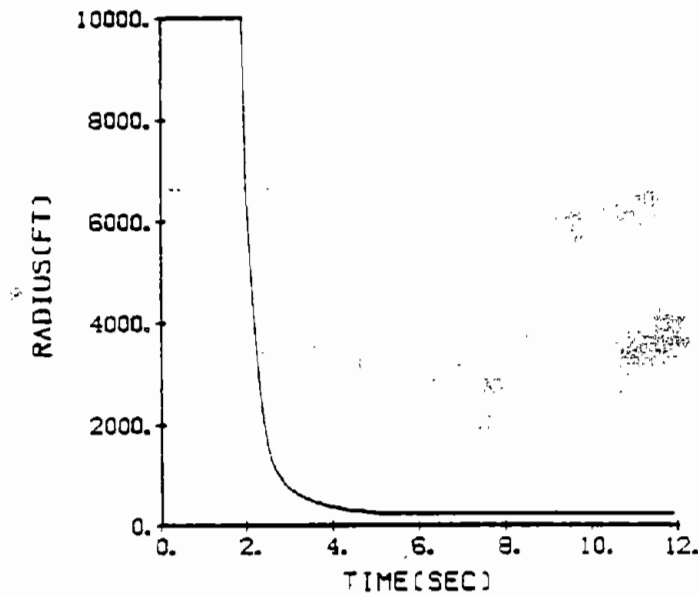
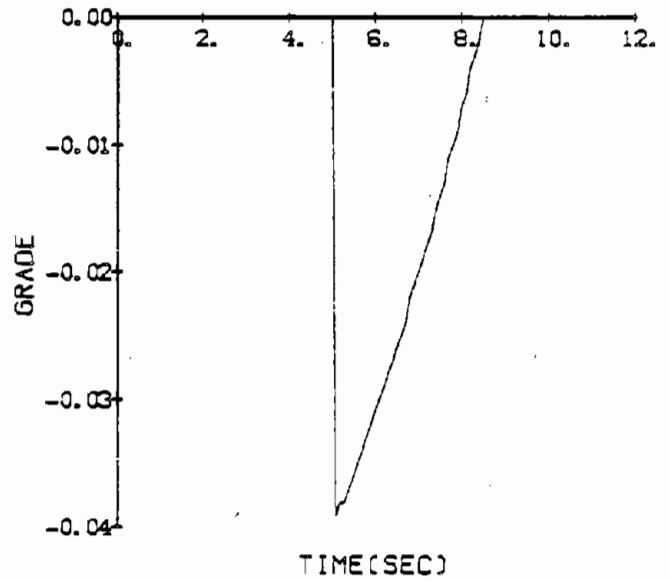
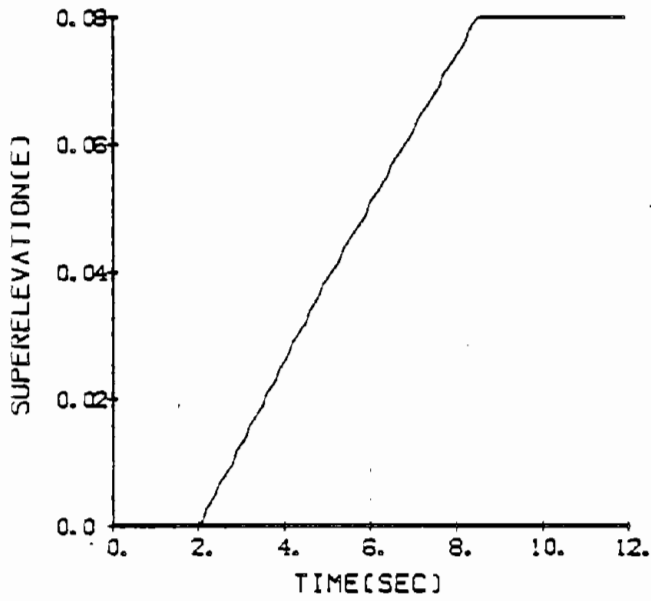
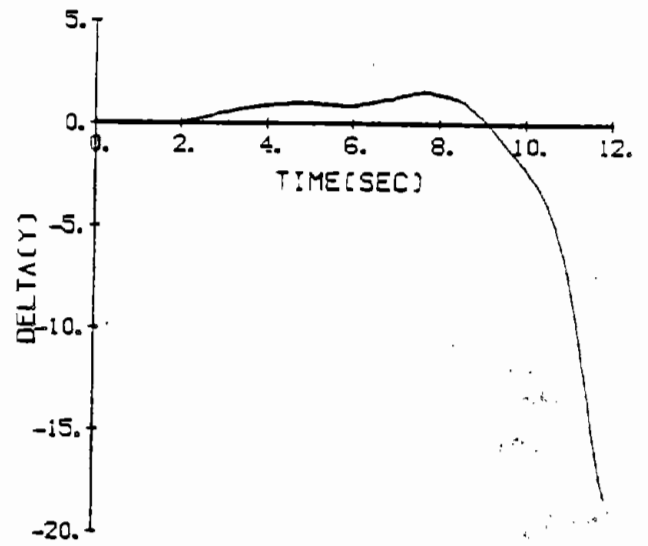
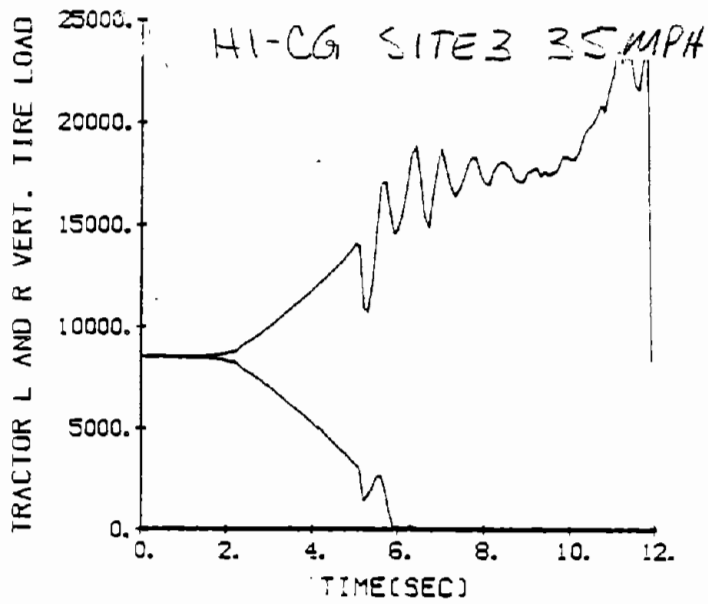

Figure 27. (continued)

SITE 4 BASELINE 55 MPH, 15 PSI BRAKE INPUT

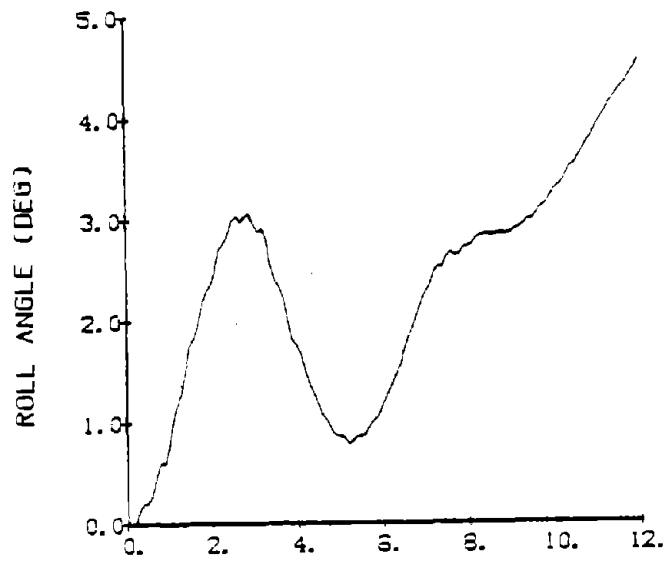
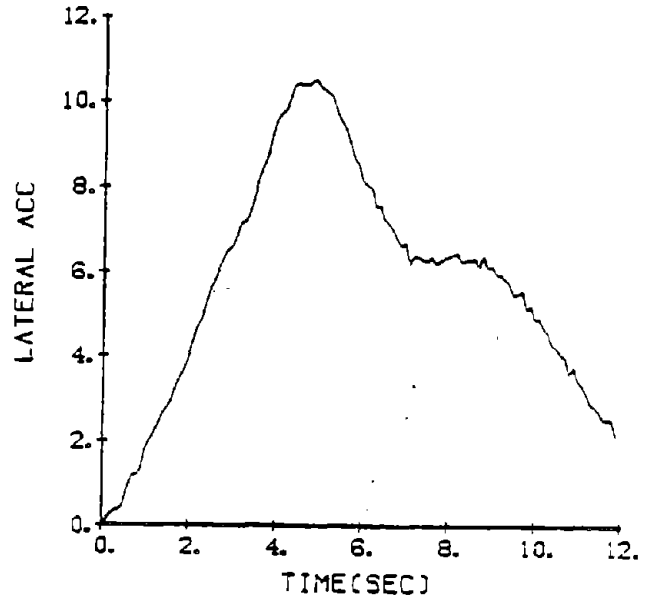
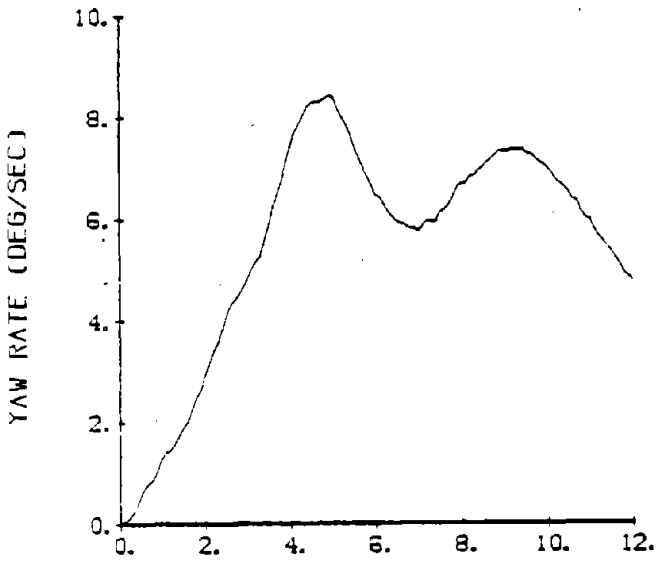
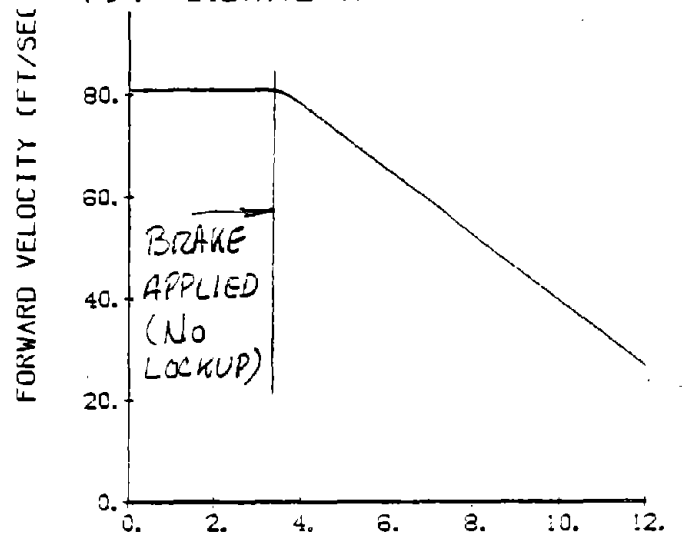
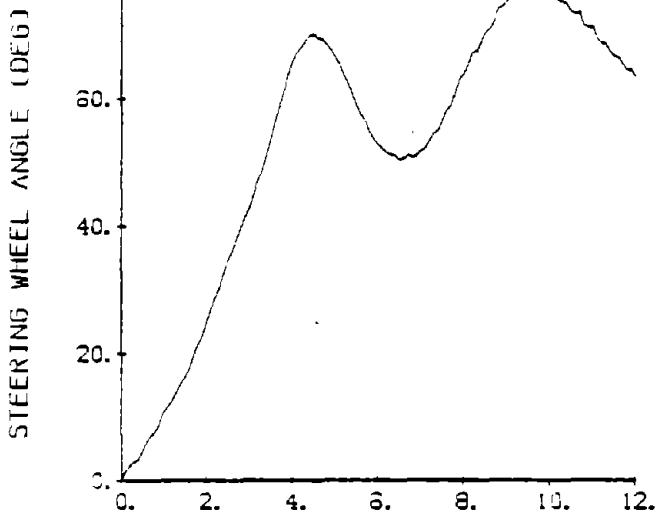

Figure 28. Site 4 base-line, 55 mi/h.

SITE 4, BASELINE, 55 MPH, 15 PSI

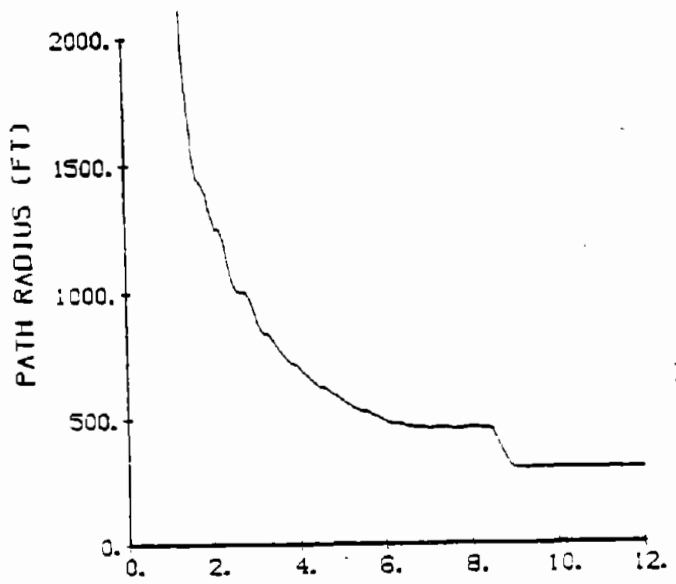
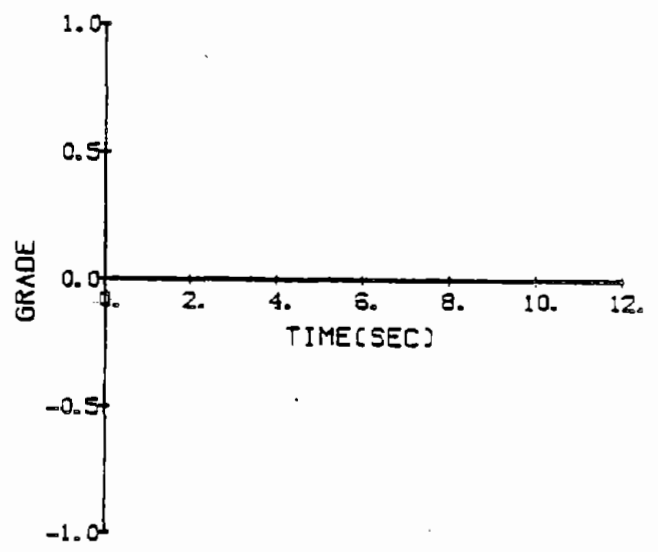
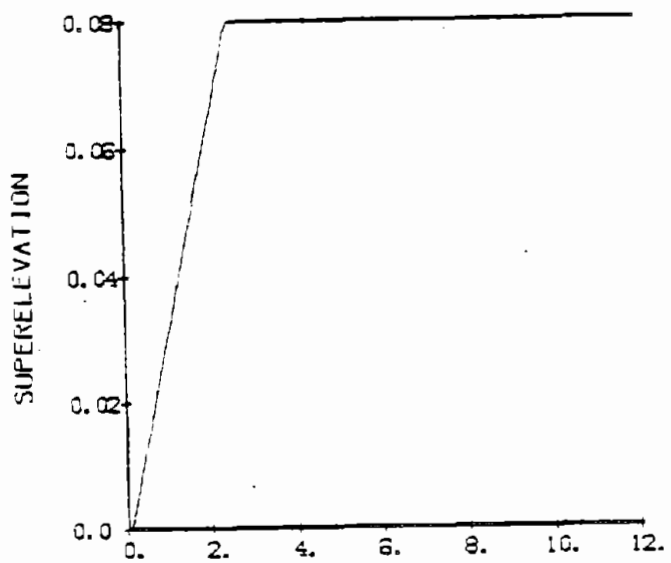
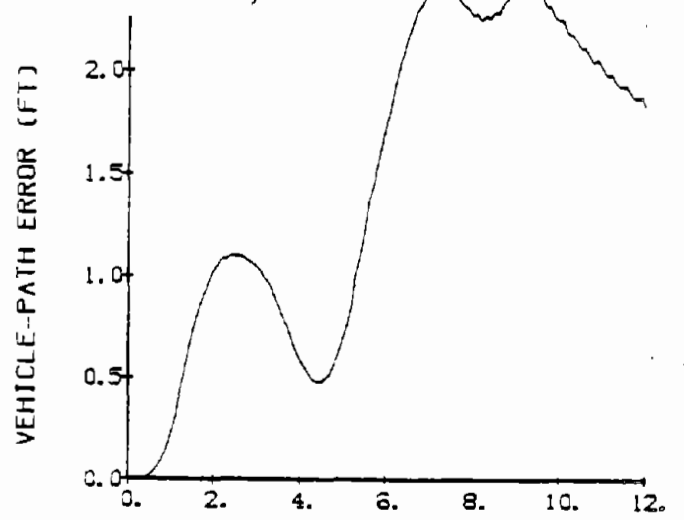
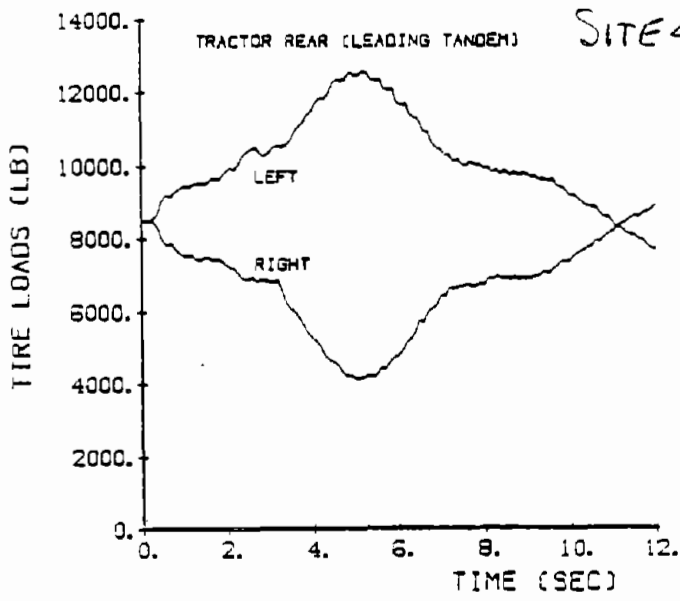

Figure 28. (continued)

SITE NO. 4 - EMPTY VEHICLE
 $M = 0.50$ 55 MPH
 20 PSI BRAKE INPUT

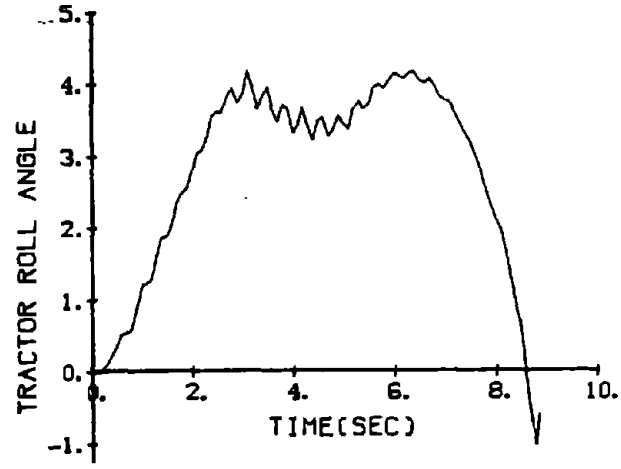
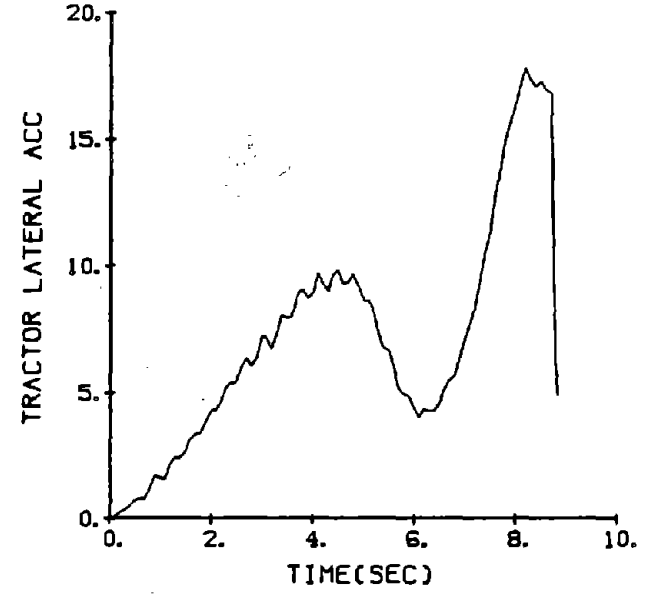
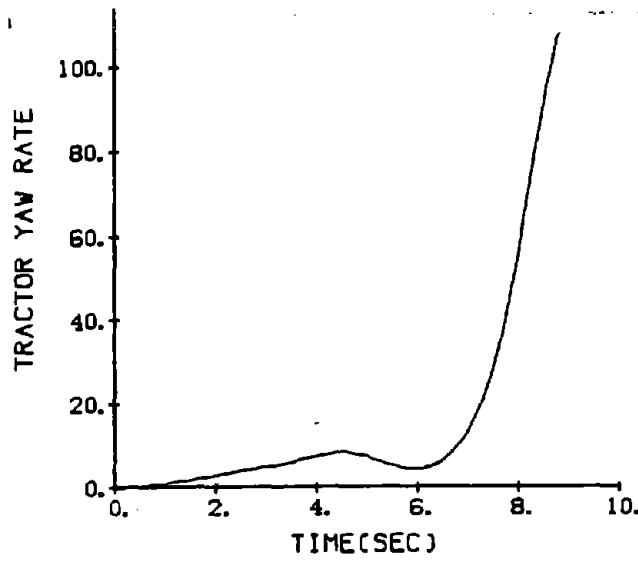
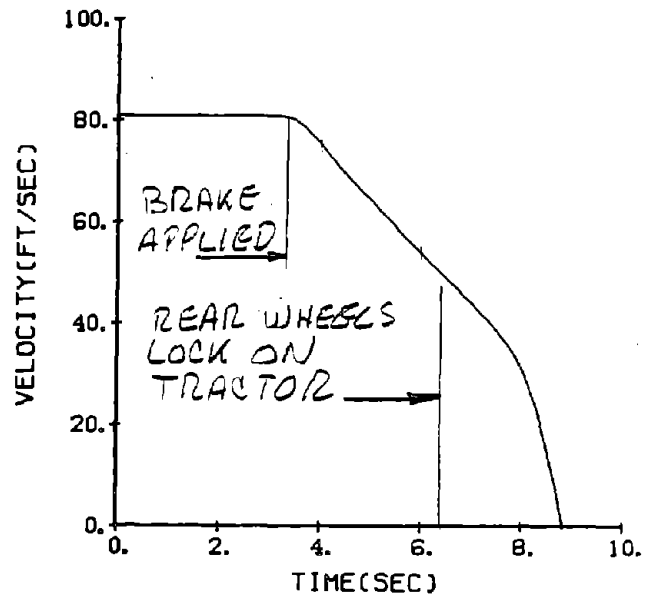
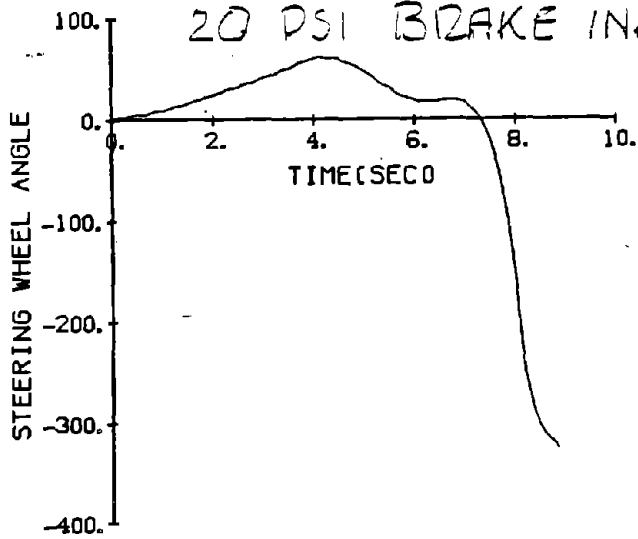

Figure 29. Site 4 - empty vehicle
 $M = 0.50$, 55 mi/h,
 20 PSI.

SITE NO. 4 - EMPTY VGH.
 M=0.50, 55 MPH, 20 PSI

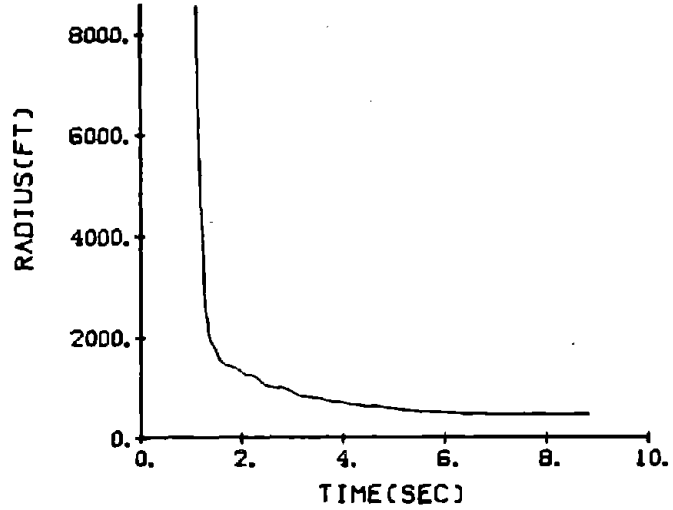
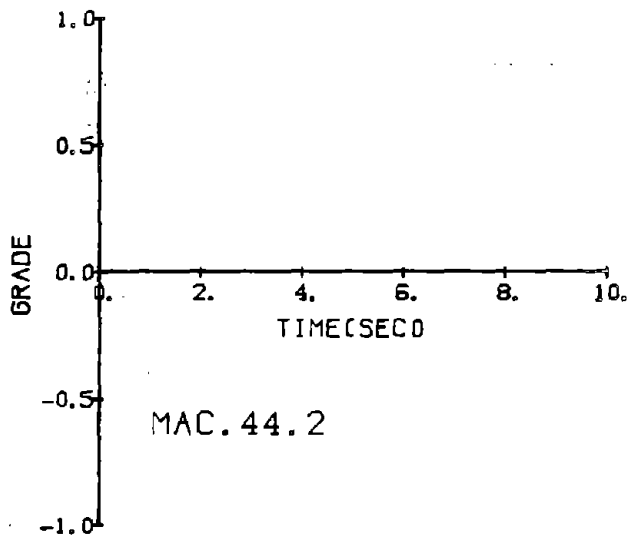
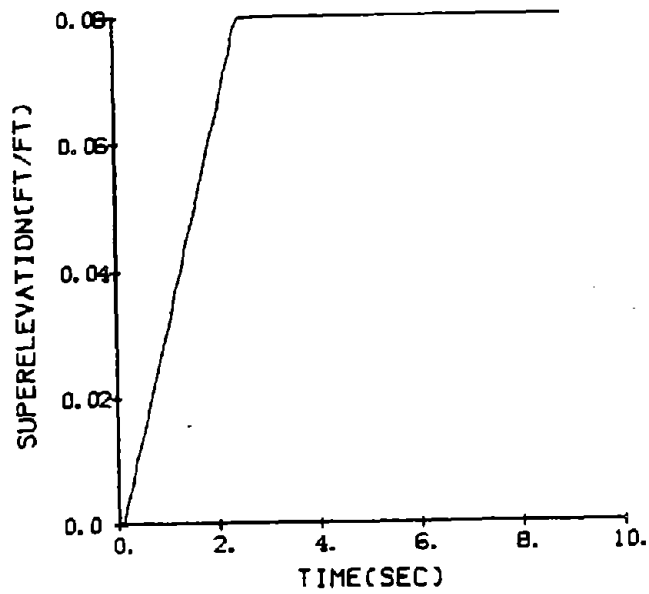
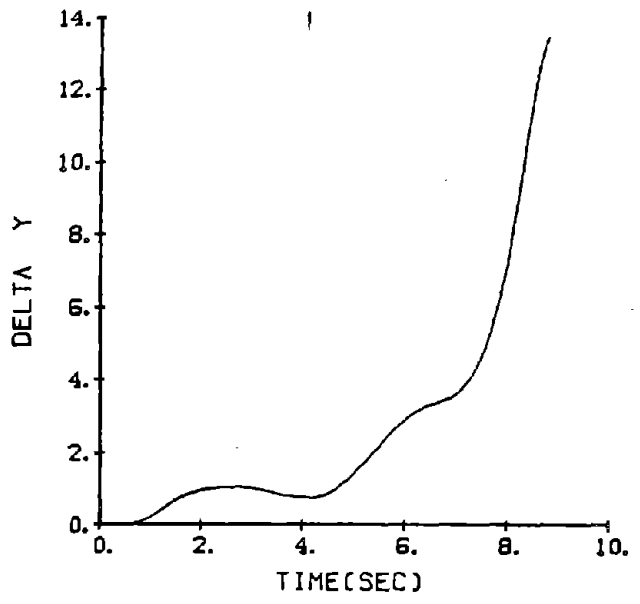
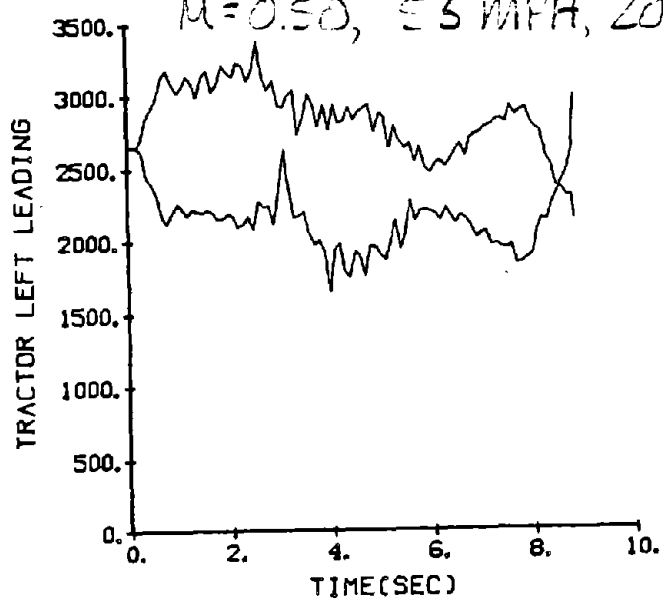
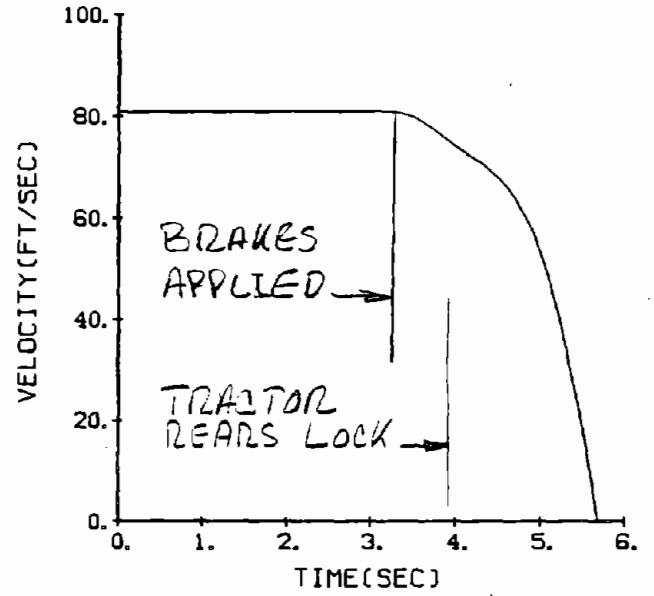
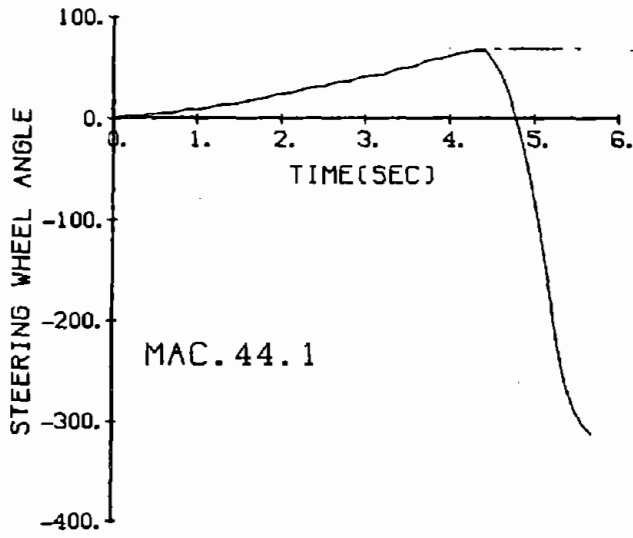

Figure 29. (continued)

SITE No. 4 - EMPTY VEHICLE

$\mu = 0.50$, 55 MPH

30 PSI BRAKE INPUT



MAC. 44.1, 30 PSI, $F = 0.5$

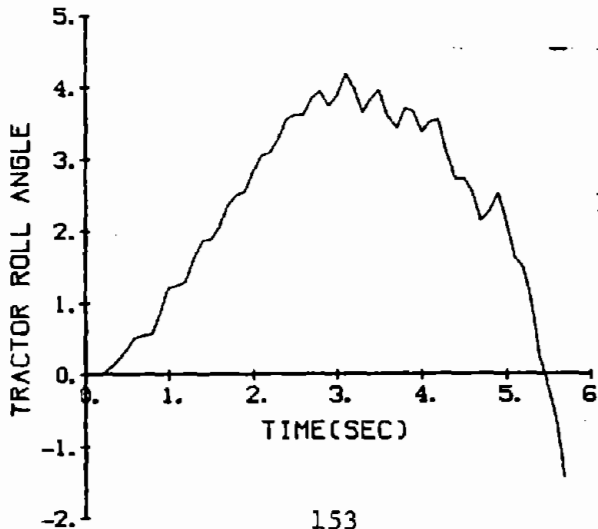
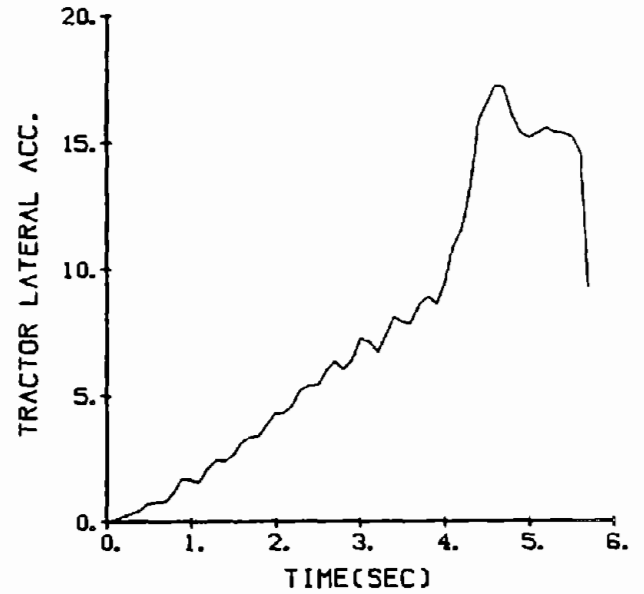
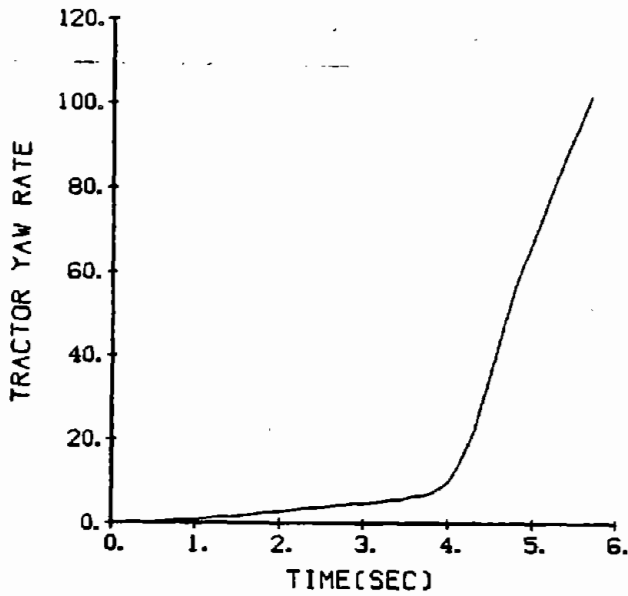

Figure 30. Site 4 - empt
 $M = 0.50$,
 55 mi/h,
 30 PSI.

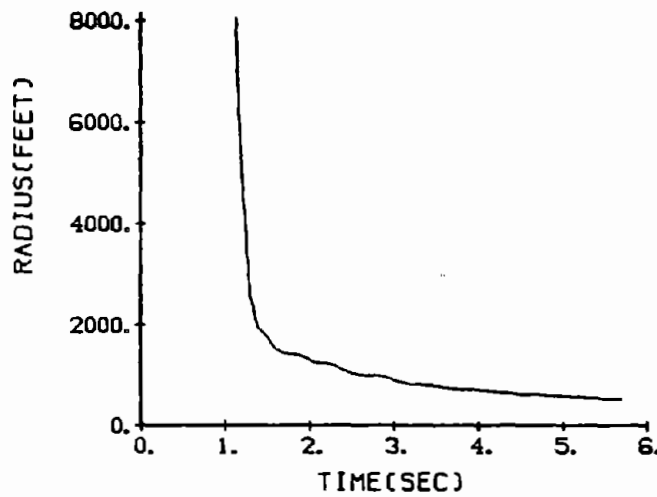
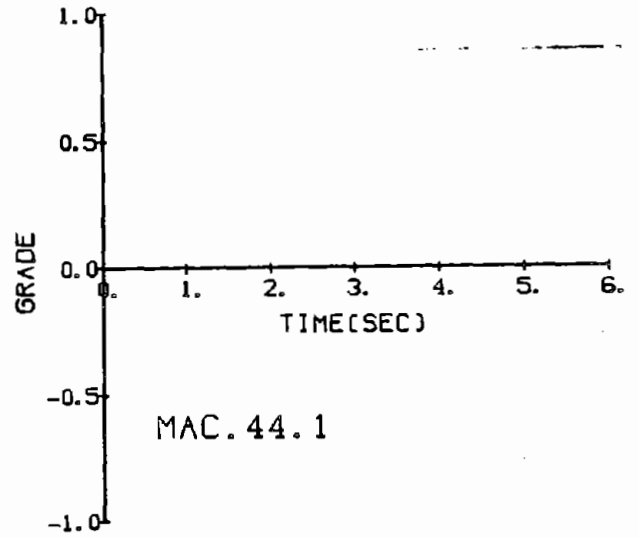
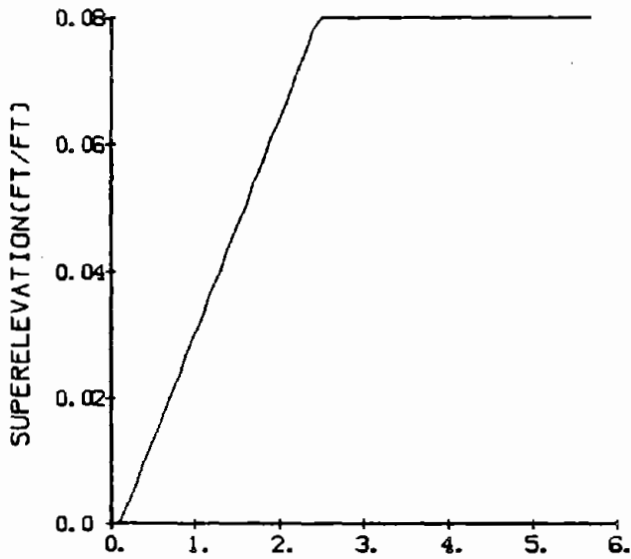
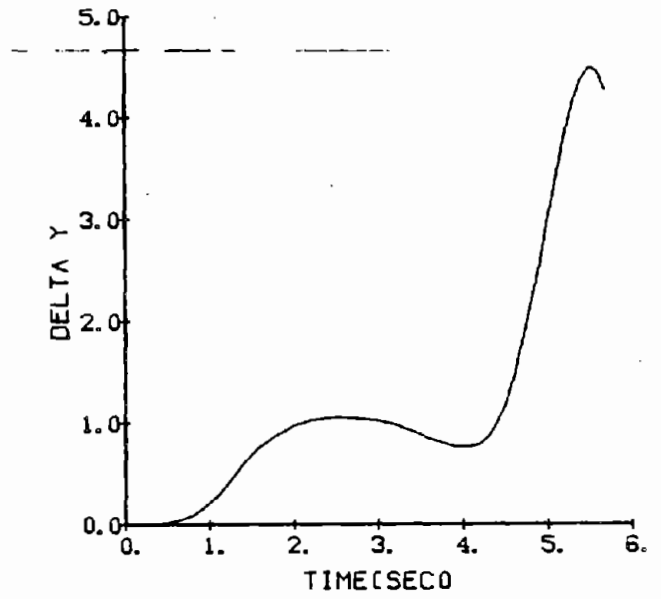
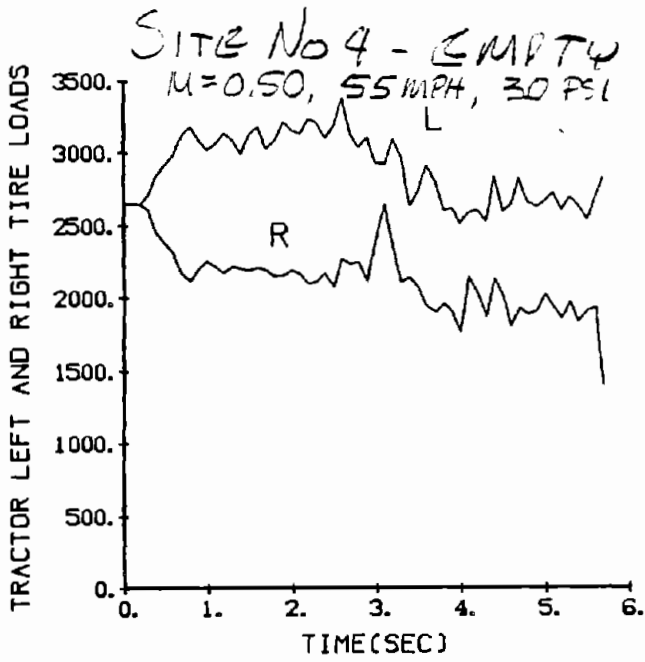

Figure 30. (continued)

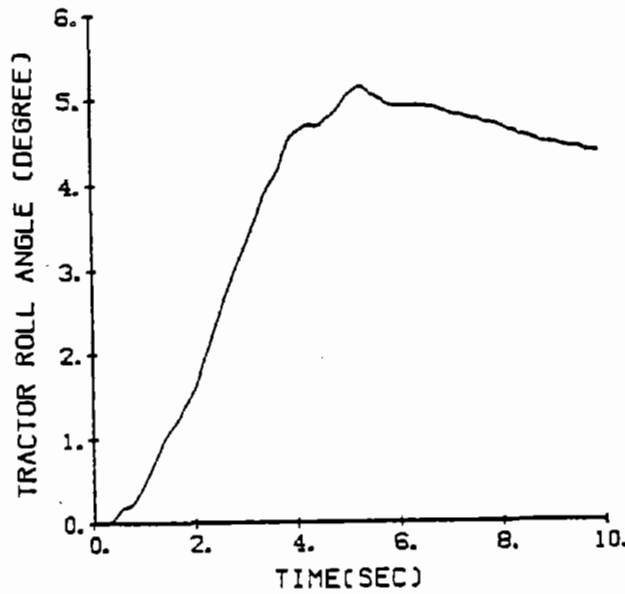
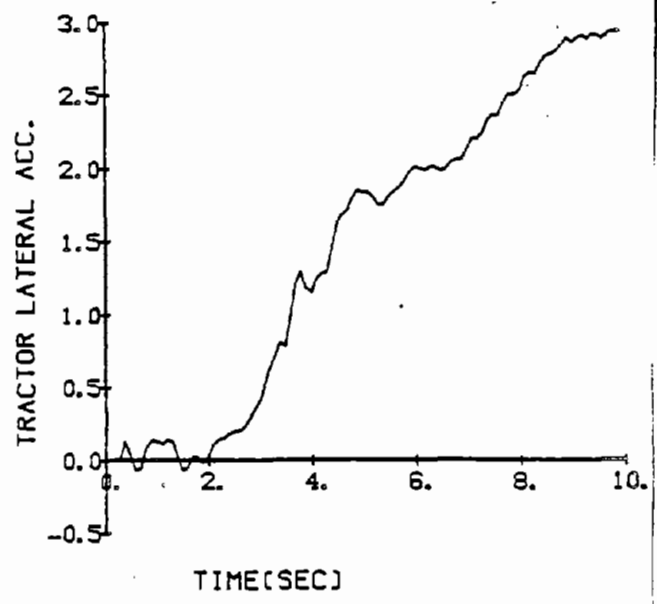
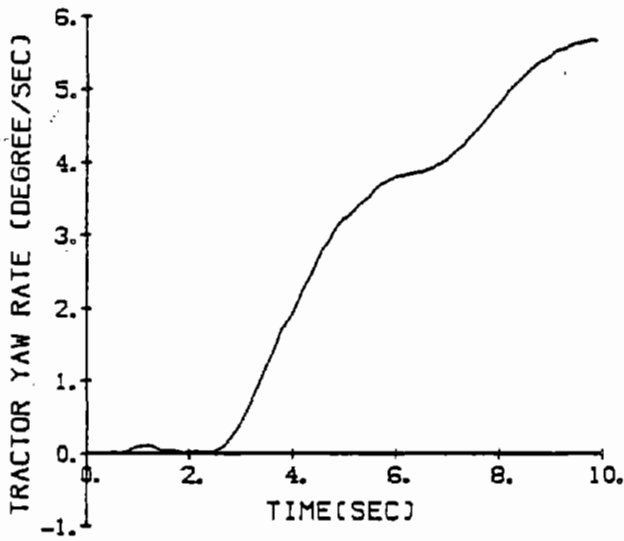
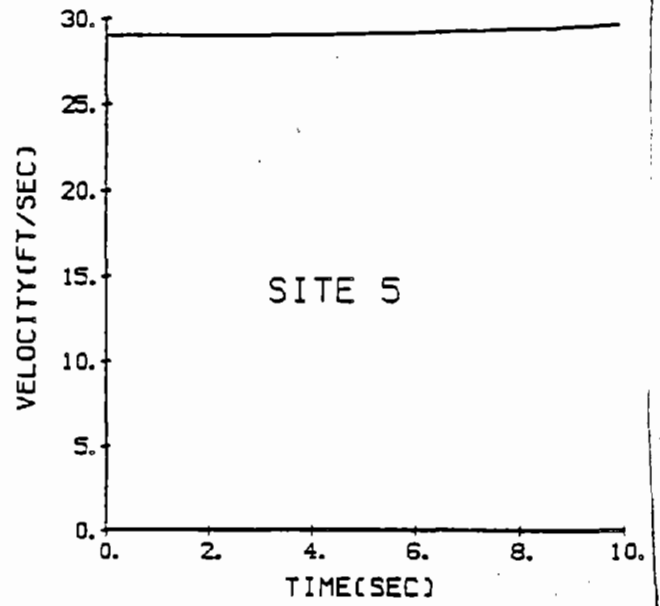
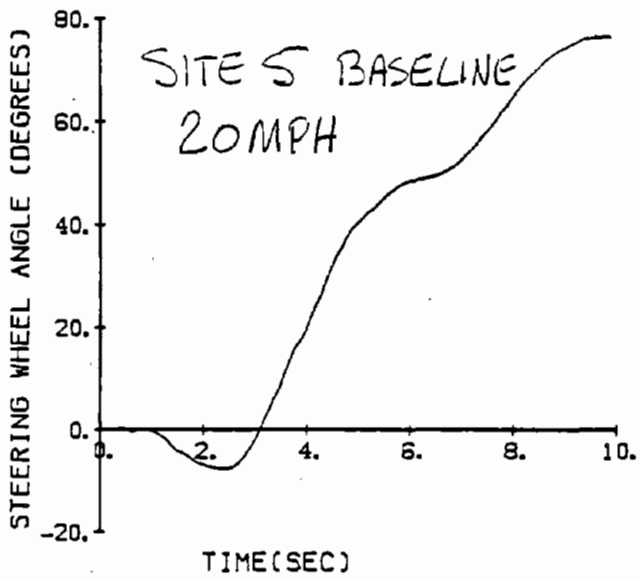

Figure 31. Site 5 baseline, 20 mi/h.

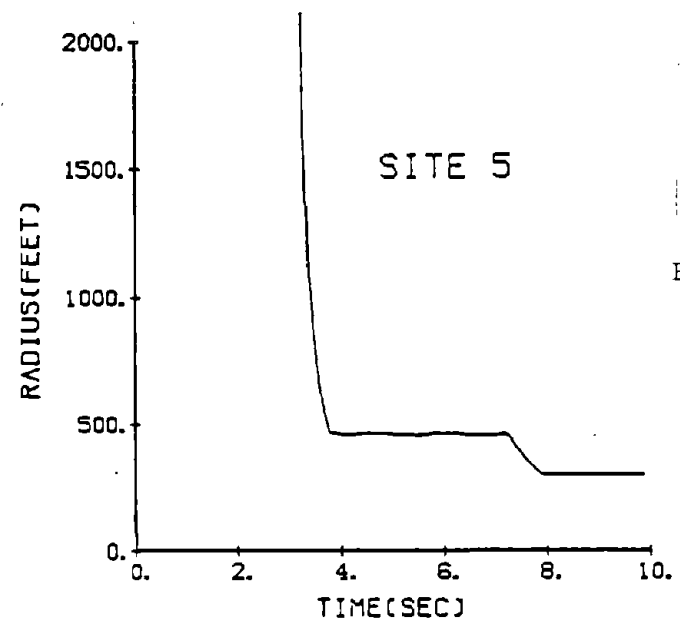
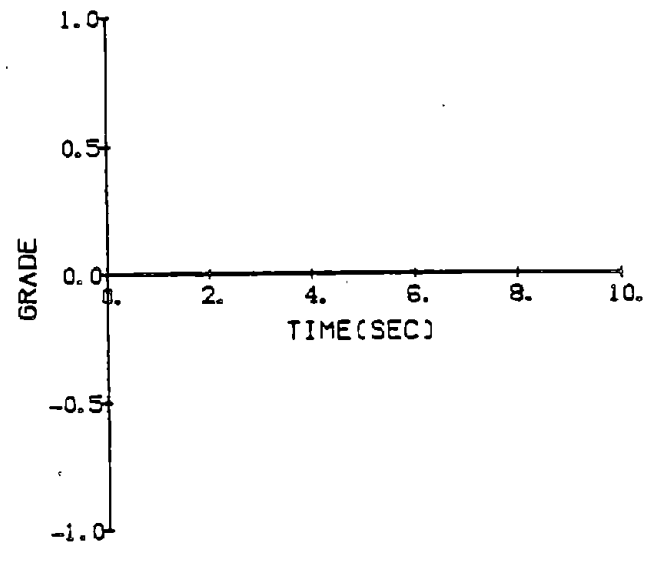
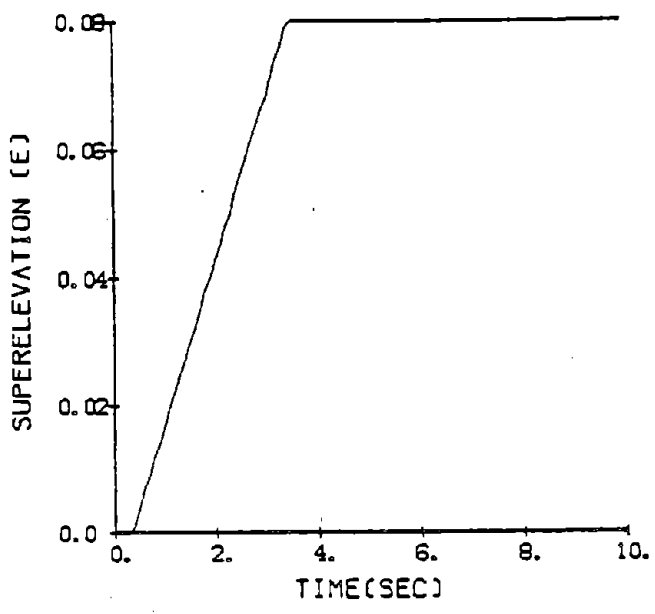
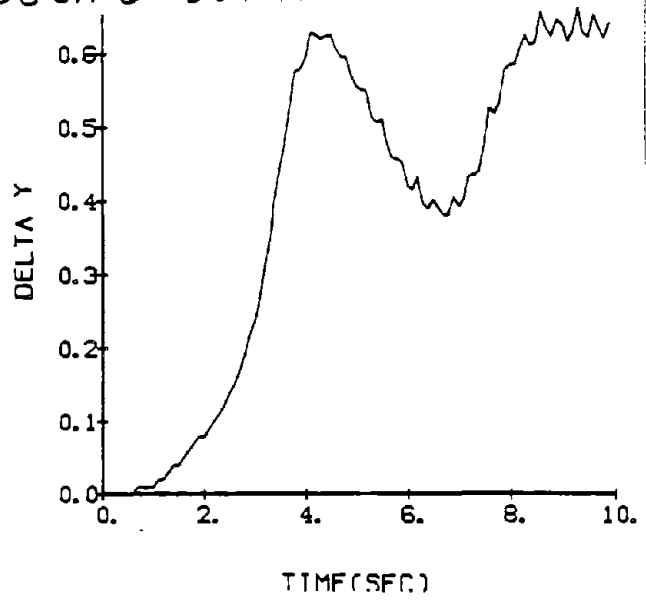
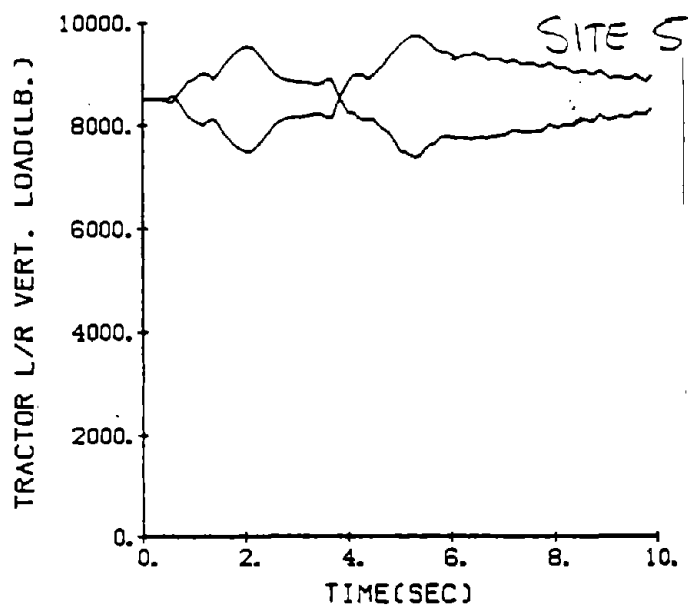
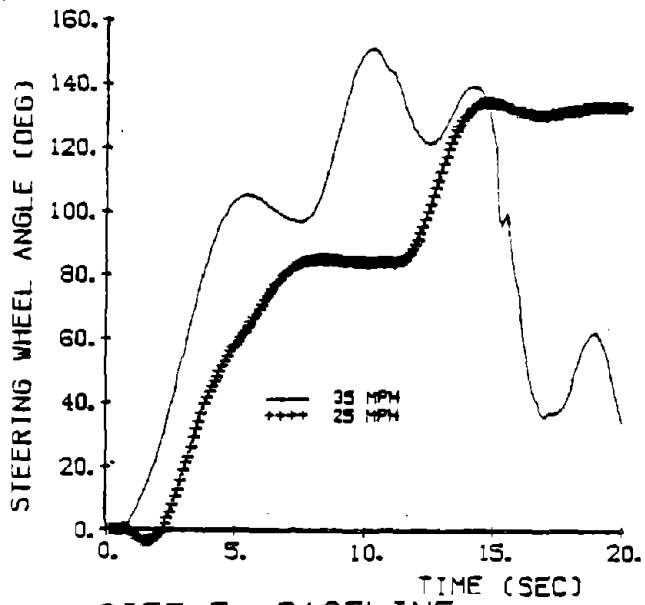

Figure 31. (continued)



SITE 5 BASELINE 25 & 35 MPH

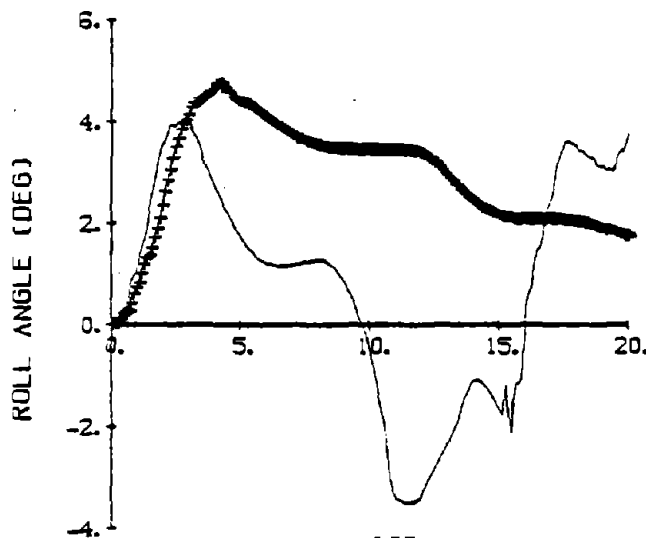
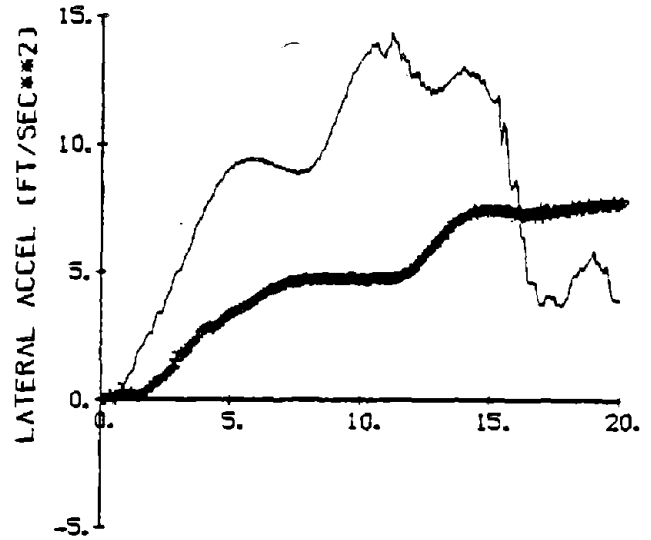
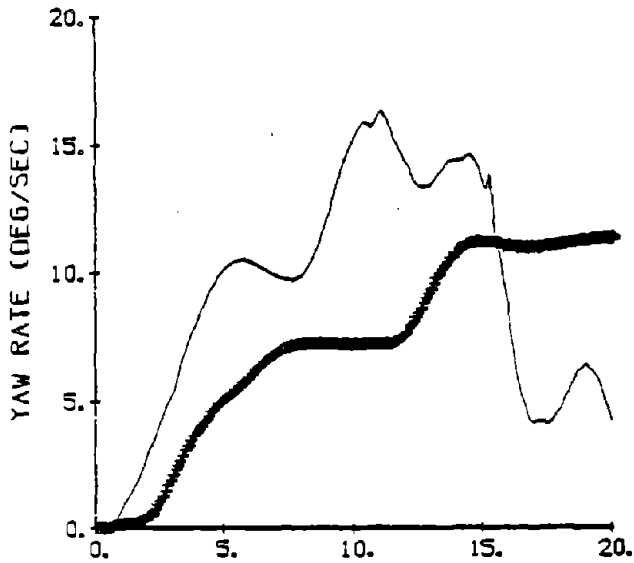
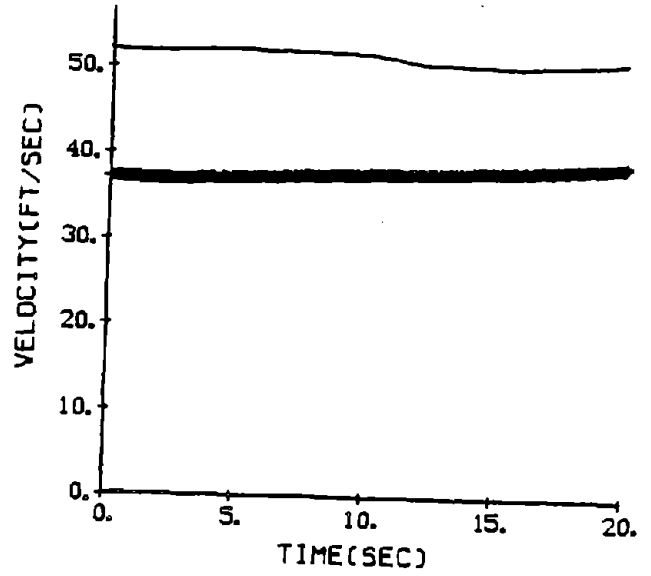

Figure 32. Site 5 base-
line, 25 and
35 mi/h.

SITE 5 BASELINE 25 & 30 MPH

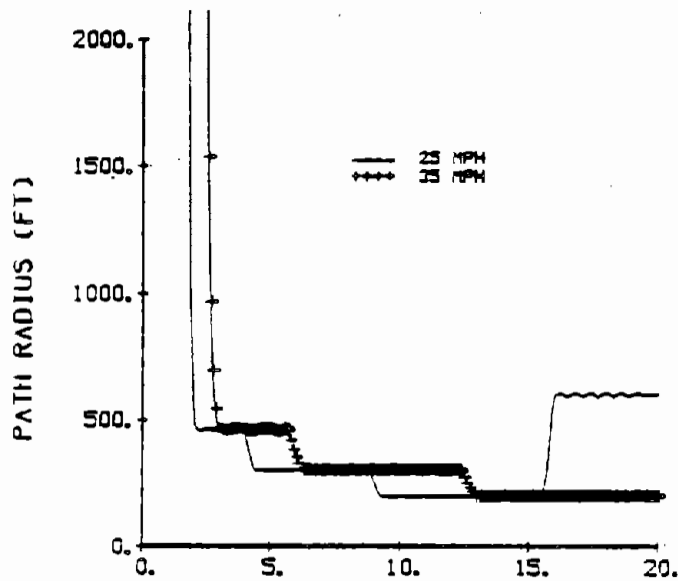
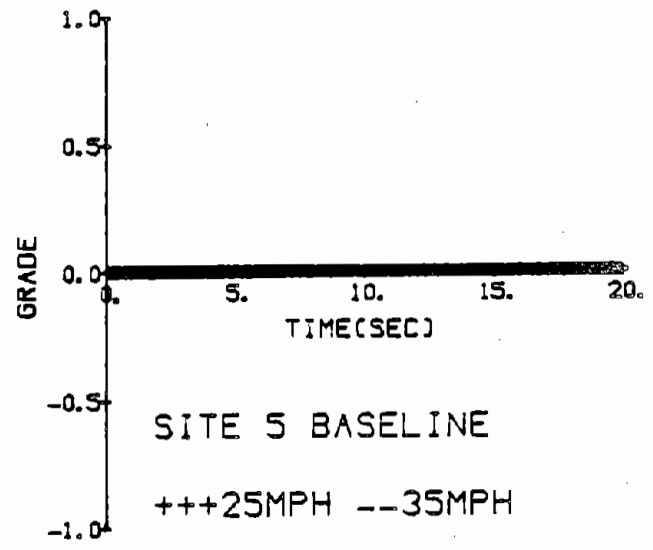
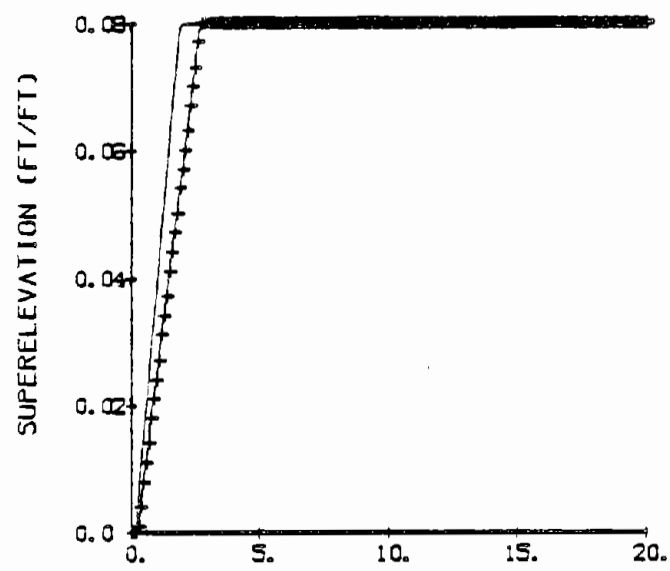
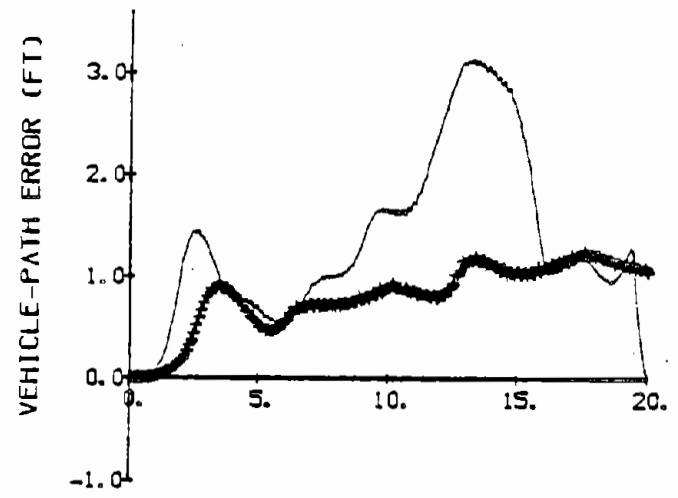
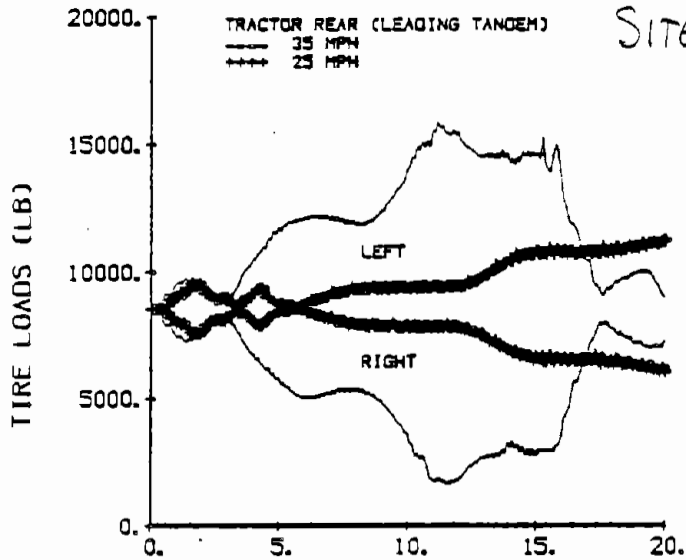

Figure 32. (continued)

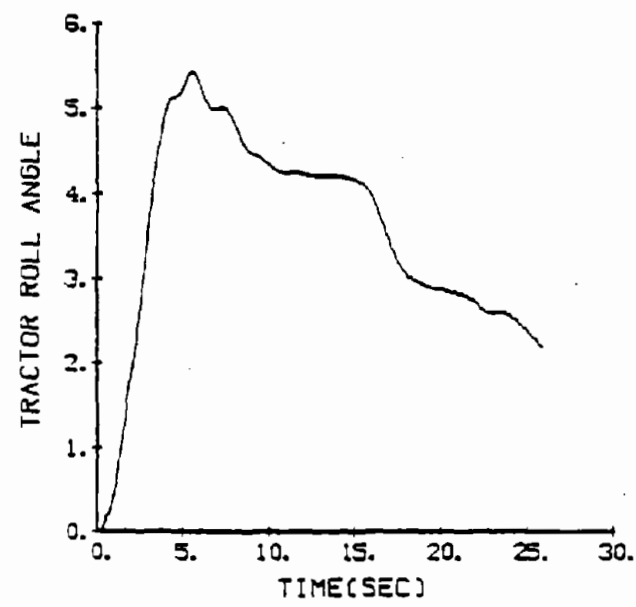
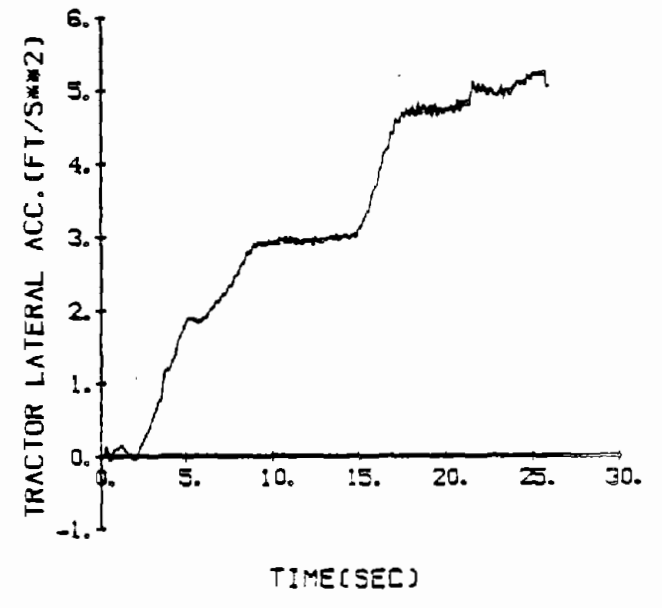
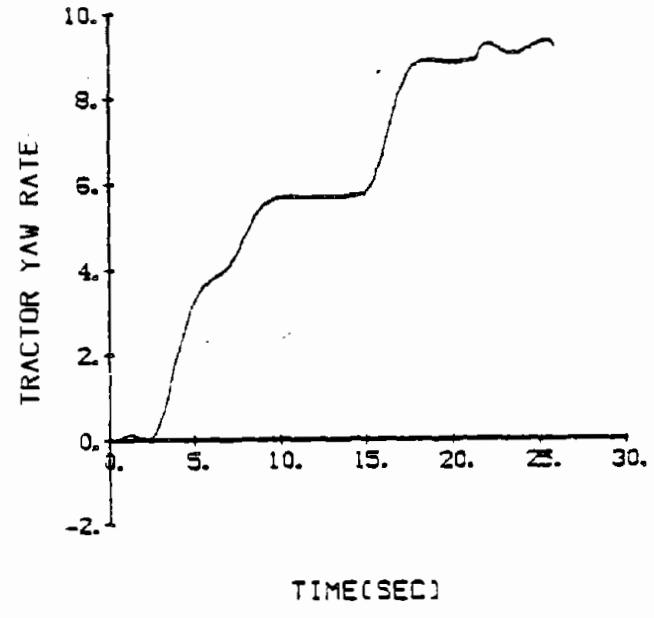
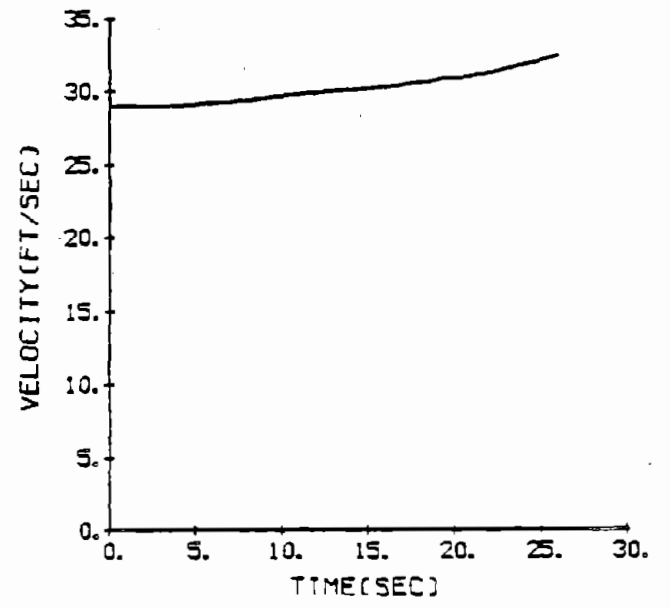
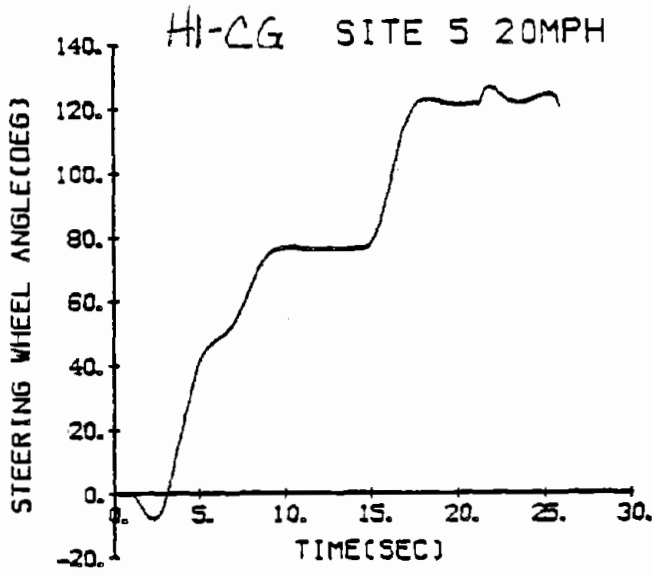

Figure 33. Site 5, hi-c.g., 20 mi/h.

TRACTOR L AND R VERT. TIRE LOAD

H1-CG SITE 5 20MPH

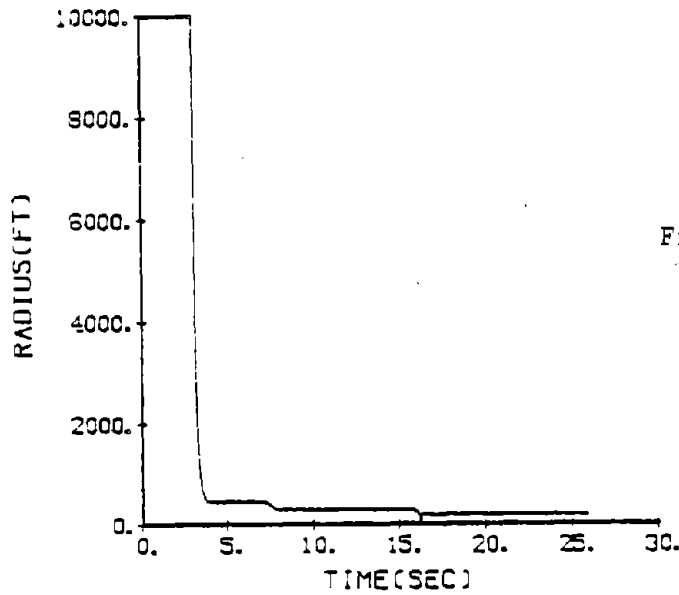
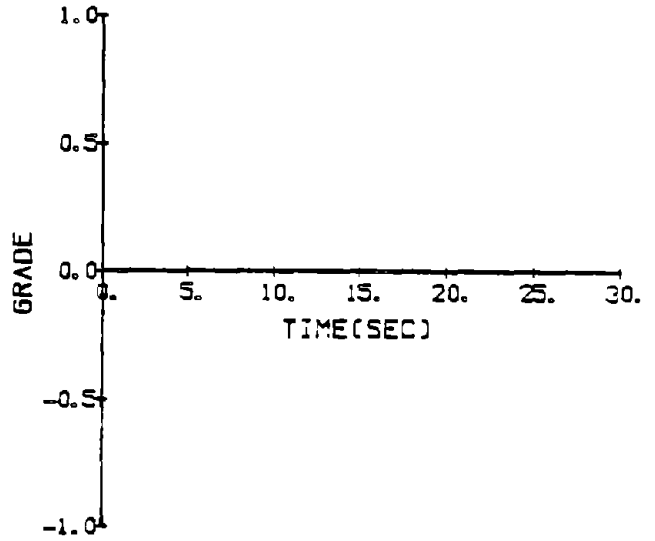
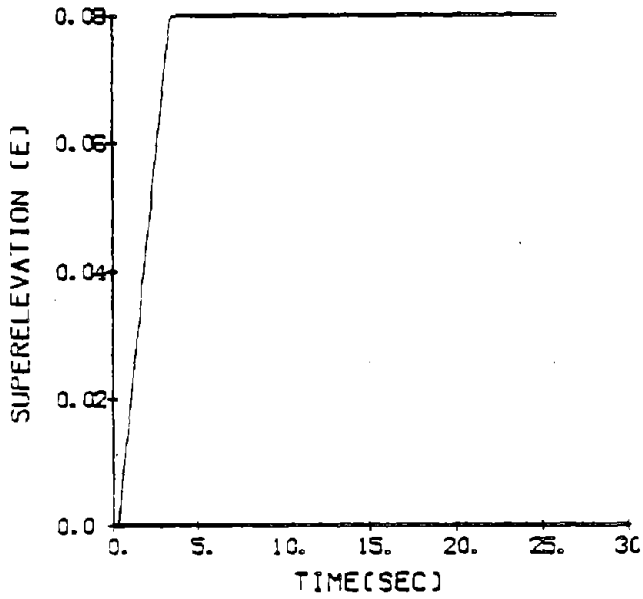
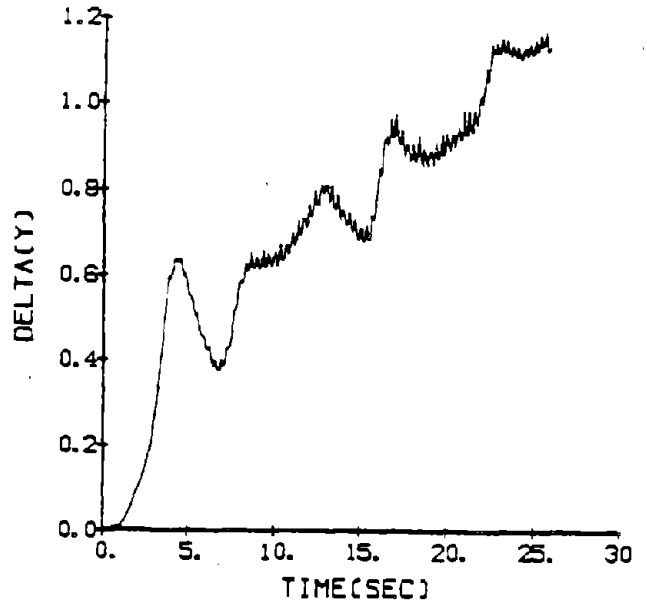
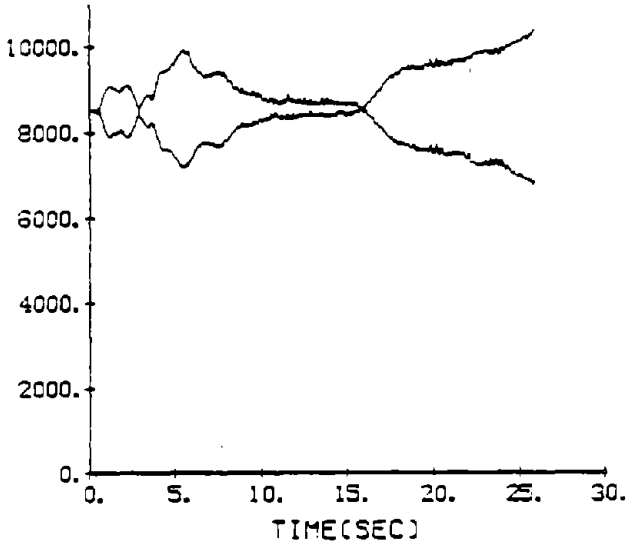

Figure 33. (continued)

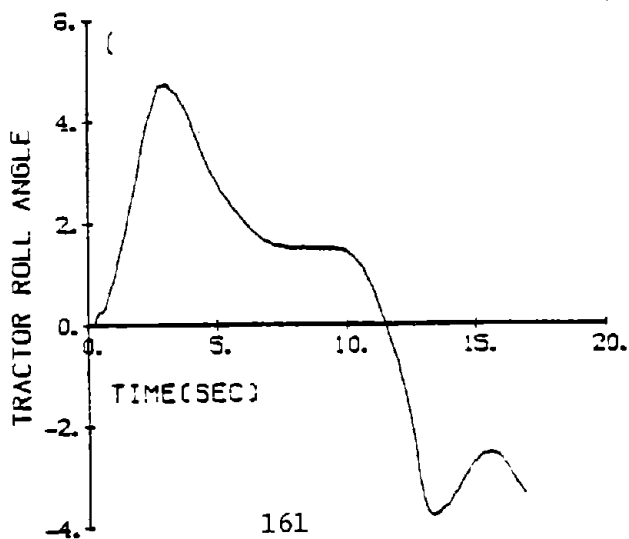
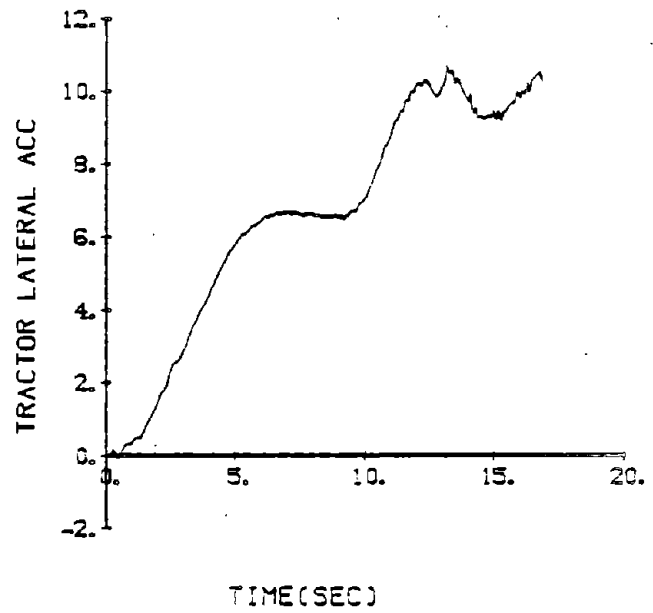
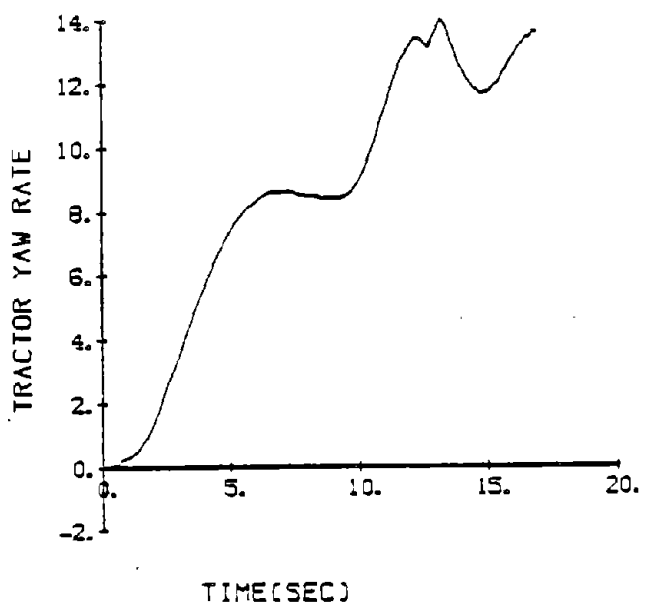
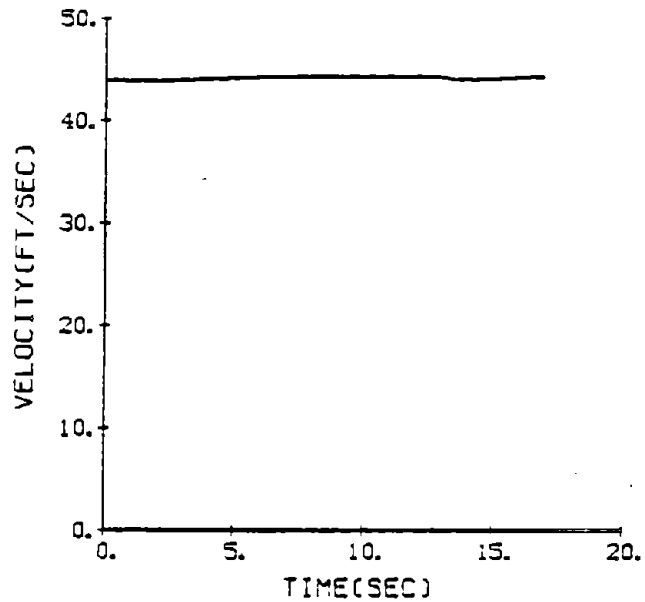
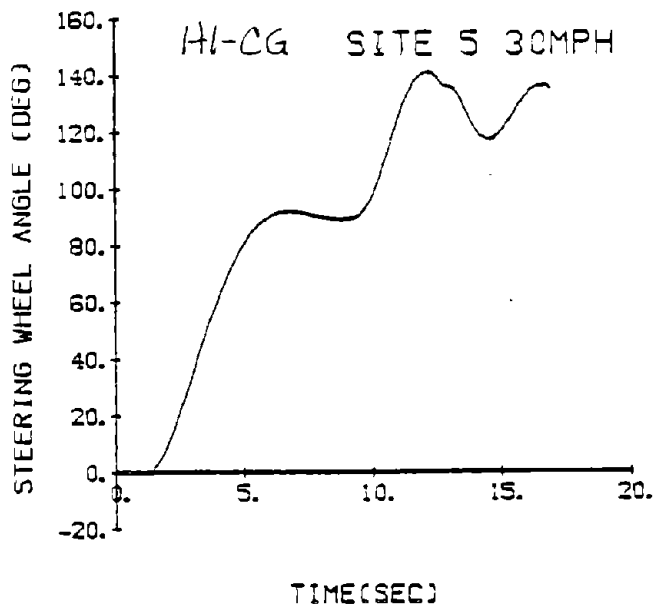

Figure 34. Site 5, hi-c.g., 30 mi/h.

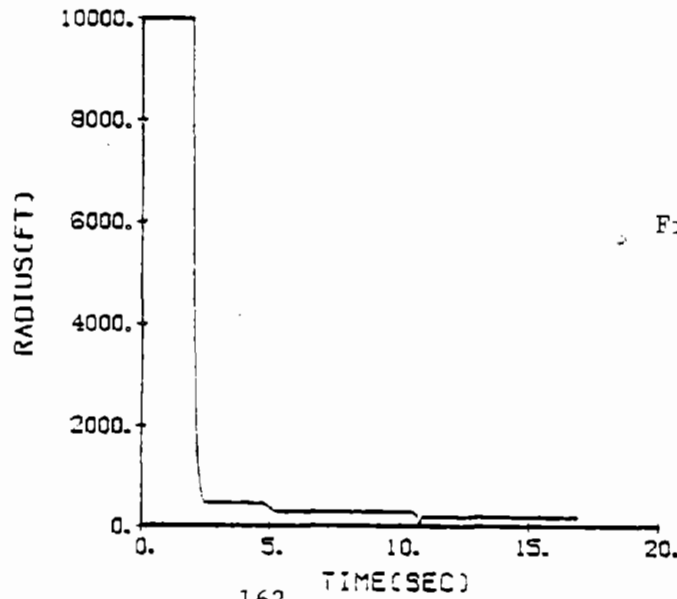
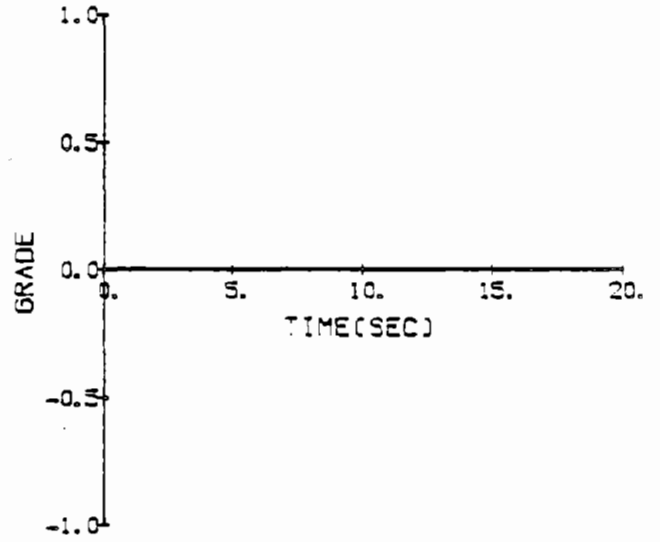
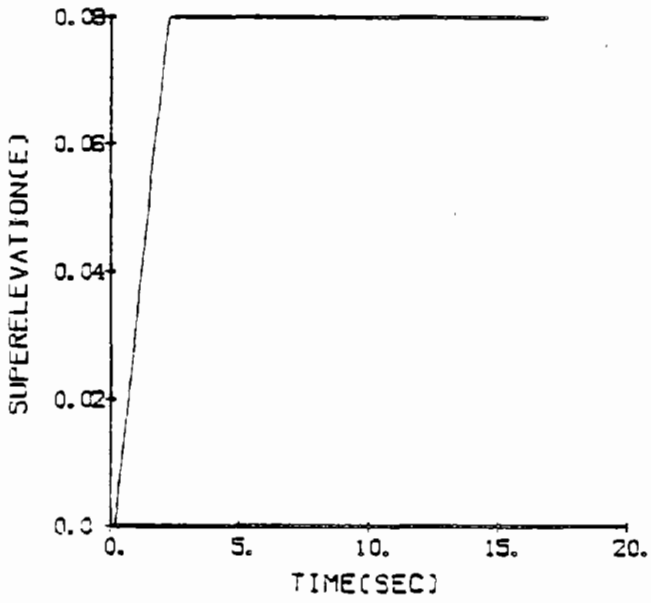
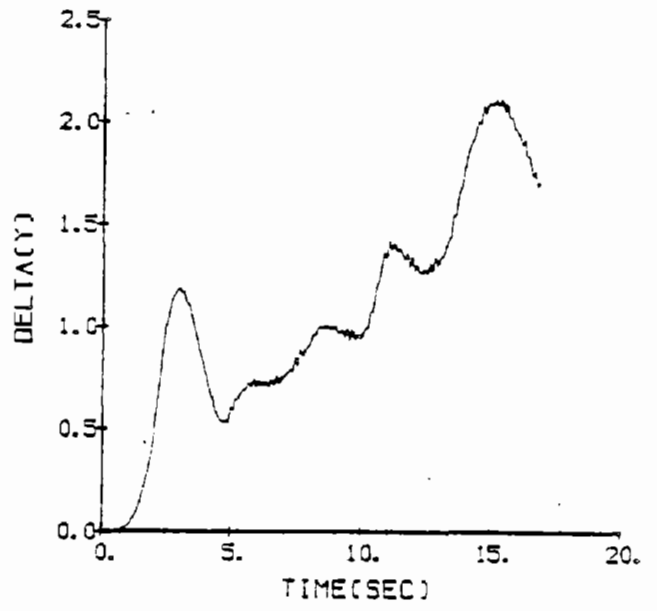
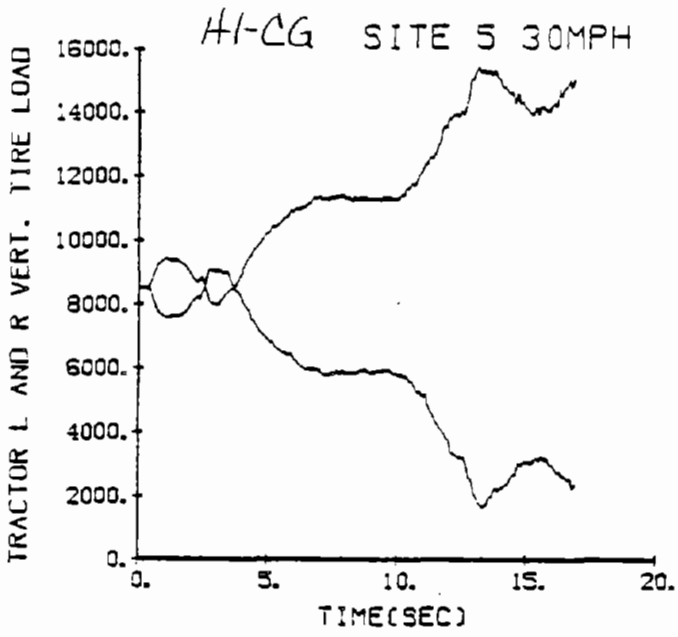

Figure 34. (continued)

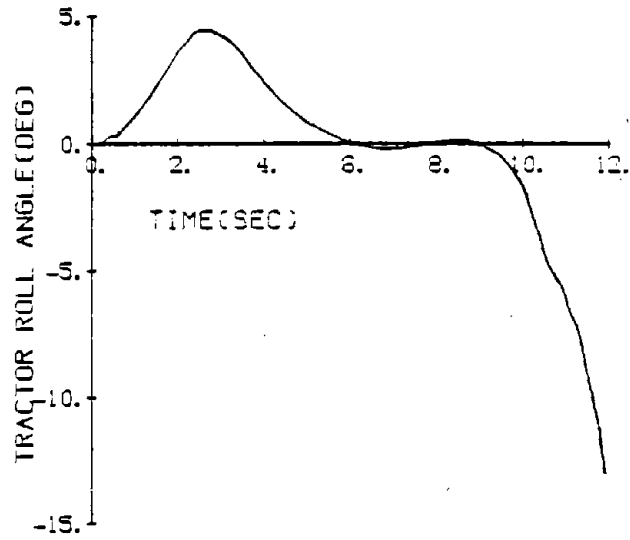
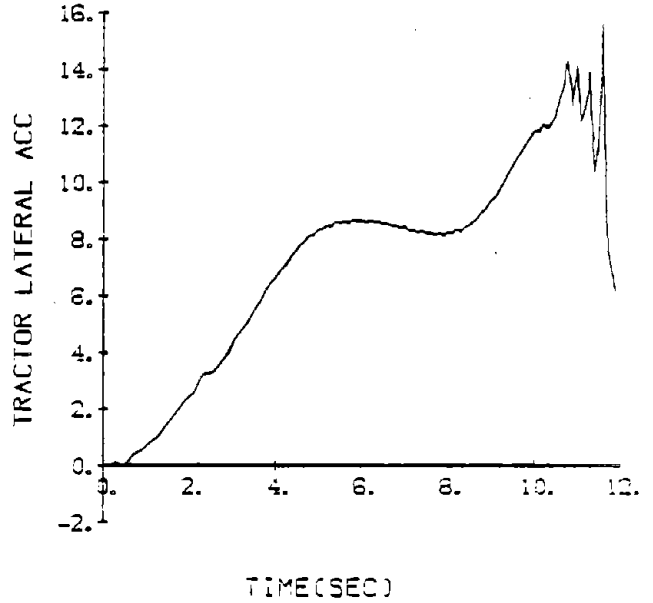
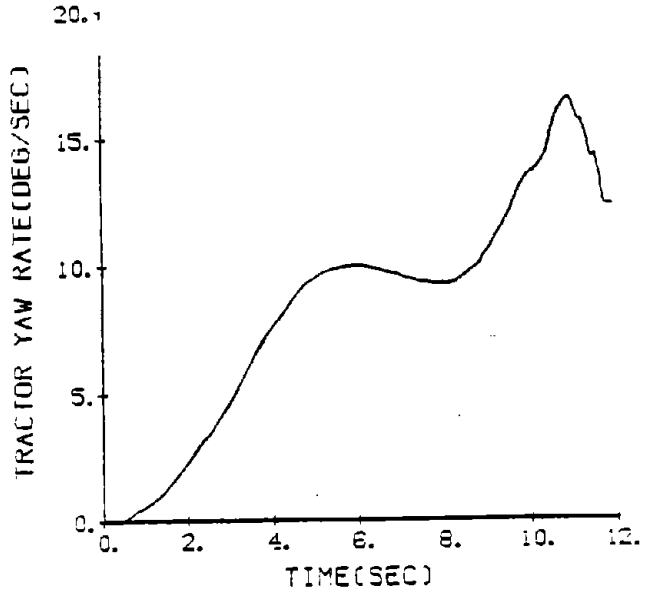
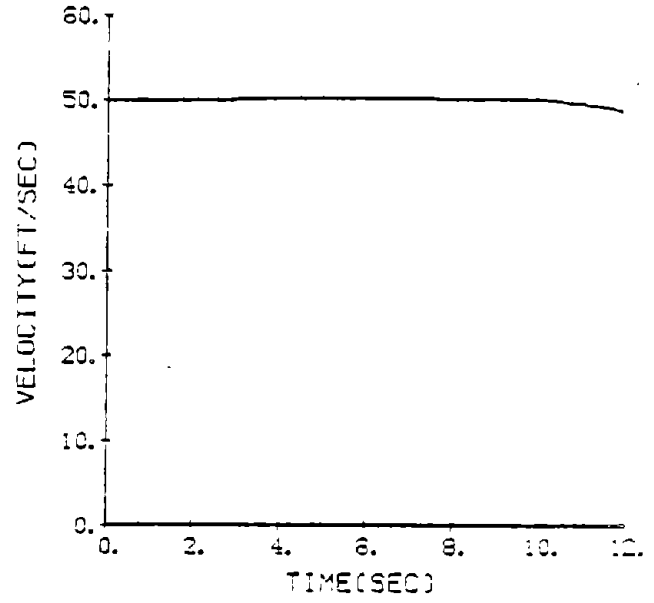
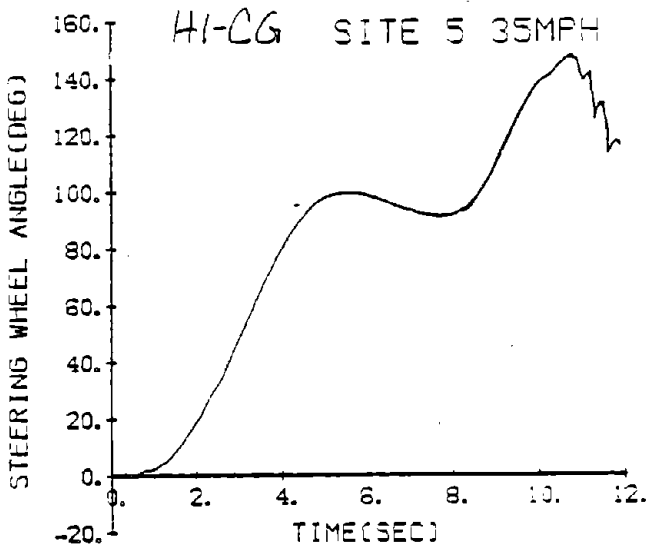

Figure 35. Site 5, hi-c.g., 35 mi/h.

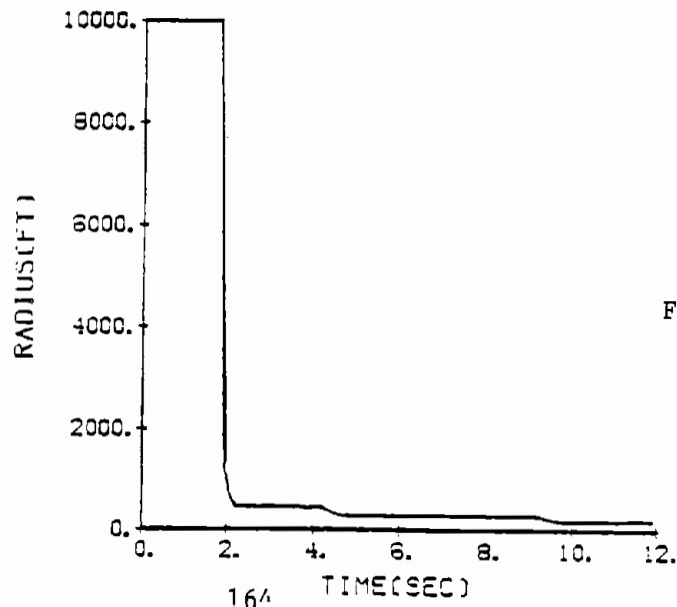
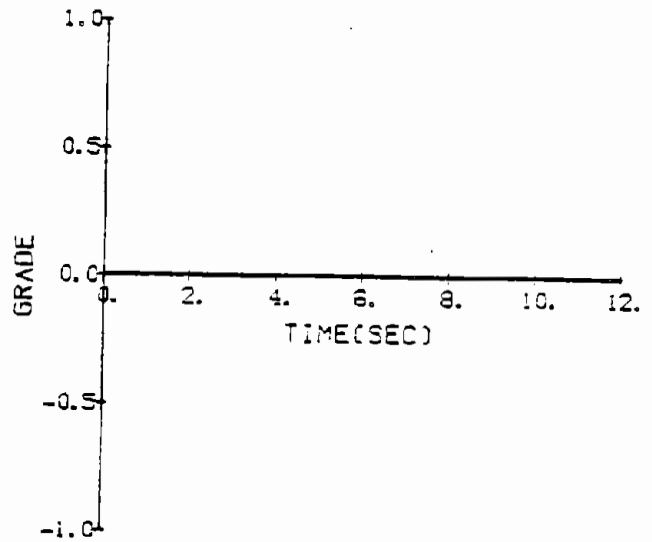
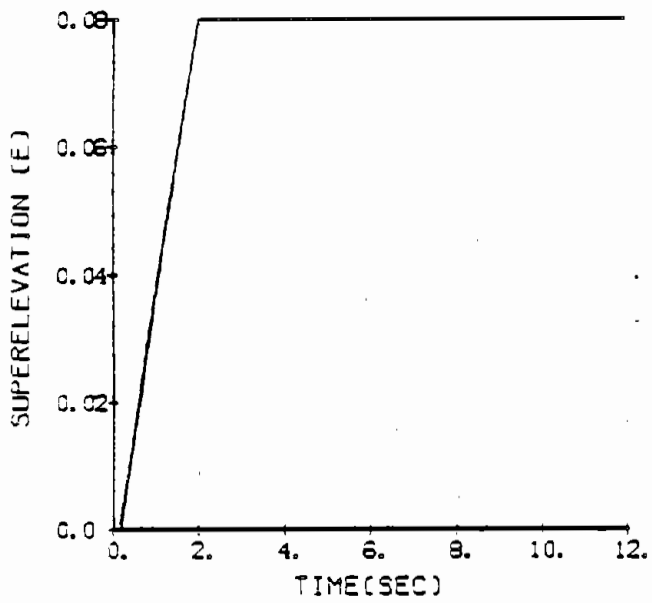
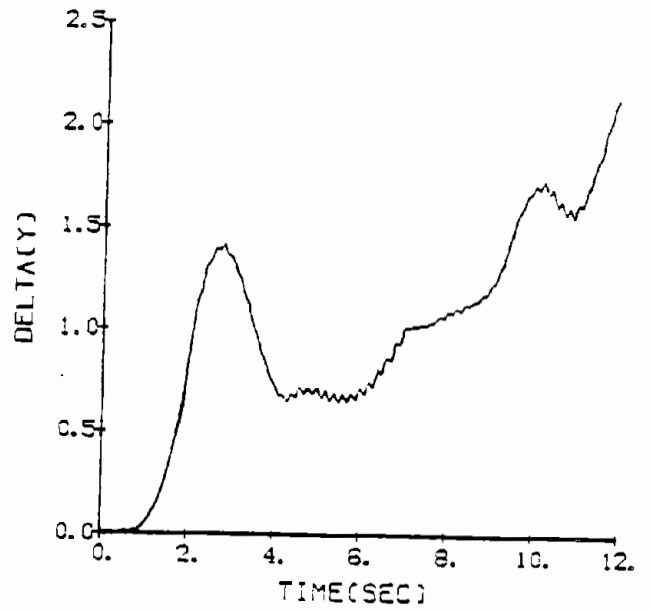
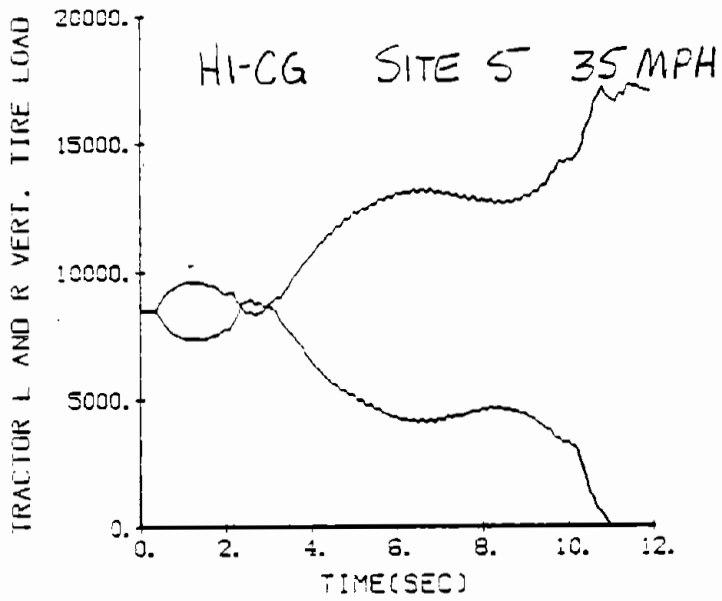

Figure 35. (continued)

SITE 6-55 mph
BASELINE

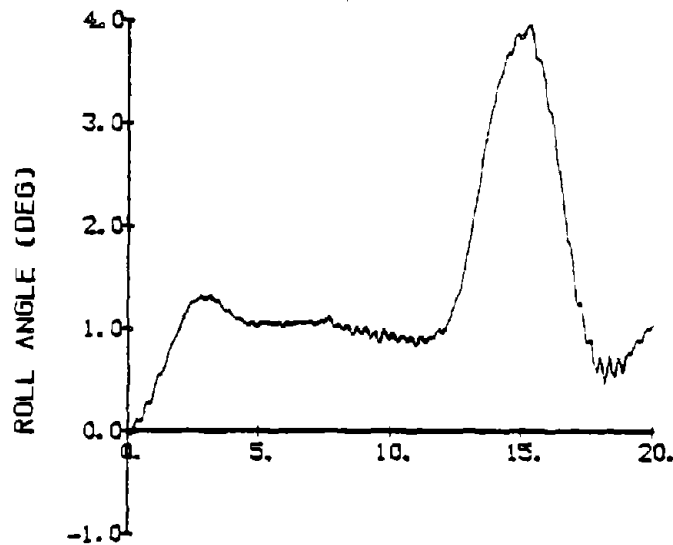
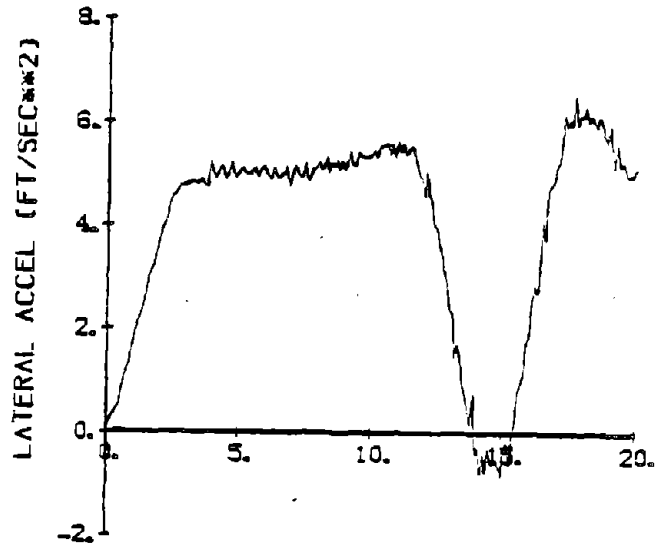
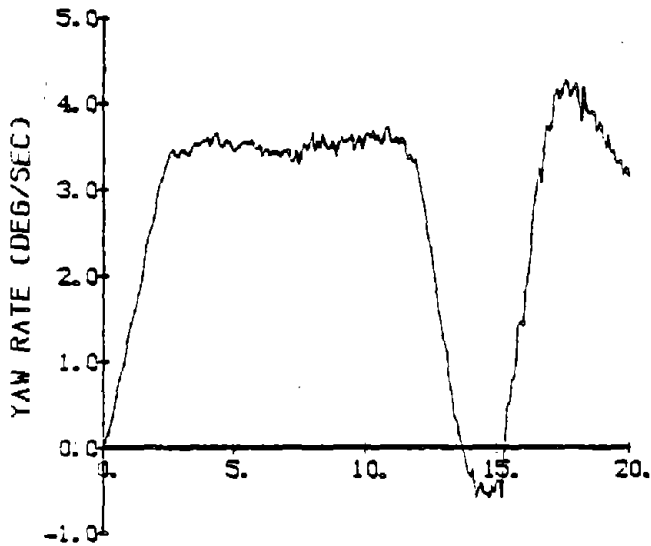
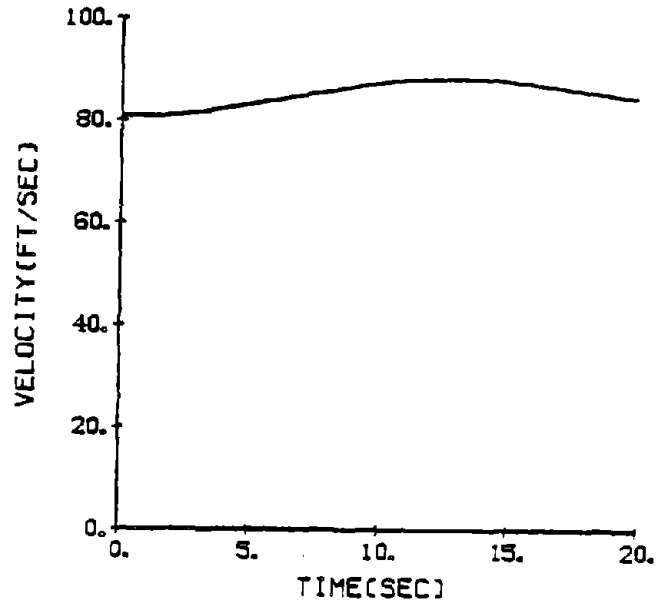
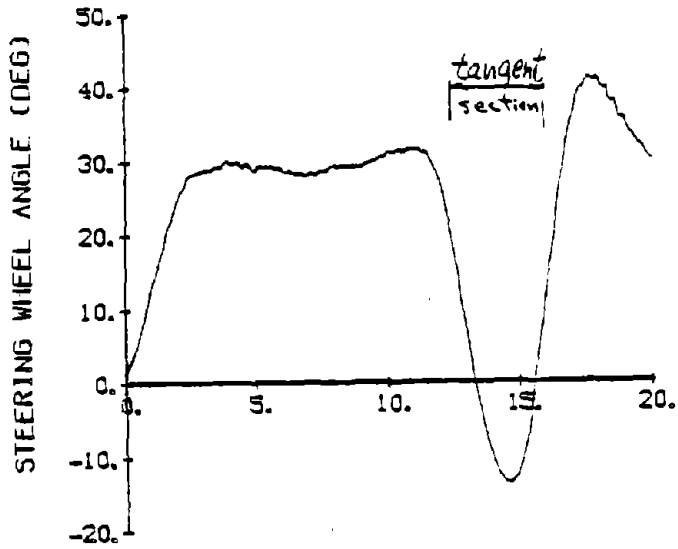

Figure 36. Site 6 base-
line, 55 mi/h.

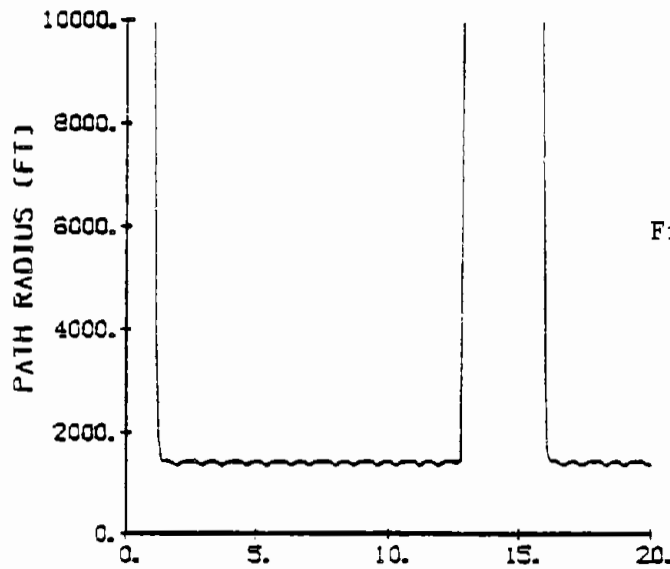
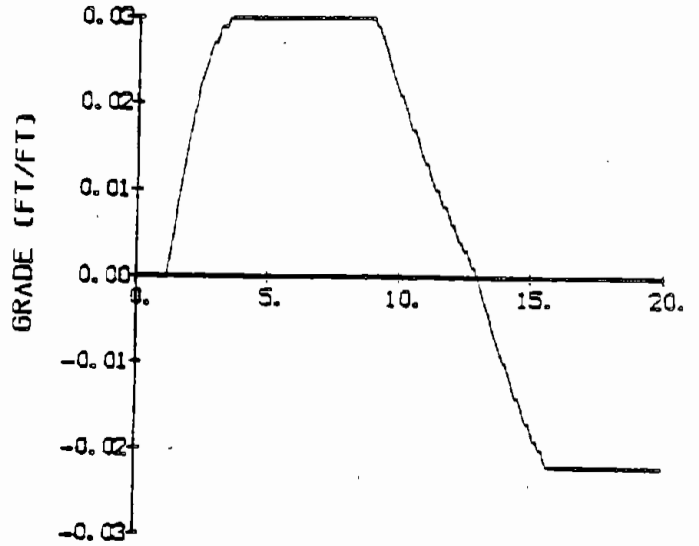
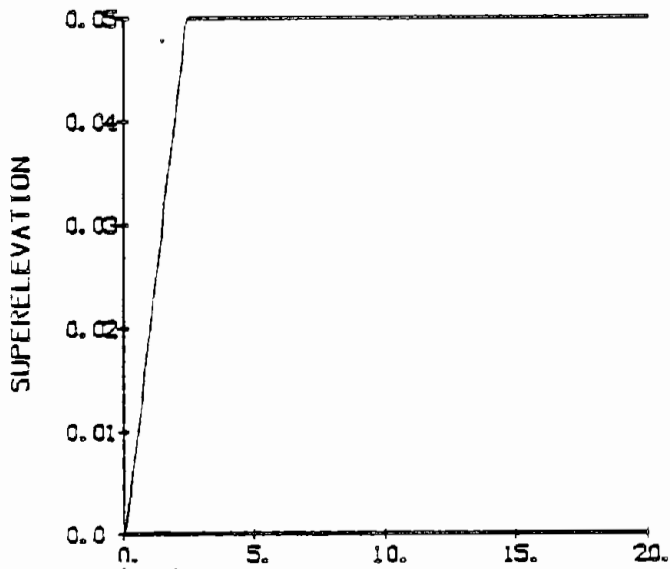
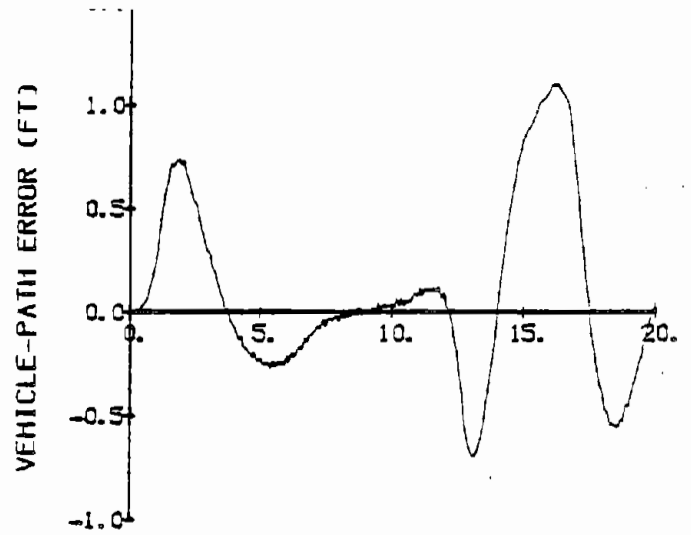
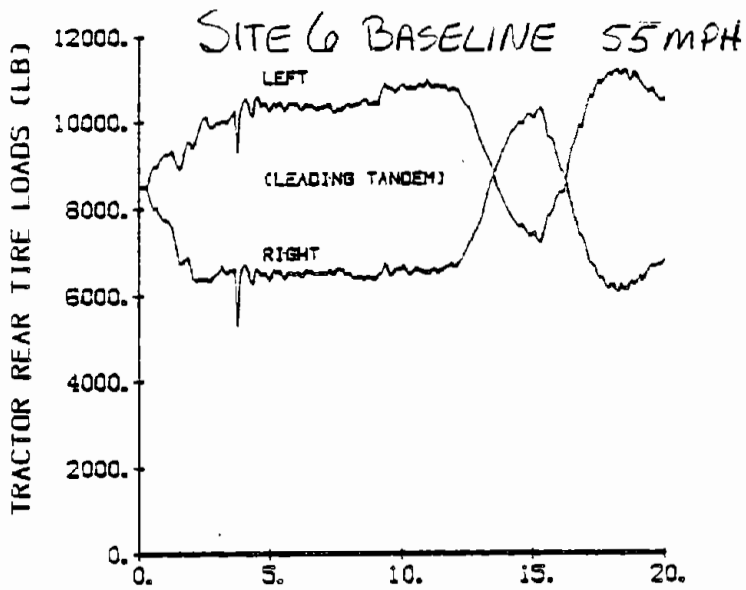

Figure 36. (continued)

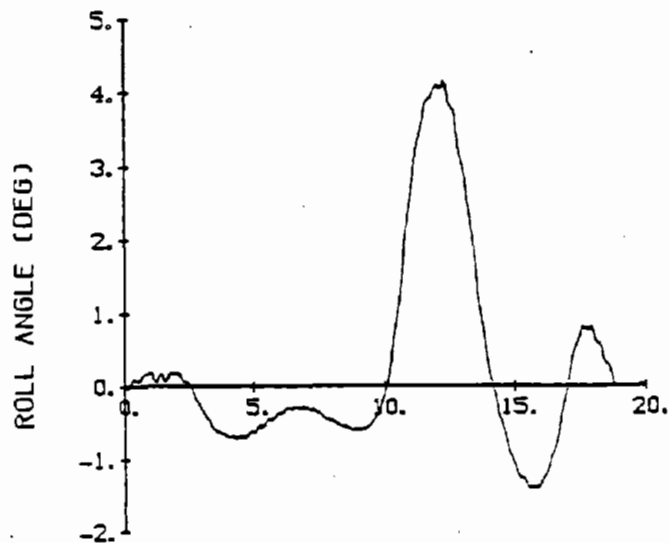
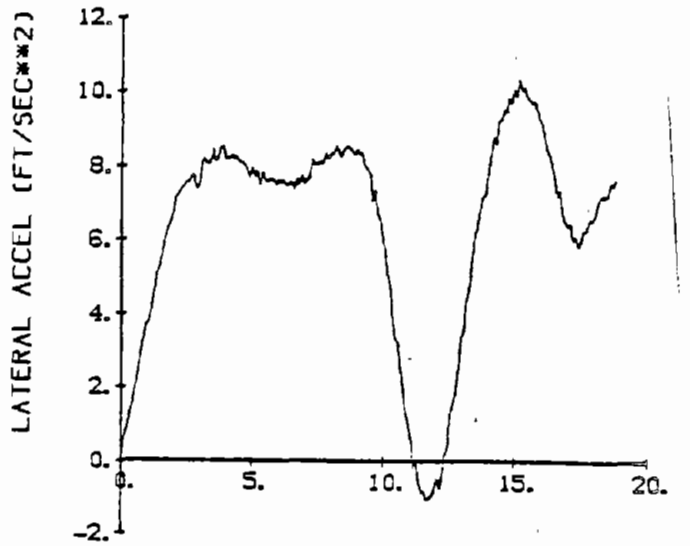
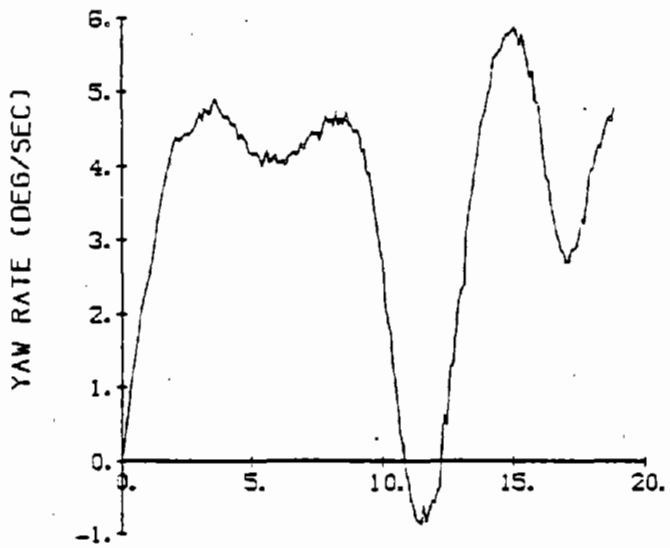
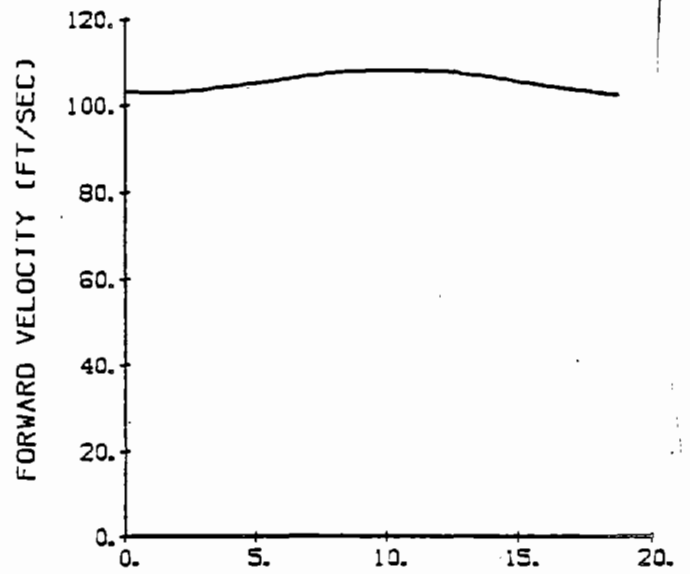
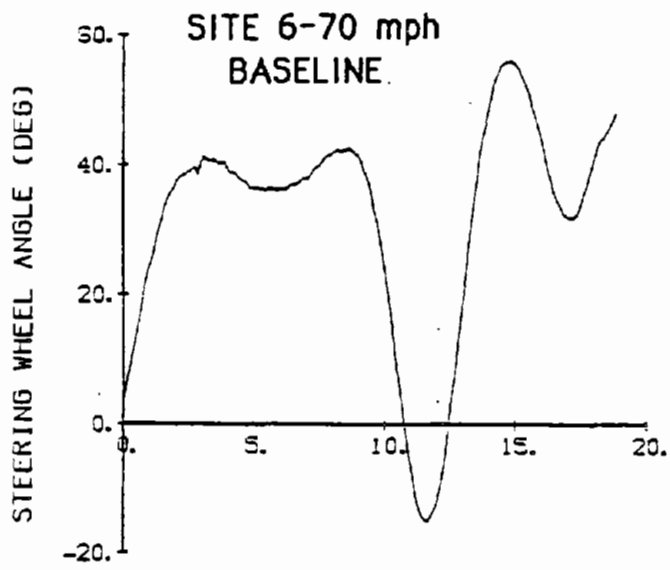

Figure 37. Site 6 base-
line, 70 mi/h

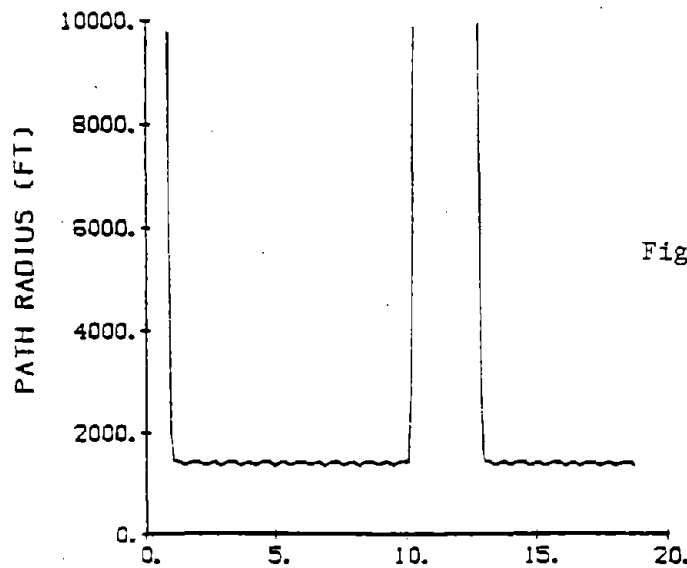
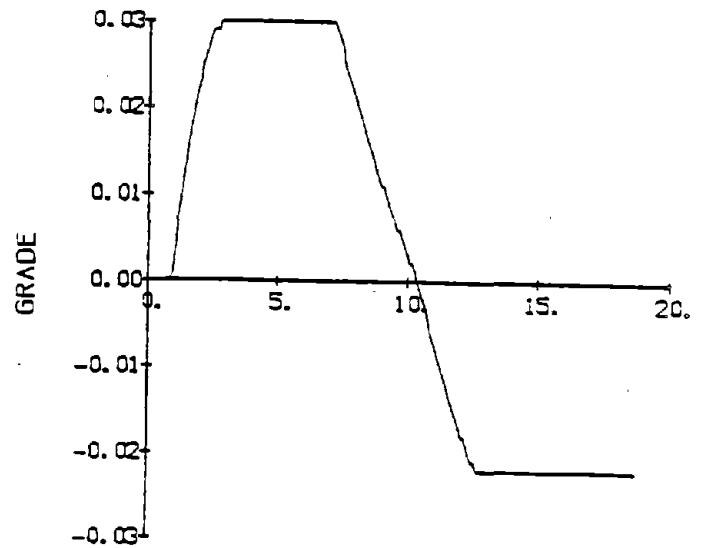
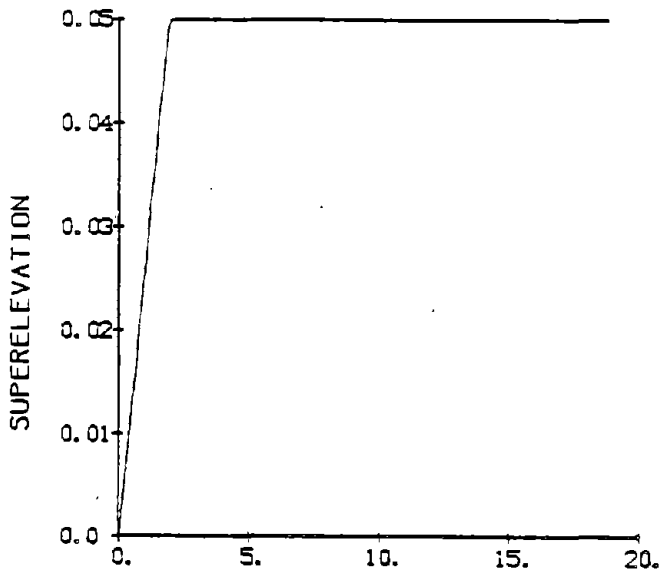
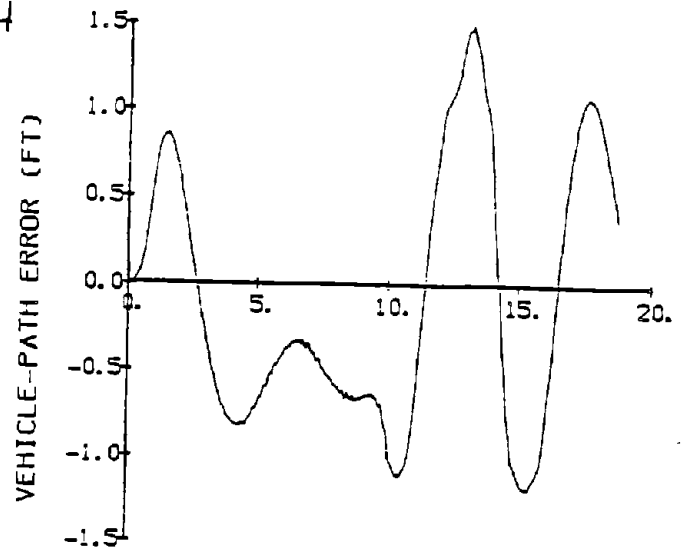
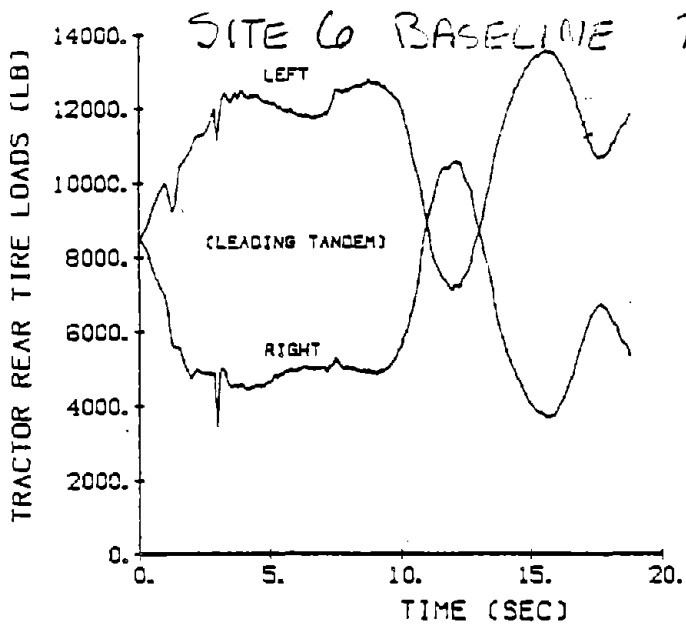

Figure 37. (continued)

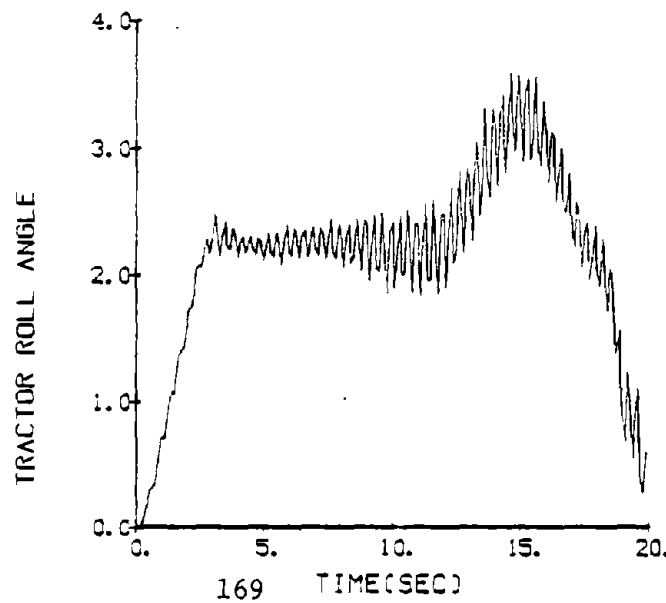
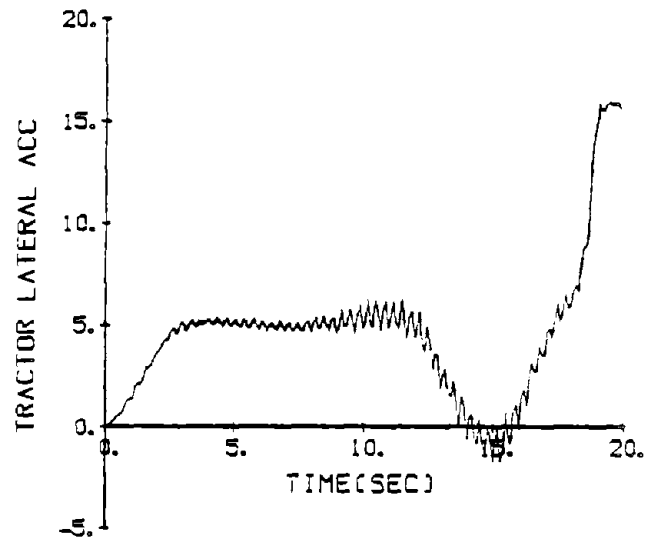
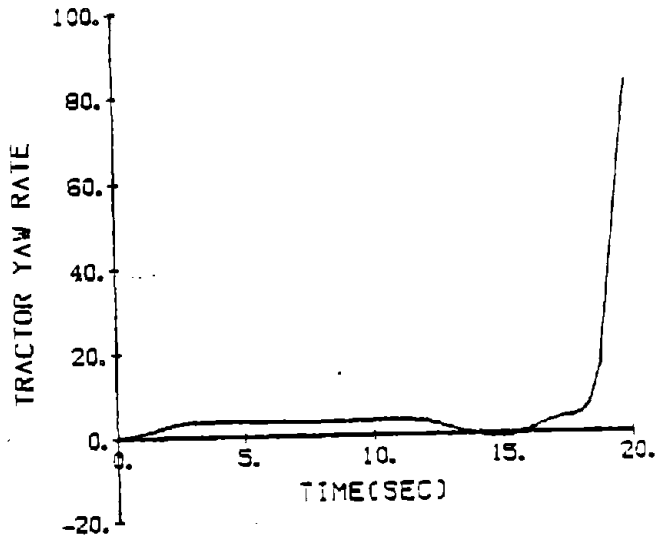
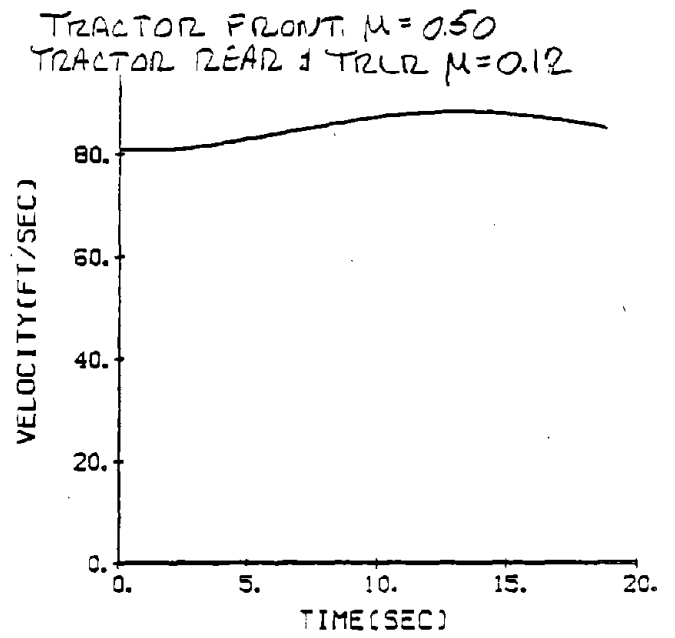
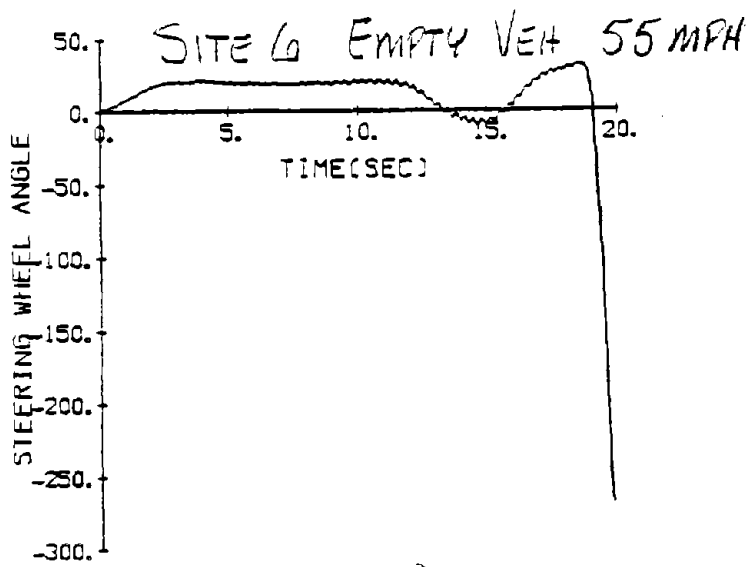

Figure 38. Site 6, empty vehicle, 55 mi/h.

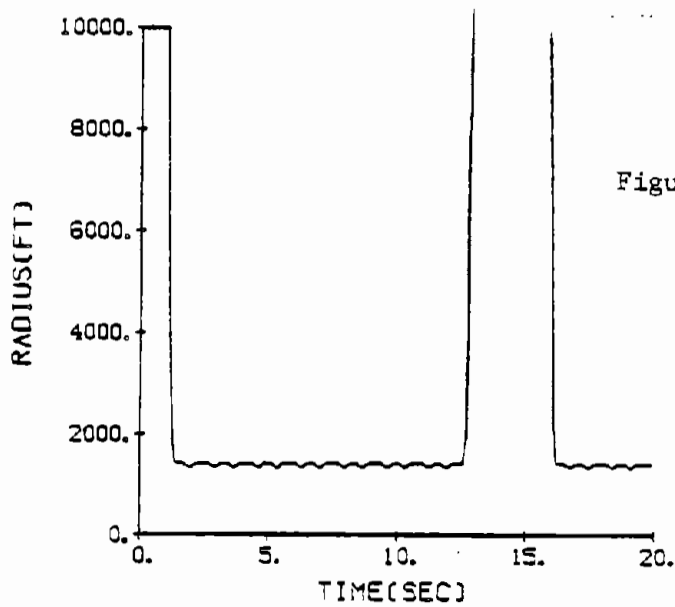
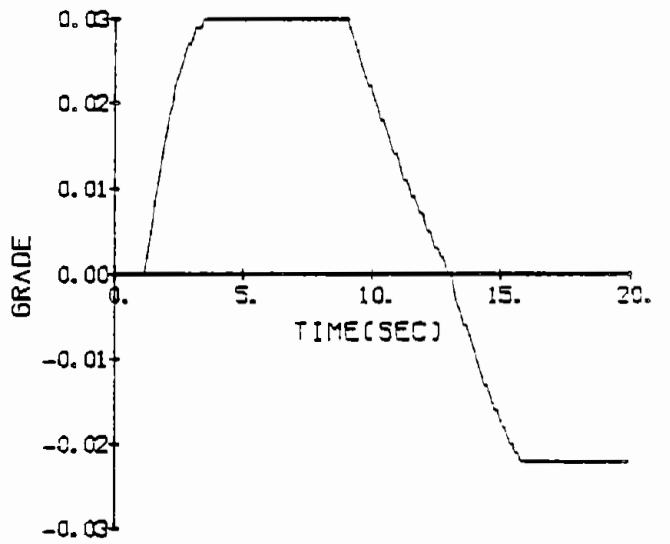
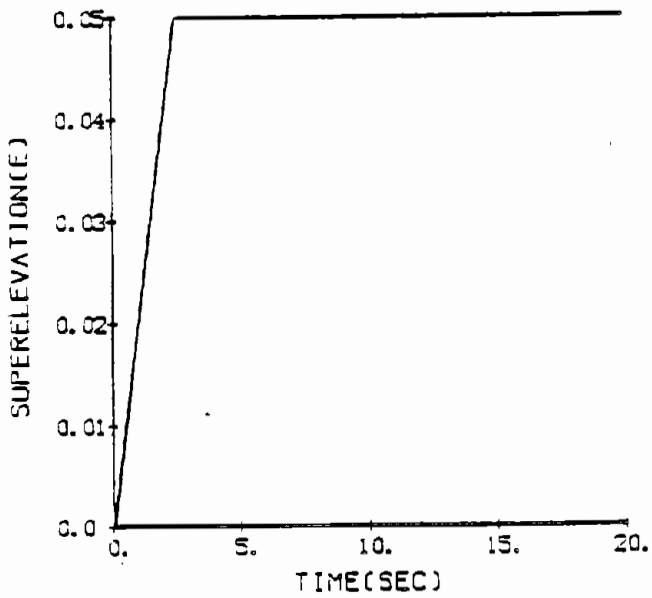
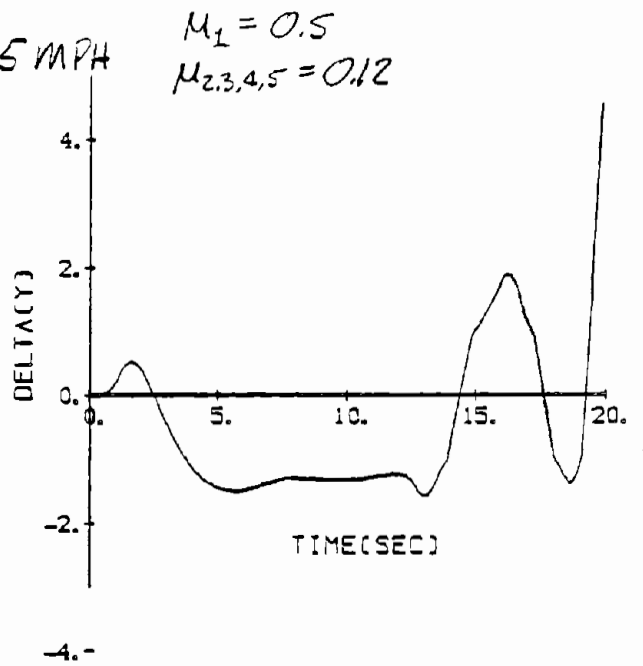
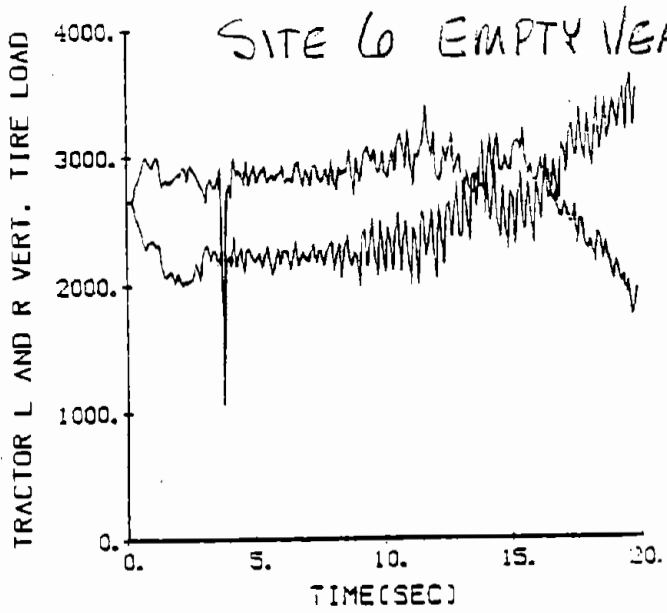

Figure 38. (continued)

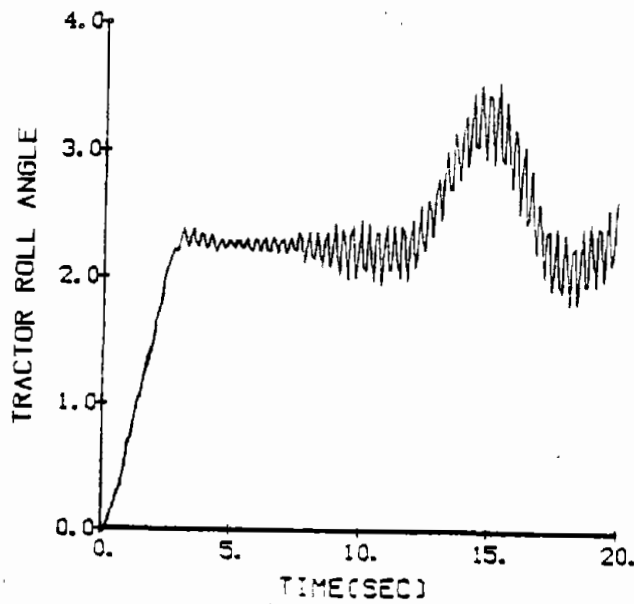
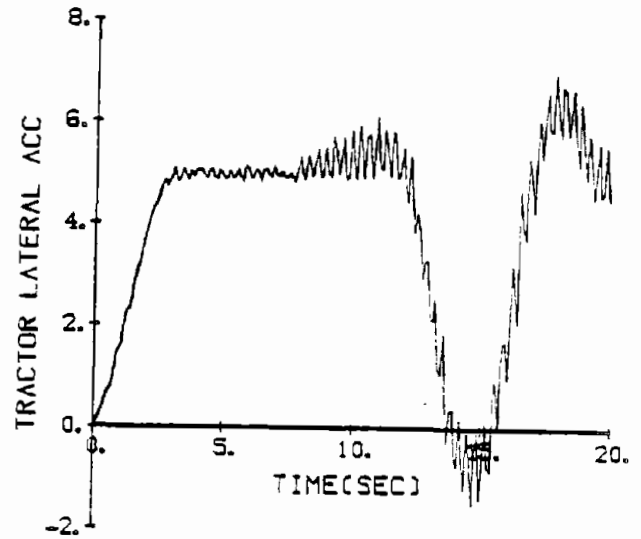
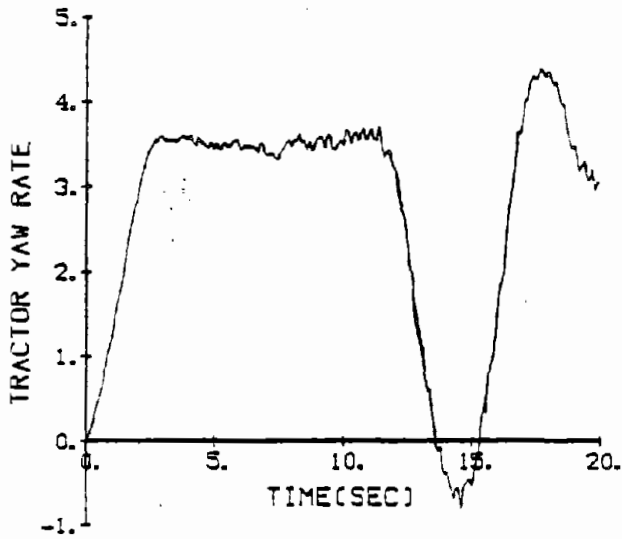
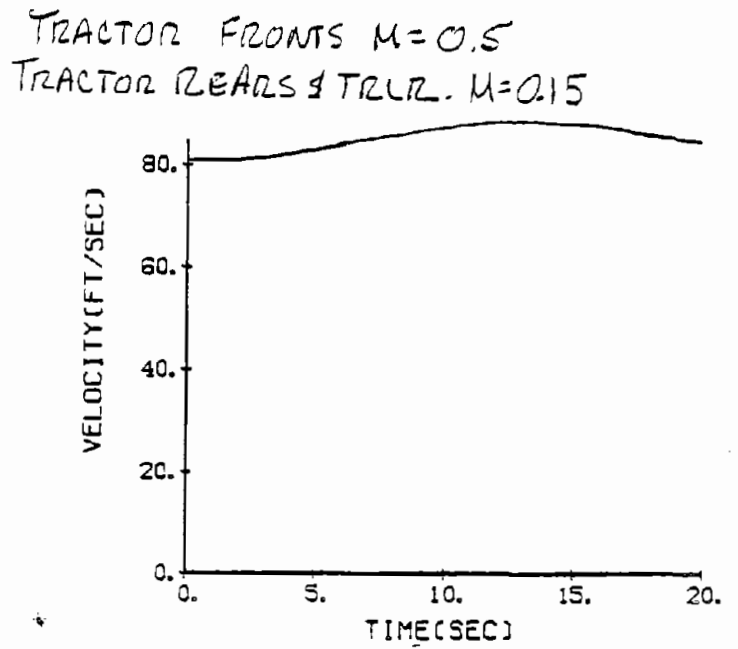
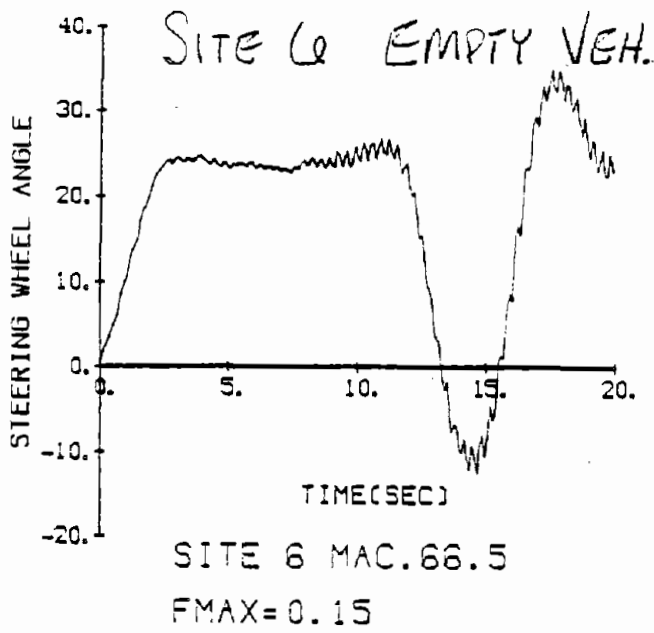

Figure 39. Site 6, empty vehicle, 55 mi/h

SITE 60 EMPTY 55 MPH

$M_1 = 0.5$

$M_{2,3,4,5} = 0.15$

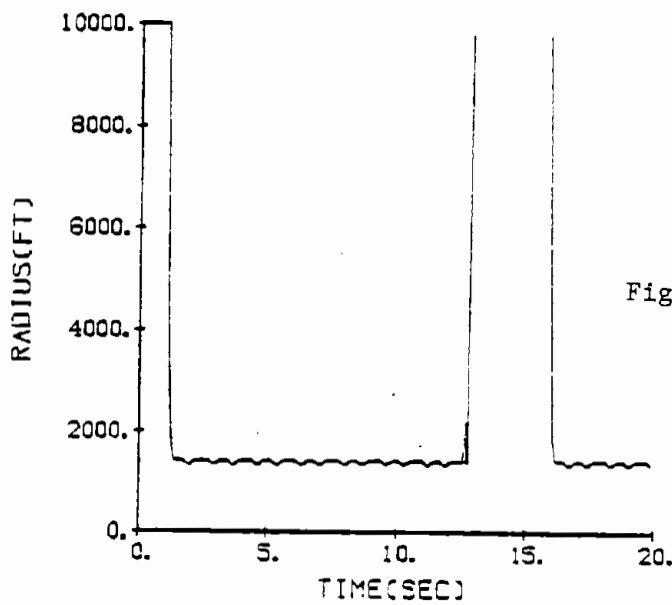
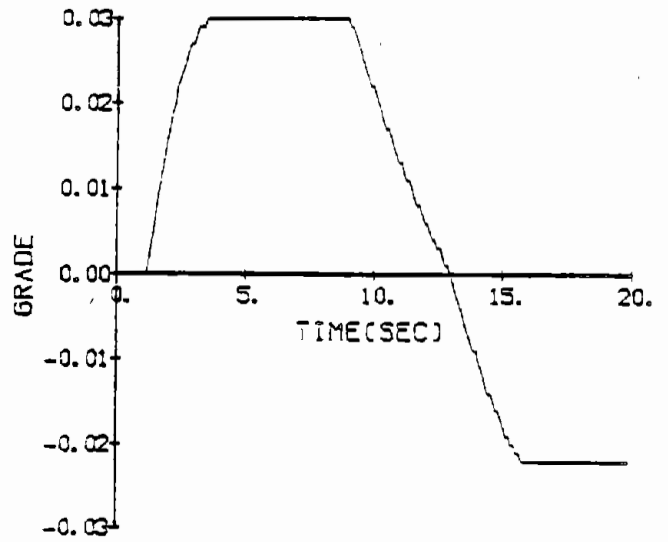
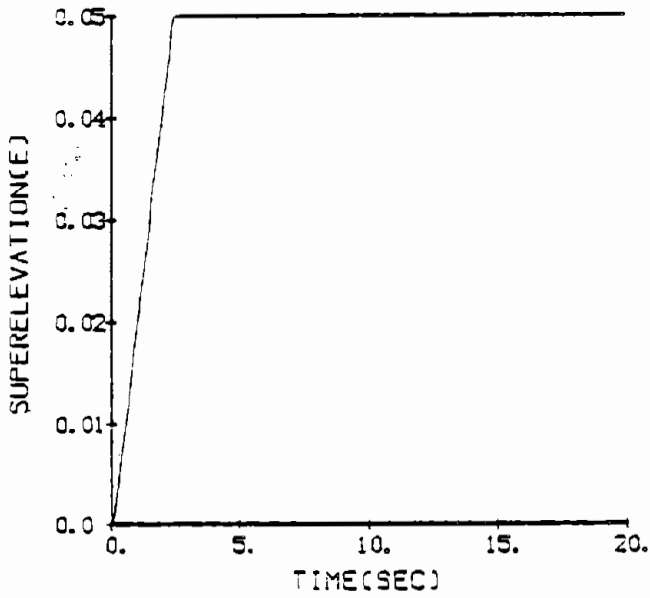
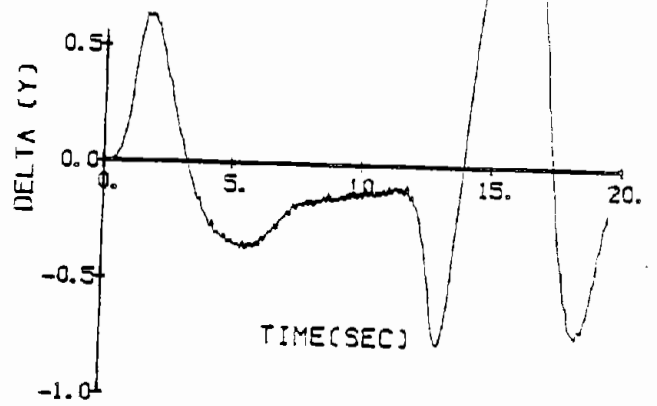
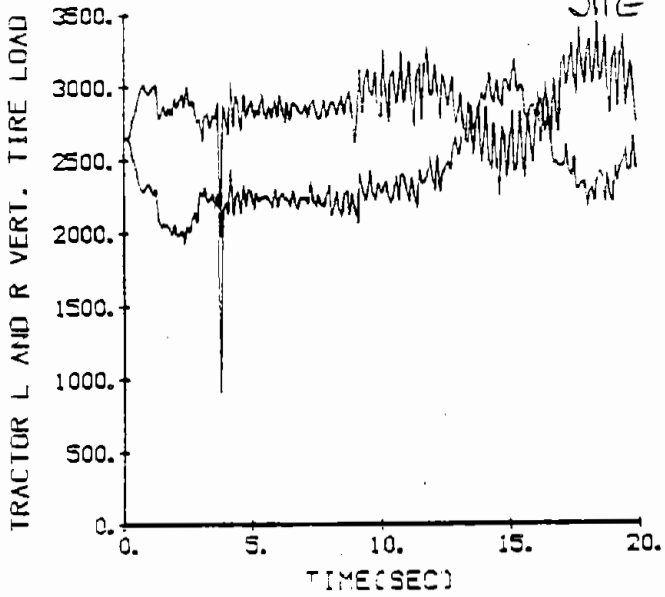
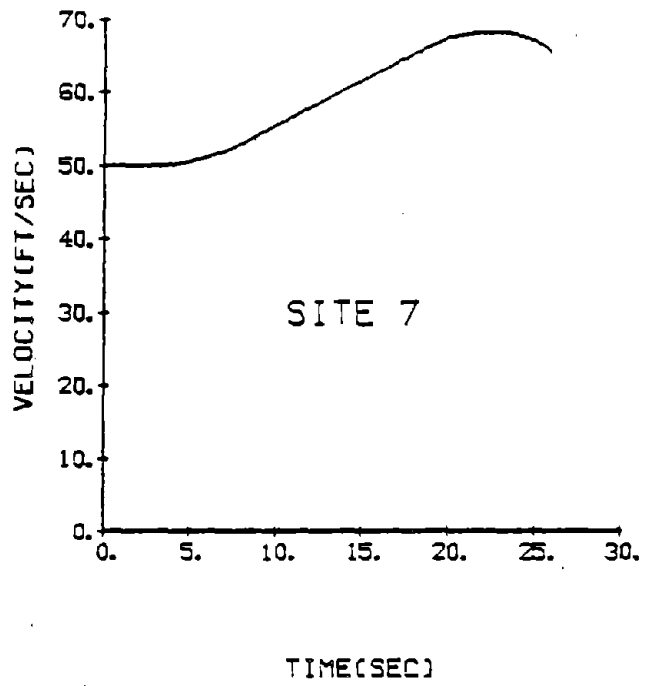
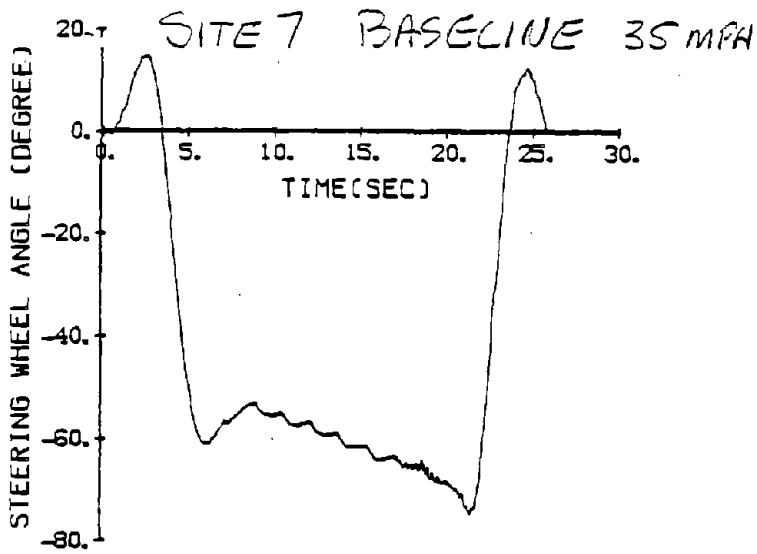

Figure 39. (continued)



TRACTOR YAW RATE (DEGREE/SEC)

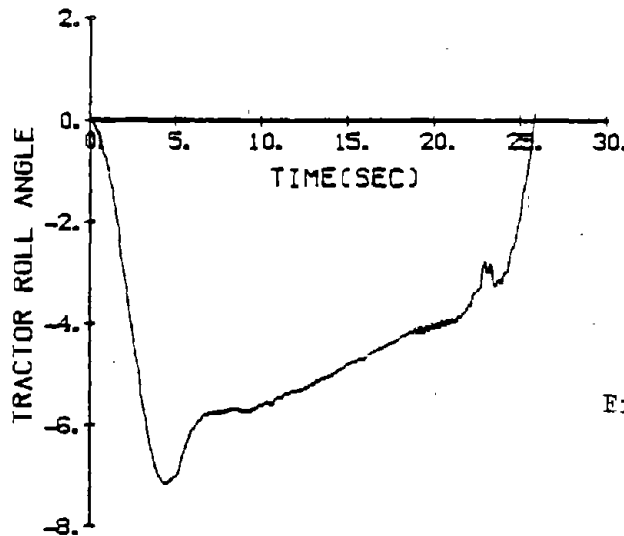
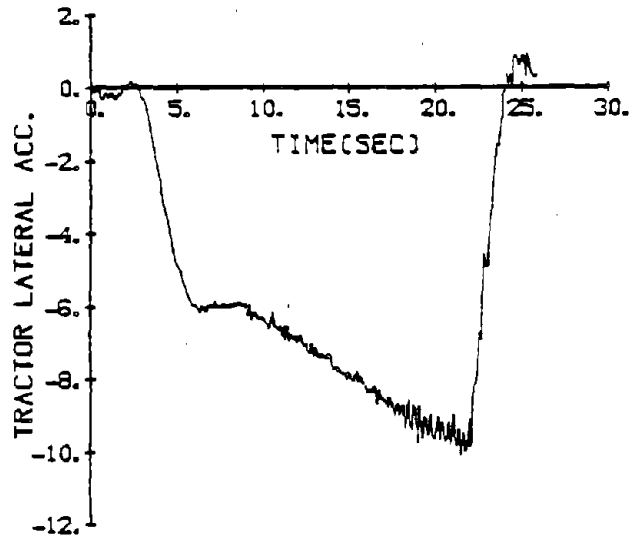
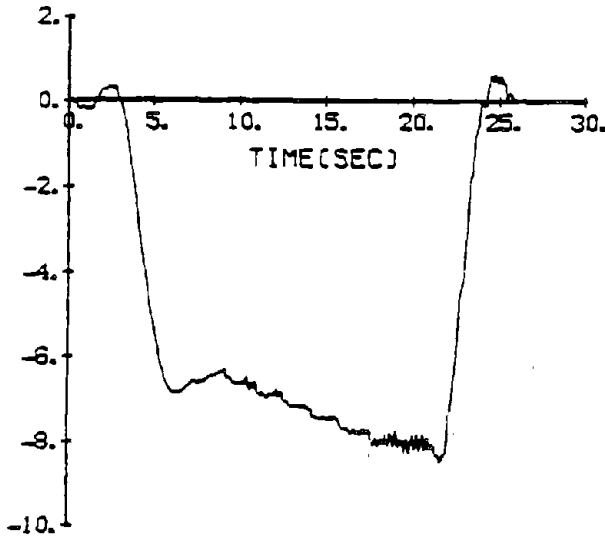

Figure 40. Site 7 baseline, 35 mi/h.

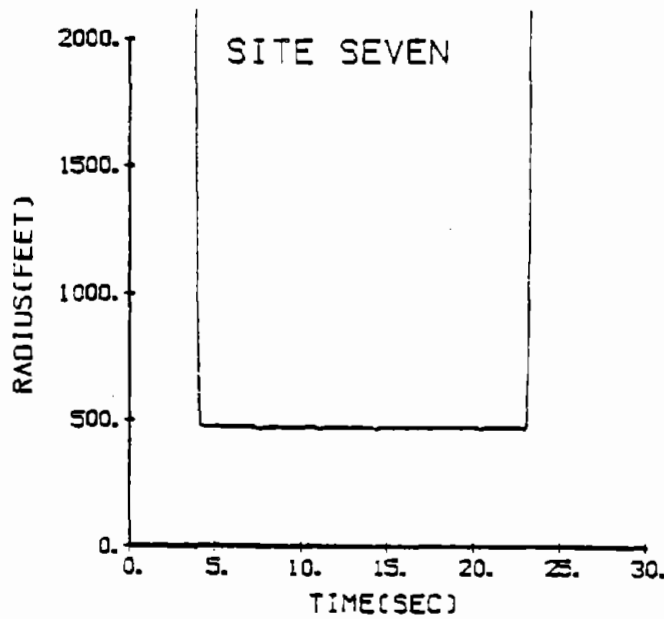
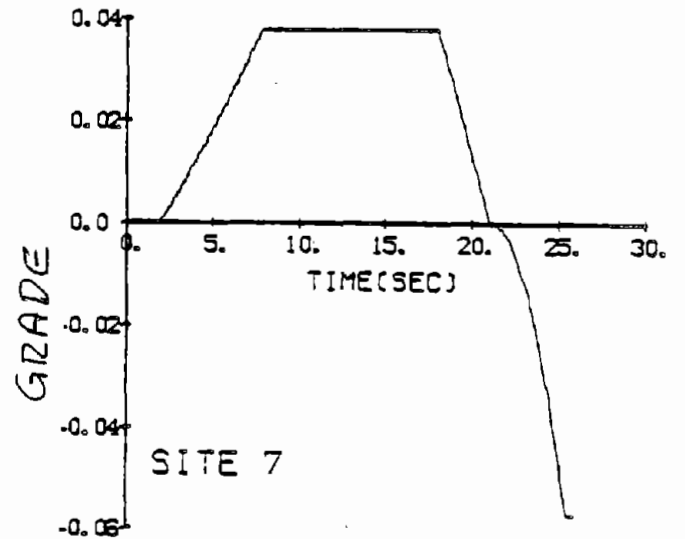
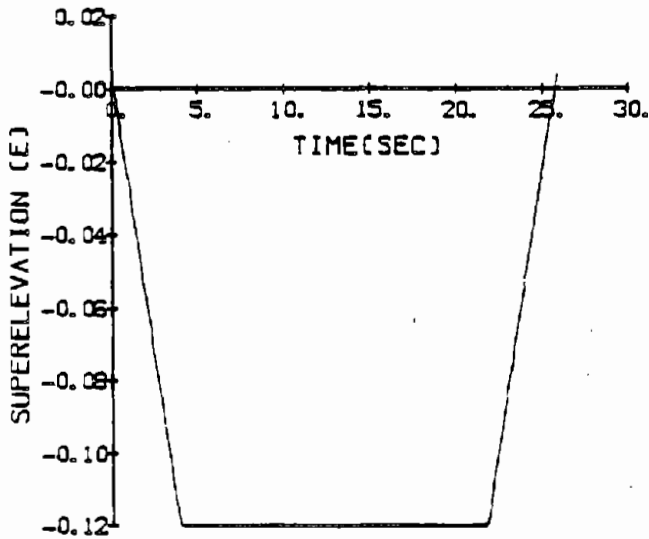
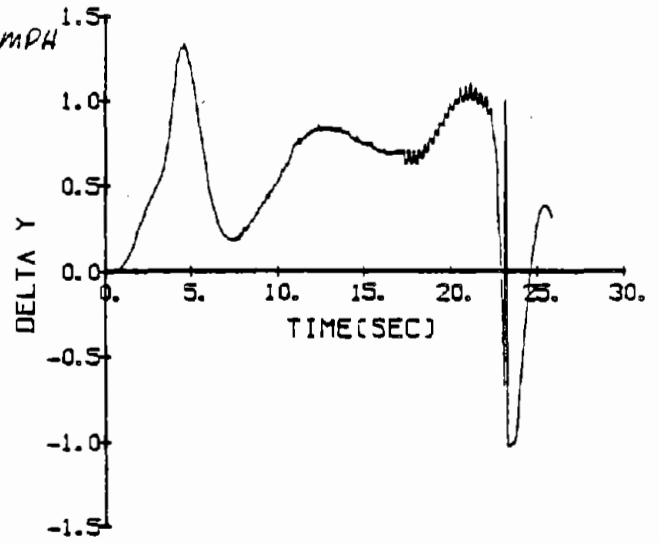
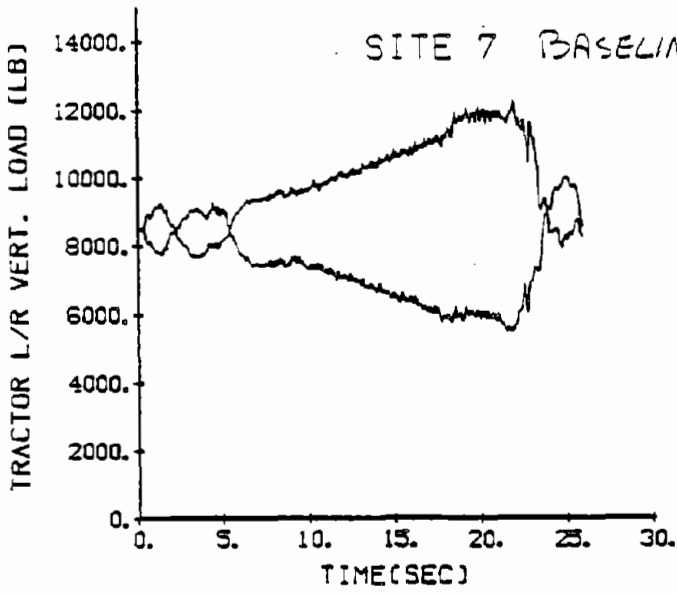

Figure 40. (continued)

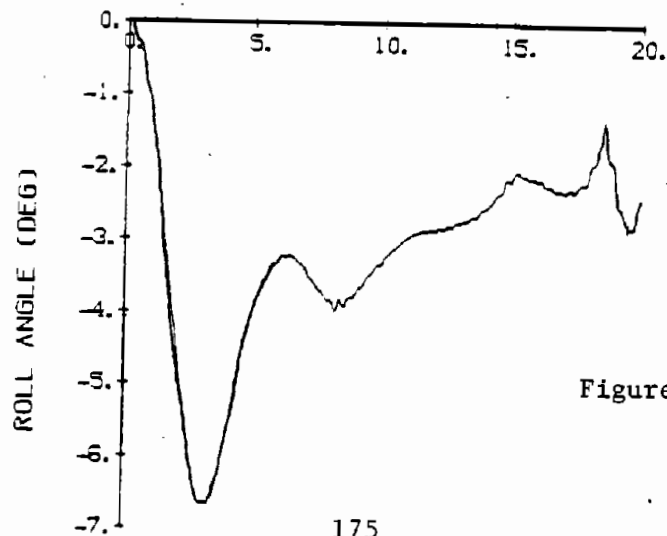
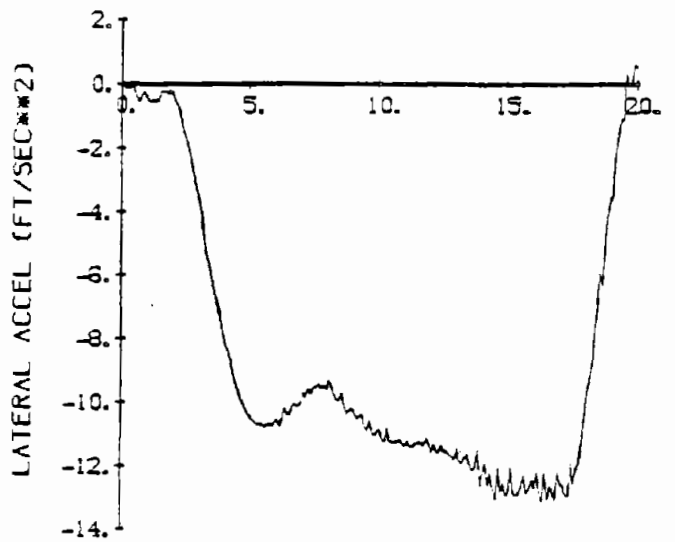
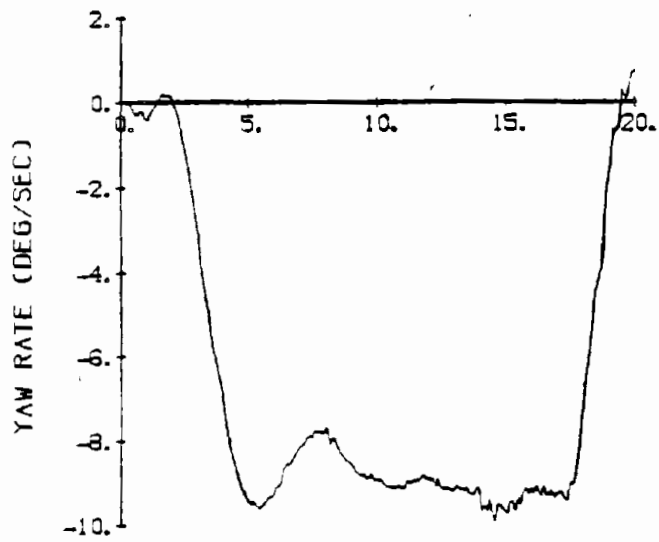
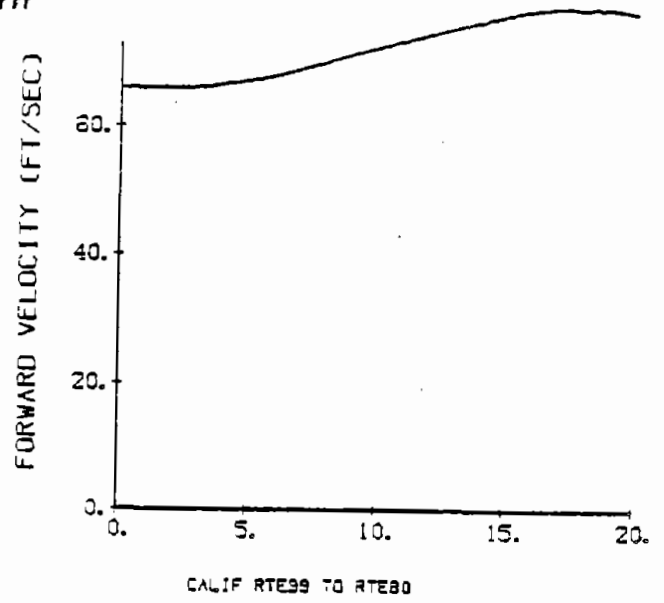
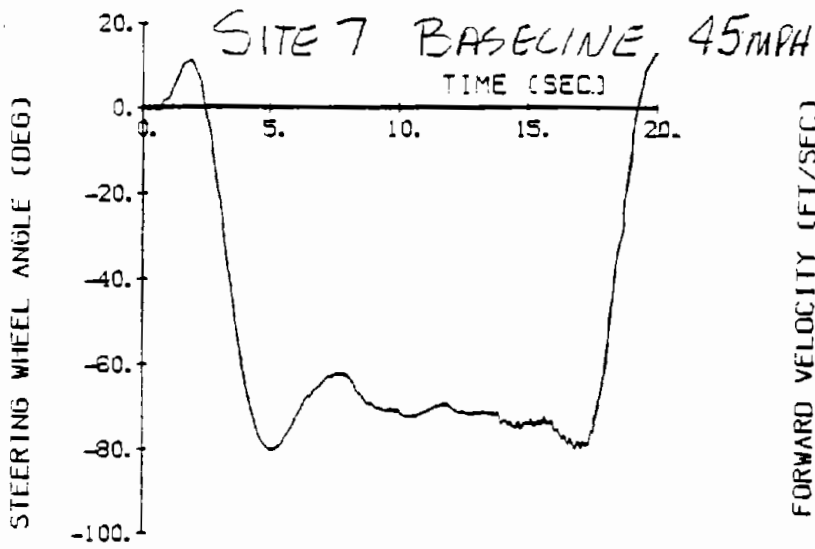

Figure 41. Site 7 baseline, 45 mi/h.

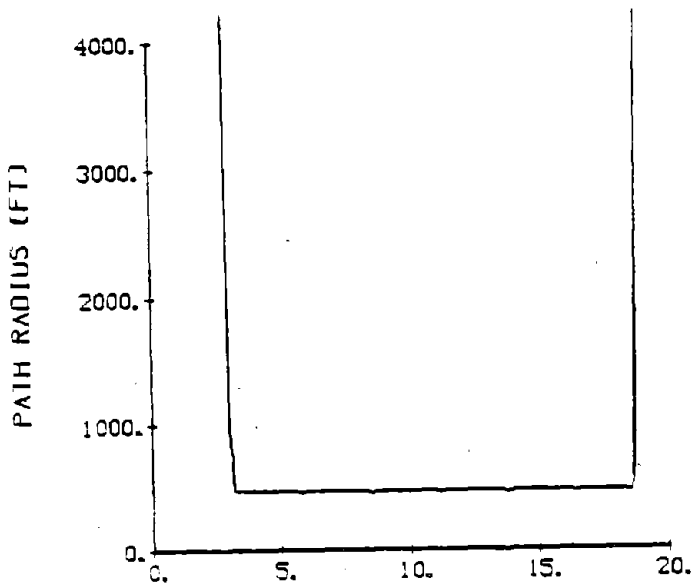
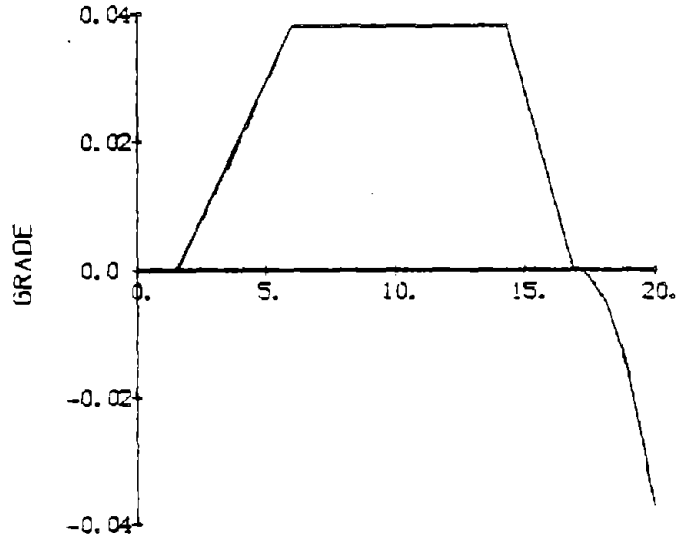
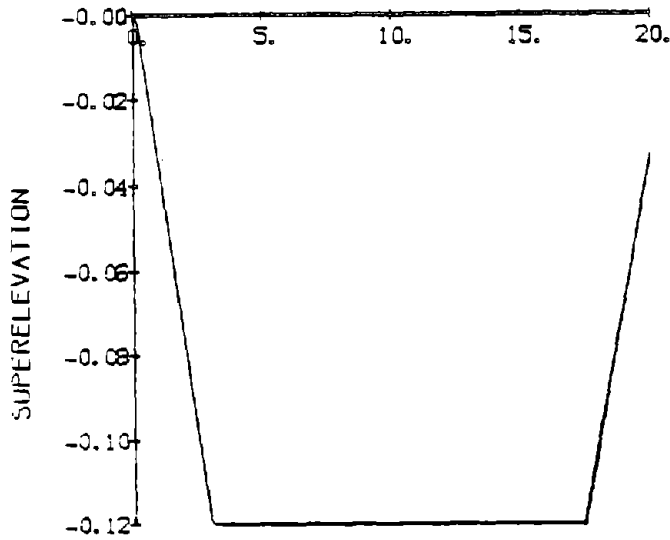
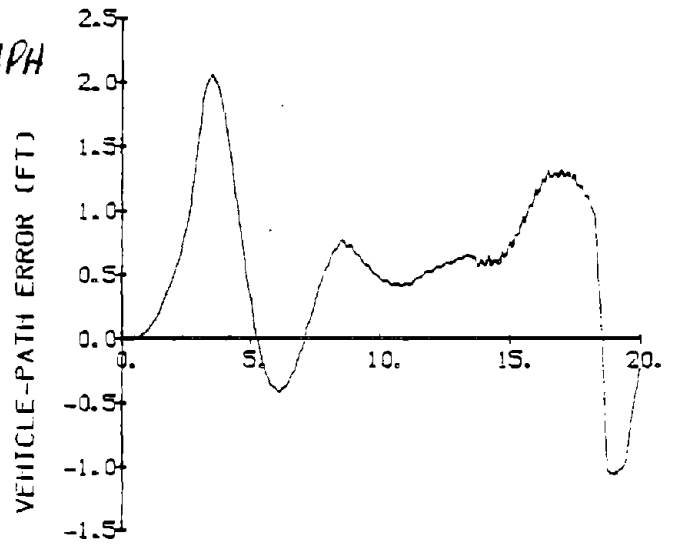
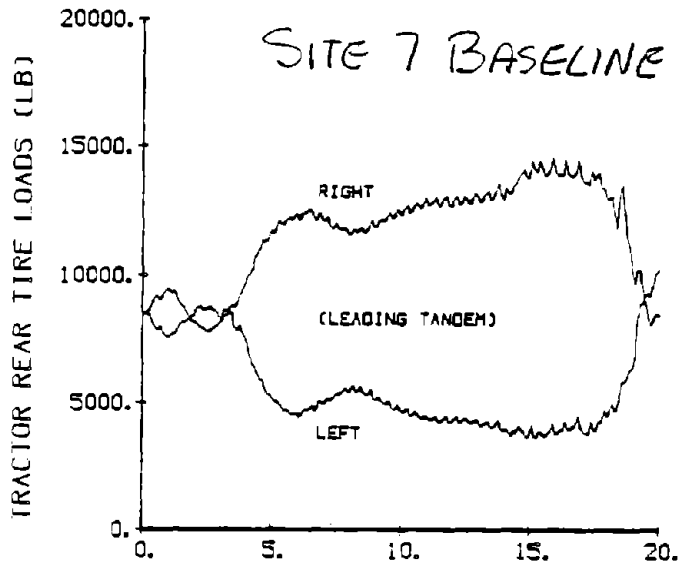

Figure 41. (continued)

HI-CG SITE 7 35 MPH

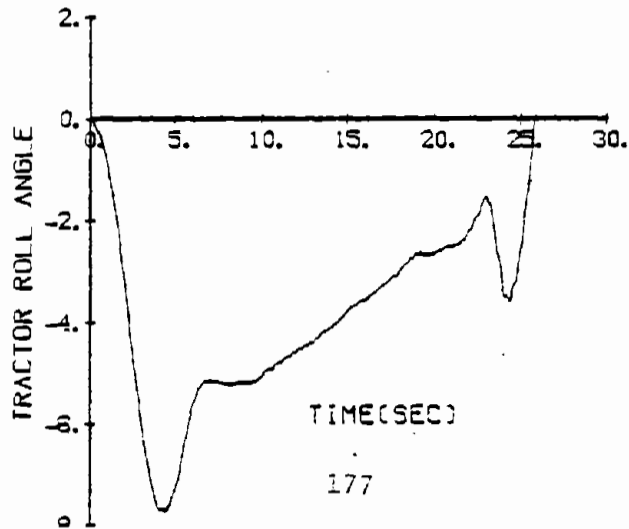
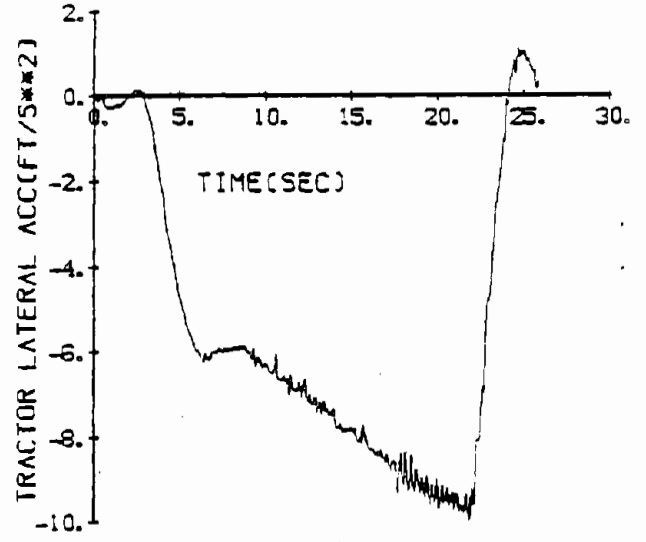
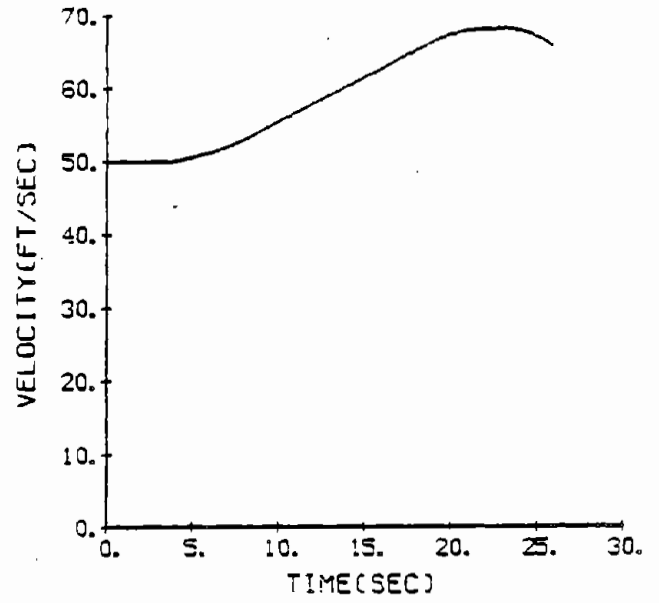
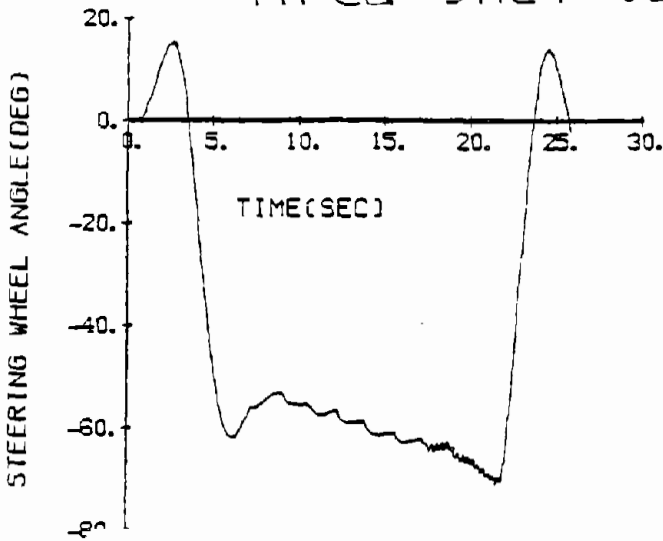

Figure 42. Site 7, hi-c.g., 35 mi/h.

H1-CG SITE 7 35 MPH

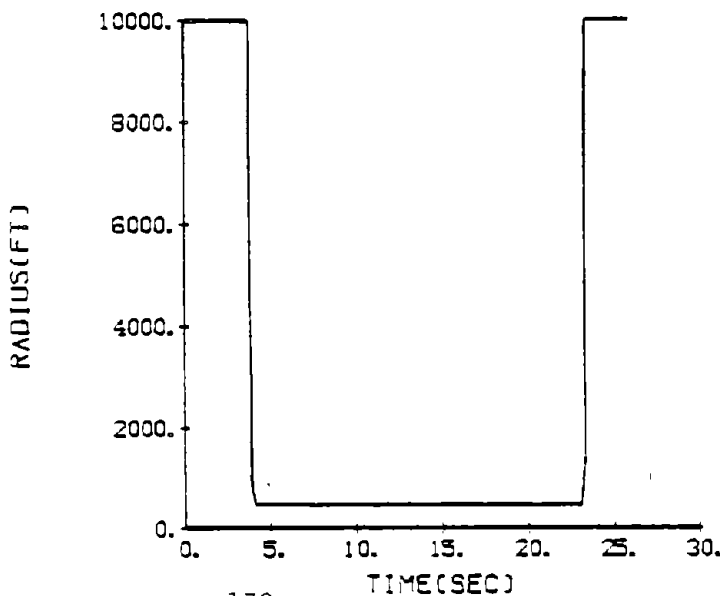
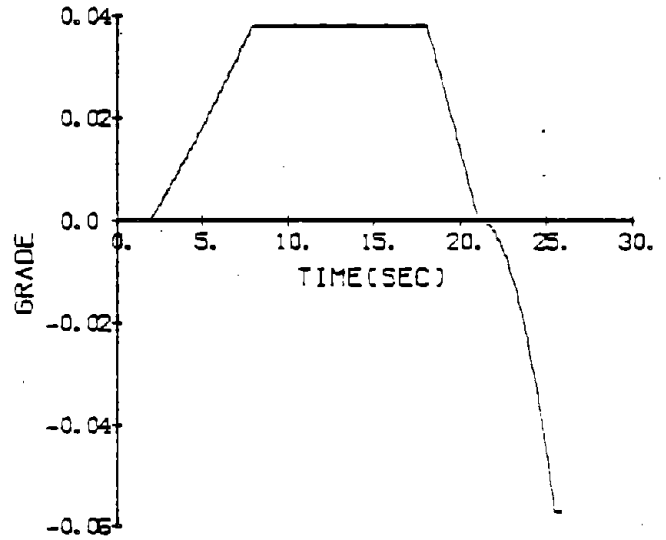
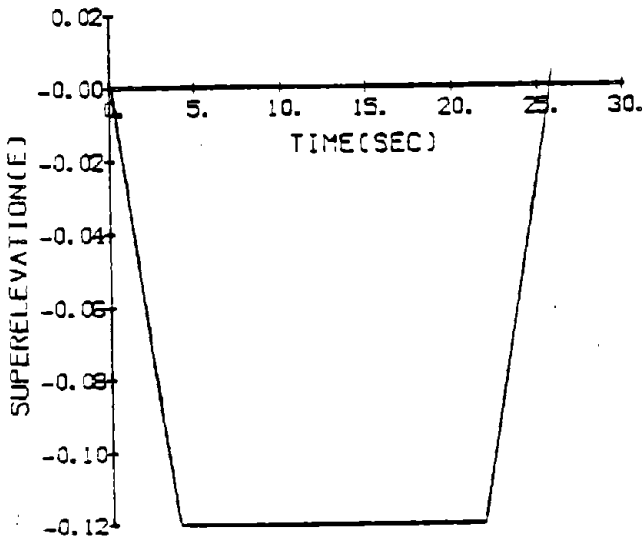
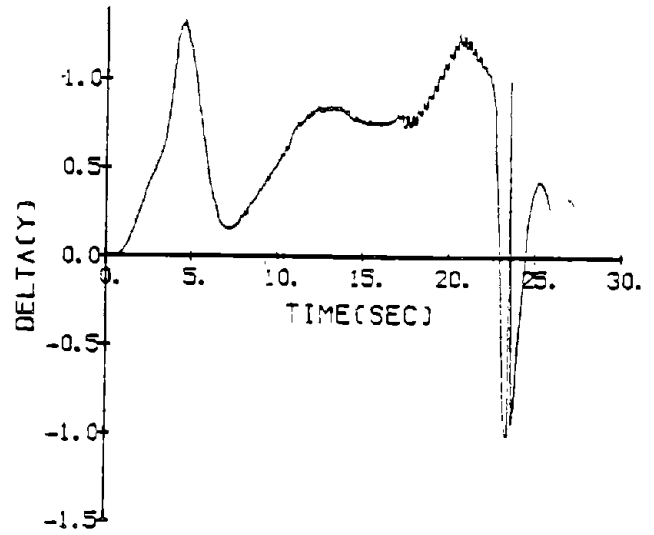
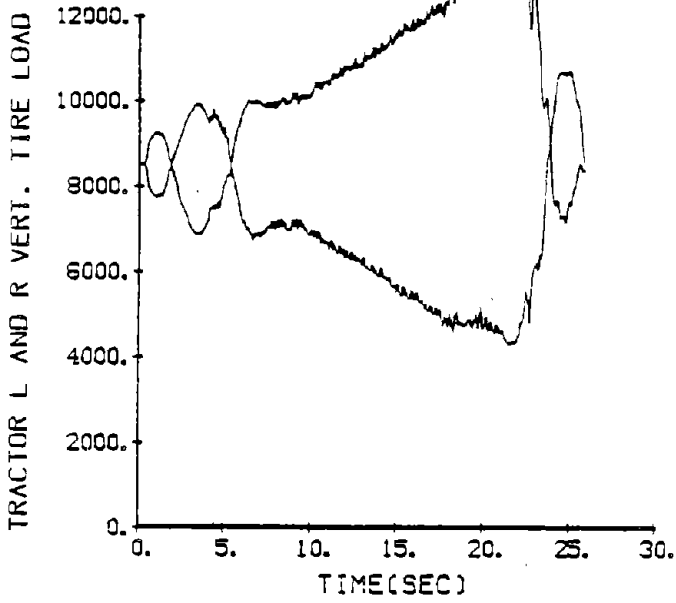

Figure 42. (continued)

HI-CG SITE 7 45 MPH

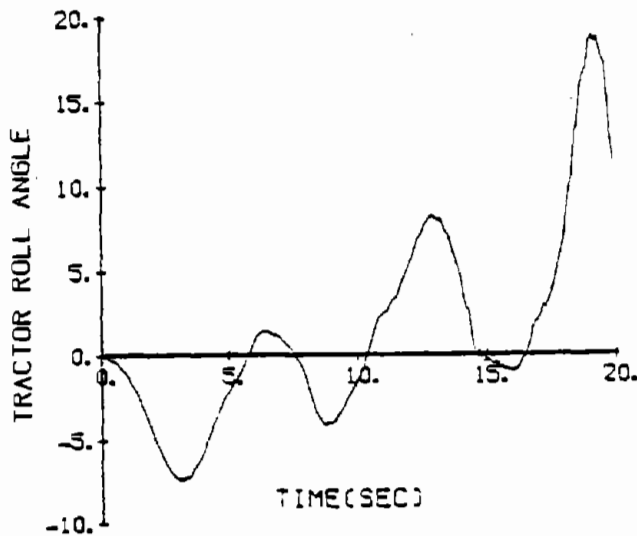
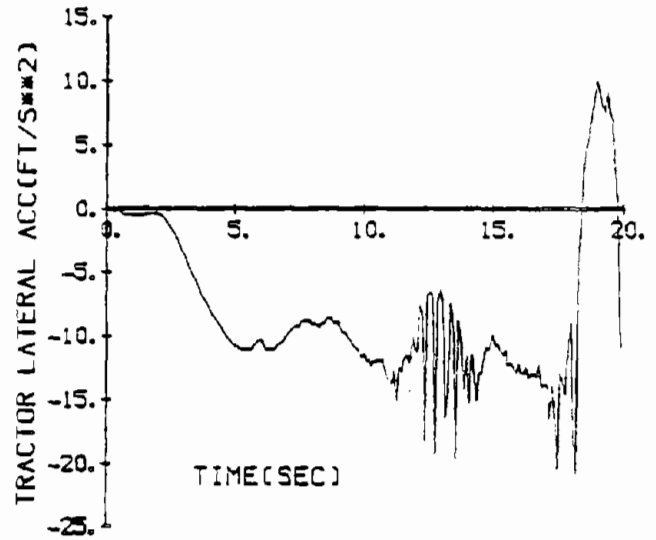
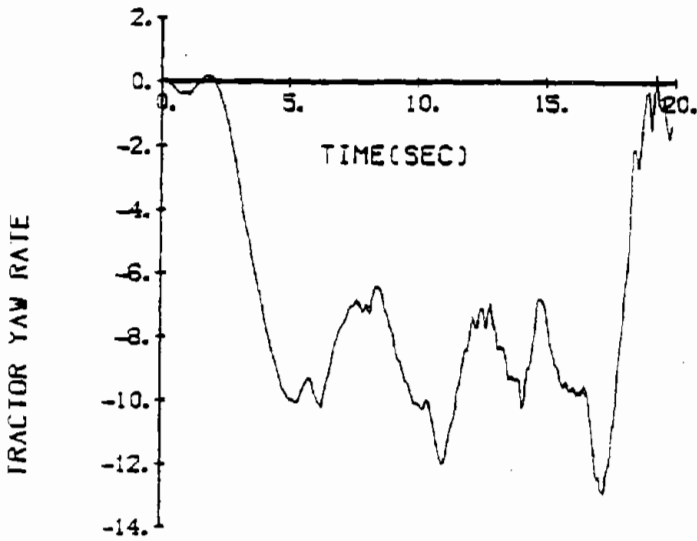
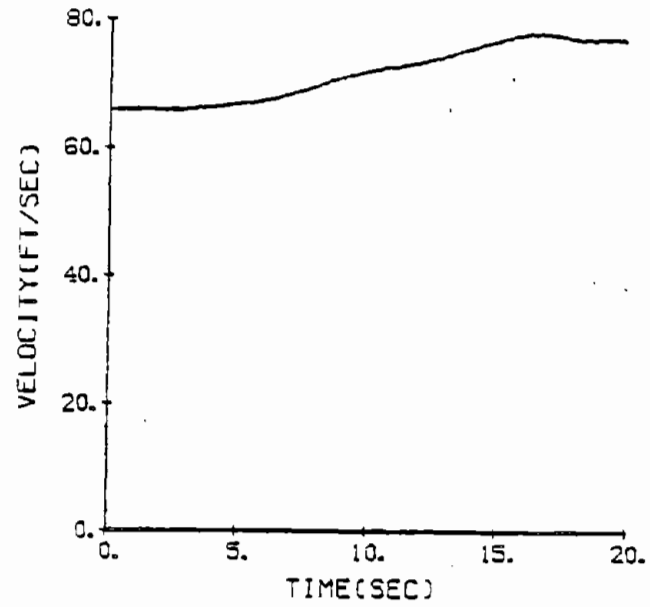
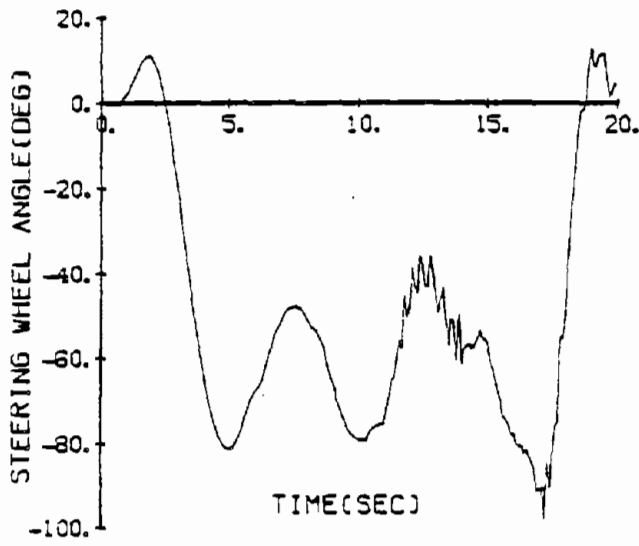

Figure 43. Site 7, hi-c.g. 45 mi/h.

HI-CG SITE 7 45 MPH

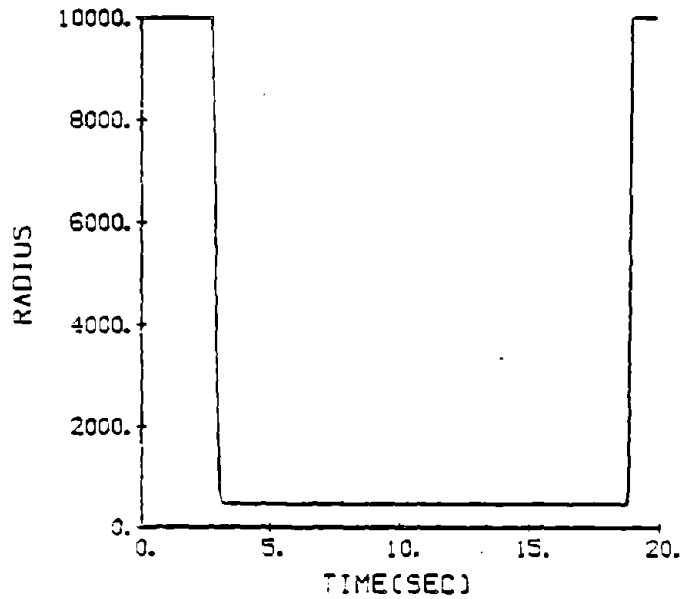
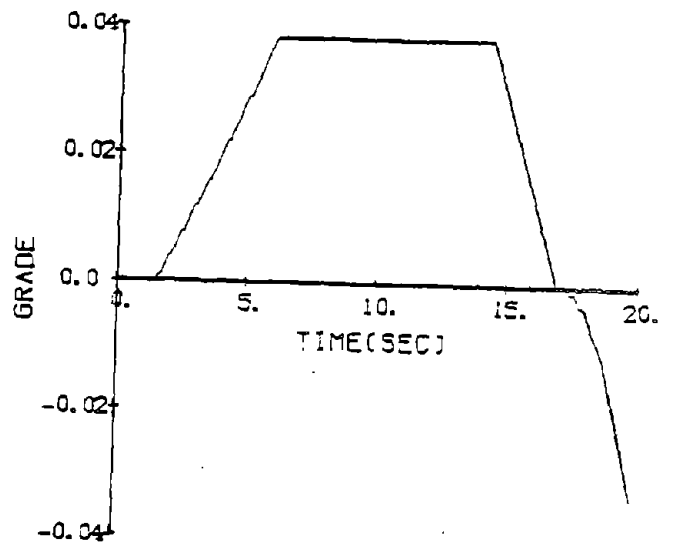
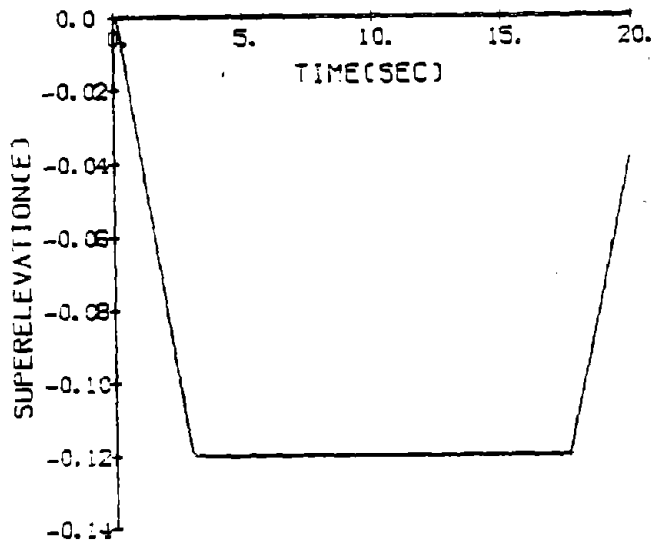
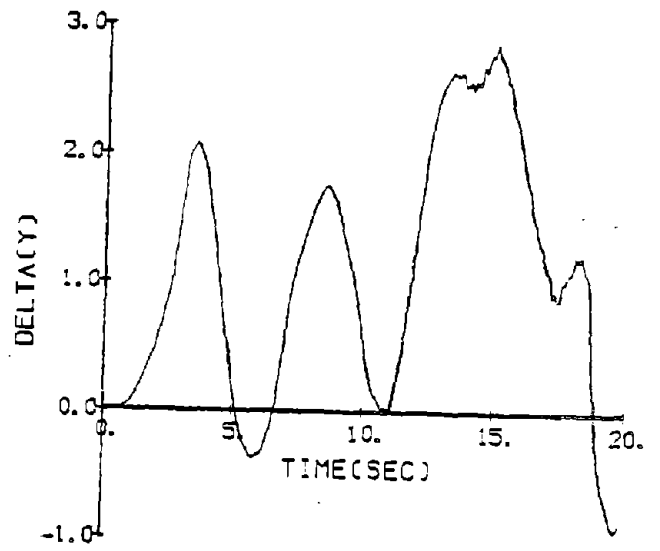
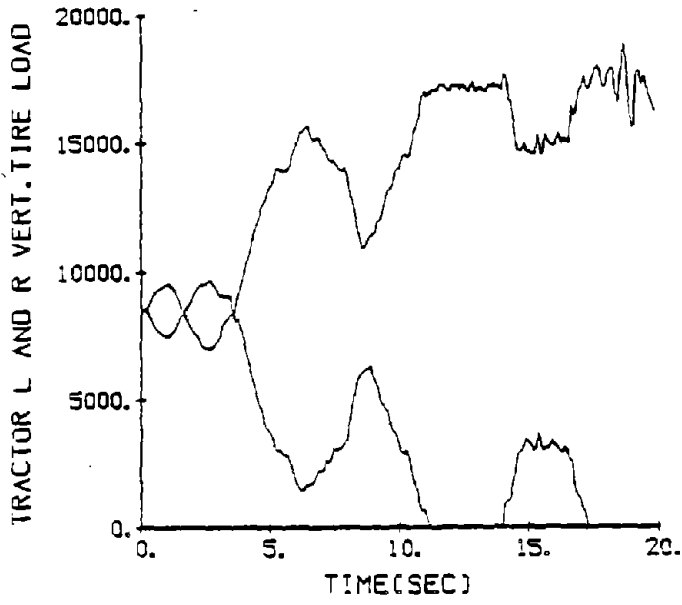
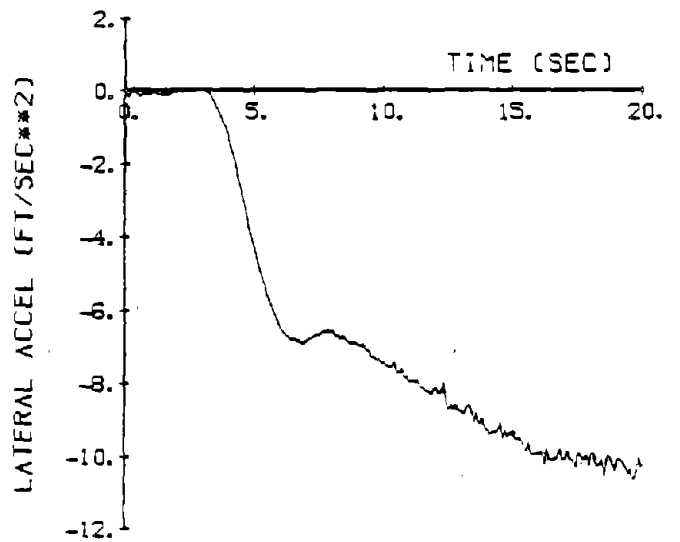
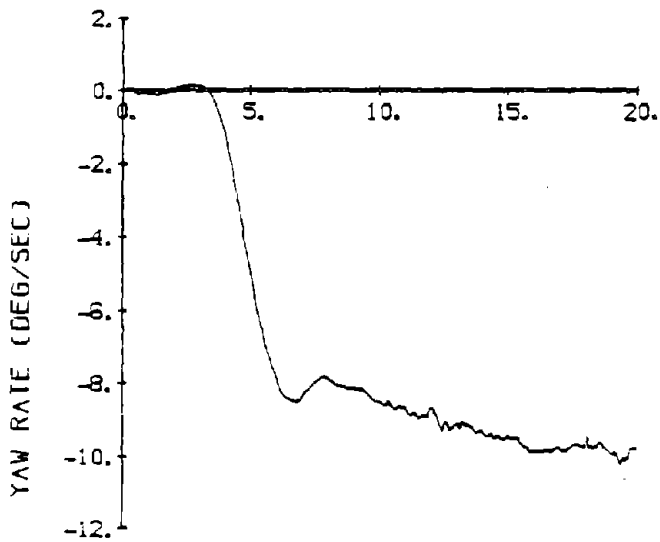
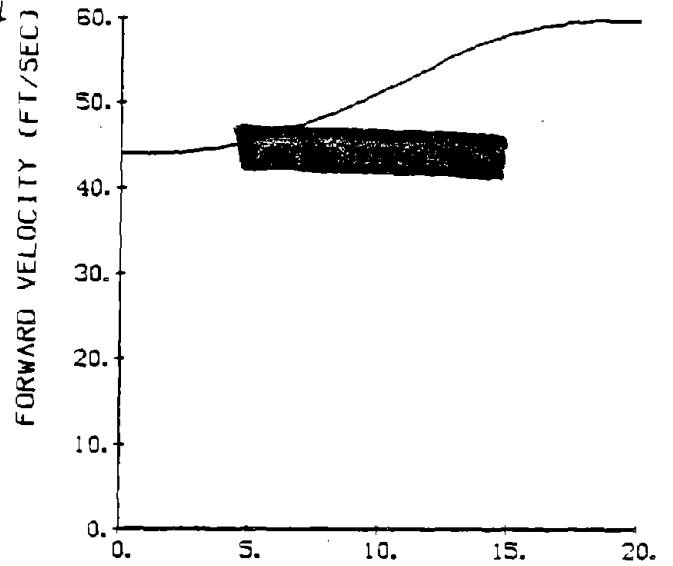
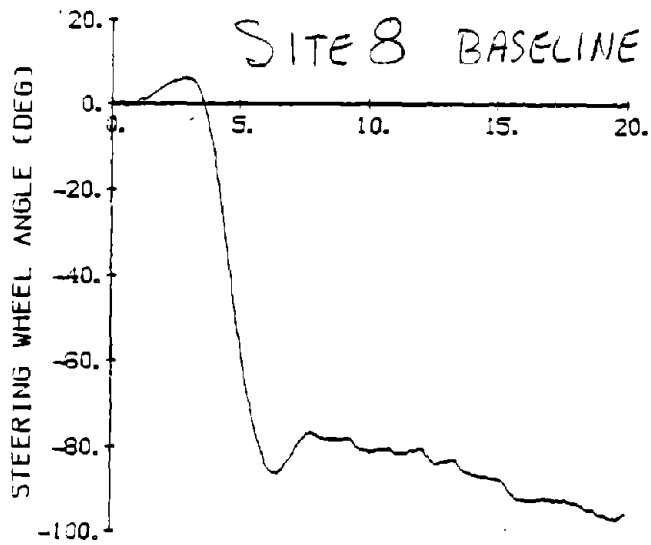

Figure 43. (continued)



RTE 175 / 170 (LOS ANGELES)
5-AXLE TR-SEMI 40 MPH INITIAL SPEED

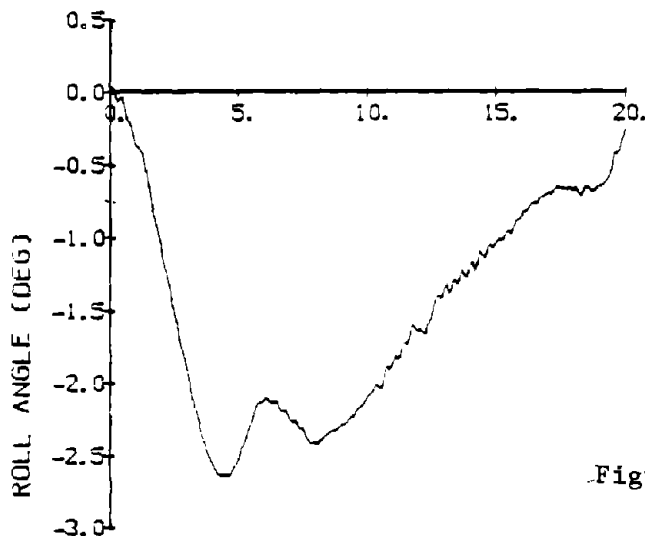

Figure 44. Site 8, baseline, 30 mi/h.

SITE 8 BASELINE 30 MPH

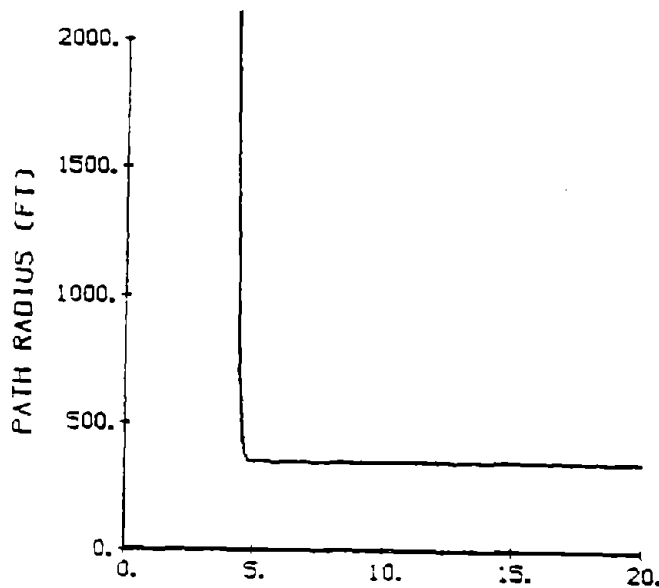
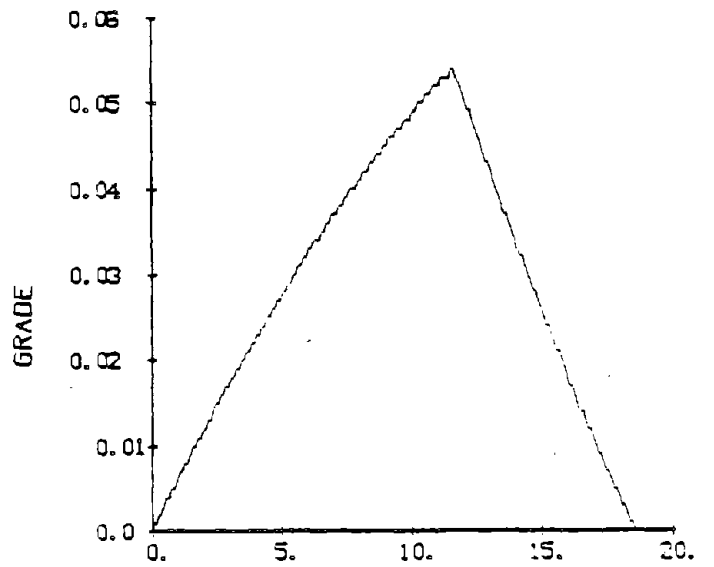
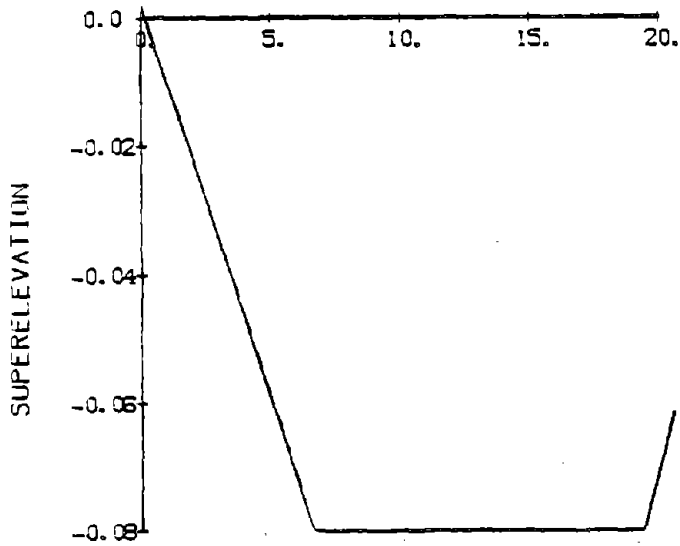
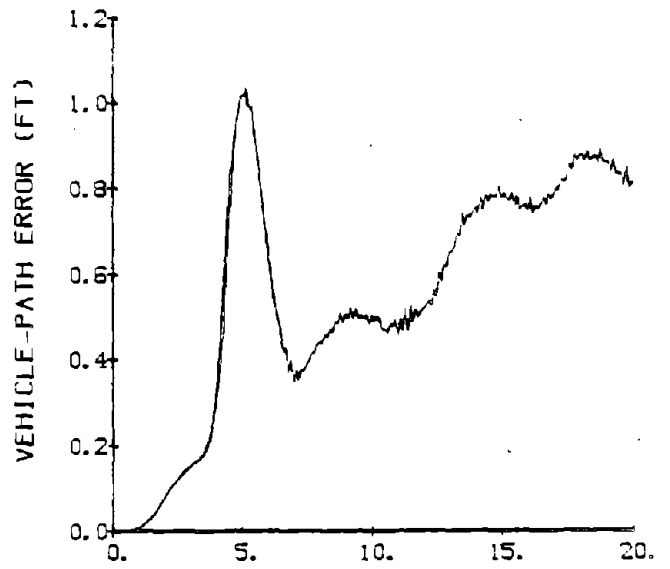
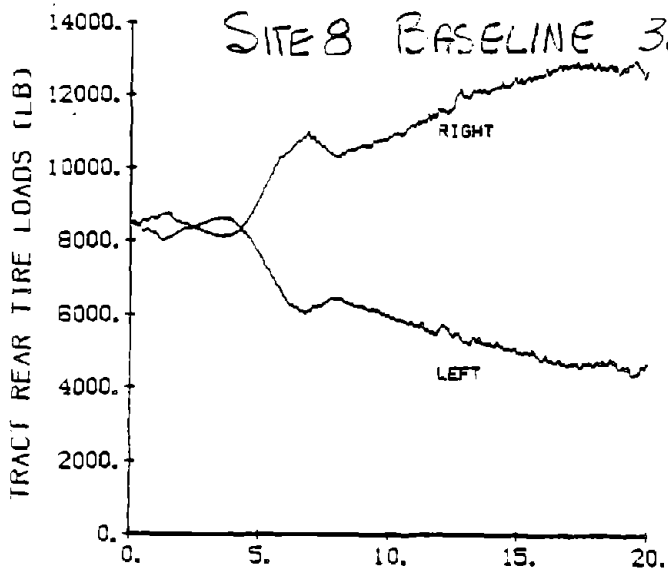

Figure 44. (continued)

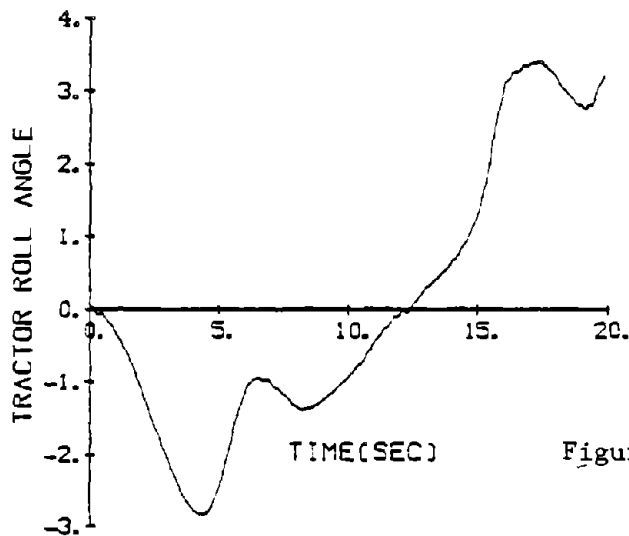
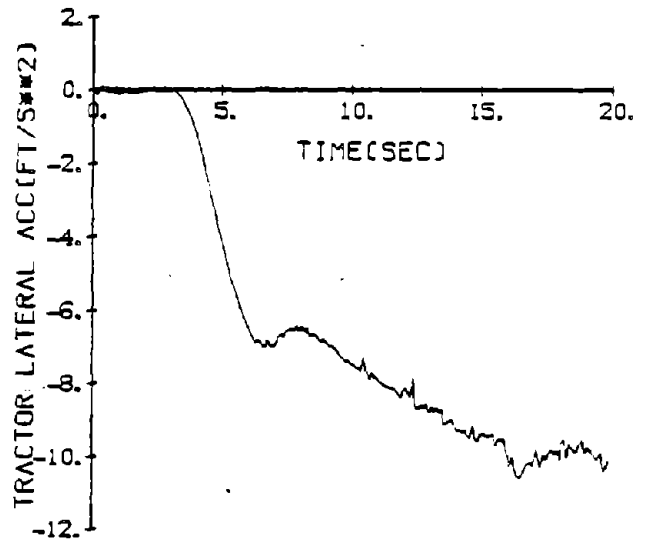
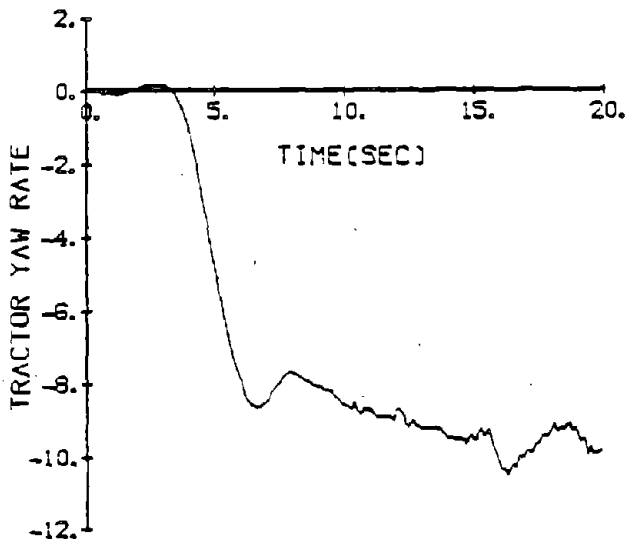
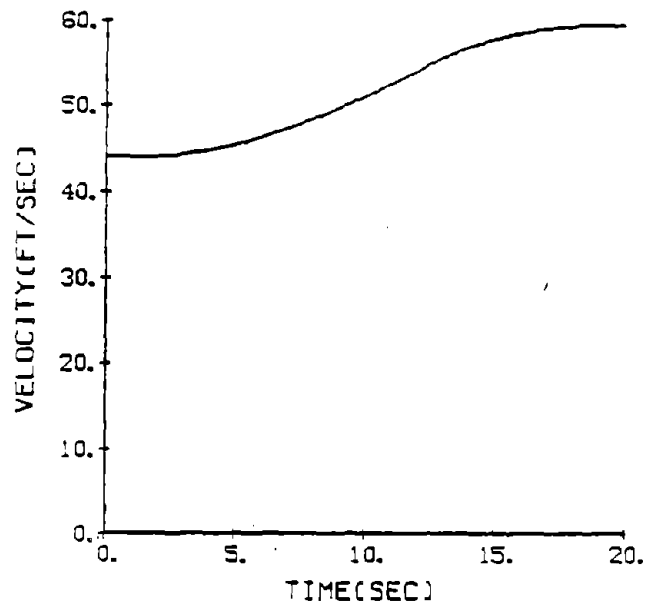
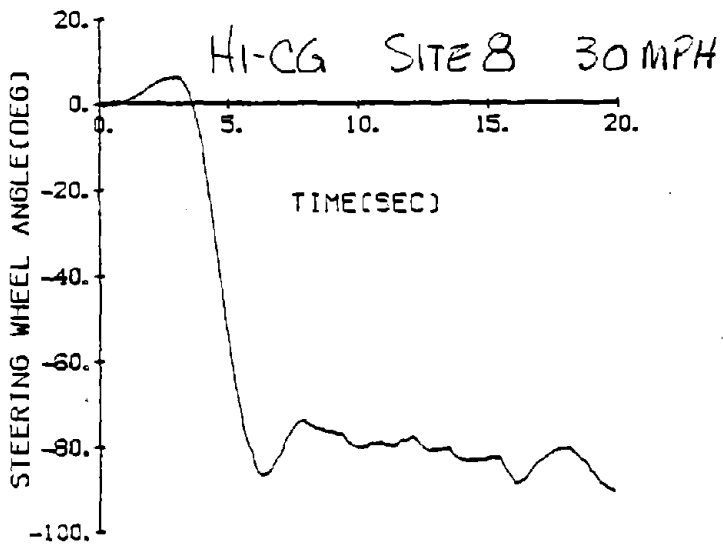

Figure 45. Site 8, hi-c.g., 30 mi/h.

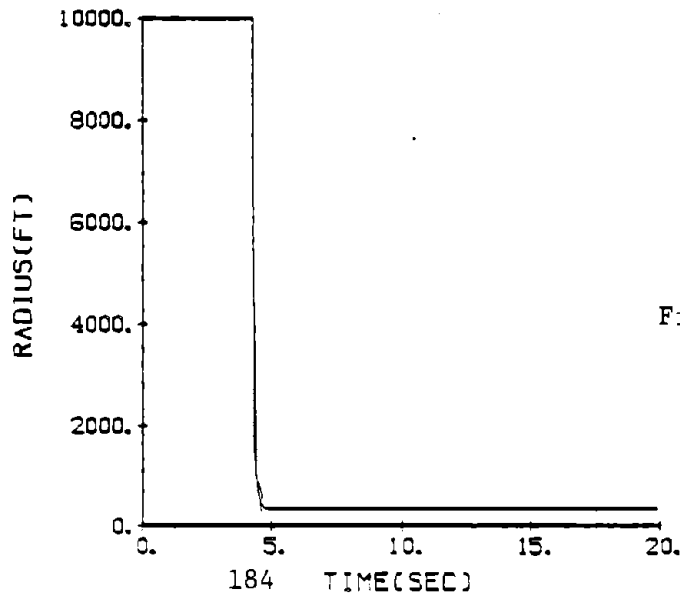
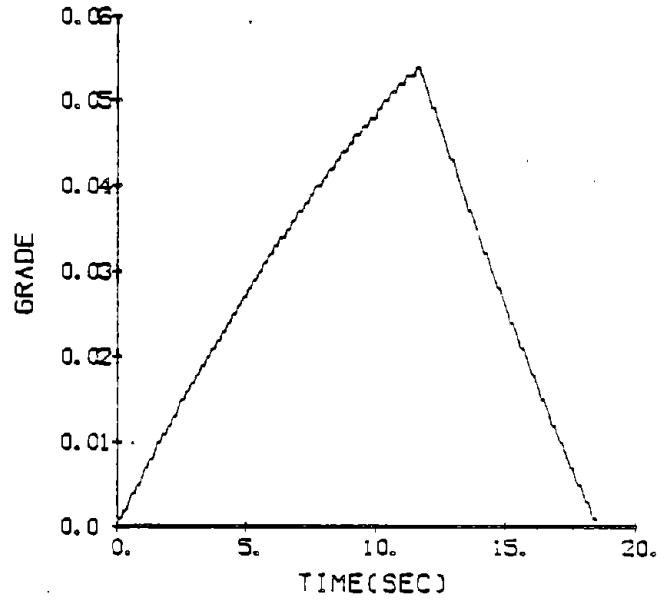
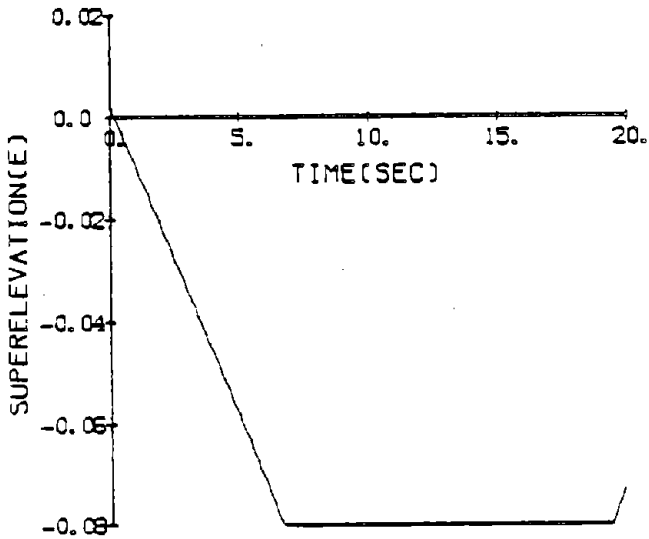
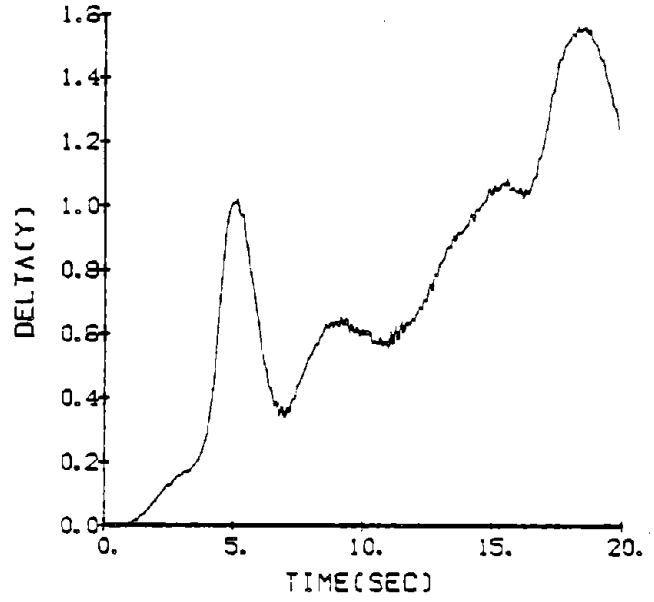
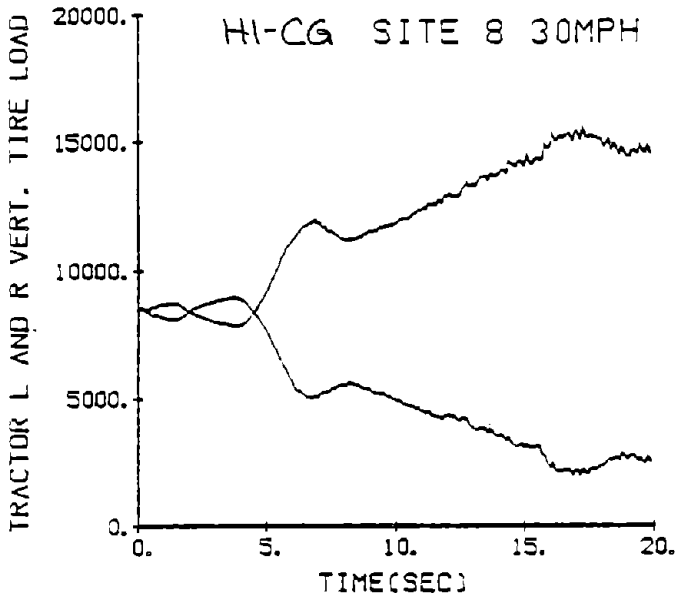

Figure 45. (continued)

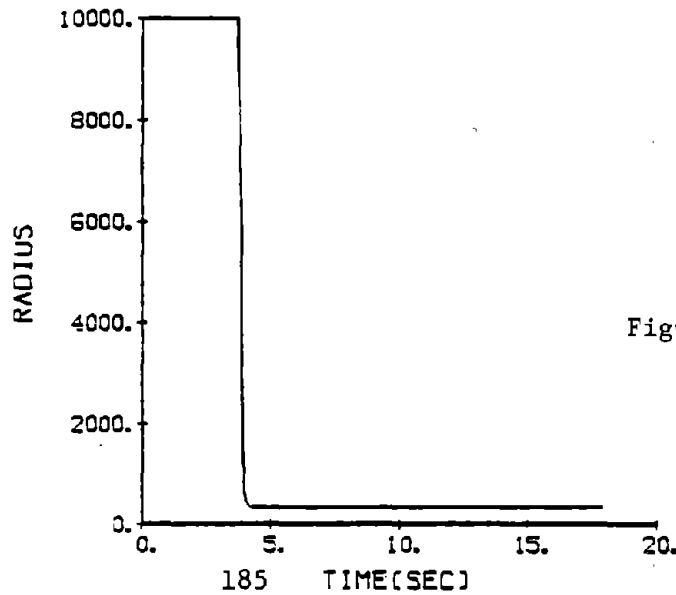
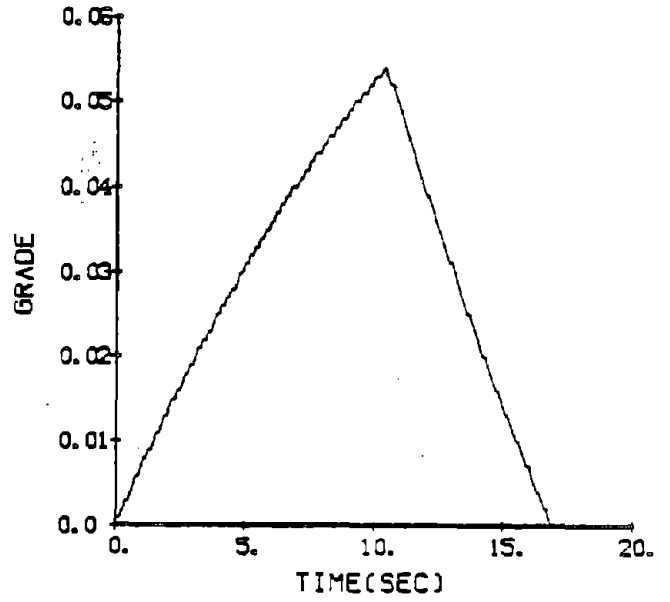
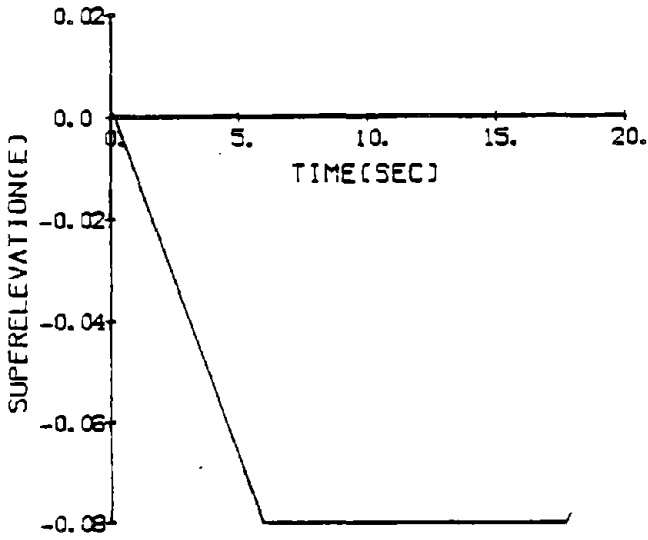
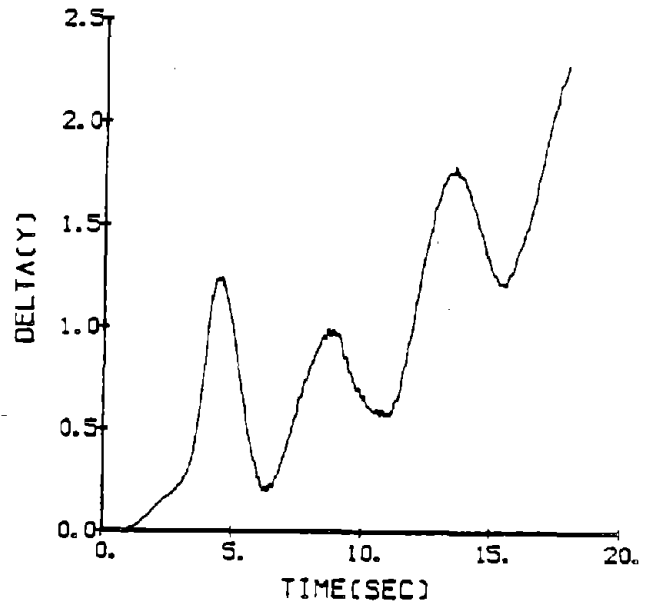
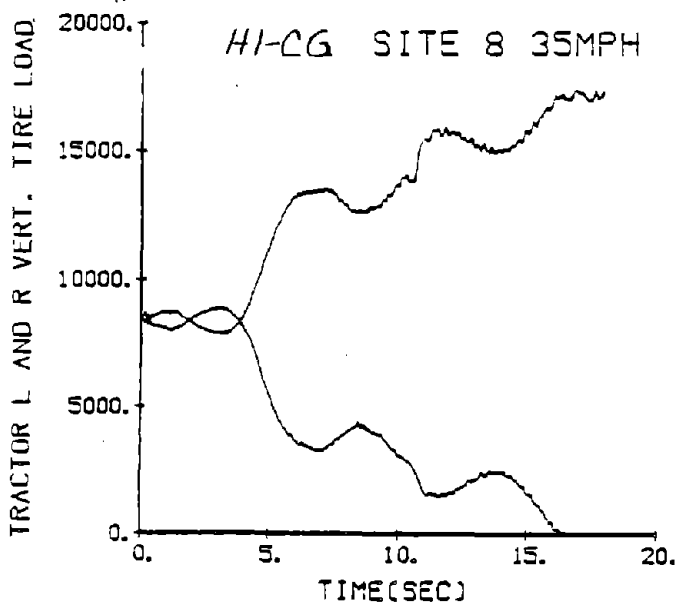

Figure 46. Site 8, hi-c.g., 35 mi/h.

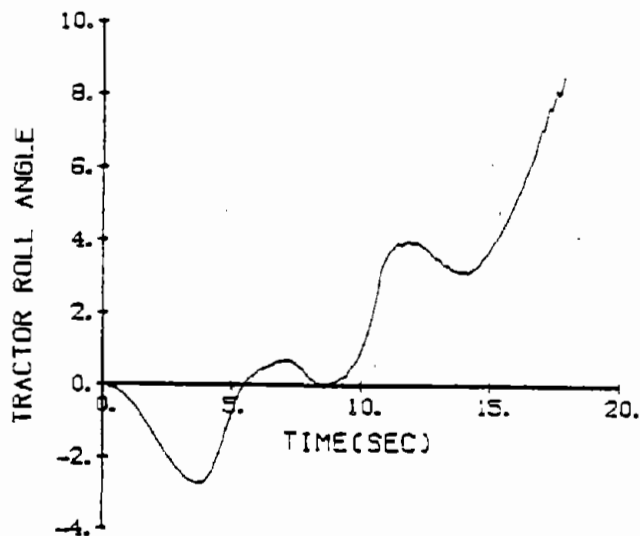
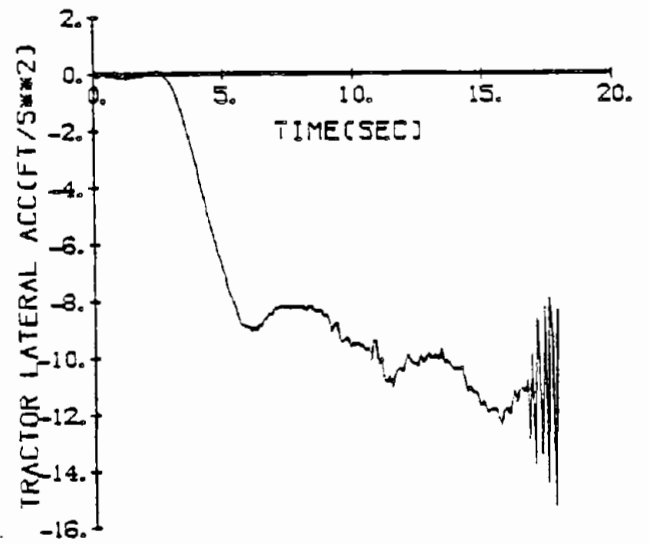
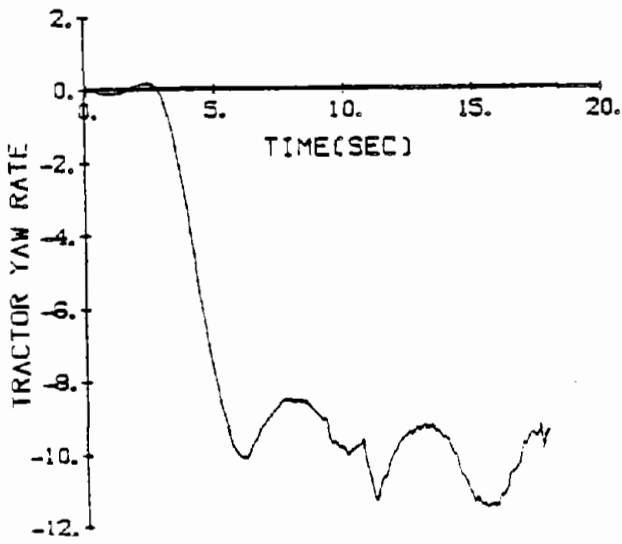
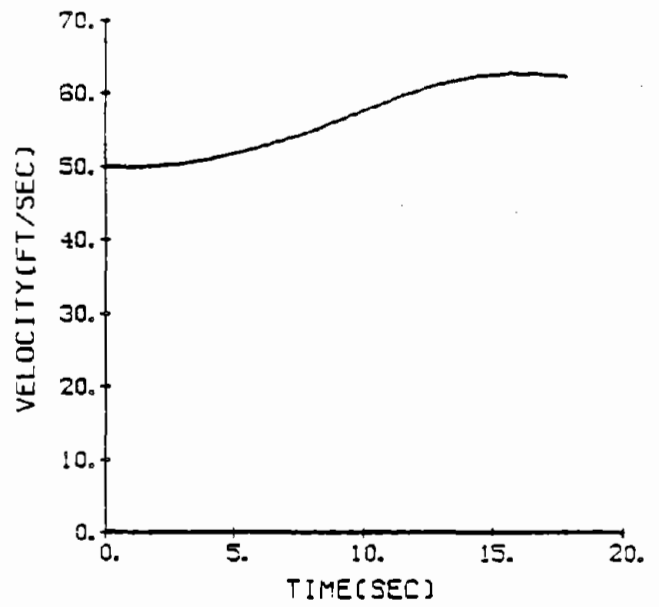
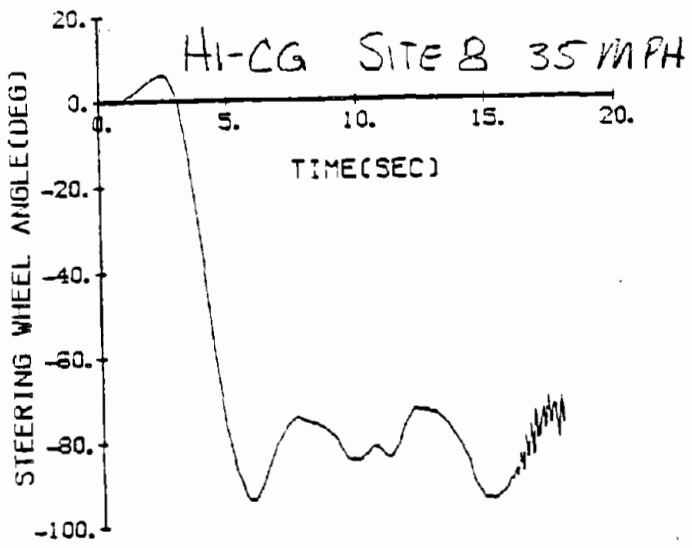

Figure 46. (continued)

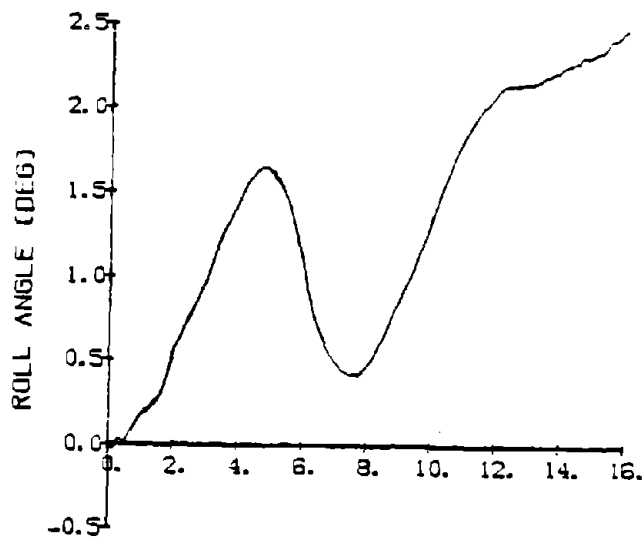
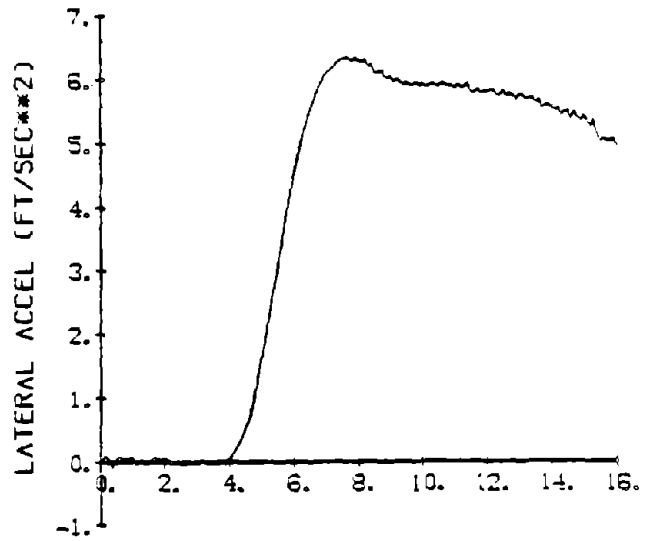
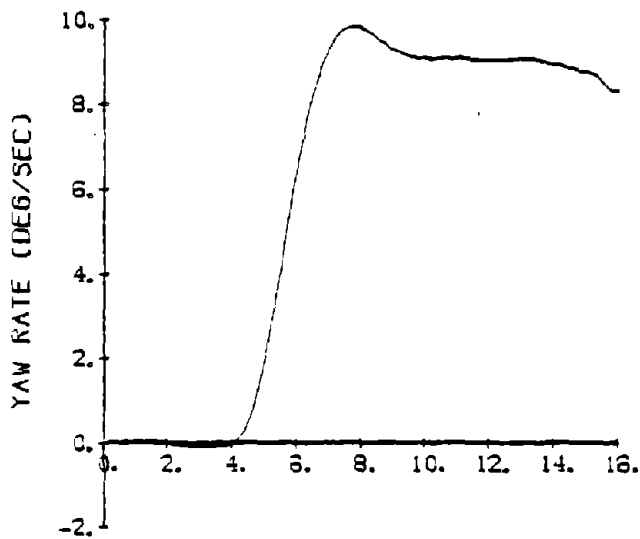
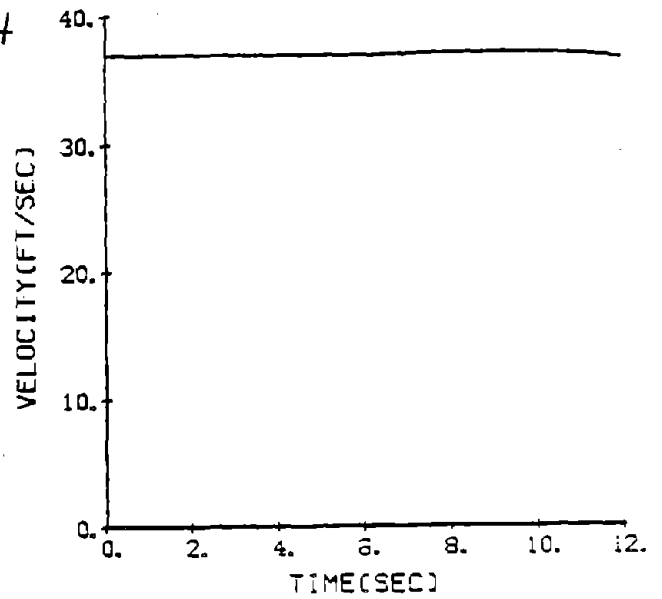
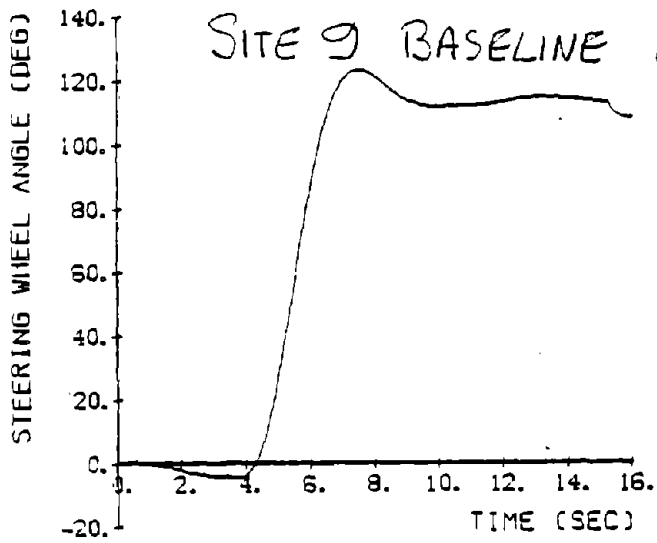

Figure 47. Site 9 base-
line, 25 mi/h.

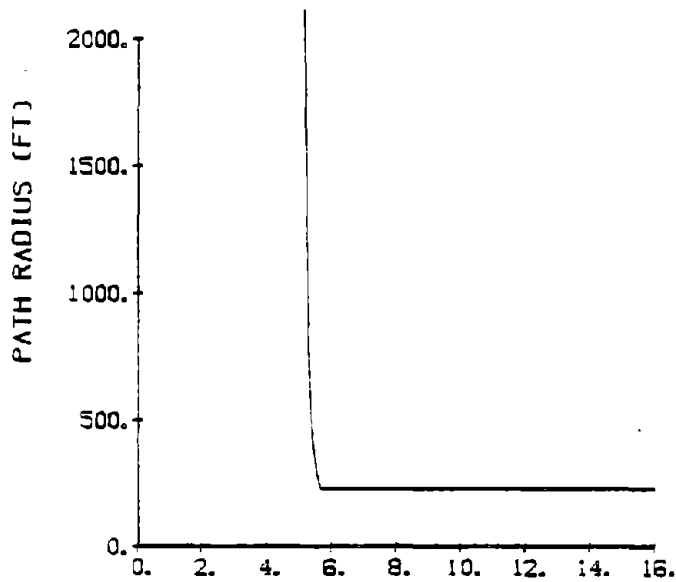
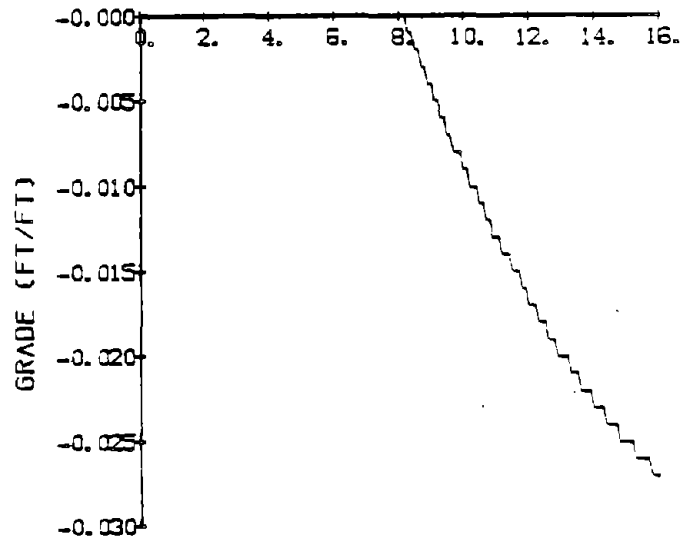
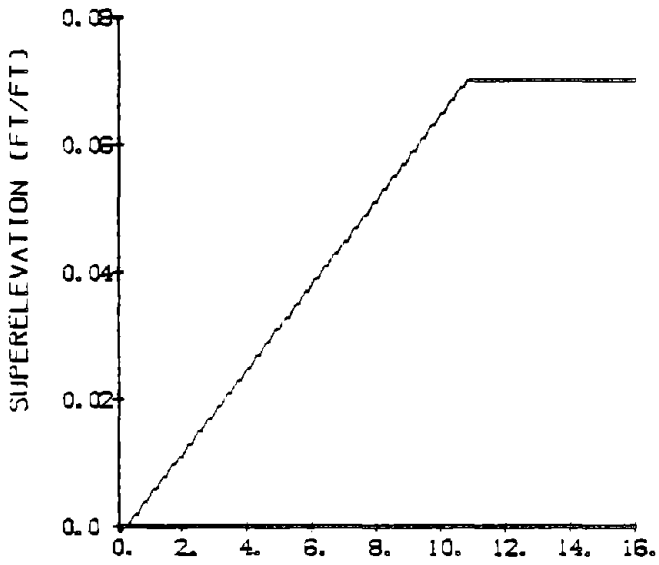
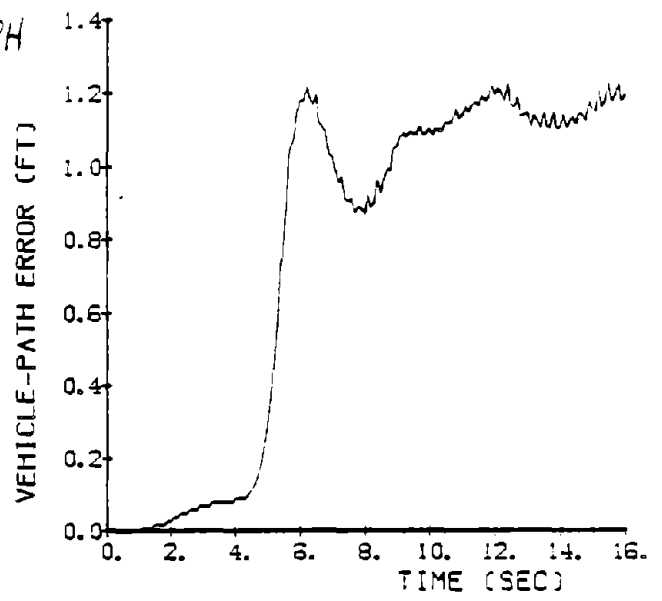
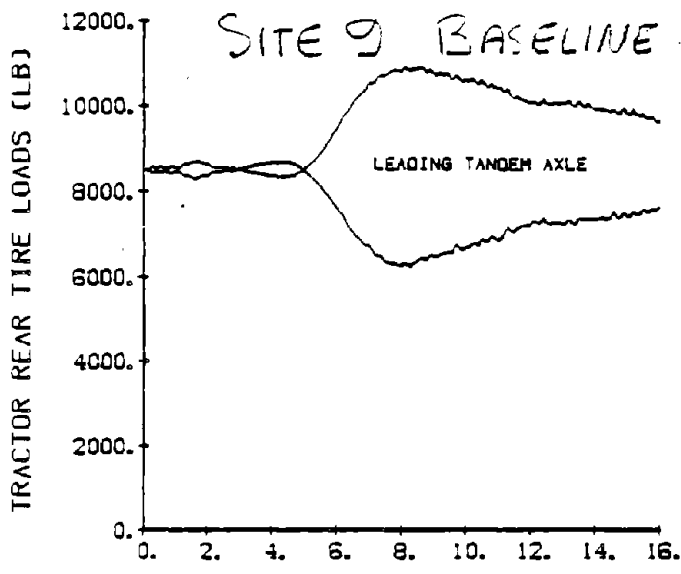
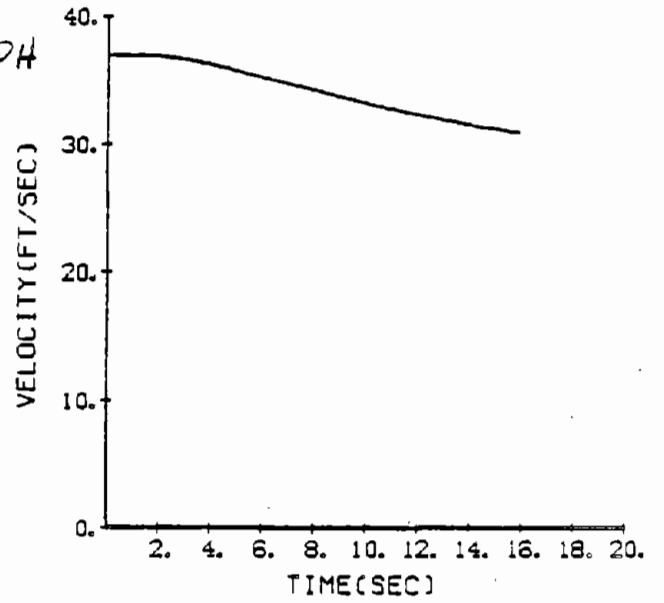
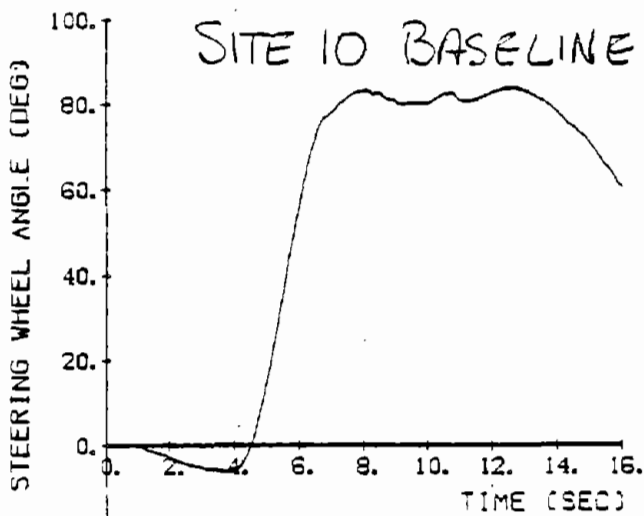

Figure 47. (continued)



SITE 10 BASELINE, 25MPH

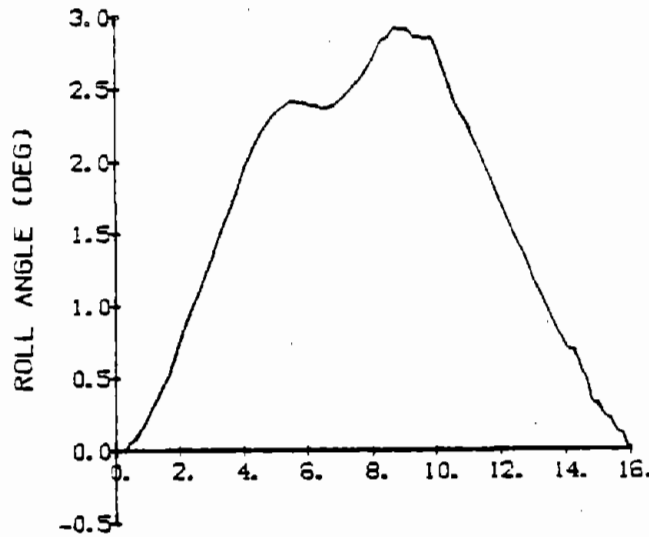
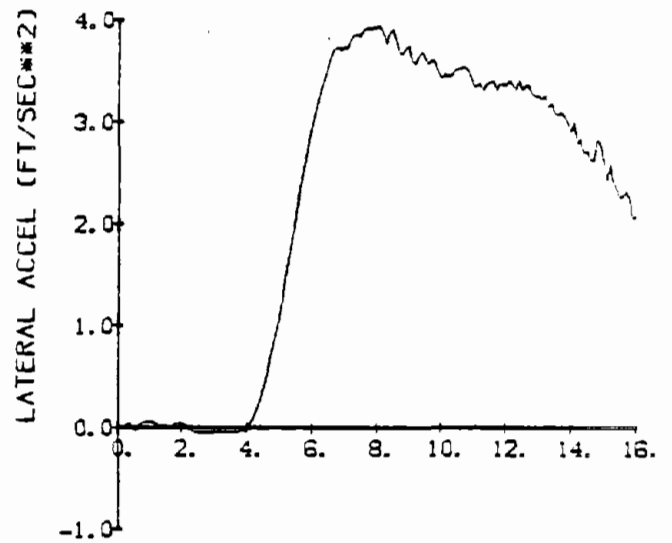
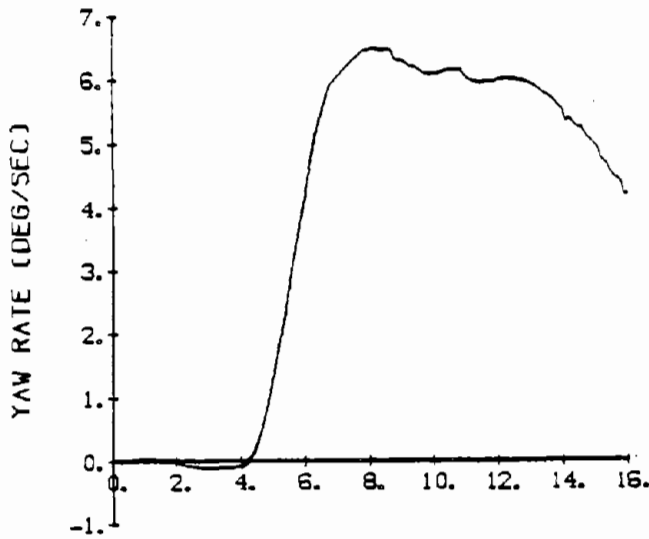

Figure 48. Site 10 base-line, 25 mi/h.

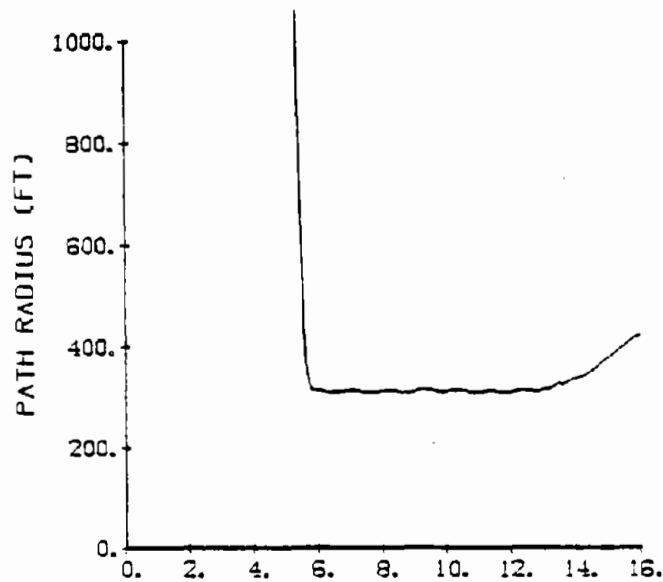
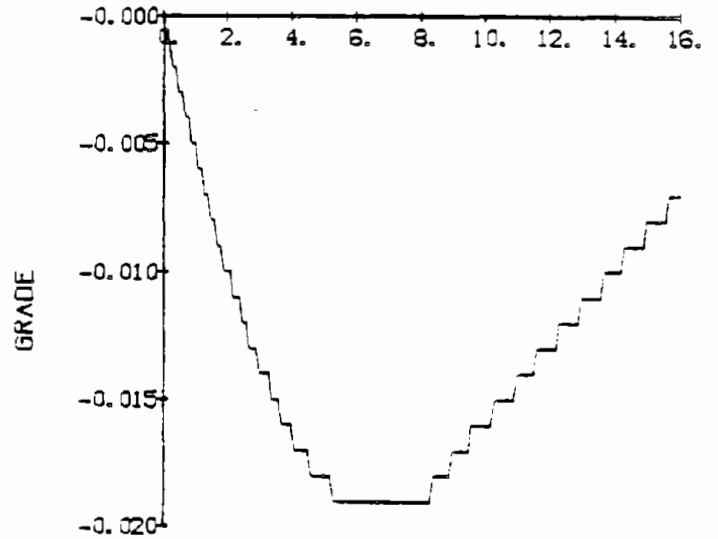
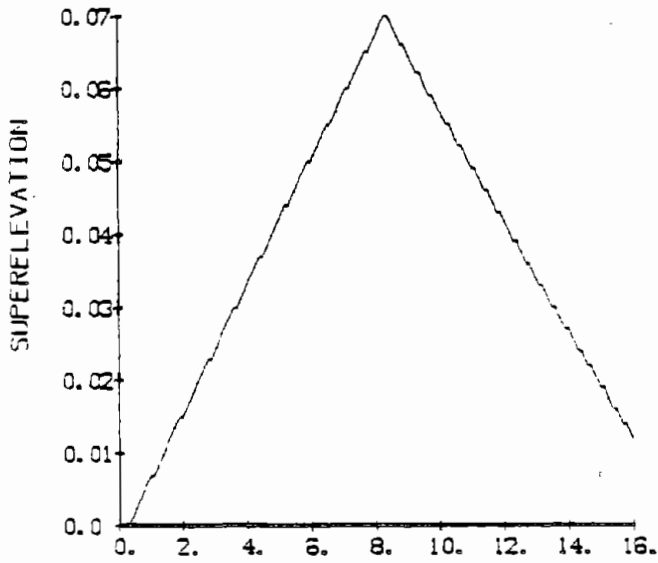
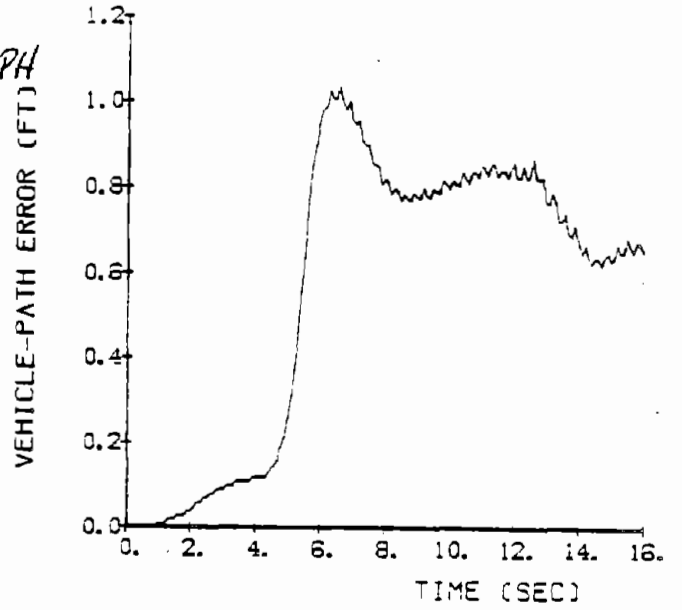
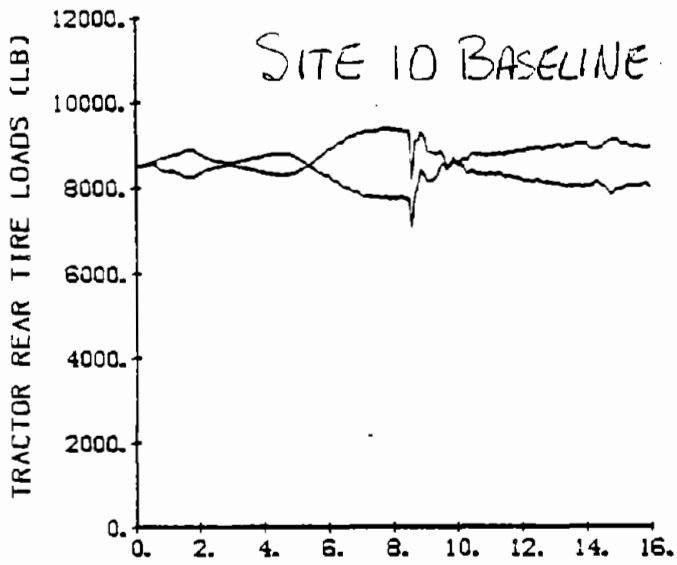

Figure 48. (continued)

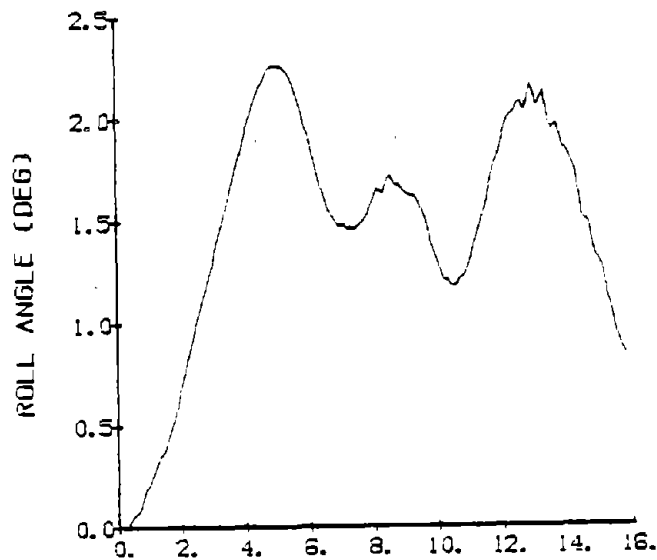
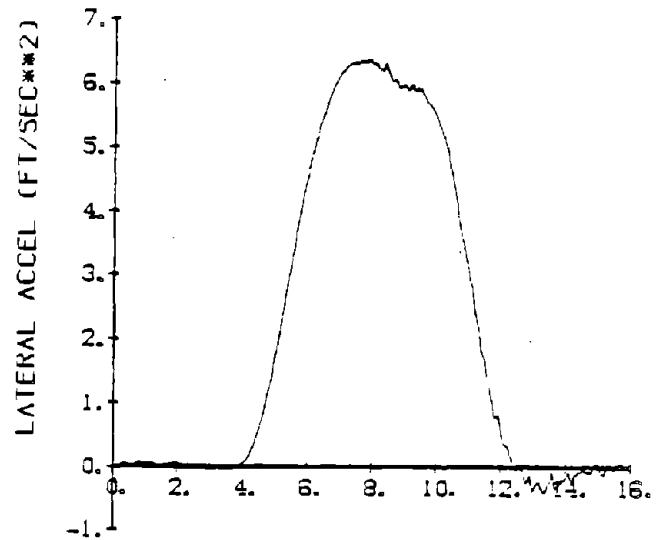
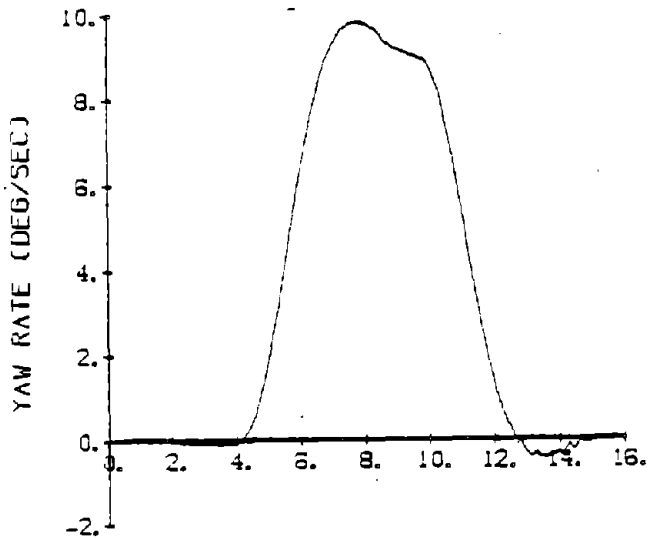
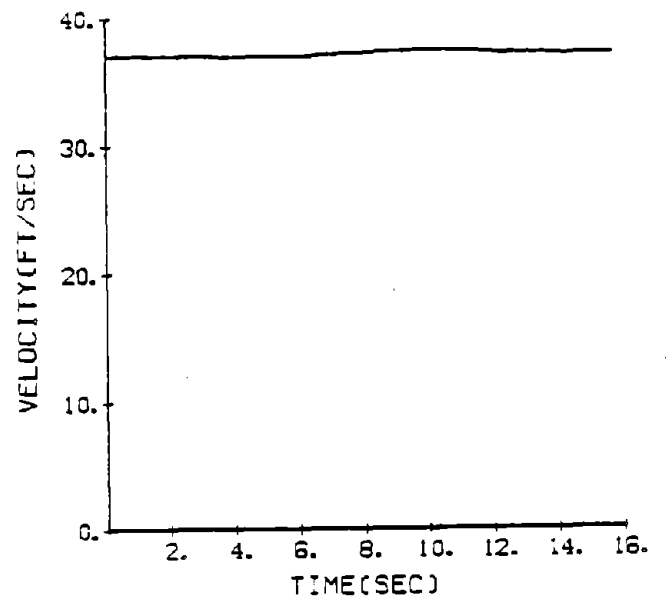
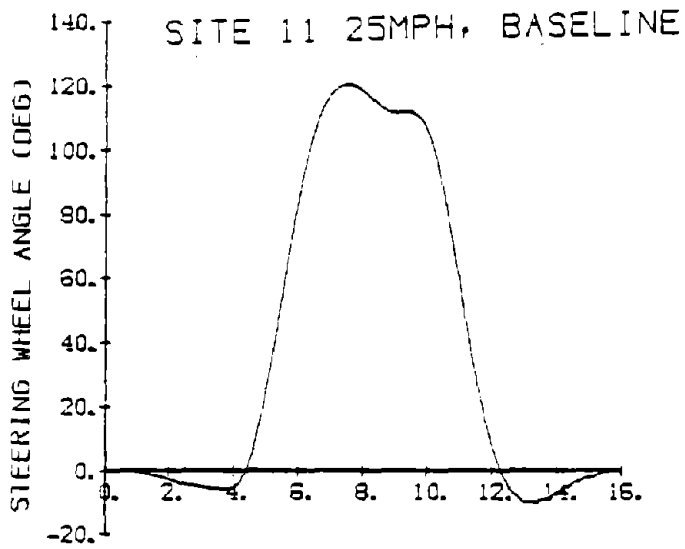

Figure 49. Site 11 baseline, 25 mi/h.

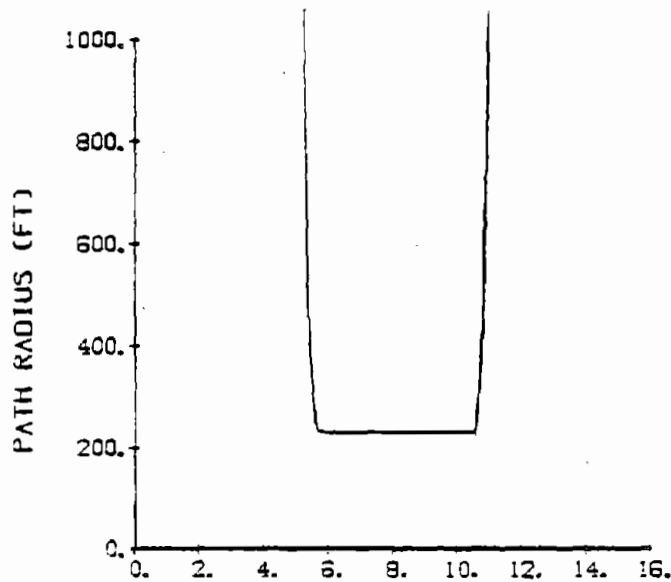
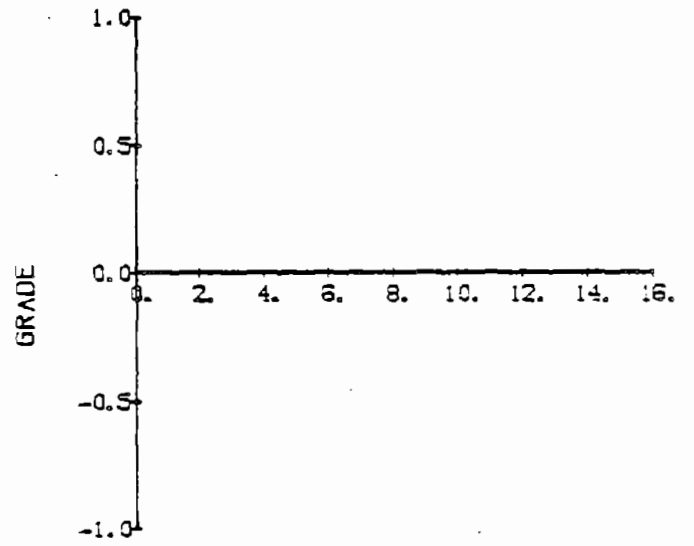
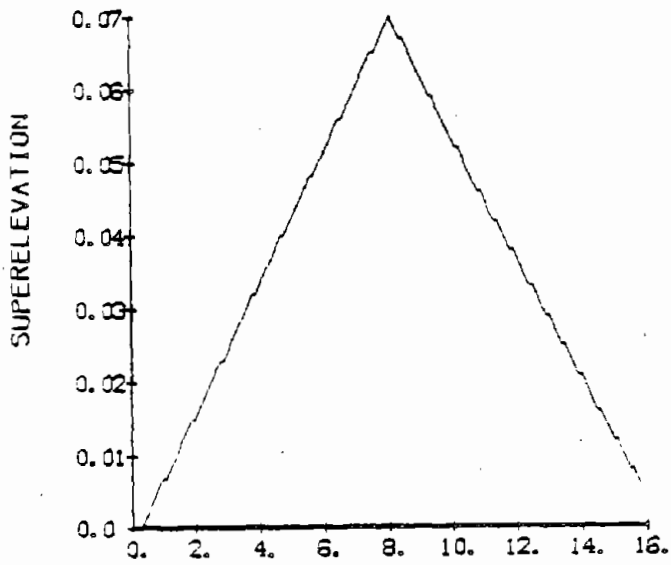
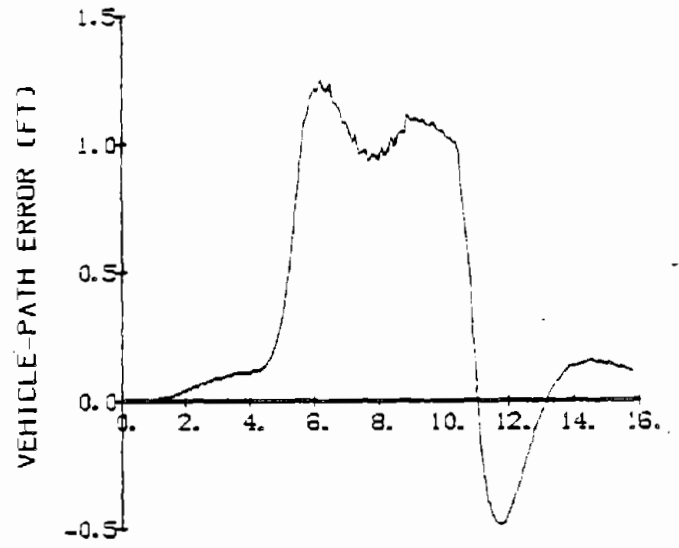
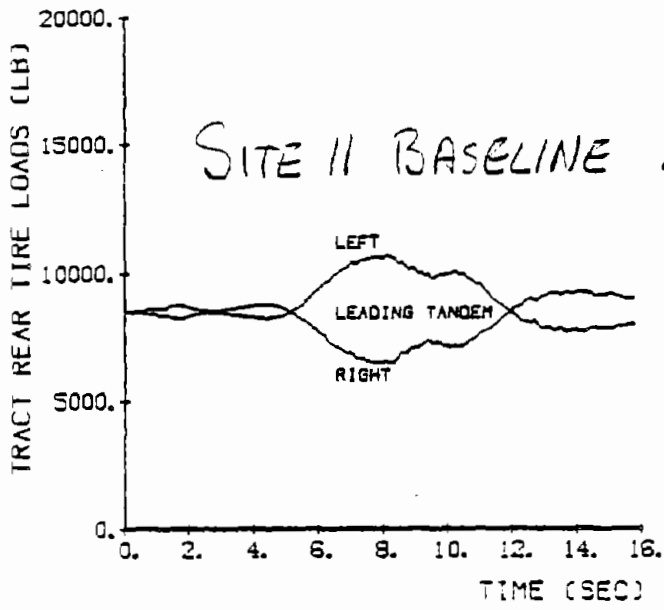

Figure 49. (continued)

SITE 12 BASELINE 40 MPH

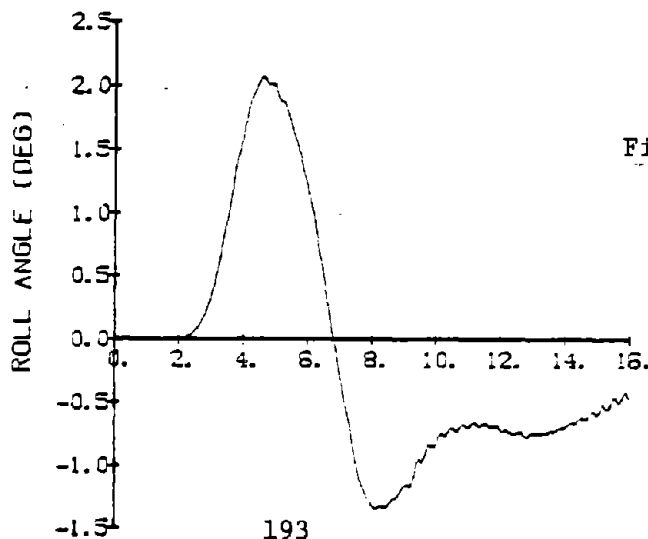
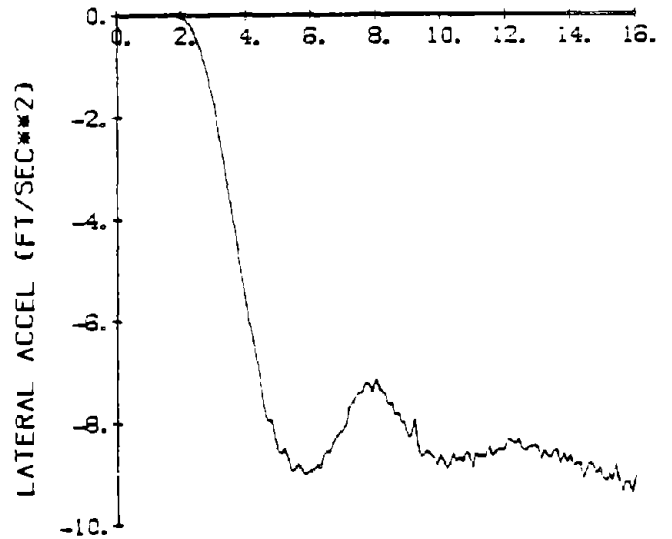
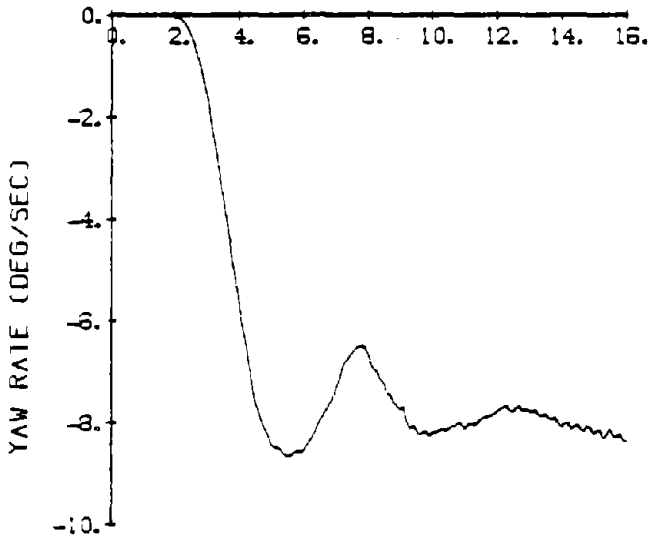
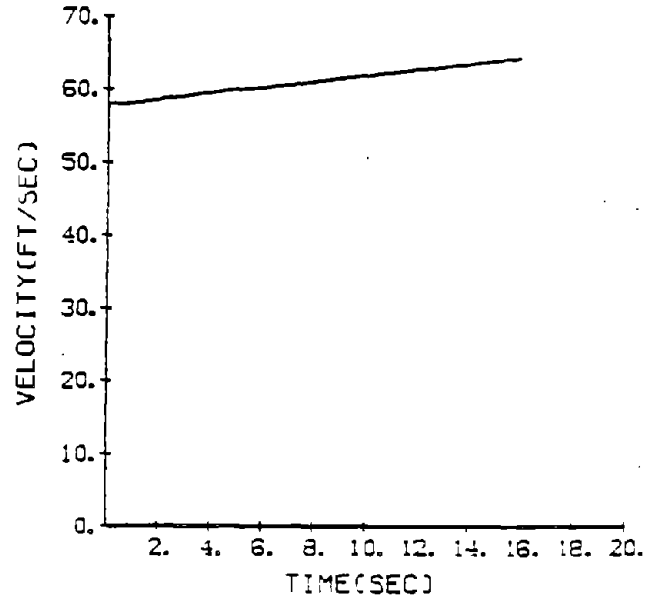
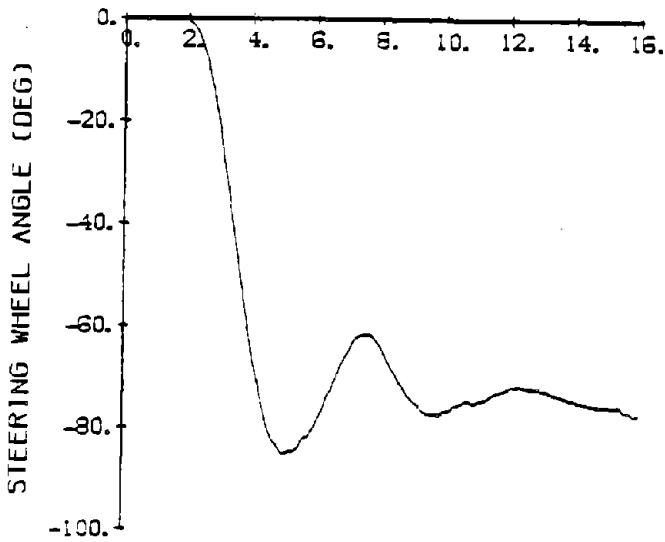

Figure 50. Site 12 baseline, 40 mi/h.

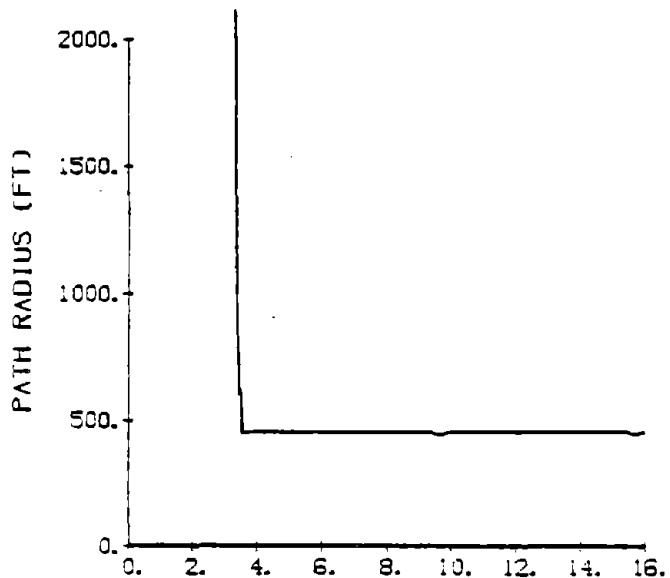
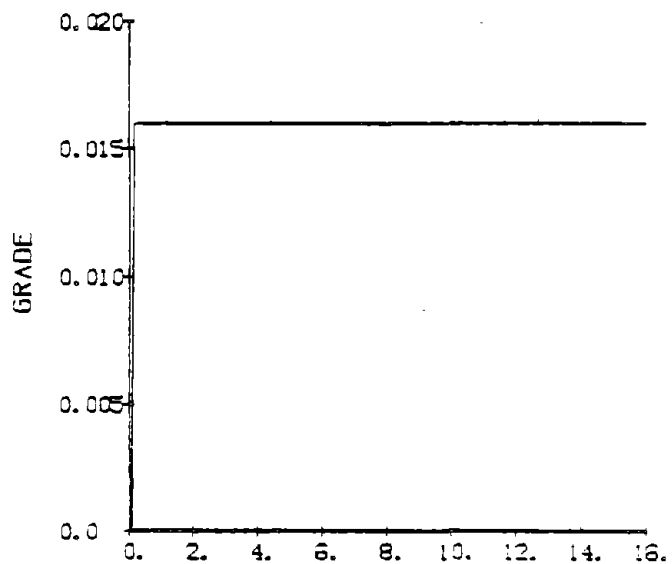
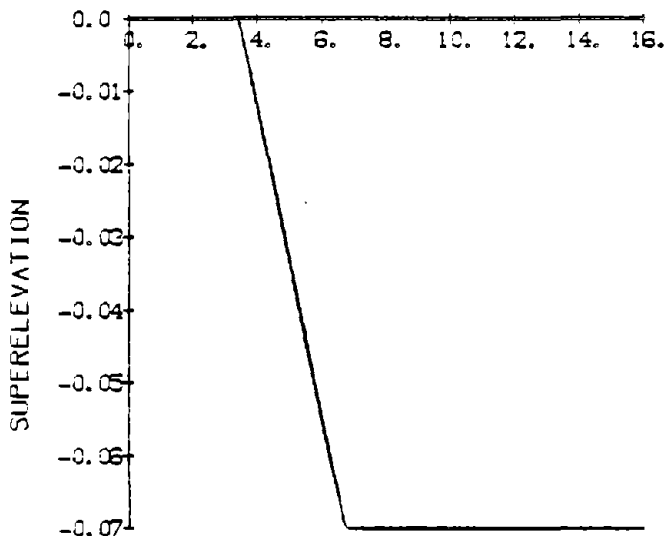
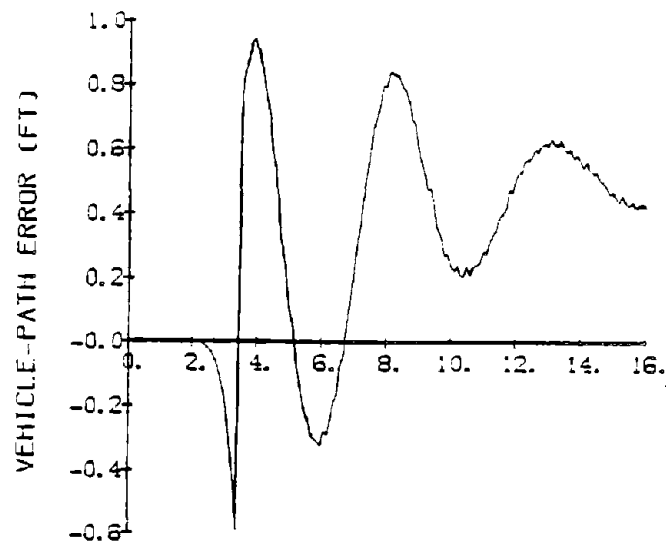
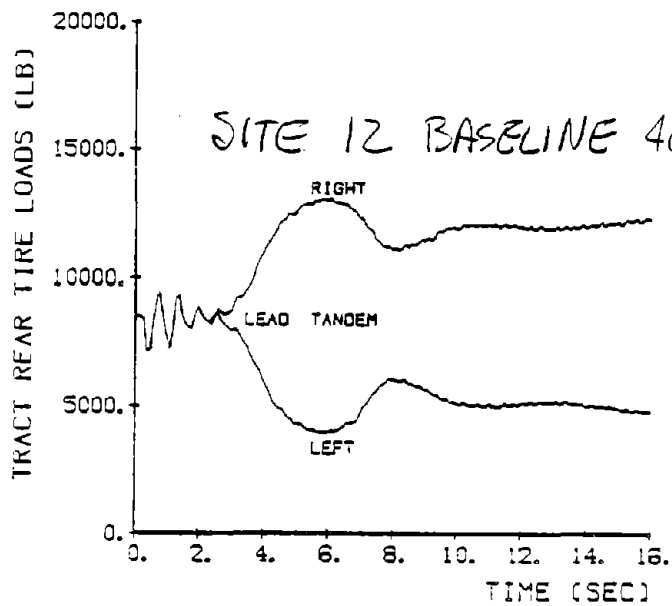

Figure 50. (continued)

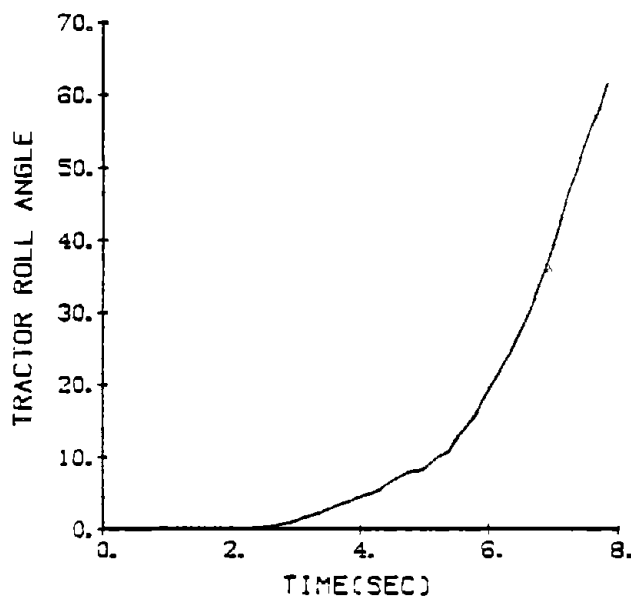
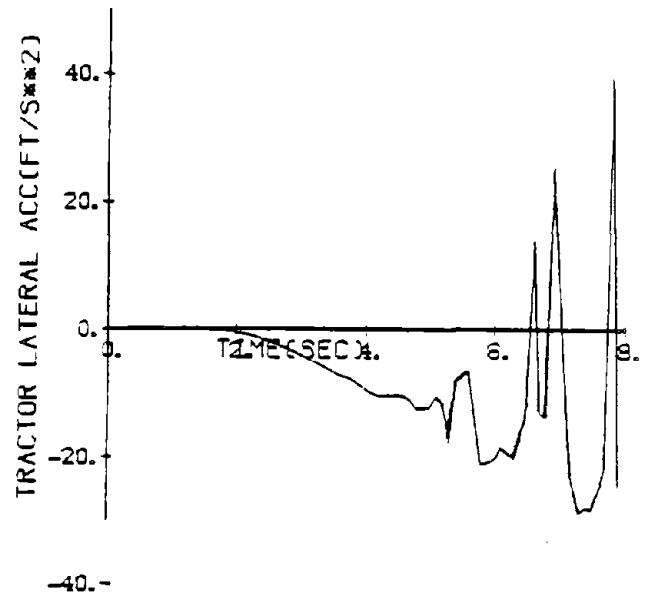
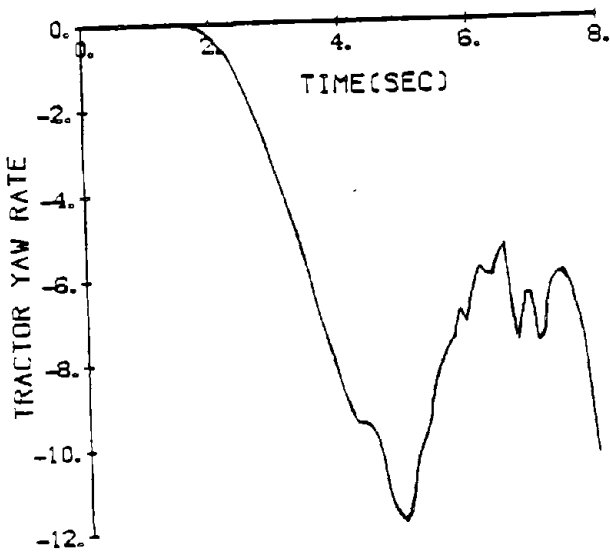
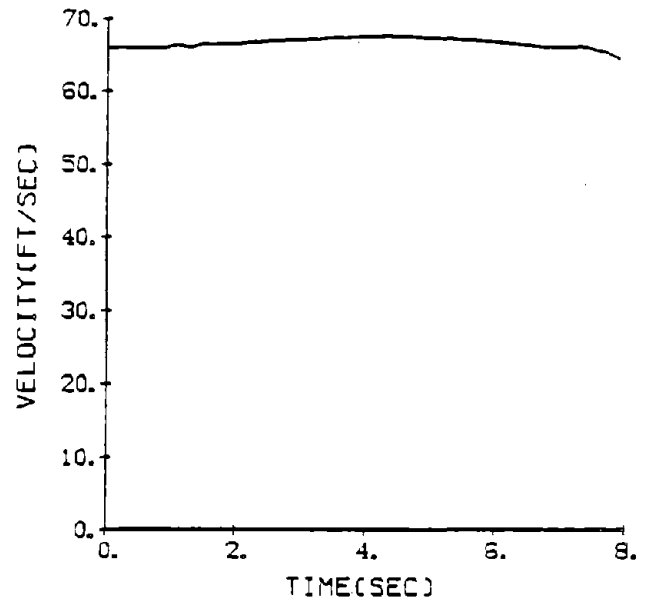
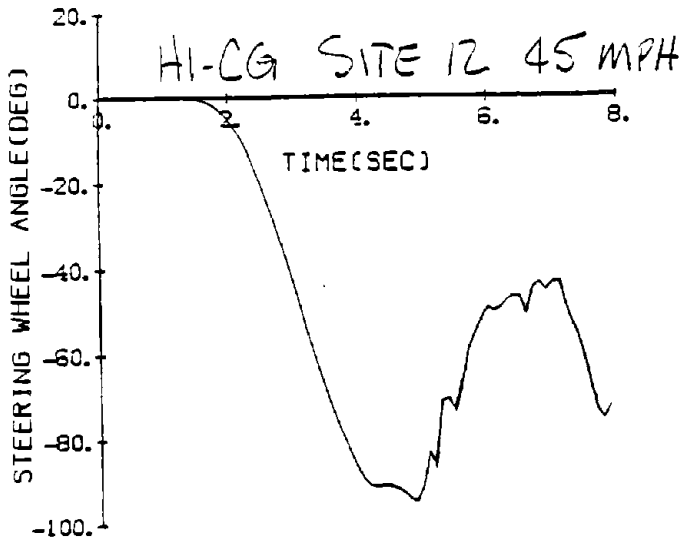

Figure 51. Site 12, hi-c.g
45 mi/h.

HI-CG SITE 12 45 MPH

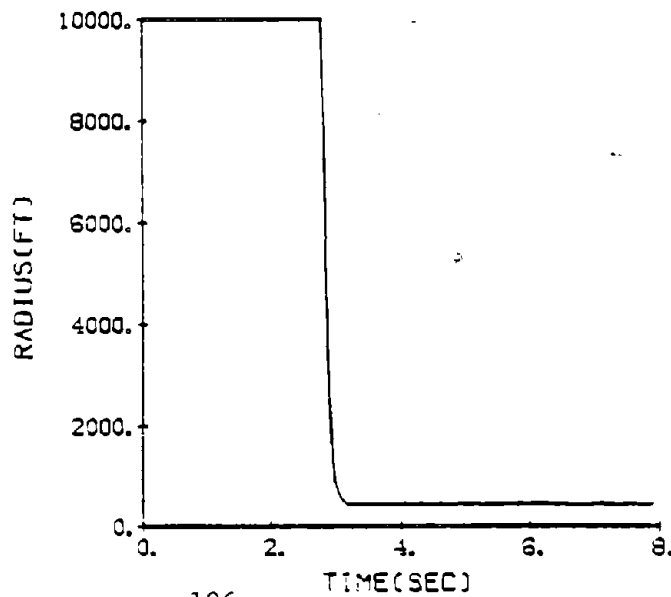
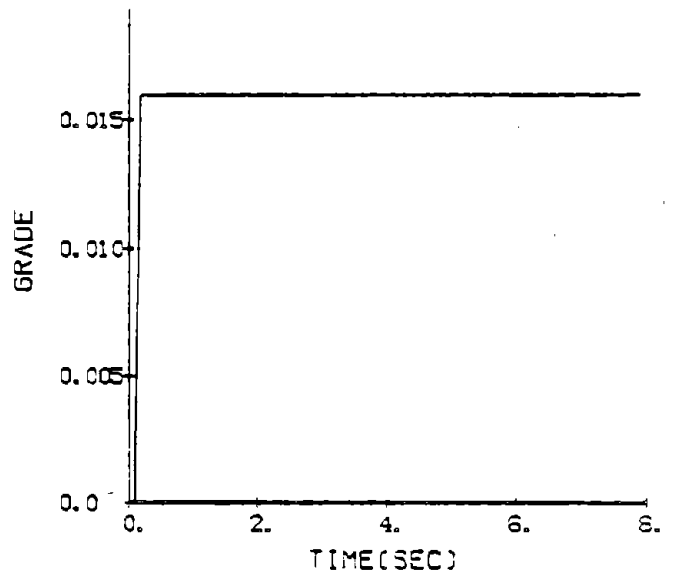
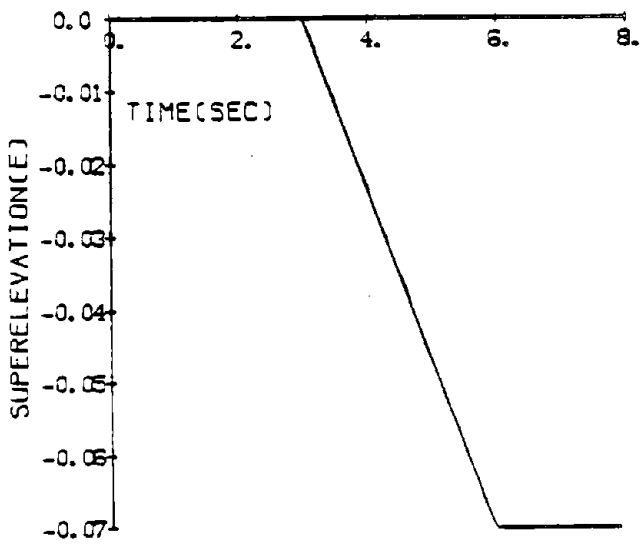
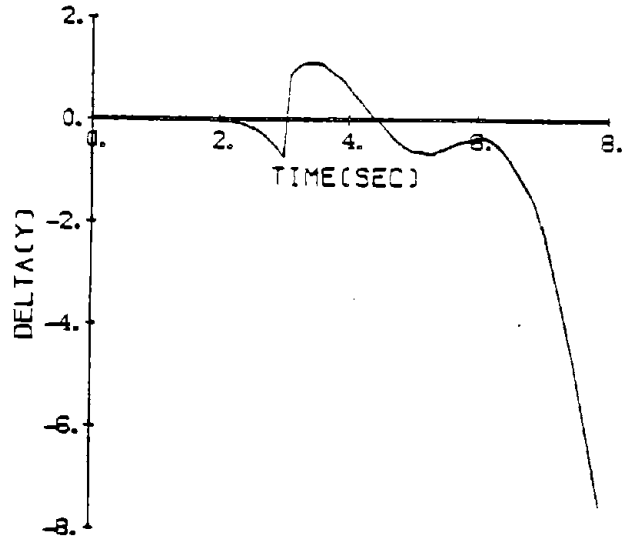
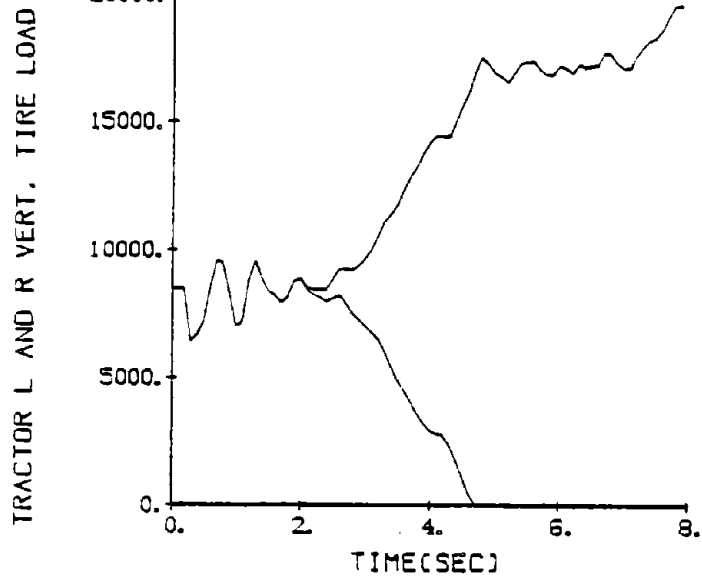

Figure 51. (continued)

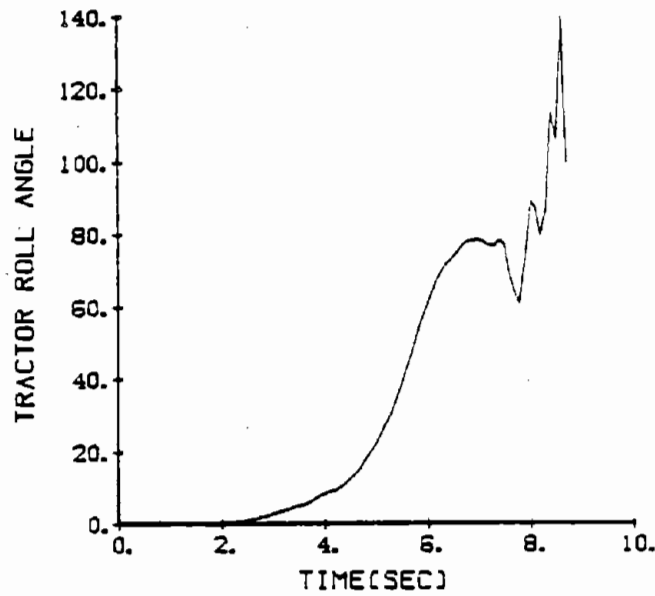
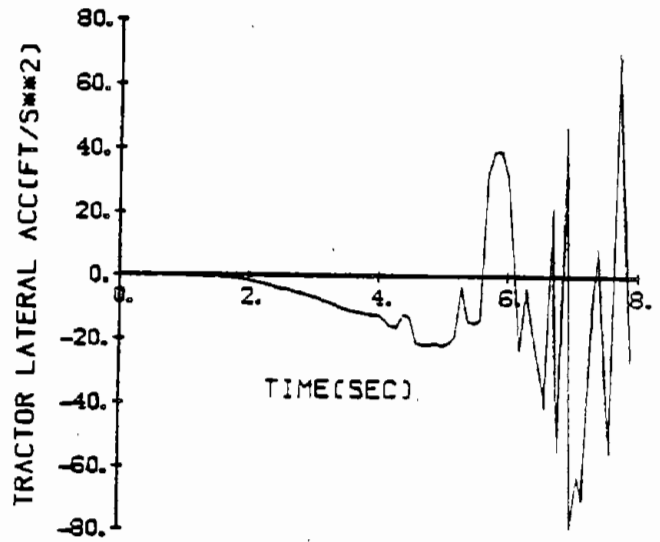
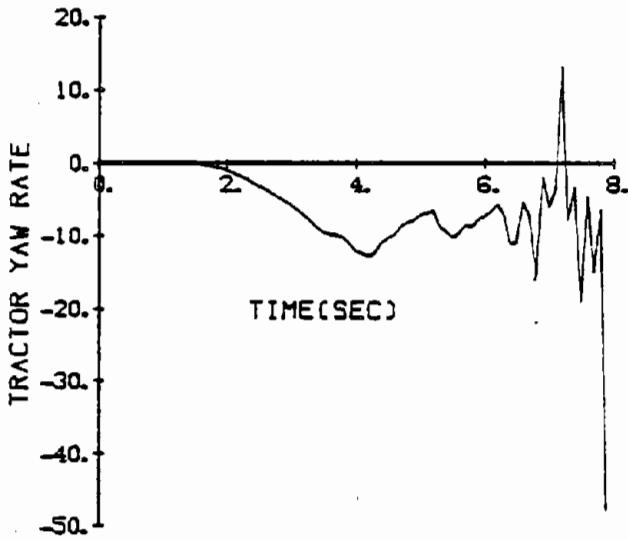
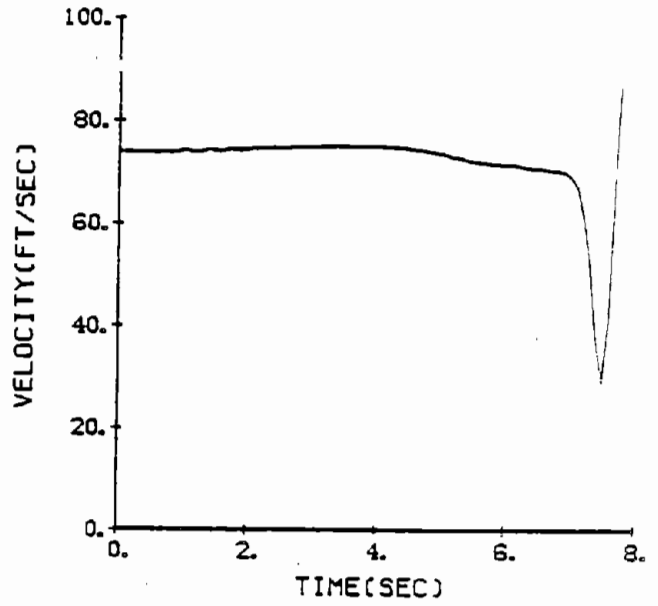
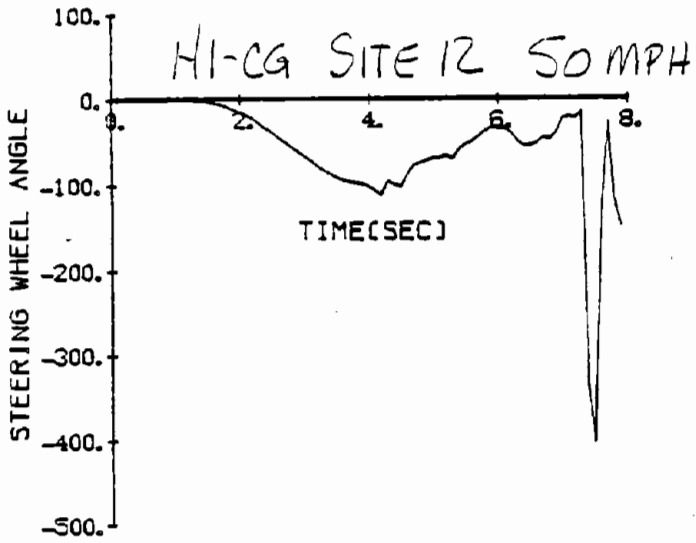
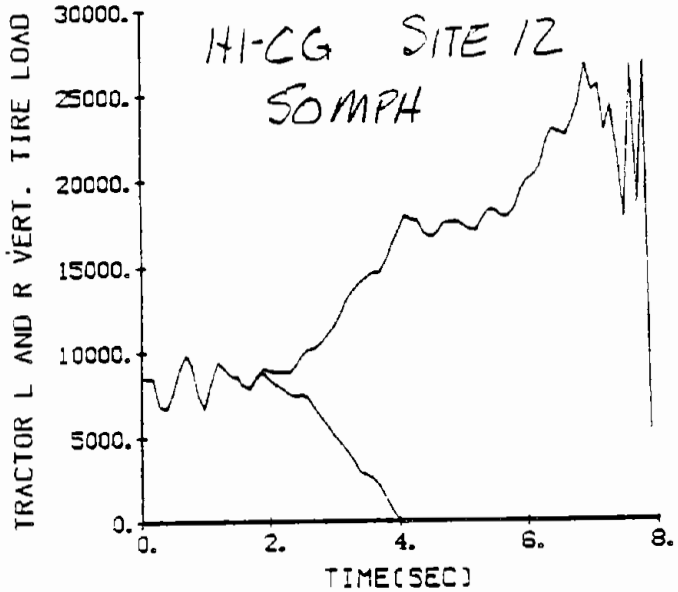
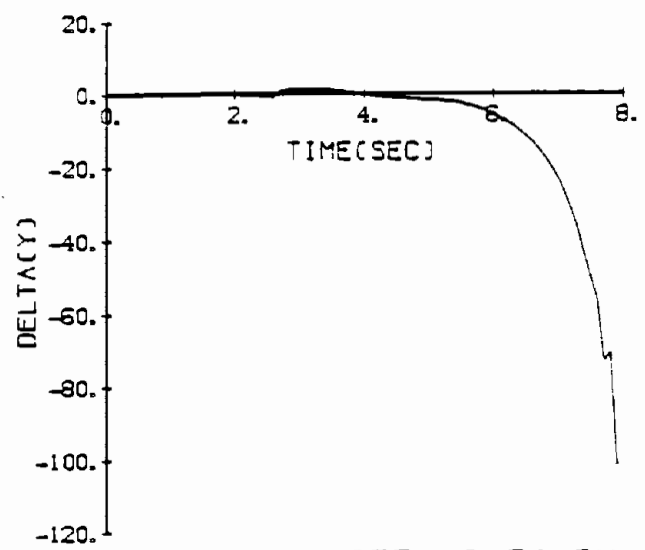

Figure 52. Site 12,
hi-c.g.,
50 mi/h.



ODD VEH. SITE 12 50MPH



ODD VEH. SITE 12 50MPH

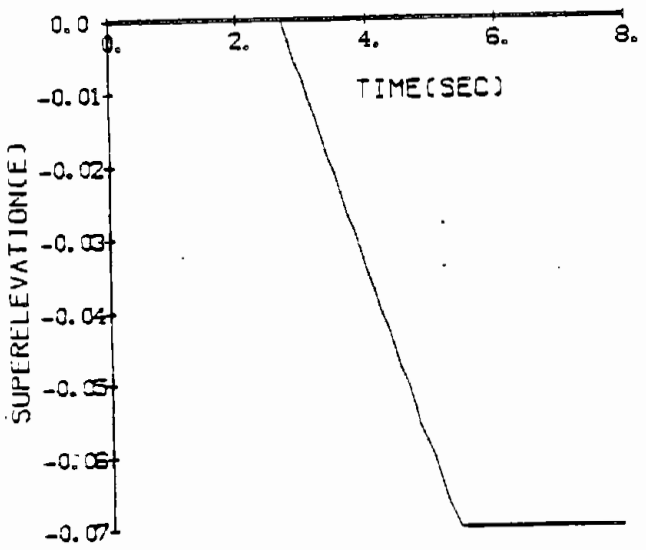

ODD VEH. SITE 12 50MPH

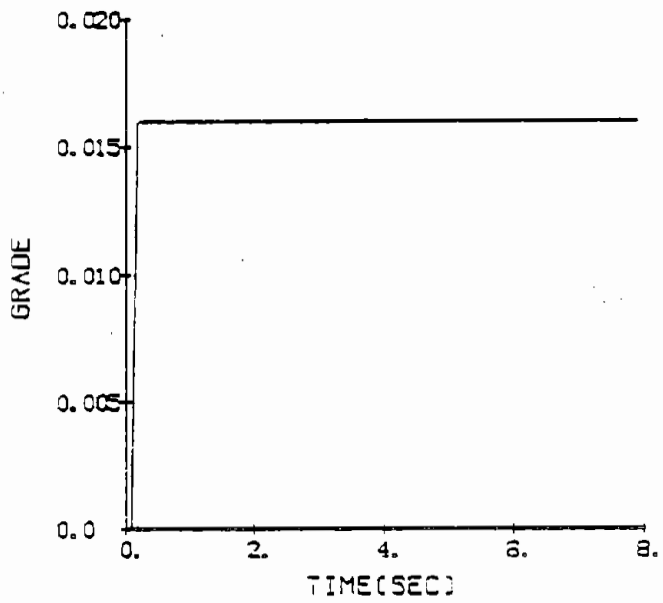

ODD VEH. SITE 12 50MPH

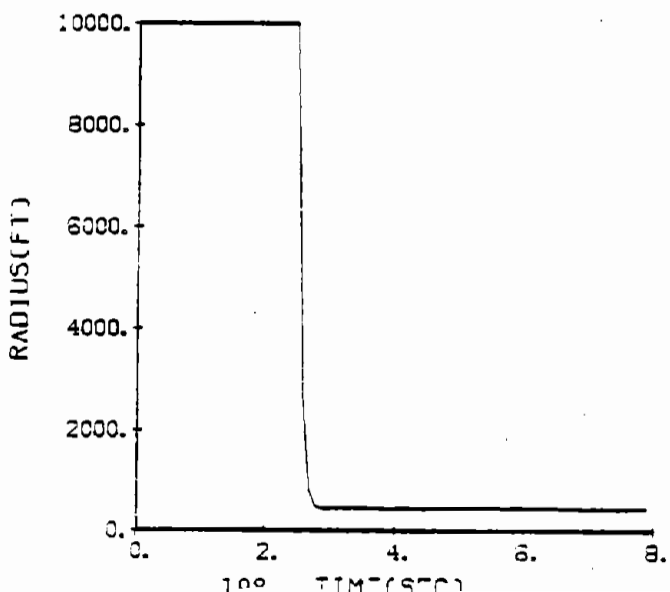

Figure 52. (continued)

SITE 13, BASELINE 35MPH

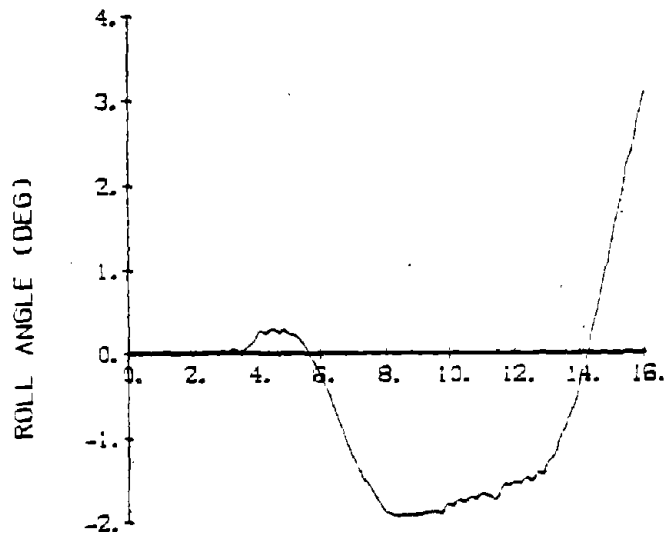
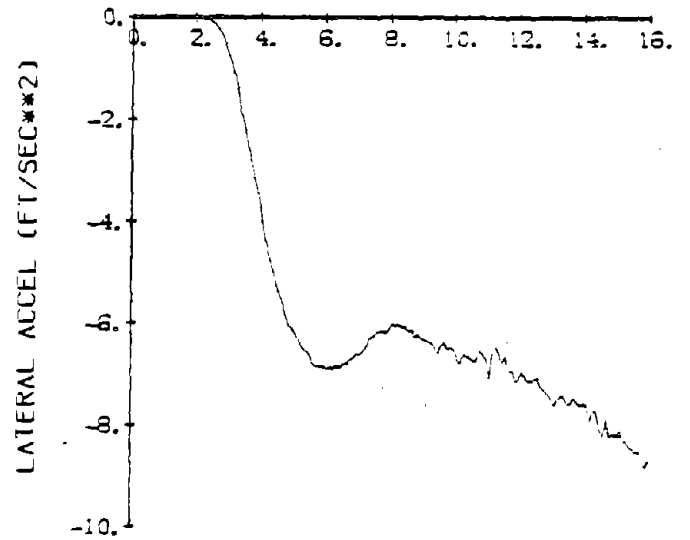
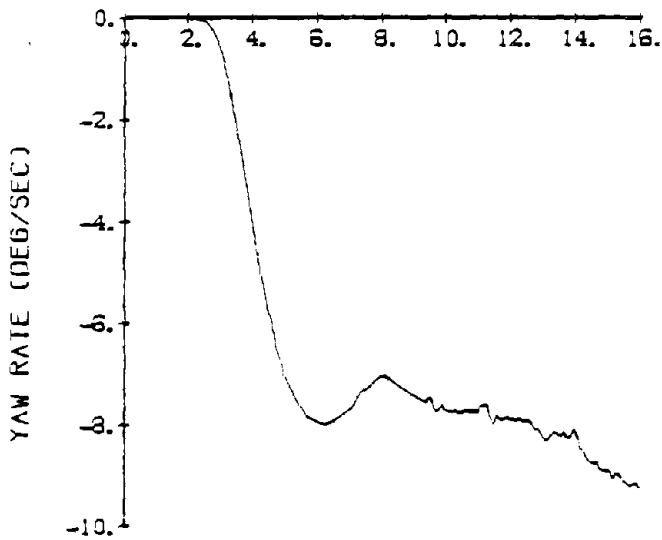
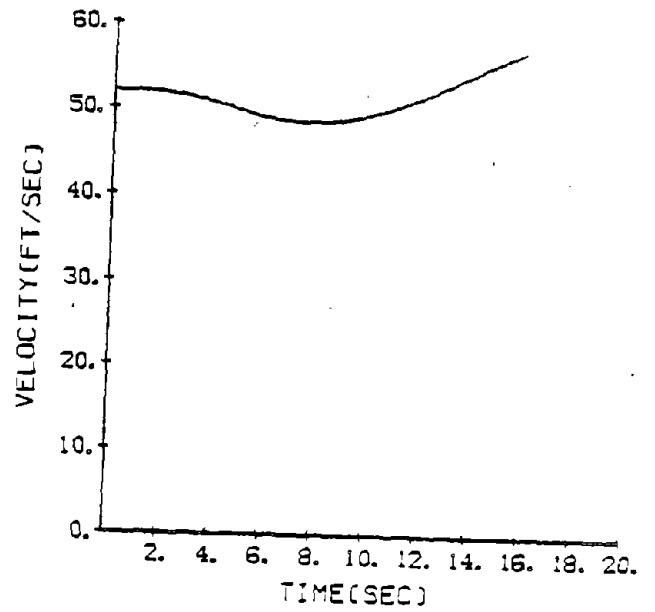
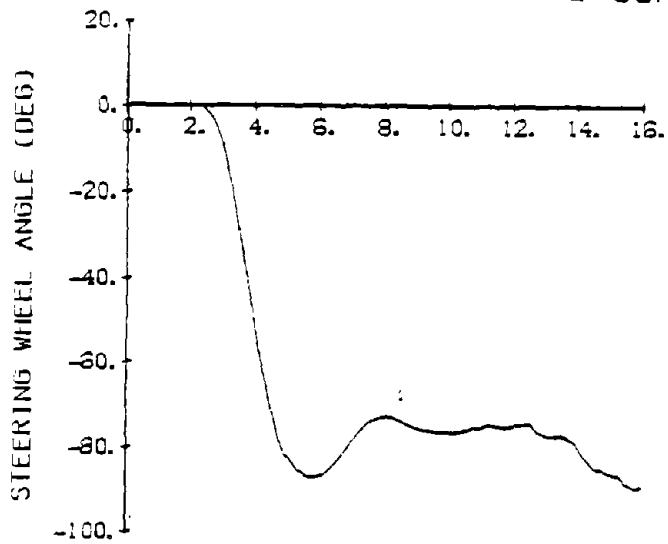

Figure 53. Site 13 baseline, 35 mi/h.

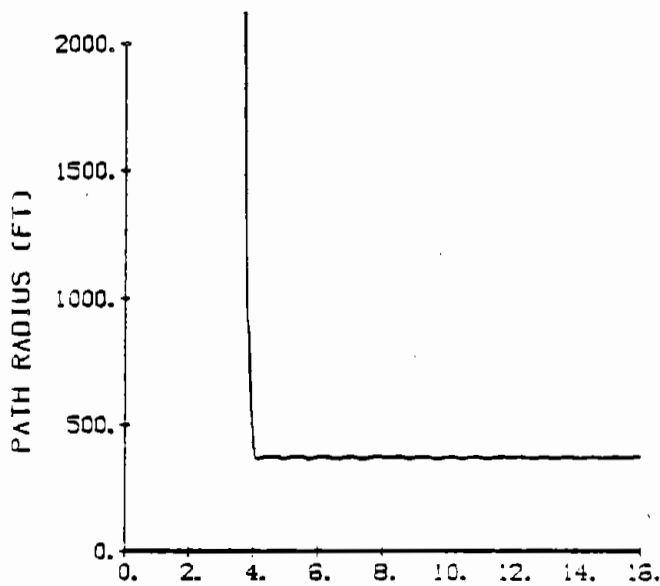
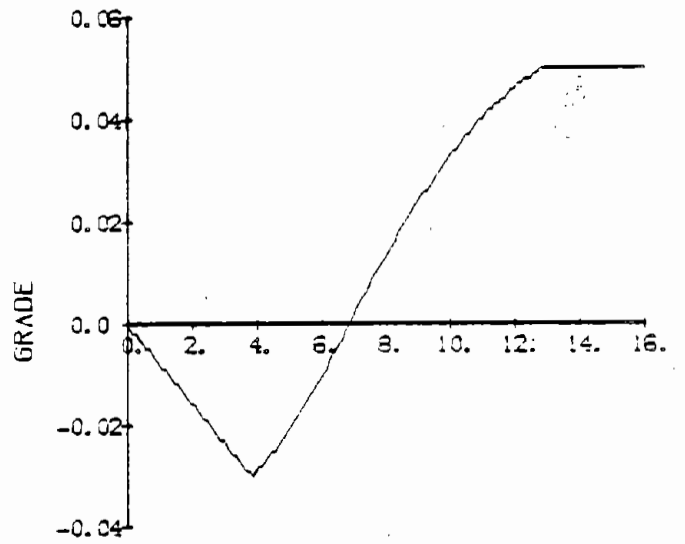
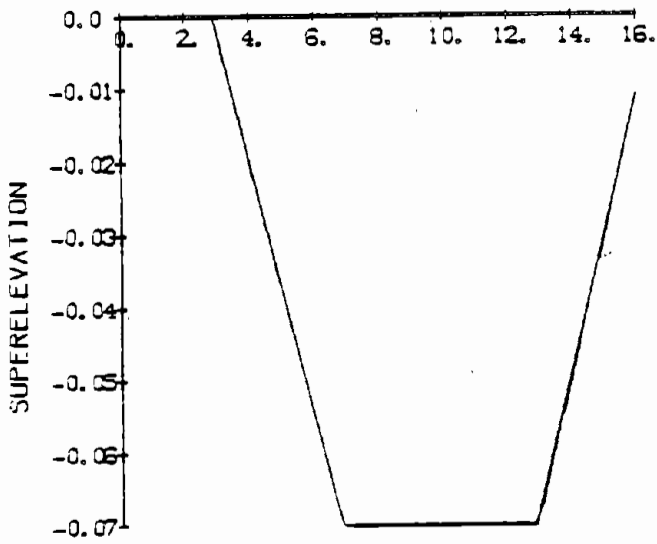
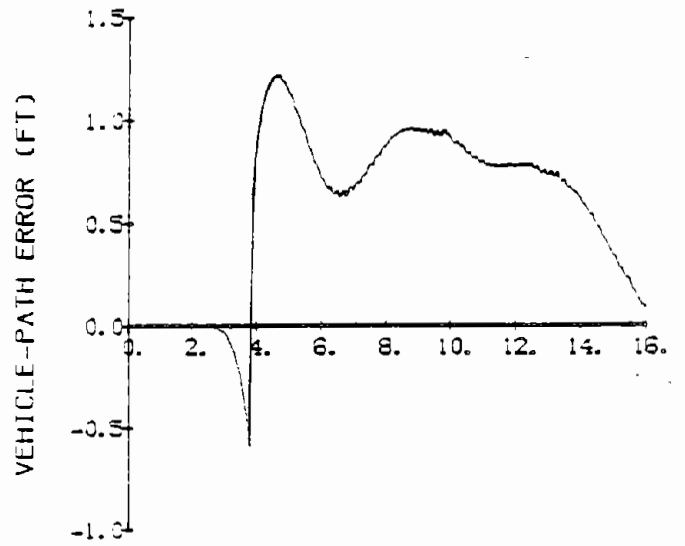
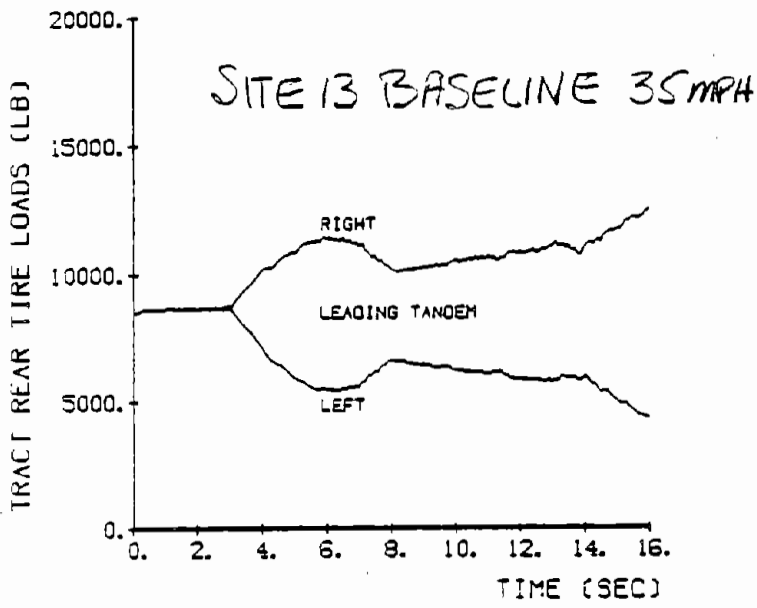

Figure 53. (continued)

SITE 14 BASELINE 40MPH

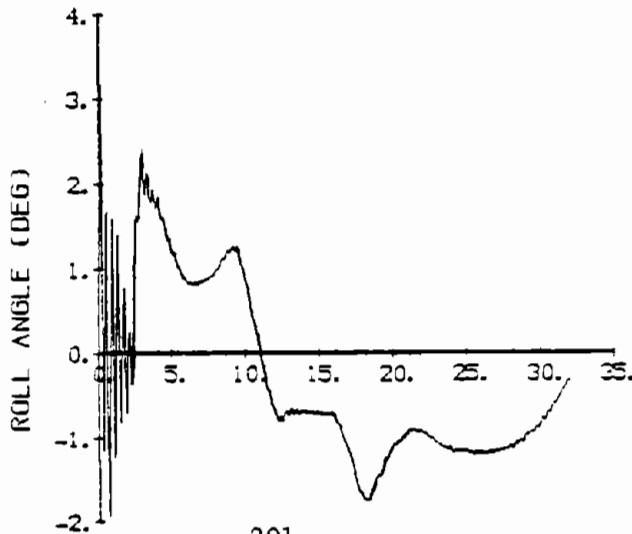
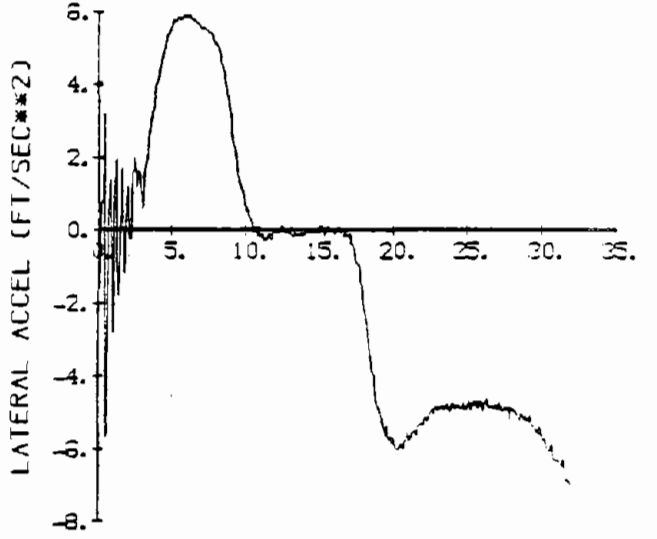
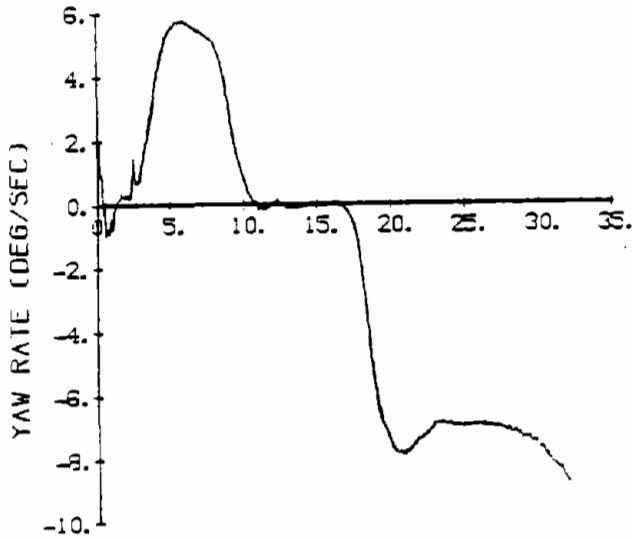
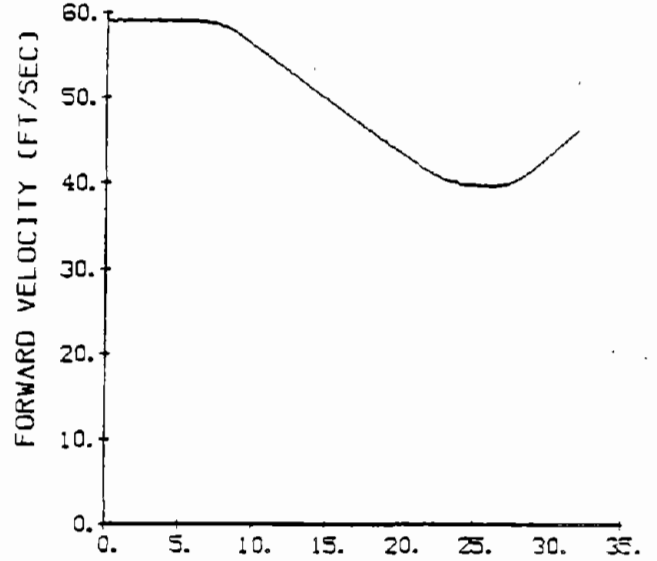
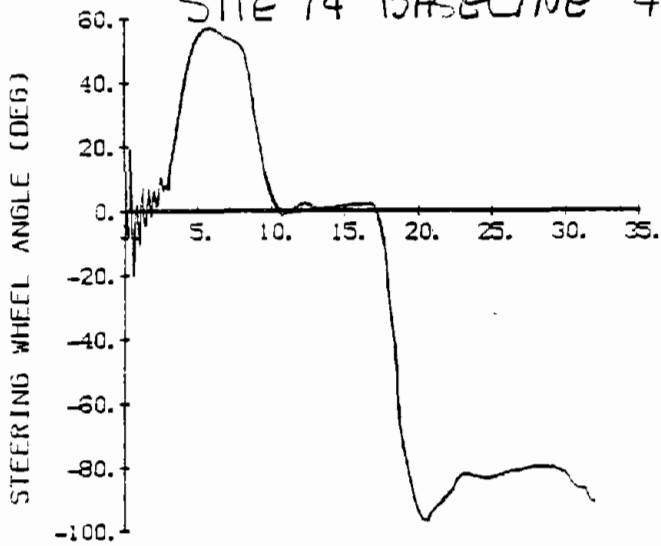

Figure 54. Site 14 baseline, 40 mi/h.

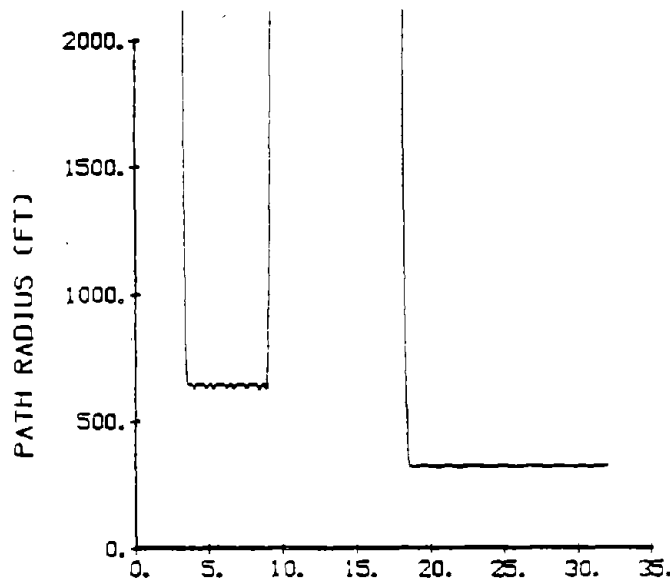
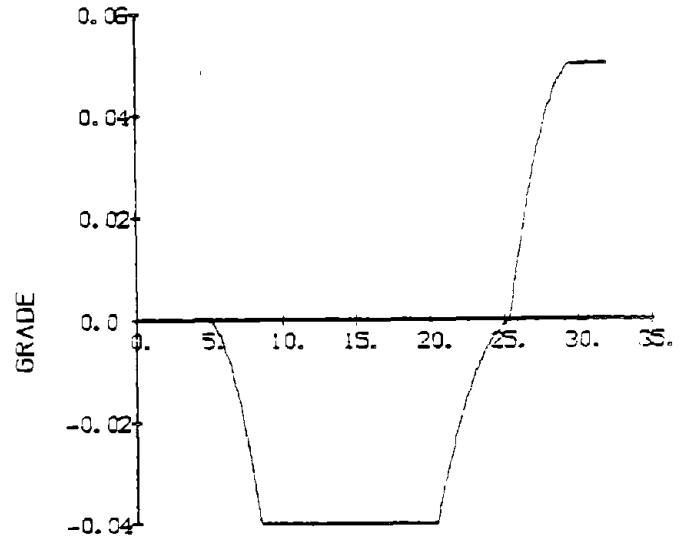
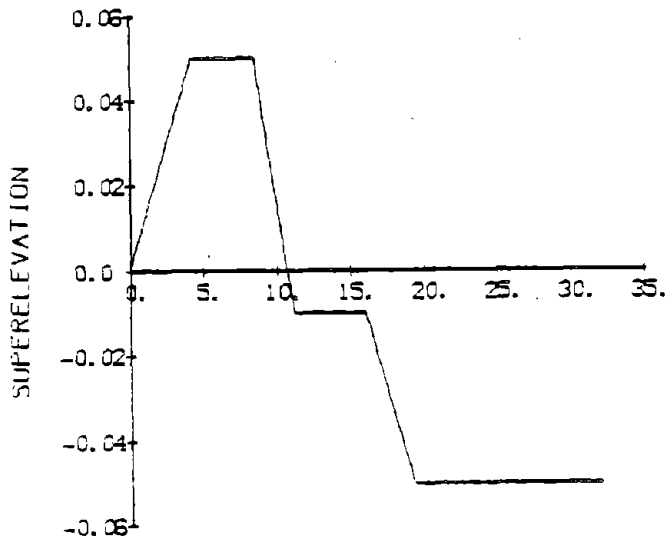
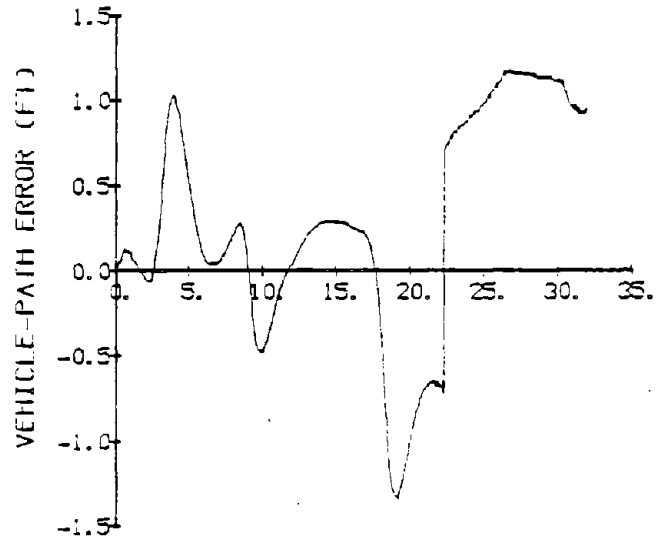
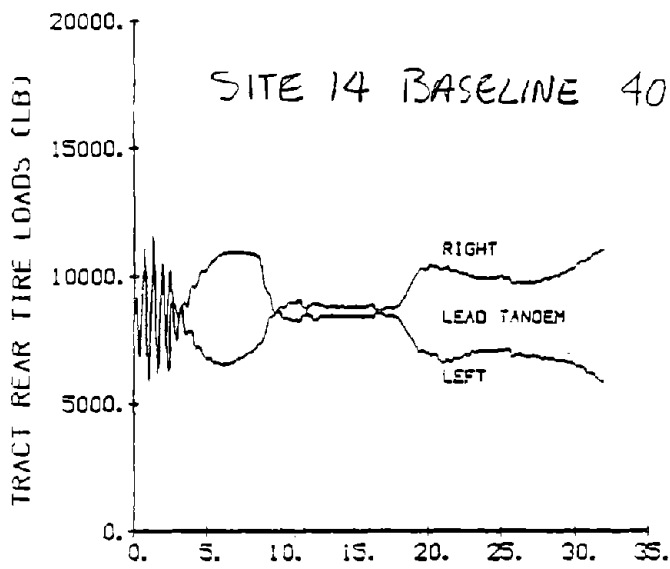

Figure 54. (continued)

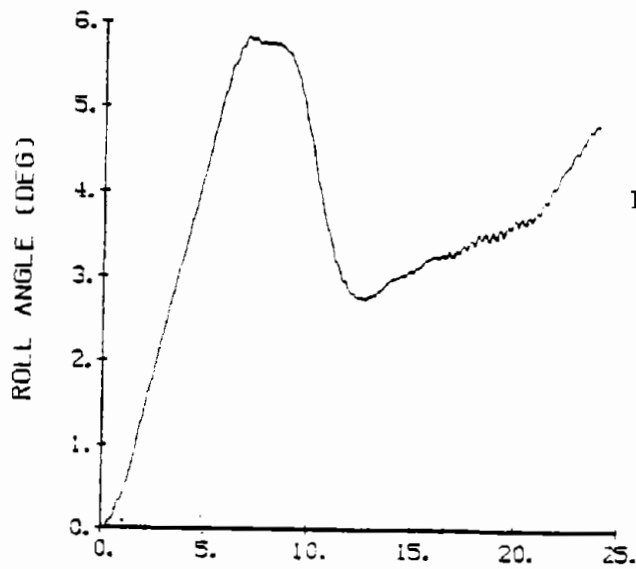
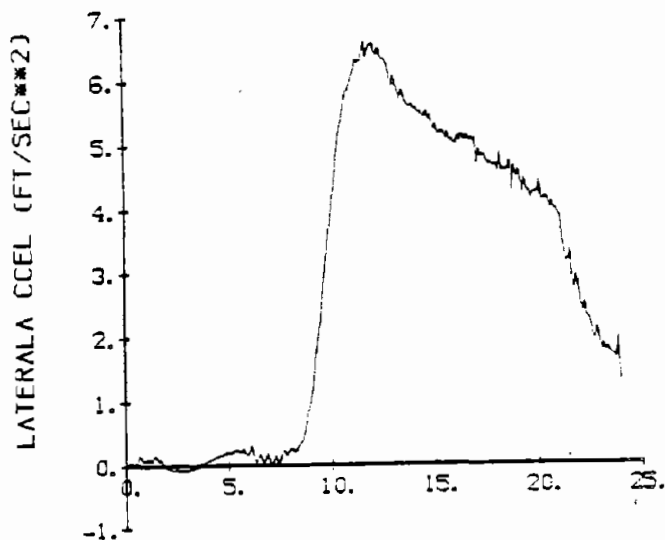
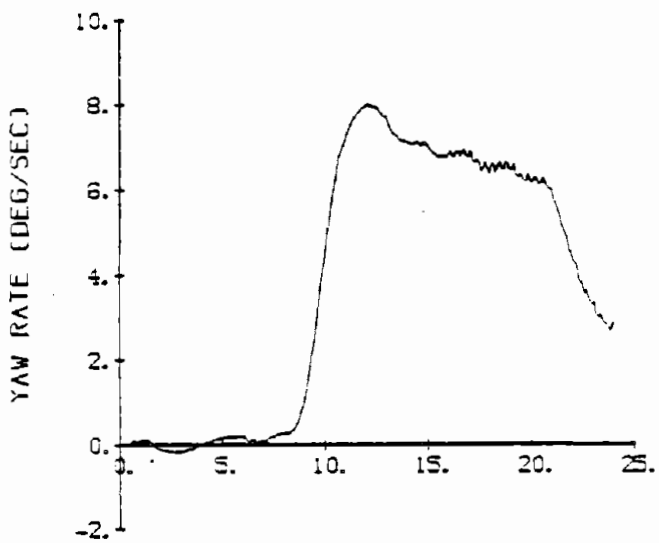
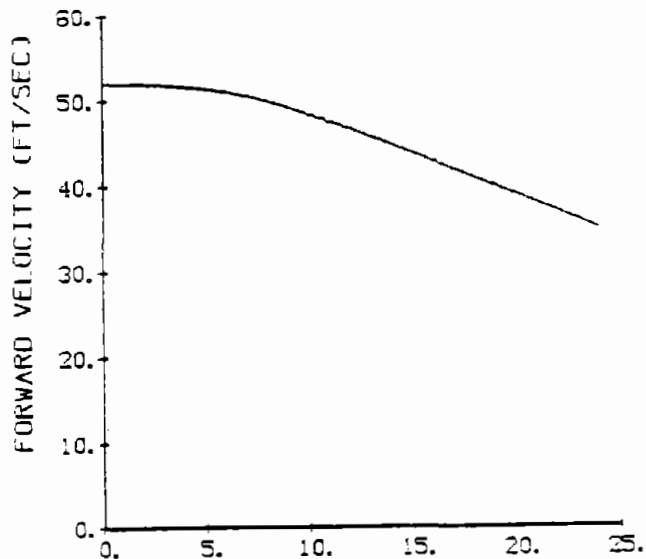
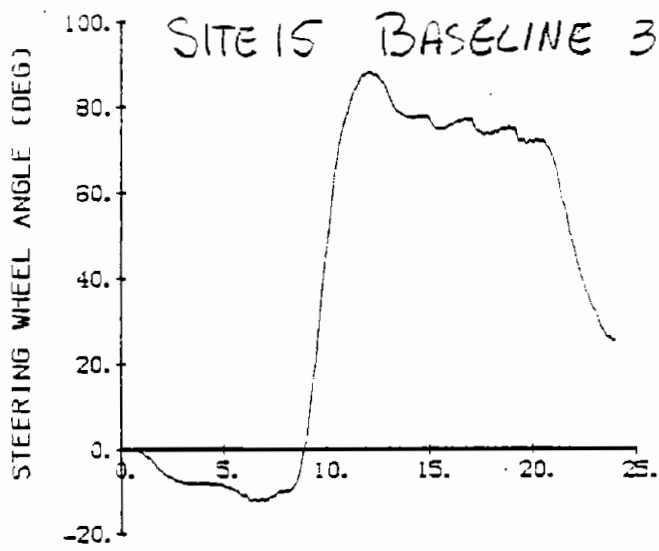

Figure 55. Site 15 baseline 35 mi/h.

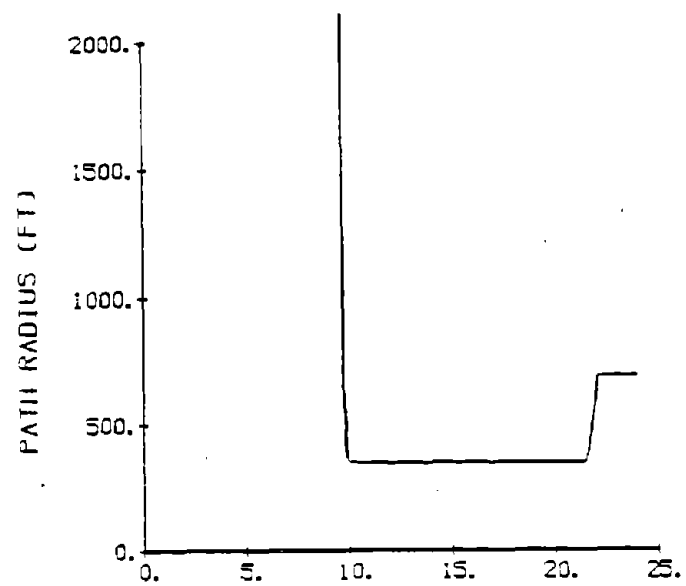
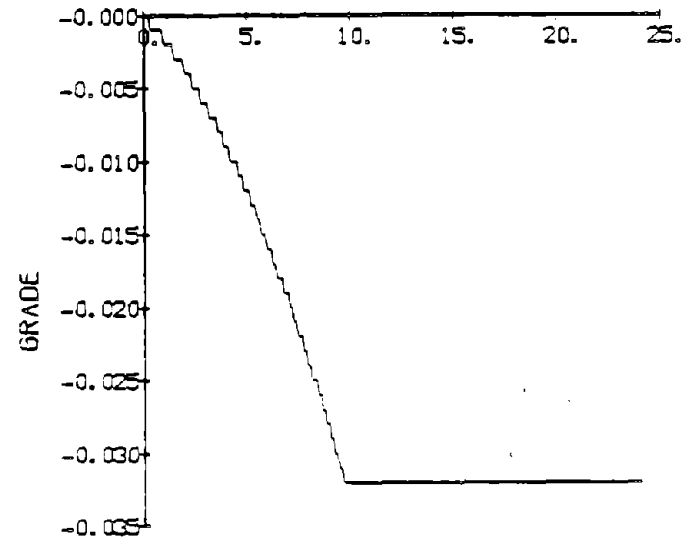
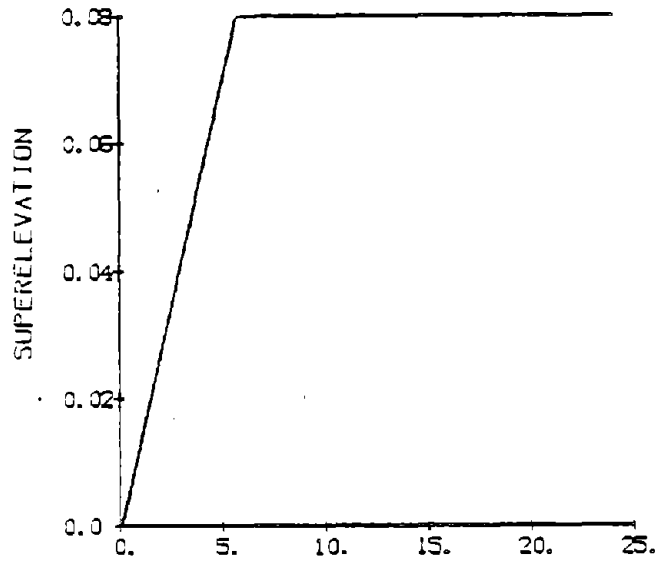
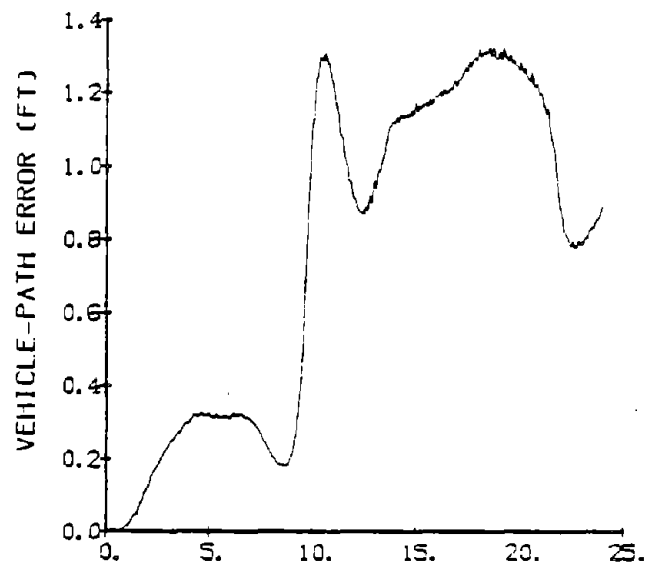
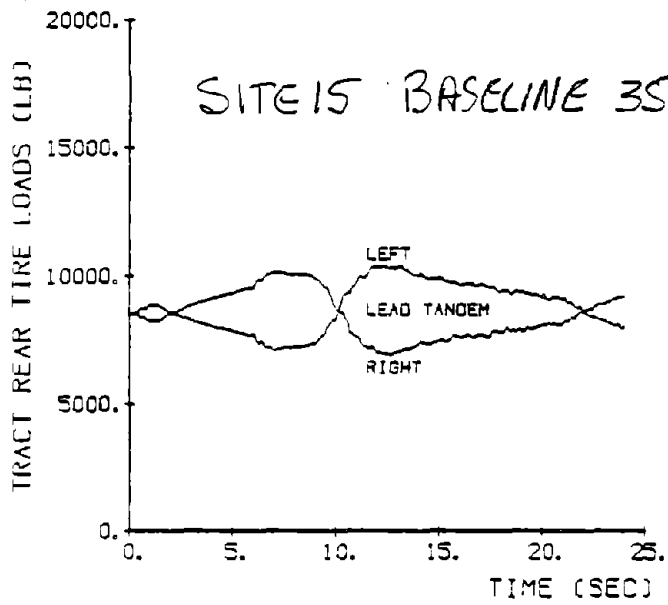

Figure 55. (continued)