

Publication No. FHWA-RD-90-085

June 1990

Development of Additional Federal Outdoor Impact Laboratory (FOIL) Facilities

**Volume II: Validation of the
FOIL Pendulum Upgrade**

REPRODUCED BY
U.S. DEPARTMENT OF COMMERCE
NATIONAL TECHNICAL
INFORMATION SERVICE
SPRINGFIELD, VA 22161



US Department of Transportation
Federal Highway Administration

Research, Development, and Technology
Turner-Fairbank Highway Research Center
6300 Georgetown Pike
McLean, Virginia 22101-2296

NOTICE

This document is disseminated under the sponsorship of the Department of Transportation in the interest of information exchange. The United States Government assumes no liability for the contents or use thereof. The contents of this report reflect the view of the contractor, who is responsible for the accuracy of the data presented herein. The contents do not necessarily reflect the official views or policy of the Department of Transportation. This report does not constitute a standard, specification, or regulation.

The United States Government does not endorse products or manufacturers. Trade or manufacturers' names appear herein solely because they are considered essential to the object of this report.

1. <u>Report No.</u> FHWA-RD-90-085		PB 91-106823		3. <u>Recipient's Catalog No.</u>	
4. <u>Title and Subtitle</u> DEVELOPMENT OF ADDITIONAL FEDERAL OUTDOOR IMPACT LABORATORY (FOIL) FACILITIES, FINAL REPORT - Volume II Validation of the FOIL Pendulum Upgrade		5. <u>Report Date</u> June 1990		6. <u>Performing Organization Code</u>	
7. <u>Author(s)</u> A. Hansen, J. Hinch, N. Santelli, C. Hott, C. Brown and N. Totani		8. <u>Performing Organization Report No.</u>		9. <u>Performing Organization Name and Address</u> The Scientex Corporation Engineering Systems Division 1750 New York Avenue, Northwest Washington, DC 20006	
10. <u>Work Unit No. (TRAIS)</u> NCP 3A5F3052		11. <u>Contract or Grant No.</u> DTFH61-87-Z-00044		12. <u>Sponsoring Agency Name and Address</u> Office of Safety and Traffic Operations R&D Federal Highway Administration 6300 Georgetown Pike McLean, Virginia 22101-2296	
13. <u>Type of Report and Period Covered</u> Final Report June 1987 - June 1990		14. <u>Sponsoring Agency Code</u>		15. <u>Supplementary Notes</u> FHWA Contracting Officer's Technical Representative: Martin W. Hargrave, HSR-20	
16. <u>Abstract</u> This report documents the design, development and validation of an upgraded pendulum for the Federal Outdoor Impact Laboratory. The pendulum, which is designed to simulate the low-speed impact of a small automobile into breakaway luminaire and sign supports, has been upgraded with an 1800-lb (817 kg) mass, a new crushable nose design, special features to reduce pendulum harmonic ringing after impact, a new sweeper plate design, and provision for mounting on board accelerometers. Additional facility modifications developed as a part of this upgrade include a removable rigid foundation for mounting luminaire and sign supports and a new speed trap system. Testing conducted on the new pendulum system confirmed the adequate operation of the new speed trap system and the acceptability of the removable rigid foundation. In addition, the pendulum crush characteristics were shown to be in agreement with the crush characteristics of the bogie vehicle put into service in 1985, and to closely model the crush of the automobile which was used as a basis for the pendulum development. Tests with the new sweeper plate design confirmed its proper performance, though the breakaway force level was 50 percent higher than the design value. Tests with actual luminaire supports demonstrated that the pendulum could indeed be used to simulate the low-speed impact of a small car into sign and luminaire supports, though there were anomalies in the data from the slip base testing. The new speed trap system and the new sweeper plate were recommended for implementation at the pendulum facility, though the attachment bolts of the sweeper plate should be replaced with lower strength bolts so that the breakaway force level is reduced. The pendulum was recommended for evaluation of anchor base, transformer base, progressive shear, coupling mounted and other breakaway luminaire and sign supports which have already been shown to perform satisfactorily with the bogie vehicle. However, further research was recommended to evaluate the anomalies in the results of the slip base testing (with automobiles and with surrogates like the pendulum and bogie) before the pendulum is used for slip base evaluations. This is Volume II of a two-volume final report. Volume I is entitled "Preliminary Design Study For Upgrading FOIL to Test With Heavier Vehicles," Publication No. FHWA-RD-89-172.					
17. <u>Key Words</u> Pendulum FOIL Impacts Rigid instrumented pole		Luminaire supports Surrogate vehicles Speed traps		18. <u>Distribution Statement</u> No restrictions. This document is available to the public through the National Technical Information Service, Springfield, Virginia 22161.	
19. <u>Security Classif. (of this report)</u> Unclassified		20. <u>Security Classif. (of this page)</u> Unclassified		21. <u>No. of Pages</u> 29	
22. <u>Price</u>					

SI* (MODERN METRIC) CONVERSION FACTORS

APPROXIMATE CONVERSIONS TO SI UNITS

Symbol	When You Know	Multiply By	To Find	Symbol
LENGTH				
in	inches	25.4	millimetres	mm
ft	feet	0.305	metres	m
yd	yards	0.914	metres	m
mi	miles	1.61	kilometres	km
AREA				
in ²	square inches	645.2	millimetres squared	mm ²
ft ²	square feet	0.093	metres squared	m ²
yd ²	square yards	0.836	metres squared	m ²
ac	acres	0.405	hectares	ha
mi ²	square miles	2.59	kilometres squared	km ²
VOLUME				
fl oz	fluid ounces	29.57	millilitres	mL
gal	gallons	3.785	litres	L
ft ³	cubic feet	0.028	metres cubed	m ³
yd ³	cubic yards	0.765	metres cubed	m ³
MASS				
oz	ounces	28.35	grams	g
lb	pounds	0.454	kilograms	kg
T	short tons (2000 lb)	0.907	megagrams	Mg
TEMPERATURE (exact)				
°F	Fahrenheit temperature	$5(F-32)/9$	Celsius temperature	°C

NOTE: Volumes greater than 1000 L shall be shown in m³.

APPROXIMATE CONVERSIONS FROM SI UNITS

Symbol	When You Know	Multiply By	To Find	Symbol
LENGTH				
mm	millimetres	0.039	inches	in
m	metres	3.28	feet	ft
m	metres	1.09	yards	yd
km	kilometres	0.621	miles	mi
AREA				
mm ²	millimetres squared	0.0016	square inches	in ²
m ²	metres squared	10.764	square feet	ft ²
ha	hectares	2.47	acres	ac
km ²	kilometres squared	0.386	square miles	mi ²
VOLUME				
mL	millilitres	0.034	fluid ounces	fl oz
L	litres	0.264	gallons	gal
m ³	metres cubed	35.315	cubic feet	ft ³
m ³	metres cubed	1.308	cubic yards	yd ³
MASS				
g	grams	0.035	ounces	oz
kg	kilograms	2.205	pounds	lb
Mg	megagrams	1.102	short tons (2000 lb)	T
TEMPERATURE (exact)				
°C	Celsius temperature	$1.8C + 32$	Fahrenheit temperature	°F

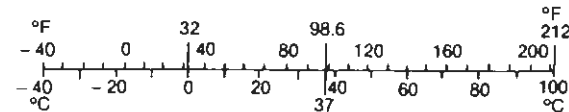

* SI is the symbol for the International System of Measurement

(Revised April 1989)

TABLE OF CONTENTS

<u>Section</u>	<u>Page</u>
INTRODUCTION.....	1
SYSTEM DESIGN.....	2
Pendulum.....	2
(a) Design alternative assessment.....	2
(b) Mass design.....	4
(c) Sliding nose design.....	5
(d) Accelerometer mounting.....	5
(e) Sweeper plate design.....	7
Test Article Mounting System.....	7
Speed Trap System.....	9
Design Documentation.....	11
SYSTEM VALIDATION.....	13
Validation Plan.....	13
Results.....	13
(a) Pendulum weight.....	13
(b) Speed trap functionality tests.....	14
(c) Rigid instrumented pole tests.....	14
(d) Luminaire support tests.....	16
Slip base luminaire supports.....	16
Anchor base luminaire supports.....	16
(e) Sweeper plate tests.....	18
DISCUSSION AND CONCLUSIONS.....	21
Speed Trap System.....	21
Pendulum Force-Deflection Characteristics.....	21
Luminaire Support Testing.....	23
Sweeper Plate Functionality.....	23
RECOMMENDATIONS.....	24
REFERENCES.....	25

LIST OF FIGURES

<u>Figure</u>		<u>Page</u>
1	Schematic of new pendulum.....	3
2	Pendulum mass.....	4
3	Sliding nose design.....	5
4	Schematic of honeycomb nose cartridge placement.....	6
5	Rigid sweeper plate design.....	7
6	Test article mounting system.....	8
7	Mounting system span beam.....	9
8	Schematic of speed trap system.....	10
9	Speed trap system mounted at the pendulum site.....	11
10	Schematic of rigid instrumented pole.....	15
11	Typical slip base luminaire support.....	17
12	Typical anchor base luminaire support.....	19
13	Pendulum with rigid sweeper plate attached.....	20
14	Average vehicle force versus displacement.....	22

LIST OF TABLES

<u>Table</u>		<u>Page</u>
1	Pendulum upgrade drawings.....	12
2	Pendulum upgrade test matrix.....	13
3	Pendulum component weights.....	13
4	Speed trap validation results.....	14
5	Rigid instrumented pole test results.....	16
6	Slip base luminaire support test results.....	16
7	Anchor base luminaire support test results.....	18
8	Pendulum rigid sweeper plate stub test summary.....	18
9	Pendulum rigid sweeper plate anchor base luminaire support test summary.....	20
10	Average maximum load cell results.....	21

INTRODUCTION

This report documents the design, development and validation of an upgraded pendulum for the Federal Outdoor Impact Laboratory (FOIL). The pendulum, which is designed to simulate the low-speed impact of a small vehicle into breakaway luminaire and sign supports, has been upgraded in the following areas:

- An 1800-lb (817-kg) mass to replace the previous, heavier mass.
- New crushable nose design.
- New speed trap design.
- Special design features to reduce the harmonic ringing of the pendulum after impact.
- Provision for mounting the on board accelerometers.
- A rigid, removable foundation to mount luminaire and sign supports and the rigid instrumented pole.
- New sweeper plate design.

The next section of this report discusses the design alternatives that were considered, and provides details on the new pendulum mass, the sliding nose, the accelerometer mounting, and the sweeper plate. The new test article mounting foundation is then described, followed by the speed trap system. Design documentation is then listed.

SYSTEM DESIGN

Pendulum

(a) Design alternative assessment

The original pendulum mass at the FOIL was composed of two solid blocks of steel rigidly fastened together to form the equivalent of a single steel block. Since steel has low internal damping, it oscillates (or rings) at its natural frequency for some time after it is impacted. Essentially, the original pendulum mass was a very stiff spring with no damper. The ringing is seen by accelerometers as cyclic loading of very low amplitude at the system's natural frequency.

An analysis was completed and tests were conducted to verify the natural frequency of the pendulum. It was determined that resonance occurred at about 2880 Hz, with the ringing damping to 5 percent of its peak 30 ms after impact.⁽¹⁾ Accelerometers then in use at the FOIL would be affected by oscillations in this frequency range, so different accelerometers, with a much higher resonance frequency (5000 Hz), were adopted for future testing.

In addition to specifying different accelerometers, the new design incorporated features to increase the damping of the system, and included the following capabilities:

- Provision for redundant longitudinal accelerometers, mounted to prevent damage from falling poles or other test hazards.
- Utilization of a new sliding nose design similar to that used on the FOIL bogie.
- Mounting capability for both rigid and breakaway sweeper plates.
- Designed for stability during impact so that excessive yawing and pitching do not occur.
- Designed to a fixed weight of 1700 lb (772 kg), excluding the nose.

Three alternative designs were considered for the new pendulum:⁽¹⁾

- (1) Design the pendulum mass such that the ringing frequency is at a level which will be essentially eliminated by low pass filtering used in data analysis.
- (2) Fabricate the pendulum from materials which do not ring.
- (3) Design the pendulum in a sandwich configuration of dissimilar materials to damp out the ringing.

Design (3) was selected for development, using a concrete central mass with steel front and rear plates, shown conceptually in figure 1. The features of

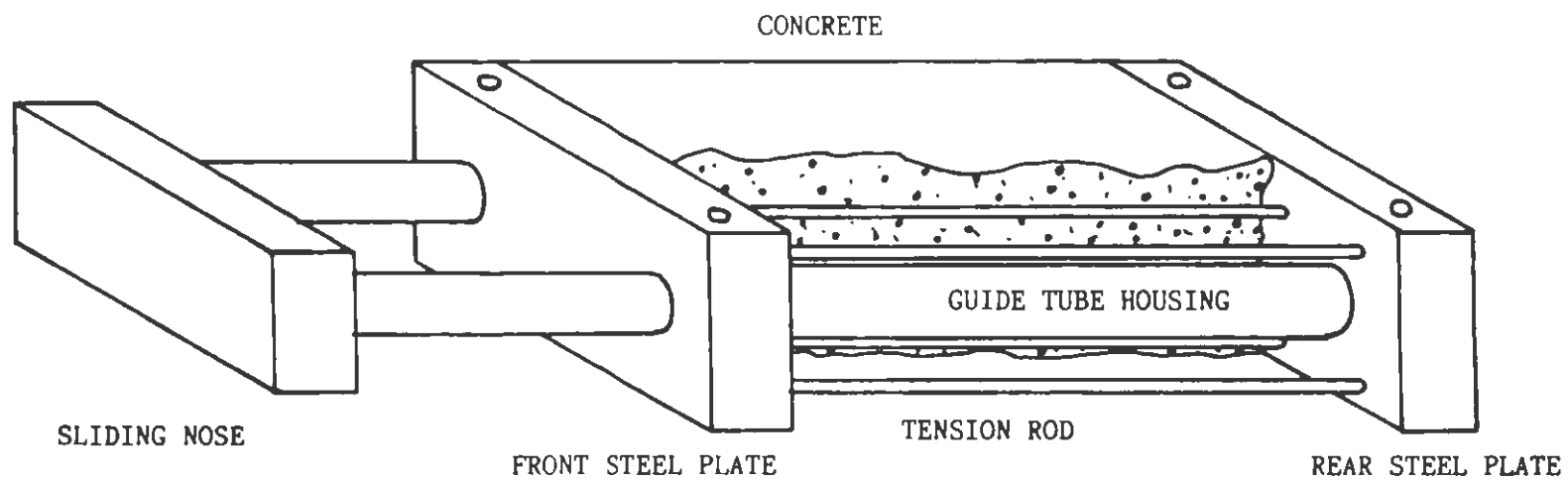

Figure 1. Schematic of new pendulum.

this design and supporting systems are discussed below. Discussions of design particulars, including the analyses conducted, are presented in detail in the final design documentation.⁽²⁾

(b) Mass design

The pendulum mass assembly is shown in figure 2. This design consists of a central steel-reinforced concrete mass with steel front and rear plates. The plates are connected by nose guide tube housings and by steel all thread rods that are pre-tensioned to keep the concrete in compression. The concrete was cast between the plates. After the concrete cured, the pretension rods were tightened to specification. The heavy steel end plates spread the load over the face of the pendulum such that the compressive stress seen by the concrete is below 1000 psi (6.9×10^6 Pa) at a 100,000-lb (444,000-N) load. The steel plates also reduce the required volume of concrete.

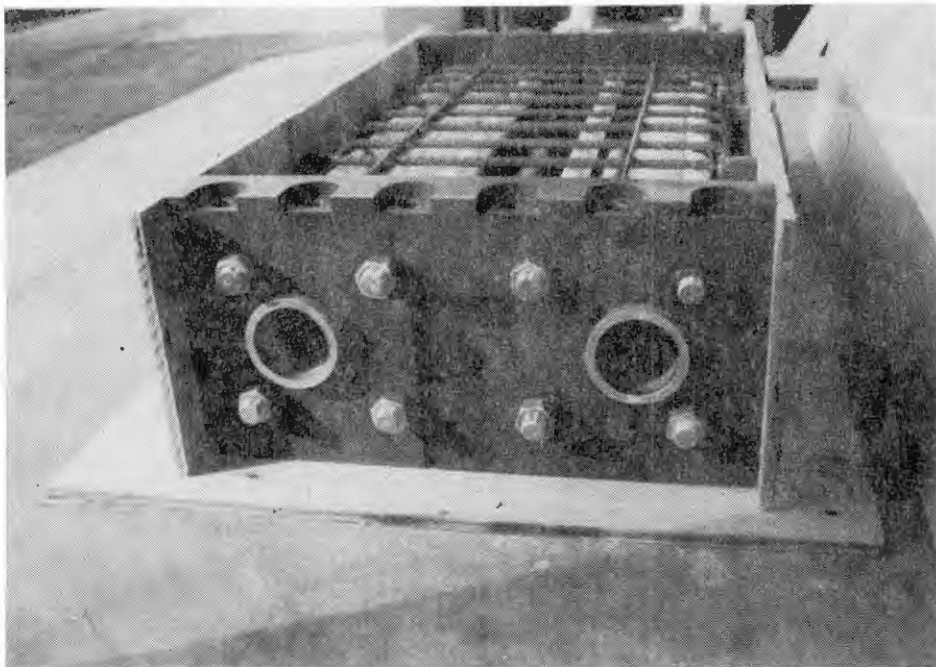

Figure 2. Pendulum mass.

To achieve yaw and pitch stability, the pendulum mass was designed with large mass moments of inertia, approximately 80 percent greater than the previous pendulum. However, these values are still only about 12 percent of the moments of a small automobile, due to the distribution of the automobile mass over a much larger volume than is practical with a pendulum.

(c) Sliding nose design

The sliding nose design is shown in figure 3. This design is identical to the FOIL bogie nose, with the guide tubes fixed to the nose and allowed to slide into the body of the pendulum. No tubes protrude from the pendulum during or after impact.

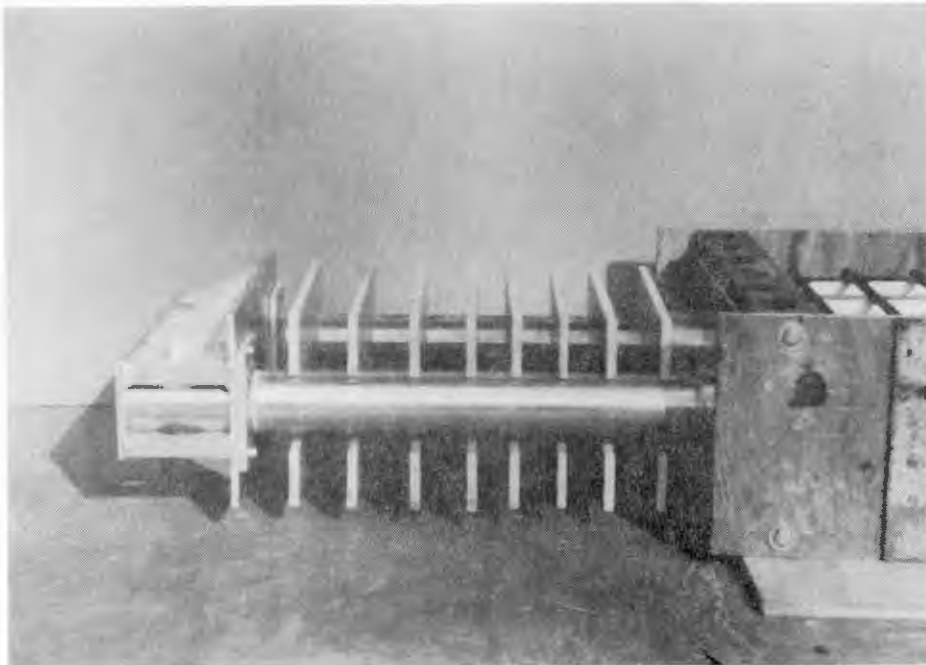

Figure 3. Sliding nose design.

Vehicle crush is modelled with honeycomb cartridges separated with phenolic spacers, as shown in figure 4. These parts are all interchangeable with the FOIL bogie, so that no additional spare parts need to be inventoried.

(d) Accelerometer mounting

A recess is provided for accelerometer mounting at the center of the rear face of the rear steel plate, in line with the center of gravity of the pendulum body. The recess protects the instrumentation from falling test articles, and also from secondary impacts as the pendulum swings back and forth through the impact area after the initial impact. The cable from the accelerometers to the data acquisition equipment is routed up a rear pendulum suspension cable to the pendulum support frame and then down a rear support leg, so that it can not be damaged during a test.

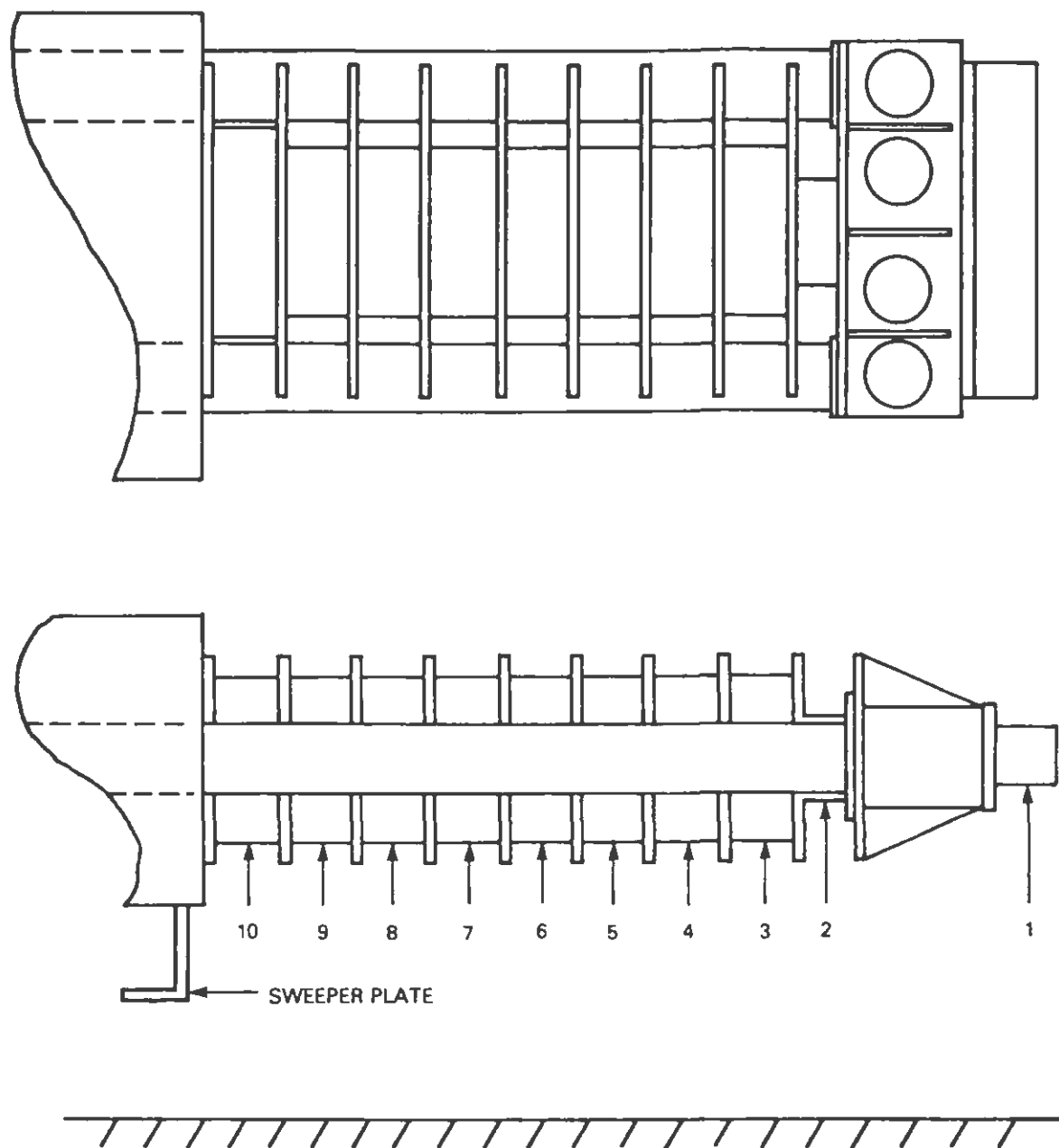

Figure 4. Schematic of honeycomb nose cartridge placement.

(e) Sweeper plate design

Two sweeper plates have been provided for the new pendulum. The first is identical to the bogie sweeper, and uses a steel angle attached to a perforated plate. The second sweeper, shown in figure 5, simulates a very strong automobile undercarriage, and has been designed to shear from the pendulum mass at a load of 50,000 lb (222,000 N). This load level was selected to provide the greatest strength possible without endangering the integrity of the new pendulum mass.

The front of the sweeper is made of removable aluminum blocks of different thicknesses so that the height of the sweeper can be adjusted. The blocks are braced with a reinforced steel plate which also protects the blocks from secondary impacts into test article stubs that may remain on the foundation or in the ground as the pendulum continues to swing back and forth after the initial impact.

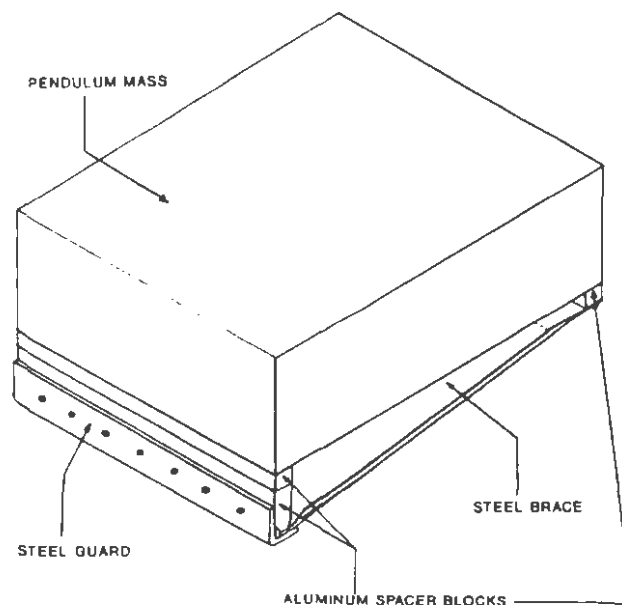

Figure 5. Rigid sweeper plate design.

Test Article Mounting System

A rigid mounting system, shown in figure 6, has been provided as part of the pendulum upgrade, and can accommodate the rigid instrumented pole and sign and luminaire supports. It has been designed to limit the horizontal motion of the rigid instrumented pole (or the foundation when a pole or sign support is mounted to it) to 0.005 in (0.013 cm) when subjected to a static load of 50,000 lb (222,000 N).

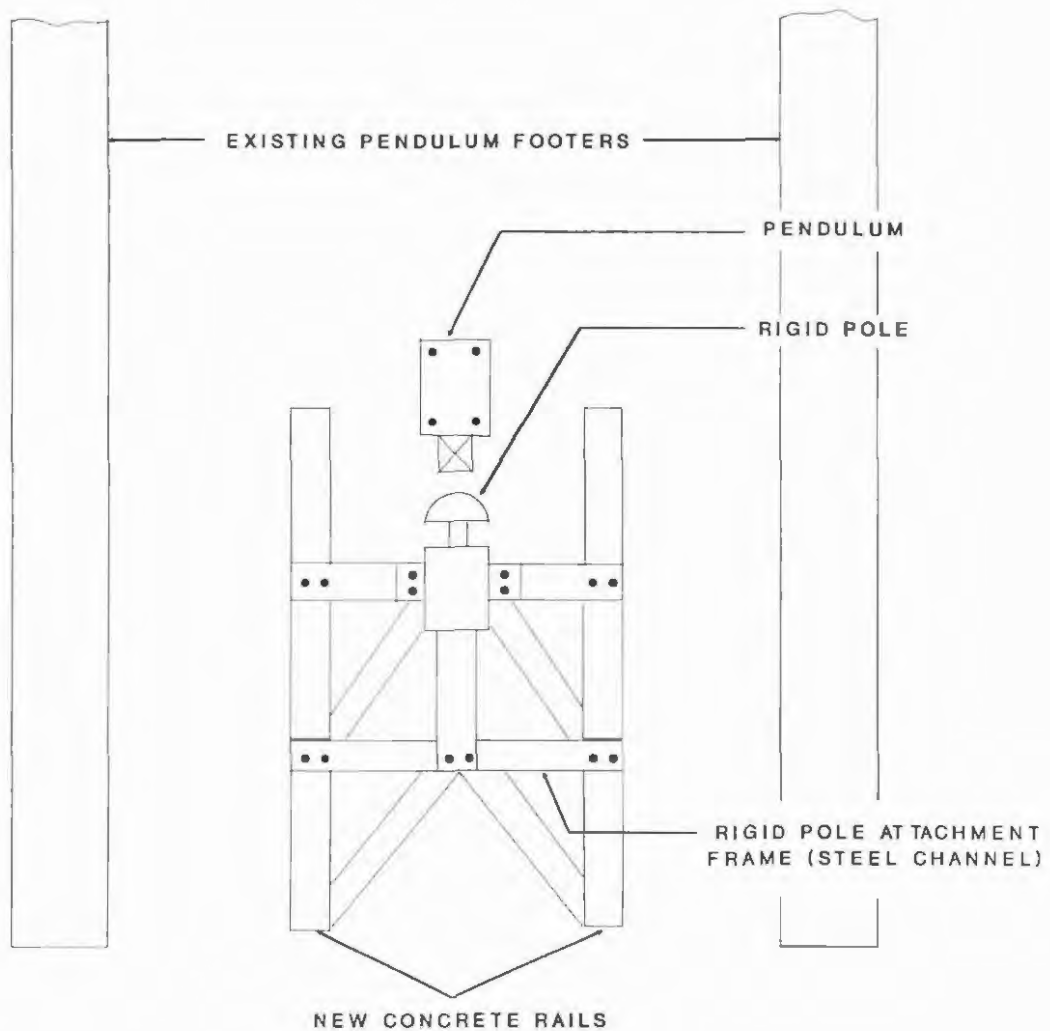

Figure 6. Test article mounting system.

The mounting system consists of a front and a rear main cross beam, each supported by two upper and two lower diagonal braces. In addition, the main beams are coupled with a span beam (figure 7) to minimize the deflection of the front beam when luminaire or sign supports are mounted. The front cross beam can accommodate the universal mounting plate which is also used on the FOIL runway, so that no additional mounting hardware needs to be fabricated.

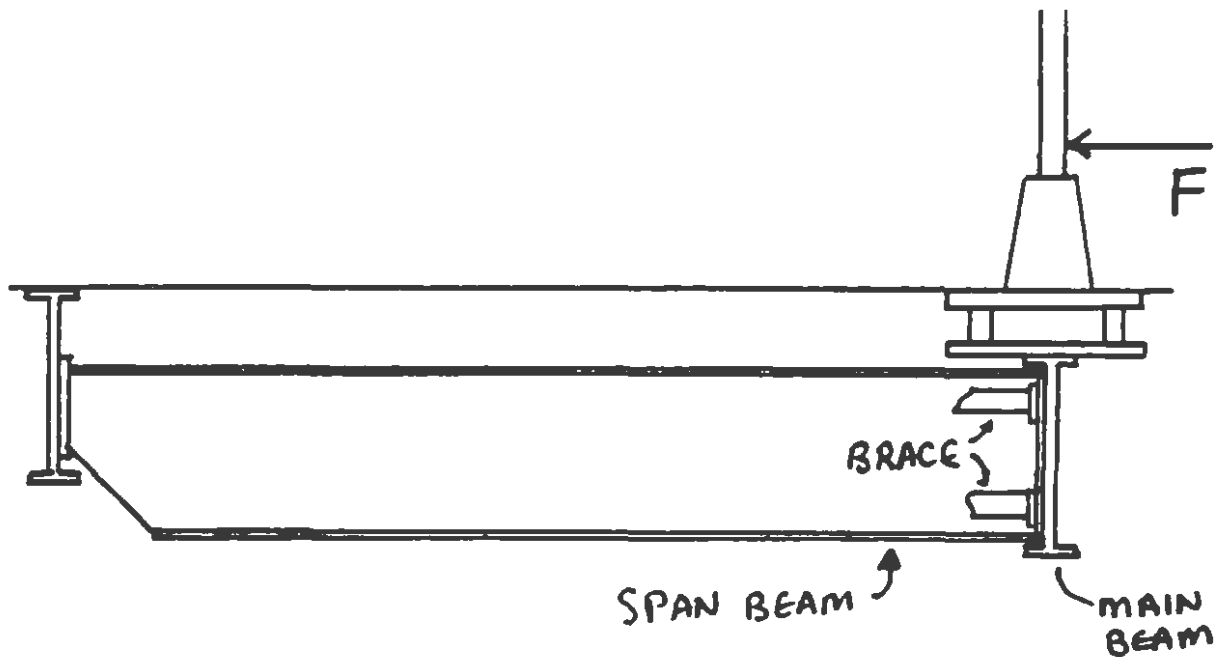

Figure 7. Mounting system span beam.

The steel frame mounts between two concrete foundations which run longitudinally next to the path of the pendulum, so as not to interfere with direct burial device testing (which can be conducted by removing the steel frame). The area under the frame is graded for drainage, and covered with gravel. A sump is provided, and is drained to a nearby culvert.

Speed Trap System

The new pendulum speed trap system, shown conceptually in figure 8, consists of four LED scanner and receiver pairs which send and receive, respectively, infrared light across the trajectory of the pendulum. The time for the pendulum to pass from one light path to the next is used with the known distance between each light path to determine the pendulum speed.

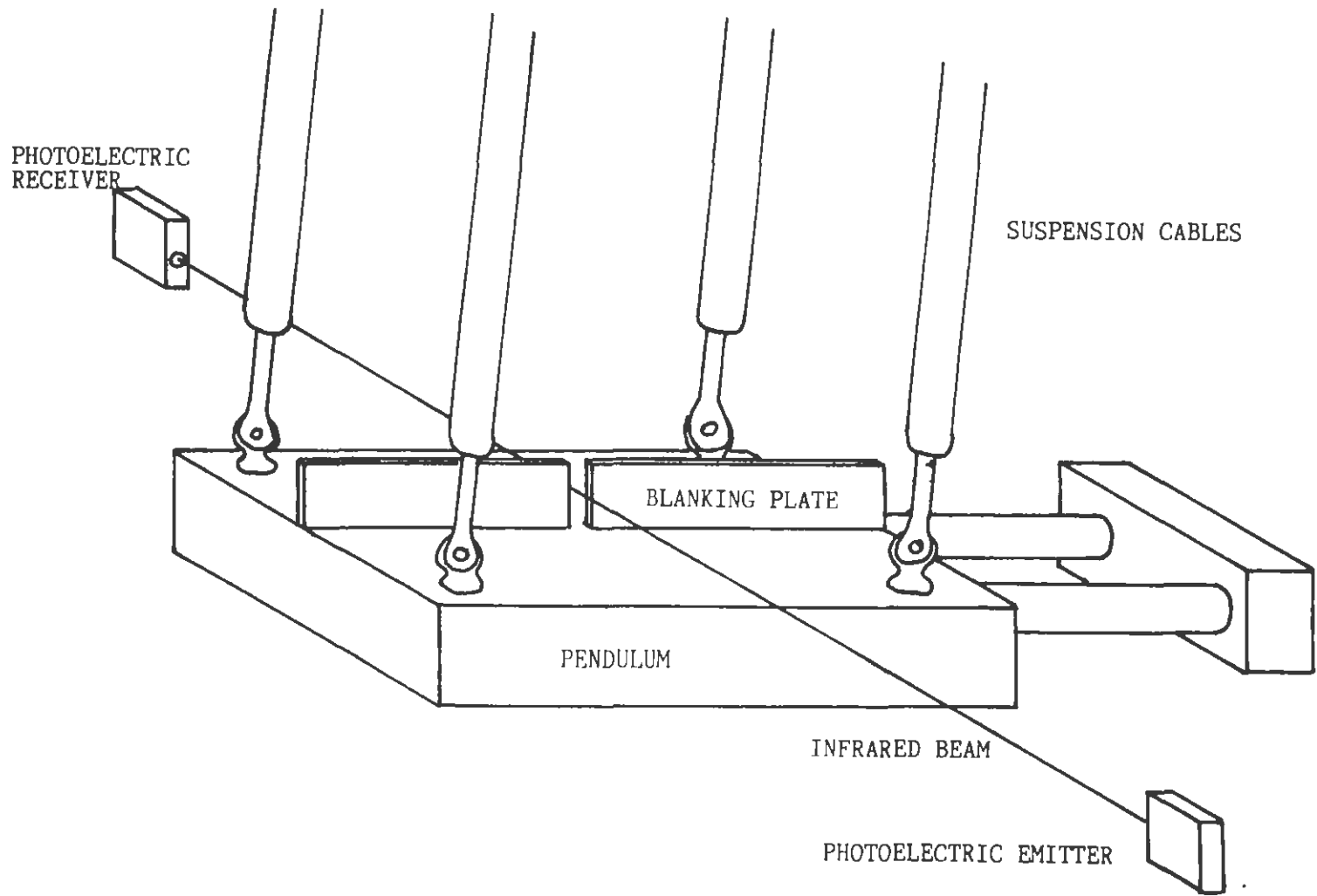

Figure 8. Schematic of speed trap system.

The new system is shown installed at the FOIL in figure 9, and has been designed to provide an accurate measure of pendulum pre-impact and post-impact speed. Four steel stands support four units each, two senders and two receivers placed in an interleaved pattern, allowing the sensors to be placed closer together without signal interference. A blanking plate is mounted longitudinally on the top of the pendulum, as shown in figure 2, so that only one light path can be active at any given time.



Figure 9. Speed trap system mounted at the pendulum site.

Design Documentation

The entire design of the pendulum upgrade has been documented in the preliminary design plan, the final design plan, and a series of drawings which are maintained at the FOIL.^(1,2) The drawings are divided into three main assemblies: the pendulum, the test article mounting system, and the speed trap, as listed in table 1.

Table 1. Pendulum upgrade drawings.

<u>Drawing No.</u>	<u>Title</u>
<u>Pendulum</u>	
1870-D-100	Pendulum assembly drawing
1870-D-101	Front plate
1870-D-102	Rear plate
1870-B-103	Tie rods
1870-B-104	PVC covers
1870-B-105	Spacer for sweeper plate
1870-B-106	Front beam for sweeper plate
1870-D-107	Brace plate for sweeper plate
1870-B-108	Bolt for sweeper plate mounting
1870-B-109	Weight plate anchor assembly
<u>Mounting system</u>	
1870-D-150	Mounting system assembly drawing
1870-D-151	Main beam
1870-D-152	Brace beam
1870-D-153	Base plates
1870-D-154	Footer
1870-B-155	Gusset
1870-B-156	Mounting plate
<u>Speed trap system</u>	
1870-D-180	Speed trap system assembly drawing
1870-B-181	Base plate
1870-D-182	Sensor mount
1870-B-183	Blanking plate
1870-C-184	Wiring diagram

SYSTEM VALIDATION

Validation Plan

The validation of the pendulum upgrade included weight verification, speed trap system functionality, pendulum nose crush characteristics using the rigid instrumented pole, full-scale crash tests into luminaire supports, and proof of concept tests using the new sweeper plate design.⁽²⁾ An outline of the test matrix is shown in table 2.

Table 2. Pendulum upgrade test matrix.

<u>Series</u>	<u>Focus</u>	<u>Description</u>
1	Weight	Confirm weight in different configurations
2	Speed trap	Verify functionality of speed trap system
3	Nose crush	Rigid pole test series, compare with similar bogie and automobile tests
4	Luminaires	Slip base pole Anchor base pole
5	Sweeper plate	Anchor base shear test Anchor base pole test Rigid stub test.

Results

The results of the pendulum validation tests have been documented in two separate reports, the first focusing on the rigid pole tests, and the second on the luminaire support testing.^(3,4) The results are summarized below.

(a) Pendulum weight

The weight of the pendulum was confirmed using load cells at the FOIL, and the results are presented in table 3. The weight of the entire system can be adjusted to different test weights by removing or adding the 10-lb (4.5-kg) weight plates.

Table 3. Pendulum component weights.

<u>Component</u>	<u>Weight (lb)</u>
Body	1510
Nose	50
Spacers	45
Bogie style sweeper plate	15
Weight plates (10 lb each)	230
Total weight	1850
1 lb = 0.45 kg	

(b) Speed trap functionality tests

Three tests were conducted to verify that the speed trap performed satisfactorily. For all of these tests, the pendulum was allowed to swing freely after release, with no impact. The results of the tests are shown in table 4.

Table 4. Speed trap validation results

<u>Test number</u>	<u>Pre speed (ft/s)</u>		<u>Post speed (ft/s)</u>	
	<u>electronic</u>	<u>film</u>	<u>electronic</u>	<u>film</u>
89P027	29.3	29.2	28.6	28.3
89P028	29.3	29.3	28.3	28.4
89P029	29.2	29.4	28.2	28.5

1 ft/s = 0.305 m/s

(c) Rigid instrumented pole tests

For each of the tests in this series, the pendulum impacted the rigid instrumented pole. The pole, sketched in figure 10, was designed to be operated at the FOIL to measure vehicle crush characteristics. The impact face of this device consists of a semicircular section of extra-heavy-walled pipe attached to two connecting rods. Each rod end is fastened to a load cell. The force outputs from the load cells are added together to obtain the total crush force.

Two series of tests were completed at the FOIL, with four tests conducted at 10 mi/h (4.5 m/s) and five at 20 mi/h (8.9 m/s).⁽³⁾ The lower speed tests were conducted to check the pendulum body and sliding nose performance at a low energy level, and to ensure that the rigid instrumented pole foundation did not move during the impact. High-speed cameras were placed to observe the pendulum body and nose and the rigid instrumented pole. These tests confirmed that the pendulum and pole performed satisfactorily.

The next test series was then conducted, with the first three tests focused on determining the force displacement characteristics of the pendulum. The results of these tests are listed in table 5, and compare the accelerometer data with the load cell data. The last two tests were then conducted to quantify the pitching motion of the pendulum body as it starts to rebound from the rigid pole, a phenomena observed in the above three tests, but not in pole tests conducted with the previous pendulum. There was no appreciable pitching until after the pendulum started to rebound, and the pitch angle,

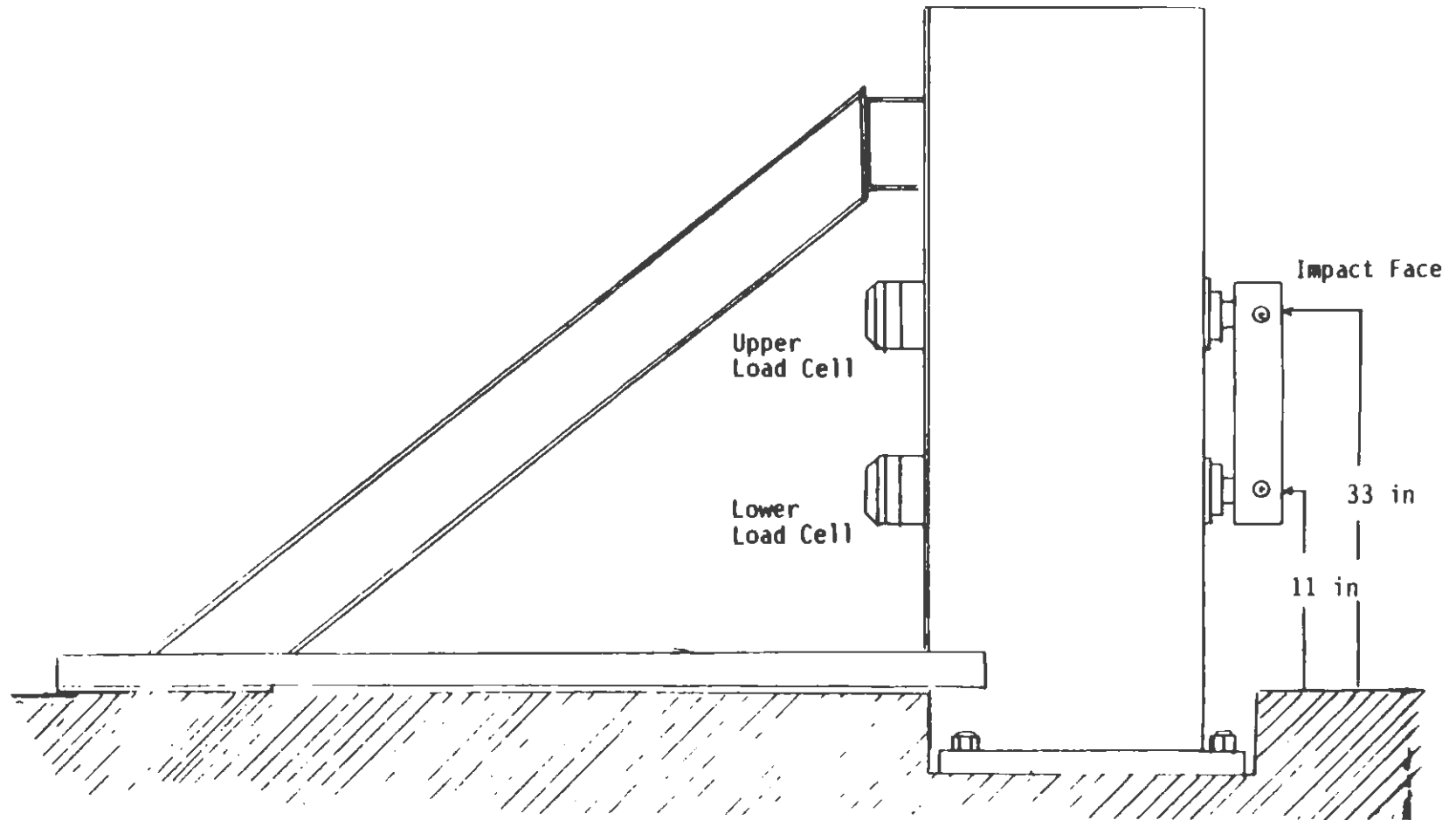

1 in = 2.54 cm

Figure 10. Schematic of rigid instrumented pole.

measured from high-speed film, was determined to reach a maximum of approximately 12 degrees (nose down).

Table 5. Rigid instrumented pole test results.

<u>Test number</u>	<u>Impact speed (ft/s)</u>		<u>Accelerometer maximum</u>		<u>Load cell maximum</u>	
	<u>electronic</u>	<u>film</u>	<u>crush (in)</u>	<u>force (kips)</u>	<u>crush (in)</u>	<u>force (kips)</u>
89P034	29.4	28.8	23.0	28.5	23.0	28.9
89P035	29.0	28.9	22.1	28.5	22.4	28.7
89P036	29.3	29.1	22.2	28.3	22.5	28.1

1 ft/s = 0.305 m/s

1 kip = 4440 N

1 in = 2.54 cm

(d) Luminaire support tests

Slip base luminaire supports. Two tests were performed with a triangular three bolt slip base luminaire support at 20 mi/h (8.9 m/s).⁽⁴⁾ The supports had twin mast arms, with a 53-lb (24.1-kg) dummy luminaire on each arm. A photograph of one of these luminaire supports is shown in figure 11. Identical luminaire supports were previously tested at the FOIL.^(6,6)

The results of the pendulum testing are compared with the other FOIL testing in table 6. There are significant differences in the measured velocity changes between the different test series. The pendulum produced a velocity change on the order of 10 ft/s (3.1 m/s), the bogie (during a test series in 1987) 15 ft/s (4.6 m/s), and the bogie and automobile (during a test series in 1989) about 21 ft/s (6.4 m/s).

Table 6. Slip base luminaire support test results.

<u>Test number</u>	<u>Vehicle</u>	<u>Velocity change (ft/s)</u>
90P007	Pendulum	10.4
90P008	Pendulum	8.9
87F033	Bogie	15.0
89F019	Bogie	19.9
89F018	Automobile	22.3

1 ft/s = 0.305 m/s

Anchor base luminaire supports. One test was conducted with an anchor base luminaire support.⁽⁴⁾ The support consisted of a fiberglass pole epoxy



Figure 11. Typical slip base luminaire support.

glued to an aluminum anchor base, and included a single mast arm with a 52-lb (23.6-kg) dummy luminaire attached. The impact speed was 20 mi/h (8.9 m/s). A photograph of the support is shown in figure 12.

The result of the pendulum test is compared with a previous FOIL bogie test in table 7.⁽⁷⁾ The results compare favorably, contrary to the slip base results listed above.

Table 7. Anchor base luminaire support test results.

<u>Test number</u>	<u>Vehicle</u>	<u>Velocity change (ft/s)</u>
90P009	Pendulum	8.3
87F068	Bogie	10.2

1 ft/s = 0.305 m/s

(e) Sweeper plate tests

Four tests were performed with the new rigid sweeper plate attached to the pendulum body, as shown in figure 13. In the first three tests, a rigid stub attached to the pendulum foundation was impacted. The test results are summarized in table 8. In tests 90P010 and 90P011, the pendulum sweeper plate impacted the rigid stub and bounced back. In test 90P012, the sweeper plate hit the rigid stub, momentarily pushing the stub and the mounting foundation back about 0.8 in (2.0 cm). The sweeper then sheared away at the indicated force level, with the foundation and stub returning to their normal rest position.

Table 8. Pendulum rigid sweeper plate stub test summary.

<u>Test number</u>	<u>Impact speed (ft/s)</u>	<u>Maximum force (lb)</u>
90P010	7.2	10,500
90P011	14.6	58,200
90P012	22.8	75,400

1 ft/s = 0.305 m/s
1 lb = 4.44 N

For the fourth rigid sweeper plate test (number 90P013), an anchor base luminaire support identical to the one used in two previous tests was impacted at 20 mi/h (8.9 m/s). The results are presented in table 9, and include the data from the previous tests where the current sweeper plate design was used.

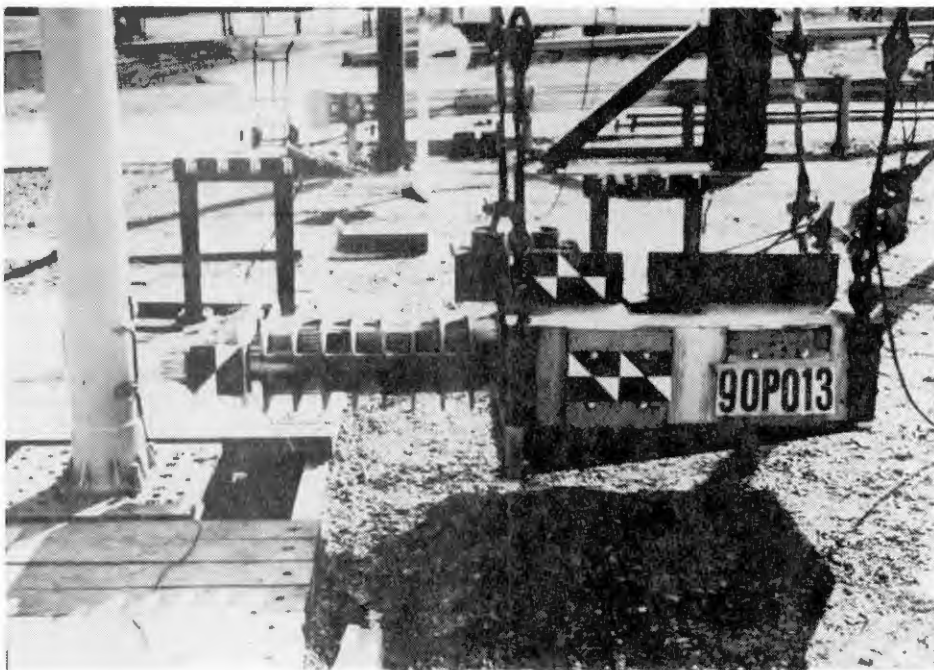
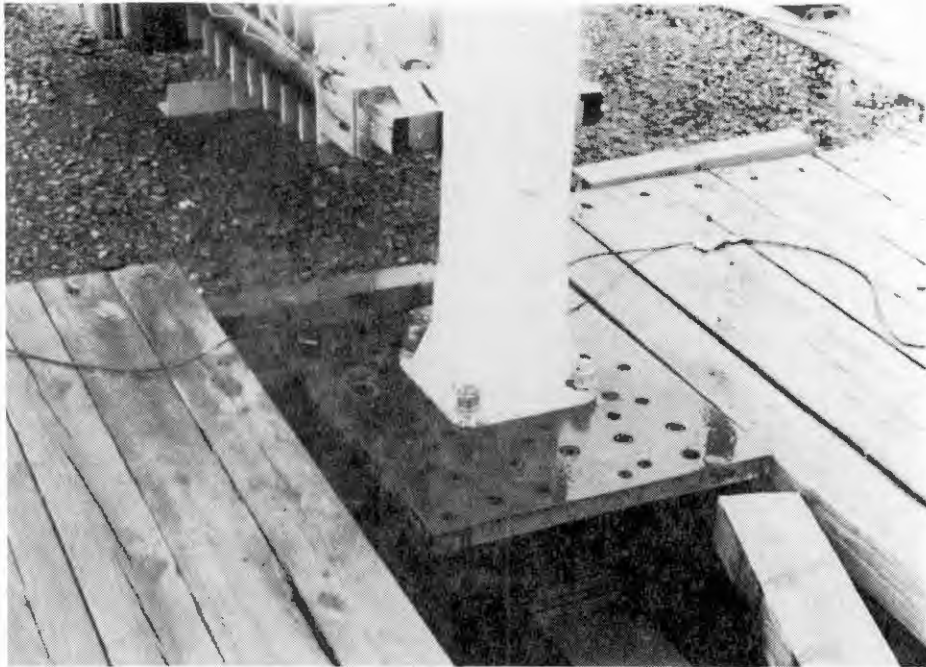

Figure 12. Typical anchor base luminaire support.

The velocity change is significantly higher for the test where the rigid sweeper plate was installed.

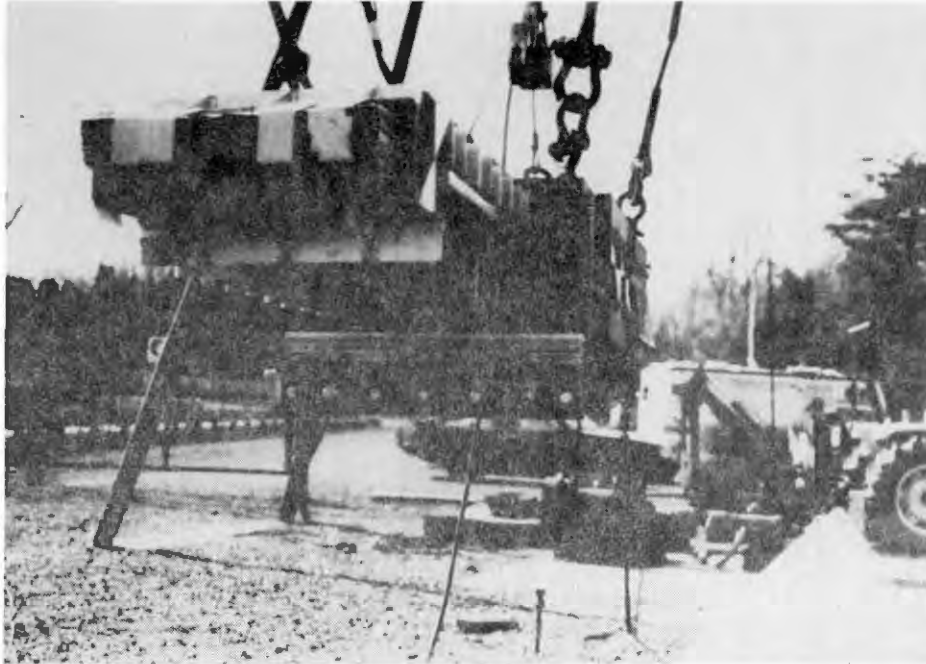

Figure 13. Pendulum with rigid sweeper plate attached.

Table 9. Pendulum rigid sweeper plate anchor base luminaire support test summary.

<u>Test number</u>	<u>Vehicle</u>	<u>Sweeper plate</u>	<u>Velocity change (ft/s)</u>
90P009	Pendulum	Current	8.3
87F068	Bogie	Current	10.2
90P013	Pendulum	Rigid	16.3
1 ft/s = 0.305 m/s			

DISCUSSION AND CONCLUSIONS

Speed Trap System

The data presented in table 4 compare the calculated speeds from the new speed trap system with the calculated speeds from the analysis of high-speed film. The results indicate that the speed trap data are in agreement with the film data, verifying operation of the new system.

Pendulum Force-Deflection Characteristics

The results of the pendulum tests into the rigid instrumented pole were summarized in table 5. The maximum displacement and force vary between the tests. However, the variations are small, and are most likely due to the small variations in impact speed, coupled with minor variations in the honeycomb cartridge size and material characteristics.

The time histories of force versus displacement, using the load cell data from the rigid instrumented pole, have been averaged together, and are compared to averaged FOIL bogie results and averaged 1979 Volkswagen Rabbit results in table 10 and figure 14.^(3,5) (The crushable noses on the bogie and the pendulum were designed to simulate impact into a 1979 Rabbit.)

Table 10. Average maximum load cell results.

<u>Vehicle</u>	<u>Crush (in)</u>	<u>Force (kips)</u>
Pendulum	22.6	28.6
Bogie	23.9	32.8
1979 Rabbit	22.2	28.6

1 in = 25.4 mm
1 kip = 4440 N

The data show that the maximum crush and the maximum force of the pendulum compare quite favorably with the automobile, and that they are both somewhat less than the bogie. However, the differences in maximum values are rarely important with breakaway devices, because these high force levels are not reached when a device breaks away with a reasonable change in velocity. A more realistic comparison is at lower force-displacement values. Figure 14 reveals that the pendulum and the bogie force-displacement characteristics are almost identical, with significant differences only appearing when the bogie continues to crush to a greater depth, achieving high force levels. In addition, both the bogie and the pendulum only deviate from the automobile at low displacements. These differences between the surrogate vehicles and the

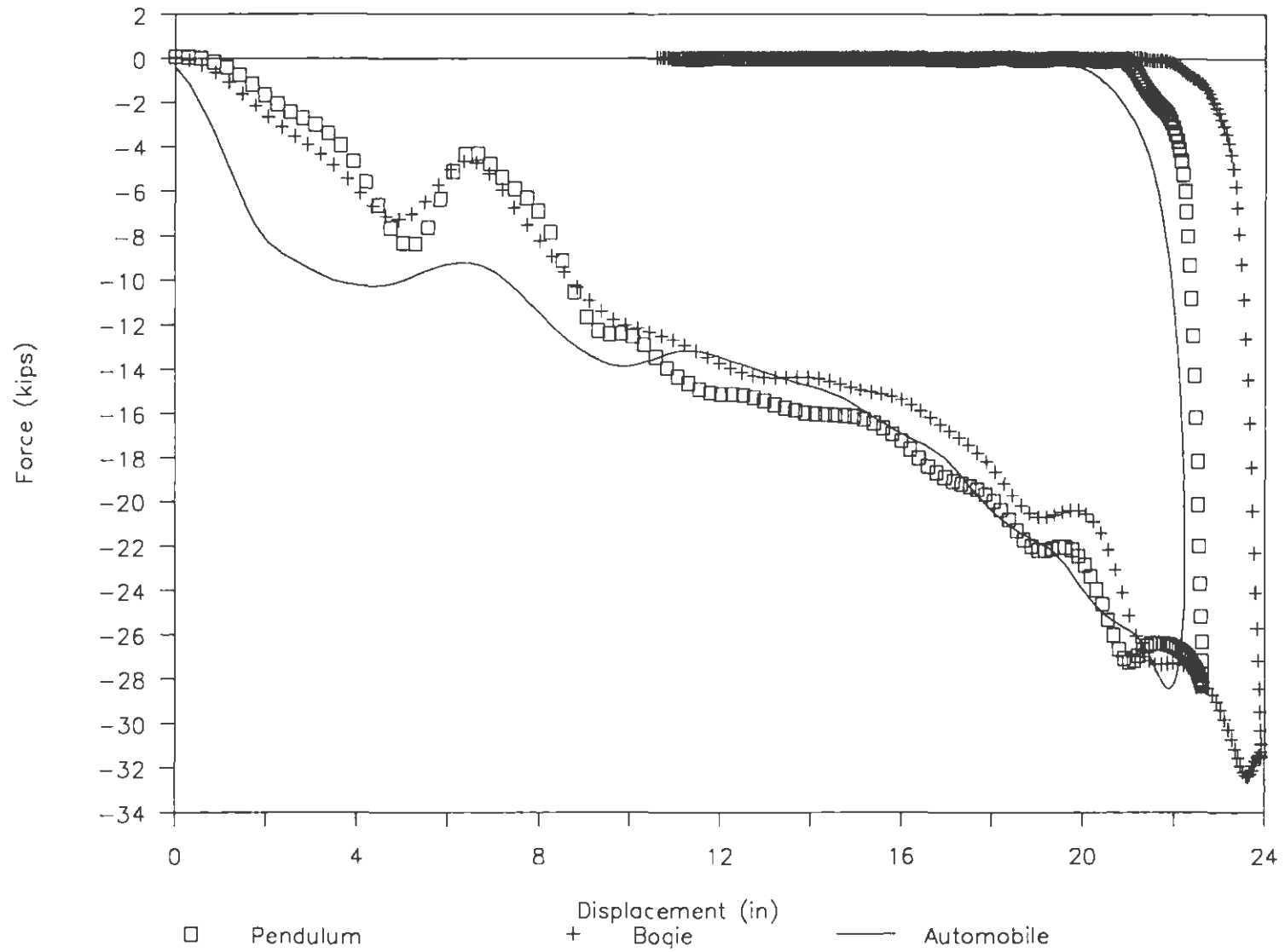

1 kip = 4440 N
1 in = 2.54 cm

Figure 14. Average vehicle force versus displacement.

automobile have been documented previously, and have been accepted as reasonable for FOIL testing.⁽⁶⁾

Luminaire Support Testing

The result of the anchor base luminaire support test was consistent with the test previously conducted at the FOIL, confirming that the pendulum is suitable for anchor base testing. Though testing was not performed on transformer base, progressive shear or coupling mounted supports, these devices have been satisfactorily tested with the FOIL bogie, and similar performance is expected with the pendulum (because the force-deflection characteristics of the two surrogates are practically identical).

The results of the slip base testing, however, deviated significantly from previous test results, as shown in table 6. These differences may be attributable to differences between the pendulum, the bogie, and an automobile. However, the velocity change data also show a large discrepancy in the two identical bogie tests. Analysis has shown that the change in velocity for a slip base is highly dependent on the breakaway force of the slip surface, which is a function of the clamping force and the effective coefficient of friction. Therefore, the differences could be due to variations in the breakaway force levels, caused, in part, by differences in the effective coefficient of friction (the clamping loads were carefully controlled using strain gauged bolts).

Sweeper Plate Functionality

The rigid sweeper plate tests into a rigid stub revealed that the sweeper does indeed break away from the pendulum when impacting a very strong target. However, the breakaway force level for the new sweeper design (utilizing the specified grade five bolts) is 50 percent greater than the design load of 50,000 lb (222,000 N). This greater load caused the entire pendulum foundation to shift momentarily.

The result from the one rigid sweeper plate test into an anchor base luminaire support indicates that a significant increase in velocity change can be expected if a vehicle with a strong undercarriage impacts a luminaire support with a strong stub which interacts with the vehicle undercarriage. (The anchor base tested in this series has already been redesigned to break away with an acceptable stub height, so that a large increase in velocity change would not be expected.)

RECOMMENDATIONS

- The new speed trap system should be adopted for use at the FOIL pendulum facility.
- The current sweeper plate can be used on the pendulum. If the new, rigid sweeper plate is used, the strength of the mounting bolts should be reduced from grade 5 to grade 2, reducing the breakaway force level to about 90 percent of design load.
- Additional research should be conducted to further quantify the effect of a rigid sweeper plate on breakaway luminaire support performance. Policy will then need to be established with regard to use of the sweeper plate in certification and other testing.
- The pendulum can be used to determine the low speed breakaway performance of anchor base luminaire supports. In addition, it should be acceptable for evaluating transformer base, progressive shear, coupling mounted and other breakaway supports which have already been shown to perform satisfactorily with the FOIL bogie. However, further research should be conducted to evaluate the anomalies in the results of the slip base testing (with automobiles and surrogate vehicles).

REFERENCES

1. J.A. Bloom, A.G. Hansen and J.A. Hinch, "Pendulum Upgrade Preliminary Plan," Analysis Group, Inc. Report 9000-2, Washington, DC (October 1987).
2. J.A. Hinch, D. Stout and J.A. Bloom, "Pendulum Upgrade Final Plan," Analysis Group, Inc. Report 9000-3, Washington, DC (March 1988).
3. C. Hott, C. Brown and N. Totani, "Crush Characteristics of the 1800 lb Pendulum," FHWA-RD-90-059, Federal Highway Administration, Washington, DC (March 1990).
4. C. Hott, C. Brown and N. Totani, "Impact Tests of Luminaire Supports With the 1800 lb Pendulum," FHWA-RD-90-064, Federal Highway Administration, Washington, DC (June 1990).
5. C. Hott, C. Brown and N. Totani, "Crush Characteristics of the Breakaway Bogie," FHWA-RD-89-107, Federal Highway Administration, Washington, DC (March 1989).
6. C. Hott, C. Brown and N. Totani, "Luminaire Support Capability Test Program - Test Report of a Breakaway Luminaire Support Tested at the Federal Outdoor Impact Laboratory (FOIL), Test Numbers 87F033, 87F034," Federal Highway Administration, Washington, DC (May 1987).
7. C. Hott, C. Brown and N. Totani, "Luminaire Support Capability Test Program - Test Report of a Breakaway Luminaire Support Tested at the Federal Outdoor Impact Laboratory (FOIL), Test Numbers 87F068, 87F070," Federal Highway Administration, Washington, DC (May 1987).

