



PB97-171292

NTIS[®]
Information is our business.

**TESTING OF NEW BRIDGE RAIL AND TRANSITION
DESIGNS. VOLUME 7. APPENDIX F. 32-IN
(813-MM) F-SHAPE BRIDGE RAILING**

TEXAS TRANSPORTATION INST., COLLEGE STATION

JUN 97

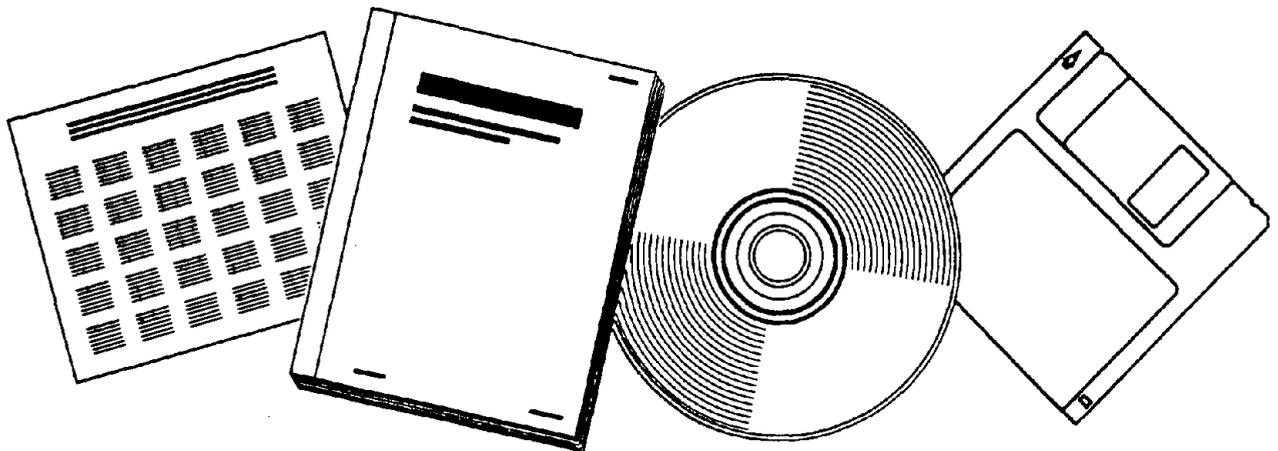

U.S. DEPARTMENT OF COMMERCE
National Technical Information Service





PB97-171292

Testing of New Bridge Rail and Transition Designs

Volume VII: Appendix F

32-in (813-mm) F-Shape Bridge Railing

PUBLICATION NO. FHWA-RD-93-064

JUNE 1997



U.S. Department of Transportation
Federal Highway Administration

Research and Development
Turner-Fairbank Highway Research Center
6300 Georgetown Pike
McLean, VA 22101-2296

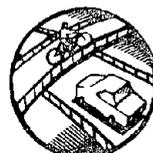

REPRODUCED BY: **NTIS**
U.S. Department of Commerce
National Technical Information Service
Springfield, Virginia 22161

FOREWORD

This report presents the results of a State Planning and Research (SP&R) pooled-fund study to develop safer bridge rail and transition designs. This pooled-fund study was sponsored by the Federal Highway Administration, 23 States, and the District of Columbia. A panel of representatives from those agencies selected the designs to be studied. Ten bridge rails and two transitions were designed and crash tested in accordance with the recommendations for the various Performance Levels in the *1989 AASHTO Guide Specifications for Bridge Railings*. Acceptable performance was demonstrated for all of the crash tested designs.

Detailed drawings are presented for documentation and to facilitate implementation.

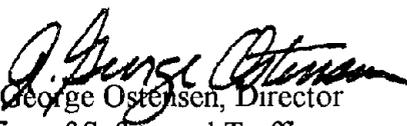
A. George Ostensen, Director
Office of Safety and Traffic
Operations, Research and
Development

NOTICE

This document is disseminated under the sponsorship of the Department of Transportation in the interest of information exchange. The United States Government assumes no liability for its contents or use thereof. This report does not constitute a standard, specification, or regulation.

The United States Government does not endorse products or manufacturers. Trade and manufacturer's names appear in this report only because they are considered essential to the object of the document.

1. Report No. FHWA-RD-93-064		 PB97-171292		3. Recipient's Catalog No.	
4. Title and Subtitle TESTING OF NEW BRIDGE RAIL AND TRANSITION DESIGNS Volume VII: Appendix F 32-in (813-mm) F-Shape Bridge Railing				5. Report Date June 1997	
7. Author(s) C. Eugene Buth, T. J. Hirsch, and Wanda L. Menges				6. Performing Organization Code	
9. Performing Organization Name and Address Texas Transportation Institute The Texas A&M University System College Station, Texas 77843-3135				8. Performing Organization Report No. Research Foundation 7069	
12. Sponsoring Agency Name and Address Office of Safety & Traffic Operations R&D Federal Highway Administration 6300 Georgetown Pike McLean, Virginia 22101-2296				10. Work Unit No. NCP No. 3A5C0042	
				11. Contract or Grant No. DTFH61-86-C-00071	
15. Supplementary Notes Research performed in cooperation with DOT, FHWA Research Study Title: Pooled Funds Bridge Rail Study Contracting Officer's Technical Representative (COTR) - Charles F. McDevitt				13. Type of Report and Period Covered Final Report August 1986 - September 1993	
				14. Sponsoring Agency Code	
16. Abstract The 32-in (813-mm) F-shape concrete parapet is similar to the New Jersey safety shape. The F-shape was designed and tested to performance level two of the 1989 <i>Guide Specifications for Bridge Railings</i> and acceptable performance was obtained. Computed ultimate strength of the railing with the steel reinforcement used was 59 kips (263 kN). This volume is the seventh in a series. The other volumes in the series are: Volume I: Technical Report; Volume II: Appendix A, "Oregon Side Mounted Bridge Railing;" Volume III: Appendix B, "BR27D Bridge Railing;" Volume IV: Appendix C, "Illinois 2399-1 Bridge Railing;" Volume V: Appendix D, "32-in (813-mm) (813-mm) Concrete Parapet Bridge Railing;" Volume VI: Appendix E, "32-in (813-mm) (813-mm) New Jersey Safety Shape;" Volume VIII: Appendix G, "BR27C Bridge Railing;" Volume IX: Appendix H, "Illinois Side Mount Bridge Rail;" Volume X: Appendix I, "42-in (1.07-m) Concrete Parapet Bridge Railing;" Volume XI: Appendix J, "42-in (1.07-m) F-Shape Bridge Railing;" Volume XII: Appendix K, "Oregon Transition;" Volume XIII: Appendix L, "32-in (813-mm) (813-mm) Thrie-Beam Transition;" and Volume XIV: Appendix M, "Axial Tensile Strength of Thrie and W-Beam Terminal Connectors."					
17. Key Words Bridge Rail, Longitudinal Barriers, Barrier Collision Forces, Ultimate Strength, Yieldline Analysis, Full-Scale Crash Tests, Highway Safety			18. Distribution Statement No restrictions. This document is available to the public through the National Technical Information Service 5285 Port Royal Road Springfield, Virginia 22161		
19. Security Classif. (of this report) Unclassified		20. Security Classif. (of this page) Unclassified		21. No. of Pages 121	22. Price

SI* (MODERN METRIC) CONVERSION FACTORS

APPROXIMATE CONVERSIONS TO SI UNITS					APPROXIMATE CONVERSIONS FROM SI UNITS				
Symbol	When You Know	Multiply By	To Find	Symbol	Symbol	When You Know	Multiply By	To Find	Symbol
LENGTH					LENGTH				
in	inches	25.4	millimeters	mm	mm	millimeters	0.039	inches	in
ft	feet	0.305	meters	m	m	meters	3.28	feet	ft
yd	yards	0.914	meters	m	m	meters	1.09	yards	yd
mi	miles	1.61	kilometers	km	km	kilometers	0.621	miles	mi
AREA					AREA				
in ²	square inches	645.2	square millimeters	mm ²	mm ²	square millimeters	0.0016	square inches	in ²
ft ²	square feet	0.093	square meters	m ²	m ²	square meters	10.764	square feet	ft ²
yd ²	square yards	0.836	square meters	m ²	m ²	square meters	1.195	square yards	yd ²
ac	acres	0.405	hectares	ha	ha	hectares	2.47	acres	ac
mi ²	square miles	2.59	square kilometers	km ²	km ²	square kilometers	0.386	square miles	mi ²
VOLUME					VOLUME				
fl oz	fluid ounces	29.57	milliliters	mL	mL	milliliters	0.034	fluid ounces	fl oz
gal	gallons	3.785	liters	L	L	liters	0.264	gallons	gal
ft ³	cubic feet	0.028	cubic meters	m ³	m ³	cubic meters	35.71	cubic feet	ft ³
yd ³	cubic yards	0.765	cubic meters	m ³	m ³	cubic meters	1.307	cubic yards	yd ³
MASS					MASS				
oz	ounces	28.35	grams	g	g	grams	0.035	ounces	oz
lb	pounds	0.454	kilograms	kg	kg	kilograms	2.202	pounds	lb
T	short tons (2000 lb)	0.907	megagrams (or "metric ton")	Mg (or "t")	Mg (or "t")	megagrams (or "metric ton")	1.103	short tons (2000 lb)	T
TEMPERATURE (exact)					TEMPERATURE (exact)				
°F	Fahrenheit temperature	5(F-32)/9 or (F-32)/1.8	Celsius temperature	°C	°C	Celsius temperature	1.8C + 32	Fahrenheit temperature	°F
ILLUMINATION					ILLUMINATION				
fc	foot-candles	10.76	lux	lx	lx	lux	0.0929	foot-candles	fc
fl	foot-Lamberts	3.426	candela/m ²	cd/m ²	cd/m ²	candela/m ²	0.2919	foot-Lamberts	fl
FORCE and PRESSURE or STRESS					FORCE and PRESSURE or STRESS				
lbf	poundforce	4.45	newtons	N	N	newtons	0.225	poundforce	lbf
lbf/in ²	poundforce per square inch	6.89	kilopascals	kPa	kPa	kilopascals	0.145	poundforce per square inch	lbf/in ²

* SI is the symbol for the International System of Units. Appropriate rounding should be made to comply with Section 4 of ASTM E380.

(Revised September 1993)

TABLE OF CONTENTS

<u>Chapter</u>	<u>Page</u>
1. DESIGN OF RAILING	1
2. CRASH TEST PROCEDURES	3
3. FULL-SCALE CRASH TESTS	7
TEST 7069-3	7
Test Description	7
Test Results	7
Conclusions	8
TEST 7069-4	25
Test Description	25
Test Results	25
Conclusions	26
TEST 7069-8	44
Test Description	44
Test Results	45
Conclusions	45
TEST 7069-9	66
Test Description	66
Test Results	66
Conclusions	67
TEST 7069-11	88
Test Description	88
Test Results	88
Conclusions	89
4. STRENGTH CALCULATIONS	111
REFERENCES	113

LIST OF FIGURES

<u>Figure No.</u>	<u>Page</u>
1. 32-in (813-mm) F-shape bridge railing	2
2. Vehicle before test 7069-3	9
3. 32-in (813-mm) F-shape bridge railing before test 7069-3	10
4. Vehicle properties for test 7069-3	11
5. 32-in (813-mm) F-shape bridge railing after test 7069-3	12
6. Vehicle after test 7069-3	13
7. Summary of results for test 7069-3	14
8. Sequential photographs for test 7069-3	18
9. Interior sequential photographs for test 7069-3	20
10. Vehicle angular displacements for test 7069-3	21
11. Vehicle longitudinal accelerometer trace for test 7069-3 (accelerometer located near center-of-gravity)	22
12. Vehicle lateral accelerometer trace for test 7069-3 (accelerometer located near center-of-gravity)	23
13. Vehicle vertical accelerometer trace for test 7069-3 (accelerometer located near center-of-gravity)	24
14. Vehicle and instrumentation before test 7069-4	27
15. Vehicle/bridge railing geometrics for test 7069-4	28
16. 32-in (813-mm) F-shape bridge railing before test 7069-4	29
17. Vehicle properties for test 7069-4	30
18. 32-in (813-mm) F-shape bridge railing after test 7069-4	31
19. Vehicle after test 7069-4	32
20. Summary of results for test 7069-4	33
21. Sequential photographs for test 7069-4	35
22. Interior sequential photographs for test 7069-4	37
23. Vehicle angular displacements for test 7069-4	38
24. Vehicle longitudinal accelerometer trace for test 7069-4 (accelerometer located near center-of-gravity)	39
25. Vehicle lateral accelerometer trace for test 7069-4 (accelerometer located near center-of-gravity)	40
26. Vehicle vertical accelerometer trace for test 7069-4 (accelerometer located near center-of-gravity)	41
27. Vehicle longitudinal accelerometer trace for test 7069-4 (accelerometer located at rear of vehicle)	42
28. Vehicle lateral accelerometer trace for test 7069-4 (accelerometer located at rear of vehicle)	43
29. Vehicle before test 7069-8	46
30. Vehicle/bridge railing geometrics for test 7069-8	47
31. 32-in (813-mm) F-shape bridge railing before test 7069-8	48
32. Vehicle properties for test 7069-8	49
33. 32-in (813-mm) F-shape bridge railing after test 7069-8	50
34. Damage to top of bridge railing caused by lower edge of bed of vehicle	51

LIST OF FIGURES (Continued)

<u>Figure No.</u>		<u>Page</u>
35.	Vehicle after test 7069-8	52
36.	Summary of results for test 7069-8	53
37.	Sequential photographs for test 7069-8	57
38.	Perpendicular sequential photographs for test 7069-8	59
39.	Vehicle angular displacements for test 7069-8	60
40.	Vehicle longitudinal accelerometer trace for test 7069-8 (accelerometer located near center-of-gravity)	61
41.	Vehicle lateral accelerometer trace for test 7069-8 (accelerometer located near center-of-gravity)	62
42.	Vehicle vertical accelerometer trace for test 7069-8 (accelerometer located near center-of-gravity)	63
43.	Vehicle longitudinal accelerometer trace for test 7069-8 (accelerometer located at front of vehicle)	64
44.	Vehicle lateral accelerometer trace for test 7069-8 (accelerometer located at front of vehicle)	65
45.	Vehicle before test 7069-9	68
46.	Vehicle/bridge railing geometrics for test 7069-9	69
47.	32-in (813-mm) F-shape bridge railing before test 7069-9	70
48.	Vehicle properties for test 7069-9	71
49.	32-in (813-mm) F-shape bridge railing after test 7069-9	72
50.	Damage to top of bridge railing and to lower edge truck bed	73
51.	Vehicle after test 7069-9	74
52.	Summary of results for test 7069-9	75
53.	Sequential photographs for test 7069-9	77
54.	Perpendicular sequential photographs for test 7069-9	79
55.	Vehicle angular displacements for test 7069-9	80
56.	Longitudinal accelerometer trace for test 7069-9 (accelerometer located near center-of-gravity)	81
57.	Lateral accelerometer trace for test 7069-9 (accelerometer located near center-of-gravity)	82
58.	Vertical accelerometer trace for test 7069-9 (accelerometer located near center-of-gravity)	83
59.	Longitudinal accelerometer trace for test 7069-9 (accelerometer located at front of vehicle)	84
60.	Lateral accelerometer trace for test 7069-9 (accelerometer located at front of vehicle)	85
61.	Longitudinal accelerometer trace for test 7069-9 (accelerometer located at rear of vehicle)	86
62.	Lateral accelerometer trace for test 7069-9 (accelerometer located at rear of vehicle)	87
63.	Vehicle before test 7069-11	90
64.	Vehicle/bridge railing geometrics for test 7069-11	91

LIST OF FIGURES (Continued)

<u>Figure No.</u>		<u>Page</u>
65.	32-in (813-mm) F-shape bridge railing before test 7069-11	92
66.	Vehicle properties for test 7069-11	93
67.	Accelerometer locations for test 7069-11	94
68.	32-in (813-mm) bridge railing after test 7069-11	95
69.	Vehicle after test 7069-11	96
70.	Summary of results for test 7069-11	97
71.	Sequential photographs for test 7069-11	99
72.	Perpendicular sequential photographs for test 7069-11	101
73.	Vehicle angular displacements for test 7069-11	102
74.	Vehicle longitudinal accelerometer trace for test 7069-11 (accelerometer located near center-of-gravity)	103
75.	Vehicle lateral accelerometer trace for test 7069-11 (accelerometer located near center-of-gravity)	104
76.	Vehicle vertical accelerometer trace for test 7069-11 (accelerometer located near center-of-gravity)	105
77.	Vehicle longitudinal accelerometer trace for test 7069-11 (accelerometer located at front of vehicle)	106
78.	Vehicle lateral accelerometer trace for test 7069-11 (accelerometer located at front of vehicle)	107
79.	Vehicle longitudinal accelerometer trace for test 7069-11 (accelerometer located at rear of vehicle)	108
80.	Vehicle lateral accelerometer trace for test 7069-11 (accelerometer located at rear of vehicle)	109
81.	Yieldline failure pattern for concrete parapet	112

LIST OF TABLES

<u>Table No.</u>		<u>Page</u>
1.	Evaluation of crash test no. 7069-3	15
2.	Bridge railing performance levels and crash test criteria	16
3.	Evaluation of crash test no. 7069-4	34
4.	Evaluation of crash test no. 7069-8	54
5.	Bridge railing performance levels and crash test criteria	55
6.	Evaluation of crash test no. 7069-9	76
7.	Evaluation of crash test no. 7069-11	98



CHAPTER 1. DESIGN OF RAILING

The 32-in (813-mm) F-shape was originally designed to meet performance level two of the proposed 1987 version of the *Guide Specifications for Bridge Railings*.⁽¹⁾ The required strength test from that proposed version was 5,400-lb (2 452-kg) pickup traveling at 65 mi/h (105 km/h) and impacting at 20 degrees. The design force used for this test condition was 56 kips (249 kN) of line load uniformly distributed over 42 in (1.07 m) at 24 in (610 mm) above the deck surface. The railing was eventually tested to performance level two requirements of the 1989 *Guide Specifications for Bridge Railings* which requires strength test conditions of 18,000 lb (8 172 kg) | 50 mi/h (80.5 km/h) | 15 degrees.⁽²⁾ The design force for this condition is 56 kips (249 kN) of line load uniformly distributed over 42 in (1.07 m) at 29 in (737 mm) above the deck surface.

A cross section of the railing design is shown in figure 1. Total height of the F-shape is 32 in (813 mm). It has a lower 3-in (76-mm) high vertical section, a middle 7-in (177-mm) high inclined surface of 55 degrees, and an upper 22-in (559-mm) high inclined surface of 84 degrees. It has a bottom width of 14.7 in (373 mm) and a top width of 7.5 in (191 mm). The slope at the bottom of the rail serves to limit the damage done to vehicles impacting at low angles by causing the front tire to ride up on the rail and redirect itself back to the pavement. A thickened portion at the top of the rail serves to increase the longitudinal distribution of force within the F-shape and allow more length of F-shape and deck to resist the collision force.

Eight #4 longitudinal bars were used in the F-shape. The vertical steel was #5 rebar at 8-in (200-mm) spacing. Specified concrete strength was 3,600 psi (34 800 kPa) at 28 days and specified steel yield was 40,000 psi (275 600 kPa). The cantilevered deck was supported on a foundation so that the deck overhang was 39 in (990 mm).

The strength of the railing was computed using yieldline analysis procedures.⁽³⁾ The strength computations are presented on the following pages. The analysis predicts the length of the failure mechanism to be 8.3 ft (2.5 m) and the total ultimate load capacity to be 59 kips (262 kN). The analysis also shows that the yield lines are confined to the F-shape rather than extending into the bridge deck.

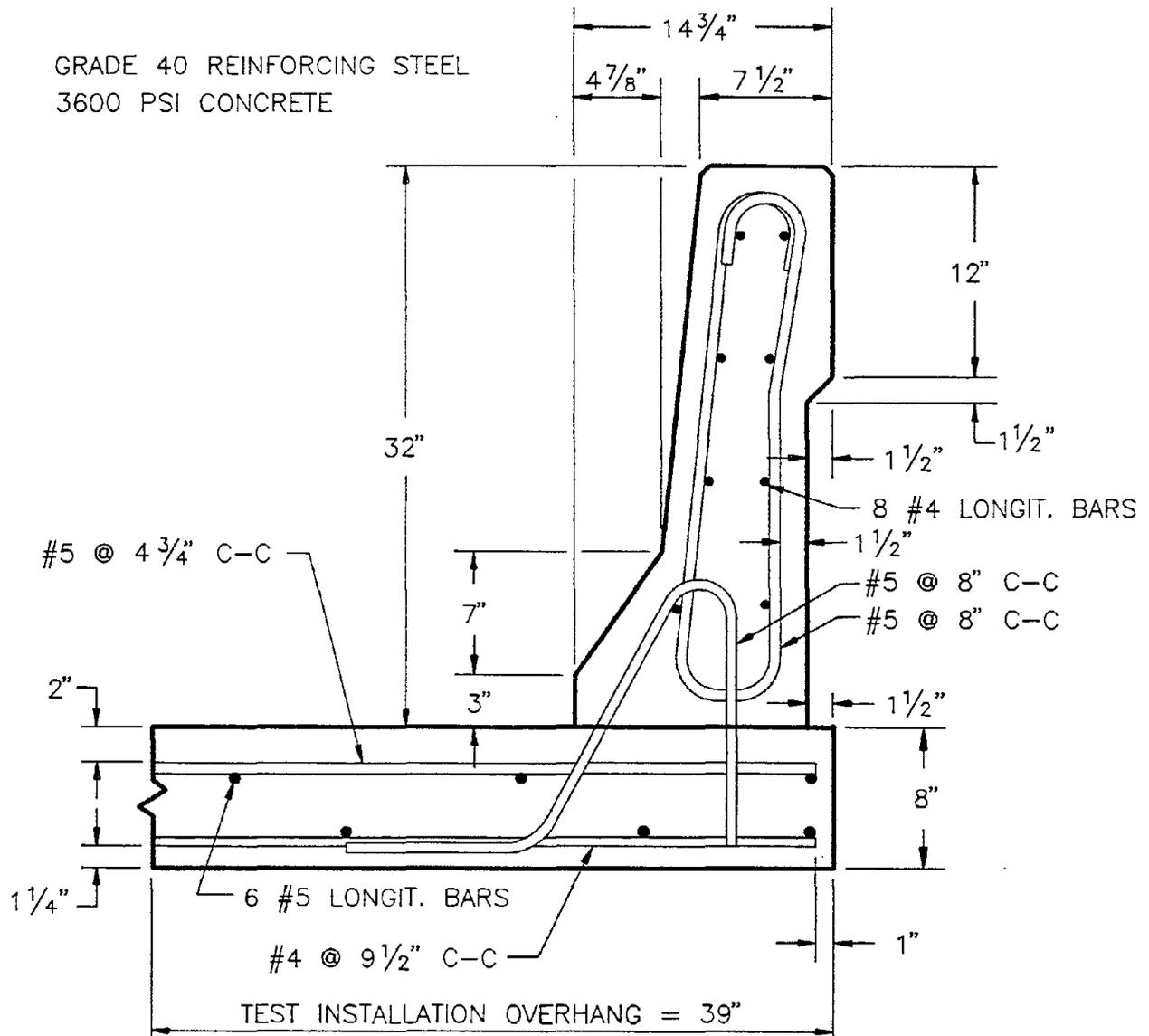

Figure 1. 32-in (813-mm) F-shape bridge railing.

CHAPTER 2. CRASH TEST PROCEDURES

The 32-in (813-mm) F-shape bridge railing was tested to performance level two requirements.⁽¹⁾ The following nominal test conditions were used:

1,800-lb (817-kg) passenger car | 60 mi/h (96.6 km/h) | 20 degrees (test 7069-3)
5,400-lb (2 452-kg) pickup | 65 mi/h (104.7 km/h) | 20 degrees (test 7069-4)
18,000-lb (8 172-kg) single-unit truck | 50 mi/h (80.5 km/h) | 15 degrees (tests 7069-8, 9, 11)

Each vehicle was instrumented with three solid-state angular rate transducers to measure yaw, pitch, and roll rates and a triaxial accelerometer mounted near the center-of-gravity. In addition, the pickup and 18,000-lb (8 172-kg) trucks were instrumented with two biaxial accelerometers: one mounted forward of the center-of-gravity and one mounted in the rear of the vehicle. The accelerometers were strain gauge type with a linear millivolt output proportional to acceleration. The electronic signals from the accelerometers and transducers were transmitted to a base station by means of constant bandwidth FM/FM telemetry link for recording on magnetic tape and for display on a real-time strip chart. Provision was made for transmission of calibration signals before and after each test, and an accurate time reference signal was simultaneously recorded with the data.

Pressure sensitive contact switches on the bumper of each vehicle were actuated just prior to impact by wooden dowels to indicate elapsed time over a known distance and provide a measurement of impact velocity. Each initial contact also produced an "event" mark on the data record to establish the instant of impact. Data from the electronic transducers were digitized using a microcomputer for analysis and evaluation of performance.

The multiplex of data channels transmitted on one radio frequency was received at a data acquisition station and demultiplexed into separate tracks of Intermediate Range Instrumentation Group (I.R.I.G.) tape recorders. After the test, the data were played back from the tape machines, filtered with an SAE J211 filter, and digitized using a microcomputer for analysis and evaluation of performance.

Alderson Research Laboratories Hybrid II, 50th percentile anthropomorphic dummies were used in the passenger car and the pickup. One uninstrumented dummy was placed in the driver position of the automobile and two uninstrumented dummies were placed in the pickup truck--one in the driver seat and one in the passenger seat. No dummies were placed in the single-unit truck. Each dummy was restrained with standard restraint equipment seat belts. No dummies were carried in the single-unit trucks.

The digitized data obtained from the electronic transducers were then processed using two computer programs: DIGITIZE and PLOTANGLE. Brief descriptions on the functions of these two computer programs are as follows.

The DIGITIZE program uses digitized data from vehicle-mounted linear accelerometers to compute occupant/compartiment impact velocities, time of occupant/compartiment impact after vehicle impact, highest 0.010-s averages of vehicle

acceleration after occupant/compartment impacts, and time of highest 0.010-s averages. The DIGITIZE program also calculates a vehicle impact velocity and the change in vehicle velocity at the end of a given impulse period. In addition, maximum average accelerations over a 0.050-s intervals in each of three directions are computed. Acceleration versus time curves for the longitudinal, lateral, and vertical directions are then plotted from the digitized data of the vehicle-mounted linear accelerometers using a commercially available software package (QUATTRO PRO). For each of these graphs, a 0.050-s average window was calculated at the center of each 0.050-s interval and then plotted with the first 0.050-s average plotted at 0.026 s.

The PLOTANGLE program uses the digitized data from yaw, pitch, and roll rate charts to compute angular displacements in degrees at 0.001-s intervals and then instructs a plotter to draw a reproducible plot of yaw, pitch, and roll versus time. It should be noted that these angular displacements are sequence dependent with the sequence yaw, pitch, and roll for the data presented herein. These displacements are in reference to the vehicle-fixed coordinate system with the initial position and orientation of the vehicle-fixed coordinate system being that which existed at initial impact.

Photographic coverage of the tests included three high-speed cameras: one over head with a field of view perpendicular to the ground and directly over the impact point, one placed to have a field of view parallel to and aligned with the railing system at the downstream end, and a third placed perpendicular to the front of the railing system. In the passenger car and pickup tests, a high-speed camera was placed onboard the vehicle to record the actions of the dummy(ies) during the test. A flash bulb activated by pressure sensitive tape switches was positioned on the impacting vehicle to indicate the instant of contact with the railing system and was visible from each camera. The films from these high-speed cameras were analyzed on a computer-linked motion analyzer to observe phenomena occurring during the collision and to obtain time-event, displacement, and angular data. A 16-mm movie cine, a professional video camera, and a 3/4-in (19 mm) video recorder along with 35-mm cameras were used for documentary purposes and to record conditions of the test vehicle and railing system before and after the test.

The passenger car and pickup were towed into the test installation using a steel cable guidance and reverse two system. A steel cable for guiding the test vehicle was stretched along the path, anchored at each end, and threaded through an attachment to the front wheel of the test vehicle, passed around a pulley near the impact point, through a pulley on the tow vehicle, and then anchored to the ground such that the tow vehicle moved away from the test site. A 2-to-1 speed ratio between the test and tow vehicle existed with this system. Immediately prior to impact with the railing system, the test vehicle was released to be free-wheeling and unrestrained. The vehicle remained free-wheeling, i.e., no steering or braking inputs, until the vehicle cleared the immediate area of the test site. At this time brakes on the vehicle were activated to bring the vehicle to a safe and controlled stop.

The 18,000-lb (8 172-kg) trucks were guided into the test installation using a remote controlled guidance system. Due to mechanical and instrumentation failures during the first two tests with the 18,000-lb (8 172-kg) truck, the nominal test speed of 50 mi/h (80.5 km/h)

was not attained, requiring a total of three tests to be performed to acquire the required speed.

CHAPTER 3. FULL-SCALE CRASH TESTS

TEST 7069-3

Test Description

The 1980 Honda (see figure 2) was directed into the 32-in (813-mm) F-shape bridge railing (figure 3) using a cable reverse tow and guidance system. Test inertia mass of the vehicle was 1,800 lb (817 kg) and its gross static mass was 1,966 lb (893 kg). The height to the lower edge of the vehicle bumper was 14.0 in (356 mm) and it was 19.5 in (495 mm) to the top of the bumper. Other dimensions and information on the test vehicle are given in figure 4. The vehicle was free-wheeling and unrestrained just prior to impact.

The speed of the vehicle at impact was 60.1 mi/h (96.7 km/h) and the angle of impact was 21.4 degrees. The vehicle impacted the bridge railing at midlength. At approximately 0.025 s after impact the right front tire began to ride up the concrete face of the bridge railing, and by 0.034 s the vehicle began to redirect. As the vehicle continued forward, the right side of the vehicle continued to ride up the face of the bridge railing, and at 0.186 s the left front wheel left the ground. The rear of the vehicle hit the railing at 0.189 s, and at 0.271 s the vehicle was parallel with the railing. The vehicle lost contact with the railing at 0.276 s after impact. As the vehicle exited the railing, it had a yaw angle of 0.9 degree and a trajectory path of 6.2 degrees. The vehicle brakes were applied and the vehicle subsequently came to rest 209 ft (64 m) downstream and 27 ft (8 m) behind the point of impact.

As can be seen in figure 5, the bridge railing received cosmetic damage only. There were tire marks on the face of the bridge railing indicating the vehicle rose a maximum height of about 27 in (686 mm). The vehicle was in contact with the bridge railing for 10.3 ft (3.1 m).

The vehicle sustained extensive damage to the right front as shown in figure 6. Maximum crush at the right front corner at bumper height was 9.0 in (229 mm). The right front and right rear wheel rims were bent and the wheel assembly and suspension damaged. The passenger door was bent and jammed and the right side was dented and scraped. The hood was bent and shifted to the left. The windshield frame was bent and the windshield was cracked. The roof of the vehicle was buckled and twisted.

Test Results

Impact speed was 60.1 mi/h (96.7 km/h) and the angle of impact was 21.4 degrees. The exit speed at time of contact (0.276 s) was 53.0 mi/h (85.3 km/h) and the vehicle trajectory path was 6.2 degrees with a vehicle yaw angle of 0.9 degree. The effective coefficient of friction was calculated to be 0.33. Occupant impact velocity was 19.0 ft/s (5.8 m/s) in the longitudinal direction and 23.7 ft/s (7.2 m/s) in the lateral direction. The highest 0.010-s occupant ridedown accelerations were -2.1 g (longitudinal) and 4.9 g (lateral). These data and other pertinent information from the test are summarized in figure 7.

Sequential photographs of the test are shown in figures 8 and 9. Vehicular angular displacements are displayed in figure 10. Vehicular acceleration versus time traces filtered with SAE J211 filters are presented in figures 11, 12, and 13. These data were further analyzed to obtain 0.050-s average accelerations versus time. A 0.050-s interval immediately prior to impact was averaged to establish zero acceleration. The data were then processed with a moving 0.050-s average window with the first 0.050-s average plotted at 0.026 s for each trace. The maximum 0.050-s averages were -8.0 g (longitudinal) and 12.8 g (lateral).

Conclusions

The 32-in (813-mm) F-shape bridge railing contained and smoothly redirected the vehicle with no lateral movement of the bridge railing. There were no debris or detached elements. There was no intrusion into the occupant compartment although some deformation of the compartment occurred. The vehicle trajectory at loss of contact indicated minimum intrusion into adjacent traffic lanes. The vehicle remained upright and stable during the entire test period. See table 1 for a more detailed description.



Figure 2. Vehicle before test 7069-3.

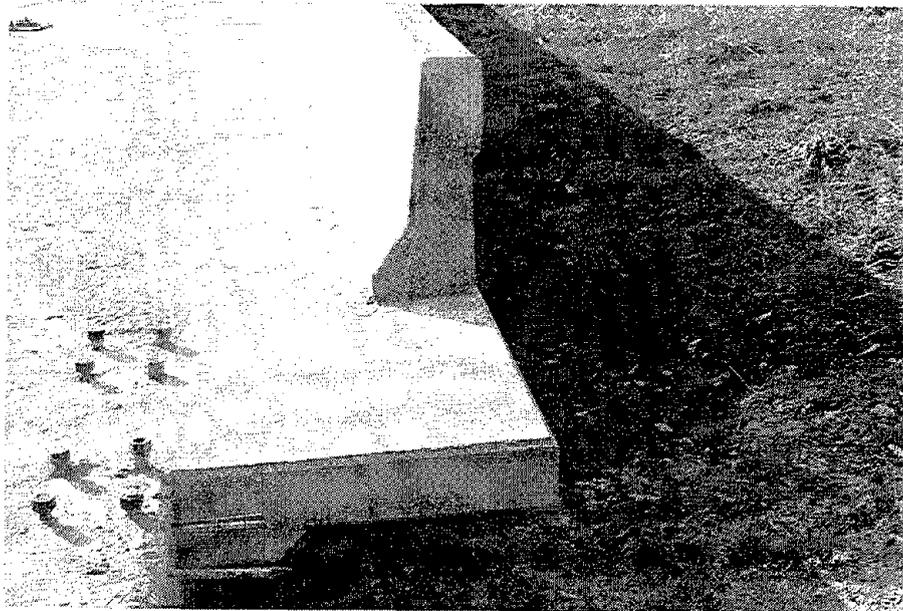

Figure 3. 32-in (813-mm) F-shape bridge railing before test 7069-3.

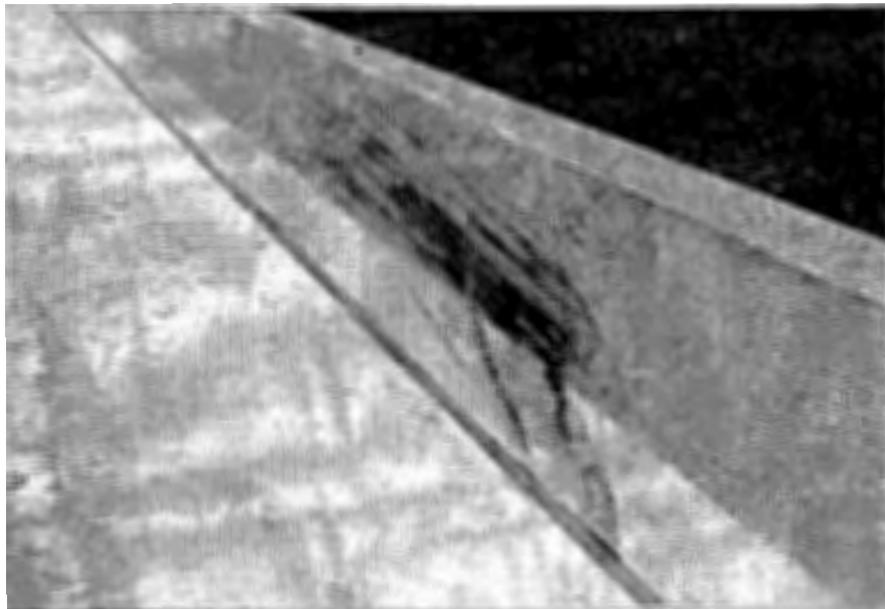

Figure 5. 32-in (813-mm) F-shape bridge railing after test 7069-13.

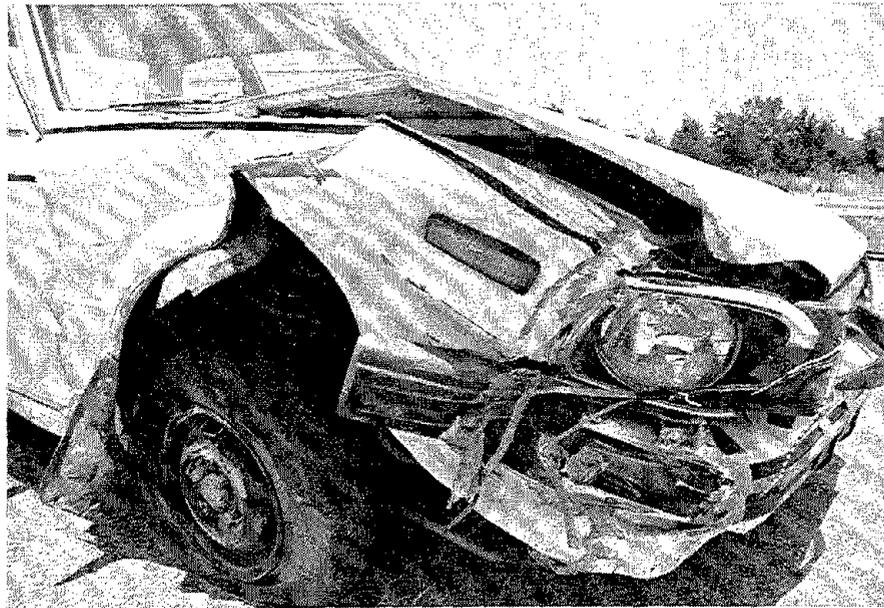
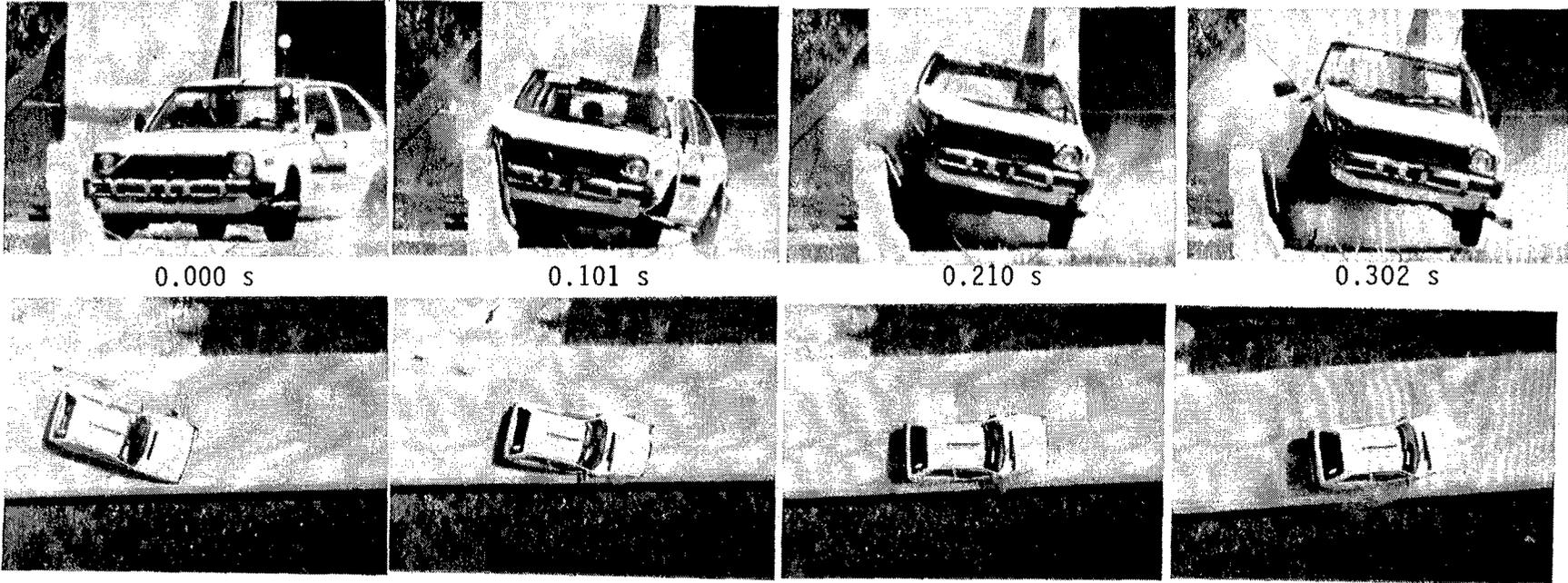
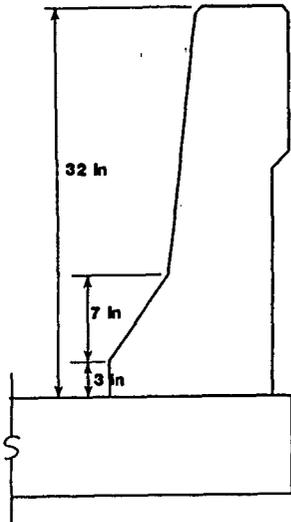

Figure 6. Vehicle after test 7069-3.



14



(1 in = 25.4 mm)

Test No.	7069-3	Impact Speed. . .	60.1 mi/h (96.7 km/h)
Date	7/28/87	Impact Angle. . .	21.4 deg
Test Installation . . .	32-in (813-mm) F-Shape	Exit Speed. . . .	53.0 mi/h (85.3 km/h)
	Bridge Railing	Exit Trajectory .	6.2 deg
Installation Length . .	100 ft (30 m)	Vehicle Accelerations	
Vehicle	1980 Honda	(Max. 0.050-sec Avg)	
	1300 DX	Longitudinal. . .	-8.0 g
Vehicle Weight		Lateral	12.8 g
Test Inertia	1,800 lb (817 kg)	Occupant Impact Velocity	
Gross Static	1,966 lb (893 kg)	Longitudinal. . .	19.0 ft/s (5.8 m/s)
Vehicle Damage Classification		Lateral	23.7 ft/s (7.2 m/s)
TAD	01RFQ4	Occupant Ridedown Accelerations	
CDC	01FREK3 & 01RFEW4	Longitudinal. . .	-2.1 g
Maximum Vehicle Crush .	9.0 in (229 mm)	Lateral	4.9 g

Figure 7. Summary of results for test 7069-3.

Table 1. Evaluation of crash test no. 7069-3.
 {32-in (81-cm) F-Shape Bridge Railing [1,800 lb (817 kg)|60.1 mi/h (96.7 km/h)|21.4 degrees]}

CRITERIA		TEST RESULTS		PASS/FAIL*
A.	Must contain vehicle	Vehicle was contained		Pass
B.	Debris shall not penetrate passenger compartment	No debris penetrated passenger compartment		Pass
C.	Passenger compartment must have essentially no deformation	Acceptable deformation		Pass
D.	Vehicle must remain upright	Vehicle remained upright		Pass
E.	Must smoothly redirect the vehicle	Vehicle was smoothly redirected		Pass
F.	Effective coefficient of friction	<u>μ</u>	<u>Assessment</u>	
		0 - .25	Good	
		.26 - .35	Fair	
		> .35	Marginal	
		<u>μ</u>	<u>Assessment</u>	
		.33	Fair	Pass
G.	Shall be less than			
	<u>Occupant Impact Velocity - ft/s (m/s)</u>	<u>Occupant Impact Velocity - ft/s (m/s)</u>		
	Longitudinal	Longitudinal	Lateral	
	30 (9.2)	19.0 (5.8)	23.7 (7.2)	Pass
	<u>Occupant Ridedown Accelerations - g's</u>	<u>Occupant Ridedown Accelerations - g's</u>		
	Longitudinal	Longitudinal	Lateral	
	15	-2.1	4.9	Pass
H.	Exit angle shall be less than 12 degrees	Exit angle was 6.2 degrees		Pass

* A, B, C, D and G are required. E, F, and H are desired. (See table 2)

Table 2. Bridge railing performance levels and crash test criteria
(Guide Specifications for Bridge Railings, proposed). (1)

PERFORMANCE LEVELS		TEST SPEEDS -- mph ^{1,2}			
		TEST VEHICLE DESCRIPTIONS AND IMPACT ANGLES			
		Small Automobile	Pickup Truck	Intercity Bus (loose ballast)	Van-Type Tractor-Trailer ⁴ No. 2
		W = 1.8 Kips A = 5.4' B = 5.5' H _{cg} = 19" θ = 20 deg.	W = 5.4 Kips A = 8.9' B = 6.5' H _{cg} = 33" θ = 20 deg.	W = 40.0 Kips A = 23.2' B = 8.0' H _{cg} = 56" θ = 15 deg.	W = 80.0 Kips A = 13.1' B = 8.0' H _{cg} = 72" R = 0.5θ θ = 15 deg.
PL-1		50	45		
PL-2		60	65		
PL-3		60	65	60	
PL-4		60	65		55
CRASH TEST EVALUATION CRITERIA ³	Required	a,b,c,d,g	a,b,c,d	a,b,c,d	a,b,c
	Desirable ⁵	e,f,h	e,f,g,h	e,f,h	d,e,f,h
<p>Notes:</p> <p>1. Except as noted, all full-scale tests shall be conducted and reported in accordance with the requirements in NCHRP Report No. 230. In addition, the maximum loads that can be transmitted from the bridge railing to the bridge deck are to be determined from static force measurements or ultimate strength analysis and reported.</p> <p>2. Permissible tolerances on the test speeds and angles are as follows:</p> <p style="padding-left: 40px;">Speed -1.0 mph +2.5 mph Angle -1.0 deg. +2.5 deg.</p> <p>Tests that indicate acceptable railing performance but that exceed the allowable upper tolerances will be accepted.</p> <p>3. Criteria for evaluating bridge railing crash test results are as follows:</p> <p>a. The test article shall contain the vehicle; neither the vehicle nor its cargo shall penetrate or go over the installation. Controlled lateral deflection of the test article is acceptable.</p> <p>b. Detached elements, fragments, or other debris from the test article shall not penetrate or show potential for penetrating the passenger compartment or present undue hazard to other traffic.</p> <p>c. Integrity of the passenger compartment must be maintained with no intrusion and essentially no deformation.</p> <p>d. The vehicle shall remain upright during and after collision.</p>					

Table 2. Bridge railing performance levels and crash test criteria
(Guide Specifications for Bridge Railings, proposed continued).⁽¹⁾

Notes (cont.):

- e. The test article shall smoothly redirect the vehicle. A redirection is deemed smooth if the rear of the vehicle or, in the case of a combination vehicle, the rear of the tractor or trailer does not yaw more than 5 degrees away from the railing from time of impact until the vehicle separates from the railing.
- f. The smoothness of the vehicle-railing interaction is further assessed by the effective coefficient of friction μ :

μ	Assessment
0 - 0.25	Good
0.26 - 0.35	Fair
> 0.35	Marginal

where $\mu = (\cos\theta - V_p/V)/\sin\theta$

- g. The impact velocity of a hypothetical front-seat passenger against the vehicle interior, calculated from vehicle accelerations and 2.0-ft. longitudinal and 1.0-ft. lateral displacements, shall be less than:

Occupant Impact Velocity - fps	
Longitudinal	Lateral
30	25

and the vehicle highest 10-ms average accelerations subsequent to the instant of hypothetical passenger impact should be less than:

Occupant Ridedown Accelerations - g's	
Longitudinal	Lateral
15	15

- h. Vehicle exit angle from the barrier shall not be more than 12 degrees. Within 100 ft. after losing contact with the railing, the vehicle shall move no more than 20 ft. plus the vehicle width from the line of the traffic face of the railing. The brakes shall not be applied until the vehicle has traveled at least 100 ft. from the point of initial impact.

- 4. Values A and R are estimated values describing the test vehicle and its loading. Values of A and R are described in the figure below and calculated as follows:

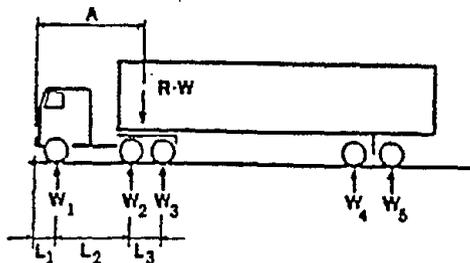

$$A = L_1 + \frac{W_2 L_2 + W_3 (L_2 + L_3)}{W_1 + W_2 + W_3}$$

$$R = \frac{W_1 + W_2 + W_3}{W}$$

$$W = W_1 + W_2 + W_3 + W_4 + W_5$$

= total vehicle weight.

- 5. Test articles that do not meet the "desirable" evaluation criteria shall have their performance evaluated by a designated authority that will decide whether the test article is likely to meet its intended use requirements.

1 kip = 4.45 kN
1 mi/h = 1.609 km/h
1 ft = 0.305 m

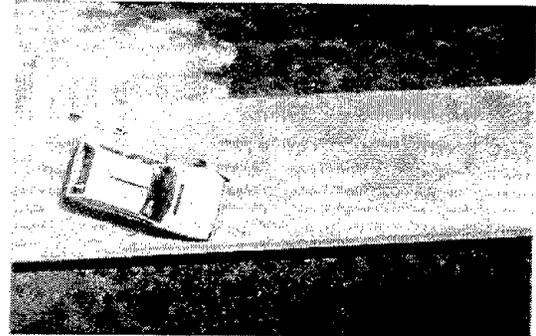

0.000 s

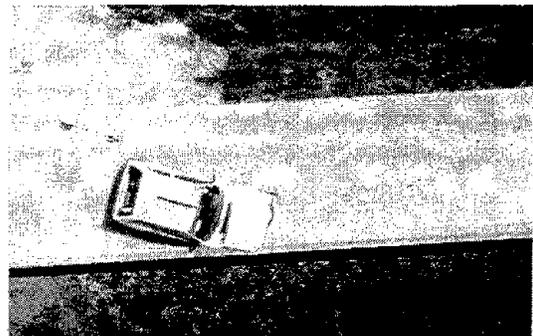

0.050 s

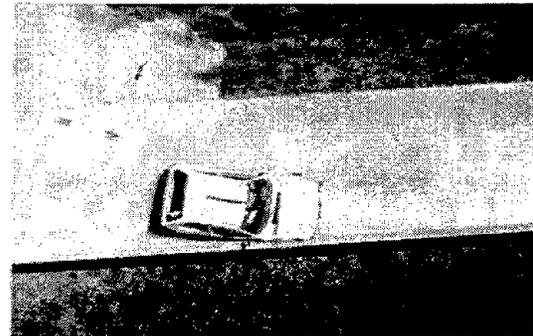

0.101 s

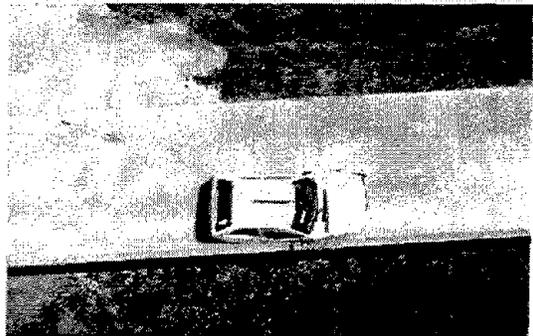

0.151 s

Figure 8. Sequential photographs for test 7069-3.

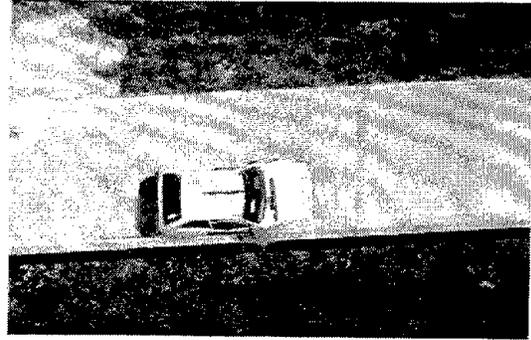

0.201 s

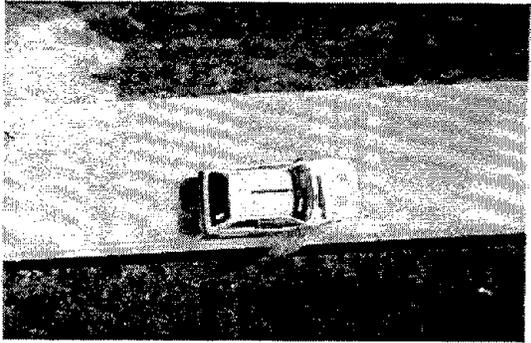

0.252 s



0.302 s

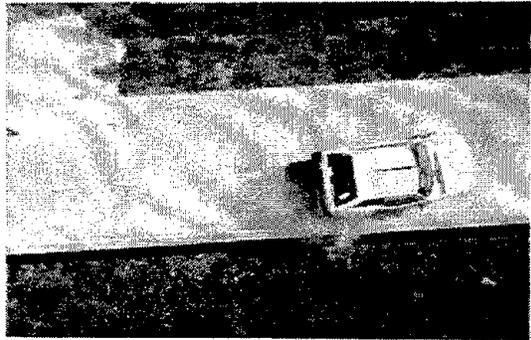

0.372 s

Figure 8. Sequential photographs for test 7069-3 (continued).



0.000 s



0.206 s



0.046 s



0.252 s



0.103 s



0.298 s



0.149 s



0.367 s

Figure 9. Interior sequential photographs for test 7069-3.

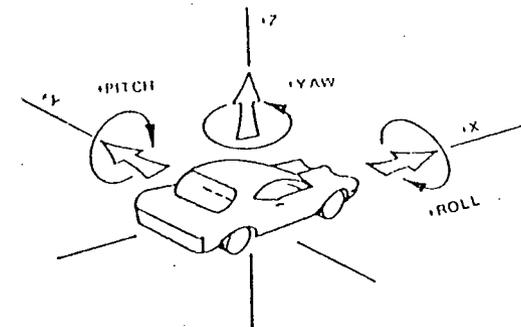
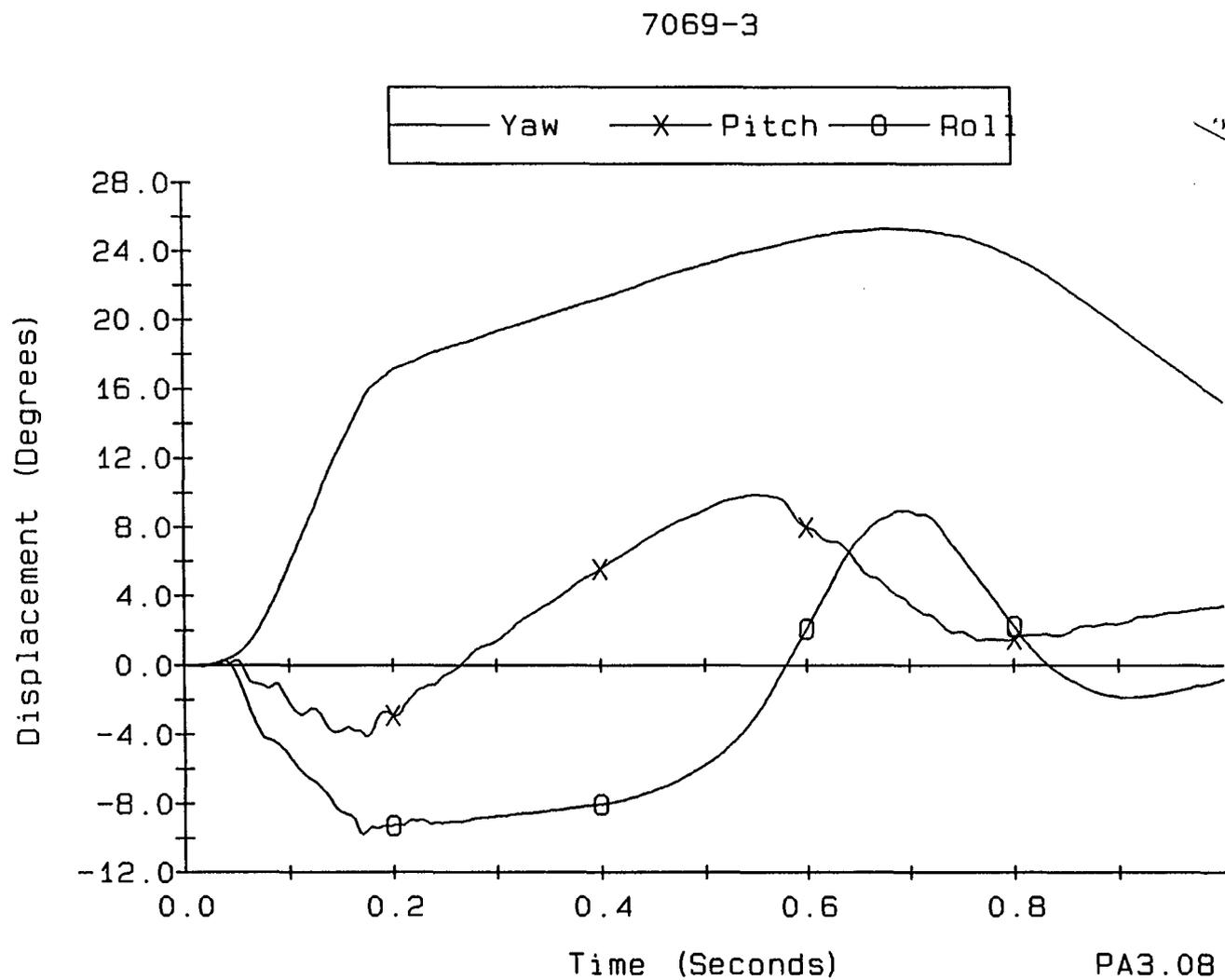

Axes are vehicle fixed.
Sequence for determining
orientation is:

1. Yaw
2. Pitch
3. Roll

Figure 10. Vehicle angular displacements for test 7069-3.

CRASH TEST 7069-3
Accelerometer near center-of-gravity

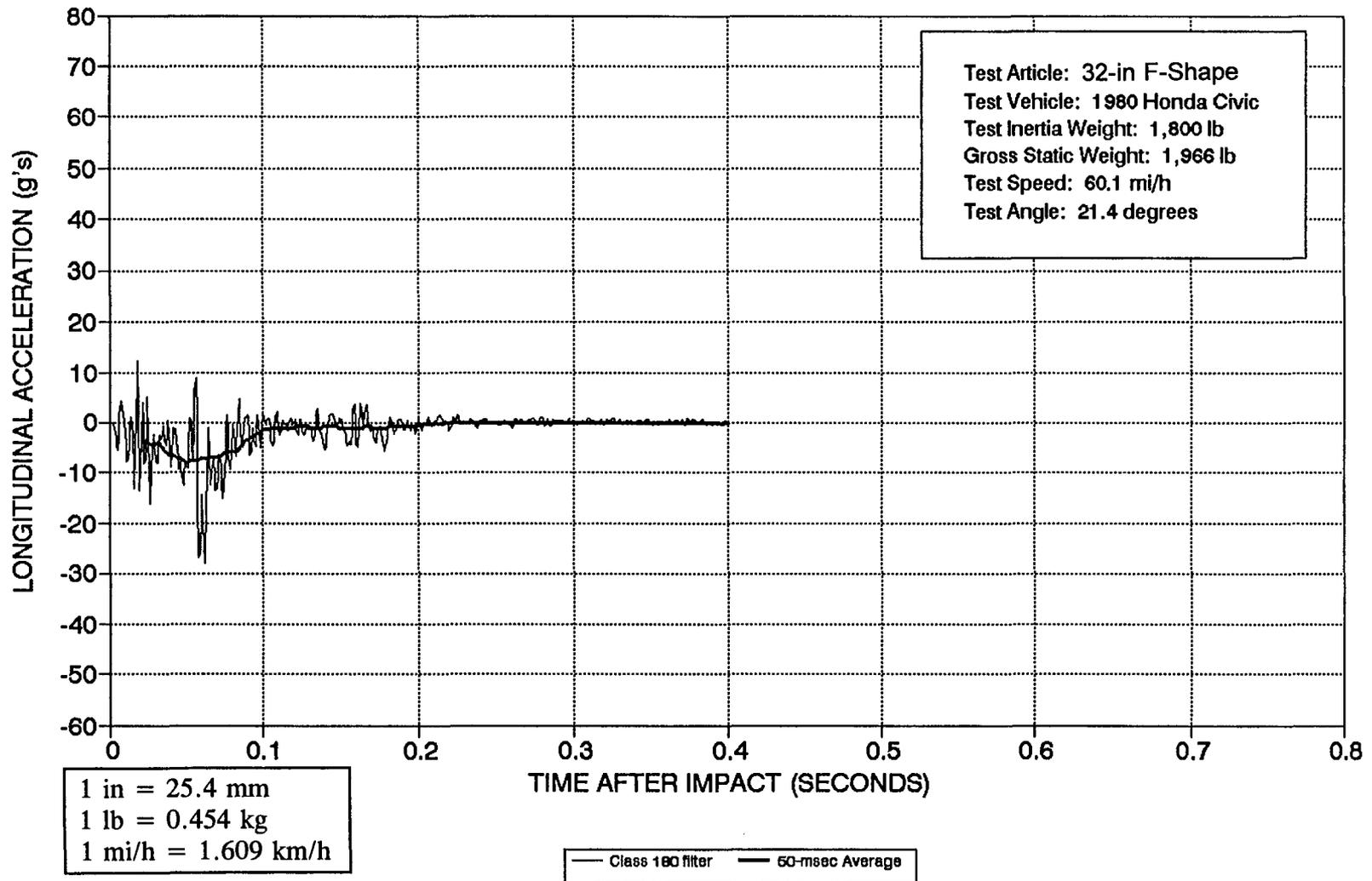

Figure 11. Vehicle longitudinal accelerometer trace for test 7069-3 (accelerometer located near center-of-gravity).

CRASH TEST 7069-3

Accelerometer near center-of-gravity

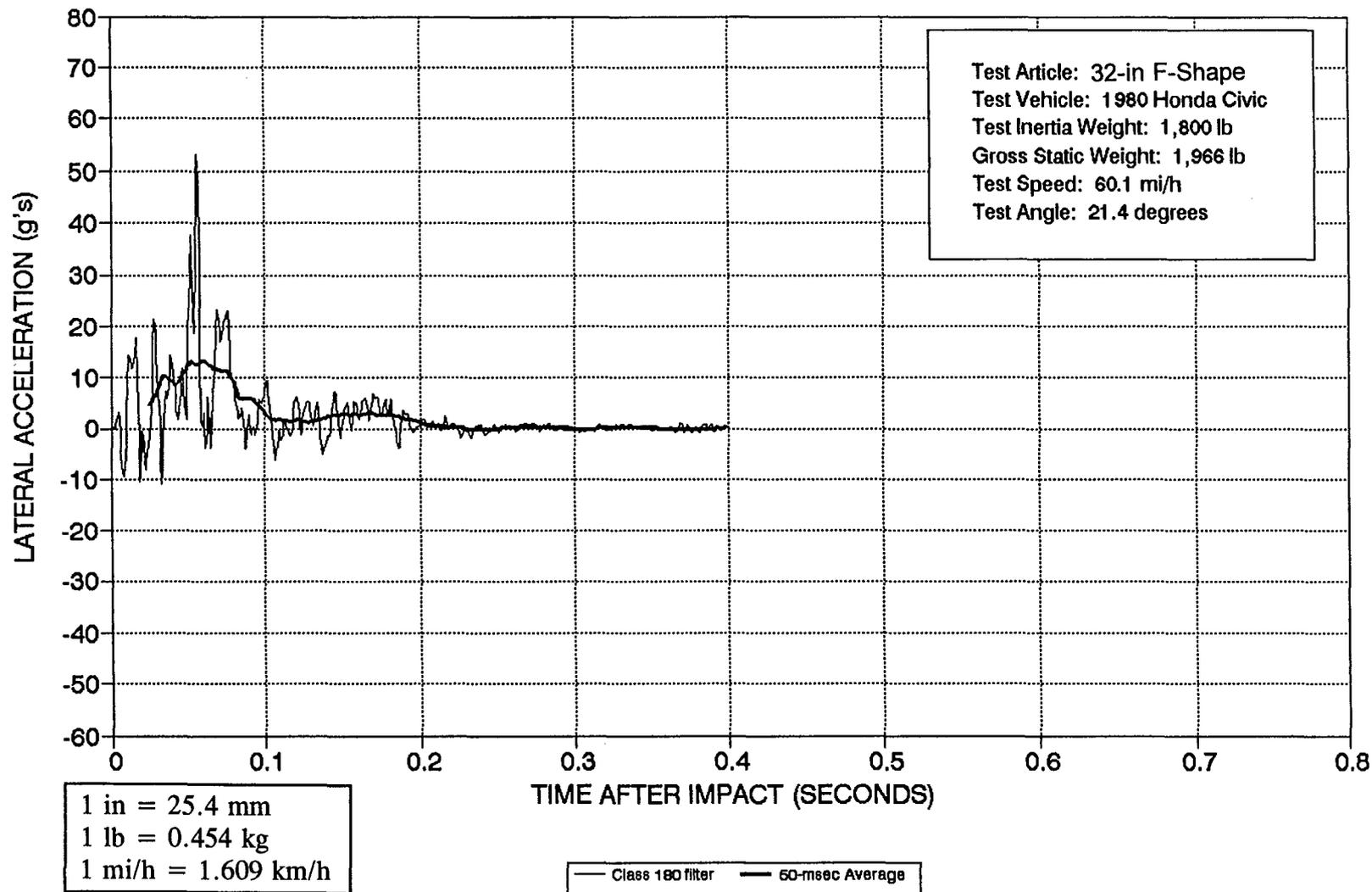

Figure 12. Vehicle lateral accelerometer trace for test 7069-3 (accelerometer located near center-of-gravity).

CRASH TEST 7069-3
Accelerometer near center-of-gravity

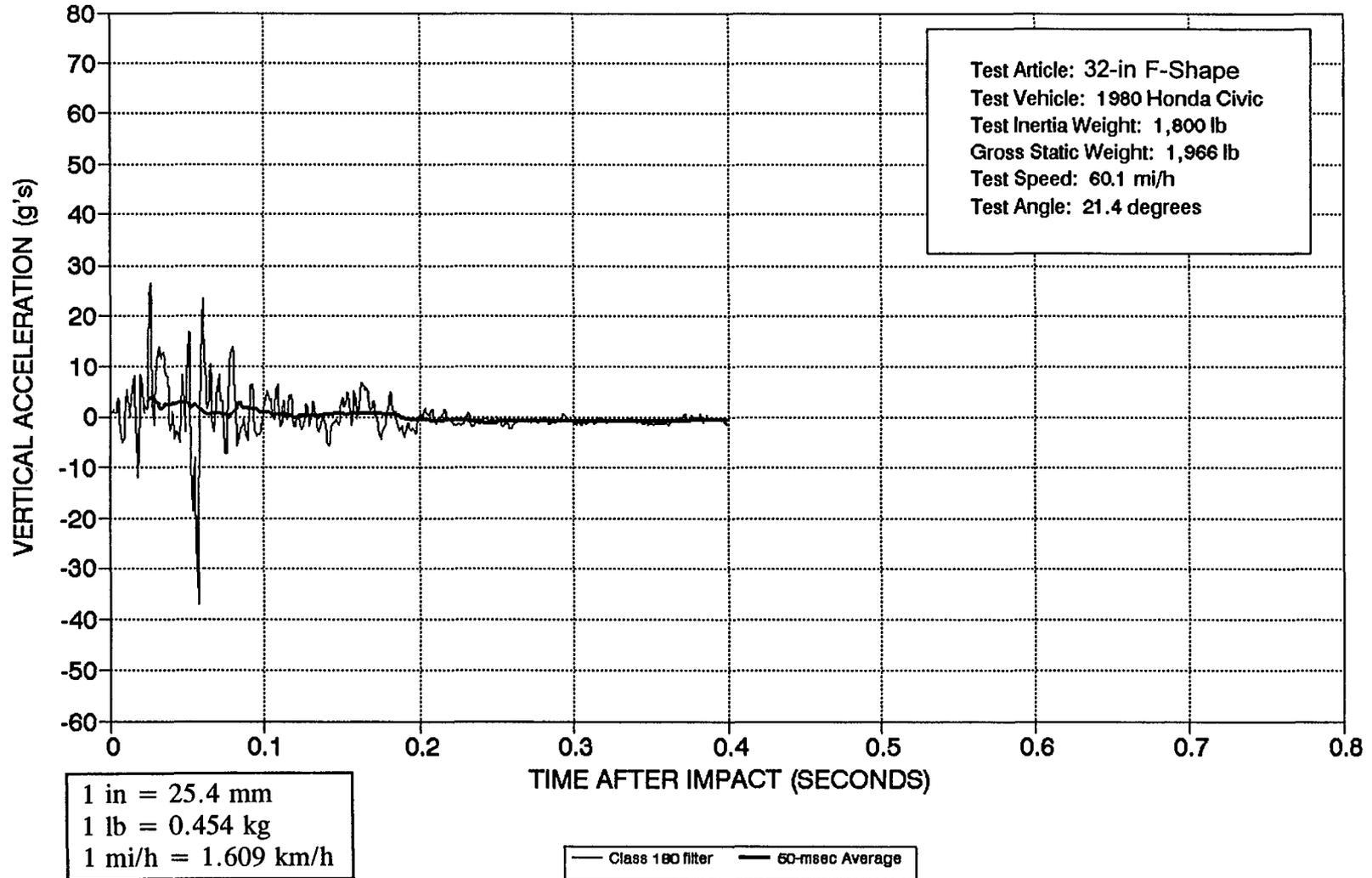

Figure 13. Vehicle vertical accelerometer trace for test 7069-3 (accelerometer located near center-of-gravity).

TEST 7069-4

Test Description

The 1981 Chevrolet pickup (figures 14 and 15) was directed into the bridge railing (figure 16) using a cable reverse tow and guidance system. Test inertia mass of the vehicle was 5,440 lb (2 470 kg) and its gross static mass was 5,780 lb (2 624 kg). The height to the lower edge of the vehicle bumper was 17.0 in (432 mm) and it was 26.25 in (667 mm) to the top of the bumper. Other dimensions and information on the test vehicle are given in figure 17. The vehicle was free-wheeling and unrestrained just prior to impact.

The speed of the vehicle at impact was 65.4 mi/h (105.2 km/h) and the angle of impact was 20.4 degrees. [The 1987 proposed test matrix required 65 mi/h (104.7 km/h), but the 1989 Guide Specification requires 60 mi/h (96.6 km/h).] The vehicle impacted the bridge railing at midlength. At approximately 0.013 s after impact the right front wheel began to ride up the face of the bridge railing, and at 0.019 s the right front tire aired out. The vehicle began to redirect as the rear end began to slide toward the bridge railing. The dummies began to move abruptly to the right at 0.046 s, and at 0.106 s the passenger head of the dummy shattered the right side window glass. At 0.139 s the left front wheel left the ground, and at 0.141 s the rear of the vehicle slapped the bridge railing and aired out the right rear tire. By 0.154 s the vehicle was totally airborne and remained so as it became parallel with the railing (at 0.179 s) and exited the railing (at 0.238 s). The left front wheel touched down at 0.287 s and the right touched down at 0.433 s. The vehicle exited the railing with a yaw angle of 0.4 degrees and a vehicle trajectory path of 7.4 degrees. The brakes were applied and the vehicle subsequently came to rest 240 ft (73 m) downstream and 37 ft (11 m) behind the point of impact.

As can be seen in figure 18, the railing received cosmetic damage and some scraping. There were tire marks on the face of the bridge railing which indicated the vehicle rose a maximum height of 24 in (610 mm) above the ground. The vehicle was in contact with the bridge railing for 18.0 ft (5.5 m).

The vehicle sustained extensive damage to the right side as shown in figure 19. Maximum crush at the right front corner at bumper height was 5.0 in (127 mm). The right front and right rear wheel rims were bent and the tires aired out. The wheel assembly and suspension was damaged. The passenger door was bent and jammed and the window broken out. The right rear panel was dented and scraped. The hood was bent and shifted to the left. The cab of the vehicle was twisted.

Test Results

Impact speed was 65.4 mi/h (105.2 km/h) and the angle of impact was 20.4 degrees. The exit speed at time of contact (0.238 s) was 56.9 mi/h (91.6 km/h) and the vehicle trajectory path was 7.3 degrees with a vehicle yaw angle of 0.4 degrees. The effective coefficient of friction was calculated to be 0.31. Occupant impact velocity was 12.5 ft/s (3.8 m/s) in the longitudinal direction and 24.1 ft/s (7.3 m/s) in the lateral direction. The highest

0.010-s occupant ridedown accelerations were -1.2 g (longitudinal) and 5.9 g (lateral). These data and other pertinent information from the test are summarized in figure 20 and table 3. Sequential photographs are shown in figures 21 and 22. Vehicular angular displacements are displayed in figure 23. Vehicular accelerations versus time traces filtered with SAE J211 filters are presented in figures 24 through 28. These data were further analyzed to obtain 0.050-s average accelerations versus time. A 0.050-s interval immediately prior to impact was averaged to establish zero acceleration. The data were then processed with a moving 0.050-s average window with the first 0.050-s average plotted at 0.026 s for each trace. The maximum 0.050-s averages were -4.7 g (longitudinal) and 13.1 g (lateral).

Conclusions

The 32-in (813-mm) F-shape bridge railing contained and smoothly redirected the vehicle with minimal lateral movement of the bridge railing. There were no debris or detached elements. There was no intrusion into the occupant compartment although some deformation of the right door occurred. The vehicle trajectory at loss of contact indicated minimum intrusion into adjacent traffic lanes. The vehicle remained upright and stable during the entire test period. See table 3 for a more detailed description.



Figure 14. Vehicle and instrumentation before test 7069-4.



Figure 15. Vehicle/bridge railing geometrics for test 7069-4.

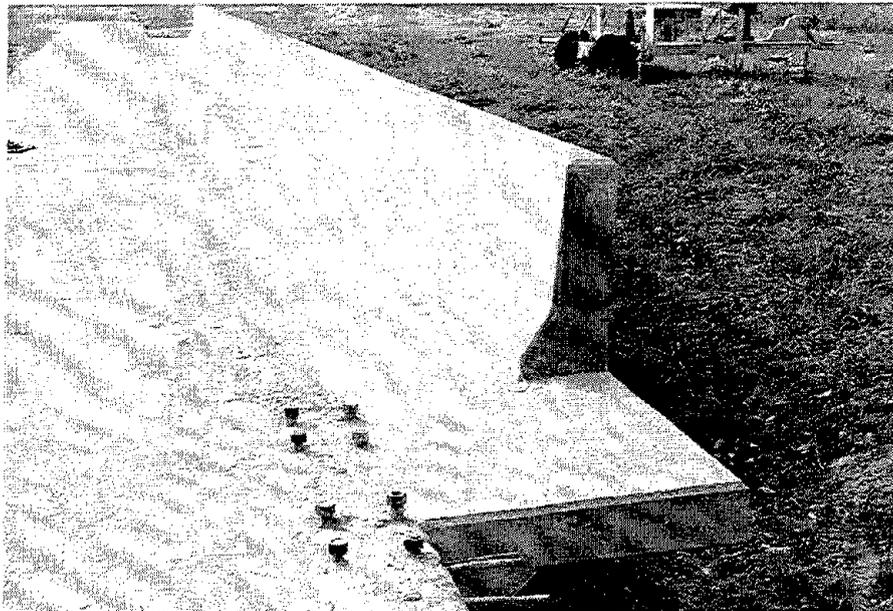
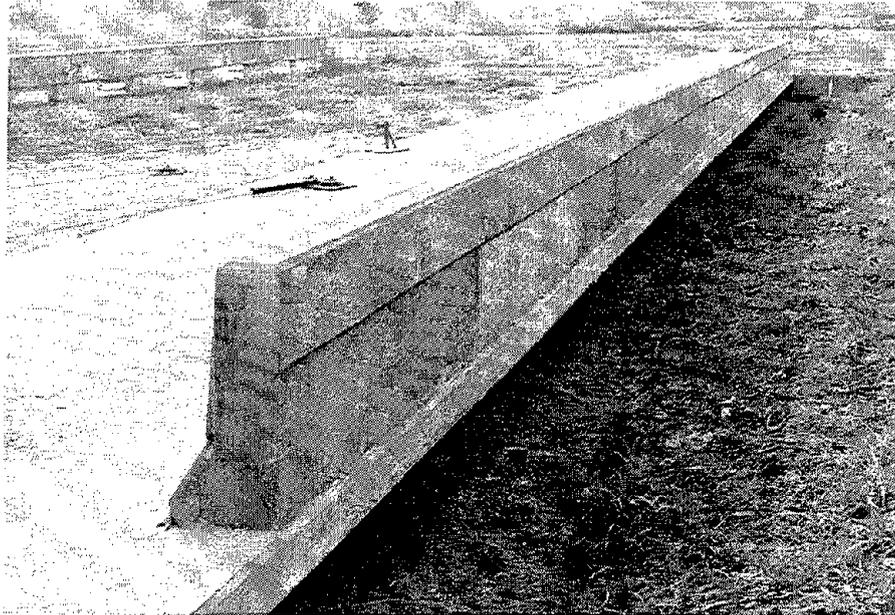
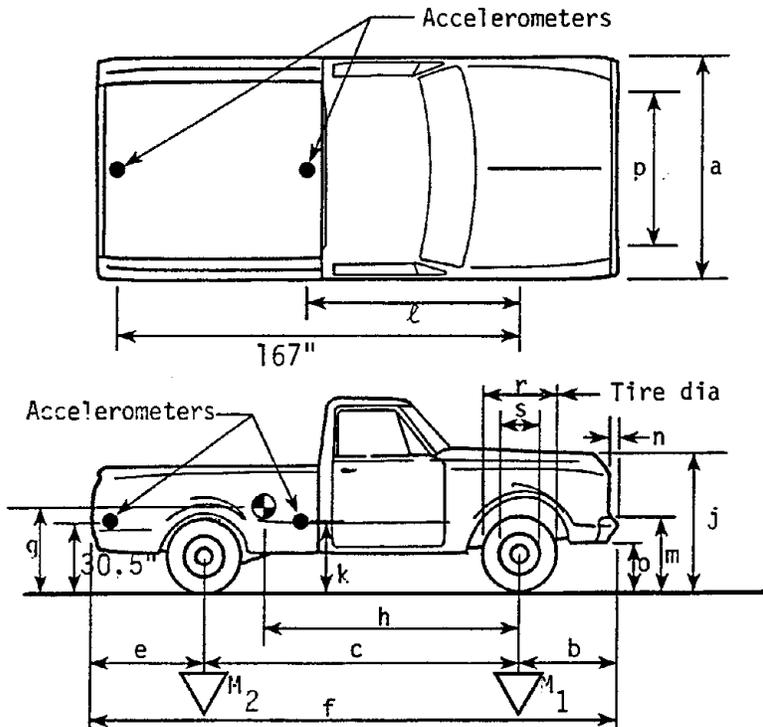

Figure 16. 32-in (813-mm) F-shape bridge railing before test 7069-4.

Date: 7-30-87 Test No.: 7069-4 VIN: 1GCGC24M7BS180051
 Make: Chevrolet Model: Scottsdale Year: 1981 Odometer: 112314
 Tire Size: 9.50R16.5 Ply Rating: 4 Bias Ply: X Belted: Radial:

Tire Condition: good
 fair
 badly worn



Vehicle Geometry - inches
 a 70 1/4 b 33 1/2
 c 132 d*71
 e 50 1/4 f 215.75
 g 26.1 h 66.7
 i ---- j 44 1/4
 k 30 1/2 l 72 1/2
 m 26 1/4 n 4
 o 17 p 65 1/2
 r 29 s 17

Engine Type: V8
 Engine CID: 350

Transmission Type:
 Automatic or Manual
 FWD or RWD or 4WD
 Body Type: PU

Steering Column Collapse Mechanism:
 Behind wheel units
 Convoluted tube
 Cylindrical mesh units
 Embedded ball
 NOT collapsible
 Other energy absorption
 Unknown

4-wheel weight for c.g. det. lf 1340 rf 1350 lr 1400 rr 1350

Mass - pounds	Curb	Test Inertial	Gross Static
M_1	<u>2667</u>	<u>2690</u>	<u>2890</u>
M_2	<u>2210</u>	<u>2750</u>	<u>2890</u>
M_T	<u>4877</u>	<u>5440</u>	<u>5780</u>

Note any damage to vehicle prior to test:

Brakes:
 Front: disc X drum
 Rear: disc drum X

*d = overall height of vehicle

1 in = 25.4 mm
1 lb = 0.454 kg

Figure 17. Vehicle properties for test 7069-4.

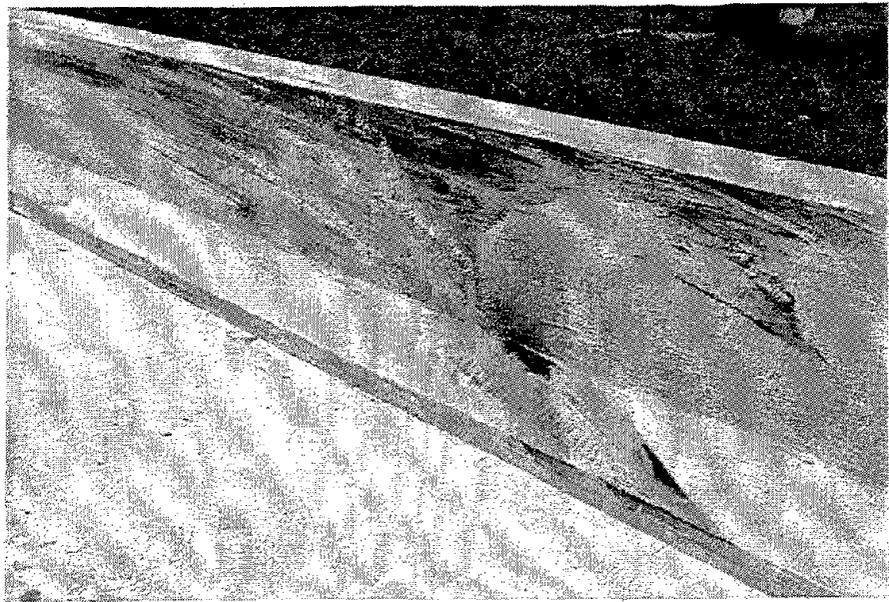
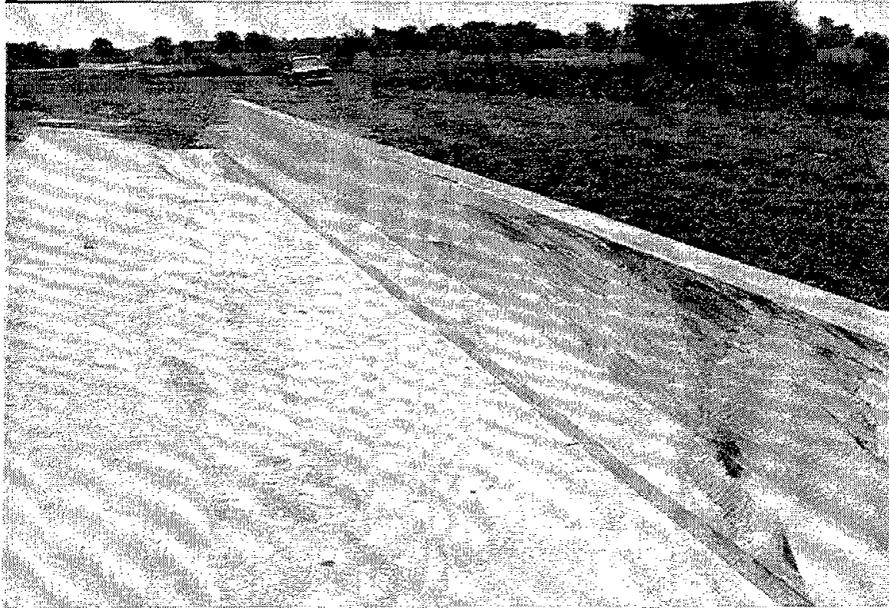
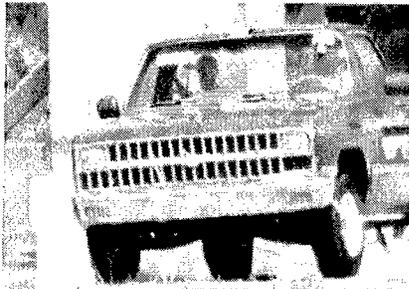

Figure 18. 32-in (813-mm) F-shape bridge railing after test 7069-4.



Figure 19. Vehicle after test 7069-4.



0.000 s



0.099 s



0.201 s



0.308 s

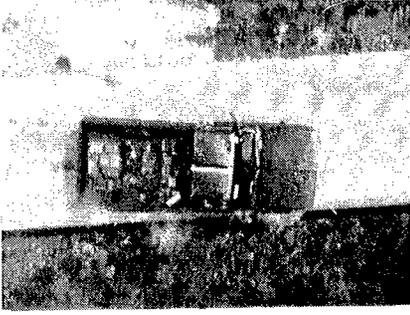
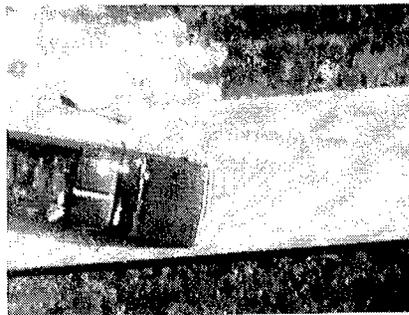

33

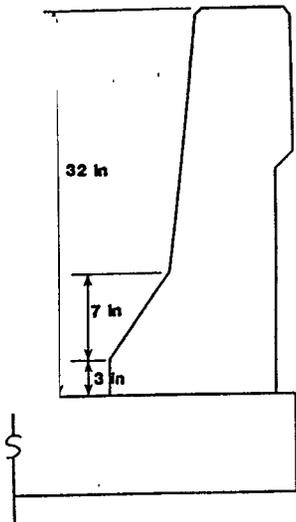

(1 in = 25.4 mm)

Test No.	7069-4	Impact Speed. . .	65.4 mi/h (105.2 km/h)
Date	7/30/87	Impact Angle. . .	20.4 deg
Test Installation . . .	32-in (813-mm) F-Shape Bridge Railing	Exit Speed. . . .	56.9 mi/h (91.6 km/h)
Installation Length . .	100 ft (30 m)	Exit Trajectory .	7.4 deg
Vehicle	1981 Chevrolet Pickup	Vehicle Accelerations (Max. 0.050-sec Avg)	
Vehicle Weight		Longitudinal. . .	-4.7 g
Test Inertia	5,440 lb (2,470 kg)	Lateral	13.1 g
Gross Static	5,780 lb (2,624 kg)	Occupant Impact Velocity	
Vehicle Damage Classification		Longitudinal. . .	12.5 ft/s (3.8 m/s)
TAD	01RD4	Lateral	24.1 ft/s (7.3 m/s)
CDC	01FREK2 & 01RYEW3	Occupant Ridedown Accelerations	
Maximum Vehicle Crush .	5.0 in (127 mm)	Longitudinal. . .	-1.2 g
		Lateral	5.9 g

Figure 20. Summary of results for test 7069-4.

Table 3. Evaluation of crash test no. 7069-4.
 {32-in (81 cm) F-Shape Bridge Railing [5,440 lb (2 470 kg)|65.4 mi/h (105.2 km/h)|20.4 degrees]}

CRITERIA		TEST RESULTS		PASS/FAIL*
A.	Must contain vehicle	Vehicle was contained		Pass
B.	Debris shall not penetrate passenger compartment	No debris penetrated passenger compartment		Pass
C.	Passenger compartment must have essentially no deformation	Minimal deformation		Pass
D.	Vehicle must remain upright	Vehicle did remained upright		Pass
E.	Must smoothly redirect the vehicle	Vehicle was smoothly redirected		Pass
F.	Effective coefficient of friction	μ	Assessment	
		0 - .25	Good	
		.26 - .35	Fair	
		> .35	Marginal	
		.31	Good	Pass
G.	Shall be less than			
	<u>Occupant Impact Velocity - ft/s (m/s)</u>	<u>Occupant Impact Velocity - ft/s (m/s)</u>		
	Longitudinal Lateral	Longitudinal	Lateral	Pass
	30 (9.2) 25 (7.6)	12.5 (3.8)	24.1 (7.3)	
	<u>Occupant Ridedown Accelerations - g's</u>	<u>Occupant Ridedown Accelerations - g's</u>		
	Longitudinal Lateral	Longitudinal	Lateral	Pass
	15 15	-1.2	5.9	
H.	Exit angle shall be less than 12 degrees	Exit angle was 7.3 degrees		Pass

* A, B, C, and D are required. E, F, G, and H are desired. (See table 2)

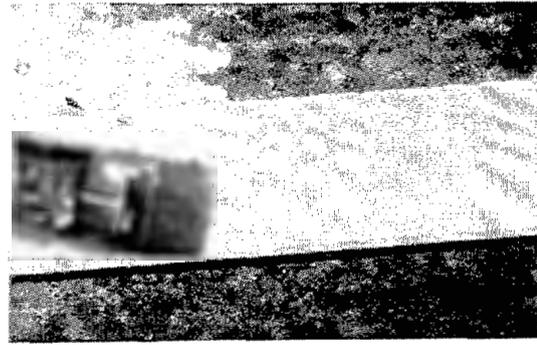

0.000 s

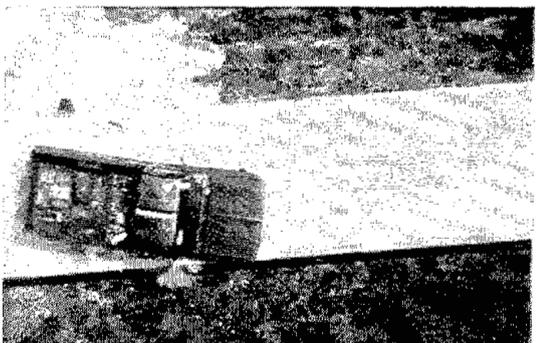

0.051 s

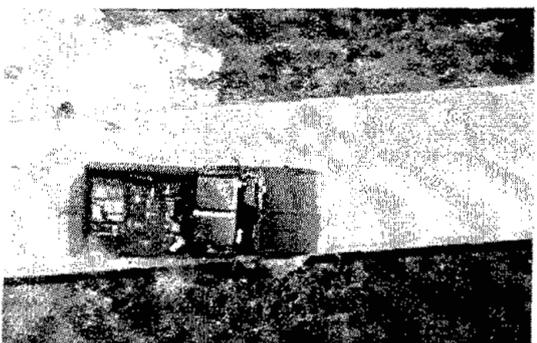

0.099 s

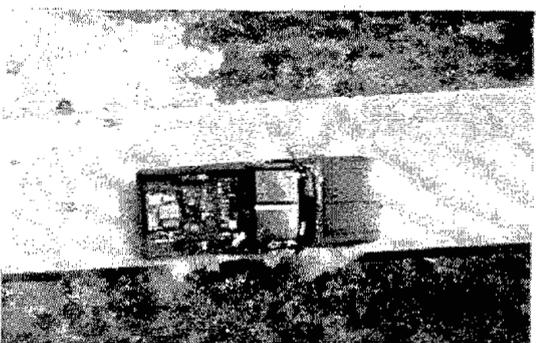

0.150 s

Figure 21. Sequential photographs for test 7069-4.

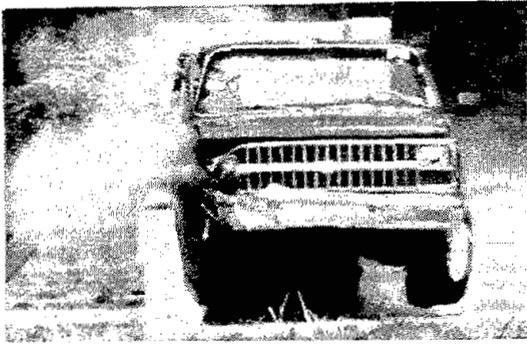

0.201 s

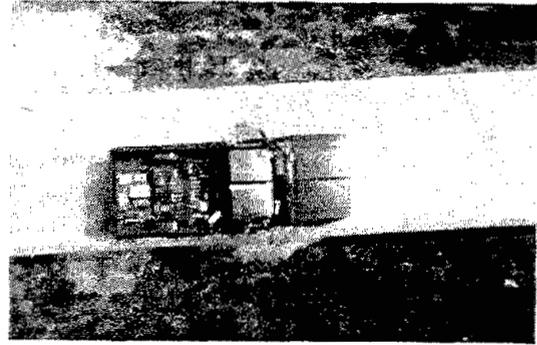

0.250 s

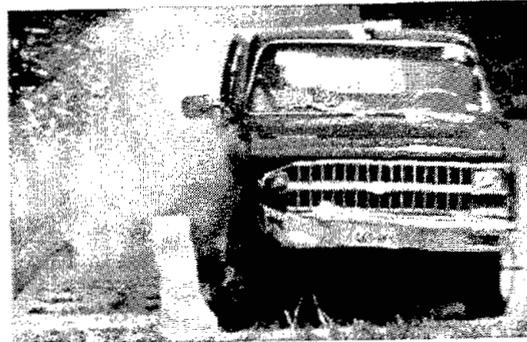
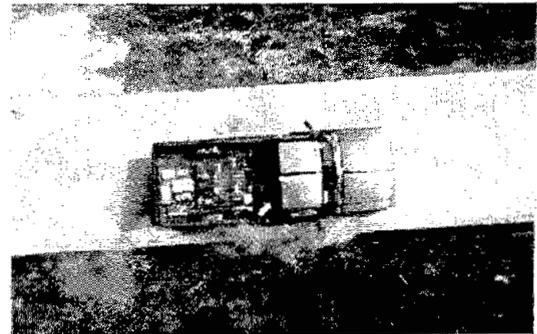

0.308 s

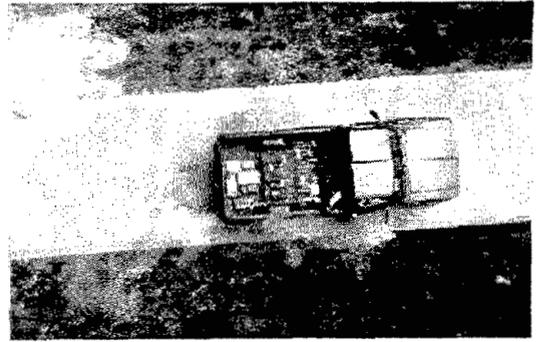

0.376 s

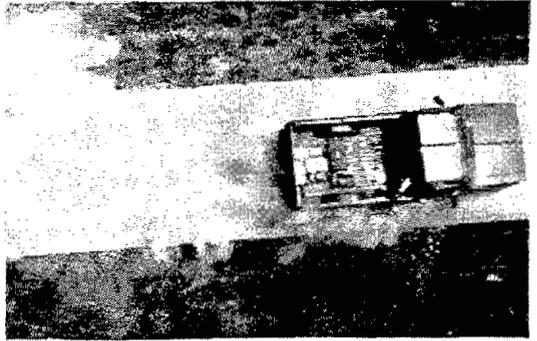

Figure 21. Sequential photographs for test 7069-4 (continued).



0.000 s



0.197 s



0.046 s

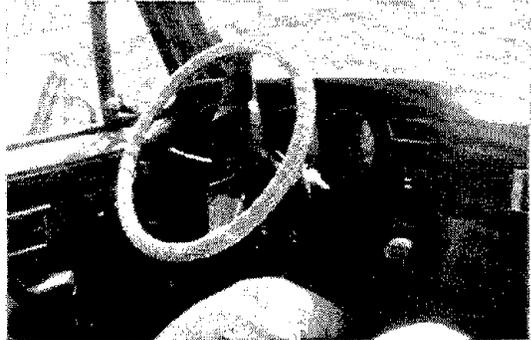

0.255 s



0.104 s

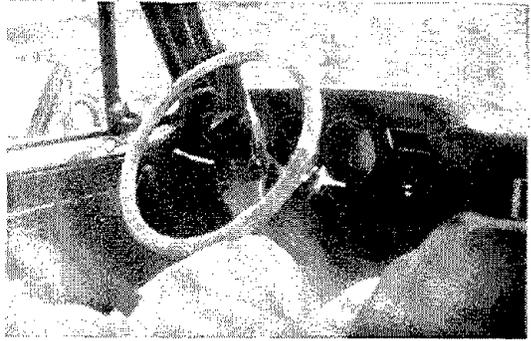

0.313 s



0.151 s



0.371 s

Figure 22. Interior sequential photographs for test 7069-4.

7069-4

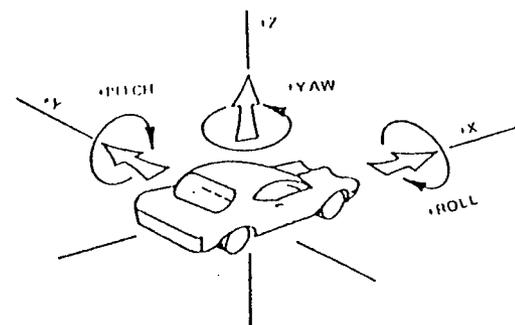
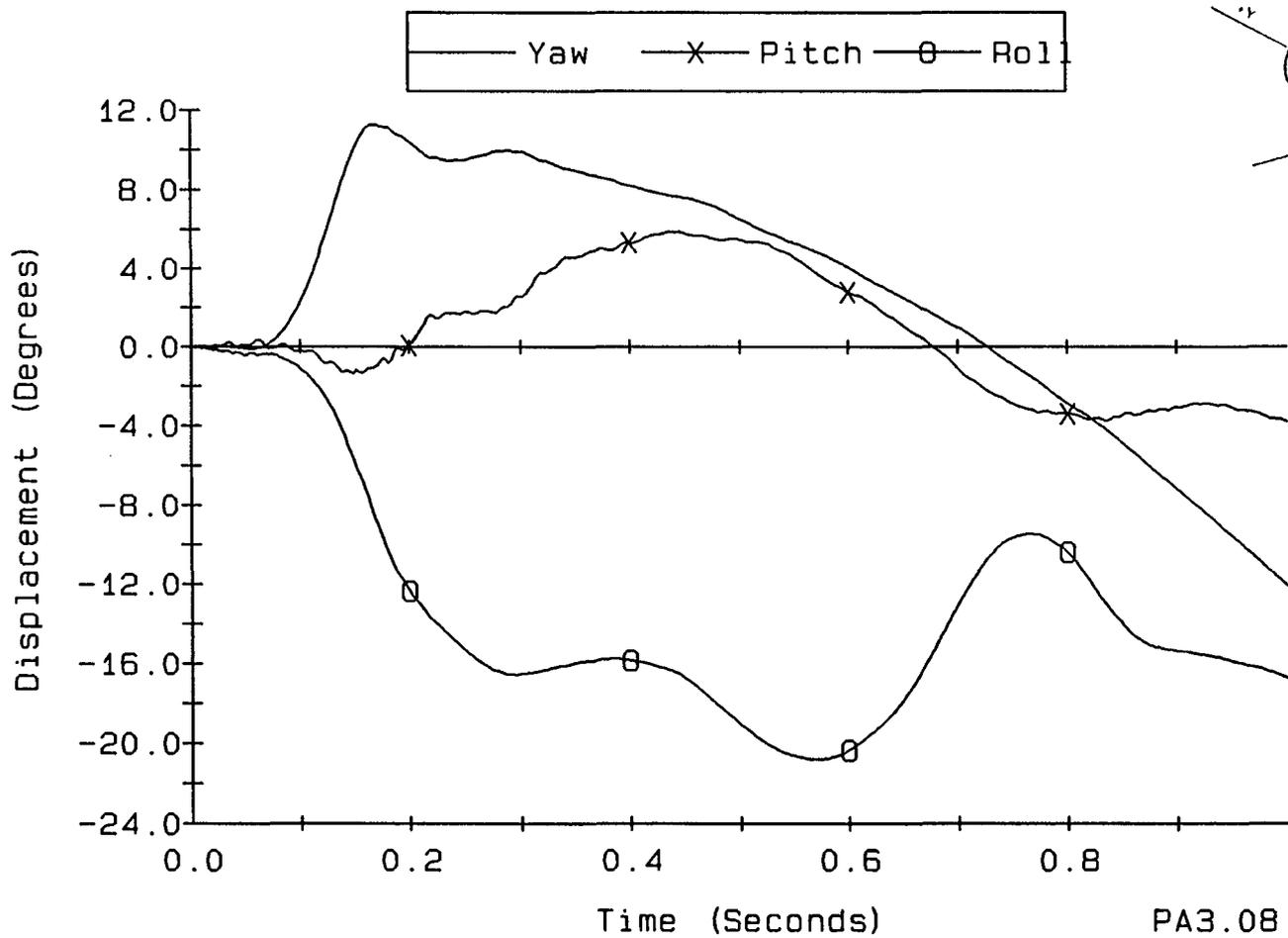

Axes are vehicle fixed.
Sequence for determining orientation is:

1. Yaw
2. Pitch
3. Roll

Figure 23. Vehicle angular displacements for test 7069-4.

CRASH TEST 7069-4

Accelerometer near center-of-gravity

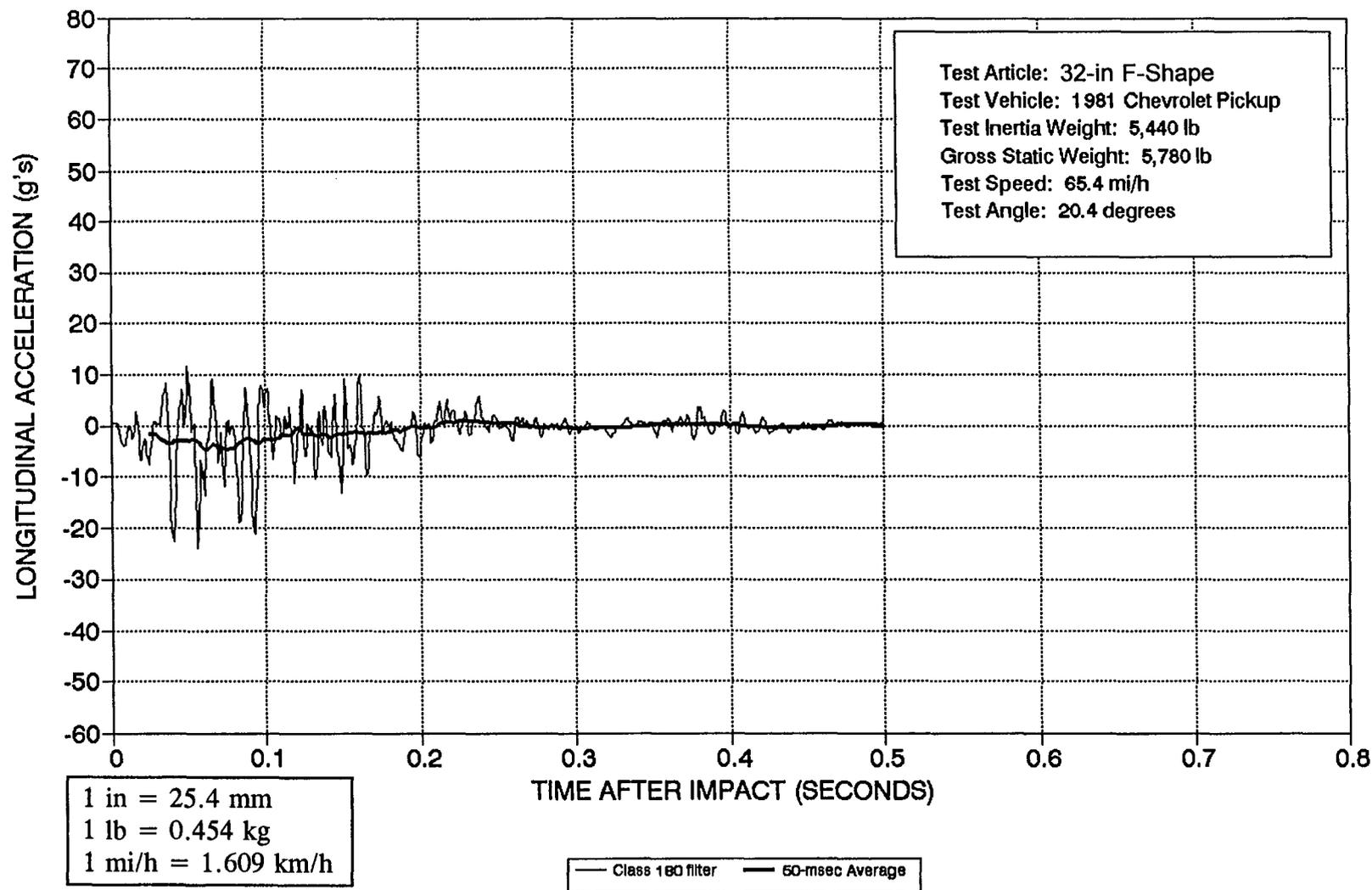

Figure 24. Vehicle longitudinal accelerometer trace for test 7069-4 (accelerometer located at center-of-gravity).

CRASH TEST 7069-4
Accelerometer near center-of-gravity

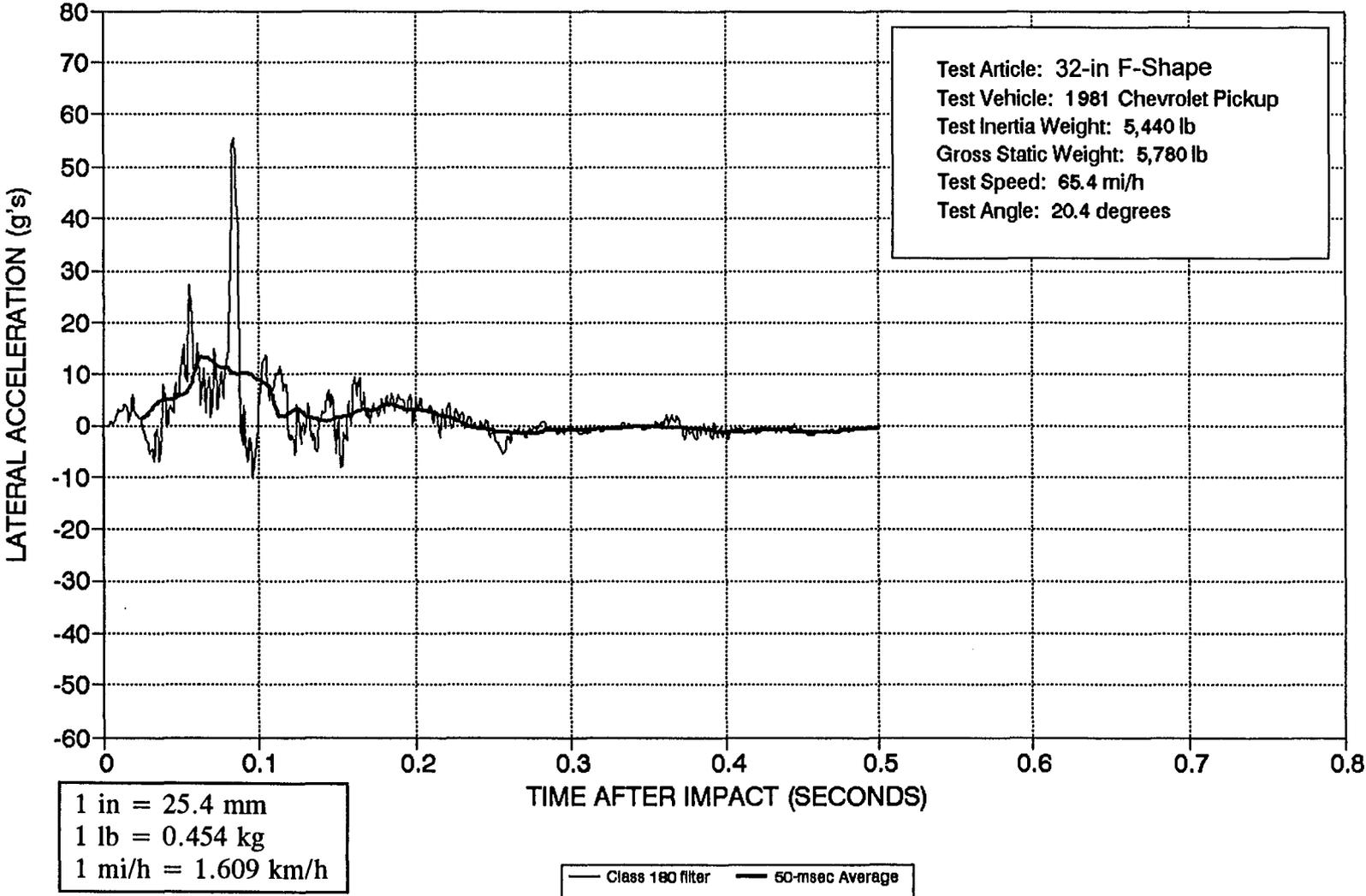

Figure 25. Vehicle lateral accelerometer trace for test 7069-4 (accelerometer located at center-of-gravity).

CRASH TEST 7069-4
Accelerometer near center-of-gravity

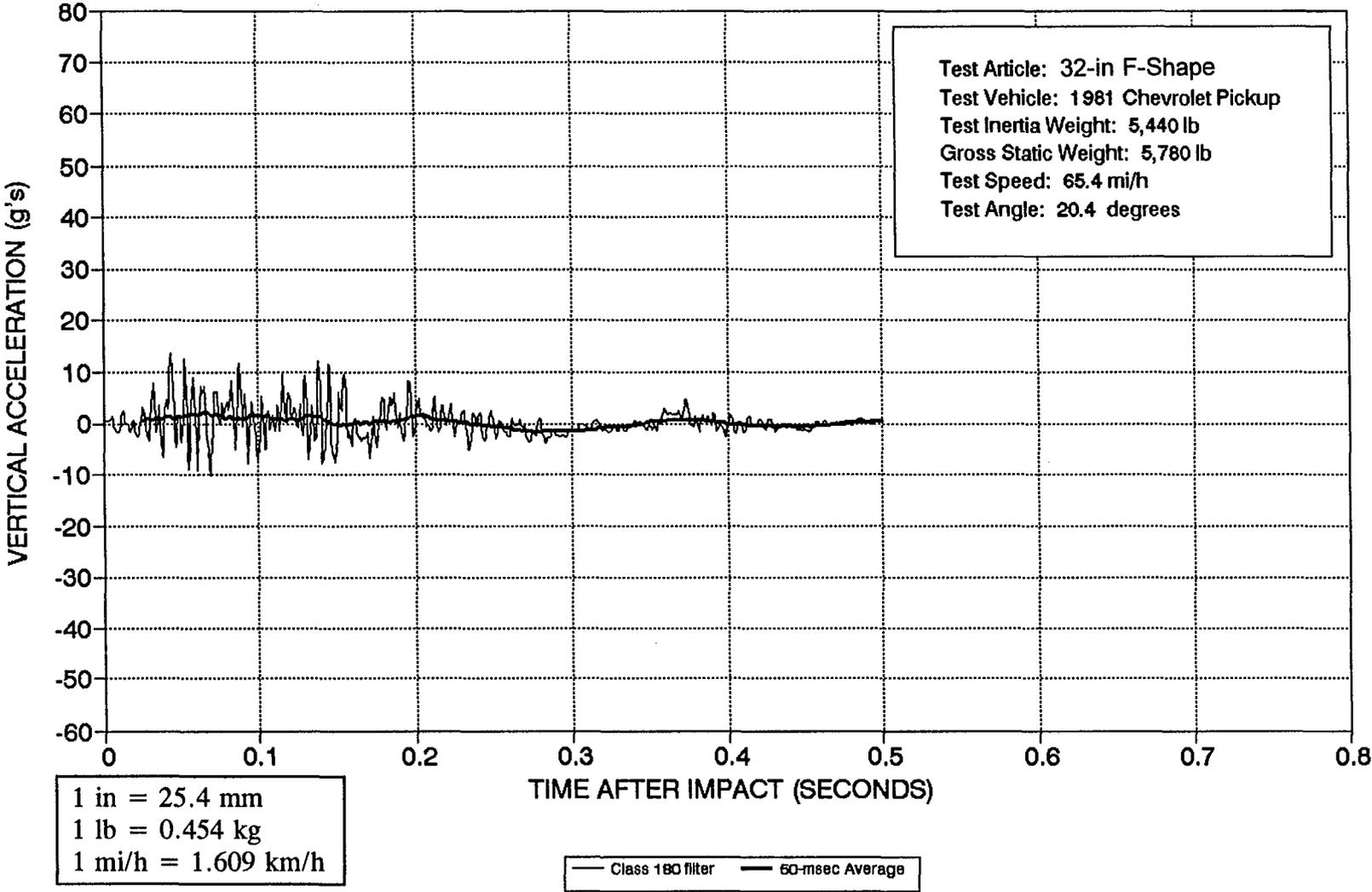

Figure 26. Vehicle vertical accelerometer trace for test 7069-4 (accelerometer located at center-of-gravity).

CRASH TEST 7069-4
Accelerometer at rear of vehicle

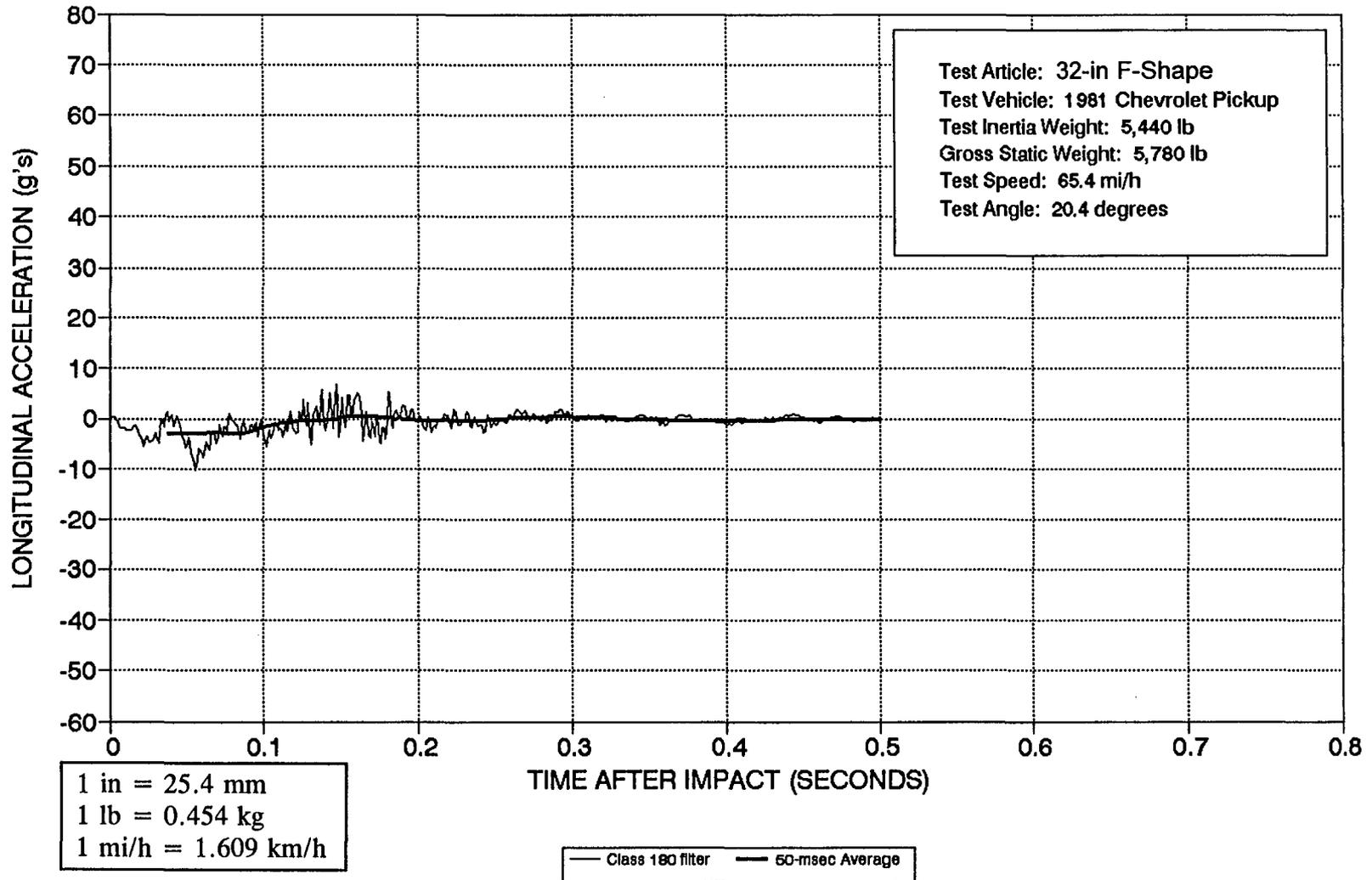

Figure 27. Vehicle longitudinal accelerometer trace for test 7069-4 (accelerometer located at rear of vehicle).

CRASH TEST 7069-4
Accelerometer at rear of vehicle

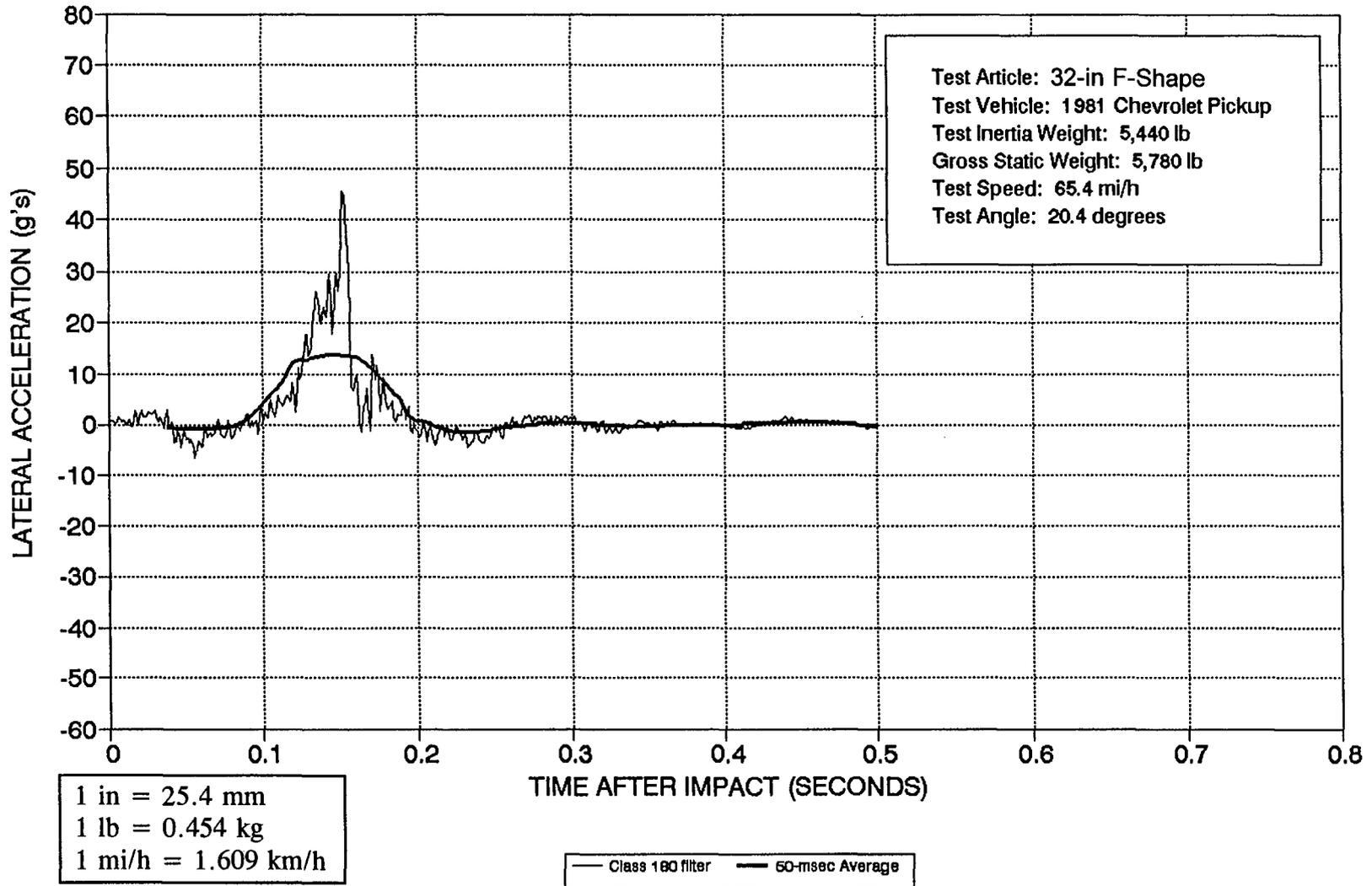

Figure 28. Vehicle lateral accelerometer trace for test 7069-4 (accelerometer located at rear of vehicle).

TEST 7069-8

NOTE: In test 7069-8, the engine of the test vehicle (which was remotely controlled) stalled, causing the impact speed of the test vehicle to be lower than specified in the crash test requirements [46.7 mi/h (75.2 km/h) vs. 50 mi/h (80.5 km/h)]. The test was repeated (7069-9) and again the impact speed was too low [47.3 mi/h (76.2 km/h) vs. 50 mi/h (80.5 km/h)]. In a third test (7069-11), an impact speed of 52.1 mi/h (132.3 km/h) was attained. Descriptions for all three of these tests are included in this report.

Test Description

The 1982 Ford single-unit truck (figures 29 and 30) was directed into the 32-in (813-mm) F-shape bridge railing (figure 31) using a remote control guidance system. Empty weight of the vehicle was 13,850 lb (6 288 kg) and its test inertia weight was 18,050 lb (8 195 kg). The height to the lower edge of the vehicle bumper was 19.5 in (495 mm) and it was 27.75 in (705 mm) to the top of the bumper. Other dimensions and information on the test vehicle are given in figure 32. The vehicle was free-wheeling and unrestrained just prior to impact.

The speed of the vehicle at impact was 46.7 mi/h (75.1 km/h) and the angle of impact was 15.0 degrees. The vehicle impacted the bridge railing at midlength. At approximately 0.021 s after impact the right front wheel began to ride up the face of the bridge railing, and at 0.163 s the left front tire began to leave the ground. The vehicle began to redirect at 0.184 s as the rear end began to slide toward the bridge railing. At 0.343 s the left rear wheels left the ground, and at approximately 0.448 s the rear of the vehicle slapped the bridge railing. By approximately 0.495 s the vehicle became parallel with the railing and was continuing to roll to the right. As the vehicle continued along the railing the lower edge of the bed rode along the top of the railing. A maximum roll angle of 34 degrees was achieved at about 1.286 s. The vehicle slid off the end of the bridge railing at about 1.713 s after impact. The brakes were applied and the vehicle subsequently came to rest 186 ft (57 m) downstream.

As can be seen in figure 33, the railing received cosmetic damage and some scraping. There were tire marks on the face of the bridge railing and along the top. The top of the bridge railing was scraped along the remaining length from the lower edge of the bed of the truck (see figure 34). The vehicle was in contact with the bridge railing for 60 ft (18 m).

The vehicle sustained extensive damage to the right side as shown in figure 35. Maximum crush at the right front corner at bumper height was 6.0 in (152 mm). The right front wheel rim was bent and the tire damaged. The spring and spring shackle were broken loose from the axle. The steering gear box and steering cylinder were damaged. Also, the fuel tank broke loose from the truck.

Test Results

Impact speed was 46.7 mi/h (75.1 km/h) and the angle of impact was 15.0 degrees. The exit speed was not attainable. The effective coefficient of friction was calculated to be 0.76. The occupant impact velocity was 11.9 ft/s (3.6 m/s) in the longitudinal direction and 9.2 ft/s (2.8 m/s) in the lateral direction. The highest 0.010-s occupant ridedown accelerations were -3.8 g (longitudinal) and 6.1 g (lateral). These data and other pertinent information from the test are summarized in figure 36 and table 4. Sequential photographs are shown in figures 37 and 38. Vehicular angular displacements are displayed in figure 39.

Vehicular accelerations versus time traces filtered with SAE J211 filters are presented in figures 40 through 44. These data were further analyzed to obtain 0.050-s average accelerations versus time. A 0.050-s interval immediately prior to impact was averaged to establish zero acceleration. The data were then processed with a moving 0.050-s average window with the first 0.050-s average plotted at 0.026-s for each trace. The maximum 0.050-s averages were -2.2 g (longitudinal) and 3.4 g (lateral).

Conclusions

The 32-in (813-mm) F-shape bridge railing contained and smoothly redirected the vehicle with no lateral movement of the bridge railing. There were no debris or detached elements. There was no intrusion into the occupant compartment. The vehicle trajectory at loss of contact indicated minimum intrusion into adjacent traffic lanes. The vehicle remained upright and marginally stable during the entire test period. See table 4 for a more detailed description.



Figure 29. Vehicle before test 7069-8.



Figure 30. Vehicle/bridge railing geometrics for test 7069-8.

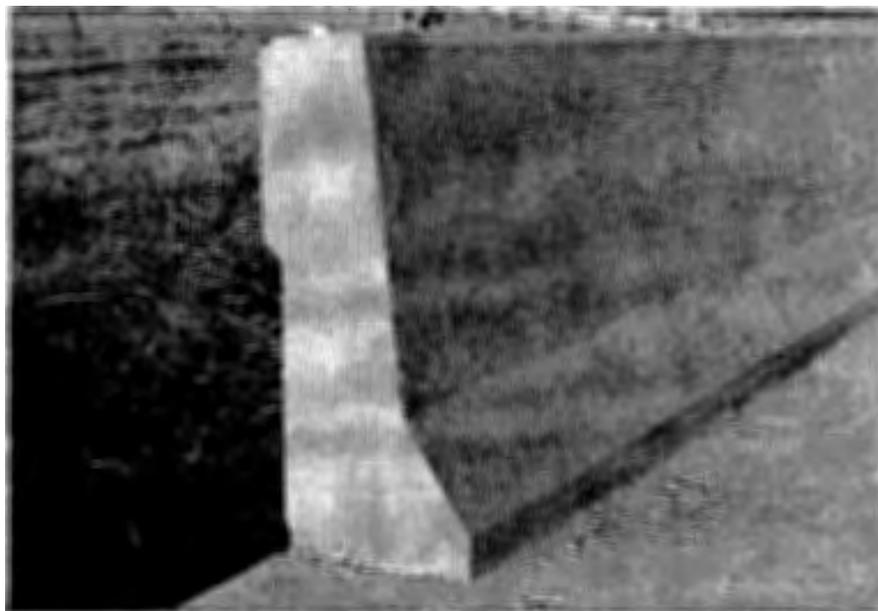
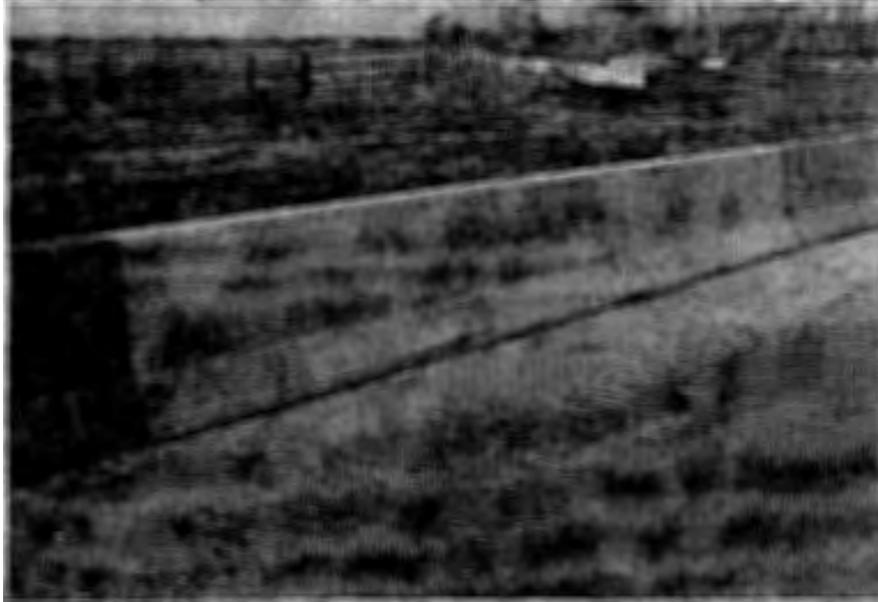
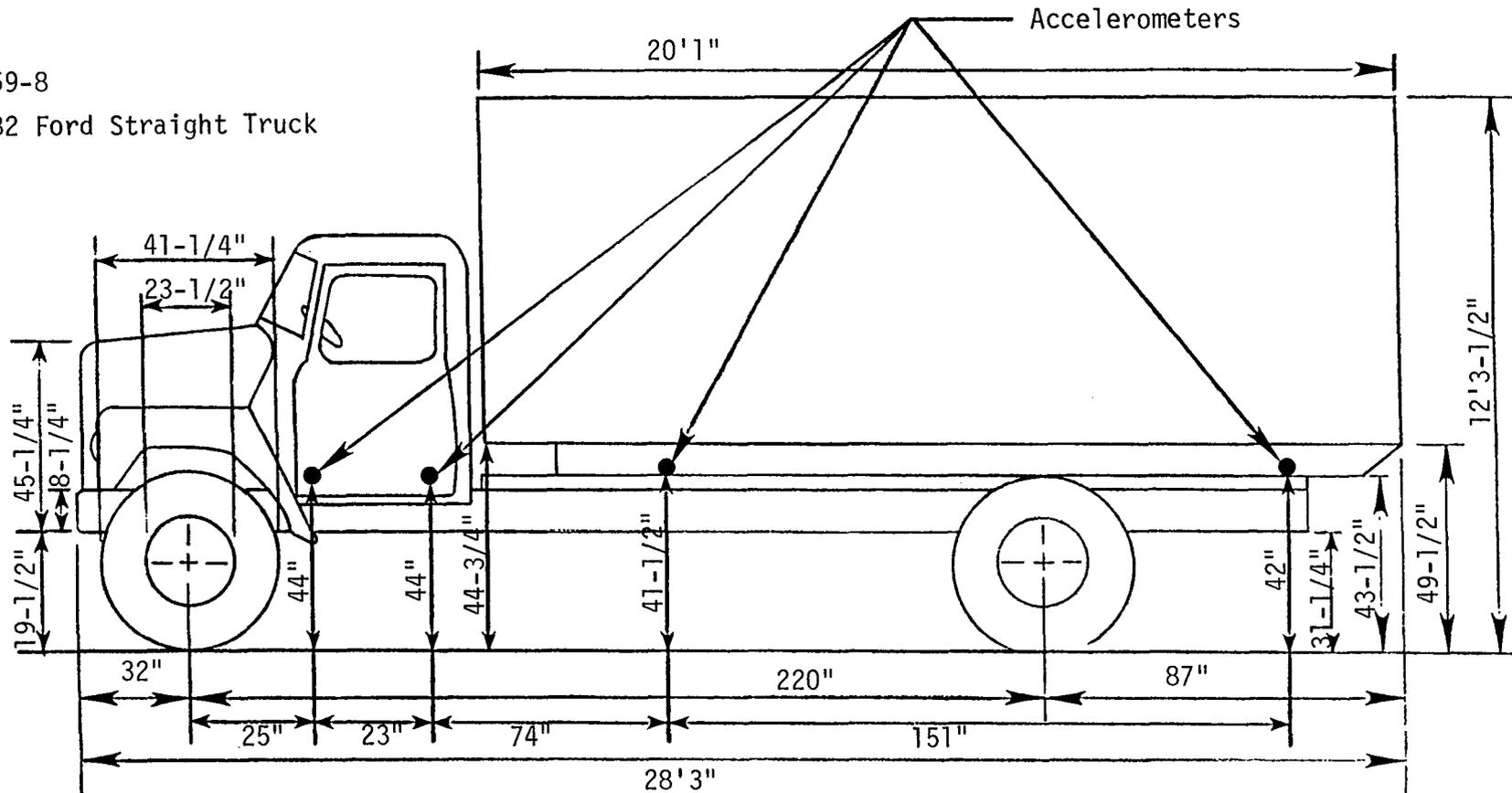

Figure 31. 32-in (813-mm) F-shape bridge railing before test 7069-8.

7069-8
1982 Ford Straight Truck

49



EMPTY WEIGHTS

Weight on Front Axle : LF 3,420 RF 3,630

Weight on Rear Axle : LR 3,520 RR 3,280

TOTAL EMPTY WEIGHT : 13,850

1 in = 25.4 mm

LOADED WEIGHTS

Weight on Front Axle : LF 3,900 RF 4,050

Weight on Rear Axle : RF 5,100 RR 4,800

TOTAL LOADED WEIGHT : 17,850
+ 200 lbs added
18,050 just prior
to testing

Figure 32. Vehicle properties for test 7069-8.

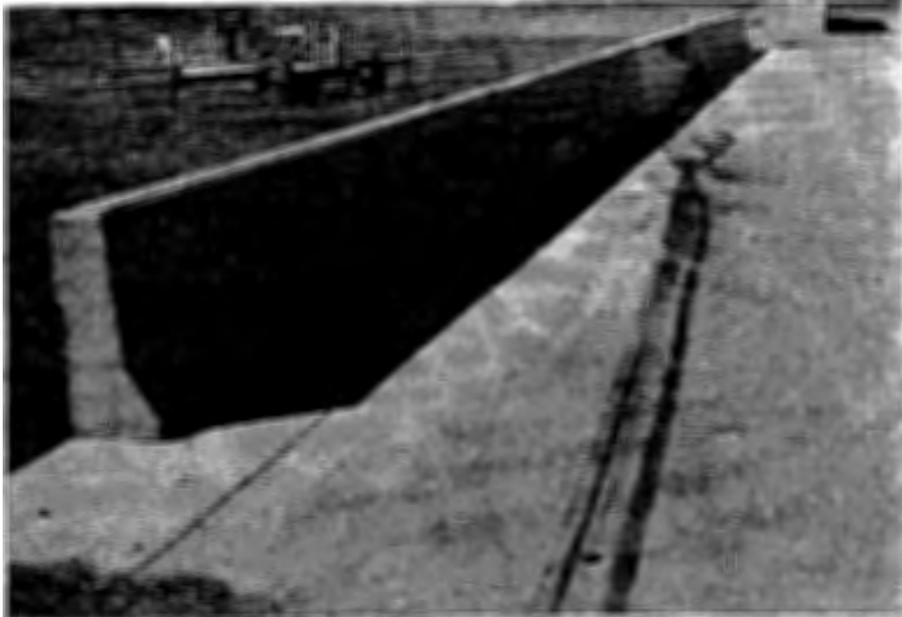

Figure 33. 32-in (813-mm) F-shape bridge railing after test 7069-8.

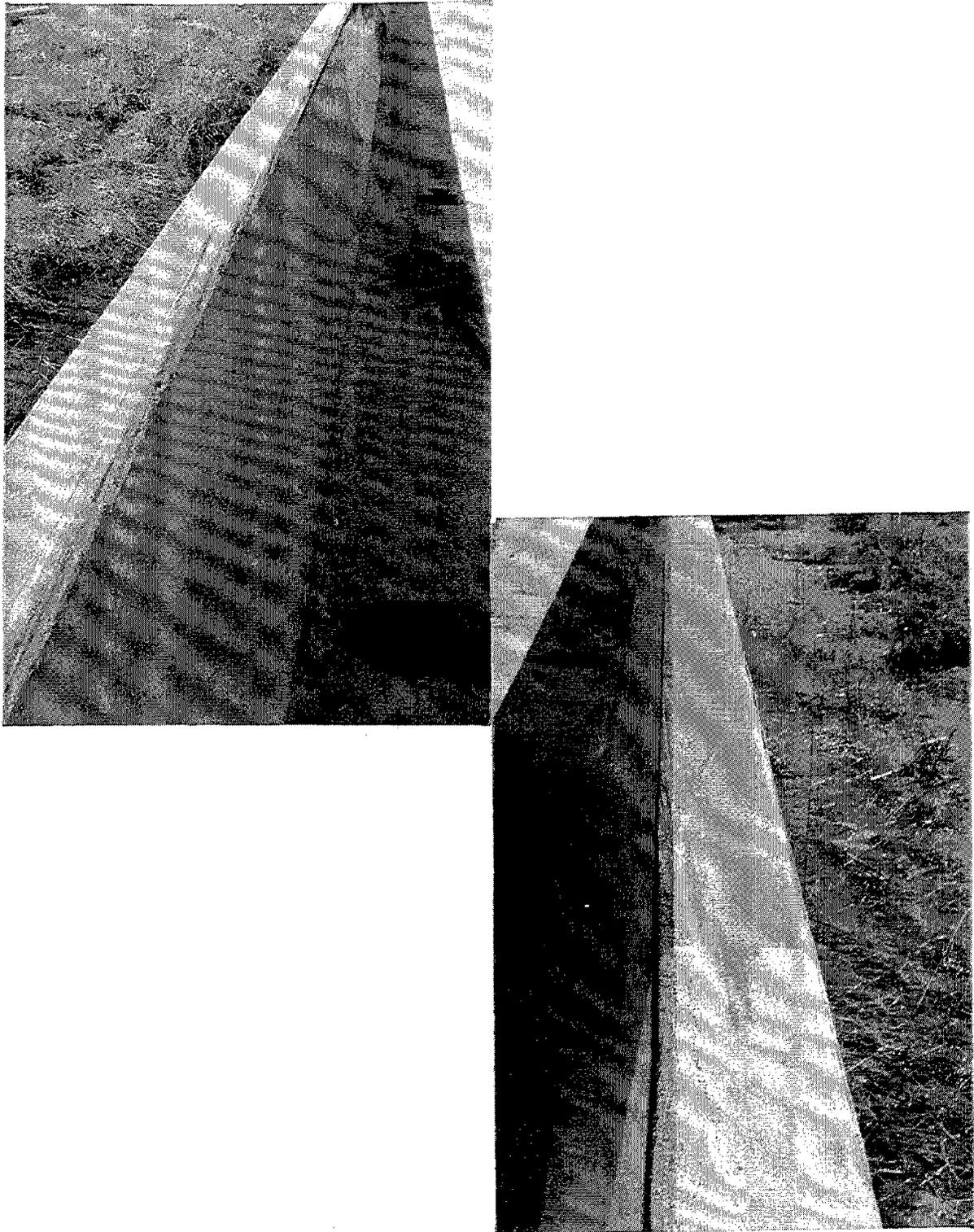
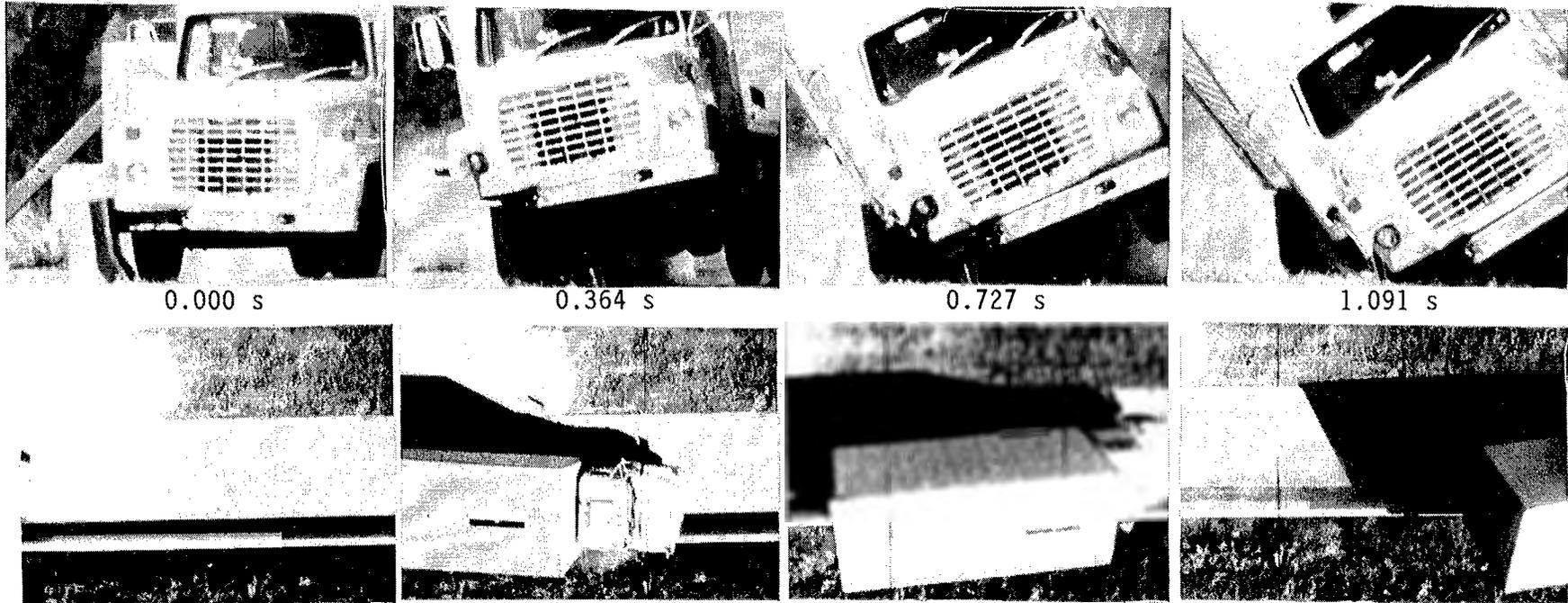

Figure 34. Damage to top of bridge railing caused by lower edge of bed of vehicle.



Figure 35. Vehicle after test 7069-8.



53

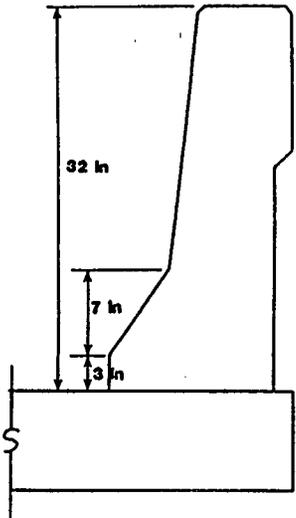

(1 in = 25.4 mm)

Test No.	7069-8	Impact Speed. . . .	46.7 mi/h (75.1 km/h)
Date	1/28/88	Impact Angle. . . .	15.0 deg
Test Installation . . .	32-in (813-mm) F-Shape	Exit Speed	N/A
	Bridge Railing	Exit Trajectory . .	5.0 deg
Installation Length . .	100 ft (30 m)	Vehicle Accelerations	
Vehicle	1982 Ford	(Max. 0.050-sec Avg)	
	Single-Unit Truck	Longitudinal. . . .	-2.2 g
Vehicle Weight		Lateral	3.4 g
Empty Weight	13,050 lb (6,288 kg)	Occupant Impact Velocity	
Test Inertia	18,050 lb (8,195 kg)	Longitudinal. . . .	11.8 ft/s (3.6 m/s)
Maximum Vehicle Crush .	6.0 in (152 mm)	Lateral	9.2 ft/s (2.8 m/s)
		Occupant Ridedown Accelerations	
		Longitudinal. . . .	-3.8 g
		Lateral	6.1 g

Figure 36. Summary of results for test 7069-8.

Table 4. Evaluation of crash test no. 7069-8.
 {32-in (81 cm) F-shape Bridge Rail [18,050 lb (8 195 kg)|46.7 mi/h (75.1 km/h)|15.0 degrees]}

CRITERIA		TEST RESULTS		PASS/FAIL*
A.	Must contain vehicle	Vehicle was contained		Pass
B.	Debris shall not penetrate passenger compartment	No debris penetrated passenger compartment		Pass
C.	Passenger compartment must have essentially no deformation	Acceptable deformation		Pass
D.	Vehicle must remain upright	Vehicle remained upright		Pass
E.	Must smoothly redirect the vehicle	Vehicle was smoothly redirected		Pass
F.	Effective coefficient of friction	<u>μ</u>	<u>Assessment</u>	Pass
		0 - .25	Good	Not applicable because not redirected into traffic.
		.26 - .35	Fair	
		> .35	Marginal	
G.	Shall be less than	<u>μ</u>	<u>Assessment</u>	Pass
		.76	Not applicable because not redirected into traffic.	
		<u>Occupant Impact Velocity - ft/s (m/s)</u>		N/A
		Longitudinal	Lateral	
		30 (9.2)	25 (7.6)	
		<u>Occupant Ridedown Accelerations - g's</u>		N/A
		Longitudinal	Lateral	
		15	15	
		<u>Occupant Impact Velocity - ft/s (m/s)</u>		N/A
		Longitudinal	Lateral	
		11.8 (3.6)	9.2 (2.8)	
		<u>Occupant Ridedown Accelerations - g's</u>		N/A
		Longitudinal	Lateral	
		-3.8	6.1	
H.	Exit angle shall be less than 12 degrees	about 5 degrees		

* A, B, C, and D are required. E, F, and H are desired. G is not applicable for this test. (See table 5)

Table 2. Bridge railing performance levels and crash test criteria.
(Excerpt from 1989 AASHTO *Guide Specifications for Bridge Railings*)⁽²⁾

		TEST SPEEDS—mph ^{1,2}			
		TEST VEHICLE DESCRIPTIONS AND IMPACT ANGLES			
PERFORMANCE LEVELS		Small Automobile	Pickup Truck	Medium Single-Unit Truck	Van-Type Tractor-Trailer ⁴
			W = 1.8 Kips A = 5.4' ± 0.1' B = 5.5' H _{cg} = 20" ± 1" θ = 20 deg.	W = 5.4 Kips A = 8.5' ± 0.1' B = 6.5' H _{cg} = 27" ± 1" θ = 20 deg.	W = 18.0 Kips A = 12.8' ± 0.2' B = 7.5' H _{cg} = 49" ± 1" θ = 15 deg.
	PL-1	50	45		
	PL-2	60	60	50	
	PL-3	60	60		50
CRASH TEST EVALUATION CRITERIA ³	Required	a, b, c, d, g	a, b, c, d	a, b, c	a, b, c
	Desirable ⁵	e, f, h	e, f, g, h	d, e, f, h	d, e, f, h

Notes:

1. Except as noted, all full-scale tests shall be conducted and reported in accordance with the requirements in NCHRP Report No. 230. In addition, the maximum loads that can be transmitted from the bridge railing to the bridge deck are to be determined from static force measurements or ultimate strength analysis and reported.
2. Permissible tolerances on the test speeds and angles are as follows:

Speed	-1.0 mph	+2.5 mph
Angle	-1.0 deg.	+2.5 deg.

Tests that indicate acceptable railing performance but that exceed the allowable upper tolerances will be accepted.

3. Criteria for evaluating bridge railing crash test results are as follows:
 - a. The test article shall contain the vehicle; neither the vehicle nor its cargo shall penetrate or go over the installation. Controlled lateral deflection of the test article is acceptable.
 - b. Detached elements, fragments, or other debris from the test article shall not penetrate or show potential for penetrating the passenger compartment or present undue hazard to other traffic.
 - c. Integrity of the passenger compartment must be maintained with no intrusion and essentially no deformation.
 - d. The vehicle shall remain upright during and after collision.
 - e. The test article shall smoothly redirect the vehicle. A redirection is deemed smooth if the rear of the vehicle or, in the case of a combination vehicle, the rear of the tractor or trailer does not yaw more than 5 degrees away from the railing from time of impact until the vehicle separates from the railing.
 - f. The smoothness of the vehicle-railing interaction is further assessed by the effective coefficient of friction, μ :

μ	Assessment
0-0.25	Good
0.26-0.35	Fair
>0.35	Marginal

where $\mu = (\cos\theta - V_p/V)/\sin\theta$

Table 5. Bridge railing performance levels and crash test criteria.
 (Exerpt from 1989 AASHTO *Guide Specifications for Bridge Railings*)⁽²⁾
 (continued)

- g. The impact velocity of a hypothetical front-seat passenger against the vehicle interior, calculated from vehicle accelerations and 2.0-ft. longitudinal and 1.0-ft. lateral displacements, shall be less than:

Occupant Impact Velocity—fps	
Longitudinal	Lateral
30	25

and the vehicle highest 10-ms average accelerations subsequent to the instant of hypothetical passenger impact should be less than:

Occupant Ridedown Acceleration—g's	
Longitudinal	Lateral
15	15

- h. Vehicle exit angle from the barrier shall not be more than 12 degrees. Within 100 ft. plus the length of the test vehicle from the point of initial impact with the railing, the railing side of the vehicle shall move no more than 20-ft. from the line of the traffic face of the railing. The brakes shall not be applied until the vehicle has traveled at least 100-ft. plus the length of the test vehicle from the point of initial impact.
4. Values A and R are estimated values describing the test vehicle and its loading. Values of A and R are described in the figure below and calculated as follows:

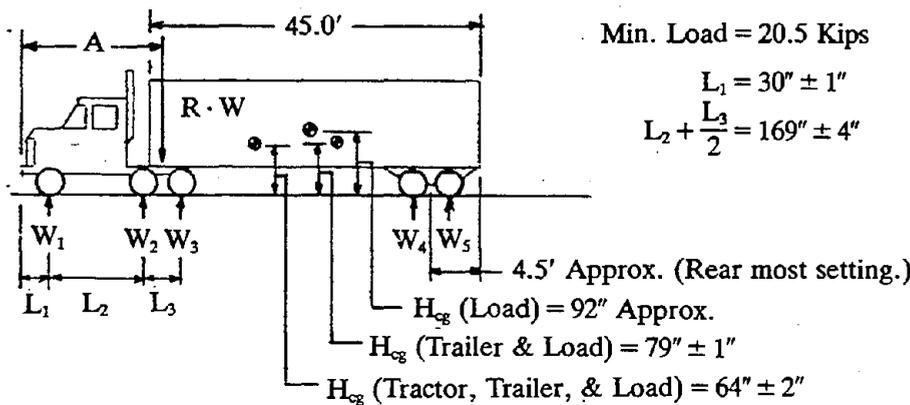

$$A = L_1 + \frac{W_2 L_2 + W_3 (L_2 + L_3)}{W_1 + W_2 + W_3}$$

$$R = \frac{W_1 + W_2 + W_3}{W}$$

$$W = W_1 + W_2 + W_3 + W_4 + W_5$$

= total vehicle weight.

5. Test articles that do not meet the desirable evaluation criteria shall have their performance evaluated by a designated authority that will decide whether the test article is likely to meet its intended use requirements.

1 mi = 1.61 km
1 kip = 4.45 kN
1 in = 25.4 mm

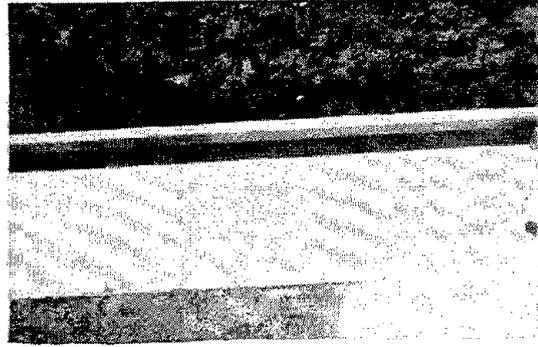

0.000 s

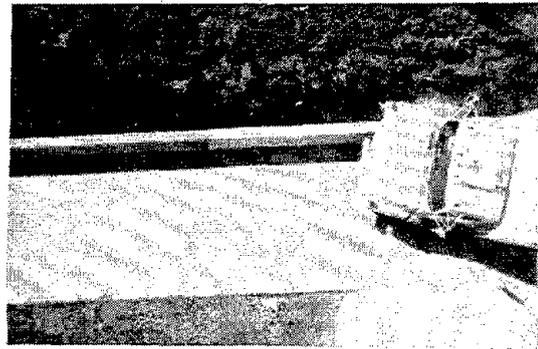
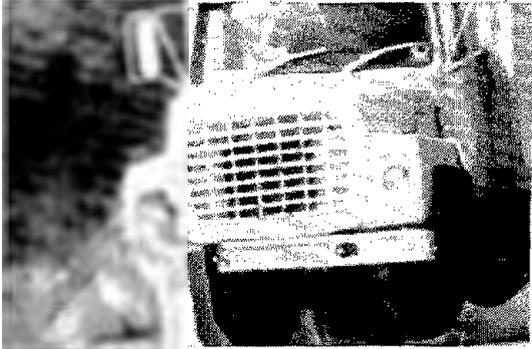

0.182 s

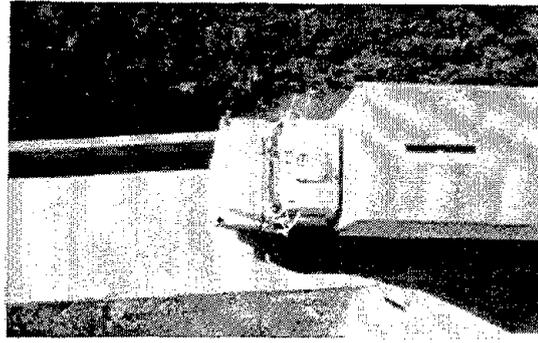
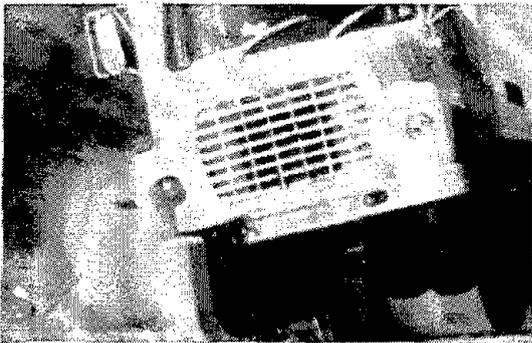

0.364 s

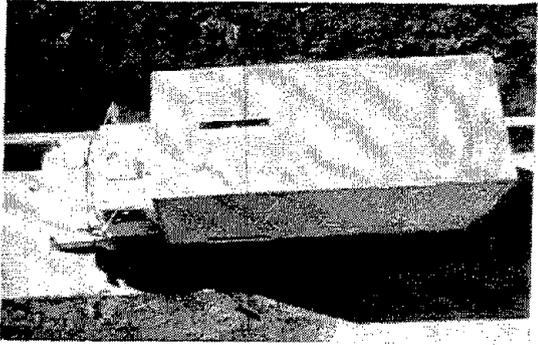

0.546 s

Figure 37. Sequential photographs for test 7069-8.

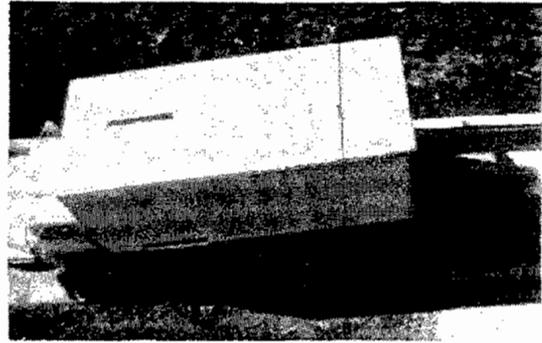
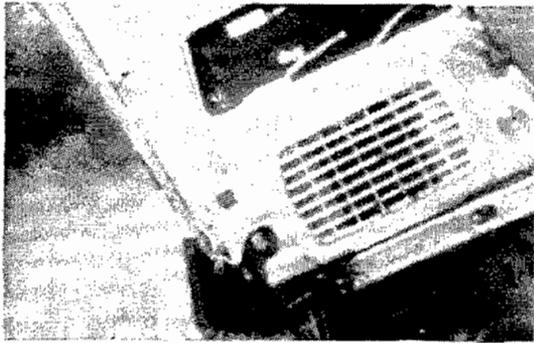

0.727 s

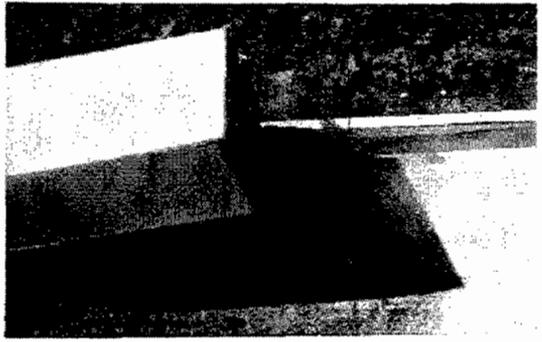
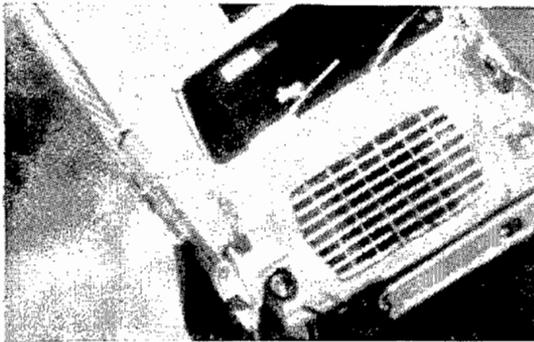

0.909 s

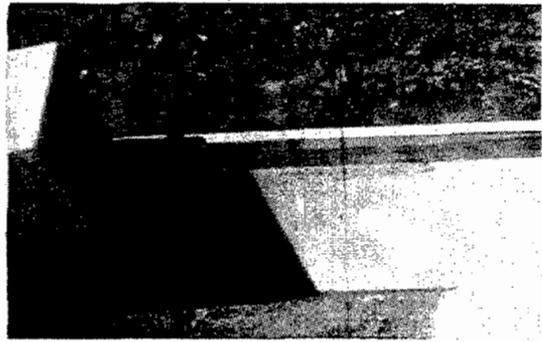

1.091 s

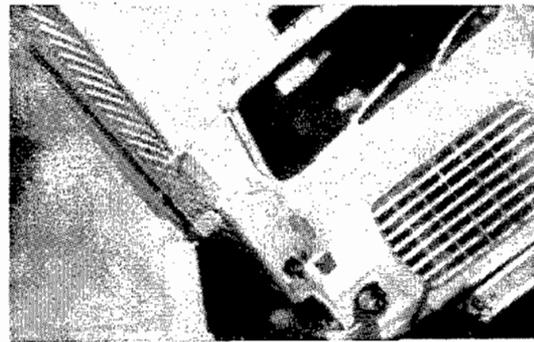

1.273 s

Figure 37. Sequential photographs for test 7069-8 (continued).



0.000 s

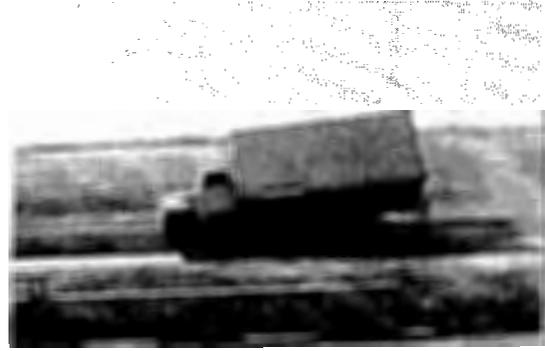

0.727 s



0.182 s



0.909 s

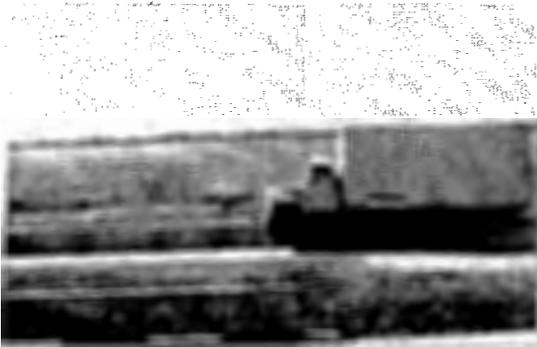

0.364 s



1.091 s



0.546 s



1.273 s

Figure 38. Perpendicular sequential photographs for test 7069-8.

7069-8

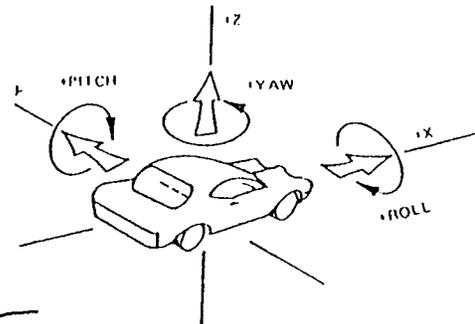
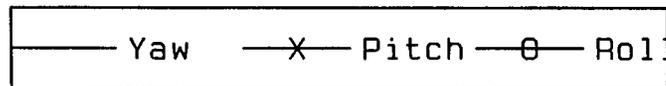

Axes are vehicle fixed.
Sequence for determining orientation is:

1. Yaw
2. Pitch
3. Roll

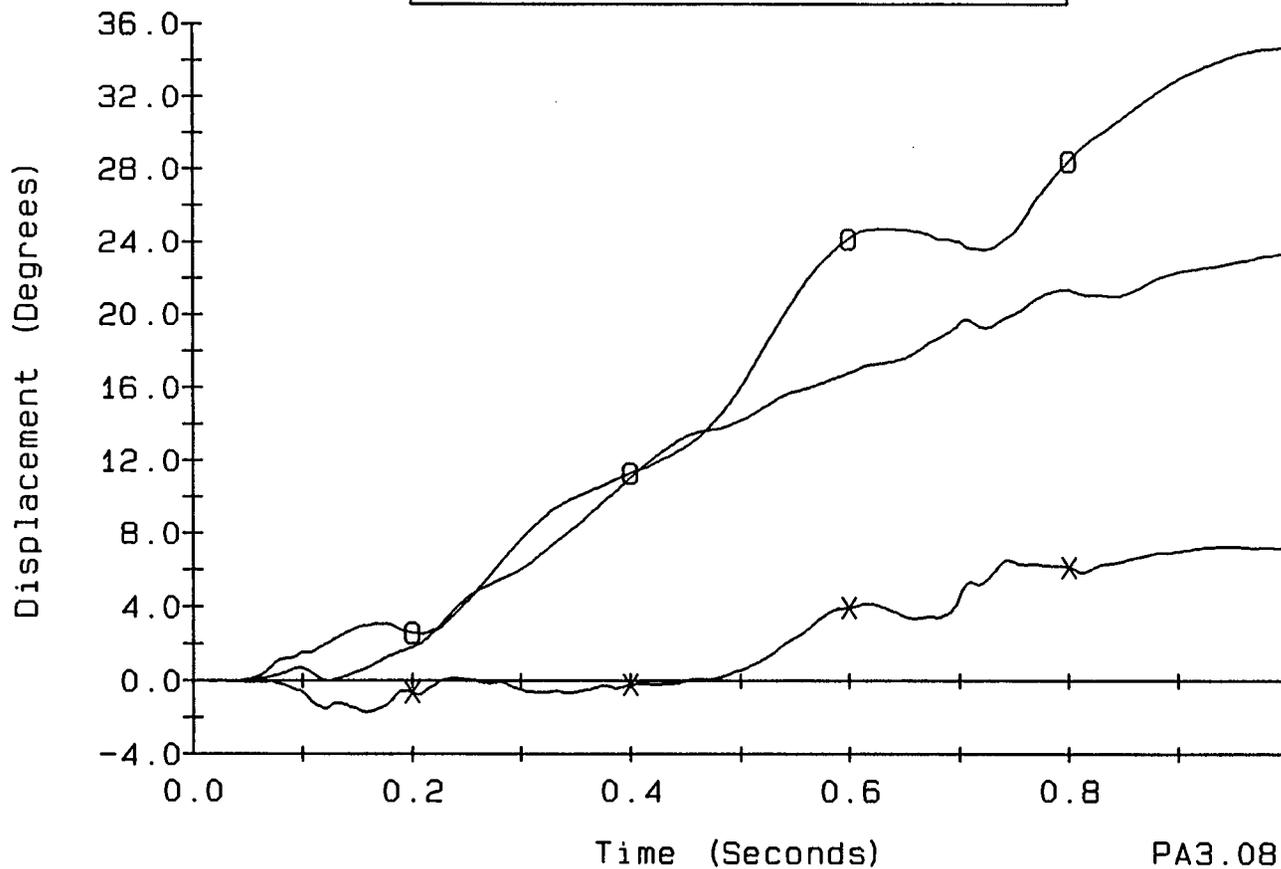

09

PA3.08

Figure 39. Vehicle angular displacements for test 7069-8.

CRASH TEST 7069-8
Accelerometer near center-of-gravity

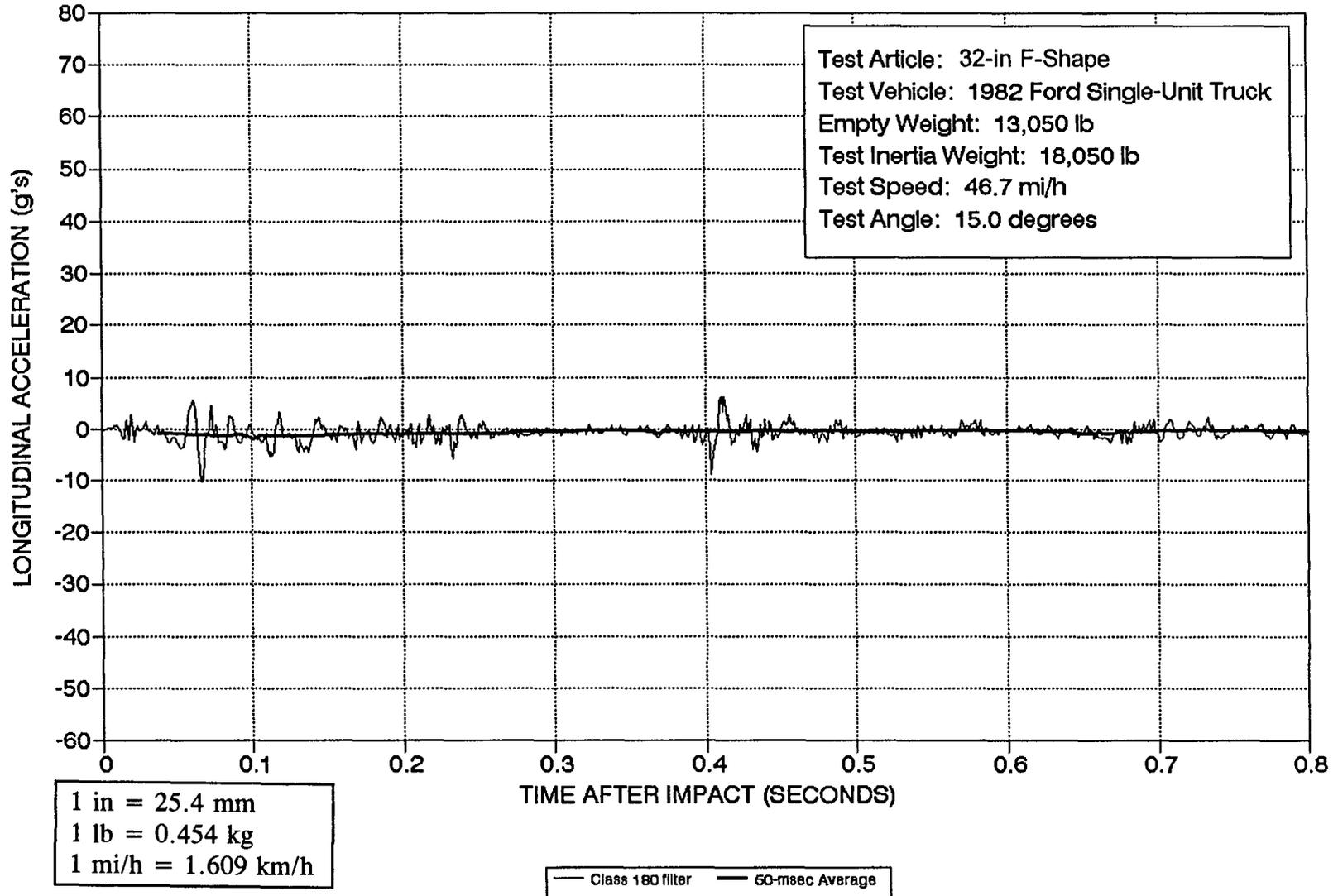

Figure 40. Vehicle longitudinal accelerometer trace for test 7069-8 (accelerometer located near center-of-gravity).

CRASH TEST 7069-8
Accelerometer near center-of-gravity

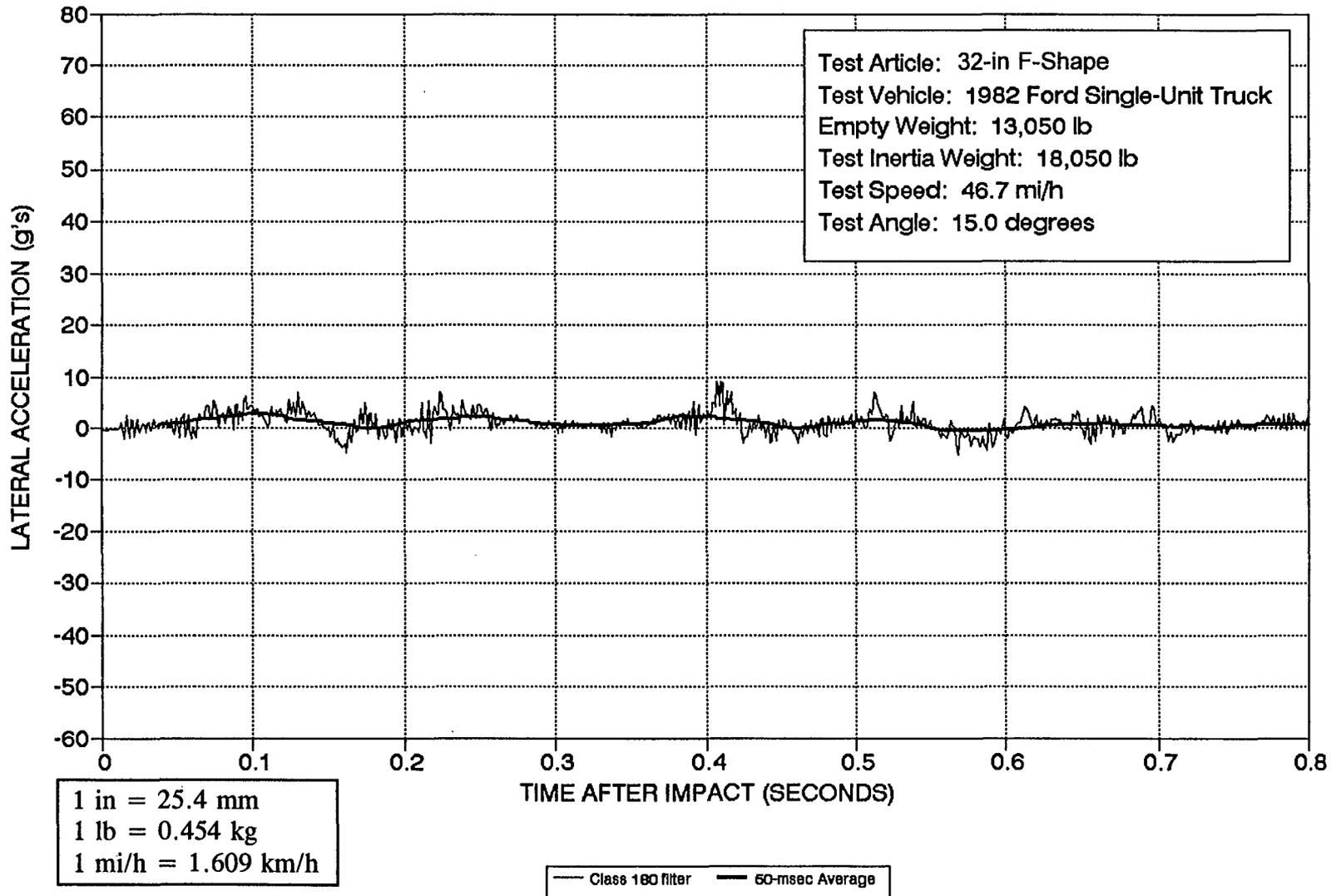

Figure 41. Vehicle lateral accelerometer trace for test 7069-8 (accelerometer located near center-of-gravity).

CRASH TEST 7069-8
Accelerometer near center-of-gravity

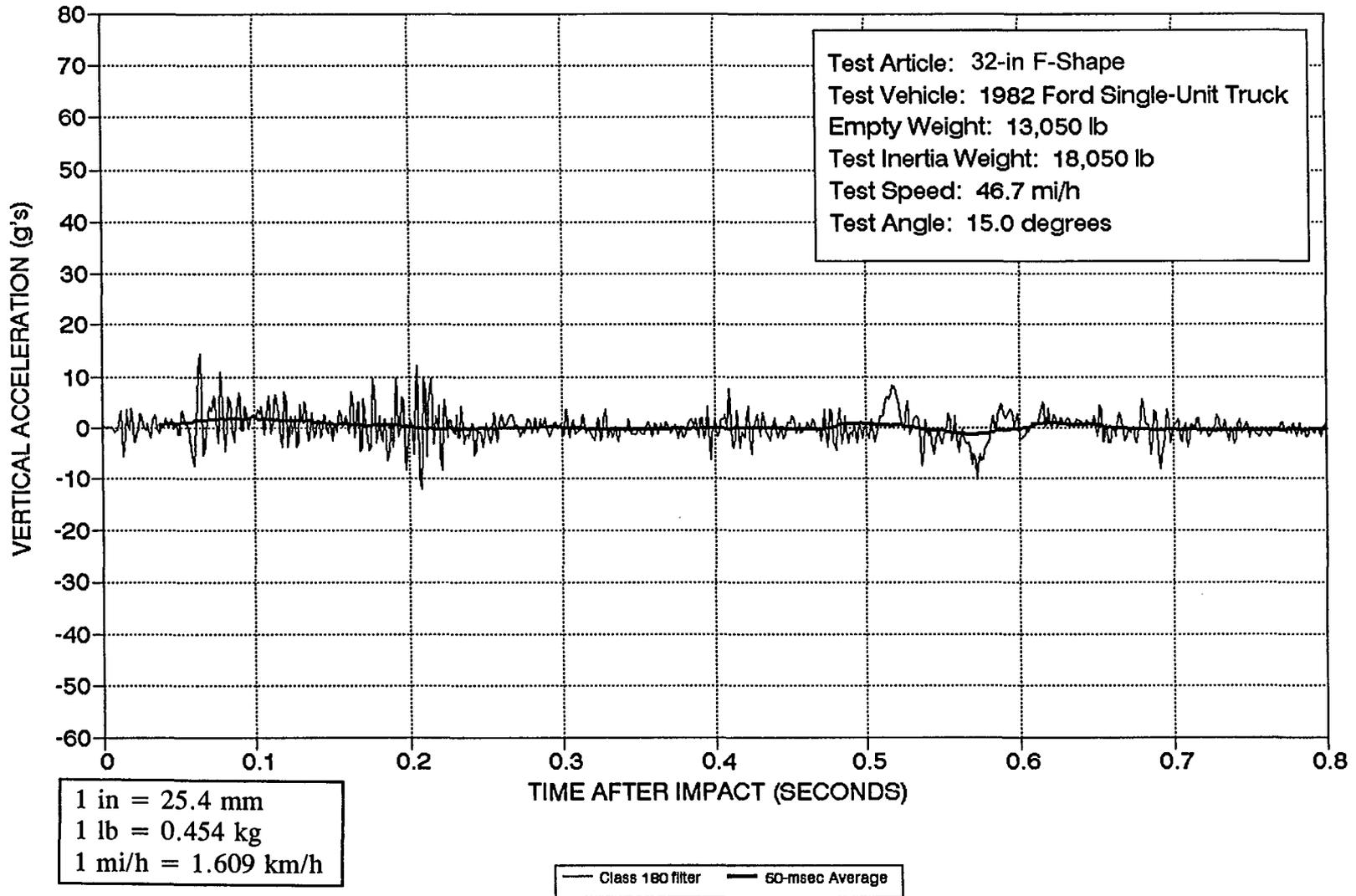

Figure 42. Vehicle vertical accelerometer trace for test 7069-8 (accelerometer located near center-of-gravity).

CRASH TEST 7069-8

Accelerometer at front of vehicle

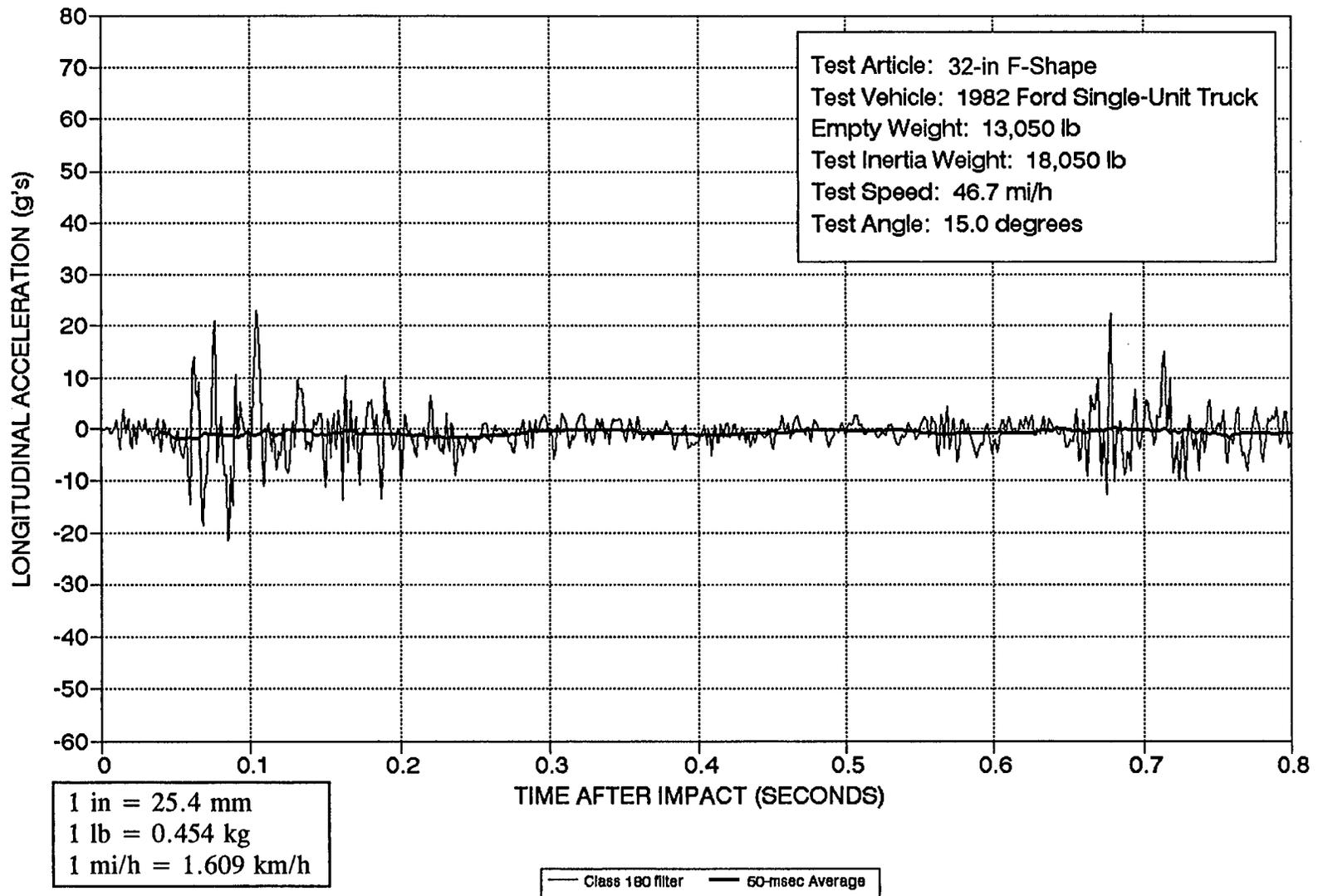

Figure 43. Vehicle longitudinal accelerometer trace for test 7069-8 (accelerometer located at front of vehicle).

CRASH TEST 7069-8
Accelerometer at front of vehicle

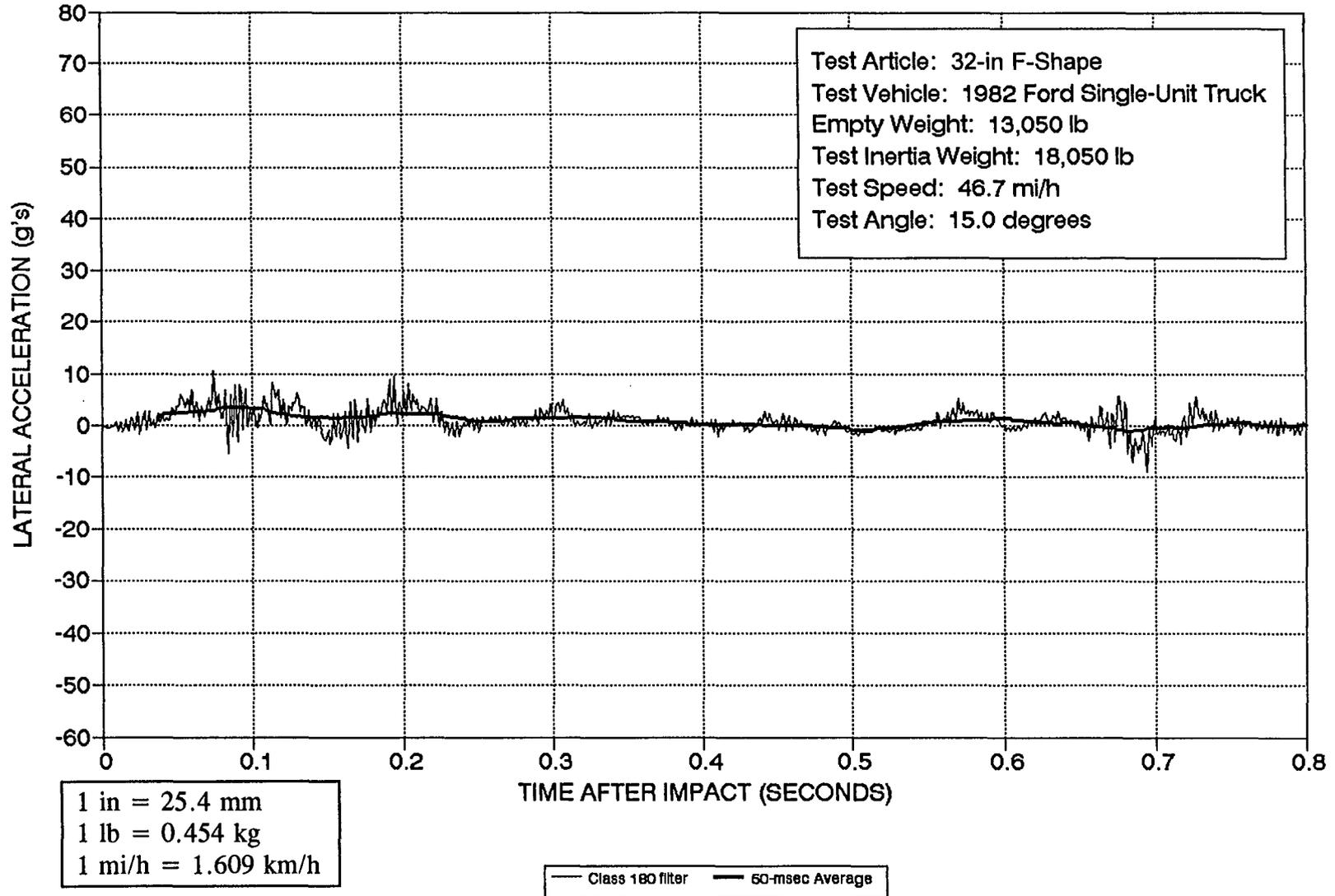

Figure 44. Vehicle lateral accelerometer trace for test 7069-8 (accelerometer located at front of vehicle).

TEST 7069-9

Test Description

The 1982 Ford single-unit truck (figures 45 and 46) was directed into the bridge railing (figure 47) using a remote controlled guidance system. Empty weight of the vehicle was 13,850 lb (6 288 kg) and its test inertia weight was 18,050 lb (8 195 kg). The height to the lower edge of the vehicle bumper was 19.25 in (489 mm) and it was 28.00 in (711 mm) to the top of the bumper. Other dimensions and information on the test vehicle are given in figure 48. The vehicle was free-wheeling and unrestrained just prior to impact.

The speed of the vehicle at impact was 47.3 mi/h (76.1 km/h) and the angle of impact was 15.3 degrees. The vehicle impacted the bridge railing at midlength. At approximately 0.017 s after impact the right front wheel began to ride up the face of the bridge railing, and at 0.153 s the left front tire began to leave the ground. The vehicle began to redirect at 0.156 s as the rear end began to slide toward the bridge railing. At 0.292 s the left rear wheels left the ground, and at 0.421 s the rear of the vehicle slapped the bridge railing. By approximately 0.523 s the vehicle became parallel with the railing and was continuing to roll to the right. As the vehicle continued along the railing, the lower edge of the bed rode along the top of the railing. A maximum roll angle of 25 degrees was achieved at about 0.886 s. The vehicle slid off the end of the bridge railing at about 1.326 s after impact. The brakes were applied and the vehicle subsequently came to rest 150 ft (46 m) downstream.

As can be seen in figure 49, the railing received cosmetic damage and some scraping. There were tire marks on the face of the bridge railing and along the top. The top of the bridge railing was scraped along the remaining length from the lower edge of the bed of the truck (see figure 50). The vehicle was in contact with the bridge railing for 58 ft (18 m).

The vehicle sustained extensive damage to the right side as shown in figure 51. Maximum crush at the right front corner at bumper height was 16.0 in (406 mm). The right front wheel rim was bent and the tire damaged. The spring and spring shackle were broken loose from the axle and the axle torn loose on the left side. The steering gear box and steering cylinder were damaged. Also, the fuel tank broke loose from the truck.

Test Results

Impact speed was 47.3 mi/h (76.1 km/h) and the angle of impact was 15.3 degrees. The exit speed was 34.5 mi/h (55.5 km/h). The effective coefficient of friction was calculated to be 0.09. Occupant impact velocity was 11.7 ft/s (3.6 m/s) in the longitudinal direction and 9.9 ft/s (3.0 m/s) in the lateral direction. The highest 0.010-s occupant ridedown accelerations were -2.7 g (longitudinal) and 6.8 g (lateral). These data and other pertinent information from the test are summarized in figure 52 and table 6. Sequential photographs are shown in figures 53 and 54. Vehicle angular displacements are displayed in figure 55. Vehicular accelerations versus time traces filtered with SAE J211 filters are

presented in figures 56 through 62. These data were further analyzed to obtain 0.050-s average accelerations versus time. A 0.050-s interval immediately prior to impact was averaged to establish zero acceleration. The data were then processed with a moving 0.050-s average window with the first 0.050-s average plotted at 0.026 s. The maximum 0.050-s averages were -2.0 g (longitudinal) and 2.9 g (lateral).

Conclusions

The 32-in (813-mm) F-shape bridge railing contained and smoothly redirected the vehicle with no lateral movement of the bridge railing. There were no debris or detached elements. There was no intrusion into the occupant compartment. The vehicle trajectory at loss of contact indicated minimum intrusion into adjacent traffic lanes. The vehicle remained upright and marginally stable during the entire test period. See table 6 for a more detailed description.

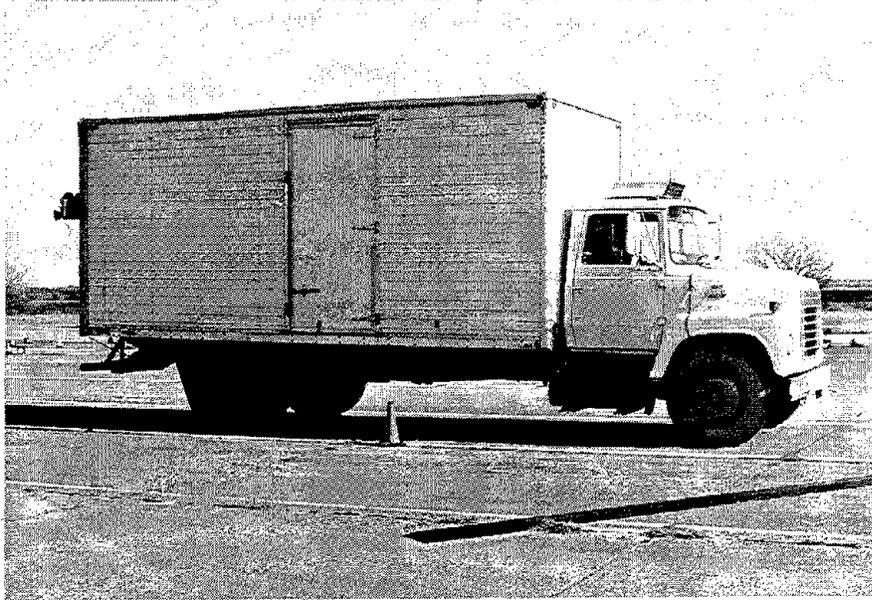

Figure 45. Vehicle before test 7069-9.

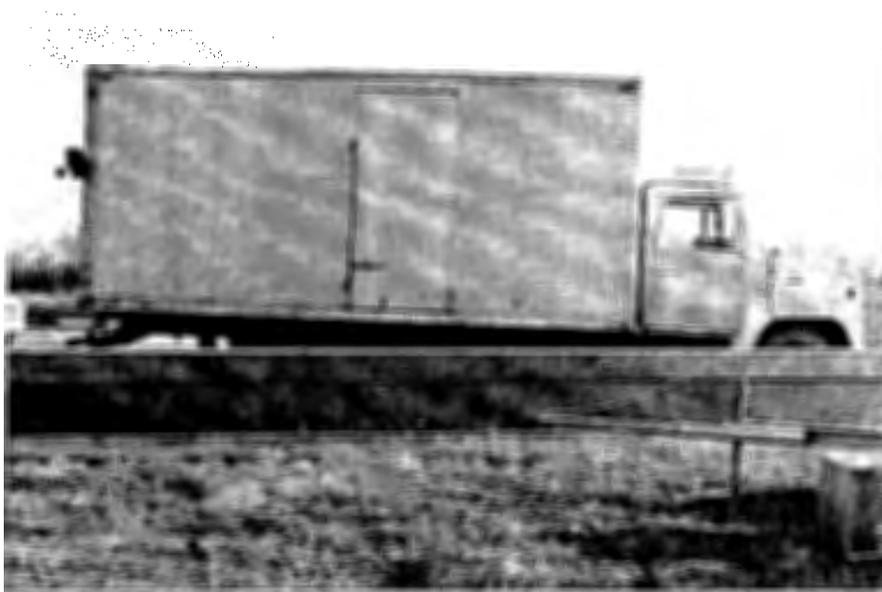
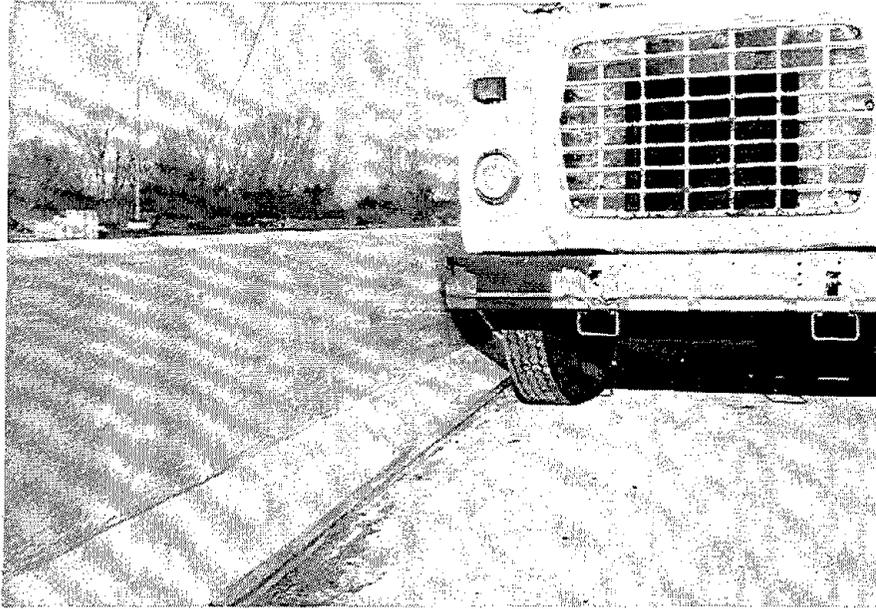

Figure 46. Vehicle/bridge railing geometrics for test 7069-9.

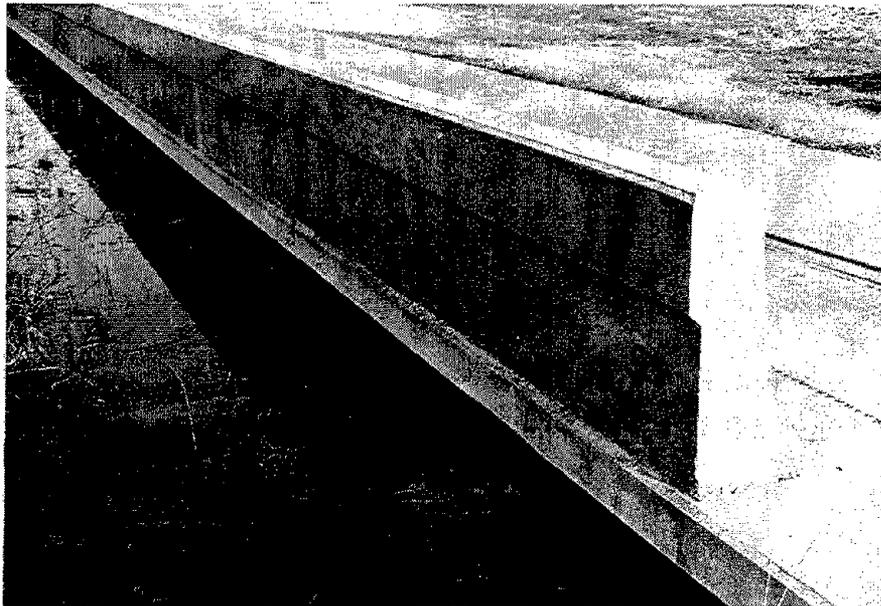
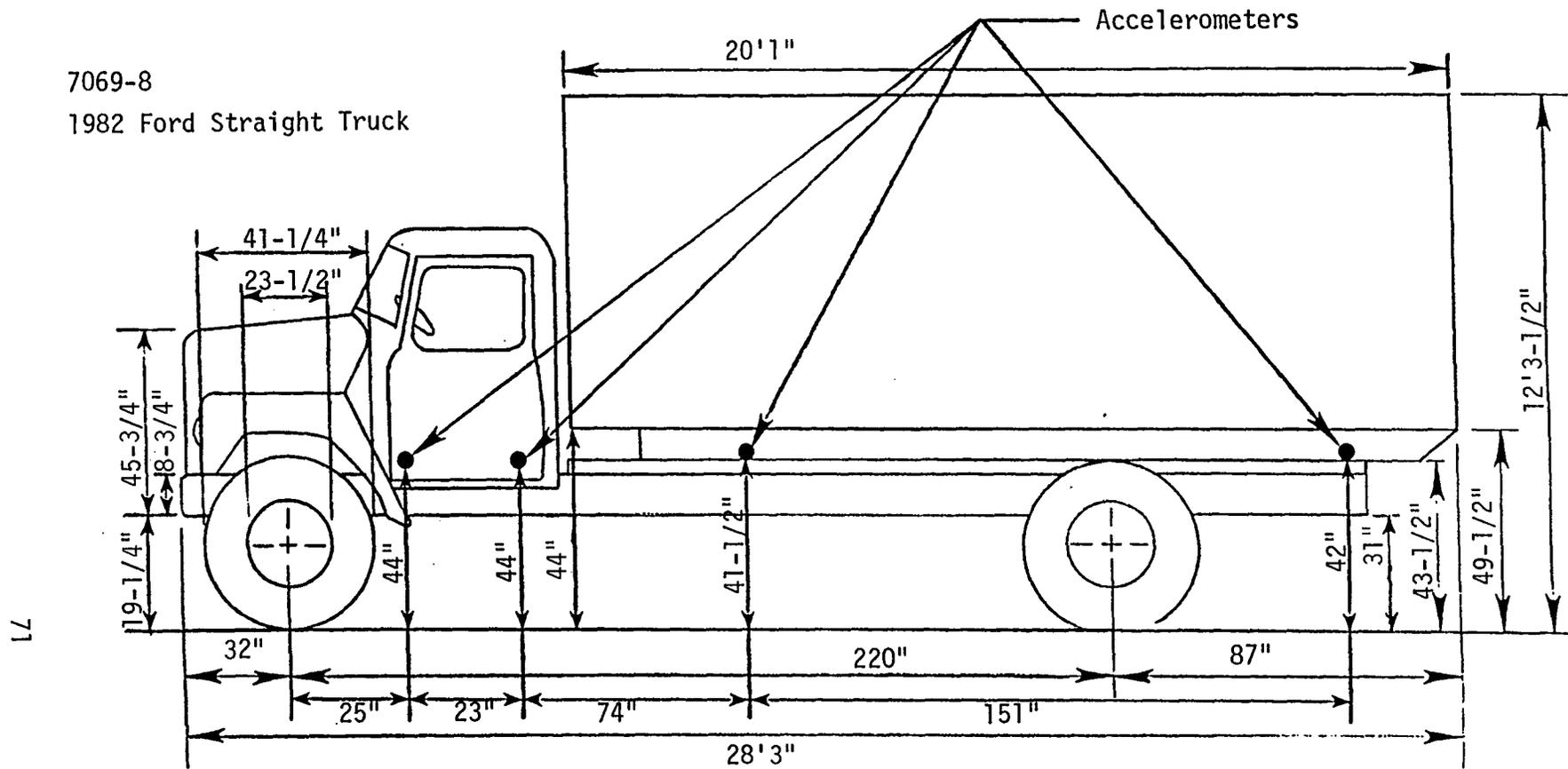

Figure 47. 32-in (813-mm) F-shape bridge railing before test 7069-9.

7069-8
1982 Ford Straight Truck



EMPTY WEIGHTS

Weight on Front Axle : LF 3,420 RF 3,630

Weight on Rear Axle : LR 3,520 RR 3,280

TOTAL EMPTY WEIGHT : 13,850

LOADED WEIGHTS

Weight on Front Axle : 7,820

Weight on Rear Axle : 10,230

TOTAL LOADED WEIGHT : 18,050

1 in = 25.4 mm

Figure 48. Vehicle properties for test 7069-9.

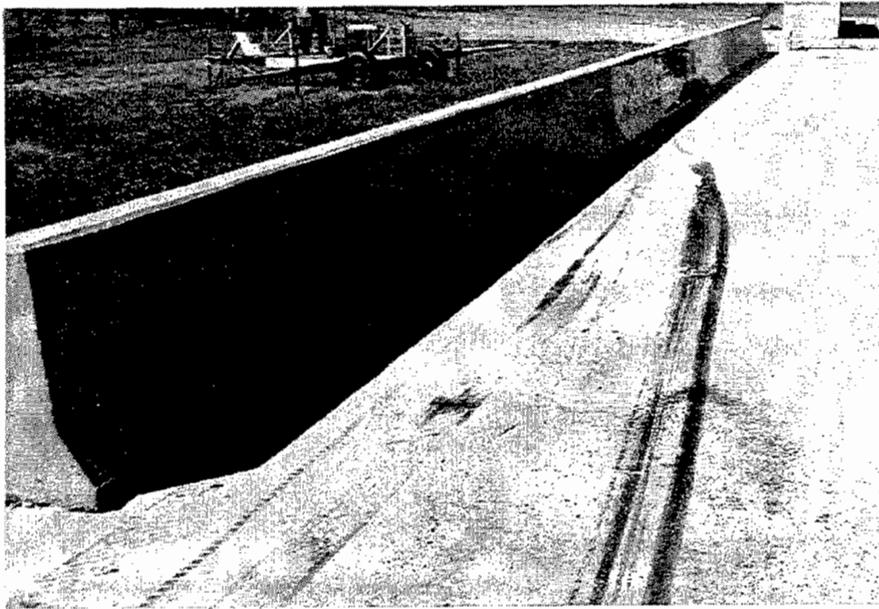

Figure 49. 32-in (813-mm) F-shape bridge railing after test 7069-9.

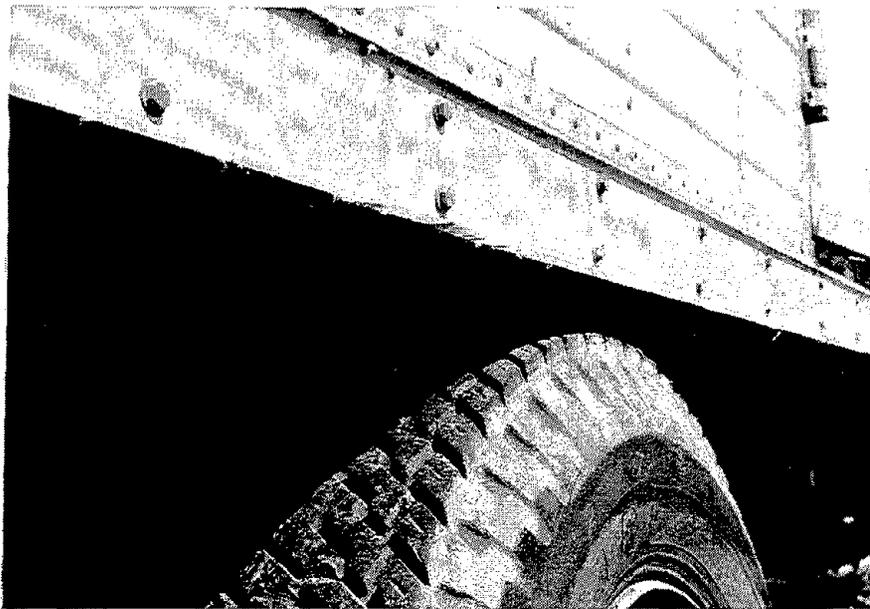
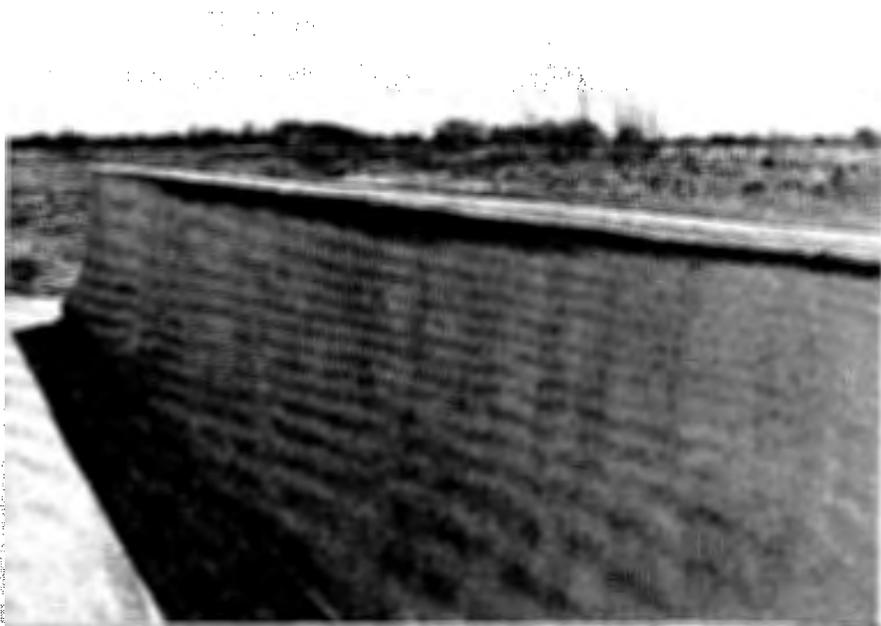
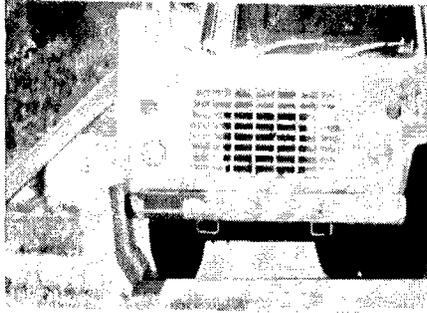

Figure 50. Damage to top of bridge railing and to lower edge truck bed.



Figure 51. Vehicle after test 7069-9.



0.000 s

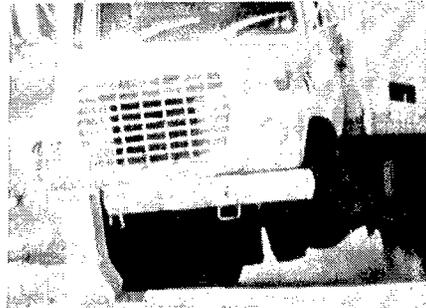

0.243 s

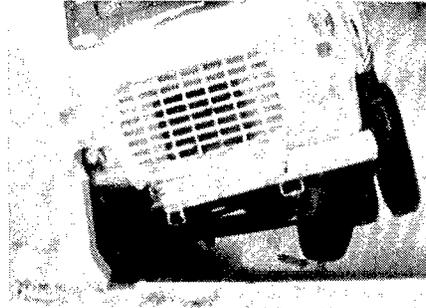

0.486 s

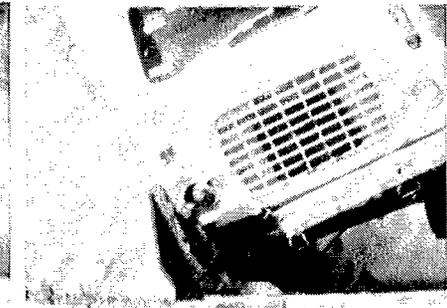

0.730 s

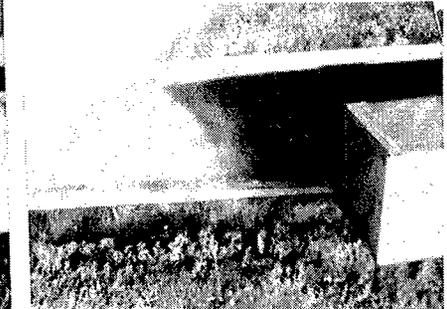
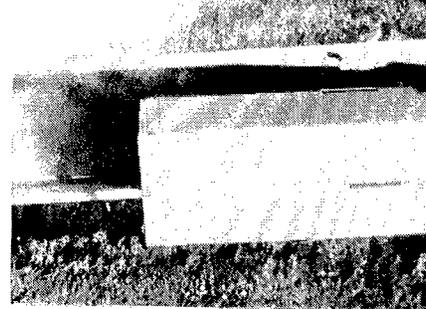
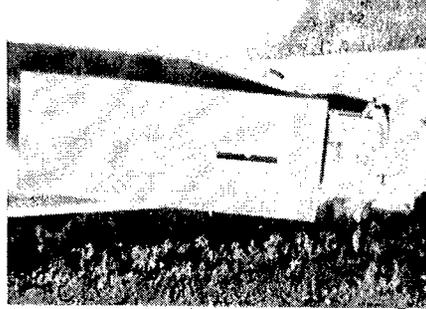
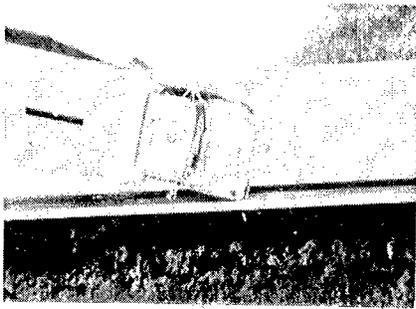

75

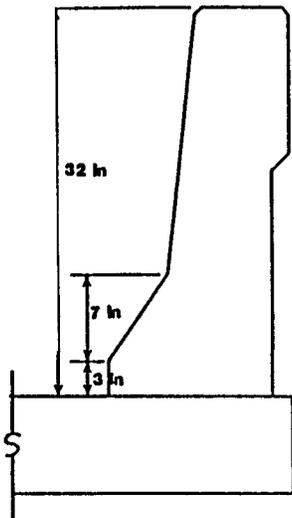

(1 in = 25.4 mm)

Test No. 7069-9
 Date 2/23/88
 Test Installation . . . 32-in (813-mm) F-Shape
 Bridge Railing
 Installation Length. . . 100 ft (30 m)
 Vehicle 1982 Ford
 Single-Unit Truck
 Vehicle Weight
 Empty Weight 13,050 lb (6,288 kg)
 Test Inertia 18,050 lb (8,195 kg)
 Maximum Vehicle Crush . 16.0 in (406 mm)

Impact Speed. . . 47.3 mi/h (76.1 km/h)
 Impact Angle. . . 15.3 deg
 Exit Speed. . . . 34.5 mi/h (55.5 km/h)
 Exit Trajectory . 2.0 deg
 Vehicle Accelerations
 (Max. 0.050-sec Avg)
 Longitudinal. . -2.0 g
 Lateral 2.9 g
 Occupant Impact Velocity
 Longitudinal. . 11.7 ft/s (3.6 m/s)
 Lateral 9.9 ft/s (3.0 m/s)
 Occupant Ridedown Accelerations
 Longitudinal. . -2.7 g
 Lateral 6.8 g

Figure 52. Summary of results for test 7069-9.

Table 6. Evaluation of crash test no. 7069-9.
 {32 in (81 cm) F-shape Bridge Railing [18,050 lb (8 195 kg)|47.3 mi/h (76.1 km/h)|15.3 degrees]}

<u>CRITERIA</u>		<u>TEST RESULTS</u>		<u>PASS/FAIL</u>
A.	Must contain vehicle	Vehicle was contained		Pass
B.	Debris shall not penetrate passenger compartment	No debris penetrated passenger compartment		Pass
C.	Passenger compartment must have essentially no deformation	Acceptable deformation		Pass
D.	Vehicle must remain upright	Vehicle remained upright		Pass
E.	Must smoothly redirect the vehicle	Vehicle was smoothly redirected		Pass
F.	Effective coefficient of friction			Pass
	<u>μ</u>	<u>Assessment</u>	<u>μ</u>	<u>Assessment</u>
	0 - .25	Good	.09	Good
	.26 - .35	Fair		
	> .35	Marginal		
G.	Shall be less than			
	<u>Occupant Impact Velocity - ft/s (m/s)</u>	<u>Occupant Impact Velocity - ft/s (m/s)</u>		N/A
	Longitudinal	Longitudinal	Lateral	
	30 (9.2)	11.7 (3.6)	9.9 (3.0)	
	<u>Occupant Ridedown Accelerations - g's</u>	<u>Occupant Ridedown Accelerations - g's</u>		N/A
	Longitudinal	Longitudinal	Lateral	
	15	-2.7	6.8	
H.	Exit angle shall be less than 12 degrees	about 2 degrees		

* A, B, C, D are required. E, F, and H are desired. G is not applicable for this test. (See table 5)

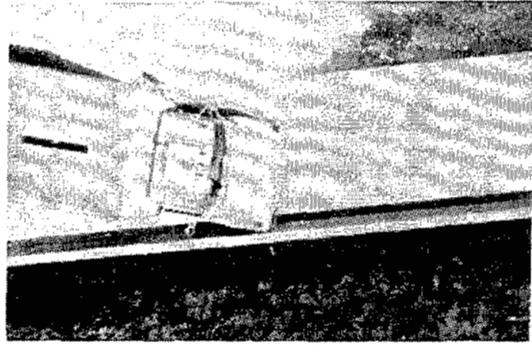

0.000 s

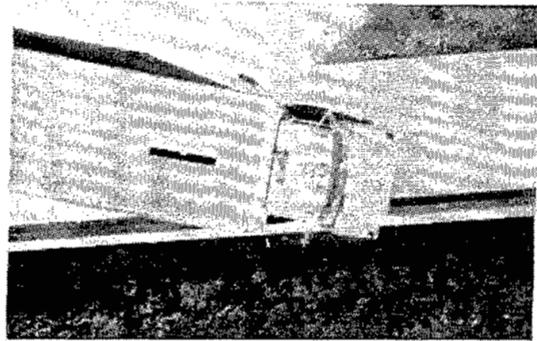

0.122 s

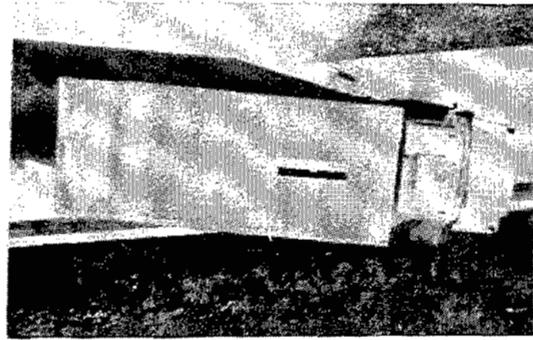

0.243 s



0.365 s

Figure 53. Sequential photographs for test 7069-9.

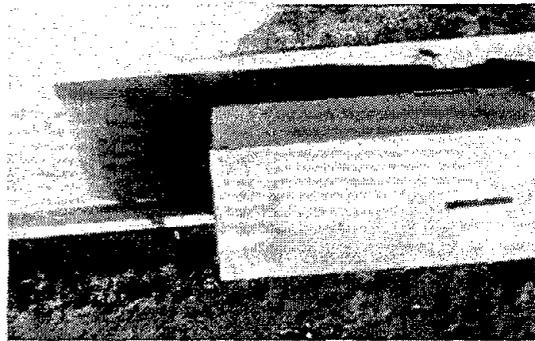

0.486 s

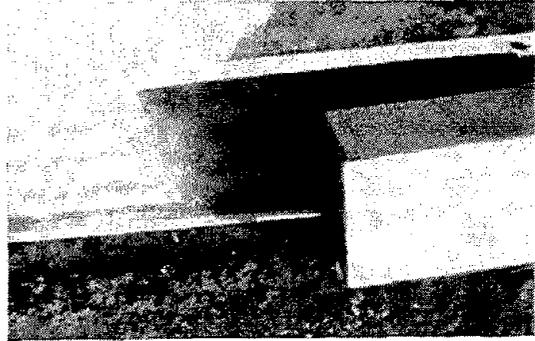

0.608 s

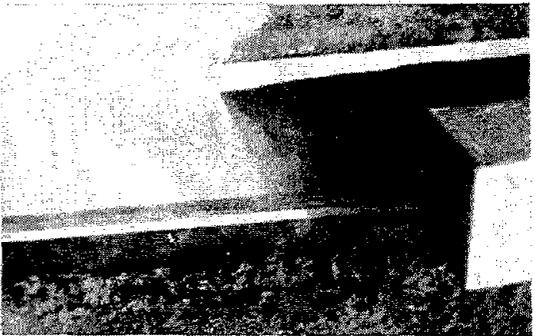
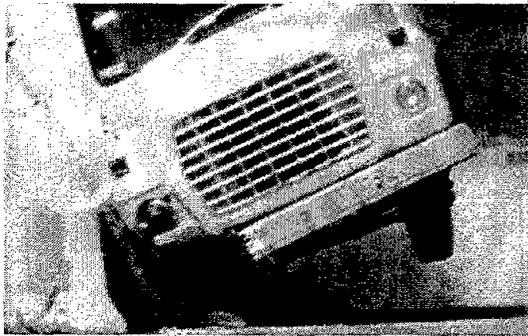

0.730 s

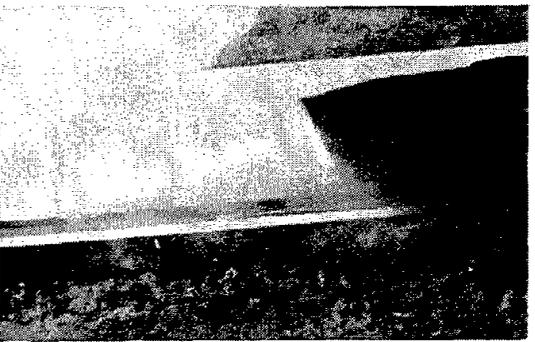

0.851 s

Figure 53. Sequential photographs for test 7069-9 (continued).

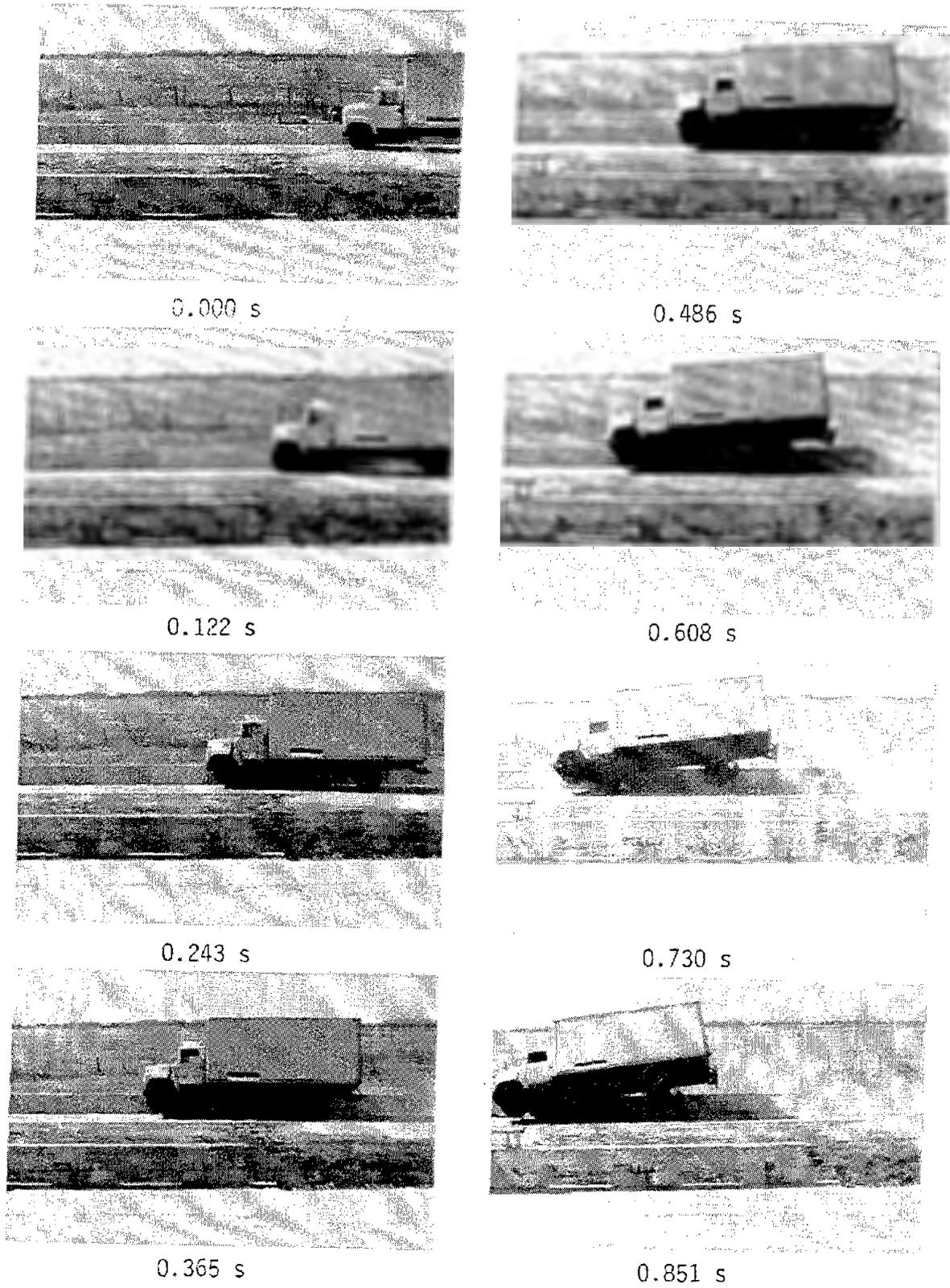
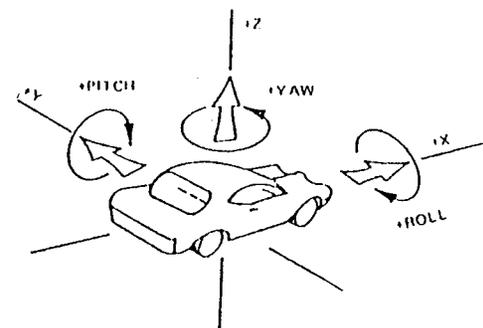
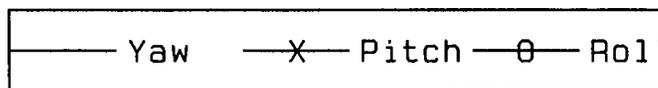

Figure 54. Perpendicular sequential photographs for test 7069-9.

7069-9



Axes are vehicle fixed.
Sequence for determining orientation is:

1. Yaw
2. Pitch
3. Roll

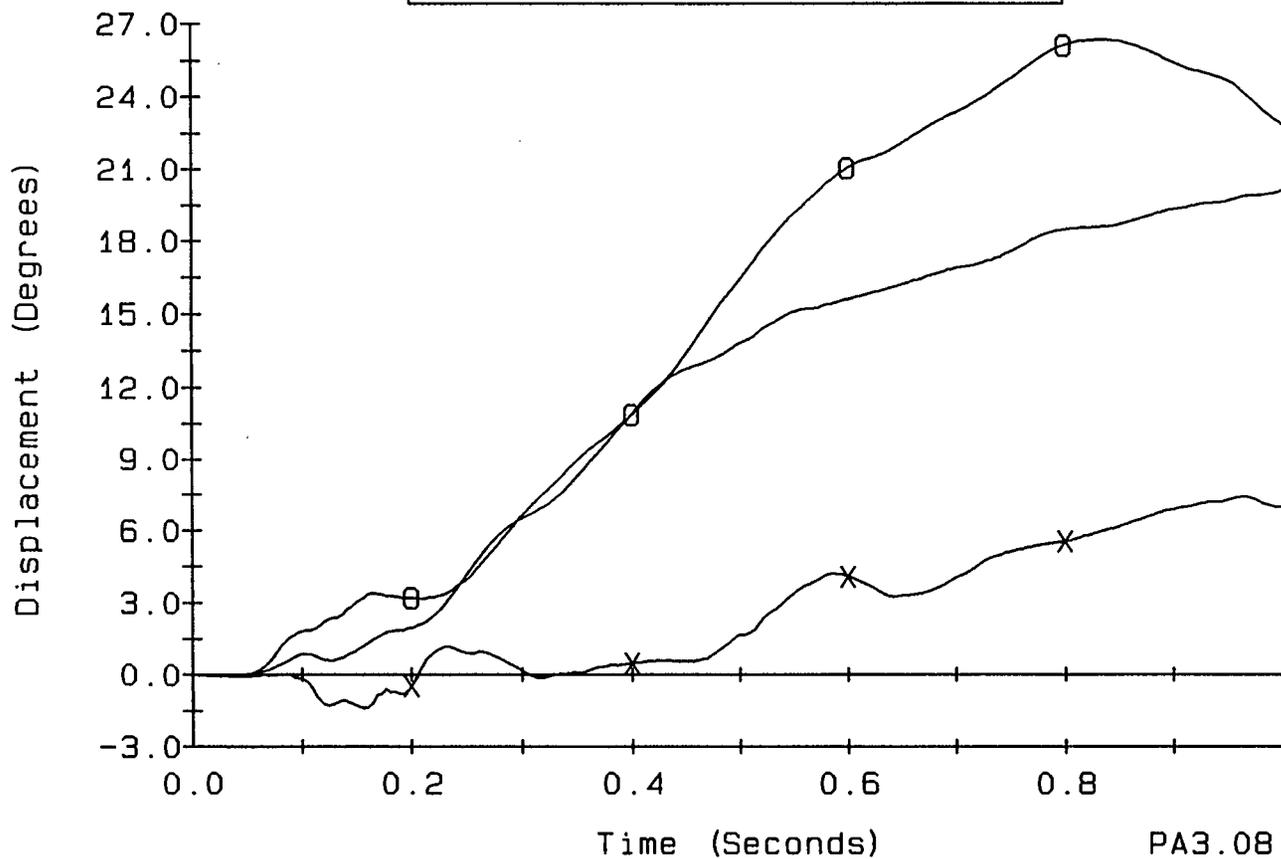

Figure 55. Vehicle angular displacements for test 7069-9.

CRASH TEST 7069-9

Accelerometer near center-of-gravity

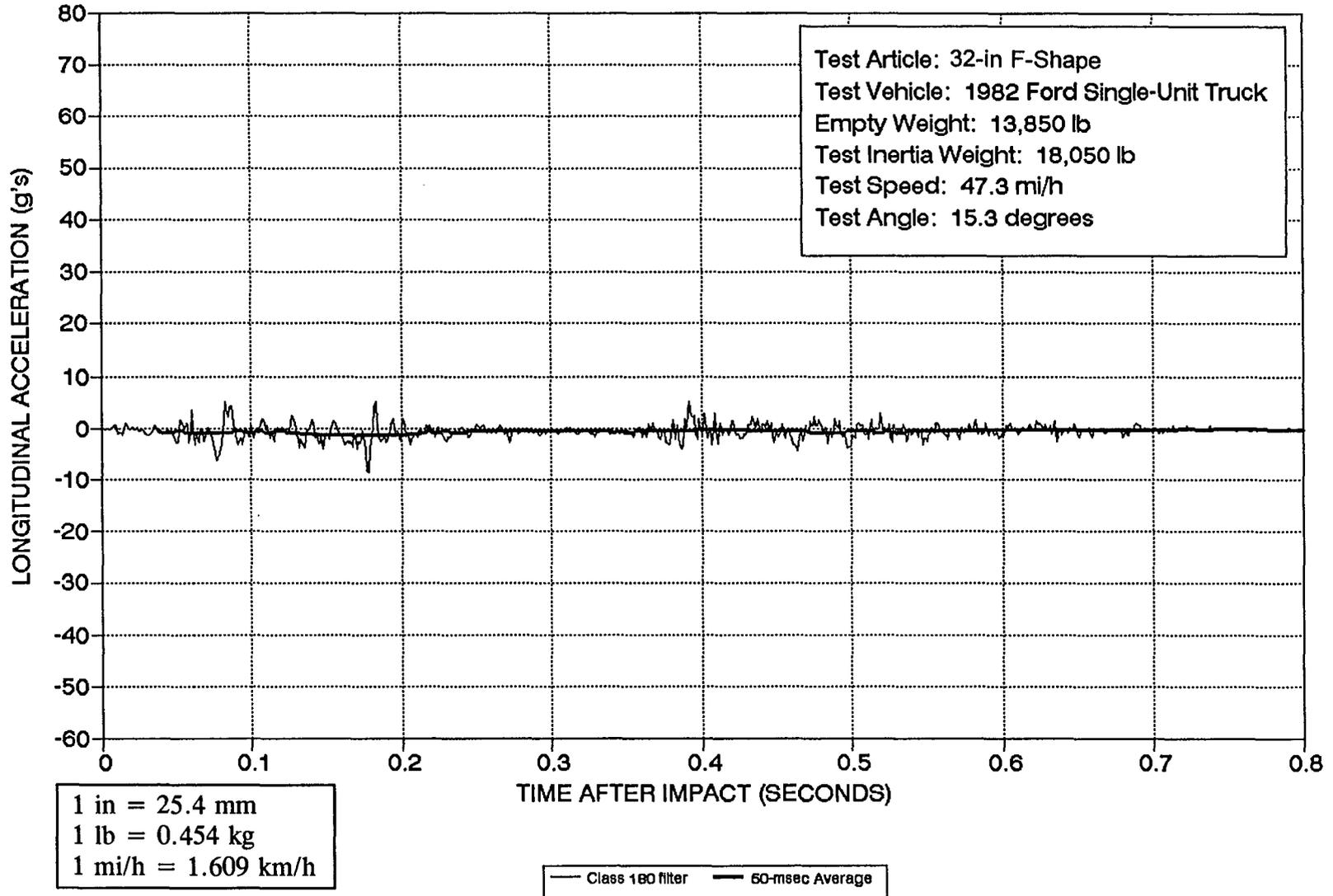

Figure 56. Longitudinal accelerometer trace for test 7069-9 (accelerometer located near center-of-gravity).

CRASH TEST 7069-9

Accelerometer near center-of-gravity

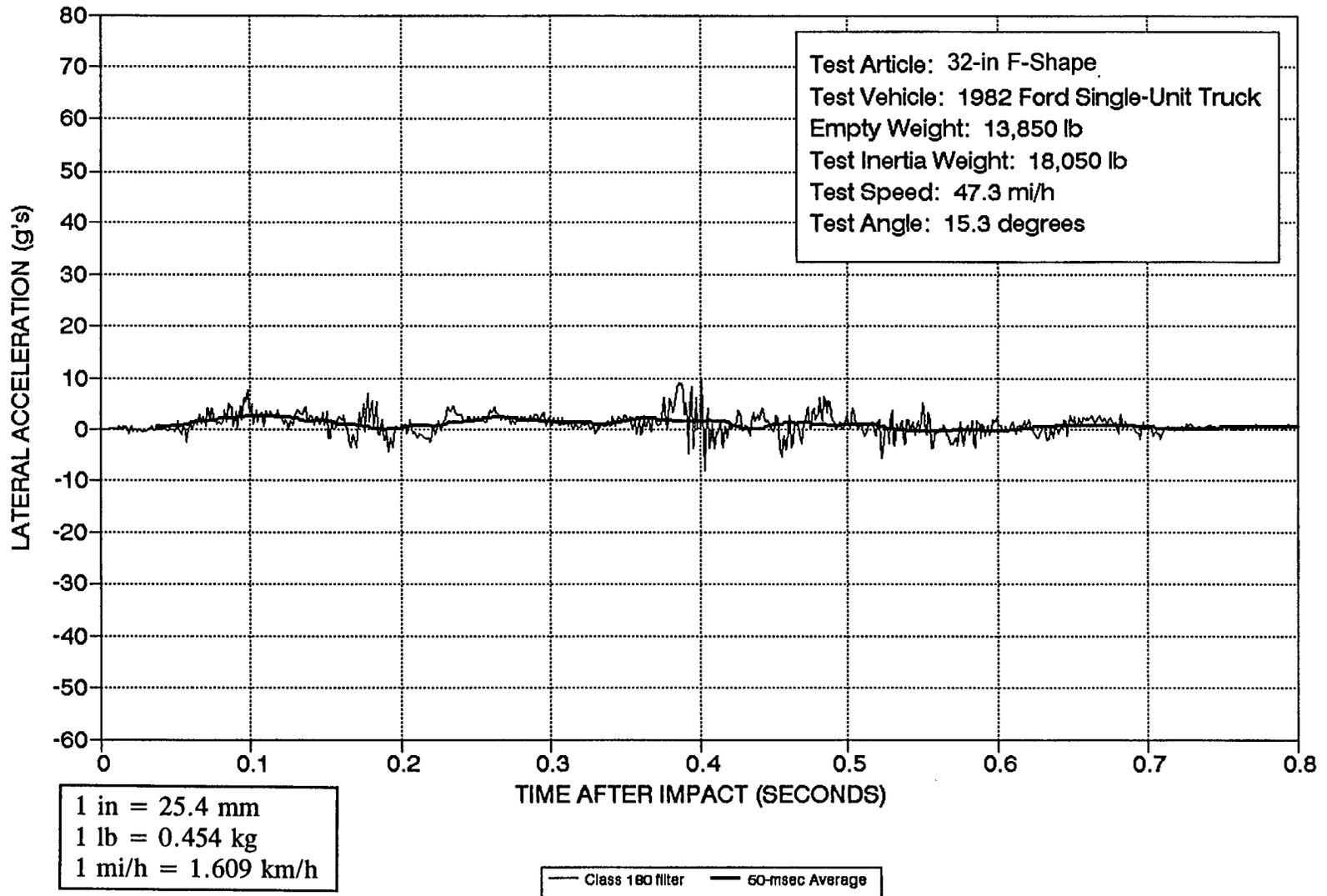

Figure 57. Lateral accelerometer trace for test 7069-9 (accelerometer located near center-of-gravity).

CRASH TEST 7069-9
Accelerometer near center-of-gravity

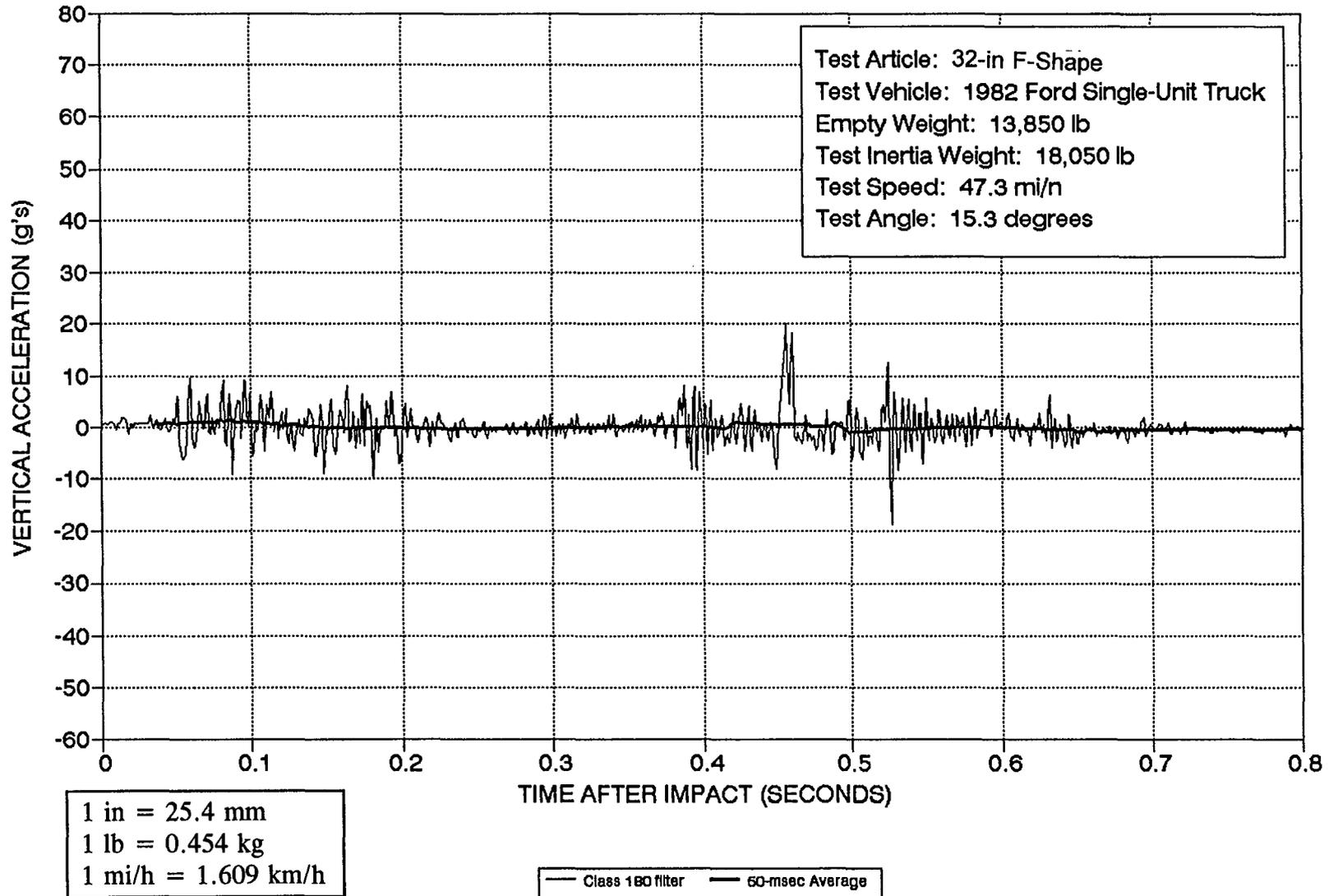

Figure 58. Vertical accelerometer trace for test 7069-9
(accelerometer located near center-of-gravity).

CRASH TEST 7069-9
Accelerometer at front of vehicle

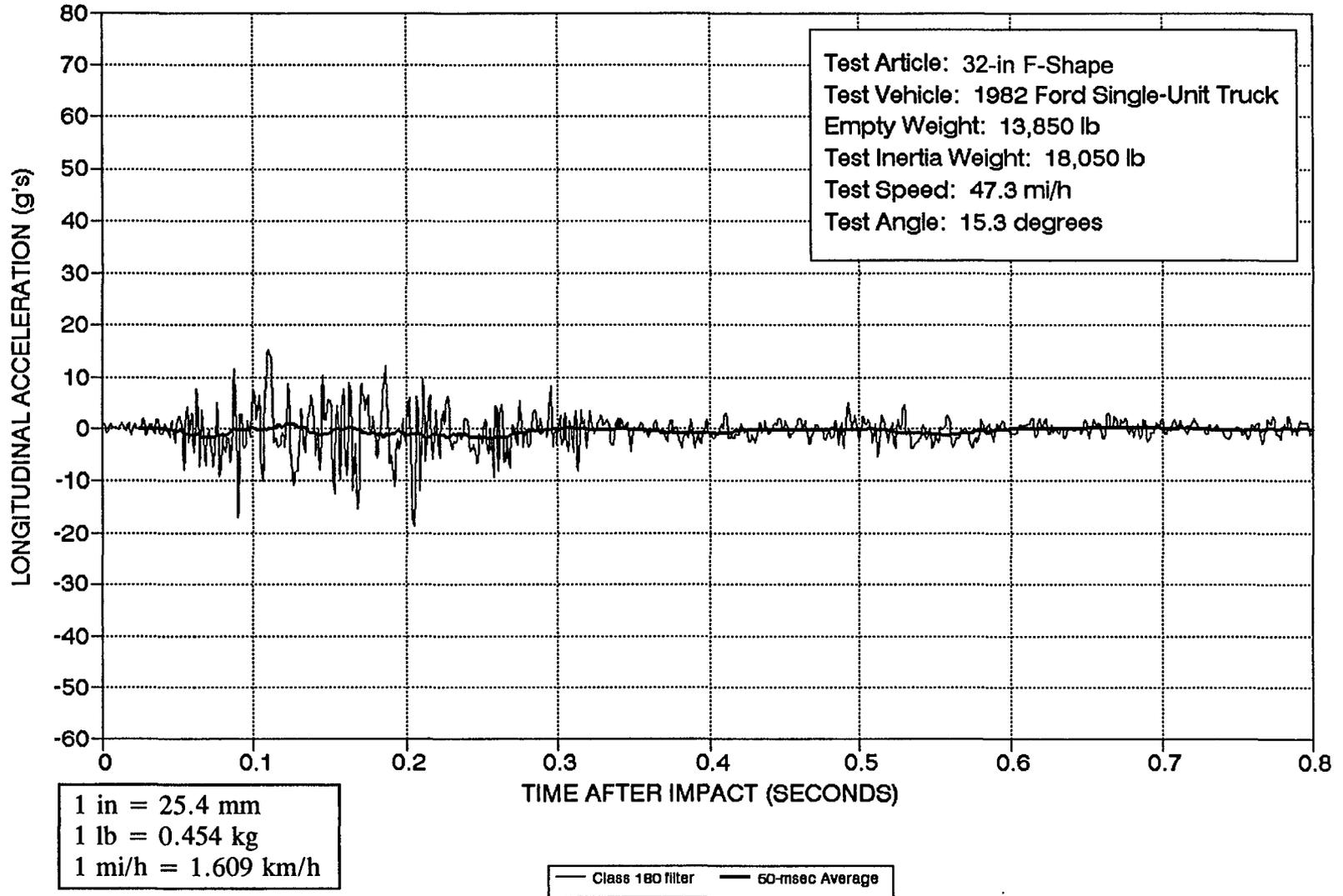

Figure 59. Longitudinal accelerometer trace for test 7069-9
(accelerometer located at front of vehicle).

CRASH TEST 7069-9
Accelerometer at front of vehicle

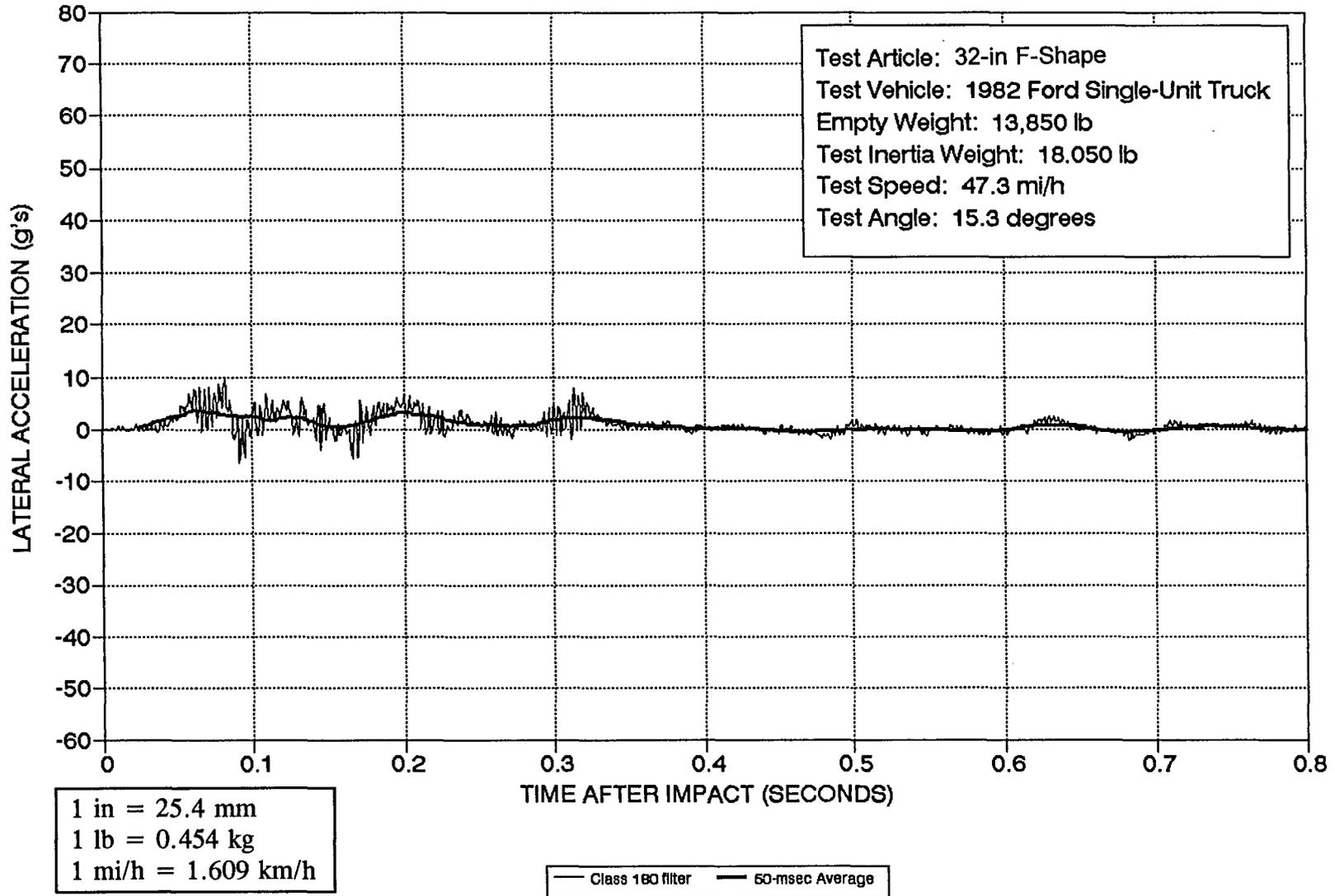

Figure 60. Lateral accelerometer trace for test 7069-9
(accelerometer located at front of vehicle).

CRASH TEST 7069-9
Accelerometer at rear of vehicle

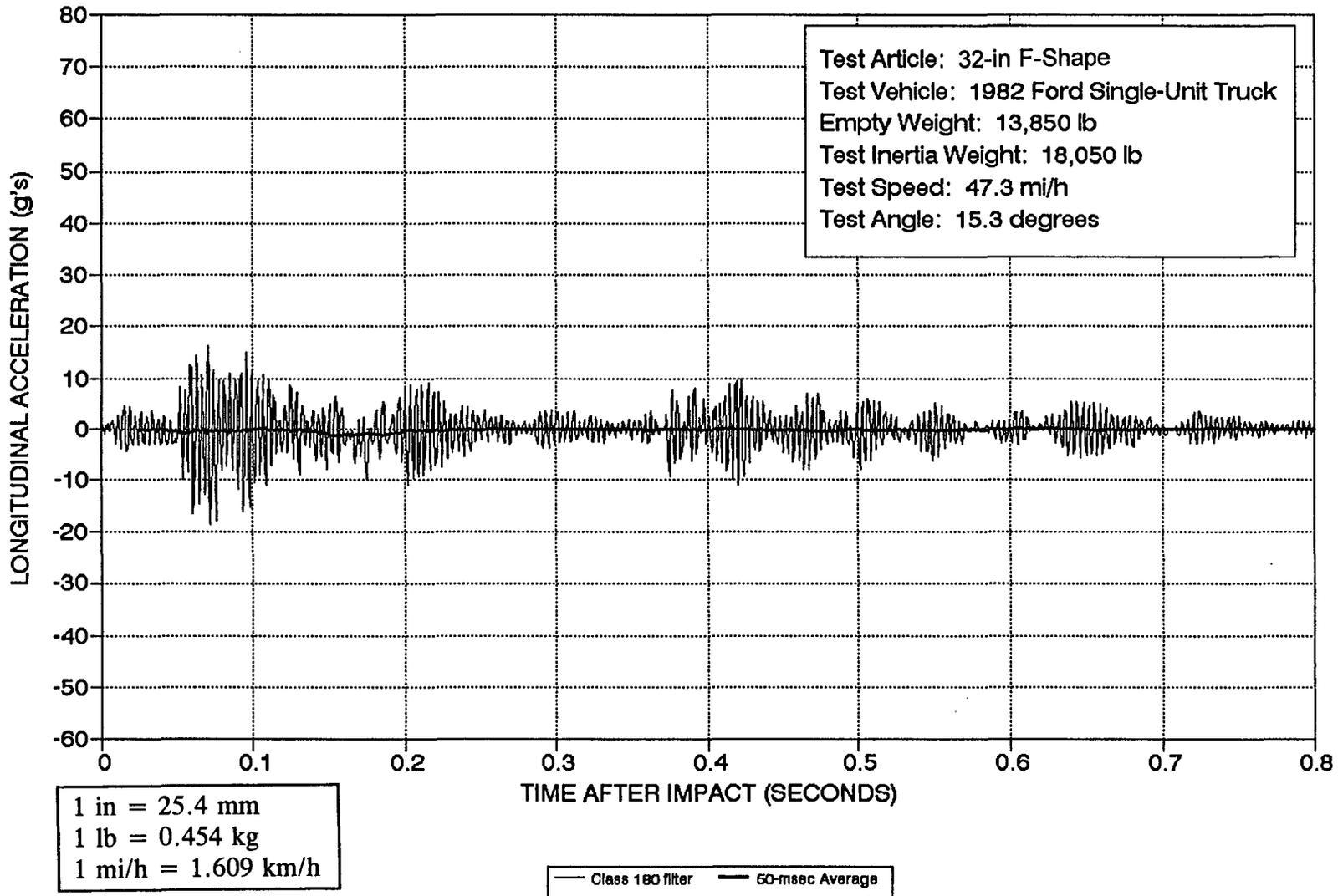

Figure 61. Longitudinal accelerometer trace for test 7069-9
(accelerometer located at rear of vehicle).

CRASH TEST 7069-9

Accelerometer at rear of vehicle

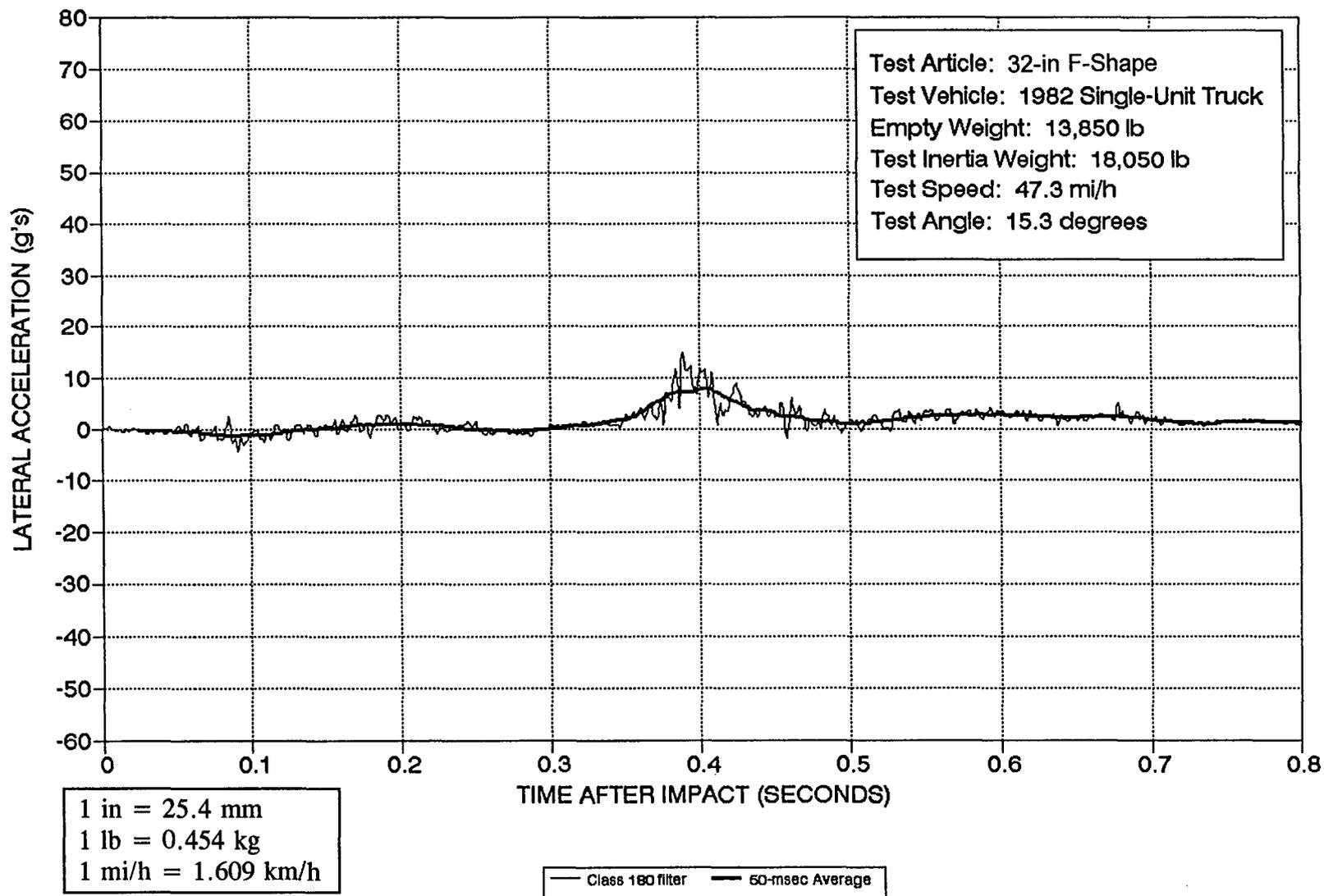

Figure 62. Lateral accelerometer trace for test 7069-9 (accelerometer located at rear of vehicle).

TEST 7069-11

Test Description

The 1982 Ford 7000 single-unit truck (figures 63 and 64) was directed into the 32-in (813-mm) F-shape bridge railing (figure 65) using a remote control guidance system. The empty weight of the vehicle was 18,000 lb (8 172 kg) and its test inertia weight was 18,000 lb (8 172 kg). The height to the lower edge of the vehicle bumper was 18.75 in (476 mm) and it was 28.75 in (730 mm) to the top of the bumper. Other dimensions and information on the test vehicle are given in figures 66 and 67. The vehicle was free-wheeling and unrestrained just prior to impact.

The speed of the vehicle at impact was 52.1 mi/h (83.8 km/h) and the angle of impact was 14.8 degrees. The vehicle impacted the bridge railing at midlength. At approximately 0.022 s after impact the right front wheel began to ride up the face of the bridge railing, and at 0.132 s the left front tire began to leave the ground. The vehicle began to redirect at 0.144 s as the rear end began to slide toward the bridge railing. At 0.240 s the left rear wheels left the ground, and at 0.350 s the rear of the vehicle slapped the bridge railing. By approximately 0.524 s the vehicle became parallel with the railing and was continuing to roll to the right. As the vehicle continued along the railing, the lower edge of the bed rode along the top of the railing. A maximum roll angle of 31 degrees was achieved at about 0.683 s. The vehicle slid off the end of the bridge railing at approximately 1.346 s after impact. The brakes were applied and the vehicle subsequently came to rest 231 ft (70 m) downstream.

As can be seen in figure 68, the railing received cosmetic damage and some scraping. There were tire marks on the face of the bridge railing and along the top. The top of the bridge railing was scraped along the remaining length from the lower edge of the bed of the truck. The vehicle was in contact with the bridge railing for 39 ft (12 m).

The vehicle sustained extensive damage to the right side as shown in figure 69. Maximum crush at the right front corner at bumper height was 20.0 (508 mm). The front axle was torn loose which caused damage to the springs, shackles, U-bolts, and tie rods. The steering arm and cylinder were damaged and the oil pan was dented. Also, the fuel tank broke loose from the truck.

Test Results

Impact speed was 52.1 mi/h (83.8 km/h) and the angle of impact was 14.8 degrees. The exit speed was not available. Exit angle was about 0 degrees. The effective coefficient of friction was calculated to be 0.12. Occupant impact velocity was 5.7 ft/s (1.7 m/s) in the longitudinal direction and 8.2 ft/s (2.5 m/s) in the lateral direction. The highest 0.010-s occupant ridedown accelerations were 1.3 g (longitudinal) and 5.4 g (lateral). These data and other pertinent information from the test are summarized in figure 70 and table 7. Sequential photographs are shown in figures 71 and 72. Vehicular angular displacements are displayed in figure 73. Vehicle accelerations versus time traces filtered with SAE J211

filters are presented in figures 74 through 80. These data were further analyzed to obtain 0.050-s average accelerations versus time. The maximum 0.050-s averages were -1.4 g (longitudinal) and 3.9 g (lateral).

Conclusions

The 32-in (813-mm) F-shape bridge railing contained and smoothly redirected the vehicle with no lateral movement of the bridge railing. There were no debris or detached elements. There was no intrusion into the occupant compartment. The vehicle trajectory at loss of contact indicated minimum intrusion into adjacent traffic lanes. The vehicle remained upright and marginally stable during the entire test period. See table 7 for a more detailed description.

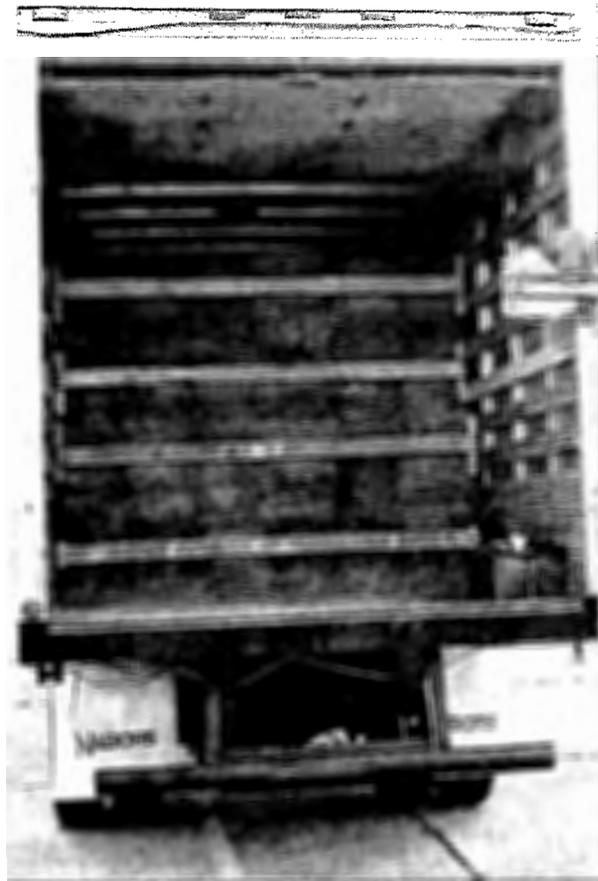

Figure 63. Vehicle before test 7069-11.



Figure 64. Vehicle/bridge railing geometrics for test 7069-11.

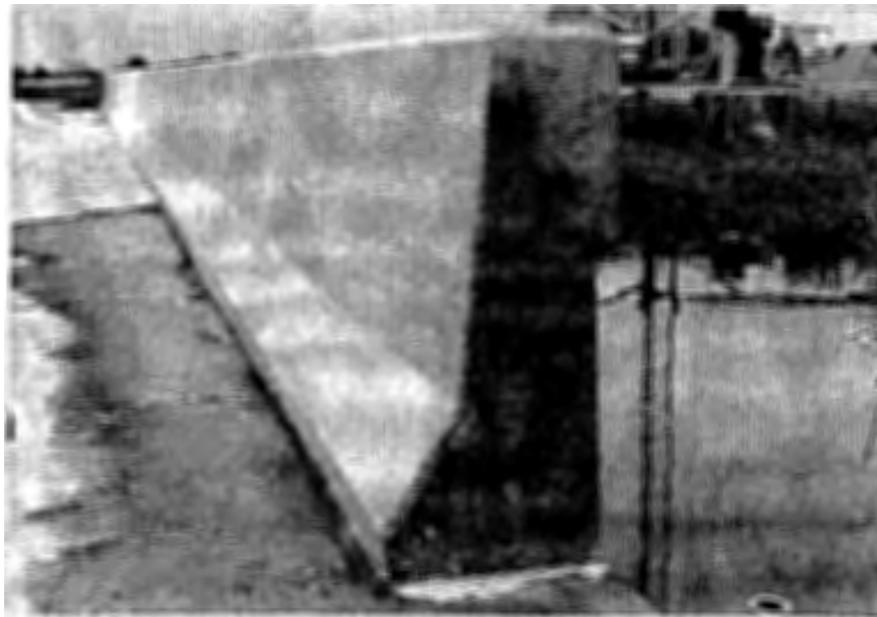
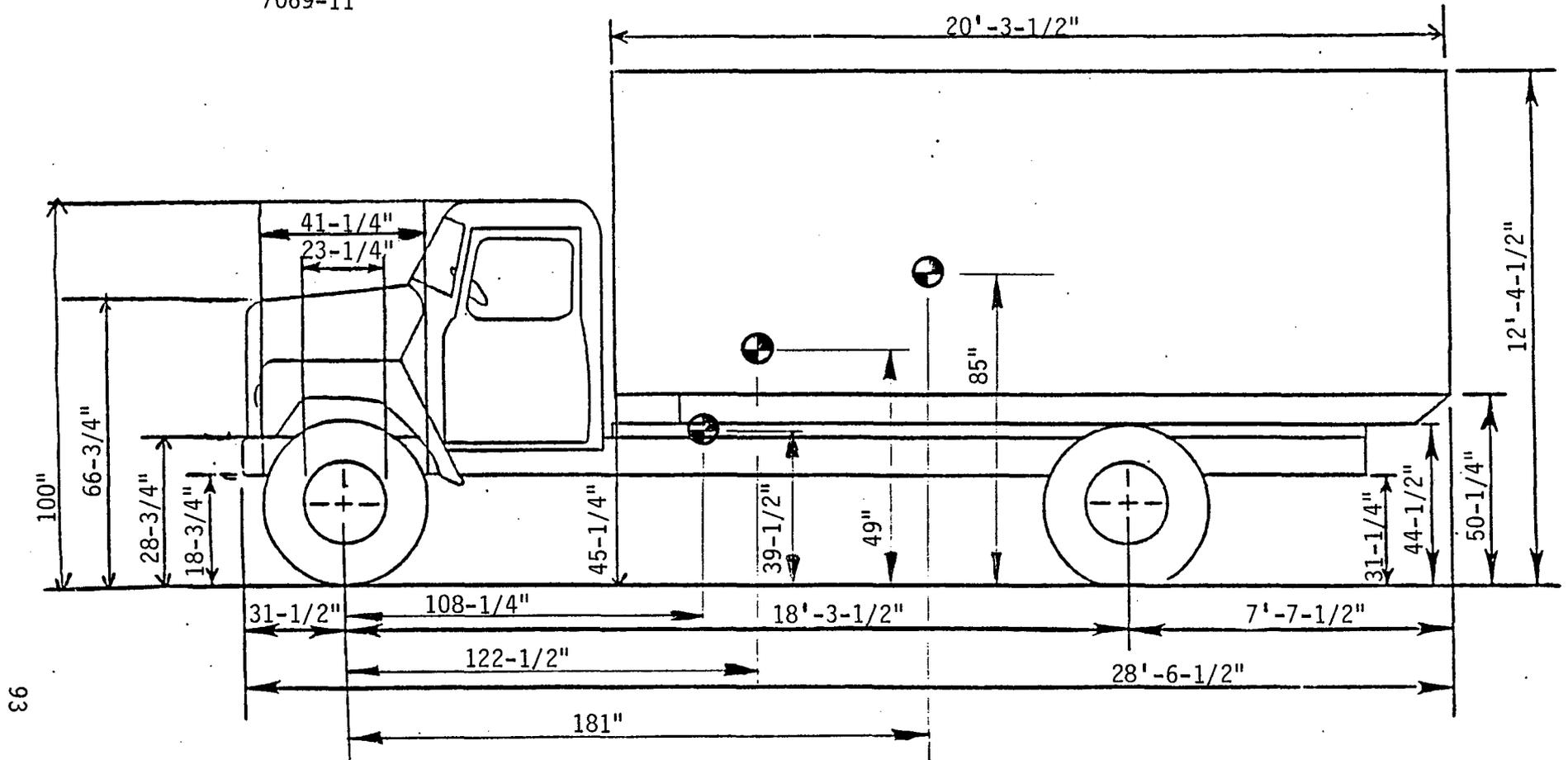

Figure 65. 32-in (813-mm) F-shape bridge railing before test 7069-11.



93

EMPTY WEIGHTS

Weight on Front Axle	<u>6920</u>
Weight on Rear Axle	<u>6610</u>
TOTAL EMPTY WEIGHT	<u>13530</u>

LOADED WEIGHTS

Weight on Front Axle	<u>7980</u>
Weight on Rear Axle	<u>10020</u>
TOTAL LOAD WEIGHT	<u>18000</u>

1 in = 25.4 mm

Figure 66. Vehicle properties for test 7069-11.

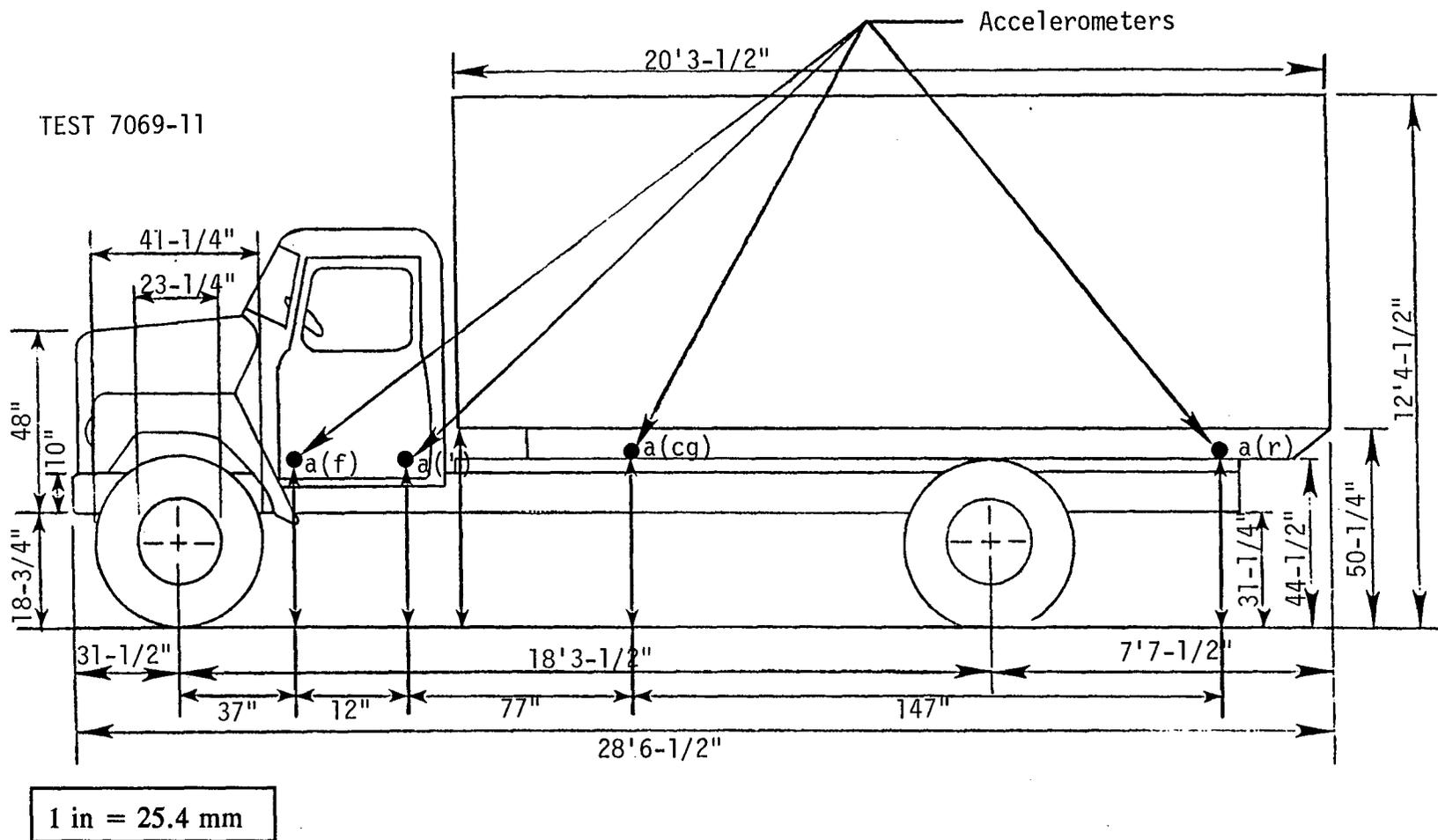

Figure 67. Accelerometer locations for test 7069-11.

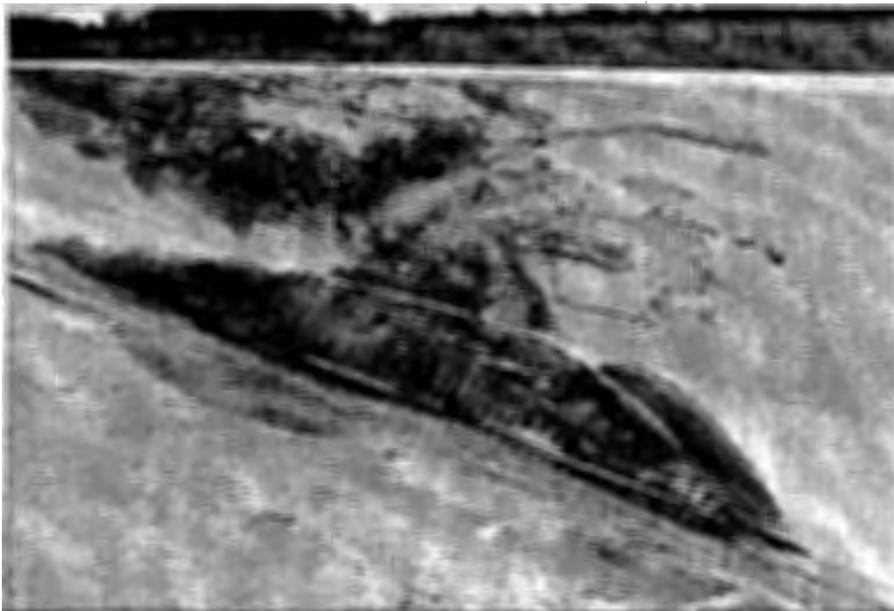
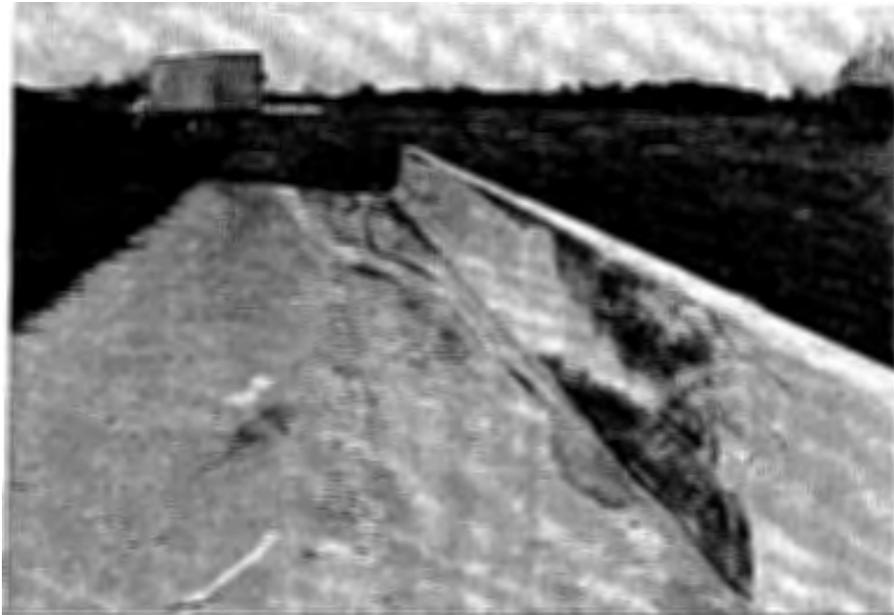
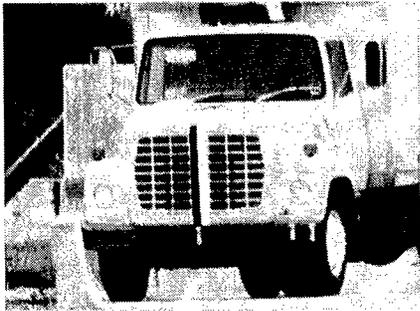

Figure 68. 32-in (813-mm) bridge railing after test 7069-11.



Figure 69. Vehicle after test 7069-11.



0.000 s



0.158 s



0.474 s

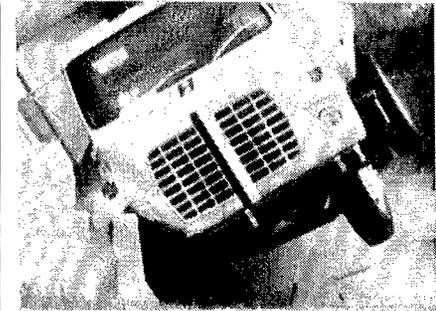

0.790 s

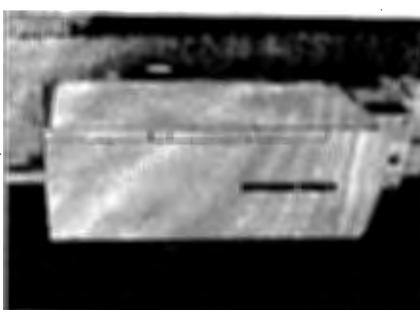

97

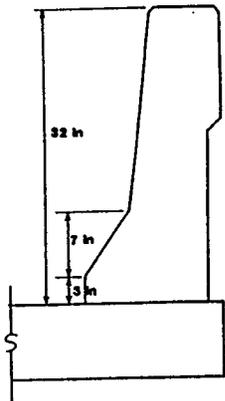

(1 in = 25.4 mm)

Test No.	7069-11	Impact Speed. . . .	52.1 mi/h (83.8 km/h)
Date	3/30/88	Impact Angle. . . .	14.8 deg
Test Installation . . .	32-in (813-mm) F-Shape	Exit Speed	Not Available
	Bridge Railing	Exit Trajectory . .	0 deg
Installation Length . .	100 ft (30 m)	Vehicle Accelerations	
Vehicle	1982 Ford 7000	(Max. 0.050-sec Avg)	
	Single-Unit Truck	Longitudinal. . . .	-1.4 g
Vehicle Weight		Lateral	3.9 g
Empty Weight	13,530 lb (6,145 kg)	Occupant Impact Velocity	
Test Inertia	18,000 lb (8,172 kg)	Longitudinal. . . .	5.7 ft/s (1.7 m/s)
Maximum Vehicle Crush .	20.0 in (508 mm)	Lateral	8.2 ft/s (2.5 m/s)
		Occupant Ridedown Accelerations	
		Longitudinal. . . .	1.3 g
		Lateral	5.4 g

Figure 70. Summary of results for test 7069-11.

Table 7. Evaluation of crash test no. 7069-11.
 {32-in (81 cm) F-Shape Bridge Railing [18,000 lb (8 172 kg)|52.1 mi/h (83.8 km/h)|14.8 degrees]}

CRITERIA		TEST RESULTS		PASS/FAIL*	
A.	Must contain vehicle	Vehicle was contained		Pass	
B.	Debris shall not penetrate passenger compartment	No debris penetrated passenger compartment		Pass	
C.	Passenger compartment must have essentially no deformation	Acceptable information		Pass	
D.	Vehicle must remain upright	Vehicle remained upright		Pass	
E.	Must smoothly redirect the vehicle	Vehicle was smoothly redirected		Pass	
F.	Effective coefficient of friction				
	<u>μ</u>	<u>Assessment</u>	<u>μ</u>	<u>Assessment</u>	
	0 - .25	Good	.12	Good	Pass
	.26 - .35	Fair			
	> .35	Marginal			
G.	Shall be less than				
	<u>Occupant Impact Velocity - ft/s (m/s)</u>	<u>Occupant Impact Velocity - ft/s (m/s)</u>		N/A	
	Longitudinal	Lateral	Longitudinal	Lateral	
	30 (9.2)	25 (7.6)	5.7 (1.7)	8.2 (2.5)	
	<u>Occupant Ridedown Accelerations - g's</u>	<u>Occupant Ridedown Accelerations - g's</u>		N/A	
	Longitudinal	Lateral	Longitudinal	Lateral	
	15	15	1.3	5.4	
H.	Exit angle shall be less than 12 degrees	about 0 degrees		Pass	

* A, B, C, and D are required. E, F, and H are desired. G is not applicable for this test. (See table 5)



0.000 s

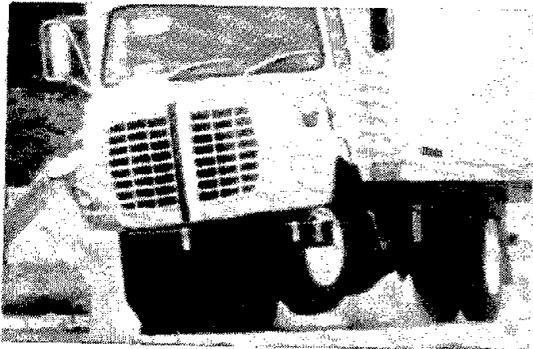

0.158 s

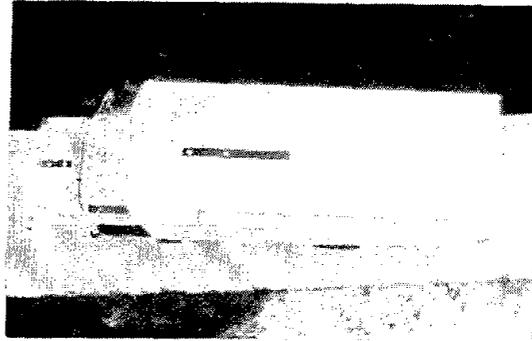
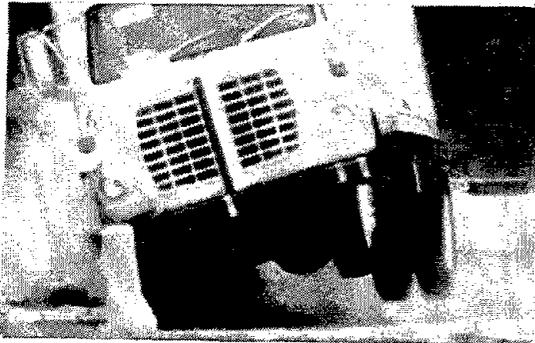

0.316 s

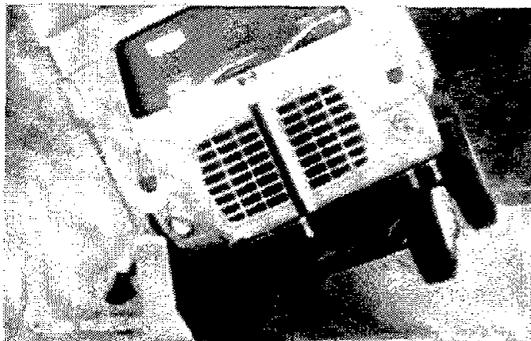

0.474 s

Figure 71. Sequential photographs for test 7069-11.

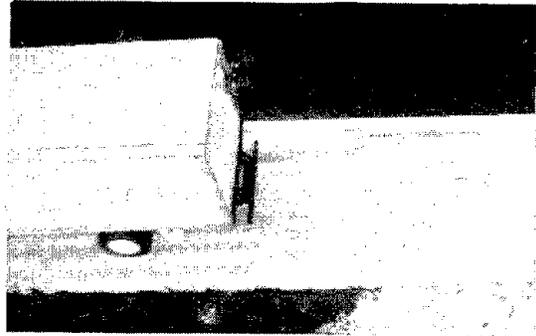
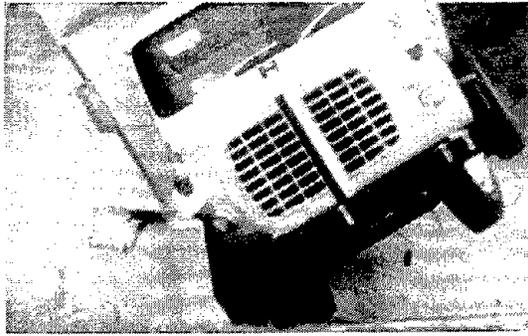

0.632 s

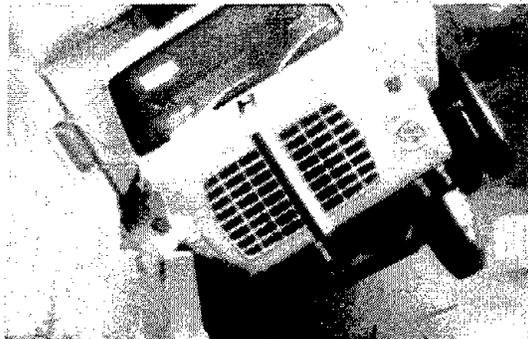

0.790 s

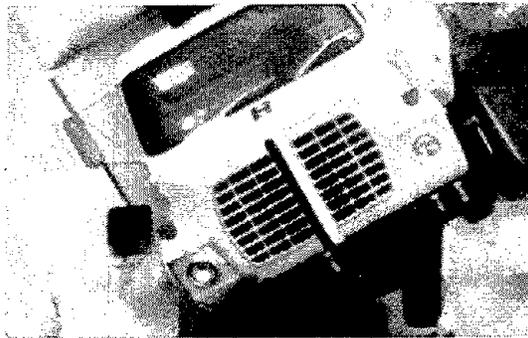

Out of view

0.951 s

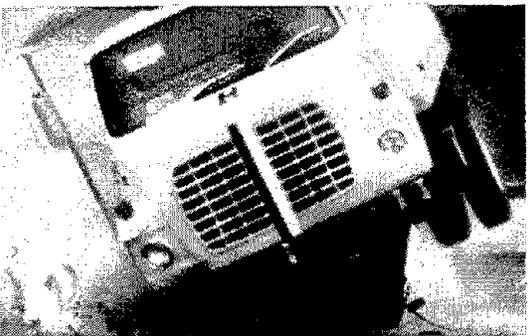

Out of view

1.111 s

Figure 71. Sequential photographs for test 7069-11 (continued).



0.000 s

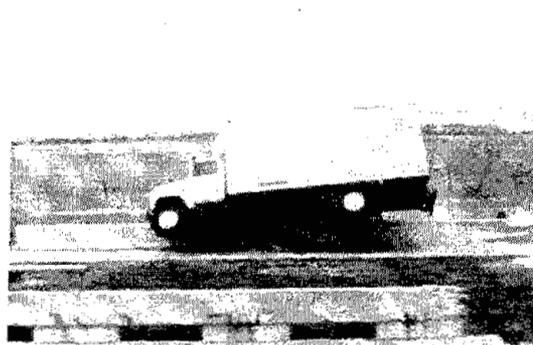

0.632 s

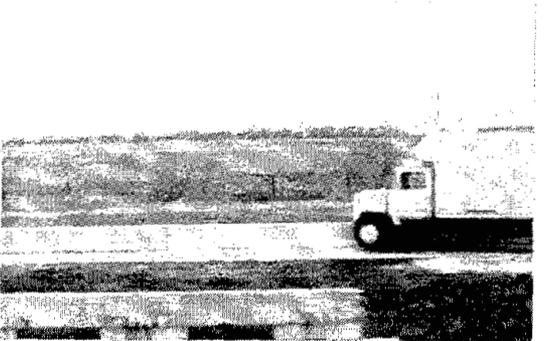

0.158 s

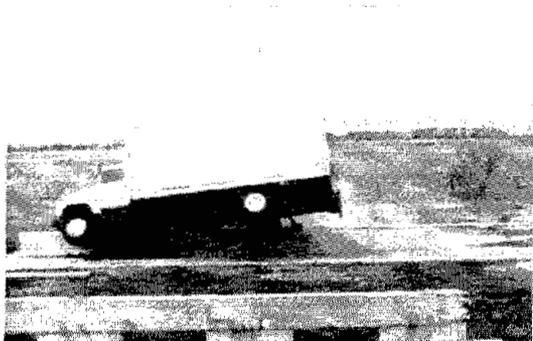

0.790 s

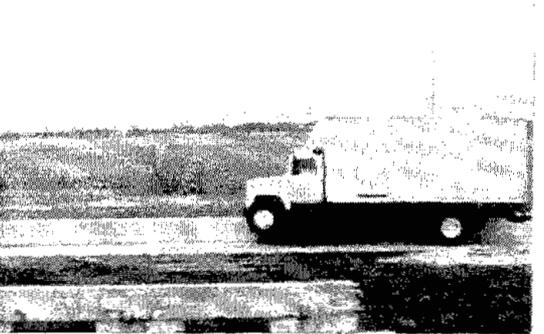

0.316 s

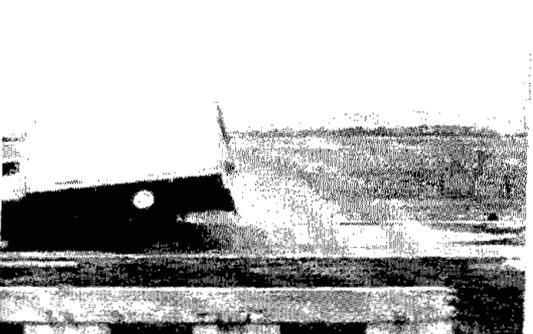

0.951 s

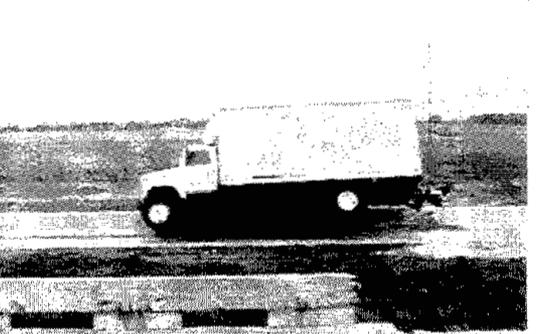

0.474 s

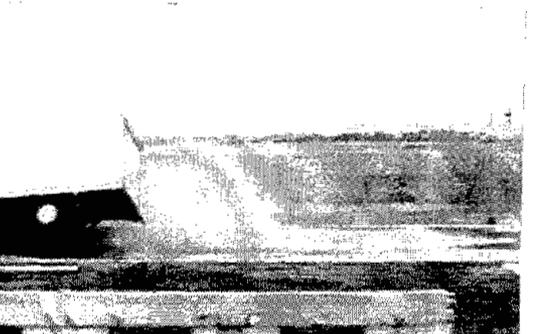

1.111 s

Figure 72. Perpendicular sequential photographs for test 7069-11.

7069-11

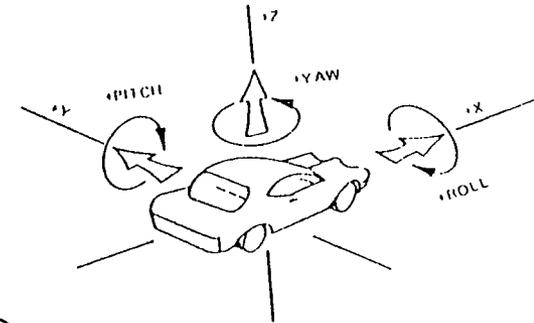
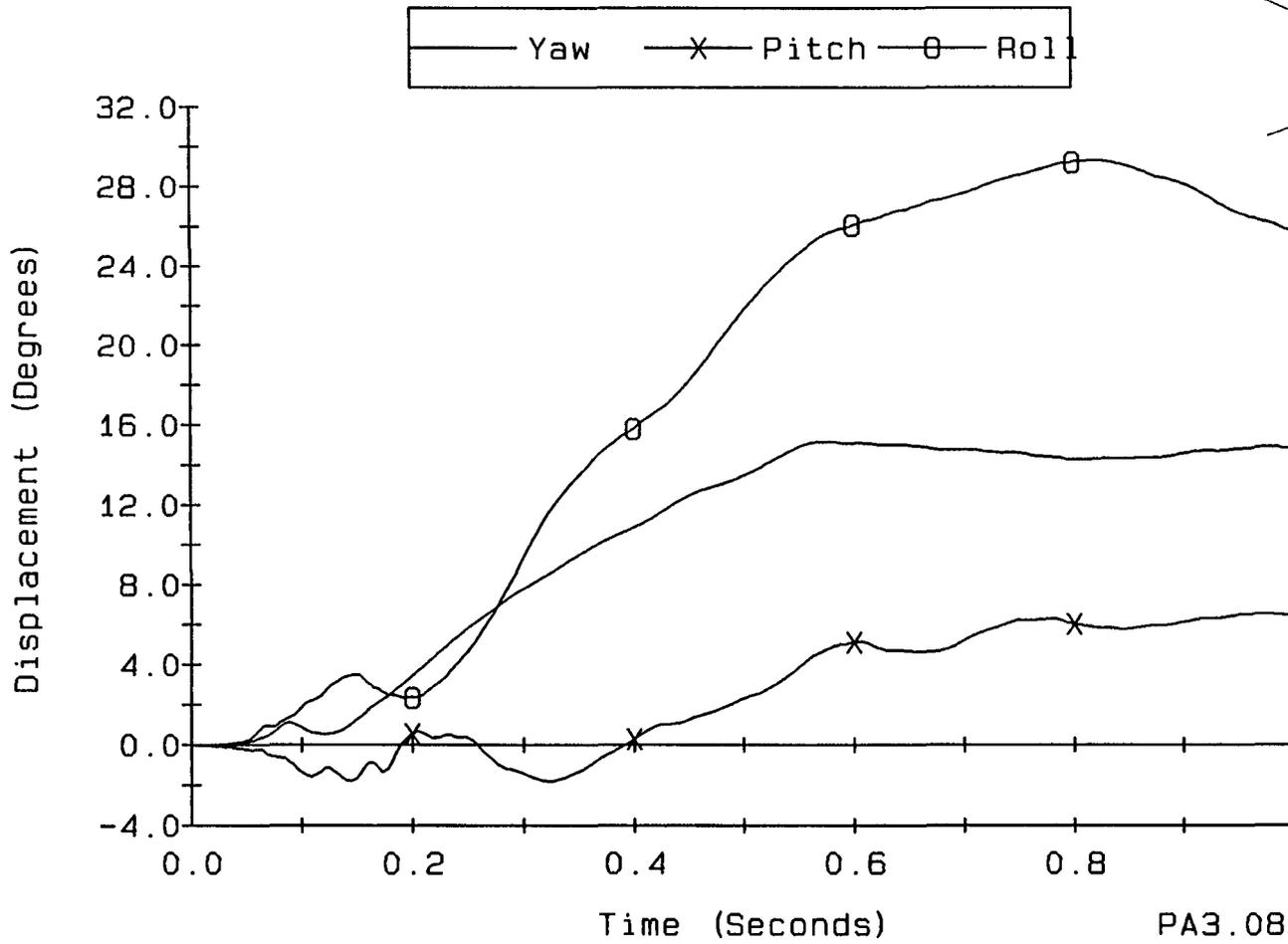

Axes are vehicle fixed.
Sequence for determining orientation is:

1. Yaw
2. Pitch
3. Roll

102

Figure 73. Vehicle angular displacements for test 7069-11.

CRASH TEST 7069-11

Accelerometer near center-of-gravity

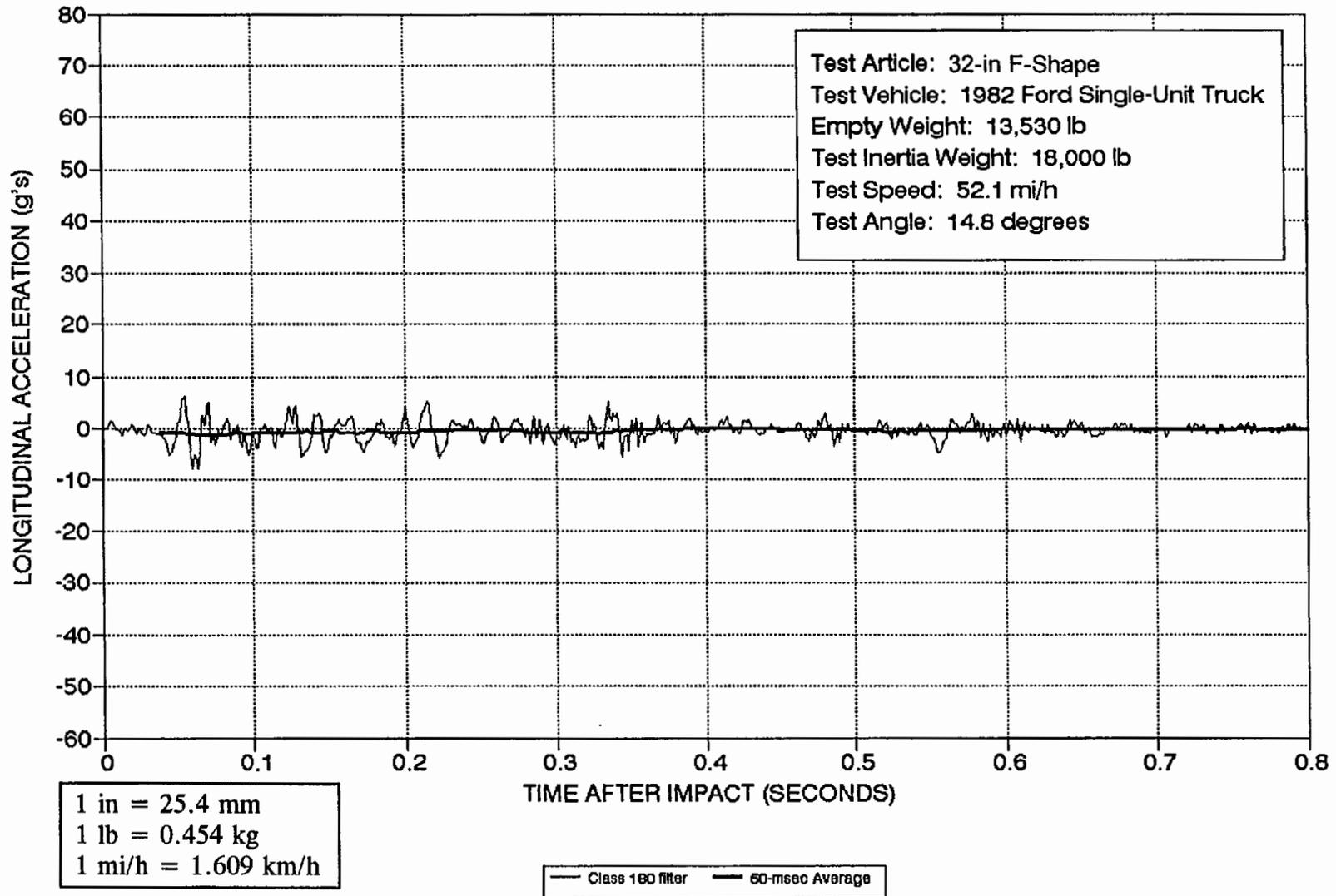

Figure 74. Vehicle longitudinal accelerometer trace for test 7069-11 (accelerometer located near center-of-gravity).

CRASH TEST 7069-11
Accelerometer near center-of-gravity

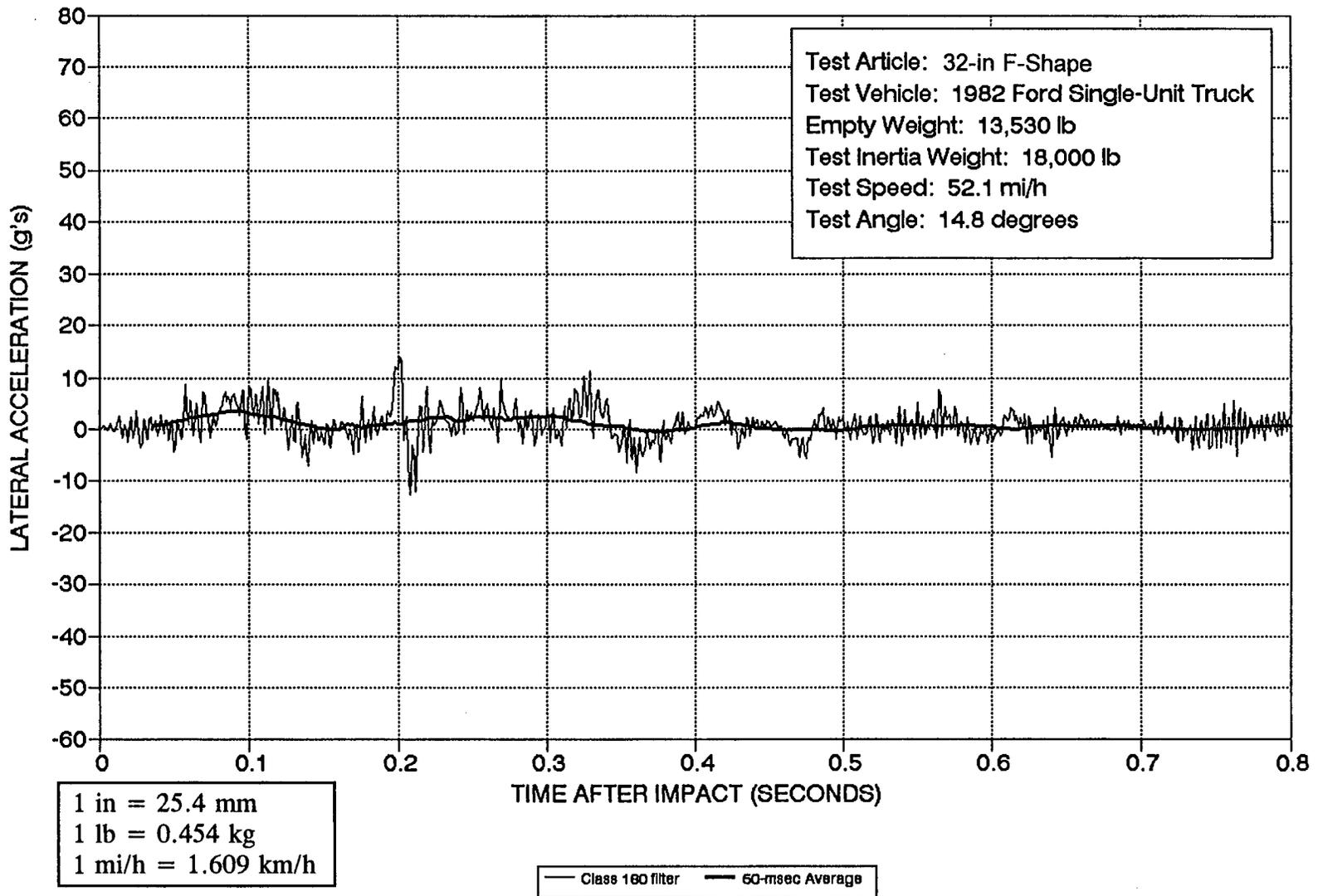

Figure 75. Vehicle lateral accelerometer trace for test 7069-11 (accelerometer located near center-of-gravity).

CRASH TEST 7069-11

Accelerometer near center-of-gravity

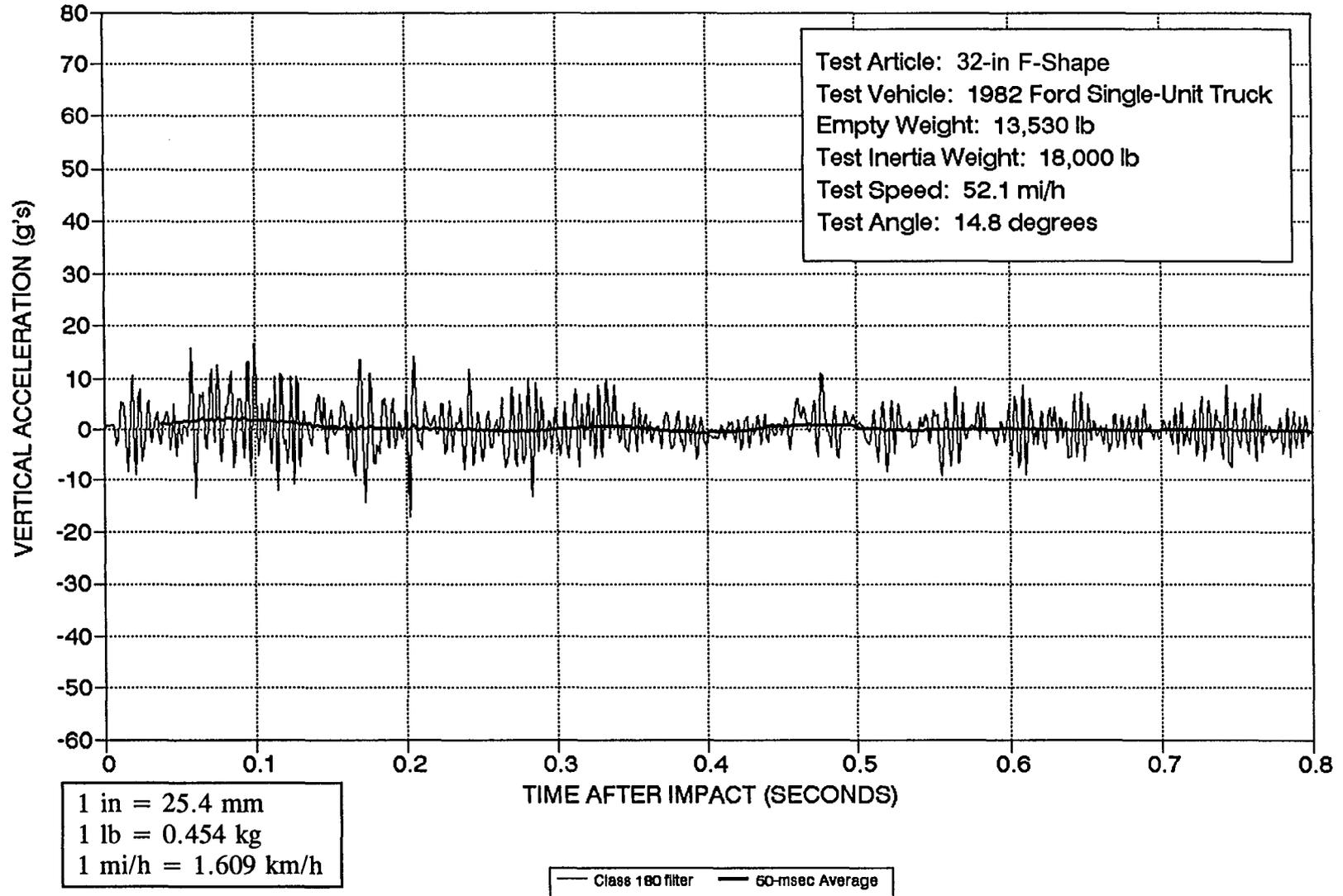
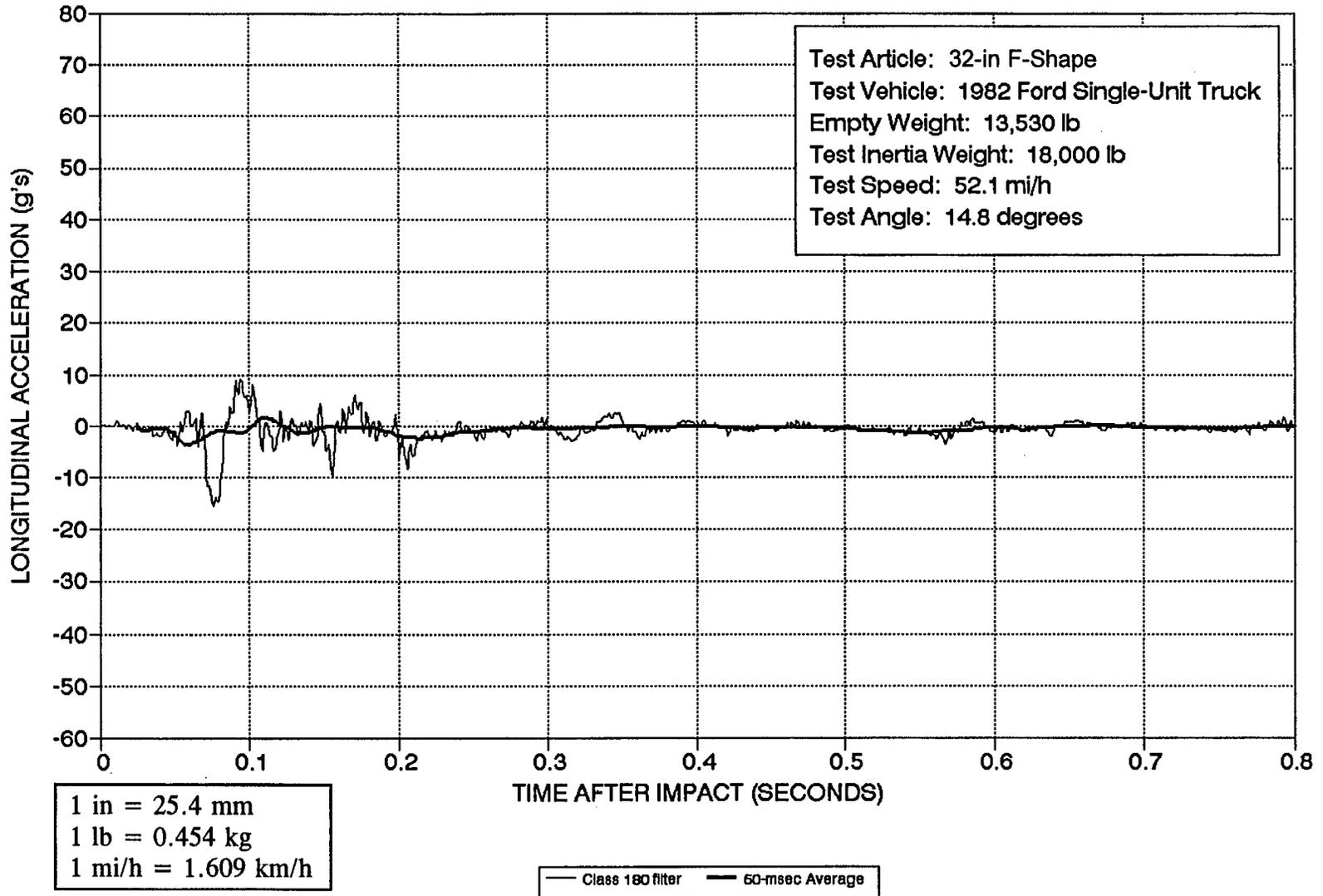

Figure 76. Vehicle vertical accelerometer trace for test 7069-11 (accelerometer located near center-of-gravity).

CRASH TEST 7069-11
Accelerometer at front of vehicle



106

Figure 77. Vehicle longitudinal accelerometer trace for test 7069-11 (accelerometer located at front of vehicle).

CRASH TEST 7069-11
Accelerometer at front of vehicle

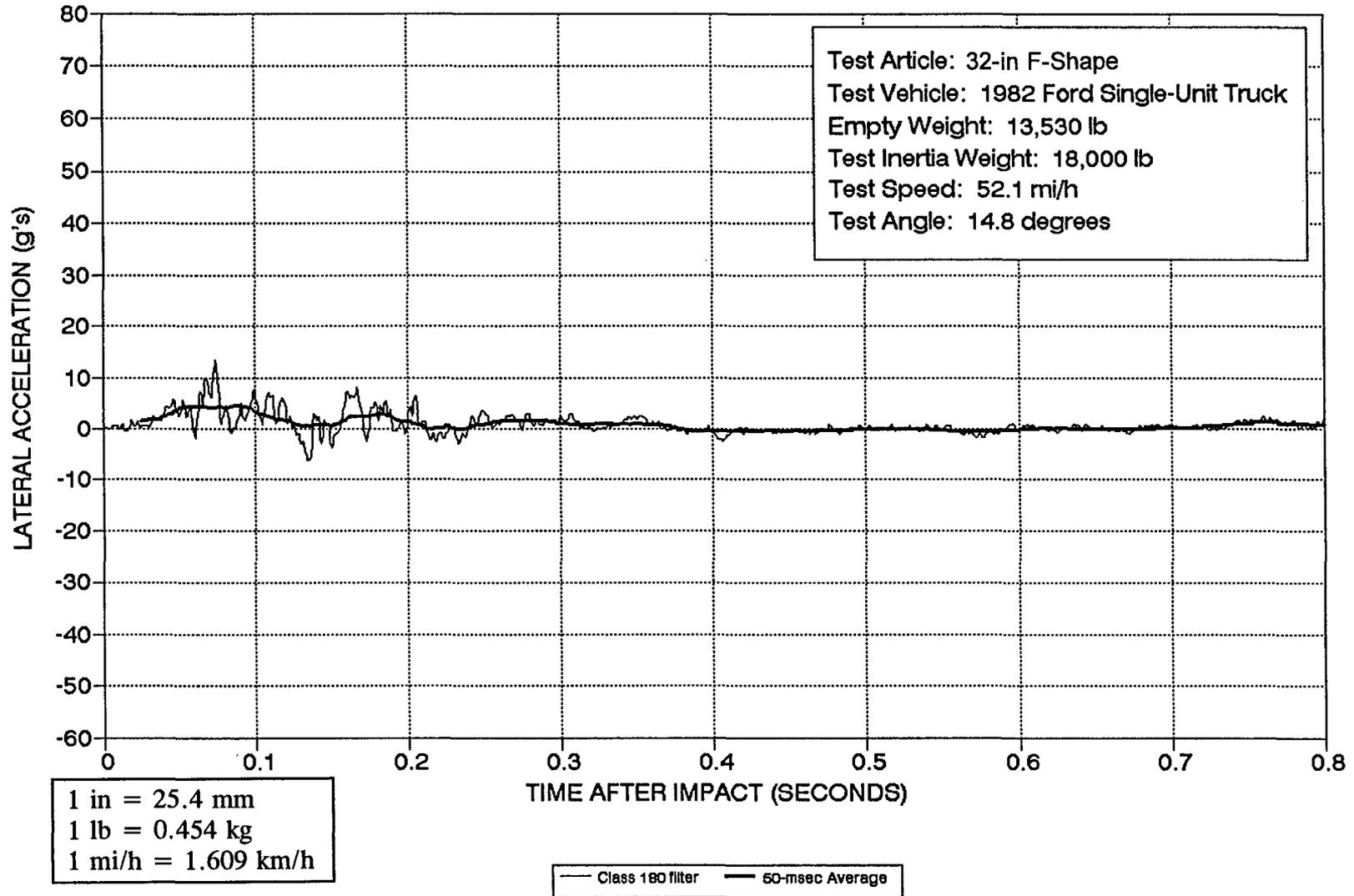

107

Figure 78. Vehicle lateral accelerometer trace for test 7069-11 (accelerometer located at front of vehicle).

CRASH TEST 7069-11
Accelerometer at rear of vehicle

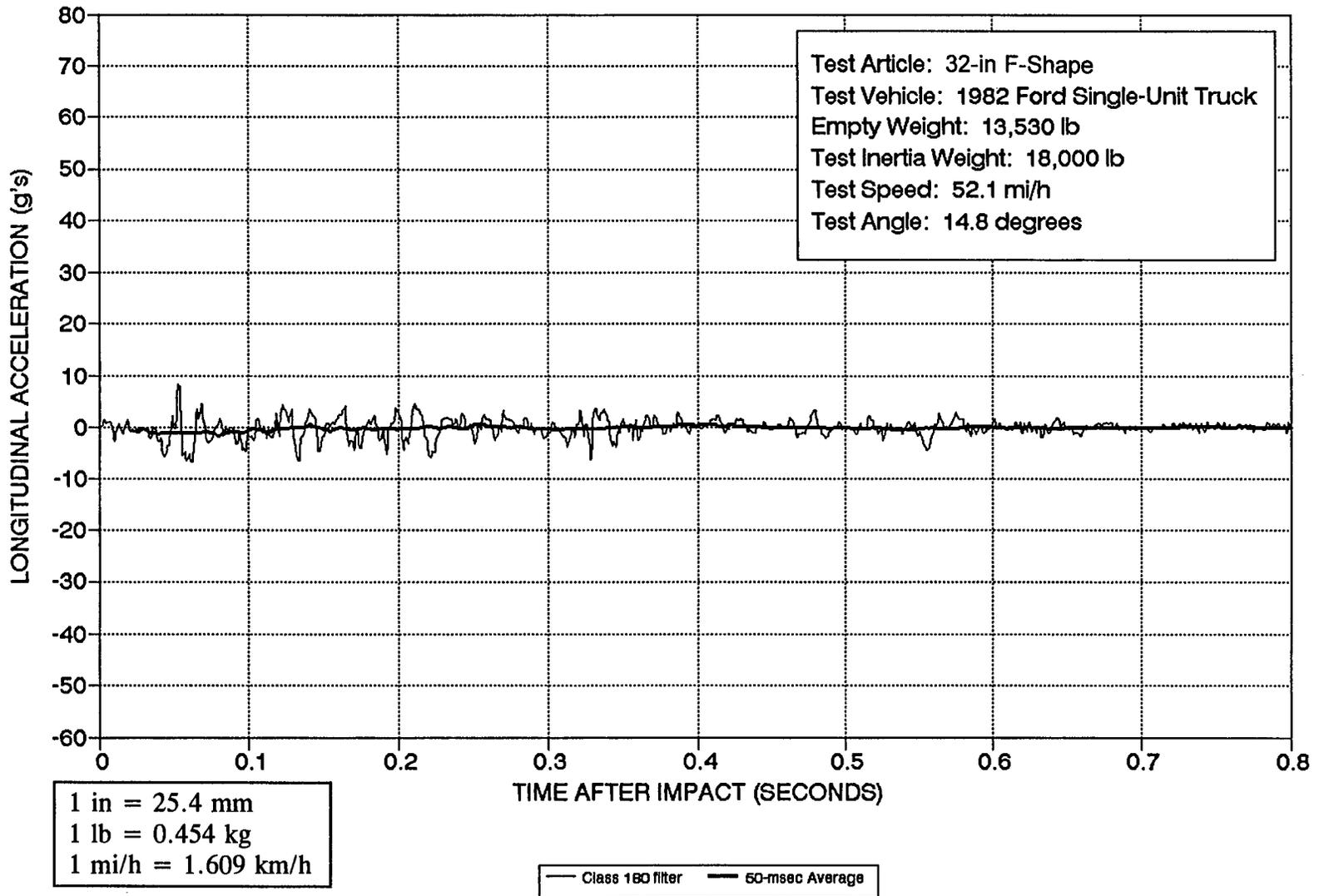
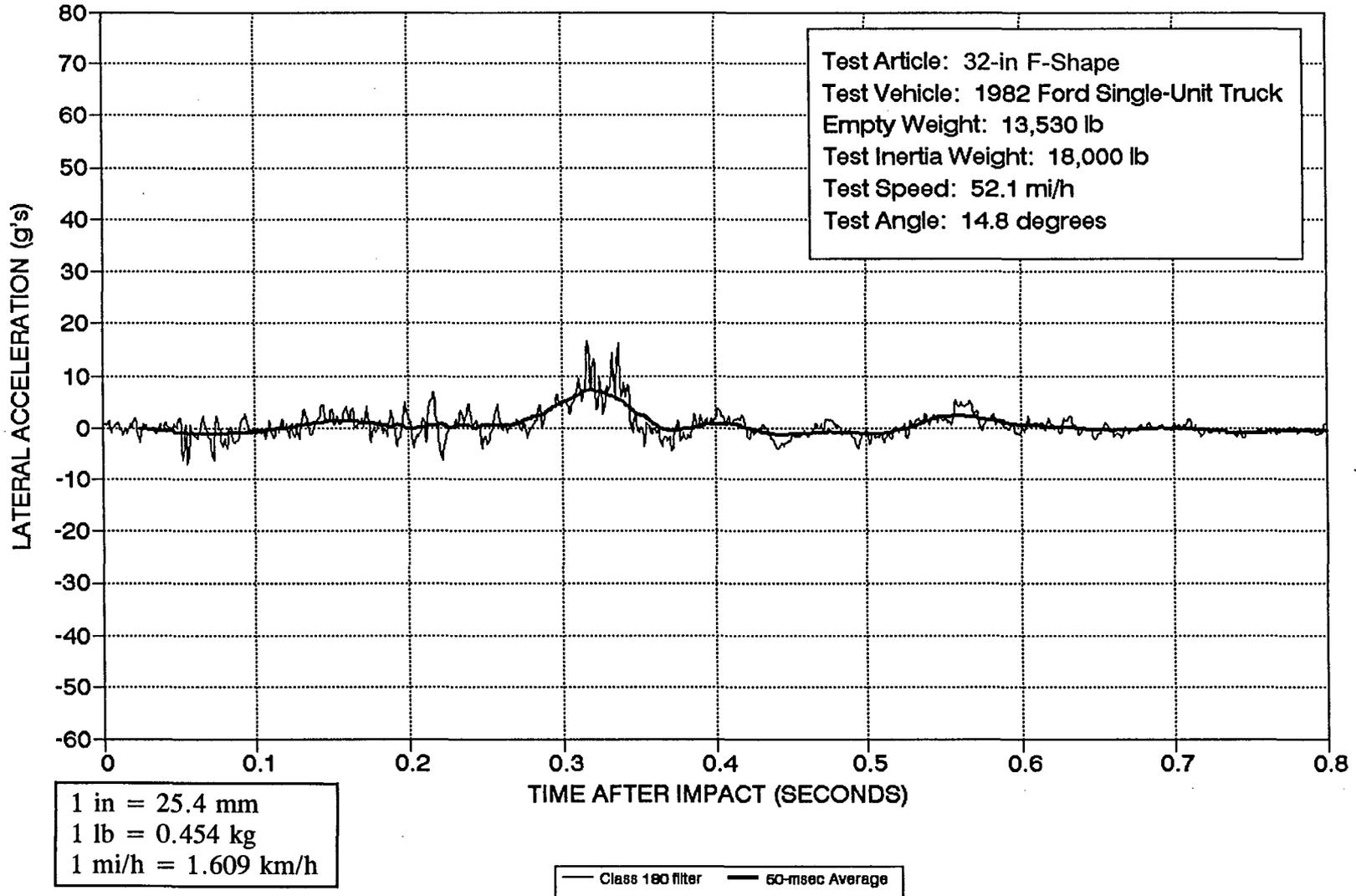

Figure 79. Vehicle longitudinal accelerometer trace for test 7069-11 (accelerometer located at rear of vehicle).

CRASH TEST 7069-11
Accelerometer at rear of vehicle



109

Figure 80. Vehicle lateral accelerometer trace for test 7069-11 (accelerometer located at rear of vehicle).

4. STRENGTH CALCULATIONS

Analysis of strength of the railing is based on yieldline failure pattern and equations shown in figure 72. Force from a colliding vehicle is idealized as being a uniformly distributed line load extending over 3.5 ft (1.07 m). The load may be applied at any location along the railing. Length of the failure pattern depends on the relative bending moment capacities of various elements of the railing. The computed cantilever moment capacity of parapet, M_c , is 10.6 ft-k/ft (47.2 m-kN/m) and the moment capacity about a vertical axis, M_w , is 4.89 ft-k/ft (21.8 m-kN/m). The additional moment capacity of the stiffening beam along the top of the parapet, M_b , is 6.8 ft-kips (9.2 m-kN). These values result in a length of yieldline pattern of 8.3 ft (211 mm) and the strength of the parapet is 59.1 kips (263 kN) located at the top of the parapet.

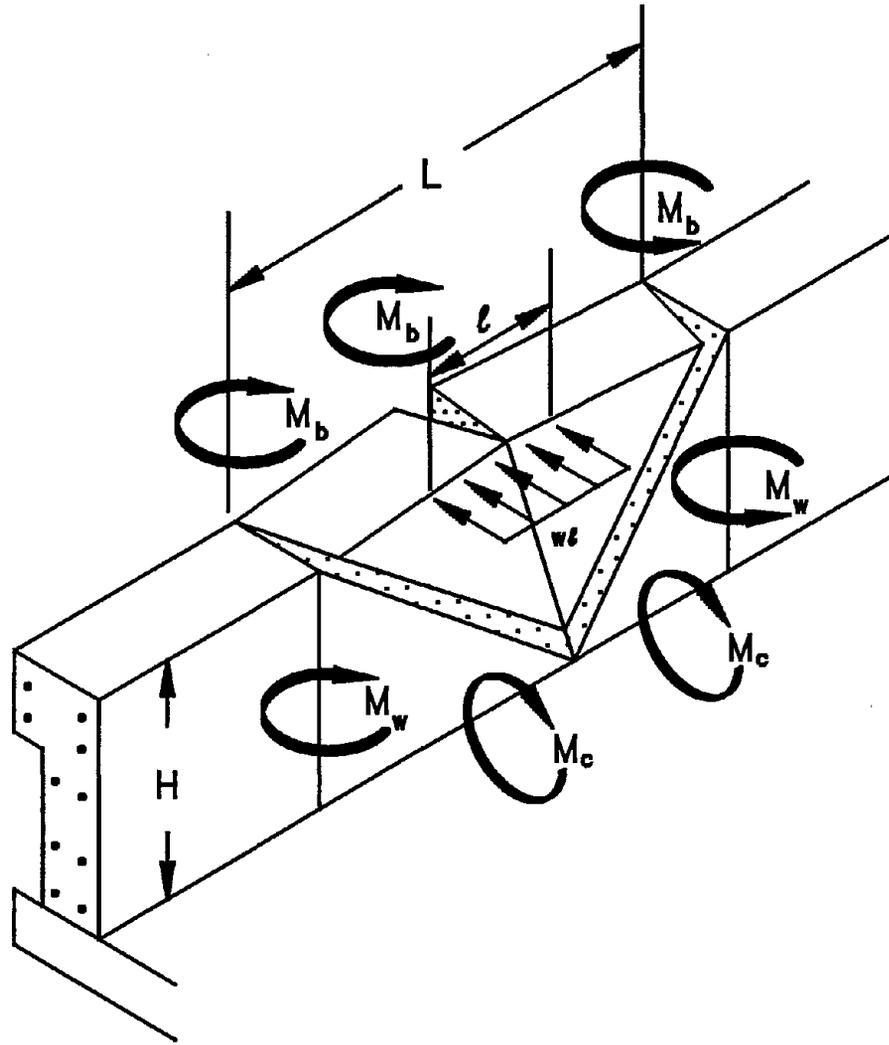

$$L = \frac{l}{2} + \sqrt{\left(\frac{l}{2}\right)^2 + \frac{8H(M_b + M_w H)}{M_c}}$$

$$(wl)_{\text{ult}} = \frac{8M_b}{L - \frac{l}{2}} + \frac{8M_w H}{L - \frac{l}{2}} + \frac{M_c L^2}{H\left(L - \frac{l}{2}\right)}$$

Figure 81. Yieldline failure pattern for concrete parapet.

REFERENCES

1. *Guide Specifications for Bridge Railings*, proposed, American Association of State Highway and Transportation Officials (AASHTO), Washington, DC, April 2, 1987.
2. *Guide Specifications For Bridge Railings*, American Association of State Highway and Transportation Officials (AASHTO), Washington, DC, 1989.
3. Hirsch, T. J., "Analytical Evaluation of Texas Bridge Rails to Contain Buses and Trucks," Research Report 230-2, Texas Transportation Institute, Texas A&M University, College Station, TX, August 1978.

NTIS does not permit return of items for credit or refund. A replacement will be provided if an error is made in filling your order, if the item was received in damaged condition, or if the item is defective.

Reproduced by NTIS

National Technical Information Service
Springfield, VA 22161

***This report was printed specifically for your order
from nearly 3 million titles available in our collection.***

For economy and efficiency, NTIS does not maintain stock of its vast collection of technical reports. Rather, most documents are printed for each order. Documents that are not in electronic format are reproduced from master archival copies and are the best possible reproductions available. If you have any questions concerning this document or any order you have placed with NTIS, please call our Customer Service Department at (703) 487-4660.

About NTIS

NTIS collects scientific, technical, engineering, and business related information — then organizes, maintains, and disseminates that information in a variety of formats — from microfiche to online services. The NTIS collection of nearly 3 million titles includes reports describing research conducted or sponsored by federal agencies and their contractors; statistical and business information; U.S. military publications; audiovisual products; computer software and electronic databases developed by federal agencies; training tools; and technical reports prepared by research organizations worldwide. Approximately 100,000 *new* titles are added and indexed into the NTIS collection annually.

For more information about NTIS products and services, call NTIS at (703) 487-4650 and request the free *NTIS Catalog of Products and Services*, PR-827LPG, or visit the NTIS Web site <http://www.ntis.gov>.

NTIS

***Your indispensable resource for government-sponsored
information—U.S. and worldwide***





U.S. DEPARTMENT OF COMMERCE
Technology Administration
National Technical Information Service
Springfield, VA 22161 (703) 487-4650
